

WESTENDORF

ALL PRODUCT GUIDE

www.loaders.com



FAMILY OWNED AND
OPERATED IN THE HEART
OF AMERICA SINCE 1934



PAST, PRESENT AND FUTURE

At Westendorf our sole purpose has been innovation for over 85 years. While others constantly change who is going to manufacture their loaders, we concentrate on taking all of the knowledge we have gained over the years to make our loaders operate in the best and most efficient way possible, all to make your life easier.

Our experienced staff is detail-oriented, professional, committed, and offers the “human touch” needed in customer service. We, as a family owned company, approach service with an authentic commitment to accurate and honest advice, and provide safe and simple ways to make the best decisions for your operation.



WESTENDORF MFG. CO., INC.

P.O. BOX 29, ONAWA, IA 51040
Ph: 712.423.2762 | 877-MY-LOADER

Email: sales@westendorfmfg.com
Website: www.loaders.com
Online Parts Store: store.loaders.com



CONTENTS

4

WHY WESTENDORF

Developed with the customer in mind, Westendorf loaders offer added value, increased power, more versatility and...

18

COMPACT LOADERS

Compact Series | 18
Compact Loader Attachments | 32

28

FRONT END LOADERS

Westendorf Loader (WL) Series | 34
Traction Action (TA) Series | 44
Xtra Traction Action (XTA) Series | 64
Limited Series | 72
MAX Series | 80
Freedom Mount (FM) Series | 90

106

MORE PRODUCTS

Landscraper™ | 106
Hay Man Bale Limo | 108
Wagon Packages & Running Gears | 109
Cool Cap™ Tractor Shade Canopy | 110
Thrifty-Lift™ & 3-Point Implements | 111
Hydra-Snap™ Hydraulic Manifolds & Dump Spreader | 112
Auto-Dump™ | 113
Dual Changer MAX | 113

116

ATTACHMENTS

Buckets & Adapters | 116 - 118
Snowblades & V-Plows | 120 - 121
Heavy Lifting Essentials | 120 - 121
Bale Spears | 122 - 123
Grab Forks & Specialty Grapples | 124 - 125
Brush Crushers™ | 126 - 127





LEADING PRODUCTS

Developed with the customer in mind.



In addition to manufacturing high-quality products, Westendorf realizes that our strategy must also include a value that is based on our customers' requirements and feedback. Westendorf delivers the best overall value and highest return on your investment with complete, customer-driven solutions that increase productivity, reduce costs and minimize downtime. Westendorf has been constantly developing and improving its products in close cooperation with customers for over 85 years.

BEST OVERALL VALUE

Value, like beauty, is in the eye of the beholder. The things people value in life are as unique as their experiences and aspirations. In farming, ranching or just business in general, value is dictated by goals,

budgets, and seasonal deadlines; a mass of forces that change as quickly as the weather from week to week and project to project. At the end of the day, value is all about results. It is getting the best return on "every" dollar spent.

LOWEST TOTAL COST OF OWNERSHIP

Westendorf looks beyond price to deliver the lowest total cost of ownership while maintaining the best resale value in the industry. The price of a loader is only a small fraction of what our customers actually spend. Factoring in unwanted downtime, maintenance and process inefficiencies, you now begin to appreciate the total cost of ownership. Our customers get speed, efficiency, flexibility, high resale and the lowest total cost of ownership.

VALUE IS WHAT CUSTOMERS SAY IT IS

To deliver value, we must first define it—in our customers' terms. At Westendorf we listen. We take the time to get to know our customers, understand their day-to-day challenges and pinpoint their needs. We help customers explore their options and offer innovative material handling solutions to match their needs, rather than a "one-size-fits-all" approach.

Our solutions can fit tight budgets, work seamlessly with existing implements and commonly exceed the desired results. As the leader of loader innovation, we serve our customers one at a time and work to be a partner in their success. We deliver no matter how our customers define value, or how often their definition changes.



We deliver the best overall value and the highest return on your investment with complete, customer-driven material handling solutions that save you time and reduce costs.

WE OFFER MORE

We offer more applications and the best multi-tractor versatility of any loader on the market today. You can choose from nearly 100 attachments that will turn your loader into your best friend, it is the helping hand you've been looking for that will complete any task at hand and quickly become that all-around-the-yard tool you've been looking for.

With over 20,000 bracket fits to date, easily share a loader between different makes and models of tractors. Move your loader to the cab tractor for winter snow removal or to the open station tractor for summer hay handling.

CUTTING EDGE

In recent years we've invested in cutting edge technologies, robotic welders, CNC lasers, 3-D design and interactive online environments in order to bring you, our valued customer, the service, parts, documentation and quality products you expect and deserve. Join our family of happy, satisfied and proud Westendorf customers today.



FAMILY OWNED AND OPERATED IN THE HEART OF AMERICA SINCE 1934





23 REASONS WHY WESTENDORF

You've always wanted a Westendorf; it's time to get one.



You work hard, and you deserve a loader that is designed to handle day-to-day use and performs as well as your favorite pair of gloves. You've always wanted a Westendorf. Now it's time to get one.

Let's take a look at some of the reasons why a Westendorf is the right loader for you.

QUALITY WORKMANSHIP

1. Double tapered arm design with interior I-beam reinforcements.
2. Computer controlled manufacturing.
3. Over 85 years of experience and knowledge goes into each product.
4. Each loader is built in the USA and quality inspected before shipping.

INCREASED VALUE

5. Maintains the highest resale value at auctions and at trade-in.
6. No Hidden Charges! Complete, all-in-one package pricing!

VERSATILITY

7. Share a loader between multiple tractors for seasonal or daily tasks.
8. Upgrade loaders without changing all the brackets.
9. Easily access tractor for maintenance.
10. Terrific line of over 60 quick-change attachments to choose from.

SEE & FEEL THE DIFFERENCE

11. Low profile increases visibility.
12. Custom loader colors and decals.
13. Bigger, stronger buckets with clean and spacious rib-free interior.

INDUSTRY PIONEERS

14. Inventive ideas like Power-Mount™, Freedom-Mount™, Snap-Attach™ and Hydra-Snap™ are just a few of the patented firsts.
15. A Westendorf does the job! You can Will it to your grandchildren.
16. Power linkage allows maximum bucket action and breakout power.
17. Leads the industry in lift height.
18. New products are designed to retrofit the existing product line.

FIT AND DURABILITY

19. Highest grade materials like HSLA steel and larger diameter pins are used to increase durability.
20. Largest fit history with over 20,000 fits for 2WD and 4WD tractors.
21. All components are manufactured on site for long-term parts availability.

POWER PLUS...

22. Rest easy knowing your Westendorf will have the strength to match your tractor with its double tapered, reinforced arm design.
23. Bucket's position on the tractor increases visibility, capacity and comfort during operation.



“It’s not how much steel you use, but it’s where you put the steel that really counts.”

IT’S WHAT YOU DON’T SEE THAT REALLY COUNTS!

Westendorf has been around since 1934. Since then, we’ve developed a simple design concept that has proven itself over and over throughout the years.

Westendorf loaders are strong and durable, yet they are considerably lighter in weight than most loaders on the market. When comparing strength per weight, we win hands down. You should be carrying heavy payloads, not a heavy loader that can overload or bog down your tractor. We specialize in designing loaders for heavy use and have learned from

experience where to put the steel. Found on all loaders in our lineup, the double tapered arm is the key to strength. It reduces strain on your tractor and carries larger payloads at the same time. Our patented interior I-beam offers even more reinforcement to the loader’s arm to keep the loader light, but very strong.

Westendorf raises the bar once again with a new triple force arm design. The double taper is the first line of defense. The second is the curved arch in the arm. The third is the box I-beam construction. Combine all three and you get a loader that matches the strength of today’s very powerful front-wheel assist tractors. Go ahead and plow into an oversized pile of manure

and raise that heaped bucket with ease. Time and time again Westendorf loaders have proven their value under the harshest field tests. With a well built loader, you can meet the challenges of every day use for a very long time.



DOUBLE TAPERED ARM

Reduces strain on the tractor, aids in withstanding side-pressure, and the internal I-beam adds strength.



PROFESSIONALLY ENGINEERED

It's the fit that makes the difference

We fit more tractors than anyone else while remaining current with today's market; However we also maintain fits for older loaders. We have over 20,000 fits on both two and four-wheel drive tractors and it's growing everyday.

Westendorf loaders are made to fit. They are professionally engineered and designed to offer the lowest profile. The low-profile design doesn't just look better, it increases visibility and performance by allowing maximum oscillation and turning radius. Just like your

favorite pair of work gloves, a Westendorf loader fits well, has a rugged design and doesn't interfere with the task at hand.

Not only does a Westendorf loader fit your tractor well, it can easily be adjusted to fit several different tractors with additional brackets. This feature allows two things: first, you can use a Westendorf loader on multiple tractors in your operation to switch from an open-air cab in the summer months or to an enclosed cab for hauling snow during the winter months; second, you retain amazing resale value on your Westendorf loader, the highest of any brand on the market today. You can sell or easily upgrade your loader because it can be adapted to fit a different tractor in the same horsepower range. Westendorf makes lifetime loaders—they often outlive the tractor are on!



CUSTOMIZING IS WHAT WE DO BEST!

Specialized options are available for your loader to customize the fit to your tractor. Next to the model number on the loader tower, you will find letters ranging from A-H, which indicate any specialized features of your loader.

- A D** **Tower:** Indicates a custom tower to fit a specific tractor frame.
- B** **Mechanical Self-Leveling:** Increase safety & time economics while raising the lift capacity 20%. Ideal for the inexperienced user.
- H** **Hydraulic Self-Leveling:** Replace any existing hydraulic manifold, old or new. This will turn any model loader into a self-leveling loader.
- C E** **Cylinder:** Upgrade bucket or lift cylinders on a loader for added power and strength.
- T** **Third Function:** Loader has an additional hydraulic line to run hydraulically-powered attachments.
- SP** **Special:** Some tractor models require special modifications to the tower or loader frame.





Photo provided by:
Shanda Gingery
Moscow, ID

THE LATEST TECHNOLOGY CAN BE YOURS

There's no need to buy a new tractor and invest a large sum of money to get the latest loader technology. Since the late 50's Westendorf leads the industry with new innovative advancements in front-end loader technology. When you buy a Westendorf loader, you can take advantage of an extensive tractor-loader fit history. As a Westendorf owner, this allows you several key advantages.

KEY ADVANTAGE 1:

With the purchase of a second set of mounting brackets, you will be able to interchange a single loader on multiple tractors. The hydraulic mounting takes less than one minute and doesn't require any dangerous kick stands or tools.

KEY ADVANTAGE 2:

You can purchase a new loader equipped with all the modern day bells and whistles without having to invest a lot of money in a new tractor. We maintain thousands of specifications on older model tractors to offer more versatility and increase resale values.

KEY ADVANTAGE 3:

During the design process for new technology, we make sure any updates made to loaders and their components will retrofit and remain interchangeable with the older Westendorf loader models still being used today. We still supply a complete line of replacement parts for loaders that were built over 50 years ago.

TIRE OSCILLATION?

Westendorf loaders let you experience the tire freedom your tractor was designed with, even if you have large front tires. Keep fenders on most models with 30" row settings without turning limitations or stops.





LOADER RESEARCH CAN BE TRICKY

Consider all research areas to avoid common mistakes.

THE BEST WAY TO SELECT THE RIGHT LOADER

There are several ways you can go about selecting a loader, however best way is to select a loader based on your current and future needs. First and foremost, you must consider the chores and types of materials you will be handling. Will you need a specific lift height to stack bales three high? Will you be handling seed and need to lift a minimum of 3,000 pounds to the full height? Let us know what you want to do with your new loader, and we will exceed your expectations every time!

DON'T ASSUME PERFORMANCE

Assuming all loaders are pretty much the same in construction or capabilities can leave you wanting more.

INTERPRETING SPECIFICATIONS

Don't assume specifications, such as lift capacity or breakout force, are measured the same way by all companies. Pay particular attention to "where" they are measured. Many variables can skew specifications. See how to compare these details on pages 12-13.

BUYING USED IS NOT CHEAPER

The initial loader price may be less however, figuring in mounts, hoses, manifold and hydraulic components can add up very quickly to nearly the same as the price of a new unit.

DON'T SHOP BY PRICE ALONE

You can buy a fast food meal for less money, but don't expect it to taste like home cookin'. Selecting the right loader for the tasks at hand will pay off in performance and user convenience that you will appreciate with every use.

ARE YOU COMPARING APPLES TO APPLES?

There are many things to consider when comparing loaders. At Westendorf, we price loaders in a “complete” package. Make sure you compare the following value added components when purchasing a new loader.

Quick Mount: All Westendorf loaders include either the Power-Mount™ or Freedom Mount™ easy on/easy off hydraulic mounting and dismounting system.

Quick Attach: Standard on most loader models. Value: \$700-\$1500

Quality Bucket: The bucket included in the package can impact the overall price of a loader package. Value: up to \$1300

Hoses & Manifold: These commonly overlooked items can add several hundred dollars to a loader package, especially if you are considering a third function line.

Bucket Gauge Rod: It's like buying a car without a speedometer. Value: \$100

Mounting Brackets: Mounting brackets are included in the loader package price. Value: depends on the loader size.

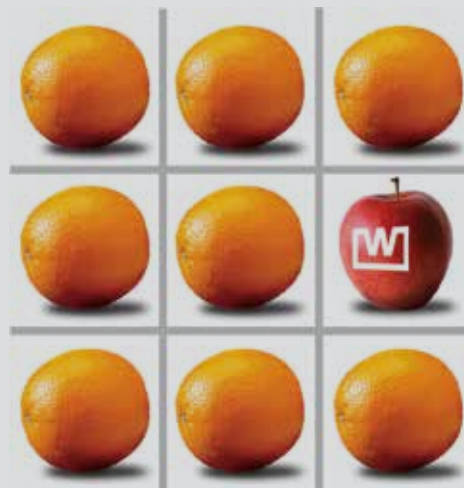

ALL LOADERS COME OFF EASILY

That is true, however it is getting the loader back ON the tractor that you should be concerned about. Be sure to review a manual for the mounting procedure BEFORE you buy. A Power-Mount™ or Freedom-Mount™ loader will free your tractor for field work or tractor maintenance in less than one minute. No hammers, punches or concrete slabs are required.

“ I really wish to compliment you people on the fine loaders you build. I have a Westendorf loader as do many of my neighbors, and they all like them very much. Built in the good ole USA!”

*GALEN BENTON
Worthington, MN*

OEM IS NOT THE BEST LOADER

Don't assume that the loader built by the tractor's original equipment manufacturer (OEM) is the best option for your tractor or your material handling needs. At Westendorf, we specialize in loaders, a loader is not an accessory or afterthought. We beat the OEM model in lift capacity, lift height and overall fit to the tractor every time.

SERVICE AND PARTS

Almost every tractor OEM that outsources loaders and components limits long-term part and service capabilities. Westendorf manufactures their loaders and components in the U.S.A. for fast delivery and long-term availability. Parts are still available for products that were sold in the 1950's.





KNOW THE FACTS BEFORE YOU BUY

Make an informed and educated buying decision.



We deliver the highest resale value with over 20,000 fits to ensure you are getting the best overall value and the highest return on your investment. Complete, customer-driven material handling solutions save you time and reduce costs. Westendorf loaders are field tested by the heaviest of users to ensure they meet the highest standards of performance.

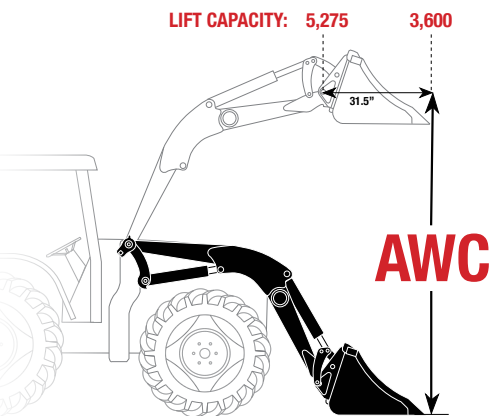

AWC: Is the capacity at the full height and 31.5" forward of the pivot pin.

ACTUAL WORKING CAPACITY (AWC)

Making comparisons by using the actual working capacity (AWC) of a loader will tell you the true power and shows the actual strength potential of the loader.

AWC is measured at the full height of the loader, 31.5" forward of the pivot pin. The lift capacity should always be compared at the full height of the loader, not at 59" from the ground or at ground level. These numbers as well as breakout capacities can look impressive, however only the AWC simulates the loader's true potential such as carrying a bucket full of dirt or large round bale. If the AWC is good, the capacity at 59", pivot pin or breakout position will be more than sufficient to do what you want the loader to do and more.

WHAT YOU NEED TO KNOW

When shopping for a loader, one can easily get tangled up in comparing numbers from one loader to the next. Specifications can be helpful, but can also be misleading and skewed. When looking at numbers, make sure all measurements were taken in the same conditions and locations (i.e. PSI or inches from the pin). You should disregard breakout capacities or measurements taken at the pin. The most reliable performance ranking is the AWC.

When you compare the lift capacity at the pivot pin, be prepared to experience less capacity and lower performance. Many companies use different measurement points or test at different PSI ratings to get more favorable performance results.



“When I went shopping for a loader, I did some old fashioned research, and word of mouth told me that Westendorf was the way to go. Everybody I talked to only had good things to say, especially if I ever needed replacement parts. So, after getting my Westendorf, I can tell you that it is the best loader I have ever seen. I like the way it mounts and dismounts, the quick-attach system, and overall fit and performance. My brother liked it so much after trying it out, he bought the exact same loader 2 weeks later. Now we can share attachments and get twice as much done.” *DONALD KLINDT, Iowa*

HOW PSI CAN AFFECT CAPACITY

If the pounds per square (PSI) is increased OR decreased in your tractor, this will directly affect the speed and lift capacity of the loader. For example, if a loader's lift capacity is 4,800 lbs. at 2,200 PSI, changing the PSI to 2,800 will result in a lift capacity of approximately 6,100 lbs. Not all companies test loader capacity at the same PSI, so when comparing lift capacity, be sure to make a note of the PSI rate used during testing.

MAXIMUM AXLE CAPACITY

Every tractor has a rated front axle capacity. We pay particular attention to each manufacturer's ratings and select the right loader for the tractor. With over 50 to choose from, we don't need to over- or under-rate a loader's performance to fit the tractor. It's like buying the right size work gloves; if they're too big or too small, it makes work cumbersome and uncomfortable. Pairing the right loader with the tractor makes a big difference.

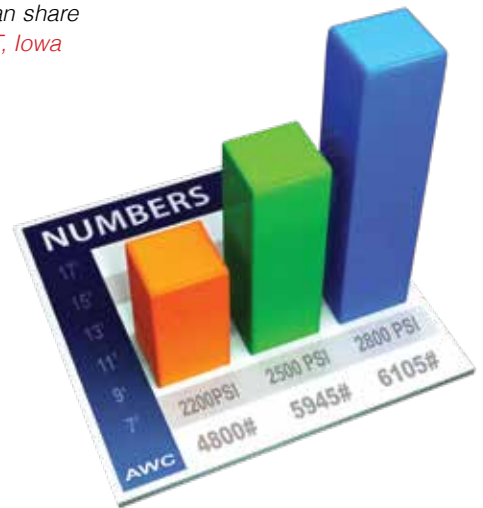

These are specifications from the same loader. Be sure and read *How PSI Can Affect Capacity*.





PRACTICAL SOLUTIONS

-To match the tasks at hand.



Westendorf offers valve and joystick packages that will plumb directly into your tractor's hydraulic system to help you meet your material handling needs.

- 1) Joystick direct mount to valve
- 2) Remote cable joystick and valve
- 3) Electronic joystick and valve



JOYSTICK PACKAGE OPTIONS

- 3rd Function Electric or Hydraulic
- Pressure Flow Compensated System
- Level UP Hydraulic Self-Leveling

PRECISION CONTROL

Experience precision like never before with this new valve and first-class cable joystick. It gives you the kind of fingertip control that you can only dream about. The ergonomic design fits comfortably in the palm of your hand and the adjustable mounting bracket has been designed for operator ease. With this in-line valve, you get quick, clean and compact installation. If you have a need for the 3rd function to operate a grab fork or other style attachment, it is available with an electric 3rd spool fingertip control. For heavy forklift users, order this with the new Level UP Advantage.

COMFORT WHILE WORKING

Staying comfortable while working is important; it reduces operator fatigue and equipment wear. Westendorf offers three upgrades to increase comfort while working.

- 1) Electronic Joystick - offers remote fingertip functions that are programmable such as return-to-dig, bucket-rattle, and precision mode for working in tight spaces.
- 2) Self-Leveling - adds comfort and confidence while working to prevent spillage by keeping the load level.
- 3) Comfort Ride - Plumbed into the loader's lift cylinders, this add-on hydraulic valve acts like a shock absorber and minimizes bouncing for a smoother ride.



A MUST HAVE

The new Remote Control Coupler is activated by an Electro-Hydraulic control button conveniently located in the cab for fast attachment changes from the comfort of the tractor's seat. Regulated by small internal cylinders, the plungers are secured with hydraulic pressure. Indicators on each coupler monitor the connection so you can SEE the attachment latch from the seat. This economical user-friendly solution DOES NOT require added hoses or 3rd function additions to your tractor. It has all the same great features as the Original Snap-Attach™, so you can still use your Westendorf attachments.

“ The joystick and valve are what the younger generation wants. It's a good price for what it is.”

LEAMON DONEGAN
Donegan Repair-Tennessee

IT'S A SNAP

A system above all the rest, the patented Snap-Attach™ System has a self-aligning V-guide to automatically center the attachment for trouble free alignment every time. It also keeps the connection tight. Other flat models on the market are hard to align and show excessive wear with use. The V-shape will always stay tight because the harder you push, the tighter the connection becomes. Stop pounding and aligning pins and convert your loader today to the tried and true Snap-Attach™ system.





IN THIS CASE, BIGGER IS BETTER...

Products that are faster, stronger and more efficient.



Westendorf “standard” buckets are bigger than most competitors’ high-capacity buckets. Since we’ve been manufacturing loaders, our buckets have been the best in the industry. The exclusive patented bucket shape is only available from Westendorf.

Westendorf buckets have a welded-in cutting edge to give you more

strength without adding weight. Bolt-on options are available for specific applications. The sides of the bucket are ribbed for increased strength. The bottom bracing is perpendicular to the cutting edge, and aligned with the couplers and loader arms. This patented design allows the forces and shock of digging to travel through the bucket and disperse into the loader without causing damage. Buckets are available from 36” to 120” wide, with capacities from 4 cubic feet to 54 cubic feet. Bucket replacement parts, like replaceable weld-on or bolt-on blades, are readily available. Compare sizes and you’ll be amazed!

IT'S WHY EVERYONE LOVES THEIR WESTENDORF

We go the extra mile to ensure you’ll have the fastest, easiest and most versatile mounting and dismounting system in the industry. As the innovator of the original patent in 1979, this tried and true all-hydraulic mounting system has been refined and perfected over the years. It allows

AS SEEN IN FARM SHOW MAGAZINE



My Westendorf loader is my best buy. I really like the bucket mounting system.

The loader itself is also easy to take off and put back on and doesn't require any tools. The company offers many different size loaders to fit any tractor.”

LEROY KLESEL—Hallettsville, TX

Customize your bucket with:

- Quick-Tach Bucket Teeth
- Back Drag Blade
- Grab Forks



Westendorf High-Volume Bucket
 Westendorf Heavy-Duty High-Capacity Bucket
 Westendorf Standard High-Capacity Bucket
 Standard Competitors' High-Capacity Bucket



your loader to be dismounted in less than one minute without the use of tools. There are no complicated components or dangerous kickstands to misplace, store, lose or damage.

A Westendorf loader uses the hydraulic cylinders and existing components to move the loader on and off the tractor. When the loader goes on, it automatically locks itself on so you don't have to get off the tractor to align or pound in pins. No need for a concrete slab either. Just set it on any level surface. If it gets bogged down in mud or freezes to the ground, you can simply hook up the loader to your tractor hydraulics to reposition it. The self-aligning bracket system will automatically adjust the loader's position as you drive into the loader. It's that simple.

WORK IN COMFORT

Staying comfortable while working is important; it reduces operator fatigue and equipment wear. Westendorf offers three upgrades to increase comfort while working.

- 1) **Electronic Joystick** - fingertip control with programmable functions such as return-to-dig, bucket-chatter and precision mode for working in tight spaces.
- 2) **Self-Leveling** - adds confidence while working to prevent spillage by keep the load level.
- 3) **Comfort Ride** - acts like a shock absorber and minimizes bouncing loads for a smoother ride across long distances or over rough terrain. This add-on uses the loader's lift cylinders as shock absorbers.

“ I left the loader on for a year before I decided to try to take it off. I was amazed at how quick and easy it came off, and it was just as easy to put back on. It is far and away the easiest loader to mount and dismount that I've ever owned...”

MIKE RECKER—Iowa

PATENTED BUCKET SHAPE

Just like a Dixie cup or a sand mold, a Westendorf bucket has a double tapered design that allows material to dump freely and easily. Order a Westendorf bucket with other brand adapters and quick-attach systems, such as skid-steer. See page 119.



COMPACT SERIES

Our mini to mid-sized high strength loader series has got you covered. Designed to fit tractors up to 90 horsepower, it's the perfect loader for your two or four wheel drive compact tractor. The Compact Series turns any compact tractor into a real workhorse.

The patented design puts quality, strength, good looks and ease of handling into a loader that makes work fun. You're going to love the new precision fingertip control and Power-Mount™ feature to free up your tractor for other uses without having your loader in the way. The smart bucket design is made to clean out quickly. The amazing low-profile design gives you great visibility, and the power linkage gives you great rollback and dump angles. The list goes on and on.

Select from a complete lineup of attachments that are practical, functional and look excellent on your tractor.



WESTENDORF MFG. CO., INC.

P.O. BOX 29, ONAWA, IA 51040
Ph: 712.423.2762 | 877-MY-LOADER

Email: sales@westendorfmfg.com
Website: www.loaders.com
Online Parts Store: store.loaders.com



MINI-MATIC COMPACT LOADER

– developed with “big” loader performance in mind.

Just because this line of loaders is designed for the compact tractor, doesn't mean it won't pack a punch or offer the same time-saving benefits as a “big” loader. Westendorf maintains the legendary power and user-friendly focus in this smaller line of loaders. There's no sense getting a loader if it isn't going to do what you need it to do.



PAYLOAD IS WHAT REALLY MATTERS

Lift capacity, especially in a compact loader is an important criteria when selecting the right loader for the tasks at hand. A double tapered arm design allows for two very important benefits. First, it adds tremendous strength to the loader to resist side-to-side pressures; and second, it results in a lighter weight design which allows you to lift more payload safely while staying within your tractor's front axle rating.

IT'S THE LITTLE THINGS THAT MATTER

It's our attention to detail that you'll appreciate every time you use your loader.

- Reliable quick-attach bucket
- Valve and joystick package
- Hydra-Snap™ one-lever manifold
- Smart clean-out bucket design
- Low-profile fit for good visibility
- Largest selection of innovative material handling attachments ensure you'll get a reliable loader that will get the job done right.



RESULTS

We deliver the best overall customer-driven results with the most power and highest lift in the industry.

“ My TA-111 loader is absolutely amazing. It has saved me hours of work. You can't believe the size of rocks this loader can lift. It even moved a telephone pole with a glob of cement block on it. I can move 7 or 8 poles at one time. There is nothing that has served me better or as well as this front-end loader. The quality and construction of this TA-111 certainly outdoes all others.”

GORDON ARTENO
Tennessee



IT'S FAST!

Of course, the Compact Series* loaders come with the time-tested and patented Quick-Attach system. That saves you time and money, and that's what Westendorf is all about.

*TA-52 & TA-55 available with pin type or skid-steer style buckets.

POWER-LINKAGE

What does power-linkage mean to you? It means you will have all the power you need and more to get the job done right without the hassle of material spilling off the front edge of the bucket.

MORE ATTACHMENTS

Choose from a wide selection of attachments—more options than any other loader in its class on the market today.

CLEAN OPEN BUCKET

The Compact Series loaders have a patented bucket design which is tapered on all sides. It has a rib-free interior for quick, no-stick release of materials. It's tapered like an ice cube tray so snow and other materials that typically tend to stick will release easily.

IT'S ALL ABOUT PRECISION

The precision joystick gives you the kind of fingertip control that you can only dream about. Its adjustable bracket is designed for operator comfort. The in-line valve allows clean, quick and compact installation plus, the quick connectors are color coded for simple identification.



EASY HANDLING

Tailor-fit brackets and patented loader design make it possible to position the loader and bucket back on the tractor while providing added stability and balanced weight distribution to enhance the overall feel, performance and handling.

REACH NEW HEIGHTS

Compact Series loaders have incredible lifting power and amazing lift heights (up to 11') in a small, good-looking package. You can stack whatever you have, wherever you want it in one smooth motion.



LOOKING OUT FOR YOU

The superior fit of the Westendorf low-profile design keeps the loader out of your field of vision so you can see where you are going. Our tailor-fit mounting brackets position the loader in the best possible position, keeping the bucket close to the front axle for additional stability and power.

SIMPLE MOUNTING SYSTEM

Maintain resale value by buying a loader that can fit many different tractors. The Power-Mount™ makes it easy to share the same loader between tractors. The simplicity and speed of the mounting system lets you take your loader off or put it on in just minutes without any tools or dangerous stands.



QUALITY CYLINDERS

Westendorf cylinders are manufactured to internal quality levels based on over 85 years experience. Metal piston rings and chrome-plated piston rods add more protection from rust corrosion and stroke wear.

CUSTOM OPTIONS

Build a loader package to meet your material handling needs. Add custom loader options such as:

- Hydra-Snap™ one lever hose coupling
- Skid-steer adapter plate
- Comfort Ride
- Custom tractor matching paint
- Power-plus cylinder upgrade



MINI-MATIC

Small loaders with big benefits.

“ I can't begin to tell you how useful my Brush Crushers™ are; I was able to cut a large quantity of fire wood in a short amount of time and the size of the logs I was lifting was amazing. I am very happy with my purchase. I found myself looking around to see what else I could lift.”

TOM MURGO
Rhode Island



TA-52

**SMALL PACKAGE
WITH PLENTY OF MUSCLE**

**10-24 HP »
1350 LBS. AT 6'1"»**

The TA-52 is the ideal fit for smaller tractors and lawn mowers. It is an economical loader that has two strong bucket cylinders. It is a sturdy, compact loader for the rural homeowner who wants to move snow, dirt, pick up materials such as brush, move small bales, clean out stables, landscape and more. Its excellent lift height for its size can load into a pickup or trailer. The extra-wide sub-frame increases visibility while working and accommodates side-mount mufflers.

Base package: Hydraulic Power-Mount™, 1-3/4" Bucket Cylinder, 1-1/2" Lift Cylinder, Mounting & Hose Kit, Bucket Gauge Rod and 48" Bucket.

Options: Bucket Teeth, 54" Bucket, Hydra-Snap™, Comfort Ride, Regen Valve & Joystick Package and Attachments.



TA-55

**RIGHT SIZE
WITH HIGHER LIFT**

**10-24 HP »
1150 LBS. AT 7'2"**

The TA-55 is the economical loader for the rural homeowner. It has excellent clearance for easy tractor maintenance. Quickly move snow or dirt, pick up trash, load pickups, haul feed or small bales, spread gravel and sand, clean horse stables and more. The TA-55 is the ideal loader for snow removal and all types of material handling around the yard. The loader has excellent visibility along the tractor's hood with an extra-wide sub-frame to accommodate side-mount mufflers.

Base package: Hydraulic Power-Mount™, 1-3/4" Bucket Cylinder, 1-1/2" Lift Cylinder, Mounting & Hose Kit, Regen Valve & Joystick Package, Bucket Gauge Rod and 48" Bucket.

Options: Bucket Teeth, 54" Bucket, Hydra-Snap™, Comfort Ride and Attachments.



The ideal compliment to the Power-Mount™ system, the Hydra-Snap™ makes connecting or disconnecting the loader to the tractor a breeze. Keep your hands clean, and don't worry about mixing up hoses any more. Just rotate the lever and ALL hoses couple at once.

TA-111 THE ULTIMATE COMPACT LOADER

17-35 HP »
2300 LBS. AT 8'3"

The TA-111 provides the full features of the larger Westendorf in a smaller package, complete with low-profile design and quick-attach bucket. It works with belly mounted mowers and has an adjustable front wrap to allow a 6" adjustment up and down or front and back. There are over 300 fits for old or new tractor models. It is a great chore loader, and is excellent for material handling and snow removal.

Base package: Hydraulic Power-Mount™, 2" Bucket and Lift Cylinders, Mounting & Hose Kit, Precision Joystick, Bucket Gauge Rod and 60" Bucket.

Options: Bucket Teeth, Skid-Steer Adapter and Buckets, Hydra-Snap™, Precision Valve with Regen Spool, Comfort Ride and Attachments.

**NEW - SNOW SCRAPER BY
WESTENDORF IN SMALLER
5' & 6' WIDTHS...PP. 120-121**



TA-140 THE "BOOMER"
BUDDY

2WD: 15-35 HP » 2300 LBS. AT 7'7"
4WD: 15-30 HP »

Turn your compact tractor into a real workhorse. This beauty is designed for horse owners, acreage owners, or anyone who needs the power to move things fast and easy. Uniquely designed to match your super steer's turning radius, this tractor will always look its best with Westendorf's clean bracket design. It works with most belly mounted mowers and has a complete line of attachments.

Base package: Hydraulic Power-Mount™, 2" Bucket and Lift Cylinders, Quick Attach, Mounting & Hose Kit, Bucket Gauge Rod and 60" Bucket.

Options: Bucket Teeth, Skid-Steer Adapter and Buckets, Hydra-Snap™, Comfort Ride and Attachments.



If you have both a skid steer and loader, why not share attachments? New adapters are now available from Westendorf to convert the TA-111, TA-140, TA-160, TA-170, and TA-180 into a skid steer compatible quick attach system.

A quick-attach system turns your loader into a user-friendly, multi-purpose tool. Removing the bucket and changing attachments is quick and easy.





POWER MOUNT™

It really is this easy!

Mount or dismount your loader in less than 2 minutes without the use of tools or dangerous kick stands. Is it time to mow? Just back out of your loader to free your tractor for the task at hand.



TA-160 INCREDIBLE LIFTING POWER

The TA-160 is a smooth-shaped loader designed for the serious weekender that needs to handle large round bales. It has incredible lifting power in a small, good-looking package. Scooping snow, moving hay, performing dirt work or unloading pallets, this beauty is ready to work. It features an open tapered bucket for quick clean out, clean bracket design for better tire clearance and low-profile fit to let you see clearly what you are doing and where you are driving.

2WD: 20-60 HP » 2700 LBS. AT 9'5"
4WD: 20-50 HP »

Base package: Hydraulic Power-Mount™, 2" Bucket and Lift Cylinders, Quick Attach, Mounting & Hose Kit, Precision Valve with Regen Spool, Bucket Gauge Rod and 60" Bucket.

Options: Bucket Teeth, 66" Bucket, Skid-Steer Adapter and Buckets, Hydra-Snap™, Comfort Ride, Precision Joystick and Attachments.



POWERFUL

Small loaders with big benefits—precision joystick, low profile fit, clean open bucket and quiet ride.



TA-170 MORE LOADER WITH LOTS OF EXTRAS

This mid-sized, high-strength loader has a great profile. It is for the everyday heavy user or contractor. Extra features like low-profile, power linkage, tapered bucket, cushioned spring ride, reinforced arms, and clean bracket design for excellent visibility and tire clearance give it a professional feel and performance. Experience precision like never before with the optional ergonomically designed precision joystick and valve. The loader package includes all hoses and mounting brackets.

**2WD: 20-70 HP » 2380 LBS. AT 10'2"
4WD: 20-65 HP »**

Base package: Hydraulic Power-Mount™, 2" Bucket and Lift Cylinders, Quick Attach, Mounting & Hose Kit, Bucket Gauge Rod and 60" Bucket.

Options: Bucket Teeth, 66" and 72" Buckets, Lift Cylinder Updgrade, Skid-Steer Adapter, 66" and 72" Skid-Steer Buckets, Hydra-Snap™, Comfort Ride, Precision Joystick, Precision Valve with Regen Spool and Attachments.



Get a cushioned, quiet ride when driving with the loader mounted on the tractor. (TA-170 & 175)

TA-175 LOADED WITH POWER AND FEATURES

Ideal for the everyday heavy user, dirt work or hay handler. The TA-175 offers all the same features as the TA-170 plus more capacity. Share implements between your skid-steer and loader as the TA-175 includes the universal skid-steer adapter. It's a smooth operating loader with low-profile fit for good visibility. Excellent dump and rollback angles, smart bucket for quick clean out, cushioned ride, reinforced arms and clean bracket design are included with the loader package.

2WD: 20-70 HP » 3690 LBS. AT 10'2"
4WD: 20-65 HP »

Base package: Hydraulic Power-Mount™, 2" Bucket Cylinders, 2-1/2" Lift Cylinders, Skid-Steer Quick Attach, Mounting & Hose Kit, Bucket Gauge Rod and 72" Skid-Steer Bucket.

Options: Hydra-Snap™, Comfort Ride, Precision Valve with Regen Spool, Precision Joystick and Attachments.



SMART DESIGN

Professionally engineered for the everyday user.

SMART PAC CYLINDERS

Patented design with swaged ends that increase power and automatically compress the packings during assembly for reliability and manufacturing consistency.

QUICK-ATTACH

Add the versatility you need to take on any material handling situation. The simple design is strong, doesn't require any tools and has fewer moving parts to wear out over time.

COLOR MATCHING

For you brand loyal enthusiasts who would like your loader painted to match your tractor, just let us know when placing your loader order.

MULTI-USE DESIGN

The loader's tower doubles as a grill guard and support system for the loader when in the dismantled position.



TA-180

**REACHING
AMAZING NEW HEIGHTS**

**2WD: 20-90 HP » 4725 LBS. AT 11'
4WD: 20-80 HP »**

The TA-180 has an incredible lift height of 11 feet with a low-profile fit. Think about it! You can stack whatever you have, wherever you want it. Plus, when you combine it with the famous, time-tested Quick-Attach™ system, you can change from your bucket to a spear, forklift, Brush Crusher™ or other attachment in just minutes to take on any material handling task at hand.

Base package: Hydraulic Power-Mount™, 2-1/2" Bucket and Lift Cylinder, Quick Attach, Mounting & Hose Kit, Bucket Gauge Rod and 60" Bucket.

Options: Bucket Teeth, 66" and 72" Buckets, Skid-Steer Adapter, 66" and 72" Skid-Steer Buckets, Hydra-Snap™, Comfort Ride, Precision Valve with Regen Spool, Precision Joystick and Attachments.



TA-185

NEW SHAPE AND CUSTOM FEATURES

The TA-185 loader is the ideal fit for the heavy-duty user and contractor, built for everyday, heavy use. This loader has a professional feel, lower profile fit along the tractor's hood, an impressive lift height of 11 feet, bucket linkage, tapered bucket, reinforced arms, and in-line valve with precision joystick. The TA-185 includes a new contoured shape, wider frame to accommodate side mount mufflers, standard with the skid steer adapter and 72" skid steer bucket.

2WD: 20-90 HP » 4725 LBS. AT 11'
4WD: 20-80 HP »

Base package: Hydraulic Power-Mount™, 2-1/2" Bucket and Lift Cylinders, Mounting & Hose Kit, Precision Valve with Regen Spool, Precision Joystick, Bucket Gauge Rod and 72" Skid-Steer Bucket.

Options: Bucket Teeth, Hydra-Snap™, Comfort Ride and Attachments.



JUST SWAP IT!

Using the right tool for the job is easy!



Whether you're moving brush or maintaining the driveway, using the "right tool for the job" is easy. Westendorf's time-tested quick-attach system is simple, reliable and will put a smile on your face every time you use it.

TOOL FREE—MODERN DESIGN

The design is a tool free solution plus, it's easy to use and reliable. The quick-attach design has fewer moving parts to wear out over time which makes the Westendorf quick-attach system more reliable while reducing the time required for maintenance. This system has been tested over time and is proven to work well in the compact tractor industry.



COMPACT SERIES ATTACHMENTS	TA-52	TA-55	TA-111	TA-140	TA-160	TA-170	TA-175	TA-180	TA-185
Dozer Blade 60"	✓	✓	✓	✓	✓	✓	✓	✓	✓
Snow Scraper™ 60"	✓	✓							
Snow Scraper™ 72"			✓	✓	✓	✓		✓	
V-Plow 72"			✓	✓	✓	✓	✓	✓	✓
Forklift 42" (pin attach)	✓	✓							
Forklift 42" (quick attach)			✓	✓	✓	✓	✓	✓	✓
Bale Spear					✓	✓	✓	✓	✓
Bale Spear (skid steer attach)						(1)	✓	(1)	✓
Quick-tach Bucket Teeth 48"	✓	✓							
Quick-tach Bucket Teeth 60"			✓	✓	✓	✓	✓	✓	✓
Brush Crusher™ 3000	✓	✓							
Brush Crusher™ 4000			✓	✓	✓	✓	✓	✓	✓
Brush Crusher™ 4300			(1)	(1)	(1)	(1)	✓	(1)	✓
Brush Crusher™ 7700			(1)	(1)	(1)	(1)	✓	(1)	✓

(1) Requires skid-steer adapter

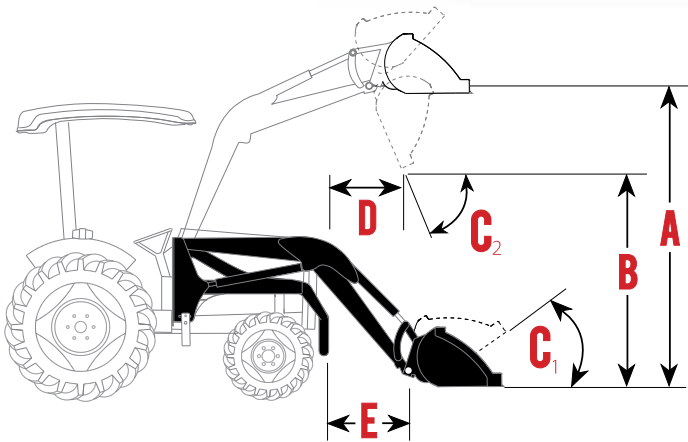

SPECIFICATIONS	TA-52	TA-55	TA-111	TA-140	TA-160	TA-170	TA-175	TA-180	TA-185
A Full Height (ground to pin)	6'1" / 73"	7'2" / 86"	8'3" / 99"	7'7" / 91"	9'5" / 113"	10'2" / 122"	10'2" / 122"	11' / 132"	11' / 132"
B Clearance (bucket dump)	52"	69"	78"	68"	96"	98"	98"	109"	109"
C₁ Dump Angle	20°	15°	15°	22°	30°	27°	27°	16°	20°
C₂ Rollback Angle	45°	45°	55°	47°	31°	51°	51°	49°	60°
D Reach at Max Height	24"	22"	27"	40"	33"	18"	18"	28"	28"
E Reach at Ground Level (to pin)	12"	12"	17"	22"	20"	24"	24"	22"	22"
	1800 PSI 2200 PSI	1800 PSI 2200 PSI	1800 PSI 2200 PSI	1800 PSI 2200 PSI	1800 PSI 2200 PSI	1800 PSI 2200 PSI	1800 PSI 2200 PSI	1800 PSI 2200 PSI	1800 PSI 2200 PSI
Lift Capacity - AWC* (19.65" from pin)	900+ 1100+	700 855	1400 1710	1400 1710	1650 2020	1450 1770	2250 2750	2880 3520	2880 3520
Lift Capacity - at Pivot Pin	1200+ 1350+	940 1150	1880 2300	1880 2300	2210 2700	1950 2380	3020 3690	3865 4725	3865 4725
Lift Cylinder - Standard Optional	1-1/2"	1-1/2"	2"	2"	2"	2" 2-1/2"	2-1/2"	2-1/2"	2-1/2"
Bucket Cylinder - Standard Optional	1-3/4"	1-3/4"	2"	2"	2"	2"	2"	2"	2"
Bucket Sizes Available	48", 54"	48", 54"	60", 66"	60", 66"	60", 66"	60", 66", 72"	60", 66", 72"	60", 66", 72"	60", 66", 72"

*For additional information on AWC Capacity - see page 12. Above specifications are based on ASABE S301.3 standard. Specifications may vary depending on the tractor, front axle configuration, tire size, hydraulic system and type of attachment. Design specifications are subject to change without notice or obligation.

WL SERIES

The tried and true lineup of Westendorf loaders fit tractors up to 160 horsepower and include a loader that's perfect for your 2-wheel drive tractor. The WL Series' simple, yet rugged design, first-class workmanship, get-it-done performance and unmatched power will make quick work of any task.

- Level position indicator
- Hydraulic Power-Mount™
- Snap-Attach™ System
- Hydra-Snap™ one-step coupling
- Standard high-capacity bucket
- Amazingly low-profile design

The list goes on and on.

When you're shopping for a loader, no matter what the size or range, versatility, performance and workmanship are important; so is the value. Our Westendorf loaders are backed by over 85 years of experience and are built to maintain the highest resale values on the market today.



WESTENDORF MFG. CO., INC.

P.O. BOX 29, ONAWA, IA 51040
Ph: 712.423.2762 | 877-MY-LOADER

Email: sales@westendorfmfg.com
Website: www.loaders.com
Online Parts Store: store.loaders.com



“ This is the finest loader I have ever seen. This thing is incredibly easy to install and remove. I cannot imagine owning any other loader!”

ALLEN GROSS

“ I've hauled everything in this loader but the Queen of England!”
SCOTT YEARGIN – Ottawa, Kansas

LEGENDARY 2WD LOADER SERIES

– Ideal for your old or new 2WD tractor.

This line of loaders is designed and tailored to fit 2WD tractors. Reap the benefits of this tried and true 2WD design with a larger power triangle for unmatched strength, a better fit along the tractor's hood, faster operation on older tractors and an unmatched integrated feel during operation.



POWER-MOUNT™ - TOWER SUPPORTS THE LOADER

When it's time to plant or use the tractor for field work, just park your loader in minutes with Westendorf's Power-Mount™ system. Others “say” theirs is easy, but none match the speed, ease and simplicity of this all-matic hydraulic system. Power-Mount™ does NOT require tools or dangerous kick stands and can be on OR off in just minutes.

RELIABILITY YOU CAN COUNT ON

Since the 1960's, this original series has withstood the test of time, and has evolved into the ideal loader for your 2WD tractor. The larger power triangle, double tapered arms, overall arm to cylinder proportions and the way it mounts to the tractor take into account every aspect of a 2WD tractor. It minimizes strain on the lighter duty front axle while offering the same performance, lift height and capacities of a 4WD loader.



IDEAL MATCH

Becomes ONE with the tractor.



IT'S A SNAP!

The WL Series loaders come with the time-tested Snap-Attach™ system. It is reliable and makes removing the bucket fast and easy. Change to other attachments in minutes and lock one back on without getting off the tractor.

BIG BUCKETS

High capacity buckets come standard on all WL loaders. Bucket reinforcements keep material from getting hung up inside the bucket and are used to quick attach grapple forks. Add custom options such as built-in chain hooks or back drag blade.

MORE ATTACHMENTS

Choose attachments such as quick-dismount grapple forks, Brush Crushers™, bale spears, forklifts, dozer blades, v-plows, snow scrapers and more.

CUSTOMIZE IT FOR TASKS

The WL-21 has a unique capability which allows setting the loader's boom cylinder to a Power Plus position for increased capacity, breakout and digging depth. Or, you can set it to the "high lift" position when the task requires more height.

THE "POWER TRIANGLE"

The smaller front tires of 2WD tractors allow the lift cylinders to be positioned lower on the tower creating a near perfect equilateral triangle between the three connection points illustrated above. In addition to increasing the lift capacity, it allows the use of smaller cylinders for increased operation speed, with the same performance as larger cylinders. Ideal for older 2WD tractors with limited hydraulic output.

“ I have three Westendorf loaders and I've owned them for over 30 years. I use my TA-26 and WL-42C for round bales, they are the best high lift loaders for hay. The quick-attach is nice and it's easy to convert other attachments on the market to my Westendorf loaders. None are broken or busted up. They still work and look good!"

ROGER GASWINT - Iowa

TRIED AND TRUE

Simple rugged design has outperformed all other loaders for over 50 years. Just ask your grandfather. With over 85 years of experience, Westendorf KNOWS where to put the steel when designing a legendary workhorse loader to keep the loader light and the stress off your tractor.



TRIPLE SEAL HOSE FITTINGS

Flare-less fittings offer three separate levels of leak defense. They handle higher burst pressures and can be used with heavier tubing to withstand the higher hydraulic pressures found in today's tractors.

SIMPLE MOUNTING SYSTEM

Bracketry is simple and is based on the horse collar principle distributing the weight through the entire frame instead of just over the front axle.



QUALITY COMPONENTS

To prevent wear, bushings have a grease relief chamber around the pins to distribute grease evenly during operation. The torsion tube is positioned for optimum visibility and goes through both walls of the arm to resist twisting.

QUALITY CYLINDERS

Westendorf cylinders are manufactured to internal quality levels based on over 85 years experience. Metal piston rings and chrome-plated piston rods add more protection from rust corrosion and stroke wear.

BECOMES ONE WITH THE TRACTOR

With no large front tires to get in the way, a 2WD loader can be positioned farther back on the tractor. This impacts how the loader and tractor feel "together" during operation. A 4WD loader is designed to fit and reach over large front tires. As a result, placing it on a 2WD tractor will require the loader to sit farther forward and higher along the hood.





SYNERGY

This WL loader and tractor team will impress.



FEEL THE DIFFERENCE

When you lift a large round bale or a bucket full of manure experience more power and stability with a WL loader that fits low and sits back on the tractor.

AUTO-LOCK

The auto-lock feature will automatically lock the loader to the tractor without you leaving the tractor's seat. Just rotate the locks to release the loader for dismount.

COLOR MATCHING

For you brand loyal enthusiasts who would like your loader painted to match your tractor, just let us know when you place your loader order.

NO TUNNEL VISION HERE

The low-profile fit of the WL Series loaders will let you see clearly in all directions while working faster and safer.



WL-21

**WESTENDORF POWER
IN A SMALLER SIZE**

**2WD: UP TO 80 HP »
5925 LBS. AT 10'**

The WL-21 or the original Jiffy Loader™ is the perfect fit for that smaller 2WD tractor, while maintaining all the strength and durability that we put into our larger loaders. It is great for moving hay, feeding livestock or cleaning up around the yard. The WL-21 has a unique capability which allows setting the loader's boom cylinder to a Power Plus position for increased capacity, breakout and digging depth. Or, you can set it to the "high lift" position when the task at hand requires more lift height.

Base package: Snap-Attach™, Hydraulic Power-Mount™, 2-1/2" Bucket and Lift Cylinders, Mounting & Hose Kit, MA-40 Hydraulic Manifold, Bucket Gauge Rod and 72" Bucket.

Options: Skid-Steer Adapter, Hydra-Snap™, Comfort Ride, 3rd Steel Line, Back Drag Blade, Bucket Teeth, Rotational Indicators, Level UP Advantage, Precision Joystick and Valve w/Regen Spool and Attachments.

“ I went to pick up a new WL-21 loader at the factory, and you know, it was fun! Those guys bent over backwards. It’s about time somebody said something about being built in the GOOD OLD USA again. Tell them boys doin’ the weldin’ to keep up the good work...they got it better than NASA when it comes to steel!”

NORMAN L. WILLEY
Willey Farms - Yale, IA

WL-27 THE WL SERIES WORKHORSE

The WL-27 is ready for any chore your tractor can handle. The WL-27 is considered an outstanding hay loader. Even with its impressive 12' lift height, the WL-27 maintains an amazing low-profile position on the frame. The double tapered arms follow most hood-lines providing excellent visibility while working. It's an all-around good looking loader for any 2WD tractor, old or new. The WL-27 is one powerful loader that will get all those jobs done quickly and efficiently. It falls between the WL-21 and WL-42 for fits and features.

**2WD: UP TO 100 HP »
5450 LBS. AT 12'**

Base package: Hydraulic Power-Mount™, 2-1/2" Bucket and Lift Cylinders, Snap-Attach™, Mounting & Hose Kit, MA-40 Hydraulic Manifold, Bucket Gauge Rod and 72" Bucket.

Options: 84" Bucket, Skid-Steer Adapter and Buckets, Hydra-Snap™, Comfort Ride, 3rd Steel Line, Back Drag Blade, Bucket Teeth, Rotational Indicators, Level UP Advantage, Precision Joystick and Valve w/Regen Spool and Attachments.



TRIED & TRUE

Our flagship loader with over 500 fits.

“ I've had my WL-42 loader for 24 years and haven't had to ever put a weld on it!
WARREN DIBBLE - Minnesota



WL-42 PLATINUM PACKAGE

The Platinum Package is designed to uphold the "tried and true" legacy of the original WL-42, while offering many of the modern conveniences that our customers have grown to need. We've improved the dump and rollback angles, and added the Remote Control Coupler so you can stay in your cab while changing attachments with the push of a button! Also included are the rotational bucket and height indicators, 3" lift cylinders, higher lift height (up to 13') and the Flat Face Hydra-Snap™. If you are a current WL-40 or WL-42 owner, the Platinum Package is an easy update. With a few hose modifications and the Power-Mount™ system, you can swap out the loaders using your existing mounts.

**2WD: UP TO 160 HP »
7025 LBS. AT 13'**

Base package: Hydraulic Power-Mount™, 3" Bucket and Lift Cylinders, Remote Control Coupler, Flat Face Hydra-Snap™ Manifold, Mounting & Hose Kit, Rotational Indicators, Power-Linkage and 84" Large Capacity Bucket.

Options: Mechanical Self-Leveling, 96" Bucket, HDHC Specialty Buckets, Skid-Steer Adapter and Buckets, Comfort Ride, 3rd Steel Line, Level UP Advantage, Precision Joystick and Valve w/ Regen Spool and Attachments.



WL-42 POWER PLUS A WHOLE LOT MORE

Commonly referred to as our “Tried & True” loader, the WL-42 is our flagship loader. We’ve been asked if we are ever going to change it? Our reply...Why change something that has served our customers so well for over 50 years? It is hands down the best 2WD loader for your dollar. Plus, its resale value is impressive. The WL-42 has the strength and long-term durability to provide you many, many years of service. Its classic styling lends itself well to old or new 2WD tractors. It is a comfortable loader to operate. You won’t find a more reliable, committed or better fitting loader on the market today. It features the original on and off without stands and the Snap-Attach™ for quick attachment changes as a standard package component.

**2WD: UP TO 160 HP »
7025 LBS. AT 12’6”**

Base package: Hydraulic Power-Mount™, 2-1/2" Bucket Cylinders, 3" Lift Cylinders, Snap-Attach™, Mounting & Hose Kit, MA-40 Hydraulic Manifold, Bucket Gauge Rod and 84" Large Capacity Bucket.

Options: Mechanical Self-Leveling, 3" Bucket Cylinders, 96" Bucket, HDHC Specialty Buckets, Skid-Steer Adapter and Buckets, Hydra-Snap™, Comfort Ride, 3rd Steel Line, Back Drag Blade, Bucket Teeth, Rotational Indicators, Level UP Advantage, Precision Joystick and Valve w/ Regen Spool and Attachments.



TOOL FREE

Cost effective—time tested design.



Since its introduction over 50 years ago, the Original Snap-Attach™ system has retained its rank as the #1 quick change attachment system on the market. A system above all the rest, the patented Snap-Attach™ System has a self-aligning V-guide to automatically center the attachment for trouble free alignment every time. It also keeps the connection tight. Other flat models on the market are

hard to align and show excessive wear. The V-guide will always stay tight because the harder you push, the tighter the connection becomes. This system keeps the pivot pin closer to the bucket for better bucket action. This system has been tested over time and it is one of the top reasons customers give for loving their Westendorf loader. Stop pounding and aligning pins; convert your loader today.

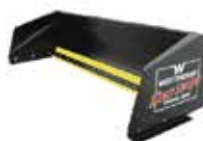

WL SERIES ATTACHMENTS	WL-21	WL-27	WL-42	WL-42 PLATINUM
Brush Crusher™ 4000	✓			
Brush Crusher™ 5000	✓	✓	✓	✓
Brush Crusher™ 6000	✓	✓	✓	✓
Brush Crusher™ 7700	(1)			
Brush Crusher™ 8200	✓	✓	✓	✓
Bucket Mount Bale Spear	✓	✓		
Three-Prong Bale Spear	✓	✓	✓	✓
Two-Prong Bale Spear	✓	✓	✓	✓
Four-Prong Bale Spear	✓	✓	✓	✓
Stack-Saver I (Round Bales)	✓	✓	✓	✓
Stack-Saver II (Square or Round Bales)	✓	✓	✓	✓

WL SERIES ATTACHMENTS	WL-21	WL-27	WL-42	WL-42 PLATINUM
Dozer Blade 84"	✓	✓	✓	✓
Dozer Blade 96"			✓	✓
Snow Scraper™ 96"	✓	✓		
Snow Scraper™ 120"		✓	✓	✓
V-Plow 96"	✓	✓	✓	✓
Forklift 42"	✓	✓	✓	✓
Forklift 48"	✓	✓	✓	✓
Bale Handler			✓	✓
Squeezer™	✓	✓	✓	✓
Quick-tach Bucket Teeth 72"	✓	✓		
Quick-tach Bucket Teeth 84"			✓	✓

(1) Requires skid-steer adapter (2) Requires HDHC Bucket



“ I have an Allis-Chalmers 460 loader; I recently set it up with the Snap-Attach™ system and it works great! I go from moving round bales to moving pallets to scooping manure in seconds!”

BRIAN R. YOUNG

Agricultural Education - Trimble County

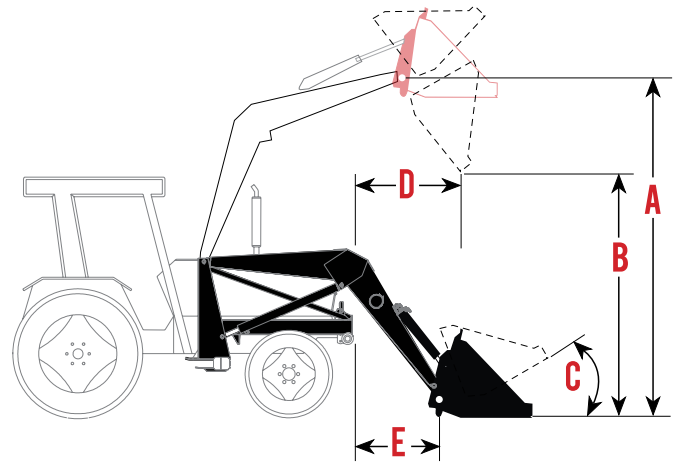

WL SERIES ATTACHMENTS	WL-21	WL-27	WL-42	WL-42 PLATINUM
Z-47 Feeder Bucket			✓	✓
Jiffy Monster Grab Fork	✓	✓		
Monster Grab Fork - Straight Teeth			✓	✓
Monster Grab Fork - Curved Teeth		✓	✓	✓
Quick Mount Claw			✓	✓
Sabretooth™/Tine Bucket	✓	✓	✓	✓
Fork Bucket	✓	✓	✓	✓
Rock Bucket	✓	✓	✓	✓
Cat Claw™			✓	✓
Cat Claw™ 3-D			(2)	(2)

WL SPECIFICATIONS	WL-21	WL-27	WL-42	WL-42 PLATINUM
A Full Height (ground to pin)	10' / 120"	12' / 144"	12' 6" / 150"	13' / 156"
B Clearance (bucket dump)	94"	120"	130"	130"
C Rollback Dump Angle	5°	12°	9°	35° 65°
D Reach at Max Height	34"	32"	30"	
E Reach at Ground Level (to pin)	20"	28"	32"	32"
	2500 psi 3000 psi	2500 psi 3000 psi	2500 psi 3000 psi	2500 psi 3000 psi
Lift Capacity-AWC* (31.5" from pin)	3000 3600	3100 3720	4000 4800	4000 4800
Lift Capacity-at Pivot Pin	4935 5925	4540 5450	5860 7025	5860 7025
Lift Cylinder-Std. Optional	2-1/2"	2-1/2"	3"	3"
Bucket Cylinder-Std. Optional	2-1/2"	2-1/2"	2-1/2" 3"	3"
Bucket Sizes Available	72", 84"	72", 84"	84", 96"	84", 96"

*For additional information on AWC Capacity - see page 12. Above specifications are based on ASABE S301.3 standard. Specifications may vary depending on the tractor, front axle configuration, tire size, hydraulic system and type of attachment. Design specifications are subject to change without notice or obligation.

TA SERIES

Our expansive Traction Action (TA) product line includes a wide variety from Mid-Sized loaders to Super-Sized loaders designed to fit 2WD and 4WD tractors ranging from 10 HP to 240 HP. Nobody knows loaders like Westendorf. No matter what the need or which tractor you are trying to fit, Westendorf can fit you into a loader that's a cut above the rest.

Just look at some of the key features that create the Westendorf advantage.

- Hydraulic Power-Mount™
- Snap-Attach™ System
- Custom adjust brackets
- I-Beam construction
- Level-Matic™
- Low-Profile design for 4WD tractors
- Hydra-Snap™ one-step coupling
- Comfort Ride



WESTENDORF MFG. CO., INC.

P.O. BOX 29, ONAWA, IA 51040
Ph: 712.423.2762 | 877-MY-LOADER

Email: sales@westendorfmfg.com
Website: www.loaders.com
Online Parts Store: store.loaders.com



TRACTION ACTION POWER

– raise the standards of performance.

The mid-sized to super-sized loader series is designed for 2WD and 4WD tractors from 30 HP to 240 HP. Get that extra oomph you need at heights up to 17'4" and be able to stack what you want—where you want it—while maintaining the professional feel of a loader that fits properly.



EXTRAS THAT “FIT” YOUR NEEDS

At Westendorf, we pay close attention to the small details and offer many custom features that make your overall loader experience user-friendly and hassle-free. Our customers’ favorite features are standard in our loader packages: Snap-Attach™, Power-Mount™, bigger buckets and gauge rod. You can add extras such as a Back Drag Blade, Hydra-Snap™, larger cylinders, valve and joystick or rotational indicators.

FEEL AND SEE THE DIFFERENCE

Don’t settle for a loader that doesn’t fit. A well fitting loader will feel like part of the tractor, not an extension from it. The competitor loader shown on page 46 will have huge visibility issues. Its position on the tractor is too high, creating a tunnel. With over 50 loaders to choose from, we can select the right “size” loader for your tractor so you don’t have to make sacrifices to get the power you need.



HANDY

When you pair the right tools for the job, your operation will run smoother and more efficiently.



“ *If you want a fantastic loader that slides on and off quickly, Westendorf is the loader for you. I used a WL-42 for years, parted with it, and got me a John Deere 740... biggest mistake I ever made! The 740 didn't slide off like the Westendorf models. The 740 is a joke the way it comes on and off; I can't wait to have a Westendorf on the farm again! Just another satisfied Westendorf customer. Keep up the great job!”*

PHIL BECK - Nebraska



WE PUT IT WHERE IT COUNTS!

It's not how much steel you can use to make the arm strong, but where you position the steel to maximize the arm strength. This prevents unnecessary stress on the tractor.

Westendorf's "exclusive" arm design resists extra side forces that the four-wheel drive tractor introduces. The double tapered arm is designed with an internal I-beam welded inside the arm to create a double wall on the top and bottom. This puts the metal where it belongs, increasing lift capacity, arm strength and resistance to twisting. This concept allows you to lift higher capacity payloads, instead of hauling around a bulky, heavy loader.

SUPERIOR FIT

The superior fit of the Westendorf low-profile design keeps the loader out of your field of vision, so you can see where you are going. Keeping the bucket close to the front axle for additional stability and lower on the frame will allow you to "see" clearly while working.

THE IDEAL COMPANION

Connect the loader to the tractor in seconds with the Hydra-Snap™ one-lever hose coupling manifold. Just align the keyed plate and rotate the handle. It prevents hose mix ups and is a much "cleaner" alternative to connecting individual hoses. Also available with flat face couplers.



#1 REASON—POWER-MOUNT™

The key reason Westendorf owners love their loaders is there are no pins to realign or tools required when mounting or dismounting. You won't need a slab of concrete, just park it on any level surface and let the tractor do all the work.

#2 REASON—SNAP-ATTACH™

The original quick-attach system was introduced over 50 years ago. Its design consistency has withstood the test of time. Change attachments without tools or extra trips off the tractor. This system automatically latches from the comfort of the cab.



UNI-FIT MOUNTING SYSTEM

Fine tune the fit to the tractor with the Uni-Fit bracket system. A well-fitting loader increases stability and just like your favorite pair of work gloves—feels “good” and is more comfortable. In addition to allowing the best fit, the uni-fit system also automatically locks the loader to the tractor.

SELF-LEVELING?

The key factor in determining whether to add a self-leveling kit has to do with what tasks you plan to perform with your loader. If you handle hay or load pallets frequently, then yes—you'll appreciate a loader that stays level. Choose from either mechanical or hydraulic self-leveling options.



QUALITY CYLINDERS

Westendorf cylinders are manufactured to internal quality levels based on over 85 years experience. Metal piston rings and chrome-plated piston rods add more protection from rust corrosion and stroke wear.

CUSTOM OPTIONS

Build a loader package to meet your material handling needs. Add custom loader options such as:

- Bigger buckets
- Chain hooks
- Back drag blade w/teeth
- Comfort Ride
- Custom tractor matching paint



RUGGED

The perfect size loader with an internal I-beam—for tractors up to 90 HP.

QUICK-ATTACH (TA-25)

The quick-attach adapter is economical and it will auto-lock the attachment to the loader without multiple trips off the tractor.

TA-25

**QUALITY
PRICED RIGHT**

**2WD: 30-90 HP » 5275 LBS. AT 9'4"»
4WD: 30-70 HP »**

The TA-25 loader has over 700 fits. It is a great example of Westendorf quality at the right price. The TA-25 is a well-built, low-profile loader for nurseries and small cattle feeders and is built for the every day user. It has the same great Power-Mount™ feature of the larger loaders and also includes an economical quick-change bucket system that automatically locks into the next attachment without multiple trips off the tractor. With its newly updated arched knee area, its modern styling matches today's sleeker and lower profile tractor hoods.

Base package: Hydraulic Power-Mount™, 2" Bucket Cylinder, 2-1/2" Lift Cylinder, Mounting & Hose Kit, Quick-Attach, MA-40 Hydraulic Manifold, Bucket Gauge Rod and 60" Bucket.

Options: 72" Bucket, 66" or 72" Skid-Steer Bucket and Adapter, 3rd Steel Line, Rotational Indicators, Hydra-Snap™ Manifold, Comfort Ride, Precision Joystick and Valve w/Regen Spool and Attachments.

“ I have never had a loader that I have used so much and that has served my every need, like my Westendorf TA-25... I'm a rancher in Colorado and have had many loaders... You do make a far superior product and I boast to all my ranch friends that they should be so lucky.”

KENNETH CURE - Colorado

SNAP-ATTACH™ (TA-26)

The Snap-Attach™ system for fast, tool-free implement changes. Just roll back your bucket, and it automatically locks the attachment to the loader.

POWER-LINKAGE (TA-26)

Additional linkage between the bucket and loader arms for increased dump and rollback angles.

SELF-LEVELING

Convert your TA-26 into a mechanical, low-profile self-leveling loader. This add-on kit is available at the time of purchase or at a later date. The modification does not require different cylinders or components to make the conversion.



TA-26

**#1 CUSTOMER PREFERRED
LOADER WITH OVER 1300 FITS**

**2WD: 30-120 HP » 5275 LBS. AT 10'5"
4WD: 30-90 HP »**

With over 1,300 fits, this is our most popular 4WD loader. The power linkage, slide locks, shoe adjustments, case hardened pins, and add-on self-leveling kit have proven that the TA-26 is the best all-around loader for versatility and dependability. Its unique I-beam construction and double tapered arms give it superior strength and a low-profile fit, all in one package. Standard with the original Snap-Attach™ quick change system and a solid-built 72" bucket, the TA-26 loader is a great general use loader package.

Base package: Hydraulic Power-Mount™, 2-1/2" Bucket Cylinder, 3" Lift Cylinder, Mounting & Hose Kit, Snap-Attach™, MA-40 Hydraulic Manifold, Bucket Gauge Rod and 72" Bucket.

Options: 84" Bucket, 72" or 84" Skid-Steer Bucket and Adapter, Mechanical Self-Leveling Kit, Level UP Advantage, 3rd Steel Line, Rotational Indicators, Hydra-Snap™ Manifold, Comfort Ride, Precision Joystick and Valve w/Regen Spool and Attachments.



TA-26 PLUS THE NEXT GENERATION

2WD: 30-120 HP » 5275 LBS. AT 10'5"
4WD: 30-90 HP »

This fully loaded package has all the same great features as the TA-26 loader PLUS it includes an updated, modern shape and styling over the entire loader. It features the Snap-Attach™, Hydra-Snap™ one lever multi-unit coupling system, rotational full-range bucket indicator and grease-from-the-end pins for easy maintenance. It works with the same mounting brackets as the TA-26 making this an easy upgrade for existing owners.

Base package: Hydraulic Power-Mount™, 2-1/2" Bucket Cylinder, 3" Lift Cylinder, Mounting & Hose Kit, Snap-Attach™, Hydra-Snap™ Manifold, Rotational Level Indicator and 72" Bucket.

Options: 84" Bucket, 72" or 84" Skid-Steer Bucket and Adapter, Level UP Advantage, 3rd Steel Line, Comfort Ride, Precision Joystick and Valve w/ Regen Spool and Attachments.

HIGH-LIFT

The TA-26-12 stacks bales three high easily with the 12' lift height

PERFORMANCE

—Added features to increase efficiency.

HYDRA-SNAP™

Save time and temper with this one-lever hydraulic manifold. Quickly connect all four (or six) hoses in one smooth motion. Optional flat face couplers available.

CUSTOM ADJUST BRACKETS

Fine-tune the loader's fit to your tractor's frame for more comfort and better visibility during operation.

ROTATIONAL INDICATORS

Monitor the bucket's position at a glance to speed up material handling and repetitive tasks such as stacking hay.

TA-26¹²

**MORE LIFT
HEIGHT**

**2WD: 30-120 HP » 5615 LBS. AT 12'
4WD: 30-90 HP »**

With all the same great features as the TA-26 and the TA-26 Plus loaders, the TA-26-12 loader package gives you additional lift height to 12'. This is ideal for those that need the extra height for handling hay. It also includes both the rotational level and height indicators. The level indicator monitors the bucket position from rolled back to fully dumped, while the height indicator monitors the arm position from the ground to loader's full lift height. This perfect tool speeds up stacking hay and loading trailers.

Base package: Hydraulic Power-Mount™, 2-1/2" Bucket Cylinder, 3" Lift Cylinder, Mounting & Hose Kit, Snap-Attach™, Hydra-Snap™ Manifold, Rotational Level and Height Indicators and 72" Bucket.

Options: 84" Bucket, 72" or 84" Skid-Steer Bucket and Adapter, Level UP Advantage, 3rd Steel Line, Comfort Ride, Precision Joystick and Valve w/Regen Spool and Attachments.



CLEARANCE

Premiere hay loader with higher lift and capacity.



“ I bought a TA-28 Plus, and we installed it ourselves. It went on very easy, and we were very impressed with the instructions. I would recommend this unit to anyone.”

TOM DOTZLER - Aitken, MN

TA-28 THE PREMIERE HAY LOADER

The TA-28 is the proven loader built for front-wheel assist tractors. This mid-sized loader has a great profile and is an excellent hay loader with a lift height of 13'4" at a competitive price. It comes standard with a big 84" bucket that people really like. It is an ideal loader for the person coming from a WL-42 loader on a 2 wheel drive tractor upgrading to a 4 wheel drive tractor.

**2WD: UP TO 160 HP » 7475 LBS. AT 13'4"
4WD: UP TO 120 HP »**

Base package: Hydraulic Power-Mount™, 2-1/2" Bucket Cylinder, 3" Lift Cylinder, Mounting & Hose Kit, Snap-Attach™, Hydra-Snap™ Manifold, Rotational Level Indicator and 72" Bucket.

Options: 84" Bucket, 72" or 84" Skid-Steer Bucket and Adapter, Level UP Advantage, 3rd Steel Line, Comfort Ride, Precision Joystick and Valve w/ Regen Spool and Attachments.

“ I bought a JD 7320 tractor and a Westendorf TA-28 loader. I wouldn't trade my Westendorf for two of those green ones. A friend of mine has the same tractor with a JD loader on it; he has broken the quick couplers twice, and almost tipped over because of how far the loader sits out in front of the tractor. I also have a WL-21 and my brother has a WL-42 and a TA-28. We both love them!”

BOBBY PLENGE - Missouri



TA-28 PLUS

**STREAMLINED FIT FOR
POWERFUL 4WD TRACTORS**

**2WD: UP TO 165 HP » 7475 LBS. AT 13'4"
4WD: UP TO 135 HP »**

The TA-28 Plus provides more features with a strong, clean profile and fit. Developed for the demanding everyday heavy user, the reinforced arms ensure strength to match the larger HP tractors. Case hardened, high-wear 1-1/4" pins have grease relief bushings for superior wear and zerks on the ends for easy maintenance. Low-profile fit ensures clear sight-lines for safer operation. Shown with Cat Claw 3-D three dimensional grab fork. It is a quick-mount/dismount design and fits 84" and 96" high capacity buckets. It crushes, pulls, fills and handles unforgiving and hard to handle loads with ease.

Base package: Hydraulic Power-Mount™, 3" Bucket Cylinder, 3" Lift Cylinder, Mounting & Hose Kit, Snap-Attach™, MA-40 Hydraulic Manifold, Bucket Gauge Rod and 84" Bucket.

Options: 84" & 90" Large Capacity Buckets, 84" or 90" Skid-Steer Bucket and Adapter, Level UP Advantage, 3rd Steel Line, Comfort Ride, Precision Joystick and Valve w/Regen Spool and Attachments.



 *I bought those brush grabber things & love 'em!*

ROY HUNTINGTON
Missouri

WHAT REALLY CONVINCED ME OF ITS STRENGTH IS THE FOLLOWING STORY:

I had a fire break out in the barn, when over 2,000 gallons of gasoline started on fire. The fire melted the tires right off the tractor, melted the tractor's hood and busted up the cab. The loader was scorched and the decals and hoses had melted off. I wasn't sure about the loader's condition so I called my local Westendorf dealer to take a look. He told me that my loader had an internal I-beam or double wall construction and the

loader wasn't damaged. I couldn't believe it didn't split the loader's frame. Nothing was warped and no welds were broken. The bucket was still in excellent condition.

I took it up the road to a body shop, had it sand blasted, repainted, and reinstalled the hoses. Even after 10 years, I never had to sharpen the bucket's blade. I leveled dirt and pushed out sprouts, yet the blade stayed sharp.

I really like the easy hook-up system. I can sit in the tractor seat and see what I am working with. The low-profile fit allows me to see to align the quick-attach units. All I have to do is back up, hook on the other attachment and I am back to work.

My Westendorf loader is a really fine outfit - that's for sure. I definitely wouldn't buy anything but a Westendorf."



TA-29

THE BEST OF
BOTH WORLDS

You can do almost anything you want with this loader. Whatever you can break out at the bottom, you can lift all the way to the top. The heavy-duty 3" lift cylinders allow the loader to lift a **5000 pound payload** from the ground to over 13 feet in one fluid motion. This amazing loader has the true mechanical self-leveling BOTH up and down, yet an amazingly low-profile fit for increased visibility.

2WD: UP TO 165 HP » 8790 LBS. AT 13'2"
4WD: UP TO 135 HP »

Base package: Hydraulic Power-Mount™, 3" Bucket and Lift Cylinders, Snap-Attach™, Mechanical Self-Leveling, Mounting & Hose Kit, MA-40 Hydraulic Manifold, Bucket Gauge Rod and 84" Bucket.

Options: 84" and 90" Large Capacity Buckets, Hydra-Snap™, Comfort Ride, 3rd Steel Line, Rotational Height Indicator, Level UP Advantage, Precision Joystick and Valve w/Regen Spool and Attachments.



“ Westendorf has renewed my optimism that you can still get a quality product at a fair price.”



TA-45

**THE TA-45 IS
THE TA-28 ON STEROIDS**

**2WD: UP TO 160 HP » 7475 LBS. AT 13'4"
4WD: UP TO 130 HP »**

The TA-45 loader is an upscale TA-28, introduced to fit the 20 series tractors with a 40 series attachment spacing. It's great for the user who has a WL-42 and upgrades to a 4WD tractor, but he still needs the 40 series spacing to use his existing attachments. It's a good feedlot loader with a big lift capacity. Other features include power-linkage, smooth low-profile design and 3" bucket cylinders. It's a great candidate for narrower hooded tractors.

Base package: Hydraulic Power-Mount™, 3" Bucket Cylinder, 3" Lift Cylinder, Mounting & Hose Kit, Snap-Attach™, MA-40 Hydraulic Manifold, Bucket Gauge Rod and 84" Large Capacity Bucket.

Options: 90" & 96" Large Capacity Buckets, Level UP Advantage, 3rd Steel Line, Comfort Ride, Rotational Height Indicator, Precision Joystick and Valve w/Regen Spool and Attachments.



“Placing bales with the Stack Saver II on the flatbed that fit together tightly and straight made the hauler smile with approval.”

WES EVANS
Evans Quarter Horses - Washington

ALL-PURPOSE

Turn your tractor into a real workhorse with big benefits.

I am writing to you about my Westendorf TA-45 loader and attachments. In my nearly fifty years of experience running equipment, both construction and ranch/farm, my TA-45 is undoubtedly the best loader that I have used in its class.

When I was a young boy, my Dad explained something to me that has left a life-long impression on me. He told me, *“If you want good quality oats, you need to pay a fair price; if, however, you can be satisfied with oats that have been though the horse once, they come a little cheaper”*.

Like many others, I have fallen prey to charlatan companies that claim superior quality and workmanship. For someone like me, who appreciates a well-made piece of equipment that performs as it is intended, Westendorf has renewed my optimism that today you can still get a quality product at a fair price.

Checking and servicing the tractor air filters is a breeze with the Power-Mount system. No tools, no hassle; in a few short minutes I am able to simply back out the loader, giving me clearance to get the job done. With the Snap-Attach,

changing from the bucket to the hay attachment could not be made easier.

As you can see, winters drop heavy snowfall in northeast Washington. Moving and piling one hundred plus inches of snow in a season is no problem with the TA-45. I have been able to keep the barnyard and access roads clear during snowfalls that crippled the local county roads department.

Thank you Westendorf for making a high quality product that is fairly priced.



TA-46

THE TA-26'S
BIG BROTHER

2WD: UP TO 190 HP » 7560 LBS. AT 13'10"
4WD: UP TO 165 HP »

The TA-46 is ideal for the heavy-duty cattle producer. It has longer arms to get over the front tires, this allows excellent digging depths. It is an excellent loader for the cattle guys who have bigger tractors with bigger tires.

LOW-PROFILE SELF-LEVELING ADD-ON KIT

Mechanical self-leveling can be added to a TA-26, TA-26 Plus or TA-46 loader package. The low-profile patented design hugs the loader's arm for a clear field of vision. This add-on kit increases lift capacity of the loader by 20% .

Base package: Hydraulic Power-Mount™, 3" Bucket Cylinder, 3" Lift Cylinder, Mounting & Hose Kit, Snap-Attach™, MA-40 Hydraulic Manifold, Bucket Gauge Rod and 84" Large Capacity Bucket.

Options: 90" & 96" Large Capacity Buckets, Level UP Advantage, 3rd Steel Line, Add-On Mechanical Self-Leveling, Comfort Ride, Rotational Indicators, Precision Joystick and Valve w/Regen Spool and Attachments.

“Everyone says its the Cadillac - but it's the Mercedes! It's a good heavy loader with good visibility. Other loaders sit a foot and a half above the hood and that makes it hard to see. I love the quick on and off feature because I don't have to lay down in the mud to take the loader off.”

H. B. BURCH - Kentucky

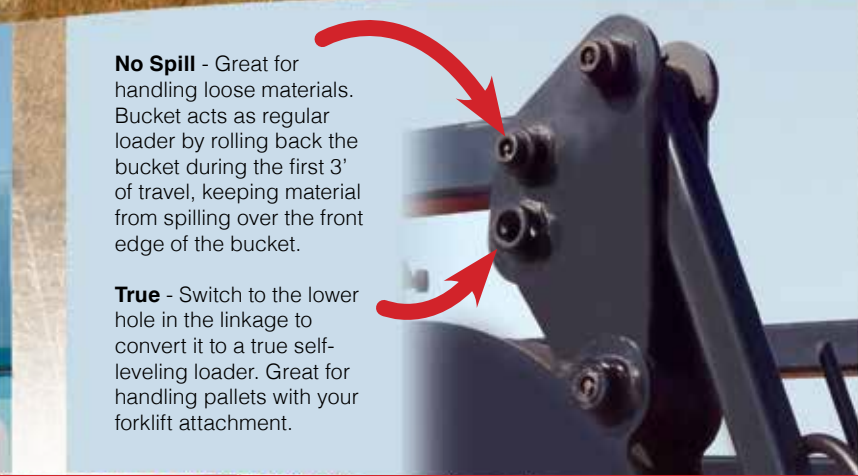

No Spill - Great for handling loose materials. Bucket acts as regular loader by rolling back the bucket during the first 3' of travel, keeping material from spilling over the front edge of the bucket.

True - Switch to the lower hole in the linkage to convert it to a true self-leveling loader. Great for handling pallets with your forklift attachment.

TA-48

THE ULTIMATE SELF-LEVELING LOADER

2WD: UP TO 210 HP » 8430 LBS. AT 14'6"
4WD: UP TO 185 HP »

Whether you're hauling loose materials like silage or bulky materials like seed pallets, we have a self-leveling loader that is versatile enough to accommodate the different materials you haul throughout the year. The TA-48 has two different settings on the mechanical self-leveling linkage which allow you to have "true" self-leveling or "no-spill" self-leveling. It's the only loader in the industry to offer this versatility.

Base package: Hydraulic Power-Mount™, 3" Bucket Cylinder, 3" Lift Cylinder, Mechanical Self-Leveling, Mounting & Hose Kit, Snap-Attach™, MA-40 Hydraulic Manifold, Bucket Gauge Rod and 84" Large Capacity Bucket.

Options: 90" & 96" Large Capacity Buckets, Level UP Advantage, 3rd Steel Line, Comfort Ride, Rotational Indicators, Precision Joystick and Valve w/Regen Spool and Attachments.



OUTSTANDING

Reaching new heights with high-lift loaders



BALE HANDLER

Pick up and handle 12 to 15 small square bales at one time.

ROTATIONAL INDICATORS

Speed up repetitive tasks with a rotational indicator. Easily monitor the bucket tilt at a glance or the loader's position from the ground to the full height.

HYDRA-SNAP™

Upgrade to the Hydra-Snap™ one-lever manifold to connect or disconnect hoses from the tractor.

LOW PROFILE FIT

Most high lift loaders on the market obstruct the operator's vision while driving or working. Westendorf's adjustable uni-fit mounting system positions the loader on the tractor low along the hood-line for the best possible visibility while working.

TA-76

**A HAY LOADER -
NO DOUBT ABOUT IT**

**2WD: 15-35 HP » 2300 LBS. AT 7'7"
4WD: 15-30 HP »**

The TA-76 is the ultimate loader for feeders and hay users. With an amazing 15'2" lift height, this loader is built to last with double torsion tubes, 3" lift cylinder and big, 96" large capacity bucket. The TA-76 is a power loader built for the heavy-duty user. You can really dig, not just lift high with it. It has the wider frame for wider 70 series attachments.

Base package: Hydraulic Power-Mount™, 3" Bucket Cylinder, 3" Lift Cylinder, Mounting & Hose Kit, Snap-Attach™, MA-40 Hydraulic Manifold, Bucket Gauge Rod and 96" Large Capacity Bucket.

Options: 3-1/2" Lift Cylinder, 108"-112" Buckets, Level UP Advantage, 3rd Steel Line, Hydra-Snap™ Manifold, Comfort Ride, Rotational Indicators, Precision Joystick and Valve w/Regen Spool and Attachments.

“ Gentlemen, I just attended the Farm Progress show. I want to comment on the equipment which you had displayed. I was impressed! I am a retired engineer with 12 patents and now go to shows to see what is new and where things are going with machinery. Most of the stuff is just bigger and more expensive. Your engineers are to be congratulated for some creative design work. Please give them a pat on the back from an old man who did some innovative work in his time, too. Congratulations!”

JOHN CHAPMAN



TA-77

**WANT MORE LIFT
HEIGHT? YOU GOT IT!**

**2WD: UP TO 240 HP » 9140 LBS. AT 17'4"
4WD: UP TO 225 HP »**

The TA-77 offers all the benefits of the TA-76, and it adds an additional 2' of lift height. It's the highest in the industry. It comes with bigger lift cylinders for more power at greater heights. It is ideal for commercial hay operations with its great reach and 17'4" lift height.

Base package: Hydraulic Power-Mount™, 3" Bucket Cylinder, 3 1/2" Lift Cylinder, Mounting & Hose Kit, Snap-Attach™, MA-40 Hydraulic Manifold, Bucket Gauge Rod and 96" Large Capacity Bucket.

Options: 108"-112" Buckets, Level UP Advantage, 3rd Steel Line, Hydra-Snap™ Manifold, Comfort Ride, Rotational Indicators, Precision Joystick and Valve w/ Regen Spool and Attachments.



IT'S A SNAP

Cost effective—time tested design.



TA SERIES ATTACHMENTS	TA-25	TA-26/26+/26 ¹²	TA-28	TA-28+/29	TA-45/46/48	TA-76/77
Brush Crusher™ 4000	✓					
Brush Crusher™ 5000		✓	✓	✓	✓	✓
Brush Crusher™ 6000		✓	✓	✓	✓	✓
Brush Crusher™ 7700	(1)					
Brush Crusher™ 8200		✓	✓	✓	✓	✓
Three-Prong Bale Spear	✓	✓	✓	✓	✓	(2)
Two-Prong Bale Spear	✓	✓	✓	✓	✓	(2)
Four-Prong Bale Spear			✓	✓	✓	✓
Four-Tine Double Bale Spear				✓	✓	✓
Stack-Saver I (Round Bales)		✓	✓	✓	✓	✓
Stack-Saver II (Square or Round Bales)	✓	✓	✓	✓	✓	✓
Dozer Blade 84"		✓	✓	✓	✓	✓
Dozer Blade 96"				✓	✓	✓
Dozer Blade 120"						✓
Snow Scraper™ 96"		✓	✓	✓	✓	✓
Snow Scraper™ 120"				✓	✓	✓
Snow Scraper™ 144"						✓
V-Plow 72"	✓					
V-Plow 96"		✓	✓	✓	✓	✓

TA SERIES ATTACHMENTS	TA-25	TA-26/26+/26 ¹²	TA-28	TA-28+/29	TA-45/46/48	TA-76/77
Forklift 42"	✓	✓	✓	✓	✓	✓
Forklift 48"	✓	✓	✓	✓	✓	✓
Extendable Boom	✓	✓	✓	✓	✓	✓
Bale Handler		✓	✓	✓	✓	✓
Squeezer™		✓	✓	✓	✓	✓
Bucket Mount Bale Spear		✓	✓	✓		
Quick-tach Bucket Teeth 72"	✓	✓				
Quick-tach Bucket Teeth 84"			✓	✓	✓	✓
Z-47 Feeder Bucket			✓	✓	✓	✓
Jifty Monster Grab Fork		✓				
Monster Grab Fork - Straight Teeth					✓	✓
Monster Grab Fork - Curved Teeth			✓	✓	✓	✓
Quick Mount Claw			✓	✓	✓	✓
Sabretooth™/Tine Bucket	✓	✓	✓	✓	✓	✓
Fork Bucket		✓	✓	✓	✓	✓
Rock Bucket	✓	✓	✓	✓	✓	✓
Cat Claw™ 84"			✓	✓	✓	
Cat Claw™ 96"				✓	✓	✓
Cat Claw™ 3-D				(3)	(3)	(3)

(1) Requires skid-steer adapter (2) Requires SP-76 (3) Requires HDHC Bucket

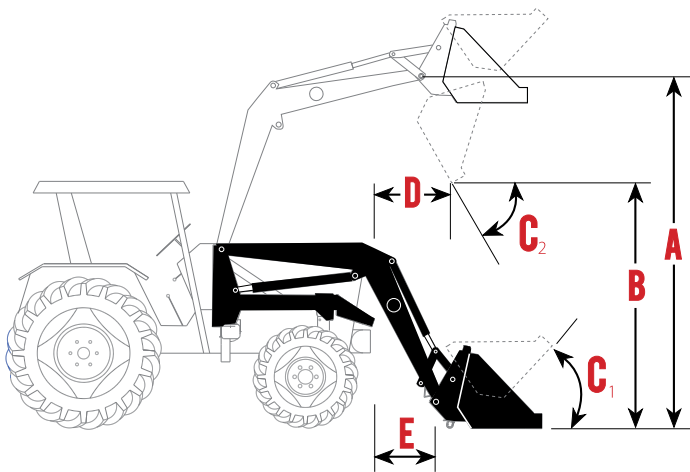

**SKID-STEER
ADAPTER... P. 119**



TA SPECIFICATIONS	TA-25	TA-26 TA-26+	TA-26 ¹²	TA-28	TA-28+	TA-29	TA-45	TA-46	TA-48	TA-76	TA-77
A Full Height (ground to pin)	9'4" 112"	10'5" 125"	12' 144"	13' 4" 160"	13' 4" 160"	13' 2" 158"	13' 4" 160"	13' 10" 166"	14' 6" 174"	15' 2" 180"	17' 4" 208"
B Clearance (bucket dump)	97"	100"	119"	133"	133"	152"	127"	131"	136"	127"	170"
C₁ Rollback Angle	20°	27°	27°	24°	33°	35°	34°	29°	34°	34°	29°
C₂ Dump Angle	42°	45°	45°	28°	35°	45°	35°	58°	45°	35°	58°
D Reach at Max Height	28"	31"	36"	24"	20"	23"	21"	15"	28"	21"	15"
E Reach at Ground Level (to pin)	18"	19.5"	26"	23"	23"	23.5"	21"	22"	25"	24"	50"
	2500 PSI 3000 PSI	2500 PSI 3000 PSI	2500 PSI 3000 PSI	2500 PSI 3000 PSI	2500 PSI 3000 PSI	2500 PSI 3000 PSI	2500 PSI 3000 PSI	2500 PSI 3000 PSI	2500 PSI 3000 PSI	2500 PSI 3000 PSI	2500 PSI 3000 PSI
Lift Capacity - AWC* (31.5" from pin)	3000 3600	3000 3600	3200 3480	4255 5106	4255 5100	5000 6000	4255 5100	4300 5100	4800 5760	4255 5100	5200 6240
Lift Capacity - at Pivot Pin	4395 5275	4395 5275	4680 5615	6230 7475	6230 7476	7325 8790	6230 7475	6300 7560	7030 8430	6230 7475	7620 9140
Lift Cylinder - Std. Opt.	2-1/2" 3"	3"	3"	3"	3"	3"	3"	3"	3"	3" 3-1/2"	3-1/2"
Bucket Cylinder - Std. Opt.	2-1/2" 3"	2-1/2" 3"	2-1/2" 3"	2-1/2" 3"	3"	3"	3"	3"	3"	3"	3"
Bucket Sizes Available	60", 66", 72"	72", 84", SS	72", 84", SS	84", 84" LC, 90"	84", 84" LC, SS, 90", 96", HDHC	84", 84" LC, 90", 96", HDHC	84" LC, 90", 96", HDHC	84" LC, 90", 96", HDHC	84" LC, 90", 96", HDHC	96", 108", HDHC	96", 108", HDHC

*For additional information on AWC Capacity - see page 12. Above specifications are based on ASABE S301.3 standard. Specifications may vary depending on the tractor, front axle configuration, tire size, hydraulic system and type of attachment. Design specifications are subject to change without notice or obligation.

XTA SERIES

Modern styling for modern tractors with the BIG EXTRAS you want; these loaders are built for today's larger, stronger front-wheel assist tractors. It is an excellent loader for everyday use for handling materials such as manure, silage and hay.

These high-lift loaders have an excellent low-profile fit for increased visibility and clear sight-lines while working. XTA loaders offer great oscillation, works with narrow row settings and it fits most tractor models with fenders. Mount or dismount this big loader in just minutes with the patented hydraulic Power-Mount™ feature.

Patented Snap-Attach™ System. Heavy-duty construction and large diameter, grease-from-the-end pins with replaceable bushings. Hydra-Snap™ one-step coupling. Rotational Level Indicator and more.



WESTENDORF MFG. CO., INC.

P.O. BOX 29, ONAWA, IA 51040
Ph: 712.423.2762 | 877-MY-LOADER

Email: sales@westendorfmfg.com
Website: www.loaders.com
Online Parts Store: store.loaders.com

“Last year I purchased an XTA-700A with a Cat Claw 3-D grab fork. It is a fantastic piece of equipment!”

DICK HINES - Iowa



CONVENIENT

BIG Extras for big tractors

XTA loaders are excellent for everyday use when handling materials such as manure, silage and hay. These high-lift loaders have an excellent low-profile fit for increased visibility and clear sight-lines while working. It offers great oscillation and fits narrow rows for 2WD and 4WD tractors up to 250 HP.

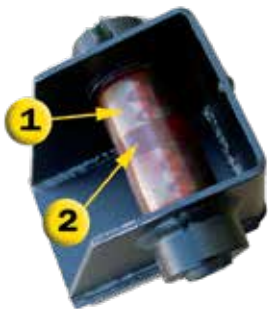

PRACTICAL SOLUTIONS

When you use your loader every day to feed cattle, stack hay or load pallets, Westendorf's practical solutions will keep you smiling. Grease-from-the-end pins are case hardened, large diameter, easy to reach and faster to access for more efficient maintenance.

The rugged design is shown to the left. The pin design utilizes an industrial strength, replaceable spring bushing with built-in wear guards (1) and oversized grease pocket (2) to allow an even and quick release of grease while working.

BIG DOESN'T MEAN BULKY

Dismounting this super-sized loader series is a breeze with the Hydra-Snap™ and the Power-Mount™ feature. Because larger tractors are commonly used for field work, additional improvements to this series, such as custom brackets and tower designs, allow models to work with narrow 30" row settings, fit tractors with large front tires and keep fenders for most models. This series is the most versatile and durable choice for high horsepower tractors.



CONVENIENT

Every aspect of a Westendorf loader is designed for “your” convenience.

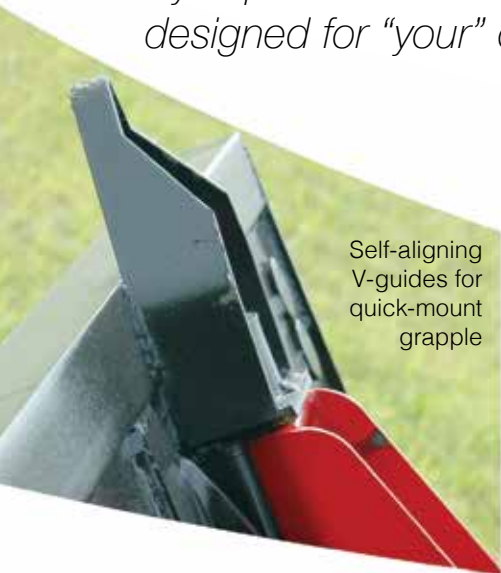

Self-aligning V-guides for quick-mount grapple



“ I have a Genesis New Holland 8670 and Westendorf customized an XTA-700 with an extra long tower to fit the Super Steer model. I am in the process of hooking up the joystick to my tractor. The guy at Westendorf really knew his stuff and helped me understand how to plumb in the joystick. Westendorf is a good company; they are always concerned and willing to listen to feedback and suggestions from the field to update and improve their product line.”

DICK HINES - Iowa

ORDER A CUSTOM BUCKET

Considering a grapple at a later date? Why not order the bracketry installed at the factory when you order your loader? It makes the installation of the grapple hassle-free when you decide to upgrade.

SNAP-ATTACH™

The original quick-change system, introduced to the market over 40 years ago, is consistent in design and has withstood the test of time.

POWER-LINKAGE

Both loaders in the XTA series benefit from power-linkage. It is a series of linkages located behind the quick coupler and before the bucket cylinder connection. It increases the bucket's dump and rollback angles and adds increased bucket power.

HAVE YOU SEEN THE LIGHT?

No, we haven't found a new storage space for those dangerous stands and keeper pins... A Westendorf loader DOES NOT require the use of stands to dismount the loader. The most important things about our torsion tube are that it intersects “both” walls for strength and is positioned out of the way so you can still see the couplers and implements while working.

POWER-MOUNT™

Hands down, it is the key reason why Westendorf owners love their loader. The true Power-Mount™ capabilities let your tractor hydraulics do all the work. No pins to realign, no tools required, and no hassles. Go from feeding cattle to doing field work in just minutes.



ONE-LEVER HOSE COUPLING

Save time and temper with the Hydra-Snap™, a one-lever manifold that connects all hoses in one smooth motion. Standard in the XTA loader package, the Hydra-Snap™ is the perfect companion for quick dismount and prevents hose mix ups. For the cleanest connection, consider the flat face coupler upgrade.

PRECISION WHEN YOU NEED IT

The rotational level indicator monitors the implement's positions from rolled back to fully dumped. Add a height indicator to speed up daily repetitive tasks.



HOW DO I KNOW IF I NEED A SELF-LEVELING LOADER?

The key factor in determining whether to add mechanical or hydraulic self-leveling kit has to do with what tasks you want to perform with your loader. If you handle hay or load pallets frequently, then yes—you'll appreciate a forklift or spear that stays level as you raise the loader.

QUALITY CYLINDERS

Westendorf cylinders are manufactured to internal quality levels based on over 85 years experience. Metal piston rings and chrome-plated piston rods add more protection from rust corrosion and stroke wear.

SIMPLE MOUNTING SYSTEM

Maintain resale value by buying a loader that can fit many different tractors. The Power-Mount™ makes it easy to share the same loader between tractors. The simplicity and speed of the mounting system lets you take your loader off or put it on in just minutes without any tools or dangerous stands.

CUSTOM OPTIONS

Build a loader package to meet your material handling needs. The XTA series offers multiple tower modifications to accommodate various frame style tractors. Add items such as:

- Big bucket & chain hooks
- Grapple forks
- Comfort ride
- Mechanical self-leveling
- Custom paint color



“ I Thank you for making amazing loaders, I've been a proud owner for many years and never had any issues.”

CASEY OSBORNE
Adrian, MO



XTA-400 MODERN STYLING FOR THE MODERN TRACTOR

Built for the larger, stronger 2WD and 4WD tractors, the XTA Series gives you the BIG extras you need. It fits most tractor models with fenders, allows great oscillation and works with narrow rows. It features heavy duty, replaceable 2 -1/4" bushings with chrome-vanadium spring steel inserts, grease-from-the-end pins and Westendorf's legendary power linkage for extra rollback and dump angles. Considering the size of this loader, it is the easiest large loader to mount and dismount on the market today.

2WD: UP TO 200 HP » 7900 LBS. AT 13'
4WD: UP TO 175 HP »

Base package: Hydraulic Power-Mount™, 3" Bucket Cylinder, 3" Lift Cylinder, Mounting & Hose Kit, Snap-Attach™, Hydra-Snap™ Manifold, Rotational Level Indicator and 84" Large Capacity Bucket.

Options: 3-1/2" Lift Cylinder, 90"-112" Buckets, Mechanical Self-Leveling, 3rd Steel Line, Comfort Ride, Rotational Height Indicator, Precision Joystick and Valve w/Regen Spool and Attachments.

EXTRAS

Big loaders with bigger benefits.

HYDRA-SNAP™

Standard on the XTA Series the Hydra-Snap™ one-lever manifold connects or disconnects hoses from the tractor with one lever.

CUSTOM FIT

XTA loaders fit big tractors with good oscillation, narrow row settings and the ability to keep fenders on most models.

ROTATIONAL INDICATORS

Standard on the XTA Series, the rotational bucket and level indicators easily monitor the loader's position at a glance to speed up repetitive tasks.

ATTACHMENTS & OPTIONS

A wide range of attachments and premium hydraulic components, such as the programmable electronic joystick, can increase your comfort, precision and efficiency while working.



XTA-700 THE "BIG" EXTRAS YOU WANT

The XTA-700 is the larger version of the XTA-400. It is ideal for heavy material handling such as manure, hay and silage. It was designed for taller, bigger and heavy-duty use tractors. It fits most tractors on the narrow 30" rows and many with fenders.

2WD: UP TO 250 HP » 10,900 LBS. AT 15'
4WD: UP TO 210 HP »

Base package: Hydraulic Power-Mount™, 3" Bucket Cylinder, 3 1/2" Lift Cylinder, Mounting & Hose Kit, Snap-Attach™, Hydra-Snap™ Manifold, Rotational Level Indicator and 96" Large Capacity Bucket.

Options: 90"-112" Buckets, Mechanical Self-Leveling, 3rd Steel Line, Comfort Ride, Rotational Height Indicator, Precision Joystick and Valve w/Regen Spool and Attachments.



IT'S A SNAP

V-Shaped—self-aligning design.



Since its introduction over 50 years ago, the Original Snap-Attach™ system has retained its rank as the #1 quick change attachment system on the market. A system above all the rest, the patented Snap-Attach™ System has a self-aligning V-guide to automatically center the attachment for trouble free alignment every time. It also keeps the connection tight. Other flat models on the market are

hard to align and show excessive wear, but the V-guide will always stay tight because the harder you push, the tighter the connection becomes. This system keeps the pivot pin closer to the bucket for better bucket action. This system has been tested over time and it is one of the top reasons customers give for loving their Westendorf loader.

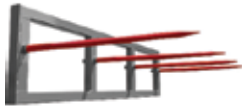

XTA SERIES ATTACHMENTS	XTA-400	XTA-700
Brush Crusher™ 5000	✓	✓
Brush Crusher™ 6000	✓	✓
Brush Crusher™ 8200	✓	✓
Three-Prong Bale Spear	✓	✓
Two-Prong Bale Spear	✓	✓
Four-Prong Bale Spear	✓	✓
Bale Handler	✓	✓
Squeezer™	✓	✓
Four-Tine Double Bale Spear	✓	✓
Stack-Saver I (Round Bales)	✓	✓
Stack-Saver II (Square or Round Bales)	✓	✓

XTA SERIES ATTACHMENTS	XTA-400	XTA-700
Dozer Blade 84"	✓	✓
Dozer Blade 96"	✓	✓
Dozer Blade 120"	✓	✓
Snow Scraper™ 96"	✓	✓
Snow Scraper™ 120"	✓	✓
Snow Scraper™ 144"		✓
V-Plow 96"	✓	✓
Forklift 42"	✓	✓
Forklift 48"	✓	✓
Quick-tach Bucket Teeth 84"	✓	✓

(1) Requires 96" Large Capacity Bucket (2) Requires HDHC Bucket



“As an owner of a weld shop, I was continuously fixing and repairing loaders. When I bought myself a loader, I was determined it was going to be a Westendorf loader. Nobody else had one like it. Whenever my customers saw my loader, they would say “That’s the stoutest loader I’ve ever seen!” It was built stronger, and I never had any trouble with it.”

BILL GOSSETT - Illinois

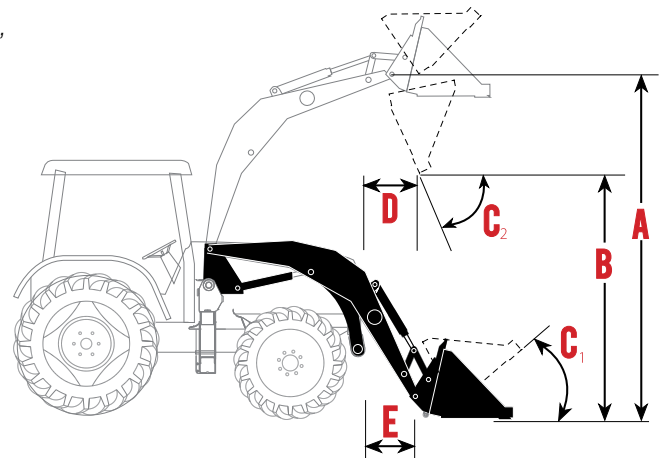

XTA SERIES ATTACHMENTS	XTA-400	XTA-700
Z-47 Feeder Bucket	✓	✓
Monster Grab Fork - Straight Teeth	✓	✓
Monster Grab Fork - Curved Teeth	✓	✓
Quick Mount Claw	✓	✓
Sabretooth™/Tine Bucket	✓	✓
Fork Bucket	✓	✓
Rock Bucket	✓	✓
Cat Claw™ 84"	✓	(1)
Cat Claw™ 96"		✓
Cat Claw™ 3-D	(2)	(2)

XTA SPECIFICATIONS	XTA-400	XTA-700
A Full Height (ground to pin)	13' / 156"	15' / 180"
B Clearance (bucket dump)	120"	141"
C₁ Rollback Angle	27°	34°
C₂ Dump Angle	48°	47°
D Reach at Max Height	20"	31"
E Reach at Ground Level (to pin)	23"	32"
	2500 psi 3000 psi	2500 psi 3000 psi
Lift Capacity - AWC* (31.5" from pin)	4500 5400	6200 7440
Lift Capacity - at Pivot Pin	6590 7900	9080 10900
Lift Cylinder - Standard Optional	3" 3-1/2"	3-1/2"
Bucket Cylinder - Standard Optional	3"	3"
Bucket Sizes Available	84", 90", 96", HDHC	96", 108", HDHC

*For additional information on AWC Capacity - see page 12. Above specifications are based on ASABE S301.3 standard. Specifications may vary depending on the tractor, front axle configuration, tire size, hydraulic system and type of attachment. Design specifications are subject to change without notice or obligation.

LIMITED SERIES

The Limited Series loaders offer the same quality, performance, and strength that customers have come to expect from Westendorf. Packed with the latest features and innovations, the Limited Series loaders come equipped with the self-aligning, self-standing and self-locking Smart-Lock™ mounting system. Also included are the patented Smart-Pac cylinders, incredible low-profile visibility, max tire clearance, solid brackets, unquestionable arm strength, and the famous Westendorf Snap-Attach™ system for quick attachment changes. Its attractive price makes the Limited Loader hard to pass up.

Westendorf loaders are known for their many advantages—but the proof is in their performance. The Limited Loader series will do everything you want a loader to do, all at a best value price.



WESTENDORF MFG. CO., INC.

P.O. BOX 29, ONAWA, IA 51040
Ph: 712.423.2762 | 877-MY-LOADER

Email: sales@westendorfmfg.com
Website: www.loaders.com
Online Parts Store: store.loaders.com

“ I love the loader and have not found another with the ease of use in connecting and dis-connecting nor the stability. You have a great product!”

DORAN C. PENDLETON SR.
Newburgh, MO



SMART TECHNOLOGY

– developed with the customer in mind.

Packed with the latest features and innovations, this series utilizes the latest in loader technology, including Smart-Pac cylinders, Smart-Lock mounting system and the Snap-Attach™ attachment mounting system.



BIGGER TIRES? NO PROBLEM

Accommodate larger tires without limiting your loader's capabilities. The Smart-Lock mounting system positions the loader in the ideal position on the tractor resulting in excellent visibility for working. It clears tires ranging from 28.5" and up and offers added below ground digging depth.

CYLINDER INNOVATIONS

Increased reliability and improved long-term performance equal a smart solution from Westendorf. The patented top-shelf Smart-Pac cylinder eliminates all external hoses, lines, and fittings. The swaged barrel automatically compresses the seals past the barrel's edge during assembly for consistent quality every time.



SUPERIOR PERFORMANCE



SMART-LOCK

Just rotate the lock over the top of the loader bracket to release the loader from tractor. While mounting, the Smart-Lock automatically latches to the mounting brackets.



AT-A-GLANCE LOAD MONITORING

The "easy view" lift gauge rod quickly monitors the bucket's position while working. This simple solution from Westendorf allows you to work faster and more efficiently. The indicator is positioned along the right loader arm.

FREEDOM MOUNT™

Free your tractor for field work or maintenance in just minutes. Need to feed cattle or clear snow? No problem, quickly mount the Limited loader from the comfort of your cab. No Stands. No Time. No Tools. No Pins required. The self-aligning, self-latching Smart-Lock system makes mounting and dismounting your loader easy and hassle-free.

MAX TIRE CLEARANCE

Experience tire freedom and keep fenders on most tractor models with optimum row settings to maximize your turning and oscillation ability. The loader is mounted in the middle of the tractor, rather than the front to allow added tire clearance for the tires.

SOLID BRACKETS

The self-aligning tower and solid bracket design provides a secure, stable connection to the tractor. The simple bracket design adds more strength to your loader. This loader is available with the Transformer bracket system; a bracket system available from Westendorf, which quickly transforms OEM loader brackets to fit the Limited loader's mounting connections.

POWER-LINKAGE

The added linkage between the loader's arms and the Snap-Attach™ coupler increases the dump and roll back angles of the loader. It also boosts the bucket power and action.



LOW-PROFILE VISIBILITY

Most high lift loaders on the market obstruct the operator's vision while driving or working. Westendorf's mounting system positions the loader on the tractor low along the hood-line for the best possible visibility while working.



SNAP-ATTACH™ COUPLING SYSTEM

A system above all the rest, the patented Snap-Attach™ System has a self-aligning V-guide to automatically center the attachment for trouble free alignment every time. It also keeps the connection tight. Other flat models on the market are hard to align and show excessive wear with use. The V-shape will always stay tight because the harder you push, the tighter the connection becomes.

BUCKET REPUTATION

Westendorf "standard" buckets are bigger than most competitors' high-capacity buckets. Since we've been manufacturing loaders, our buckets have been the best in the industry. We know how to build a bucket that lasts. The tapered, rib-free interior empties quickly, and is reinforced externally to absorb the shock of digging.



SMARTER DESIGN

*Boost efficiency and
performance.*



420L LIMITED SERIES—
LIMITLESS PERFORMANCE

4WD: UP TO 120 HP »
5275# AT 11' 6"

The 420 Limited loader offers the same quality, performance, and strength that customers have come to expect from Westendorf. Packed with the latest features and innovations, the Limited Series loaders come equipped with the self-aligning, self-standing and self-locking Smart-Lock™ mounting system. Smart-Pac cylinders, incredible low-profile visibility, max tire clearance, solid brackets and the Snap-Attach™ system (20 series spacing) for quick attachment changes are included.

Base package: Freedom-Mount™, 3" Smart-Pac Bucket and Lift Cylinders, Snap-Attach™, Smart-Lock, Hydra-Snap™, Mounting & Hose Kit, Grill Guard on most fits, Grease-From-The-End Pins, Rotational Indicators and 84" Large Capacity Bucket.

Options: 90" Large Capacity Bucket, 3rd Steel Line, Level Up Advantage, Comfort Ride, All Electronic Valve and Joystick Package and Attachments.



440L

QUALITY—
PRICED RIGHT

The 440 Limited loader offers the latest features and innovations. They come equipped with the Smart-Lock™ mounting system in addition to Smart-Pac cylinders, a flat face coupling manifold, incredible low-profile visibility, max tire clearance, solid brackets, unquestionable arm strength, and the famous Westendorf Snap-Attach system for quick attachment changes. Its attractive price makes the Limited loader hard to pass up.

4WD: UP TO 120 HP »
5275 LBS. AT 11' 6"

Base package: Freedom-Mount™, 3" Smart-Pac Lineless Bucket Cylinder, 3 1/2" Lineless Lift Cylinder, Snap-Attach™, Smart-Lock, Hydra-Snap™, Mounting & Hose Kit, Grill Guard on most fits, Grease-From-The-End Pins, Rotational Indicators and 84" Large Capacity Bucket.

Options: 90" Large Capacity Bucket, 3rd Steel Line, Level Up Advantage, Comfort Ride, All Electronic Valve and Joystick Package and Attachments.



IT'S A SNAP!

Change attachments with NO trips in and out of the cab!



Since its introduction over 50 years ago, the Original Snap-Attach™ system has retained its rank as the #1 quick change attachment system on the market. A system above all the rest, the patented Snap-Attach™ System has a self-aligning V-guide to automatically center the attachment for trouble free alignment every time. It also keeps the connection tight. Other flat models on the market

are hard to align and show excessive wear, but the V-guide will always stay tight because the harder you push, the tighter the connection becomes. This system keeps the pivot pin closer to the bucket for better bucket action. This system is economical, reliable, time-tested and one of the top reasons customers give us for loving their Westendorf loader.



LIMITED ATTACHMENTS	LIMITED 420	LIMITED 440
Brush Crusher™ 5000	✓	✓
Brush Crusher™ 6000	✓	✓
Brush Crusher™ 7700	(1)	
Brush Crusher™ 8200	✓	✓
Bucket Mount Bale Spear	✓	✓
Three-Prong Bale Spear	✓	✓
Two-Prong Bale Spear	✓	✓
Four-Prong Bale Spear	✓	✓
Stack-Saver I (Round Bales)	✓	✓
Stack-Saver II (Square or Round Bales)	✓	✓

LIMITED ATTACHMENTS	LIMITED 420	LIMITED 440
Dozer Blade 84"	✓	✓
Dozer Blade 96"		✓
Snow Scraper™ 96"	✓	✓
Snow Scraper™ 120"	✓	✓
V-Plow 96"	✓	✓
Forklift 42"	✓	✓
Forklift 48"	✓	✓
Bale Handler	✓	✓
Squeezer™	✓	✓
Quick-tach Bucket Teeth 72"	✓	
Quick-tach Bucket Teeth 84"		✓

(1) Requires skid-steer adapter (2) Requires 90° bucket



“ I really like the quick-tach bucket teeth. They work really good for scooping manure, an you were the only company I found that had a quick-tack style so the teeth don't need to be bolted on. When I want them off they're off and when I want them on, they're on in just a few minutes. That's quite a patent and loader you have. I like everything about my TA-28 loader - It's the best. I clear a lot of manure, as I have a lot of cattle. I use it to haul wood and handle brush. It's got good lift height (over 13') and works great for stacking bales. I couldn't get along without it! ”

Chester Speer - Maywood, Missouri

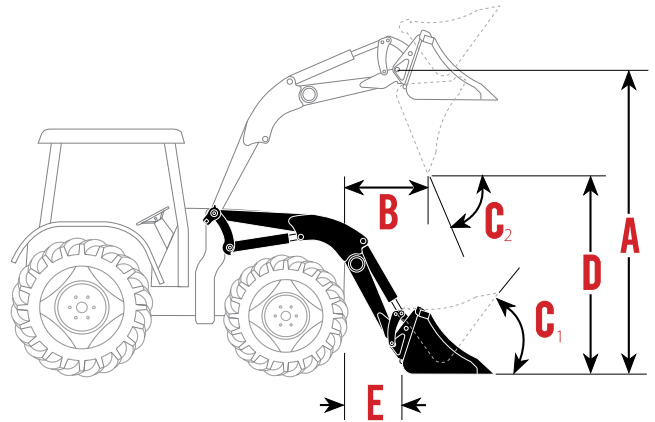

LIMITED ATTACHMENTS	LIMITED420	LIMITED440
Z-47 Feeder Bucket	✓	✓
Jiffy Monster Grab Fork	✓	✓
Monster Grab Fork - Straight Teeth	(2)	(2)
Monster Grab Fork - Curved Teeth	(2)	✓
Sabretooth™/Tine Bucket	✓	✓
Fork Bucket	✓	✓
Rock Bucket	✓	✓
Cat Claw™ 3-D	✓	✓

LIMITED SPECIFICATIONS	LIMITED 420	LIMITED 440
A Full Height (ground to pin)	116" / 138"	116" / 138"
B Clearance (bucket dump)	110"	110"
C₁ Rollback Angle	42°	42°
C₂ Dump Angle	50°	50°
D Reach at Max Height	33"	33"
E Reach at Ground Level (to pin)	27"	27"
	2500 psi 3000 psi	2500 psi 3000 psi
Lift Capacity - AWC* (31.5" from pin)	3000 3600	3000 3600
Lift Capacity - at Pivot Pin	4395 5275	4395 5275
Lift Cylinder - Standard	3-1/2"	3-1/2"
Bucket Cylinder - Standard	3"	3"
Bucket Sizes Available	84", 90"	84", 90"

*For additional information on AWC Capacity - see page 12. Above specifications are based on ASABE S301.3 standard. Specifications may vary depending on the tractor, front axle configuration, tire size, hydraulic system and type of attachment. Design specifications are subject to change without notice or obligation.

MAX SERIES

These extra strong MAX loaders have an intelligent design that offers unsurpassed quality, performance, and strength. MAX loaders feature unmatched styling, fast and easy implement changes with the push of a button, and no-spill Flat Face Hydra-Snap™ for quick hydraulic hook ups.

The tailored shape eliminates tunnel vision that normally comes with other loaders. The Smart-Lock system is a self-aligning, self-standing, and self-locking mounting system. Its simple, solid-mount design with Max Grip will boost your confidence when mounting or dismounting a loader.

Westendorf loaders are known for their many advantages—but the proof is in their performance. The MAX will do everything you want a loader to do, and more.



WESTENDORF MFG. CO., INC.

P.O. BOX 29, ONAWA, IA 51040
Ph: 712.423.2762 | 877-MY-LOADER

Email: sales@westendorfmfg.com
Website: www.loaders.com
Online Parts Store: store.loaders.com



The MAX doesn't just look great - it's an incredible loader that outperforms the rest!



UNPARALLELED PERFORMANCE

– MAX shows off its many advantages.

Packed with more benefits and time-saving features, the new MAX Loader is the solution you've been looking for to make your material handling tasks easier and faster than you could have ever thought possible.



THE NEXT GENERATION

For over 85 years Westendorf has been engineering new loader innovations. You asked and we listened to your feedback and requests for more power, easier implement changes, and more efficient mounting and dismounting system. From the large, heavy-duty grease-from-the-end pins to the time-saving Remote Control Coupler, every last detail integrated into the MAX loaders will make you smile.

SMARTER HYDRAULICS

The enhanced hydraulic system has nearly eliminated unwanted downtime due to a snagged hose or snapped fitting. Routed internally, all hoses are of the highest quality and hidden from view, yet are quickly accessible if necessary. Patented Smart-Pac Lineless Cylinders, the Flat Face Hydra-Snap™ manifold, Remote Control Coupler and optional 3rd function work seamlessly with your tractor's current hydraulic system.





FREEDOM MOUNTING

It really is this easy!

Enjoy the freedom of mounting the MAX loader from the comfort of your cab. No Stands. No Time. No Tools. No Pins required. Just set the loader on the bucket, release the Smart-Locks and use the loader's hydraulics to release the loader from the tractor.



LOW PROFILE VISIBILITY

The loader fits properly with the bucket close and arms that compliment the tractor's hood contour.

FLAT-FACE HYDRA-SNAP™

Westendorf is the only manufacturer to offer a coupling system that both couples AND uncouples under pressure! Quickly hook up all of your hoses and electronics with the turn of one, easy-to-operate handle. The Flat Face Hydra-Snap™ also keeps the connections clean with a built-in dust cover, and the parking plate provides convenient storage too. It's the perfect compliment to the quick mount feature of this loader.



UNSURPASSED

Load more! Dump higher! Work faster!



MAX ADVANTAGES

1. Freedom-Mount™
2. Smart-Lock™
3. Low-Profile visibility
4. Remote Control Coupler
5. Flat Face Hydra-Snap™
6. Max Tire Clearance
7. Performance Plus
8. Smart-Pac / Lineless Cylinders
9. Concealed Hydraulics
10. Arm Strength
11. Bucket Reputation
12. Solid Brackets
13. More Functions
14. Full Featured
15. Attachments Plus
16. Loader Envoy

PERFORMANCE PLUS

Westendorf loaders are known for their many advantages - but the proof is in their performance. The MAX will do everything you want a loader to do, and more.

BUCKET REPUTATION

Famous for bigger, stronger and cleaner bucket designs, we know how to build a bucket that lasts. The tapered, rib-free interior empties quickly and is reinforced externally for added strength.

ATTACHMENTS PLUS

When paired with the ability to change implements from the cab, the wide selection of buckets, spears, grapples, blades, plows, and specialty attachments make the MAX your one-stop-shop for your material handling solution.

SMARTER CONNECTIONS

The solid mount bracket system simply rotates over the tower, self-locking the loader in place. It is a self-aligning and self-tightening system; the more you use the loader the tighter the connection becomes.

LINELESS CYLINDER TECHNOLOGY

Increased reliability and improved long-term performance equal a SMART solution from Westendorf. The Smart-Pac cylinder eliminates all external hoses, lines, and fittings for a cleaner appearance and longer hydraulic life. The patented swaged barrel automatically compresses the seals past the barrel's edge during assembly for consistent quality every time.



MAX TIRE CLEARANCE

Experience tire freedom and keep fenders on most tractor models with optimum row settings to maximize your turning and oscillation ability.

CONCEALED HYDRAULICS

The MAX's plug and play hidden hydraulic system offers freedom and unobstructed visibility. The hoses are routed inside the arms and positioned behind a sculptured jacket to protect the lines, suppress wear, and prevent snags - with style.

ARM STRENGTH

Our patented interior I-beam positions the steel where it really matters most, maintaining an optimum loader weight. This allows you to carry more payload rather than a big, heavy loader that can bog down your tractor.

SOLID BRACKETS

The self-aligning tower and solid bracket combine, providing a SECURE connection. The brackets are precisely engineered for a consistent and tailored fit to your tractor.



MORE FUNCTIONS

The MAX offers a wide variety of integrated functions such as the easy-to-read rotational indicators, multiple function joystick, the comfort ride system to reduce operator fatigue and equipment wear, hydraulic self-leveling, smooth ride fender, and more.

FULL FEATURED

The smaller details are what really make a difference for long-term reliability and performance. Large, heavy-duty grease-from-the-end pins with 2-sided locks, integrated grill guard, rotational bucket level indicator, power-linkage, high energy decal package, and an optional synchronizer bar are just a few.



REMOTE CONTROL COUPLER

Change attachments from the cab with the push of a button. Whether it's raining, snowing, sweltering hot, below zero, or you just don't feel like climbing in and out of your tractor all day long, the Remote Control Coupler makes it so you don't have to! No more hammering out pins or prying levers either. It's so quick and easy, you'll always use the right tool for the job.



EXCELLENCE

These extra strong MAX loaders are truly in a class of their own.



“ *It has been a real good loader, and I would be lost without it. I'd spread my butter with it if I could! I like how easy the remote control coupler makes changing attachments and I would recommend the comfort ride option to everyone.* **”**

BILL QUICK - Redding, IA



MAX420 AN UNDENIABLE WOW FACTOR

The MAX has an intelligent design that offers unsurpassed quality, performance, and strength. Unmatched styling, fast and easy attachment changes with the push of a button, Freedom Mounting that doesn't require parking stands, tools, or time, and, no-spill Flat Face Hydra-Snap™ for quick hydraulic hook ups are just a few of the MAX's 16 BIG Advantages The Other Guys Just Don't Have.

**4WD: UP TO 120 HP »
5275 LBS. AT 11' 6"**

Base package: Freedom-Mount™, 3" Smart-Pac Lineless Bucket Cylinder, 3 1/2" Lineless Lift Cylinder, Remote Control Coupler, Smart-Lock, Hydra-Snap™, Mounting & Hose Kit, Grill Guard on most fits, Grease-From-The-End Pins, Rotational Indicators and 84" Large Capacity Bucket.

Options: 90" Large Capacity Bucket, 3rd Steel Line, Level Up Advantage, Comfort Ride, All Electronic Valve and Joystick Package and Attachments.



MAX440

PROOF IS IN THE PERFORMANCE

The MAX440 has the same great features as the MAX420, such as the Remote Control Coupler, Hydra-Snap™, and Freedom Mount stand-free dismounting system. The MAX440 will accommodate wider attachments at the 40 series spacing.

4WD: UP TO 120 HP »
5275 LBS. AT 11' 6"

Base package: Freedom-Mount™, 3" Smart-Pac Lineless Bucket Cylinder, 3 1/2" Lineless Lift Cylinder, Remote Control Coupler, Smart-Lock, Hydra-Snap™, Mounting & Hose Kit, Grill Guard on most fits, Grease-From-The-End Pins, Rotational Indicators and 84" Large Capacity Bucket.

Options: 90" Large Capacity Bucket, 3rd Steel Line, Level Up Advantage, Comfort Ride, All Electronic Valve and Joystick Package and Attachments.



PUSH A BUTTON!

Change attachments with NO trips in and out of the cab!

One feature that you will really appreciate is the patented remote control coupler. This is a standard component on all MAX loaders. It is professionally engineered to work with your existing tractor's hydraulic system and it does not require a third hydraulic pool to function. With every use, you'll smile and give yourself a pat on the back for making a smart, value based purchase.



Then smile a second time because you're in the cab, and not out in the sweltering heat or in below zero temperatures trying to hammer out pins or pry up levers. The optional synchronizer bar is shown above. The loader's stealth valve directs the hydraulic oil through an internal electro hydraulic cylinder, and the plunger is activated with the push of a button.



MAX SERIES ATTACHMENTS	MAX420	MAX440
Brush Crusher™ 5000	✓	✓
Brush Crusher™ 6000	✓	✓
Brush Crusher™ 7700	(1)	
Brush Crusher™ 8200	✓	✓
Bucket Mount Bale Spear	✓	✓
Three-Prong Bale Spear	✓	✓
Two-Prong Bale Spear	✓	✓
Four-Prong Bale Spear	✓	✓
Stack-Saver I (Round Bales)	✓	✓
Stack-Saver II (Square or Round Bales)	✓	✓

MAX SERIES ATTACHMENTS	MAX420	MAX440
Dozer Blade 84"	✓	✓
Dozer Blade 96"		✓
Snow Scraper™ 96"	✓	✓
Snow Scraper™ 120"	✓	✓
V-Plow 96"	✓	✓
Forklift 42"	✓	✓
Forklift 48"	✓	✓
Bale Handler	✓	✓
Squeezer™	✓	✓
Quick-tach Bucket Teeth 72"	✓	
Quick-tach Bucket Teeth 84"		✓

(1) Requires skid-steer adapter (2) Requires 90° bucket



We're better connected than any loader on the market. Thanks to our unique patented design, the weight of the loader is efficiently used to accomplish changing attachments from the cab with just a push of a button. We welcome you to compare. The others' claim of universal or euro style come nowhere near this new patented design, plus you can get conversion kits to utilize any attachment you or your neighbor already own... see page 119.

“ I like the ease of taking the loader on and off the tractor, and how easy it is to change out attachments with the remote control coupler.”

Jim Olson - Logan, IA

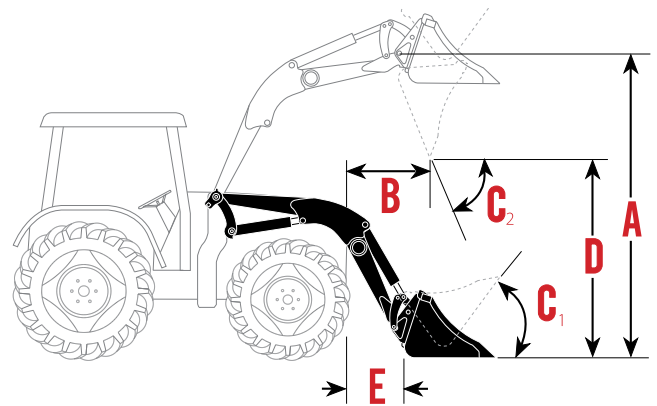

MAX SERIES ATTACHMENTS	MAX420	MAX440
Z-47 Feeder Bucket	✓	✓
Jiffy Monster Grab Fork	✓	✓
Monster Grab Fork - Straight Teeth	(2)	(2)
Monster Grab Fork - Curved Teeth	(2)	✓
Sabretooth™/Tine Bucket	✓	✓
Fork Bucket	✓	✓
Rock Bucket	✓	✓
Cat Claw™ 3-D	✓	✓

MAX SPECIFICATIONS	MAX420	MAX440
A Full Height (ground to pin)	11'6" / 138"	11'6" / 138"
B Clearance (bucket dump)	110"	110"
C₁ Rollback Angle	42°	42°
C₂ Dump Angle	50°	50°
D Reach at Max Height	33"	33"
E Reach at Ground Level (to pin)	27"	27"
	2500 psi 3000 psi	2500 psi 3000 psi
Lift Capacity - AWC* (31.5" from pin)	3000 3600	3000 3600
Lift Capacity - at Pivot Pin	4395 5275	4395 5275
Lift Cylinder - Standard Optional	3-1/2"	3-1/2"
Bucket Cylinder - Standard Optional	3"	3"
Bucket Sizes Available	84", 90"	84", 90"

*For additional information on AWC Capacity - see page 12. Above specifications are based on ASABE S301.3 standard. Specifications may vary depending on the tractor, front axle configuration, tire size, hydraulic system and type of attachment. Design specifications are subject to change without notice or obligation.

FREEDOM MOUNT™ SERIES

The Freedom Mount™ series is built with the most cutting-edge technology by some of the smartest design engineers, experienced weld technicians and brilliant research and development teams. So, you're getting the latest technological advances and a loader that isn't in danger of becoming obsolete anytime soon.

The new Freedom Mount™ loader is a prime example of a top of the line, dynamically designed loader that offers the best visibility on the market, precision positioning, a triple-force arm, plug-n-play hidden hydraulic system, perfect bucket with double bolt-on cutting edge, one-piece mounting bracket, remote control coupler for lightening fast implement changes and an all new mounting system that gives new meaning to the term quick on and off.



WESTENDORF MFG. CO., INC.

P.O. BOX 29, ONAWA, IA 51040
Ph: 712.423.2762 | 877-MY-LOADER

Email: sales@westendorfmfg.com
Website: www.loaders.com
Online Parts Store: store.loaders.com



It works great for stock bales; I even pick up two at one time and take them to the cattle yard saving myself multiple trips."

DAVE & KARLA MCGRAIN
Iowa

INTELLIGENT LOADER DESIGN

— developed with "smart" loader technology.

Form meets function. Only Freedom Mount™ loaders have the unique design that allows you the freedom to use the bucket to take the loader on and off without the need for tools or dangerous kick stands.



THE WOW FACTOR

The styling of the new Freedom Mount loaders not only has an undeniable WOW factor, but an intelligent design which places the hydraulic hoses inside the sleek and sturdy arms. This not only suppresses wear and tear, but the loader's stream-lined profile allows for beautiful, unencumbered visibility that no other loader comes close to offering. No wonder Westendorf's Freedom Mount loaders are the envy of the industry. Don't let them talk you into anything less.

WE SPEAK LOADER

At Westendorf, we not only speak loader, but our sole purpose has been patenting loader innovation for over 85 years. While other companies are constantly changing who is going to manufacture their loaders, we concentrate on taking all of the knowledge we have gained over the years to make our loaders operate in the best and most efficient way possible—all to make your life easier. Westendorf's revolutionary patented Freedom Mount™ loaders offer unsurpassed quality, performance and strength.



TAILORED

*The Envy of the Loader Industry
–Freedom Mount™ patented features*



HIGH LIFT AND LOW PROFILE FIT

So how do we give you the best of both world's—a high lift loader with a low profile fit? It's the patented cylinder positioning inside the loader's arm that gives you the freedom to fit very large front tires while keeping the loader positioned low along the tractor's hood. The precision loader positioning maintains excellent sight-lines in all directions and gives you the balanced control and comfortable operation you've been looking for in a loader.



HEIGHT INDICATOR



LEVEL INDICATOR



I love the Freedom Mount loader; it's a great piece of equipment, and it fits my John Deere great. I left the loader on for a year before I decided to try to take it off. I was amazed at how quick and easy it came off, and it was just as easy to put back on. It is far and away the easiest loader to mount and dismount that I've ever owned."

MIKE RECKER

Iowa



THE PERFECT BUCKET

This construction grade bucket features a clean rib-free interior with outside reinforcements. The tapered design empties materials quickly without sticking. Correctly positioned steel runners reinforce the bucket and help absorb the shock of digging. The high-carbon steel welded-in cutting edge and 8" bolt-on blade are standard.

LOAD MONITORING AT A GLANCE

It's easy to speed up repetitive tasks with the patented position indicators. The Height Indicator monitors loader arm position from the ground to maximum height. The Level Indicator monitors the bucket's position from rolled back to fully dumped.



HYDRA-SNAP™

This isn't just another coupling system, but a multi-unit, one-lever system that allows fast connection of hoses. It's the ideal time-saving companion to compliment the quick mount feature of this loader.

PRECISION LOADER POSITIONING

The Freedom Mount™ design makes it possible to position the loader and bucket back on the tractor providing stability and balanced weight distribution, enhancing the overall feel of performance and handling.

THEIR FIT



OUR FIT



TRIPLE FORCE ARM

Westendorf raises the bar once again with its triple force arm. The double taper is the first line of defense. The second is the curved arch in the arm. The third is the box I-beam construction. Combine all three and you get a loader that matches the strength of powerful FWA tractors. Plow into that oversized pile of manure and raise a heaping bucket with ease.

THE STRENGTH IS IN THE DESIGN

As with all our previous Westendorf loader arm designs, the tapered arm is the key to strength. Reduce strain on your tractor and carry larger payloads at the same time. Our patented design adds more reinforcements to the loader's arm and keeps the loader light, so you can carry heavier loads.



FITS LIKE YOUR FAVORITE PAIR OF GLOVES

The strong, one-piece computer designed bracket is tailor fit to your tractor for optimum positioning of the loader. The V-shaped mounting ramp inside the loader's tower is a simple, auto-locking, self-guiding mounting system. The brackets have a composite design that is stronger and more versatile to accommodate today's challenging sculpted frames. This clean bracket design perfectly blends the Freedom Mount loader to your tractor. Brackets have nearly double the surface area of other systems on the market, and they boast large easy-grease pins in all high wear locations.



- ✓ Low profile fit that looks great
- ✓ Maximum wheel clearance
- ✓ Attachment changes “from the cab”
- ✓ Quick mount loader without stands
- ✓ Great visibility in all directions
- ✓ All hydraulic lines are protected
- ✓ Box I-beam arm construction

ON OR OFF IN LESS THAN 2 MINUTES

Freedom Mount™ loaders truly allow you to auto-lock and go to work without additional trips off the tractor. Mounting and dismounting has achieved a new level of versatility so you can run your operation more efficiently. Enjoy this added freedom and remove that loader when it's time to plant or do maintenance on your tractor.



ENGINEERED FOR MAXIMUM STRENGTH

Self-locking chain hooks, 8” bolt-on blade and tubular steel top rail fortify this incredibly strong bucket against the most brutal working conditions.

NON-SMASHING PERFORMANCE

Each bracket set includes* a custom engineered grill guard. Provided for your tractor's protection when handling unruly loads of brush or when working in tight areas such as up against the trailer's side rail when stacking hay.



**Introductory offer for a limited time.*

BEST VISIBILITY

Whether you're feeding cattle or stacking hay, every job requires clear visibility of the bucket and work area for efficiency. That's why our arms were specifically designed to enable you to see in all directions, thanks to their arched low-profile fit that follows the hood of your tractor.

TIRE FREEDOM

The Freedom Mount™ loaders fit large front tires while allowing you to keep fenders on most models. They also fit tractors with suspended front axles such as Triple Link and Terraglide or even New Holland's Super Steer models while maintaining a low fit along the hood for optimum visibility.



FREEDOM

This loader looks great AND it lays claim to the most ground-breaking dismounting and mounting process in decades.



A 'SMART' IDEA

This new, top-shelf series of cylinders flaunts a patented “smart pac” swaged barrel and lineless cylinder technology that automatically compresses the gland and its packings past the barrel’s edge during assembly eliminating external hose fittings and hoses. Patents Pending.

JUST PLUG IT IN - NO WRENCHES

The smart pack cylinders are equipped with Plug-’n-Play hydraulic fittings; the female fittings are docked in the end of the cylinder, so you simply “plug-in” the male ends to connect. Fittings feature a swivel so the hoses move freely, and automatically adjust to varying pressures while working.

A TRULY VISIONARY CONCEPT

Imagine if you never had to worry about snagging a hose or snapping off a fitting with a load of gnarly brush. We’ve reduced your maintenance time and repairs by eliminating external hoses, steel lines and fittings from both the cylinders and loader arms.

CUSTOM OPTIONS

Customize your Freedom Mount™ loader with:

- Quality electronic valve & joystick
- Comfort ride system
- T-line for hydraulic attachments
- Custom matching paint & decals



FM-540

QUALITY YOU WILL FEEL;
INGENUITY YOU WILL USE

4WD UP TO 130 HP »
5670 LBS. AT 13'

The FM-540 loader is a step up from the popular TA-28 loader series with added strength, modern features and 13' lift height. The patented triple force arms, lineless hydraulic system, Freedom-Mount™ bucket, Hydra-Snap™ hydraulic manifolds, rotational indicators and big grease-from-the-end pins allow for exceptional performance on today's powerful front-wheel assist tractors. Ideal for tractors with large front tires.

Base package: Freedom-Mount™, 3-1/2" Smart Pac Lineless Bucket and Lift Cylinders, Mounting & Hose Kit, Remote Control Coupler, Hydra-Snap™, Radiator Grill Guard, Rotational Level Indicator, Rotational Height Indicator and 86" Large Capacity Bucket with Bolt-on Blade.

Options: Level UP Advantage, 3rd Steel Line, Comfort Ride, All Electronic Valve & Joystick Package and Attachments.

PROFESSIONAL

Loaders with BIG benefits

QUALITY COMPONENTS

Westendorf doesn't cut any corners where quality and longevity are concerned. Nearly 2" case hardened, easy grease-from-the-end pins are located in all high wear areas.

PLUG 'N PLAY

This loader and its cylinders are equipped with new Plug-'n-Play hydraulic fittings; fittings do not require wrenches and swivel so the hoses move freely and automatically adjust to varying pressures while working, reducing wear.

INCREASED BUCKET ACTION

More power to get the job done without hassles of material spilling off the front edge of the bucket. Power-Linkage increases the implement angles for added power and strength you need everyday.

IDEAL MATCH

Ensure you have the strength to match the powerful FWA tractors of today with the wide arm area, extended flange and tapered box build.



FM-550

SEE AND FEEL
THE DIFFERENCE

4WD UP TO 165 HP »
7340 LBS. AT 14'

The FM-550 loader is designed for strength and functionality. Its sleek, low-profile shape provides clearer sight-lines and amazing visibility in all directions. The patented, lineless cylinders and hydraulic system, superior free flow bucket, Hydra-Snap™, rotational indicators and extra heavy bucket with bolt-on blade offer heavy-duty users all the extras to match the higher demands of today's large front-wheel assist tractors.

Base package: Freedom-Mount™, 3-1/2" Smart Pac Lineless Bucket and Lift Cylinders, Mounting & Hose Kit, Remote Control Coupler, Hydra-Snap™ Manifolds, Radiator Grill Guard, Rotational Level Indicator, Rotational Height Indicator and 98" Large Capacity Bucket with Bolt-on Blade.

Options: Level UP Advantage, 3rd Steel Line, Comfort Ride, All Electronic Valve & Joystick Package and Attachments.



WESTENDORF FM-560

MONITOR LOAD POSITION WITH A GLANCE

Speed up operations efficiently with rotational indicators; these are great for repetitive tasks such as stacking hay and pallet work.



FM-560

DYNAMICALLY DESIGNED FOR YOUR TRACTOR

**4WD UP TO 200 HP »
7990 LBS. AT 15'**

The FM-560 loader is designed for larger 6 cylinder tractors. It has the same sleek low-profile patented Freedom Mount™ shape that provides the clearest sight-lines in the industry. The patented lineless cylinders and hydraulic system, Hydra-Snap™ manifolds, rotational indicators and larger heavy-duty bucket with bolt-on blade offer today's heavy-duty user all the extras that he needs to match the higher demands of today's large front-wheel assist tractors.

Base package: Freedom-Mount™, 3-1/2" Smart Pac Lineless Bucket and Lift Cylinders, Mounting & Hose Kit, Remote Control Coupler, Hydra-Snap™ Manifolds, Radiator Grill Guard, Rotational Level Indicator, Rotational Height Indicator and 98" Large Capacity Bucket with Bolt-on Blade.

Options: 108" Large Capacity Bucket with Bolt-on Blade, Level UP Advantage, 3rd Steel Line, Comfort Ride, All Electronic Valve & Joystick Package and Attachments.

REACHING NEW HEIGHTS

*Higher lift and more power with
the same low profile fit*



I decided it was time to upgrade, and I wanted a Westendorf so I took a look at the FM-560 loader and was sold. I really like the looks of the loader; it's a modern loader for a modern tractor. The day the tractor and loader were delivered, my son, Philip, liked it too; he took his girlfriend out for a cruise around the section."

DAVE AND KARLA MCGRAIN
Iowa



FM-570

**A MODERN LOADER FOR A
MODERN TRACTOR**

**4WD UP TO 210 HP »
7990 LBS. AT 15'**

The FM-570 loader has all the same benefits of the FM-560, and it adapts to wider framed tractors with large front tires. It has the same sleek, low-profile, patented Freedom Mount™ shape that provides the clearest sight-lines in the industry. The patented, lineless cylinders and hydraulic system, Hydra-Snap™ manifolds, rotational indicators, free flow bucket and double tapered I-beam arms ensure you will have the strength in your loader to match the strength of your tractor.

Base package: Freedom-Mount™, 3-1/2" Smart Pac Lineless Bucket and Lift Cylinders, Mounting & Hose Kit, Remote Control Coupler, Hydra-Snap™ Manifolds, Radiator Grill Guard, Rotational Level Indicator, Rotational Height Indicator and 98" Large Capacity Bucket with Bolt-on Blade.

Options: 108" Large Capacity Bucket with Bolt-on Blade, Level UP Advantage, 3rd Steel Line, Comfort Ride, All Electronic Valve & Joystick Package and Attachments.



IDEAL MATCH

A big loader to match the strength of your big tractor



ON OR OFF IN LESS THAN 2 MINUTES

Freedom Mount™ loaders truly allow you to auto-lock and go to work without additional trips off the tractor. Mounting and dismounting has achieved a new level of versatility so you can run your operation more efficiently. Enjoy this added freedom and remove that loader when it's time to plant or do maintenance on your tractor.



FM-580

MUSCLE YOU WON'T BELIEVE

4WD: 260 HP » 9600 LBS. AT 16'

The FM-580 is a powerful loader for larger tractors above 260 HP. It has all the same modern day features such as patented, lineless cylinders and hydraulic system, Hydra-Snap™ manifolds, huge bucket with double bolt-on blade and double tapered I-beam arms ensure you will have the strength in your loader to match the strength of your tractor. Backed by years of extensive research, this Westendorf loader will turn your big tractor into the most versatile and powerful material handling machine in your operation.

Base package: Freedom-Mount™, 3-1/2" Lineless Smart Pac Bucket Cylinders, 4" Lineless Smart Pack Lift Cylinders, Mounting & Hose Kit, Remote Control Coupler, Hydra-Snap™ Manifolds, Radiator Grill Guard, Rotational Level Indicator, and 98" Large Capacity Bucket with Bolt-on Blade.

Options: 108" Large Capacity Bucket with Bolt-on Blade, Rotational Height Indicator, Level UP Advantage, 3rd Steel Line, Comfort Ride, All Electronic Valve & Joystick Package and Attachments.



FM-585

**CUSTOM FIT FOR
WIDER HOOD TRACTORS**

4WD: 260 HP » 9600 LBS. AT 16'

The FM-585 is the granddaddy of the Freedom Mount™ series. It has all the same modern day features as the FM-580 with a wider tower to accommodate larger tractor tires and tractors with wider hoods. Optimize your tractor's potential for the large tasks at hand, such as dirt work and snow removal. With the patented Freedom Mount™ quick on and off feature, your tractor can be ready at any time for field work or other non-loader work.

Base package: Freedom-Mount™, 3-1/2" Lineless Smart Pac Bucket Cylinders, 4" Lineless Smart Pack Lift Cylinders, Mounting & Hose Kit, Remote Control Coupler, Hydra-Snap™ Manifolds, Radiator Grill Guard, Rotational Level Indicator, and 98" Large Capacity Bucket with Bolt-on Blade.

Options: 108" Large Capacity Bucket with Bolt-on Blade, Rotational Height Indicator, Level UP Advantage, 3rd Steel Line, Comfort Ride, All Electronic Valve & Joystick Package and Attachments.



REMOTE CONTROL

Quick-attach with the push of a button!

One feature that you will really appreciate is the patented remote control coupler. This is a standard component on all Freedom Mount loaders. It is professionally engineered to work with your existing tractor's hydraulic system and it does not require a third hydraulic spool to function. With every use, you'll smile and give yourself a pat on the back for making a smart, value based purchase.



Shown with optional synchronizer bar.

Loader's Stealth Valve directs oil to Electro Hydraulic Internal cylinder, activating plunger

Then smile a second time because you're in the cab, and not out in the sweltering heat or in below zero temperatures trying to hammer out pins or pry up levers. The optional synchronizer bar is shown above. The loader's stealth valve directs the hydraulic oil through an internal electro hydraulic cylinder, and the plunger is activated with the push of a button.

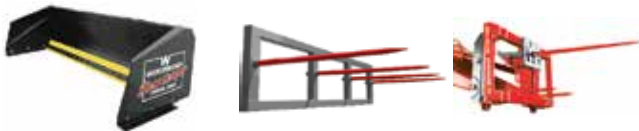

FREEDOM MOUNT ATTACHMENTS	FM-540	FM-550	FM-560	FM-570	FM-580	FM-585
Two-Prong Bale Spear	✓	✓	✓	✓	✓	✓
Three-Prong Bale Spear	✓	✓	✓	✓	✓	✓
Four-Prong Bale Spear	✓	✓	✓	✓	✓	✓
Four-Tine Double Bale Spear	✓	✓	✓	✓	✓	✓
Stack-Saver I (Round Bales)	✓	✓	✓	✓	✓	✓
Stack-Saver II (Square or Round Bales)	✓	✓	✓	✓	✓	✓
Dozer Blade 84"	✓	✓	✓	✓	✓	✓
Dozer Blade 96"	✓	✓	✓	✓	✓	✓
Dozer Blade 120"				✓	✓	✓
Snow Scraper™ 96"	✓	✓	✓	✓	✓	✓
Snow Scraper™ 120"	✓	✓	✓	✓	✓	✓
Snow Scraper™ 144"				✓	✓	✓
V-Plow 96"	✓	✓	✓	✓	✓	✓

FREEDOM MOUNT ATTACHMENTS	FM-540	FM-550	FM-560	FM-570	FM-580	FM-585
Brush Crusher™ 5000	✓	✓	✓	✓	✓	✓
Brush Crusher™ 6000	✓	✓	✓	✓	✓	✓
Brush Crusher™ 8200	✓	✓	✓	✓	✓	✓
Forklift 42"	✓	✓	✓	✓	✓	✓
Forklift 48"	✓	✓	✓	✓	✓	✓
Extendable Boom	✓	✓	✓	✓	✓	✓
Bale Handler	✓	✓	✓	✓	✓	✓
Squeezer™	✓	✓	✓	✓	✓	✓
Z-47 Feeder Bucket	✓	✓	✓	✓	✓	✓
Sabretooth™/Tine Bucket	✓	✓	✓	✓	✓	✓
Fork Bucket	✓	✓	✓	✓	✓	✓
Rock Bucket	✓	✓	✓	✓	✓	✓
Cat Claw™ 3-D	✓	✓	✓	✓	✓	✓

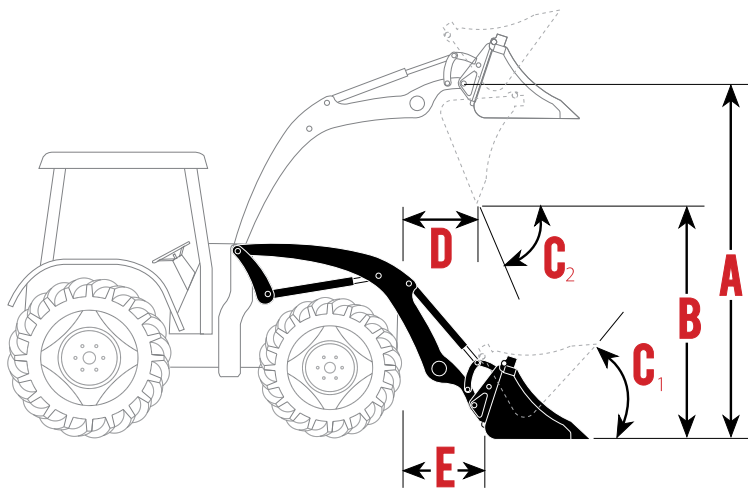

“ It has been a real good loader, and I would be lost without it. I'd spread my butter with it if I could! I like how easy the remote control coupler makes changing attachments and I would recommend the comfort ride option to everyone.”

BILL QUICK - Redding, IA

FM SPECIFICATIONS	FM-540	FM-550	FM-560	FM-570	FM-580	FM-585
A Full Height (ground to pin)	13' / 156"	14' / 168"	15' / 180"	15' / 180"	16' / 192"	16' / 192"
B Clearance (bucket dump)	102"	126"	136"	136"	141"	141"
C₁ Rollback Angle	38°	36°	40°	40°	42°	42°
C₂ Dump Angle	60°	55°	47°	47°	50°	50°
D Reach at Max Height	35"	16"	9"	9"	35"	35"
E Reach at Ground Level (to pin)	35"	31"	16"	16"	35"	35"
	2800 PSI 3000 PSI	2800 PSI 3000 PSI	2800 PSI 3000 PSI	2800 PSI 3000 PSI	2800 PSI 3000 PSI	2800 PSI 3000 PSI
Lift Capacity - AWC* (31.5" from pin)	3600 3860	3900 4180	4700 5035	4700 5035	6740 7220	6740 7220
Lift Capacity - at Pivot Pin	5290 5670	6850 7340	7460 7990	7460 7990	8830 9460	8830 9460
Lift Cylinder - Std. Opt.	3"	3-1/2"	3-1/2"	3-1/2"	3-1/2"	3-1/2"
Bucket Cylinder - Std. Opt.	3"	3-1/2"	3-1/2"	3-1/2"	4"	4"
Bucket Sizes Available	86"	98", 108"	98", 108"	98", 108"	98", 108"	98", 108"

*For additional information on AWC Capacity - see page 12. Above specifications are based on ASABE S301.3 standard. Specifications may vary depending on the tractor, front axle configuration, tire size, hydraulic system and type of attachment. Design specifications are subject to change without notice or obligation.

MORE PRODUCTS

Westendorf Manufacturing doesn't just make loaders, but a wide variety of quality farm equipment such as wagons, scrapers, manure spreaders and more to make your day-to-day operations run more smoothly and efficiently.

Landscraper™	p. 106
Hay Man Bale Limo	p. 108
Wagons and Running Gears	p. 109
Tractor Canopies	p. 110
3-Point Implements	p. 111
Hydra-Snap™	p. 112
Dump Spreader	p. 112
Auto-Dump™	p. 113
Dual Changer Max	p. 113



WESTENDORF MFG. CO., INC.

P.O. BOX 29, ONAWA, IA 51040
Ph: 712.423.2762 | 877-MY-LOADER

Email: sales@westendorfmfg.com
Website: www.loaders.com
Online Parts Store: store.loaders.com



VERSATILE FARM EQUIPMENT

– *Developed with "you" in mind*

For over 85 years, we have striven to produce the highest quality, time-saving farm equipment, while maintaining the Westendorf "made in the USA" tradition. You can trust that the highest quality steel, hardware and components are used in every Westendorf product.



MENTALITY THAT MATTERS

We, as a family owned company, approach product design with an authentic commitment to provide the best value implements for your operation. We've invested in cutting edge technologies, robotic welders, CNC lasers and 3-D design in order to bring you the service, parts, documentation and quality products you expect and deserve.

WELCOME TO THE FAMILY

Join our family of happy, satisfied customers that benefit from the Westendorf advantage:

- Practical solutions
- Best overall value
- Operator comfort
- Precision engineering
- Customer focused design
- Cutting-edge technology
- Over 85 years of experience



LANDSCRAPER™

The MOST versatile piece of equipment you will ever own!

Whether you're reclaiming land, forming and maintaining ditches, constructing terraces, removing snow, spreading rock, or keeping lanes and roads smooth, the convenient features of the Landscrapper™ will allow you to perform your task in the toughest conditions. You will welcome the versatility it brings to the job site. Not only does it get the job done, it gets it done with

ease by allowing complete operation without ever having to leave the tractor's seat! This versatile tool allows you to do many tasks such as maintaining gravel driveways, baseball/softball fields, and beaches. You can also easily grade and level tough compacted soil, form & maintain drainage ditches, spread rock & gravel, construct terraces you can use it to clear snow in the winter.

LANDSCRAPER™

Quality built with professional grade performance and features. The extra strong bolt-on tongue constructed of square tubular steel and a large weight box allows easy adjustment to the cutting pressure. This unique system allows each wheel to be adjusted to provide 0-12" tilt of the cutting bar.

Base package: 3" Lift Cylinder, Hose Kit, Remote Control Coupler, Hydra-Snap™ Manifolds, Manual Tilt Adjustment, Depth Gauge Rod and Cut Angle Gauge Rod.

Options: Hydraulic Tilt Cylinder, Bolt-on Blade, Rotational Indicators, Jack & Transport lock and Tires (7.60 x 15).





WL-5
5' UTILITY LANDSCRAPER™

The 5' Utility Landscrapper™ attaches to your ATV/UTV or to your 3-point on your small tractor to reclaim your driveways, ditches and more. Standard package includes four adjustable steel digging teeth to break up tough, packed dirt, electric lift, heavy-duty weight box, built-in back blade. 60" wide for optimal mobility and coverage.

WL-6 | WL-6
6' LANDSCRAPER™

You asked; We listened... The popular Westendorf Landscrapper™ is now available in a 6' wide model for use on smaller utility tractors. Built with the same quality features and customizable options as the larger models, the 6' width has optimal mobility and excellent coverage.

WL-8 | WL-10 | WL-12
8', 10' OR 12' LANDSCRAPER™

Strong and durable because Westendorf uses high strength steel and a reinforced construction for maximum performance on the job. The 6" high carbon steel cutting edge carves through dirt, gravel, and snow with ease. The bolt-on tongue connects into the frame, which runs directly through to the back of the box. This feature, plus added supports welded from the front of the frame to the back of the box, makes the Landscrapper™ one of the most powerful box scrapers on the market. The heavy-duty weight box has room for adding weight such as rocks or sandbags to increase the drag of your Landscrapper™.



THE WESTENDORF ADVANTAGE!

Strong and durable because Westendorf uses high strength steel and a reinforced construction for maximum performance. The Landscrapper™ is one of the most powerful box scrapers on the market. Customize your Landscrapper™ to fit your needs.

OPTIONS *Customize your Landscrapper!*



BOLT-ON BLADE

Extra heavy users may want to consider adding a second six inch high carbon steel bolt-on cutting edge.



JACK & TRANSPORT LOCK

Quickly lock the Landscrapper in the raised position for fast transport around the yard and around the work site.



ROTATIONAL INDICATORS

Replace the standard gauge rods with rotational indicators to monitor both depth and cut angle at a glance.



HYDRAULIC TILT

Add the optional hydraulic tilt to make up to 12" tilt adjustments to either side from the comfort of your cab.



NEW



HAY MAN BALE LIMO

Time is money—move up to 22 bales at a time!

Save time and carry more bales with every trip. The new Bale Limo accommodates 6 bales on each side with room for 5 additional bales on each side to be in a second row, for a total 22 bale capacity. It is built to last with a long truss work design which uses a full solid tube from the front to the rear axle. Bale carriages are lower in the center

and wider at the outside so bales push to the middle and snug together well. Additional features include bumper units on the front and rear to prevent rolling, a heavy duty fender, custom goose-neck design, built-in poly cushion to reduce shock and bouncing while hauling, and extendable—spring assist tongue for easy hook-up. Also available with optional brake package.

HAY MAN BALE LIMO

Quality built 12 place hay trailer with professional grade performance and features.

- Tubular design is strong and lightweight
- Cross members bolt on for adjustability
- Heavy-duty hubs and rims
- Extendable tongue with easy spring-assist hook-up
- Isolation pads act as protection from shocks with heavy loads and reduce stress while towing
- Steerable front axle for easy turning

Hub Specifications: 8-bolt hubs on front, 10-bolt hub on rear with 4 1/2" spindle axle,

Options: Brake package.



LEGENDARY

Westendorf wagons and running gears



ADD-ON

H-N-G HITCH-N-GO™
Easily attach wagons, hay racks and trailers quickly from the tractor's seat. Patented spring mechanism allows trailing over rough terrain and pulls directly from draw bar for strength and safety.



Our heavy duty wagons and gears are engineered for many years of rugged use. With so many extra advantages, combined with a competitive price, you are sure to get the best value for your dollar. With features like a gravity flow box that empties in less than a minute, low-profile design and built-in rocking bolsters, you can expect

years of trouble free use. Known for their extra short turning radius and trailing ability, Westendorf gears give you flexibility in the field, in the yard and on the road. Select the size gear, tires and components that best match your hauling needs. Models range from 10 to 16 ton capacity with low profile and tandem options.

WAGON PACKAGES

PARTNO.	BUSHEL	GEAR
WW-325	300	10 Ton
WW-H375	350	12 Ton
WW-H425	400	12 Ton
WW-L375	350	14 Ton
WW-L425	400	14 Ton
WW-T425	400	16 Ton

WAGON GEARS

RATING	PARTNO.	SPINDLE	TREAD
10 Ton	WW-1610	1-15/16"	73"
12 Ton	WW-2012	2-1/4"	75"
14 Ton	WW-2214	2-1/2"	88"
14 Ton Tandem	TW-2014	2-1/4"	75"
16 Ton	WW-2416	3"	79"



WAGONS & GEARS

- Easy, spring assist hook-up
- Anti-wear bushings
- Built-in rocking bolster
- Steel wrap-around corners
- Sharp turning radius with excellent trailing
- Engineered for maximum load distribution
- Easy access ladder with room between the box
- Reliable steering structure, tie rod and pin construction

- Reach Clamp allows adjustments to the gear's length to fit an existing box, hay rack or flatbed

Options: Brake package & tires.



A SHADY DEAL!

An affordable solution you won't regret!

The Cool Cap™ tractor shade canopy has a distinctive shape and clean automotive finish. Available in two versions, a high gloss, iso-ceramic finish which provides a durable UV resistance to minimize sun fading and a dura-poly canopy which is rigid in strength yet flexible and resilient to hold up to bumps and bangs during use. Adding a shade canopy

to your tractor will save you from the irritations of sunburns and dangers of heat exhaustion, sun stroke and skin cancer. Choose from low-profile fixed or easy-off mounting brackets. The universal design of the brackets will fit round or square ROPS up to 6" in diameter. Built-in tilt adjustment for slanted ROPS and reflector package is included.



LOW PROFILE FIXED BRACKETS



EASY-OFF BRACKETS

I bought my Westendorf sun shade and it's been great. I should have bought one years ago. It is amazing how much cooler I am while working in the summertime."

MARK NUSSBAUM
Missouri

COOL CAP™ SIZING

DESCRIPTION	DIMENSIONS
SMALL Tractor Canopy	36" x 42"
LARGE Tractor Canopy	45" x 52"
X-LARGE Tractor Canopy	57" x 64"

For more information, visit www.loaders.com/canopies



“ I have a 60" version of the Rear-Ender Auto-Dump on my YM2000 for a few years. It works great for the investment. I have spread and leveled gravel, dug drainage reliefs on field edges, and it really works great for moving snow. Add a hydraulic stop link (high lifter kit) and it becomes a heck of a machine.”

STEVE - Wenona, Illinois



HF-43

SCISSORS LIFT

An economical solution to haul an extra bale on the rear of the tractor with the bale spear attachment OR load and unload pallets quickly and safely with the forklift attachment.

- Lift capacity: to 3500#

VERSATILITY

Put your tractor's 3-point to use!

Look no further for economical material handling solutions. Utilize your tractor's 3-point to transform your tractor into a versatile tool for stacking pallets and moving hay. The **Thrifty Lift™** is available with fixed or adjustable pallet forks or a bale spear attachment. The optional top link cylinder adds hydraulic leveling and tilt features.

AUTO-DUMP™

Add year round versatility to your ATV, UTV, mover or garden tractor.

- No axillary hydraulics
- Mounts to any 3-point (categories 0, 1, 2, or 3)
- Optional high-lifter unit available when you need it
- One lever dumps, resets and returns to dig position

THRIFTY LIFT™

Increase productivity by carrying material up front with your loader and in back with your Thrifty Lift™.

- Up to 3500# approx. 6'6" high
- Ideal for 28" x 42" pallets
- One lever automatically dumps, resets and returns to dig
- Available with bale spear or a fixed/adjustable pallet fork
- Optional top link cylinder for tilt function

The **Scissors Lift** is also available with pallet fork or spear attachment, but does not require hydraulics. The Scissors Lift works off the tractor's 3-point. The **Auto-Dump™** is great for digging, scooping and hauling material of all types. It works with a one-lever control, the same lever that controls your 3-point. It can dig, scrape, level, bank and backfill.



For more information, visit www.loaders.com/attachments



MORE PRODUCTS

—Practical solutions to simplify your life



In addition to manufacturing high-quality products, Westendorf realizes that our strategy must also include a value based on our customers' requirements and feedback. For more information on time-saving products by Westendorf, visit www.loaders.com.

HYDRA-SNAP™

Tired of hassling with hydraulic hose couplers? Consider the Flat Face Hydra-Snap™ upgrade; it's the perfect Power-Mount™ companion. It eliminates the messy job of connecting hydraulic hoses. This uniquely designed multi-coupling system saves both time and environment. Connect all hoses and electronics while under pressure with one easy to operate comfort grip handle. Available in one, two and three spool models to match your coupling applications.



ELECTRONIC FLOW CONTROL

Operates from the comfort of the cab by adjusting the dial to regulate the dump speed in relation to the expellers for consistent spreading pattern.

DUMP SPREADER

The all-hydraulic dump spreader is ideal for use with semi-liquid materials. Its smooth interior is continuously welded for strength and durability and materials move easily on the super-slick finish. Dual action expellers spread material in a 20' width. It does not have a rear gate with seals or tracks that can leak, chains that can break or aprons to freeze up. The patented dump motion centers the load over the wheel base so the spreader remains balanced and steady at all heights and terrain types. An optional electronic dump switch allows hauling with a non-hydraulic vehicle while still being able to empty the box.



AUTO-DUMP™

Add year-round versatility with the Auto-Dump™. This material handling system is the ideal solution for your UTV, ATV, mower or garden tractor. There are no auxiliary hydraulics needed, and it mounts on any 3-point hitch. The heavy-duty design is light enough to be shipped rapidly and economically, yet durable enough to hold up to daily use. Options include: lighting package, top spill guard, bucket platform, forklift teeth and grass and leaf attachment.

“Westendorf has renewed my optimism that today you can still get a quality product at a fair price.”

WES EVANS
Evans Quarter Horses - Washington

DUAL CHANGER MAX

Makes changing duals a one-man job! In as little as 5 minutes pick up a dual rim and tire with the loader, transport it and mount it on your tractor. Easily align and position the tire with 3-way alignment!

HOW IT WORKS:

- 1) A wheel on the end of the boom rotates the tire to align the holes for mounting.
- 2) A telescoping boom moves the wheel forward and back up to 16”.
- 3) A hydraulic jack allows precise height adjustment.



ATTACHMENTS

Westendorf's complete lineup of attachments work with most loaders on the market today. Westendorf manufactures many quick-attach systems and different styles of adapters to turn your loader into the ultimate material handling tool. Increase efficiency and save time by making it easy to use the right tool for the job!

Buckets	p. 116
Bucket Options	p. 117
Adapters & Couplers	p. 118
Forklifts	pp. 120-121
SnowScraper	pp. 120-121
V-Plows	pp. 120-121
Boom	pp. 120-121
Dozer Blades	pp. 120-121
Bale Spears	pp. 122-123
Grab Forks	pp. 124-125
Brush Crushers	pp. 126-127



WESTENDORF MFG. CO., INC.

P.O. BOX 29, ONAWA, IA 51040
Ph: 712.423.2762 | 877-MY-LOADER

Email: sales@westendorfmfg.com
Website: www.loaders.com
Online Parts Store: store.loaders.com



EXPAND YOUR POSSIBILITIES

– Attachments and quick-attach systems that really work!

Designed with you in mind, Westendorf's line of attachments address everyday material handling tasks with efficiencies in mind. Clear snow faster with a box blade and stack bales higher, faster and more evenly with the StackSaver™. Whatever your task at hand, Westendorf's lineup of attachments will transform your loader into the ultimate material handling tool.

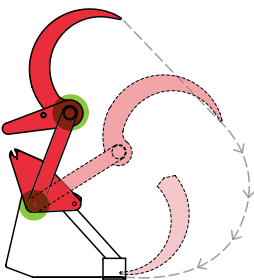

GOT BRUSH?

Westendorf's new patented Brush Crushers™ can make those labor intensive tasks like clearing trees and moving brush a whole lot easier. Both mechanical and hydraulic models are available to work with 2-spool and 3-spool hydraulic systems.

DIG IT!

The best buckets in the industry with sizes up to 120" wide and capacities up to 54 cu. ft. Take advantage of special features such as teeth, back drag blade and tapered walls for quick clean out to match your material handling tasks at hand.

STACK IT!

Westendorf's complete lineup of bale spears allow for custom tine configurations. Models with mechanical push off and several custom hay handling attachments allow handling of two round bales and up to 15 small square bales at the same time.

GRAB IT!

If you like how fast our loaders come off, you'll love our even faster line of quick-mount grab forks. From the monster grab fork to the triple-action cat claw, installation takes just minutes. Install it when you need it, take it off when you don't—all without the use of tools.



YOU'LL DIG IT!

In this case, bigger is better...

Westendorf standard-grade buckets, in most cases, are larger than the competitors' high-capacity buckets. Many of our buckets are designed with patented, tapered sides for quick release of materials that won't stick. The shock of digging can put a lot of strain on your bucket and your loader. The key to a well-built bucket is "where" the bracing is positioned. Westendorf's patented bucket design allows the loader, not the bucket, to

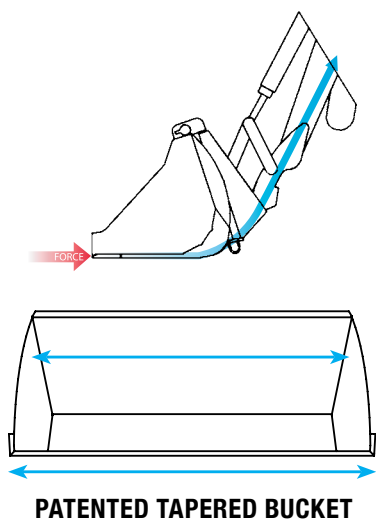

fully support the shock while digging. Even though our standard buckets far exceed the competitions' buckets, we have an extra heavy-duty, high-capacity (HDHC) bucket line that has even larger capacities. These HDHC buckets have either a weld-on double blade or bolted-on double blade. All buckets are available with multiple styles of adapters and quick-attach systems such as skid-steer, Euro style, pin style and more.



NEW

RB-74

ROCK BUCKET

The 74" durable, rock picking bucket has heavy-duty teeth perfectly spaced to let loose dirt through.



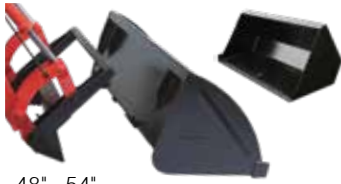

48" - 54"

COMPACT SERIES

Designed to fit the compact loaders, accommodates both pin style or quick-attach adapters.



66" - 72"

SKID STEER

Available on specific loader models, it has a capacity of up to 19 cubic feet.



72" - 96"

STANDARD

Strong, weld-in cutting blade and heavy duty top rail with added capacity up to 1.2 cubic yards.



96" - 108"

LARGE CAPACITY

A coveted tool for serious material handling jobs with capacity up to 1.6 cubic yards.



84"

MAX

Clean, no-rib interior with weld-in cutting edge and capacity up to 25 cubic feet.



98" - 108"

FREEDOM MOUNT

Bolt-on cutting blade and tapered sides for quick clean out with capacity up to 1.75 cubic yards.



96"

HIGH VOLUME LOW DENSITY

Carry huge 2.5 cubic yards of lightweight materials. Tapered, arched sides for quick clean out.



96"

HEAVY DUTY HIGH CAPACITY

Patented, tapered design has dual weld-on or bolt-on blades. Capacity up to 1.75 cubic yards.



84"

Z-47 FEEDER BUCKET

It rakes, it grabs, it scoops, it dozes, all without changing attachments. Capacity of 1.6 cubic feet.

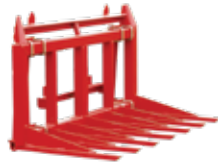

60"

FORK BUCKET

Built with seven heavy, square teeth, excellent for hauling silage or cleaning out barns.



60"

TINE BUCKET

Features eight spring steel off-set tines and two straight side tines. Shown with Sabretooth.



112"

FEED BUNK BUCKET

Clear material away under a feed bunk where regular buckets can't reach, 1.4 cubic yard capacity.

BUCKET OPTIONS *Customization is what we do best!*



SP-22

BUCKET MOUNT BALE SPEAR



DC-1

MAX DUAL TIRE CHANGER



COMPACT SERIES

QUICK-TACH BUCKET TEETH



48" - 96" BUCKETS

HEAVY DUTY BUCKET TEETH



SELF-LOCKING DESIGN CHAIN HOOKS



RK-40 EASY ON & OFF RAKE TEETH



WITH TEETH OR WITHOUT BACK DRAG BLADE



BTB-345 | BTB-390 HEAVY DUTY BUCKET TEETH



SNAP-ATTACH™ ADVANTAGE

The original quick-attach introduced in the 1970's has remained consistent and reliable for nearly 50 years.

The Original Snap-Attach™ system has retained its rank as the #1 quick change attachment system on the market. A system above all the rest, the patented Snap-Attach™ System has a self-aligning V-guide to automatically center the attachment for trouble free alignment every time. It also keeps the connection tight. Other flat models on the market are hard to align and show excessive

wear, but the V-guide will always stay tight because the harder you push, the tighter the connection becomes. This system keeps the pivot pin closer to the bucket for more power and better bucket action. This system has been tested over time and it is one of the top reasons customers give for loving their Westendorf loader. Stop pounding and aligning pins; convert your loader today.

EASY TO USE.

Hook upper pins into top holes of the attachment, raise attachment off the ground and roll back to lock the attachment into place.



I have an Allis-Chalmers 460 loader; I recently set it up with the Snap-Attach™ system and it works great! I go from moving round bales to moving pallets to scooping manure in seconds!"

BRIAN R. YOUNG

Agricultural Education - Trimble County

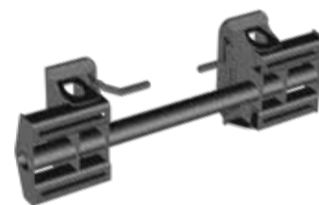

NEW

C-76

ADAPTER CONVERSION

Convert ANY loader on the market to fit skid-steer attachments.





C-51
ADAPTER CONVERSION
Skid-steer to Westendorf 20/40 series attachment with Snap-Attach™.



C-61
ADAPTER CONVERSION
Euro style to Westendorf 20/40 series attachment with Snap-Attach™.



C-53/54/57 | C-63/64
EURO COUPLER
Euro style couplers for Westendorf loaders with or without bucket linkage.



C-56 | C-66
EURO ADAPTER
Convert attachments to Euro style with the Global 1 (C-56) or Global 2 (C-66) options.

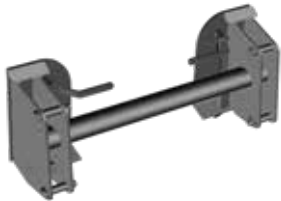

C-20/22/23/25/30/31
SKID STEER COUPLER
Convert your Westendorf loader to use skid steer attachments.

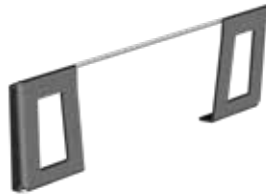

C-78
SKID STEER ADAPTER
Convert any attachment to skid steer quick attach.



C-8/16 | C-14
QUICK ATTACH SYSTEM
Coupler and adapter for the compact Westendorf loaders.

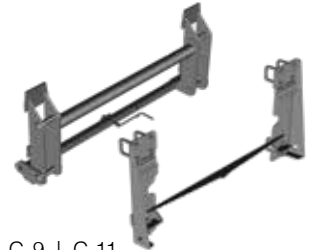

C-9 | C-11
QUICK ATTACH SYSTEM
Coupler and adapter for the TA-25 Westendorf loader.

THE SNAP-ATTACH™ SYSTEM *simple, time-tested and reliable*

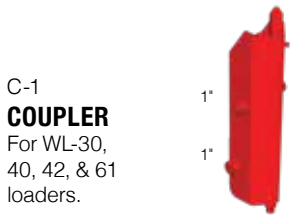

C-1
COUPLER
For WL-30, 40, 42, & 61 loaders.

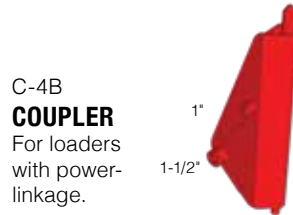

C-4B
COUPLER
For loaders with power-linkage.

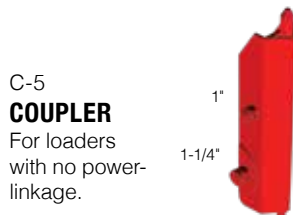

C-5
COUPLER
For loaders with no power-linkage.



C-6
COUPLER
For WL-20, 21, & 23 loaders.

1" Std.
1-1/8"
1-1/4"
OR
1-1/2"
PINS



C-40
COUPLER
For Freedom Mount & MAX loaders.

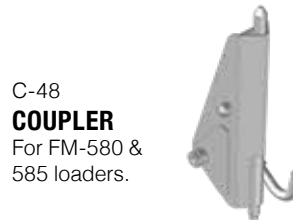

C-48
COUPLER
For FM-580 & 585 loaders.

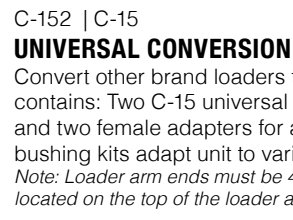

C-152 | C-15
UNIVERSAL CONVERSION KIT
Convert other brand loaders to Snap-Attach. Kit contains: Two C-15 universal couplers with 1" pins and two female adapters for attachment. Optional bushing kits adapt unit to various pin diameters.
Note: Loader arm ends must be 4.5" or less and cylinders located on the top of the loader arms.



QCS-200/400/700
SYNC BAR
Keep couplers aligned with the handy sync bar. Available for 20, 40 & 70 series loaders.



C-2 | C-24/47
WELD-ON ADAPTERS
For attachments, choose the single or double model if you need to share attachments between loader series.



C-3 | C-34/37
BOLT-ON ADAPTERS
For attachments, choose the single or double model if you need to share attachments between loader series.

CUSTOM
HAVE A SPECIAL APPLICATION?
Contact us with your project idea and special applications. We manufacture custom equipment to solve material handling solutions daily—let us help you save time and work more efficiently too.



ATTACHMENTS FOR

COMPACT LOADERS



Engineered with the same attention to detail and quality as our big loader implements; these smaller attachments will let you tackle any job you have on your acreage with speed and efficiency.

ESSENTIALS

For your everyday chores.

Whether you're handling seed pallets or clearing mountains of snow, having the right tool for the job will get the job done quickly and efficiently. Westendorf carries a full line of material handling attachments for both compact loaders and heavy-duty larger loaders. When paired with the tried and true Snap-Attach™ system or the new Remote

Control Coupler, using the right tool for the job becomes easy. For moving snow, consider the v-plow, Snow Scraper or a dozer blade. For handling pallets, bulk seed and other heavy items, we have several forklift attachment to choose from. We recommend the Level Up Advantage when handling a large number of pallets on a regular basis.



I like the quick attach feature...

I change attachments three times a day on my TA-26. I have a pallet fork, bucket and

hay spear that keep my 800 head of cattle fed.

WAYNE EMBRY
Kentucky





FLM-42 | FLA-42

FORK LIFT

Carry pallets and heavy items efficiently. Standard with quick-attach to fit your compact loader.



DB-60

DOZER BLADE

Excellent dirt work tool for landscaping with a solid, one-piece shell and high wear blade.



SBB-5 | SBB-6

SNOW SCRAPER

Move snow three to five times faster with a Snow Scraper than with a bucket, 5' or 6' models.



VP-72

V-PLOW

This 72' wide v-plow works great on any compact loader. Choose several quick-attach options.

HEAVY-DUTY *Loader Attachments*



DB-84 | DB-96 | DB-120

DOZER BLADE

An excellent tool for packing silage and doing heavy dirt work. Designed to match the strength of large loaders in widths up to 120" wide. All blades are built with a solid, one-piece shell, and 1/2" x 6" blade with wear bars on the bottom.



FL-42 | FL-48

FORK LIFT

Carry pallets, bulk seed and heavy items more efficiently. Available with different sized teeth and built-in spill guard. Choose the shorter teeth to prevent the forks from sticking through your pallet. Industrial strength teeth are easily adjustable without tools.



VP-72 | VP-96

V-PLOW

The Westendorf V-Plow is patterned after the snow plows you see on highways, designed to roll and throw the snow away. It does a great job of clearing a quick path. Adjustable feet raise and lower to determine blade height to prevent the back of the blade from digging into the ground. A built-in guide lifts the plow over uneven ridges and terrain.



SBB-8 | SBB-10 | SBB-12

SNOW SCRAPER

The ideal tool to clear mountains of snow quickly; it is also useful in capturing manure, silage, grain, mud, refuse, and other materials. Its smooth blade and rib-free interior keep materials from sticking. It can be mounted on a loader, skid-steer or on the tractor's 3-point. Optional top extension available, shown with optional poly blade and skid kit.



EB-34

EXTENDABLE BOOM

This multi-use tool is a must around the yard. Move many items quickly and easily. Easy, tool-free adjustments to multiple lengths from 89" to 114".

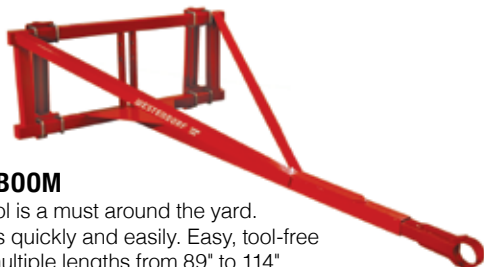

TOP EXTENSION

Increase your capacity by upgrading your box or dozer blade with this heavy-duty mesh top extension. Multiple lengths are available to fit 8' to 12' blades.



BALE SPEARS

—and additional hay handling equipment.

If you've ever handled bales, you know how annoying it can be to have a tight bale that doesn't want to come off the spear. Westendorf's assortment of bale spears are universal in design; yet, versatile enough to match any hay handling need. Ranging from models to fit your compact tractor or heavy-duty, extra-wide models that can carry multiple bales in one trip, Westendorf uses top quality components and spears that are made of heat treated forged steel for durability.

Having used an original three-prong spear with success for several years, I am especially impressed with the Stack Saver II that I purchased. I thought that having a push bar needing no additional hydraulic line was an interesting concept. Then I used it to stack one-ton square bales three high in the barn. Despite limited clearance, I was able to create straight, safe stacks in a time efficient manner. Stacking and unloading the semi-truck is no problem. Placing bales on the flatbed that fit together tightly and straight made the hauler smile with approval.

WES EVANS
Evans Quarter Horses
Chattaroy, WA



NEW

SP-2B

FOUR-TINE DOUBLE SPEAR

Transport two round bales and cut your handling time in half. The spear placement provides optimal weight distribution for longevity of the spears.

The full tapered length easily penetrates and releases from the bale. If you handle a larger number of hay bales, consider the Stack Saver™ series of bale spears. The automatic mechanical push-off feature speeds up your operation and eliminates this sticky problem without the added expense of hydraulic cylinders. Choose any tine configuration and an adapter to fit your loader. Snap-Attach™, pin style or skid-steer style adapters are available.

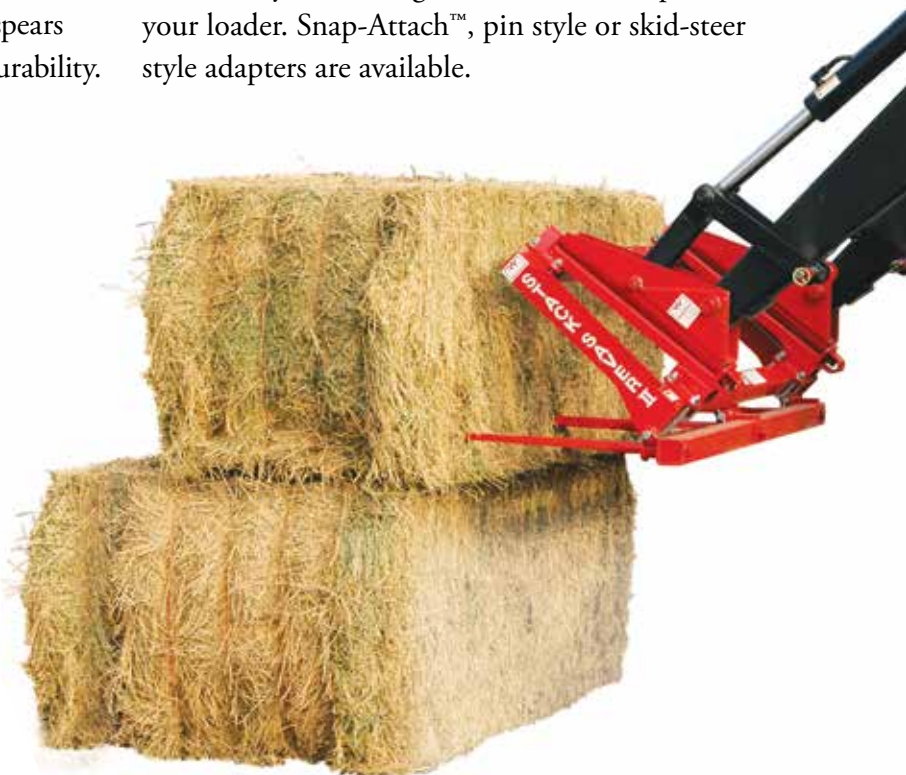



BS-22
BUCKET MOUNT SPEAR
 Our single economy spear is for 20 series buckets and fits over the center rib, aligns with a hole to pin in place.



SP-160
100 SERIES BALE SPEAR
 Mounts and dismounts in seconds without the use of tools. Keeps weight close to the loader for more lift. One long spear.



SP-42 | SP-72
TWO-PRONG BALE SPEAR
 For square or round bales. Spears are elevated to prevent cutting the twine. Two 49-1/4" spears (44" usable length).



SP-74
FOUR-PRONG BALE SPEAR
 Our four-prong bale spear is designed with four long, tapered, forged spears; ideal for carrying very large square bales.



SP-43 | SP-76
THREE-PRONG BALE SPEARS
 The SP-43 is for the 20 and 40 series loaders. Use the SP-76 with wider framed 70 series loaders. Quality heat treated forged steel spears ensure easy penetration and release. Both units include one long spear and with two short stabilizing spears. (Long spear is 49-1/4" long with 44" usable length)

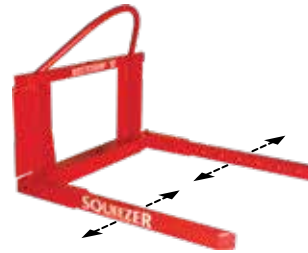

SQ-80
SQUEEZER™
 54" hydraulic arms grab bales and squeeze securely for transport. Tilts the bale from end to side, opens to 78", closes to 48" and includes cylinders and hoses.



BH-15
BALE HANDLER
 Handle 12 to 15 small square bales. Powered by dual cylinders, sharp curved hooks penetrate & lock bales in place for transport. Includes cylinders and hoses.



SS-I (ROUND BALES)
STACK SAVER I



SS-II-3L
STACK SAVER II



SS-II-3
STACK SAVER II



SS-II-4
STACK SAVER II

PUSH IT OFF WITHOUT HYDRAULICS!

This patented bale spear utilizes the frame to hold the bale in place as the bucket cylinders' tilting action releases the spears. Just stack the bale, tilt bucket cylinders to hold the bale in place and back away to release the spears from the bale. No third lever required.



STACK



HOLD



RELEASE



GRAB FORKS

—And material handling equipment.

It's "on" when you need it and "off" when you don't. Westendorf grab forks are specifically designed to power-mount to the bucket for convenience. Easily carry bales and loose materials while keeping the load secure at the source. Westendorf carries a full line of quality grab forks.

CAT CLAW 3D GRAB FORK

This new generation grab fork crushes, pulls, fills and handles many unforgiving, hard to handle loads with ease. It is designed with compound capabilities, multiple movements and triple actions. The V-shaped curved teeth are tapered and braced to handle increased side pressures and resist twisting. Dual hydraulic cylinders operate in unison off one hydraulic lever and when open, the teeth sit back behind the front edge of the bucket.

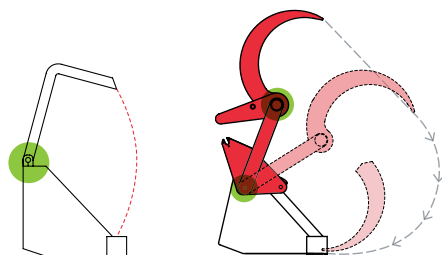

Standard Action

Patented 3D Triple Action



GF-32 | TINE BUCKET
SABRETOOTH

VERSATILE

A simple and economical grapple that bolts over the Westendorf fork bucket or tine bucket's frame. Excellent for hauling silage and moving hay bales. Package includes Sabretooth with two high tensile, forged, curved teeth and hydraulic hoses or steel line hose kit.

They vary from simple, economic solutions to more advanced, heavy duty solutions. Consider a monster grab fork, quick mount claw, the new Cat Claw grapple or the Z-47 feeder bucket—the ultimate tool for dairy and cattle feeders. For more information, visit www.loaders.com/attachments/grab-forks.





GF-84-3D | GF-96-3D
CAT CLAW 3D GRAB FORK

Enjoy tool-free on and off in minutes without the use of tools. The GF-84-3D and GF-96-3D are available for 84" and 96" large capacity buckets. When open, the teeth are positioned behind the front edge of the bucket. They can reach out and pull material into the bucket. The GF-184/196-3D models are for buckets with square tube top rails found on the Custom Contour, Max, Freedom Mount and heavy duty high capacity buckets.



GF-184-3D | GF-196-3D



Z-47
Z-47 FEEDER BUCKET

It is the all around attachment—it grabs like a grab fork; it scoops like a bucket; it dozes like a blade—all without changing to a different attachment. It is the ideal tool for cattle and dairy feeders. The clam-shell style opening of this bucket is unique; its teeth open so wide to fit around a round bale. The teeth are on both the top and bottom edges of the bucket. When they are shut, they overlap and close tightly.



GF-20
JIFFY MONSTER GRAB FORK

Power-mount grab fork has three sharp teeth and a power cylinder to aid in bale penetration. Works with 20 series buckets.



GF-51
MONSTER GRAB FORK

Designed for 40/70 series buckets, the GF-51 has four replaceable, straight teeth, power-mounts and secures with a single lever.



GF-28
GF-52
MONSTER GRAB FORK

GF-28 (20 series) and GF-52 (40/70 series) have four replaceable, curved teeth that transport large round bales without penetration.



GF-64
QUICK MOUNT CLAW

Long, replaceable arched teeth open wide and easily penetrate a round bale. Includes a built-in stand for easy dismounting.

**PATENTED
POWER-MOUNT
GRAB FORKS!**

Westendorf grab forks are designed to be easily mounted or dismounted from the bucket without stands or the use of tools. Self-aligning teepees make mounting just as simple.

Dismounting: Release latch. Roll back bucket and set grab fork on the ground. Once upright, back away and unhook hoses.



RELEASE



SET ON GROUND



BACK AWAY



GOT BRUSH?

The only way to handle gnarly brush—while staying in your tractor's seat!

Make those painful labor intensive tasks like clearing trees, handling brush or even cleaning up after a storm—Fun! All the work is done from the comfort of your cab. Get the extra helping hand you need when picking up large piles of brush or removing fallen trees. Crush with power yet, when needed they can be gentle and precise. Removing the weight of the bucket and positioning the load closer to the loader pin

increases load capacity. It also allows you to see better and penetrate deeper into the load's center. Choose between mechanical and hydraulic models. The mechanical series cost less and does not require a third function lever. Since the teeth are not rigid, they are able to open and close independently to conform around lopsided and uneven loads. The hydraulic series work with skid-loaders and loaders equipped with an additional third function lever.



NEW

BC-4200 **BRUSH CRUSHER™**

Adjustable teeth to optimize tooth action. It is simple, easy and doesn't require additional hydraulics. Fits John Deere quick attach and is painted green to match!



*Those Brush Crushers
are the Cat's Meow!*

GREG LESSORD
New York





BC-4300
BRUSH CRUSHER™

A universal skid-steer Brush Crusher has the same grabbing action and fits compact loaders with skid-steer quick-attach up to 70 HP.



BC-3000
BRUSH CRUSHER™

Ideal for a compact loader with limited capacity. Works with the TA-52 and TA-55 Westendorf loaders or other brand loaders without a quick-attach system.



BC-4000
BRUSH CRUSHER™

The original double-action Brush Crusher™, an economical solution for compact loaders with added functionality for professional users.



BC-5000
BRUSH CRUSHER™

The largest mechanical Brush Crusher in the series fits other brand loaders and the WL, TA, XTA, CC, FM loader series.



BC-6000
BRUSH CRUSHER™

Hydraulic power teeth operate independently and offer added control, versatility and power. Shown with optional tie-bar. Fits loaders with Snap-Attach™.



BC-7700
BRUSH CRUSHER™

A multi-use tool designed for skid steers and loaders with a skid-steer adapter. This one-piece, 56" wide unit has power-teeth and is ideal for the heavy user.



BC-700
BRUSH CRUSHER™

Finishing teeth from the BC-7700 can be dismantled when handling bulky loads, and quickly installed to rake and pick up finer materials.



BC-8200
MONSTER BRUSH CRUSHER™

Handle all types of materials with this 72" wide unit. The upper teeth conform easily to handle lopsided loads with ease.

WHAT CUSTOMERS SAY *about their Brush Crusher!*

“ I tore down about 60 little buildings with it so far. This Brush Crusher is awesome! ”

“ Jobs that would have been messy and taken me hours were done in just minutes! ”

“ Moving brush has never been easier. The Brush Crusher makes clearing my land a snap! ”

“ The Brush Crusher is fun to operate. It makes tree work less of a manual task. ”

“ This is the best way to move heavy, awkward loads. ”

“ I was amazed at the power these teeth have! ”





SHARE IT!

Didn't your mother tell you it was nice to share?



Westendorf makes it easy to interchange a single loader between multiple tractors. Enjoy the added comfort of switching your loader to a cab tractor for winter chores or moving it to a cooler, open station tractor in the summer.



WESTENDORF RELIABILITY

When you buy a Westendorf loader, you can have confidence in the ability to access parts, hydraulic components and mounting brackets for years to come. With over 20,000 bracket fits to date, you can move your loader to your next new tractor or share it between the cab tractor or the open station tractor for summer hay handling.

- 1) Interchange one loader between multiple tractors.
- 2) Get current technology without investing money in a new tractor.
- 3) New design updates will retrofit or interchange with existing products in the field.

INSTALLING A LOADER HAS NEVER BEEN THIS EASY

At Westendorf you can purchase the latest loader equipped with all the modern day bells and whistles even if your tractor is already equipped with factory loader-ready brackets.

Westendorf lets you work with what you already have installed on your tractor. We've created the new Transformer Bracket, it integrates with all factory ready brackets. Just pin the Transformer Bracket over the top of the existing factory brackets on your tractor, hook up your hydraulic manifold and drive into your new loader.



We ARE better connected
 — find it online at www.loaders.com

RESOURCES ARE ONLY A CLICK AWAY

Loads of information on our interactive website is just a click away. Stay current on industry trends, research new loader technology, browse our vast line of quick-change attachments and find out what Westendorf customers have to say about their recent experiences.

SUBMIT A FIT REQUEST

If you are unable to find the loader for the tractor you wish to mount, please call us toll free at 1-877-695-6233. You may also submit your fit request on our website at www.loaders.com. We fit new tractors daily.

TELL US WHAT YOU THINK

Designing quality and time-saving farm equipment is our goal. We thrive on helping our customers achieve their material handling goals. We invite you to tell us about your ideas and experiences.

Email your loader or attachment photos and product feedback to marketing@westendorfmfg.com or mail them to:
 Westendorf Mfg. Co., Inc.
 Attn: Marketing Dept.,
 PO Box 29
 Onawa, IA 51040

ONLINE RESOURCES

- Loader Selector
- Tractor Fits and Bracket Chart
- Shop Replacement Parts
- Shop Attachments
- Dealer Locator
- Warranty Registration
- Product Videos
- Customer Feedback
- Service Request
- Events Calendar and more...





GET CONNECTED

—The Westendorf Way!



Of course, we're better connected than any loader on the market. We are famous for our patented technology, we welcome you to compare. While others are constantly changing who is going to manufacture their loaders. We concentrate on taking all of the knowledge we have gained over the years to make our loaders operate in the best and most efficient way possible, all to make your life easier.



ORIGINAL POWER-MOUNT™

Westendorf's patented loader mounting and dismounting system is time tested and refined—some of the first loaders built in the 50's featured this all-hydraulic mounting system. Why take a chance? Trust the original innovator of the auto-locking power-mount loader.

ORIGINAL SNAP-ATTACH™

It is the original quick attach system introduced to the loader industry. The patented Snap-Attach™ quick change attachment system offers v-shaped adapters for trouble-free alignment every time. Just roll back your bucket and the plungers snap-lock into the attachment. See p. 119 for couplers and adapters.

FLAT FACE HYDRA-SNAP™

Tired of hassling with hydraulic hose couplers? Consider the Flat Face Hydra-Snap™ upgrade; it's the perfect Power-Mount™ companion. This uniquely designed multi-coupling system saves both time and environment. Connect all hoses and electronics while under pressure with one easy to operate comfort grip handle.

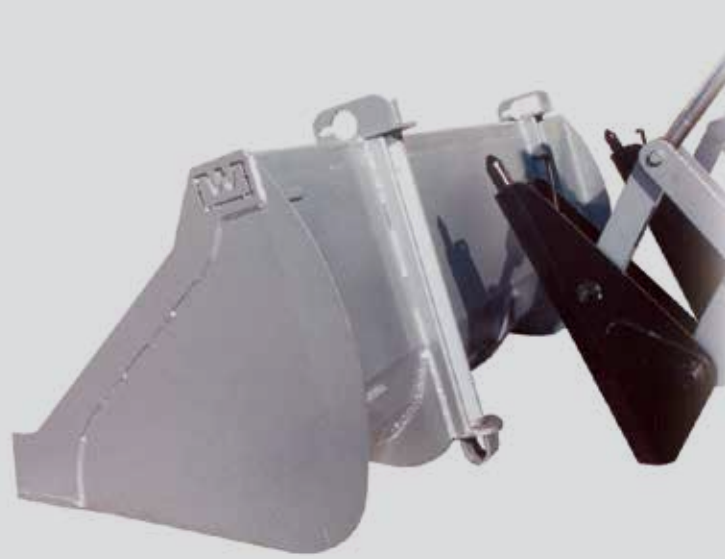

REMOTE CONTROL COUPLER

Our famous patented Remote Control Coupler will spoil you like no other because you can change attachments as you like by pushing a button inside the cab. This is done without the need to add another hydraulic lever. The weight of the loader is efficiently used to accomplish this.

MORE PATENTS

- Transformer Bracket
- Stabilization Bracket
- Brush Crushers
- Back Drag Blade
- Cat Claw 3D Grab Fork
- Quick-Mount Claw
- Tractor Shade Canopy
- Stack Saver
- Tapered Bucket Design
- Lift-Height Extender and more

LINELESS SMART-PAC CYLINDERS

Increased reliability and improved long-term performance of the patented Smart-Pac cylinder eliminates all external hoses, lines and fittings for a cleaner appearance. The swagged barrel automatically compresses the seals past the barrel's edge during assembly for consistent quality every time.

FREEDOM MOUNT™

Only Westendorf allows you the freedom to use the bucket to take the loader on and off without the need for a time-wasting kick stand. This mounting system automatically locks on the tractor eliminating extra trips out of the cab; plus, not having to get out and dismantle and store those cumbersome support stands saves time, money and temper.



