

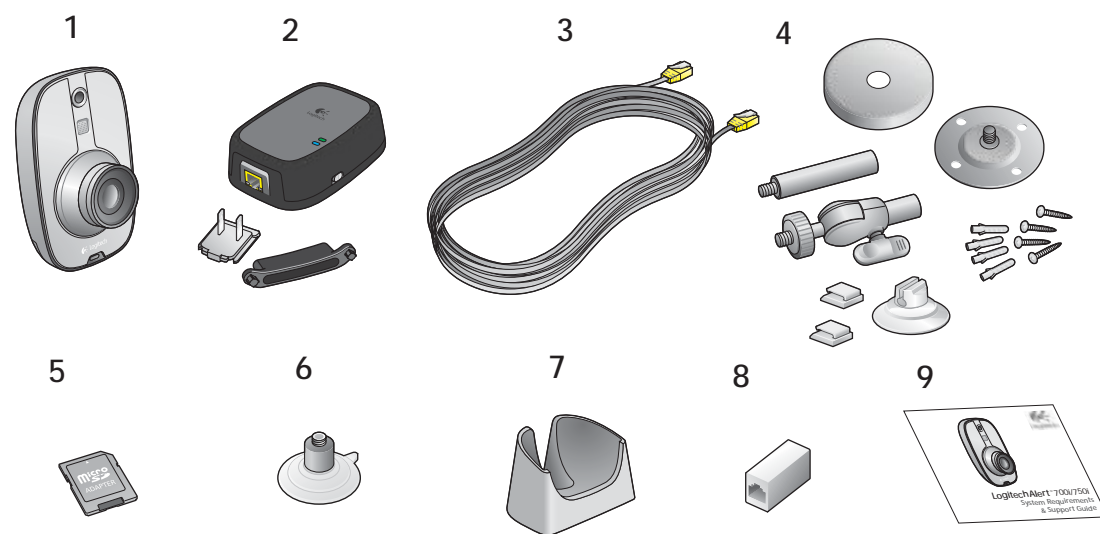

Add-On Camera



- 1 Logitech Alert Camera
- 2 Camera power supply
- 3 Power supply cable (yellow tips)
- 4 Mounting accessories
- 5 microSD™ card adapter
- 6 Suction cup
- 7 Desktop stand
- 8 Power supply cable extender
- 9 System Requirements Guide



Legal Warning

Certain uses of security camera products and audio devices, such as employee monitoring, surreptitious viewing and recording of images and/or audio, or the use, publication or distribution of image and/or audio recordings, are prohibited or restricted by country, state and local laws.

Be sure to comply with the laws in your country, state, and locality when using Logitech Alert products and services.

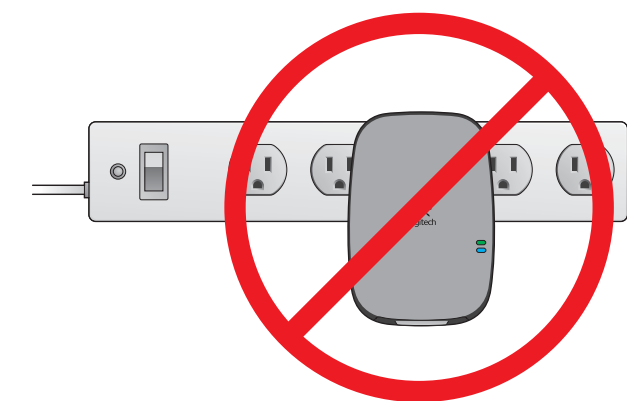

Power Supply Install Note

Do NOT plug the power supply into a surge protector or power strip as they interfere with the cameras. Surge protectors are built-in to the power supply and protect the cameras.

The power supply must be plugged directly into your wall outlet.

1 Run Logitech Alert Commander

Before you begin the installation, read all instructions.

⚠ Logitech Alert Master System required.



1) Be sure that Logitech Alert Commander software is running on the PC before beginning installation of camera.

2 Plug in Your Camera

When prompted to connect your camera:

- 1) Remove the hatch from the back of the camera. 1a) Plug the yellow cable connector into the port. 1b) Use the lock slider to lock the connector in place.
- 2) Plug the yellow cable into the power supply port. 2a) Plug the power supply into an outlet near the PC where the software is installed.

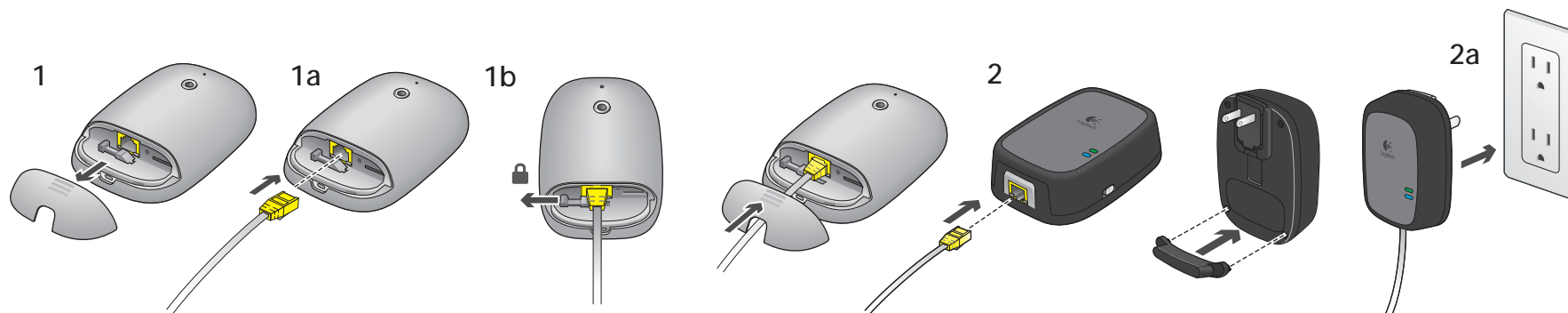

• Shortly after connecting, your camera will appear in Alert Commander software. You can now move the camera to its desired location.

3 Choose Your Camera Location

On a desk or table

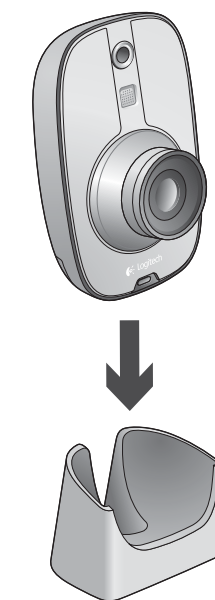

On a window looking out or in

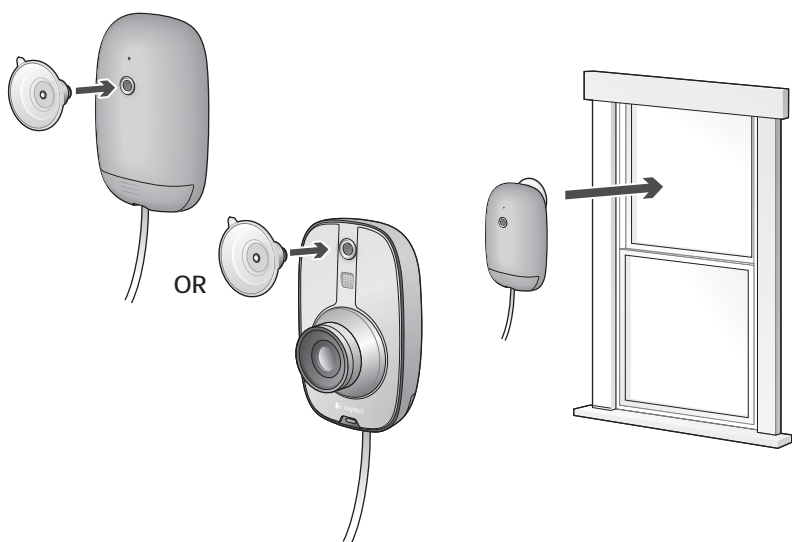

Clean the window's surface and the inside area of the suction cup before applying it to the window. Periodically press the suction cup against the glass to strengthen its bond to the window.

Using In-the-box Accessories

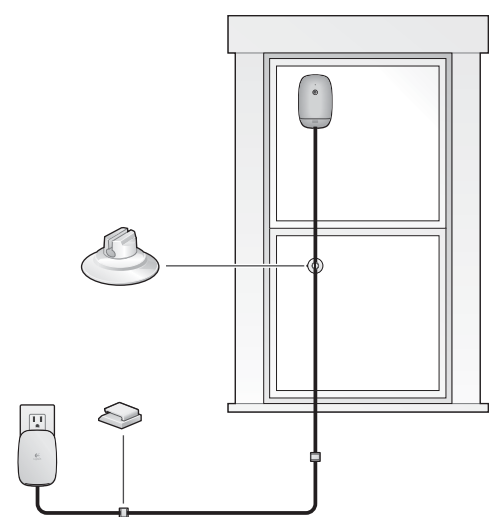

You can use the mini-suction cup and cable wall clips to help route the power supply cable (yellow connector) along the window's edge and provide additional security to that camera.

Wall/Ceiling Mounting Instructions

The wall mount allows you to easily fasten your camera to a ceiling or wall. 1) Start by pre-drilling holes into the wall and screwing in the mounting base. 2) Assemble the mounting arm and attach it to the base. 3) Attach the camera to the mounting arm.

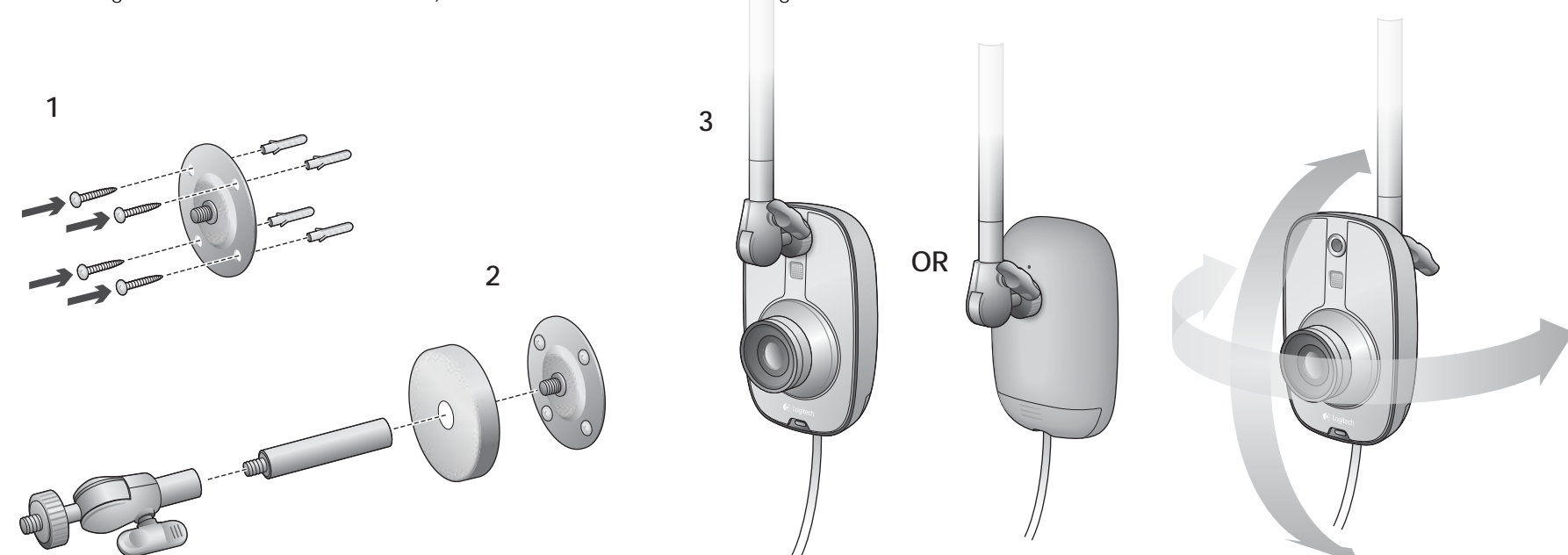

FAQs

Where can I find more information?

Commander Help

You can press the F1 key from any screen in the Alert Commander to access the online Help system.

Knowledge Base

Troubleshooting help is available at www.logitech.com/support

Customer Support

Call 1.888.469.4543

Refer to System Requirements Guide.



HELP



What do I do if the power supply cable (yellow connector) is too short?

To lengthen, either use a coupler or purchase a longer ethernet (CAT-5e) cable.

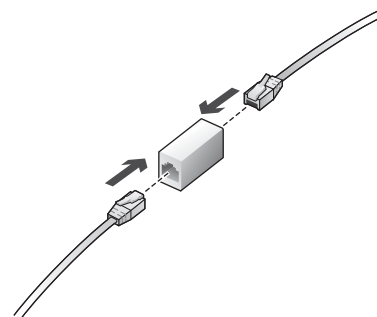

Want to see more FAQs?

Go to www.logitech.com/security/support

Troubleshooting camera connection:

What if camera/video disappears?

- 1) Test another outlet for your camera, perhaps one closer to your PC.
- 2) Verify that the camera power supply and the network bridge are plugged directly into a power outlet and not a power strip.
- 3) Check firewall settings or press the F1 key in Commander Software for additional help.
- 4) Go to Settings > Cameras > Add/Find > Find Cameras.
- 5) Reset the camera. See instructions in "Camera Reset Instructions."

Camera Reset Instructions

Insert a paper clip into the reset hole located on the back of the camera and press gently and then release.

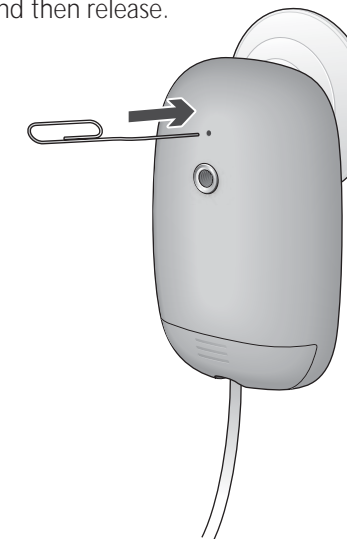

If the camera does not appear after reset, go to Settings > Cameras > Add/Find > Find Cameras. If the camera still does not operate, contact technical support.

Resetting the camera will restore the camera to factory settings. However, it will not delete video recorded on the microSD card.

Reading the Diagnostic LEDs

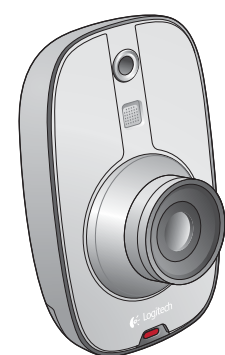

Motion LED

How do I know the camera is recording?

- Camera is ready to record (Red)
- Camera is recording (Red, blinking)

Turning Off Motion and Diagnostic LEDs

You can turn off the motion and diagnostic LEDs in the Settings > Cameras > Camera > Show LED for...

See F1 Help for instructions.



Camera Diagnostic LED

Which LED colors indicate "camera is working"?

- Connected to Internet (Green)
- Connected to Alert Commander (Purple)
- Connected to Alert Commander & Internet (Blue)
- Upgrading Firmware (White)
- Camera in standalone mode (Yellow)
- Not connected to Alert Commander or Internet (Light Blue)



Camera Diagnostic LED

Which LED colors indicate "camera is not working"?

- Camera boot-up failed * (Red blinking)
- microSD card read/write failure - No microSD card * (Alternating Red / Yellow, blinking)

* See Camera Reset Instructions for assistance.

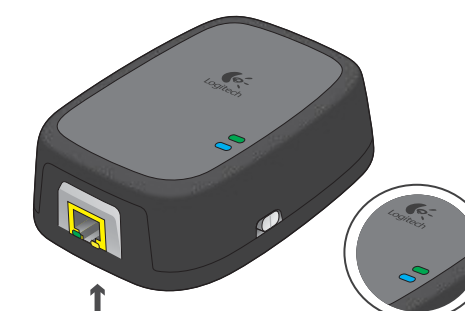

Power Supply Diagnostic LEDs

Power Supply Network Status LEDs

What do these LEDs tell me?

- Traffic and data is flowing (Green)
- Connection with Ethernet/LAN (Yellow)

What do these LEDs tell me?

- Link to Power Supply (Green)
- Shows network traffic (Blue)

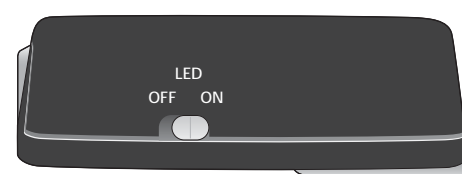

On/Off switch for Power Supply LEDs

How do I turn these LEDs off?

Use the switch located on the side of the power supply to disable these diagnostic LEDs.

www.logitech.com

© 2010 Logitech. All rights reserved. Logitech, the Logitech logo, and other Logitech marks are owned by Logitech and may be registered. All other trademarks are the property of their respective owners. Logitech assumes no responsibility for any errors that may appear in this manual. Information contained herein is subject to change without notice.

620-002008 rev004

Using the microSD™ card adapter

NOTE: Unplug the camera before removing, replacing, or upgrading your microSD card.

To review the video on the microSD card, we recommend using Logitech Alert Commander.

To review the video on the microSD card without Logitech Alert Commander:

1) Open the hatch on the bottom of the camera and remove the microSD card from its port.

2) Plug the microSD card into the adapter.

3) Plug the adapter into the PC's SD card slot.

- View video recordings using the free Apple QuickTime player or other player that supports H.264 video playback. (To download QuickTime, visit <http://www.apple.com/quicktime/download/>)

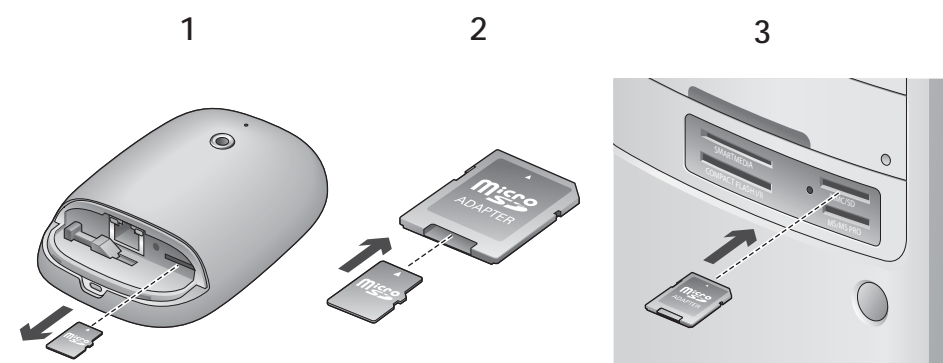

! microSD card must be installed in the camera for recording to occur.

microSD Logo is a trademark of SD-3C, LLC.