



FREQUENCY CONVERTER

FC-401

INSTRUCTION MANUAL

en

We thank you for selecting Mikasa Plate Compactor.
For your safe and proper operation, please read this manual and
be always sure to keep it ready for reference.



<http://www.mikasas.com>

102-01104



Table Of Contents

1. Preface	1
2. Machine Application, Warning, Structure And Power Transfer	1
3. Warning Labels	2
4. Precautions For Safety.....	2
4.1 General Precautions WARNING	2
4.2 Precautions About Cabtyre Cord And Socket & Plug	2
4.3 Precautions About Where To Use Machine	3
4.4 Precautions Before Operation	3
4.5 Precautions When Working	3
4.6 Precautions After Work	4
4.7 Precautions In Lifting	4
4.8 Precautions In Transportation / Safekeeping	5
4.9 Precautions In Maintenance	5
4.10 Installation Of Every Decal	6
4.11 Descriptions Of Symbols Used On Warning Labels	7
5. General View.....	8
5.1 Dimensions(mm)	8
5.2 Parts Name And Positions Of Device	9
6. Specifications	10
6.1 Specifications	10
6.2 Number Of Utilizable Units	10
6.3 Length And Cord Size	10
7. Operation	11,12
8. Stop Operation	13
9. Maintenance And Safekeeping	14
10. Troubleshooting	15,16
11. Wiring Diagram	17

1. Preface

Thank you for purchasing Mikasa FC-401 type FREQUENCY CONVERTER.

- This instruction manual describes the proper methods for using Mikasa FREQUENCY CONVERTER, as well as simple checks and maintenances. Be sure to read this instruction manual before operation, in order to get full use of the excellent performance of this machine, and to improve your operation and to perform engineering work effectively.
- After reading this manual, store it in a handy location for easy reference.
- For inquiries about repair parts, parts list, service manuals, and repair of the machine, please contact the shop where you purchased, our sales office, or Mikasa Parts Service Center.

In addition, parts list is available on the MIKASA website at:
<http://www.mikasas.com/english/>

Illustrations and Figures in this manual may be different from the machine you actually purchased due to design changes and other reasons for improvement.

2. Machine Application, Warning, Structure And Power Transfer

Applications

A special power converter to drive a concrete vibrator with built-in high frequency induction motor for concrete compaction (high frequency vibrator) and a high frequency self oscillating motor. Converts commercial power of 50Hz three-phase AC380V into 200Hz three-phase 48V power for high frequency induction motor.

Warning about incorrect applications and techniques

The concrete vibrator for concrete compaction that can be connected is either a vibrator (high frequency vibrator) that is inserted into concrete to directly send vibration to the concrete from inside or a high frequency self oscillating motor that is fixed on a formwork or a table to send vibration indirectly to the concrete. Do not try to connect a work machine not specified. Please use with the commercial power of 50Hz three-phase AC380V or an equivalent power from a power generator. Do not use other power source. Use only 50Hz when using the commercial power of three-phase AC380V. Otherwise, the vibrator as well as the electric control system of the converter will be damaged. Do not alter the connection plug and outlet to try to connect to an internal vibrator of different specification or a machine designed for general commercial power. Also, do not use with the voltage that is beyond the power converter's allowable input voltage range. Otherwise, the vibrator and the special power converter might be damaged and there arises a risk of electric shock.

Structure

Mikasa FC-401 converter is a motor generator type power converter (AC-AC converter) for directly converting 50Hz three-phase AC 380V into a power with a frequency four times higher. With a 6.85KVA (three-phase 380V • 10.4A • 50Hz) three-phase induction motor connected to the input side, the converter is started by an auto-breaker switch. To the output side, a rotor of 4.0KVA (three-phase 48V • 48A • 200Hz) high frequency generator attached to the motor is connected. The output side wire of the stator on the generation side is connected to the outlet for high frequency vibrator inside the control box via a circuit protector, and when the circuit protector is turned on, current flows to the outlet for the vibrator. In the control box, in addition to the auto-breaker and the outlet, there is a magnet switch for over load control and phase failure protection.

3. Warning Labels

The triangle shaped  marks used in this manual and on the decals stuck on the main body indicate common hazards. Be sure to read and observe the cautions described.

 Warning labels indicating hazards to humans and to equipment.

 **DANGER:** Denotes an extreme hazard. It calls attention to a procedure, practice, condition or the like, which, if not correctly performed or adhered to, is likely to result in serious injury or death.





 **WARNING:** Denotes a hazard. It calls attention to a procedure, practice, condition or the like, which, if not correctly performed or adhered to, could result in serious injury or death.

 **CAUTION:** Denotes a hazard. It calls attention to a procedure, practice, condition or the like, which, if not correctly performed or adhered to, could result in injury to people and may damage or destroy the product.



Precautions (without a triangular mark): Failure to follow the instructions may result in damage to property.

4. Precautions For Safety

4.1 General Precautions WARNING

 WARNING:	<ul style="list-style-type: none"> ● Do not work in the following conditions. <ul style="list-style-type: none"> ○ If you do not feel well due to overwork or illness. ○ If you are taking any medicine. ○ If you are under the influence of alcohol. 	
 CAUTION:	<ul style="list-style-type: none"> ● Read this instruction manual carefully and handle the machine as described so that you can work safely. ● Make sure you thoroughly understand the construction and operation of the machine. ● Please check each part before work, and execute the scheduled check and alignment regularly. ● To work safely, always wear protective clothing (helmet, insulation shoes, rubber gloves, safety glasses etc.) and appropriate work clothes. ● Please wear Hearing protector (noise protective equipment of ear muff or ear stoppers) by all means. ● Always check the machine to make sure that it is normal before starting operation. ● The decals on the machine body (operating methods, warning decals, etc.) are very important to ensure safety. Keep the machine body clean so that they can be read at all times. If any decal cannot be read, replace it with a new one. ● It is very dangerous if children come into contact with the machine. Take the utmost care about how and where the machine is stored. ● Before performing any maintenance, be sure to turn off the machine. ● Mikasa does not accept any liability for accidents or problems caused as a result of not using genuine Mikasa parts or if the machine has been modified. 	 

4.2 Precautions About Cabtyre Cord And Socket & Plug

 CAUTION:	<ul style="list-style-type: none"> ● Check of the cabtyre cord Confirm that insulator / conductor part does not crop out by a rift or the wear of mantle (sheath). Because abrasion is comparatively intense, change the cabtyre cord for a new article early. Check the damage and transformation of the cord, and the socket & plug by fever. The exposure of conductor part is in danger of an electric shock and the fire by the short circuit. The transformation of code is in danger of disconnection and the short circuit. ● Do enough thickness (size) retention of the cabtyre cord for a flowing electric current. The voltage falls in proportion to the length of the code. 	
---	---	---



4.3 Precautions About Where To Use Machine

 DANGER:	<ul style="list-style-type: none"> ● Choose machine space where rain and water do not hang, without the puddle . When machine gets wet, be in danger of the short circuit. Provide a suitable breaker at the power source of input side for safety. ● Do not use personal computers and electronics in neighborhood of the converter. By the effect of noise to grow, be in danger of the damage. ● Do not operate the machine near open fires. When flammable fuel volatilizes, be in danger of the explosion. ● To avoid any dust and fine sand, select the place of converter keeping dry and clean in operation and storage. 	
--	---	--



4.4 Precautions Before Operation

 CAUTION:	<ul style="list-style-type: none"> ● Check the clamping condition of each part. Cause the big failure that does not think that a screw loosens by vibration. Tighten the screw well. ● Switch position checks "OFF". It become the cause of the accident that you do not think to start suddenly. ● Check plug and socket. When joint falls out, repair it immediately. When you just use it, heat generation is critical. ● Check a patch (extension) code. The cable cord use a thing without a damage. The joint be careful to short circuits. 	
---	---	--

4.5 Precautions When Working

 DANGER:	<ul style="list-style-type: none"> ● Work enough with care without being careless. Work in a handling method, the way of work, the situation of circumference carefully enough with care. Let savvy act. Do not use it after having been tired, or after the medication took it, or after having drunk. ● Do not do an unprepared start. In the state that turned on switch, do not be connected to the power supply. Check that the switch is turned off before connecting input plug to power supply. ● Do not treat a cord violently. <ul style="list-style-type: none"> ▪ When you pull the socket, do not pull the cord. ▪ Do not hang the machine with the cord. ▪ Do not bring a cord close to some places of heat / oil / sharp corner. ▪ Do not wire place where a vehicle passes the cord. <p>As for the above, a worker is in danger of an electric shock, and the cord is in danger of disconnection and the short circuit.</p> <ul style="list-style-type: none"> ● Do not use the vibrator which cannot operate ON/OFF with a switch. 	
 CAUTION:	<ul style="list-style-type: none"> ● Be careful to transportation and the movement. <ul style="list-style-type: none"> ▪ Do not pull a cord forcibly, and do not hang it. ▪ The cord rounds it and bundles it up, and do transportation and movement having the pipe part of the machine. Do not touch neighboring obstacles (a steel frame or a reinforcing rod) on this occasion. 	
 DANGER:	<ul style="list-style-type: none"> ● Cancel work at the time of the abnormality. When you hear an abnormal sound causes something wrong with the machine, you switch it off promptly, and cancel use. And you contact the purchase or the place where one go to for rent, and ask it for check and repair. ● When you do not use it, turn off a switch by all means. 	

4.5 Precautions When Working

 DANGER:	<ul style="list-style-type: none"> ● Use equal or less than possible number vibrators. Table of Usable Number of High Cycle Vibrators The numbers that can use refer to table of "Usable Number of High Cycle Vibrators". Do not absolutely use vibrators more than possible number. ● Pay attention to overload operation. When the output of a converter exceeded rated value, FC-4 N type stops the output. It protects the machine and implement (vibrator and External Vibrating Motor etc.). ● About direct rays of the sun and rainwater Use at a place where avoids direct rays of sun and rainwater does not influence. <ul style="list-style-type: none"> ▪ Do not wear water in operation. ▪ Do not run it on a puddle. ▪ Do not use it during rain. ● Prevention of an electric shock <ul style="list-style-type: none"> ▪ Do not operate a machine by the hand which got wet. ▪ Do not use it in rain and snow. ● Prevention of a fire Do not put dangerous materials (oils and fats, celluloid, gunpowder, etc.) and inflammables (paper, small piece of wood, etc.) in circumference of a machine. Delete fire with being ignitable. ● The stop of converter When stops work and stays away from the converter, stop it by all means. 	
 WARNING:	<ul style="list-style-type: none"> ● Use ropes of fall prevention in high place work, and get security. ● Do not bring a child close to converter. Do not let a cord and converter touch it besides a worker. 	

4.6 Precautions After Work

 CAUTION:	<ul style="list-style-type: none"> ● Procedure of a stop <ol style="list-style-type: none"> ① Turn a vibrator switch into O F F. ② Turn a switch of a converter into O F F. ③ Detach a vibrator plug. Besides, if power supply cord has a plug, and detach it. Must not pull a cord. It causes an electric shock and disconnection. ● Caution of housing Do not put heavy goods on a plug and a cord of a converter. It causes disconnection and trouble. 	
---	--	--

4.7 Precautions In Lifting

Loading and unloading work by crane needs the lifting license. Be sure to work a licensing holder in crane.

 DANGER:	<ul style="list-style-type: none"> ● Be sure to work the license holder of crane operation and slings. ● Before work of lifting, check any damage of body parts (especially, lifting hook, or others) or looseness / omission of screws, and be sure safe. ● Stop the converter at the time of the lifting. ● Use enough wire rope of the strength. ● Never put any person or animal under the lifted machine. ● For safety, do not lift the machine up more than required height. 	
--	--	--

4.8 Precautions In Transportation / Safekeeping

 WARNING:	<ul style="list-style-type: none">● Stop the converter at the time of the transportation.● By all means detach plug and socket before transporting the machine .● Fix the machine well not to move and fall down.	
---	---	--

4.9 Precautions In Maintenance

 CAUTION:	<ul style="list-style-type: none">● Appropriate maintenance is always required for safety operation and to maintain performance of the machine. Pay full attention in the condition of the machine, and maintain good condition. Especially improper maintenance of lifting-related part becomes cause of serious accident.● Do work after lower temperature of machine. In addition, be careful not to burn itself enough.● Do the check alignment in situation that stopped converter by all means. There is badly injured danger when you are rolled up in a reel. After maintenance fulfillment, check the installation of safety protection parts of the machine. Especially, check bolts and nuts thoroughly. When you do maintenance with dismantlement, refer to maintenance manual regularly, and work safely.● Washing of a part Washing use non-inflammable treated oil. Blow enough after washing, and do not leave an oil.● Pay attention to ventilation The place where indoor and ventilation are bad, has danger of gas poisoning. Do enough ventilation.● Read instruction manual and service manual Read the manual before check (maintenance) of converter, understand enough maintenance method, and do check (maintenance) with care safely. Serviceman must have enough knowledge and technology.● When a terminal part of a socket is damaged, repair (change) it.	
---	--	--

4.10 Installation Of Every Decal

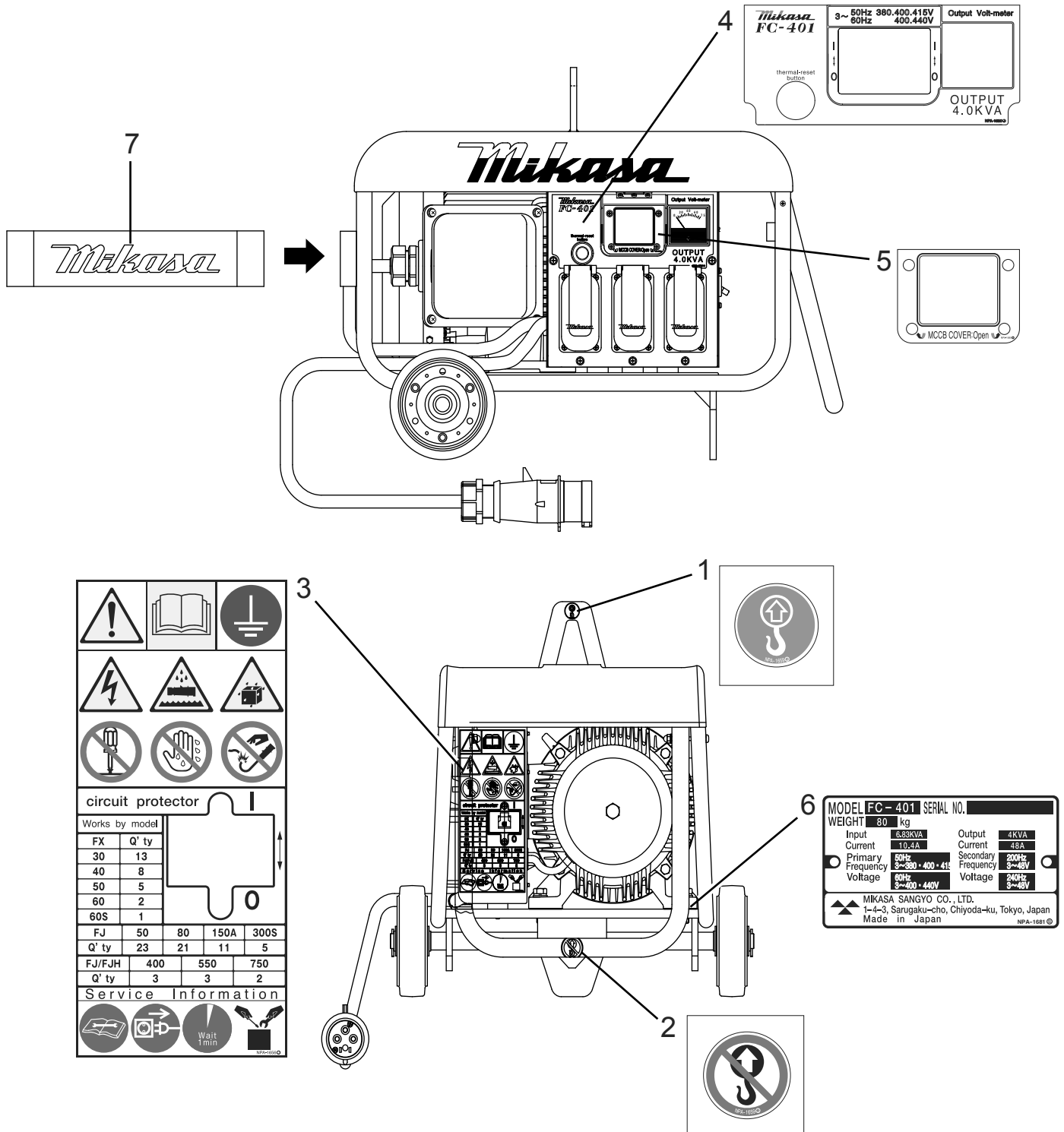

PARTS LIST of NAME PLATES

REF No.	PART No.	PART NAME	Q' TY	REMARK	
1	9202-16590	DECAL, LIFTING LABEL SET	Hanging Position	1	NPA-1659
2			Hanging Prohibited Part		
3	9202-16560	DECAL, CAUTION / FC-401	1	NPA-1656	
4	9202-16800	DECAL, TYPE(50/60Hz) / FC-401	Front Panel	1	NPA-1680
5			MCCB Cover	1	
6	9202-16810	PLATE, SERIAL NO.(50/60Hz) / FC-401	1	NPA-1681	
7	9201-09560	DECAL, MIKASA(250 WHITE)	1	NP-956	

4.11 Descriptions Of Symbols Used On Warning Labels



Unplugging of the power plug with wet hand is prohibited

Do not unplug the power plug with wet hand.



Never touch a broken cord

Do not touch the broken part when a cord is broken. Carefully unplug the power cord to avoid electric shock. Have the cord repaired professionally.

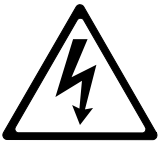

Watch out for electric leak and electric shock

Be careful not to get electric shock. Please use ground-fault interrupter at the power source.



Connect ground wire

To protect workers from electric shock, always ground securely.



Hanging prohibited part

Do not hang the machine at this part.



Disassembly prohibited

While current is flowing or if you are not sure whether the power is cut, do not disassemble nor alter the converter. Electric shock, fire or burn might occur.



Caution against water immersion of power plug

Do not let the power plug immersed in water and avoid it from getting wet. Electric shock or malfunction might occur.

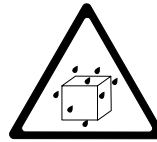

Use in the rain not allowed

Do not use the converter in the rain.



Carefully read the operation manual

Before using, please read necessary operation manual. Also, always keep the manual at hand.



Never touch with wet hand

Do not touch the converter with wet hand. Electric shock or burn accident might occur.



Hanging position

When hanging the converter, hang a hook or hoisting attachment at this location indicated by this label.



Other danger

Handle the converter by paying attention to the potential danger that is associated with its use.

For service (repair)



Read service manual carefully

When you do repair work on this converter, always read the service manual. Also, repair work has to be done by a service person who has mastered a skill for repair.

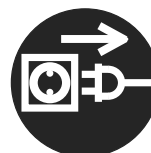

Unplugging of the power plug

When doing repair work of the converter, always unplug the power plug from the outlet.



Disassembly start time

When disassembling, wait for one minute after the converter is unplugged.

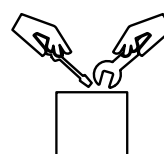

Disassembly of the converter

Use appropriate tool for disassembly and do disassembly in an area suitable for such work.

5. General View

5.1 Dimensions (mm)

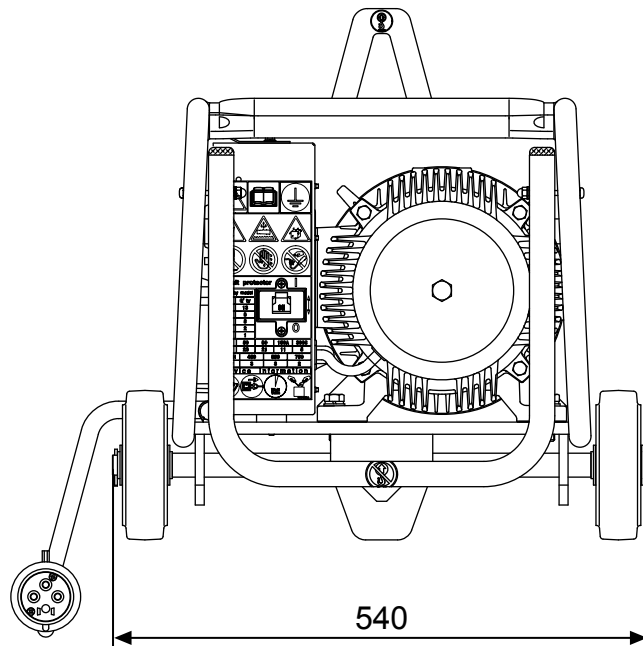
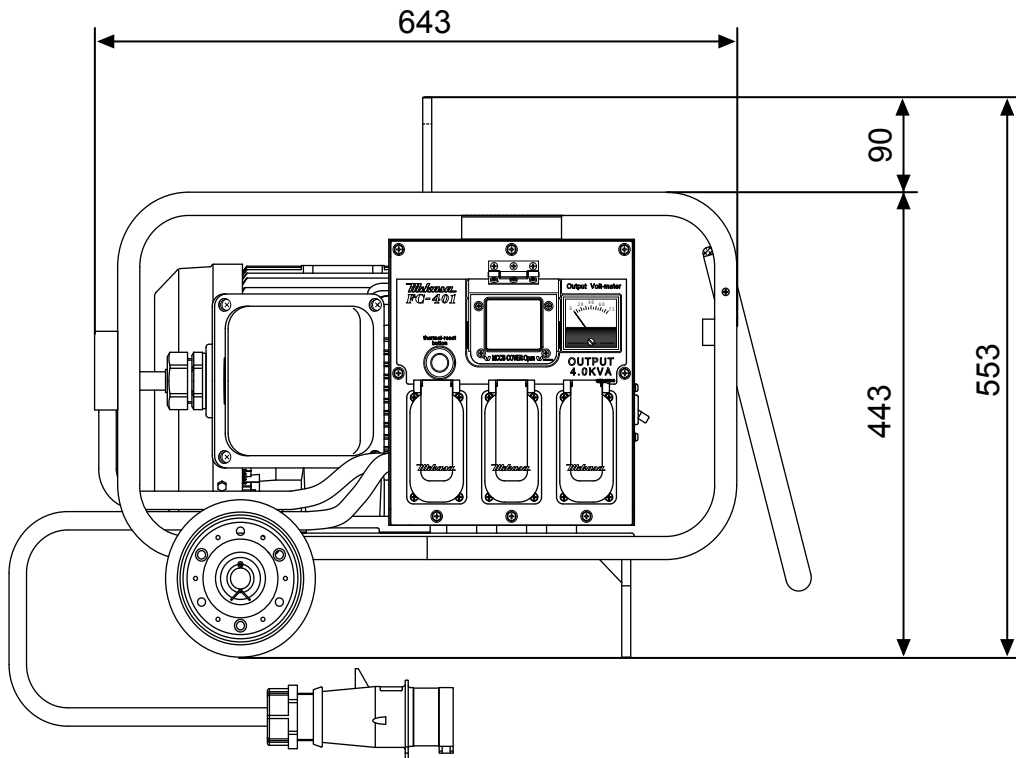

5.2 Part names and positions of device

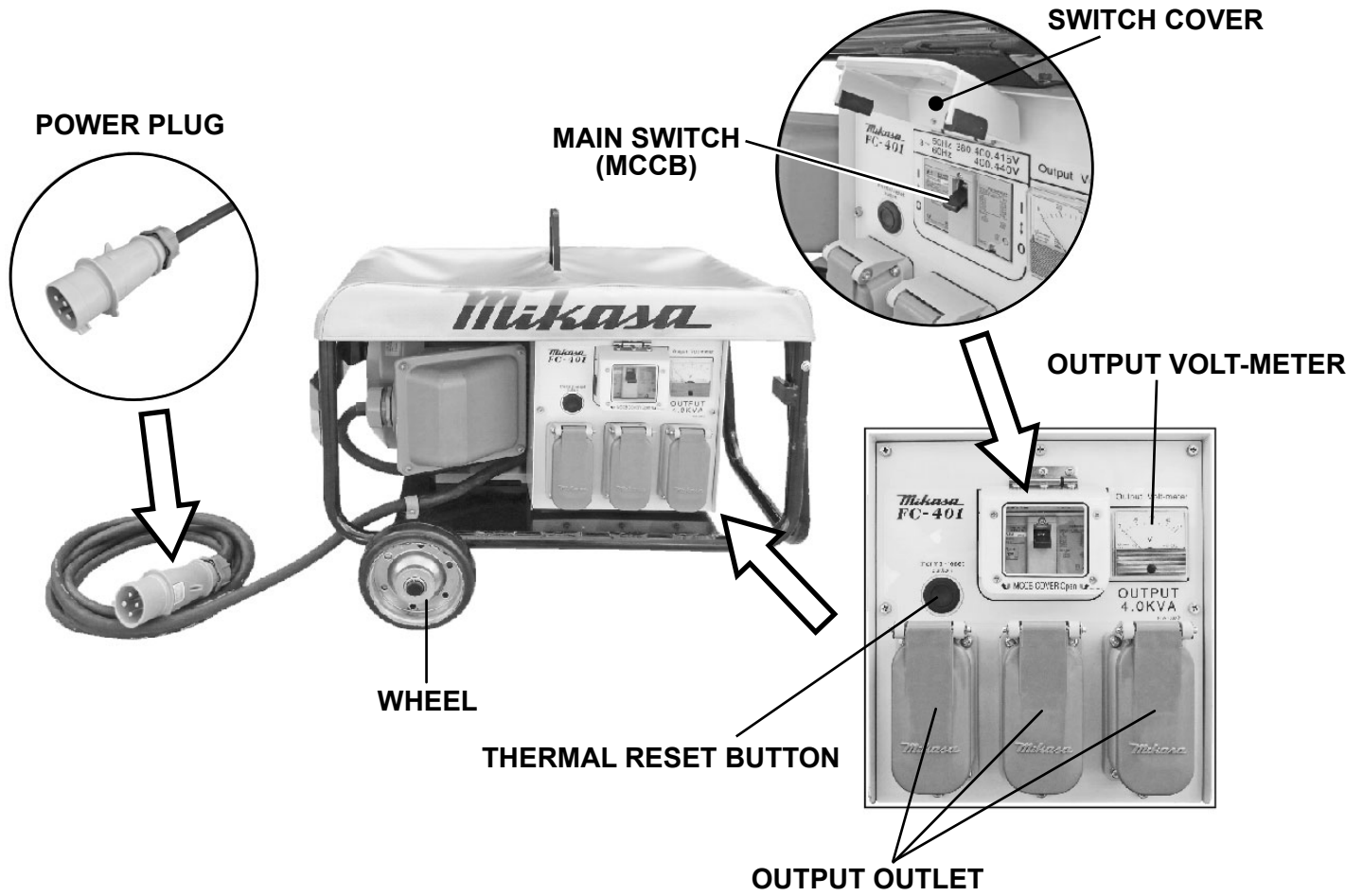

CIRCUIT PROTECTOR SWITCH

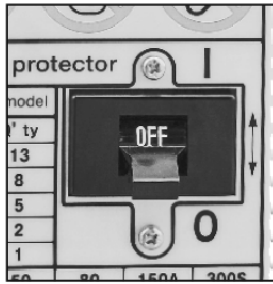

HOOK (HANGING POSITION)



HANDLE (FOR MOVING)

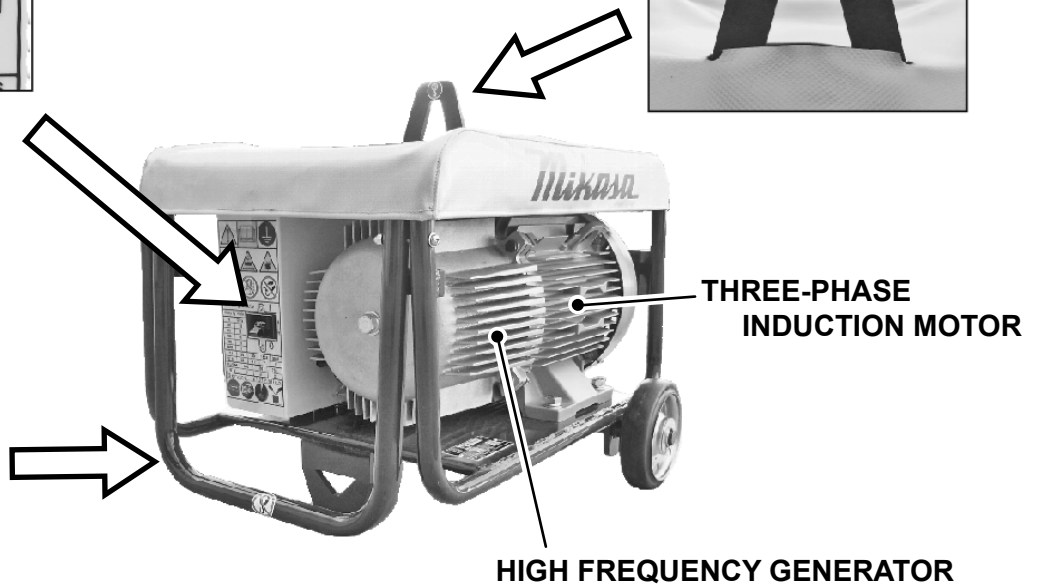

6. Specifications

6.1 Specifications

Type		FC-401		
Overall Height		553mm		
Overall Length		643mm		
Overall Width		540mm		
Total Weight		80kg		
INPUT	Input	6.83KVA		
	Phase	3 ~		
	Primary Voltage	50Hz	380 · 400 · 415V	
		60Hz	400 · 440V	
	Current	10.4A		
Frequency	50/60Hz			
OUTPUT	Output	4KVA		
	Phase	3 ~		
	Secondary Voltage	48V		
	Current	48A		
	Frequency	200/240Hz		
Numbers of receptacles		3		

6.2 Number Of Utilizable Units

Type	FX/FH/FD/FXS/FXB/FZ									FJ			FJ/FJH			
	30	40	50	60	60S	70	90	110	130	50	80	150A	FJ300S	FJ550	FJ750A	FJH750
FC-401	13	8	5	2	1	1	2	1	1	23	21	11	5	3	2	2

6.3 Length And Cord Size

(extension cord between converter and vibrator.)

Size of cabtyre cord (cross-section area)	L (m)			
	FX-30E (RE)	FX-40E (RE)	FX-50E (RE)	FX-60E (RE)
3.5 mm ²	80	50	30	—
5.5 mm ²	130	80	50	20
8 mm ²	200	120	80	35
14 mm ²	350	220	140	70

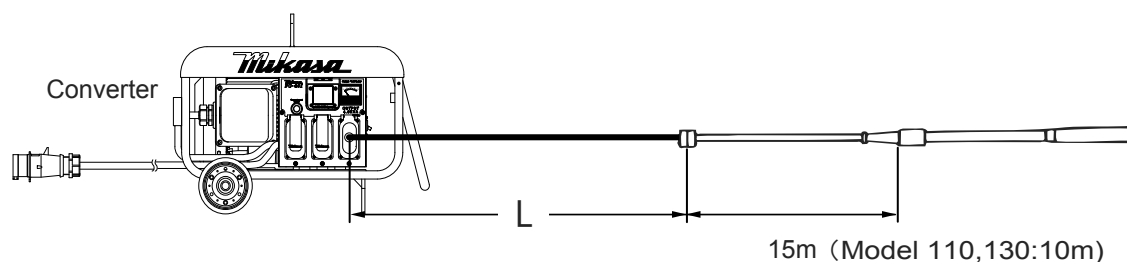

7. Operation

- 7.1 Make sure that the power is appropriate for the specification of the converter. Also check to see if the voltage is in the normal range by using measurement device such as voltage tester and electrical circuit security device that can check the power rating.
- 7.2 Plug the power cord to the outlet.
- 7.3 Open the switch cover. Turn on the switch of main switch (MCCB). Read the output voltmeter of the converter to make sure it is 53V - 57V. (Fig.1, Fig.2)

⚠ CAUTION

If phase failure (current not flowing in one of the three phases) occurs at starting, the electromagnetic switch operates to disable the converter. If that happens, shut the power and solve the problem. Then, press the thermal reset button. For details, please refer to p.12 "Electromagnetic switch".



Fig.1

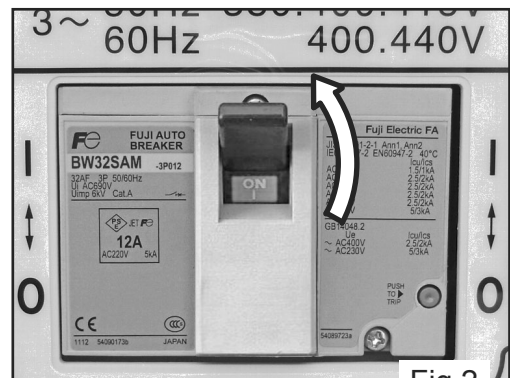

Fig.2

- 7.4 Make sure the switch of the machines (vibrator, self oscillating motor) is turned off.
- 7.5 Turn on the switch of circuit protector (secondary side). (Fig.3)

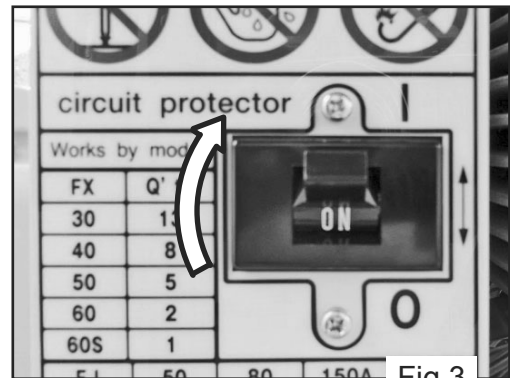

Fig.3

- 7.6 Securely insert the male plug of the machine all the way into the output outlet of the converter. (Fig.4)

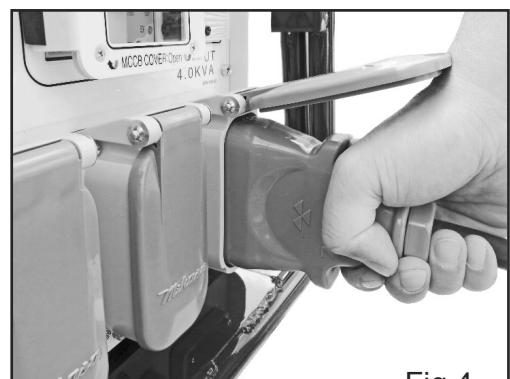

Fig.4

- 7.7 MCheck to make sure that the claw of the output outlet cover is securely catching the male plug and the plug does not come off even when the cord is pulled lightly. (Fig.5)
- 7.8 Start concrete casting by turning the switch of the machines (vibrator, self oscillating motor) one by one.

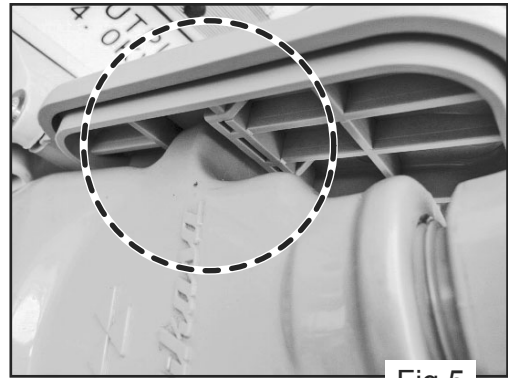

Fig.5

⚠ CAUTION

If there is an abnormality in the machine, the circuit breaker (secondary side) switch will turn off automatically. If that happens, first stop the converter for safety reason, then check the machines (vibrator, self oscillating motor) one by one. After the problem is solved, turn the switch on again.

7.9 ELECTROMAGNETIC SWITCH

This converter contains an “electromagnetic switch”. The electromagnetic switch shuts the power automatically if the following condition exists.

- **Before operation**
 - a) Phase failure (current not flowing in one of the three phases before starting)
- **During operation**
 - a) Abnormal heat generation (thermal abnormality) of the motor during operation
 - b) Phase failure during operation (current not flowing in one of the three phases during operation)

Recovery method

For abnormal heat generation (thermal abnormality), wait until the converter cools down, then press the thermal reset button on the front of the control box. (Fig.6)

For phase failure, check the power plug outlet. If the problem is solved, the electromagnetic switch will return to normal to let the current flow. In case if the electromagnetic switch still does not let the current flow, there might be trouble with the converter. Shut the power safely by paying attention to the risk of electric shock and electric leakage, and have the converter checked and repaired.

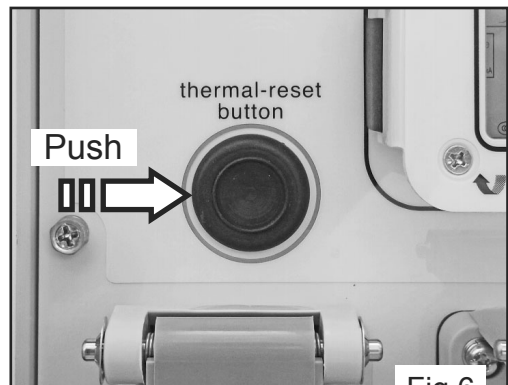

Fig.6

⚠ CAUTION

For recovery process of the electromagnetic switch, always turn off the main switch (MCCB) and the circuit protector (secondary side) first.

8. Stop Operation

- 8.1 After concrete casting work is finished, turn off the switch of the machines one by one. Then, unplug the machines from the output outlet.

- 8.2 Turn off the switch of circuit protector (secondary side). (Fig.7)

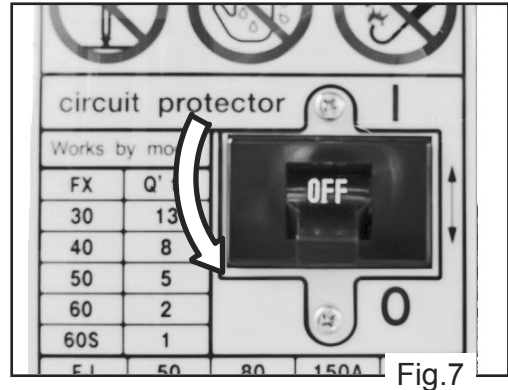

Fig.7

- 8.3 Open the switch cover, and turn off the switch of the main switch (MCCB). (Fig.8. Fig.9)

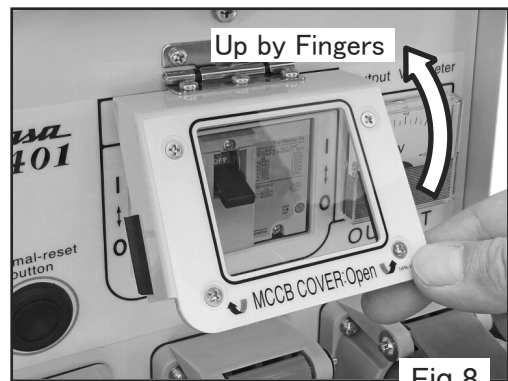

Fig.8

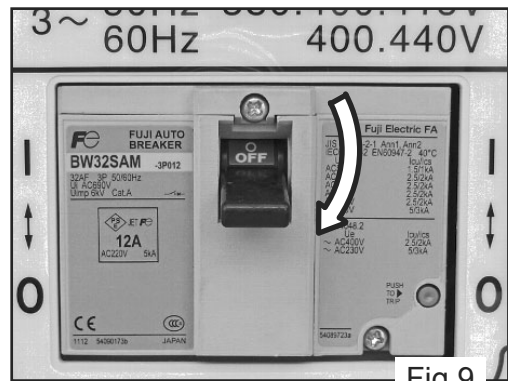

Fig.9

9. Maintenance And Safekeeping

- 9.1 ACheck the power plug and outlet to see if they are dirty or have rust, deformation or breakage.
- 9.2 Check the power cord to see if it is worn, cracked or crushed.
- 9.3 Check the switches to see if there is looseness or breakage.
- 9.4 Wipe off the mortar, etc. attached on the converter after the work is finished.
- 9.5 Do not wash the converter in water.
- 9.6 Check each part for loosened screws and bolts.
- 9.7 Store indoor protected from rain or water.
- 9.8 To prevent accumulation of dust, use the cover that comes with the converter.
If lost or damaged, replace it with a new one.

10. Troubleshooting

<p>1</p>	<p>Connect the input plug to the primary power source. But it does not cause solenoid contactor to turn ON.</p>	<p>CAUSES</p> <p>a. Power source defective. (Open phase or input voltage too low). - Check the power source.</p> <p>b. Solenoid contactor (relay) defective. (Contact melted or deficient connection.) - Replace or connect properly. * Apply proper primary voltage (see the name plate of the connector) to voltage coil of the relay. Excessively low voltage develops a chattering, causing the contact to melt.</p> <p>c. Breaker switch is OFF. (Due to overheating, impact or vibration, the breaker switch may go OFF.) - Return it to ON. (If thermal switch is actuating... overheated ..., allow it to cool down before turning it ON.)</p>
<p>2</p>	<p>Turning ON the starter switch, but it does not cause the converter to start..</p>	<p>CAUSES</p> <p>a. Starter switch (γ-Δ switch) defective or connection deficient. - Replace or connect properly.</p> <p>b. Stator coil on motor end defective, due to burning, broken wire or deficient connection. - Replace or rewind.</p> <p>c. Wirings deficient Broken or defective lead wire connection, or improper wiring. - Replace lead wire, correct defective connection for normal wiring.</p>
<p>3</p>	<p>Troubles after starting. 3.1 Secondary voltage improper after starting.</p>	<p>CAUSES</p> <p>a. Input power source improper, voltage too low (generator capacity insufficient or cable too long), or voltages not balanced. - Correct the input power source.</p> <p>b. Stator or rotor on motor end defective due to burning or broken wire. - Replace or rewind</p> <p>c. Connection between motor and generator ends improper. Motor end and generator end should electrically turn in opposite direction, but they do not. - Reverse two phases on motor end.</p> <p>d. Contact between carbon brush and slip ring deficient due to excessively worn carbon brush, no contact or defect on sliding surfaces of carbon brush and slip ring. - Replace carbon brush, regrind slip ring, etc.</p>

<p>3</p>	<p>3.2 Although normal secondary voltage is powered, at no load operation, it drops when load is applied.</p>	<p>CAUSES</p> <ul style="list-style-type: none"> a. Load (attachment) defective, due to overloading, open phase, short circuit or deficient contact. <ul style="list-style-type: none"> - Correct the load. b. Input capacity insufficient. Capacity insufficient when generator is used. <ul style="list-style-type: none"> - Use the one with normal capacity. c. Rotor or stator coil defective, due to burning or deficient contact. <ul style="list-style-type: none"> - Replace or rewind.
<p>3</p>	<p>3.3 Thermal switch actuates due to overheating.</p>	<p>CAUSES</p> <ul style="list-style-type: none"> a. Converter cooling ventilation inlet or outlet blocks up. <ul style="list-style-type: none"> - Remove obstacle. b. Load excessive, open phase or short circuit. <ul style="list-style-type: none"> - Correct the load. c. Voltages of three phases not balanced. <ul style="list-style-type: none"> - Correct to be normal. d. Rotor or stator is short circuit or burnt. <ul style="list-style-type: none"> - Rewind or replace.
<p>3</p>	<p>3.4 High noise of rotation.</p>	<p>CAUSES</p> <ul style="list-style-type: none"> a. Bearing defective <ul style="list-style-type: none"> - Replace bearing. b. Rotor or stator defective. <ul style="list-style-type: none"> - Rewind or replace.

11. Wiring Diagram

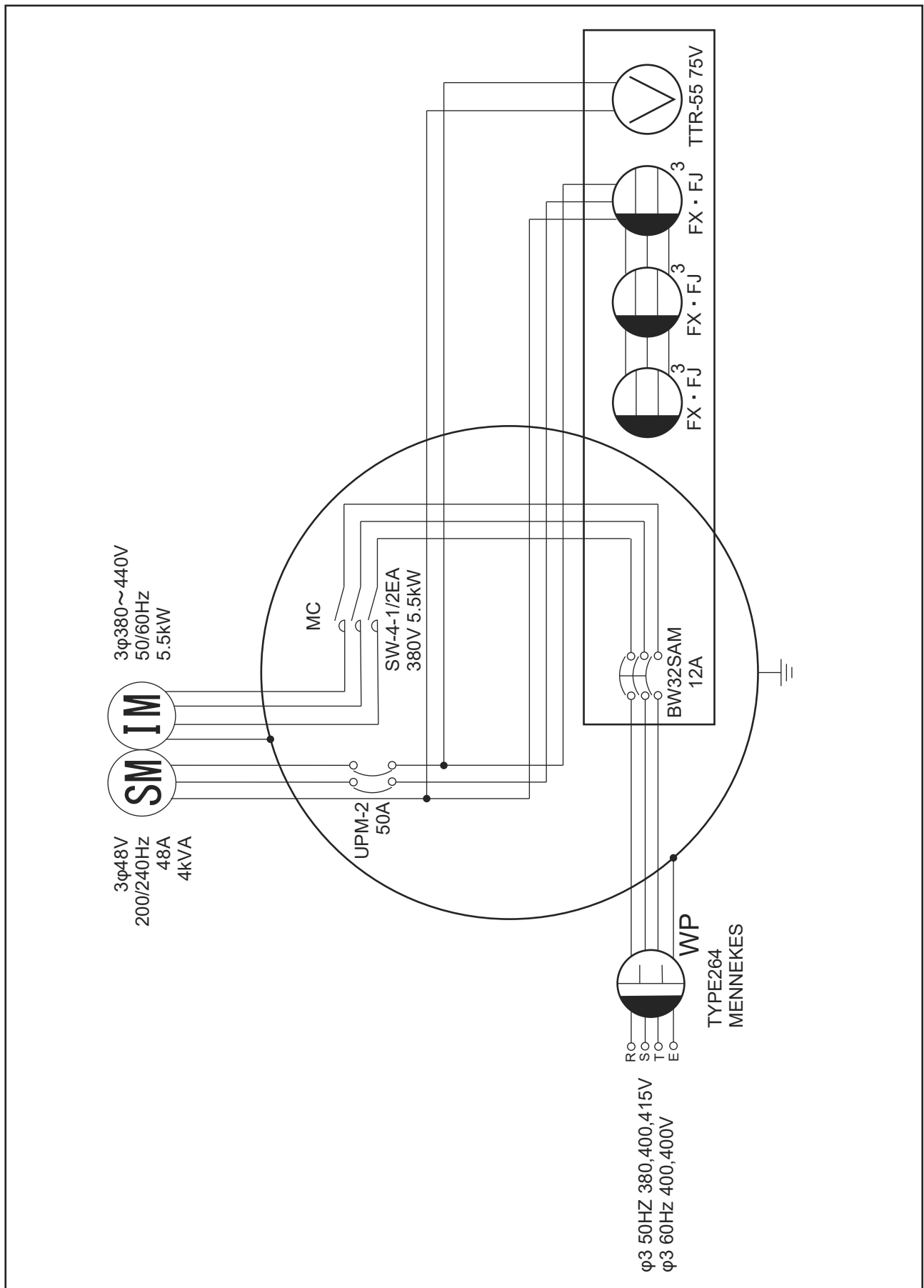

Mikasa

MIKASA SANGYO CO., LTD.

1-4-3, Kanda-Sarugakucho, Chiyoda-ku, Tokyo, 101-0064, Japan

PRINTED IN JAPAN