



Weatherproof GPS Time and Position Information



- GPS time base for MOBOTIX cameras with MxBus
- New camera alarms available (position, speed, illumination, temperature)
- Remote installation (max. 100 m/110 yd wire length)
- Complete set including mounting supplies

Reliable GPS time base for MOBOTIX systems, includes outdoor temperature and illumination sensors; connects via 2-wire cable

Connecting the MX-GPS-Box

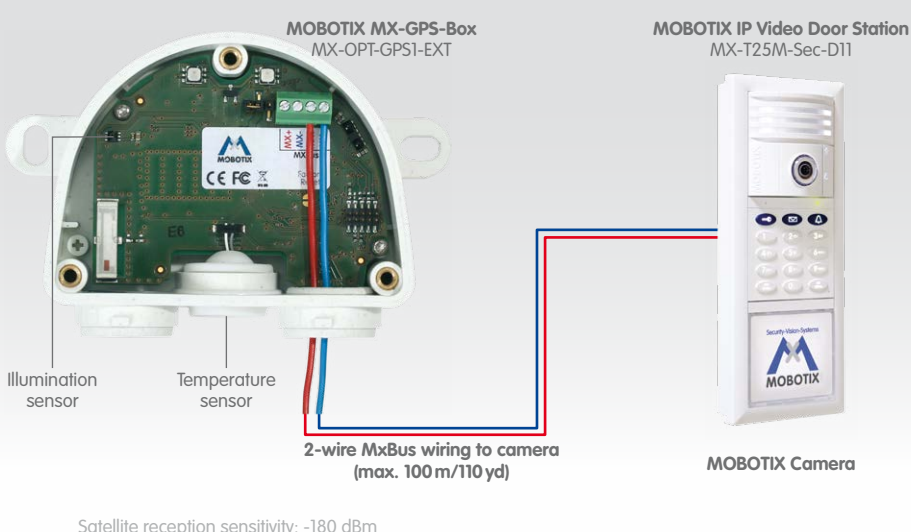

Installation Instructions

1. Find a suitable mounting position

To guarantee optimum reception of the GPS signals by the MX-GPS-Box, you should find a spot on the outside of a building, which provides a clear view of the sky (max. 100 m/110 yd wire length between the MOBOTIX camera and the MX-GPS-Box).

2. Attach the box

Attach the MX-GPS-Box at the mounting position with the cable ports pointing downwards. Next, remove the box cover (three screws). *Do not remove the white sealing plug (left) or the temperature sensor (center)!*

3. Prepare the MxBus wires

Before proceeding, make sure there is no voltage on the MxBus wires!

Cut the supplied or existing MxBus wires to size (2-wire, 0.6 to 0.8 mm diameter). When using **wires without sheath**, strip the insulation of the wires for 5 mm and push the wires through the eight-wire plug (right).

When using a **cable with sheath**, remove the pre-installed eight-wire plug and insert the appropriate cable plug (3 to 5 mm or 5 to 7 mm). Press the rubber plug into the casing in such a way that the rims stick out equally on both sides. Push the cable through the plug, remove the sheath on a length of 15 mm and strip the insulation of the wires for about 5 mm.

4. Connect the MxBus wires to the terminal

Connect the MxBus wires to the screw terminals using the screwdriver. Make sure to maintain the polarity (see sticker in front of the terminal). Mount the cover back onto the box (torque 0.4 Nm).

5. Connect the MxBus wires to the opposite side

Connect the MxBus wires as described in the corresponding manual to the MOBOTIX camera or to another MxBus module connected to a camera (e.g. Keypad, Security Door Opener). Make sure not to exceed the overall length of the MxBus wiring of 100 m/110 yd.

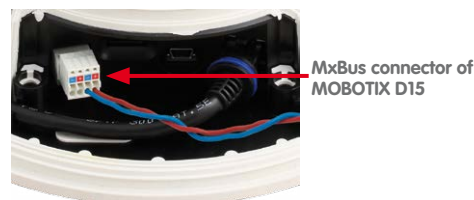
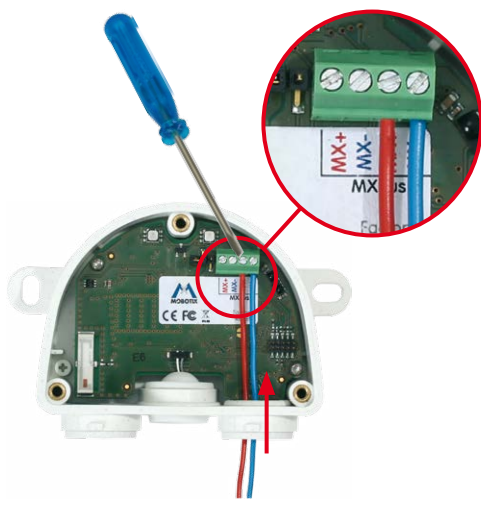
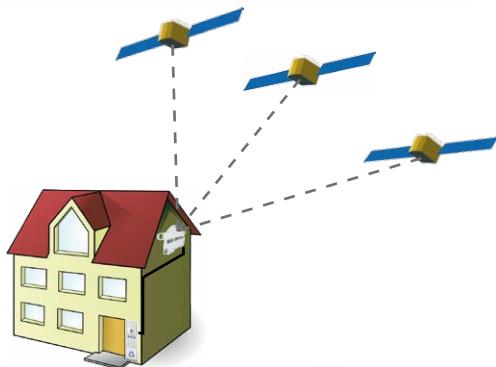

Drilling Template for the MX-GPS-Box

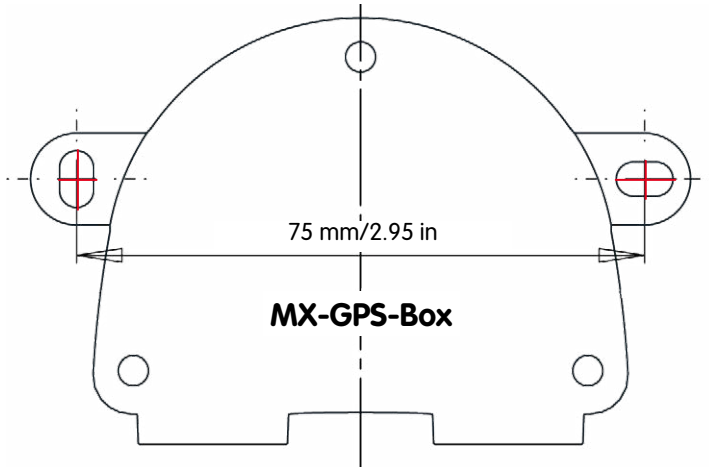

Initial Operation of a New IP Video Door Station

When installing a new MOBOTIX IP Video Door Station for the first time, the MX-GPS-Box will be found automatically when using the Auto Configuration feature. In the process, the entire system will be set to use the box as time server (see *IP Video Door Station System Manual Part 2* on www.mobotix.com).

Innovations - Made in Germany

The German company MOBOTIX AG is known as the leading pioneer in network camera technology and its decentralized concept has made high-resolution video systems cost-efficient.

MOBOTIX AG • D-67722 Langmeil • Phone: +49 6302 9816-103 • Fax: +49 6302 9816-190 • sales@mobotix.com

LED Signaling

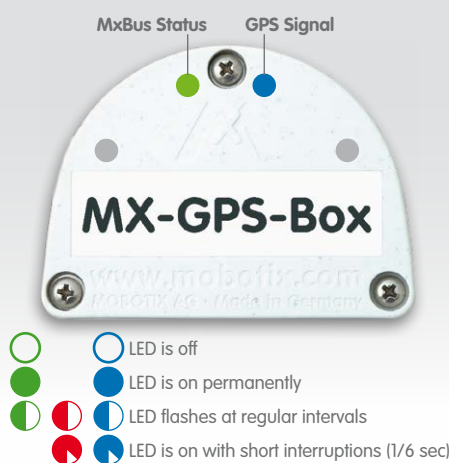

LED	Meaning
MxBus Status (left)	MxBus not connected
	Regular operation
	Unencrypted communication
	No bus communication (e.g. invalid encryption)
GPS Signal (right)	No GPS data available
	Only time data available
	2D position data available
	Full 3D position data available

Manually Initializing the MX-GPS-Box

1. Open the MOBOTIX camera's user interface in the browser

- Enter the IP address of the camera that is connected to the MX-GPS-Box in the browser (admin access rights required): `http://<camera IP address>`
- Click on the **Admin Menu** button in the Live screen of the camera.

2. Activate the MxBus interface

- In the **Hardware Configuration** section, click on **Manage MxBus Modules**.
- If you have not yet done so, activate the **MxBus Interface** in the **Manage MxBus Modules** dialog: Click on the **Connect** button in the **MxBus Interface** section. After about 15 to 20 seconds, the status changes to **New device(s) available**, the **Device Type** shows **GPS Module** with the status **Addressable** in the **Devices** section.

3. Activate MX-GPS-Box as MxBus module

- In the **Manage MxBus Modules** dialog, **Devices** section, **GPS Module** line, click on the **Activate** button. After about 10 to 15 seconds, the status changes to **Active** and the status LED of the MX-GPS-Box (left) is solid green.

4. Set the MX-GPS-Box as time base

The MX-GPS-Box can be used as GPS time base for the entire MOBOTIX system, thus providing accurate time for synchronizing the system:

- In the Live screen of the camera, click on **Admin Menu > Camera Administration > Time and Date**.
- Make sure that **Time Server Protocol** has been set to **NTP**.
- Enter **127.127.1.0** in an empty field in the **Time Settings > Time Servers** section. Do not remove the other NTP servers since they increase the redundancy (provided they can be reached).
- Click on **Set**, then on **Close** and permanently store the configuration.
- Reboot the camera (**Admin Menu > General Tasks > Reboot**).
- Wait for at least 5 minutes after rebooting, then open the **Admin Menu > Camera Administration > Time and Date** dialog and check the **Local NTP Service** section. You should now see the **„GPS.“** entry in the **refid** column.
- Enter the IP address of this camera as NTP time server in the corresponding dialog for all other cameras.

5. Set up additional events for GPS position, GPS velocity, temperature and illumination

Using these events, the connected MOBOTIX camera can trigger an alarm if it leaves or reaches the defined position, exceeds or goes below the defined speed or if the sensors detect changes in temperature or illumination (not available for Web and Basic models):

- In the Live screen of the camera, click on **Setup Menu > Event Control > Event Overview**.
- Click on the **Edit** button in the **Environment Events** section.
- Click on **Add new profile** at the bottom of the dialog, select the desired **Event Sensor Type** and enter a new name for the profile (e.g. **GP** for **GPS Position**, **GT** for **Temperature** at the MX-GPS-Box). When defining new temperature or illumination events, you also need to set the **Sensor Source** to **GPS-Box**.
- Set the parameters of the selected sensor as required (e.g. use the current position as **Anchor Position** by clicking on the **Set to Current Position** button).
- Continue to define the other events you need by creating individual profiles with descriptive names (click on **?** to see the help topic for this dialog).
- Click on **Set**, then on **Close** and permanently store the configuration.

Note on Using "GPS Position" as Event

When using **GPS Position** as environment event, you need to consider the **precision of the GPS data**. The precision also changes due to external factors (e.g. number of currently received satellites, weather). You should thus set a value for **Distance** that is large enough to avoid false alarms. In order to get a suitable value, click on **i** in the top right corner of the browser and determine the precision in the **Sensors > GPS Position** section of the **Camera Status** dialog.

6. Define actions for the additional events

- In the Live screen of the camera, click on **Setup Menu > Event Control > Action Group Overview**.
- Click on the **Add new group** button at the bottom of the dialog.
- Enter a descriptive name for the group, then click on the **Edit** button in this line.
- Highlight the corresponding events in the **Event Selection** list and add the desired actions by clicking on **Add new action** (see help topic for this dialog by clicking on **?**).
- Click on **Set**, then on **Close** and permanently store the configuration.

7. Store the camera configuration

- In the Live screen of the camera, click on **Admin Menu > Configuration > Store** and permanently store the camera configuration (without rebooting).
- Save the camera configuration to the local computer (**Admin Menu > Configuration > Save**).

Resetting the MX-GPS-Box

If the MX-GPS-Box had been connected to a different camera before, the left LED (MxBus status) may be blinking red after establishing the MxBus connection. In this case, you need to reset the connected and activated MX-GPS-Box to **factory defaults**:

- Remove the box cover (three screws).
- Bridge the contact surfaces below the **Factory Reset** label (red circle in figure) using a screw driver, for example (both LEDs are flashing red/blue with increasing frequency).
- Only remove the bridge if both LEDs of the MX-GPS-Box are flashing green on/off 3 times to indicate that the process has finished successfully.
- Mount the cover back onto the box (torque 1 to 1.2 Nm).
- Set up the MX-GPS-Box in the camera (see **Manually Initializing the MX-GPS-Box** above).



Notes

- The MOBOTIX MX-GPS-Box is to be used only for providing sensor data (GPS position/velocity, temperature, illumination) for MOBOTIX cameras in IP65 environments.
- For MOBOTIX cameras with MxBus connector and software version MX-V4.1.1.21 or higher.
- Additional events not available on MOBOTIX Web and Basic camera models.
- The GPS data's precision changes due to external factors (e.g. number of currently received satellites, weather).
- Make sure that you adhere to all relevant laws, regulations and that you fulfill all certification requirements for the intended use.
- Reception sensitivity: -180 dBm
- Torque for all box cover screws: 0.4 Nm.
- When using the cable plug for the MxBus wiring (eight-wire plug or cable plug 3 to 5 mm or 5 to 7 mm, right), make sure that you press the plug into the casing in such a way that the rims stick out equally on both sides.
- The length of the entire MxBus wiring must not exceed 100m/110yd.
- Diameter of the MxBus wires: 0.6 to 0.8 mm (0.8 mm are recommended to avoid line losses).

Innovations - Made in Germany

The German company MOBOTIX AG is known as the leading pioneer in network camera technology and its decentralized concept has made high-resolution video systems cost-efficient.

MOBOTIX AG • D-67722 Langmeil • Phone: +49 6302 9816-103 • Fax: +49 6302 9816-190 • sales@mobotix.com