

MODERN DRUMMER™

The International Magazine Exclusively For Drummers



\$2.25
(In USA)
AUGUST 1984

Levon HELM

Billy Idol's
Thommy Price

Bob Moses

MD's Special
Focus On Atlantic City

Plus:
Drumming
For Dancers

Philly Joe
TRANSCRIPTION

Baby Dodds
REMEMBERED

White. Lightning.

Lightning as in speed. Lightning as in power.
Lightning as in the energy that drives Yes.
Alan White supplies it all.

We just supply the thunder.



LUDWIG[®]

A SELMER COMPANY

P.O. Box 310 • Elkhart, IN 46515

For an Alan White poster, send \$1 to "Alan White,"
P.O. Box 310, Elkhart, IN 46515.
For a copy of the full-color, 104-page Ludwig Total
Percussion Catalog, send \$3.



CONTENTS

Cover Photo by Robert Herman

FEATURES

LEVON HELM

During the late '60s and early '70s, Bob Dylan and The Band were musically a winning combination, due in part to the drumming and singing talents of Levon Helm. The Band went on to record many classics until their breakup in 1976. Here, Levon discusses his background, his work with Dylan and The Band, and the various projects he has been involved with during the past few years.

by Robyn Flans 8

THOMMY PRICE

Price, one of the hottest new drummers on the scene today, is currently the power behind Billy Idol. Before joining Idol, Tommy had a five-year gig with Mink DeVille, followed by a year with Scandal. In this interview, Tommy reveals the responsibilities of working with a top act, his experiences with music video, and how the rock 'n' roll life-style is not all glamour.

by Connie Fisher 14

BOB MOSES

Bob Moses is truly an original personality in the music world. Although he is known primarily in the jazz idiom for his masterful drumming, he is also an active composer and artist. He talks about his influences, his technique, and the philosophies behind his various forms of self-expression.

by Chip Stern 18

DRUMMING IN ATLANTIC CITY

by Rick Van Horn 22

WILL DOWER

Australian Sessionman

by Rick Van Horn 24

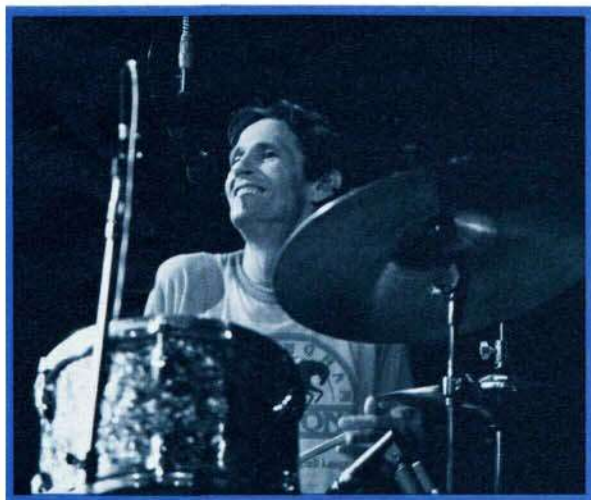

Photo by Fred Carneau



Photo by Rick Malkin

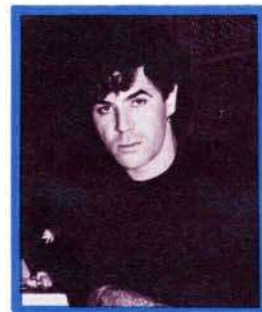

Photo by Michael Jachles

COLUMNS

EDUCATION

CONCEPTS

Drummers And Put-Downs
by Roy Burns 28

LISTENER'S GUIDE

by Peter Erskine and Denny Carmassi 30

ROCK PERSPECTIVES

Beat Study #13
by David Garibaldi 52

SHOW DRUMMERS' SEMINAR

Dance Accompaniment
by Lou Grass! 72

THE MUSICAL DRUMMER

Evaluating "Marimba Blues"
by Bill Molenhof 76

ROCK 'N' JAZZ CLINIC

Funk With 32nd Notes
by Paul Nieft, Jr. 88

CLUB SCENE

Attention To Detail
by Rick Van Horn 90

DRUM SOLOIST

Philly Joe Jones: "Lazy Bird"
by Dan Tomlinson 96

EQUIPMENT

PRODUCT CLOSE-UP

Remo *PTS* Update
by Bob Saydlowski, Jr. 102

JUST DRUMS 114

PROFILES

PORTRAITS

Tom Ardolino
by Laurice Niemtus 32

FROM THE PAST

Baby Dodds
by Danny L. Read 54

ON THE MOVE

James D. Miller and Bob Pignatiello. 78

IN THE STUDIO

Jim Plank
by Ted Dyer 84

REVIEWS

ON TRACK 46

NEWS

UPDATE

by Robyn Flans 108

INDUSTRY HAPPENINGS ... 110

DEPARTMENTS

EDITOR'S OVERVIEW 2

READER'S PLATFORM 4

ASK A PRO 6

DRUM MARKET 98

IT'S QUESTIONABLE 106

EDITOR'S OVERVIEW

Introducing *MODERN PERCUSSIONIST*



Throughout the eight years of *Modern Drummer*, we've received numerous pleas from various factions of the drumming audience for more insight into certain areas of percussion. The requests have come primarily from players representing four major areas of specialization: orchestral percussion, mallets, Latin American drumming, and drum & bugle corps.

Of course, we've made several attempts over the years to reserve a portion of editorial space for each of these diverse areas. But regular readership studies have always clearly indicated to us that the majority of *MD* readers were drumset players, interested in jazz, rock, fusion, studio and commercial drumming. And because of this, we've always been somewhat hesitant to devote a great deal of feature or column department space to the other varied percussion specialties.

We've always been faced with the task of maintaining *MD's* focus on drumset to satisfy the bulk of the readership, while trying not to alienate the peripheral areas. In truth, we've never found a way to do it, simply because it's extremely difficult to be all things to all people. The only solution would be to start up another magazine catering exclusively to the needs of that segment of the readership which we seemed to be ignoring. This is precisely what we've decided to do. After a full year of editorial, design and planning meetings, we're proud to announce the birth of *MD's* sister publication, *Modern Percussionist*, a new magazine for the serious drummer/percussionist.

Basically, *Modern Percussionist* will follow in the editorial and design footsteps of *Modern Drummer*, though the thrust of all feature material will be directed towards artists from the world of orchestral, mallet, Latin American and drum & bugle corps percussion. We'll be offering the serious percussionist insight that could only be obtained in a magazine of this type.

MP's column departments have also been designed to address the needs of this special audience. Columns like *The Orchestral Percussionist*, *Timp Talk*, *Vibraphone Viewpoint*, *Marimba Perspectives*, *Latin Symposium*, *Corps Scene* and *The Marching Percussionist*, among others, will be authored by some of the most knowledgeable authorities in their respective fields. Of course, there will also be a question & answer department, an opportunity to question the pros, new product information, book and record reviews, updates on interesting percussion events, and a wealth of essential information for the serious player.

Modern Percussionist will make its debut in December of this year, and will be released on a quarterly basis for starters. We feel strongly that *MP* will fill a void which has existed in the serious percussion world for some time now. And it's our intention to fill that void by presenting informative and entertaining material for those involved in the world of percussion, in a fashion similar to *Modern Drummer*.

Further details on what you can look forward to in each issue, along with subscription information, can be found elsewhere in this issue.

RS

STAFF:

EDITOR/PUBLISHER

Ronald Spagnardi

FEATURES EDITOR

Rick Mattingly

MANAGING EDITOR

Rick Van Horn

ASSOCIATE EDITORS

Susan Hannum

William F. Miller

ART DIRECTOR

David Creamer

ADVERTISING DIRECTOR

Kevin W. Kearns

ASSOCIATE PUBLISHER

Isabel Spagnardi

ADMINISTRATIVE MANAGER

Ann Thompson

ASSISTANT ADMINISTRATIVE MANAGER

Ellen Urry

DEALER SERVICE MANAGER

Janet Gola

CIRCULATION

Leo L. Spagnardi

Robin De Paul

Lori-Jean Syintsakos

Tracy Kearney

SALES PROMOTION MANAGER

Evelyn Urry

MD ADVISORY BOARD

Henry Adler, Carmine Appice, Louie Bellson, Bill Bruford, Roy Burns, Jim Chapin, Billy Cobham, Les DeMerle, Len DiMuzio, Charlie Donnelly, Saul Goodman, Danny Gottlieb, Sonny Igoe, Jaimoe Johanson, Jim Keltner, Don Lamond, Mel Lewis, Peter Magadini, George Marsh, Butch Miles, Joe Morello, Neil Peart, Charlie Perry, Charli Persip, Arthur Press, Paul T. Riddle, Ed Shaughnessy, Ed Thigpen, Max Weinberg.

CONTRIBUTING WRITERS

Susan Alexander, Charles M. Bernstein, Scott K. Fish, Robyn Flans, Simon Goodwin, Dave Levine, Robert Santelli, Bob Saydlowski, Jr., Chip Stern, Robin Tolleson, T. Bruce Wittet.

MODERN DRUMMER Magazine (ISSN 0194-4533) is published monthly by Modern Drummer Publications, Inc., 1000 Clifton Avenue, Clifton, NJ. 07013. Second Class Postage paid at Clifton, NJ. 07015 and at additional mailing offices. Copyrighted 1984 by Modern Drummer Publications, Inc. All rights reserved. Reproduction without the permission of the publisher is prohibited. **SUBSCRIPTIONS:** \$21.95 per year, \$39.95, two years. Single copies \$2.25. **MANUSCRIPTS:** Modern Drummer welcomes manuscripts, however, cannot assume responsibility for them. Manuscripts must be accompanied by a self-addressed stamped envelope. **CHANGE OF ADDRESS:** Allow at least six weeks for a change. Please provide both old and new address. **MUSIC DEALERS:** Modern Drummer is available for resale at bulk rates. Direct correspondence to Modern Drummer Publications, Inc., 1000 Clifton Avenue, Clifton, NJ. 07013. (201) 778-1700. **POSTMASTER:** Send Address Changes to Modern Drummer, 1000 Clifton Avenue, Clifton, NJ. 07013.

lightning Rod



Rod Morgenstein has given the world of percussion some of the most musical lightning licks yet heard. The long-time drummer for The Dregs and now for The Steve Morse Band, Rod's playing is charged with originality and feeling.

Rod's choice in drums? Premier. Why? Let him tell you.

"Premier drums have character. The 'shell within a shell' concept of Resonator drums gives the sound a richness that's getting harder to come by. With other drums sounding more and more alike, it's good to find a kit with a personality."

If you're looking for a drum set that sounds like you—not every other drummer in town—try Premier and make a little lightning of your own.

Premier Drums— at selected percussion dealers.

Premier

Premier Percussion USA, Inc.
105 Fifth Avenue • Garden City Park, NY 11040

READER'S PLATFORM

LARRIE LONDIN

I enjoy *Modern Drummer* very much. I enjoy articles about all types of drummers, including those involved with country music. The Larrie Londin story was great! As a former rock and jazz drummer who has played country music for the last 10 years, I can identify with the article. There is room in music for all types of drumming, and most country drummers that I know are comfortable with all types of music. Keep up the good work, and don't forget about Nashville music.

Wayne Scott
Clarksville, TN

Concerning your cover story on Larrie Londin (May '84), one is tempted to say "About time!" Everyone in the business has known about this magnificent drummer for years; perhaps now the younger players will be inspired to catch one of his live performances. This can only serve to raise the standards of contemporary drumming.

While Larrie's fame is primarily for studio/session work, his live playing must be seen, heard, and felt to be believed. Had he come to prominence via the "popular group" route, as opposed to the relatively anonymous studio scene, I strongly suspect that younger audiences would have more respect for the *musical* approach to modern drumming than they seem to have. No amount of random cymbal crashing or theatrical flash can compare to the kind of earth-shattering, on-the-money drumming Larrie offers. He is, to be sure, one of the world-class "crowd killers," proving that the musical way is always the most exciting way. Larrie's wife, Debbie, is also a world-class fine lady, and she also runs a drum store!

Burt Dotson
Tulahoma, TN

TEXAN TALKS

I'd like to commend y'all on your continuous quality production of *Modern Drummer*. I've renewed my subscription again, mainly because of the valuable information and advice that I find in the magazine. The interviews are always fun to read, too.

I've been playing drums for about 25 years, off and on, and for the past three years in a semi-professional mode. However, I've never experienced as much personal musical growth as I have since I've been reading *Modern Drummer*. The business-related information and advice are so applicable that I've taken great pains to be sure other musicians (guitarists, pianists, sound engineers) are aware of them by passing the magazine around. Now *that's* a compliment.

Tom Chard
Cedar Park, TX

PHIL COLLINS ON DRUMS

I'd just like to clear up the point raised by Ricky Mintz in your March issue, regarding the pictures taken of me in my article a few months previous. The pictures of me playing the Pearl drums were taken quite a while ago, when the interview was first talked about. When the interview was actually finished, I had by that time been approached by Gretsch and I leapt at the chance to endorse those drums. I would add, however, that I still possess my two Premier kits, two Pearl kits, and four Gretsch kits (new and very old), as well as a dozen snare drums of varying descent! I will continue to use all these drums for whatever sound I wish to make, on whatever diverse projects I am involved with. They all sound so different, it would be bloody-minded not to use them just because I am supposed to use one type of drum.

Phil Collins
Hammersmith, England

KEITH COPELAND

I just read your article on Keith Copeland. Great! Last year I had the honor of meeting Keith and later doing some studying with him. Keith was wonderful. He picked me up at the airport in New York, and let me stay at his house. We would hang out in the city and go to record stores. But the most important thing was the *lessons*. It was a great trip. I just wanted you to know what a fine person he is and what an excellent teacher he is. Thanks again, Keith.

David Via
Greensboro, NC

THANKS TO PEARL

I wrote a letter to you some time back regarding a problem I had with the finish on my Pearl drums. You forwarded the letter to Pearl, and they promptly contacted me by phone.

I have never done business with such an accommodating company. After I explained the problem to them, they told me to ship the drumshells to them freight collect. They re-covered them and immediately shipped them back to me.

I would recommend Pearl drums to anyone, as they truly stand behind their product. Thanks so much for your help. A tip of the hat to Pearl drums, and a tip of the hat to a fine magazine.

Norman Tooley
Beulah, MI

OVERSEAS CONNECTION

For years I had been looking for a magazine exclusively for drummers, but this sought-after jewel always eluded me. In South Africa, where I used to live, everything is so isolated, especially in the arts.

Then, a glimmer of hope... I had heard of a magazine called *Modern Drummer* which offered an overseas subscription. Believe it or not, it took me over two years to obtain the address, and it's the best thing that could have happened to me. I have been playing for 12 years, and have been a pro for about five. In South Africa there is not much in the way of musical inspiration, thus I had to continually find ways of inspiring myself. With *MD*, reading about the way name drummers felt about the art, attitudes, approaches, etc., was really refreshing. It was good to know I wasn't the only one who went through all those little frustrations.

By the time this reaches *MD*, I will have been in England for some time. It's ironic that it took me two years to obtain the subscription address, and then after obtaining it, I moved to a country where *MD* is readily available. Anyway, I'm really happy to be getting your magazine now; it is truly the greatest around. Cheers!

George L. Voros
London, England

LARGER BASS DRUMS

In the February '84 issue, Hal Blaine gave advice to a young drummer which I believe to be inaccurate. The drummer was debating on whether to buy a new drumset with a 22" or a 26" bass drum. What Hal failed to mention is that as drum size *increases*, the action *decreases*. Also, if the rack toms are mounted on the 26" bass drum, they will be four inches higher than on the 22", possibly too high for someone who's been using very small bass drums. Hal was right when he said you can play anything on a 26" that you can on a 22". What he didn't say was that it is more difficult with a giant bass drum.

Jim Redden
Upland, PA

SWEATY HANDS SOLUTION

I have a solution for sweaty hands causing sticks to slip, which I've been using for about 10 years. It's bowler's grip cream, which you can get at any bowling alley. It comes in a tiny jar, which easily fits into your stick bag; one jar costs about a buck and lasts a few years. The main advantage I find with it is that, the wetter it gets, the more effective it is. It makes the stick feel like one of those with the rubber covering. It comes under two names that I know of: *Claro Grip Cream* and *Pro-Grip*, made by Claro Labs, South Bend, IN 46613, and DBA Products Co., St. Louis, MO 63104, respectively. I find that either works quite well.

Ben Beckley
New Rochelle, NY

Continued on page 101

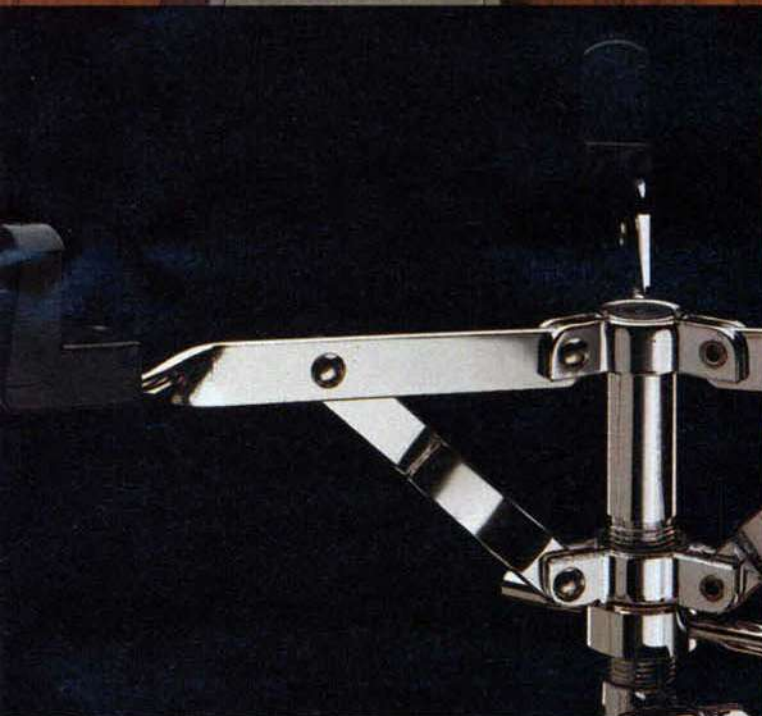
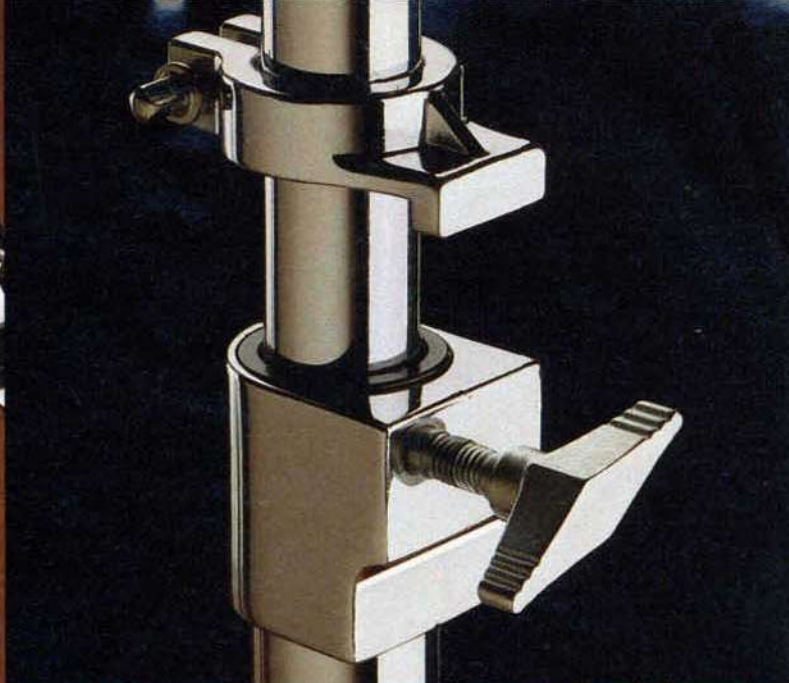
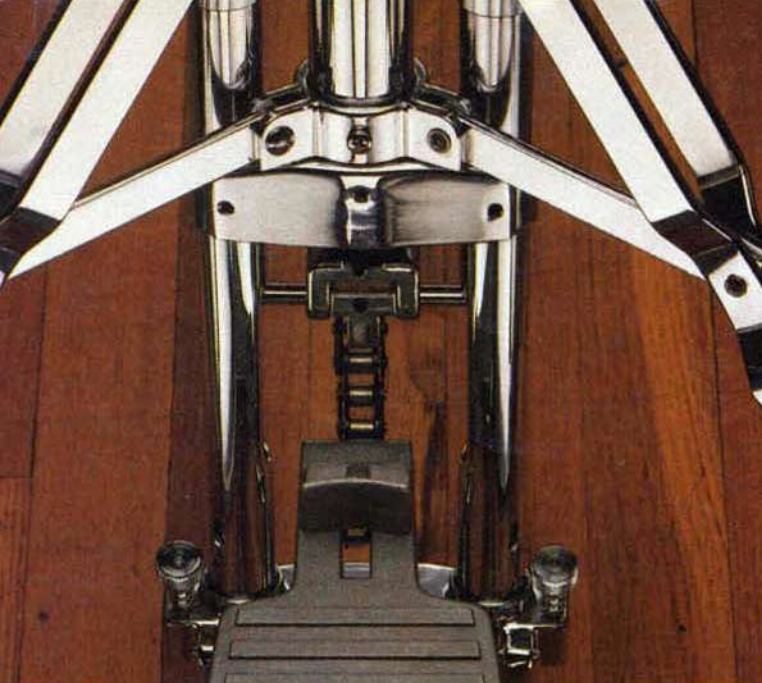

Solid State Hardware

Hard-driving drumming calls for heavy-duty hardware. And that's where Rogers' R-380 hardware comes in a solid first.

You'll find Rogers durability and dependability in the double-legged tripod bases. Height adjustment joints have nylon bushings to eliminate vibration transmission. And you get a no-slip iron grip with just a quarter turn of the thumbscrew.

The short-base snare stand adds stability where you need it most. The cymbal boomstand has a moveable counterweight for perfect balance and optimum cymbal placement.

The R-380 chain-drive hi-hat is smooth, quiet and tough. And, of course, Rogers' famous

Memriloc® technology goes into tom-tom and cymbal holders that feature infinite adjustment and memory.

Just like the Rogers kit with the same name, R-380 hardware means *solid* value for your money. Ask about it at your Rogers dealer today.

ROGERS®

ASK A PRO

BILL BRUFORD



Photo by Paul Jonason

Q. I really like your playing on *Music For Piano And Drums*. How did you tune your bass drum on that album? Also, what is your cymbal setup—especially the hi-hat? When I saw you live, you held the sticks at the tips and played the cymbals "praying mantis style." You also spun the hi-hat as you

splashed it. Why did you do that?

Thomas Griff in
Scarsdale, NY

A. Thanks for your kind comments on the album. The bass drum was a Tama 22" Superstar with one Remo Ambassador head on the batter side and a modest amount of dampening. I allowed it to ring longer than I would in a normal electric group situation. The cymbal setup was: 18" Sound Creation bright ride, 20" Formula 602 medium flat ride, 20" Formula 602 heavy ride, 18" 2002 crash, 16" 2002 medium crash, and 14" Sound Edge hi-hats—all Paiste cymbals.

I seem to change my left stick grip, particularly, from butt end to tip quite frequently, as the power, tone and delicacy in the stroke seem to demand. I'm afraid I have no idea what "praying mantis style" means, but it sounds great. No doubt I was spinning the hi-hat cymbals in an effort to get them to "sit" properly on the stand and come together cleanly.

DENNY CARMASSI



Photo by E. Shaw Green

Q. I really enjoyed your interview in the September '83 issue of *MD*. In the photo on page 20 you appear to have a large, chrome-plated curving bar that holds up your tom setup. What sort of hardware setup is this, and how are the toms attached? Is this a custom rig, or is it commercially available?

S.L.
Urbana, OH

A. The bar that you are referring to, I believe, is made by North Drums. It comes with three tom-tom mounts, which slide up and down, as well as around, the bar and give you a great deal of flexibility as far as drum placement goes. My drum tech, Gary Clark, machined these mounts to handle my setup.

LARRIE LONDIN

Q. I would like to know, as a drummer, how would I apply the Nashville number system to the drumkit?

F.L.
Nashville, TN

A. The number system is no more than a chord chart, so as a drummer, you would use the number system in the same way as you would use any chord chart. What makes the number sys-

tem so great for mallet players is that they don't have to transpose. On a number chart, "one" is the key you're in, so if "one" is C, then a "four" chord is an F, and so on. The number system is just a faster way to make a chart, and if someone's not sure of the key, it really comes in handy. For a helping hand on this system, I recommend *The Nashville Number System*, by Arthur D. Levine, published by Gibralter Press, of Nashville.

STAN LYNCH

Q. Your time is great, and your philosophy of music makes a lot of sense. I'm trying to learn the traditional grip, and everybody, including my teacher, is discouraging me, telling me that it's too hard. How long did it take you to learn traditional grip? And finally, why did you settle on Tama for your set?

Leor Beary
Berkeley, CA

A. I took about three years of drum lessons that were more involved with field drumming and rudiments than trap drumming, and in rudimental drumming it's essential to learn traditional grip. It took me about two years to train my hand to get the power from the traditional grip. As for my drums, when the Heartbreakers started recording *Damn The Torpedos* I rented lots of drums, and when I set up the Tamas they sounded the best.

GERRY SPEISER

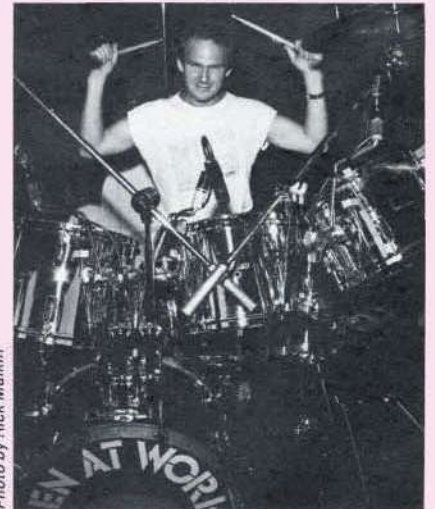

Photo by Rick Maikin

Q. I recently saw you in concert with Men At Work, and I think you are a talented and powerful musician. Would you please describe your current drum and cymbal setup?

James Cadornin
Clifton, NJ

A. The drums I use are all Pearl, with standard depths. The sizes are: 8" 10", 12", 13" and 14" rack toms, a 16" floor tom, and a 22" kick drum. I use a variety of snare drums. As far as cymbals go, I use Sabians, and they include a 10" splash, 14" hi-hats, two 17" crashes, a 20" ride and a 20" swish. I'm not using any electronic drums or effects at the moment, although I have tried several.



Finding the right sounds is a matter of looking in the right places. —Stewart Copeland

Stewart Copeland's playing is a sensuous integration of sounds and rhythms. His keen awareness of sound and pulse developed from his musical experiences in the Middle East, Africa, Europe and his native America.

His search for the right cymbal sounds led him to Paiste—the widest cymbal selection anywhere in the world. In his own words:

"Sound and rhythm are inescapable parts of life. What I do on the drum set is to really tie into this rhythm of life and let it drive whatever music I'm playing. In practical terms, this leads to a lot of experimentation with sounds.

"My Paiste cymbals are an amazingly expressive collection of instruments.

Some speak very fast, others swell like waves—some are rough and aggressive, while others are soft and polite.

"So you see, finding the right sounds is a matter of looking in the right places".

Look for yourself. Visit a Paiste Sound Center. And for a copy of the *Paiste Cymbal Manual and Profiles 3* book of bio's and information about hundreds of the world's top drummers and percussionists, send \$3.00 to cover postage and handling to:

Paiste America, Inc. • 460 Atlas Street • Brea, CA 92621
Paiste Canada Ltd/Ltee. • 7750 Route Transcanadienne
St. Laurent • PQ H4T 1A5



Stewart Copeland's
Paiste cymbal set . . .

PAiSte
CYMBALS SOUNDS GONGS

by Robyn Flans

Evon

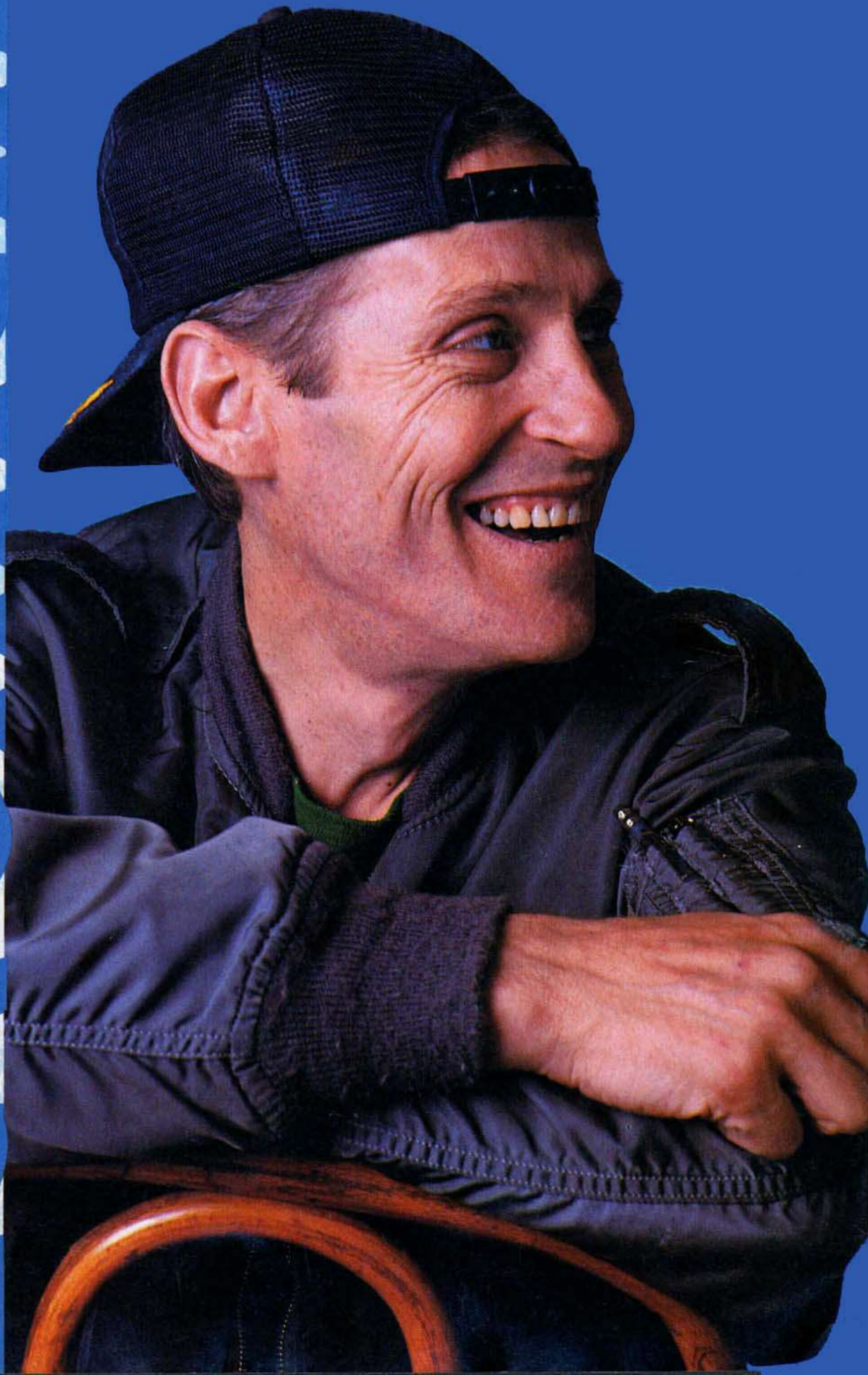

THERE'S something so refreshing about meeting Levon Helm. Amidst an industry full of people with pretensions and exaggerated airs of self-importance, Levon doesn't know how to be anything but Levon. I think we were friends the instant we met. He's like that—warm handshake, smiling eyes and a down-home manner that demands you be the same. The first time I met him and his wife, Sandy, he was in L.A. for a couple of days recording vocals for the soundtrack of *The Best Revenge*, a film in which he also acted. We spent a warm, laughter-filled evening, and by its end, they had invited me to their home in Woodstock, New York—not for the interview, but to enjoy the peaceful surroundings.

It turned out that Levon would have preferred it if I had done just that. It's not that he isn't cooperative or has anything against interviews; it's just that he doesn't think he has enough to say to warrant an interview. His technical knowledge is limited and it's difficult for him to explain how he does what he does. The key is simple: He just does it; he feels it. Feel is an impossible word to define, but in the drum dictionary, Levon Helm is the definition. When you listen to him sing, his voice is like a warm fire on a cold night. You can't help but smile when you watch him play cat and mouse with the drums either. He's laid-back and quiet, and then there's the sly, stealthy approach before he pounces in a sudden playfulness. Also, there's always a smile on his face. In fact, if he isn't having fun, he won't do it.

Levon has enjoyed everything to which he has given his attention, beginning with his days with Ronnie Hawkins & The Hawks to his present acting career and Band reunion. The Band began its evolution when Levon Helm and several other Arkansans moved to Canada in 1958 to back Ronnie Hawkins. During 1961, Robbie Robertson replaced the previous guitar player and within a few months all the Arkansans, with the exception of Helm, were replaced by Canadians Rick Danko (bass), Richard Manuel (keyboards, drums) and Garth Hudson (keyboards, brass, woodwinds). The Hawks parted company with Hawkins in 1963, however, and in 1965, fate brought them together with Bob Dylan.

Their association with Dylan, though, only acted as a springboard for their own talents and it wasn't long before the group became a sensation on its own. After such classics as "The Night They Drove Old Dixie Down," "The Weight" and "Cripple Creek," The Band announced its retirement and gave a farewell performance at Bill Graham's Winterland in San Francisco on Thanksgiving night, 1976. The Last Waltz documents the history of The Band and that memorable night, and is one of the finest music films in existence.

Since then, Levon has involved himself in a variety of projects. He has recorded three solo albums, toured with the Muscle Shoals All-Stars, worked with the Cate Brothers, worked just as a duo with Rick Danko, and if you want a musical treat, get a copy of the album *The Legend Of Jesse James*. Levon plays drums and has the role of Jesse James in this fine piece of musical theater written by Paul Kennerley, which also features Emmylou Harris, Johnny Cash, Charlie Daniels, Albert Lee, Rodney Crowell and Rosanne Cash. As for Helm's acting career, he has appeared in such projects as *Coal Miner's Daughter*, *The Best Revenge*, *The Right Stuff*, *The Dollmaker* (TV film), and even an episode of *Seven Brides For Seven Brothers*.

When I asked Levon if the mediums of music and film related, he replied, "You try to do the same thing for a scene that you do for a song. You try to bring it to life and get it like the director wants it, the same as you do a record. You're supposed to let your producer guide you. That's who's supposed to help you get it so that it's got the right ingredients in there: life and breath; heart and soul." Those are the words I would use to describe Levon and everything he does.

RF: Why did you end up as a drummer?

LH: I don't know. I guess it's from being born in Elaine, Arkansas. That's a pretty basic part of America where there's a lot of good basic music. Drums just always sounded like the most fun part of that good music for me. I had the opportunity to see some of the traveling minstrel shows years ago, with the house band, the chorus line, the comedians and singers. In those kinds of shows, with horns and a full rhythm section, the drums always looked like the best seat in the house. That sound of cymbals and the snare drum popping in there like that just sounded like Saturday night and good times.

RF: Is it accurate to say that your strongest musical influences were country and blues?

LH: Yes. That's native to the geography in Phillips County, all through that part of the Delta—the Memphis/Mid-South part. As I was coming up through school, Carl Perkins, Johnny Cash and Elvis started. A lot of the country and blues influences started blending, and good hybrids of rock 'n' roll developed out of those mixes. That's really basically it for me. I've always thought that my snare drum should sound a lot like J.M. Van Eaton's snare drum on Jerry Lee's record of "Whole Lotta Shakin'." That's usually the way I try to fix it. I like that sort of a dull "thud" sound with lots of wood, using the snare for the beat. I like the bass drum kind of toned down, and I usually muffle the toms down quite a bit more than is usual. I think that's just mainly my personal taste.

A long time ago, The Band tried mixing some records on our own. Everything we mixed sounded good in the studio, but we'd take it home and we couldn't hardly hear it over our speakers. We'd mix it very bass heavy because that's what we liked. We were a rhythm section and the way we could hear ourselves was if we turned everything up. [laughs] I've always thought that one had a bit of an advantage being in the percussion department, particularly playing drums.

RF: What was the Jungle Bush Beaters?

LH: That was a high school group I played with. We had an electric guitar and stand-up doghouse bass with a mic' on it—some sort of a pickup that had been rigged up. There was another guitar, and a kid playing a snare drum with a couple of brushes, I think.

RF: Not you?

LH: No, I was playing one of the guitars. The Jungle Bush Beaters didn't last too long as a group, but we had a pretty good time while we did.

RF: I get the impression you have a good time with everything you do.

LH: Well, I try to. I don't fool with a lot of things that I can't have fun with. There's not much reward in that. For instance, after we mixed the album that you couldn't hear over a speaker, I shied away from engineering, you might say.

RF: Was Jungle Bush Beaters your first band?

LH: I guess it was, although my sister and I used to play together as kids.

RF: What did she play?

LH: My sis played a washtub bass, I played guitar, and we had a guitarist who would play with us on occasion. When my sister started getting a bit older and grew shy of that washtub, she quit and we started getting a few new members into the group. There was usually myself, Thurlo Brown, God rest him, and a couple other fellows from around Marvell, Arkansas.

Not having seen anywhere else, it seemed like a lot of music was going on right there with Sonny Boy Williamson down at the radio station in Helena. Ralph DeJernett, Bubba Stewart and the boys were playing out at the pool hall there in Marvell. There'd be a one-man jug band coming through and advertisements up for a big minstrel show that would be coming to town. Then Bill Monroe & the Bluegrass Boys might be there the week after that. They used to come through with a tent show also. So it was okay for music. We could get Memphis and Shreveport, Louisiana, on the radio station, and reach all the way to

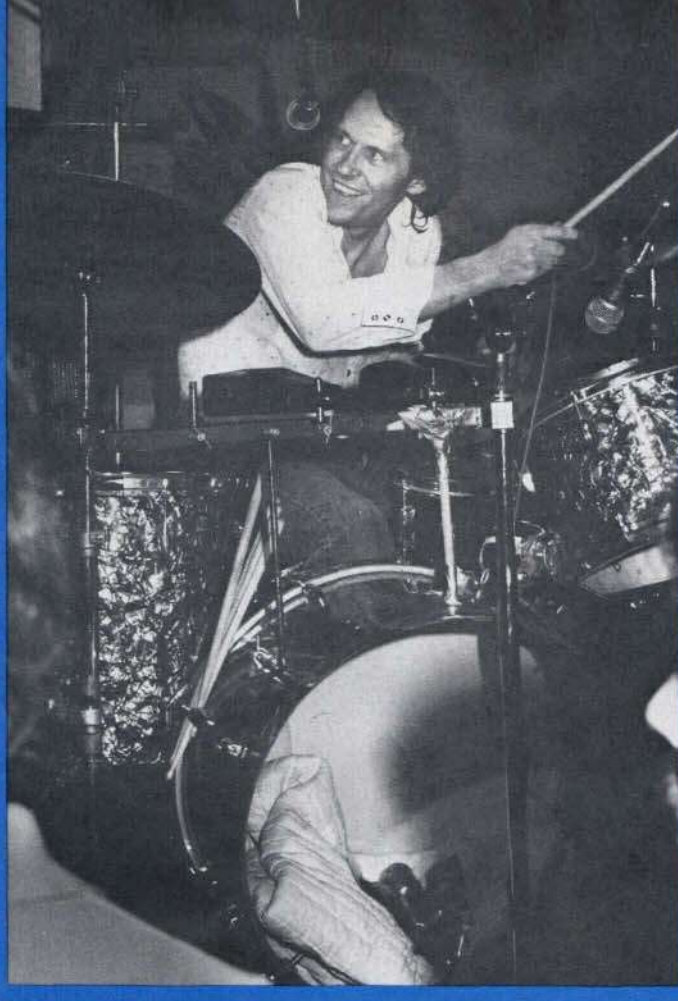

Oklahoma City and Nashville.

RF: I assume that the Jungle Bush Beaters played cover tunes.

LH: We sort of jammed along. We would do current hits of the day for the dances we would play. We were bad to do jams and instrumentals and things. We didn't have any sort of a tried-and-proven formula, or approach or anything. We just played. Thurlo Brown was one of the best guitar players around that part of the country. There were several good musicians from there. Conway Twitty was always our local hero when I was growing up. He had a series of good bands.

RF: What did you aspire to?

LH: I wanted to sit in, if Conway would let me. And he did a couple of times. He's alright.

RF: What did you play?

LH: Well, I don't know if any of them let me take their guitars, but I sat in and maybe sang a song or something. I was there mainly to observe and to be amazed.

RF: What was the first gig you did as a drummer?

LH: Well, Conway had a guitar player named Jimmy Ray Paulman. Jimmy Ray and Ronnie Hawkins formed a group called The Hawks. There weren't a lot of drummers around at the time so I kind of got in there, playing with Ronnie.

RF: How old were you when The Hawks happened?

LH: I was in high school but I was trying to get out of high school. The only thing slowing me up was grades, [laughs] I really had rambling on my mind. I wanted to go. One of the prettiest sights in the world was a big Cadillac rolling down the road with a doghouse bass tied to the top of it. That looked like the car I wanted to be in.

RF: Was being a musician your intent?

LH: I guess so, from way back, because I started being in those school shows and things, when we would have them, singing or playing the guitar a little bit. I had played with two or three high school bands, and I just hit it lucky when I got out and talked to Jimmy Ray, Ronnie, George, and Will "Pop" Jones—another cousin of theirs who was a piano player. We hit the road together and just played music.

RF: So you went as the drummer at that point?

LH: Yes, with a borrowed set of drums.

RF: You didn't even have your own yet?

LH: No, I didn't have those yet. But a friend of mine at home finally took me to Memphis and bought me a set. He advised me that I should go ahead and get in the musicians' union. He gave me a set of drums and said, "Stay on the job, son."

RF: What did your parents think of that?

LH: Well, if dad and mom could have had their preference, they probably would have preferred that I be a doctor, a lawyer, a scientist, or a great humanitarian. They wanted me to go to school, but don't we all want what's best for each other? They've been pretty good. My dad used to play country dances when he was growing up.

RF: What did he play?

LH: He played guitar. He sings good and my mom's got a good alto voice. We always enjoyed music, but it never did fascinate them like it did me.

RF: Did you do "Music night at the Helm house"?

LH: Oh yeah. My dad and I played music. He teaches me a song or two every time I'm home.

RF: Do you still sit around and jam?

LH: Yeah, we do. It is fun. He still knows a lot of the old songs he used to perform and play for dances, so we make little tapes together.

RF: Did you play along with records when you were young?

LH: Oh sure, I beat the dashboard off a car. When "Keep A-Knockin'" came out with Little Richard it just really knocked me out. I couldn't get enough of that and still can't.

RF: Did you have any drum idols at that time?

LH: Earl Palmer just about wrapped it up for me. He was my favorite for a long time. I liked all of the records by Little Richard. I used to enjoy Muddy Waters records and Jimmy Reed records out of Chicago. The Phillip Upchurch/AI Duncan rhythm combination played a lot of those records.

RF: Since you have not been formally trained on any of your instruments, including your voice, it's amazing how fluent you are.

LH: Well, I've had all the lessons I could get. I've learned from everybody I've ever met.



RF: Just picking their brains?

LH: Yeah, just by being with them, and playing with all the musicians and the people who I grew up with. I've worked on some of my fundamentals a little bit and I've taken it maybe a notch above an elementary level, but I'm really not schooled at all. I don't read well. I don't write well.

RF: Do you feel like that matters?

LH: Yeah, I do. I think that I could be a lot better at it if I did.

RF: When it comes to feel, though, sometimes the technical aspects are overrated.

LH: But I think the reading makes you quicker. Everybody's feeling the music, so if you give it good concentration, good energy, good heart and good performance, the song will play *you*, but the more you can learn, I think, the better it will help you. The more good records you can hear and the more drummers you can hear, the more you learn.

RF: So you can execute that feeling.

LH: Yeah, within yourself. You don't have to look at it like you're copying somebody. I've done something that I've felt I might have just "found." And I did. I found it stuck way back in my head. It was something I'd heard way back.

RF: To me, your playing and singing all revolve around heart. That's not something you can learn. What does that come from?

LH: I don't know. I guess that's just music, right? I do it the best I can. Thank you for the kind words, but, hell, when I'm singing I can hear myself very well, and I don't sound like Ray Charles. The least I can do is try. I know the way to do it is to put as much life into the song as I can. You can either get it to breathe or you can't. I know that's the only way to get the song to play you, so that's where the tickle is. What helps is to have a musician like Garth Hudson playing beside you, kind of bouncing the ball back and forth with you. Then you've got a chance to do better than you can alone, and then you might be able to play above your head.

RF: Playing with good musicians can inspire you.

LH: I think that might be the key.

RF: When did the singing enter into it?

LH: Well, somebody's got to sing. They won't hire you unless you do a few good songs, right? If you don't sing, they might have to hire a singer.

RF: Singing drummers are not a dime a dozen. It's a real rare kind of thing.

LH: That's obvious, [laughs] It's easy to see why.

RF: Is it difficult?

LH: It's just another way that some of us have to do it.

RF: When you first started singing and playing, did you encounter any difficulties, like keeping time?

LH: Some songs will fit that and some songs won't. When you can sing a song rhythmically, right in there with the main pulse, then it might be an advantage. It's a lot of fun when it's that kind of song, because I can just raise hell with it, answer every phrase and set up every verse. With anything that doesn't fit or doesn't come natural, I just have to go ahead and admit that Richard Manuel should sing it, or somebody else in the group ought to do it.

RF: You were singing back in your younger days too.

LH: I used to sing more when I played guitar than when I played drums.

RF: Did it feel more natural?

LH: I guess most drummers are into the general



Photo by Randy Bachman

playing of the music as opposed to wanting to get out and sing the song, so to speak. Maybe that's why singers usually play piano, guitar or an instrument like that.

RF: When did you begin playing the mandolin?

LH: Probably the first time one became available. It's one of those traditional instruments. It's a pretty sound and it's right at the heartstrings of a certain flavor of music for me. I've always loved that sound. It's like a harmonica for me. The dobro and banjo have that same ring to them for me. A piano, the mother of instruments, is beautiful and warm, but it doesn't have that particular ring that I'm talking about—heartstrings.

RF: Do you feel that playing other instruments makes your approach to the drums more melodic?

LH: It would be nice if it could. I know I play all the other instruments like a drum.

RF: What does that mean?

LH: Anytime I switch to another instrument, I just immediately turn it into another kind of drum, so that I can understand it better. Rhythmically I just find my little contribution, the pattern, the pulse and the rhythm of the song.

RF: When you went off with Ronnie Hawkins, you met the rest of the members who later became The Band. What was your first impression playing together in The Hawks?

LH: Well, every day for me was Sunday back in those days. I just liked traveling and playing. We seemed to be getting along alright. We'd even run in and out of



New York City every now and then, and be on television. There was always something going on.

RF: Did you feel a certain magic when you first played with them?

LH: We didn't deal in those kinds of terms. We looked at it in terms of feelings—if things would feel right, lay right and if we could create that mood. But people would come and go, and the only thing you could really work towards was some sort of a consistency and quality of musicianship. Ronnie would always try to hire the best musicians he could find, nat-

urally. We just all ended up playing it, and we got the reputation after a while of being a pretty good bar band around the country. That's just because we love music.

RF: When The Hawks broke away, you became the leader of that band. Why did that happen?

LH: Because I had been in the band the longest.

RF: What were your responsibilities as leader?

LH: I had to do most of the driving. Other than that, nothing serious. I think different members would come forward in certain situations. It was always sort of a democratic group. We would always share the money.

RF: How long did you play as The Hawks before Bob Dylan entered the picture?

LH: I guess we were around for a year or two like that. We had a couple of different aliases that we went by, but it didn't seem to help, [laughs] We would try something new, but business wouldn't noticeably pick up a whole lot. We ran across Bob at that particular time and that was just some real good God-given timing for us, as it turned out. That opened it up for us to finally get a recording contract. We signed to Capitol Records as The Crackers. The first record didn't have a name on it because Capitol wasn't crazy about putting "by The Crackers" on it. So on the back of it they put our family pictures, and then "The Band" along with the names of our band members.

RF: As in "this is the band that played the album."

LH: When the second record came out, they still didn't like The Crackers and that's when it started being called The Band. I voted to call it The Crackers. I'm no fool.

RF: The story goes that Dylan saw you playing in some club somewhere.

LH: We had a mutual friend, Mary Martin from Toronto, who introduced us. Bob needed a group, and we needed a break, so lo and behold, the two things coincided.

RF: Were you very familiar with his music?

LH: No, I wasn't. I was into B.B. King, Muddy Waters and I still felt Ray Charles had the best band.

RF: Why did only you and Robertson play the first gig at Forest Hills? Many accounts suggest that it was because the band was initially skeptical about playing with Dylan.

LH: No, no. There were other musicians involved at the time and there was no room for any of us. Then some room appeared for Robbie and me to play with them, so the two of us ended up playing it. All together there were five pieces. We got together and had a couple rehearsals to go over the tunes. It sounded like country music to me. I thought the songs were a little bit long. But that's alright with me.

RF: After you did the Forest Hills gig, technically The Band—or The Crackers, alias The Hawks—joined Dylan. Why didn't you go on the '65-'66 tour?

LH: I did some of the American part but I stayed in the Memphis area when the show moved to Sydney, Melbourne and London.

RF: Was it because you weren't ready?

LH: I just didn't want to go. We had played the American part and that part was pretty good. But back in those days when you played for some of the folk-purist crowds, the electrical portion, which was us, would get all the booing and the hissing and stuff. After a while it wasn't a whole lot of fun. It wasn't like I was ready to go into a hospital and give up or anything like that, but I figured maybe we should practice or something.

RF: Why did you decide to do the rest of it?

LH: Times change, people change, and music changes a little. People's ears change. We just continued along, the same as always. It was just a shorter tour for me—a shorter dose.

RF: What were some highlights about playing with Dylan?

LH: We certainly owe a lot to our relationship. It's done a lot for us in everything from trying to construct a song to being able to catch the attention of a recording concern.

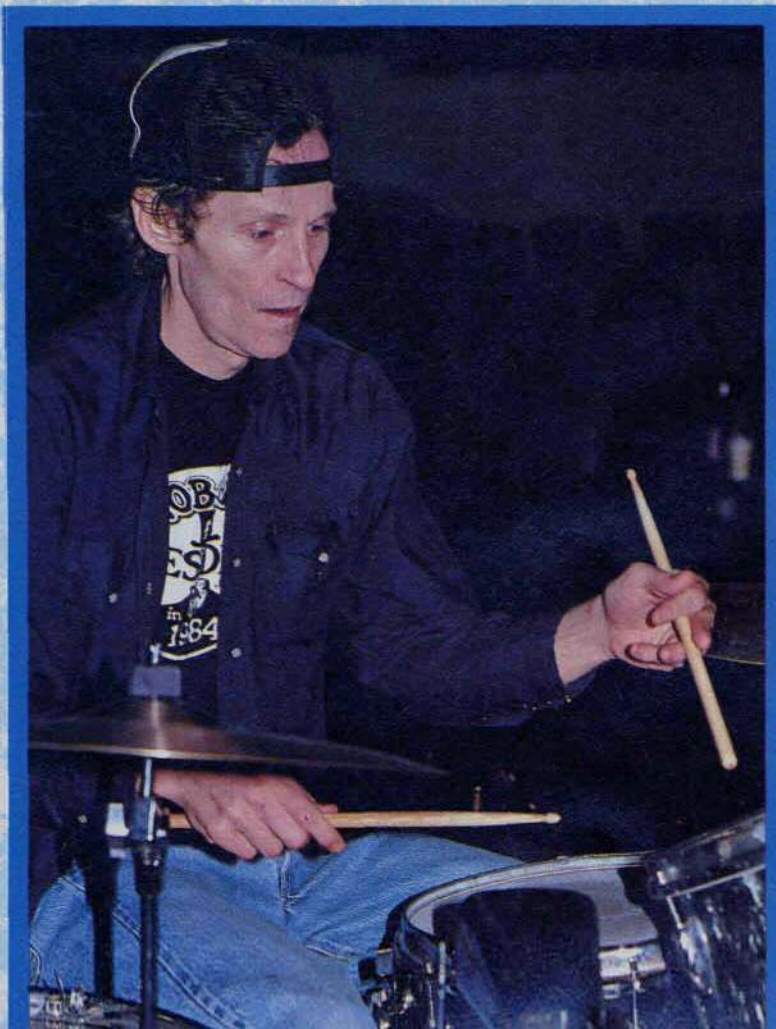

"THERE WERE NEVER ANY RULES. WE DIDN'T KNOW ANY, SO MOST OF OUR STUFF WAS TRIAL AND ERROR."

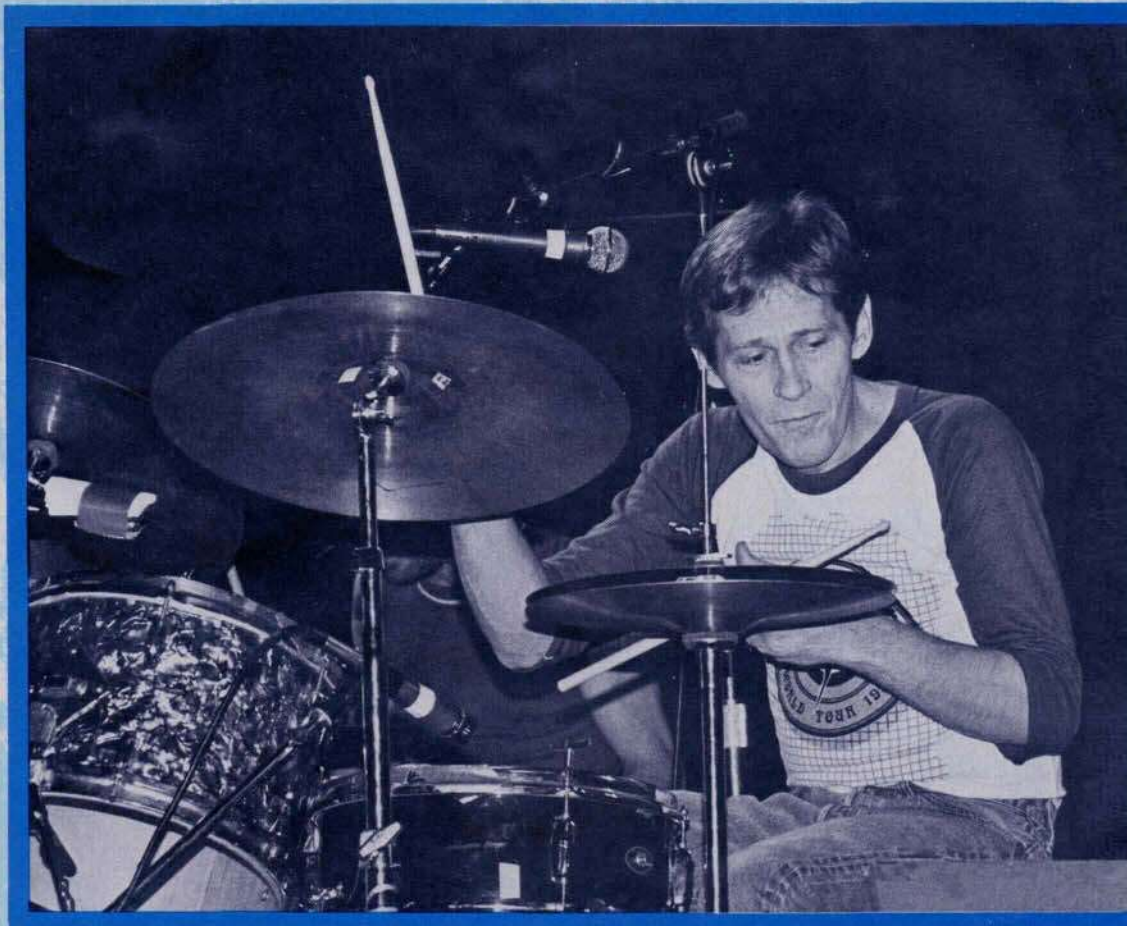

It's going to take me a while longer to even understand it all. It was certainly one of the highlights of my musical career to play with Bob, tour with him, and go through some of the times we had a chance to go through together. He's a great musician and a lot of fun to make music with. He can sit down and make music any time he wants to. Most of the times we played together, it just really suited my style because I like walking on the edge.

RF: From what I understand, Dylan's show is pretty improvisational.

LH: Yeahboy! Nice and loose. Let's not overprepare. My man Bob. I'm with you Bobby! You could just about throw away the game plan for a show, which makes a lot of people nervous, but it tickles me.

RF: Isn't that harder almost?

LH: Hell no! He does it right.

RF: Why do you say that?

LH: That's the way to do it—get together, run over a few songs, and figure out what key you're going to do them in. What are you going to do, sit there and beat a blister on your foot? I'd rather save it 'til we have to.

RF: There wasn't even a set list, was there?

LH: As long as you know what you want to do, it's okay.

RF: That could make some musicians crazy.

LH: I think most people can roll with it like that. You just go out and play music for an hour or two or three—however long you want to and however much the crowd wants—and when everybody has had a good time, you say goodnight. I can't put my heart into doing it any other way. I can't beat a blister on my hand or foot until I'm supposed to. I just don't feel it.

RF: I would imagine that having to respond to what everybody's doing instead of preparing something keeps you stimulated.

LH: Yeah, you've got to stay on your toes. I like it. It's skating in the fast lane alright.

RF: There are definite advantages to that. Many people on a tour get really bored with the same thing every night.

LH: I think if they do, they better do some other tunes or something. If you feel like you're getting into a rut with a song, a night off usually fixes

it. Then you can come out and do it fresh. You can do it brand new the next night.

RF: With The Band, you play other instruments, and you are able to get off the drums on occasion. Does that tend to keep you fresh too?

LH: I think so. It's a lot of fun switching around like that. We always did it mainly to accommodate Garth. Garth's

continued on page 36

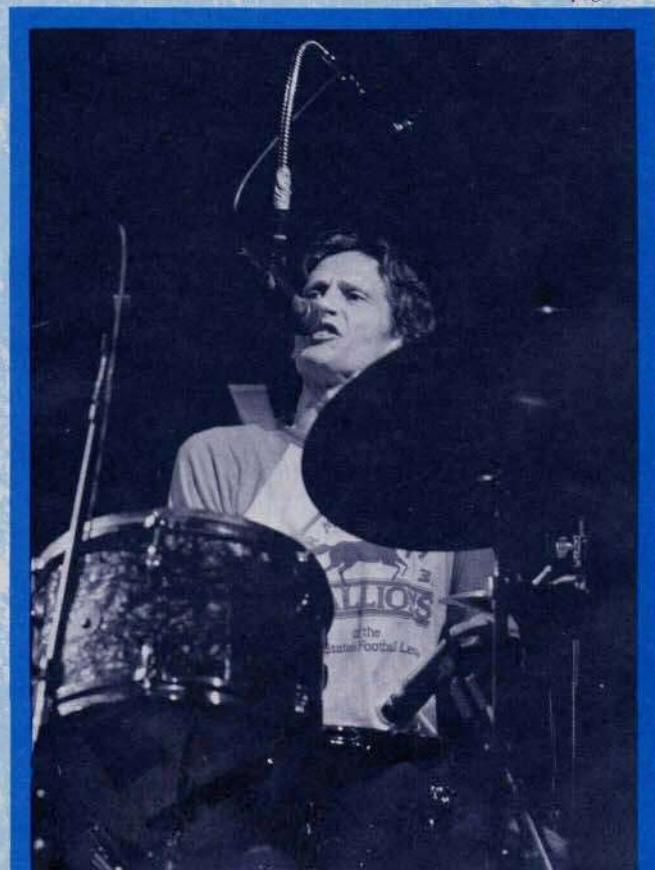

T P

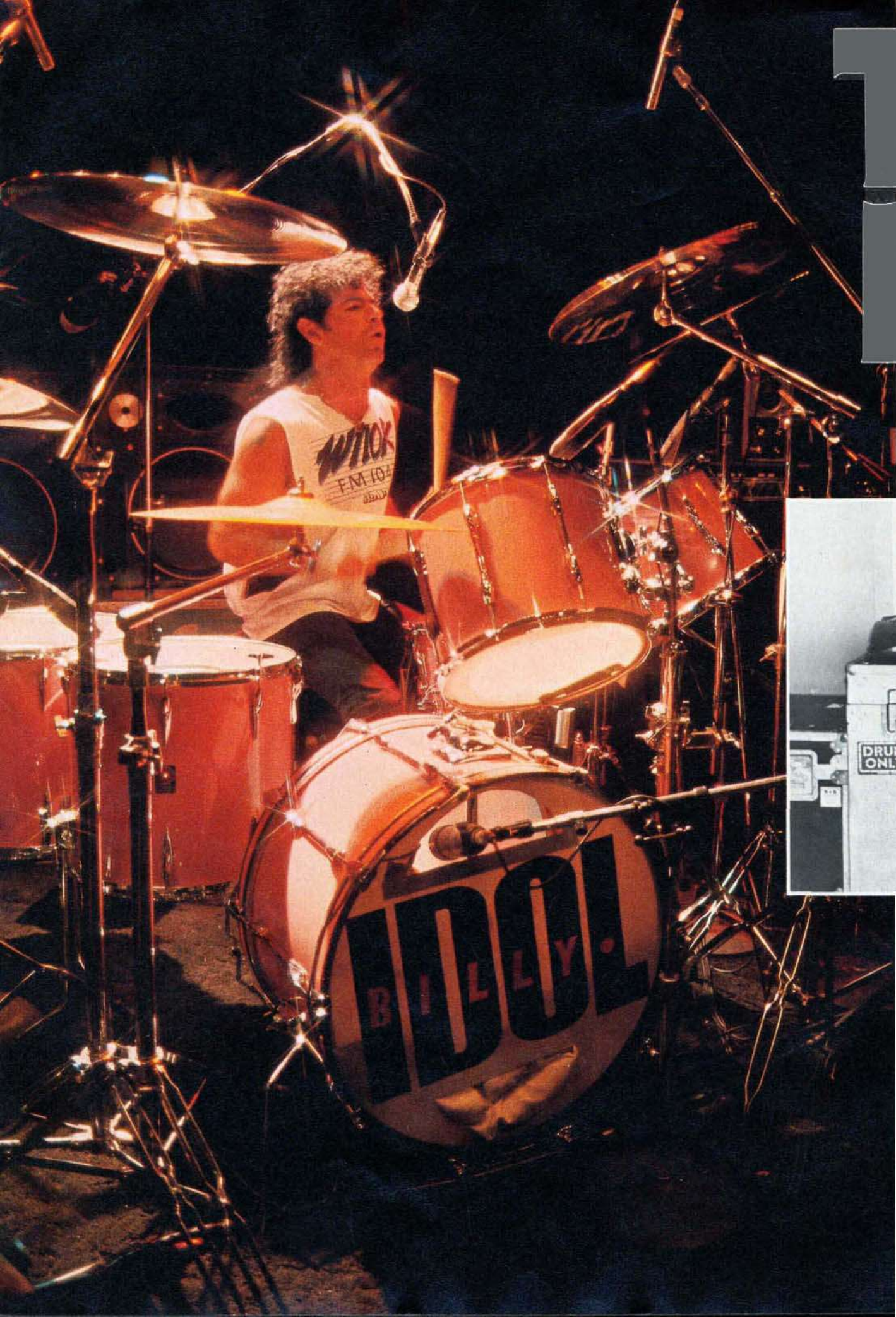

Photo by Michael Jaehres

T P

Thommy Price

by Connie Fisher

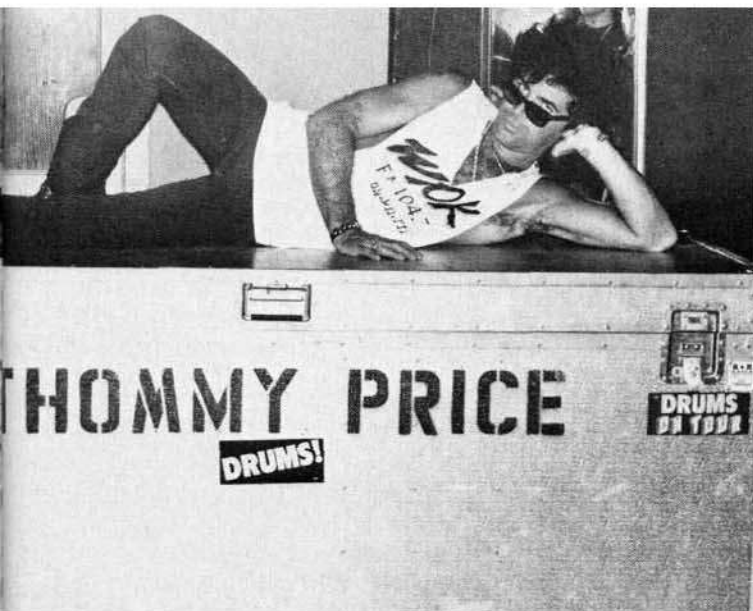

Photo by Michael Jachles

Thunder & Lightning

"**T**HIS man is rock 'n' roll history," Billy Idol declared to a recent concert crowd as he introduced drummer Thommy Price. It's true. Born and raised in the tough, lean and hungry streets of Brooklyn, Thommy got his first gig at a local dance club at the age of ten, and he's worked steadily ever since. That adds up to 17 years of rock 'n' roll drumming, making him a bona-fide veteran at only 27.

Thommy Price is a straight-ahead kind of guy. He looks at you, straight ahead, with kind, clear blue eyes. He's mostly self-taught as a drummer, relying on his instincts when he's behind the drums, and you get the feeling that he's always handled his life offstage that same way. Anchoring the energized poetry of Billy Idol, he sledgehammers his drums with the awesome power and commanding stage presence of one of the most aggressive drummers in all rock 'n' roll. He is perpetually on attack, crouching low as he rips and slashes at his cymbals. Then, leaping to his feet, he grabs them in a headlock with both hands and wrestles them to silence, like a lion finishing off its prey. Every once in a while, he'll deftly twirl his drumsticks, then send one soaring high above, to the audience's breathless delight. And to show you he can do it all, if the mood is right, he'll fill an open space with the precision and clarity of a jazz or classical master. But for the most part, Thommy's a warrior in the front lines—a no-frills, soul and guts show off force. And in conversation, he pulls no punches—no cute "smile for the camera" verbal tricks. He's as honest a talker as he is a drummer—always positive, always optimistic—straight ahead.

I first interviewed Thommy backstage at the Capitol Theatre in Passaic, New Jersey—a blue-collar, rock 'n' roll town. He was there for two grueling marathon days and nights of videotaping the title cut from Billy Idol's *Rebel Yell* album. It's a straightforward, close-up camera presentation of the incredibly tight band performing for a live audience of pumped-up, "just got lucky" kids who were picked up off the street hours before.

Here was a new side to rock 'n' roll drumming, a new demand on the reserves of energy and concentration needed to make it in the big time—video drummer. Makeup girls, sponge in hand, dab at your face every hour or two. Someone's adjusting the fringe on your vest; it was out of place on the last take. Five people armed with cameras swarm at you like bees, within inches of your nose. The director wants you to stare directly into the camera just after you crash the cymbals near the end of the song. Worst of all is the waiting—waiting for the video crew to get the lights just right, waiting for the stagehands to show up to move some equipment, waiting in the dressing rooms between the endless takes, waiting for hours not even knowing what you're waiting for. Nobody told you that you would have to be an actor too, when you first banged away on your drums as a kid, dreaming about playing live on stage before thousands. Now it's mostly you and the camera crew, acting out the same song in perfect time to the recording, over and over again.

But Thommy doesn't seem to mind it all too much. He has chosen to be a rock 'n' roll drummer, and video is now part of it. Even when the director declared it a wrap at 1:00 A.M. on the second night, then changed his mind minutes later and called the band back from the dressing room for one last take, Thommy just smiled and stood up, ready to go at it again.



Photo by Fred Carneau

Maybe his unflappable attitude is the result of all those 17 years of experience. But even though he's been in the music business so long, playing everything from jingles to disco to a five-year gig with Mink De Ville and a little more than a year with Scandal in 1982-83, somehow Thommy seems to have really come into his own with Billy Idol. The sense of excitement was palpable both in the audience and backstage as the band gave all they had for the "Rebel Yell" video and then plugged in for a spontaneous live concert for the fans when the taping was done. Billy Idol is happening in 1984, and his new thunder and lightning drummer is a significant part of it.

And it was more of the same when I saw Thommy at the Capitol again a month later, this time at a sold-out concert performance. After the show, we continued our conversation, and Mike "Moto" Malvasio, Thommy's drum roadie, joined in with some interesting comments on Thommy's personal style and technical setup.

CF: Thommy, the last time we talked, you were going into the studio to do the drum work for Scandal's album. Now you've joined Billy Idol, and everybody's talking about the powerful, thundering drums on the *Rebel Yell* album and the strong impact they've made on Billy Idol's sound. It's all happened fast. How did the change in bands come about?

TP: When I was working at Electric Lady for Scandal's album, we were in the downstairs studio. Billy's group was upstairs working on *Rebel Yell*, and they were having trouble getting the right drummer. The drummer had to play along with a LinnDrum and get the timing right, of course, but at the same time sound natural, like he wasn't thinking about the Linn. And no one was able to do that.

MM: And we had tons of drummers coming in from all over—good drummers with names you would recognize. But it was strange to see; they just couldn't work with Linn. Everybody was starting to get kind of uptight. We were spending a lot of studio time trying to find the right drummer.

TP: Then Michael Frondelli, the engineer on *Rebel Yell*, heard that I was in the other studio. Michael's a good friend of mine—we'd worked together at Electric Lady on a few records—and he asked me to come up and try playing. Billy wasn't even in the studio at the time; it was just the producer, Keith Forsey, Steve Stevens the guitarist, and Steve Webster on bass. So I just went up there. The first song we did was "Blue Highway." I sat down, put on the headphones, and we got the song in two takes!

CF: What exactly did you have in your headphones while you were playing?

TP: I had the Linn, which was programmed like a Cabasa, a hi-hat, and a cowbell; Steve Stevens and Steve Webster both playing live; and my own drums.

CF: Did the Linn pose any problems at all for you?

TP: None whatsoever. It helped me.

CF: How?

TP: Well, it kept me right on line. It was programmed with an easy, swing sort of timing that was very comfortable to play to.

CF: What problems did the other drummers have?

TP: They couldn't make it sound on line; they couldn't play along with it and still keep a human feel. They probably focused in on the Linn for time, excluding the band and the feel of the song.

CF: They couldn't play off it; they played with it?

TP: Exactly. And I just fell right into it. I kind of fell in between the cracks. I would still listen to the band and really didn't have to think about the Linn for timing, because my timing is pretty good. All I had to think about was the feeling of the song.

MM: I've worked with a lot of drummers, both in concert performances and in the studio, and Thommy can hold time with the best of them, with or without the Linn.

CF: It sounds like they were using the Linn in the same function as a click track.



Photo by Michael Jachles

Billy Idol on Tommy Price

Tommy has added so much to the group, in many ways that I can't even put into words. Of course, during the making of *Rebel Yell*, after we tried for three months to find the right drummer, Tommy just about saved us by the skin of our teeth. Without him, we certainly couldn't have done the album to the same degree of satisfaction. I've been looking, ever since I came from England, for the kind of drummer I love—one who can play rock 'n' roll, but with a modern rhythm, a modern heavy style; one who can handle what's needed for modern rock 'n' roll drumming, which is to be fast, but without overplaying—to be simple. Charlie Watts is kind of like that, and Tommy Price is one of the few others that I've known. He whacks it down, and he whacks it down with *soul*. It's taken me three years to find him, but now I've got a backbone to my group.

We're a rhythm 'n' groove, soul rock 'n' roll group. And if I don't have a drummer with soul playing behind me, how the hell am I supposed to sing like that? But Tommy plays into the groove so great. He's feeling exactly the way I push with the music, the way I move with it, the way I'm thinking in my mind, and the way the lyrics and the song are. He's interpreting it as he goes along like I am, even though there's a framework. Now I've got a drummer who understand me—someone who plays music that isn't just *my* music; it's *his* music. With all that he has behind him as a drummer, and all that he knows and feels about rock 'n' roll, Tommy will expand his role in the group; I know he'll have a hand in the writing from now on.

Most importantly, what Tommy's helped to add is a *future* to our group, because without finding the backbone—without finding the right drummer—I haven't got much of a future as someone who seriously wants to have a band around me and not a bunch of players who change every album or whatever. With a solid drummer like Tommy, I feel like we have a solid future.

TP: Yes, but without that annoying "CLICK, CLICK, CLICK." The studio click track is really aggravating. It sounds like someone knocking at your door, or like Chinese water torture. And sometimes when you can't hear it and they crank it up, it goes right through your head. But with the Linn, it's quite comfortable. They can crank it all the way up, and it's like hearing a real hi-hat or Cabasa.

CF: Actually, then, to you this is a case of one electronic studio device, the *LinnDrum*, improving on another, the click track, and coming up with something more acceptable and more natural to the musician.

TP: Definitely. When a guitarist and a bassist, for example, are

Photo by Michael Jachles

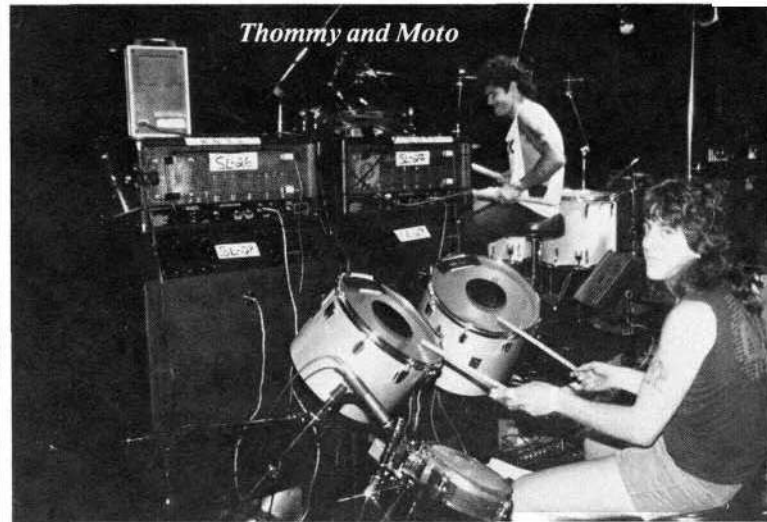

playing along with a Linn, it doesn't sound like they're playing with a click track. It sounds like they're playing along with real drums, without thinking, "Oh, I've got to be right on this click." In recording most of the songs on the *Rebel Yell* album, we used the basic *LinnDrum* program I described for timing, knowing that it would be taken out in the final mix. Then sometimes other Linn textures were overdubbed in, as on the title song, "Rebel Yell," for instance. With a few songs, like "Crank Call," we didn't use the Linn at all. Then "Flesh For Fantasy" is all Linn, and it sounds great on that song.

CF: Apparently you're not intimidated by the Linn.

TP: No, not at all. It's great. Some players are afraid it's going to take over their jobs, like factory workers who get paranoid that robots will take over theirs. But that will never happen. The sound of the Linn is amazing, and it can be used to get some interesting effects, but it doesn't sound human. There's no human swing to it. A *LinnDrum* is like any machine. It has its advantages and its disadvantages.

CF: So you were the drummer who could give what was needed for *Rebel Yell*. Did you work on both albums at the same time, then?

TP: Yes. I'd be doing Scandal's record in the downstairs studio, and then as soon as there was a break in the action, I'd run upstairs and play a few tracks on Billy's record, then run downstairs and finish up a few tracks for Scandal, then run back upstairs again! [laughs] And it was like that for two weeks.

continued on page 60

Photo by Michael Jachles





Photo by Rick Malkin

Bob MOSES

Watching Bob Moses hover over his drums at Right Track Studios in Manhattan like a marionette spider, deadpanning Buster Keatonish responses to the groove of fellow-percussionists Don Alias, Billy Hart and Pheeroan ak Laff, I thought back to what he'd told me when I suggested we do an interview: "Cool—but I don't want to be portrayed as a drummer." Yet here he was surrounded by Boo-Bams, LinnDrum computers and the cream of contemporary drummers making an album of dance-like rhythm grooves, where the ritual aspect of the traps and congas was front and center. It was poetry in motion as they say—a wealth of rhythmic slang and contrapuntal cadences that just as often sounded like synthesizers as acoustic instruments, without bass guitar or keyboard in sight. And yet he didn't want to be portrayed as a drummer in *Modern Drummer*. What gives?

Well, appearances are deceiving, and too often we fixate on the more obvious aspects of an artist's craft, when a deeper truth lies somewhere below the surface. It is not enough to ask what someone plays, or how that person plays it, as it is to ask why? Why? Why become an artist? For many, it is not a matter of choice, but a calling, and clearly this is the case with Bob Moses. His imaginative, phantasmagoric dreamworld is reflected in his drumming, but not defined by it. Saying that art imitates life is an old cliché, but few drummers have ever pursued this goal with the single-minded verve of Bob Moses.

Best known among jazz fans for his crackling action-painting behind Gary Burton, Steve Swallow, Steve Kuhn, Sheila Jordan, Jaco Pastorius and Pat Metheny, Moses perfected a loose, deceptively frenetic soundscape that somehow split the difference between the symmetrical elisions of a Max Roach and the controlled spasticities of Roy Haynes. In Moses' hands, firm, pulsating grooves would suddenly dissolve as if subjected to a psychic acid bath, dissolving into streamers of cymbal explosions and bombarded tom-toms, yet remaining as lithe and centered as a galloping antelope. Bob Moses' drumming always threatened to self-destruct, yet this looseness was deceptive—order masquerading as chaos.

More to the point, he is a composer masquerading as a drummer, for who is more likely to be a conductor of notions in motion than a drummer, or less likely to be acknowledged as such? Yet with the release of his first two Gramavision albums

by Chip Stern

When Elephants Dream of Music and Visit With The Great Spirit (and the imminent release of his drum book, *Drum Wisdom*), Moses looms as a potentially major force in American music—a homegrown baby of the urban jungle, as if Charles Ives had lived among the Incas of Peru. Where his first album suggests an amoebic, shifting impressionism redolent of Gil Evans, his latest album synthesizes the tumult of Charles Mingus with a "funkified" tribal groove, centered in his woody, high-stepping drumming, and his multi-tiered layers of texture and color—a sanctified blend of jazz, rock, funk, bohemian poetry and the third world.

In truth, Bob Moses—wry, witty, opinionated, spacy and unpredictable—is much more than a drummer, and his music much more than an artificial fusion of air-play prayers. The fusion has always been there, because he never acknowledged a difference between styles and, in fact, often seems as if he were trying to play them simultaneously. Also, as a member of *The Free Spirits* and the original Gary Burton Quartet he was there at the very birth of what we now call fusion. So this interview is concerned less with the nuts and bolts of drums, drummers and drumming, than it is with a representation of an original mind. What follows is an overview of the attitudes and dreams that shaped Bob Moses' art, rather than the art itself. It is also an overview of the method by which Moses came out of the wilderness of his fuzzy-headed inspirations, and into the realms of discipline and control by which he channeled his art, as well as a discussion of where he hopes to take it. When drummers dream of music, anything is possible.

CS: How would you characterize yourself as a drummer and what you're trying to do musically?

BM: I'm a teamwork man. I have no stake in improvisation. I'm into parts. I like it when it sounds like traditional music, but not something you could pin down as if we'd been doing it that way for 400 years, like salsa or Latin. That's what I'm going for. I'm into parts and holding the fort.

CS: Isn't that a kind of strange attitude for a drummer? Aren't you supposed to be liberated?

BM: Well, I'll tell you, I never knew what

we were trying to be liberated from. Music? To me devotion is the opposite of liberation; devotion is like commitment to something. Also, I don't play for enjoyment either. I play for the results, and the best results don't necessarily come from freedom, although they can; it depends on who it is and the moment, of course. But I don't rule out any tactic, and I find that the more composed things are, the better they work out—especially with rhythm things. On *Visit With The Great Spirit*, there's almost no live playing. Almost all the record was done first with drums and bass, then percussion, then guitar and horns, then synthesizer and whatever else I thought was needed. So I don't think I could ever go back to live recording. I have no desire to do so. But then, who knows? I'm an extreme person, so I could change my mind.

CS: Well, you're great for extremes, but you're also great with instinctual responses to a jazz ensemble, so I'd hope that would remain some part of what you're doing.

BM: Well, my music is simultaneously further out, and more inside and traditional than anything I'm hearing now. My whole thing is emotion. Sometimes the blues is the only music with enough emotion to cut through. Of course, you can play blues without emotion, which is what a lot of people are doing now. They play the blues without throwing in any of the clichés that make it the blues—like they want to disguise it or something. I like the older, pre-Charlie Parker blues style because there's more emotion in it for me, even though it's not as sophisticated. Even in my own music, it bothers me when it just becomes a head trip—an ego thing—where I can't cut through all the artfulness I spent years developing. I really don't expect popularity until my music gets as good as the Wailers or Michael Jackson. And I really mean that. To me, that music isn't just more popular; it's better.

CS: Why is it better?

BM: Because it's not an in-joke. It's not a treatise on craftsmanship. It entertains. It's really more noble to reach out to people and entertain. Ideally you want to have that and the art, too, but I suppose what really reaches me is the functionality of it. And as it is, my music is still just communicating with the elite; it's getting closer all the time to the average folks. A lot of it is just letting go, so you don't have to show that you know so much.

CS: You just don't have to demonstrate that all the time.

BM: I'm into a real precision control thing. My concept is not about long, drawn-out solos. In fact, I want all solos to be amazingly brief, unless they're ex-

DREAMER

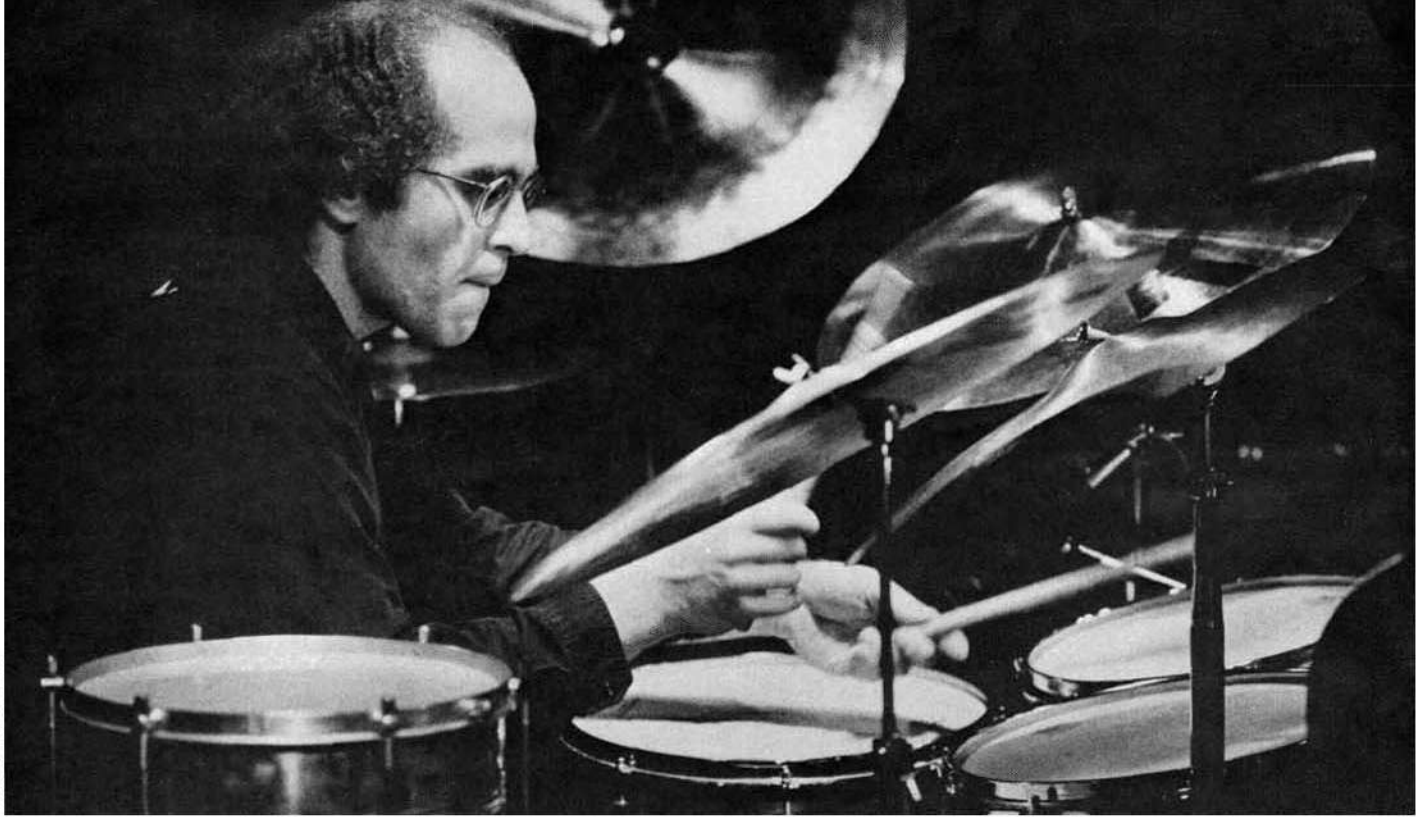

tremely incandescent, and even then I want them to end just short of reaching the maximum. See, I'll trance out when I *listen* to my music—it's meant to be an aural movie—but not in the *playing* process.

To tell you the truth, I'm looking forward to somebody dominating me, with some purpose, by saying, "Take this head off; tape this; put a pillow over there." I'm anxious for an engineer to tell me how Jerry Marotta gets that tom sound on the Peter Gabriel record. See, I already know how to get *my* sound. What I want is to try to reach some people. I'd love to sell out.

Photo by Rick Malkin



CS: If only you get your price.

BM: It's not that high. Sell in, sell out, sell sideways—I'm not into the money *per se*, as little money as I make. What interests me is the musical challenge of playing pop music creatively. I don't think it's any less of an art than playing jazz. I always wondered why jazz musicians don't listen to hit singles, because there's so much to learn about craft.

CS: You know why they don't? Because in many ways it's harder to play.

BM: In many ways? In *every* way! And that's what scares jazz musicians to death. I don't know many jazz drummers who can cut that music. I mean, except for the real greats, jazz drummers are a dime a dozen. With pop music, chops aren't so important. You have to play a lot simpler, keep it in the pocket, and not try to play everything all the time.

CS: What's the basis for your solo ideas?

BM: I always begin with an idea of what I want to play, and that usually takes the form of a melodic framework. I never just play the first thing that comes to my mind and go from thing to thing. I might have to sit back and think about what it is I want to play. It's not that I can't change or go to something else, but it has to be built on a solid framework, and when I change, I move to another definite idea. There should never be a time when there isn't a central idea, which is why everyone sounds better playing with a band than playing alone. That's why I try to bring that focus to my soloing, because variations on a theme are a lot different than just playing a lot of different themes. Once you establish a central theme it will make things clearer for the listener.

The first rule in my book is that you should always play from something; never start from nothing. Music, by its very nature, is very abstract. What can be more abstract than sound in the air? So even if you abstract an idea, at least make it recognizable. That's why lately I've been listening a lot to drummers like Bill Bruford, Stewart Copeland and Jerry Marotta. I just love Jerry Marotta; he's a monster. Those English drummers like Bruford and Copeland project so much power in their playing; what they don't have is a certain roundness to their sound, which is why sometimes it comes off as a little stiff.

CS: It's not in their environment.

BM: Right, but I think if they wanted to cop it, they could. But what they play is great and I wish I could play some of the things they do. When they play a funk thing, the impact is so strong that it makes up for how straight it feels, whereas if I played the same thing it would be coming from more of a black, New Orleans approach. What I'm trying to do now, is to get the power of those cats with the feeling and roundness of a Zigaboo Modeliste, and the tone of a Zigaboo as well, because American drummers seem to be more in touch with the pitch and timbre of the drums. But a lot of what I'm reaching for now has to do with the impact and power of Bruford and Copeland. You can hear all that on the new album.

CS: But you've had a big, warm tone on your drums—even when you had the kit tuned up high and tight.

BM: Well, the impact of the drums on the new album is much more prominent than on most jazz records where you hear cymbal, snare, and not much tom and bass.

Since I've been using two bass drums it's great, because even if you can't always hear that deeper drum, you can feel it, and it makes everything sound rounder and more present.

CS: How do you tune your drums?

BM: I tune them like the blues [hums a passage]. It's like fourth, minor third, tonic and then maybe the tonic below on the bass. The snare drum isn't so pitched, I don't think.

CS: You always had a nice pitched sound on the snare. On *Bright Size Life* with Jaco and Metheny, it sounded as if you had the snare mechanism off for the entire album.

BM: Sure. I do that a lot, because I'm really into the toms, and in getting timbale-type effects off the rims and all. Right now on my current kit, I even have a Brazilian drum called the *Retinique* out over my floor toms, which gives me a big, fat, metal drum sound, so I can come up off the big wood drums and get all of these accents and vowel sounds instead of just hitting another cymbal. An open snare goes well with that, because the snare, to me, has certain military connotations, whereas I'm coming more from third world dance musics—although, obviously, where they mixed is in American music. Of course I love to use it for that funky march. I'm real good at that, although Steve Gadd is the master of that style.

CS: Why are you using those short drumsticks? Is it because it's more like hand drumming?

BM: That's it exactly. For a long time I'd practice in this place I was living mostly on brushes, and it was uncomfortable for me to go to a longer stick, although I've been using them again recently without any discomfort. But with these shorter sticks, it feels more like the extension of the hands when I'm playing congas or something like that. It just feels more natural to me.

CS: Your work on record used to be dominated by a razor-sharp, hyper-crisp cymbal sound. But now when you do go to the cymbals the sound is wet and soaring. What are you going for?

BM: I used to be into very dry cymbals, but now I seem to go for something much warmer and more resonant, and if I want to, I know how to pull the definition out and get them to say *ping*. Zildjian made a couple of mini-cup K's for me that are like the best of that kind. I hardly use the cymbals anymore; I'm much more into the drums. I'm using a pair of bass drums that are tuned wide open, and the only muffling I'm using are those Dr. Scholl's Corn Pads, so they're really deep. Gradually I've come to the point where everything on top is tuned much deeper, too. I used to tune my toms and snares really tight, and I have a small Sonor kit that's tuned that way for when I get calls to do gigs like that, which isn't all that often, but I'm not into that top cymbal, tight jazz sound anymore. I want to *feel* the drums—elemental

**"I ALWAYS
WONDERED WHY
JAZZ MUSICIANS
DON'T LISTEN TO
HITSINGLES,
BECAUSE THERE'S
SO MUCH TO LEARN
ABOUT CRAFT."**

drumming with no bullshit and no flash; that's what I'm reaching for. And there's such beautiful tone to these Eames drums—big, pretty and strong.

CS: What do you practice?

BM: I don't practice.

CS: Come on, man, you sound like you've been practicing. Your playing and the music you're writing sound so much fuller.



BM: See, drumming is not a casual thing with me and it takes up so much energy. For me, the only thing is the final experience—the playing. There's nothing else to practice other than that; that's so intense, and I think so hard about every note. It's like anytime I play a drum I'm thinking about how this is my life; this has got to be like a finished thing. That's a lot of pres-

continued on page 80

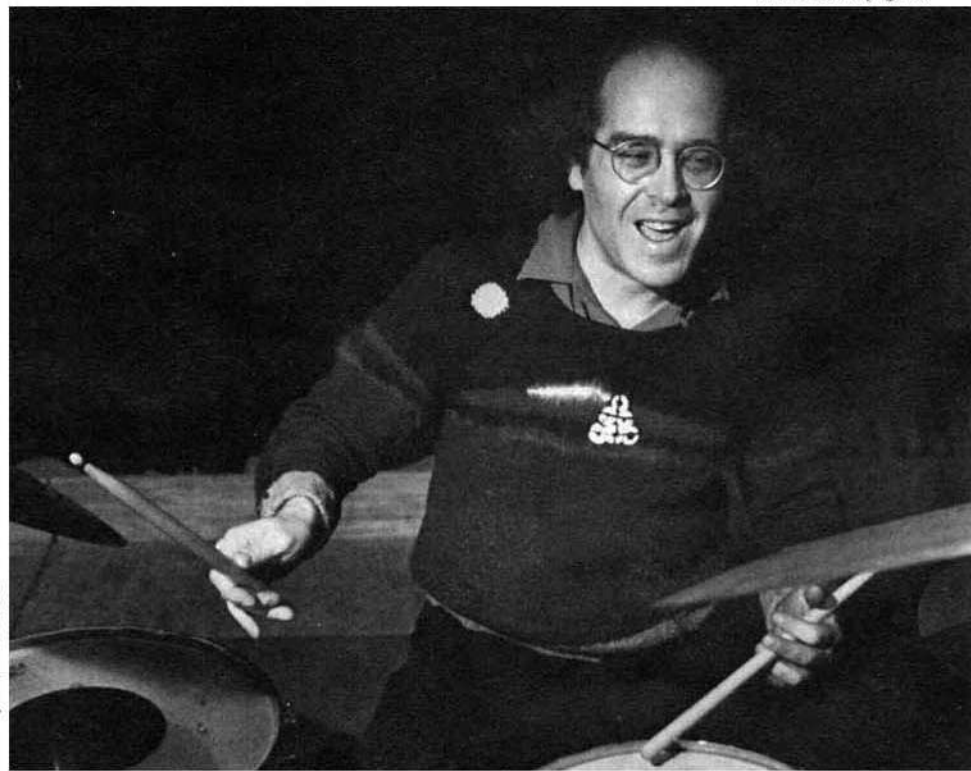

Photo by Raymond Ross

Drummers ATLANTIC CITY

IN 1978, the citizens of New Jersey approved a referendum, legalizing casino gambling in Atlantic City. With the advent of gambling came an expansion in the entertainment industry as well. Where once Atlantic City was known for its ballrooms and appearances by all the big bands of the past, now the Boardwalk boasts Las Vegas-style showrooms featuring major artists and glittering production revues. Lounges present musical groups of all descriptions, at virtually any hour of the day or night. The city also contains a number of clubs offering a wide variety of entertainment.

Is Atlantic City the new El Dorado for the professional drummer? What kind of jobs are available, and what are the pros and cons a drummer should be aware of before considering a possible relocation to the Atlantic City area? Is it a market offering long-term, career-oriented musical employment, or just a boom town in which to play lucrative, but short-term traveling gigs? Is it wide open to any talented and ambitious drummer, or a closed shop, difficult to break into and highly competitive?

What is the union situation? In order to answer those questions, Modern Drummer spoke to a group of individuals representing a cross-section of the entertainment business. Although these people were interviewed separately, for the purpose of clarity we are presenting their comments in an imaginary "round-table" format.

Background

Upon the passage of the 1978 referendum, the first casino/hotel to open was Resorts International, followed in rapid succession by names familiar to Las Vegas patrons, such as the Sands, Caesars, the Tropicana, and the Golden Nugget, along with new names like Playboy, Bally's Park Place, Harrah's Marina and the converted grande dame of Atlantic City's glory days, the Claridge. Harrah's at Trump Plaza opened in June of '84, and two other casino/hotels are under construction at this writing.

Major Showroom Entertainment

Our discussion on the topic of casino showrooms included Dick Paul, musical

director for Caesars; Tom Cantone, Entertainment Vice-President for the Sands; Bob Peiffer, Secretary of Local 661-708 of the American Federation of Musicians; Michael Pedicin, musical director for the Tropicana and contractor for Playboy; Paul Mann, musical director for the Sands, and Carl Mottola, drummer for the Caesars orchestra.

RVH: How would you describe the entertainment scene here, as far as the major showrooms are concerned?

PAUL: What we're working with now, generally, is a weekend town. At Caesars we're doing seven nights a week—and I think there are two other places that are doing that—because we're running a small revue Monday through Thursday which features variety acts, and then on weekends we use headliners. But other than that, the hotels only run weekend entertainment. We also get some self-contained acts like the Pointer Sisters or Tina Turner. Then the whole band is off during that period of time. There's no violation of contract, because we are not guaranteed a certain number of days to work.

RVH: Tom, why are the headliner shows strictly weekends?

CANTONE: It depends on the season. Through the entire summer we have headliners every night of the week. After Labor Day we go into a posture of weekends only, and even then not every weekend. Our policy is to bring in entertainment on an availability basis, when we feel that the return on our investment is going to be there. Otherwise, we will simply keep the showroom dark.

PEIFFER: It's a spasmodic condition right now, because the Casino Control Commission deregulated the entertainment portion of the Casino Control Act. That act, which legalized casino gambling



Showroom drummer Carl Mottola . . .

ing In NTIC TY

by Rick Van Horn

in the first place, stated that there would be entertainment seven days a week in the showrooms. Right now, we don't know if there's going to be a show next week or if there isn't, in any given hotel, because the hotels are no longer bound by law to have that show. Also, with the new situation, acts come in self-contained, as Dick said, and the hotels don't *have* to hire *anybody*.
RVH: I had been under the impression that there was a union requirement for standby players from the local when traveling players were used in the showrooms. Is that a thing of the past?

PEIFFER: No, it's not. The Philadelphia local, for example, just signed a collective bargaining agreement with the theaters of the Shubert organization. The local can do this, because they're dealing with an employer *per se*. But here, the hotels are not the employers. The only hotel that admits to being the employer—and only of their house band—is Resorts. The others work with independent contractors, or "vendors," who in turn employ the musicians. We're appealing to the National Labor Relations Board to change the laws to state, in effect, that if the owner of the hotel tells you when to go to work, where to go to work, what hours to work, etc., the hotel owner is, in fact, the employer. There's an amendment to the Taft-Hartley Act pending in the Senate and the House, basically stating my premise, but the law doesn't state it now. So it puts us in a very precarious position.

RVH: The term "house orchestra" would imply a full-time, on-staff, payroll group of musicians employed by the hotel itself. I gather that's a misconception.

PAUL: It's been a long time since anybody's done that anywhere. Contracting is now the general situation. As a matter of fact, this is one of the last remaining cities

where there are house bands of any description, even on the contracting basis that exists here.

RVH: As musical director at Caesars, Dick, are you also a contractor?

PAUL: I'm what Bob called a "vendor." I'm an outside, independent contractor dealing with Caesars exclusively, as my one account.

RVH: So although you're not technically on the payroll, for all practical purposes you are the house musical director for Caesars.

PAUL: Right.

RVH: Mike, how do musical directors deal with the uncertainty of show schedules that Bob mentioned?

PEDICIN: My contract with the Tropicana has always had a minimum of 15 pieces, and as of last March it went to 22 pieces for the rest of the year. Even if there's a comedian, or a self-contained act, we still open the show. So the musicians on my band will work 48 weeks per year. I also contract for Playboy—I hire the musical director there—and there I've got six pieces on a steady contract. They are a

house band that works, and gets paid, regardless of what other act is on. For example, when Tony Bennett came in, and Buddy Rich's band was playing for him, my band got paid anyway. Not all the contractors in all the hotels are able to do that, but I think it's the responsibility of contractors like me to keep the band working. If I'm employing 22 here and six there, it's my responsibility to talk the casino into the fact that they need a steady band. Fortunately, that's what I've been able to do. All the musicians are my employees: straight-ahead health and welfare . . . pensions . . . I usually have a 40-employee payroll every week.

RVH: Do most of the showroom musicians live here in the Atlantic City area?

PEDICIN: Most have not grown up here, but everybody who's working here now has pretty much put in the time in the area, and has transferred into this union local. Once you have your card here, it doesn't matter where you live, so there are players like Carl who commute six days a week from Philadelphia, and a couple who come down from New York for the weekend

continued on page 92



... on stage with the Caesars orchestra.

WILL DOWER

THERE'S no denying that in recent months a very significant amount of the world's innovative music and musicians have been coming from Australia. One has only to look at the hit songs and top acts to see names like Men at Work, AC/DC, Air Supply, Little River Band, and of course, artists like Olivia Newton-John, the Cibb Brothers, and Rick Springfield. It's not that Australia hasn't had fine artists all along, but it seems that they have come into focus more in the last few years. We had the "British Invasion" of the early '60s; now it seems that the '80s will be the generation of the "Aussie Invasion."

One of the important drumming figures in contemporary Australian music is Will Dower, who might be described as an Australian combination of Ed Shaughnessy and Hal Blaine. Will is one of Australia's top studio drummers, and performs regularly as the drummer in the stage bands of two major network TV shows. He also tours the country as a backup drummer for one of Australia's biggest singing stars.

Along with his son Mark, who is himself a fine drummer (and at the tender age of 17, is also backing one of Australia's top touring acts), Will recently came to the U.S. to investigate the American music scene by hearing as many top players and touring as many of the studios, clubs and drum schools as possible. He and Mark took a break from their frantic traveling schedule to visit MD's offices, and give their views on the Australian music industry.

RVH: Let's start by getting a little background on Will.

WD: I work with TCN-9, one of the major networks in the country, and certainly the major network for music. I do a show called *The Mike Walsh Show*, a five-day show that goes out live Monday through Thursday, and then Friday's show is taped on Thursday. Seven years ago I was offered the job of full-time drummer, to do the entire thing. I suggested to the music director at the time that I didn't think it would be a good idea, because you get locked into those shows, and with any television show you don't know if you'll be on for a year, five years, or whatever. I had seen situations in the past where people had been working on shows that folded, and there was nothing for the drummers to do—no

jingles available or records, because other drummers were doing them. I suggested that we do a week on, and a week off, in the initial stages. He had to think about it, and came back with, "Why don't we make it one week on, and two weeks off, which would be even better, and not only different drummers, but three entirely different bands." So we have three, ten-piece bands that rotate; it's quite unique. The beauty is, of course, that we can take time off to do tours, and if it happens to cross over my week, I just swap with someone else.

RVH: Is there only one musical director?

WD: Right—his name is Jeff Harvey, and he coordinates the whole lot.

RVH: Is this similar to the Johnny Carson show?

WD: Yes—it's a talk show. We'll generally have an opening number—a bright, up-tempo tune—and then some sort of production number during the show with a musical guest, and then another closing number, so it's usually at least three tunes per show. We get to back artists from all over the world. I also play drums for *The Michael Parkinson Show*. Michael is an interviewer, much like David Frost. Parkinson is huge in England, and he comes out now and does six months in Australia. That show uses about a 15-piece orchestra.

Apart from that, I do lots and lots of jingles. For seven years straight I did the *Coke* ads that are done in Australia, and of those seven years, three or four times those ads won the worldwide award for the best ads of the year. I've done a lot of records; I have about 65 albums to my credit, backing country artists, big bands—a bit of everything. You have to do that in Australia; it's very hard to specialize. You'll go broke if you specialize. I also tour and back cabaret artists. I work with a guy called Barry Crocker, and his backing singer used to be Olivia Newton-John. A female singer we had in the act back in '65 for a few months turned out to be Helen Reddy. I backed the Bee Gees when they first started—all these Australian acts that have made it big. And me—I'm still working in Australia!

RVH: Herein the U.S., we have just a few drummers who have dominated the studio scene for many years. Is it the same type of closed-shop situation in Australia, where it might not be *what* you know but *who* you know that gets you a break in the recording business?

WD: I think it's a bit more open. It's not so much who you know, although that of course helps, but I think it's more of "the right person for the right job." There are two guys who have literally done most of the sessions in Sydney for the last ten years. One is Doug Gallacher, and I am the other. Doug and I have done just about all the major albums, jingles, TV shows and so on. But there are a number of very good up-and-coming young players, and a lot of other good players in different areas. For instance, I don't consider myself really good in all areas, so if a producer rings me for a job, I always ask, "What is the brief? What's it all about?" And if the producer says, "Well, it's sort of a new wave-type song" then . . . I'm 41 years of age, and I'd be the first one to say, "I'm not the right drummer. You should get those drummers who are playing with the new wave-type bands, and they'll do better for you." A lot of that does go on in Australia, I believe. There are a lot of recommendations for the younger musicians, so I think they do have a good chance of breaking in. If that's "who you know," then there is some of that going on. But, for instance, in the case of Mark being my son, that's not enough for him to necessarily make it. On any production, be it a jingle, a record or anything else, money is the operative thing, and time is money—especially in Australia, where we're on such low budgets. You can't afford to have turkeys playing drums; if they don't cover it, out they go.

RVH: How much actual studio work is going on within Australia, in terms of major artist recordings?

WD: Well, there are several Australian labels, though they have to come to the U.S. for major, worldwide distribution. But we do have facilities for recording in Australia that I believe are as good as any in the world. For instance, Duran Duran have just spent six months in Australia recording their new album. We have studios going digital; we have everything that Mark and I have seen so far at any of the studios we've been to on the West Coast. The microphones, and every kind of equipment we've looked at are identical to what is used in Australia. Certainly in the drum department we are totally up-to-date. We've only found one piece of equipment over here—Tama's extension hi-hat—that

AUSTRALIAN SESSION



MAN

by Rick Van Horn

we can't get yet in Australia. I think the number of foreign artists coming to record in Australia would be indicative of how good our equipment is.

RVH: What about recording for advertising?

WD: Advertising is a huge area of employment for Australian musicians, because we are not allowed to use any U.S. ads, or any other overseas advertising at all. Everything has to be done in Australia. So I've had to copy a lot of American drummers, and hear a lot of American tracks which are being brought in. An advertiser will come in with something and say, "We have found this campaign successful in the U.S., and we want to duplicate it here."

RVH: So they walk in to Will Dower and say, "We want you to sound just like Hal Blaine, or Jim Keltner," or so on?

WD: Right, and we go in and listen to their tracks. Then we go out and get the required drumkit. It might need a *RotoTom* effect, or they might want power toms. I have any number of snare drums available, because of my association with the Billy Hyde Music Stores. I can just walk in and borrow anything I need. From there it's up to the engineer and myself to come up with the exact sound that was done in 1983 on Paramount stage number whatever it was, with Hal Blaine. That happens a lot.

RVH: Talking about engineers, one of the major differences of opinion among studio players here involves working with engineers. Many of the veterans feel that you should cooperate completely with an engineer, and make any changes the engineer deems necessary. However, some of the younger players feel that they were hired because they play the way they do, and sound the way they do, and they shouldn't have to change any of that to suit an engineer. What is your philosophy about that?

WD: That's a really good question. My reaction initially when I started was to go with the engineer. I was young, just starting to do sessions, and I thought these people knew everything. Besides, my kit didn't sound that good, and they were able to make it sound better than I could make it sound. So I said fine to whatever they told me. Then what happened was, I started to do a lot of sessions, and I made it my point to become as friendly as possible with the engineers. They are the ones who are going to make the sound good or bad. So I do try

to create a rapport. And since Sydney is not a huge town with a lot of studios—there are only about ten recording studios and four TV studios—there are only about 14 or 15 people who I have to get to know. I try to get to know them as people and I try to get an idea of where their ears are at—what sort of records they listen to; what sort of sounds. I even bring in tapes on my *Walkman* and say, "Have a listen to this new album by whomever, and see what you think of it." It could be a Steve Gadd sound or a Jeff Porcaro sound. I use a sort of subliminal advertising to get under their guard. The bottom line for me is that finally I have a kit that I think sounds right,

"I REALLY BELIEVE THE ENGLISH AND THE AMERICAN DRUM SOUND OF TODAY IS OVERPROCESSED. I BELIEVE WE'RE GETTING AWAY FROM WHAT DRUMS ARE ABOUT."

and I really want it to sound like that on the recording. That producer has hired Will Dower because that's the sound I get.

RVH: And by now you've established your credibility to the point where others are trying to get the "Will Dower sound."

WD: Right. And I do believe that we are producing what I would consider an Australian drum sound, which is different from an American drum sound.

RVH: How so?

WD: Well, I'll stick my neck out here. I really believe the English and the American drum sound of today—and I'm talking now on a broad basis—is overprocessed. I believe we're getting away from what drums are about. When we visited with Harvey Mason a week and a half ago, he told us he had done nine sessions that week, and six of them were on Simmons drums.

RVH: They certainly are the hot item in

production in this country.

WD: Right. But the drum machines and Simmons drums are mostly dying out in Australia. It's amazing. I would have thought they were going to go straight up, but instead they've dropped off. Before I left, I had three calls. One was for a jingle and a couple were for record albums. I had to go back and re-do the drums—real drums—over the top of drum machines and Simmons drums, because when the artists and clients concerned heard the original tracks, they said, "Oh no, not *that* sound again!"

RVH: Many American studio players have told us that, if they don't come to the studio prepared with a live kit, a Simmons kit and in some cases a programmable drum computer, they just can't get work.

WD: I'm quite sure that's already passing at home. I consider that I have a fairly good finger on the pulse, and judging by my experience, it really is over the top. We've gone through the whole thing, with *DMX* devices, and *Clap Traps*, and all the big disco things. We've done all that. The hit parade tunes here are exactly the same as in Australia, so it's interesting that you are still into what I call this overprocessed sound. That's all a lot of fun, but what happened to the instrument itself? Let's get back to drums. And I do believe that we have a sound. There's a tune down in Australia called "Made My Day," with Ricky Fatah on drums, that has the best-sounding acoustic backbeat I have ever heard. No tricks, no *LinnDrums*, nothing—just beautifully produced. What it has is enough human element to make you say, "Hey, this is something new; we're back to that!" I think Australia is leading, with an Australian sound. I believe we get a very good live sound on our television shows. We are live to air; there's no post-production. A lot of care goes into them—a lot of thought. When I go back to Channel Nine in a few weeks, we'll take a kit in there and we'll spend a whole day just tuning that kit for the air. We'll spend six, seven, eight hours or whatever it takes, getting that kit EQ'd and ready for air.

RVH: How do you go about tuning for TV? Do the hot lights make a difference?

WD: Minimal. We have a band shell on the show, which is air-conditioned. It has a series of spotlights for featuring different members of the orchestra if need be, but

basically it's temperature controlled. I've gone back to tuning with everything wide open. I use Pearl drums, with power toms, for work of all kinds. We have a kit that's set up in the studio all the time for taping. Most of the studios in Sydney have a basic kit, and then you just bring in your favorite cymbals or snare, or special toms if you need them. I usually use an 8" tom, and sometimes a 10", then a 12" and a 13", and a 16" floor tom. I run clear *Diplomats* on the bottoms, as thin as possible, and on top I use *Pinstripes*. My system of tuning is to hit it, and listen to it go "boomp, boomp, BOOOOM." When it gets to that one point where it really sounds good, that's it. I don't tune to any pitch or anything like that. At some stage that drum is going to sound very good, and it takes a lot of tuning, with good ears, to get that final "booom." Once I get that nice, open, fat sound, then I can adjust; generally I find I drop the top head just marginally to get that little drop-off of pitch—that sinking sound. And then I just go around the whole kit like that. No taping; I tried *Deadringers* for a while—they were okay—but now I just tune wide open. With the bass drum we prefer the dead, fat sound of a pillow inside, with the front head on with just a little hole to stick a microphone in. The reaction to the drum sound has been astonishing! I get a lot of mail from all over Australia, asking me how I get that sound on TV. I just explain it to them as I've done to you, and tell them that it's the sound that does go out to air. And we're proud of it! It's a good sound. Various American groups have been over, played it, heard the playbacks later and just loved it. So I believe that that tuning is ideal. I believe, as I said, it's an Australian sound, and it's nothing more than going back to letting the drum do its job.

RVH: A lot of young drummers today have grown up listening to the studio-tuned drums, or the re-mixed and re-engineered sound of drums affected by electronics. When these young players hear recordings by players who stuck to the older style of tuning, such as John Bonham or Mitch Mitchell, they're just knocked out.

WD: Well, I went right through all of that. I jumped right on the *Syndrums* when they came out. I was virtually the only drummer using them in Sydney, and I was

using them on everything—shows, jingles, albums—but that was because every producer wanted them. I've used all the tricks, but they seem to have faded from popularity with us now, and we're back to a good basic drum sound. I'm not just a purist. I love all the tricks, but really, to me, the drum sounds around the world are very "McDonalds": They really are just processed. Let's get back to just playing the drums.

RVH: As an Australian musician, how do you feel about the amount of top-quality music and headline artists that are coming out of Australia in every style—the "Aus-

tralian Invasion" of the '80s, as a lot of the music press has put it?

WD: I think that "Down Under" we just have some amazing talent, in all aspects of life, not just music. I think we proved that by taking the America's Cup from you in yachting, through sheer tenacity. That was a tremendous national pride thing. I think that the talent has always been there, and what is happening now is that our ad people and publicity people are finally getting off their backsides and pushing the Australian product. Look at our movies; our good ones are just superb, and have taken

continued on page 100



Will Dower on drums, with Mark Dower on percussion

Drummers And Put -Downs

The drummer, more than any other musician, is routinely subjected to dumb, uninformed put-downs. It seems to start very early in life. For example, very young drummers-to-be might hear their parents say, "Oh no, not the drums. They are so loud. Can't you play the piano or the flute instead?" My favorite comment from these early days was made by a "friend" who suggested to my mother, "Perhaps your son should learn to play a real musical instrument first!" Another one was, "Why do you have to take lessons just to pound on the drums?" I also liked, "It's easy to play the drums because you don't have to read the notes."

Occasionally, we still hear lines from other band members such as, "Don't play any fills; just keep the beat. We'll play the music." The most prevalent comment might be, "Can you play more like so-and-so?" I usually say in response, "Can you play the guitar like Joe Pass or Jeff Beck?" Usually the guitarist will just smile and say, "Are you kidding?" and proceed to ignore my comment. Another common line is, "Why can't you play more like the last drummer we had?" I suppose the one that really hurts is when the band singer (who often cannot even spell the word rhythm) says, "You play well, but you don't have a big enough or flashy enough drumset. We've decided to hire someone else."

I feel that there are a number of reasons why this attitude seems to prevail in each generation. Parents who must listen to a young drummer practice will sometimes wonder if it is all worth it. Listening to someone practice can be much more trying than listening to a long concert. However, with reasonable practice hours, a practice pad, and some mutual consideration, a good understanding between parents and student can be worked out.

Another reason for taking drumming so lightly is that really good drummers make it look easy. After so many years of practicing and playing, drummers become so at home at the drumset that it appears that they may not be trying hard. Also, if the song is a simple pop tune with a fairly ordinary drum rhythm, it can seem to the uninitiated that there is not much to it. However, once they sit down at the drums and actually attempt four-way coordination, they change their minds quickly. The first

response is, "Wow! This is tougher than it looks. I had no idea."

In schools, the band director rushes in at 8:00 A.M. and shouts to a roomful of eager musicians (who are all warming up at once), "Quiet! We have to tune up the band. Drummers, be quiet." That may make you feel that you are not part of the band. The director doesn't intend a comment like that to be a put-down (usually). It's just that directors have many responsibilities and not too much time to satisfy them.

If you happen to be playing at a dance or party, there is often no stage or bandstand. The drums are set up on a rug on the floor. As the evening wears on (especially New Year's or other holidays involving drinking), some clown might dance by and strike one of your cymbals. I personally don't understand this type of behavior, but certain individuals seem to take great delight in it. When asked to stop this type of stupidity, the individual will usually say, "What's the difference? They're just drums!"

I guess that it is understandable that a nonmusician simply does not know enough about music to appreciate drums as true musical instruments—the first musical instruments, as irate drummers are fond of pointing out to others. First or not, drums have come a long way in the last 50 years or so.

Parents sometimes go into shock when they hear the price of a drumset or a 20" cymbal. Equipment is expensive, but so much goes into making a fine drum or cymbal that the average person cannot see or appreciate what is involved. This is one reason to study drumming and music, so that it is possible for you to make intelligent choices when purchasing and using equipment. The more you know about something, the less time and money you waste.

Another reason that other musicians are hard on drummers is that drummers are so important. Every beat we play (or don't play) has a profound effect on all of the other players. This is true of all instruments, but not to the degree that it is true for drummers. The drummer really establishes the "feel" in a band. Naturally, the rest of the rhythm section is vitally important, but when it comes to the groove and the tempo, everyone looks to the drum-

mer. This is the drummer's responsibility in a band, and it is a great one. The drummer, in a way, is like the quarterback on a football team. Everyone depends on this person.

Perhaps another reason that musicians give drummers a hard time is that it takes experience to become an accomplished drummer. You can't get it all out of books or in the practice room. Experience is gained by playing and more playing. With experience you learn not only what to play, but what to leave out. This is equally important and it takes some time to gain this perspective. If the drummer is young and in a band of older players, life can be difficult. If you are talented and sincerely try to learn and improve, the other musicians will become more helpful and supportive as you improve.

Being a good drummer is no easy task. It takes dedication to be the best you can be. You have to "pay your dues." You must go through many of the trials associated with being a drummer, including unkind comments by others. However, take heart! Things *are* getting better. Drumming is developing and expanding. (We even have our own magazine!)

If you hit one of the difficult situations I've described, I suggest that you quietly explain the following (or something like it) to the other person or persons: "The drums are true musical instruments. They are both difficult and expensive to make. They are both difficult and expensive to learn to play well. I respect music; therefore I respect your instrument and your job. I would appreciate the same kind of consideration and respect for my instrument and my job."



**REPRINTS of most
MD Feature Articles
and columns ARE
available! Call the
office for a
price quote**



JONATHAN MOFFETT

THE ONE-HANDED CYMBAL CATCH

Late one evening during a marathon practice session at his home in New Orleans, Jonathan Moffett came up with a special technique to do a cymbal crash within the rhythm pattern without affecting the overall flow or timing of the rhythm. By hitting and catching the cymbal with the same hand, he found that his other hand and feet could continue the rhythm beneath the cymbal catch.

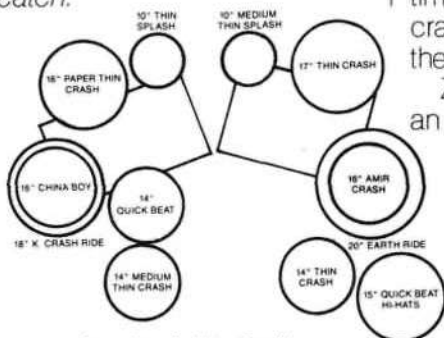

"You hit the side of the cymbal midway up the stick, slide it off the edge, then you catch the cymbal with the same hand for a controlled 'choke' effect. I can control the amount of cymbal decay after the first hit by timing the closing of my hand. This gives me anything from a knife-edge sound to a hi-hat effect. Doing the catch with both hands lets me double the effect.

"I've found this technique to be especially effective for soloing and easily applicable to odd time accent situations.

When you do it between alternating hands, it can be mixed into the rhythm for some very colorful drum/cymbal combinations.

"With the Jacksons, I'll use it to accent certain moments before the vocal chorus. Or when Michael makes a move and stops real quick, I'll accent that with a catch. You've got to do it fast and drop back into the rhythm without breaking time. My Thin and Paper Thin crashes work well here because they're easy to control."

Zildjian cymbals have played an important part in the ongoing development of Jonathan's exciting approach to the drum set.

"Zildjian helps me make those special statements in

my music — they're always exploring new sounds. From my early growing years 'til now, A. Zildjians have helped me find my sound. The A. Zildjian Brilliants are my personal favorites. They have a bright, sparkling sound that works great live or in the studio where your equipment is under the most intense scrutiny.

"When I hear a dark passage in the music, I call upon my K. Zildjians. My new Amirs give me that cutting edge when I need it. I incorporate a representative of each Zildjian cymbal into my various set-ups to give me that spectrum of colors in sound that I use to paint my pictures in music."

Avedis Zildjian Company,
Cymbal Makers Since 1623
Longwater Drive, Norwell,
Mass. 02061, USA

Jonathan Moffett is currently on tour with
Michael Jackson & The Jacksons

Zildjian®
The only serious choice.



LISTENER'S GUIDE

PETER ERSKINE

Q. For readers who'd like to listen to albums that most represent your drumming, which ones would you recommend?

Album	Artist	Label	Catalog #
Modern Times	Steps Ahead	Elektra/Musician	60351-E
Steps Ahead	Steps Ahead	Elektra/Musician	60168-1
Peter Erskine	Peter Erskine	Contemporary	14010
8:30	Weather Report	Columbia	PC2-3603C
Night Passage	Weather Report	Columbia	PC-36793
Weather Report	Weather Report	Columbia	FC-37616
Mr. Gone	Weather Report	Columbia	PC-35358
Word Of Mouth	Jaco Pastorius	Warner Bros.	BSK 3535
Invitation	Jaco Pastorius	Warner Bros.	1-23876
Foxie	Bob James	Columbia	FC 38801
Swinggrass '83	Swinggrass	Antilles	AN 1014
Bop City	Ben Sidran	Antilles	AN 1012

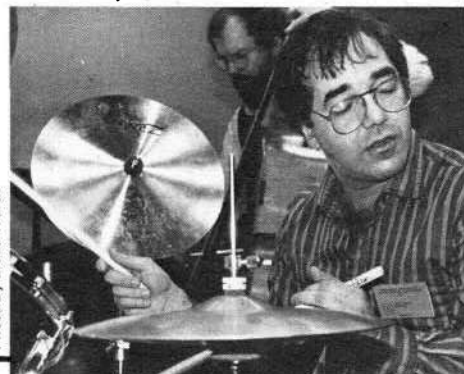

Q. Which records do you listen to most for inspiration?

Album	Artist	Drummer	Label	Catalog #
Mysterious Traveller	Weather Report	Ishmael Wilburn	Columbia	PC32494
Heavy Weather	Weather Report	Alex Acuna	Columbia	PC 34418
A Love Supreme	John Coltrane	Elvin Jones	Impulse (MCA)	29017
Four And More	Miles Davis	Tony Williams	Columbia	PC9253
Believe It	Tony Williams Lifetime	Tony Williams	Columbia	PC 33836
Cannonball Adderley Sextet in New York	Cannonball Adderley	Louis Hayes	Riverside	Out of print

Any recordings with Philly Joe Jones, Jack DeJohnette, Roy Haynes or Art Blakey. I also like to listen to Stewart Copeland, Jeff Porcaro, Steve Gadd, Steve Jordan, Shelly Manne, Mel Lewis, Bob Moses, and the stuff coming out of New York now with Jerry Gonzalez, Ignacio Berroa, Steve Berrios, et al., on it. I always enjoy listening to Vic Firth on timpani and Buster Bailey on snare drum. Omar Hakim sounds real good on the new Weather Report album too.

DENNY CARMASSI

Q. For readers who'd like to listen to albums that most represent your drumming, which ones would you recommend?

Album	Artist	Label	Catalog #
Montrose	Montrose	Warner Bros.	BS 2740
Paper Money	Montrose	Warner Bros.	BS 2823
Passionworks	Heart	Epic	QE 38800
Gamma 3	Gamma	Elektra	60034
Cafe Racers	Kim Carnes	EMI America	SO-17106
The Key Of Kool	Mitchell Froom	Slash	25064-1



Q. Which records do you listen to most for inspiration?

Album	Artist	Drummer	Label	Catalog #
Believe It	Tony Williams Lifetime	Tony Williams	Columbia	PC 33836
Million Dollar Legs	Tony Williams Lifetime	Tony Williams	Columbia	PC 34263
Ajoo	King Sunny Ade'	Various	Makossa	M2401
Synchro System	King Sunny Ade'	Various	Island	MLPS9737
Juju Music	King Sunny Ade'	Various	Island	MLPS9712
Velvet Darkness	Allan Holdsworth	Narada Michael Walden	CTI	CTI 6068
Espresso	Gong	Pierre Moerlen	Virgin	PZ 34428
Group 87	Group 87	Terry Bozzio	Columbia	NJC 36338
Exposure	Robert Fripp	Narada Michael Walden & Phil Collins	Polydor	PD 1 6201
Security	Peter Gabriel	Jerry Marotta	Geffen	GHS2011
Plays Live	Peter Gabriel	Jerry Marotta	Geffen	2GHS4012F
Music For Piano And Drums	Moraz-Bruford	Bill Bruford	EG	EGED 33



Peter Erskine



Harvey Mason



Steve Smith



Vinnie Colaiuta



Denny Carmassi

“What do these great artists have in common?”



Akira Tama



Omar Hakim



Rod Morgenstein



Danny Gottlieb



Gregg Bissonette

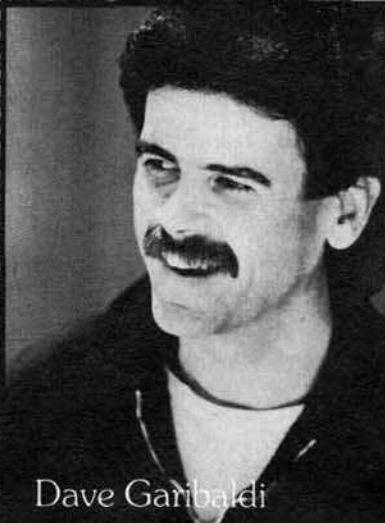

Dave Garibaldi



Keith Copeland



Paul Riddle



Ed Soph

They all make time with my sticks?
For free brochure
Vic Firth Inc.
Box 10 Dover, Ma.
02030 USA





Photo by Anastasia Furtace/Kaleidoscope

You'd never guess that Tom Ardolino is a drummer just by looking at him. He's neither lean and sinewy like Ginger Baker, nor is he the smooth, cool Kenney Jones or Charlie Watts type. He doesn't have that tense, ready-to-spring look that so many drummers wear constantly. No, Ardolino looks like a carefree young boy with bouncy black banana curls and a shy, tentative smile. He's even a little chubby, with a bounce in his step.

However, for anyone who has ever seen him work, it's hard to reconcile this perky, impish youthfulness with the demon he becomes behind his drums. He is the fuel used by NRBQ, the New Rhythm and Blues Quartet, a band that has been around for more than a decade playing Eastern colleges, inner-city clubs and cow towns with equal relish. Finally, NRBQ is getting some attention, largely due to its 1983 album, *Grooves In Orbit*, which is the best and most fun piece of business the NRBQ guys have ever etched into vinyl. The album got people all over the country out to see this group, but it doesn't explain half of what NRBQ is really about.

The phrase that came to me one night, while watching the band play its annual hometown show in Louisville, Kentucky, is "anarchy made fun." I think that phrase describes more about NRBQ than anything on the group's albums—originally recorded on the Red Rooster label, but now available on Bearsville. What you get at an NRBQ show is an evening of surprises, regardless of whether you are a new fan or an old one. First, they'll tear into a pop standard like "This Old House," tak-

ing it entirely seriously and making it more joyous than it has ever been before. Next, they might decide to dismantle entirely something they don't think too highly of, such as Gordon Lightfoot's "The Wreck Of The Edmund Fitzgerald," under the pretense of playing the crowd's favorites. They might bring on Skeeter Davis, one of the group's favorite artists, or they might pull out "The Box," into which fans can place requests that the band actually plays and seems to enjoy. They promise that no song will stump them.

This is not to say that NRBQ is a cover band. Their own tunes, such as pop ditties like "When Things Was Cheap" or raunched up rock like "Me And The Boys," are the best songs they do. These various styles are held together by the enthusiasm and attitude of the performers. The band is comprised of Terry Adams, primary composer and keyboardist, Al Anderson, guitarist, Joey Spampinalo, bassist, and Tom Ardolino, drummer. At present, NRBQ also includes *The Whole Wheat Horns*: Adams' brother Donn on trombone and Keith Spring on sax.

Ardolino is actually the newest member of the band, with ten years in the saddle. NRBQ is his first and only band; he stated that he can't imagine playing with anyone else. Some of what Ardolino says tends to sound ingenuous, but that's not what he's about. Instead, he comes across like the world's last great innocent, and he comes across that way every time you talk to him. When I caught up with him just after a gig, he was thrilled to be interviewed, but surprised that such a script and technical

Tom

publication as Modern Drummer wanted a story about him. "I really don't know much about drums," he said, but we persevered.

LN: When did you become interested in music?

TA: I remember records all the way back to age two, but the first one that really got to me was the Hollywood Flames' "Buzz, Buzz, Buzz." And I was stuck from that point on. I've always been around records since then. I had two brothers who were both in their teens when I was a toddler, so there was music around the house for as long as I can remember.

LN: What inspired you to become a musician?

TA: The Beatles had a big effect on me. For my ninth birthday, I picked out *Meet The Beatles*. I already had records, of course. I had the Chipmunks first album, and I always liked the Coasters and the Monkees. I was still young enough for that stuff. I knew, even then, that they weren't the Beatles, but they were fun.

I'd started drumming on pots and pans. I'd go out to the kitchen, and take out all my mom's pots and the lids. Then I'd just play around. I guess I just liked the sounds, but then somebody gave me a set of brushes and that kept me going. There was this kid down the street who had a set of drums. He wanted to borrow some of my albums, and I made a deal with him. He could borrow my albums if I could play for an hour on his drums. I just went at it and had fun. I played with the records I liked, but I didn't really think about it. I just really liked doing it. I didn't think I'd be doing this forever. For a while, I wanted to be a DJ—when I was about eight or nine—but I knew I wanted to be connected with music.

LN: What about your education? Did you ever study drums or play in the high school bands?

TA: I guess I was a good student. In high school, I was in the honor society because it got me out of class. Getting good grades was easy. Music also got you out of class, so I played the piano. But the principal didn't like it because I'd play Cecil Taylor-type music. By the time I got to high school, I was already that way, but I never was in a band or music classes. Marching band was just not for me. I had a friend at a different school who would always want to play stuff like "Up, Up And Away" with the stage band, but I always just

Ardolino

wanted to play the stuff I liked.

LN: You said that you never studied music, but you played Cecil Taylor. How did that happen? Could you read music?

TA: Well, I had an old clavinet at home, and I'd just play by ear. But with Cecil Taylor, what I meant was, I like the way he gets wild. I didn't know what I was doing; he does. But I was letting it all out—what I had heard in his playing—sort of relating to his ideas. But, no, I can't *really* play Cecil Taylor.

LN: What about other bands before NRBQ? When were you first in a band?

TA: NRBQ is my first band. I always just played by myself down in the basement, to my records. One Christmas, I got one drum and a cymbal. The next Christmas I got a really cheap set. After that, I was always in the basement. Friends would come over and play my clavinet. One guy had a bass; it was wild to play with a bass player.

LN: Did you say that NRBQ is *your first* band? How did you get into such an accomplished group if you'd never played before?

TA: Well, it's a crazy story. In 1970, when I was old enough to see bands playing live, I went to downtown Springfield, Massachusetts, to a movie theater where bands would play. That's where I first heard NRBQ, and something just came over me, like a smell in the room or something. So I wrote a letter to Terry and he answered me. We started trading tapes. I finally met them, introduced myself, and Terry invited me to visit. By this time, I knew all of their music, and they were my favorite band.

I visited Terry, and one day when they played a club, they got an encore. Well, the drummer had gone off stage and just never came back. So Joey said, "Get on the drums!" I was so afraid, but Joey said, "Do it!" Terry had seen that we thought the same through our letters. Even now, a lot of times, we think the same thing. Everyone's like that in the band; we're all good friends. Anyway, we played the encore song—"Do You Feel It"—and Al couldn't believe it wasn't the regular drummer. He was really surprised! We got a big laugh out of that, because he's usually laid back and low-key, but he was really shocked.

LN: So they just asked you to join, right then and there?

TA: Well, no. It was a few years later, when I was about 19. Their drummer was

leaving because the band was moving to Florida. Terry found me at my job at K-Mart—the only other job I've ever had—and asked if I wanted to join. I said sure. It just about knocked me over, but I knew all the songs. I had known them for years by then and I knew how all of them ended. Once we started rehearsing, it was easy. My biggest problem was playing too soft, and Terry would keep saying, "Play louder!" We'd do full-hour rehearsals at which I would play as loud as I could to get in practice. For the first couple of months, I had six fingers that would bleed every night. Not any more though—I have real big callouses now. No Ivory Soap ads for me.

LN: What is it like to work with guys like Terry and Donn?

TA: You never know what's going to happen next, and that's what keeps it interesting. Our sets are never the same. Terry calls them, and sometimes there will be something we never played before. All of a sudden, we might do a Tom Jones medley—"It's Not Unusual" and "What's New Pussycat"—because we listen to all kinds of stuff all the time. A lot of times with a new song, we just do it on stage. Sometimes, the first time is the best.

We did an album with Skeeter Davis called *End Of The World*, which is coming out in England. Everyone in the band likes her, and Red Rooster was going to put out an album on the Davis Sisters 45s. But we're open to all kinds of influences. I like a lot of people—Jonathan Richman, the Japanese, the Incredible Casuals, who have a 45 on Red Rooster. That band has a drummer who was a friend of mine in Springfield—the guy in the stage band in high school. I also like Akiko Yano, Sun Ra—well, everyone's crazy over Sun Ra. The Shaggs are our favorite! And Burt Bacharach. We're just trying to make the best music we can.

LN: Are you putting me on? That's a pretty diverse list of influences, and I doubt that anyone would ever think of Sun Ra as one of NRBQ's influences.

TA: No, it's no put on, really. Sun Ra just plays anything. There are no rules but it makes sense, and yet it's always surprising. I believe he could do anything and make it understandable. Burt Bacharach, on the other hand, writes great songs—real songs. Lately, so much of the stuff I've heard has no real melody, and his melodies are great. Of course, the Beach Boys'

Brian Wilson's melodies are the best; they give me goose bumps and I like that. The Shaggs are just unique and unaffected. They have no outside influences; they just go at it, and I think that's what all of us like about them.

LN: Do you rehearse a lot when you're not on the road?

TA: No, not really. Sometimes one of the guys will arrange something, and we'll all try it out. The real basic stuff about reading or arranging I can understand, depending on how it's put to me. But usually, I just go for it, and we work things out when we're all together. We'll start playing, and if it isn't right, we hear it right away. That comes from everyone liking the same stuff. We're always trying to find something new to play.

LN: Do you have any off time on the road? What's that life like?

TA: We do a lot of riding and a lot of listening to tapes on the bus. And we eat a lot of grilled cheese sandwiches; Al's the only one who eats meat, so usually we end up at HoJo's. I'm always trying to find a record store in every town we play. I like used record stores, and I just like to rummage. Sometimes I'll go to "collectors' " stores, but they charge you a lot more. Basically, we go to eat, get ready to play, play, watch TV, sleep, and then do it all over again.

LN: But that can't keep the band going. That sounds awful, in fact. What does keep the band going, especially in light of the need to succeed or be out of a label?

TA: It's just the love of playing music and doing it our way. People are always trying to tell us not to go in too many directions, to concentrate on one thing, and then we'll be a hit. But that would be useless. We have to like what we're doing first. We hope the people will like it too, but first we have to like it.

LN: Do you all have families? Do they ever travel with you?

TA: Well, not families. I don't plan to have any kids. But everyone in the band has a girlfriend. They don't travel with us, because it would be confusing. When we're playing, it's just the band and there's nothing for them to do.

LN: Which drummer influenced your sound most? Who do you continue to listen to and like?

TA: I thought Frankie Dunlop, who was with Thelonious Monk in the '60s, was really great. And I liked Ringo, of course, and Charlie Watts. I really like what Watts

Maxwin[®] by PEARL



GET THE PEARL FEEL FOR UNDER \$800

CST905 - 5 piece set

THE PRO-DRUMMER CHOICE — True Pearl name holds value

- Pearl double braced heavy duty hardware with stop lock memory for easy set up
- Super Strong 9 ply mahogany shell
- Remo® heads — All metal parts precision hand fitted to eliminate vibration

7 piece set as shown with W06 and W10 concert toms and stand \$930

Available in 13 colors Cymbals not included

Maxwin® By Pearl 3 drum starter sets from \$350



3451 W. Commercial Ave. Northbrook, IL 60062

plays. He plays the beat really well, and he's just right there without ever butting in. There aren't many soloists I can listen to, but I love Art Blakey and Earl Palmer. I have a lot of old records they played on. I also like the Meters and the Neville Brothers; it's as much fun to play second line as it is to listen to.

LN: What is it you like about Palmer and Blakey?

TA: Both of them just play great on any record they're on. It's everything—the beat, the dynamics. Sometimes it's what they *don't* play rather than how many beats they can fit.

LN: Do you do exercises or anything to keep your technique together?

TA: Well, I'd always like to do more, but we've been happy the way we are. It seems like hardly anyone really swings anymore, and I like my playing to be more feeling than technical.

LN: Have you ever worked with a metronome or a click track?

TA: No. A metronome seems like it would be really wrong. Why would anyone do that? It doesn't seem like a good idea to me, because it would get too mechanical. No, that seems really wrong to me.

LN: Do you have a "philosophy" of the drums or a strict idea about how you want to play?

TA: I just want to back everyone up well. I don't have any real technical knowledge, so it's basically modifying my playing to

whatever's happening, which changes every night. Every single night it comes out differently. I don't like complexity for the sake of complexity. And I'm a loose player; not tight. I like to fit with everything else going on. Once in a while, I'll flip out and play something funny—not to show off, but just for fun. Mainly, I don't want to be bored, so I like the idea of no rules. There's also no group discussion. I just wish everyone would play softer so I wouldn't have to beat so hard all the time.

LN: What equipment do you use?

TA: Just regular drums—one tom and one floor tom. I don't have a thousand drums around me, just a regular old kit. A lot of times, I won't even see my drums until we go on stage. And I don't tune anything. I just try to keep the sound I like.

LN: Have you tried any of the new electronic drums?

TA: No, not yet, but it seems like it might be fun. There must be some good way to use them, but maybe I just don't like them.

It just seems like people are using them instead of good drummers, and they have a machine-like sound I don't like. Or at least, I haven't heard anything I like so far.

LN: Do you still play in your basement?

TA: No, I don't play by myself anymore at all. I don't even have a drumset at my house or a practice pad. I've never had one.

LN: So where are you now? Are there worlds yet to conquer or goals you've yet to reach?

TA: Well, no one's going to tell me what to play or how to play—especially not in this band. I get a little input from my girlfriend or other friends, but life really revolves around the band. There's really nothing else but the band. Really, there's no thinking about the future, even though we know things will change. There's always change, but we just go from day to day. But I don't think we're missing anything. In fact, I don't think we could do anything else. And I know there's no one else I'd like to play with. This is the life right now.



Here is what a few master-drummer-percussionists have to say about «The Sound of Brushes».

After knowing Ed for 10, these many years, I can say with his experience, this book on The Sound of Brushes, I recommend. **«Papa» Jo Jones**

Ed Thigpen is the greatest, and «The Sound of Brushes» proves it! **Tony Williams**

Truly a good book from one of the masters of the drums. I recommend this book of a lost art that is very important. **Billy Higgins**

This is the most complete brush book written. **Jeff Hamilton**

An articulate, progressive, well organized approach to brush playing. An absolute must for any serious drummer. Great Success! **Vic Firth**

Send M.O. or Check in U.S. \$ 12,95 + 2,00 postage for The Sound of Brushes and \$ 4,95 + 1,00 postage for Rhythm Analysis and Basic Co-ordination to Donald Meade/Action-Reaction U.S.A. 617 East 83rd St., Chicago, ILL. 60619.

Too often, brushwork has been ignored as much as possible by students and teachers alike. Naturally, this has resulted in some pretty bad brushwork in this day and age. Ed Thigpen has called upon his vast knowledge and written a book that should be included in every drummer's library, be he student or teacher, novice or professional. It's time someone wrote a definitive book on brushes and I believe that Ed Thigpen has done just that! Thank you, Ed!

Butch Miles

After speaking to Ed Thigpen and listening to the accompanying cassette tape, I've come to the conclusion that this book, «The Sound of Brushes», is an essential element in everyone's educational library. Put it in the section marked «Percussion, Traps, Contemporary». Try it! You'll like it!

Billy Cobham

I would like to endorse your book and feel that it is a great teaching aid I would use for students. Brushes are totally ignored by so many young drummers today that I feel your book is even more valuable and should be exposed. Good luck with it and I hope it's a «hit»!

Harvey Mason

Ed Thigpen's «Sound of Brushes» book is a must for every serious drummer who wants to become a well rounded musician in the music business.

Jack De Johnette

Concerning «Rhythm Analysis and Basic Co-ordination»: Thanks to Ed Thigpen for giving us a book with a definite approach towards developing the creative aspect of modern drumming.

Max Roach

ORIGINAL DRUM STICK KEY RING



Send check or money order for \$3.50
Postage and Handling included.

VATER'S PERCUSSION INC.

28 Burnley Road
Norwood, Mass. 02062
Mfg. of private label drum sticks

NAME _____
ADDRESS _____
CITY _____
STATE _____ ZIP _____
Offer good Continental U.S. only

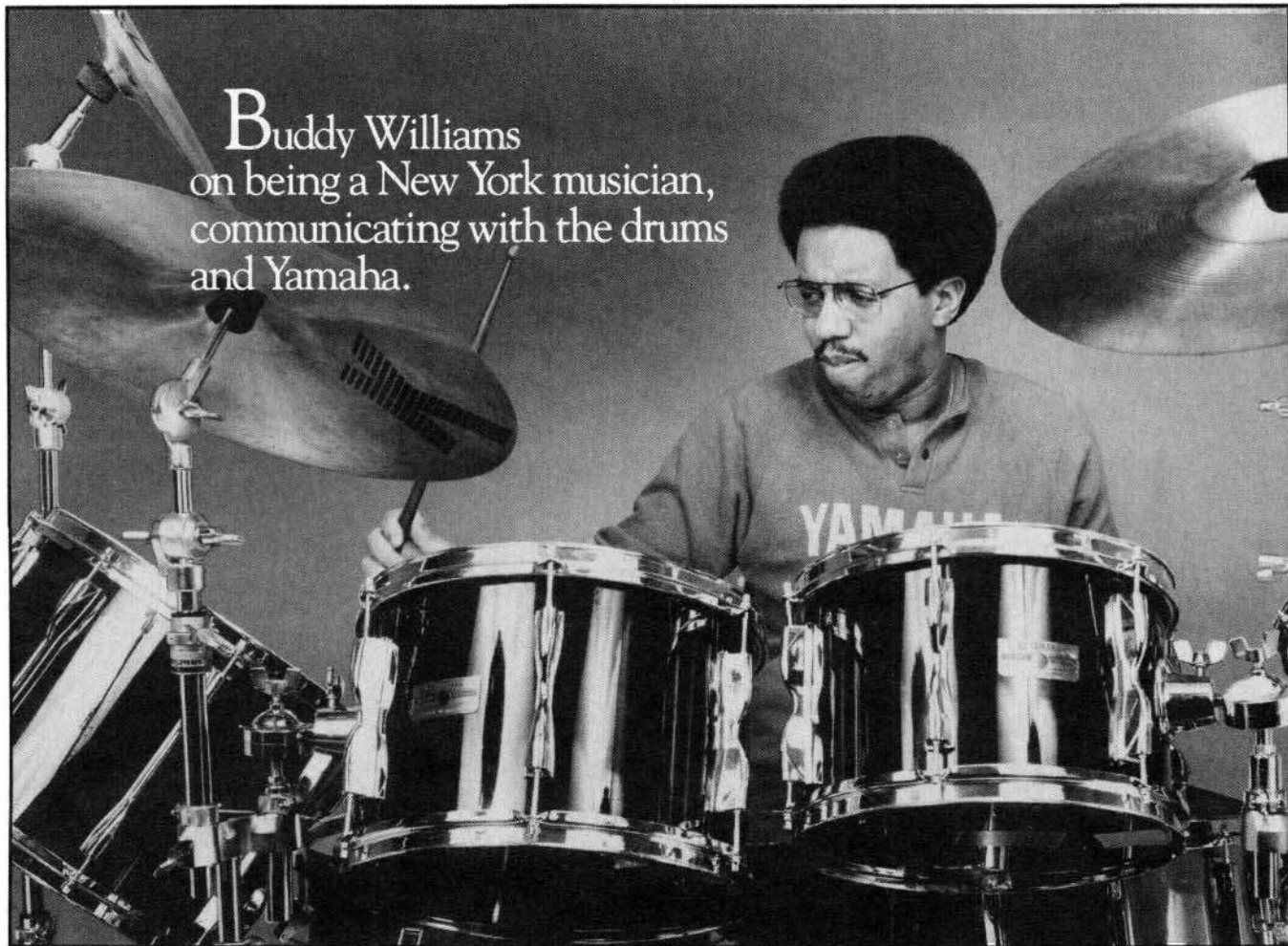

Buddy Williams
on being a New York musician,
communicating with the drums
and Yamaha.

"I'm proud to say that I'm a New York musician. My day will consist of a 10, 11 or one o'clock jingle, an afternoon rehearsal for somebody's concert and then I'll either play a club that night or 'Saturday Night Live.' That's four different styles in four different worlds."

"I'm a team person when I play. I don't feel that the band revolves around *me*. If my part doesn't fit in with the rest of the rhythm section, then I'm not making it. I'm not happy.

"I hear these sounds in my head that should go inside the music, the overall sound that we're trying to get across. As musicians, we're trying to *communicate*. If I'm not communicating with the other guys or I'm not feeling right within the music, then we're not getting it over."

"The sound of Yamaha drums are the closest to the sounds I hear inside my head. They let me get across what I hear and what I feel needs to be inside the music. Sometimes I have to hit 'em hard for loud situations and I know they'll be there. They're dependable. When I played with Roberta Flack, I had to be sensitive enough to do "The First Time Ever I Saw Your Face" and still get the part across. These Yamahas let me do that.

"Yamaha drums are very personal to me.

I've always felt they were the last of the hand made drums. I went to Japan and visited their factory and they wanted to hear my ideas because I was a drummer who played their instrument.

"I don't know what Yamaha's formula is and I don't want to know. I just play 'em, I'm not in the business of making them. I just know they're more *applicable* for what I do than anything else on the market, and I get to play a lot of different drums.

"Sometimes I'll walk into a studio and have to play other drums, but I'll always ask for Yamaha. I was on the road with Dave Sanborn last year and I had to use a straight-out-of-the-box Tour Series set in an emergency and it worked out fine."

"I think of my drums as my 'kids.' Very rarely do I let other people play them unless it's unavoidable, a bottom line situation. Me and my kids have to lock up and have an understanding. It's a *feel*."

The reason why Yamaha System Drums meet the demands of many of today's top drummers is because they're "Drummer Designed." For more information and to receive Yamaha's *Drum Lines* newspaper, write to Yamaha Musical Products, Division of Yamaha International Corporation, 3050 Breton Rd. S.E., P.O. Box 7271, Grand Rapids, MI 49510.

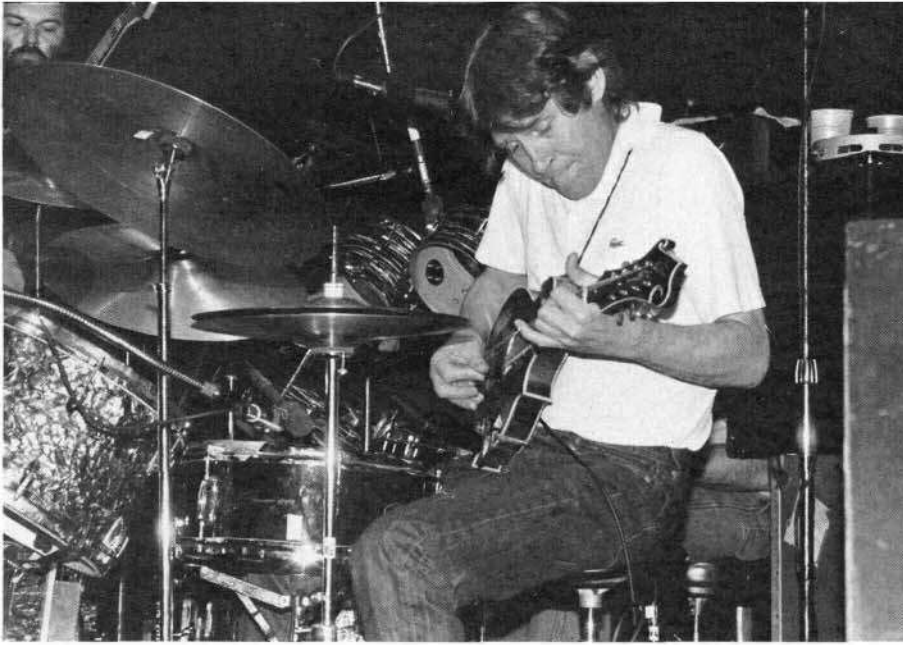

Helm continued from page 13

one of those musicians who can do that stuff in a real way, from woodwinds to brass to keyboards and so on. But it is fun to go over and play mandolin on a song and be a part of the rhythm section from that formation. Then I can go back into the single lane. It's fun for the music, and the different textures make for different rhythm sections.

RF: You mentioned that working with Dy-

lan helped the members of The Band with their writing.

LH: It sure did. We learned a whole lot from him. We had never done a lot of recording, songwriting, playing shows or anything before we worked with him. All we had really done was try to practice our craft by playing honky-tonks and dance halls.

RF: Did the writing actually start during

the time with Dylan?

LH: That's when it started coming together. That's when Richard and Robbie, and even the rest of us, got the opportunity to see it that way. All of a sudden it was a new game, so I'm sure that we profited more than Bob. But I know that we had a good time, and I would like to think that we rubbed off a few good things onto him.

RF: Do you feel that you had to change your style when you played with Dylan?

LH: Yeah. I think that we started playing more of ourselves, instead of copying something that we liked and respected or something we knew the crowd wanted to hear. By then we were getting to the age where we would have a little more personal input. So I think that the time and Bob's influence certainly helped us and encouraged us to play with a more personal style, and to play as well as we could. We learned a lot through that period. Having the opportunity to work with somebody who knows as much as Bob knows about music sure didn't hurt us a bit.

RF: Then when you began to work exclusively in The Band context, did you find that you were even freer to give your input?

LH: Playing with Bob encouraged that kind of growth because there were no rules, other than that the song should sound good and be fun to play.

RF: He never really suggested how he wanted a song to be played?

ONLY PRO



LH: Not really. He liked to throw the game plan away and just play. It was different every night, and as long as there was a key established that we were going to play in, the tempo and melody could change according to the mood. If it was later in the show we might have backed the tempo down a little bit or whatever.

RF: Being the drummer, you probably established the tempo.

LH: Once we got started, I took it wherever I wanted to go. I wish I could play like I've heard some of the great studio musicians play over the years, but I just get so excited and carried away with it at times that I can feel my tempo rising. Sometimes I can hear myself laying back too much, but back when we played with Bob, a lot of tunes had really not been played yet, so there were no established arrangements for some of the stuff.

RF: Take me to a Dylan recording session. How did you guys work? Was there much overdubbing?

LH: I've never recorded a whole lot with Bob. I've had the pleasure a few times, and it was always pretty much the same as the way we played a show. We'd go over the tune, and without beating it to death, try to do it as well as we could. We'd do it once or twice, and then go on to the next one. I've never been involved in any overdubs and all that. I don't think he enjoys that. I'm not real fond of it myself. I have to do it because I can rarely get it right all the time,

all the way. Usually I'll have a brief little stumbling spot in there. I'll swear to myself that I didn't lose concentration, but something will just kind of waver there just for a brief instant. When it does, it's kind of like somebody's fingernails on a blackboard—*my* nails and *my* board.

RF: So you go back and fix it.

LH: Yeah, I have to admit it when the engineer and other musicians look at me. I know they're right. I hear it too. So I stumble back in there and re-sing it sometimes. But I don't like to, and I told some other people that from here on out in my life I'm not going to do a damn thing that I don't want to do, unless I just have to.

RF: Do you prefer live performing to recording?

LH: Yes I do. Playing live is more fun.

RF: Any particular reason?

LH: People.

RF: Instant feedback?

LH: Yeah. Instant electricity. The crowd is just as important as the group. It takes everything to make it work.

RF: Who was the first person you recorded with?

LH: I guess Ronnie Hawkins. I've never been what you would call "in demand" for sessions. I've played a few sessions with some friends and I like to do it. I'm one of those slow learners. I have to do it a few times usually to get it right, so I work on those "special" projects.

RF: A studio is a whole different thing.

Even the way you have to hit the drum is different. It's not quite as spontaneous.

LH: You take a guy like Roger Hawkins, from Muscle Shoals, and he could write a book just on the different ways that you can hit a drum, the ways to tune that same drum, the different frequencies, responses and attacks that you can get from it, the difference in the way you hold your stick, the grip that you use, and the size of stick. He's one of those people, like Keltner, who can walk into a room, look at the room and know which cymbals are going to sound the best for that microphone. They have developed their ears to such a fine degree of hearing that it's amazing. It's a wonderful lesson in concentration.

RF: Certainly you're aware of the elements you were suggesting Roger could write a book about.

LH: Sure. I care and I really appreciate those who can do it. I enjoy, as much as anybody—except maybe them—the fact that they can do it.

RF: But Levon, you've been tuning drums for how long now?

LH: Well, I've tuned mine for a while.

RF: Then you must have a method that you use.

LH: I have my own method, but I take a lot of ideas from others. I listen, and that is where I learn how to clean up my sound, how to get my records to sound clean and how to approach it. On the *Big Pink* album, those tom-tom sounds are tuned a

D•MARK!



Only Pro-Mark offers you such a great variety of drumsticks – more than 80 models in Japanese White Oak, Golden Oak™ and American Hickory to give you the size, weight and feel that's just right for you. We help you sound your best.

Only Pro-Mark!

pro-mark

10706 Craighead Dr. Houston, TX 77025
(713) 666-2525

Our new catalogue is free. Write for yours today.

CAMBER III®

ACTION!

CAMBER III®

CAMBER III® continues its remarkable advancement. Now there are over forty sound colorations to choose from in a variety of alloys, from splash through crash including hi-hats and rides.

CAMBER III®

101 HORTON AVE., P.O. BOX 807, LYNBROOK, NY 11536

Please send me your free "Choosing a Cymbal" booklet.

MD-8-84

Name _____

Address _____

City _____

State _____ Zip _____

My favorite music store is _____

I currently own _____ drums (brand) and _____ cymbals (brand).

then back off. Then you save it up, too. Sometimes you need to have that consistent pattern to lay the pulse in. Sometimes the pulse doesn't want to be shown like that.

RF: Have you used any effects on the drums at all?

LH: No, nothing other than different echoes and things like that—chamber or the board echoes. We did a little trick once, singing through a hose. That's kind of interesting.

RF: A voice box?

LH: Yeah, you run it through an instrument. Then you run the hose into your mouth, sing, and play whatever notes correspond. They'll come through that hose while you hold it in the corner of your mouth. It's like your voice coming out plus an instrument coming through there.

RF: Did you do that on record?

LH: Yeah, we did. It's on a tune by Frogman Henry called "Ain't Got No Home."

RF: How important is the bass player-drummer relationship?

LH: It's very important. Those two can make it a whole lot easier on the guitar player and the piano player by tightening it right up. When you can work with someone the way Phil Upchurch and Al Duncan worked together, and when you can record and have that opportunity to listen to yourselves and be able to critique each other, that's when those combinations have a chance to start really working well.

Any combination of musicians you can think of who play consistently together, have some good things going about their approach to a song. That song "King Harvest" has one of those bass drum kind of pulse things. The bass goes with it in that regard. It sets up the backbeat. It kind of leaves that gap and that over-the-edge kind of effect to it. When it gets down to the chorus, it kind of rears back and starts swinging through the chorus. Then the bass starts more of a walking-type pattern—more of a traditional and more melodic bass line. Then the bass drum starts to support the landing zones as you circle through the chord progression there.

RF: Would you say that there is an approach of, say, playing behind the beat?

LH: That's the way it kind of sounds. That's the way I've heard that explained by people who can hear it right off the bat. They can hear certain players and know where they are from by the way they play. For me, that late, leave-a-pocket-for-the-backbeat style is the Memphis way of playing, like they do in Muscle Shoals. It's a country, R&B kind of feel. I don't know, maybe it's the old echo that was on the Sun Records or something—that old doghouse bass fiddle before a snare drum, when it would slap on those records. But it does sound most comfortable and it feels the best to me when I can get it right in there just when it hits in that real soft spot. There's a real soft spot right in there.

When I can lay it in that place I like it the best. To me, it gives the song breathing room and it keeps the dynamics of the song in proportion. I wish I could do it any way I wanted to, but it just doesn't sound right to me any other way. I feel like I'm incorrect at times, too, mainly when I pick it up just a little bit or lag it back a little. You've got to keep that sort of thing together. Lord, it's worse than a fine-tooth comb. When the song wants to pick up and go a little faster towards the end, it's hard for me to resist.

RF: Can you think of certain favorite or fun Dylan and/or The Band tracks that you've done and how they came together?

LH: I could tell you which songs I like. "Forever Young" by Dylan is one of my favorite songs. It's a great song. But I don't know, I just enjoy them.

RF: What about favorite Band projects?

LH: I remember our *Rock Of Ages* album. That was a good night. The album was live and I'm glad now that we recorded it. I was having so much fun at the time, though, that I wouldn't have cared either way. Everything just seemed logo right. Nobody's concentration was affected by anything. If you pour some music on whatever's wrong, it'll sure help out. My favorite albums that we did were the ones where we worked with Alan Toussaint, who is one of the great musical minds of our time. That was a lot of fun. I love horns, and the bigger the band, the better it sounds to my ear. It was great hearing Snookie Young over there hitting that top trumpet note. That's first class.

RF: Can you think of particular Band tunes you like?

LH: "King Harvest" is one. I really like the bass drum pattern and then we left a corresponding hole for the backbeat. That was one track where I got my drums sounding the way I wanted them to. There's enough wood in the sound. You could hear the stick, the bell of the cymbal and so on. You have to realize it's been a while since I've done some of this stuff, and honest to God, I don't listen to it. I enjoyed everything we did. I had a good time with it. Sometimes we would have to record a song for a while, until the song would come on and we could cultivate it voice-wise, arrangement-wise, and get all the choruses straight. So I enjoyed them. I think all musicians want that advantage of being able to listen to themselves. That's when you have a chance to get a track that you like. You've got the chance to hear yourself. You can go back, take a little tape off the snare drum or fix things around to get your kit sounding right. Then you can really correct some of your mistakes and play those things that sound better.

The fun part of it, for me, was always to go in, record and get the songs right. If we couldn't get a song right, we'd just take the last cut we had of it, put it over to the side and go on to something else rather than get



Become a North star.



Stars aren't born overnight...and nobody knows that better than the working drummer. That's why more drummers on the long climb depend on North drum hardware for durability and value. North spotlights a full line of Standard and Deluxe stands, thrones and accessories...all built to withstand even the most aggressive styles of drumming. So, when you're looking for the best drum hardware value, go where the stars shine brightest... go North.

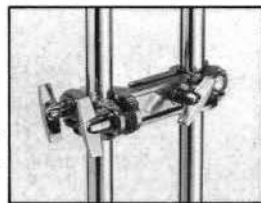
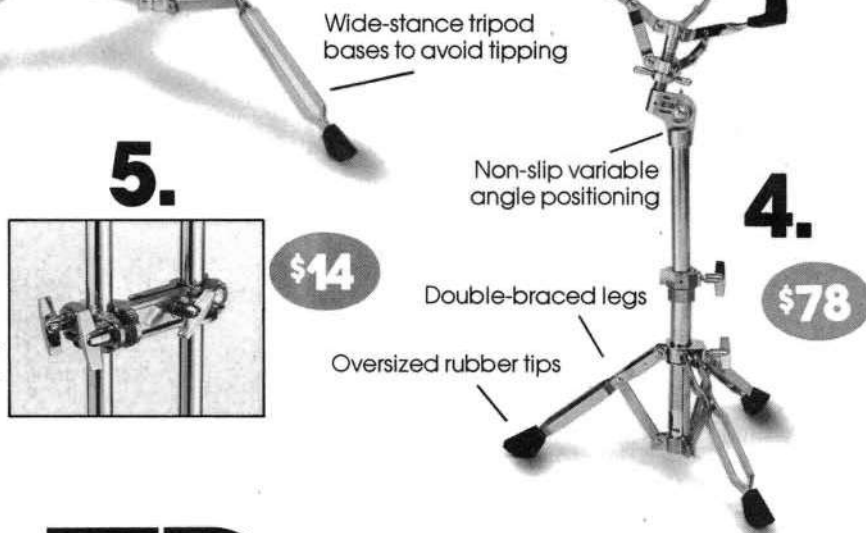

- 1 Model D-48 Combo Throne
- 2 Model C-22 Boom Cymbal Stand
- 3 Model H-32 Deluxe Hi Hat
- 4 Model S-15 Deluxe Snare Drum Stand
- 5 Model AT-800 Multi-clamp system



For further information and catalogs featuring the full line of North Percussion products, send \$1.00 for postage and handling to: North, 590-A Apollo Street, Brea, CA 92621

NORTH PERCUSSION

bogged down with the tune. Later on we'd double back. "Cripple Creek" was one of those songs. It took a long time for us to get that one in the right slot. I can't remember how it was when we first started, but it was a couple of basic ideas that Robbie had and that Richard had worked on a bit. Then we all started working on it and it just took time for the song to seep into us. It was like it just had to simmer with everybody, so everybody could find where the song really was.

RF: When I watched *The Last Waltz* again recently, I had this overwhelming feeling, particularly when you guys played the Neil Diamond and Neil Young tunes, that there was a real distinct style. Can you tell me what you feel the components of that sound are?

LH: Probably what Garth does to our rhythm section and just how he makes his sound. And everybody really enjoys playing, you know. It's an honest effort, though, to blend it in there just right and give them the best support they could ever want, hopefully.

RF: I think a lot of the music's feel comes from the drums.

LH: It's just that a lot of our songs are in that rhythm—sort of lean as opposed to more free flowing.

RF: A real pocket.

LH: It's not a hesitation, but it's just more rhythmic.

RF: Everyone describes The Band as kind

of loose.

LH: I don't blame them, [laughs] I would too. You can't fool them all the time.

RF: Obviously, as we sit here and laugh about it, it's not all that loose, because you made records and you played those records live.

LH: A few times.

RF: So there had to be some sort of a structure involved there.

LH: Oh yeah, sure. There are verses and choruses, kickoffs and endings. We all love musical architecture; there's no doubt about that.

RF: When recording with The Band, how much freedom did you have to create what you did?

LH: We've always had whatever we needed. There were never any rules. We didn't know any, so most of our stuff was trial and error. It wasn't like there was ever any lack of or too much freedom or responsibility. You live with a tape recorder, you turn it on, you play the song and you listen to it. You hear what you're doing and try to smooth it out, get it better and get your part correct.

RF: But whoever wrote the tune didn't come in and say, "Play such and such." You had the freedom to create your part.

LH: Well, if Robbie or Richard would come in with a piece of a song or an idea for a song and we would start working on it, after a while it would fit or it wouldn't fit. We'd have to work on it, more or less,

to find out certain things about it, like who should try to sing it.

RF: How are those decisions made?

LH: Just by playing the songs and experimenting with them. After trial and error, you can either make it come around or you can't. By the time we would be ready to record a song, we would usually have tried it different ways, and we would know for sure that it was the best way we could do it. We didn't care about who did the song, what instrument we played, or anything like that. When we changed it around, and Richard played drums, and I played mandolin, we were always looking to have some fun.

RF: The Band performed its last show on Thanksgiving 1976. Were you ready for it to end when it did?

LH: Well, yeah. I'm ready for whatever the day is, but it wasn't my idea. If I had to make that decision on my own, I don't know if I would have made it or not. But I was just as happy as anybody else to turn a new page and start out on some new projects. I never subscribe to the stay-at-home policy. I'm not sick of the road or sick of eating in good restaurants around the country. I like to travel and go to Japan, go to the sushi bars and sleep late every day.

I was just concerned with having a good time. I was thankful as hell that a few people took the time to listen to it. The longer it went, the more the new wore off. By the time The Band did *The Last Waltz*, the chemistry had changed, and it wasn't a big thrill anymore to live that studio kind of life. It was a whole lot of fun at first, but after a while it got to be enough. It used to take us a reasonable amount of time to get it to where we felt we could live with it. The chemistry has got to be right, and I think, as we got down towards the end of our contract with Capitol Records, it had grown from a privilege and pleasure into an obligation. I don't know how all that stuff happens, but you do need to keep a good perspective on it. Everybody had other ideas, other projects and different adventures they wanted to have, so *The Last Waltz* was a good idea at that time.

RF: You did some of your solo projects in Muscle Shoals.

LH: Right. I went down to Muscle Shoals and cut one, and then I went to Nashville and cut one. Then I went back down to Muscle Shoals and cut another with Jimmy Johnson and the boys.

RF: Was the recording experience different there?

LH: I think it's a more relaxed atmosphere. They've just got an easy way of going about it. Their musicians are excellent, as we all know, so it is a pleasure any time.

RF: You did a tour called the Muscle Shoals All-Stars with Russell Smith, formerly of the Amazing Rhythm Aces. How did that come about?

LH: Just another little project that kind of came through. It was just another oppor-

One Giant Step For Drummers

Corder Drum Co.
 MANUFACTURER OF QUALITY DRUMS
 2607 Triana Boulevard • Huntsville, AL 35805

WRITE FOR FREE CATALOG AND PRICE LIST

COURTESY OF THE ALABAMA SPACE AND ROCKET CENTER



**Suddenly,
All Other
Cymbals
Become
Obsolete.**

Jan Uvena JAN UVENA of ALCATRAZZ

"I've used them all and none compares to Avanti. Finally, Avanti gives me a personal sound all my own... alive, powerful with strong accents when I want it. I won't play any other."

THE MOST IMPORTANT PART OF THE AVANTI WARRANTY



If the sound of any Avanti cymbal does not please the user for any reason, we will replace it without charge anytime after 30 days and before 90 days from purchase date.

AvantiTM

101 HORTON AVENUE
P.O. BOX 807A
LYNBROOK, N.Y. 11563

- Please send the Avanti story, **FREE!**
 - Also send me your colorful 22" x 33" poster. I am enclosing \$2.
- Name _____
- Address _____
- City _____ State _____ Zip _____
- My favorite store is _____

THE MODERN DRUMMER LIBRARY

New From MD's Book Division . . .

Drum Wisdom by Bob Moses

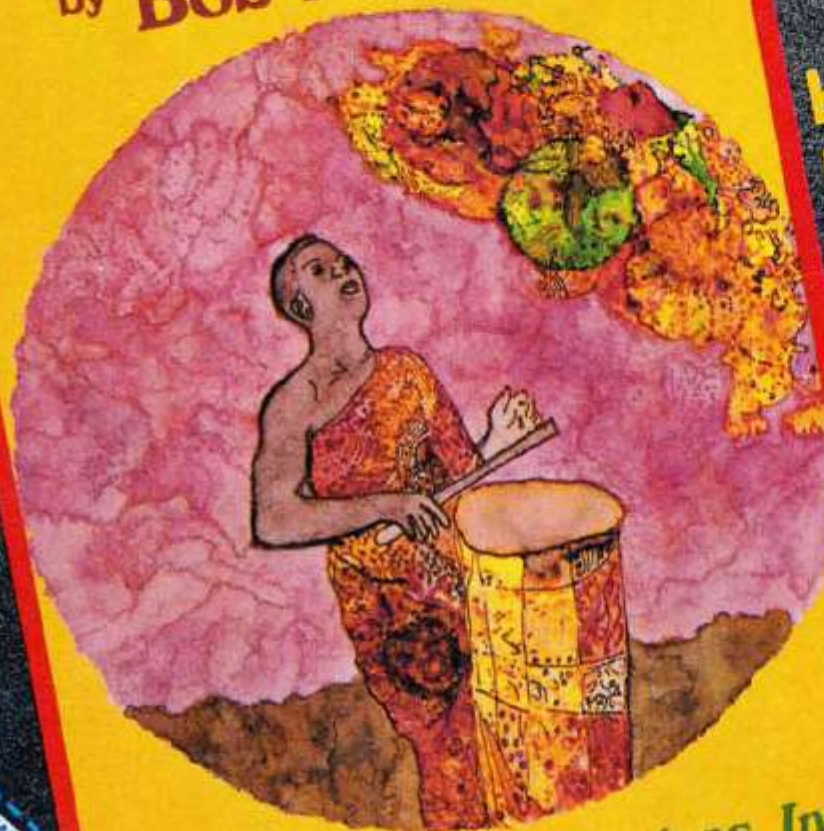

MODERN DRUMMER Publications, Inc.

Serious drumming students should take note. **DRUM WISDOM** is the one book you won't want to miss.

Drum Wisdom

by **Bob Moses**



Finally, a drum book that offers much more than page after page of dull exercises. **DRUM WISDOM** is a clear presentation of the unique and refreshing concepts developed by one of the most exceptional drummers of our time.

- Learn about Bob's ideas on . . .
- Thinking Musically
 - Internal Hearing
 - Playing Off Of Melodies And Vamps
 - The 8/8 Concept
 - Understanding Resolution Points
 - Drumming & Movement
 - The Non-Independent Style . . . and much more

Order your copy TODAY!!

QUANTITY	DESCRIPTION	COST
	DRUM WISDOM	\$6.50
	MASTER STUDIES	\$7.50
	THE BEST OF MD	\$9.95
	THE FIRST YEAR	\$7.50
	MODERN DRUMMER BOOK DIVISION	
	GRAND TOTAL	
	TOTAL	

MAIL TO: MODERN DRUMMER BOOK DIVISION
1000 Clifton Ave., Clifton, NJ 07015

NAME _____
ADDRESS _____
CITY _____
STATE _____
ZIP _____

Enclose check or money order (no cash) payable to:
MODERN DRUMMER BOOK DIVISION

Payable in U.S. Funds

Includes postage and handling

Please allow 6 to 8 weeks for delivery

Items may be shipped separately

Dealer inquiries welcome

tunity to have a good time, play some shows and cut some songs. Good times don't last long sometimes, but it was fun while it lasted.

RF: Why did you use double drummers for the Muscle Shoals All-Stars and the recent Band reunion concerts?

LH: It's fun when we both play together on a song and just kick the hell out of it with four arms and four legs. There are some numbers we can do that on, and then there are other numbers where one of us will play more of a percussion idea and let the other one carry the body of the song. I think it's just better musically. It's like having the other Cate Brothers' voices. [The Cate Brothers are opening the reunion shows as well performing with The Band.] All the Cate Brothers sing and they sing well, so when we play together, even if we do one of our old tunes, the tune sounds better having three keyboards instead of two, and five voices instead of three. It sounds like more fun and it is.

RF: What was it like doing solo projects after you'd been working within a unit for so long?

LH: It was a good time in a lot of respects, but it was a little bit of frustration in some other respects. I never could quite get a solo project to flip over just right in a commercial sort of way. There were two or three albums which were okay, but they never sold. So there is the frustration of trying to do as well on your own as you can

with your buddies, and you've got to live with that.

RF: How did acting enter into your life?

LH: Pure luck and just good circumstance. I know Tommy Lee Jones and he was bighearted enough to mention me to Michael Apted. Michael Apted, by the grace of God, called me and gave me the job in *Coal Miner's Daughter*. I didn't have a Hollywood agent or anybody to do it for me. Everybody was wonderful, and it was such a good movie that it made anybody connected with it look good.

RF: Talking about being bighearted, sometimes I think somebody who is sensitive, like you are, can be eaten up by this industry. It can be ruthless at times. Is it difficult being a "good ol' boy"?

LH: Well, the world is ruthless, but hell, I'm like everybody else. I'm happiest if things are going well, and if things are going slow, I'm itchy. I don't have any horror stories about bad experiences.

RF: Not horror stories, but just how somebody with a heart of gold deals with the industry. It must be very hard sometimes.

LH: I'm sure everybody else's heart is just as tender as mine. We're all dealt with the same hand here, so to speak. I feel like I've had it a lot better than most people. I've had the opportunity to travel and play music just about all my life. Hell, I haven't cultivated cotton since I was 17.

RF: Did you do that?

LH: Sure. So it looks like a pretty good

deal to me. I have nothing but good reports. I don't have a lot of that experience that you're talking about. The rock star stuff never came up for us. The Band was never attacked by groupies before, during or after any show that we ever played. We never played that many shows to begin with. It's been straight up and down for me. I used to play for dances, and now I play for dances, records and sometimes TV shows. I've just had the opportunity to do more. The Band never really played big concert tours. We never sold millions and millions of albums, so I don't know about that.

RF: What caused the Band reunion?

LH: Good luck and good friends. Some good promoters and people up in Canada wanted to see if we'd play. They put a tour together, and we played it and had a pretty good time doing it. When Rick and I have played together in the Woodstock area and when I have traveled around with the Cate boys, people have always asked when The Band would get back together.

RF: Will The Band continue to tour?

LH: I hope so. If Garth says yes, we will. Garth is the key—the one who will rub off on the rest of us and make the rest of us sound real good too. If everybody wants to, that's the most fun you can have. It always has been for me. I like to get within handshaking distance of the crowd. If it happens, they know it, we know it and that's all we came there for.

MOVING TO A NEW ADDRESS?

Attach your present mailing label here, or write in your old address. Please include customer code number.

New Address

NAME: _____

ADDRESS: _____

CITY: _____ **STATE:** _____ **ZIP:** _____

REMO'S

WARREN



Better Products For Better Percussion

from **REMO, INC.**

12804 Raymer Street
North Hollywood
California 91605
(818) 983-2600

A Salute to Warren White
Ice Capades' driving drummer whose extended touring with his PTS drumset proves the point: PTS performs!

Send in a copy of this ad, \$3 and your size for \$8 value Remo T-shirt. Limit 1 per ad.

ON TRACK



RUSH—*Grace Under Pressure*. Mercury 818 476-1 M-1. G. Lee: bs, synth, vcl. A. Lifeson: gtr, synth. Neil Peart; dr, perc, elec perc. *Distant Early Warning/After Image/Red Sector A/The Enemy Within/The Body Electric/Kid Gloves/Red Lenses/Between The Wheels*.

Neil Peart is no stranger to MD readers, and *Grace Under Pressure* is an obvious example of why he has achieved such notability. This album is a refreshing change from earlier Rush works in a few ways. First of all, there is a strong cohesiveness between Peart's lyrics and the overall musical statements. The lyrics actually work hand-in-hand with the music, as opposed to being placed over what seems to be instrumental sections. This makes the album more enjoyable from a general listener's point of view.

Of course, there is the usual display of Peart's masterful technique, but he seems more concerned with enhancing the group sound on this work than on previous recordings. Peart combines electronic and acoustic percussion in a very musical and interesting way which fits right in with the compositions. One of the best things about the playing on this album is that these tunes are generally more concerned with "feel" than sheer technique. Besides playing through intricate meter changes, hard rock sections, and the usual identifiable Rush characteristics, Peart (along with the band) has added a quality that hasn't always been their main concern: the point of view that, along with the complicated and involved fills, the songs should also be concerned with the "groove." Peart's

Reviewers: Richard Egart, Rick Mattingly, William F. Miller, Rick Van Horn

playing is always very interesting, and *Grace Under Pressure* is another reason why he is rock drumming's most influential player. *WFM*



BOB MOSES—*Visit With The Great Spirit*. Gramavision GR 8307. T. Okoshi: trp, fglhn. B. Mintzer, D. Liebman, G. Garzone, D. Gross, H. Johnson, T. Coe: wdwnds. J. D'earth: el trp. D. Sanborn: al sx. M. Gibbs: trb. J. Harris: bs, gtr. L. Goines, S. Swallow, E. Gomez: bs. S. Kuhn: pno. D. Brown, C. Korman: synth. B. Frisell, J. Scofield: gtr. M. Monteiro, B. Martin, C. Silva, R. De Francesco, J. Levatin, D. Gottlieb: perc. H. Hieda, R. Shiota, K. Baker: voice. Rahboat Moses: dr, repinique, timb, talking dr, hum dr, cuica, voice, wood fl, synth. *Fan Man/Deepest Blue/Machupicchu/Visit With The Great Spirit / Moktional / Carinho/Suite Bahia*.

Bob Moses has something in common with Michael Jackson: Bob's not like other guys either. He doesn't play the drums like anyone else; the music he writes doesn't sound like the music anyone else writes; his painting and poetry defy comparison to anyone else's work. The result is that this album is full of unique sounds and moods. Sometimes it almost sounds like Duke Ellington, but not really. At other times it reminds one of the jungle—but just where is this particular jungle that has elements from both Brazil and Brooklyn? Don't let me give the impression that this is just a hodgepodge, however. Every note was under Bob's control, and there is remarkable unity

and cohesion to this music. Much credit should be given to Gramavision for allowing an original voice to be heard. *RM*



MISSING PERSONS—*Rhyme & Reason*. Capitol ST-12315. D. Bozzio: vcl. Terry Bozzio: elec. & acous. perc., synth, vcl. W. Cuccurullo: gtr, vcl. C. Wild: synth. P. O'Hearn: synth, bs. *The Closer That You Get/Give/Now Is The Time (For Love)/Surrender Your Heart/Clandestine People/Right Now/All Fall Down/Racing Against Time/Waiting For A Million Years/If Only For The Moment*.

Terry Bozzio has always been recognized as a fine player, and yet he wasn't really doing anything all that different from anyone else; he just did it better. But with Missing Persons, Terry has found his own voice, of which there are two primary elements. First is the sound: This is an '80s electronic drum sound, but it's being triggered by a musician—not a machine. Second is what's being played: Bozzio seldom lays down a "beat," in the traditional sense. Rather, his drum parts are integral elements of the overall arrangements of the songs. The drums are interesting throughout, but they never intrude on the other instruments or vocals; everything works together. And after you've checked out the drumming, pay attention to Terry's composing. He had his hand in every tune on the album, and there are some interesting tunes here—both musically and lyrically. Missing Persons fits right in with the "techno-pop" of '84, but—make no mistake—

this is a band of players, and the technology is going to have to keep up with them. *RM*



GO-GO'S—*Talk Show*. IRS SP70041. C. Caffey: gtr, kbds, vcl. B. Carlisle: vcl. Gina Schock: dr. K. Valentine: bs, gtr, vcl. J. Wiedlin: gtr, vcl. *Turn To You/You Thought/Capture The Light/I'm The Only One/Mercenary/I'm With You/Yes Or No/Head Over Heels/Forget That Day/Beneath The Blue Sky*.

As on the first two Go-Go's albums, Gina Schock's drumming is strong and powerful, and the sound is fat. But for the first time with this group, the other instruments are equally strong, making the total sound more integrated, as opposed to strong drums overpowering thin guitars. The Go-Go's music is becoming more sophisticated both in sound and content, but they still have that garage-band enthusiasm giving life to their music. *RE*



ELVIN JONES—*Brother John*. Palo Alto PA8039-N. Elvin Jones: dr. P. La Barbera: tn & sp sx. K. Kirkland: pno. R. Workman: bs. *Necessary Evil/October's Child/Harmonique/Whatever Possessed Me/Familiar Ground/Why Try To*

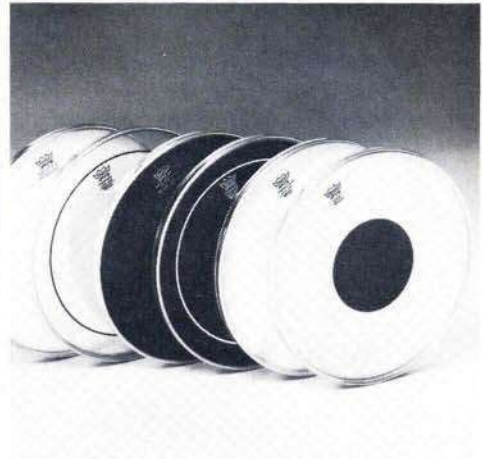
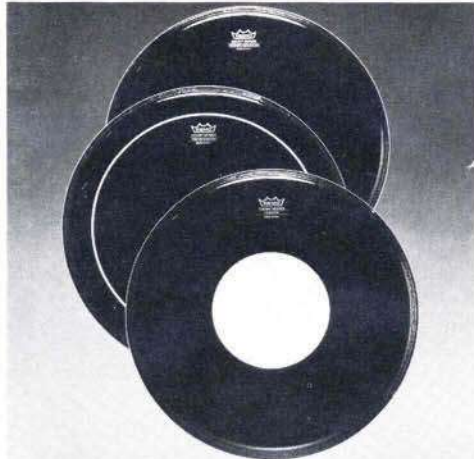

The Remo Drum Revolution goes ON...



Better Products for Better Percussion
FROM **REMO** USA
REMO, INC. 12804 Raymer Street
North Hollywood, CA 91605
(818) 983-2600

Send in a copy of this ad, \$3 and your size for \$8 value Remo T-shirt. Limit 1 per ad.

Change Me Now/Minor Blues/Brother John.

Elvin Jones is perhaps best known for his intensity, his explosiveness, and his enthusiasm. But what is often overlooked is Elvin's sensitivity, which is evident not only in the delicacy with which he often plays, but also in the way he listens to the musicians he is playing with, and provides the appropriate setting for what they are doing. That side of Elvin is shown to full advantage on this latest release, which spotlights Pat La Barbera, who has been playing in Elvin's band for many years, but who, curiously, has seldom appeared on record with Jones. That is more than made up for on this disc; in many ways, this is more La Barbera's date than it is Jones'. But Elvin's presence is evident, nonetheless, as he supports the other players in his own unique way. It's a slightly different side of Jones, but one that deserves attention. *RM*



JIM BROCK—*Lion Song*. HMC Records HM# 2060. Jim Brock: dr, congas, timbales, chica, shekere, bells, whistle, chimes, triangle, mbira, surdo, shakers, berimbau, caxixi, wd blocks, accdn, tabla, flexitone, autohp, marimba, sitar, donno dr, quinto, gong, vcls. D. Hawthorne, R. Brendle, S. Chiodo: bs. D. Floyd: kybds. G. Mayone: pno. J. Stack: pno, vbs. R. Bernsen, A. Ferreri, V. Sachs: gtr. P. Thompson: fl, pic. D. McClure, T. Hayes: sx. R. Alexander: trp, flghn. M. Balogh: tbn. J. Boyce: steel dr. C. Cooper, J. Hawthorn, G. Dionne, D. Dobbins, C. Marley, J. Perrin, S. Kirkpatrick, C. Osborne: bkgnd vcls. *Mellow Mellons/Twenty Small Cigars/Lion Song / Arulla San Antonio/Shootin' The Breeze/Family Talk/O'vazio/Portraits/Behind the Ceramic Par-*

rot/Ponta De Areia.

As you might expect from the list of instruments Jim Brock plays, this album is a nice display of percussion virtuosity. What you might not expect is that this is not a percussion show. What Brock does is use the magic of multiple tracking to allow himself to appear as a very tasteful percussion section on some excellent contemporary music, not as the outstanding feature of that music but in a colorful and meaningful accompanist's role. The tunes involving other musicians are generally sambaesque in nature, and very pleasant listening. Interspersed with those are Brock's interesting departures into African ("Lion Song"), Carribean ("Arulla San Antonio") and even Indian ("Portraits") motifs. Brock's drumset work is not his strongest feature, except on "Ponta De Areia," which contains a very dynamic passage that is quite a departure from the rest of the album. Here the drums come to the fore. Otherwise, Brock seems content to play the multiple supporting role, and he does so with taste and creativity at the same time, allowing some excellent solo work by many of the other musicians to shine. This is not avant-garde music; it's extremely listenable contemporary instrumental music, with here and there a little something different thrown in for spice. *RVH*

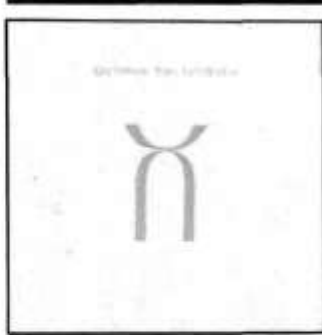

KING CRIMSON—*Three Of A Perfect Pair*. Warner Bros./Eg. Records Ltd. 25071-1. A. Belew: vcl, gtr. R. Fripp: gtr. T. Levin: bs, stick synth, bgr vcl. Bill Bruford: acoust and elect dr. *Three Of A Perfect Pair/Model Man/Sleepless/Man With An Open Heart / Nuages (That Which Passes, Passes Like Clouds)/Industry/Dig Me / No Warning / Larks*

Tongues In Aspice Part HI.

Robert Fripp has called King Crimson "group virtuosity." That may be true, but that would not be possible without musicians of an exceptional level. The compositions on this recording rate alongside the best of the current configuration's first two albums. Whether the numbers have vocals (about half the album) or are instrumentals, the band plays with a great deal of expression, yet always sounds in control and extremely precise. Maybe that's why Bruford's playing sounds so right. His playing is the ultimate in precision. At times he duplicates rhythms played by the other members, and at other times he craftily plays a contrapuntal figure which enhances what is going on. As usual, his combinations of acoustic and electric percussion are far superior to those of anyone else on record. On the first side of the album he plays with restraint, thoughtfully choosing each note. On side two, which contains more instrumentals, Bruford does stretch out a bit, but ever so tastefully. *Three Of A Perfect Pair* is another example of the kind of intelligent playing that we have learned to expect from Bill Bruford. *WFM*

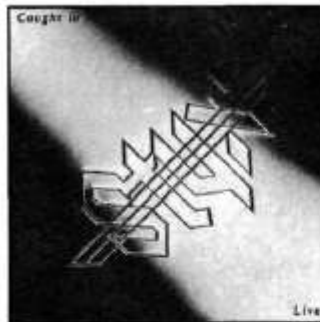

STVX—*Caught In The Act*. A&M SP-6514. C. Panozzo: bs, vcl. D. DeYoung: kybds, vcl. J. Young: gtr, str synth, vcl. John Panozzo: dr, perc. T. Shaw: gtr, vcl. *Music Time/Mr. Roboto/Too Much Time On My Hands/Babe/Snowblind/The Best Of Times/Suite Madame Blue/Rockin' The Paradise/Blue Collar Man (Long Nights)/Miss America / Don't Let It End/Fooling Yourself (The Angry Young Man)/Crystal Ball/Come Sail Away.*

The true test for a group of

musicians is a live performance, for there, without benefit of click tracks and overdubs, you find out how they really play their instruments. Except for the first two tunes, this double album was recorded at a live concert, and the group members prove that they can hold their own on their respective instruments. The variety of tunes gives John Panozzo a chance to run the gamut from delicate ballads to all-out rockers. He also shows that a large drumset does not have to be used for bombast; instead, it can simply provide a variety of colors, allowing each tune to have a distinctive character. Overall, the adrenaline of the live performance gives the songs a bit of an edge, compared to the studio versions. It's an edge that serves them well. *RM*



STEPS AHEAD—*Modern Times*. Elektra Musician 60351-1-E. W. Bernhardt: kybd. M. Brecker: tn & sp sx. E. Gomez: bs. Mike Mainieri: vbs, marimba, synth vbs. Peter Erskine: dr, perc, DMX dr synth. C. Loeb: gtr. C. Peyton: synth. T. Levin: stick. *Safari/OOPS/Self Portrait/Modern Times/Radio-Active/Now You Know/Old Town.*

This album succeeds on many levels. As expected, the playing on this record is outstanding. Coupled with well-written tunes full of emotion and technical excellence, *Modern Times* is a joy to behold. There are times in which the sound is somewhat reminiscent of an East Coast Weather Report, but these are few and far between. These musicians intertwine state-of-the-art electronic effects with their massive acoustic prowess to produce unique sounds which are quite scintillating.

On this recording, Erskine relates how a drummer and musician *can* be one in the same. If

Simply Superior.



More hit songs are written with the LinnDrum, demoed with the LinnDrum, re-recorded with the LinnDrum, and performed with the LinnDrum than any other digital drum machine – maybe more than all of the others combined!

Why? The sounds are simply superior. Listen to the long decay of our adjustable hi-hat, the crystal clear quality of our cymbals, and the full frequency response of our drum sounds.

And we now offer over 100 alternate sounds, including electronic drums and a wide variety of sound effects (so the LinnDrum can sound like most any drummer

or drum machine). These sounds come on plug-in sound chips and are easily changed by the owner. Because of the LinnDrum's advanced design, most alternate sounds cost only \$40. Custom sound chips – made from your own sounds – are available too on a special order basis.

- Now with new price – \$2495 list.
 - Now with single step programming.
 - Now with an extensive alternate sounds library (over 100 new sounds)
 - Now with expanded song capacity (up to 250 steps per song)
 - Now with selectable 24, 48 or 96 pulse per 1/4 note clock output (for direct syncing to most popular sequencers)
 - Now with optional memory expansion (more than doubles memory capacity)
- LINNDRUM OWNERS: New features can be added to your unit for a small charge.

Call or write us for a free demo record, brochure, and the name of your nearest dealer.

From the inventors of the digital drum machine:

Linn LINN ELECTRONICS, INC.

18720 Oxnard Street
Tarzana, California 91356
(818) 708-8131

you were to sit back and imagine exactly how these tracks should sound, it would come out sounding like what Erskine has put down here: absolutely perfect. Each tune offers an array of interesting techniques and ideas on the drums, but one must look past the sheer technique involved and realize how these techniques are used to make the tunes happen. This is an album that should not be missed. *WFM*



DICK MELDONIAN/SONNY IGOE AND THEIR BIG SWING JAZZ BAND—*Plays Gene Roland Music*. Progressive Pro 7062. L. Ball, S. Davis, C. Pasin, P. Sunkil: trp, flg. G. Hessler, D. Kirkland, J. Pugh: tbn. D. Bagni: bar sx. E. Wasserman: al sx. G. Cappucio, G. Keller: tn sx. D. Melodinan: al, tn & sp sx. J. Six: bs. G. Syran: pno. Sonny Igoe: dr. *When You Done Went/Richard's Almanac/Abscam/Sax Fifth Avenue/Road Stop/Papa Come Home/Blues In One's Flat/Moondog/Voice Of The Virgo*.

This album is at once contemporary and classic. The Meldonian/Igoe band plays swing in a classic sense: exciting yet approachable, and even danceable. Gene Roland was a composer/arranger whose extensive credits date back into the heyday of the big *dance* bands. Yet his tunes here are fresh, enjoyable, and contemporary, since this album was recorded just a year or so before his death in 1982.

Sonny Igoe's drumming is a lesson in taste and control through all of the charts, as would be expected from a player of his reputation both as a performer and a teacher. When he does solo—notably on "Papa Come Home" and "When You Done Went"—the sparkle and precision of a master are readily apparent, along

with one of the best drum *sounds* I've heard on this type of album in some time. The drums are not only tuned marvelously, but they are also balanced well in the overall band mix, so that all of the finesse displayed by Igoe is completely audible. Pick this album up to listen, learn, and enjoy. *RVH*



WEATHER REPORT—*Domino Theory*. Columbia FC 39147. J. Zawinul: kybd. W. Shorter: sx. Omar Hakim: dr. V. Bailey: bs. Jose Rossy: perc. C. Anderson: vcl. *Can It Be Done/D Waltz/The Peasant/Predator/Blue Sound-Note 3/Swamp Cabbage/Domino Theory*.

Omar Hakim is a drummer you should check out! If you haven't had a chance to yet, here is a good opportunity. Hakim handles Weather Report difficulties with ease, knowing when to lay back and when to really "kick." On tunes like "Can It Be Done" and "The Peasant," he is the epitome of taste and understatement, but on "D" Waltz" and "Predator," he grooves hard and displays some exciting and original fills. Pay attention to his intricate hi-hat work. Along with playing drums, Hakim had the coproducer's duties on this album. Maybe that accounts for some of the rhythmic continuity happening here.

Domino Theory is, at times, a fine showcase for Hakim's playing, being a major, positive contributor to the album. Jose Rossy on percussion also makes his presence known very tastefully, always complementing what's happening without getting in the way. However, there were moments when he could have been louder in the mix. Regardless, the album is very satisfying from a drumming standpoint. *WFM*



THE IMPROVISATIONAL ARTS QUINTET—*No Compromise*. Prescription Records. Alvin Fielder: dr. K. Jordan: tn sx. E. Heron: bs. Kim Jordan: fl. C. Kerr: trp. *Ettenro Ocelamn / A New Cycle / Three Pastels / A Song For C Melody / Last Trip To Jackson*.

When first listened to, this album of "free jazz" appears to be an amalgamation of unorganized sounds. However, once past the initial shock, one realizes the amount of musicality and technique it takes to perform this style well. The IAQ (Improvisational Arts Quintet) really does "groove," and the music has energy and "drive." The drumming is the center on which the songs are based, and Fielder leads the group through difficult sections with confidence. Although not for the masses, this album is a good introduction into free jazz. *WFM*



BRENT BRACE—*Valley Girl Jazz*. Progressive Records PRO 7071. B. Brace: dr, synth. P. Johnson: tn sx, fl. S. Solomon: tn sx, sp sx, pno, synth. C. Verheyen: grt. C. Nenneker: bs. S. Wilkinson: vcl. *Valley Dance/Golden Hour/565-8611/All The Children / Malibu Sunset/Orient Connection/You Could Have Told Me/Latino Funk/Remembrance/Car In The Fast Lane*.

Here is a tight, rehearsed group performing some light,

jazz-rock material. The album is well recorded and very clear in its production. Brace's drumming fits perfectly, gently moving the band through ballads, medium funk and some Latin samba-type feels. On "Latino Funk," an odd-meter piece with a solo section in seven, Brace propels the soloists without getting in the way. There are different Latin motifs throughout this album, and they are each approached differently. Some are played with brushes, and others with a heavier, funk-drumming influence. Brace's playing is fine, but he could have "dug in" a bit more as he did during his solo on "Car In The Fast Lane." On the whole, this is a tasteful album. *WFM*



THE FENTS—*First Offense*. Not Yachting Records VIP 101. A. Holzman: kybds. T. Hall: grt. B. Hodges: bs. Larry Anderson: dr. *Artichoke / Baxter Ward / Special Buns / Day Hike / Four's A Crowd / Stick In The Mud / The Skunk / Clutch Cargo*.

This is the first album by this L.A.-based jazz/rock quartet, and it's an ambitious and promising debut. The group is strong on enthusiasm and technique, presenting lots of odd-time and quick-change contemporary fusion. Drummer Larry Anderson works well with the other instruments when playing matching figures, and his overall playing is tight, precise and tasty. He does show a slight time problem when playing drum fills that set up choruses and lead passages. What we hear on this album is the freshness and enthusiasm of a talented young group; all they need now is a little time to mature as an ensemble, and The Fents could become important, high-energy jazz/rock artists. *RVH*





ELECTRONIC DRUM
Fightman

"BLOW YOUR MIND... BUT NOT YOUR NEIGHBOR'S!"

Mike Baird



Jim Keltner



Pearl's "Fightman" allows you to play "wide open" at home without disturbing anyone! You actually hear acoustic, powerful drum sounds silently (headphones) or live. Line Out jacks are furnished for connecting the "Fightman" to an external amplifier. It's extremely touch sensitive so your various sticking attacks are faithfully reproduced. The built-in "click" track allows you to finally practice "time" with that in-the-studio "feel". Now you can play along with your favorite records and tapes, quietly. Pearl's "Fightman" is truly an innovation in electronic drum development.

And as Jim Keltner and Mike Baird say, "This is the ultimate in home practicing! Plus, the pads are extremely sensitive and feel great just like a drum!"

FM-80 Complete "Fightman" \$1,169.00

Includes:

FM-50 Basic "Fightman" Two Toms, one Floor Tom, Bass Drum and Snare Drum; the corresponding hardware and connecting cords; and control board. **\$899.00**

FH-14 "Fightman" 14" Hi-Hats(PR)

FC-18 "Fightman" 18" Ride/ Crash Cymbal(x2)

*Hi-Hat Stand, Cymbal Stands and Foot Pedal are not included.



Pearl[®]

For a full color catalog, please send \$2.00 for postage and handling to:

In U.S.A.: Pearl International, Inc., P.O. Box 111240, Nashville, TN, 37222-1240,
In Canada: Pearl Dep., 3331 Jacombs Road, Richmond, B.C. V6V 1Z8

Beat Stu

The following material is from my soon-to-be-released book. The key to having the correct sound for the exercises is having two sound levels in the hands: accents (eight inches from the playing surface) and non-accents (one-half inch from the playing surface). Make sure that the accents are played with equal force in all limbs, as this balances the dynamic relationships between the hi-hat, snare drum and bass drum. Try playing the accents at *a. forte* (*f*) volume, and the non-accents at a *piano* (*p*) or *pianissimo* (*pp*) volume.

Use the following pattern before and after each of the exercises:

H.H.
S.D.
B.D.

No. 1 $\text{♩} = 140$

No. 2

No. 3

No. 4

No. 5

dy # 13

No. 6

No. 7

No. 8

Emerald[®]

LIMITED EDITION

Introduces:

MIDNIGHT

BLACK SHELLS ● **BLACK HEADS** ● **BLACK HARDWARE**

LIFETIME GUARANTEE

AS SPECIFIED IN MANUFACTURER'S WARRANTY CARD

Set Consists Of:

ALL TUNNEL TOMS

Your Choice:

SINGLE-STRAP Hardware
DOUBLE-STRAP Hardware



JUST A BEAT AHEAD

If you can't find EMERALD in your area,
write for a free catalog and dealer nearest you.

EMERALD MUSICAL INSTRUMENTS, INC. P.O. BOX 3275 CHATSWORTH, CA 91313-3275 USA

by Danny L. Read



Photo Courtesy of Institute of Jazz Studies/Rutgers University

Warren "Baby" Dodds was born in New Orleans in 1898. Although he is generally regarded as the first great jazz drummer, it's only been within the past 20 years or so that his contributions have been widely heralded. This is due, in part, to the remembrances of Chicago drummer George Wettling, one of the first to reveal Dodds' influence.

While listening to Dodds at Chicago's Lincoln Gardens with King Oliver's Creole Jazz Band in the early '20s, Wettling remarked, "The Oliver band had a beat that musicians are still trying to get. Dodds had a forceful beat and didn't mess up the band with a lot of technical nonsense. He was a subtle drummer with a variety of color and effects. He also had the greatest press roll."

Wettling wasn't the only drummer to acknowledge Dodds' influence. In an incident described in *The Jazz Makers*, Max Roach tells of being awed after hearing Dodds. "I was struck with the range and constant shifting of tonal colors Baby Dodds displayed as he moved all over his set, and as he continued to vary the sound of his beat according to soloist, development of solo, and other changing contextual needs within a single piece."

Philly Joe Jones in a taped interview commented that, "Dodds was Swingin' so much that I was late an entire set. I was fined 30 bucks, but I couldn't leave. I sat down and just stayed."

Critics have also recognized Dodds' importance. According to Thomas Shultz, "Baby Dodds was perhaps the best example of a swinging, military-influenced

drummer. He showed the drive and swing this style can generate." Russel Roth wrote, "It was Dodds who served as a kind of repository upon which other drummers could draw for the traditional elements in jazz rhythm." And *The Jazz Journal's* Barry McRae noted that, "Dodds was the first to avoid the metronomic pulse of the ragtime bands and assert his own personality with imaginative changes of rhythmic emphasis."

Dodds took his first drum lessons from Dave Perkins at the age of 14, while working in a New Orleans sack-making factory. He later studied with Walter Brundy and Henry Zeno, the drummer with Buddy Bolden. Dodds was also influenced by Mack Murray, Bolden's original drummer, and by Louis Cottrell. Cottrell played with Manuel Perez in Chicago in 1915, and in 1923 with Armand Piron's New Orleans Orchestra. Dodds, who is said to have been the first jazz drummer to fully exploit the capabilities of the bass drum, was also greatly influenced by the bass drummer with the Third Olympia Band, a man named Ernest Trepagnier.

Baby Dodds' first professional jobs were parades with Bunk Johnson, but his first full-time job was with Willie Hightower's American Stars. Prior to 1918, Dodds' playing experiences included house drummer at The Fewclothes Cabaret in New Orleans, and stints with Manuel Manetta, Frankie Dusen's Eagle Band and Papa Celestin. With the closing of Storyville, New Orleans' red-light district which offered employment for jazz musicians, and the subsequent exodus of musicians north on the riverboats, Dodds found his first job with a name band in 1918. The group included Fate Marable and Louis Armstrong.

In 1921, he joined King Oliver's Creole Jazz Band in San Francisco. This band was to become the first important full-fledged jazz group in the history of jazz. Dodds became the most influential jazz drummer of the 1920s, and it was here that he made his first recordings. One of the most important early engagements of the Oliver band, which then included both Dodds and Armstrong, was at the Lincoln Gardens in Chicago.

Because of the inadequacy of early recording techniques, Dodds' recordings

with Oliver are limited to the use of woodblocks, though the press roll technique is well represented on such tunes as "Chimes Blues," "Froggie Moore," "Canal Street Blues," "Mandy Lee Blues," and "Snake Rag." Although the press roll was born out of military band drumming, and although Dodds wasn't the first to adapt it for jazz use, "in Baby's hands the press roll became a subtle vehicle for expression," said Bruce King in an analytical article that appeared in the now defunct *Jazz Review*. "One of Dodds' principal contributions to jazz drumming was the ability to listen and interact with the ensemble by providing changes in rhythmic patterns and texture corresponding to similar changes in the wind instruments. By interacting with the ensemble, Dodds actually became a melodic drummer by filling in gaps within the musical structure, and by tying phrases together most often by the use of the press roll. Although the fill-ins he provided were very simplistic by today's standards, they were the origin of the drum break and the drum solo itself. His concept of melodic drumming, though primitive and quite functional, was the forerunner of Max Roach and other drummers who capitalized on this principle."

Dodds' famous press roll was basically a five-stroke roll at fast tempos, a seven-stroke at medium tempos, and a nine-stroke at slow tempos. The roll was usually played on the snare drum rim or woodblocks.

5 Stroke: Fast 7 Stroke: Med. 9 Stroke: Slow



Later Became:



Dodds' technique was rooted in ensemble style. He changed rhythmic patterns and sonorities depending on what the lead instruments were doing, and he filled out gaps within the arrangement. When jazz evolved to more of a soloistic style, and Papa Jo Jones and Kenny Clarke trans-



For every drummer who wishes his inputs were as great as his output... the Drummer's Mixer from Shure.

Drummers now have the freedom to mike their drums any way they want, without worrying about taking up too many channels on the main board. With the M268 from Shure, you can plug in up to eight microphones, mix them any way you want, and use only one channel of your band's PA. And you'll get the same great sound as if your microphones were plugged directly into the main board.

Best of all, the M268 includes several design features that will be especially appreciated by drummers. The mixer has four microphone/instrument channels. Each features an XLR-type connector and a 1/4" phone jack to handle either low or high impedance microphones and instruments. All of the connectors can be used simultaneously, providing a total of eight inputs. Phantom (simplex) power is

provided to eliminate the need for a separate power supply for condenser microphones.

What's more, there's never a problem with distortion since active gain controls handle even the hottest sounds from your microphones without overloading.

And, for easy expansion as your drum kit grows, each unit also features a mix bus so an additional M268 Mixer can be connected for even more inputs.

The Drummer's Mixer from Shure—all the inputs your playing ever needs.

For more information on the Drummer's Mixer, call or write Shure Brothers Inc., 222 Hartrey Ave., Evanston, IL 60204, (312) 866-2553.

SHURE®

THE SOUND OF THE PROFESSIONALS®... WORLDWIDE

ferred the basic beat to the hi-hat and ride cymbal, respectively, it became the soloists' responsibility to fill in the open spots. Dodds was the first drummer to play a steady beat on the ride cymbal. Although his ride-cymbal rhythm consisted of quarter notes on beats 2 and 4, Bruce King has observed that, "there are good reasons for crediting him with the basic idea of riding the cymbals." King also feels that Dodds was the first drummer to explore the different sonorities produced by striking the cymbal in different ways and in different places. By doing this, Dodds could actually emphasize the intervals contained within a melodic passage. To the same purpose, Dodds was also one of the first to

tune his tom-toms to specific intervals.

After leaving King Oliver, Dodds played with Honore Dutrey in Chicago in 1924, and also with cornetist Freddie Keppard and clarinetist Johnny Dodds. Between 1925 and 1930, Dodds played with Lil Armstrong, Ralph Brown, Charlie Elgar and Hugh Swift. After the Oliver recordings in the early '20s, his remaining recording activity during that decade was with Louis Armstrong & His Hot Seven. These do little to demonstrate his abilities, however, since for the most part, the drums are inaudible.

During the 1930s, in addition to helping his brother Johnny run a fleet of taxis in Chicago, Dodds did club work, and from

1936 to 1939, was house drummer at The Three Deuces. In the early '40s, he recorded "Ain't Misbehavin'," "Blues For You Johnny," "Save It Pretty Mama," and "Stomp Jones" with soprano saxophonist Sidney Bechet. The rhythmic ideas on several of his brief solos shift between double and half-time, much the same as the rhythmic ideas of bop players Charlie Parker and Dizzy Gillespie.

While in New York in 1946, he recorded a fascinating album for Frederic Ramsey, Jr., entitled *Baby Dodds: Talking and Drum Solos* (Folkways, FJ-2290). Here Dodds not only demonstrated his drumming techniques, but also discussed his style, and jazz drumming in general. The album includes Dodds' comments on his playing career with King Oliver, Louis Armstrong and others, a discussion of the press roll, a demonstration of his accompaniment to slow blues and a march, and four drum solos. "Rudiments," one of the album's solos, offers a demonstration of another of Dodds' unusual tonal innovations called "nerve beats." According to Bruce King, this effect was achieved "by loosely holding two drumsticks in one hand and making them rattle through the contraction and expansion of the nerves between the elbow and shoulder. It is technically difficult, since the rattles must be as quick and precise as a drum roll."

In 1948, Dodds made his first and only trip to Europe to perform with clarinetist Mezz Mezzrow. Upon returning to New York, he played with Art Hodes, and in 1948, returned to Chicago to play with trombonist Miff Mole. After suffering strokes in 1949 and 1950, he again played in New York with trumpeter Natty Dominique, but was taken ill in 1952 and returned to Chicago after making his last major professional appearance. Although partially paralyzed, he did perform occasionally from 1952 until his retirement in 1957.

Because of additions and design changes in various components of the drumset, there is no direct link from the drumming style of Baby Dodds to the styles of today's jazz drummers. However, through specific concepts and techniques, Dodds has influenced virtually every drummer since the early '20s. Drummers such as Zutty Singleton, Gene Krupa, Dave Tough, George Wettling, Chick Webb, Jo Jones, Sid Catlett and Max Roach bear a direct influence. And as Bruce King so aptly suggested: "Any drummer who is concerned with tonal patterns, timbre, texture and rhythmic variation, belongs to Baby's tradition."

NEW JERSEY PERCUSSION

50 West Main St.
Rockaway, NJ 07866



(201) 625-8134

SEND FOR
MONTHLY SPECIALS

"For Your Drum and Percussion Needs"

In A/B tests, this tiny condenser microphone equals any world-class professional microphone. Any size, any price.

Compare the Isomax II to any other microphone. Even though it measures only $\frac{5}{16}$ " x $\frac{5}{8}$ " and costs just \$189.95,* it equals any world-class microphone in signal purity.

And Isomax goes where other microphones cannot: Under guitar strings near the bridge, inside drums, inside pianos, clipped to horns and woodwinds, taped to amplifiers (up to 150 dB sound level!). Isomax opens up a whole new world of miking techniques — far too many to mention here. We've prepared information sheets on this subject which we will be happy to send to you free upon request. We'll also send an Isomax brochure with complete specifications.

Call or write today.

* Pro net price for Omnidirectional, Cardioid, Hypercardioid, and Bidirectional models.



COUNTRYMAN ASSOCIATES INC.
417 Stanford Ave., Redwood City, CA 94063 • (415) 364-9988



JIM DINELLA makes your CONGA COME ALIVE!

Book: \$7 ppd. (\$8 outside US)
T-shirt: \$6 ppd. (\$7 outside US)
List Size: Sm, Med., Lg., X-Lg.
BRASS RING ENT.
P.O. Box 1312, Toms River, NJ 08754



E-drum

Digital Percussion Module

Real sounds. Total dynamic control.

Introducing E-drum. A breakthrough in electronic percussion from the company that has pioneered affordable digital sampling technology.

The E-drum digital percussion module combines the clarity and precision of digitally recorded sounds with the dynamics and spontaneity of live drumming. It is a completely self-contained electronic drum that accepts interchangeable E-drum sound cartridges, each containing one or two sounds in solid-state memory. The extensive cartridge library includes a wide selection of acoustic and electronic drums as well as numerous percussion instruments and sound effects, with more sounds being constantly added. (Of course, since E-drum sounds are recorded digitally rather than synthesized, there is no limit to what they can be. How about being able to solo with the sounds of cannons, breaking glass, or colliding automobiles?)

But the E-drum's real strength lies in its responsiveness to your playing, offering extraordinary expressive control over both volume and pitch. The E-drum pad can be set to respond to your particular style: from the lightest of finger taps to the heaviest metal sticking. A decay adjustment as well as a (very) active equalizer allow the E-drum's sounds to be tailored to your individual tastes.

The E-drum's unique external trigger input accepts triggers from synthesizers, sequencers, or drum machines, as well as virtually any audio source. The dynamics of the triggering signal are detected and duplicated by the E-drum, making it possible for E-drums to be played expressively from a miked drum set. You can even use an E-drum to replace an already recorded drum track with a completely different sound while still retaining the rhythm, expression and dynamics of the original performance.

The E-drum. A revolution in electronic drumming. Available today from E-mu Systems.

E-mu Systems, Inc.
applied magic for the arts
2815 Chanticleer, Santa Cruz, CA 95062
(408) 476-4424



SABIAN S

Kenney Jones/The Who

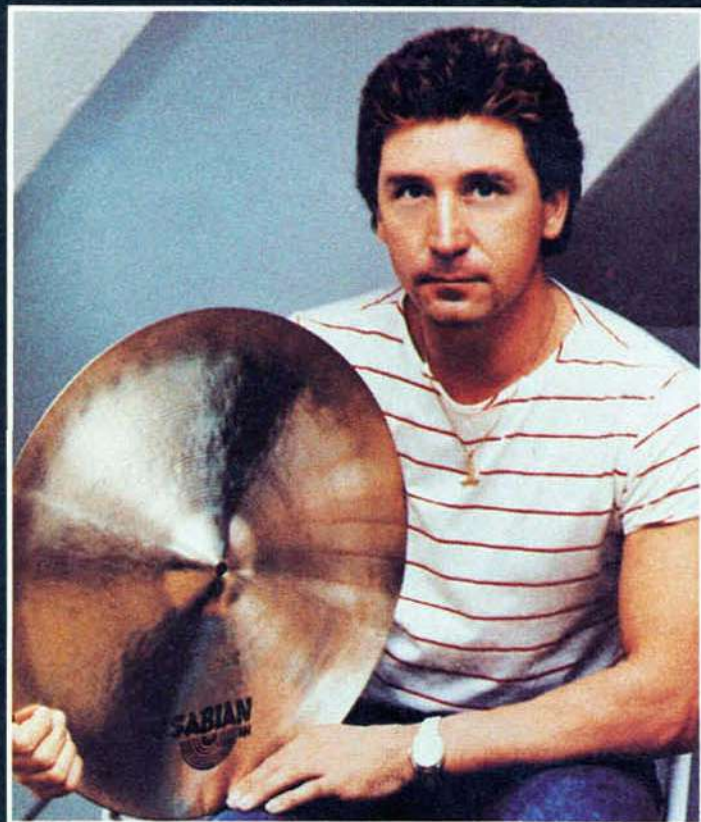

Harvey Mason/L.A. Session Master

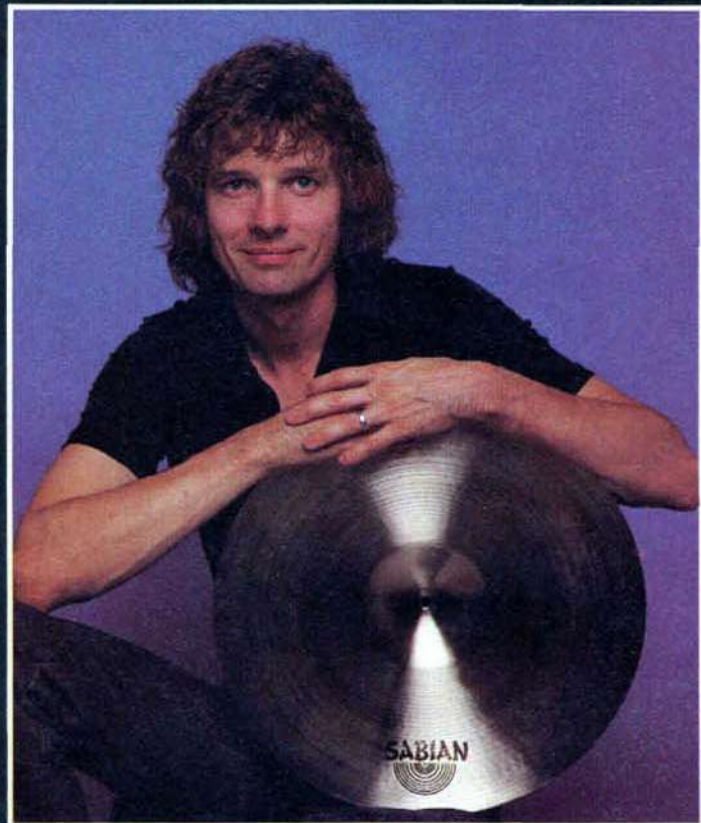
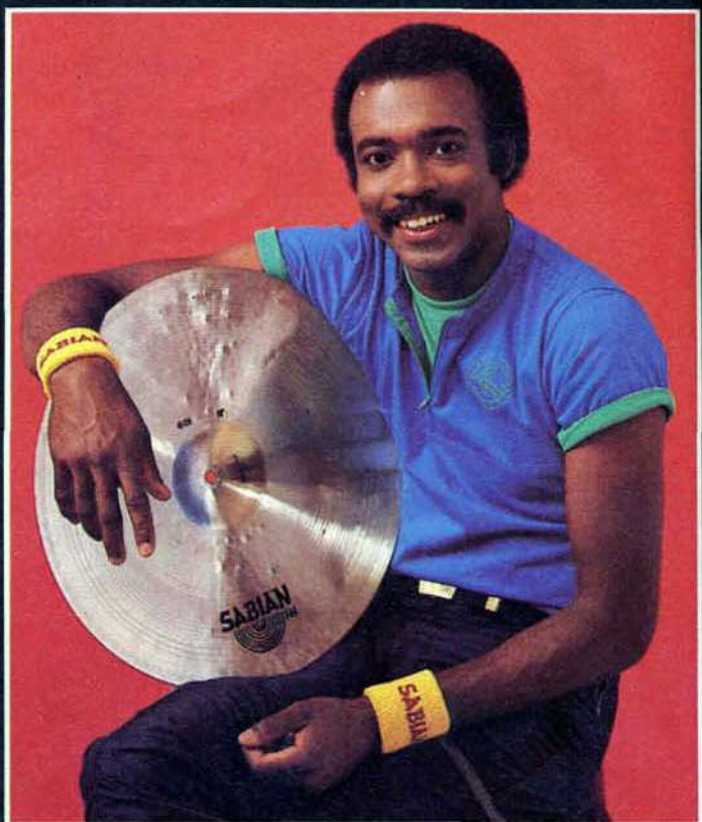

Gil Moore/Triumph



Jeff Watts/Wynton Marsalis Quintet



And a special thanks to: Ed Thigpen • Keith Copeland • Bernie Aubin • Jorn Anderson • Tony Braunagel • Mike Baird • Jerry Mercer • Kevin McKenzie • Gary McCracken • Bob Stone • Fred Satterfield • Ringo Starr • Chris Taylor •

Sabian Ltd., 4800 Sheppard Ave. East, #115, Scarborough, Ontario.

WITCHERS

Phil Collins/international artist

Graham Lear/L.A. Studios

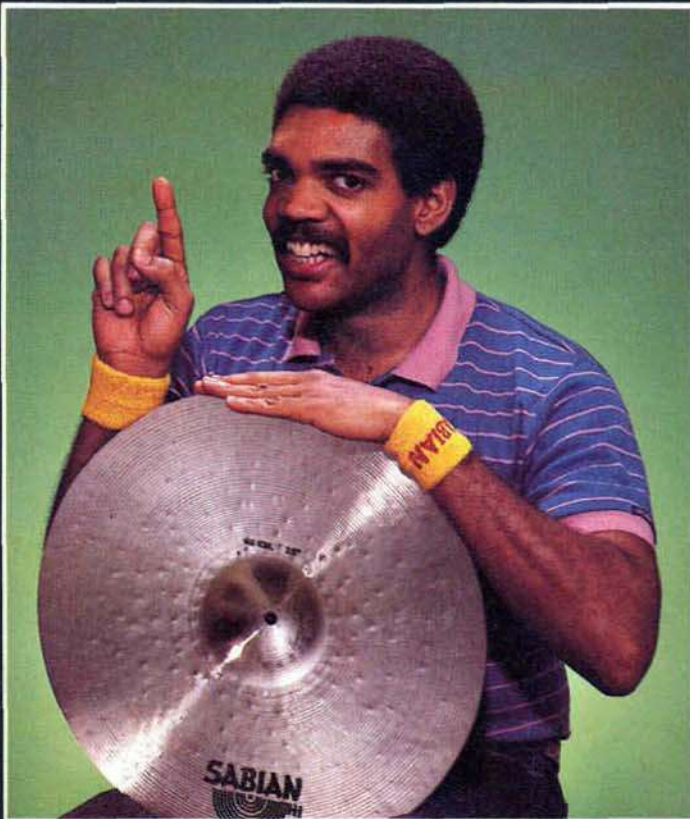
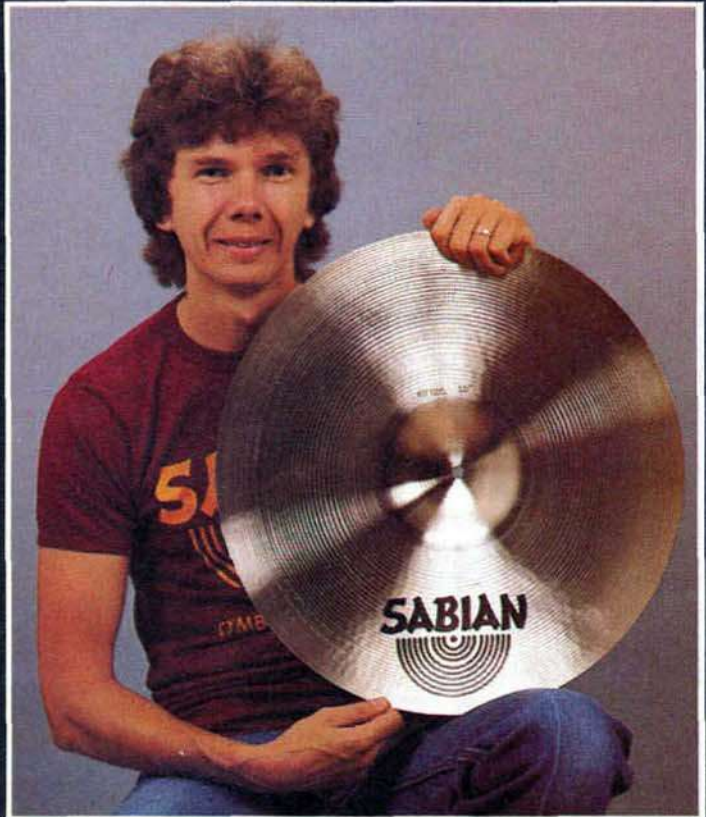
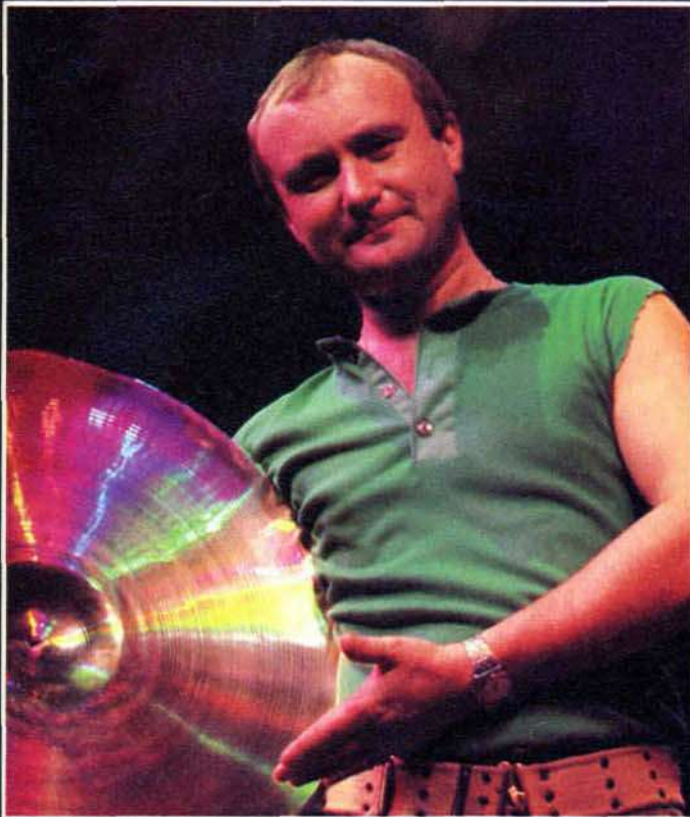

Gerry Brown/Lionel Richie

Frankie Banali/Quiet Riot

Danny Bigay • Jerry Speiser • Vincent Dee • Paul DeLong • Robert Ego • Steve Ferrone • Hank Guaglianone • Tim Gehrt
Eddie Tuduri • Pete Thomas • Roger Taylor • Larry Tolfree • Debbie Katz • Gil Moore • Michael Carvin

M1S 4N5, Canada Telex 065-26227 Write for Sabian promos information.



Price continued from page 17

CF: That must have been hectic.

TP: Oh, that was only the beginning. After the albums, even though I had recorded the drum parts for *Rebel Yell*, I was still definitely with Scandal. Then Billy's group had some sort of trouble with their drummer and they called me to play some gigs on the East Coast in late '83. So I toured with them for about a month and then did some other gigs with Scandal. It was a wild two-month period. Sometimes I didn't know if I was coming or going. Sometimes I was doing both at once. It was like leading two lives! The

craziest night was New Year's Eve. I ushered in 1984 with Billy on the MTV New Year's Eve special, which took place at the Savoy in midtown Manhattan. Our set started at 11:30 and ended at about 12:30. Then as soon as I finished that set, I had to jump in the limo and get through New York traffic, on New Year's Eve yet, all the way downtown to the Ritz, where I had a gig with Scandal that started at 1:30. The whole midtown area was completely closed off to traffic because of the thousands of people who gather around Times Square waiting for the ball—or is it the apple?—to drop at midnight. So the driver had to go in a big square instead of just driving through town, and it took an hour to go 30 blocks. In the meantime, Moto had to rush down to make sure that I had another drumset ready and waiting for me. What a night that was! I haven't really been right since! [laughs] It was right after New Year's that I decided to stay with Billy.

CF: Can you say what helped you make that decision?

TP: It was being on the road, playing the concerts with Billy's band, the comradeship, the excitement of the live performances, and the music. This is what I really want to do. That's it in a nutshell. It's what I feel strongly about playing now, at this point in my life. A year ago, I was really into Scandal—into that kind of rock 'n' roll, which is a lot lighter. And it's still great. I love their music. But my tastes sort of changed, and playing with Billy gives me a little bit more. I can use everything I have now, not only my power, but everything. I don't have to hold anything back.

CF: You had to hold back a little with the other groups you've played with?

TP: Well—yeah, probably. I might have, yes. My real rock 'n' roll playing couldn't come out. I couldn't growl. Maybe it wasn't so much holding back as not going to the limit.

CF: To the danger zone.

TP: [laughs] To the danger zone! And Billy gives me a lot of space. The drums are prominent. It's definitely a part of the new record. The mark of Price is there. And playing live, I have the freedom to change a lot of the parts on the songs, instead of just sticking to the

14 good reasons why are better than

1,2,3,4,5,6,7,8. SuperSticks last over *eight* times as long as wood sticks.



11. SuperSticks come with nylon tips (for a darker sound) and with polycarbonate tips (for a brighter sound). Both types available with regular or Magnum size tips.

13. Sets are matched to within 1/2 gram.

12. SuperSticks respond faster than wood sticks.

same things every night. I don't go by the book anymore, at all. I'm free. Of course I have to keep the basic thing happening, but I fool around with it and try different parts, so I don't get bored.

MM: But when Thommy does something new, he doesn't interrupt the flow of the song. If they want to do something new, a lot of drummers will throw in something that's *way out* and doesn't fit in with the song.

CF: A *tour deforce*.

MM: Right. Thommy tries new things every night, but they fit. It's intuitive with him.

TP: Well, the other band members pick up on what I'm doing, too, without me saying a thing. There's a lot of free interplay, and it's happened *fast* to us. It's just going to get better, because the more we play these songs, the more we really feel free to change things from the way they are on the record.

CF: Do you do that together as a group?

TP: Yeah. When we go to a soundcheck before we play, instead of just doing a soundcheck, we fool around to come up with something new—try things out to keep it interesting. After all, the fans already know what's on the record. They want to hear something different. They can handle it. And we even tear up the list of songs, sometimes, in the middle of a performance. The other night we did "L. A. Woman" for an encore—spontaneously, with no rehearsal—and it came off great.

CF: It's good when you feel confident enough to move away from the record version, and abandon the formulas and the set patterns. Some groups seem to sell the public short. It's like they get hardening of the arteries.

TP: They play it too safe, and they get rigid. I guess they're afraid their fans will leave if they change, so they don't take the chances.

CF: You've got to take chances.

TP: You do. Otherwise, you'll probably go crazy. Even in Scandal, the guys were a little afraid to go a little bit out. They always wanted to stay with what was on the record and stick to the formula. There's nothing wrong with changing a little bit here and

there, keeping it interesting, and keeping *us* interested, especially after you've been on tour for nine months, playing the same songs every night with no changes at all. Forget about it!

CF: And don't you think being willing to change is going to give a band more longevity?

TP: Absolutely. If you stick to the same thing, the rest of the world is bound to pass you by. Hey, but don't get me wrong. I had a good thing with Scandal. It was hard to leave them. I spent some restless nights making up my mind. But this thing with Billy is what I really want to do. That's what it comes down to. And the people with Scandal really understood that; they were very gracious. They saw that I belonged with this band. That's a hard thing to admit sometimes, but they handled my moving on with nothing but class.

CF: So that meant you didn't have to leave with a heavy heart.

TP: Exactly. They just made it real easy for me to call them up and say, "Look, this is what's happening."

CF: Let's break away from your recent history. How did you get started on drums?

TP: I grew up in the Bay Ridge section of Brooklyn—a tough, blue-collar, Irish and Italian neighborhood. I don't remember when I actually started playing. I was always banging on furniture, walls, whatever. It just came naturally to me. I was tearing the house down, so my parents bought me some drums when I was about seven or eight. I loved it. I played on them day and night.

CF: Did you take lessons?

TP: No. Well, I took a few, just to learn how to read, when I was about ten, after my mother said, "Maybe you should go for lessons if you're so serious about the drums." But I liked learning from records. I didn't really want to know too much about technique because I was really having a good time learning the way I was learning. And then when I had to sit in this little room in the local music school with this guy trying to teach me how to read, I was really bored. So after a while, I would take the 15 dollars and go to the movies! [laughs]

CF: Did your mother find out?

Duraline SuperSticks Wooden Sticks:

9. SuperSticks come in five sizes: 55, 60, 65, 75 and 100 grams—to match any style of playing.

10. SuperSticks don't warp.

DURALINE 65

14. Porous surface keeps SuperSticks from slipping out of wet hands.

Isn't it time you got yourself out of the woods?

DURALINE™

11300 Rush St., So. El Monte, CA 91733



\$1388 INTRODUCTORY PRICE

- 11 PIECE DRUMSET
- 9-PLY HARDWOOD SHELLS
- HEAVY DUTY HARDWARE
- DOUBLE BRACED STANDS
- CHROME SNARE w/ PARALLEL ACTION STRAINER MECHANISM
- FREE DRUM THRONE UNTIL AUG. 31
- SPECIAL 5pc. CYMBAL SET \$129 LIST



\$4 down, balance \$45.00
(415) 550-8600

Rototoms • **YAMAHA** • **ROGERS** • **LP** • **Avedis Zildjian Co.**
HUMEN & BERG
LUDWIG
REGAL TIP DRUM STICKS
GITTSCH
TOPICAL CORPORATION
CS DUPLEX
CB700
EVANS
SYNARE
DEAGAN
Pearl
MSPERC
SONOR
SYNDRUM
Gon Bops of California **GOOD VIBES MALLETS** **Factory Imports Co.**
ROSS MUSICAL INSTRUMENTS **ISLAND MUSICAL SUPPLIES** **AFRICAN IMPORTS**

DISCOUNT DRUM WORLD

456 N. ORANGE AVE., ORLANDO, FLA. 32801
(305) 843-2025 PAUL JAFFE, Mgr.

LARGEST AND MOST COMPLETE DRUM AND PERCUSSION SHOP IN THE SOUTH

- WE CARRY ALL MAJOR BRANDS
- CALL AND COMPARE OUR PRICES
- IMMEDIATE DELIVERY
- CASES AND SMALL PARTS
- COMPLETE PERCUSSION LIBRARY
- RENTALS
- VISA & MASTER CHARGE ACCEPTED

Stingerland
KAMA
DECATUR INSTRUMENTS
Werco
Remo
CAMBER
Premier
DURALINE
KRUT
PAISTE
PRO-MARK
D'ALEO'S OF CALIFORNIA
SAUL GOODMAN
Per-Del
Playa Azul

TP: Yeah, she used to call up the music store and check up on me. "Hey, Tony, is my son there?" Actually, though, it was from the music school that my first group was formed. They'd take the best guitar player from a class, the best drummer, and so on, and they would form a group. So the school got four of us kids together and sponsored us. It was great. We called ourselves The Tablets. And we performed in this place in Brooklyn which is now called 2001. It's where they filmed *Saturday Night! Fever*. We would play there every Saturday afternoon opening for this all-girl band called The Butterflies. It was great to be playing in front of an audience every week, when I was still a ten-year-old kid in grade school. Then, as we grew up together—we were about 14—we started playing in other places in Brooklyn.

CF: What kind of music did you play?

TP: It was all guitar instrumentals—Venture's songs, like "Walk, Don't Run" and "Pipeline." After a while, I started singing, because no one else wanted to. They were all too shy. And at that time, I was really getting into The Young Rascals. It was actually from Dino Danelli that I developed a lot of my style. Everybody in those days was listening to the Beatles and the Stones. I was too, but for me, it was The Young Rascals. In those days, you never heard a drummer play *so powerfully!* God, I remember when I first heard Dino on record; it was like, *listen* to this guy! I couldn't believe it. I could picture this drummer really playing hard in the studio, really *going* for it, and just the simplicity of his drumming! The great thing about him was that he knew technical stuff; he did technical fills once in a while. But then other times, like in the song "Lonely Too Long," he just really laid right into it and played real hard, simple, and solid. And those were the songs I related to—"Good Lovin'," "People Gotta Be Free," "Mickey's Monkey." I also liked The Young Rascals because they sounded black, and I was really into R & B records—that heavy Motown drum sound.

I remember how in those early days my drummer friends would ask, "Who are you into? Who's your favorite besides Dino?" But I never really *studied* him, like a kid will take, say, John Bonham, and really cop his style. I'd listen to a lot of drummers and maybe take a little from one and little from another, but it would still always be *me*. I've always strived for originality.

I'm still a big fan of Dino, though. I always carry the old Young Rascals tapes with me on the road. George Sewitt, our road manager, was the Young Rascals' road manager for years. Every once in a while when we're on the road, I'll sit down on the bus with him and say, "George, give me a little more information on Dino."

CF: Did you ever meet him?

TP: I always wanted to meet him, and it was a year ago that I actually got to work with him in the studio on an album for a new artist known as "Steven C." Dino played on about half of the tracks and I played on the rest.

CF: It must have been like a childhood dream.

TP: [eyes lighting up] *Forget* about it! And he's still amazing—just as good as he ever was. Judi Dozier, our keyboard player, used to play with Dino. Now he's the drummer with Little Steven & The Disciples of Soul.

CF: The first time I saw you play, I had a feeling you came from a working-class background. You're a *worker* on the drums—gutsy, nothing overly intellectual. Can you see how coming from Brooklyn shaped your style?

TP: I don't know; it makes you streetwise, gives you that street sense. It gives you your attitude and that's in me. That's part of my whole trip. They can't take it away from me. I come from people who work hard for a living, who aren't afraid to get their hands dirty, who speak their minds plainly, and who can carry the heavy load. In Brooklyn I learned about struggle, about toughness, and about enjoying life. If that comes out in my drumming, I guess it all started in Brooklyn.

CF: What happened after Brooklyn?

TP: Well, I moved out to Staten Island when I was a teenager. It was incredible. I met a lot of musicians out there, including Kasim Sulton, the bass player with Todd Rundgren—I grew up with Kasim—Earl Slick, Sandy Gennaro, Frankie LaRocka—he's with

Bryan Adams now—Tommy Morriengiello, who's with Ian Hunter, Joey Vasta, Jr., the bassist with Mink DeVille, and David Johansen. We were all out of the same mold. Then I graduated high school and went right out on the road with a band. There was no doubt in my mind what I wanted to do. I stayed out about six months on the road. I'd be driving the truck, because I was the son of a truck driver and the only one who knew how to drive a stick-shift. It was hard. I was only 17, and it was my first time away from my family. It was like, "Okay, let's make a man out of him, or let him sink!"

CF: And did your family support you during all that?

TP: All the way. They *always* supported me. They were always right in back of me. My father was so great. He never let me down.

I had a lot of friends in Brooklyn who wanted to play drums, and their folks would say, "Oh, it's just a fad. You'll get over it."

CF: Get a real job.

TP: Yeah, get a real job. But it was never like that with my father. He was a big part of making me feel that I could make it, and of giving me my self-confidence.

CF: That's rare.

TP: It is. Definitely. When all my friends' folks were hounding them to "make something of themselves," they would only put maybe 25% or 50% into their playing. And that's all they got back—only what they put into it. But I always had this feeling that, if I put everything into it—100%—and I *believed* in it, *something* was going to happen.

CF: It sounds almost like Pollyanna, but it's true.

TP: Yeah, I know. I always believed that was what did it for me. Everything I had I put into it. Probably the reason I feel so positive about what I'm doing now goes back to my family. They always said, "If you want to try to make it as a drummer, do it. And if it happens, fine. If it doesn't happen, at least you tried. You know you gave it your best shot." It must be terrible to be 50 years old, and look back and wish you'd had the guts to try. God, there are times when I wonder what I'd be doing now if I hadn't become a drummer. I don't know. I hate to say it, but so many of my friends didn't make it. I come from a real bad neighborhood in Brooklyn. All of my old friends are either in Bellevue or dead from overdoses. But I was the lucky one. I've got to thank my folks for helping me develop the courage and the confidence to survive the odds.

CF: What happened next after your first road experience?

TP: Well, I stayed with that band until I was about 19, but it was a top-40 band and I wanted to do something different. So I quit that and started doing jingles—playing on commercials.

CF: How did you get into that?

TP: There was a friend of mine from Staten Island whose father was a producer for jingles, and he just got me in one day. They needed a drummer for some army commercials, so I did a bunch of army commercials, a Burger King commercial . . . [Billy Idol, overhearing, this tidbit, laughs, curls his lip, and bursts into a chorus of "Have it your way, have it your way."] I only did a few jingles, actually, but it was really beneficial because that was what introduced me to the studio, which is a whole different thing from live playing. And from the studio, I met a whole new group of people—producers, engineers—all those other outside people. An entirely new world opened up. It was then that I worked with a Brooklyn group called Flame, and we did a record for RCA which Jimmy Iovine produced. I did some other things with Jimmy—a D. L. Byron record, some stuff for the score of the movie *Times Square*, some work with The Motors. And then just from working with Jimmy, I met whole new circles of people and started doing all kinds of things.

CF: Can you characterize the work you did in the studio at that time?

TP: A broad range of music. I did a few songs for that guy Sylvester, who did hard-core disco. I played on German artist Udo Lindenberg's *No Panic On The Titanic*. He's very hot in Europe. I played for Ronnie Spector and Tom Verlaine, did some country & western, and a lot of other things.

CF: You seem to be an easy-to-get-along-with guy, which could

D.O.G. PERCUSSION Introduces Puppy Punch™ Pad

More Projection

Longer Lasting

Deeper Sound

Better Definition

Self Adhesive



Improves Any Bass Drum Sound
Studio or Live!



let
Puppy
Punch™ Pad
do All the Work.

\$2.50 Each Pad

(TN Res. Add 19¢ S. Tax Per Pad)
Send Money Order/Check
Free Freight
No C.O.D.'s. No Cash Please

D.O.G. Percussion
111-19th Ave. So.,
Nashville, TN 37203

Klic-Trac™

AT LAST...

Until now you've had trouble working with a metronome . . . why . . . because you can't hear it.

Well, AXE has solved the problem! We've developed a micro-size headphone metronome you wear on your belt, allowing you complete freedom of movement, and you hear the klics the way session players do in the studio . . . thru headphones.

AXE's Klic-Trac is the perfect drummer's metronome, allowing you to use it even when playing a full set of drums . . . plus you have full control of both tempo and volume, and it's compatible with all stereo headphones.

A clean, tight, precise sound, long battery life and hi-quality construction make Klic-Trac a valuable addition to any player's equipment.

AT LAST . . . A metronome that makes sense.

See AXE's Klic-Trac at your local dealer or for further information write,



ARTISTS X-PONENT ENGINEERING
P.O. Box 2331 • Dept. MD • Menlo Park, California 94025

WE'RE NEW YORK'S #1 DRUM SHOP FOR A REASON.

Several reasons, actually. The Modern Drum Shop is owned and operated by drummer Joe Cusatis, for professional and aspiring drummers. So we know, better than anyone else, what you need when it comes to

• Repairs

From spurs to snare beds, we do it right—fast. Because complete, professional drum service is our business.

• Custom-made drums

The stuff that dreams are made of. Choose from assorted natural wood or pearl finishes in a variety of colors.

• Shells

Standard and custom depths, finished or unfinished—our shells will dramatically improve your sound, at a cost well below what you would expect.

• Prices

As low as our quality is high, every day of the year.

So whether you need to brush up your chops, purchase a set, or repair that rattle in your snare, give us a call. Better still, stop by the Modern Drum Shop, and find out why we're number one with drummers everywhere.



The Modern Drum Shop

167 West 46th Street
New York, NY 10036
(212) 575-8893



explain why people want you. No star trips for you.

TP: No star trips. You've got to work with people. You just can't go into the studio with an attitude. It's my job. Why am I going to screw up my job?

CF: So it doesn't bother you if you're not playing your favorite kind of music?

TP: Well, it's not like putting me to work in a lumberyard or something. I'm still playing the drums. I'm still making a living by what I do best. There have been some demos or a few things I played on that I didn't particularly care for, but I never *hated* anything, and most times things ended up better than they started out. You never know where something will lead to.

CF: You take things as they come.

TP: Exactly.

CF: And apparently things kept coming after those early days in the studio. Can you summarize your list of credits between then and Scandal?

TP: Well, I toured with Mink DeVille on and off for almost five years, from about 1978 to about 1982; I did two albums with him, *Le Chat Bleu* and *Coup de Grace*. During that same period, I toured and recorded two albums with the singer Helen Schneider. And I toured with Robert Gordon for a good part of 1982. Those were the main things.

CF: Billy Idol is a bold and dynamic performer, as much in the tradition of the theater as rock 'n' roll. With him, you've moved into a synthesis of rock with theater, with the costumes, the makeup, and the stage effects. Do you feel comfortable with that?

TP: Yeah, I like it. You have to do something different from the everyday. That's what the stage is for. You might as well use it, you know. And I guess I've got a little of the ham in me. I like to throw my drumsticks in the air. It's fun. And I like to sing. I did all the background vocals for Scandal, and I'll do some with Billy.

It's true that theater and rock are merging. You could see it in early precedents like Alice Cooper and David Bowie. Now with the

impact of video, it's really accelerating. Some groups are building really elaborate sets, trying to duplicate backgrounds in their videos, and taking them out on the road. And the audiences seem to love all the theatrics; they love to see someone like Steve Stevens cavorting around the stage. He can play, no doubt about that, *and* he's fun to watch. Why not? I guess they figure, if we're just going to stand there and play, they can stay home and listen to the record. Theatrics are frosting on the cake. We don't let them get in the way of our playing. But I really like watching the audiences *enjoy* the show. You can feel they're into it.

CF: How do you feel about all the makeup they put on you for the video?

TP: It's a pain in the ass. [laughs] For the concerts, I just put a little makeup on myself. I do it real fast. And it's off by the second song, anyway. I sweat it all off.

CF: When the close-up cameras were on you for the video, were they telling you how to act or to make certain gestures?

TP: Yes. Like on the part right before the chorus where the drum has a little buildup, the director told me just to exaggerate it a little, look out toward the camera and grimace a little more.

CF: Could that affect your playing at other times, having thought consciously about how you looked during a videotaping, for hours on end?

TP: No, I don't think so. When I play live, I always let my feelings and the music take over, and let it happen. Anyway, what they sometimes make you do in videos is uncomfortable. You wouldn't naturally do things their way. But that's how it has gone in every video I've worked on. The director takes over. The director's job is to tell you how to act, so you go along with it. Often you get directors who are used to making feature-length movies and to working with actors. But they're not working with actors; they're working with musicians. They want you to do certain things sometimes that are just physically impossible. They don't realize it. Even if you're only "drum-syncing" to the record, you still have to hold time, and you can't stand on your head simultaneously. Do you know what I mean? If you sweat while you're playing, you still have to sweat. You're not an actor. You're a musician. And it's hard sometimes to be both. But you can handle it, as long as you know who you are and you don't forget it.

I guess it *could* happen someday that someone would be cut out of a drumming job because that drummer doesn't *act* as well as another, even though the original drummer plays as well, or better than the other. But I hope not. I don't mind doing videos, as long as it's only two or three a year, [laughs] But the music is always what I'm here for.

CF: I never realized what an ordeal video-making must be for the musicians.

TP: Oh, the "Rebel Yell" one hasn't been too bad. So far the worst that's happened is my wife Debbie noticed this morning that the hairs on the back of my neck have been singed off from the hot lights they had behind me. I *thought* it was getting pretty hot back there! I remember the "Love's Got A Line On You" video I did with Scandal. There we were, standing out in the freezing cold at four o'clock in the morning, still trying to look cool after they'd had us taping for 22 hours straight. Now *that* was an ordeal!

CF: With all the types of stresses you're subjected to as a professional drummer—the traveling, the late hours, the videos—how do you manage to take care of your health?

TP: I try to stay healthy. I take vitamins, especially since I sometimes can't eat right on the road. Sometimes I just don't have the time. But nowadays we're all trying to take better care of ourselves, musicians included. To die young at 27—it's already been done, you know. It's *in* to be straight. You can act as crazy as you want on stage, but that's just on stage. Musicians are really taking care of their health more. And wanting to live a long life is nothing to be ashamed of.

MM: Thommy doesn't drink or anything else before a show. Even on New Year's Eve he didn't have a drink. On stage, he drinks water. That's it. And really, it's hard to be in his shoes at a show, when you see a bunch of people you know and everyone's partying

**suppliers of electronic drums
to Japan since 1983**

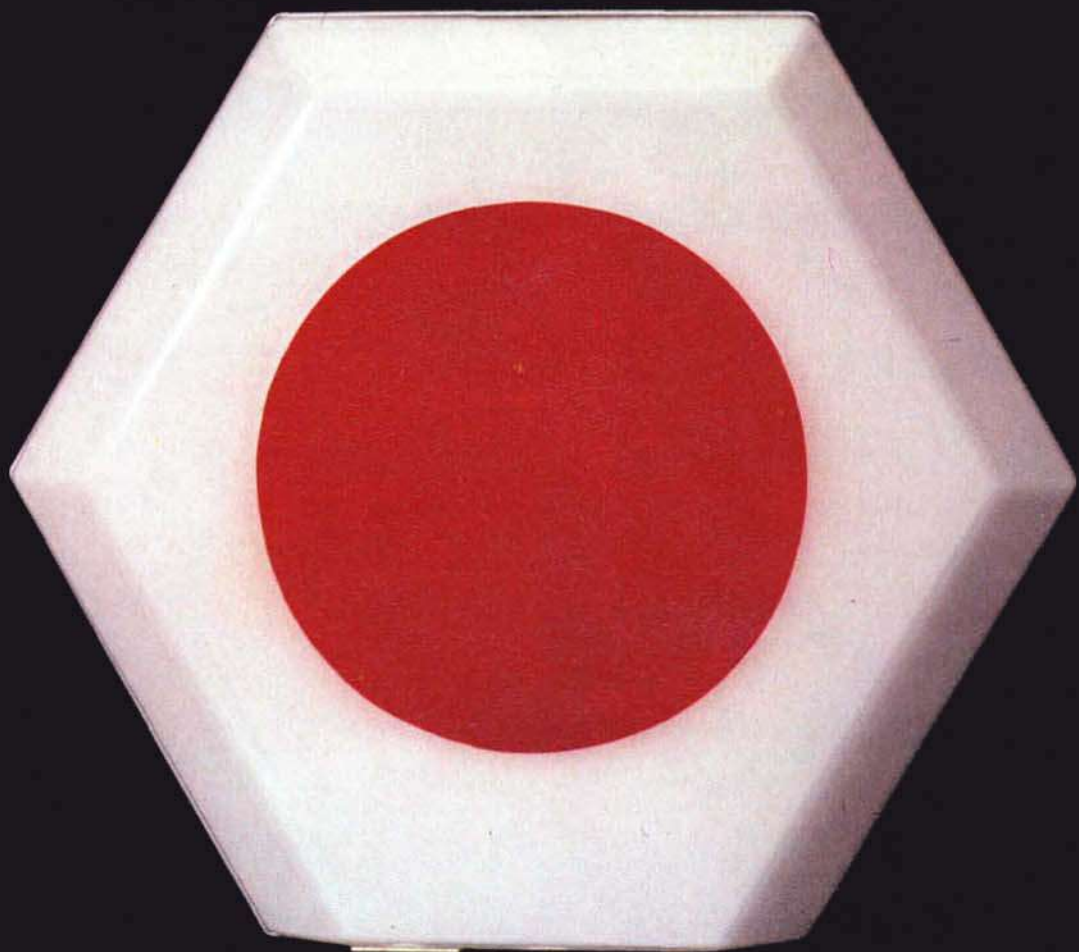

... **SIMMONS**

Simmons Electronic Drums, manufactured in St. Albans, England are now
available in thirtytwo countries including Japan.
Check them out at your local dealer.

Simmons Group Centre Inc.
P.O. Box 1444, Reseda, CA 91335
(818) 884-2653

CAN YOU READ THIS ?



EXPLODING
THE READING
MYTH!

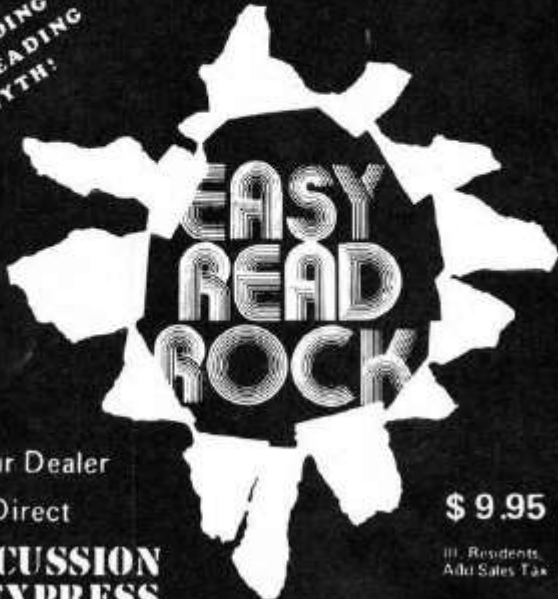

At your Dealer

or Direct

**PERCUSSION
EXPRESS**

P. O. Box 1731 Rockford, IL 61110

\$ 9.95

Ill. Residents,
Add Sales Tax

and having a good time, and you're sitting there drinking water. It's got to be hard.

CF: Thommy, what do you do to prepare yourself before a show?

TP: I like to rest. A lot of drummers have their practice pads, and I used to do that—the rudiments, with the real heavy drumsticks, 3B's or something—like a baseball player warming up with two bats. I even used to have one of those Remo drum pad setups when I was with Mink DeVille that I would set up in the dressing room. But then people started to get really annoyed, [laughs]

CF: Is that why you stopped warming up before a show?

TP: No. When you're on the road, you're playing almost every night, and the last thing you want to do—the last thing I want to do, anyway—is sit there and play before I go on. I'm warmed up by the first or second song anyway.

MM: Also, Thommy, if you warmed up for half an hour every night, your arms would already have half an hour's mileage on them when you started the set. When Thommy goes on stage, the first half hour of the set is his first half hour of playing that night. So he's still got it in him. That's what probably gets him through all those nights of banging away without tiring.

CF: What you're both saying is, "Why run five miles before a marathon?"

TP: Exactly. Another thing that happens is, not too often, but sometimes before a show I'll get a little uptight. Actually, I get the most nervous, not when I'm playing in front of thousands of people, but when I'm playing with my family there. I'll find myself in the dressing room with a set of drumsticks, and I'm just holding them or tapping them on my knees or something.

CF: Looking at your hands, I see you've got layer upon layer upon layer of calluses. Does a hard-hitting drummer like you have to play with pain?

TP: Well, a lot of drummers wear gloves, but these are like gloves to me. [laughs] What's weird about these calluses is that, even though I've had them ever since I've been playing, if I take off for

two weeks they'll start to go away. And as soon as I start to play again, I'll be in pain. Also, I've had a few problems with my back. I think that's an occupational hazard with drummers. I used to see a chiropractor about five years ago, but I don't anymore; my back is pretty good now. Part of the problem was that I always used to sit really low at my drums, with my back hunched over. Then it seemed that, no matter what I did and no matter where I went, I was hunched over. Then it got worse when I got this enormous drumset, and there was *no way* I was going to get at any of the drums sitting way down on the floor like I was. I was going for these drums and asking [jumps up, lunges way out with his arm], "Why isn't this stick reaching that cymbal?" So I lifted the seat up high, stretched my legs out, and sat up straighter when I played.

CF: Do you think that it could have been more than playing comfort that brought you out from behind the drums? Maybe you were getting more confidence; maybe you felt you *belonged* there, sitting up a little higher on stage.

TP: Maybe. It could be. I remember thinking, "Hey, people are actually out there!" Before, with all those big drums in front of me, no one could see me.

CF: Could you briefly describe Thommy's present drum setup, Moto?

MM: It's pretty basic. All his drums are Premier. On the bass drum there's a 24" head, and we use a white *Ambassador* batter. We use a felt beater, not a wood one. We use a 14" snare with a *Pinstripe* head. We have 13" and 14" rack toms, and a 16" and an 18" on the floor. On the bottom of all four toms we use white *Ambassador* batters, and on the tops we use clear *Ambassador* batters. They're thin heads. They sound good, especially live, but because they're thin, they dent and we have to change them almost every day. For miking, we use Shure *SM-57s*. The snare is miked from the top and also the bottom to get a more deep-sounding pop. The cymbals are Zildjian. We have a 22" ride and two 18" crashes, one on the left and one on the right, and 14" hi-hats. And we've just added two Pangs, an 18" and a 20", on the right. I polish the cymbals every night. I do the tuning for Thommy, and as I said, I have to change the heads every day or at least every other day. When I put the heads on, I tighten them up by hand, and then I turn each lug around one or two times. Then I always stand on the heads and jump up and down on them before I tune them. That stretches out the head and cracks the bead around the rim so it doesn't happen in the middle of the show and change the sound. I got the idea when I was working in a club and I asked this sound guy, who weighed 350 pounds, to stand on a bass drum. I figured, if *he* doesn't go through it, I won't go through it. I weigh 155 pounds and I've been standing on drumheads for seven years now. For *the first time*, last week, I went through one. But it was a faulty head, so that was good because it probably wouldn't have lasted through the night.

CF: What about sticks, Thommy?

TP: I just started using new sticks, *5B Regal Tips*. I was using *5A's* for a long time, but I switched because I always wound up using the butt ends of the *5A's*. I decided, why not just use the right end of the heavier stick? Plus, whenever they send us a gross of sticks, we're always picking out the darker ones, which are from the harder, heavier heart of the wood, so now we ask for the darker ones.

CF: Your pink drums have become a part of your signature, haven't they?

TP: Yes, I'm the guy with the pink drums. That all came about in England when I was with Mink DeVille and Premier approached me to do an endorsement. I saw their colors and said, "Let's do something wild." Pink went with Mink DeVille's pink and black, '50s staging, so they made me some pink drums. Now it's become part of my thing, and it's great. All musicians need to carve out their own styles, to find things that single them out as individuals, both visually and sound-wise. And now it's funny. I'll show up at a gig and someone will come up to me and ask, "Where do I know you from? I know those drums." Not me—my drums!

CF: Have you ever tried any of the new drums, like the Simmons,

What do you want from an electronic drum kit?



We put this question to hundreds of drummers and got a unanimous reply: great sounds, total flexibility, visual appeal and a modest price tag.

So we armed the SDS 8 with the legendary Simmons sound. We gave it separate channels for bass drum, snare drum, high, medium and low toms, each with an individually selectable factory pre-set sound and a highly versatile user-programmable option.

We provided a remote footswitching

facility to change all channel pre-sets simultaneously, and incorporated a stereo mixer and individual audio outputs for maximum flexibility.

We employed newly improved hexagonal drum pads, with softened playing surfaces, to allow unparalleled dynamic control and complete an electronic percussion system worthy of the name that revolutionised drums.

And the price tag? Well, perhaps we made just one compromise.

SIMMONS

Group Centre Inc.

Unit B, 5115 Douglas Fir Road, Calabasas, CA 91302 Tel: 213-884-2653

How Would You Like To . . .

study *timpani* with



**Vic
Firth**

pick up *drum corps*
tips from



**Dennis
DeLucia**

discuss *vibes* with



**Dave
Samuels**

take *marimba* lessons from



**Leigh
Howard
Stevens**

learn about *orchestral percussion*



from
**Arthur
Press**

To fill the needs of those who are involved in every area of percussion,
MODERN DRUMMER Publications is proud to announce

MODERN PERCUSSIONIST

A Contemporary Magazine for the Serious Drummer/Percussionist

Each issue of *Modern Percussionist Magazine* will be packed with information concerning orchestral and classical percussion, keyboard percussion, Latin and ethnic percussion, and drum corps and marching percussion. We'll interview the performers who are setting the standards to find out what they are doing, why they are doing it, and how they are doing it.

In addition, through our column departments you'll be able to get advice from such artists as Vic Firth, Leigh Howard Stevens, Dennis DeLucia, Arthur Press and Dave Samuels, as well as learn about percussion ensemble, contemporary percussion, and Latin instruments. We'll also review the latest records and publications that are of interest to percussionists, advise you of new products, and even answer your questions about percussion. *Modern Percussionist* will be published four times a year, beginning in December. Look for it soon!

If you're serious about percussion, you can't afford to miss a single issue of *Modern Percussionist*.

COMING

for instance?

TP: I rented a set for about four days once, but they didn't do much for me. Maybe I have to learn more about them. And just last week Moto and I tried two Simmons pads. There's a part in "Rebel Yell" where, when we're doing it live, Moto does a buildup on two toms miked up behind me. And I figured that if we could get the Simmons to sound better than those toms, we should do it. But they didn't even come close to those real drums.

CF: When you hit the cymbals, you're more of a ripper and a slasher. Instead of crashing down with the sticks, you often rip up from under. Why do you do that?

TP: It looks good, [laughs] Yeah, I usually crash the cymbals down on my left hand and go up on my right. It's for the visual effect; it's showmanship. The sound is the same.

CF: Let's talk about your approach to drumming. Seeing you play live with the Billy Idol band, I'm impressed first with the tightness of the group and second with the sense of confidence and power that you radiate as the drummer. How would you describe your function in the band?

TP: Probably as the engine. I'm the motor. I'm not bragging, but I think the problem they had in the band before I got in was that they didn't have a drummer strong enough to really push the guys—someone who could leave them free to play without worrying about the drums. With the drums on line, they can do their thing. A player like Steve Stevens is like a balloon free-flying off into space. And I'm the string, anchoring him down on the ground. With that security, he can just take off and not get lost. I hit rock solid. I just lay it down—lay right into the beat, heart and soul, powerful and simple. Simplicity is sometimes the best, you know. I'd rather hear a drummer play a fill that's simple and allow some space in a song: leave that hole instead of saying, "Oh, there's a hole. I've got to fill it." The space is there for a reason. Why not leave some room for a few seconds? To me that makes more sense.

CF: There are a few who might belittle you for your simplicity and your rock-solid style of drumming. They might say, "Look at Stewart Copeland and at Neil Peart; look at all the fancy stuff they do." How would you answer that?

TP: Well, I'd probably tell them to go out and get somebody like Stewart Copeland. I love Stewart Copeland. As a matter of fact, he came to see me backstage just the other night. But I know who I am and so do other people. That's why I get hired for the things I do. They wouldn't hire me for a Stewart Copeland record. They hire me to be Thommy Price. I'm not going to change for anyone. I don't want to. I don't have to.

CF: I think I know how you're going to answer this, but I'll ask anyway: How do you feel about drum solos?

TP: [big grimace] They're boring. I hate them. I hate them. I hate listening to them, [laughs]

CF: And you're a drummer.

TP: Yeah. But I really despise drum solos.

CF: So obviously you don't do drum solos in your concerts.

TP: Oh, I've done them.

CF: Why?

TP: Well, because we had to fill up a lot of time! "Thommy, go out and do a ten-minute drum solo!" Oooh. [moans as if in agony]

CF: So you'd rather go to the dentist?

TP: DENTIST? DENTIST? Would I rather go to the dentist? Oh, definitely! I'd rather have those drills going on my teeth—definitely.

CF: It seems many times that I hear a drum solo that shows off the drummer's technical skill, but in the context of the music, it doesn't make sense.

TP: Well, some of them actually do make sense. I've seen Mickey Curry from Hall & Oates do a drum solo that was incredible, only because it was so simple; it was really funky. I mean the guy's got chops and he's a great drummer, but in the solo he played funky and lean. I watched him every night for three weeks last summer when Scandal was touring with Hall & Oates, and the kind of solos that he did were the kind that I would do if, if ...

CF: If somebody forced you to do a solo.

TP: Right!

CF: Are you satisfied with your progress as a drummer?

TP: Well, yes. I never feel like I'm standing still. I feel like I'm getting better and growing all the time. I listen to records I did in the past and I can see where I've learned things since then and where I've branched out.

CF: Give me an example.

TP: Well, there's a song we do in concert called "Shooting Stars," and there are a few sort of ska-type feels that I've recently tried on the Pangs, off the beat. And I know Stewart Copeland opened me up to that. There's always more to learn. I try to soak everything in. If I had time, I'd learn how to read better. It would help my songwriting. I'd learn how to play the piano. Right now I only know the guitar, besides the drums. Mentally, I'm ready to go in and do a project on my own. I'd like to learn a few more things, technically. But it's not that far away. I talked to a friend last night about doing a solo album. And I know when I finally do go in on my own, it's still going to be the first try at it—the outline. And the next time I'll improve on that. It can always get better; that's always the case.

CF: Besides contemplating a solo project, have you ever thought of fronting your own band?

TP: Yeah, I'd love to. That's the ultimate, for every musician.

CF: If you were to imagine the Thommy Price Band, what would it sound like?

TP: Oh, describing it in terms of a sound you've heard, I guess it would be like Phil Collins—like the *Face Value* album. That album is a lot different from early Genesis albums. That's when I really started getting into his simplicity and the way he lays right into the groove and plays with a lot of soul—primitive. I like the way the drums are a big part of the arrangement. I like that whole kind of thing that's real moody, real hypnotic, mesmerizing, repeating itself like a chant.

CF: That's really the basis of drumming, that repetitive rhythm that gets inside you and takes over, like in ancient tribal rituals.

TP: That's what I try to do in my songwriting—to build that kind

PROTECT YOUR MD'S

Back issues of *Modern Drummer* are fast becoming collectors items. Protect your investment with these deluxe magazine files. A great, inexpensive way to keep your valuable issues neat, clean and readily available for easy reference!

Each file holds 18 issues, looks like leather, and comes in vivid blue with MD's logo and trademark imprinted in rich gold.

Mail to:
The Highsmith Co.
P.O. Box 25-MD
Fort Atkinson
WI
53538
ENCLOSE
CHECK OR
MONEY ORDER

QUANTITY DESCRIPTION MD FILE NAME ADDRESS CITY STATE ZIP

COB TACH \$6.50 (3 or more \$3.65 ea.) TOTAL

RESONANT

Patented Drum Sticks

The most BEAUTIFUL and ATTRACTIVE drum stick on the market, and the ONLY drum sticks with "built-in COMFORT"

The patented GRIP feels GREAT and when you try new beats, you will find that you CAN play BETTER and FASTER than with standard wood sticks.

Available in Hickory in 2B, 5B, 5A, 7A, Jazz in Wood or Nylon tip, Rock/Roll Knockers also with grip: \$6.50 plus \$1.00 postage.

And Now! For the HARD Rock Drummer, Densiwood drum sticks in 2B & 5B, Wood or Nylon tip, and Rock has no tip, both ends butted. Densiwood sticks are heavier and longer lasting than Hickory and are VERY LOUD!

Introductory price: \$8.50 plus \$1.00 postage.

RESONANT DRUM STICKS

P.O. Box 11007

Torrance, CA 90510-1007

Dealers write or call

(213) 328-1354



center rolls music
rolls music center
music center rolls
center rolls music

Percussion Keyboards
 Guitars Multitrack Lighting
 Sound Systems Amplifiers

800-336-0199

"Competitive Worldwide"

1065 West Broad Street
Falls Church, Virginia 22046

of rhythm, that kind of groove. But you know, when I try to talk about other drummers, I don't really care to *analyze* them, technically. I can tell you how they make me feel—how they affect my emotions—because when I listen to a record, I listen to the drums, but I really *don't* listen to the drums, if you know what I mean. I listen to the *music*. I want to *feel* the sound, not analyze it. It's the same when I'm in the studio and I want to learn a song. Instead of them putting a chart in front of me and me trying to understand it, I'd rather try to understand the *song*: try to understand what the lyrics are about, try to understand where the changes are, try to *feel* the song more than *read* the song, and try to play it from the heart.

CF: You talk a lot about feelings, emotions, and playing from the heart. I've just realized that I've spoken to you for hours, and the subject of money has never come up. That's almost unheard of in the 1980s! You're really not in it for the money, are you?
TP: No. I haven't gotten to that point, and I don't think I ever will. If I were only in it for the money, I would just continue to move on. Just a few weeks ago, another group took me to dinner and said, "We'll pay you double what Billy's giving you." I'm not making any more money now than I was making with Scandal. Not really. But I moved on because of the *music*. I love the *music* I'm doing now. I could make tons more money than I make now. I could stay in New York all year 'round and get double-and-a-half scale for doing records and other studio work—grab some fast money, work that 9 to 5, go in the studio every day, knock out about 47,000 jingles, and go home. I've done it before, when I really needed the money. But I always feel like I'm cheating myself. I like being a part of a group; I like performing for people all over the world. That's what it's all about.

CF: You're one of the most confident, positive-thinking musicians I've met. Does anything get you down?

TP: Being away from my wife, when I'm on the road—being away from my home. My wife is very supportive and understanding. We've been together for six or seven years, and we've really merged. We were complete opposites when we met. She was a biochemist, and I was the lunatic drummer. I talk to her almost every day when I'm on tour. She's my contact with reality. When we've got guards posted by our hotel rooms, and everyone wants to meet us, and everything gets crazy, she reminds me that I'm still the same Thommy Price who goes to the laundromat back home on Staten Island.

CF: I'm sure it's exciting for you to be right in the center of a rock group rising to real prominence. And it seems you've had a large measure of success before this; you've always had a gig for the last 17 years. It *could* dry up for a little while someday. It happens to the best of them. Did you ever consider how you might handle that?

TP: Yeah ... it would be tough. I've been very lucky so far. It would be tough. Well, I know the studio's always there, but ... I could really appreciate the opportunity to concentrate more on my songwriting. Now, I just do a little on the bus and little in my hotel room—bits and pieces. It would be good to have time to write and learn.

You know what I'd like to do? Someday I'd like to work with wood. My grandfather was a carpenter, and I used to go down to his basement as a little kid and fool around.

CF: He was pounding, too—right? Only with a hammer instead of drumsticks.

TP: Yeah. It all goes back to that. I suppose I'm just doing my own variation on that—a different groove, a little more creative. That's actually what I'd do; I'd love to work with wood like he did. He'd build these amazing grandfather clocks out of pianos [stops to think]. Now you've really got me going! It was those clocks and the way they kept time, so beautifully, with the pendulum and all, that always fascinated me so much.

CF: Another tie-in with the drumming—the timekeeper.

TP: Yes. It's so funny, when you think of it, how your past can shape your future, and you don't even realize what's happening to you at the time. I guess I was "in training" to be a drummer from the very beginning.



A drummer's hands... His most prized possession

*To insure the ultimate in creative
achievement, a drummer must have at his
fingertips the finest equipment available.*

*Put your
percussion
needs
in
the hands
of the
Professionals...*

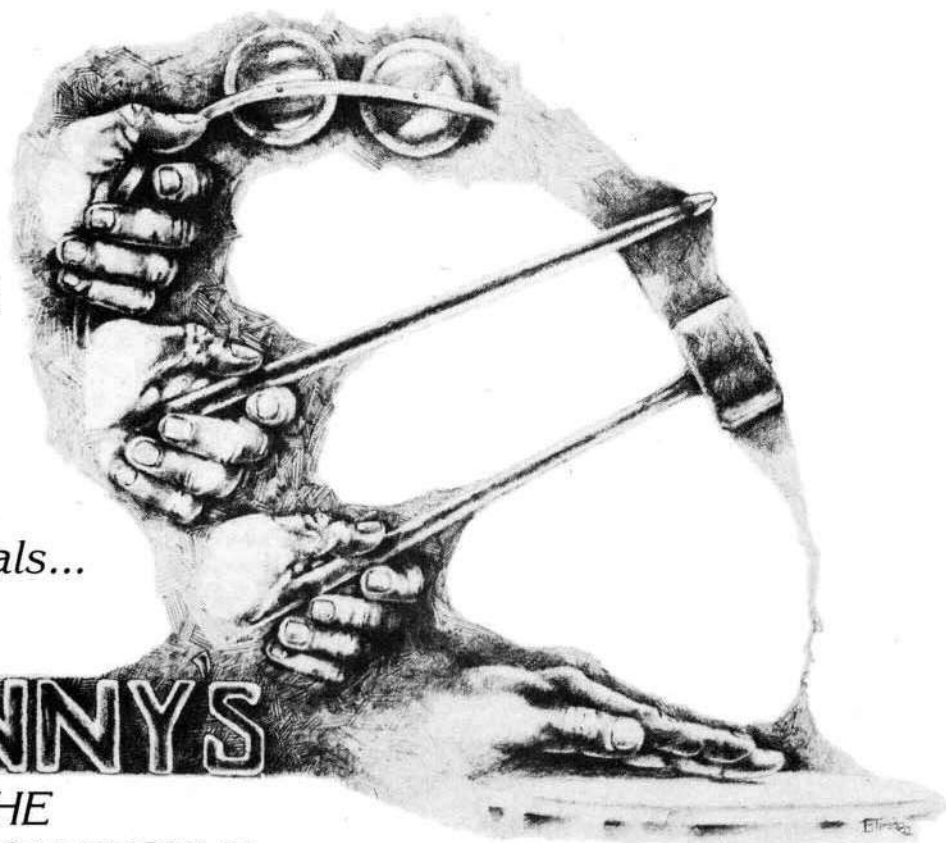

MANNYS

THE
PERCUSSION PEOPLE

**156 W. 48th St.
N.Y., N.Y. 10036
(212) 819-0577**

Dance Accompaniment

The contemporary drummer is chronically faced with the twofold challenge of earning a living and finding outlets for his or her creativity. One of the most fertile areas of potential employment, capable of satisfying both of the above criteria yet often overlooked, is the field of dance accompaniment. The image you may have of a dance accompanist is that of a pianist playing classical excerpts while students do *plies* at the ballet *barre*; in reality, the entire percussion family of instruments (including piano) is the one most frequently used for dance accompaniment. Percussionists are used extensively for modern dance, ethnic dance (African, Middle Eastern, Latin American, etc.) and jazz dance.

The Function Of The Dance Accompanist

The function of the dance accompanist is primarily to keep time, just as time is the *primary* function of a drummer in a band. Time, after all, is the continuum against which both music and dance occur. Once the accompanist has established the rhythmic foundation, his or her sensitivity to the dance environment, and ability to be creative within that context, come into play. The accompanist should support the movement sequence by reinforcing the rhythmic structure, texture, dynamics and mood of the phrase. Live music energizes a class far more than either recorded accompaniment or an instructor's counting possibly could, thus encouraging students to work harder and longer to learn a part or solve a problem. Live music also frees the instructor to coach students on the quality of their movements, rather than being forced to continually count time for them. A good accompanist also adds an element of control to a class by establishing clear cues, so that students will begin and end their movement on time, stay in meter, and be better able to concentrate on moving, rather than counting. The accompanist may give a lecture on rhythmic analysis, explaining the fundamentals of counting rhythms, duple and triple meter, and odd time signatures. An experienced accompanist can also lead a warm-up, or even run an entire class if need be, in the absence of the instructor.

Pros And Cons

Accompanying dance classes does require working irregular and sometimes early hours; fortunately though, a large

percentage of accompanist work takes place at times when most bands are not gigging. Although accompanist pay is not the highest, the extra income is handy, and it sure beats doing something nonmusical! As with any aspect of the music business, the more experienced and in demand you become, the more you are worth to the people who utilize your skills.

I've heard some musicians complain about boredom, or not getting a chance to stretch out enough while playing for dance. Personally, I see it as a great opportunity for creativity and self-expression. Once the basic needs of the class are fulfilled, you will generally have a free hand in determining the timbre, texture and shape of the sound. It's a chance to play and be paid for it. What you make of it depends on you.

Although the dance accompanist is always in a supportive role and has little status in the academic world, the drummer's ego is generally well conditioned to being in the background and not getting enough recognition. However, accompanist work does provide the opportunity to work in a clean, smoke-free environment, with people who appreciate your contribution.

If you are fortunate enough to be employed by a college or university, you may earn a better hourly rate than you could playing in a dance studio. You may also receive some employee benefits, such as health and unemployment insurance and a pension plan. Some schools offer faculty members the opportunity to take courses for credit free of charge. As a faculty or staff member, you will have free access to the pool, weight room, library, practice rooms and media center, where you can sign out audio and video recording equipment, records, tapes, films, etc. One more result of playing for dance is that you may gain a whole new following for the bands you play in!

Tips On Accompaniment

1. Pay close attention to the instruction. A good accompanist is alert for cues to begin and end.
2. Play the rhythm simply and clearly until the dancers are comfortable with the movement. Once the dancers are secure, you can elaborate on the rhythm, play polyrhythms, accents, syncopation, double time, half time, etc.
3. Keep steady time, but don't just keep time. Use a variety of instruments to

change the color and texture of the music. The percussion family includes drums, cymbals, shakers, rattles, metal instruments, wooden instruments, and an endless array of sticks, mallets, brushes and beaters. Taking advantage of them will keep your music free and spirited, so that it can provide a variety of stimuli for the dancers.

4. Don't play too loudly! Remember your job is to *accompany*, and the instructor will need to give directions and instruction over your music.

5. Participate in some dance classes yourself. It helps to know what it's like on the other side of the fence, and the flexibility, strength and coordination you gain will certainly enhance your drumming.

6. Keep a notebook. If you improvise something that seems to work very well, make a note of it and memorize it so that you can use it again.

7. Be on time! The most fundamental element of professionalism is getting to work on time.

8. Be cooperative and flexible. Be willing to change what you are playing if it doesn't seem to work, or if the instructor asks you to. Be open to suggestions, and offer suggestions where appropriate. Help the weaker students to hear and feel the beat; offer to operate sound equipment and tape recorders; make tapes for students and teachers; and take an interest in the progress of the class.

Finding A Job

Finding a job as an accompanist or composer for dance is no different from finding any other gig. You should have a sincere interest in playing in that context and be willing to pay some dues in order to gain experience. Attend dance performances in your area, especially those that come under the category of modern dance, and speak with the dancers and musicians. Show enthusiasm for their work and express your desire to become involved. Many modern dancers like to improvise and to "jam" with musicians. Remember, when a gig comes up, people tend to hire the individuals they've been jamming or rehearsing with.

Although an accompanist does not need to be a composer, the ability to create original music for dance performances is invaluable. Therefore, the ability to write such music combined with your talents as an accompanist will enhance your chances

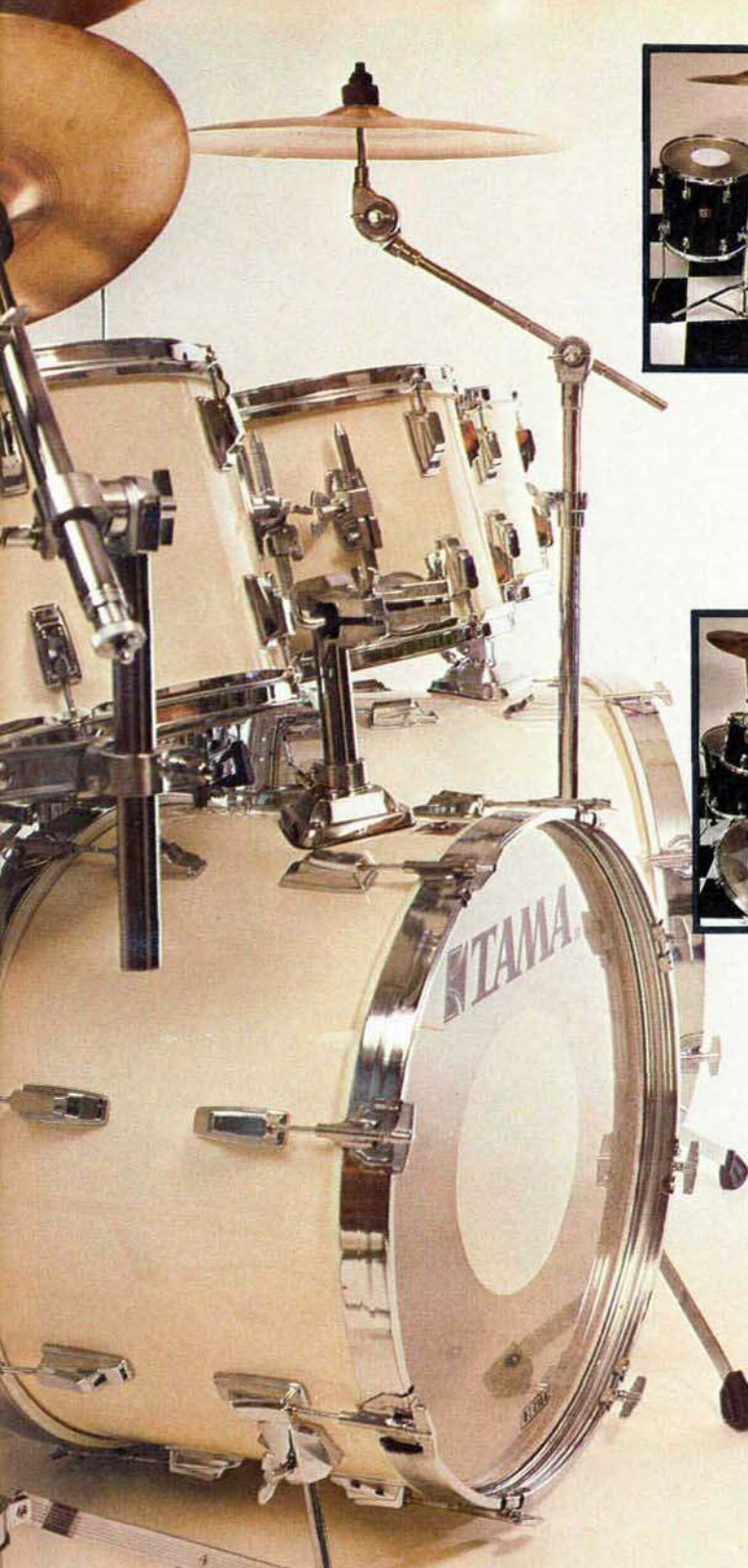

5-PIECE SET
SS505JBK
TOTAL SET PRICE
Under 875.99



6-PIECE SET
SS505AWH Under 875.99
7038AWH Under 220.99
(18" floor tom)
TOTAL SET PRICE
Under 1095.99



7-PIECE SET
SS505JBK Under 875.99
SS512JBK Under 310.99
(8" and 10" tom toms w/ stand)
(straight cymbal stand)
TOTAL SET PRICE
Under 1185.99



8-PIECE SET
SS505AWH Under 875.99
SS514AWH Under 375.99
(10" and 14" tom toms w/ stand)
(boom cymbal stand)
7038AWH Under 220.99
(18" floor tom)
TOTAL SET PRICE
Under 1470.99



9-PIECE SET with X-HAT
SS505JBK Under 875.99
SS514JBK Under 375.99
(10" and 14" tom toms w/ stand)
(boom cymbal stand)
7038JBK Under 220.99 (18" floor tom)
7022JBK Under 320.99 (22" bass drum)
895 Under 80.99 (X-HAT)
TOTAL SET PRICE
Under 1860.99
*THIS SET SHOWN WITH TOM
HOLDER INSTEAD OF TOM STAND

...As Versatile As Your Imagination

At Tama, we feel imagination and versatility are two of the most critical qualities a drummer can possess. TAMA Swingstar Drums compliment these qualities in today's drummer by providing the widest variety of set-ups at prices any upcoming pro can afford.



Look for this banner at your authorized Tama dealer.

The 1984 Swingstar line features many design improvements such as newly designed lugs, a keylock Omni-Sphere tom mount, and the new standard in middle weight hardware - TAMA Stagmaster. Visit your authorized Tama dealer for a look at all the exciting possibilities available with Swingstar Drums.

For a full color catalog send \$2.00 to: Tama, dept. MD; P.O. Box 886, Bensalem, PA 19020; 17421 "B" East Gale Ave., City of Industry, CA 91748
P.O. Box 2009, Idaho Falls, ID 83403; In Canada: 6969 Trans Canada Highway, Suite 105, St-Laurent, Quebec, Canada H4T1V8

who reads **MODERN DRUMMER™** ?



Photo by Michael Jachles

Tommy Aldridge

From professionals like **Tommy Aldridge** to those who have recently started playing, drummers at every level know that they can keep up with what's happening by reading *Modern Drummer* every month. You can too! Subscribe today, and don't miss a single issue.

See Attached Subscription Card For Ordering Information

for employment in this area.

Phone or visit local dance studios, colleges, universities, adult education centers, etc., and find out if live accompaniment is used. Find out who the dance accompanists are in your area and check out what they are doing. You will probably be allowed to observe a class if you ask. Let them know that you are interested if they ever need a sub. Follow up by staying in touch with people and letting them hear what you are doing. Don't give up!

Summary

My own experience as both an accompanist and composer for modern dance has been most rewarding on many levels. Musically, I have had many opportunities to explore and develop my creativity within boundaries other than those normally encountered in music. I've learned much from dancers about stretching, breathing, nutrition, centering, and overall body efficiency. Also, being around people who train as arduously as dancers must is always an inspiration to do more myself. Since dancers frequently rely upon musical accompaniment, artistic set design, and creative lighting to enhance their performances, they need to be aware of a variety of other art forms. Because of this, my own awareness of other musical genres, as well as art forms outside music, has been greatly expanded and enriched. Last but not least, several of my most rewarding friendships are a direct result of my involvement with dance. As you explore the field of music for dance, I hope you will be as richly rewarded in your pursuits as I have been in mine!

Lou Grassi has been creating music for modern dance since 1971. He has provided accompaniment for some of the leading teachers of modern dance, as well as creating scores for some of the finest choreographers in the field. He is the dance accompanist at Jersey City State College, and at various times has been resident percussionist for the dance department at Brockport State University and at the American Dance Asylum.





TRUSTED WORLDWIDE FOR OVER 50 YEARS!

EAMES	SLINGERLAND	NORTH
GRETSCH	SONOR	OM PERC.
LUDWIG	TAMA	MUSSER
PEARL	YAMAHA	DEAGAN
PREMIER	DRUM WORKSHOP	ZILDJIAN
ROGERS	GONBOPS	PAISTE
SIMMONS	LATIN PERC	SABIAN

GREAT PRICES, WE SHIP EVERYWHERE
(203) 442-9600

 20 Bank St. • New London, CT. 06320 



- | | | |
|--|---|--|
| #12 - AUGUST 1979
Billy Cobham, Elvin Jones,
Jimmy Cobb. | #29 - DECEMBER 1981
Ringo Starr, Mitch Mitchell. | #40 - FEBRUARY 1983
Jeff Porcaro, Clem Burke,
Billy Higgins. |
| #13 - OCTOBER 1979
Gene Krupa Tribute Issue,
Michael Shrieve. | #30 - FEBRUARY 1982
Philly Joe Hones, Stix Hooper. | #41 - MARCH 1983
Kenney Jones, Kenny Clare, Ginger
Baker. |
| #17 - JUNE 1980
Carl Palmer, Derek Pellicci,
Great Jazz Drummers—
Part I. | #31 - APRIL 1982
Max Weinberg, Narada
Michael Walden, Danny Gott-
lieb. | #43 - MAY 1983
Earl Palmer, Chad Wackerman,
Eli Konikoff. |
| #18 - AUGUST 1980
Chet McCracken & Keith
Knudsen, Ed Green. | #32 - MAY 1982
Aynsley Dunbar, Alex Acuna. | #44 - JUNE 1983
Bill Buford, Mike Clark, Mark
Craney |
| #22 - APRIL 1981
Hal Blaine, Gil Moore, P.L.T.
Close-Up. | #33 - JUNE 1982
Max Roach, Keith Moon, Vic
Firth. | #45 - JULY 1983
Steve Gadd, Myron Grombacher,
Drumsticks: The Full Story. |
| #23 - MAY 1981
Jalmoe Johnson-Butch Trucks,
Roger Hawkins, Buddy Har-
man, Paul T. Riddle. | #34 - JULY 1982
John Panozzo, Graham Lear, Martin
Chambers. | #46 - AUGUST 1983
Airo, Mark Herndon, Fran
Christina. |
| #25 - JULY 1981
Harvey Mason, Alan Gratzer,
Bassist: On Drummers. | #35 - AUG/SEPT 1982
Charlie Watts, Ed Mann,
David Dix. | #47 - SEPTEMBER 1983
MBoom, Eric Carr, Denny Carmassi. |
| #26 - AUGUST 1981
Billy Kreuzman, Mickey
Hart, James Bradley, Jr. | #37 - NOVEMBER 1982
Vinnie Colaiuta, Barry Altschul,
Liberty DeVitto. | #48 - OCTOBER 1983
Alex Van Halen, Phillip Wilson,
Frank Beard. |
| #27 - OCTOBER 1981
Shelly Manne, Tommy
Aldridge. | #38 - DECEMBER 1982
Elvin Jones, John Densmore,
Miking & Recording Drums. | #49 - NOVEMBER 1983
Phil Collins, Joe LaBarbera,
Inside Sabian. |
| #28 - NOVEMBER 1981
Jim Keltner, Terry Bozzio, Ed
Blackwell. | #39 - JANUARY 1983
Peter Erskine, Chester Thompson,
Jim Gordon. | #50 - DECEMBER 1983
Carl Palmer, Simon Kirke,
Guide to Drum Computers. |

Yes, I've missed some copies! Please send me the issues checked off below. All back issues are \$3.50 each. My payment for \$ _____ is enclosed. 47

- | | | | | | | | | | |
|-----------------------------|-----------------------------|-----------------------------|-----------------------------|-----------------------------|-----------------------------|-----------------------------|-----------------------------|-----------------------------|-----------------------------|
| 12 <input type="checkbox"/> | 18 <input type="checkbox"/> | 25 <input type="checkbox"/> | 28 <input type="checkbox"/> | 31 <input type="checkbox"/> | 34 <input type="checkbox"/> | 37 <input type="checkbox"/> | 40 <input type="checkbox"/> | 44 <input type="checkbox"/> | 48 <input type="checkbox"/> |
| 13 <input type="checkbox"/> | 22 <input type="checkbox"/> | 26 <input type="checkbox"/> | 29 <input type="checkbox"/> | 32 <input type="checkbox"/> | 35 <input type="checkbox"/> | 38 <input type="checkbox"/> | 41 <input type="checkbox"/> | 45 <input type="checkbox"/> | 49 <input type="checkbox"/> |
| 17 <input type="checkbox"/> | 23 <input type="checkbox"/> | 27 <input type="checkbox"/> | 30 <input type="checkbox"/> | 33 <input type="checkbox"/> | 36 <input type="checkbox"/> | 39 <input type="checkbox"/> | 43 <input type="checkbox"/> | 46 <input type="checkbox"/> | 50 <input type="checkbox"/> |

SEND TO:
NAME _____

ADDRESS _____

CITY _____ STATE _____ ZIP _____
MAIL TO: MODERN DRUMMER BACK ISSUE SERVICE
1000 CLIFTON AVE., CLIFTON, NJ 07013

Evaluating "Marimba Blues"

Continuing our analysis of the "blues" form in this article, I intend to illustrate and draw together previously discussed materials so that you will be able to play a blues tune, and hopefully create your own in the future. We will also take a look at three common compositional devices you should know: *motivic development*, *turnaround*, and *cadence*.

Last time you learned that a blues is a 12-bar form, employing dominant 7th chords (I,3,5,7) on the tonic (I), sub-dominant (IV), and dominant (V) chord functions. The time feel of the original blues, as in jazz, is the triplet subdivision of the quarter note with an emphasis on 2 and 4:



Take a look at the melody of "Marimba Blues." We have three, four-bar phrases: The first phrase is stated (#1) and then repeated (#2). Phrase #3 is the variation, yet it is still related to the initial theme. This is the typical blues melody. The lead voice states an idea, the group responds in the space after the idea, this call-and-response is repeated, and then the variation is sung by the leader with all joining in at the end of the form. Thematic repetition is a very important concept in music, and you can practice this on your drums as well as on your keyboard. Memorize the melody. Then solo on the form at the drums *while singing the melody*.

Notice the use of activity and rest in the melodic line. Bars 1-2, 5-6, and 9-10 move, while 3-4, 7-8 and 11-12 hold long tones. Also notice that the last three 8th notes of bars 2, 6, and 10 are identical. Using the same melodic material in this thematic fashion is called *motivic development*, and is essential to communicating a strong, clear idea to the listener. One idea is repeated and/or reworked to give continuity and compositional integrity to the music. To illustrate how this works on the drumset, play the following time pattern on the ride cymbal and hi-hat, while singing the melody to "Marimba Blues":

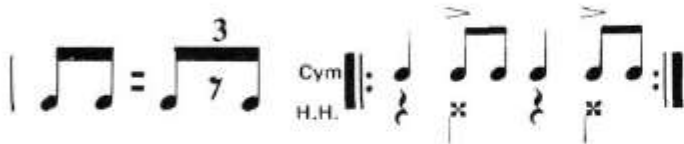

Now, try the following:

1. Along with the above, play the melodic line on the snare drum.
2. Along with the above, play the melodic line on the bass drum.
3. Along with the above, play the melodic line between the bass and snare.
4. Do any of 1 through 3 on bars 1-2, 5-6 and 9-10, where the line moves, and solo in the bars which hold: 3-4, 7-8, 11-12. This relates your drumming to the music.

Notice the use of the blues scale: 1,b3, 4,b5, 5,b7, or in the case of our melody B, D, E, F, F#, A. What are the *chord tones* of our tonic or "one" chord? B, D#, F# and A. This melody sounds good because: (1) One basic, clear idea is repeated, with enough space

that the listener can absorb the information, and (2) the melody contains some colorful notes from the blues scale, which create tension and interest when played against the chord tone foundation.

While you have the *chord tones* in the harmonic foundation of the music, the melody on top uses *blues notes* against this foundation to create the indigenous blues sound. Other examples include bar 10, where the A natural is the flat 3rd against F#, A#, C#, E, and bar 11, which has Bb and G natural against chord tones E, G#, B, D.

If you remember our basic 12-bar form from last month, you'll recall that the 11th and 12th bars simply return to the tonic, or target chord, (I7). In "Marimba Blues" that chord is B7. However, by creating a short chord sequence, and avoiding the tonic B7 in bars 11 and 12, we can create a much strong momentum and greater intensity and we *do* reach the B7 target at the top of the form in bar 1 for the next chorus. We can illustrate this as follows:

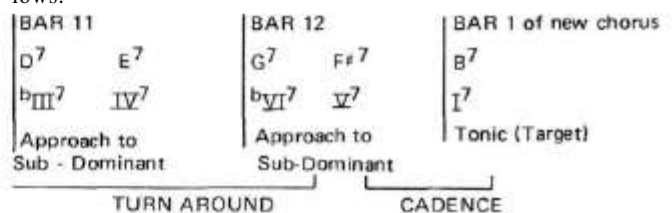

The *turnaround* (D7, E7, G7, F#7) is the device which creates momentum and increases the tension for the cadence resolution back to the tonic key area. This frequently occurs at the end of a section of a tune or at the end of a tune, so it is an emotional point in the music which the drummer should support. In the "Marimba Blues" turnaround, the rhythm section plays triplets on each quarter note to drive the music on to the top of the next chorus. The *cadence* is the closing, resolution, or relaxing of the tension created by the turnaround when the return to the tonic (target) is made. The most common cadence is the V-I, or dominant-tonic relationship. Another common one is IV-I. Think of how everyone sings "Amen" at the end of a church hymn. The IV-I cadence is called the "Amen" or plagal cadence. "Marimba Blues" uses both of the cadences I've mentioned.

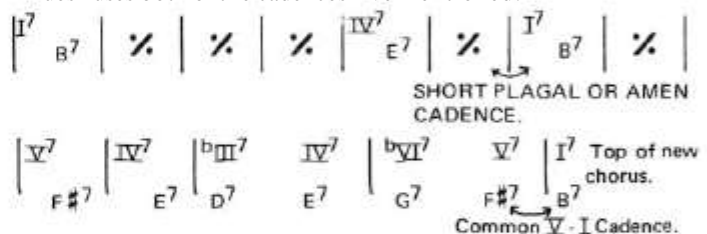

If you have spent even a short portion of your daily practice time on the musical ideas we have worked on thus far, you might very well be able to compose your own blues tune. The most important thing to remember is to listen critically to whatever you come up with, so that you are sure it *sounds good*. Next time, we will review the material we've covered so far in this series.

If you are interested in obtaining a recording of "Marimba Blues" as a study aid, contact Bill through Modern Drummer, or at 57 Beach Street, New York, NY 10013.



I was born James D. Miller (the "D" stands for drums, I think) on June 13, 1953, in Indianapolis, Indiana. I started piano lessons at age six; by the time I was in the seventh grade I was already hooked on drums. The bass drum spot in the school band was vacant, and I was the lucky guy who filled it. I moved up to snare the next year, and started taking lessons with Jack Wagley, percussionist with the Indianapolis Symphony Orchestra. I've also studied at the drum clinics of Alan Dawson, Ed Shaughnessy, J. C. Heard, and John Von Ohlen. But most of my education (and inspiration) has come from listening to records and checking out my favorite drummers live, especially Elvin Jones and Jack DeJohnette.

I consider myself very fortunate that most of the bands I've been involved with, regardless of all their various stylistic directions, were interested in performing original material. I believe that these experiences made me aware of the limitless possibilities for self-expression through creative music, and very conscious of the "sound mass" being projected at any given moment. Significantly, when I freelanced with numerous jazz trios and quartets in the Philadelphia area, I was told that they hired me because I *listened*, and consequently made the band sound better. A sensitive, sympathetic drummer can easily make the big difference between "just another night of music" for all concerned, and a tight, professional, seemingly arranged "show," even if the musicians have never played together before!

This brings me to my favorite subject: I am co-leader of Reverie, a Philadelphia-based original instrumental ensemble. We've been together for almost five years now, which has enabled us to develop both a distinctive sound and a sizable following. Reverie has performed at clubs, colleges, and theaters throughout the East Coast and the South, and we've appeared with John Blake, Bobby Hutcherson, Woody Shaw, Jeff Lorber, Sun Ra, Phil Woods, Wynton Marsalis, Philly Joe Jones (opening for Philly was equal to 100 condensed drum lessons!), and Larry Coryell, who makes a guest appearance on our first album, *Reverie*. In the summer of '83 we played the Kool Jazz Festival in Philadel-

James D. Miller

phia and released our second LP, *Watch The Skies*. Both of our albums were completely independent projects, on our own label, Encounter Records; conceived, produced, written, arranged, and performed, by Reverie.

Now allow me to offer what I consider to be the most important piece of advice I can give: If you are serious about your music, then you must realize that this is a business! You must somehow learn to divide your time fairly equally between practicing your craft (improving your talent) and taking care of business (improving your chances for success). I've even found an advantage in this. After all the hassles, the phone calls, the letters, etc.—when you finally get up on stage and play, it's such a release! There's such sheer joy and exuberance at being able to shut off all the other pressures and just have a good time! It's a delicate balance that, once achieved, has its own rewards, particularly in a band that operates synergistically, as we do.

As far as equipment goes, I have a Tama *Superstar* set that I use with Reverie. They sound similar to Gretsch (6-ply, like Gretsch, but birch instead of maple), but I think they're slightly sturdier, and more "road worthy." My beloved old set of Gretsch drums is "semi-retired" to our rehearsal space (although I still use them for recording), and I also have a set of Sonor for work outside the band. The Sonor drums seem to be easier to control in low-volume situations. All three sets are small jazz kits with 18" bass drums, because I've found that you can get an 18" to sound as big as you want, but you could never get the tone that an 18" puts out with a bigger drum. I use all Paiste cymbals, Remo heads, and Pro-Mark sticks, only because they're readily available everywhere.

My last comments: Follow your heart. The bargain bins are full of records that were coldly calculated to be commercial and they still didn't sell, so you might as well do what *you* want. After all, if you *do* eventually "make it," your output will represent you for the rest of your life, so it better be something you believe in. Instead of changing your music to fit current trends, just persevere, and eventually the intelligent listeners you wish to reach will hear what you're doing.



Being into music, I always wanted to play an instrument well. During my junior year of high school (1978), I took up guitar and played for three or four years. I felt I wasn't going to get any better, so I decided to take up drumming instead. I always felt more comfortable with rhythm than notes, so the shift was fairly natural. I began listening to my favorite records, this time trying to single out what the drummers were doing. It was interesting to separate the music into its component parts, and see how rhythms and melodies fit together. I learned from listening to albums and playing by myself.

I progressed enough in the first months to move up to a better set of drums. It was in August of 1982, about a month after purchasing the new set, that I lost half of my right forearm in an industrial accident. I was in the hospital for three weeks, and one of the first things I thought of was, "How will I ever be able to play the drums now?" I had only been playing for a short time before the accident and wanted to continue. At age 21, my future looked pretty bleak. Yet I never thought about getting rid of the drums. I didn't know how I would do it, but I was determined not only to play again, but to keep on progressing to the point where I would be good enough to play in a band.

When I got home from the hospital I had a cast on my right arm. I began playing along to records with my left arm just to keep it limber and to keep in practice. Previously my left arm and hand had been used much less than my right because I was right-handed. A few days later, I replaced my old cymbals. I did most of my equipment buying at the Guitar Center on 95th Street in Chicago. While there, a man came up to me and, noticing my injured arm, asked me if I played the drums. He introduced himself as Vince Willburn, Jr., drummer of the Miles Davis Group. I told him I was playing with my left arm until something could be rigged up for regular playing. He told me that it was good to use my left arm completely, as most drummers

Bob Pignatiello

don't fully utilize it. His advice, and later his friendship, strongly influenced my determination and progressive recovery. I began to become adept at playing cymbals, as well as toms and snares, with my left arm.

I began visiting O. & P. Labs, Inc., in Homewood, Illinois, an out-patient center that was making my prosthesis (artificial arm). I was possessed with the desire to play the drums with both hands and I was concerned about the possibilities of their designing something for me. When I asked if something could be made for me to allow me to play drums again, they told me they would try, but I later found out that they had no idea how they were going to accomplish it. After three months, Mike Brnck (assisted by George Eubank) developed my drumming prosthesis. The device is a piece of plastic, laminated and molded. It is held on the arm with a rubber sleeve. A tightening screw at the end enables it to hold the drumstick securely.

As you would expect, there are disadvantages to playing this way, but there are advantages as well. The main disadvantage is the obvious loss of wrist action or "touch" in my right arm, since all movement comes from the elbow and shoulder. This also limits hitting crash cymbals with that arm for the same reason. On the plus side, my right arm doesn't get as tired without the wear on the wrist, and my left arm is much more dexterous than it ever had been, allowing for a more fluid playing style.

Among my favorite players are Jeff Porcaro, Steve Jordan, Bill Bruford, John Panozzo, Rod Morgenstein, and Graham Lear. Two of my strongest influences are Steve Smith of Journey and Terry Bozzio of Missing Persons. I like Smith's earlier jazz-flavored playing with Jean-Luc Ponty and Bozzio's recent work with U.K. and Missing Persons. However, my main influence has always come from Alex Van Halen. I especially like his use of *Octobans* and his powerful display of cymbal talent. Every time Van Halen comes to town, I try to see them. I had tickets for their concert in August of 1982, but unfortunately the show was the same day as my accident. I still have my unused ticket.

I'm now playing Yamaha drums: an

8x12 rack tom, a 16x16 floor tom, a 14x22 bass drum and a 6 1/2X 14 snare. I use Remo *Pinstripe* heads, a *DW-5000* pedal, and Yamaha hardware. My Zildjian cymbals include a 16" K. crash, an 18" K. crash, a 22" *Amir* ride, 14" *New-Beat* hi-hats, and an 18" China type.

I'm presently involved in a band that plays clubs and bars in the Chicago vicinity. I'm also doing lectures and demonstra-

tions about drumming with my prosthesis, at various schools in my area. My goals include continuing to strive to be the best drummer I can be. I am also interested in branching out into other areas of percussion. I hope with practice, diligence, and talent to earn the praise and respect of my peers. It hasn't been easy, but I never expected it to be. Nothing you really want ever is.



Why does he sound so good?

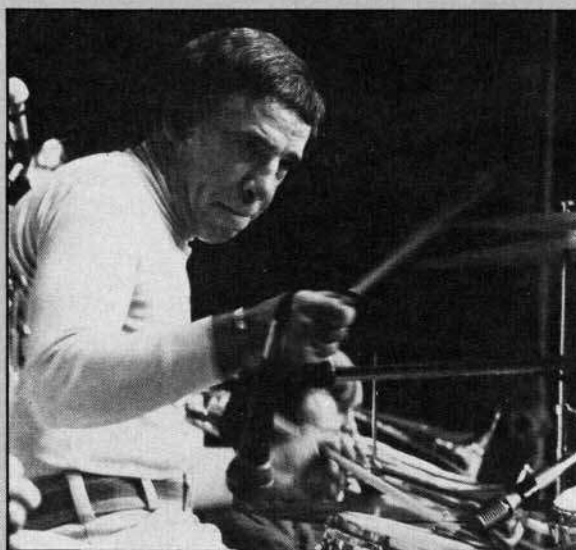

Find out in
INSIDE BUDDY RICH

by Jim Nesbitt in collaboration with Buddy Rich

Capturing the vigorous spirit of Buddy's playing, this new book presents key aspects of the master drummer's incredible technique. Transcripts of his recorded works are featured, including the famous WEST SIDE STORY solo, along with quotes, anecdotes, patterns, licks, fills and breaks; price \$9.50. Available from your local music supplier -- write us today for a FREE BROCHURE!!



Kendor Music, Inc.

music publishers

Main & Grove Sts.

P.O. Box 278

Delevan, New York 14042

U.S.A.

sure, and it doesn't come lightly. I have to be in a whole state of mind to play, and in the course of my regular day I can't really afford to go into that state of mind. I have to really get high—not on cannabis or anything . . .

CS: But on the music itself . . .

BM: Right, so that I'm really out. I don't have that much time to do that.

CS: How much time do you spend writing?

BM: Usually I only compose on the inspiration of the moment, but I've been doing more lately, because Jonathan Rose (of Gramavision) has been giving me a lot of projects to do. I don't know what I'd be doing now if he hadn't taken an interest in me and given me a chance to work out some of my ideas, because it's not like I write every day at some specific time, although I try to sit down every day and work things out. But *that's* so intense, too. It's not just a pleasurable thing; it's not something I do to get off. Music, to me, is not something you use just to get off; it's like a ritual, and a very serious responsibility. That, to me, brings the music higher, and balances me.

CS: Well, genius tends to favor the prepared mind. So you must have done something at some point. Let's put it this way: What did you practice when you started out on the drums?

BM: That's a good question. I didn't practice anything. It was always a finished thing. Basically, I used to just play all the time.

CS: Yet you know how to read. How did you learn that?

BM: Well, somebody showed me that in school—showed me notes, showed me the staff—and I figured that out. I learned all that in the third grade, I think. And I had friends who were musicians, friends of the family like [guitarist] Mundell Lowe. But basically, I learned from just playing. I would practice stuff I might be called upon to do on a gig. At that time it was a lot of jazz, so I'd practice fast swing, tunes like "Cherokee," mambos, backbeats, and shuffles.

CS: But how did you learn to gain command of the drums? You never played from a drum book or studied with a drum teacher?

BM: Oh, I had some teachers, but I don't credit them with anything in my development.

CS: Well, what did *they* think they were doing for you? Or perhaps I should ask, when did you first realize you were a drummer?

BM: That's a good question . . . That's got me stumped, man. I think it was from the very first time I played. In the sense of career it was very clear to me, judging by my personality, that the only two options available to me were the traditional ghetto options, which were sports and music. I was actually a pretty good athlete, but I wasn't particularly big; I didn't have the

body for it. I played basketball, football and baseball. In baseball, Willie Mays was my man, not so much for the hitting as for his fielding. That was my specialty, and I could make amazing catches, because at the crack of a bat I could tell exactly where the ball was going.

CS: Where was this?

BM: In Queens. I don't remember where because we moved around a whole lot: Forest Hills, Cue Gardens, 108th St. . . . Eventually I got real hot to live in the city [Manhattan] because Queens was like

CS: Long Island in drag . . .

BM: Yeah. A lot of little white kids—small babies. I didn't feel that any of the adults were particularly hip, and I missed the culture. I used to go into Manhattan a lot to see movies and music, and eventually I kept bugging my parents. I don't know if that was the only reason; I did threaten to run away from home if they didn't move to Manhattan. I don't know whether I would have.

CS: So is that when you moved to the place on Central Park West?

BM: No, but pretty close—same neighborhood: 97th between West End Avenue and Broadway. That was my old stomping ground. They used to have the hippest ping-pong place run by this cat, Marty Reisman, who was like the top American player. I used to go there and get hustled by these guys, but it was a great learning experience. I'd lose a few quarters. These guys would spot you 18 points, let you get two, with only one more to go for 21, and you would figure they would have to miss *one*, but they never did, and they'd just waste you. So I really used to enjoy that. It picked up my reaction time, that's for sure.

CS: Let's get a time frame for this. When were you born?

BM: January 28, 1948. I moved into Manhattan at the end of the sixth grade. And it was a big difference; I dug it immediately.

CS: What did Manhattan offer you that you were aware of?

BM: Mostly jazz clubs and movies. Around the neighborhood there were six or seven great theaters within a three-block walk. And I used to go to Birdland where they had the "Peanut Gallery," and a lot of other clubs. I used to go to a place called the Jazz Showplace where Mingus had a gig for almost a year with a quartet including Eric Dolphy, Ted Curson and Dannie Richmond, and every Sunday I'd go down to see a matinee, where you could get in if you were a kid. I was able to hear this music when I was 12 or 13, and allowed to sit in, too. I got to play with Dolphy. I knew him very well. And every Sunday they'd have me sit in for a couple of tunes. You can ask Dannie Richmond. I see him all the time, and he's always super friendly. I keep meaning to ask him, "Hey, man, what did you think?" But the cats must

have seen something in me, because they were nice enough to let me play.

CS: So it really was a jazz workshop, not some bullshit?

BM: Oh no, it was on-the-job learning—*on-the-spot*.

CS: So, when did you finally get some drums and cymbals?

BM: Well, I'd had a drum since I was ten years old. My godfather, Ed Shaughnessy, gave me a drum. He was a friend of my father's.

CS: What did your father and mother do?

BM: Well, they did a lot of things over the years. But my father had a connection to the music business, because he did publicity, and helped a lot of cats with their business. They grew up on the scene. My mother was very hip. They grew up in Harlem. They knew everybody in Duke Ellington's band. And my Uncle Norman was very hip, too. Grandfather had a cleaning store up there—funky, you know. And my father was a would-be playwright who never really made it, but he was hip, you know. They knew Billie Holiday very well. Art Tatum, Coleman Hawkins, all those cats—they were there. My uncle studied trumpet with Frankie Newton. And I carried that on. And at the time we moved to Central Park West, Max Roach, Art Blakey, Elvin Jones and Rashaan Roland Kirk were all living there. It was a killer.

So anyway, Shaughnessy gave me a tom-tom after I asked for it. I was aware of seeing this kid at camp do a snare drum solo, and here were these 300 people watching him, going "Oooh, wow." So my motivation was very shallow at first; I just wanted to be liked, I guess. So I thought, "I can do that, and then I'll have 300 people looking at me." But that's cool, because the more I think about it, later on I got into music for music's sake, and admired a lot of people who were very underground. They weren't really being heard, but they continued with their art anyway. Now I think it's very good, practical motivation, because it forces you to come out of yourself and think about how you're affecting people. There's kind of a thing that became fashionable in the jazz mode of thought where you didn't care about the audience; "We're so into the music and the art that we're going to do the hippest thing we can and hope you like it." But I'm more into having a beautiful effect—moving people; entertaining them. If you're an entertainer as well as an artist, it makes you a much more rounded and complete artist. It forces you to discipline yourself, package yourself and reach out. I think that a lot of really great art could be very popular. Like in the movies, Alfred Hitchcock was a great filmmaker and artist, but everybody could dig what he was doing. I'd like to get to that stage. I don't believe that being popular has to diminish the art. For me, the art is a given, but after

all these years, I'm more concerned with establishing the balance of the entertainment and communications.

CS: It was probably there all the time, but there was the peer pressure of being accepted as an authentic jazz musician.

BM: In my case, it was a self-defeating thing, because a lot of my heroes were people who were rigidly pure in their pursuit. It was very admirable, but in a lot of ways they boxed themselves into a corner. Since they were my heroes, there was a natural patterning after them. The way I describe those people is as "inspiring losers": basically losers, but really inspiring. As they go down in flames the few who know acknowledge, "They were neglected geniuses; they were really heavy." Yet as much as I loved those cats, there was a very negative aspect to it.

CS: They never swerved from their pursuit.

BM: But my thing is that you can take the knowledge that you have and . . .

CS: Reach out to people.

BM: Right, so that they don't have to be initiates to be drawn into it.

CS: I'm interested in the motivation behind your music, and why you were drawn to this art form loosely called jazz. You don't get to sit in with Mingus and Dolphy at the tender age of 12—after two years of whacking away aimlessly—unless there's some sort of very strong drive and curiosity, where you were pursuing something, with, if not discipline, at least some forethought.

BM: No doubt I have some talent. I'm a very intelligent person and I have a natural compositional mind. I've always had thousands of ideas, and a knack for form and composing; things I wrote when I was 12 and 13, knowing nothing about music—just totally instinctual—have held up with anything I'm doing now. They're not as involved because I was lazy in a way. I'm now more disciplined as a writer. There was a piano in the house and I'd write things.

CS: But you never studied piano?

BM: No. But I used to have vibes and that was my first axe. I played vibes right through my teens, doing some of my first gigs in Latin bands. And I studied a little bit with Teddy Charles, who was one of the first four-mallet players, although he didn't do it in the modern Gary Burton style, but very soulfully. So I guess it was tangential, but I knew a little bit about the keyboard. But I never took a whole bunch of lessons; I just started writing. When I first started out I didn't know about chord symbols, so I'd write the whole chord out on the piano. And it's interesting, but I've gotten back to doing that. If I want to help the musician, I'll give chord symbols. But other times I'll deliberately not give them, just to force the musicians into my voicing. However, the reason I don't usually give them chord symbols is so *they'll play off of*

the melody. A lot of people don't even put the melody in. For a horn harmony or a piano, they'll just give you the changes, which already puts you into a real linear thing improvising-wise. I'd rather put in the melody if I'm just going to do one, because I prefer for people to play slower and more thematically. But I'm digressing.

As a kid, with all the talent I had, I think the quality those cats saw in me was *love*: that I really loved what they were doing; that I was serious and not bullshitting. And I think when they see that, most of the truly great musicians are really open. I can think of numerous examples of that. For instance, when I was a little bit older, but still not really playing—weak in so many ways—I had a gig in the Catskills with Dave Liebman. He was also in that stage, maybe more so, because I, at least, lived in Manhattan and knew a lot of hip cats, and Liebs was just a kid from Brooklyn. Shit, he wasn't even as hip as me [laughs], although since then, in many ways, he's surpassed me. Anyway, Herbie Hancock came up with my folks. At the time he lived right next door to us, and he knew my parents. They met on the street and told him, "Hey, we'll go up and visit Bob. He's got a gig upstate and they've got a swimming pool and everything. Do you want to come?" And Herbie said, "Sure, I ain't doing nothing." So he came to the ballroom that night and played with us. No bass—just piano, tenor and drums. He was so open and loving, and enjoying the experience, when realistically, objectively, it was nowhere near what he was used to playing with Tony Williams and Wayne Shorter. But I'd seen him play with Miles, and I felt the same amount of joy and love and giving and real interest in the music—just trying to make it sound better. And there was no attitude, because he could feel the love. It turns out he was right, because Leibman and I eventually turned into good players, but we sure weren't at that point.

CS: But he could feel the sincerity, and a good musician will hear what you *want to play*, even if it isn't fully formed at the moment. I guess the main thing is to play with musicians who are so strong that they can pull you along and set a strong example. Because too many musicians don't listen; they don't talk and breathe with the music. It's about interaction. That's the real freedom music.

BM: Absolutely, and cats like Max Roach, Roy Haynes, Art Blakey, Philly Joe Jones and Dannie Richmond had a real strong sense of structure and composition in their playing. In a sense, that's what really attracted me. There was a lot of freedom in the music, but they were great enough composers that they could deal with the freedom, which brings me to an interesting point: To me, freedom, in the improvisational sense of spontaneity, is not the important issue at all. I said this in *down beat*, and I thought people would hit the

roof, but it slipped right by them. The aspect of freedom in music doesn't interest me at all; what interests me are the results. Mingus, in particular, got an amazing amount of control and structure in his bands spontaneously; as it was happening he got you to think, by sheer force of character, like he did—to improvise a part as if he had written it. He got some amazing things out of improvisers because he made the context so strong; people played so differently with him. Duke Ellington was also a magician and a master psychologist. Mingus often did it through brute force.

CS: Duke would organize a structure where everyone could put in their two cents and make a composition, but he was like the ultimate editor.

BM: And he knew who to get and how to direct that person. The most important part of any composition is how you get to play it. I always go for people with balanced talents, so it doesn't lean in any one direction. I've had people who were really childlike and primitive next to some amazing virtuosos, and it works.

I bring out the best in cats; I really do. I make them play better than I've heard them in other circumstances, just because I won't settle for anything less, and I won't let them get away with their typical responses. I believe in making them go way past what they think they're capable of.

CS: You could call it "comprovisation."

BM: Yes, you could; I'll accept that. But, like anything, I'm equating it with the Almighty. The Almighty is nameless, or has thousands of names. There is no one name.

CS: When did you first realize that you had a living relationship with magic and otherness in your life and in your music?

BM: Pretty early. It had to do with dreams. I've always been a very disciplined dreamer, and I was always aware that, when I was dreaming, it was a very important and delightful part of my day. A lot of people don't like to sleep because they feel like they're missing something, but I feel when I'm awake that I'm missing something, because my dreams present more interesting possibilities. Dreams can combine dimensions in ways that you usually don't when you're awake in the body state. When you're asleep you could be underwater, you could be in the air, or you could change shapes. I've always loved visionary trips.

Also, I'll go on trips that are dedicated to that purpose. Like I went to Mexico, Hawaii, Brazil and Peru last year. And those trips are to concentrate on the dream part, because when you go to another place where you don't even speak the language, and you're in a totally strange environment, it's like being in a dream. I use that experience when I come back to New York, and I always have.

CS: Didn't you once say there was a specific dimension you used to visit where you

tried to bring the music back from?

BM: That's right. That's part of my history, too. There was a time when I was very consciously disciplining the dream to go to a specific place. I haven't been going there recently. The dreams have been going to another place of late: It's called Casta Laquinga.

CS: How are the laws of gravity and such different than here?

BM: In the Casta Laquingan scheme of evolution, the species I was with was maybe equivalent to a bear—tree climbers. We did have a type of music that was very interesting. But there was some other music that would come from dome beings that were invisible to us, and that music was something beyond my description. The only comparison I could make is maybe the way a dog perceives Bartok or Schoenberg. The music that we played, which was much simpler, is actually equivalent to the Earth music that everybody thinks is so far out. What these other beings were doing was like Bach, only a thousand times more systematized—mathematical to the nth degree.

CS: Back to planet Earth. Again, why the drums?

BM: I could have played any instrument, but I was playing all of them within the drums. Sometimes I play bass lines on the drums. I have them tuned to play bass, really. Sometimes I play like a saxophone—sometimes drums. Within the drums I hear all of the orchestral functions; sometimes I'll play melody or a bass line. Also, I write all the time, and my main thing was always composition. For the first couple of years, I wasn't sure of which instrument I would play. I did play some acoustic bass, classical style. I had a trumpet for a while. I always had xylophone and vibes. If, at the time, electric bass had been the thing, I probably would have gone with that. When I went to camp I studied a classical sort of thing with the bow, and it was beautiful, but the electric thing is more my concept of what the bass is. It got to the point where the other instruments just got too hard. On trumpet I could never get much past middle C, and when I got to F, my lip

started to kill me. Vibes I liked, but except for Latin gigs they became less and less practical, because unless you have Gary Burton-type chops, you can't comp. So the drums became sort of practical, because everyone needs a drummer. And in a way, drums were easier, in the sense of sounding credible—at first. To become a great drummer is, if anything, harder than any other instrument. But to be merely functional is quicker. I even played bass clarinet for about a year; I played in Ben Webster's style, with a big, sweet, expressive sound, a big vibrato, and a lot of sub-tones and growls to vary the dynamics in a phrase.

CS: For somebody who just sort of picked up the drums without "practicing," you had practical experience on virtually every instrument in the orchestra.

BM: And painting, too. I've always done that. As far as I'm concerned, it's the same impulse. Sometimes when I'm at the drums, I'm painting. The drums just seemed to be the most functional. Perhaps I loved the drums more. Hearing people like Max Roach, who had such a beautiful, sensual tone, was inspiring. It was a very physical instrument.

CS: Yet Max had a very stately, architectural approach.

BM: But I quickly realized that that was not my approach at all. I was much more into sloppy motion. It would be interesting to see how Max would paint; I imagine it would be an almost austere, Japanese style in a way. But with my paintings—as you can see from the album cover—even though they have a strong structure, they're filled in with a lot of soft texture. It's like leaves or something in nature; there's a mushiness.

CS: As if the water had got in and washed out some color, or maybe washed some in.

BM: Exactly. So they're running together. Yet there's a very strong linear structure. Those all start off as line drawings done with fine magic markers. When I have all the lines defined, then I start smearing them together with a brush and water, so that I get a very precise feel mixed with the organic. That's always been my concept:

starting with a very simple, obvious, elemental structure, and at the same time an almost-chaotic organic movement going against that.

This concept actually relates very closely to the *groove canon*, which is a concept that I use quite a lot, and the groove canon invokes something I call the *internal hearing* concept, which will be prominently featured in my drum book. The thing about the groove canon is this: I love vamps and ostinatos. But I've found that no matter how hip the vamp, you reach a point of diminishing returns where you get tired of it. So I'm employing a very old concept, although I've never heard anybody else use it this way, called groove canons or groove rounds. I take a figure or rhythm pattern, and have the group divide it and play it in several different places, perhaps two beats apart. For instance, on *Visit With The Great Spirit* there's one piece where I use the groove canon called "Suite Bahia." It's based on a two-bar figure in seven, which is used in three different places. Theoretically I could use it in seven places before it got back to unison again. The effect is of an incredibly strong groove, but you could listen to it over and over again without ever figuring it out. With vamp tunes you can figure out where the center is—the clave. That doesn't necessarily make it less compelling, but somehow it loses a bit of the mystery. However, with groove canons you can sense that there's an order, but you can't put your finger on where the 1 is. And there's something inexorable about it, like a train, but there is no single 1. For me, it makes vamps more listenable without taking away from the dancing power.

Learning to do these things is very good for your internal hearing. Internal hearing postulates that a lot of times you're not actually listening to what's going on; you're listening to what you're playing off of. When I have people do a round like this and come in with the same rhythm two beats later, they usually start listening to what I'm doing and we end up in unison. This concept requires "creative ignoring." The basic rule is this: If there's any danger that anything you play or someone else plays can throw you off of your basic internal idea—which is what you're using the groove to focus in on—then you cannot afford to listen to it. The stronger you develop your internal hearing, the more you can listen.

See, the key to what I call "organic drumming"—which is what Elvin, or Jack DeJohnette, or I do—is a simple, grid-like structure. I call it the 8/8 structure, because generally I don't think faster than 8th notes. If we're dealing with a 4/4, one of my methodologies is to work on the eight points individually as resolution points, so that you master the eight points and learn to hold them in your head. Eventually they can be held so strongly that you

Let's make music!

The complete music store in your mail box

Send \$1.00 for catalog applied to first order

DRUMS and more

Fire • Stage Effects • Disco Lights • Fog Machines • Stage Lighting designed for musicians

41 Shore Drive
Huntington Bay
New York, 11743

FREECUT MUSIC

cus-tom (kūs'təm)

1. Made or done to order; as in
The Percussion Center

THE TRUE MEANING OF CUSTOM

"We Can Do It"

The PERCUSSION CENTER:
1701 N. HARRISON FORT WAYNE, INDIANA 46808
1 (800) 348-1782 1 (800) 552-1975 - Indiana Residents

will be able to play anything—different tempos and time signatures, things that are almost indecipherable—organic—like the waves of the ocean or the rustling of the leaves.

CS: So your grid is very flexible?

BM: No. The grid is very rigid. What goes on top can be very flexible, and it can only be this flexible because of the fact that the grid I'm keeping inside is extremely rigid and never bends. And in fact, a lot of what goes on top is very instinctual rather than conscious. My conscious being generally dwells on the internal. You can be as complex as you want externally, but internally you keep it simple. That's the key to internal hearing. I could play "Stella By Starlight" at a medium bounce, and play a fast seven against it, without losing the 4/4 swing form because I'm holding to that 8/8 grid. So in that way I can take movement and motion from life and put that in my music—the shape of a wave; the beautiful way an egret flies across a valley from tree to tree; the way Dr. J looks when he goes in for a slam dunk.

CS: Before you arrived at the groove canon, how did you establish your center as a drummer? What disciplines of the mind, heart and ear did you work on?

BM: Good question. For ten years I practiced that 8/8 grid, and I never played a thing where I didn't have a specific resolution in mind. Sometimes the song itself will suggest it. When it wasn't given, I would impose one. And when I was young I played a lot of organic drumming, which one might characterize as sloppy.

CS: Sounds like you played more dependent than independent.

BM: I was capable of playing freely, but I was always concerned with making it swing harder. And after my initial Elvinish phases, I disciplined myself to stick with that grid and play nothing extraneous, so that those points became automatic—like a feeling. I practiced all that for years to master the drums. That's what I studied, and found thousands of ways of resolving them, and what beats sounded best with them. So having come through all this dogmatic stuff, now I'm able to get back to that feeling I had as a child when I first began playing. But now I have that authority, so even when I'm playing organically, cats can still relate to my internal rhythm.

See, the art is incidental, and comes much later. I've always had the art, creativity and soul; those are given. But what I needed to make me complete and what had been my weakness was mastering the structure.

CS: How does your groove canon relate to your harmonic canon?

BM: I have very distinct theories about melody and harmony. I write a lot of things where there are different tempos, tonalities and rhythms, which is in the tradition of somebody like Charles Ives. Like on "Suite Bahia" there are three or four

overdubs in seven, but the melody is at a much slower tempo in 4/4, and the sevens are anchored by a 2/4 figure. That's something I also always do with odd meters, which is to invariably play backbeat which makes them swing more, so you're not hitting 1 every two bars. Max used to do that: play 4/4 on the hi-hat and then play seven on top. So I'll do that by layering all sorts of things over a basic four.

CS: Given everything you've just described to me, how come you don't want to be characterized as a drummer? What's the matter with that?

BM: Because I just think it's an incomplete picture. Basically, I'm a nature-mystic-visionary. That's where my talent lies, and that manifests in my drumming, composition, painting, poetry, dance and movement. They're all expressions of what I do.

Drumming is one of the strongest things I've done, precisely because it was the thing I was the least talented at of them all; it was the hardest for me. See, when you're composing, you're in charge of the overview, which is where I excel. In making an album, I hear it as a movie; I think cinematically. My problem has always been the execution, not the inspiration. Drumming has always kicked my ass because, as a sideman, I'm trying to execute somebody else's concept as good as it can be. As a working drummer, I was obliged to master the givens of styles and stylists: Max Roach, Philly Joe Jones, Art Blakey, Roy Haynes. Doing club dates, I had to learn to play rumbas and cha-chas and mambos. I had to play funk and rock things, and learn to play with a Charlie Watts feeling. Whereas in painting, I never felt like I had to master figure drawing; I just started to do my painting. Yet my painting and composition are not primitive. My first composition, when I was 14, was a perfect example of polytonality. I had no idea of what that meant; it was just common sense.

It's like if you mix more than one kind of color, so that it's not all primary colors: You get a more subtle blend. People always considered the interval of a second dissonant, but to me it's a very beautiful and necessary color. So I'm breaking all sorts of rules according to the way they'd teach chord scales at Berklee—like using minor harmonies against major chords. Basically, what I'm saying is that, if you mix two beautiful things, even if they're totally different, you'll get a third reality which is mysterious and beautiful.

CS: Who are your antecedents for this approach?

BM: Among composers, Ives and Messiaen. They liked to juxtapose separate realities. But in a sense, most of my influences come from real life. I perceive life and sound like a blind person. I used to listen to the grass sing as the wind whipped through, while cars sped up and came towards me or faded by. I would hear them as a symphony of sounds and changing

itches. I like to make sense of the seemingly chaotic by superimposing it against an arbitrary grid of my own design—giving it a context.

It's like when I read about Renaissance Italians who were masters of depth perspective. They'd actually go to the top of a tower for a view, and they would bring a grid made of wood—like an empty checkerboard—through which they could look at a landscape. In that way, they could take this chaotic scene of natural life that had no obligation to be symmetrical, and portray it against a symmetrical grid, which enabled them to really see the reality that was there. I do the same thing with sound, so that you no longer have an isolated area of sound, but it's falling against a particular rhythm.

Now the people I listen to who helped me develop this perspective on real life were Louis Armstrong, Duke Ellington, Charles Mingus, Rashaan Roland Kirk, and Thelonius Monk; I've listened to and been inspired by Elmo Hope, Edgar Bateman, Hermeto Pascoal, Herbie Nichols, King Sunny Ade, Bob Marley, and Ray Charles singing country & western music. I also listen to Peter Gabriel; I like his stuff a lot. I like what Robert Fripp, Bill Bruford and Stewart Copeland are doing; I've listened to James Brown, African music, samba-school, and pop. When I was a kid, I listened mostly to jazz, because at that time in the '60s, it seemed like the most vital thing happening. I don't necessarily feel that way anymore.

To sum up, at this point in life, I don't feel that there's any one form of music that's innately superior to another; I also do not feel that sophistication necessarily makes for better music, because I'm a heart musician, and that's what makes music for me.



AUTHOR-TEACHER-DRUMMER
TED REED
"It's the Best Around"
MODEL NO. 4P "PRO"



45 models available

FREE CATALOG

"Set-the-Pace" PEDAL PRACTICE PADS
Ralph C. Pace
Box 63, TR, North White Plains, N.Y. 10603



Jim Plank

You probably haven't heard of Jim Plank, but chances are excellent that you've heard him play. Plank's empathetic flair with the keyboard percussion instruments, and all percussion instruments in addition to the drums, plus his skills as a composer, make him a fixture in Southern California studios. Peers say his distinguishing features are his scope as a percussionist and his total musicality. Plank is probably the most complete drummer you've never heard of, and that's the way he likes it.

"I'm sure he would like to be recognized by a wider audience," says Shelly Manne, who describes himself as Plank's "very close" friend. "But he's a quiet, unassuming guy and he has his priorities. He is very musical and very sensitive. His style isn't bombastic; it's a style that complements the music he plays. His personality is such that he will subordinate himself to make the music better. There aren't too many people like that. And the scope of his playing is quite large. He's an excellent percussionist, and at the same time, a very modern drummer who can play in any bag. He's very underrated. I'm glad *Modern Drummer* is doing an article on him."

There are several reasons why Plank is not a national name. He shuns the limelight—"Privacy agrees with me," he says—in a business where bloated egos are the norm. But the main reason is his decision to stay in San Diego. The 40-year-old Plank says he eschews the high-profile New York and Los Angeles markets because he and his wife of 18 years, Carmen, are firmly established vocationally in San Diego, where they find a healthier environment in which to raise their two sons. But there are musical reasons besides the personal ones.

If he left into the musical fray of Los Angeles, Plank says the scuffle to survive would prevent him from indulging his wide

range of musical interests. Plank is under contract with both the San Diego Opera Orchestra and the San Diego Symphony Orchestra, and holds the drum chair in a local big band, for which he composes. He also takes a class in Afro-Cuban music and works on a first-call basis for nearly all visiting artists. This is in addition to a heavy studio schedule. Although 15-hour days are not unusual, and the crush of his many commitments makes for a frenzied schedule, Plank has realized his goal: He has found a place where he can command the best and most profitable dates while working in a variety of musical contexts.

"My situation has always been one where I can do a lot of things and it's worked for me," says Plank. "When I was in my early 20's, I kept thinking, 'I've got to move to Los Angeles and try to make a niche for myself there.' And it never was one of those things deep down that I really wanted to do, or I would have done it by now. I'm happier having a chance to explore different things on my own. The areas of music I'm interested in, especially in the world of percussion, are very broad, and I truly like all of them.

"In a sense this is a weakness. I've often said to myself, 'This is too much to do all at once, and you've got to eliminate something.' But I've never been able to eliminate anything; that's the dilemma I've had over the years. Even if I had all the money in the world, I'd still be running like hell trying to learn as much as I could because I love it."

Plank may worry about spreading himself too thin, but studio contractors are delighted with his versatility. Despite the recent deterioration of the jazz-club scene in San Diego, Plank remains supremely employable. "He is brighter than most, and he's very businesslike in everything," says Steve O'Connor, an in-demand San Diego producer, writer and arranger. "His musicality is great; it can't be topped. He's up on all the new styles and he has a great historical sense. I've seen him go through an historical thing where he reviews all the significant drummers, doing what each is famous for. He's one of those people with tremendous roots in his playing. He's very adaptable; whatever is called for, he's right there with exactly what's needed. He also has a great sense of classical literature. He would be great wherever he went. Why he stays here is a mystery."

The reason is because he does not vie for prestigious session work. "I'm not good enough to be a star studio player," Plank claims. The bulk of his studio dates are jingles, and television- and radio-station identification packages. The qualities that ensure his studio success are a rock-solid mastery of metered time, enabling him to use the click track easily and overdub layer after layer of percussion; the ability to read quickly and interpret charts that are often hastily or incorrectly written; and the scope to play an astonishing range of percussion instruments.

"In most studio work, you're not playing great music," says Plank. "Some people see it as glamorous, others see it as factory work, and the reality is somewhere in between. The key is to breathe some life into that little smattering of ink on the page. It's part experience and part intuition. Over a period of time you see common phrases, and you kind of know how to deal with them; that gives you the ability to watch for the ones that are unusual. There are often bars where the phrase might be a little shorter or longer than you expect. I zero in on those and bring them into context with what's on either side."

Frequently, Plank is given a free hand in creating percussion tracks. How does he know what is needed? "I can't answer that completely," he says. "It's intuition, listening to what's going on around you and utilizing your free-association abilities. Part of it comes from my orchestral background, knowing how an instrument is traditionally used, what its sonic area is, and how it relates to other instruments. The other thing is to stay up on all the new third-world percussion devices. The thing about being a percussionist is that there is so much to know. You end up with trunks full of cowbells, woodblocks, tambourines and pop guns. Part of the chore and the pleasure of being a percussionist is the continual search for new sounds."

Anyone who evaluates Plank as a percussionist is also struck by the extent to which his knowledge of the harmonic side of music enhances his skills. Percussion is often merely the garnish on the musical plate, but Plank finds sounds that complement core elements in music. It is possible that percussion is the most original aspect of Plank's musicianship. As a drummer, his style is elegant and precise rather than dominant and visceral. He says he strives



Just Published

Straight Talk from Some of Rock's Great Drummers

Johnny Bee Hal Blaine Dino Danelli D. J. Fontana Russ Kunkel
Ringo Starr Charlie Watts Dave Clark Kenney Jones Earl Palmer
"Pretty" Purdie Roger Hawkins Jim Keltner Levon Helm

What They're Saying about The Big Beat:

"The Big Beat finally gives credit where it's due—to the boys at the back of the bandstand who get it all started. A must for musicians and good reading for those of us who just listen, too."

Dave Marsh,
author of BORN TO RUN:
THE BRUCE SPRINGSTEEN STORY

"In asking the right questions of the right artists, Max Weinberg has illuminated one of the most neglected areas of rock musicianship. Anyone seriously interested in learning how the music developed cannot afford to be without The Big Beat, an essential addition to rock literature."

David McGee,
Managing Editor, RECORD magazine

"... A unique glimpse into the heartbeat of rock & roll."

Vic Garbarini,
Editor, MUSICIAN magazine

During the past year, Max Weinberg, drummer with Bruce Springsteen and the E Street Band, talked with 14 of rock's great drummers, and those conversations are now published as *The Big Beat*. As a result of Weinberg's empathy with his fellow drummers, *The Big Beat* is full of fascinating history, controversial claims, and revelations about the drummers, their drumming techniques, and their fellow musicians.

Dino Danelli of the Rascals, Johnny Bee of Mitch Ryder and the Detroit Wheels, and Levon Helm of the Band, as well as the British supergroup drummers—Charlie Watts of the Rolling Stones, Kenney Jones of the Who, Dave Clark, and, of course, Ringo Starr—discuss their influences and mentors, reveal studio session secrets, explain how they arrived at their individual sounds, and offer indispensable playing tips. Hal Blaine and Earl Palmer give behind-the-scenes views of Phil Spector's legendary recording sessions, and they and their fellow session greats Russ Kunkel, Jim Keltner, Roger Hawkins, and "Pretty" Purdie discuss the special demands and rewards of freelance drumming.

Also included is D. J. Fontana's first interview ever, in which he recalls his days on the road as Elvis Presley's original drummer and bandmate.

Supplemented with discographies and many never-before-published photographs, the book is a loving tribute to those drummers who have defined the Big Beat.

PLEASE RUSH ME _____ COPY(IES) OF **The Big Beat** (Book #5485-9) by Max Weinberg @ \$11.45 per copy (\$9.95 plus \$1.50 postage and handling).
Illinois residents add 8% sales tax
California residents add 6% sales tax

CHECK OR MONEY ORDER TO
BEST PUBLICATIONS ENCLOSED

CHARGE MY VISA MASTERCARD

EXPIRATION DATE _____

CARD NO. _____

SIGNATURE _____

NAME _____

ADDRESS _____

CITY/STATE/ZIP _____

BEST PUBLICATIONS, Dept. MD
180 N. Michigan Ave., Chicago, IL 60601

If you are not completely satisfied, simply return your book(s) for a full immediate refund.

OFFER EXPIRES 12-31-84

MD0884

for an exact interpretation of a given style, and maintains that an accompanying instrument like the drumset should enhance the group sound.

"I'm probably one of those people who, given five different situations, will sound five different ways," says Plank. "What I play on the drums is a reaction to what's going on around me. The drums have to build a foundation for the music that's out in front. That's why I'm not that interested in technique. I see myself more as a general musician than as a drummer. I just happen to play the drums."

Plank says the bulk of his skills are the result of on-the-job training rather than practice. The one exception to this was his study of keyboard percussion instruments

with Earl Hatch of Los Angeles, an association Plank recalls with affection. "I practiced hard to learn mallets, but I learned the drums by playing," says Plank. "I'm sure I would be a much more proficient player had I been able to study the drumset. But there was nobody in California at that time who was teaching the drumset, at least that I was aware of. My years of practicing were spent playing, whether it was the bass drum in some chamber orchestra, or playing bebop at some terrible saloon. Percussion instruments are a lot more satisfying to play with other people. It's the interaction that makes music fun; it's a social experience. So many drummers have phenomenal chops, but it's like their hands are motivating their musical selves. I figure that, if you have a concept of a sound, you'll find a way to make it. The best drummers make a musical statement. They may not be able to make a roll or hold the sticks in a so-called 'correct' way, but they sound great. Who cares how they get it out? If you have to take one or the other, forget the practicing. But the ideal situation would be to study with someone like Alan Dawson, who has a wonderful methodology, and play a lot besides."

Before a musical statement can be made, however, equipment must be transported, and as a studio musician, Plank takes nearly as many pains to move drums and percussion items as he does to play them. He must be on time with the right equip-

ment for the right date. Since there are no cartage services in San Diego, Plank must move his own equipment. On a two- or three-session day, his van is crammed with a multi-tom drumset, timpani, sets of vibes and marimbas, a xylophone, countless cymbals, and box after box of percussion items. "I don't get any exercise, but I don't need it: My thing is aerobic percussion," jokes Plank, who receives cartage fees for his muscular labors. Also, he often faces complex logistical problems since he uses several storage facilities. To make sure he has all the percussion items for a second date when there is not time to empty and reload his van, Plank makes special arrangements.

"If I'm in a real rush, like when I have a morning date in San Diego and have to be in L.A. for the afternoon, I've got a special kit of stuff," he explains. "I take a cymbal bag, a snare drum and this little box of effects. In that box I have a standard woodblock and two piccolo woodblocks, three triangles—10", 8" and 6"—two sets of sleighbells one half-step apart, several finger cymbals of various pitch, a siren, police whistle, sandpaper blocks, an 8" splash cymbal, a set of wind chimes, several triangle beaters, and tambourines, with and without heads."

The drums Plank uses vary according to the musical situation. In the studios he primarily uses either a single- or double-headed multi-tom kit. The former consists of a 20" Ludwig bass drum and a 6", 8", 10", 12", 13", and 14" fiberglass Pearl toms with coated *Ambassador* heads. The double-headed setup features a 22" Ludwig bass with 10", 12", 13" and 14" fiberglass Pearl toms which sport *Pinstripe* heads on top and coated *Ambassadors* on the bottom. He also owns two large sets of Gretsch, used mostly for show work. One consists of a 24" bass, and 12", 13", 16" and 18" double-headed toms; the other consists of a 22" bass, and 13" and 16" toms, also double-headed. This is in addition to three bebop outfits—20" bass, 8" and 14" toms—made by Leedy, Ludwig and Gretsch.

"I use different drums for different types of music," says Plank. "In the studio, it depends on which studio you're working at, what music you're playing, and the engineer. If I'm playing a piano trio, I'll use my little Leedy or Gretsch set tuned fairly high with a pretty open bass drum. I got that Leedy set in the '60s, and I really like it; I've made lots of records with it. But in the last few years I've been picking up a lot of Gretsch drums from the early '60s, which was sort of the golden age of Gretsch drums, and I've bought them all used, very inexpensively. I take them to a guy in San Diego named Paul Bleifuss, who reworks them."

Bleifuss peels off the pearl coating and refinishes the outer surfaces, sands the shells so that the heads rest on a perfectly

SOLID TIME

NO MORE RUSHING OR DRAGGING!!!!

The **SOLID TIME CASSETTE SERIES** is a computer generated practice tape that teaches you to be completely accurate and in control of the time at any tempo. Better than practicing with a metronome or records.

GET CONTROL OF THE TIME!!!!

Send \$9.95 to **SOLID TIME PRODUCTS**
Box 823, Goleta, Ca. 93116

NEW! GIG RUG™ Pat. Pend
The only drum rug with a Bass Drum Barrier. L.T. from LUG LOCK



"No more creeping bass drum". Gregg Bissonette - "The Master" TV show.
"Very light and portable". Dave Miller - Woody Herman Band.
"Like Lug Lock, GIG RUG keeps things in place". Carl Allen - Freddie Hubbard Quintet.

Also using GIG RUG: Gil Moore - Triumph; Tony Johnson - Commander Cody; Billy West - Leon Russell; Doug Florence - The Pointer Sisters; Mike Baird; Mark Craney.

STOP CHASING YOUR BASS DRUM!!

Send \$49 (US) for GIG RUG (includes handling)
NY State residents add 7%. No C.O.D.'s
Colors: Red, Brown and Blue

L.T. Lug Lock, Inc.
Box 204 Tonawanda, NY 14151
"PRACTICAL SOLUTIONS"
Dealer Inquiries Welcome

- 5 1/2 ft. Square - Large enough to go under all your drums and stands.
- Portable - Folds into a 2 ft. roll. Fits in trap case.
- Lightweight - Made of thin, strong, indoor/outdoor carpet.
- 20" Barrier - Allows bass drum to be off-set from center.
- Inexpensive - Why pay more for a rug that doesn't have a bass drum barrier?
- A MUST for the road and one-nighters.

flat surface, and bevels the bearing edges of the shell so they support drumheads like the bridge of a guitar supports the strings. Plank maintains that drums sound better when liberated from their decorative pearl covering, and that they are more resonant and can be tuned more finely when the bearing edges are sharp.

Although he uses Paiste cymbals in the studio and praises their ability to cut through amplification, Plank's favorites are the original K. Zildjians. "I use Paistes for everyday studio work because I can bash on them hard and they work okay," says Plank. "I like the K. Zildjians—the old Istanbul K's. They have that real earthy character, plus they feel wonderful to play. They have a give to them; they don't have that tabletop feel that the A's have. The only things on the market today that are close to the old K's are the Sabian hand-hammered cymbals."

As one would suspect from a drummer who prefers Gretsch drums and K. Zildjian cymbals, Plank's jazz roots are in bebop. Although he began his professional career at age 16 with the San Diego Symphony, Plank says the deciding moment in his musical life came during his early teens. "I'd go to the ballrooms with my dad to hear big band music, and in junior high I started listening to bebop," says Plank. "My life has never been quite the same since."

As his interest in music blossomed into a passion, Plank found much quality music in San Diego, and he recalls his adventures with fondness. "When I was 14 or 15 I went to see Shelly Manne, who was playing near the airport. Of course, you had to be 21 to get into clubs, so I snuck into the kitchen and stayed for about 45 minutes before they caught me. That was the first time I got to see Shelly live. I saw Louie Bellson and Sam Woodard with Duke's band. One time Max Roach was the guest artist and he played half the evening. I saw Leroy Vinegar and Billy Higgins, and Billy had that wonderful time just like he does now. I saw Cal Tjader's classic band with Mongo and Willy Bobo. And one time I heard Art Blakey's band, the Jazz Messengers, when he had one of his classic bands in '56 or '57 right after Horace Silver left. Blakey was an absolute madman at the time, and getting to hear him play was unbelievable. I went back to the dressing rooms and we talked about how to become a jazz musician. 'If you guys want to be jazz musicians, you come to New York and sleep on my floor,' he said. 'That's how you get to be a jazz musician: You sleep on cats' floors in New York.' That kind of thing is indelibly marked on my mind: hearing Blakey make those rolls and play the time like he did. That's living, especially when you're young and all of a sudden you've found this thing that becomes an insatiable interest in your life."

Despite the joy of musical discovery, Plank says his late teens and 20's were a

troubled time. Bothered by the limited employment possibilities for musicians at that time—Plank's father was a theater musician who was put out of work by talking pictures—yet harboring a strong passion to play, he postponed the final career decision long enough to pick up a degree in sociology from San Diego State. "Sociology was something I was interested in, and I was looking for something else to do as a living, even at that point, thinking that music couldn't support me. I wanted an area of knowledge that would provide employment, so I went to school during the day and played at night. In the early '60s there were always places to play and people to play with."

Although he was seriously considering other vocations, Plank still vigorously acquired musical knowledge in both jazz and orchestral idioms. It was at this time that Plank became friends with Shelly Manne. "We struck up an acquaintance and spent practically the whole night in a restaurant talking about drums," Manne recalls. "I liked him. He was a very modest person and was very serious about playing." John Guerin also remembers Plank from this period, when he used to observe Guerin at sessions and rehearsals. "He's a very musical guy—always has been," says Guerin. "We weren't really close because he was a few years behind me, but he was a real keen observer." After graduation from San Diego State, Plank made his career deci-

sion and went on the road for two years with Rosemary Clooney and The Four Freshmen before returning to San Diego.

Plank's plans for the future are surprising. "In my latter years I'm going to sell all my percussion equipment and buy a nice piano. I love to play the drums in a bebop situation, I enjoy the mallet instruments in a solo situation, and I'd like to learn the piano. All the rest of it is basically working stuff; it doesn't mean anything to me in an artistic sense. I'm not in love with playing the xylophone. I want to play the music of the Impressionistic composers on the piano. I'm serious. That's what I'm going to do at some point."



Drum Stick Necklace

2 mini gold-plated drum sticks on fine chain. For him/her. Elegant! Looks expensive! Only \$11.95 ea. Two-\$22. Add 75¢ postage. Gift boxed, \$\$ Back Offer.

IMPERIAL, Box 66-D, N.Y., N.Y. 10022

DRUMMERS! DRUM RECOVERING KITS AVAILABLE. Over 25 choices of Pearls, Sparkles, Satin Flames and Woodgrains. Send \$1.00 for full information and samples (refundable on first order). **PRECISION DRUM COMPANY**, Dept. C, 151 California Road; Yorktown Heights, N.Y. 10598

Larrie! Blasticks! and Calato!

Larrie Londin . . . the most wanted drummer in Nashville for any session. Just listen to the hundreds of platinum and golds he's recorded

to find out why he's in such demand. Besides, who doesn't like Larrie?

Larrie Londin . . . an original.
Blasticks . . . the original.

Larrie's choice:
Blasticks by Calato
Our exciting new brush-sticks.



At local music stores or write for free catalog:
Calato
4501 Hyde Park Blvd.
Niagara Falls, NY 14305
For Calato T-shirt send \$8.00. (No cash)
Specify S.M.L.XL.

calato
We invented
Regal Tip®

Funk With 32nd Notes

In this study I've applied single and double strokes in 32nd-note value to the funk style. Because the rock/funk feel is based on straight 8th notes, the 32nd notes work very well. The tempo is slow (quarter note = 72-80 beats per minute), and the dynamics and feel, as always, are very important. The idea here is to play the backbeat as accents, preferably as rimshots. The surrounding 32nd notes should be much softer (*p*). The bass drum notes should be loud (*f*). The right hand stays on the hi-hat, the left hand on the snare drum. Try playing this study with the butt ends of both sticks for a thicker sound.

After developing examples 1 through 10, take one of the stud-

ies and alternate it with one bar of simple time (as in 11 and 12), or play three bars of time and then one bar of the 32nd-note patterns (as in 13). The patterns could also be used at the end of an eight-bar phrase as a fill or turnaround.

In order to help develop these ideas into your own style, write out a slow funk groove of your own (a two- or four-bar phrase). Then, write in the 32nd notes in the last bar of your phrase. That way you'll be thinking your ideas through with the addition of the 32nd notes.

Relax while playing these exercises, and keep in mind that the feel is more important than how fast the patterns are performed.

1

H.H. open
H.H. w/foot

Example 1: A 4/4 drum pattern. The right hand (H.H.) plays an open hi-hat on the first beat and a hi-hat with foot on the second beat. The left hand (S.D.) plays a snare drum pattern with 32nd notes on the first and second beats, and a snare drum on the third and fourth beats.

2

Example 2: A 4/4 drum pattern. The left hand (S.D.) plays a snare drum pattern with 32nd notes on the first and second beats, and a snare drum on the third and fourth beats.

3

Example 3: A 4/4 drum pattern. The left hand (S.D.) plays a snare drum pattern with 32nd notes on the first and second beats, and a snare drum on the third and fourth beats.

4

Example 4: A 4/4 drum pattern. The left hand (S.D.) plays a snare drum pattern with 32nd notes on the first and second beats, and a snare drum on the third and fourth beats.

5

Example 5: A 4/4 drum pattern. The left hand (S.D.) plays a snare drum pattern with 32nd notes on the first and second beats, and a snare drum on the third and fourth beats.

6

Example 6: A 4/4 drum pattern. The left hand (S.D.) plays a snare drum pattern with 32nd notes on the first and second beats, and a snare drum on the third and fourth beats.

7

Example 7: A 4/4 drum pattern. The left hand (S.D.) plays a snare drum pattern with 32nd notes on the first and second beats, and a snare drum on the third and fourth beats.

8

Example 8: A 4/4 drum pattern. The left hand (S.D.) plays a snare drum pattern with 32nd notes on the first and second beats, and a snare drum on the third and fourth beats.

9

Example 9: A 4/4 drum pattern. The left hand (S.D.) plays a snare drum pattern with 32nd notes on the first and second beats, and a snare drum on the third and fourth beats.

10

Example 10: A 4/4 drum pattern. The left hand (S.D.) plays a snare drum pattern with 32nd notes on the first and second beats, and a snare drum on the third and fourth beats.

11

12

13

WHY IS THIS MAN ...

TRAP HAPPY?

He has the new
—TRAP & ACCESSORY BAG—
 from
SLOBEAT PERCUSSION

Available with optional shoulder strap
 Dimensions: 27" long
 11" wide
 13" high

WHY A TRAP BAG?

- Holds all your stands and accessories
- Fits into spaces bulky trap cases can't fit
- Costs much less than conventional cases
- Reduces risk of back strain when lifting from trunk or hatchback
- Tough Tolex II construction: Lightweight, waterproof, rip proof, fire resistant, virtually indestructible
- Built to last; all seams double-stitched

PHOTOS BY MARY PUEBLEN-STEIN

Don't forget to try **SLOBEAT** Cymbal Cleaner and the new Black Widow bass drum beaters in wood or felt.

See the new **TRAP & ACCESSORY BAG** at your favorite music store!

SLOBEAT PERCUSSION PRODUCTS

NEW ADDRESS! (303) 674-4043 P.O. Box 175 EVERGREEN, CO 80439-0175

NEW

Free Drum Catalog

Call:
1-800-348-5003

Or Write:
The Woodwind & The Brasswind
 50741-D U.S. 31 North
 South Bend, IN 46637

Attention To Detail

In recent months, I've had more opportunity to go out and see other club bands perform than I've had in many previous years. I've been able to evaluate—from the point of view of an audience member—what makes the difference between a good band and *excellent* one, and what separates a talented drummer from an *outstanding performer* on the drums. I believe that the difference can be summed up in one phrase: attention to detail. While the vast majority of club groups meet the basic requirements necessary to get and keep them working, a few exhibit the attention to detail that makes them that little bit better, that little bit more entertaining, and most likely, that little bit more marketable.

Conversely, it's those drummers and those groups who fail to pay attention to the details that tend to leave a poor impression on their customers, even when the largest portion of their performance is fine. In fact, the better the overall performance level, the more the small omissions stand out. In other words, the better you are, the better you have to be, because more is expected of you.

I'm going to give a few examples of what I mean, based on what I've seen and heard recently from the groups I've watched performing. This will by no means be a comprehensive list of do's and don'ts, but it will give you an idea of the kinds of things that have the potential to greatly increase the quality of your performance, or greatly diminish that quality by their absence.

Drum Sound

It never ceases to amaze me that drummers can be such fanatics about certain elements of their drum sound, and almost totally oblivious to others. I'm not going to discuss proper overall set tuning for club work; I've mentioned in the past that I think a medium tuning is best when you have to play a wide variety of styles. But whether you use that sort of tuning, a flat and funky studio tuning, or a big and boomy rock tuning, the important thing is to pay attention to the overall effect. Is the drum sound consistent from drum to drum? Do the drums complement each other; do they produce an ensemble sound? In other words, do you play on a *drumset*, or a collection of several different sizes of drums? I recently heard a drummer who had a large kit, including timbales, rack and floor toms, and quite a bit of per-

ussion. I looked forward to hearing some interesting drumming, and I was not disappointed in that respect. But I was disappointed in the sound he produced. The timbales sounded tight and ringy, as one would expect. The rack toms were flat and very dull—the cardboard sound—while the floor toms had tremendous depth and resonance. The bass drum was single-headed and miked up, and gave a very tight, high-pitched attack sound, with very little depth or punch.

Had this drummer been the type of player who selectively and deliberately used different portions of this widely varied set for different songs, I would have understood such a non-homogeneous tuning. But he was playing pretty standard fills, using all of the drums on a pretty much equal basis, as one would on any drumset. The result was a very uneven sound from his kit, which, in turn, made his performance sound unpolished and unprofessional. When I spoke to this drummer later, he told me, verbatim: "I don't pay much attention to my tuning; the crowd here is so dead, they wouldn't know the difference." There's a good chance that the crowd senses this drummer's attitude through the sounds he produces, and it doesn't surprise me that they are "dead" in terms of their reaction to his playing. An attempt to improve his output might result in an improvement in their reaction to it.

In another club I visited, the band specialized in hard rock. The drummer's kit featured deep-shelled toms and a tremendously powerful bass drum. The drummer worked the toms frequently with impressive fills, and it was apparent that he was tom-oriented. It was made more apparent, unfortunately, by the fact that his snare sound was totally inconsistent with the rest of the kit. It was a deep snare, yet it was tuned very tightly, and heavily muffled. I asked the drummer if this was because of some miking problem, or even done at the request of the rest of the band. He told me that the snare had been tuned that way when he bought it from a friend—who had played jazz/funk in a horn band—and he hadn't gotten around to changing the tuning yet. I didn't ask how long ago he had purchased the snare, because it didn't really matter. He hadn't considered the importance of immediately adjusting his snare to fit his own set and his own playing; consequently, he was performing on a

piece of equipment that demonstrated his inattention to detail with every backbeat.

It seems to me that all the really fine drummers I've heard performing in clubs had certain similar elements in their drum sound—no matter what the basic tuning might be. Their drums were consistent, they were well-maintained (no hanging snare wires to buzz, no cracked heads, no cracked cymbals, no squeaking pedals) and the tuning suited the type of music being played. Details like this should be taken into consideration—and attended to—by every drummer who hopes to maximize the impact of his or her performance before the music ever starts.

Band Mix

This is not always an area that is under the drummer's control, but every drummer should be aware of the potential for disaster represented by an unbalanced sound mix. I saw a very talented show band recently, whose act featured a wide variety of styles, excellent vocals, exciting stage presence—all the elements of an outstanding performance. Unfortunately for them, their sound mix had two drastic flaws. One was that the vocals were too far down—a problem common to many club groups. A second, much more aggravating problem was that the bass drum was mixed up so high that it was the loudest element of the band's sound. I'm the first person to enjoy a good solid bass drum, and the foundational beat is very important to a dance band, but this level far exceeded the need, resulting in a very unpleasant "pile-driving" effect behind the dance tunes, and a totally inappropriate plodding behind otherwise gentle, moving ballads. The fact that this group employed a sound technician made such a situation inexcusable, underscored by the fact that the sound tech spent most of the evening seated at the board, just off stage, *behind* the sound cabinets! A sound technician should listen to the mix from out in the room, where the audience hears it. If the sound board can't be out there, the technician should walk out front frequently to listen, and then return to the board to make any necessary adjustments. If you don't have a sound technician and the band is handling the mix from on stage—admittedly a more difficult situation in which to achieve a good balance—it is the drummer's responsibility to make sure that the drums are mixed

properly. They must be balanced among themselves, as well as balanced in the overall band sound. You need to have someone whose judgment you can trust listen from out in the room and give you an indication of your balance *while you play!* Nobody in your band can play the way you do, so it does you little good to have someone else bang on the snare or kick the bass drum while you go out front yourself.

The point of my example is that an otherwise top-notch band's performance was dramatically impaired by this inattention to one small detail that could have been corrected merely by adjusting a dial. On the other hand, we've all heard bands whose playing was only adequate, but whose sound was so well balanced that their performance was tremendously enjoyable and they drew enthusiastic crowds.

Arrangements

I have never been a proponent of the "exact copy" philosophy. I believe that every band has the right to make a given song their own—to inject some of their own identity into the song. On the other hand, I also recognize the necessity to keep the familiar tunes familiar, so that the audience can relate to them and enjoy them—and thus the band—to the fullest. There's an unwritten principle in club music which basically states that the older or more obscure a song, the more liberties you can take with it; conversely, the newer and more popular it is, the more you need to stick to the recorded arrangement. Even if your band decides to make certain changes in a popular tune, it is critical to keep those characteristics that gave the tune its popularity in the first place, and the bigger the hit, the more important it becomes to "play it straight." When you lose sight of this detail, you run the risk of alienating your audience by appearing to show a poor regard for what might be their favorite music. At the very least, you can affect them, subconsciously, so that they don't react favorably to the music, even though they think—and you wish—they would.

A case in point occurred with the same show band I mentioned previously. At the conclusion of one of their sets, they launched into their "finale," which was Michael Jackson's "Beat It." As soon as they started the introductory phrases, the audience recognized the tune, an anticipatory "Ahh" went up and the floor became packed. But when the band moved into the body of the tune, the drummer was playing an inappropriate bass drum pattern! It wasn't a variation on the original; it wasn't just different; it was *wrong!* Everything else in the tune was fine, but the basic beat

was not what the audience was familiar with. So they danced ... for a while. But no one was smiling, and in twos and threes they left the floor. I actually heard one young woman say, as she passed me on the way to her seat, "I don't understand it; it's my favorite song, and I couldn't dance to it."

Of course, not every inattention to detail that a band might exhibit relates to the drummer, but I think a drummer has more details to be concerned with than perhaps any other musician in a club group. Each little detail offers a potential boost or a potential pitfall, in regard to the band's per-

formance. Take a moment to evaluate all the small things that are often taken for granted—or overlooked entirely—in the repetition and (sometimes) apathy that club performing can involve. If you spend a little effort on those details, you can not only improve your act, but keep your concentration level high and become more creative in an overall performance sense. 

**REPRINTS of most
MD Feature Articles
and columns ARE
available! Call the
office for a
price quote**



CHARLES PERRY'S Drumming Dynamics

A System for Contemporary
Drum-Set Performance
**PRIVATE INSTRUCTION—
MASTER CLASSES—CLINICS**

- Jazz
- Fusion
- Big Band
- Rock
- Super Technique

Dealer Inquiries Welcome,
Ask About Our Visiting School
For more information contact:



Tony Drago

Charles Perry's
Percussion Enterprises, Inc. (516)
285 Long Beach Rd. 483-6616
Hempstead, NY 11550

Good looks from Ludwig.

Ludwig doesn't just make drum outfits, it also outfits drummers—with satin jackets, jerseys, T-shirts, sweat bands and other quality items that'll help you dress the part.

For a free full-color catalog, see your Ludwig dealer or write to: Ludwig Specialty Items, P.O. Box 310, Elkhart, IN 46515.

Offer good only in the U.S.A.



Ludwig[®]

A SELMER COMPANY
P.O. Box 310 • Elkhart, IN 46515



shows.

RVH: Paul, do musical director/contractors like you have a tendency to keep the same people on the band, creating what is essentially a "house" band even though they are not "house" employees?

MANN: Yes, and it's to our advantage to do that. When you have the same people playing together, they develop the same intonation. Also, they know where the off-beat of 1 is. If the drummer's got a punch marked on the music on the off-beat of 1, you'd be surprised where other people in the band can think that is.

RVH: How long has your current drummer been with you?

MANN: Harry Himles is my drummer, and he's been with me for 20 years. He's one of the premiere drummers in this business.

RVH: Can a player who's been on the band so long keep a strong feeling for the contemporary styles of the younger headline artists?

MANN: The drummers here who have been on the bands a long time have stayed there because they have kept current; they are aware of what the new styles are. Otherwise, they wouldn't be on the bands.

RVH: We've had letters saying Atlantic City is very hard to break into. Dick, how do you feel about that?

PAUL: There simply has to be an opening. The timing is all-important. A drummer could come into town and play really well, and I'll wish that drummer was going to be here awhile, against the possibility that a chair will open up and I'll need that person. But good players like that usually can't hang around. They're generally in town with a group, and concerned with making a living. Even if they'd like to stay, it isn't possible for them.

RVH: Could a hot drummer in a road group use a lounge appearance here to catch a musical director's eye, and perhaps land a showroom spot?

PEDICIN: It's happened on my band. The bass player, drummer, keyboard player and guitar player were all lounge players when I picked them up.

RVH: Are the musical directors really out there looking?

PEDICIN: I am, but I think some of the

older ones get comfortable with the people they know, and kind of get complacent about it. It's easier to use the people you know and can depend on. I like the energy and fire that young players are able to bring into a big band or orchestra situation—something older players generally don't do. So I'm always looking.

RVH: So it might be a good idea for an act working the East Coast to book a couple of weeks in Atlantic City, with the idea of catching the eyes of local contractors and promoters?

MANN: Oh yes. But I have to qualify that by saying that, even if I saw a drummer who absolutely knocked my socks off, I would not replace Harry, because Harry serves my purposes more than adequately. Besides, my reputation as a contractor/employer of integrity, honesty and loyalty would be destroyed if I were to do that. If I have someone who's not making the chair, that's a different story. But as long as I have someone who's really filling the chair, I'm not going to replace my drummer with someone hot who happens to come in.

RVH: So are the Atlantic City showrooms a closed shop?

MANN: I think the nature of the business makes it a closed shop. We've got nine major showrooms in town, and they're not all functioning all the time. So at best, there's room for only nine drummers. How many drummers can come into town and hope to land such a gig? And out of the nine major showrooms, there are three or four drummers who are working enough to be making what you'd call a living at it. The others augment by playing outside club dates—private things.

PEDICIN: That's right. And there's more than just the showrooms in the hotels. A lot of them use local rhythm sections to play for the singing acts in the lounges. As an example, in all of the lounges at the Golden Nugget, there are local musicians. They bring singing stars into the lounges—like Billy Daniels or Keely Smith—who always perform with a local rhythm section. So there are places for drummers other than in the showrooms specifically. You start in the lounges until you get your name around, and then you get a call or two.

RVH: Let's talk about drummers coming into town from somewhere else, looking for showroom or lounge work, and trying to make their names known. What's their best course of action?

PAUL: Go to the rehearsal bands.

RVH: What is a rehearsal band?

PAUL: There are a couple of bands around town that just get together to blow, and you're always welcome to just come in and play. It's the age-old thing about the music profession: You can be made, or you can be destroyed, in one session. If you come in and you've got a headache and you play badly, everybody in town knows it. And if you play well, everybody in town knows about that. Whether you play shows or not—whether or not you can play jazz, pop and rock—it doesn't take long for the word to get around town about a new person's abilities.

PEIFFER: That is exactly what I tell anyone who comes in to the union local office or calls me. I would say to your hypothetical drummer, "I don't know you; I've never heard you play. As for presenting me with a resume, I could type up a resume that would knock your head off; it doesn't mean a thing. If you have a few weeks, come into town, and make your presence felt." If you transfer into this local, immediately upon transferring in you're permitted to play club dates—casuals. If a drummer comes in and plays one date—a wedding, a bar mitzvah, whatever—or plays with a rehearsal band, and does a really tremendous job, the next day everybody on the street is going to know that there's one hell of a drummer in town. The word gets out, and that drummer's going to start getting calls.

MANN: The rehearsal bands are one good method, but they don't create opportunities. Remember, there still has to be an opening for a new player.

RVH: Can you break in by subbing for someone in a showroom orchestra?

PEDICIN: Yes. That's usually the way, in fact.

RVH: Are there ever open call auditions?

PEDICIN: There are, at times. I've had auditions, and I think most of the other directors have had auditions at times, just to find out who's around.

MANN: Auditions don't really tell you the whole story. You get your recommendations usually by word of mouth—one contractor telling another—or you talk to some of your musicians and they tell you about a player who's really great. So when you have an opening, you give that player a shot.

RVH: If I'm a new drummer in town, should I talk directly to a musical director—introduce myself, as it were?

PEDICIN: I think that's the best thing to do down here, because Atlantic City is not like New York, with a lot of nightclubs where you can just hang out and sit in. There are a few little spots, but not enough

THOROUGHbred MUSIC'S
Percussion Unlimited



FLORIDA'S
LARGEST
INVENTORY

A. J. Altieri
Manager

(813) 238-8893
2204 E. Hillsborough Ave.
Tampa, Florida 33610

VALLEY DRUM SHOP (Everything For The Drummer)

SALES—SERVICE REPEARLING

Always a sale on new & used drums, cymbals, stands, pedals, cases, etc.

We build custom 7" x 14" Maple Snare Drums.

(818) 994-1755

13636 Burbank Blvd.
Van Nuys, CA 91401

to really do that. I guess it still boils down to who you know, and if you can get that one little break.

RVH: Dick, do you maintain a "little black book" of names to contact when you need to fill a chair? How do you assemble those names?

PAUL: I'm a rhythm player, and I pride myself on knowing who the good rhythm section players are in town. When it comes to a horn or reed, I rely on the lead players in those sections to know who the good players are for their section. When it comes to drummers, I've played with a lot of the drummers in town and so I know who to call for a given situation. And it's not always a case of playing ability. A player might have the skills, but might not be the kind of player that I like. I have that prerogative as the bandleader and contractor.

RVH: Let's talk for a moment about the physical working conditions for a showroom drummer. Carl, as the "house" drummer at Caesars, do you provide the drumset on stage?

MOTTOLA: No, it's the house's—the cymbals; everything—and it's top quality. Naturally, it's available to the drummer in a headliner's rhythm section as well.

RVH: When you're going to be sharing the set with the headliner's drummer, how do you deal with physical differences? Suppose you like to set up very low, and the other drummer prefers to set up high. Do you get together at a rehearsal and compromise?

MOTTOLA: No ... I just play it however the guest drummer sets it up. The headliner's act gets top priority, including the headliner's drummer.

RVH: Is a house set standard in the showrooms?

MOTTOLA: Yes, and several of the lounges also provide a set. The one here is a good Tama set, with five toms, three cymbals, and a complete miking setup.

PAUL: Another nice thing is that anytime we need something, it's requisitioned, and it's there that night.

MOTTOLA: Even a drumhead!

Special Projects

RVH: So far we've only spoken about the conditions for drummers backing headliner shows. There are also revues happening here, which we should discuss, as well as some non-traditional projects involving drummers. For instance, the Sands recently opened a new showroom production that is a radical departure from either the headliner or the revue formats. Tom, could you explain what this new style of show is based on?

CANTONE: First let me define some terms. A "headliner" show involves a single name performer or act, on whom the entire show is focused. There might be an opening act and there might not, but in either case a drummer would just play the

artist's charts all night long. A conventional "revue" is the feathers and the showgirls—that type of Las Vegas look, with novelty acts featuring a variety of performers. In this case, the drummer would be required to play in many different musical styles—what would amount to a vaudeville show format.

RVH: How is your new production different?

CANTONE: It's more modern, more contemporary. We're doing away with the "Vegas" look, and spotlighting the headliner in a more young-adult format. If you've seen someone like Peter Allen in concert, you get an idea of what it's about. Probably the main difference from your point of view is the selection of the musicians. Instead of the traditional backup orchestra, we wanted an all-star band of seven very high-powered musicians. They were selected from all over the country. These seven men can do what maybe 20 traditional orchestra musicians couldn't do. Our percussionist is an absolute monster, and our drummer's credentials are a mile long. That's the caliber that we were going after, and we got it. And I think this demonstrates another opportunity for drummers in a showroom, besides the traditional orchestra format.

Not every drummer playing in a showroom is backing any sort of show at all. Nor did every drummer get an Atlantic City gig by coming to Atlantic City to look for it. For instance, Vic Peterson may be holding down the most unique drumming gig in town—performing both as a drummer and as an onstage character in a musical play called "I Love My Wife" at the Claridge hotel.

RVH: Vic, how long is your show scheduled to run?

PETERSON: Three months, five nights a week.

RVH: That's quite different from the weekend headliner acts that appear at the other rooms.

PETERSON: Well, this is a full-on theatrical production, and we had to have a certain guaranteed booking. We're also hoping that a musical stage play will offer a different kind of attraction to the hotel customers.

RVH: Are you a local resident?

PETERSON: No, I'm actually from L.A., so this whole scene is quite a different thing for me.

RVH: Was your show put together in L.A. and brought here?

PETERSON: No, it was put together right here, in about four days.

RVH: How did you get the gig?

PETERSON: I had done *Cabaret* in California for Jack Bunch, who is also the director for this show. I'm primarily a percussionist—mallets, Latin, etc.—and pit work is my forte. I've worked with the Fifth Dimension, the Four Tops, Mary Wells, and a bunch of other people, so I'm at least familiar with a showroom situation. But this gig has so many new things! Number one, this is my first time singing; I'm not a singer. Number two, there's no reading; everything has to be memorized. As we say in L.A., you've got first-time or second-time readers, or else you've got a memorizer. I am not normally a memorizer, to say the least.

RVH: You're also not normally a set drummer, yet you're playing drumset on this gig.

PETERSON: Well, I get a lot of work on drums, but it's not really my personal favorite. It always seems that you get called for the axe you practice the least. In this situation—a four-piece band playing on stage and incorporated as characters into the stage action—everything is so brand new that it makes it a very interesting thing to do. It certainly is different from what any other drummer in Atlantic City is doing.

Casino Lounges

Possibly the most important performance area in Atlantic City, in terms of employment potential for drummers, is the casino/hotel lounges. We talked about the lounge situation with Tom Cantone and Bob Peiffer, and added the views of Neil Appel, Vice President of Complex IV Artists' Management, and Linn Tanzman, Entertainment Director for the Sands.

RVH: Tom, as an entertainment vice-president for a casino/hotel, what are you looking for when you consider a lounge

DIAL-A-DRUM
presented by Chet Doboe
(516) 292-0838
Call today and listen to
hot drum ideas and stimulating
drum talk, all for the
price of a phone call!

Call us and we'll prove it to you.

WE'RE THE BEST

One of the largest drum shops in the world

WE BEAT MAILORDER DEALS NATIONWIDE

The Drum Shop—Houston
1511 W. Alabama St.,
Houston, TX 77098
(713) 524-1577

act?

CANTONE: We need a versatile show band that can play a lot of different kinds of music. On the casino floor, it's a festival, and we want a group that's going to contribute to that carnival spirit. We want a young, contemporary feeling from high-energy groups.

APPEL: On the casino floor, near the slots where there's noise and where people are yelling at the crap tables, you can have a screaming show band that attracts people. But you can't put a super-draw band three stories away from the casino floor, because then people are going to stay. The further away from the tables you get, the less draw type of act you need.

CANTONE: You have to remember the role of entertainment here, whether in the lounges or the showrooms. It's strictly to provide an extra activity for people while they are here. It's not to keep them away from the gambling floor; it's to provide background—to draw them into the hotel in the hope that they'll play in the casino.

RVH: Neil, speaking as an artists' manager, how do you feel about that philosophy?

APPEL: As much as we want to conform to what the casino would like, if I were to base my performer's entire reputation on *not* being a draw, I'd be remiss in my duties as a manager. There is a fine line. We want bands that people are attracted to, but that will not jeopardize their employment with their own performance. In a lounge adjacent to a gourmet dining room, I can't have my drummer going crazy at nine o'clock at night. At eleven, when the dining room is closed, then the band can feature the drummer. As for the drummer's role in a casino band, a band is as exciting as its weakest link, and sometimes a good drummer can compensate for a weaker link. The drummer is a real forceful thing in any group; I don't think you can overstate the drummer's role. If I were being interviewed by *Guitar Player*, I'd say the same thing. I build every one of my performing groups the same way: I start with the drummer. Our lounge acts travel self-contained; our showroom acts always travel with a conductor and a drummer.

RVH: Do the hotels deal primarily with acts based here locally in the Atlantic City area, or do you book mostly traveling acts?

CANTONE: It's a mixture of both. We take a look at all available talent, whether they're in the area or not. Most of the lounge talent we've been using up to now has been somewhat local—booked through local contractors.

RVH: Linn, is lounge entertainment seasonal, like the main showrooms?

TANZMAN: Lounge entertainment here runs all the time, every night, regardless of whether the main showroom is on or off.

RVH: Do the acts change from night to night? You wouldn't work the same act

seven nights a week in a given lounge, would you?

TANZMAN: It's all scheduled, and we do vary the acts. Quite often two or more acts will work the same lounge on a given night.

CANTONE: We bring them in on a rotating basis. Four weeks is usually what we give them; the minimum is probably two weeks.

RVH: Are rooms provided for traveling acts as part of the contract?

APPEL: As far as the casinos are concerned, they can't accommodate the groups with rooms in the manner usual for traveling bands. They have to keep all their rooms available for gambling customers. So the groups have to find rooms elsewhere. After all, there are a lot of groups across the country that are not making three thousand dollars a week, let alone five or six thousand, but the bands here *are* making that kind of money. The casinos look at it like this: "We're paying them a ton of money. Let them fare for themselves." That sounds callous, but I honestly think the casinos here give more respect to the performers they employ than anyplace else in the country. Even if the performers complain about the hours or a lousy sound system . . . how many places in the country do you come in and have any sound system? Large instruments like pianos and drumsets are often provided by the house, and most lounges have a sound technician. So there are definite pluses as well as minuses to working here.

RVH: Let's say I'm with a Midwest bar band who wants to break into Atlantic City. Would it be a good idea to come to a management company such as yours to benefit from your guidance and established connections?

APPEL: Let's put it this way: There are literally thousands of groups that are submitted down here. You can go into the entertainment division of any hotel and see 200 portfolios with 200 tapes. How can anyone tell anything about a show band from a tape? I own a 24-track recording studio in Boston, and I can make you and me sound like the best band in the world. For bands wanting to break into Atlantic City, I think that management is the only way. The buyers have put their trust in managers like me; they know that I'm not going to risk my reputation by sending in a group that I put together yesterday.

RVH: Could individual drummers contact you about putting them with a group?

APPEL: Certainly. With the number of acts we have now, there's always somebody leaving. I'd tell the drummers to send me a resume—not a tape of how they play, but a resume of who they've worked with. That tells me more of what I need to know. Perhaps I'll have them sit in with one of my groups, so I can get a gut feeling about them. If they are professional and don't give a negative appearance on stage, it's a plus. Ninety percent of selling is appear-

ance down here. A musician always has a stigma to overcome. If you look at any of our groups in the lounges here, they're dressed very well.

RVH: What about working through booking agents?

APPEL: Agents are fine in some cases. If you have a group, you live in New Hampshire, you're playing 30 weeks a year at the local Holiday Inn and ten weeks a year in New York City, and you have ten weeks left to fill up, you can come down here, look up some agents in the phone book, call them, submit a tape, and maybe they'll get you work. But it's the group that doesn't want to do 30 weeks in New Hampshire; the group that's looking to be somewhere further next year . . . to do that without management is ridiculous.

RVH: All of the musicians in the showrooms are AF of M members, but that isn't the case in the lounges. I've been told that that's because if an entertainment director goes out to see a group, and they're perfect for that director's lounge, he or she doesn't really care if they're union or not. Tom, is that a fair summation of your policy at the Sands?

CANTONE: In the lounges, if the music is good and the talent is there, we book accordingly. In the main room, it's all union.

PEIFFER: In the new collective bargaining agreement we're working on, one of the provisions is that whether a group is union or non-union, they will still get the union wage. Obviously, the hotel would then enjoy no particular advantage by hiring non-union players, and that's the whole purpose of that provision. But other than that, we have no control over who the casinos hire.

Work Off The Boardwalk

We discussed this subject with Neil Appel, Bob Peiffer and Paul Mann.

RVH: Let's get away from the Boardwalk and the casinos for a moment. Is there a strong club scene happening here?

APPEL: There are some good clubs, dance rooms and rock rooms here in town that flourish; you can't get into them on a busy night. Bands of all styles are represented in those clubs, including rock, pop and C&W music.

RVH: Do the local clubs hire predominantly local bands, or rather traveling top-40 acts?

PEIFFER: The local clubs tend to have their own circuit, within the surrounding area. The bands will work a few weeks here, a few there. Most don't work with agents, but rather do their own booking, and stay fairly close to the area. However, we do have groups that come in, controlled by an agent or booking office who make their deals.

RVH: Realistically speaking, are the local clubs more likely to hire non-union bands?

PEIFFER: They can go any route they please. It's dollars and cents. If a band—

union or non-union—draws people, the clubs are going to use them. But if a non-union band doesn't draw people, the clubs are not going to use them anyway just because they're cheaper.

RVH: How many clubs are here within the local's jurisdiction?

PEIFFER: The nine casino/hotels are all triple-A scale. We have four country clubs and six other hotels listed in the double-A class, but very few of those use steady players. They hire musicians as needed, for private functions. The offshore clubs—the top-40 and rock clubs—are class A or B, and there might be 30 or so of those.

RVH: Do the local clubs benefit from the people who come to town for the casinos?

PEIFFER: I don't think that the local clubs benefit one iota, because the casino hotels are self-contained. Once you go in, you don't have to leave; everything you want or need is in the hotel.

RVH: Would you say that the local players feel competition from all the traveling players who come in here?

PEIFFER: Not individually. For the local players that are working here in town, the money they can make here is a decent living.

RVH: What about casual work, such as conventions?

PEIFFER: The town itself can no longer handle a national convention because the hotels won't commit themselves to giving three hundred rooms for a particular week or weekend. They need those rooms for the people who go to the tables. Until something is done about that, such as a new convention center and more hotels—which are both in the planning stages now—we can only handle smaller functions. The amount of work for drummers playing convention bookings is pretty minimal right now.

MANN: I think you'll see that from the moment the first brick is laid for a new convention center, and some large conventions are booked, the hotels will see the immediate benefit and expand the number of their rooms. When that happens, in my opinion, Atlantic City will go from being sold-out on weekends only, 52 weeks a year, to being sold out completely, 300 or more days a year. And of course, that will open up many more jobs for drummers—no question about it.

RVH: One of the major reasons for allowing gambling in Atlantic City in the first place was to encourage redevelopment of the city itself. Has that been taking place?

PEIFFER: Outside of Pacific Avenue and the Boardwalk, where the casinos are located, Atlantic City is in pretty bad shape. The spin-off for the local businesses has not been what it was supposed to be. Yet it must happen if the city is to progress.

MANN: It will happen when all the people involved—the hotels, the city, the politicians—get together and agree that we have one goal, one target. Everyone will

benefit and profit from a convention center, and from expansion of the airport, and other forms of transportation and urban development that need to be undertaken. When all this finally happens, you're going to see Atlantic City as one of the hottest convention and attraction cities in the world.

Conclusions

RVH: The bottom line for this piece is whether or not Atlantic City would be a good place for a drummer to consider as a career move. Can a drummer come here and find the work opportunities he or she is seeking?

PEDICIN: I think so, definitely. There are good players in town who don't work steadily, that's for sure, but that's the case anywhere. You'd have to have 50 casinos here for all the good players that are here to work. But I still think the better players will find a place.

PAUL: In the nightclub business, let's say that this is probably the best place to be. If someone is going to pursue a career in the saloon business, this is the only place left.

MANN: Realistically, I would have to say that the opportunities for a drummer coming into town are not hopeful—at the moment—unless that drummer is willing to stick it out long enough to become known. As far as a showroom is concerned, he or she had better be a top drummer. But lounge groups are being formed all the time.

MOTTOLA: I think Atlantic City is in its infancy now. In years to come it will develop further.

CANTONE: The pay is good; the hours are good. A lot of jobs have been provided in the entertainment field, and with three more casinos under construction and others planned, the growth will continue.

PEIFFER: If we're going to assume that we've got one great drummer who'd like to come here to work, I would say that yes, the potential for a career is here. And there is a potential here for the future that's going to be great. I can foresee one hell of a town here. I really mean it.

Although not represented in the above "round table," the following people provided assistance that was instrumental in the preparation of this report. We offer our appreciation and thanks for their help: Dennis Gorski, Public Relations Director, Caesars Casino/Hotel; Glen Lillie, Public Relations Director, Tropicana Casino/Hotel; Marsha Wachsmann, Public Relations Director, Claridge Casino/Hotel; Ron Ponzio, Musical Director, Resorts International Casino/Hotel; David Paimar, drummer, and Robert DuPree Hailey, percussionist, for "Clint Holmes Celebration" show, Sands Casino/Hotel; Joanie Peteani, drummer/vocalist, "Then and Now" band; Ernie Thomas, drummer/trombonist, "Then and Now" band; Jim Lovgren, drummer, "The Push Band;" Barbara Vogl, Atlantic City Casino/Hotel Association.

Chet McCracken with Joe Walsh says:

"FOR SOUND,
you can compare the Hi-Energy Mics
to any on the market today."

"FOR PRICE,
there IS no comparison."



The Hi-Energy Miking System is unlike any other. Consider these features:

- New Technology Condenser Microphone
- No phasing problems
- Handles an incredible 161 dB SPL
- Eliminates boom stands and stage rumble
- More volume before feedback
- Shock mounted clamps set up fast and easy
- Natural, uncolored drum sound
- No need to drill holes in the drum shells
- Hot, clean signal at the board

AQUARIAN AQUARIAN ACCESSORIES CORP.
1140 N. Tustin Ave. • Anaheim, California 92807 • (714) 632-0230

More REAL drum sound at a great price.

DRUM SOLOIST

Transcribed by Dan Tomlinson



Photo by Tom Copl

Philly Joe Jones

"Lazy Bird"

This solo is taken from "Lazy Bird," on John Coltrane's *Blue Trane* album (Blue Note, BLP-1577-815 77), recorded in 1957. Note that measures 15-20 and 27-30 are written to show the roll pulse played. The effect is that of a closed roll with accents.

T.T.
S.D.
F.T.
B.D.
H.H.
w/ft.

rimshot $\text{♩} = 126$

one hand

RUDIMENTS?? WHO NEEDS 'EM?

Every "SERIOUS" drummer! That's who! Now for less than the cost of one private lesson, you can have rudimental knowledge that will last a lifetime! Knowledge that will develop stick control, dynamics, power, endurance and an endless playing vocabulary on your drum kit. Superstar or beginner you'll be amazed at the new found confidence the RU-MASTER™ series will make in your performance! Created by a professional of over 20 years, and a member of N.A.R.D. for over 17 years.

This package contains a book of notations and a cassette, not only explaining each rudiment, but actual execution from open to close to open. You should hear what you're missing!

Send \$13.95, check or money order, post paid to:

RU MASTER Vol. I Box 15635
No. Hollywood, Ca. 91615-5635
 Outside U.S. add \$2.00. Ca. Res. add 6½% sales tax.

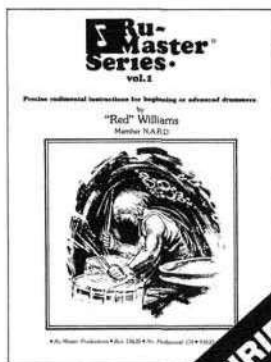

**DEALER INQUIRIES
INVITED**

TALK TO A PROFESSIONAL About Drums



Call the Sam Ash Professionals. They know their equipment and understand your needs. And you're dealing with the biggest in the business - a 60 year old company with a \$7 million dollar inventory. Why not get the best selection, the best price and the best advice from the Sam Ash Professionals?

ALL THE TOP BRANDS including Ludwig, Tama, Pearl, Slingerland, Gretsch, Sonor, Rogers, Samson, CB 700, Latin Percussion and Cosmic Percussion. Cymbals by Avedis Zildjian, K. Zildjian, Paiste, Sabian, Camber

PLUS ALL YOUR OTHER NEEDS—case, covers, stands, pedals, hands, sticks, drum machines

800-645-3518

IN NEW YORK CITY: (212) 347-7757
 IN NY STATE: (800) 632-2322
 ON LONG ISLAND: (516) 485-2122
 TWX 510-222-1630 SAM ASH HEMP

Since 1924

Sam Ash
MUSIC STORES



124 Fulton Avenue, Hempstead, New York 11550

DRUM MARKET

Anything to sell or trade? Looking to buy? A service to offer? Advertise it in **DRUM MARKET**, read by drummers nationwide. Rate—60¢ per word. 100 words maximum. Payment must accompany order. Mail your ad with remittance to MD, c/o Drum Market, 1000 Clifton Ave., Clifton, N.J. 07013.

FOR SALE

RECOVER YOUR DRUMS in classic black or white. A five-piece set costs less than \$50. Send 25¢ for samples, information and prices. **PERCUSSION SERVICES**, 3115 Hanna Ave., Cincinnati OH 45211.

ALL REMO, LUDWIG & EVANS Drumheads at a huge savings!!! All **ZILDJIAN & PAISTE** Cymbals at lowest prices! Huge Drumstick savings on the following: All Promark, Fibes, Bunkens, Pearl & Regal Tip, and we Roll 'em!!! Amazing low prices on all drums & accessories. Bizarre Guitare, 2677 Oddie Blvd., Reno, Nevada 89512 (702-331-1001) Plus, No Sales Tax on Out of State Sales!

BOSTON AREA: Drums and equipment, John Horrigan 472-6672

DRUMS! DRUMS! Radio King Snare's 5 1/2 to 7 1/2, Leedy's, Ludwig, Slingerland, Gretsch, Tama sets & accessories; Zildjians, Paiste, new & used, Buy, Sell, Trade. S & S Drums, (516) 796-8848.

Drum World—Major Brands. Mail Order Service Nation Wide. Competitive Pricing, 1106 Castle Shannon Blvd., Pgh., PA 15234 (412) 343-2600.

HARDROCK—HEAVYMETAL DRUMMING Bonzo Beats contains the beats, fills and solos that powered Led Blimp over the top. Send \$10 to Newton Press, 528 So. Guadalupe, Redondo Bch. CA. 90277.

Dallas Metroplex: I buy, sell, repair, recondition, refinish, and recover drums in Denton. Call me. (817) 566-1015.

Warm Up! with **XERSTICK 1XP** weighted drum sticks. The most important sticks you'll ever own. Strengthens finger, wrist and arm muscles; relieves fatigue; improves accuracy. Ask your dealer, or send \$8.50 pr. pair ppd. to: **XERSTICK**, 249 Fletcher St., Tonawanda, NY 14150 NY State residents add 7% sales tax. **DEALER INQUIRES INVITED.**

USED ZILDJIAN HATS—15" new beats \$120.00—14" K's; new top, CONSTANTINO PLE bottom \$200.00. 1-316-326-7960

Keplinger Solid Stainless™ and Solid Brass™ snare shells available in custom and standard sizes. New Keplinger Orchestral Line: *Brass Piccolo* and custom sized aluminum *Parade* and *Tambour Provencales*. For info write: **Soundynamics, Inc.** P.O. Box 31973, Seattle, WA. 98103-0073 (206) 632-5496.

DRUMMERS: BRAND NEW AMAZING NYLON FINGER RING INVENTION—TWIRLS DRUMSTICKS! FITS ALL. ONLY ONE IN THE WORLD. MAKES NICE GIFT. TWO RINGS WITH INSTRUCTIONS \$7.95 ppd. ALSO DRUMSTICKS "TWIRLERS" WITH BUILT IN CONTROL TWIRLING RINGS \$13.95 pr. ppd. TWIRLASTICK, BOX 5126, Dept. M.D., POLAND, OHIO 44514

CLASSIC SNARES AND SETS *Leedy *Leedy & Ludwig *Ludwig & Ludwig * Rogers *Radio King * Gretsch* TOP QUALITY "We Have Some Nice Pieces", 843 N.E. Northgate Way, Seattle, WA 98125 (206) 363-1854

Thriving Drumshop for sale. Located in mid-west. Owner desires to retire. I did it in six years, so can you. Write: Ward Richards, 5297 Sandlewood Ct., Columbus, Ohio 43229.

MIDWEST'S LARGEST PERCUSSION MUSIC INVENTORY, (solos-ensembles-meathods) Large discounts. Most Accessories—Hds/Sticks—Supplies. Prepaid or C.O.D. Drum Specialist, 1740 MacLean Ct., Glenview, IL 60025 (312) 724-3937

EAMES HAND-MADE BIRCH MASTER-TONE DRUM SHELLS—Three complete TOM TOM lines—one of 6 ply (1/4"), 9 ply (3/8"), and 12 ply (1/2") construction; two Bass Drum lines including our 18" depth series; and three snare drum lines featuring our 15 ply MASTER MODEL. Each Shell is 100% hand crafted from start to finish in the Tradition of fine Drum Making. All Shells are available unfinished, or in Natural Wood Gloss or Matt Finish. Write for our free brochure today. Eames Drum Co., 229 Hamilton St., Saugus, Ma. 01906 (617) 233-1404.

SAVE ON QUALITY USED DRUMS FOR BEGINNERS AND PROFESSIONALS. FULL SETS, PARTS, ZILDJIAN, PAISTE, CAMBER, PEDALS, STANDS, CASES. ED ... 212-296-8723.

Gretsch Snare and Parade Bass. Over 60 yrs. old. Wood Hoops and Shell. Calfskin Heads. Playable in Good Shape. \$390.00. David J. Tacsik, 47 West Heights, Youngstown, Ohio 44509 1-(216)-792-3202 or 799-8291.

Slingerland Radio King 3 Piece White Pearl. Snare, Floor Tom, Bass. Original Heads, Cases, Stands, and Hardware. Very Good Condition. \$975.00 David J. Tacsik, 47 West Heights, Youngstown, Ohio 44509 1-(216)-792-3202, or 799-8291.

ATTENTION COLLECTORS: TRIXON 1950s S.D. MINT. \$150.00. WFL 1940s S.D. MINT. \$150.00. VINTAGE RADIO KING, LUDWIG, WFL, LEEDY, LEEDY-STROUP, GRETSCH, K. ZILDJIAN. ED ... 212-296-8723

CONGAS!! CONGAS!! CONGAS!! Hand made, traditional Afro Cuban Congas. Superior hardware and design for higher tensioning, better sound and durability. Easy to handle, fantastic to play. Send for information. Afro Cuban Congas, 81 Pine St. #3, Camb. MA 02139.

PAISTE 30" GONG WITH STAND AND FLIGHT CASE. BEST OFFER. KIRK (217) 352-7265

PA, NJ, DE—I repair, recondition, refinish, and recover drums. (215) 647-2259.

STUDY MATERIALS

TWIRL DRUMSTICKS the way top pros do (Appice, Aldridge) **NO DEVICES NECESSARY!** DRUM CORP STICK TWIRLING shows you how to EASILY perform single or multiple drumstick twirls. Send \$8.95 to Heirborne, Box 26051, Indpls, IN. 46226

THEE BEAT BOOK: \$15.00 John Horrigan, 12 Goddard St., Quincy, MA 02169

A-LICK-A-DAY—The book that puts ideas in your head. 365 ear-catching fills revealing techniques to play those licks most only talk about. Stressing the incorporation of bass and hi-hat, it also covers many sticking alternatives. Guaranteed to increase your drumming vocabulary. \$9.95 for book; \$11.95 for 2 tapes, \$19.00 for all. Send to: Kevin McDonald, 500 Walnut Court, Centerville, In. 47330.

VIDEO CASSETTE DRUM LESSONS! Rent or buy! Send \$1.00 for sample study material and brochure to: George Walden, 77 Friendly Rd., Hicksville, N.Y. 11801

Unique concept oriented material. *Interpretive Sticking* contains material for beginners to pros. Rock to Avant Garde Jazz. Send \$10.00 to Martin Bradfield, P.O. Box 216, Spring City, PA 19475

ROCK DRUMS OFF THE RECORD. (TONY CASELLI, NORTHWESTERN UNIVERISTY STAFF) 96 pages and 3-hour tape cassettes transcribed funk beats-solos. Learn Cobham, Gadd, Garibaldi, Guerin, Mason, others. Complete \$26.45. Book along \$9.50. **JOBING-DATE HANDBOOK** with 2-hour cassettes "learn to earn" play all styles jazz-Latin-disco-Greek, etc. Complete \$16.00 Book along \$6.00. "Boss" Bossa Nova hundreds of Brush-stick patterns beginner to pro \$5.00 **FUNKTIONAL ROCK VOLUMES I AND II** thousands of Rock Patterns \$5.00 each, \$9.00 both. Optional tape cassettes \$13.00 Volume I. Postpaid. Tony Caselli Publications, 79 E. Wildwood Drive, Barrington, IL 60010 (312) 526-5123.

SOUND DRUMMING: The bible of drumming technique and musicianship. Not just another beats/fills book—a musical education for the beginning/intermediate student. Includes discussions of technique development, musicianship, style, and improvisation, plus an easy way to alter your existing set for noiseless practice. **DRUMMER'S EDGE:** The different drum book. The most advanced drum book ever written. Contains creativity development techniques which promote the smooth translation of ideas into music. This book reaches as far as you want to take it. \$9.95 plus \$1.00 shipping each; both books \$18.00 postpaid. Author is Yale B.A. with 10 years teaching experience. Stro Corporation of America, 1 Stro Boulevard, Box 65-Y, New Britain, CT 06050

HOME STUDY AUDIO TAPES (60 Minutes) includes study booklet: \$11.95 ea. General Drum set/Technique builder, Rock Drum set, Jazz Drum set, Intro to Mallet Instruments, Intro to Tympani, Conga Drum, Bongos/Bongo Bell and Timbali. Video cassettes also available: \$49.95 ea. (2 Hours). NJ residents add 6% sales tax. New Jersey School of Percussion, 14 Northfield Ave., W. Orange, NJ 07052.

EASY READ ROCK—The book that will teach you to read...painlessly! Open the door to your future with this exciting new TWO COLOR concept (for beginners-teachers-pros). Includes accents, fills and never before published Rock licks. Send \$9.95 for book, \$9.95 for EASY READ cassette (complete with music) or \$18.00 for entire package. Ill. res. add sales tax. Check or M.O. to PERCUSSION EXPRESS, P.O. Box 1731, Rockford, IL 61110

THE MOST COMPLETE DRUM TUNING STUDY AVAILABLE. ANALYTIC DRUM TUNING WAS REVIEWED AND RECOMMENDED BY MODERN DRUMMER. GET THE DRUM SOUND OF YOUR CHOICE. SEND \$7.95 TO: STEVEN WALKER, BOX 26051, INDIANAPOLIS, IN 46226

ROCK DRUM CHARTS-VOL. 1 Featuring transcriptions of Peart, Bonham, Collins, Copeland, and more! Send \$4.00 to: George Walden, 77 Friendly Rd., Hicksville, N.Y. 11801

FUSION CHARTS—Accurate drum charts to some of today's leading fusion artists. NOW EXPANDED. Everything from Al DiMeola to ZAPPA. Send \$1.00 for ordering information and listing. Send \$2.00 for all above and sample chart. Send to: Kevin McDonald, 500 Walnut Court, Centerville, In. 47330.

Publications by Chet Doboe—State of the Art drum books for beginners to pro. **READING RHYTHM BOOK 1**—The Beginning; a thorough presentation which develops strong reading ability.—\$6.00. **RUDIMENT CITY**—Contains over 250 American, Swiss and New Drum Rudiments. Develops chops and rhythm vocabulary for drum set, drum corps and orchestral players.—\$7.50. 75¢ postage one book; \$1.00 for both. There's more—Write for NEW FREE catalog. 427 Uniondale Ave., Uniondale, NY 11553.

GET LOCKIED IN: Can't hear your metronome? Now available. **CLICK TRACK** recorded on cassettes. HEAR the click while playing the set. 20 different tempos. \$8.50 each cassette. Solid Time Products Box 823, Goleta, Ca. 93116

INSTRUCTION

TIDEWATER, VIRGINIA area: Drum Set, Snare Drum, Electronics, Mallets, Timpani, Eric Hall, B.S.M.E. 804/583 DRUM (3786).

DRUM INSTRUCTION! *Beginners, intermediate. Advanced-all styles. Fully equipped studio, convenient Manhattan location. A comprehensively applied program designed to develop all aspects of drum technique.* CHARLES DAVIDMAN (212) 242-0485.

Baltimore, MD area: Drum Instruction with Grant Menefee, B.M. Berklee College of Music. All Styles and levels. (301) 247-0411.

In the S.F. Bay Area JOHN XEPLOEAS author of STUDIES FOR THE CONTEMPORARY DRUMMER will accept serious drum students. Develop all the needed skills for today's drumming. Call (415) 881-5432.

JIM PAYNE—author of FUNK DRUMMING, Mel Bay Pub., recording & touring professional, offering instruction. Intermediate-advanced. Reading, rudiments, coordination. Rock, Funk, Jazz. NYC 212/226-7889.

ORANGE COUNTY, CALIFORNIA: Accepting students for Drum Set. Glenn Young (714) 770-7760.

DALLAS AREA Drumset, snare drum, vibes, all levels. Frank Heye, NTSU jazz Ed. degree. Redbird Mall Melody Shop. (214) 296-2961.

New Jersey School of Percussion: Private Instruction, Workshops, Classes and Ensembles. Home study audio and VHS video cassettes also available. Obtain information from Glenn Weber, 14 Northfield Ave., West Orange, NJ 07052. (201) 738-3113.

NEW ORLEANS area: Study with Joey Farris, the co-author of STUDIO FUNK DRUMMING with Roy Burns. (504) 488-9644.

N.Y.C. DRUM & PERCUSSION LESSONS—Beginners to advanced. Reading, STUDIO & BWAY Show Charts, Rock, Jazz, Latin. Vibes, Xylo, Conga, J. Goodman (A Chorus Line) (212) 951-7511.

To Serious Drummers, I am Now accepting a Limited amount of students. My course deals with specific studies on progressive rock and Fusion. Learn concepts of Bozzio, Gedd, Phillips, Copeland, Peart, Bruford, Cobham, Williams, Moon, Bonham. Study Soloing, Grooves, Oddtime, Polyrythms, Funk, Record Transcriptions, Melodic Playing, Studio work, Gladstone; Finger; Molar Techniques, Solid Time. Get strong creative results. Jeff (516) 681-9556.

CONGA LESSONS IN NEW YORK. Learn to play traditional and popular Cuban, Haitian and Brazilian rhythms as well as how to apply them to Rock, Jazz, Funk, Disco, etc. Study with JOHN AMIRA, author of "Congas and Caribbean Percussion" in the August 1982 Issue of Modern Drummer. Call (212) 691-3123

SCHOOL FOR MUSICAL PERFORMANCE Specializing in Drumset and Mallet instrument Studies. Private instruction on all instruments. Voice, theory and songwriting. Jazz and Rock Ensemble Workshops—Rehearsal Space Available—Musical director, David Kovlins, B.A., M.A., M.S.M., 910 Kings Highway, Brooklyn, NY 11223 (212) 339-4969.

DRUMMERS: Learn ALL styles of drumming on ALL the percussion instruments, including mallets. Call for appointment. JOHN BOCK DRUMS STUDIO, 914-592-9593.

ART AND SCIENCE OF MUSICAL DRUMMING All levels and concepts of Musical Creativity. Discover greater sensitivity to sound, touch and dexterity. ARMAND SANTARELLI. ATLANTIC CITY (609) 822-9577, PHILADELPHIA (215) 567-2869.

PROFESSIONAL DRUM INSTRUCTION. JAZZ... ROCK... LATIN... DISCO. RUDIMENTS... READING. BEGINNERS AND ADVANCED STUDENTS. OZONE PARK, QUEENS, N.Y. ED... 212-296-8723

BOSTON AREA: Including Quincy, Marshfield, Waltham, Norwell, Woburn, Danvers, Portsmouth, N.H., JOHN HERRIGAN SCHOOL OF MODERN DRUMMING—Beginners to Professional (617) 472-6672.

THE CHET DOBOE CORRESPONDENCE PROGRAM. Study thru the mail. A personalized program using cassettes, books & charts. Rock, Funk, Reggae, Jazz, Solos, Reading & More! All levels. Write for free information, 427 Uniondale Ave., Uniondale, NY 11553.

WANTED

BOSTON AREA: Drums and equipment, John Horrigan 472-6672

ISTANBUL-K's JOHN HERRIGAN (617) 472-6672.

Used DCI Music Video drum tapes (White, Purdie, & Horton). Hertz, 1620 Baltimore, Waterloo, Iowa 50702.

DRUMMERS REFERRAL SERVICE. Drummers looking for work. Bands looking for a drummer. J.D.'s DRUM STUDIO (217) 787-0385.

Find bands to join. Find Musicians and gigs. Write Musicians National Hot Line, Box 7733, Murray, UT 84107. Phone 801-268-2000.

CASH PAID FOR DRUMS. COMPLETE SETS OR PARTS. CYMBALS, PEDALS, HARDWARE. ANY DRUM EQUIPMENT. ANY MAKE, ANY CONDITION. N.Y.C., L.I. AREA ONLY. ED... 212-296-8723.

Teacher-Experienced Green Bay Drummer, 30, seeks a teacher. Will travel some. (Milwaukee, Madison) Kurt. (414) 435-6025

the world by storm. In Southern California you can pick up a paper at any given time and there will be *Man From Snowy River*, *Gallipoli*, *Breaker Morant*. There are half-a-dozen good movies that we've seen on bills here in the U.S. just in the time we've been here. And that's half a dozen more than we've seen from Britain, or Japan or anywhere else. I think it's because of our good marketing people, who are pushing our products and artists for worldwide distribution more now than in the past. For instance, Air Supply doesn't really rate a very big mention at home—they wouldn't fill a hall—but they're very popular in America. We've always had talented people. For instance, we have, I think, the makings of one of the greatest drummers the world is ever going to see. Get ready for him! His name is David Jones, and he's with a group called Pyramid.

Mark Dower: They're into real jazz/rock; they're the one band ever—and this is true . . . ever—to be asked to do a second concert at Montreux. They were so popular that the crowd went wild, and asked them to come back and do another show.

WD: David Jones is really a name I want to mention, because he is possibly—here we go—of his kind, the finest drummer I've ever heard.

MD: He's been doing clinics in Japan.

WD: He's a wonderful clinician, and probably the most innovative new drummer of today.

RVH: What age is he?

MD: Twenty-six. A real Vinnie Colaiuta type.

RVH: Ah—I was wondering who you might compare him to that we might already know here.

WD: Well—he's David Jones. I wouldn't put him into any sort of bag at all. He is into that sort of fusion, odd-time thing, but he is the cleanest, nicest thing I've ever heard on the drums. I'm really sticking my neck out there, but I don't think I'm just being parochial, because in our travels here we've heard Harvey Mason, Peter Erskine, and we just love them all.

MD: Another guy who ought to get more credit in America is Virgil Donati. He was over here about six years or so ago, and went on the road with the Brecker Brothers.

WD: Melbourne is the drummer's town in Australia; most of the hot drummers come from there. It's the second-largest Greek population city in the world, and one of the largest Italian populations. So when you see names like Virgil Donati or Derek

Pellici [of the Little River Band], you can bet they're from Melbourne.

RVH: Is that where the work is?

WD: No, Sydney is where the work is. But my theory is that Melbourne is the drummer's town because Billy Hyde, of the Billy Hyde Drum Clinic store chain, was a very wonderful teacher who lived in Melbourne and taught a lot of these people. Sydney produces more workmanlike drummers. I'm from the west coast—from Perth—so I don't really fit into that mold. But we mentioned David Jones, and we should also mention Don Sleishman. There are products that are causing a bit of a stir now [such as double bass pedals and resonance-enhancing mounting systems] that he actually did years ago.

MD: And Chris Brody! He makes these incredible snare drums. He's from Perth, where there's a kind of tree called the Jarra tree. He takes the whole tree, chops it down, and bores a hole straight up the middle.

RVH: He makes the drum out of the entire tree trunk?

MD: Right. He sticks it in a kiln to dry it out. We were just in L.A., and Tom Brechtlein was jamming on a kit with one of these snare drums. Harvey Mason's got one. In L.A. they can't get enough of them. Chris makes lots of sticks too.

WD: I'm still waiting for some power toms of this type. Talk about Australian drum sounds! It'll be Australians leading the way back!

RVH: Back to the hollow log.

WD: It virtually is the hollow log. This wood was used on the tops of desks when I was a high school boy. Some of those desks were 80 or 90 years old, and you just couldn't carve your name in them. It makes very heavy drums, but beautiful!

RVH: Now that we've talked about Australian drummers, I'm going to throw you a little curve here. Would Australia, and especially Sydney, be a good place for talented American drummers to go to in order to find work, since the sheer numbers of players here makes job-hunting difficult?

WD: They would have to be very well-rounded drummers if they wanted to do a lot of work. Let me tell you quickly about Sydney. At last count, we had about 1,500 clubs in New South Wales, which is the state in which Sydney is located. There's a lot of work there for musicians, singers, etc. We have a lucrative income from backing people who tour these clubs. These are supper clubs, with capacities from 500 to upwards of 3,000. Our big ones are comparable in size—although not in production—to some of your Vegas showrooms.

MD: We have these clubs where you can go into the bar, or you can go into the auditorium and see the show, and you don't have to pay to see it.

WD: Or if you do, it's very cheap—two dollars or so—but most times it's free. Hearing all this, American drummers might say, "Right, let's catch the next boat and go!" But what they find is that these acts—the top-of-the-bill ones—require a drummer who can play a lot of styles. Our acts are varied in their approach. They'll do something with a country feel, then a big band thing—whatever. It's essential that you can read, and I mean sight read, to do well in the clubs in Sydney, because you won't necessarily be with that one act all the time. If you get into a club band—a house band—you can have a different act every night. There's generally no rehearsal. They just give you an hour's show, talk the charts down and say, "Right—go!" Quite a lot of visiting drummers who've come out from various countries are very good in one area. They come out to Australia and find that suddenly they're thrown into a situation where they have to play everything, and perhaps they're not quite ready for that. So Sydney is quite a specialized town that turns out quite good—I think—workmanlike musicians. I know that, particularly, artists and musical directors from America are always very impressed with how quickly the Australian musicians get through rehearsals. They just sight read straight down usually, unless it's a very difficult piece, to the point where an artist like Peter Allen—who's one of our own originally—didn't even bother to bring his rhythm section on his last tour. He used an Australian rhythm section. Doug Gallacher was the drummer, by the way. Various other acts are being talked into using Australian rhythm sections. Shirley MacLaine came out last time with just her own drummer, because she does such a big dance routine and the drummer is so terribly important, but no one else.

RVH: Assuming an American drummer comes equipped with technical qualifications, would that drummer have trouble finding work in Sydney because of being American?

MD: The thing about Australia, is that it's such a small-town sort of atmosphere, especially Sydney. There was one—we won't mention any names—young American who came to fill in with one of our top bands, and everybody said straightaway, "Well, we better hear him." So what happened was every drummer in town showed up at The Basement that night to hear this guy, expecting him to be great, expecting him to be Harvey Mason or something, and he was simply not up to their expectations. It might not even be that he played badly; maybe nobody could have been up to those expectations. But people were very quick to put him down, and the word got out very quickly.

WD: Small-town gossip, you see. I'm afraid it happens.

Soft Rubber Pads
 Now available fullsize 100% pure gum rubber pads to place on top of hard surfaced Electronic Drums. Tested and proven. Checks & money orders only. Payable to

7.95 each
 34.95 set of 4
 post paid in U.S.A. only

Set-the-Pace (Nash. Div.) JR BOX 23334
 Nashville, TN 37202-3334

MD: And even if you come in and knock everybody out, it might not get around, because they won't say anything unless they can say it's bad.

WD: The same guy is quite a good drummer, and in certain bags plays very well. He certainly does have the funk thing right down. But the situation arose where a pro-

ducer used him for a session, and he was unable to stay with a click track. So straightaway, the whole exercise was negated. He was not trained by the metronome. That's the sort of thing you'll find, coming to Sydney as an American drummer, or an English drummer, or any foreign drummer. You'll really have to be well

prepared, well accredited, and be ready to really be very good. Otherwise, you're going to find that you're up against some bloody good players there. Now, you won't get out and hear—like we did last night—a Peter Erskine, where you just sit there with your jaw on the floor, but they will play the situations required very well.

Reader's Platform continued from page 4

INSIDE GRETSCH

It was great to read the "Inside" story on Gretsch drums. It's true . . . many top drummers who endorse other companies light up at the sound of their Gretsch set. I've been "spankin'" Gretsch drums for 25 years, and have always appreciated the company's preservation of "that sound." Anyhow, keep up *your* dedicated work. The articles on the great master drummers who have come up through the years are greatly appreciated by many of us. Sometimes, with age comes wisdom. Let's see more articles on the wise ones.

John Von Ohlen
Sunman, IN

EVANGELIST SPEAKS

After reading your May issue, I decided I just had to write and tell you what a great job I think you're doing. I learned so much from the Larrie Londin article—mostly things I usually had just wondered about. I travel with an evangelistic team, playing contemporary Gospel music, and your magazine is my main contact with the rest of the drumming world (as far as keeping updated on equipment, etc.). I have also learned tremendously from various articles. Keep up the truly great work.

Curtis Butler
Ninety Six, SC

PLASTIC VS. LACQUER

There has been a lot of talk lately about plastic coverings versus a natural finish, with some claiming that the plastic impairs the sound of a drum. The best sounding drums I ever heard were those back in the '60s; one set was blue sparkle and another was gold sparkle.

The glue that is used to glue the plastic onto a shell dries hard, so the shell, the glue, and the plastic actually become one. It's just as though the shell was made with another thin ply. Actually, some natural finishes are coated with five or six coats of lacquer, which can build up almost as thick as a plastic covering. The fact is, it makes no difference what's on the outside of a shell. A good sound comes from the perfectness of the shell and rims, and a drummer who knows how to use the proper basic tuning techniques. So, if you like blue sparkle drums, then by all means use them.

Charlie Lynch
Greenwood, DE

ALEX, VINNIE & CHAD

I would like to share a recent experience that I had. While vacationing in Los Angeles, I contacted three of the finest drummers there—Alex Acuna, Vinnie Colaiuta and Chad Wackerman—hoping to be able to study with them. Despite their obviously busy schedules, they all managed to squeeze me in. I was very pleasantly surprised to find all three very friendly, receptive, and genuinely concerned with my questions as a drummer. They were all willing to answer each and every question that I asked them, and to share all their knowledge with me. If it hadn't been for their schedules, I know that they all would have spent much more time with me.

My real reason for writing this letter is to let *MD* readers know that the drummers you listen to on records and respect as musicians are also the kind of people you would respect as human beings. Alex, Vinnie and Chad, thank you again.

Mike Pultro
Atlantic City, NJ

MUSICAL DRUMMER

I would like to compliment Mr. Bill Molenhof for his informative article in the *Musical Drummer* column, entitled "The Scale." I have already learned quite a bit from it, and I believe that it is essential for drummers to acquaint themselves with this knowledge in order to become well-rounded percussionists, and musicians as a whole. I would enjoy seeing more articles of this nature in future issues.

Jerome A. Abraham
Atwater, CA

WORKINGMAN'S THOUGHTS

I'm a working drummer in Manhattan, on the East Side, doing a trio gig. I want to congratulate you on a fine magazine. I really enjoy reading it, and the honesty of some of the world's greatest drummers is very inspiring. Keep up the good work.

Louis J. Spina
Ossining, NY

Make music your life!
FIVE TOWNS COLLEGE
• Jazz Performance • Music Instrument Technology
• Audio Recording (24-track) • Music Business
Call (516) 783-8800 or write:
Dept. MD/2165 Seaford Ave., Seaford, N.Y. 11783

ROY & HARVEY

Living in rural northern Alabama, I don't get too many chances to see well-known drummers, other than at rock or country concerts in Huntsville or Birmingham. However, through the efforts of the Gretsch company and Joe's Midsouth Music, I was able to see two fine drummers—Roy Burns and Harvey Mason—in clinic. I had read how talented these two drummers are, and found what I had read to be accurate, if not an understatement, during the course of the clinic.

About an hour into the clinic, we were all asked to go to the basement of a neighboring building because the area was under a tornado warning. Obviously disappointed at the delay of the clinic, we all hurried to the basement. As I was walking down the stairs, I turned around and there was Roy Burns coming down the stairs behind me. For the remaining 30-45 minutes of the tornado warning, a small group of delighted drummers gathered around Mr. Burns, and asked question after question—all cheerfully answered. A little while later, we moved to a neighboring hall where we also talked to Mr. Mason. I'd like to thank both of these gentlemen for being so patient and for presenting a wonderful clinic. I'd also like to thank the Gretsch company, and Joe's Midsouth Music, for presenting these two fine performers.

Mike Kennamer
Grant, AL

THANKS FOR THE MOTIVATION

I have been an *MD* reader for about three years now, and have enjoyed every issue. Your magazine has helped me play better and get better jobs. It has also helped me get through bad times when I couldn't find a band. It's so good to read about famous drummers who went through hard times and came through. I may never be a star, but because of your magazine, I will be able to play as well as I can and enjoy my music much more. Thank you for putting out such a fine publication, and for helping people like me to be better drummers. Keep up the good work!

J.L. Theriot, Jr.
Breaux Bridge, LA

Remo *PTS* Update

Since my last review of the *PTS* products, Remo has made some advances and additions in their *Pre-Tuned* lines, which are surely worth looking at.

PTS Junior Pro Kit

To start very young drummers off right, Remo has developed a "kid-sized" *PTS* drumkit. The *Junior Pro* is available in a three-piece setup with a 10 x 16 bass drum, a 6 x 10 tom-tom, and a 4 x 12 snare drum, and a four-piece kit which adds a 10 x 12 floor tom. Both models include a snare stand, bass drum pedal, tom-tom holder (a long knurled L-rod), plus a 12" cymbal with bass drum shell-mount holder.

The *Junior Pro* uses the same *Acousticon* shells as the regular *PTS* kits. (*Acousticon* shells are made of a sophisticated Kraft paper impregnated with glues and resins, and then compressed to a wood density.) The kit also uses the same unique pre-tuned heads: Bright on the snare drum, and Mellow on the toms and bass drum. One difference lies in the snare drum: Instead of an external strainer, Remo has devised a knob-operated wire brush which is internally mounted. The brush rests on the bottom head to serve as "snare." The resulting sound has a lot of

looseness to it, but gets the general point across for kids.

The *Junior Pro* is miles above those paper drumsets found in department stores across the country. It is actually a miniature set of drums which, with the *Pre-Tunedheads*, sounds absolutely great! The kits are available in blue, red, or yellow and are just superb for kids. (Their parents may even want to take a turn!) The four-piece outfit retails at \$199.95, the three-piece at \$165.00.

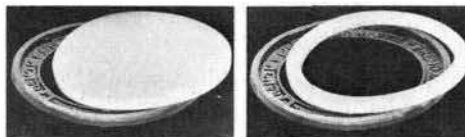

Remo Muff'ls

Since *PTS* drums do not have any sort of muffling device, Remo developed a unique product which provides four choices of dampening with no mechanical attachments whatsoever. The drum dampening begins with a plastic O-ring tray that sits on the bearing edge of the drum, under the batter head. This plastic tray cuts 80% of the drum's overring, since it muffles the head around the edge of the collar, which is where most overtones emanate from.

For a greater degree of muffle, a foam O-ring can be added to eliminate overring completely. This ring resembles a *Dead-ringer*, but is of a different density foam, and it rests inside a circular channel on the plastic tray. Total batter head surface muffling is accomplished by using the full foam disc instead of the foam ring. In this case, the foam disc touches the full area of the head, reducing normal drumhead vibrations. Placing another full foam disc at the bottom of the drum cuts out all resonance, transforming the drumkit into a *practice* kit.

The *Muff'ls* are usable on all *PTS* drums, as well as on any conventional drums. They are available separately in



DLX/DX-7500 DEEP-FORCE SERIES

equipped with Super Hoops
Don't get left behind, look at PEARL first.....
All the other drum companies do!



DX-22D-50 Illustrated in No.33 Pure White Cymbals not included

The Full Spectrum of Sound.

From a "Dead" sound to a "Live" sound—only Pearl offers the full spectrum of sound! Pearl's history and expertise in the manufacture of powerful sounding drums has created the new DLX/DX-7500 series. "Super Hoops" and Remo's "Pinstripe" heads on the batter sides are the standard features on all DLX/DX-7500 series drums. This combination produces an infinite variety of the powerful and heavy sounds required in today's varied playing situations. Always a leader on the world drum scene, Pearl has established another innovation worth calling "The new dimension in drum sounds." Pearl's high technology and refined craftsmanship are fully expressed in the sophisticated lacquer finished DLX-7500 and the covered DX-7500 series. A variety of the most asked for set configurations meets today's musical needs. DLX/DX-7500 series come from Pearl's tradition of excellence—"One step ahead of the rest" in designing drums.

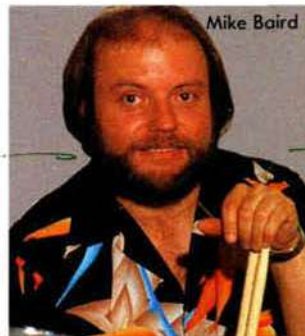

Mike Baird

"The sound is great ... nice, clean, and warm. Real good tonal qualities. Now Pearl offers a choice of shells ... and this new birch series is really happening in the studio" Mike Baird

Pearl[®]

For a full color catalog, please send \$2.00 for postage and handling to:
In U.S.A. Pearl International, Inc., P.O. Box 111240, Nashville, TN 37222-1240.
In Canada: Pearl Dep., 3331 Jacombs Road, Richmond, B.C. V6V 1Z6

One Smash Hit Deserves Another.

You don't have to put up with a forest of heavy mic stands surrounding your drum kit. Not with the miniature, multi-application Fender M-1 mic.

The M-1 is a cardioid condenser mic with exceptional sonic performance...with a staggering 148+ dB spl capability. So you can enjoy the superior isolation of ultra-close miking—without risk of overload distortion. And it's easy to mount anywhere.

Hear this dramatic advance in microphones now at your Fender Pro Sound dealer. It's a sure hit in almost any application.



sizes from 10" to 22", or can be purchased in sets. The *Ring Control* package includes the plastic tray and a foam O-ring. Retail cost ranges from \$4.50 to \$12.00 (depending on size). The *Sound Control* package has the plastic tray and two full foam discs, with prices ranging from \$5.00 to \$13.50. Remo has found a simple, inexpensive, effective way to muffle those annoying overtones on any drum, and to make silent practice on your own kit possible.

PTS Improvements

At the time of my previous *PTS* review (December '82), Remo was just getting started with their *PTS* products. They have since forged ahead in refining and enlarging the line, making it even more attractive for professional use.

6 1/2 x 14 Snare Drum

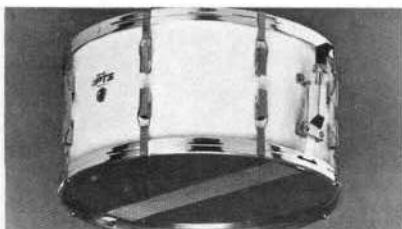

A 5 1/2" deep snare has replaced the 5" drum on all kits, and Remo has added an

optional 6 1/2 X 14 snare drum. The snare throw-off has been improved; Remo is now using a sturdier design, made by the Pearl factory. It is a side-throw strainer with fine-tune adjustment knob, and definitely works better than the previous model. The bass drum spurs have been beefed up and now feature threaded tips. Both the hi-hat stand and bass drum pedal have been changed to chain-pull. The action of the drum pedal is quite good, but the hi-hat still has a stiff "feel."

Double Tom-Tom Holders



Remo is offering a new double tom-tom floor stand for use with *PTS* drums. It has a single-braced tripod base and uses Pearl's old-style swivel ball hex arms. The most amazing thing is its list price of only \$58.50! (Hopefully, Remo will improve their tom-tom holder on the kits. At present, it has a different design than the one on the floor stand, and could use some beefing up and perhaps some lengthening as well.)

Available drumkit colors have been expanded to include white, black, and concord blue. The covering has been upgraded with the development of *Quadura*, a new plastic laminate which solves the past problem of wrinkling and ungluing. 7x10 and 12x14 tom-toms have been added, and even more tom-tom sizes are planned.



There are now three different series of outfits, each offering three-, four- or five-piece setups: the *3000*, with a 22" bass, the *2000*, with smaller drums overall, and the *1000*, which features all single-headed drums. Best of all, the price of the top five-piece kit has not changed since my first review: \$390.00 with hardware.

One interesting fact is that Remo is now making lug-tunable *PTS* kits for Slingerland, Kaman (distributors of CB-700), and Chas. Alden (distributors of Sonor). These kits enable fine-tuning of the pre-tuned heads for those who desire that flexibility. Remo has also added ethnic percussion to the *PTS* line. Currently available is a 4 x 16 Irish drum, 14" and 16" African tar drums, Brazilian tambourim, and a cuica (with a replaceable head).

Not content with stopping here, Remo recently introduced *PTS/CS* heads in Bright, Mellow and Dark tunings. These have the same qualities of the conventional CS clear heads. However, like the original coated *PTS* heads, they are of course, pre-tuned.

The development of Remo's *Pre-Tuned System* is quite an exciting thing to watch. In all honesty, I am completely blown away by its sound, affordability, and concept. My hat is off to Remo Belli for developing something that truly is revolutionary in the world of drums.



INTRODUCING THE STAR OF STICKS

Be Seen As You've Never Been Heard Before

Just turn out the lights and turn on the Stars. New. Brilliant. Explosively entertaining. Rapisarda illuminating sticks create a fascinating visual experience never before seen on stage. Or on tape.

Rapisarda Stars are quality maple sticks. Self-contained. Hermetically sealed. Batteries and LEDs are designed to outlast the sticks.

For incredible live performances and unlimited video applications, Rapisarda Stars are a coming entertainment phenomenon. They're available in some retail stores, but you may find the quickest way to get a pair is to MAIL THE COUPON BELOW.

RAPISARDA STAR

Made in U.S.A. Patent Pending
Dealer inquiries invited.

Send check or money order to RAPISARDA STAR, INC. 2650 Myrtle Ave., Suite B-7, Monrovia, CA 91016.

Name _____
Address _____
City _____
Quantity _____

State _____
@ \$19.95 per pair (includes handling and shipping). Zip _____

Total amount enclosed \$ _____
Allow 3 to 6 weeks for delivery.
Offer good except where prohibited, restricted or taxed.



IT'S QUESTIONABLE

Have a problem? A question? Ask MD. Address all questions to: Modern Drummer, c/o It's Questionable, 870 Pompton Ave., Cedar Grove, NJ 07009. Questions cannot be answered personally.

Q. I have a set of Pearl clear fiberglass drums purchased new in 1975. What are supposed to be the differences in sound characteristics between these drums and wooden drums? Why were the clear drums discontinued, while Pearl still makes a fiberglass shell (F series)?

L.B.

New York, NY

A. We referred your question to Mr. Al Duffy, Production Manager for Research and Development at Pearl International. He gave us this reply: "Pearl's 'see-through' line of drums were made from clear, or tinted, acrylic tubing, which differs from the fiberglass shells in that the acrylic has no reinforcing net of fiberglass in the structure. As in all musical instruments, the matter of sound is very subjective. No two ears will hear alike. The popularity of the acrylic shells seemed to stem from the extremely bright and projective timbre of the drums, as opposed to the warm, darker sound of wood shells. Another factor was the unique cosmetic quality of being able to look through the instruments. The market always determines what a manufacturer offers, and the back-to-wood movement is responsible for the end of the transparent shells. In fact, the demand for 8-ply all-maple shells has become so heavy that we have now suspended production of our fiberglass drums."

Q. I have been looking for a good beginner's drumkit for about three weeks, and I have found that drums for sale at pawnshops are much less expensive than at music stores. I'm wondering if there's some sort of catch to it. Do you have any suggestions for shopping at pawnshops?

D.W.

Columbus, OH

A. Pawnshops can be an excellent source of good used drum equipment, but you have to know, going in, exactly what you're looking for. There will not be a trained musical equipment salesperson there to help you shop. Also, prices at pawnshops can be lower because they offer no service after the sale, and carry no support lines of accessory equipment (such as sticks, heads, etc.) that add to the store's overhead. You must be cautious, however, about buying extremely cheap merchandise with either no brand name or one you've never heard of. This is generally poor-quality import equipment, which is no bargain at any price. If you plan to buy a student kit, or a budget-line kit offered by a name drum company, you might be better off going to a music store where you can obtain some qualified guidance as you shop. If, on the other hand, you're looking for a used, but high-quality, name-brand set that someone had to sell quickly, a pawnshop can sometimes be a source of real "gems."

Q. I am using Evans Black Gold heads on the bottoms of all my toms, and they really complement the shells. These only come in the heavy-duty, two-ply line. I was wondering if Evans has any plans to produce any thinner black heads, comparable to a Remo Diplomat!

S.L.

San Louis Obispo, CA

A. We spoke to Jim Beals at Evans, who told us that they have found that a twin-ply head works best with their plastic formula and dying process, therefore they do not make a thin head and have no plans to do so. However, Remo has recently introduced their line of Ebony heads, which includes a black Ambassador head. While not as thin as a Diplomat, the Ambassador head is a single-ply, medium-duty head, and might be closer to what you're looking for. Remo has plans to expand their Ebony line, and will likely be introducing a Diplomat weight in the near future.

Q. I'd like to add some temple blocks to my existing set and use them in conjunction with the other drums. I've looked at a few, but they weren't recommended to be used with sticks, only with mallets. Are there any made to withstand using sticks as well as mallets?

S.G.

Burbank, CA

A. Temple blocks are carefully crafted of carved or shaped wood, generally fairly thin, or thinner in the center than on the sides. This is to maximize the resonance and projection. Any time you strike them with something as hard as, or harder than, they are—such as a wooden drumstick—you run the risk of cracking them. If you play very lightly, with the tip of the stick, you can use a stick on a temple block, much as you would on a standard woodblock. However, if you intend to use them in conjunction with drumset playing at today's volume levels, striking them with sticks is almost certain to damage them. A temple block made thick enough to withstand the impact of a hard drumstick strike would probably have very little sound to offer.

Q. I have an 8 x 12 tom, which I wish to convert to an 11 x 12. I hope to do this by cutting three inches off an extra drumshell I have and attaching it by screwing the lugs on top of the joined shells. What type of cutting instrument should I use to get an even cut? Do you think this idea would work?

R.R.

Havertown, PA

A. We referred your question to top drum customizer Pat Foley, who advised against trying the operation you describe. Although some artists do join complete shells, using the counterhoops at the top and bottom to gain strength at the joining point (as well as offering a larger surface for the glue joint), trying to affix a section of one shell to another is more likely to create difficulties, and much less likely to give you the sound you are looking for. Pat suggested that the best way he knew of to obtain a deep-shelled tom sound was to purchase a deep-shelled tom.

Q. During the halftime performance of the Rose Bowl game, I noticed that the marching bands' drumheads had the Rose Bowl logo on them. Was this logo a label or decal of some sort, or was it printed on the drumhead itself? If the drumheads were especially printed, who did this for the bowl participants? If the logo was a label, can you tell me who made it up, so that I can get in touch with them?

J.D.

Davie, FL

A. The drumheads for the halftime participants, and for all of the marching drummers in the Rose Parade as well (a total of 633 drumheads for 23 bands), were provided by Remo, Inc. The Rose logos were decals, laminated to the heads at the Remo plant. For further information on the source of the decals, we suggest you contact the Sales & Marketing Department, Remo, Inc., 12804 Raymer St., N. Hollywood, CA, 91605.

Q. In your February '84 issue, in the *Just Drums* section, there was a picture and write-up on the Nady HeadMic. I've inquired at local dealers, but nobody has any knowledge of it. I would be grateful for any information you could give me to help me contact the manufacturers.

S.M.

Boardman, OH

A. You may contact Nady Systems at 1145 65th Street, Oakland, CA 94608, or call them at (415) 642-2411.



AS TIME GOES BY.



Ricky Lawson
of the Yellowjackets.

A tough customer, that Rick. One never knows what to expect next. The driving force behind Stevie Wonder, George Benson, Al Jarreau and the Yellowjackets, when they want great sound, they always come to Rick.

And with Rick, it's still the same old story. Dean Markley makes his drumsticks from only the finest select hickory, then leaves the finish off for a better grip, leaving only the great feeling of natural wood. Our special sealing process and low moisture content are all part of each perfectly balanced stick.

Of all the gin joints in all the towns in all the world he'll ever play, Rick will never use another stick, because as time goes by, Dean Markley quality remains essential.

So do yourself a favor, go down and pick up a pair at your Dean Markley dealer today. If you don't, you'll regret it, maybe not today, maybe not tomorrow, but soon and for the rest of your life.

You know, this could be the beginning of a beautiful relationship with Dean Markley.

Dean Markley
D R U M S T I C K S

UPDATE

Peter Erskine is pleased with the way the latest Steps Ahead album, *Modern Times* came out (released in April). "What's different about this album from most any other I've done is that the entire album was done to the clock, or the click as it were. We used the Oberheim *DMX* drum computer on most every tune and the *DSX* sequencing system on a few tunes. The album was more of a production album as opposed to our going in and just blowing. We layered the tracks, the reason being not only for the amount of control we had over all sorts of variables, but also for the quality and texture of the sound. By isolating certain parts of the drumkit, you not only can get a more distinct recorded quality on that part of the set, but you can also have simultaneous things happening, which would not be as easily done if you were trying to do it live. On one tune, we had the *DMX* playing the backbeat on the snare drum all the way through. That freed me up to play just the cymbals, the hi-hat and the bass drum, and I didn't have to keep worrying about playing the backbeat.

"The great thing about it was that it was a tremendous disciplining factor in terms of my tolerance, or intolerance, for the steadiness in time, or lack thereof. When you're working on an album in a production sense, listening back to it and mixing it, any deviations in time stand out. I discovered that this really helped my live playing a lot too, which was a surprise to me, as opposed to what I expected. You do enough studio stuff and you think it's going to limit your imagination. Not necessarily so—it's made me even want to do more work with the click. I used to have terrible problems with it. If you haven't done it, it's a mess the first few times, but I think it's essential for any drummer to be able to do it who's serious about doing any kind of recording work."

In addition to Steps Ahead, Peter has been playing some gigs with John Abercrombie in New York, he recorded with Bob Mintzer's big band for a Japanese release, he does occasional master classes at the Drummer's Collective, which he thinks is a great learning facility, he teaches and he's even readjusted his attitude about recording jingles and such.

"I've changed a lot of my thinking about a certain kind of free-lance recording. When I first came to New York, I had sort of a snotty attitude about free-lance work. It was an 'I can't be playing other people's music' kind of trip, which I have relaxed. The great thing about New York and Los Angeles is that the level of players is so high. There are such great players on a lot of these calls that I've just had a ball doing jingles lately."

Recent months have seen major changes for **Paul T. Riddle**, who has left the Marshall Tucker Band. His decision came on the heels of the departure of other key members. "Jerry Eubanks and Doug Gray really wanted me to go out with a new band and call it the Marshall Tucker Band. I just couldn't do it, so it was time to say, 'It was wonderful!' It's like getting a divorce, though, and it's so sentimental to me for a lot of different reasons. When Tommy died four years ago, it was so hard to go out on the road, but Franklin made it much easier. It was good, but I feel like with all the changes, it just got too difficult. The disagreements started affecting the music, so I thought it was time for me to remember the good times and what it was at its best, rather than dragging it downhill."

The parting was amiable and, in fact, you will be able to hear Paul on Doug

Yogi Horton has had a busy year thus far: projects include Martha & The Muffins (M&M), Was (Not Was), Aretha Franklin, Peter Wolfe, Cheryl Lynn, Melba Moore, Teddy Pendergrass, David Lasley, Kenny G, Bob James (including the Olympic basketball music with James), Kid Creole, Floy Joy, Fiona, Luther Vandross and assorted jingles. Toto (and **Jeff Porcaro**, of course) composed and played the Boxing Theme for the Olympics. The name of the instrumental composition is "Moodido (The March)" and will be featured as part of the Olympic telecasts, as well as in a Columbia album to be released in conjunction with the Olympics. Toto's album, *Isolation*, was released two months ago and they have just begun their summer tour of the States; they are also scheduled to do an extensive European tour, including the U.K., Scandinavia and the continent of Europe, followed by a tour of Japan and the group's first Australian trek. They hope to be home by Christmas before starting out on the second major leg of the U.S. tour commencing in early '85. **Steve Schaeffer** played on the Henry Mancini and Bill Conti tracks for the Olympics. He will also be playing in the orchestra that will open and close the events. You can also hear Steve on such films as *Oh God III* and *Grace Quigley*. **Craig Krampf** and **Chester Thompson** playing drums on Santana's newest release. Also on the album are the Santana percussionists: **Armando Peraza**, **Raul Rekow** and **Orestas Vilato**. Krampf is also on a *Diet Coke* commercial

by Robyn Flans

Gray's solo project (which could end up being released as a Marshall Tucker record). He also worked on Toy Caldwell's solo record, but these days, his prime concern is for a band he has put together with some new players as well as some Tucker band personnel. "For lack of a better description, the Throbbbers play instrumental fusion." They are currently pursuing a record deal.

"I'm really excited about it because it's something I've always been interested in doing. The beauty of it is that I've gotten to do everything I ever dreamed of doing as a kid, three times over, with the Marshall Tucker Band. I started the thing when I was 17. I've gotten to do some things for my family and I've been the luckiest guy in the world. It has also allowed me to pursue something like the Throbbbers without feeling like a gun is up to my head."

with Kim Carnes. **Steve Smith** is preparing for the recording of his third solo album. Steve has also been producing John Warren with the hopes of getting a record deal. **Larrie Londin** is on Glenn Frey's latest. Neil Young is cutting tracks with Crazy Horse, with **Ralph Molina** on drums. **Ralph Cooper** is on the road with Air Supply. **Steve Ferrone** has been on the road with Christine McVie. With the 1984 incarnation of John Mayall's Bluesbreakers is drummer **Rick Gardener**. **Tris Imboden** finished out the season of the Alan Thicke show when **Rich Schlosser** left to go on the road with James Taylor. **Bubba Bryant** recently returned from Europe with George Benson; he is currently touring the States with Benson. **Chet McCracken** has been cutting tracks with Joe Walsh and Rita Coolidge. Look for **Jackie Santos** on such albums as Dan Morette, Gregg Nesto, Armstead Christian and Paul Almedia, as well as playing on the road with Tavares. **James Ebert** has been on the road with Jan Berry and the Aloha Band. In addition to recording with Berry, he is working on a recording project with Susan Richardson and an EP with Randi Pauldi. James is also coproducing Gara. **Jim Stroud** is the new drummer with the Marshall Tucker Band. We would like to express our condolences to **Ed Shaughnessy**, whose son Jim was recently killed in an automobile accident. Congratulations to Lisa and Kenny **Aronoff** on the birth of their son, David Nikolai.



GLX-9500/9300 super pro series.



"Super Gripper"

"TOTALLY AWESOME"

...Pearl's All New GLX "Super Pro" Series.

"Super Gripper", PEARL's exclusive new lug, an innovation without compromise. The "Super Gripper" eliminates the problems of conventional style lugs. New springless design, no need to pack lugs! The receiver nut has a special EVA plastic tubing. It "grips" the rod ensuring no back off on tuned drums. To change heads just loosen tension rod a few turns. No need to remove tension rods or washers. The lug can then be snapped open for easy Hoop/Head removal. No more fumbling around trying to find tension rods in the dark.



GLX 22D-80 Wood Road Drummer (Cymbals, stands not included)

Don't get left behind, look at PEARL first
All the other drum companies do !

PEARL's all new "Super Pro" series drums are equipped with a full line-up of innovative, attractive features. "All Maple Shells" give you a clear yet powerful sound. "Super Hoops" are PEARL's answer to die-cast hoops. Eliminate the worry of cracking with PEARL's 2.3 mm rolled steel hoops. Tune your heads as you like with even tension from lug to lug. "Independent Suspension System" is re-designed to give you Total Angle Adjustment for your mounted toms. "Hardware". The new "Super Pro Series" is outfitted with today's most asked for hardware, the best of our 800 and 900 series.

Ask the guy who know ____ "On the road or in the studio, easier head changes, fast sure tuning, today's shell sound ... incredible !!!

Jeff Porcaro (TOTO)



Pearl®

For a full color catalog, please send \$2.00 for postage and handling to: In U.S.A.:

Pearl International, Inc., P.O. Box 111240, Nashville, TN, 37222-1240. In Canada: Pearl Dep., 3331 Jacombs Road, Richmond, B.C. V6V 1Z6

INDUSTRY HAPPENINGS

INTERNATIONAL DRUMMER MEETING

The second International Drummer Meeting, a clinic/demonstration series sponsored by Equipment Prosound of Koblenz, West Germany, was held in that city earlier this year. The two-day event featured clinics by top drummers and percussionists from around the world. The first day started off with Rick Latham demonstrating funk techniques, followed by Dutch percussionist Nippie Noya on electronic devices and experimental percussion. Graham Lear was on hand demonstrating rudiments and discussing his drumming with Santana. Gerry Brown took part in the clinics, as did Harvey Mason and Louie Bellson. Hideo Yamaki, top Japanese studio drummer, made the trip, as did Simon Phillips. Steve Smith presented a clinic, and finished the first day with a

performance with Vital Information.

The second day featured a contest for young local drummers, judged by some of the major artists on hand. Bill Bruford did a clinic explaining rudiments and solo composition. German drummer Manni v. Bohr presented an excellent performance, and was followed by Billy Cobham, who was to finish the day with his clinic. But at the conclusion of his demonstration, Billy asked Simon Phillips to join him, and the two exchanged kits, to the delight of the audience. Later, Steve Smith joined the two, and the three players provided an unscheduled (and possibly never-to-be-repeated) highlight to the entire event. Plans are already under way for a third such meeting, in February of 1985.

CONCERT ARTISTS GUILD AWARD

On May 2, 1984, Douglas Wm. Walter, marimbist and vibraphonist, was selected as one of seven winners of the 1984 Concert Artists Guild Award. As a winner of this award, Walter will be presented in his New York debut in Carnegie Recital Hall during the 1984-85 season. The Guild fully sponsors this event, and will provide other performance opportunities for Walter. In addition to these concert appearances, Walter will be presented with a \$1,000 prize upon his New York debut.

Walter, who will receive his Doctorate of Musical Arts from Temple University this year, studies with Alan Abel at Temple, and David Samuels at William Paterson College in New Jersey. He will become Assistant Professor of Percussion at Indiana State University this fall. Walter holds the dis-

inction of being the first percussionist to win the Concert Artists Guild Award in the organization's 33-year history. The Guild is a non-profit organization committed to discovering exceptionally gifted emerging musicians, and providing performance opportunities and assistance for the initial development of their professional careers.

LP AND BUDWEISER

Budweiser Beer has chosen Latin Percussion's facilities to create a TV commercial to appeal to the Hispanic community. The commercial features a cast of many employees of LP at work assembling the drums, with the final touches added by Ray Barretto performing on the finished product.

PASIC '84

This year's Percussive Arts Society International Convention is scheduled from November 1-4 at the University of Michigan Campus in Ann Arbor. PASIC '84 will feature some of the world's finest percussion soloists and ensembles, as well as one of the world's largest displays of percussion instruments, music and accessories.

The following is a partial listing of the artist/clinicians that will be participating: drumset artist, Harvey Mason; classic marimbist, Vida Chenoweth; Boston Symphony Orchestra timpanist, Vic Firth; premiere Canadian percussion group, Nexus; Japanese marimba soloist, Keiko Abe; contemporary U.S. percussion ensemble, The Cincinnati Percussion Group; former Zappa drummer, Vinnie Colaiuta; electronic drumset innovator, Bill Bruford; and the award-winning drum corps, The Phantom Regiment. For complete program, registration and housing details contact: PAS, Box 697, Urbana, IL 61801. (217) 367-4098.

ARTISTS' ALLIANCE, INC. PRESENTS JAZZ SERIES

Artists' Alliance, Inc., a newly formed production company comprised of musicians as well as artists from other fields, presented the "On Time Jazz Concert Series" at the Village Gate in New York, from Memorial Day weekend through the end of June. Among the artists appearing were Roy Haynes, Craig Harris, The Sam Rivers Quartet, The Billy Harper Quintet and Oliver Lake's Jumpup.

The Alliance is a cooperative effort of such artists as Reggie Workman, Lew Tabackin, Billy Hart, Freddie Waits, and many others, who have come together to exercise greater control over the presentational opportunities for their art. The Alliance intends to continue its efforts throughout the year, and to expand its activities into other areas, hopefully including record production, multimedia performances with music, dance and theater, promotion on a national and international scale, and other endeavors.

ZILDJIAN DAY IN NEW YORK

A large portion of New York's drumming community was on hand on May 20, when the Zildjian cymbal company, with assistance from Yamaha drums and Drummer's Collective, presented "Zildjian Day In New York," a concert/clinic held at the Entermedia Theater on Manhattan's Lower East Side. The roster of artists appearing included the Drummer's Collective Third World Percussion Ensemble, Alex Acuna, Tommy Campbell, Vinnie Colaiuta, Billy Cobham, and Steve Gadd.

After the Drummer's Collective group opened the show, each major artist was afforded the opportunity to display the abilities that made his reputation. Acuna (at one point joined by a group of family and friends, at another playing along with "his band"—a Walkman cassette player) gave a virtuoso performance on combined drumset and Latin percussion. Campbell demonstrated interaction of drums and cymbals when going

Photo by Rick Mattingly



Alex Acuna

"around the set," and also exhibited an amazing facility with the "rocking" bass drum technique, sounding as though he were playing double bass with his right foot alone. Colaiuta (assisted by bassist Tim Landers) opened by playing grooves along with a tape, then went on to demonstrate fills and polyrhythms, mentioning that, even though he had done such playing with Zappa, there was little call for it in the "real world," and that he was now getting

continued on next page

BREAKTHROUGH

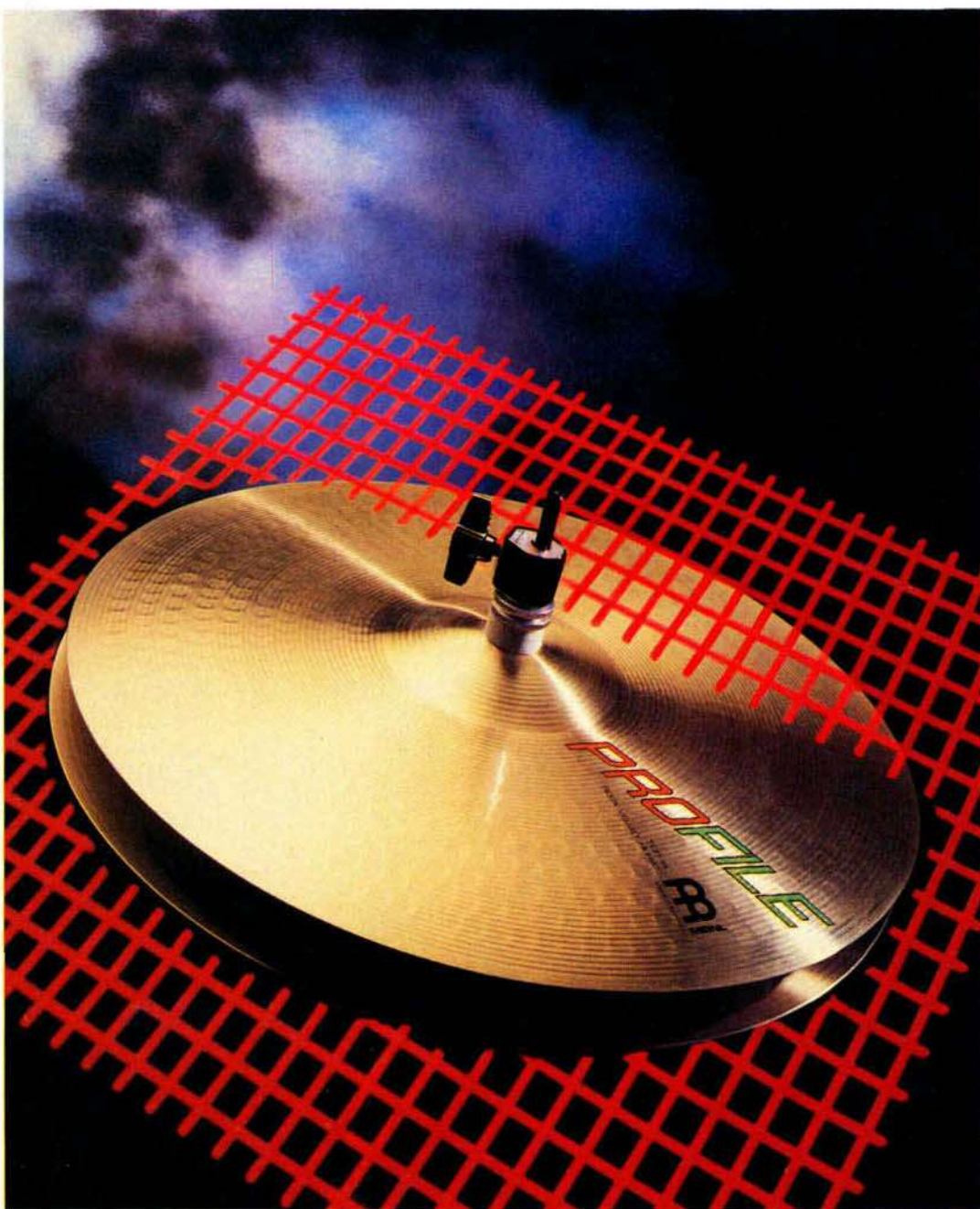

PROFILE cymbals break through with a new and unique manufacturing process, ensuring total consistency in sound, perfection hammering and a price you can live with.

We produce three ranges:

HI-TECH, the lighter range for high definition playing,
ROCK VELVET, the warm and versatile dynamic range,
VOLCANIC ROCK, for explosive power with incredible attack.



MEINL CYMBALS — YOU WILL HEAR FROM US...

USA EXCLUSIVE DISTRIBUTOR: PROFILE USA, P.O. BOX 807 P, LYNBROOK N.Y. 11563 , phone 516 887 3531

into pop music. Cobham offered a solo full of blazing speed, radical dynamic shifts, and comic relief—playing "air drums" in certain passages. He then went on to answer questions regarding specific tom fills, bass drum technique, and physical development. Gadd finished the event with some rock grooves (assisted on guitar and vocal by Eve Moon), a demonstration of how he inserts fills into time passages, and an exhibition of the fluid, fast-yet-precise sticking technique for which he is known. The event ran longer than planned, but most drummers present felt that the time was well spent.



Tommy Cambell



Vinnie Colaiuta



Billy Cobham



Steve Gadd



REMO'S

JOHN



Better
Products
For Better
Percussion

A Salute to John Guerin
Great West Coast studio and
jazz drummer, and a longtime
Friend of Remo.

from
REMO, INC.

12804 Raymer Street
North Hollywood
California 91605
(818) 983-2600

Send in a copy of this ad, \$3 and your size for \$8 value Remo T-shirt. Limit 1 per ad.

**CALL
US
TOLL
FREE!**

FOR A
SUBSCRIPTION
TO

**MODERN
DRUMMER**
The International Magazine Exclusively For Drummers

DIAL
800-221-1988



NEW JERSEY
RESIDENTS
DIAL
201-778-1700

Monday thru Friday
8:30 AM-4:30 PM E.S.T.

Clamp Down On The New Look With F.S. 101



**Look into
the future,
contact**

Silvestri Music Products Inc.,

4111 - 10th Ave. S.W.,
Calgary, Alta. T3C 1W6

Telephone (403) 246-4364

JUST DRUMS

TRAPEASE



A departure from the established methods of carrying hardware, *Trapease* is a new approach to an old problem. Convenient, compact, and lightweight, its features include an easy-grip adjustable handle, an adjustable shoulder strap, a separate space for the hi-hat extension rod, and a detachable, adjustable outer covering. *Trapease's* main innovation, however, is the way the hardware is securely fastened in an "interlocking" fashion. This allows the unit to maintain the stands in the smallest space possible, and to be completely adjustable to the individual load. For more information, contact *Trapease*, 908 Main Street, Belmar, NJ 07719, or call (201) 681-5200.

STICK HANDLER TAPE

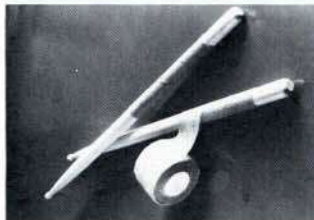

Developed to offer drummers better stick control and the ability to easily apply their own personal grip to every stick, Mechanical Music Corporation's new *Stick Handler* stick-control tape is an economical alternative to the sweatiness and expense of gloves. The self-adhesive tape was arrived at after extensive testing of dozens of potential tape materials. Each roll is capable of customizing as many as 100 sticks, yet still costs less than half the price of most drumming gloves. A *Slick Handler-wrapped* drumstick provides much better control than a bare stick, even a sanded one, and feels extremely comfortable when in use. The tape is available in red, black, tan, blue, and green, from Mechanical Music Corporation, 622 Hickory Drive, Buffalo Grove, IL 60090.

PEARL FIGHTMAN



Pearl International has introduced its new *Fightman* electronic practice system. It allows you to play "wide open" at home, without disturbing anyone. You actually hear acoustic, powerful drum sounds, either through headphones or live. Line Out jacks are furnished for connecting the *Fightman* to an external amplifier or your home stereo. A built-in click track allows you to practice time with an "in-the-studio" feel. *The Fightman* can also trigger drum machines. Two models are available: the *FM-50*, without cymbals, and the *FM-80*, which includes cymbals. For more information, contact Pearl International, P.O. Box 111240, Nashville, TN 37222-1240.

GIG RUG



L.T. Lug Lock, Inc. is now marketing a newly designed setup rug for drummers. Created for drummers who already have a trap case, the *Gig Rug* does not double as an equipment container, but rather is designed to fold up compactly into a package approximately 10" in diameter by 24" in length. A unique feature is a built-in bass drum barrier 20" in length to prevent the bass from "creeping" forward off the rug. The *Gig Rug* is made of thin, strong indoor/outdoor carpeting, and is currently available in red, brown and blue. When unfolded, the rug measures 5 1/2' x 5 1/2'. For more information, contact L.T. Lug Lock, Inc., P.O. Box 204, Tonawanda, NY 14151, or call (716) 694-1853.

PVI DRUM-KEY

PVI announces the introduction of *Drum-Key*, an electronic music interface board and software package for use with stereos, electric instrument amplifiers, and the user's Apple II series computers. *Drum-Key* uses digital recordings of 28 actual drum and percussion instruments. With *Drum-Key*, the user can compose, play, and record on disk all the percussion sounds and riffs he or she can think of, plus

play along with 100 rhythm patterns and 26 songs built into the unit.

According to Bruce Crockett, president of PVI, "*Drum-Key* is designed for everyone, from the doodler who just wants to have fun, to the serious professional who can use *Drum-Key* to teach the percussion elements of basic music theory."

The available sounds include kick bass, snare, four different tom-toms, a variety of cym-

bals, cowbell, tambourine and six sounds made by conventional drum synthesizers. Other features include: multi-track and real-time recording, programmable pattern length (up to 32 measures), user-selectable time signature and meter (28 values), programmable tempo (128 rates), programmable notes (from whole notes to 64th-note triplets), rhythm control (14 values to vary the beat), hi-res graphic screen (displays each note as entered or edited),

programmable audio and video metronome (10 different beat settings), easy-learn mode with colorful graphics display, sync out for use with external synthesizers or connection to multiple drum machines, and Apple disk storage for unlimited songs and patterns. Demo patterns and songs are included. For more information, contact PVI, Great Valley Parkway, Malvern, PA 19355, or call (215)647-3930.

WAH-WAH AND ZANGO SHAKERS



Fredrico Percussion has recently introduced two new designs in hand percussion instru-



ments. The *Wah-Wah* shakers have the original feature of the "wah-wah" effect, achieved by placing the thumb in the center of the top end, and opening and

closing the cupped hand over the bottom end while shaking. The *Zango* shaker can sound like a Cabasa or other shaker effects, depending on the shaking technique employed. Both shakers come in multi-colors, and are of all-metal construction. For further information, contact Fredrico Percussion, 152 Lancaster Blvd., Mechanicsburg, PA 17055, or call (717)766-1332.

CORRECTION

Editor's note: In the Just Drums department of our May '84 issue, we included information on the new Simmons SDS-8 electronic drumkit. Included was the statement that the kit was supplied with "two heavy-duty stands . . . included in the package." In order to keep shipping costs down, Simmons is unable to supply the stands with shipments to the U.S.; the stands are only included with shipments within the U.K.

TAMA TITAN TOUCH LOCK... STRENGTH MEETS SIMPLICITY



X-Hat

Tama introduces an exciting new concept in drum hardware - Titan Touch Lock. Titan Touch Lock combines the quality and strength you've come to expect from Tama along with the simplicity of any easy to use single cam locking system enabling fast, easy set up.

Also new from Tama are two multi clamp attachments; the All Purpose and Triple Holder clamps, each designed and engineered to make your set up as versatile as your imagination. Visit your authorized dealer for details on all the new hardware lines from Tama.



Touch Lock System



All Purpose Clamp



Omni Lock
Tom Holder



Triple Holder Clamp

TAMA

Look for this banner at your authorized Tama dealer.

For a full color catalog send \$2.00 to Tama, dept. MD • P.O. Box 886, Bensalem, PA 19020 • 17421 "B" East Gale Ave., City of Industry, CA 91748
P.O. Box 2009, Idaho Falls, ID 83403 • In Canada: 6969 Trans Canada Highway, Suite 105, St-Laurent, Quebec, Canada H411V8

ADVERTISER'S INDEX

Action/Reaction	34	NJ Percussion Center	56
Aquarian Accessories	77,95	North Percussion	41
Avanti	43	Paiste Cymbals	7
Axe Klic-Trac	63	Pearl International	51,103,109
Best Publications	85	Percussion Center	82
Brass Ring Enterprizes	56	Percussion Express	66
Camber Cymbals	39	Precision Drum Co.	87
Caruso Music Stores	75	Premier Percussion U.S.A.	3
Corder Drum Co.	42	Promark	36/37
Countryman Associates	56	Rapisarda Star Illuminating Drum Sticks	105
Dial-A-Drum	93	Regal Tip/Calato	87
Discount Music and Drum World	62	Remo	45,47,112
D.O.G. Percussion	63	Resonant Drum Sticks	70
Drum Workshop	38	R.O.C. Drums and Percussion	62
Drumming Dynamics	91	Rogers Drums	5
Drums Ltd./ Franks Drum Shop	40	Rolls Music Center	70
Duraline	60/61	Ru-Master Productions	97
E-mu Systems	57	Sabian	58/59
Emerald Musical Instruments	53	Sam Ash Music Store	97
Fender Professional Sound Products	104	"Set-The-Pace" Pedal Practice Pads	83,100
Five Towns College	101	Shure Brothers	55
Freeport Music	82	Silvestri Music Products	113
Gretsch Drums	Inside Back Cover	Simmons Electronic Drums	65,67
Imperial Creations	87	Slobeat Percussion Products	89
Kendor Music	79	Solid Time Products	86
Linn Electronics	49	Tama	73,115
L. T. Lug Lock	86	The Drum Shop-Houston	93
Ludwig Industries	91, Inside Front Cover	The Woodwind & The Brasswind	89
Manny's Music Store	71	Thoroughbred Music Store	92
Dean Markley Drum Sticks	107	Valley Drum Shop	92
Maxwin Drums	34	Vater's Percussion	34
MD Back Issues	75	Vic Firth Sticks	31
MD Library	68	Yamaha	35
Meinl	111	Zildjian	29, Outside Back Cover
Modern Drum Shop	64		

SEPTEMBER'S MD

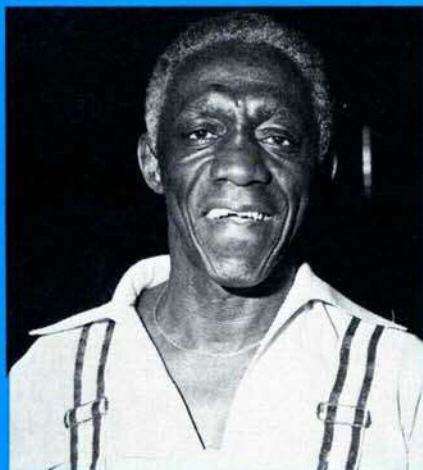

**ART
BLAKEY**



**CARMINE
APPICE**

Plus:

ARTHUR PRESS

JONATHAN MOFFETT

INSIDE YAMAHA

AND MUCH MORE... DON'T MISS IT!

WHEN YOU'RE HOT



Gerry Brown...
...(with Lionel Richie)...
...on Techware.™

"Now Gretsch has the stands and holders to go along with the Gretsch shells that have always been the greatest. The rough road use of my kit demands the durability that Techware offers. With their "Tech-Lok" patented clamps, none of my stands will let me down on the road or in the studio."



Harvey Mason (studio)...
...on natural wood finishes.

"I've always loved the sound of Gretsch drums, but in this business looks are as important as sound. The six-ply maple staggered laminated shells provide the sound...and their new colors are a knock-out. The new Natural Black Ebony is my favorite."

Phil Collins (Genesis)...
...on wood shells.

"My first real kit was a Gretsch and they've always had a lovely sound. I've always wanted a brand new set of Gretsch so I went out and bought one a few years ago. I kind of collect drums and I always keep coming back to the Gretsch sound after I try something different. Now, I am playing what I really wanted all along."



Mark Herndon (Alabama)...
...on snare drums.

"The snare drum is the most important component in any set-up. I play in all types of live and studio settings, both indoor and outdoor concerts. I must have a snare drum that cuts through even the most difficult sound situation. Both my Gretsch wood shell and brass shell snare drums provide me with the clarity and projection that only Gretsch can provide."

Standard of the World



P.O. BOX 1250
 GALLATIN, TN 37066
 615-452-0083
 Telex 786571 (Gretsch Gatn)

ZILDJIAN CRASH CYMBALS AND THE ART OF PUNCTUATION

Punctuating the flow of the music with crashes is based on drawing the sound *out* of the cymbal. It doesn't matter whether you get your crash sound by cuffing the cymbal on the side, glancing it or popping it on the shoulder or bell.

But using different playing techniques to get the full variety of possible crash effects is only half the story. You need a crash cymbal with all of those sound possibilities built into it. Each Zildjian crash has a totally individualized tonal blend that responds to *all* of your playing techniques so that you can express yourself better as a drummer.

Zildjian

You can choose from six different types of Avedis Zildjian crash cymbals for an unparalleled variety of tonal ranges and attack/decay characteristics. Each Zildjian crash is painstakingly crafted to the world's most exacting standards — our own.

Ranging from the super-fast, sensitive response of the Paper Thin Crash to the powerful and cutting projection of the Rock Crash, every A. Zildjian cymbal produces a rich "musical" sound with shimmering overtones.

Depending on the particular blend you're looking for, take the time to *listen* to a variety of cymbals. Like Zildjian's Medium Thin Crash, the world's most popular crash cymbal, which provides exceptional pitch flexibility, high end response and sustain. Our popular Medium Crash produces a robust, full-bodied sound with a higher pitch.

K

The legendary reputation of K. Zildjian cymbals comes from their deep, dark sound and dry tonal character. The K. Dark Crash epitomizes this classic sound and works extremely well in tandem with Zildjian A's to widen the dimensions of your overall sound.

amir

The Amir Crash has a crisp, bright, fast-rising sound with a smooth decay and controlled overtones. Both

the 16" and 18" sized Amir Crashes can blend in well with any Zildjian set-up.

IMPULSE

The new Zildjian Impulse line's raw explosive attack and long range projection of the rhythmic pulse is embodied in the Impulse crash. Its focused overtone threshold allows repeated crashes without overtone build-up.

The limitless sounds, tone colors and textures implicit in Zildjian crash cymbals are an important part of developing your individual drum sound. If you really *play* your crash cymbals, you can't help but hear the differences that exist among them. And those differences are what make Zildjian the only serious choice. For a white paper on Zildjian Crash Cymbals, please write to the Avedis Zildjian Company, Longwater Drive, Norwell, Mass 02061.

Zildjian®

The only serious choice.

