

Workshop Manual

TE 630 / 2011 I.E.
SMS 630 / 2011 I.E.

Part. N. 8000 H2051 (02-2010)



Husqvarna

HUSQVARNA MOTORCYCLES S.R.L. - Varese disclaims all liabilities for any errors or omissions in this manual and reserves the right to make changes to reflect on-going product development. Illustrations in the manual may differ from actual components. No reproduction in full or in part without written authorisation.

1st edition (02-2010)

Workshop Manual

TE 630 / 2011 I.E. SMS 630 / 2011 I.E.

Copyright by
HUSQVARNA MOTORCYCLES S.R.L.
BMW Group
Technical Service
Via Nino Bixio, 8
21024
(Varese) - Italy
tel. ++39 0332 75.61.11
tel. ++39 0332 756 558
www.husqvarna-motorcycles.com

1st edition (02-2010)
Printed in Italy
Print no. 8000 H2051

MODELS COVERED (from serial number onwards)

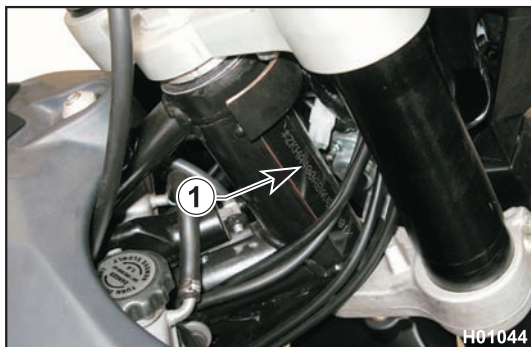

TE 630: ZKHA4 01AA B V 000001
TE 630 (USA): ZKHKD EKP# B V 000001
SMS 630: ZKHA4 01AB B V 000001
SMS 630 (USA): ZKHLD EKP# B V 000001

1. Chassis serial number

FOREWORD, TABLE OF CONTENTS

Foreword

This publication is designed for use by **HUSQVARNA** Service Centres to assist authorised personnel in the maintenance and repair of the models covered in this manual. The technical information provided in this manual is a critical complement to operator training and operators should become thoroughly familiar with it.

For ease of understanding, diagrams and photographs are provided next to the text.

Notes with special significance are identified as follows throughout the manual:



Accident-prevention rules for operator and persons working nearby.



Damage to vehicle and/or its components may result from incompliance with relevant instructions.



Additional information concerning the operation covered in the text.

Useful tips

To prevent problems and ensure effective service work, observe the following **HUSQVARNA** recommendations:

- before repair, evaluate the customer's description of the problem and ask the appropriate questions to clearly identify problem symptoms;
- diagnose the problem and identify the causes clearly. This manual provides basic background information that must be supplemented with the operator's expertise and specific training available through **HUSQVARNA** held at regular periods;
- plan ahead before starting work: gather any spare parts and tools to avoid unnecessary delays;
- avoid unnecessary disassembly work to get to the part that needs repairing.

Always read the relevant instructions and follow the disassembly sequence outlined in this manual.

Recommended shop practices

- 1 Always replace gaskets, sealing rings and split pins with new ones.
- 2 When loosening or tightening nuts or bolts, always begin with the bigger ones or from the centre. Tighten to the specified torque and follow a cross pattern.
- 3 Always mark any parts or positions that might be confused upon assembly.
- 4 Use genuine **HUSQVARNA** parts and the recommended lubricant brands.
- 5 Use special tools where specified.
- 6 Technical Bulletins might contain more up-to-date setting data and procedures than this manual. Be sure to read them.

IMPORTANT: Where not specified, reassembled components must be tightened to the proper torque as indicated in the tables provided in Chapter "x".



FOREWORD, TABLE OF CONTENTS

Table of Contents

Title	Section
Foreword, Table of Contents	a
Important Notices	b
General Information	A
Maintenance	B
Troubleshooting	C
Settings and Adjustments	D
General Procedures	E
Engine Disassembly	F
Engine Overhaul	G
Engine Reassembly	H
Front Suspension	I
Rear Suspension	J
Brakes	L
Electrical System	M
Engine Cooling	N
Hydraulically Controlled Clutch	P
Optional Components	Q
Fuel Injection System	S
Special Tools	W
Tightening Torque Figures	X
Chassis and Wheels	Y

NOTES

Unless otherwise specified, data and specifications apply to all models.



IMPORTANT NOTICES



Section

b





IMPORTANT NOTICES



TE and **SMS** models are STREET LEGAL motorcycles; they are guaranteed exempt from functional defects and covered with legal guarantee, as far as the STANDARD CONFIGURATION IS MAINTAINED and the suggested maintenance table shown in Section "B" is observed.

IMPORTANT

VEHICLE CONFIGURATION as outlined below is a prerequisite for the warranty to remain valid:

A) STANDARD MOTORCYCLE, FOR ROAD USE.



* In order to maintain the vehicle's "Guarantee of Functionality", the client must follow the maintenance programme indicated in Section B by having the required maintenance inspections carried out at authorised HUSQVARNA dealers. The cost for changing parts and for the labour necessary in order to comply with the maintenance plan is charged to the Client. The warranty becomes NULL AND VOID if the motorcycle is rented.

Notes

Left and right side is determined when seated on motorcycle.

Z: number of teeth

A: Austria

AUS: Australia

B: Belgium

BR: Brazil

CDN: Canada

CH: Switzerland

D: Germany

E: Spain

F: France

FIN: Finland

GB: Great Britain

I: Italy

J: Japan

USA: United States of America

Unless otherwise specified, data and instructions apply to all market variants.



GENERAL INFORMATION

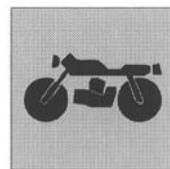

Section

A



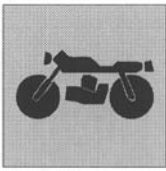

GENERAL INFORMATION

Engine	A.3
Timing system	A.3
Fuel system	A.3
Lubrication	A.3
Cooling	A.3
Ignition system.....	A.3
Starter	A.3
Drive and Transmission	A.3
Chassis.....	A.4
Suspension.....	A.4
Brakes	A.4
Wheels.....	A.4
Tyres.....	A.5
Electrical components location.....	A.5
Overall dimensions - Weight.....	A.6
Capacities.....	A.7



GENERAL INFORMATION

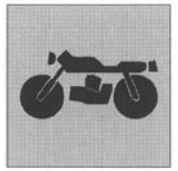

Engine

Type..... single cylinder, 4 stroke
Cooling Liquid with double radiator and heater fan
Bore 100 mm
Stroke 76.4 mm
Displacement..... 600 cu.cm
Compression ratio 12.4:1
Starting electric

Timing system

Type double overhead camshaft chain operated; 4 valve
Valve clearance (cold with engine)
Intake..... 0.10 ÷ 0.15 mm
Exhaust..... 0.15 ÷ 0.20 mm

Fuel system

Type..... Electronic injection feed
Air cleaning: dry air filter

Lubrication

Type..... Dry sump with positive displacement pump and cartridge filter

Cooling

Liquid with double radiator and electric fan
Coolant capacity 1.2 Litres

Ignition system

Type..... Electronic, inductive
with adjustable advance (digital control)
Spark plug type..... NGK CR8EB
Spark plug gap 0.7 - 0.8 mm

Drive and transmission

Clutch: oil bath multiple disc clutch, hydraulic control
Transmission: constant mesh gear type
Motion is transmitted from engine to gearbox primary shaft through spur gears

Primary drive
Drive pinion gear Z 32
Clutch ring gear Z 75

Transmission ratio 2.343

Gear ratios:

Type..... constant mesh gear type

Transmission ratio

(TE)

1st gear..... 2.615 (z 34/13)
2nd gear 1.812 (z 29/16)
3rd gear 1.350 (z 27/20)
4th gear 1.091 (z 24/22)
5th gear 0.916 (z 22/24)
6th gear 0.769 (z 20/26)

FINAL RATIOS (SMS)

1st gear..... 2.615 (z 34/13)
2nd gear 1.812 (z 29/16)
3rd gear 1.350 (z 27/20)
4th gear 1.091 (z 24/22)
5th gear 0.957 (z 22/23)
6th gear 0.880 (z 22/25)



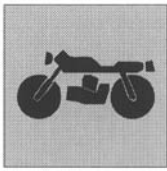

GENERAL INFORMATION

Secondary drive

Motion is transmitted from gearbox to rear wheel by 5/8" x 1/4" final drive chain ("D.I.D." 520 DS or "REGINA" 135 RX3)

Transmission sprocket	Z 15
Rear wheel sprocket (TE).....	Z 42
Rear wheel sprocket (SMS).....	Z 38
Transmission ratio (TE)	2.800
Transmission ratio (SMS).....	2.533
Transmission chain dimensions	5/8"x1/4"

Final ratios

(TE)	
1st gear.....	17.163
2nd gear	11.894
3rd gear	8.859
4th gear	7.159
5th gear	6.016
6th gear	5.048
(SMS)	
1st gear.....	15.529
2nd gear	10.762
3rd gear	8.016
4th gear	6.477
5th gear	5.679
6th gear	5.225

Chassis

Type.....single frame, in circular sectioned tubes, in steel; rear chassis in squared sectioned tubes in light alloy.

Suspension

Front

Type "Upside-down" telescopic hydraulic front fork with advanced axle (adjustable in rebound stroke); tubes ø 45 mm

Leg axis stroke (TE)	270 mm
Leg axis stroke (SMS)	250 mm

Rear

Type.....progressive with hydraulic single shock absorber
(preload regulation of spring and hydraulic brake in compression and extension)

Wheel stroke (TE).....	320 mm
Wheel stroke (SMS)	290 mm

Brakes

Front

Type (TE)..... fixed disc Ø 260 mm
with hydraulic control and floating calliper

Type (SMS)..... floating disk Ø 320 mm
with hydraulic command and radial fixed calliper

Rear

Type.....fixed disc Ø 220 mm with hydraulic control and floating calliper

Wheels

Rims

Front (TE)	in light alloy: 1.6"x21"
Front (SMS).....	in light alloy: 3.50"x17"
Rear (TE).....	in light alloy: 2.15"x18"
Rear (SMS).....	in light alloy: 4.25"x17"





Tyres

Front

(TE)..... 90/90x21"
 (SMS) 120/70x17"

Rear

(TE)..... 140/80x18"
 (SMS) 150/60x17"

Cold tyre pressure (TE)

Front

Rider only 1.2 Kg/cm²
 Rider and passenger 1.5 Kg/cm²

Rear

Rider only 1.5 Kg/cm²
 Rider and passenger 1.8 Kg/cm²

Cold tyre pressure (SMS)

Front

Rider only 1.8 Kg/cm²
 Rider and passenger 2.0 Kg/cm²

Rear

Rider only 2.0 Kg/cm²
 Rider and passenger 2.2 Kg/cm²

ELECTRICAL COMPONENTS LOCATION

The ignition system includes the following elements:

- Generator on the inner side of L.H. crankcase half cover;
- Electronic ignition coil under the fuel tank;
- Electronic control unit under the saddle;
- Voltage regulator on the R.H. side of the rear chassis;
- Spark plug on the R.H. side of the cylinder head;
- 12V-700W starter motor behind the engine cylinder;
- Solenoid starter located on the fuse holder plate, under the saddle;
- M.A.Q.S. sensor (pressure, throttle position, air temperature) on throttle body.

The electrical system includes the following elements:

- 12V-14Ah battery under the saddle;
- Turning indicators flasher located on the utilities holder plate, under the saddle;
- Relays located on the utilities holder plate, under the saddle;
- Electric fan relay;
- Injector, Lambda sensor, fuel pump, coil relay;
- Horn, turning indicators, stop lights, low and high beam lights relay;
- Electric fan;
- Fuses located on the utilities holder plate, under the saddle;
- Fuse FP- 15A (cable sheath marked "P"): fuel pump, HT coil, lambda sensor heater, injector;
- Fuse FM- 15A (cable sheath marked "M"): 12V depending on ignition switch, (system voltage), parking lights;
- Fuse FDC- 20A (cable sheath marked "DC"): electric fan, rear stop light, high beam, low beam, turning indicators, horn, instrument panel power supply (instrument functions display).
- Rollover sensor (SMS) located on the utilities holder plate, under the saddle;
- Coolant temperature sensor;
- Lambda sensor;
- Headlamp with 12V-60/55W twin halogen bulb and 12V-5W parking light bulb;
- LED tail light;
- 12V-10W turning indicator bulbs;
- Fuel pump inside the fuel tank.



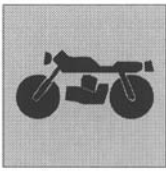

GENERAL INFORMATION

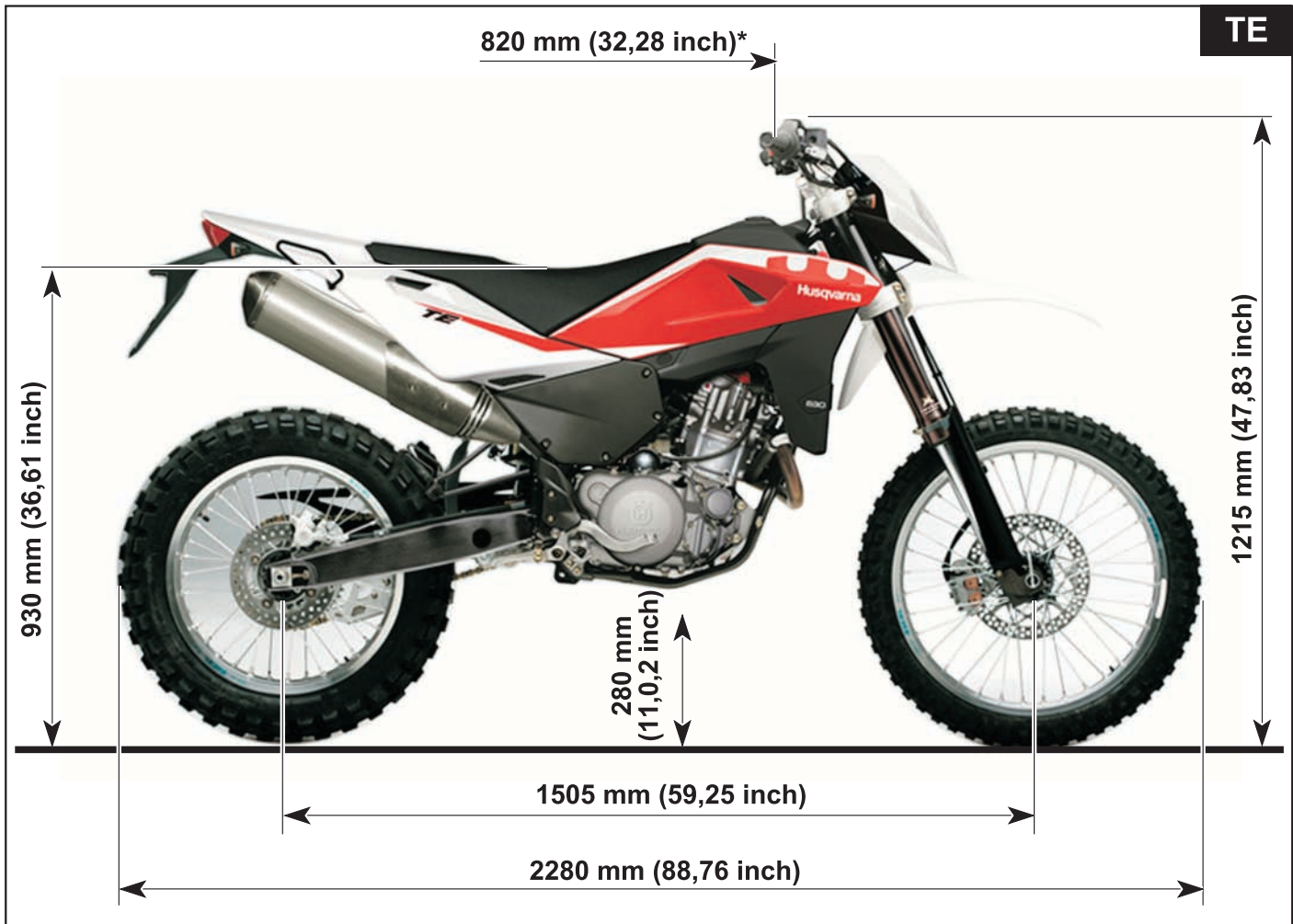

Overall dimensions - Weight

Kerb weight, without fuel

(TE):..... 150 Kg (330.69 lb)

(SMS): 158 Kg (348.33 lb)

*: max. width



GENERAL INFORMATION

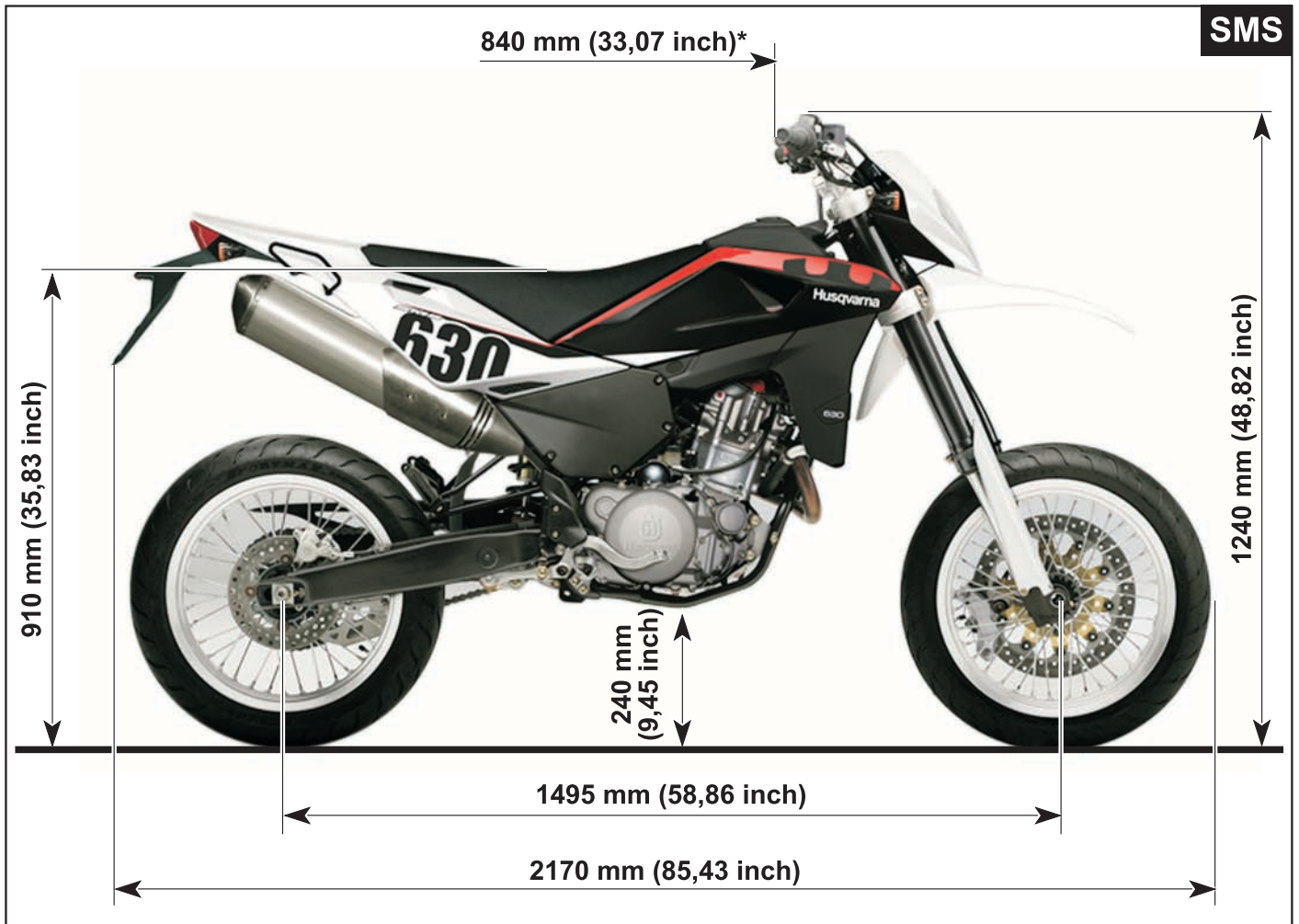
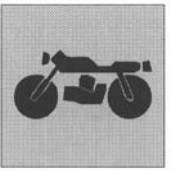

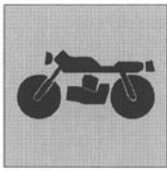

GENERAL INFORMATION

Capacities	Type	Quantity
Fuel tank including reserve	98 octane unleaded fuel	12 litres (3.17 GAL)
Reserve fuel (warning light goes on)		2.5 litres (0.66 GAL)
Gearbox/engine oil	CASTROL POWER 1 RACING 10W-50	2 litres (0.53 GAL) (oil change and oil filter replacement)
Gearbox/engine oil	CASTROL POWER 1 RACING 10W-50	1.8 litres (0.48 GAL) (oil change)
Front fork oil	CASTROL SYNTHETIC FORK OIL 5W	610 cc (37.22 CU IN)
Rear shock absorber oil	CASTROL SYNTHETIC FORK OIL 5W	
Coolant	CASTROL MOTORCYCLE COOLANT	1.2 litres (0.27 GAL)
Brake system fluid	CASTROL RESPONSE SUPER DOT 4	
Clutch fluid	CASTROL FORK OIL 10W	
Secondary drive chain lubrication	CASTROL CHAIN LUBE RACING	
Grease lubrication	CASTROL LM GREASE 2	
Electric contact protection	CASTROL METAL PARTS CLEANER	
Fillers for radiator	AREXONS LIQUID FILLER	
Air filter oil	CASTROL FOAMAIR FILTER OIL	
Air filter cleaner	CASTROL FOAMAIR FILTER CLEANER	

IMPORTANT - Do not add any additives to fuel or lubricants.



MAINTENANCE



Section

B





MAINTENANCE

SCHEDULED MAINTENANCE CHART (TO BE CARRIED OUT AT THE HUSQVARNA DEALER)

TE - SMS - STANDARD MOTORCYCLE, FOR ROAD USE (DERATED)	AFTER FIRST 1000 KM	AFTER FIRST 5000 KM	AFTER FIRST 10000 KM	AFTER FIRST 15000 KM	AFTER FIRST 20000 KM	REPLACE AS REQUIRED
PART	SERVICE COUPON	SERVICE COUPON	SERVICE COUPON	SERVICE COUPON	SERVICE COUPON	
VALVES	C (*)	C (*)	C (*)	C (*)	C (*)	
INTAKE/EXHAUST ROCKER ARMS			C		C	
TIMING CHAIN					S	
TIMING CHAIN SLIDER					S	
TIMING DRIVEN GEAR					S	
SPARK PLUG		P	S	P	S	
SPARK PLUG CAP		C	C	C	C	
ENGINE OIL	S	S	S	S	S	
ENGINE OIL INTAKE FILTER	P		P		P	
CLUTCH CUSH DRIVE DAMPER			C		C	
ENGINE OIL FILTER CARTRIDGE	S		S		S	
AIR FILTER	P	P/S (**)	S	P/S (**)	S	
CLUTCH AND BRAKE FLUIDS	C	C	S	C	S	
BRAKE HYDRAULIC CONTROLS	C	C	C	C	C	
BRAKE PADS WEAR	C		C		S	
BOWDEN CABLES	C	P	P	P	P	
THROTTLE CONTROL	C	C	C	C	C	
TYRE PRESSURE AND WEAR	C	C	C	C	C	
ELECTRIC FAN	C		C		C	
HEADLAMP BEAM HEIGHT	C					
LIGHTS/INDICATIONS/HORN	C	C	C	C	C	
BATTERY		C	C	C	C	
WHEEL SPOKES TENSION	C	C	C	C	C	
STEERING BEARINGS PLAY	C		C		C	
SECONDARY DRIVE CHAIN/TENSIONER ROLLERS	CL	CL	S	CL	S	
CHAIN	CL	CL	S	CL	S	
REAR CHAIN SPROCKET/TRANSMISSION SPROCKET		C	S	C	S	
SIDE STAND SCREWS	C	C	C	C	C	



MAINTENANCE



SCHEDULED MAINTENANCE CHART (TO BE CARRIED OUT AT THE HUSQVARNA DEALER)						
TE - SMS - STANDARD MOTORCYCLE, FOR ROAD USE (DERATED)	AFTER FIRST 1000 KM	AFTER FIRST 5000 KM	AFTER FIRST 10000 KM	AFTER FIRST 15000 KM	AFTER FIRST 20000 KM	REPLACE AS REQUIRED
PART	SERVICE COUPON	SERVICE COUPON	SERVICE COUPON	SERVICE COUPON	SERVICE COUPON	
WHEEL HUB BEARINGS			C		C	
FRONT FORK OIL			S/R		S/R	
OVERALL TIGHTENING OF NUTS AND BOLTS	C	C	C	C	C	
LUBRICATION/GREASING	L	L	L	L	L	

LEGEND

- C: CHECK
- C (*): CHECK CLEARANCE
- P: CLEAN
- P/S (**): CLEAN OR CHANGE (depending on the conditions of use of the motorcycle)
- S: REPLACE
- L: LUBRICATION
- R: FORK OVERHAUL

NOTES:

- REPLACE GASKETS AND SEALS AFTER EACH REMOVAL;
- REPLACE SCREWS AND BOLTS IF DAMAGED;
- PERFORM A GENERAL INSPECTION AFTER RIDING ON MUDDY OR SANDY TERRAIN.





Section

C





TROUBLESHOOTING

ENGINE

Trouble	Cause	Remedy	
Engine does not start or it hardly starts	Insufficient compression		
	1. Piston seizure	Replace	
	2. Connecting rod small or big end seized	Replace	
	3. Worn piston rings	Replace	
	4. Worn cylinder	Replace	
	5. Cylinder head loosely tightened	Tighten	
	6. Head gasket leaking	Replace	
	7. Spark plug loose	Tighten	
	8. Incorrect valve clearances	Adjust	
	9. Weak or seized valve springs	Replace	
	10. Seized valves	Replace	
		Weak or no spark	
		1. Spark plug faulty	Replace
		2. Fouled or wet spark plug	Clean or dry
		3. Spark plug electrode gap too wide	Adjust
		4. Ignition coil faulty	Replace
		5. High-tension cables open circuit or shorted	Check
		6. Electronic control unit faulty	Replace
		7. Right-hand switch faulty	Replace
	The engine stops easily	1. Dirty spark plug	Clean
		2. Electronic control unit faulty	Replace
		3. Low idle	Adjust
Engine is noisy	Noise seems to come from piston		
	1. Too much piston-to-cylinder clearance	Replace	
	2. Worn piston rings or piston grooves	Replace	
	3. Too much carbon build-up in combustion chamber or on piston crown	Clean	
	4. Worn drop link	Replace	
	5. Valve clearances too large	Adjust	
	6. Weak or seized valve springs	Replace	
	7. Worn timing chain	Replace	
	8. Incorrect timing chain tension	Adjust	
		Noise seems to come from crankshaft	
		1. Worn main bearings	Replace
		2. Connecting rod big end has too much side clearance or end float	Replace
		3. Crankshaft gear damaged	Replace
		4. Crankshaft locknut loose	Tighten



TROUBLESHOOTING



Trouble	Cause	Remedy
	Noise seems to come from the clutch	
	1. Worn plates	Replace
	2. Too much clearance between clutch housing and friction plates	Replace
	Noise seems to come from gearbox	
	1. Worn gears	Replace
	2. Worn gear grooves	Replace
The noise seems to come from the secondary transmission chain	1. Chain stretched or incorrectly adjusted 2. Worn transmission sprockets	Replace or adjust Replace
The clutch slides	1. Clutch adjuster screw with insufficient clearance 2. Weak clutch springs 3. Worn clutch plates	Adjust Replace Replace
The clutch is tight	1. Clutch adjuster screw with exceeding clearance 2. Non uniform spring load 3. Bent clutch plates	Adjust Replace Replace
The gears cannot be inserted	1. Bent or seized gearbox forks 2. Worn gear ratchets 3. Damaged shifter fork shafts	Replace Replace Replace
Gear shift pedal does not return in position	1. Weak or broken selector return spring 2. Worn shifter forks	Replace Replace
The gears are disengaged	1. Worn sliding gear engagements 2. Worn gear grooves 3. Worn dog slots in gears 4. Worn selector shaft splines 5. Damaged shifter fork shafts	Replace Replace Replace Replace Replace
Engine power lack	1. Dirty air filter 2. Poor fuel quality 3. Intake coupling loose 4. Spark plug electrode gap too wide 5. Insufficient compression 6. Incorrect valve clearance 7. Valve seats or guides faulty 8. Weak or seized valve springs	Clean Replace Tighten Adjust Identify cause Adjust Replace Replace
The engine overheats	1. Dirty combustion chamber and/or piston crown with carbon deposits 2. Insufficient oil in engine or wrong oil 3. Obstructions blocking air flow on radiator 4. Cylinder head gasket leaking 5. Clutch slips 6. Cooling fan faulty	Clean Top up or change Clean Replace Adjust Replace thermal switch





TROUBLESHOOTING

CHASSIS

Trouble	Cause	Remedy
The handlebar is hard to turn	<ol style="list-style-type: none">1. Tyre pressure insufficient2. Bearing adjuster ring nut or steering stem nut overtightened3. Bent steering stem4. Worn or seized steering bearings	<p>Inflate</p> <p>Adjust</p> <p>Replace bottom yoke</p> <p>Replace</p>
The handlebar vibrates	<ol style="list-style-type: none">1. Bent fork legs2. Bent front wheel axle3. Warped chassis4. Bent front wheel rim5. Worn front wheel bearings	<p>Replace</p> <p>Replace</p> <p>Replace</p> <p>Replace</p> <p>Replace</p>
Shock absorption is too hard	<ol style="list-style-type: none">1. Exceeding oil quantity in fork legs2. Fork oil viscosity too high3. Overinflated tyres4. Improperly set rear shock absorber	<p>Drain the exceeding oil</p> <p>Change</p> <p>Deflate</p> <p>Adjust</p>
Shock absorption is too soft	<ol style="list-style-type: none">1. Insufficient oil quantity in fork legs2. Fork oil viscosity too low3. Weak fork springs4. Weak rear shock absorber spring5. Improperly set rear shock absorber	<p>Top up</p> <p>Change</p> <p>Replace</p> <p>Replace</p> <p>Adjust</p>
Wheel (front and rear) vibrates	<ol style="list-style-type: none">1. Bent wheel rim2. Worn wheel hub bearings3. Incorrect spoke tension4. Wheel axle nut loose5. Worn rear swinging arm bearings6. Improperly adjusted chain tensioners7. Improperly balanced wheel	<p>Replace</p> <p>Replace</p> <p>Adjust</p> <p>Tighten</p> <p>Replace</p> <p>Adjust</p> <p>Balance</p>
Rear suspension is noisy	<ol style="list-style-type: none">1. Worn spacers or connecting rod bearings2. Worn shock absorber ball joints3. Shock absorber faulty	<p>Replace</p> <p>Replace</p> <p>Replace</p>
Insufficient braking (front and rear)	<ol style="list-style-type: none">1. Air presence in braking system circuit2. Insufficient fluid in tank3. Worn brake pad and/or disc4. Damaged disc5. Improperly adjusted brake pedal6. Water in brake system	<p>Bleed</p> <p>Top up</p> <p>Replace</p> <p>Replace</p> <p>Adjust</p> <p>Change fluid</p>



TROUBLESHOOTING



ELECTRICAL SYSTEM (see also Section M)

Trouble	Cause	Remedy
The spark plug gets dirty easily	<ol style="list-style-type: none">1. Mixture too rich2. Dirty air filter3. Worn piston rings4. Worn piston or cylinder liner	Adjust carburettor Clean Replace Replace
Spark plug electrodes overheat	<ol style="list-style-type: none">1. Mixture too lean2. Spark plug electrode gap too close3. Heat rating too high	Adjust carburettor Adjust Replace with recommended spark plug
Generator does not provide charge or is not providing enough charge	<ol style="list-style-type: none">1. Cable arriving to the voltage regulator badly connected or shorted2. Voltage regulator faulty3. Generator coil faulty	Connect correctly or replace Replace Replace
Overload generator	<ol style="list-style-type: none">1. Voltage regulator faulty	Replace
Battery does not hold charge	<ol style="list-style-type: none">1. Battery terminals dirty	Clean
Starter motor does not start or slips	<ol style="list-style-type: none">1. Battery is flat2. Control on R.H. switch faulty3. Starter relay faulty4. Starter motor faulty5. Worn starter gears6. Worn or damaged freewheel rollers	Charge Replace Replace Repair or replace Replace Replace freewheel

FUEL INJECTION SYSTEM (See Section S)



SETTINGS AND ADJUSTMENTS

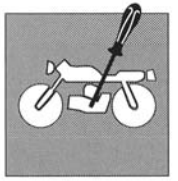

Section

D



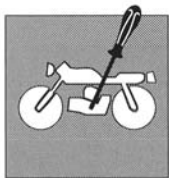

SETTINGS AND ADJUSTMENTS

Saddle removal.....	D.4
Tank removal	D.4
Tank removal	D.5
Tank disassembly	D.8
Valve clearance adjustment.....	D.10
Throttle cable adjustment	D.11
Enrichener lever play adjustment	D.11
Idle adjustment	D.12
Engine oil level check.....	D.12
Engine oil replacement, oil filter replacement.....	D.13
Mesh filters cleaning.....	D.14
Coolant level check	D.16
Coolant replacement	D.17
Clutch plate replacement.....	D.18
Clutch disassembly.....	D.18
Hydraulic clutch lever adjustment and fluid level check	D.19
Front brake lever adjustment and fluid level check	D.20
Rear brake pedal adjustment	D.21
Rear brake pedal free play adjustment.....	D.21
Rear brake fluid level check	D.22
Air filter check.....	D.22
Air filter cleaning	D.23
Chain adjustment	D.24
Chain lubrication.....	D.25
Removal and cleaning.....	D.25
Washing a chain without O-rings.....	D.25
Chain guide roller, chain guide eye, chain slider	D.25
Lubricating an O-ring chain	D.25
Suspension.....	D.26
Rear shock absorber adjustment.....	D.27
Shock absorber spring preload adjustment.....	D.28
Shock absorber compression and rebound damping adjustment	D.29
MARZOCCHI front fork adjustment.....	D.30
Fork oil level	D.31
MARZOCCHI front fork springs.....	D.32
Steering bearing clearance adjustment.....	D.33
Supply hose check	D.34
Exhaust system check.....	D.35



SETTINGS AND ADJUSTMENTS

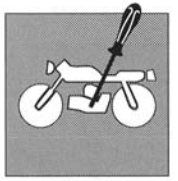

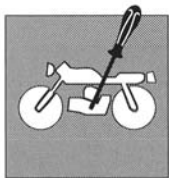

SETTINGS AND ADJUSTMENTS

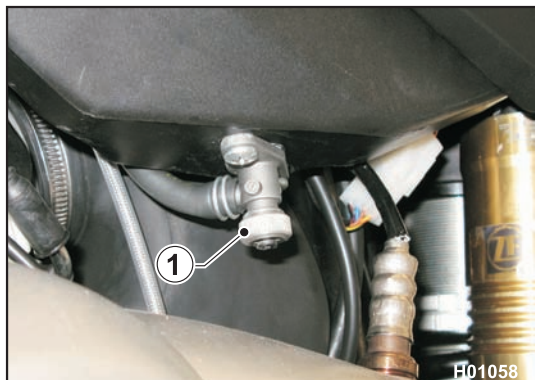

Tank removal

Remove the saddle as described in the relevant paragraph.
Close both fuel cocks (1).

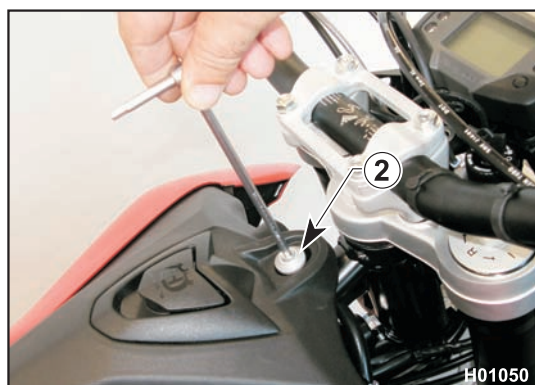
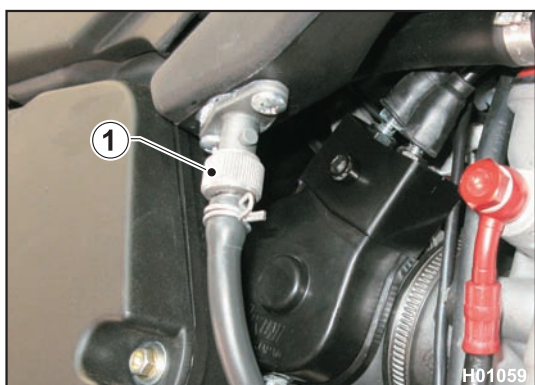

Use a 6 mm Allen wrench to loosen the screw (2) and remove the screw with its spacer.

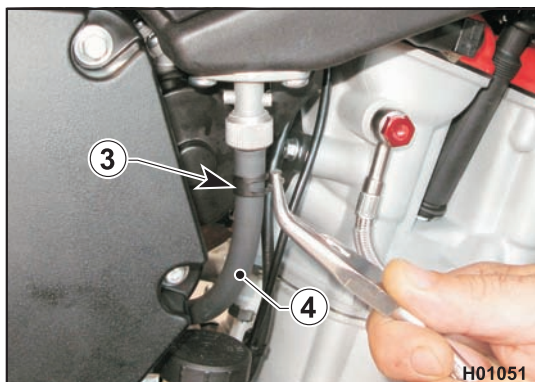

Place a vessel under the R.H. cock to collect fuel.

Loosen clamp (3) and disconnect tube (4) from the fuel cock. Let the fuel drain out.



SETTINGS AND ADJUSTMENTS

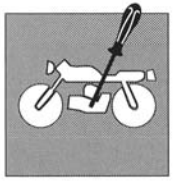

Remove the covers (5) located on the R.H. and L.H. side of the tank.

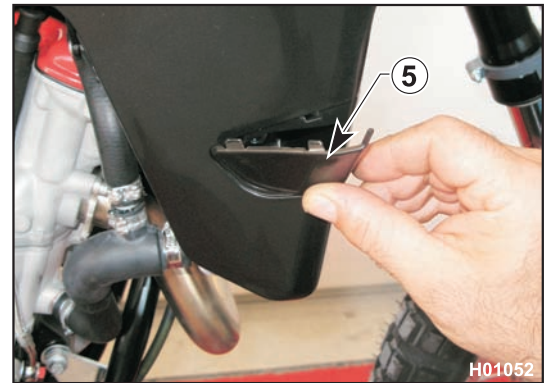

Loosen the screws (6) using an 8 mm wrench.

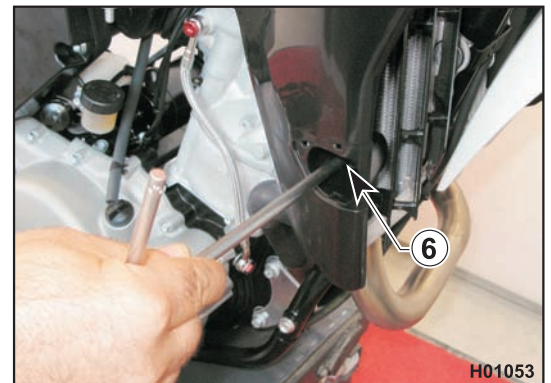

Move to the left side of the tank, slacken clamp (9) and disconnect the breather hose (10).

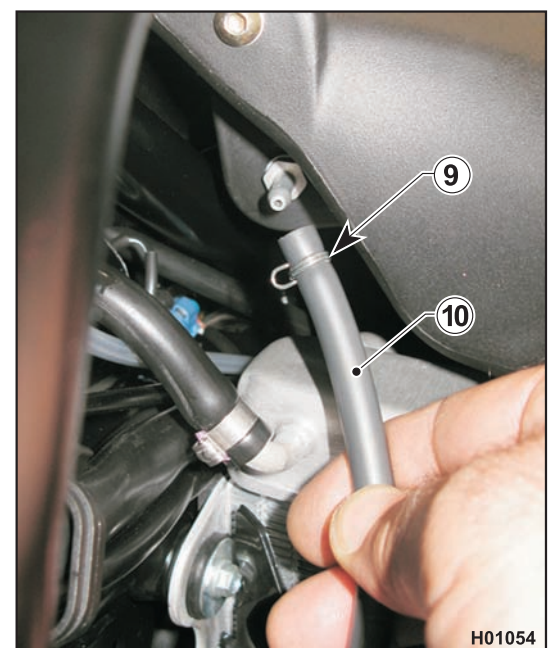

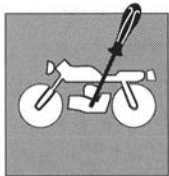

SETTINGS AND ADJUSTMENTS

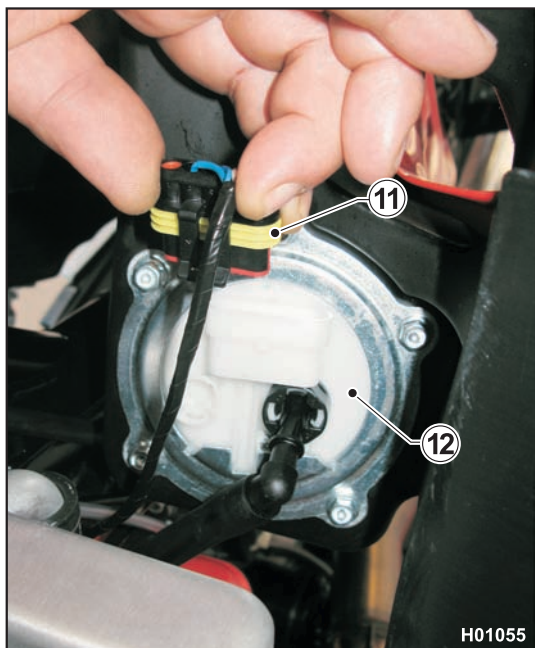

Raise the tank from the front end and disconnect the fuel pump (12) connector (11).

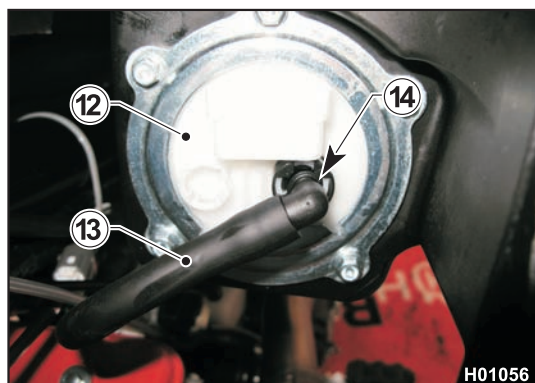

Disconnect the hose (13) connecting tank to throttle body; press down the ring (14) and disconnect hose (13) from pump (12).



Raise the tank (15) and remove it together with the scoops.

Reassemble all parts in the reverse order compared to disassembly and tighten screws to the specified torque (see Section X).



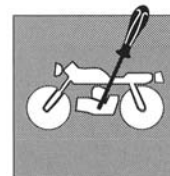

Valve clearance adjustment

Remove spark plug (1), the four head cover screws (2) and head cover.



Engage the 2nd gear and push and pull the motorcycle back and forth to bring the piston to Top Dead Centre. In this condition, the notch on the head will be lined up with the two dots on the camshaft drive gear as shown in the figure.



Use a feeler gauge to make sure clearance is 0.10-0.15 mm on the INTAKE side and 0.15-0.20 mm on the EXHAUST side.

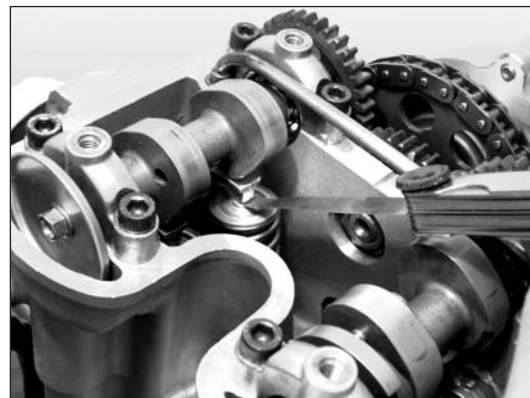

If not so, raise the retaining clip (3) using a spring tool, push rocker arm aside, extract shim with a pair of tweezers and check shim thickness. Depending on what you find, fit a new shim with the required thickness (replacement shims are available in a 1.60 mm to 2.60 mm thickness range, in 0.05 mm increments) and set clip and rocker arm back into place. Check valve clearances again. If clearances are correct, refit the parts you have removed reversing the disassembly procedure.

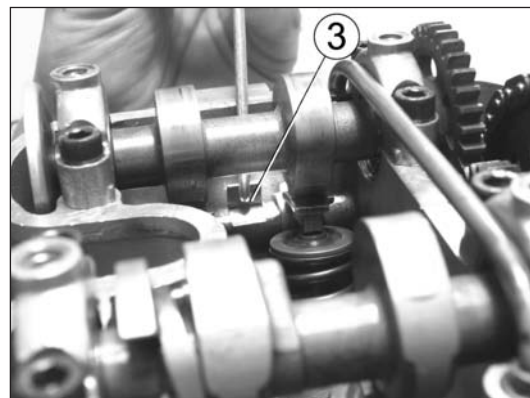

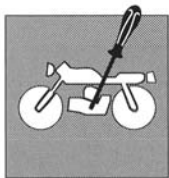

SETTINGS AND ADJUSTMENTS

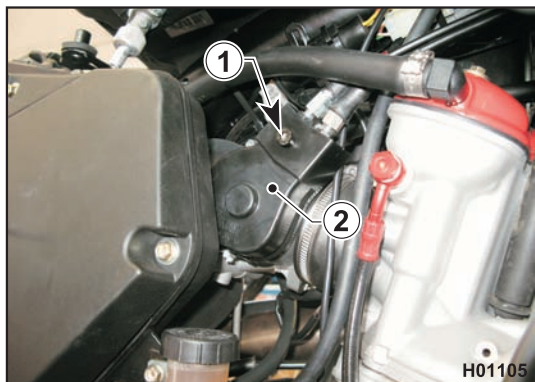

Throttle cable adjustment

To check the correct adjustment of the throttle cable, operate as follows:

- Remove the fuel tank as described in the relevant paragraph.
- Loosen screw (1) and remove the protection cover (2);

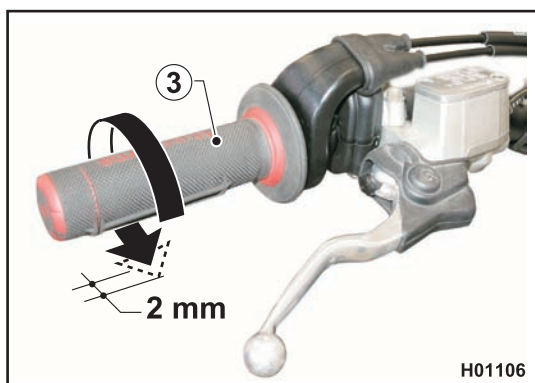

- Turn throttle twistgrip (3) and make sure it has about 2 mm free play;

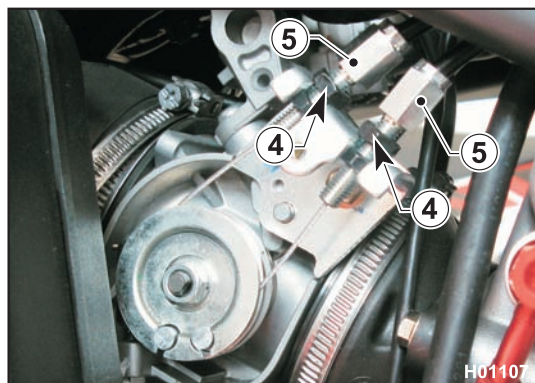

- if it is not so, loosen the lock nuts (4) and suitably turn the adjuster screws (5) (loosen to decrease play or tighten to increase it);
- tighten back the lock nuts (4);
- reassemble all parts, in the reverse order compared to disassembly.



Operation with damaged throttle cable could result in an unsafe riding condition.



**Exhaust gas contains poisonous carbon monoxide.
Never run the engine indoors.**

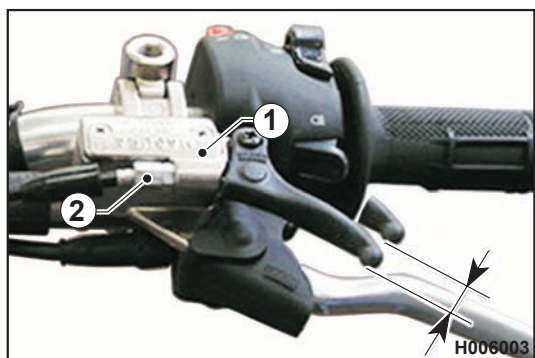

Enricher lever play adjustment

The lever (1) holder features an adjuster screw (2) to adjust free play. Free play should be about 3 mm: if not so, loosen the check nut and turn the adjuster screw as required (loosen to decrease play or tighten to increase it).



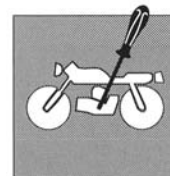

Idle adjustment

Adjust the carburettor with warm engine and with the throttle control in closed position. Proceed as follows:

- turn the idle speed adjustment screw (1) on the throttle body, located on the right-hand side of the vehicle, until the idle speed of 1650 RPM is reached (turn clockwise to increase the speed and anticlockwise to reduce the speed).

To do this, you need to reach the adjuster screw from airbox front end, using the supplied 8-10 wrench, and work lengthwise with respect to the motorcycle.

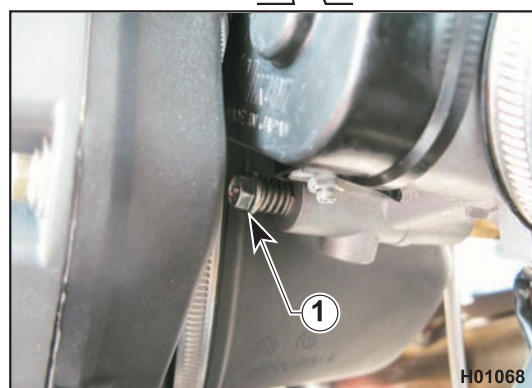

Engine oil level check

Keeping the motorcycle level and upright, check the oil level through the inspection window (1) on the right crankcase.

Make sure the level is in between the MIN and MAX notches.

To top up, remove the filler cap (2).



Perform this operation with warmed-up engine



Be careful not to touch hot engine oil

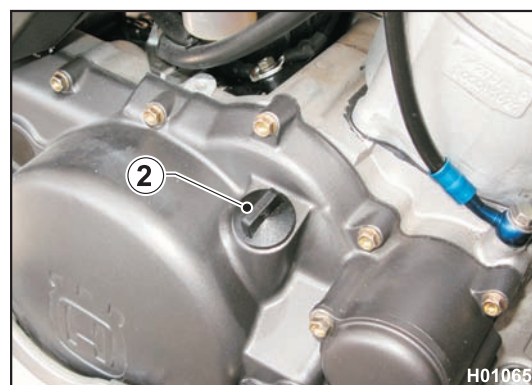
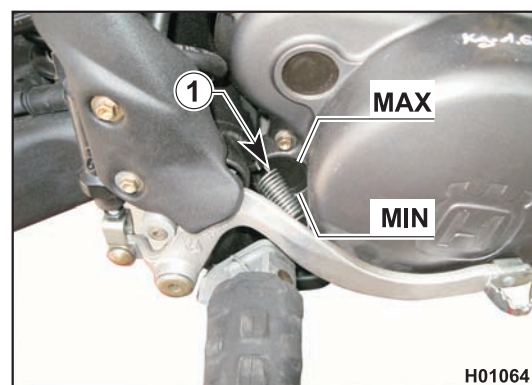

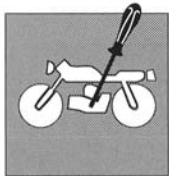

SETTINGS AND ADJUSTMENTS

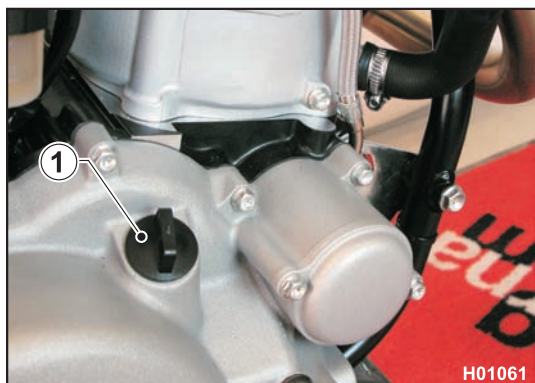

Engine oil replacement, oil filter replacement



Be careful not to touch hot engine oil.

To change engine oil, **warm up engine** and proceed as follows:

- Keep the motorcycle upright and place an oil drain pan under the engine.
- Remove filler cap (1) and drain plugs (2) and (3).
- Drain all engine oil.
- Refit drain plugs (M14 plug (3): 24 Nm/ 2.45 Kg-m/ 18.1 ft-lb; M22 plug (2): 60 Nm/ 6.1 Kg-m/ 44 ft-lb) and gaskets; be sure to clean off any debris collected by the magnet core of plug (2).

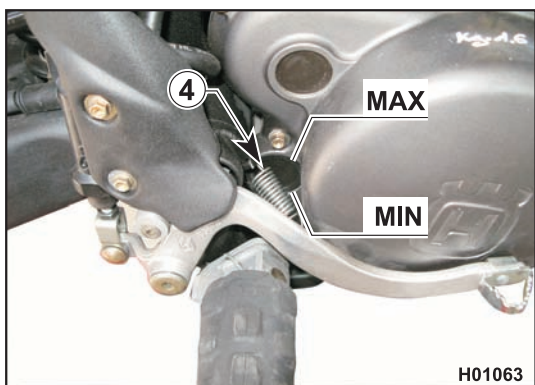
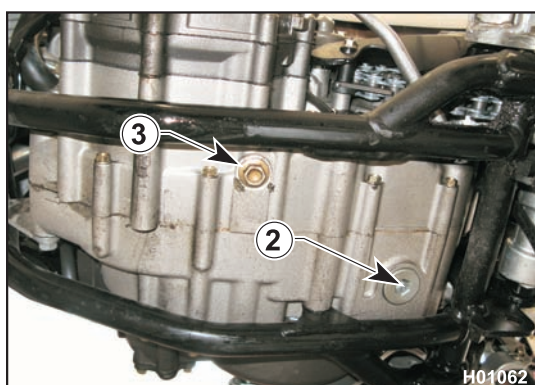

- Fill the specified quantity of oil (see capacities table in Section A) through the filler hole. Let the engine idle for a few minutes, stop it and wait a few minutes to let oil settle inside the crankcase. With the motorcycle upright, make sure the level is in between the MIN and MAX notches looking through the oil window (4) behind the rear brake pedal.

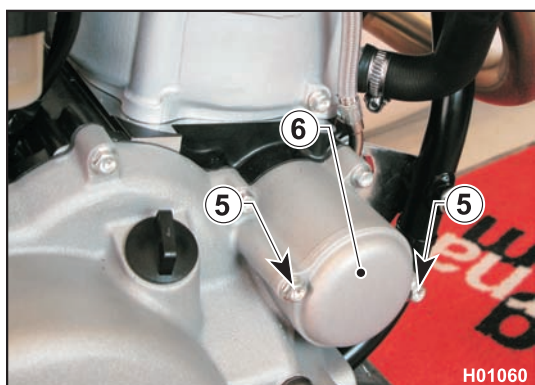

- To change the oil filter cartridge, loosen the two retaining screws (5) and remove the cover (6) with its O-ring.



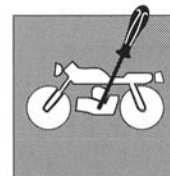

Pull out spring (7) and cartridge (8); reassemble in reverse order as for removal and change the O-ring (screws 5: 9.3 Nm/ 0.95 Kgm/ 6.9 ft-lb).

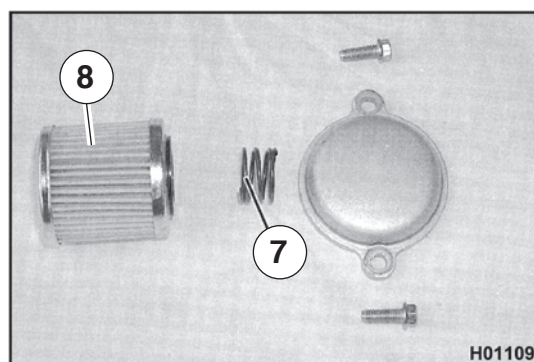
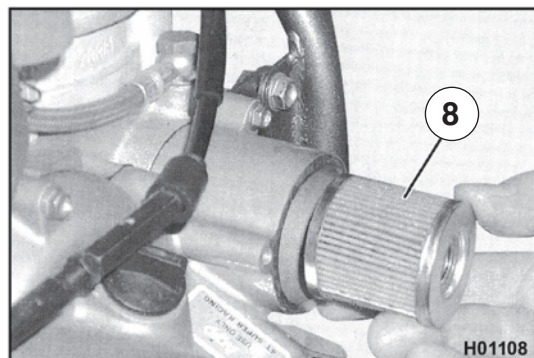

Mesh filters cleaning

- Drain engine oil as described in the relevant paragraph.

Filter on right side of engine.

- Remove the rear brake lever (1) as follows: disengage the return spring and use a 6 mm wrench to loosen the Allen screw (2).
- Loosen the eleven M6-L30 screws (3) and the two M6-L40 screws (4) using an 8 mm ring wrench and then remove the clutch cover (5) complete with filter and oil pump.

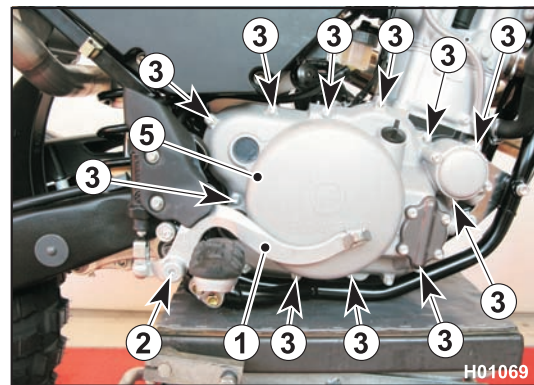

- Remove the filter (6), wash it with petrol and blow it with compressed air and then refit it exactly in the original position.
- Reassemble all parts in the reverse order compared to disassembly and tighten screws to the specified torque (see Section X).

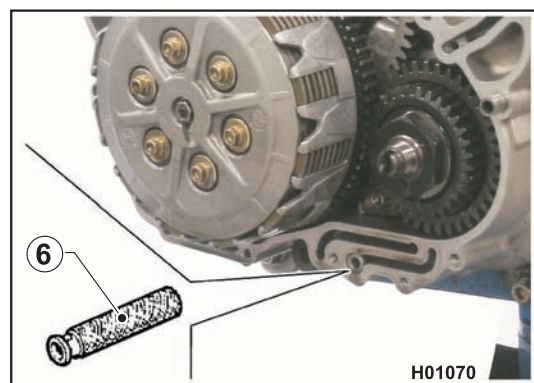

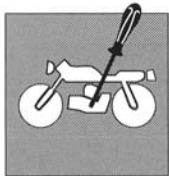

SETTINGS AND ADJUSTMENTS

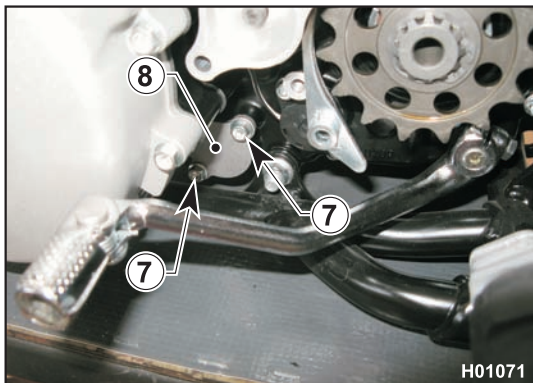

Filters on left side of engine.

- Loosen the screws (7) using an 8 mm wrench and remove the cover (8).
- Remove filters (9) (10) and their gaskets.
- Wash filters with petrol and blow them with compressed air; refit filters exactly in their original positions using new gaskets (11) which you will have greased properly.
- Refit cover (8) and tighten the screws (7) to the specified torque (see Section X).

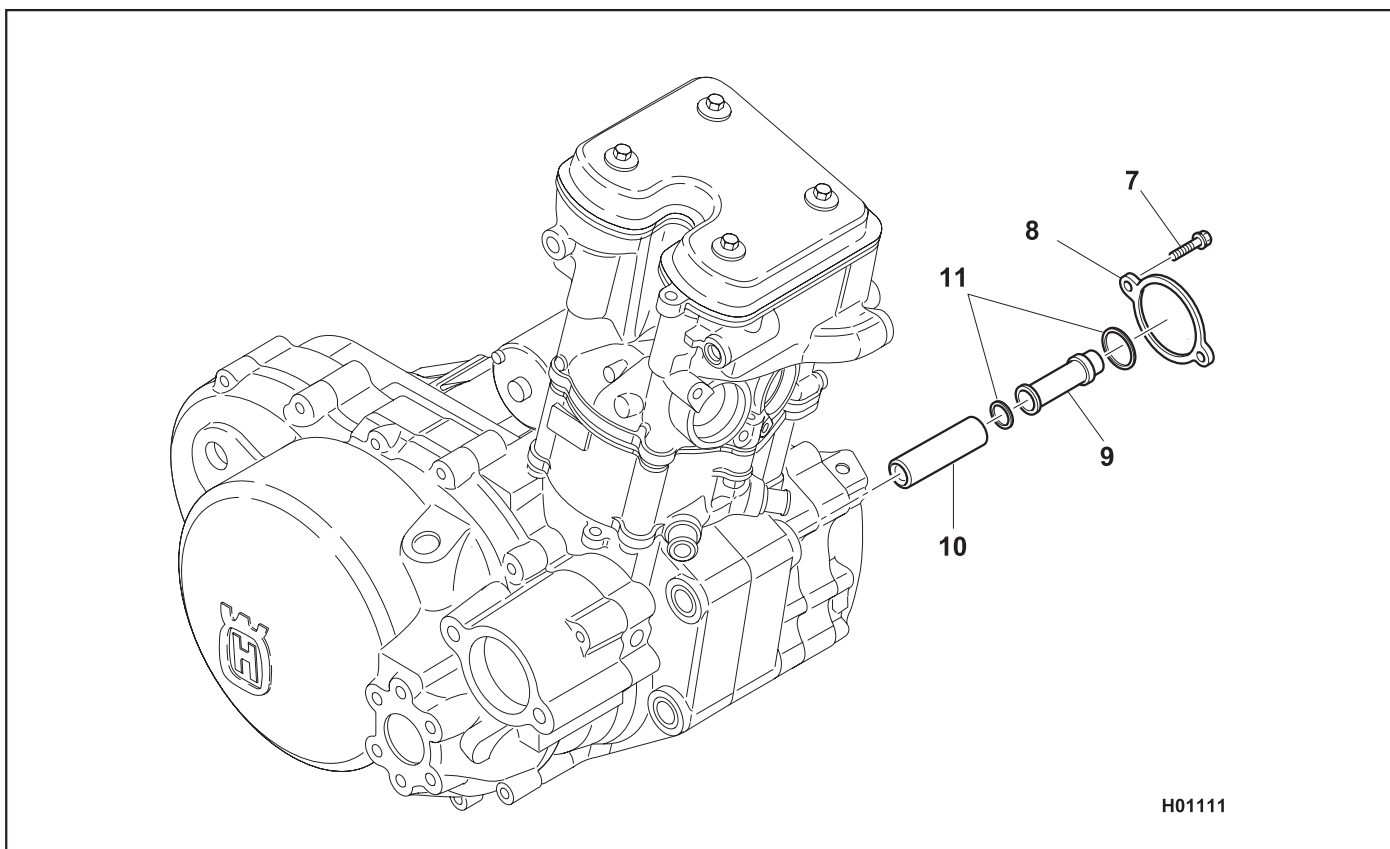

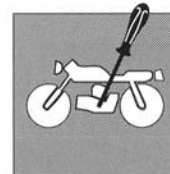

Coolant level check

Check level (1) in right-hand radiator when engine is cold (place the motorcycle so that it is perpendicular to the ground). The coolant should be approximately 10 mm above cells and besides, it shall not exceed the middle of the expansion tank (2) located in front of the rear shock absorber.

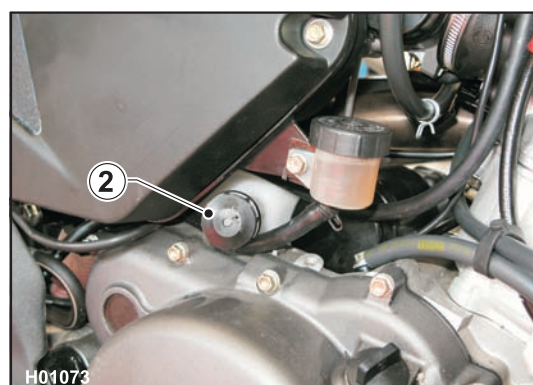
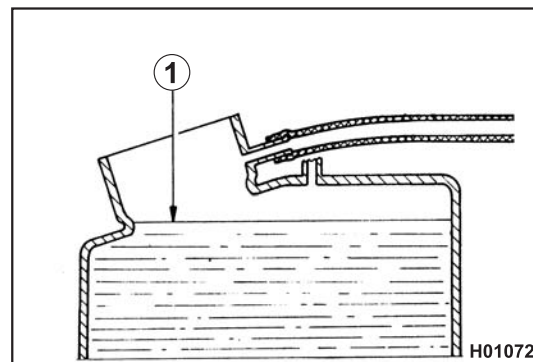

The radiator cap (3) features two locking positions, the first one is for prior discharge of pressure from the cooling system.



Avoid removing radiator cap (3) when engine is hot, as coolant may spout out and cause scalding.

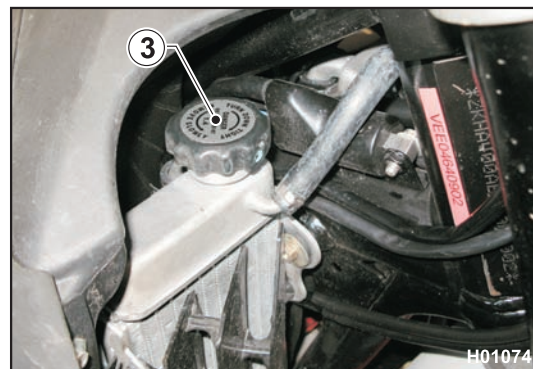

Because the cooling fan (4) can be activated even when the start switch is in OFF position, always keep at a safe distance from the fan blades.



Difficulties may arise in eliminating coolant from painted surfaces. If this occurs, wash off with water.

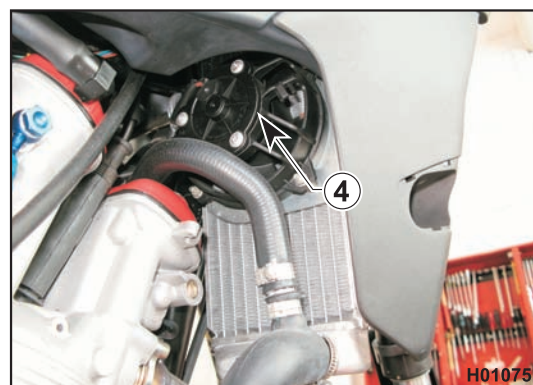

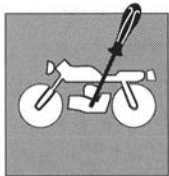

SETTINGS AND ADJUSTMENTS



Coolant replacement



Coolant shall be replaced with cold engine and coolant.

Standard procedure

- Place a vessel on the R.H. side of the cylinder, under the coolant drain screw (1). FIRST remove the screw (1) using a ... mm wrench, then SLOWLY open the R.H. radiator cap (2); slope the motorcycle on the right side to drain the coolant easily in the vessel. Reassemble the screw (1).

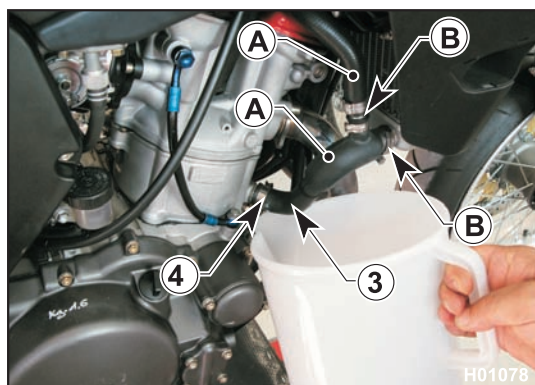
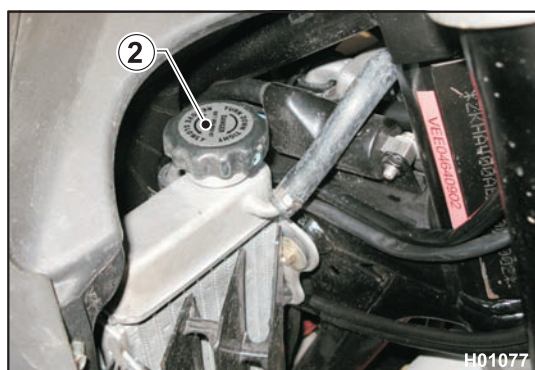

Fast procedure

- Place a vessel on the R.H. side of the cylinder, under the tube (3).
- Loosen clamp (4) and disconnect tube (3) from the engine.
- SLOWLY open the R.H. radiator cap (2); slope the motorcycle on the right side to drain the coolant easily in the vessel.
- Reassemble the tube (3) and tighten the clamp (4) (See Section X or Section F for tightening torque)

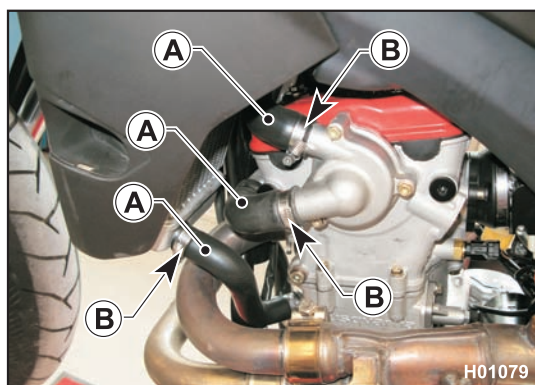

Standard procedure

- Pour the necessary quantity of coolant in the radiator then warm up the engine in order to eliminate any possible air bubbles.
- Allow the coolant to cool down then remove cap (2) and check the level as explained under "Coolant level check".
- Periodically check the connecting hoses (see "Section B"); this will avoid coolant leakage and consequent engine seizure. If hoses (A) show cracks, swelling or hardening due to sheaths desiccation, their replacement shall be advisable.
- Check the correct tightening of the clamps (B).



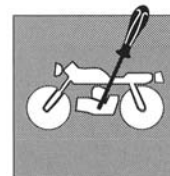

Clutch plate replacement

- Drain engine oil as described in the relevant paragraph.
- Remove the rear brake lever (1) as follows: disengage the return spring and use a 6 mm wrench to loosen the Allen screw (2).
- Loosen the eleven M6-L30 screws (3) and the two M6-L40 screws (4) using an 8 mm ring wrench and then remove the clutch cover (5) complete with filter and oil pump.

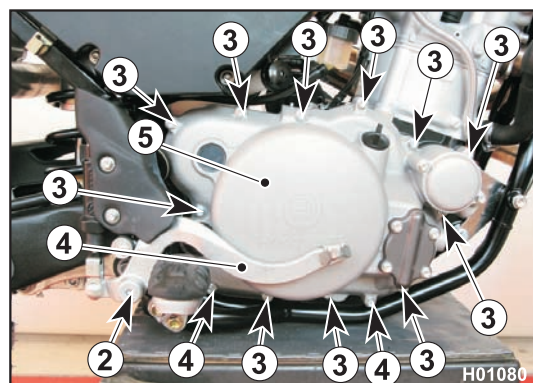

Clutch disassembly

- Using an 8 mm wrench, unscrew the six screws (6) securing the clutch springs. Remove washer, springs, pressure plate (7), washer, axial bearing (8) and clutch plate pack (10).
- Collect actuator plate (9) and rod (5) from gearbox input shaft.
- Lubricate the new plates with engine oil and install them (always start with a friction plate).

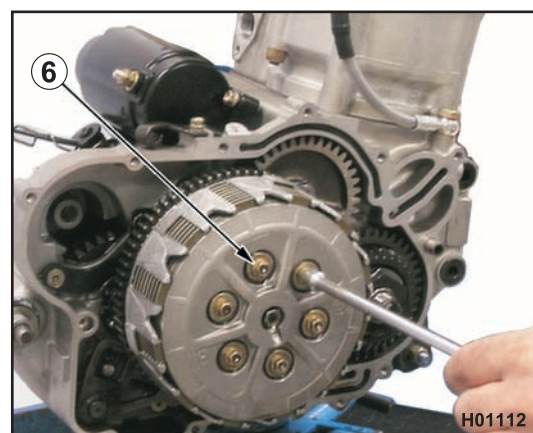

Refit clutch actuator plate, bearing and pressure plate.

Tighten the spring screws gradually in a cross pattern (8 Nm - 0.8 Kgm - 5.8 ft/lb).

When refitting the clutch cover (8 Nm - 0.8 Kgm - 5.8 ft/lb), check gasket for wear and replace as required.

 For additional information on assembly procedures, see Section "H" Engine assembly.

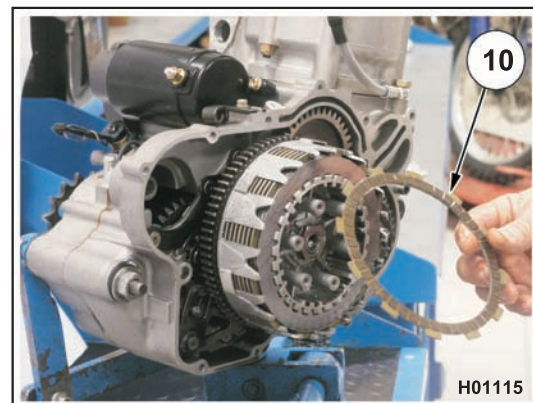
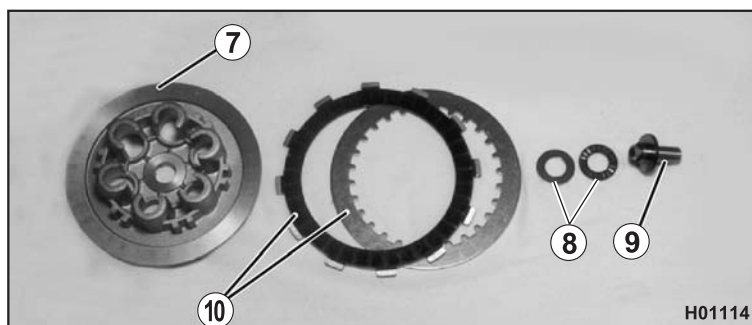
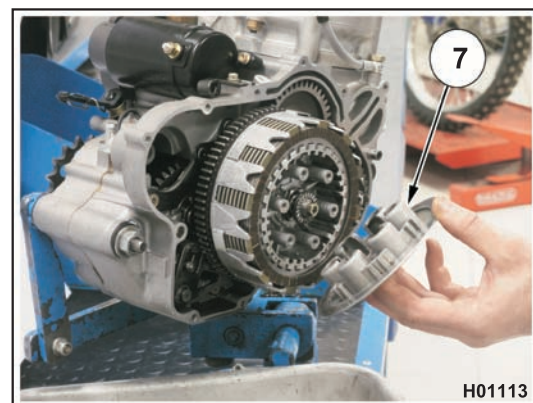

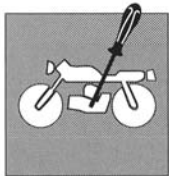

SETTINGS AND ADJUSTMENTS



Hydraulic clutch lever adjustment and fluid level check

Free play (A) must be at least 3 mm.

The lever position can be adjusted to suit the rider hand size.

To decrease the lever distance from the handgrip, rotate the adjuster (B) CLOCKWISE.

To increase the lever distance from the handgrip, rotate the adjuster (B) COUNTER CLOCKWISE.

Fluid level is checked as follows:

- remove screws (1), cover (2) and rubber diaphragm from the control;
- keep the control cylinder (3) in a horizontal position and make sure that fluid level has not dropped lower than 4 mm (0.16 in.) below the upper edge (D) of master cylinder body;
- if needed, top up with the fluid specified in the CAPACITIES TABLE, SECTION A.

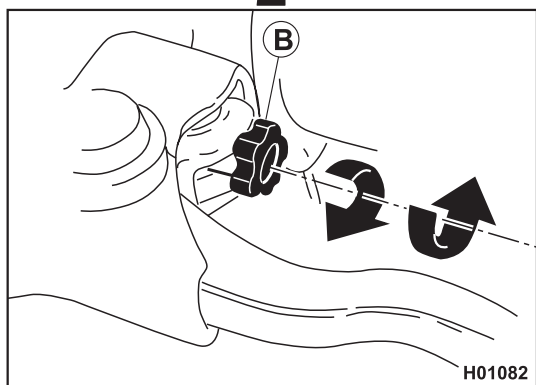

NEVER use brake fluid.

Refit any parts you have removed.

Periodically check the connecting hose (see "Scheduled Maintenance Chart"); if hose (C) is worn or cracked, its replacement is advised.

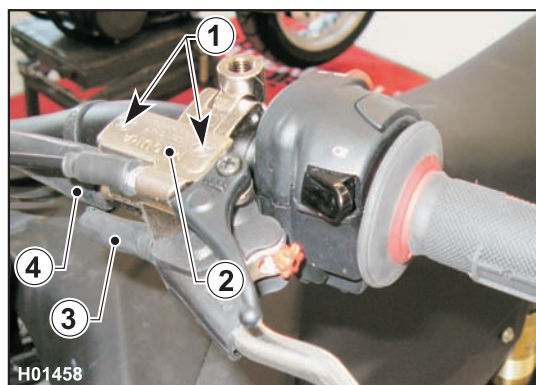
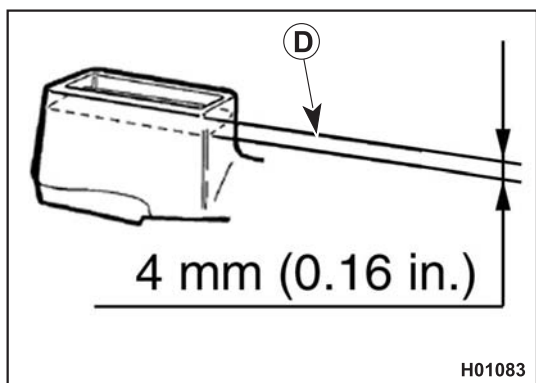

SETTINGS AND ADJUSTMENTS

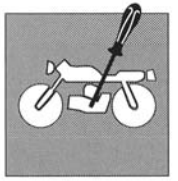

Front brake lever adjustment and fluid level check

On the SMS model the lever position can be adjusted (4 settings available) to suit the rider hand size.

To decrease the lever distance from the handgrip, turn the adjuster (B) CLOCKWISE. To increase the lever distance from the handgrip, turn the adjuster (B) COUNTER CLOCKWISE. On the TE models the adjuster (2), located on the control lever, allows adjusting of the free play (a).

Free play (a) must be at least 3 mm.

The level of the fluid in master cylinder reservoir must never be below the minimum value (1), which can be checked from the window on the rear side of the master cylinder body (TE). For (SMS) model, check the level on the clear reservoir.

A decrease of the fluid level will let air into the system, hence an extension of the lever stroke.



If the brake lever feels mushy when pulled, there may be air in the brake line or the brake may be defective: CHECK THE BRAKING SYSTEM (see Section "L").



Too much brake lever free play may reduce braking action: CHECK BRAKE PAD THICKNESS (see Section "L").



Do not spill brake fluid onto any painted surface or lens (for example lights lens).



Do not mix two brands of fluid. Completely change the brake fluid in the brake system if you wish to switch to another fluid brand.



Brake fluid may cause irritation. Avoid contact with skin or eyes. In case of contact, flush thoroughly with water and call a doctor if your eyes were exposed.

A: to increase clearance

B: to decrease clearance

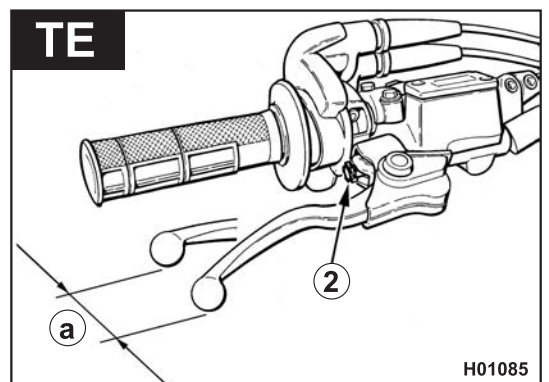
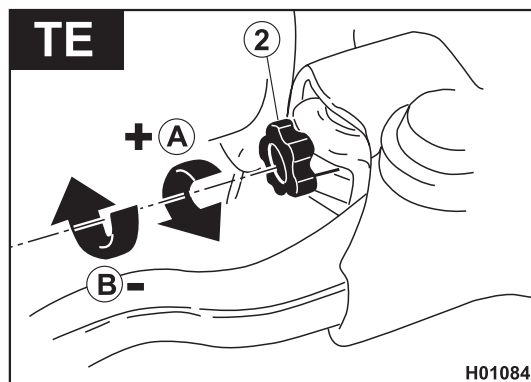
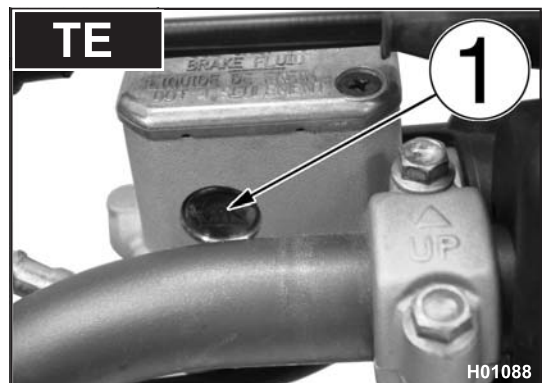
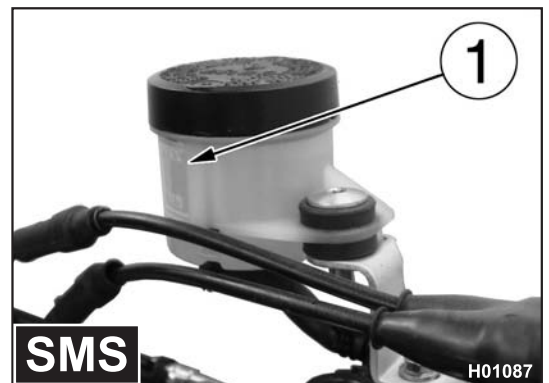
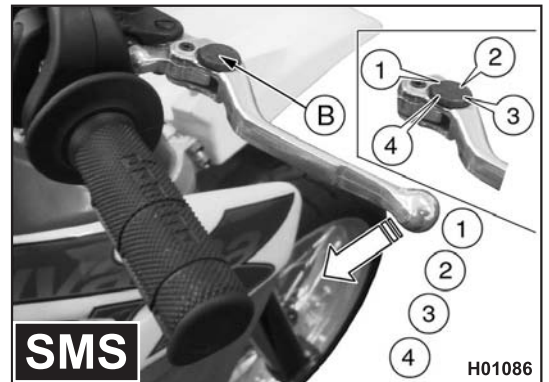

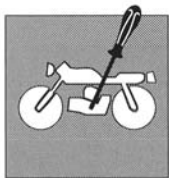

SETTINGS AND ADJUSTMENTS

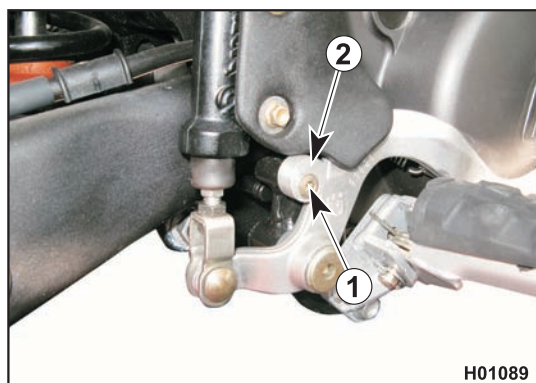

Rear brake pedal position adjustment

The position of the rear brake pedal with respect to the footrest may be adjusted according to individual needs.

For adjusting, proceed as follows:

- Loosen the screw (1).
- turn the cam (2) in order to raise or lower the brake pedal (3) within the range available (A);
- When finished, tighten the screw (1).

Once this adjustment is completed, adjust the free play of the pedal following the instructions provided in paragraph "Rear brake pedal free play adjustment".

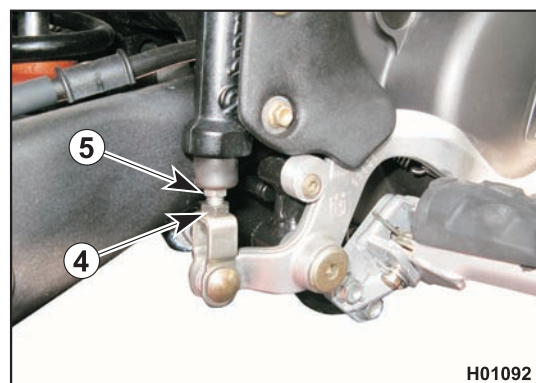
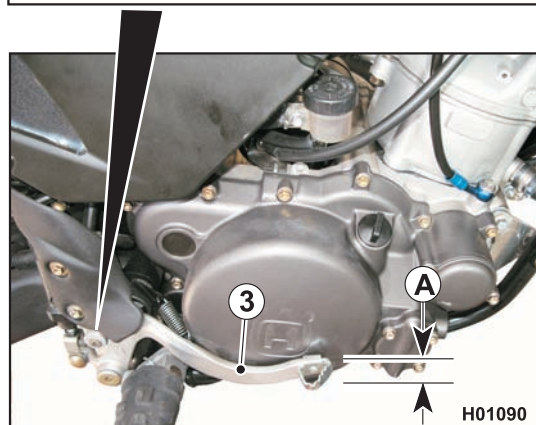

Rear brake pedal free play adjustment

The rear brake pedal (3) should have a free play (B) (5 mm) before the brakes begin to bite. Should this not happen, operate as follows:

- loosen nut (4);
- operate the pump rod (5) to increase or decrease the free play;
- tighten nut (4) at the end of the operation.



When the free play requirement is not met, the brake pads will be subjected to an early wear that may lead to TOTAL BRAKE INEFFECTIVENESS.



If the brake pedal feels mushy when pulled, there may be air in the brake line or the brake may be defective. CHECK THE BRAKING SYSTEM (see Section L).

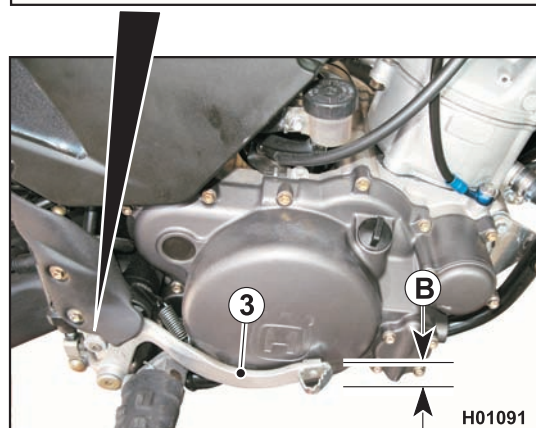

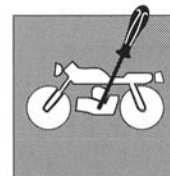

Rear brake fluid level check

Master cylinder fluid level shall never drop below the minimum notch shown on the clear reservoir (1).

A decrease of the fluid level will let air into the system, hence an extension of the lever stroke.



If the brake pedal feels mushy when pulled, there may be air in the brake lines or the brake may be defective. Since it is dangerous to operate the motorcycle under such conditions, have the brake system immediately checked (see Section L)



Do not spill brake fluid onto any painted surface or light lens.



Do not mix two brands of fluid. Completely change the brake fluid in the brake system if you wish to switch to another fluid brand.



Brake fluid may cause irritation. Avoid contact with skin or eyes. In case of contact, flush thoroughly with water and call a doctor if your eyes were exposed.

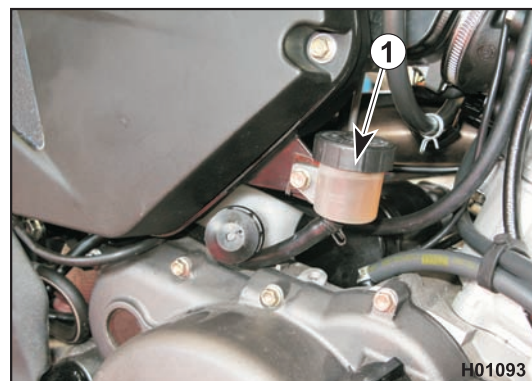

H01093

Air filter check

- Insert the key in latch (1) then turn clockwise to release the saddle lock; remove the saddle.



H01049

- Disengage rear right-hand side panel (2) from filter cover then slide it toward vehicle front.



H01094

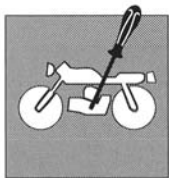

SETTINGS AND ADJUSTMENTS

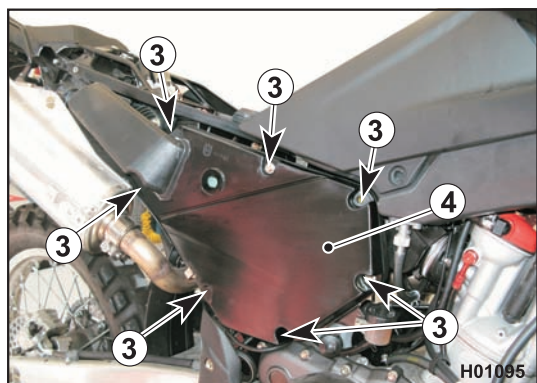

- Loosen the seven screws (3) and remove the filter cover (4).



The screws have a different length, it is recommended to mark them in order to favour correct reassembly.



- Remove the filter (5) together with support frame.

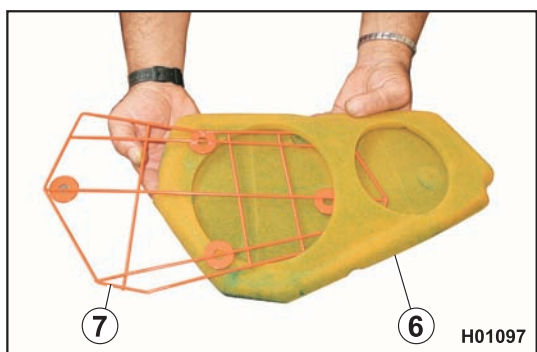

- Slide out the filtering element (6) from the support frame (7).

Air filter cleaning

Wash the filter with a specific detergent (CASTROL FOAM AIR FILTER CLEANER or similar) then dry it fully (wash filter with gasoline only in case of need). Plunge the filter in special oil for filters (CASTROL FOAM AIR FILTER OIL or similar), then wring it to drain superfluous oil.



Do not use fuel or a low flash-point solvent to clean the filtering element. A fire or explosion could result.



Clean the filtering element in a well ventilated area and do not allow sparks or flames anywhere near the working area.



SETTINGS AND ADJUSTMENTS

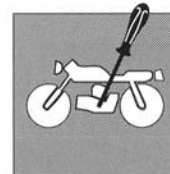

Chain adjustment

Chain should be checked, adjusted and lubricated as per the Maintenance Chart to ensure safety and prevent excessive wear. If the chain becomes badly worn or is poorly adjusted (i.e., if it is too loose or too taut), it could escape from sprocket or break.

Make sure that the chain features a slack (A) measuring approximately 12 mm, as shown in the nameplate (1) on swingarm.

If it is not, proceed as follows:

- on the right side, with a 27 mm Allen wrench, loosen the locking nut (2) of the wheel axle;

- loosen the check nuts (3) on both chain tensioners with a 12 mm wrench and work on the screws (4) with a 10 mm wrench to achieve the right tension;
- when the adjustment is completed, tighten the check nuts (3) and the wheel axle nut (2) (142.1 Nm - 14.5 Kgm - 104.8 ft/lb).

After adjustment, always make sure that chain has a slack of 12 mm.

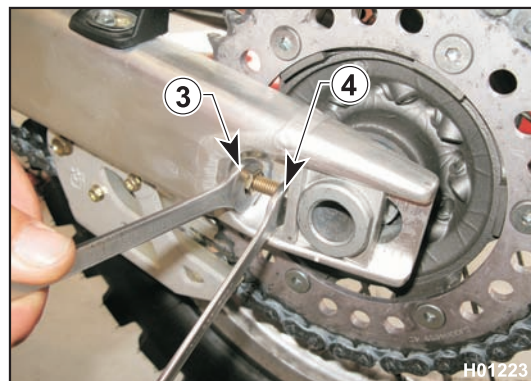
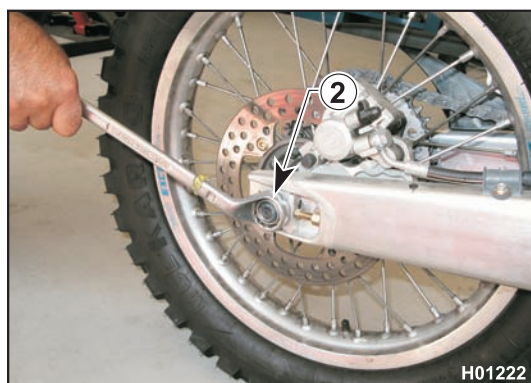
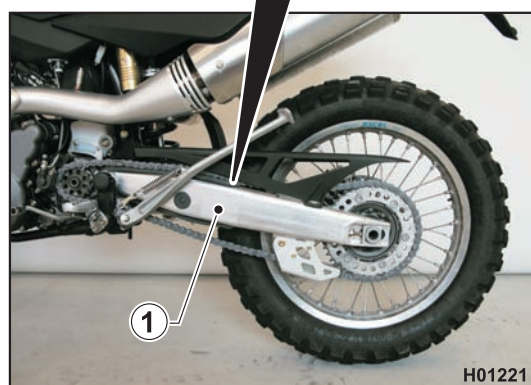
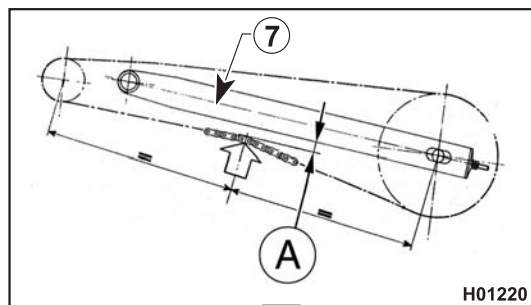

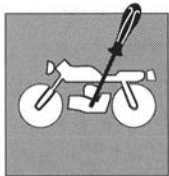

SETTINGS AND ADJUSTMENTS



H006004

Chain lubrication

Lubricate the chain following these instructions.



Never use grease to lubricate the chain. Grease helps to accumulate dust and mud, which act as abrasive and help to rapidly wear out the chain, the front and rear sprockets.

Disassembling and cleaning

When particularly dirty, remove and clean the chain before lubrication. Proceed as follows:

- Set a stand or a block under the engine and see that the rear wheel is lifted from the ground.
- Remove: screws (1), sprocket guard (2), clip (3), master link (4) with its O-rings and chain (5). To reassemble, reverse the above procedure.

Make sure that the chain is neither worn out nor damaged. If the rollers or the links are damaged, replace the chain by following the instructions given in the Scheduled Maintenance Chart. Ensure that the sprockets are not damaged. Wash and clean the chain as described hereunder.

Washing a chain without O-rings

Wash using petroleum, naphtha or paraffin oil. Never use fuel, trichloroethylene or solvents, as the O-rings may get damaged.

Use instead special sprays for chains with O-rings.

Lubricating an O-ring chain

Lubricate all metallic and rubber (O-ring) elements using a brush and engine oil with SAE 80-90 viscosity, inside and outside parts.

If the chain has been cut, reassemble it using the master link.

Assemble the master link clip (3) by setting the closed side facing the chain direction of rotation, as shown in the figure.

Reassemble all parts, in the reverse order compared to disassembly.



The master link is the most critical safety part in the drive chain. Even if the master links are reusable when in good conditions, for safety purposes we advise using a new master link when reassembling the chain. Accurately adjust the chain as described in the relevant paragraph.



The chain lubricant shall NEVER get in contact with the tyres or the rear brake disc.



Chain tensioner roller, chain guide roller, chain guide, chain slider
Check the wear of the above-mentioned elements and replace them when necessary.



Check the chain guide alignment, and remember that a bent element can cause chain early wear. In this case, chain might unwrap from the sprocket.

Accurately adjust the chain as described in the relevant paragraph.

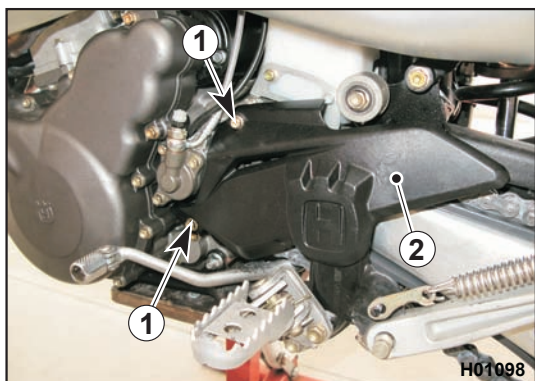

H01098

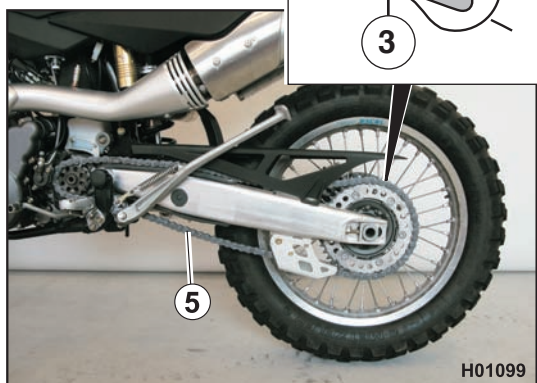
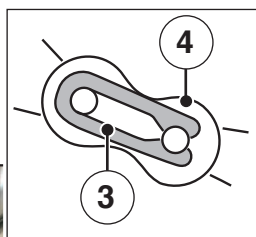

H01099



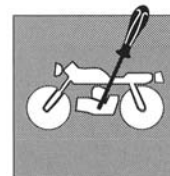

Suspension

Standard suspensions setting derives from several extensive demanding tests in various usage conditions of the TE and SMS vehicles. If you intend to use them on more specific ground, following are a few guidelines for setup. Always start from the suspensions standard setting before making any change. Afterwards, increase or decrease the adjusting clicks, one at a time.

HARD GROUND

Front fork: softer compression setting.
Shock absorber: softer compression setting.

SANDY GROUND

Front fork: harder compression setting.
Shock absorber: harder compression, and especially harder rebound settings.
Work on the spring preload to lower the motorcycle riding height (rear end).

MUDDY GROUND

Front fork: harder compression setting.
Shock absorber: harder compression and rebound settings; Work on the spring preload to lift the motorcycle riding height (rear end).



ALWAYS remember that all the motorcycles and their parts used in competitions of any type are excluded from the warranty and that all modifications to standard configuration cause THE VEHICLE NON COMPLIANCE WITH TYPE-APPROVAL REQUIREMENTS and it is hence unsuitable for circulating on public roads: consequently it may be used only in "CLOSED CIRCUITS" by authorised subjects holding the relevant driving licence or authorisation.



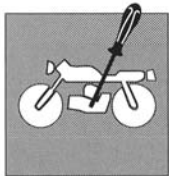

SETTINGS AND ADJUSTMENTS

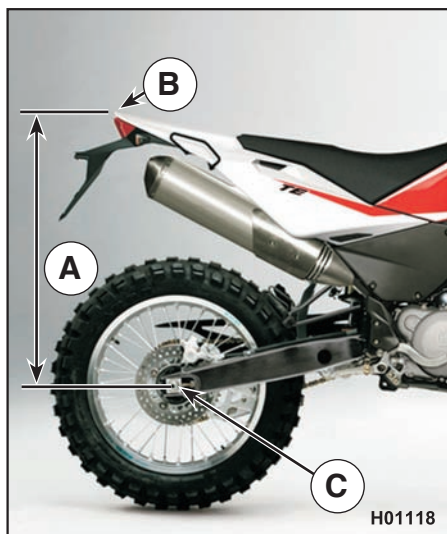

B: rear mudguard top height
C: rear wheel axle height

Shock absorber adjustment

The rear shock absorber is calibrated for running with the rider plus a small bag only. It is thus recommended to adjust the shock absorber setting (spring preload) when riding with a passenger.

Proceed as follows:

1. Place the motorcycle on the stand and measure distance (A).
2. Sit on the motorcycle in normal riding position with full riding gear on.
3. Have someone else measure distance (A) again.
4. The difference between these two measurements is the distance the rear end settles when the rider sits on the motorcycle (RIDER SAG). Recommended rider sag is 90 mm with a cold shock absorber and 85-87 mm with a warm shock absorber.
5. To achieve correct rider sag for your weight, adjust the spring preload of the shock absorber (see relevant paragraph).



The shock absorber adjustment affects both the stability and the handling of the motorcycle. After changing the standard suspension setting, ride with care. We advise measuring the reference distance "A" before making any change.



Never disassemble the shock absorber, which contains compressed gas. Contact your Husqvarna Dealer for any major service.



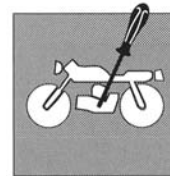

Shock absorber spring preload adjustment

Proceed as follows:

1. Insert the key in latch (1) then turn clockwise to release the saddle lock; remove the saddle.
2. Disengage rear left-hand side panel (2) then slide it toward vehicle front.
3. Clean lock ring nut (3) and adjuster ring nut (4) of the spring (5).
4. Either with a hook wrench or an aluminium punch, loosen the lock ring nut.
5. Turn the adjuster ring nut as required.
6. Adjust preload to suit your weight or riding style and tighten the lock ring nut firmly (tightening torque 50 Nm - 5 Kgm - 67.8 ft/lb).
7. Reassemble the L.H. side panel and the saddle.



Be careful not to touch hot exhaust pipe while adjusting the shock absorber.

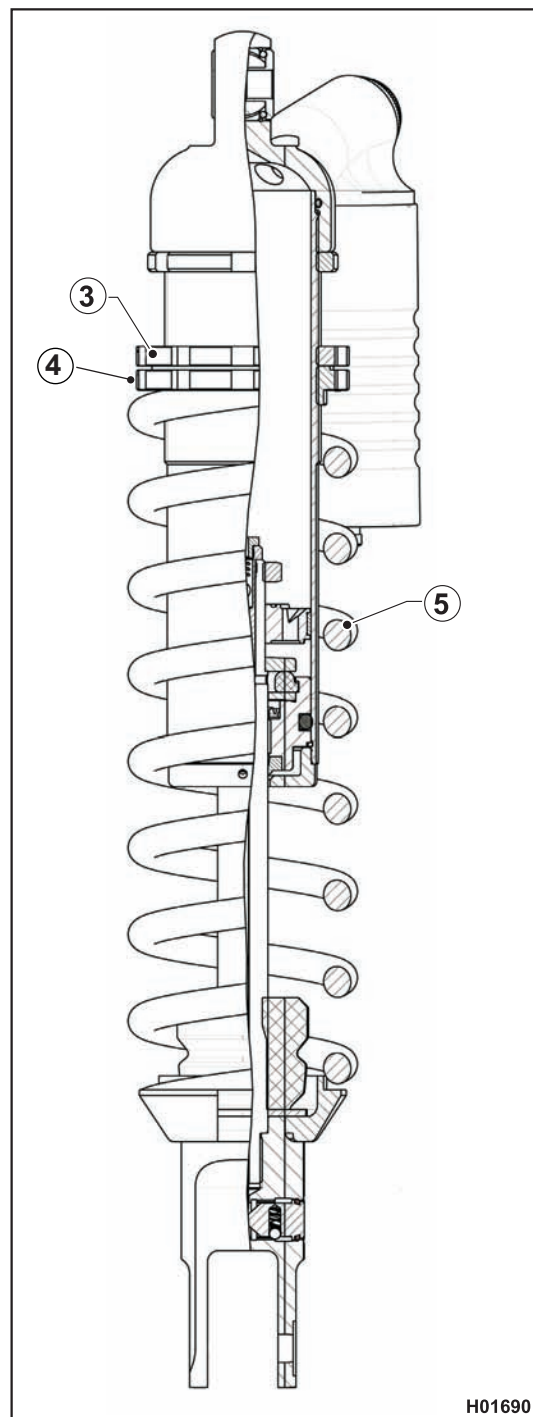
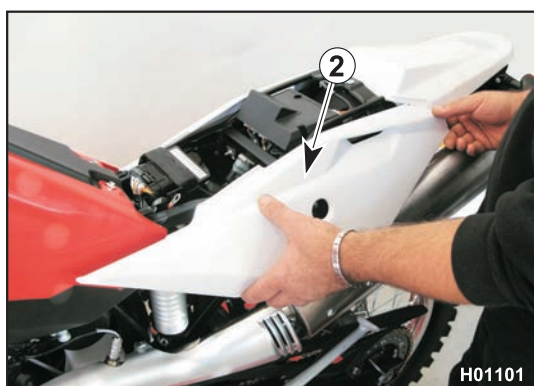

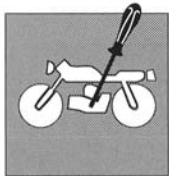

SETTINGS AND ADJUSTMENTS

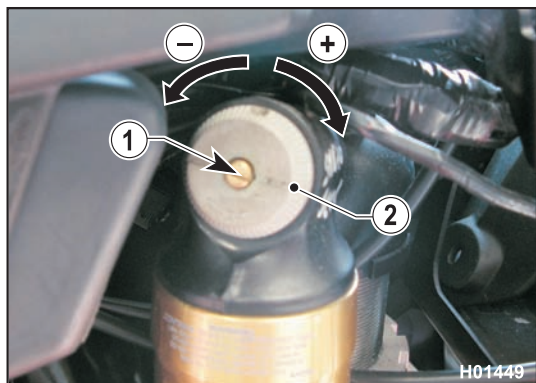

Shock absorber damping adjustment

Adjustment of the compression stroke is independent from the rebound stroke.

A) COMPRESSION - Standard setting:

- 1) Low damping speed:
fully open
(adjuster 1)
- 2) High damping speed:
fully open
(adjuster 2)

To reset the standard setting, turn upper adjuster screws (1) and (2) clockwise until reaching fully closed position. Then turn them back the number of clicks specified above.

In order to obtain a smooth braking action, turn the adjuster screws counter clockwise. Vice versa to obtain a harder braking action.

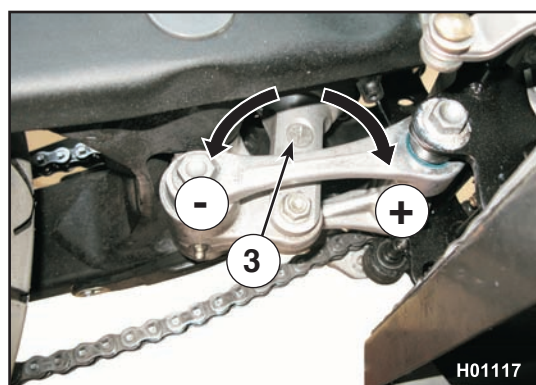

B) REBOUND - Standard setting:

- TE: -20 clicks (± 2 clicks)
- SMS: -26 clicks (± 2 clicks)

To reset the standard setting, turn lower adjuster (3) clockwise until reaching fully closed position. Then turn it back by the mentioned clicks.

In order to obtain a smooth braking action, turn the adjuster screw counter clockwise. Vice versa to obtain a harder braking action.



SETTINGS AND ADJUSTMENTS

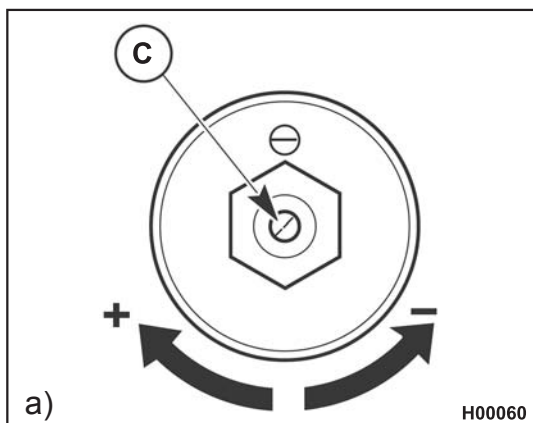
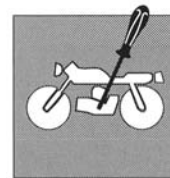

MARZOCCHI front fork adjustment

a) REBOUND (TOP ADJUSTER)

Standard setting: -12 clicks.

To reset standard setting, turn adjuster (C) clockwise to reach the fully closed position; then, turn it back by the mentioned clicks. In order to obtain a smooth braking action, turn the adjuster screw counter clockwise. Vice versa to obtain a harder braking action.

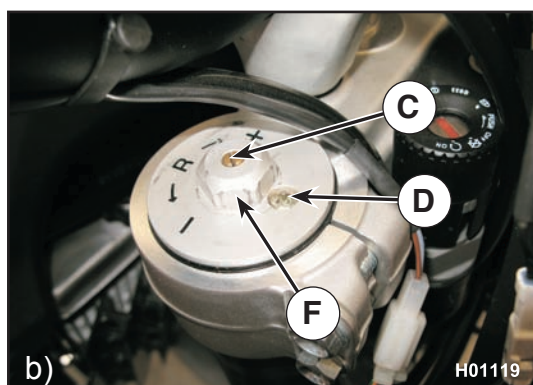

b) air vent (to carry out after each competition, or monthly).

Set the motorcycle on a central stand, release the fork fully extended and loosen the air vent valve (D). Once this operation is over, tighten the valve.



NEVER loosen the screw (F).

NOTE: Never force the adjuster screws beyond the maximum open and closed positions.



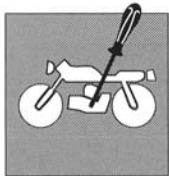

SETTINGS AND ADJUSTMENTS

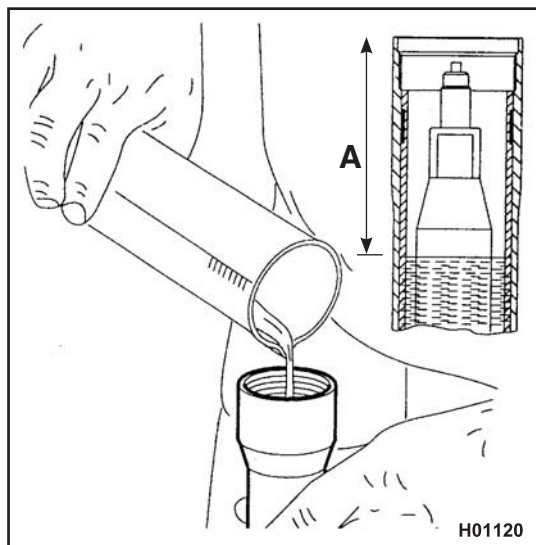

Fork oil level

For regular fork operation, both legs must be provided with the necessary oil quantity. Remove the fork legs from the fork to check the oil level. Work as follows:

- remove the damper rod caps;
- remove springs from the legs letting the oil drain into the legs;
- bring fork to stroke end;
- check that the level is at distance "A" below the upper limit of damper rod.

Oil quantity in each fork leg

- TE: 630 cm³
- SMS: 600 cm³

A=80mm (3.15 in.) - TE

A=90mm (3.54 in.) - SMS

NOTE: Flexibility index of the standard springs:

K=5 N/mm (TE)

K=5.4 N/mm (SMS)

NOTE: Always replace both the spring and the spacers to keep the preload value unchanged.



SETTINGS AND ADJUSTMENTS

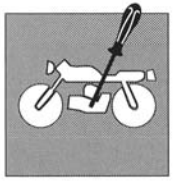

MARZOCCHI front fork springs

STANDARD

K=4.8 N/mm (spring + spacer part no. 8000 H1994)

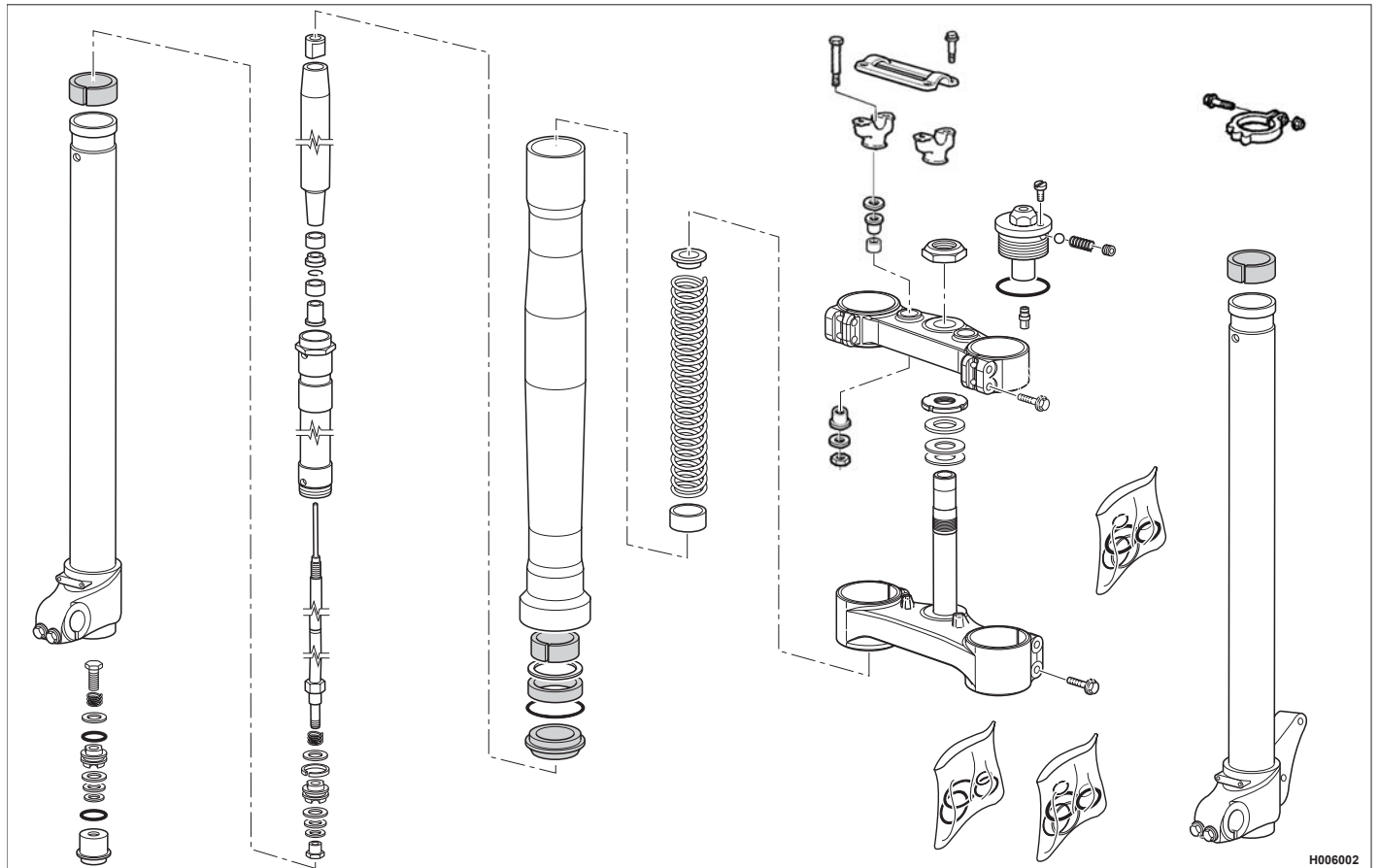

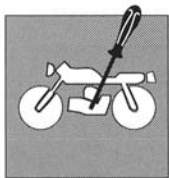

SETTINGS AND ADJUSTMENTS

Steering bearing clearance adjustment

For safety reasons, the steering should always be adjusted so that the handlebar turns freely and without play. To check steering adjustment, set a stand or a block under the engine and see that the front wheel is lifted from the ground. Press lightly on the handlebar grips to cause the front end to rotate; the handlebar should turn smoothly. Sit on the ground in front of the front wheel and hold the lower ends of the fork legs. Push and pull in a front to rear motion to feel for play.

If any play is detected, adjust as follows:

- Loosen the steering head tube nut (1);
- Loosen the four bolts (3) that secure the fork legs to the steering head; - Turn the steering head tube ring nut (2) clockwise using the special key until achieving correct play adjustment;
- tighten the steering head tube nut (1) to 8-9 Kgm. (78.4-88.3 Nm);
- Tighten the four bolts (3) on the steering head to 22.5-26.5 Nm (2.3-2.7 Kgm).

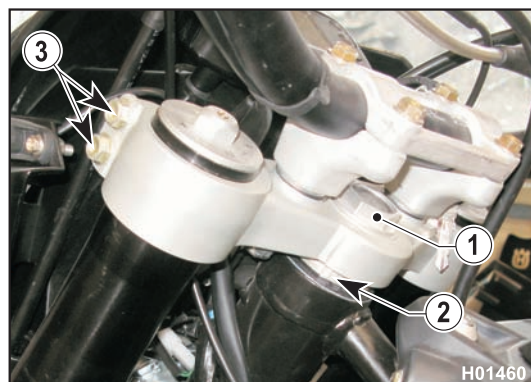

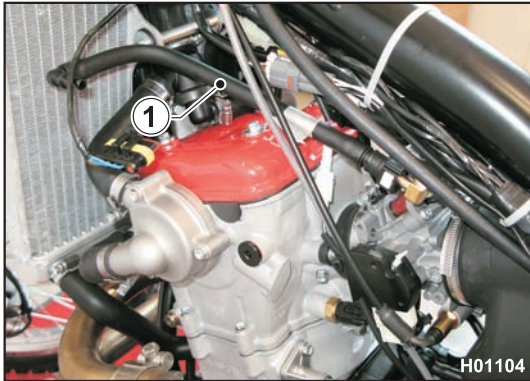
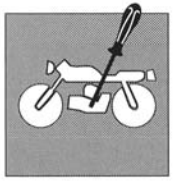

Supply hose check

Remove saddle and tank as outlined in the relevant paragraphs.

Check the hose (1) running from pump to throttle body (2).

To replace the hose, squeeze the two retainer tabs (3) on throttle body fitting.

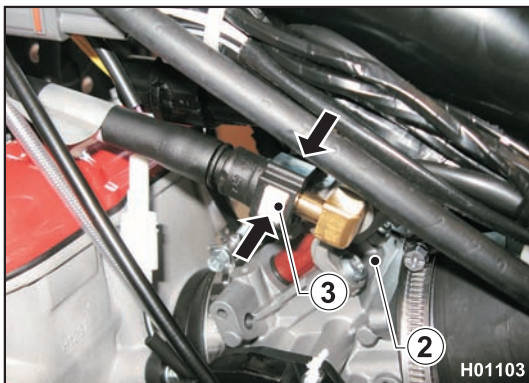

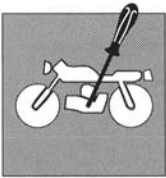

SETTINGS AND ADJUSTMENTS

Exhaust system check

Remove exhaust system components as described in Section "E".
Check pipes (1), (2) and (3) and silencers (4) for cracks or damage:
replace if cracked or damaged.

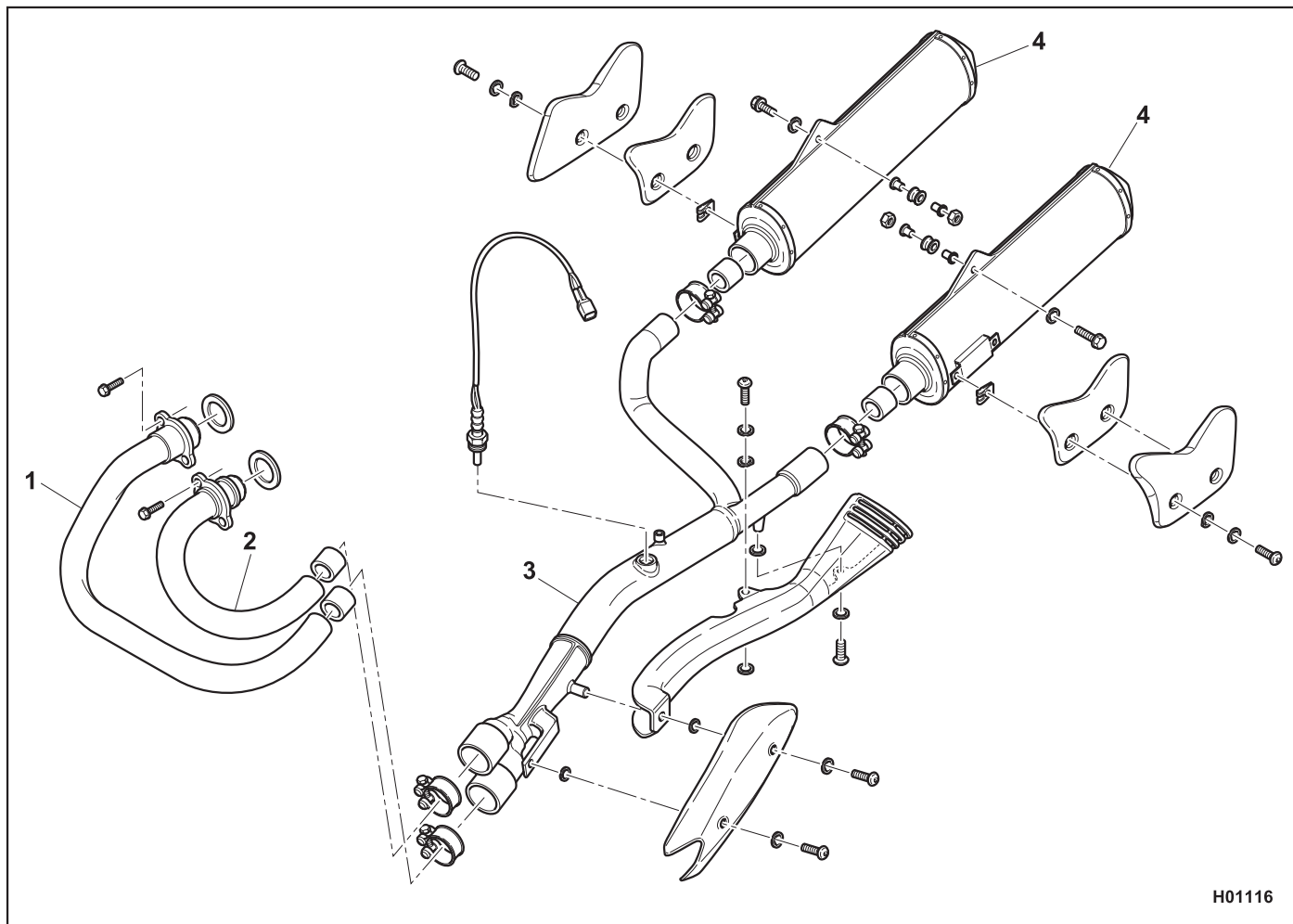



Section

E





GENERAL PROCEDURES

Foreword	E.3
Saddle removal.....	E.4
Side panel removal.....	E.4
Battery removal	E.5
Exhaust system removal	E.6
Air box removal.....	E.10
Throttle body removal.....	E.12
Removing the rear chassis complete with mudguard.....	E.14
Fuel tank removal.....	E.17
Fuel tank disassembly (scoops and fuel pump)	E.20
Expansion tank removal	E.22
Removing utilities (solenoid starter, relays, fuses, flasher).....	E.23
Electronic control unit removal	E.24
Voltage regulator removal.....	E.24
Ignition coil removal.....	E.24
Electric cooling fan removal.....	E.25
Front mudguard removal.	E.25
Horn removal	E.25
Headlamp removal and bulb replacement.....	E.26
Digital dashboard removal.....	E.28
Headlamp fairing removal.....	E.29
Ignition switch removal.	E.30
Thermal expansion valve removal.....	E.31
Secondary drive chain removal	E.32
Engine removal.....	E.32
Radiator removal	E.37



GENERAL PROCEDURES

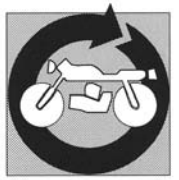

Foreword

This section describes the operations preliminary to engine removal. Please note that, in order to gain access to certain motorcycle components (rear shock absorber, electrical parts, wiring, etc.), it may be necessary to partially remove some parts.



RIGHT-HAND SIDE

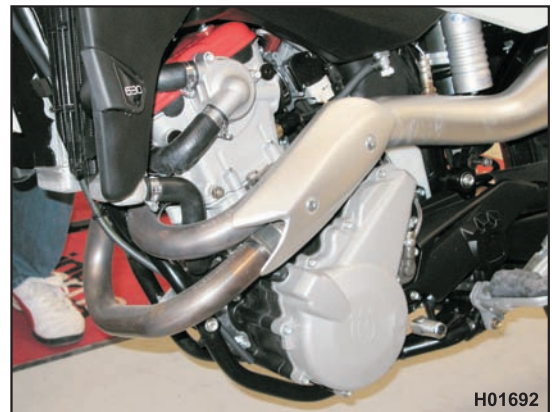

LEFT-HAND SIDE



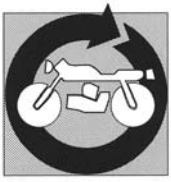

GENERAL PROCEDURES

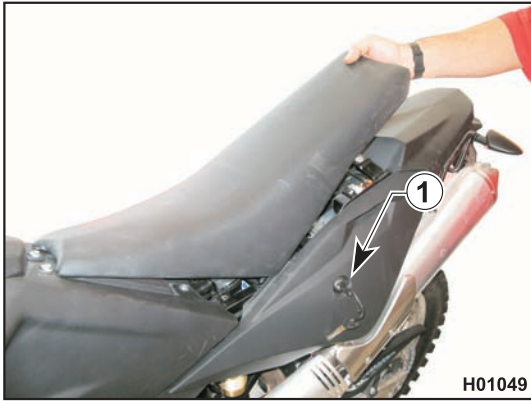

Saddle removal

- Insert the key in latch (1) then turn clockwise to release the saddle lock; remove the saddle.



Side panel removal

- Remove the saddle as described in the relevant paragraph.
- Disengage rear side panels (2) and (3) then slide them toward vehicle front.

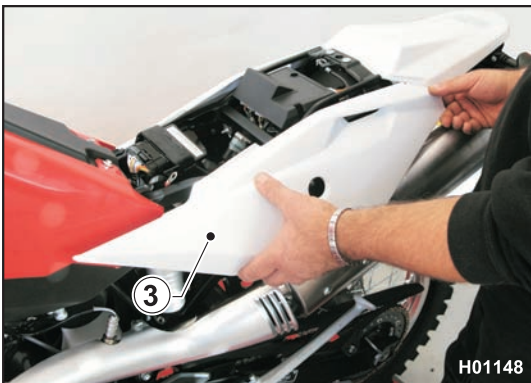

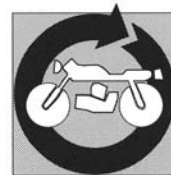

Battery removal

- Remove the saddle as described in the relevant paragraph.
- Release the elastic strap (3) holding the battery.
- First remove the BLACK negative cable (8 mm Allen wrench), then the RED positive cable (when reassembling, first connect the RED positive cable, then the BLACK negative cable); remove the battery (1) from its housing.

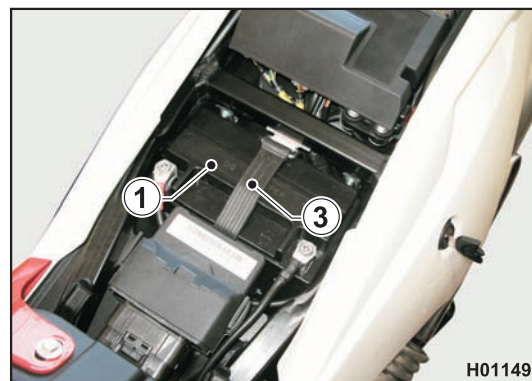

H01149



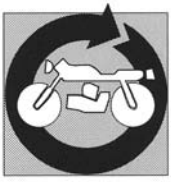

GENERAL PROCEDURES

Exhaust system removal

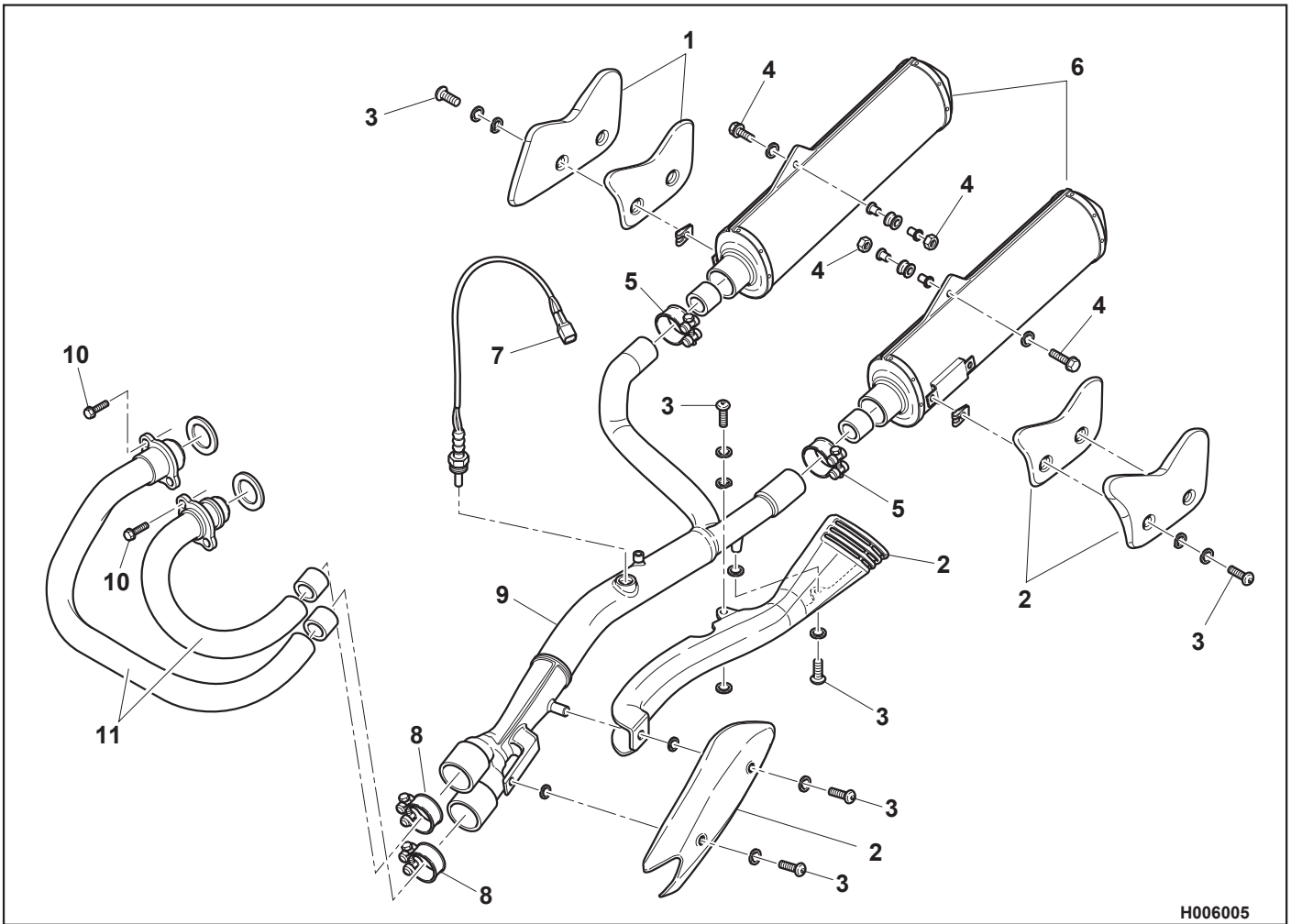

H006005



GENERAL PROCEDURES

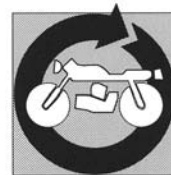

- Remove R.H. guard (1) and L.H. guards (2) loosening the screws (3) with a 4 mm Allen wrench.
- Remove saddle and side panels as described in the relevant paragraph.

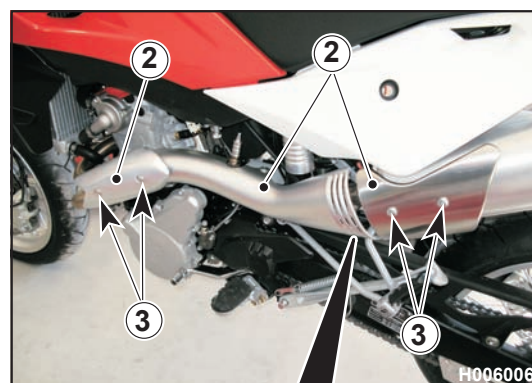

- Loosen the screws (4) securing silencers to rear chassis using an 8 mm ring wrench on the outside and a 10 mm ring wrench on the inside.





GENERAL PROCEDURES

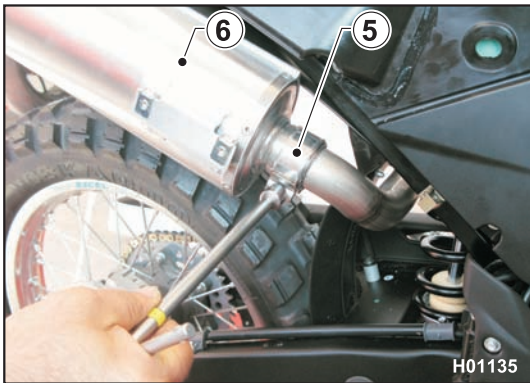

- Loosen metal clip (5) using a 13 mm wrench and remove the silencers (6).

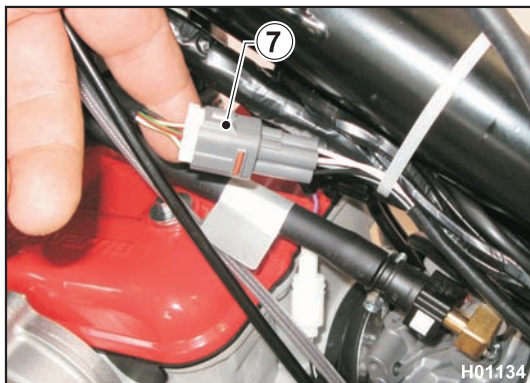

- Disconnect the Lambda sensor connector (7).



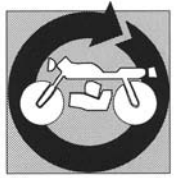

- Loosen the two clamps (8) using a 13 mm ring wrench and remove the central pipe (9).

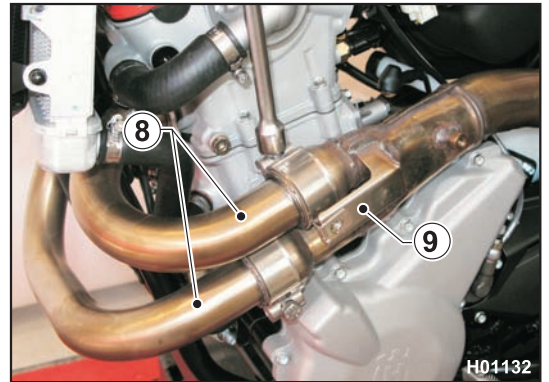

- Loosen the four screws (10) of the exhaust manifolds (11) using a 4 mm Allen wrench and remove the manifolds with their rings.

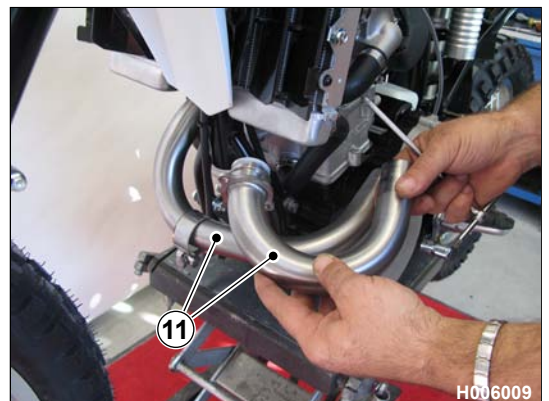
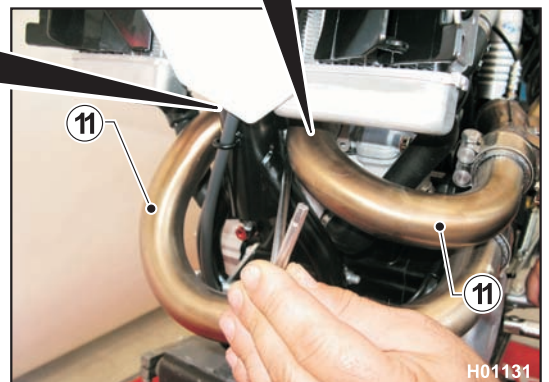
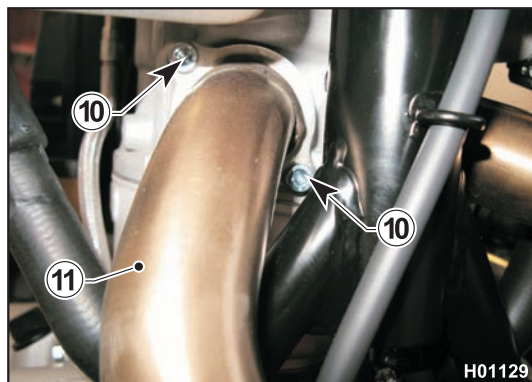
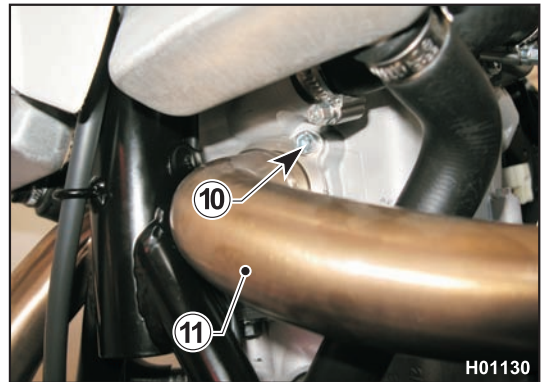

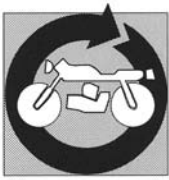

GENERAL PROCEDURES

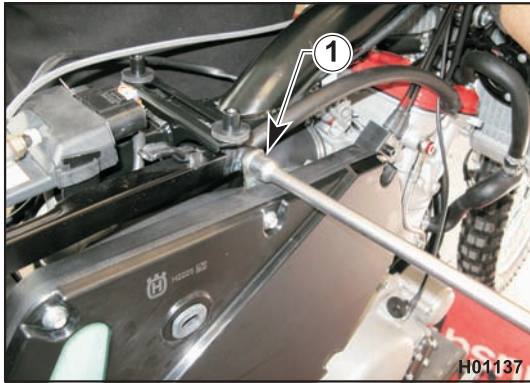

Air box removal

- Remove saddle, right-hand side panel and tank as outlined in the relevant paragraphs.
- Loosen the upper locking nut (1) using a 12 mm ring wrench.

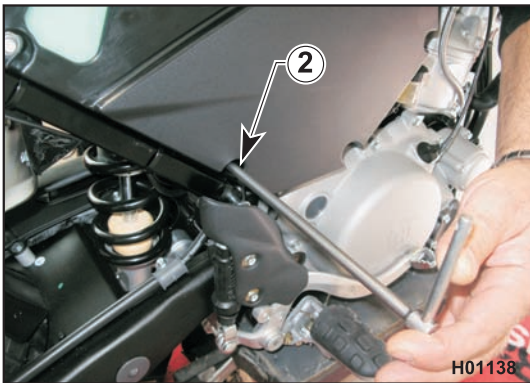

- Loosen the lower screw (2) securing air box to chassis using an 8 mm ring wrench.

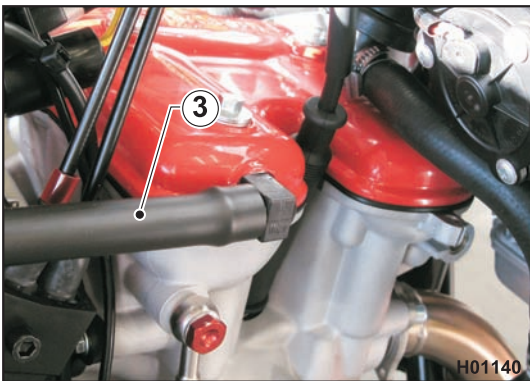

- Remove the hose (3) connecting filter to head.

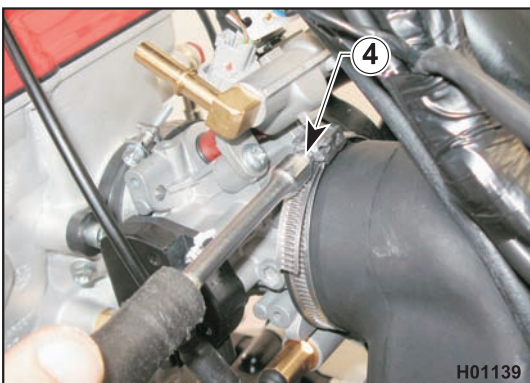

- Move to the left side of the motorcycle and loosen clamp (4) that secures filter to throttle body; use a 7 mm ring wrench.



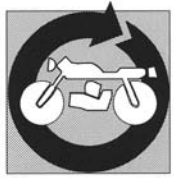

- Remove the complete air box (5) easing it off in rear to front motion.

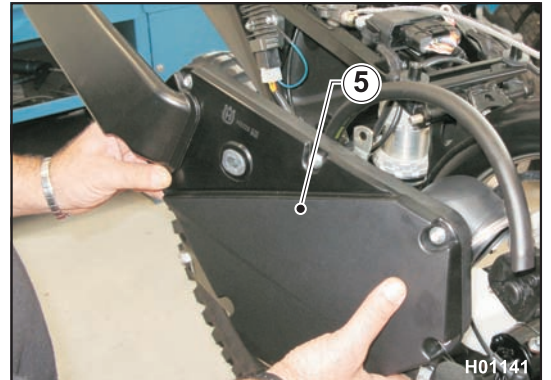

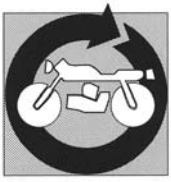

GENERAL PROCEDURES

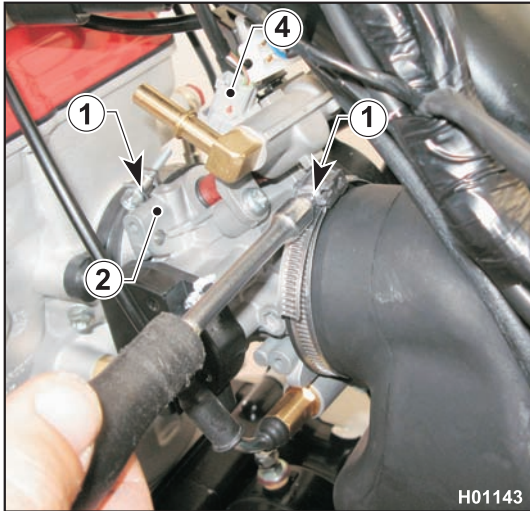

Throttle body removal

- Remove tank, saddle and left-hand side panel as outlined in the relevant paragraphs.
- Loosen the clamps (1) securing throttle body (2) to air box hose coupling and head.

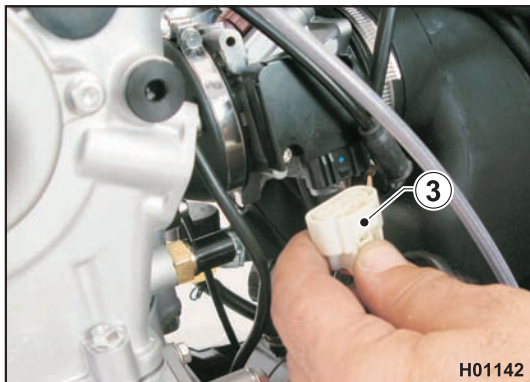

- Disconnect the M.A.Q.S. sensor connector (3) from the throttle body.
- Disconnect the wiring harness connector (4) from the throttle body.

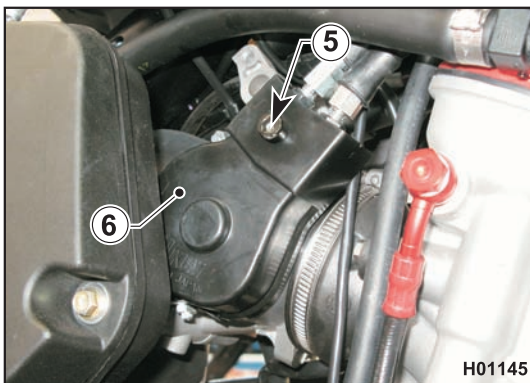

- Loosen screw (5) and remove the cover (6).



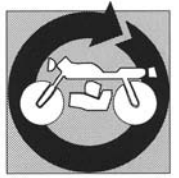

- Slacken adjusters (7) and disconnect the throttle cables (8).

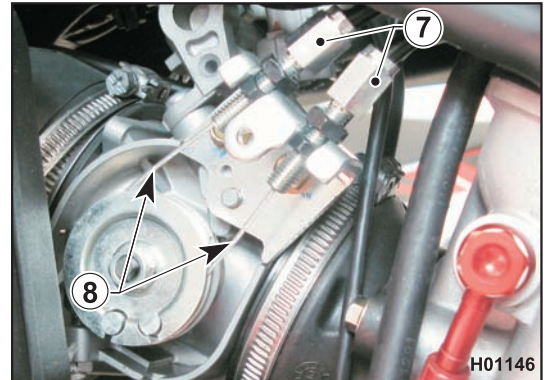

- Remove the starter cable (9).
- Remove the throttle body (2); on assembly, adjust the throttle cable as outlined in "Section D".

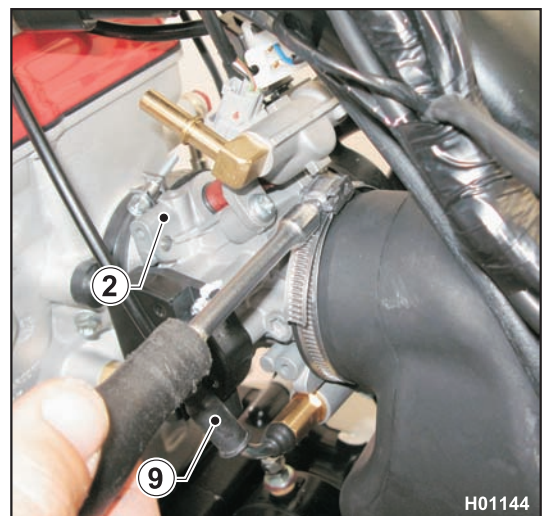

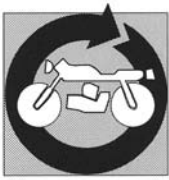

GENERAL PROCEDURES

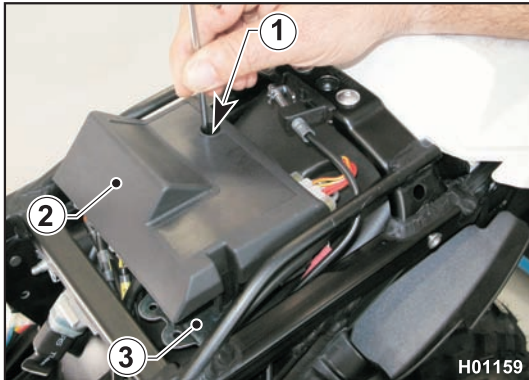

Removing the rear chassis complete with mudguard

- Remove fuel tank, saddle, side panels, battery, air box, silencers and central exhaust pipe as outlined in the relevant paragraphs.
- Shear the plastic clips securing main wiring harness.
- Use a 3 mm Allen wrench to loosen the screw (1) and remove the cover (2) of the utilities holder plate (3).

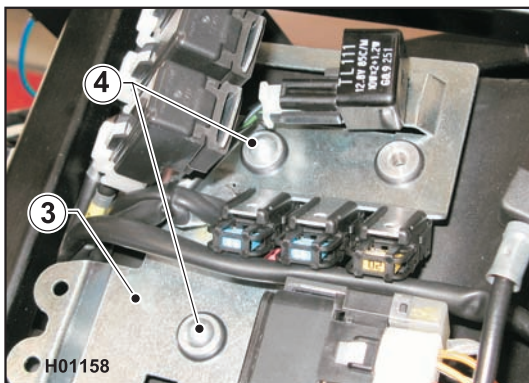

- Loosen the two screws (4) of the utilities holder plate (3).

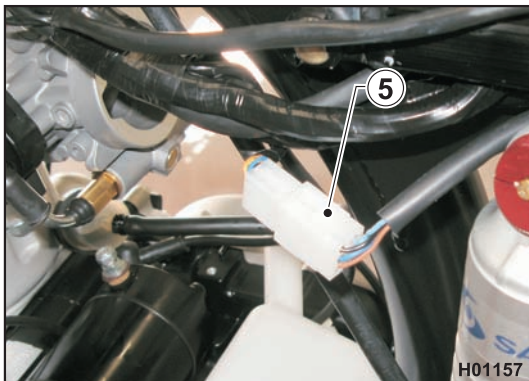

- Disconnect the connector (5) of the rear wiring harness.

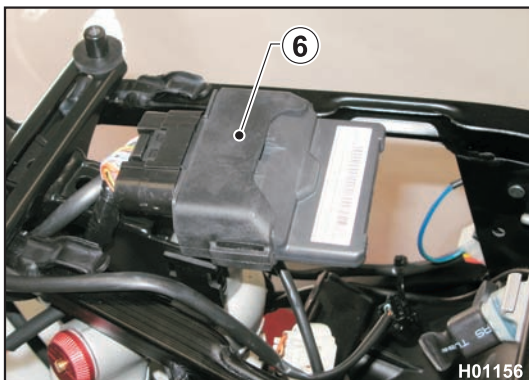

- Disconnect the electronic control unit (6) complete with flexible mounting from the rear chassis.



GENERAL PROCEDURES

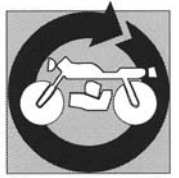

- Loosen the four screws (7) of the internal mudguard (8) using an 8 mm Allen wrench.
- Push down the internal mudguard (8) and then slide the utilities holder plate (3) toward vehicle front to remove it.

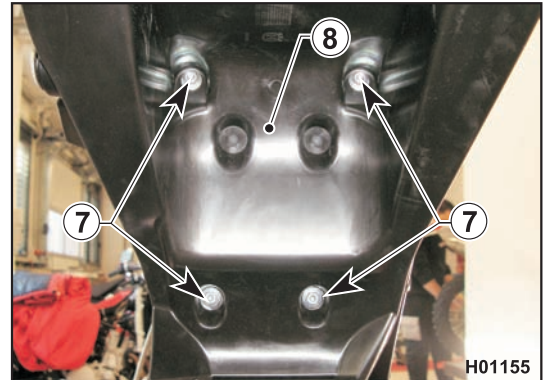

- Loosen the two screws (9) and remove the rear brake master cylinder cover (10).

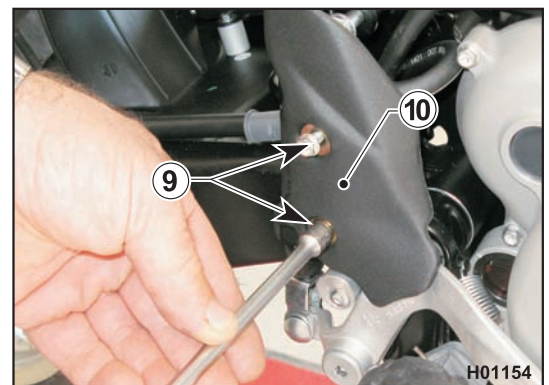

- Loosen the screws (11) securing footpegs and rear chassis to chassis (6 mm Allen wrench).

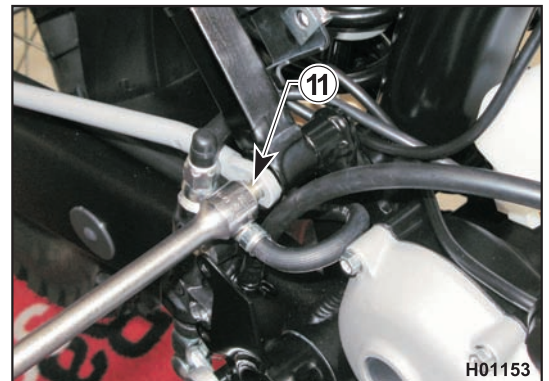

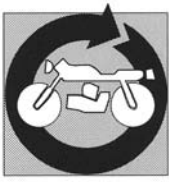

GENERAL PROCEDURES

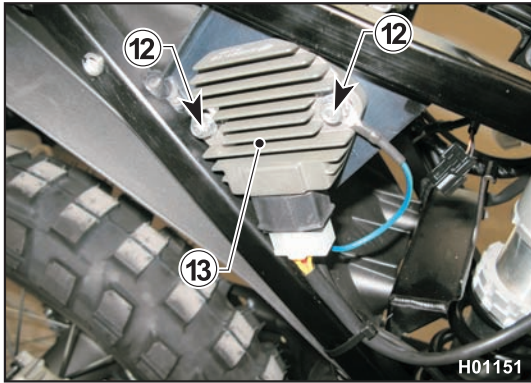

- Loosen the two nuts (12) of the voltage regulator (13) and remove it.

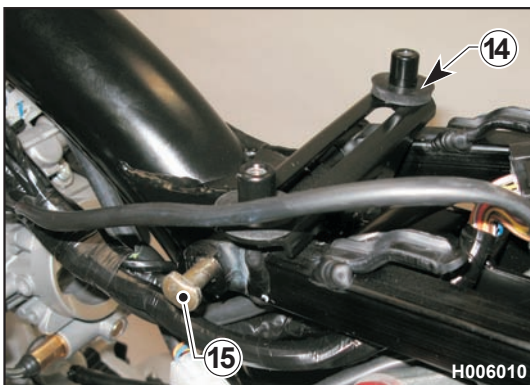

- Unscrew the top locking nut (14), extract the pin (15) and remove the rear chassis sliding it toward the rear end of the vehicle.



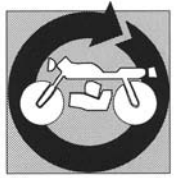

Fuel tank removal

- Remove the saddle as described in the relevant paragraph.
- Close both fuel cocks (1)

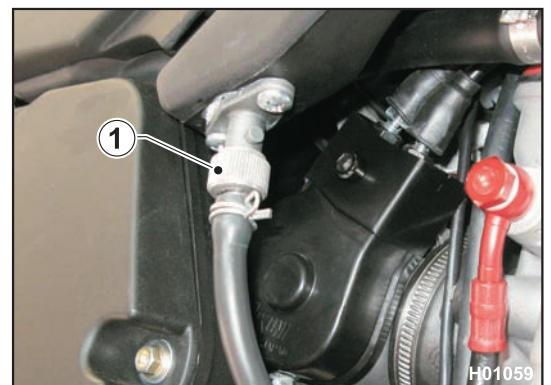
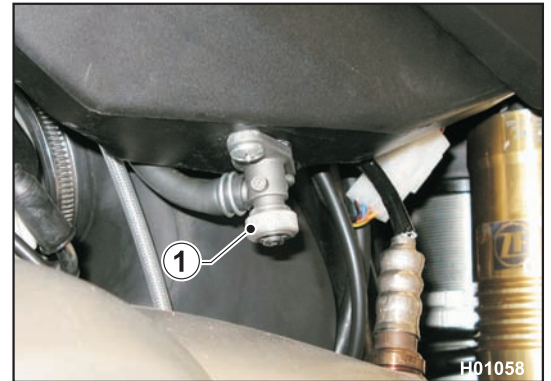

- Use a 6 mm Allen wrench to loosen the screw (2) and remove the screw with its spacer.
- Place a vessel under the R.H. cock to collect fuel.

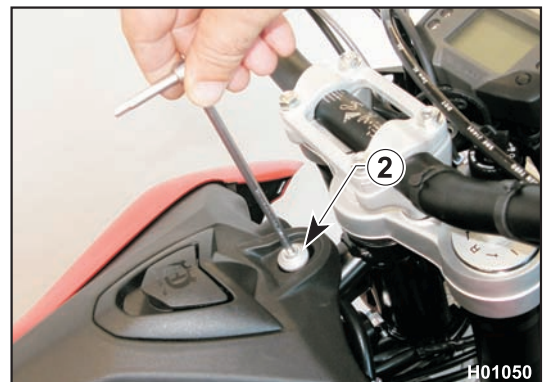

- Loosen clamp (3) and disconnect tube (4) from the fuel cock. Let the fuel drain out.

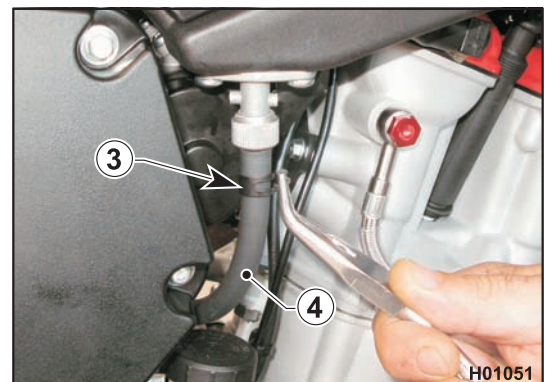

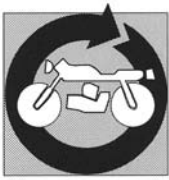

GENERAL PROCEDURES

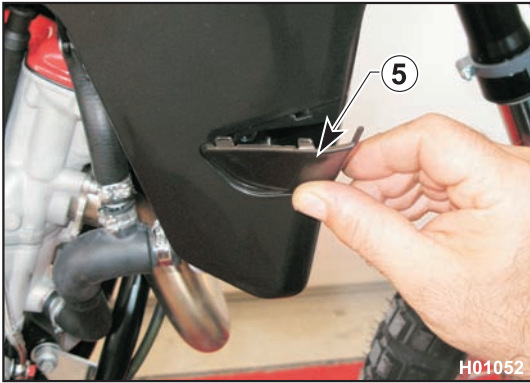

- Remove the covers (5) located on the R.H. and L.H. side of the tank.

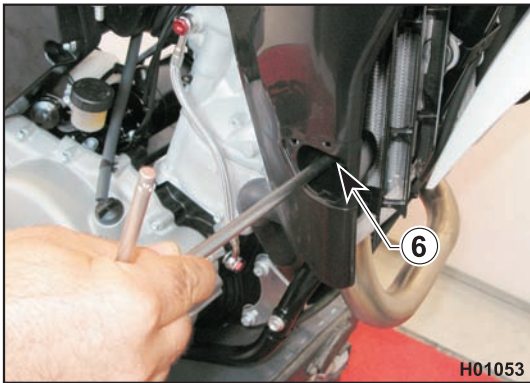

- Loosen the screws (6) using an 8 mm wrench.

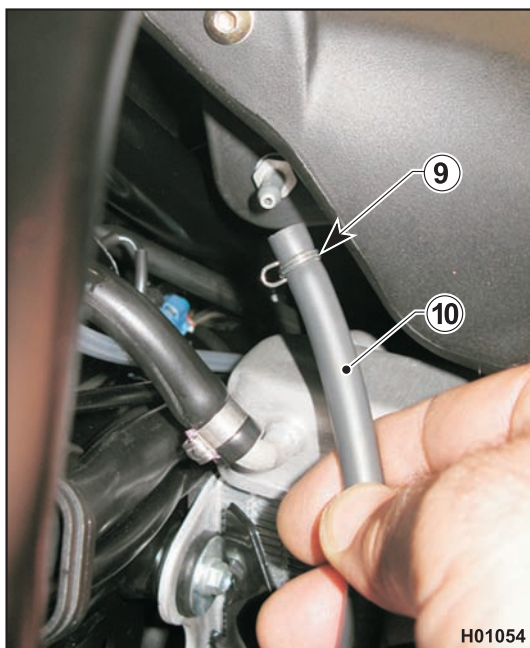

- Move to the left side of the tank, slacken clamp (9) and disconnect the breather hose (10).



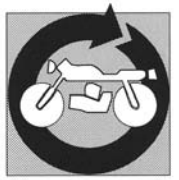

- Raise the tank from the front end and disconnect the fuel pump (12) connector (11).

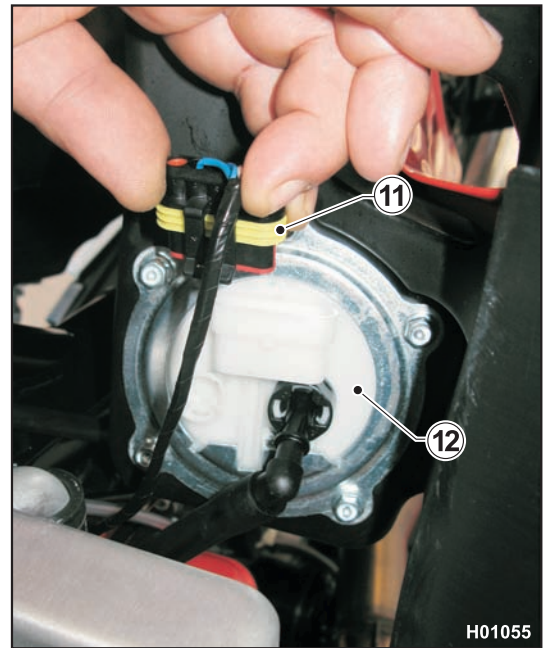

- Disconnect the hose (13) connecting tank to throttle body; press down the ring (14) and disconnect hose (13) from pump (12).

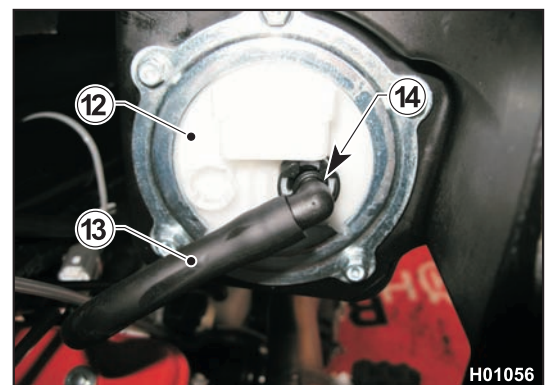

- Raise the tank (15) and remove it together with the scoops.
- Reassemble all parts in the reverse order compared to disassembly and tighten screws to the specified torque (see Section X)



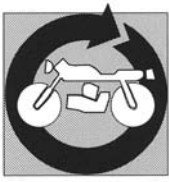

GENERAL PROCEDURES

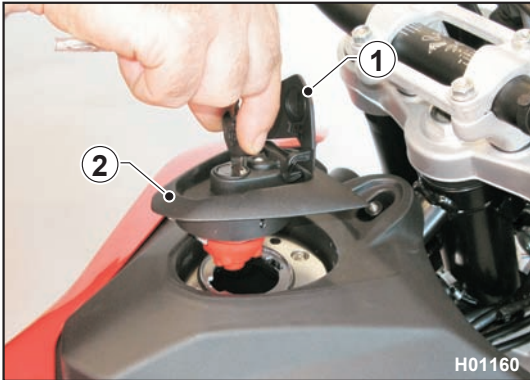

Fuel tank disassembly (scoops and fuel pump)



Before disassembling the tank, open both fuel cocks and drain it completely.

- Remove the fuel tank as described in the relevant paragraph.
- Raise the cover (1), insert the key, turn it and remove the cap (2).

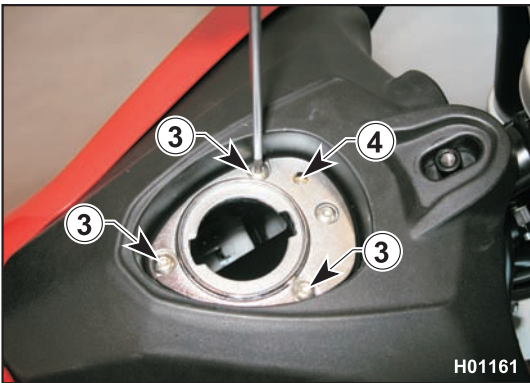

- Use a 3 mm Allen wrench to loosen the M5 screws (3) and a 4 mm Allen wrench to loosen the M6 screw (4); then remove the fuel cap flange.

- Loosen the screws (7) using an 8 mm ring wrench and remove right (5) and left scoops (6).



On assembly, make sure the bushings (8) are correctly positioned in the scoops before tightening the screws (7).

- Loosen the screws (9) using an 8 mm ring wrench and remove the fuel pump (10)

IMPORTANT: Make sure to position gasket (11) correctly on assembly.

- Use a screwdriver to loosen the screws (12) and remove the cocks (13).

IMPORTANT: Make sure to position gaskets (14) correctly when refitting the cocks.

- Reassemble all parts in the reverse order compared to disassembly and tighten screws to the specified torque (see Section X)



GENERAL PROCEDURES

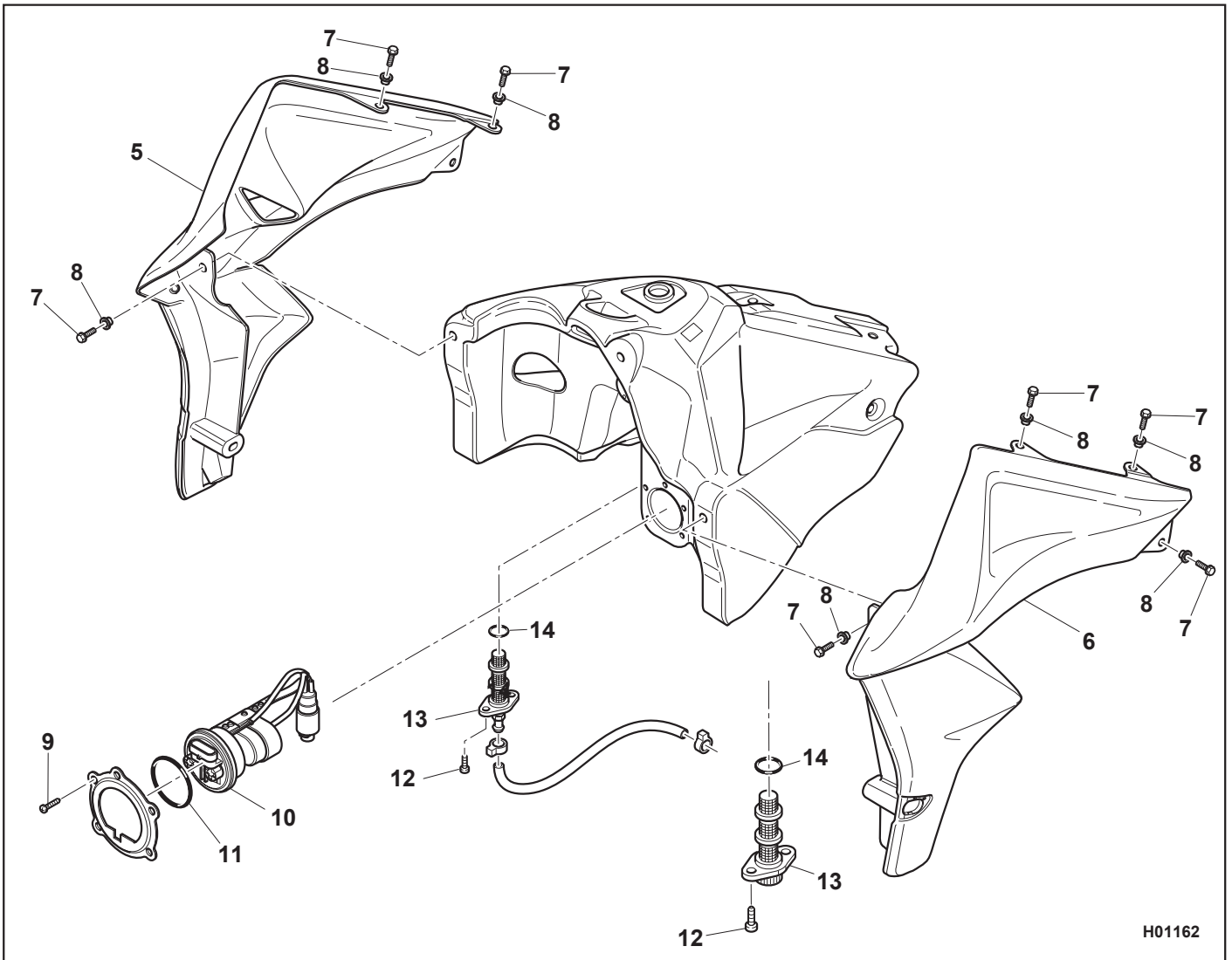

H01162



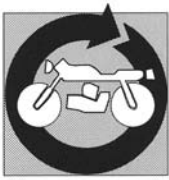

GENERAL PROCEDURES

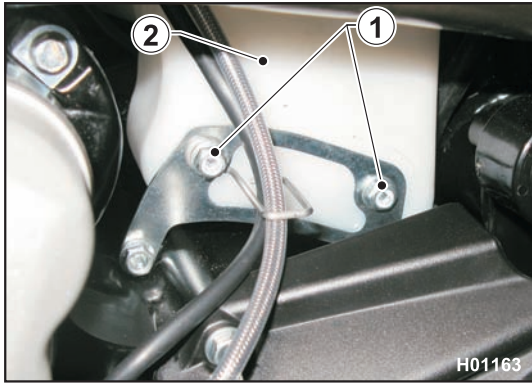

Expansion tank removal

- Remove fuel tank, saddle, right-hand side panel and air box as outlined in the relevant paragraphs.
- Loosen the two upper retaining screws (1) of the expansion tank (2) on the left side of the motorcycle.
- Disconnect breather hose from radiator cap.
- Remove the expansion tank (2) from the right side of the motorcycle.

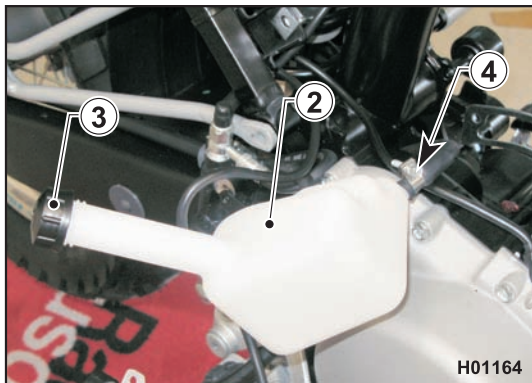

- Remove the cap (3) and drain all fluid.
- Loosen the clamp (4) and disconnect the breather hose.





Removing utilities (solenoid starter, relays, fuses, flasher)

- Remove the saddle as described in the relevant paragraph.
- Loosen screw (1) and remove the cover (2).

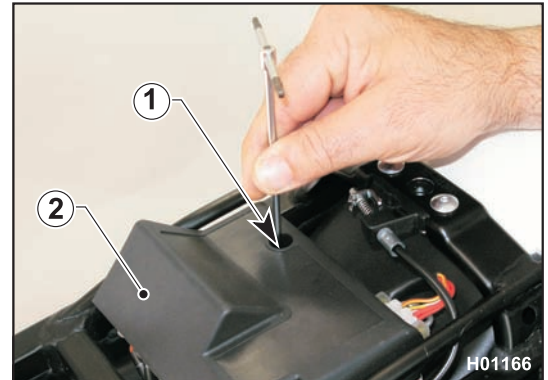

- The utilities holder plate (3) holds:
 - 4) Solenoid starter; disconnect connector (5) and remove solenoid starter from plate with its flexible mount.
 - 6) Flasher; release it from its seat and disconnect the connector (7).
 - 8) Fuses; take off the protection cap (9) and remove the blade fuses.
 - 10) Relays; release the fuses from their seat and remove them with the flexible mount, then remove the connector.
 - 11) Rollover sensor (SMS only); loosen the two screws (12) to remove it.

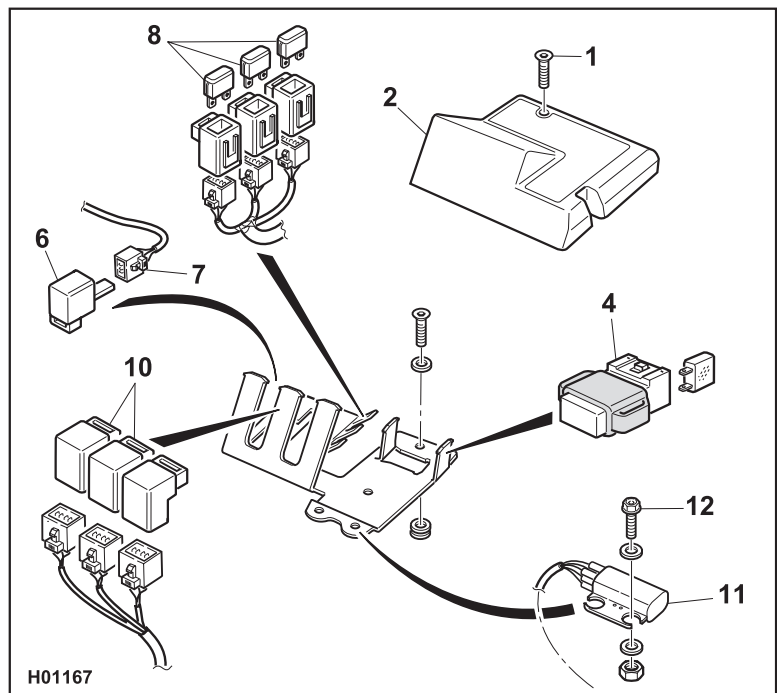
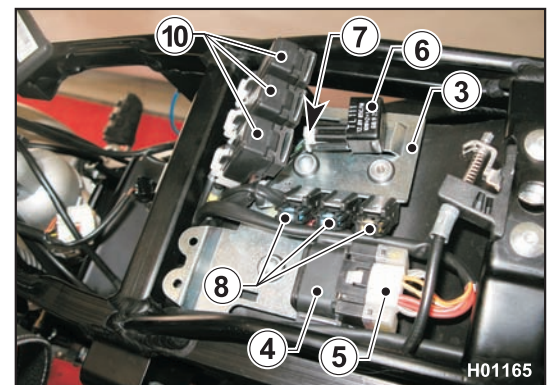



GENERAL PROCEDURES

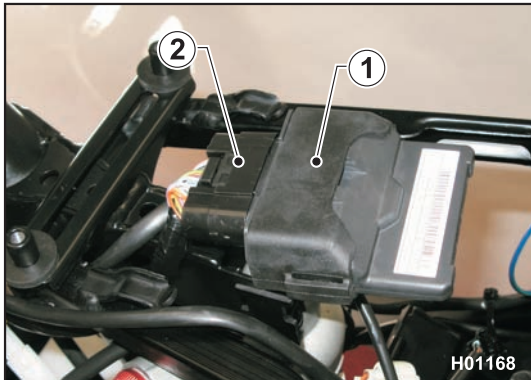

Electronic control unit removal

- Remove the saddle as described in the relevant paragraph.
- Raise the electronic control unit (1) with its flexible mount and detach it from the rear chassis.
- Disconnect the connector (2).

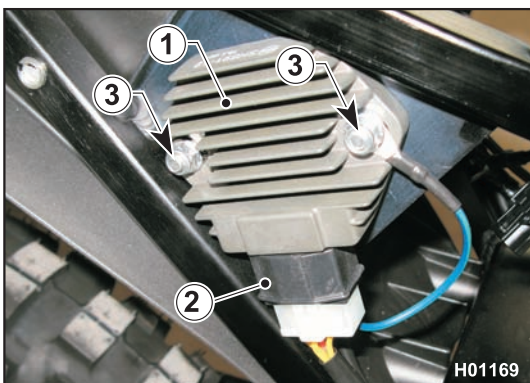

Voltage regulator removal.

- Remove saddle, right-hand side panel and air box cover as outlined in the relevant paragraphs.
- Loosen the two screws (1), disconnect the connector (2) and remove the voltage regulator (3).



Ignition coil removal

- Remove: saddle and fuel tank as described in the relevant paragraphs.
- Remove the spark plug cap (1).

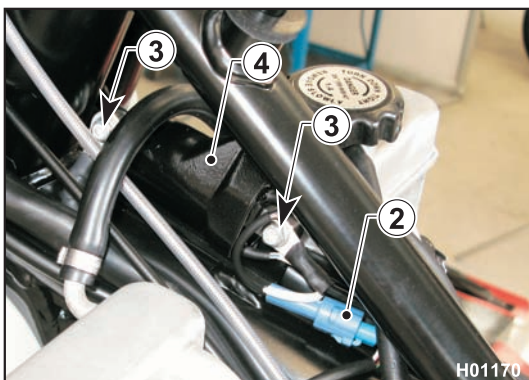

- Disconnect the connector (2).





- Remove the retaining screws (3) and then the coil (4).

Electric cooling fan removal

- Remove saddle and tank as outlined in the relevant paragraphs.
- Loosen screw (1) and remove the connector (2).
- Remove the electric fan (3) together with its bracket (4).
- Loosen the three screws (5) using a 7 mm wrench and take the electric fan (3) off the bracket (4).

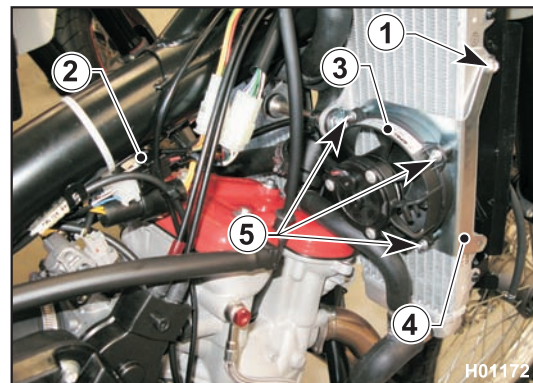

Front mudguard removal.

- Loosen the four screws (1) using an 8 mm ring wrench and remove the mudguard (2).

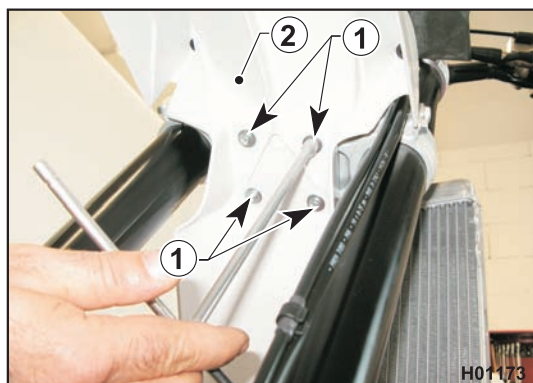

Horn removal.

- Remove the front mudguard as described in the relevant paragraph.
- Loosen the retaining screw (1) of the horn (2) with an 8 mm ring wrench.

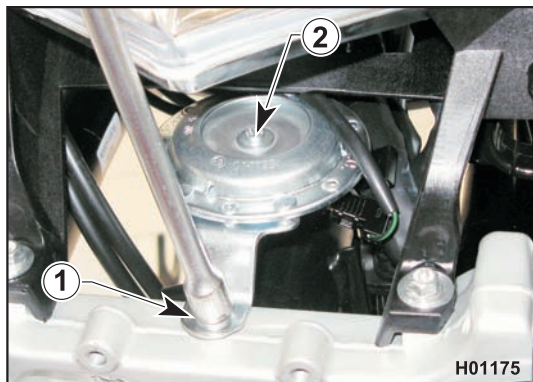

- Disconnect the two connectors (3).

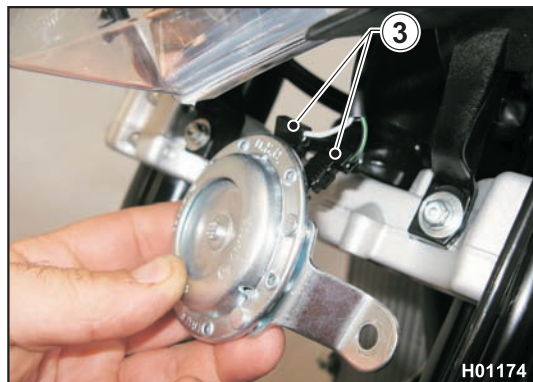

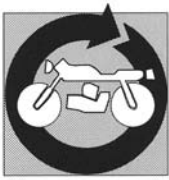

GENERAL PROCEDURES



Headlamp removal

- Proceed as follows to reach the headlamp bulbs:
- pull out the front fairing (1) to remove it;

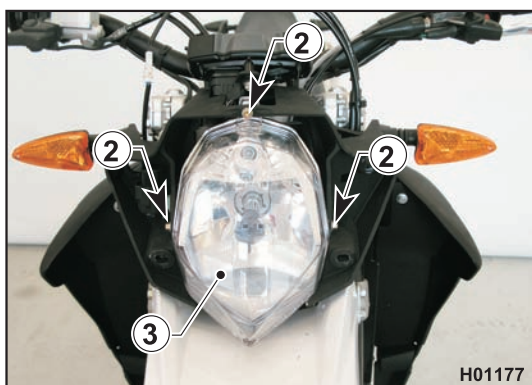

- loosen the three screws (2) and remove the headlamp (3);





On assembly, make sure the midline of side screw heads (2) lines up with the notch (C) on the support.

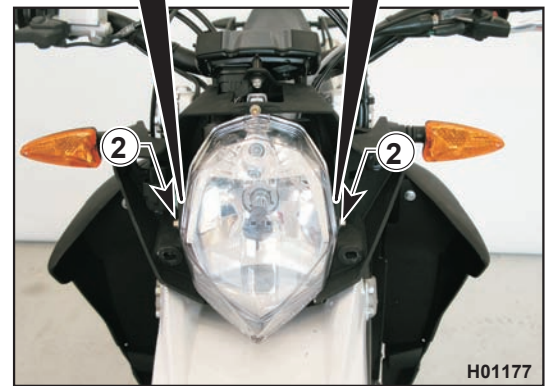
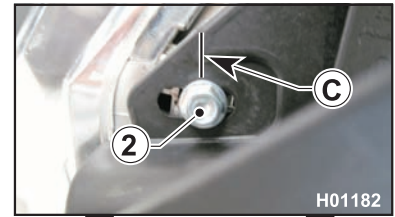

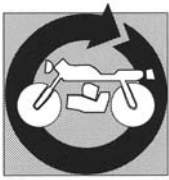

GENERAL PROCEDURES

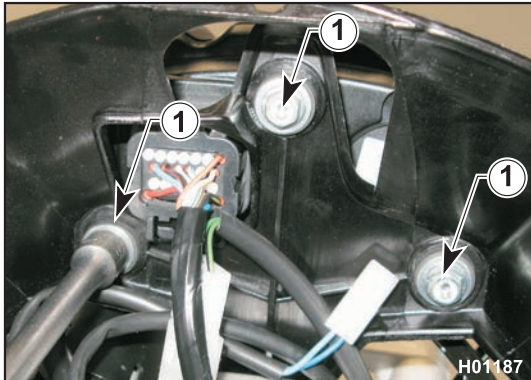

Digital dashboard removal.

- Remove the headlamp as described in the relevant paragraph.
- Loosen the three screws (1) using an 8 mm ring wrench; be sure to collect the spacers.

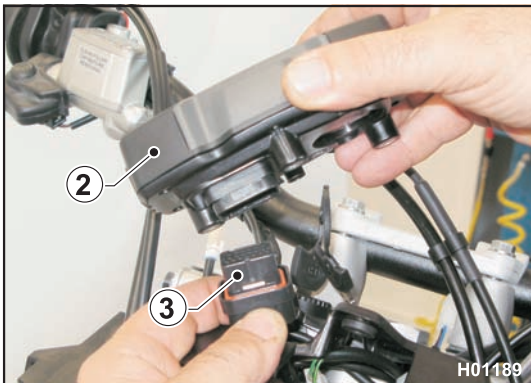
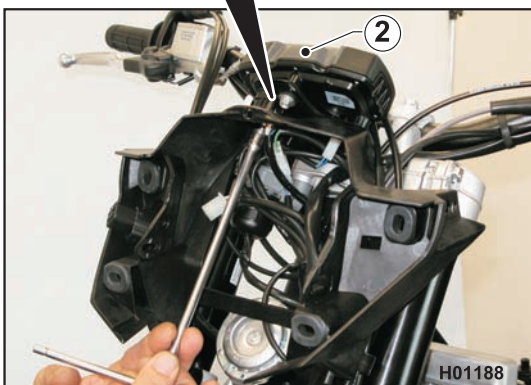

- Raise the dashboard (2) and disconnect the connector (3).



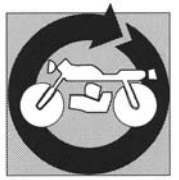

Headlamp fairing removal.

- Remove headlamp, front mudguard and digital dashboard as outlined in the relevant paragraphs.
- Disconnect the diagnostic connector (1).

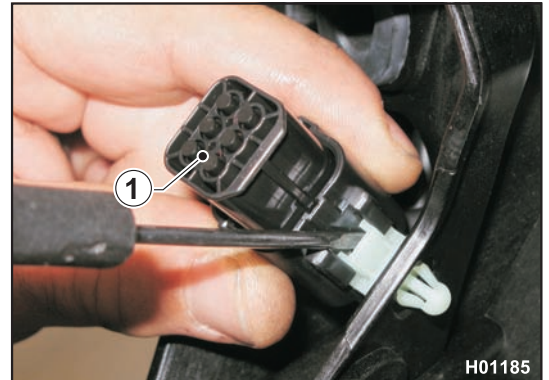

- Loosen the three screws (2) using an 8 mm ring wrench, open the clamp (3), slip off brake and trip meter cables and remove headlamp fairing (4).

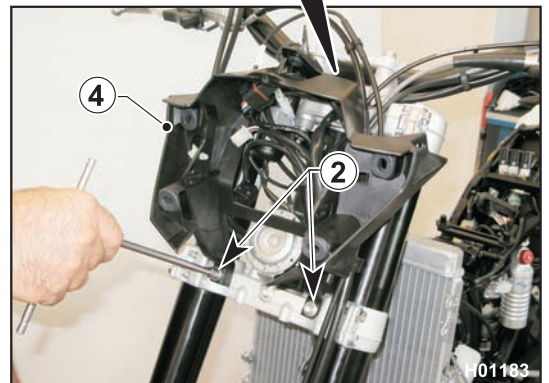
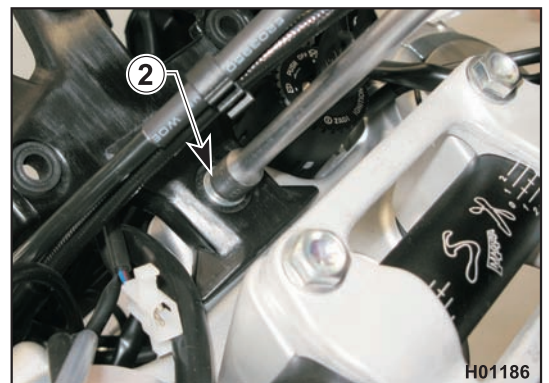

On assembly, make sure to position bushing (5) and rubbers (6) correctly.

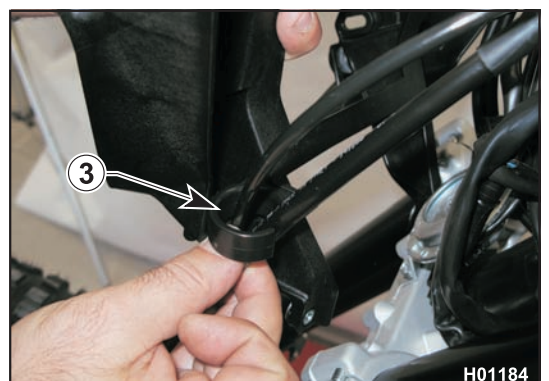
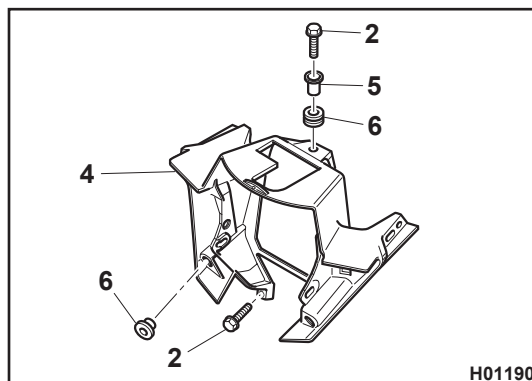

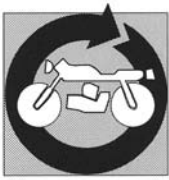

GENERAL PROCEDURES



Ignition switch removal.

- Remove headlamp fairing, saddle and tank as outlined in the relevant paragraphs.

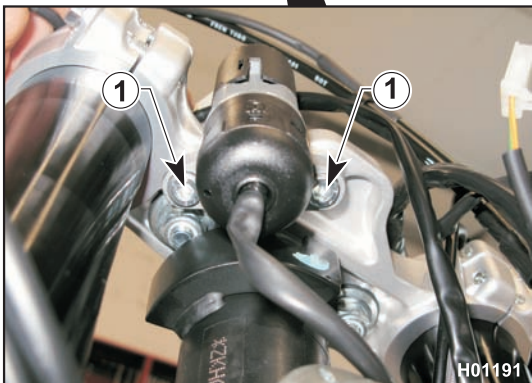

- Loosen the two screws (1) using a 6 mm Allen wrench.

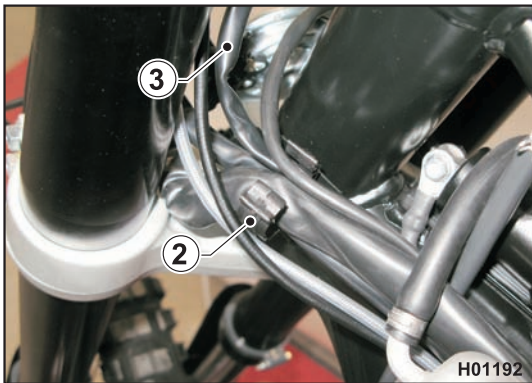

- Release the clamp (2) and slip off the cable (3).

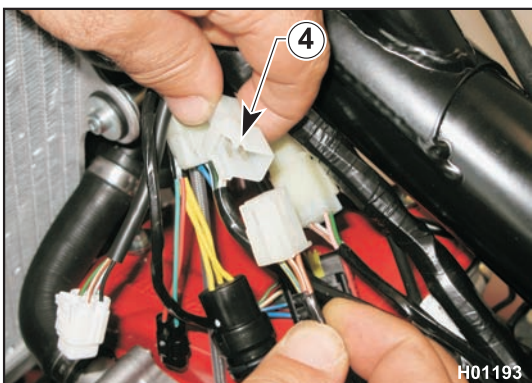

- Disconnect the connector (4).



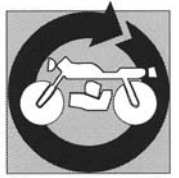

Thermal expansion valve removal.

- Remove saddle and tank as outlined in the relevant paragraphs.
- Drain coolant from the radiators as described in "Section D".
- Disconnect the three clamps (1), disconnect the hoses (2) from the thermal expansion valve (3) and remove the valve.

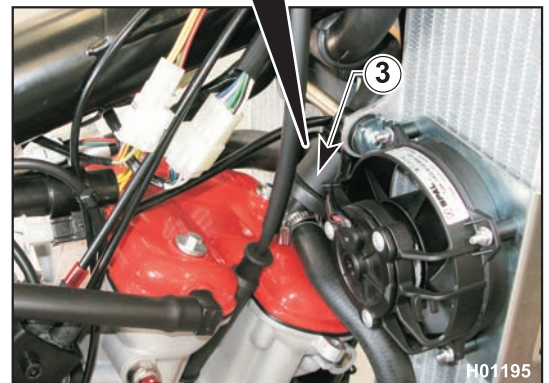
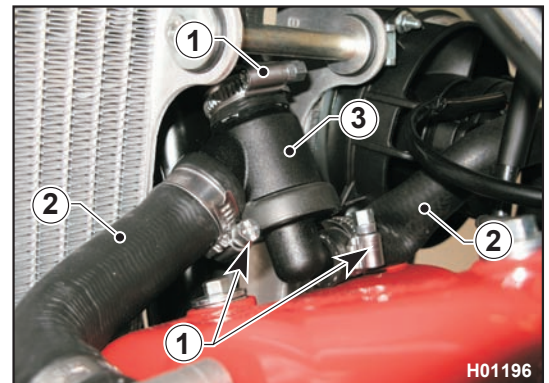

NOTE: After refitting the thermal expansion valve, fill with coolant as outlined in "Section D".

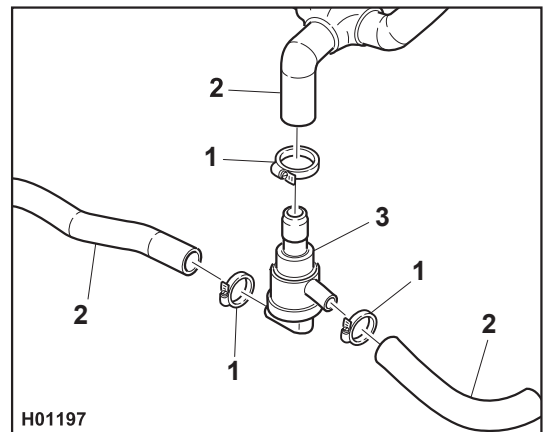

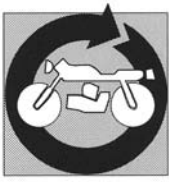

GENERAL PROCEDURES

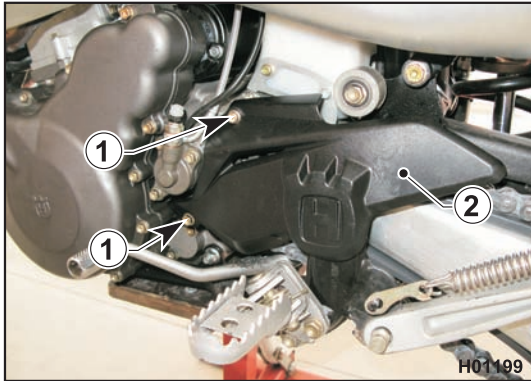

Secondary drive chain removal

The following procedure applies to both O-ring chains and chains without O-rings:

- Remove: screws (1), sprocket guard (2), clip (3), master link (4) and chain (5).

NOTE: On assembly, follow the instructions given on the paragraph covering the chain in Section "D".

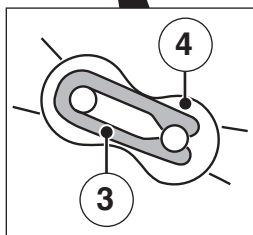
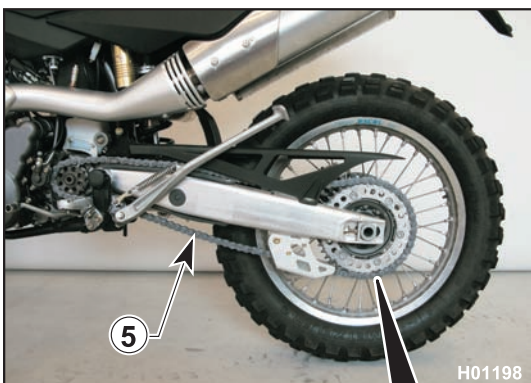

Engine removal

- Remove the saddle as described in the relevant paragraph.
- Remove the side panels as described in the relevant paragraph.
- Remove the fuel tank as described in the relevant paragraph.
- Remove the exhaust system as described in the relevant paragraph.
- Remove the chain as described in the relevant paragraph.
- Drain coolant from the radiators as described in Section "D".
- Remove the air filter as described in the relevant paragraph.
- Remove the throttle body as described in the relevant paragraph.
- Remove the expansion tank as described in the relevant paragraph.





- Loosen the two screws (1) and screw (1a) of the clutch actuator (2) using an 8 mm ring wrench and remove the actuator.



Make sure to refit screw (1a) in the original position on assembly.



Make sure no one pulls the clutch lever with the actuator removed.

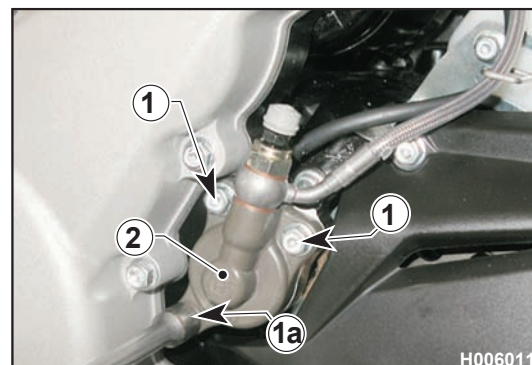

- Disconnect the two ignition connectors (3) and the gear sensor connector (4).

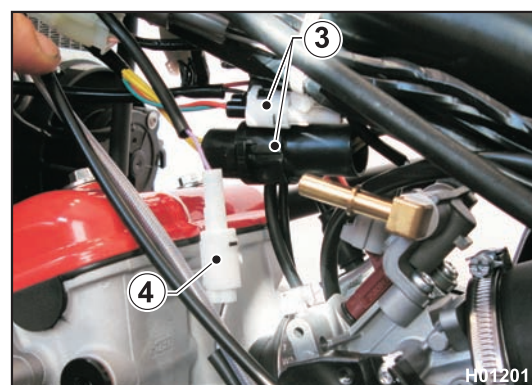

- Loosen the screw (5) of the starter motor electric connection using a 10 mm ring wrench and loosen the ground cable screw (6) with an 8 mm ring wrench.

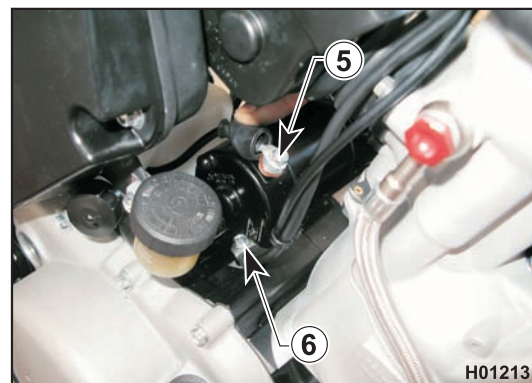

- Disconnect the connector (7) from the temperature sensor (8).

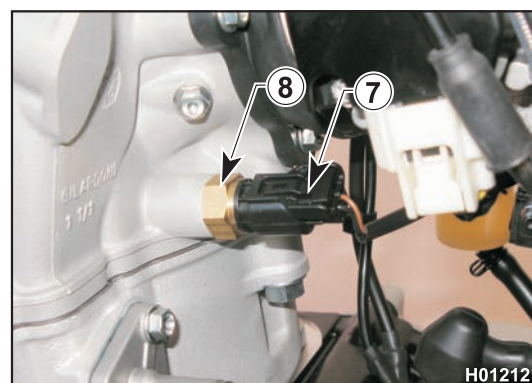

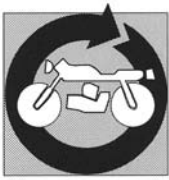

GENERAL PROCEDURES

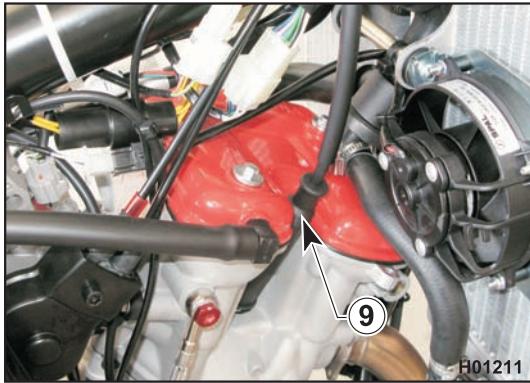

- Take off the spark plug cap (9).

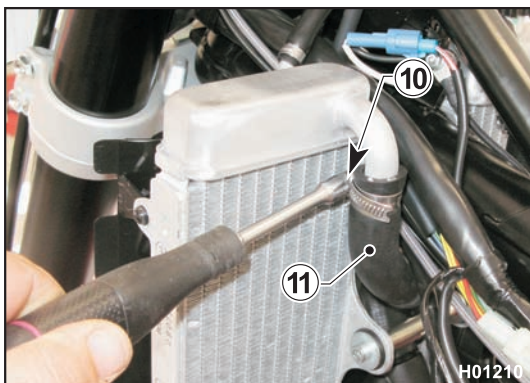

- Loosen the clamp (10) using a 7 mm ring wrench and disconnect the hose (11) from the left-hand radiator to make room for the ignition connectors (3).

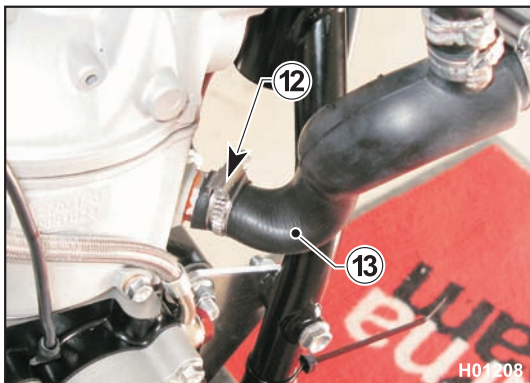

- Loosen the clamps (12) using a 7 mm ring wrench and detach the hoses (13) from the engine.

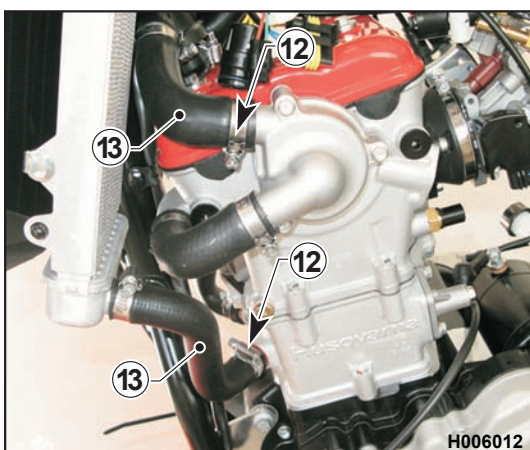

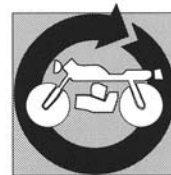

- Loosen the two screws (14) using an 8 mm ring wrench and remove the rear brake master cylinder guard (15)

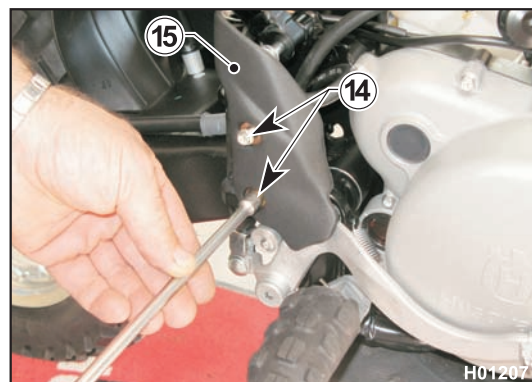

- Disengage the rear brake pedal return spring (16).



- Loosen the nut (17) of the rear engine mounting bolt using a 22 mm socket wrench.

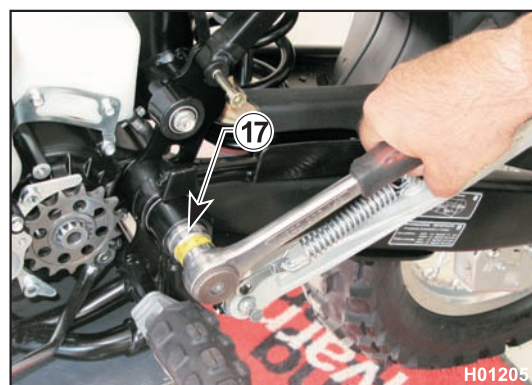

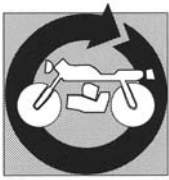

GENERAL PROCEDURES

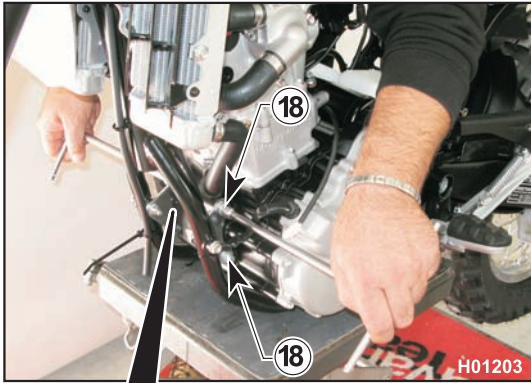

- Loosen the nut of the front bolts (18) using a 10 mm ring wrench on the left-hand side and a 12 mm wrench on the right-hand side, but do not remove the bolts.

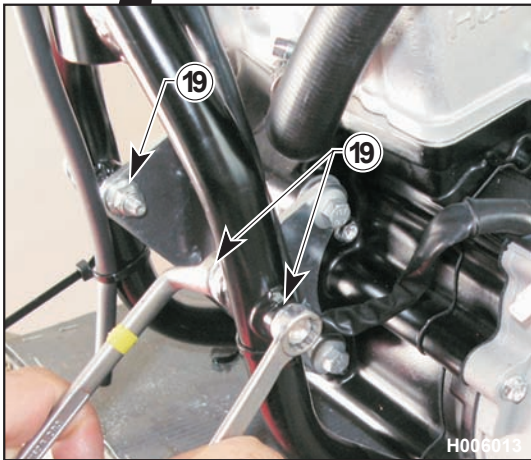

- Loosen the bolts (19) of the engine front mounting brackets using two 12 mm ring wrenches.

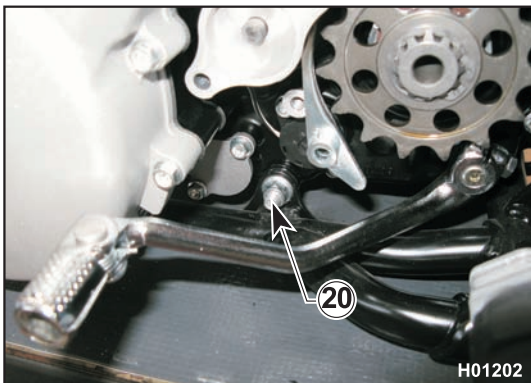

- Loosen the nut (20) of the front bolts using a 10 mm ring wrench on the left-hand side and a 12 mm wrench on the right-hand side.
- Make sure the gear sensor and ignition cables have been released.
- Keep the engine raised and remove the two front bolts (18) on the left side and the lower (20) and rear bolts (17) on the right side of the engine; then remove the engine from one side.
- Place the engine on a rotating stand to perform the procedures described in Sections "F-G-H".



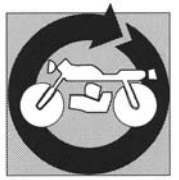

Radiator removal

- Remove the fuel tank together with scoops and spoilers as outlined in the relevant paragraphs.
- Remove the electric cooling fan and its bracket as described in the relevant paragraph.
- Drain all coolant as described in the relevant paragraph (see Section "D").
- Release the grids (1) and remove them.

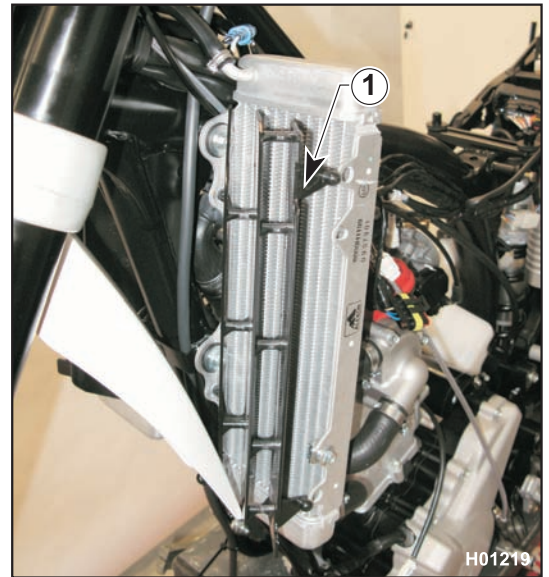

- Loosen the clamps (2) and disconnect the hoses (3) from the left-hand radiator (4).
- Open the clamp (6) and disconnect the hose (7).

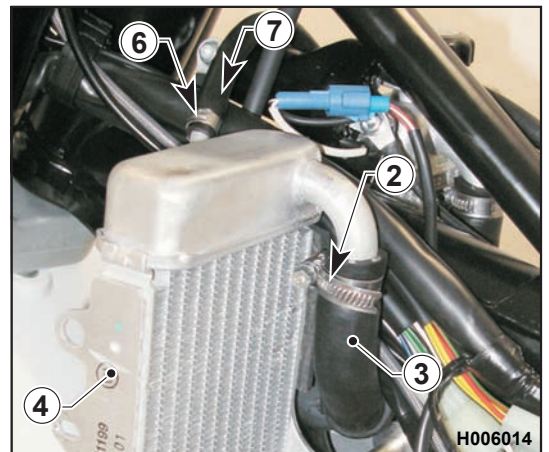

- Disconnect the breather hose (8).
- Loosen the clamps (9) and disconnect the hoses (10) from the right-hand radiator.

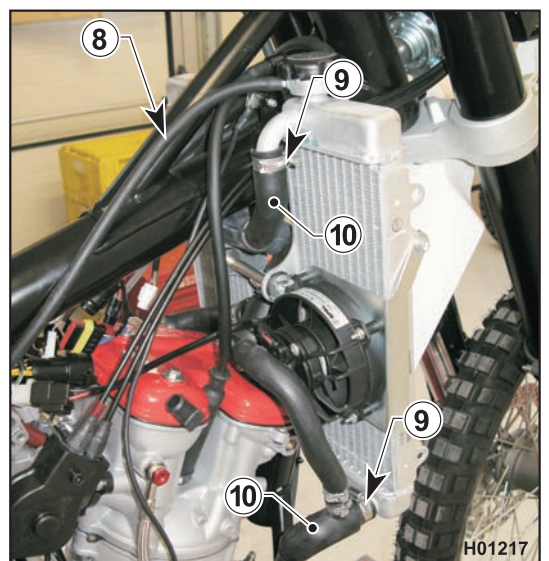

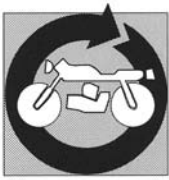

GENERAL PROCEDURES

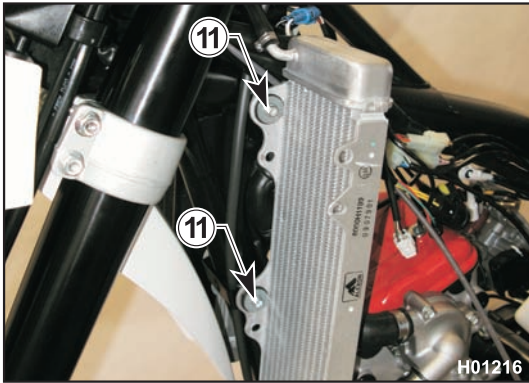

- Use a 7 mm ring wrench to loosen the two screws (11) and a 5 mm Allen wrench to loosen the central screw (12). Remove the left-hand radiator (13).

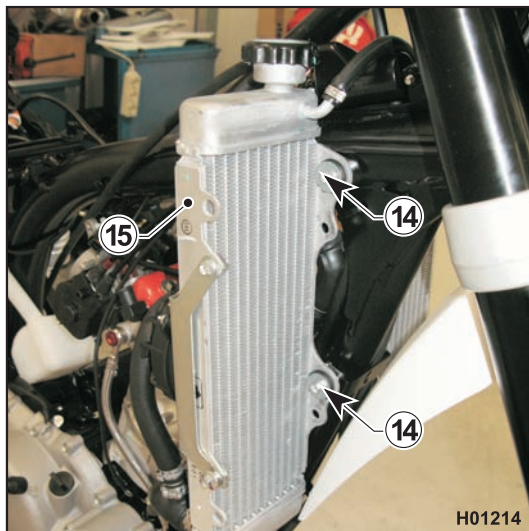
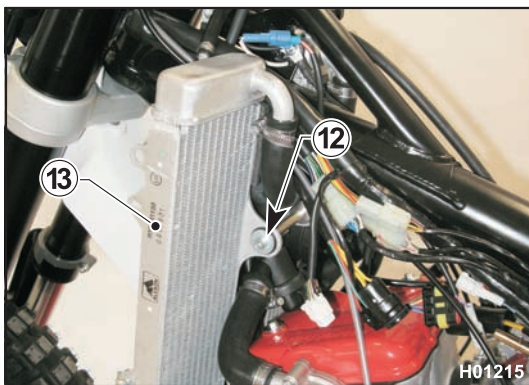

- Loosen the two screws (14) using a 7 mm ring wrench and remove the right-hand radiator (15).



ENGINE DISASSEMBLY

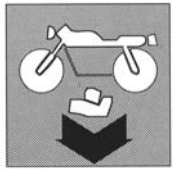

Section

F



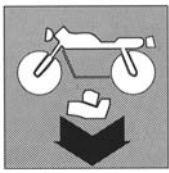

ENGINE DISASSEMBLY

Layout of engine components	F.3
Cylinder head cover removal.....	F.4
Camshaft removal	F.4
Water pump body removal	F.8
Water pump disassembly	F.8
Cylinder head removal.....	F.9
Valve removal	F.12
Cylinder removal.....	F.14
Piston removal	F.15
Flywheel removal	F.15
Clutch cover removal.....	F.18
Oil filters removal	F.19
Clutch disassembly.....	F.20
Clutch actuator removal.....	F.23
Starter motor flange removal.....	F.24
Starter motor removal.....	F.24
Gearbox drive shaft removal	F.25
Gear sensor removal	F.27
Crankcase, crankshaft and countershaft disassembly	F.28
Left crankcase seal replacement.....	F.31
Countershaft removal	F.32
Gearbox disassembly	F.32
Crankshaft removal	F.33
Crankshaft components removal.....	F.34
Right crankcase crankshaft seal removal.....	F.35
Crankcase bearings removal.....	F.35
Oil pump disassembly	F.36
Stator removal	F.36



ENGINE DISASSEMBLY

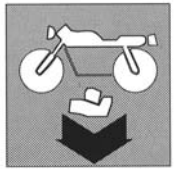

Layout of engine components

- 1 Cylinder head cover
- 2 Cylinder head
- 3 Chain tensioner
- 4 Cylinder
- 5 Starter motor
- 6 Head lubrication pipe
- 7 Oil pump
- 8 Clutch cover
- 9 Oil filter
- 10 Water pump
- 11 Ignition cover

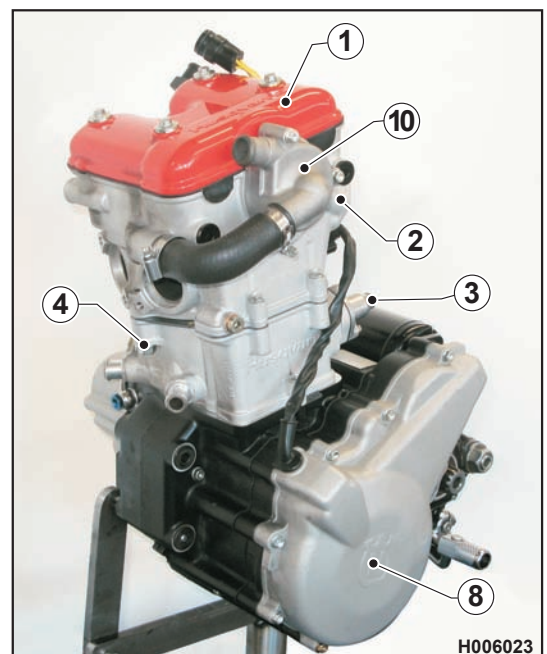
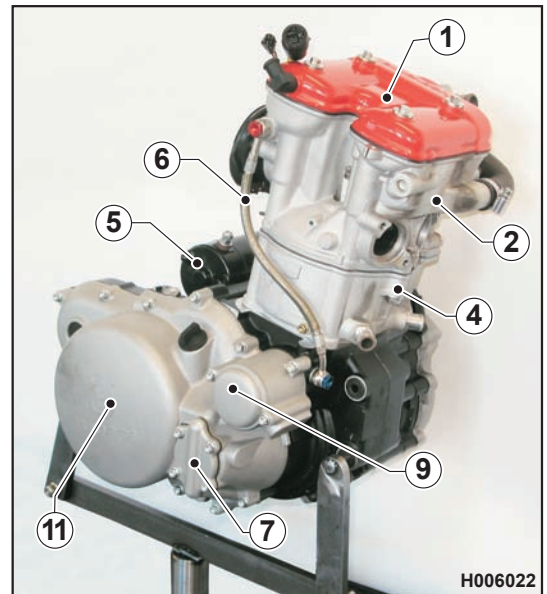

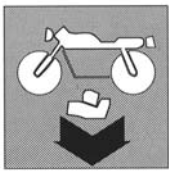

ENGINE DISASSEMBLY

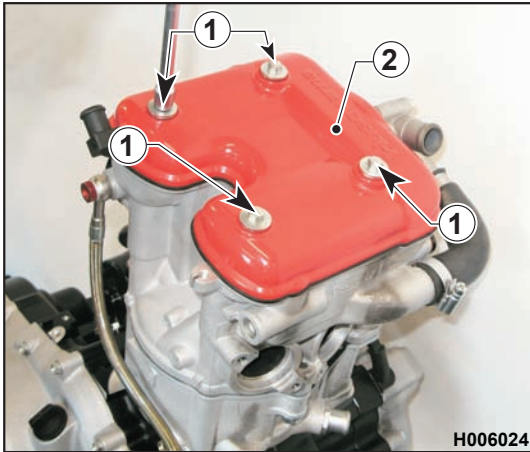

Cylinder head cover removal

- Remove the four retaining screws (1) (8 mm wrench) and remove the head cover (2) with its gasket.

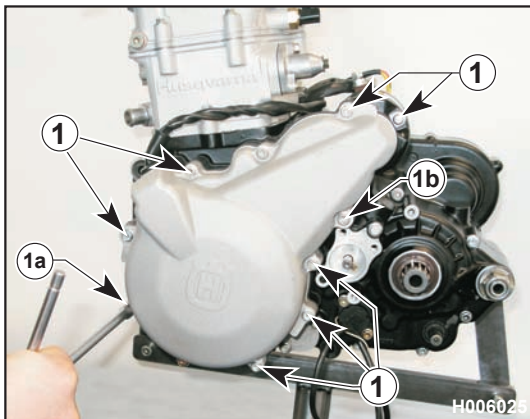

Camshaft removal

- Remove the head cover as described in the relevant paragraph.
- Remove the eight screws (1) securing the ignition cover (2) (8 mm wrench) and remove the cover together with stator (3), timing drive gears (4) and gasket.



The two longer screws (1a and 1b) (L=65mm) must be refitted in their original positions.



Make sure to collect the starter drive bushing (5); remove it from the flange (6) and fit it on the shaft (7) of starter drive gear (4).

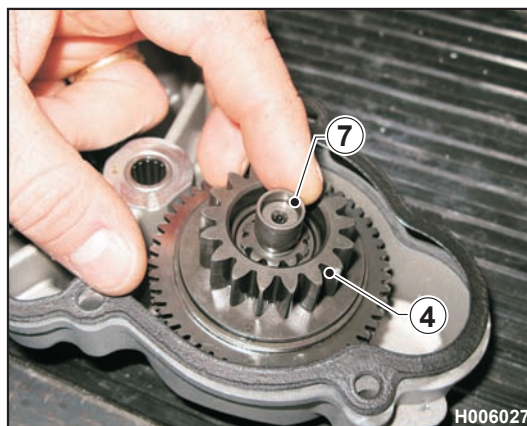
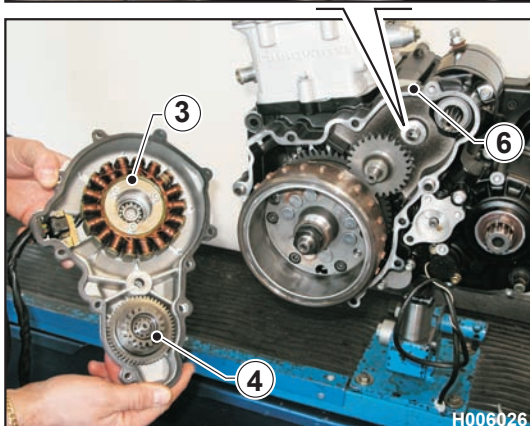
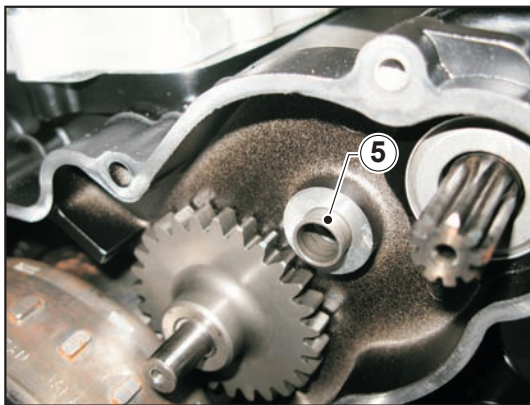

ENGINE DISASSEMBLY

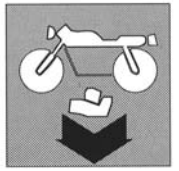

- Using a 24 mm wrench, bring the piston to T.D.C. at the end of the compression stroke. In this condition, the mark (8) on the head will be lined with the mark (9) on camshaft drive gear (10).

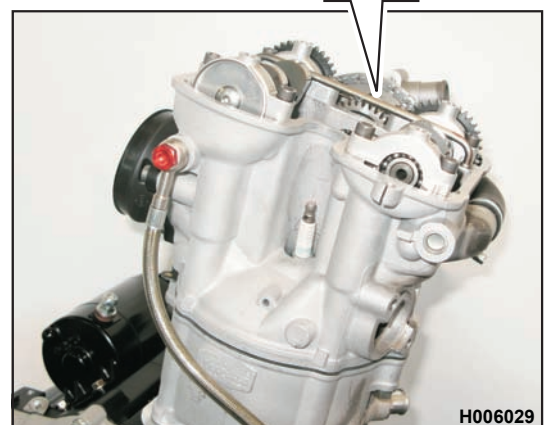
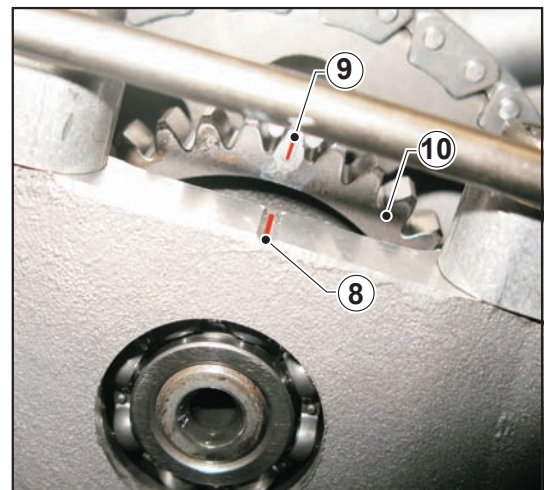
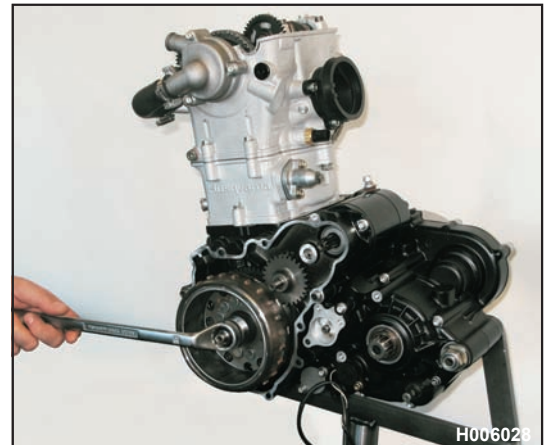

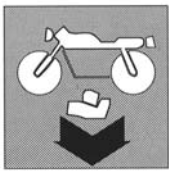

ENGINE DISASSEMBLY

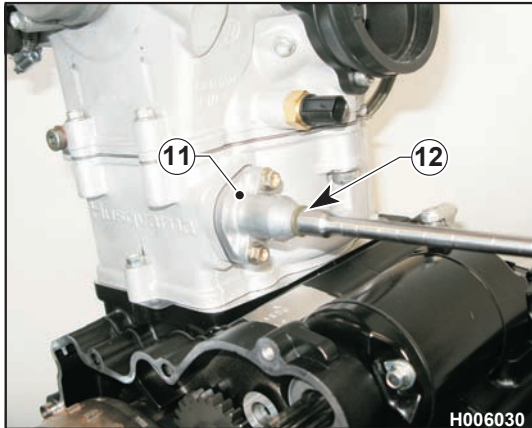

- Remove the chain tensioner (11) as follows:
- Loosen the screw (12) with an 8 mm wrench.

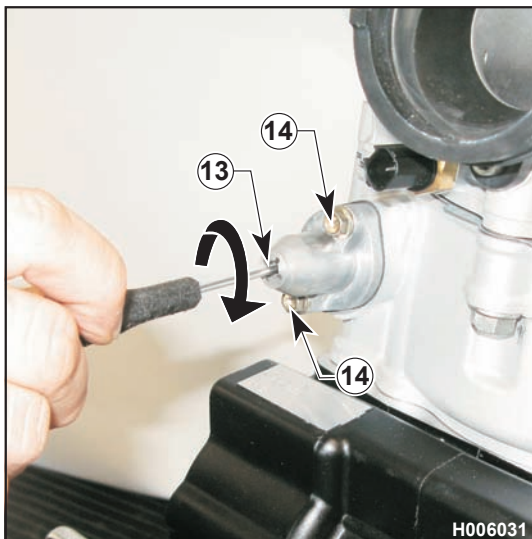

- Use a flat head screwdriver to release spring tension turning screw (13) fully clockwise.
- Loosen the two screws (14) using an 8 mm wrench and remove the chain tensioner (11).



ENGINE DISASSEMBLY

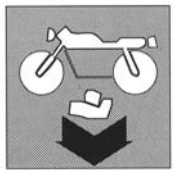

- Remove the eight screws (15) securing the camshaft (17) caps (16) (5 mm Allen wrench) and remove the camshafts tightening one of the screws you have removed into the threaded holes (18).

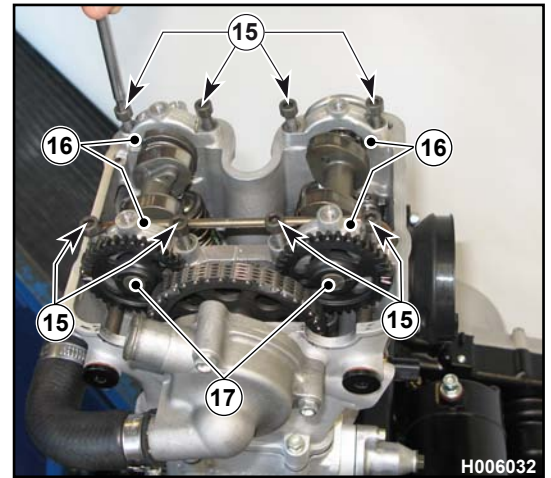

- Remove the oil pipe (19) and the camshafts (17).

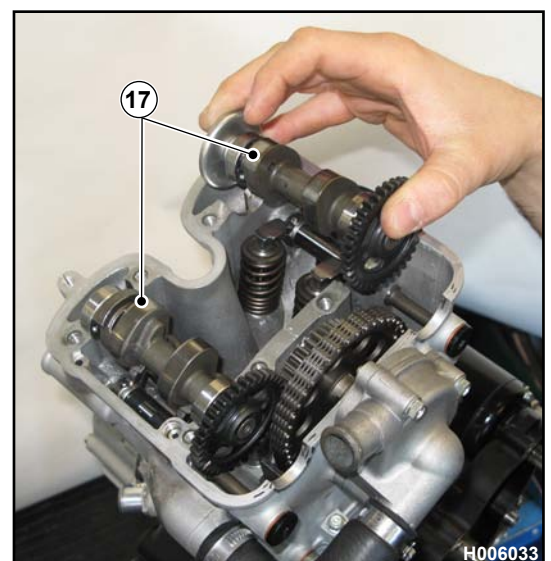
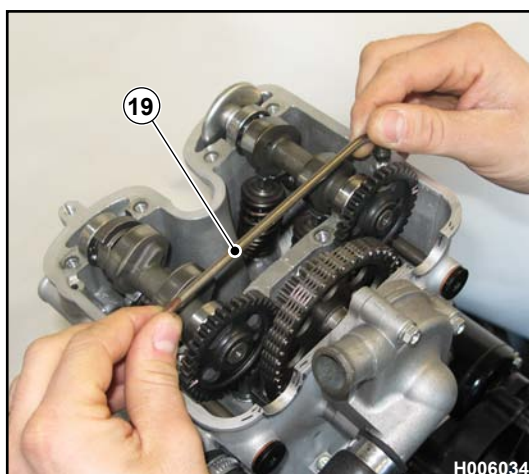
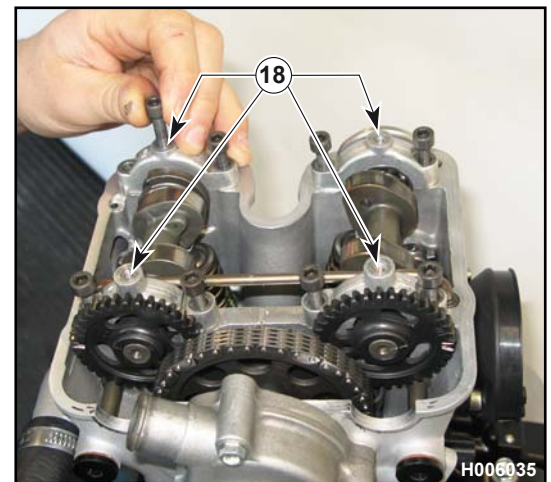

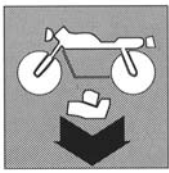

ENGINE DISASSEMBLY

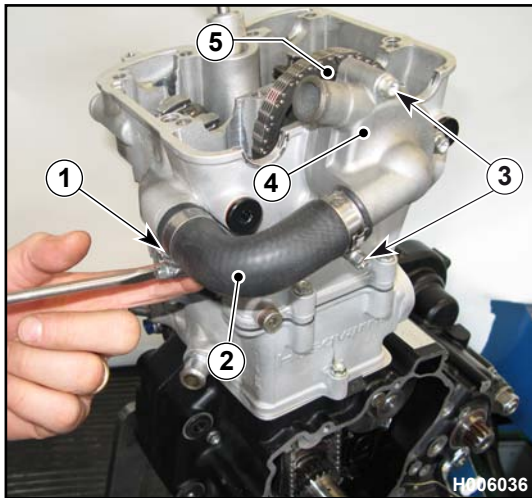

Water pump body removal

- Remove head cover, camshafts and chain tensioner as described in the relevant paragraph.
- Loosen the clamp (1) securing the water pump to cylinder head tube (2) and take the tube out of the head.
- Remove the two screws (3) securing pump body (4) to head (8 mm wrench) and remove pump body and timing drive gear (5).



Check the seal (8) for wear on assembly; replace if damaged.

Water pump disassembly

- Loosen the screw (9) with an 8 mm wrench to take pump body apart.
- Loosen the nut (10) to remove the impeller (11).
- Remove shaft (12) to replace bearing (13) and seal (14).



Check the seal (15) for wear on assembly; replace if damaged.

- Reassemble all parts in the reverse order compared to disassembly and tighten nut (10) to 4.9 Nm/ 0.5 Kgm/ 3.6 ft/lb+LOCTITE 648).

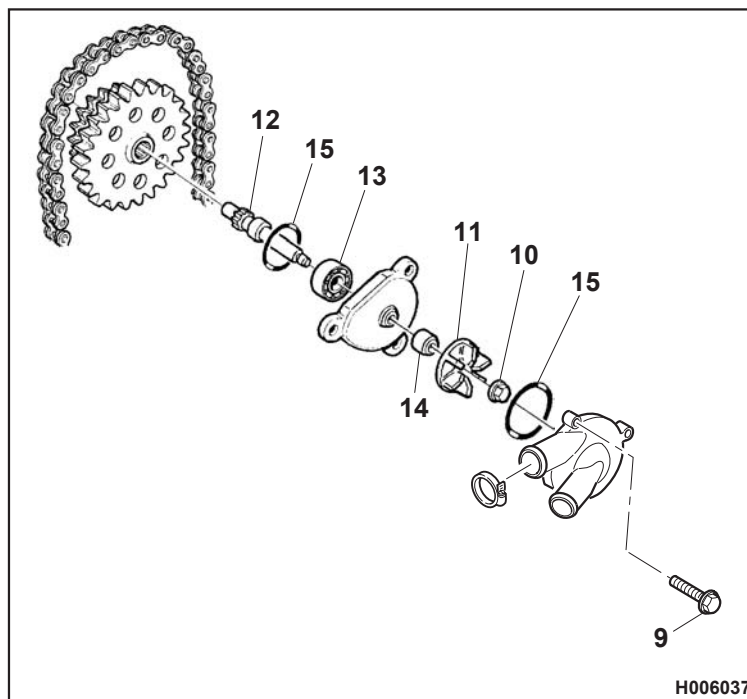

ENGINE DISASSEMBLY

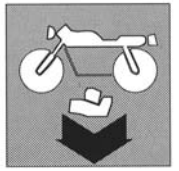

Cylinder head removal

- Remove head cover, camshafts, chain tensioner and water pump as described in the relevant paragraph.
- Remove the two screws (1) on the left side (8 mm wrench) and the nuts (2) located up front and at the rear under the head (13 mm wrench).

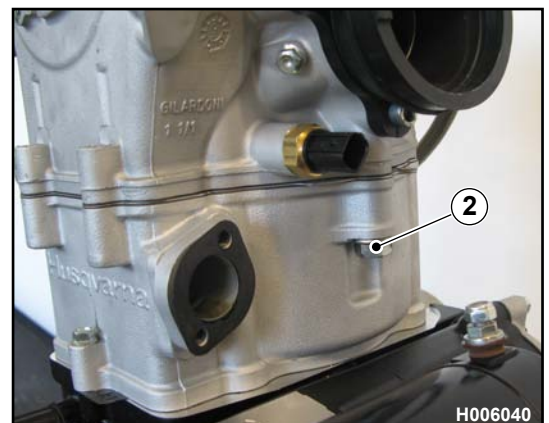
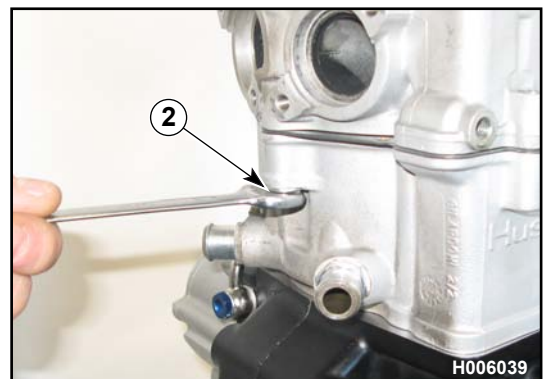
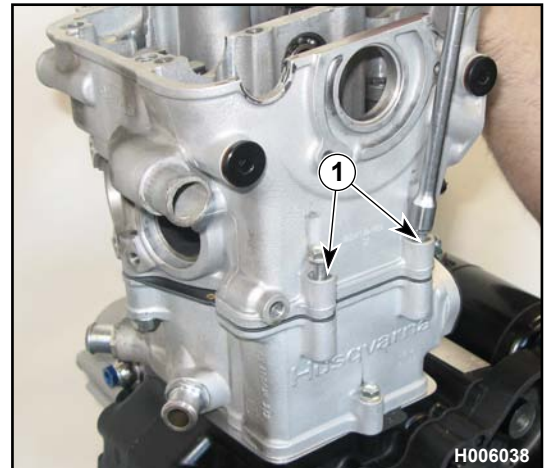

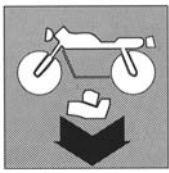

ENGINE DISASSEMBLY

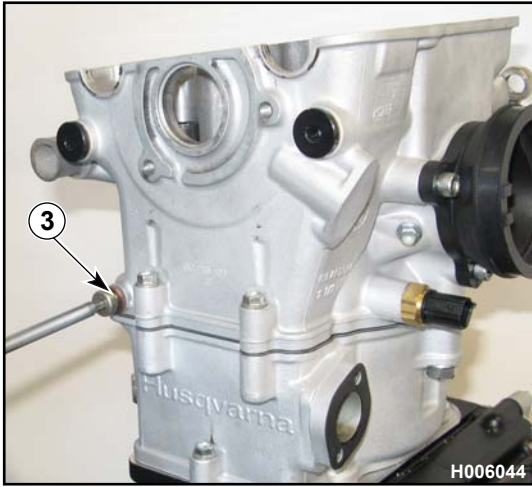

- Use a 5 mm Allen wrench to loosen the screw (3) and remove the chain slider (4).

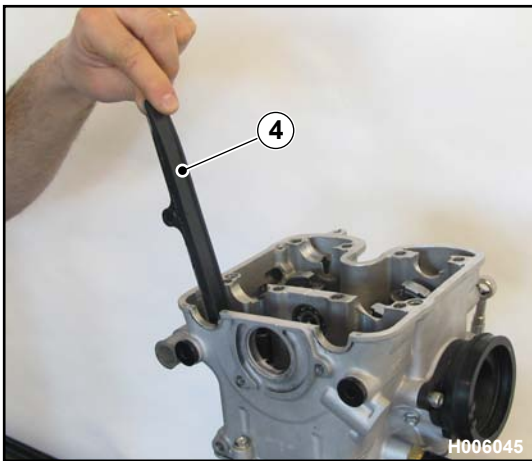

ENGINE DISASSEMBLY

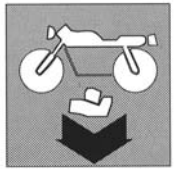

- Remove the four stud bolts (5) inside cylinder head (6) (10 mm Allen wrench) in a cross pattern.
Remove the cylinder head and its gasket (7).

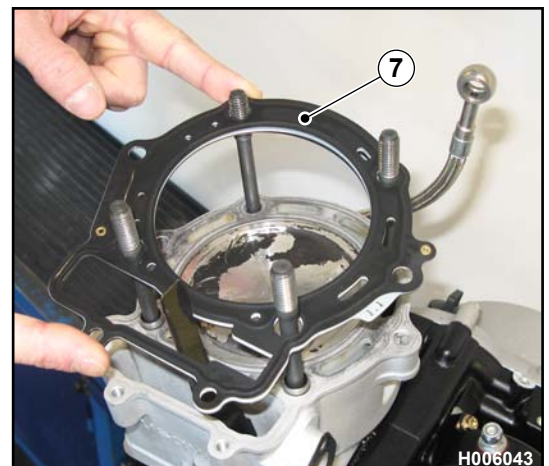
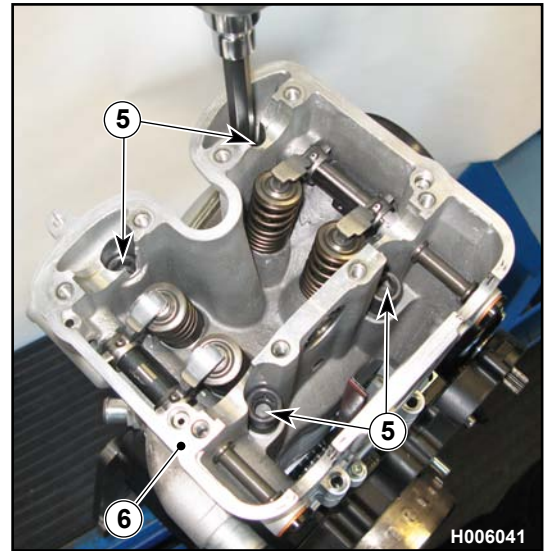

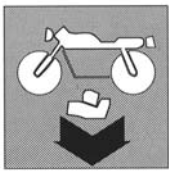

ENGINE DISASSEMBLY



Valve removal

- Remove the cylinder head as described in the relevant paragraph. Remove the rocker arm spring spacers (1) using a hook. Remove the rocker arm shaft screws (2) (6 mm Allen wrench) and then remove rocker arm shafts (3) and rocker arms (4).



Mark the valves and their components so as to refit in their original positions on assembly.

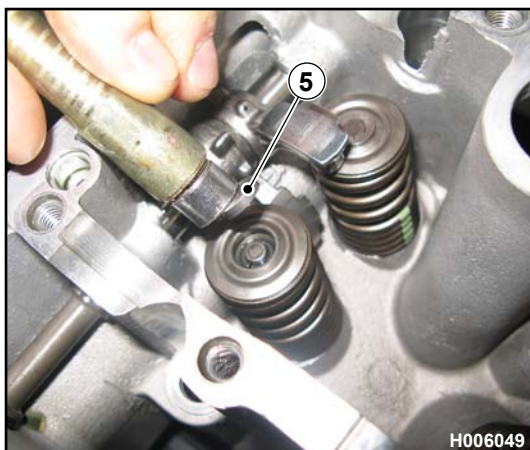
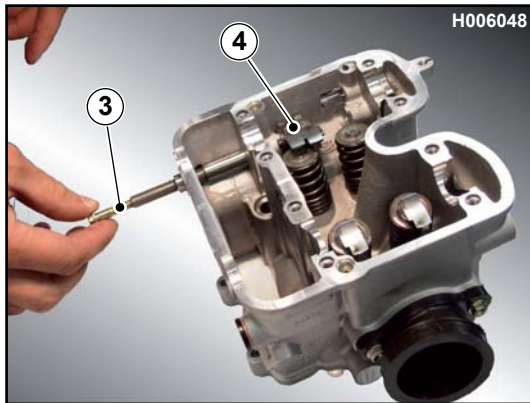
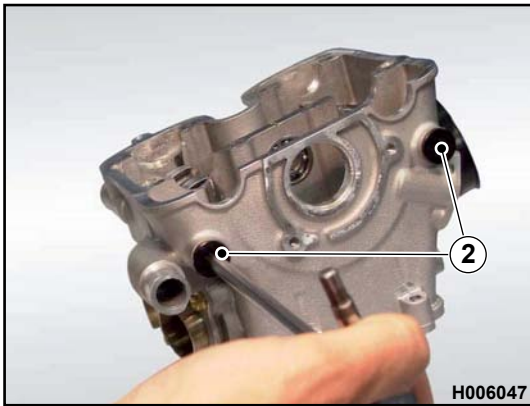

- Remove the shims (5) using a small magnet.



ENGINE DISASSEMBLY

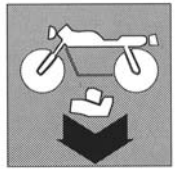

Use a valve spring compressor (6) to compress the valve springs. Be careful not to damage the mating surfaces that contact the gasket or those of the combustion chamber. Make sure the valve spring compressor is aligned straight on the spring, or you might bend the valve stem. Do not compress the springs too much or they will weaken.

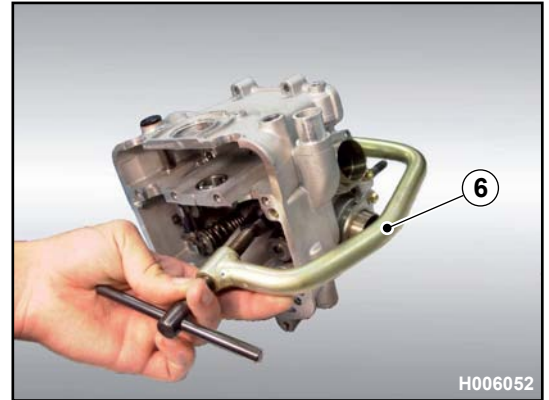

- Mark all parts to ensure that they are refitted in their original positions on assembly. If the valve collets (7) have caused burrs on the valve stems, remove them before removing the valves.

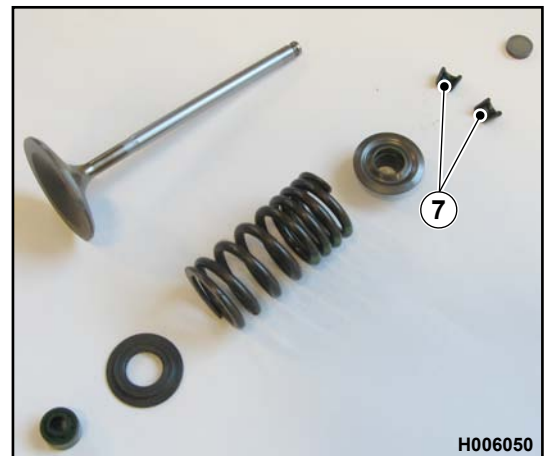

- Remove the seals (8) from the valve guides. Remember that seals must be replaced on assembly.

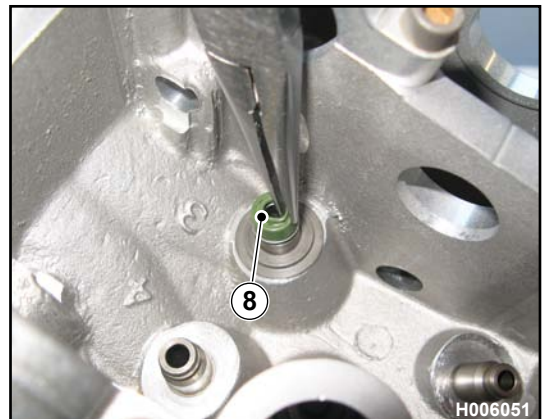

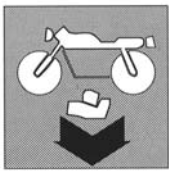

ENGINE DISASSEMBLY



Cylinder removal

Remove the head as described in the relevant paragraph.

- Remove the centring bushings (1).



- Loosen the cylinder retaining screw (2) using an 8 mm wrench.

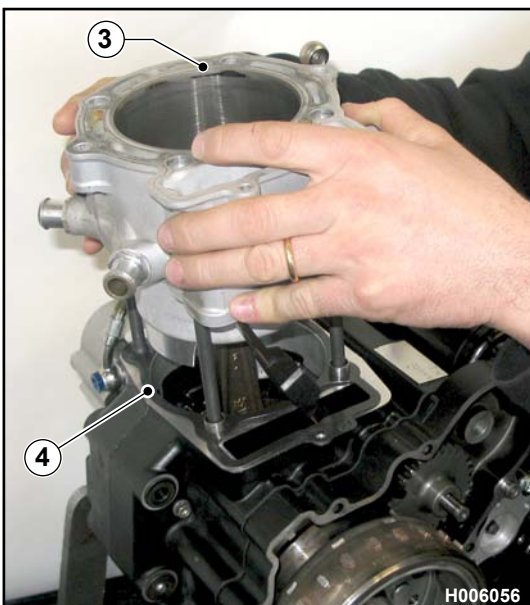

- Remove the cylinder (3) with its gasket (4).



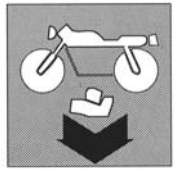

Piston removal

- Remove the piston retaining rings (1), slide out the piston pin (2) and remove the piston (3).

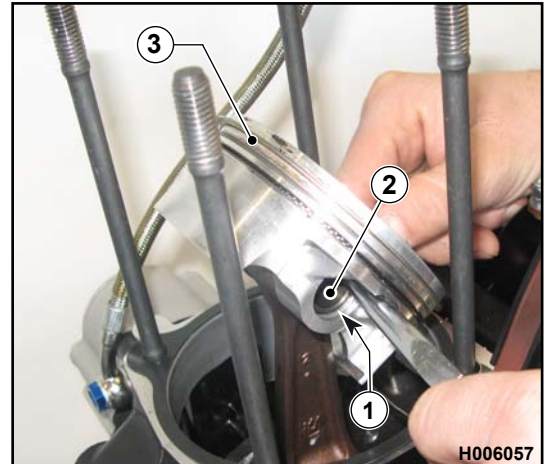

Flywheel removal

Remove the ignition cover as described in the relevant paragraph.

- Loosen the nut (1) and washer (2) securing the rotor (3) (24 mm wrench).

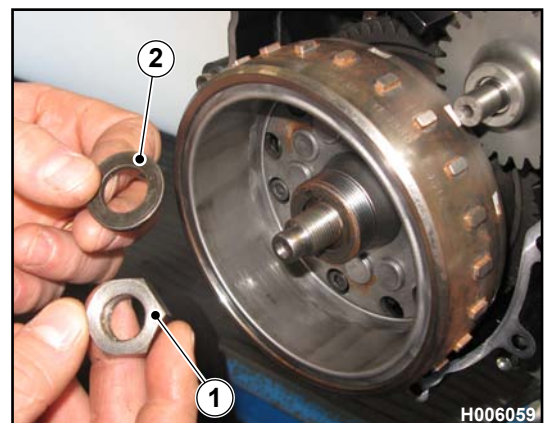
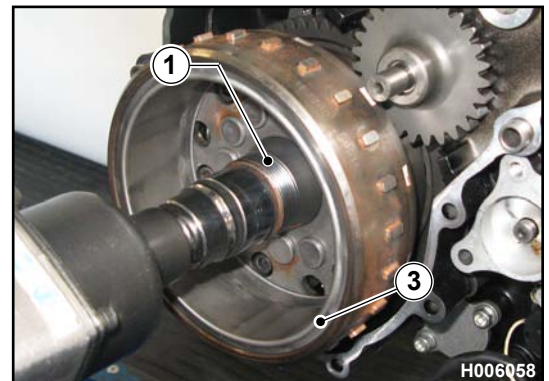

- Fit guard (4) to the crankshaft.

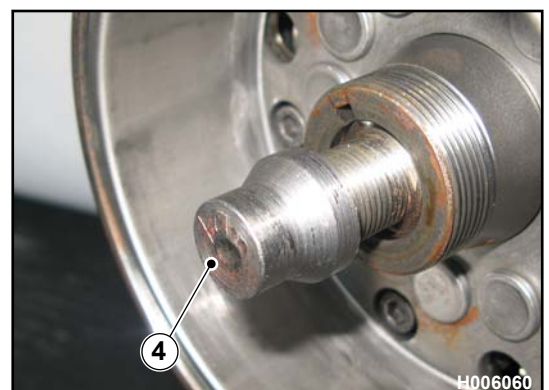

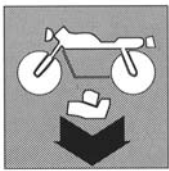

ENGINE DISASSEMBLY

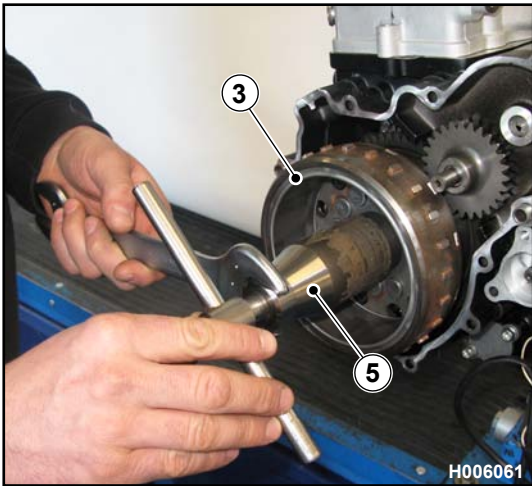

- Remove the rotor (3) using the puller (5) (part no. [8000 39523](#)).

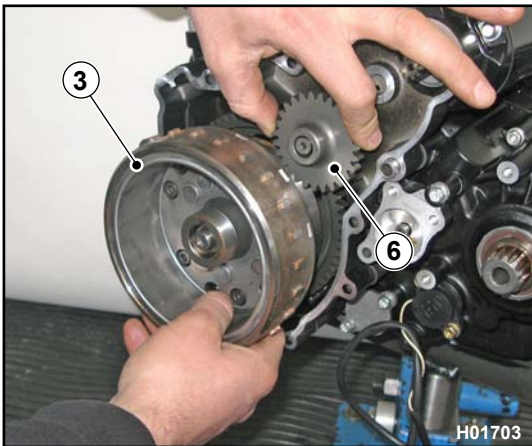

- Remove the flywheel (3) together with freewheel and idler gear (6).

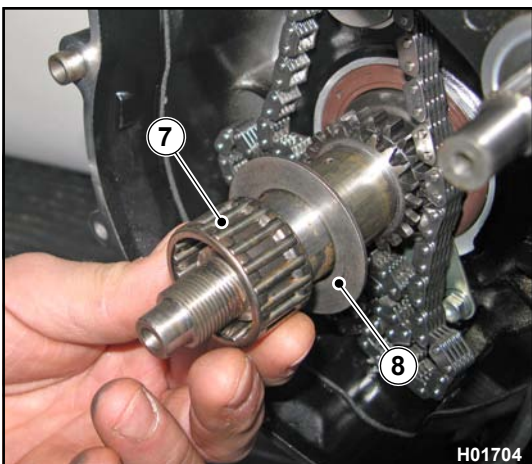

- Remove the roller cage (7) and the washer (8);



ENGINE DISASSEMBLY

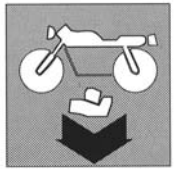

- Remove the screws (9) (5 mm Allen wrench) and inspect the freewheel; roller races should show no signs of wear or damage. Ensure that all gears are in good condition.

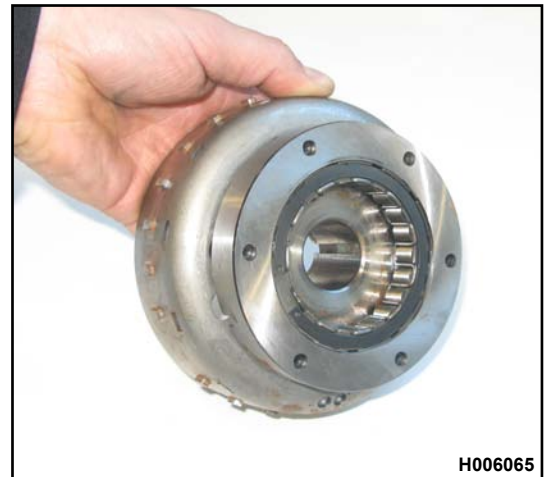
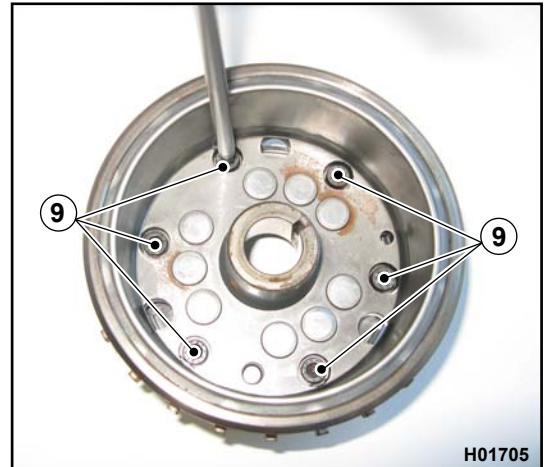

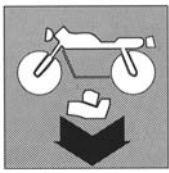

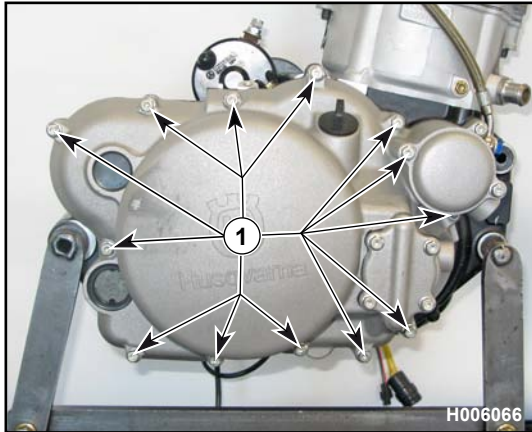

ENGINE DISASSEMBLY



Clutch cover removal

 Before removing the clutch cover, drain engine oil as described in the relevant Section.

- Remove the thirteen screws (1) securing the cover (2) (8 mm wrench) and remove cover (2) and gasket (3).

 The screws are not all the same length; mark them with their positions to ensure correct reassembly.

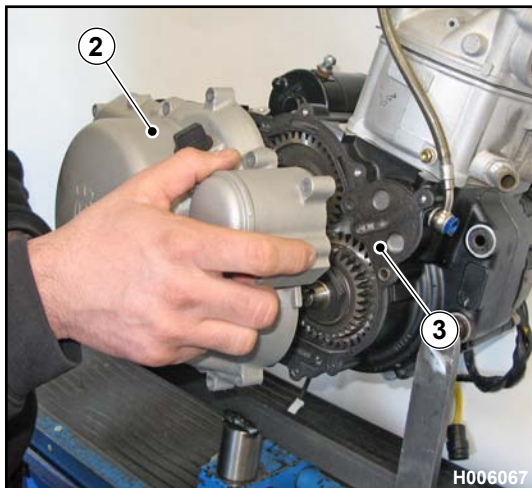

- Remove the bushings (5).

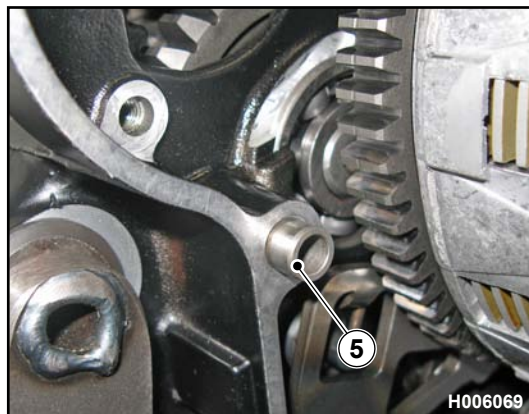

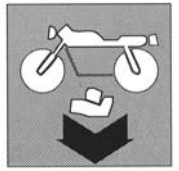

Oil filters removal

Mesh filter

- Remove the clutch cover as described in the relevant paragraph.
- Extract mesh filter (1) from its seat using long nose pliers.
- Wash filter with petrol and blow with compressed air; refit filter with the short pin facing outside.

Reassemble all parts, in the reverse order compared to disassembly.

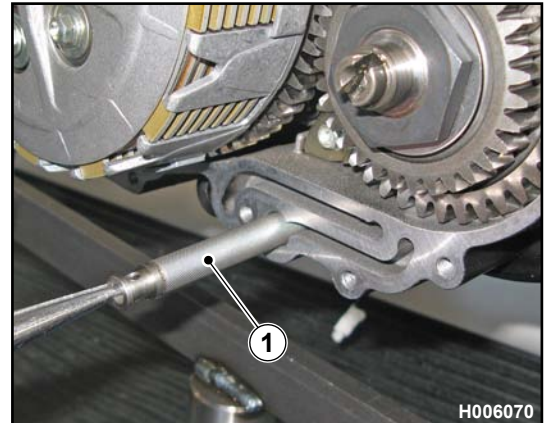

Cartridge filter

- Loosen the screws (2) (8 mm wrench) and remove cover (3), spring (4) and filter (5).
- Replace the filter (5) and make sure to fit it with the rubber end (6) facing into the engine.
- Check the O-ring (7) and replace it if damaged.

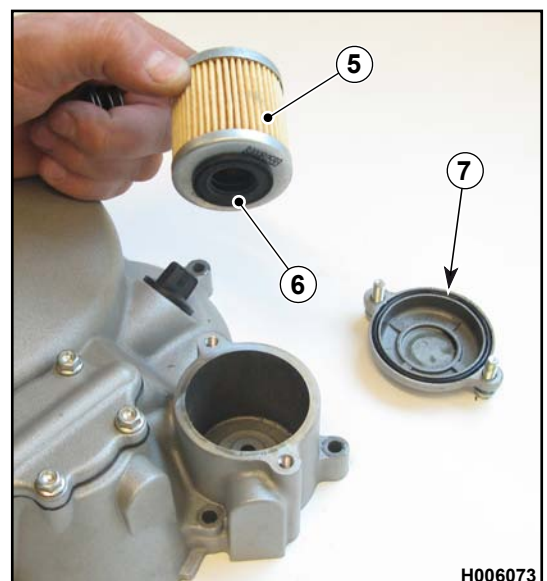
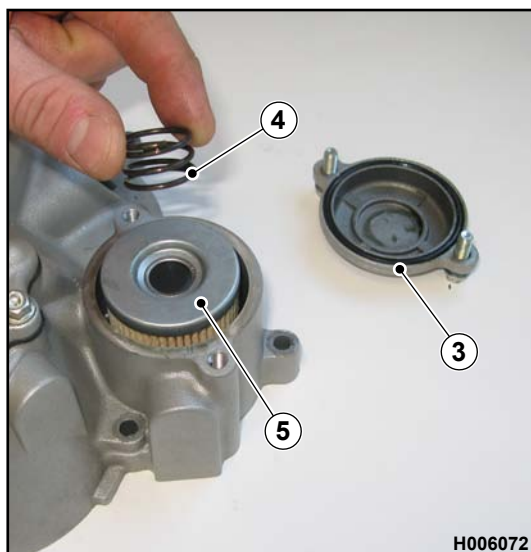
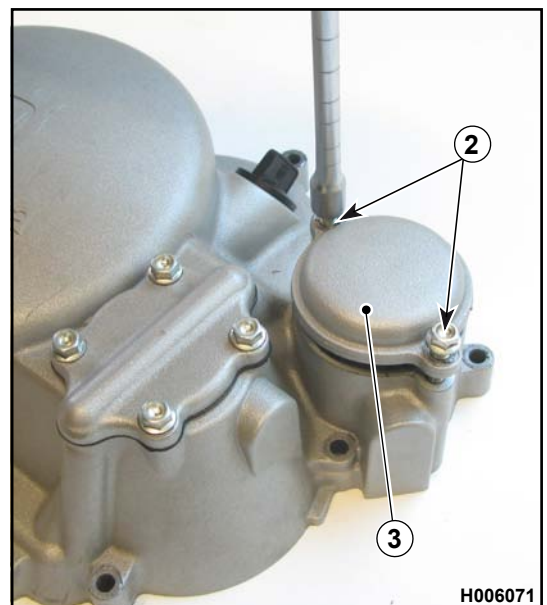

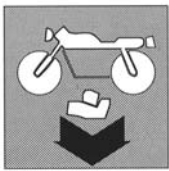

ENGINE DISASSEMBLY

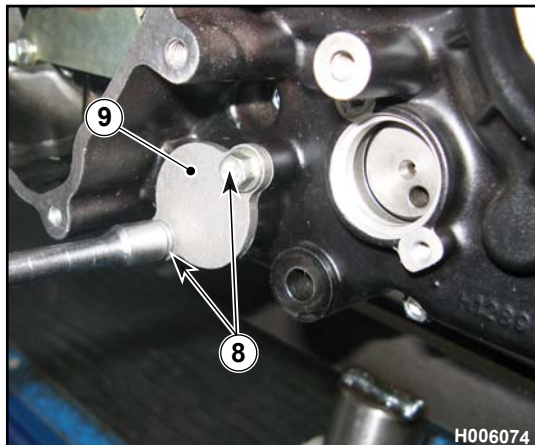

Mesh filters on flywheel side

- Loosen the screws (8) (8 mm wrench) and remove cover (9).
- Extract the two mesh filters (10), wash them with petrol and blow with compressed air.
- Reassemble all parts, in the reverse order compared to disassembly. Check cover seal for damage.

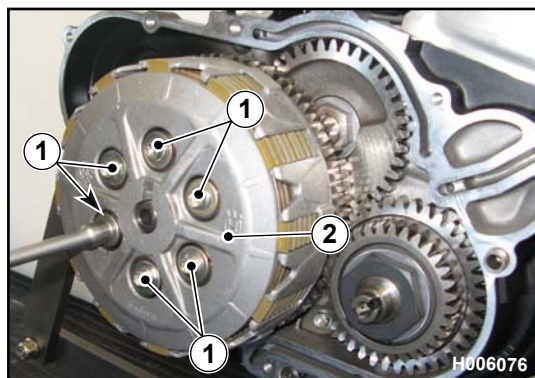
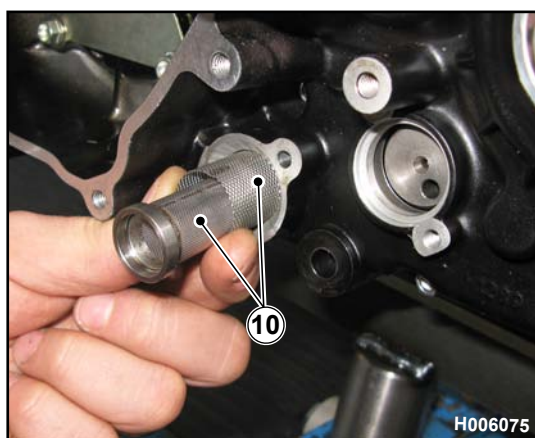

Clutch disassembly

Remove the clutch cover as described in the relevant paragraph.

- Using an 8 mm wrench, unscrew the six screws (1) securing the clutch springs. Remove springs, pressure plate (2) with actuator (3) bearing (4) and shim.

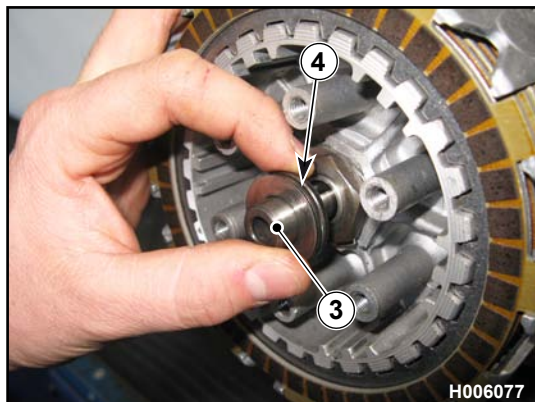

ENGINE DISASSEMBLY

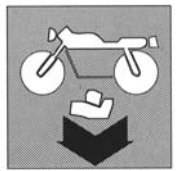

- Extract the plates (5).

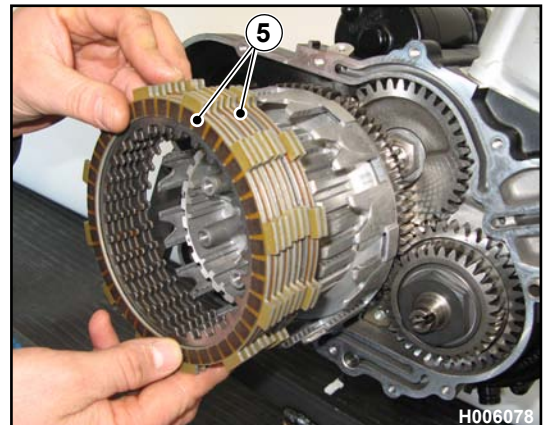

- Straighten the tab of the lock washer (6).

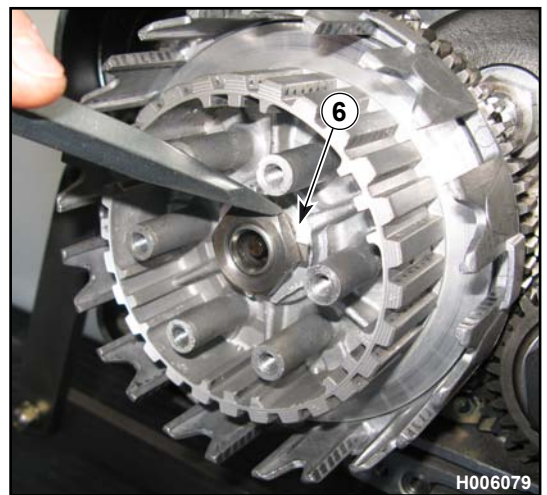

- Remove the nut (7) with its lock washer (27 mm wrench) using the clutch removal tool (A) (part no. 8000 39524).

- Remove the hub (8).

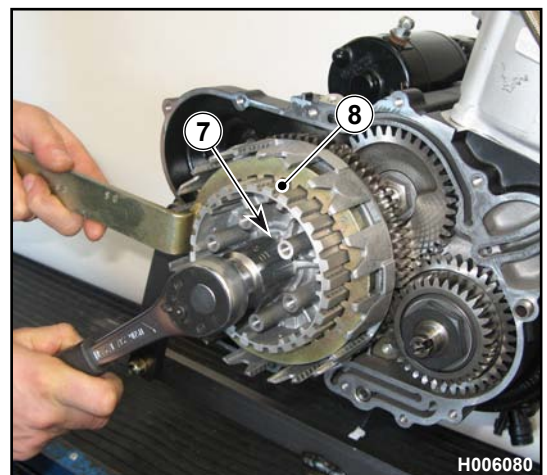

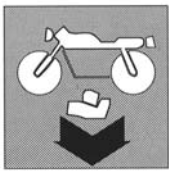

ENGINE DISASSEMBLY

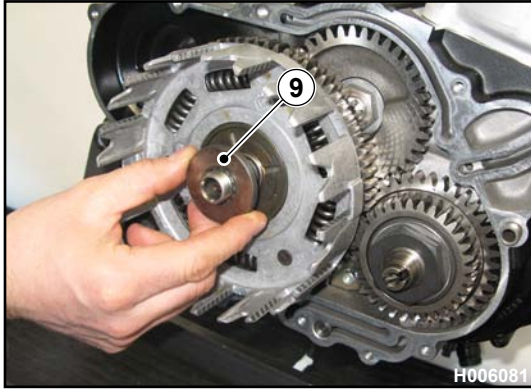

- Remove the splined spacer (9).

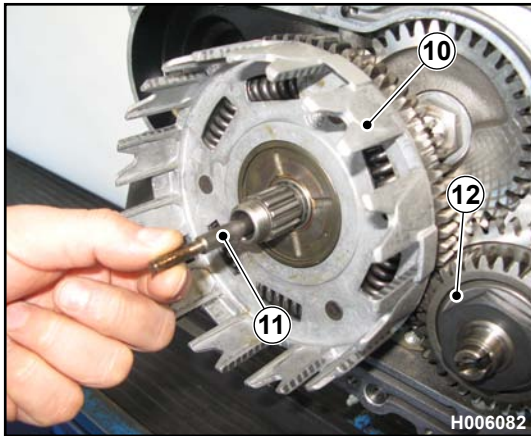

- Remove clutch housing (10) and clutch pushrod (11).



Clutch housing and drive gear (12) must always be replaced as a set.

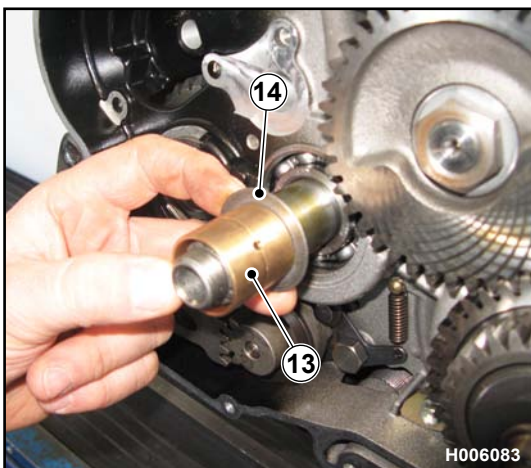

- Remove the bushing (13) and its washer (14).



ENGINE DISASSEMBLY

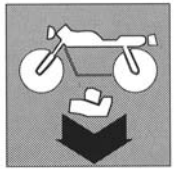

Clutch actuator removal

- Loosen the two screws (1) and screw (1a) of the clutch actuator (2) using an 8 mm ring wrench; remove the actuator.



Make sure to refit screw (1a) in the original position on assembly.

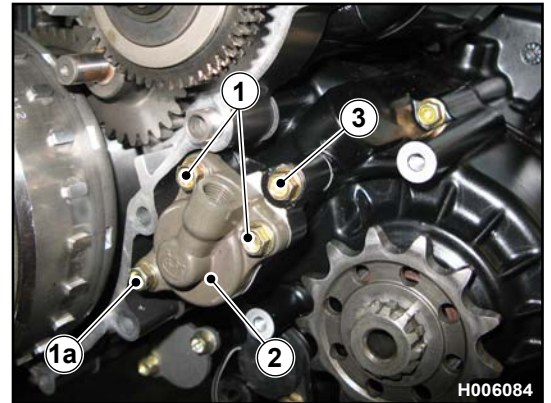

- Loosen screw (3) and remove the actuator flange (4). Check seal (5) and replace it if damaged.



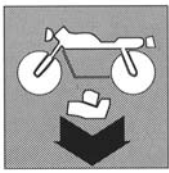

ENGINE DISASSEMBLY

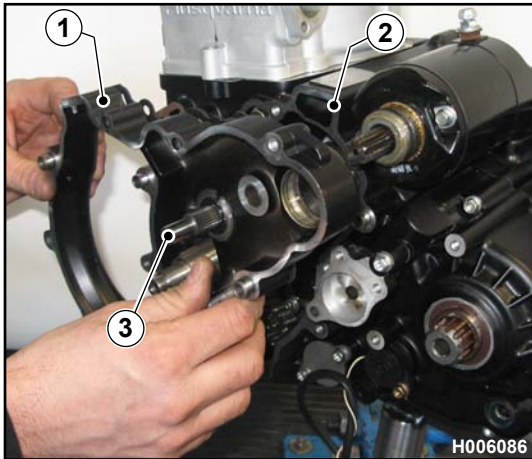

Starter motor flange removal

Remove the ignition cover together with starter drive gear as described in the relevant paragraph.

- Remove the flywheel with its drive gear;
- Remove the flange (1) (tapping gently on the projections with a rubber hammer) with its gasket (2), the second drive gear (3) and the centring bushings (4).
- To remove the drive unit (3), remove snap ring (5), washer (6) and seal (7), and then slide off the drive unit (3) from the opposite end.

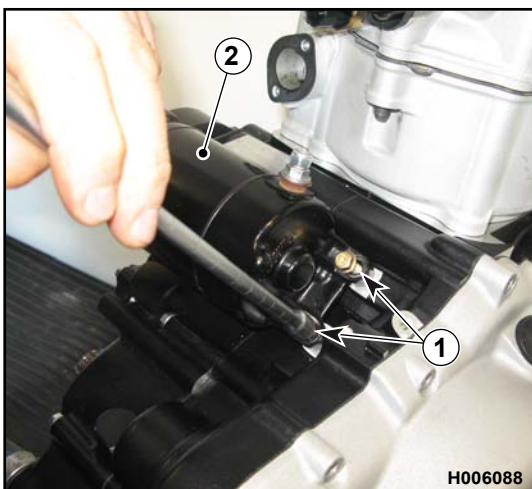
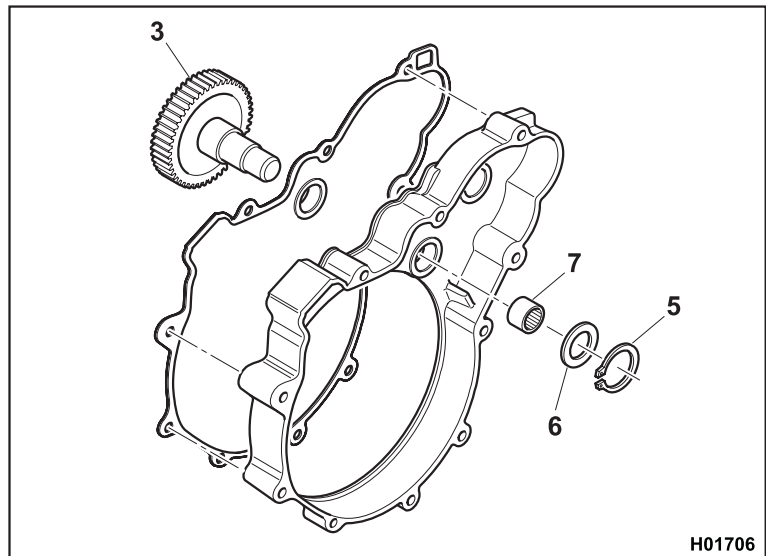
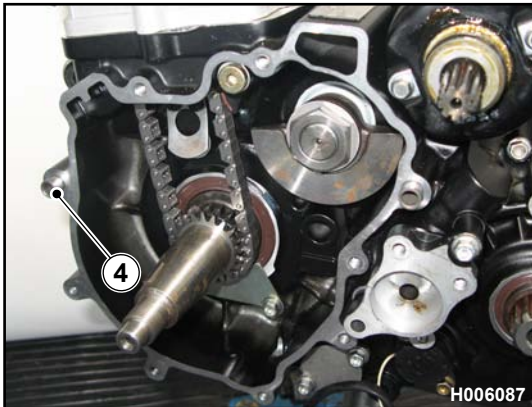

Starter motor removal

- Remove the starter motor flange as described in the relevant paragraph.
- Loosen the two screws (1) and remove the starter motor (2).



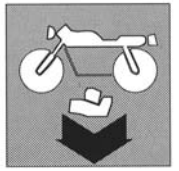

Gearbox drive shaft removal

- Pull out the selector shaft (1).

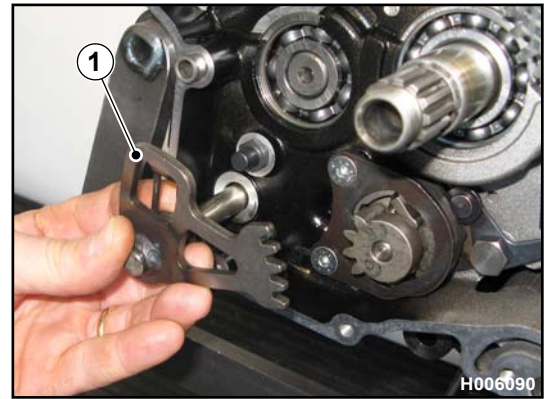

- Loosen the two 4 mm socket head screws (2) and remove plate (3) and selector sector gear (4).



Be careful not to lose sector gear assembly components.

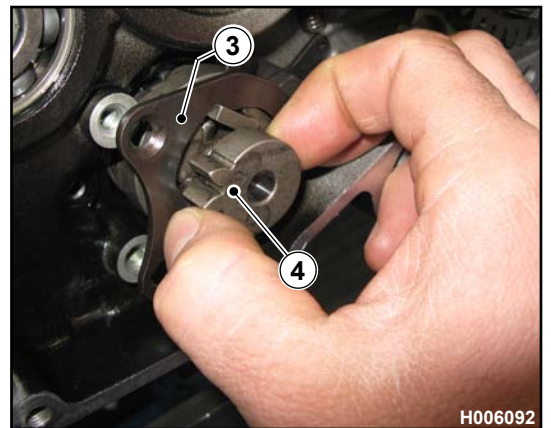
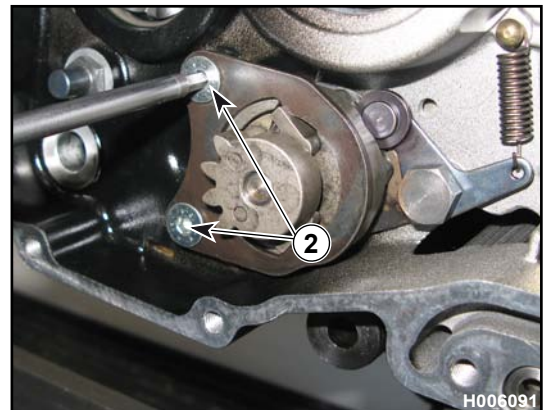

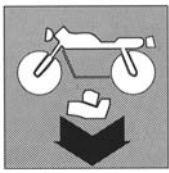

ENGINE DISASSEMBLY

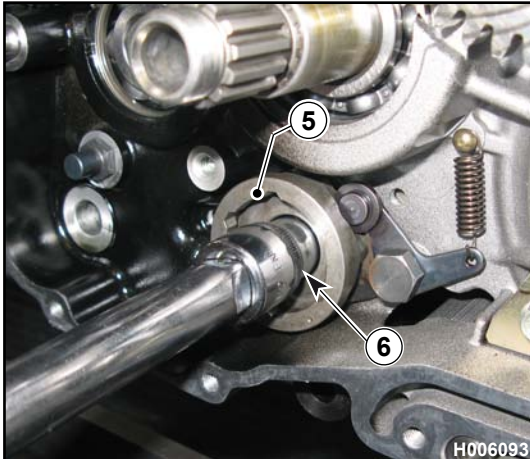

- Remove the drum (5) loosening the central shaft (6) with a 12 mm Allen wrench.

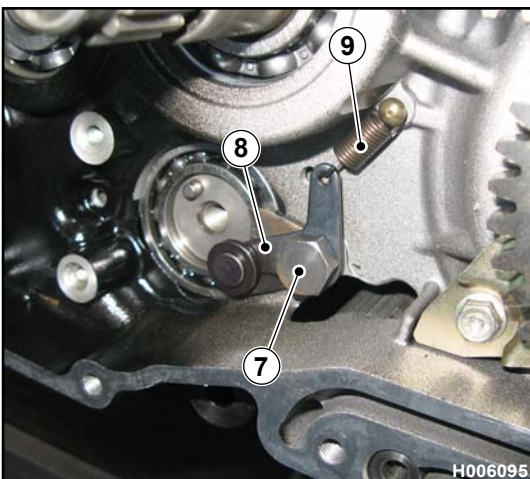
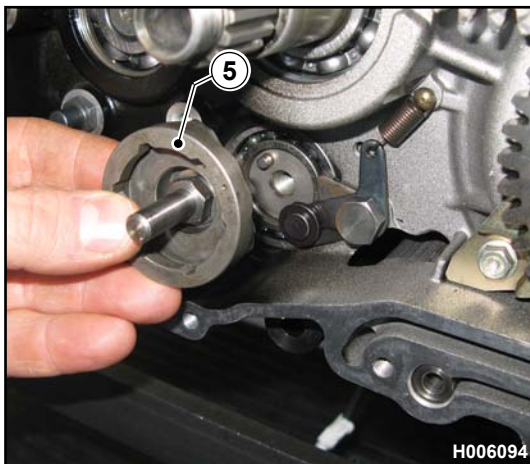

- Use a 13 mm socket wrench to loosen the retaining screw (7) of the ratchet (8) and remove ratchet and spring (9).



ENGINE DISASSEMBLY

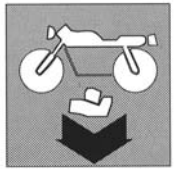

Gear sensor removal

- Loosen the screws (1) using an 8 mm Allen wrench and remove the sensor (2).

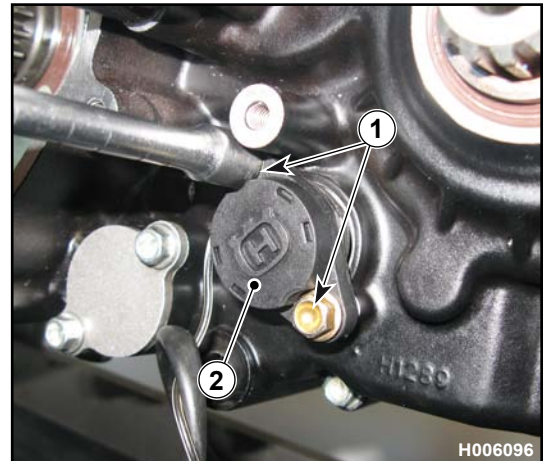

- Remove pushrod (3) and spring (4).

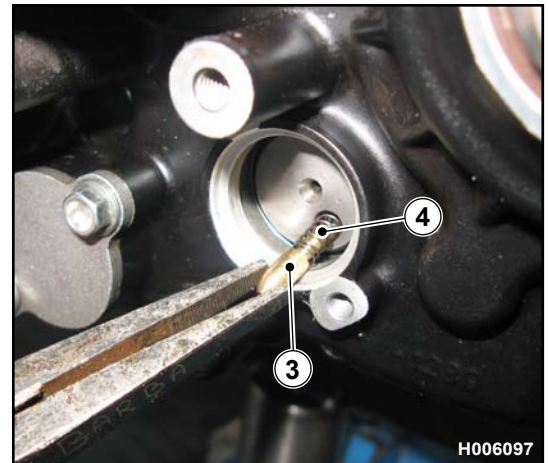

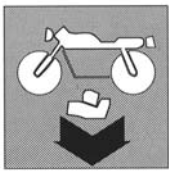

ENGINE DISASSEMBLY

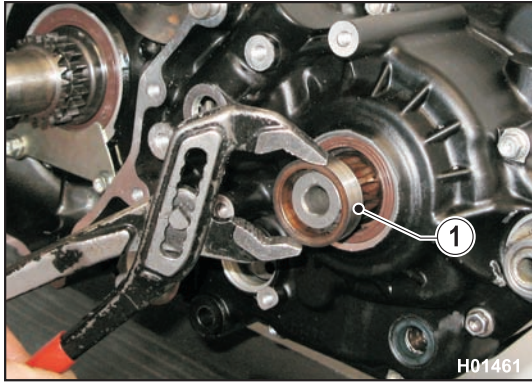

Crankcase, crankshaft and countershaft disassembly

Remove head, cylinder, piston, right and left crankcase, starter motor flange with starter motor, filters on flywheel side and gear sensor, as described in the relevant paragraphs.

- Remove bushing (1) on the sprocket shaft and extract the O-ring (2) using a small screwdriver.

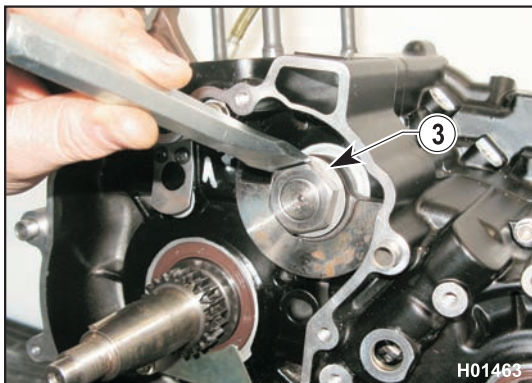
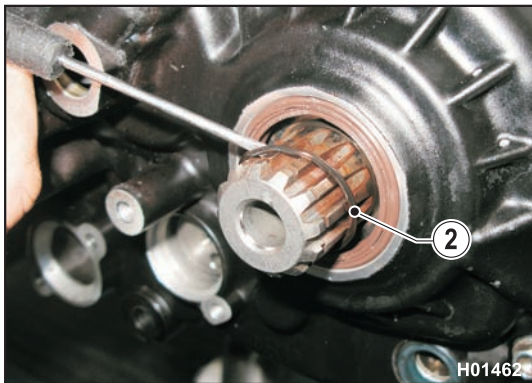

- Lift the tab of the lock washer (3) using a chisel.

- Loosen the countershaft nut (4) using an impact screwdriver (27 mm key) and remove counterweight (5) and washer (3).

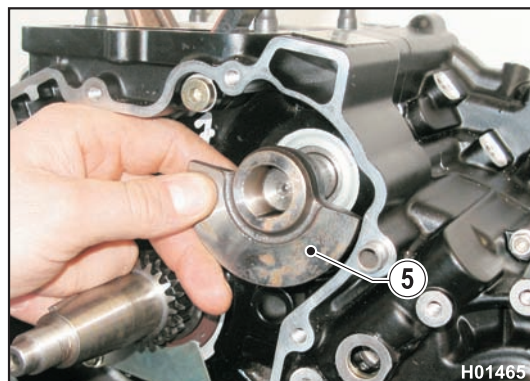
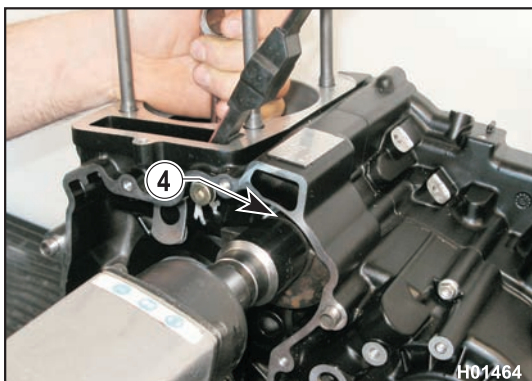

ENGINE DISASSEMBLY

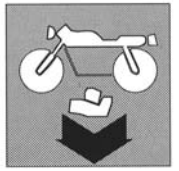

- Turn the engine over and lift the tab of lock washer (6) using a chisel.

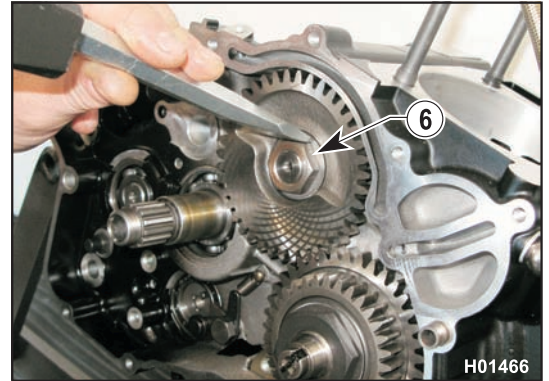

- Loosen the countershaft nut (7) using an impact screwdriver (24 mm key) and remove gear (8) and washer (6).

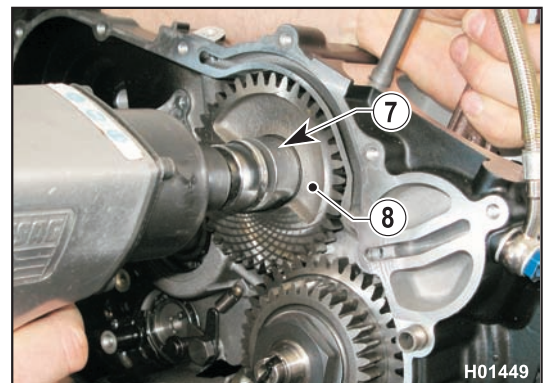
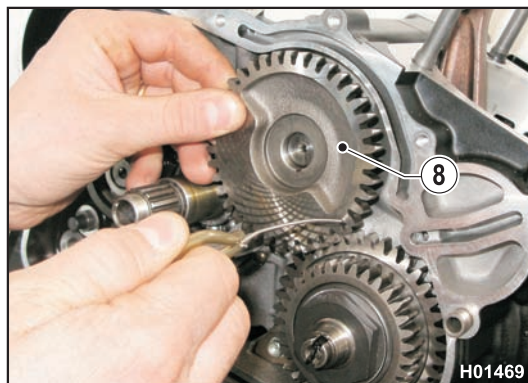

- Lift the tab of the lock washer (9) using a chisel.

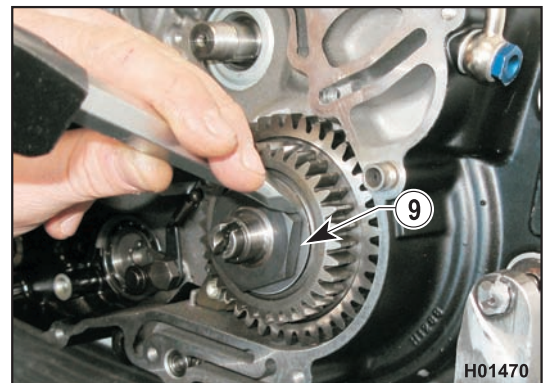

- Hold the connecting rod with one hand and loosen the crankshaft gear nut (10) using an impact screwdriver (38 mm key).

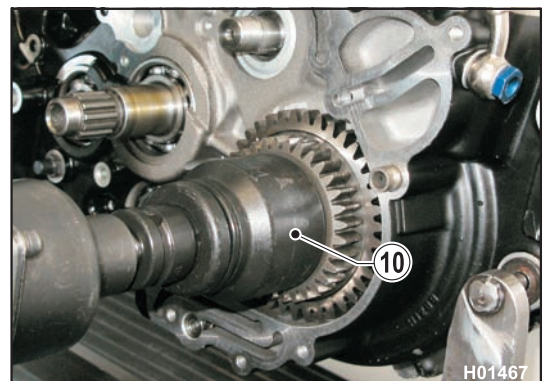

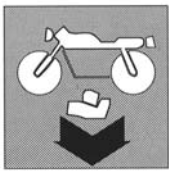

ENGINE DISASSEMBLY

- Remove clutch housing drive gear (11) and countershaft drive gear (12).

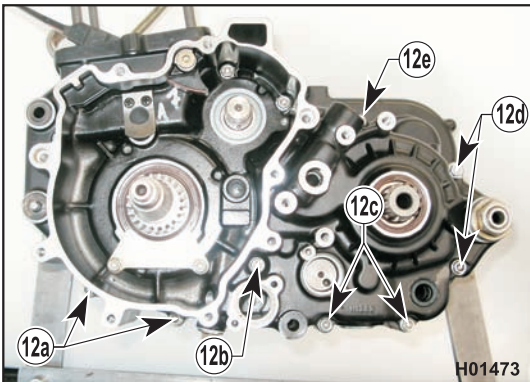
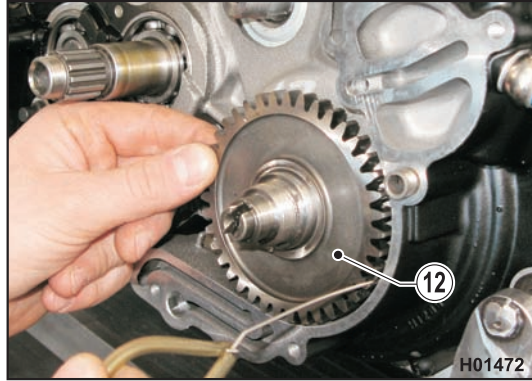
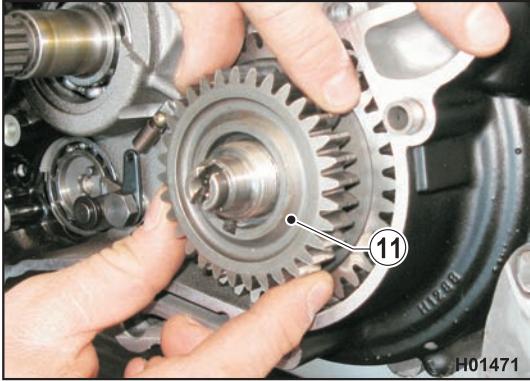

- Turn the engine over.
- Loosen the crankcase screws (12) using an 8 mm socket wrench;



WARNING: The screws are not all the same length, mark them so as to refit them in their original positions on assembly; the central screws has a copper washer.

- 12a=** M6 x 55 mm
- 12b=** M6 x 55 mm + copper washer
- 12c=** M6 x 55 mm
- 12d=** M6 x 65 mm

- Secure the puller no. 8000 89743 to the left crankcase and separate the two crankcase halves.

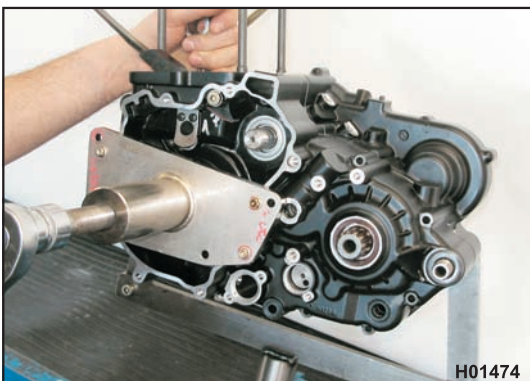

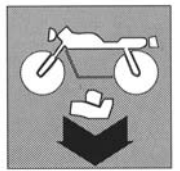

Left crankcase seal replacement

- Remove the sprocket seal (1) with a screwdriver.



WARNING: On assembly, position the seal flush with the crankcase.

- Loosen the screws (2) using an 8 mm wrench and remove the plate (3) retaining the crankshaft seal (4).

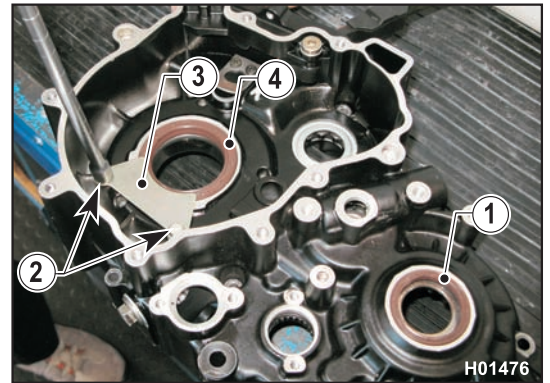

- Remove the seal (4) with a screwdriver.



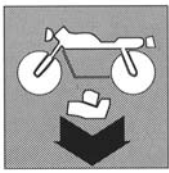

ENGINE DISASSEMBLY



Countershaft removal

- Tap the countershaft (1) with a rubber hammer and remove it from the crankcase.



Gearbox disassembly

- Remove the shaft (1) of the output shaft shifter forks.

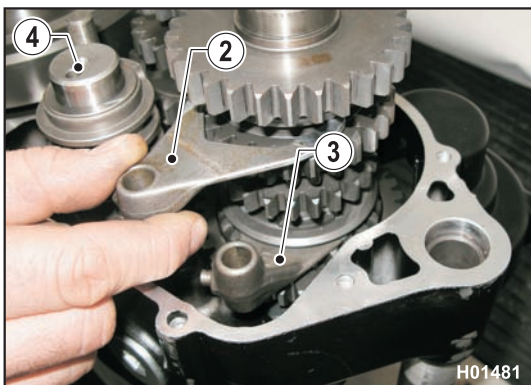

- Release the forks (2) and (3) from the drum (4) and remove them.

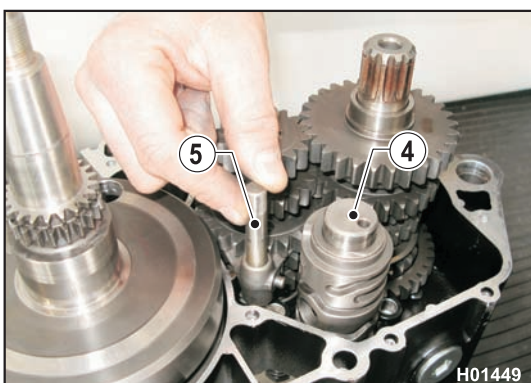

- Remove the input shaft fork shaft (5) and remove the drum (4).



ENGINE DISASSEMBLY

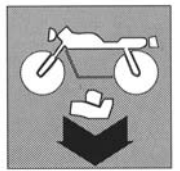

- Remove the input shaft fork (6).

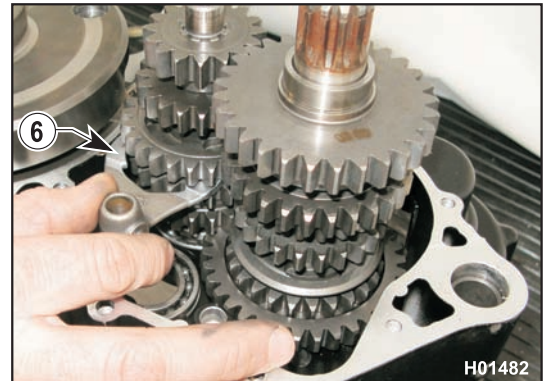

- Remove input shaft (7) and output shaft (8) being careful not to lose any shims (if fitted).

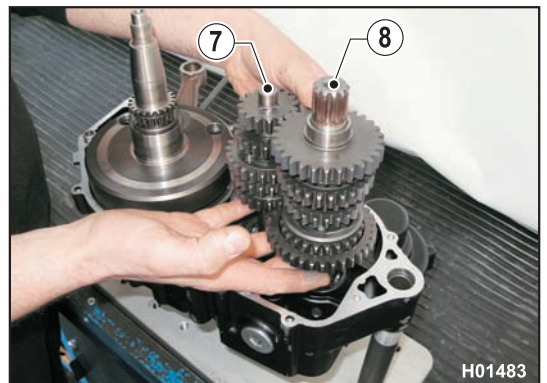

Crankshaft removal

- Slide the puller (1) (part no. 8000 89743) over the right end of the crankshaft.

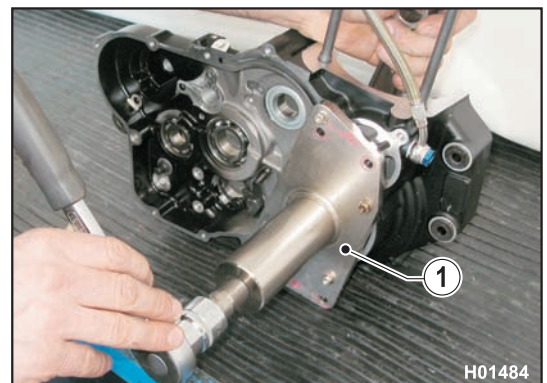

- Secure the puller to the crankcase half and remove the crankshaft (2) from the opposite side.

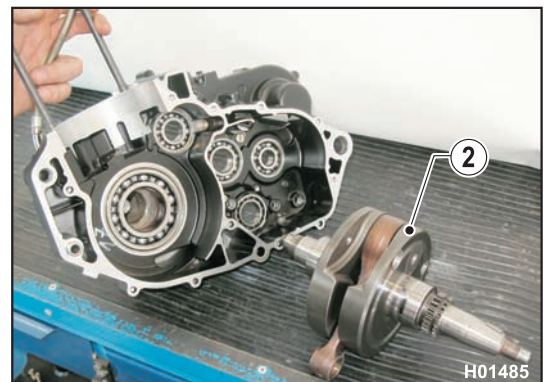

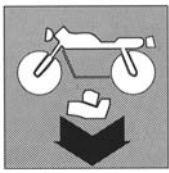

ENGINE DISASSEMBLY

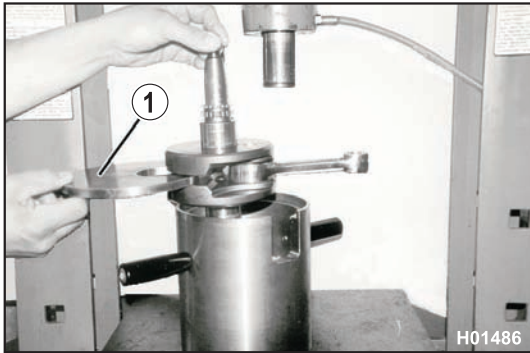

Crankshaft components removal

- Insert a plate (1) between the two flywheel halves.



- Remove the crank pin from one of the flywheel halves using a press. Remove connecting rod and needle roller bearing.

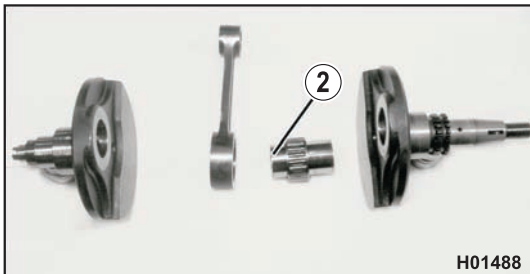

- Turn the shaft and remove the crank pin (2). Remove the threaded cap and clean the crank pin.



ENGINE DISASSEMBLY

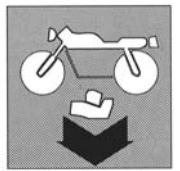

Right crankcase crankshaft seal removal

- Loosen the screw (1) with an 8 mm wrench and remove the plate (2).
- Remove the seal (3) with a screwdriver.

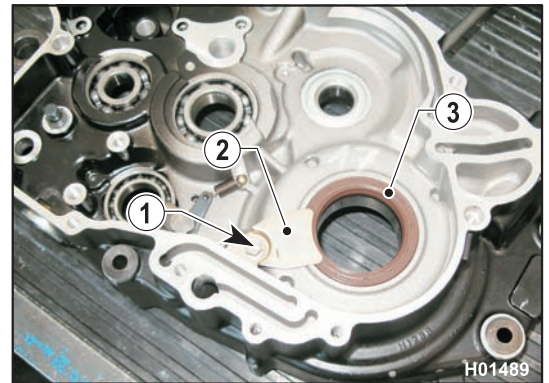

Crankcase bearings removal

- Remove the retaining plates (1) and (2) from the crankcase halves.

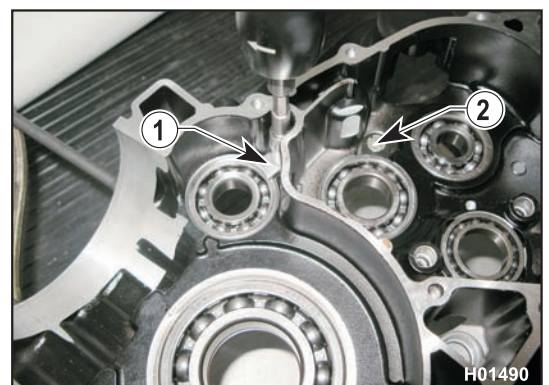

- Heat up the crankcase halves to around 125 °C in a furnace and extract the bearings using a suitable driver tool.



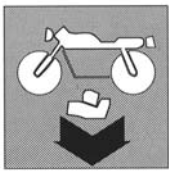

ENGINE DISASSEMBLY



Oil pump disassembly

- Take the clutch cover (which you have removed previously) and remove the four screws (1) (8 mm wrench) securing the small cover; remove all components until getting to the oil pump drive shaft (2).

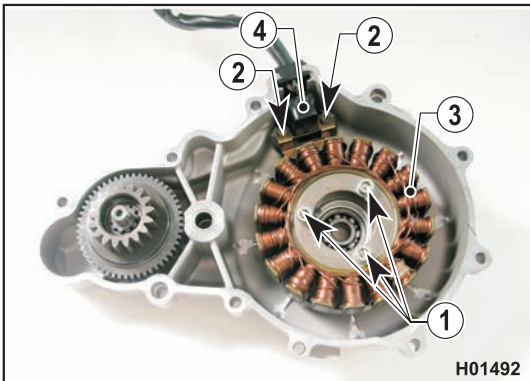
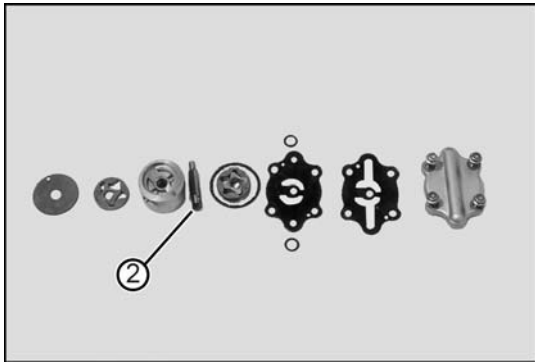

Stator removal

- Take the ignition cover (which you have removed previously) and remove the five Allen screws [three 6 mm screws (1) and two 4 mm screws (2)]; remove stator (3) and pick-up sensor (4) from the left cover.



ENGINE OVERHAUL

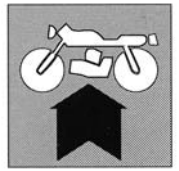

Cleaning parts	G.2
Clearances	G.2
Cylinder head	G.2
Valve seat refacing	G.3
Valve guide	G.5
Valve guide replacement	G.5
Valve	G.6
Valve spring	G.6
Valve installation	G.7
Rocker arm inspection	G.8
Camshaft	G.9
Timing chain and gears	G.10
Timing chain tensioners	G.10
Cylinder	G.11
Piston	G.11
Cylinder to piston clearance	G.12
Piston pin	G.13
Piston rings	G.14
Piston ring to cylinder clearance	G.14
Piston ring to groove clearance	G.15
Big end radial clearance	G.16
Big end radial clearance	G.16
Balancing countershaft	G.16
Crankshaft	G.17
Crankshaft straightness	G.17
Small end bushing replacement	G.17
Clutch	G.18
Friction plate to clutch housing clearance	G.19
Clutch spring	G.19
Shifter forks and gears	G.21
Selector drum	G.21
Selector drum to shifter fork pins clearance	G.22
Oil pump disassembly	G.23

Section

G



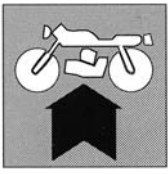

ENGINE OVERHAUL

Cleaning parts

All parts must be cleaned with gasoline and dried with compressed air.



Flammable vapours develop during this procedure and metal filings blown by compressed air may get into your eyes. Perform this procedure away from open flames or sources of ignition and wear an eye protection.

Clearances

To ensure the best operating conditions and maximum performance, all clearances must be within the specified tolerance. A tight fit will lead to seizure as moving parts heat up, whereas a loose fit will cause annoying vibration resulting in early wear of moving parts.

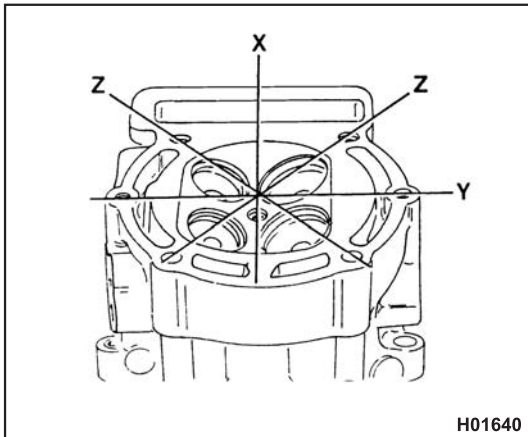

Cylinder head

Remove fouling deposits from the combustion chamber using a rounded scraper.



Do not use sharp tools or you might damage valve seats and spark plug thread.

Check the machined surface of the cylinder head for warpage using a straight-edge and a feeler gauge at the positions shown in the figure. If warpage exceeds the service limit at any one point, grind the cylinder mating surface.

Head warpage: service limit 0.05 mm.



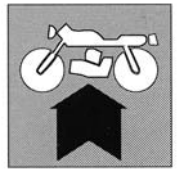

Valve seat refacing

Clean off any fouling deposits from the valve. Apply Prussian Blue to the valve and rotate it in its seat using a rubber hose or other similar tool. Remove the valve and measure the width "X" of the seating face. If width is greater than 1.5 mm, the seat needs to be refaced.

The standard width (measured as shown) of the seating face of the valve is:
 A = 0.9-1.1 mm for INTAKE
 A = 0.9-1.0 mm for EXHAUST

 Valves cannot be ground and must be replaced if damaged.

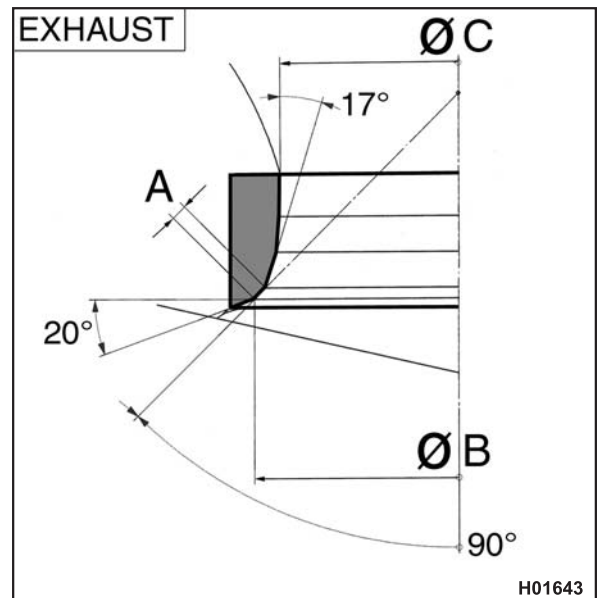
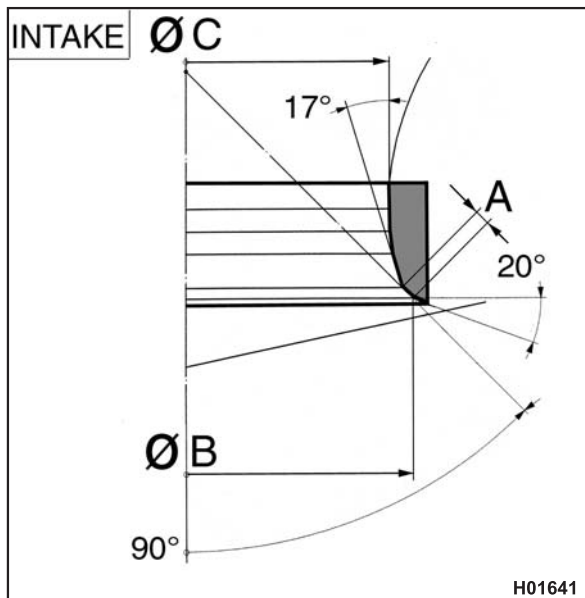
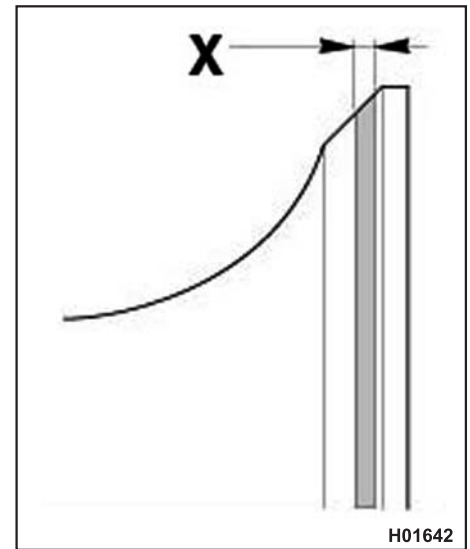

INTAKE	B	36,60÷36,65 mm 1,441÷1,443 in.
	C	33 mm 1,299 in.
EXHAUST	B	30,60÷30,65 mm 1,205÷1,207 in.
	C	27,5 mm 1,083 in.



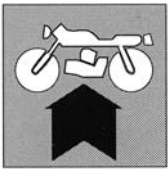

ENGINE OVERHAUL

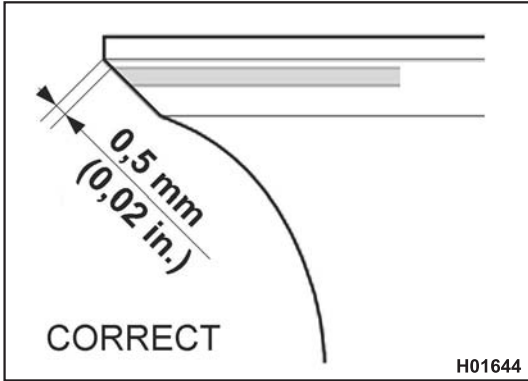

Inspect valve seat and reface it if you find any signs of damages. Correct valve seating position is very important. Use a dye to check seat contact surface position, it should be 0.5 mm from valve edge.

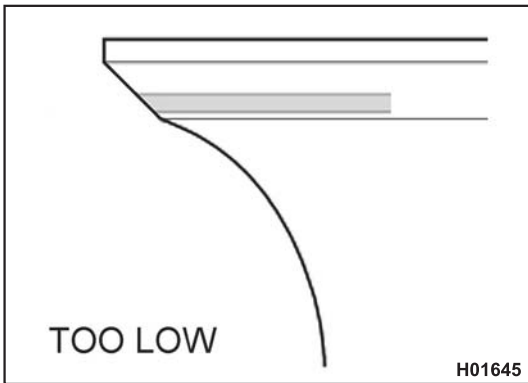

If seat contact surface is too low on valve face, reface the seat with 73° and 45° cutters.

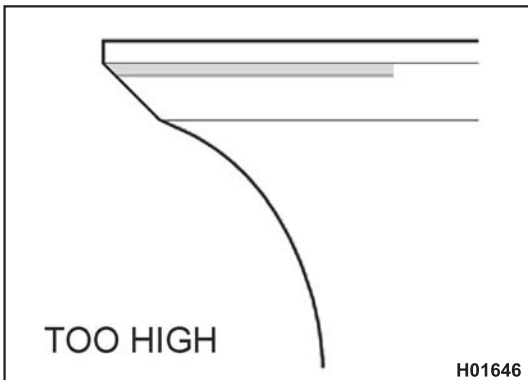

If the contact surface is too high on valve face, reface the seat with 20° and 45° cutters. Ensure that seat contact surface is the correct width.



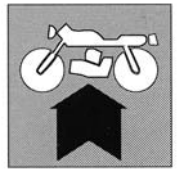

Valve guide

Perform a careful visual inspection of the valve guide.
 To determine wear, measure valve to valve guide clearance in the "x" and "y" directions (at right angles to each other) using a suitably positioned dial gauge.
 Intake valve: normal clearance: 0.008 - 0.035 mm
 Service limit: 0.05 mm
 Exhaust valve: normal clearance: 0.018 - 0.045 mm
 Service limit: 0.08 mm

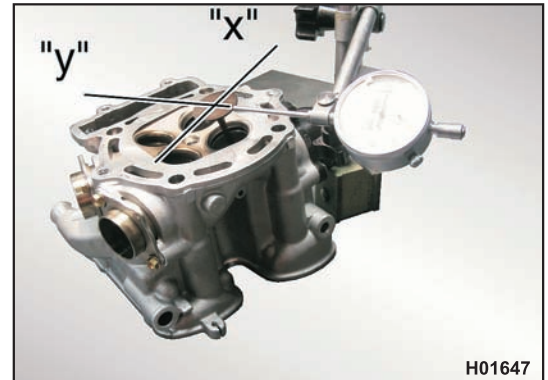

Valve guide replacement

Remove the valve guide from the cylinder head using a suitable punch.
 Make sure that the cylinder head is not damaged.



Heat up the head in a furnace up to 170 °C.
 Install the new guide from the top of the head using a suitable punch. Smear the guide with oil before installation. Fit new sealing rings.

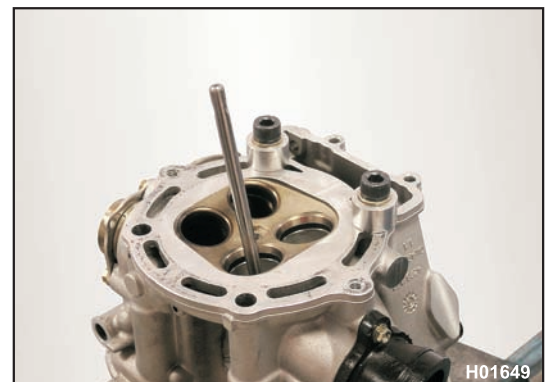

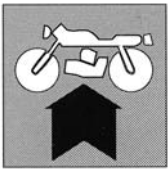

ENGINE OVERHAUL

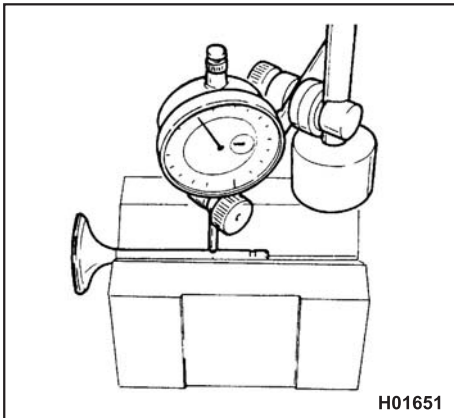

Ream the valve guide using a suitable reamer and lubricate with cutting fluid. Rotate the reamer when extracting it to avoid scoring the valve guide.



When a valve guide is changed, the valve seat must be refaced.

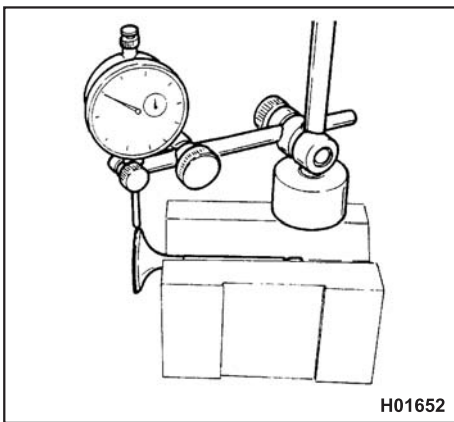

Valve

Inspect valve stem and valve seating face to make sure they are in good condition. There should be no signs of pitting, cracking, distortion or wear. Check for the following:

- Valve stem runout: place valve on a V block and measure runout with a dial gauge. (Service limit: 0.05 mm).
- Valve head out-of-round: place valve on a V block and check with a dial gauge at right angles to the head while turning the valve. (Service limit: 0.03 mm).

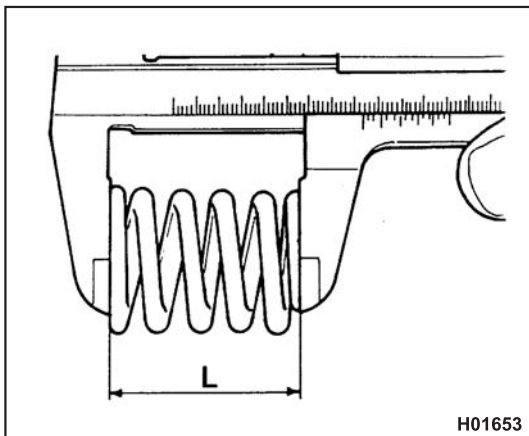

Valve spring

Check free length "L". If outside the specified service limit, replace the springs.

Spring: L = 43.4 mm - Service limit: 41 mm



Replace all valve springs whenever any one spring exceeds the service limit.

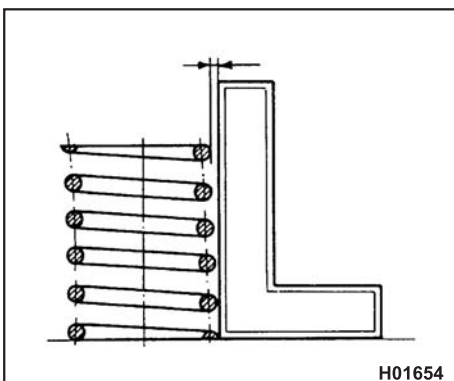

Check the valve springs for proper squareness. Maximum acceptable deviation is 1.5 mm on each side.



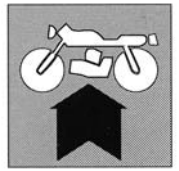

Valve installation

Smear valve guides and stems with oil before installation.
Fit sealing ring (1), springs (2) and valve spring retainer (3).

Use tool no. 8000 39521 to compress the valve springs and install the valve collets (4).



Do not compress the springs too much and avoid damage to the cylinder head.

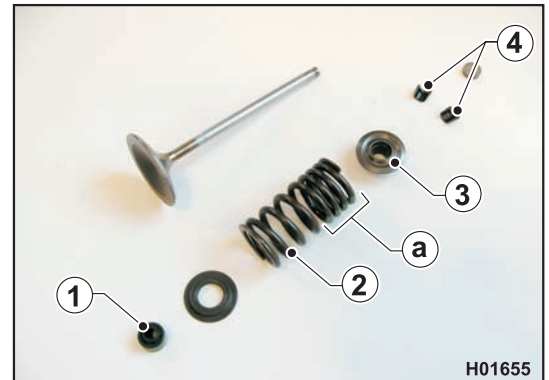

a: Head side



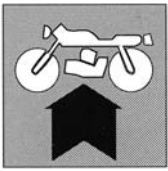

ENGINE OVERHAUL



Lightly tap valve stem with a plastic hammer to help the valve collets become fully seated.



Tap the valve stem tip to avoid pushing the valve off centre.

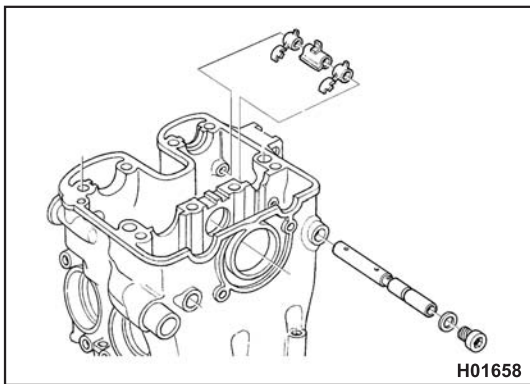

Rocker arm inspection

Check rocker arm to shaft clearance. Measure rocker arm inside diameter and shaft diameter and calculate clearance. Maximum clearance 0.1 mm. If the limit is exceeded, replace both rocker arms. On assembly, tighten shaft bolts to 25 Nm-2.55 Kgm-18.4 ft/lb. (+LOCTITE 243).

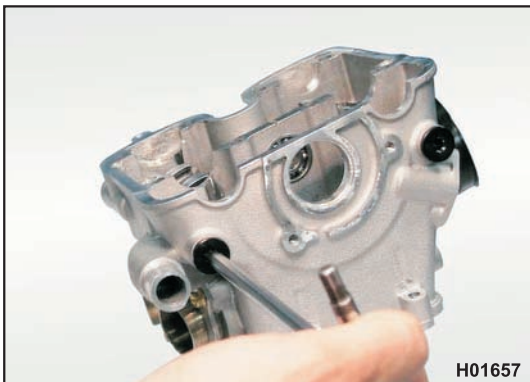

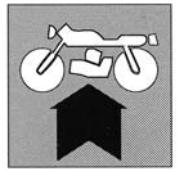

Camshaft

Check the contact faces of the lobes for streaks, scoring, dents and waviness. Clamp the camshaft between centres and check deviation using two dial gauges. Service limit: 0.1 mm. Check that the lobes are in pristine conditions, without signs of scoring or distortion.

Height "H" of lobes when new
 INTAKE = 36.57 mm
 EXHAUST = 35.94 mm

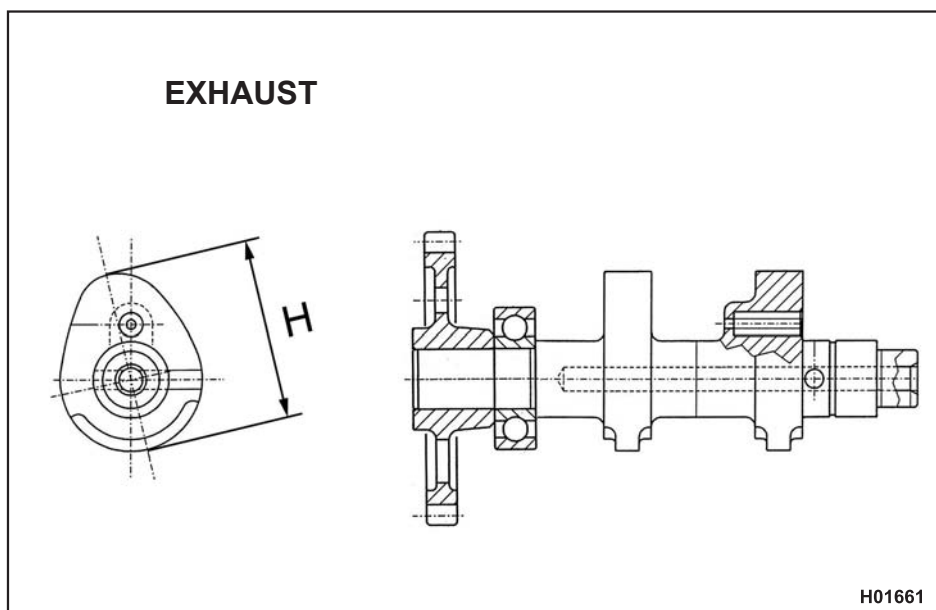
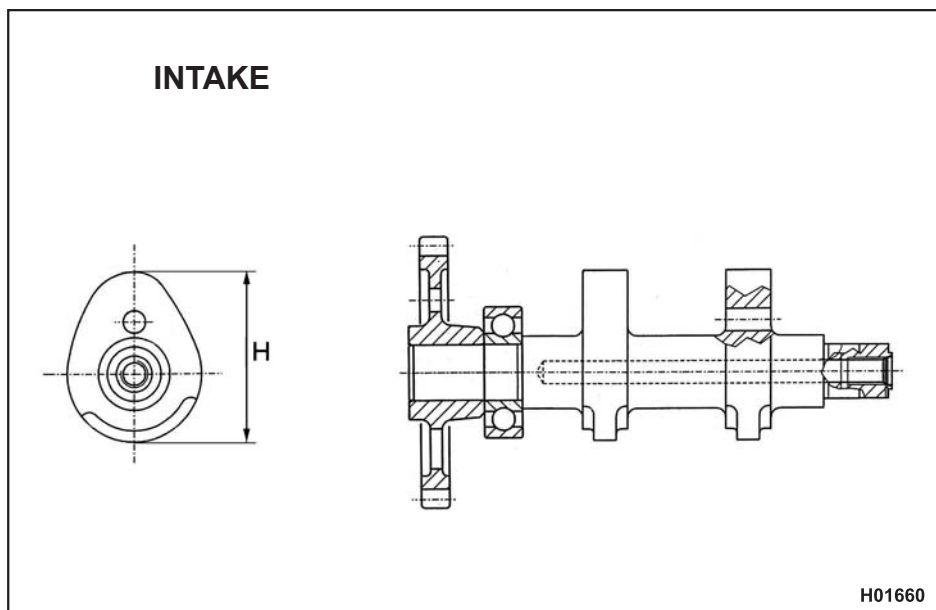
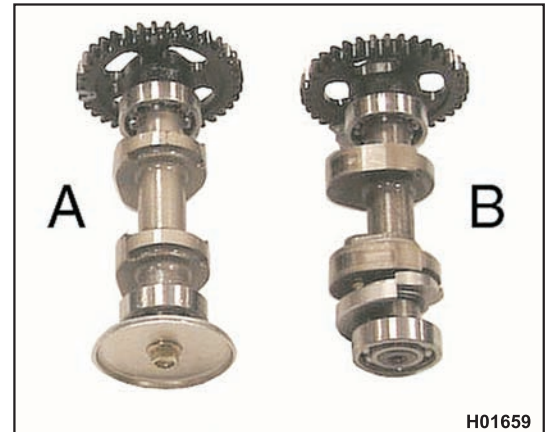

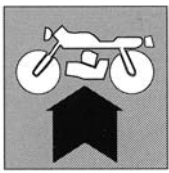

ENGINE OVERHAUL

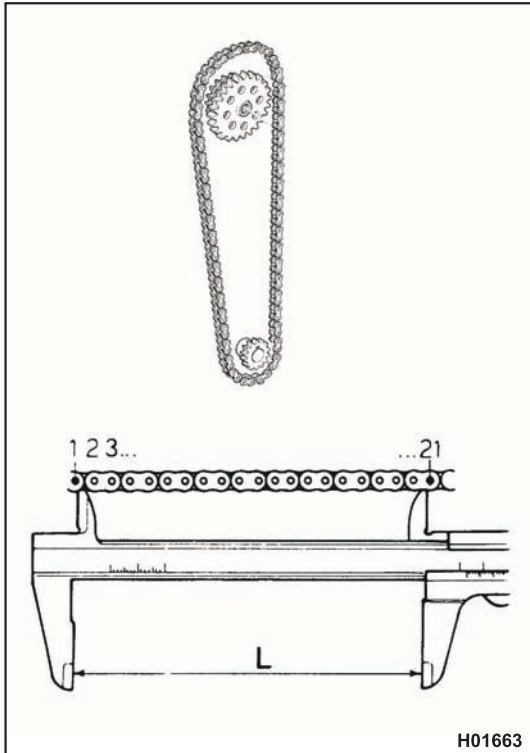

Timing chain and gears

Check the chain for wear at each engine overhaul.
Replace chain is too noisy or worn.

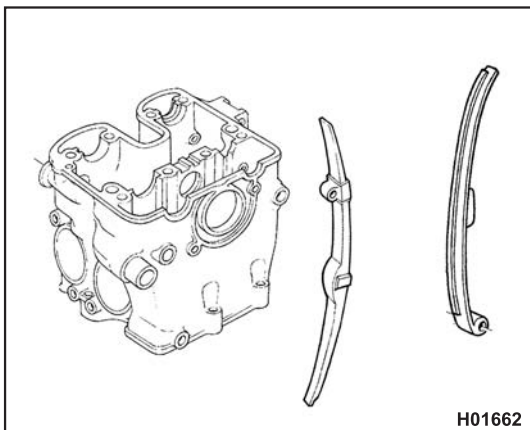

Timing chain tensioners

Chain tensioners must be replaced when the lower area of the wear indicators is worn down to the metal.



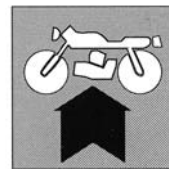

Cylinder

Check the walls for dents or scuffing. Measure cylinder bore diameter at three different positions. Measure each diameter in two directions at right angles to each other to determine taper and out-of-round.

Max. taper (wear limit): 0.05 mm.

Max. out-of-round (wear limit): 0.05 mm.

If cylinder is worn beyond these limits, replace both cylinder and piston. The liner undergoes a special hardening treatment and cannot be ground.

Piston

Clean off any carbon deposits from piston crown and grooves. Perform a careful visual inspection of the piston and check its dimensions. There should be no signs of forcing, scuffing, cracking or other damage.

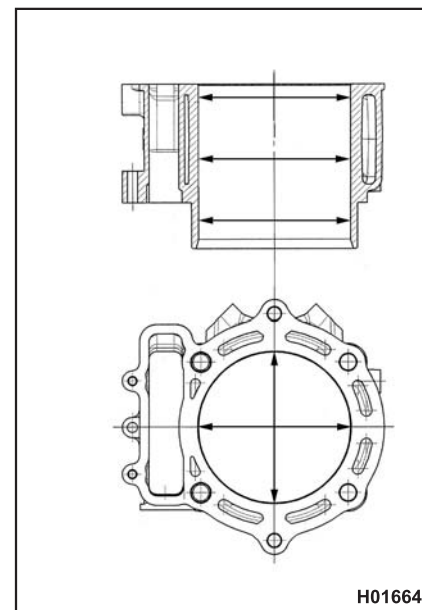

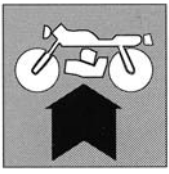

ENGINE OVERHAUL

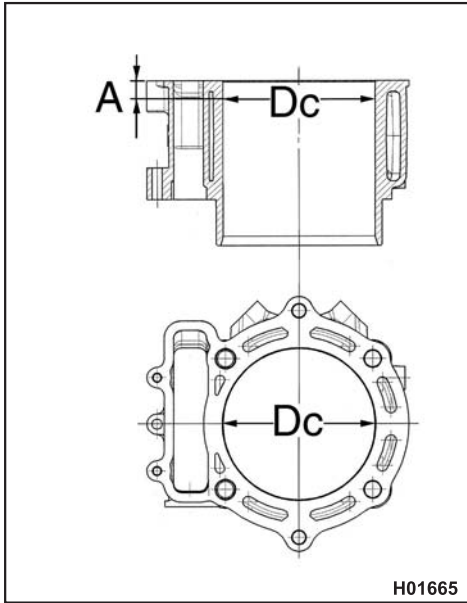

Cylinder to piston clearance

Cylinder diameter

Measure inside diameter (Dc) with an internal bore micrometer 10 mm below the edge (distance "A").

Piston diameter

Measure piston diameter (Dp) 8-9 mm above skirt edge (distance "B").

Clearance is calculated as follows = $Dc - Dp$.

CLEARANCE (Dc-Dp)	SERVICE LIMIT
0.025-0.055 mm (0.0010-0.0022 in.)	0.12 mm (0.0047 in)

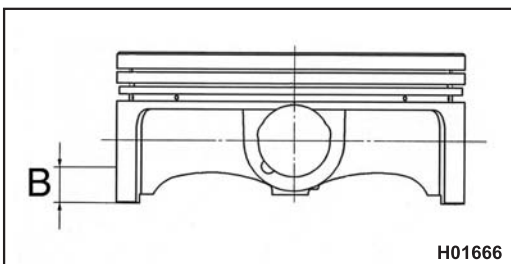

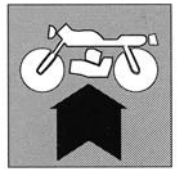

Piston pin

The piston pin must be perfectly smooth, with no signs of scoring, dents or bluing due to overheating.

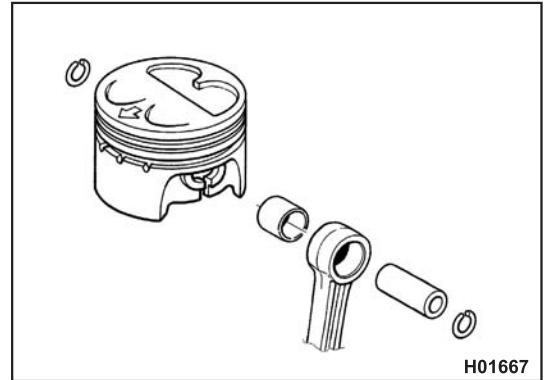

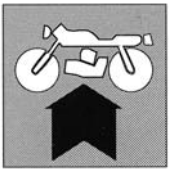

ENGINE OVERHAUL

Piston rings

They should show no signs of forcing or scoring.
Replacement pistons come with piston rings and piston pin.

Piston ring to cylinder clearance

Insert the piston ring at the bottom of the bore (where minimum wear occurs) taking care to position it squarely and measure end gap.

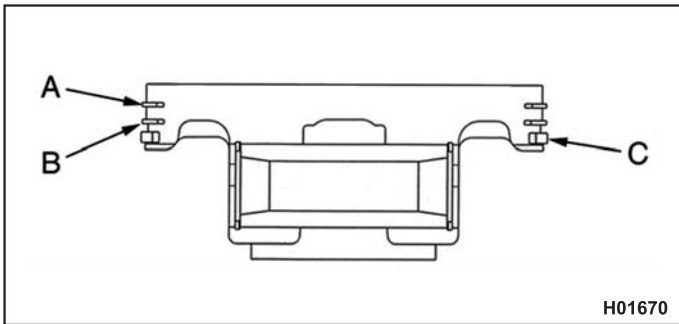

H01670

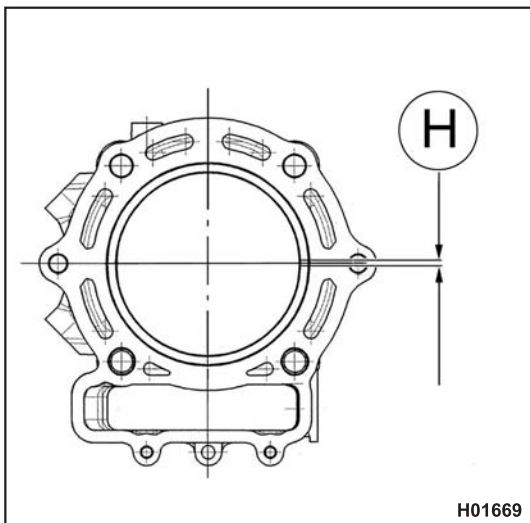

H01669

PISTON	MOUNTING CLEARANCE (H)	SERVICE LIMIT
"A"	0.20-0.45 mm (0.00787-0.0177 in.)	0.7 mm (0.027 in.)
"B"	0.20-0.45 mm (0.00787-0.0177 in.)	0.7 mm (0.027 in.)
"C"	0.10-0.20 mm (0.00394-0.00787 in.)	0.35 mm (0.014 in.)



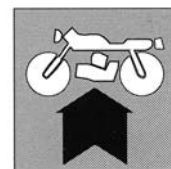

Piston ring to groove clearance

Use a feeler gauge to measure the axial clearance (H) of piston rings. If the piston ring is marked on one side, that side must be facing up.

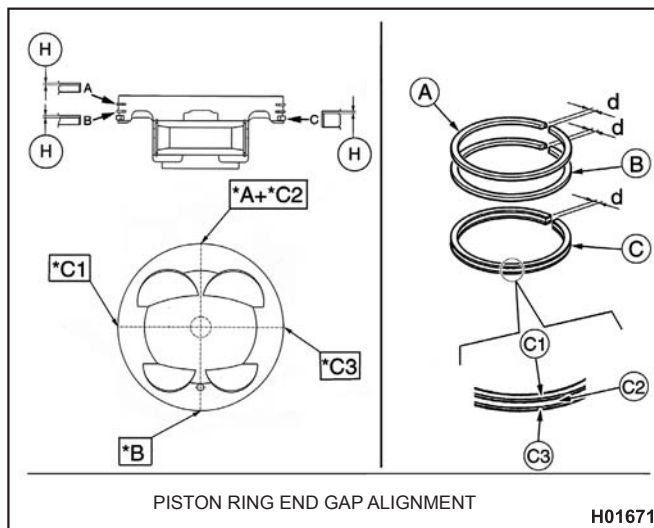

Piston pin to small end clearance (A): 0.012-0.027 mm.
Big end side clearance (B): 0.026-0.036 mm.

SERVICE LIMIT: 0.055 mm
SERVICE LIMIT: 0.080 mm

*: position of end gap "d"

PISTON	MOUNTING CLEARANCE (H)	SERVICE LIMIT
"A"	0.030-0.065 mm (0.00012-0.0025 in.)	0.13 mm (0.0051 in.)
"B"	0.020-0.055 mm (0.0008-0.0022 in.)	0.11 mm (0.0043 in.)
"C"	0.010-0.180 mm (0.0004-0.0071 in.)	0.35 mm (0.0138 in.)

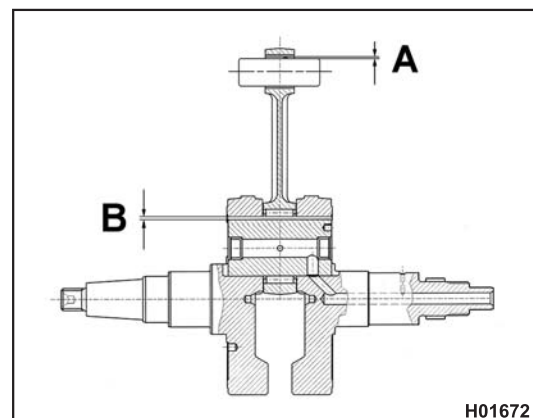

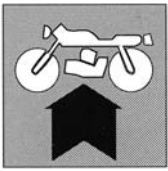

ENGINE OVERHAUL

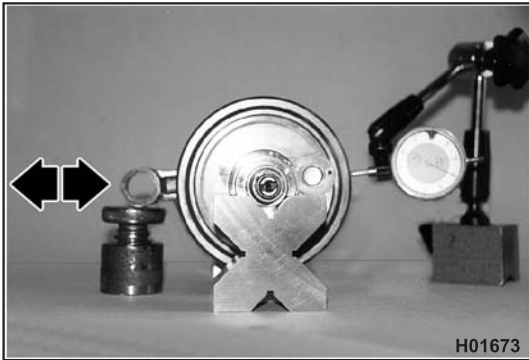

Big end radial clearance

STANDARD	WEAR LIMIT
0.02-0.028 mm (0.0008-0.00112 in.)	0.04 mm (0.0016 in)

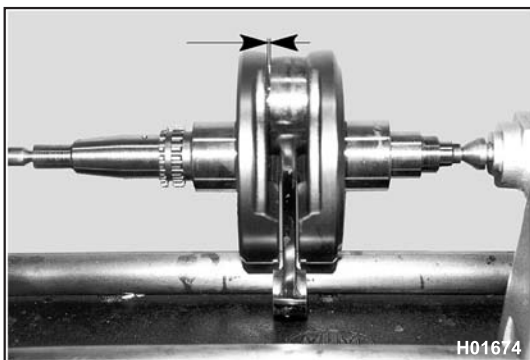

Big end radial clearance

STANDARD	WEAR LIMIT
0.50-0.70 mm (0.0197-0.0275 in.)	0.080 mm (0.00315 in)

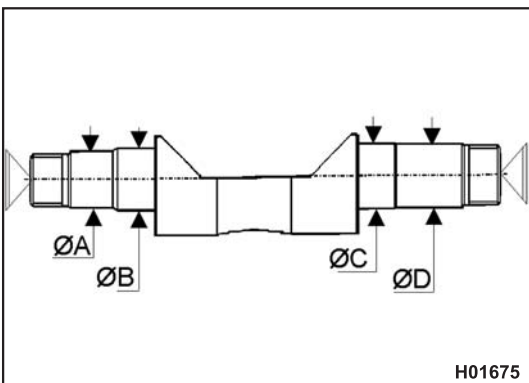

Balancing countershaft

Clamp the countershaft between centres and check that journals run concentric using a dial gauge (maximum runout allowed 0.02 mm).

Measure diameters A,B,C and D:

ØA wear limit = 16.945 mm.

ØB wear limit = 19.965 mm.

ØC wear limit = 19.965 mm.

ØD wear limit = 19.960 mm.



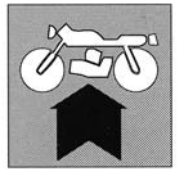

Crankshaft

Main journals and crank pins should show no scoring or scuffing. Threads, keyways and splines must be in good condition. Clamp the shaft between centres and check that crank pins run concentric using a dial gauge (maximum runout allowed 0.02 mm).

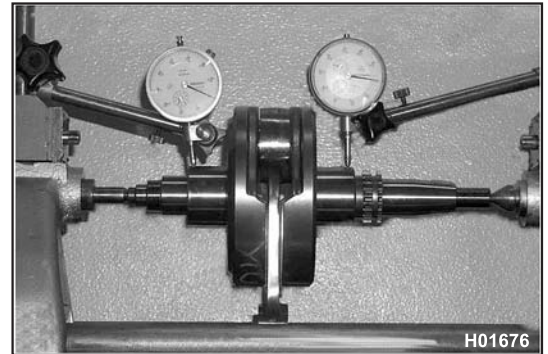

Crankshaft straightness

STANDARD	MAX WEAR LIMIT
less than 0.03 mm (0.012 in)	0.05 mm (0.0019 in)

Small end bushing replacement

You will need an appropriate punch and a press to change the bushing. Smear the outer face of the bushings with moly grease before installation. The bushing should be mounted with an interference fit of: 0.049-0.095 mm (0.00196-0.0038 in.) Match the oil holes of the new bushing with those in the connecting rod; ream the bushing bore to 20 mm $^{+0.022}_{+0.012}$ (0.79 in $^{+0.00088}_{+0.00048}$). Check bore concentricity as shown in the diagram.

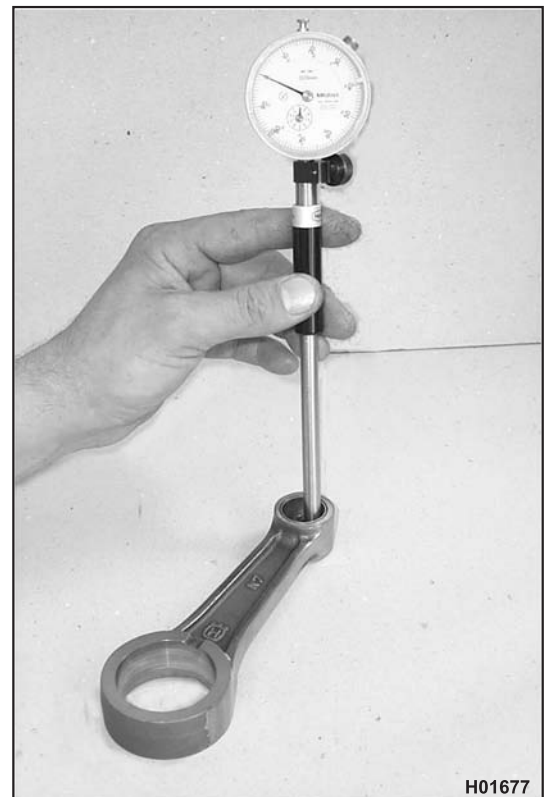
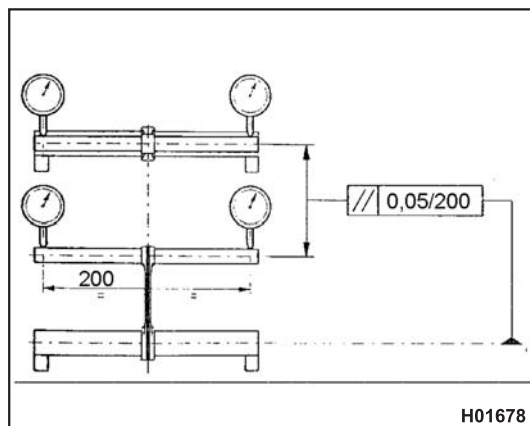

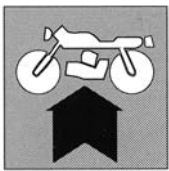

ENGINE OVERHAUL

Clutch

Inspect all clutch components to make sure they are in the best conditions. Clutch plates should show no signs of bluing, scoring or distortion. Measure the thickness of friction plates.

Plate thickness when new: 2.92-3.08 mm (0.1149-0.1212 in.)

Service limit: 2.65 mm (0.106 in.).

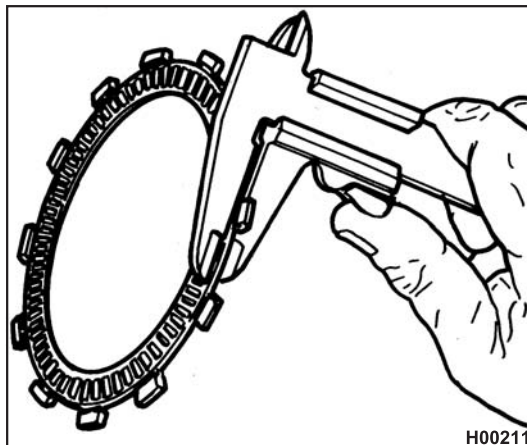

Place each (friction and steel) plate on a surface plate and check for distortion using a feeler gauge; Use a feeler gauge.

Service limit: 0.15 mm (0.006 in.)

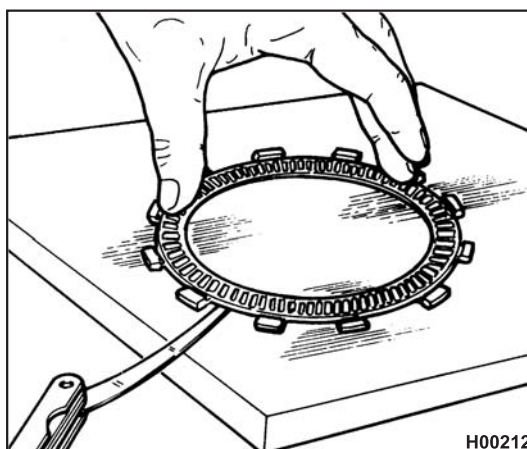

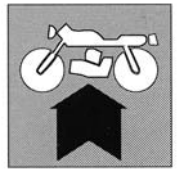

Friction plate to clutch housing clearance

Measure clearance "A" between clutch housing (2) and plate (1) with a feeler gauge and compare measured clearance with the table below.

STANDARD	SERVICE LIMIT
0.30-0.50 mm (0.012-0.020 in.)	0.6 mm (0.024 in.)

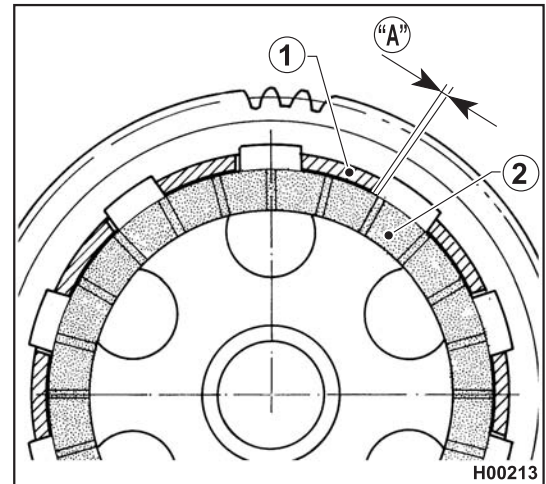

If measured clearance exceeds the service limit, replace clutch plates or housing and repeat measurement. If measurement is still outside the service limit, replace the complete clutch assembly.

Clutch spring

Measure the free length "L" of each spring with a calliper.
 New spring L= 41 mm (1.61 in.).
 Service limit: 39 mm (1.38 in.).
 Change any spring that is outside the service limit.

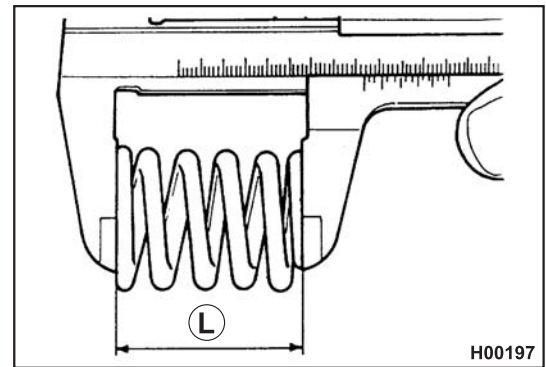

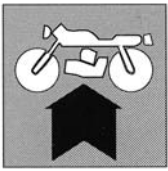

ENGINE OVERHAUL

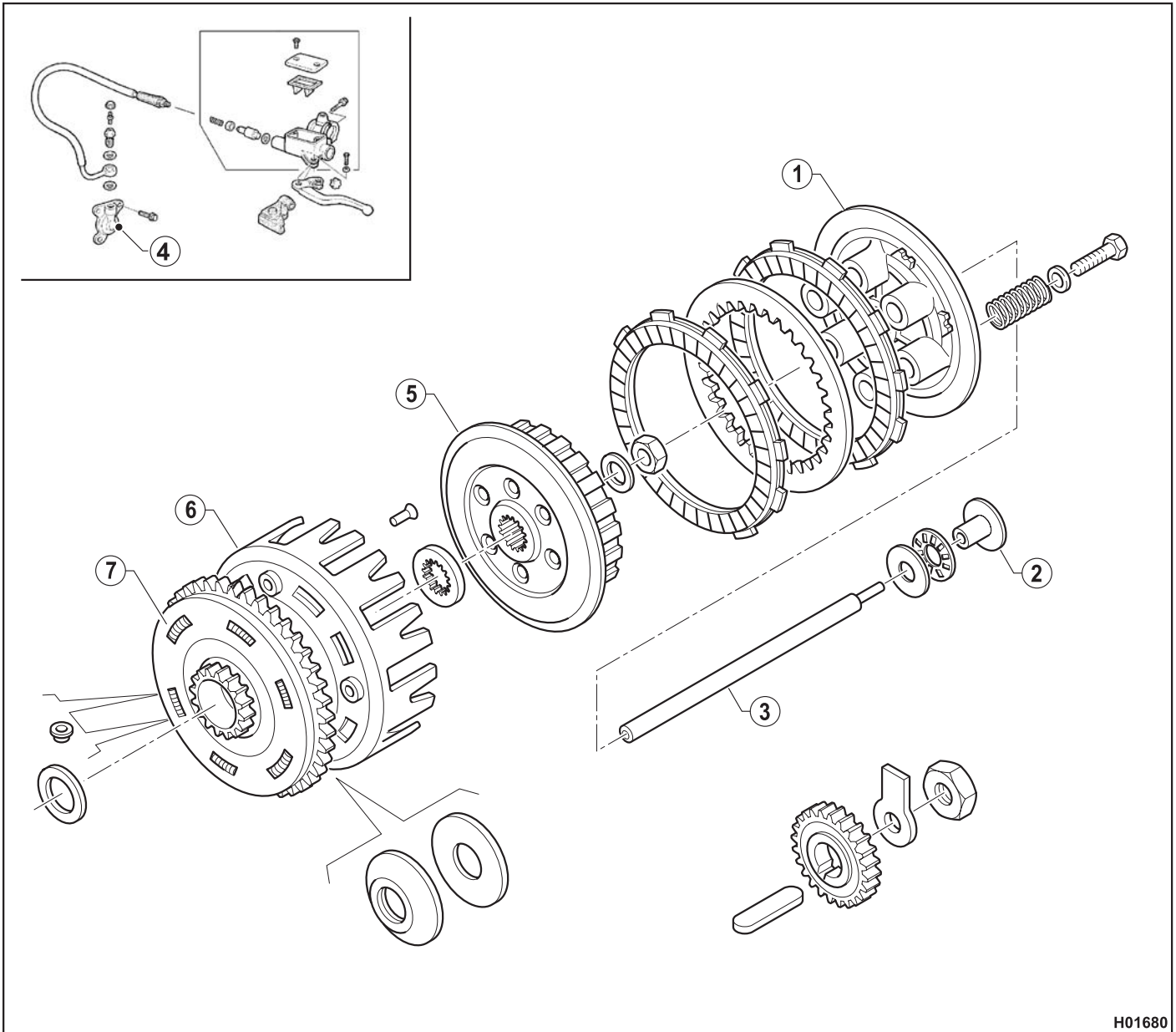

H01680

1- Pressure plate, 2- Clutch actuator plate, 3- Pushrod, 4- Piston assembly: Check these parts for signs of wear or failure. If any are found, replace the part.

5- Clutch hub: Check the steel plate slots for signs of wear or failure. If any are found, replace the part.

6- Clutch housing: Check the friction plate slots for signs of wear or failure.
Check the needle roller bearing seats for signs of wear. If any are found, replace the part.

7- Primary drive gear pair: Check gear teeth for signs of wear or failure. If any are found, replace the part.



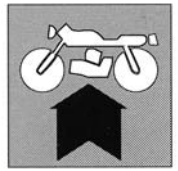

Shifter forks and gears

Visually inspect the shifter forks (1) and replace any bent forks. A bent fork will make gears hard to engage or let the transmission jump out of gear unexpectedly under loading.

Check the clearance of the each shifter fork in its gear groove using a feeler gauge. If any one of the three gears is outside the service limit, measure the width of gear groove and fork thickness to determine which component needs to be replaced. Shifter fork to groove clearance (new fork and gear): 0.070 - 0.225 mm (0.0028 - 0.0088 in.)

Service limit: 0.26 mm (0.010 in.).

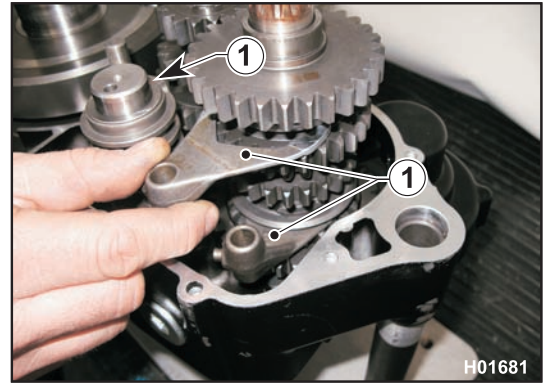

H01681

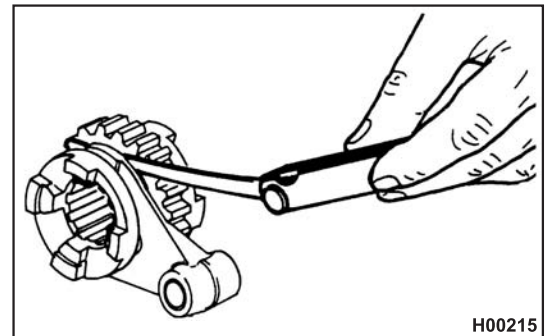

H00215

Selector drum

Check drum grooves for wear or dents and make sure the selector drum is not bent, worn or damaged.

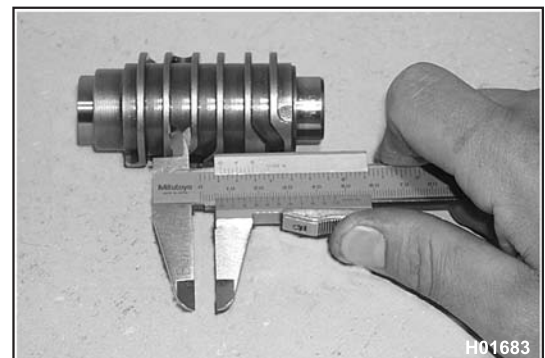

H01683



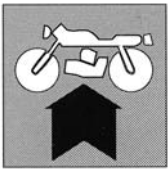

ENGINE OVERHAUL

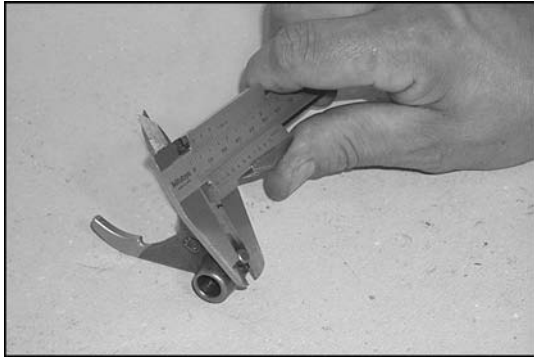

Selector drum to shifter fork pins clearance

Determine clearance between shifter fork pin and drum groove taking the necessary measurements with a calliper. If service limit is exceeded, compare the components with new parts to determine which one needs to be removed.

Shifter fork to drum groove clearance (from new):

0.15-0.35 mm (0.006-0.014 in.)

Service limit: 0.5 mm (0.02 in.)

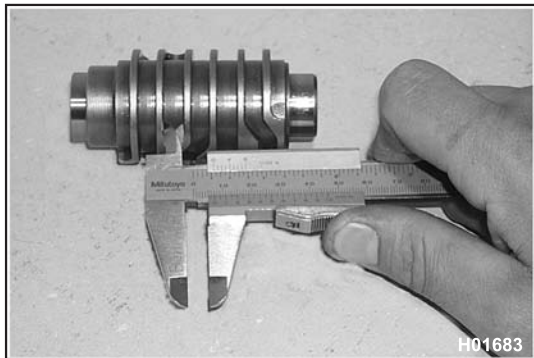

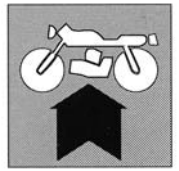

Oil pump disassembly

Remove the oil pump from the right crankcase as described in the Section "F". Check side clearance to determine whether the pump needs replacing; use a feeler gauge and a straight-edge.

If pump rotors (1) and (2) have been separated from pump body, make sure to line up the dots on inner and outer rotors on assembly. Check pump body mating face for scoring, dents or scuffing.



On assembly, inspect the seals (3) and make sure the pins (4) are located correctly; for tightening torque figures, see Sections "H" and "X".

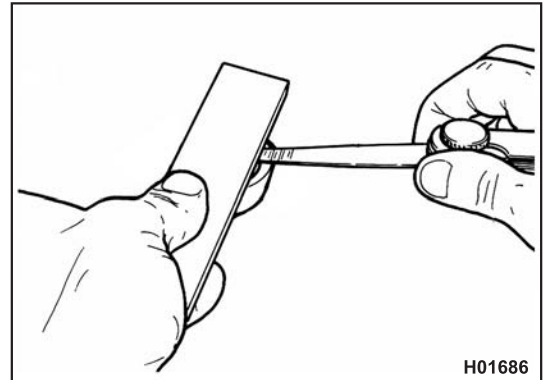

H01686

Side clearance	0.10 mm (0.0039 in.)
----------------	-------------------------

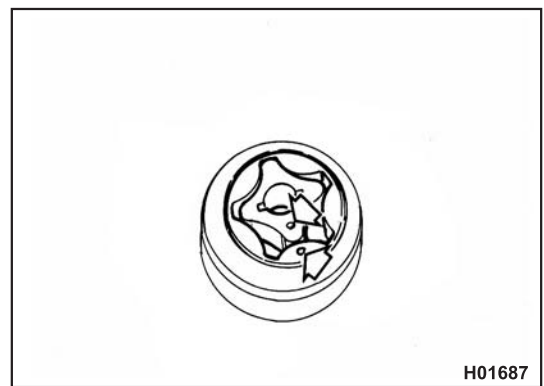

H01687

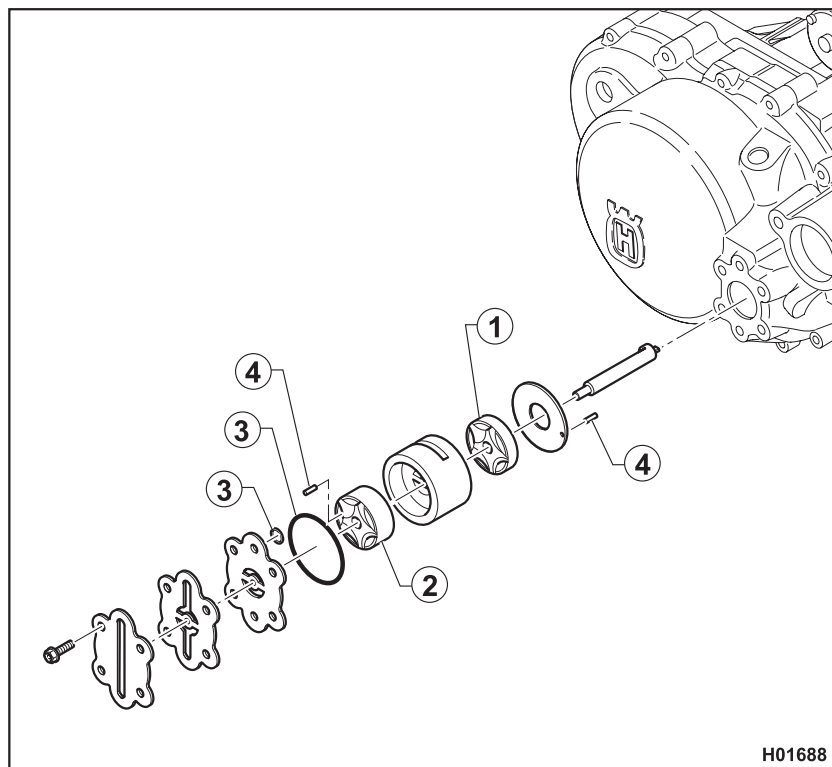

H01688



ENGINE REASSEMBLY

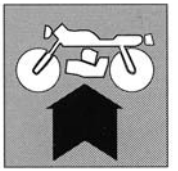

Section

H



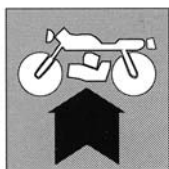

ENGINE REASSEMBLY

General.....	H.3
Assembly and lubrication instructions (CRANK- ALTERNATOR- LUBRICATION- LEFT CRANKCASE HALF)	H.4
Tightening torque figures	H.5
Assembly and lubrication instructions	H.6
GEARBOX - GEAR SHIFT CONTROL.....	H.6
Tightening torque figures	H.7
Assembly and lubrication instructions (CLUTCH - KICK START- LUBRICATION- RIGHT CRANKCASE HALF)	H.8
Tightening torque figures	H.9
Assembly and lubrication instructions (HEAD - CYLINDER - PISTON - TIMING SYSTEM - WATER PUMP - SPARK PLUG)	H.10
Tightening torque figures	H.11
Crankshaft installation	H.12
Input shaft.....	H.15
Output shaft	H.16
Crankcase assembly	H.17
Gear sensor installation.....	H.23
Gear shift control assembly	H.24
Crankshaft gears installation	H.27
Countershaft weight/gear installation.	H.27
Clutch assembly	H.30
Piston ring installation.....	H.33
Piston and cylinder installation	H.33
Cylinder head gasket selection table.....	H.35
Cylinder head installation	H.36
Water pump installation.	H.38
Timing chain tensioner installation	H.39
Camshaft installation	H.40
Cylinder head cover and spark plug installation.....	H.42
Flywheel and flywheel cover installation.....	H.43
Sprocket installation	H.46
Oil pump and filter cartridge assembly	H.46
Right crankcase assembly.....	H.47
Clutch actuator installation	H.48



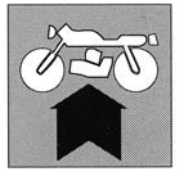

General

To reassemble, reverse the disassembly procedure. Any special instructions concerning reassembly are expressly highlighted in the text. Always replace gaskets, oil seals, metal retainers, sealing washers made from deformable material (copper, aluminium, fibre, etc.) and self-locking nuts after removal. Bearing specifications and dimensions have been calculated for a certain life. We recommend replacing the bearings - especially those exposed to heavy loading - also considering that checking them for wear is not an easy procedure. These recommendations are in addition to the dimensional checks of individual components specified in the relevant section (see Section G "ENGINE OVERHAUL"). Cleaning all components thoroughly is critical to reliability; bearings and any wear parts must be lubricated with engine oil before assembly. Screws, nuts and bolts must be tightened to the specified torque (see pages H.4-H.11 and Section X "TIGHTENING TORQUE FIGURES").



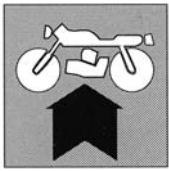

ENGINE REASSEMBLY

Assembly and lubrication instructions

CRANK- ALTERNATOR- LUBRICATION- LEFT CRANKCASE HALF

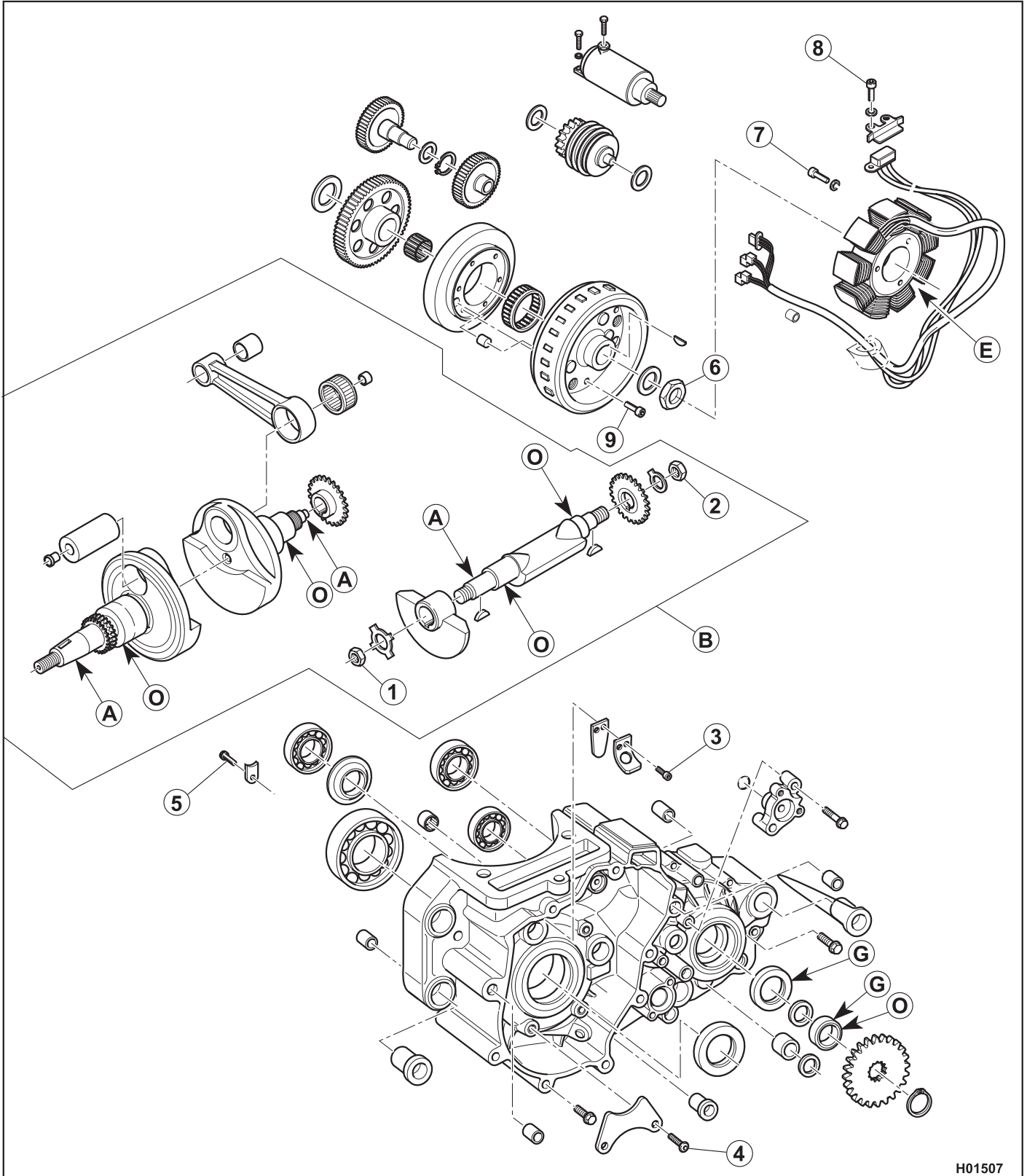

H01507



ENGINE REASSEMBLY

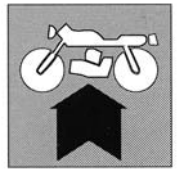

Tightening torque figures

1	M18 x 1.25	70 Nm- 7.2 Kgm- 51.63 ft/lb
2	M16 x 1.25	70 Nm- 7.2 Kgm- 51.63 ft/lb
3	M4 x 4.07 (+Loctite 243)	3 Nm- 0.3 Kgm- 2.21 ft/lb
4	M5 x 0.8	8 Nm- 0.8 Kgm- 5.90 ft/lb
5	M5 x 0.8 (+Loctite 243)	8 Nm- 0.8 Kgm- 5.90 ft/lb
6	M16 x 1.25	130 Nm- 13.2 Kgm- 95.88 ft/lb
7	M6 x 1 (+Loctite 270)	8 Nm- 0.8 Kgm- 5.90 ft/lb
8	M4 x 0.7 (+Loctite 272)	3 Nm- 0.3 Kgm- 2.21 ft/lb
9	M6 x 1 (+Loctite 270)	20 Nm- 2 Kgm- 14.75 ft/lb

LUBRICATION POINTS-NOTES	LUBRICANT-INSTALLATION INSTRUCTIONS
A	Degrease
B	Apply engine oil on installation
E	Line up stator mark with cover mark
G	WATER RESISTANT grease
O	Engine oil



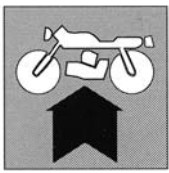

ENGINE REASSEMBLY

Assembly and lubrication instructions

GEARBOX - GEAR SHIFT CONTROL

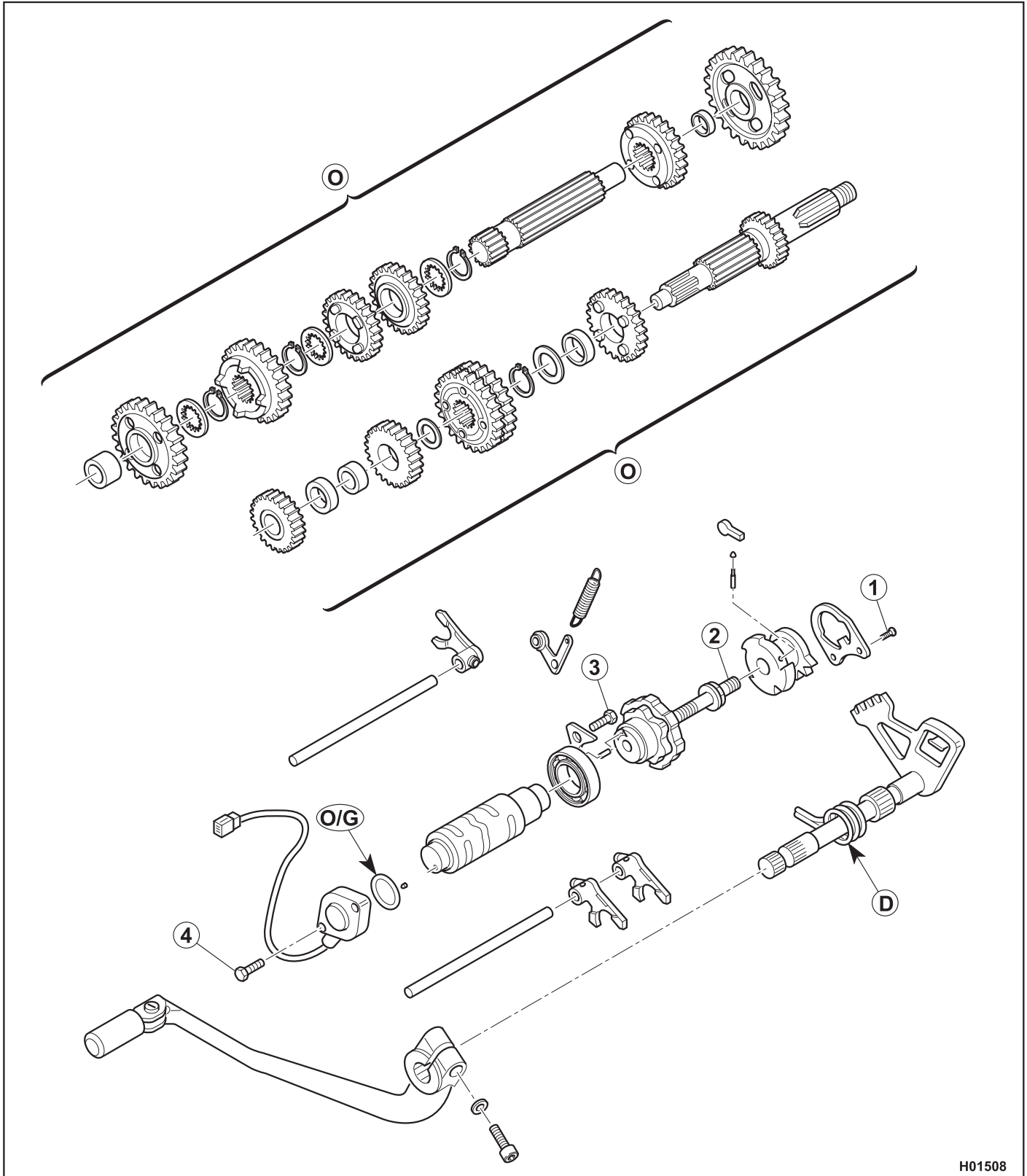

H01508



ENGINE REASSEMBLY

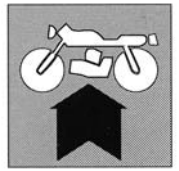

Tightening torque figures

1	M6x1	10 Nm- 1.02 Kgm- 7.38 ft/lb
2	M8 x 1.25 (+LOCTITE 243)	28 Nm- 2.85 Kgm- 20.65 ft/lb
3	M6 x 1 (+LOCTITE 243)	9 Nm- 0.92 Kgm- 6.64 ft/lb
4	M5 x 0.8 (+LOCTITE 243)	8 Nm- 0.8 Kgm- 5.90 ft/lb

LUBRICATION POINTS-NOTES	LUBRICANT-INSTALLATION INSTRUCTIONS
D	Install with open end pointing to engine centre
O	Engine oil
O/G	Engine oil or WATER RESISTANT grease



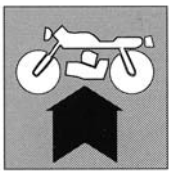

ENGINE REASSEMBLY

Assembly and lubrication instructions

CLUTCH- KICK START- LUBRICATION- RIGHT CRANKCASE HALF

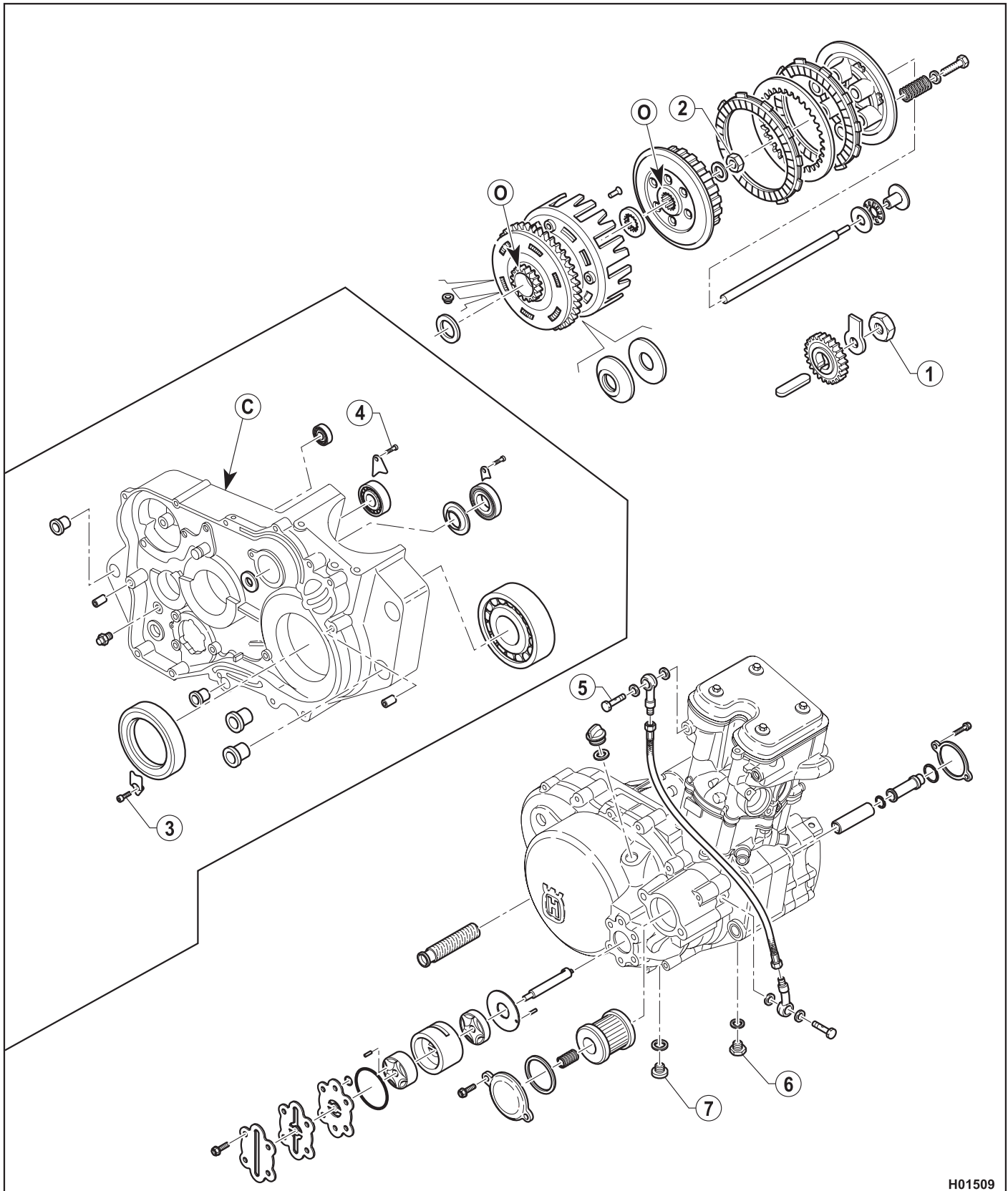

H01509



ENGINE REASSEMBLY

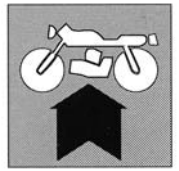

Tightening torque figures

1	M24 x 1.25 (+LOCTITE 243)	100 Nm- 10.2 Kgm- 73.76 ft/lb
2	M18 x 1	61.7 Nm- 6.3 Kgm- 45.73 ft/lb
3	M6 x 1 (+LOCTITE 243)	9 Nm- 0.92 Kgm- 6.64 ft/lb
4	M6 x 1 (+LOCTITE 243)	9 Nm- 0.92 Kgm- 6.64 ft/lb
5	M10 x 1	15 Nm- 1.5 Kgm- 3.69 ft/lb
6	M14 x 1.5	24 Nm- 2.45 Kgm- 17.70 ft/lb
7	M22 x 1.5	30 Nm- 3 Kgm- 22.13 ft/lb

LUBRICATION POINTS-NOTES	LUBRICANT-INSTALLATION INSTRUCTIONS
O	Engine oil
C	Join crankcase halves using Loctite 5205



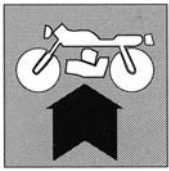

ENGINE REASSEMBLY

Assembly and lubrication instructions

HEAD - CYLINDER - PISTON - TIMING SYSTEM - WATER PUMP - SPARK PLUG

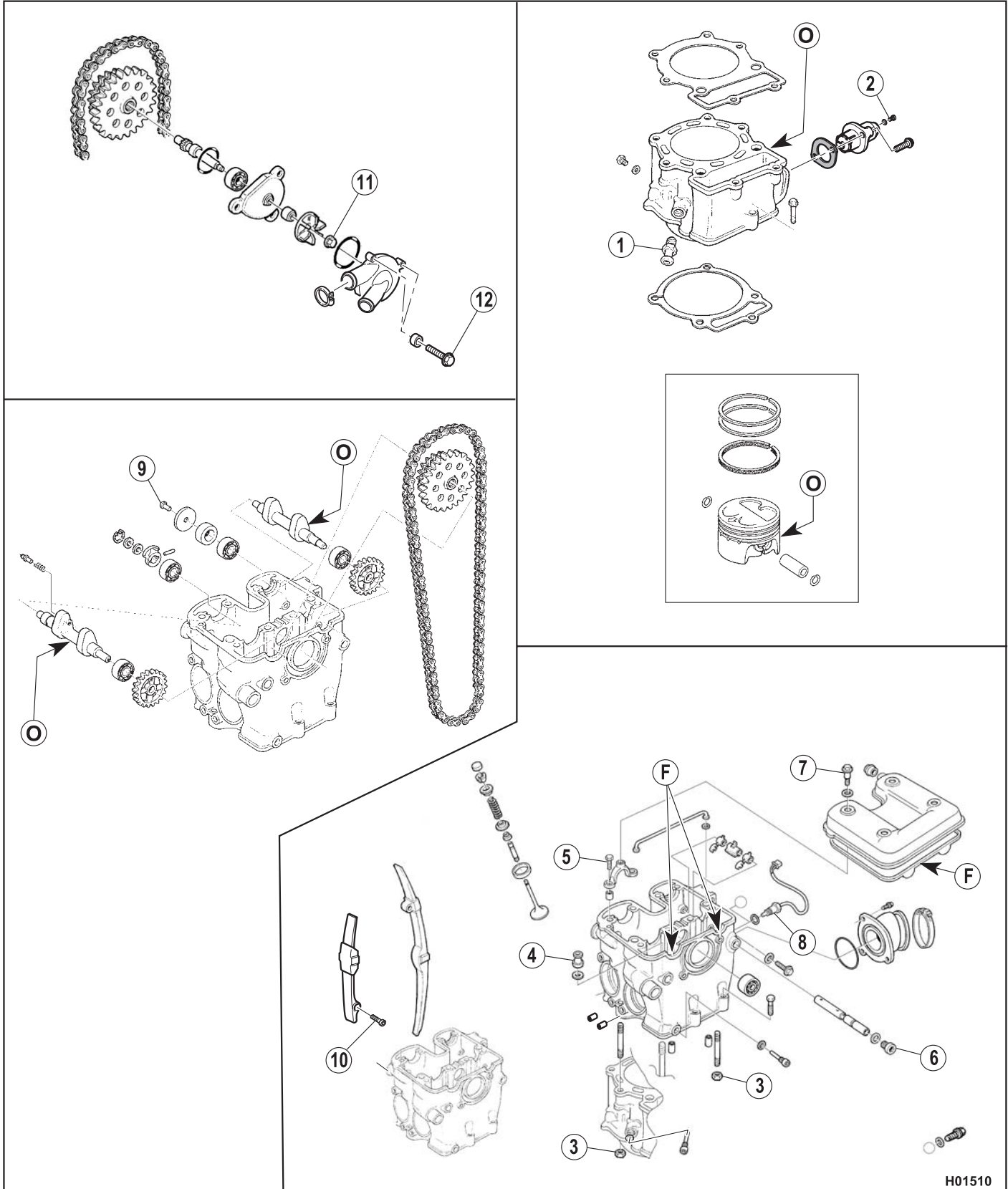

H01510



ENGINE REASSEMBLY

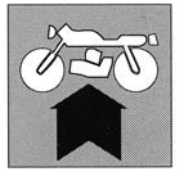

Tightening torque figures

1	M14 x 1.5 (+LOCTITE 542)	25 Nm- 2.55 Kgm- 18.44 ft/lb
2	M6 x 1	5 Nm- 0.5 Kgm- 3.69 ft/lb
3	M8 x 1.25	15 Nm- 1.5 Kgm- 11.6 ft/lb
4	M10 x 1.5 (MOLIKOTE HSC -COPPER GREASE)	37 Nm +90°- 3.8 Kgm +90°- 27.29 ft/lb+90°
5	M6 x 1	12 Nm- 1.2 Kgm- 8.85 ft/lb
6	M14 x 1.5 (+LOCTITE 243)	25 Nm- 2.55 Kgm- 18.44 ft/lb
7	M6 x 1	8 Nm- 0.8 Kgm- 5.9 ft/lb
8	M10 x 1.25 (ENGINES WITH ELECTRONIC INJECTION)	15 ^{±1} Nm- 1.5 ^{±1} Kgm- 11.06 ft/lb
9	M6 x 1 (+LOCTITE 243)	8 Nm- 0.8 Kgm- 5.90 ft/lb
10	M8 x 1.25	12 Nm- 1.23 Kgm- 8.85 ft/lb
11	M5 x 0.8 (+LOCTITE 243)	6 Nm- 0.6 Kgm- 4.43 ft/lb
12	M6 x 1 (+LOCTITE 542)	8 Nm- 0.8 Kgm- 5.90 ft/lb

LUBRICATION POINTS-NOTES	LUBRICANT-INSTALLATION INSTRUCTIONS
F	Use sealant "AREXONS RHODORSEAL 5552" on installation
O	Engine oil



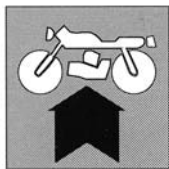

ENGINE REASSEMBLY

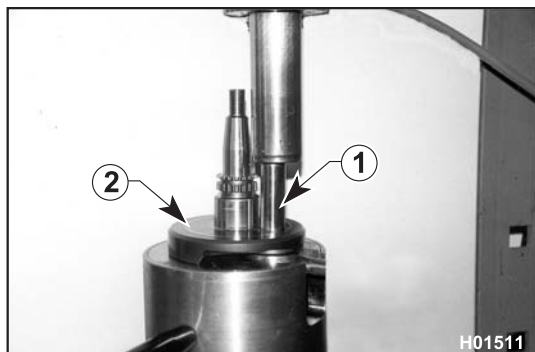

Crankshaft assembly

Clean the oil galleries thoroughly. Lubricate the crank pin (1) with engine oil and insert it into the flywheel half (2).



WARNING: Match the oil passage holes Fig."A".

Fit the needle roller bearing (3) and lubricate it the engine oil. Install the connecting rod (4) and the second flywheel half (5) and align the two flywheel halves using a square.

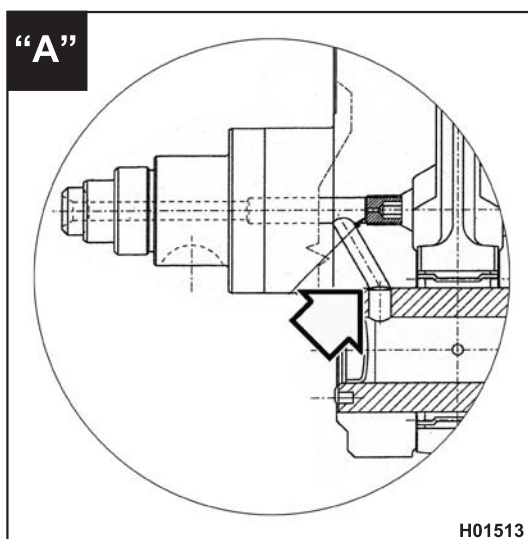
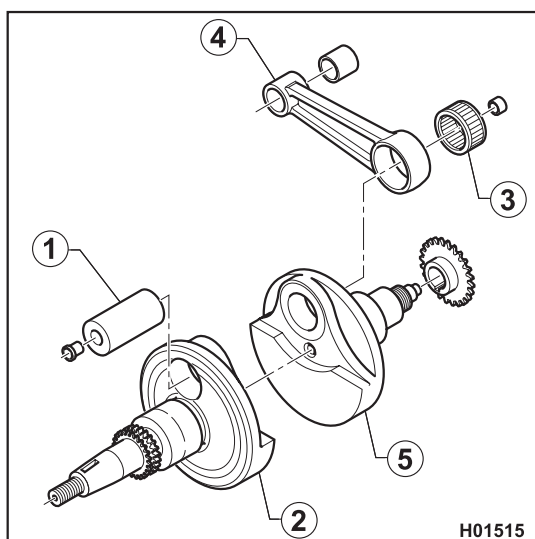
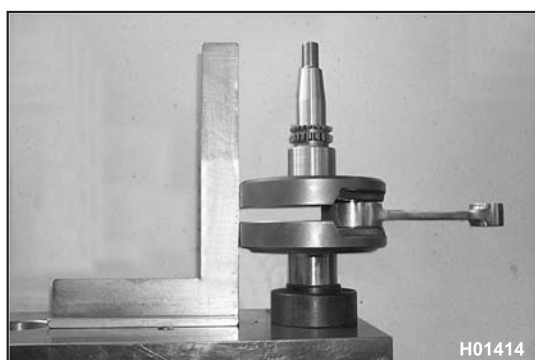

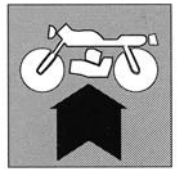

Finally, join the parts using a press.

Make sure the pin does not protrude at either ends as you join the flywheel halves. Observe mounting dimension "A" and set crank pin (1) at distance "B" on the right flywheel half.

A = 6.35 - 64.45 mm
(2.574-2.578 in.)

B = 0.9 - 1.1 mm
(0.036 - 0.044 in.)

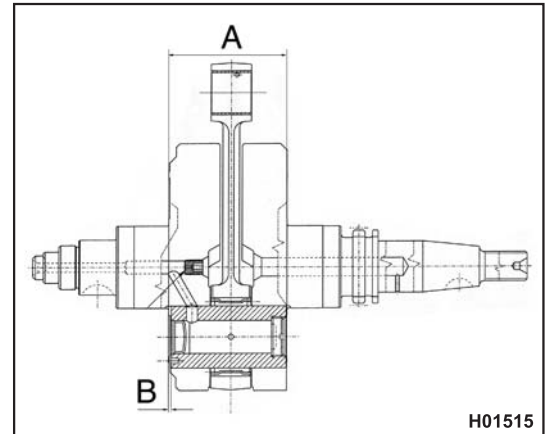

Measure axial clearance "D" of connecting rod to flywheels; it should be 0.45-0.7 mm (0.018-0.03 in.).

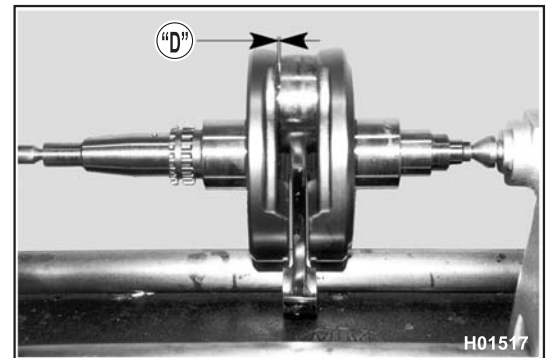

Measure crankshaft runout at the bearing locations "C". Runout must not exceed 0.03 mm (0.0012 in).
Straighten the crankshaft using a copper hammer.

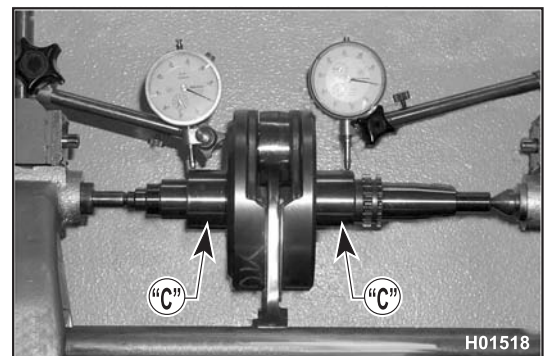

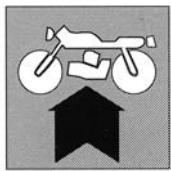

ENGINE REASSEMBLY

Input shaft

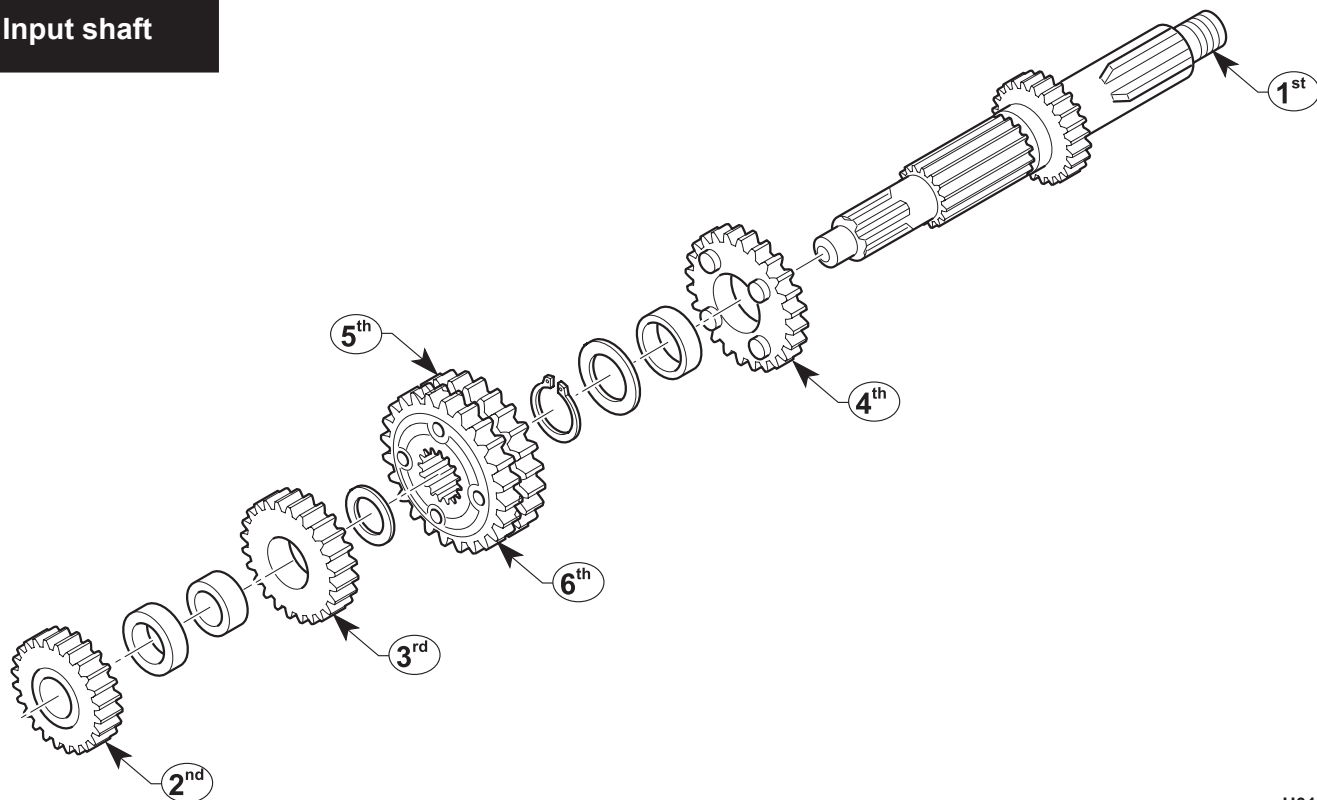

H01519

Output shaft

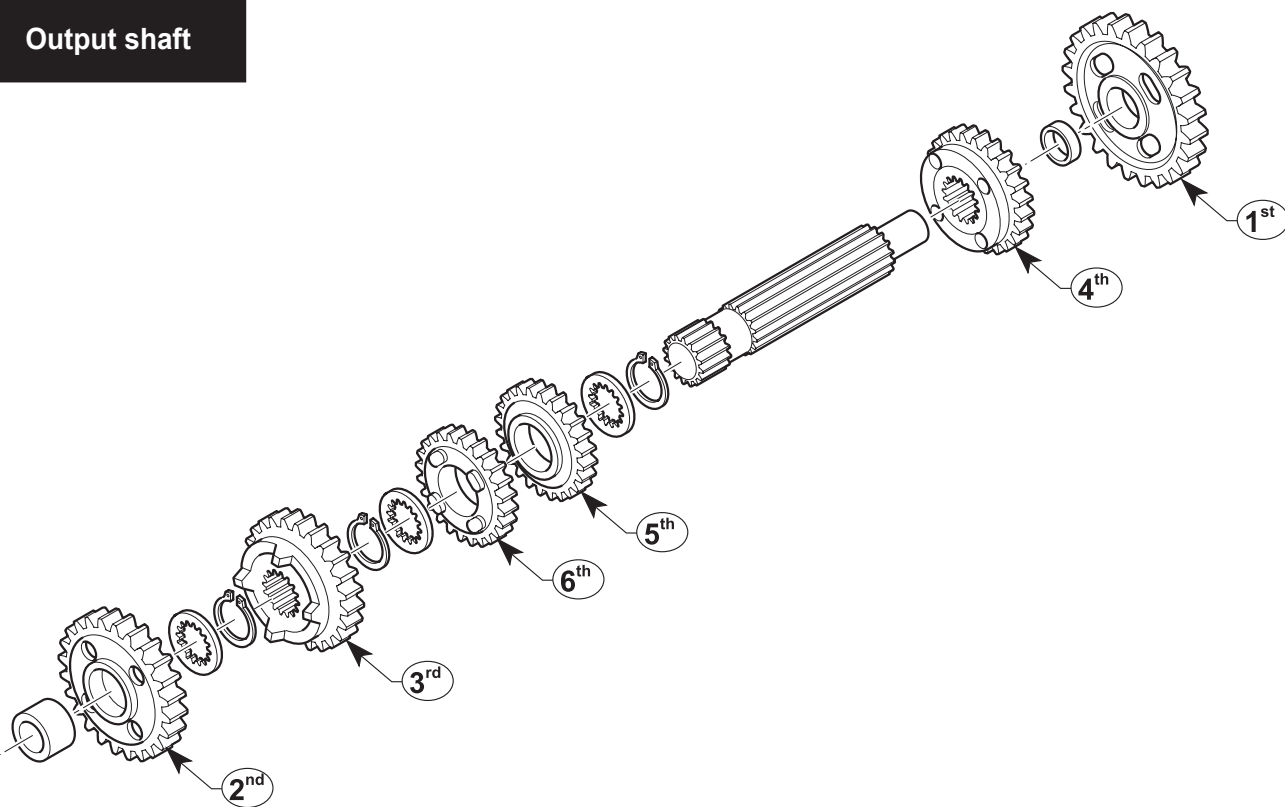

H01520



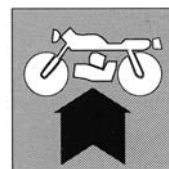

Input shaft

- Fit bushing (2) to the input shaft (1). Lubricate inner and outer face with Molikote G-n plus grease before installation.
- Fit 4th gear (3), washer (4) and retaining ring (5) with the rounded edges of washer and retaining ring facing the gear.
- Fit 5th/6th sliding gear (6).
- Fit washer (7) with the rounded edge facing the gear.
- Fit plain bearing (8). Lubricate inner and outer face with Molikote G-n plus grease before installation.
- Fit 3rd gear (9).
- Fit spacer (10) and 2nd gear (11).

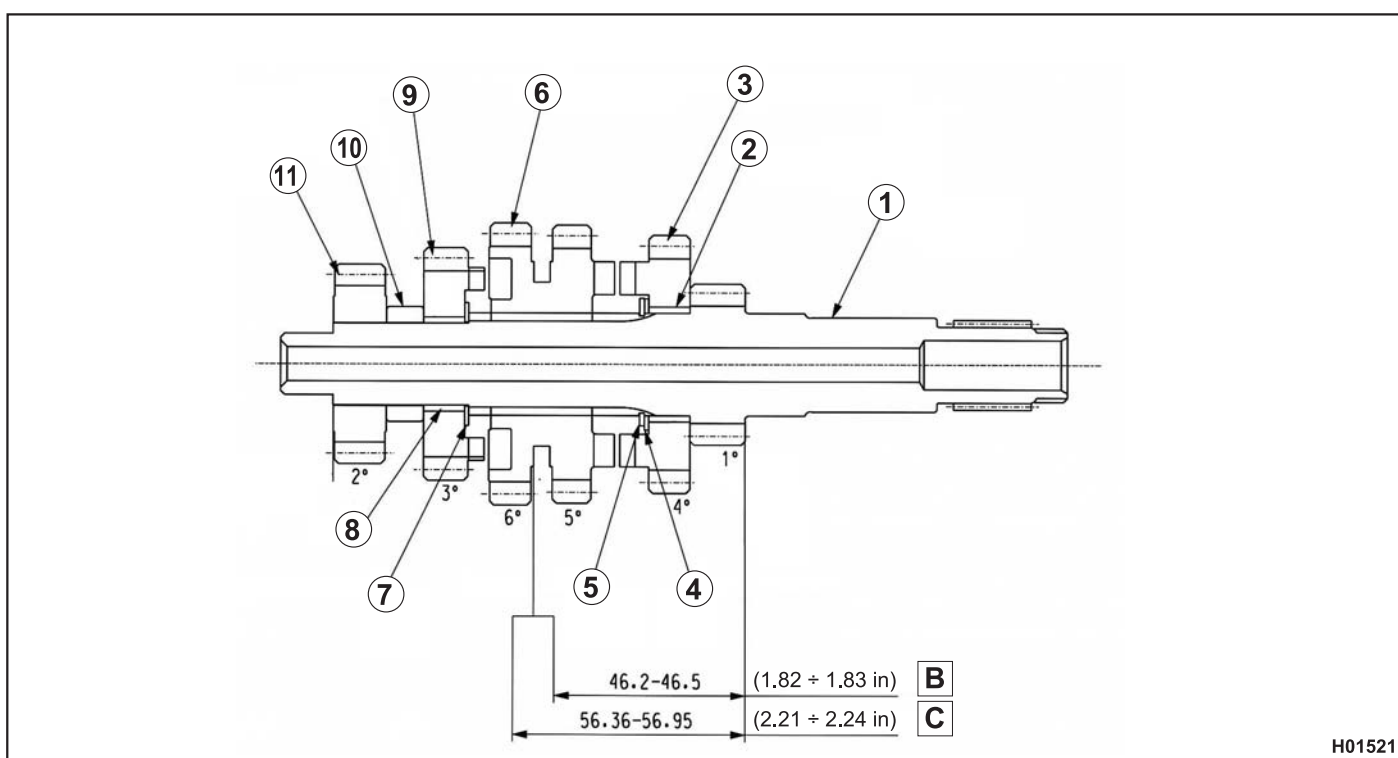

H01521

	TE	SMS
1st	13	13
2nd	16	16
3rd	20	20
4th	22	22
5th	24	23
6th	26	25

B: Control dimension with 4th gear engaged.

C: Control dimension with 3rd gear engaged.



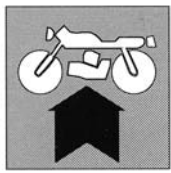

ENGINE REASSEMBLY

Output shaft

- Fit bushing (2) to the output shaft (1). Lubricate inner and outer face with Molikote G-n plus grease before installation.
- Fit 2nd gear with the splined side facing 3rd gear.
- Fit washer (4) and retaining ring (5) with the rounded edges of washer and retaining ring facing the gear.
- Fit 3rd gear (6) as shown.
- Fit retaining ring (7) and washer (8) with the rounded edges of washer and retaining ring facing the gear.
- Fit 6th gear (9).
- Fit 5th gear (10).
- Fit washer (11) and retaining ring (12) with the rounded edges of washer and retaining ring facing the gear.

NOTE: 5th and 6th gears should turn freely against each another.

- Fit 4th gear (13) with the flange facing 5th gear.
- Fit bushing (14) to the input shaft (1). Lubricate inner and outer face with Molikote G-n plus grease before installation.
- Fit 1st gear (15) with the bevelled edge facing 4th gear.

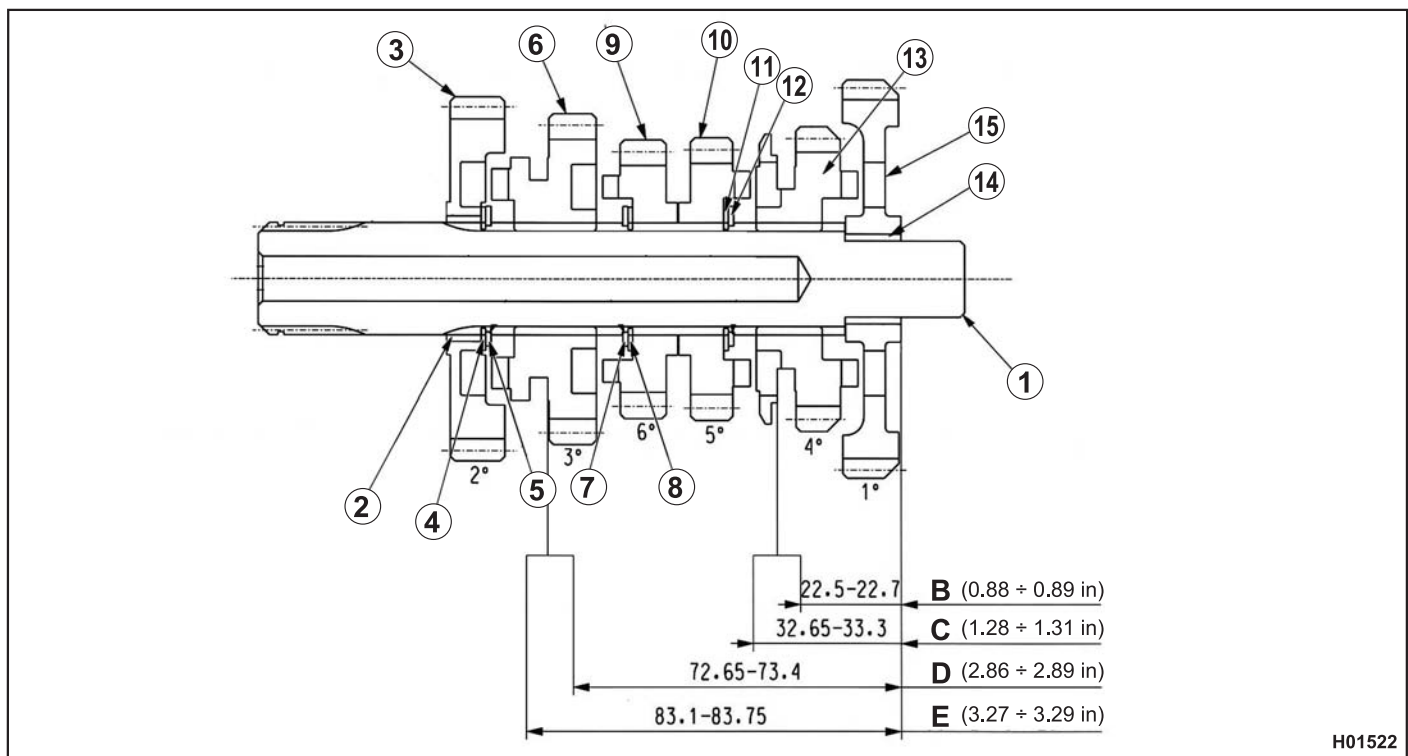

	TE	SMS
1st	34	34
2nd	29	29
3rd	27	27
4th	24	24
5th	22	22
6th	20	22

- B:** Control dimension with 1st gear engaged
- C:** Control dimension with 5th gear engaged
- D:** Control dimension with 6th gear engaged
- E:** Control dimension with 2nd gear engaged



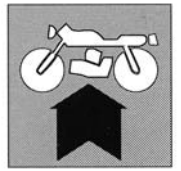

Crankcase assembly

Clean the crankcase half mating faces and place crankcase half on tool no. 8000 90662.

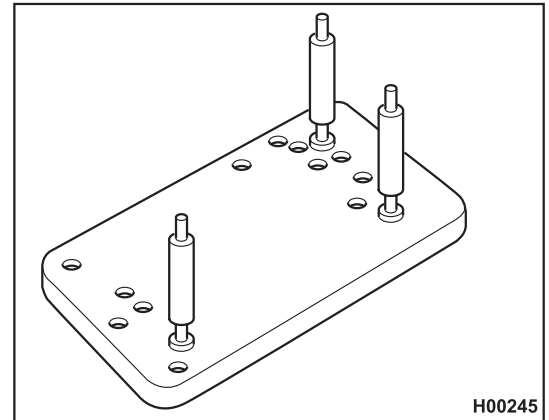

- Heat up to around 125 °C and drive the ball bearings into each crankcase half using a suitable driver tool.



- Fit the retaining plates (1) and (2) to the crankcase bearings. (See Section "x" for tightening torque figures)

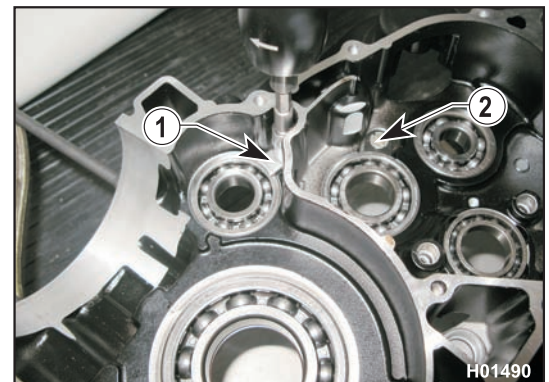

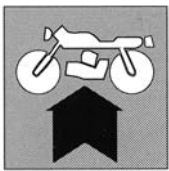

ENGINE REASSEMBLY

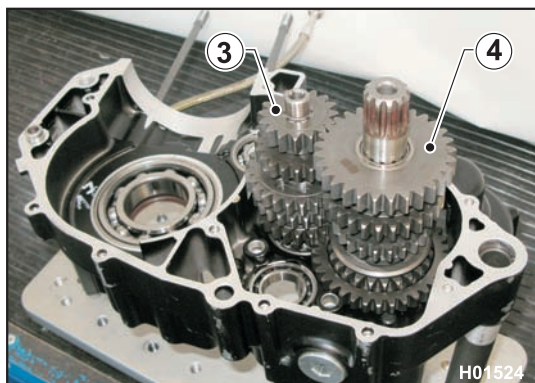

Install the input and output shaft assembly pushing them fully home into the right crankcase half and make sure input (3) and output shaft (4) gears are flush.

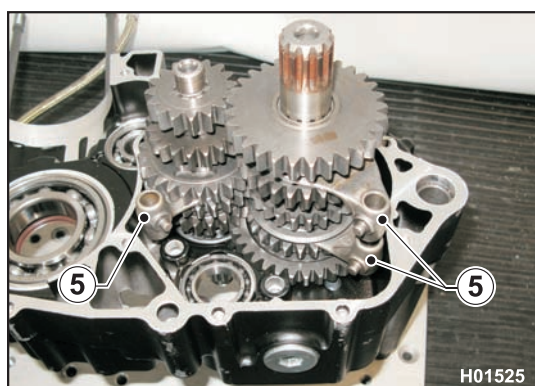

Lubricate the shifter forks (5) with engine oil and install them.



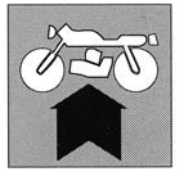

Insert the selector drum (6) into its seat.

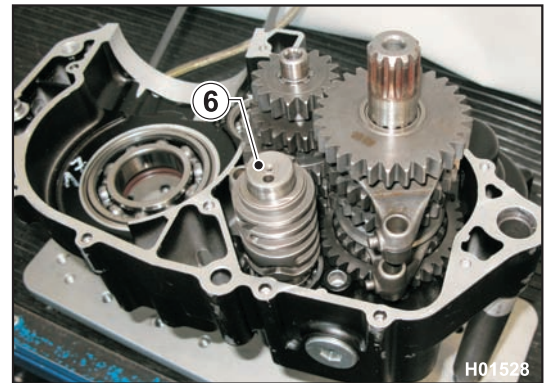

Install the fork shafts (7) and (8) and make sure the forks move freely.
Make sure the fork pins (9) are correctly located in the drum grooves (6).
Rotate the selector drum to test operation.

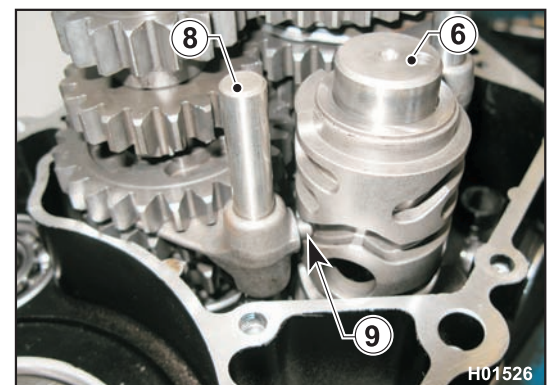
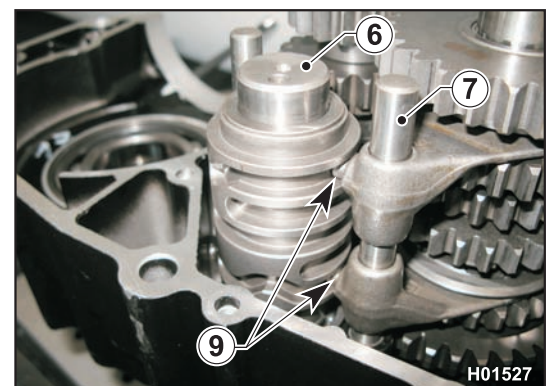

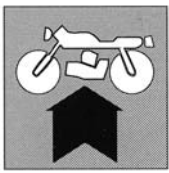

ENGINE REASSEMBLY

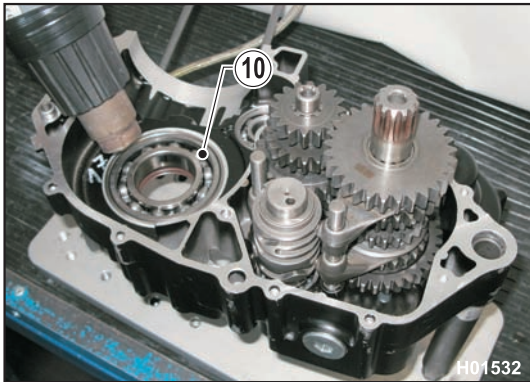

Heat up the crankshaft bearing (10) and install the crankshaft (11).

Fit the countershaft (12) onto its bearing.

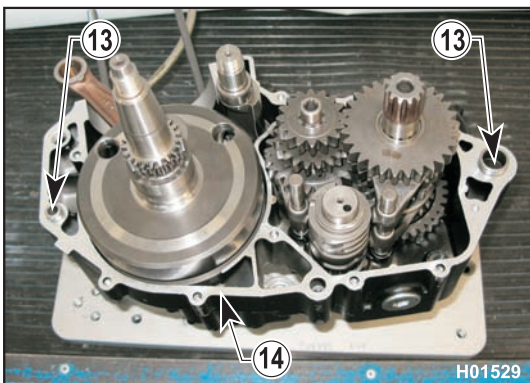
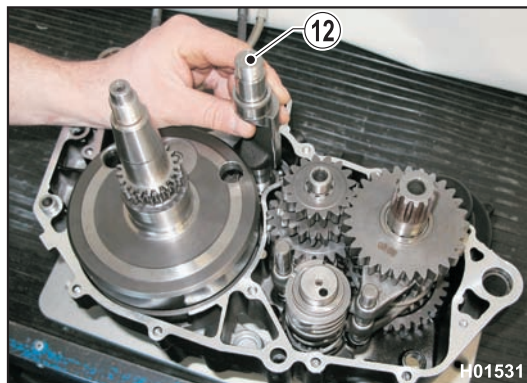

Make sure both crankcase locating bushings (13) are in place.

Apply a layer of "LOCTITE 5205" on the right crankcase mating surface (14).



ENGINE REASSEMBLY

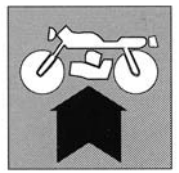

Heat up the left crankcase bearing locations and install the crankcase.

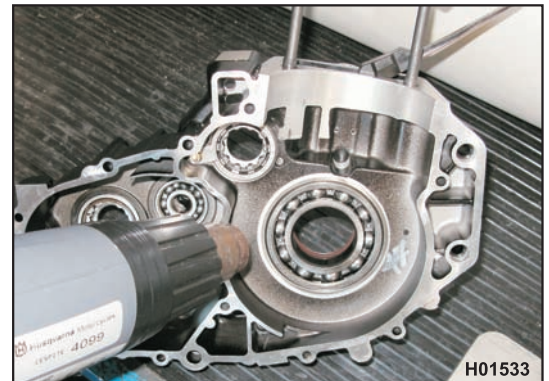

Grease the sprocket bearing bushing (15) and fit it into the bearing; fit the left crankcase half onto the right crankcase half.

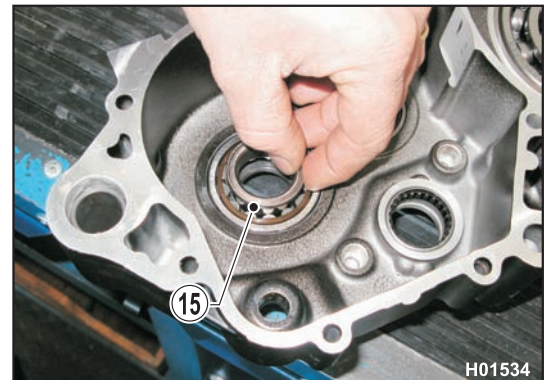

To join the crankcase halves, tap with a plastic hammer.

Tighten the screws (16) using an 8 mm wrench. Make sure to fit the screws in the correct positions according the pattern shown.

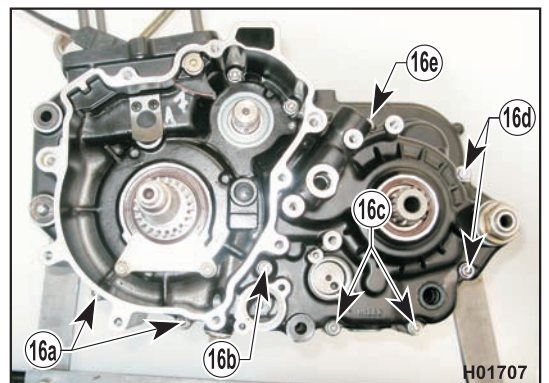

- 12a= M6 x 55 mm
- 12b= M6 x 55 mm + copper washer
- 12c= M6 x 55 mm
- 12d= M6 x 65 mm



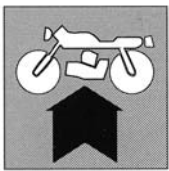

ENGINE REASSEMBLY

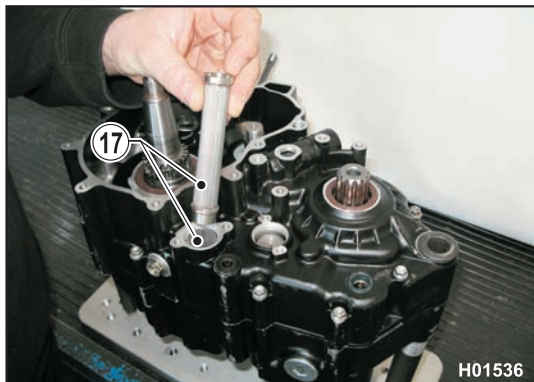

Install mesh filters (17) and their cover (18) and tighten the screws (19) with an 8 mm wrench (see Section "X" for tightening torque figures).

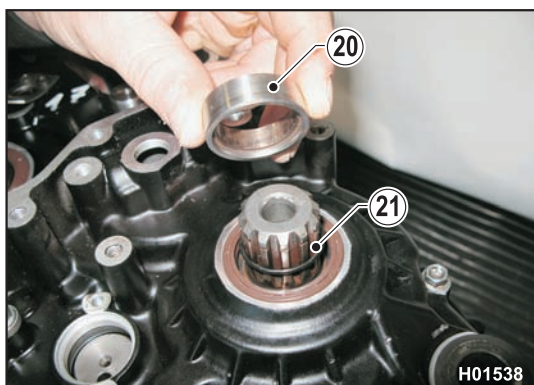
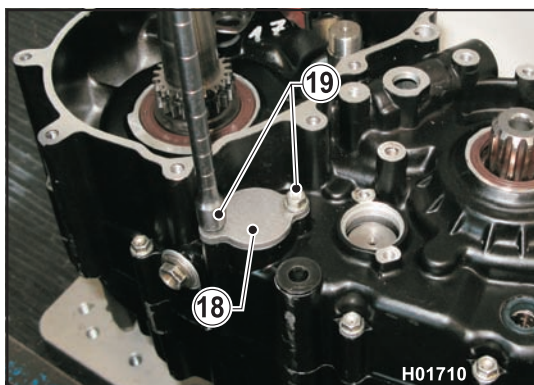

Insert bushing (20) with its O-ring (21); the O-ring groove must be facing into the engine.



Cover the upper section of the engine with a cloth, a sponge or the like to prevent screws or other parts from accidentally falling into the engine.



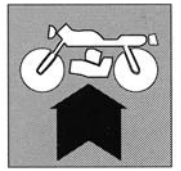

Gear sensor installation.

Insert spring (1) and pushrod (2) into their seat (3).

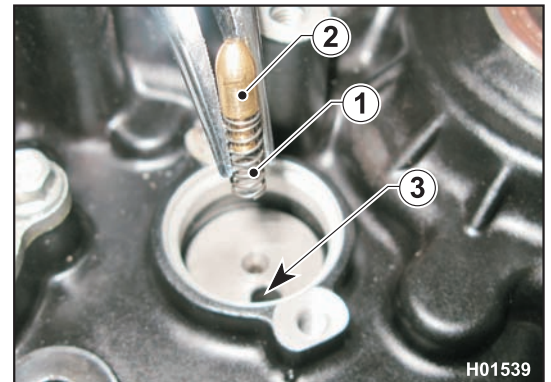

Fit the sensor (4); make sure to install the gasket. Tighten the screws (5) 8 N/m; 0.8 Kgm; 5.8 ft/lb.

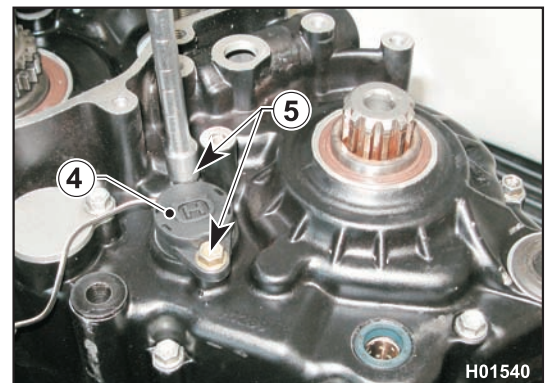

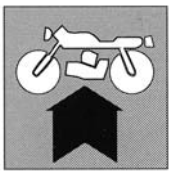

ENGINE REASSEMBLY

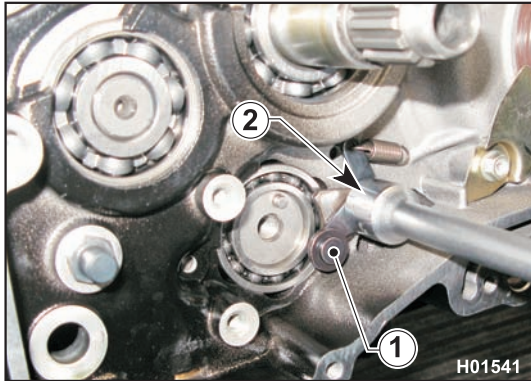

Gear shift control assembly

Install the ratchet (1) and tighten the screw (2) (13 mm wrench; 28 N/m; 2.8 Kgm; 20.65 ft/lb).

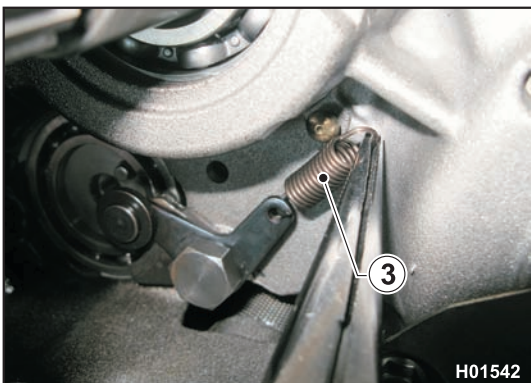

Engage the spring (3) with the suitable pin.

Install the selector drum (4) making sure the tab (5) locates in the recess (6) and secure drum with its screw (7). (Apply Loctite 243, tighten to 28 Nm; 2.8 Kgm; 20.65 ft/lb using a 12 mm wrench).

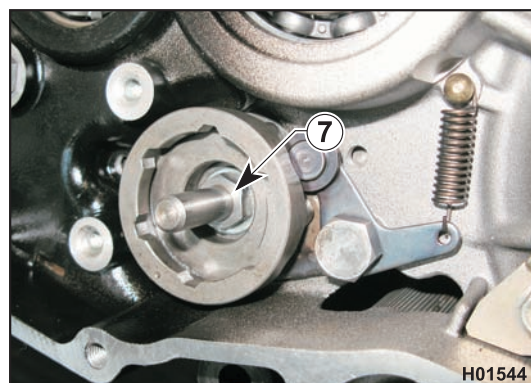
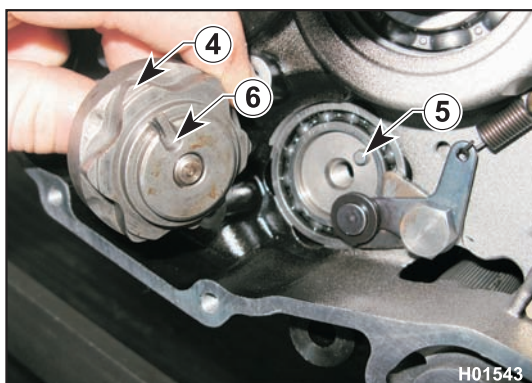

ENGINE REASSEMBLY

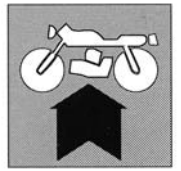

Operate shifter and transmission shaft to test gearbox for proper operation.
Refit the ratchet assembly (8) together with the plate, making sure ratchets and springs are in the correct positions.

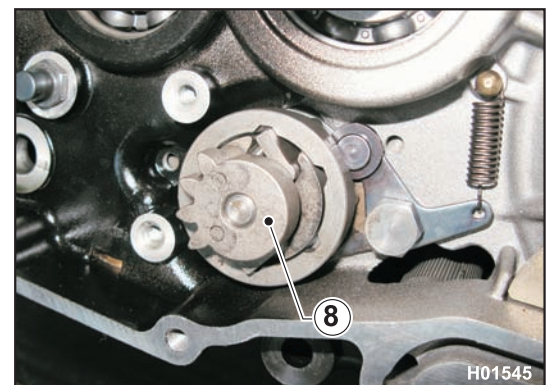
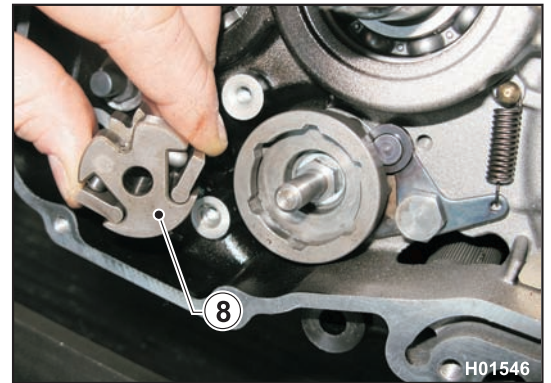

Tighten the screws (9) of plate (10) using a 4 mm Allen wrench (Loctite 243; 9.3 Nm; 0.93 Kgm; 6.85 ft/lb).

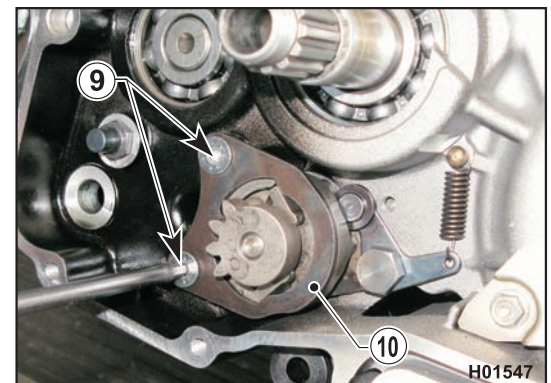

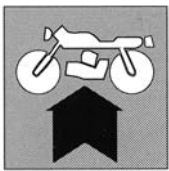

ENGINE REASSEMBLY

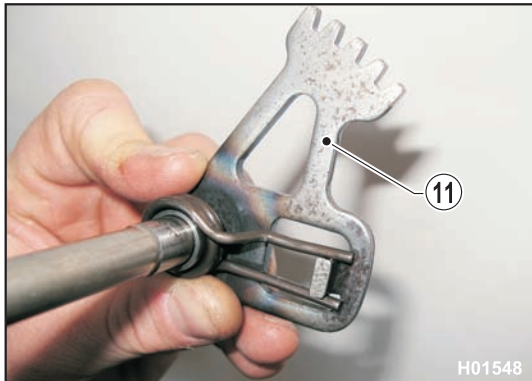

Make sure the spring (11) of the gear shift lever shaft is positioned correctly.

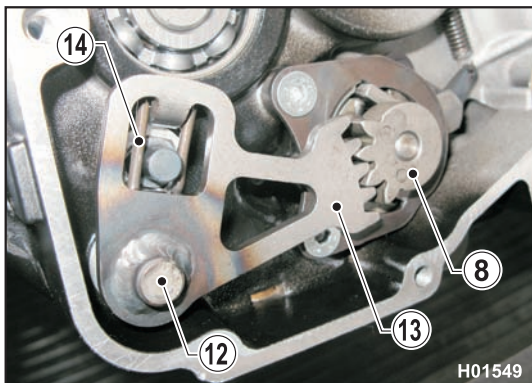

Lubricate the shaft with engine oil and insert the shaft (12) into the crankcase so that the teeth (13) mesh with sector gear (8) teeth and spring (14) locates to its abutment pin.

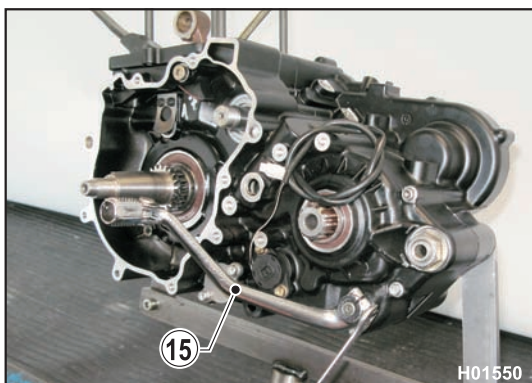

Install the gear shift lever (15) and operate the gearbox manually (10 mm wrench; 9 Nm; 0.9 Kgm; 6.64 ft/lb).



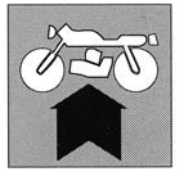

Crankshaft gears installation.

Fit the countershaft driving gear (1) to the crankshaft with the timing dot facing out.

Fit the input shaft driving gear (2) with the bevelled side facing out.

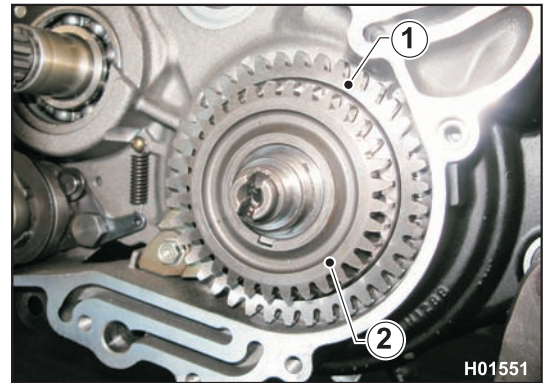

Countershaft weight/gear installation.

Fit the countershaft gear (1) line up its dot with that of the crankshaft gear (2) to set timing.

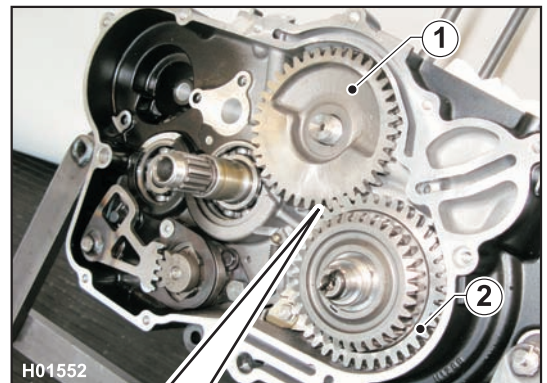

Fit the lock washer (3) onto the gear making sure the tab locates into the key-way.

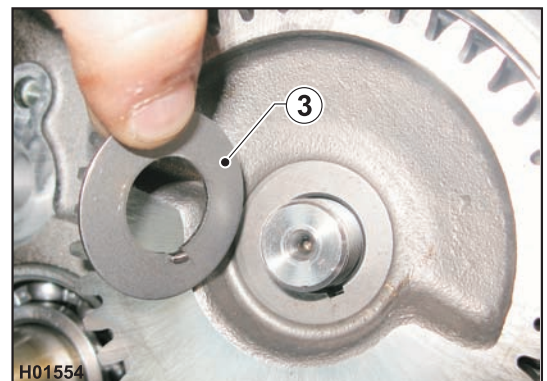

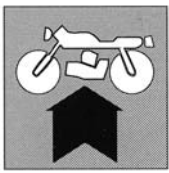

ENGINE REASSEMBLY

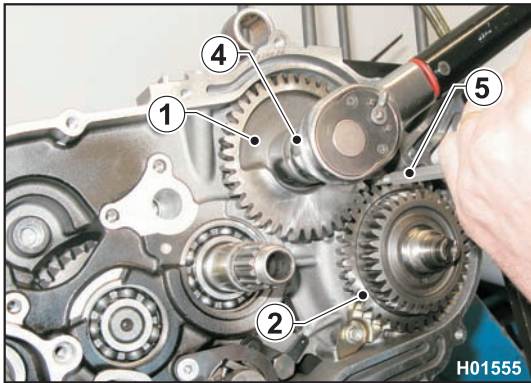

Tighten the nut (4) with a 27 mm wrench to 70 N/m; 7 Kgm; 51.58 ft/lb placing an aluminium shim (5) between countershaft gear (1) and crankshaft gear (2).

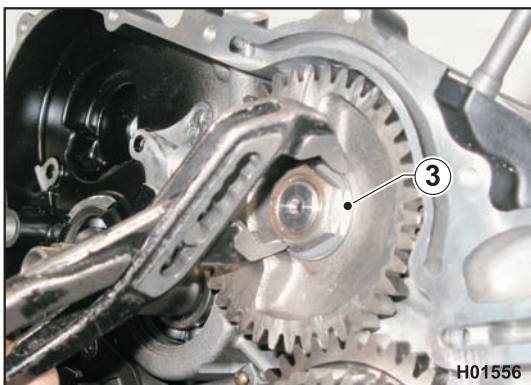

Bend the lock washer (3).

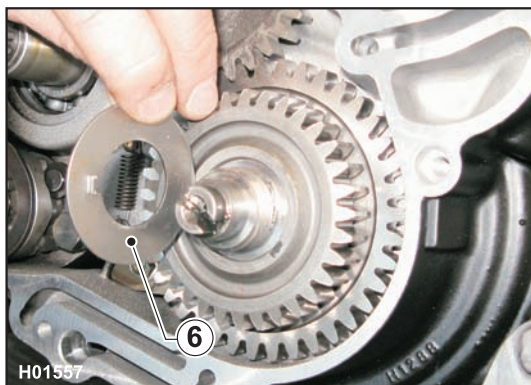

Fit the lock washer (6) onto the crankshaft gear making sure the tab locates into the keyway.

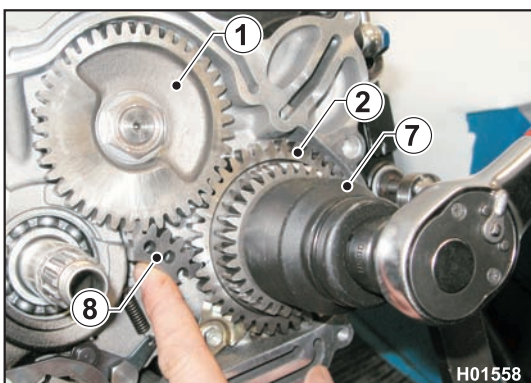

Tighten the nut (7) with a 38 mm wrench to 100 N/m; 10 Kgm; 73.69 ft/lb placing a half gear (8) between countershaft gear (1) and crankshaft gear (2).



ENGINE REASSEMBLY

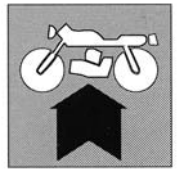

Turn the engine over.

Fit the counterweight (9) to the countershaft.

Fit the lock washer (10) onto the shaft making sure the tab locates into the keyway.

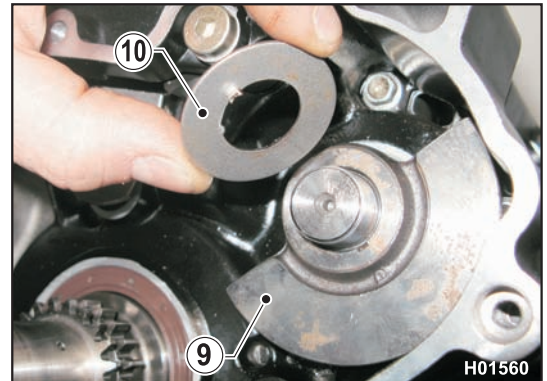

Tighten the nut (11) with a 27 mm wrench to 70 N/m; 7 Kgm; 51.58 ft/lb placing a half gear at the opposite side of the engine between countershaft gear (1) and crankshaft gear (2).

Bend the lock washer (10).

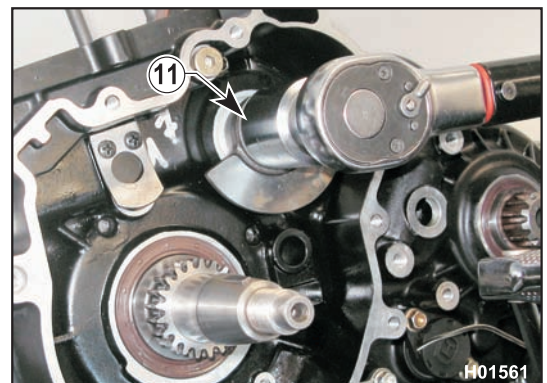

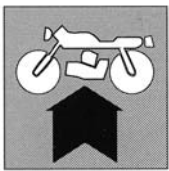

ENGINE REASSEMBLY

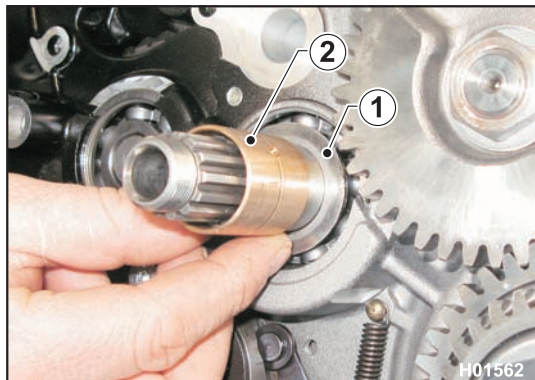

Clutch assembly

Slide washer (1) and bushing (2) over the shaft (lubricate with engine oil).

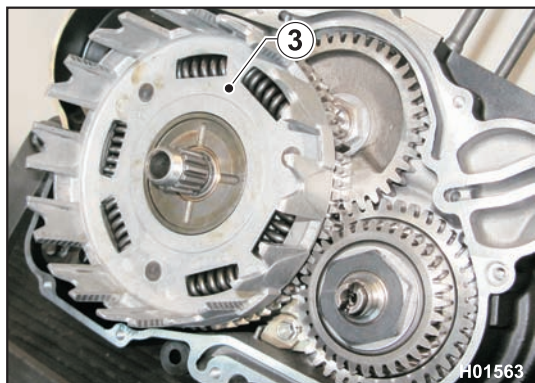

Lubricate the shaft with engine oil and fit the clutch housing (3).

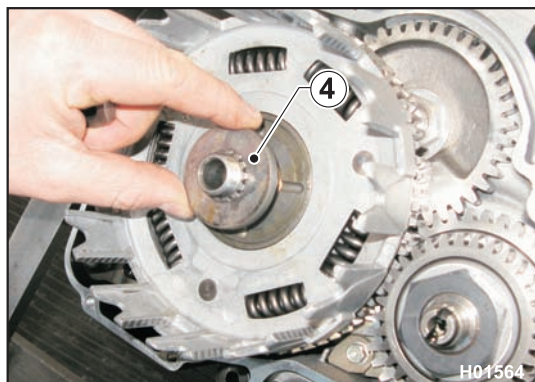

Fit the splined spacer (4).



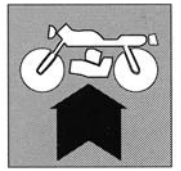

Fit the clutch hub (5) and its lock washer (6).

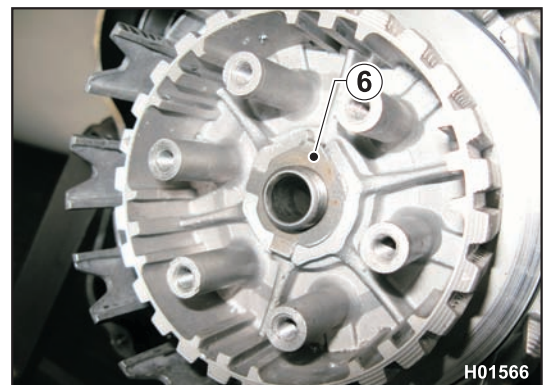
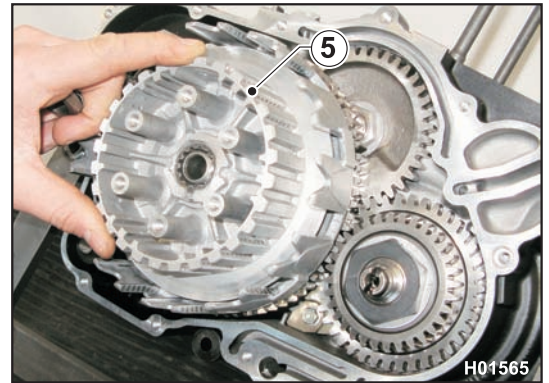

Use the suitable tool (7) to prevent rotation and tighten the nut (8) with a 27 mm wrench to 61.7 Nm; 6.17 Kgm; 45.47 ft/lb.

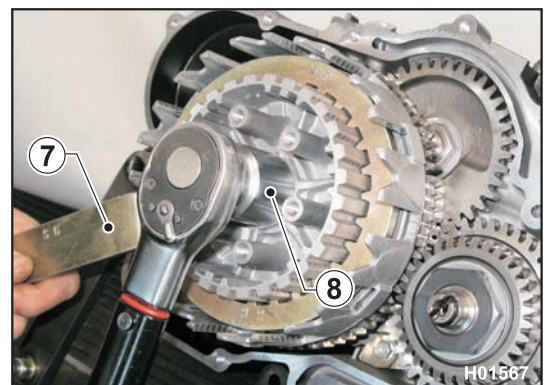

Bend the lock washer (6).

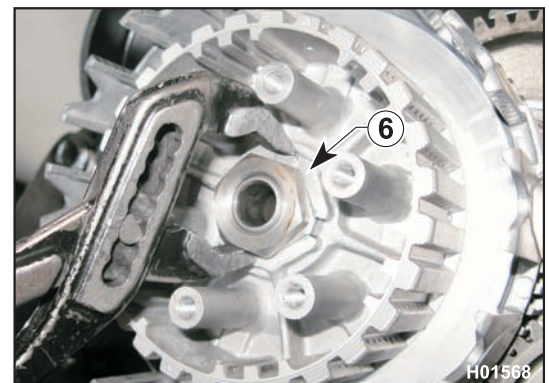

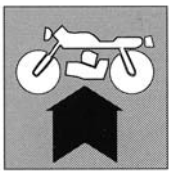

ENGINE REASSEMBLY

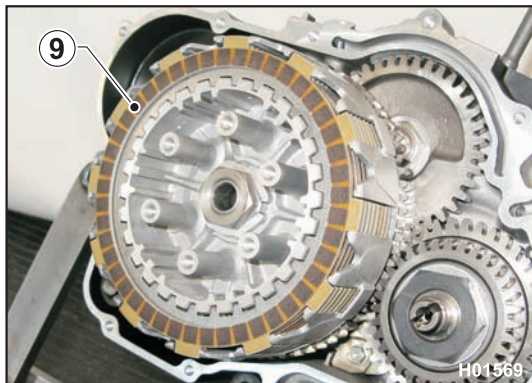

Refit the plates (9) (install a friction plate first and then a steel plate and keep alternating between friction and steel plates; the last to go in should be a steel plate). Fit actuator plate (10), thrust bearing (11), thrust washer (12), pressure plate (13) and springs (14). Tighten the spring screws (15) gradually in a cross pattern (5 Nm, 0.5 Kgm, 3.6 ft/lb).

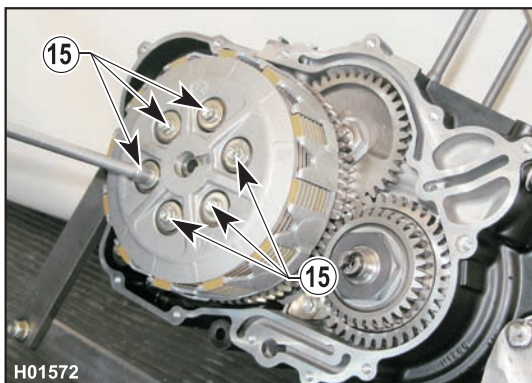
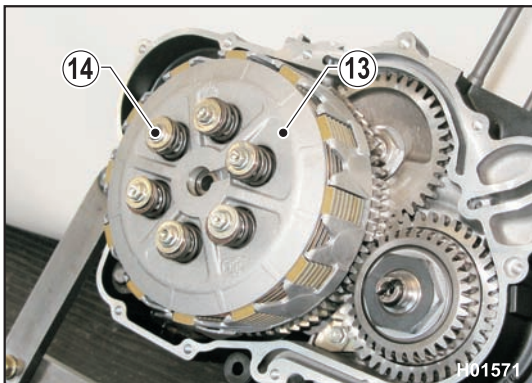
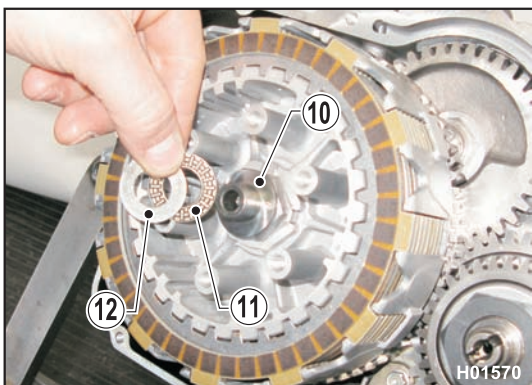

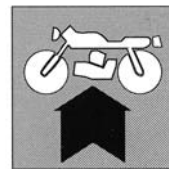

Piston ring installation

Fit the piston rings as shown in the diagram. If the piston ring is marked on one side, that side must be facing up.

*: position of end gap "d"

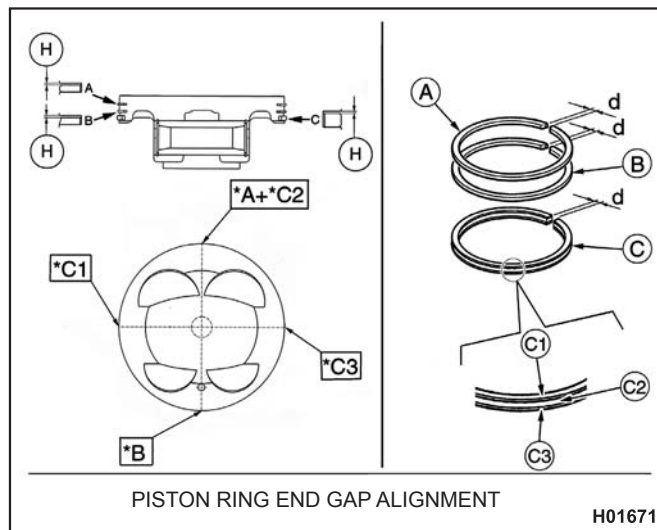

Piston and cylinder installation

Remove the cylinder protection (1).
Install a new cylinder foot gasket (2).

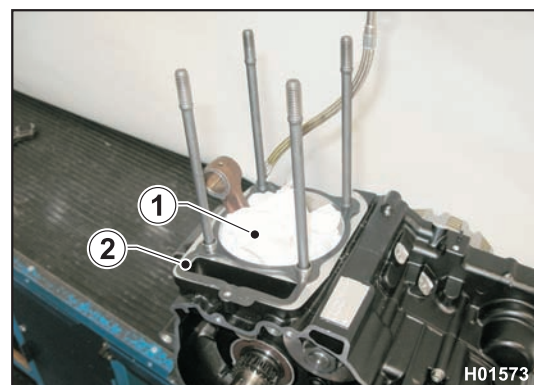

Assemble piston (3) to connecting rod (4) (lubricate with engine oil) and fit the piston pin retaining rings (5).

Make sure the arrow mark on the piston is pointing to the front end.

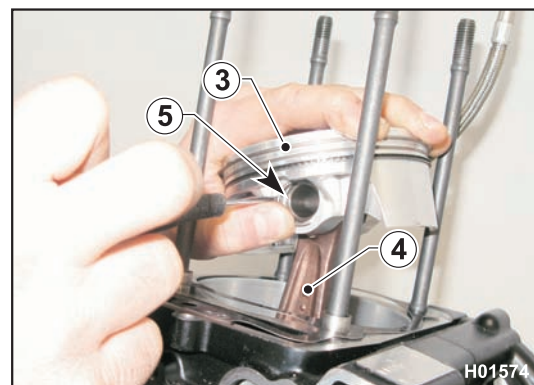

Make sure that the locating pins (6) are in place.



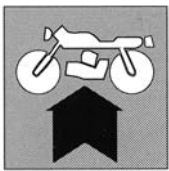

ENGINE REASSEMBLY

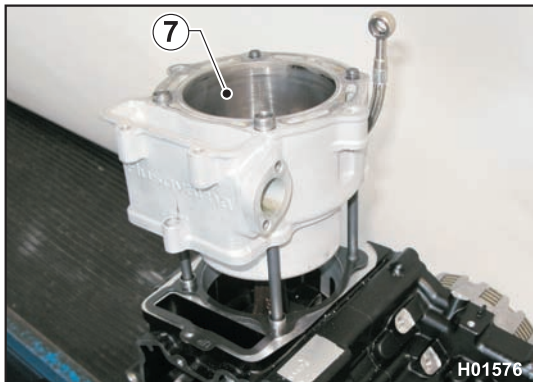

Lubricate the cylinder liner (7) with engine oil and slide it over the piston rings.

Fit the two locating bushings (8).

Secure the cylinder (7) to the crankcase tightening screw (9) with an 8 mm wrench (see Section "X" for tightening torque figures).

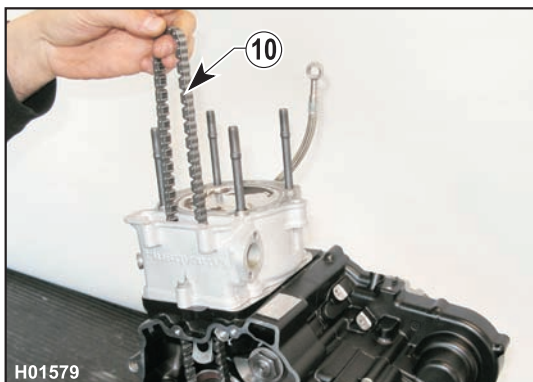
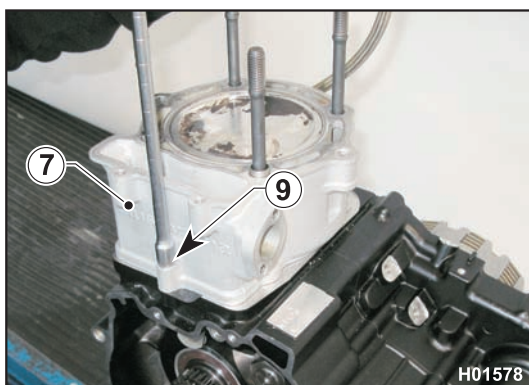
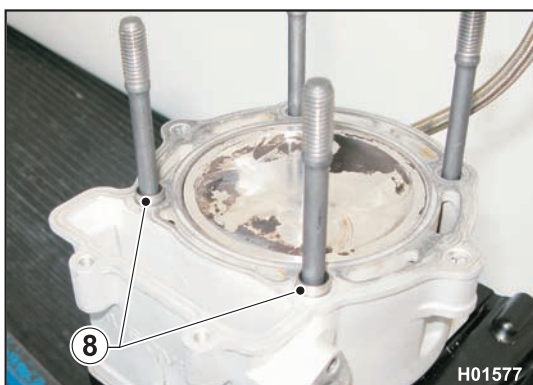

Install the timing chain (10).

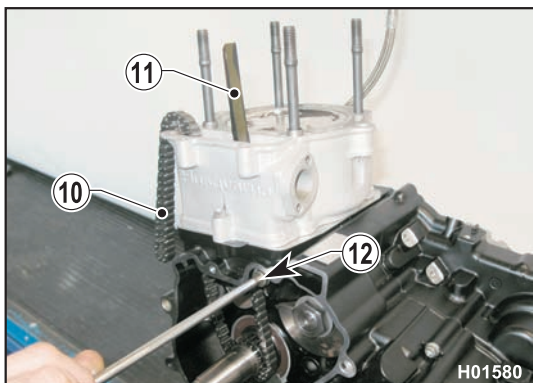

Position the slider (11) and tighten screw (12) using a 5 mm Allen wrench (see Section "X" for tightening torque figures).



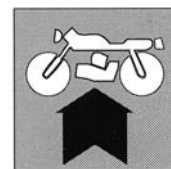

Fit screws and spacers (13) to temporarily secure the cylinder liner (7).
(2 spacers)

Use a 10 mm Allen wrench; 25 Nm; 2.5 Kgm; 18.44 ft/lb.

Make sure that the piston is at Top Dead Centre.

Measure distance "A" on the two machined faces "B" of the piston and choose the appropriate head gasket according to the table.

Remove spacers and screws (13) and fit the appropriate head gasket.

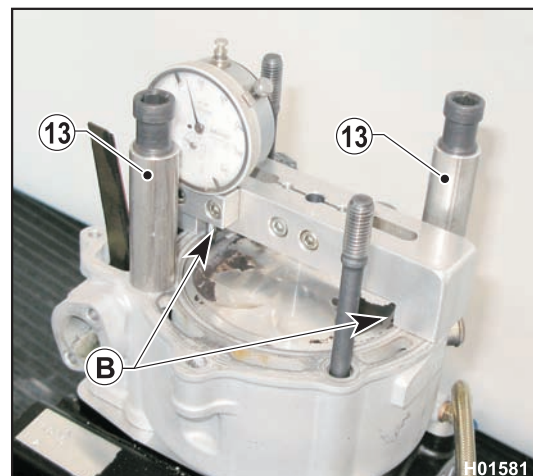

Cylinder head gasket selection table

Bring piston to T.D.C. at the end of the compression stroke, measure distance "A" between piston crown and head gasket mating face and select the appropriate gasket according to the table below.

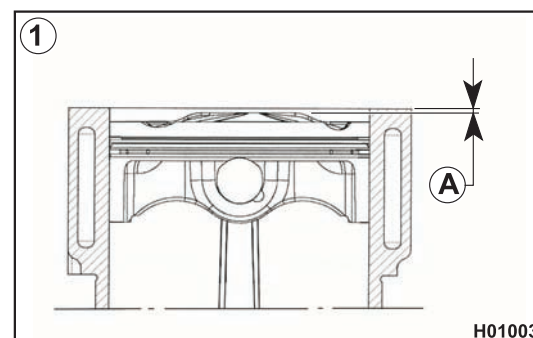

CONDITION (see diagram)	"A"	Gasket thickness	Gasket part no.
1) (piston lower than cylinder mating face)	-0.5 ± 0.05 mm	1.1 mm	8A00 H0937
1) (piston lower than cylinder mating face)	-0.6 ± 0.05 mm	1 mm	8B00 H0937
1) (piston lower than cylinder mating face)	-0.4 ± 0.05 mm	1.2 mm	8000 H0937



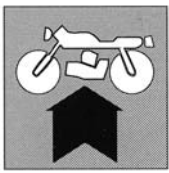

ENGINE REASSEMBLY

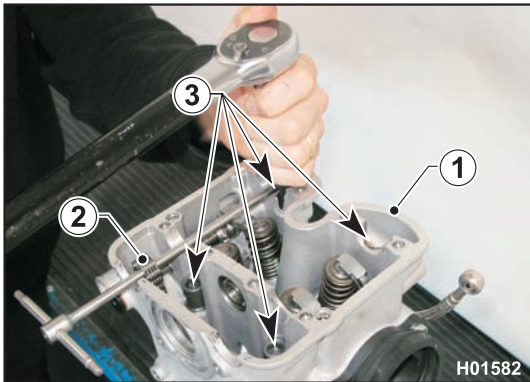

Cylinder head installation

For valve installation instructions, please see Section "G".

Always use a new head gasket on assembly: see the "Cylinder head gasket selection table".

Install the head (1) while supporting the timing chain (2) with a tool. Tighten the head bolts (3) gradually in a cross pattern to 38 Nm+90°; 3.8 Kgm+90°; 28.03 +90° ft/lb (using a 10 mm Allen wrench).

Tighten the two head to cylinder nuts (4) at the sides with a 13 mm wrench (see Section "X" for tightening torque figures).

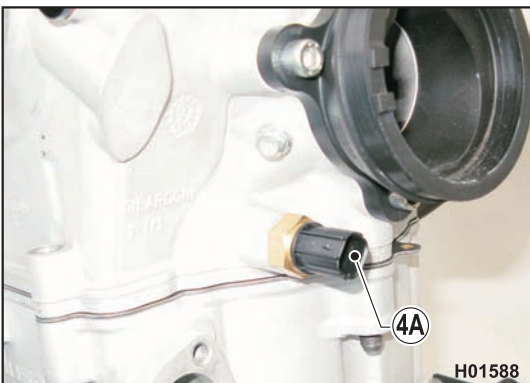
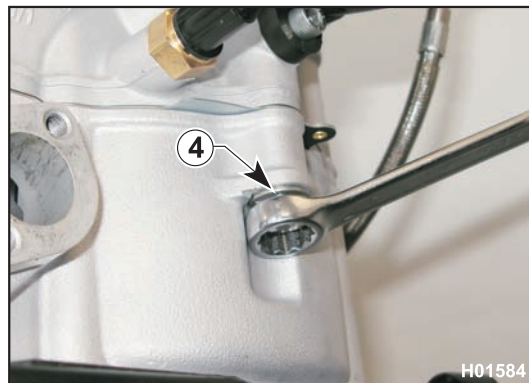
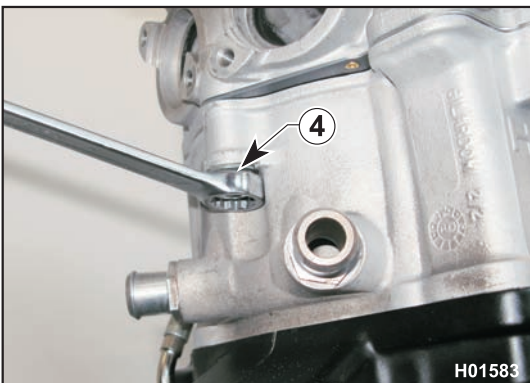

Refit the cooling water temperature sensor (4A) using a 17 mm ring wrench; 15 Nm; 1.5 Kgm; 11.6 ft/lb).

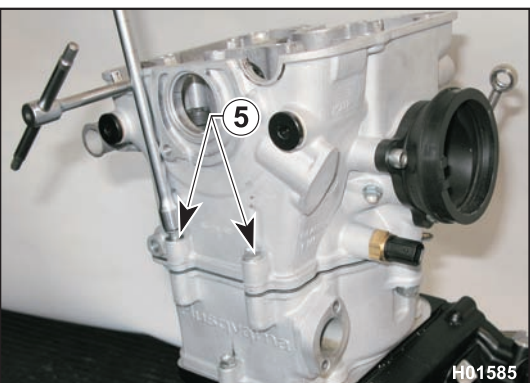

Tighten the two head to cylinder bolts (5) with an 8 mm wrench (see Section "X" for tightening torque figures).



ENGINE REASSEMBLY

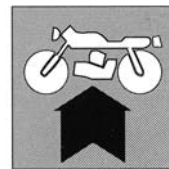

Insert the fixed slider (6) and secure it into place tightening the retaining screw (7) with a 5 mm Allen wrench (see Section "X" for tightening torque figures).

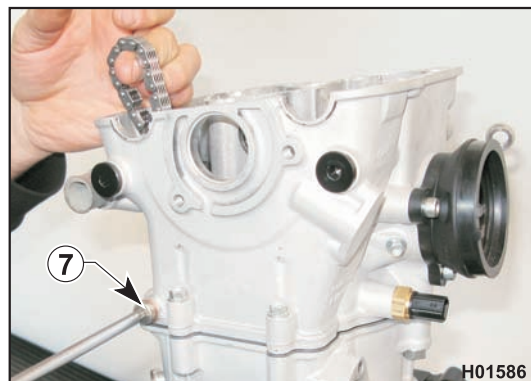
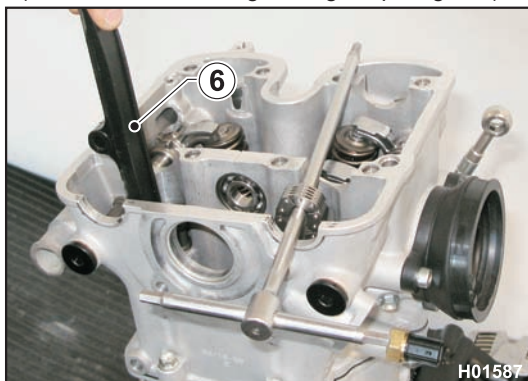

Refit the four shims (8) on the valves as marked on removal.

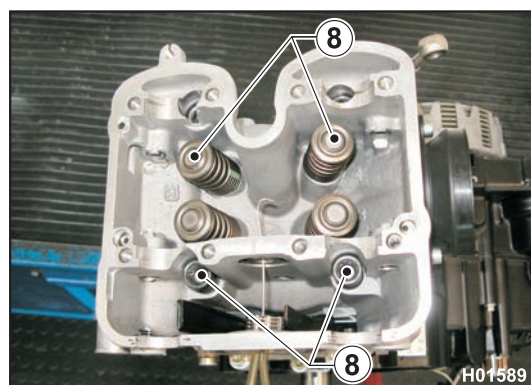

Fit the shafts (9) of the rocker arms (10) as marked on removal with the slotted end facing outwards.

Tighten the screws (11) with a 6 Allen wrench (see Section "X" for tightening torque figures).

Fit the two spring spacers (12).

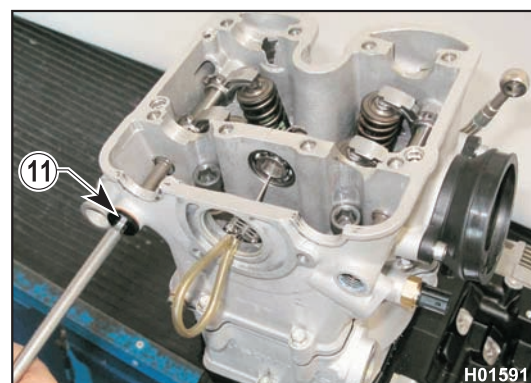
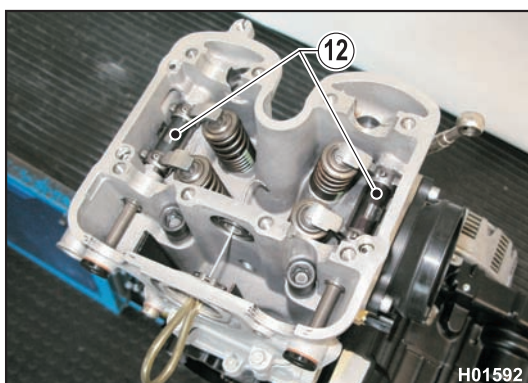
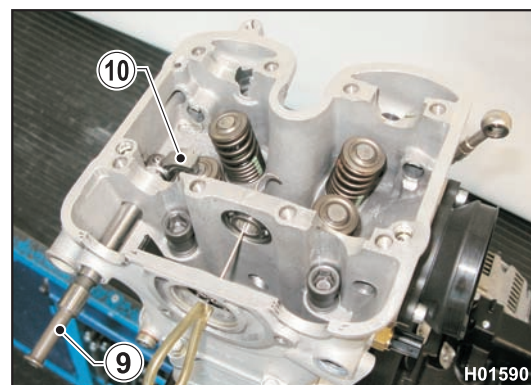

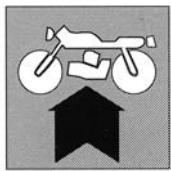

ENGINE REASSEMBLY

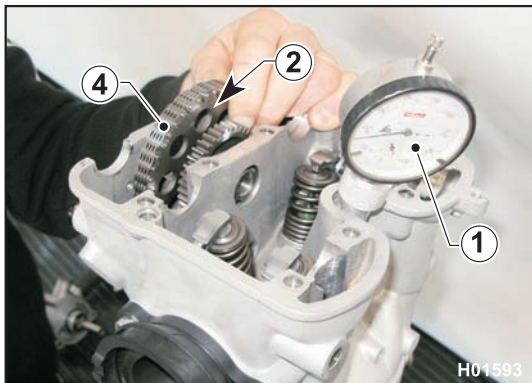

Water pump installation

Secure a dial gauge (1) to the spark plug hole.

Turn the crankshaft manually until bringing the piston to Top Dead Centre.

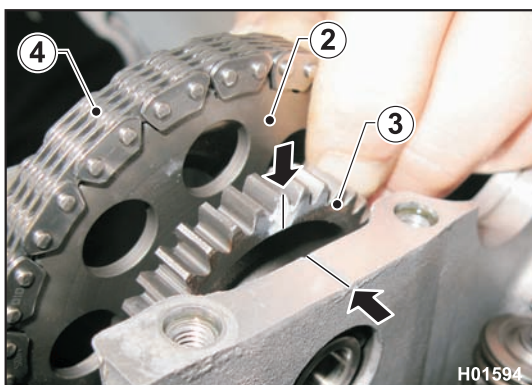

Insert the timing drive gear (2) into the head lining up the notch on the camshaft drive gear (3) with the notch on the head mating face.

Install the chain on the gear (4).

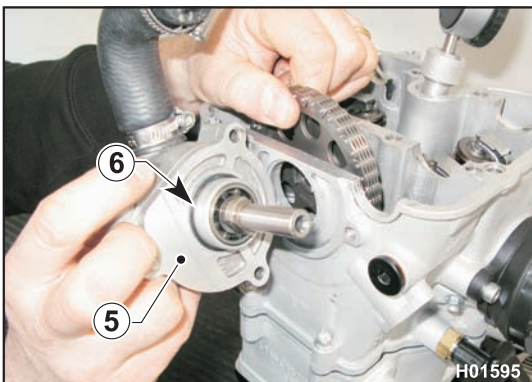

Fit the water pump (5) to the head; check the O-ring (6) for damage.

Tighten the screws (7) with an 8 mm wrench to 8 Nm; 0.8 Kgm; 5.8 ft/lb + Loctite 542.

Connect the rubber hose (8) and tighten the clamp (9).

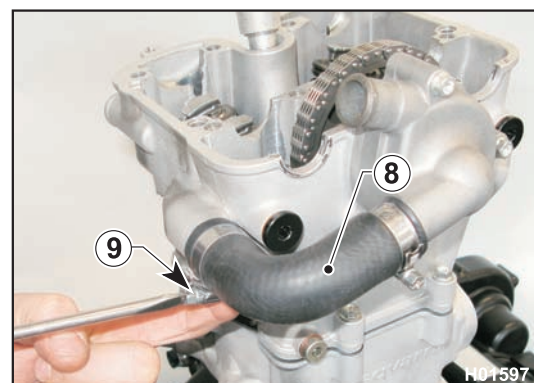
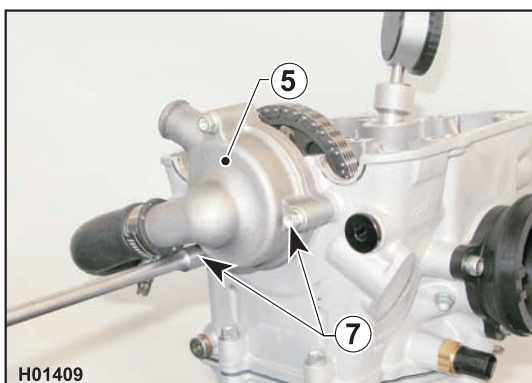

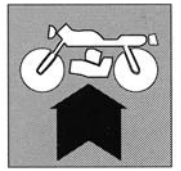

Timing chain tensioner installation

Refit the chain tensioner (1) and its gasket. Tighten the two screws (2) using an 8 mm wrench (10 Nm, 1.0 Kgm, 7.25 ft/lb).

Release the chain tensioner (1) using a screwdriver (turn counter clockwise).

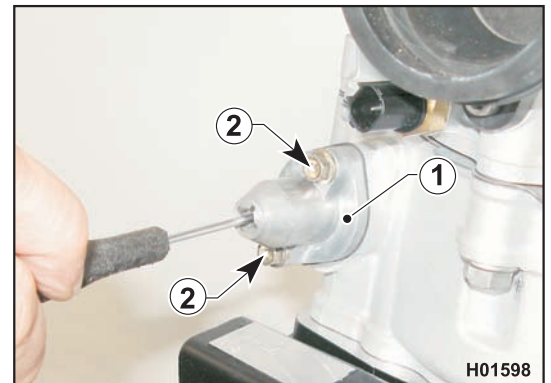

Refit the screw (3) with its washer (8 mm wrench).

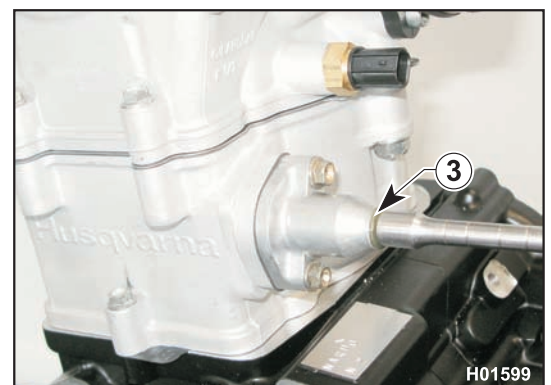

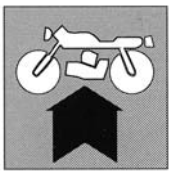

ENGINE REASSEMBLY

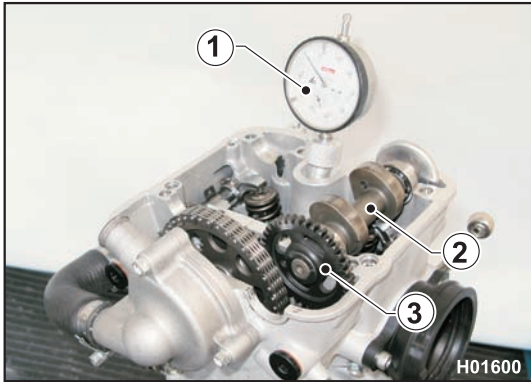

Camshaft installation

Secure a dial gauge (1) to the spark plug hole.

Turn the crankshaft manually until bringing the piston to Top Dead Centre.

Insert the camshaft drive gear (2) into the head lining up the dot on gear (3) with the head mating face. Make sure the dot on the inboard side of gear (3) is lined up with the dot on the left of the timing gear (4).

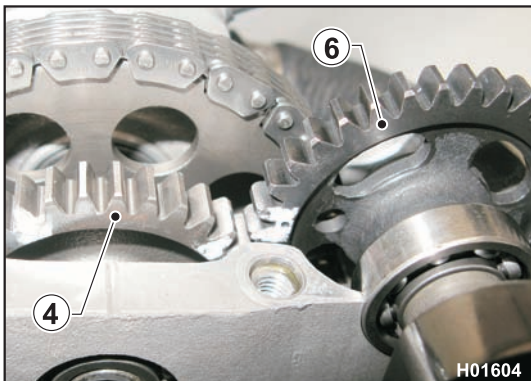
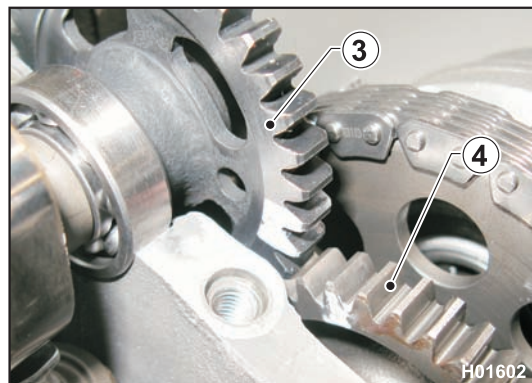
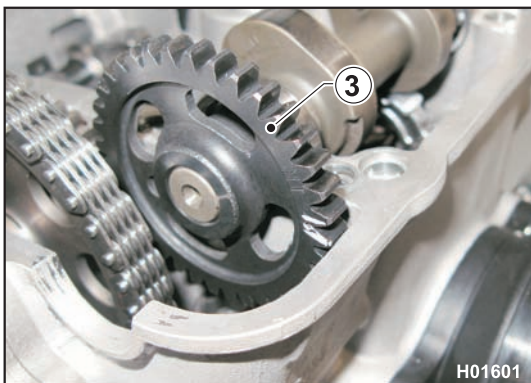

Install the exhaust camshaft (5) lining up the dot on gear (6) with the head mating face. Make sure the dot on the inboard side of gear (6) is lined up with the dot on the right of the timing gear (4).

Refit the oil pipe (7) with the curved end (7a) at the intake camshaft end.

Lubricate lobes, springs and rocker arms with engine oil.

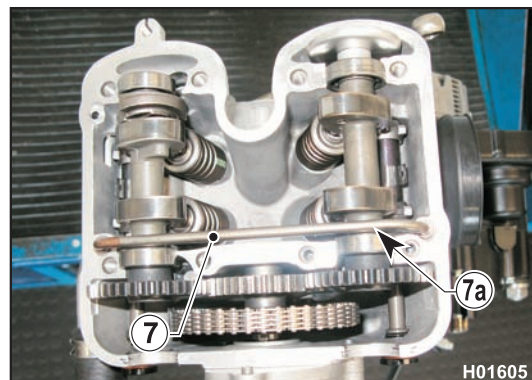
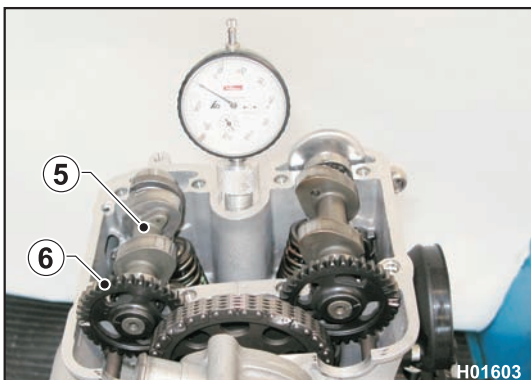

ENGINE REASSEMBLY

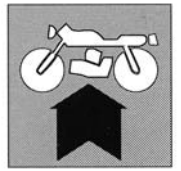

Make sure that the centring bushings are in place in the caps.
 Refit the camshaft caps (8) and tighten the screws (9) with a 5 mm Allen wrench;
 12 Nm; 1.2 Kgm; 8.85 ft/lb as marked on removal.

Apply a 38 mm wrench to the clutch side gear and turn the crankshaft manually
 a few turns to check for free, smooth rotation without any tight points, then bring
 it back to Top Dead Centre position.

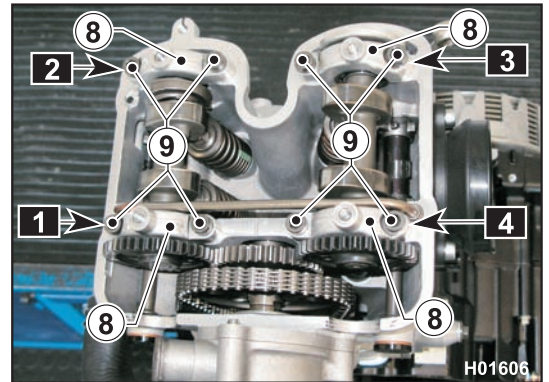

Use a feeler gauge (10) to check clearance between rocker arm and shim.
 Correct values are as follows:

- intake: 15 hundredths
- exhaust: 20 hundredths.

If clearance is not as specified, release the spring spacer using a hook, push
 aside rocker arm (11) and change the shim (12).



Replacement shims are available in a 1.60 mm to 2.60 mm thickness range, in
 0.05 mm increments.

Thickness (S) of the new shim is determined as follows:

$$S = (G1 - G) + S1$$

S = Thickness of new shim

G1 = Measured valve clearance

G = Specified valve clearance

S1 = Thickness of old shim

On assembly, check valve clearances.

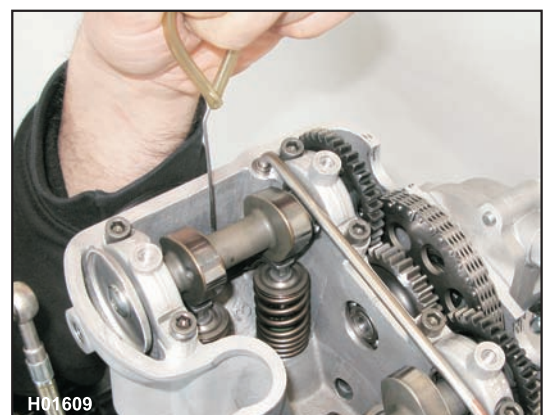
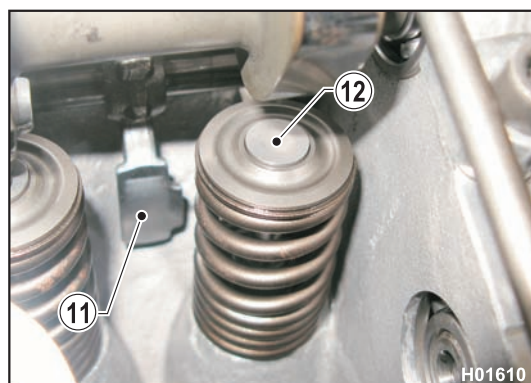
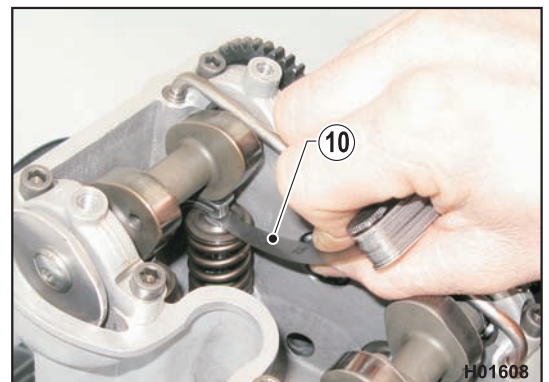

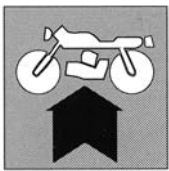

ENGINE REASSEMBLY

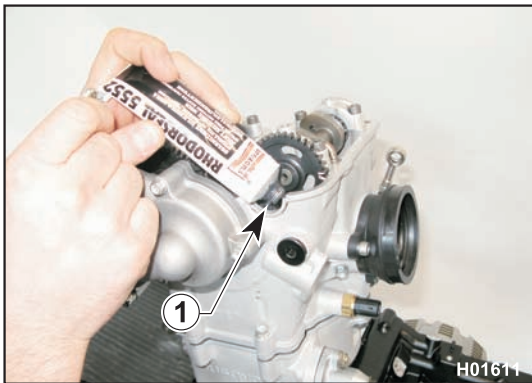

Cylinder head cover and spark plug installation.

Smear Arexons 5552 compound on the half-round cutouts (1).

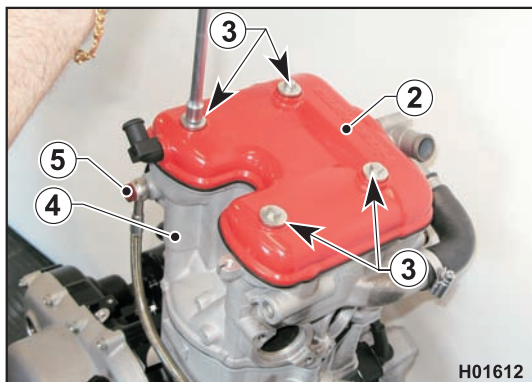

Refit head cover (2) and tighten the screws (3) in a cross pattern. 8 mm wrench, 8 Nm; 0.8 Kgm; 5.8 ft/lb.

Refit the lubrication pipe to the head (4) and tighten the drilled bolt (5). 8 mm wrench; 8 Nm; 0.8 Kgm; 5.90 ft/lb.

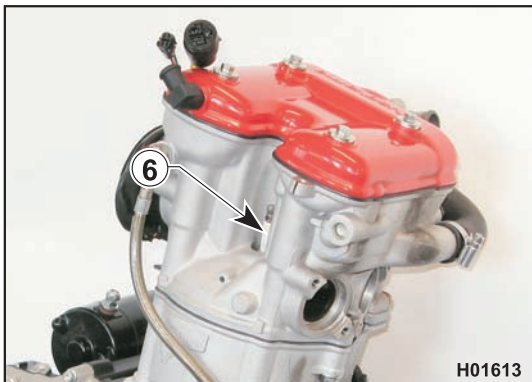

Refit the Spark plug (6); 10-12 Nm; 1.0-1.2 Kgm; 7.2-8.9 ft/lb.



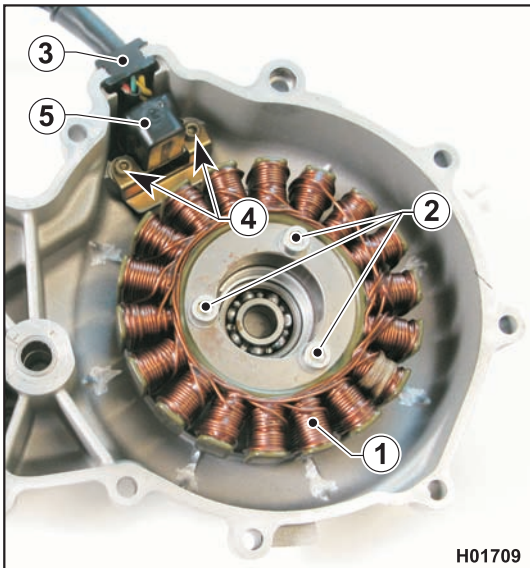
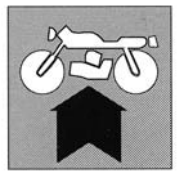

Flywheel and flywheel cover installation.

Install the stator (1) with its mark lined up with the flywheel cover mark and tighten the three retaining screws (2) (use a 5 mm Allen wrench; 8 Nm; 0.8 Kgm; 5.9 ft/lb + Loctite 272).

Insert the cable guide (3) into its seat in the cover and tighten the two retaining screws (4) of the pick-up sensor (5) with its plate using a 3 mm Allen wrench (3 Nm; 0.3 Kgm; 2.21 ft/lb + Loctite 272).



Make sure the two centring bushings (6) are in place.

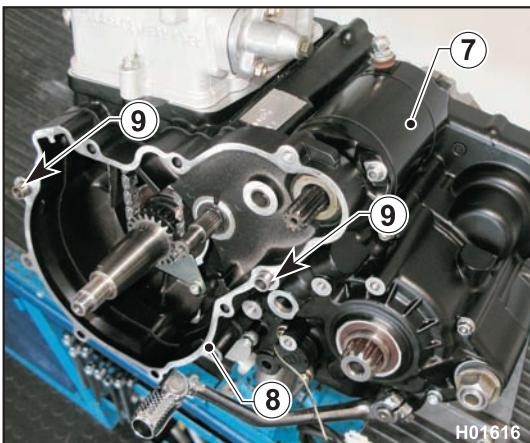
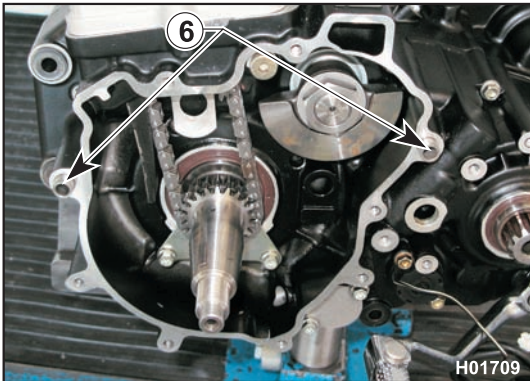

Fit the gasket to the crankcase, locate the starter motor (7) to its flange (8) and install on the crankcase.

Make sure the two locating bushings (9) are positioned correctly.

Fit washer (10) and roller cage (11) to the crankshaft.

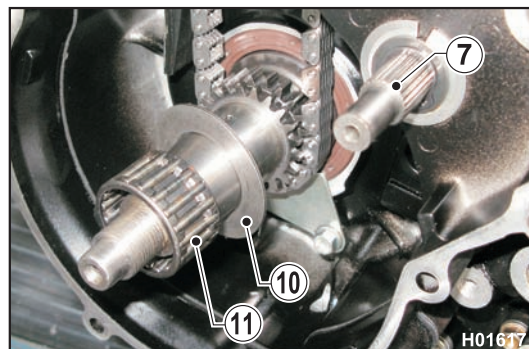

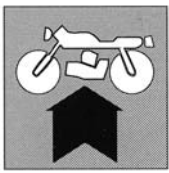

ENGINE REASSEMBLY

Fit the freewheel gear (12) to the flywheel (13) and tighten the screws (14) (5 mm Allen wrench) (see Section "X" for tightening torque figures).

Degrease crankshaft taper end and flywheel bore and smear crankshaft taper end with Loctite 270.

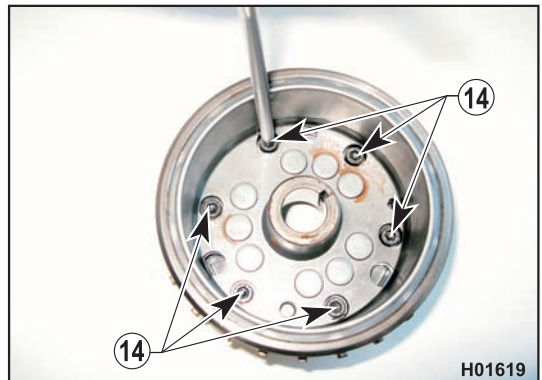
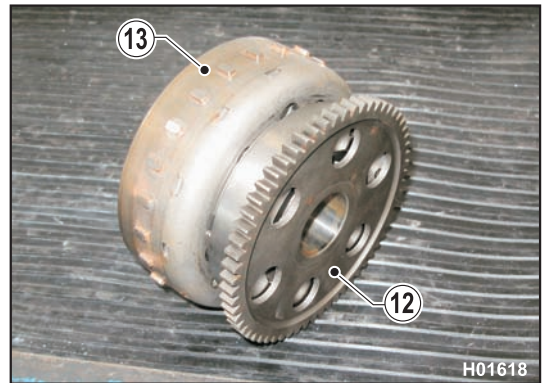

Install flywheel (13) together with drive gear (14).

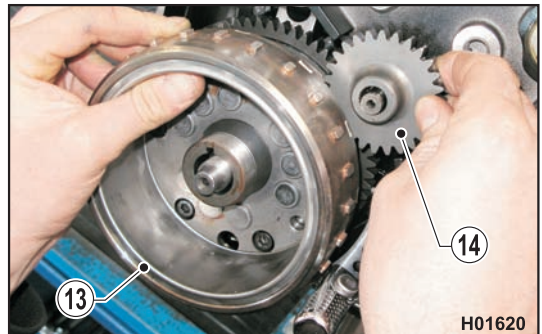

Fit washer (15) and nut (16) and tighten with a 24 mm wrench; 130 Nm; 13.0 Kgm; 95.89 ft/lb fitting a dummy gear to the crankshaft gears at the opposite end.

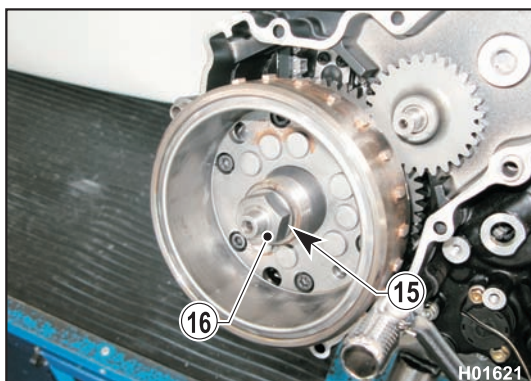

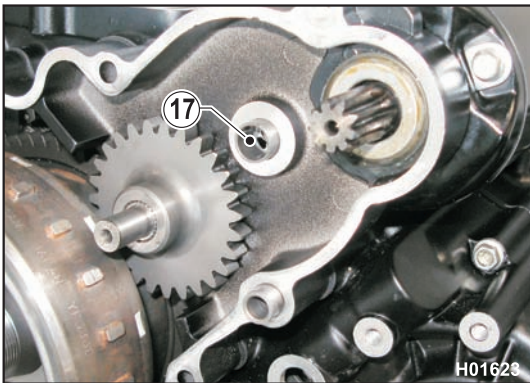
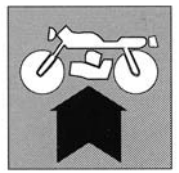

Fit bushing (17) and starter motor drive gear (18).

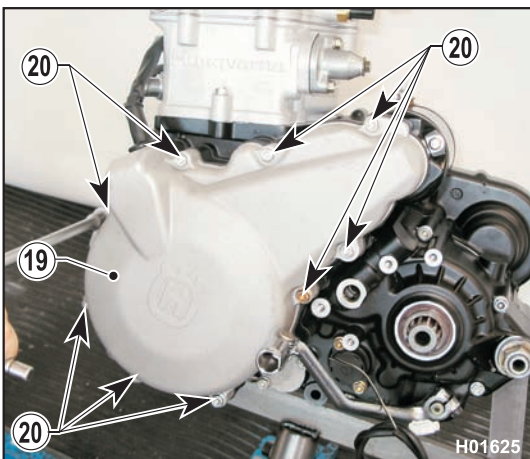
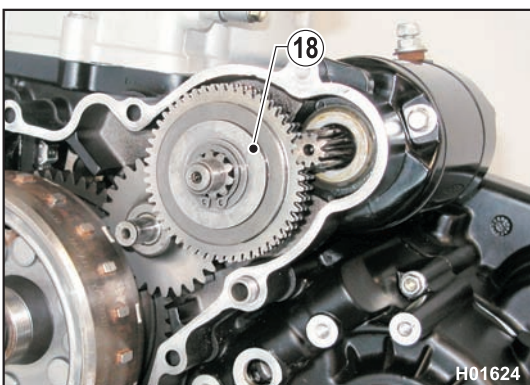

Install gasket and cover (19) and tighten the screws (20) in a cross pattern with an 8 mm wrench (see Section "X" for tightening torque figures). Screws (20) are not all the same length; make sure to refit them in their original positions.

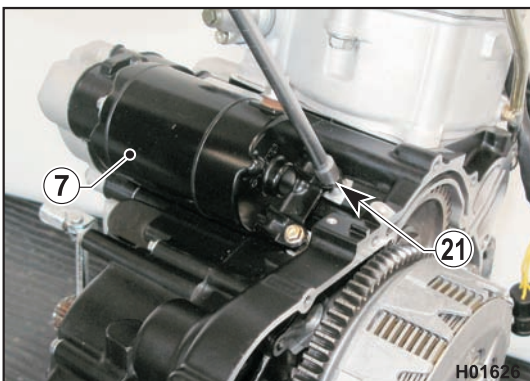

Secure starter motor (7) tightening screw (21). 8 mm wrench (see Section "X" for tightening torque figures).



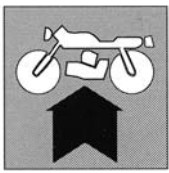

ENGINE REASSEMBLY

Sprocket installation

Fit the sprocket (1) and its circlip (2).

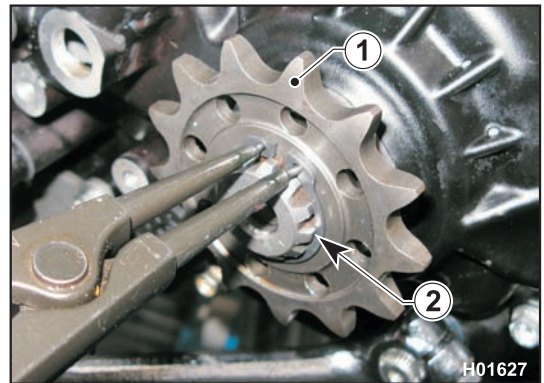

Oil pump and filter cartridge assembly

Assemble oil pump components in the order shown.

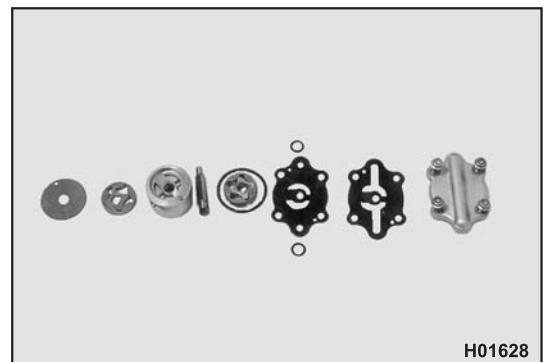

Secure the cover using the four screws (1) (9 Nm-0.9 Kgm-6.5 ft/lb).
Refit the filter cartridge (2) and secure the cover using the two screws (9 Nm-0.9 Kgm-6.5 ft/lb).

Fit a new gasket and install the complete cover (3) using the thirteen retaining screws (9 Nm-0.9 Kgm-6.5 ft/lb).

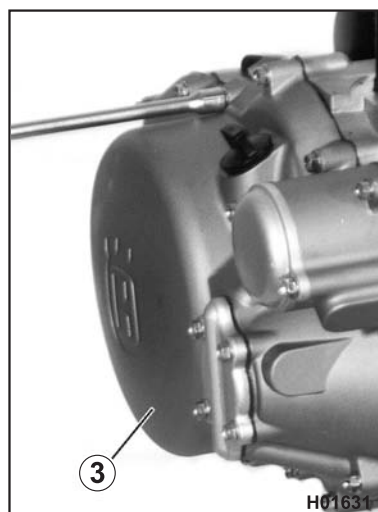
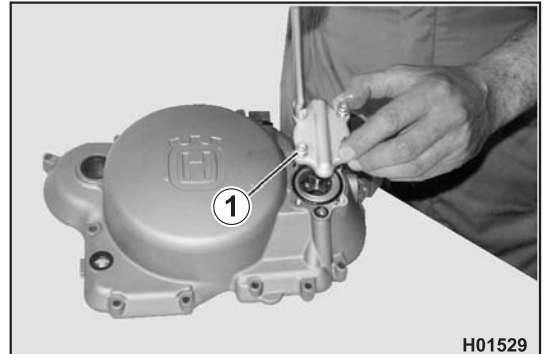

ENGINE REASSEMBLY

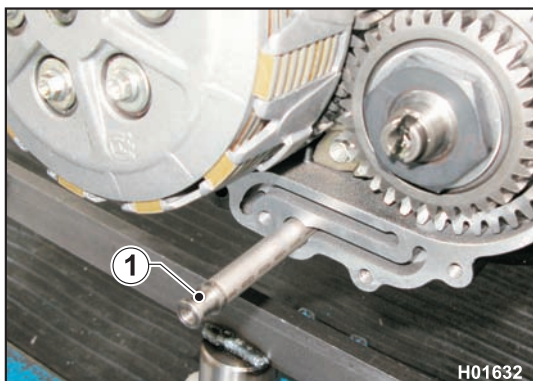
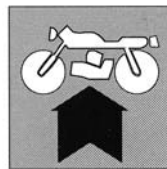

Right crankcase assembly

Fit the mesh filter (1) with the perforated end facing outwards.

Fit the two locating bushings (2) into the crankcase.

Refit the gasket (3).

Refit the cover (4) making sure to mate pump shaft (5) with the slotted end (6) of the output shaft (gently rock the sprocket to facilitate installation).

Tighten the screws (7) in a cross pattern with an 8 wrench (see Section "X" for tightening torque figures).

Screws (7) are not all the same length; make sure to refit them in their original positions.

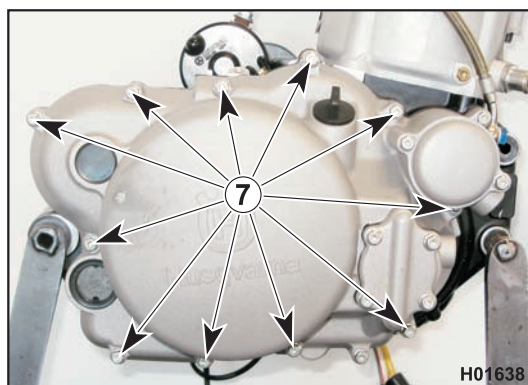
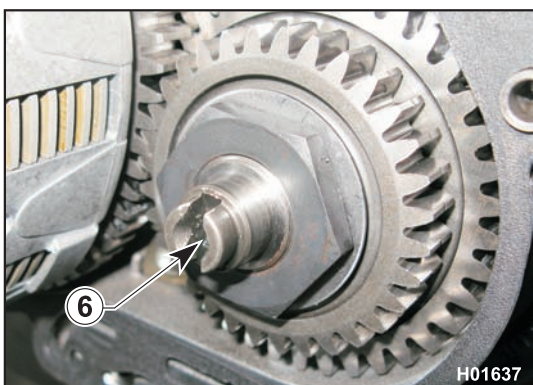
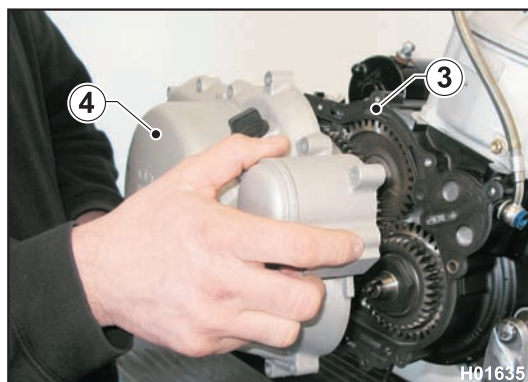
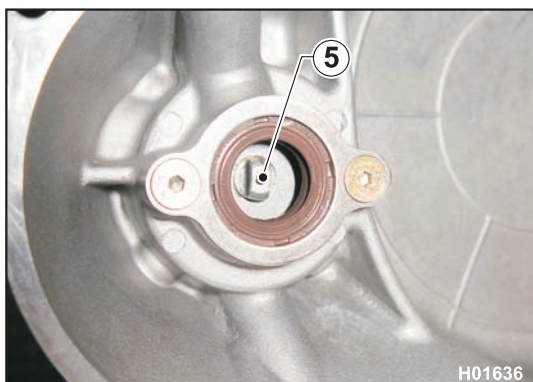
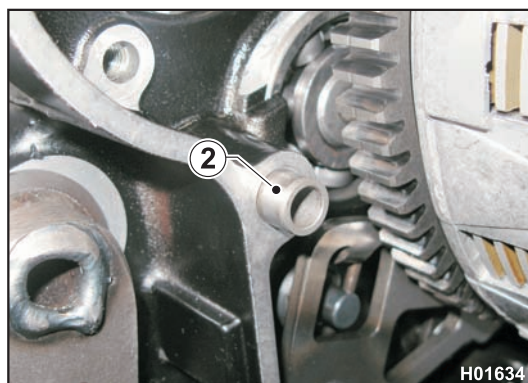
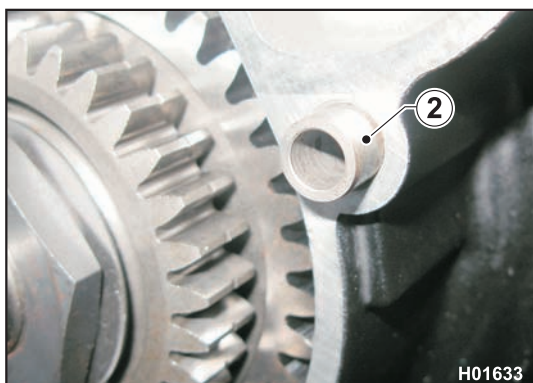

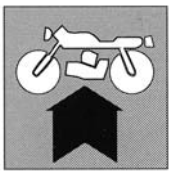

ENGINE REASSEMBLY

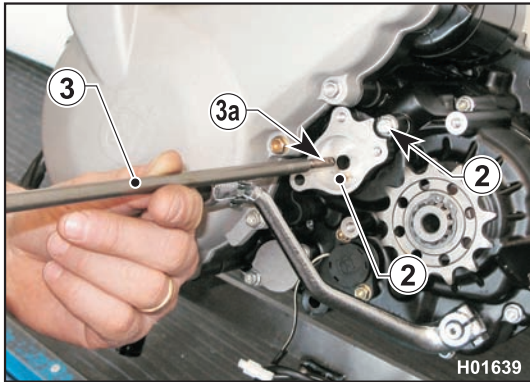

Clutch actuator installation

Refit the flange (1) and tighten the screw (2). 8 mm wrench (see Section "X" for tightening torque figures).

Insert the clutch pushrod (3) thinner end (3a) first.



FRONT SUSPENSION

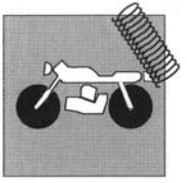

Section



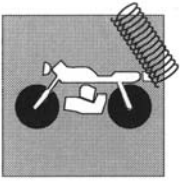

FRONT SUSPENSION

Front fork removal	1.4
Marzocchi manual	1.5



FRONT SUSPENSION

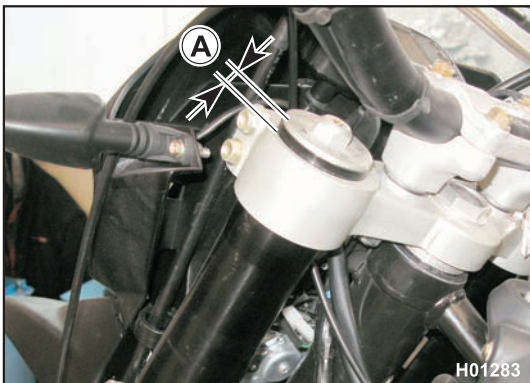
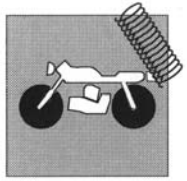

Front fork removal

Measure height "A" (it will need to be restored to original value on assembly). Set a block under the engine and see that the front wheel is lifted from the ground and then proceed as follows:

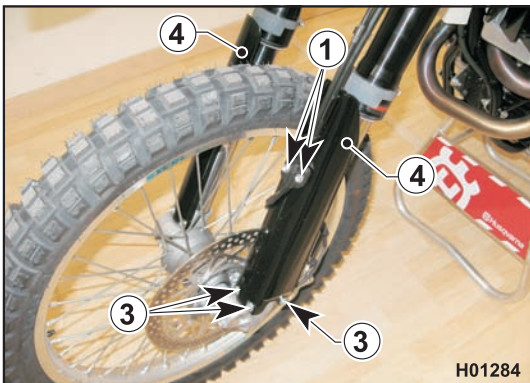

- remove the screws (1) and the brake line clamp (2) on the left-hand side;
- remove the six screws (3) and the fork leg guards (4);
- remove the brake calliper from the L.H. fork leg loosening the two retaining screws (5);
- remove the front wheel as described in Section "Y";

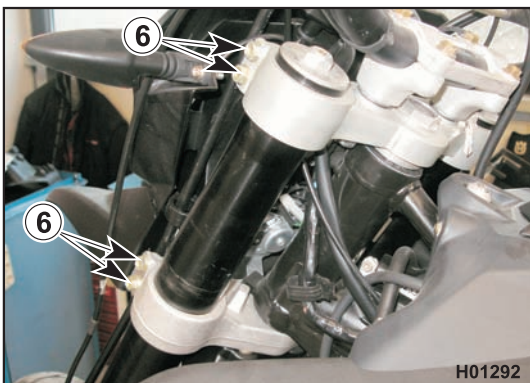
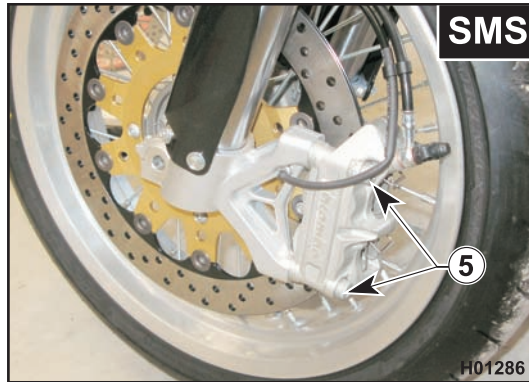
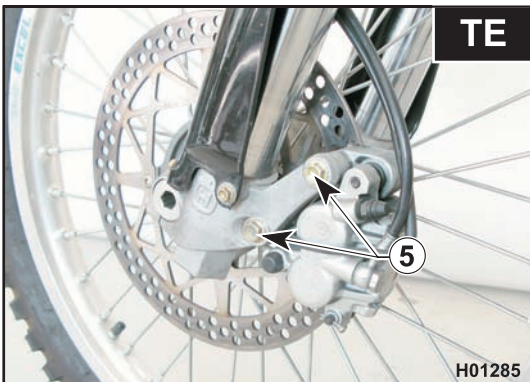

- loosen the bolts (6) that secure the fork legs to steering head and bottom yoke;
- remove the fork legs.

Refit the front wheel as described in Section "Y".

Set height "A" back to original value.

Refit the brake calliper tightening the screws (5) to 25.48 - 2.6 Kgm - 18.79 ft/lb and screws (6) to 25 Nm - 2.5 Kgm - 18.50 ft/lb.



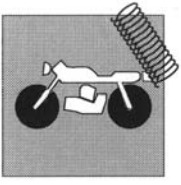

FRONT SUSPENSION



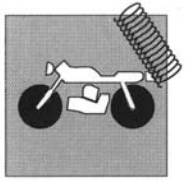

MARZOCCHI MANUAL



marzocchi

ISTRUZIONI PER L'USO E LA MANUTENZIONE
USE AND MAINTENANCE INSTRUCTION MANUAL
MODE D'EMPLOI ET ENTRETIEN
BETRIEBS- UND WARTUNGSANLEITUNG
INSTRUCCIONES PARA EL USO Y MANTENIMIENTO

SHIVER

45 Factory Works

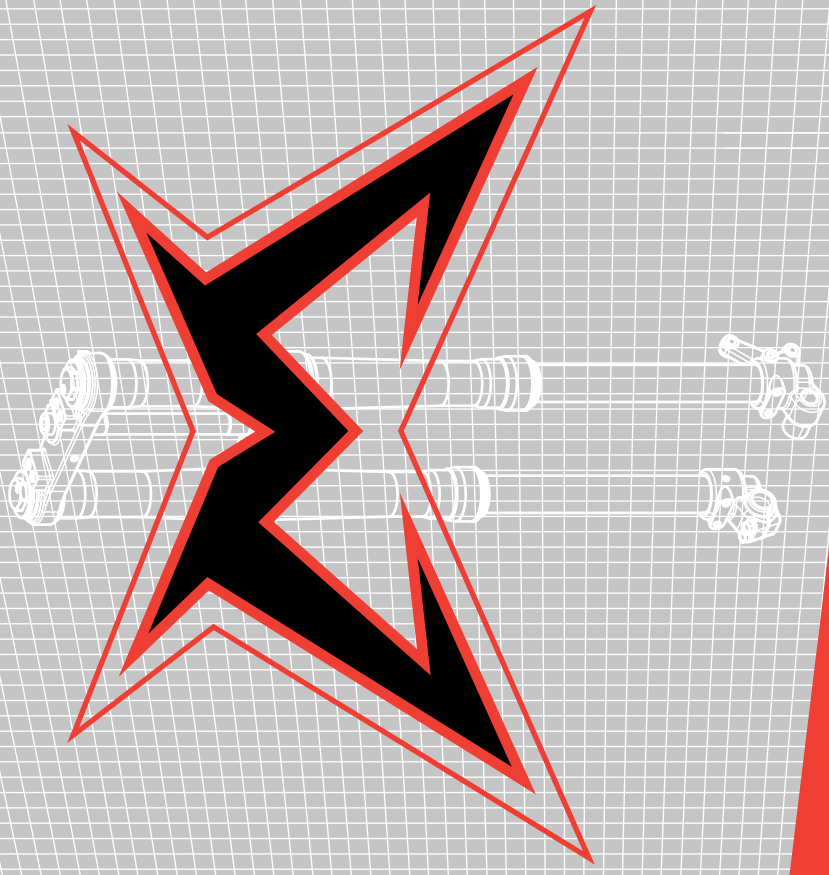

GENERAL WARNINGS FOR OWNERS MANUAL



WARNING

Failure to follow these instructions could result in failure of the product, an accident, personal injury or death.

1. USE OF THE MANUAL

- Carefully read, follow and understand the instructions given in this manual. It is an essential part of the product, and you should keep it in a safe place for future reference.
- If the use and maintenance instructions provided in this manual are not properly performed, or if the other instructions in this manual are not followed, an accident could occur, resulting in an accident, serious injury or death.
- Please be advised that suspension system installation and repair requires specialized knowledge, tools and experience. General mechanical aptitude may not be sufficient to properly install or repair your suspension system. Please have your suspension system installed and/or serviced only by your motorcycle retailer or an authorized Marzocchi Service Center.
- Never make any modification whatsoever to any component of your suspension system.

NORME DI SICUREZZA PER L'UTILIZZATORE DEL MANUALE



ATTENZIONE

La non corretta osservazione delle procedure indicate nel presente manuale, può provocare danni al prodotto, incidenti, infortuni o addirittura la morte del motociclista.

1. USO DEL MANUALE

- Leggere attentamente, comprendere e seguire scrupolosamente le istruzioni presenti in questo manuale. E' una parte essenziale del prodotto, e bisogna conservarlo in un posto sicuro in modo da poterlo consultare in futuro.
- Se le istruzioni di uso e manutenzione fornite in questo manuale non sono seguite diligentemente, può capitare un incidente più o meno serio, anche mortale.
- Ricordarsi che l'installazione e la riparazione della forcella richiedono una conoscenza molto approfondita, strumenti adeguati ed esperienza. Una semplice e generica attitudine alla meccanica può non essere sufficiente ad installare o riparare il sistema di sospensione correttamente. L'installazione e/o la manutenzione della forcella DEVE essere effettuata solo ed unicamente presso il proprio distributore di moto o presso centro autorizzato Marzocchi, ed utilizzando esclusivamente ricambi originali.
- Non intervenire in nessun modo sulla forcella o sui suoi componenti.

AVERTISSEMENT GENERAL POUR LES USAGERS DU MANUEL



ATTENTION

Le manque d'attention à ces instructions peut entraîner des dommages sur le matériel, des accidents, des lésions graves ou la mort.

1. USAGE DU MANUEL

- Lisez attentivement et suivez les instructions du manuel. Il fait partie intégrante du produit et doit être conservé à portée de main pour être consulté.
- Le fait de ne pas suivre scrupuleusement les instructions d'usage, d'entretien ou toute autres indications du manuel peut entraîner des accidents, des lésions graves ou la mort.
- Notez bien que l'installation et la réparation de tout système de suspension requièrent des connaissances spécifiques, des outils adaptés et de l'expérience. Les notions générales de mécanique ne sont pas suffisantes. Toutes les opérations d'installation, de réparation ou de modification doivent être effectuées dans son propre distributeur de moto ou un centre Marzocchi agréé.
- Vous ne devez jamais effectuer vous même une opération de réparation ou de modification du système de suspension.

SICHERHEITSHINWEISE FÜR DEN BENUTZER DES HANDBUCHS



ACHTUNG

Vorsicht diese Hinweise zusammen mit dem Gabelhandbuch durchlesen und die Anweisungen unbedingt beachten!

Eine nicht korrekt erfolgte Nutzung des Produktes nach dem vorliegenden Handbuch, kann zu schweren Unfällen oder auch schlimmstenfalls zum Tod führen.

1. ANWENDUNG DES HANDBUCHS

- Die in diesem Handbuch enthaltenen Anleitungen aufmerksam durchlesen; das Handbuch ist eine Bestandteil des Produktes und muss so aufbewahrt werden, dass auch in der Zukunft schnell darin nachgeschlagen werden kann.
- Eine nicht korrekte wie im vorliegenden Handbuch beschriebene Anwendung und Instandhaltung des Produktes, kann zu schweren Unfällen oder auch schlimmstenfalls zum Tod führen.
- Serviceeingriffe und Reparatur an der Federgabel, bedürfen der Kenntnis und der Erfahrung eines Fachmanns und den Einsatz von geeignetem Werkzeug. Eine allgemeine Kenntnis ist für die Reparatur und den Service einer Federgabel nicht ausreichend. Bitte lassen Sie Eingriffe an der Federgabel nur von einer Verteiler durchführen.
- Auf keinen Fall Änderungen an den Originalteilen des Produktes vornehmen und nur Originalersatzteile von Marzocchi verwenden.

ADVERTENCIAS GENERALES PARA USUARIOS DEL MANUAL



¡PRECAUCION!

La falta de atención a estas instrucciones puede causar daños en el material, accidentes, lesiones graves o la muerte.

1. USO DEL MANUAL

- Lea atentamente y siga las instrucciones del manual. Es una parte esencial del producto y debe mantenerlo siempre a mano para su consulta.
- El seguimiento incorrecto de las instrucciones de uso y mantenimiento o cualquier otra indicación puede causar accidentes, lesiones graves o la muerte.
- Tenga en cuenta que la instalación y reparación de cualquier sistema de suspensión requiere conocimiento específico, herramientas y experiencia. Las nociones generales de mecánica pueden no ser suficientes. Todos los trabajos de instalación o reparación deben llevarse a cabo por un tienda de motos o un Centro Marzocchi autorizado.
- Nunca debe hacerse ninguna modificación en ninguna pieza del sistema de suspensión.

A. GENERAL SAFETY RECOMMENDATIONS

- Be sure to use the correct suspension system for the terrain on which you ride. Check with your motorcycle retailer, or Marzocchi, for assistance in selecting the correct suspension system.
- **Please note that there are inherent risks associated with off road motorcycle riding, motocross and or cross country riding.** You could be seriously injured or killed while engaged in those riding styles. Learn how to ride, never ride beyond your capabilities, be sure to use the proper safety equipment, and be sure that all your riding equipment is in excellent condition.
- The lifespan of Marzocchi products depends on many factors, such as riding style and riding conditions. Impacts, falls, improper use or harsh use in general may compromise the structural integrity of the suspension system and significantly reduce its lifespan. Please have your motorcycle regularly inspected by a qualified mechanic for any oil leaks, cracks, deformation, or other signs of fatigue. The frequency of inspection depends on many factors; check with your motorcycle retailer or authorized Marzocchi representative to select a schedule that is best for you. The harder you ride, the more often you must inspect and maintain your suspension system. If the inspection reveals any deformation, cracks, impact marks, stress marks or bent parts, no matter how slight, immediately have a your motorcycle retailer or Certified Marzocchi Repair Center inspect the suspension system before you ride again.

A. AVVERTENZE GENERALI DI SICUREZZA

- Assicurarsi di utilizzare la forcella adatta al tipo di terreno dove si corre. Consultarsi con un distributore di moto o con Marzocchi per scegliere la forcella più adatta alle proprie esigenze.
- **Non dimenticare che ci sono rischi associati all' off road, motocross, cross country, rally e supermotard.** Praticando alcuni di questi stili si rischia l'infortunio o la morte. Imparate come andare in moto, non andare oltre le proprie abilità e i propri limiti, usare l'equipaggiamento di sicurezza appropriato, e assicurarsi che esso sia in perfette condizioni.
- La vita dei prodotti Marzocchi dipende da una serie di fattori, tipo lo stile di guida e le condizioni del terreno. Impatti, cadute, uso improprio o troppo aggressivo del mezzo possono compromettere l'integrità strutturale della forcella, e ridurre in modo significativo la sua durata. In caso di inconvenienti quali perdite d'olio, crepe, deformazioni o altri segni di usura, è consigliabile far controllare la forcella presso un meccanico specializzato. La frequenza dei controlli dipende da vari fattori; concordare con un centro riparazioni Marzocchi un programma per ogni singola esigenza. Più aggressivo è lo stile, più frequenti devono essere i controlli e la manutenzione sulla forcella. Se l'ispezione rivela una qualche deformazione, rottura o segni conseguenti ad un urto, di qualunque entità si tratti, conviene immediatamente rivolgersi ad centro autorizzato Marzocchi prima di utilizzarla di nuovo.

A. RECOMMANDATIONS GENERALES DE SECURITE

- Assurez-vous que votre fourche est prévue au genre de terrain ou on roule. Consulter Marzocchi a fin de choisir la fourche la plus appropriée a ses exigences.
- **On ne doit pas oublier qu'il y a des risques associés a l'off road, motocross, cross country, rally et supermotard.** Avec chacune de ces pratiques vous pouvez souffrir de lésions graves ou perdre la vie. Apprenez comment pédaler et ne dépasser jamais vos limites. Assurez vous d'utiliser le matériel de sécurité adéquat et vérifiez qu'il est en parfait état.
- La durée de vie des produits Marzocchi dépend de nombreux facteurs , comme le style de conduite et les conditions d'utilisations. Les coups, les chutes, l'usage inadéquat ou extrême en générale peut compromettre la sécurité et la solidité de la structure. Faites réviser votre fourche régulièrement et faites contrôler par un mécanicien qualifié si elle ne présente pas de fuite d'huile, de coup, de déformation, ou tout autre forme d'irrégularité. La fréquence des révisions dépend de nombreux facteurs. Un centre Marzocchi agréé peut vous recommander une fréquence d'entretien qui convient. Si la révision révèle quelque anomalie que ce soit, même minime, faites la contrôler immédiatement dans un centre technique Marzocchi avant de la réutiliser.

A. ALLGEMEINE SICHERHEITSHINWEISE

- Stellen Sie sicher, dass Sie die passende Federgabel an der besonderen Erde benutzen. Bitte lassen Sie sich durch den Fachhändler beraten um die passende Gabel zu finden.
- **Nicht vergessen, dass es Riska gibt, die mit Off Road, Motocross, Cross Country, Rally und Supermotard verbunden sind.** Nicht vergessen, dass verbunden mit den verschiedenen Fahrstilen, Situationen auftreten können, die zu schweren Unfällen führen können. Bitte auf keinen Fall die eigenen Fähigkeiten überschätzen. Immer die richtige Ausrüstung verwenden und sich versichern, dass sie sich in einwandfreiem Zustand befindet..
- Die Haltbarkeit der Marzocchi Produkte hängt von verschiedenen Umständen z.B. dem Fahrstil und der Beschaffenheit des Untergrundes ab. Stürze, Unfälle, falscher oder aggressiver Gebrauch können die strukturelle Integrität der Gabel und dadurch ihre Lebensdauer reduzieren. Bitte regelmäßig die Gabel durch einen Fachmann auf eine Öl-Leckage, Risse, eine Missbildung oder anderen Verschleiß kontrollieren. Die Häufigkeit der Kontrolle hängt vom Einsatzbereich ab. Hierzu bitte den Fachhändler zu rate ziehen, um die optimale Vorgehensweise abzustimmen. Falls die Prüfung einige Schäden oder auch nur die Vermutung eines Schadens zeigt , ist es gleichgültig wie schwer die Schade ist, man muss sofort ein Fachhändler vor einer weiteren Nutzung aufgesucht werden.

A. RECOMENDACIONES GENERALES DE SEGURIDAD

- Utilice siempre la suspension correcta para cada curso. Controle con su tienda de moto o con Marzocchi cual suspension utilizar en el curso elegido.
- **Considere que siempre hay riesgos cuando se va "off road", cuando se hace motocross o cuando se va pare cursos extremos.** Con cualquiera de estos estilos puede sufrir lesiones graves o la muerte. Aprenda como debe pedalear y nunca exceda el limite de sus posibilidades. Asegúrese de que utiliza el equipo de seguridad adecuado y que está todo en perfecto estado.
- La durabilidad de los productos Marzocchi depende de muchos factores, como el estilo de pedaleo y las condiciones. Los golpes, caídas, uso inadecuado o extremo en general pueden comprometer la seguridad de la estructura. Por favor revise su horquilla regularmente y que un mecánico cualificado compruebe si tiene pérdidas de aceite, golpes, deformaciones o cualquier otro tipo de irregularidad. La frecuencia de la revisión depende de muchos factores. Un Centro Marzocchi autorizado puede recomendarle la frecuencia que le conviene. Si la revisión revela cualquier tipo de anomalía, por pequeña que sea, por favor remítala inmediatamente a un Centro de Servicio Marzocchi antes de volver a utilizarla.
- Debe llevar siempre un casco colocado y abrochado correctamente que haya sido

- Indossare sempre un casco protettivo certificato dal dipartimento dei trasporti (DOT), SNELL o CE; di misura appropriata e fissato saldamente; usare inoltre tutto l'equipaggiamento necessario per guidare in assoluta sicurezza.

B. PRIMA DI OGNI UTILIZZO

- Controllare che nessun componente della moto risulti piegato, danneggiato o in qualche modo deformato.
- Assicurarsi che tutti i dadi e le viti siano regolati correttamente e che i pneumatici siano gonfiati alla giusta pressione.
- Rispettare le leggi e le disposizioni in vigore nel paese di utilizzo della moto; osservare sempre tutti i segnali stradali, le insegne e le disposizioni durante la guida.

Evitare usi impropri della forcella

Bisogna imparare come guidare compatibilmente con le proprie capacità. Anche solo poche ore di utilizzo inappropriato possono portare la forcella ad un grado di usura equivalente a quello di anni di normale utilizzo.

Bisogna imparare COME superare gli ostacoli nel percorso. L'urto di ostacoli come rocce, alberi e concavità provoca alla forcella stress per i quali non è stata progettata.

Anche l'atterrare impropriamente dopo un salto sottopone la forcella a stress che non è in grado di assorbire. Salti o balzi sono consentiti solo nel

- Always wear a properly fitted and fastened helmet that has been approved by the Department of Transportation (DOT), SNELL or CE, and any other safety equipment necessary for your riding style.

B. BEFORE EVERY RIDE

- Check that none of the components to your suspension system, or the remainder of your motorcycle, are bent, deformed, cracked or otherwise damaged.
- Check that all nuts and bolts are properly adjusted and the tires are inflated to the correct pressure.
- Learn and follow the local motorcycle laws and regulations, and obey all traffic signals, signs and laws while you ride.

Do not misuse or abuse your suspension system

Learn how to ride, and always ride within your abilities. An out-of-control ride puts the equivalent of years of hard use on your suspension system after only a few rides.

Learn how to properly flow around obstacles on the trail. Hitting obstacles such as rocks, trees, or holes straight on puts forces on your suspension system it was not designed to absorb.

Landing improperly after a jump or drop also puts forces on your suspension system it was

- Vous devez toujours porter un casque placé et attaché correctement qui a été approuvé par DOT (Département des transports) , SNELL ou CE et le reste de l'équipement de sécurité adapté à votre pratique.

B. AVANT CHAQUE SORTIE

- Vérifiez qu'aucun élément de la suspension ou du reste du vélo n'est endommagé, déformé, ou rayé.
- Assurez-vous que tous les écrous et les vis sont bien ajustés et que la pression de gonflage des pneus est correcte.
- Apprenez à respecter les lois et les réglementations locales et obéissez à tous les signaux du code de la route.

Ne faites pas une mauvaise utilisation ou un usage abusif de votre fourche

Ne faites pas une mauvaise utilisation ou un usage abusif de votre fourche. Apprenez à piloter et roulez toujours en fonction de vos capacités. Un pilotage abusif ou sans contrôle a les même conséquences sur votre fourche que plusieurs années d'utilisation très intensive, après seulement quelques sorties. Apprenez comment éviter les obstacles du terrain de manière adaptée. Heurter des obstacles comme des rochers, des arbres ou des gros trous fait subir à votre fourche des forces et des contraintes qui ne sont pas prévues dans son utilisation.

Une mauvaise réception de saut ou de marche

- Setzen Sie immer einen Seitens der DOT (Department of Transportation), CE oder SNELL zugelassenen Schutzhelm auf. Dieser Helm muss von der Größe geeignet und gut eingestellt sein. Tragen Sie immer eine, Ihrem Fahrstil entsprechende Sicherheitsbekleidung.

B. BVORKONTROLLEN

- Überzeugen Sie sich davon, dass keine der Motorradkomponenten verbogen, bzw. beschädigt sind oder andere unübliche Dinge zeigen.
- Sicherstellen, dass alle Muttern und Schrauben korrekt eingestellt und die Reifen mit dem richtigen Druck aufgeblasen sind.

- Halten Sie sich an die im jeweiligen Land geltenden Gesetze und Verfügungen und beachten Sie während der Fahrt immer die Angaben durch die Verkehrszeichen, Schilder und die geltenden Verfügungen.

Gabeln nicht falsch benutzen, sondern nur dem Einsatzbereich entsprechend einsetzen

Bitte die Gabel nicht falsch einsetzen oder die falsche Gabel benutzen. Im Einklang mit Ihren Fähigkeiten das Motorrad benutzen. Lernen mit dem Produkt umzugehen. Ein überdurchschnittlicher Einsatz oder falscher Einsatz, ist wie jahrelanger Gebrauch des Motorrades und erhöht den Verschleiß. Lernen Sie wie man die Hindernisse des Weges überquert. Ein zu starker Stoss eines Hindernisses kann zu Kräften führen, für deren Aufnahme ihre Federgabel nicht konstruiert ist.

aprobado por DOT, SNELL o CE y el resto de equipo de seguridad necesario para su estilo.

B. ANTES DE CADA SALIDA

- Compruebe que ninguno de los componentes de su suspensión o del resto de la Motocicleta esté doblado, golpeado, deformado o dañado en general.
- Asegúrese de que todos los pernos y las tuercas estén ajustados adecuadamente, y que los neumáticos estén inflados a la presión correcta.
- Aprenda y siga las leyes y regulaciones locales y obedezca todas las señales de tráfico y las leyes cuando salga.

Las horquillas no deben someterse a falta de uso o abuso.

No someta su horquilla a una falta de uso o abuso innecesario. Aprenda como utilizarla y siempre dentro de sus posibilidades. Utilizarla sin control sólo unas pocas veces supondrá el equivalente a años de mal uso.

Debe aprender como evitar los obstáculos que surjan durante el recorrido. Chocar directamente con rocas, árboles o agujeros puede someter la horquilla a una presión cuyo diseño no puede absorber.

Aterrizar incorrectamente después de un salto o descenso también puede someter la horquilla a una presión cuyo diseño no puede absorber. **Sólo** debe realizar saltos y descensos en zonas que dispongan de una pequeña rampa o desnivel para ayudar a su motocicleta a absorber el impacto generado durante el aterrizaje asegurándose de que las dos ruedas toquen el suelo a la vez. Cualquier otro tipo de

not designed to absorb. You should **only** perform jumps or drops when a transition is available to help absorb the impact forces generated during the landing, and both wheels should smoothly make contact with the transition at the same time. Any other type of landing is dangerous, as it could result in a component part failure and an accident. The steepness and length of the transition depends on the height from which you jump or drop. Every situation is different for every rider; consult with an experienced rider before attempting any jump or drop.



WARNING

Failure to properly flow around obstacles on the trail, or failure to properly land after a jump or drop could cause your suspension system to fail, resulting in a loss of control and serious injury or death to the rider.

If you ever have any comments, questions or concerns, please contact the Marzocchi local distributor.

caso in cui siano disponibili passerelle o rampe di discesa che aiutino la moto ad assorbire le forze di impatto, e che entrambe le ruote tocchino terra nello stesso momento. Qualunque altro tipo di atterraggio è pericoloso, e può provocare incidenti o il danneggiamento del prodotto. Accertarsi che la pendenza e la lunghezza della passerella o della rampa di discesa siano adeguati all'altezza dalla quale si salta e alle proprie capacità.



ATTENZIONE

Errori nel superamento di ostacoli durante il percorso, o errori di atterraggio dopo un salto possono provocare la rottura della forcella, con conseguente perdita di controllo della moto stessa e incidenti gravi, talvolta mortali.

In caso di suggerimenti, richieste o dubbi, contattare il distributore Marzocchi locale.

fait également subir des forces et des contraintes inadaptées à votre fourche. Vous ne devez réaliser un saut ou sauter une marche que si la réception est en pente afin d'aider votre vélo à absorber les forces engendrées par la réception. Lors de la réception vos roues doivent, en douceur, rentrer en contact en même temps avec la rampe ou la réception. Tout autre type de réception est dangereuse et peut entraîner une défaillance de certaines pièces ou un accident. L'inclinaison et la longueur de la réception dépendent de la hauteur de la quelle vous sautez. Chaque situation est différente selon chacun, consultez un pilote expérimenté avant de tenter un saut ou une marche.



ATTENTION

Les dommages dus à un mauvais passage d'obstacles ainsi qu'à une mauvaise réception de saut peuvent causer la défaillance de votre fourche entraînant une perte de contrôle et des blessures graves voir la mort.

Si vous avez une question ou un doute contactez Marzocchi.

Auch die falsche Landung nach einem Sprung kann die Gabel schwer beschädigen. Ein unpassender Sprung, der nicht zum Einsatzbereich der Gabel passt, kann auch die Haltbarkeit der Gabel beeinflussen. Sprünge sind nur erlaubt, wenn der Ablauf des Sprunges nicht gegen ein Hindernis endet. Die Landung soll den Aufschlag mildern. Nach Möglichkeit mit beiden Rädern gleichzeitig aufkommen. Alle andere Landungen sind gefährlich und können mit der Schädigung von Komponenten des Motorrads und einem Unfall enden. Die Steilheit und die Länge des Anlaufes, sowie die Rampe beim Absprung beeinflussen die Höhe des Sprunges. Jede Situation ist anders und benötigt ein besonderes Fahrkönnen. Bitte einen erfahrenen Radfahrer vor einem besonderen Sprung befragen.



ACHTUNG

Ein Fehler beim Überfahren von Hindernissen, oder ein Fehler bei der Landung nach einem Sprung, kann den Bruch der Gabel, mit Verlust der Kontrolle über das Motorrad bedeuten und schwere über gar tödliche Unfälle verursachen.

Für jegliche Fragen, Anregungen und bei Zweifeln, wenden Sie sich bitte an Ihren Fachhändler.

aterrizaje es peligroso ya que puede dañar alguna parte de la motocicleta y causar un accidente. La pendiente y longitud de la rampa o desnivel, dependerán de la altura desde la que salte o descienda. Cada situación es diferente para cada corredor. Consulte con un corredor experto antes de realizar cualquier salto o descenso.



¡PRECAUCION!

No evitar los obstáculos que surjan durante el recorrido o realizar un aterrizaje incorrecto después de un salto o descenso, puede dañar cualquier pieza de la motocicleta causando pérdida de control, fuertes lesiones o la muerte.

Si tiene cualquier comentario o duda, por favor contacte con Marzocchi.

INDICE

1	Premesse	14
1.1	Convenzioni	18
1.1.1	Orientamento forcella	18
1.1.2	Pittogrammi redazionali	18
1.1.3	Attrezzature	20
2	Generalità	22
2.1	Caratteristiche	22
2.2	Componenti della forcella	26
3	Norme generali di sicurezza	30
3.1	Norme per la presa in morsa	34
4	Manutenzione	36
4.1	Inconvenienti - cause - rimedi	36
4.2	Tabella manutenzione periodica	40
4.3	Pulizia raschiapolvere	42
4.4	Spurgo aria	44
4.5	Scarico olio	46
4.6	Smontaggio gruppo pompante e valvola di fondo	50
4.7	Scomposizione stelo - portastelo e rimozione anelli di tenuta	56
4.8	Revisione e modifica taratura cartuccia e valvola di fondo	60
4.8.1	Revisione cartuccia (freno in estensione)	60
4.8.2	Revisione valvola di fondo (freno in compressione)	64
4.9	Ricomposizione stelo - portastelo e montaggio anelli di tenuta	68
4.11	Riempimento olio	80
4.12	Rimontaggio forcella sul motociclo	84

CONTENTS

1	Introduction	14
1.1	Conventions	18
1.1.1	Orientation of the fork	18
1.1.2	Editorial pictograms	18
1.1.3	Equipment	20
2	General information	22
2.1	Characteristics	22
2.2	Components of the fork	26
3	General safety regulations	30
3.1	Instructions for clamping in the vice ...	34
4	Maintenance	36
4.1	Problems - Possible causes - Solutions	36
4.2	Periodical maintenance table	40
4.3	Cleaning the dust seal	42
4.4	Bleeding the air	44
4.5	Draining the oil	46
4.6	Braking down the pumping element and the bottom valve	50
4.7	Braking down the fork leg - slider and removing the oil seals	56
4.8	Overhauling and modifying the cartridge and bottom valve setting	60
4.8.1	Cartridge overhauling (rebound braking)	60
4.8.2	Bottom valve overhauling (compression braking)	64
4.9	Re-assembling the fork leg - slider and oil seals	68

INDEX

1 Introduction	15
1.1 Conventions	19
1.1.1 Orientation de la fourche	19
1.1.2 Pictogrammes rédactionnels	19
1.1.3 Equipement	21
2 Généralités	23
2.1 Caractéristiques	23
2.2 Composants de la fourche	29
3 Normes générales de sécurité	31
3.1 Normes pour l'utilisation de l'étau	35
4 Entretien	37
4.1 Inconvénients - causes - remèdes	37
4.2 Tableau d'entretien périodique	41
4.3 Nettoyage du cache-pousière	43
4.4 Purge de l'air	45
4.5 Vidange de l'huile	47
4.6 Démontage du groupe amortisseur et clapet de pied	51
4.7 Démontage du fourreau - porte fourreau et enlèvement des joints d'étanchéité	57
4.8 Révision et modification réglage cartouche et clapet de pied	61
4.8.1 Révision cartouche (freinage en détente)	61
4.8.2 Révision clapet de pied (freinage en compression)	65
4.9 Remontage du fourreau - porte fourreau et montage des joints d'étanchéité	69
4.10 Remontage du groupe amortisseur et clapet de pied	75

INHALTSVERZEICHNIS

1 Vorwort	15
1.1 Konventionen	19
1.1.1 Richtungsangaben Gabel	19
1.1.2 Verwendete Piktogramme	19
1.1.3 Werkzeug	21
2 Allgemeines	23
2.1 Merkmale	23
2.2 Bestandteile der Gabel	29
3 Allgemeine sicherheitsbestimmungen 31	
3.1 Vorschriften für das Einspannen	35
4 Wartung	37
4.1 Störungen - Ursachen - Abhilfe	37
4.2 Tabelle für Turnusmäßige Wartung	41
4.3 Reinigung Staubstreifer	43
4.4 Entlüftung	45
4.5 Ölablass	47
4.6 Zerlegung Pumpengruppe und Bodenventil	51
4.7 Zerlegung Holm - Gleitrohr und Entfernung der Dichtringe	57
4.8 Überholung und Änderung der Kartusche- und Bodenventileinstellung	61
4.8.1 Überholung der Kartusche (Zugstufendämpfung)	61
4.8.2 Überholung des Bodenventils (Druckstufendämpfung)	65
4.9 Zusammenbau Holm - Gleitrohr und Anbringung Dichtringe	69
4.10 Zusammenbau Pumpengruppe und Bodenventil	74

ÍNDICE

1 Preliminar	15
1.1 Convenciones	19
1.1.1 Orientación de la horquilla	19
1.1.2 Pictogramas redaccionales	19
1.1.3 Herramientas	21
2 Generalidades	23
2.1 Características	23
2.2 Componentes de la horquilla	29
3 Normas generales de seguridad	31
3.1 Normas para la colocación en una prensa de banco	35
4 Mantenimiento	37
4.1 Inconvenientes - causas - remedios	37
4.2 Tabla de mantenimiento periódico	41
4.3 Limpieza del guardapolvo	43
4.4 Purga de aire	45
4.5 Descarga de aceite	47
4.6 Decomposición elemento de bomba y válvula de pie	51
4.7 Decomposición barra de horquilla - botella y eliminación de los retenes	57
4.8 Revisión y modificación ajuste cartucho y válvula de pie	61
4.8.1 Revisión cartucho (freno en rebote) 61	
4.8.2 Revisión válvula de pie (freno en compresión)	65
4.9 Recomposición barra de horquilla / botella y montaje retenes	69
4.10 Recomposición elemento de bomba y válvula de pie	75

5 Tarature	86
5.1 Registro estensione	86
5.2 Registro compressione	88
6 Tabelle	90
6.1 Tabella 1 - Coppie di serraggio	90
6.2 Tabella 2 - Olio e quantità	90
6.3 Tabella 3 - Taratura standard	91
6.4 Tabella 4 - Molle	91
Note	93
7 Garanzia	94

4.10 Re-assembling the pumping element unit and the bottom valve	74
4.11 Filling with oil	80
4.12 Fitting the fork back on the motorcycle	84
5 Adjustments	86
5.1 Rebound adjustment	86
5.2 Compression adjustment	88
6 Tables	90
6.1 Table 1 - Tightening torques	90
6.2 Table 2 - Oil and quantity	90
6.3 Table 3 - Standard setting	91
6.4 Table 4 - Springs	91
Notes	93
7 Warranty	94

4.11 Remplissage de l'huile	81
4.12 Remontage de la fourche sur le motocycle	85
5 Réglages	87
5.1 Réglage détente	87
5.2 Réglage compression	89
6 Tableaux	90
6.1 Tableau 1 - Couples de serrage	90
6.2 Tableau 2 - Huile et quantité	90
6.3 Tableau 3 - Réglage standard	91
6.4 Tableau 4 - Ressorts	91
Notes	93
7 Garantie	95

4.10 Zusammenbau Pumpengruppe und Bodenventil	75
4.11 Einfüllen des Öls	81
4.12 Montage der Gabel am Motorrad	85
5 Einstellung	87
5.1 Zugstufeneinstellung	87
5.2 Druckstufeneinstellung	89
6 Tabellen	90
6.1 Tabelle 1 - Anzugsmomente	90
6.2 Tabelle 2 - Öl und Menge	90
6.3 Tabelle 3 - Standard Einstellung	91
6.4 Tabelle 4 - Federn	91
Anmerkungen	93
7 Garantieerklärung	95

4.11 Relleno de aceite	81
4.12 Reensamblaje de la horquilla en la motocicleta	85
5 Ajustes	87
5.1 Ajuste rebote	87
5.2 Ajuste compresión	89
6 Tablas	90
6.1 Tabla 1 - Pares de torsión	90
6.2 Tabla 2 - Aceite y cantidad	90
6.3 Tabla 3 - Ajuste estándar	91
6.4 Tabla 4 - Muelles	91
Notas	93
7 Garantía	95

1 PREMESSE

Il presente manuale contiene informazioni importanti relative al montaggio, all'utilizzo e alla manutenzione del sistema di sospensione da voi scelto e deve quindi essere letto con estrema attenzione.

Prima di iniziare la lettura occorre leggere attentamente e apprendere quanto contenuto nella sezione "Norme di sicurezza per l'utilizzatore del manuale".

Quanto contenuto nella sezione "Norme di sicurezza per l'utilizzatore del manuale" dovrà essere tenuto in considerazione sia durante l'uso che durante la manutenzione della forcella MARZOCCHI.

In caso di domande in merito alla cura e alla manutenzione del vostro sistema di sospensione, contattate direttamente il servizio di assistenza più vicino che potrete individuare consultando l'elenco all'indirizzo internet www.marzocchi.com.



ATTENZIONE

Il presente manuale non ha il compito di spiegare il montaggio/smontaggio della forcella dal motociclo, della ruota, dell'impianto frenante, degli organi di sterzo e di qualunque altro componente direttamente o indirettamente connesso alla forcella ma non facente parte della stessa.

La Casa si riserva pertanto il diritto di apportare ai prodotti, in qualsiasi momento e senza avviso, quelle modifiche ritenute utili per migliorarli o per qualsiasi esigenza di carattere costruttivo e commerciale.

1 INTRODUCTION

This manual contains important information on the assembly, use and maintenance of the suspension system you have chosen and must therefore be read with extreme care.

Before reading this manual please carefully read the information contained in the "General warnings for owners manual" section.

The information contained in the "General warnings for owners manual" section will have to be followed for both, the MARZOCCHI forks' use and maintenance.

If you have any questions regarding the care and maintenance of your suspension system, please contact your nearest service center directly. A list of service centers can be found on the internet page www.marzocchi.com.



WARNING

This manual does not explain how to assemble/disassemble the motorcycle fork, the wheel, brakes, steering set or any other component directly or indirectly associated with the fork but not actually part of the same.

The manufacturer therefore reserves the right to make changes to the products, at any time and without prior notice to improve the products or to meet any productive or commercial requirements.

1 INTRODUCTION

Ce manuel contient des informations importantes relatives au montage, à l'utilisation et à l'entretien du système de suspension que vous avez choisi. Il doit donc être lu avec une extrême attention.

Avant d'aborder la lecture, il faudra lire attentivement et apprendre les instructions reportées dans la section « Avertissement général pour les usagers du manuel ».

Les informations reportées dans la section « Avertissement général pour les usagers du manuel » devront être considérées pendant l'utilisation aussi bien que pendant l'entretien de la fourche MARZOCCHI.

En cas de doute concernant les soins et l'entretien de votre système de suspension, contactez directement le service d'assistance le plus proche que vous pourrez localiser en consultant la liste présente à l'adresse Internet www.marzocchi.com.



ATTENTION

Ce manuel n'a pas pour objectif d'expliquer le montage/démontage de la fourche du/sur le motorcycle, de la roue, du système de freinage, des composants de direction ni d'aucun autre composant directement ou indirectement lié à la fourche mais ne faisant pas partie de celle-ci.

La Société se réserve le droit d'apporter à ses produits, à tout moment et sans préavis, toute modification qui se révélerait utile pour leur amélioration ou pour toute autre exigence à caractère constructif et commercial.

1 VORWORT

Das vorliegende Handbuch enthält wichtige Informationen zur Montage, zum Betrieb und zur Wartung Ihres Federungssystems und ist daher mit größter Aufmerksamkeit durchzulesen.

Vor der Lesung ist es nötig, die „Sicherheitshinweise für den Benutzer des Handbuchs“ mit größter Aufmerksamkeit durchzulesen. Die in dem „Sicherheitshinweise für den Benutzer des Handbuchs“ -Abschnitt enthaltenen Informationen müssen für beide, den Gebrauch sowie die Wartung der MARZOCCHI Gabel, in Betracht genommen werden.

Wenn Sie Fragen zur Pflege und Wartung Ihres Federungssystems haben, wenden Sie sich direkt an den nächsten Kundendienst, den Sie auf der Vertreterliste unter der Internet-Adresse www.marzocchi.com finden können.



ACHTUNG

Das vorliegende Handbuch hat nicht den Zweck, den Ein-/Ausbau der Motorradgabel, des Rades, der Bremsanlage, der Lenkvorrichtung oder irgendwelcher anderer Komponenten zu erklären, die direkt oder indirekt mit der Gabel verbunden sind, aber kein Teil von ihr sind.

Der Hersteller behält sich daher das Recht vor, jederzeit und ohne Ankündigung alle Änderungen an den Produkten vorzunehmen, die er zu ihrer Verbesserung oder wegen irgendwelcher konstruktiver oder kommerzieller Erfordernisse für nötig hält.

1 PRELIMINAR

El presente manual contiene informaciones importantes relativas al montaje, utilización y mantenimiento del sistema de suspensión que ha elegido y por lo tanto debe ser leído con mucha atención.

Antes de empezar la lectura, lea atentamente el contenido del párrafo "Advertencias generales para usuarios del manual".

El contenido del párrafo "Advertencias generales para usuarios del manual" tendrá que ser considerado ya sea durante el uso como durante el mantenimiento de la horquilla MARZOCCHI.

Si tiene cualquier pregunta sobre el cuidado y mantenimiento de su suspensión, por favor contacte con el centro autorizado más cercano que puede encontrar en la página de Internet www.marzocchi.com.



¡PRECAUCION!

El presente manual no sirve para explicar el montaje/desmontaje de la horquilla de la motocicleta, de la rueda, del grupo de freno, de las piezas de la dirección o de cualquier otro componente directa o indirectamente relacionado con la horquilla pero que no forma parte de ella.

El Constructor se reserva el derecho de añadir a los productos, en cualquier momento y sin preaviso, cualquier modificación que considere útil para mejorarlos o por cualquier exigencia de carácter constructivo o comercial.

**ATTENZIONE**

L'utilizzatore e il manutentore sono gli unici responsabili della corretta applicazione delle istruzioni di assemblaggio contenute nel presente libretto.

Guidate sempre nel pieno rispetto delle norme di sicurezza e prestando sempre la massima attenzione.

**NOTA**

Per ulteriori informazioni relative a tarature, kit upgrade, kit revisione forcelle visita www.marzocchi.com alla pagina Prodotti aftermarket moto.

**WARNING**

The user and the service technician are the only people responsible for the correct application of the assembly instructions in the present manual. Always ride in the full respect of the rules of the road and any relevant safety regulations.

**REMEMBER**

For further information concerning the fork setting, upgrade kits and overhauling kits visit our website www.marzocchi.com in the section Products/aftermarket moto.

**ATTENTION**

L'utilisateur et le réparateur sont les seuls responsables de l'application correcte des instructions d'assemblage contenues dans ce livret.

Conduisez toujours en respectant toutes les règles de sécurité et avec la plus grande attention.

**NOTE**

Pour d'autres renseignements concernant le réglage de la fourche, upgrade kit, kit de révision, visitez le site www.marzocchi.com à la page produits aftermarket moto.

**ACHTUNG**

Der Benutzer und der Wartungstechniker sind allein verantwortlich für die vorschriftsmäßige Anwendung der in diesem Handbuch enthaltenen Zusammenbauanleitungen.

Fahren Sie immer unter voller Beachtung der Sicherheitsbestimmungen und mit größter Umsicht.

**WICHTIG**

Für weitere Informationen über Dampfung, Kit upgrade, Kit überholung, bitte besuchen unseren Website www.marzocchi.com in der Produkte Aftermarket Motorrad Abteilung.

**¡PRECAUCION!**

El utilizador y el encargado del mantenimiento son los únicos responsables de la correcta aplicación de las instrucciones de ensamble contenidas en el presente manual.
Conduzca siempre respetando las normas de seguridad y prestando siempre la máxima atención.

**NOTA**

Für weitere Informationen über Dampfung, Kit upgrade, Kit überholung, bitte besuchen unseren Website www.marzocchi.com in der Produkte Aftermarket Motorrad Abteilung.

1.1 Convenzioni

1.1.1 Orientamento forcella

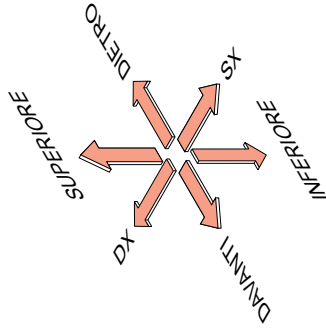

1.1.2 Pittogrammi redazionali



ATTENZIONE

Le descrizioni precedute da questo simbolo, contengono informazioni, prescrizioni o procedure che, se non rispettate, possono causare danni o malfunzionamenti della forcella, incidenti (anche mortali) all'utilizzatore o danni ambientali.



NOTA

Le descrizioni precedute da questo simbolo, contengono informazioni, prescrizioni o procedure consigliate da MARZOCCHI per un migliore utilizzo della forcella.

1.1 Convenzioni

1.1.1 Orientation of the fork

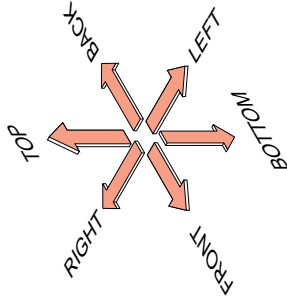

1.1.2 Editorial pictograms



WARNING

Descriptions preceded by this symbol contain information, instructions or procedures, which, if not respected, can cause damage or bad function to the fork, accidents to the user (even fatal ones) or damage to the environment.



REMEMBER

Descriptions preceded by this symbol contain information, prescriptions or procedures recommended by MARZOCCHI for the best fork's use.

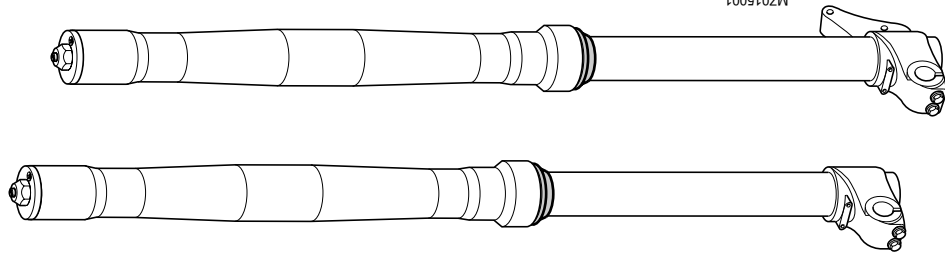

1.1 Conventions

1.1.1 Orientation de la fourche

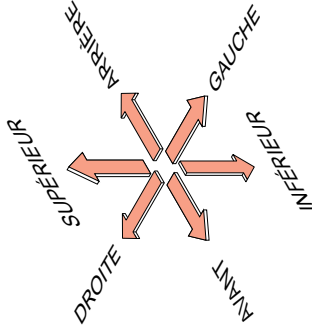

1.1.2 Pictogrammes rédactionnels



ATTENTION

Les descriptions précédées par ce symbole contiennent des informations, des instructions ou des procédures qui, si elles ne sont pas respectées, peuvent endommager la fourche ou en causer le mauvais fonctionnement, donner vie à des accidents (même mortels) pour l'utilisateur ou nuire à l'environnement.



NOTE

Les descriptions précédées par ce symbole contiennent des informations, des instructions ou des procédures conseillées par MARZOCCHI pour une meilleure utilisation de la fourche.

1.1 Conventionen

1.1.1 Richtungsangaben Gabel

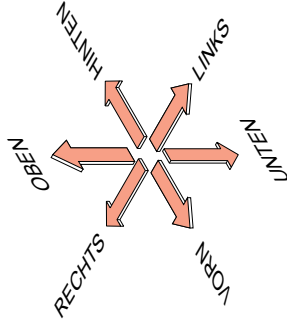

1.1.2 Verwendete Piktogramme



ACHTUNG

Die Beschreibungen, die von diesem Symbol vorgegangen sind, enthalten Informationen, Vorschriften oder Prozeduren, die, wenn sie nicht beachtet werden, Schäden an der Gabel, Unfällen (auch tödlich) des Benutzers, oder Umweltschäden verursachen können.



WICHTIG

Die Beschreibungen, die von diesem Symbol vorgegangen sind, enthalten Informationen, Vorschriften oder Prozeduren, die von MARZOCCHI zur besseren Benutzung der Gabel empfohlen werden.

1.1 Convenciones

1.1.1 Orientación de la horquilla

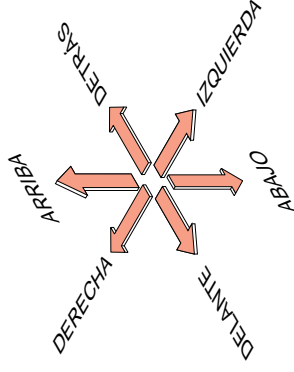

1.1.2 Pictogramas redaccionales



¡PRECAUCION!

Las descripciones precedidas por este símbolo contienen la información, instrucciones o procedimientos, que, si no se respetan, pueden causar daños o funcionamiento defectuoso a la horquilla, accidentes (incluso la muerte) al usuario o al medio ambiente.



NOTA











Las descripciones precedidas por este símbolo contienen información, prescripciones o procedimientos recomendados por MARZOCCHI para mejorar el uso de la horquilla.

1.1.3 Attrezzature



All'inizio di ogni paragrafo di manutenzione sono indicate sotto forma iconografica le attrezzature necessarie per svolgere la manutenzione descritta.

1.1.3 Equipment

At the beginning of each maintenance paragraph you will find some icons showing the tools you will need for the job.

Attrezzature commerciali - Commercial equipment	
	Chiave fissa da 12 mm 12 mm spanner
	Chiave fissa da 18 mm 18 mm spanner
	Cacciavite a taglio di piccole dimensioni Small flat tip screwdriver
	Morsa con ganasce in materiale tenero Vice with padded jaws
	Contenitore con imboccatura larga Container with wide mouth
	Grasso siliconato spray Silicone grease spray
	Chiave fissa da 17 mm 17 mm spanner
	Chiave a bussola da 21 mm 21 mm tube wrench
	Pennello Brush
	Misurino graduato Graduated container
	Grasso Grease

Attrezzature specifiche - Specific equipment

	Introduttore Marzocchi Cod. R5080AC Marzocchi Introducer Cod. R5080AC		Attrezzo bloccaggio custodia Marzocchi Cod. R5081AA Marzocchi body lock tooling Code R5081AA
	Asta recupero cartuccia Marzocchi Cod. R5051AC Marzocchi cartridge extraction tooling Code R5051AC		

1.1.3 Equipement

















Au début de chaque paragraphe d'entretien, les équipements nécessaires pour effectuer l'opération décrite sont indiqués sous forme iconographique.

1.1.3 Werkzeug







Am Anfang jedes Wartungsparagrafen werden die Symbole für das zur Durchführung der beschriebenen Wartungsarbeit nötige Werkzeug gezeigt.

1.1.3 Herramientas

Al principio de cada párrafo se indican con iconos las herramientas necesarias para efectuar el mantenimiento descrito.

Equipements commerciaux - Im Handel erhältliches Werkzeug - Herramientas comerciales		
 Clé de 12 mm 12 mm - Maulschlüssel Llave fija de 12 mm	 Clé de 13 mm 13 mm - Maulschlüssel Llave fija de 13 mm	 Clé de 17 mm 17 mm - Maulschlüssel Llave fija de 17 mm
 Clé de 18 mm 18 mm - Maulschlüssel Llave fija de 18 mm	 Clé de 19 mm 19 mm - Maulschlüssel Llave fija de 19 mm	 Clé à tube de 21 mm 21 mm Steckschlüssel Llave tubular de 21 mm
 Tournevis plat de petite dimension Kleiner Schraubendreher Destornillador pequeño	 Tournevis cruciforme de type PH Kreuzschlitzschraubendreher Typ PH Destornillador de estrella tipo PH	 Pinceau Pinsel Pinsel
 Etau à mâchoires en matériau souple Spannstock mit Spannbacken aus weichem Material Prensa de banco con mordazas de material blando	 Règle millimétrée Linearmaßstab Regla graduada en milímetros	 Verre mesureur gradué Messbecher Medidor graduado
 Récipient avec embouchure large Behälter mit weiter Öffnung Recipiente de boca grande	 Ruban adhésif Klebeband Cinta adhesiva	 Graisse Fett Grasa
 Graisse à la silicone en spray Silikonfett spray Grasa a la silicona spray		

Equipements spécifiques - Spezialwerkzeug - Herramientas específicas

 R5080AC	 R5081AA	 R5081AA
Introducteur Marzocchi Code R5080AC Einschubzylinder Marzocchi Art. R5080AC Introductor Marzocchi Cód. R5080AC	Outil de blocage corps Marzocchi Réf. R5081AA Marzocchi Hülseklammerwerkzeug Art. R5081AA Herramienta bloqueo protección Marzocchi Cód. R5081AA	
 R5051AC	 R5051AC	 R5051AC
Tige d'extraction cartouche Marzocchi Réf. R5051AC Marzocchi Kartuschenausziehstab Art. R5051AC Vástago extracción cartucho Marzocchi Cód. R5051AC		

2 GENERALITÀ

Shiver 45 Factory Works è una forcella teleidraulica a steli rovesciati con perno avanzato.

La forcella Shiver 45 Factory Works utilizza un sistema di smorzamento multivalvola e molla per il carico statico.

Lo smorzamento idraulico in compressione è realizzato da una speciale valvola posta sulla nella parte inferiore di ogni stelo, lo smorzamento idraulico di estensione avviene mediante l'utilizzo di una cartuccia interna ad ogni tubo portante.

Ogni stelo è dotato di registri esterni per la regolazione della fase di compressione e di estensione.

Nel tappo superiore di entrambi gli steli è presente una vite per lo spurgo dell'aria interna del fodero.

2.1 Caratteristiche

Tubi Portanti

In acciaio speciale ad alta resistenza, con trattamento di cromatura e speciale trattamento superficiale di indurimento (TIN).

Portasteli

Realizzati in lega di alluminio lavorata con CNC, anodizzati e lucidati internamente.

Boccole di Scorrimento

Con riporto in teflon, esenti da attrito di primo distacco.

Guarnizioni

Anelli di tenuta progettati al computer assicurano massima tenuta in compressione e minimo attrito in estensione.

2 GENERAL INFORMATION

Shiver 45 Factory Works is a telehydraulic upside down fork, with advanced axle.

The Shiver 45 Factory Works is based on a multivalve damping system and spring for static load.

The compression hydraulic damping is made through a special valve located in each fork's leg lower area, whereas the rebound hydraulic damping is made through a cartridge located inside each stanchion.

Each fork's leg is provided with external adjusters for the compression and extension adjustment.

On both fork's legs upper cap you can find a screw for the slider inner air bleed.

2.1 Characteristics

Stanchion tubes

Made of special, chromed, high-resistance steel, with a special hardening surface treatment (TIN).

Sliders

Made of CNC aluminium alloy, anodised and polished inside.

Sliding bushings

With Teflon facing, free from static friction.

Seals

Computer designed seal rings guarantee the best seal under compression and the minimum friction during rebound.

2 GÉNÉRALITÉS

Shiver 45 Factory Works est une fourche télehydraulique renversée à axe déporté.

La fourche Shiver 45 Factory Works utilise un système d'amortissement multivannes et un ressort de charge statique.

L'amortissement hydraulique en compression est réalisé grâce à une soupape spéciale située dans la partie inférieure de chaque fourreau ; l'amortissement hydraulique en détente est réalisé à travers l'utilisation d'une cartouche à l'intérieur de chaque tube plongeur.

Chaque fourreau est équipé de registres extérieurs pour le réglage de la phase de compression et de détente.

Sur le bouchon supérieur des deux fourreaux est située une vis pour la purge de l'air qui se trouve à l'intérieur du porte fourreau.

2.1 Caractéristiques

Tubes plongeurs

En acier spécial très résistant, avec traitement de chromage et traitement spécial de durcissement de la surface (TIN).

Porte-fourreaux

En alliage d'aluminium et usinés CNC, anodisés et polis à l'intérieur.

Bagues de glissement

Avec revêtement en Téflon, sans frottement au départ.

Joints

Joints d'étanchéité conçus à l'ordinateur qui assurent une étanchéité maximale en compression et un frottement minimal en détente.

2 ALLGEMEINES

Die Shiver 45 Factory Works ist eine telehydraulische Upside-Down Gabel mit vorgeschobener Achse.

Die Shiver 45 Factory Works Gabel verfügt über ein Mehrventil-Dämpfsystem und Feder zur statischen Belastung.

Die hydraulische Druckstufendämpfung wird durch ein spezielles Ventil verwirklicht, das sich im unteren Gebiet jedes Holmes befindet; die hydraulische Zugstufendämpfung wird durch eine Kartusche verwirklicht, die sich innerhalb von jedem Standrohr befindet.

Beide Holme verfügen über außenliegende Einstellungen für die Druck- und Zugstufeneinstellung.

Im oberen Verschluss beider Holme befindet sich eine Schraube für die Entlüftung der im Gleitrohr liegenden Luft.

2.1 Merkmale

Tauchrohre

Aus hochwertigem, verchromtem Spezialstahl, mit Härtungsoberflächenbehandlung (TIN)

Gleitrohre

Aus CNC-verarbeiteter Aluminiumlegierung, eloxiert und innen poliert.

Gleitbuchsen

Mit Teflonbelag, ohne Anlaufreibung.

Dichtungen

Am Computer entworfene Dichtringe gewährleisten maximale Dichtigkeit in der Druckstufe und minimalen Reibung in der Zugstufe.

2 GENERALIDADES

Shiver 45 Factory Works es una horquilla telehidráulica invertida de eje avanzado. La horquilla Shiver 45 Factory Works funciona con un sistema de amortiguación multiválvula y muelle para carga estática.

La amortiguación hidráulica en compresión se hace por medio de una válvula especial situada en la parte inferior de cada barra; La amortiguación hidráulica en rebote se hace por medio de un cartucho al interior de cada barra. Cada barra está equipada con ajustes exteriores para la regulación de las fases de compresión y de rebote.

En el tapón superior de las dos barras está colocado un tornillo para la purga del aire contenido al interior de la botella.

2.1 Características

Barras

De acero especial con alta resistencia, con tratamientos superficiales de galvanización y de endurecimiento (TIN)

Botellas

En aleación de aluminio, trabajadas con CNC, anodizadas y bruñidas al interior.

Casquillos guía

Con material adicional de teflón, sin roce estático.

Retenes

Retenes proyectados con el ordenador que aseguran la máxima hermeticidad en compresión y el mínimo roce en rebote.

Molle

Realizzate in acciaio, sono disponibili con diverse costanti di rigidità (**K**). Per informazioni più dettagliate fare riferimento alla Tabella 4 - Molle.

Olio

MARZOCCHI a formula speciale, elimina la formazione di schiuma e mantiene inalterate le caratteristiche di viscosità in ogni condizione di lavoro; esente da attrito di primo distacco. Per informazioni più dettagliate fare riferimento alla Tabella 2 - Olio e quantità.

Springs

Made of steel, they are available in different stiffness (**K**). For more detailed information please refer to Table 4 - Springs.

Oil

MARZOCCHI with special formula. It eliminates the formation of foam and keeps the viscosity characteristics unchanged in any working condition; free from static friction. For more detailed information please refer to Table 2 - Oil and quantity.

Ressorts

En acier, disponibles en plusieurs duretés (K).
Pour des informations plus détaillées se reporter au Tableau 4 - Ressorts.

Huile

Marzocchi à formule spéciale qui prévient la formation de mousse et maintient les caractéristiques de viscosité inaltérées, quelles que soient les conditions de fonctionnement ; sans frottement au départ.

Pour des informations plus détaillées se reporter au Tableau 2 - Huile et quantité.

Federn

Aus Stahl, in verschiedenen Härten (K) verfügbar. Für ausführlichere Informationen siehe Tabelle 4 - Federn.

Öl

MARZOCCHI-Spezialöl, verhindert Schaumbildung und erhält die Viskositätseigenschaften unter allen Arbeitsbedingungen unverändert; ohne Anlaufreibung.

Für ausführlichere Informationen siehe Tabelle 2 - Öl und Füllmengen.

Muelles

De acero, disponibles constantes de rigidez (K) diferentes. Para informaciones más detalladas consulte la Tabla 4 - Muelles.

Aceite

MARZOCCHI de especial fórmula, elimina la formación de espuma y mantiene inalteradas las características de viscosidad en cualquier condición de trabajo, sin roce estático.

Para informaciones más detalladas consulte la Tabla 2 - Aceite y cantidad.

2.2 Componenti della forcella

La forcella Shiver 45 Factory Works utilizza un sistema di smorzamento multivalvola che si contraddistingue per la uguale configurazione dei due steli. Ogni stelo costituisce pertanto un sistema completo di sospensione a cui fare riferimento quando si opera una registrazione.

- 5) Tubo portante
- 8) Boccola di scorrimento inferiore
- 9) Scodellino
- 10) Anello di tenuta
- 12) Raschiapolvere
- 13) Portastelo esterno
- 19) Registro a vite della compressione
- 21) Molla
- 24) Guidamolla
- 25) Tubetto di precarica
- 28) Tamponi di fondo
- 30) Custodia della cartuccia
- 31) Asta interna
- 32) Asta del pompante
- 33) Molla richiamo lamelle
- 34) Lamella pistone estensione
- 36) Pistone del pompante
- 37) Pacco lamelle pistone freno estensione
- 39) Boccola di scorrimento superiore
- 41) Valvola di fondo
- 43) Lamella valvola compressione
- 45) Pistone della valvola di fondo
- 46) Pacco lamelle valvola freno compressione
- 48) Tappo
- 70) Portaruota
- 71) Vite di registro dell'estensione
- 72) Spillo conico
- 73) Tappo custodia

Per comprendere meglio il funzionamento della forcella, nella figura a lato sono indicati con diversi colori le parti in movimento vincolate alla ruota (fondo evidenziato), da quelle che rimangono solidali al telaio del motociclo (fondo chiaro).

2.2 Components of the fork

The Shiver 45 Factory Works fork is based on a multivalve damping system that is exactly the same on both fork's legs. Each fork's leg is therefore a complete suspension system which you must refer to when adjusting any part of the fork.

- 5) Stanchion tube
- 8) Lower sliding bushing
- 9) Spring cup
- 10) Oil seal
- 12) Dust seal
- 13) Outer slider
- 19) Compression adjustment screw
- 21) Spring
- 24) Spring guide
- 25) Pre-load tube
- 28) Foot buffer
- 30) Cartridge body
- 31) Inner rod
- 32) Pumping element rod
- 33) Washers recall spring
- 34) Rebound piston washer
- 36) Pumping element piston
- 37) Rebound damping piston washers stack
- 39) Upper sliding bushing
- 41) Bottom valve
- 43) Compression valve washer
- 45) Bottom valve piston
- 46) Compression damping piston washers' stack
- 48) Cap
- 70) Wheel axle clamp
- 71) Rebound adjustment screw
- 72) Conic pin
- 73) Body cap

In order to better understand how the fork works, in the figure here beside the moving parts holding the wheel are indicated with different colours (background highlighted) from those that remain fixed to the motorcycle frame (light background).

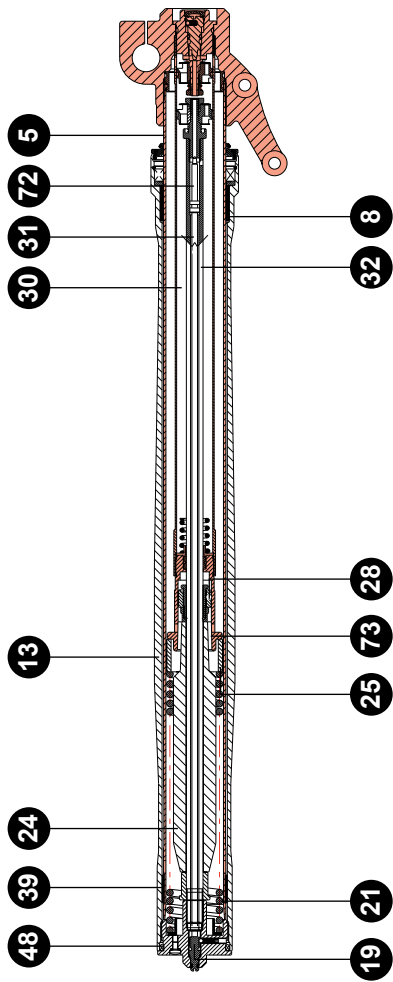
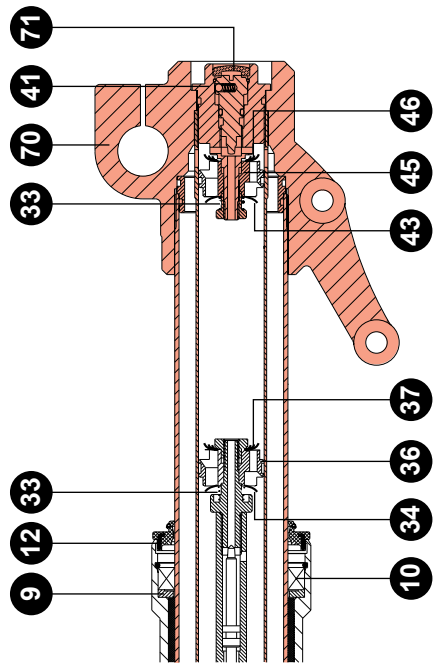

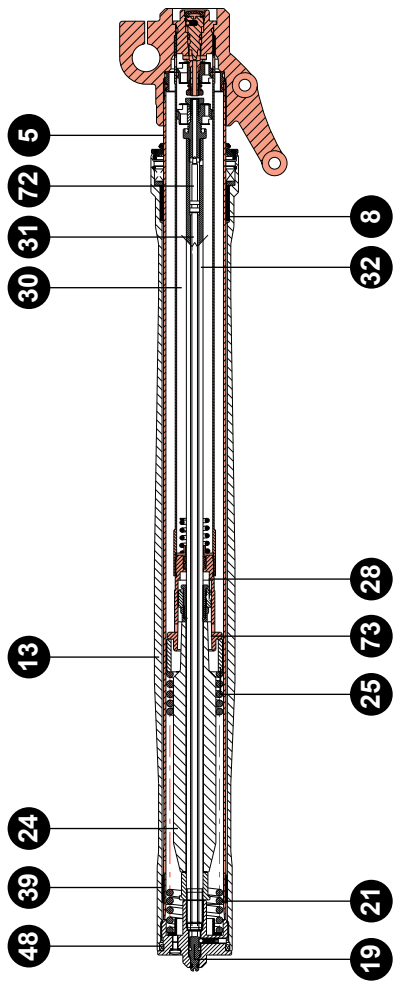
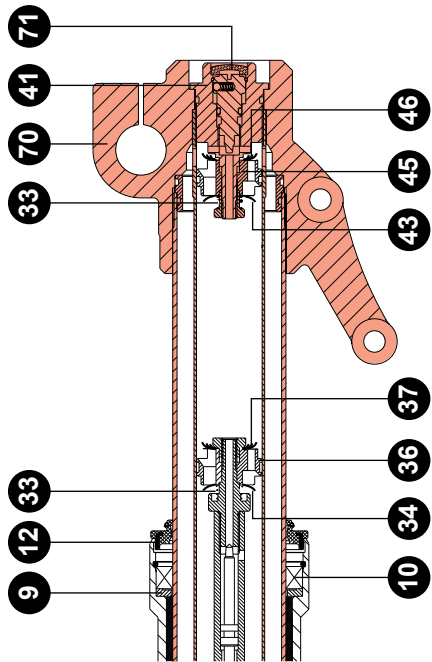

2.2 Composants de la fourche

La fourche Shiver 45 Factory Works utilise un système d'amortissement hydraulique multivannes qui est le même dans les deux fourreaux. Chaque fourreau représente donc un système de suspension complet auquel il faut se référer lors d'une opération de réglage.

- 5) Plongeur
- 8) Bague de glissement inférieur
- 9) Cuvette
- 10) Joint d'étanchéité
- 12) Cache-pousière
- 13) Porte-fourreau extérieur
- 19) Vis réglage compression
- 21) Ressort
- 24) Guide ressort
- 25) Tube de pré-charge
- 28) Tampon de fond
- 30) Corps de la cartouche
- 31) Tige intérieure
- 32) Tige amortisseur
- 33) Ressort renvoi lamelles
- 34) Lamelle piston détente
- 36) Piston de l'amortisseur
- 37) Paquet de lamelles piston freinage détente
- 39) Bague de glissement supérieure
- 41) Clapet de pied
- 43) Lamelle clapet compression
- 45) Piston clapet de pied
- 46) Paquet lamelles clapet freinage compression
- 48) Bouchon
- 70) Support de roue
- 71) Vis réglage détente
- 72) Épingle conique
- 73) Bouchon corps

Pour mieux comprendre le fonctionnement de la fourche, dans le schéma à côté on a différencié les pièces en mouvement liées à la roue (fond en évidence) des pièces demeurant solitaires au cadre du motorcycle (fond clair).

2.2 Bestandteile der Gabel

Die Shiver 45 Factory Works Gabel verfügt über ein Mehrventil-Dämpfsystem, das auf beiden Holmen zu sehen ist. Jeder Holm ist deshalb ein komplettes Federungssystem, auf das man sich beziehen muss, wenn man eine Einstellung durchführen will.

- 5) Tauchrohr
- 8) Untere Gleitbuchse
- 9) Teller
- 10) Dichtung
- 12) Staubabstreifer
- 13) Gleitrohr
- 19) Druckstufeneinstellungsschraube
- 21) Feder
- 24) Federnülse
- 25) Vorspannung
- 28) Bodenpuffer
- 30) Kartuschenhülse
- 31) Innenstab
- 33) Pumpenelementstab
- 34) Lamellenrückfeder
- 36) Pumpenelementkolben
- 37) Paket von Lamellen des Zugstufendämpfungs kolben
- 39) Obere Gleitbuchse
- 41) Bodenventil
- 43) Druckstufenventillamelle
- 45) Bodenventilkolben
- 46) Paket von Lamellen des Druckstufendämpfungs kolben
- 48) Verschluss
- 70) Radaufnahme
- 71) Zugstufendämpfungs schraube
- 72) Kegelförmige Nadel
- 73) Hülseverschluss

Zum besseren Verständnis der Funktionsweise der Gabel, sind in der anliegenden Abbildung, die mit dem Rad verbundenen beweglichen Teile (hervorgehobener Hintergrund) und die fest mit dem Rahmen des Motorrads verbundenen Teile (heller Hintergrund) in unterschiedlichen Farben dargestellt.

2.2 Componentes de la horquilla

La horquilla Shiver 45 Factory Works utiliza un sistema de amortiguación multiválvulas que tiene la misma configuración en las dos barras. Cada barra es por lo tanto un sistema completo de suspensión a lo que hacer referencia en caso de cualquier regulación.

- 5) Barra de horquilla
- 8) Casquillo guía inferior
- 9) Asiento del muelle
- 10) Retén
- 12) Guardapolvo
- 13) Botella exterior
- 19) Tornillo ajuste amortiguación en compresión
- 21) Muelle
- 24) Guía de muelle
- 25) Tubo de precarga
- 28) Almohadilla de pie
- 30) Protección del cartucho
- 31) Vástago interior
- 32) Vástago elemento de bomba
- 33) Muelle retorno laminitas
- 34) Laminita pistón rebote
- 36) Pistón elemento de bomba
- 37) Paquete laminitas pistón freno rebote
- 39) Casquillo guía superior
- 41) Válvula de pie
- 43) Laminilla válvula compresión
- 45) Pistón válvula de pie
- 46) Paquete laminillas pistón freno compresión
- 48) Tapón
- 70) Portarueda
- 71) Tornillo ajuste amortiguación en rebote
- 72) Clavija cónica
- 73) Tapón protección

Para comprender mejor el uso de la horquilla, se indican en la figura al lado, con colores diferentes, las partes en movimiento vinculadas a la rueda (fondo evidenciado), de las que están integradas en el chasis de la motocicleta (fondo claro).

3 NORME GENERALI DI SICUREZZA

- Dopo uno smontaggio completo, utilizzare sempre, per il rimontaggio, guarnizioni di tenuta nuove originali Marzocchi.
- Per il serraggio di due viti o dadi vicini, seguire sempre la sequenza 1-2-1 utilizzando chiavi dinamometriche; rispettare le coppie di serraggio previste (vedi Tabella 1 - Coppie di serraggio).
- Evitare assolutamente di utilizzare per la pulizia solventi infiammabili o corrosivi che potrebbero danneggiare le guarnizioni di tenuta. Utilizzare eventualmente detergenti specifici non corrosivi, non infiammabili o ad alto punto di infiammabilità compatibili con i materiali delle guarnizioni di tenuta e preferibilmente biodegradabili.
- Prima del rimontaggio, lubrificare sempre con olio per forcelle tutte le parti in contatto relativo.
- In previsione di lunghi periodi di inattività, lubrificare sempre con olio per forcelle tutte le parti in contatto relativo.
- Non disperdere mai lubrificanti, solventi o detergenti non completamente biodegradabili nell'ambiente; essi devono essere raccolti e conservati in appositi contenitori, quindi smaltiti secondo le norme vigenti.
- Sui labbri degli anelli di tenuta applicare sempre grasso prima del rimontaggio.
- Utilizzare solamente chiavi metriche e non in pollici. Le chiavi con misure in pollici possono avere dimensioni simili a quelle in millimetri, ma possono danneggiare le viti e rendere poi impossibile la svitatura.
- Per svitare le viti con impronta a taglio o a

3 GENERAL SAFETY REGULATIONS

- After a complete breakdown, always use new, original Marzocchi seals when reassembling.
- To tighten two bolts or nuts that are near each other, always follow the sequence 1-2-1 using a torque wrench; respect the indicated tightening torques (see Table 1 - Tightening Torques).
- Never use flammable or corrosive solvents to clean the parts, as these could damage the seals. If necessary use specific detergents that are not corrosive, not flammable or have a high flash point, compatible with the seals materials and preferably biodegradable.
- Before reassembling, always lubricate the parts of the fork in contact.
- If you are planning not to use your fork for a long time, always lubricate the forks components that are in contact with some fork's oil.
- Never pour lubricants, solvents or detergents which are not completely biodegradable in the environment; these must be collected and kept in the relevant special containers, then disposed of according to the regulations in force.
- Always grease the seals lips before reassembling.
- Use only metric spanners, not imperial spanners, which may have similar sizes, but can damage the bolts and make it impossible to unscrew them.

3 NORMES GÉNÉRALES DE SÉCURITÉ

- Après un démontage complet, toujours utiliser des joints neufs originaux Marzocchi lors du remontage.
- Pour le serrage de deux vis ou de deux écrous proches l'un de l'autre, toujours suivre la séquence 1-2-1 en utilisant des clés dynamométriques. Respecter les couples de serrage prévus (voir Tableau - Couples de serrage).
- Éviter absolument d'utiliser des solvants inflammables ou corrosifs pour le nettoyage : ceux-ci pourraient endommager les joints. Utiliser éventuellement des détergents spécifiques non corrosifs, ininflammables ou à seuil d'inflammabilité élevé, compatibles avec les matériaux des joints, et de préférence, biodégradables.
- Avant le remontage, lubrifier toujours les parties en contact avec de l'huile pour fourches.
- En prévision d'une longue période d'inactivité, lubrifier toujours les parties en contact, en utilisant de l'huile pour fourches.
- Ne jamais rejeter les lubrifiants ou détergents qui ne sont pas totalement biodégradables dans la nature : ceux-ci doivent être recueillis et conservés dans des conteneurs spécifiques, puis éliminés conformément aux normes en vigueur.
- Toujours enduire de graisse les lèvres des joints avant de les monter.
- N'utiliser que des clés métriques et non pas en pouces. Les clés en pouces peuvent présenter des dimensions semblables à celles en millimètres, mais elles peuvent endommager les vis et les rendre impossible à dévisser.
- Pour dévisser les vis fendues ou cruciformes,

3 ALLGEMEINE SICHERHEITSBESTIMMUNGEN

- Nach einem vollständigen Ausbau, beim Wiedereinbau immer neue, originelle Marzocchi Dichtungen verwenden.
- Beim Anziehen von zwei benachbarten Schrauben oder Muttern immer die Reihenfolge 1-2-1 einhalten und Drehmomentschlüssel verwenden; die vorgesehenen Anzugsmomente beachten (siehe Tabelle 1 - Anzugsmomente).
- Zur Reinigung auf keinen Fall entzündliche oder beizende Lösungsmittel verwenden, da diese die Dichtungen beschädigen können. Gegebenenfalls nicht beizende Spezialreinigungsmittel verwenden, die nicht entzündlich sind oder einen hohen Flammpunkt haben, mit den Materialien der Dichtungen verträglich und nach Möglichkeit biologisch abbaubar sind.
- Vor dem Wiedereinbau immer alle Kontaktteile mit Öl für Gabeln schmieren.
- Vor langem nicht Nutzen immer alle Kontaktteile mit Öl für Gabeln schmieren.
- Niemals Schmiermittel, Lösungsmittel oder Reinigungsmittel, die nicht vollständig biologisch abbaubar sind, wegschütten; sie müssen gesammelt und in geeigneten Behältern aufbewahrt werden, um dann nach den geltenden Bestimmungen entsorgt zu werden.
- Vor dem Wiedereinbau immer Fett auf die Lippen der Dichtringe auftragen.
- Ausschließlich metrische Schlüssel, keine Zollschlüssel verwenden. Schlüssel mit Zollmaßen können zwar ähnliche Größen haben wie die mit Millimetermaßen, aber sie können die Schrauben beschädigen und das Wiederaufdrehen unmöglich machen.
- Zum Aufdrehen von Schlitz-

3 NORMAS GENERALES DE SEGURIDAD

- Después de un desmontaje, utilice siempre juntas nuevas originales Marzocchi cuando vuelva a remontar la horquilla.
- Para apretar dos tornillos o tuercas cercanas, siga siempre la secuencia 1-2-1 utilizando llaves dinamométricas; respete los pares de torsión previstos (véase Tabla 1 - Pares de torsión).
- Evite absolutamente para limpiar la utilización de solventes inflamables o corrosivos que pudieran dañar las juntas de hermeticidad. Utilice detergentes específicos no corrosivos, no inflamables o con un alto punto de inflamabilidad compatibles con los materiales de las juntas y preferiblemente biodegradables.
- Antes del montaje, lubrique siempre con aceite para horquillas todas las partes en contacto.
- Si no va a utilizar la horquilla durante un tiempo, lubrique siempre los componentes de la horquilla que estén en contacto con aceite.
- No esparcir en el ambiente lubricantes, solventes o detergentes no completamente biodegradables; estos deben ser recogidos y conservados en recipientes especiales para ser después eliminados según la normativa vigente.
- En los labios de los retenes aplique siempre grasa antes de volver a montarlos.
- Utilice solamente llaves métricas y no de pulgadas. Las llaves con medidas en pulgadas pueden tener dimensiones parecidas a las de milímetros pero pueden dañar los tornillos e imposibilitar el desmontaje.
- Para destornillar los tornillos con cabeza de corte o de cruz, use destornilladores con

croce, usare un cacciavite con dimensione ed impronta adeguata.

- Nelle fasi in cui si utilizza il cacciavite per montare o smontare anelli metallici di fermo, guarnizioni o-ring, boccole guida, segmenti di tenuta, evitare di rigare i componenti maneggiati con la punta del cacciavite.
- Procedere alle operazioni di manutenzione/revisione solo se si è certi di possedere le capacità e l'attrezzatura necessaria per la corretta esecuzione; in caso contrario o di incertezze rivolgersi ad un centro assistenza autorizzato, presso il quale, personale specializzato dotato di attrezzi appropriati e ricambi originali, potrà manutenzione e revisionare la vostra forcella ripristinandola in condizioni pari al prodotto nuovo.
- Utilizzare solamente parti di ricambio originali.
- Prima di effettuare operazioni di manutenzione/revisione accertarsi di essere in possesso dei ricambi indispensabili per eseguire la revisione completa di entrambi gli steli (n°2 paraoli, n°2 raschiapolvere, n°2 segmenti del pistone).
- Operare in ambienti puliti, ordinati e ben illuminati, per quanto possibile evitare di effettuare la manutenzione all'aperto.
- Prima di effettuare operazioni di manutenzione sulla forcella, è consigliabile provvedere ad un accurato lavaggio di tutta la moto e in particolare della forcella.
- Verificare rigorosamente che nella zona di lavoro non vi sia presenza di trucioli metallici o polvere.
- È consigliabile procedere alla revisione di uno stelo alla volta.
- Non modificare i componenti della forcella.

- Use the correct size and sort of screwdriver to unscrew slotted or crosshead screws.
- When using a screwdriver to assemble or disassemble metal stop rings, o-rings, sliding bushings or seal segments, avoid scratching or cutting the components with the screwdriver tip.
- Only proceed to maintenance/overhaul operations if you are sure you are able to do it and you have got the right tools to do so. If this is not the case, or if you are unsure, please contact an authorized service center, where specialized technicians with the right tools and original spare parts will service and overhaul your fork, putting it back into its original working conditions.
- Only use original spare parts.
- Before servicing/overhauling make sure you have all the spare parts you need for the complete overhaul of both the fork legs (n°2 oil seals, n°2 dust seals, n°2 piston segments).
- Work in a clean, ordered and well-lit place; if possible, avoid servicing outdoors.
- Before servicing the fork, we recommend washing the motorcycle thoroughly and in particular washing the fork well.
- Carefully check there are no metal shavings or dust in the work area.
- We recommend overhauling one fork leg at a time.
- Do not modify the components of the fork.

utiliser un tournevis de dimension et de forme adaptées.

- Dans les étapes où l'on utilise le tournevis pour monter ou démonter les joints d'arrêt métalliques, les joints toriques, les bagues de glissement et les autres joints, éviter de rayer ou entailler les composants manipulés avec la pointe du tournevis.
- Procéder aux opérations d'entretien / réglage uniquement si l'on est certain de posséder les compétences et l'outillage nécessaires pour une exécution correcte. Dans le cas contraire ou en cas de doute, s'adresser à un centre d'assistance agréé, dont le personnel spécialisé disposant d'outils appropriés et de pièces détachées d'origines, pourra entretenir et régler votre fourche pour la remettre en des conditions semblables au produit neuf.
- Utiliser uniquement des pièces détachées d'origines.
- Avant d'effectuer des opérations d'entretien / réglage, s'assurer de posséder les pièces détachées indispensables pour la révision complète des deux fourreaux (n° 2 joints, n° 2 cache-pousière, n° 2 segments du piston).
- Opérer en milieu propre, rangé et bien éclairé. Éviter autant que possible d'effectuer l'entretien à l'extérieur.
- Avant d'effectuer des opérations d'entretien sur la fourche, il est conseillé de laver soigneusement toute la moto, et en particulier la fourche.
- Vérifier rigoureusement qu'il n'y a pas de copeaux métalliques ni de poussière dans la zone de travail.
- Il est conseillé d'effectuer la révision d'un seul fourreau à la fois.
- Ne pas modifier les composants de la fourche.

Kreuzschlitzschrauben einen Schraubendreher von geeigneter Größe und Art verwenden.

- Wenn der Schraubendreher zum Anbringen oder Ausbauen von Halterungen aus Metall, Rundummidichtungen, Führungsbuchsen oder Dichtungssegmenten benutzt wird, die bearbeiteten Teile nicht mit der Spitze des Schraubendrehers riefen oder einschneiden.
- Beginnen Sie mit Wartungs-/Überholungsarbeiten nur dann, wenn Sie sicher sind, dass Sie die nötigen Fertigkeiten und Werkzeuge für ihre vorschriftsmäßige Durchführung besitzen; wenn das nicht der Fall ist oder wenn Zweifel bestehen, wenden Sie sich an einen autorisierten Kundendienst, wo Fachpersonal mit geeignetem Werkzeug und Originalersatzteilen Ihre Gabel wartet und überholt und sie wieder in den Zustand eines Neuteils versetzt.
- Nur Originalersatzteile verwenden.
- Vergewissern Sie sich vor Beginn von Wartungs-/Überholungsarbeiten, dass Sie die notwendigen Ersatzteile für die vollständige Überholung beider Holme besitzen (N.2 Öldichtung, N. 2 Staubabstreifer, N. 2 Kolbensegmente)
- In sauberen, ordentlichen und gut beleuchteten Räumen arbeiten, die Durchführung der Wartung im Freien nach Möglichkeit vermeiden.
- Vor Durchführung von Wartungsarbeiten an der Gabel empfiehlt es sich, eine sorgfältige Reinigung des ganzen Motorrads und insbesondere der Gabel vorzunehmen.
- Genauestens überprüfen, ob sich im Arbeitsbereich Metallspäne oder Staub befinden.
- Es wird empfohlen, jeweils nur einen Holm zu überholen.
- Die Komponenten der Gabel nicht verändern.

dimensiones y formas apropiadas.

- En las fases en las que se utiliza el destornillador para montar o desmontar anillos de seguridad en metal, juntas tóricas, casquillos de guía, segmentos de hermeticidad, evite rallar o cortar los componentes manejados con la punta del destornillador.
- Proceda con las operaciones de mantenimiento / revisión solo si está seguro de poseer la capacidad y las herramientas necesarias para una correcta ejecución; en caso contrario o de incertidumbre diríjase a un centro de asistencia autorizado, en el cual personal especializado dotado de herramientas apropiadas y recambios originales podrá hacer el mantenimiento y revisar la horquilla restableciéndola a las condiciones originales de un producto nuevo.
- Utilice solamente partes de recambio originales.
- Antes de efectuar operaciones de mantenimiento / revisión asegúrese de poseer los recambios necesarios para la revisión completa de ambas barras (n. 2 retenes, n. 2 guardapolvos, n. 2 segmentos pistón).
- Trabaje en ambientes limpios, ordenados y bien iluminados, y si es posible evite efectuar el mantenimiento en espacio abierto.
- Antes de efectuar operaciones de mantenimiento en la horquilla, se aconseja efectuar un lavado cuidadoso de toda la moto y en particular de la horquilla.
- Compruebe cuidadosamente que en la zona de trabajo no haya virutas metálicas o polvo.
- Se aconseja proceder con la revisión de las barras una a la vez.
- No modifique los componentes de la horquilla.

3.1 Norme per la presa in morsa

Per alcune procedure di manutenzione può essere necessario utilizzare la morsa per serrare alcuni componenti della forcella.



ATTENZIONE

Un utilizzo non corretto della morsa può arrecare danni irreparabili alla forcella.

Rispettare scrupolosamente le seguenti indicazioni:

- limitare l'uso della morsa a quelle operazioni dove l'utilizzo della stessa è indispensabile;
- dotare la morsa di ganasce in materiale tenero;
- evitare di eccedere nel serraggio della morsa;
- evitare di fissare alla morsa parti della forcella in cui anche una minima ovalizzazione potrebbe danneggiare definitivamente il pezzo.

Nella figura sono evidenziate le zone consigliate per fissare la forcella alla morsa.

- A** - Piede portaruota.
- B** - Portastelo nella zona di fissaggio della base di sterzo.
- C** - Asta del pompante nella parte superiore alla sede dell'anello di battuta del guidamolla.
- D** - Presa di chiave della valvola di fondo.

3.1 Instructions for clamping in the vice

For some maintenance procedures you may have to use the vice to clamp some components of the fork.



WARNING

The incorrect use of the vice can cause irreparable damage to the fork.

Scrupulously follow the instructions below:

- Limit the use of the vice to those operations where the use of the same is absolutely necessary;
- Use a vice with padded jaws;
- Avoid over tightening the vice;
- Avoid clamping parts of the fork where even slight ovalization could damage the part;

The figure shows the zones recommended for fixing the fork in the vice.

- A** - Wheel axle clamp
- B** - Slider in the steering crown fixing zone
- C** - Top part of pumping element rod above the seat of the spring guide stop ring.
- D** - Bottom valve spanner seizing

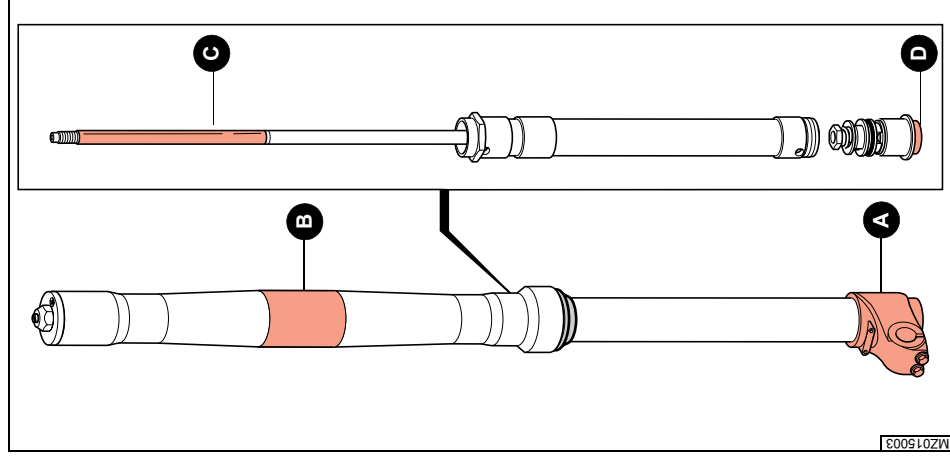

M2015003

3.1 Normes pour l'utilisation de l'étau

Pour certaines opérations d'entretien, il peut être nécessaire d'utiliser l'étau afin de serrer quelques composants de la fourche.



ATTENTION

Une utilisation incorrecte de l'étau peut endommager la fourche de façon irréversible.

Respecter rigoureusement les indications suivantes:

- limiter l'utilisation de l'étau aux opérations pour lesquelles il est absolument indispensable;
 - doter l'étau de mâchoires en matériau souple;
 - éviter tout serrage excessif de l'étau;
 - éviter de fixer à l'étau des pièces de la fourche dont une ovalisation minimale pourrait endommager définitivement la pièce elle-même.
- Sur la figure sont montrées les zones conseillées pour le serrage de la fourche dans l'étau.
- A** - Support de roue.
B - Porte-fourreau dans la zone de fixation du té de direction inférieur.
C - Tige de l'amortisseur dans la partie supérieure au logement du joint de butée du guide ressort.
D - Prise de clé clapet de pied.

3.1 Vorschriften für das Einspannen

Für manche Wartungsprozeduren kann es notwendig sein, zum Einspannen bestimmter Komponenten der Gabel den Spannstock zu verwenden.



ACHTUNG

Bei nicht vorschriftsmäßigem Gebrauch des Spannstocks kann die Gabel irreparable Schäden davontragen.

Die folgenden Hinweise sind genauestens zu beachten:

- Die Benutzung des Spannstocks auf die Arbeiten beschränken, bei denen sie unerlässlich ist;
 - den Spannstock mit Spannbacken aus weichem Material bestücken;
 - beim Anziehen des Spannstocks nicht übertreiben;
 - keine Gabelteile im Spannstock befestigen, bei denen auch eine minimale Unrundheit das Teil unbrauchbar machen würde.
- In der Abbildung sind die empfohlenen Bereiche für die Befestigung der Gabel im Spannstock markiert.
- A** - Radaufnahmefuß.
B - Gleitrohr in der Befestigungszone der Gabelbrücke unten.
C - Stab des Pumpenelements im Teil oberhalb des Anschlagrahms der Federhülse.
D - Bodenventilschlüsseleingriff

3.1 Normas para la colocación en una prensa de banco

Para algunos procedimientos de mantenimiento puede ser necesario utilizar una prensa de banco para apretar algunos componentes de la horquilla.



¡PRECAUCION!

Una no correcta utilización de la prensa puede producir daños irreparables a la horquilla.

Respete escrupulosamente las siguientes indicaciones:

- limite el uso de la prensa a aquellas operaciones donde su utilización sea indispensable;
 - ponga en la prensa mordazas de material blando;
 - no exceda cuando aprieta la prensa;
 - evite fijar en la prensa partes de la horquilla cuya mínima ovalización podría provocar un daño definitivo a la parte misma.
- En la figura se evidencian las zonas aconsejadas para fijar la horquilla a la prensa.
- A** - Pie portarueda.
B - Botella en la zona de fijación de la platina inferior.
C - Varilla del hidráulico en la parte superior de la sede del anillo de tope de la guía del muelle.
D - Agarre válvula de pie

4 MANUTENZIONE

4.1 Inconvenienti - cause - rimedi

Questo paragrafo riporta alcuni inconvenienti che possono verificarsi nell'utilizzo della forcella, ne indica le cause che possono averli provocati e suggerisce l'eventuale rimedio.
Consultare sempre questa tabella prima di intervenire sulla forcella.

4 MAINTENANCE

4.1 Problems - Possible causes - Solutions

This paragraph indicates some of the problems which may arise during the working life of the fork, as well as the possible causes of these problems and any solutions to the same. Always consult this Table before working on the fork.

Inconveniente - Problem	Causa - Cause	Rimedio - Solution
Perdita di olio dall'anello di tenuta Oil leaking from the oil seal	Anello di tenuta usurato - Worn oil seal Tubo portante rigato - Scratched stanchion tube Anello di tenuta sporco - Dirty oil seal	Sostituire l'anello di tenuta - Replace the oil seal Sostituire il tubo portante e l'anello di tenuta Replace the stanchion tube and the oil seal Sostituire l'anello di tenuta, il raschiapolvere e l'olio Replace the oil seal, the dust seal and the oil
Perdita di olio dal fondo dello stelo Oil leaking from the bottom of the fork leg	Guarnizione OR della valvola di fondo rovinata Damaged bottom valve O-ring Valvola di fondo lenta - Bottom valve loose Boccole di scorrimento usurate Worn sliding bushings Olio esausto - Old oil	Sostituire la guarnizione OR - Replace O-ring Serrare la valvola di fondo - Tighten bottom valve Sostituire le boccole di scorrimento Replace the sliding bushings Sostituire l'olio - Change the oil
Perdita di sensibilità Loss of sensitivity	Steli non correttamente allineati Fork legs not aligned correctly Spillo interno all'asta bloccato The pin inside the rod is stuck	Allentare il perno-ruota ed eseguire il corretto allineamento (vedi par 4. 12) Loosen the wheel axle and align the fork correctly (see Par. 4.2)
Scarsa scorrevolezza degli steli Fork legs not sliding properly	Vite registro bloccata The adjustment screw is stuck Presenza di impurità nell'olio - Impurities in the oil Valvole intasate da impurità Valves are blocked with impurities	Pulire o sostituire l'asta - Clean or replace rod Smontare e pulire la vite di registro Take off and clean adjustment screw Sostituire l'olio avendo cura di pulire accuratamente i componenti interni della forcella Change the oil making sure the forks' inside components are properly cleaned
La forcella non reagisce alle variazioni di registro The fork does not react to adjustment variations		

4 ENTRETIEN

4.1 Inconvénients - causes - remèdes

Ce paragraphe indique quelques inconvénients qui peuvent se présenter lors de l'utilisation de la fourche ainsi que leur cause éventuelle et les solutions possibles.

Toujours consulter ce tableau avant toute intervention sur la fourche.

4 WARTUNG

4.1 Störungen - Ursachen - Abhilfe

In diesem Paragraph werden einige Störungen aufgeführt, die sich beim Einsatz der Gabel ergeben können, dazu die möglichen Ursachen und Vorschläge für die eventuelle Abhilfe. Immer erst in dieser Tabelle nachsehen, bevor Eingriffe an der Gabel vorgenommen werden.

4 MANTENIMIENTO

4.1 Inconvenientes - causas - remedios

Este párrafo cita algunos inconvenientes que pueden verificarse con la utilización de la horquilla, indica las causas que pueden haberlos provocado y sugiere un posible remedio. Consulte siempre esta tabla antes de intervenir en la horquilla.

Inconvénient - Störung Inconveniente	Cause - Ursache - Causa	Remède - Abhilfe - Remedio
Perte d'huile du joint d'étanchéité Ölverlust am Dichtring Pérdida de aceite desde el retén	Le joint d'étanchéité est détérioré Dichtring verschlissen Retén consumido	Remplacer le joint d'étanchéité Sustituya el retén
	Le plongeur est rayé - Tauchrohr verkratzt Barra rayada	Remplacer le plongeur et le joint d'étanchéité Tauchrohr und Dichtring auswechseln Sustituya la barra y el retén
	Le joint d'étanchéité est sale Dichtring verschmutzt Retén sucio	Remplacer le joint d'étanchéité, le cache-pousière et l'huile Dichtring, Staubabstreifer und Öl auswechseln Sustituya el retén, el guardapolvo y el aceite
Perte d'huile du fond du fourreau Ölverlust am Holmboden Pérdida de aceite del fondo de la barra	Le joint torique du clapet de pied est endommagé Bodenventil O-Ring verschlissen Anillo O-ring de la válvula de pie dañado	Remplacer le joint torique - O-Ring auswechseln Sustituya el anillo O-ring
	Clapet de pied desserré - Bodenventil locker Válvula de pie floja	Serrer le clapet de pied - Bodenventil anziehen Apriete la válvula de pie
Perte de sensibilité Sensibilitätsverlust Pérdida de sensibilidad	Les bagues de glissement sont détériorées Gleitbuchsen verschlissen Casquillos guía gastados	Remplacer les bagues de glissement Gleitbuchsen auswechseln Sustituya los casquillos guía
	L'huile est usée - Öl verbraucht - Aceite consumido	Vidanger l'huile - Öl wechseln - Sustituya el aceite
Glissement insuffisant des fourreaux Schlechtes Gleiten der Holme Poco deslizamiento de las barras	Les fourreaux ne sont pas alignés correctement Holme nicht vorschriftsmäßig ausgerichtet Barras no alineadas correctamente	Desserrer l'axe de roue et l'aligner correctement (voir par. 4.12) Den Radbolzen lockern und die vorschriftsmäßige Ausrichtung durchführen (Siehe par. 4.12) Afloje el perno rueda y efectúe un alineamiento correcto (Véase párrafo 4.12)

<p>La forcella si dimostra troppo "morbida" in ogni configurazione dei registri Fork is too smooth with any adjustment</p>	<p>Livello dell'olio inferiore a quello consigliato Oil level too low</p> <p>Viscosità dell'olio troppo bassa - Oil viscosity too low</p> <p>Molla troppo "tenera" o fuori servizio Too soft or damaged spring</p>	<p>Ripristinare il corretto livello dell'olio Re-establish correct oil level</p> <p>Sostituire l'olio utilizzando uno con viscosità maggiore Replace the oil with a higher viscosity one</p> <p>Sostituire la molla - Replace the spring</p>
<p>La forcella si dimostra troppo "dura" in ogni configurazione dei registri Fork is too stiff with any adjustment</p>	<p>Livello dell'olio superiore a quello consigliato Oil level too high</p> <p>Viscosità dell'olio troppo elevata Oil viscosity too high</p> <p>Molla troppo "dura" - Too hard spring</p>	<p>Ripristinare il corretto livello dell'olio Re-establish correct oil level</p> <p>Sostituire l'olio utilizzando uno con viscosità inferiore Replace the oil with a lower viscosity one</p> <p>Sostituire la molla - Replace the spring</p>

<p>La fourche ne réagit pas aux variations de réglage</p> <p>Die Gabel spricht nicht die Einstellungsänderungen auf</p> <p>La horquilla no reacciona a los cambios de regulación</p>	<p>Epingle à l'intérieur de la tige bloquée</p> <p>Stabsinnennadel blockiert</p> <p>Clavija al interior del vástago bloqueada</p>	<p>Nettoyer ou remplacer la tige</p> <p>Den Stab reinigen oder auswechseln</p> <p>Limpie o sustituya el vástago</p>
<p>La fourche est trop « souple » avec tout réglage</p> <p>Die Gabel ist zu „schwach“ mit allen Einstellungen</p> <p>La horquilla es demasiado « blanda » en todas las regulaciones</p>	<p>Vis de réglage bloquée - Einstellschraube blockiert</p> <p>Tornillo de regulación bloqueado</p> <p>Présence d'impuretés dans l'huile</p> <p>Unreinheiten im Öl</p> <p>Hay impuridades en el aceite</p> <p>Clapets bloqués par les impuretés</p> <p>Ventile durch Unreinheiten verstopft</p> <p>Válvulas obstruidas por las impuridades</p> <p>Niveau de l'huile trop bas</p> <p>Ölvolumen zu niedrig</p> <p>Nivel de aceite demasiado bajo</p> <p>Viscosité de l'huile trop basse</p> <p>Öviskosität zu niedrig</p> <p>Viscosidad del aceite demasiado baja</p> <p>Ressort trop souple ou inutilisable</p> <p>Feder zu schwach oder beschädigt</p> <p>Muelle demasiado blando o no funciona</p>	<p>Die Einstellschraube abnehmen und reinigen</p> <p>Saque y limpie el tornillo de regulación</p> <p>Remplacer l'huile en ayant soin de bien nettoyer les composants intérieurs de la fourche</p> <p>Das Öl wechseln und alle innere Komponente der Gabel reinigen</p> <p>Sustituya el aceite limpiando con cuidado los componentes interiores de la horquilla</p> <p>Rétablir le niveau d'huile correct</p> <p>Das richtige Ölvolumen ergänzen</p> <p>Reestablezca el nivel de aceite correcto</p> <p>Remplacer l'huile par un autre ayant plus de viscosité</p> <p>Das Öl mit einem höheren Viskosität wechseln</p> <p>Sustituya el aceite utilizando otro con viscosidad mayor</p> <p>Remplacer le ressort - Die Feder auswechseln</p> <p>Sustituya el muelle</p>
<p>La fourche est trop « dure » avec tout réglage</p> <p>Die Gabel ist zu „hart“ mit allen Einstellungen</p> <p>La horquilla es demasiado « dura » en todas las regulaciones</p>	<p>Niveau de l'huile trop haut</p> <p>Ölvolumen zu hoch</p> <p>Nivel de aceite demasiado elevado</p> <p>Viscosité de l'huile trop haute</p> <p>Öviskosität zu hoch</p> <p>Viscosidad del aceite demasiado elevada</p> <p>Ressort trop dur ou inutilisable</p> <p>Feder zu hart oder beschädigt</p> <p>Muelle demasiado duro o no funciona</p>	<p>Remplacer l'huile par un autre ayant moins de viscosité</p> <p>Das Öl mit einem niedrigeren Viskosität wechseln</p> <p>Sustituya el aceite utilizando otro con viscosidad menor</p> <p>Remplacer le ressort - Die Feder auswechseln</p> <p>Sustituya el muelle</p>

4.2 Tabella manutenzione periodica

Operazioni di manutenzione generale General maintenance operations	Utilizzo - Use		
	Intenso - Intense	Regolarità - Road	Normale - Normal
	Cross - Tout terrain	Cross - Tout terrain	Regolarità - Road
Verifica serraggio bulloneria alla coppia prescritta Check screws tightening up to required torque	Prima di ogni utilizzo Before every ride		
Pulizia raschiapolvere Clean the dust seal	Dopo ogni gara After every race 6 ore Every 6 hours	Dopo ogni gara After every race 20 ore Every 20 hours	Dopo ogni uso After every use 60 ore Every 60 hours
Sostituzione olio Change the oil	6 ore Every 6 hours	30 ore Every 30 hours	60 ore Every 60 hours
Sostituzione anelli di tenuta Replace the sealing rings	6 ore Every 6 hours	30 ore Every 30 hours	60 ore Every 60 hours

4.2 Periodical maintenance table

Quando la sospensione viene utilizzata su terreni fangosi o sabbiosi, consigliamo di eseguire le operazioni di manutenzione ad intervalli più ravvicinati del **30%**.

If the fork is used on mudded or sandy grounds, the maintenance operations shall be carried out more frequently **30%**.

4.2 Tableau d'entretien périodique

4.2 Tabelle für Turnusmäßige Wartung

4.2 Tabla de mantenimiento periódico

	Utilisation - Einsatz - Utilización		
	Intensive - Intensiv - Intensivo	Normale - Normal - Normal	Régularité - Straße - Regularidad
	Tout terrain - Cross	Régularité - Straße - Regularidad	Tout terrain - Cross
Opérations d'entretien général Allgemeine Wartungsarbeiten Operaciones de mantenimiento general	Avant chaque utilisation Vor jedem Einsatz Antes de cada salida		
Vérification du serrage des vis au couple prévu Überprüfung der Schraubenanzugsmomente Control torsiones específicas correctas de los pernos			
Nettoyage du cache-poussière Reinigung Staubabstreifer Limpieza guardapolvo	Après chaque compétition Nach jedem Rennen Después de cada competición	Après chaque utilisation Nach jedem Einsatz Después de cada utilización	Après chaque utilisation Nach jedem Einsatz Después de cada utilización
Vidange de l'huile Ölwechsel Sustitución aceite	Toutes les 6 heures 6 Stunden Cada 6 horas	Toutes les 20 heures 20 Stunden Cada 20 horas	Toutes les 30 heures 30 Stunden Cada 30 horas
Remplacement des joints d'étanchéité Auswechslung der Dichtringe Sustitución retenes	Toutes les 6 heures 6 Stunden Cada 6 horas	Toutes les 20 heures 20 Stunden Cada 20 horas	Toutes les 60 heures 60 Stunden Cada 60 horas

Au cas où la fourche serait utilisée sur des terrains boueux ou sableux, les opérations d'entretien doivent être exécutées plus souvent **30%**.

Falls die Gabel auf schlammigem oder sandigem Gelände benutzt wird, empfehlen wir, die Wartungsarbeiten in kürzeren Abständen **30%** durchzuführen.

En el caso en que la horquilla se utilice en terrenos lodosos o arenosos, las operaciones de mantenimiento tendrán que hacerse más a menudo **30%**.

4.3 Pulizia raschiapolvere

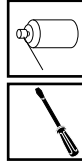

NOTA

Questa operazione può essere eseguita a forcella installata sul motociclo.

Smontaggio

- Pulire accuratamente il tubo portante (6) prima di eseguire questa operazione.
- Con un piccolo cacciavite scalzare il raschiapolvere (12) dal portastelo (13), evitando di rigare il tubo portante.
- Abbassare il raschiapolvere lungo il tubo portante e con un getto d'aria compressa pulire l'interno del raschiapolvere e la sede sul portastelo.



ATTENZIONE

Evitare assolutamente di utilizzare attrezzi metallici per eliminare particelle di sporco.

- Far compiere agli steli una breve corsa e rimuovere dai tubi portanti le eventuali impurità.
- Lubrificare con grasso silconato il raschiapolvere e la superficie visibile dell'anello di tenuta.

Rimontaggio

- Rimontare in sede il raschiapolvere (12) facendo pressione con le mani.

4.3 Cleaning the dust seal

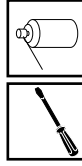

REMEMBER

This operation can be carried out with the fork installed on the motorcycle.

Dismantling

- Carefully clean the stanchion tube (6) before carrying out this operation.
- With a small screwdriver prize the dust seal (12) off the slider (13), without scratching the stanchion tube.
- Slide the dust seal along the stanchion tube and clean inside the dust seal and its seat on the slider with a jet of compressed air.



WARNING

Never use metal tools to clean any particles of dirt.

- Compress the fork legs slightly and remove any traces of dirt from the stanchion tubes.
- Lubricate the dust seal and the visible surface of the oil seal with silicon grease.

Re-assembly

- Re-assemble the dust seal (12) in its seat, pressing it home with your hands.

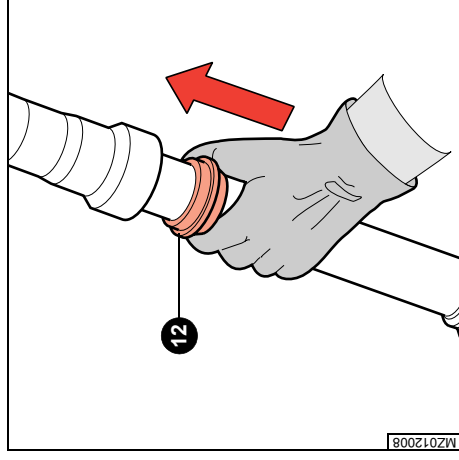
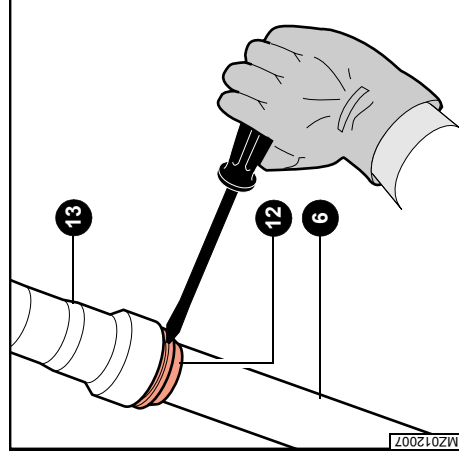

4.3 Nettoyage du cache-poussière

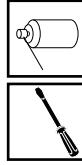

NOTE

Cette opération peut être effectuée avec fourche montée sur le motorcycle.

Démontage

- Nettoyer avec soin le plongeur (6) avant d'effectuer cette opération.
- A l'aide d'un petit tournevis, ôter le cache-poussière (12) du porte-fourreau (13) en évitant de rayer le plongeur.
- Abaisser le cache-poussière le long du plongeur et nettoyer l'intérieur du cache-poussière et le logement sur le porte-fourreau à l'air comprimé.



ATTENTION

Éviter absolument d'utiliser des outils métalliques pour éliminer les particules de saleté.

- Déplacer un peu les fourreaux et éliminer des plongeurs toutes les impuretés.
 - Lubrifier le cache-poussière et la surface visible du joint d'étanchéité avec de la graisse à la silicone.
- Remontage**
- Monter à nouveau le cache-poussière (12) dans son logement en exerçant une pression avec les mains.

4.3 Reinigung Staubabstreifer

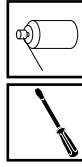

WICHTIG

Für diese Arbeit braucht die Gabel nicht vom Motorrad abmontiert zu werden.

Ausbau

- Vor Durchführung dieser Arbeit das Tauchrohr (6) sorgfältig reinigen.
- Den Staubabstreifer (12) mit einem kleinen Schraubendreher vom Gleitrohr (13) abdrücken, dabei darauf achten, dass das Tauchrohr nicht verkratzt wird.
- Den Staubabstreifer entlang dem Tauchrohr nach unten führen und mit einem Druckluftstrahl den Innenbereich des Staubabstreifers und seinen Sitz am Gleitrohr säubern.



ACHTUNG

Die Verwendung von Metallwerkzeugen für das Abtragen von Schmutzteilen ist unbedingt zu vermeiden.

- Die Holme einen kurzen Hub ausführen lassen, dann die eventuell an den Tauchrohren vorhandenen Verunreinigungen entfernen.
 - Den Staubabstreifer und die sichtbare Oberfläche des Dichtrings mit Silikonfett schmieren.
- Wiedereinbau**
- Den Staubabstreifer (12) mit den Händen wieder an seinen Platz drücken.

4.3 Limpieza del guardapolvo

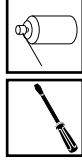

NOTA

Esta operación puede ser efectuada con la horquilla instalada en la motocicleta.

Desmontaje

- Limpie cuidadosamente la barra de horquilla (6) antes de efectuar esta operación.
- Con un destornillador pequeño saque el guardapolvo (12) de la botella (13), evitando de rayar la barra.
- Baje el guardapolvo a lo largo de la barra y con un chorro de aire comprimido limpie el interior del guardapolvo y su alojamiento en la botella.



¡PRECAUCION!

Evite absolutamente utilizar herramientas metálicas para eliminar partículas de suciedad.

- Desplace la horquilla y elimine de las barras eventuales impurezas.
 - Lubrique con grasa a la silicona el guardapolvo y la superficie visible del retén.
- Reensamblaje**
- Vuelva a montar en su lugar el guardapolvo (12) presionando con las manos.

4.4 Spurgo aria



NOTA

Questa operazione deve essere eseguita a forcella installata sul motociclo con steli completamente estesi (ruota anteriore sollevata da terra).

La pressione generata dall'aria che può entrare all'interno degli steli durante l'utilizzo, per la particolare conformazione degli anelli di tenuta può essere trattenuta e causare malfunzionamenti alla forcella.

Smontaggio

- Mensilmente o dopo ogni gara, è necessario svitare con un cacciavite a croce, in entrambi gli steli, la vite di spurgo aria (14) posta nella parte superiore del portastelo, per scaricare la pressione che può crearsi all'interno.
- Verificare lo stato dell'anello di tenuta (50); se necessario sostituirlo.

Rimontaggio

- Serrare la vite di spurgo aria (14) alla coppia prescritta (vedi Tabella 1 - Coppie di serraggio), prestando attenzione a non danneggiare l'anello di tenuta (50).

4.4 Bleeding the air



REMEMBER

This operation must be carried out with the fork assembled on the motorcycle and with the fork's legs fully extended (front wheel off the ground).

The pressure generated by the air that can get into the fork legs while the motorcycle is being used and which, due to the special shape of the oil seals remains trapped inside, can cause the fork to malfunction.

Dismantling

- Monthly or after every race use a crosshead screwdriver to unscrew the air bleed screw (14) in both the fork legs on the top part of the slider, to drain the pressure that can build up inside.
- Check the state of the oil seal (50); replace if necessary.

Re-assembly

- Tighten the air bleed screw (20) to the recommended torque (see Table 1 - Tightening torques), being careful not to damage the oil seal (50).

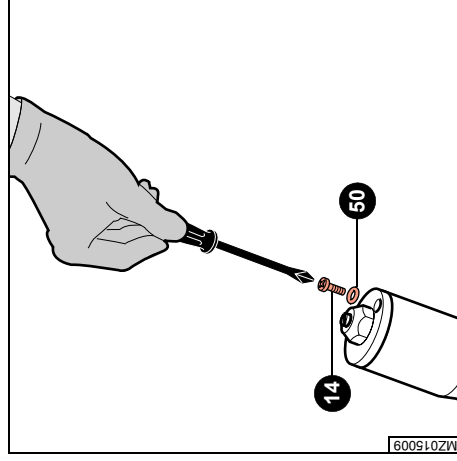

M2015009

4.4 Purge de l'air



NOTE

Cette opération doit être exécutée en gardant la fourche installée sur le motorcycle, les fourreaux entièrement baissés (roue avant soulevée du sol).

La pression générée par l'air qui peut entrer dans les fourreaux lors de l'utilisation et qui ne peut pas sortir du fait de la configuration particulière des joints d'étanchéité, peut entraîner un fonctionnement incorrect de la fourche.

Démontage

- Tous les mois ou après chaque compétition, il est nécessaire de dévisser la vis de purge d'air (14) placée sur la partie supérieure de chaque porte-fourreau à l'aide d'un tournevis cruciforme afin d'éliminer la pression pouvant se créer à l'intérieur des fourreaux.
- Vérifier l'état du joint d'étanchéité (50); le remplacer si nécessaire.

Remontage

- Serrer la vis de purge d'air (14) au couple conseillé (voir Tableau 1 - Couples de serrage) en faisant attention à ne pas endommager le joint d'étanchéité (50).

4.4 Entlüftung



WICHTIG

Um diese Arbeit durchzuführen, muss die Gabel am Motorrad eingebaut und die Holme vollständig ausgefedert sein (Vorderrad vom Boden abgehoben).

Wenn bei der Benutzung Luft in das Innere der Holme eindringt, kann sie wegen der besonderen Form der Dichtringe nicht mehr austreten und einen Druck erzeugen, der Funktionsstörungen der Gabel verursachen kann.

Ausbau

- Jeden Monat oder nach jedem Rennen muss an beiden Holmen die Entlüftungsschraube (14) im oberen Teil des Gleitrohrs mit einem Kreuzschlitzschraubendreher aufgedreht werden, um den eventuell im Inneren entstandenen Druck abzulassen.
- Den Zustand des Dichtings (50) überprüfen; falls nötig, auswechseln.

Wiedereinbau

- Die Entlüftungsschraube (14) mit dem vorgeschriebenen Anzugsmoment (siehe Tabelle 1 - Anzugsmomente) anziehen, dabei darauf achten, dass der Dichtring (50) nicht beschädigt wird.

4.4 Purga de aire



NOTA

Esta operación debe llevarse a cabo con la horquilla montada en la moto y las botellas completamente extendidas (la rueda delantera no debe tocar el suelo).

La presión generada por el aire que puede entrar en las botellas mientras usa la horquilla y que, debido a la forma especial de los retenes puede quedar atrapada dentro, puede causar el mal funcionamiento de la horquilla.

Desmontaje

- Cada mes o después de cada competición, es necesario desmontar con un destornillador de estrella, en ambas barras, el tornillo de purga de aire (14) colocado en la parte superior de la botella, para descargar la presión que se puede crear en su interior.
- Compruebe el estado del retén (50); si es necesario sustitúyalo.

Reensamblaje

- Apriete el tornillo de purga de aire (14) al par de torsión indicado (véase Tabla 1 - Pares de torsión), prestando atención a no dañar el retén (50).

4.5 Scarico olio



ATTENZIONE
Questa operazione non può essere eseguita a forcella installata sul motociclo.

**NOTA**

È consigliabile allentare leggermente il tappo di chiusura, prima di rimuovere lo stelo dalle piastre di sterzo.

- Rimuovere lo stelo dalle piastre di sterzo secondo la procedura prevista dal costruttore del motociclo.
- Fissare lo stelo in morsa.
- Svitare completamente il tappo di chiusura (48), servendosi di una chiave da 19 mm.
- Abbassare lentamente il portastelo sul tubo portante.
- Spingere verso il basso lo scodellino guidamolla (20) e la molla (21) in modo da potere inserire una chiave da 19 mm nel controdado (23).
- Tenere fisso il controdado (23) con chiave da 19 mm, e servendosi di una seconda chiave sempre da 19 mm svitare completamente il tappo di chiusura (48).

4.5 Draining the oil



WARNING
This operation cannot be carried out with the fork installed on the motorcycle.

**REMEMBER**

We recommend loosening the fork cap a little before removing the fork leg from the fork yokes.

- Remove the fork leg from the fork yokes according to the procedure in the motorcycle owner's manual.
- Clamp the fork leg in the vice.
- Remove the fork cap (48) with the 19 mm spanner.
- Slowly lower the slider on the stanchion tube.
- Push the guide spring cap (20) and the spring (21) downwards, so that you can reach the locknut (23) with the 19 mm spanner.
- Holding the locknut (23) with a 19 mm spanner, use another 19 mm spanner to unscrew the fork cap (48) completely.

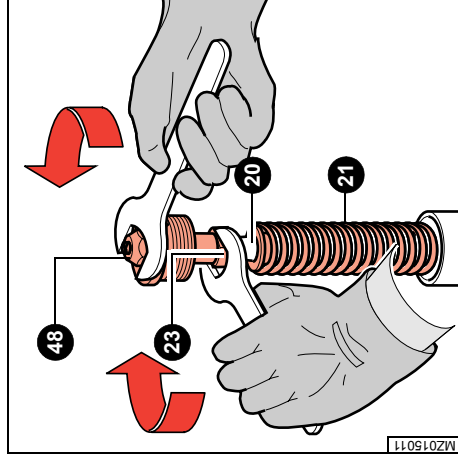
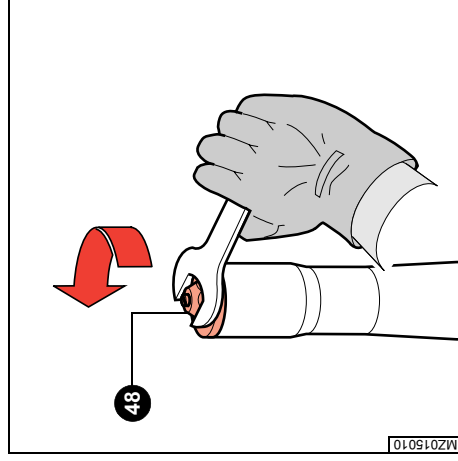

4.5 Vidange de l'huile



ATTENTION

Cette opération ne peut pas être effectuée avec la fourche montée sur le motorcycle.



NOTE

Il est conseillé de desserrer un peu le bouchon de fermeture avant de démonter le fourreau du Té supérieur et inférieur.

- Démontez le fourreau du Té supérieur et inférieur en suivant les instructions fournies par le constructeur du motorcycle.
- Serrer le fourreau avec l'étai.
- Dévisser complètement le bouchon de fermeture (48) avec une clé de 19 mm.
- Abaisser lentement le porte-fourreau sur le plongeur.
- Poussez vers le bas la cuvette guide ressort (20) et le ressort (21) de façon à ce qu'il soit possible d'insérer une clé de 19 mm sur le contre-écrou (23).
- Maintenir le contre-écrou (23) en position avec une clé de 19 mm et, à l'aide d'une autre clé de 19 mm, desserrer complètement le bouchon de fermeture (48).

4.5 Ölablass



ACHTUNG

Dieser Arbeitsschritt darf nicht bei am Motorrad montierter Gabel ausgeführt werden.



WICHTIG

Es empfiehlt sich, den Verschluss etwas zu lockern, bevor der Holm von den Gabelbrücken abgenommen wird.

- Den Holm nach der vom Hersteller des Motorrads vorgesehenen Prozedur von den Gabelbrücken abnehmen.
- Den Holm im Spannstock einspannen.
- Den Verschluss (48) mit dem 19 mm-Schlüssel vollständig aufschrauben.
- Das Gleitrohr langsam auf das Tauchrohr nach unten ziehen.
- Den Federhülseteller (20) und die Feder (21) so weit nach unten drücken, dass ein 19 mm-Schlüssel auf die Kontermutter (23) gesetzt werden kann.
- Die Kontermutter (23) mit einer 19 mm-Schlüssel festhalten und mit einer anderen 19 mm-Schlüssel den Verschluss (48) vollständig ausschrauben.

4.5 Descarga de aceite



¡PRECAUCIÓN!

Esta operación no puede llevarse con la horquilla instalada en la motocicleta.



NOTA

Se aconseja aflojar levemente el tapón de cierre, antes de sacar la barra de las pletinas de dirección.

- Saque la barra de las pletinas de dirección según el procedimiento previsto por el constructor de la motocicleta.
- Sujete la barra en la prensa.
- Afloje completamente el tapón de cierre (48) con la llave de 19 mm.
- Baje lentamente la botella en la barra.
- Empuje hacia abajo el tubo de precarga (20) y el muelle (21) de manera que se pueda introducir una llave de 19 mm en la contratuercia (23).
- Tenga fija la contratuercia (23) con una llave de 19 mm, y ayudándose con otra llave de 19 mm afloje completamente el tapón de cierre (48).

- Sfilare il tappo di chiusura (48), lo scodellino guidamolita (20), la molla (21) e il tubetto di precarica (25).
- Sfilare dall'estremità dell'asta (32), l'asta interna di rinvio del registro (31).
- Sbloccare lo stelo (5) dalla morsa e ruotarlo verso un recipiente di dimensioni adeguate in maniera tale da far defluire l'olio contenuto; per favorire lo svuotamento è necessario effettuare alcune pompate.

**NOTA**

È disponibile a ricambio l'attrezzo **R5051AC**, che avvitato sulla parte terminale dell'asta ne facilita il recupero dall'interno del portastelo.

**NOTA**

Osservando l'aspetto, la densità e la qualità dell'olio esausto è possibile valutare le condizioni degli elementi di tenuta e di guida; se l'olio si presenta denso e scuro con presenza di particelle solide è necessario procedere alla sostituzione delle boccole guida e degli elementi di tenuta.

**NOTA**

Nel paragrafo 4.11 è illustrata la procedura per il montaggio e il riempimento olio.

- Remove the fork cap (48), the guide spring cap (20), the spring (21) and the preload tube (25).
- Remove from the rod's edge (32), the adjustment return inner rod (31).
- Free the fork leg (5) from the vice and tip it into a container of a suitable size to drain the oil; pump the fork to help the oil flow out.

**REMEMBER**

The **R5051AC** is available as spare part: if you tighten it on the rod's edge, you can make the rod extraction from the inner part of the slider easier.

**REMEMBER**

Check appearance, density and quality of the old oil to get an idea of the oil seal and guiding elements condition. If the oil is dense and dark with solid particles in it, you will have to replace the guide bushings and the sealing elements.

**REMEMBER**

Paragraph 4.11 describes the procedure for assembling and filling with oil.

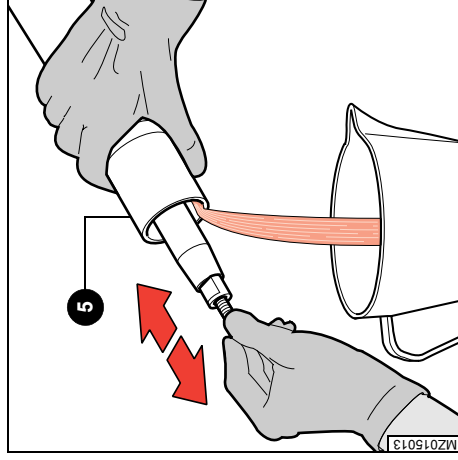
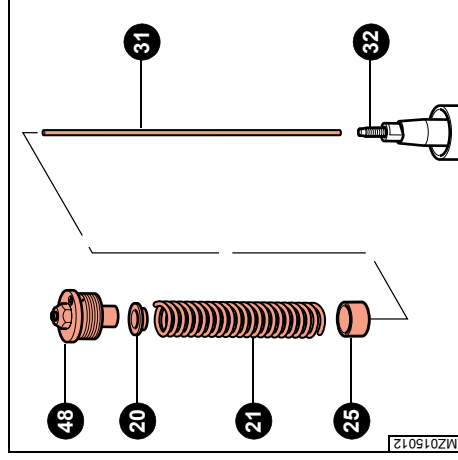

- Sortir le bouchon de fermeture (48), la cuvette guide ressort (20), le ressort (21) et le petit tube de pré-charge (25).
- Sortir de l'extrémité de la tige (32), la tige intérieure de renvoi réglage (31).

- Dégager le fourreau (5) de l'étai et l'orienter vers un récipient de grande capacité pour faire écouler l'huile à son intérieur; pour favoriser la vidange de l'huile, il est nécessaire d'effectuer quelques pompages.

**NOTE**

L'outil **R5051AC** est disponible en pièce détachée : en le serrant sur la partie terminale de la tige, l'extraction de la tige elle-même de l'intérieur du porte-fourreau sera plus facile.

**NOTE**

En observant l'aspect, la densité et la qualité de l'huile usée, il est possible d'évaluer l'état des éléments d'étanchéité et de glissement. Si l'huile est dense et sombre, avec des particules solides, il s'avère nécessaire de remplacer les bagues de glissement et les joints d'étanchéité.

**NOTE**

Le paragraphe 4.11 illustre la procédure pour le montage et le remplissage de l'huile.

- Den Verschluss (48), den Federhülseteller (20) die Feder (21) und den Vorspannung (25) abnehmen.

- Den inneren Rückruffstab (31) vom Stabsende (32) abnehmen.

- Den Holm (5) aus dem Spannstock nehmen und auf einen ausreichend großen Behälter hin kippen, damit das Öl ablaufen kann; zum Unterstützen der Entleerung müssen ein paar Pumpbewegungen gemacht werden.

**WICHTIG**

Das Werkzeug **R5051AC** ist als Ersatzteil verfügbar; wenn es am Stabsende eingeschraubt wird, ist es einfacher, den Stab selbst vom Gleitrohresinnere abzunehmen.

**WICHTIG**

Wenn man das Aussehen, die Dichte und die Qualität des verbrauchten Öls betrachtet, kann man Rückschlüsse auf den Zustand der Dicht- und Führungselemente ziehen. Wenn das Öl dickflüssig und dunkel ist und Festkörperchen aufweist, ist eine Auswechslung der Führungsbuchsen und der Dichtelemente erforderlich.

**WICHTIG**

Im Paragraph 4.11 ist die Prozedur für den Einbau und das Einfüllen des Öls erläutert.

- Saque el tapón de cierre (48), el asiento guía de muelle (20), el muelle (21) y el tubo de precarga (25).

- Saque el vástago de transmisión de regulación (31) de la extremidad del vástago (32).

- Desbloquee la barra (5) de la prensa y gírela hacia un recipiente de dimensiones adecuadas de manera que pueda versar el aceite que contiene; para favorecer el vaciado es necesario efectuar algunos bombeos.

**NOTA**

La herramienta **R5051AC** está disponible para los repuestos: aprietandola en la parte terminal del vástago, le extracción del mismo de la botella será más fácil.

**NOTA**

Observando el aspecto, la densidad y la calidad del aceite consumido es posible evaluar las condiciones de los elementos de retención y de guía; si el aceite se presenta denso y oscuro con presencia de partículas sólidas es necesario proceder a la sustitución de los casquillos de guía y de los elementos de hermeticidad.

**NOTA**

En el párrafo 4.11 está ilustrado el procedimiento para el montaje y el relleno de aceite.

4.6 Smontaggio gruppo pompante e valvola di fondo

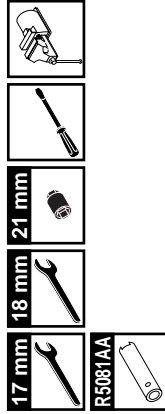

ATTENZIONE

Questa operazione deve essere eseguita solamente dopo avere scaricato completamente l'olio contenuto all'interno dello stelo.

- Bloccare il piede portaruota del tubo portante in morsa.
- Introdurre l'attrezzo **R5081AA** all'interno dello stelo in maniera tale da bloccare la rotazione della custodia; per ottenere il bloccaggio occorre che l'asola ricavata all'estremità inferiore dell'attrezzo vada ad inserirsi perfettamente nell'esagono della custodia.



ATTENZIONE

Nella parte superiore dell'attrezzo sono presenti due fori diametralmente opposti nei quali è possibile inserire un perno per facilitarne il bloccaggio. Tuttavia l'attrezzo non deve essere ruotato per alcun motivo ma solamente utilizzato per tenere fermi i componenti interni allo stelo.

- Con la chiave a bussola da 21 mm svitare la valvola di fondo (**41**).
- Rimuovere il gruppo valvola di fondo (**41**).
- Sfilare il gruppo ammortizzatore (**21**) dal tubo portante (**5**).

4.6 Braking down the pumping element and the bottom valve

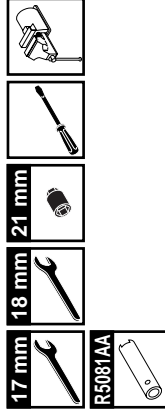

WARNING

This operation must be done only after having drained all of the oil out of the fork leg.

- Clamp the wheel axle clamp in the vice.
- Insert the **R5081AA** tooling inside the fork leg in a way that you can block the body rotation; to do so, the slot obtained at the tooling lower edge must be perfectly inserted into the body hexagon.



WARNING

In the tooling upper part there are two opposite holes where you can insert an axle to make the blocking easier. However, the tooling must not be rotated in any case, but only used to hold the fork leg inner parts.

- Using the 21 mm tube wrench unscrew the bottom valve (**41**).
- Remove the bottom valve set (**41**).
- Take off the damping set (**21**) from the stanchion tube (**5**).

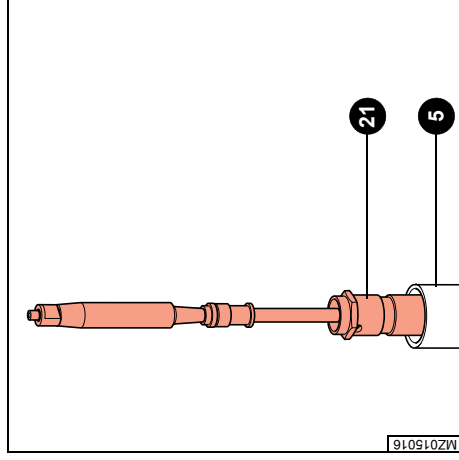
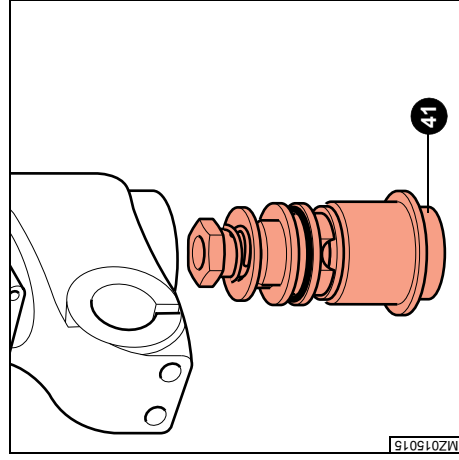

4.6 Démontage du groupe amortisseur et clapet de pied

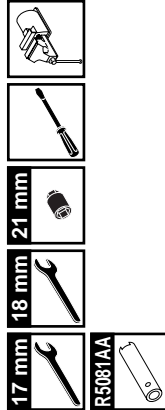

⚠ ATTENTION

Cette opération doit être effectuée seulement après avoir vidangé complètement l'huile contenue à l'intérieur du fourreau.

- Bloquer le support de roue du plongeur dans l'état.
- Introduire l'outil **R5081AA** à l'intérieur du fourreau ; pour faire cela il est nécessaire que la fente obtenue à l'extrémité inférieure de l'outil soit exactement insérée dans l'hexagone du corps.

⚠ ATTENTION

Dans la partie supérieure de l'outil vous trouvez deux trous opposés où il est possible d'introduire un pivot pour en faciliter le blocage. L'outil ne doit quand-même être tourné en aucun cas, mais il doit seulement être utilisé pour garder les composants intérieurs du fourreau immobiles.

- Dévisser le clapet de pied (41) avec une clé à tube de 21 mm.
- Ôter le groupe clapet de pied (41).
- Ôter le groupe amortisseur (21) du plongeur (5).

4.6 Zerlegung Pumpengruppe und Bodenventil

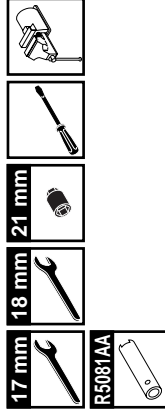

⚠ ACHTUNG

Dieser Arbeitsschritt darf erst ausgeführt werden, nachdem das Öl im Inneren des Gleitrohres vollständig abgelassen ist.

- Die Radaufnahme des Standrohres einspannen.
- Das Gerät **R5081AA** in den Holm so einsetzen, dass die Hülserotation blockiert wird; um die Blockierung zu erreichen ist es nötig, dass das am Gerätsextremität liegende Langloch sich perfekt in den Hülsesehskant einstimmt.

⚠ ACHTUNG

Im oberen Gerätegebiet sind zwei diametral entgegengesetzte Löcher zu sehen, wo eine Achse eingesetzt werden kann, um die Blockierung einfacher zu machen. Das Gerät kann jedoch auf keinen Fall rotiert werden, sondern nur zur Blockierung der innenliegenden Komponenten des Holmes benutzt werden.

- Mit einer 21 mm Steckschlüssel das Bodenventil (41) ausschrauben.
- Die Bodenventilgruppe (41) abnehmen.
- Die Pumpengruppe (21) aus dem Standrohr (5) abnehmen.

4.6 Decomposición elemento de bomba y válvula de pie

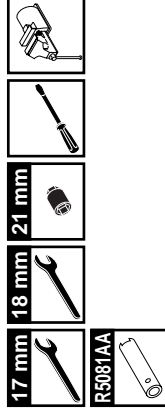

⚠ ¡PRECAUCION!

Esta operación debe llevarse sólo después de haber descargado completamente el aceite contenido en el interior de la botella.

- Bloquee el portarueda de la barra en la prensa
- Inserte la herramienta **R5081AA** al interior de la barra de manera que la rotación de la protección esté bloqueada; para hacer esto es necesario que el ojete obtenido en la extremidad inferior de la herramienta se inserte perfectamente en el hexágono de la protección.

⚠ ¡PRECAUCION!

En la zona superior de la herramienta hay dos agujeros diametralmente opuestos donde se puede insertar un eje para hacer el bloqueo más fácil. No obstante, la herramineta no se debe rotar para ninguna razón, sino sólo utilizarse para tener fijos los componentes interiores de la barra.

- Con una llave tubular de 21 mm desatornille la válvula de pie (41).
- Saque el conjunto válvula de pie (41)
- Saque el grupo de amortiguación (21) de la barra (5).

- Svitare e rimuovere il controdado (23) e sfilare il guidamolla (24).
- Per poter operare sul pompante è necessario rimuovere i componenti del tampone di fine corsa: tenere bloccato il dado del tampone di fondo (26) con chiave da 18 mm e svitare il puntale (29) con chiave esagonale da 17 mm.
- Sfilare la il dado superiore (26) e il tampone di fondo (28).
- Con un piccolo cacciavite scalzare l'anello di fermo (27) dall'asta.
- Rimuovere dall'asta, l'anello di fermo (27) e il puntale (29).

- Unscrew and remove the locknut (23) and take off the guide spring (24).
- In order to be able to act on the pumping element you will need to remove the foot buffer components: hold the foot buffer nut (26) using a 18 mm spanner and unscrew the push rod (29) with a 17 mm hexagonal spanner.
- Remove the upper nut (26) and the foot buffer (28).
- Using a small screwdriver prize the stop ring (27) off the rod.
- Remove the stop ring (27) and the push rod (29) off the rod.

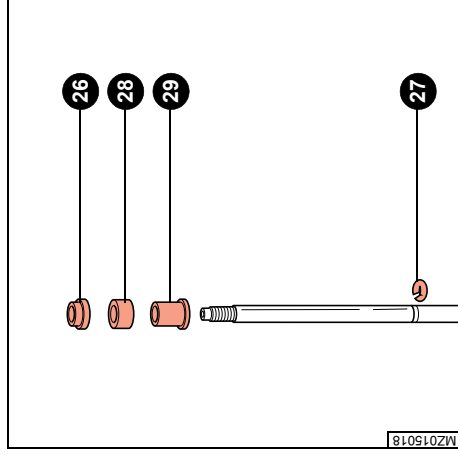
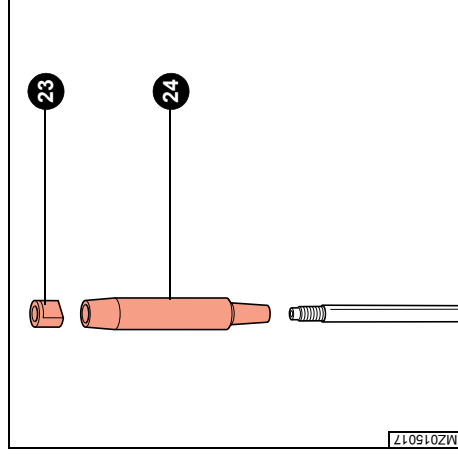

- Dévisser et ôter le contre-écrou (23) et enlever le guide ressort (24).
- Afin de pouvoir opérer sur le groupe amortisseur il est nécessaire d'ôter tous les composants du tampon de butée : garder l'écrou du tampon de fond (26) bloqué avec une clé de 18 mm et dévisser l'embout (29) avec une clé hexagonale de 17 mm.
- Enlever l'écrou supérieur (26) et le tampon de fond (28).
- Déchausser le joint d'arrêt (27) de la tige avec un petit tournevis.
- Ôter de la tige le joint d'arrêt (27) et l'embout (29).

- Die Gegenmutter (23) ausschrauben und abnehmen und die Federhülse (24) herausziehen.
- Um auf der Pumpengruppe arbeiten zu können, ist es nötig, die Bodenpufferteile zu entfernen: die Mutter des Bodenpuffers (26) mit einer 18 mm Schlüssel blockiert halten und die Spitze (29) mit einer 17 mm Sechskantschlüssel ausschrauben.
- Die obere Mutter (26) und den Bodenpuffer (28) herausziehen.
- Mit einem kleinen Schraubendreher den Haltering (27) vom Stab aufheben.
- Den Haltering (27) und die Spitze (29) vom Stab abnehmen.

- Desatornille la contratuercia (23) y saque la guía del muelle (24).
- Para hacer operaciones sobre el elemento de bomba es necesario sacar los componentes de la almohadilla de pie: tenga fija la tuerca de la almohadilla de pie (26) con una llave de 18 mm y desatornille la varilla de empuje (29) con una llave hexagonal de 17 mm.
- Saque la tuerca superior (26) y la almohadilla de pie (28).
- Con un destornillador pequeño descalze el anillo de seguridad (27) del vástago.
- Saque el anillo de seguridad (27) y la varilla de empuje (29) del vástago.

- Spingere l'asta (32) verso l'interno della custodia (30) per poter sfilare il pompante completo dal basso.

**NOTA**

Il pompante è completamente revisionabile e tarabile.

Nel paragrafo 4.8 è illustrata la procedura per la revisione e la modifica della taratura del pompante.

- Verificare l'usura del segmento (35)

**NOTA**

Nel paragrafo 4.10 è illustrata la procedura per la ricomposizione del gruppo pompante e della valvola di fondo.

- Push the rod (32) towards the inside area of the body (30) to be able to slide the complete pumping element out, starting from the bottom.

**REMEMBER**

The pumping element can be completely overhauled and adjusted.

Paragraph 4.8 shows how to overhaul and modify the pumping element setting

- Verify the segment (35) wear.

**REMEMBER**

Paragraph 4.10 shows how to re-assemble the pumping element and the bottom valve.

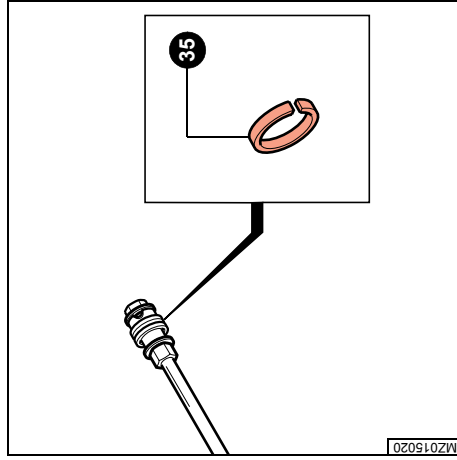
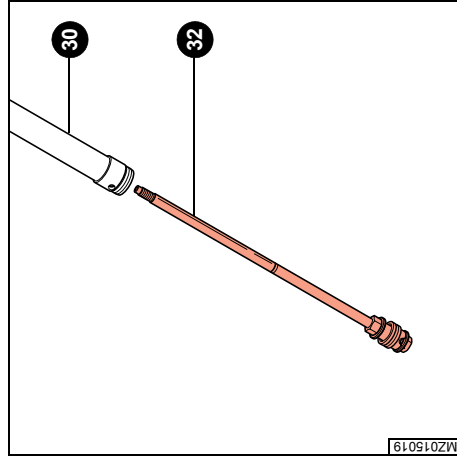

- Poussez la tige (32) vers l'intérieur du corps (30) afin de pouvoir enlever le groupe amortisseur complet du fond.

**NOTE**

Le groupe amortisseur peut être révisé et réglé complètement.

Dans le paragraphe 4.8 l'on montre la procédure de révision et de modification du réglage du groupe amortisseur.

- Contrôler si le segment (35) est détérioré.

**NOTE**

Dans le paragraphe 4.10 l'on montre la procédure de remontage du groupe amortisseur et du clapet de pied.

- Den Stab (32) nach das Hülseinnere (30) stoßen, damit die komplette Pumpengruppe vom Boden herausgezogen werden kann.

**WICHTIG**

Das Pumpenelement ist vollständig überholbar und kalibrierbar.

Im Paragraph 4.8 wird die Prozedur zur Überholung und Änderung des Pumpenelementeinstellung erklärt.

- Den Segmentverschleiß (35) überprüfen.

**WICHTIG**

Im Paragraph 4.10 wird die Prozedur zum Zusammenbau Pumpenelementeinstellung erklärt.

- Empuje el vástago (32) hacia el interior de la protección (30) para poder sacar el elemento de bomba completo desde la parte inferior.

**NOTA**

El elemento de bomba se puede revisar y regular completamente.

En el párrafo 4.8 está ilustrado el procedimiento para revisar y modificar la regulación del elemento de bomba.

- Controle el desgaste del segmento (35)

**NOTA**

En el párrafo 4.10 está ilustrado el procedimiento para recomponer el elemento de bomba y la válvula de pie.

4.7 Scomposizione stelo - portastelo e rimozione anelli di tenuta



- Rimuovere il raschiapolvere (12) dalla sede, utilizzando un piccolo cacciavite a taglio.

4.7 Braking down the fork leg – slider and removing the oil seals

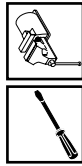

- Remove the dust seal (12) from its seat, using a small flat-tip screwdriver.

- Con il medesimo cacciavite rimuovere l'anello metallico di fermo (11).

- With the same screwdriver remove the metal stop ring (11).

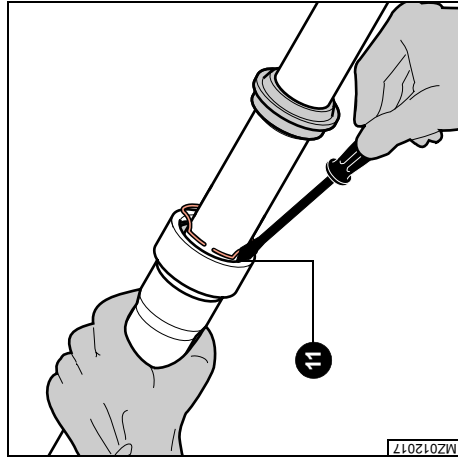
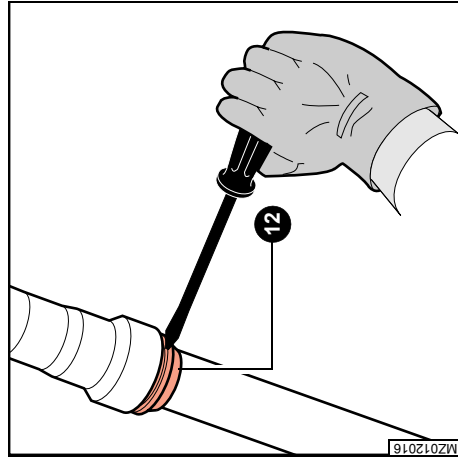

4.7 Démontage du fourreau - porte fourreau et enlèvement des joints d'étanchéité



- Démontez le cache-pousière (12) de son logement à l'aide d'un petit tournevis plat.

- Avec ce même tournevis, ôtez le jonc d'arrêt métallique (11).

4.7 Zerlegung Holm - Gleitrohr und Entfernung der Dichtringe



- Den Staubstreifer (12) mit einem kleinen Schraubendreher abnehmen.

- Mit demselben Schraubendreher den metallenen Haltering (11) abnehmen.

4.7 Decomposición barra de horquilla - botella y eliminación de los retenes



- Saque el guardapolvo (12) de su sede utilizando un destornillador pequeño.

- Con el mismo destornillador elimine el anillo metálico de seguridad (11).

- Sfilare il tubo portante (6) dal portastelo (13); per separare questi due elementi è necessario tirarli energicamente. Con questa operazione verranno rimossi dal portastelo l'anello di tenuta (10), lo scodellino (9) e la boccola guida inferiore (8).
- Rimuovere a mano la boccola guida superiore (39). Qualora questa operazione risulti difficile da eseguire manualmente è possibile aiutarsi inserendo un cacciavite a taglio nella fessura della boccola.
- Rimuovere dal tubo portante la boccola guida inferiore (8), lo scodellino (9), l'anello di tenuta (10), l'anello di fermo (11) e il raschiapolvere (12).



ATTENZIONE

Gli anelli di tenuta e i raschiapolvere rimossi non devono essere riutilizzati.



NOTA

Nel paragrafo 4.9 è illustrata la procedura per il montaggio degli elementi di tenuta e la ricomposizione stelo - portastelo.

- Pull the stanchion tube (6) out of the slider (13); to separate these two elements you will have to pull hard. With this operation the oil seal (10), the spring cup (9) and the bottom guide bushing (8) will be removed from the slider.
- Remove the top guide bushing (39) by hand. If this operation is difficult by hand, use a flat-tip screwdriver in the bushing groove.
- Remove the bottom guide bushing (8), the spring cup (9), the oil seal (10), the stop ring (11) and the dust seal (12) from the stanchion tube.



WARNING

The old oil seals and dust seals must not be used again.



REMEMBER

Paragraph 4.9 describes the procedure for assembling the seal elements and re-assembling the fork leg - slider.

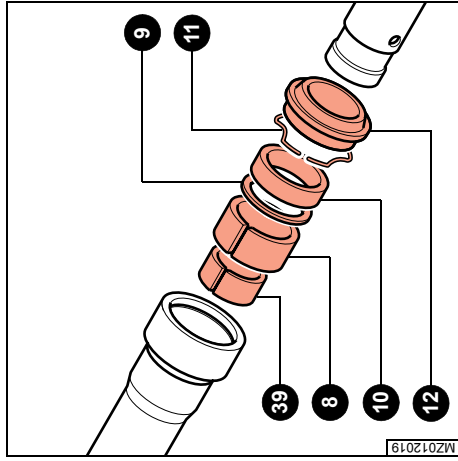
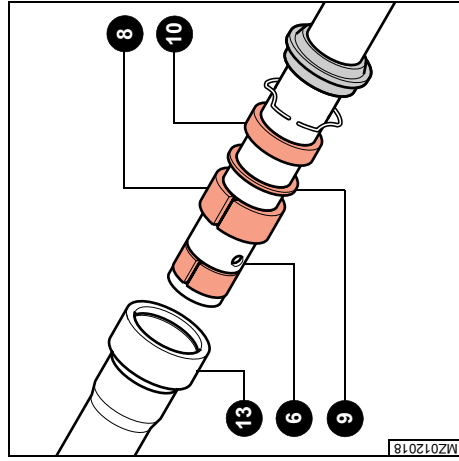

- Faire sortir le plongeur (6) du porte-fourreau (13); pour séparer les deux éléments il est nécessaire de les tirer énergiquement. Cette opération permet de démonter du porte-fourreau le joint d'étanchéité (10), la cuvette (9) et la bague de glissement inférieure (8).
- Enlever à la main la bague de glissement supérieure (39). Si cette opération s'avère difficile à exécuter à la main, il est possible d'insérer un tournevis plat dans la fissure de la bague.
- Enlever du plongeur la bague de glissement inférieure (8), la cuvette (9), le joint d'étanchéité (10), le jonc d'arrêt (11) et le cache-poussière (12).



ATTENTION

Les joints d'étanchéité et les cache-poussière démontés ne peuvent pas être réutilisés.



NOTE

Le paragraphe 4.9 illustre la procédure de montage des éléments d'étanchéité et d'assemblage du fourreau / porte-fourreau.

- Das Tauchrohr (6) aus dem Gleitrohr (13) ziehen; zum Trennen dieser beiden Elemente muss energisch angezogen werden. Mit diesem Vorgang werden der Dichtring (10), der Teller (9) und die untere Führungsbuchse (8) aus dem Gleitrohr geholt.
- Die obere Führungsbuchse (39) von Hand abnehmen. Falls dies von Hand schwer ausführbar ist, kann man sich durch Einsetzen eines Schraubendrehers in den Schlitz der Buchse behelfen.
- Die untere Führungsbuchse (8), den Teller (9), den Dichtring (10), den Haltering (11) und den Staubabstreifer (12) aus dem Tauchrohr entnehmen.



ACHTUNG

Die abgenommenen Dichtringe und Staubabstreifer dürfen nicht wiederverwendet werden.



REMEMBER

Im Paragraph 4.9 ist die Prozedur für den Einbau der Dichtelemente und den Zusammenbau Holm - Gleitrohr erläutert.

- Saque la barra (6) de la botella (13); para separar estos dos elementos es necesario tirar con fuerza. Con esta operación se sacarán de la botella el retén (10), el asiento del muelle (9) y el casquillo guía inferior (8).
- Saque a mano el casquillo guía superior (39). Si esta operación resultase difícil de efectuar a mano se puede ayudar introduciendo un destornillador en el orificio del casquillo.
- Saque de la barra el casquillo guía inferior (8), el asiento del muelle (9), el retén (10), el anillo de seguridad (11) y el guardapolvo (12).



¡PRECAUCION!

Los retenes y los guardapolvos eliminados no se deben volver a utilizar.



NOTA

En el párrafo 4.9 está ilustrado el procedimiento para el montaje de los elementos y la recomposición de barra - botella.

4.8 Revisione e modifica taratura cartuccia e valvola di fondo

4.8.1 Revisione cartuccia (freno in estensione)



Smontaggio:

- Bloccare, in morsa, la parte fresata dell'asta (32).
- Svitare il dado (38), servendosi di una chiave da 12 o 13 mm a seconda del tipo di dado installato.
- Rimuovere nell'ordine, il dado (38), la lamella o il pacco di lamelle che regolano l'estensione (37), il pistone (36) completo di segmento (35), la lamella (34) e la molla (33).

4.8 Overhauling and modifying the cartridge and bottom valve setting

4.8.1 Cartridge overhauling (rebound braking)



Dismantling

- Clamp in the vice the rod (32) milled area.
- Unscrew the nut (38) using a 12 or 13 mm spanner, according to the mounted nut.
- Remove the nut (38), the washer or the washers' stack regulating the rebound (37), the piston (36) complete with the segment (35), the washer (34) and the spring (33), following this order.

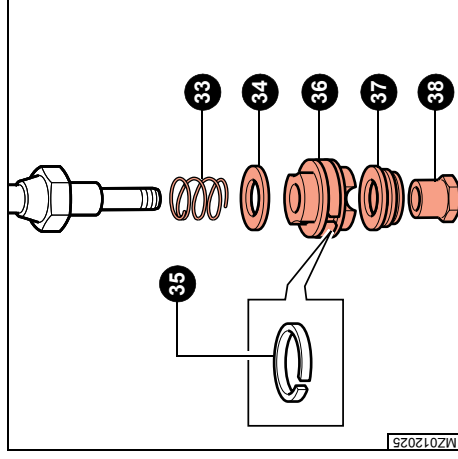
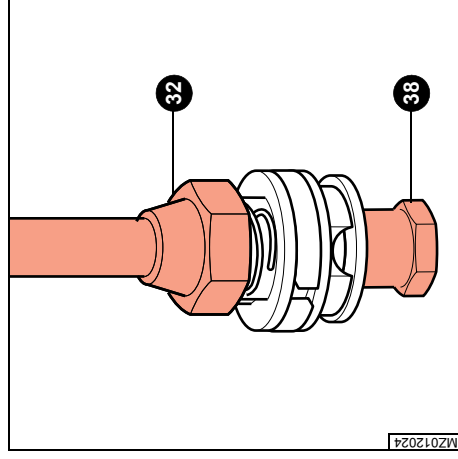

4.8 Révision et modification réglage cartouche et clapet de pied

4.8.1 Révision cartouche (freinage en détente)



Démontage

- Bloquer dans l'étai la partie fraisé de la tige (32).
- Dévisser l'écrou (38) en utilisant une clé de 12 ou de 13 mm selon le type d'écrou installé.
- Ôter l'écrou (38), la lamelle ou le groupe de lamelles qui régle la détente (37), le piston (36) complet de segment (35), la lamelle (34) et le ressort (33) en suivant cet ordre.

4.8 Überholung und Änderung der Kartusche- und Bodenventileinstellung

4.8.1 Überholung der Kartusche (Zugstufendämpfung)



Zerlegung

- Die Stabsgefräsenzzone (32) einspannen.
- Mit einer 12 oder 13 mm Schlüssel die Mutter (38) ausschrauben, gemäß der eingebauten Mutter.
- Die Mutter (38), die Lamelle oder das Paket von Lamellen (37), die die Zugstufe einstellen, den Kolben (36) mit dem Segment (35), die Lamelle (34) und die Feder (33) in dieser Reihenfolge abnehmen.

4.8 Revisión y modificación ajuste cartucho y válvula de pie

4.8.1 Revisión cartucho (freno en rebote)



Desmontaje

- Bloquee en la prensa la parte fresada del vástago (32).
- Desatornille la tuerca (38) con una llave de 12 o 13 mm, según el tipo de turca utilizada.
- Quite la tuerca (38), la laminilla o el paquete de laminillas (37) que ajustan el rebote, el pistón (36) con su segmento (35), la laminilla (34) y el muelle (33), siguiendo este orden.

Montaggio:**NOTA**

Le lamelle (37) e il pistone (36) determinano il freno in estensione. Qualora fosse necessario è possibile modificare il comportamento della forcella in fase di estensione sostituendo le lamelle (37) ed il pistone (36) con elementi aventi differenti caratteristiche.

**ATTENZIONE**

Utilizzare solamente lamelle e pistoni originali Marzocchi, non modificare i componenti.

- Se necessario sostituire il segmento del pistone (35).
- Inserire, nell'ordine, nella parte terminale dell'asta la molla (33), la lamella (34), il pistone (36) completo di segmento (35), la lamella o le lamelle che regolano l'estensione (37).

**ATTENZIONE**

Il pistone deve essere orientato in maniera tale che i fori con diametro minore siano rivolti verso le lamelle di taratura (37).

- Avvitare a mano il dado (38).
- Bloccare, in morsa, la parte fresata dell'asta ammortizzante (32).
- Servendosi di una chiave adeguata (12 oppure 13 mm a seconda del tipo di dado installato) serrare il dado (38) alla coppia prescritta (vedi Tabella 1 - Coppie di serraggio).

Assembling:**REMEMBER**

The washers (37) and the piston (36) are the ones causing the rebound braking. It is possible, if needed, to modify the fork's behaviour during the rebound phase, by replacing the washers (37) and the piston (36) with other components having different characteristics.

**WARNING**

Only use original Marzocchi washers and pistons, do not modify the components.

- Replace the piston segment (35) if needed.
- Insert on the rod edge the spring (33), the washer (34), the piston (36) complete with the segment (35), the washer or the washers stack regulating the rebound (37), following this order.

**WARNING**

The piston must be oriented in a way that the holes having smaller diameter are placed towards the setting washers (37).

- Tighten the nut (38) manually.
- Clamp in the vice the damping rod (32) milled area.
- Using a proper spanner (12 or 13 mm according to the installed nut) tighten the nut (38) up to the required torque (see Table 1 – Tightening torques).

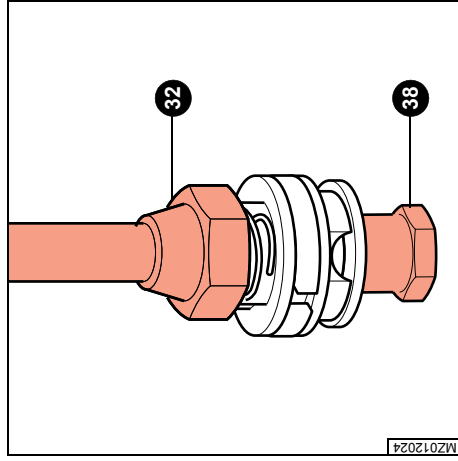
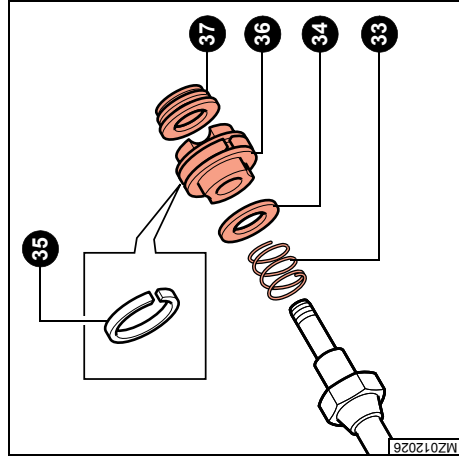

Montage



NOTE

Les lamelles (37) et le piston (36) causent le freinage en détente. Au cas où il serait nécessaire, il est possible de modifier la conduite de la fourche pendant la phase de détente en remplaçant les lamelles (37) et le piston (36) par d'autres composants ayant des caractéristiques différentes.



ATTENTION

Utiliser exclusivement des lamelles et des pistons originaux Marzocchi ; ne pas modifier les composants.

- Si nécessaire, remplacer le segment du piston (35).
- Introduire dans la partie terminale de la tige le ressort (33), la lamelle (34), le piston (36) complet de segment (35), la lamelle ou les lamelles qui régissent la détente (37) en suivant cet ordre.



ATTENTION

Le piston doit être installé de façon que les trous ayant le diamètre plus petit soient dirigés vers les lamelles de réglage (37).

- Serrer l'écrou (38) manuellement.
- Bloquer dans l'étau la partie fraisée de la tige amortisseur(32).
- Serrer l'écrou (38) en utilisant une clé de 12 ou de 13 mm selon le type d'écrou installé, au couple de serrage prévu (voir Tableau 1 - Couples de serrage).

Zusammenbau



WICHTIG

Die Lamellen (37) und der Kolben (36) verursachen die Zugstufendämpfung. Wenn nötig, ist es auch möglich, das Gabelverhalten während der Zugstufenphase zu ändern, durch den Ersatz der Lamellen (37) und des Kolbens (36) mit anderen Teilen, die verschiedene Merkmale aufweisen.



ACHTUNG

Ausschließlich Original-Marzocchi Lamellen und Kolben verwenden; die Komponenten nicht ändern.

- Wenn nötig, den Kolbensegment (35) ersetzen.
- Die Feder (33), die Lamelle (34), den Kolben (36) mit dem Segment (35), die Lamelle oder das Paket von Lamellen (37), die die Zugstufe einstellen in dieser Reihenfolge am Stabende einsetzen.



ACHTUNG

Der Kolben muss so montiert werden, dass die Löcher, die einen kleineren Durchmesser aufweisen, nach die Einstellungs lamellen (37) gerichtet sind.

- Die Mutter (38) manuell anziehen.
- Die Stabsgefrästzone (32) einspannen.
- Mit einer geeigneten Schlüssel (12 oder 13 mm gemäß der eingebauten Mutter) die Mutter (38) mit dem vorgeschriebenen Anzugsmoment (siehe Tabelle 1 - Anzugsmomente) anziehen.

Montaje:



NOTA

Las laminitas (37) y el pistón (36) causan la amortiguación en rebote. Si necesario, es posible modificar el comportamiento de la horquilla en la fase de rebote, remplazando las laminitas (37) y el pistón (36) por otros particulares que tengan características diferentes.



¡PRECAUCION!

¡Sólo utilice laminitas y pistones originales Marzocchi; no modifique los particulares.

- Si necesario, reemplazar el segmento del pistón (35).
- Inserte en la parte terminal del vástago el muelle (33), la laminita (34), el pistón (36) con su segmento (35), la laminita o las laminitas (37) que ajustan el rebote, siguiendo este orden.



¡PRECAUCION!

El pistón tiene que orientarse con los agujeros que tienen el diámetro menor hacia las laminitas de regulación (37).

- Atornille la tuerca (38) a mano.
- Bloquee en la prensa la parte fresada del vástago de amortiguación (32).
- Apriete la tuerca (38) con una llave de 12 o 13 mm, según el tipo de turca utilizada, hasta el par de torsión correcto (ver Tabla 1 - Pares de torsión).

4.8.2 Revisione valvola di fondo (freno in compressione)



Smontaggio:

- Bloccare, in morsa, la vite di fondo attraverso la presa di chiave (47).
- Servendosi di una chiave da 13 mm svitare il dado (42).
- Rimuovere nell'ordine, il dado (42), la molla (33), la lamella (43), il pistone (45) completo anello o-ring (44), la lamella o il pacco di lamelle che regolano la compressione (46).

4.8.2 Bottom valve overhauling (compression braking)



Dismantling

- Clamp in the vice the bottom screw through the spanner seizing (47).
- Using a 13 mm spanner unscrew the nut (42).
- Remove the nut (42), the spring (33), the washer (43), the piston (45) complete with the o-ring (44), the washer or the washers' stack regulating the compression (46), following this order.

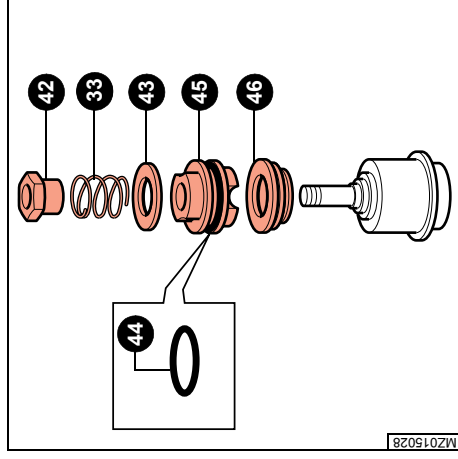
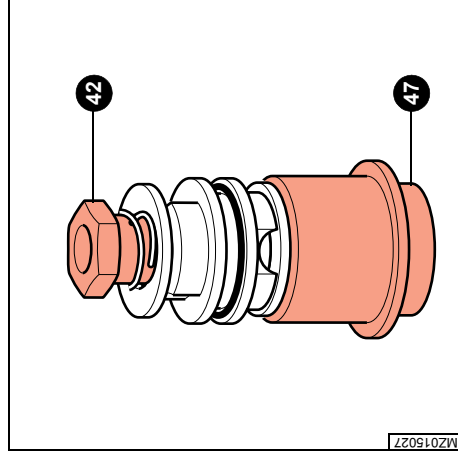

4.8.2 Révision clapet de pied (freinage en compression)



Démontage :

- Bloquer dans l'étau la vis de fond par la prise de clé (47).
- En utilisant une clé de 13 mm dévisser l'écrou (42).
- Ôter l'écrou (42), le ressort (33), la lamelle (43), le piston (45) complet de jonc d'arrêt (44), la lamelle ou le groupe de lamelles qui régissent la compression (46), en suivant cet ordre.

4.8.2 Überholung des Bodenventils (Druckstufendämpfung)



Zerlegung

- Die Bodenschraube durch den Eingriff (47) einspannen.
- Mit einer 13 mm Schlüssel die Mutter (42) ausschrauben.
- Die Mutter (42), die Feder (33), die Lamelle (43), den Kolben (45) mit dem O-Ring (44), die Lamelle oder das Paket von Lamellen (46), die die Druckstufe einstellen, in dieser Reihenfolge abnehmen.

4.8.2 Revisión válvula de pie (freno en compresión)



Desmontaje

- Bloquee el tornillo de pie a través del agarre (47).
- Con una llave de 13 mm desatornille la tuerca (42).
- Quite la tuerca (42), el muelle (33), la laminilla (43), el pistón (45) con su anillo O-ring (44), la laminilla o el paquete de laminillas (46) que ajustan la compresión, siguiendo este orden.

Montaggio:**NOTA**

Le lamelle (46) e il pistone (45) determinano il freno in compressione. Qualora fosse necessario è possibile modificare il comportamento della forcella in fase di compressione sostituendo le lamelle (46) ed il pistone (45) con elementi aventi differenti caratteristiche.

**ATTENZIONE**

Utilizzare solamente lamelle e pistoni originali Marzocchi, non modificare i componenti.

- Se necessario sostituire l'anello o-ring del pistone (44).
- Inserire, nell'ordine, nella valvola di fondo, la lamella o il pacco di lamelle che regolano la compressione (46), il pistone (45) completo anello o-ring (44), la lamella (43) e la molla (33).

**ATTENZIONE**

Il pistone deve essere orientato in maniera tale che i fori con diametro minore siano rivolti verso le lamelle di taratura (46).

- Avvitare a mano il dado (42).
- Bloccare, in morsa, la vite di fondo attraverso la presa di chiave (47).
- Servendosi di una chiave da 13 mm serrare il dado (42) alla coppia prescritta (vedi Tabella 1 - Coppie di serraggio).

Assembling**REMEMBER**

The washers (46) and the piston (45) are the ones causing the compression braking. It is possible, if needed, to modify the fork's behaviour during the compression phase, by replacing the washers (46) and the piston (45) with other components having different characteristics.

**WARNING**

Only use original Marzocchi washers and pistons, do not modify the components.

- Replace the piston o-ring (44) if needed.
- Insert in the bottom valve the washer or the washers' stack regulating the compression (46), the piston (45), complete with the o-ring (44), the washer (43) and the spring (33), following this order.

**WARNING**

The piston must be oriented in a way that the holes having smaller diameter are placed towards the setting washers (46).

- Tighten the nut (42) by hand.
- Lock the bottom screw in the vice through the spanner seizing (47).
- Using a 13 mm spanner tighten the nut (42) up to the required torque (see Table 1 - Tightening torques).

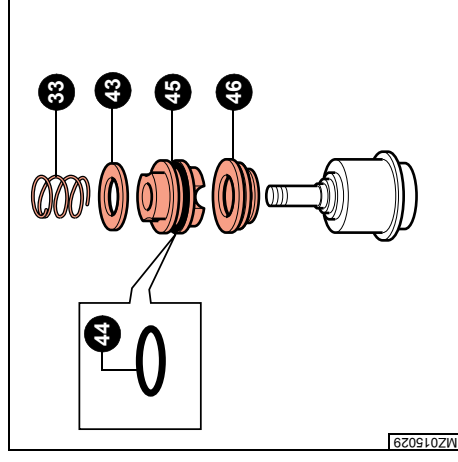

MZ015029

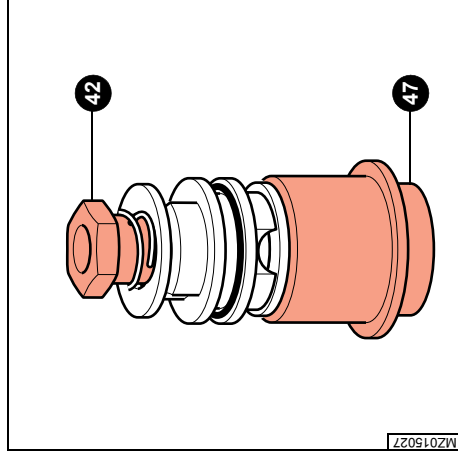

MZ015027

Montage:**NOTE**

Les lamelles (46) et le piston (45) causent le freinage en compression. Au cas où il serait nécessaire, il est possible de modifier la conduite de la fourche pendant la phase de compression en remplaçant les lamelles (46) et le piston (45) par d'autres composants ayant des caractéristiques différentes.

**ATTENTION**

Utiliser exclusivement des lamelles et des pistons originaux Marzocchi ; ne pas modifier les composants.

- Si nécessaire, remplacer le jonc d'arrêt du piston (44).
- Introduire, dans le clapet de fond la lamelle ou le groupe de lamelles qui régle la compression (46), le piston (45) complet de jonc d'arrêt (44), la lamelle (43) et le ressort (33).

**ATTENTION**

Le piston doit être installé de façon que les trous ayant le diamètre plus petit soient dirigés vers les lamelles de réglage (46).

- Serrer l'écrou (42) manuellement.
- Bloquer dans l'étau la vis de fond par la prise de clé (47).
- En utilisant une clé de 13 mm serrer l'écrou (42) au couple de serrage prévu (voir Tableau 1 - Couples de serrage).

Zusammenbau:**WICHTIG**

Die Lamellen (46) und der Kolben (45) verursachen die Druckstufendämpfung. Wenn nötig, ist es auch möglich, das Gabelverhalten während der Druckstufenphase zu ändern, durch den Ersatz der Lamellen (46) und des Kolbens (45) mit anderen Teilen, die verschiedene Merkmale aufweisen.

**ACHTUNG**

Ausschließlich Original-Marzocchi Lamellen und Kolben verwenden; die Komponenten nicht ändern.

- Wenn nötig, den O-Ring (44) des Kolbens auswechseln.
- Die Lamelle oder das Paket von Lamellen (46), die die Druckstufe einstellen, den Kolben (45) mit dem O-Ring (44), die Lamelle (43) und die Feder (33) in dieser Reihenfolge in das Bodenventil einsetzen.

**ACHTUNG**

Der Kolben muss so montiert werden, dass die Löcher, die einen kleineren Durchmesser aufweisen, nach die Einstellungslamellen (46) gerichtet sind.

- Die Mutter (42) manuell anziehen.
- Die Bodenschraube durch den Eingriff (47) einspannen.
- Mit einer 13 mm Schlüssel die Mutter (42) mit dem vorgeschriebenen Anzugsmoment (siehe Tabelle 1 - Anzugsmomente) anziehen.

Montaje:**NOTA**

Las laminillas (46) y el pistón (45) causan la amortiguación en compresión. Si necesario, es posible modificar el comportamiento de la horquilla en la fase de compresión, reemplazando las laminillas (46) y el pistón (45) por otros particulares que tengan características diferentes.

**¡PRECAUCION!**

Sólo utilice laminillas y pistones originales Marzocchi; no modifique los particulares.

- Si necesario, reemplazar el anillo O-ring del pistón (44).
- Inserte en la válvula de pie la laminilla o el paquete de laminillas (46) que ajustan la compresión, el pistón (45) con su anillo O-ring (44), la laminilla (43) y el muelle (33), siguiendo este orden.

**¡PRECAUCION!**

El pistón tiene que orientarse con los agujeros que tienen el diámetro menor hacia las laminillas de regulación (46).

- Atornille la tuerca (42) a mano.
- Bloquee en la prensa el tornillo de pie a través del agarre (47).
- Apriete la tuerca (42), con una llave de 13 mm hasta el par de torsión correcto (ver Tabla 1 - Pares de torsión).

4.9 Ricomposizione stelo - portastelo e montaggio anelli di tenuta

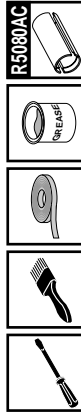

NOTA

Gli anelli di tenuta e i raschiapolvere rimossi non devono essere riutilizzati.

Prima di procedere al rimontaggio, verificare le condizioni delle boccole di guida; se risultano rigate o graffiate sostituirle. Verificare il rivestimento in teflon delle boccole di guida che deve essere integro.

- Applicare all'estremità del tubo portante del nastro adesivo in maniera tale da coprire la sede della boccola superiore.
- Lubrificare leggermente con grasso il raschiapolvere e l'anello di tenuta.
- Inserire nel tubo portante con il seguente ordine: il raschiapolvere (12), l'anello di fermo (11), l'anello di tenuta (10), lo scodellino (9) e la boccola guida inferiore (8).



ATTENZIONE

Prestare attenzione all'orientamento dell'anello di tenuta (10), esso deve essere inserito in maniera tale che la parte cava sia rivolta verso lo scodellino (9).

4.9 Re-assembling the fork leg – slider and oil seals

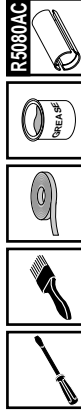

REMEMBER

The old oil seals and dust seals must not be used again.

Before re-assembling, check the conditions of the guide bushings; replace them if they are scratched or grooved. Check the Teflon coating of the guide bushings which must be in a good condition.

- Apply some adhesive tape to the end of the stanchion tube so that it covers the seat of the top bushing.
- Smear the dust seal and the oil seal with some grease.
- Insert the following components in the stanchion tube in this order: dust seal (12), stop ring (11), oil seal (10), spring cup (9) and bottom guide bushing (8).



WARNING

Make sure the oil seal (10) is correctly oriented in a way that the hollow side is turned towards the spring cup (9).

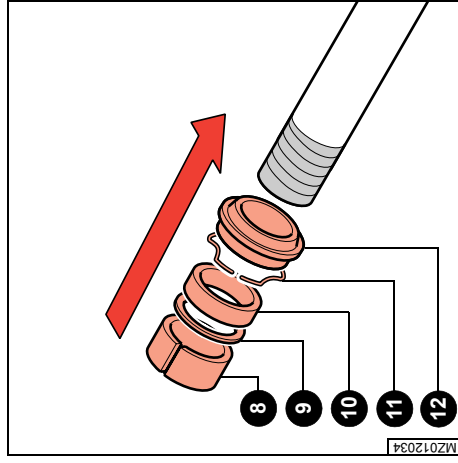
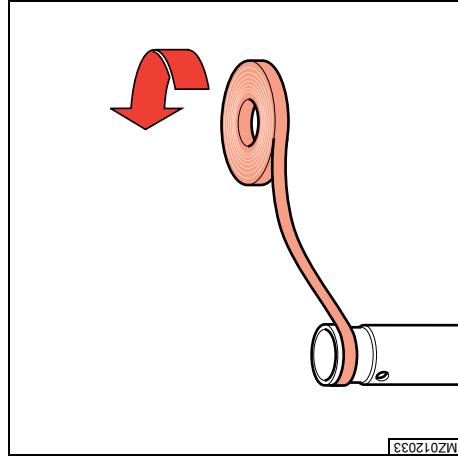

4.9 Remontage du fourreau - porte fourreau et montage des joints d'étanchéité

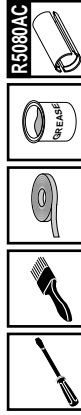

NOTE

Les joints d'étanchéité et les cache-poussoirs démontés ne peuvent pas être réutilisés. Avant de procéder au remontage, vérifiez l'état des bagues de glissement; si elles sont rayées ou griffées, les remplacer. Vérifier le revêtement en téflon des bagues de glissement et s'assurer qu'il est intact.

- Appliquer du ruban adhésif à l'extrémité du plongeur afin de couvrir le logement de la bague supérieure.
- Étaler un peu de graisse sur le cache-poussoir et le joint d'étanchéité.
- Introduire dans l'ordre suivant le cache-poussoir (12), le jonc d'arrêt (11), le joint d'étanchéité (10), la cuvette (9) et la bague de glissement inférieure (8) dans le plongeur.



ATTENTION

Prêter attention à l'orientation du joint d'étanchéité (10), qui doit être inséré de façon à avoir la partie creuse tournée vers la cuvette (9).

4.9 Zusammenbau Holm - Gleitrohr und Anbringung Dichtringe

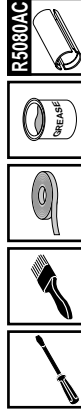

WICHTIG

Die abgenommenen Dichtringe und Staubabstreifer dürfen nicht wiederverwendet werden. Vor Beginn des Wiedereinbaus den Zustand der Führungsbuchsen überprüfen; wenn sie gerieft oder zerkratzt sind, auswechseln. Die Teflonbeschichtung der Führungsbuchsen überprüfen; sie muss unversehrt sein.

- Das Ende des Tauchrohrs so mit einem Klebeband umwickeln, dass der Sitz der oberen Buchse abgedeckt ist.
- Den Staubabstreifer und den Dichtring leicht einfetten.
- In dieser Reihenfolge in das Tauchrohr einsetzen: Staubabstreifer (12), Haltering (11), Dichtring (10), Teller (9) und untere Führungsbuchse (8).



ACHTUNG

Seien Sie besonders aufmerksam, den Dichtring (10) so einzurichten, dass die Hohlseite sich gegenüber den Teller (9) findet.

4.9 Reconposición barra de horquilla / botella y montaje retenes

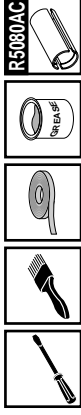

NOTA

Los retenes y los guardapolvos eliminados no se deben volver a utilizar. Antes de volver a montarlos, compruebe las condiciones de los casquillos de guía; si están rayados o arañados sustitúyalos. Compruebe el forro de teflón de los casquillos de guía que debe ser íntegro.

- Aplique cinta adhesiva en una extremidad de la barra de manera que cubra la sede del casquillo superior.
- Lubrique ligeramente con grasa el guardapolvo y el retén.
- Introduzca en la barra con el siguiente orden: el guardapolvo (12), el anillo de seguridad (11), el retén (10), el asiento del muelle (9) y el casquillo guía inferior (8).



¡PRECAUCIÓN!

Preste atención a la orientación del retén (10) que tiene que insertarse de manera que el lado hueco esté dirigido hacia el asiento del muelle (9).

- Rimuovere il nastro adesivo applicato all'estremità del tubo portante, eliminando le eventuali tracce di adesivo rimaste.
- Inserire a mano la boccola di guida superiore (39).



NOTA

Qualora l'inserimento della boccola di guida risulti difficile da eseguire manualmente è possibile aiutarsi inserendo un cacciavite a taglio nella fessura della boccola.

- Introdurre delicatamente il tubo portante nel portastelo, prestando la massima attenzione a non danneggiare la boccola guida superiore.
- Accompagnare la boccola guida inferiore fino al contatto con il portastelo, lo scodellino e l'anello di tenuta.
- Montare sul tubo portante (5) l'apposito introduttore e con questo spingendo sull'anello di tenuta (10) introdurre in sede la boccola guida inferiore, lo scodellino e l'anello di tenuta.

- Remove the adhesive tape from the end of the stanchion tube, cleaning any traces of adhesive left on the fork.
- Insert the top guide bushing (39) by hand.



REMEMBER

If this operation is difficult by hand, use a flat-tip screwdriver in the bushing groove.

- Delicately introduce the stanchion tube into the slider, being very careful not to damage the top guide bushing.
- Guide the bottom guide bushing until it comes into contact with the slider, the spring cup and the oil seal.
- Mount the special introducer on the stanchion tube (5) and use this, by pushing on the oil seal (10), to insert the bottom guide bushing, the spring cup and the oil seal.

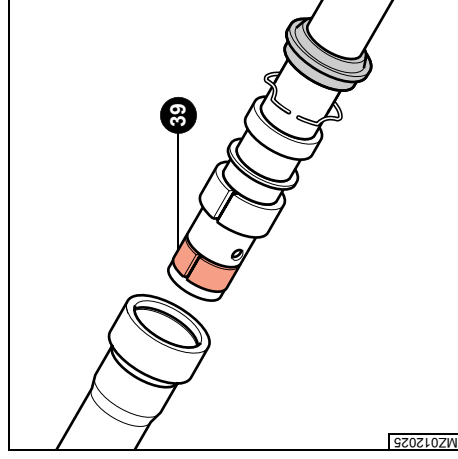

MZ012025

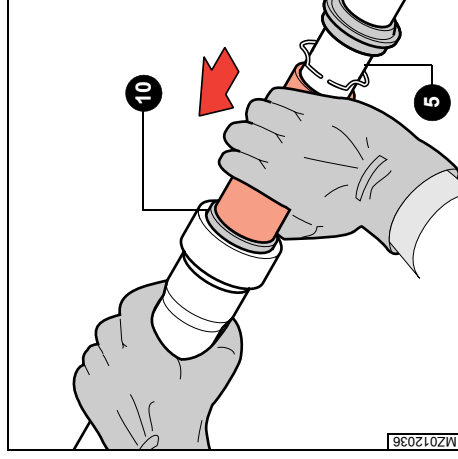

MZ012036

- Enlever le ruban adhésif de l'extrémité du plongeur en éliminant, au besoin, toute trace de colle.
- Introduire à la main la bague de glissement supérieure (39).

**NOTE**

Si l'introduction de la bague de glissement s'avère difficile à exécuter à la main, il est possible d'utiliser un tournevis plat en insérant la tête dans la fissure de la bague.

- Introduire avec soin le plongeur dans le porte-fourreau en faisant attention à ne pas endommager la bague de glissement supérieure.
- Amener la bague de glissement inférieure en contact avec le porte-fourreau, la cuvette et le joint.
- Monter sur le plongeur (5) l'outil introducteur spécial et, en poussant ce dernier contre le joint d'étanchéité (10), introduire la bague de glissement inférieure, la cuvette et le joint dans le logement prévu.

- Das Klebeband am Ende des Tauchrohrs abnehmen und eventuelle Kleberspuren beseitigen.

- Die obere Führungsbuchse (39) von Hand einsetzen.

**WICHTIG**

Falls das Einsetzen der Führungsbuchse von Hand schwer ausführbar ist, kann man sich durch Einsetzen eines Schraubendrehers in den Schlitz der Buchse behelfen.

- Das Tauchrohr vorsichtig in das Gleitrohr eingeschoben, dabei sorgfältig darauf achten, dass die obere Führungsbuchse nicht beschädigt wird.
- Die untere Führungsbuchse bis zur Berührung mit dem Gleitrohr, dem Teller und dem Dichtring einführen.
- Den zugehörigen Einschubzylinder am Tauchrohr (5) anbringen und damit auf den Dichtring (10) drücken, um die untere Führungsbuchse, den Teller und den Dichtring einzuschieben.

- Elimine la cinta adhesiva colocada en el extremo de la barra, eliminando eventuales restos de adhesivo.

- Introduzca a mano el casquillo guía superior (39).

**NOTA**

Si fuera difícil introducir manualmente el casquillo guía se puede ayudar introduciendo un destornillador en el orificio del casquillo.

- Introduzca delicadamente la barra en la botella, prestando la máxima atención a no dañar el casquillo guía superior.
- Acompañe el casquillo guía inferior hasta el contacto con la botella, el asiento del muelle y el retén.
- Monte en el tubo portante (5) el introductor especial y con éste empujando en el retén (10) introduzca en su sede el casquillo guía inferior, el asiento y el retén.

- Mount the stop ring (11) using a small flat-tip screwdriver, checking it fits perfectly into its groove and being very careful not to scratch the stanchion tube.

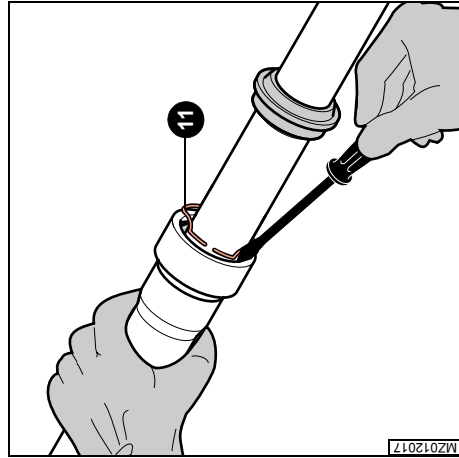

- Re-assemble the dust seal (12) in its seat, pressing it home with your hands.

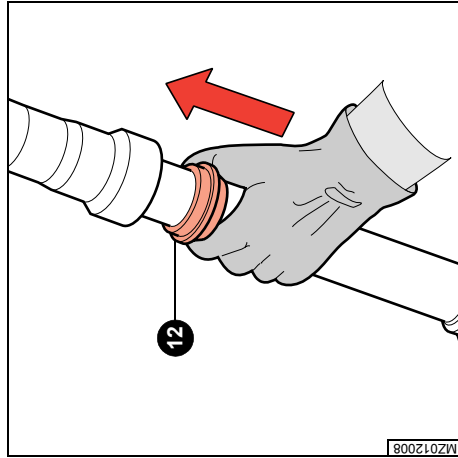

- Montare l'anello di fermo (11) servendosi di un piccolo cacciavite a taglio verificando che risulti perfettamente inserito nella apposita gola e facendo molta attenzione a non rigare il tubo portante.

- Inserire in sede il raschiapolvere (12) facendo pressione con le mani.

- Monter le jonc d'arrêt (11) à l'aide d'un petit tournevis plat et vérifier qu'il est parfaitement en place dans la gorge spéciale en faisant attention à ne pas rayer le plongeur.
- Monter à nouveau le cache-poussière (12) en exerçant une pression avec les mains.

- Den Haltering (11) anbringen, dazu einen kleinen Schraubendreher zu Hilfe nehmen, der perfekt in die entsprechende Rille passt, und sorgfältig dabei darauf achten, dass das Tauchrohr nicht verkratzt wird.
- Den Staubabstreifer (12) durch Drücken mit den Händen wieder einsetzen.

- Monte el anillo de seguridad (11) ayudándose con un destornillador pequeño comprobando que se introduzca perfectamente en su ranura y prestando mucha atención a no rayar la barra de horquilla.
- Introduzca en su sede el guardapolvo (12) presionando con las manos.

4.10 Re-assembling the pumping element unit and the bottom valve

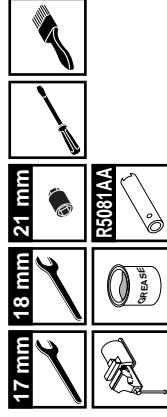

- Insert the pumping element rod (32) into the body (30)



REMEMBER

In both pumping elements there is a sealing segment; before the assembling make sure that it is not worn or damaged. Replace if necessary. Take great care and if necessary use a small flat-tip screwdriver to help the pumping element piston into the sleeve.

Insert the piston without any interference.

- Insert the foot buffer push rod (29) into the rod (32); this must be done in a way that the spanner seizing side is oriented towards the body (30) and the metal ring seat (F) is exceeded.
- Insert the metal ring (27) into the proper seat (F)
- Bring the push rod (29) into contact with the stop ring.
- Insert the foot buffer (28); this must be inserted keeping the oil flow slots towards the push rod.
- Insert the upper nut (26) and tighten it on the push rod (29).

4.10 Ricomposizione gruppo pompante e valvola di fondo

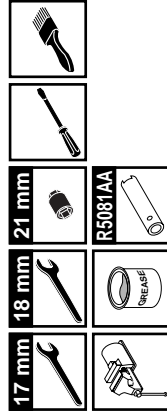

- Inserire l'asta del pompante (32) all'interno della custodia (30).



NOTA

In entrambi i pompanti è presente un segmento di tenuta; prima del montaggio verificare che essi non siano usurati o danneggiati, qualora sia necessario sostituirli.

Prestare la massima attenzione ed eventualmente aiutarsi con un piccolo cacciavite a taglio per facilitare l'inserimento del pistone del pompante nel tubetto-custodia.

L'inserimento del pistone deve avvenire senza interferenze.

- Introdurre nell'asta (32) il puntale (29) del tampone di fine corsa; l'inserimento deve avvenire in maniera tale che il lato con la presa di chiave sia rivolto verso la custodia (30) e che venga superata la sede per il filo metallico (F).
- Inserire il filo metallico (27) nell'apposita gola (F).
- Portare il puntale (29) a contatto con l'anello di fermo.
- Introdurre il tampone di fondo (28); il tampone di fondo va inserito con le asole per il passaggio dell'olio rivolte verso il puntale.
- Introdurre il dado superiore (26) ed avvitarlo sul puntale (29).

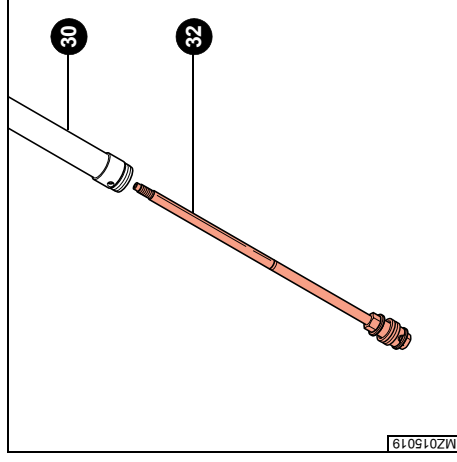

MZO15019

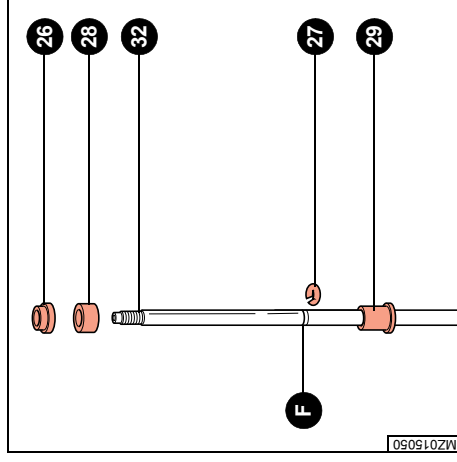

MZO15050

4.10 Remontage du groupe amortisseur et clapet de pied

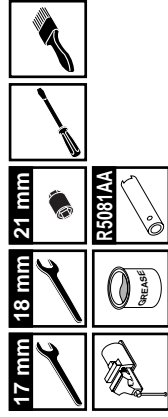

- Introduire la tige du groupe amortisseur (32) dans le corps (30).



NOTE

Sur les deux groupes amortisseurs se trouve un segment d'étanchéité. Avant le remontage vérifier que ce segment n'est pas détérioré ou endommagé; le remplacer si nécessaire. Agir avec beaucoup de précautions et, le cas échéant, s'aider avec un petit tournevis plat pour simplifier l'introduction du piston de l'amortisseur dans le corps tubulaire. L'introduction du piston doit se faire sans interférences.

- Introduire sur la tige (32), l'embout (29) du tampon de butée; cela doit se faire de façon que le côté de la prise de clé soit dirigé vers le corps (30) et que le siège du fil métallique (F) soit dépassée.
- Introduire le fil métallique (27) dans son siège (F).
- Mener l'embout (29) jusqu'au contact avec le jonc d'arrêt.
- Introduire le tampon de fond (28); celui-ci doit être inséré en ayant les feintes pour le passage de l'huile dirigés vers l'embout.
- Insérer l'écrou supérieur (26) et le serrer sur l'embout (29).

4.10 Zusammenbau Pumpengruppe und Bodenventil

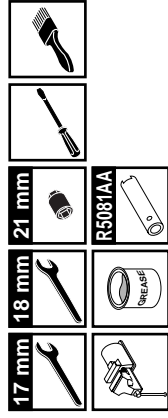

- Den Pumpenelementstab (32) in die Hülse (30) einsetzen.



WICHTIG

In beiden Pumpenelementen ist ein Dichtsegment angebracht; vor dem Wiedereinbau überprüfen, ob es abgenutzt oder beschädigt ist, falls auswechseln. Beim Einsetzen des Kolbens des Pumpenelements in die Schutzhülse mit größter Vorsicht vorgehen und sich gegebenenfalls mit einem kleinen Schraubendreher behelfen. Das Einsetzen des Kolbens muss ohne Anstoßen erfolgen.

- Die Spitze (29) des Bodenpuffers in den Stab (32) einsetzen; das muss so durchgeführt werden, dass die Seite mit dem Schlüsselgriff nach der Hülse (30) gerichtet ist, und dass der Sitz (F) für den Metalldraht (27) übersteigt wird.
- Den Metalldraht (27) in seinen Sitz (F) einsetzen.
- Die Spitze (29) bis zur Berührung mit dem Haltering anbringen.
- Den Bodenpuffer so einsetzen (28), dass die Langlöcher für den Öldurchfluss nach der Spitze gerichtet sind.
- Die obere Mutter (26) anbringen und sie auf die Spitze (29) anziehen.

4.10 Reconposición elemento de bomba y válvula de pie

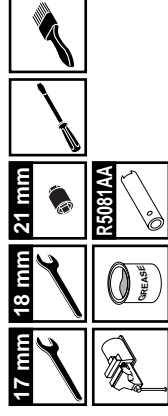

- Inserte el vástago del elemento de bomba (32) en la protección (30).



NOTA

En los dos elementos de bomba hay un segmento de retención; antes de volver a montarlos compruebe que no estén gastados o dañados, si fuera necesario, sustitúyalos. Preste la máxima atención y eventualmente ayúdese con un destornillador pequeño para facilitar la introducción del pistón del elemento de bomba en el tubo de protección. La introducción del se debe producir sin interferencias.

- Inserte en el vástago (32) la varilla de empuje (29) de la almohadilla de pie; la inserción tiene que hacerse de manera que el lado con el agarre esté dirigido hacia la protección (30) y que el asiento del alambre (F) sea sobrepasado.
- Lleve el alambre (27) en su asiento (F).
- Lleve la varilla de empuje (29) hasta el contacto con el alambre.
- Inserte la almohadilla de pie (28); esta tiene que insertarse de manera que los ojets para el flujo de aceite estén dirigidos hacia la varilla de empuje.
- Inserte la tuerca superior (26) y apriete en la varilla de empuje (29).

- Tenendo fermo il dado **(26)** con chiave da 18 mm, serrare il puntale **(29)**, alla coppia prescritta (vedi Tabella 1 coppie di serraggio), servendosi di chiave da 17 mm.
- Inserire nell'asta del pompante **(32)** il guidamolla **(24)**; il guidamolla va inserito con la parte di diametro minore rivolta verso il tampono di fondo.
- Avvitare a fondo il controdado **(23)** senza serrare.

- Hold the nut **(26)** with a 18 mm spanner and tighten the push rod **(29)** up to the required torque (see Table 1 - Tightening Torques), using a 17 mm spanner.
- Insert the guide spring **(24)** in the pumping element rod **(32)**; the guide spring must have the smaller diameter side towards the foot buffer.
- Screw the locknut **(23)** till the end without tightening.

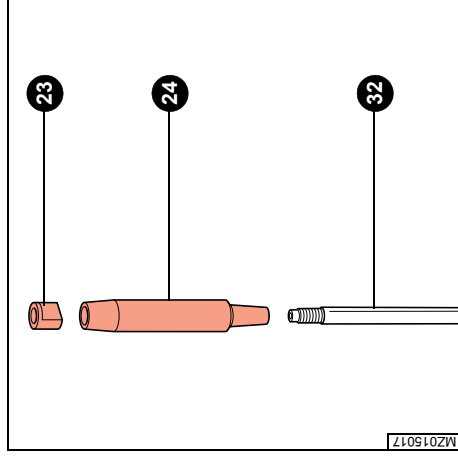
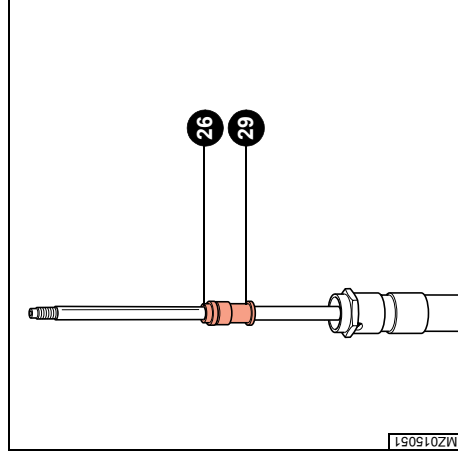

- Garder immobile l'écrou **(26)** avec une clé de 18 mm et serrer l'embout **(29)** au couple de serrage prévu (voir Tableau 1 - Couples de serrage), en utilisant une clé de 17 mm.
- Introduire le guide ressort **(24)** dans la tige du groupe amortisseur **(32)** ; le guide ressort doit être inséré du côté ayant le diamètre plus petit dirigé vers le tampon de fond.
- Visser à fond le contre-écrou **(23)** sans serrer.

- Die Mutter **(26)** mit einer 18 mm Schlüssel blockieren und die Spitze **(29)** mit einer 17 mm Schlüssel mit dem vorgeschriebenen Anzugsmoment anziehen (siehe Tabelle 1 - Anzugsmomente).
- Die Federhülse **(24)** in den Pumpenelementstab **(32)** so einsetzen , dass die Seite mit kleinerem Durchmesser nach dem Bodendpuffer gerichtet ist.
- Die Gegenmutter **(23)** einschrauben, ohne festmachen.

- Tenga fija la tuerca **(26)** con una llave de 18 mm y con una llave de 17 mm apriete la varilla de empuje **(29)** hasta el par de torsión correcto (véase Tabla 1 - Pares de torsión).
- Inserte en el vóstagó del elemento de bomba **(32)** la guía del muelle **(24)**; esta tiene que insertarse con la parte de diámetro menor hacia la almohadilla de pie.
- Atornille la contratuercas **(23)** sin apretar.

- Spingere il pompante preassemblato (23) fino alla battuta con il tubo portante (5).
- Avvitare a mano la valvola di fondo
- Introdurre l'attrezzo **R5081AA** all'interno dello stelo in maniera tale da bloccare la rotazione della custodia; per ottenere il bloccaggio occorre che l'asola ricavata all'estremità inferiore dell'attrezzo vada ad inserirsi perfettamente nell'esagono della custodia.



ATTENZIONE

Nella parte superiore dell'attrezzo sono presenti due fori diametralmente opposti nei quali è possibile inserire un perno per facilitarne il bloccaggio. Tuttavia l'attrezzo non deve essere ruotato per alcun motivo ma solamente utilizzato per tenere fermi i componenti interni allo stelo.

- Con chiave a bussola da 21 mm, avvitare la valvola di fondo (41) alla coppia prescritta (vedi Tabella 1 - Coppie di serraggio).

- Push the pre-assembled pumping element (23) until it is in contact with the stanchion tube (5).
- Tighten the bottom valve by hand.
- Insert the **R5081AA** tooling inside the fork leg in a way that you can block the body rotation; to do so, the slot obtained at the tooling bottom edge must be perfectly inserted into the body hexagon.



WARNING

In the tooling upper part there are two opposite holes where you can insert an axle to make blocking easier. However, the tooling must not be rotated in any case, but only used to hold the fork leg inner parts.

- Using a 21 mm tube wrench tighten the bottom valve (41) up to the required torque (see Table 1 - Tightening Torques).

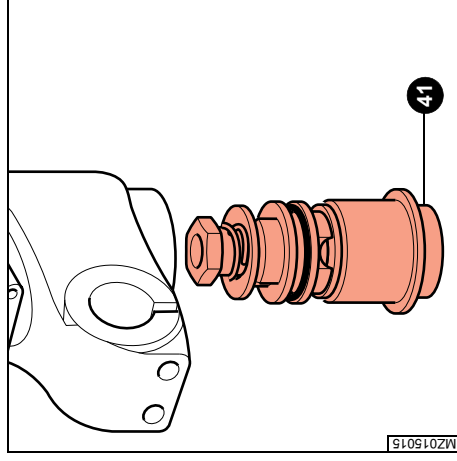
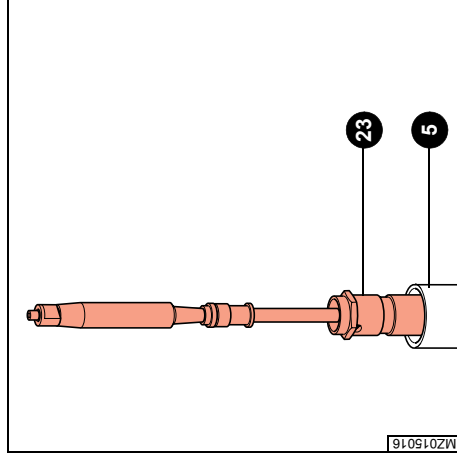

- Pousser le groupe amortisseur pré assemblé (23) jusqu'au contact avec le plongeur (5).
- Serrer le clapet de pied à la main.
- Introduire l'outil **R5081AA** à l'intérieur du fourreau de façon que la rotation du corps soit bloquée ; pour faire cela il est nécessaire que la fente obtenue à l'extrémité inférieure de l'outil soit exactement insérée dans l'hexagone du corps.



ATTENTION

Dans la partie supérieure de l'outil vous trouvez deux trous opposés où il est possible d'introduire un pivot pour en faciliter le blocage. L'outil ne doit quand-même être tourné en aucun cas, mais il doit seulement être utilisé pour garder les composants intérieurs du fourreau immobiles.

- Avec une clé à tube de 21 mm serrer le clapet de pied (41) au couple de serrage prévu (voir Tableau 1 - Couples de serrage).

- Den vormontierte Pumpenelement (23) bis zur Berührung mit dem Standrohr (5) stoßen.
- Das Bodenventil von Hand einschrauben.
- Das Gerät **R5081AA** in den Holm so einsetzen, dass die Hülserotation blockiert wird; um die Blockierung zu erreichen ist es nötig, dass das am Geräteextremität liegende Langloch sich perfekt in den Hülsesechskant einsetzt.



ACHTUNG

Im oberen Gerätegebiet sind zwei diametral entgegengesetzte Löcher zu sehen, wo eine Achse eingesetzt werden kann, um die Blockierung einfacher zu machen. Das Gerät kann jedoch auf keinen Fall rotiert werden, sondern nur zur Blockierung der innenliegenden Komponenten des Holmes benutzt werden.

- Mit einer 21 mm Steckschlüssel das Bodenventil (41) mit dem vorgeschriebenen Anzugsmoment anziehen (siehe Tabelle 1 - Anzugsmomente).

- Empuje el elemento de bomba preensamblado (23) hasta el contacto con la barra (5).
- Apriete la válvula de pie de mano.
- Inserte la herramienta **R5081AA** al interior de la barra de manera que la rotación de la protección esté bloqueada; para hacer esto es necesario que el ojeo obtenido en la extremidad inferior de la herramienta se inserte perfectamente en el hexágono de la protección.



¡PRECAUCION!

En la zona superior de la herramienta hay dos agujeros diametralmente opuestos donde se puede insertar un eje para hacer el bloqueo más fácil. No obstante la herramineta no se debe rotar para ninguna razón, sino sólo utilizarse para tener fijos los componentes interiores de la barra.

- Con una llave tubular de 21 mm apriete la válvula de pie (41) hasta el par de torsión correcto (véase Tabla 1 - Pares de torsión).

4.11 Riempimento olio

19 mm



NOTA

È disponibile a ricambio l'attrezzo **R5051AC**, che avvitato sulla parte terminale dell'asta ne facilita il recupero dall'interno del portastelo.

- Sollevare completamente il portastelo sul tubo portante.
- Preparare in un misurino graduato la quantità di olio da versare nello stelo (vedi Tabella 2 - Olio e quantità).
- Versare all'interno del portastelo (13) circa 2/3 dell'olio necessario, quindi effettuare alcune pompate per eliminare l'aria.
- Procedere fino a versare la quantità necessaria.
- Abbassare il portastelo sul tubo portante fino alla battuta del raschiapolvere sul piede portaruota.
- Attendere alcuni minuti e verificare il volume aria (vedi Tabella 2 - Olio e quantità) ed eventualmente ripristinare il livello.



NOTA

Un volume d'aria inferiore o superiore, o un tipo di olio diverso da quello prescritto possono modificare il comportamento della forcella in ogni sua fase.

- Sollevare il portastelo (13) sul tubo portante (5).
- Inserire l'asta interna di rinvio del registro (31).
- Inserire il tubetto di precarica (21), la molla (25) e lo scodellino guidamolla (20).
- Avvitare a fondo il tappo di chiusura (48).

4.11 Filling with oil

19 mm



REMEMBER

The **R5051AC** is available as spare part: if you tighten it on the rod's edge, you can make the rod extraction from the inner part of the slider easier.

- Lift the slider completely on the stanchion tube.
- Prepare the quantity of oil to pour into the fork leg (see Table 2 - Oil and quantity).
- Pour roughly 2/3 of the required oil into the slider (13), then pump the fork a few times to remove any traces of air.
- Pour the rest of the oil in.
- Lower the slider on the stanchion tube until it reaches the dust seal stop on the wheel axle clamp.
- Wait a few minutes and check the air volume (see Table 2 - Oil and quantity) and if necessary refill to the right level.



REMEMBER

A lower or higher volume of air, or a type of oil other than the recommended type can change the behaviour of the fork in every phase.

- Lift the slider (13) on the stanchion tube (5).
- Insert the adjustment return inner rod (31).
- Insert the preload tube (21), the spring (25) and the guide spring cup (20).
- Screw the fork cap (48) down.

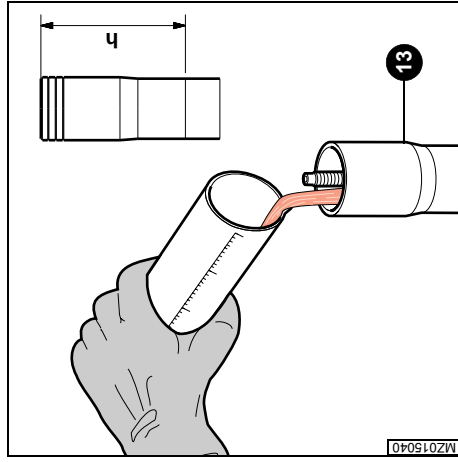

MZ015040

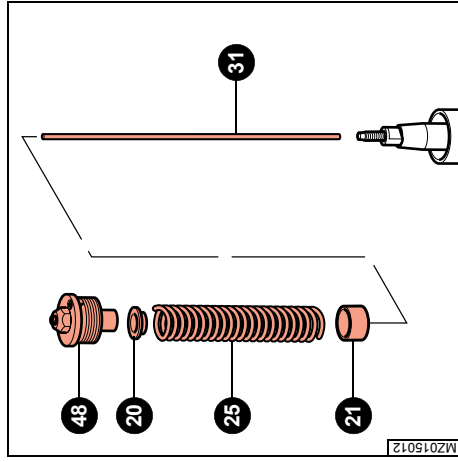

MZ015012

4.11 Remplissage de l'huile

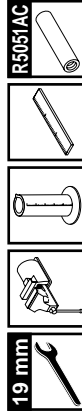

NOTE

L'outil **R5051AC** est disponible en pièce détachée : en le serrant sur la partie terminale de la tige, l'extraction de la tige elle-même de l'intérieur du porte-fourreau sera plus facile.

- Lever complètement le porte-fourreau.
- Dans un verre mesureur gradué préparer la quantité d'huile qui doit être versée dans le fourreau (voir Tableau 2 - Huile et quantité).
- Verser à l'intérieur du porte-fourreau (13) environ 2/3 de l'huile nécessaire, puis effectuer quelques pompes pour éliminer l'air à l'intérieur.
- Procéder en versant la quantité nécessaire.
- Abaisser le porte-fourreau sur le plongeur jusqu'à ce que le cache-poussière s'appuie sur le support de roue.
- Attendre quelques minutes et vérifier le volume d'air (voir Tableau 2 - Huile et quantité). Au besoin, rétablir le niveau.



NOTE

Un volume d'air inférieur ou supérieur ou un type d'huile différent de ceux conseillés peuvent modifier le comportement de la fourche.

- Lever le porte-fourreau (13) sur le plongeur (5).
- Introduire la tige interne de renvoi réglage (31).
- Introduire le petit tube de pré-charge (21), le ressort (25) et la cuvette guide ressort (20).
- Serrer à fond le bouchon de fermeture (48).

4.11 Einfüllen des Öls

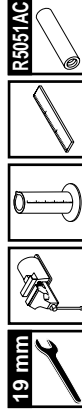

WICHTIG

Das Werkzeug **R5051AC** ist als Ersatzteil verfügbar; wenn es am Stabsende eingeschraubt wird, ist es einfacher, den Stab selbst vom Gleitrohrinnere abzunehmen.

- Das Gleitrohr vollständig auf das Standrohr hochschieben.
- In einem Messbecher die Ölmenge bereitstellen, die in den Holm eingefüllt werden soll (siehe Tabelle 2 - Öl und Füllmengen).
- Etwa 2/3 des benötigten Öls in das Gleitrohr (13) einfüllen, dann einige Pumpbewegungen ausführen, um die Luft auszutreiben.
- Die restliche Ölmenge einfüllen.
- Das Gleitrohr vom Tauchrohr nach unten ziehen, bis der Staubabstreifer am Radaufnahmefuß ansitzt.
- Einige Minuten warten, dann das Luftvolumen kontrollieren (siehe Tabelle 2 - Öl und Füllmengen) und gegebenenfalls Öl nachfüllen.



WICHTIG

Ein geringeres oder höheres Luftvolumen oder ein anderes als das vorgeschriebene Öl können das Verhalten der Gabel in jeder Phase ändern.

- Das Gleitrohr (13) über das Tauchrohr (5) hochschieben.
- Den inneren Rückrufstab (31) einsetzen.
- Den Vorspannung (21), die Feder (24) und den Federhülseteller (20) einsetzen.
- Den Verschluss (48) ganz zuschrauben.

4.11 Relleno de aceite

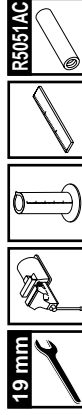

NOTA

La herramienta **R5051AC** está disponible para los repuestos: aprietandola en la parte terminal del vástago, le extracción del mismo de la botella será más fácil.

- Alce completamente la botella en la barra.
- Prepare en un recipiente graduado la cantidad de aceite que debe versar en la barra de horquilla (véase Tabla 2 - Aceite y cantidad).
- Introduzca en el interior de la botella (13) aprox. 2/3 del aceite necesario y efectúe varios bombeos para eliminar el aire.
- Proceda hasta versar la cantidad necesaria.
- Baje la botella en la barra de horquilla hasta el tope del guardapoivo en el pie portarueda.
- Espere unos minutos y compruebe el volumen del aire (véase Tabla 2 - Aceite y cantidad) y eventualmente rellene hasta el nivel.



NOTA

Un volumen de aire inferior o superior, o un tipo de aceite diferente del indicado pueden modificar el comportamiento de la horquilla en cada una de sus fases.

- Alce la botella (13) en la barra de horquilla (5).
- Inserte el vástago interior de transmisión regulación (31).
- Introduzca el tubo de precarga (21), el muelle (25) y el asiento guía del muelle (20).
- Apriete hasta el fondo el tapón de cierre (48).

- Svitare completamente la vite di registro **(R)**, corrispondente al registro aperto.
- Utilizzando due chiavi da 19 mm stringere il controdado **(23)** sul tappo **(48)** alla coppia prescritta (vedi Tabella 1 - Coppie di serraggio).
- Sollevare il portastelo sul tubo portante.
- Serrare, con la chiave da 19 mm, alla coppia prescritta (vedi Tabella 1 - Coppie di serraggio), il tappo di chiusura **(48)** sul portastelo.
- Ripristinare la corretta taratura agendo sulla vite di registro **(R)** (vedi *paragrafo 5*).

- Fully unscrew the adjustment screw **(R)**, which corresponds to the open adjuster.
- Using two 19 mm spanners tighten locknut **(23)** on the cap **(48)** up to the required torque (see Table 1 - Tightening torques).
- Lift the slider on the stanchion tube.
- Tighten fork cap **(48)** on the slider with the 19 mm spanner to the recommended torque (see Table 1 - Tightening torques).
- Re-establish the correct setting by turning the adjustment screw **(R)** (see *paragraph 5*).

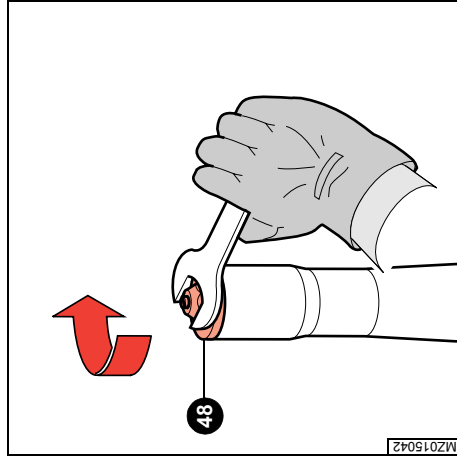
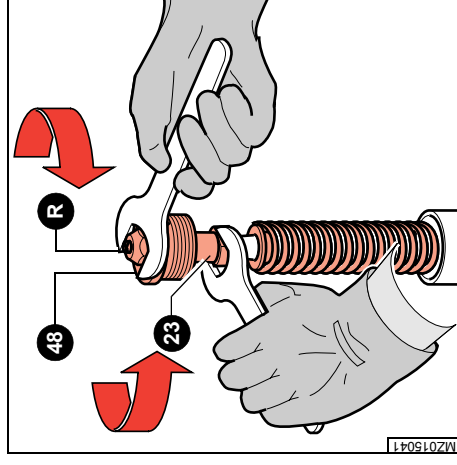

- Dévisser entièrement la vis de réglage **(R)**, correspondant au registre ouvert.
- A l'aide de deux clés de 19 mm, serrer le contre-écrou **(23)** sur le bouchon **(48)** au couple prévu (voir Tableau 1 - Couples de serrage).
- Lever le porte-fourreau sur le plongeur.
- A l'aide de la clé de 19 mm, serrer le bouchon de fermeture **(48)** sur le porte fourreau au couple prévu (voir Tableau 1 - Couples de serrage).
- Rétablir le réglage correct en intervenant sur la vis de réglage **(R)** (voir *paragraphe 5*).

- Die Einstellschraube **(R)**, die dem offenen Einsteller entspricht, komplett ausschrauben.
- Mit zwei 19 mm-Schlüsseln die Kontermutter **(23)** auf dem Verschluss **(48)** mit dem vorgeschriebenen Anzugsmoment (siehe Tabelle 1 - Anzugsmomente) anziehen.
- Das Gleitrohr über das Tauchrohr hochschieben.
- Mit der 19 mm-Schlüssel den Verschluss **(48)** mit dem vorgeschriebenen Anzugsmoment (siehe Tabelle 1 - Anzugsmomente) anziehen.
- Die richtige Einstellung durch die Einstellschraube **(R)** (siehe *Paragraph 5*) rückstellen.

- Desatornille competamente el tornillo de regulación **(R)** que corresponde al ajuste abierto.
- Utilizando dos llaves de 19 mm apriete la contratuercas **(23)** en el tapón **(48)** al par de torsión indicado (véase Tabla 1 - Pares de torsión).
- Alce la botella en la barra de horquilla.
- Con la llave de 19 mm, apriete el tapón de cierre **(48)** en la botella al par de torsión indicado (véase Tabla 1 - Pares de torsión).
- Reestablezca el ajuste correcto accionando el tornillo de regulación **(R)** (véase *párrafo 5*).

4.12 Rimontaggio forcella sul motociclo



ATTENZIONE

L'installazione della forcella sul telaio deve essere eseguita rispettando le specifiche del Costruttore del motociclo per quanto riguarda gli organi di sterzo, di frenatura e il fissaggio della ruota. Un montaggio non corretto può pregiudicare la sicurezza e l'incolumità del pilota.

Per un corretto funzionamento della forcella la ruota deve essere installata sulla forcella nella seguente maniera:

- Inserire il perno attraverso il portaruota destro, la ruota e il portaruota sinistro.
- Avvitare il dado del perno sul lato sinistro e serrare a fondo.
- Fare compiere alcune escursioni complete agli steli della forcella.
- Serrare le due viti del portaruota destro con sequenza 1-2-1.



ATTENZIONE

Nel caso in cui la forcella sia corredata da testa e crocera fa fede la procedura di installazione contenuta nel manuale del costruttore della moto.

4.12 Fitting the fork back on the motorcycle



WARNING

Fit the fork back onto the frame following the instructions in the motorcycle manufacturer's manual, as for the steering elements, brakes and wheel. The incorrect assembly of these elements can be dangerous for the rider.

For the fork to work correctly, the wheel must be installed on the fork as follows:

- Insert the axle through the right wheel axle clamp, the wheel and the left wheel axle clamp.
- Screw down the nut on the left side of the axle and tighten fully.
- Fully compress the fork a few times.
- Tighten the two bolts on the right wheel axle clamp following the sequence 1-2-1.



WARNING

In case the fork is equipped by the upper and lower crown please follow the assembly instructions included in the motorbike user's manual.

4.12 Remontage de la fourche sur le motorcycle



ATTENTION

L'installation de la fourche sur le cadre doit être effectuée en respectant les spécifications du Constructeur du motorcycle en ce qui concerne les organes de direction, de freinage et la fixation de la roue. Un montage incorrect peut nuire à la sécurité du pilote.

Pour un fonctionnement correct de la fourche, la roue doit être montée sur la fourche comme suit:

- Introduire l'axe à travers le support de roue droit, la roue et le support de roue gauche.
- Visser l'érou de l'axe sur le côté gauche et serrer à fond.
- Comprimer la fourche à fond quelques fois.
- Serrer les deux vis du support de roue droit selon une séquence 1-2-1.



ATTENTION

Pour d'autres renseignements concernant le réglage de la fourche, upgrade kit, kit de révision, visitez le site www.marzocchi.com à la page produits aftermarket moto.

4.12 Montage der Gabel am Motorrad



ACHTUNG

Der Einbau der Gabel in den Rahmen muss, was die Lenk- und Bremsorgane sowie die Befestigungsteile des Rads betrifft, unter Beachtung der Anleitung des Motorradherstellers erfolgen. Eine nicht vorschriftsmäßig ausgeführte Montage kann die Sicherheit des Fahrers gefährden.

Für ein einwandfreies Funktionieren der Gabel muss das Rad folgendermaßen auf die Gabel montiert werden:

- Den Bolzen durch die rechte Radaufnahme, das Rad und die linke Radaufnahme schieben.
- Die Bolzenmutter auf der linken Seite anschrauben und fest anziehen.
- Die Gabelholme ein paar Mal vollständig ausfahren lassen.
- Die beiden Schrauben der rechten Radaufnahme in der Reihenfolge 1-2-1 anziehen.



ACHTUNG

Falls die Gabel aus oben und unten Gabelbrücke ausgerüstet wird, bitte folgen das Prozedurverfahren, das im Motorrad Handbuch ist.

4.12 Reensamblaje de la horquilla en la motocicleta



¡PRECAUCION!

La instalación de la horquilla en el chasis debe ser efectuada respetando las especificaciones técnicas del Constructor de la motocicleta en lo que se refiere a las piezas de la dirección, del freno y de la sujeción de la rueda. Un montaje non correcto puede comprometer la seguridad y la incolumidad del piloto.

Para un funcionamiento correcto de la horquilla la rueda debe ser instalada en la horquilla de la siguiente manera:

- Introduzca el perno a través del portarueda derecho, la rueda y el portarueda izquierdo.
- Atornille la tuerca del perno en el lado izquierdo y apriete hasta el fondo.
- Realice algunas compresiones completas de las barras de horquilla.
- Apriete los dos tornillos del portarueda derecho con secuencia 1 - 2 - 1.



¡PRECAUCION!

Si la horquilla ya tiene pletina y puente el procedimiento de instalación que se tiene que observar es el contenido en el manual del constructor de la moto.

5 TARATURE

5.1 Registro estensione



La taratura del freno in estensione (o freno di ritorno) può essere eseguita, agendo sulla vite di registro (R) presente sui tappi superiori di entrambi gli steli.



NOTA

Per modificare la taratura del freno in estensione partire sempre dalla posizione di tutto chiuso (registro completamente girato in senso orario). Ogni posizione del registro è identificata da un "click".

- Ruotando, servendosi di un cacciavite con impronta adeguata, il registro (R) in senso orario si aumenta la frenatura idraulica di ritorno, rendendo in questo modo la forcella più lenta nella fase di ritorno.
- Ruotando, servendosi di un cacciavite con impronta adeguata, il registro (R) in senso antiorario si riduce la frenatura idraulica di ritorno, rendendo in questo modo la forcella più reattiva nella fase di ritorno.



ATTENZIONE

Non forzare oltre i fincorsa il registro (R).

5 ADJUSTMENTS

5.1 Rebound adjustment



The extension (or rebound) damping adjustment can be made by acting on the adjustment screw (R) you can see on the upper cap of both legs.



REMEMBER

To modify the rebound braking adjustment, always start from the "fully closed" position (the screw is fully turned clockwise). Each screw position can be recognized by a "click".

- When turning the adjuster (R) clockwise, using a proper spanner, you will increase the rebound hydraulic damping, making the fork slower during the rebound phase.
- When turning the adjuster (R) counterclockwise, using a proper spanner, you will decrease the rebound hydraulic damping, making the fork more responsive during the rebound phase.



WARNING

Do not force the adjustment screw (R) past its limits.

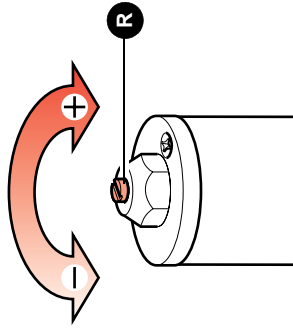

MZ015043

5 RÉGLAGES

5.1 Réglage détente



Le réglage de l'amortissement en extension (ou amortissement en détente) de la fourche peut être effectué à travers la vis de réglage (R), située sur les bouchons supérieurs des deux fourreaux.



NOTE

*Pour modifier le réglage de l'amortissement en détente, il faut toujours commencer par la position de complètement serré (vis complètement tournée dans le sens des aiguilles d'une montre).
Chaque position de réglage peut être reconnue par un « click ».*

• À l'aide d'un tournevis plat de forme adaptée tourner la vis de réglage (R) dans le sens des aiguilles d'une montre pour augmenter l'amortissement hydraulique en détente : de cette façon, la fourche sera plus lente en phase de détente.

• À l'aide d'un tournevis plat de forme adaptée tourner la vis de réglage (R) dans le sens contraire aux aiguilles d'une montre pour réduire l'amortissement hydraulique en détente : de cette façon, la fourche sera plus réactive en phase de détente.



ATTENTION

Ne pas forcer la vis de réglage (R) au-delà des butées.

5 EINSTELLUNG

5.1 Zugstufeneinstellung



Durch die Einstellschraube (R), die auf dem oberen Verschluss beider Gabelholme angeordnet ist, können Sie die Gabelzugstufendämpfung einstellen.



WICHTIG

*Um die Zugstufendämpfungseinstellung zu ändern, immer von der „völlig geschlossenen“ Position anfangen (die Einstellschraube ist komplett im Uhrzeigersinn gedreht).
Jede Einstellposition ist durch ein „klick“ erkennbar.*

• Durch Drehen der Einstellschraube (R) mit einem Schraubendreher von geeigneter Art im Uhrzeigersinn können Sie die Zugstufendämpfung erhöhen; die Gabel wird deshalb langsamer während der Zugstufenphase.

• Durch Drehen der Einstellschraube (R) mit einem Schraubendreher von geeigneter Art gegen den Uhrzeigersinn können Sie die Zugstufendämpfung reduzieren; die Gabel wird deshalb schneller während der Zugstufenphase.



ACHTUNG

Die Einstellschraube (R) nie über ihren Endanschlag hinaus anziehen.

5 AJUSTES

5.1 Ajuste rebote



El ajuste de la amortiguación en rebote de la horquilla puede hacerse a través del tornillo de regulación (R) que se encuentra en el tapón superior de las dos barras.



NOTA

Para modificar la regulación del freno de rebote, empiece siempre desde la posición de "todo cerrado" (ajuste completamente girado en el sentido de las agujas del reloj).

Cada posición de regulación se puede reconocer por un "click".

• Cuando gira el regulador (R), por medio de un destornillador de tamaño adecuado, en el sentido de las agujas del reloj, aumenta la amortiguación hidráulica del rebote, haciendo que la horquilla vuelva lentamente durante la fase del rebote.

• Cuando gira el regulador (R), por medio de un destornillador de tamaño adecuado, en el sentido contrario de las agujas del reloj, disminuye la amortiguación hidráulica del rebote, haciendo que la horquilla sea más sensible durante la fase de rebote.



¡PRECAUCIÓN!

No fuerces el regulador (R) más allá de su tope.

5.2 Registro compressione



La taratura del freno in compressione può essere eseguita, agendo sulla vite di registro (C) presente nella parte inferiore di ogni stelo.



NOTA

Per modificare la taratura del freno in compressione partire sempre dalla posizione di tutto chiuso (registro completamente girato in senso orario).

Ogni posizione del registro è identificata da un "click".

- Rimuovere il tappo di protezione in plastica.
- Ruotando, servendosi di un cacciavite con impronta adeguata, il registro (C) in senso orario si aumenta la frenatura idraulica di compressione, riducendo a parità di sollecitazione la corsa compiuta dalla forcella.
- Ruotando, servendosi di un cacciavite con impronta adeguata, il registro (C) in senso antiorario si riduce la frenatura idraulica di compressione, rendendo la forcella più cedevole di fronte alle asperità del terreno.



ATTENZIONE

Non forzare oltre i fincorsa il registro (C).

- Rimontare il tappo di protezione in plastica.

5.2 Compression adjustment



The compression damping adjustment can be made by acting on the adjustment screw (C) you can see at the bottom of both fork legs.



REMEMBER

To modify the compression braking adjustment, always start from the "fully closed" position (the screw is fully turned clockwise). Each screw position can be recognized by a "click".

- Remove the plastic cap
- When turning the adjuster (C) clockwise, using a proper spanner, you will increase the compression hydraulic damping, reducing the travel made by the fork, under the same stress.
- When turning the adjuster (C) counterclockwise, using a proper spanner, you will decrease the compression hydraulic damping, making the fork softer against ground harshness.



WARNING

Do not force the adjustment screw (C) past its limits.

- Put the plastic cap back to its seat.

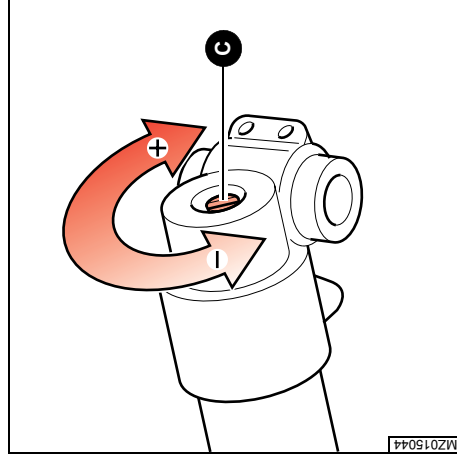

5.2 Réglage compression



Le réglage de l'amortissement en compression de la fourche peut être effectué à travers la vis de réglage marquée par la lettre (C), située dans la partie inférieure de chaque fourreau.



NOTE

Pour modifier le réglage de l'amortissement en compression, il faut toujours commencer par la position de complètement serré (vis complètement tournée dans le sens des aiguilles d'une montre). Chaque position de réglage peut être reconnue par un « click ».

- Ôter le bouchon de protection en plastique.
- À l'aide d'un tournevis plat de forme adaptée tourner la vis de réglage (C) dans le sens des aiguilles d'une montre pour augmenter l'amortissement hydraulique en compression : de cette façon, l'on réduit le débattement fait par la fourche, à égalité de sollicitation
- À l'aide d'un tournevis plat de forme adaptée tourner la vis de réglage (C) dans le sens contraire aux aiguilles d'une montre pour réduire l'amortissement hydraulique en compression: de cette façon, la fourche sera plus souple face aux aspérités du sol.



ATTENTION

Ne pas forcer la vis de réglage (C) au-delà des butées.

- Remonter le bouchon de protection en plastique.

5.2 Druckstufeneinstellung



Durch die Einstellschraube (C), die im unteren Gebiet beider Holme angeordnet ist, können Sie die Gabeldruckstufendämpfung einstellen.



WICHTIG

Um die Druckstufendämpfungseinstellung zu ändern, immer von der „völlig geschlossenen“ Position anfangen (die Einstellschraube ist komplett im Uhrzeigersinn gedreht). Jede Einstellposition ist durch ein „klick“ erkennbar.

- Den Plastikschutzverschluss abnehmen.
- Durch Drehen der Einstellschraube (C) mit einem Schraubendreher von geeigneter Art im Uhrzeigersinn können Sie die hydraulische Druckstufenbremse erhöhen; bei gleicher Beanspruchung, wird der Federweg kürzer.

- Durch Drehen der Einstellschraube (C) mit einem Schraubendreher von geeigneter Art gegen Uhrzeigersinn können Sie die hydraulische Druckstufenbremse reduzieren; die Gabel wird deshalb weicher gegenüber den Unebenheiten.



ACHTUNG

Die Einstellschraube (C) nie über ihren Endanschlag hinaus anziehen.

- Den Plastikschutzverschluss wieder einsetzen.

5.2 Ajuste compresión



El ajuste de la amortiguación en compresión de la horquilla puede hacerse a través del tornillo de regulación (C) que se encuentra en la parte inferior de cada barra.



NOTA

Para modificar la regulación del freno de compresión, emplee siempre desde la posición de "todo cerrado" (ajuste completamente girado en el sentido de las agujas del reloj).
Cada posición de regulación se puede reconocer por un "click".

- Saque el tapón de protección de plástico.
- Cuando gira el regulador (C), por medio de un destornillador de tamaño adecuado, en el sentido de las agujas del reloj, aumenta la compresión hidráulica, reduciendo el recorrido que hace la horquilla bajo la misma presión.
- Cuando gira el regulador (C), por medio de un destornillador de tamaño adecuado, en el sentido contrario a las agujas del reloj, disminuye la compresión hidráulica, haciendo que la horquilla se hunda frente a los obstáculos.



¡PRECAUCION!

No fuerces el regulador (C) más allá de su tope.

- Reensamble el tapón de protección de plástico.

6 TABELLE • TABLES • TABLEAUX • TABELLEN • TABLAS

6.1 Tabella 1 - Coppie di serraggio • Table 1 - Tightening torques • Tableau 1 - Couples de serrage Tabelle 1 - Anzugsmomente • Tabla 1 - Pares de torsión

Elemento da serrare - Element to tighten - Élément à serrer - Schraubetelement - Elemento por apretar	Coppie di serraggio (Nm) - Tightening torque (Nm) - Couples de serrage (Nm) - Anzugsmomente (Nm) - Par de torsión (Nm)
Vite di fondo - Foot screw - Vis de fond - Bodenschraube - Tornillo de fondo	50
Controdado su tappo - Locknut on cap - Contre-écrou sur bouchon - Kontermutter zum Verschluss - Contratuercas en el tapón	30
Tappo su asta - Cap on rod - Bouchon sur tige - Verschluss auf Stab Tapón en el vástago	10
Tappo su portastelo - Cap on slider - Bouchon sur porte fourreau - Verschluss auf Gleitrohr - Tapón en la botella	25
Vite spurgo aria - Air bleed screw - Vis de purge de l'air - Luftauslassschraube - Tornillo de purga aire	7
Tampone di fondo - Foot buffer - Tampon de fond - Bodenpuffer - Almohadilla de pie	15

6.2 Tabella 2 - Olio e quantità • Table 2 - Oil and quantity • Tableau 2 - Huile et quantité • Tabelle 2 - Öl und Menge Tabla 2 - Aceite y cantidad

Tipo - Type - Type - Typ - Tipo	Clima - Climate - Climat - Klima - Clima	Quantità - Quantity - Quantité - Menge - Cantidad	Volume aria - Air volume - Volume d'air - Luftvolumen - Volumen aire
Olio MARZOCCHI cod. 55 00 13 SAE 7,5	Temperato		
MARZOCCHI oil code 55 00 13 SAE 7.5	Temperate		
Huile MARZOCCHI code 55 00 13 SAE 7,5	Tempéré	610 cc	90 mm
Öl MARZOCCHI Art. 55 00 13 SAE 7,5	Gehärtet		
Aceite MARZOCCHI cód. 55 00 13 SAE 7,5	Templado		
Olio MARZOCCHI cod. 55 00 46 SAE 5	Rígido		
MARZOCCHI oil code 55 00 046 SAE 5	Rigorous		
Huile MARZOCCHI code 55 00 46 SAE 5	Rigoureux	610 cc	90 mm
Öl MARZOCCHI Art. 55 00 46 SAE 5	Streng		
Aceite MARZOCCHI cód. 55 00 46 SAE 5	Rígido		

**6.3 Tabella 3 - Taratura standard • Table 3 - Standard setting • Tableau 3 - Réglage standard
Tabelle 3 - Standard Einstellung • Tabla 3 - Ajuste estándar**

Compressione - Compression - Compression - Druckstufe - Compresión	12 click (dalla posizione tutto chiuso) 12 clicks (form fully closed position) 12 clicks (de la position « complètement serré ») 12 clicks (von der „völlig geschlossene“ Position) 12 clicks (de la posición "completamente cerrado")
Estensione - Rebound - Détente - Zugstufe - Rebote	10 click (dalla posizione tutto chiuso) 10 clicks (form fully closed position) 10 clicks (de la position « complètement serré ») 10 clicks (von der „völlig geschlossene“ Position) 10 clicks (de la posición "completamente cerrado")

6.4 Tabella 4 - Molle • Table 4 - Springs • Tableau 4 - Ressorts • Tabelle 4 - Federn • Tabla 4 - Muelles

Costante molla (K) - Spring rate (K) Dureté du ressort (K) - Federhärte (K) Dureza del muelle (K)	Codice - Code Référence - Artikel Código	Lunghezza - Length Longueur - Länge Longitud	Ø filo - Ø wire - Ø fil Ø Draht - Ø hilo	n° spire - n. of coils n. de spires - Windungen n. n. de espiras
3,8	5141144	435 mm	4,5 mm	-
4	5141145	470 mm	4,8 mm	-
4,2	5141146	460 mm	4,8 mm	-
4,5	5141147	460 mm	4,8 mm	-
4,8	5141148	475 mm	5 mm	-
5	5141149	470 mm	5 mm	-
4 / 4,4	5141150	470 mm	4,8 mm	-
4,2 / 4,6	5141151	460 mm	4,8 mm	-

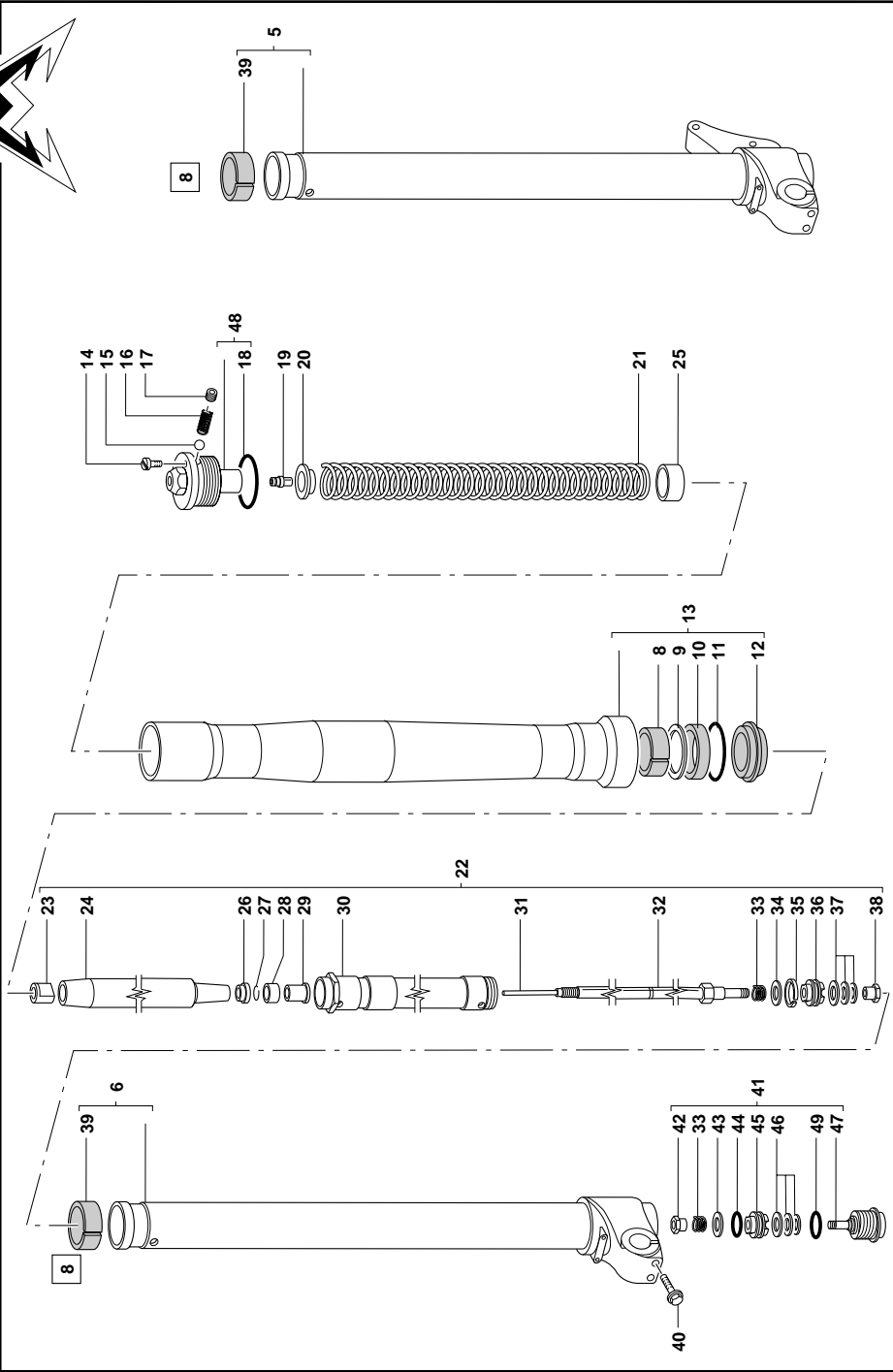

7 WARRANTY

If any component of the Marzocchi Suspension System is found to be defective in materials or workmanship within the term of this Limited Two Years Warranty (the "Agreement"), the defective component will be repaired or replaced, at the option of Marzocchi S.p.A., free of charge, within 30 (thirty) days after receipt of the Suspension System by an authorized Marzocchi dealer, freight prepaid, together with the original retail invoice or other evidence of the date of purchase.

- 1. NOT COVERED:** This warranty does not cover damage resulting from accidents, alteration, neglect, misuse or abuse, lack of reasonable and proper maintenance, improper assembly, repairs improperly performed or replacement parts or accessories not conforming to Marzocchi S.p.A.'s specifications, modifications not recommended or approved in writing by Marzocchi S.p.A., activities such as acrobatics, stunt jumping, ramp riding and / or normal wear and deterioration occasioned by the use of the vehicle. This warranty does not cover the components that are subject to normal use wear. These components are: oil, oil seals, dust seals and sliding bushings. We therefore ask you to verify (or have your dealer verify it) their condition at the moment you purchase the fork, as this is the only time you will be allowed to have such components replaced. This warranty also does not include any expenses related to the transportation of the

7 GARANZIA

Nel caso in cui vengano riscontrati difetti attinenti a materiali o lavorazione su uno qualsiasi dei componenti del sistema di sospensione Marzocchi entro i termini stabiliti dalla presente garanzia (2 anni), il medesimo componente difettoso dovrà essere riparato o sostituito, a facoltà della Marzocchi S.p.A., gratuitamente, entro 30 (trenta) giorni dello stesso da parte di un rivenditore autorizzato Marzocchi nolo prepagato, unitamente allo scontrino di acquisto attestante la data.

- 1. LA GARANZIA NON COPRE.** La presente garanzia non opera in caso di danni derivanti da incidenti, modifica, negligenza, uso improprio od abuso, mancata esecuzione di una ragionevole ed appropriata manutenzione, montaggio anomalo, riparazioni non eseguite correttamente od installazione impropria dei pezzi di ricambio, uso di pezzi di ricambio od accessori non conformi alle specifiche fornite dalla Marzocchi S.p.A., esecuzione di modifiche non raccomandate od approvate per iscritto da Marzocchi S.p.A., svolgimento di attività quali virtuosismi acrobatici, salti acrobatici, arrampicate e/o normale usura e deterioramento a seguito dell'utilizzo del mezzo. La presente garanzia non copre i componenti soggetti a normale usura per utilizzo. Questi sono: olio, anelli di tenuta, raschiapolvere e bocche di scorrimento vi preghiamo pertanto di verificare (o farvi verificare dal rivenditore) il loro stato al momento dell'acquisto della forcella perche' solo in quel momento sara'

7 GARANTIE

Au cas où l'un des composants du système de suspension Marzocchi présenterait des défauts matériels ou de fabrication dans deux (2) ans à dater de la date du premier achat, Marzocchi s'engage à le réparer ou, à son choix, à le remplacer gratuitement, dans 30 (trente) jours de la réception de la pièce defectueuse de la part d'un revendeur autorisé Marzocchi, port prépayé en joignant la facture originale d'achat ou autre document qui donne preuve de l'achat.

1. **LA GARANTIE NE COUVRE PAS:** La présente garantie ne s'appliquera pas si les réclamations sont consécutives à des incidents, des modifications, des négligences, toute utilisation impropre ou abusive, l'absence totale d'entretien, un montage non conforme, toute réparation effectuée sommairement ou toute installation impropre de pièces détachées, l'utilisation de pièces détachées ou accessoires non conformes aux spécificités fournies par Marzocchi S.p.A., toute modification n'ayant été ni conseillée ni recommandée ou approuvée par une autorisation écrite Marzocchi S.p.A., toute activité "acrobatique", sauts acrobatiques grimpée et/ou usure normale et détérioration dues à l'utilisation de la bicyclette.
- La présente garantie ne s'applique pas aux composants qui sont exposés à l'usure normale due à l'emploi des composants mêmes. Il s'agit de : huile, joints d'étanchéité, cache-pousière et bagues de glissement. Nous vous prions donc de bien vouloir vérifier au moment de l'achat de la

7 GARANTIEERKLÄRUNG

Diese Garantie gilt für den Zeitraum von zwei (2) Jahre (ab Kaufsdatum). Wenn innerhalb dieser Zeitspanne irgendwelche Mängel, die das Material oder die Verarbeitung eines beliebigen Teils des Federungssystems Marzocchi betreffen, auftritt, wird das beschädigte Teil, nach Vorlage der originalen Rechnung oder anderen Beweis des Kaufsdatums, kostenlos repariert werden oder ausgetauscht nach Ermessen der Marzocchi S.p.A., innerhalb von 30 (dreißig) Tagen vom Empfang bei einem Marzocchi Händler des Teils frei Haus.

1. **VON DER GARANTIE AUSGESCHLOSSEN.** Diese Garantie gilt nicht bei Schaden, die auf Unfälle, Abänderung und Nachlässigkeit zurückzuführen sind, bei falschem Gebrauch oder Missbrauch, bei fehlender Ausführung einer vernünftigen und angebrachten Reparatur, bei falscher Montage, bei falsch ausgeführten Reparaturen oder unsachgerechter Installation von Teilen, bei Gebrauch von Teilen oder Zubehör, die nicht mit denen der Marzocchi S.p.A. übereinstimmen, bei Ausführung von Abänderungen, die nicht von der Marzocchi S.p.A. schriftlich bestätigt oder empfohlen wurden, bei Akrobatikstücken, bei akrobatischen Sprüngen, bei Rampensprüngen und/oder bei normaler Abnutzung und Verschleiß nach dem Gebrauch des Fahrzeugs.
- Diese Garantie gilt nicht bei den Komponenten, die dem normalen

7 GARANTÍA

En caso de defectos de material o de trabajo en cualquier componente del sistema de suspensión Marzocchi dentro de los términos establecidos por la presente garantía (2 años), Marzocchi S.p.A. tendrá que arreglar o reemplazar gratuitamente el mismo componente defectuoso dentro de 30 (treinta) días, por medio de un revendedor autorizado Marzocchi, franco a domicilio, junto a la factura original de compra u otro documento que indique la fecha de compra.

1. **LA GARANTÍA NO CUBRE:** esta garantía no cubre los daños causados por accidentes, alteración, negligencia, mala aplicación o abuso, falta de ejecución de un razonable y apropiado mantenimiento, montaje anómalo, reparaciones ejecutadas de manera incorrecta, o instalación impropia de los repuestos, uso de repuestos o accesorios que no correspondan a las características establecidas por Marzocchi S.p.A., ejecución de modificaciones no recomendadas o aprobadas por escrito por Marzocchi S.p.A., desarrollo de actividades como virtuosidades acrobáticas, saltos acrobáticos, subidas y/o normal desgaste y deterioro causado por el uso del vehículo.
- Esta garantía no cubre los componentes que van sujetos al normal desgaste debido al uso. Estos componentes son: aceite, retenes, guardapolvos y casquillos guía. Les rogamos por lo tanto controlar (o hacer controlar a Su revendedor) la condición de los componentes sobredichos al momento

possibile farvi sostituire i suddetti componenti."

La presente garanzia, inoltre, non copre le eventuali spese sostenute per il trasporto del sistema di sospensione Marzocchi a, o da un rivenditore autorizzato Marzocchi, i costi della manodopera richiesta per rimuovere dal veicolo il suddetto sistema di sospensione Marzocchi oppure l'indennizzo richiesto per porre riparo al disagio dovuto al mancato utilizzo del sistema di sospensione Marzocchi durante il periodo nel quale esso si trova in riparazione. **La presente garanzia decadrà automaticamente nel caso in cui il numero di serie del sistema di sospensione Marzocchi venga alterato, cancellato, reso illeggibile o sottoposto a qualsiasi tipo di manomissione.**

2. **ACQUIRENTE.** La presente garanzia viene concessa unicamente all'acquirente originale del sistema di sospensione Marzocchi e non si intende a terzi. I diritti spettanti all'acquirente ai sensi della presente garanzia non possono essere ceduti.
3. **DURATA.** La presente garanzia inizierà dalla data di acquisto e durerà per un periodo di due (2) anni. Fa fede la data della fattura o scontrino fiscale che deve essere conservato.
4. **PROCEDURA.** Nel caso in cui venga riscontrato un difetto coperto dalla presente garanzia, l'acquirente dovrà contattare il Rivenditore od un centro di assistenza Marzocchi.
5. **CONTRATTO INDIVISIBILE.** La presente garanzia sostituisce tutte le garanzie

Marzocchi Suspension System to or from an authorized Marzocchi dealer, labor costs to remove the Marzocchi Suspension System from the vehicle, or compensation for inconvenience or loss of use while the Marzocchi Suspension System is being repaired. **This warranty will be automatically void if serial number of the Marzocchi Suspension System is altered, erased defaced or otherwise subject to any tempering.**

2. **PURCHASER.** This warranty is made only with the original purchaser of the Marzocchi Suspension System and does not extend to any third parties. The rights of the purchaser under this warranty may not be assigned.
3. **TERM.** The term of this warranty shall commence on the date of purchase and shall continue for a period of two (2) years from the date of the original purchase; is worth the invoice date or the ticket, that must be kept.
4. **PROCEDURE.** In event of a defect covered by this warranty, the purchaser should contact an authorized dealer or a Marzocchi Service Centre.
5. **ENTIRE AGREEMENT.** This warranty supersedes any and all oral or express warranties, statements or undertakings that may previously have been made, and

fourche (ou de le faire vérifier par votre revendeur) l'état de ces composants, car il ne sera possible de les remplacer qu'à ce moment.

La présente garantie ne se s'applique pas aux frais éventuels de transport du système de suspension Marzocchi chez ou à partir d'un revendeur autorisé Marzocchi, les coûts de main-d'œuvre nécessaire pour déposer le système de suspension Marzocchi de la bicyclette ou le dédomagement demandé pour le désagrément de ne pas avoir pu utiliser le système de suspension Marzocchi pendant la période de réparation. **La garantie va automatiquement dechoir au cas où le numéro de série du système de suspension Marzocchi est altéré, effacé, rendu illisible ou de toute façon modifié.**

- 2. ACHETEUR.** La présente garantie est accordée uniquement à l'acheteur d'origine du système de suspension Marzocchi et ne s'applique pas aux tiers. Les droits de l'acheteurs aux termes de la présente garantie ne pourront pas être cédés.
- 3. DURÉE.** La présente garantie commence à partir de la date d'achat et continue pour une période deux (2) ans à dater du premier achat. Vous devez conserver la facture et la fiche qui démontre la date de l'achat.
- 4. PROCÉDURE.** Au cas où l'acheteur constaterait un défaut couvert par la présente garantie, il devra contacter le Revendeur ou un Centre d'Assistance Marzocchi.
- 5. CONTRAT INDIVISIBLE.** La présente

Gebrauchsverschleiß unterliegen. Solche Komponente sind: Öl, Öldichtungen, Staubabstreifern und Gleitbuchsen. Wir bitten Sie deshalb, bei dem Gabeleinkauf den Zustand solcher Komponenten zu überprüfen (oder von Ihrem Händler überprüfen zu lassen), da es nur bei dieser Zeit möglich sein wird, sie zu ersetzen.

Weiters deckt diese Garantie nicht eventuelle Kosten, die für den Transport von oder zum autorisiertem Händler des Federungssystem Marzocchi aufwendet wurden, den Arbeitslohn zur Demontage des Federungssystem Marzocchi von dem Fahrzeug oder die Entschädigung infolge Nutzungsausfalls des Federungssystem Marzocchi während der Reparaturzeit. **Die Garantie wird automatisch verfallen, falls die Seriennummer verändert, beschädigt oder entfernt wurde.**

- 2. KÄUFER.** Diese Garantie wird ausschließlich dem ursprünglichem Käufern des Federungssystem Marzocchi gewährt und nicht Dritten. Die Käuferrechte im Sinne dieser Garantie dürfen nicht veräußert werden.
- 3. DAUER.** Diese Garantie betrifft den Zeitraum von zwei (2) Jahre ab dem Kaufdatum und endet nach dem Ablauf des obengenannten Zeitraums. Als unumgängliche Bedingung für die Garantiegültigkeit, muss der Käufer die Rechnung oder den Schein bewahren, um die Einkaufstag zu zeigen.
- 4. VERFAHREN.** Wenn ein von dieser Garantie gedeckter Schaden festgestellt wird, soll der Käufer einen Marzocchi

de la compra de la horquilla, ya que sólo en este momento será posible sustituirlos.

Además, esta garantía no cubre los gastos eventuales de transporte del sistema de suspensión Marzocchi hasta o desde un revendedor autorizado Marzocchi, los gastos de mano de obra necesarios para la rimoción del vehículo del sistema de suspensión Marzocchi, o bien la indemnización para la incomodidad debida a la falta de utilización del sistema de suspensión Marzocchi durante el periodo en el que se está reparando. **Esta garantía decaerá automáticamente si el número de serie del sistema de suspensión Marzocchi sea alterado, borrado, no se pueda leer o haya sido dañado de alguna manera.**

- 2. COMPRADOR:** esta garantía se concede únicamente al comprador original del sistema de suspensión Marzocchi y no se entiende extendida a terceros. Los derechos que pertenecen al comprador según los términos de esta garantía, no se pueden ceder.
- 3. DURACIÓN:** esta garantía empezará a partir de la fecha de compra y durará por un período de dos (2) años. Como fecha se entiende la fecha de la factura o del talón fiscal que tendrá que ser conservado.
- 4. PROCEDIMIENTO:** en caso que se verifique un defecto cubierto por esta garantía, el comprador tendrá que ponerse en contacto con el revendedor o con un centro de asistencia Marzocchi.

implicite od esplicito, dichiarazione od impegni stipulati precedentemente e rappresenta il contratto indivisibile tra le parti con riferimento alla garanzia di questo sistema di sospensione Marzocchi. Tutte le garanzie implicite od esplicito non contenute nel presente documento sono espressamente escluse.

6. DANNI. Salvo espressamente prescritto dalla presente garanzia, Marzocchi S.p.A. NON SARA' RITENUTA RESPONSABILE PER EVENTUALI DANNI INDIRETTI OD EMERGENTI ASSOCIATI AD UN RECLAMO AI SENSI DEL PRESENTE ACCORDO, LADDOVE IL RECLAMO SIA BASATO SUL CONTRATTO, ILLECITO OD ALTRO. Le dichiarazioni di garanzia sopra menzionate sono esclusive e in luogo di tutti gli altri rimedi. Alcuni stati non permettono l'esclusione o la limitazione di danni indiretti od emergenti, quindi tale limitazione od esclusione non può applicarsi.

7. RINUNCIA. EVENTUALI GARANZIE IMPLICITE DI COMMERCIALITA' OD IDONEITA' PER UNO SCOPO PARTICOLARE E TUTTE LE GARANZIE IMPLICITE DERIVANTI DAL CORSO DEGLI AFFARI, CONSUETUDINI DEL MESTIERE.

PER STATUTO OD ALTRO SONO STRETTAMENTE LIMITATE AI PERIODI CITATI IN QUESTA GARANZIA SCRITTA. La presente garanzia costituirà l'unico ed esclusivo rimedio per l'acquirente in riferimento al presente acquisto. In caso di una presunta violazione di qualunque garanzia od azione legale intentata dall'acquirente sulla base di presunta

contains the entire agreement of the parties with respect to the warranty of this Marzocchi Suspension System. Any and all warranties not contained in this warranty are specifically excluded.

6. DAMAGES. Except as expressly provided by this warranty, Marzocchi S.p.A. SHALL NOT BE RESPONSIBLE FOR ANY INCIDENTAL OR CONSEQUENTIAL DAMAGES ASSOCIATED WITH THE USE OF THE MARZOCCHI SUSPENSION SYSTEM OR A CLAIM UNDER THIS AGREEMENT, WHETHER THE CLAIM IS BASED ON CONTRACT, TORT OR OTHERWISE. The foregoing statements of warranty are exclusive and lieu of all other remedies. Some states do not allow the exclusion or limitation of incidental or consequential damages, so thus limitation or exclusion may not apply to you.

7. DISCLAIMER. ANY IMPLIED WARRANTY OF MERCHANTABILITY OR FITNESS FOR A PARTICULAR PURPOSE AND ALL IMPLIED WARRANTIES ARISING FROM A COURSE OF DEALING, USAGE OF TRADE, BY STATUTE OR OTHERWISE, IS HEREBY STRICTLY LIMITED TO THE TERM OF THIS WRITTEN WARRANTY. This Agreement shall be the sole and exclusive remedy available to the Purchaser with respect to this purchase. In the event of any alleged breach of any warranty or any legal action brought by the purchaser based on alleged negligence or other tortious

garantie remplace toutes les garanties implicites ou explicites, déclaration ou engagements préalablement stipulés et représente le contrat indivisible entre les parties avec référence à la garantie de ce système de suspension Marzocchi. Toutes les garanties implicites ou explicites non contenues dans le présent document sont expressément exclues.

6. DOMMAGES. Marzocchi S.p.A. DÉCLINE TOUTE RESPONSABILITÉ POUR LES ÉVÉNUELS DOMMAGES INDIRECTS OU DÉRIVANTS, LIÉS A UNE RÉCLAMATION AUX TERMES DU PRÉSENT ACCORD, SI LA RÉCLAMATION EST BASÉE SUR LE CONTRAT, ILLICITE OU AUTRE sauf pour les clauses prévues dans la présente garantie. Les déclarations de garantie sus-mentionnées annulent et remplacent tout autre accord. Certains états ne permettent pas d'exclure ni de limiter les dommages indirects ou dérivants, par conséquent cette limitation ou exclusion ne pourra pas s'appliquer.

7. RENONCEMENT. LES ÉVENTUELLES GARANTIES PRÉVOYANT LA COMMERCIALISATION OU L'IDONÉITÉ DANS UN BUT SPÉCIFIQUE ET TOUTES LES GARANTIES IMPLICITES DÉRIVANT DU COURS DES AFFAIRES ET DE L'USAGE DE L'ART, PAR STATUT OU AUTRE, SONT ÉTROITEMENT LIMITÉES À LA PÉRIODE CITÉE DANS CETTE GARANTIE ÉCRITE. La présente garantie constituera la solution unique et exclusive pour l'acheteur en référence au présent

Händler oder eine Marzocchi Kundendienststelle aufsuchen.

5. AUSSCHLIESSUNGSKLAUSEL. Diese Garantie ersetzt alle einbezogenen und ausdrücklichen Garantien, alle vorher abgeschlossenen Erklärungen oder Verbindlichkeiten und bildet den ausschließlichen Vertrag zwischen den Vertragspartnern bezüglich der Garantie dieses Federungssystems Marzocchi. Alle einbezogenen und ausdrücklichen Garantien, die nicht in dieser Garantie erscheinen, sind ausdrücklich ausgeschlossen.

6. SCHADEN. Sofern nicht ausdrücklich in dieser Garantie vorgeschrieben, KANN MARZOCCHI S.P.A., GEMÄß DIESEM VERTRAG, NICHT FÜR BEANSTANDETETE INDIREKTE ODER FOLGESCHÄDEN HAFTBAR GEMACHT WERDEN, FALLS DIE BEASTANDUNG DURCH ANDERE VERTRÄGE, UNRECHTMÄSSIGKEITEN ODER ANDERE RECHTSBEHELFE BEGRÜNDET WIRD. Die oben erwähnten Garantie Erklärungen sind exklusiv und ersetzen alle anderen Rechtsbehelfe. Einige Staaten erlauben keine

Ausschließung oder Begrenzung von indirekten oder eingetretenen Schäden, deshalb kann dort diese Ausschließung und Begrenzung nicht angewandt werden.

7. RÜCKTRITT. EVENTUELLE INBEGRIFFENE HANDELS- ODER EIGNUNGSGARANTIEEN ZU EINEM BESONDEREN ZWECK UND ALLE ANDEREN INBEGRIFFENEN GARANTIEEN, DIE SICH AUS DEM LAUF

5. CONTRATO INDIVISIBLE: esta garantía reemplaza todas garantías implícitas o explícitas, declaraciones o compromisos estipulados previamente, y representa el contrato indivisible entre las partes, con referencia a la garantía de este sistema de suspensión Marzocchi. Todas las garantías implícitas o explícitas que no sean incluidas en este documento son expresamente excluidas.

6. DAÑOS: excepto que expresamente prescrito por esta garantía, Marzocchi S.p.A. NO SERÁ CONSIDERADA RESPONSABLE PARA EVENTUALES DAÑOS INDIRECTOS O EMERGENTES ASOCIADOS A UNA RECLAMACIÓN SEGÚN LOS TÉRMINOS DE ESTE ACUERDO, DONDE LA RECLAMACIÓN SE BASE SOBRE EL CONTRATO, ILCITO U OTRO. Las declaraciones de garantía sobredichas son exclusivas y en lugar de todos los otros remedios. Hay estados donde no se permite la exclusión o la limitación de daños indirectos o emergentes, por lo tanto esta limitación o exclusión no se puede aplicar.

7. RENUNCIA: LAS EVENTUALES GARANTÍAS IMPLÍCITAS DE SER COMERCIALIZABLE O APTIDAD PARA UN OBJETIVO EN PARTICULAR Y TODAS LAS GARANTÍAS IMPLÍCITAS QUE DERIVAN DEL CURSO DE LOS NEGOCIOS, CONVENCIONES DEL OFICIO POR ESTATUTO U OTRO SON ESTRECHAMENTE LIMITADAS A LOS PERÍODOS CITADOS EN ESTA

negligenza od altro comportamento illecito da parte della Marzocchi S.p.A., il solo ed esclusivo rimedio per l'acquirente sarà costituito dalla riparazione o sostituzione dei materiali risultati difettosi, sulla base di quanto precedentemente stabilito. Nessun rivenditore e nessun altro agente o dipendente della Marzocchi S.p.A., è autorizzato ad apportare variazioni, estendere od ampliare la presente garanzia.

8. AVVERTENZA. Installare, riparare ed usare sempre il sistema di sospensione Marzocchi in conformità alle indicazioni riportate nel rispettivo "Manuale di istruzioni" fornito dalla Marzocchi S.p.A.

9. ALTRI DIRITTI. Questa garanzia vi assicura specifici diritti legali; altri eventuali diritti possono variare a seconda dello stato di appartenenza (solo per USA).

10. LEGGE APPLICABILE. Qualsiasi controversia dovesse insorgere che non sia prevista dalla presente garanzia o derivi dall'uso del sistema di sospensione Marzocchi, sarà risolta in base alle leggi Italiane, presso il foro di Bologna, Italia.



ATTENZIONE

Desideriamo ringraziarvi per aver acquistato questo sistema di sospensione Marzocchi. Nel caso in cui, entro periodi previsti dalla presente garanzia, venga riscontrato un difetto coperto ai sensi della medesima, spedire, porto prepagato il sistema di sospensione Marzocchi presso un rivenditore autorizzato o a un Centro di Assistenza Marzocchi, allegando copia della

conduct by Marzocchi S.p.A. the Purchaser's sole and exclusive remedy will be repair or replacement of defective materials as stated above. No dealer and no other agent or employee of Marzocchi S.p.A. is authorized to modify, extend or enlarge this warranty.

8. WARNING. Always install, repair and use your Marzocchi Suspension System in strict compliance with it's owner's manual.

9. OTHER RIGHTS. This warranty gives you the specific legal rights, and you have also other rights which vary from state to state (USA only).

10. APPLICABLE LAW. Any disputes arising out of this agreement or caused by the use of this Marzocchi Suspension System will be governed by the laws of the country of Italy and will be decided by the Courts of Bologna, Italy.



WARNING

Thank you for the purchase of this Marzocchi Suspension System. If any defect covered under the warranty appears with the agreed terms, send the Marzocchi Suspension System, postage prepaid, to an authorized dealer or to a Marzocchi Service Center including a copy of the invoice or the ticket.

achat. En cas de violation présumée de la garantie au d'action légale intentée par l'acheteur sur la base d'une prétendue négligence ou autre comportement illicite de la part de Marzocchi S.p.A., l'acheteur pourra uniquement obtenir la réparation ou le remplacement des composants défectueux, sur la base des conditions préalablement établies. Aucun revendeur et aucun autre agent ou employé Marzocchi S.p.A. n'est autorisé à modifier, étendre ou amplifier la présente garantie.

- 8. AVERTISSEMENT.** Toujours installer, réparer et utiliser le système de suspension Marzocchi conformément aux indications mentionnées dans le « Manuel d'instructions » fourni par Marzocchi S.p.A.
- 9. AUTRES DROITS.** Cette garantie vous donne des droits spécifiques et il est possible que vous avez aussi d'autres droits qui varient selon l'état d'appartenance (seulement pour les Etats Unis).

- 10. LOI APPLICABLE.** Tout litige qui puisse naître et qui ne soit pas prévu par cette garantie ou par l'utilisation du système de suspension Marzocchi, seront résolus selon les lois italiennes, près du tribunal de Bologne, Italie.



ATTENTION

Nous vous remercions d'avoir choisi ce système de suspension Marzocchi.

Au cas où vous constateriez un défaut couvert aux termes de la garantie pendant sa période de validité, retournez, en port

DER GESCHÄFTE, DEM
GEWEREBEGEBAHREN, DEN
GESELLSCHAFTSVER TRÄGEN ODER
ANDEREM ERGEBEN, SIND UNBEDINGT
AUF DEN IN DIESER GARANTIE
ANGEBENEN ZEITRAUM BESCHRÄNKT.

Diese Garantie stellt den einzigen und exklusiven Rechtsbehelf für den Käufer bezüglich seines Kaufs dar. Im Falle einer vermeintlichen Verletzung einer beliebigen Garantie oder eines gerichtlichen Vorgehens des Käufers, begründet durch eine angemessene Nachlässigkeit oder jedes andere ungesetzliche Verhalten der Marzocchi S.p.A., besteht das einzige und exklusive Mittel für den Käufer in der Reparatur oder dem Austausch der beschädigten Teile, so wie oben vereinbart. Kein Händler und kein anderer Vertreter oder Mitarbeiter der Marzocchi S.p.A., hat das Recht diese Garantie zu ändern, beziehungsweise zu erweitern.

- 8. HINWEIS.** Installieren, benutzen und gebrauchen Sie das Federungssystem Marzocchi immer in Übereinstimmung mit den Angaben des Benutzerhandbuchs, das von Marzocchi S.p.A. mitgeliefert wird

- 9. ANDERE RECHTE.** Diese Garantie gewährleistet bestimmte Rechte. Sie kann auch andere Rechte gewährleisten, je nach Ihrem Herkunftsland (nur für USA)..

- 10. ANWENDBARES RECHT.** Im Falle von Rechtsstreifen, die von dieser Garantie oder dem Gebrauch des Marzocchi Federungssystems nicht vorgesehen sind, ist das italienische Recht gültig, bei dem Gericht von Bologna, Italien.

GARANTÍA ESCRITA. Este garantía va a constituir el único y exclusivo remedio para el comprador con referencia a este compra. En caso de presunta violación de cualquiera garantía o procedimientos ententados por el comprador en base a presunta negligencia u otra conducta ilícita de la parte de Marzocchi S.p.A., el único y exclusivo remedio para el comprador será la reparación o la sustitución de las piezas defectuosas, en consideración de lo que fue establecido previamente. Ningun revendedor y ningun otro agente o dependiente de Marzocchi S.p.A., es autorizado a hacer variaciones, a prolongar o extender esta garantía.

- 8. ADVERTENCIA:** instalar, reparar y utilizar siempre el sistema de suspensión Marzocchi en conformidad a las instrucciones contenidas en el respectivo "Manual de instrucción" provisto por Marzocchi S.p.A.

- 9. OTROS DERECHOS:** esta garantía les asegura específicos derechos legales; otros derechos eventuales pueden variar según el estado de pertenencia (para USA solamente)

- 10. LEY APLICABLE:** cualquiera controversia que no sea incluida en esta garantía o bien que derive del uso del sistema de suspensión Marzocchi se resolverá en base a las leyes italianas, en el foro de Bologna, Italia.

fattura o scontrino fiscale.

In tal caso, Vi preghiamo di aver cura di riportare nome, cognome, indirizzo data di acquisto specificando il tipo di problema o difetto rilevato.

La filosofia di Marzocchi S.p.A., è quella di offrire un servizio all'insegna della cortesia ed efficienza in riferimento ai reclami sottoposti nel corso della garanzia. Trattate con cura il sistema di sospensione Marzocchi. Se sospettate che il medesimo sia danneggiato, potete contattare il Rivenditore od un Centro di Assistenza Marzocchi.

When doing so, please state your full name, address, date of purchase and explain the problem of defect.

The policy of Marzocchi S.p.A. is to offer courteous and efficient service with respect to warranty claims .

Please take care of your Marzocchi Suspension System and in case you suspect it can be damaged, please contact your dealer or a Marzocchi Service Center.

Il marchio MARZOCCHI è concesso in licenza da Marzocchi S.p.A.

The MARZOCCHI trademark is given under licence by Marzocchi S.p.A.

prépayé, le système de suspension Marzocchi à un Revendeur autorisé ou à un Centre d'Assistance Marzocchi, en attachant copie de la facture ou de la fiche. Dans ce cas, nous vous prions d'indiquer votre nom, prénom, adresse, date d'achat en spécifiant le type de problème ou le défaut que vous avez constaté. Marzocchi S.p.A. désire offrir un service aimable et efficace pour répondre aux réclamations durant la période de validité de la garantie. Prenez soin de votre système de suspension Marzocchi vous craignez qu'il soit, endommagé, contactez votre Revendeur ou un Centre d'Assistance Marzocchi.

Le marque MARZOCCHI est accordé sous licence par Marzocchi S.p.A.



ACHTUNG

Wir möchten uns bei Ihnen für den Kauf dieses Federungssystems von Marzocchi bedanken. Wenn ein von der Garantie gedeckter Schaden festgestellt wird, schicken Sie das Federungssystem Marzocchi portofrei an Ihren Händler oder an eine Kundendienststelle Marzocchi, mit einer Kopie der Rechnung oder des Scheines eingeschlossen. In diesem Falle möchten wir Sie bitten, dass Sie genau Ihren Namen, Nachnamen, Adresse, Kaufdatum mit Beschreibung des Problems oder des aufgefundenen Schadens angeben. Marzocchi S.p.A. arbeitet nach dem Konzept, einen garantiebezogenen Reklamationservice anzubieten. Benutzen Sie Ihr Federsystem Marzocchi mit Sorgfalt. Wenn Sie annehmen, daß Dieses beschädigt ist, können Sie sich an Ihren Händler oder an eine Kundendienststelle wenden.

Die MARZOCCHI-Marke wird von Marzocchi S.p.A. in Lizenz gestatten.



¡PRECAUCION!

Les agradecemos para haber comprado este sistema de suspensión Marzocchi. En caso que se verifique un defecto cubierto por esta garantía, dentro de los términos de la misma, les rogamos enviar, franco a domicilio, el sistema de suspensión Marzocchi a un revendedor autorizado o bien un centro de asistencia Marzocchi, adjuntando copia de la factura o del talón fiscal. En este caso, les rogamos indicar nombre, apellido, dirección, fecha de compra y especificar el tipo de problema o defecto observado. La filosofía de Marzocchi S.p.A. es la de ofrecer un servicio de cortesía y eficiencia con referencia a las reclamaciones sometidas en el curso de la garantía. Traten el sistema de suspensión Marzocchi con cuidado. Si sospechan que el mismo sea dañado, pueden ponerse en contacto con el revendedor o bien con un centro de asistencia Marzocchi.

La marca MARZOCCHI es concedida en licencia por Marzocchi S.p.A.

Cod. 900890

Giugno - 2003 - Edizione 00



MARZOCCHI S.p.A.

Via Grazia, 2

40069 Lavino di Zola Predosa - Bologna

ITALY

Ph - +39 - (0)51 - 61 68 711

Fx - +39 - (0)51 - 75 88 57

REAR SUSPENSION

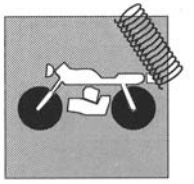

Section

J



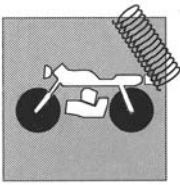

REAR SUSPENSION

Rear shock absorber	J.3
Lubrication points (grease)	J.3
Rear suspension.....	J.4
Rear shock absorber removal	J.5
Disassembling, servicing and assembling the rear shock absorber.....	J.6
Spring servicing.....	J.6
Shock absorber inspection	J.7
Reservoir cap with its valve removal	J.7
Piston assembly inspections	J.10
Seal replacement.....	J.10
Checking the setting.....	J.11
Reservoir replacement	J.14
Floating piston removal	J.14
Shock absorber assembly	J.15
Shock absorber damping adjustment.....	J.19
Disassembling and servicing the swinging arm.....	J.20
Servicing the swinging arm shaft.....	J.22
Servicing the rear suspension drop drag link	J.22
Chain roller, chain guide, chain slider.....	J.23



REAR SUSPENSION

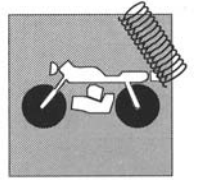

Rear shock absorber

TIGHTENING TORQUE FIGURES
1, 2: 52.4 Nm/ 5.35 Kgm/ 38.6 ft/lb

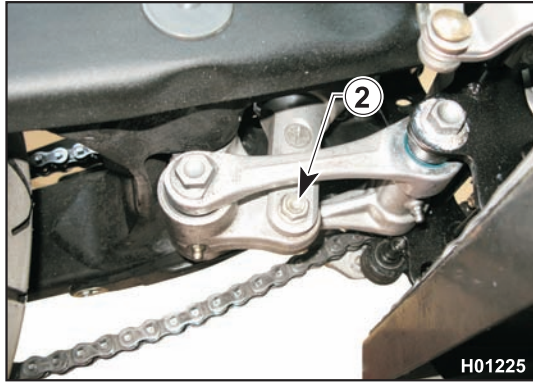
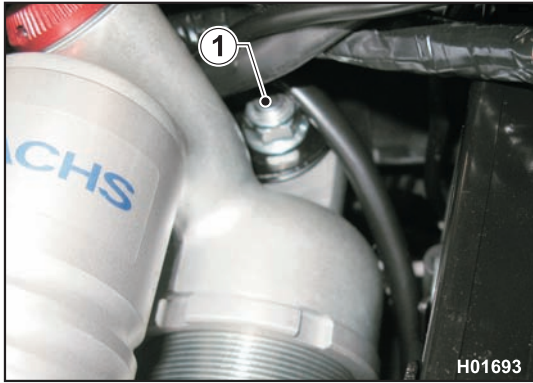

Lubrication points (grease)

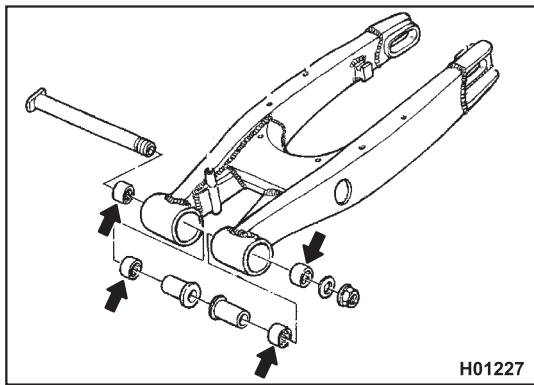
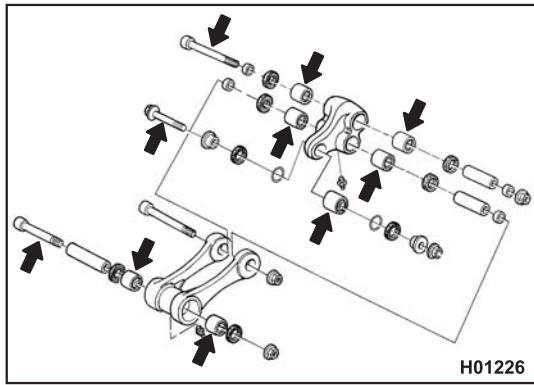

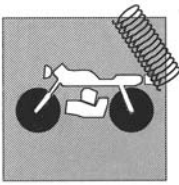

REAR SUSPENSION

Rear suspension

The rising-rate rear suspension is made up of a shock absorber, a linkage system and a swinging arm. The spring preload of the shock absorber can be adjusted to suit riding and terrain conditions. Hydraulic damping is also adjustable using outer adjuster screws. Periodically check all components for wear.

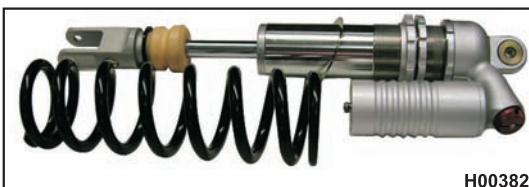
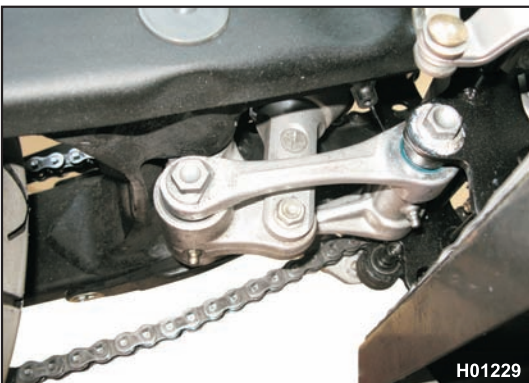

REAR SUSPENSION

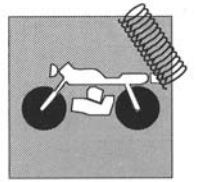

Rear shock absorber removal

Set a block under the engine and see that the rear wheel is lifted from the ground.

Remove saddle, side panels, silencer and rear chassis (see Section "E" - General Procedures). Loosen the front clamp (1) of the intake coupling.



Remove the front bolt (2) securing the suspension linkage to the chassis, the bottom (3) and top (4) shock absorber mounting bolts and remove the shock absorber (5).

IMPORTANT: On assembly, fit the bottom locking nut (3) of the shock absorber on the LEFT SIDE.

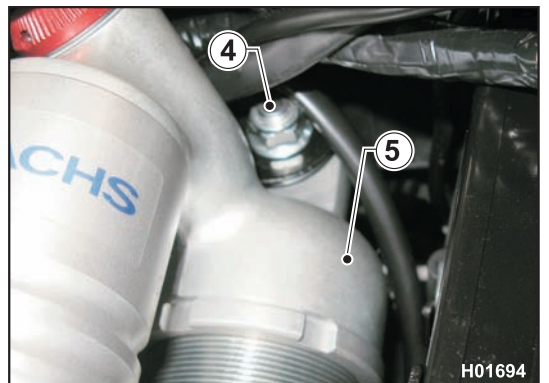
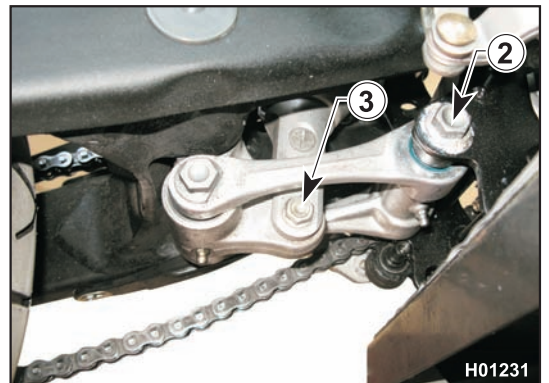

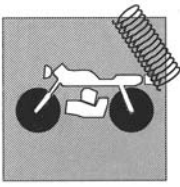

REAR SUSPENSION



Disassembling, servicing and assembling the rear shock absorber

Clean the shock absorber before disassembly.

SPRING SERVICING

Measure the spring in place before removal.

Spring removal: clamp the shock absorber in a vice taking care to avoid distorting it. Slacken lock ring nut and ring nut, spring retainer and spring.



REAR SUSPENSION

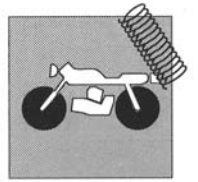

Measure spring free length.
SERVICE LIMIT: $245^{+/-1.5}$ mm.
Change the spring if length is outside the service limit.

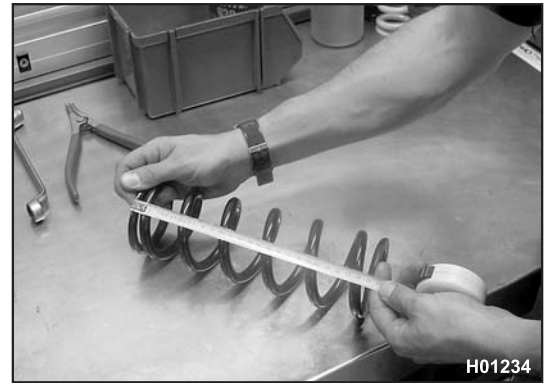

SHOCK ABSORBER INSPECTION

Visually inspect the shock absorber and look for oil leaks or other issues. Replace the shock absorber if needed.

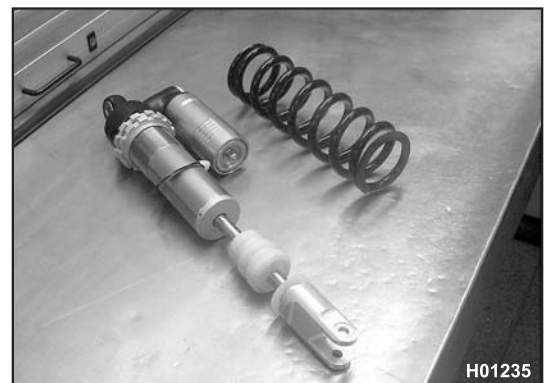

Push on the reservoir valve to discharge the gas.



Aim valve away from you to prevent any debris from getting into your eyes.



Reservoir cap and valve removal

Locate a suitable tool to reservoir cap and push down on cap until gaining access to the retaining ring.



Push down with your hand and use great care.



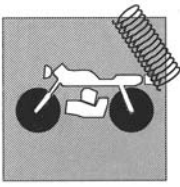

REAR SUSPENSION



Prise out the retaining ring using two small screwdrivers. Take care not to damage the inner surface.

To remove the retaining ring, first prise one end of the ring out of its groove. Then slide out the other end, slip the tip of a screwdriver between ring and reservoir and prise off with the other screwdriver. Take out the retaining ring. Check the grooves in reservoir body for burrs. If any burrs are detected, they must be removed and the grooves must be reconditioned.



Screw a pipe with inner thread onto the cap and extract the cap using pliers.



REAR SUSPENSION

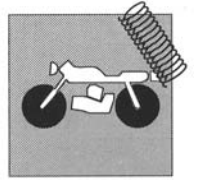

Place the shock absorber on a bench. Unscrew or knock out the cover (depending on the model).

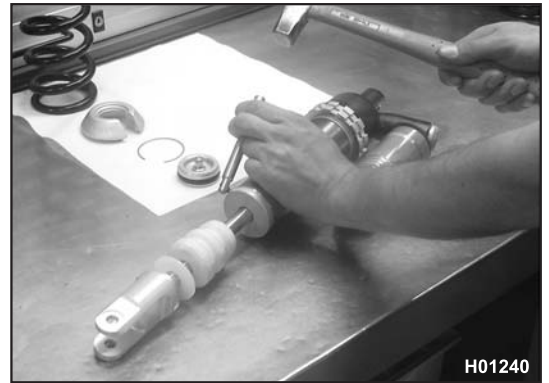

Once the tank cap is removed, push the rod guide down into the body so as to expose the circlip groove and remove the circlip with a screwdriver.



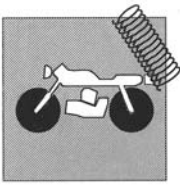

REAR SUSPENSION



Keep the shock absorber in the vice taking in nearly vertical position. If you drain the oil, you will need to replace the reservoir floating piston. Pour the oil into a clean pan and leave it to settle.



Piston assembly inspections

- 1) Check the seal for wear or damage (replace if worn or damaged)
- 2) Check the O-ring on the rod guide. Replace if scored.
- 3) Check the surface of the chrome-plated rod for dents or scoring. If any damage is found, seal and DU bush will be damaged as well and you will need to replace the rod guide, too. (Rod, rod guide and clevis are supplied as a set).



Seal replacement

If you need to replace the seal, unscrew the clevis, slide off the rod guide and fit a new seal. Reassemble and refit the clevis securing it with Loctite and tightening to 50 Nm (5 kgm; 36.9 ft/lb).



REAR SUSPENSION

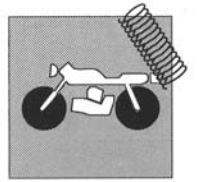

Checking the setting

If the suspension is not operating properly and you need to adjust compression damping, loosen the knob dowel (heat with an air gun before loosening).



Proceed as follows:

loosen the ring nut with the suitable key, slide off all parts noting their positions to ensure correct assembly.



REAR SUSPENSION

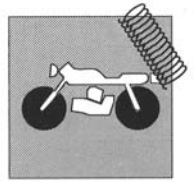

After the inspection, refit piston, disc, spring and slotted ring. Slide the needle shaft off the cap, tighten the ring, insert into slot pressing lightly and secure in place tightening the cap to 30 Nm (3 kgm; 29.2 ft/lb).



It is strictly forbidden to change the compression washers. This could cause the shock absorber to explode while in service.

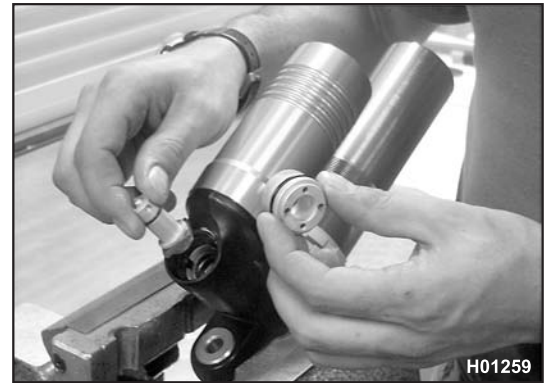

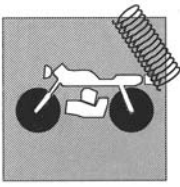

REAR SUSPENSION



H01262

Reservoir replacement

In the event the reservoir needs to be replaced, heat the area near the threaded end with an air gun and loosen using suitable equipment.

Replace the reservoir O-ring. Grease the O-ring being careful not to smear the thread in the mount.

Apply Loctite and screw on the reservoir being careful not to damage the O-ring. Tighten to 40 Nm (4 Kgm; 39.2 ft/lb).

NOTE: Perform these procedures in a clean environment and clean any components to be reused.



H01263

Floating piston removal

If you have drained the shock oil, you will need to remove the floating piston. Extract the floating piston using pliers and be careful not to score the reservoir. Replace the reservoir if it shows any surface damage.



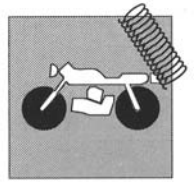

SHOCK ABSORBER ASSEMBLY

Wash the shock absorber body thoroughly with a degreasing product. Make sure it is fully dry. Blow with compressed air if needed.

Clamp the shock absorber eye in a vice with aluminium or bronze jaws (or use a shop rag to protect the eye). Fill 70-80 cu cm (4.3-4.9 cu. in.) of oil into the shock absorber body.



Insert the complete piston rod into the shock absorber body, taking care not to damage the sliding surface; push rod with piston and mount, but leave a gap to top up with oil later.

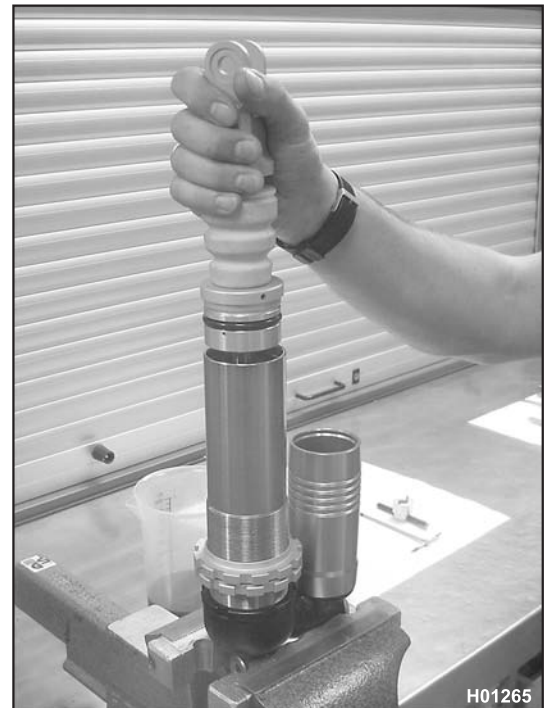

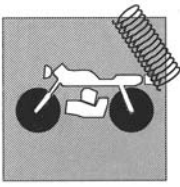

REAR SUSPENSION

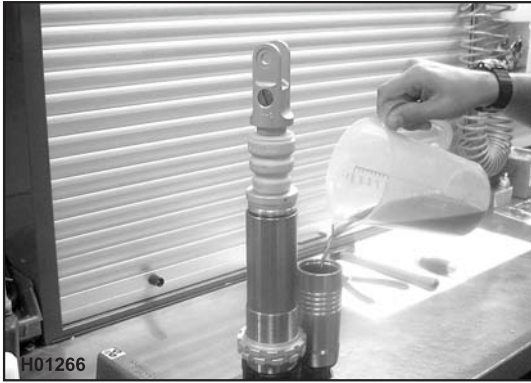

Fit a new O-ring to the floating piston (always use a new O-ring after removal). Fill the reservoir with oil, then quickly insert the floating piston into the reservoir (see picture).



Push the floating piston quickly down to reservoir bottom while holding the rod steady in the appropriate position for top-up. The oil inside the reservoir will flow into the shock absorber body and fill it up to a certain level as it seeps through the piston washers. These operations need to be performed quickly to avoid the ingress of air.



REAR SUSPENSION

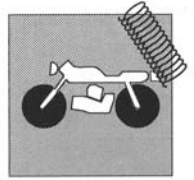

Top up with oil up to nearly 2 cm (0.8 in.) below shock body edge. Pump the rod up and down through 5 - 6 cm (2-2.4 in.) strokes four or five times to expel any air trapped under the piston.



Pump slowly or the floating piston might become displaced due to cavitation or compression. Top up with oil up to the circlip groove, while slowly setting the rod so the inner bumper is level with the groove.



Hold the rod steady and slide the rod guide into the shock absorber cylinder. Push the rod guide down into the body past the circlip groove. Insert the circlip making sure it is securely in place. Pull the rod upwards to bring the rod guide in working position.



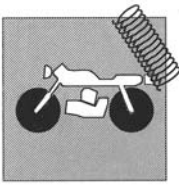

REAR SUSPENSION



Refit the reservoir cap with its valve. Fit it into the reservoir and fit the circlip into the groove.

Fill nitrogen (or air) through the valve and pressurise to 10-12 bar. Refit the cap to the valve and check for oil or air leaks.

Drive the cap onto the body.

Refitting bumper and washer.

If you have replaced the bumper, clamp the rod in a vice with bronze or aluminium jaws, apply Loctite to the mount and tighten to about 50 Nm. Refit the spring and set to initial preload using ring nut and lock ring nut.



All liability is disclaimed for any damage resulting from procedures other than those described in this manual.

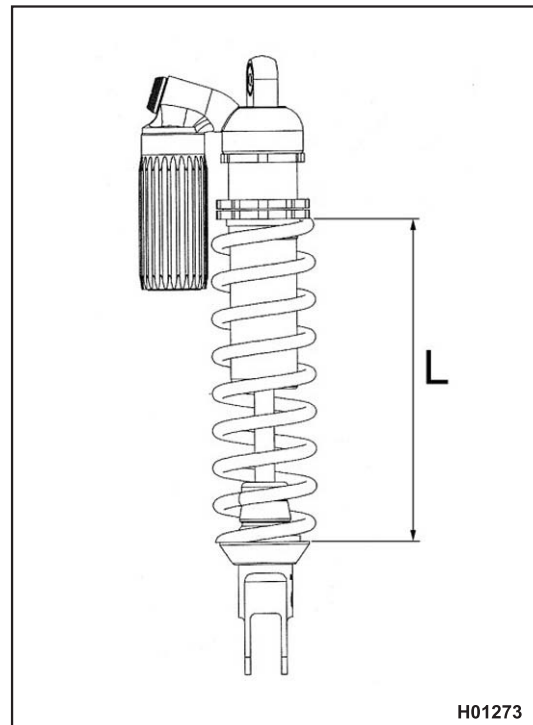

$L = 234,5 \div 237,5 \text{ mm (9.23} \div \text{9.35 in.)}$



REAR SUSPENSION

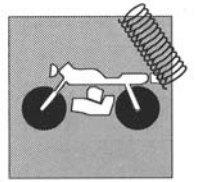

Shock absorber damping adjustment

Adjustment of the compression stroke is independent from the rebound stroke.

A) COMPRESSION - Standard setting:

- 1) Low damping speed: fully open
- 2) High damping speed: fully open

To reset the standard setting, turn upper adjuster screws clockwise until reaching fully closed position. Then turn them back the number of clicks specified above. In order to obtain a smooth braking action, turn the adjuster screws counter clockwise. Vice versa to obtain a harder braking action.

B) REBOUND (TE) - Standard setting: -20 clicks (± 2 clicks)

B) REBOUND (SMS) - Standard setting: -26 clicks (± 2 clicks)

Standard setting: turn lower adjuster screw clockwise to fully closed position, and then turn it back the number of clicks specified above. In order to obtain a smooth braking action, turn the adjuster screw counter clockwise. Vice versa to obtain a harder braking action.

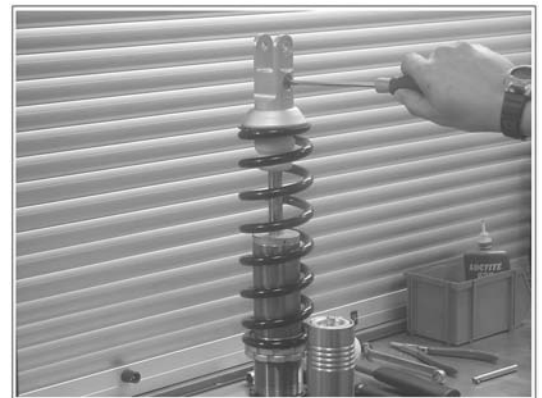
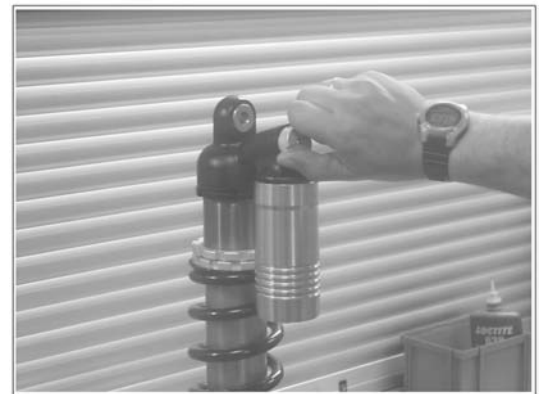
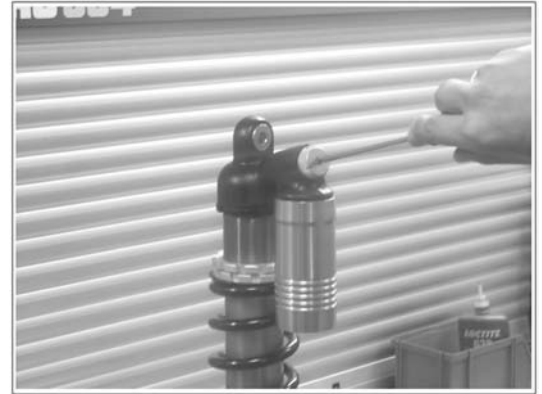

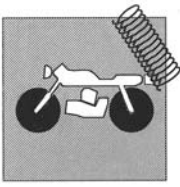

REAR SUSPENSION

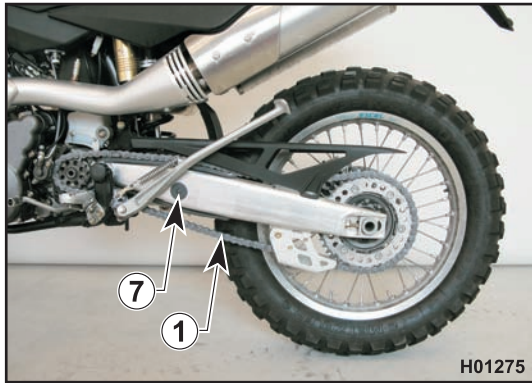

Disassembling and servicing the swinging arm.

Set a stand or a block under the engine and see that the rear wheel is lifted from the ground.

Remove the rear wheel as described in "Section Y".

Remove the final drive chain (1) as described in "Section E".

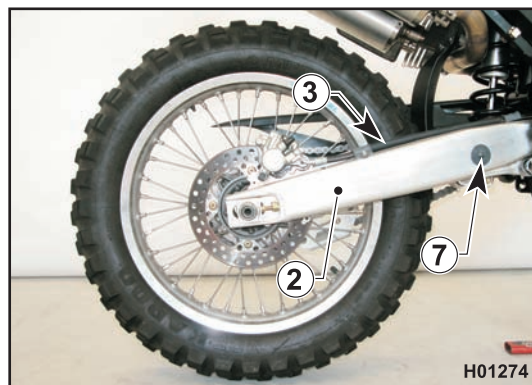

Detach the rear brake line (3) from the swinging arm (2).

Loosen the screws (4) using a 7 mm ring wrench and remove the guard (5).

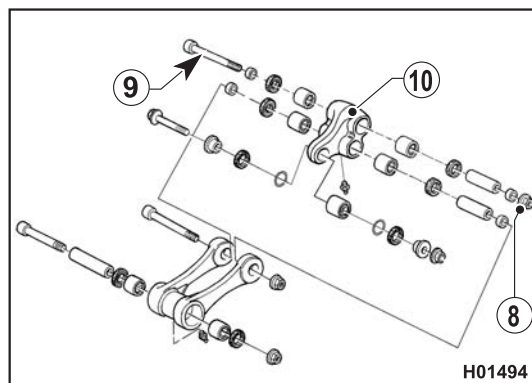

Remove the caps (7) at both ends and use a mm socket wrench to loosen the nut (8) of the bolt (9) securing the drop link (10) at the top end.



REAR SUSPENSION

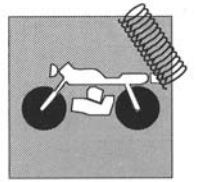

Disengage the rear brake pedal return spring (6).

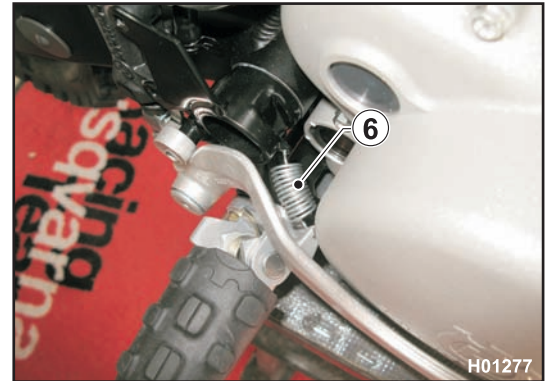

TIGHTENING TORQUE FIGURES
8=80 Nm - 8.2 Kgm - 59 ft/lb
11=122.5 Nm - 12.5 Kgm - 90.3 ft/lb (+LOCTITE 243)

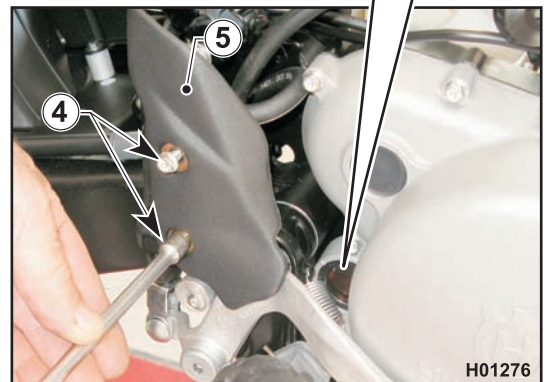

Loosen the nut (11) using a 22 mm socket wrench and remove the rear engine/swinging arm mounting bolt (12) from the right-hand side. Remove the swinging arm (2) pulling towards the rear end of the motorcycle.



Check swinging arm shaft straightness and manually check the roller cages (13) and their bushings (14) for wear; turn the bushing (14) inside the roller cage (13); if you feel any tightness or hear noise, replace them.

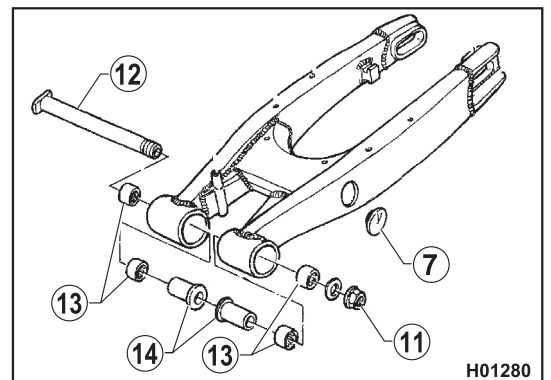

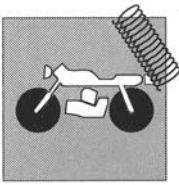

REAR SUSPENSION

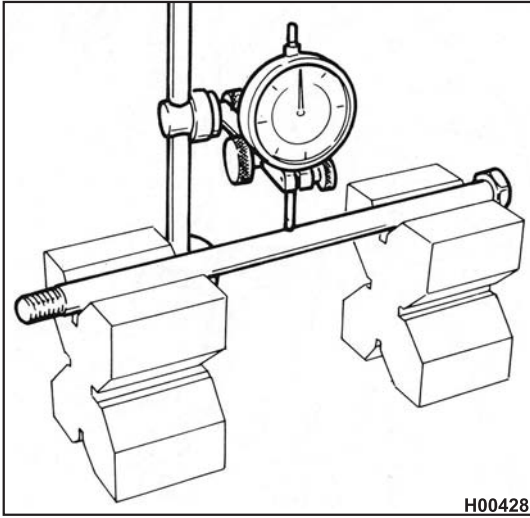

Servicing the swinging arm shaft

Check shaft taper using a dial gauge. Place the shaft on two identical reference blocks. Turn the shaft and move the dial gauge horizontally to determine the amount of distortion.

Service limit: 0.30 mm.

H00428

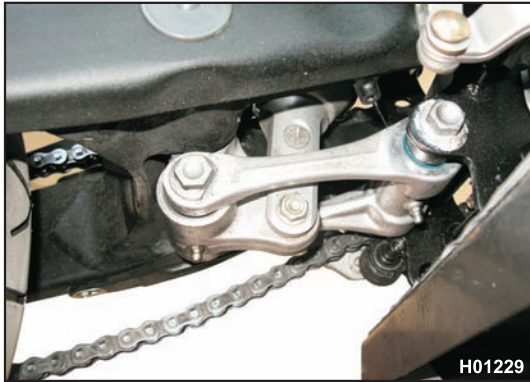

Servicing the rear suspension drop and drag link

With drop link (1) and drag link (2) still in place (connected to swinging arm and chassis, respectively), rock them both back and forth in all directions to check for radial and axial clearance. Some axial clearance in the drop drag link is required for the swinging arm to achieve the ideal position for proper operation. If any radial play is detected, remove the part from swinging arm or chassis and check inner spacer (A) and bearings (B) for wear.



Grease the inner race of the bearings before refitting them.

H01229

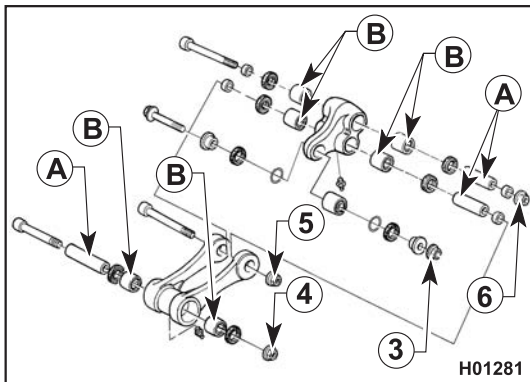

H01281

TIGHTENING TORQUE FIGURES

3=52.4 Nm - 5.35 Kgm - 38.6 ft/lb

4,5,6=80 Nm - 8.2 Kgm - 59 ft/lb



REAR SUSPENSION

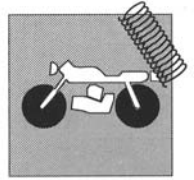

Chain roller, chain guide, chain slider

Check the wear of the above-mentioned elements and replace them when necessary.



Check the chain guide alignment, and remember that a bent element can cause chain early wear. In this case, chain might unwrap from the sprocket.

- 1 Chain roller
 - 2 Chain guide
 - 3 Chain slider
- a Master link clip

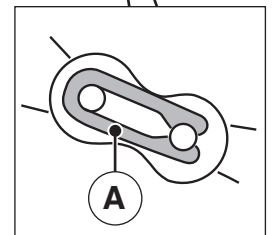
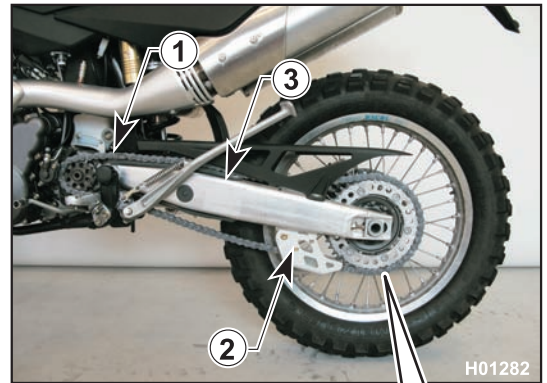

BRAKES

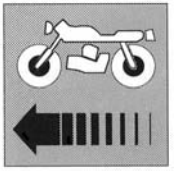

Section



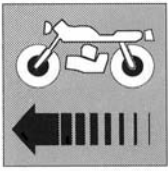

BRAKES

Braking system	L.3
Brake disc.....	L.4
Checking brake pads for wear / replacing the pads	L.5
Pads cleaning.....	L. 5
Bleeding the front braking system (TE).....	L.7
Bleeding the front braking system (SMS).....	L.8
Bleeding the rear braking system	L.10
Changing the fluid.....	L.11



BRAKES

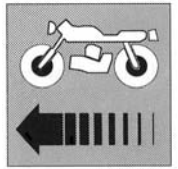

Braking system

The braking system uses two independent circuits. Each system is equipped with a brake calliper connected to a master cylinder with a fluid reservoir.

1. Front brake lever
2. Front brake master cylinder with fluid reservoir (TE)
2. Front brake master cylinder (SMS)
- 2A. Fluid reservoir (SMS)
3. Front brake line
4. Front brake calliper
5. Front brake disc
6. Rear brake fluid reservoir
7. Rear brake line
8. Rear brake calliper
9. Rear brake disc
10. Rear brake master cylinder
11. Rear brake control pedal

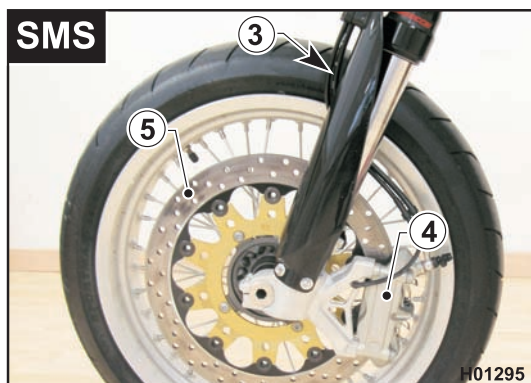
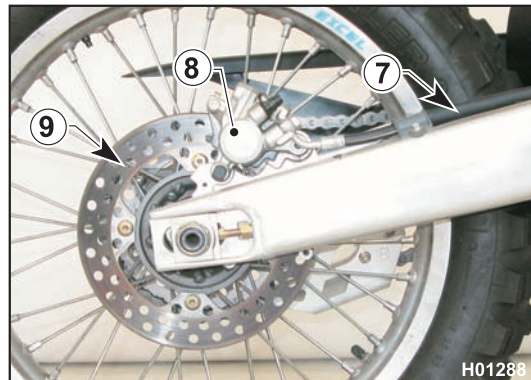
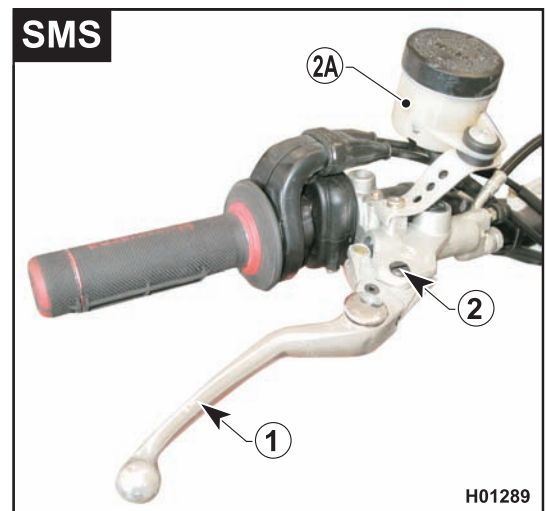
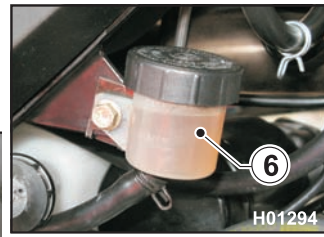
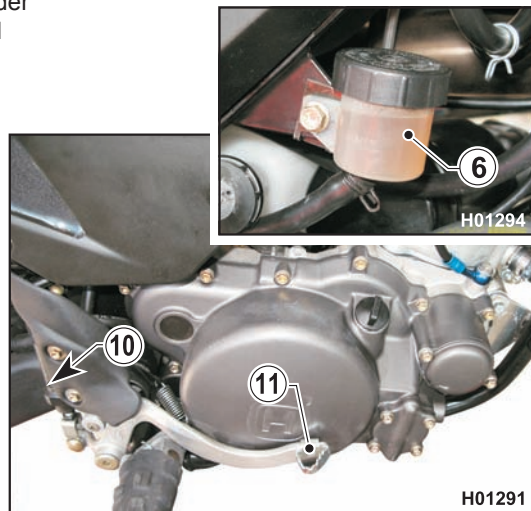
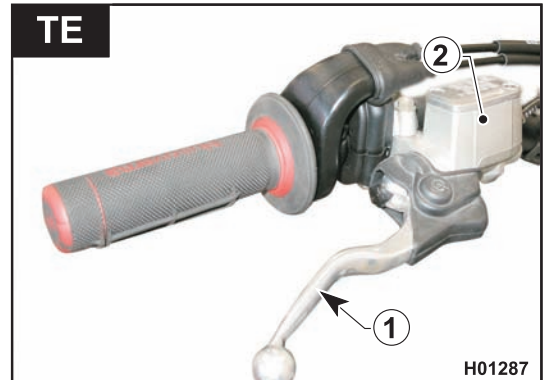

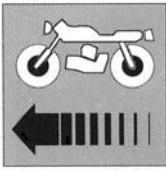

BRAKES



Brake disc

Checking the brake disc is an important safety procedure; the disc must be spotless, i.e. free from corrosion, oil or other dirt or deep scoring.

Front brake disc diameter: 260 mm (TE) - 320 mm (SMS)

Front brake disc thickness (when new): 3.0 mm (TE) - 5.0 mm (SMS)

Wear limit: 2.5 mm (TE) - 4.5 mm (SMS)

Rear brake disc diameter: 220 mm

Rear brake disc thickness (when new): 4.0 mm

Wear limit: 3.5 mm

Disc warpage must not exceed 0.15 mm (check disc mounted on the rim with a dial gauge).

To remove the disc from the wheel rim, you need to loosen the four retaining screws. On assembly, clean all mating surfaces thoroughly and tighten the screws to the specified torque.

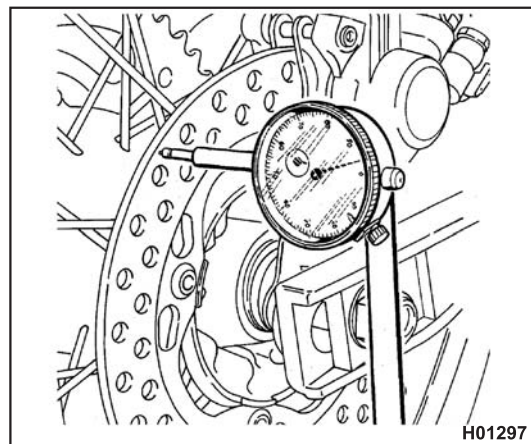
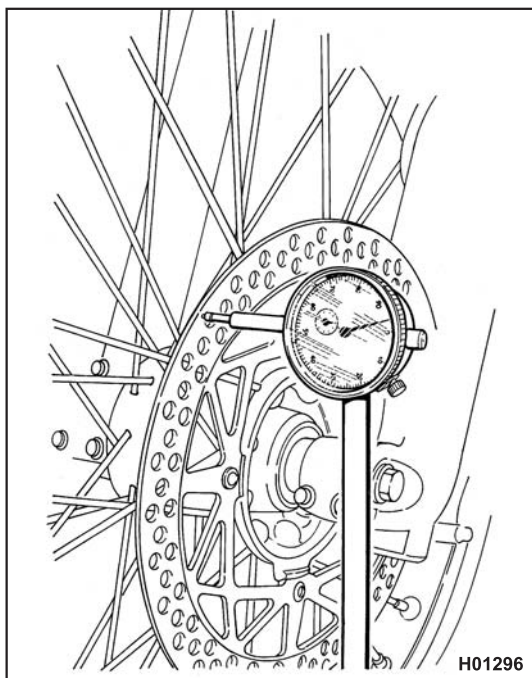

BRAKES

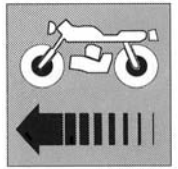

Checking brake pads for wear / replacing the pads

Check brake pad wear.

Service limit "A"

- 3.8 mm (front and rear pads)

If service limit is exceeded, always replace the pads in pairs.

Pads cleaning

Be careful that no brake fluid or any oil gets on brake pads or discs. Clean off with alcohol any fluid or oil that inadvertently gets on the pads or disc.

Replace the pads with new ones if they cannot be cleaned satisfactorily.

BRAKE PADS REMOVAL

TE front/TE-SMS rear

- Remove clips (1).
- Slide out pin (2).
- Remove pads.

SMS front

- Press on clips (3).
- Slide out pins (4).
- Remove clips (3).
- Remove pads.



Do not work the brake lever or pedal while removing the pads.

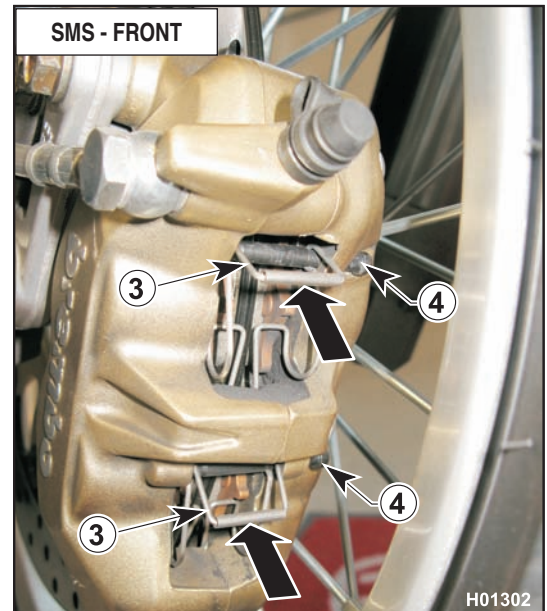
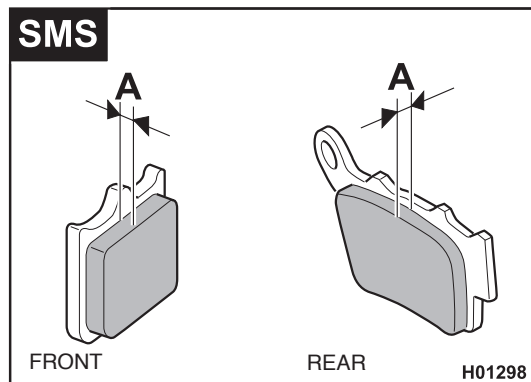
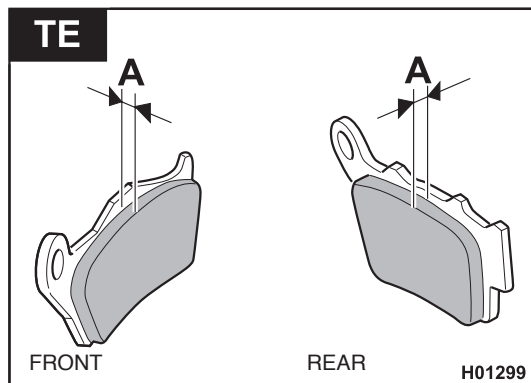
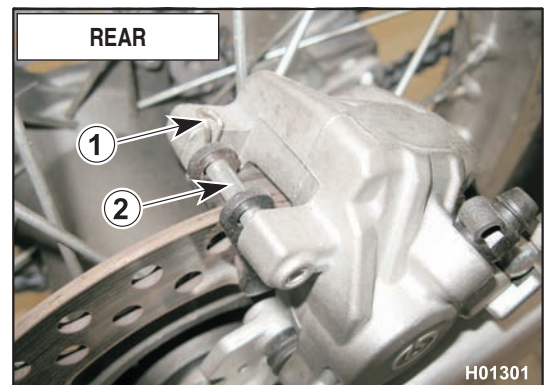
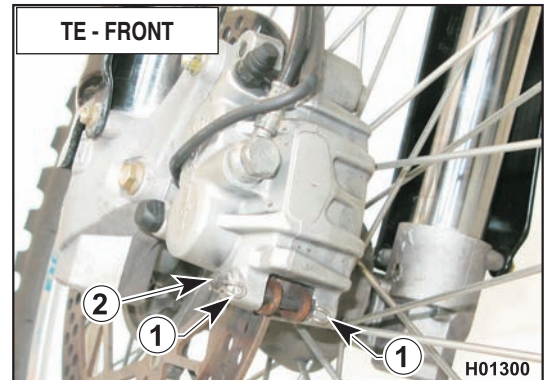

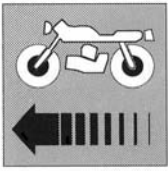

BRAKES

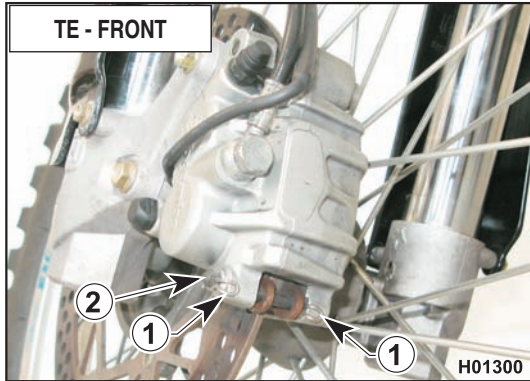

INSTALLATION OF BRAKE PADS

TE front/TE-SMS rear

- Install new brake pads.
- Reassemble pin (2) and clips (1).

SMS front

- Install new brake pads.
- Install clips (3) by pushing them toward the calliper.
- Install the pins (4).
- Pull clips (3) out, to make sure they are engaged on pins (4)

The above procedure eliminates the need to bleed the braking system after replacing the pads. Simply operate the control lever several times until bringing the pistons back to their normal position.

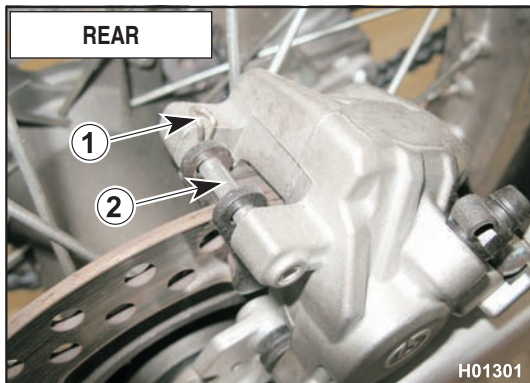

Drain some fluid from the reservoir when replacing the pads, or the pistons backing up into the cylinders might cause fluid to spill out of the reservoir.

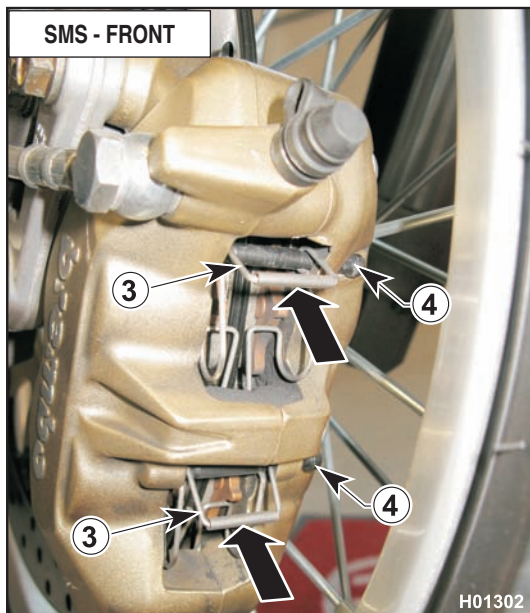

BRAKES

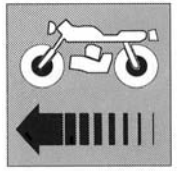

BLEEDING THE FRONT BRAKING SYSTEM (TE)

A long travel and mushy feel of the brake lever indicate that there is air in the system and the brake needs bleeding. Bleeding is also required after changing brake fluid.

Proceed as follows.

- Take the rubber cover off the bleed valve (1).
- Attach a clear plastic hose to the calliper bleed valve and place the other end of the hose in a vessel (make sure the hose end stays dipped in the fluid throughout the procedure).
- Remove the reservoir cover (2) and the rubber gaiter and fill the reservoir with fresh fluid.
- Slacken the bleed valve and operate the lever (3) repeatedly until the fluid flowing out of the hose looks clear and free of air bubbles: now tighten the bleed valve.
- Top up fluid level (A) and refit rubber gaiter and reservoir cover (2).

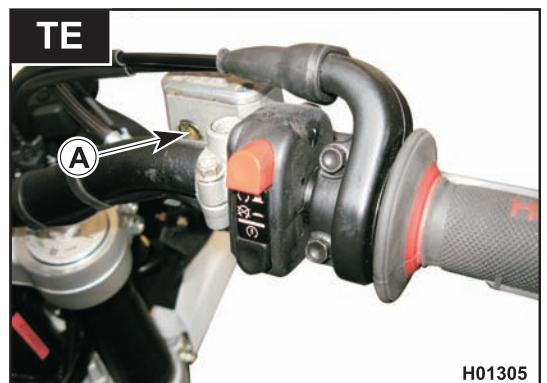
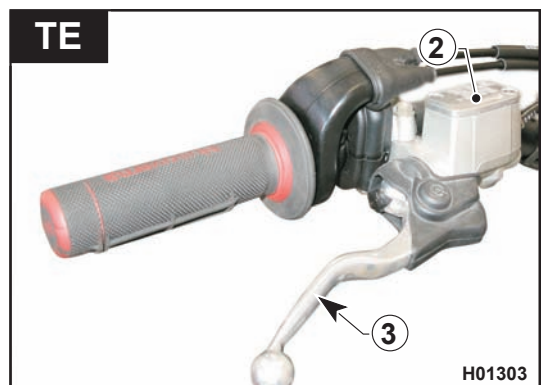
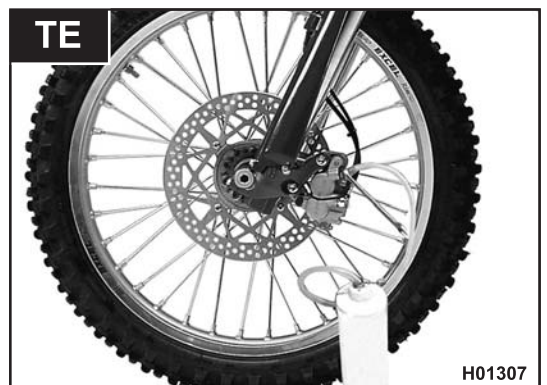
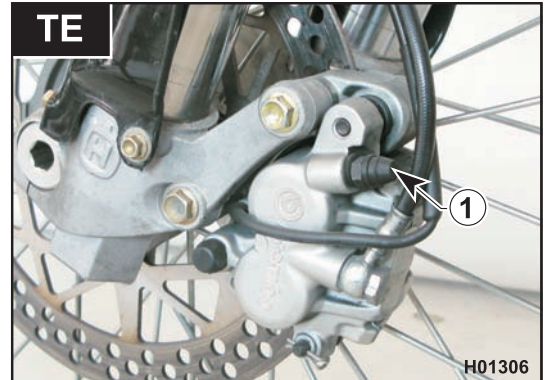

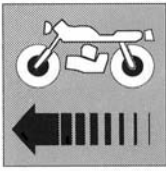

BRAKES

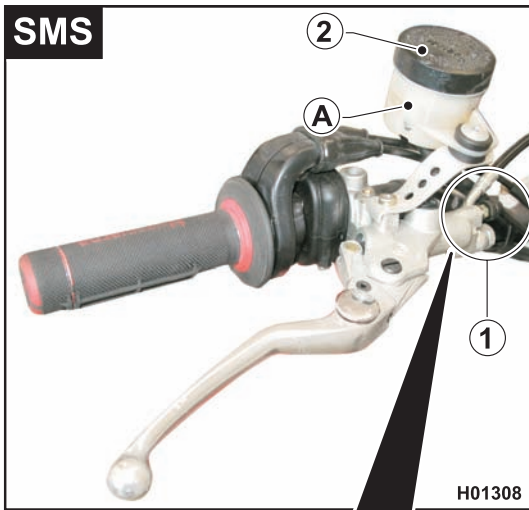

BLEEDING THE FRONT BRAKING SYSTEM (SMS)

A long travel and mushy feel of the brake lever indicate that there is air in the system and the brake needs bleeding. Bleeding is also required after changing brake fluid.

To bleed the front brake, begin with the control on the handlebar and then bleed the calliper: the procedure is the same.

Proceed as follows.

- Take the rubber cover off the bleed valve (1) or (1A).

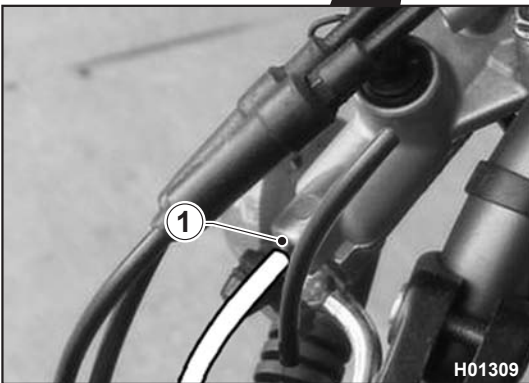

- Attach a clear plastic hose to the calliper bleed valve and place the other end of the hose in a vessel (make sure the hose end stays dipped in the fluid throughout the procedure).

- Remove the reservoir cover (2) and the rubber gaiter and fill the reservoir with fresh fluid.

- Slacken the bleed valve and operate the lever repeatedly until the fluid flowing out of the hose looks clear and free of air bubbles: now tighten the bleed valve.

- Top up fluid level (A) and refit rubber gaiter and reservoir cover (2).

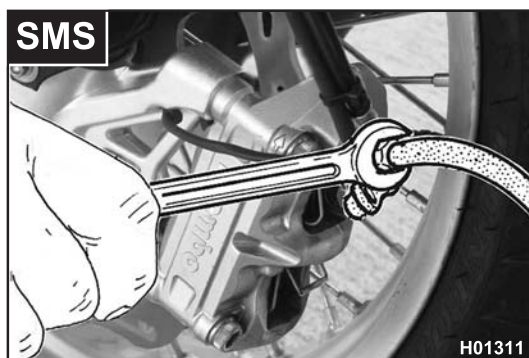

BRAKES

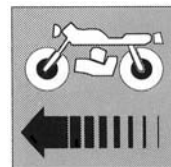

Fluid level inside the reservoir shall never drop below the minimum notch during the bleeding procedure.



Brake fluid is corrosive. In the event of contact with eyes, rinse with abundant water.



Motorcycle handlebar must be turned to the left during the bleeding procedure. This will keep the master cylinder reservoir higher, making bleeding easier.



The bleeding procedure does not remove all air from the circuit; any small amounts of air left in the circuit will disappear after a short period of usage; this will eliminate the mushy feel of the lever and restore its travel to proper length.



If brake lever or brake pedal feel mush after a fall or a repair resulting in loss of braking, bleed the circuit as described above.



Bleed valve tightening torque: 12-16 Nm, 1.2-1.6 Kgm, 8.8-11.8 ft/lb.



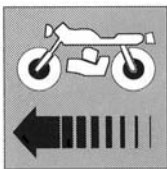

BRAKES

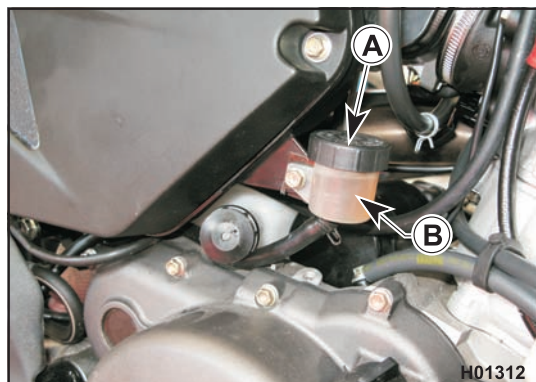

Bleeding the rear braking system

A long travel and mushy feel of the brake pedal indicate that there is air in the system and the brake needs bleeding.

Bleeding procedure is as follows:

- Remove reservoir cover (A) (rubber gaiter), and diaphragm and fill with fluid (DOT 4).

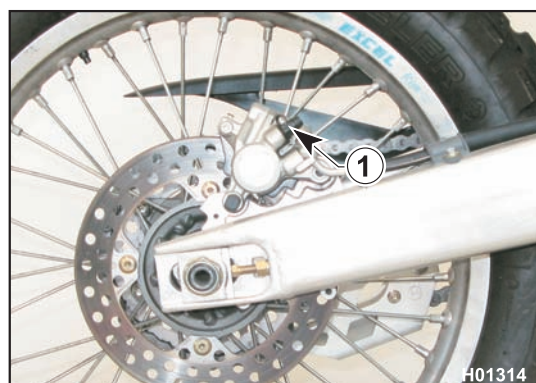

- Attach a clear plastic hose to the calliper bleed valve (1) and place the other end of the hose in a vessel.

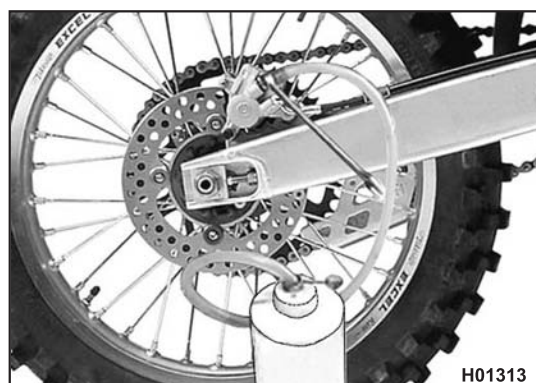

- Press the pedal (2) fully down.
- Loosen the bleed valve and drain the fluid (only air at first), then slightly close the valve.
- Release the pedal and wait a few seconds. Repeat the process until you see only fluid coming out of the hose.
- Tighten the bleed valve to the specified torque and check fluid level (B) in the reservoir before refitting the cover (A) and the rubber gaiter. If the bleeding procedure was performed correctly, the pedal will no longer have that mushy feel. If not so, repeat the procedure.



Fluid level inside the reservoir shall never drop below the minimum notch during the bleeding procedure.



If brake lever or brake pedal feel mushy after a fall or after a repair, resulting in loss of braking, bleed the circuit as described above.



Bleed valve tightening torque: 12-16 Nm, 1.2-1.6 Kgm, 8.8-11.8 ft/lb.



BRAKES

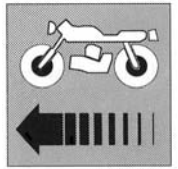

Changing the fluid

Brake fluid should be checked and changed as per the "Maintenance Chart" (see Section B), or earlier if contaminated with debris or water.



Do not change brake fluid in the rain or with a strong wind.



Use only fluid taken from a sealed container (DOT 4). Never reuse brake fluid.



Avoid the ingress of contaminants such as dirt, water, etc. into the reservoir.



Do not keep the reservoir open without its cover longer than necessary; this would increase the risk of contamination.



Handle the fluid with care to avoid damage to painted parts.



Do not mix two brands of fluid. This would reduce boil-over point, leading to loss of braking efficiency or degrading of rubber parts.

Replacement procedure is as follows:

- Take the rubber cover (1) or (1A) off the bleed valve (2) or (2A).
- Attach a clear plastic hose to the calliper bleed valve and place the other end of the hose in a vessel.

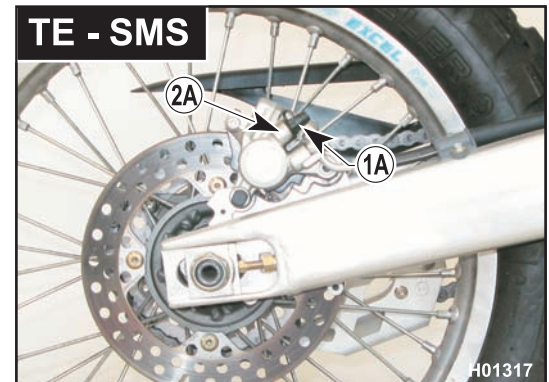
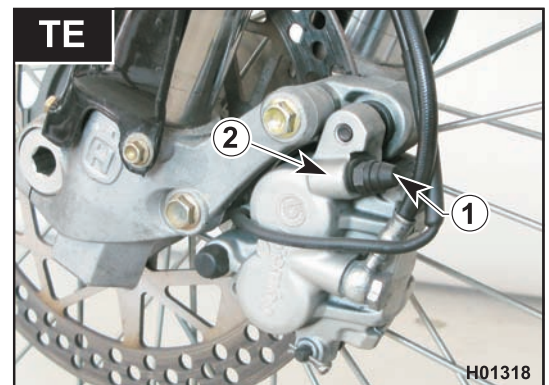
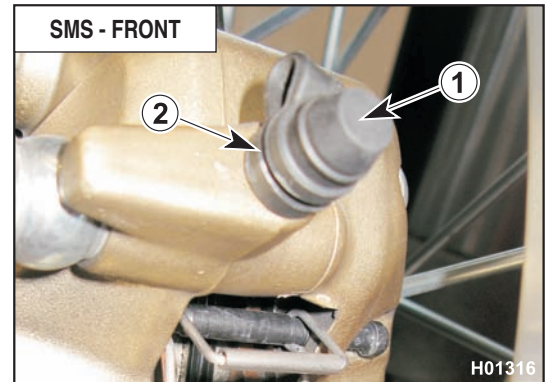

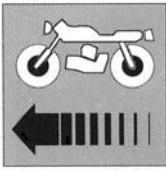

BRAKES

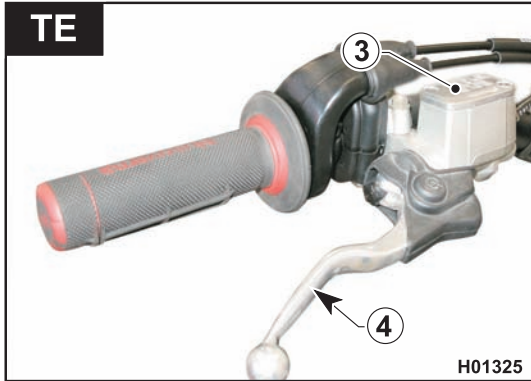

- Remove the reservoir cover (3) or (3A) and the rubber gaiter.
 - Loosen the bleed valve (2) or (2A) on the calliper.
 - Pump the brake lever (4) or the brake pedal (4A) until draining all fluid.
 - Tighten the bleed valve and fill the reservoir with fresh fluid.
 - Loosen the bleed valve, operate lever or pedal, tighten the valve keeping lever or pedal pressed and then release quickly.
 - Repeat the process until the circuit is full and you can see clear fluid coming out of the plastic hose: now tighten the bleed valve.
 - Top up with fluid up to level (A) or (B) and refit rubber gaiter and reservoir cover.
- After changing the fluid, you will need to bleed air from the circuit.

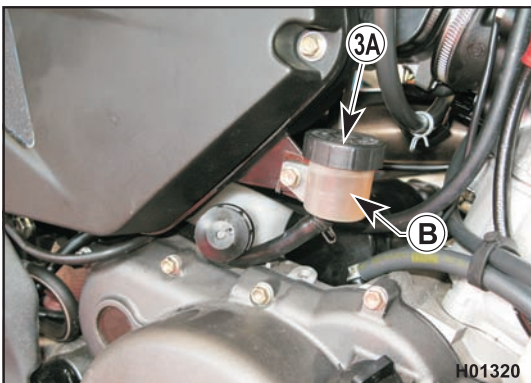
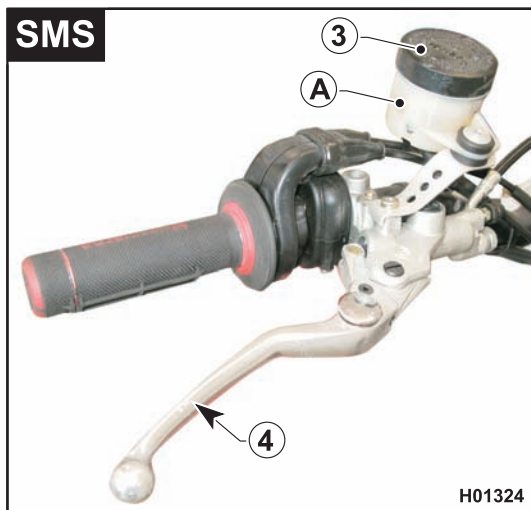
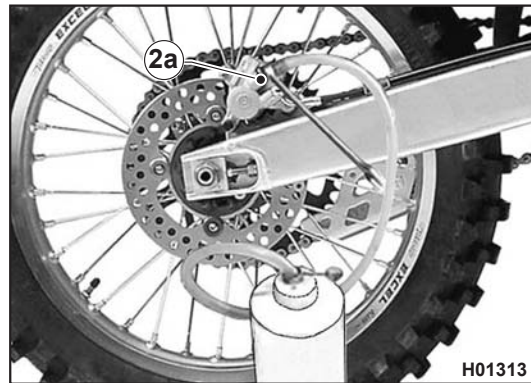
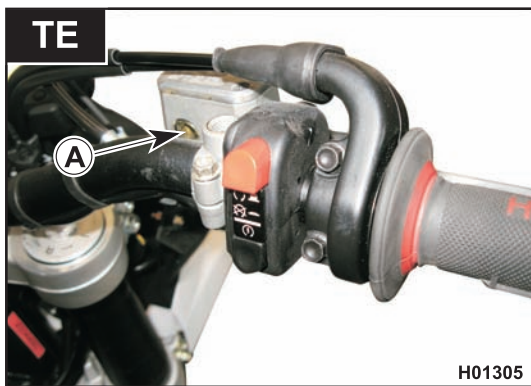

BRAKES

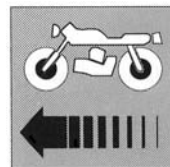

Brake fluid quickly corrodes painted surfaces, remove any traces of spills immediately.

Brake fluid may cause irritation. Avoid contact with skin or eyes. In case of contact, flush thoroughly with water and call a doctor if your eyes were exposed.



Periodically check the connecting hoses (C) and (D) (see Scheduled Maintenance Chart, Section B): replace worn or cracked hoses.

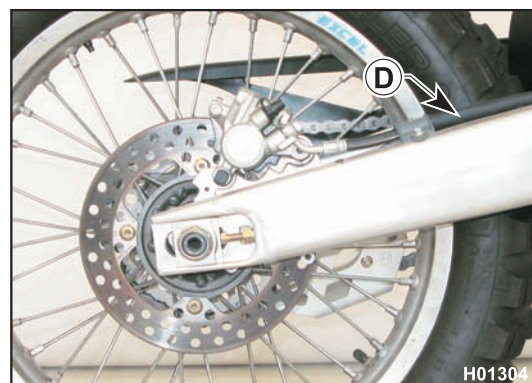
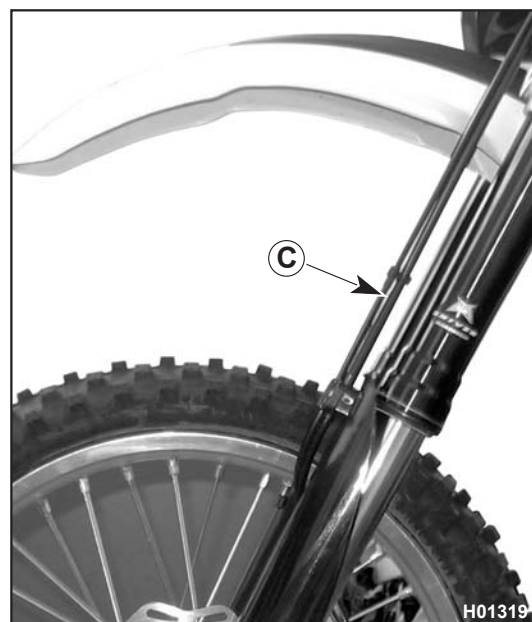

ELECTRICAL SYSTEM

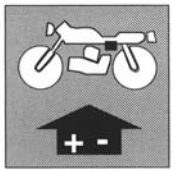

Section

M



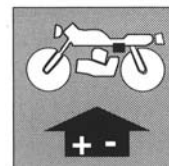

Wiring diagram	M.5
Key to wiring diagram	M.5
Colour coding key	M.5
LOCATION OF ELECTRICAL COMPONENTS.....	M.6
WIRING DIAGRAM	M.10
CHARGING SYSTEM	M.10
CHARGING SYSTEM INSPECTIONS	M.11
Current loss at the battery	M.11
Regulated voltage.....	M.11
Generator inspection	M.12
Generator no-load performance	M.13
Voltage regulator/rectifier inspection	M.13
Wiring diagram	M.13
Colour coding key.....	M.13
STARTING SYSTEM.....	M.14
Wiring diagram	M.14
STARTING SYSTEM INSPECTION.....	M.15
Starter motor test curves	M.16
Starter motor maintenance.....	M.16
Solenoid starter inspection	M.17
Solenoid starter wiring diagram	M.17
Electronic ignition system.....	M.18
Checking ignition coil windings resistance	M.20
Electronic control unit (ECU)	M.21
Spark plug	M.22
Gear position sensor inspection (GPS: Gear Position Sensor).....	M.23
Battery	M.24
Battery charger.....	M.24
HEADLIGHT ADJUSTMENT	M.26
Headlamp bulbs replacement.....	M.27
Tail light replacement.....	M.29
Number plate bulb replacement	M.29
Turning indicator bulb replacement	M.30
Rear turning indicator removal	M.30
Front turning indicator removal.....	M.31
Number plate light removal.....	M.32
Number plate holder removal	M.33
Rear mudguard removal.....	M.33
Left-hand switch	M.34
Colour coding key.....	M.34
Right-hand switch.....	M.35
Colour coding key.....	M.35
FUSES.....	M.36
SEMICONDUCTOR PARTS.....	M.36
CONNECTORS	M.37
COUPLERS.....	M.37
DIGITAL DASHBOARD, WARNING LIGHTS	M.38
1- SPEED (kmh or mph) / ODO / RPM	M.39
2- SPEED / H / RPM.....	M.39
3- SPEED / CLOCK / RPM.....	M.39
4- SPEED / TRIP 1 / RPM.....	M.40
5- SPEED / STP 1 / RPM	M.40
6- SPEED / AVS 1 / RPM	M.40
7- SPEED / MAX SPEED / RPM	M.41
8- SPEED / TRIP 2 / RPM.....	M.41
9- TRP 2 / CLOCK / RPM.....	M.41
10- SPEED /RPM (engine r.p.m. numerical value).....	M.41



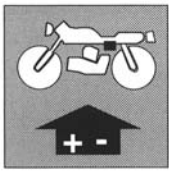

ELECTRICAL SYSTEM

TROUBLESHOOTING	M.42
CHARGING SYSTEM	M.42
STARTING SYSTEM.....	M.42
ELECTRONIC IGNITION SYSTEM.....	M.42
Wiring	M.43
Cable routing and electrical parts installation instructions.....	M.44
• Coil position and connector connection	M.44
• Position of utilities	M.44
• Electronic control unit position	M.45
• Voltage regulator position.....	M.45
• Securing the starter motor/solenoid starter cable	M.45
• Securing the engine / chassis / battery ground cables.....	M.45
• Wiring connection to voltage regulator.....	M.46
• Electric fan connection.....	M.46
• Injector connection.....	M.46
• MAQS connector connection	M.46
• Engine water temperature connector	M.46
• Lambda sensor position and connector	M.47
• Ignition switch and left-hand switch connection	M.47
• Right-hand switch connection	M.47
• Ignition and gear sensor cable connection	M.48
• Rear stop connection.....	M.48
• Securing the handlebar wiring harness.....	M.48
• Securing the dashboard bracket connectors	M.49
• Headlamp, front turning indicators, STOP light connection	M.49
Cable routing	M.49
• Routing of steering head tube wiring	M.49
• Securing the main wiring harness.....	M.50
• Securing the gear sensor, Lambda sensor, Stop micro switch cables... M.50	
• Securing the wiring harness to the rear chassis	M.50
• Securing the wiring harness to the mudguard	M.50
IMPORTANT	M.51



ELECTRICAL SYSTEM

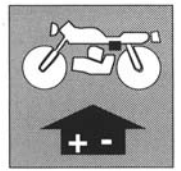

Wiring diagram

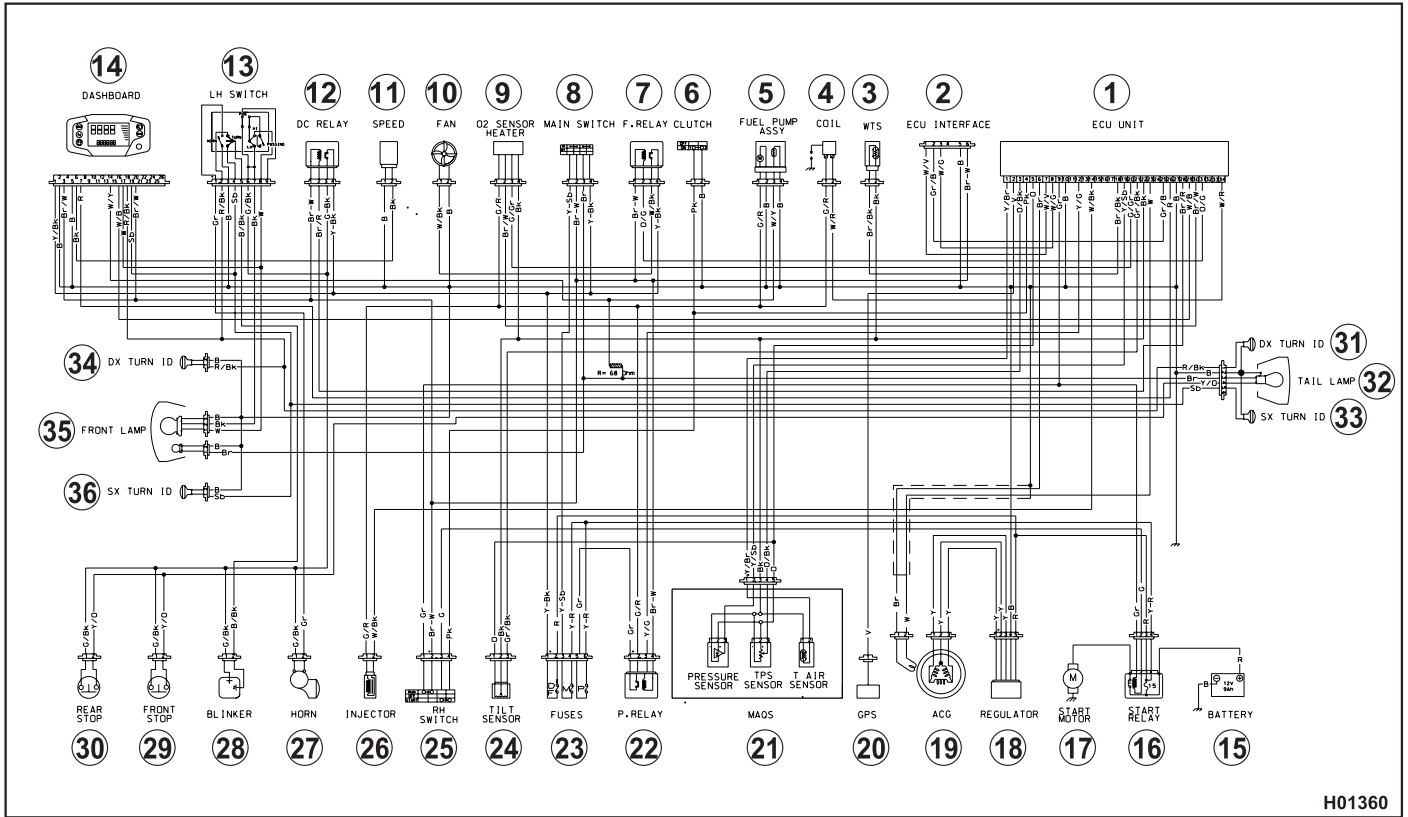

H01360

Key to wiring diagram

- 1. Electronic control unit
- 2. Control unit interface
- 3. Coolant temperature sensor
- 4. HT coil
- 5. Fuel pump
- 6. Clutch microswitch
- 7. Electric fan relay
- 8. Ignition switch
- 9. Lambda sensor
- 10. Cooling fan
- 11. Speed sensor
- 12. DC relay
- 13. L.H. switch
- 14. Instrument
- 15. Battery
- 16. Electric start remote control switch
- 17. Starter motor
- 18. Voltage regulator
- 19. Alternator
- 20. Gear sensor
- 21. M.A.Q.S. (37+38+39)
- 22. Power relay
- 23. Fuses
- 24. Rollover sensor (SMS)
(Stops engine in case of crash)
- 25. R.H. switch
- 26. Injector
- 27. Warning horn
- 28. Turning indicators flasher

- 29. Front stop switch
- 30. Rear stop switch
- 31. Rear R.H. turning indicator
- 32. Tail light
- 33. Rear L.H. turning indicator
- 34. Front R.H. turning indicator
- 35. Headlamp
- 36. Front L.H. turning indicator

Colour coding key

B	Blue	R	Red
B/Bk	Blue/Black	R/Bk	Red/Black
Bk	Black	Sb	Sky blue
Br	Brown	V	Violet
Br/Bk	Brown/Black	W	White
Br/R	Brown/Red	W/B	White/Blue
Br/W	Brown/White	W/Bk	White/Black
G	Green	W/G	White/Green
G/Bk	Green/Black	W/R	White/Red
G/Gr	Green/Grey	W/V	White/Violet
G/R	Green/Red	W/Y	White/Yellow
Gr	Grey	Y	Yellow
Gr/B	Grey/Blue	Y/Bk	Yellow/Black
Gr/Bk	Grey/Black	Y/Br	Yellow/Brown
O	Orange	Y/G	Yellow/Green
O/Bk	Orange/Black	Y/O	Yellow/Orange
O/G	Orange/Green	Y/Sb	Yellow/Sky blue
PK	Pink	Y/R	Yellow/Red



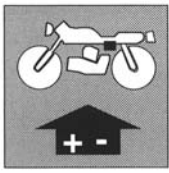

ELECTRICAL SYSTEM

ELECTRICAL COMPONENTS LOCATION

The ignition system includes the following elements:

- Generator (1), on the inner side of L.H. crankcase half cover;

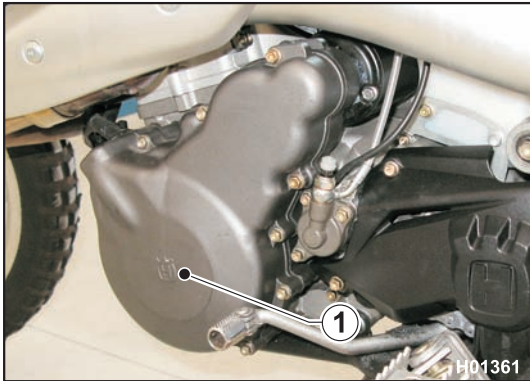

- Electronic ignition coil (2) under the fuel tank;

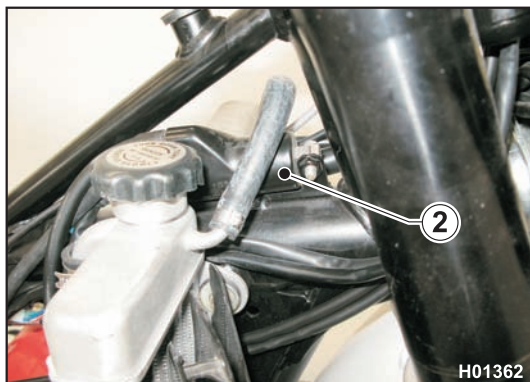

- Electronic control unit (3) under the saddle;

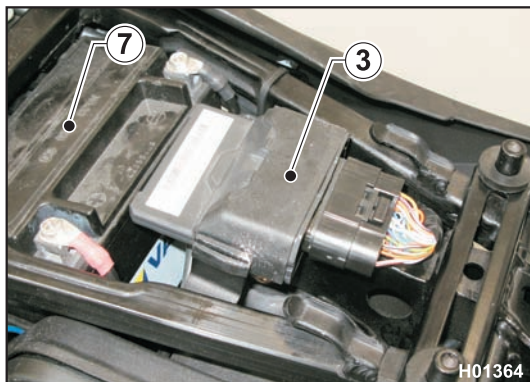

- Voltage regulator (4) on the R.H. side of the rear chassis;

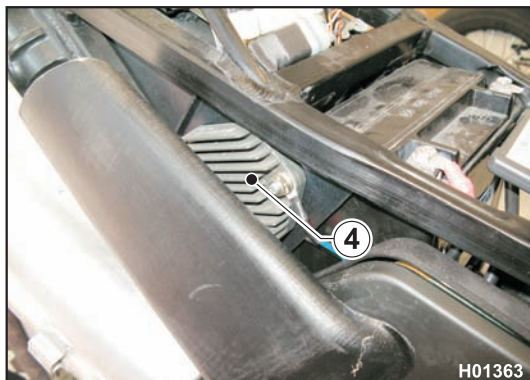

ELECTRICAL SYSTEM

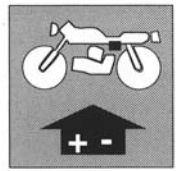

- Spark plug (5) on the R.H. side of the cylinder head;

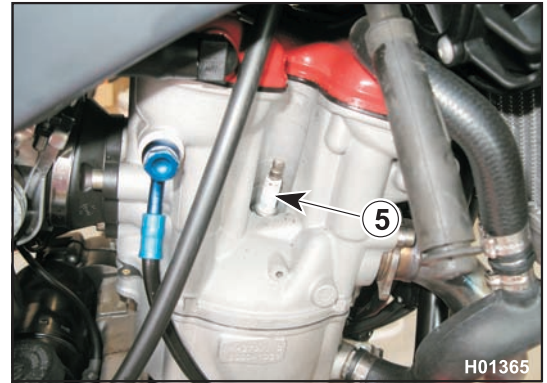

- 12V-700W Starter motor (6) behind the cylinder;



- Solenoid starter (8) located on the fuse holder plate, under the saddle;

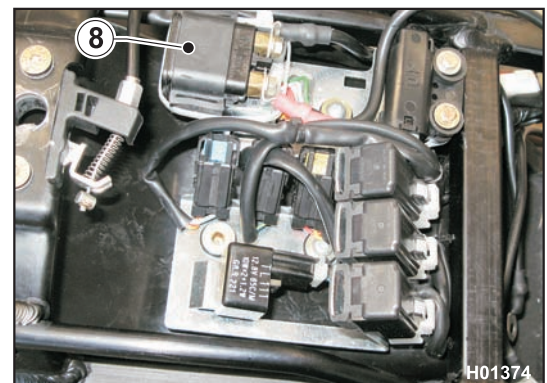

- M.A.Q.S. sensor (air temperature, pressure, throttle position) (10) on throttle body.

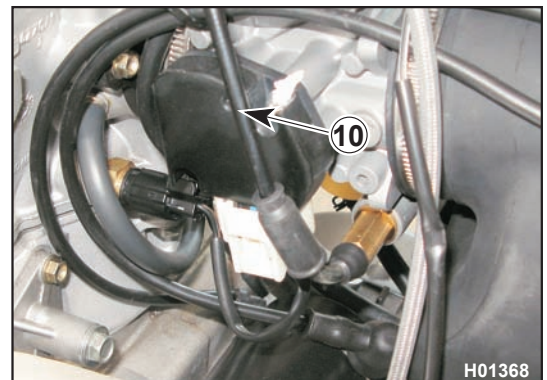

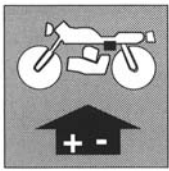

ELECTRICAL SYSTEM

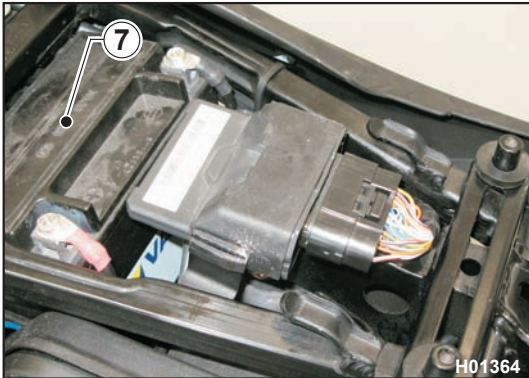

The electrical system includes the following elements:
 - 12V-14Ah Battery (7) under the saddle;

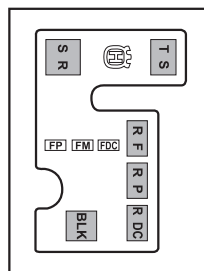
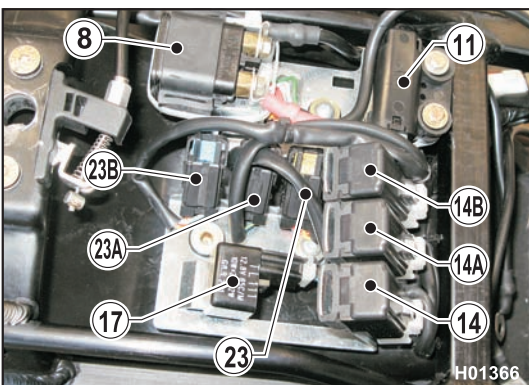

- Turning indicators flasher (17) located on the utilities holder plate, under the saddle;
- Relays located on the utilities holder plate, under the saddle;
 - Electric fan relay (14);
 - Injector, Lambda sensor, fuel pump, coil relay (14A);
 - Horn, turning indicators, stop lights, low and high beam lights relay (14B);
- Electric fan (16);
- Fuses located on the utilities holder plate, under the saddle;
 - Fuse 23, FP- 15A (cable sheath marked "P"): fuel pump, HT coil, lambda sensor heater, injector;
 - Fuse 23A, FM- 15A (cable sheath marked "M"): 12V depending on ignition switch (system voltage), parking lights;
 - Fuse 23B, FDC- 20A (cable sheath marked "DC"): electric fan, rear stop light, high beam, low beam, turning indicators, horn, instrument panel power supply (instrument functions display).
- Rollover sensor (11) (SMS) located on the utilities holder plate, under the saddle;

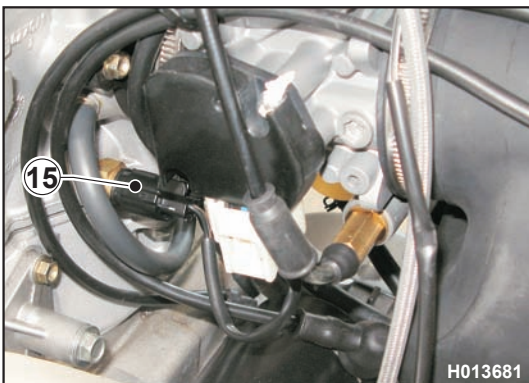
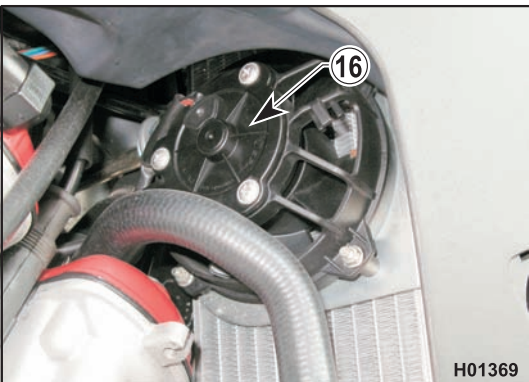

- Coolant temperature sensor (15);



ELECTRICAL SYSTEM

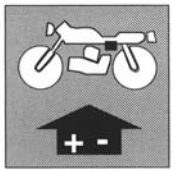

- Lambda sensor (18);

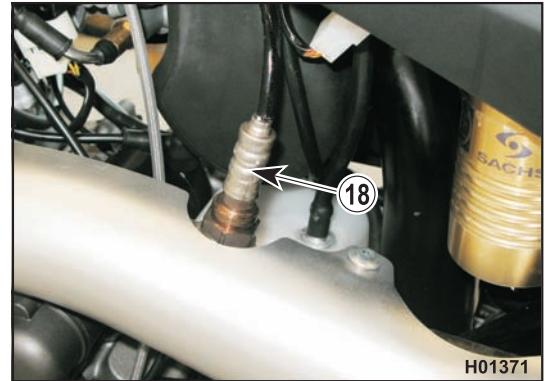

- Headlamp (20) with twin halogen bulb of 12V-60/55W and parking light bulb of 12V-5W;



- The tail light (21) is a LED light;
- Turning indicators (22) 12V-10W bulb;

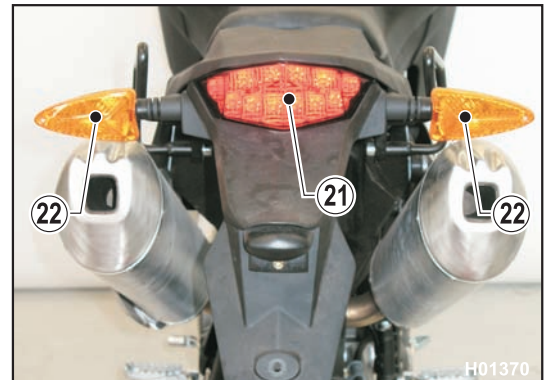

- Fuel pump (19) inside the fuel tank.

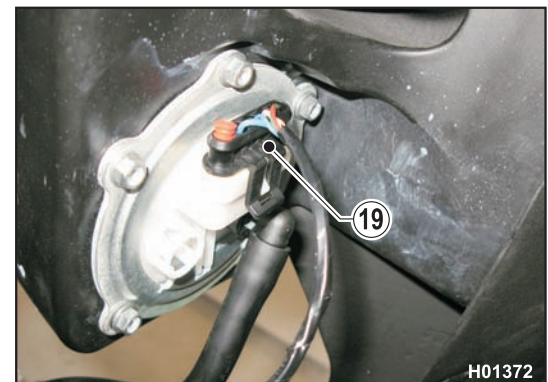

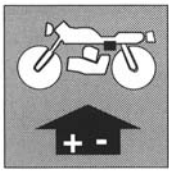

ELECTRICAL SYSTEM

WIRING DIAGRAM

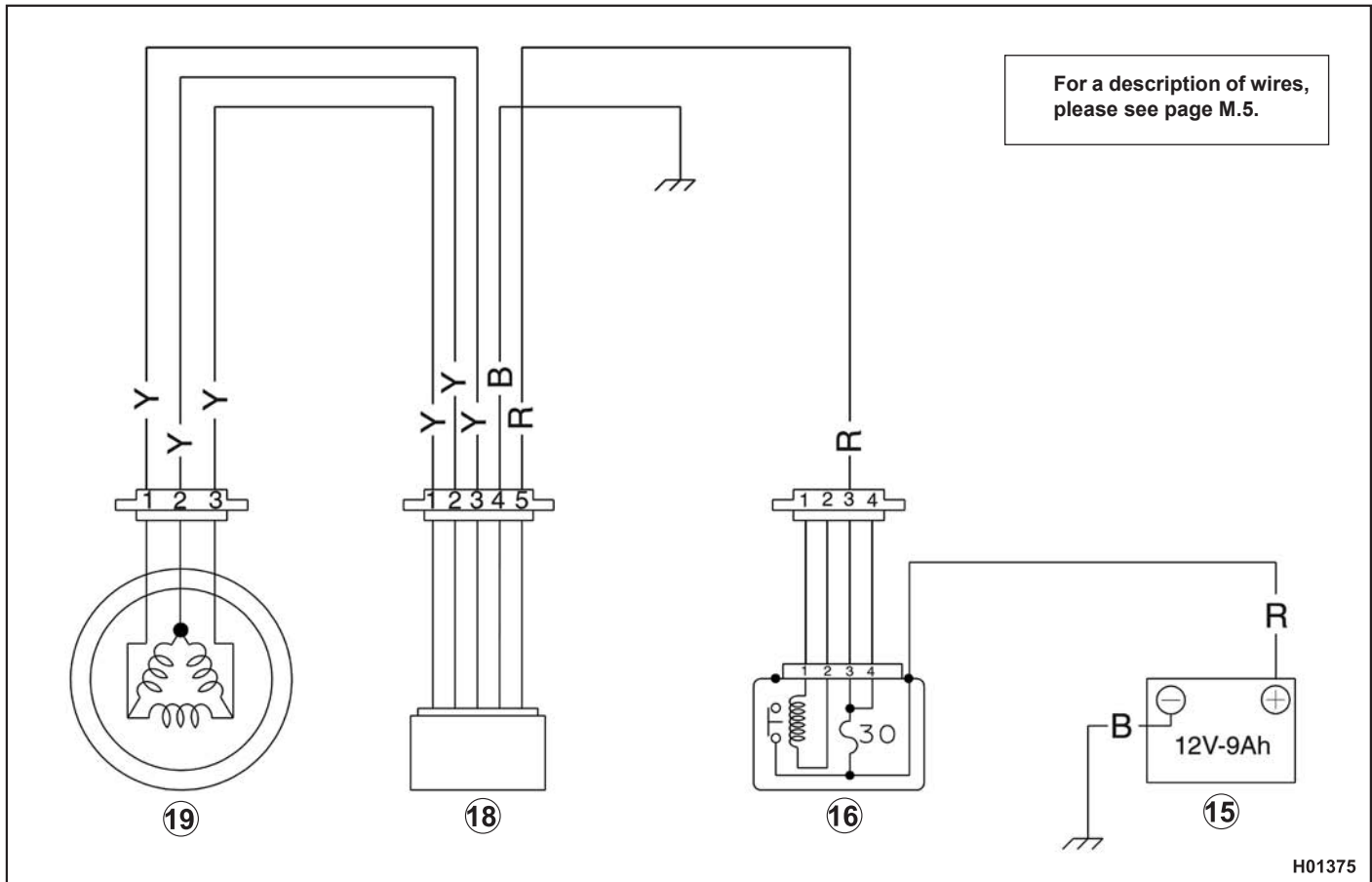

CHARGING SYSTEM

The alternated current produced by the generator is converted into direct current by the voltage regulator/rectifier. The voltage regulator/rectifier serves a dual purpose: it provides overvoltage protection for the battery and converts alternated current into direct current. All components listed above help keep voltage constant and protect the battery against overloading.

- Battery (15).
- Solenoid starter (16);
- Voltage regulator/rectifier (18);
- Generator (19).



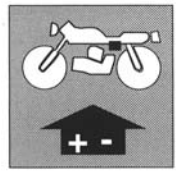

CHARGING SYSTEM INSPECTIONS

Current loss at the battery

Remove the saddle (as described in the relevant section) to gain access to the battery.

Disconnect the BLUE negative cable from the battery.

Measure current across the negative terminal of the battery and the negative cable using a meter. A reading greater than 1 mA indicates current loss.



If the vehicle is to remain unused for long periods, it is recommended to disconnect the battery from the electrical system and store it in a dry place.



H01376

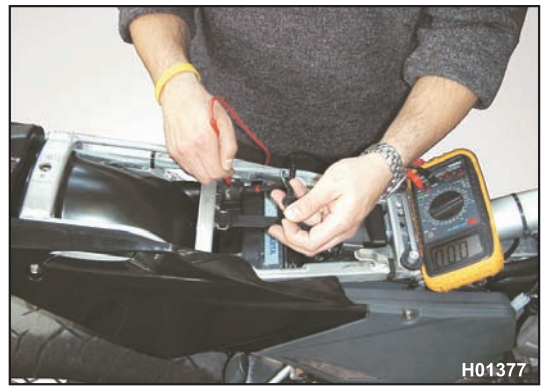

H01377

Regulated voltage

Remove the saddle (as described in the relevant section) to gain access to the battery.

With the engine warmed up and running at slightly above 3000 rpm, measure voltage across the positive and negative terminal of the battery using a meter (the battery must be charged when performing this test). If reading is outside a 12.5-15.1 V range, check generator and voltage regulator/rectifier as described in the relevant paragraph.



H01378



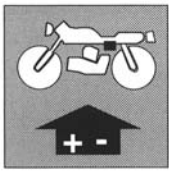

ELECTRICAL SYSTEM

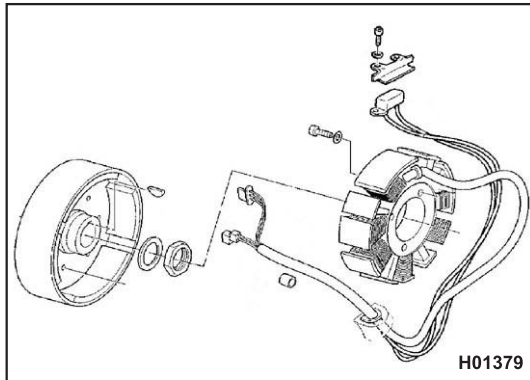

Generator inspection

- A: Set the meter to the "Impedance" scale and take measurement at 2-way connector to check pick-up. Reading should be: 100 Ohm (+/- 20%) at 20°C
- B: Set the meter to the "Impedance" scale and check battery charging. Any and all combinations of the three wires should give the following reading: 0.21 Ohm (+/- 15%) at 20 °C
- C: Check that NONE of the three wires has continuity to ground.



At each engine overhaul, clean flywheel rotor to remove any debris suspended in swirling oil and captured by the magnets.

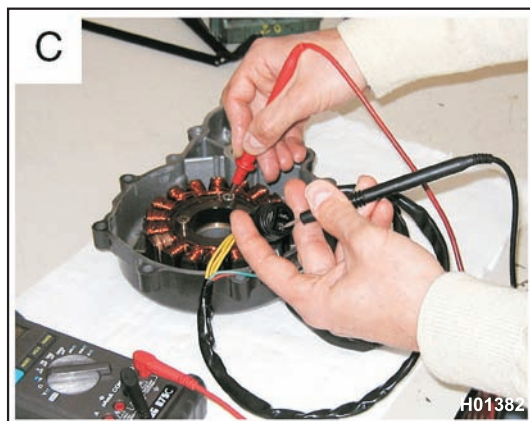
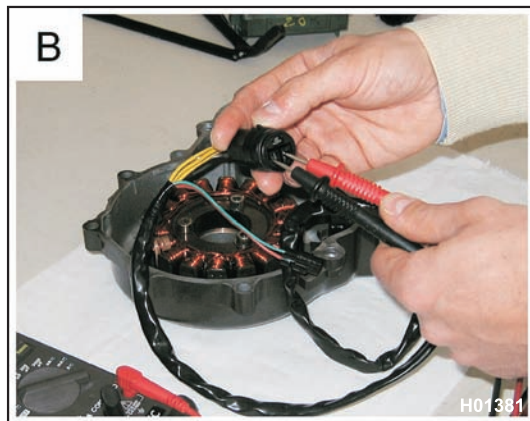

ELECTRICAL SYSTEM

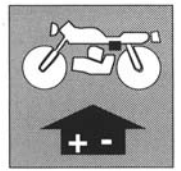

Generator no-load performance

- 1- Battery charging current
- 2- RPM

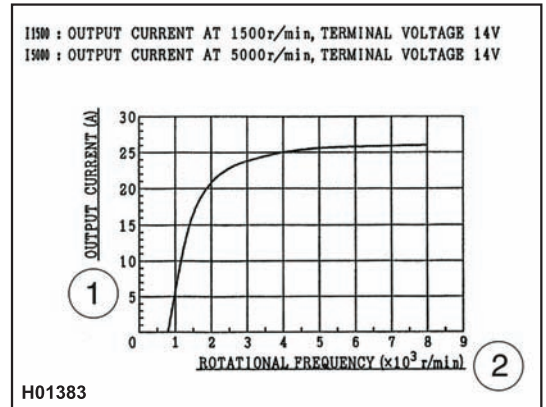

Voltage regulator/rectifier inspection

The voltage regulator/rectifier (18) incorporates the diodes used to rectify the generator current output. It also incorporates an electronic device that adjusts charging voltage to battery charge: if battery charge is low, charging voltage will be lower.



Do not disconnect the battery cables while the engine is running, or the regulator will suffer irreparable damage.

With the ignition on and the battery charged (12.5-13 V), start the engine: if battery voltage fails to rise (14.5 V) within the next two minutes, change the regulator as outlined in the relevant section.

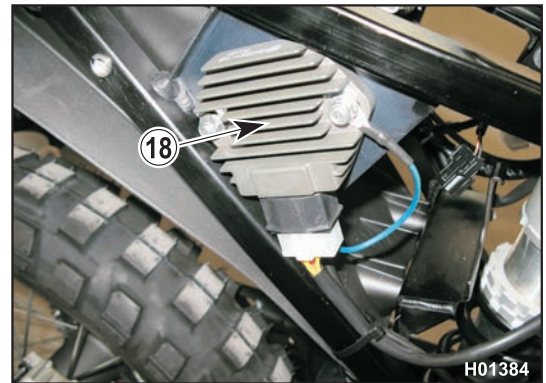

Wiring diagram

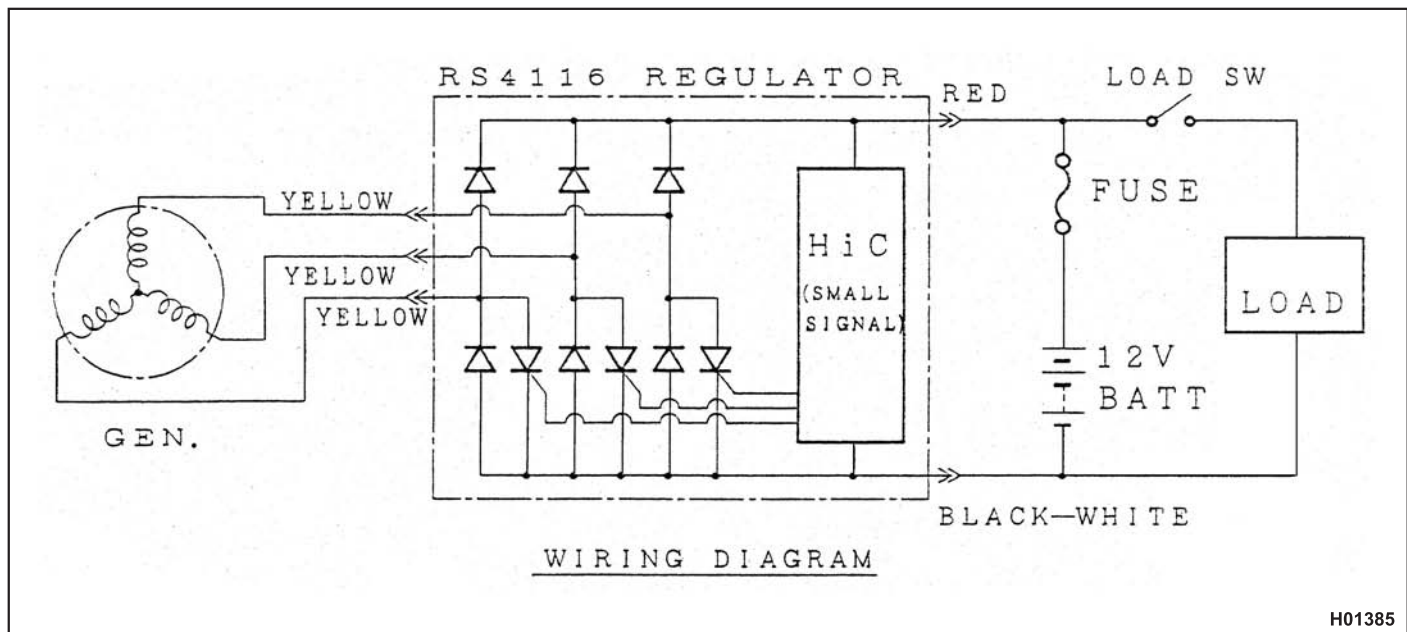

Colour coding key

- Yellow = Giallo
- Red= Rosso
- Black/White = Nero /Bianco



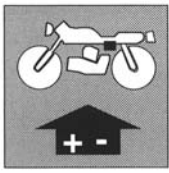

ELECTRICAL SYSTEM

STARTING SYSTEM

Pull in the clutch lever and hold it squeezed until the engine starts.

When the starter button is pressed, the starter relay is energised and closes the circuit that connects starter motor and battery.

- Clutch microswitch (6);
- Ignition switch (8);
- Battery (15);
- Solenoid starter (16);
- Starter motor (17);
- Fuses (23);
- R.H. switch (25);

Wiring diagram

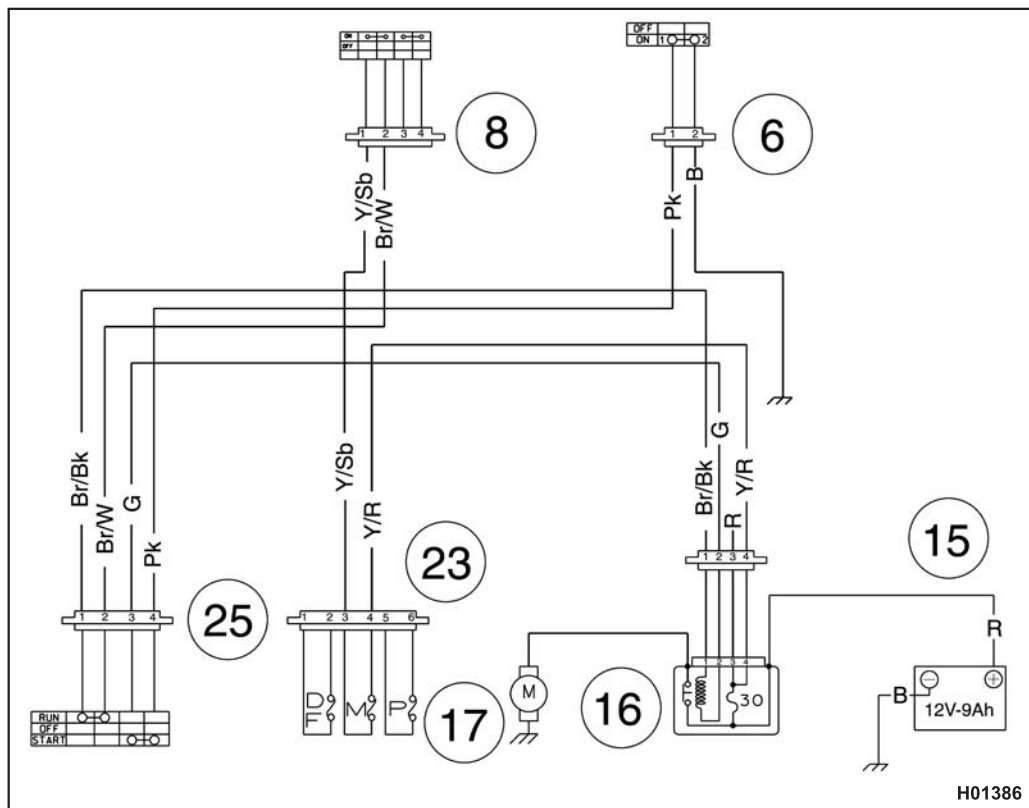

For a description of wires,
please see page M.5.



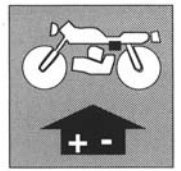

STARTING SYSTEM INSPECTION

Starter motor removal

Remove the starter motor as described in Section "F".

Starter motor inspection

Whenever a starter motor fault is detected, check the starter motor as follows:

- connect a meter across ground and starter motor contact;
- check for continuity between the positive pole and motor ground. If no continuity is found, replace the starter motor.

Starter motor

Rated voltage: 12V

Current draw: 700 W

No-load test

Voltage: 11.5 V

Current: 22 A

Speed: 7000 rpm

Cranking test

Voltage: 8.5 V

Current: 165 A

Torque: 1.86 Nm - 0.19 Kgm - 1.33 ft/lb



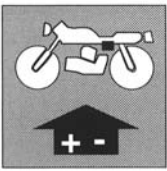

ELECTRICAL SYSTEM

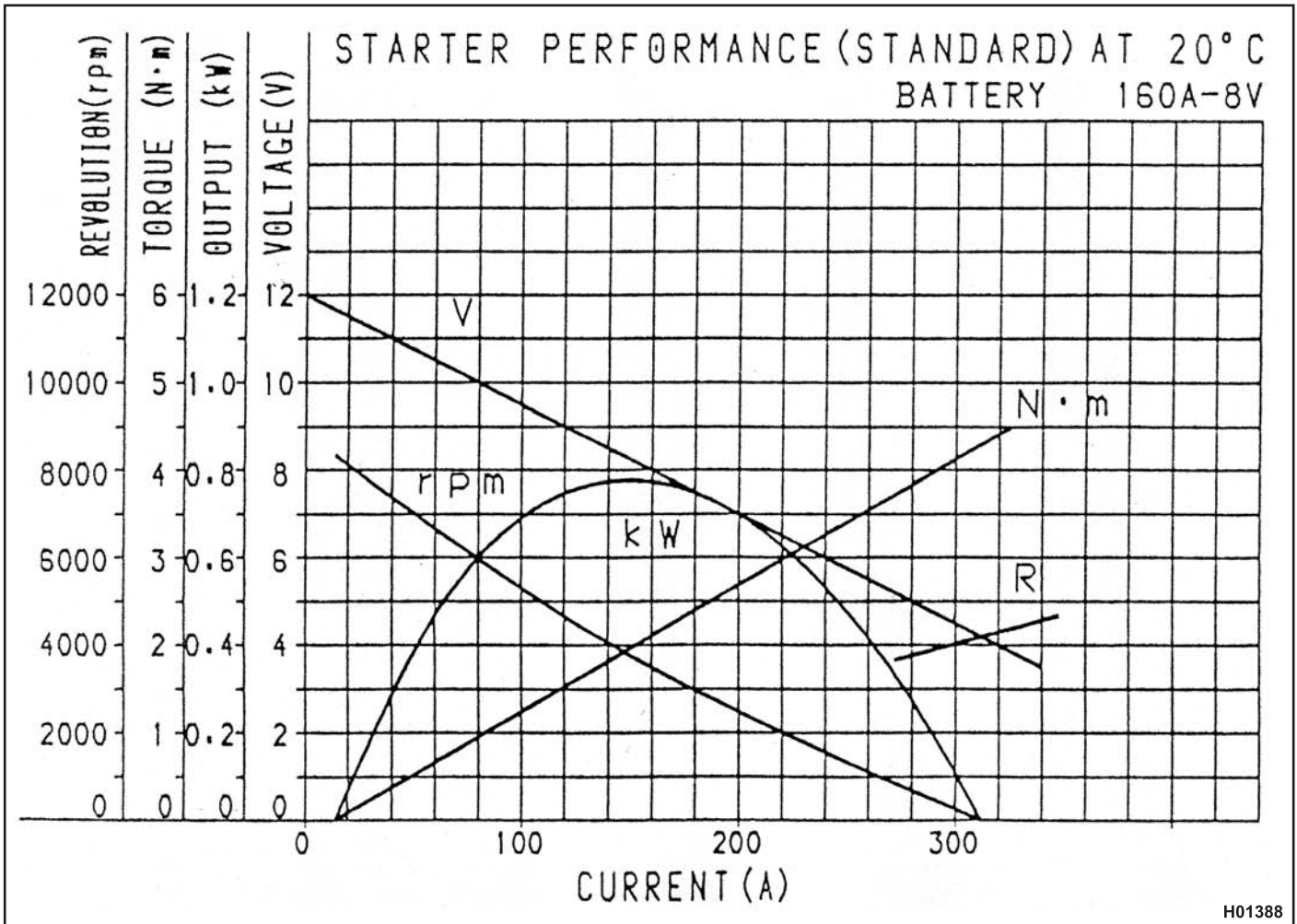

STARTER MOTOR TEST CURVES

Key

- 1- Output power
- 2- Torque
- 3- RPM
- 4- Light voltage
- 5- Charging current

Starter motor test curves

Starter motor maintenance

Starter motor maintenance consists in inspecting brushes for wear and checking the electrical and mechanical insulation between stator and rotor. Accurately grease starter motor moving parts with "CASTROL LM GREASE 2".



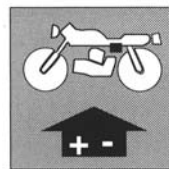

Solenoid starter inspection

Remove the saddle as described in Section "E".
Loosen screw (2) and remove the cover (1).

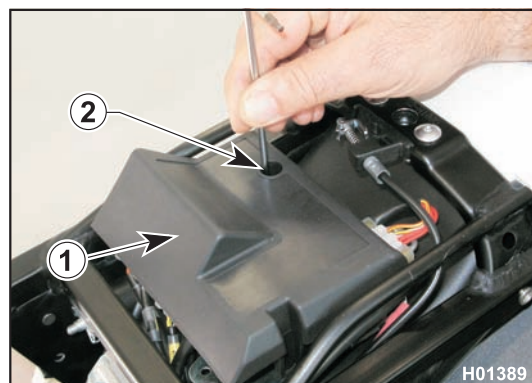

Disconnect the starter relay connector (3).

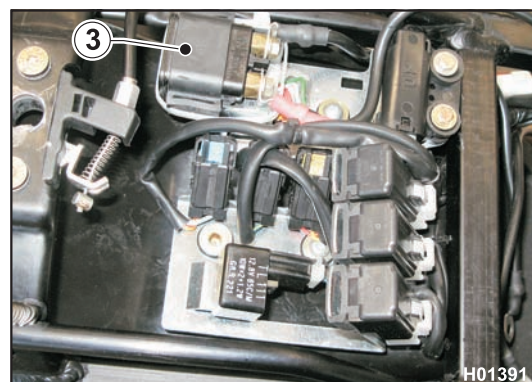

Disconnect the cables (4) at the battery negative terminal to avoid possible short circuits during disassembly.

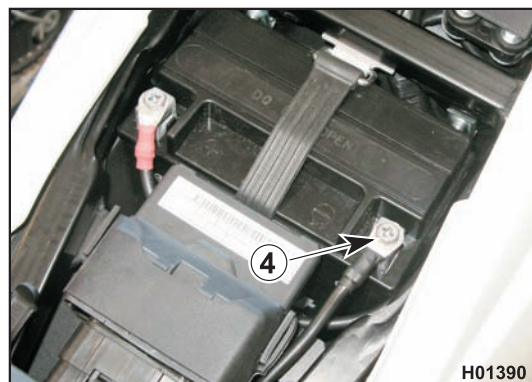

Disconnect the starter motor and battery positive cable wires at relay end. Apply 12 Volts to relay terminals (5) and (6) and check for continuity between terminals B-M. **Do not feed battery voltage to the relay longer than 5 seconds or the relay might overheat, leading to winding damage.** Use a multimeter to establish whether the winding is open circuit or resistance exists. A winding in good condition will give the following resistance readings.

Meter scale setting: Ohm

Starter relay resistance. Standard: 3-6 Ω

Solenoid starter wiring diagram

5 = Ground

6 = +12V

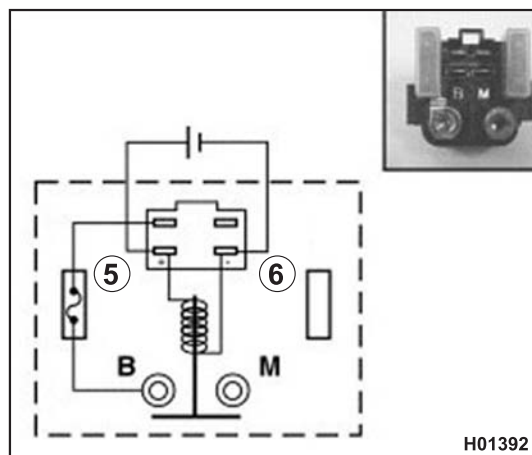

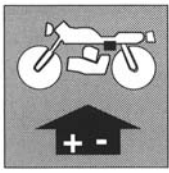

ELECTRICAL SYSTEM

Electronic ignition system

The ignition system is controlled by the ECU. The ignition is an integrated digital electronic ignition system with static timing and advance using intermittent sequential phased electronic fuel injection. This ignition system is composed of a crankshaft position (pick-up) sensor, an ECU, an ignition coil and an intake manifold pressure sensor. The ignition coil is fed by the battery through a power relay and is controlled by the ECU. Ignition timing is accurately determined based on engine RPM and accelerator position. In addition to these key parameters, inputs from the intake air temperature and pressure sensor and from the coolant sensor are also used to control ignition timing.



ELECTRICAL SYSTEM

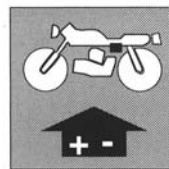

Wiring diagram

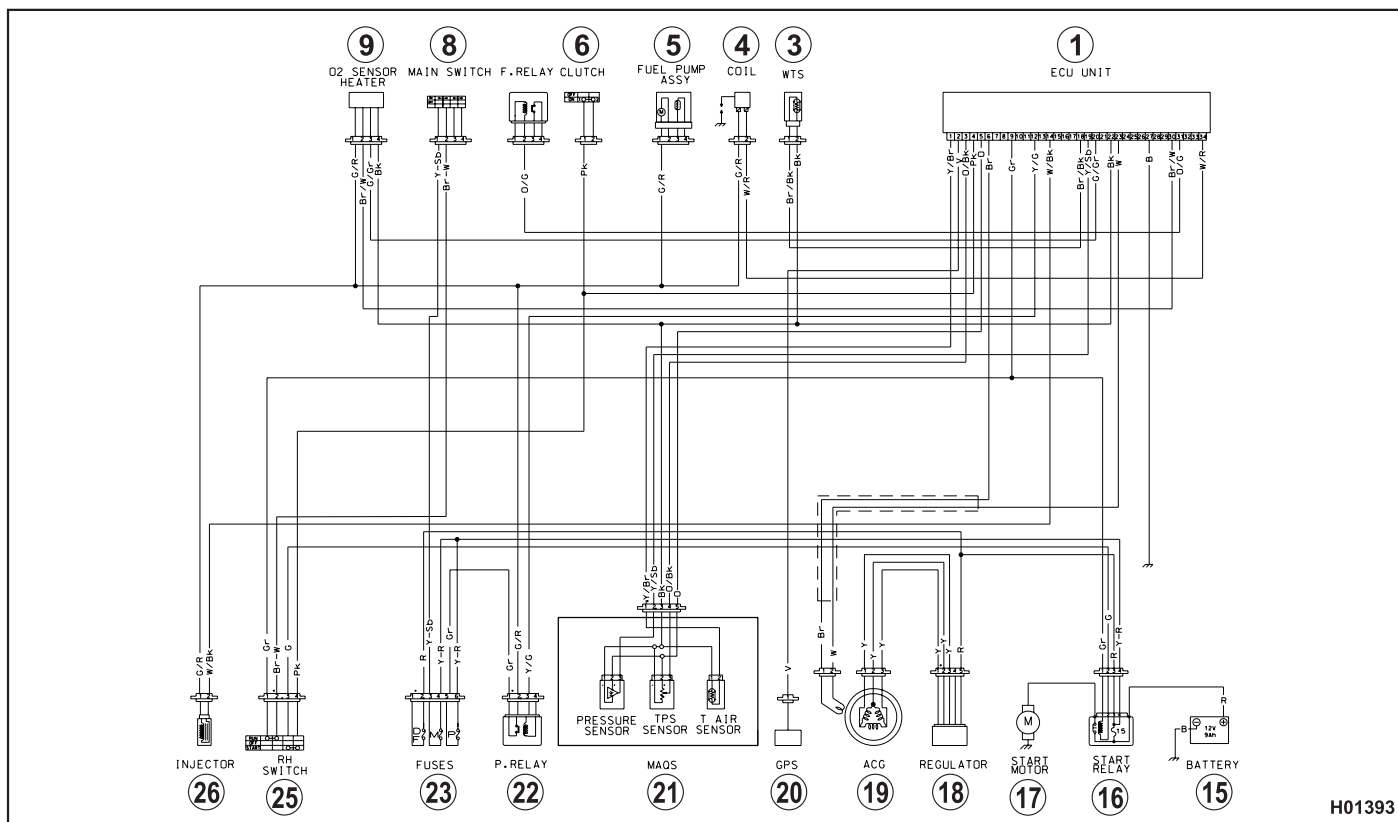

H01393

- Electronic control unit (1) (ECU)
- Water temperature sensor (3)
- Ignition coil (4)
- Fuel pump (5)
- Clutch microswitch (6)
- Ignition switch (8)
- Lambda sensor (9)
- Battery (15)
- Solenoid starter (16)
- Starter motor (17)
- Voltage regulator/rectifier (18)
- Alternator (19)
- Gear sensor (20)
- M.A.Q.S. sensor (21) (pressure sensor, TPS, air temperature sensor)
- Power relay (22)
- Fuse (23)
- R.H. switch (25)
- Injector (26)

For a description of wires, please see page M.5



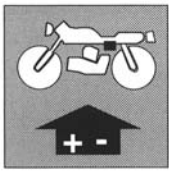

ELECTRICAL SYSTEM

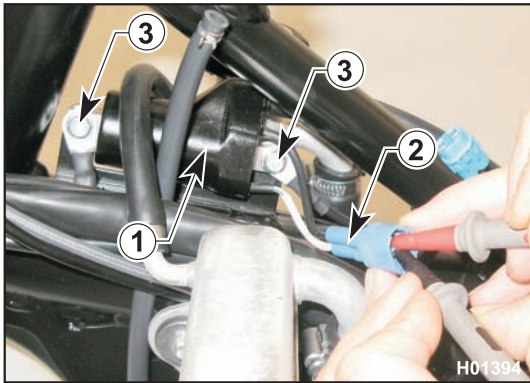

Checking ignition coil windings resistance

Remove the fuel tank (as described in Section "D") to gain access to the coil (1). Disconnect the coil connector (2) from the wiring, remove retaining screws (3) and coil (1) and measure resistance in the primary and secondary windings with a meter.



A

A: primary winding resistance: 4.5 Ohm (+/- 15%) at 20 °C.

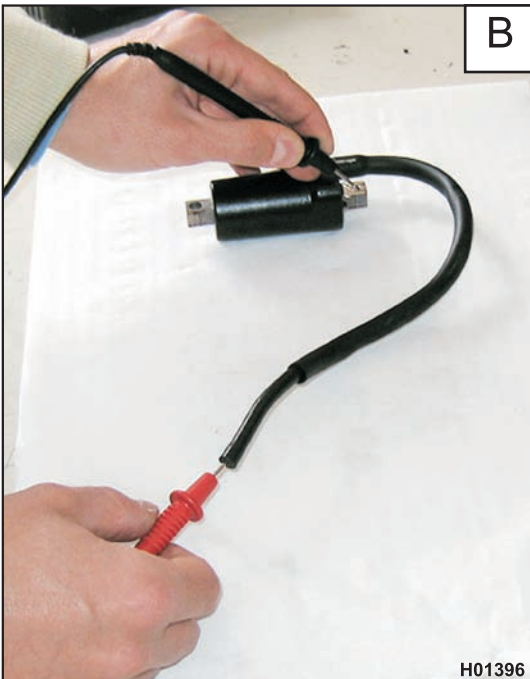

B

B: secondary winding resistance: 19.5 KOhm (+/- 20%) at 20°C (without spark plug cap cable).
If resistance is outside the specified limits, replace the coil. Also check the resistance of the terminal cap contacting the spark plug.



ELECTRICAL SYSTEM

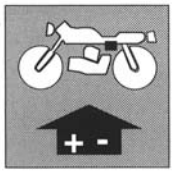

C: terminal cap resistance: 5 KOhm (+/- 10%) at 20 °C.
If resistance is outside the specified limits, replace the cap.

NOTE: The area where the coil is secured must be totally free from oxide and paint.
A faulty ground contact will damage the coil and cause ignition problems.



Electronic control unit (ECU)

Remove the saddle as described in Section "E" to gain access to the electronic control unit (1).

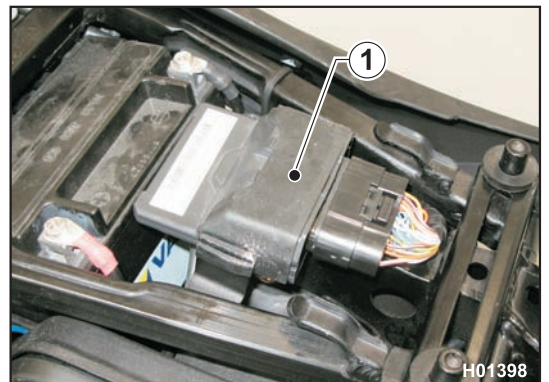

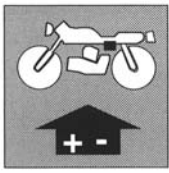

ELECTRICAL SYSTEM

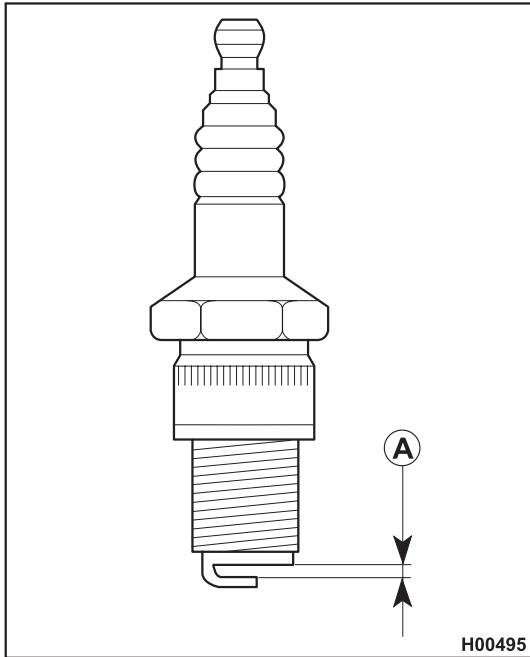

Spark plug

Check electrode gap "A" (0.7 mm) of spark plug (1). A wider gap may cause difficulties in starting the engine and overload the coil. A gap that is too narrow may cause difficulties when accelerating, when idling or poor performance at low speed. Clean off any dirt around spark plug base before removing the spark plug. It is good practice to closely inspect the spark plug after removal, as any deposits on it and the colour of the insulator provide useful indications on spark plug heat rating, carburetion, ignition and the general condition of the engine. Before refitting the spark plug, accurately clean the insulator with a wire brush. Smear some graphite grease on spark plug thread, do it fully home finger tight then tighten it to 10÷12 Nm torque. Loosen the spark plug then tighten it again to 10÷12 Nm. Spark plugs which have cracked insulators or corroded electrodes should be replaced.

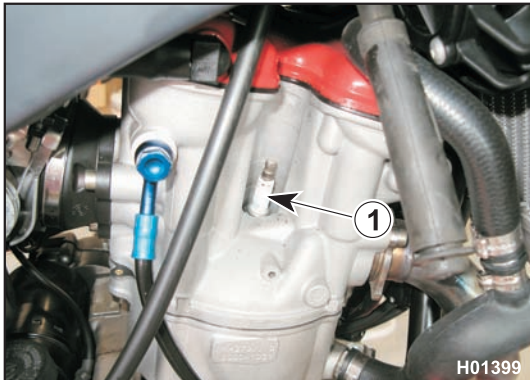

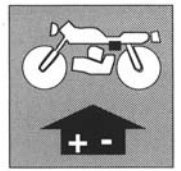

Gear position sensor inspection (GPS: Gear Position Sensor)

Set the meter to the “Ohm” scale and disconnect the alternator six-way connector (1) from the main wiring harness. Touch one meter probe to engine ground and insert the other probe into the connector hole for the WHITE/BLACK gear sensor wire (2). The lever (3) is placed on the left-hand side of the engine. After each gear shift, it automatically returns to the horizontal position. First gear is engaged by pushing the lever downwards; for other gears push it upwards. Check the readings provided in the relevant table.

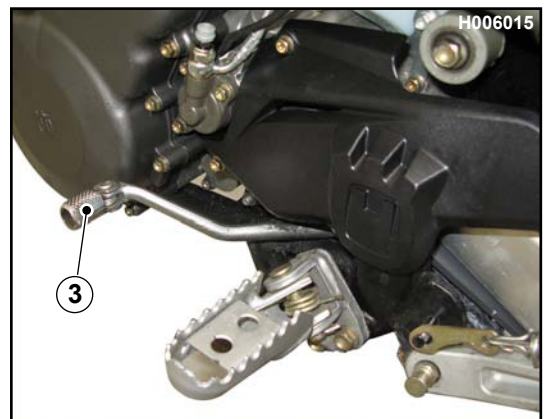
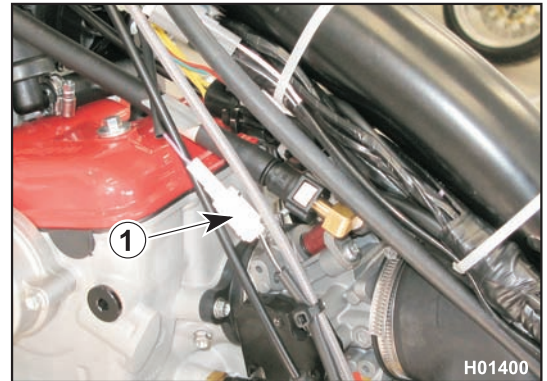

A	NEUTRAL	312-319 Ω
B	1st	725-739 Ω
C	2nd	1.31-1.34 Ω
D	3rd	2.18-2.23 K Ω
E	4th	3.61-3.68 K Ω
F	5th	6.58-6.71 K Ω
G	6th	15.2-15.5 K Ω

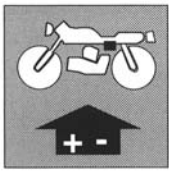

ELECTRICAL SYSTEM



Battery

The sealed battery does not require any maintenance. Replace the battery in the event of electrolyte leaks.

If the vehicle remains unused for long periods, it is recommended to disconnect the battery from the electrical system and store it in a dry place.

- After an intensive use of the battery, it is advisable to carry out a standard slow charging cycle (12V-14Ah battery: 1.4A for 10 hours).
- Quick charging is advised only in situations of extreme necessity since the life of lead elements is drastically reduced by such cycle (12V-14Ah battery: 2.5A for 2 hours).

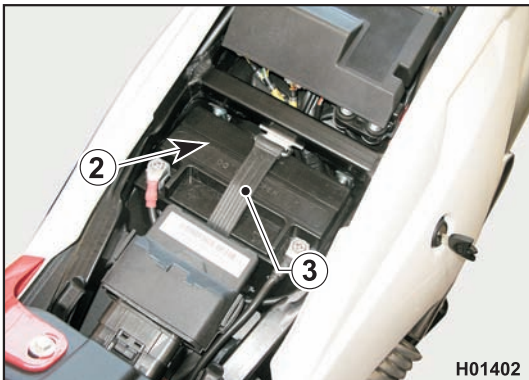

Battery charger

To gain access to the battery (2):

- Insert the key in latch (1) then turn clockwise to release the saddle lock; remove the saddle.
- Release the elastic strap (3) holding the battery;
- first remove the BLACK or BLUE negative cable, then the RED positive cable (when reassembling, first connect the RED positive cable, then the BLACK or BLUE negative cable);
- remove the battery (2) from its housing.

Check, using a voltmeter, that battery voltage is not less than 12.5 V.

If it is not so, the battery needs to be charged.

Using a battery charger with a constant voltage, first connect the RED positive cable to the battery positive terminal then the BLACK or BLUE negative cable to the battery negative terminal.

The voltage reaches a constant value only after a few hours, therefore it is suggested NOT to measure it immediately after having charged or discharged the battery.

Always check the battery charge before reinstalling it on the vehicle.

The battery should be kept clean and the terminals coated with grease.



ELECTRICAL SYSTEM

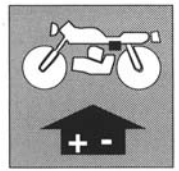

The battery contains sulphuric acid. Avoid contact with skin, eyes or clothing.

Antidote:

EXTERNAL - Flush with water.

INTERNAL - Drink large quantities of water or milk. After milk, take magnesium, beaten eggs or vegetable oil. Immediately call a doctor.

Eyes: Flush with water for no less than 15 minutes and get prompt medical attention.



If the battery is left unused, it has to be in any case recharged with slow cycle (12V-14Ah battery: 1.4A for 10 hours) at least every 3 weeks.



Batteries produce explosive gas, ventilate when charging or using indoors. When using a battery charger, always connect the battery before turning on the charger. This procedure prevents sparks at the battery terminals which could ignite any battery gases.



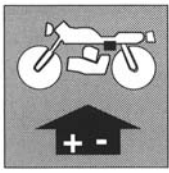

ELECTRICAL SYSTEM

HEADLIGHT ADJUSTMENT

When checking the proper aiming of the headlight beam: inflate tyres at the right pressure, have a person sit astride the motorcycle and set the motorcycle perpendicular to its longitudinal axis at 10 m from a wall or screen. Then trace a horizontal line at the height of headlight centre and a vertical one, in line with vehicle longitudinal axis.

If possible, execute this operation in a shaded place.

When the low beam is on, the upper edge between dark and lit zone should be at $\frac{9}{10}$ th of headlight centre from ground.

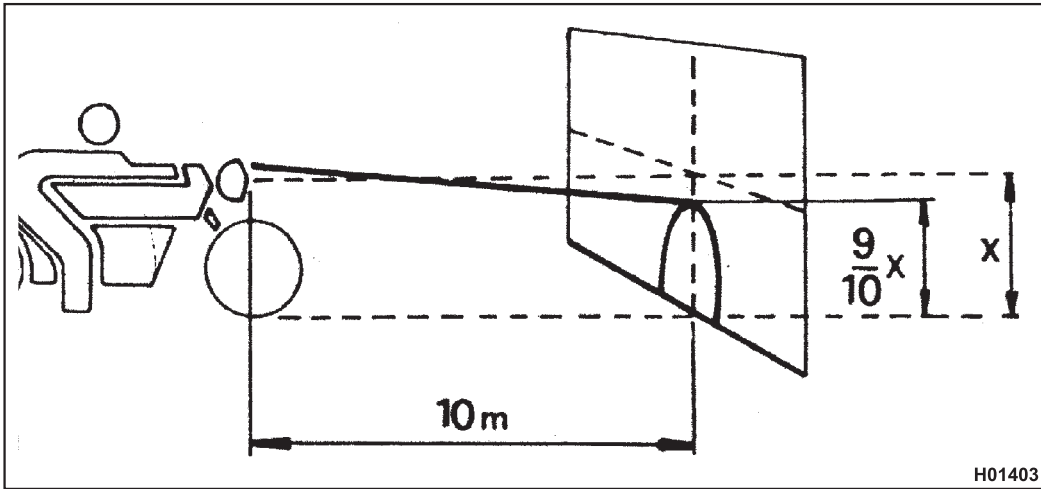

Beam height can be adjusted as follows:

- pull out the front fairing (1) to remove it;
- loosen the two screws (2);
- work adjuster screw (3);
tighten to lower the beam,
loosen to raise the beam.

Once set, reverse the above procedure to reassemble.

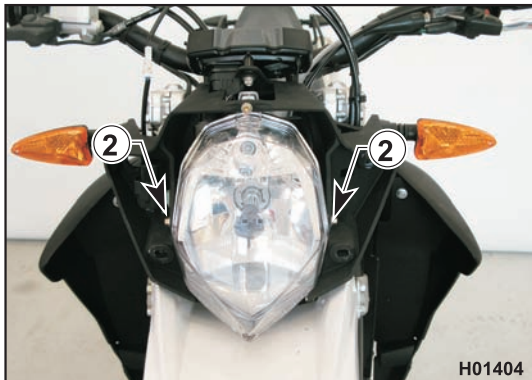

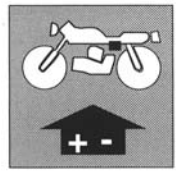

Headlamp bulbs replacement

Proceed as follows to reach the headlamp bulbs:

- pull out the front fairing (1) to remove it;
- loosen the three screws (2) and remove the headlamp (3);
- detach connector (4) from the bulb;
- slide off the rubber gaiter (5);
- release the bulb holder clips (6) and take out bulb (7);

Note: Headlamp bulb (7) is of the halogen type; be careful when replacing it since the glass part shall not be touched with bare hands.

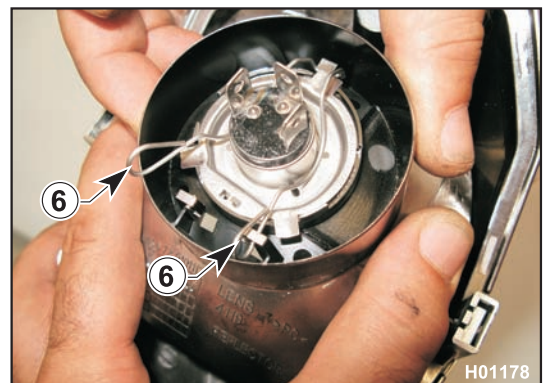
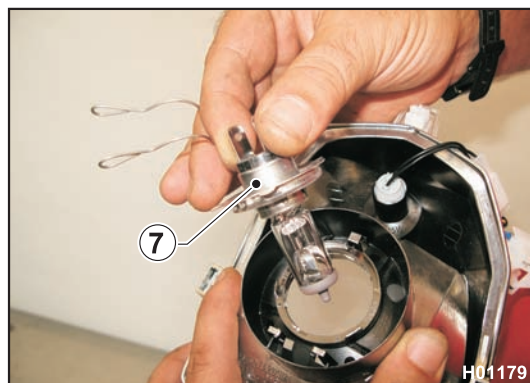
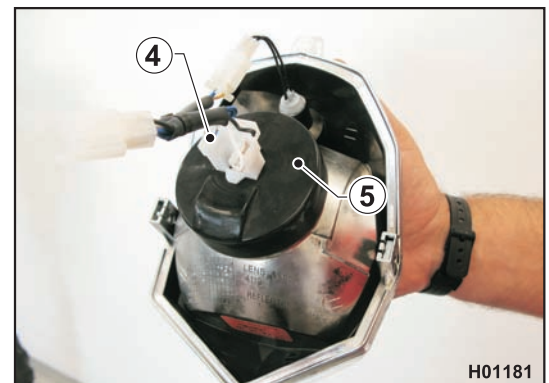
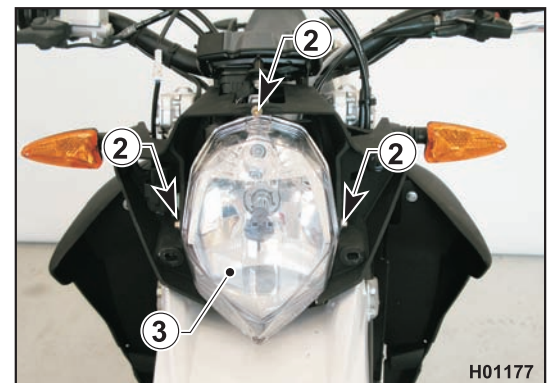

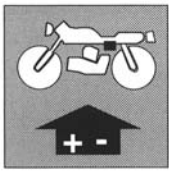

ELECTRICAL SYSTEM

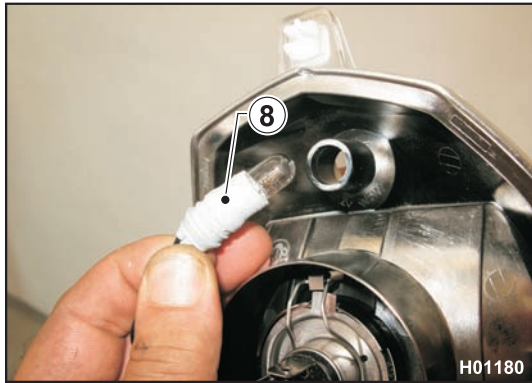

To replace the parking light bulb (8) extract it from the inside cover.

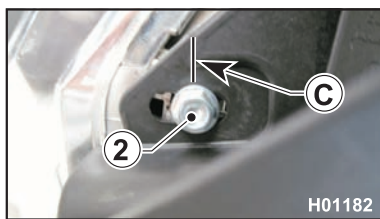

After replacement, reassemble any removed parts making sure to set the centre of side screws (2) at the notch (C) on the support.

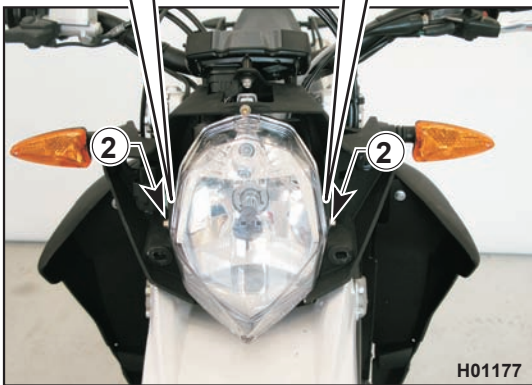

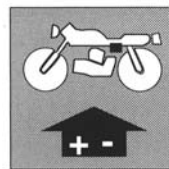

Tail light replacement

Remove the tail light as follows:

- Loosen the two screws (1) under the rear mudguard.
- Extract the tail light (2) and disconnect the connector (3).

Once the tail light has been replaced, reverse the above procedure to reassemble.



Be careful not to overtighten the screws.

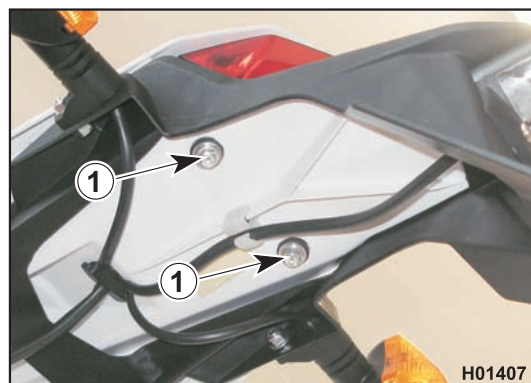

Number plate bulb replacement

- Loosen screw (1) and remove the number plate bulb (2) from the mudguard.
- Extract the bulb holder (3) with the bulb (4) from the housing.
- Pull the bulb (4) to detach it from bulb holder.

Once the bulb has been replaced, reverse the above procedure to reassemble.

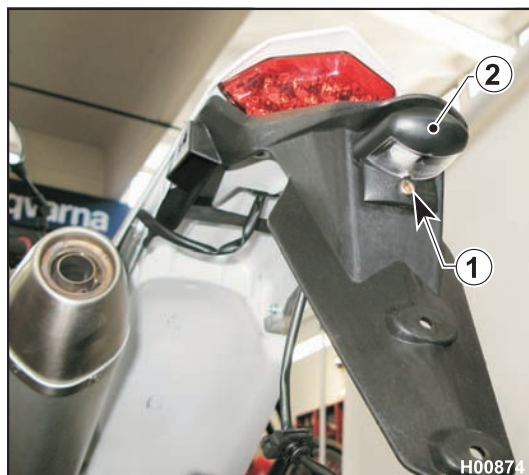

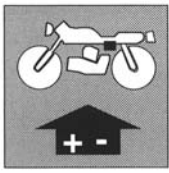

ELECTRICAL SYSTEM

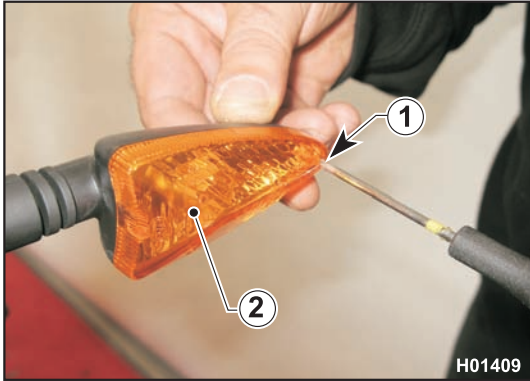

Turning indicator bulb replacement

- Loosen the screw (1) with a Phillips screwdriver.
- Remove the lens (2)



- Remove the bayonet-style bulb (3); push in and turn bulb to remove.
- Once the bulb has been replaced, reverse the removal procedure to reassemble.

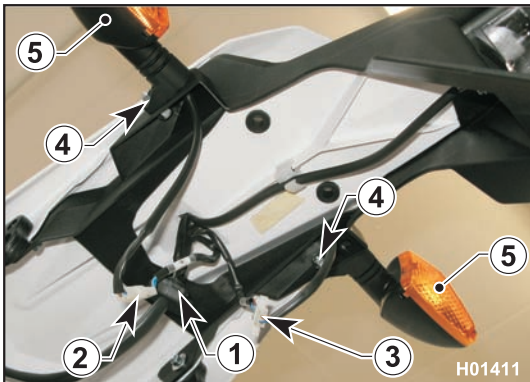

Rear turning indicator removal

- Remove the tail light as described in the relevant paragraph
- Detach the rubber gaiter (1) and extract the right and left turning indicator cables with their connectors.
- Disconnect the LH (2) and RH (3) connectors.
- Loosen the screws (4) using an 8 mm Allen wrench on the outside and a 10 mm wrench on the inside and then remove the turning indicators (5).



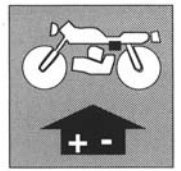

Front turning indicator removal

- Remove headlamp cover and headlamp as described in the relevant paragraph.
- Disconnect connector (1), left turning indicator, connector (2) and right turning indicator.

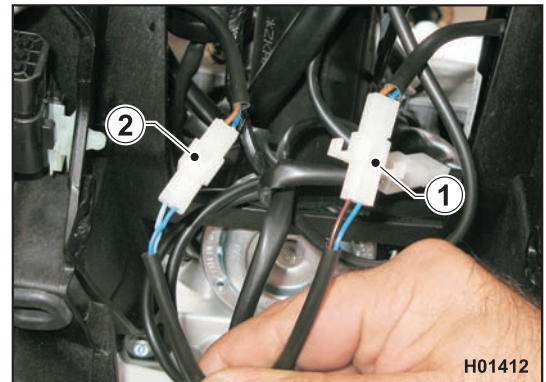

- Loosen the screws (3) using an 8 mm Allen wrench on the outside and a 10 mm wrench on the inside and then remove the turning indicators (4).

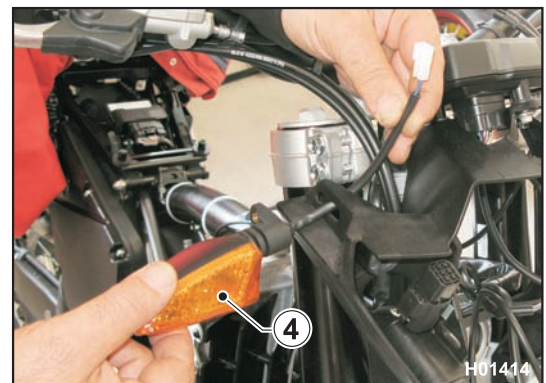
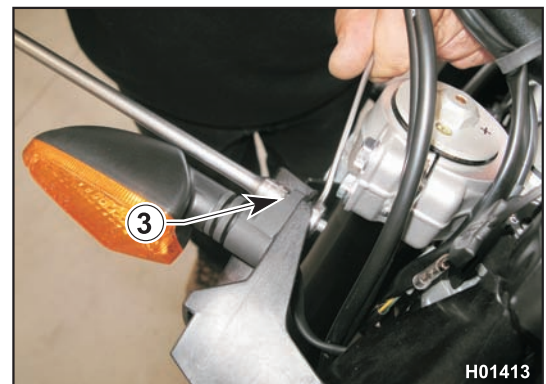

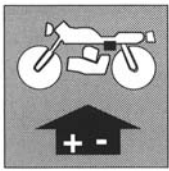

ELECTRICAL SYSTEM

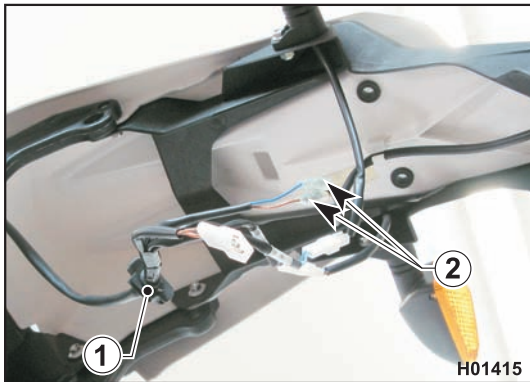

Number plate light removal

- Remove the tail light as described in the relevant paragraph
- Detach the rubber gaiter (1) and extract the turning indicator and number plate cables.
- Disconnect the two connectors (2).

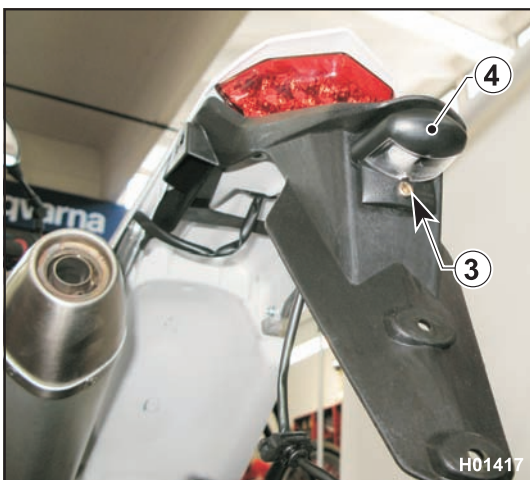

- Use a 4 mm Allen wrench on the outside and an 8 mm ring wrench on the inside to loosen the screw (3), remove the tail light (4) and extract the bulb (5) together with its bulb holder.

Once the bulb has been replaced, reverse the above procedure to reassemble.

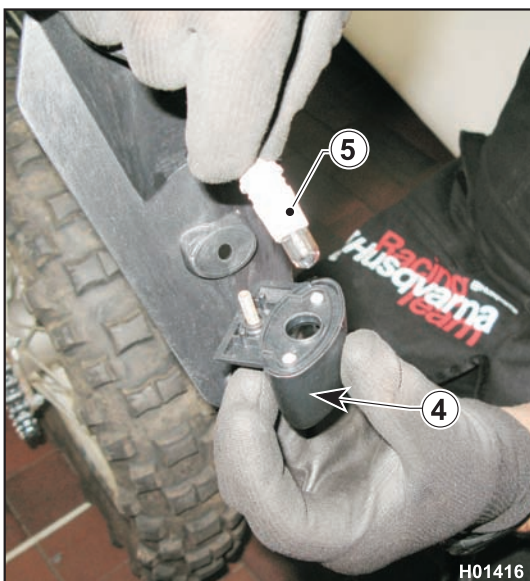

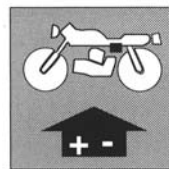

Number plate holder removal

- Remove the tail light as described in the relevant paragraph
- Detach the rubber gaiter (1), extract the turning indicator, tail light and number plate light cables (2) and disconnect them.
- Loosen the two screws (3) using an 8 mm Allen wrench and remove the number plate holder (4) together with the turning indicators.

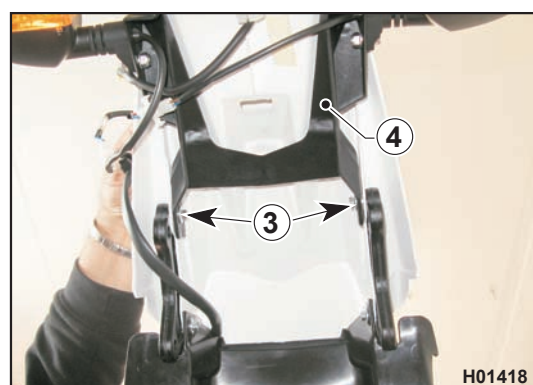
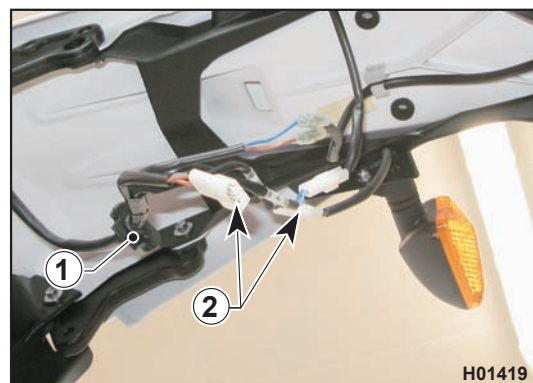

Rear mudguard removal

- Remove the tail light as described in the relevant paragraph
- Detach the rubber gaiter (1), extract the turning indicator, tail light and number plate light cables (2) and disconnect them.
- Loosen the four screws (3) using an 8 mm Allen wrench and remove the mudguard (4) together with the number plate holder (5).

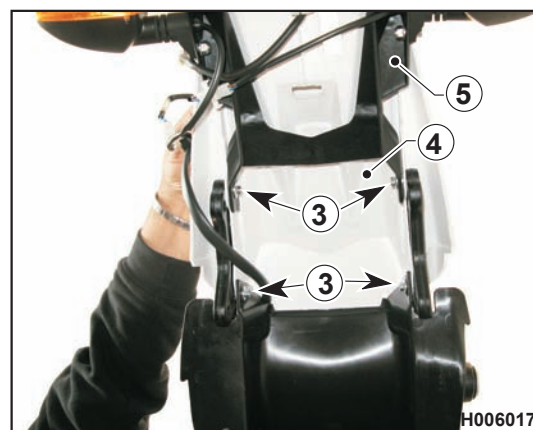
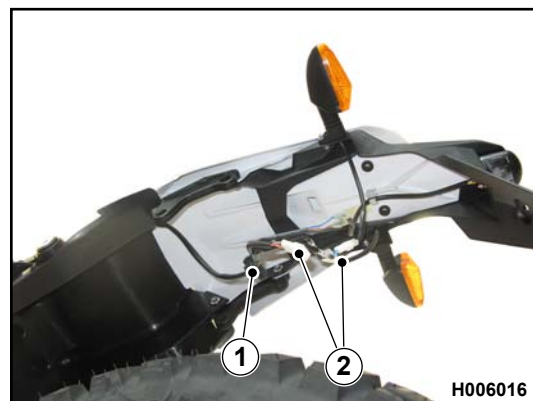

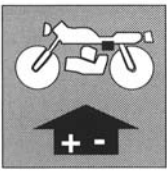

ELECTRICAL SYSTEM

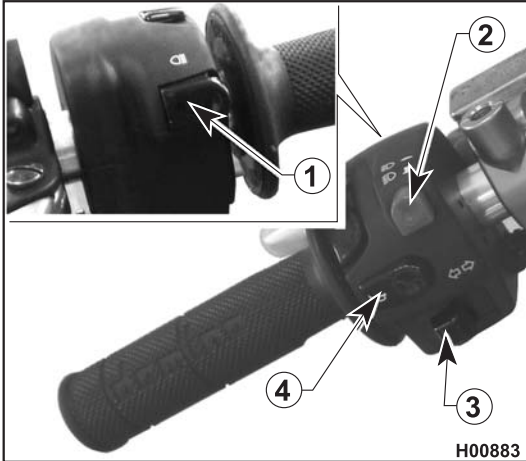

Left-hand switch

1. High beam flasher (self-cancelling)
2. High beam switch
 Low beam switch
3. Left-hand turning indicators (self-cancelling)
 Right-hand turning indicators (self-cancelling)
 To deactivate the turning indicators, press the control lever after it is returned to the centre.
4. Horn.

H00883

LIGHTING SWITCH					FLASHER SWITCH				HORN SWITCH						
COLORE		1		2		COLORE		Sb	B-Bk	R	CARICO NOMINALE	COLORE		CARICO NOMINALE	
POSIZIONE		G-W	W	G-Bk	Y	POSIZIONE					Rated load	A RIPOSO (OFF)	Gr	G	Rated load
•						◀		○	○		52 W				
•						N	PREMUTO (OFF)						○	○	60 W
•						▶			○	○	52 W				
CARICO NOMINALE-Rated load • = 0 W ◀▶ = 30 W ☀ = 30+80 W					DIMMER SWITCH				PASSING SWITCH						
COLORE		W		Bk		COLORE		W		W-B		COLORE		W	
POSIZIONE						POSIZIONE							POSIZIONE		
HI		○	○			80 W	A RIPOSO (OFF)								
LO			○	○		80 W	PREMUTO (On)	○	○						

H00887

Colour coding key

B	Blue
Bk	Black
B-Bk	Blue-Black
B-W	Blue-White
G	Green
G-Bk	Green-Black
G-W	Green-White
Gr	Grey
Y	Yellow
R	Red
Sb	Sky blue
W	White
W-B	White-Blue
W-Bk	White-Black

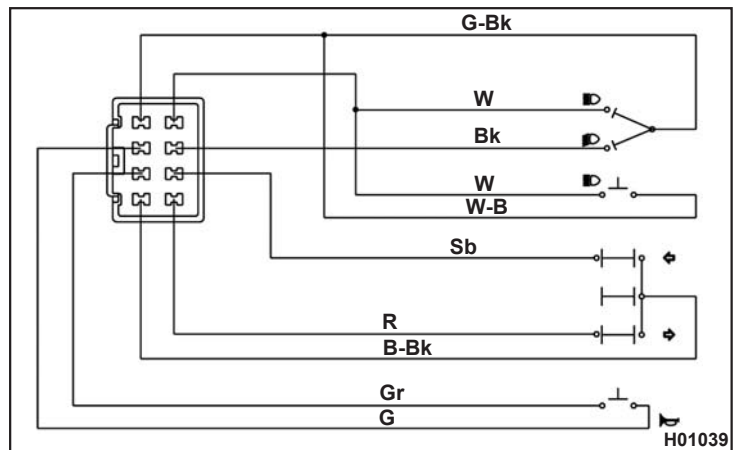

H01039



ELECTRICAL SYSTEM

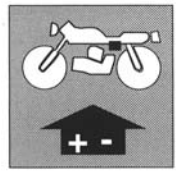

Right-hand switch

1. Engine start button
2. Engine start/stop switch

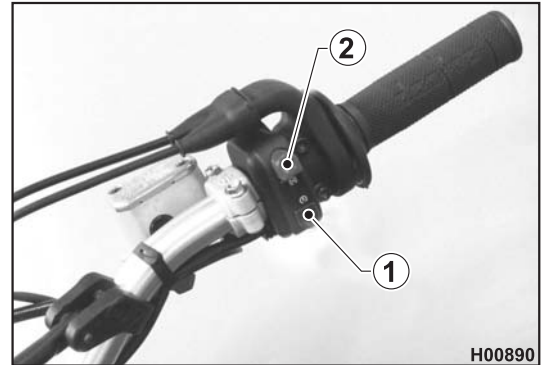

H00890

START SWITCH			ENGINE STOP SWITCH				
	B	Br/Bk	TENS. NOM. Nom. voltage		Br	Y/Sb	TENS. NOM. Nom. voltage
OFF							300V(12V)
ON			12V				300V(12V)
CORRENTE NOMINALE Current load 3 A			CORRENTE NOMINALE - Current load = 0.6 A (3 A) = 0.6 A (3 A)				

H01040

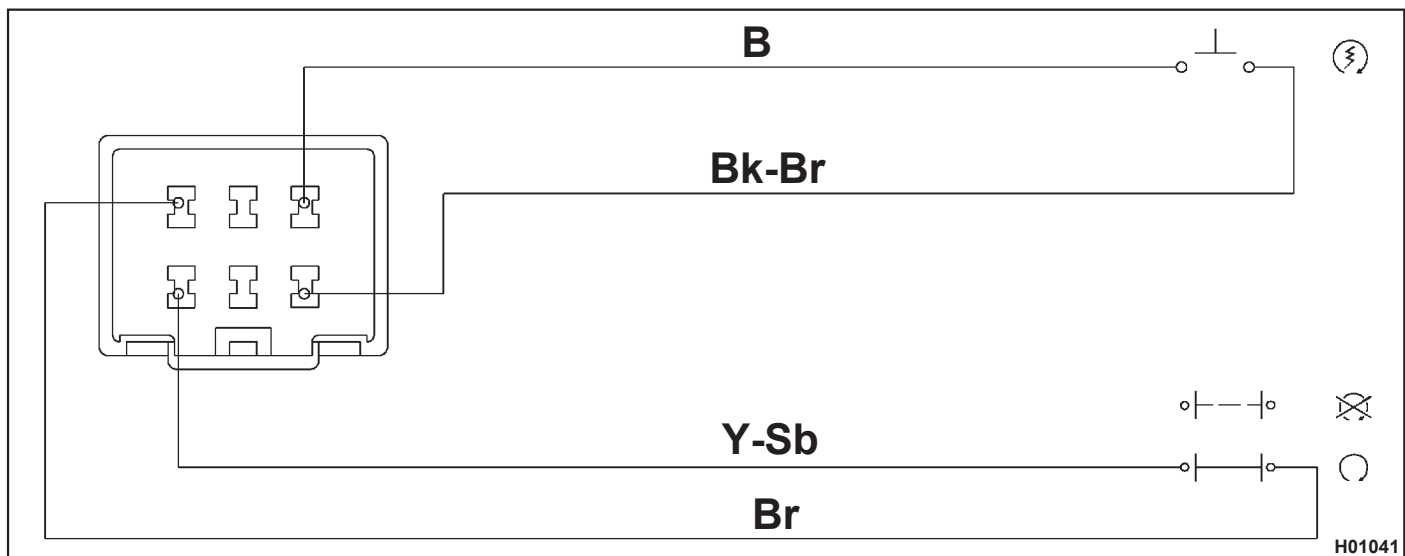

H01041

Colour coding key

- B Blue
- Br Brown
- Br-Bk Brown-Black
- Y-Sb Yellow-Sky blue



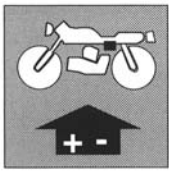

ELECTRICAL SYSTEM

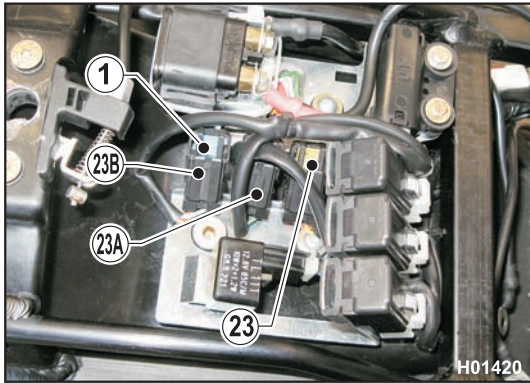

FUSES

- When you find a blown fuse (1), always investigate and eliminate the cause before replacing it.
- Never replace a fuse with another fuse with a different rating.
- Never use a wire or other makeshift repair techniques instead of installing a new fuse.

The following fuses are available on the utilities holder plate:

- Fuse 23, FP- 15A (cable sheath marked "P"): fuel pump, HT coil, lambda sensor heater, injector;
- Fuse 23A, FM- 15A (cable sheath marked "M"): 12V depending on ignition switch (system voltage), parking lights;
- Fuse 23B, FDC- 20A (cable sheath marked "DC"): electric fan, rear stop light, high beam, low beam, turning indicators, horn, instrument panel power supply (instrument functions display).

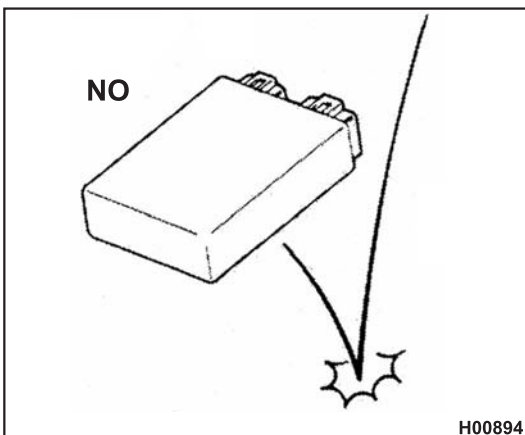

SEMICONDUCTOR PARTS

- Be careful to never drop parts that incorporate a semiconductor, such as the ECU or the voltage regulator/rectifier.
- Closely follow the relevant instructions when inspecting these parts. An improper procedure may lead to severe damage.



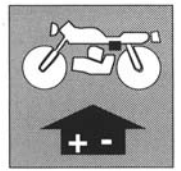

CONNECTORS

- When connecting a connector, push until you hear a click.
- Check connector for signs of corrosion or dirt and inspect its cover for damage.

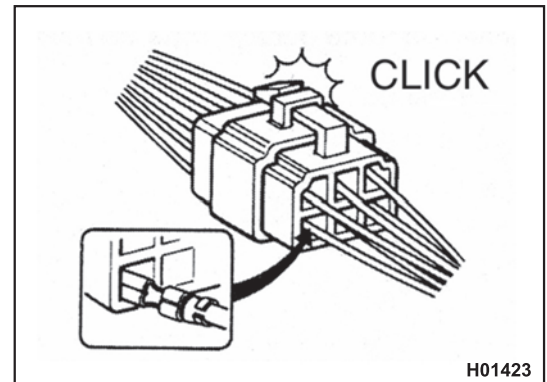

COUPLERS

- When working with lock-type couplers, make sure to release the lock before disconnecting and push coupler fully in when connecting it.
- When disconnecting the connector, make sure to grab connector body and do not pull on the wires.
- Check coupler terminals to ensure they are not loose or bent.
- Check terminals for signs of corrosion or dirt.

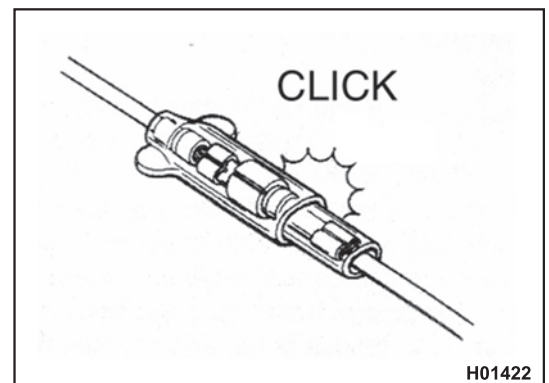

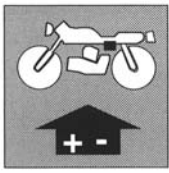

ELECTRICAL SYSTEM



DIGITAL DASHBOARD, WARNING LIGHTS

The motorcycle is fitted with a digital instrument on which 5 warning lights are also available: high beam lights, low beam lights (with display lighting), turning indicators, neutral gear and fuel reserve.

- 1 - BLUE warning light "High beam"
- 2 - GREEN warning light "Low beam"
- 3 - GREEN warning light "Turning indicators"
- 4 - GREEN warning light "Neutral"
- 5 - ORANGE warning light "Fuel reserve"

Note:

- After engine starts, the dashboard shows the SW version for the 2 seconds; after the check routine, the dashboard shows the last planned function.
- When the engine is turned off, the dashboard does not show any functions.
- To select instrument functions and reset functions, use the SCROLL button (A)
- Available functions are listed below in the order they appear when selecting them.

- 1 - SPEED / ODO
- 2 - SPEED / H
- 3 - SPEED / CLOCK
- 4 - SPEED / TRIP 1
- 5 - SPEED / STP 1
- 6 - SPEED / AVS 1
- 7 - SPEED / MAX SPEED
- 8 - SPEED / TRIP 2
- 9 - SPEED / TRP 2 / CLOCK
- 10 - SPEED / RPM (numerical value)

Note: The RPM function seen on the vertical bar indicator is ALWAYS active.



Functions of the GREEN warning light (4) "NEUTRAL" in case of FUEL INJECTION SYSTEM malfunction (contact your local HUSQVARNA Dealer)

- a) With the GEARBOX NOT in NEUTRAL position: the warning light FLASHES INTERMITTENTLY.
- b) With the GEARBOX in NEUTRAL position: the warning light is initially constantly ON then it FLASHES TWICE IN RAPID SUCCESSION then returns to being constantly ON. This cycle repeats itself.

After eliminating the malfunction, the warning light (4) returns to its normal operation.



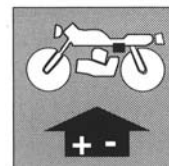

1- SPEED (kmh or mph) / ODO / RPM (figure 1)

- SPEED: vehicle speed - maximum value: 299 kmh or 299mph;
- ODO: odometer- maximum value: 99999 km or 62136.5 mi;
- RPM: engine r.p.m. shown on the vertical bar indicator.

To change unit from kilometres to miles or miles to kilometres, proceed as follows:

- 1) set to figure 1, place the ignition key in the OFF position and push the knob SCROLL (A);
- 2) place the ignition key in the ON position while pressing the SCROLL wheel for 3 seconds (A)

To confirm the conversion, "SET" and the Miles and mph or km and kmh segments will activate for 3 seconds; display will then go back to the standard function shown in Fig.1.

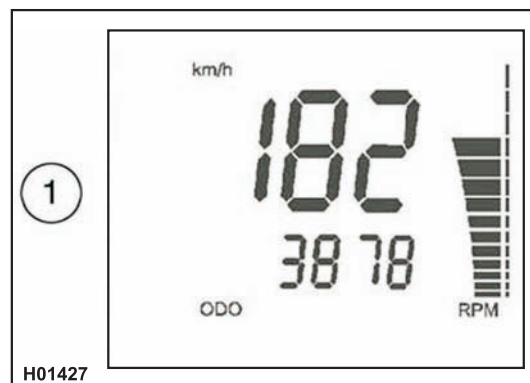

Note:

After the previously described operation, the ODO setting will be converted and all other data reset (the H Counter is unchanged).

2- SPEED / H / RPM (figure 2)

- SPEED: speed - maximum value: 299 kmh or 299mph;
- H: shows the engine running hours (data are saved to permanent memory every 10 minutes).
- Maximum value: 9999:59;
- RPM: engine r.p.m. shown on the vertical bar indicator.

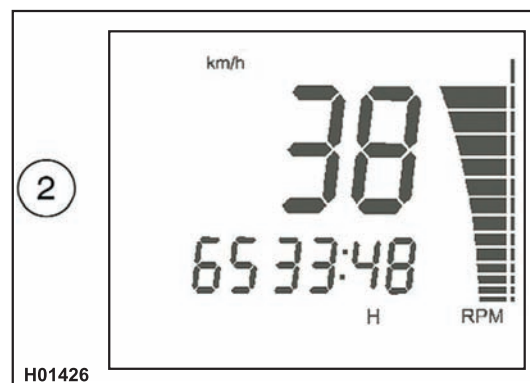

3- SPEED / CLOCK / RPM (figure 3)

- SPEED: speed - maximum value: 299 kmh or 299mph;
- CLOCK: Clock- reading from 0:00 to 23:59:59 (data will be lost after disconnecting the battery).

To reset the clock, push the SCROLL button (A) and hold for more than 3 seconds in order to increase the hour value; release button and after 3 seconds the minutes can be increased;

- RPM: engine r.p.m. shown on the vertical bar indicator.



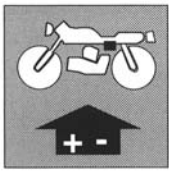

ELECTRICAL SYSTEM

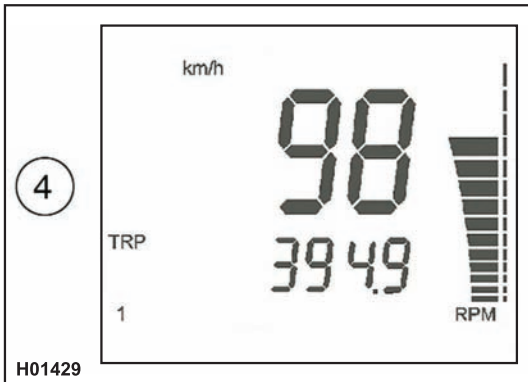

4- SPEED / TRIP 1 / RPM (figure 4)

- SPEED: speed - maximum value: 299 kmh or 299 mph;
- TRIP 1: distance - maximum value: 999.9 km or 621,31 mi (data will be lost after disconnecting the battery).

Resetting the STP 1 also resets the TRIP 1 and AVS 1 data.

The function TRIP 1 is ON together with the function STP 1 (*).

- RPM: engine r.p.m. shown on the vertical bar indicator.
(*): see figure 5

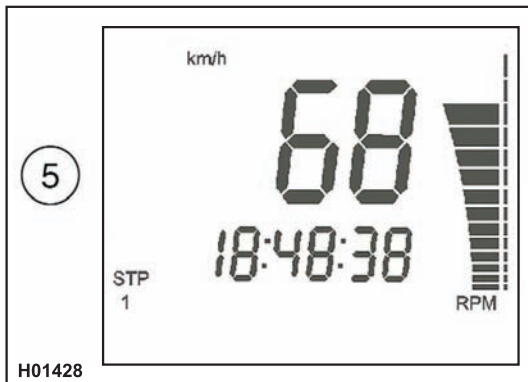

5- SPEED / STP 1 / RPM (figure 5)

- SPEED: speed - maximum value: 299 kmh or 299mph;
- STP 1: miles/kilometres covered time
- Reading from 0:00 to 23:59:59 (data will be lost after disconnecting the battery).

To activate the function STP 1, push the SCROLL button (A) and hold for more than 3 seconds.

- 1st step: activate function;
- 2nd step: stop counters.
- 3rd step: reset STP 1, TRIP 1 and AVS 1 data;
- 4th step: activate function;
- 5th step: stop counters.

and so on

NOTE: STP 1 data+TRIP 1 data=AVS 1 (*).

- RPM: engine r.p.m. shown on the vertical bar indicator.
(*): see figure 6

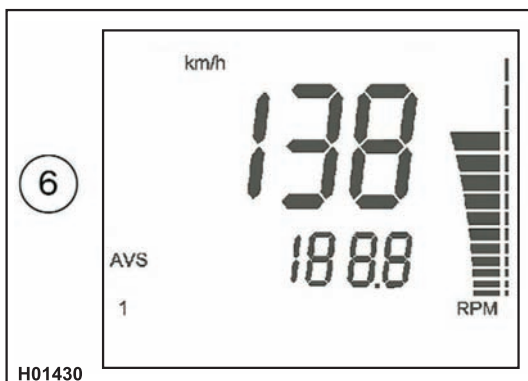

6- SPEED / AVS 1 / RPM (figure 6)

- SPEED: speed - maximum value: 299 kmh or 299 mph;
- AVS 1: shows the average vehicle speed, according to covered distance (TRIP 1) and time (STP1) (data will be lost after disconnecting the battery).

NOTE: Resetting the STP 1 also resets the TRIP 1 and AVS 1 data.

- RPM: engine r.p.m. shown on the vertical bar indicator.



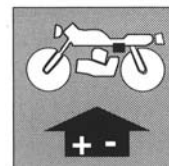

7- SPEED / V MAX / RPM (figure 7)

- SPEED: speed - maximum value: 299 kmh or 299mph;
- V MAX: Shows the maximum speed reached by the vehicle, in kmh or mph.

Maximum value: 299 kmh or 299 mph. To set to zero V MAX, push the knob SCROLL (A) for more than 3 seconds;

- RPM: engine r.p.m. shown on the vertical bar indicator.

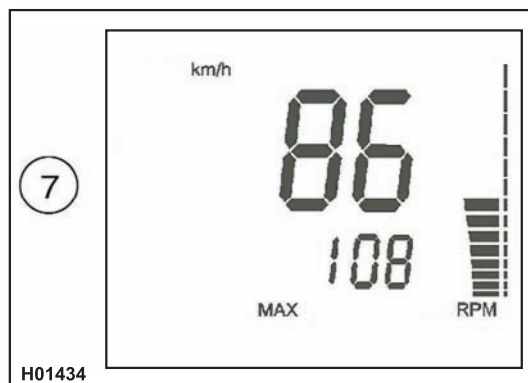

8- SPEED / TRIP 2 / RPM (figure 8)

- SPEED: speed - maximum value: 299 kmh or 299 mph;
- TRIP 2: distance - maximum value: 999.9 km/miles (data will be lost after disconnecting the battery);

To reset TRIP 2, push the SCROLL button (A) and hold for more than 3 seconds;

- RPM: engine r.p.m. shown on the vertical bar indicator.

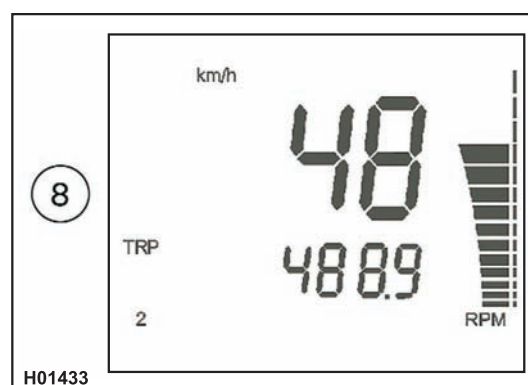

9- TRP 2 / CLOCK / RPM (figure 9)

- TRIP 2: distance - maximum value: 999.9 km/miles (data will be lost after disconnecting the battery);

To reset TRIP 2, push the SCROLL button (A) and hold for more than 3 seconds;

- CLOCK: Clock- reading from 0:00 to 23:59:59 (data will be lost after disconnecting the battery).

To reset the clock, push the knob SCROLL (A) for more than 3 seconds in order to increase the hours; release the knob then, after 3 seconds, it is possible to increase the minutes;

- RPM: engine r.p.m. shown on the vertical bar indicator.



10- SPEED /RPM (engine r.p.m. numerical value) (figure 10)

- SPEED: speed - maximum value: 299 kmh or 299 mph;
- RPM: engine r.p.m.; both vertical bar indicator and numerical value are on.

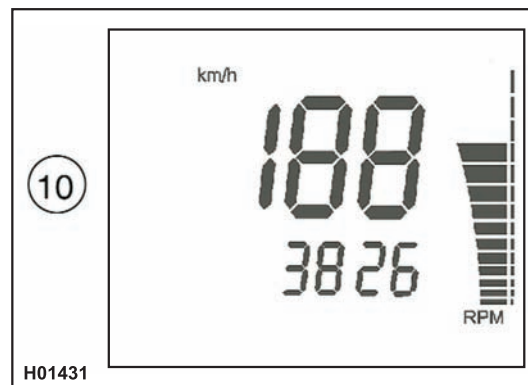

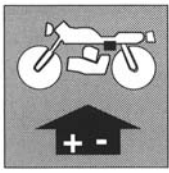

ELECTRICAL SYSTEM

TROUBLESHOOTING

CHARGING SYSTEM

A battery that does not hold charge might be a symptom of:

- 1) current loss (see paragraph "Current loss at the battery");
- 2) incorrect voltage (see paragraph "Regulated voltage");
- 3) no continuity in generator (see paragraph "Checking generator stator windings resistance");
- 4) incorrect no-load performance of generator (see paragraph "Generator no-load performance");
- 5) voltage regulator malfunction (see paragraph "Voltage regulator/rectifier inspection")

- a battery overload indicates:

- 1) faulty voltage regulator (see paragraph "Voltage regulator/rectifier inspection");
- 2) faulty battery (see paragraph "Current loss at the battery").

STARTING SYSTEM

If the starter motor does not start, this might be a symptom of:

- 1) faulty solenoid starter (see paragraph "Solenoid starter inspection");
- 2) loose starter motor cable;
- 3) faulty starter motor (see paragraph "Starter motor inspection");
- 4) flat battery (see paragraph "Battery charger").

ELECTRONIC IGNITION SYSTEM

A weak or missing spark might be a symptom of:

- 1) incorrect connections in the electrical system;
- 2) faulty spark plug or wrong heat rating or incorrect spark plug gap (see paragraph "Spark plug");
- 3) faulty ignition coil (see paragraph "Checking coil windings resistance");
- 4) faulty spark plug cap (see paragraph "Checking coil windings resistance").



ELECTRICAL SYSTEM

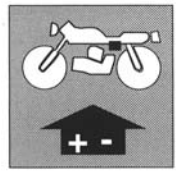

Wiring

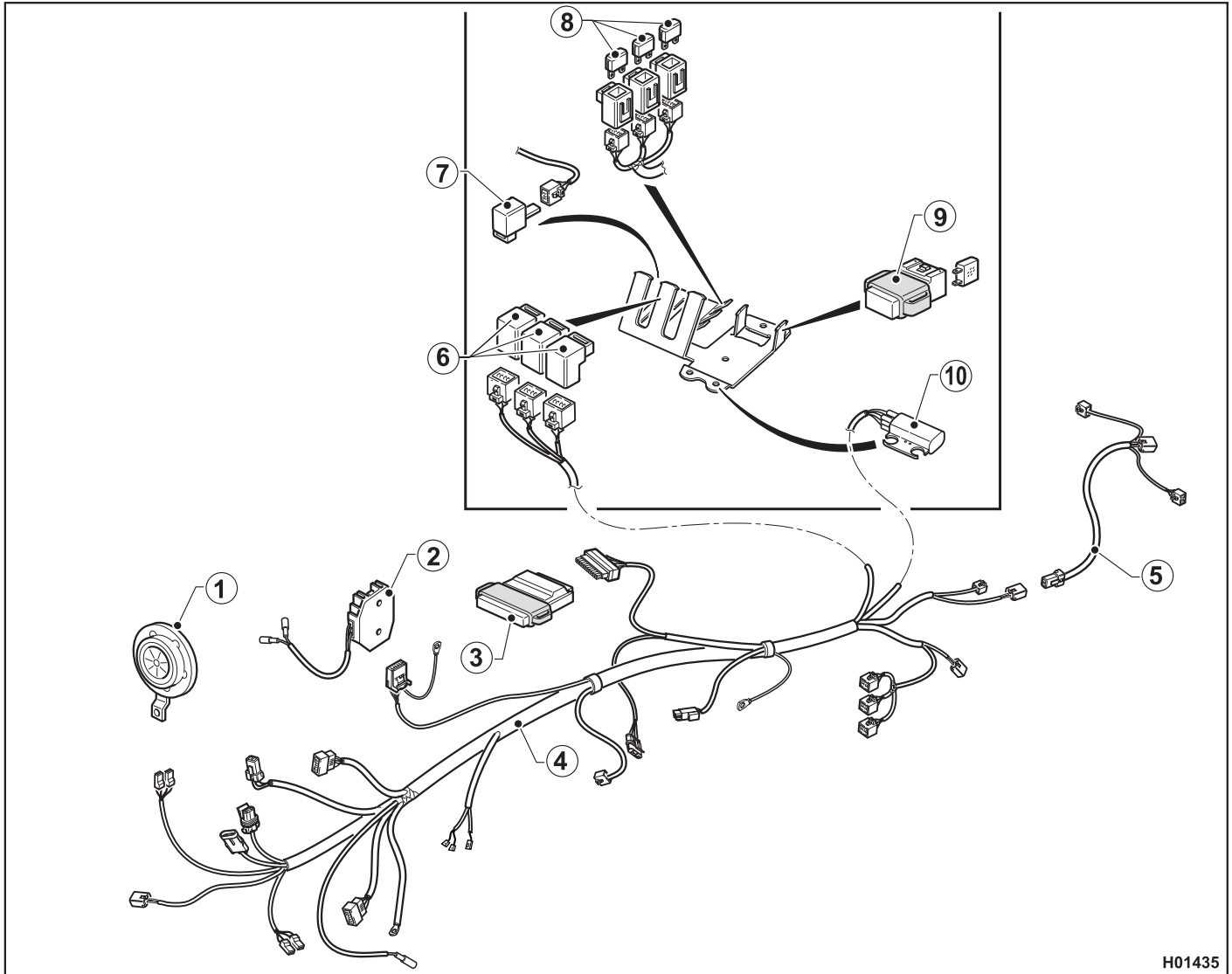

H01435

- 1 Horn
- 2 Voltage regulator
- 3 Electronic control unit
- 4 Main wiring harness
- 5 Rear wiring harness :Turning indicators
:Tail light
:Number plate light
- 6 Relay
- 7 Turning indicator flasher
- 8 Fuses
- 9 Solenoid starter
- 10 Rollover sensor (SMS)



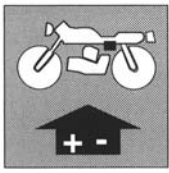

ELECTRICAL SYSTEM

Cable routing and electrical parts installation instructions

• Coil position and connector connection

Connect the HT coil (1) as shown in the figure
 Secure the main wiring harness ground to screw (A).
 Secure the engine ground to screw (B)
 Connect connector (C) to the main wiring harness.

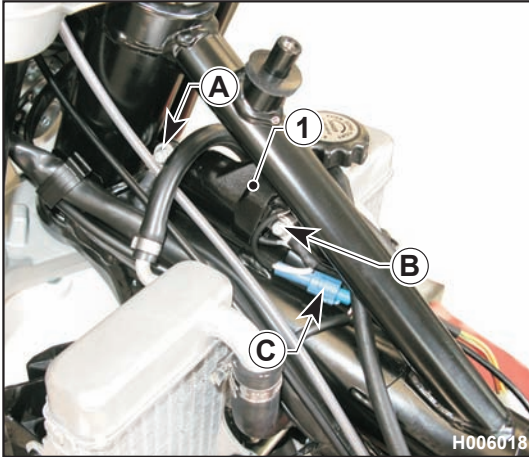

• Position of utilities

Secured to utilities holder plate under the saddle.

- 1) Solenoid starter
- 2) Rollover sensor
- 3) Relay (Injector, Lambda Sensor, Fuel Pump, Coil)
- 4) Electric fan relay
- 5) Horn, turning indicators, stop lights, low and high beam lights relay.
- 6) Turning indicator flasher
- 7) Fuse 23, FP- 15A (cable sheath marked "P"): fuel pump, HT coil, lambda sensor heater, injector;
- 8) Fuse 23A, FM- 15A (cable sheath marked "M"): 12V depending on ignition switch (system voltage), parking lights;
- 9) Fuse 23B, FDC- 20A (cable sheath marked "DC"): electric fan, rear stop light, high beam, low beam, turning indicators, horn, instrument panel power supply (instrument functions display).

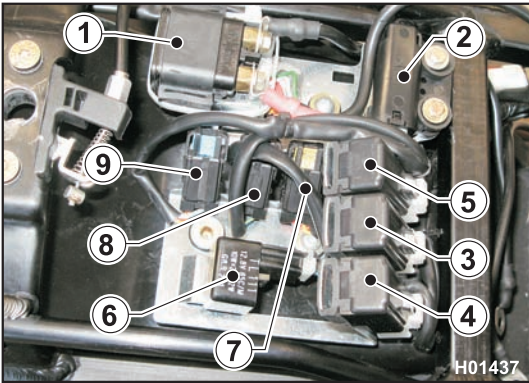

ELECTRICAL SYSTEM

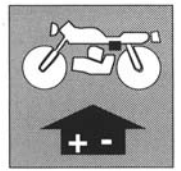

- **Electronic control unit position (10)**

Mounted on flexible mount under the saddle

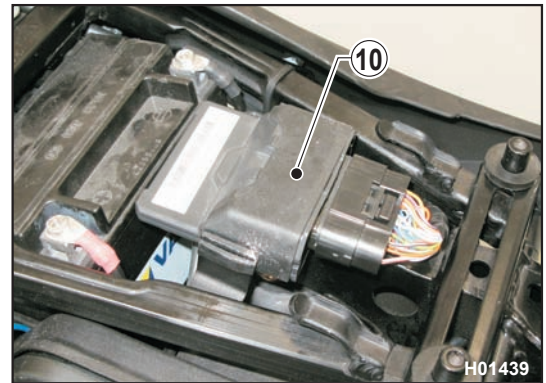

- **Voltage regulator position (11)**

Coat voltage regulator with heat grease.



- **Securing the starter motor/solenoid starter cable**

Connect the starter motor/solenoid starter cable (12) as shown in the figure.

- **Securing the engine / chassis / battery ground cables (13)**

The engine ground to chassis and engine ground to battery cables are secured to the screw found on the right engine crankcase.

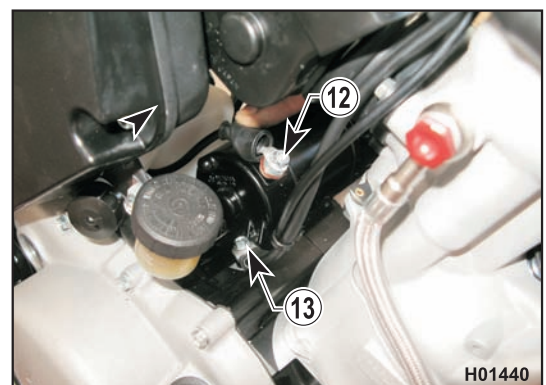

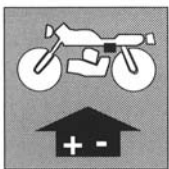

ELECTRICAL SYSTEM

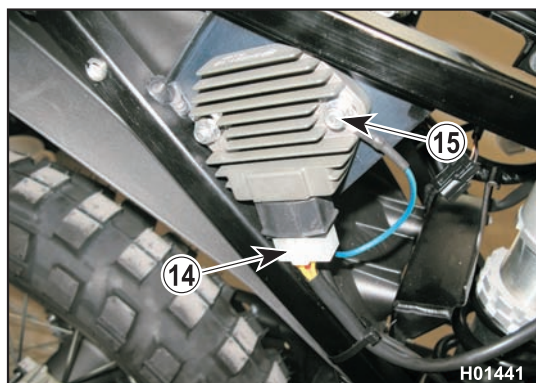

- **Wiring connection to voltage regulator**

Connect connector (14) to the regulator and tighten the ground cable (15) to the regulator retaining screw.

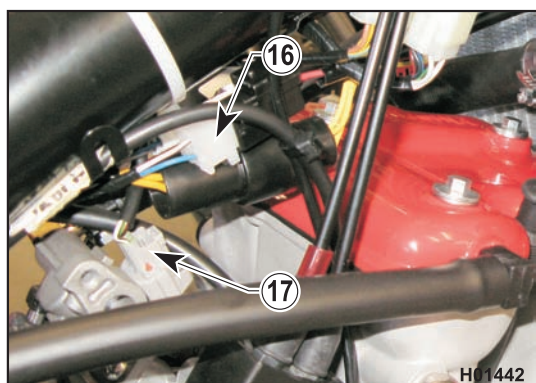

- **Electric fan connection**

Connect the electric fan connector (16).

- **Injector connection**

Connect the connector (17) to the throttle body.



- **MAQS connector connection**

Connect the connector (18) as shown.

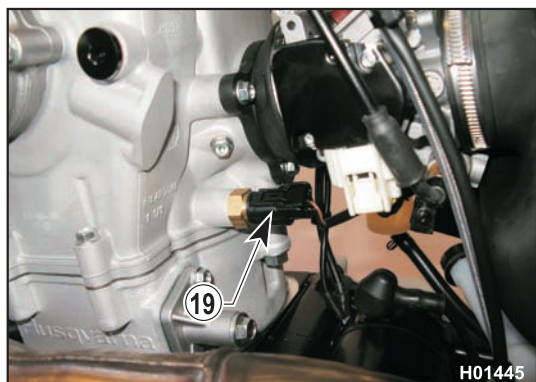

- **Engine water temperature connector**

Connect the engine water temperature connectors (19) to the thermostat.



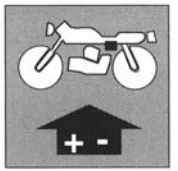

- **Lambda sensor position and connector**

Tighten the Lambda sensor (20) into its seat.

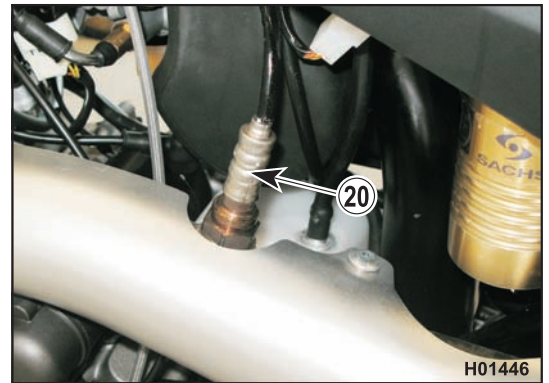

Connect the Lambda sensor connector (21) as shown.



- **Ignition switch and left-hand switch connection**

Connect the ignition switch (22) and left-hand switch (23) connectors as shown.

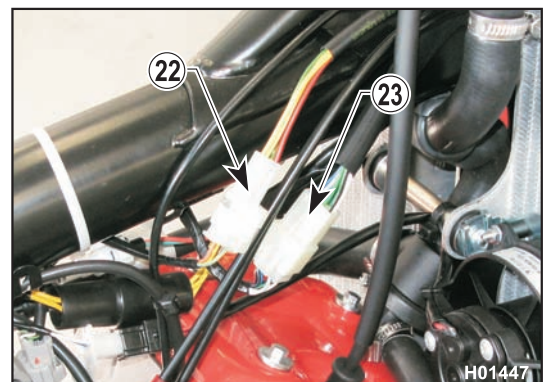

- **Right-hand switch connection**

Connect connector (24) as shown



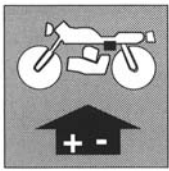

ELECTRICAL SYSTEM

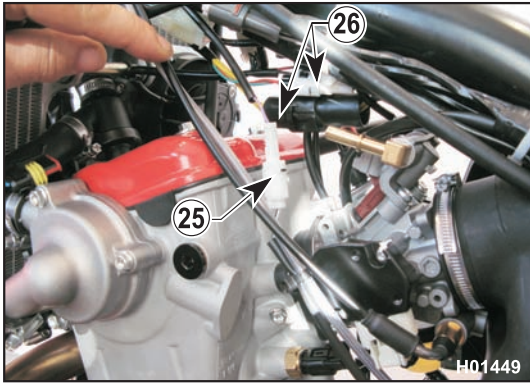

- **Ignition and gear sensor cable connection**

Connect the ignition (25) and gear sensor (26) connectors as shown.

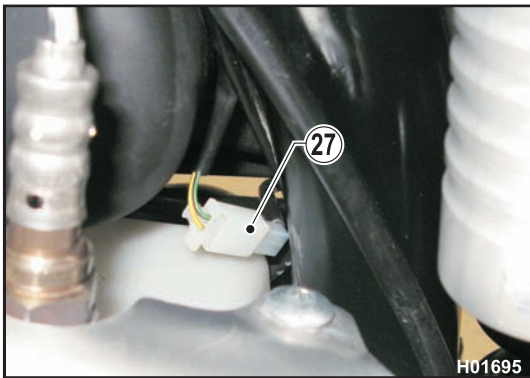

- **Rear stop connection**

Connect the wiring connector (27) to the rear STOP sensor.

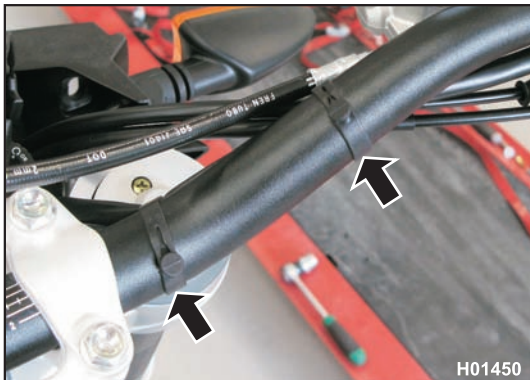

- **Securing the handlebar wiring harness**

Strap wiring to handlebar with rubber clips as shown in the figure.

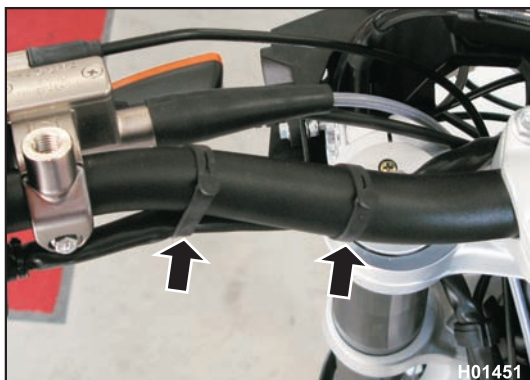

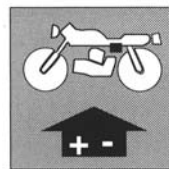

• Securing the dashboard bracket connectors

Secure dashboard connector (35) and diagnostic connector (36) using the suitable clip. Fit the cap to the diagnostic connector (36).

• Headlamp, front turning indicators, STOP light connection

Connect the headlamp unit to the matching connector.
 Connect the connectors (39) to the turning indicators.
 Connect the connector (40) to the front brake lever.
 Connect the connector (37) to the speed sensor.

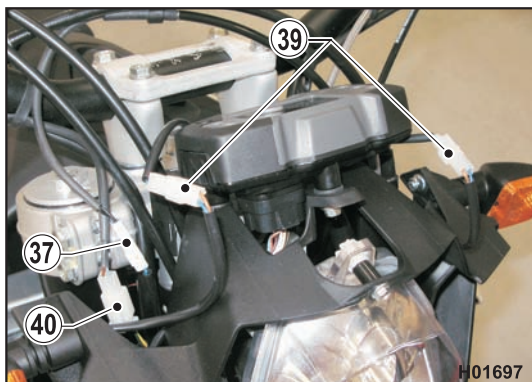

CABLE ROUTING

• Routing of steering head tube wiring

- Route the main wiring harness cables (1) on the left of the steering head tube into clip (2).
- Route the main wiring harness cables (3) on the right of the steering head tube and secure them with clip (4).
- Route the cables (5) over the bottom yoke.

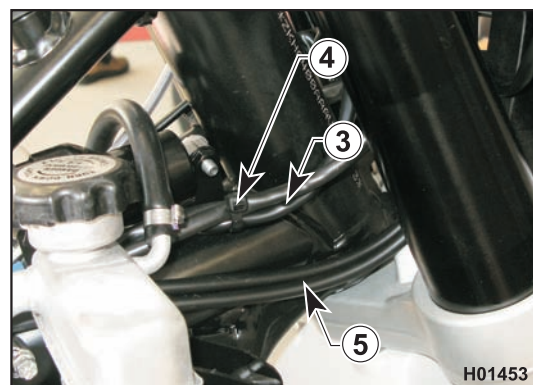
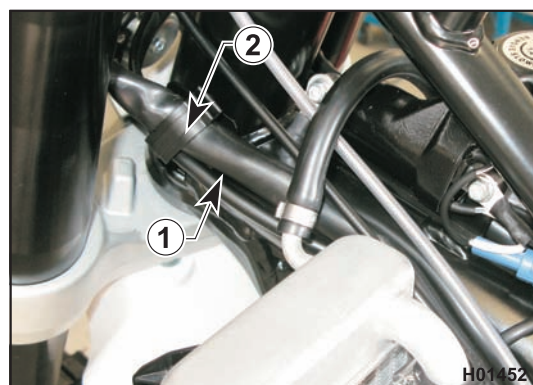

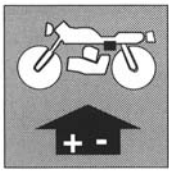

ELECTRICAL SYSTEM

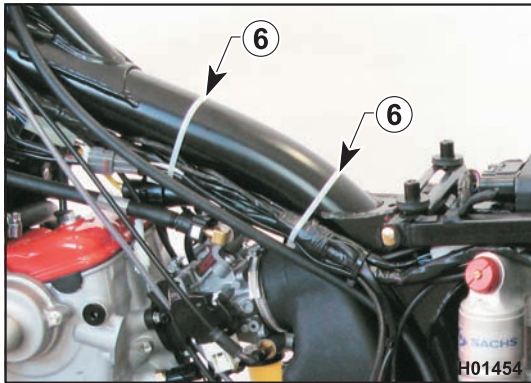

• Securing the wiring harness

Strap main wiring harness to chassis with clips (6).

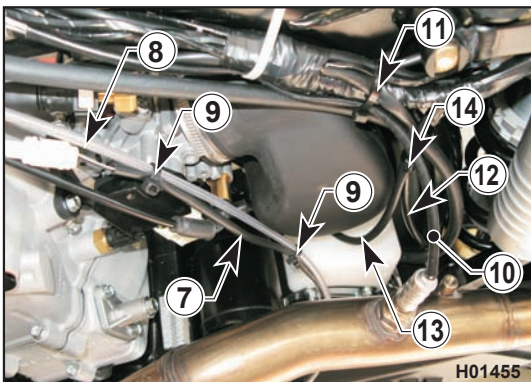

• Securing the gear sensor, Lambda sensor, Stop micro switch cables.

- Strap the gear sensor cable (7) to the clutch hose (8) with clips (9)
- Strap the Lambda sensor cable (10) to the wiring harness with clip (11).
- Strap the stop micro switch cable (12) to the battery negative cable (13) with clip (14).

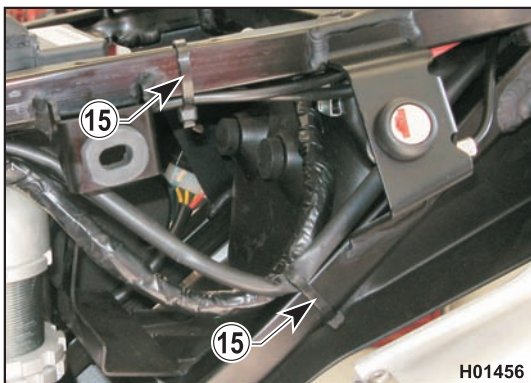

• Securing the wiring harness to the rear chassis

- Strap main wiring harness and light/turning indicator wiring harness to the rear chassis with clips (15) (route it over the rear shock absorber).

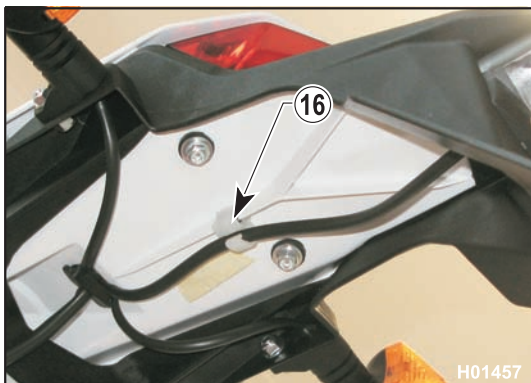

• Securing the wiring harness to the mudguard

- Secure the number plate light wiring harness to the clip (16).



ELECTRICAL SYSTEM

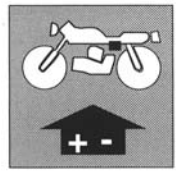

IMPORTANT

Before washing the motorcycle, it is necessary to duly protect the following parts from water:

- a) Rear opening of the muffler;
- b) Clutch and front brake levers, handgrips, handlebar switches;
- c) Air filter intake;
- d) Steering head, wheel bearings;
- e) Rear suspension drag drop link.

In addition to these precautions, **NEVER ALLOW HIGH-PRESSURE AIR OR WATER to get in contact with any ELECTRICAL PARTS, the FUEL INJECTION SYSTEM, and especially the electronic control unit (1).**

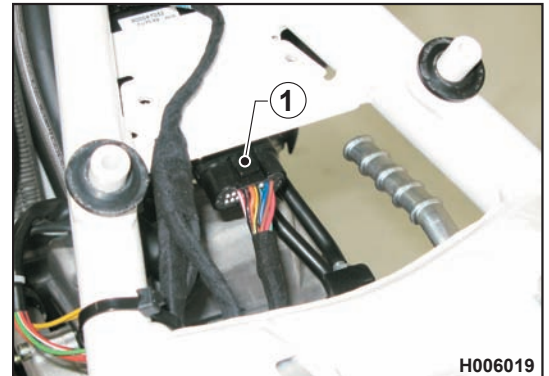

ENGINE COOLING

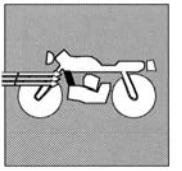

Section

N



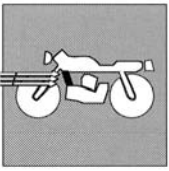

ENGINE COOLING

Coolant level check	N.3
Cooling circuit	N.4
Engine cooling system overhaul	N.5



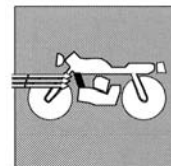

Coolant level check

Coolant takes the heat from the piston-cylinder-and-head assembly and transfers it to the radiator, where it is released to the atmosphere. Checking coolant level at regular periods is critical to ensuring proper operation of the cooling system.



Without cooling medium (water), no heat exchange occurs between cylinder head and radiator. The cylinder and piston assembly will overheat and seize and in the worst scenario, crankshaft damage may result.

If the event of engine overheating, check that the radiator is full. Level in the radiator must be checked from cold (see Section D). In the event you need to check level when the engine is hot, be sure to discharge pressure gradually. The radiator cap (1) has a pressure-relief position to depressurize the system safely.



Failure to follow the above instructions will create a risk of scalding for operator and any persons standing nearby. Because the cooling fan (2) can be activated even when the start switch is in OFF position, always keep at a safe distance from the fan blades.

- A. Coolant level
- B. Breather hose

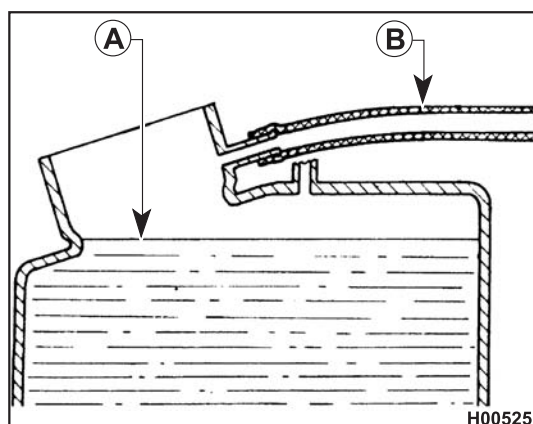
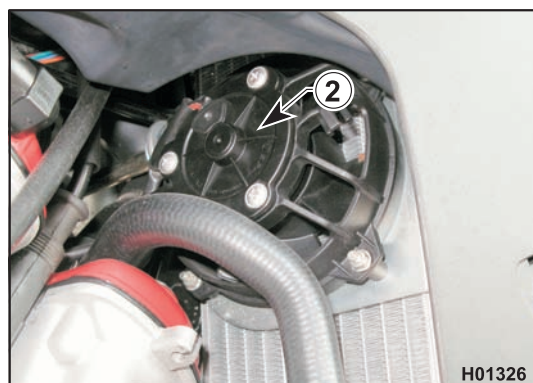

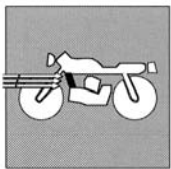

ENGINE COOLING

Cooling circuit

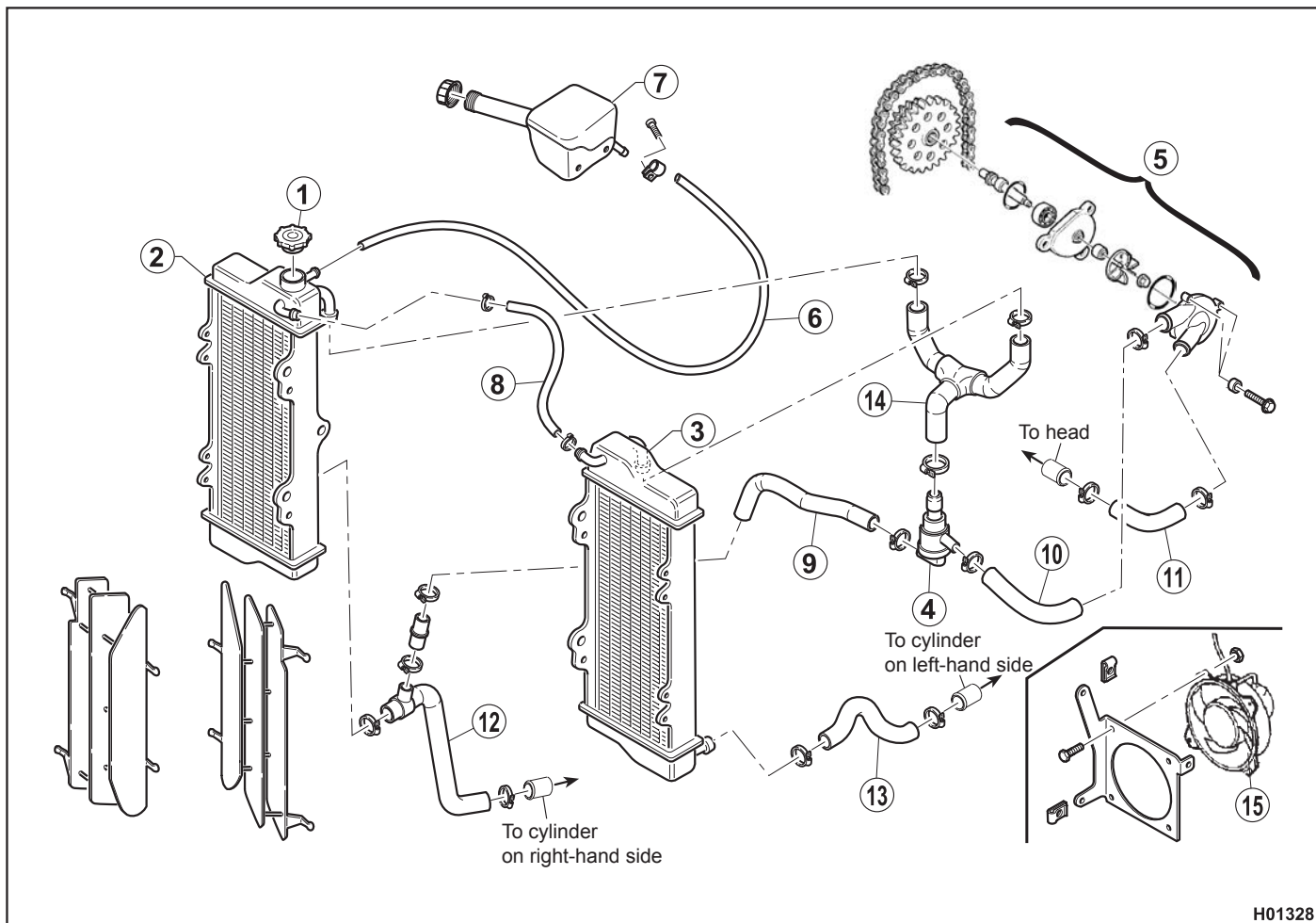

H01328

The forced circulation cooling system uses a centrifugal pump (located to the left of the head) and two down-draft radiators.

- 1 Radiator cap
- 2 Right-hand radiator
- 3 Left-hand radiator
- 4 Fitting
- 5 Water pump
- 6 Breather hose
- 7 Radiator connecting pipe
- 8 Radiators to cylinder head pipe
- 9 Water pump to fitting pipe
- 10 Fitting to left-hand radiator pipe
- 11 Fitting to right-hand radiator pipe



ENGINE COOLING

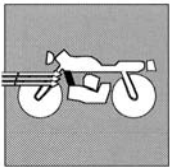

Engine cooling system overhaul (TC)

If the coolant runs too hot, check the radiators. Any foreign matter trapped between the fins (such as leaves, bugs, mud, etc.) will obstruct air flow and must be removed carefully to avoid damage to radiator. Straighten any bent fins to ensure free flow of air. If the cooling mass is clogged or damaged, no more than 20% of its surface must be affected. If damage exceeds this limit, the radiator must be replaced. Periodically check the connecting hoses (see Section B, "Scheduled Maintenance Chart"); this will avoid coolant leakage and consequent engine seizure. If hoses show cracks, swelling or hardening due to sheaths desiccation, their replacement shall be advisable. Check the correct tightening of the clamps.

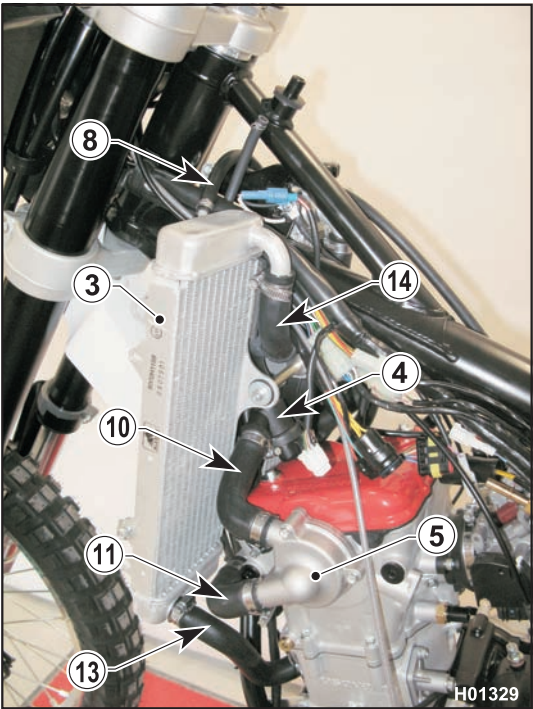
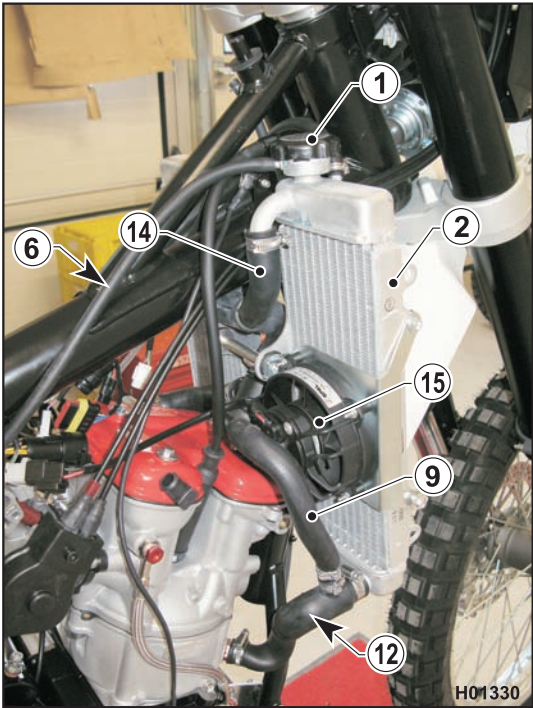

HYDRAULICALLY CONTROLLED CLUTCH

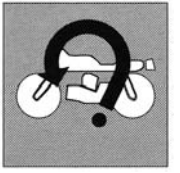

Section

P



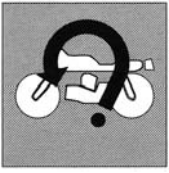

HYDRAULICALLY CONTROLLED CLUTCH

Hydraulic clutch system.....	P.3
Draining clutch fluid	P.4
Clutch master cylinder servicing.....	P.5
Bleeding the clutch system.....	P.6



HYDRAULICALLY CONTROLLED CLUTCH

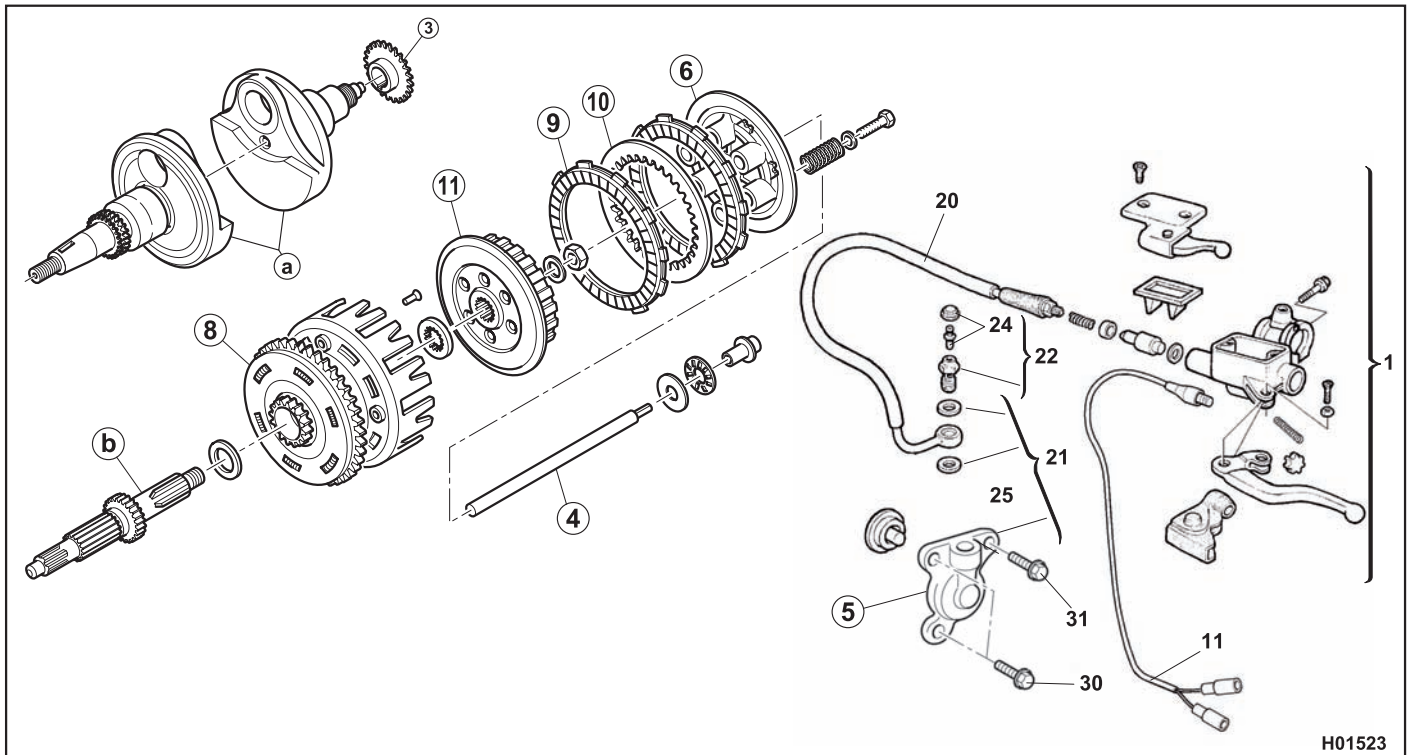
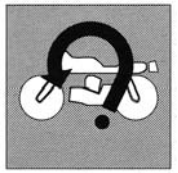

H01523

Hydraulic clutch system

The hydraulic circuit is composed of a master cylinder (1) with its reservoir located on the left side of the handlebar, and a piston (5) installed on the left crankcase half. The clutch is disengaged by the piston (5) that actuates the pushrod (4) to operate the pressure plate (6). Drive is transmitted from the crankshaft (a) to the gearbox input shaft (b) via the gear on the clutch housing (8). The clutch housing accommodates friction plates (9) and steel plates (10) that operate the clutch hub (11) secured to the gearbox input shaft.

- 1 Clutch master cylinder
- 2 Clutch lever
- 3 Master cylinder to piston hose
- 4 Pushrod
- 5 Piston assembly
- 6 Pressure plate
- 7 Bleed fitting
- 8 Clutch housing with clutch ring gear
- 9 Steel plate
- 10 Friction plate
- 11 Clutch hub
- a Crankshaft
- b Gearbox input shaft



The fluid used in the hydraulic circuit will damage painted parts if spilled on them. Handle it with care when servicing the system.



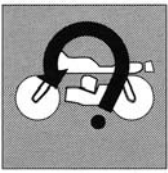

HYDRAULICALLY CONTROLLED CLUTCH



Draining clutch fluid

- Remove cap "A".
- Connect a plastic hose to the bleed valve (1) and loosen the valve turning it back 1 or 2 turns.
- Remove reservoir cap (2) and gasket (3) and operate the control lever (4) until draining all fluid.

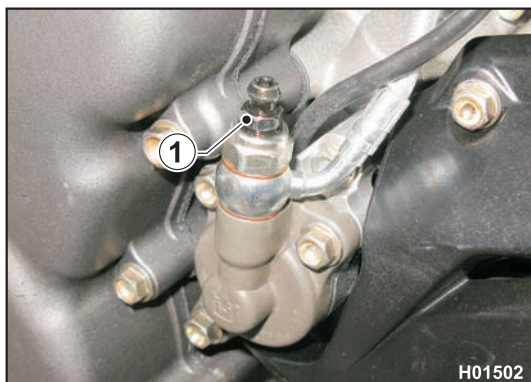
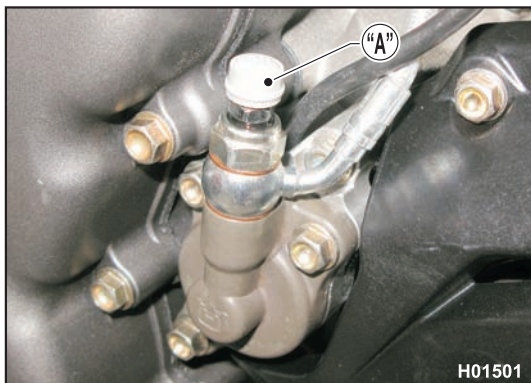
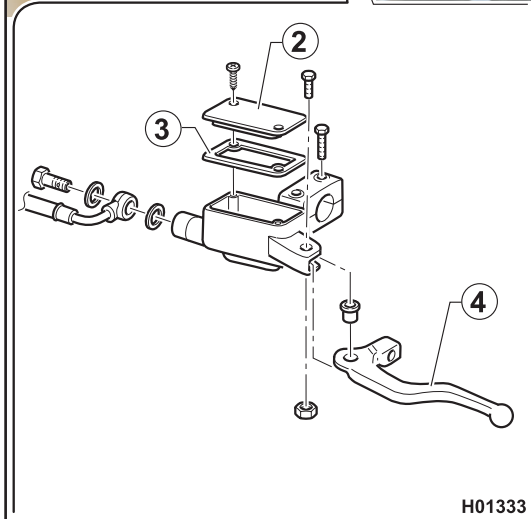

HYDRAULICALLY CONTROLLED CLUTCH

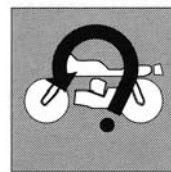

Clutch master cylinder servicing

Drain the circuit, detach the master cylinder from the left side of the handlebar and take it apart. Replace all seals, reassemble the master cylinder and refit it to the handlebar. Reconnect the hose and fill fresh fluid into the reservoir; bleed the system as described in the relevant paragraph.

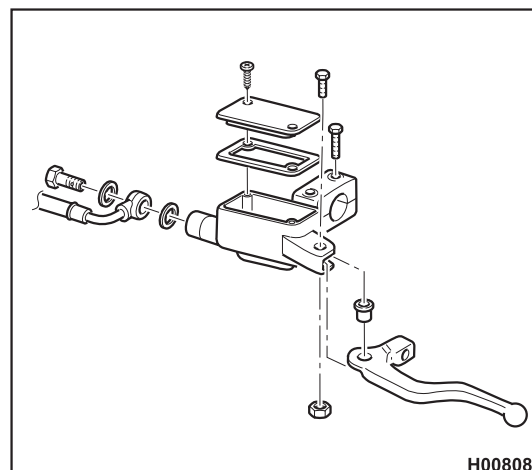

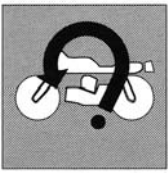

HYDRAULICALLY CONTROLLED CLUTCH

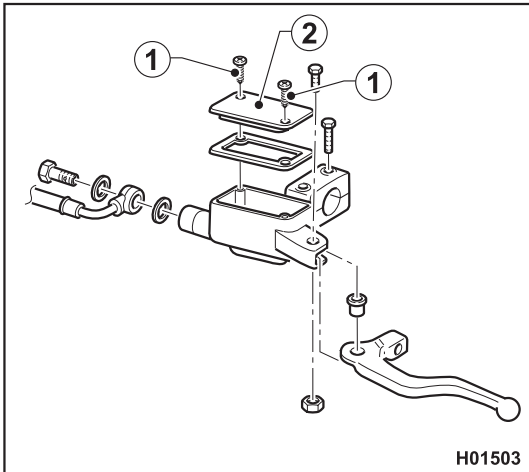

Bleeding the clutch system

A long travel and mushy feel of the clutch lever indicate that there is air in the system and the clutch hydraulic system needs bleeding. Bleeding procedure is as follows:



NEVER use brake fluid.

- Remove screws (1), cover (2) and rubber diaphragm;
- Remove the rubber gaiter (3);

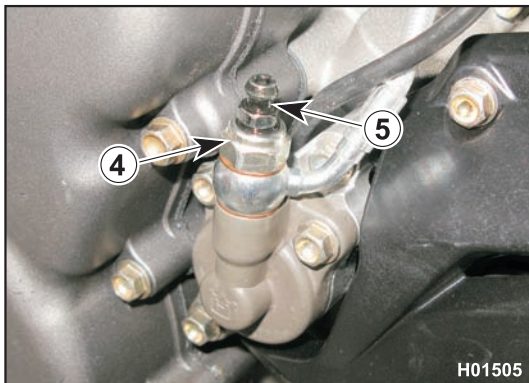
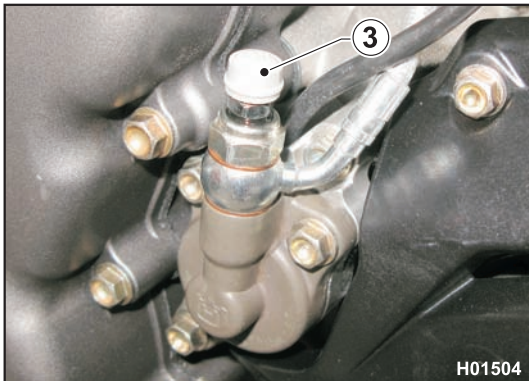

- Loosen the nipple (4)
- Connect a hose to a syringe and fit the other end of the hose to the fitting (5) of nipple (4);
- Add the fluid specified in the LUBRICANT CHART.

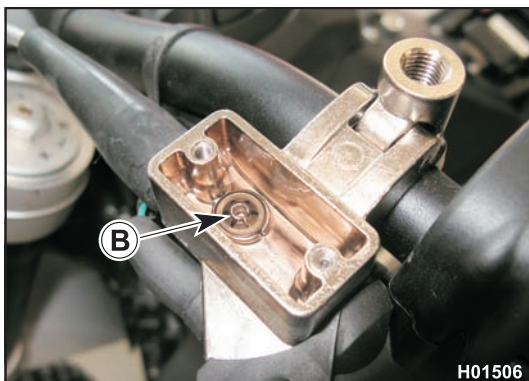

- Keep adding fluid until the fluid flowing out of the hole (B) on the pump body looks CLEAR of air bubbles.



HYDRAULICALLY CONTROLLED CLUTCH

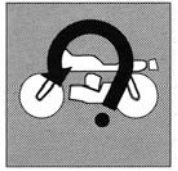

Check that fluid level is not lower than 4 mm below the upper edge (A) of master cylinder body. Refit any parts you have removed.



Fluid level inside the reservoir shall never drop below the minimum notch during the bleeding procedure.



Hydraulic fluid is corrosive. In the event of contact with eyes, rinse with abundant water.



Motorcycle handlebar must be turned to the right during the bleeding procedure. This will keep the master cylinder reservoir higher, making bleeding easier.



The bleeding procedure does not remove all air from the circuit; any small amounts of air left in the circuit will disappear after a short period of usage; this will eliminate the mushy feel of the lever and restore its travel to proper length.



Bleed valve tightening torque: 12-16 Nm, 1.2-1.6 Kgm, 8.7-11.6 ft/lb.

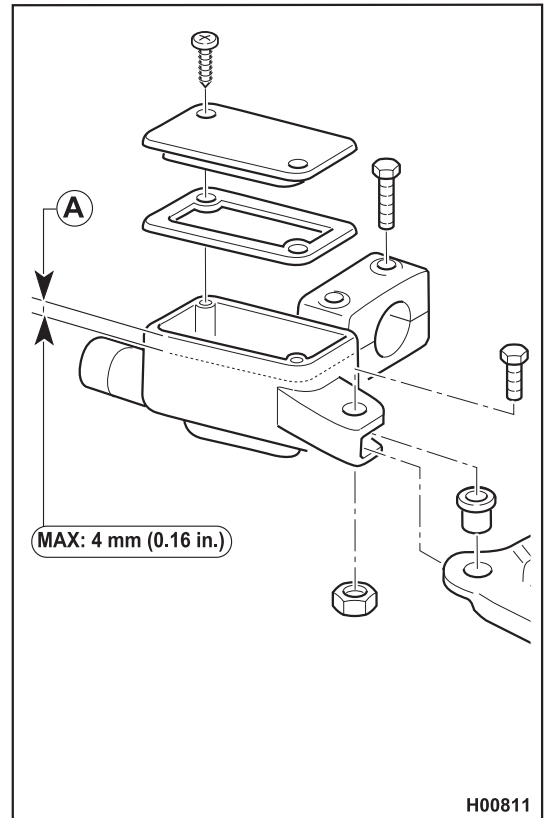

OPTIONAL COMPONENTS



Section

Q





OPTIONAL COMPONENTS

OPTIONAL COMPONENTS (TE)

Pos.	Part No.	Description
1	8A00A8006	CENTRE STAND ASSEMBLY (1)
2	8A0078466	ROTATION BUSHING (1)
3	800060898	SCREW TTEI M6x1-CH5 L15 (1)
4	800030319	WASHER D20-D6.4-THK2.5 (1)
5	800098910	STAND RETURN SPRING (1)
6	800048802	RUBBER BLOCK (2)
7	8B0096837	*CHAIN SPROCKET Z=48 (1)
7	8A0096837	*CHAIN SPROCKET Z=47 (1)
7	800096837	*CHAIN SPROCKET Z=46 (1)

OPTIONAL COMPONENTS (SMS)

Pos.	Part No.	Description
1	8000A8006	CENTRE STAND ASSEMBLY (1)
2	8A0078466	ROTATION BUSHING (1)
3	800060898	SCREW TTEI M6x1-CH5 L15 (1)
4	800030319	WASHER D20-D6.4-THK2.5 (1)
5	800098910	STAND RETURN SPRING (1)
6	800048802	RUBBER BLOCK (2)
7	800096837	*CHAIN SPROCKET Z=46 (1)
7	8B00A4859	*CHAIN SPROCKET Z=44 (1)
7	8A00A4859	*CHAIN SPROCKET Z=43 (1)

*** : "RACING" USE**

The assembly of these parts causes **THE VEHICLE NON COMPLIANCE WITH TYPE-APPROVAL REQUIREMENTS** and it is hence unsuitable for circulating on public roads: consequently it may be used only in "CLOSED CIRCUITS" by authorised subjects holding the relevant driving licence or authorisation.



OPTIONAL COMPONENTS

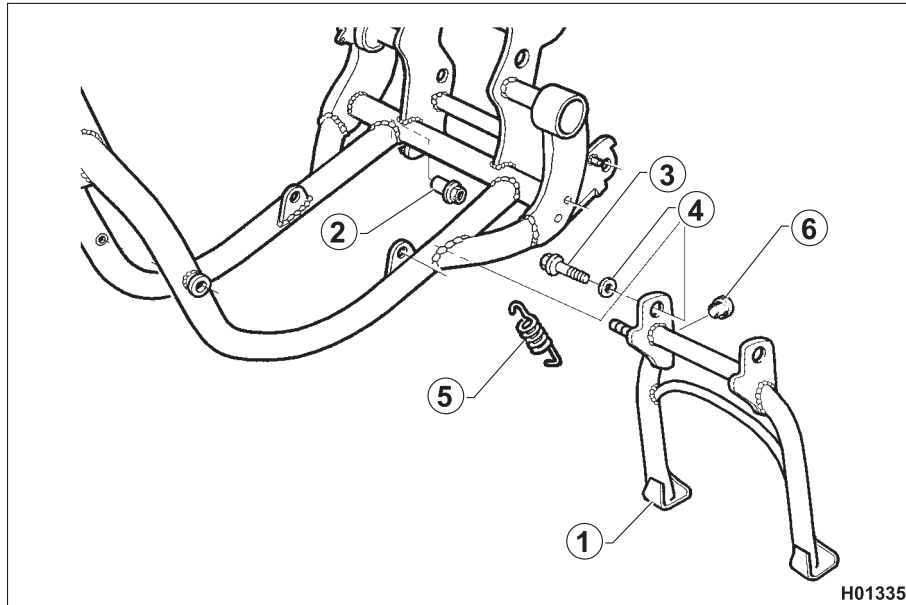

FUEL INJECTION SYSTEM

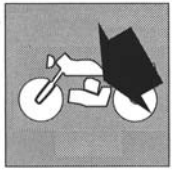

Section

S



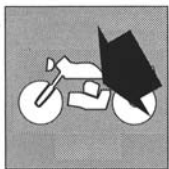

FUEL INJECTION SYSTEM

FUEL INJECTION SYSTEM.....	S.3
Operation Manual for "DIAGNOSTIC TOOL SOFTWARE KIT" for fuel injection system.....	S.4
Fuel pump test.....	S.6
Relay test	S.7



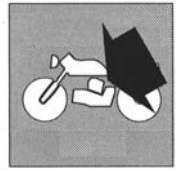

FUEL INJECTION SYSTEM

The fuel injection system is composed of fuel tank (1), electric pump (2), pipe (3) and injector (4). The fuel in the tank is pumped by the pump. The pressurised fuel flows into the injector installed on the throttle body (6). The electronic control unit (5) located under the saddle signals the injector to open and a fan-shaped spray of fuel is injected into the combustion chamber.

The parameters that play a role in determining proper fuel delivery under all operating conditions are as follows:

- Air temperature in the intake manifold;
- Engine coolant temperature;
- Atmospheric pressure in the intake manifold (in current location and at current altitude);
- Throttle opening;
- SMS 630 Rollover;
- Lean or rich mixture (LAMBDA sensor);
- Battery voltage;
- Sensor power supply unit;
- Gear shift position;
- Fuel injection pulse width;
- Ignition coil;
- Lambda sensor heater.

The DIAGNOSTIC TOOL SOFTWARE KIT (see page S.3-S.4) lets you test the components listed above in the event of a fuel injection malfunction.

The electric fuel pump (2) is installed on the bottom of the tank (1) and is composed of rotor, magnet, impeller, brushes, control valve and relief valve. The electronic control unit (5) switches the pump ON/OFF.

To remove the fuel pump, you first need to remove the fuel tank as described in Section "E" (fuel pump inspection is covered in a separate paragraph).

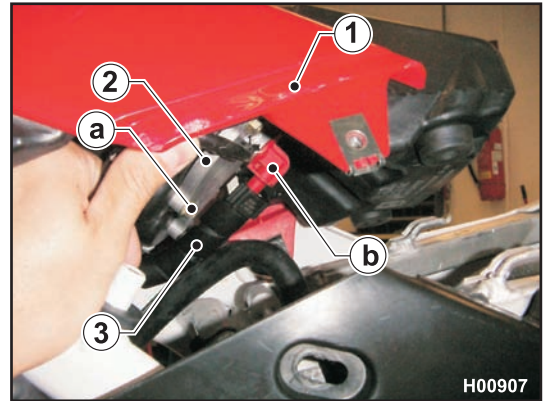

H00907

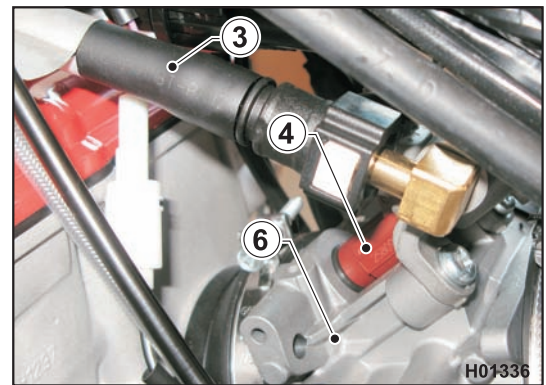

H01336

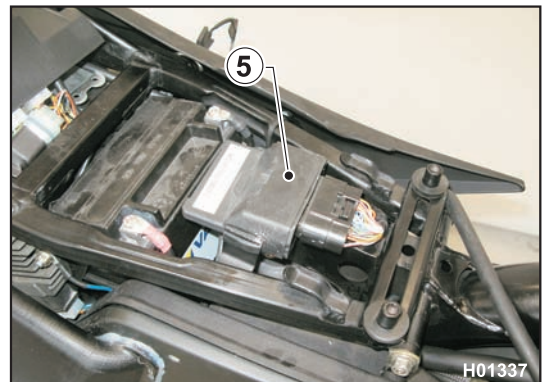

H01337

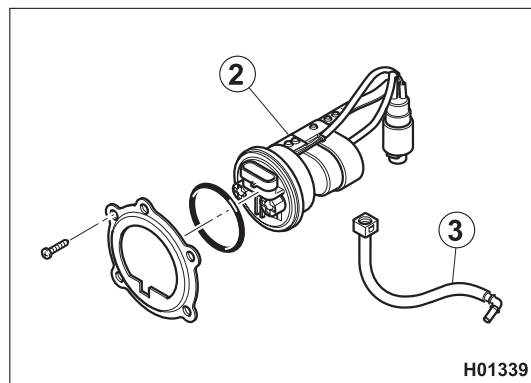

H01339

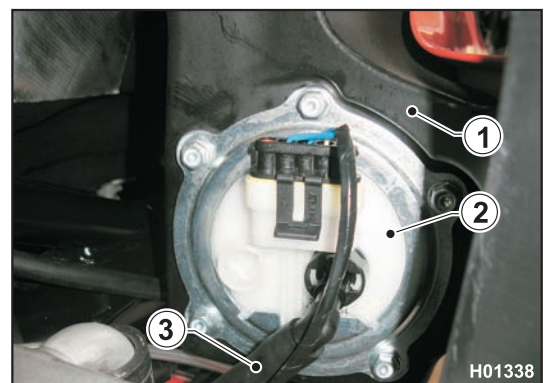

H01338



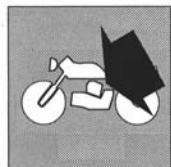

FUEL INJECTION SYSTEM



Operation Manual for "DIAGNOSTIC TOOL SOFTWARE KIT" for fuel injection system.

The fuel injection system does not require scheduled maintenance. The DIAGNOSTIC TOOL SOFTWARE KIT part no. 8A00 A9634 lets you test system components in the event of a malfunction. A malfunction is indicated by the word "FAIL" appearing in the right-hand portion of the dashboard display when the ignition key is set to ON and the right switch is set to RUN.

The DIAGNOSTIC TOOL SOFTWARE KIT (A) is composed of:

- "Diagnostic Tool" Software CD-ROM, including User Guide (PDF), Operation Manual (PDF);
- User Guide hard-copy;
- Operation Manual hard-copy;
- PC cable for connection to electronic control unit (ECU) connector.



After installing the Diagnostic Tool Software according to the instructions provided in the User Guide, proceed as follows:

- remove the front fairing (1);

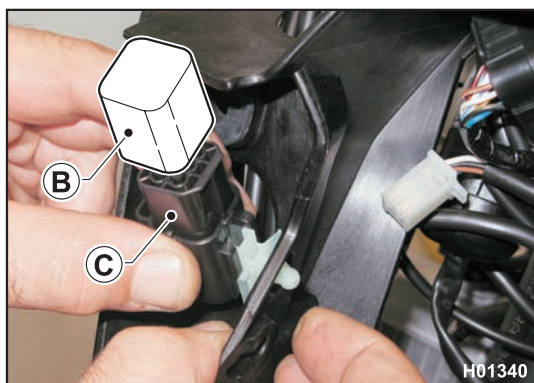

- slip off the cap (B) of the ECU interface connector (C);
- connect the Kit cable (D) to the connector (C) and the serial port (E) of your PC;
- turn the ignition key (F) to ON and set the right switch (G) to RUN;
- start the "Diagnostic Tool" software you have installed and perform the required tests.



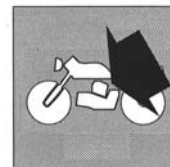

If the throttle body (H) has been removed and/or replaced, the TPS will need to be re-initialised using options "TPS idle setting" (see Operation Manual) and "Feedback Correction" (Operation Manual). For "Feedback Correction Value", see fig. 9-3-4 on page S.6.



This diagnostic software can check the following injection parameters:

- 1 - AIR TEMPERATURE (air temperature in the intake manifold);
- 2 - WATER TEMPERATURE (engine coolant temperature);
- 3 - AIR PRESSURE (atmospheric pressure in current location and at current altitude);
- 4 - THROTTLE POSITION (throttle opening rate);
- 5 - TILT SENSOR (SMS: detects rollover);
- 6 - O2 SENSOR (detects lean or rich mixture);
- 7 - BATTERY SENSOR (battery voltage);
- 8 - SENSOR POWER SUPPLY (power supply unit feeding the sensors);
- 9 - GEAR SHIFT POSITION (currently selected gear shift position);
- 10 - INJECTOR (fuel injection pulse width);
- 11 - IGNITION COIL (device that stores energy in the reel and discharges it to the spark plug);
- 12 - O2 SENSOR HEATER (heats O2 sensor up to a temperature that will provide a stable output).

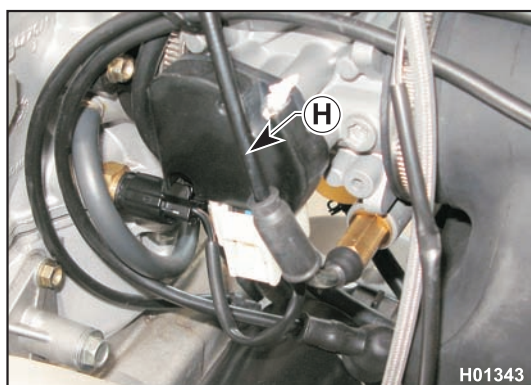
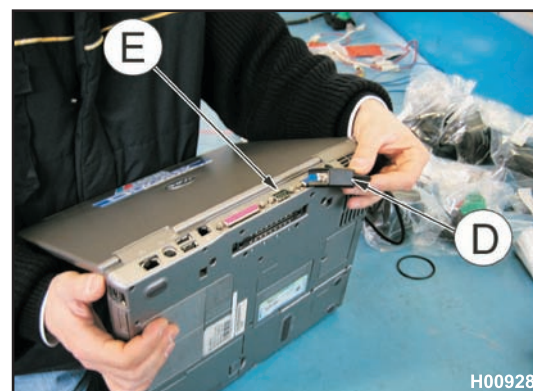
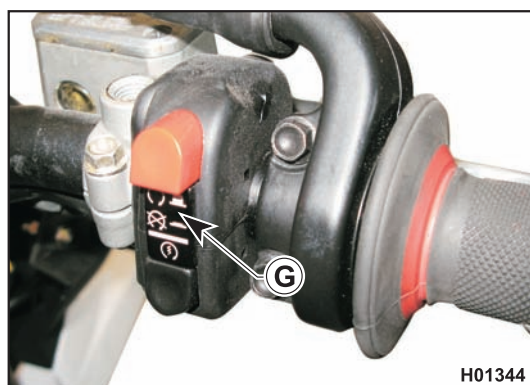
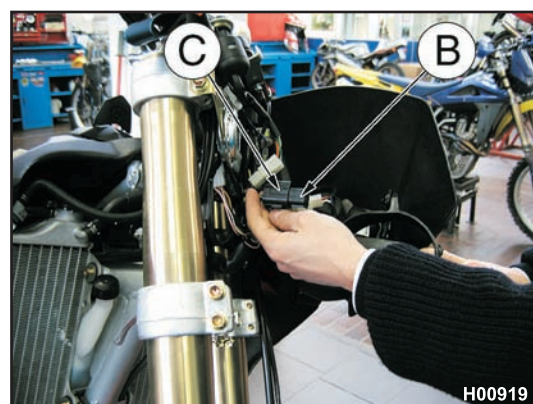
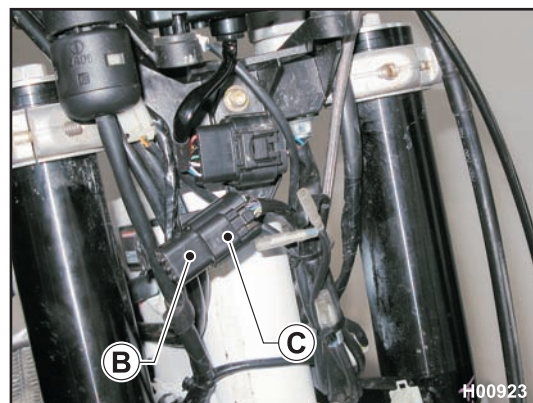

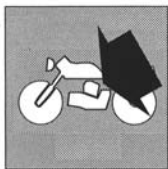

FUEL INJECTION SYSTEM



In addition to identifying any current malfunction, the software stores past malfunctions that have been resolved: store malfunctions can be deleted following the instructions provided in the Operation Manual.



The ECU stores the number of service hours of the engine (tolerance range: ± 1 hour). The first equipment ECU also stores the vehicle identification number (VIN) and engine number (engine no.) of the motorcycle. If ECU is replaced, the new ECU will only report engine service hours.

NOTES

The green neutral light ONLY turns on when the ignition key is set to ON and the right switch to RUN.

When the ignition key is turned to the ON position, the front and rear lights and the display light up.

Left switch functions and the stop light can ONLY be selected when the engine is running.

For fuel pump and relay inspections, see relevant paragraphs.

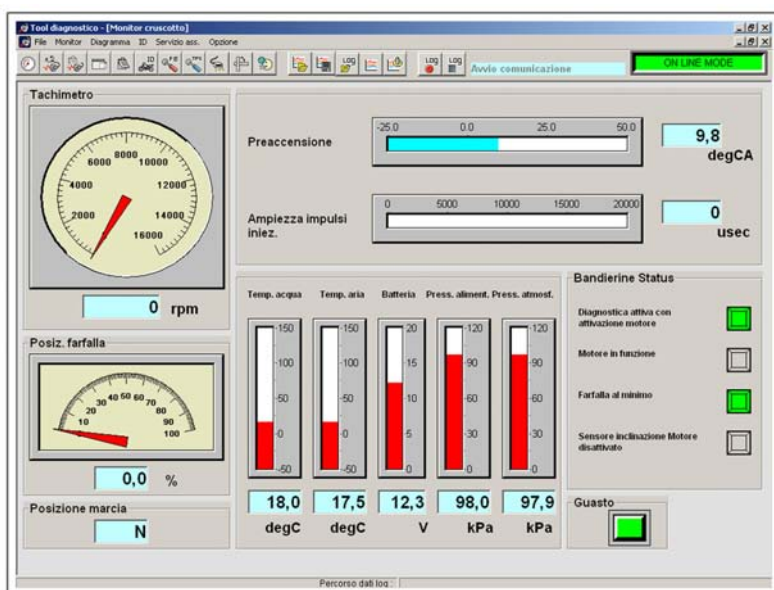

Set setting No.1 so as to set "Feedback Correction" to around 100%

Settings No.2 and 3: DO NOT ALTER THESE SETTINGS (100%)

Fig. 9-3-4



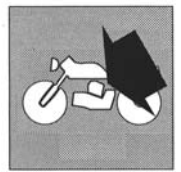

Fuel pump inspection

Remove the pump as described on page S.2.

fuel reserve sensor

Make sure there is no fuel left in the sensor and then set the meter to the "Impedance" scale and measure across contacts T3 and T4. Correct value is as follows: 1.3 KOhm (+/- 10%) at 20 °C.

pump operation

Connect contacts T5 and (-) T2 to a power supply unit with constant 12V output and make sure that the pump runs.



Never keep the pump connected to the power supply unit for more than 3 seconds in a row.

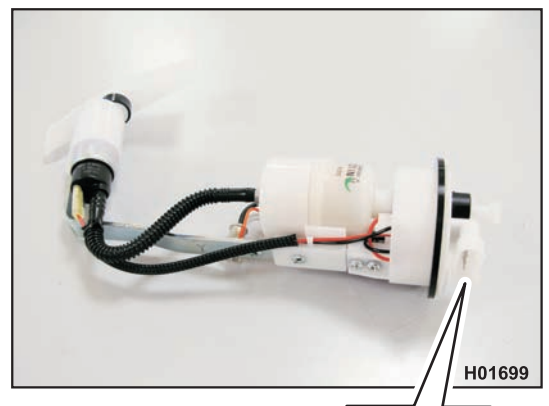
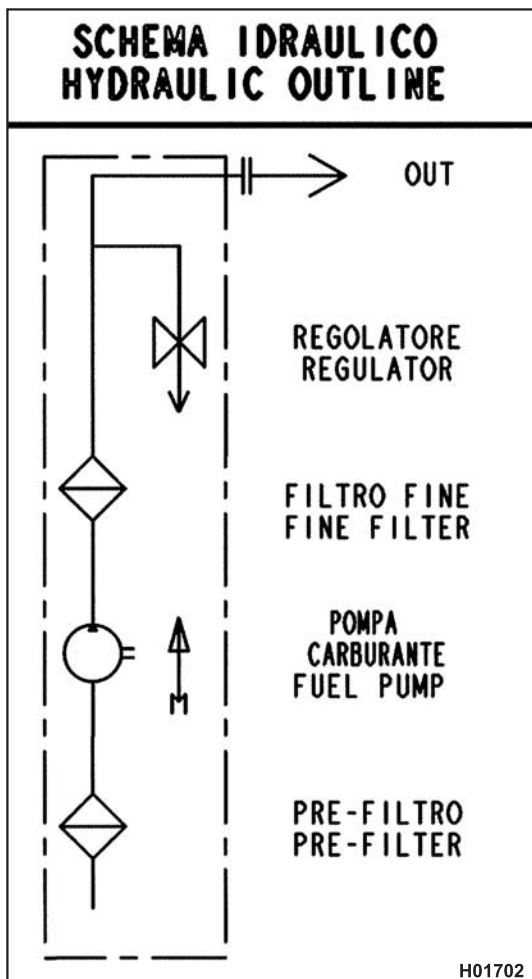
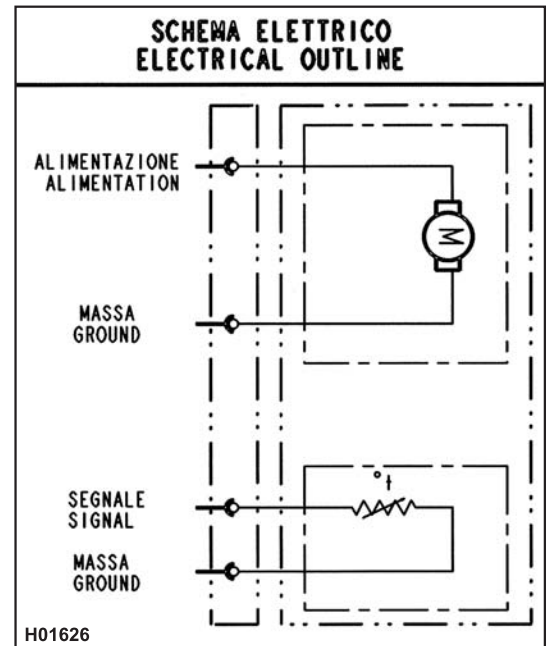

T1	Terminal 1 Not occupied
T2	Terminal 2 Pump power supply Negative terminal -
T3	Terminal 3 Thermistor Ground (Reserve)
T4	Terminal 4 Thermistor Ground (Reserve)
T5	Terminal 5 Pump power supply Positive terminal +

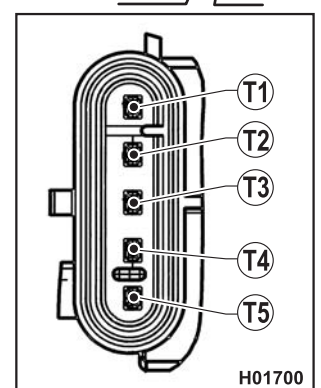

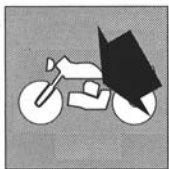

FUEL INJECTION SYSTEM

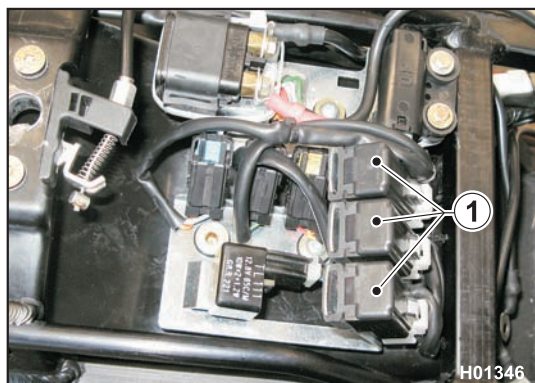

Relay test

Remove cover of saddle and utilities as described in "Section E". Remove the relays (1) located on the utilities holder plate.

A: Set the meter to the "Impedance" scale and check the energiser coil for proper operation. Reading should be: 80 Ohm (+/- 10%) at 20 °C.

B: Set the meter to "Continuity" mode and check the circuit is open.

C: Feed the coil from a power supply unit with stable 12V output and make sure that the circuit closes.

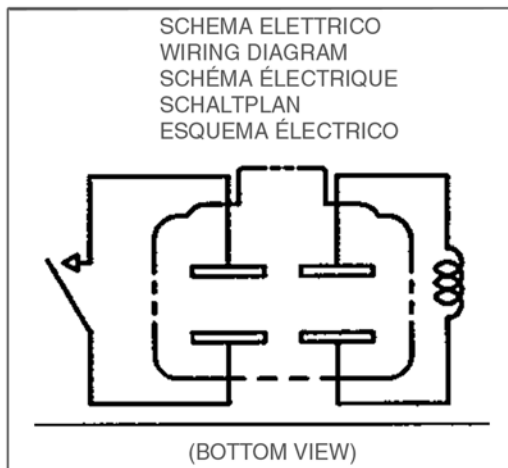
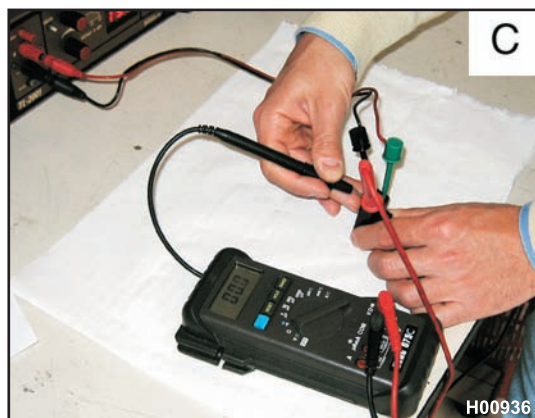
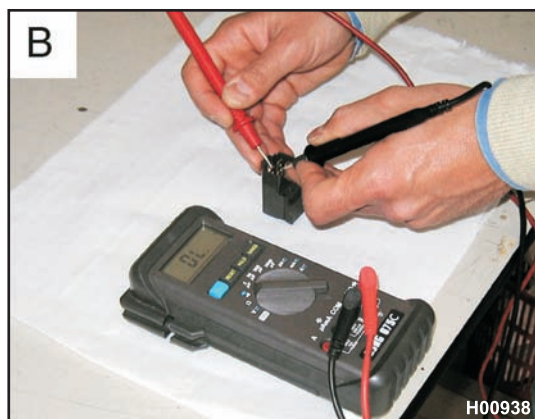
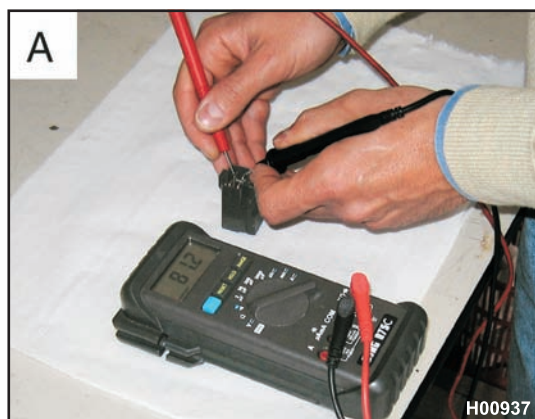

SPECIAL TOOLS

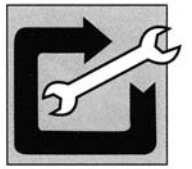

Section **W**





SPECIAL TOOLS

SPECIAL TOOLS

- | | | |
|----|--------------|---------------------------------------|
| 1 | (8000 89743) | Crankcase puller |
| 3 | (8000 39523) | Flywheel puller |
| 5 | (8000 90662) | Engine jig |
| 7 | (8000 A8072) | Flywheel removal tool |
| 8 | (8000 A1625) | Dial gauge mount |
| 10 | (8A00 H1387) | Diagnostic CD |
| 12 | (8000 39521) | Valve installation / removal tool |
| 13 | (1519 84701) | Spring hook |
| 14 | (8000 39524) | Clutch hub tool |
| 15 | (8000 90611) | Crankcase bearing puller |
| 21 | (8000 83254) | Crankshaft guard for flywheel removal |
| 23 | (8000 H1154) | ECU programming kit |

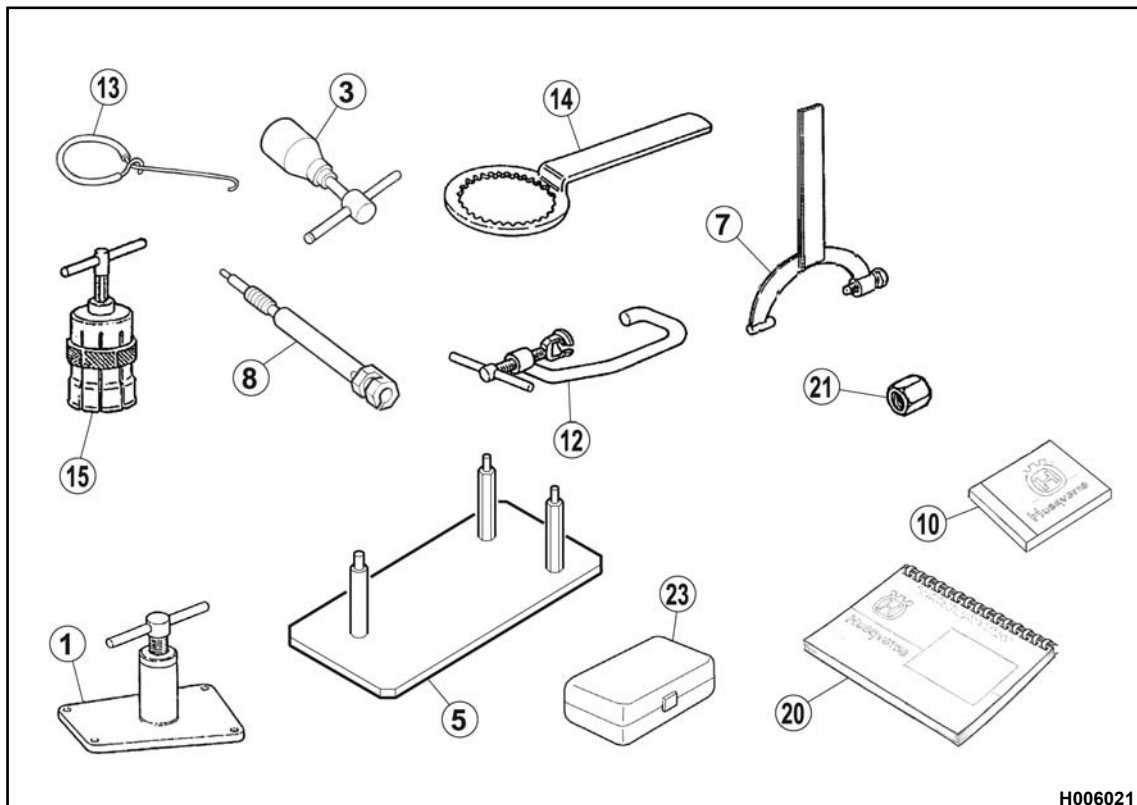

TIGHTENING TORQUE FIGURES

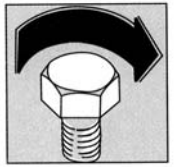

Section



Tighten all nuts and screws to the specified torque using a torque wrench. If not tightened securely, a nut or a screw might become damaged or work itself loose, causing damage to motorcycle and injury to rider. An overtightened nut or screw might become damaged, its thread might strip, or the nut/screw might fail and work itself loose. Listed in the table are the tightening torque figures for the most important nuts and screws, which have determined in accordance with thread diameter, pitch and specific application. These figures are obtained after cleaning the threads with solvent.



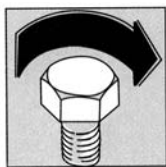

TIGHTENING TORQUE FIGURES

TIGHTENING TORQUE FIGURES (+/- 5%) ENGINE (8000 H1759)

Engine/Cylinder-Head

N° DISEGNO DRAWING N°	DESCRIZIONE DESCRIPTION	DIMENSIONI DIMENSION	COPPIA DI SERRAGGIO TORQUE WRENCH SETTINGS ± 5 %		NOTE NOTE	
			CARICO DI ROTTURA ULTIMATE STRENGTH N / mmq	N m Kg m		
Z00054700	DADO FISSAGGIO TESTA HEAD FASTENING NUT	M 8x1.25	590 - 785	15	1.5	
800091589	DADO FISSAGGIO TESTA E CILINDRO FASTENING NUT CYLINDER-HEAD	M 10x1.5	800 min	37 + 90°	3.8 + 90°	MOLIKOTE HSC (RAMATO)
8A0085071	VITE CAPPELLO CAMMES CAMSHAFT HOLDER SCREW	M 6x1	1200 min	12	1.2	
800099711	TAPPO PERNO BILANCIERE ROCKER ARM PIN PLUG	M 14x1.5	560 min	25	2.55	LOCTITE N° 243
800091587	VITE FISS. COPERCHIO TESTA HEAD COVER FASTENING SCREW	M 6x1	800 min	8	0.8	
80A0A0574	VITE TE FORATA PER RACCORDO HOSE DRILLED FASTENING SCREW	M 10x1	500 min	15	1.5	
800063885	RACCORDO PORTACOMMA UNION PIPE	M 14x1.5	330 min	25	2.55	LOCTITE N° 542
8000A6736	SENSORE TEMPERATURA ACQUA WATER TEMPERATURE SENSOR	M 10x1.25		15 ±1	1.5 ±0.1	MOTORI CON I. E.
ZD0067997	VITE CANISTER CANISTER SCREW	M 5x0.8	800 min		0.5	LOCTITE N° 243 MOTORI DAL MY 09 ESCLUSO VARIANTI USA

Motore/Manovellismo

N° DISEGNO DRAWING N°	DESCRIZIONE DESCRIPTION	DIMENSIONI DIMENSION	COPPIA DI SERRAGGIO TORQUE WRENCH SETTINGS ± 5 %		NOTE NOTE	
			CARICO DI ROTTURA ULTIMATE STRENGTH N / mmq	N m Kg m		
800071031	DADO FISSAGGIO MASSA GROUND NUT FASTENING	M18x1.25	870-1140	70	7.2	
800003170	DADO FISSAGGIO INGRANAGGIO COTRALBERO COUNTERSHAFT GEAR NUT FASTENING	M16x1.25	600 min	70	7.2	
800047871	GRANO HEXAGONAL SCREW	M8x1.25	800 min	11	1.12	LOCTITE N° 243

Motore/Trasmissione

N° DISEGNO DRAWING N°	DESCRIZIONE DESCRIPTION	DIMENSIONI DIMENSION	COPPIA DI SERRAGGIO TORQUE WRENCH SETTINGS ± 5 %		NOTE NOTE	
			CARICO DI ROTTURA ULTIMATE STRENGTH N / mmq	N m Kg m		
800086006	DADO FISSAGGIO INGRANAGGIO CONDUTTORE DRIVING GEAR FASTENING NUT	M 24x1.25	870-1140	100	10.2	LOCTITE N° 243

Motore/Distribuzione

N° DISEGNO DRAWING N°	DESCRIZIONE DESCRIPTION	DIMENSIONI DIMENSION	COPPIA DI SERRAGGIO TORQUE WRENCH SETTINGS ± 5 %		NOTE NOTE	
			CARICO DI ROTTURA ULTIMATE STRENGTH N / mmq	N m Kg m		
Z00055699	VITE FISS. DISCO CENTRIFUGO CENTRIFUGAL DISK FASTENING SCREW	M 6x1	800 min	8	0.8	LOCTITE N° 243
161535902	VITE FISSAGGIO PATTINO SLIDER FASTENING SCREW	M 8x1.25	800 min	12	1.23	
	TAPPO RITEGNO MOLLA TENDITORE SEAL PLUG FOR TENSIONER SPRING	M 6x1	----	5	0.5	

Motore/Basamento

N° DISEGNO DRAWING N°	DESCRIZIONE DESCRIPTION	DIMENSIONI DIMENSION	COPPIA DI SERRAGGIO TORQUE WRENCH SETTINGS ± 5 %		NOTE NOTE	
			CARICO DI ROTTURA ULTIMATE STRENGTH N / mmq	N m Kg m		
60ND02866	VITE FISSAGGIO LAMELLA VALVOLA OLIO OIL VALVE PLATE SCREW FASTENING	M 4x0.7	500 min	3	0.3	LOCTITE N° 243
Z00062725	VITE FISSAGGIO PIASTRINA PER PARAOLIO OIL SEAL PLATE SCREW FASTENING	M 6x1	800 min	9	0.92	LOCTITE N° 243
800049608	VITE FISSAGGIO RITEGNO ANELLO TENUTA SEAL RING BLOCK SCREW FASTENING	M 5x0.8	1040 min	6	0.61	LOCTITE N° 243
Z00042643	VITE FISS. PIASTRINA RITEGNO CUSC. ALBERO PRIMARIO PRIMARY SHAFT BEARING PLATE SCREW FASTENING	M 6x1	800 min	9	0.92	LOCTITE N° 243
ZA0066525	VITE FISS. PIASTRINA RITEGNO CUSCINETTO BEARING PLATE SCREW FASTENING	M 5x0.8	800 min	8	0.8	LOCTITE N° 243
ZA0067997	VITE FISS. PIASTRINA PER PARAOLIO OIL SEAL PLATE SCREW FASTENING	M 5x0.8	800 min	8	0.8	

1 Nm = 0.73756 ft/lb



TIGHTENING TORQUE FIGURES

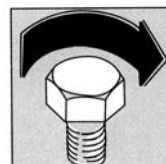

Engine/Lubrication System

N° DISEGNO DRAWING N°	DESCRIZIONE DESCRIPTION	DIMENSIONI DIMENSION	CARICO DI ROTTURA ULTIMATE STRENGTH	COPPIA DI SERRAGGIO TORQUE WRENCH SETTINGS ± 5 %		NOTE NOTE
			N / mmq	N m	Kg m	
800075415	TAPPO SCARICO OLIO DRAIN OIL PLUG	M 14x1.5	500 min	24	2.45	
800096747	TAPPO SCARICO OLIO DRAIN OIL PLUG	M 22x1.5	330 min	30	3.0	

Engine/Electrical System

N° DISEGNO DRAWING N°	DESCRIZIONE DESCRIPTION	DIMENSIONI DIMENSION	CARICO DI ROTTURA ULTIMATE STRENGTH	COPPIA DI SERRAGGIO TORQUE WRENCH SETTINGS ± 5 %		NOTE NOTE
			N / mmq	N m	Kg m	
800049004	DADO FISSAGGIO VOLANO FLYWHEEL FASTENING NUT	M 16x1.25	835-1130	130	13.2	
60N102511	VITE FISSAGGIO STATORE STATOR FASTENING SCREW	M 6x1	800 min	8	0.8	LOCTITE N° 270
8000A0573	CANDELA ACCENSIONE SPARK PLUG	M 10x1	-----	12	1.23	MOLIKOTE HSC (RAMATO)
60N102461	VITE FISSAGGIO PICK-UP PICK-UP FASTENING SCREW	M 4x0.7	800 min	3	0.3	LOCTITE N° 272
8A0078674	VITE FISSAGGIO ANELLO ESTERNO ROTORE ROTOR RING SREW FASTENING	M 6x1	1040 min	20	2	LOCTITE N° 270

Engine/Clutch

N° DISEGNO DRAWING N°	DESCRIZIONE DESCRIPTION	DIMENSIONI DIMENSION	CARICO DI ROTTURA ULTIMATE STRENGTH	COPPIA DI SERRAGGIO TORQUE WRENCH SETTINGS ± 5 %		NOTE NOTE
			N / mmq	N m	Kg m	
800036856	DADO FISSAGGIO MOZZO E CAMPANA HUB AND HOUSING FASTENING NUT	M 18x1	835 - 1130	61.7	6.3	

Engine/Gear shift control

N° DISEGNO DRAWING N°	DESCRIZIONE DESCRIPTION	DIMENSIONI DIMENSION	CARICO DI ROTTURA ULTIMATE STRENGTH	COPPIA DI SERRAGGIO TORQUE WRENCH SETTINGS ± 5 %		NOTE NOTE
			N / mmq	N m	Kg m	
Y00028327	VITE FISSAGGIO PIASTRINA DISINNESTO RELEASE PLATE FASTENING SCREW	M 6x1	1040 min	10	1.02	
800071011	VITE FISS. TAMBURO SELETORE GEARSHIFT SPROCKET FASTENING SCREW	M 8x1.25	800 min	28	2.85	LOCTITE N° 243
8B0054139	VITE FISSAGGIO SALTERELLO CLICK FASTENING SCREW	M 6x1	780-980	9	0.92	LOCTITE N° 243
8C0067997	VITE FISSAGGIO SEGNALE MARCE GEAR SENSOR FASTENING SCREW	M 5x0.8	800 min	8	0.8	LOCTITE N° 243

Engine/Cooling System

N° DISEGNO DRAWING N°	DESCRIZIONE DESCRIPTION	DIMENSIONI DIMENSION	CARICO DI ROTTURA ULTIMATE STRENGTH	COPPIA DI SERRAGGIO TORQUE WRENCH SETTINGS ± 5 %		NOTE NOTE
			N / mmq	N m	Kg m	
Z00056443	DADO FISS. GIRANTE POMPA ACQUA WATER ROTOR PUMPS NUT FASTENING	M 5x0.8	600 min	6	0.6	LOCTITE N° 243
Z00062730	VITE FISSAGGIO CORPO POMPA ACQUA WATER PUMPS BODY FASTENING SCREW	M 6x1	800 min	8	0.8	LOCTITE N° 542

DOVE NON DIVERSAMENTE INDICATO COPPIE DI SERRAGGIO STANDARD PER LE SEGUENTI FILETTATURE IF NOT OTHERWISE SPECIFIED, STANDARD TIGHTENING TORQUES FOR THE FOLLOWING THREAD	DIMENSIONI DIMENSION	CARICO DI ROTTURA ULTIMATE STRENGTH	COPPIA DI SERRAGGIO TORQUE WRENCH SETTINGS ± 5 %	
		N / mmq	N m	Kg m
	M 5x0.8	800 MINIMO MINIMUM	6	0.6
	M 6x1		8	0.8
M 8x1.25	25		2.55	

1 Nm = 0.73756 ft/lb



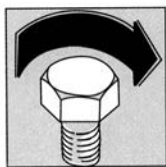

TIGHTENING TORQUE FIGURES

TIGHTENING TORQUE FIGURES (+/- 5%) CHASSIS (93909)

N° DISEGNO DRAWING N°	DESCRIZIONE DESCRIPTION	DIMENSIONI DIMENSIONS	CLASSE DI RESISTEN- PROPERTY CLASS	COPPIA DI SERRAGGIO TORQUE WRENCH SETTINGS		NOTE NOTES
				N / mmq	Kg m ±5%	
8000 62796	VITE FISSAGGIO RULLO CATENA SCREW, CHAIN ROLLER ATTACHMENT	M8 x 1.25	800 min	26.95	2.75	
8000 62725	VITE FISSAGGIO RULLO CATENA SCREW, CHAIN ROLLER ATTACHMENT	M6 x 1	800 min	10.4	1.05	-SOLO MOD. VRE, SM -VRE, SM MODELS ONLY
8000 69056	VITE FISS. INFER. TELAIO POSTERIORE SCREW, LOWER REAR FRAME ATTACHMENT	M8 x 1.25	800 min.	25.5	2.6	
8B00 69056	VITE FISS. TELAIO-PIASTRA ROTORE SCREW, ENGINE-FRAME PLATE ATTACH	M8 x 1.25	800 min.	35.3	3.6	- LOCTITE 270
8E00 69056	VITE FISS. TELAIO SUPERIORE-PIASTRA ROTORE SCREW, UPPER FRAME-ENGINE PLATE ATTACH	M8 x 1.25	800 min.	35.3	3.6	- LOCTITE 270
8I00 69056	VITE FISS. TELAIO INFERIORE-PIASTRA ROTORE SCREW, LOWER FRAME-ENGINE PLATE ATTACH	M8 x 1.25	800 min.	35.3	3.6	- LOCTITE 270
8000 80277	VITE FISS. TELAIO-PIASTRA ROTORE SCREW, ENGINE-FRAME PLATE ATTACH	M8 x 1.25	1000 min.	35.3	3.6	
8C00 69112	VITE FISS. INFERIORE TELAIO POSTERIORE LOWER REAR FRAME FASTENING SCREW	M8 x 1.25	1000 min.	25.5	2.6	
8000 69111	VITE FISSAGGIO SUPERIORE TELAIO POSTERIORE SCREW, UPPER REAR FRAME ATTACHMENT	M8 x 1.25	800 min.	25.5	2.6	
8000 61357	VITE FISSAGGIO SUPERIORE TELAIO POSTERIORE SCREW, UPPER REAR FRAME ATTACHMENT	M8 x 1.25	800 min.	25.5	2.6	-SOLO MOD. VRE, SM -VRE, SM MODELS ONLY
8000 43928	PIASTRA FISSAGGIO SUPERIORE/INFERIORE TELAIO POSTERIORE NUT, UPPER/LOWER REAR FRAME ATTACHMENT	M8 x 1.25	800 min.	25.5	2.6	
8000 73458	VITE FISSAGGIO ANTERIORE ROTORE SCREW, ENGINE FRONT ATTACHMENT	M8 x 1.25	1000 min	35.3	3.6	-SOLO MOD. 250cc, 360cc -250cc, 360cc MODELS ONLY
8A00 73458	VITE FISSAGGIO ANTERIORE ED INFERIORE ROTORE SCREW, ENGINE UPPER AND LOWER ATTACHMENT	M8 x 1.25	1000 min.	35.3	3.6	-SOLO MOD. 250cc, 360cc -250cc, 360cc MODELS ONLY
8G00 73458	VITE FISSAGGIO INFERIORE ROTORE SCREW, ENGINE LOWER ATTACHMENT	M8 x 1.25	1000 min.	35.3	3.6	
8N00 73458	VITE FISSAGGIO ANTERIORE ROTORE SCREW, ENGINE FRONT ATTACHMENT	M8 x 1.25	1000 min	35.3	3.6	-SOLO MOD. 125cc -125cc MODELS ONLY
8P00 73458	VITE FISSAGGIO INFERIORE ROTORE SCREW, ENGINE LOWER ATTACHMENT	M8 x 1.25	1000 min.	35.3	3.6	-SOLO MOD. 125cc -125cc MODELS ONLY
8000 62795	VITE FISSAGGIO PIASTRA - TELAIO SCREW, PLATE - FRAME ATTACHMENT	M8 x 1.25	800 min.	25.5	2.6	-SOLO MOD. VR, CR -VR, CR MODELS ONLY
8000 62795	VITE FISSAGGIO PIASTRA - ROTORE SCREW, PLATE - ENGINE ATTACHMENT	M8 x 1.25	800 min.	25.5	2.6	- LOCTITE 243
8000 97976	VITE ROTAZIONE GAMBA LATERALE SCREW, SIDE STAND ROTATION	M8 x 1.25	800 min.	11.75	1.2	-SOLO MOD. VR -VR MODIF.S ONLY - LOCTITE 243
8000 97977	VITE ROTAZIONE GAMBA LATERALE SCREW, SIDE STAND ROTATION	M8 x 1.25	800 min.	11.75	1.2	-SOLO MOD. TE -TE MODIF.S ONLY - LOCTITE 243
8A00 97977	VITE ROTAZIONE GAMBA LATERALE SCREW, SIDE STAND ROTATION	M8 x 1.25	800 min.	11.75	1.2	- LOCTITE 243
8000 A0266	VITE ROTAZIONE GAMBA LATERALE SCREW, SIDE STAND ROTATION	M8 x 1.25	800 min.	11.75	1.2	- LOCTITE 243
8A00 62797	VITE FISSAGGIO PIASTRA-TESTA ROTORE SCREW, ENGINE HEAD- PLATE ATTACHMENT	M10 x 1.25	1000 min.	27.95	2.85	-SOLO MOD.250cc-360cc -ONLY 250cc-360cc MOD.
8000 62795	VITE FISSAGGIO PIASTRA-TESTA ROTORE SCREW, ENGINE HEAD- PLATE ATTACHMENT	M8 x 1.25	800 min.	25.5	2.6	-SOLO MOD. VR 125cc, CR 125cc -VR 125-CR 125 MODELS ONLY
8B00 69056	VITE FISS. SOPPORTO POGGIPIEDI POST. REAR FOOT REST SUPPORT FAST. SCREW	M8 x 1.25	800 min.	25.5	2.6	-SOLO MOD. VRE, SM -VRE, SM MODELS ONLY
8000 62725	VITE FISS. FASCETTA ENGINE STOP ENGINE STOP CLIP SCREW	M6 x 1	800 min.	10.4	1.05	-SOLO MOD. CR -CR MODELS ONLY
8000 62725	VITE FISS. SERRATURA CASCO HELMET LOCK FASTENING SCREW	M6 x 1	800 min.	10.4	1.05	-SOLO MOD. VRE, SM -VRE, SM MODELS ONLY
8000 60898	VITE FISS. RIPARO COLLA ROTORE SCREW, ENGINE GUARD ATTACH	M6 x 1	1000 min.	14.7	1.5	
8000 62627	VITE FISS. PIASTRA CAVALLETTINO SCREW, SIDE STAND PLATE ATTACHMENT	M6 x 1	800 min.	10.4	1.05	-SOLO MOD. TE/02 -TE/02 MODELS ONLY

1 Nm = 0.73756 ft/lb

NOTE: Unless otherwise specified, standard torque values for the different thread sizes are as follows

M5x0.8	5.6-6.2 Nm	0.57-0.63 Kgm	4.1-4.5 ft/lb
M6x1	7.6-8.4 Nm	0.80-0.85 Kgm	5.8-6.1 ft/lb
M8x1.25	24-26 Nm	2.4-2.6 Kgm	17.3-18.8 ft/lb



TIGHTENING TORQUE FIGURES

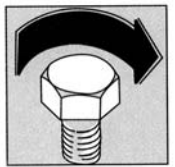

TIGHTENING TORQUE FIGURES (+/- 5%) HANDLEBAR AND CONTROLS (99669)

N° DISEGNO DRAWING N°	DESCRIZIONE DESCRIPTION	DIMENSIONI DIMENSIONS	CLASSE DI RESISTEN- PROPERTY CLASS	COPPIA DI SERRAGGIO TORQUE WRENCH SETTINGS		NOTE NOTES
				N / mmq	Kg m ±5%	
8000 62729	VITE FISS. CAVALLOTTI CON. FRIZIONE E FRENO ANTERIORE SCREW, CLUTCH AND FRONT BRAKE U-BOLT ATTACH.	M6 x 1	800 min	4.9	0.5	
8000 62728	VITE FISS. CAVALLOTTI CON. FRIZIONE E FRENO ANTERIORE SCREW, CLUTCH AND FRONT BRAKE U-BOLT ATTACH.	M6 x 1	800 min	4.9	0.5	
8000 62728	VITE FISS. SUPPORTI CORDINO GAS SCREW, GAS SUPPORTS ATTACH.	M6 x 1	800 min	4.9	0.5	
8000 57155	VITE FISS. RACCORDO TUBO POMPA FRENO ANI. (DIS. 77740) SCREW, FRONT MASTER CYLINDER PIPE UNION	M10 x 1	500 min	19.0	1.95	DATI SERR. BREMBO: 17 - 20 Nm
8000 57155	VITE FISS. RACCORDO TUBO POMPA FRENO ANI. (DIS. 93109) SCREW, FRONT MASTER CYLINDER PIPE UNION	M10 x 1	500 min	24.7	2.5	-SOLO MOD. CR, TC (-DATI SERR. BREMBO: 23 - 26 Nm)
8000 55902	VITE FISSAGGIO PEDALE FRENO SCREW, BRAKE PEDAL ATTACHMENT	M10 x 1.25	1200 min	41.65	4.25	(A) -LOCTITE 243
8000 62726	VITE FISSAGGIO POMPA FRENO POSTERIORE SCREW, REAR BRAKE PUMP ATTACHMENT	M6 x 1	800 min.	10.4	1.05	
8000 57155	VITE FISS. RACCORDO TUBO POMPA FRENO POST. SCREW, REAR MASTER CYLINDER PIPE UNION	M10 x 1	500 min	19.0	1.95	-SOLO MOD. CR (-DATI SERR. BREMBO: 17 - 20 Nm) -CR MODELS ONLY (-BREMBO TORQUE V. SET: 17 - 20 Nm)
8000 62725	VITE FISSAGGIO PIASTRINA-POMPA FRENO ANI. SCREW, PLATE-FRONT BRAKE PUMP ATTACHMENT	M6 x 1	800 min.	10.4	1.05	-SOLO MOD. SHR -SHR MODELS ONLY
8000 62725	VITE FISSAGGIO SERBATOIO LIQUIDO FRENI SCREW, BRAKE FLUID TANK ATTACHMENT	M6 x 1	800 min.	2.45	0.25	
8000 62727	VITE FISSAGGIO SERBATOIO LIQUIDO FRENI SCREW, BRAKE FLUID TANK ATTACHMENT	M6 x 1	800 min.	2.45	0.25	
8000 62727	VITE FISSAGGIO POMPA FRENO POSTERIORE SCREW, REAR BRAKE PUMP ATTACHMENT	M6 x 1	800 min.	2.45	0.25	
8000 37891	INTERRUTTORE STOP STOP SWITCH	M10 x 1		19.0	1.5	-SOLO MOD. VR, VRE, SM (-DATI SERR. BREMBO: 17 - 20 Nm) -VR, VRE, SM MODELS ONLY
8000 94849	INTERRUTTORE STOP STOP SWITCH	M10 x 1		19.0	1.5	-SOLO MOD. TE, SHR (-DATI SERR. BREMBO: 17 - 20 Nm) -TE, SHR MODELS ONLY
60N1 07701	VITE FISS. CONNETTORE-INTERRUTTORE STOP SCREW, JACK-STOP SWITCH	M2 x 0.4		0.84	0.09	-SOLO MOD. SHR -SHR MODELS ONLY
8A00 55241	VITE FISS. CANNA REGOLAZIONE PEDALE FRENO BRAKE LEVER ADJUSTMENT CAM FASTENING SCREW	M6 x 1	1000 min.	14.7	1.95	
8A00 67997	VITE FISS. PIASTRINA GUIDAFILO SCREW, THREAD PLATE ATTACHMENT	M6 x 1	800 min.	6.0	0.6	(A)
8000 62730	VITE FISS. PIASTRINA-SERBATOIO LIQUIDO FRENI ANI. SCREW, PLATE-FRONT BRAKE FLUID TANK ATTACH.	M6 x 1	800 min.	2.45	0.25	-SOLO MOD. SHR -SHR MODELS ONLY
8000 62712	VITE FISS. TAPPO SERBATOIO OLIO FRENI SCREW, BRKE FLUID TANK CAP ATTACH	M3 x 0.5		1.5	0.15	-SOLO MOD. SHR -SHR MODELS ONLY
8000 62728	VITE FISS. CAVALLOTTI SCREW, U-BOLT ATTACH	M6 x 1	800 min.	4.9	0.5	

1 Nm = 0.73756 ft/lb

TIGHTENING TORQUE FIGURES (+/- 5%) FRONT SUSPENSION (99669)

N° DISEGNO DRAWING N°	DESCRIZIONE DESCRIPTION	DIMENSIONI DIMENSIONS	CLASSE DI RESISTEN- PROPERTY CLASS	COPPIA DI SERRAGGIO TORQUE WRENCH SETTINGS		NOTE NOTES
				N / mmq	Kg m ±5%	
8000 62796	VITE FISSAGGIO GAMBE FORCELLA SCREW, FORK LEGS ATTACHMENT	M8 x 1.25	800 min.	25.0	2.55	-SOLO MOD. VR, CR (-DATI SERR. MARZOCCHI: 25 Nm) -VR, CR MODELS ONLY (-MARZOCCHI TORQUE V. SET: 25 Nm)
60N1 02557	VITE FISSAGGIO GAMBE FORCELLA SCREW, FORK LEGS ATTACHMENT	M8 x 1.25	800 min.	25.0	2.55	-SOLO MOD. VRE, SM (-DATI SERR. MARZOCCHI: 25 Nm) -VRE, SM MOD. ONLY (-MARZOCCHI TORQUE V. SET: 25 Nm)
8000 62729	VITE BLOCCAGGIO PERNO RUOTA ANTER. SCREW, FRONT WHEEL PIN LOCKING	M6 x 1	800 min.	10.4	1.05	-DATI SERR. MARZOCCHI: 10 Nm -MARZOCCHI TORQUE V. SET: 10 Nm
8000 83395	GHIERA PERNO DI STERZO STEERING PIN RING NUT	M25 x 1	600 min.	3.45	0.35	
8A00 87717	GHIERA PERNO DI STERZO STEERING PIN RING NUT	M25 x 1	600 min.	3.45	0.35	-SOLO MOD. TC, CR -TC, CR MODELS ONLY
8000 69315	DADO PER PERNO DI STERZO NUT, STEERING PIN ATTACHMENT	M24 x 1	400 min	83.3	8.5	
8000 62733	VITE FISSAGGIO MORSETTO SUPER MANUBRIO SCREW, UPPER CLAMP ATTACHMENT	M8 x 1.25	800 min.	28.4	2.9	
8C00 69056	VITE FISSAGGIO MORSETTO SUPER MANUBRIO SCREW, UPPER CLAMP ATTACHMENT	M8 x 1.25	800 min.	28.4	2.9	-SOLO MOD. VR, CR -VR, CR MODELS ONLY
60N1 01219	VITE FISSAGGIO SUPPORTO MANUBRIO SCREW, HANDLEBAR HOLDER ATTACHMENT	M10 x 1.5	800 min.	21.1	2.15	
8000 67997	VITE FISSAGGIO PARASTELLI SCREW, FORK LEGS GUARD ATTACHMENT	M5 x 0.8	800 min.	7.85	0.8	
8B00 66525	VITE FISSAGGIO ANELLI SCREW, RINGS ATTACHMENT	M5 x 0.8	800 min.	2.45	0.25	

1 Nm = 0.73756 ft/lb





TIGHTENING TORQUE FIGURES

TIGHTENING TORQUE FIGURES (+/- 5%) REAR SUSPENSION (99669)

N° DISEGNO DRAWING N°	DESCRIZIONE DESCRIPTION	DIMENSIONI DIMENSIONS	CLASSE DI RESISTEN. PROPERTY CLASS	COPPIA DI SERRAGGIO TORQUE WRENCH SETTINGS		NOTE NOTES
				N / mmq	Kg m ±5%	
8000 71623	DADO FISS. PERNO FORCELLONE NUT, REAR FORK PIN ATTACH	M16 x 1.5	1000 min	122.5	12.5	- LOCTITE 243
8A00 69138	VITE FISSAGGIO TELAIN - TIRANTE SCREW, FRAME-TIE ROD ATTACHMENT	M10 x 1.25	1000 min.	73.6	7.5	-SOLO MOD. VR, VRE, SM -VR, VRE, SM MODELS ONLY
8000 42023	DADO FISS. BILANCIERE-FORCELLONE/TIRANTE-BILANCIERE NUT, ROCKER ARM-R.FORK/TIE ROD-ROCKER ARM	M12 x 1.25	600 min.	80	8.2	-SOLO MOD. VR (MOD.VRE, SM SOLO PER TIRANTE-BIL.) -VR MODELS ONLY (VRE, SM MOD. FOR TIE ROD-R.A. ONLY)
8000 42023	DADO FISS. BILANCIERE-FORCELLONE/TIRANTE-BILANCIERE NUT, ROCKER ARM-R.FORK/TIE ROD-ROCKER ARM	M12 x 1.25	600 min.	80	8.2	-SOLO MOD. CR -CR MODELS ONLY
8000 42023	DADO FISSAGGIO TELAIN - TIRANTE NUT, FRAME-TIE ROD ATTACHMENT	M12 x 1.25	600 min.	80	8.2	-SOLO MOD. CR -CR MODELS ONLY
8000 42023	DADO FISS. BILANCIERE-FORCELLONE NUT, ROCKER ARM-R.FORK	M12 x 1.25	600 min.	80	8.2	-SOLO MOD. VRE, SM -VRE, SM MODELS ONLY
8000 01412	INGRASSATORE LUBRICATOR	M6 x 1		2.95	0.3	
8A00 62797	VITE FISS. AMMORTIZ. - TELAIN/BILANCIERE-TELAIN SCREW, SHOCK ABSORBER-FRAME/ROCKER ARM-FRAME	M10x1.25	800 min.	52.4	5.35	
8000 62797	VITE FISS. BILANCIERE-AMMORTIZZATORE SCREW, ROCKER ARM-SHOCK ABSORBER	M10x1.25	800 min.	52.4	5.35	
8000 62797	VITE FISS. TELAIN-AMMORTIZZATORE SCREW, FRAME-SHOCK ABSORBER	M10x1.25	800 min.	52.4	5.35	
8000 62795	VITE FISSAGGIO STAFFA GUIDACATENA-FORCELLONE SCREW, DRIVE CHAIN SLIDE-REAR FORK ATTACHMENT	M8 x 1.25	800 min.	25.0	2.55	-SOLO MOD. VR, VRE, SM -VR, VRE, SM MODELS ONLY
8000 62731	VITE FISSAGGIO GUIDACATENA - STAFFA SCREW, DRIVE CHAIN - PLATE ATTACHMENT	M6 x 1	800 min.	2.0	0.2	- LOCTITE 243
8000 62795	VITE FISSAGGIO ANT. STAFFA GUIDACATENA - FORCELL. SCREW, DRIVE CHAIN FRONT ATTACHMENT	M8 x 1.25	800 min.	10.4	1.05	-SOLO MOD. CR, TC -CR, TC MODELS ONLY - LOCTITE 243
8000 62725	VITE FISSAGGIO POST. STAFFA GUIDACATENA - FORCELL. SCREW, DRIVE CHAIN REAR ATTACHMENT	M6 x 1	800 min.	10.4	1.05	-SOLO MOD. CR, TC -CR, TC MODELS ONLY - LOCTITE 243
8000 67997	VITE FISS. INF. PATTINO CATENA E PASSATUDD FRENO SCREW, CHAIN SLIDE, LOWER ATTACH AND PIPE BR. CLAMP	M5 x 0.8	800 min.	4.4	0.45	-ANCHE PER FISSAGGIO SUP. MODELLI CR, TC -ALSO FOR UPPER ATTACH., CR, TC MODELS
8A00 67997	VITE FISS. SUP. - ANTERIORE COPRICATENA SCREW, CHAIN GUARD UPPER-FRONT ATTACH	M5 x 0.8	800 min.	4.4	0.45	
8C00 67997	VITE FISS. SUP. - ANTERIORE COPRICATENA E PATTINO SCREW, CHAIN SLIDE AND GUARD UPPER-FRONT ATTACH	M5 x 0.8	800 min.	4.4	0.45	
8000 20536	VITE FISS. POST. PATTINO CATENA E PASSATUDD POST. SCREW, REAR PIPE AND CHAIN SLIDE REAR ATTACH	D=4.8		4.4	0.45	-SOLO MOD. CR, TC -CR, TC MODELS ONLY
60N1 01059	VITE FISS. RETRO ED ANTERIORE COPRICATENA SCREW, CHAIN GUARD REAR AND FRONT ATTACH.	M5 x 0.8	800 min.	4.4	0.45	
8000 17810	DADO FISS. TENDICATENA NUT, CHAIN STRETCHER ATTACH.	M8 x 1.25	600 min.	22.5	2.3	
8E00 67545	VITE FISS. GUIDACATENA SCREW, DRIVE CHAIN ATTACHMENT	M6 x 1	800 min.	10.4	1.05	

1 Nm = 0.73756 ft/lb



TIGHTENING TORQUE FIGURES

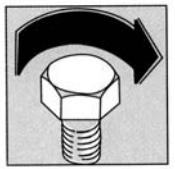

TIGHTENING TORQUE FIGURES (+/- 5%) FAIRINGS AND MUDGUARDS (99669)

N° DISEGNO DRAWING N°	DESCRIZIONE DESCRIPTION	DIMENSIONI DIMENSIONS	CLASSE DI RESISTEN. PROPERTY CLASS	COPPIA DI SERRAGGIO TORQUE WRENCH SETTINGS		NOTE NOTES
			N / mmq	N m ±5%	Kg m ±5%	
8000 36467	VITE FISSAGGIO CONVOGLIATORE A SERBATOIO SCREW CONVEYOR-TANK ATTACHMENT	M6 x 1	800 min.	6.0	0.6	
8000 62726	VITE FISSAGGIO INFERIORE PORTANUMERO ANTERIORE SCREW LOWER PANEL FRONT ATTACHMENT	M6 x 1	800 min.	10.4	1.05	-SOLO MOD. CR, TC -CR, TC MODELS ONLY
8000 62726	VITE FISSAGGIO PROTEZIONE AMMORTIZZATORE SCREW SHOCK ABSORBER PROTECTION ATTACHMENT	M6 x 1	800 min.	6.0	0.6	
8000 62726	-VITE FISS. PORTATARGA -SCREW PLATE HOLDER ATTACH	M6 x 1	800 min.	6.0	0.6	-SOLO MOD. TE -TE MODELS ONLY
8000 62726	-VITE FISS. POS. PARAFANGO POSTERIORE E RINFORZI -SCREW REAR MUDGUARD & REINFORCEMENTS REAR ATTACH	M6 x 1	800 min.	6.0	0.6	
8000 62726	VITE FISSAGGIO INFERIORE PORTANUMERO SCREW LOW NUMBER BOARD ATTACHMENT	M6 x 1	800 min.	10.4	1.05	
8000 62726	VITE FISSAGGIO PANNELLO/PORTANUMERO LATERALE SCREW LOWER/SIDE PANEL ATTACHMENT	M6 x 1	800 min.	3.45	0.35	
8000 62727	VITE FISSAGGIO PARAFANGO ANTERIORE SCREW FRONT MUDGUARD ATTACHMENT	M6 x 1	800 min.	10.4	1.05	
8000 62727	VITE FISSAGGIO PROTEZIONE RADIATORE SCREW RADIATOR GUARD ATTACHMENT	M6 x 1	800 min.	6.0	0.6	
8000 62727	VITE FISSAGGIO PORTANUMERO LATERALE SCREW SIDE PANELS ATTACHMENT	M6 x 1	800 min.	3.45	0.35	
8000 62727	VITE FISS. POST. PANNELLO LATERALE DX E SX SCREW RH AND LH SIDE PANELS REAR ATTACH	M6 x 1	800 min.	3.45	0.35	
8000 62727	VITE FISS. PROTEZIONE INF. AMMORTIZZATORE POST. SCREW REAR SHOCK ABSORBER PROTECTION GUARD ATTACH	M6 x 1	800 min.	6.0	0.6	
8000 62727	-VITE FISS. PORTATARGA -SCREW PLATE HOLDER ATTACH	M6 x 1	800 min.	6.0	0.6	-SOLO MOD. VR, VE -VR, VE MODELS ONLY
8000 62727	VITE FISSAGGIO PANNELLO/PORTAN. LATERALE-TELAIETTO SCREW LOWER/SIDE PANEL-REAR FRAME ATTACHMENT	M6 x 1	800 min.	6.0	0.6	
8000 62728	VITE FISS. PANNELLO/PORTAN. LATERALE-SCATOLA FILTRO SCREW LOWER/SIDE PANEL-FILTER AIR BOX ATTACHMENT	M6 x 1	800 min.	6.0	0.6	
8000 62728	VITE FISSAGGIO PARAFANGO POSTERIORE SCREW REAR MUDGUARD ATTACHMENT	M6 x 1	800 min.	10.4	1.05	
8000 62728	-VITE FISS. ANT. PANNELLO LATERALE DX -SCREW RH SIDE PANEL FRONT ATTACH	M6 x 1	800 min.	3.45	0.35	
8000 62730	VITE FISSAGGIO COPOLINO PORTAFARO SCREW HEADLAMP FAIRING ATTACHMENT	M6 x 1	800 min.	10.4	1.05	
8000 67997	VITE FISSAGGIO SUPERIORE PORTANUMERO ANTERIORE SCREW UPPER PANEL FRONT ATTACHMENT	M5 x 0.8	800 min.	6.0	0.6	-SOLO MOD. CR, TC -CR, TC MODELS ONLY
8000 67997	-VITE FISS. SUP. ANTERIORE COPRICALTERNA -SCREW CHAIN GUARD UPPER - FRONT ATTACH	M5 x 0.8		4.4	0.45	-SOLO MOD. VR, VRE, SM -VR, VRE, SM MODELS ONLY
8000 36467	-VITE FISS. CONVOGLIATORI A SERBATOIO -SCREW CONVEYORS TO TANK ATTACH	M6 x 1	800 min.	6.0	0.6	
8000 67545	-VITE FISS. SUP. PROTEZIONE AMMORTIZZATORE -SCREW SHOCK ABS. GUARD UPPER ATTACH	M6 x 1	800 min.	6.0	0.6	
8000 67545	-VITE FISS. ANT. PANNELLO LATERALE SX -SCREW LH SIDE PANEL FRONT ATTACH	M6 x 1	800 min.	3.45	0.35	
8000 40717	DADO FISS. CADADOLITRO -NUT REAR REFLECTOR ATTACH	M4 x 0.7	600 min.	1.9	0.2	
8000 37283	VITE FISS. ANELLO A COPOLINO SCREW RING-HEADLAMP FAIRING ATTACH	D = 3.5		1.9	0.2	

1 Nm = 0.73756 ft/lb

TIGHTENING TORQUE FIGURES (+/- 5%) ELECTRICAL SYSTEM (99669)

N° DISEGNO DRAWING N°	DESCRIZIONE DESCRIPTION	DIMENSIONI DIMENSIONS	CLASSE DI RESISTEN. PROPERTY CLASS	COPPIA DI SERRAGGIO TORQUE WRENCH SETTINGS		NOTE NOTES
			N / mmq	N m ±5%	Kg m ±5%	
8000 62728	VITE FISSAGGIO INDICATORI DI DIREZIONE SCREW BLINKERS ATTACHMENT	M6 x 1	800 min.	6.0	0.6	-SOLO MOD. TE-SHR -TE-SHR MODELS ONLY (LOCTITE 243 PER GRUPPO OTTICO)
8000 62726	VITE FISSAGGIO AMMORTIZZATORE AUSTICO SCREW HORN ATTACHMENT	M6 x 1	800 min.	10.4	1.05	-SOLO MOD. VR, VRE, SM -VR, VRE, SM MODELS ONLY
60N4 95615	VITE FISSAGGIO GRUPPO OTTICO POSTERIORE SCREW REAR OPTICAL GROUP ATTACHMENT	D = 3.9		1.45	0.15	-SOLO MOD. TE-SHR-VRE -TE-SHR-VRE MODELS ONLY
60N4 98033	VITE FISSAGGIO GRUPPO OTTICO ANTERIORE SCREW FRONT OPTICAL GROUP ATTACHMENT	D = 3.9		1.45	0.15	
8000 A0953	VITE FISSAGGIO GRUPPO OTTICO POSTERIORE SCREW REAR OPTICAL GROUP ATTACHMENT	D = 3.9		1.45	0.15	
8000 62725	VITE FISSAGGIO MASSA SCREW EARTH ATTACHMENT	M6 x 1	800 min.	10.4	1.05	
8000 62725	VITE FISS. TASCETTA TERRA/AVV. SCHEMI SCREW CLIP ATTACHMENT	M6 x 1	800 min.	10.4	1.05	
8SA0 67545	VITE FISSAGGIO CAVI TELEFONICI SCREW STARTER CABLES ATTACHMENT	M6 x 1	800 min.	10.4	1.05	

1 Nm = 0.73756 ft/lb





TIGHTENING TORQUE FIGURES

TIGHTENING TORQUE FIGURES (+/- 5%) FUEL SYSTEM (99669)

N° DISEGNO DRAWING N°	DESCRIZIONE DESCRIPTION	DIMENSIONI DIMENSIONS	CLASSE DI RESISTEN. PROPERTY CLASS	COPPIA DI SERRAGGIO TORQUE WRENCH SETTINGS		NOTE NOTES
				N / mmq	Kg m ±5%	
8000 41240	VITE FISSAGGIO TAMPONE PER SERBATOIO SCREW, PAD ATTACHMENT	M8 x 1.25	800 min.	22.5	2.3	
60N1 02507	VITE FISSAGGIO TAMPONE PER SERBATOIO SCREW, PAD ATTACHMENT	M6 x 1	800 min.	10.4	1.05	
8000 37745	VITE FISSAGGIO RUBINETTO BENZINA SCREW, FUEL COCK ATTACHMENT	D = 5.5	..	2.45	0.25	
8A00 67545	VITE FISSAGGIO POSTERIORE SERBATOIO SCREW, TANK REAR ATTACHMENT	M6 x 1	800 min.	10.4	1.05	
60N1 04134	VITE FISSAGGIO ATT. SELLA SU SERBATOIO SCREW, SEAT ATTACHMENT ON FUEL TANK	M6 x 1	500 min.	6.0	0.6	
60N1 04134	VITE FISSAGGIO DISTANZIALE SELLA SCREW, SEAT SPACER ATTACHMENT	M6 x 1	500 min.	6.0	0.6	
8D00 67545	VITE FISSAGGIO DISTANZIALE SELLA SCREW, SEAT SPACER ATTACHMENT	M6 x 1	500 min.	6.0	0.6	
8000 62725	VITE FISSAGGIO ANTERIORE SCATOLA FILTRO SCREW, FILTER BOX FRONT ATTACHMENT	M6 x 1	800 min.	10.4	1.05	
8000 62726	VITE FISSAGGIO ANTERIORE SCATOLA FILTRO SCREW, FILTER BOX FRONT ATTACHMENT	M6 x 1	800 min.	10.4	1.05	
8000 62726	VITE FISSAGGIO ANTERIORE SERBATOIO SCREW, TANK FRONT ATTACHMENT	M6 x 1	800 min.	10.4	1.05	
8000 62727	VITE FISSAGGIO COPERCHIO SCATOLA FILTRO SCREW, FILTER BOX COVER ATTACHMENT	M6 x 1	800 min.	3.5	0.35	
8000 62728	VITE FISSAGGIO POSTERIORE SCATOLA FILTRO SCREW, FILTER BOX REAR ATTACHMENT	M6 x 1	800 min.	10.4	1.05	
8000 40718	DADO FISSAGGIO FLANGIA SCATOLA FILTRO NUT, FILTER BOX FLANGE ATTACHMENT	M5 x 0.8	600 min.	3.45	0.35	

1 Nm = 0.73756 ft/lb

TIGHTENING TORQUE FIGURES (+/- 5%) WHEELS AND BRAKES (99669)

N° DISEGNO DRAWING N°	DESCRIZIONE DESCRIPTION	DIMENSIONI DIMENSIONS	CLASSE DI RESISTEN. PROPERTY CLASS	COPPIA DI SERRAGGIO TORQUE WRENCH SETTINGS		NOTE NOTES
				N / mmq	Kg m ±5%	
8000 62733	VITE FISSAGGIO PIAZZA FRENO ANTERIORE SCREW, FRONT BRAKE CALIPER ATTACHMENT	M8 x 1.25	800 min.	25.5	2.6	
8000 57155	VITE FISS. RACCORDO TUBO PIAZZA FRENO ANT. E POST. SCREW, FRONT AND REAR CALIPER PIPE UNION	M10 x 1	500 min.	19.0	1.95	-DATI SERR. BREMBO: 17 - 20 Nm -BREMBO TORQUE W. SET: 17 - 20 Nm
8000 48773	VITE FISSAGGIO PERNO RUOTA ANTERIORE SCREW, FRONT WHEEL PIN ATTACHMENT	M10 x 1.5	1200 min.	51.45	5.25	
8000 94060	VITE FISSAGGIO PIAZZA FRENO ANTERIORE A PIASTRA SCREW, FRONT BRAKE CALIPER-PLATE ATTACH.	M10 x 1.5	800 min.	25.5	2.6	-SOLO MODELLI SMR -SMR MODELS ONLY
8000 94060	VITE FISSAGGIO PIASTRA A PIEDINO SCREW, FRONT BRAKE CALIPER-BOTTOM FORK ATTACH.	M10 x 1.5	800 min.	25.5	2.6	-SOLO MODELLI SMR -SMR MODELS ONLY
8000 96933	TAPPO PERNO RUOTA ANTERIORE FRONT WHEEL PIN PLUG	M20 x 1.5		51.45	5.25	-SOLO MODELLI TC -TC MODELS ONLY
8A00 55241	VITE FISSAGGIO DISCO FRENO ANTERIORE SCREW, FRONT BRAKE DISC ATTACHMENT	M6 x 1	1000 min.	14.7	1.5	- LOCTITE 243
69N4 29004	NIPPLES PER RAGGIO RUOTA ANTERIORE FRONT WHEEL SPOKE NIPPLES	M4.07x0.75		4.4	0.45	
8000 A0081	NIPPLES PER RAGGIO RUOTA ANTERIORE FRONT WHEEL SPOKE NIPPLES	M4.07x0.75		4.4	0.45	
8000 43928	DADO FRENO FISSAGGIO CORONA NUT, SPROCKET ATTACHMENT	M8 x 1.25	800 min.	34.3	3.5	- LOCTITE 243
8000 55878	VITE FISSAGGIO DISCO FRENO POSTERIORE SCREW, REAR BRAKE DISC ATTACHMENT	M6 x 1	1000 min.	14.7	1.5	- LOCTITE 243
8000 62726	VITE FISSAGGIO DISCO FRENO POSTERIORE SCREW, REAR BRAKE DISC ATTACHMENT	M6 x 1	1000 min.	14.7	1.5	- LOCTITE 243
8000 96940	PERNO RUOTA POSTERIORE REAR WHEEL PIN	M20 x 1.5	1000 min.	142.1	14.5	-SOLO MOD. VR, CR -VR, CR MODELS ONLY
8D00 64938	PERNO RUOTA POSTERIORE REAR WHEEL PIN	M20 x 1.5	1000 min.	142.1	14.5	-SOLO MOD. VRE, SM -VRE, SM MODELS ONLY
69N4 29005	NIPPLES PER RAGGIO RUOTA POSTERIORE FRONT WHEEL SPOKE NIPPLES	M4.5x0.75		4.4	0.45	
8000 A0086	NIPPLES PER RAGGIO RUOTA POSTERIORE FRONT WHEEL SPOKE NIPPLES	M4.5x0.75		4.4	0.45	
8000 93072	DADO PERNO RUOTA POSTERIORE NUT, REAR WHEEL PIN	M20 x 1.5	1000 min.	142.1	14.5	
8000 62153	VITE FISSAGGIO PIGNONE SCREW, PINION ATTACHMENT	M8 x 1.25	800 min.	24.6	2.5	-SOLO MOD. VR 360 -VR 360 MODELS ONLY
60N1 01140	VITE FISSAGGIO PIGNONE SCREW, PINION ATTACHMENT	M8 x 1.25	800 min.	24.6	2.5	-SOLO MOD. VRE -VRE MODELS ONLY
8A00 92876	VITE FISSAGGIO DISCO FRENO ANTERIORE SCREW, FRONT BRAKE DISC ATTACHMENT	M8 x 1.25	1000 min.	34.7	3.54	
8000 28327	VITE FISS. PIASTRA COPRICHATENA A CARTER SCREW, CHAIN GUARD PLATE-CARTER	M6 x 1	800 min.	10.4	1.05	
8000 62725	VITE FISS. COPERCHIO A PIASTRA SCREW, CAP-PLATE ATTACHMENT	M6 x 1	800 min.	10.4	1.05	

1 Nm = 0.73756 ft/lb



TIGHTENING TORQUE FIGURES

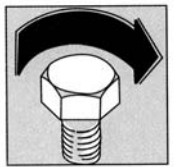

TIGHTENING TORQUE FIGURES (+/- 5%) EXHAUST (99669)

N° DISEGNO DRAWING N°	DESCRIZIONE DESCRIPTION	DIMENSIONI DIMENSIONS	CLASSE DI RESISTEN. PROPERTY CLASS	COPPIE DI SERRAGGIO TORQUE WRENCH SETTINGS		NOTE NOTES
				N / mmq	kg m+5%	
8000 62725	VITE FISSAGGIO RACCORDO SILENZIATORE A TELAIU SCREW, SILENT PIPE UNION TO FRAME ATTACH.	M6 x 1	800 min.	10.4	1.05	
8000 62725	VITE FISSAGGIO ANTIVIBRANTE AL TELAIU E AL TUUU SCREW, SILENT BLOCK TO FRAME AND PIPE ATTACH.	M6 x 1	800 min.	10.4	1.05	
8000 62726	VITE FISSAGGIO ANTIVIBRANTE AL TUUU SCREW, SILENT BLOCK TO PIPE ATTACH.	M6 x 1	800 min.	10.4	1.05	-SOLO MOD. SM -SM MODELS ONLY
8000 62730	VITE FISSAGGIO SILENZIATORE SCREW, EXHAUST ATTACHMENT	M6 x 1	800 min.	10.4	1.05	
8A00 67545	VITE FISSAGGIO ANTERIORE SILENZIATORE SCREW, FRONT EXHAUST ATTACHMENT	M6 x 1	800 min.	10.4	1.05	
8E00 67545	VITE FISSAGGIO POSTERIORE SILENZIATORE SCREW, REAR EXHAUST ATTACHMENT	M6 x 1	800 min.	10.4	1.05	
8000 62731	VITE FISSAGGIO POSTERIORE SILENZIATORE SCREW, REAR EXHAUST ATTACHMENT	M6 x 1	800 min.	10.4	1.05	
8000 60898	VITE FISSAGGIO GRIGLIA A TUBU SCARICU SCREW, GRILL TO EXHAUST PIPE ATTACH.	M6 x 1	1000 min.	14.7	1.5	
60N4 07335	VITE FISSAGGIO TUBU SCARICU ALLA TESTA SCREW, EXHAUST PIPE TO ENGINE HEAD ATTACH.	M6 x 1	800 min.	10.4	1.05	
8000 62726	VITE FISSAGGIO TUBU SCARICU ALLA TESTA SCREW, EXHAUST PIPE TO ENGINE HEAD ATTACH.	M6 x 1	800 min.	10.4	1.05	

1 Nm = 0.73756 ft/lb

TIGHTENING TORQUE FIGURES (+/- 5%) INSTRUMENTS (99669)

N° DISEGNO DRAWING N°	DESCRIZIONE DESCRIPTION	DIMENSIONI DIMENSIONS	CLASSE DI RESISTEN. PROPERTY CLASS	COPPIE DI SERRAGGIO TORQUE WRENCH SETTINGS		NOTE NOTES
				N / mmq	kg m+5%	
8000 61313	DADO FISSAGGIO CONTARU NUT, ODOMETER ATTACHMENT	M6 x 1	600 min.	6.0	0.6	-SOLO MOD. WRE, SM -WRE, SM MODELS ONLY
8000 67997	VITE FISSAGGIO PIASTINA SUFFORTU CONTARU SCREW, ODOMETER PLATE ATTACHMENT	M5 x 0.8	800 min.	6.0	0.6	-SOLO MOD. WRE, SM -WRE, SM MODELS ONLY
8A00 67997	VITE FISSAGGIO GUIDACABU A PIASTINA DI STERZU SCREW, CABLE GUIDE-STEERING GEAR PLATE ATTACHMENT	M5 x 0.8	800 min.	6.0	0.6	-SOLO MOD. WRE, SM -WRE, SM MODELS ONLY
8B00 66525	VITE FISSAGGIO ANELLO GUIDA TRASNISSTIONE SCREW, DRIVE GUIDE RING ATTACH.	M5 x 0.8	800 min.	2.45	0.25	-SOLO MOD. WRE, SM -WRE, SM MODELS ONLY
8B00 66525	VITE FISSAGGIO ANELLO CABU CONTARU SCREW, ODOMETER CABLE RING ATTACHMENT	M5 x 0.8	800 min.	2.45	0.25	-SOLO MOD. WRE, SM -WRE, SM MODELS ONLY
8000 89069	VITE FISSAGGIO STRUMENTU SCREW, INSTRUMENT ATTACHMENT	D=4.8		3.45	0.35	

1 Nm = 0.73756 ft/lb

TIGHTENING TORQUE FIGURES (+/- 5%) COOLING SYSTEM (99669)

N° DISEGNO DRAWING N°	DESCRIZIONE DESCRIPTION	DIMENSIONI DIMENSIONS	CLASSE DI RESISTEN. PROPERTY CLASS	COPPIE DI SERRAGGIO TORQUE WRENCH SETTINGS		NOTE NOTES
				N / mmq	kg m+5%	
60N1 02525	VITE FISSAGGIO RADIATORE INTERMEDIU SCREW, INTERM. RADIATORS ATTACHMENT	M6 x 1	800 min.	7.0	0.72	
8000 62725	VITE FISSAGGIO ANELLO GUIDATUBU SCREW, PIPEGUIDE RING ATTACHMENT	M6 x 1	800 min.	10.4	1.05	
8000 62725	VITE FISSAGGIO RADIATORE SUPERIORE SCREW, UPPER RADIATORS ATTACHMENT	M6 x 1	800 min.	7.0	0.72	
8000 62728	VITE FISSAGGIO RADIATORE INFERIORE SCREW, LOWER RADIATORS ATTACHMENT	M6 x 1	800 min.	7.0	0.72	
8000 62729	VITE FISSAGGIO RADIATORE SCREW, RADIATORS ATTACHMENT	M6 x 1	800 min.	7.0	0.72	

1 Nm = 0.73756 ft/lb



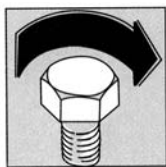

TIGHTENING TORQUE FIGURES

NOTE: Unless otherwise specified, standard torque values for the different thread sizes are as follows (+/- 5%)

Steel screws on plastic, with metal spacers	M4	2 Nm	0.2 Kgm	1.45 ft/lb
Steel screws on brass, copper, aluminium	M4	2 Nm	0.2 Kgm	1.45 ft/lb
Steel screws on iron, steel	M4	3 Nm	0.3 Kgm	2.2 ft/lb
Steel screws on plastic, with metal spacers	M5	4 Nm	0.4 Kgm	3 ft/lb
Steel screws on brass, copper, aluminium	M5	4 Nm	0.4 Kgm	3 ft/lb
Steel screws on iron, steel	M5	6 Nm	0.6 Kgm	4.4 ft/lb
Steel screws on plastic, with metal spacers	M6	6.5 Nm	0.65 Kgm	4.8 ft/lb
Steel screws on brass, copper, aluminium	M6	6.5 Nm	0.65 Kgm	4.8 ft/lb
Steel screws on iron, steel	M6	10.5 Nm	1 Kgm	7.7 ft/lb
Steel screws on brass, copper, aluminium	M8	16 Nm	1.6 Kgm	11.8 ft/lb
Steel screws on iron, steel	M8	26 Nm	2.6 Kgm	19.1 ft/lb
Steel screws on iron, steel	M10	52 Nm	5.2 Kgm	38.3 ft/lb
Steel screws on iron, steel	M12	100 Nm	10 Kgm	73.8 ft/lb
Steel screws on iron, steel	M14	145 Nm	14.5 Kgm	107 ft/lb



CHASSIS AND WHEELS



Section

Y





CHASSIS AND WHEELS

Chassis.....	Y.3
Lubrication points (lubricant)	Y.4
Front wheel.....	Y.5
Front wheel removal.....	Y.6
Front wheel installation.....	Y.7
Rear wheel	Y.8
Rear wheel removal.....	Y.9
Wheel servicing	Y.10
Wheel axle warpage	Y.10
Axle runout over 100 mm	Y.10
Wheel spokes.....	Y.11
Wheel rim warpage.....	Y.11
Rear chain sprocket, secondary drive sprocket and chain	Y.12
Tightening torque figures	Y.12
Checking chain and sprockets for wear.....	Y.13



CHASSIS AND WHEELS

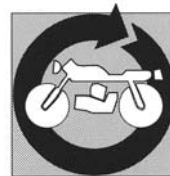

Chassis

The single frame branches off at the exhaust and is made of steel tubes with circular, rectangular and ellipsoidal section; the rear chassis is made from light alloy.



A badly damaged chassis must be replaced.





CHASSIS AND WHEELS

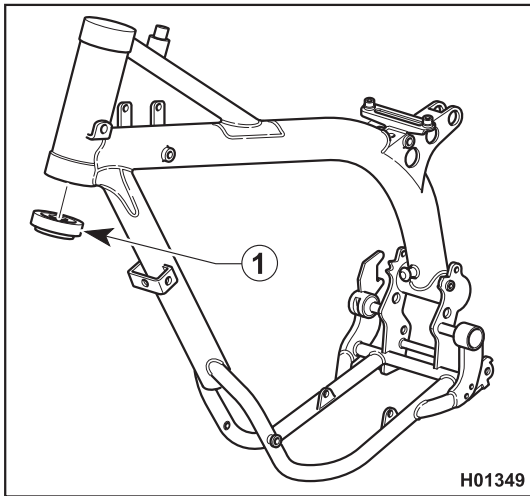

Lubrication points (lubricant)

- 1 Steering bearings (grease)

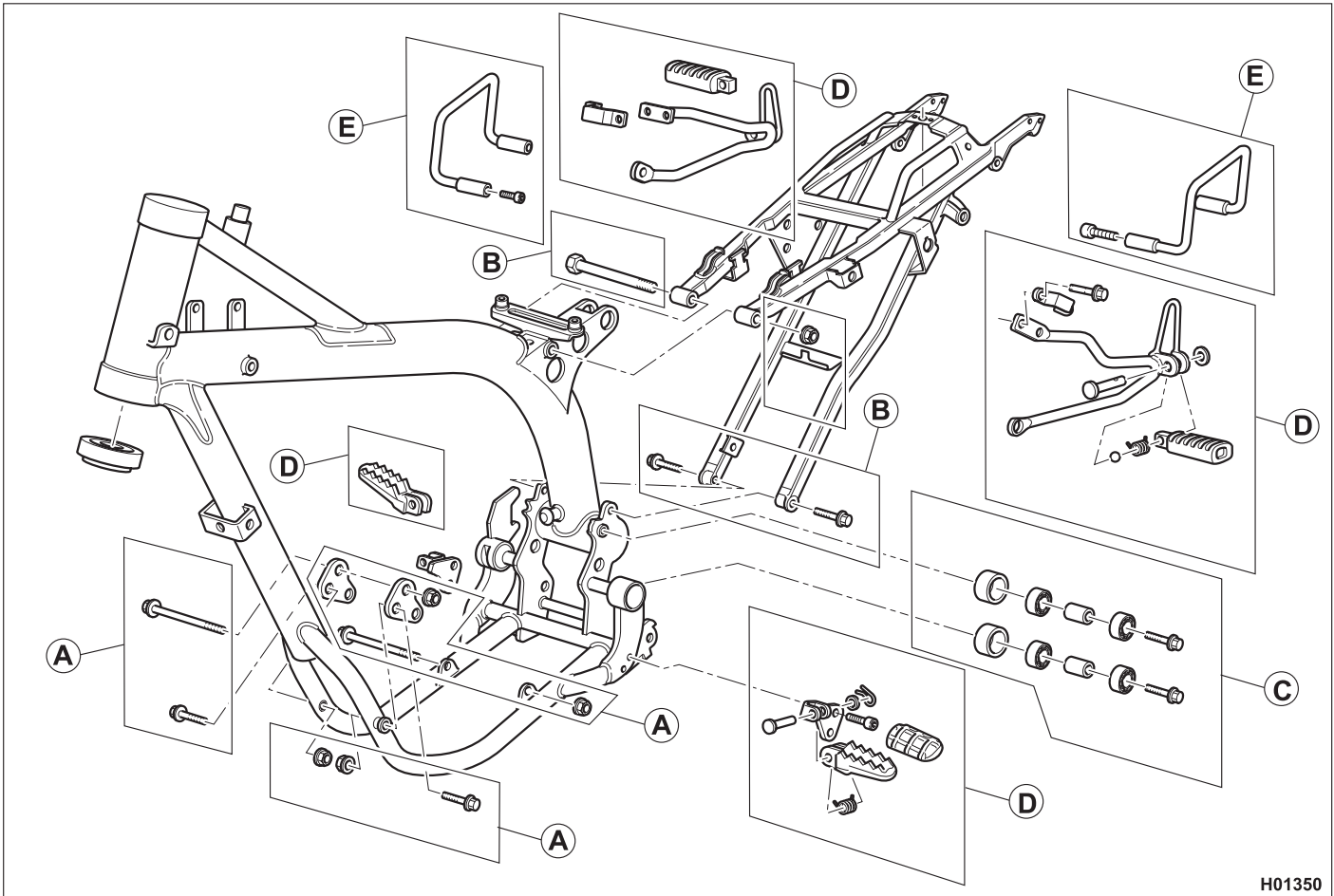

Check the assemblies shown in the figure for cracks or damage.

If any are found, replace the part.

- A ENGINE MOUNTING BOLTS AND BRACKETS
- B REAR CHASSIS MOUNTING BOLTS
- C CHAIN GUIDE ROLLER/BEARING
- D FOOTPEGS/PINS/SPRINGS
- E PASSENGER GRAB HANDLES





Front wheel

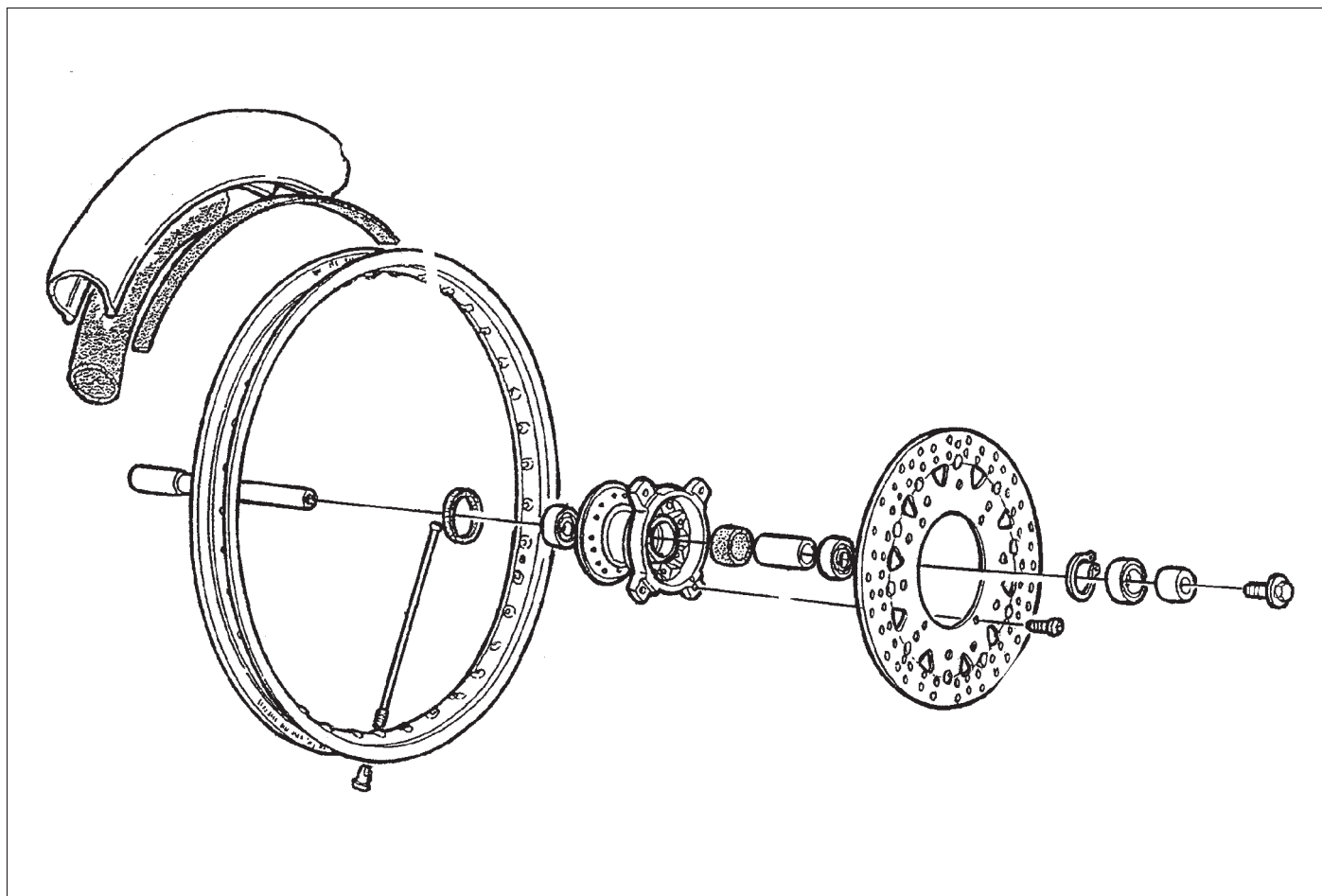

Light alloy wheel hub and rim with high-strength steel spokes.

RIMS

Front (TE) in light alloy: 1.6"x21"
 Front (SMS) in light alloy: 3.50"x17"

TYRES

Front
 (TE) 90/90x21"
 (SMS) 120/70x17"

COLD TYRE PRESSURE (TE)

Front
 Rider only 1.2 Kg/cm²
 Rider and passenger 1.5 Kg/cm²

COLD TYRE PRESSURE (SMS)

Front
 Rider only 1.8 Kg/cm²
 Rider and passenger 2.0 Kg/cm²





CHASSIS AND WHEELS



Removing the front wheel

Set a stand or a block under the engine and see that the front wheel is lifted from the ground.

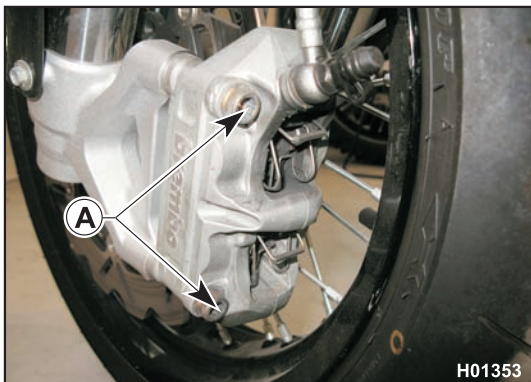

SMS: Remove the screws (A) and the brake calliper.

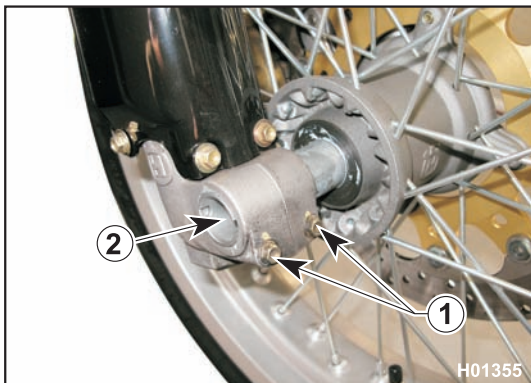

Loosen the bolts (1) holding the wheel axle (2) to the front fork mounts.

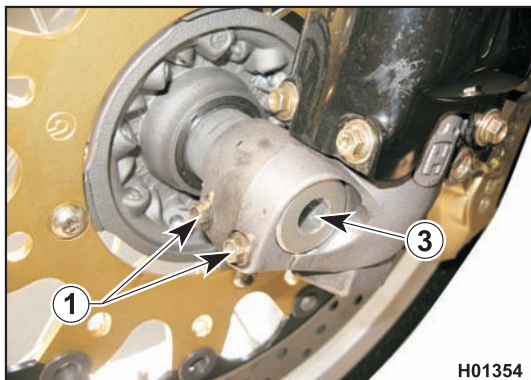

Hold the head of the wheel axle in place, and unscrew the bolt (3) on the opposite side; draw the wheel axle out.



Do not operate the front brake lever when the wheel has been removed; this causes the calliper pistons to move outwards.



After removal, lay down the wheel with brake disc on top.





Reassembling the front wheel

Fit the L.H. spacer (D) on the wheel hub.

(TE)

Fit the wheel between the fork legs so as to set the brake disc into the calliper.

FINAL RATIOS (SMS)

Fit the wheel between the fork legs.

Fit the wheel axle (2) from the R.H. side, after greasing it and push it fully home against the L.H. fork leg; during this operation, the wheel should be turned.

Tighten the screw (3) on the fork L.H. side but DO NOT lock it. Now, pump for a while, pushing the handlebar downwards until you are sure that the fork legs are perfectly aligned. Lock: the screws (1) on the R.H. leg (10.4 Nm, 1.05 Kgm, 7.7 ft/lb), the screw (3) on the L.H. side (51.45 Nm, 5.25 Kgm, 38 ft/lb), the screws (1) on the L.H. leg (10.4 Nm, 1.05 Kgm, 7.7 ft-lb).

(SMS)

Fit the brake calliper on the disc; assemble the calliper on its mounting plate and tighten the two screws (A) to 25.5 Nm/ 2.6 Kgm/ 18.8 ft-lb. Ensure that the brake disc slides between the calliper pads without any friction or hard spots.



After reassembly, pull the brake control lever until the pads are against the brake disc.

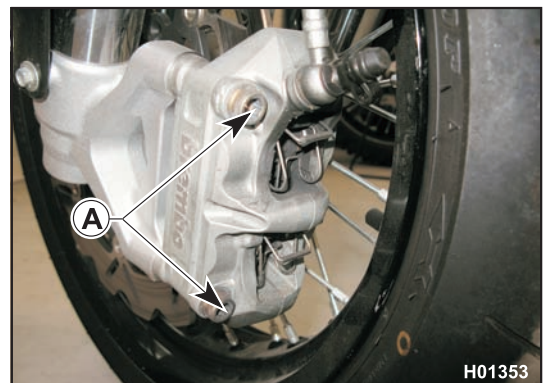
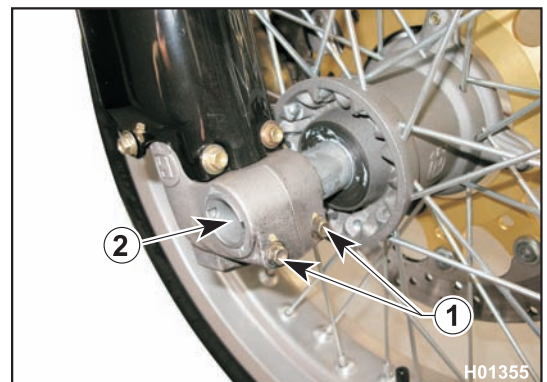
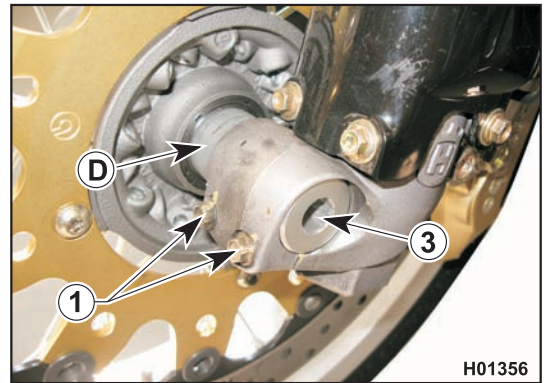



CHASSIS AND WHEELS

Rear wheel

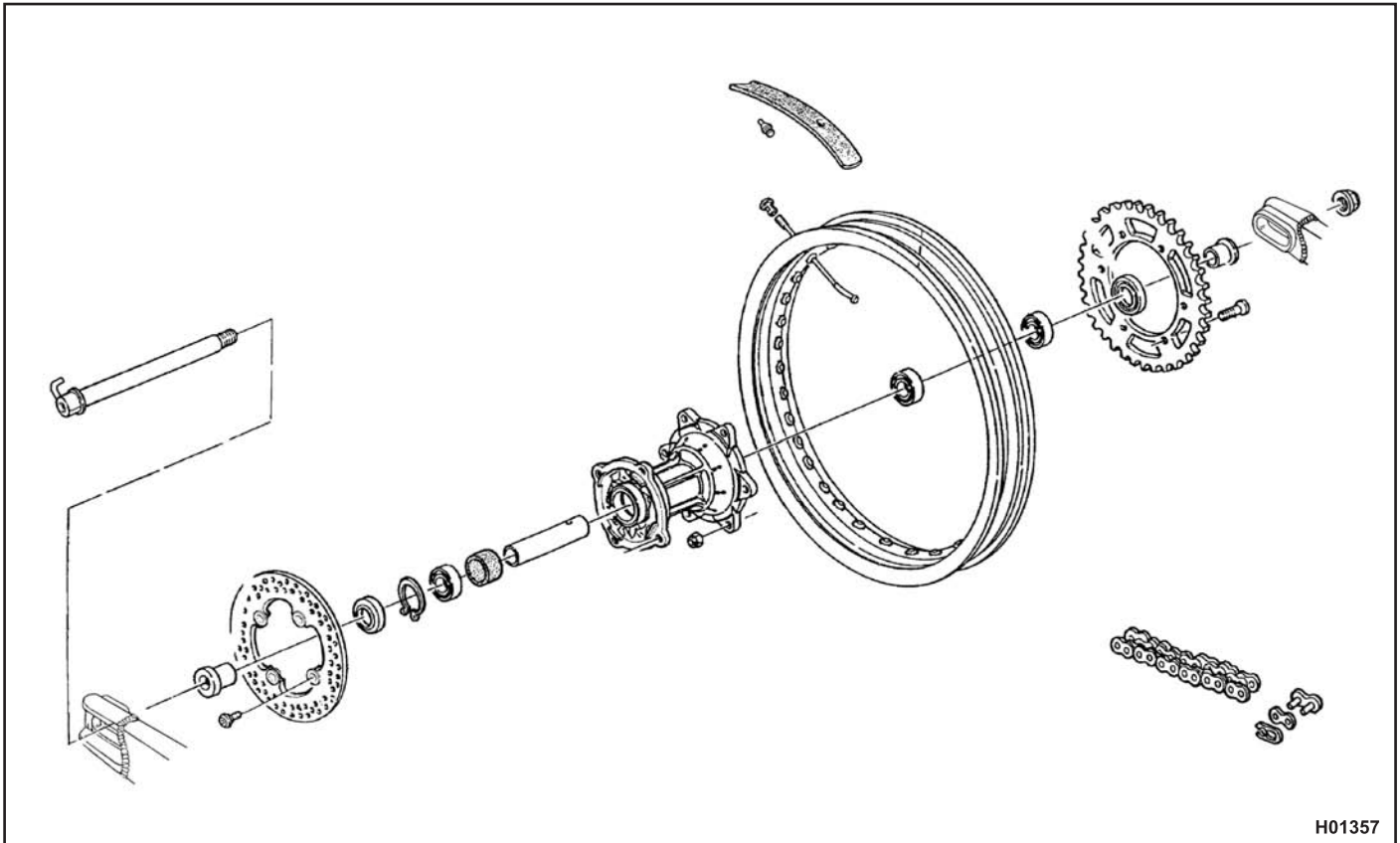

Light alloy wheel hub and rim with high-strength steel spokes.

RIMS

Rear (TE)..... in light alloy: 2.15"x18"
Rear (SMS)..... in light alloy: 4.25"x17"

TYRES

Rear
(TE)..... 140/80x18"
(SMS) 150/60x17"

COLD TYRE PRESSURE (TE)

Rear
Rider only 1.5 Kg/cm²
Rider and passenger 1.8 Kg/cm²

COLD TYRE PRESSURE (SMS)

Rear
Rider only 2.0 Kg/cm²
Rider and passenger 2.2 Kg/cm²





Removing the rear wheel

Set a stand or a block under the engine and see that the rear wheel is lifted from the ground.

Unscrew the nut (1) of the wheel axle (3) and extract it. It is not necessary to loosen the chain tensioners (2); in this way, the chain tension will remain unchanged after reassembly. Extract the complete rear wheel, keeping the spacers located at the hub sides. To reassemble, reverse the above procedure remembering to insert the brake disc into the calliper.



Do not operate the rear brake pedal when the wheel has been removed; this causes the calliper pistons to move outwards.



After removal, lay down the wheel with brake disc on top.



After reassembly, depress the brake pedal until the pads are against the brake disc.

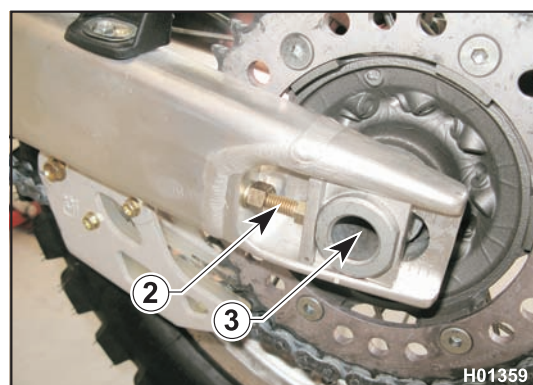
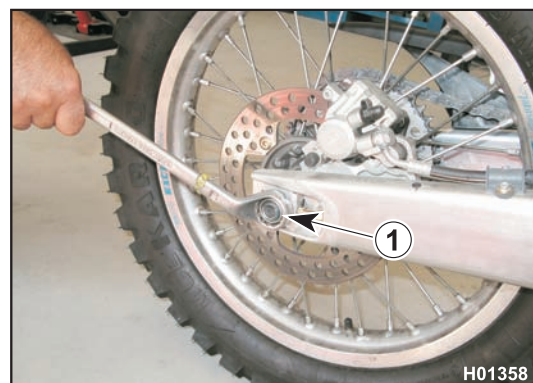

Tightening torque figures
1: 142.1 Nm, 14.5 Kgm, 104.8 ft/lb



CHASSIS AND WHEELS

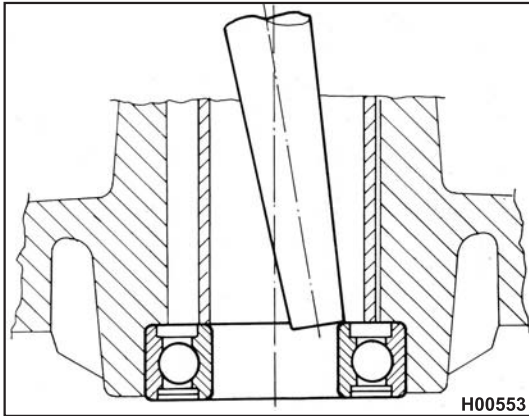

Wheel servicing

Check the wheel hub bearings for wear. If you find too much (radial or axial) clearance, replace the bearings as follows:

- place the hub on a flat surface with an appropriate hole (for when you knock out the bearing);
- use a hammer and a punch to knock out the bearing; apply pressure only on the inner race of the bearing (see figure);
- tap at different positions so as to keep the bearing square in its seat;
- remove the spacer and use the same procedure for the other bearing.



Discard the bearings after removal. Never reuse them.

Before installing the new bearings, check to ensure the seat is clean and shows no grooves or scratches. Lubricate the seat before installing the bearing. Drive the bearing into place using the special installer that only applies pressure to the outer race. Fit the spacer and the other bearing. Check for perfect alignment as you slide the axle into place.



Wheels should be balanced after each service.

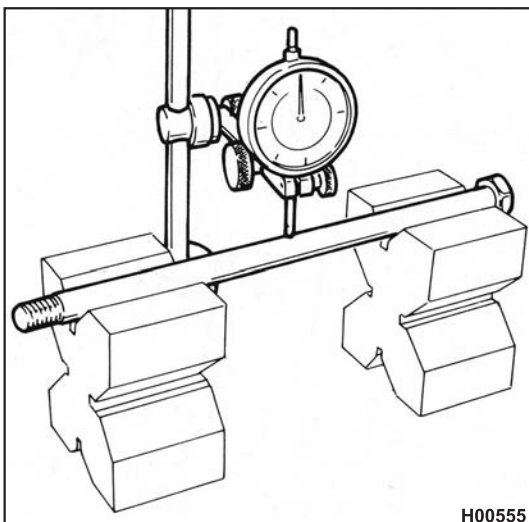
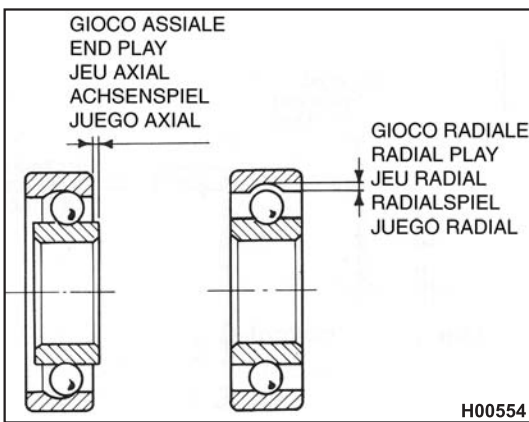

Wheel axle warpage

If warped beyond the maximum limit allowed, the axle must be straightened or replaced. Replace the axle if it cannot be straightened so as to meet the maximum limit allowed.

Axle runout over 100 mm

Wheel axle	Standard	Max limit
Wheel axle	less than 0.1 mm	0.2 mm (0.0078 in.)





Wheel spokes

Make sure all nipples are firmly tightened (4.4 Nm, 0.45 Kgm, 3.2 ft/lb). Re-tighten if needed. Improper tightening will affect motorcycle stability; for a quick check, simply tap the spokes with the tip of a metal tool (such as a screwdriver): a clear, crisp sound indicates proper tightening, a dull sound means that the spokes need to be tightened.

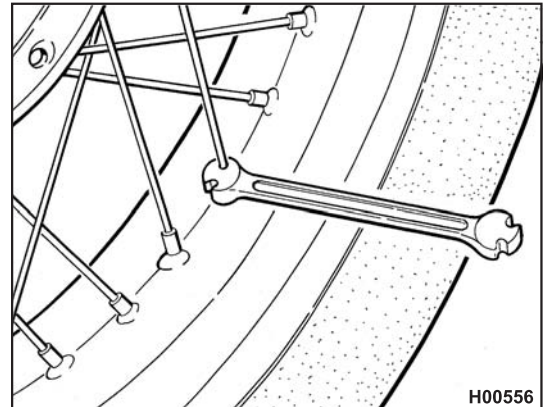

Wheel rim warpage

The table below reports the allowed limits for wheel rim warpage. Exceeding runout or out-of-round are generally due to worn bearings. When this is the case, replace the bearings. If this does not solve the problem, change the wheel rim or the wheel.

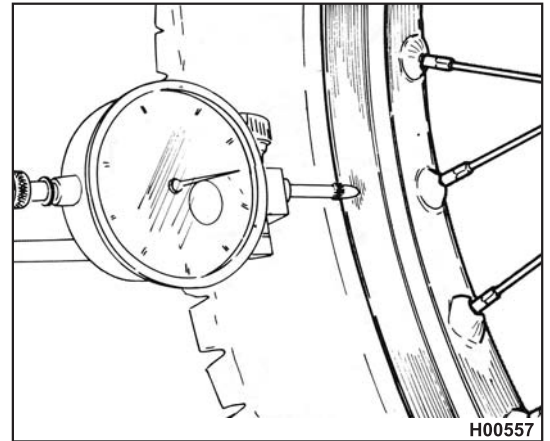

Standard		Max limit
Side runout	less than 0.5 mm	2 mm (0.078 in.)
Out-of-round	less than 0.8 mm	

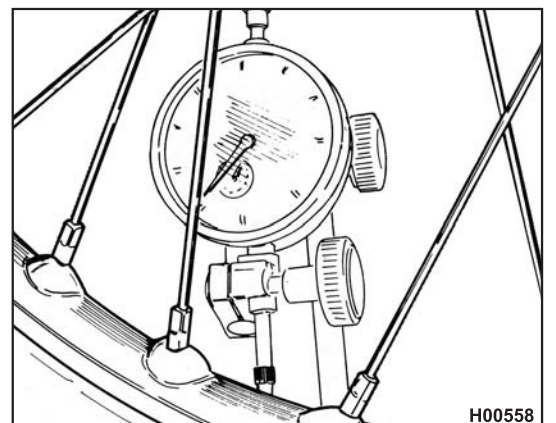



CHASSIS AND WHEELS

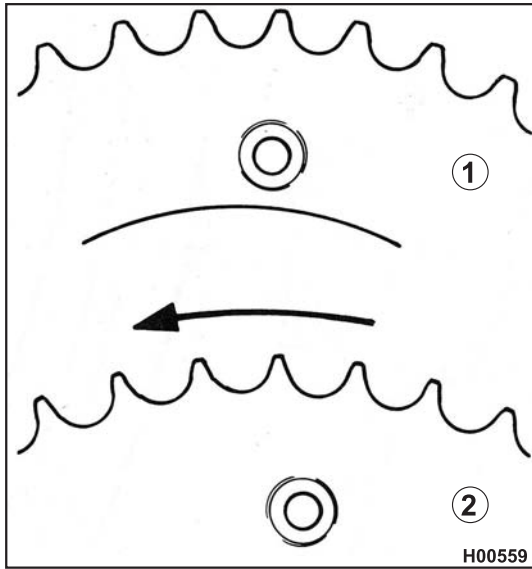

Rear chain sprocket, secondary drive sprocket and chain

The figure at the side shows the profiles of a normally worn and an exceedingly worn sprocket.

- 1 Normal wear
- 2 Exceeding wear

If the sprocket is exceedingly worn, replace it after loosening the six screws that retain it to the hub.



Chain and sprockets must always be replaced as a set.

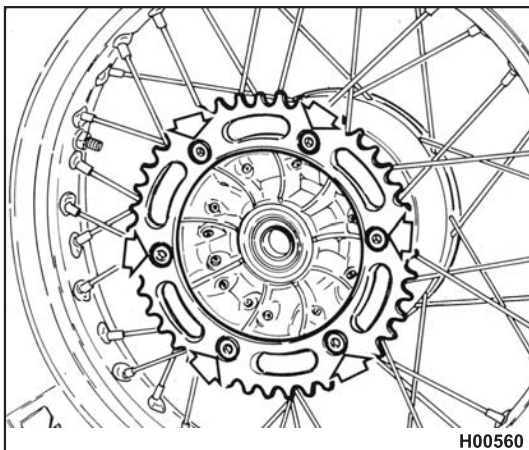

Tightening torque figures

3: 34.3 Nm, 3.5 Kgm, 25.3 ft/lb + LOCTITE 243

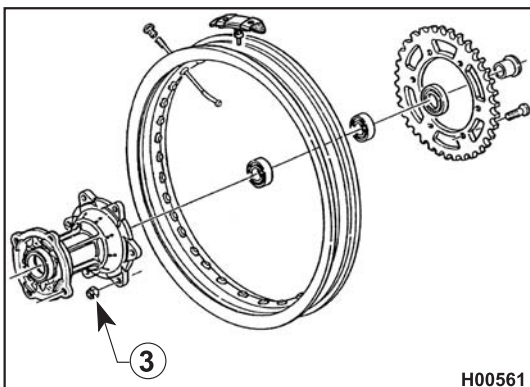



Checking chain and sprockets for wear

Check chain wear as follows:

- turn the adjuster screws to stretch the chain taut;
- mark 20 chain links;
- measure distance "A" (centre distance between 1st and 21st link).

Check the transmission sprocket for damage or wear. When worn down like the sprocket shown in the figure, it must be replaced.



Wheel misalignment causes abnormal wear, making the motorcycle unsafe to ride.



Dirt caked on sprockets and chain collected while riding on muddy or wet terrain increases chain tension. If you expect to ride on muddy or wet terrain, slacken the chain a bit. Riding on muddy terrain significantly increases chain and sprocket wear.

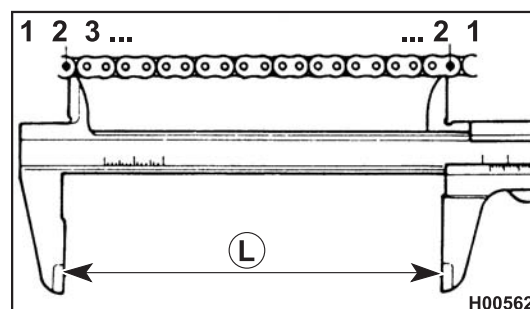

H00562

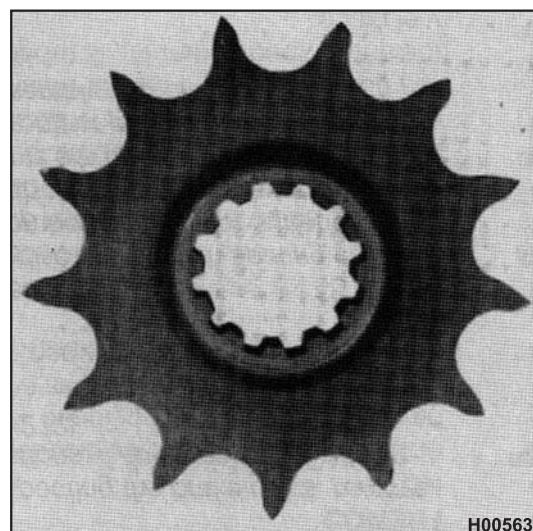

H00563

