

Telma's quality retarders in demand

Telma SA, the world leader in designing, manufacture and sales of electromagnetic retarders, has its products fitted in major commercial vehicles and related products to be launched at Auto Expo 2012.

The company, over 60 years old, with its headquarters at Cergy-Pontoise near Paris, offers a range of products. The first of them is an axial product which is fitted in the driveline. The second product is the focal retarder fitted on the transmission or the drive axle. The third one is a light weight product line. These systems are widely used on heavy trucks, transit buses, shuttle buses, motor-coaches, fire trucks, ambulances and other vehicles.

Telma retarders can be found in many products on display at Auto Expo, including the newly-launched Volvo, AMW and Eaton.

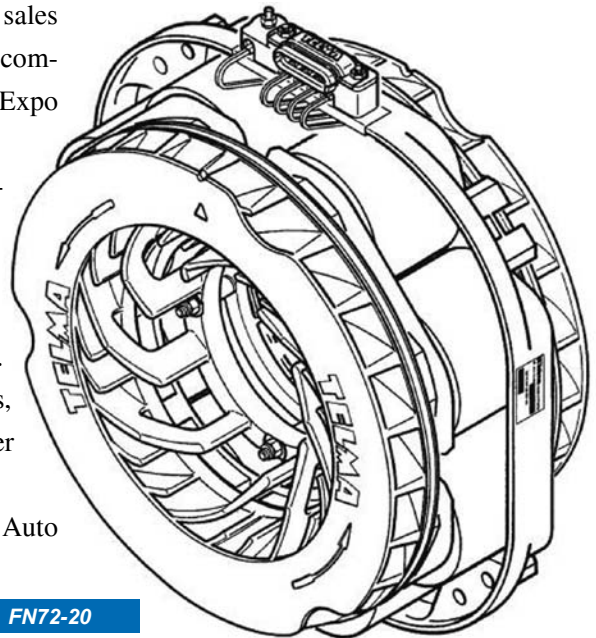

FN72-20



FN71-95

TELMA @ AUTO EXPO 2012

- Telma Focal retarder FN71-95 is directly mounted on the gear box in Volvo's Asia Bus
- Telma Axial retarder FN72-20 is mounted on the chassis in between the propeller shaft in AMW's 6X2 Multi Axle Front Engine bus
- Telma focal retarder FC71-40 is fitted in Eaton India's 6 speed AMT