

ENGLISH

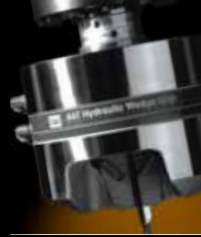

2024

SERVICES & ACCESSORIES
サービス & アクセサリー
SERVICE ET ACCESSOIRES
SERVICE UND ZUBEHÖR
服务与附件



MTS AFTERMARKET SOLUTIONS
be certain.

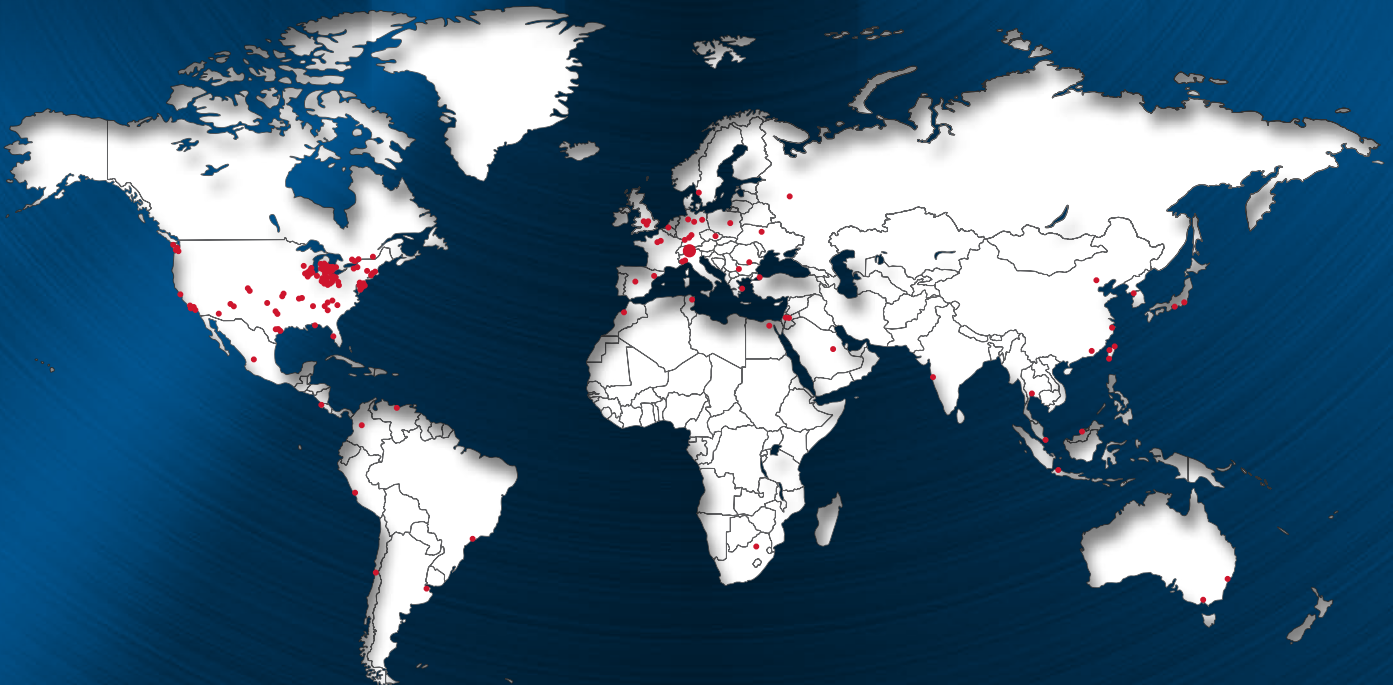

L'ENGAGEMENT MONDIAL, LA PRÉSENCE LOCALE 信守全球承诺, 专注本地服务 GLOBALE VERPFLICHTUNG,
REGIONALE BETREUUNG GLOBAL COMMITMENT, LOCAL DEDICATION グローバル コミットメント、地域レベルの貢献

Welcome to the MTS Services, Maintenance Parts and Accessories Catalog for 2024

Test and product development professionals rely on MTS to help increase lab productivity and accelerate time to market. Around the world, test engineers recognize that our solutions enable efficient test, measurement and simulation for a wide range of products and materials. Whether you need to evaluate advanced composites and alloys or test full-scale automobiles, airplanes, bridges or buildings, MTS testing solutions make possible many of the innovations that are changing how our world works.

Reliable Testing Solutions

Choosing the correct equipment, components and accessories to accomplish your test objectives is important because generating accurate test data requires reliable test equipment. MTS provides some of the most reliable and longest lasting test equipment on the market, and this catalog includes items to help you maximize equipment performance and longevity. Due to the wide range of solutions that MTS produces, including custom testing solutions, not every available item is listed within this catalog. If you cannot find a specific item, please contact your nearest MTS support office.

Responsive Global Service

With one of the largest, most experienced global service networks of any testing solutions provider, MTS can address your global testing needs quickly and efficiently. Local service and consulting representation throughout the world helps you maximize uptime and productivity. Additionally, MTS is adding connectivity to the lab to allow greater insight into equipment health and to streamline lab operations.

Table of Contents

INTRODUCTION	2-6	TESTING SYSTEM COMPONENTS	158-175
Welcome Letter	2	Introduction	158
Table of Contents	3	201 Hydraulic Actuators	159-160
How to Contact and Order from MTS	4	242 Hydraulic Actuators	161
Contacting MTS	5	244 Hydraulic Actuators	162
MTS Services	6	248 Hydraulic Actuators	163
		249 Swivel Base & Rod Ends	164-165
SERVICES	7-33	252 Servovalves	166
Training	7	215 & 216 Rotary Actuators	167
Routine Maintenance	8-9	Rotary Actuator Options	168
Fluid Assessment Services	9	515 Hydraulic Power Units	169
Onsite Calibration	10-14	Multi-Pump Control Manager (MPCM)	170
Factory Calibration Services	15	295 Hydraulic Service Manifold	171
Metrology Calibration Services	16-17	SafeGuard Technology	172
Remanufacture Using SureCoat Technology	18-21	Isolation Service Manifold	173
Remanufacture Programs	22-25	Testline Modular Components	174
Software Support Plan	26-28	Additional Components	175
RPC & cRPC Connect Software Products	28		
Echo® Remote Monitoring	29-31	MTS MAINTENANCE PARTS	176-223
Warranty Coverage	32	Introduction	176
		Hydraulic Tools & Sample Bottles	177
LOAD CELLS	34-43	Accumulator Parts	178
Introduction	34	Actuator Parts	179-183
Servo-hydraulic Load Cells	35-36	Spares Kits	184
Force Transducers/Load Cells = Criterion & Exceed	37-39	Load Frame Parts	185-186
Electromechanical Load Cells	40-41	Cables	187-190
Load Cell Adapters	42-43	Replacement Lamps	190
		Adapter Cables for 3rd Part Equipment	191
EXTENSOMETERS	44-79	Grip Parts	192
Introduction	44-45	Hydraulic Hoses	193
How to Select an Extensometer	46	Hydraulic Power Unit Parts	194-199
Application Index	47	Hydraulic Service Manifold Parts	200-201
Functional Index	48	Filter Elements	202
Axial Extensometers	49-61	Flushing & Shut-Off Valves	202
High Temperature Extensometers	62-64	SWIFT® Parts	203-204
Specialty Extensometers	65-69	FlatTrac® & Rolling Road Systems Parts	205
MTS Advantage Optical Extensometer (AOX)	70-71	Series 329 Road Simulator Parts & Durability Parts	206-207
MTS Advantage Video Extensometer (AVX)	72-73	329 System Parts	208
Laser Extensometer	74	Model 329 4 DOF PC Road Simulator Parts	209-212
Other Applications	75	Model 329 6 DOF Road Simulator Actuator Parts	213
Clip-On Displacement Gages	76	Model 329 6 DOF PC Road Simulator Parts	214-216
Displacement Gages	77	Model 329 4 DOF LT Road Simulator Parts	217-218
Extensometer Calibrator	78	Model 329 6 DOF LT Road Simulator Parts	219-221
DCPD	79	MAST Parts	222
		320 Rebuild Kits	223
GRIPS & FIXTURES	80-147	EXCHANGE PROGRAMS	224-237
Introduction	80-81	Introduction	224
Polymer Matrix Composites Fixtures Index	82	Just In Case™	225
Servo-hydraulic Grips & Fixtures	83-99	Electronics	226-232
Monotonic Grips	100-132	Onsite Exchange Programs	233-235
MTS Fundamental™ Grips & Fixtures	133	MTS Series 252 & 256 Servovalves	236
Bionix® Grips	134-138	Remanufacture Programs - Actuators	237
Bionix EnviroBath	139-140		
Composites Fixtures	141-147	COMPANY LOCATIONS	238-239
		Company Locations	238-239
FURNACES & CHAMBERS	148-157		
Introduction	148		
Furnaces & Temperature Controller	149		
Environmental Simulation	150-153		
Thermomechanical Fatigue (TMF)	154-155		
Environmental Chambers & Specifications	156-157		

How to Contact and Order from MTS

With a global presence and local support, MTS has sales, service and training resources located near our customers. At the end of this catalog you will find a complete list of local offices and contact information. Simply call or e-mail the nearest location to get in touch with a local representative.

MTS Teams Dedicated to Serve You

When you chose MTS for your test system solution needs, you gained access to a complete support network of teams who are ready to assist you. The teams on this page support the services and products offered within this catalog. There are many more MTS teams who support customers by consulting on, developing and installing custom or advanced testing systems.

ORDER SERVICES

This team researches repair and service parts and processes pick and ship orders that have no labor or custom content. Order Services also develops quotations for standard repair, maintenance, and service parts.

TECHNICAL SUPPORT

Support and assistance in answering technical questions that you may encounter when using your MTS testing system software and equipment is provided by Technical Support. See section below for information on how to contact this group.

SERVICE SALES

This group assists in arranging onsite services and consultation in developing service planning plus support for current service contracts. They will also provide quote support for products and services that require field service involvement.

SALES ENGINEERS

The Sales Engineers provide support and consultation when you have standard system or product expansion needs. They are readily available to provide you with information and assistance on new test systems, system upgrades, and new equipment for your full range of testing needs.

FIELD SERVICE

Your local source for onsite equipment installation is the Field Service team. They also perform onsite routine maintenance, calibrations and repair, or product exchange services for your equipment.

FIELD SERVICE COORDINATION AND SCHEDULING

This group will establish initial onsite service appointments, answer questions and help with scheduling priorities. They help accommodate schedule changes. Validate and clarify scope of work for onsite tasks to be performed while providing management of Field Service Resources.

CUSTOMER TRAINING

Standard and customized classroom training on MTS equipment and technology is available for those of all levels of technical ability. Training can be done at regional training centers or onsite. See the list of training centers in this section of the catalog to arrange for training.

Contacting MTS by...

PHONE

Call your local office listed on pages 240 and 241 of this catalog. Our North America Customer Care Center is also available at 1-800-328-2255 between the hours of 7:00 a.m. and 5:00 p.m. (USA Central time) Monday through Friday.



INTERNET

Contact us online at www.mts.com. Use the website to learn more about MTS and the products and services you need to ensure the highest levels of testing performance. Simply select the Contact Us link from the menu in the top right of any page on the site to initiate an electronic information request. To contact MTS by e-mail, find the e-mail address for your local office in this section of the catalog, or send an e-mail to info@mts.com. If sending an e-mail, please include information about the reason for your inquiry as well as how we should respond back to you.

Contacting MTS

Contacting Technical Support

MTS provides a full range of support services after your system is installed. If you have any questions about a system or product, contact Technical Support in one of the following ways.

INTERNET

- » Go to my.mts.com and click on the "Submit a ticket" button on the top right of the page
- » E-mail, tech.support@mts.com

TELEPHONE

- » 1-800-328-2255 - toll free in U.S.;
- » +1-952-937-4000 - outside U.S.

CALL PREPARATION

The Customer Care Center agent will ask you for some information to get you the help you need as quickly as possible. To help provide prompt support, please gather the following information prior to contacting MTS:

General information (essential)

- » Company name
- » Company address
- » MTS site number
- » Your name and phone number
- » All applicable support contract numbers

Describe the problem you are experiencing

- » How long has the problem been occurring?
- » Can you reproduce the problem?
- » Were any hardware or software changes made to the system before the problem occurred?

What to Expect When You Call

1. Your call will be registered by the Customer Care Center agent. The agent will ask for your site number.
2. The Customer Care Center agent may also ask you to verify information noted in the Call Preparation section.
3. What is the nature of your call today? The Customer Care Center agent will need to know if you are calling for technical support, to order parts, or to request a service call, to name a few.
4. If you have made a previous call regarding your issue, we can recall your file. You'll need to tell the Customer Care Center agent the following:
 - a. The MTS service request or the MTS quote number
5. The Customer Care Center agent, or another MTS employee, may ask you to perform certain tasks so we can identify the problem.
6. If you are calling to place an order, please have the following information ready:
 - a. MTS site number
 - b. Purchase order number, which you will need to complete your order.



MTS Services

Test professionals throughout the world rely on MTS Systems's innovative technologies, high-quality testing systems and applications expertise to optimize their testing programs. We have the experience to support your test equipment from pre-installation to de-commission and at every point in between. MTS has the service solutions to meet your needs for test schedule predictability, data integrity, system performance optimization and budget management.

ONSITE SERVICES

Although MTS builds some of the most rugged test solutions available, the constant motions and forces applied to test specimens can ultimately take their toll on the test systems as well. Our field service engineers have a worldwide reputation for applications expertise, and will respond to your request for support or repair quickly and efficiently. MTS can also assist with installation or movement of lab equipment – including disassembly, packing for transportation and installation at the new location. In addition, we offer consumables and spare parts for new-generation MTS equipment and most of our legacy systems.

ENGINEERING SERVICES

MTS offers a complete set of professional engineering services, including systems engineering, test consulting and facilities design services. MTS experts will listen to your test objectives, analyze your situation, and translate your desires to specific system requirements and an actionable plan. We can provide test designs, fixture engineering, control system evaluation, data collection and results analysis. By referencing the best practices of test labs worldwide, MTS can help you design test facilities, including hydraulic distribution systems. Let MTS help you develop long-range lab investment plans that support your business growth strategies or research plans.

CALIBRATION & ALIGNMENT

All test labs must calibrate their testing equipment to help ensure data accuracy. MTS provides top-quality calibration services accredited by A2LA to ISO/IEC 17025 standards. We can complete calibration at your location, or in our factory metrology labs. We also offer a range of services, including load frame alignment services, designed to help minimize data variance.

TRAINING

MTS training programs are designed to improve technician efficiency and maximize system performance. Expertly led and completely customizable, the courses provide hands-on learning to make sure you are thoroughly familiar with your

test systems and know how to operate them effectively. In addition to a broad selection of standard courses, MTS can customize courses to meet your specific lab needs and deliver the training at our Training Center or your workplace. MTS classroom training is available at Regional Training Centers located in the U.S., South Korea and Germany. All of our course offerings can be presented onsite at your facility.



MAINTENANCE & MONITORING

Making sure that equipment is ready for use when needed and test projects are completed on time without unexpected breakdowns are important aspects of test lab management. Based on decades of service experiences, MTS has a set of well-defined routine maintenance offerings tailored for specific systems and components, to help extend equipment life and provide you with confidence in your equipment. MTS has hydraulic fluid monitoring and maintenance programs that will help you optimize test system performance. Our condition based monitoring tools help you better understand equipment condition and anticipate potential issues before they become larger problems. And our real-time, remote monitoring software solution for the entire lab can be accessed anywhere by any Web-enabled device – smart phone, laptop or tablet, for increased visibility and productivity in the lab.

UPGRADE SOLUTIONS

As technology improves, an upgrade is often the most economical way of expanding your lab capabilities and extending the life of existing test equipment. MTS offers upgrades and replacements for all areas of your test system: mechanical components, controllers and software. Upgrade your old hydraulic power unit to a new, efficient one and save money. Our Software Support Plans make it easy to stay current with rapidly changing software technology. Within your contract period, you will automatically receive updates to all software covered in your contract.

Training

Course Selection

Factory Training Courses

Software Operation Courses	AMERICAS TRAINING CENTER	ASIA TRAINING CENTER	EUROPE TRAINING CENTER	Service Product Code
MTS Hardware Concepts & MTS Series 793 Software	√	√		TRCAHOMTWC
MTS Series 793 Software with MultiPurpose TestWare® (MPT) Test Design	√	√	√	TRCMTSC
MTS Series 793 Software with MTS TestSuite™ Elite (mpe) Test Design	√	√	√	TRCMTSMSC
MTS TestSuite Multipurpose Elite (mpe) Software	√	√	√	TRMTSMSC
MTS TestSuite TW Software	√	√	√	TRTSTWEC
MTS Acumen® Operation with MTS TestSuite Multipurpose Elite Software	√			TTRACUMTSMPE
AeroPro™ Operator	√			TRAPOC
AeroPro Administrator	√	√		TRAPAC
Fatigue & Fracture with MTS TestSuite Software	√			TRFFSC
RPC Connect Basic Software Operation	√	√		TRRPCCBSOC
RPC Connect Advanced Software Operation	√	√		TRRPCCASOC
RPC Connect User Transition from RPC Pro	√	√		TRRPCCUTRANSC
Component RPC Connect Software Operation	√	√		TRCRPCCSOC

Test System Operation & Application Theory Courses				Service Product Code
Damper Test System Operation	√			TRDTSOC
Durability Testing Technology	√	√		TRDTC
Elastomer Testing on Controllers with MTS Series 793 Software	√	√	√	TRETC793C
Test Rig Design	√			TRTRDC

Training/Consulting Package

Description	Service Product Code
MTS TestSuite MPE Training/Consulting Package <i>(Contact MTS Training for details)</i>	TTRTSMPETCP
MTS TestSuite TWE Training/Consulting Package <i>(2 days software training plus 2 days consulting on custom test methods)</i>	TTRTSTWETCP

On-Line Training

Online Introductory	Service Product Code
Series 793 Configuration	TTR793CONFIG
Series 793 Operator Introduction	TTR793OPINTRO
MultiPurpose TestWare Operator Introduction	TTR793MPTINTRO
TestSuite mpe Operator Introduction	TTRTSMPEOPINTR
TestSuite twe Operator Introduction	TTRTSTWEOPINTR
TestSuite twe Test Design & Results	TTRTSTWEEXPDTA

Online Hands-On	Service Product Code
Series 793 Software with Hands-On Exercises	TTR793HANDSON
MultiPurpose TestWare Software with Hands-On Exercises	TTRMPHANDSON
TestSuite MPE Software with Hands-On Exercises	TTRMPEHANDSON
TestSuite TWE Software with Hands-On Exercises	TTRTWEHANDSON

Training alternatives

MTS can provide onsite presentations of all course offerings. MTS also has the expert capability to develop custom courses on a broad range of test-related subjects not covered in the course schedule. *(Please allow three months for onsite course scheduling.)*

Routine Maintenance

Description	Service Product Code
Hydraulic Power Unit	
HPU (500 hr)	MRMHPU1
HPU (1,000 hr)*	MRMHPU2
HPU (1,500 hr)	MRMHPU3
HPU (2,000 hr)*	MRMHPU4
Servohydraulic Load Frame	
SH Frame (500 hr)	MRMFRAME1
SH Frame (1,000 hr)	MRMFRAME2
SH Frame (1,500 hr)	MRMFRAME3
SH Frame (2,000 hr)*	MRMFRAME4
Static-Hydraulic Load Frame	
StH Criterion Frame (2,000 hr)*	MRMFRAMESTC
Electromechanical Load Frame	
EM Frame (2,000 hr)	MRMFRAMEEM
EM Criterion Frame (2,000 hr)	MRMFRAMEEMC
Electrodynamic Load Frame	
ED Acumen Frame (2,000 hr)	MRMACU1
Controller	
Controller (2,000 hr)*	MRMCONTROL
Series 329 6DOF Road Simulator	
Per Corner (500 hr)	MRM3296D1
Per Corner (1,000 hr)	MRM3296D2
Per Corner (1,500 hr)	MRM3296D3
Per Corner (2,000 hr)*	MRM3296D4
Longitudinal Restraint Option 6DOF Per Corner (every 500 hrs)	MRM3296DLR
Static Support Option 6DOF Per Corner (every 500 hrs)	MRM3296DSS
XY Positioner Option 6DOF & 4DOF Per Corner (every 500 hrs)	MRM329XY
Brake Intensifier Option 6DOF & 4DOF Per System (every 2000 hrs)*	MRM329BI

Routine Maintenance Package pricing does not include materials. Each specific MTS equipment model may or may not require materials at each RM interval.

Routine Maintenance Packages may not apply to all MTS equipment models. Please contact our service sales representative to verify equipment eligibility.

*Note: Filters and/or materials replaced during this service.

Routine Maintenance & Fluid Assessment Services

Description	Service Product Code
Tire Rolling Resistance - Hydraulic	
Tire Rolling Resistance - Hydraulic (500 hr)*	MRMRRH1
Tire Rolling Resistance - Hydraulic (1000 hr)*	MRMRRH2
Tire Rolling Resistance - Hydraulic (1500 hr)*	MRMRRH3
Tire Rolling Resistance - Hydraulic (2000 hr)*	MRMRRH4
Tire Rolling Resistance - Hydraulic Carriage Option (500 & 1500 hr)	MRMRRHO1
Tire Rolling Resistance - Hydraulic Carriage Option (1000 & 2000 hr)*	MRMRRHO2

Tire Rolling Resistance - Electric	
Tire Rolling Resistance - Electric (500 hr)*	MRMRRE1
Tire Rolling Resistance - Electric (1000 hr)*	MRMRRE2
Tire Rolling Resistance - Electric (1500 hr)*	MRMRRE3
Tire Rolling Resistance - Electric (2000 hr)*	MRMRRE4
Tire Rolling Resistance - Electric Carriage Option (500 & 1500 hr)	MRMRREO1
Tire Rolling Resistance - Electric Carriage Option (1000 & 2000 hr)*	MRMRREO2

Tire Tread Wear Simulation	
Tire Tread Wear - Hydraulic (500 hr)*	MRMTWH1
Tire Tread Wear - Hydraulic (1000 hr)*	MRMTWH2
Tire Tread Wear - Hydraulic (1500 hr)*	MRMTWH3
Tire Tread Wear - Hydraulic (2000 hr)*	MRMTWH4
Tire Tread Wear - Hydraulic Carriage Option (500 & 1500 hr)	MRMTWHO1
Tire Tread Wear - Hydraulic Carriage Option (1000 & 2000 hr)*	MRMTWHO2

Routine Maintenance Package pricing does not include materials. Each specific MTS equipment model may or may not require materials at each RM interval. Routine Maintenance Packages may not apply to all MTS equipment models. Please contact our service sales representative to verify equipment eligibility.

**Note: Filters and/or materials replaced during this service.*

MTS Fluid Care Program	
Program Management Per Sample Point	FFCPCONSULT
FSE Sampling Per Bottle (Use P/N 100-188-132)	

MTS Fluid Analysis	
FSE Sampling Per Bottle (Use P/N 100-188-132)	

Fluid Replacement Service*	
Replace hydraulic fluid* (systems <30 gpm)	MRMFLUIDCHG1
Replace hydraulic fluid* (systems 30 to 100 gpm)	MRMFLUIDCHG2

**Note: Fluid is not included and customer is responsible for disposal*

HPU Performance Check	
	SPARHC1ST
	SPARHCADD

Onsite Calibration Services

Calibration Standards Fee

	Service Product Code
One charge per calibration incident, Load Cells 0-300 kN, LVDT, etc. Load Cells 500-5000 kN and Torque*	CALSTDFEE
International Tool/Standard Fee	INTLTOOLSTDFEE

MTS Field Service is A2LA Accredited to perform on-site calibrations. Our Scope of Accreditation to ISO/IEC 17025-2005 covers many calibration types.

» Pricing is based on specimen and fixturing removed, leaving the system ready to be calibrated. Additional time required to prepare the system for calibration will be charged at current Field Service Engineer rates.

» Consult factory for models not listed.

» Calibrations are to current revision of applicable standard unless otherwise noted.

» ASTM E4 certification may not apply to electromechanical calibrations.

* This standards fee can vary by country.

Please contact your local MTS representative.

Load Cell to Relevant ASTM E4 or ISO 7500 Standards***

First Readout Device	Service Product Code
Deadweight up to 100 lbs	CDWTO100
Axial 0 to 1 KIP Metric Equivalent 0 to 5 kN (Single range Acumen only/2 to 100% full-scale)	CT1KAA
Axial 0 to 5 KIP Metric Equivalent 0 to 25 kN** (Single range EM & Criterion/10 to 100% full-scale)	C5KAA
Axial 0 to 20 KIP Metric Equivalent 0 to 100 kN [up to 2 ranges (tension/compression)]	C20KAA
Axial 0 to 100 KIP Metric Equivalent 0 to 250 kN (tension/compression)]	C100KAA
Axial 0 to 240 KIP Metric Equivalent 0 to 500 kN [up to 2 ranges (tension/compression)]	C240KAA
Axial 0 to 500 KIP Metric Equivalent 0 to 1000 kN [up to 2 ranges (tension/compression)]	C500KAA
Axial 0 to 1000 KIP Metric Equivalent 0 to 5000 kN [up to 2 ranges (tension/compression)]	C1000KAA
Torque 0 to 60K inch-pound Metric Equivalent (0 to 6800 N.m) 1 range	C60KTA
Torque 0 to 200K inch-pound Metric Equivalent (0 to 22000 N.m) 1 range	C200KTA
Torque 0 to 750K inch-pound Metric Equivalent (0 to 85000 N.m) 1 range	C750KTA
ASTM E4 or ISO 7500*** readout verification, each additional readout device/additional bridges	CASTME4

** For multiple ranges, use the Axial 0 to 20 kip.

Criterion and Exceed Systems (EM only) - Single Range

	Service Product Code
Force Calibration, Deadweight up to 500 N EM only (Single range 0.5% / 10 to 100% full-scale)	CODW500NCEM
Axial Force Calibration 0 to 30 kN EM only (Single range 0.5% / 10 to 100% full-scale)	COA30KNCEM
Axial Force Calibration 0 to 100 kN EM only (Single range 0.5% / 10 to 100% full-scale)	COA100KNCEM
Axial Force Calibration 0 to 300 kN EM only (Single range 0.5% / 10 to 100% full-scale)	COA300KNCEM
Axial Force Calibration 0 to 600 kN EM only (Single range 0.5% / 10 to 100% full-scale)	COA600KNCEM

Criterion and Exceed Systems (EM only) - Exten Range

	Service Product Code
Axial Force Calibration - Extended Range, 0 to 30 kN EM only (Extended range 0.5% / at points below 10% full-scale)	COA30KNCEMER
Axial Force Calibration - Extended Range, 0 to 100 kN EM only (Extended range 0.5% / at points below 10% full-scale)	COA100KNEMER

*** Accreditation can vary by country. Please contact your local MTS representative to confirm.

Pricing for some ISO cals may be slightly higher.

Multi-Axis Force Transducer (Load Cell)

	Service Product Code
Bi-axial (restraint) load cell	
Model 670.67B-03/04	CBIAXCAL1
Model 670.67B-10/11	CBIAXCAL2
Tri-axial 833 Elastomer load cell Utilizing hardware Matrix box (Matrix module and system controller required)	CTRIAXCAL1
Tri-axial 833 Elastomer load cell Utilizing SW and calculated channels (System controller with conditioners required)	CTRIAXCAL2

Onsite Calibration Services

Displacement Transducers

Type	Service Product Code
Acumen Displacement Calibration	CDTACU
Servo-hydraulic displacement (LVDT)	CLVDT
Rotary position transducer	CRVDT
Delta P transducer	CDELTA PCAL
Electromechanical test system verification (includes both Speed and Displacement)	CSPDTMTS
Speed and Displacement Criterion and Exceed EM only (Single Range 0.5% / Displacement to ASTM E2309)	COSPDTCEM

Reference ASTM E2658 available upon request.

Clip-On Displacement Gages (COD)

Calibration of COD gages for use in compliance with ASTM** E399, E561, E1290, and E1820.

ASTM Clip-on Displacement Gage	Service Product Code
Calibration (Models Covered: 632.02, 632.03, 632.05, 632.06, & Equivalents)	CCODCAL

**ASTM E399 standard test method for plane-strain fracture toughness of metallic materials.

ASTM E561 standard practice for R-curve determination.

ASTM E1820 standard test method for measurement of fracture toughness.

Extensometer Calibration to Relevant ASTM E83/ISO 9513 Standards

	Service Product Code
Axial Extensometers (per extensometer) (Models Covered: 632.11, 632.12, 632.24, 632.25, 632.27, 632.29, 632.31, 632.90, 632.94, 634.12, 634.25, 634.28 & Equivalents)	CAXIALEXTCAL
Bi-Axial Extensometers (Models Covered: 632.8X & Equivalents)	CBIALEXTCAL
Diametral Extensometers (Models Covered: 632.18, 632.19, 632.20 & Equivalents)	CDIAEXTCAL
Averaging Axial Extensometers (Models Covered: 632.17 & Equivalents)	CAVGEXTCAL
Cross Sectional Strain Extensometers (Models Covered: 632.23 & Equivalents)	CCSSTREXTCAL
High Temperature Axial Extensometers (Models Covered: 632.4X, 632.5X, 632.6X & Equivalents)	CHITEMPEXTCL
Immersible Extensometers (Models Covered: 632.70 & Equivalents)	CIMMEXTCAL
Small Gage Length Extensometers (Models Covered: 632.13, 632.26 & Equivalents)	CSGLEXTCAL
Circumferential Extensometers (Models Covered: 632.92 & Equivalents)	CCIREXTCAL
High Elongation Extensometers (Models Covered: DXL-Ext & Equivalents)	CHIELEXTCAL
Biomedical Extensometers (Models Covered: 632.32 & Equivalents)	CBIMEDEXTCAL

Other Calibration Items

	Service Product Code
Non-MTS Calibration Custom Quote	
LDH Machine Calibrations 866.5X	CLDH866.5X
LX Cal Extensometer	CLXEXTCAL
AVX Cal Extensometer	CAVXEXTCAL
AVX Cal Extensometer Extra Working Distance	CAVXEXCALELEWD
FlexDAC Calibration ONSITE (1st chassis)	CFLEXDACCAL
FlexDAC Calibration ONSITE (each additional chassis)	CFLEXDACCALADD
FlexTest Calibration ONSITE 494.16 / 494.21 / 494.25 / 494.45 / 494.46 (Single AC/DC conditioner or A/D or D/A)	CFLXTEST494CAL
FlexTest Calibration ONSITE 494.26 (2 AC/DC conditioners)	CALFLXTST49426
FlexTest Calibration ONSITE 494.41 / 494.42 / 494.43 (All FT40)	CALFLXTST49440
FlexTest Calibration AC Option (per board or DUC, 494.26 = 2 DUCs)	CALFLXTST494AC

Static Alignment Verification to Relevant ASTM E1012/NASM 1312B

Dynamic Force Verification to Relevant ASTM E467/NASM 1312B

Onsite Calibration Services

Time and Material Calibrations

Some systems must be calibrated under a time and material method. An example would be a system without a load unit that requires the use of a fabricated reaction base. Standard load unit systems will always be calibrated under the fixed fee method. When a system is calibrated using the time and material method, these charges apply:

- » Time-and-material Standards fee for each standard used
- » Each additional load cell using the same load cell standard
- » Zone charges (based on applicable zone charge)
- » Labor (based on applicable labor rate)

Flat-Trac® Calibrations

Flat-Trac calibrations should be performed at least annually, or when any component in the chain of mechanical or electrical components comprising a selected software channel is replaced or repaired.

	New Matrix Generation Calibration	Current Matrix Calibration
	Service Product Code	Service Product Code
Free rolling calibration	CNMFTCFR	CCMFTCFR
Each additional free rolling matrix	CNMFTCFRA	CCMFTCFRA
Adder for spindle drive calibration	CNMFTCSD	CCMFTCSD
Each additional spindle drive matrix	CNMFTCSDA	CCMFTCSDA
Slip angle calibration (stand-alone)		CCMFTCSA
Camber angle calibration (stand-alone)		CCMFTCCA

New Matrix Generation pricing includes the following activities when applicable:

- » A/D and D/A calibrations
- » Camber angle calibration
- » Slip angle calibration
- » Calibrating the calibration standard (Flat-Trac II)
- » Force and moment calibration
- » Belt speed calibration
- » Generation of calibration matrix
- » Pre- and post-calibration data
- » Verify inertial compensation (Flat-Trac III)
- » Calibrate inflation pressure
- » Calibrate ambient and tire temperatures
- » Spindle speed calibration
- » Shunt calibration
- » Loaded radius calibration
- » Verification of matrix through calibration check

Onsite Calibration Services

Calibration for 329 Passenger Road Simulators

Load Cells and Displacement Transducer Calibration	Without brake Service Product Code	With brake Service Product Code
Corner	CCORNERA	CCORNERAB
1/2 Car	CHALFCARA	CHALFCARAB
Full Car	CFULLCARA	CFULLCARAB

Load Cell Calibration (only)

Corner	CCORNERL	CCORNERLB
1/2 Car	CHALFCARL	CHALFCARLB
Full Car	CFULLCARL	CFULLCARLB

Displacement Transducer Calibration (only)

Corner	CCORNERD	CCORNERDB
1/2 Car	CHALFCARD	CHALFCARDB
Full Car	CFULLCARD	CFULLCARDDB

Displacement Transducer Calibration (only)

Load Cells and Displacement Transducer Calibration	Without brake Service Product Code	With brake Service Product Code
Corner	CLTCORNERA	CLTCORNERAB
1/2 Truck	CLTHALFCARA	CLTHALFCARAB
Full Truck	CLTFULLCARA	CLTFULLCARAB

Load Cell Calibration (only)

Corner	CLTCORNERL	CLTCORNERLB
1/2 Truck	CLTHALFCARL	CLTHALFCARLB
Full Truck	CLTFULLCARL	CLTFULLCARLB

Displacement Transducer Calibration (only)

Corner	CLTCORNERD	CLTCORNERDB
1/2 Truck	CLTHALFCARD	CLTHALFCARDB
Full Truck	CLTFULLCARD	CLTFULLCARDDB

Note: zone charges are not included in pricing.

Onsite Calibration Services

Calibration of Multi-Axial Simulation Table (MAST™) Systems

6 Channel MAST 323	End-To-End-Calibration	Service Product Code
Package 1	6 accelerometers	323C6MSTACC
Package 2	6 accelerometers and 6 LVDT	323C6MSTACCL
Package 3	6 accelerometers, 6 LVDT,and ASC D/A-A/D	323C6MSTACCLAD
6 Channel MAST 353	End-To-End-Calibration	Service Product Code
Package 1	6 accelerometers	353C6MSTACC
Package 2	6 accelerometers and 6 LVDT	353C6MSTACCL
Package 3	6 accelerometers, 6 LVDT,and ASC D/A-A/D	353C6MSTACCLAD

Note:

- Prices include calibration standard fee but travel expenses (zone, airfare, etc.) are not included.

- 353 MAST Packages 2 & 3 require 2 FSEs - Prices above include labor for both FSEs, but not travel.

Onsite Accelerometer Calibration

Type	Service Product Code
Single Axis- Transducer only	CACC
Tri-Axis - Transducer only	CTRIAC
Single Axis - Transducer with conditioner	CACCCOND
Tri-Axis - Transducer with conditioner	CTRIACC

Static Alignment Verification

Type	Service Product Code
Static twelve gage alignment STATIC12	CSTATIC12

Perform to ASTM E1012

Dynamic Force Verification

Type	Service Product Code
Dynamic Force Verification	CDYNAMICCAL

Perform to ASTM E467

Factory Calibration Services

Factory Calibration

Load Cell	Service Product Code
<i>Calibration up to 220,000 lbf (As Found / As Left Data Provided) Single Range / Single Readout Device*</i>	
Axial up to 22 kip (Metric Equivalent–up to 100 kN)	FFCFTA1
Additional Range / Readout Device	FFCADDR
Axial >22 kip to 240 kip(Metric Equivalent- >100 kN to 1000 kN)	FFCFTA2
Additional Range / Readout Device	FFCADDR
Multi-Axis Load Cell	
Bi-axial (restraint) load cell	
Model 670.67B-03/04	FFCBARFT1
Model 670.67B-10/11	FFCBARFT2
Tri-axial 833 Elastomer load cell Utilizing hardware Matrix box (Matrix module and system controller required)	FFCTAEFT1
Tri-axial 833 Elastomer load cell Utilizing SW and calculated channels (System controller with conditioners required)	FFCTAEFT2
Torque Transducer	
<i>Calibration up to 12,000 lbf-in (As Found / As Left Data Provided)</i>	
Torque up to 12,000 lbf Metric Equivalent- up to 1300 Nm	
Single Range / Single Readout Device	FFCTCT1
Additional Range / Readout Device	FFCADDR
Cod Gauges	
Model 632.02 & 632.03 Clip-on displacement gage	FFCCOD1
Model 632.06 1 Arm Bandit displacement gage	FFCCOD2
Extensometer**	
<i>Single Range / Single Readout Device* (As Found / As Left Data Provided)</i>	
Axial Extensometers (per extensometer) (Models Covered: 632.11, 632.12, 632.24, 632.25, 632.27, 632.29, 632.90, 632.94, 634.12, 634.25, 634.28, 634.31 & Equivalents)	FFCEA
Bi-Axial Extensometers (Models Covered: 632.8X & Equivalents)	FFCEBA
Diametral Extensometers (Models Covered: 632.18, 632.19, 632.20 & Equivalents)	FFCEDE
Averaging Axial Extensometers (Models Covered: 632.17 & Equivalents)	FFCEAA
Cross Sectional Strain Extensometers (Models Covered: 632.23 & Equivalents)	FFCECSS
High Temperature Axial Extensometers (Models Covered: 632.4X, 632.5X, 632.6X & Equivalents)	FFCEHTA
Immersible Extensometers (Models Covered: 632.70 & Equivalents)	FFCEI
Small Gage Length Extensometers (Models Covered: 632.13, 632.26 & Equivalents)	FFCESGL
Circumferential Extensometers (Models Covered: 632.92 & Equivalents)	FFCEC
High Elongation Extensometers (Models Covered: DXL-Ext & Equivalents)	FFCEHE
Biomedical Extensometers (Models Covered: 632.32 & Equivalents)	FFCEB
Additional Range/Readout Device	FFCADDR

* Single Range (Minimum of 9 data points from 2% to 100%. Applies to 493 and 494 product lines except 493.21 and 494.21)

** Not relevant to ASTM E83 or ISO9513 Standards

SWIFT and SWIFT EVO System Calibrations

SWIFT calibration prices are per calibration*

Model	Service Product Code
SWIFT 10, 20, 30, & 40 transducer*	FFCSW1
SWIFT 45 & 50	FFCSW2

* PRICE is for Aluminum, Titanium or Stainless Steel units

* PRICE includes Spinning and Non-spinning accessories

* PRICES do not include rims and /or hub adapters

* PRICES are subject to change without notice

* SWIFT Loaner Program is no longer available



Metrology Laboratory Services

Load Cells Astm E74, En 10002-3, And Iso 376 Calibrations	Service Product Code
Load cell - unidirectional up to 25 kip	MMTFTU25
Load cell - bidirectional up to 25 kip	MMTFTB25
Load cell - unidirectional up to 100 kip	MMTFTU100
Load cell - bidirectional up to 100 kip	MMTFTB100
Load cell - unidirectional up to 240 kip	MMTFTU240
Load cell - bidirectional up to 240 kip	MMTFTB240
Load cell with dual bridge – add	MMTFTDBA
Various other Force related M&TE	MMTMTEF

Torque Transducer

Flange style transducers only. Additional costs may apply due to required fixturing

Torque transducers up to 12,000 lbf-in (Bidirectional, ASTM E2428)	MMTTQ1
Torque transducers up to 12,000 lbf-in (Unidirectional, ASTM E2428)	MMTTQ2
Torque transducers up to 12,000 lbf-in (Unidirectional, non-ASTM)	MMTTQ3
Torque transducers up to 100,000 lbf-in (Bidirectional, ASTM E2428)	MMTTQ4
Torque transducers up to 100,000 lbf-in (Unidirectional, ASTM E2428)	MMTTQ5
Various other Torque related M&TE	MMTMTEF

Notes:

Unidirectional Force: Compression and/or tension ascending only data points.

Bidirectional Force: Compression and/or tension ascending and descending data points.

Unidirectional Torque: Clockwise and/or counter-clockwise ascending only data points.

Bidirectional Torque: Clockwise and/or counter-clockwise ascending and descending data points.

Non-ASTM: Performance to manufacturers specifications.

Vibration

Accelerometer - single axis	MMTVIB1
Accelerometer - triaxial	MMTVIB2
Charge amplifiers/Signal conditioners	MMTVIB4
Various other Vibration related M&TE	MMTMTEV

Electrical Instruments/Devices

Provide manufacturer and model number to confirm availability	MMTEID
---	--------

Dimensional and Mechanical Instruments/Devices

Provide manufacturer and model number to confirm availability for Rotary Encoders and dimensional related M&TE	MMTDMID
--	---------

Temperature and Humidity

Provide manufacturer and model confirm availability	MMTTH
---	-------

Time and Frequency

Provide manufacturer and model number to confirm availability	MMTTF
---	-------

Other MTS Product Calibrations

MTS LX series laser extensometers (single standard calibration)	MMTLE1
709 alignment system (data acquisition and signal conditioning electronics)	MMTAS2
Extensometer Calibrators	MMTEC
Additional ranges or custom calibration	MMTADDRCC

Actuators Eligible for Remanufacture using *SureCoat® Technology*

These may qualify for 10 day actuator quick-turn program, contact MTS for details

Model 244.xx

Model Number	Stroke Length	Direct Replacement Actuators Still Available	New Production	Service Product Code
244.11	4-inch	Yes		CYLRM24411X04
244.11	6-inch	Yes		CYLRM24411X06
244.11	8-inch	Yes		CYLRM24411X08
244.11	10-inch	Yes		CYLRM24411X10
244.11	12-inch	Yes		CYLRM24411X12
244.11	14-inch	Yes		CYLRM24411X14
244.11	16-inch	Yes		CYLRM24411X16
244.11	18-inch	Yes		CYLRM24411X18
244.11	20-inch	Yes		CYLRM24411X20
244.12	4-inch	Yes		CYLRM24412X04
244.12	6-inch	Yes		CYLRM24412X06
244.12	8-inch	Yes		CYLRM24412X08
244.12	10-inch	Yes		CYLRM24412X10
244.12	12-inch	Yes		CYLRM24412X12
244.12	14-inch	Yes		CYLRM24412X14
244.12	16-inch	Yes		CYLRM24412X16
244.12	18-inch	Yes		CYLRM24412X18
244.12	20-inch	Yes		CYLRM24412X20
244.20	4-inch	Yes		CYLRM24420X04
244.20	6-inch	Yes		CYLRM24420X06
244.20	8-inch	Yes		CYLRM24420X08
244.20	10-inch	Yes		CYLRM24420X10
244.20	12-inch	Yes		CYLRM24420X12
244.20	14-inch	Yes		CYLRM24420X14
244.20	16-inch	Yes		CYLRM24420X16
244.20	18-inch	Yes		CYLRM24420X18
244.20	20-inch	Yes		CYLRM24420X20
244.21	4-inch	Yes		CYLRM24421X04
244.21	6-inch	Yes		CYLRM24421X06
244.21	8-inch	Yes		CYLRM24421X08
244.21	10-inch	Yes		CYLRM24421X10
244.21	12-inch	Yes		CYLRM24421X12
244.21	14-inch	Yes		CYLRM24421X14
244.21	16-inch	Yes		CYLRM24421X16
244.21	18-inch	Yes		CYLRM24421X18
244.21	20-inch	Yes		CYLRM24421X20
244.22	4-inch	Yes		CYLRM24422X04
244.22	6-inch	Yes		CYLRM24422X06
244.22	8-inch	Yes		CYLRM24422X08
244.22	10-inch	Yes		CYLRM24422X10
244.22	12-inch	Yes		CYLRM24422X12
244.22	14-inch	Yes		CYLRM24422X14
244.22	16-inch	Yes		CYLRM24422X16
244.22	18-inch	Yes		CYLRM24422X18
244.22	20-inch	Yes		CYLRM24422X20

(continued...)

Actuators Eligible for Remanufacture using *SureCoat Technology*

These may qualify for 10 day actuator quick-turn program, contact MTS for details

Model 244.xx (continued)

Model Number	Stroke Length	Direct Replacement Actuators	New Production Still Available	Service Product Code
244.23	4-inch	Yes	Yes	CYLRM24423X04
244.23	6-inch	Yes	Yes	CYLRM24423X06
244.23	8-inch	Yes	Yes	CYLRM24423X08
244.23	10-inch	Yes	Yes	CYLRM24423X10
244.23	12-inch	Yes	Yes	CYLRM24423X12
244.23	14-inch	Yes	Yes	CYLRM24423X14
244.23	16-inch	Yes	Yes	CYLRM24423X16
244.23	18-inch	Yes	Yes	CYLRM24423X18
244.23	20-inch	Yes	Yes	CYLRM24423X20
244.31	4-inch	Yes	Yes	CYLRM24431X04
244.31	6-inch	Yes	Yes	CYLRM24431X06
244.31	8-inch	Yes	Yes	CYLRM24431X08
244.31	10-inch	Yes	Yes	CYLRM24431X10
244.31	12-inch	Yes	Yes	CYLRM24431X12
244.31	14-inch	Yes	Yes	CYLRM24431X14
244.31	16-inch	Yes	Yes	CYLRM24431X16
244.31	18-inch	Yes	Yes	CYLRM24431X18
244.31	20-inch	Yes	Yes	CYLRM24431X20
244.41	4-inch	Yes	Yes	CYLRM24441X04
244.41	6-inch	Yes	Yes	CYLRM24441X06
244.41	8-inch	Yes	Yes	CYLRM24441X08
244.41	10-inch	Yes	Yes	CYLRM24441X10
244.41	12-inch	Yes	Yes	CYLRM24441X12
244.41	14-inch	Yes	Yes	CYLRM24441X14
244.41	16-inch	Yes	Yes	CYLRM24441X16
244.41	18-inch	Yes	Yes	CYLRM24441X18
244.41	20-inch	Yes	Yes	CYLRM24441X20

For all other non-standard 244 actuator remanufactures, please contact MTS

Load Frames Eligible for Remanufacture using *SureCoat Technology*

Model 318

Standard, non-special models

Model Number	Capacity	Stroke Length	Threads	Part Kit Number	Service Product Code
318.10	100 kn	4-inch	English	100-484-438	CYR31810X4E100
318.10	100 kn	4-inch	Metric	100-484-439	CYR31810X4M100
318.10	100 kn	6-inch	English	100-484-440	CYR31810X6E100
318.10	100 kn	6-inch	Metric	100-484-441	CYR31810X6M100
318.10	100 kn	10-inch	English	100-484-442	CYR3181010E100
318.10	100 kn	10-inch	Metric	100-484-443	CYR3181010M100
318.25	100 kn	4-inch	English	100-484-240	CYR31825X4E100
318.25	100 kn	4-inch	Metric	100-484-241	CYR31825X4M100
318.25	100 kn	6-inch	English	100-484-242	CYR31825X6E100
318.25	100 kn	6-inch	Metric	100-484-243	CYR31825X6M100
318.25	100 kn	10-inch	English	100-484-264	CYR3182510E100
318.25	100 kn	10-inch	Metric	100-484-265	CYR3182510M100
318.25	250 kn	4-inch	English	100-484-266	CYR31825X4E250
318.25	250 kn	4-inch	Metric	100-484-267	CYR31825X4M250
318.25	250 kn	6-inch	English	100-484-268	CYR31825X6E250
318.25	250 kn	6-inch	Metric	100-484-269	CYR31825X6M250
318.25	250 kn	10-inch	English	100-484-270	CYR3182510E250
318.25	250 kn	10-inch	Metric	100-484-271	CYR3182510M250

For all crosshead mount and other non standard 318 remanufactures, please consult MTS.

Pricing is for standard parts only, labor and additional parts are extra.

Load Frames Eligible for Remanufacture using *SureCoat Technology*

Model 370

Standard, non-special models

Model Number	Capacity	Stroke Length	Actuator Rating	Bearing Type	Part Kit Number
370.10	100 kn	4 -inch	15 kn	Stepped	058-565-009
370.10	100 kn	4-inch	15 kn	Hydrostatic	058-565-010
370.10	100 kn	6-inch	15 kn	Stepped	058-565-011
370.10	100 kn	6-inch	15 kn	Hydrostatic	058-565-012
370.10	100 kn	10-inch	15 kn	Stepped	058-565-013
370.10	100 kn	10-inch	15 kn	Hydrostatic	058-565-014
370.10	100 kn	4-inch	25 kn	Stepped	058-565-015
370.10	100 kn	4-inch	25 kn	Hydrostatic	058-565-016
370.10	100 kn	6-inch	25 kn	Stepped	058-565-017
370.10	100 kn	6-inch	25 kn	Hydrostatic	058-565-018
370.10	100 kn	10-inch	25 kn	Stepped	058-565-019
370.10	100 kn	10-inch	25 kn	Hydrostatic	058-565-020
370.10	100 kn	4-inch	50 kn	Stepped	058-565-021
370.10	100 kn	4-inch	50 kn	Hydrostatic	058-565-022
370.10	100 kn	6-inch	50 kn	Stepped	058-565-023
370.10	100 kn	6-inch	50 kn	Hydrostatic	058-565-024
370.10	100 kn	10-inch	50 kn	Stepped	058-565-025
370.10	100 kn	10-inch	50 kn	Hydrostatic	058-565-026
370.10	100 kn	10-inch	67 kn	Stepped	058-565-027
370.10	100 kn	10-inch	67 kn	Hydrostatic	058-565-028
370.10	100 kn	4-inch	100 kn	Stepped	058-565-029
370.10	100 kn	4-inch	100 kn	Hydrostatic	058-565-030
370.10	100 kn	4-inch	100 kn	Stepped	058-565-031
370.10	100 kn	4-inch	100 kn	Hydrostatic	058-565-032
370.10/25	100/250 kn	6-inch	100 kn	Stepped	058-565-033
370.10/25	100/250 kn	6-inch	100 kn	Hydrostatic	058-565-034
370.10/25	100/250 kn	10-inch	100 kn	Stepped	058-565-035
370.10/25	100/250 kn	10-inch	100 kn	Hydrostatic	058-565-036
370.25	250 kn	6-inch	250 kn	Stepped	058-565-037
370.25	250 kn	6-inch	250 kn	Hydrostatic	058-565-038
370.25	250 kn	10-inch	250 kn	Stepped	058-565-039
370.25	250 kn	10-inch	250 kn	Hydrostatic	058-565-040
370.50	500 kn	6-inch	500 kn	Stepped	058-565-041
370.50	500 kn	6-inch	500 kn	Hydrostatic	058-565-042

370 Tabletop Load Frames

Model Number	Capacity	Stroke Length	Actuator Rating	Bearing Type	Part Kit Number
370.02	25 kn	4-inch	15 kn	Stepped	058-565-001
370.02	25 kn	4-inch	15 kn	Stepped	058-565-002
370.02	25 kn	6-inch	15 kn	Stepped	058-565-003
370.02	25 kn	6-inch	15 kn	Stepped	058-565-004
370.02	25 kn	6-inch	25 kn	Stepped	058-565-005
370.02	25 kn	6-inch	25 kn	Stepped	058-565-006
370.02	25 kn	4-inch	25 kn	Stepped	058-565-007
370.02	25 kn	4-inch	25 kn	Stepped	058-565-008

Pricing is for standard parts only, labor and additional parts are extra.



Standard Chrome Piston Actuator *Remanufacture Programs*

Model 201.xx

Model Number	Stroke Length	Direct Replacement Actuators Still Available	New Production	Service Product Code
201.10	10-inch	Yes		CYLRM20110X10
201.10	20-inch	Yes		CYLRM20110X20
201.10	30-inch	Yes		CYLRM20110X30
201.10	40-inch	Yes		CYLRM20110X40
201.11	10-inch	Yes		CYLRM20111X10
201.11	20-inch	Yes		CYLRM20111X20
201.11	30-inch	Yes		CYLRM20111X30
201.11	40-inch	Yes		CYLRM20111X40
201.17	10-inch	Yes		CYLRM20117X10
201.17	20-inch	Yes		CYLRM20117X20
201.17	30-inch	Yes		CYLRM20117X30
201.17	40-inch	Yes		CYLRM20117X40
201.20	10-inch	Yes		CYLRM20120X10
201.20	20-inch	Yes		CYLRM20120X20
201.20	30-inch	Yes		CYLRM20120X30
201.20	40-inch	Yes		CYLRM20120X40
201.25	10-inch	Yes		CYLRM20125X10
201.25	20-inch	Yes		CYLRM20125X20
201.25	30-inch	Yes		CYLRM20125X30
201.25	40-inch	Yes		CYLRM20125X40
201.30	10-inch	Yes		CYLRM20130X10
201.30	20-inch	Yes		CYLRM20130X20
201.30	30-inch	Yes		CYLRM20130X30
201.30	40-inch	Yes		CYLRM20130X40
201.35	10-inch	Yes		CYLRM20135X10
201.35	20-inch	Yes		CYLRM20135X20
201.35	30-inch	Yes		CYLRM20135X30
201.35	40-inch	Yes		CYLRM20135X40
201.40	10-inch	Yes		CYLRM20140X10
201.40	20-inch	Yes		CYLRM20140X20
201.40	30-inch	Yes		CYLRM20140X30
201.40	40-inch	Yes		CYLRM20140X40
201.45	10-inch	Yes		CYLRM20145X10
201.45	20-inch	Yes		CYLRM20145X20
201.45	30-inch	Yes		CYLRM20145X30
201.45	40-inch	Yes		CYLRM20145X40
201.50	10-inch	Yes		CYLRM20150X10
201.50	20-inch	Yes		CYLRM20150X20
201.50	30-inch	Yes		CYLRM20150X30
201.50	40-inch	Yes		CYLRM20150X40
201.60	10-inch	Yes		CYLRM20160X10
201.60	20-inch	Yes		CYLRM20160X20
201.60	30-inch	Yes		CYLRM20160X30
201.60	40-inch	Yes		CYLRM20160X40
201.70	10-inch	Yes		CYLRM20170X10
201.70	20-inch	Yes		CYLRM20170X20
201.70	30-inch	Yes		CYLRM20170X30
201.70	40-inch	Yes		CYLRM20170X40

Standard Chrome Piston Actuator *Remanufacture Programs*

Model 204.xx

Model Number	Stroke Length	Direct Replacement Actuators Still Available	New Production Still Available	Service Product Code
204.08	1.1 kip	No		RRA20408
204.09	2.2 kip	No		RRA20409
204.11	2.5 kip	No		RRA20411
204.12	4.0 kip	No		RRA20412
204.13	6.0 kip	No		RRA20413
204.21	6.0 kip	No		RRA20421
204.22	9.0 kip	No		RRA20422
204.23	12 kip	No		RRA20423
204.24	20 kip	No		RRA20424
204.25	24 kip	No		RRA20425
204.26	35 kip	No		RRA20426
204.31	50 kip	No		RRA20431
204.32	70 kip	No		RRA20432
204.41	100 kip	No		RRA20441
204.42	150 kip	No		RRA20442
204.51	3.3 kip	No		RRA20451
204.52	5.5 kip	No		RRA20452
204.61	11 kip	No		RRA20461
204.62	15 kip	No		RRA20462
204.63	22 kip	No		RRA20463
204.64	35 kip	No		RRA20464
204.71	55 kip	No		RRA20471
204.72	77 kip	No		RRA20472
204.81	110 kip	No		RRA20481
204.82	165 kip	No		RRA20482
204.91	220 kip	No		RRA20491

Note: These units are no longer in production; exact replacement of these units is not possible. MTS does carry functional replacements.

Model 242.xx

Model Number	Stroke Length	Direct Replacement Actuators Still Available	New Production Still Available	Service Product Code
242.00	2-inch	Yes		CYLRM24200X02
242.00	4-inch	Yes		CYLRM24200X04
242.00	6-inch	Yes		CYLRM24200X06
242.01	2-inch	Yes		CYLRM24201X02
242.01	4-inch	Yes		CYLRM24201X04
242.01	6-inch	Yes		CYLRM24201X06
242.02	2-inch	Yes		CYLRM24202X02
242.02	4-inch	Yes		CYLRM24202X04
242.02	6-inch	Yes		CYLRM24202X06
242.03	2-inch	Yes		CYLRM24203X02
242.03	4-inch	Yes		CYLRM24203X04
242.03	6-inch	Yes		CYLRM24203X06

Standard Chrome Piston Actuator *Remanufacture Programs*

Model 248.xx

Model Number	Stroke Length	Direct Replacement Actuators Still Available	New Production Still Available	Service Product Code
248.01	2-inch	Yes	Yes	CYLRM24801X02
248.01	4-inch	Yes	Yes	CYLRM24801X04
248.01	6-inch	Yes	Yes	CYLRM24801X06
248.01	10-inch	Yes	Yes	CYLRM24801X10
248.02	2-inch	Yes	Yes	CYLRM24802X02
248.02	4-inch	Yes	Yes	CYLRM24802X04
248.02	6-inch	Yes	Yes	CYLRM24802X06
248.02	10-inch	Yes	Yes	CYLRM24802X10
248.03	2-inch	Yes	Yes	CYLRM24803X02
248.03	4-inch	Yes	Yes	CYLRM24803X04
248.03	6-inch	Yes	Yes	CYLRM24803X06
248.03	10-inch	Yes	Yes	CYLRM24803X10
248.04	2-inch	Yes	Yes	CYLRM24804X02
248.04	4-inch	Yes	Yes	CYLRM24804X04
248.04	6-inch	Yes	Yes	CYLRM24804X06
248.04	10-inch	Yes	Yes	CYLRM24804X10
248.05	2-inch	Yes	Yes	CYLRM24805X02
248.05	4-inch	Yes	Yes	CYLRM24805X04
248.05	6-inch	Yes	Yes	CYLRM24805X06
248.05	10-inch	Yes	Yes	CYLRM24805X10
248.11	2-inch	Yes	Yes	CYLRM24811X02
248.11	4-inch	Yes	Yes	CYLRM24811X04
248.11	6-inch	Yes	Yes	CYLRM24811X06
248.11	10-inch	Yes	Yes	CYLRM24811X10
248.12	2-inch	Yes	Yes	CYLRM24812X02
248.12	4-inch	Yes	Yes	CYLRM24812X04
248.12	6-inch	Yes	Yes	CYLRM24812X06
248.12	10-inch	Yes	Yes	CYLRM24812X10

Software Support Plans

The MTS Software Support Plan is a simple, cost-effective way to keep your organization's vital test systems running smoothly.

A Software Support Plan provides a variety of benefits for MTS software customers;

- » Resolve software issues quickly with priority access to MTS technical support via phone, email, or remote login.

- » Training provides greater knowledge and productivity for your test operations staff.*
- » Keep your MTS software up-to-date and performing optimally, with updates downloadable through the myMTS portal

*RPC/cRPC and AeroPro customers get tuition-free training for 1 seat in up to 2 courses per 12 month increment of contract period.

TestSuite customers get access to online technical training videos, available on my.mts.com.

When SSP is purchased, it must be purchased for all licenses and options purchased. Partial coverage is not permitted.

Application Software

Software	Module	Service Product Code
TestSuite		
	Multipurpose Elite	MESTSME
	TW Elite Servohydraulic	MESTSTWESH
	TW Elite EM	MESTSTWECI
	TW Elite MPE Servohydraulic	MESTSTWEMPESH

793 Controller System Software

Software	Module	Service Product Code
793 System Software		
	Supports FlexTest 40 and FlexTest SE Controllers without MPT	MESFTSENMP
	Supports FlexTest 60/100/200 and FlexTest GT Controllers without MPT	MESFTGTNMPT
	Supports FlexTest 40 and FlexTest SE Controllers with MPT	MESFTSE
	Supports FlexTest 60/100/200 and FlexTest GT Controllers with MPT	MESFTGT

793 Application Software

Software	Module	Service Product Code
Elastomer		
	Basic Elastomer Application Bundle (Includes 793.31, 793.32, 793.33)	MES793EBE
Damper Test		
	MTS Damper Software (Includes all customer purchased options)	MESDT
Wind/Civil		
	AeroPro Control	MES793GCEPM

AeroPro Software

Software	Module	Service Product Code
AeroPro (793 controller system software included)		
	Wind/Civil Materials Test Software (Includes 793.61/62/63/64/66/67)	MESSAFTPC

Note: 793 controller system software SSP AND ALL 793 application software SSP must be purchased together for the SSP to be valid. Customer must have/purchase the latest version of software in order to purchase SSP. An upgrade in software may require a FlexTest controller upgrade.

Software Support Plans

STEX Pro Software

Software	Module	Service Product Code
STEX Pro	Premier Package	MESSTEXPP

RPC Connect Software Products

Software	Module	Service Product Code
RPC Connect Software Products		
	SSP RPC Conn ANALYZE	SSRPCCAN
	SSP RPC Conn BASE TEST (1 MONITOR INCL)	SSRPCCBT1
	SSP RPC Conn Base Editing	SSRPCCCE
	SSP RPC Conn FULL TEST	SSRPCCFT
	SSP RPC Conn Fatigue Monitoring	SSRPCCFTMON
	SSP RPC Conn MODEL	SSRPCCM
	SSP RPC Conn Project Manager	SSRPCCPM
	SSP RPC Conn Point by Point Monitoring	SSRPCCPTMON
	SSP RPC Conn SETUP	SSRPCCS
	SSP RPC Conn SIMULATE	SSRPCCSI
	SSP RPC Conn Spectral Monitoring	SSRPCCSPTMON
	SSP RPC Conn Trend Monitoring	SSRPCCTRDMON
	SSP RPC Conn VIRTUAL TEST OPTION	SSRPCCVTO
	SSP RPC Conn ZERO CROSSING PEAK TOOL	SSRPCCZCPT
	SSP RPC Conn RIDE COMFORT	SSRPCCRC
	SSP RPC Conn Linear Elastic Fatigue	SSRPCCLEF

Note: For a customer with a FlexTest controller to have a supported RPC configuration they must have the latest 793 software. When selling an RPC SSP contract to FlexTest customers, a FlexTest upgrade may be required and a 793 system software SSP contract is required. See the 793 Controller System Software section of this document for pricing and requirements.

Software Support Plans

RPC Connect Software Products

Software	Module	Service Product Code
cRPC Connect Software Products		
	SSP cRPC Conn Advanced Analysis	SSPCRPCCAA
	SSP cRPC Conn Advanced Editing	SSPCRPCCAE
	SSP cRPC Conn Adaptive Inverse Modeling	SSPCRPCCAIM
	SSP cRPC Conn Batch Processing	SSPCRPCCBP
	SSP cRPC Conn Comp Test Development	SSPCRPCCCPUTST
	SSP cRPC Conn Component Test Generation	SSPCRPCCCTG
	SSP cRPC Conn Drive File Development	SSPCRPCCDFDP
	SSP cRPC Conn Durability Test No Monitor	SSPCRPCCDT
	SSP cRPC Conn Durability Test	SSPCRPCCDTP
	SSP cRPC Conn Data Validation	SSPCRPCCDVP
	SSP cRPC Conn Edit and Analysis	SSPCRPCCEAP
	SSP cRPC Conn FRF Diagnostics	SSPCRPCCFRFD
	SSP cRPC Conn Fatigue Sensitive Editing	SSPCRPCCFSE
	SSP cRPC Conn Histogram Analysis	SSPCRPCCHA
	SSP cRPC Conn Modulation Analysis	SSPCRPCMA
	SSP cRPC Conn Matrix Editing	SSPCRPCME
	SSP cRPC Conn Matlab Interface	SSPCRPCMI
	SSP cRPC Conn Drive File Dev and Test	SSPCRPCPDFDTP
	SSP cRPC Conn Region Analysis	SSPCRPCRA
	SSP cRPC Conn Ride Comfort	SSPCRPCRC
	SSP cRPC Conn Simultaneous Excitation	SSPCRPCSE
	SSP cRPC Conn Simulate	SSPCRPCSP
	SSP cRPC Conn Test Spectral Monitoring	SSPCRPCSPTMON
	SSP cRPC Conn Test Fatigue Monitoring	SSPCRPCCTFM
	SSP cRPC Conn Time History Fatigue	SSPCRPCCTHF
	SSP cRPC Conn Trigger	SSPCRPCCTO
	SSP cRPC Conn Test Trend Monitoring	SSPCRPCCTRDMON
	SSP cRPC Conn Test Point by Point Mon	SSPCRPCCTSTBPB
	SSP cRPC Conn Virtual Test	SSPCRPCCVTO
	SSP cRPC Conn Linear Elastic Fatigue	SSPCRPCCLEF
	SSP cRPC Conn Additional User	SSPCRPCADDU



All MTS Echo Health Monitoring packages provide:

- » Core sensors
- » Real-time monitoring of signals
- » User-defined alerts
- » Interactive trending charts
- » MTS 24/7 Proprietary Algorithm Protection
- » Health dashboard:
 - Actionable recommendations
 - Predictive trending for recommended maintenance

Proactively Protect Your HPU From Common Failures

Health monitoring helps ensure the maximum operating performance and service life for your hydraulic power unit (HPU). MTS Echo[®] Health Monitoring provides the tools to properly identify threats to hydraulic system health and keep your system in optimum condition.

With MTS Echo Health Monitoring, a modular set of options allows you to choose the level of monitoring that best meets your needs. With the Connectivity hardware as a base, you can add packages to monitor temperature, fluid condition, heat exchanger performance and more from any web-enabled device, including smartphones, laptops and tablets.

Each package provides the core sensors necessary for the real-time monitoring of signals. You will be able to set user-defined alerts to notify you of potential concerns. You will also have access to interactive trending data and a health dashboard that offers actionable recommendations for intervention and maintenance.

With 24/7 access to system performance measurements and trends over time, you can maintain your hydraulic systems in the most efficient manner. Condition-based monitoring allows for early detection of potential issues and prevents unnecessary downtime for unneeded maintenance. Convenient, secure connection to hydraulic system condition parameters will help you make the best decisions regarding HPU operation.

BENEFITS

- » Test schedule predictability
- » Test system lifecycle extension
- » Data integrity
- » Budget management

COMPATIBLE HPUS

- » MTS SilentFlo HPUs
- » MTS SilentFlo 505 G1 HPUs*
- » MTS Model 506 HPUs*

** With upgraded controls, HMI information can also be monitored*

Echo[®] Remote Monitoring

MTS Echo Health Monitoring

Standard Recommended Packages

Protect your HPU investment and ongoing lab operations with 24/7 Health Monitoring of your HPU. Start with the recommended packages and add-on for extended protection.

TEMPERATURE PACKAGE

Monitor HPU temperatures for early detection of an over-temperature alarm or fault. These fault notifications can prevent unplanned downtime and minimize the risk of downstream damage. Maintaining a stable temperature is critical to the performance of your test system. Elevated temperature is also indicative of potential system failure.

FLUID CONTAMINATION PACKAGE

Hydraulic power units and servovalves can be damaged by fluid contaminated with particles that are larger than the clearance between lubricated surfaces. These hard particles create more wear contaminant by continually scraping off softer metals, like copper, to further accelerate component failures. This package will help identify conditions that may lead to motor shelling, pressure instability and servovalve instability.

HEAT EXCHANGER FLOW PACKAGE

This package monitors several parameters including changes in the thermal transfer over time and water consumption. Trending the water consumption can identify failed water solenoids or indicate when someone has forgotten to turn on the water supply, giving the operator time to turn on the supply and cool the hydraulic fluid to prevent an over temp shutdown. When combined with the temperature package, Heat Exchanger efficiency also can be tracked.

HPU Health Monitoring Packages Aligned to Common Failure Mode

Health Monitoring Packages	Over-Temp Faults	Heat Exchanger Failures	Contamination	Motor & Pump Failures	Catastrophe Prevention	Service Product Code
Temperature	Yes	Yes, temperature	No	Wear & tear Fouling	Medium	ECHOHMT
Contamination	No	Yes, water saturation	Particulate contamination Water saturation	Wear & tear Fouling	High	ECHOHMFC
Heat Flow Exchanger	Yes	Cooling System failures Heat Exchanger failures Cooling water flow	Water saturation	No	High	ECHOHMHXF

MTS Echo Health Monitoring

Additional Packages

Extend Fault protection with additional stand-alone packages.

POWER MONITORING PACKAGE

Expand your health protection by monitoring your HPU power, including 3- phase voltage, current and energy consumption. This package provides insight into HPU efficiency and enables early warning of pump or motor failures. This package can give you visibility to energy consumption and help improve energy management.

ACCUMULATOR PRE-CHARGE & FILTRATION PACKAGE

Manage hydraulic distribution by monitoring accumulators and filters. Remote monitoring will indicate which accumulators need charging so the hydraulic distribution system can readily manage flow demand. Monitoring filtration can help detect inadequacies that may lead to actuator scoring and potential component failure. The predictive trending and analytics provided in this package will optimize maintenance.

LEAK DETECTION PACKAGE

Protect your lab and the environment by monitoring for early detection of hose rupture, manifold failures and fitting leaks. Improve environmental health and safety while protecting against catastrophic hydraulic fluid loss.

HPU Health Monitoring Packages Aligned to Common Failure Modes

Health Monitoring Packages	Over-Temp Faults	Failures Modes	Contamination	Motor & Pump Failures	Catastrophe Prevention	Service Product Code
Power	No	Energy usage	No	Early fault detection possible	Low	ECHOHMP
Accumulator Pre-charge and Filtration	No	Output pressure accumulators Clogged filters	No	No	Medium	ECHOHMF
Leak Detection	No	Hose rupture Fittings Manifold failures	No	No	Low	ECHOMLD

Warranty Coverage

Overview

MTS builds some of the most rugged and reliable testing equipment on the market. We also stand behind our products and services with extensive warranty options. In addition to providing standard warranty coverage on new equipment and service parts, MTS offers optional extended warranties for equipment and components to help ensure your equipment is ready for testing when you need it.

Standard Warranty – Equipment

MTS warrants its equipment to be free from defects in material and workmanship under normal use, given proper installation and maintenance, for 12 months from the date of shipment of your product. Defective equipment may be repaired or replaced at MTS' option.

Standard Warranty – Parts & Services

Warranty periods for service products start with the product shipment from MTS. Replacement, exchange, remanufacture, or repair of a system component does not extend the warranty coverage of the entire system. Coverage on system components is as follows:

PURCHASED PARTS

Parts with a model number	12 months
Parts without a model number	90 days

EXCHANGE, REMANUFACTURE OR REPAIR PROGRAMS

Exchange	12 months
Remanufacture	12 months
Repair	90 days

OTHER SERVICES

Factory calibrations	90 days
Field calibrations	90 days
Field service labor	90 days

Extended Warranty

An Extended Warranty is available for purchase as part of an MTS Service Plan. Under this plan option, MTS will troubleshoot and repair or replace your failed equipment and/or components during a 12-month plan period.

An Extended Warranty is designed to help protect you from incurring unplanned material and labor expenses and includes the following:

- » Labor to troubleshoot and repair equipment
 - » Parts to repair equipment
 - » Exchange, remanufacture or repair as authorized by MTS
- It is easy to add coverage for your entire laboratory, or for only a portion of your MTS equipment

Extended Warranty Coverage

CONTROLLERS

- » MTS FlexTest® 40
- » MTS FlexTest 60
- » MTS FlexTest 100
- » MTS FlexTest 200

LOAD FRAMES

- » Series 311
- » Series 322
- » Series 370
- » MTS Landmark®
- » MTS Acumen®
- » MTS Criterion®
- » MTS Exceed®

HYDRAULIC POWER UNITS

- » MTS SilentFlo™ 515 hydraulic power units

ACTUATORS

- » MTS DuraGlide®
- » Series 201
- » Series 215
- » Series 242
- » Series 244

Extended Warranty Exclusions

- » MTS reserves the right to exclude any product from coverage. Please contact your sales engineer for complete details of product eligibility
- » Upgrades and updates required due to obsolete hardware and software cannot be part of an Extended Warranty
- » Hydraulic fluid is not covered under an Extended Warranty

MTS reserves the right to change products, services, and prices without notice.

If your system or product is more than 3 years old, a condition assessment may need to be performed by MTS to confirm availability. MTS serial number for each covered item must be recorded within the Service Plan contract.



Notes

LOAD CELLS

Highly accurate load cells deliver high stiffness, stability and linearity for a full range of both static and dynamic testing applications. They are constructed from aircraft quality military specification materials, which are heat treated to ensure uniform hardness and minimize distortion.



Load Cells

Introduction	34
Servohydraulic Load Cells	35-36
Force Transducers/Load Cells - Criterion & Exceed	37-39
Electromechanical Load Cells	40-41
Load Cell Adapters	42-43

Load Cells for Servohydraulic Systems

- » MTS axial, dynamic fatigue-rated load cells reduce errors caused by extraneous side loads or loading changes caused by geometry shifts in the specimen
- » Monolithic design incorporates high axial stiffness
- » Calibration, cables and attachment kits are sold separately
- » TEDs (Transducer Electronic Data Sheets) available – many models are available with TEDS, the self-identification capabilities that follow the IEEE 1451.4 standard
- » Dynamic performance – low deflection and high stiffness give you better dynamic performance
- » High output – provides you with excellent resolution and reading accuracy
- » Radially oriented beams – enable the unit to resist off-axis loads and moments for greater accuracy
- » High degree of component concentricity and parallelism – provide you with greater accuracy during your test setup
- » Unique proprietary wiring technique used on the bridge allows for minimal susceptibility to stray magnetic fields
- » Interchangeable – simple mounting makes installation and changing easy
- » Ability to stack load cells to test smaller/larger specimens in same load frame
- » Large choice of sizes – increases versatility

Dual bridge options available – contact MTS

Axial, Low Capacity Load Cells

Metric Units

Model	Force Capacity	Thread Size	Part Number
661.09B-20	10 N	M6 x 1	051-340-602
661.09B-21	100 N	M6 x 1	051-340-604

US Customary Units

Model	Force Capacity	Thread Size	Part Number
661.09A-20	2 lbf	0.25 in - 28	051-340-601
661.09A-21	22 lbf	0.25 in - 28	051-340-603



These load cells are fatigue rated.



Axial, Dynamic Fatigue-Rated Load Cells

Metric Units

Model	Force Capacity	Thread Size	Part Number
661.11B-01	250 N	M6 x 1	050-781-905
661.11B-02	500 N	M6 x 1	050-781-906
661.18F-01	1 kN	M12 x 1.25	050-459-902
661.18F-02	2.5 kN	M12 x 1.25	050-459-904
661.19F-01	5 kN	M12 x 1.25	045-438-102
661.19F-02	10 kN	M12 x 1.25	045-438-104
661.19F-03	15 kN	M12 x 1.25	045-438-106
661.19F-04	25 kN	M12 x 1.25	045-438-108
661.20F-01	25 kN	M27 x 2	045-430-004
661.20F-02	50 kN	M27 x 2	045-430-005
661.20F-03	100 kN	M27 x 2	045-430-006

US Customary Units

Model	Force Capacity	Thread Size	Part Number
661.11A-01	50 lbf	0.25 in - 28	050-781-901
661.11A-02	100 lbf	0.25 in - 28	050-781-902
661.18E-01	220 lbf	0.50 in - 20	050-459-901
661.18E-02	550 lbf	0.50 in - 20	050-459-903
661.19E-01	1.1 kip	0.50 in - 20	045-438-101
661.19E-02	2 kip	0.50 in - 20	045-438-103
661.19E-03	3 kip	0.50 in - 20	045-438-105
661.19E-04	5 kip	0.50 in - 20	045-438-107
661.20E-01	5 kip	1.00 in - 14	045-430-001
661.20E-02	11 kip	1.00 in - 14	045-430-002
661.20E-03	22 kip	1.00 in - 14	045-430-003

Load Cells For Servohydraulic Systems

Axial, Dynamic Fatigue-Rated Load Cells

Single Bridge

Metric Units

Model	Force Capacity	Thread Size	Part Number
661.22D-01	250 kN	M36 x 2	042-361-802
661.23F-01	500 kN	M52 x 2	044-445-002
661.31F-01	1000 kN	M76 x 2	045-190-502
661.34F-01	1500 kN	M90 x 2	045-225-902
661.36D-03	2500 kN	M125 x 4	046-311-702

US Customary Units

Model	Force Capacity	Thread Size	Part Number
661.22C-01	55 kip	1.50 in - 12	042-361-801
661.23E-01	110 kip	2.00 in - 12	044-445-001
661.31E-01	220 kip	3.00 in - 12	045-190-501
661.34E-01	330 kip	1.25 in - 12	045-225-901
661.36C-03	550 kip	1.50 in - 12	046-311-701

Axial, Dynamic Fatigue-Rated Load Cells

Single Bridge

Metric Units

Model	Force Capacity	Thread Size	Part Number
661.11H-01	250 N	M6 x 1	057-117-901
661.11H-02	500 N	M6 x 1	057-117-902
661.11H-03	1000 N	M6 x 1	057-117-903
661.18H-01	1000 N	M12 x 1.25	057-118-001
661.18H-02	2.5 kN	M12 x 1.25	057-118-002
661.19H-01	5 kN	M12 x 1.25	057-118-101
661.19H-02	10 kN	M12 x 1.25	057-118-102
661.19H-03	15 kN	M12 x 1.25	057-118-103
661.19H-04	25 kN	M12 x 1.25	057-118-104
661.20H-02	50 kN	M27 x 2	057-118-201
661.20H-03	100 kN	M27 x 2	057-118-202
661.22H-01	250 kN	M36 x 2	057-263-701
661.23H-01	500 kN	M52 x 2	057-263-801



661.22H-01 Load Cell

Axial-Torsional Load Cells

Metric Units

Model	Axial force	Torsional force	Thread Size	Part Number
662.20D-01	2.5 kN	25 N.m	M6 x 1	049-611-002
662.20D-03	10 kN	100 N.m	M8 x 1.25	049-381-502
662.20D-04	15 kN	150 N.m	M8 x 1.25	050-457-702
662.20D-05	25 kN	250 N.m	M10 x 1.5	050-027-102

US Customary Units

Model	Axial force	Torsional force	Thread Size	Part Number
662.20C-01	550 lbf	250 in.lbf	1/4 in - 20	049-611-001
662.20C-03	2200 lbf	1000 in.lbf	5/16 in - 18	049-381-501
662.20C-04	3300 lbf	1500 in.lbf	5/16 in - 18	050-457-701
662.20C-05	5500 lbf	2500 in.lbf	3/8 in - 16	050-027-101



662.XX Load Cell

Axial-Torsional Load Cells with Integrated TEDS

Metric Units

Model	Axial force	Torsional force	Thread Size	Part Number
662.20H-01	2.5 kN	25 N.m	M6 x 1	057-202-601
662.20H-03	10 kN	100 N.m	M8 x 1.25	057-202-701
662.20H-04	15 kN	150 N.m	M8 x 1.25	057-202-702
662.20H-05	25 kN	250 N.m	M10 x 1.5	057-202-801

Force Transducers / Load Cells - Criterion

S-Beam Load Cells for Criterion Systems

- » S-Beam load cells for Criterion systems are designed for accuracy and linearity
- » Measures axial loads using S-shaped design with a single embedded strain gage
- » Offers exceptional value and extreme simplicity for low-capacity testing with minimal side loads
- » **Applications:** Ideal for low-force tension and compression testing of plastics, elastomers (rubbers), and paper



LSB.503

Specifications

Model	Part Number	Type	Force Rating	Accuracy	Overload Protection	Mounting Thread
LSB.100	057-513-001	S-beam	1 N	class 0.5 from 1 to 100%	800% of capacity	M6 x 1
LSB.500	057-481-201	S-beam	5 N	class 0.5 from 1 to 100%	800% of capacity	M6 x 1
LSB.101	057-481-202	S-beam	10 N	class 0.5 from 1 to 100%	800% of capacity	M6 x 1
LSB.251	057-481-203	S-beam	25 N	class 0.5 from 1 to 100%	800% of capacity	M6 x 1
LSB.501	057-481-204	S-beam	50 N	class 0.5 from 1 to 100%	800% of capacity	M6 x 1
LSB.102	057-481-205	S-beam	100 N	class 0.5 from 1 to 100%	800% of capacity	M6 x 1
LSB.252	057-481-206	S-beam	250 N	class 0.5 from 1 to 100%	800% of capacity	M6 x 1
LSB.502	057-481-301	S-beam	500 N	class 0.5 from 1 to 100%	420% of capacity	M6 x 1
LSB.103	057-481-302	S-beam	1000 N	class 0.5 from 1 to 100%	420% of capacity	M6 x 1
LSB.203	057-481-303	S-beam	2000 N	class 0.5 from 1 to 100%	420% of capacity	M6 x 1
LSB.503	057-496-001	S-beam	5000 N	class 0.5 from 1 to 100%	420% of capacity	M12 x 1.25

Low Profile Bending Beam Load Cells for Criterion Systems

- » Bending beam load cells for Criterion systems are designed for high accuracy, stiffness, overturning moment, stability, and linearity
- » Measure moderate axial loads using a compact design with four embedded strain gages
- » Low profile maximizes available test space
- » **Applications:** Ideal for low-force tension and compression testing of soft metals, plastics and reinforced plastics



LPB.102

Specifications

Model	Part Number	Type	Force Rating	Accuracy	Overload Protection	Mounting Thread
LPB.102	057-481-401	Low profile bending	100 N	class 0.5 from 1 to 100%	150% of capacity	M6 x 1
LPB.252	057-481-402	Low profile bending	250 N	class 0.5 from 1 to 100%	150% of capacity	M6 x 1
LPB.502	057-481-403	Low profile bending	500 N	class 0.5 from 1 to 100%	150% of capacity	M6 x 1

Force Transducers / Load Cells - Criterion

Low Profile Shear Beam Load Cells for Criterion Systems

- » Shear beam load cells for Criterion systems are designed for high accuracy, stiffness, overturning moment, stability, and linearity
- » Measure moderately high axial loads using a unique design of four embedded strain gages
- » Low profile maximizes available test space
- » **Applications:** Ideal for low-force tension and compression testing of brittle metals and composites



LPS.103

Specifications

Model	Part Number	Type	Force Rating	Accuracy	Overload Protection	Mounting Thread
LPS.103	057-481-501	Low profile shear beam	1 kN	class 0.5 from 1 to 100%	150% of capacity	M12 x 1.25
LPS.253	057-481-502	Low profile shear beam	2.5 kN	class 0.5 from 1 to 100%	150% of capacity	M12 x 1.25
LPS.503	057-481-503	Low profile shear beam	5 kN	class 0.5 from 1 to 100%	150% of capacity	M12 x 1.25
LPS.104	057-481-504	Low profile shear beam	10 kN	class 0.5 from 1 to 100%	150% of capacity	M12 x 1.25
LPS.204	057-481-506	Low profile shear beam	20 kN	class 0.5 from 1 to 100%	150% of capacity	M12 x 1.25
LPS.304	057-481-505	Low profile shear beam	30 kN	class 0.5 from 1 to 100%	150% of capacity	M12 x 1.25
LPS.504	057-481-701	Low profile shear beam	50 kN	class 0.5 from 1 to 100%	150% of capacity	M27 x 2
LPS.105	057-481-702	Low profile shear beam	100 kN	class 0.5 from 1 to 100%	150% of capacity	M27 x 2
LPS.155	057-481-703	Low profile shear beam	150 kN	class 0.5 from 1 to 100%	150% of capacity	M27 x 2
LPS.205	057-481-901	Low profile shear beam	200 kN	class 0.5 from 1 to 100%	150% of capacity	M36 x 2
LPS.305	057-481-801	Low profile shear beam	300 kN	class 0.5 from 1 to 100%	150% of capacity	M36 x 2
LPS.505	058-497-801	Low profile shear beam	500 kN	class 0.5 from 1 to 100%	150% of capacity	M72 x 2
LPS.605	058-497-802	Low profile shear beam	600 kN	class 0.5 from 1 to 100%	150% of capacity	M72 x 2

Force Transducers / Load Cells - Exceed

S-Beam Load Cells for Exceed Systems

- » S-beam load cells for Exceed systems are designed for accuracy and linearity
- » Measures axial loads using S-shaped design with a single embedded strain gage
- » Offers exceptional value and extreme simplicity for low-capacity testing with minimal side loads
- » **Applications:** Ideal for low-force tension and compression testing of plastics, elastomers (rubbers), and paper



BSS-XS-100KGY

LPS-2KGY

Specifications

Model	Part Number	Load Cell Type	Mounting Threads	Capacity
LPS-0.6KGY	100-475-294	S-beam	M6X1.0	5 N
LPS-1KGY	100-475-293	S-beam	M6X1.0	10 N
LPS-2KGY	100-475-292	S-beam	M6X1.0	20 N
BAB-XS-5MY	100-475-291	S-beam	M8X1.25	50 N
BAB-XS-10MY	100-475-290	S-beam	M8X1.25	100 N
BSA-XS-25KGY	100-475-289	S-beam	M6X1.0	250 N
BSA-XS-50KGY	100-475-227	S-beam	M6X1.0	500 N
BSS-XS-100KGY	100-475-288	S-beam	M10X1.5	1 kN
BSS-200KGY	100-475-287	S-beam	M12X1.75	2 kN
BSS-XS-500KGY	100-475-286	S-beam	M12X1.75	5 kN
BSS-XS-1TY	100-474-950	S-beam	M12X1.75	10 kN

Low Profile Shear Beam Load Cells for Exceed Systems

- » Shear beam load cells for Exceed systems are designed for accuracy, stiffness, stability, and linearity
- » Measure moderately high axial loads
- » Low profile maximizes available test space
- » **Applications:** Ideal for low-force tension and compression testing of brittle metals and composites



DBSL-XS-10TY

Specifications

Model	Part Number	Load Cell Type	Mounting Threads	Capacity
DBSL-2TY	100-474-953	Low profile shear beam	M16X1.5	20 kN
DBSL-3TY	100-474-954	Low profile shear beam	M16X1.5	30 kN
DBSL-5TY	100-474-955	Low profile shear beam	M16X1.5	50 kN
DBSL-XS-5TY	100-474-956	Low profile shear beam	M24X1.5	50 kN
DBSL-XS-10TY	100-474-957	Low profile shear beam	M24X1.5	100 kN
LPS.205Y	100-467-455	Low profile shear beam	M36X3	200 kN
LPS.305Y	100-466-085	Low profile shear beam	M36X3	300 kN
LPS.605Y	058-503-302	Low profile shear beam	M72X3	600 kN

Load Cells for Insight & Insight Renew Universal Test Systems

Refer www.mtsmonotonic.com for a complete list of all monotonic load cells for MTS Exceed and MTS Criterion Systems

- » Highly accurate MTS load cells for MTS Insight and Insight Renew are designed to offer world-class stiffness, stability, and linearity.
- » Provide overload and side load protection
- » Designed with built-in shunt resistors to facilitate regular verification of accuracy using calibration routines featured in MTS software.
- » Load cells feature TEDS (Transducer Electronic Data Sheets) self-identification capabilities that follow the IEEE 1451.4 standard



Low Profile Load Cell



S-Beam Load Cell



S-Beam Load Cells with TEDS for Insight Universal Test Systems

Metric Units

Model	Force Capacity	Thread Size	Part Number
S-Beam	5 N (1 lbf)	M6x1	056-932-601
S-Beam	10 N (2 lbf)	M6x1	056-932-602
S-Beam	25 N (5 lbf)	M6x1	056-932-603
S-Beam	50 N (10 lbf)	M6x1	056-932-604
S-Beam	100 N (20 lbf)	M6x1	056-932-605
S-Beam	250 N (50 lbf)	M6x1	056-932-606
S-Beam	500 N (110 lbf)	M6x1	056-932-701
S-Beam	1 kN (220 lbf)	M6x1	056-932-702
S-Beam	2 kN (450 lbf)	M6x1	056-932-703
Low Profile	125 N (25 lbf)	M6x1	056-932-801
Low Profile	250 N (50 lbf)	M6x1	056-932-802
Low Profile	500 N (110 lbf)	M6x1	056-932-803
Low Profile	1 kN (225 lbf)	M12x1.25	056-932-901
Low Profile	2.5 kN (550 lbf)	M12x1.25	056-932-902
Low Profile	5 kN (1,100 lbf)	M12x1.25	056-932-903
Low Profile	10 kN (2,200 lbf)	M12x1.25	056-932-904
Low Profile	30 kN (6,600 lbf)	M12x1.25	056-932-905
Low Profile	50 kN (11,000 lbf)	M16x1.5	056-933-201
Low Profile	100 kN (22,500 lbf)	M27x2	056-933-001
Low Profile	150 kN (33,750 lbf)	M27x2	056-933-002
Low Profile	200 kN (45,000 lbf)	M36x2	056-933-301
Low Profile	300 kN (67,500 lbf)	M36x2	056-933-101

Load Cells for MTS Acumen Electrodynamic Test Systems

Replacement MTS Acumen System Load Cell Kits with Built-in Accelerometer

- » Designed for the MTS Acumen Electrodynamic Test Systems, these axial, dynamic fatigue rated load cells can be mounted either to the actuator or to the T-slot table
- » Dynamic performance – low deflection and high stiffness give you better dynamic performance
- » High output – provides you with excellent resolution and reading accuracy
- » Accelerometer – Integrated acceleration sensor enables load cell to be mounted on moving actuator
- » Piloted load cell – simplifies load cell installation and minimizes the need for a separate alignment fixture
- » Radially oriented beams – enable the unit to resist off-axis loads and moments for greater accuracy
- » High degree of component concentricity and parallelism – provide you with greater accuracy during your test setup
- » Unique proprietary wiring technique used on the bridge allows for minimal susceptibility to stray magnetic fields
- » Interchangeable – simple mounting makes installation and changing easy
- » Ability to stack lower force transducers to test smaller specimens in same load frame
- » Integrated TEDS



Metric Units

Model	Force Capacity	Thread Size	Kit Part Number*	Factory Calibrated Kit Part Number*
661.18SE-01	1.5 kN	M6 x 1	057-560-101	057-560-106
661.18SE-02	3 kN	M6 x 1	057-560-102	057-560-107

*Kits include load cell, mounting hardware, CD and protective case

Tandem Load Cell Kits with TEDS for MTS Acumen Systems

- » Compact axial, dynamic fatigue rated load cells mount easily to the MTS Acumen system load cells
- » Smaller force capacity load cell increases the resolution test data when testing at the lower end of the system load cell's capacity.
- » Dynamic performance – low deflection and high stiffness give you better dynamic performance
- » High output – provides you with excellent resolution and reading accuracy
- » Radially oriented beams – enable the unit to resist off-axis loads and moments for greater accuracy
- » High degree of component concentricity and parallelism – provide you with greater accuracy during your test setup
- » Unique proprietary wiring technique used on the bridge allows for minimal susceptibility to stray magnetic fields.
- » Interchangeable – simple mounting makes installation and changing easy
- » Easily mounted to electrodynamic system load cells.
- » Integrated TEDS



Metric Units

Model	Force Capacity	Thread Size	Kit Part Number*	Factory Calibrated Kit Part Number*
661.11H	10 N	M6 x 1	057-560-111	057-560-112
661.11H	25 N	M6 x 1	057-560-113	057-560-114
661.11H	50 N	M6 x 1	057-560-115	057-560-116
661.11H-04	125 N	M6 x 1	057-560-105	057-560-110
661.11H-01	250 N	M6 x 1	057-560-104	057-560-109
661.11H-02	500 N	M6 x 1	057-560-103	057-560-108

*Kits include load cell, mounting hardware and spanner wrench

Load Cell Adapters

Adapter Introduction

MTS is pleased to offer a wide variety of load cell adapters to meet all of your special needs. Our adapters are made to the best possible specifications and adhere to the industry standards. In many cases, we offer more than one type of material so you may choose the lightweight aluminum or the heavy duty steel adapters. If there is an adapter you would like that you do not see listed, contact your sales engineer.

USE PIGGYBACK ADAPTERS FOR MOUNTING LOW CAPACITY LOAD CELLS

- » Adapters provide a convenient way to mount a lower capacity load cell to a large capacity load cell
- » Piggyback adapters eliminate the need to remove the larger load cell when a lower capacity test is needed for testing
- » Piggyback adapters are available for all load cell combinations



Piggyback

From Thread Size	To Thread Size	Part Number
0.5 in - 20	1 in - 14	100-082-366
0.25 in - 28	1 in - 14	100-082-361
0.25 in - 28	1.5 in - 12	100-082-608
0.25 in - 28	0.5 in - 20	100-082-319
M16 x 1.5	M24 x 1.5	100-105-984
1 in - 14	1.5 in - 12	100-082-598
M12 x 1.25	M6 x 1	100-093-064
1 in - 14	1 in - 14	100-179-743

AXIAL MONOTONIC AND DYNAMIC FATIGUE-RATED LOWER FORCE LOAD CELL KITS

- » Tandem Piggyback adapters have much of the same functionality as the standard piggyback adapters; however, the Tandem Piggyback adapters have locking rings
- » Locking rings allow you to preload the threads to eliminate the slack in the load train



Tandem Piggyback

From Thread Size	To Thread Size	Part Number
M6 x 1	M16 x 1.5	056-871-102
M12 x 1.25	M27 x 2	056-871-106
M12 x 1.25	M36 x 2	056-871-107
M12 x 1.25	M16 x 1.5	056-871-105
M16 x 1.5	M27 x 2	056-871-108
M16 x 1.5	M36 x 2	056-871-109
M27 x 2	M36 x 2	056-871-110
M6 x 1	M12 x 1.25	056-871-101
M6 x 1	M36 x 2	056-871-104
M6 x 1	M27 x 2	056-871-103

CLEVIS PIN

- » With a clevis pin, you can easily and quickly change out your grips and fixtures without decreasing the force of your test
- » MTS offers a wide variety of clevis pin devices that meet industry standards



Clevis Pin

Thread Size	Connection Type	Pin Diameter	Clevis Diameter	Part Number
M27 x 2	Df	0.5 in	1.25 in	100-140-862
1 in - 14	Df	0.5 in	1.25 in	100-088-645
0.25 in - 28	Df	0.5 in	1.25 in	100-092-552
M24 x 1.5	Df	0.5 in	1.25 in	100-092-905
0.5 in - 20	Df	0.5 in	1.25 in	100-088-650
M12 x 1.25	Bf	0.187 in	0.5 in	100-093-049
0.25 in - 28	Bf	0.187 in	0.5 in	100-092-914
0.25 in - 28	Cf	0.25 in	0.625 in	100-092-547

CONVERSION ADAPTER

- » MTS offers a wide variety of conversion adapters to help you quickly change from one type or style of clevis adapter to another without the costs associated with a full adapter



Conversion Adapter

Thread Size	Clevis Pin Connection	Type	Part Number
30 mm	15f	Male to Female	100-093-030
0.5 in - 20	15f	Male to Female	100-093-001
1.25 in - 12	30f	Male to Female	100-092-991
0.625 in - 18	15f	Male to Female	100-092-996
1.25 in	Cf	Male to Female	100-092-880
0.25 in - 28	Df	Male to Female	100-081-395
1.50 in - 12	Df	Male to Female	100-082-558
0.5 in - 20	Cf	Male to Female	100-081-868
0.5 in - 20	Bf	Male to Female	100-081-862
1 in - 14	Cf	Male to Female	100-081-873

Insight Load Cell Mounting Kits

Thread Size	Workstations	Part Number
M36 x 2	200 & 300	056-904-512
M27 x 2	200 & 300	056-904-511
M16 x 1.5	200 & 300	056-904-510
M27 x 2	100 & 150	056-904-509
M16 x 1.5	100 & 150	056-904-508
M12 x 1.25	100 & 150	056-904-507
M16 x 1.5	30 & 50	056-904-506
M12 x 1.25	30 & 50	056-904-505
M6 x 1	30 & 50	056-904-504
M12 x 1.25	5 & 10	056-904-503
M6 x 1	5 & 10	056-904-502
M6 x 1	1 & 2	056-904-501

EXTENSOMETERS

Extensometers are used for measuring and/or controlling strain in tension, compression and fatigue testing applications. Measuring on the specimen significantly increases the reliability of your data. Relying on the crosshead or actuator movement of your materials test system will measure too much – machine deflection, grip deflection, and possible slippage are all captured in the load train displacement measurement.



Extensometer Table of Contents

Introduction	44-45
How to Select an Extensometer	46
Application Index	47
Functional Index	48
Axial Extensometers	49-61
High Temperature Extensometers	62-64
Specialty Extensometers	65-69
MTS Advantage Optical Extensometer (AOX)	70-71
MTS Advantage Video Extensometer (AVX)	72-73
Laser Extensometer	74
Other Applications	75
Clip-On Displacement Gages	76
Displacement Gages	77
Extensometer Calibrator	78
MTS Direct Current Potential Drop (DCPD) Solution	79

Extensometers

Accuracy is Key

Pioneered to Perfection

MTS pioneered and perfected the cross-flexure design that ensures true center point bending of its extensometers. Precision, resistive-type foil strain gages are bonded to the MTS cross-flexure to form a 4-arm fully active Wheatstone bridge.

- » Bridges of 350 ohms and 1000 ohms are used
- » Output, depending on the unit is 2 mV/V to 6 mV/V
- » Nominal excitation range from 5 to 12 V DC for room temperature testing

HIGH PERFORMANCE, HIGH QUALITY

- » Proven stability over 30+ years of usage
- » Built-in over-travel protection provides repeatable accurate data from test initiation through specimen failure
- » Quickly and accurately set-up your extensometer using the zero set pin or zero stop
- » Cross-flexure design ensures the strain gages are subjected to true center point bending and the same force, time after time

- » Small, lightweight design – most are under 35 g mass
- » MTS extensometer models are available for both static and dynamic testing
- » MTS extensometers meet or exceed requirements for calibration according to ASTM E83 Class B1 and ISO 9513 Class 0.5 standards

CAN'T FIND WHAT YOU NEED?

- » Our extensometer portfolio contains hundreds and hundreds of additional dynamic rated extensometers. Contact your local sales representative or applications engineer to find the model that meets your exact needs
- » Custom models are also available upon request

MTS Extensometer Repair & Rework

Why go through the process of certifying a new extensometer when the one you have still does the job? Many of our extensometers survive tens of thousands of tests without a problem – so if the unit only needs a new zero set pin or cables let us repair it for you. Contact your local sales representative for details.

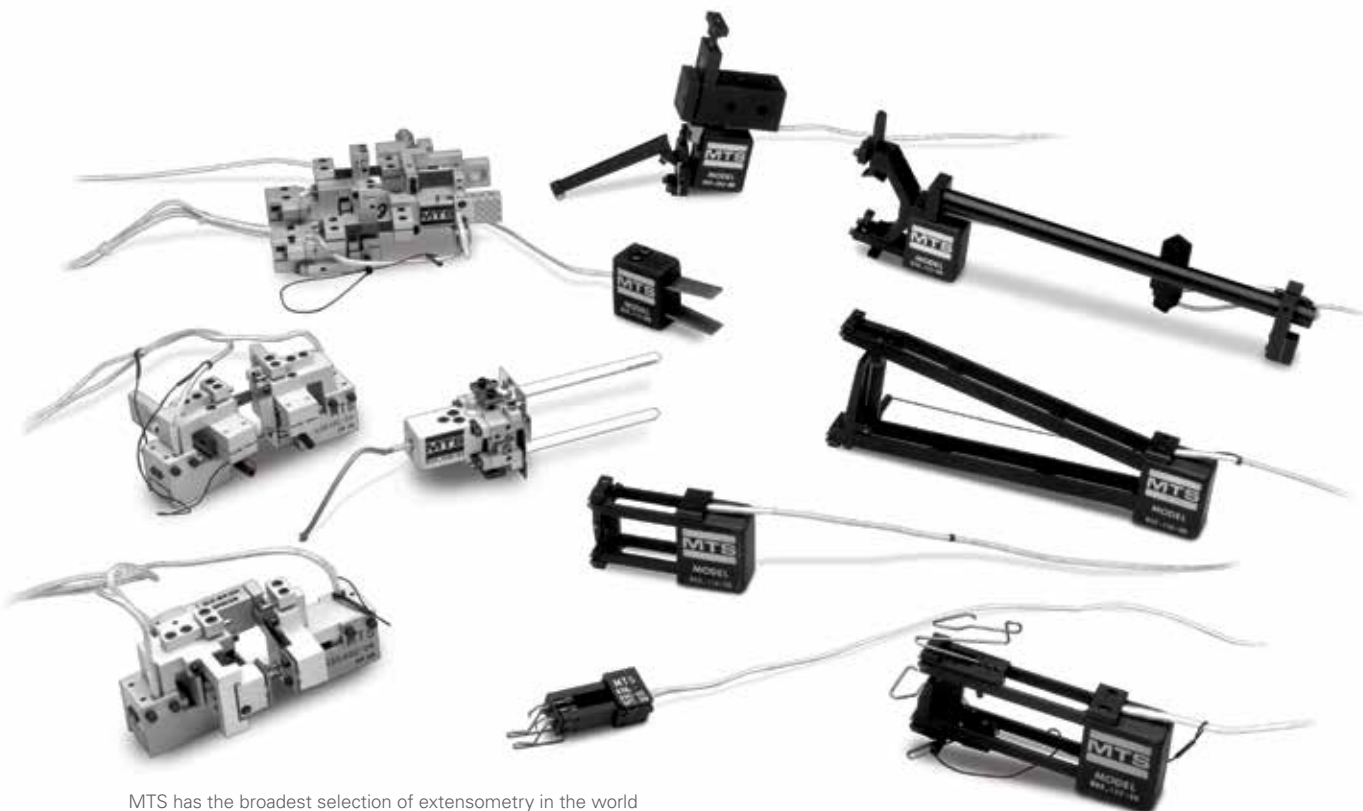

MTS has the broadest selection of extensometry in the world

How to Select an Axial Extensometer

Start With the Specimen

What shape is your specimen?

MTS offers contact extensometers with gage lengths between 3 mm (0.12 in) and 100 mm (3.93 in). Select an extensometer with a gage length slightly shorter than the gage section of your specimen.

Whether the specimen cross-section is round or flat determines which type of knife edges to use with the extensometer. Straight knife edges are standard in our extensometers and are recommended for testing round specimens. Knife edges with 3-point specimen contact are typically used when testing flat specimens and they include one single-point and one double-point contact knife edge.

What is your specimen made of?

Both the physical response of the test material and the test method itself, influence how far the specimen will travel. Ductile metals may see more than a 15% strain during a tensile test to failure but a fatigue test on the same metal may be limited to 1%. Plastic and rubber materials have higher elongation than metals and often require extensometers with a greater measurement range. Stiff materials, such as ceramics, should be tested with extensometers with smaller measurement ranges. Higher resolution measurements typically require extensometers with lower full scale strain ranges.

Next, Think About the Test Method

Are you performing a monotonic or dynamic test?

Monotonic Testing: MTS Fundamental Series 635 Extensometers are ideal for measuring strain in tension testing applications. Their design is optimized for monotonic testing. Series 635 Extensometers should not be used for testing in compression.



Dynamic Testing: Extensometers supported by and clipped directly onto a specimen exert a small bending stress on the specimen. Extensometers that are lighter weight and closer to the specimen create smaller bending moments. MTS Model 632.29 extensometers are ideal for measuring strain in wires and small organic specimens, because they have small gage lengths, low mass and mount very close to the specimen.

In dynamic testing, if the frequency of the test cycle matches the natural frequency of the extensometer, the extensometer can begin to vibrate increasing the noise in the strain measurement signal. Our dynamic extensometers are designed with high natural frequencies to ensure that this never happens. Dynamic extensometer MTS Model 632.27 has an optimized design for a higher natural frequency above other 634 and 632 models. The MTS Model 632.27 is designed for fatigue applications up to 150 Hz.



Will testing take place in a furnace, environmental chamber or liquid bath?

Check out MTS model 632.5x extensometers for high-temperature applications up to 1200°C (2200°F). These models are mounted outside a furnace and are available with options for air or water cooling. Water cooling is the most effective for keeping the extensometer body at a constant temperature and maintaining low noise in the data measured.

Model 633.11 is designed for elevated temperature testing without external cooling. This model can be used within an environmental chamber up to 540°C (1000°F).

Most of our 632 and 634 extensometers include models that can be used in cryogenic applications as cold as -269°C (-452°F).

Are you following a standard test procedure?

Refer to the application index on the next page to find suggested model numbers for specific applications and ASTM standards.

When to Select a Non-Contact Extensometer

When your specimen response measurement requirements are more demanding than conventional contact measurement techniques, MTS non-contact extensometry is the preferred choice.



- » **Perfect for Delicate Specimens:** When testing a specimen that is fragile, brittle or irregularly shaped, MTS non-contact extensometry prevents damage caused by the contact forces of a clip on extensometer.
- » **Take Multiple Measurements:** The MTS Advantage Video Extensometer allows you to take up to 200 measurements on one specimen. One video extensometer can replace dozens of contact extensometers.
- » **Protect Your Investment:** Measurements through failure can be taken without any threat of damage to the video extensometer so tests can run without interruption.

Extensometer Application Index

Use this helpful index to determine which extensometers are best suited for your application. Please contact us for more information.

Application	Extensometer Options	See Pages
Metals		
Tensile (ASTM E8)	632.13/.24 & 634.11/.12/.25/.28/.31; 635; FAX; AOX; AVX	50, 51, 53, 54, 55, 58, 59, 70, 72
Compression (ASTM E9)	632.13/.26/.27 & 634.11/.12/.31; AOX; AVX;	50, 51, 52, 55, 70, 72
KIC - Fracture Toughness (ASTM)	632.02 ASTM Standard; 632.03 MTS Enhanced; 632.65 (High Temperature)	76
Pre-Cracking (ASTM E399)	632.05 (High Frequency)	please call
JIC (ASTM E1290)	632.03 with Long Travel Option	76
Crack Growth - Bend (ASTM E399)	632.03	76
Fatigue Crack Growth (ASTM E647)	632.03 with Long Travel Option; 632.05 (High Frequency)	76
High Cycle Fatigue	632.27 (Low Strain)	52
Low Cycle Fatigue (ASTM E606)	632.13/.18/.19/.20 & 634.11/.12/.31	50, 51, 55, 62, 63, 68
Low Cycle Fatigue (High Temp)	632.50/.51/.57	62, 63, (please call for .57)
Low Cycle Fatigue (High Temp)	632.53/.54	62
Advanced Materials		
Bend (MIL SPEC 1942, JIS 1601R)	632.06	77
Tensile/Compression	632.26; AOX; AVX; FAX	50, 59, 70, 72
High Temperature (CMC's MMC's)	632.5X	62, 63
Itra High Temperature Bend	632.70	please call
Composites		
Tensile (ASTM D3039)	632.17/.85 & 634.11/.31; AOX; AVX	51, 55, 65, 66, 70, 72
Compression (ASTM D695)	632.17 & 634.11/.31; AOX; AVX	51, 55, 65, 70, 72
±45° Shear Test (ASTM D3518)	632.17 & 634.11/.31; AVX;	51, 55, 65, 72
Flexure (ASTM D790)	632.06 & 634.11/.31	51, 55, 77
Tension/Tension Fatigue (ASTM D3479)	632.17/.85 & 634.11/.31	51, 55, 65, 66
Plastics		
Tensile (ASTM D638)	632.17/.24/.85 & 634.12/.25/.31, 635, LX 500/1500; FAX; AOX, AVX; AHX 850	51, 53, 54, 55, 58, 59, 60, 65, 66, 70, 72, 74
Rock Mechanics		
Triaxial Comp. Strength (ASTM D2664)	632.90/.92	please call
Triaxial Creep (ASTM D4406)	632.90/.92	please call
Bio-Materials	632.29 & 634.11/.12/.25/.31, LX 500; FAX; AOX; AVX	49, 51, 53, 55, 59, 70, 72
Axial/Torsional	632.68/.80	please call
Immersible Extensometer	632.79	69
High Temperature		
Air Cooled	632.53/.54	62
Water Cooled	632.51/.68	63, (please call for .68)
Uncooled	632.53/.54/.70	62
Fracture Mechanics		
Fracture Toughness	632.02/.03; 632.65 (High Temperature)	76
Pre-Cracking	632.05 (High Frequency)	please call
Bend		
Displacement	632.06	77
Crack Growth	632.03	76
High Temperature	632.70	please call
Fatigue & Fracture		
Crack Growth	632.03 with Long Travel Option; 632.05 & 632.65	76
High Cycle	632.27 (Low Strain)	51
Low Cycle Mechanics	632.13/.18/.19/.20 & 634.11/.12/.31	50, 51, 55, 68
Low Cycle (High Temp)	632.50/.51/.53/.54/.57	62, 63, 75
Tensile/Compression Testing		
Tensile	632.13/.24 & 634.11/.12/.25/.28/.31; 635; FAX; AOX; AVX; AHX 850	50, 51, 53, 54, 55, 58, 59, 60, 70, 72
Compression	632.13/.26/.27 & 634.12/.25/.31; AOX; AVX; FAX	50, 51, 52, 55, 59, 70, 72
Poisson's Ratio	632.18/.19/.20/.23/.85 & 634.12/.25/.31; AVX;	51, 53, 55, 66, 67, 68, 72
Elastic Limit	632.26/.27/.29; AOX; AVX;	49, 50, 52, 70, 72

Extensometer Functional Index

Axial Contact Extensometers

DYNAMIC MODELS (TENSION/COMPRESSION)

Metric Units

US Customary Units

Model Number	Gage Length	Measuring Range: Strain (Travel)	Model Number	Gage Length	Measuring Range: Strain (Travel)	See Page
632.29F-20	3 mm	±8% (±0.24 mm)	632.29E-20	0.12 in	±8% (±0.0096 in)	49
632.29F-30	5 mm	-10%/+30% (-0.5 mm/+1.5 mm)	632.29E-30	0.2 in	-10%/+30% (-0.02 in/+0.06 in)	49
632.29F-30	6 mm	±4% (±0.24 mm)	632.29E-3X	0.24 in	±4% (±0.0096 in)	49
632.26F-3X	8 mm	±6% (±0.48 mm)	632.26E-3X	0.3 in	±6% (±0.018 in)	50
632.26F-2X	8 mm	±15% (±1.2 mm)	632.26E-2X	0.3 in	±15% (±0.045 in)	50
632.13F-2X	10 mm	±15% (±1.5 mm)	632.13E-2X	0.5 in	±15% (±0.075 in)	50
632.26F-4X	12 mm	±9% (±1.1 mm)	632.26E-4X	0.5 in	±9% (±0.045 in)	50
632.27F-3X	25 mm	±2% (±0.5 mm)	632.27E-3X	1.0 in	±2% (±0.02 in)	52
632.27F-2X	25 mm	±4% (±1.0 mm)	632.27E-2X	1.0 in	±4% (±0.04 in)	52
634.11F-2X	25 mm	+20%/-10% (+5 mm/-2.5 mm)	634.11E-2X	1.0 in	+20%/-10% (+0.2 in/-0.1 in)	51
634.12F-2X	25 mm	+50%/-10% (+12.5 mm/-2.5 mm)	634.12E-2X	1.0 in	+50%/-10% (+0.5 in/-0.1 in)	51
634.25F-2X	50 mm	+50%/-10% (+25 mm/-5 mm)	634.25E-2X	2.0 in	+50%/-10% (+1.0 in/-0.2 in)	53
634.31F-2X	10-50 mm	variable (+4 mm/-2 mm)	634.31E-2X	0.5-2.0 in	variable (+0.2 in/-0.1 in)	55

MONOTONIC MODELS (TENSION ONLY)

Metric Units

US Customary Units

Model Number	Gage Length	Measuring Range: Strain (Travel)	Model Number	Gage Length	Measuring Range: Strain (Travel)	See Page
635.25F-05	25 mm	+20% (+5 mm)				58
634.11F-5x	25 mm	+20% (+5 mm)	634.11E-5X	1.0 in	+20% (+0.2 in)	51
634.12F-5x	25 mm	+50% (+12.5 mm)	634.12E-5X	1.0 in	+50% (+0.5 in)	51
632.24F-50	25 mm	+100% (+25 mm)	632.24E-50	1.0 in	+100% (+1.0 in)	54
635.50F-05	50 mm	+10% (+5 mm)	634.25E-5X	2.0 in	+50% (+1.0 in)	53, 58
635.50F-10	50 mm	+20% (+10 mm)	634.28E-24	2.0 in	+100% (+2.0 in)	54, 58
635.50F-25	50 mm	+50% (+25 mm)				58
634.25F-5x	50 mm	+50% (+25 mm)				53
634.28F-24	50 mm	+100% (+50 mm)				54
635.100F-10	100 mm	+10% (+10 mm)				58

Axial Extensometers

Miniature Extensometers: <6 mm (<0.23 in) Gage Length

- » MTS Model 632.29 Extensometers are really small, because sometimes there just is not enough room. Most models are only 15.3 mm (0.60 in) tall and weigh roughly 6 g
- » Typical applications include testing of small wires, brittle or fragile materials, small organic specimens, or expensive materials
- » Includes a gage fixture for proper gage length setting and a 1000 Ohm fully-active Wheatstone bridge for high sensitivity
- » Meets or exceeds requirements for calibration according to ASTM E83 Class B1 and ISO 9513 Class 0.5 standards

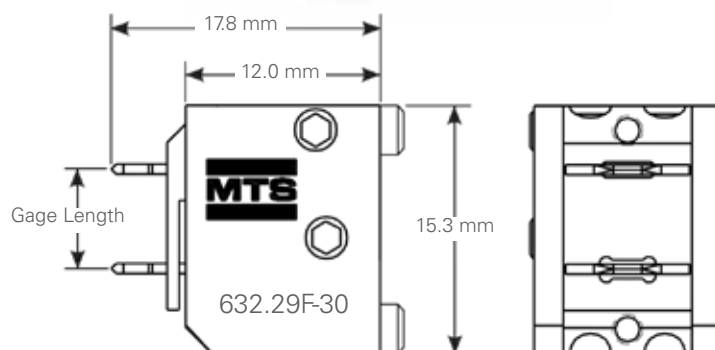

Metric Units

Model	Gage Length	Measuring Range (% Strain)	Height	Length	Temperature Range min/max*	Activation Force	Includes Quick Attachment Kit for Flat and Round Specimens	Part number
632.29F-20	3 mm	±8%	15.3 mm	17.8 mm	-100°C / 150°C	30 g		047-402-102
632.29F-30	5 mm	-10% / 30%	15.3 mm	36.8 mm	-100°C / 150°C	30 g	x	047-402-108
632.29F-30	6 mm	±4%	15.3 mm	17.8 mm	-100°C / 150°C	30 g		047-402-104

US Customary Units

Model	Gage Length	Measuring Range (% Strain)	Height	Length	Temperature Range min/max*	Activation Force	Includes Quick Attachment Kit for Flat and Round Specimens	Part number
632.29E-20	0.12 in	±8%	0.60 in	0.70 in	-150°F / 300°F	30 g		047-402-101

*These units may be used at 25°C (50°F) higher than the listed temperatures, but only for durations less than 24 hours.

Quick Attachment Kits

Improve your productivity by selecting the part number that includes a quick attachment kit. Includes adapters for flat and round specimens.



Axial Extensometers

Axial Extensometers with <25 mm (<1 in) Gage Length

- » Models 632.13 and 632.26 extensometers are ideal for testing small specimens
- » Measuring range is equally divided into tensile and compressive range
- » Includes knife edges and manual attachment fixtures for round specimens
- » Select the -21 or -31 model for cryogenic testing down to -269°C (-452°F)
- » Models include quick attachment kits for round and flat specimens where indicated. Additional quick attachment kits are available upon request
- » Meets or exceeds requirements for calibration according to ASTM E83 Class B1 and ISO 9513 Class 0.5 standards

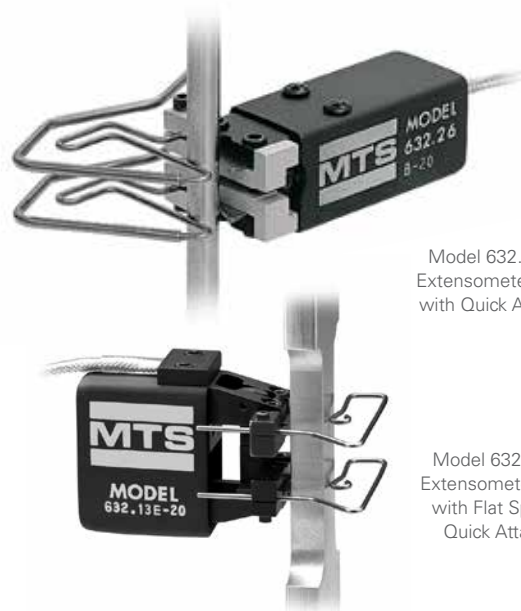

Model 632.26 Axial Extensometer (shown with Quick Attach Kit)

Model 632.13 Axial Extensometer (shown with Flat Specimen Quick Attach Kit)

Metric Units

Model	Gage Length	Measuring Range (% Strain)	Height	Length	Temperature min/max*	Activation Force	Includes Quick Attachment Kit	Part number
632.26F-3x	8 mm	±6%	17.5mm	44.5 mm				
632.26F-30					-100°C / 150°C	40 g		047-401-810
632.26F-30					-100°C / 150°C	40 g	x	047-401-821
632.26F-31					-269°C / 65°C	40 g		047-401-811
632.26F-2x	8 mm	±15%	17.5 mm	44.5 mm				
632.26F-20					-100°C / 150°C	40 g		047-401-804
632.26F-20					-100°C / 150°C	40 g	x	047-401-849
632.26F-23					-100°C / 175°C	60 g		047-401-806
632.13F-2x	10 mm	±15%	32.8 mm	41.1 mm				
632.13F-20					-100°C / 150°C	45 g		047-401-004
632.13F-20					-100°C / 150°C	45 g	x	047-401-010
632.13F-21					-269°C / 65°C	45 g		047-401-005
632.13F-23					-100°C / 175°C	65 g		047-401-006
632.26F-4x	12 mm	±9%	18.8 mm	44.5 mm				
632.26F-40					-100°C / 150°C	40 g		047-401-816
632.26F-40					-100°C / 150°C	40 g	x	047-401-822

US Customary Units

Model	Gage Length	Measuring Range (% Strain)	Height	Length	Temperature min/max*	Activation Force	Includes Quick Attachment Kit	Part number
632.26E-3x	0.300 in	±6%	0.69 in	0.175 in				
632.26E-30					-150°F / 300°F	40 g		047-401-807
632.26E-2x	0.300 in	±15%	0.69 in	0.175 in				
632.26E-20					-150°F / 300°F	40 g		047-401-801
632.13E-2x	0.500 in	±15%	1.29 in	1.62 in				
632.13E-20					-150°F / 300°F	45 g		047-401-001
632.13E-20					-150°F / 300°F	45 g	x	047-401-007
632.13E-21					-452°F / 150°F	45 g		047-401-002
632.26E-4x	0.500 in	±9%	0.74 in	1.75 in				
632.26E-40					-150°F / 300°F	40 g		047-401-813
632.26E-41					-452°F / 150°F	40 g		047-401-814
632.26E-43					-150°F / 350°F	60 g		047-401-815

*These units may be used at 25°C (50°F) higher than the listed temperatures, but only for durations less than 24 hours.

Axial Extensometers

Axial Extensometers with 25 mm (1 in) Gage Length

- » Ideal for a variety of applications including metals, plastics, rubbers, and composites
- » Low activation force without slipping on your specimen
- » High natural frequency and sensitivity make them useful in determining properties during failure
- » Select the -21 model for cryogenic testing down to -269°C (-452°F)
- » All part numbers include knife edges, quick attachment fixtures for flat and round specimens, and standard elastic attachment kit
- » Meets or exceeds requirements for calibration according to ASTM E83 Class B1 and ISO 9513 Class 0.5 standards



Metric Units

Model	Gage Length	Measuring Range (% Strain)	Height	Length	Temperature min/max*	Activation Force	Includes Quick Attachment Kit	Part number
634.11F-2x	25 mm	+20% / -10%	33.0 mm	73.4 mm				
634.11F-21					-269°C / 65°C*	35 g	x	052-251-807
634.11F-24					-85°C / 120°C*	35 g	x	052-251-808
634.11F-25					-100°C / 175°C	45 g	x	052-251-809
634.11F-5x	25 mm	+20%	33.0 mm	73.4 mm				
634.11F-54					-85°C / 120°C*	35 g	x	052-251-811
634.11F-55					-100°C / 175°C	45 g	x	052-251-812
634.12F-2x	25 mm	+50% / -10%	33.0 mm	82.8 mm				
634.12F-21					-269°C / 65°C*	45 g	x	051-191-507
634.12F-24					-85°C / 120°C*	45 g	x	051-191-508
634.12F-25					-100°C / 175°C	55 g	x	051-191-509
634.12F-5x	25 mm	+50%	33.0 mm	82.8 mm				
634.12F-51					-269°C / 65°C*	45 g	x	051-191-510
634.12F-54					-85°C / 120°C*	45 g	x	051-191-511
634.12F-55					-100°C / 175°C	55 g	x	051-191-512

US Customary Units

Model	Gage Length	Measuring Range (% Strain)	Height	Length	Temperature min/max*	Activation Force	Includes Quick Attachment Kit	Part number
634.11E-2X	1.00 in	+20% / -10%	1.30 in	2.89 in				
634.11E-21					-452°F / 150°F*	35 g	x	052-251-801
634.11E-24					-120°F / 250°F*	35 g	x	052-251-802
634.11E-25					-150°F / 350°F	45 g	x	052-251-803
634.11E-5X	1.00 in	+20%	1.30 in	2.82 in				
634.11E-54					-120°F / 250°F *	35 g	x	052-251-805
634.11E-55					-150°F / 350°F	45 g	x	052-251-806
634.12E-2X	1.00 in	+50% / -10%	1.30 in	3.26 in				
634.12E-21					-452°F / 150°F*	45 g	x	051-191-501
634.12E-24					-120°F / 250°F*	45 g	x	051-191-502
634.12E-25					-150°F / 350°F	55 g	x	051-191-503
634.12E-5X	1.00 in	+50%	1.30 in	3.26 in				
634.12E-54					-120°F / 250°F*	45 g	x	051-191-505

*These units may be used at 25°C (50°F) higher than the listed temperatures, but only for durations less than 24 hours. See the MTS Fundamental Series 635 Extensometers on page 58 for an affordable monotonic only option.

Axial Extensometers

Low Strain, High Frequency Axial Extensometers with 25 mm (1 in) Gage Lengths

- » Small measuring ranges make Model 632.27 extensometers highly sensitive to detecting small displacement changes in ceramics and ceramic matrix composites
- » Extremely short arms and high natural frequencies ensure that this extensometer measures accurate strains at up to 150 Hz
- » Meets or exceeds requirements for calibration according to ASTM E83 Class B1 and ISO 9513 Class 0.5 standards



Metric Units

Model	Gage Length	Measuring Range (% Strain)	Height	Length	Temperature Range min/max*	Activation Force	Includes Quick Attachment Kit for Flat and Round Specimens	Part number
632.27F-2x	25 mm	±4%	33.0 mm	44.1 mm				
632.27F-20					-100°C / 150°C	60 g		047-401-904
632.27F-21					-269°C / 65 °C	60 g		047-401-905
632.27F-23					-100°C / 175°C	90 g		047-401-906
632.27F-3x	25 mm	±2%	33.0 mm	44.1 mm				
632.27F-30					-100°C / 150°C	60 g		047-402-004
632.27F-31					-100°C / 150°C	60 g		047-402-005
632.27F-33					-100°C / 150°C	60 g		047-402-006

US Customary Units

Model	Gage Length	Measuring Range (% Strain)	Height	Length	Temperature Range min/max*	Activation Force	Includes Quick Attachment Kit for Flat and Round Specimens	Part number
632.27E-2x	1 in	±4%	1.30 in	1.62 in				
632.27E-20					-150°F / 350°F	60 g		047-401-901
632.27E-3x	1 in	±2%	1.30 in	1.62 in				
632.27E-30					-150°F / 350°F	60 g		047-402-001

*These units may be used at 25°C (50 °F) higher than the listed temperatures, but only for durations less than 24 hours.

Testing at High Temperatures?

MTS offers a full range of high temperature extensometers that work with our chambers and furnaces.

See pages 62-64 for details.



Axial Extensometers

Axial Extensometers with 50 mm (2 in) Gage Length

- » Ideally suited for tensile testing of plastics, rubber, and elastomers
- » Long travel and mechanical stops enable you to leave it on the specimen through failure without damaging the unit
- » Activation forces as low as 30 g prevent specimen damage without slipping
- » Select the -21 or -51 model for cryogenic testing down to -269°C (-452°F)
- » All part numbers include hardened knife edges, quick attachment fixtures for flat and round specimens, and standard elastic attachment kits
- » Meets or exceeds requirements for calibration according to ASTM E83 Class B1 and ISO 9513 Class 0.5 standards



Metric Units

Model	Gage Length	Measuring Range (% Strain)	Height	Length	Temperature Range min/max*	Activation Force	Includes Quick Attachment Kit for Flat and Round Specimens	Part number
634.25F-2x	50 mm	+50% / -10%	58.4 mm	151.4 mm				
634.25F-21					-269°C / 65°C*	30 g	x	051-191-607
634.25F-24					-85°C / 120°C*	30 g	x	051-191-608
634.25F-25					-100°C / 175°C	45 g	x	051-191-609
634.25F-5x	50 mm	+50%	58.4 mm	151.4 mm				
634.25F-51					-269°C / 65°C*	30 g	x	051-191-610
634.25F-54					-85°C / 120°C*	30 g	x	051-191-611
634.25F-55					-100°C / 175°C	45 g	x	051-191-612

See the MTS Fundamental Series 635 Extensometers on page 58 for an affordable monotonic only option.

US Customary Units

Model	Gage Length	Measuring Range (% Strain)	Height	Length	Temperature Range min/max*	Activation Force	Includes Quick Attachment Kit for Flat and Round Specimens	Part number
634.25E-2x	2.00 in	+50% / -10%	2.3 in	5.96 in				
634.25E-21					-452°F / 150°F*	30 g	x	051-191-601
634.25E-24					-120°F / 250°F*	30 g	x	051-191-602
634.25E-25					-150°F / 350°F	45 g	x	051-191-603
634.25E-5x	2.00 in	+50%	2.3 in	5.96 in				
634.25E-51					-452°F / 150°F*	30 g	x	051-191-604
634.25E-54					-120°F / 250°F*	30 g	x	051-191-605
634.25E-55					-150°F / 350°F	45 g	x	051-191-606

*These units may be used at 25°C (50°F) higher than the listed temperatures, but only for durations less than 24 hours.
See the MTS Fundamental Series 635 Extensometers on page 58 for an affordable monotonic only option.

Axial Extensometers

Enhanced Travel Axial Extensometers

- » Designed for plastics, rubber, and elastomer testing, these extensometers can measure up to 100% strain
- » Utilizes a zero-stop for setting the initial gage length and simplifying mounting. Simply hold the arms together and attach the extensometer to the specimen
- » All part numbers include our quick attachment fixtures



Metric Units

Model	Gage Length	Measuring Range (% Strain)	Height	Length	Temperature Range min/max*	Activation Force	Includes Quick Attachment Kit for Flat and Round Specimens	Part number
632.24F-5x	25 mm	+100%	33 mm	123.2 mm				
632.24F-50					-100°C /150°C	30 g	x	047-401-602
634.28F-2x	50 mm	+100%	73.7 mm	155.6 mm				
634.28F-24					-85°C /120°C	55 g	x	056-355-802

US Customary Units

Model	Gage Length	Measuring Range (% Strain)	Height	Length	Temperature Range min/max*	Activation Force	Includes Quick Attachment Kit for Flat and Round Specimens	Part number
632.24E-5x	1 in	+100%	1.3 in	4.85 in				
632.24E-50					-150°F / 300°F	30 g	x	047-401-601
634.28E-2x	2 in	+100%	2.9 in	6.13 in				
634.24E-24					-120°F / 250°F	55 g	x	056-355-801

*These units may be used at 25°C (50°F) higher than the listed temperatures, but only for durations less than 24 hours.

Axial Extensometers

Axial Extensometers with Multiple Gage Lengths

- » Measure and control strain on a variety of different specimen types using this configurable extensometer
- » Features multiple gage lengths to provide flexibility to run a variety of tests without recalibration
 - 9 gage lengths available between 10 mm and 50 mm in the metric models
 - 6 gage lengths available in the US customary models
- » Easy gage length changeover reduces set-up time between tests
- » Quick attachment fixtures are included and can accommodate:
 - Round specimens with diameters from 2.5 to 14.0 mm (0.10 to 0.56 in)
 - Flat specimens ranging in thickness from 10.5 to 26.0 mm (0.42 to 1.02 in)
- » Meets or exceeds requirements for calibration according to ASTM E83 Class B2 and ISO 9513 Class 0.5 standards



Metric Units	
Available Gage Length	Measuring Range (% Strain, rounded to nearest 1%)
10 mm	+40% / -20%
15 mm	+27% / -13%
20 mm	+20% / -10%
25 mm	+16% / -8%
30 mm	+13% / -7%
35 mm	+11% / -6%
40 mm	+10% / -5%
45 mm	+9% / -4%
50 mm	+8% / -4%

US Customary Units	
Available Gage Length	Measuring Range (% Strain, rounded to nearest 1%)
0.500 in	+40% / -20%
0.750 in	+27% / -13%
1.000 in	+20% / -10%
1.500 in	+13% / -4%
1.750 in	+11% / -6%
2.000 in	+10% / -5%

Metric Units

Model	Gage Length	Measuring Range (% Strain)	Height (min/max)	Length	Temperature Range min/max	Activation Force	Includes Quick Attachment Kit for Flat and Round Specimens	Part number
634.31F-2x	See Above		32.5 mm / 59.4 mm	73.8 mm				
634.31F-21					-269°C / 65°C*	32 g	x	052-251-904
634.31F-24					-85°C / 120°C*	32 g	x	052-251-905
634.31F-25					-100°C / 175°C	40 g	x	052-251-906

Each 634.31F-2x extensometer includes components to set it to the nine gage lengths listed. The extensometer weighs between 36 and 42 g, depending on the mass of the components in use.

US Customary Units

Model	Gage Length	Measuring Range (% Strain)	Height (min/max)	Length	Temperature Range min/max	Activation Force	Includes Quick Attachment Kit for Flat and Round Specimens	Part number
634.31E-2x	See Above		1.28 in / 2.34 in	2.9 in				
634.31E-21					-452°F / 150°F*	40 g	x	052-251-901
634.31E-24					-120°F / 250°F*	40 g	x	052-251-902
634.31E-25					-150°F / 350°F	50 g	x	052-251-903

Each 634.31E-2x extensometer includes components to set it to the nine gage lengths listed. The extensometer weighs between 36 and 42 g, depending on the mass of the components in use.

Accessories for Axial Extensometers

Gage Length Extenders

Expand the Range of Use of Your Existing Extensometer

- » Gage length extender kits modify the gage length of existing extensometers to perform strain measurements on specimens which have non-standard gage lengths
- » Travel of the extensometers is not affected by the addition of extenders, but the strain measuring range will be reduced
- » Each extender/extensometer combination requires separate calibration



Metric Units

Extender Model	Extensometer Models (Type)	Gage Length with Extender	Part Number
634.15C-30	634.11/12 (F)	50 mm	051-191-901
634.15C-31	634.11/12 (F)	100 mm	051-191-902
634.15C-32	634.11/12 (F)	150 mm	051-191-903
634.15C-33	634.11/12 (F)	200 mm	051-191-904
634.15C-37	Kit of 50, 100, 150, & 200 mm extenders	Kit of 50, 100, 150, & 200 mm extenders	051-191-905
634.15C-40	634.25 (F)	100 mm	051-191-908
634.15C-41	634.25 (F)	150 mm	051-191-909
634.15C-42	634.25 (F)	200 mm	051-191-910
634.15C-47	Kit of 100, 150, & 200 mm extenders	Kit of 100, 150, & 200 mm extenders	051-191-911

US Customary Units

Extender Model	Extensometer Models (Type)	Gage Length with Extender	Part Number
634.15B-30	634.11/12 (E)	2 in	051-191-801
634.15B-31	634.11/12 (E)	4 in	051-191-802
634.15B-32	634.11/12 (E)	6 in	051-191-803
634.15B-33	634.11/12 (E)	8 in	051-191-804
634.15B-37	Kit of 2, 4, 6, & 8 in extenders	Kit of 2, 4, 6, & 8 in extenders	051-191-805
634.15B-40	634.25 (E)	4 in	051-191-808
634.15B-41	634.25 (E)	6 in	051-191-809
634.15B-42	634.25 (E)	8 in	051-191-810
634.15B-47	Kit of 4, 6, & 8 in extenders	Kit of 4, 6, & 8 in extenders	051-191-811

Extenders for additional models and gage lengths available upon request.

Quick Attachment Kits & Replacement Parts

- » Improve your productivity by buying a Quick Attachment Kit for your extensometer
- » Includes adapters for flat and round specimens

Description	Part Number
Quick Attach Spring Set (includes 2 springs)	
For all 634.xx models except 634.31F	047-201-911
For Model 634.31F	047-201-920
Spring Retainer (holds 1 spring in place)	055-467-601

Accessories for Axial Extensometers

Specimen Attachment Kits

Large Diameter Specimen Attachment Kit

- » Recommended for specimens larger than 32 mm (1.25 in) in diameter
- » Provides a more effective attachment angle and increases the normal force pressing the extensometer onto the specimen
- » Increases stability of the extensometer on the specimen
- » Includes two remote spring attachment bracket assemblies that mount on the extensometer arms and an assortment of 16 tension springs
- » For use with models 632.11/.12/.25 and 634.11/.12/.25



Replacement Knife Edges for Extensometers

- » Replacements for those provided with extensometers
- » Stainless steel with a Rockwell hardness of Rc 58 to 60
- » Round specimen knife edges have a 90° included angle
- » Flat specimen knife edges provide three point specimen contact by means of one single point and one double point contact knife edge

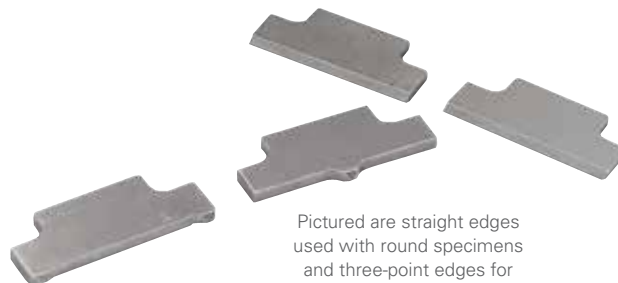

Pictured are straight edges used with round specimens and three-point edges for use with flat specimens.

Flat Specimen Attachment Kit – Wire Form Method

- » Mounts a heavy duty, remote spring bracket assembly to the arms of the extensometer
- » Formed wire reacts with the force of the springs directly across from the knife edges



Flat Specimen Attachment Kit – Disc Method

- » Primarily used for specimens less than 12 mm (0.5 in) in width
- » Effectively makes specimen appear as a round specimen for extensometer mounting purposes



Description	634.xx Part Number	632.xx Part Number
Large Diameter Kit for 63x.11/.12/.25	053-063-001	038-863-801
Flat Specimen Attachment Kit – Disc Method	100-020-108	034-505-201
Flat Specimen Attachment Kit– Wire Form Method, for specimens up to 25 mm (1 in) wide	100-058-679	

Extenders for additional models and gage lengths available upon request.

MTS Fundamental Series 635 Extensometers

Monotonic Extensometers for Tensile Testing

- » Series 635 extensometers are specially designed for popular monotonic axial tensile strain measurement. They are an economic choice, ideal for large volume QA/QC testing.
- » Features proprietary strain gaged elements made from special heat-treated alloy
- » Ground profile, dual-member flexure provides for very low activation force with excellent strength
- » True center-point bending resulting in low hysteresis and exceptionally accurate strain readings
- » Mechanical stops can be attached through specimen failure without damaging the unit
- » Zero-set pin enables accurate and consistent determination of the initial gage length
- » Not intended for immersion in water or other liquids
- » Hardened, replaceable knife edges for flat and round specimens are included
- » Patented MTS quick-attach springs for fast and easy specimen attachment are included
- » Standard 1.5 m (60 in) cable is included
- » Typical Linearity¹ is 0.08% of range
- » Accuracy² designed to meet ASTM E83 Class B1 and ISO 9513 Class 0.5 standards
- » Temperature Range is 4°C to 50°C (40°F to 120°F)
- » **Applications:** Axial tensile strain measurements for large volume QA/QC testing



Axial Extensometers for Monotonic Testing Only, MTS Fundamental Series 635

Model	Gage Length	Maximum Travel	Maximum Strain	Length (from knife edge to back of housing)	Height (from bottom to top)	Part number
635.25F-05	25 mm	+5 mm	20%	77.5 mm (3.1 in)	39.6 mm (1.1 in)	057-863-506
635.50F-05	50 mm	+5 mm	10%	77.5 mm (3.1 in)	59.2 mm (2.3 in)	057-863-505
635.50F-10	50 mm	+10 mm	20%	77.5 mm (3.1 in)	61.5 mm (2.4 in)	057-863-504
635.50F-25	50 mm	+25 mm	50%	153.7 mm (6.1 in)	69.1 mm (2.7 in)	057-863-503
635.100F-10	100 mm	+10 mm	10%	77.5 mm (3.1 in)	111.8 mm (4.4 in)	057-863-502
635.100F-25	100 mm	+25 mm	25%	153.7 mm (6.1 in)	119.1 mm (4.7 in)	057-863-501

Notes:

¹ Linearity stated is for ascending data and is the deviation from best fit straight line thru zero expressed as a percent of full scale.

² Calibrations are separate. These extensometers leave the factory with a quality validation and verification by sampling three measurement points to validate performance. The 635 series extensometers are intended to meet ASTM class B-1 and ISO class 0.5.

Fundamental™ Automatic Extensometer (FAX)

Automatic Extensometer for Criterion® and Exceed® Universal Test Systems

- » FAX1352 automatic extensometer is compatible with MTS Criterion and Exceed Universal Test Systems
- » Designed for longevity
- » Optimized for high-volume testing of single gage length specimens
- » Rotational Mount allows the operator to quickly rotate the FAX out of the test area for easy access to the specimen
- » Ideal for axial strain measurement for tensile testing on Universal Test Systems



Axial Model Specifications

Model	FAX1352
Part Number	100-530-550
Frame Family	Criterion & Exceed
Measuring Range	0 - 80 mm (0 - 3.1 in)
Gage Length*	12.5 – 200 mm (0.5 – 7.9 in)
Thickness or Diameter Range	Flats: 0.2 - 40 mm (0.0008 – 1.57 in) Rounds: 0.2 - 40 mm (0.0008 – 1.57 in)
Relative Error	±1%
Axial Resolution	≤0.2 μm
Temperature Range	5°C (41°F) to 40°C (104°F)
Height	530 mm (20.9 in)
Width	120 mm (4.7 in)
Depth	673 mm (26.5 in)
Input Power	100-240 VAC 50/60Hz 1.4A

* Recalibration is required whenever the specimen gage length is change



FAX1352

Rotational Mounts

Advantage™ High Elongation Extensometer (AHX850)

High Elongation Extensometer for Criterion® Universal Test Systems

- » AHX850 high elongation extensometer is compatible with MTS Criterion Universal Test Systems
- » High-resolution optical digital encoder eliminates noise, signal drift, and output changes
- » Balanced design with optimized arm and head weights
- » Swings away from test area when not in use
- » Meets or exceeds requirements for calibration according to ASTM E83 Class B1 and ISO 9513 Class 0.5 standards

- » The gripping force is applied using adjustable springs
- » **Applications:** Ideal for accurately measuring strain in specimens prone to large displacement while in tension such as polymers and other elastomers

AHX850 High Elongation Extensometers

Model	AHX850
Part Number	100-512-885
Frame Family	Criterion
Measuring Range	10 - 850 mm (0.4 - 33.4 in)
Standard Gage Length	10 mm (0.4 in) 20 mm (0.8 in) 25 mm (1.0 in) 50 mm (2.0 in) 75 mm (2.95 in) 100 mm (3.9 in)
Maximum Specimen Dimensions	Width: 20 mm (0.8 in) Thickness: 30 mm (1.2 in)
Relative Error	1%
Resolution	0.006 mm (0.0002 in)
Temperature Range	5°C (41°F) to 50°C (122°F)
Height	1025 mm (40.4 in)
Width	90 mm (3.54 in)
Depth	310 mm (12.2 in)

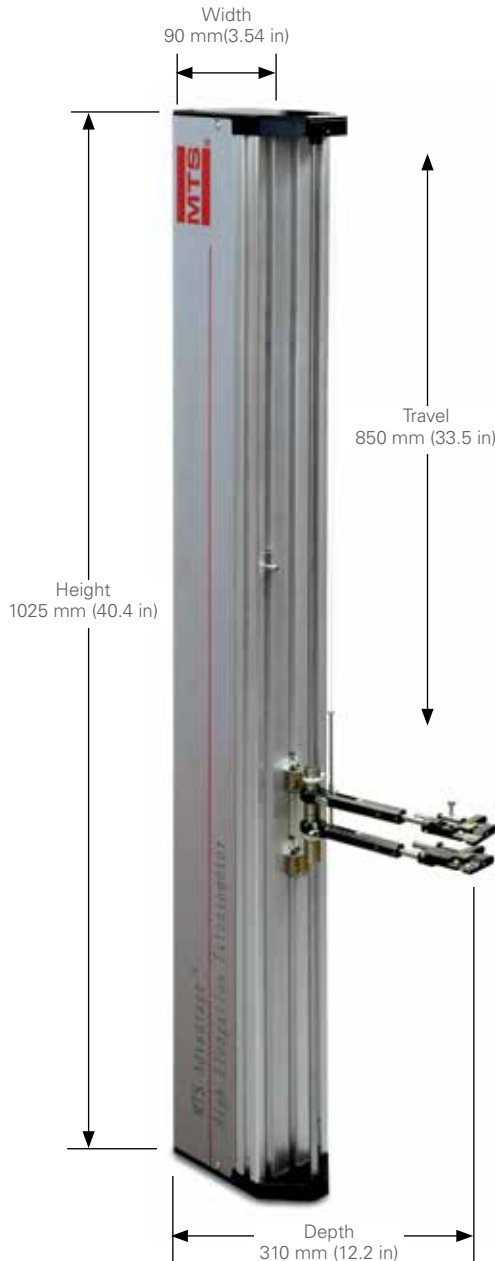

LTX850 Long Travel Extensometer

High Elongation Extensometer for Exceed® Universal Test Systems

- » High elongation extensometer compatible with MTS Exceed Universal Test Systems
- » Durable high strength aluminum structure
- » Dual independent digital input channels for upper and lower arms ensure accurate and reliable measurement
- » Changeable knife edges, adjustable gripping forces, and balance head and arm weight allow smooth following of material strain change with minimal stickiness
- » Meets or exceeds requirements for calibration according to ASTM E83 Class B1 and ISO 9513 Class 0.5 standards
- » The gripping force is applied using adjustable springs
- » **Applications:** Ideal for accurately measuring strain in specimens prone to large displacement while in tension such as polymers and other elastomer

LTX 850 High Elongation Extensometers

Part Number	100-542-797
Frame Family	Exceed
Measuring Range	10 - 850 mm (0.4 - 33.4 in)
Standard Gage Length	10 mm (0.4 in) 20 mm (0.8 in) 25 mm (1.0 in) 50 mm (2.0 in) 75 mm (2.95 in)
Maximum Specimen Dimensions	Width: 20 mm (0.8 in) Thickness: 30 mm (1.2 in)
Relative Error	1%
Resolution	0.006 mm (0.0002 in)
Temperature Range	5°C (41°F) to 50°C (122°F)
Height	1030 mm (40.6 in)
Width	90 mm (3.54 in)
Depth	255 mm (10 in)

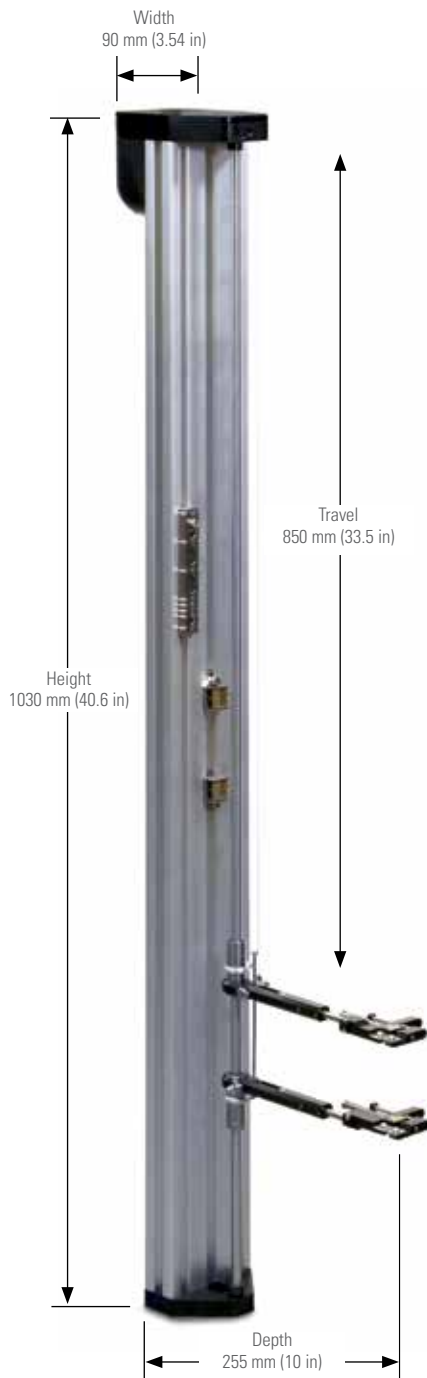

High Temperature Extensometers

Air Cooled High Temperature Extensometers

- » Designed for measuring axial strain in high temperature tension, compression, and through-zero fatigue testing applications up to 1200°C (2200°F)
- » Includes ceramic extension rods that extend into the furnace and minimize rod creep, thermal expansion errors, and conduction losses from the specimen
- » Contact force varies by model. Select from models with 100 g, 300 g, 400 g, or 780 g contact forces
- » Air cooling required
- » Additional models and rod geometries available upon request
- » Meets or exceeds requirements for calibration according to ASTM E83 Class B1 and ISO 9513 Class 0.5 standards



Metric Units

Model	Option	Gage Length	Measuring Range (% Strain)	Maximum Temperature	Contact Force	Ceramic Extension Rods Included	Part number
632.50F-08	006,080	10 mm	+20%/-10%	1200°C	780 g	Qty 4, V-chisel Edge Rods, 3.50 mm (.138 in) rod diameter, 85 mm (3.35 in) long	047-402-538 ¹
632.54F-11	–	12 mm	+20%/-10%	1200°C	100 g	Qty 4, V-chisel Edge Rods, 2.0 mm (.0787 in) rod diameter, 85 mm (3.35 in) long	047-404-304 ¹
632.53F-14	–	12 mm	+20%/-10%	1200°C	260 g	Qty 4, V-chisel Edge Rods, 3.50 mm (.138 in) rod diameter, 85 mm (3.35 in) long	047-404-104 ¹
632.53F-14	–	12 mm	+20%/-10%	1200°C	300 g	Qty 4, V-chisel Edge Rods, 3.50 mm (.138 in) rod diameter, 85 mm (3.35 in) long	047-404-105 ¹
632.53F-14	–	12 mm	+20%/-10%	1200°C	400 g	Qty 4, V-chisel Edge Rods, 3.50 mm (.138 in) rod diameter, 85 mm (3.35 in) long	047-404-106 ¹
632.50F-04	006,080	12 mm	+20%/-10%	1200°C	780 g	Qty 4, V-chisel Edge Rods, 3.50 mm (.138 in) rod diameter, 85 mm (3.35 in) long	047-402-539 ¹
632.54F-11	–	25 mm	+10%/-5%	1200°C	100 g	Qty 4, V-chisel Edge Rods, 2.0 mm (.0787 in) rod diameter, 85 mm (3.35 in) long	047-404-303 ¹
632.53F-11	–	25 mm	+20%/-10%	1200°C	260 g	Qty 2, V-chisel Edge Rods, 3.50 mm (.138 in) rod diameter, 85 mm (3.35 in) long	047-404-110 ¹
632.53F-11	–	25 mm	+10%/-5%	1200°C	300 g	Qty 4, V-chisel Edge Rods, 3.50 mm (.138 in) rod diameter, 85 mm (3.35 in) long	047-404-111 ¹
632.53F-11	–	25 mm	+10%/-5%	1200°C	400 g	Qty 4, V-chisel Edge Rods, 3.50 mm (.138 in) rod diameter, 85 mm (3.35 in) long	047-404-112 ¹
632.50F-01	006,077	25 mm	+15%/-15%	1200°C	400 g	Qty 4, V-chisel Edge Rods, 3.50 mm (.138 in) rod diameter, 94 mm (3.7 in) long	047-402-548 ¹

US Customary Units

Model	Option	Gage Length	Measuring Range (% Strain)	Maximum Temperature	Contact Force	Ceramic Extension Rods Included	Part number
632.54E-14	–	0.50 in	+20%/-10%	2200°F	100 g	Qty 4, V-chisel Edge Rods, 2.0 mm (.0787 in) rod diameter, 85 mm (3.35 in) long	047-404-302 ¹
632.53E-14	–	0.50 in	+20%/-10%	2200°F	260 g	Qty 4, V-chisel Edge Rods, 3.50 mm (.138 in) rod diameter, 85 mm (3.35 in) long	047-404-101 ¹
632.53E-14	–	0.50 in	+20%/-10%	2200°F	300 g	Qty 4, V-chisel Edge Rods, 3.50 mm (.138 in) rod diameter, 85 mm (3.35 in) long	047-404-102 ¹
632.53E-14	–	0.50 in	+20%/-10%	2200°F	400 g	Qty 4, V-chisel Edge Rods, 3.50 mm (.138 in) rod diameter, 85 mm (3.35 in) long	047-402-103 ¹
632.50E-04	006,080	0.50 in	+20%/-10%	2200°F	780 g	Qty 4, V-chisel Edge Rods, 3.50 mm (.138 in) rod diameter, 85 mm (3.35 in) long	047-402-525 ¹
632.54E-14	–	1.00 in	+10%/-5%	2200°F	100 g	Qty 4, V-chisel Edge Rods, 3.50 mm (.138 in) rod diameter, 85 mm (3.35 in) long	047-402-301 ¹
632.53E-11	–	1.00 in	+10%/-5%	2200°F	260 g	Qty 4, V-chisel Edge Rods, 3.50 mm (.138 in) rod diameter, 85 mm (3.35 in) long	047-404-107 ¹
632.53E-11	–	1.00 in	+10%/-5%	2200°F	300 g	Qty 4, V-chisel Edge Rods, 3.50 mm (.138 in) rod diameter, 85 mm (3.35 in) long	047-404-108 ¹
632.53E-11	–	1.00 in	+10%/-5%	2200°F	400 g	Qty 4, V-chisel Edge Rods, 3.50 mm (.138 in) rod diameter, 85 mm (3.35 in) long	047-404-109 ¹
632.50E-01	006,077	1.00 in	+15%/-15%	2200°F	400 g	Qty 4, V-chisel Edge Rods, 3.50 mm (.138 in) rod diameter, 94 mm (3.7 in) long	047-402-547 ¹

¹ Mount is not required when using with 653.xx.B furnace, for other installations contact MTS

High Temperature Extensometers

Water Cooled High Temperature Extensometers

- » Designed for measuring axial strain in high temperature tension, compression, and through-zero fatigue testing applications up to 1200°C (2200°F)
- » Water cooling is more effective at keeping the extensometer body at a constant temperature and reducing noise in the data measured
- » Includes ceramic extension rods that extend into the furnace and minimize rod creep, thermal expansion errors, and conduction losses from the specimen
- » Contact force varies by model. Select from models with 400 g or 780 g contact forces.
- » Water cooling required
- » Additional models and rod geometries available upon request
- » Meets or exceeds requirements for calibration according to ASTM E83 Class B1 and ISO 9513 Class 0.5 standards



Metric Units

Model	Option	Gage Length	Measuring Range (% Strain)	Maximum Temperature	Contact Force	Ceramic Extension Rods Included	Part number
632.51F-04	006,080	12 mm	+20% / -10%	1200°C	780 g	Qty 2, V-chisel Edge Rods, 3.50 mm (.138 in) rod diameter, 85 mm (3.35 in) long	047-402-651 ¹
632.51F-01	006,077	25 mm	+15% / -10%	1200°C	400 g	Qty 2, V-chisel Edge Rods, 3.50 mm (.138 in) rod diameter, 94 mm (3.7 in) long	047-402-652 ¹

US Customary Units

Model	Option	Gage Length	Measuring Range (% Strain)	Maximum Temperature	Contact Force	Ceramic Extension Rods Included	Part number
632.51E-04	006,080	0.50 in	+20% / -10%	2200°F	780 g	Qty 2, V-chisel Edge Rods, 3.50 mm (.138 in) rod diameter, 85 mm (3.35 in) long	047-402-650 ¹
632.51F-01	006,077	1.00 in	+15% / -10%	1200°C	400 g	Qty 2, V-chisel Edge Rods, 3.50 mm (.138 in) rod diameter, 94 mm (3.7 in) long	047-402-653 ¹

¹ Mount is not required when using with 653.xx.B furnace, for other installations contact MTS.

High Temperature Extensometers

Elevated Temperature Axial Extensometer for Use in Chambers

- » Designed for measuring axial strain in elevated temperature testing environments without external cooling
- » Provides stable output, with low creep, for both tension and fatigue testing applications at temperatures from 40°C to 540°C (100° to 1000°F) and up to 85% relative humidity.
- » Fatigue rated up to 30 Hz
- » Compatible with controllers that use 494 or 493 series hardware. Not available for MTS electromechanical systems
- » Packed in a rugged storage case that contains the instrument, converter module, spare parts, springs, attachment devices, and tools



Metric Units

Model	Gage Length	Measuring Range (% Strain)	Height	Length	Temperature Range Min/Max*	Activation Force	Includes Attachment Kit
633.11M-15	25.00 mm	+16 / -8%	34.7 mm	35.8 mm	40°C / 540°C	60 g	x

US Customary Units

Model	Gage Length	Measuring Range (% Strain)	Height	Length	Temperature Range Min/Max*	Activation Force	Includes Attachment Kit
633.11L-15	1.000 in	+16 / -8%	1.4 in	2.2 in	100°F to 1000°F	60 g	x

¹ Relative humidity in excess of 85% may cause erroneous output. This erroneous output will disappear when chamber is elevated above ambient.

² Maximum operating frequency stated for sinusoidal displacements of 0.05 mm (0.002 in) amplitude or less.

* May be used 25°C (50°F) higher than specified for short durations less than 24 hours.

Specialty Extensometers

Averaging Axial Extensometer

- » Simultaneously measures axial deflection on the opposite sides of the specimen and then sums those measurements to provide a single average strain output
- » Measuring strain on both sides of the specimen reduces errors in strain measurements caused by bending strains, resulting in more accurate elastic modulus values
- » Units can be used to perform testing on solid or tubular composite or metal specimens of almost any configuration
- » Easily adjustable from 3 mm to 32 mm (0.12 in to 1.26 in) in diameter for round specimens
- » Easily adjustable for up to 51 mm (2 in) width for flat specimens
- » Low strain range detects small displacement changes in ceramics and composites
- » Meets or exceeds requirements for calibration according to ASTM E83 Class B1 and ISO 9513 Class 0.5 standards

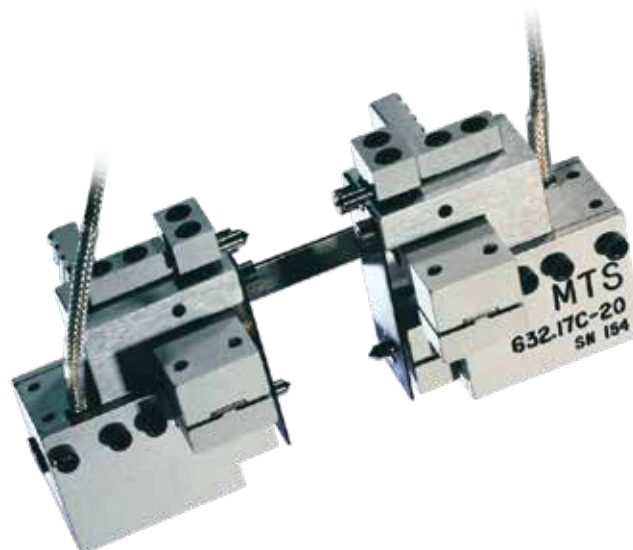

Metric Units

Model	Gage Length	Measuring Range (% Strain)	Height	Length	Depth	Temperature Range Min/Max*	Part Number
632.17F-x0							
632.17F-40	10 ±0.05 mm	+12% / -5%	63.5 mm	101.6 mm	38.1 mm	-100°C / 150°C	047-404-802
632.17F-20	25 ±0.05 mm	+5% / -2%	63.5 mm	101.6 mm	38.1 mm	-100°C / 150°C	047-401-102

US Customary Units

Model	Gage Length	Measuring Range (% Strain)	Height	Length	Depth	Temperature Range Min/Max*	Part Number
632.17E-x0							
632.17E-30	0.5 ±0.002 in	+10% / -4%	2.5 in	4.0 in	1.5 in	-150°F / 300°F	047-404-801
632.17E-20	1.0 ±0.002 in	+5% / -2%	2.5 in	4.0 in	1.5 in	-150°F / 300°F	047-401-101

*These units may be used at 25°C (50 °F) higher than the listed temperatures, but only for durations less than 24 hours.

Specialty Extensometers

Biaxial Extensometer

- » Measure the cross-sectional, diametral, or average axial strain with a single extensometer
- » Readily attach to many shapes and sizes of specimens
- » If you are worried about mechanical crosstalk between the axial and transverse channels, select Model 632.85x-05. This model operates only with conical point contacts.
- » If you have very thin specimens (i.e. sheet metal), select Model 632.85x-14. This model is designed for use with either conical point or v-chisel specimen contacts. Two output signals require separate conditioning for the averaged axial and the cross-sectional signals.
- » Meets or exceeds requirements for calibration according to ASTM E83 Class B1 and ISO 9513 Class 0.5 standards



Metric Units

Model	Gage Length	Axial Travel	Transverse Travel	Height	Length	Depth	Temperature Range Min/Max*	Part Number
632.85F-xx								
632.85F-05	25±0.05 mm	+1.25 to -0.50 mm	±0.5 mm	101.6 mm	38.1 mm	101.6 mm	-100°C / 150°C	047-403-502
632.85F-14	25±0.05 mm	+1.25 to -0.50 mm	0.5 mm	101.6 mm	38.1 mm	101.6 mm	-100°C / 150°C	047-403-506

US Customary Units

Model	Gage Length	Axial Travel	Transverse Travel	Height	Length	Depth	Temperature Range Min/Max*	Part Number
632.85E-xx								
632.85E-05	1.000±0.002 in	+0.050 to -0.020 in	±0.02 in	4.0 in	1.5 in	4.0 in	-150°F / 300°F	047-403-501
632.85E-14	1.000±0.002 in	+0.050 to -0.020 in	±0.02 in	4.0 in	1.5 in	4.0 in	-150°F / 300°F	047-403-505

*These units may be used at 25°C (50 °F) higher than the listed temperatures, but only for durations less than 24 hours.

Specialty Extensometers

Cross-Sectional Strain Extensometer

- » Measures cross-sectional strain and when used with a long gage length or enhanced travel extensometers (pages 53 and 54), it is ideal for determining the “R” value for plastics and sheet metal
- » Free floating feature enables it to travel with the specimen as it is elongated during axial loading



Metric Units

Model	Gage Width	Travel	Specimen Thickness	Temperature Range Min/Max*	Clamp Force	Part Number
632.23F-x0						
632.23F-20	12.7 ± 0.5 mm	-4 to 0 mm	0.5 to 5 mm	-100°C / 150°C	400 g	047-401-502
632.23F-30	20 ± 1 mm	-4 to 0 mm	0.5 to 5 mm	-100°C / 150°C	400 g	047-401-504
632.23F-30	25 ± 1 mm	-4 to 0 mm	0.5 to 5 mm	-100°C / 150°C	400 g	047-401-506

US Customary Units

Model	Gage Width	Travel	Specimen Thickness	Temperature Range Min/Max*	Clamp Force	Part Number
632.23E-x0						
632.23E-20	0.5 ± 0.02 in	-0.16 to 0 in	0.02 to 0.2 in	-150°F / 300°F	400 g	047-401-501

*These units may be used at 25°C (50 °F) higher than the listed temperatures, but only for durations less than 24 hours.

Specialty Extensometers

Diametral Extensometer

- » Ideal for measuring diametral strain in tension or compression
- » Designed for measuring cross sectional area changes on round specimens and helping to measure Poisson's ratio
- » Models available for testing at ambient, cryogenic, and elevated temperatures
- » Contact MTS for options for transverse measurements of specimens with rectangular cross sections



Metric Units

Model	Gage Diameter	Travel	Height	Length	Temperature Range Min/Max*	Clamp Force	Part Number
632.18F-2x	6.1 mm to 26 mm	±2 mm	12.7 mm	191 mm			
632.18F-20					-100°C / 150°C	400 g	047-401-204
632.18F-21					-265°C / 65°C	400 g	047-401-205
632.19F-2x	3.6 mm to 13 mm	±1 mm	12.7 mm	191 mm			
632.19F-20					-100°C / 150°C	400 g	047-401-304
632.20F-2x	2 mm to 7.9 mm	±0.5 mm	12.7 mm	191 mm			
632.20F-20					-100°C / 150°C	400 g	047-401-404

US Customary Units

Model	Gage Diameter	Travel	Height	Length	Temperature Range Min/Max*	Clamp Force	Part Number
632.18E-2x	0.24 in to 1.02 in	±0.08 in	0.5 in	7.5 in			
632.18E-20					-150°F / 300°F	400 g	047-401-201
632.19E-2x	0.14 in to 0.52 in	±0.04 in	0.5 in	7.5 in			
632.19E-20					-150°F / 300°F	400 g	047-401-301
632.20E-2x	0.14 in to 0.31 in	±0.02 in	0.5 in	7.5 in			
632.20E-20					-150°F / 300°F	400 g	047-401-403

*These units may be used at 25°C (50 °F) higher than the listed temperatures, but only for durations less than 24 hours.

Specialty Extensometers

Immersible Extensometer

- » Provide accurate strain measurement while totally immersed in water or saline solution
- » Designed for both tension and fatigue testing up to 30 Hz
- » Accurately translates specimen displacement to the hermetically sealed LVDT using a patented parallel flexure system
- » Gage Length extenders to extend gage length to 200 mm (8.0 in)
- » AC conditioning required

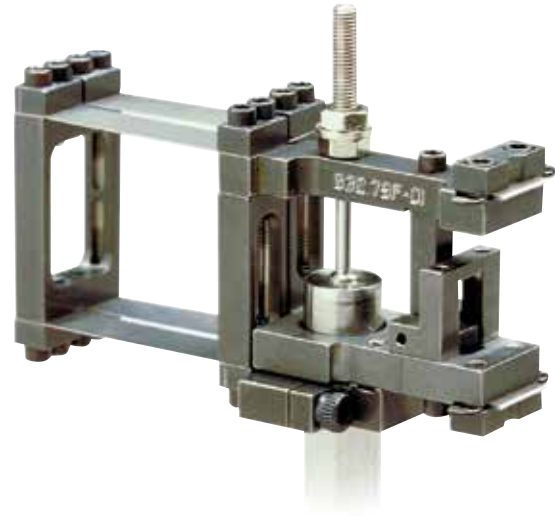

Metric Units

Model	Gage Length	Measuring Range (% Strain)	Height	Length	Temperature Range Min/Max*	Activation Force	Part Number
632.79F-01	25 mm	±20%	76 mm	69.1 mm	-15°C to 85°C	60 g	050-855-602

US Customary Units

Model	Gage Length	Measuring Range (% Strain)	Height	Length	Temperature Range Min/Max*	Activation Force	Part Number
632.79E-01	1 in	±20%	3.0 in	2.7 in	4°F to 185°F	60 g	050-855-601

MTS Advantage™ Optical Extensometer (AOX)

As simple to use as a traditional contacting extensometer, the MTS Advantage™ Optical Extensometer (AOX) also provides all the precision and productivity advantages of a non-contacting strain measurement solution. Whether you are measuring QC tensile strength, long-term fatigue or crack growth, the MTS AOX optics packages can accommodate everything from the fine resolution measurements needed for low modulus ceramic and metallic materials, to the high-elongation requirements (>1000% strain) for viscoelastic plastic and elastomer materials. The MTS AOX is also an ideal solution for evaluating challenging specimens, such as those created from foils, fine wires and polymer films.



Advantages of Optical Extensometry

Faster Test Completion

Similar to a contacting extensometer, once the MTS AOX is set up, it is always measuring. This capability saves time, especially when running repetitive tests. Other productivity enhancements include:

- » **Faster Throughput:** Instant Reset feature auto-starts strain measurement for the next specimen, increasing productivity for repetitive QC testing
- » **Real-time Digital Output:** High-speed data stream with software tools for control and status
- » **No Post-processing Required:** Even when using the highest data rates, all data is sent directly to your test system.

Improved Accuracy

From pre-test calibration and alignment to reliable measurement, the MTS AOX provides the accuracy you require:

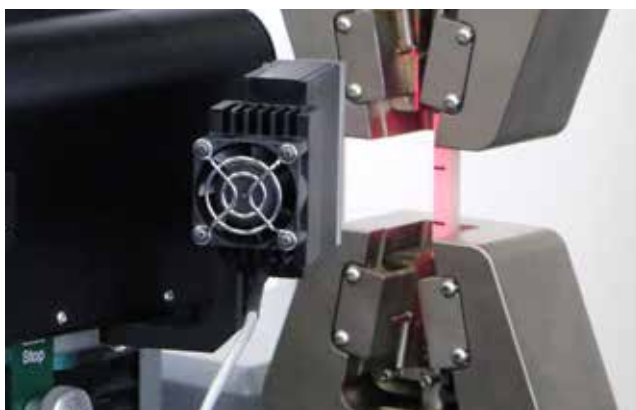

- » **A2LA Accredited Factory Calibration:** Fully calibrated using comprehensive processes to correct for scaling, skew, lens distortion, and uneven lighting
- » **Laser-Assist Alignment System:** Provides an instant visual check for specimen alignment and optics positioning
- » **Retractable, High-stiffness Mounting:** Maintains maximum dynamic range and vibration avoidance
- » **Reliable, Automatic Mark Detection:** Accurate tracking of bright or dark marks beyond 1000% strain and speeds >1500 mm/second
- » **Precision Telecentric Lens Option:** Helps compensate for out-of-plane measurement errors
- » **Robust Strain Control:** Built-in high-speed 16-bit analog output; not susceptible to unpredictable cyclic bias errors.

Simple Set-up & Operation

The MTS AOX runs on the test system computer and therefore does not require an additional computer and monitor. Other ways this extensometer simplifies testing:

- » **No Grids or Bars Required for Pre-test Calibration:** Can start your test sooner
- » **Multi-line Specimen Marking:** Optional methods automatically identify and report the region of highest strain concentration, in real-time
- » **Wide Range of Filter and Optical Settings:** Easily optimize performance for many different materials and specimens

Precision Telecentric Lens Packages

AOX PT lens systems are recommended for precision strain measurements (used for material strains <10%, normally metals, composites, etc.)

Precision Telecentric Lens Systems			Typical Gage Lengths vs Maximum Strain/Travel		
Model Number	Field-of-View (FOV)	Working Distance (WD)	Gage Length	Max Strain	Max Elongation
AOX-52PT-System	52 mm	150 mm	10 mm	320%	32 mm
			12 mm	250%	30 mm
			20 mm	110%	22 mm
			25 mm	65%	17 mm
			30 mm	40%	12 mm
40 mm	5%	2 mm			
Model Number	Field-of-View (FOV)	Working Distance (WD)	Gage Length	Max Strain	Max Elongation
AOX-78PT-System	78 mm	200 mm	10 mm	580%	58 mm
			12 mm	470%	56 mm
			20 mm	240%	48 mm
			25 mm	170%	43 mm
			50 mm	35%	18 mm
65 mm	5%	3 mm			
Model Number	Field-of-View (FOV)	Working Distance (WD)	Gage Length	Max Strain	Max Elongation
AOX-130PT-System	130 mm	210 mm	10 mm	≥1000%	110 mm
			12 mm	900%	108 mm
			25 mm	380%	95 mm
			50 mm	140%	70 mm
			75 mm	60%	45 mm
100 mm	20%	20 mm			

Conventional Entocentric Lens Packages

AOX CE lens systems are recommended for higher strain measurements (used for material strains >10%, normally plastics, elastomers, etc.)

Conventional Entocentric Lens Systems			Typical Gage Lengths vs Maximum Strain/Travel		
Model Number	Field-of-View (FOV)	Working Distance (WD)	Gage Length	Max Strain	Max Elongation
AOX-200CE-System	200 mm	220 mm	10 mm	>1000%	180 mm
			25 mm	660%	165 mm
			50 mm	280%	140 mm
			75 mm	150%	115 mm
			100 mm	90%	90 mm
			150 mm	25%	40 mm
180 mm	5%	10 mm			
Model Number	Field-of-View (FOV)	Working Distance (WD)	Gage Length	Max Strain	Max Elongation
AOX-250CE-System	250 mm	280 mm	10 mm	>1000%	230 mm
			25 mm	860%	215 mm
			50 mm	380%	190 mm
			75 mm	220%	165 mm
			100 mm	140%	140 mm
			150 mm	60%	90 mm
200 mm	20%	40 mm			
Model Number	Field-of-View (FOV)	Working Distance (WD)	Gage Length	Max Strain	Max Elongation
AOX-500CE-System	500 mm	270 mm	10 mm	≥1000%	480 mm
			25 mm	≥1000%	465 mm
			50 mm	880%	440 mm
			100 mm	390%	390 mm
			200 mm	145%	290 mm
			300 mm	63%	190 mm
400 mm	23%	90 mm			

» The MTS AOX will work with any gage length that is within the range for the lens options that are listed above.

» The maximum strain values are approximate and include a margin of 5-10 mm to provide for reasonable ease-of-use.

» A gage length of 4 times (or more) of the specimen width or diameter is recommended for most applications.

* Additional Working Distance and Field-of-View options are available.

MTS Advantage™ Video Extensometer (AVX)

The MTS Advantage Video Extensometer delivers the flexibility, accuracy and repeatability needed in applications where it is difficult to measure strain using conventional means. This extensometer combines several features that make it an outstanding choice to measure strain, rotation and displacement of plastics, metals, composites and high-elongation materials.

- » Magnetic-return support arm for easy specimen access and precise positioning
- » Sixteen quick-attach measurement heads supporting a wide array of gage lengths and strain ranges
- » Pass/fail calibration verification blocks and software calibration wizard to confirm setup to desired ASTM E83 or ISO 9513 class
- » Mounting options on left, right, front or back of load frame

Advantages of Video Extensometry

- » Measures samples through failure without the risk of damage to your extensometer
- » Perfect for fragile, brittle or irregularly shaped specimens
- » Allows up to 200 measurements in real-time
- » Allows repeatable measurements to be made after the physical test is complete
- » Ideal option for measuring in high-temperature or submerged

User-friendly Software Enables Quick Measurements

- » Drag and drop a full selection of measurement devices onto your specimen
- » Select from 10 different measurement devices to determine position, displacement, distance or rotation
- » Virtual strain measurement devices convert motion into axial strain, dual average strain, Poisson's ratio, shear strain and 2D strain maps
- » Understand results quickly with intuitive graphical displays
- » Ethernet communication between systems sends ± 10 V signals to the MTS TestSuite TW software



Upgrade to 2D Digital Image Correlation (DIC)

- » Create planar strain maps with real-time measurements
- » Output 2D contour plots where color gradients show levels of strain
- » Define the x-axis and show E_{xx} , E_{yy} or E_{xy}
- » Identify areas of high stress, crack option or other discontinuities
- » Toggle between all measurement options without reprocessing a test

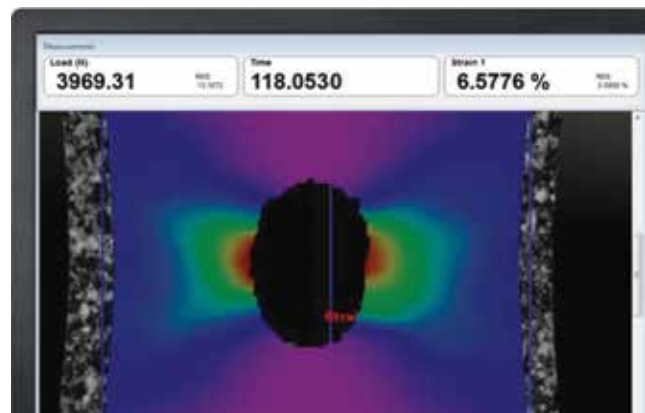

2D Strain Map

Measurement Head Specifications

Each AVX Measurement Head includes an inspected, traceable validation block, which can be used to confirm calibration at the beginning of a series of tests. Validation blocks are serialized and include an ISO 17025 Accreditation Calibration Report.

XT-100 Series Measurement Heads

Ideal for determining higher strain (>10%) materials properties such as yield point & elongation, and for long gage lengths. All models are capable of meeting Class B-2 (ASTM E-83) & Class 0.5 (ISO 9513) at the specified gage lengths and strain ranges (>10%). They are also capable of meeting Class B-1 (ASTM E-83) over most of their operating range (gage lengths where maximum axial tensile strain less than 600%).

The XT-100 series operate at measurement rates from 0.1 - 500 Hz.



AVX Measurement Head	Maximum Axial Tensile Strain Range (%) at Specified Gage Length (mm) ¹					Maximum Axial Compressive Strain Range (%) at Specified Gage Length (mm) ¹					Maximum Transverse Gage Length (mm) ²	Typical Extension Resolution (μm) ³	Minimum Specimen Width for Measurements (mm) ⁴		Maximum Tracking Speed (mm /min) ²	Field of View (mm)
	10	25	50	100	200	10	25	50	100	200			Axial	Transverse		
XT-101	280	70	-	-	-	40	40	-	-	-	10	0.3	1.5	4	1350	57 x 16
XT-102	530	170	50	-	-	40	40	40	-	-	19	0.4	2.4	7	2100	98 x 27
XT-103	840	300	120	25	-	-	40	40	40	-	29	0.6	3.4	10	3200	150 x 42
XT-104	1000	460	200	65	-	-	40	40	40	-	43	0.9	5	14	4600	220 x 62
XT-105	-	800	360	150	40	-	-	40	40	40	70	1.4	8	23	7200	350 x 100
XT-106	-	1000	500	220	70	-	-	40	40	40	65	1.8	11	30	9400	460 x 100
XT-107	-	-	800	360	150	-	-	-	40	40	-	2.8	16	-	14000	700 x 100

1. Strain ranges assume a distance between the grips of twice the GL, with a centrally positioned gage. Actual strain ranges may be greater or less than these values, depending on gage positioning, grip separation and specimen behavior.

2. Maximum transverse GL and tracking speed is quoted at a measurement rate of 100 Hz.

3. Resolution is based on typical lab performance.

4. For Class B-1, minimum specimen width for transverse gage lengths should be increased by 65%.

Note: Working distance is 480 mm.

XT-200 Series Measurement Heads

Ideal for determining low strain materials properties (from 0.01%), such as tensile & compressive modulus, Poisson's ratio & R-value. All models are capable of meeting Class B-1 (ASTM E-83) & Class 0.5 (ISO 9513) at the specified gage lengths and strain ranges.

The XT-200 series are our highest accuracy measurement heads. These models operate at measurement rates from 0.1 - 30 Hz.

The XT-250 series are suitable for many high accuracy dynamic applications, and operate at measurement rates from 0.1 - 500 Hz.



AVX Measurement Head	Maximum Axial Tensile Strain Range (%) at Specified Gage Length (mm) ¹			Maximum Axial Compressive Strain Range (%) at Specified Gage Length (mm) ¹			Maximum Transverse Gage Length (mm) ²	Typical Extension Resolution (μm) ³	Minimum Specimen Width for Measurements (mm)		Maximum Tracking Speed (mm /min) ²	Field of View (mm)
	10	25	50	10	25	50			Axial	Transverse		
XT-204	300	80	10	40	40	25	45	0.18	1.0	4.6	250	61 x 51
XT-205	460	145	40	40	40	40	63	0.25	1.4	6.4	350	86 x 72
XT-254	390	120	25	40	40	40	15	0.3	1.7	8	1900	76 x 21
XT-255	580	190	65	40	40	40	21	0.4	2.4	11	2600	107 x 30

1. Specified strain ranges assume a distance between the grips of twice the GL, with a centrally positioned gage. Actual strain ranges may be greater or less than these values, depending on gage positioning, grip separation and specimen behavior.

2. Maximum transverse GL and tracking speed is quoted at a measurement rate of 15Hz (XT-20x series) and 100 Hz (XT-25x series).

3. Resolution based on typical lab performance.

Note: Working distance is 273 mm and is subject to +/- 5% tolerance.

Laser Extensometers

MTS offers the LX 500 Extensometer. This high performance device is completely self-contained, easily transportable, and easy to use with its digital display and four-button keypad. It can be operated from the rear control panel or remotely via the RS-232 interface. The unique scanning laser beam technique, used to measure elongation entirely from one side of the specimen, eliminates the need for a separate receiver mounted on the opposite side of the specimen.

FEATURES

- » Selectable averaging of 2 to 512 scans
- » Measures the initial gage length of the specimen directly
- » Can measure strain simultaneously over three segments within the specimen's gage length
- » Meets ASTM B1 extensometer classification (25 mm/1 in and longer gage length)
- » Measurements are updated 100 times per second.
- » Analog output port for closed loop strain control or for input to a data acquisition board, chart recorder, and so forth
- » Parallel beam design accommodates operation through chamber glass, a clear bath, water, and so forth
- » Certified for compliance with the Center for Devices and Radiological Health as a Class II product



Model	Maximum Travel	Resolution	Non-Linearity Maximum	Repeatability	Analog Output	Part numbers* 115V±10%	Part numbers* 230V±10%
LX 500	8-127 mm (0.3-5.0 in)	0.001 mm (0.0001 in)	±0.025 mm (±0.001 in)	±0.003 mm (±0.0001 in)	16 bit selectable range, ±10 V full scale	055-283-101	055-283-102

*Includes tripod, mounting plates, instruction manual, line cord, and tripod head.

Accessories	Measurement	Part numbers
Retroreflective Tape	3.2 mm x 7.6 mm (1/8 in x 25 ft)	100-039-188
Retroreflective Tape	6.4 mm x 7.6 mm (1/4 in x 25 ft)	100-039-189
Retroreflective Tape, Submersible (water)	3.2 mm x 7.6 mm (1/8 in x 25 ft)	100-214-873
Retroreflective Target, High Temp. (900°F), Non-adhesive	2.5 mm x 76.2 mm (0.1 in x 3 in)	100-039-190
Laser Cart, Vertical Adjustment	913 mm x 1556 mm (36 in x 61 in)	100-165-138

Other Applications

With over 101 different models, MTS has the largest offering of extensometers in the world. In fact, here's a list of some of our other models that you won't find in this catalog. Contact us if you're interested in any of these capabilities!

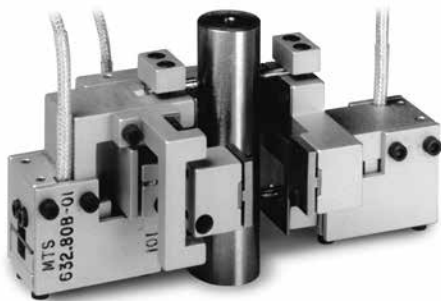

Model 632.80 for Ambient Axial Torsional Measurement

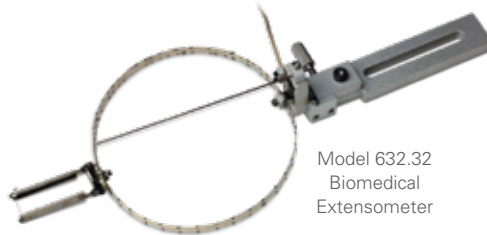

Model 632.32 Biomedical Extensometer



Model 632.06H-94 Metal Formability Extensometer



Model 632.57 with Mounting Bracket

BIOMEDICAL SOFT TISSUE OR SIMILAR MATERIAL (MODEL 632.32)

Ultra-low contact force with serrated knife edges.

HIGH-TEMPERATURE AXIAL APPLICATIONS (MODELS 632.50/.51/.53/.54/.57)

Many options available. Air-cooled, water-cooled, vacuum, and temperatures to 1600°C (2900°F).

HIGH-TEMPERATURE DIAMETRAL/TRANSVERSE APPLICATIONS (MODELS 632.60/61)

Standard models to 1000°C (2200°F).

HIGH-TEMPERATURE AXIAL TORSIONAL APPLICATIONS (MODELS 632.68 AND 632.80)

Simultaneous measurement of axial and torsional strain. The Model 632.80 has a temperature range of -100°C to 150°C (-150°F to 300°F), while the high-temperature version Model 632.68 is rated up to 1200°C (2200°F).

AXIAL ROCK MECHANICS APPLICATION (MODEL 632.90)

Models available for use in air, or in high pressure, single measurement, and averaged axial applications.

CIRCUMFERENTIAL APPLICATION (MODEL 632.92)

Unique roller chain design provides low hysteresis.



Model 632.92H-05 Extensometer on Marble Core Specimen

Clip-On Displacement Gages

- » Double cantilever displacement-type gages are primarily used in fracture mechanics testing, K_{IC} , J_{IC} , crack growth and R-curve determination
- » Useful for measuring the displacements of components and specimens with odd geometries, performing elongation studies, and testing pipes, bars and rods
- » Compatible with a variety of specimens including compact tension, WOL, round compact tension, C-shaped, bend, and other common specimens or panels
- » Can be immersed in a wide variety of non-conductive fluids without special precautions
- » Model 632.02 Clip-On gages when testing to ASTM E399
- » Model 632.03 Clip-On Gages are our most accurate featuring improved slot geometry and three-point contact knife edges. Options are available with longer travel for J-integral and crack growth tests
- » Replacement knife edges available upon request
- » Additional models available, contact your sales representative for more options

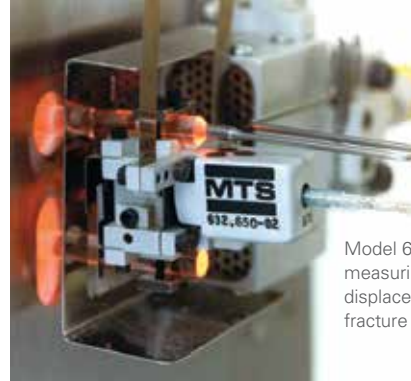

Model 632.65 is ideal for measuring crack opening displacement for hot fracture mechanics testing.

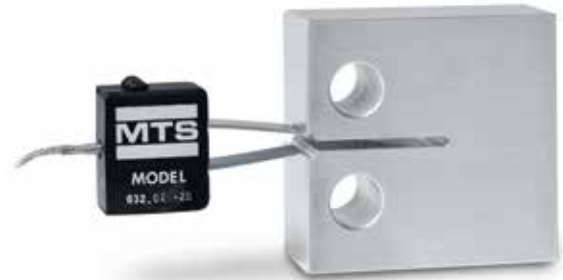

Standard equipment includes the gage and storage case, two reusable hardened knife edges for attachment to the specimen, and an instruction manual.



Pictured are 632.02 and 632.03/05 Clip-On Gage knife edges.

Metric Units

Model/Opt	Gage Length	Travel	Maximum Frequency	Compressed Force	Height/Length	Temperature Min/Max	Part Number
632.02F-2x	5 mm	+3 / -1 mm	50 Hz	2500 g	30.5 / 48.3 mm		
632.02F-20						-100°C / 150°C	047-400-104
632.03-2x	12 mm	4 mm	100 Hz	2500 g			
632.03F-20						-100°C / 150°C	047-400-204
632.03-3X							
Option 001	2 mm	4 mm				-100°C / 150°C	047-400-310
Option 002	2.5 mm	4 mm				-100°C / 150°C	047-400-311
632.65E-03	15.24 mm	+10 / -1.0 mm	10 Hz	200 g		1000°C max	

US Customary Units

Model/Opt	Gage Length	Travel	Maximum Frequency	Compressed Force	Height/Length	Temperature Min/Max	Part Number
632.02E-2x / --	0.2000 in	+0.100 / -0.05 in	50 Hz	2500 g	1.2 / 1.9 in		
632.02E-20						-150°F / 300°F	047-400-101
632.03E-20	0.475 in	0.15 in	100 Hz	2500 g			
						-150°F / 300°F	047-400-201
632.03E-3X							
Option 001	0.075 in	0.15 in				-150°F / 300°F	047-400-301
Option 002	0.10 in	0.15 in				-150°F / 300°F	047-400-302
632.65E-03	.600 in	+0.400 / -0.040 in	10 Hz	200 g		1800°F max	

Displacement Gages

- » Versatile design measures specimens, fixtures, shafts, or the movement of any other component during a test
- » Designed for use where small deformations must be measured such as bend tests or tests with unusual geometries
- » Over-travel protection included:
 - Gage arm releases if it travels too far or when a side load is applied.
 - Gage arm can be reset without changing the body position
- » Comes with an adjustable mounting block
- » Displacement measurements can be made with the gage in contact against a specimen or an active component in the force train



Model/Opt	Travel	Zero Adjust	Force At Zero	Height	Length	Temperature Range Min/Max	Part Number
632.06H-2x / --	±4 mm (±0.16 in)	8 mm (0.30 in)	150 g	101 mm (4 in)	101 mm (4 in)	-100°C / 150°C (-150°F / 300°F)	047-400-501
632.06H-20						-100°C / 175°C (-150°F / 350°F)	047-400-503
632.06H-23						-100°C / 150°C (-150°F / 300°F)	047-400-504
632.06H-3x/ 001	±2 mm (±0.08 in)	8 mm (0.30 in)	150 g	101 mm (4 in)	101 mm (4 in)	-100°C / 175°C (-150°F / 350°F)	047-400-506
632.06H-30						-100°C / 150°C (-150°F / 300°F)	047-400-507
632.06H-33						-100°C / 175°C (-150°F / 350°F)	047-400-510
632.06H-3x/ 002	±1 mm (±0.04 in)	8 mm (0.30 in)	250 g	101 mm (4 in)	69 mm (2.7 in)	-100°C / 150°C (-150°F / 300°F)	047-400-512
632.06H-30						-100°C / 175°C (-150°F / 350°F)	047-400-513
632.06H-3x/ 003	±6 mm (±0.25 in)	8 mm (0.30 in)	150 g	101 mm (4 in)	101 mm (4 in)	-100°C / 150°C (-150°F / 300°F)	047-400-516
632.06H-30						-100°C / 175°C (-150°F / 350°F)	047-400-517
632.06H-3x/ 004	±8 mm (±0.32 in)	8 mm (0.30 in)	100 g	101 mm (4 in)	140 mm (5.5 in)	-100°C / 150°C (-150°F / 300°F)	047-400-518
632.06H-30						-100°C / 175°C (-150°F / 350°F)	047-400-519
632.06H-3x/ 005	±12.5 mm (±0.50 in)	8 mm (0.30 in)	80 g	101 mm (4 in)	190 mm (7.5 in)	-100°C / 150°C (-150°F / 300°F)	047-400-520
632.06H-30						-270°C / 65°C (-452°F / 150°F)	047-400-516
632.06H-31						-100°C / 175°C (-150°F / 350°F)	047-400-517
632.06H-33						-100°C / 175°C (-150°F / 350°F)	047-400-518
632.06H-3x/ 006	±25 mm (±0.50 in)	8 mm (0.30 in)	35 g	101 mm (4 in)	343 mm (13.5 in)	-100°C / 150°C (-150°F / 300°F)	047-400-519
632.06H-30						-270°C / 65°C (-452°F / 150°F)	047-400-520
632.06H-31							

Extensometer Calibrator



Model 650.03 Extensometer Calibrator with axial setup

Model 650.03

The MTS Model 650.03 Extensometer Calibrator is a precise instrument designed and built for rugged, long-lasting durability. It gives you freedom from wear; vital for the high accuracy required for precise calibrator verification of high resolution instruments.

The micrometer head has a spindle with a large diameter lead screw to reduce wear and resulting backlash and to provide higher strength and stiffness. Larger mounting diameters reduce the unit stress required in

mounting the micrometer head to the frame. The micrometer head is large for easy readability, accurate adjustment, and improved repeatability of gage calibration.

1. Standard Axial includes Extensometer models 632.11/12/13/24/25/26/27/31, 634.11/12/25/31 set-up with straight knife edges and attachment for round specimens. Some specific knife edges or attachment kits may require other sizes of specimen adapters. The installation drawing for the extensometer will identify the specimen size range.

2. Standard High Temperature Axial includes 632.53/54 with standard length rods, 632.50/51 with length options 075, 076, 077,078, 079 and 080. Calibration require rods with either conical point (with Dimpled Specimen) or V-chisel rod end geometry (with optional 9.5 mm round).

Extensometer model	632.02	632.03/05	Standard Axial (1)	Extended GL Axial	632.06	632.06 Option 006	632.18/.19/.20	632.29	632.17/.85 Axial	632.85 Transverse	Standard Hi Temp Axial (2)	632.92, 632.11 OR .12 w/ 632.21 Kit
--------------------	--------	-----------	--------------------	-------------------	--------	-------------------	----------------	--------	------------------	-------------------	----------------------------	-------------------------------------

650.03 Calibrator frame in fitted case	031-508-302	Required for all										
Micrometer head, U.S. customary (0.00005 in graduation)	031-508-205	Required for all, choose one										
Micrometer head, Metric (0.001 mm graduation)	031-508-206	Required for all, choose one										

CALIBRATOR KITS

Calibrator Kit, Basic Specimen Adapters	100-049-249	•	•	opt					•	•		•
Calibrator Kit, Model 632.03/.05 Knife Edges	100-049-250		•									
Calibrator Kit, Model 632.02 Knife Edges	100-049-251	•										
Calibrator Kit, Standard, 12.7 mm (0.50 in), Round Spec.	100-049-270		•	•								
Calibrator Kit, Frame Invert	100-049-252			•	•	•						•
Calibrator Kit, Extended, 12.7 mm (0.50 in), Round Spec.	100-049-253			•								
Calibrator Kit, Dimpled, 9.5 mm (0.375 in) Round Spec.	100-054-156											•
Calibrator Kit, 9.5 mm (0.375 in) Round Specimen	100-049-255			opt						opt		
Calibrator Kit, 3.2 mm (0.125 in) Round Specimen	100-049-256			opt				•				
Calibrator Kit, Mounting Bracket for Model 632.53/.54	100-054-133										•	
Calibrator Kit, Model 632.18/.19/.20 Diametral Extensometers	100-049-258						•					
Calibrator Kit, Displacement Gages	100-049-259				•	•						
Calibrator Kit, Model 632.06 Option 006 Adapter	100-054-796					•						
Calibrator Kit, Model 632.17/.85 Axial	100-049-260								•			
Calibrator Kit, Model 632.85 Transverse	100-049-261									•		
Calibrator Kit, Model 632.92/.21 Circumferential	100-049-262											•

Find the model of the extensometer, then follow the column down to determine the kit(s) required to calibrate the extensometer.

MTS Direct Current Potential Drop (DCPD) Solution

Integrated Software & Hardware Package Allowing Accurate and Efficient Measurement of Fatigue Crack Growth

Direct Current Potential Drop (DCPD) measures the change in resistance of a specimen, which correlates directly with crack growth. It is an effective way to collect fatigue crack growth data in high-temperature tests and other challenging environments. DCPD is used to overcome the challenges that make contact extensometry and compliance calculations impractical for crack length measurement. Unfortunately, to get the best results, some DCPD solutions require excessive set-up time while others limit flexibility.

The MTS DCPD Solution features integrated software and hardware for test control, data analysis, and results reporting. It greatly simplifies DCPD test configuration using the powerful automation tools built into MTS TestSuite software. Integrated into MTS FlexTest 40 Controllers and MTS TestSuite Software, the MTS DCPD solution eliminates the challenges that can arise with non-integrated components from multiple suppliers. This provides a convenient and comprehensive way to incorporate DCPD into your material testing programs.

This solution uses the reversing DCPD method. By monitoring load and potential (voltage) data from a loaded specimen and a reference specimen, it determines crack length by calculating ratios of potential on both. Applying a calibration equation to the ratios produces the crack length. The current is switched on and off (reversed) to correct for thermocouple effects.

Comprehensive DCPD Solution

This solution offers a comprehensive approach for adding DCPD to your materials testing program. It includes the software and hardware required for integrated DCPD test development and execution. The MTS DCPD Testing Solution includes:

- » High-fidelity MTS DCPD Measurement System (2- or 7-channel configuration)
- » Modular Preamplifier(s)
- » MTS TestSuite DCPD Module supports 2-channel DCPD system (includes all test templates, report templates and calculations for ASTM-compliant fatigue crack growth assessments). Support for DCPD systems greater than 2 channels is available upon request
- » Includes MTS TestSuite Multipurpose Analyzer for automated or manual analysis
- » Required software (not included): MPE or MPX and Microsoft Excel 2016 or newer to view reports



- » Recommended software: MTS Reporter to create or edit reports post-test and to create or edit report templates
- » Setup specimen kit for verifying hardware setup and test configuration
- » Setup, installation and equipment verification by MTS
- » Additional training, consulting and template modifications are available.

KEY FEATURES

- » Compatible with MTS Series 318 and MTS Landmark® test systems for electrical isolation
- » Integrates with MTS FlexTest Controller (Model 40) and MTS TestSuite Software
- » Designed for low noise
- » Modular Preamplifier maintains signal integrity
- » Compliant to CE, CSA and NRTL
- » Available with advanced consultation, template changes and training.

Overall

Current:	Adjustable 0 - 20 Amps DC Maximum
Voltage:	5 Volts DC Maximum
Gain:	x 5,000 or x 50,000
Gain Accuracy:	0.5% Typical, 2% Maximum
Filter:	50 Hz and 300 Hz
Bandwidth:	300 Hz Maximum
Output:	±10 Volts DC

Main Chassis

Gain:	1x or 10x
-------	-----------

Preamp

Gain:	5,000x
-------	--------

GRIPS & FIXTURES

For every material test – from basic tensile or fracture mechanics to ultra high temperature – MTS offers the best specimen test interface option. From fixtures designed to accommodate extensometers to compression platens for rock mechanics, our grips and fixtures will meet your testing needs.

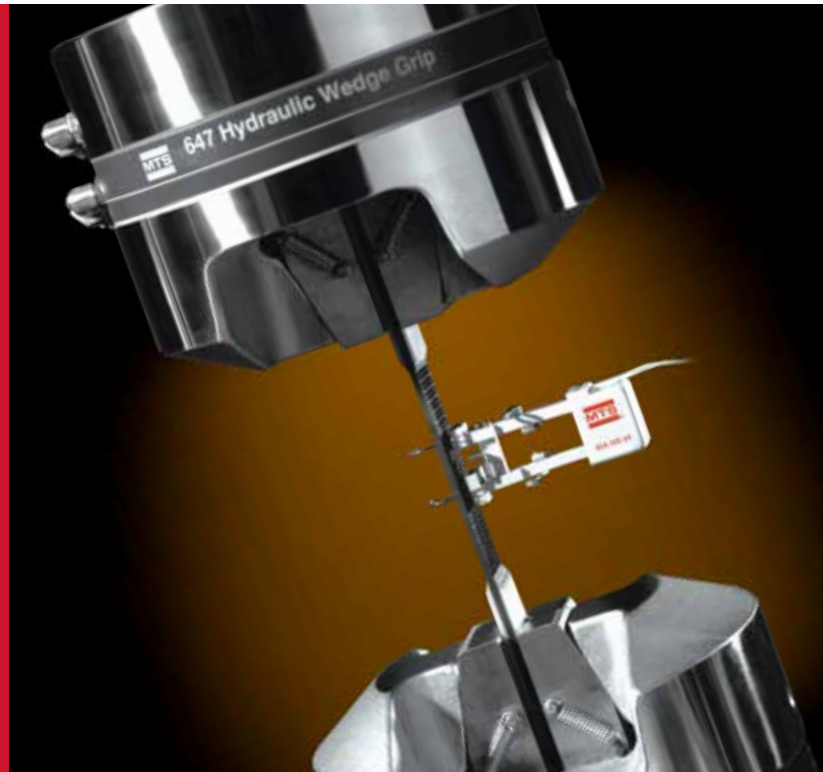

Grips & Fixtures

Introduction	80-81
Polymer Matrix Composites Fixtures Index	82
Servohydraulic Grips & Fixtures	83-99
Monotonic Grips	100-132
MTS Fundamental™ Grips & Fixtures	133
Bionix® Grips	134-138
Bionix EnviroBath	139-140
Composites Fixtures	141-147

MTS Grips

Durable and Versatile

When it comes to grips, MTS offers the best in the business. Our Series 647 Hydraulic Wedge Grips, for example, set the standard for ease-of-use, accuracy, and repeatability. We offer grips designed for specialized applications such as high-temperature, low-cycle fatigue and fracture testing.

For electrodynamic systems, MTS has an expanding selection of grips designed to meet typical application requirements, supplementing the existing low force offering.

Three categories of electromechanical accessories are available to help you match your application needs, whether it be demanding R&D testing of advanced composites and alloys; standard testing of plastics, textiles, and other materials; or complex testing for the medical markets. For a broader selection of electromechanical grips, please refer to the "Accessories for MTS Criterion System" or "Accessories for MTS Exceed" catalogs.

Whether you need a 10 N manual grip or a 2500 kN hydraulic grip, we've got it all.

Available options for most MTS grips include:

- » Choice of gripping surfaces
- » Mounting hardware
- » Water cooling kits (hydraulic grips)
- » Alignment fixtures, software, and strain-gaged specimens to assure proper load train alignment.

A small sampling of specimens that MTS grips can accommodate. MTS grips are precise and repeatable, ensuring that your specimen is held in the same manner each time.



Fixtures

MTS fixtures often go beyond the industry standard design to make them easier to use, more durable, and to provide you with more precise test data. Some can be modified to accommodate special measurement devices such as extensometers. Others may be constructed out of special materials to withstand higher temperatures, corrosive environments, or simply to provide longer life.

Can't find what you need?

We offer many more grips and fixtures. Contact your local sales representative or applications engineer to find the model that meets your exact needs.

Polymer Matrix Composites Fixtures Application Index

A Comprehensive Array of Polymer Matrix Composites / Fibre Reinforced Plastics Accessories

MTS complements its electromechanical and servohydraulic testing lines with a comprehensive array of accessories to fulfill a full spectrum of polymer matrix composite material testing – from basic quality control, to demanding research and development applications.

CAN'T FIND WHAT YOU NEED?

We offer many more grips and fixtures. We can offer higher temperature version of many of the fixtures. Contact your local sales representative to find the model that meets your exact needs.

	Application	Test Standard	Fixture Option	See Page
Laminae & Laminate	Tensile	ISO 527-4 & 5, ASTM D3039, EN 2561, EN 2597	Model 647 Side-Loading Hydraulic Wedge Grip	83
			MTS Advantage Wedge Action Grips	112
	Compression	ISO 14126 Method 1A ISO 14126 Method 1B ASTM D3410 ASTM D6641	Modified Celanese Compression Loading Fixture	141
			IITRI Compression Loading Fixture	141
			Combined Loading Compression (CLC) Test Fixture	142
	Flexure	ISO 14125	Model 642.01 3- & 4-Point Bend Fixture with Roller Assembly Size 10 mm Diameter	92
			Model WA204A 3-Point Plastic Bend Fixture with Loading Edge R5 Supporting R2 or R5	132
		ASTM D7264	Model 642.01 or 642.10 3- & 4-Point Bend Fixture with Roller Assembly Size 10 mm Diameter	92
			Model WA204A 3-Point Plastic Bend Fixture with Loading Edge & Supporting R5	132
		EN 2562	Model 642.10 3- & 4-Point Bend Fixture with Roller Assembly Size 25 mm (loading) & 10 mm (support) Diameter	92
		EN 2746	Model 642.01 3- & 4-Point Bend Fixture with Roller Assembly Size 10 mm (loading) & 4 mm (support) Diameter	92
			Model WA204A 3-Point Plastic Bend Fixture with Loading Edge R5 Supporting R2	132
		Shear	ISO 14129, ASTM D3518 ASTM D5379 ASTM D7078	Model 647 Side-Loading Hydraulic Wedge Grips
	MTS Advantage Wedge Action Grips			112
	V-Notched Beam (Iosipescu) Shear Fixture			143
	V-Notched Rail Shear Test Fixture			142
	Interlaminar Shear	ISO 14130 ASTM D2344 EN 2377	Short Beam Shear and Three-Point Flexure Fixture	143
			Model WA204A with Loading Edge R5 Supporting R2	132
			Short Beam Shear and Three-Point Flexure Fixture	143
Model WA204A with Loading Edge R5 Supporting R2			132	
Fracture Mechanics	ASTM D6671	Mixed Mode Bending Fixture	144	
Fatigue (tension / tension)	ISO 13003, ASTM D3479	Model 647 Side-Loading Hydraulic Wedge Grip	83	
Structural	Tension (open & filled hole)	ASTM D5766, ASTM D6742, ASTM D7615	Model 647 Side-Loading Hydraulic Wedge Grip	83
	Compression (open & filled hole)	ASTM D6484, ASTM 6742, BS 07260, ASTM D7615	Open / Filled Hole Compression Fixture	144
	Compression After Impact	ASTM D7137	Compression After Impact Test Fixture	145
Sandwich Structures	Tension	ASTM C273, ASTM C394	Flatwise Plane Shear Fixture, Tensile Mode	145
	Compression	ASTM C273, ASTM C394	Flatwise Plane Shear Fixture, Compression Mode	146
	Flexure / Shear	ASTM D5467, ASTM C393, ASTM D7249, ASTM D7250	Three- & Four-Point Sandwich Beam Flexure / Shear Fixture	147
Adhesives	Peel	ASTM D1781	Climbing Drum Peel Fixture	146

Multipurpose, Side Loading Hydraulic Wedge Grips

The MTS Series 647 Hydraulic Wedge Grips are versatile, easy-to-load grips for a wide range of tensile and fatigue applications. The symmetrical housing design ensures an even specimen loading across the entire face of the wedge. The lateral movement of the wedges won't change the gripping position on the specimen once the grips are activated.

Features

- » These grips clamp onto your specimen in the same position, test after test, to minimize the bending strains that can invalidate your test results
- » Tension and fatigue capability
- » Adjustable pressure allows these grips to be used for testing a variety of materials
- » A wide variety of wedges are available to meet your requirements
- » Side loading capability for easy specimen insertion.

Four Versions of the 647 Family

- » Axial – This model has all of the standard features described above
- » Aluminum – The 647.02 (Axial model only) grip housings are made of aluminum. This lightweight design provides excellent response in high frequency applications and makes them ideal for tabletop use. It weighs only 7 kg (15 lb)
- » Axial-Torsional – This capability is available in three capacity ranges
- » All Temperature – These models allow for temperatures to 540°C (1000°F). Contact MTS for additional information.

For use on non-hydraulic load frames or for high temperature applications below -7°C (20°F) or above +66°C (+150°F), see our hydraulic grip supplies on pages 96-97.

All grips are sold as pairs.

All wedges and attachment kits are sold separately.



TECH NOTE

Attachment Kits

The term "attachment kit" can refer to any of the hardware required to connect your grips to your system. This is an important item to remember since the attachment kits are generally sold separately. With a "matched" system (the load frame, load cell, and actuator all have the same capacity rating, like 100 kN), a basic attachment kit is required. This can consist of either spiral washers and a mounting stud, a cap screw, or pin and clevis depending on the specific grip and load frame. Inserts or loading washers may be required if there are variances from a matched system. If you have questions, please contact MTS for assistance with defining the correct attachment kit.

Multipurpose, Side Loading Hydraulic Wedge Grips

Axial Model 647 Grip Specifications

Model	Dynamic Force	Static Force	Pressure	Temperature* Min/Max	Overall Height
647.02B	25 kN (5.5 kip)	31 kN (7 kip)	20 MPa (3,000 psi)	-40°C/177°C (-40°F/350°F)	131 mm (5.2 in)
647.10A	100 kN (22 kip)	120 kN (27 kip)	20 MPa (3,000 psi)	-40°C/177°C (-40°F/350°F)	188 mm (7.4 in)
647.25A	250 kN (55 kip)	333 kN (75 kip)	70 MPa (10,000 psi)	-40°C/177°C (-40°F/350°F)	249 mm (9.8 in)
647.50A	500 kN (110 kip)	550 kN (120 kip)	70 MPa (10,000 psi)	-18°C to 65°C (0°F to 150°F)	291 mm (11.5 in)

*Temperatures above 77°C/150°F require a stand-alone grip supply and extension rods.

Model	Diameter	Weight	Metric/US Customary Stud Size	Part Number
647.02B	180 mm (7.1 in)	7 kg (15.4 lb)	M12 x 1.25 (1/2"-20)	056-670-901
647.10A	180 mm (7.1 in)	30 kg (66.1 lb)	M27 x 2 (1"-14)	047-080-605
647.25A	295 mm (11.6 in)	77 kg (170 lb)	M36 x 2 (1 1/2"-12)	047-080-905
647.50A	358 mm (14.1 in)	148 kg (324 lb)	M52 x 2 (2"-12)	047-595-505

Wedges and attachment kits sold separately.



Axial-Torsional Model 647 Grip Specifications

Model	Dynamic Force	Torsional Force	Pressure	Temperature* Min/Max	Overall Height
647.02B-22	25 kN (5.5 kip)	220 N.m (2000 in.lb)	21 MPa (3000 psi)	-40°C/150°C (-40°F/300°F)	135 mm (5.3 in)
647.10A-05	100 kN (22 kip)	550 N.m (5000 in.lb)	21 MPa (3000 psi)	-40°C/121°C (-40°F/250°F)	188 mm (7.4 in)
647.10A-11	100 kN (22 kip)	1,100 N.m (10,000 in.lb)	21 MPa (3000 psi)	-40°C/121°C (-40°F/250°F)	224 mm (8.8 in)
647.25A-22	250 kN (55 kip)	2,200 N.m (20,000 in.lb)	69 MPa (10,000 psi)	-18°C/65°C (0°F/150°F)	343 mm (13.5 in)

*Temperatures above 77°C/150°F require a stand-alone grip supply and extension rods.

Model	Diameter	Weight	Mounting	Part Number
647.02B-22	150 mm (6.0 in)	8 kg (16 lb)	40 mm dia.	100-026-042
647.10A-05	203 mm (8.0 in)	27 kg (60 lb)	M68 x 2 (LH)	049-157-301
647.10A-11	203 mm (8.0 in)	34 kg (75 lb)	M68 x 2 (LH)	049-817-001
647.25A-22	266 mm (10.5 in)	95 kg (210 lb)	M92 x 3 (LH)	056-124-001

Wedges for Series 647 Wedge Grips Offer a Variety of Surfaces

MTS Wedges Come in a Variety of Surfaces to Meet Your Requirements

- » Diamond tip steel – aggressive surface for gripping soft materials (steel, plastic)
- » Sawtooth – designed for increased holding capacity in tension tests
- » Surfalloy – grit incorporated onto the wedge surface for testing brittle samples
- » Serrated – universal surface for soft metals on vee wedges

MTS employs a unique wedge design that significantly reduces the stress concentration on the specimen, enabling even very brittle composites to be gripped securely without grip-induced failure.

MTS 647 Wedges can be ordered with a water-cooled option. These wedges are used with a Water Cooling Kit that is purchased separately.

Model 647 All-Temperature Wedges are available for the all-temperature grips. Contact MTS for additional information.

Water Cooling Kit

There are two versions of the Water Cooling Kit. Both versions include hoses, fittings, metering valves and a manifold that attaches magnetically to your load frame or other flat, steel surface. One version also includes water flow switches. Some MTS products, such as the Model 653 furnace, support integration with the flow switches, enabling protection of the equipment in the event of a water supply failure. Please check with an MTS Applications Engineer to determine if your equipment is compatible with the flow switch protection circuit.

Wedges are sold in matched sets of four.

Models 645.012 and 647.02 Water-Cooled Flats

Surface	Specimen Thickness	Useable Width	Part Number
Diamond tip steel	0-7.1 mm (0-0.28 in)	25 mm (1 in)	052-818-701
Surfalloy	0-7.1 mm (0-0.28 in)	25 mm (1 in)	052-818-702

Insertion depth 38 mm (1.5 in). Temperature Range -130°C (-200°F) to 315°C (600°F).

Models 645.012 and 647.02 Water-Cooled Rounds

Surface	Specimen Diameter	Part Number
Surfalloy	10.0 mm (0.3937 in)	052-818-703

Insertion depth 38 mm (1.5 in). Temperature Range -130°C (-200°F) to 315°C (600°F).

Wedges for Models 645.012 and 647.02B Axial, Axial-Torsional Grips, and 10 kN Advantage Pneumatic Grips

Specifications	
Temperature Range:	-40°C to 177°C (-40°F to 350°F)

The diamond impressions in the specimen provide good gripping without causing failure.

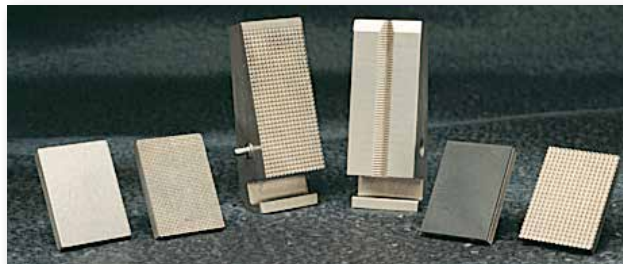

Model 647.02B Flat Specimen Wedges

Surface	Specimen Thickness	Usable Width	Part Number
Sawtooth	0-7.2 mm (0-0.28 in)	25 mm (1 in)	050-507-906
Sawtooth	5.3-12.4 mm (0.21-0.49 in)	25 mm (1 in)	050-507-964
Sawtooth	7.2-14.4 mm (0.28-0.57 in)	25 mm (1 in)	050-507-907
Sawtooth	13.4-20.5 mm (0.53-0.81 in)	25 mm (1 in)	050-507-901
Sawtooth	18.8-25.9 mm (0.74-1.02 in)	25 mm (1 in)	050-507-905
Surfalloy	0-7.2 mm (0-0.28 in)	25 mm (1 in)	050-507-917
Surfalloy	7.2-14.4 mm (0.28-0.57 in)	25 mm (1 in)	050-507-918
Surfalloy	13.4-20.5 mm (0.53-0.81 in)	25 mm (1 in)	050-507-904
Sawtooth	0-7.1 mm (0-0.28 in)	50 mm (2 in)	054-585-001
Sawtooth	7.1-13.4 mm (0.28-0.57 in)	50 mm (2 in)	054-585-002
Sawtooth	13.5-20.5 mm (0.53-0.81 in)	50 mm (2 in)	054-585-003
Sawtooth	16.9-24.0 mm (0.66-0.95 in)	50 mm (2 in)	054-585-004

Insertion depth 38 mm (1.5 in)

Model 647.02B Round Specimen Wedges

Surface	Specimen Diameter	Part Number
Surfalloy	10.0 mm (0.3937 in)	050-507-912
Surfalloy	15.0 mm (0.5906 in)	050-507-913
Surfalloy	25.0 mm (0.9843 in)	050-507-914
Surfalloy	12.7 mm (0.5000 in)	050-507-915
Surfalloy	25.4 (1.0000 in)	050-507-916
Surfalloy	12.0 mm (0.4724 in)	050-507-934
Surfalloy	8.0 mm (0.3149 in)	050-507-935
Surfalloy	20 mm (0.7874 in)	050-507-937
Surfalloy	10.0 mm (0.3937 in)	052-818-703

Insertion depth 38 mm (1.5 in)

Model 647.02B Vee Specimen Wedges

Surface	For Specimen Diameters	
	When Side/Top Loading	
Surface	When Side/Top Loading	Part Number
Diamond tip steel	3.0-8.1/9.4 mm (0.12-0.32/0.37 in)	050-507-908
Diamond tip steel	8.9-10.9/15.2 mm (0.35-0.43/0.60 in)	050-507-909
Diamond tip steel	14.0-18.0/20.8 mm (0.55-0.71/0.82 in)	050-507-910
Diamond tip steel	20.1-22.9/27.2 mm (0.79-0.90/1.07 in)	050-507-911
Diamond tip steel	7.1-7.9/12.7 mm (0.28-0.31/0.50 in)	050-507-965
Diamond tip steel	10.9-13.2/16.5 mm (0.43-0.52/0.65 in)	050-507-966

Insertion depth 38 mm (1.5 in)

Wedges for Model 647.10 for Axial and Axial-Torsional Grips

Model 647.10 Flat Specimen Wedges

Surface	Specimen Thickness	Usable Width	Part Number
Diamond tip steel	0–7.6 mm (0–0.3 in)	44 mm (1.75 in)	041-842-101
Diamond tip steel	7.1–14.2 mm (0.28–0.56 in)	44 mm (1.75 in)	041-842-102
Diamond tip steel	11.7–19.1 mm (0.46–0.75 in)	44 mm (1.75 in)	041-842-109
Wide diamond tip steel	0–7.6 mm (0–0.3 in)	76 mm (3.0 in)	046-198-604
Wide diamond tip steel	7.1–14.2 mm (0.28–0.56 in)	76 mm (3.0 in)	046-198-603
Surfallo	0–7.9 mm (0–0.31 in)	44 mm (1.75 in)	041-842-108
Surfallo	7.1–14.2 mm (0.28–0.56 in)	44 mm (1.75 in)	041-842-111
Surfallo	11.7–19.1 mm (0.46–0.75 in)	44 mm (1.75 in)	041-842-121
Wide surfallo	0–7.6 mm (0–0.3 in)	76 mm (3.0 in)	046-198-602
Wide surfallo	7.1–14.2 mm (0.28–0.56 in)	76 mm (3.0 in)	046-198-601

Insertion depth 63.5 mm (2.5 in)

Water-Cooled Flats	Specimen Thickness	Usable Width	Part Number
Diamond tip steel	0–7.6 mm (0–0.3 in)	44 mm (1.75 in)	046-838-702
Diamond tip steel	7.1–14.2 mm (0.28–0.56 in)	44 mm (1.75 in)	046-838-701
Diamond tip steel	11.7–19.1 mm (0.46–0.75 in)	44 mm (1.75 in)	046-838-713
Surfallo	0–7.6 mm (0–0.3 in)	44 mm (1.75 in)	046-838-705
Surfallo	7.1–14.2 mm (0.28–0.56 in)	44 mm (1.75 in)	046-838-706

Insertion depth 63.5 mm (2.5 in)

Model 647.10 Round Specimen Wedges

Surface	Specimen Diameter	Part Number
Surfallo	12.0 mm (0.4724 in)	041-842-134
Surfallo	15.0 mm (0.5906 in)	041-842-135
Surfallo	20.0 mm (0.7874 in)	041-842-136
Surfallo	12.7 mm (0.5000 in)	041-842-132
Surfallo	19.0 mm (0.7500 in)	041-842-133
Surfallo	25.4 mm (1.0000 in)	041-842-149

Insertion depth 63.5 mm (2.5 in)

Water-Cooled Rounds	Specimen Diameter	Part Number
Surfallo	12.0 mm (0.4724 in)	046-838-716
Surfallo	15.0 mm (0.5906 in)	046-838-717
Surfallo	20.0 mm (0.7874 in)	046-838-718
Surfallo	12.7 mm (0.5000 in)	046-838-714

Insertion depth 63.5 mm (2.5 in)

Model 647.10 Vee Specimen Wedges

Surface	For Specimen Diameter When Side/Top Loading	Part Number
90° Serrated	5.8–10.2/11.9 mm (0.23–0.4/0.47 in)	041-842-103
90° Serrated	10.9–12.7/16.5 mm (0.43–0.5/0.65 in)	041-842-104
90° Serrated	17–17/22.9 mm (0.67–0.67/0.9 in)	041-842-110

Insertion depth 63.5 mm (2.5 in)

Water-Cooled Vees	For Specimen Diameter When Side/Top Loading	Part Number
90° Serrated	5.8–10.2/11.9 mm (0.23–0.4/0.47 in)	046-838-703
90° Serrated	10.9–12.7/16.5 mm (0.43–0.5/0.65 in)	046-838-704

Insertion depth 63.5 mm (2.5 in)

Water cooling kit	Part Number
Water Cooling Kit, with flow switches	057-697-502
Water Cooling Kit, without flow switches	057-697-505

Required for Series 647 Water Cooled Wedges
Includes 3.6 m (12 ft) of hose for connection to water source.
Attaches magnetically to load frame base or other flat steel surface.

Wedges for Model 647.25 for Axial and Axial-Torsional Grips

Model 647.25 Flat Specimen Wedges

Surface	Specimen Thickness	Usable Width	Part Number
Diamond tip steel	1-11.9 mm (0.04-0.47 in)	50 mm (2.0 in)	041-842-201
Diamond tip steel	6.1-17 mm (0.24-0.67 in)	50 mm (2.0 in)	041-842-202
Diamond tip steel	15-25.9 mm (0.59-1.02 in)	50 mm (2.0 in)	041-842-203
Wide diamond tip steel	1-11.9 mm (0.04-0.47 in)	102 mm (4.0 in)	046-198-804
Wide diamond tip steel	15-25.9 mm (0.59-1.02 in)	102 mm (4.0 in)	046-198-805
Wide diamond tip steel	6.1-17 mm (0.24-0.67 in)	102 mm (4.0 in)	046-198-806
Surfallo	1-11.9 mm (0.04-0.47 in)	50 mm (2.0 in)	041-842-207
Surfallo	6.1-17 mm (0.24-0.67 in)	50 mm (2.0 in)	041-842-208
Surfallo	15-25.9 mm (0.59-1.02 in)	50 mm (2.0 in)	041-842-209
Wide surfallo	1-11.9 mm (0.04-0.47 in)	102 mm (4.0 in)	046-198-817
Wide surfallo	6.1-17 mm (0.24-0.67 in)	102 mm (4.0 in)	046-198-802
Wide surfallo	15-25.9 mm (0.59-1.02 in)	102 mm (4.0 in)	046-198-803

Insertion depth 89 mm (3.5 in)

Water-Cooled Flats	Specimen Thickness	Usable Width	Part Number
Diamond tip steel	1-11.9 mm (0.04-0.47 in)	50 mm (2.0 in)	045-966-201
Diamond tip steel	6.1-17.0 mm (0.24-0.67 in)	50 mm (2.0 in)	045-966-202
Diamond tip steel	15-25.9 mm (0.59-1.02 in)	50 mm (2.0 in)	045-966-204
Surfallo	1-11.9 mm (0.04-0.47 in)	50 mm (2.0 in)	045-966-205
90° Serrations	1-11.9 mm (0.04-0.47 in)	50 mm (2.0 in)	045-966-208
90° Serrations	6.1-17.0 mm (0.24-0.67 in)	50 mm (2.0 in)	045-966-209
90° Serrations	15-25.9 mm (0.59-1.02 in)	50 mm (2.0 in)	045-966-210

Insertion depth 89 mm (3.5 in)

Model 647.25 Round Specimen Wedges

Surface	Specimen Diameter	Part Number
Surfallo	15.0 mm (0.5906 in)	041-842-231
Surfallo	20.0 mm (0.7874 in)	041-842-232
Surfallo	30.0 mm (1.1811 in)	041-842-233
Surfallo	12.7 mm (0.5000 in)	041-842-234
Surfallo	25.4 mm (1.0000 in)	041-842-235

Insertion depth 89 mm (3.5 in)

Model 647.25 Vee Specimen Wedges

Surface	For Specimen Diameter When Side/Top Loading	Part Number
Serrated	6.4–10.2/13.5 mm (0.25–0.40/0.53 in)	041-842-206
Serrated	10.7–16.8/19.9 mm (0.42–0.66/0.78 in)	041-842-204
Serrated	16.8–20.0/26.2 mm (0.66–0.79/1.03 in)	041-842-205

Insertion depth 89 mm (3.5 in)

Water-Cooled Vees	For Specimen Diameter When Side/Top Loading	Part Number
Serrated	16.8–20.0/26.2 mm (0.66–0.79/1.03 in)	045-966-203
Serrated	6.4–10.2/13.5 mm (0.25–0.40/0.53 in)	045-966-206
Serrated	10.7–16.8/19.8 mm (0.42–0.66/0.78 in)	045-966-207

Insertion depth 89 mm (3.5 in)

Water cooling kit	Part Number
Water Cooling Kit, with flow switches	057-697-502
Water Cooling Kit, without flow switches	057-697-505

Required for Series 647 Water Cooled Wedges

Includes 3.6 m (12 ft) of hose for connection to water source.

Attaches magnetically to load frame base or other flat steel surface.

Wedges for Model 647.50, 647.100, and 647.250 Axial Grips

Model 647.50 Flat Specimen Wedges

Surface	Specimen Thickness	Usable Width	Part Number
Diamond tip steel	0–10.9 mm (0.00–0.43 in)	102 mm (4.0 in)	047-641-606
Diamond tip steel	10.2–21.1 mm (0.40–0.83 in)	102 mm (4.0 in)	047-641-607
Diamond tip steel	20.3–31.2 mm (0.80–1.23 in)	102 mm (4.0 in)	047-641-608
Diamond tip steel	30.5–41.4 mm (1.20–1.63 in)	102 mm (4.0 in)	047-641-609
Diamond tip steel	40.6–51.6 mm (1.60–2.03 in)	102 mm (4.0 in)	047-641-610
Surfallo	0–10.9 mm (0.0–0.43 in)	102 mm (4.0 in)	047-641-611
Surfallo	10.2–21.1 mm (0.40–0.83 in)	102 mm (4.0 in)	047-641-612
Surfallo	20.3–31.2 mm (0.80–1.23 in)	102 mm (4.0 in)	047-641-613
Wide diamond tip steel	20.3–31.2 mm (0.80–1.23 in)	203 mm (8.0 in)	048-966-301
Wide diamond tip steel	10.2–21.1 mm (0.40–0.83 in)	203 mm (8.0 in)	048-966-303
Wide diamond tip steel	20.3–31.2 mm (0.80–1.23 in)	203 mm (8.0 in)	048-966-304
Wide diamond tip steel	30.5–41.4 mm (1.20–1.63 in)	203 mm (8.0 in)	048-966-305
Wide diamond tip steel	40.6–51.6 mm (1.60–2.03 in)	203 mm (8.0 in)	048-966-306
Wide diamond tip steel	0–10.9 mm (0.0–0.43 in)	203 mm (8.0 in)	048-966-307

Insertion depth 89 mm (3.5 in)

Model 647.50 Vee Specimen Wedges

Surface	For Specimen Diameters When Side/Top Loading	Part Number
90° Serrated	6.4–12.7/15.5 mm (0.25–0.50/0.61 in)	047-641-601
90° Serrated	15.2–18.3/24.4 mm (0.60–0.72/0.96 in)	047-641-602
90° Serrated	24.1–25.1/33.5 mm (0.95–0.99/1.32 in)	047-641-603
90° Serrated	33.0–33.0/42.4 mm (1.30–1.30/1.67 in)	047-641-604
90° Serrated	41.9–41.9/51.3 mm (1.65–1.65/2.02 in)	047-641-605

Insertion depth 89 mm (3.5 in)

Hydraulic Collet Grips Are Ideal for Fatigue Testing

The MTS Series 646 Collet Grips offer the best value of any fatigue testing grips available. The design of the Series 646 Grips allows for excellent repeatability from one specimen to the next, minimizing bending strains. Loading is simply a matter of sliding the specimen into the smooth collet. There are no expensive threads or button ends to machine and no additional bolts or collars to install. The Series 646 Grips were designed primarily for round specimens. A special high temperature collet package is available for the 646.10 that utilizes the extension rods supplied with our Model 680 High Temperature Grips. This package will provide you with the same high-temperature capabilities as the 680 grips, and requires the same specimen adapters (see page 95).



See pages 96-97 for our grip supplies.
Pressure 45 MPa (6500 psi)

Axial Model 646 Specifications

Model	Force	Temperature	Height	Diameter	Mounting Thread Size	Part Number
646.10B	100 kN (22 kip)	-40°C to 65°C (-40°F to 150°F)	114 mm (4.50 in)	171 mm (6.75 in)	M27x2 (1"-14)	042-481-807
646.25B	250 kN (55 kip)	-40°C to 65°C (-40°F to 150°F)	171 mm (6.75 in)	254 mm (10.0 in)	M36x2 (1 1/2"-12)	042-481-705

Grips are sold in pairs.

Axial-Torsional Model 646 Specifications

Model	Axial Force	Torsional Force	Temperature	Height	Diameter	Mounting Thread Size	Part Number
646.10B	100 kN (22 kip)	1100 N.m (10,000 in.lb)	-40°C to 65°C (-40°F to 150°F)	147 mm (5.8 in)	171 mm (6.75 in)	M68x2	043-816-502
646.25B	250 kN (55 kip)	2200 N.m (20,000 in.lb)	-40°C to 65°C (-40°F to 150°F)	231 mm (9.1 in)	254 mm (10.0 in)	M92x3	043-816-301

Grips are sold in pairs.

Metric Collet Sizes

Grip Model	Specimen Type	Part Number
646.10-XX	Round 10 mm diameter	038-058-917
646.10-XX	Round 12 mm diameter	038-058-903
646.10-XX	Round 15 mm diameter	038-058-902
646.10-XX	Round 30 mm diameter	038-058-901
646.25-XX	Round 20 mm diameter	038-059-203
646.25-XX	Round 25 mm diameter	038-059-207
646.25-XX	Round 40 mm diameter	038-059-223

US Customary Collet Sizes

Grip Model	Specimen Type	Part Number
646.10-XX	Round 0.25 in diameter	038-058-905
646.10-XX	Round 0.50 in diameter	038-058-907
646.10-XX	Round 0.75 in diameter	038-058-909
646.10-XX	Round 1.0 in diameter	038-058-908
646.25-XX	Round 1.0 in diameter	038-059-202

Water cooling kit	Part Number
Water Cooling Kit, with flow switches	057-697-502
Water Cooling Kit, without flow switches	057-697-505

Required for Series 647 Water Cooled Wedges
Includes 3.6 m (12 ft) of hose for connection to water source.
Attaches magnetically to load frame base or other flat steel surface.

High Temperature Package Components	Part Number
Furnace Extension Kit for 646.10	045-337-601
Hand Pump	100-254-831
Specimen Adapters	See page 95

Fatigue-rated Side Loading Pneumatic Wedge Grips

The MTS Series 645 Fatigue-rated Pneumatic Wedge Grips provide the versatility and reliability you won't find in other pneumatic grips. The symmetrical housing design ensures even specimen loading across the entire face of the wedge. Based on proven MTS designs, the lateral movement of the wedges won't change the gripping position on the specimen when the grips are energized.



FEATURES AND BENEFITS

- » Ideally suited to MTS Acumen electrodynamic load frames, as well as other materials test systems
- » These grips clamp onto your specimen in the same position, test after test, to minimize the bending strains that can invalidate your test results
- » Tension and fatigue capability
- » Adjustable pressure allows these grips to be used for testing a variety of materials
- » A wide variety of wedges are available to meet your requirements
- » Side loading capability for easy specimen insertion.

All grips are sold as pairs.

All wedges and attachment kits are sold separately.

The 645.012 wedge tables can be found on page 85.

Axial Model 645 Specifications

Model	Force	Temperature	Pressure	Overall Height	Diameter	Part Number
645.002	2 kN (0.44 kip)	-40°C to 200°C (-40°F to 400°F)	0.55 MPa (80 psi)	131 mm (5.15 in)	104 mm (4.1 in)	100-242-422
645.005	5 kN (1.1 kip)	-40°C to 200°C (-40°F to 400°F)	0.55 MPa (80 psi)	133 mm (5.25 in)	147 mm (5.8 in)	100-242-417
645.012	12 kN (2.7 kip)	-40°C to 200°C (-40°F to 400°F)	1.03 MPa (150 psi)	142 mm (5.6 in)	175 mm (6.9 in)	100-415-143

Grips are sold in pairs.

645.005

Model 645.002 & 645.005 Flat Specimen Wedges

Description	For Specimen Diameters When Side/Top Loading	Part Number
Flat Specimen Sawtooth Wedge Set	0-7.2 mm (0-0.28 in)	050-507-938
Flat Specimen Sawtooth Wedge Set	3.3-10.6 mm (0.13-0.42 in)	050-507-939
Flat Specimen Sawtooth Wedge Set	5.4-12.4 mm (0.21-0.49 in)	050-507-940
Flat Specimen Surfalloy Wedge Set	0-7.2 mm (0-0.28 in)	050-507-941
Flat Specimen Surfalloy Wedge Set	3.3-10.6 mm (0.13-0.42 in)	050-507-942
Flat Specimen Surfalloy Wedge Set	5.4-12.4 mm (0.21-0.49 in)	050-507-943

Insertion depth 38 mm (1.5 in)

Model 645.002 & 645.005 Vee Specimen Wedges

Description	For Specimen Diameters When Side/Top Loading	Part Number
Vee Wedge Set Diamond tip steel	3-7.8 mm (0.12-0.31 in)	050-507-944
Vee Wedge Set Diamond tip steel	7.1-7.8/12.7 mm (0.28-0.31/0.5 in)	050-507-945
Vee Wedge Set Diamond tip steel	10.9-13.2/16.5 mm (0.43-0.52/0.65 in)	050-507-946
Vee Wedge Set Diamond tip steel	14.4-15.7/20.3 mm (0.57-0.62/0.80 in)	050-507-947

Insertion depth 38 mm (1.5 in)

Accessories

Description	Part Number
Fundamental Pneumatic Grip Supply	100-231-865
Mounting & Cables, Fundamental Grip Supply to Acumen	100-263-782

Compression Platens

Model 643 Compression Platens

MTS Model 643 Compression Platens are made from case-hardened alloy steel with hard chrome plating. The platens have a smooth face with etched concentric rings, enabling the specimen to be centered visually for better test results. The upper platen is available with a spherical seat for improved alignment and ensuring even pressure across the entire surface of the specimen. Model 643 compression platens are offered in three configurations: Fixed & Spherical, Two Fixed, and One Fixed.

Units range in diameter from 60 mm (2.4 in) to 300 mm (12 in) and are designed for a unit stress of 689 MPa (100,000 psi) static (275 MPa (40,000 psi) dynamic) centered on the bearing surfaces. The usable temperature range is -129°C to 177°C (-200°F to +350°F).

Specifications

Model	Maximum Specimen Diameter	Mounting Thread Insert Sizes
643.06B	60 mm (2.4 in)	M12 x 1.25 /1/2"-20
643.10B	100 mm (4 in)	M27 x 2 /1"-14
643.15B	150 mm (6 in)	M27 x 2 /1"-14
643.20B	200 mm (8 in)	M27 x 2 /1"-14
643.30B	300 mm (12 in)	M52 x 2 /2"-12

Model	Description	Part Number
643.06B-01	Fixed & Spherical	050-292-603
643.06B-03	Two Fixed	050-292-503
643.06B-05	One Fixed	050-612-103
643.10B-01	Fixed & Spherical	050-292-803
643.10B-03	Two Fixed	050-292-703
643.10B-05	One Fixed	050-612-203
643.15B-01	Fixed & Spherical	050-293-003
643.15B-03	Two Fixed	050-292-903
643.15B-05	One Fixed	050-612-303
643.20B-01	Fixed & Spherical	053-042-503
643.20B-03	Two Fixed	053-042-803
643.20B-05	One Fixed	053-042-703
643.30B-01	Fixed & Spherical	050-293-203
643.30B-03	Two Fixed	050-293-103
643.30B-05	One Fixed	050-612-403



Bend Fixtures

MTS Model 642 Bend Fixtures are configured to meet a variety of testing requirements. The fixtures have adjustable spans with easy-to-use, permanently attached scales for equal positioning of the rollers. The hardened rollers ensure test result accuracy by reducing undesirable loading and frictional forces on the specimen. All models can be used for both 3- and 4-point tests.

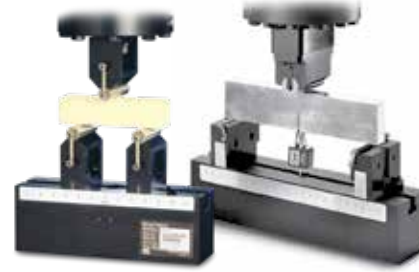

MODEL 642.001

- » 1, 2, 3, 4, and 5 mm rollers are included
- » Adjustable spans
- » Metric and US Customary scales.



MODEL 642.25:

- » Well-suited for ASTM E-399 fracture toughness tests
- » Adjustable spans
- » Metric and US Customary scales.



MODELS 642.01 AND 642.10:

- » Model 642.01 can be used to meet ASTM D790, ASTM D7264, EN 2746, ISO 14125. The minimum nominal specimen thickness for the 4-point loading setup required by ISO 12125 Method B, is limited to 24 mm for smallest upper span.
- » Model 642.10 can be used to meet ASTM E399, ASTM D7264 and EN 2562. The minimum nominal specimen thickness for the 4-point loading setup required by ASTM D7264, is limited to 24 mm for smallest upper span.
- » Flexible configurations provide either a region of constant stress or a line of maximum stress
- » Adjustable spans
- » Metric and US Customary scales.

Model	Type	UPPER Fixture Span	LOWER Fixture Span	Force Rating*	Temperature Range	Combined Height**	Part Number
642.001	3 & 4 point bend fixture		14-60 mm (0.6-2.4 in)	0.9 kN (200 lbf)	-129°C to 150°C (-200°F to 300°F)	61 mm (2.4 in)	100-027-125
642.01A-01	3 point bend fixture	NA	24-152 mm (0.94-6.0 in)***	10 kN (2.2 kip)	-129°C to 150°C (-200°F to 300°F)	172 mm (6.8 in)	051-427-701
642.01A-02	3 & 4 point bend fixture	24-76 mm (0.94-3.0 in)***	24-152 mm (0.94-6.0 in)***	10 kN (2.2 kip)	-129°C to 150°C (-200°F to 300°F)	243 mm (9.6 in)	051-427-801
642.10B-01	3 point bend fixture	NA	38-305 mm (1.5-12.0 in)****	100 kN (22 kip)	-129°C to 177°C (-200°F to 350°F)	273 mm (10.75 in)	050-032-601
642.10B-02	3 & 4 point bend fixture	53-152 mm (2.08-6.0 in)****	38-305 mm (1.5-12.0 in)****	100 kN (22 kip)	-129°C to 177°C (-200°F to 350°F)	356 mm (14.00 in)	050-032-701
642.25B-01	3 point bend fixture	NA	79-610 mm (3.12-24.0 in)*****	250 kN (55 kip)	-129°C to 177°C (-200°F to 350°F)	470 mm (18.50 in)	050-876-201
642.25B-02	3 & 4 point bend fixture	50.8-203 mm (2-8 in)*****	79-610 mm (3.12-24.0 in)*****	250 kN (55 kip)	-129°C to 177°C (-200°F to 350°F)	660 mm (26.00 in)	050-876-301

* Static and dynamic force rating depends upon roller diameter.
 ** Dimension depends upon roller diameter. Largest roller diameter shown.
 *** Dimension depends upon roller diameter. 6.35 mm (0.25 in) roller diameter shown.
 **** Dimension depends upon roller diameter. 25 mm (1 in) roller diameter shown.
 ***** Dimension depends upon roller diameter. 50.8 mm (2 in) roller diameter shown.

Model 642.01

Roller Assemblies*

Diameter	Part Number
5 mm	051-284-601
10 mm	051-284-603
0.25 in	051-284-602
0.50 in	051-284-604

Model 642.10 Roller Assemblies*

Diameter	Part Number	Diameter	Part Number
5 mm	049-578-501	0.25 in	049-578-502
10 mm	049-578-503	0.375 in	049-578-510
15 mm	049-578-505	0.50 in	049-578-504
20 mm	049-578-507	0.75 in	049-578-506
25 mm	049-578-509	1.00 in	049-578-508

Model 642.25 Roller Assemblies*

Diameter	Part Number	Diameter	Part Number
20 mm	050-875-202	0.75 in	050-875-201
30 mm	050-875-204	1.00 in	050-875-203
40 mm	050-875-207	1.75 in	050-875-208
50 mm	050-875-209		

*Includes one roller and attachment springs.
 Order quantity 3 for 3-point bend and 4 for 4-point bend configurations.
 Roller assemblies listed above are not included with bend fixtures and must be purchased separately.

Alignment Fixture, Software, and Strain-Gaged Specimens

Save Time and Get Better Data

Alignment Software for up to 12-Gage Specimens

MTS Alignment hardware and software acquires, analyzes, and displays bending strains for alignment and bending strain verification purposes. Its graphical interface quickly allows you to align your system or to verify how much bending strain you currently have. One of the key attributes of this software is that it can separate the bending strain of the specimen from that of the load train.

The best method of determining bending strain is to use a strain-gaged specimen. This product interfaces directly with a strain-gaged specimen and displays bending strain graphically on the screen of your PC. Continual scanning of bending strains allows you to align your system or verify the bending strain while cycling load. When finished, an Excel report can be generated to certify your system.

Features

- » Supports 12-gage specimens for best results. Also accommodates 4, 6, 8, and 9 gage specimens
- » Data acquisition and conditioning is external to the PC. This allows for much more PC flexibility, including laptops
- » This alignment system ensures compliance with industry standards: ASTM E1012, GES400 (NADCAP), GE450 and ISOTC 164SC5WG11
- » The "Alignment Wizard" verbally instructs the user how to perform concentric and angular adjustments
- » Accepts a calibrated load signal for a bending percent and bending strain versus load validation graph
- » Separates the specimen eccentricities from the system alignment.

Alignment Fixture

The MTS Model 609 Alignment Fixture for material testing systems saves time compared to manual alignment methods.

The main feature of the Model 609 Alignment Fixture is its capability to perform alignment adjustments while the load train is fully preloaded. This eliminates any inaccuracies involved in trying to account for the small changes in alignment that frequently occur during the preloading process.



In addition, because the fixture remains preloaded at all times, previous alignment adjustments are not lost when small changes in alignment are required.

The Model 609 Alignment Fixtures are compatible with MTS load frames, excluding MTS Exceed. The alignment fixtures are also readily adaptable to other load frames.

Testing Results Hitting the Target?

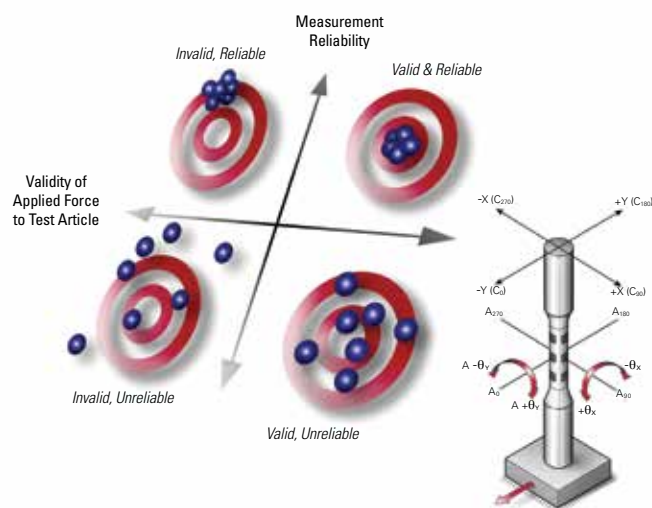

Alignment Fixture

Specimens for Alignment Use

MTS offers round and flat standardized strain-gaged specimens for alignment use. Each specimen has 12 gages so you can correct both concentric and angular misalignments.

The gages are bonded with oven-cured epoxy for long life and are covered to prevent damage from handling. The specimen material is 4340 steel and is heat treated to safely allow stresses to 413 MPa (60,000 psi).

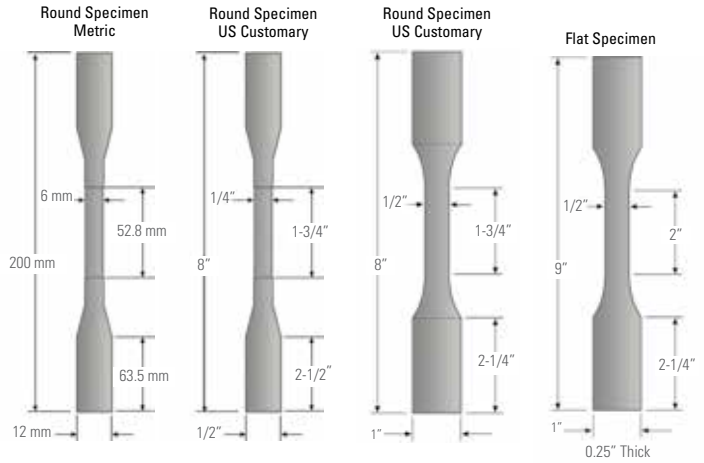

Model 609 Alignment Fixtures for Model 312 & 318 Load Frames

Model	Load Frame Force Capacity	Height	Diameter	Stud Size/Length	Metric Part Number	US Customary Part Number
609.02A-01	25 kN (5.5 kip)	72 mm (2.81 in)	121 mm (4.75 in)	M12 x 1.25/355 mm (1/2"-20/14.0 in)	049-083-402	049-083-401
609.10A-01	100 kN (22 kip)	72 mm (2.81 in)	121 mm (4.75 in)	M27 x 2/343 mm (1"-14/13.5 in)	049-083-502	049-083-501
609.25A-01	250 kN (55 kip)	80 mm (3.12 in)	162 mm (6.38 in)	M36 x 2/462 mm (1 1/2"-12/18.2 in)	049-083-602	049-083-601
609.50A-01	500 kN (110 kip)	181 mm (7.11 in)	254 mm (10 in)	M52 x 2/686 mm (2"-12/27 in)	051-499-202	051-499-201

Model 609 Alignment Fixtures for Model 370 Load Frames

Model	Stud Size/Length	Height	Diameter	Capacity	Load Frame Model	Mounting Location	Part Number
609.02	M12 x 1.25 mm x 13.5	73 mm	124 mm	25 kN	370.10	Base Plate	057-206-701
609.10	M27 x 2 mm x 14.50	73 mm	124 mm	100 kN	370.10	Base Plate	057-206-301
609.10	M27 x 2 mm x 16.75	73 mm	124 mm	100 kN	370.25	Base Plate	057-206-307
609.25	M36 x 2 mm x 17.25	80 mm	162 mm	250 kN	370.25	Base Plate	057-206-302
609.25	M36 x 2 mm x 24.00	80 mm	162 mm	250 kN	370.50	Base Plate	057-206-308
609.50	M52 x 2 mm x 25.00	181 mm	254 mm	500 kN	370.50	Base Plate	057-206-303
609.02	M12 x 1.25 mm x 11.25	73 mm	124 mm	25 kN	370.02	Crosshead	057-206-201
609.02	M12 x 1.25 mm x 16.25	73 mm	124 mm	25 kN	370.10	Crosshead	057-206-702
609.10	M27 x 2 mm x 17.00	73 mm	124 mm	100 kN	370.10	Crosshead	057-206-304
609.10	M27 x 2 mm x 19.50	73 mm	124 mm	100 kN	370.25	Crosshead	057-206-309
609.25	M36 x 2 mm x 20.00	80 mm	162 mm	250 kN	370.25	Crosshead	057-206-305
609.25	M36 x 2 mm x 20.00	80 mm	162 mm	250 kN	370.50	Crosshead	057-206-310
609.50	M52 x 2 mm x 21.00	181 mm	254 mm	500 kN	370.50	Crosshead	057-206-306

REQUIRED ADAPTER KIT ORDERING INFORMATION FOR THE MODEL 609 ALIGNMENT FIXTURE (FOR LOAD FRAMES OTHER THAN MTS' MODELS 370, 318, AND 312)

- A Load cell thread size
- B Load cell thread depth
- C Crosshead height
- D Crosshead through-hole diameter
- E Dimensional information of any counter-bores in either the top or bottom of the crosshead

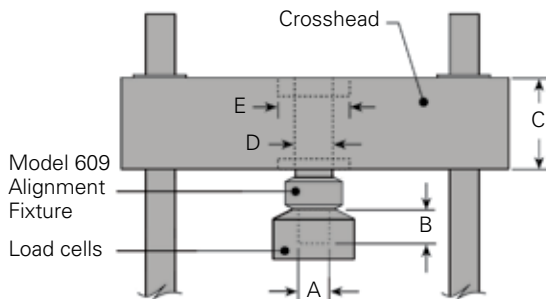

Specimens	Part Number
Round, 0.5 in (diameter)	056-651-701
Round, 1 in (diameter)	056-651-705
Round, 12 mm (diameter)	056-651-703
Flat, 3.175 mm (0.125 in) (thick)	056-651-711
Flat, 6.35 mm (0.25 in) (thick)	056-651-702
Round Hollow, 0.75 in (diameter)	056-651-708

709.20E Alignment Data Acquisition and Conditioning Units

Voltage/Plug	Part Number	Certified Part Number
115 V AC, US Plug, CE	058-570-901	058-570-906
230 V AC, US Plug, CE	058-570-902	058-570-907
230 V AC, Euro Plug, CE	058-570-903	058-570-908
230 V, UK/Ireland Cordset, CE	058-570-904	058-570-909
230 V AC, Chinese Cordset, CE	058-570-905	058-570-910

For other plug options, contact MTS

Alignment Software*	Part Number
709.20E-03 Alignment Software	100-554-833

*Requires Windows 10. Supports 709.20E Alignment Data Acquisition and Conditioning Units with MTS Part Numbers 058-570-9XX, 57-675-5XX & 56-776-6XX.

High-Temperature LCF Grips

MTS Model 680 High-Temperature Grips were expressly designed for high-temperature, low-cycle fatigue testing, but can also be used for other types of tension-compression or tension-only testing. The grip heads and extension rods are constructed of high-temperature, super alloys selected to extend into the heated zone of the furnace, minimizing the thermal gradients within the specimen. Accessories for these grips include a hand pump (required), your choice of buttonhead or threaded specimen adapters, and a water cooling kit.

Specifications

Model Number	Force Rating*		Weight (each)	Dimensions (see photo)			Thread Size	Part Number
	@700°C (1300°F)	@1000° (1832°F)		A	B	C		
680.01B	15 kip	2 kip	20 lb	1.5 in	4.6 in	4.9 in	1-14 UNS	044-057-103
680.01B	68 kN	8.9 kN	9 kg	38 mm	117 mm	124 mm	M27x2	044-057-103

*Note: Force rating decreases linearly with temperature between the ratings shown

Accessories

Type	Part Number
Hand Pump (Required)	100-254-832
Water Cooling Kit, with flow switches	057-697-502
Replacement Seal Kit	040-985-901

Specimen Adapters	Dimensions	Part Number
Buttonhead	0.25 in dia. shank, 0.75-0.85 in dia. button	041-901-902
Buttonhead	0.40 in dia. shank, 0.75-0.85 in dia. button	041-901-904
Buttonhead	0.50 in dia. shank, 0.75-0.85 in dia. button	041-901-901
Buttonhead	12 mm dia. shank, 21.1-21.6 mm dia. button	041-901-903
Threaded	1/2 in-13 UNC-2B	041-901-801
Threaded	M12 x1.75 mm	041-901-802



Grip Supplies and Intensifiers

MTS Model 685 self-contained, hydraulic Grip Supplies have been engineered for both performance and ease of use. There are two grip supplies and one grip intensifier to choose from.

STANDARD FEATURES INCLUDE:

- » Directional control valve for each grip
- » Center valve detent, allowing unparalleled control of over gripping
- » Continuous positive pressure design, providing high pressure stability over the entire operating range
- » Separate flow control valve for control of grip engagement speed
- » Independent grip circuits eliminate crosstalk.
- » Easy to maintain and service
- » Accommodate a wide range of electrical connections

MODEL 685.22 AND MODEL 685.10 STAND ALONE HYDRAULIC GRIP SUPPLIES

The 685.22 and 685.10 units feature a self-contained hydraulic pump, a 0.75 kW (1 hp) electric motor, a 11.3 l (3 gal) reservoir, a 10-micron absolute return line filter, and hoses for connection to grips. These units are furnished with individual directional control valves for upper and lower grips. The grip supplies use a special hydraulic fluid which allows the grips to be used in environmental chambers at elevated temperatures. They are designed to run continuously, which results in good pressure stability and easy adjustment of the output pressure. Grip closure rate is also adjustable. Since the grip supplies are self-contained systems, they allow the use of hydraulic grips on non-hydraulic test systems.



MODEL 685.60 HYDRAULIC GRIP INTENSIFIER

The 685.60 Hydraulic Grip Intensifier, which utilizes an innovative fluid-to-fluid intensification system, is used with grips that require a pressure higher than the normal system hydraulic pressure. Two versions are available with factory adjusted output pressures of 45 MPa (6,500 psi) and 69 MPa (10,000 psi). The output pressure is adjustable from 10 MPa (1,500 psi) up to the grip supply output rating.

To minimize the set-up time of larger grips, a high volume upgrade kit is available.



Model**	Description	Pressure Range	Setting Repeatability	Operating Temperature	Weight	Electrical Power Requirements	Part Number
685.10E-05	Stand-alone grip supply	10-70 MPa (1,500-10,000 psi)	±0.7 MPa (±100 psi)	-40 to 177°C (-40 to 350°F)	76 kg (170 lb)	115 V (60 Hz)	057-509-601
685.10E-06	Stand-alone grip supply	10-70 MPa (1,500-10,000 psi)	±0.7 MPa (±100 psi)	-40 to 177°C (-40 to 350°F)	76 kg (170 lb)	100-115 V (50 Hz)	057-509-602
685.10E-07	Stand-alone grip supply	10-70 MPa (1,500-10,000 psi)	±0.7 MPa (±100 psi)	-40 to 177°C (-40 to 350°F)	76 kg (170 lb)	208-230 V (60 Hz)	057-509-603
685.10E-08	Stand-alone grip supply	10-70 MPa (1,500-10,000 psi)	±0.7 MPa (±100 psi)	-40 to 177°C (-40 to 350°F)	76 kg (170 lb)	200-240 V (50 Hz)	057-509-604
685.22D-05	Stand-alone grip supply	0.7-21 MPa (100-3,000 psi)	±0.07 MPa (±10 psi)	-40 to 177°C (-40 to 350°F)	76 kg (170 lb)	115 V (60 Hz)	057-598-001
685.22D-06	Stand-alone grip supply	0.7-21 MPa (100-3,000 psi)	±0.07 MPa (±10 psi)	-40 to 177°C (-40 to 350°F)	76 kg (170 lb)	100-115 V (50 Hz)	057-598-002
685.22D-07	Stand-alone grip supply	0.7-21 MPa (100-3,000 psi)	±0.07 MPa (±10 psi)	-40 to 177°C (-40 to 350°F)	76 kg (170 lb)	208-230 V (60 Hz)	057-598-003
685.22D-08	Stand-alone grip supply	0.7-21 MPa (100-3,000 psi)	±0.07 MPa (±10 psi)	-40 to 177°C (-40 to 350°F)	76 kg (170 lb)	200-240 V (50 Hz)	057-598-004
685.60C-02*	Hydraulic system intensifier	10-45 MPa (1,500-6,500 psi)	±0.07 MPa (±100 psi)	-18 to 66°C (0 to 150°F)	39 kg (87 lb)	–	057-597-901
685.60C-03*	Hydraulic system intensifier	10-70 MPa (1,500-10,000 psi)	±0.07 MPa (±100 psi)	-18 to 66°C (0 to 150°F)	39 kg (87 lb)	–	057-597-902

*Optional kit available to minimize set-up time of larger grips.

**Pressure Stability: ±100 psi (1% of operating range). Continuous pump operation.

FILTRATION

- » 10 micron

HYDRAULIC FLUID

- » Mobile 525 SHC (685.10 & 685.22)

MAXIMUM AMBIENT TEMPERATURE

- » 32°C (90°F)

DIMENSIONS (SEE PHOTO)

- » Depth: 431.8 mm (17.0 in)
- » Width: 444.5 mm (17.5 in)
- » Height: 914.4 mm (36.0 in)



Hydraulic Grip Control Kit

Load Frame Mounted Grip Control Unit

The MTS Model 685.53 Grip Control Unit accurately controls pressure to hydraulic grips. Each grip can be actuated independently. The kit includes the grip control unit, hydraulic hoses to the hydraulic power supply, hydraulic hoses to the grips, and a universal mounting bracket. The control unit requires 21 MPa (3,000 psi) input pressure and can control the pressure to the grips from 0.7 MPa to 20 MPa (100 psi to 3,000) psi with a resolution of ± 0.07 MPa (± 10 psi). This range and resolution allow the user to select the proper grip pressure so it holds the specimen sufficiently without damaging it. The stability of the controlled pressure is ± 0.5 MPa (± 25 psi) yielding no extraneous load fluctuations within your test. The clamping speed of the grips is also adjustable.



Model	Load Frame (Color)	Pressure Capacity	Used for Grip Model Numbers	Part Number
685.53A-01*	Load Frame Mounted Grip Control (brown)	21 MPa /3,000 psi	647.02/.10	044-667-001
685.53C-02	Load Frame Mtd. Grip Control 318.10/.25 (gray)	21 MPa /3,000 psi	647.02/.10	050-195-402

* JIC 6 drain hose is required if 318 load frame does not have lift and locks.

Fracture Mechanics Clevis Grips

The MTS Model 640.20B Fracture Mechanics Grips are manufactured per ASTM E-399 specifications. They are the most popular grips used for fracture toughness and fatigue crack growth rate tests. They are constructed from high-strength, aircraft-quality 4340 steel and are machined to the exacting tolerances required by ASTM. The package includes two grips, two .4W pins, and four spring retainers.



Model	Specimen Width	Static Force	Pin Diameter	Mounting Thread
640.20B-X1	12.7 mm (0.50 in)	60 kN (13.6 kip)	12.2 mm (0.48 in)	M27 x 2 (1"-14)
640.20C-X3	25.4 mm (1.00 in)	60 kN (13.6 kip)	12.2 mm (0.48 in)	M27 x 2 (1"-14)

Temperature Rating
-129°C to 177°C

Model	Metric Part Number
640.20B-21	007-172-745
640.20C-03	007-172-743

Temperature Rating
-200°F to 350°F

Model	US Customary Part Number
640.20B-01	007-172-741
640.20C-03	007-172-743

MTS Advantage Pneumatic Grip Controllers

MTS Advantage Pneumatic Grip Controller/Supply

- » Required for proper operation of MTS Advantage Pneumatic Grips.
- » Provides precise control of open/close functions, air pressure regulation and flow
- » Magnetic-mount handset or optional footswitch that makes specimen loading hassle-free



APC1850

MTS Fundamental Pneumatic Grip Controller/Supply

- » Required for proper operation of MTS Fundamental Pneumatic Bollard and Vise Grips
- » Provides precise control of open/close functions, air pressure regulation and flow



FPC2850

Specifications

Model	APC1850	FPC2850
Part Number	100-393-631	100-416-592
Grip Actuation Type	MTS Advantage Single Action Pneumatic	MTS Fundamental Dual Action Pneumatic
Recommended Output Pressure	0.27 - 0.55 MPa (40 - 80 psi)	0.27 - 0.55 MPa (40 - 80 psi)
Temperature Rating (<i>Controller</i>)	5°C (41°F) to 40°C (104°F)	5°C (41°F) to 40°C (104°F)
Air Tubing Diameter	6 mm	6 mm
Temperature Rating (<i>Tuding</i>)	-170°C (-275°F) to 260°C (500°F)	-170°C (-275°F) to 260°C (500°F)
Input Power	100-240VAC, 50/60 Hz (single phase)	100-240VAC, 50/60 Hz (single phase)
Power rating	5.5 W	5.5 W
Height	330 mm (13.0 in)	330 mm (13.0 in)
Width	127 mm (5.0 in)	127 mm (5.0 in)
Depth	210 mm (8.3 in)	210 mm (8.3 in)
Weight	7 kg (15.4 lb)	7 kg (15.4 lb)

Grip Controller/Supply Options

Model	Part Number	Handswitch	Footswitch	Air Filter Assembly
APC1850	100-393-631	100-393-629	100-393-630	100-041-199
FPC2850	100-416-592	100-393-629	100-393-630	100-041-199

A Comprehensive Array of Electromechanical Accessories - *Monotonic*

Grips and Fixtures for Electromechanical Systems

MTS complements its electromechanical testing lines with a comprehensive array of accessories to conduct a full spectrum of material and small component testing – from basic quality control, to complex biomedical simulations, to

demanding research and development applications. This catalog includes several distinct accessory families to accommodate your specific and evolving testing needs:

MTS Advantage Accessories

Highly versatile and full-featured wedge, pneumatic, and screw action grips for demanding R&D testing of advanced composites and alloys. Ideal for the specific needs of the high-end researcher, this accessory family accommodates a very broad range

of clamping force and temperature requirements and features numerous control and grip face options. MTS stands behind the MTS Advantage family line with a three-year warranty – one of the best in the industry!



MTS Fundamental Accessories

Basic affordable grips and fixtures for standard testing of plastics, textiles, rubber, wire, rope, and more. These accessories feature a universal adapter design and optional threaded frame adapters to facilitate easy installation

onto both MTS electromechanical and servohydraulic load frame systems, as well as other electromechanical test systems. Anti-rotation features and integrated alignment pins enhance test accuracy and repeatability.

Criterion Test Systems

Can't find what you need?

We offer many more grips and fixtures. Contact your local sales representative or applications engineer to find the model that meets your exact needs.



Application of Grips and Fixtures - *Monotonic*

Grips and fixtures are critical components to material testing. Testing results might be compromised if incorrect grips or fixtures are used. MTS offers a large variety of grips and fixtures and this catalog includes popular items that are compatible with specimens defined by commonly adopted testing standards such as ASTM, ISO, DN, GB, BS, JIS and more. For additional grips and fixtures or custom designs, please contact MTS sales or application engineers.

Selection of Grips and Fixtures

Four main criteria to consider when selecting grips and fixtures:

1. TEST STANDARD

Test standards define the dimensions and shape of specimens. Often, there are many different grips that can be used to address a single test standard. If you are not certain about which grip to use for your application, please contact us.

2. SPECIMEN AND TEST METHOD

Besides the dimension and shape of specimens, the surface texture is an important factor in grip selections. For tensile tests, slipping, premature damage and cracking in the grip are quite common due to incorrect grip selection. For help determining the right grip, contact your MTS application engineer.

3. ATTACHMENT KITS

The term "attachment kit" can refer to any of the hardware required to connect your grips to your system. This is an important item to remember since the attachment kits are generally sold separately.

4. STANDARD ADAPTERS

Generally grips and fixtures will be equipped with adapters of standard dimensions to be used with clevis adapters of the frames. The advantages of using standard adapters are easy installation, accurate mounting and maximum compatibility.



Electromechanical Attachment Scheme

Clevis Pin Connection	Type B	Type C (AL)	Type C (STL)	Type D	Type E	Type F	Type 20	Type 40
Max. Load Capacity	10 N (2.2 lbf)	200 N (45 lbf)	2.5 kN (562 lbf)	150 kN (33720 lbf)	300 kN (67440 lbf)	600 kN (134885 lbf)	30 kN (6740 lbf)	100 kN (22480 lbf)
Clevis Diameter (X)	12.7 mm (0.50 in)	15.9 mm (0.625 in)	15.9 mm (0.625 in)	31.7 mm (1.25 in)	60 mm (2.36 in)	90 mm (3.54 in)	20 mm (0.787 in)	40 mm (1.57 in)
Pin Diameter (Y)	4.7 mm (0.186 in)	6.4 mm (0.25 in)	6.4 mm (0.25 in)	12.7 mm (0.50 in)	28 mm (1.1 in)	40 mm (1.57 in)	10 mm (0.039 in)	18 mm (0.71 in)

Adapters - Monotonic

Conversion Adapters

Grips and fixtures with other standard adapters can be used on the frames with other size standard clevis adapters with a set of suitable conversion adapters.

Conversion adapters allow you to use the same grips and fixtures on both MTS Exceed and MTS Criterion load frames.



Specifications

Part Number	100-302-950	100-302-947	100-302-952	100-302-948	100-302-951	100-302-953	100-302-949	100-260-836	100-281-224
Attachment Type (m-f)	20-D	40-20	D-20	E-20	40-D	D-40	E-40	E-D	F-E
Max. Load Capacity	30 kN (6740)	30 kN (6740)	30 kN (6740)	30 kN (6740)	100 kN (22480 lbf)	100 kN (22480 lbf)	100 kN (22480 lbf)	150 kN (33720 lbf)	300 kN (67440 lbf)
A (male clevis)	Type 20	Type 40	Type D	Type E	Type 40	Type D	Type E	Type E	Type F
B (female clevis)	Type D	Type 20	Type 20	Type 20	Type D	Type 40	Type 40	Type D	Type E
C (pin to pin height)	68.5 mm (2.7 in)	58 mm (2.3 in)	72.5 mm (2.9 in)	80 mm (3.2 in)	91 mm (3.6 in)	89.5 mm (3.5 in)	90 mm (3.5 in)	97 mm (3.8 in)	160 mm (6.3 in)
Lock Nut	M24 × 1.5	M45 × 2	M35 × 1.5	M64 × 2	M45 × 2	M35 × 1.5	M64 × 2	M64 × 2	M95 × 2

Universal Joint

Universal joints are used to help maintain axial load alignment in tensile loading applications.

Specifications

Model	FWX105
Part Number	100-258-159
Grip Type	Universal Joint
Force Capacity	100 kN (22,000 lbf)
Upper Grip Weight	3.9 kg (8.6 lbs)
Temperature Rating	0°C (32°F) to 50°C (122°F)
Attachment Type	D
Grip Height	185 mm (7.3 in)
Grip Width	84 mm (3.4 in)



Universal Joint

Tension Grips - *Monotonic*

Hydraulic Activation

MTS Fundamental Hydraulic Side Grips

- » Affordable hydraulic side grips that deliver constant gripping force for tensile applications
- » Side-loading, quick-acting U-shaped grips allow for easy specimen insertion
- » Stable clamping force minimizes slipping and maximizes accuracy and repeatability
- » Capable of off-center specimen tests
- » Adjustable pressure provides proper grip force for a variety of materials
- » Grips are sold in pairs
- » Wide variety of specimen interfaces are available to meet your varied differing specimen profiles, materials and surfaces
- » All specimen interfaces (“faces”) are sold separately
- » Hydraulic grip controller/supply unit is sold separately
- » **Applications:** High-force tensile testing of steel, rebar, ceramics, composites, plastics and wood/paper products



FDYA504A

Specifications

Model	FDYA504A	FDYB105A
Part Number	100-408-988	100-302-638
Grip Type	Hydraulic Single Side	Hydraulic Single Side
Force Capacity	50 kN (11,000 lbf)	100 kN (22,500 lbf)
Upper Grip Weight	25 kg (55.1 lb)	42 kg (92.6 lb)
Temperature Rating	0°C (32°F) to 50°C (122°F)	0°C (32°F) to 50°C (122°F)
Attachment Type	D	D
Combined Upper/Lower Grip Height	446 mm (17.6 in)	506 mm (19.9 in)
Grip Width	301 mm (11.9 in)	358 mm (14.1 in)
Maximum Input Pressure	20 MPa (3000 psi)	20 MPa (3000 psi)

FDYA504A Optional Faces

Model	Part Number	Profile	Surface	Height	Width	Temperature Range	Specimen Range
FDYA504A.03	100-302-842	Flat	Sawtooth Steel	60 mm (2.3 in)	98 mm (3.8 in)	0°C (32°F) to 50°C (122°F)	0-18 mm (0-0.7 in)
FDYA504A.04	100-302-843	Vee	Serrated Steel	60 mm (2.3 in)	98 mm (3.8 in)	0°C (32°F) to 50°C (122°F)	ø4-ø12 mm (0.2-0.5 in)
FDYA504A.05	100-302-844	Vee	Serrated Steel	60 mm (2.3 in)	98 mm (3.8 in)	0°C (32°F) to 50°C (122°F)	ø12-ø20 mm (0.5-0.8 in)

FDYB105A Optional Faces

Model	Part Number	Profile	Surface	Height	Width	Temperature Range	Specimen Range
FDYB105A.03	100-302-845	Flat	Sawtooth Steel	60 mm (2.3 in)	98 mm (3.8 in)	0°C (32°F) to 50°C (122°F)	0-28 mm (0-1.1 in)
FDYB105A.04	100-302-846	Vee	Serrated Steel	60 mm (2.3 in)	98 mm (3.8 in)	0°C (32°F) to 50°C (122°F)	ø4-ø12 mm (0.2-0.5 in)
FDYB105A.05	100-302-847	Vee	Serrated Steel	60 mm (2.3 in)	98 mm (3.8 in)	0°C (32°F) to 50°C (122°F)	ø12-ø28 mm (0.5-1.1 in)

Tension Grips - *Monotonic*

Hydraulic Activation

MTS Fundamental Hydraulic Wedge Grips

- » Affordable hydraulic wedge grips for higher force capacity tensile applications
- » Side loading capability for easy specimen insertion
- » Grips are sold in pairs
- » Wide variety of wedges (specimen interfaces) are available to meet your varied requirements
- » All specimen interfaces (wedges) are sold separately
- » Hydraulic grip controller/supply unit is sold separately
- » **Applications:** High-precision tensile testing of metals, ceramics, composites, plastics, wood/paper products



Specifications

Model	FVD305	FVD605
Part Number	100-336-772	100-369-052
Grip Type	Hydraulic Wedge	Hydraulic Wedge
Force Capacity	300 kN (66,440 lbf)	600 kN (134,885 lbf)
Upper Grip Weight	92.5 kg (204 lb)	165 kg (364 lb)
Temperature Rating	0°C (32°F) to 50°C (122°F)	0°C (32°F) to 50°C (122°F)
Attachment Type	E	M52 x 2
Combined Upper/Lower Grip Height	756 mm (29.8 in)	976 mm (38.4 in)
Grip Width	270 mm (10.6 in)	330 mm (13 in)
Maximum Input Pressure	20 MPa (3,000 psi)	20 MPa (3,000 psi)

Tension Faces - *Monotonic*

FYD305 Grip Optional Faces

Model	Part Number	Profile	Surface	Height	Width	Temperature Range	Specimen Range	Compatible Grip(s)
FYD305.01	100-465-487	Flat	Sawtooth Steel	68 mm (2.7 in)	70 mm (2.75 in)	0°C (32°F) to 50°C (122°F)	0-6 mm (0-0.23 in)	FYD305
FYD305.02	100-465-488	Flat	Sawtooth Steel	68 mm (2.7 in)	70 mm (2.75 in)	0°C (32°F) to 50°C (122°F)	6-18 mm (0.23-0.7 in)	FYD305
FYD305.03	100-465-489	Flat	Sawtooth Steel	68 mm (2.7 in)	70 mm (2.75 in)	0°C (32°F) to 50°C (122°F)	18-30 mm (0.7-1.18 in)	FYD305
FYD305.04	100-465-484	Vee	Serrated Steel	68 mm (2.7 in)	70 mm (2.75 in)	0°C (32°F) to 50°C (122°F)	Ø6-16 mm (0.23-0.63 in) Side & Top	FYD305
FYD305.05	100-465-485	Vee	Serrated Steel	68 mm (2.7 in)	70 mm (2.75 in)	0°C (32°F) to 50°C (122°F)	Ø16-26 mm (0.63-1.02 in) Side & Top	FYD305
FYD305.06	100-465-486	Vee	Serrated Steel	68 mm (2.7 in)	70 mm (2.75 in)	0°C (32°F) to 50°C (122°F)	Ø26-36 mm (1.02-1.41 in) Side & Top	FYD305
FYD305.07	100-465-490	Vee	Rebar	68 mm (2.7 in)	70 mm (2.75 in)	0°C (32°F) to 50°C (122°F)	Ø6-16 mm (0.23-0.63 in)	FYD305
FYD305.08	100-465-491	Vee	Rebar	68 mm (2.7 in)	70 mm (2.75 in)	0°C (32°F) to 50°C (122°F)	Ø16-26 mm (0.63-1.02 in)	FYD305
FYD305.09	100-465-492	Vee	Rebar	68 mm (2.7 in)	70 mm (2.75 in)	0°C (32°F) to 50°C (122°F)	Ø26-36 mm (1.02-1.42 in)	FYD305
FYD305.10	100-629-970	Flat	Sawtooth Steel	68 mm (2.7 in)	70 mm (2.75 in)	0°C (32°F) to 50°C (122°F)	30-36 mm (1.18-1.42 in)	FYD305
FYD305.11	100-629-971	Flat	Sawtooth Steel	68 mm (2.7 in)	70 mm (2.75 in)	0°C (32°F) to 50°C (122°F)	36-40 mm (1.42-1.57 in)	FYD305

FYD605 Grip Optional Faces

FYD605.01	100-490-363	Flat	Sawtooth Steel	83 mm (3.3 in)	90 mm (3.5 in)	0°C (32°F) to 50°C (122°F)	0-6 mm (0-0.23 in)	FYD605
FYD605.02	100-490-364	Flat	Sawtooth Steel	83 mm (3.3 in)	90 mm (3.5 in)	0°C (32°F) to 50°C (122°F)	6-23 mm (0.23-0.9 in)	FYD605
FYD605.03	100-490-365	Flat	Sawtooth Steel	83 mm (3.3 in)	90 mm (3.5 in)	0°C (32°F) to 50°C (122°F)	23-40 mm (0.9-1.57 in)	FYD605
FYD605.04	100-490-366	Vee	Sawtooth Steel	83 mm (3.3 in)	90 mm (3.5 in)	0°C (32°F) to 50°C (122°F)	Ø6-12 mm (0.23-0.47 in)	FYD605
FYD605.05	100-490-367	Vee	Sawtooth Steel	83 mm (3.3 in)	90 mm (3.5 in)	0°C (32°F) to 50°C (122°F)	Ø12-27 mm (0.47-1.06 in)	FYD605
FYD605.06	100-490-368	Vee	Sawtooth Steel	83 mm (3.3 in)	90 mm (3.5 in)	0°C (32°F) to 50°C (122°F)	Ø27-42 mm (1.06-1.65 in)	FYD605
FYD605.07	100-490-369	Vee	Rebar	83 mm (3.3 in)	90 mm (3.5 in)	0°C (32°F) to 50°C (122°F)	Ø6-12 mm (0.23-0.47 in)	FYD605
FYD605.08	100-490-370	Vee	Rebar	83 mm (3.3 in)	90 mm (3.5 in)	0°C (32°F) to 50°C (122°F)	Ø12-27 mm (0.47-1.06 in)	FYD605
FYD605.09	100-490-371	Vee	Rebar	83 mm (3.3 in)	90 mm (3.5 in)	0°C (32°F) to 50°C (122°F)	Ø27-42 mm (1.06-1.65 in)	FYD605
FYD605.10	100-504-191	Vee	Sawtooth Steel	83 mm (3.3 in)	90 mm (3.5 in)	0°C (32°F) to 50°C (122°F)	Ø4-6 mm (0.15-0.23 in)	FYD605

100/200 N and 2 kN MTS Advantage Pneumatic Grips - *Monotonic*

- » Versatile, high-performance pneumatic vise grips designed for a wide range of tensile applications
- » Designed and machined to precise tolerances, eliminating side loads
- » Lightweight to perform low force tests while minimizing your low-capacity load cells capacity
- » Dual-acting grip faces simultaneously move to the centerline of the grip to ensure correct specimen alignment and eliminate bending strains
- » Grips are sold in pairs
- » All specimen interfaces ("faces") are sold separately
- » Operation requires a dry, filtered air supply sold separately
- » Pneumatic gripping controller sold separately
- » **Applications:** Tensile testing of low-breaking-strength specimens, thin sheets, films, tapes, elastomers, plastics, rigid and semi-rigid films and sheets



APG101



APG202



APG203



APG104

Specifications

Model	APG101	APG202	APG203	APG104
Part Number	100-032-017	100-036-576	100-282-342	100-034-623
Grip Type	Pneumatic Vise	Pneumatic Vise	Pneumatic Vise	Pneumatic Wedge
Force Capacity	0.01 kN (2.25 lbf)	0.2 kN (450 lbf)	2 kN (450 lbf)	10 kN (2200 lbf)
Upper Grip Weight	0.27 kg (0.6 lb)	1 kg (2.2 lb)	3.2 kg (7.0 lb)	6.8 kg (15 lb)
Temperature Rating	-40°C (-40°F) to 200°C (400°F)	-40°C (-40°F) to 200°C (400°F)	-40°C (-40°F) to 200°C (400°F)	-40°C (-40°F) to 200°C (400°F)
Attachment Type	B	C	D	D
Combined Upper/Lower Grip Height	326 mm (12.8 in)	360 mm (14.2 in)	454 mm (17.8 in)	396 mm (15.6 in)
Grip Width	71 mm (2.8 in)	114 mm (4.5 in)	147 mm (5.8 in)	210 mm (8.3 in)
Maximum Input Pressure	0.55 MPa (80 PSI)	0.55 MPa (80 PSI)	0.55 MPa (80 PSI)	0.55 MPa (80 PSI)
Compatible Grip Controller Type	MTS Advantage Single Acting Pneumatic Grip Controller/Supply	MTS Advantage Single Acting Pneumatic Grip Controller/Supply	MTS Advantage Single Acting Pneumatic Grip Controller/Supply	MTS Advantage Single Acting Pneumatic Grip Controller/Supply

Tension Grips - *Monotonic*

Manual Activation

MTS Advantage Screw Grips

- » High-performance, versatile screw grips with approximately twice the clamp force of comparably rated pneumatic grips
- » Dual-acting grip faces ensure correct specimen alignment and eliminate bending strains
- » Alignment guide assures concentricity
- » Faces pivot for self-alignment and reduced likelihood of breakage at the specimen face contact
- » Quick and easy interchangeable faces are compatible with MTS pneumatic grips
- » Flexible mounting allows adapters to be easily changed
- » Accommodates threaded configurations
- » Knurled screw for hand tightening of specimen during installation
- » Low profile grip body increases test space, provides room to hold flexible specimens above and below the faces
- » Side-loading design suitable for use in environmental chambers
- » Can be used in a fixed (one side follows through) and non-fixed (both sides follow through) configuration
- » Interchangeable, resilient pucks to allow follow through action, to compensate for specimen neck-down, minimize damage to delicate specimens, and increase clamp load for difficult specimens
- » Temperature range of -129°C to 200°C (-200°F to 400°F) when using the aluminum version of the pucks described above.
- » Grips are sold in pairs
- » All specimen interfaces ("faces") are sold separately
- » **Applications:** Tensile testing of metals, plastics, polymers, and wood with ability to test lap shear specimens



ASG102



ASG503



ASG104

Specifications

Model	ASG102	ASG203	ASG503	ASG104
Part Number	055-426-701	055-426-801	055-426-901	100-030-185
Grip Type	Manual Screw	Manual Screw	Manual Screw	Manual Screw
Force Capacity	0.01 kN (2.25 lbf)	0.2 kN (45 lbf)	2 kN (450 lbf)	10 kN (2,250 lbf)
Upper Grip Weight	0.27 kg (0.6 lb)	1 kg (2.2 lb)	3.2 kg (7.0 lb)	6.8 kg (15.0 lb)
Temperature Rating	-40°C (-40°F) to 200°C (400°F)	-40°C (-40°F) to 200°C (400°F)	-40°C (-40°F) to 200°C (400°F)	-40°C (-40°F) to 200°C (400°F)
Attachment Type	C	D	D	D
Combined Upper/Lower Grip Height	236 mm (9.3 in)	294 mm (11.6 in)	350 mm (13.8 in)	352 mm (13.9 in)
Grip Width	130 mm (5.1 in)	164 mm (6.5 in)	211 mm (8.3 in)	210.6 mm (8.29 in)

Tension Faces - *Monotonic*

APG101 Grip Optional Faces

Model	Part Number	Profile	Surface	Height	Width	Temperature Range	Specimen Range	Compatible Grip Model
APG101.01	056-163-701	Flat	Smooth Steel	8 mm (0.3 in)	15 mm (0.6 in)	-40°C (-40°F) to 200°C (400°F)	0-5 mm (0-0.2 in)	APG101
APG101.02	056-163-702	Flat	Serrated Steel	8 mm (0.3 in)	15 mm (0.6 in)	-40°C (-40°F) to 200°C (400°F)	0-5 mm (0-0.2 in)	APG101
APG101.03	056-163-703	Flat	Smooth Rubber	8 mm (0.3 in)	15 mm (0.6 in)	-40°C (-40°F) to 200°C (400°F)	0-5 mm (0-0.2 in)	APG101

APG202 & APG203 and ASG102 & ASG203 Grip Optional Faces

Model	Part Number	Profile	Surface	Height	Width	Temperature Range	Specimen Range	Compatible Grip Model
APG203.01	056-163-801	Flat	Smooth Steel	25 mm (1.0 in)	25 mm (1.0 in)	-40°C (-40°F) to 200°C (400°F)	APG202: 0-10 mm (0-0.39 in) APG203: 0-12 mm (0-0.47 in) ASG102: 0-12 mm (0-0.47 in) ASG203: 0-19 mm (0-0.75 in)	APG202 APG203 ASG102 ASG203
APG203.02	056-163-802	Flat	Corrugated Rubber	25 mm (1.0 in)	25 mm (1.0 in)	-40°C (-40°F) to 200°C (400°F)	APG202: 0-10 mm (0-0.39 in) APG203: 0-12 mm (0-0.47 in) ASG102: 0-12 mm (0-0.47 in) ASG203: 0-19 mm (0-0.75 in)	APG202 APG203 ASG102 ASG203
APG203.03	056-163-803	Flat	Serrated Steel	25 mm (1.0 in)	25 mm (1.0 in)	-40°C (-40°F) to 200°C (400°F)	APG202: 0-10 mm (0-0.39 in) APG203: 0-12 mm (0-0.47 in) ASG102: 0-12 mm (0-0.47 in) ASG203: 0-19 mm (0-0.75 in)	APG202 APG203 ASG102 ASG203
APG203.04	056-163-804	Flat	Diamond Tip Steel	25 mm (1.0 in)	25 mm (1.0 in)	-40°C (-40°F) to 200°C (400°F)	APG202: 0-10 mm (0-0.39 in) APG203: 0-12 mm (0-0.47 in) ASG102: 0-12 mm (0-0.47 in) ASG203: 0-19 mm (0-0.75 in)	APG202 APG203 ASG102 ASG203
APG203.05	056-163-805	Flat	Matte Rubber	25 mm (1.0 in)	25 mm (1.0 in)	0°C (32°F) to 50°C (122°F)	APG202: 0-10 mm (0-0.39 in) APG203: 0-12 mm (0-0.47 in) ASG102: 0-12 mm (0-0.47 in) ASG203: 0-19 mm (0-0.75 in)	APG202 APG203 ASG102 ASG203
APG203.06	056-163-806	Flat	Corrugated Rubber	25 mm (1.0 in)	25 mm (1.0 in)	0°C (32°F) to 50°C (122°F)	APG202: 0-10 mm (0-0.39 in) APG203: 0-12 mm (0-0.47 in) ASG102: 0-12 mm (0-0.47 in) ASG203: 0-19 mm (0-0.75 in)	APG202 APG203 ASG102 ASG203
APG203.07	056-163-807	Flat	Smooth Rubber	25 mm (1.0 in)	25 mm (1.0 in)	0°C (32°F) to 50°C (122°F)	APG202: 0-10 mm (0-0.39 in) APG203: 0-12 mm (0-0.47 in) ASG102: 0-12 mm (0-0.47 in) ASG203: 0-19 mm (0-0.75 in)	APG202 APG203 ASG102 ASG203
APG203.08	056-163-808	Flat	Line Contact steel R4.75 mm (0.187 in)	13 mm (0.5 in)	25 mm (1.0 in)	-40°C (-40°F) to 200°C (400°F)	APG202: 0-10 mm (0-0.39 in) APG203: 0-12 mm (0-0.47 in) ASG102: 0-12 mm (0-0.47 in) ASG203: 0-19 mm (0-0.75 in)	APG202 APG203 ASG102 ASG203
APG203.09	056-163-809	Flat	Smooth Steel	25 mm (1.0 in)	75 mm (3.0 in)	-40°C (-40°F) to 200°C (400°F)	APG202: 0-10 mm (0-0.39 in) APG203: 0-12 mm (0-0.47 in) ASG102: 0-12 mm (0-0.47 in) ASG203: 0-19 mm (0-0.75 in)	APG202 APG203 ASG102 ASG203
APG203.10	056-163-810	Flat	Corrugated Steel	25 mm (1.0 in)	75 mm (3.0 in)	-40°C (-40°F) to 200°C (400°F)	APG202: 0-10 mm (0-0.39 in) APG203: 0-12 mm (0-0.47 in) ASG102: 0-12 mm (0-0.47 in) ASG203: 0-19 mm (0-0.75 in)	APG202 APG203 ASG102 ASG203

Tension Faces - Monotonic

APG202 & APG203 and ASG102 & ASG203 Grip Optional Faces (continued)

Model	Part Number	Profile	Surface	Height	Width	Temperature Range	Specimen Range	Compatible Grip Model
APG203.11	056-163-811	Flat	Serrated Steel	25 mm (1.0 in)	75 mm (3.0 in)	-40°C (-40°F) to 200°C (400°F)	APG202: 0-10 mm (0-0.39 in) APG203: 0-12 mm (0-0.47 in) ASG102: 0-12 mm (0-0.47 in) ASG203: 0-19 mm (0-0.75 in)	APG202 APG203 ASG102 ASG203
APG203.12	056-163-812	Flat	Diamond Tip Steel	25 mm (1.0 in)	75 mm (3.0 in)	-40°C (-40°F) to 200°C (400°F)	APG202: 0-10 mm (0-0.39 in) APG203: 0-12 mm (0-0.47 in) ASG102: 0-12 mm (0-0.47 in) ASG203: 0-19 mm (0-0.75 in)	APG202 APG203 ASG102 ASG203
APG203.13	056-163-813	Flat	Matte Rubber	25 mm (1.0 in)	75 mm (3.0 in)	0°C (32°F) to 50°C (122°F)	APG202: 0-10 mm (0-0.39 in) APG203: 0-12 mm (0-0.47 in) ASG102: 0-12 mm (0-0.47 in) ASG203: 0-19 mm (0-0.75 in)	APG202 APG203 ASG102 ASG203
APG203.14	056-163-814	Flat	Corrugated Rubber	25 mm (1.0 in)	75 mm (3.0 in)	0°C (32°F) to 50°C (122°F)	APG202: 0-10 mm (0-0.39 in) APG203: 0-12 mm (0-0.47 in) ASG102: 0-12 mm (0-0.47 in) ASG203: 0-19 mm (0-0.75 in)	APG202 APG203 ASG102 ASG203
APG203.15	056-163-815	Flat	Smooth Rubber	25 mm (1.0 in)	75 mm (3.0 in)	0°C (32°F) to 50°C (122°F)	APG202: 0-10 mm (0-0.39 in) APG203: 0-12 mm (0-0.47 in) ASG102: 0-12 mm (0-0.47 in) ASG203: 0-19 mm (0-0.75 in)	APG202 APG203 ASG102 ASG203
APG203.16	056-163-816	Flat	Smooth Steel	38 mm (1.5 in)	58 mm (2.3 in)	-40°C (-40°F) to 200°C (400°F)	APG202: 0-10 mm (0-0.39 in) APG203: 0-12 mm (0-0.47 in) ASG102: 0-12 mm (0-0.47 in) ASG203: 0-19 mm (0-0.75 in)	APG202 APG203 ASG102 ASG203
APG203.17	056-163-817	Flat	Corrugated Steel	38 mm (1.5 in)	58 mm (2.3 in)	-40°C (-40°F) to 200°C (400°F)	APG202: 0-10 mm (0-0.39 in) APG203: 0-12 mm (0-0.47 in) ASG102: 0-12 mm (0-0.47 in) ASG203: 0-19 mm (0-0.75 in)	APG202 APG203 ASG102 ASG203
APG203.18	056-163-818	Flat	Serrated Steel	38 mm (1.5 in)	58 mm (2.3 in)	-40°C (-40°F) to 200°C (400°F)	APG202: 0-10 mm (0-0.39 in) APG203: 0-12 mm (0-0.47 in) ASG102: 0-12 mm (0-0.47 in) ASG203: 0-19 mm (0-0.75 in)	APG202 APG203 ASG102 ASG203
APG203.19	056-163-819	Flat	Diamond Tip Steel	38 mm (1.5 in)	58 mm (2.3 in)	-40°C (-40°F) to 200°C (400°F)	APG202: 0-10 mm (0-0.39 in) APG203: 0-12 mm (0-0.47 in) ASG102: 0-12 mm (0-0.47 in) ASG203: 0-19 mm (0-0.75 in)	APG202 APG203 ASG102 ASG203
APG203.20	056-163-820	Flat	Matte Rubber	38 mm (1.5 in)	58 mm (2.3 in)	0°C (32°F) to 50°C (122°F)	APG202: 0-10 mm (0-0.39 in) APG203: 0-12 mm (0-0.47 in) ASG102: 0-12 mm (0-0.47 in) ASG203: 0-19 mm (0-0.75 in)	APG202 APG203 ASG102 ASG203
APG203.21	056-163-821	Flat	Corrugated Rubber	38 mm (1.5 in)	58 mm (2.3 in)	0°C (32°F) to 50°C (122°F)	APG202: 0-10 mm (0-0.39 in) APG203: 0-12 mm (0-0.47 in) ASG102: 0-12 mm (0-0.47 in) ASG203: 0-19 mm (0-0.75 in)	APG202 APG203 ASG102 ASG203
APG203.22	056-163-822	Flat	Smooth Rubber	38 mm (1.5 in)	58 mm (2.3 in)	0°C (32°F) to 50°C (122°F)	APG202: 0-10 mm (0-0.39 in) APG203: 0-12 mm (0-0.47 in) ASG102: 0-12 mm (0-0.47 in) ASG203: 0-19 mm (0-0.75 in)	APG202 APG203 ASG102 ASG203
APG203.23	056-163-823	Flat	Line contact steel R4.75mm (0.187 in)	13 mm (0.5 in)	58 mm (2.3 in)	-40°C (-40°F) to 200°C (400°F)	APG202: 0-10 mm (0-0.39 in) APG203: 0-12 mm (0-0.47 in) ASG102: 0-12 mm (0-0.47 in) ASG203: 0-19 mm (0-0.75 in)	APG202 APG203 ASG102 ASG203

(continued next page...)

Tension Faces - Monotonic

APG202 & APG203 and ASG102 & ASG203 Grip Optional Faces (continued)

Model	Part Number	Profile	Surface	Height	Width	Temperature Range	Specimen Range	Compatible Grip Model
APG203.24	056-163-824	Flat	Grab Test Steel	38 mm (1.5 in), contact area 25mm (1.0 in)	58 mm (2.3 in), contact area 38mm (1.5 in)	-40°C (-40°F) to 200°C (400°F)	APG202: 0-10 mm (0-0.39 in) APG203: 0-12 mm (0-0.47 in) ASG102: 0-12 mm (0-0.47 in) ASG203: 0-19 mm (0-0.75 in)	APG202 APG203 ASG102 ASG203
APG203.25	056-163-825	Flat	Smooth Rubber	12 mm (0.5 in)	25 mm (1.0 in)	0°C (32°F) to 50°C (122°F)	APG202: 0-10 mm (0-0.39 in) APG203: 0-12 mm (0-0.47 in) ASG102: 0-12 mm (0-0.47 in) ASG203: 0-19 mm (0-0.75 in)	APG202 APG203 ASG102 ASG203
APG203.26	056-163-826	Flat	Smooth rubber/ line contact R4.75mm (0.187 in)	25 mm (1.0 in)	25 mm (1.0 in)	0°C (32°F) to 50°C (122°F)	APG202: 0-10 mm (0-0.39 in) APG203: 0-12 mm (0-0.47 in)	APG202 APG203
APG203.27	056-163-827	Flat	Smooth rubber/ line contact R4.75mm (0.187 in)	38 mm (1.5 in)	58 mm (2.3 in)	0°C (32°F) to 50°C (122°F)	APG202: 0-10 mm (0-0.39 in) APG203: 0-12 mm (0-0.47 in)	APG202 APG203
APG203.28	056-163-828	Flat	Diamond Tip Steel	25 mm (1.0 in)	150 mm (5.9 in)	-40°C (-40°F) to 200°C (400°F)	APG202: 0-10 mm (0-0.39 in) APG203: 0-12 mm (0-0.47 in)	APG202 APG203
APG203.29	056-163-829	Flat	Smooth rubber/ line contact R2.5mm (0.098 in)	25 mm (1.0 in)	25 mm (1.0 in)	-40°C (-40°F) to 200°C (400°F)	APG202: 0-10 mm (0-0.39 in) APG203: 0-12 mm (0-0.47 in)	APG202 APG203
APG203.30	056-163-830	Flat	Smooth Rubber	25 mm (1.0 in)	150 mm (5.9 in)	0°C (32°F) to 50°C (122°F)	APG202: 0-10 mm (0-0.39 in) APG203: 0-12 mm (0-0.47 in)	APG202 APG203
APG203.31	056-163-832	Flat	Smooth Rubber	25 mm (1.0 in)	100 mm (3.9 in)	0°C (32°F) to 50°C (122°F)	APG202: 0-10 mm (0-0.39 in) APG203: 0-12 mm (0-0.47 in)	APG202 APG203

ASG503 & ASG104 Grip Optional Faces

Model	Part Number	Profile	Surface	Height	Width	Temperature Range	Specimen Range	Compatible Grip(s)
ASG104.01	056-163-901	Flat	Smooth Steel	50 mm (2.0 in)	75 mm (3.0 in)	-40°C (-40°F) to 200°C (400°F)	0-25 mm (0-1.0 in)	ASG503
ASG104.02	056-163-902	Flat	Corrugated Steel	50 mm (2.0 in)	75 mm (3.0 in)	-40°C (-40°F) to 200°C (400°F)	0-25 mm (0-1.0 in)	ASG503 ASG104
ASG104.03	056-163-903	Flat	Serrated Steel	50 mm (2.0 in)	75 mm (3.0 in)	-40°C (-40°F) to 200°C (400°F)	0-25 mm (0-1.0 in)	ASG503 ASG104
ASG104.04	056-163-904	Flat	Diamond Tip Steel	50 mm (2.0 in)	75 mm (3.0 in)	-40°C (-40°F) to 200°C (400°F)	0-25 mm (0-1.0 in)	ASG503 ASG104
ASG104.05	056-163-905	Flat	Matte Rubber	50 mm (2.0 in)	75 mm (3.0 in)	0°C (32°F) to 50°C (122°F)	0-25 mm (0-1.0 in)	ASG503 ASG104
ASG104.06	056-163-906	Flat	Corrugated Rubber	50 mm (2.0 in)	75 mm (3.0 in)	0°C (32°F) to 50°C (122°F)	0-25 mm (0-1.0 in)	ASG503 ASG104
ASG104.07	056-163-907	Flat	Smooth Rubber	50 mm (2.0 in)	75 mm (3.0 in)	0°C (32°F) to 50°C (122°F)	0-25 mm (0-1.0 in)	ASG503 ASG104
ASG104.08	056-163-908	Flat	Line contact steel R4.75mm (0.187 in)	20 mm (0.8 in)	75 mm (3.0 in)	-40°C (-40°F) to 200°C (400°F)	0-25 mm (0-1.0 in)	ASG503 ASG104
ASG104.09	056-163-909	Flat	Grab Test Steel	50 mm (2.0 in), contact area 25mm (1.0 in)	75 mm (3.0 in), contact area 25mm (1.0 in)	-40°C (-40°F) to 200°C (400°F)	0-25 mm (0-1.0 in)	ASG503 ASG104
ASG104.10	056-163-910	Flat	Line rubber/ line contact R4.75mm (0.187 in)	50 mm (2.0 in)	75 mm (3.0 in)	0°C (32°F) to 50°C (122°F)	0-25 mm (0-1.0 in)	ASG503 ASG104

Tension Wedges - Monotonic

MTS Advantage APG104 Grip Wedges

Model	Part Number	Profile	Surface	Height	Width	Temperature Range	Specimen Range	Compatible Grip(s)
647.02B.03	050-507-905	Flat	Sawtooth Steel	38 mm (1.5 in)	25 mm (1.0 in)	-40°C (-40°F) to 177°C (350°F)	18.8-25.9 mm (0.74-1.02 in)	APG104
647.02B.04	050-507-906	Flat	Sawtooth Steel	38 mm (1.5 in)	25 mm (1.0 in)	-40°C (-40°F) to 177°C (350°F)	0-7.2 mm (0-0.28 in)	APG104
647.02B.05	050-507-907	Flat	Sawtooth Steel	38 mm (1.5 in)	25 mm (1.0 in)	-40°C (-40°F) to 177°C (350°F)	7.2-14.4 mm (0.28-0.57 in)	APG104
647.02B.06	050-507-908	Vee	Diamond Tip Steel	38 mm (1.5 in)	25 mm (1.0 in)	-40°C (-40°F) to 177°C (350°F)	ø3-8.1 mm (0.12-0.32 in) Side, ø9.4 mm (0.37 in) Top	APG104
647.02B.07	050-507-909	Vee	Diamond Tip Steel	38 mm (1.5 in)	25 mm (1.0 in)	-40°C (-40°F) to 177°C (350°F)	ø8.9-10.9 mm (0.35-0.43 in) Side, ø15.2 mm (0.60 in) Top	APG104
647.02B.08	050-507-910	Vee	Diamond Tip Steel	38 mm (1.5 in)	25 mm (1.0 in)	-40°C (-40°F) to 177°C (350°F)	ø14-18 mm (0.55-0.71 in) Side, ø20.8 mm (0.82 in) Top	APG104
647.02B.09	050-507-911	Vee	Diamond Tip Steel	38 mm (1.5 in)	25 mm (1.0 in)	-40°C (-40°F) to 177°C (350°F)	ø20.1-22.9 mm (0.79-0.90 in) Side, ø27.2 mm (1.07 in) Top	APG104
647.02B.10	050-507-912	Round	Surfallo	38 mm (1.5 in)	25 mm (1.0 in)	-40°C (-40°F) to 177°C (350°F)	ø10.0 mm (0.3937 in)	APG104
647.02B.11	050-507-913	Round	Surfallo	38 mm (1.5 in)	25 mm (1.0 in)	-40°C (-40°F) to 177°C (350°F)	ø15.0 mm (0.5906 in)	APG104
647.02B.12	050-507-914	Round	Surfallo	38 mm (1.5 in)	25 mm (1.0 in)	-40°C (-40°F) to 177°C (350°F)	Ø25.0 mm (0.9843 in)	APG104
647.02B.13	050-507-915	Round	Surfallo	38 mm (1.5 in)	25 mm (1.0 in)	-40°C (-40°F) to 177°C (350°F)	ø12.7 mm (0.5000 in)	APG104
647.02B.14	050-507-917	Flat	Surfallo	38 mm (1.5 in)	25 mm (1.0 in)	-40°C (-40°F) to 177°C (350°F)	0-7.2 mm (0-0.28 in)	APG104
647.02B.15	050-507-918	Flat	Surfallo	38 mm (1.5 in)	25 mm (1.0 in)	-40°C (-40°F) to 177°C (350°F)	7.2-14.4 mm (0.28-0.57 in)	APG104
647.02B.16	054-585-001	Flat	Sawtooth Steel	38 mm (1.5 in)	50 mm (2.0 in)	-40°C (-40°F) to 177°C (350°F)	0-7.1 mm (0-0.28 in)	APG104
647.02B.17	054-585-002	Flat	Sawtooth Steel	38 mm (1.5 in)	50 mm (2.0 in)	-40°C (-40°F) to 177°C (350°F)	7.1-13.4 mm (0.28-0.57 in)	APG104
647.02B.18	054-585-003	Flat	Sawtooth Steel	38 mm (1.5 in)	50 mm (2.0 in)	-40°C (-40°F) to 177°C (350°F)	13.5-20.5 mm (0.53-0.81 in)	APG104
647.02B.19	054-585-004	Flat	Sawtooth Steel	38 mm (1.5 in)	50 mm (2.0 in)	-40°C (-40°F) to 177°C (350°F)	16.9-24.0 mm (0.66-0.95 in)	APG104
647.02B.20	052-818-701	Flat-water cooled	Diamond Tip Steel	38 mm (1.5 in)	25 mm (1.0 in)	-130°C (-200°F) to 315°C (600°F)	0-7.1 mm (0-0.28 in)	APG104
647.02B.21	052-818-702	Flat-water cooled	Surfallo	38 mm (1.5 in)	25 mm (1.0 in)	-130°C (-200°F) to 315°C (600°F)	0-7.1 mm (0-0.28 in)	APG104

Tension Grips - *Monotonic*

Manual Activation

MTS Advantage Wedge Grips

- » High-performance, versatile wedge grips with higher clamping force than screw or pneumatic grips
- » Faces remain stationary during loading to minimize compressive or buckling forces during specimen insertion
- » Anti-rotation features and integrated alignment pins enhance test accuracy and repeatability
- » Available with interchangeable faces for serrated wedges for round or flat specimens
- » Self-tightening during testing reduces slippage
- » Grips are sold in pairs
- » All specimen interfaces (“wedges”) are sold separately
- » **Applications:** Tensile testing of metals, composites, ceramics, plastics and wood/paper products



AWG504

Specifications

Model	AWG104	AWG304	AWG504	AWG105	AWG305
Part Number	056-079-501	052-862-001	054-951-001	056-079-801	100-270-777
Grip Type	Manual Wedge	Manual Wedge	Manual Wedge	Manual Wedge	Manual Wedge
Force Capacity	10 kN (2,250 lbf)	30 kN (6,740 lbf)	50 kN (11,240 lbf)	100 kN (22,480 lbf)	300 kN (67,440 lbf)
Upper Grip Weight	4.6 kg (10.0 lb)	5 kg (11 lb)	6.4 kg (14 lb)	13.6 kg (30 lb)	53.5 kg (118 lb)
Temperature Rating	-130°C (-200°F) to 315°C (600°F)	-130°C (-200°F) to 315°C (600°F)	-130°C (-200°F) to 315°C (600°F)	-130°C (-200°F) to 315°C (600°F)	-130°C (-200°F) to 315°C (600°F)
Attachment Type	D	D	D	D	E
Combined Upper/Lower Grip Height	432 mm (17 in)	494 mm (19.5 in)	504 mm (19.8 in)	528 mm (20.8 in)	686 mm (27 in)
Grip Width	197 mm (7.8 in)	197 mm (7.8 in)	206 mm (8.1 in)	243 mm (9.6 in)	407 mm (16.0 in)

Tension Wedges - Monotonic

AWG104, AWG304 & AWG504 Grip Optional Wedges

Model	Part Number	Profile	Surface	Height	Width	Temperature Range	Specimen Range	Compatible Grip(s)
AWG504.01	053-140-801	Flat	Sawtooth Steel	50 mm (2.0 in)	25 mm (1.0 in)	-130°C (-200°F) to 315°C (600°F)	0-7.9 mm (0-0.31 in)	AWG104 AWG304 AWG504
AWG504.02	053-140-802	Flat	Sawtooth Steel	50 mm (2.0 in)	25 mm (1.0 in)	-130°C (-200°F) to 315°C (600°F)	6-13.2 mm (0.23-0.52 in)	AWG104 AWG304 AWG504
AWG504.03	053-140-803	Vee	Serrated Steel	50 mm (2.0 in)	25 mm (1.0 in)	-130°C (-200°F) to 315°C (600°F)	ø3-7.9 mm (0.12-0.31 in) Side, ø7.9 mm (0.31 in) Top	AWG104 AWG304 AWG504
AWG504.04	053-140-804	Vee	Serrated Steel	50 mm (2.0 in)	25 mm (1.0 in)	-130°C (-200°F) to 315°C (600°F)	ø7-9.5 mm (0.27-0.38 in) Side, ø12.7 mm (0.50 in) Top	AWG104 AWG304 AWG504
AWG504.05	053-140-805	Vee	Serrated Steel	50 mm (2.0 in)	25 mm (1.0 in)	-130°C (-200°F) to 315°C (600°F)	ø11.5-12.7 mm (0.45-0.50 in) Side, ø16 mm (0.63 in) Top	AWG104 AWG304 AWG504
AWG504.06	053-140-806	Flat	Surfallo	50 mm (2.0 in)	25 mm (1.0 in)	-130°C (-200°F) to 315°C (600°F)	0-7.9 mm (0-0.31 in)	AWG104 AWG304 AWG504
AWG504.07	053-140-807	Vee	Serrated Steel	50 mm (2.0 in)	25 mm (1.0 in)	-130°C (-200°F) to 315°C (600°F)	ø1.5-5 mm (0.06-0.20 in) Side, ø5 mm (0.20 in) Top	AWG104 AWG304 AWG504

AWG105 & AWG305 Grip Optional Wedges

Model	Part Number	Profile	Surface	Height	Width	Temperature Range	Specimen Range	Compatible Grip(s)
AWG305.01	053-537-401	Flat	Sawtooth Steel	70 mm (2.75 in)	50 mm (2.0 in)	-130°C (-200°F) to 315°C (600°F)	0-9 mm (0-0.35 in)	AWG105 AWG305
AWG305.02	053-537-402	Flat	Sawtooth Steel	70 mm (2.75 in)	50 mm (2.0 in)	-130°C (-200°F) to 315°C (600°F)	6.4-16 mm (0.25-0.63 in)	AWG105 AWG305
AWG305.03	053-537-403	Vee	Serrated Steel	70 mm (2.75 in)	50 mm (2.0 in)	-130°C (-200°F) to 315°C (600°F)	ø5-10.4 mm (0.20-0.41 in) Side, ø12.5 mm (0.49 in) Top	AWG105 AWG305
AWG305.04	053-537-404	Vee	Serrated Steel	70 mm (2.75 in)	50 mm (2.0 in)	-130°C (-200°F) to 315°C (600°F)	ø12.2-16.5 mm (0.48-0.61 in) Side, ø19.5 mm (0.77 in) Top	AWG105 AWG305
AWG305.05	053-537-405	Vee	Serrated Steel	70 mm (2.75 in)	50 mm (2.0 in)	-130°C (-200°F) to 315°C (600°F)	ø3.2-5.8 mm (0.12-0.23 in) Side, ø7.6 mm (0.30 in) Top	AWG105 AWG305
AWG305.06	053-537-406	Flat	Surfallo	70 mm (2.75 in)	50 mm (2.0 in)	-130°C (-200°F) to 315°C (600°F)	0-9 mm (0-0.35 in)	AWG105 AWG305
AWG305.07	053-537-407	Round	Surfallo	770 mm (2.75 in)	50 mm (2.0 in)	-130°C (-200°F) to 315°C (600°F)	ø12.70 mm (0.5000 in)	AWG105 AWG305

Tension Grips - *Monotonic*

Hydraulic Activation

MTS Fundamental Bollard Grips

- » Affordable pneumatic gripping mechanism minimizes specimen slippage
- » “Horn” style design reduces stress concentration on specimens and avoids grip-induced failures.
- » Adjustable pressure allows clamping forces to be used for testing a variety of materials
- » Grips are sold in pairs
- » Specimen interface (“face”) is integrated with each grip
- » Operation requires a dry, filtered air supply sold separately
- » Pneumatic gripping controller sold separately
- » **Applications:** Tensile testing of cords, filaments, fibers, fine wire, yarns



Specifications

Model	FCQA502A	FPB503
Part Number	100-231-830	100-139-065
Grip Type	Pneumatic Bollard	Pneumatic Bollard
Force Capacity	0.5 kN (112 lbf)	5 kN (1,125 lbf)
Upper Grip Weight	1.12 kg (2.4 lbs)	2 kg (4.4 lbs)
Temperature Rating	0°C (32°F) to 50°C (122°F)	-40°C (-40°F) to 80°C (176°F)
Attachment Type	D	D
Combined Upper/Lower Grip Height	326 mm (12.8 in)	410 mm (16 in)
Grip Width	154 mm (6.0 in)	198 mm (7.8 in)
Maximum Input Pressure	0.55 MPa (80 PSI)	0.55 MPa (80 PSI)
Compatible Grip Controller Type	MTS Fundamental Dual Acting Pneumatic Grip Controller/Supply	MTS Advantage Single Acting Pneumatic Grip Controller/Supply

Integrated Specimen Interface

Profile	Flat	Flat
Surface	Smooth Steel	Smooth Steel
Minimum Length	300 mm (11.8 in)	255 mm (10 in)
Specimen Range	0-1.5 mm (0-0.04 in)	∅0-5 mm (∅0-0.2 in)

Tension Grips - *Monotonic*

Pneumatic Activation

MTS Fundamental Pneumatic Vise Grips

- » Affordable pneumatic vise grips designed for a wide range of tensile applications
- » Anti-rotation features and integrated alignment pins enhance test accuracy and repeatability
- » Grips are sold in pairs
- » Operation requires a dry, filtered air supply sold separately
- » Pneumatic gripping controller sold separately
- » **Applications:** Tensile testing of paper, plastic film, textiles, sheet materials and packaging components

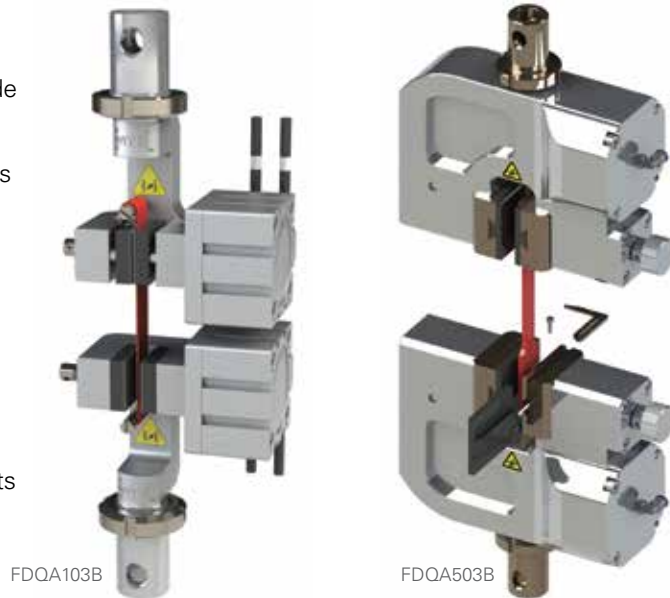

FDQA103B

FDQA503B

Specifications

Model	FDQA103B	FDQA503B
Part Number	100-231-831	100-279-862
Grip Type	Pneumatic Vise	Pneumatic Vise
Force Capacity	1 kN (225 lbf)	5 kN (1,125 lbf)
Upper Grip Weight	1.26 kg (2.7 lb)	5.48 kg (12.1 lb)
Temperature Rating	0°C (32°F) to 50°C (122°F)	0°C (32°F) to 50°C (122°F)
Attachment Type	D	D
Combined Upper/Lower Grip Height	330 mm (13 in)	430 mm (16.9 in)
Grip Width	130 mm (5.1 in)	231 mm (9.1 in)
Maximum Input Pressure	0.55 MPa (80 PSI)	0.55 MPa (80 PSI)
Compatible Grip Controller Type	MTS Fundamental Dual Acting Pneumatic Grip Controller/Supply	MTS Advantage Single Acting Pneumatic Grip Controller/Supply

FDQA103B Integrated Specimen Interface

Profile	Flat
Surface	Rubber
Height	30 mm (1.2 in)
Width	35 mm (1.4 in)
Specimen Range	0-8 mm (0-0.3 in)

FDQA503B Optional Specimen Interfaces

Model	Part Number	Profile	Surface	Height	Width	Temperature Range	Specimen Range
FDQA503B.01	100-281-153	Flat	Rubber	50 mm (2 in)	60 mm (2.4 in)	0°C (32°F) to 50°C (122°F)	0-14 mm (0-0.55 in)
FDQA503B.02	100-281-154	Flat	Sawtooth	50 mm (2 in)	60 mm (2.4 in)	0°C (32°F) to 50°C (122°F)	0-14 mm (0-0.55 in)

Tension Grips - *Monotonic*

Manual Activation

MTS Fundamental Bollard Grips

- » Affordable grips designed to reduce stress concentration on specimens and avoid grip-induced failures
- » Anti-rotation features and integrated alignment pins enhance test accuracy and repeatability
- » Grips are sold in pairs
- » Specimen interface ("face") is integrated with each grip
- » **Applications:** Tensile tests of cords, filaments, fibers, fine wire and yarn

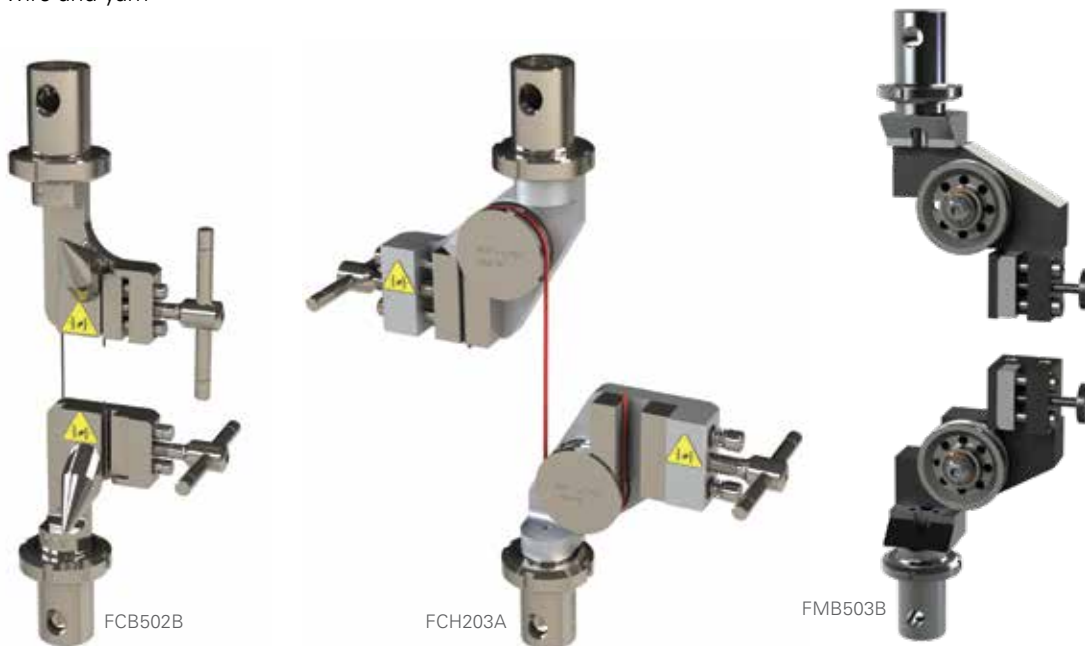

Specifications

Model	FCB502B	FCH203A	FMB503A	FMB503B
Part Number	100-231-828	100-231-829	100-034-764	100-034-765
Grip Type	Manual Bollard	Manual Bollard	Manual Bollard	Manual Bollard
Force Capacity	0.5 kN (112 lbf)	2 kN (450 lbf)	5 kN (1,125 lbf)	5 kN (1,125 lbf)
Upper Grip Weight	0.91 kg (2.0 lbs)	1.07 kg (2.4 lbs)	0.84 kg (1.8 lbs)	1.1 kg (2.4 lbs)
Temperature Rating	0°C (32°F) to 50°C (122°F)	0°C (32°F) to 50°C (122°F)	-40°C (-40°F) to 200°C (392°F)	-40°C (-40°F) to 200°C (392°F)
Attachment Type	D	D	D	D
Combined Upper/Lower Grip Height	280 mm (11 in)	316 mm (12.4 in)	310 mm (12.2 in)	368 mm (14.4 in)
Grip Width	114.4 mm (2.3 in)	177 mm (7.0 in)	108 mm (4.2 in)	134 mm (5.3 in)

Integrated Specimen Interface

Profile	Flat	Flat	Flat	Flat
Surface	Smooth Steel	Smooth Steel	Sawtooth Steel	Sawtooth Steel
Minimum Length	190 mm (7.5 in)	250 mm (4.8 in)	300 mm (11.8 in)	450 mm (17.7 in)
Specimen Range	∅0-1.5 mm (∅0-0.04 in)	∅0-1.5 mm (∅0-0.04 in)	∅0-4 mm (∅0-0.16 in)	∅0-6 mm (∅0-0.23 in)

Tension Grips - *Monotonic*

Manual Activation

MTS Fundamental High Force Bollard Grips

- » Affordable grips designed to reduce stress concentration on specimens and avoid grip-induced failures
- » Anti-rotation features and integrated alignment pins enhance test accuracy and repeatability
- » Grips are sold in pairs
- » Specimen interface ("face") is integrated with each grip
- » **Applications:** Higher force tensile tests of cords, filaments, fibers, fine wire, and yarn



FCA104B

Specifications

Model	FCA104B	ZLD204	FMB205
Part Number	100-258-157	100-302-722	100-409-047
Grip Type	Manual Bollard	Manual Bollard	Manual Bollard
Force Capacity	10 kN (2,250 lbf)	20 kN (4,500 lbf)	200 kN (45,000 lbf)
Upper Grip Weight	2.2 kg (4.8 lb)	2.07 kg (4.6 lb)	21.5 kg (47.4 lb)
Temperature Rating	0°C (32°F) to 50°C (122°F)	0°C (32°F) to 50°C (122°F)	0°C (32°F) to 50°C (122°F)
Attachment Type	D	20	E
Combined Upper/Lower Grip Height	430 mm (16.9 in)	514 mm (20.2 in)	740 mm (29.1 in)
Grip Width	166 mm (6.5 in)	55 mm (2.2 in)	281 mm (11 in)

Integrated Specimen Interface

Profile	Flat	Flat	Flat
Surface	Sawtooth Steel	Smooth Steel	Smooth Steel
Minimum Length	650 mm (25.6 in)	1040 mm (41 in)	3500 mm (137 in)
Specimen Range	ø0-2 mm (ø0-0.08 in)	ø0-15 mm (ø0-0.2 in)	ø8-12 mm (ø0.31-0.47 in)

Tension Grips - *Monotonic*

Manual Activation

MTS Fundamental Nut & Bolt Grips

- » Affordable nut and bolt grips that enable tension, proof load and wedge load tests
- » Accommodates two types of loading plates and a selection of inserts for testing bolts on a wide range of thread configurations and a wide range of nut configurations
- » Anti-rotation features and integrated alignment pins enhance test accuracy and repeatability
- » Grips are sold in pairs
- » All specimen interfaces (inserts) are sold separately
- » **Applications:** Tensile, proof load and wedge load tests of bolts, screws, studs, nuts, washers, and rivets



Specifications

Model	FLA105B	FLA305A	FLA605B
Part Number	100-258-716	100-637-668	100-532-788
Grip Type	Nut & Bolt	Nut & Bolt	Nut & Bolt
Force Capacity	100 kN (22,480 lbf)	300 kN (67,440 lbf)	600 kN (134,885 lbf)
Upper Grip Weight	4.1 kg (9.0 lb)	20 kg (44.1 lb)	16.9 kg (37.3 lb)
Temperature Rating	0°C (32°F) to 50°C (122°F)	0°C (32°F) to 50°C (122°F)	0°C (32°F) to 50°C (122°F)
Attachment Type	D	E	38 mm post
Combined Upper/Lower Grip Height	314 mm (12.3 in)	516 mm (20.3 in)	540 mm (21.2 in)
Grip Width	134 mm (5.3 in)	187 mm (7.4 in)	205 mm (8 in)

Tension Inserts - *Monotonic*

FLA105B Grip Optional Inserts

Model	Part Number	Profile	Temperature Range	Specimen Range	Compatible Grip Model
FLA105B.01	100-258-717	Bolt	0°C (32°F) to 50°C (122°F)	M4	FLA105B
FLA105B.02	100-258-718	Bolt	0°C (32°F) to 50°C (122°F)	M5	FLA105B
FLA105B.03	100-258-719	Bolt	0°C (32°F) to 50°C (122°F)	M6	FLA105B
FLA105B.04	100-258-720	Bolt	0°C (32°F) to 50°C (122°F)	M8	FLA105B
FLA105B.05	100-258-721	Bolt	0°C (32°F) to 50°C (122°F)	M10	FLA105B
FLA105B.06	100-258-722	Bolt	0°C (32°F) to 50°C (122°F)	M12	FLA105B
FLA105B.07	100-258-723	Nut	0°C (32°F) to 50°C (122°F)	M4	FLA105B
FLA105B.08	100-258-724	Nut	0°C (32°F) to 50°C (122°F)	M5	FLA105B
FLA105B.09	100-258-725	Nut	0°C (32°F) to 50°C (122°F)	M6	FLA105B
FLA105B.10	100-258-726	Nut	0°C (32°F) to 50°C (122°F)	M8	FLA105B
FLA105B.11	100-258-727	Nut	0°C (32°F) to 50°C (122°F)	M10	FLA105B
FLA105B.12	100-258-728	Nut	0°C (32°F) to 50°C (122°F)	M12	FLA105B

FLA305B Grip Optional Inserts

FLA305A.00	100-456-909	Adapter	0°C (32°F) to 50°C (122°F)	Adapter to FLA105B inserts	FLA305B
FLA305A.01	100-456-956	Bolt	0°C (32°F) to 50°C (122°F)	M12x1.75	FLA305A
FLA305A.02	100-456-958	Bolt	0°C (32°F) to 50°C (122°F)	M16x2	FLA305A
FLA305A.03	100-456-960	Bolt	0°C (32°F) to 50°C (122°F)	M20x2.5	FLA305A
FLA305A.04	100-456-962	Bolt	0°C (32°F) to 50°C (122°F)	M24x3	FLA305A
FLA305A.05	100-456-963	Bolt	0°C (32°F) to 50°C (122°F)	1/2-13	FLA305A
FLA305A.06	100-456-964	Bolt	0°C (32°F) to 50°C (122°F)	5/8-11	FLA305A
FLA305A.07	100-456-965	Bolt	0°C (32°F) to 50°C (122°F)	3/4-10	FLA305A

FLA605B Grip Optional Inserts

FLA605B.01	100-534-774	Bolt	0°C (32°F) to 50°C (122°F)	M20	FLA605B
FLA605B.02	100-534-775	Bolt	0°C (32°F) to 50°C (122°F)	M22	FLA605B
FLA605B.03	100-534-776	Bolt	0°C (32°F) to 50°C (122°F)	M24	FLA605B
FLA605B.04	100-534-777	Bolt	0°C (32°F) to 50°C (122°F)	M27	FLA605B

Tension Grips - *Monotonic*

Manual Activation

MTS Fundamental Roller Grips

- » Affordable roller grips designed for quick loading and self-tightening
- » Anti-rotation features and integrated alignment pins enhance test accuracy and repeatability
- » Wound up specimen clamping prevents stress concentration and damage outside of test range
- » Clamping force may be increased by winding the specimen around the movable part of the grip
- » Grips are sold in pairs
- » Specimen interface (“drum”) is integrated with each grip
- » **Applications:** Tensile tests of bandages, textiles, synthetics, and flexible polymers



FMR503



CB504E



FCA105C

Specifications

Model	FMR503	CB504E	FCA105C
Part Number	100-033-790	100-302-702	100-257-526
Grip Type	Manual Roller	Manual Roller	Manual Roller
Force Capacity	5 kN (1,125 lbf)	50 kN (11,250 lbf)	100 kN (22,000 lbf)
Upper Grip Weight	0.74 kg (1.6 lbs)	8.34 kg (18.4 lb)	8.34 kg (18.4 lb)
Temperature Range	-15°C (5°F) to 50°C (122°F)	0°C (32°F) to 50°C (122°F)	-50°C (-58°F) to 150°C (302°F)
Attachment Type	D	40	D
Combined Upper/Lower Grip Height	266 mm (10.5 in)	410 mm (16.1 in)	534 mm (21 in)
Grip Width	89 mm (3.5 in)	182 mm (7.2 in)	138 mm (5.4 in)

Integrated Specimen Interface

Profile	Self-Tightening Full-Round	Self-Tightening Half-Round	Self-Tightening Full-Round
Surface	Diamond Tip Steel	Smooth Steel	Smooth Steel
Minimum Length	400 mm (15.7 in)	650 mm (25.6 in)	650 mm (25.6 in)
Specimen Range	0-7.5 mm (0-0.3 in)	0-4 mm (0-0.2 in)	0-5 mm (0-0.2 in)
Maximum Width	30 mm (1.2 in)	100 mm (3.9 in)	85 mm (3.3 in)

Tension Grips - *Monotonic*

Manual Activation

MTS Fundamental Scissor Grips

- » Affordable scissor grips that feature self-tightening, self-aligning clamps
- » Anti-rotation features and integrated alignment pins enhance test accuracy and repeatability
- » Grips are sold in pairs
- » Specimen interface ("face") is integrated with each grip
- » **Applications:** Tensile testing of delicate flat, flexible specimens like foil, films, rubber, and flexible polymers

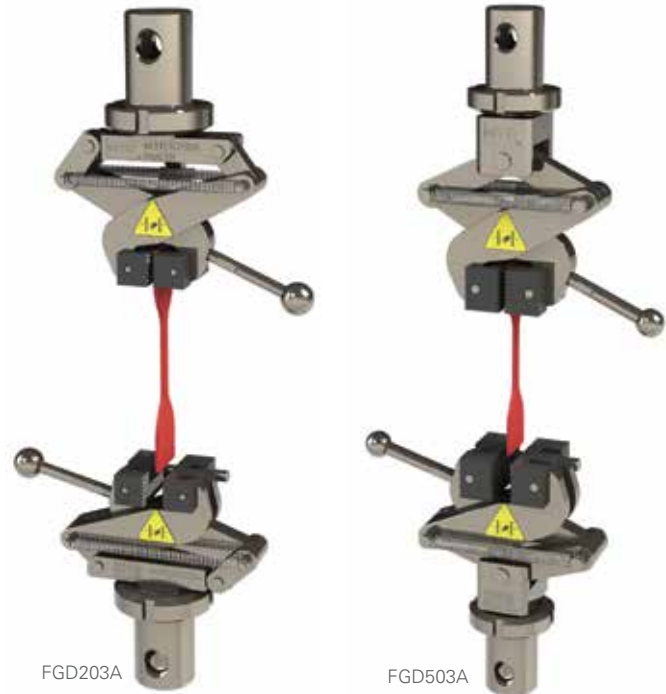

FGD203A

FGD503A

Specifications

Model	FGD203A	FGD503A
Part Number	100-231-401	100-231-402
Grip Type	Manual Scissors	Manual Scissors
Force Capacity	2 kN (450 lbf)	5 kN (1,124 lbf)
Upper Grip Weight	1.01 kg (2.2 lb)	1.74 kg (3.8 lb)
Temperature Rating	0°C (32°F) to 50°C (122°F)	0°C (32°F) to 50°C (122°F)
Attachment Type	D	D
Combined Upper/Lower Grip Height	298 mm (11.7 in)	346 mm (13.6 in)
Grip Width	164 mm (6.5 in)	194 mm (7.6 in)

Integrated Specimen Interface

	Flat	Flat
Profile	Flat	Flat
Surface	Sawtooth Steel	Sawtooth Steel
Height	16 mm (0.6 in)	25 mm (1.0 in)
Width	30 mm (1.2 in)	40 mm (1.6 in)
Specimen Range	0-12 mm (0-0.5 in)	0-14 mm (0-0.6 in)

Tension Grips - *Monotonic*

Manual Activation

MTS Fundamental Screw Grips

- » Affordable screw grips that deliver higher clamping forces than vise grips
- » Improved applications performance with manual side face adjustment and adjustable clamping position inside the grip
- » Quick-acting U-shaped grips allow specimen loading from the side for better test performance
- » Centering device provides fast and accurate specimen center force axis positioning
- » Grips are sold in pairs
- » All specimen interfaces (“faces”) are sold separately
- » **Applications:** Tensile testing of stronger, larger paper, plastic plate and film, textiles, sheet materials and packaging specimens

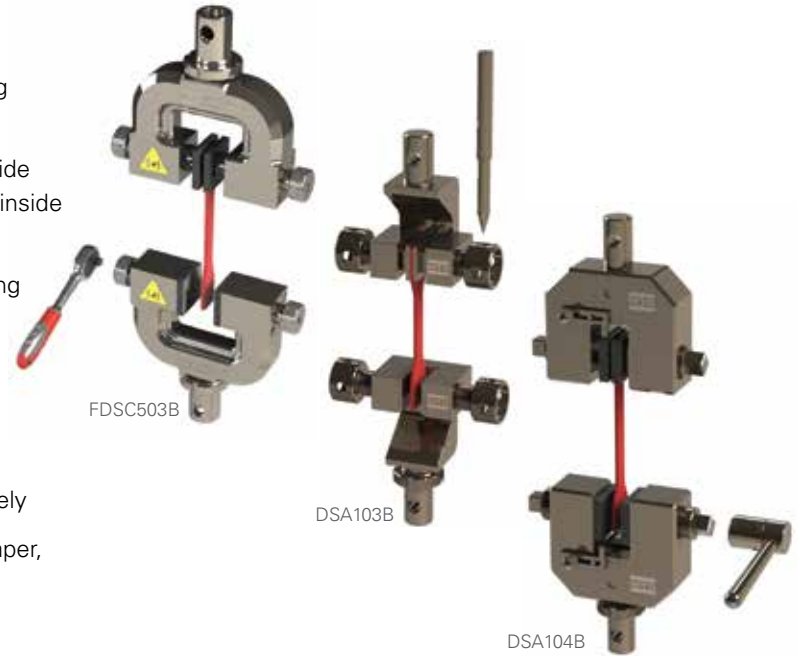

Specifications

Model	FDSC503B	DSA103B	DSA104B
Part Number	100-238-152	100-302-669	100-302-671
Grip Type	Manual Screw	Manual Screw	Manual Screw
Force Capacity	1 kN (225 lbf)	1 kN (225 lbf)	10 kN (2,250 lbf)
Upper Grip Weight	2.36 kg (5.2 lb)	0.08 kg (1.8 lb)	1.90 kg (4.2 lb)
Temperature Rating	0°C (32°F) to 50°C (122°F)	0°C (32°F) to 50°C (122°F)	0°C (32°F) to 50°C (122°F)
Attachment Type	D	20	20
Combined Upper/Lower Grip Height	298 mm (11.7 in)	201 mm (7.9 in)	234 mm (9.2 in)
Grip Width	172 mm (6.8 in)	106 mm (4.2 in)	123 mm (4.8 in)

FDSC503B Optional Specimen Interfaces

Model	Part Number	Profile	Surface	Height	Width	Temperature Range	Specimen Range
FDSC503B.01	100-238-153	Flat	Sawtooth Steel	36 mm (1.4 in)	36 mm (1.4 in)	0°C (32°F) to 50°C (122°F)	0-16 mm (0-0.6 in)
FDSC503B.02	100-238-164	Flat	Rubber	36 mm (1.4 in)	36 mm (1.4 in)	0°C (32°F) to 50°C (122°F)	0-16 mm (0-0.6 in)

DSA103B Optional Specimen Interfaces

DSA103B-02	100-311-702	Flat	Smooth Steel	24 mm (0.9 in)	26 mm (1 in)	0°C (32°F) to 50°C (122°F)	0-12 mm (0-0.5 in)
DSA103B-02A	100-311-703	Flat	Sawtooth Steel	24 mm (0.9 in)	26 mm (1 in)	0°C (32°F) to 50°C (122°F)	0-12 mm (0-0.5 in)

DSA104B Optional Specimen Interfaces

DSA104B-09/11	100-311-704	Flat	Sawtooth Steel	30 mm (1.1 in)	34 mm (1.3 in)	0°C (32°F) to 50°C (122°F)	0-14 mm (0-0.6 in)
DSA104B-10	100-311-705	Flat	Corrugated (R8) Steel	70 mm (2.7 in)	32 mm (1.2 in)	0°C (32°F) to 50°C (122°F)	0-13 mm (0-0.5 in)
DSA104B-12	100-311-706	Flat	Corrugated (R5) Steel	70 mm (2.7 in)	32 mm (1.2 in)	0°C (32°F) to 50°C (122°F)	0-12 mm (0-0.5 in)

Tension Grips - Monotonic

Manual Activation

MTS Fundamental Shoulder Grips

- » Affordable high force grips for shoulder-ended metal parts
- » Anti-rotation features and integrated alignment pins enhance test accuracy and repeatability
- » Grips are sold in pairs
- » All specimen interfaces (inserts) are sold separately
- » **Applications:** Tensile tests metal materials where the sample rests on a shoulder ledge

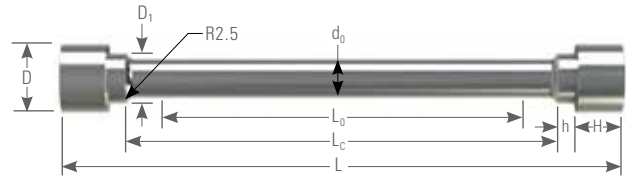

FTA105B

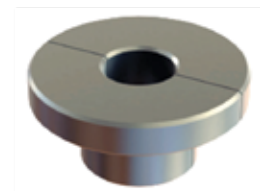

Example of Optional Interface

Specifications

Model	FTA105B	FTA305B
Part Number	100-258-715	100-296-160
Grip Type	Shoulder	Shoulder
Force Capacity	100 kN (22,480 lbf)	300 kN (67,440 lbf)
Upper Grip Weight	4.5 kg (9.9 lb)	26.0 kg (57.3 lb)
Temperature Rating	0°C (32°F) to 50°C (122°F)	0°C (32°F) to 50°C (122°F)
Attachment Type	D	E
Combined Upper/Lower Grip Height	330 mm (13 in)	526 mm (20.7 in)
Grip Width	146 mm (5.7 in)	219 mm (8.6 in)

Specimen Size

Shoulder	d ₀	D ₁	D	h	H	L ₀	L _c	L
FTA105B.01	3 mm (0.118 in)	4 mm (0.157 in)	6 mm (0.236 in)	6 mm (0.236 in)	5 mm (0.197 in)	50 mm (1.969 in)	53 mm (2.087 in)	78 mm (3.071 in)
FTA105B.02	5 mm (0.197 in)	7 mm (0.276 in)	12 mm (0.472 in)	6.5 mm (0.256 in)	8 mm (0.315 in)	50 mm (1.969 in)	55 mm (2.165 in)	88 mm (3.465 in)
FTA105B.03	6 mm (0.236 in)	8 mm (0.315 in)	13 mm (0.512 in)	7 mm (0.276 in)	10 mm (0.394 in)	50 mm (1.969 in)	56 mm (2.205 in)	94 mm (3.701 in)
FTA105B.04	8 mm (0.315 in)	10 mm (0.394 in)	15 mm (0.591 in)	8 mm (0.315 in)	10 mm (0.394 in)	50 mm (1.969 in)	58 mm (2.283 in)	98 mm (3.858 in)
FTA105B.05	10 mm (0.394 in)	13 mm (0.512 in)	18 mm (0.709 in)	12 mm (0.472 in)	12 mm (0.472 in)	50 mm (1.969 in)	60 mm (2.362 in)	113 mm (4.449 in)

Shoulder	d ₀	D ₁	D	h	H	L ₀	L _c	L
FTA305B.01	10 mm (0.394 in)	13 mm (0.512 in)	18 mm (0.709 in)	14 mm (0.551 in)	12 mm (0.472 in)	50 mm (1.969 in)	60 mm (2.362 in)	113 mm (4.449 in)
FTA305B.02	12.5 mm (0.492 in)	16 mm (0.627 in)	22 mm (0.866 in)	20 mm (0.787 in)	15 mm (0.591 in)	60 mm (2.362 in)	78 mm (3.071 in)	148 mm (5.827 in)
FTA305B.03	16 mm (0.630 in)	21 mm (0.827 in)	28 mm (1.102 in)	30 mm (1.181 in)	19 mm (0.748 in)	80 mm (3.150 in)	96 mm (3.779 in)	194 mm (7.638 in)
FTA305B.04	20 mm (0.787 in)	26 mm (1.024 in)	35 mm (1.378 in)	46 mm (1.811 in)	24 mm (0.945 in)	100 mm (3.937 in)	120 mm (4.724 in)	260 mm (10.236 in)
FTA305B.05	25 mm (0.984 in)	32 mm (1.260 in)	45 mm (1.772 in)	48 mm (1.890 in)	30 mm (1.181 in)	125 mm (4.921 in)	150 mm (5.906 in)	306 mm (12.047 in)

FTA105B Optional Specimen Interfaces

Model	Part Number	Profile	Temperature Range	Specimen Range	Compatible Grip Model
FTA105B.01	100-258-729	Shoulder	0°C (32°F) to 50°C (122°F)	∅3 mm	FTA105B
FTA105B.02	100-258-730	Shoulder	0°C (32°F) to 50°C (122°F)	∅5 mm	FTA105B
FTA105B.03	100-258-731	Shoulder	0°C (32°F) to 50°C (122°F)	∅6 mm	FTA105B
FTA105B.04	100-258-732	Shoulder	0°C (32°F) to 50°C (122°F)	∅8 mm	FTA105B
FTA105B.05	100-258-733	Shoulder	0°C (32°F) to 50°C (122°F)	∅10 mm	FTA105B

FTA305B Optional Specimen Interfaces

FTA305B.01	100-339-726	Shoulder	0°C (32°F) to 50°C (122°F)	∅10 mm	FTA305B
FTA305B.02	100-296-161	Shoulder	0°C (32°F) to 50°C (122°F)	∅12.5 mm	FTA305B
FTA305B.03	100-339-727	Shoulder	0°C (32°F) to 50°C (122°F)	∅16 mm	FTA305B
FTA305B.04	100-339-728	Shoulder	0°C (32°F) to 50°C (122°F)	∅20 mm	FTA305B
FTA305B.05	100-339-729	Shoulder	0°C (32°F) to 50°C (122°F)	∅25 mm	FTA305B

Tension Grips - *Monotonic*

Manual Activation

MTS Fundamental Vise Grips

- » Affordable vise grips
- » Anti-rotation features and integrated alignment pins enhance test accuracy and repeatability
- » Grips are sold in pairs
- » Specimen interface (“face”) is integrated with each grip
- » **Applications:** Tensile testing of paper, plastic film, textiles, sheet materials and packaging components

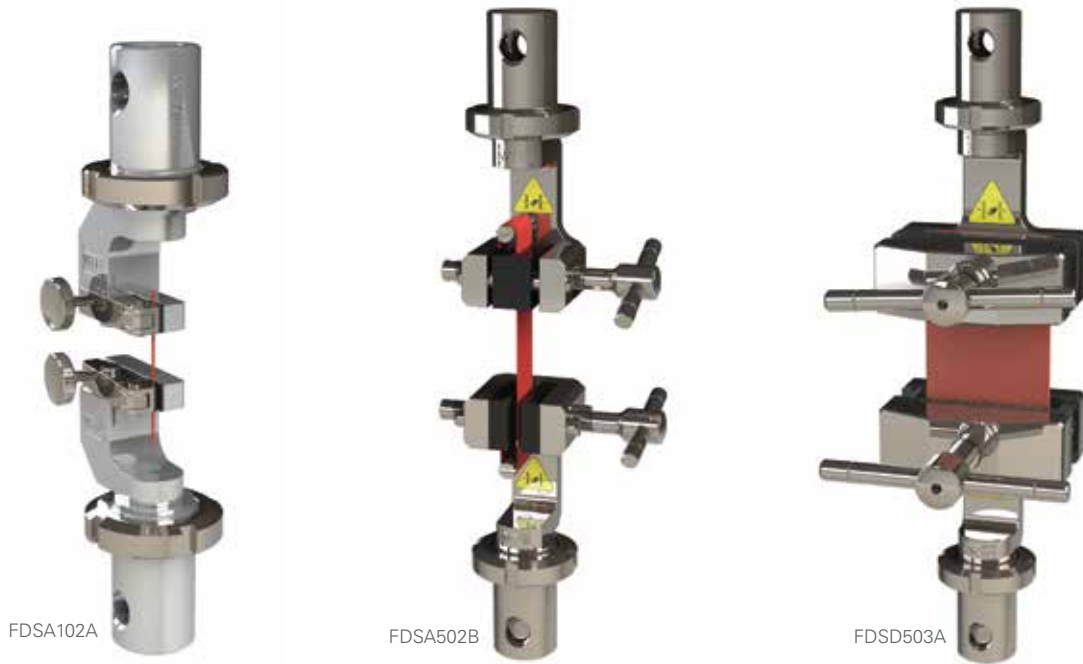

Specifications

Model	FDSA102A	FDSA502B	FDSD503A
Part Number	100-231-832	100-231-833	100-231-400
Grip Type	Manual Vise	Manual Vise	Manual Vise
Force Capacity	0.1 kN (22 lbf)	0.5 kN (112 lbf)	5 kN (1,124 lbf)
Upper Grip Weight	0.31 kg (0.7 lb)	1.0 kg (2.2 lb)	2.01 kg (4.4 lb)
Temperature Rating	0°C (32°F) to 50°C (122°F)	0°C (32°F) to 50°C (122°F)	0°C (32°F) to 50°C (122°F)
Attachment Type	D	D	D
Combined Upper/Lower Grip Height	216 mm (8.5 in)	270 mm (10.6 in)	290 mm (11.4 in)
Grip Width	71.5 mm (2.8 in)	111 mm (4.4 in)	120 mm (4.7 in)

Integrated Specimen Interface

Profile	Flat	Flat	Corrugated
Surface	Rubber	Rubber	Steel
Height	10 mm (0.4 in)	25 mm (1.0 in)	35 mm (1.4 in)
Width	10 mm (0.4 in)	35 mm (1.4 in)	65 mm (2.5 in)
Specimen Range	0-1.5 mm (0-0.04 in)	0-6 mm (0-0.2 in)	0-7 mm (0-0.03 in)

Tension Grips - *Monotonic*

Manual Activation

MTS Fundamental Vise Grips

- » Affordable vise grips for lower force testing needs
- » Anti-rotation features and integrated alignment pins enhance test accuracy and repeatability
- » Grips are sold in pairs
- » Specimen interface ("face") is integrated with each grip
- » **Applications:** Tensile testing of paper, plastic film, textiles, sheet materials and packaging components



Specifications

Model	FMV101	FMV102	BTV102
Part Number	100-033-784	100-033-242	100-167-987
Grip Type	Manual Vise	Manual Vise	Stainless Steel Manual Vise
Force Capacity	0.01 kN (2.25 lbf)	0.1 kN (22.5 lbf)	0.1 kN (22.5 lbf)
Upper Grip Weight	0.07 kg (0.15 lbs)	0.11 kg (0.25 lbs)	0.14 kg (0.3 lbs)
Temperature Rating	-20°C (-4°F) to 70°C (158°F)	-130°C (-202°F) to 177°C (350°F)	-130°C (-202°F) to 250°C (482°F)
Attachment Type	B	C	C
Combined Upper/Lower Grip Height	158 mm (6.2 in)	161 mm (6.3 in)	161 mm (6.3 in)
Grip Width	36 mm (1.4 in)	36 mm (1.4 in)	36 mm (1.4 in)

Integrated Specimen Interface

Profile	Flat	Flat	Flat
Surface	Sawtooth Steel	Sawtooth Steel	Sawtooth Steel
Specimen Range	0-3.5 mm (0-0.14 in)	0-3 mm (0-0.12 in)	0-3 mm (0-0.12 in)
Maximum Width	20 mm (0.79 in)	14 mm (0.55 in)	14 mm (0.55 in)

MTS Fundamental Vise Grip

- » Affordable vise grips for wide specimen testing
- » Specimen reference line enables better specimen positioning
- » Grips are sold in pairs
- » Specimen interface ("face") is integrated with each grip
- » **Applications:** Tensile testing of wide specimens including paper, plastic film, and textile materials



Specifications

Model	DSA204B
Part Number	100-302-673
Grip Type	Manual Vise
Force Capacity	20 kN (4,500 lbf)
Upper Grip Weight	15.61 kg (34.4 lb)
Temperature Range	0°C (32°F) to 50°C (122°F)
Attachment Type	20
Combined Upper/Lower Grip Height	313 mm (12.3 in)
Grip Width	210 mm (8.3 in)

Integrated Specimen Interface

Profile	Flat
Surface	Corrugated Steel
Height	50 mm (1.9 in)
Width	210 mm (8.3 in)
Specimen Range	0-10 mm (0-0.4 in)

Tension Grips - *Monotonic*

Manual Activation

MTS Fundamental Vise Grips

- » Affordable vise grips for higher force testing needs
- » Switching structure allows faces to be moved synchronously or separately
- » Quick-acting U-shaped grips allow specimen loading from the side for better test performance
- » Centering device provides fast and accurate specimen center force axis positioning
- » Grips are sold in pairs
- » All specimen interfaces (“faces”) are sold separately
- » **Applications:** Tensile testing of paper, plastic film, textiles, sheet materials and packaging components



Specifications

Model	DX104A	DX105A
Part Number	100-302-665	100-302-666
Grip Type	Manual Vise	Manual Vise
Force Capacity	10 kN (2,250 lbf)	100 kN (22,000 lbf)
Upper Grip Weight	9.80 kg (21.6 lb)	62 kg (136.7 lb)
Temperature Rating	0°C (32°F) to 50°C (122°F)	0°C (32°F) to 50°C (122°F)
Attachment Type	20	40
Combined Upper/Lower Grip Height	327 mm (12.9 in)	458 mm (18 in)
Grip Width	250 mm (9.8 in)	352 mm (13.9 in)

DX104A Optional Specimen Interfaces

Model	Part Number	Profile	Surface	Height	Width	Temperature Range	Specimen Range
DX104A-07	100-302-880	Flat	Sawtooth Steel	54 mm (2.1 in)	40 mm (1.6 in)	0°C (32°F) to 50°C (122°F)	0-20 mm (0-0.8 in)
DX104A-07a	100-311-711	Flat	Smooth Steel w/SiC coating	54 mm (2.1 in)	40 mm (1.6 in)	0°C (32°F) to 50°C (122°F)	0-20 mm (0-0.8 in)
DX104A-23	100-302-881	Vee	Serrated Steel	54 mm (2.1 in)	40 mm (1.6 in)	0°C (32°F) to 50°C (122°F)	ø4-ø9 mm (0.2-0.4 in)
DX104A-24	100-302-882	Vee	Serrated Steel	54 mm (2.1 in)	40 mm (1.6 in)	0°C (32°F) to 50°C (122°F)	ø9-ø14 mm (0.4-0.6 in)

DX105A Optional Specimen Interfaces

DX105A-18	100-302-884	Flat	Sawtooth Steel	70 mm (2.8 in)	60 mm (2.4 in)	0°C (32°F) to 50°C (122°F)	0-20 mm (0-0.55 in)
DX105A-19	100-302-885	Vee	Serrated Steel	70 mm (2.8 in)	60 mm (2.4 in)	0°C (32°F) to 50°C (122°F)	ø14-19 mm (ø0.55-0.75 in)

Tension Grips - *Monotonic*

Manual Activation

MTS Fundamental Wedge Grips

- » Affordable wedge grips for higher force testing needs
- » Design minimizes compressive or buckling forces during specimen insertion
- » Anti-rotation features and integrated alignment pins enhance test accuracy and repeatability
- » Grips are sold in pairs
- » All specimen interfaces (“wedges”) are sold separately
- » **Applications:** Tensile testing of strong plastics, aluminum and steel



Specifications

Model	FXSA104B	FXSA304B	FXSA105A	FXSA305A
Part Number	100-257-698	100-231-404	100-231-405	100-257-525
Grip Type	Manual Wedge	Manual Wedge	Manual Wedge	Manual Wedge
Force Capacity	10 kN (2,250 lbf)	30 kN (6,740 lbf)	100 kN (22,480 lbf)	300 kN (67,440 lbf)
Upper Grip Weight	3.10 kg (6.8 lb)	9.19 kg (20.3 lb)	14.79 kg (32.6 lb)	26.0 kg (57.3 lb)
Temperature Rating	0°C (32°F) to 50°C (122°F)	0°C (32°F) to 50°C (122°F)	0°C (32°F) to 50°C (122°F)	0°C (32°F) to 50°C (122°F)
Attachment Type	D	D	D	E
Combined Upper/Lower Grip Height	344 mm (13.5 in)	538 mm (21.2 in)	626 mm (24.6 in)	688 mm (27.1 in)
Grip Width	104 mm (4.09 in)	370 mm (14.567 in)	370 mm (14.567 in)	385 mm (15.2 in)

Tension Wedges - *Monotonic*

FXSA104B Grip Optional Wedges

Model	Part Number	Profile	Surface	Height	Width	Temperature Range	Specimen Range	Compatible Grip Model
FXSA104B.01 x 2	100-258-168	Flat	Sawtooth Steel	40 mm (1.6 in)	35 mm (1.4 in)	0°C (32°F) to 50°C (122°F)	0-7 mm (0-0.28 in)	FXSA104B
FXSA104B.02 x 2	100-258-169	Flat	Sawtooth Steel	40 mm (1.6 in)	35 mm (1.4 in)	0°C (32°F) to 50°C (122°F)	7-13 mm (0.28-0.51 in)	FXSA104B
FXSA104B.03 x 2	100-258-170	Vee	Serrated Steel	40 mm (1.6 in)	35 mm (1.4 in)	0°C (32°F) to 50°C (122°F)	ø4-ø9 mm (ø0.16-ø0.35 in)	FXSA104B
FXSA104B.04 x 2	100-258-171	Vee	Serrated Steel	40 mm (1.6 in)	35 mm (1.4 in)	0°C (32°F) to 50°C (122°F)	ø9-ø14 mm (ø0.35-ø0.55 in)	FXSA104B

FXSA304A & FXSA105A Grip Optional Wedges

FXSA105A.01	100-231-648	Flat	Sawtooth Steel	55 mm (2.2 in)	40 mm (1.6 in)	0°C (32°F) to 50°C (122°F)	0-7 mm (0-0.28 in)	FXSA304A FXSA105A
FXSA105A.02	100-231-649	Flat	Sawtooth Steel	55 mm (2.2 in)	40 mm (1.6 in)	0°C (32°F) to 50°C (122°F)	7-14 mm (0.28-0.55 in)	FXSA304A FXSA105A
FXSA105A.03	100-231-650	Flat	Sawtooth Steel	55 mm (2.2 in)	40 mm (1.6 in)	0°C (32°F) to 50°C (122°F)	14-21 mm (0.55-0.83 in)	FXSA304A FXSA105A
FXSA105A.04	100-231-651	Vee	Serrated Steel	55 mm (2.2 in)	40 mm (1.6 in)	0°C (32°F) to 50°C (122°F)	ø4-ø9 mm (ø0.16-ø0.35 in)	FXSA304A FXSA105A
FXSA105A.05	100-231-652	Vee	Serrated Steel	55 mm (2.2 in)	40 mm (1.6 in)	0°C (32°F) to 50°C (122°F)	ø9-ø14 mm (ø0.35-ø0.55 in)	FXSA304A FXSA105A
FXSA105A.06	100-231-653	Vee	Serrated Steel	55 mm (2.2 in)	440 mm (1.6 in)	0°C (32°F) to 50°C (122°F)	ø14-ø19 mm (ø0.55-ø0.75 in)	FXSA304A FXSA105A

FXSA305A Grip Optional Wedges

FXSA305A.01 x 2	100-258-160	Flat	Sawtooth Steel	62 mm (2.4 in)	50 mm (2.0 in)	0°C (32°F) to 50°C (122°F)	0-8 mm (0-0.32 in)	FXSA305A
FXSA305A.02 x 2	100-258-161	Flat	Sawtooth Steel	62 mm (2.4 in)	50 mm (2.0 in)	0°C (32°F) to 50°C (122°F)	8-16 mm (0.32-0.63 in)	FXSA305A
FXSA305A.03 x 2	100-258-162	Flat	Sawtooth Steel	62 mm (2.4 in)	50 mm (2.0 in)	0°C (32°F) to 50°C (122°F)	16-24 mm (0.63-0.95 in)	FXSA305A
FXSA305A.04 x 2	100-258-163	Flat	Sawtooth Steel	62 mm (2.4 in)	50 mm (2.0 in)	0°C (32°F) to 50°C (122°F)	24-32 mm (0.95-1.26 in)	FXSA305A
FXSA305A.05 x 2	100-258-164	Vee	Serrated Steel	62 mm (2.4 in)	50 mm (2.0 in)	0°C (32°F) to 50°C (122°F)	ø4-ø9 mm (ø0.16-ø0.35 in)	FXSA305A
FXSA305A.06 x 2	100-258-165	Vee	Serrated Steel	62 mm (2.4 in)	50 mm (2.0 in)	0°C (32°F) to 50°C (122°F)	ø9-ø16 mm (ø0.35-ø0.63 in)	FXSA305A
FXSA305A.07 x 2	100-258-166	Vee	Serrated Steel	62 mm (2.4 in)	50 mm (2.0 in)	0°C (32°F) to 50°C (122°F)	ø16-ø23 mm (ø0.63-ø0.91 in)	FXSA305A
FXSA305A.08 x 2	100-258-167	Vee	Serrated Steel	62 mm (2.4 in)	50 mm (2.0 in)	0°C (32°F) to 50°C (122°F)	ø23-ø30 mm (ø0.91-ø1.18 in)	FXSA305A

Compression Platens - *Monotonic*

MTS Fundamental Steel Compression Platens

- » Affordable steel compression platens designed for accurate testing with medium to higher force load cells
- » Precision-ground, hardened surfaces enhance platen durability
- » Specimen centering grooves, anti-rotation features and integrated alignment pins enhance test accuracy and repeatability
- » Platens are sold in pairs (upper and lower)
- » **Applications:** Compression testing of elastomers, foams, packaging, plastics, wood, and other compressible materials



FYA204A

FYB204A



FYA105A

FYC105A

FYB305A

FYC305A

Specifications

Model	FYA204A	FYB204A	FYA105A	FYC105A	FYB305A	FYC305A
Part Number	100-231-407	100-231-411	100-231-406	100-231-413	100-257-355	100-257-356
Platen Type	Fixed/Fixed Steel Platen	Fixed/Fixed Steel Platen	Fixed/Fixed Steel Platen	Fixed/Fixed Steel Platen	Fixed/Fixed Steel Platen	Fixed/Fixed Steel Platen
Force Capacity	20 kN (4,500 lbf)	20 kN (4,500 lbf)	100 kN (22,480 lbf)	100 kN (22,480 lbf)	300 kN (66,450 lbf)	300 kN (66,450 lbf)
Minimum Specimen Diameter at Maximum Force Capacity	5 mm (0.2 in)	5 mm (0.2 in)	5 mm (0.2 in)	5 mm (0.2 in)	15 mm (0.6 in)	15 mm (0.6 in)
Upper Platen Weight	1.491 kg (3.3 lbs)	3.433 kg (7.6 lbs)	2.434 kg (5.4 lbs)	6.637 kg (14.6 lbs)	8.9 kg (19.6 lbs)	12 kg (26.5 lbs)
Temperature Rating	-50°C (-58°F) to 150°C (302°F)	-50°C (-58°F) to 150°C (302°F)	-50°C (-58°F) to 150°C (302°F)	-50°C (-58°F) to 150°C (302°F)	-50°C (-58°F) to 150°C (302°F)	-50°C (-58°F) to 150°C (302°F)
Attachment Type	D	D	D	D	E	E
Combined Upper/Lower Platen Height	156 mm (6.1 in)	192 mm (7.6 in)	202 mm (8 in)	202 mm (8 in)	320 mm (12.6 in)	320 mm (12.6 in)
Platen Diameter	100 mm (3.9 in)	150 mm (5.9 in)	100 mm (3.9 in)	200 mm (7.9 in)	150 mm (5.9 in)	200 mm (7.9 in)

Compression Platens - *Monotonic*

MTS Fundamental Aluminum Compression Platens

- » Affordable lightweight aluminum compression platens designed for accurate testing with lower force load cells
- » Specimen centering grooves, anti-rotation features and integrated alignment pins enhance test accuracy and repeatability
- » Platens are sold in pairs (upper and lower)
- » **Applications:** Compression testing of elastomers, foams, sintered materials and components, plastics, wood, and other highly compressible materials



FYA502A

FYB502A

Specifications

Model	FYA502A	FYB502A
Part Number	100-231-408	100-231-412
Platen Type	Fixed/Fixed Aluminum Platen	Fixed/Fixed Aluminum Platen
Force Capacity	0.5 kN (112 lbf)	0.5 kN (112 lbf)
Minimum Specimen Diameter at Maximum Force Capacity	5 mm (0.2 in)	5 mm (0.2 in)
Upper Platen Weight	0.28 kg (0.6 lbs)	0.548 kg (1.2 lbs)
Temperature Range	-50°C (-58°F) to 100°C (212°F)	-50°C (-58°F) to 100°C (212°F)
Attachment Type	D	D
Combined Upper/Lower Platen Height	156 mm (6.1 in)	156 mm (6.1 in)
Platen Width	50 mm (2 in)	100 mm (3.9 in)

MTS Fundamental Square Compression Platens

- » Affordable square compression platens
- » Durable alloy tool steel construction with reliable surface hardness
- » Easily center specimen loading with the round or cross-line scales
- » Platens are sold in pairs (upper and lower)
- » **Applications:** Compression testing of foams packaging materials, ring stiffness of pipes and other materials



DL07589.01

Specifications

Model	DL07589.01
Part Number	100-302-770
Platen Type	Fixed/Fixed Steel Platen
Force Capacity	200 kN (45,000 lbf)
Minimum Specimen Diameter at Maximum Force Capacity	22 mm (0.9 in)
Upper Platen Weight	60.2 kg (133 lbs)
Temperature Range	0°C (32°F) to 50°C (122°F)
Attachment Type	E
Combined Upper/Lower Platen Height	310 mm (12.2 in)
Platen Width	450 mm (17.7 in)
Platen Depth	450 mm (17.7 in)

Bend Fixtures - *Monotonic*

MTS Fundamental Three Point Bend Fixtures

- » Affordable three point bend fixtures designed to support a wide variety of tests
- » Flexible configurations provide either a region of constant stress or a line of maximum stress
- » Precision machined rollers are made from corrosion-resistant hardened steel
- » Adjustable spans feature metric scales
- » **Applications:** Flexural (bend) testing of metals, composites, plastics, and other materials



FWA104A

FWA105A

FWA305A

Specifications

Model	FWA104A	FWA105A	FWA305A	FWA605
Part Number	100-231-417	100-231-418	100-258-158	100-504-190
Fixture Type	3 Point Bend Fixture	3 Point Bend Fixture	3 Point Bend Fixture	3 Point Bend Fixture
Force Capacity	10 kN (2,248 lbf)	100 kN (22,480 lbf)	300 kN (67,440 lbf)	600 kN (134,885 lbf)
Upper Fixture Weight	0.6 kg (1.32 lbs)	2 kg (4.4 lbs)	5.67 kg (12.5 lbs)	12 kg (26.5 lbs)
Temperature Rating	-50°C (-58°F) to 150°C (302°F)	-50°C (-58°F) to 150°C (302°F)	-50°C (-58°F) to 150°C (302°F)	0°C (32°F) to 50°C (122°F)
Attachment Type	D	D	E	F
Combined Upper/Lower Fixture Height	268 mm (10.6 in)	376 mm (14.8 in)	543 mm (21.4 in)	735 mm (28.9 in)
Fixture Width	226 mm (8.9 in)	464 mm (18.3 in)	561 mm (22.1 in)	186 mm (7.3 in)

Integrated Specimen Interface

Contact Radius Type	Fixed	Rolling	Rolling	Rolling
Loading Nose Radius	φ2 mm (0.08 in), 5 mm (0.2 in)	φ10 mm (0.39 in)	φ15 mm (0.59 in)	φ15 mm (0.59 in)
Supporting Nose Radius	φ2 mm (0.08 in), 5 mm (0.2 in)	φ10 mm (0.39 in)	φ15 mm (0.59 in)	φ15 mm (0.59 in)
Loading Span	40-160 mm (1.6-6.3 in)	30-360 mm (1.1-14.1 in)	30-340 mm (1.1-13.4 in)	60-370 mm (2.4-14.6 in)
Specimen Width	40 mm (1.6 in)	80 mm (3.1 in)	90 mm (3.5 in)	119 mm (4.7 in)

Bend Fixtures - *Monotonic*

MTS Fundamental Specialty Three Point Bend Fixtures

- » Affordable three point bend fixtures for more unique applications
- » Loading edge and supports can be changed to optional parts or customized designs
- » Adjustable stepless lower span on the support beam
- » The support and loading edges are constructed of alloy tool steel with reliable surface hardness and durability
- » The rollers can rotate to minimize errors caused by friction
- » Fast and accurate specimen positioning with centering device
- » **Applications:** Flexural (bend) testing of wood, metals, composites, plastics, and other materials



Method	Standard	Fixture Options
Laminae & Laminate - Flexure	ISO 14125 (3P)	Model WA204A with Loading Edge R5 Supporting R2 or R5
	ISO 14130	Model WA204A with Loading Edge R5 Supporting R2
	ASTM D7264	Model WA204A with Loading Edge R5 Supporting R5
	EN 2377	Model WA204A with Loading Edge R5 Supporting R2
	EN 2746	Model WA204A with Loading Edge R5 Supporting R2

Specifications

Model	WA204A
Part Number	100-660-347
Fixture Type	3 Point Bend Fixture
Force Capacity	20 kN (4,500 lbf)
Upper Fixture Weight	0.67 kg (1.5 lbs)
Lower Fixture Weight	9.22 kg (20.3 lbs)
Upper Adapter Style	20 mm (0.8 in)
Lower Adapter Style	20 mm (0.8 in)
Temperature Rating	0°C (32°F) to 50°C (122°F)
Attachment Type	20 mm (0.8 in)
Combined Upper/Lower Fixture Height	277 mm (10.9 in)
Fixture Width	340 mm (13.4 in)
Fixture Depth	42 mm (1.7 in)
Integrated Specimen Interface	
Contact Radius Type	Fixed
Loading Nose Radius	5 mm (0.2 in)
Supporting Nose Radius	2 mm (0.08 in), 5 mm (0.2 in)
Loading Span	20-200 mm (0.8-7.87 in)
Maximum Width	45 mm (1.8 in)

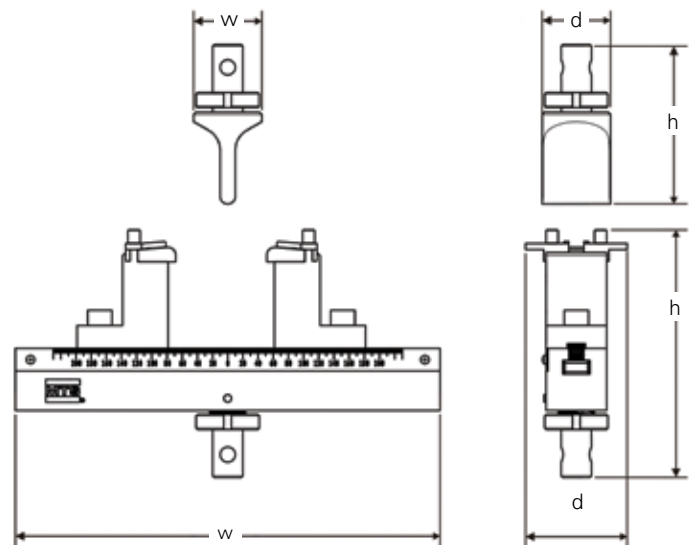

MTS Fundamental Coefficient of Friction Grips - *Monotonic*

- » Affordable coefficient of friction fixture
- » Pulley and string mechanism measures the force required to pull a friction sled over a material specimen
- » Suitable for a variety of material testing standards, including ASTM D1894 (plastic film), TAPPI T542 (paper and cardboard), TAPPI T549 (non-fibrous materials), and TAPPI T816 (corrugated).
- » Upper grip is not included.
- » **Applications:** Friction testing of plastic film, paper and cardboard, non-fibrous materials

Model	FCF103
Part Number	100-087-526
Grip Type	Coefficient of Friction
Force Capacity	1 kN (225 lbf)
Upper Grip Weight	NA
Temperature Rating	0°C (32°F) to 50°C (122°F)
Attachment Type	D
Lower Fixture Height	112 mm (4.4 in)
Fixture Width	203 mm (8 in)

Integrated Specimen Interface

Length	279.4 mm (11 in)
Maximum Thickness	5 mm (0.2 in)
Width	152.4 mm (6 in)



MTS Fundamental 90° Peel Fixture - *Monotonic*

- » Affordable 90° peel fixture designed with moveable X,Y table
- » Precision bearings maintain perpendicular axial alignment while measuring the force required to peel adhered material from a clamped-down substrate
- » Upper grip is not included.
- » **Applications:** Peel strength testing of flexible adhesive materials suitable for a variety of material testing standards including ASTM D1876, FINAT FTM1/2/3, and AFERA 4015 T4

Model	FCF452
Part Number	100-170-762
Grip Type	90° Peel
Force Capacity	0.45 kN (100 lbf)
Upper Grip Weight	NA
Temperature Rating	0°C (32°F) to 50°C (122°F)
Attachment Type	D
Lower Fixture Height	140 mm (5.5 in)
Fixture Width	404 mm (15.9 in)
Specimen Travel (Parallel to travel)	152.4 mm (6 in)
Specimen Travel (Perpendicular to travel)	101.6 mm (4 in)

Integrated Specimen Interface

Length	165 mm (6.5 in)
Thickness	3.556 mm (0.140 in)
Width	12.7-95.3 mm (0.5-3.75 in)

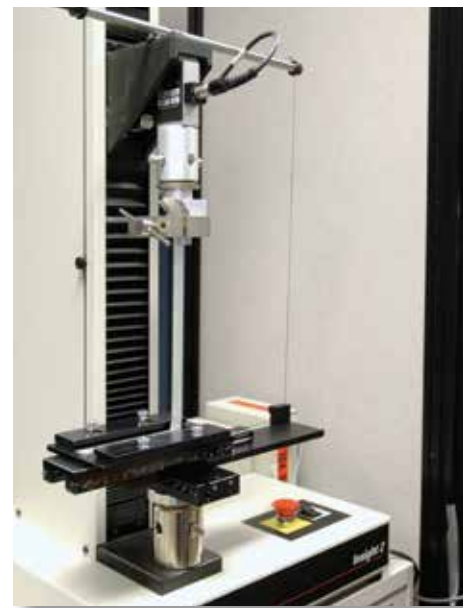

Bionix

Tension

Bionix Bollard Grips

- » Stainless steel “horn” style bollard grips are designed to reduce stress concentration on specimens and avoid grip-induced failures
- » Anti-rotation features and integrated alignment pins enhance test accuracy and repeatability
- » Passivated stainless steel – suitable for saline environmental baths
- » Grips are sold in pairs
- » Specimen interface (“face”) is integrated with each grip
- » **Applications:** Tensile testing of cords, filaments, fibers, fine wire and biomaterials



BMB103

Specifications

Model	BMB103
Part Number	100-185-264
Grip Type	Stainless Steel Manual Bollard
Force Capacity	1 kN (225 lbf)
Upper Grip Weight	1.01 kg (2.2 lb)
Temperature Rating	-130°C (-202°F) to 150°C (302°F)
Attachment Type	D
Combined Upper/Lower Grip Height	280 mm (11 in)
Grip Width	84 mm (3.3 in)

Integrated Specimen Interface

Profile	Flat
Surface	Smooth Steel
Specimen Range	0-3 mm (0-0.12 in)

Bionix Scissor Grips

- » Stainless steel scissor grips with self-tightening and self-aligning design
- » Anti-rotation features and integrated alignment pins enhance test accuracy and repeatability
- » Passivated stainless steel – suitable for saline environmental baths
- » Grips are sold in pairs
- » Specimen interface (“face”) is integrated with each grip
- » **Applications:** Tensile testing of irregular bio-materials, bone, cartilage, tendons, and replacement bio-medical components



BMS103

Specifications

Model	BMS103
Part Number	100-181-625
Grip Type	Stainless Steel Manual Scissor
Force Capacity	1 kN (225 lbf)
Upper Grip Weight	0.85 kg (1.9 lb)
Temperature Rating	-130°C (-202°F) to 250°C (482°F)
Attachment Type	D
Combined Upper/Lower Grip Height	346 mm (13.6 in)
Grip Width	108 mm (4.3 in)

Integrated Specimen Interface

Profile	Round
Surface	Diamond Tip Steel
Height	16 mm (0.6 in)
Width	25 mm (1.2 in)
Specimen Range	0-10 mm (0-0.4 in)

Bionix

Tension

Bionix Roller Grips

- » Stainless steel roller grips with self-tightening and self-aligning design
- » Anti-rotation features and integrated alignment pins enhance test accuracy and repeatability
- » Passivated stainless steel – suitable for saline environmental baths
- » Grips are sold in pairs
- » Specimen interface (“face”) is integrated with each grip
- » **Applications:** Tensile testing of bandages, bio-textiles, diapers, synthetics, and flexible polymers



Specifications

Model	BMR103	BMR203	BMR503
Part Number	100-185-262	100-184-839	100-184-841
Grip Type	Stainless Steel Roller	Stainless Steel Roller	Stainless Steel Roller
Force Capacity	1 kN (225 lbf)	2 kN (550 lbf)	5 kN (1,124 lbf)
Upper Grip Weight	1.3 kg (2.9 lb)	1.42 kg (3.1 lb)	2.26 kg (5.0 lb)
Temperature Rating	-10°C (14°F) to 50°C (122°F)	-130°C (-202°F) to 250°C (482°F)	-130°C (-202°F) to 250°C (482°F)
Attachment Type	D	D	D
Combined Upper/Lower Grip Height	280 mm (11 in)	254 mm (10 in)	274 mm (10.8 in)
Grip Width	60 mm (2.3 in)	88 mm (3.5 in)	120 mm (4.7 in)

Integrated Specimen Interface

Surface	Rubber	Diamond Tip Steel	Diamond Tip Steel
Specimen Range	0-3 mm (0-0.1 in)	0-4 mm (0-0.2 in)	0-7 mm (0-0.3 in)
Maximum Width	50 mm (2.0 in)	50 mm (2.0 in)	75 mm (2.9 in)

Bionix

Tension

Bionix Vise Grips

- » Stainless steel vise grips with a clamping screw design to tighten a vise
- » Anti-rotation features and integrated alignment pins enhance test accuracy and repeatability
- » Passivated stainless steel – suitable for saline environmental baths
- » Grips are sold in pairs
- » Specimen interface (“face”) is integrated with each grip
- » **Applications:** Tensile testing of plastic film, textile, sheet materials, bandages, bio-textiles, diapers, plastic films, packaging components and biomaterials in a fluid bath



Specifications

Model	BMV102	BMV203	BMV503
Part Number	100-186-411	100-174-783	100-186-413
Grip Type	Stainless Steel Manual Vise	Stainless Steel Manual Vise	Stainless Steel Manual Vise
Force Capacity	0.1 kN (22 lbf)	2 kN (450 lbf)	5 kN (1,124 lbf)
Upper Grip Weight	0.56 kg (1.23 lb)	1.0 kg (2.2 lb)	3.1 kg (6.8 lb)
Temperature Rating	-10°C (14°F) to 50°C (122°F)	-10°C (14°F) to 50°C (122°F)	-10°C (14°F) to 50°C (122°F)
Attachment Type	D	D	D
Combined Upper/Lower Grip Height	230 mm (9 in)	236 mm (9.3 in)	300 mm (11.8 in)
Grip Width	71.5 mm (2.8 in)	93 mm (3.7 in)	147 mm (5.8 in)

Integrated Specimen Interface

Profile	Flat	Flat	Flat
Surface	Rubber	Rubber	Rubber
Height	10 mm (0.4 in)	20 mm (0.8 in)	50 mm (2.0 in)
Width	10 mm (0.4 in)	65 mm (2.6 in)	80 mm (3.1 in)
Specimen Range	0-2 mm (0-0.08 in)	0-3.5 mm (0-0.14 in)	0-10 mm (0-0.4 in)

Bionix

Compression

Bionix Stainless Steel Compression Platens

- » Stainless steel compression platen designed for durability
- » Precision-ground, hardened surface design enhances platen durability
- » Specimen centering grooves, anti-rotation features and integrated alignment pins improve test accuracy and repeatability
- » Passivated stainless steel – suitable for saline environmental baths
- » Platens are sold in pairs (upper and lower)
- » **Applications:** Compression testing of irregular biomaterials, bone, cartilage, tendons, replacement bio-medical components



Specifications

Model	BCP104A	BCP104B	BCP104C
Part Number	100-182-229	100-182-227	100-203-455
Platen Type	Fixed/Fixed Stainless Steel Platen	Fixed/Fixed Stainless Steel Platen	Fixed/Fixed Stainless Steel Platen
Force Capacity	10 kN (2,250 lbf)	10 kN (2,250 lbf)	10 kN (2,250 lbf)
Minimum Specimen Diameter at Maximum Force Capacity	5 mm (0.2 in)	5 mm (0.2 in)	5 mm (0.2 in)
Upper Platen Weight	0.68 kg (1.5 lbs)	1.82 kg (4 lbs)	0.3 kg (0.66 lbs)
Temperature Range	-130°C (-202°F) to 250°C (482°F)	-130°C (-202°F) to 250°C (482°F)	-130°C (-202°F) to 250°C (482°F)
Attachment Type	D	D	M6 x 1
Combined Upper/Lower Platen Height	148 mm (5.9 in)	148 mm (5.9 in)	50 mm (2 in)
Platen Width	50 mm (2 in)	100 mm (3.9 in)	40 mm (1.6 in)

Bionix Spring Action Grips

Bionix Spring Action Grips are a reliable choice for low-force biomedical testing applications. Available with a variety of mounting threads and jaw surfaces, these lightweight grips are suitable for testing films, papers, and textiles at temperatures ranging from -75°C to 200°C (-103°F to 400°F). Comprised of durable stainless steel, they can be safely deployed within a saline environmental bath. All Bionix Spring Action Grip sets include two grip assemblies, two spare springs, two spare wires for link pin retainers, rubber jaw pad material, and a shipping case.



FEATURES

- » Stainless steel – suitable for saline environmental bath
- » Available with a variety of mounting threads and jaw surfaces
- » Spring action follow-through accommodates specimen neckdown
- » Faces pivot for self alignment and reduced likelihood of breakage at the specimen/face contact
- » Temperature range: -75°C to 200°C (-103°F to 400°F)
- » Applications: Films, papers, textiles
- » Force of jaw tips (jaws parallel): 32 N ± 4.4 N (7.2 lbf ± 1.1 lbf).

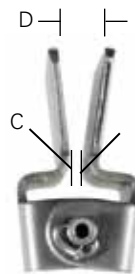

Model 10A,
fully open



Model 10A,
jaws parallel



Model 10B,
(with rubber
face), fully open



Model 10B, (with
rubber face), jaws
parallel

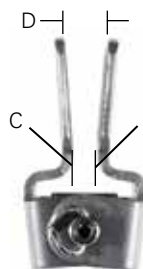

Model 10B,
fully open,
(with no rubber
face material)



Model 10B,
(with no rubber
face material),
jaws parallel

Bionix Spring Action Grips

Model	Mounting Thread	Span "B"	Span "C"	Span "D"	Jaw Surface	Part Number
10A	M6 x 1 mm	0.0	1.0 mm (0.039 in)	2.6 mm (0.103 in)	Flat Smooth	056-077-501
10A	1/4 in -28UNF	0.0	1.0 mm (0.039 in)	2.6 mm (0.103 in)	Flat Smooth	056-077-502
10B	M6 x 1 mm	0.0	1.0 mm (0.039 in)	2.6 mm (0.103 in)	Rubber Face	056-077-503
10B	1/4 in -28UNF	0.0	1.0 mm (0.039 in)	2.6 mm (0.103 in)	Rubber Face	056-077-504
10B	M6 x 1 mm	1.6 mm (0.064 in)	2.6 mm (0.103 in)	4.2 mm (0.167 in)	Flat Smooth	056-077-503
10B	1/4 in -28UNF	1.6 mm (0.064 in)	2.6 mm (0.103 in)	4.2 mm (0.167 in)	Flat Smooth	056-077-504

Bionix EnviroBath

The versatile Bionix EnviroBath facilitates accurate and efficient mechanical testing of medical device and biomaterial specimens in fluids heated to body temperatures. Engineered for biomedical and general material test applications, the Bionix EnviroBath is easy to set up, operate, and maintain and is available in a range of volume configurations to accommodate a broad variety of test specimens. A universal adapter design ensures full compatibility with all MTS electromechanical, electrodynamic and servohydraulic load frame systems, as well as other electromechanical test systems.

- » Variety of volume configurations: 1 l, 6 l, 10 l
- » Supports saline and protein-based fluids
- » Utilizes a wide selection of Bionix grips and fixtures
- » Reliable fluid temperature control mechanism
- » Compatible with video or laser extensometer
- » Optional protein-based fluid system.



Easy to disassemble to clean.



General Specifications

Temperature	
Range:	5° C above ambient to 40° C
Stability:	±2° C at 37° C
Power (V AC, Hz, A)	
US:	120 V AC, 50/60 Hz, 11 A
Europe:	240 V AC, 50 Hz, 10 A

Bionix EnviroBath

	Volume	Axial Force	Torsional Force	Internal Dimensions wxhxd	External Dimensions wxhxd
1	1 l	2.4 kN	28 N.m	100 x 200 x 56 mm 4 x 8 x 2.2 in	180 x 295 x 95 mm 7 x 11.5 x 3.65 in
6	6 l	2.4 kN	28 N.m	130 x 480 x 100 mm 5 x 19 x 3.9 in	205 x 575 x 140 mm 8 x 22.5 x 5.5 in
10	10 l	10 kN	100 N.m	215 x 305 x 150 mm 8.5 x 12 x 5.8 in	295 x 395 x 190 mm 11.5 x 15.5 x 7.4 in

Bionix EnviroBath

Options

	1 liter	6 liter	10 liter
Sprayer Option		√	√
Protein Based Fluid	√	√	√
Horizontal	√	√	√
Digital Temperature Monitor	√	√	√
Upper Pull Rod (SST)	√	√	√

Compatibility Matrix*

Grips and Fixtures	1 liter	6 liter	10 liter	Part Number
Bionix Vise Action Grips, 100 N	√	√	√	100-186-411
Model 642.001 Bend Fixture (SST)	√	√	√	100-201-456 (S/H & E/D)
Bionix Manual Thumb Screw Grip, 100 N	√	√	√	100-167-987
Bionix Compression Platens, 40 mm	√	√	√	100-203-455
Bionix Spring Action Grips		√	√	056-077-50x
Bionix Compression Platens, 50 mm		√	√	100-182-229
Bionix Vise Action Grips, 2 kN		√	√	100-174-783
Bionix Roller Action Grips, 1 kN		√	√	100-185-262
Model 642.01 Bend Fixture (SST)			√	100-203-453 (S/H & E/D)
Bionix Compression Platens, 100 mm			√	100-182-227
Model 686.01A-31 Axial Torsional Grips (SST)			√	051-882-201

Note: EnviroBath 10 is compatible with customer-supplied spinal fixture per ASTM F1717-01.

Some grips available in titanium. Contact MTS for additional information.

* Vertical Orientation

Electromechanical Load Frames

	1 liter	6 liter	10 liter
MTS Single Column Standard Length	√		√
MTS Single Column Extended Length	√	√	√
MTS Dual Column Standard and Extended Length	√	√	√
Legacy MTS load frames and Instron E/M load frames			Consult MTS

Electrodynamic Load Frames

	1 liter	6 liter	10 liter
MTS Acumen 1	√		√
MTS Acumen 3	√		√
MTS Acumen 3 A/T	√		√
MTS Acumen 12	√	√	√
MTS Acumen 12 A/T	√		√

Servohydraulic Load Frames

	1 liter	6 liter	10 liter
Bionix Tabletop Axial or Axial/Torsional	√ ¹	√ ^{1, 2}	√
MTS Landmark ³	√	√	√
Legacy MTS load frames ³			Consult MTS

¹ Additional adapter required.

² Extended columns required.

³ Cross-head mounted actuator.

Composite Fixtures

Modified Celanese Compression Loading Fixture

- » Recommended to test in accordance with ISO 14126 Method 1A
- » Constructed out of high quality stainless steel
- » Design based on the University of Wyoming Modified Celanese Compression Test Fixture
- » Supported specimen dimensions:
 - Maximum width: 12.7 mm (0.5 in)
 - Thickness (with tabs): 3.8 - 6.35 mm (0.15 - 0.25 in)
 - Length: 114.3 mm (4.5 in)
- » Includes wedges with flame sprayed high friction surface
- » Requires compression platens for mounting (*purchased separately*)



Static Force	Temperature Rating	Weight	Dimensions	Part Number
88 kN (20 kip)	-152 to 318°C (-240 to 600°F)	≈ 7.3 kg (16 lbs)	Ø 89 mm (3.5 in) x 191 mm (7.5 in)	100-351-817

IITRI Compression Loading Fixture

- » Recommended to test in accordance with ASTM D3410/ D3410M and ISO 14126 Method 1B Constructed out of high quality stainless steel
- » Supported specimen dimensions:
 - Maximum width: 25.4 mm (1 in)
 - Maximum thickness (with tabs): 15.2 mm (0.6 in)
 - Length: 140 mm (5.5 in)
- » Includes sets of wedges to accommodate specimen thicknesses from 5.1 - 10.2 mm (0.2 - 0.4 in)
Wedges that support other specimen thicknesses are available on request.
- » Requires threaded adapters or compression platens for mounting (*purchased separately*)

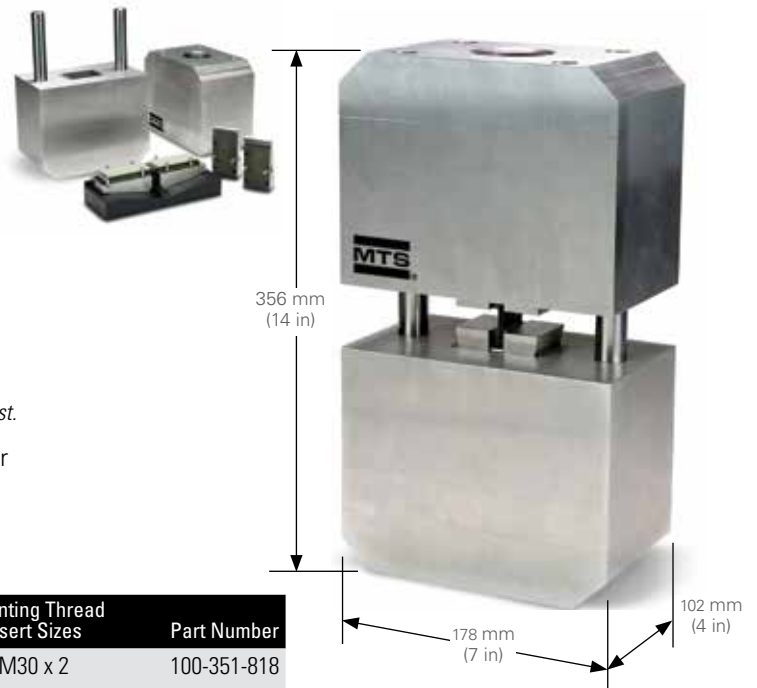

Static Force	Temperature Rating	Weight	Dimensions	Mounting Thread Insert Sizes	Part Number
267 kN (60 kip)	-152 to 318°C (-240 to 600°F)	≈ 36 kg (80 lbs)	178 mm (7 in) x 102 mm (4 in) x 356 mm (14 in)	M30 x 2	100-351-818

Composite Fixtures

Combined Loading Compression (CLC) Test Fixture

- » Recommended to test in accordance with ASTM D6641/D6641M
- » Constructed out of high quality stainless steel
- » Supported specimen dimensions:
 - Maximum width: 25.4 mm (1 in)
 - Maximum thickness (with tabs): 12.7 mm (0.5 in)
 - Length: 140 mm (5.5 in)
- » Requires compression platens for mounting (*purchased separately*)

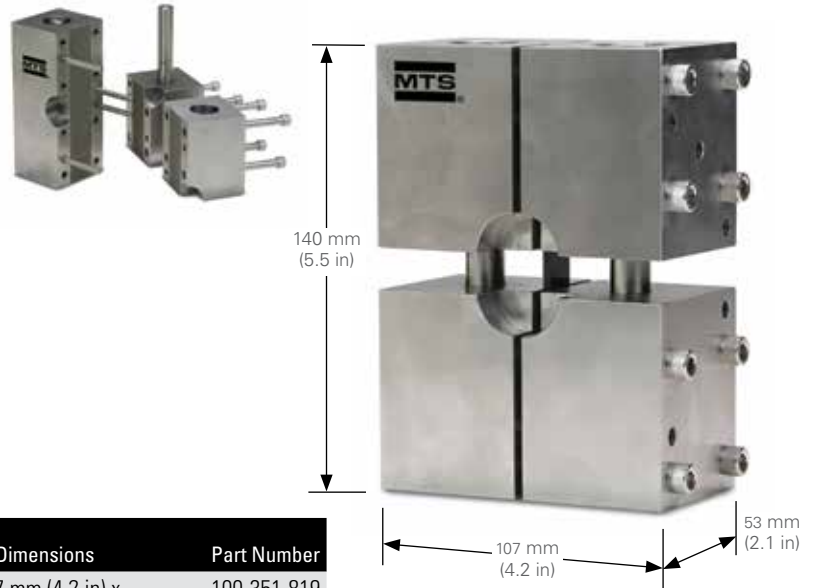

Static Force	Temperature Rating	Weight	Dimensions	Part Number
89 kN (20 kip)	-152 to 318°C (-240 to 600°F)	≈ 6.8 kg (15 lbs)	107 mm (4.2 in) x 53 mm (2.1 in) x 140 mm (5.5 in)	100-351-819

V-Notched Rail Shear Test Fixture

- » Recommended to test in accordance with ASTM D7078/D7078M
- » Constructed out of high quality stainless steel
- » Supported specimen dimensions:
 - Width: 55.6 mm (2.2 in)
 - Maximum thickness: 12.7 mm (0.5 in)
 - Maximum length: 76 mm (3.0 in)
- » Requires threaded adapter for top and bottom mounting (*purchased separately*)



Static Force	Temperature Rating	Weight	Dimensions	Mounting Thread Insert Sizes	Part Number
44 kN (10 kip)	-152 to 318°C (-240 to 600°F)	≈ 7.7 kg (17 lbs)	102 mm (4 in) x 64 mm (2.5 in) x 165 mm (6.5 in)	1" - 14	100-351-820

Composite Fixtures

V-Notched Beam (Iosipescu) Shear Fixture

- » Recommended to test in accordance with ASTM D5379/D5379M
- » Constructed out of high quality stainless steel
- » Supported Specimen Dimensions:
 - Width: 19 mm (0.75 in)
 - Thickness: 0.76 - 12.7 mm (0.03 -0.5 in)
 - Length: 76 mm (3.0 in)
 - Notch: 90 degree with 1.27 mm (0.05 in) radius minimum
- » Includes adjustable wedges
- » Requires threaded adapter for top and compression platen for bottom mounting (purchased separately)

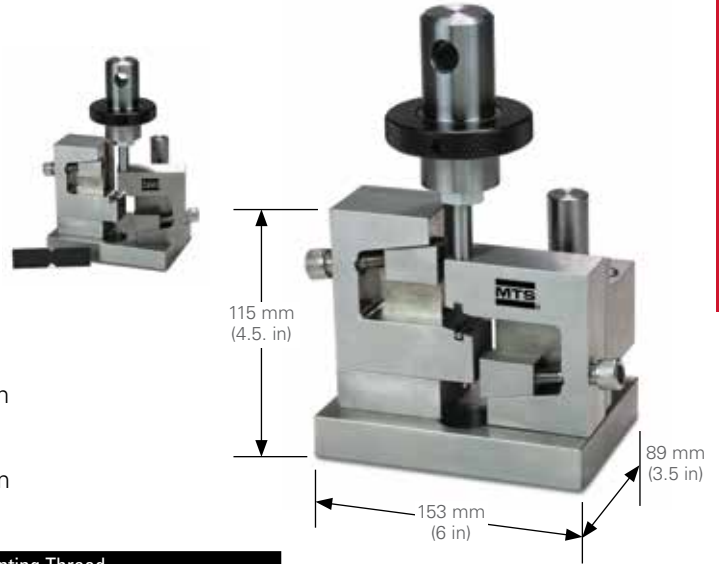

Static Force	Temperature Rating	Weight	Dimensions	Mounting Thread Insert Sizes	Part Number
44 kN (10 kip)	-152 to 318°C (-240 to 600°F)	≈ 6.8 kg (15 lbs)	153 mm (6 in) x 89 mm (3.5 in) x 115 mm (4.5 in)	1/2" - 20	100-087-239

Short-Beam Strength Fixture

- » Recommended to test in accordance with ASTM D2344 (please contact MTS for fixture in accordance to ASTM D2344M)
- » Constructed out of high quality stainless steel
- » Supported Specimen Dimensions:
 - Maximum Width: 38 mm (1.5 in)
 - Maximum Thickness: 50 mm (2 in)
 - Maximum Length: 152 mm (6 in)
- » Adjustable support span
- » Supports include specimen center tabs for accurate specimen alignment
- » Requires female clevis adapter or compression platen for top and threaded adapter or compression platen for bottom mounting (purchased separately)

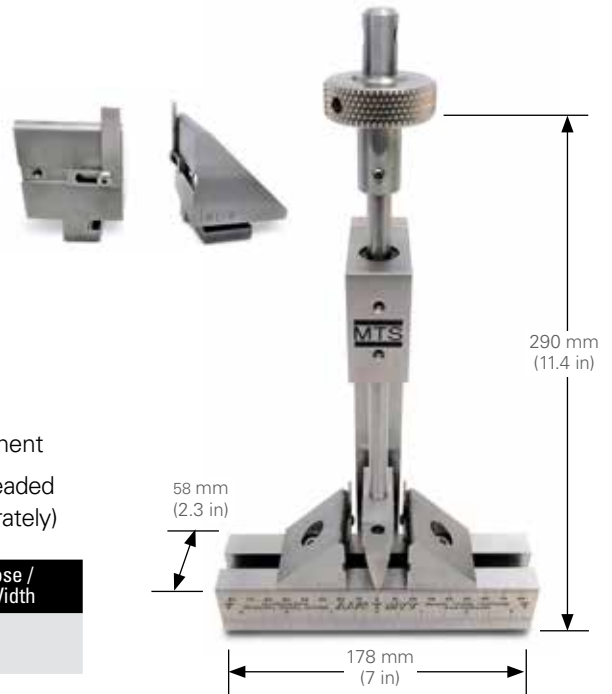

Lower Fixture Span	Loading Nose Diameter	Supports Diameter	Loading Nose / Supports Width
3.2 - 152 mm (0.125 - 6 in)	6.35 mm (0.25 in)	3.175 mm (0.125 in)	38 mm (1.5 in)

Static Force	Temperature Rating	Weight	Dimensions	Top Mounting Male Clevis	Bottom Mounting Thread Insert Sizes	Part Number
8.9 kN (2 kip)	-152 to 318°C (-240 to 600°F)	≈ 6.8 kg (15 lbs)	178 mm (7 in) x 58 mm (2.3 in) x 290 mm (11.4 in)*	12 mm (Type 0)	1/2" - 20	100-351-821

* Plus any specimen up to 51 mm (2 in)

Additional Loading Nose and Supports

Standard	Material	Lower Fixture Span	Loading Nose Diameter	Set Of Supports Diameter	Loading Nose / Supports Width	Part Number
ISO 14130	High quality stainless steel	4 - 152 mm (0.157 - 6 in)	10 mm (0.394 in)	–	38 mm (1.5 in)	100-352-347
			–	4 mm (0.157 in)		100-352-348

Composite Fixtures

Mixed Mode Bending Fixture

- » Recommended to test in accordance with ASTM D6671/ D6671M
- » Constructed out of high quality stainless steel and aluminum
- » Supported specimen dimensions:
 - Maximum width: 38 mm (1.5 in)
 - Maximum thickness: 6.35 mm (0.25 in)
 - Maximum length: 228 mm (9.0 in)
- » Includes 5 sets of specimen hinges
- » Requires threaded adapter for top and compression platen for bottom mounting (purchased separately)

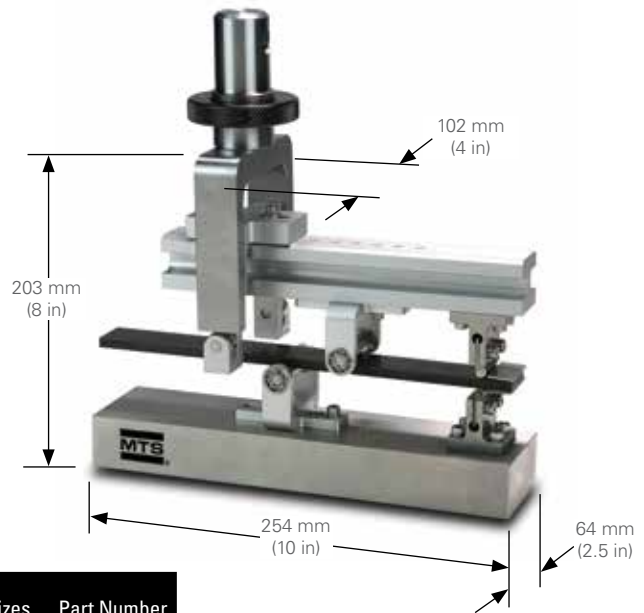

Static Force	Temperature Rating	Weight	Dimensions	Top Mounting Threaded Stud Sizes	Part Number
4.4 kN (1 kip)	-85 to 122°C (-120 to 250°F)	≈ 7.3 kg (16 lbs)	254 mm (10 in) x 102 mm (4 in) x 203 mm (8 in)	1/4" - 28	100-351-822

Open / Filled Hole Compression Fixture

- » Recommended to test in accordance with ASTM D6484, ASTM D6742 and BS 07260 (please contact MTS for fixture in accordance to ASTM D6484M and ASTM D6742M)
- » Constructed out of high quality stainless steel
- » Supported specimen dimensions:
 - Width: 38 mm (1.5 in)
 - Maximum thickness: 12.7 mm (0.5 in)
 - Maximum length: 305 mm (12 in)
- » Requires compression platens or hydraulic grips for mounting (purchased separately)

Note: Fixture thickness for gripping = 30 mm (1.18 in) + specimen thickness

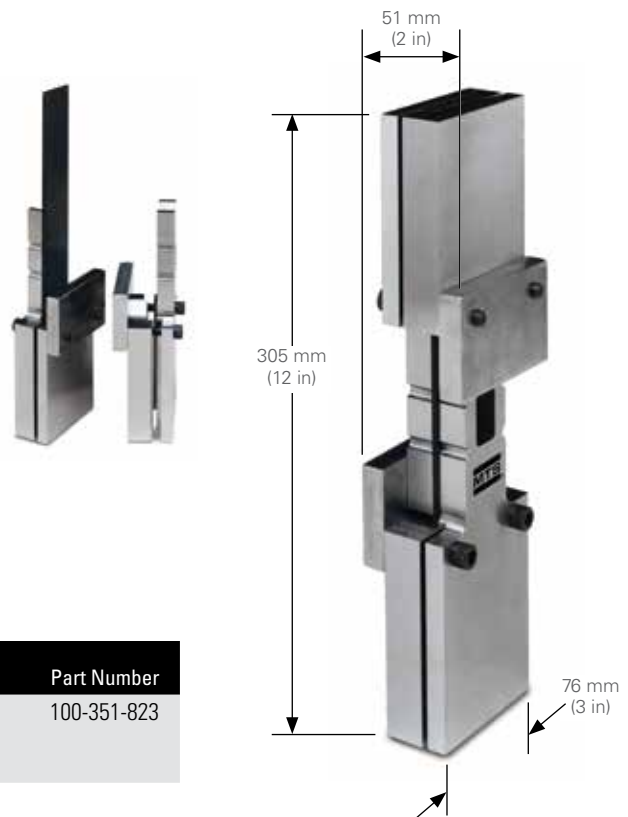

Static Force	Temperature Rating	Weight	Dimensions	Part Number
222 kN (50 kip)	-152 to 318°C (-240 to 600°F)	≈ 6.8 kg (15 lbs)	76 mm (3 in) x 51 mm (2 in) x 305 mm (12 in)	100-351-823

Composite Fixtures

Compression After Impact Test Fixture

- » Recommended to test in accordance with ASTM D7137 (please contact MTS for fixture in accordance to ASTM D7137M)
- » Constructed out of high quality stainless steel
- » Supported specimen dimensions:
 - Width: 102 mm (4 in)
 - Thickness: 3.175 - 12.7 mm (0.125 - 0.500 in)
 - Length: 152 mm (6 in)
- » Requires threaded adapter for top and compression platen for bottom mounting (purchased separately)

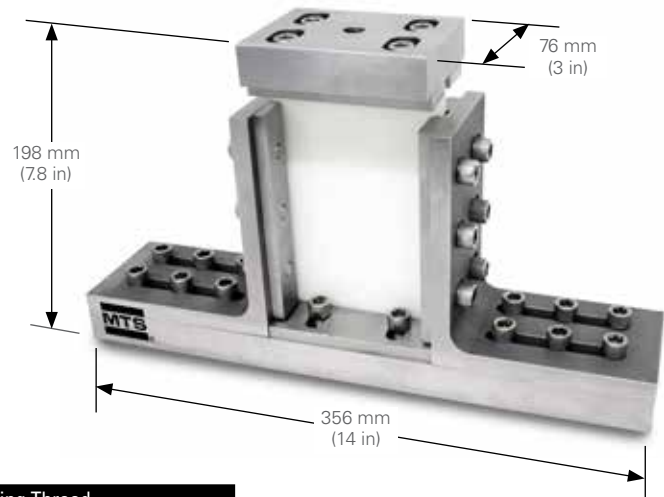

Static Force	Temperature Rating	Weight	Dimensions	Mounting Thread Insert Sizes	Part Number
222 kN (50,000 lbs)	-152 to 318°C (-240 to 600°F)	≈ 16 kg (35 lbs)	356 mm (14 in) x 76 mm (3 in) x 198 mm (7.8 in)	1/2" - 13	100-351-824

Flatwise Plane Shear Fixture, Tensile Mode

- » Recommended to test in accordance with ASTM C273/ C273M and ASTM C394/C394M (Fatigue)
- » Constructed out of high quality stainless steel
- » Includes three sets of aluminum bonding plates
- » Supported specimen dimensions:
 - Maximum width: 76 mm (3 in)
 - Thickness: 6.3 - 19.1 mm (0.25 - 0.75 in)
(optional plates for thicker samples on request)
 - Maximum length: 229 mm (9 in)
- » Requires threaded adapter for top and bottom mounting (purchased separately)

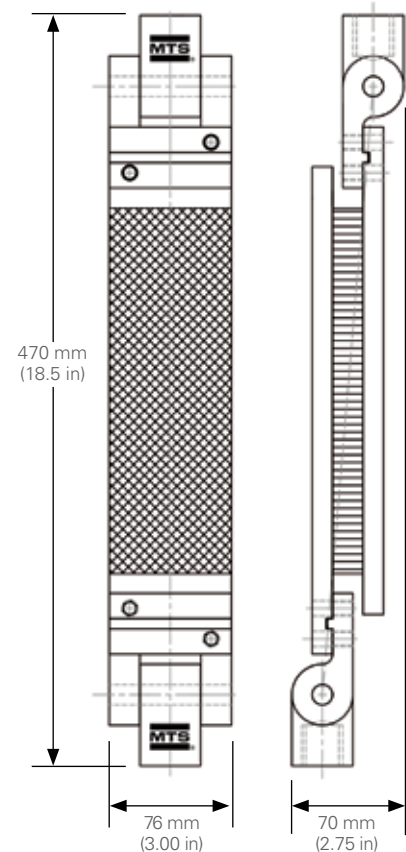

Static Force	Temperature Rating*	Weight	Dimensions	Mounting Thread Insert Sizes	Part Number
89 kN (20 kip)	-152 to 318°C (-152 to 600°F)	≈ 14.5 kg (32 lbs)	76 mm (3 in) x 70 mm (2.75 in) x 470 mm (18.5 in)	1" - 14	100-204-294

* Temperature Range of Aluminum Bonding Plates -85 to 122°C (-120 to 250°F)

Composite Fixtures

Flatwise Plane Shear Fixture, Compression Mode

- » Recommended to test in accordance with ASTM C273/ C273M and ASTM C394/C394M (Fatigue)
- » Constructed out of high quality stainless steel
- » Includes three sets of aluminum bonding plates
- » Supported specimen dimensions:
 - Maximum width: 76 mm (3 in)
 - Thickness: 6.3 - 19.1 mm (0.25 - 0.75 in) (optional plates for thicker samples on request)
 - Maximum length: 229 mm (9 in)
- » Requires threaded adapter for top and bottom mounting (purchased separately)

Static Force	Temperature Rating*	Weight	Dimensions	Mounting Thread Insert Sizes	Part Number
89 kN (20 kip)	-152 to 318°C (-152 to 600°F)	≈ 14.5 kg (32 lbs)	76 mm (3 in) x 64 mm (2.5 in) x 368 mm (14.5 in)	1" - 14	100-056-205

* Temperature Range of Aluminum Bonding Plates -85 to 122°C (-120 to 250°F).

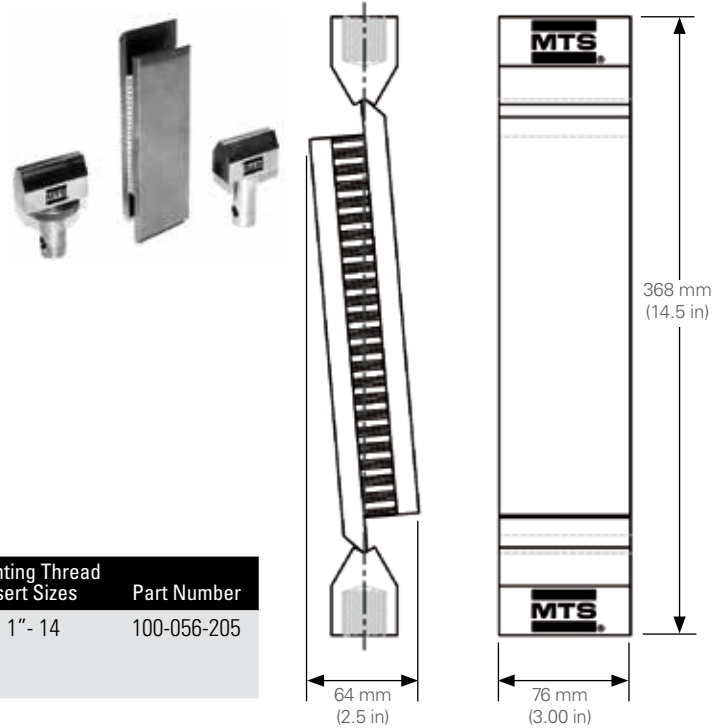

Climbing Drum Peel Fixture with Roller Type Grips

- » Recommended to test in accordance with ASTM D1781 (please contact MTS for fixture in accordance to ASTM D1781M)
- » Constructed out of high quality stainless steel with an aluminum drum
- » Supported specimen dimensions:
 - Width: 25.4 - 102 mm (1 - 4 in)
 - Thickness: 0.762 - 25.4 mm (0.03 - 1 in)
 - Length: 254 mm (10 in)
- » Requires threaded adapter for top and bottom mounting (purchased separately)

Static Force	Temperature Rating	Weight	Dimensions	Mounting Thread Insert Sizes	Part Number
2.2 kN (0.5 kip)	-85 to 122°C (-120 to 250°F)	≈ 13.6 kg (30 lbs)	183 mm (7.2 in) x 175 mm (6.9 in) x 671 mm (26.4 in)	1" - 14	100-363-421

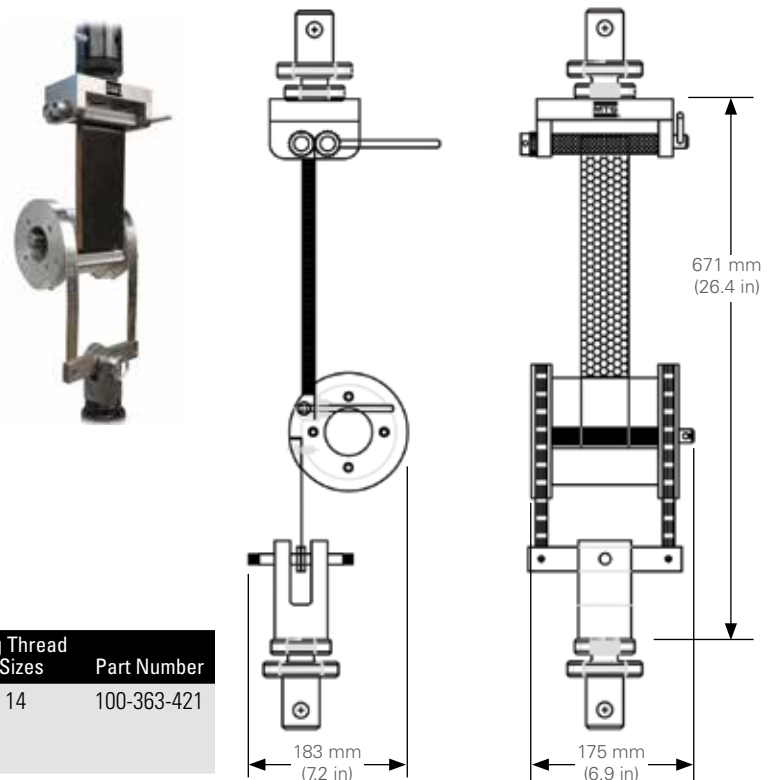

Composite Fixtures

Three & Four Point Sandwich Beam Flexure / Shear Fixture

- » Recommended to test in accordance with ASTM C393/C393M, ASTM D5467/D5467M, ASTM D7249/D7249M and ASTM D7250/D7250M
- » Constructed out of high strength steel with a durable black oxide finish (except for rollers and pads)
- » Supported specimen dimensions:
 - Maximum width: 100 mm (4 in)
 - Maximum length: 610 mm (24 in)
- » Adjustable loading and support spans
- » Loading and support bars are supplied with loading pins and flat steel loading blocks held in alignment with springs (rubber pads not included)
- » Requires threaded adapter for top and bottom mounting (purchased separately)



Upper Fixture Span	Lower Fixture Span	Loading Pins Diameter	Support Pins Diameter	Loading & Support Pins Width
51 - 305 mm (2 - 12 in))	152 - 610 mm (6 - 24 in)	25.4 mm (1 in)	25.4 mm (1 in)	100 mm (4 in)

Static Force	Temperature Rating	Weight	Dimensions	Mounting Thread Insert Sizes	Part Number
11 kN (2.5 kip)	-85 to 122°C (-120 to 250°F)	≈ 52 kg (114 lbs)	635 mm (25 in) x 114 mm (4.5 in) x 389 mm (15.3 in)	1" - 14	100-351-826

* Plus specimen thickness

FURNACES & CHAMBERS

Our high-temperature testing solutions leverage decades of collaboration with industry pioneers and innovative technologies proven to deliver accurate repeatable results. These solutions precisely replicate real-world loading of high-temperatures and other environments.

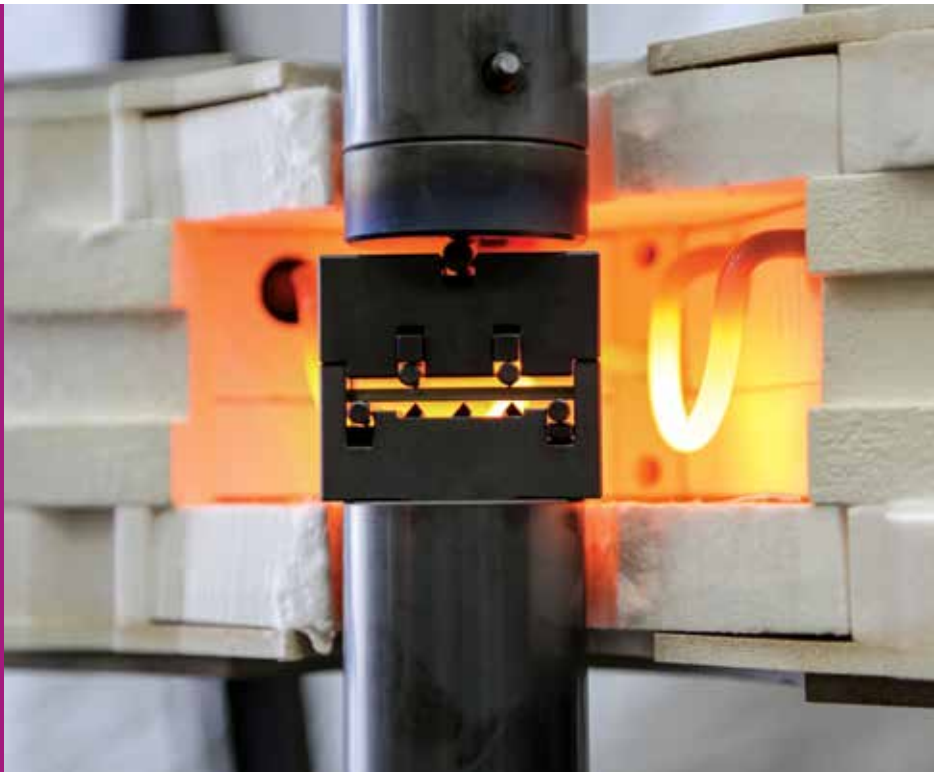

Furnaces & Chambers

Introduction	148
Furnaces & Temperature Controller	149
Environmental Simulation	150-153
Thermomechanical Fatigue (TMF)	154-155
Environmental Chambers & Specifications	156-157

Reliable Furnace and Temperature Controller

Combine Performance and Affordability

- » MTS Model 653 furnaces incorporate the MTS Model 409.83 temperature controller to provide high-temperature testing environments
- » Capable of achieving temperatures up to 1000°C (1832°F) in validated testing conditions
- » Single or multiple zone heating
- » Clamshell design streamlines test setup, furnace alignment, and specimen changeover
- » Silicon carbide heating elements and alumina fiber insulation system for low heat loss and long life
- » Multiple furnace heights to accommodate diverse test requirements
- » Mounting bracket for a variety of MTS load frames is included
- » Designed to accommodate MTS high-temperature axial extensometers
- » Multiple mounting options – on included furnace mounting bracket or optional stand for floor or table
- » Compact, ergonomic design
- » Multiple level, self-tuning PID control
- » SCR power relays included
- » Digital communications available
- » **Applications:** Ideal for high-temperatures tension, and compression testing of metals, composites, ceramics, and a wide variety of materials



* Supports testing to ASTM E606-04e1, BSI 7270, JIS Z2279, AFNOR A03-403, ISO 12106, ISO (EN) 6892-2, ASTM E21, prEN 2002-2 or GB/T 228.2 requirements.

Note: When ordering, please indicate voltage requirements and provide necessary load frame dimensions in order to determine system integration requirements.

Furnaces

Model	653.01	653.02	653.03	653.04**
Part Number	Configurable	Configurable	Configurable	Configurable
Temperature Rating*	200°C (392°F) to 1000°C (1832°F)	200°C (392°F) to 1000°C (1832°F)	200°C (392°F) to 1000°C (1832°F)	200°C (392°F) to 1000°C (1832°F)
Overall Height	55 mm (2.2 in)	85 mm (3.3 in)	126 mm (5 in)	220 mm (6.7 in)
Hot Zone Height	19 mm (0.75 in)	50 mm (1.97 in)	90 mm (3.54 in)	185 mm (7.28 in)
Hot Zone Width & Depth	50 x 50 mm (1.97 x 1.97 in)	50 x 50 mm (1.97 x 1.97 in)	62.5 x 62.5 mm (2.46 x 2.46 in)	62.5 x 62.5 mm (2.46 x 2.46 in)
Number of Zones	1	2	2	3

Thermal Gradient Verification Kit Components (Optional)	Part Number
Thermocouple Data Acquisition Kit	100-255-716
Type K Thermocouple Connector Kit	100-255-714
Thermocouple Specimen	057-743-803
Thermocouple Welding Kit	100-256-698



Environmental Simulation

Extension Rods – Chambers

- » MTS EM Extend Kits include a variety of extension rods to enhance testing flexibility and reduce test setup time.
- » All extension rods have ports for water cooling
- » Stainless steel construction minimizes heat transfer
- » Lightweight design minimizes tare weight
- » Tight tolerances ensure angular and concentric alignment are retained
- » Highly configurable to test various size specimens. Compression platens are usually low profile and will need more extension lengths. Pneumatic grips take up more space and will require fewer lengths
- » Type C, D & E kits consists of five different extension lengths that can be configured into 23 different length combinations
- » Upper extension rod can be adjusted in increments providing multiple pin-to-pin dimensions
- » Preloaded joints
- » **Applications:** Apply tension and compression in an environmental chamber to test low and high profile accessories or short and tall specimens



Type "C"



Type "D"

Load extension kits are packaged in a protective case. From left to right, the lengths are denoted as L1 through L5.

MTS EM Extend Kit

Model	EME202	EME155	EME305
Part Number	100-151-425	100-150-815	100-310-560
Type	Stainless Steel Water Cooled Extension Rod Kit	Stainless Steel Water Cooled Extension Rod Kit	Stainless Steel Water Cooled Extension Rod Kit
Force Capacity	0.2 kN (45 lbs)	150 kN (33,700 lbs)	300 kN (67,440 lbs)
Temperature Rating	-130°C (-200°F) to 315°C (600°F)	-130°C (-200°F) to 315°C (600°F)	-130°C (-200°F) to 315°C (600°F)
Attachment Type	C	D	E

Note: Optional Water Cooling Kit - 57697506.

Environmental Simulation

Extension Rods – Furnaces

MTS Fundamental Extension Rods

- » Affordable extension rods designed for high-temperature environments
- » All extension rods have water cooling ports
- » Special alloy enables high-temperature testing
- » Specimen interface can be changed while using the extension rod to reduce test setup time
- » **Applications:** Ideal for high-temperature tension and compression testing



FHA000



FHA210

Specifications

Model	FHA000	FHA001
Part Number	100-231-867	100-277-341
Type	High Temperature Alloy Water Cooled Extension Rod	High Temperature Alloy Water Cooled Extension Rod
Force Capacity	80 kN (18,000 lbf)*	80 kN (18,000 lbf)*
Temperature Rating	0°C (0°F) to 1050°C (0 - 1922°F)	0°C (0°F) to 1050°C (0 - 1922°F)
Attachment Type	D	E
Extension Rod Length	364 mm (14.3 in)	399 mm (15.7 in)
Upper Extension Rod Weight	2.9 kg (6.5 lbs)	5 kg (11 lbs)

*Force capacity at room temp, consult MTS Application Engineer for maximum force capacities at elevated temperatures.

Optional Specimen Interface Furnace Extension Rods

Model	Part Number	Profile	Height	Upper Extension Rod Weight	Temperature Range	Specimen Range
FHA110	100-231-868	Threaded	80 mm (3.1 in)	0.46 kg (1 lbs)	0°C (0°F) to 1050°C (0 - 1922°F)	M16 x 2
FHA120	100-231-869	Threaded	98 mm (3.8 in)	0.58 kg (1.3 lbs)	0°C (0°F) to 1050°C (0 - 1922°F)	M12 x 1.75
FHA210	100-231-870	Flat	68 mm (2.7 in)	0.39 kg (0.9 lbs)	0°C (0°F) to 1050°C (0 - 1922°F)	1-4 mm (0.04-0.16 in)
FHA220	100-231-871	Flat	83 mm (3.3 in)	0.74 kg (1.6 lbs)	0°C (0°F) to 1050°C (0 - 1922°F)	4-8 mm (0.16-0.31 in)

Environmental Simulation

Chambers

MTS Advantage Environmental Chambers

- » MTS Advantage environmental chambers increase range of temperatures available for materials testing
- » Enables testing at a constant temperature with very little gradient across the specimen
- » Compatible with video or laser extensometers
- » Optional heated window available
- » **Applications:** Materials testing at controlled temperatures for research, quality control and production testing of elastomeric components, tire cords, plastics, composites, laminates, etc.



AEC 10x10x32

Specifications

Model	AEC 10x10x24	AEC 10x10x32	AEC 14x17x24	AEC 14x17x32
Part Number	Configurable	Configurable	Configurable	Configurable
Temperature Rating	-129°C (-200°F) to 316°C (600°F)	-129°C (-200°F) to 316°C (600°F)	-129°C (-200°F) to 316°C (600°F)	-129°C (-200°F) to 316°C (600°F)
Internal Width	254 mm (10 in)	254 mm (10 in)	356 mm (14 in)	356 mm (14 in)
Internal Depth	254 mm (10 in)	254 mm (10 in)	432 mm (17 in)	432 mm (17 in)
Internal Height	610 mm (24 in)	813 mm (32 in)	610 mm (24 in)	813 mm (32 in)
External Width	406 mm (16 in)	406 mm (16 in)	508 mm (20 in)	508 mm (20 in)
External Depth	737 mm (29 in)	737 mm (29 in)	914 mm (36 in)	914 mm (36 in)
External Height	762 mm (30 in)	965 mm (38 in)	762 mm (30 in)	965 mm (38 in)



Thermomechanical Fatigue (TMF)

Subsystem with Induction Heating

The MTS TMF Subsystem is ideal for inducing thermal cycling in a metallic (magnetically susceptible) specimen. A combination of induction heating and air cooling allows thermomechanical fatigue tests to be performed in or out of phase with a load force. The TMF subsystem has a user-friendly design that helps operators perform repeatable test setup tasks quickly. Air cooling jets and the induction coil have easy, repeatable adjustments, meaning that specimen changes do not require as much setup time to reestablish the initial conditions. A specimen centering tool provides quick initial position for the coil. The coil is mounted on an x, y, z positioner that has manual adjustment knobs with numerical indicators allowing 50 mm of travel in 3-axes for fine positioning relative to the specimen. A quick release slide allows the coil to be easily pulled from the test space with the ability to return to its original position. Air cooling jets are also easily folded back or removed to gain access to the specimen with the same ability to snap back into the original position.

The induction coil is coated in electrically insulating material to provide an additional safety factor against electric shock. The coil, generator and RF oscillator are water cooled and interlocked for water flow. A second interlock specimen thermocouple also provides indication in the event that the primary control thermocouple becomes detached. TestSuite software templates for TMF include test setup, to establish thermal gradients, and test run to perform and report results on the TMF test.

TMF SUBSYSTEM FEATURES:

- » 10 kW RF Generator with temperature controller and secondary temperature interlock controller
- » Air-cooling jets with detachable arms and adjustable flow profiles
- » 10°C/second heating and cooling with higher open loop heating rates possible
- » Up to 1200°C
- » X,Y,Z coil with position indication and quick release slide-back mount
- » Type K or Type R thermocouple compatibility
- » Water chiller for RF generator and coil
- » Tool kit for coil centering and adjustment
- » Standard 5-turn electrically insulated induction coil
- » TestSuite Templates for setup and test control
- » Instrumented specimen for equipment checkout and validation
- » 16 channel thermocouple data acquisition module
- » Thermocouple connector kit to interface with specimen
- » Designed to accommodate MTS high-temperature axial extensometers.

When ordering, please indicate power choice of water chiller 50 Hz or 60 Hz, thermocouple type (R or K).



Environmental Chambers

Engineered for Dependable Operation

Every aspect of Series 651 Environmental Chambers was designed using decades of MTS experience developing test systems for numerous industries. These environmental chambers may include:

- » Circulating fan helps ensure small specimen temperature gradients
- » Removable "U-plug" sections allowing chambers to be moved into place after the specimen is mounted and instrumented
- » Doors that open to 180° or can be lifted away for convenient specimen access
- » Multi-panel, tempered optical quality glass windows are sealed to reduce fogging and frosting. If required for non-contacting strain measurement solutions or video monitoring, the chambers can be provided with optional defrost elements
- » Internal light to illuminate the test area is supported by 651.05 & .06. 651.10 chambers have an external light mounted to the chamber window / door
- » Mobile carts to prevent interference between chambers and the load frame

Model 651.05F-01 works in a variety of general materials testing applications -151°C (-238°F) up to 350°C (662°F) with floor-standing models of the MTS Acumen test system.

Model 651.05F-02 is ideal for general materials testing applications -151°C (-238°F) up to 350°C (662°F) with tabletop models of the MTS Acumen test system.

Model 651.06E-03 handles general materials testing -129°C (-200°F) up to 315°C (600°F) with floor-standing MTS Landmark test systems.

Model 651.10E-04 offers support for general materials testing -129°C (-200°F) up to 540°C (1000°F) with floor-standing MTS Landmark test systems.

Model 651.06E-04 is designed to accommodate large specimens or specimens that require large grips within the chamber. Works -129°C (-200°F) up to 315°C (600°F) with floor-standing MTS Landmark test systems.

Can't Find What You Need?

MTS also supplies chambers with mechanical refrigeration, humidity control, or salt fog testing. Contact your local applications engineer for more information.



Specifications

Environmental Chamber Specifications

Model	651.05F-01	651.05F-02	651.06E-03	651.06E-04	651.10E-04
Load Frame	Acumen 1 Acumen 3	Landmark Bionix Acumen 3	Landmark	Landmark	Landmark
Chamber part number	058-052-704 (US Plug) 058-052-703 (WW Plug)	058-052-702 (Acumen, US Plug) 058-052-701 (Acumen, WW Plug) 058-052-602 (w/table top legs, US Plug) 058-052-601 (w/table top legs, WW Plug)	100-639-950 (works with 494 FlexTest Controller) 100-639-951 (works with 494 FlexTest Controller) <i>(will be supplied with defrosting elements for the window)</i>	100-639-952 (works with 494 FlexTest Controller) 100-639-953 (works with 494 FlexTest Controller) <i>(will be supplied with defrosting elements for the window)</i>	100-639-954 (works with 494 FlexTest Controller) 100-639-955 (works with 494 FlexTest Controller) <i>(will be supplied with defrosting elements for the window)</i>
Cart part number[¶]	100-294-319 [#] 100-297-346	100-294-319 [#] 100-297-346	100-160-646 100-213-156**	100-160-646 100-213-156**	100-160-646 100-213-156**
Test space (nominal)	216 mm W, 228 mm D, 228 mm H (8.5 in W, 9 in D, 9 in H)	286 mm W, 305 mm D, 457 mm H (11.25 in W, 12 in D, 18 in H)	356 mm W, 432 mm D, 559 mm H (14 in W, 17 in D, 22 in H)	356 mm W, 432 mm D, 813 mm H (14 in W, 17 in D, 32 in H)	356 mm W, 432 mm D, 660 mm H (14 in W, 17 in D, 26 in H)
Removable "U-Plug" sections	Not included	Included	Included	Included	Included
Typical application	Material testing, including fatigue and fracture, tension, compression, flex/bend, etc.				
Air temperature performance*					
<i>Temperature Values (min & max)</i>	-151°C (-238°F) to 350°C (662°F)	-151°C (-238°F) to 350°C (662°F)	-129°C (-200°F) to 315°C (600°F)	-129°C (-200°F) to 315°C (600°F)	-129°C (-200°F) to 540°C (1000°F)
<i>Heating</i>	Ambient to +350°C (+660°F) in 45 minutes	Ambient to +350°C (+660°F) in 45 minutes	Ambient to +315°C (+600°F) in 30 minutes	Ambient to +315°C (+600°F) in 30 minutes	Ambient to +540°C (+1000°F) in 70 minutes
<i>LN₂ cooling</i>	Ambient to -151°C (-238°F) in 45 minutes	Ambient to -151°C (-238°F) in 45 minutes	Ambient to -129°C (-200°F) in 26 minutes	Ambient to -129°C (-200°F) in 26 minutes	Ambient to -129°C (-200°F) in 26 minutes
<i>Temperature gradient^{†,‡}</i>	±3°C or less	±3°C or less	±2°C (±5°F)	±2°C (±5°F)	±2°C (±5°F) from -129° to 260°C (-200° to 500°F) ±5°C (±10°F) from 260° to 540°C (500° to 1000°F)
<i>Temperature stability[†]</i>	±2°C (±5°F)	±2°C (±5°F)	±1°C (±3°F)	±1°C (±3°F)	±1°C (±3°F)
Cooling requirements					
<i>LN₂ cooling inlet fitting</i>	Male 1/2 in SAE 45° flare 90° angle tube fitting	Male 1/2 in SAE 45° flare 90° angle tube fitting	Male 1/2 in SAE 45° flare 90° angle tube fitting	Male 1/2 in SAE 45° flare 90° angle tube fitting	Male 1/2 in SAE 45° flare 90° angle tube fitting
<i>LN₂ pressure</i>	0.15 MPa (22 psi nominal) 0.21 MPa (30 psi max)	0.15 MPa (22 psi nominal) 0.21 MPa (30 psi max)	0.15 MPa (22 psi nominal) 0.21 MPa (30 psi max)	0.15 MPa (22 psi nominal) 0.21 MPa (30 psi max)	0.15 MPa (22 psi nominal) 0.21 MPa (30 psi max)
Heater circuit power	208/230 V AC	208/230 V AC	208/230 V AC	208/230 V AC	208/230 V AC
Requirements	50/60 Hz, single-phase; at least 20 A circuit	50/60 Hz, single-phase; at least 20 A circuit	50/60 Hz, single-phase; at least 30 A circuit	50/60 Hz, single-phase; at least 50 A circuit	50/60 Hz, single-phase; at least 50 A circuit
Weight	82 kg (180 lbs)	108 kg (250 lbs)	102 kg (225 lbs)	159 kg (350 lbs)	136 kg (300 lbs)
Light	None	120 V bulb (40 watt recommended)	115 V bulb (40 watt recommended)	115 V bulb (40 watt recommended)	External 115 V bulb (40 watt recommended)

* Performance data derived with chamber empty and access holes blocked. Consult MTS Systems for temperature performance for testing specimens having high thermal mass.

** For Landmark 370.50 only.

¶ Consult MTS for cart information specific to your configuration.

Cart stand for table top load units.

† After 30 minute stabilization time.

‡ Due to large variety of possible test setups an air gradient is given. Specimen gradient is much less.

TEST SYSTEM COMPONENTS

MTS test system components are designed to maximize the safety, reliability and energy-efficiency of hydraulic power generation, actuation and distribution. These components are specifically engineered to meet the unique and rigorous demands of mechanical testing, and since decisions related to hydraulic power and distribution have a profound impact on lab productivity, they play an increasingly important role in the lab.



Testing System Components

Introduction	158
201 Hydraulic Actuators	159-160
242 Hydraulic Actuators	161
244 Hydraulic Actuators	162
248 Hydraulic Actuators	163
249 Swivel Base & Rod Ends	164-165
252 Servovalves	166
215 & 216 Rotary Actuators	167
Rotary Actuator Options	168
515 Hydraulic Power Units	169
Multi-Pump Control Manager (MPCM)	170
295 Hydraulic Service Manifold	171
SafeGuard Technology	172
Isolation Service Manifold	173
Testline Modular Components	174
Additional Components	175

MTS DuraGlide® 201 Hydraulic Actuators

MTS Series 201 Actuators are single-ended, double-acting, fatigue-rated force generators targeted at long stroke and mid-level performance dynamic structural applications. This actuator is ideal for low frequency testing and simulation applications.

- » Proprietary seal and bearing designs that reduce friction
- » Available with or without displacement transducer to meet specific application needs
- » Low-friction seals comprise only 1% of rated load for energy-efficient operation
- » Optional hydraulic cushions to protect the actuator from the effects of high-speed or high-inertial impacts
- » Optional MTS SureCoat® Rod Finishing Technology to maximize performance and increase actuator life
- » Ready integration with a wide variety of MTS servohydraulic components

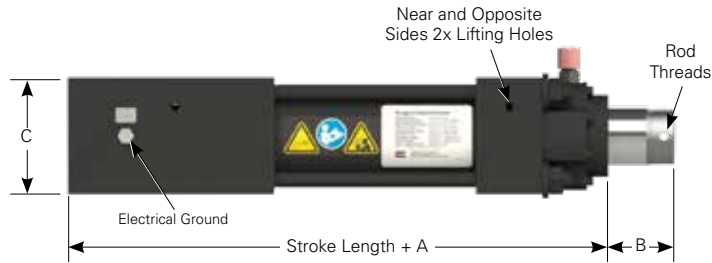

Specifications

201 Cylinder Dimensions

MODEL	Stroke Options*				Transducer Ready		Solid Rod		ROD EXTENSION FULLY RETRACTED (B)		REAR END CAP (C)		REAR END CAP MOUNTING PATTERN	
	MINIMUM		MAXIMUM		CYLINDER BODY LENGTH (A)		CYLINDER BODY LENGTH (A)						Primary	Secondary***
	mm	in	mm	in	mm	in	mm	in	mm	in	mm	in	Type 1, 249XB.M25	
201.10	100	4	1000	40**	304.8	12.00	228.6	9.00	25.4	1.00	76.2	3.00	Type 1, 249XB.M25	
201.11	100	4	1500	60**	314.2	12.37	238.0	9.37	50.8	2.00	82.6	3.25	Type 1, 249XB.M25	
201.17	100	4	1500	60**	314.2	12.37	238.0	9.37	50.8	2.00	88.9	3.50	Type 1, 249XB.M25	
201.20	100	4	1500	60**	314.2	12.37	238.0	9.37	50.8	2.00	114.3	4.50	Type 1, 249XB.M70	
201.25	100	4	1500	60**	263.4	10.37	238.0	9.37	50.8	2.00	127.0	5.00	Type 1, 249XB.M160	
201.30	100	4	1500	60	286.3	11.27	286.3	11.27	50.8	2.00	165.1	6.50	Type 1, 249XB.M160	
201.35	100	4	1500	60	305.6	12.03	286.3	11.27	50.8	2.00	190.5	7.50	Type 1, 249XB.M340	Type 1, 249XB.M160
201.40	100	4	1500	60	330.2	13.00	-	-	50.8	2.00	225.0	8.86	Type 1, 249XB.M340	
201.45	100	4	1500	60	359.4	14.15	-	-	50.8	2.00	241.3	9.50	Type 2, 249XB.M500	Type 1, 249XB.M340
201.50	100	4	1500	60	391.2	15.40	-	-	50.8	2.00	292.1	11.50	Type 2, 249XB.M500	
201.60	100	4	1500	60	410.2	16.15	-	-	50.8	2.00	355.6	14.00	Type 2, 249XB.M1000	
201.70	100	4	1500	60	475.5	18.72	-	-	50.8	2.00	406.4	16.00	Type 2, 249XB.M1000	
201.80	100	4	1500	60	499.1	19.65	-	-	50.8	2.00	457.2	18.00	Type 2, 249XB.M1750	Type 2, 249XB.M1000
201.90	100	4	1500	60	537.7	21.17	-	-	50.8	2.00	577.9	22.75	Type 2, 249XB.M1750	

*Standard stroke available in increments of 50 mm (2 in). Custom orders can be built up to 2500 mm (100 in) on select models.

**Reduced compression force rating to prevent buckling may exist on long stroke cylinders, contact MTS for more information.

***For static applications, contact MTS for more information.

MTS DuraGlide 201 Hydraulic Actuators (continued)

Specifications

201 Actuator Specifications

MODEL	ROD DIAMETER		210 bar (3000 psi)						280 bar (4000 psi)						ROD THREADS			
			BORE		TENSION		COMPRESSION		BORE		TENSION		COMPRESSION					
			mm	in	mm	in	kN	kip	kN	kip	mm	in	kN	kip			kN	kip
201.10	25.4	1.00	34.9	1.38	9.0	2	19	4	31.8	1.25	7.7	2	21	5	M12x1.25	25.4	1/2"-20	1.00
201.11	34.9	1.38	47.6	1.88	16	4	36	8	44.5	1.75	16	4	42	9	M12x1.25	25.4	1/2"-20	1.00
201.17	44.5	1.75	63.5	2.50	32	7	63	14	57.2	2.25	27	6	69	16	M27x2	44.5	1"-14	1.75
201.20	50.8	2.00	82.6	3.25	66	15	107	24	76.2	3.00	68	15	123	28	M27x2	44.5	1"-14	1.75
201.25	63.5	2.50	101.6	4.00	99	22	162	36	95.3	3.75	106	24	192	43	M27x2	44.5	1"-14	1.75
201.30	76.2	3.00	127.0	5.00	162	36	253	57	114.3	4.50	153	34	276	62	M36x2	57.2	1 1/2"-12	2.25
201.35	88.9	3.50	152.4	6.00	241	54	365	82	139.7	5.50	245	55	412	93	M36x2	57.2	1 1/2"-12	2.25
201.40	101.6	4.00	177.8	7.00	334	75	496	112	165.1	6.50	358	80	576	129	M52x2	76.2	2"-12	3.00
201.45	114.3	4.50	203.2	8.00	443	100	648	146	184.2	7.25	440	99	716	161	M52x2	76.2	2"-12	3.00
201.50	127.0	5.00	222.3	8.75	522	117	776	174	203.2	8.00	531	119	872	196	M52x2	76.2	2"-12	3.00
201.60	152.4	6.00	254.0	10.00	648	146	1013	228	228.6	9.00	613	138	1104	248	M76x2	114	3"-12	4.50
201.70	177.8	7.00	304.8	12.00	962	200	1459	328	279.4	11.00	981	221	1649	371	M90x2	133	3 1/2"-12	5.25
201.80	203.2	8.00	355.6	14.00	1337	301	1986	446	323.9	12.75	1343	302	2215	498	M90x2	133	3 1/2"-12	5.25
201.90	228.6	9.00	406.4	16.00	1773	399	2594	583	368.3	14.50	1761	396	2865	644	M125x4	171	4 1/2"-8	6.75



MTS Series 242 Hydraulic Actuators

MTS Series 242 Actuators are used in closed loop control to extend or retract and provide displacement or force into a test article. These fatigue-rated actuators incorporate a coaxially mounted transducer for displacement feedback and internal hydraulic cushions for extended service life. Featuring MTS exclusive bearing technology and low pressure seal system, low-friction Series 242 Actuators are ideal for many applications including high-frequency excitation of a test article. Combined with MTS force transducers, servovalves, and swivels, these actuators generate the precision movements and forces required in test and simulation applications.

- » Double-ended, fatigue-rated design combines balanced dynamic performance and robust side-load tolerance to maximize data fidelity
- » Full-stroke, coaxially-mounted displacement transducer
- » High-capacity, non-metallic bearings bonded directly to the end caps offer high side-load tolerance and resistance to failure from galling and seizure
- » Piston rods machined from a single piece of heat-treated alloy steel and surface coated to reduce the effects of rod banding
- » Cushions protect the actuator from the effects of high-speed and inertial forces, and prevent the actuator from contacting the end caps
- » Proprietary MTS seal and bearing designs and surface-coating processes set the industry standard for durability, longevity and performance.

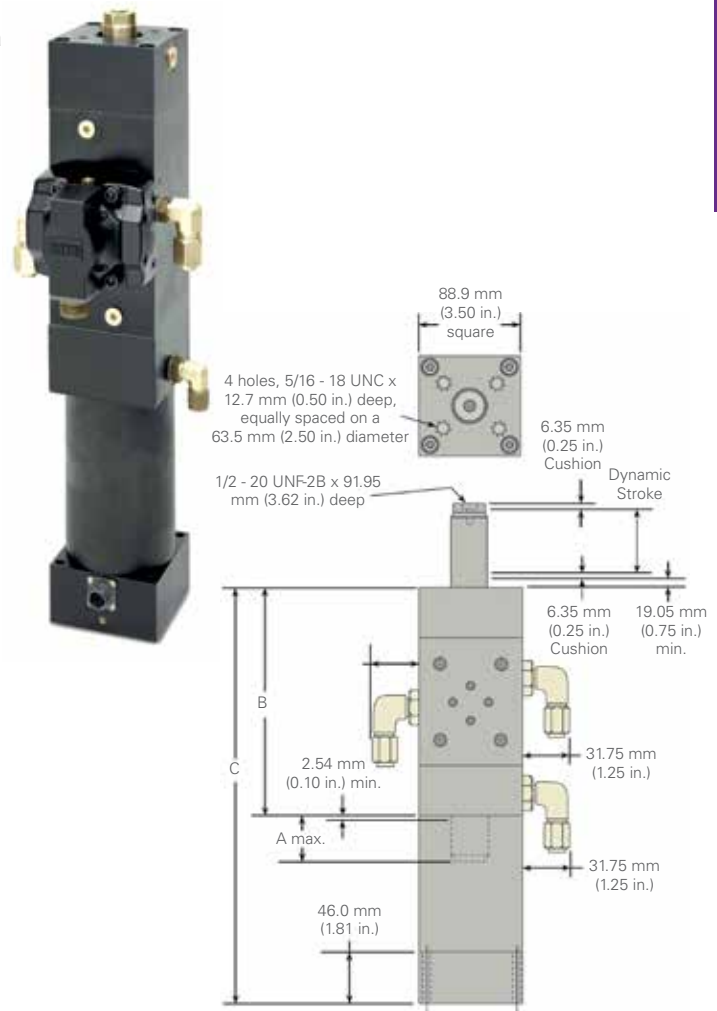

Series 242 Actuator Specifications

Model*	Force Rating [†]		Piston Area		Rod Diameter	
	kN	Kip	mm ²	in. ²	mm	in
242	2.7	0.6	137	0.21	28.6	1.12
242.01	4.5	1	270	0.42	28.6	1.12
242.02	9.8	2.2	590	0.91	28.6	1.12
242.03	14.7	3.3	760	1.18	28.6	1.12

* Each model has a standard stroke length of 101.6 or 152.4 mm (4 or 6 in. This value is total stroke minus the total cushion length, 12.7 mm (0.50 in.). Optional stroke lengths are available in 1.00 and 2.00 in. (25.4 and 50.8 mm).

† Nominal force with 17.2 MPa (2500 psi) pressure drop across the piston. Actual force may be up to 20% higher depending on servovalve size and test conditions.

Series 242 Actuator Dimensions*

Stroke (All Models)		A		B		C (Rod-Eye Bearing Swivel)		C (Closed Housing)	
mm	in.	mm	in.	mm	in.	mm	in.	mm	in.
25.4	1	41.4	1.63	215.9	8.5	322.2	12.69	308	12.13
50.8	2	66.8	2.63	215.9	8.5	347.6	13.69	333.4	13.13
101.6	4	117.6	4.63	279.4	11	461.9	18.19	447.7	17.63
152.4	6	168.4	6.63	330.2	13	563.5	22.19	549.3	21.63

* The dimensions listed are shown in drawing.

Dimensions are subject to change without notice. Contact MTS for verification of dimensions critical to your needs

MTS DuraGlide 244 Hydraulic Actuators

MTS Series 244 Actuators are double-ended, fatigue-rated and designed with proprietary materials that minimize friction, while maximizing reliability, wear resistance and ease of maintenance. They are hydraulically-powered pistons that can extend or retract (double-acting) to provide displacement or force into a test article or structure. MTS Series 244 Actuators are used worldwide in a variety of demanding applications from vehicle dynamics and structural fatigue to component testing, and are recommended for dynamic, static and fatigue applications.



244 Actuator Specifications

Model	Force Rating		Rod Threads		
	kN	lbs	Metric	US Customary	
244.11	15	3,300	M12x1.25	1/2"-20	Pressure & Return – Pressure and return line connections depend on the servovalve. Configurations with Series 252 Servovalve Manifolds have SAE -16 fittings. Series 256 Servovalve Manifolds have SAE -20 fittings. Drain – All 244 Actuators have a SAE -6 drain connection.
244.12	25	5,500	M12x1.25	1/2"-20	
244.21	50	11,000	M27x2	1"-14	
244.20	67	15,000	M27x2	1"-14	
244.22	100	22,000	M27x2	1"-14	
244.23	150	35,000	M27x2	1"-14	
244.31	250	55,000	M36x2	1 1/2"-12	
244.41	500	110,000	M52x2	2"-12	
244.51	1000	220,000	M76x2	3"-12	

Specifications subject to change without notice. Please contact MTS for specifications critical to your application.

- » Thermal spray-coated piston rods that have 10x greater service life than hard chrome-plated rods
- » Proprietary MTS seal and bearing designs and surface-coating processes set the industry standard for durability, longevity and performance
- » Double-ended, fatigue-rated design (piston rod extends from both sides) combines balanced dynamic performance and robust side-load tolerance to maximize data fidelity
- » Full-stroke, coaxially-mounted displacement transducer
- » High-capacity, non-metallic, ultra-low friction bearings bonded directly to the end caps offer high side-load tolerance and resistance to failure from galling and seizure
- » Cushions protect the actuator from the effects of high-speed and high-mass forces, and prevent the piston from contacting the end caps.

Typical Configurations for Component or Structural Testing Applications

Model	Servovalve	Load Cell	Swivel	Spiral Washers
244.11	252.2X (qty 1 or 2)	661.19E/F-03	249xx.M25	601.11-20
244.12	252.2X (qty 1 or 2)	661.19E/F-04	249xx.M25	601.11-20
244.21	252.2X (qty 1 or 2)	661.20E/F-02	249xx.M70	601.11-11
244.20	252.2X (qty 1 or 2)	661.20E/F-03	249xx.M70	601.11-11
244.22	252.2X (qty 1 or 2)	661.20E/F-03	249xx.M160	601.11-11
244.23	252.2X (qty 1 or 2)	661.22C/D-01	249xx.M160	601.11-11
244.31	252.2X (qty 1 or 2), 256 (qty 1)	661.22C/D-01	249xx.M340	601.11-19
244.41	252.2X (qty 1 or 2), 256 (qty 1)	661.23E/F-01	249xx.M500	601.11-13
244.51	252.2X (qty 1 or 2), 256 (qty 1)	661.31E/F-01	249xx.M1000	601.11-15

Stroke Length

mm	inch
100	4
150	6
200	8
250	10
300	12
350	14
400	16
450	18
500	20

Each Series 244 Actuator is available in these standard stroke lengths

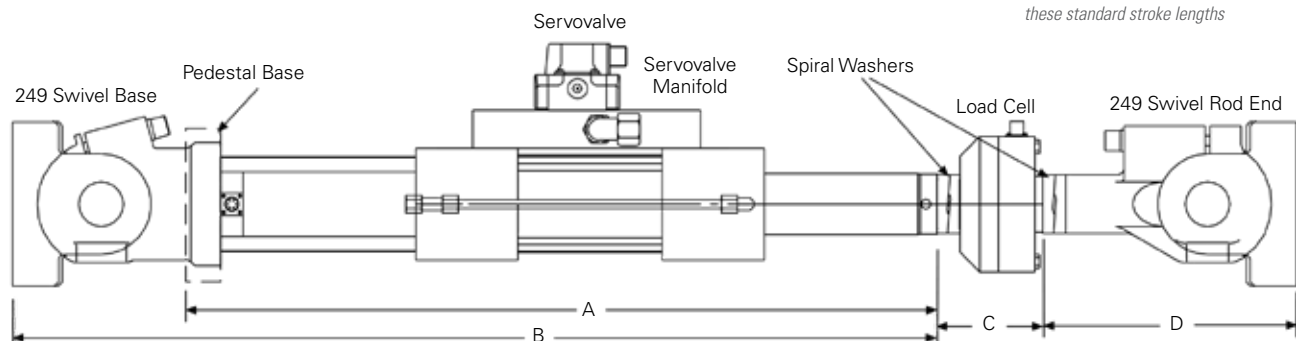

MTS Series 248 Hydraulic Actuators

MTS Series 248 Actuators are heavy-duty, double-ended, linear actuators designed specifically for vibration testing of structures and components. Hydrostatic bearings enable these actuators to withstand high side-load forces without excessive wear on the rod or bearings. The bearings are also coated with a polymer material to protect the actuator if side-load forces exceed the hydrostatic bearing capacity.

- » Recommended for low friction, low distortion, high sideload, vibration testing
- » Double-ended (piston rod extends from both sides of the equal area piston)
- » Double-acting (hydraulic pressure on both sides of the equal area piston)
- » Full stroke coaxially mounted LVDT displacement transducer
- » Hydrostatic pressure-centered bearings for continuous high speed operations
- » Pedestal base allows actuator to be mounted to a reaction mass.



Series 248 Actuator Specifications

Model	Force Rating		Piston Area		Rod Diameter	
	kN	Kip	cm ²	in. ²	mm	in.
248.01	10	2.2	5.23	0.81	80	3.15
248.02	16	3.5	8.32	1.29	80	3.15
248.03	28	6.2	14.52	2.25	80	3.15
248.04	38	8.5	20	3.1	80	3.15
248.05	50	11	25.67	3.98	80	3.15
248.11	100	22	50.77	7.87	100	3.94
248.12	160	35	81.29	12.6	100	3.94
248.21	250	55	127.03	19.69	125	4.92

Specifications are subject to change without notice. Contact MTS for verification of specifications critical to your needs.

Series 249 Swivel Base and Rod End

Series 249 Swivels are important load transferring components. Benefits these swivels provide include: minimizing backlash, forgiving offset loads, and providing a pivot to enable planned movements.

TYPICAL APPLICATIONS

Static and dynamic structural or component test systems requiring a backlash-free actuator connection that pivots.

FEATURES

- » Strong, durable, versatile swivels specifically designed for the rigorous demands of closed-loop servohydraulic testing applications.
- » Force ratings available from 25 kN (5,500 lb) to 1750 kN (400,000 lb).
- » Unique positive bearing preload adjustment eliminates backlash that causes load spikes and disturbs loading rates.
- » Design utilizes cast, fatigue resistant, ductile iron for minimum weight and maximum strength.
- » Maintenance free, non-metallic swivel bearings reduce swivel friction, eliminate the need for lubrication, and increase swivel life.

DESCRIPTION

Swivel Base – The swivel base can be used to attach the linear hydraulic actuator or other actuating devices to a reaction mass or frame for structural or component testing. It typically bolts to an actuator end cap, but can be used anywhere a backlash-free swivel connection is required. The mounting holes are designed to fit a variety of MTS actuators and fixtures.

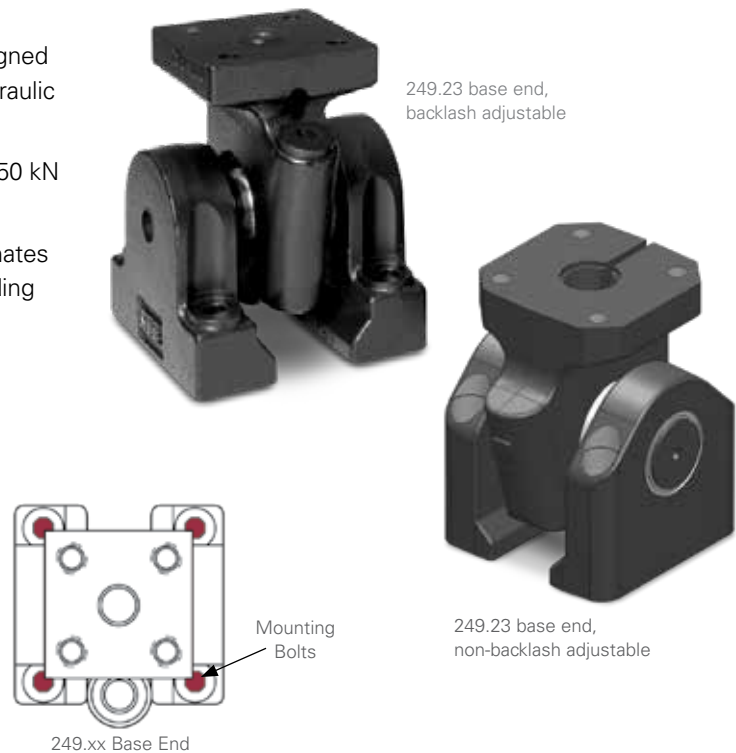

Swivel Base Specifications

Model	Force Rating	Weight	Height	Actuator End	Mounting Bolt Size		Part Number
					SI Metric	US Customary	
249B.M25	25 kN (5.5 kip)	2.7 kg (6 lb)	127 mm (5 in)	Base	M10x1.50	(3/8 in-16)	100-221-936
249B.M70	70 kN (15 kip)	12.7 kg (28 lb)	180.0 mm (7.12 in)	Base	M16x2.00	(5/8 in-11)	100-221-932
249B.M160	160 kN (35 kip)	29 kg (64 lb)	238.3 mm (9.38 in)	Base	M16x2.00	(5/8 in-11)	100-221-924
249B.M340	340 kN (77 kip)	74.3 kg (164 lb)	317.5 mm (12.5 in)	Base	M24x3.50	(1 in-8)	100-232-540
249B.M500	500 kN (110 kip)	158.3 kg (349 lb)	406.4 mm (16 in)	Base	M30x3.50	(1-1/4 in-7)	100-232-542
249B.M1000	1000 kN (220 kip)	435.9 kg (961 lb)	546.1 mm (21.5 in)	Base	M42x4.00	(1-1/2 in-6)	100-232-546
249B.M1750	1750 kN (400 kip)	1275 kg (2800 lb)	831.9 mm (32.75 in)	Base	M48x5.00	(2 in-4.5)	100-271-598
249NB.M25	25 kN (5.5 kip)	2.7 kg (6 lb)	127 mm (5 in)	Non- Adj Base	M10x1.50	(3/8 in-16)	100-221-937
249NB.M70	70 kN (15 kip)	12.7 kg (28 lb)	180.0 mm (7.12 in)	Non- Adj Base	M16x2.00	(5/8 in-11)	100-221-933
249NB.M160	160 kN (35 kip)	29 kg (64 lb)	238.3 mm (9.38 in)	Non- Adj Base	M16x2.00	(5/8 in-11)	100-221-925
249NB.M340	340 kN (77 kip)	73.9 kg (163 lb)	317.5 mm (12.5 in)	Non- Adj Base	M24x3.50	(1 in-8)	100-221-929
249NB.M500	500 kN (110 kip)	152.4 kg (336 lb)	406.4 mm (16 in)	Non- Adj Base	M30x3.50	(1-1/4 in-7)	100-227-945
249NB.M1000	1000 kN (220 kip)	439.1 kg (968 lb)	546.1 mm (21.5 in)	Non- Adj Base	M42x4.00	(1-1/2 in-6)	100-227-953
249NB.M1750	1750 kN (400 kip)	1250 kg (2750 lb)	831.9 mm (32.75 in)	Non- Adj Base	M48x5.00	(2 in-4.5)	100-271-033

Series 249 Swivel Base and Rod End

DESCRIPTION

Swivel Rod End – The swivel rod end is typically attached to the other components in the force train with a US Customary or Metric thread connector stud. A fatigue-resistant, preloaded connection between the actuator and swivel can be created by using MTS Model 601 Spiral Washers in conjunction with a threaded stud.



Swivel Rod End Specifications

Model	Force Rating	Weight	Height	Actuator End	Mounting Bolt Size		Part Number
					SI Metric	US Customary	
249R.M25	25 kN (5.5 kip)	2.3 kg (5 lb)	120.7 mm (4.75 in)	Rod	M10x1.50	(3/8 in-16)	100-221-938
249R.M70	70 kN (15 kip)	10.9 kg (24 lb)	198.2 mm (7.8 in)	Rod	M16x2.00	(5/8 in-11)	100-221-934
249R.M160	160 kN (35 kip)	25.9 kg (57 lb)	263.7 mm (10.38 in)	Rod	M16x2.00	(5/8 in-11)	100-221-926
249R.M340	340 kN (77 kip)	63.5 kg (140 lb)	355.6 mm (14 in)	Rod	M24x3.50	(1 in-8)	100-232-541
249R.M500	500 kN (110 kip)	177.8 kg (392 lb)	473 mm (18.62 in)	Rod	M30x3.50	(1-1/4 in-7)	100-232-543
249R.M1000	1000 kN (220 kip)	497.1 kg (1096 lb)	654 mm (25.75 in)	Rod	M42x4.00	(1-1/2 in-6)	100-232-547
249R.M1750							Contact MTS
249NR.M25	25 kN (5.5 kip)	2.3 kg (5 lb)	120.7 mm (4.75 in)	Non-Adj Rod	M10x1.50	(3/8 in-16)	100-221-939
249NR.M70	70 kN (15 kip)	10.9 kg (24 lb)	198.2 mm (7.8 in)	Non-Adj Rod	M16x2.00	(5/8 in-11)	100-221-935
249NR.M160	160 kN (35 kip)	26.8 kg (57 lb)	263.7 mm (10.38 in)	Non-Adj Rod	M16x2.00	(5/8 in-11)	100-221-927
249NR.M340	340 kN (77 kip)	63 kg (139 lb)	355.6 mm (14 in)	Non-Adj Rod	M24x3.50	(1 in-8)	100-221-931
249NR.M500	500 kN (110 kip)	177.8 kg (392 lb)	473 mm (18.62 in)	Non-Adj Rod	M30x3.50	(1-1/4 in-7)	100-227-947
249NR.M1000	1000 kN (220 kip)	500.3 kg (1103 lb)	654 mm (25.75 in)	Non-Adj Rod	M42x4.00	(1-1/2 in-6)	100-227-955
249NR.M1750							Contact MTS

Series 252 Servovalves

MTS Series 252 Servovalves are two stage, four-way valves designed for servocontrol of hydraulic systems. These high performance servovalves are available in a range of flow rates from 4 to 227 lpm (1 to 60 gpm).

TYPICAL APPLICATIONS

- » Position, load, or velocity control of a hydraulic actuator in highly dynamic applications
- » Pressure control in a dynamic pressurization system.

STANDARD FEATURES & BENEFITS

- » Rugged design for long operating life in dynamic applications
- » High resolution and low hysteresis for precise flow control
- » 31 MPa (4500 psi) operating pressure for Models 252.2x and 252.4x, 21 MPa (3000 psi) for Model 252.3x
- » Internal filtration to protect nozzle orifices from contamination
- » High spool-driving forces reduce the likelihood of a sticking spool due to dirty fluid
- » Standard mounting configuration for Model 252.2x allows interchangeability between valves of different flow ratings.

SERIES 252 SERVOVALVE OPTIONS

External Pilot Pressure – Series 252 Servovalves are available with a fifth port for external pilot pressure. External pilot pressure allows the second stage spool position circuit to be pressurized and controlled without applying system pressure to the actuator. This option is recommended when precise control of the servoactuator must be maintained when system pressure is first started.



Model 252.2x
Servovalve

Series 252 Servovalve Specifications

Model	Flow Rating	Pilot Pressure	90° Point @ 10% Command	Part number
252.21G-01	4 lpm (1 gpm)	No	240 Hz	056-006-101
252.21G-04	4 lpm (1 gpm)	Yes	240 Hz	056-006-104
252.22G-01	9.5 lpm (2.5 gpm)	No	240 Hz	056-006-201
252.22G-04	9.5 lpm (2.5 gpm)	Yes	240 Hz	056-006-204
252.23G-01	19 lpm (5 gpm)	No	240 Hz	056-006-301
252.23G-04	19 lpm (5 gpm)	Yes	240 Hz	056-006-304
252.24G-01	37 lpm (10 gpm)	No	200 Hz	056-006-401
252.24G-04	37 lpm (10 gpm)	Yes	200 Hz	056-006-404
252.25G-01	56 lpm (15 gpm)	No	170 Hz	056-006-501
252.25G-04	56 lpm (15 gpm)	Yes	170 Hz	056-006-504
252.26G-01	63 lpm (16.5 gpm)	No	120 Hz	056-061-301
252.26G-04	63 lpm (16.5 gpm)	Yes	120 Hz	056-061-304
252.31A-01	93 lpm (25 gpm)	Convertible	80 Hz	004-823-101
252.32A-01	151 lpm (40 gpm)	Convertible	60 Hz	004-823-201
252.33A-01	227 lpm (60 gpm)	Convertible	50 Hz	004-823-301

Weight: 1 kg (2.3 lb)

Electrical Interface: MS3106F14S-2S

Hydraulic Interface: ISO 10372-04-04-0-92

Maximum Operating Pressure: 31 MPa (4500 psi)

Series 215 & 216 Rotary Actuators

MTS Model 215 and 216 Rotary Actuators are heavy duty, torque generating devices designed for precise servo-control applications. These actuators, along with the matching accessories, create a versatile test stand for torsional testing applications.

TYPICAL APPLICATIONS

- » Fatigue and durability testing of drivetrain components such as axles, couplings, and drive shafts
- » Ultimate strength and other material tests on shafts.

STANDARD FEATURES

- » Fatigue-rated design for years of reliable service
- » Heavy duty roller bearings endure high radial loads with minimal friction
- » Hydrostatic thrust bearings to safely withstand inadvertent thrust loads
- » 90 degrees of dynamic rotation and 100 degrees of static rotation
- » Hydraulic cushions protect the vanes during full stroke, high velocity operation
- » An angular displacement transducer (ADT) provides the signal for precise angular position feedback in a closed loop servocontrol application
- » A flange adapter to attach the rotary actuator shaft to the test specimen.



Model 215 Rotary Actuator assembly

Model 216 Rotary Actuator assembly

- » The Model 215 includes an actuator mounting bracket with flexures to reduce thrust loads caused by specimen deformation when torsional loads are applied. The Model 216 includes two diaphragm flexures that attach to each end of the test specimen.

HYDRAULIC CONNECTION

Pressure & Return – Pressure and return line connections depend on the servovalve. Configurations with Series 252.2x Servovalve Manifolds have JIC-16 fittings. Series 252.3x and 256.0x Manifolds have JIC-20 fittings.

Drain – All 215 & 216 Actuators have a JIC-6 drain connection.

Rotary Actuator Specifications

Model	Rated Torque		Angular Disp.		Max. Thrust Load		Part Number
	N-M	LBF-IN	Dynamic	Static	KN	LB	
215.32	226	2,000	90°	100°	3.3	750	100-191-977
215.35	565	5,000	90°	100°	3.3	750	100-191-978
215.41	1130	10,000	90°	100°	3.3	750	100-191-979
215.42	2260	20,000	90°	100°	3.3	750	100-191-981
215.45	5650	50,000	90°	100°	5.3	1,200	100-191-994
215.51	11,300	100,000	90°	100°	5.3	1,200	100-191-995

Typical Configuration for Component Applications

Model	Servovalve	Torque Transducer	Reaction Bracket	Reaction Base
215.32	252.2x (qty 1)	663.11A-02	215.35TCRB	215.35RB
215.35	252.2x (qty 1 or 2)	663.12A-01	215.35TCRB	215.35RB
215.41	252.2x (qty 1 or 2)	663.12A-02	215.42TCRB	215.42RB
215.42	252.2x (qty 1 or 2), 252.3x (qty 1)	663.13A-02	215.42TCRB	215.42RB
215.45	252.2x (qty 1 or 2), 252.3x (qty 1)	663.13A-05	215.45TCRB	215.45RB
215.51	252.2x (qty 1 or 2), 252.3x (qty 1), 256.0x (qty 1)	663.14A-01	215.51TCRB	215.51RB
216.10	256.0x (qty 1)	663.15A-02	216.10TCRB	216.10RB
216.20	256.0x (qty 1)	663.16A-01	216.20TCRB	216.20RB
216.30	256.0x (qty 1)	663.18A-01	216.30TCRB	216.30RB

Rotary Actuator Options

Torque Cells

MTS torque cells provide a precise electrical feedback signal that is proportional to the torque applied to the specimen.

Reaction Bracket and Base

A rigid reaction frame is critical for good performance. MTS provides a complete line of reaction fixturing that provide the stiffness necessary for quality testing. When considering any durability testing, remember that MTS equipment is fatigue-rated to ensure your test schedule will not be compromised by your test apparatus.

Diaphragm Flexures

Diaphragm flexures offer the satisfaction of knowing that the test article is not becoming loaded by unwanted externals due to misalignment or an unplanned axial loading component. Be sure the testing you are performing has not become biased by unintended loads.

Series 256 Servovalves

Series 256 Servovalves are high-flow, high-performance valves of three-stage design. They are suited for 3000 psi dynamic application, and provide the user superior position, load, or velocity control resolution when applied to a Model 216 Rotary Actuator. When selecting a Model 256 Servovalve for your Model 216 Actuator, also select manifold part number 052-812-101.

Actuator Configuration

Model	Cylinder	Manifold	Adapter Flange	ADT	Flexure/Foot Mount
215.32		043-932-301		032-610-111	
215.35	047-466-001	043-932-401		032-610-111	
215.41	047-528-601	032-554-801		032-610-111	
215.42	047-535-301	032-554-801		032-610-111	
215.45	049-029-401	032-554-901		032-610-112	036-373-301
215.51	049-029-501	032-554-901		032-610-112	
216.10	050-206-901	034-676-101		032-610-115	NA
216.20		034-676-101	100-016-581	032-610-116	NA
216.30	054-128-401	034-676-101			NA

Model	Torque Cell	Reaction Bracket	Reaction Base	Diaphragm Flexure
215.32	006-437-502	043-962-701		032-553-601
215.35	006-437-504	043-962-701	044-527-001	032-553-601
215.41	006-437-505			032-553-701
215.42	006-437-507	043-962-801	044-702-901	032-553-801
215.45	006-437-510		044-703-001	032-553-901
215.51	006-437-511		044-703-001	032-554-001
216.10	006-437-513			032-554-101
216.20	006-437-514			032-554-201
216.30	006-437-516			

SERIES 215 OR 216 ACTUATOR ORDER INFORMATION

When you order a Model 215 or 216 Actuator, you receive a servoactuator assembly including the rotor actuator, a servovalve manifold, an ADT, and an actuator flexure mounting bracket.

See MTS Model 215 Product Specification number 100-007-528a and Model 216 Product Specification number 100-032-134a for additional information.

MTS Series 515 Hydraulic Power Units

- » Variable volume pumps help save energy and reduce operating costs
- » Designed to eliminate ambient heat load, reducing HVAC requirements
- » Compact design fits through a standard doorway
- » Optional Remote-Mounted Water shut-off valve saves water when the unit is shut down
- » Efficient heat transfer technology reduces cooling requirements with standard air and water cooling options
- » Advanced programmable logic controls (PLC) enable options for control and monitoring
- » Engineered for remote monitoring and multi-pump control options
- » High pressure filter available for additional system filtration at the outlet of the pump
- » Output accumulation available as an option for all sizes
- » Designed to relevant EN and UL standards; CE compliant; TÜV certified including TUV CUE Certified to EMC
- » Safety engineered to SIL-3 rating when operated in standalone mode



Model 515.04 – 515.30 Specifications

Operating pressure: 210 bar (3,000 psi)

Pump type: Variable displacement pumps

Filtration: Full flow on the return side

Maximum ambient operating temperature: 40°C (104°F)

Minimum ambient operating temperature: 5°C (40°F)

	Model 515.04	Model 515.11	Model 515.20	Model 515.30
Flow rates (for 60 Hz models)	26.5 lpm (7 gpm)	41.6 lpm (11 gpm)	75.7 lpm (20 gpm)	113.5 lpm (30 gpm)
Flow rates (for 50 Hz models)	22.7 lpm (6 gpm)	37.9 lpm (10 gpm)	62.5 lpm (16.5 gpm)	100.7 lpm (26.6 gpm)
Noise level*	58 dB(A)	60 dB(A)	63 dB(A)	63 dB(A)
Reservoir capacity (maximum)	174 L (46 gal)	174 L (46 gal)	341 L (90 gal)	341 L (90 gal)
Unit dimensions				
Width	77.0 cm (30.3 in)	77.0 cm (30.3 in)	89.7 cm (35.3 in)	89.7 cm (35.3 in)
Height	120.1 cm (47.3 in)	120.1 cm (47.3 in)	138.9 cm (54.7 in)	138.9 cm (54.7 in)
Length	114.6 cm (45.1 in)	114.6 cm (45.1 in)	163.1 cm (64.2 in)	163.1 cm (64.2 in)
Weight with maximum oil	522 kg (1,150 lb)	544 kg (1,200 lb)	862 kg (1,900 lb)	907 kg (2,000 lb)
Motor size	11 kW (15 hp)	18.5 kW (25 hp)	30 kW (40 hp)	45 kW (60 hp)

* Sound levels [dB(A)] are expressed as a free field value. Readings may vary with acoustic environment.

Specifications subject to change without notice. Please contact MTS for specifications critical to your application.

Model 515.60 – 515.180 Specifications

Operating pressure: 210 bar (3,000 psi)

Pump type: Variable displacement pumps

Filtration: Full flow on the return side

Maximum ambient operating temperature: 40°C (104°F)

Minimum ambient operating temperature: 5°C (40°F)

	Model 515.60	Model 515.90	Model 515.120	Model 515.150	Model 515.180
Flow rates (for 60 Hz models)	227 lpm (60 gpm)	340 lpm (90 gpm)	454 lpm (120 gpm)	567 lpm (150 gpm)	681 lpm (180 gpm)
Flow rates (for 50 Hz models)	200 lpm (53.2 gpm)	300 lpm (80 gpm)	400 lpm (106.4 gpm)	500 lpm (133 gpm)	600 lpm (160 gpm)
Noise level*	68 dB (A)	68 dB (A)	70 dB (A)	71 dB (A)	72 dB (A)
Reservoir capacity (maximum)	1211 L (320 gal)	1211 L (320 gal)	2,188 L (578 gal)	2,188 L (578 gal)	2,188 L (578 gal)
Unit dimensions					
Width	103.4 cm (40.7 in)	103.4 cm (40.7 in)	103.4 cm (40.7 in)	103.4 cm (40.7 in)	103.4 cm (40.7 in)
Height	199.4 cm (78.5 in)	199.4 cm (78.5 in)	199.4 cm (78.5 in)	199.4 cm (78.5 in)	199.4 cm (78.5 in)
Length	287.0 cm (113.0 in)	287.0 cm (113.0 in)	430.5 cm (169.5 in)	430.5 cm (169.5 in)	430.5 cm (169.5 in)
Weight with maximum oil	2,835 kg (6,250 lb)	3,289 kg (7,250 lb)	4,876 kg (10,750 lb)	5,330 kg (11,750 lb)	5,783 kg (12,750 lb)
Motor size	45 KW (60 Hp)	45 KW (60 Hp)	45 KW (60 Hp)	45 KW (60 Hp)	45 KW (60 Hp)
Number of Motor/pump units	2, max of 3	3	4, max of 6	5, max of 6	6

* Sound levels [dB(A)] are expressed as a free field value. Readings may vary with acoustic environment.

Specifications subject to change without notice. Please contact MTS for specifications critical to your application.

MTS Multi-Pump Control Manager (MPCM)

Manage the hydraulic power demands of Hydraulic Power Units (HPUs) as a system, rather than unit by unit. The Multi-Pump Control Manager (MPCM) shows all hydraulic power demand in a single touchscreen interface so that it can be automatically or manually managed for the best efficiency. This solution includes the Basic Connection Interface (BCI), Supervisor PC and touchscreen monitor. Control includes all control options from a unit or system level. Similarly, status information can be viewed from a unit or system level.

- » Centralized monitoring and control of up to eight hydraulically-commoned HPUs
- » Input, view or change individual station flow requirements for multiple stations from a single location
- » Monitor and control hydraulic system supply and demand to improve productivity, reduce energy costs and prolong test equipment life
- » Configurations can include up to 8 HPUs, 8 External E-Stop chains and/or Station Flow Managers, E-Stop Out, 32 channels of DIO, and 3 System Status Light Bars
- » Includes cables to connect each HPU to BCI, Supervisor PC and touchscreen monitor

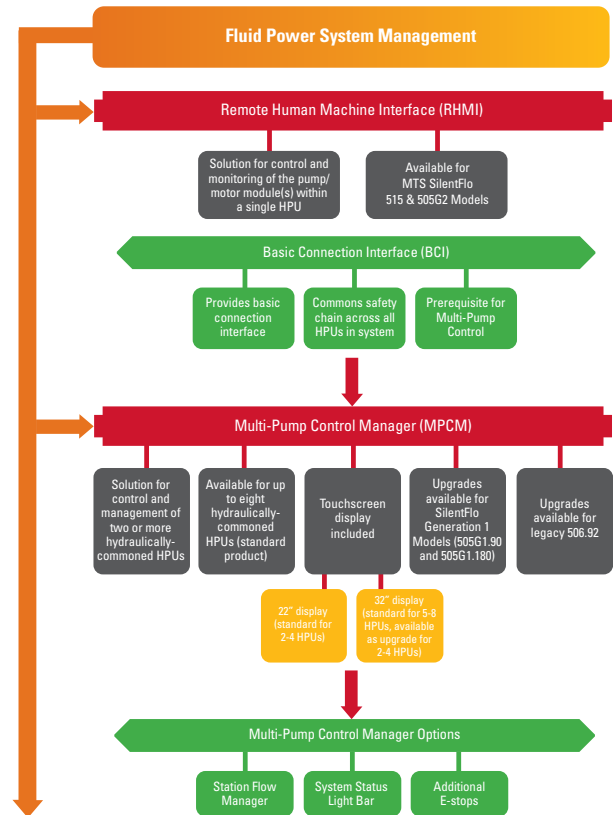

MTS Series 295 Hydraulic Service Manifold

Series 295 Hydraulic Service Manifolds (HSMs) are hydraulic pressure and flow regulation devices that control pressure to a test station independent from the main hydraulic power unit (HPU). Installing the HSM between the HPU and the actuator allows the operator to turn each hydraulic station on and off and set the low pressure level. Smooth, controlled transitions between off, low and high pressure modes enhance safety and permit predictable system control.

- » Minimizes the effects of rapid application and removal of pressure, reducing unexpected actuator movement that could be damaging to the component or assembly being tested
- » Equipped with a hydraulic circuit which provides separately filtered fluid at HPU pressure to operate the pilot stage of multistage servovalves
- » Uses accumulators to reduce pressure fluctuations caused by changing system demands
- » Available with optional SafeGuard™ technology for safety Performance Level d and e compliance



Series 295 Hydraulic Service Manifold Specifications

Description	295.1XA-XX3X	295.2XA-XX3X	295.2XA-XX4X	295.3XA-XX3X	295.3XA-XX4X
Operating Pressure	21 MPa (3000 psi)	21 MPa (3000 psi)	28 MPa (4000 psi)	21 MPa (3000 psi)	28 MPa (4000 psi)
Nominal flow	189 lpm (50 gpm)	378 lpm (100 gpm)*	378 lpm (100 gpm)	946 lpm (250 gpm)	946 lpm (250 gpm)
Variable low pressure	1 - 21 MPa (150 - 3000 psi)	1 - 21 MPa (150 - 3000 psi)	1 - 28 MPa (150 - 4000 psi)	1 - 21 MPa (150 - 3000 psi)	1 - 28 MPa (150 - 4000 psi)
Slow on/off ramp time	5.0 - 9.0 seconds	5.0 - 9.0 seconds	5.0 - 9.0 seconds	5.0 - 9.0 seconds	5.0 - 9.0 seconds
Maximum current to solenoid valves	0.3 A at 115 V AC or 1.5 A at 24 V DC	0.3 A at 115 V AC or 1.5 A at 24 V DC	0.3 A at 115 V AC or 1.5 A at 24 V DC	0.3 A at 115 V AC or 1.5 A at 24 V DC	0.3 A at 115 V AC or 1.5 A at 24 V DC

Accumulators

		295.1XA-XX3X	295.2XA-XX3X	295.2XA-XX4X	295.3XA-XX3X	295.3XA-XX4X
Pressure	min	0.94 L (0.25 gal)	3.8 L (1 gal)	3.8 L (1 gal)	3.8 L (1 gal)	3.8 L (1 gal)
	max	3.8 L (1 gal)	7.6 L (2 gal)	7.6 L (2 gal)	19.0 L (5 gal)	19.0 L (5 gal)
Return	min	0.45 l (0.12 gal)	1.9 L (0.5 gal)	1.9 L (0.5 gal)	0.94 l (0.25 gal)	0.94 l (0.25 gal)
	max	0.94 l (0.25 gal)	3.8 L (1 gal)	3.8 L (1 gal)	7.6 L (2 gal)	7.6 L (2 gal)
Pilot pressure	min	0.45 L (0.12 gal)	0.45 L (0.12 gal)	0.45 L (0.12 gal)	0.45 L (0.12 gal)	0.45 L (0.12 gal)
	max	0.94 l (0.25 gal)	—	—	0.9 L (0.25 gal)	0.94 L (0.25 gal)

Dimensions and Weights

	295.1XA-XX3X	295.2XA-XX3X	295.2XA-XX4X	295.3XA-XX3X	295.3XA-XX4X
Weight	70 kg (155 lb)	159 kg (600 lb) ¹	182 kg (600 lb) ¹	181 kg (550 lb) ²	227 kg (550 lb) ¹
Height	806 mm (31.75 in)	1067 mm (43 in) max	1067 mm (43 in)	1092 mm (43.5 in) ³	1229 mm (43.5 in)
Width (base)	363 mm (14.3 in)	362 mm (25.75 in)	362 mm (25.75 in)	403 mm (15.9 in) max	387 mm (15.9 in)
Depth (base)	359 mm (14.1 in)	394 mm (15.5 in)	400 mm (15.75 in)	394 mm (15.5 in) max	530 mm (15.5 in)

Footnotes:

* 378 lpm (100 gpm) total, 189 lpm (50 gpm) per station maximum for multi-station flow

¹ Standard size for single-station configuration; 227 kg (500 lb) maximum weight for four-station HSM

² Standard size; with optional accumulator capacity the weight is 454 kg (1000 lb) maximum

³ Standard size; with optional accumulator capacity the height is 2134 mm (84 in) maximum

Specifications are subject to change without notice. Contact MTS for verification of any critical specifications. Note: Accumulator may extend beyond HSM height.

MTS SafeGuard™ Technology

Successful testing requires protection of the test equipment and specimen, and most importantly, the test operator. Unfortunately, many systems that are designed to ensure human safety, negatively impact testing fidelity. So, although these solutions provide a safer environment, they also impede testing productivity and compromise testing accuracy. With MTS SafeGuard™ Technology, you can create a safer environment for test operators while protecting the test equipment and specimen, and maximizing test fidelity.

Meet PLd and PLe Safety Requirements

Providing a safe environment for the test operator without consideration of other factors, often compromises specimen protection or testing accuracy.

MTS SafeGuard Technology provides the right level of human safety without impeding testing fidelity or productivity.

Components of the MTS SafeGuard Solution

MTS SafeGuard Technology can be used on any mechanical test system to provide safe power isolation and safe actuator speed control.



MTS SafeGuard 273 Processor

- » Manages safety and specimen protection
- » Scalable up to 4 stations
- » Configures to each safety system
- » 4 mounting configuration options
- » Can integrate with facility safety systems



MTS SafeGuard 274 User Interface

- » Displays system configuration, system status & fault diagnostics
- » Includes system reset function
- » Includes system e-stop function
- » 3 mounting configuration options



MTS SafeGuard 275 Machine Interface

- » Connects I/O for safety functions at system (safe speed, station stop, test area enclosure)
- » Configurable per system

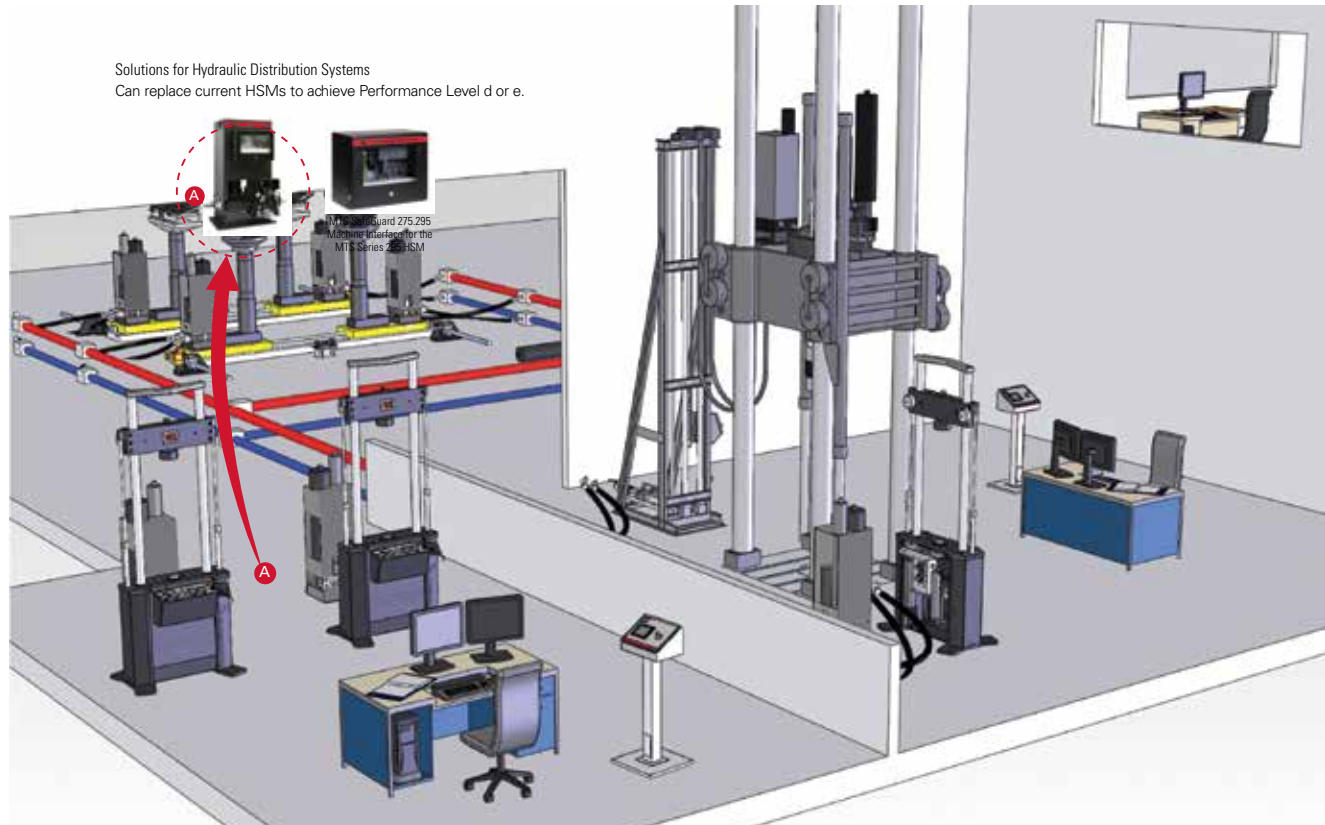

MTS Isolation Service Manifold

The Isolation Service Manifold (ISM) systematically controls hydraulic distribution and is compliant with Machinery Directive 2006/42/EC and sound engineering practice article 3 (3) of pressure equipment directive 97/23/EC. This manifold is placed between the hydraulic power unit (HPU) and the hydraulic service manifold (HSM) to prevent system over-pressurization, provide full system pressure discharge, and allow for full hydraulic power isolation downstream of the device. It is designed to work with MTS Series 293 HSMs, and MTS FlexTest® controllers, and can be adapted to work with other HPUs and HSMs. It is easy to set up in a new system or you may add it to an existing test system using the cabling in the current system.

- » Plug-and-Play service manifold complies with Machinery Directive 2006/42/EC
- » Positive isolation of hydraulic pressure
- » Pressure and valve position feedback in control loop
- » Over-pressurization relief
- » Pressure dump to return line
- » Maintenance valves to drain residual oil
- » Requires Isolation Service Manifold Controller which can be shared with one other ISM.



Isolation Service Manifold Specifications

Model	ISM02-210	ISM02-280	ISM04-210	ISM04-280	ISM10-210	ISM10-280
Flow Capacity	200 lpm (50 gpm)	200 lpm (50 gpm)	400 lpm (100 gpm)	400 lpm (100 gpm)	1000 lpm (250 gpm)	1000 lpm (250 gpm)
Pressure Rating	210 bar (3000 psi)	280 bar (4000 psi)	210 bar (3000 psi)	280 bar (4000 psi)	210 bar (3000 psi)	280 bar (4000 psi)
Control Voltage	24 VDC	24 VDC	24 VDC	24 VDC	24 VDC	24 VDC
Required Control Power	70 watts	70 watts	70 watts	70 watts	70 watts	70 watts

Dimension	ISM02-210	ISM02-280	ISM04-210	ISM04-280	ISM10-210	ISM10-280
Width	27.30 cm (10.75 in)	27.30 cm (10.75 in)	27.30 cm (10.75 in)	27.30 cm (10.75 in)	36.20 cm (14.25 in)	48.90 cm (19.25 in)
Length	42.24 cm (16.63 in)	42.24 cm (16.63 in)	42.24 cm (16.63 in)	42.24 cm (16.63 in)	60.12 cm (23.67 in)	59.64 cm (23.48 in)
Height	60.60 cm (23.86 in)	60.60 cm (23.86 in)	57.58 cm (22.67 in)	58.85 cm (23.17 in)	61.87 cm (24.36 in)	73.30 cm (28.86 in)
Weight	53.52 kg (118.0 lb)	114.53 kg (252.5 lb)	58.97 kg (130.0 lb)	124.15 kg (273.7 lb)	215.09 kg (474.2 lb)	288.48 kg (636.0 lb)

MTS TestLine™ Modular Components

Hydraulic Hoses

All reinforced hydraulic hoses supplied for the purpose of connecting hydraulic power to MTS Test components, with the exception of low pressure drain hoses, will conform to industry standards: SAE J517–, SAE J343–Test and procedures for SAE 100R, and ISO 11171–Contamination Control.

- » Silicone-free fabrication and testing
- » Oil-resistant labels with part number, date of manufacture, diameter and working pressure.



Reaction Brackets

Reaction brackets attach securely to the reaction base or T-slot table and provide a mounting surface for the torque cell. Each reaction bracket is designed to restrain a specific model torque cell.



Diaphragm Flexure Assembly

Diaphragm flexures are used at both ends of the specimen if large axial and angular deflections are generated during testing. If reaction forces exceed stated actuator operating limits, diaphragm flexures help reduce the thrust and side loads reacted by the actuator and test specimen.



Load Cells

MTS Series 661 Load Cells are designed for a wide array of static and dynamic testing applications. The cells are designed for cyclic operation in through zero tension/compression modes.



Torque Cells

Torque cells provide a precise electrical feedback signal that is proportional to the torque applied to the specimen. For more information on MTS torque cells, refer to the appropriate MTS product specification.



Additional Components

Model 601 Spiral Washers

Model	Description	Force	Temp °C Min/Max	Temp °F Min/Max	Diameter ID/OD	Spanner Pin Diameter
601.11A/B-20	Spiral Washers	25 kN (5 kip)	-129°/177°	-200°/350°	12 mm (0.50 in)/41 mm (1.62 in)	3.58 mm (0.141 in)
601.11A/B-11	Spiral Washers	100 kN (22 kip)	-129°/177°	-200°/350°	27 mm (1.00 in)/66 mm (2.62 in)	6.73 mm (0.265 in)
601.11A/B-19	Spiral Washers	250 kN (55 kip)	-129°/177°	-200°/350°	36 mm (1.50 in)/92 mm (3.62 in)	6.73 mm (0.265 in)
601.11A/B-13	Spiral Washers	500 kN (110 kip)	-129°/177°	-200°/350°	52 mm (2.00 in)/130 mm (5.12 in)	9.91 mm (0.390 in)
601.11A/B-15	Spiral Washers	1000 kN (220 kip)	-129°/177°	-200°/350°	76 mm (3.00 in)/178 mm (7.00 in)	9.91 mm (0.390 in)

The unique design of patented MTS spiral washers ensures preloading without inducing offsets in the load train. Normally sold for use on load frames, these versatile accessories can be used anywhere a backlash-free, threaded union is required. When setting the spiral washer connection, the stud must be preloaded to a minimum axial load that is 110% of test maximum.

One Set of Two Spiral Washers

Model	Metric Part Number	US Customary Pin Diameter
601.11A/B-20	040-473-120	040-473-119
601.11A/B-11	040-473-110	040-473-101
601.11A/B-19	040-473-111	040-473-102
601.11A/B-13	040-473-113	040-473-104
601.11A/B-15	040-473-115	040-473-106

Shim Kits

These kits provide multiple shims and thicknesses to allow for 360° of adjustment.

Capacity	Thread Size	Metric Part Number	US Customary Pin Diameter
25 kN (5.5 kip)	M12 x 1.25 (1/2"-20)	052-105-004	052-105-003
50, 100, 110 kN (11, 22, 25 kip)	M27 x 2 (1"-14)	052-105-006	052-105-005
250 kN (55 kip)	M36 x 2 (1 1/2"-12)	052-105-008	052-105-007
500 kN (110 kip)	M52 x 2 (2"-12)	052-105-010	052-105-009

High-Performance Lubricants for Testing Applications

Room temperature Molykote® lubricant is best suited for smooth operation of metal surfaces that are under pressure or load. It is a good anti-galling agent for grip wedges and other tough lubrication problems.

High-temperature Jet Lube anti-seize compound is best suited for smooth operation of metal surfaces that are under pressure or load at elevated temperatures (up to 2100°F). It is a good anti-galling agent for studs and other tough lubrication problems that include higher temperatures.

Description	Size	Part Number
Molykote Lubricant /Grease	17 oz	011-010-207
Anti-Seize Compound	17 oz	011-354-902

MAINTENANCE PARTS

MTS stocks a wide variety of parts to help you maintain your test equipment.

Don't see what you're looking for? Contact your service sales engineer for more information.



MTS Maintenance Parts

Introduction	176
Hydraulic Tools & Sample Bottles	177
Accumulator Parts	178
Actuator Parts	179-183
Spares Kits - Monotonic	184
Load Frame Parts - Monotonic/Servo-hydraulic	185-186
Cables	187-190
Replacement Lamps	190
Adapter Cables for 3rd Part Equipment	191
Grip Parts	192
Hydraulic Hoses	193
Hydraulic Power Unit Parts	194-199
Hydraulic Service Manifold Parts	200-201
Filter Elements	202
Flushing & Shut-Off Valves	202
SWIFT® Parts	203-204
FlatTrac® & Rolling Road Systems Parts	205
Series 329 Road Simulator Parts	206-207
329 System Parts	208
Model 329 4 DOF PC Road Simulator Parts	209-212
Model 329 6 DOF Road Simulator Actuator Parts	213
Model 329 6 DOF PC Road Simulator Parts	214-216
Model 329 4 DOF LT Road Simulator Parts	217-218
Model 329 6 DOF LT Road Simulator Parts	219-221
MAST Parts	222
320 Seal Kits	223

MTS Maintenance Parts

Hydraulic Tools & Sample Bottles

Tools – LVDT

Description	Part Number
Rod-Threaded End-LVDT Adj. (3 kg)	003-116-201
Key-Socket Head-LVDT Adj. (3 kg)	003-115-701
LVDT Plug Wrench (206) (3 kg)	004-059-901

(For 6" Stroke) Note: Consult MTS for additional lengths.

Tools – Spanner Wrench

Description	Washer size	Spanner Pin Diameter	Part Number
Spanner Wrench – Spiral Washers	19 mm to 50 mm (0.75 in to 2 in)	3.2 mm (0.125 in)	010-099-313
Spanner Wrench – Spiral Washers	32 mm to 76 mm (1.25 in to 3 in)	6.4 mm (0.250 in)	010-099-304
Spanner Wrench – Spiral Washers	50 mm to 120 mm (2 in to 4.75 in)	6.4 mm (0.250 in)	010-099-301
Spanner Wrench – Spiral Washers	115 mm to 158 mm (4.5 in to 6.25 in)	9.5 mm (0.375 in)	010-099-303

Tools – Hydraulic

Description	Part Number
Fluid Transfer Pump - Model 590.01	005-149-201

MTS Fluid Analysis Bottle Kit & Results Report

Description	Part Number
FSE Bottle - North America	100-188-132
FSE Bottle - Europe	100-188-133
FSE Bottle - South Korea	100-219-330
FSE Bottle - Japan	100-219-331
FSE Bottle - China	100-219-332

MTS Maintenance Parts

Accumulator Parts

Accumulator Seal Kits

Description	Style	Part Number
2.5 in I.D., MTS Model 111.11A	(old style)	036-548-301
	(new style)	041-463-501
4.0 in I.D., MTS Model 111.12A/B	(old style)	036-555-101
	(new style)	041-463-301
2.5 in I.D., Made by Parker	(Silver Label)	100-102-494
4.0 in I.D., Made by Parker	(Silver Label)	100-102-496

Accumulator Bladders

Description	Part Number
1 Pint Bladder	010-050-509
O-Ring, Plug	101-010-906
1 Quart Bladder	010-050-510
O-Ring, Plug	010-010-908
1 Gallon Bladder	010-050-511
O-Ring, Plug	010-010-911

Bladder Kit contains Washer & O-Ring.

Accumulator Charging Kits (7 kg)

Description	Manufacture	Part Number
Model 590.05 Charging Kit	MTS	037-698-601

Miscellaneous Accumulator Parts

Description	Part Number
Gas Valve (Accumulator)	011-012-402
Gas Valve	010-098-205
Hose Assy – Nitrogen	041-922-801
Hose Assy – Extension, 12 Inches Long	041-922-701
Valve-Chuck, High Pressure	010-098-248
Washer-Flat Copper	010-099-901
Valve Core	010-098-202
Valve Stem Extension	010-098-301
Washer-Sealing, Hard Fiber	011-480-202
Pin Removal Tool for Accumulators	011-870-101
Adjustable Spanner Wrench (For 2.5 in & 4 in I.D.)	010-099-317

Estimated weight of each is no more than 2 kg.

MTS Maintenance Parts

Actuator Parts

201.xx Actuator Seal Kits

Model	Description	Part Number
201.17	Seal Kit	057-003-401
201.2	Seal Kit	057-003-402
201.25	Seal Kit	057-003-403
201.3	Seal Kit	057-003-404
201.35	Seal Kit	057-003-405
201.40	Seal Kit	057-003-406
201.45	Seal Kit	057-003-407
201.6	Seal Kit	057-003-408
201.7	Seal Kit	057-003-409
201.80	Seal Kit	057-003-410
201.90	Seal Kit	057-003-411

204.xx Seal Kits (Linear)

Model	Rating	Description	Part Number
204.08	5 kN/1.1 kip	Old style cream-colored rod seal	008-710-012
204.08	5 kN/1.1 kip	New style blue-colored rod seal	042-451-601
204.09	10 kN/2.2 kip	Old style cream-colored rod seal	008-710-013
204.09	10 kN/2.2 kip	New style blue-colored rod seal	042-451-401
204.11	12 k N/2.5 kip	Seal Kit	008-710-014
204.12	18 kN/4 kip	Seal Kit	008-710-015
204.13	27 kN/6 kip	Seal Kit	008-710-016
204.21	27 kN/6 kip	Seal Kit	008-710-017
204.22	40 kN/9 kip	Seal Kit	008-710-018
204.23	55 kN/12 kip	Seal Kit	008-710-019
204.24	90 kN/20 kip	Seal Kit	008-710-020
204.25	110 kN/24 kip	Seal Kit	008-710-021
204.26	160 kN/35 kip	Seal Kit	008-710-022
204.31	227 kN/50 kip	Seal Kit	008-710-023
204.32	318 kN/70 kip	Seal Kit	008-710-024
204.41*	455 kN/100 kip	Seal Kit	008-710-025
204.42*	682 kN/150 kip	Seal Kit	008-710-026
204.51	15 kN/3.3 kip	Seal Kit	008-710-001
204.52	25 kN/5.5 kip	Seal Kit	008-710-002
204.61	50 kN/11 kip	Seal Kit	008-710-003
204.62	68 kN/15 kip	Seal Kit	008-710-004
204.63	100 kN/22 kip	Seal Kit	008-710-005
204.64	160 kN/35 kip	Seal Kit	008-710-006
204.71	250 kN/55 kip	Seal Kit	008-710-007
204.72	350 kN/77 kip	Seal Kit	008-710-008
204.81	500 kN/110 kip	Seal Kit	008-710-009
204.82	750 kN/165 kip	Seal Kit	008-710-010
204.91	1000 kN/220 kip	Seal Kit	008-710-011

Estimated weight of each is no more than 2 kg.

Each kit contains the parts needed to replace all existing seals.

**Normally not a stocked item. Call Order Services for delivery time.*

MTS Maintenance Parts

Actuator Parts

205.xx Seal Kits

Model	Rating	Description	Part Number
205.04	2 kip	Seal Kit	008-710-028
205.08	0.5 kip	Seal Kit	008-710-027
205.08B	0.5 kip	Seal Kit	040-226-201
205.09	1.5 kip	Seal Kit	008-710-027
205.09B	1.5 kip	Seal Kit	040-226-201
205.20	3.3 kip	Seal Kit	039-080-101
205.31	6.6 kip	Seal Kit	039-080-201

206.xx Seal Kits

Model	Rating	Description	Part Number
206.21	55 kN/12 kip	Seal Kit	008-710-031
206.31 *	127 kN/16 kip	Seal Kit	008-710-032
206.41 *	327 kN/36 kip	Seal Kit	008-710-034
206.42*	227 kN/50 kip	Seal Kit	008-710-035

*Normally not a stocked item. Call Order Services for delivery time.

231.xx Seal Kits

Model	Rating	Description	Part Number
231.02	6.2 kN	Seal Kit	045-895-201

242.xx Seal Kits

Model	Rating	Description	Part Number
242.01	All sizes	Seal Kit	042-065-501
		Seal Kit with high pressure seals	042-065-401
242.02	All sizes	Seal Kit	042-065-501
		Seal Kit with high pressure seals	042-065-402
242.03	All sizes	Seal Kit with high pressure seals	042-065-403

Estimated weight of each is no more than 2 kg.

Each kit contains the parts needed to replace all existing seals.

243.xx Seal Kits

Model	Rating	Description	Part Number
243.14	30/65 kN	Seal Kit	047-237-715
243.15*	30/65 kN	Seal Kit	047-237-714
243.17	30/65 kN	Seal Kit	047-237-701
243.20	68/109 kN	Seal Kit	047-237-702
243.25	101/166 kN	Seal Kit	047-237-703
243.30	166/259 kN	Seal Kit	047-237-704
243.35	245/373 kN	Seal Kit	047-237-705
243.39*	1523/506 kN	Seal Kit	047-237-712
243.40	298/507 kN	Seal Kit	047-237-706
243.45	455/664 kN	Seal Kit	047-237-707
243.60	663/1035 kN	Seal Kit	047-237-708
243.65*	663/1035 kN	Seal Kit	047-237-713
243.70	982/1491 kN	Seal Kit	047-237-709
243.80*	1364/2027 kN	Seal Kit	047-237-710
243.90*	2250/2727 kN	Seal Kit	047-237-711

MTS Maintenance Parts

Actuator Parts

244.xx Seal Kits (Load Frames)

Model	Rating	Description	Part Number
244.11	15 kN/3.3 kip	Seal Kit	008-710-067
244.12	25 kN/5.5 kip	Seal Kit	008-710-068
244.21	50 kN/11 kip	Seal Kit	008-710-069
244.22	100 kN/22 kip	Seal Kit	008-710-070
244.23	160 kN/35 kip	Seal Kit	008-710-071
244.31	250 kN/55 kip	Seal Kit	008-710-072
244.41	500 kN/110 kip	Seal Kit	008-710-073
244.51	1000 kN/220 kip	Seal Kit	008-710-074

Estimated weight of each is no more than 2 kg.

Each kit contains the parts needed to replace all existing seals.

244.xx G1 Seal Kits (Structural Applications)

Model	Rating	Description	Part Number
244.11	15 kN/3.3 kip	G1 Seal Kit	008-710-046
244.12	25 kN/5.5 kip	G1 Seal Kit	008-710-047
244.20	68 kN/15 kip	G1 Seal Kit	008-710-075
244.21	50 kN/11 kip	G1 Seal Kit	008-710-048
244.22	100 kN/22 kip	G1 Seal Kit	008-710-049
244.23	160 kN/35 kip	G1 Seal Kit	008-710-050
244.31	250 kN/55 kip	G1 Seal Kit	008-710-051
244.41	500 kN/110 kip	G1 Seal Kit	008-710-052
244.51	1000 kN/220 kip	G1 Seal Kit	008-710-053
O-Ring for Servovalve Manifold			010-010-710

244.xx G2 Seal Kits (Structural Applications)

Model	Rating	Description	Part Number
244.11	15 kN/3.3 kip	G2 Seal Kit	056-079-380
244.12	25 kN/5.5 kip	G2 Seal Kit	056-079-381
244.20	68 kN/15 kip	G2 Seal Kit	056-079-382
244.21	50 kN/11 kip	G2 Seal Kit	056-079-383
244.22	100 kN/22 kip	G2 Seal Kit	056-079-384
244.23	160 kN/35 kip	G2 Seal Kit	056-079-385
244.31	250 kN/55 kip	G2 Seal Kit	056-079-386
244.41	500 kN/110 kip	G2 Seal Kit	056-079-387
244.51	1000 kN/220 kip	G2 Seal Kit	056-079-388

244.xx Seal Insertion Tools

Model	Rating	Description	Part Number
244.1x	45 mm/1.75 in	Rod Seal Insertion Tool	046-591-901
244.2x	70 mm/2.75 in	Rod Seal Insertion Tool	046-592-001
244.31	95 mm/3.75 in	Rod Seal Insertion Tool	046-592-201
244.41	135 mm/5.25 in	Rod Seal Insertion Tool	046-592-101
244.51	150 mm/6.00 in	Rod Seal Insertion Tool	046-592-301

Estimated weight of seal insertion tool is 5 kg.

MTS Maintenance Parts

Actuator Parts

245.xx Seal Kits

Model	Rating	Description	Part Number
245.XX	All sizes	Seal Kit	038-736-601

247.xx Seal Kits (Structural Applications)

Model	Rating	Description	Part Number
247.11	15/47 kN	Seal Kit	008-710-054
247.12	25 /59 kN	Seal Kit	008-710-055
247.21	50/130 kN	Seal Kit	008-710-056
247.22*	100/178 kN	Seal Kit	008-710-057
247.23*	159/246 kN	Seal Kit	008-710-058
247.31	250/405 kN	Seal Kit	008-710-059
247.62*	159/373 kN	Seal Kit	008-710-061

Estimated weight of each seal kit is no more than 2 kg.

Each kit contains the parts needed to replace all existing seals.

248.xx Seal Kits

Model	Rating	Description	Part Number
248.0X	All sizes	Seal Kit	040-262-601
		Seal Kit with static support	040-262-701
248.1X	All sizes	Seal Kit	040-262-801
		Seal Kit with static support	040-262-901
248.2X	All sizes	Seal Kit	040-263-001
		Seal Kit with static support	044-711-801

MTS Maintenance Parts

Actuator Parts

215.xx Seal Kits

Model	Rating	Description	Part Number
215.35A	565 N.m Rotary Actuator	327308-01	033-283-101
215.41A	1130 N.m Actuator	327309-01	033-305-001
215.42A	2260 N.m Rotary Actuator	327310-01	033-311-901
215.45A	5650 N.m Rotary Actuator	327311-01	033-282-801
215.51A	11300 N.m Rotary Actuator	327312-01	033-276-801
215.32B	226 N.m Rotary Actuator	362540-01	036-371-601
215.35B	565 N.m Rotary Actuator	362541-01	036-371-601
215.41B	1130 N.m Actuator	362542-01	036-371-601
215.42B	2260 N.m Rotary Actuator	362543-01	036-371-601
215.45B	5650 N.m Rotary Actuator	362544-01	036-254-701
215.51B	11300 N.m Rotary Actuator	362545-01	036-254-701
215.32B	226 N.m Rotary Actuator	443061-01	036-371-601
215.35B	565 N.m Rotary Actuator	443062-01	036-371-601
215.41B	1130 N.m Actuator	443063-01	036-371-601
215.42B	2260 N.m Rotary Actuator	444064-01	036-371-601
215.45B	5650 N.m Rotary Actuator	444576-01	044-527-201
215.51B	11300 N.m Rotary Actuator	444577-01	044-527-201
215.32C	226 N.m Rotary Actuator	474661-01	047-917-101
215.35C	565 N.m Rotary Actuator	474660-01	036-371-601
215.41C	1130 N.m Actuator	475286-01	036-371-601
215.42C	2260 N.m Rotary Actuator	475353-01	036-371-601

Swivel Head/Base Spares

Model	Rating	Description	Part Number
249.12	25 kN/5.5 kip	Spares Package	051-852-401
249.20	66 kN/15 kip	Spares Package	051-852-402
249.23	155 kN/35 kip	Spares Package	051-852-403
249.31	250 kN/55 kip	Spares Package	051-852-404
249.41	500 kN/100 kip	Spares Package	051-852-405
249.42	750 kN/165 kip	Spares Package	051-852-406
249.42S	750 kN/165 kip	Spares Package	051-852-407
249.51	1000 kN/220 kip	Spares Package	051-852-408

Estimated weight of each is no more than 2 kg.

Each kit contains the parts needed to replace all existing seals.

MTS Maintenance Parts

Spares Kits - Monotonic

Same Kit for Extension Length Version

Model	Description	Part Number
C41.103Y	This kit includes certain switches, bellows, all belts, clevis pins and tools.	100-529-712
C42.503Y	This kit includes certain switches, bellows, all belts, clevis pins and tools.	100-530-555
C43.104Y	This kit includes certain switches, bellows, all belts, clevis pins and tools.	100-530-558
C43.304Y	This kit includes certain switches, bellows, all belts, clevis pins and tools.	100-530-559
C43.504Y	This kit includes certain switches, bellows, all belts, clevis pins and tools.	100-530-560
C44.304Y	This kit includes certain switches, bellows, all belts, clevis pins and tools.	100-530-562
C45.504Y	This kit includes certain switches, bellows, all belts, clevis pins and tools.	100-530-563
C45.504WY	This kit includes certain switches, bellows, all belts, clevis pins and tools.	100-530-564
C45.105Y	This kit includes certain switches, bellows, all belts, clevis pins and tools.	100-530-565
C45.305Y	This kit includes certain switches, bellows, all belts, clevis pins and tools.	100-530-566
C45.605Y	This kit includes certain switches, bellows, all belts, clevis pins and tools.	100-530-567

Note: Y on model number indicates Criterion load frame with ICE controller.

Same Kit for Extension Length Version

E42.503	This kit includes certain switches, bellows, all belts, clevis pins and tools.	100-303-303
E43.104	This kit includes certain switches, bellows, all belts, clevis pins and tools.	100-303-304
E43.504	This kit includes certain switches, bellows, all belts, clevis pins and tools.	100-367-234
E44.304	This kit includes certain switches, bellows, all belts, clevis pins and tools.	100-303-305
E45.105	This kit includes certain switches, bellows, all belts, clevis pins and tools.	100-303-306
E45.305	This kit includes certain switches, bellows, all belts, clevis pins and tools.	100-303-307
E45.605	This kit includes certain switches, bellows, all belts, clevis pins and tools.	100-303-308

Spares Kits Description

MTS Insight	Part Number
Spares Kit - Insight 1K/2K	100-187-792
Spares Kit - Insight 5K/10K	100-187-793
Spares Kit - Insight 30K/50K	100-187-794
Spares Kit - Insight 100K	100-187-795
Spares Kit - Insight 150K	100-187-796
Spares Kit - Insight 200K	100-187-797
Spares Kit - Insight 300K	100-187-798
Spares Kit - Insight 50K Wide	100-187-799
Spares Kit - XLT Extensometer 100 R Std	100-187-800
Spares Kit - XLT Extensometer 100 R Ext	100-187-801

MTS Maintenance Parts

Load Frame Parts - Monotonic

LVDT

Description	Part Number
Transducer LVDT/2 in stroke	039-075-101
Transducer LVDT/4 in stroke	039-075-102
Transducer LVDT/6 in stroke	039-075-103
Transducer LVDT/8 in stroke	039-075-111
Transducer LVDT/10 in stroke	039-075-104
Transducer LVDT/14 in stroke	039-075-105
Transducer LVDT/20 in stroke	039-075-106
Transducer LVDT/2 in stroke Transformer length 3.75 in	006-839-901
Transducer LVDT/2 in stroke Transformer length 4.63 in	006-839-902
Transducer LVDT/4 in stroke	006-839-903
Transducer LVDT/6 in stroke	006-839-904
Transducer LVDT/8 in stroke	Contact MTS
Transducer LVDT/10 in stroke	Contact MTS
252/253/256 Servovalve-LVDT	043-229-601

Estimated weight of each is no more than 2 kg.

Each kit contains the parts needed to replace all existing seals.

311.xx Seal Kits

Model	Description	Part Number
311.11 & .21	Lift Seal Kit	032-853-001
	Lock Seal Kit	032-853-301
311.31 & .41	Lift Seal Kit	032-853-101
	Lock Seal Kit (new style)	032-853-701

312.xx Seal Kits

Model	Description	Part Number
312.21	Lift Seal Kit	032-853-201
	Lock Seal Kit	032-853-301
312.31	Lift Seal Kit	032-853-401
	Lock Seal Kit	032-853-501
312.41	Lift Seal Kit	032-853-201
	Lock Seal Kit	032-853-701

Estimated weight of each is no more than 3 kg.

Each kit contains the parts needed to replace the existing seals.

MTS Maintenance Parts

Load Frame Parts - Servohydraulic

318.xx Seal Kits (810 Series)

Model	Description	Part Number
318.10	Lift Seal Kit	040-602-101
	Lock Seal Kit	040-601-801
	25 kN/5.5 kip Actuator Seal Kit	038-171-201
	50 kN/11 kip Actuator Seal Kit	038-171-101
	100 kN/22 kip Actuator Seal Kit	038-171-001
318.25 / 319.25	Lift Seal Kit	040-602-101
	Lock Seal Kit	040-601-901
	100 kN/22 kip Actuator Seal Kit	038-171-401
	250 kN/55 kip Actuator Seal Kit	038-171-301
318.50	Lift Seal Kit	040-602-201
	Lock Seal Kit	040-602-001
	250 kN/55 kip Actuator Seal Kit	038-171-601
	500 kN/110 kip Actuator Seal Kit	038-171-501

Estimated weight of each is no more than 10 kg.

Each kit contains the parts needed to replace the existing seals.

322.xx Seal Kits

Model	Description	Part Number
322.21	Lift Seal Kit	032-853-801
	Lock Seal Kit	032-853-901
322.31	Lift Seal Kit	032-853-401

370.xx Seal Kits (MTS Landmark® Systems)

Model	Description	Part Number
370.02	Lift Seal Kit (load frames manufactured after January 2010)	100-222-825
	Lift Seal Kit (load frames manufactured before January 2010)	Contact MTS
	Lock Seal Kit	100-216-447
	15 kN / 25 kN Linear Actuator Seal Kit	100-215-462
370.10	Lift Seal Kit (load frames manufactured after January 2010)	100-222-825
	Lift Seal Kit (load frames manufactured before January 2010)	Contact MTS
	Lock Seal Kit	100-216-447
	15 kN standard and hydrostatic bearing	100-195-267
	25 kN standard and hydrostatic bearing	100-195-268
	50 kN standard and hydrostatic bearing	100-195-271
	67 kN standard and hydrostatic bearing (piston hub seal N/A)	100-195-273
100 kN standard and hydrostatic bearing	100-195-274	
370.25	Lift Seal Kit (load frames manufactured after January 2010)	100-222-825
	Lift Seal Kit (load frames manufactured before January 2010)	Contact MTS
	Lock Seal Kit	100-216-448
	100 kN standard and hydrostatic bearing	100-195-274
250 kN standard and hydrostatic bearing	100-195-275	
370.50	Lift Seal Kit (load frames manufactured after January 2010)	100-222-825
	Lift Seal Kit (load frames manufactured before January 2010)	Contact MTS
	Lock Seal Kit	100-216-449
	250 kN standard and hydrostatic bearing	100-195-275
	500 kN standard and hydrostatic bearing	100-195-276

370.02 Seal Kits (Bionix Servohydraulic System)

Model	Description	Part Number
370.02	Lift Seal Kit (load frames manufactured after January 2010)	100-222-825
	Lift Seal Kit (load frames manufactured before January 2010)	Contact MTS
	Lock Seal Kit	100-216-447
	15 kN / 25 kN Linear Actuator Seal Kit	100-215-462
	Seal work on rotary actuator not recommended in the field	

MTS Maintenance Parts

Cables

Cables for FlexTest 40, 60, 100, & 200 Controllers

Description	Connector	Length	Controller	Part Number
Adapter, RJ50-D15, 4-Wire		0.3 m (1 ft)	FlexTest 40	100-187-439
Adapter, RJ50-D15, 8-Wire		0.3 m (1 ft)	FlexTest 40	057-303-001
Adapter, RJ50-D15, 4-Wire		1.5 m (5 ft)	FlexTest 60; 100; 200	057-294-001
Adapter, RJ50-D15, 8-Wire		1.5 m (5 ft)	FlexTest 60; 100; 200	057-303-002
ADT 120 Degrees		7.5 m (25 ft)	FlexTest 40; 60; 100; 200	057-309-104
ADT 120 Degrees		15 m (50 ft)	FlexTest 40; 60; 100; 200	057-309-109
ADT 300 Degrees		7.5 m (25 ft)	FlexTest 40; 60; 100; 200	057-309-204
ADT 300 Degrees		15 m (50 ft)	FlexTest 40; 60; 100; 200	057-309-209
Delta P Cell		7.5 m (25 ft)	FlexTest 40; 60; 100; 200	057-144-504
Delta P Cell		15 m (50 ft)	FlexTest 40; 60; 100; 200	057-144-509
Extensometer	PT	7.5 m (25 ft)	FlexTest 40; 60; 100; 200	057-230-704
Extensometer	PT	15 m (50 ft)	FlexTest 40; 60; 100; 200	057-230-709
Load Cell	PT	7.5 m (25 ft)	FlexTest 40; 60; 100; 200	057-099-204
Load Cell	PT	15 m (50 ft)	FlexTest 40; 60; 100; 200	057-099-209
Load Cell	MS	7.5 m (25 ft)	FlexTest 40; 60; 100; 200	057-221-604
Load Cell	MS	15 m (50 ft)	FlexTest 40; 60; 100; 200	057-221-609
HPU, Adapter Cable (Dual Control, Single Pump) 24 V DC		5 m (1.5 ft)	FlexTest 40; 60; 100; 200	005-407-801
HSM Adapter, D9P-CPC4S		0.2 m (10 in)	FlexTest 40; 60; 100; 200	100-175-734
HSM Service Manifold 290/3/4, On/Off, 115 V AC		7.5 m (25 ft)	FlexTest 40; 60; 100; 200	050-053-904
HSM Service Manifold 290/3/4, On/Off, 115 V AC		15 m (50 ft)	FlexTest 40; 60; 100; 200	050-053-909
HSM Service Manifold 290/3/4, Hi/Low, 115 V AC		7.5 m (25 ft)	FlexTest 40; 60; 100; 200	039-718-304
HSM Service Manifold 290/3/4, Hi/Low, 115 V AC		15 m (50 ft)	FlexTest 40; 60; 100; 200	039-718-309
HSM Service Manifold 290/3/4, Hi/Low, 24 V DC		7.5 m (25 ft)	FlexTest 40; 60; 100; 200	057-119-204
HSM Service Manifold 290/3/4, Hi/Low, 24 V DC		15 m (50 ft)	FlexTest 40; 60; 100; 200	057-119-209
HSM Service Manifold 298, On/Off, 24 V DC		7.5 m (25 ft)	FlexTest 40; 60; 100; 200	057-172-904
HSM Service Manifold 298, On/Off, 24 V DC		15 m (50 ft)	FlexTest 40; 60; 100; 200	057-172-909
HSM, Proportional Valve 298.12		7.5 m (25 ft)	FlexTest 40; 60; 100; 200	056-126-404
HSM, Proportional Valve 298.12		15 m (50 ft)	FlexTest 40; 60; 100; 200	056-126-409
LVDT		7.5 m (25 ft)	FlexTest 40; 60; 100; 200	057-099-104
LVDT		15 m (50 ft)	FlexTest 40; 60; 100; 200	057-099-109
Pressure - Sensotec		7.5 m (25 ft)	FlexTest 40; 60; 100; 200	057-238-804
Pressure - Sensotec		15 m (50 ft)	FlexTest 40; 60; 100; 200	057-238-809
RJ50-RJ50 for 494.16/25/26/47		30 m (100 ft)	FlexTest 40; 60; 100; 200	057-267-511
RJ50-RJ50 for 494.45/46/49		30 m (100 ft)	FlexTest 40; 60; 100; 200	057-144-111
RVDT		7.5 m (25 ft)	FlexTest 40; 60; 100; 200	057-255-604
RVDT		15 m (50 ft)	FlexTest 40; 60; 100; 200	057-255-609
Servo Valve Adapter, RJ50-D15		0.3 m (1 ft)	FlexTest 40; 60; 100; 200	100-108-342
Servo Valve LVDT, 3-Stage		7.5 m (25 ft)	FlexTest 40; 60; 100; 200	057-204-104
Servo Valve LVDT, 3-Stage		15 m (50 ft)	FlexTest 40; 60; 100; 200	057-204-109
Servo Valve, 252, 2-Stage Dual, in phase		7.5 m (25 ft)	FlexTest 40; 60; 100; 200	057-255-504
Servo Valve, 252, 2-Stage Dual, in phase		15 m (50 ft)	FlexTest 40; 60; 100; 200	057-255-509
Servo Valve, 252, 2-Stage Dual, out of phase		7.5 m (25 ft)	FlexTest 40; 60; 100; 200	057-255-404
Servo Valve, 252, 2-Stage Dual, out of phase		15 m (50 ft)	FlexTest 40; 60; 100; 200	057-255-409
Servo Valve, 252,/6 2-Stage Single		7.5 m (25 ft)	FlexTest 40; 60; 100; 200	057-193-704
Servo Valve, 252/6, 2-Stage Single		15 m (50 ft)	FlexTest 40; 60; 100; 200	057-193-709
Torque Cell	MS	7.5 m (25 ft)	FlexTest 40; 60; 100; 200	057-230-504
Torque Cell	MS	15 m (50 ft)	FlexTest 40; 60; 100; 200	057-230-509
Torque Cell	PT	7.5 m (25 ft)	FlexTest 40; 60; 100; 200	057-255-304
Torque Cell	PT	15 m (50 ft)	FlexTest 40; 60; 100; 200	057-255-309

MTS Maintenance Parts

Cables

TEDS Cables for FlexTest 40, 60, 100, 200 Controllers

Description	Connector	Length	Controller	Part Number
ADT 120 Degrees, TEDS Module	MS	1.5 m (5 ft)	FlexTest 40; 60; 100; 200	057-272-702
ADT 300 Degrees, TEDS Module	MS	1.5 m (5 ft)	FlexTest 40; 60; 100; 200	057-272-902
Delta P Cell, TEDS Module	PT	1.5 m (5 ft)	FlexTest 40; 60; 100; 200	057-273-102
Extensometer, 632.11x-90 (3 units, 1 output), 634.28, TEDS Module	PT	1.5 m (5 ft)	FlexTest 40; 60; 100; 200	057-272-610
Extensometer, 632.11x-90 (2 units, 1 output), 632.12, 632.23, 632.24, 632.92H-05, 634.12, 634.25, TEDS Module	PT	1.5 m (5 ft)	FlexTest 40; 60; 100; 200	057-272-608
Extensometer, 632.03, 632.13, 632.18, 632.20, 632.65, 632.85E Axial (001), 632.90, 632.92H-03, 632.92H-04, 634.11, 634.33, TEDS Module	PT	1.5 m (5 ft)	FlexTest 40; 60; 100; 200	057-272-606
Extensometer, 632.17 (001), 632.85F Axial (001), 634.31, TEDS Module	PT	1.5 m (5 ft)	FlexTest 40; 60; 100; 200	057-272-605
Extensometer, 632.02, 632.05, 632.06H-2x, 632.06H-3x (002) thru (006), 632.11x-90 (single unit), 632.19, 632.26-2x, 632.26-4x, 632.27-2x, TEDS Module	PT	1.5 m (5 ft)	FlexTest 40; 60; 100; 200	057-272-613
Extensometer, 632.85 (002), TEDS Module	PT	1.5 m (5 ft)	FlexTest 40; 60; 100; 200	057-272-611
Extensometer, 632.06H-3x (001), 632.17 (002), 632.27-3x, 632.29, 632.53, 632.54, 632.85 Transverse, TEDS Module	PT	1.5 m (5 ft)	FlexTest 40; 60; 100; 200	057-272-604
Extensometer, 632.26-3x TEDS Module	PT	1.5 m (5 ft)	FlexTest 40; 60; 100; 200	057-272-603
Extensometer, TEDS Module	PT	1.5 m (5 ft)	FlexTest 40; 60; 100; 200	057-272-602
Extensometer, TEDS Module	Amphenol	1.5 m (5 ft)	FlexTest 40; 60; 100; 200	057-273-302
Load Cell, 661.09A/B-2X, 661.19E/F-02/04, 661.20E/F-01/02/03, 661.36C/D-03, TEDS Module	PT	1.5 m (5 ft)	FlexTest 40; 60; 100; 200	057-273-513
Load Cell, 661.11A/B-0X, 661.18E/F-01/02, 661.19E/F-01, 661.22C/D, 661.23E/F, 661.31E/F, 661.34E/F, TEDS Module	PT	1.5 m (5 ft)	FlexTest 40; 60; 100; 200	057-273-511
Load Cell, A/T, 662.10A/B, Axial, TEDS Module	PT	1.5 m (5 ft)	FlexTest 40; 60; 100; 200	057-273-513
Load Cell, A/T, 662.10A/B, Torsional, TEDS Module	PT	1.5 m (5 ft)	FlexTest 40; 60; 100; 200	057-273-813
Load Cell, A/T, 662.20C/D-01, Axial, TEDS Module	PT	1.5 m (5 ft)	FlexTest 40; 60; 100; 200	057-273-514
Load Cell, A/T, 662.20C/D-01, Torsional, TEDS Module	PT	1.5 m (5 ft)	FlexTest 40; 60; 100; 200	057-273-814
Load Cell, A/T, 662.20C/D-03/04/05/06, Axial, TEDS Module	PT	1.5 m (5 ft)	FlexTest 40; 60; 100; 200	057-273-512
Load Cell, 662.20C/D-03/06, Torsional, TEDS Module	PT	1.5 m (5 ft)	FlexTest 40; 60; 100; 200	057-273-804
Load Cell, A/T, 662.20C/D-04/05, Torsional, TEDS Module	PT	1.5 m (5 ft)	FlexTest 40; 60; 100; 200	057-273-803
Load Cell, TEDS Module	PT	1.5 m (5 ft)	FlexTest 40; 60; 100; 200	057-273-502
Jumper Plug Kit		1.5 m (5 ft)	FlexTest 40; 60; 100; 200	100-182-496
LVDT, TEDS Module	PT	1.5 m (5 ft)	FlexTest 40; 60; 100; 200	057-273-202
Pressure Sensor, TEDS Module	PT	1.5 m (5 ft)	FlexTest 40; 60; 100; 200	057-274-002
RVDT, TEDS Module	MS	1.5 m (5 ft)	FlexTest 40; 60; 100; 200	057-272-502
System Cable, ADT 120 degrees with TEDS	JT to D9/D15	7.5 m (25 ft)	FlexTest 40; 60; 100; 200	057-316-204
System Cable, ADT 300 degrees with TEDS	JT to D9/D15	7.5 m (25 ft)	FlexTest 40; 60; 100; 200	057-316-304
System Cable, Transducer with TEDS	JT to RJ50	7.5 m (25 ft)	FlexTest 40; 60; 100; 200	057-241-404
Tempo G, TEDS Module	PT	1.5 m (5 ft)	FlexTest 40; 60; 100; 200	057-274-202
Torque, TEDS Module	MS	1.5 m (5 ft)	FlexTest 40; 60; 100; 200	057-273-902
Torque, TEDS Module	PT	1.5 m (5 ft)	FlexTest 40; 60; 100; 200	057-273-802

MTS Maintenance Parts

Cables

Cables for FlexTest SE & GT Controllers

Description	Connector	Length	Controller	Part Number
ADT 120 Degrees		7.5 m (25 ft)	FlexTest SE; FlexTest GT	056-234-804
ADT 120 Degrees		15 m (50 ft)	FlexTest SE; FlexTest GT	056-234-809
ADT 300 Degrees		7.5 m (25 ft)	FlexTest SE; FlexTest GT	056-253-104
ADT 300 Degrees		15 m (50 ft)	FlexTest SE; FlexTest GT	056-253-109
Delta P Cell – Stability		7.5 m (25 ft)	FlexTest SE; FlexTest GT	047-927-604
Delta P Cell – Stability		15 m (50 ft)	FlexTest SE; FlexTest GT	047-927-609
Extensometer	PT	7.5 m (25 ft)	FlexTest SE; FlexTest GT	050-120-004
Extensometer	PT	15 m (50 ft)	FlexTest SE; FlexTest GT	050-120-009
Load Cell	PT	7.5 m (25 ft)	FlexTest SE; FlexTest GT	046-440-204
Load Cell	PT	15 m (50 ft)	FlexTest SE; FlexTest GT	046-440-209
Load Cell	MS	7.5 m (25 ft)	FlexTest SE; FlexTest GT	046-440-604
Load Cell	MS	15 m (50 ft)	FlexTest SE; FlexTest GT	046-440-609
HSM Service Manifold; 290/3/4 On/Off, 115 V AC		7.5 m (25 ft)	FlexTest SE; FlexTest GT	050-053-904
HSM Service Manifold; 290/3/4 On/Off, 115 V AC		15 m (50 ft)	FlexTest SE; FlexTest GT	050-053-909
HSM Service Manifold 290/3/4, Hi/Low, 115 V AC		7.5 m (25 ft)	FlexTest SE; FlexTest GT	039-718-304
HSM Service Manifold 290/3/4, Hi/Low, 115 V AC		15 m (50 ft)	FlexTest SE; FlexTest GT	039-718-309
HSM Service Manifold 290/3/4, Hi/Low, 24 V DC		7.5 m (25 ft)	FlexTest SE; FlexTest GT	039-701-404
HSM Service Manifold 290/3/4, Hi/Low, 24 V DC		15 m (50 ft)	FlexTest SE; FlexTest GT	039-701-409
HSM Service Manifold 298, On/Off, 24 V DC		7.5 m (25 ft)	FlexTest SE; FlexTest GT	039-701-504
HSM Service Manifold 298, On/Off, 24 V DC		15 m (50 ft)	FlexTest SE; FlexTest GT	039-701-509
HSM, Proportional Valve 298.12		7.5 m (25 ft)	FlexTest SE; FlexTest GT	056-126-404
HSM, Proportional Valve 298.12		15 m (50 ft)	FlexTest SE; FlexTest GT	056-126-409
LVDT		7.5 m (25 ft)	FlexTest SE; FlexTest GT	046-440-304
LVDT		15 m (50 ft)	FlexTest SE; FlexTest GT	046-440-309
Pressure - Sensotec		7.5 m (25 ft)	FlexTest SE; FlexTest GT	056-253-004
Pressure - Sensotec		15 m (50 ft)	FlexTest SE; FlexTest GT	056-253-009
Servo valve & Valve LVDT, Y Adapter		5 m (1.5 ft)	FlexTest SE; FlexTest GT	039-710-501
Servo valve LVDT, 3-Stage		7.5 m (25 ft)	FlexTest SE; FlexTest GT	039-708-604
Servo valve LVDT, 3-Stage		15 m (50 ft)	FlexTest SE; FlexTest GT	039-708-609
Servo valve, 252, 2-Stage Dual, in phase		7.5 m (25 ft)	FlexTest SE; FlexTest GT	039-708-504
Servo valve, 252, 2-Stage Dual, in phase		15 m (50 ft)	FlexTest SE; FlexTest GT	039-708-509
Servo valve, 252, 2-Stage Dual, out of phase		7.5 m (25 ft)	FlexTest SE; FlexTest GT	039-708-404
Servo valve, 252, 2-Stage Dual, out of phase		15 m (50 ft)	FlexTest SE; FlexTest GT	039-708-409
Servo valve, 252, 2-Stage Single		7.5 m (25 ft)	FlexTest SE; FlexTest GT	039-708-304
Servo valve, 252, 2-Stage Single		15 m (50 ft)	FlexTest SE; FlexTest GT	039-708-309
Servo valve, 256, 3-Stage		7.5 m (25 ft)	FlexTest SE; FlexTest GT	055-439-604
Servo valve, 256, 3-Stage		15 m (50 ft)	FlexTest SE; FlexTest GT	055-439-609
Torque Cell	PT	7.5 m (25 ft)	FlexTest SE; FlexTest GT	039-704-204
Torque Cell	PT	15 m (50 ft)	FlexTest SE; FlexTest GT	039-704-209
Torque Cell	MS	7.5 m (25 ft)	FlexTest SE; FlexTest GT	051-649-504
Torque Cell	MS	15 m (50 ft)	FlexTest SE; FlexTest GT	051-649-509

MTS Maintenance Parts

Cables & Replacement Lamps

Cables for Model 407 Controllers

Description	Connector	Length	Controller	Part Number
E-STOP to HPU Control		7.5 m (25 ft)	Model 407	049-474-704
E-STOP to HPU Control		9.1 m (30 ft)	Model 407	049-474-705
E-STOP, Remote		7.5 m (25 ft)	Model 407	049-474-604
Extensometer	PT	7.5 m (25 ft)	Model 407	050-120-004
Load Cell	MS	7.5 m (25 ft)	Model 407	046-440-604
Load Cell	PT	7.5 m (25 ft)	Model 407	046-440-204
HPU Control 24 V DC		7.5 m (25 ft)	Model 407	039-708-704
HPU Control 24 V DC		9.1 m (30 ft)	Model 407	039-708-705
HSM Hi/Low, 115 V AC		7.5 m (25 ft)	Model 407	049-474-504
HSM Hi/Low, 24 V DC		7.5 m (25 ft)	Model 407	049-474-404
HSM Hi/Low, 24 V DC		9.1 m (30 ft)	Model 407	049-474-405
HSM On/Off Valve, 298.xx		7.5 m (25 ft)	Model 407	049-740-304
HSM, Proportional Valve 298.12		7.5 m (25 ft)	Model 407	049-474-304
LVDT		7.5 m (25 ft)	Model 407	046-440-304
LVDT		9.1 m (30 ft)	Model 407	046-440-305
Servo valve, 252 Dual		7.5 m (25 ft)	Model 407	046-440-404
Servo valve, 252 Dual		9.1 m (30 ft)	Model 407	046-440-405
Servo valve, 252 Single		7.5 m (25 ft)	Model 407	046-440-104
Servo valve, 252 Single		9.1 m (30 ft)	Model 407	046-440-105
System Ground Cable		7.5 m (25 ft)	Model 407	039-709-204
System Ground Cable		9.1 m (30 ft)	Model 407	039-709-205

Cables for FlexTest IIm Controllers

Description	Connector	Length	Controller	Part Number
Load Cell	MS	7.5 m (25 ft)	FlexTest IIm	046-440-604
Load Cell	PT	7.5 m (25 ft)	FlexTest IIm	046-440-204
LVDT		7.5 m (25 ft)	FlexTest IIm	046-440-304
Servo valve, 252 Dual		7.5 m (25 ft)	FlexTest IIm	046-440-404
Servo valve, 252 Single		7.5 m (25 ft)	FlexTest IIm	046-440-104

Replacement Lamps

Description	Part Number
421.21	010-076-901
436.11 (Type 334)	010-076-901
Oven Lamp	011-322-312

Estimated weight of each is no more than 2 kg.

MTS Maintenance Parts

Adapter Cables

Adapter Cables for 3rd Party Equipment

Description	Connector	Length	Controller	Part Number
Instron Extensometer to Insight Controller Cable	MS to RJ50	3m (10 ft)	Insight	100-220-824
Instron 133X Xhead Interlock to 493.01 Cable	MS to CPC	15m (50 ft)	FlexTest SE; FlexTest GT	052-750-709
Instron 3340 Act Off/Low/High to 493.08 Cable	MS to CPC	7.5m (25 ft)	FlexTest SE; FlexTest GT	052-752-304
Instron 3340 Act Off/Low/High to 493.08 Cable	MS to CPC	15m (50 ft)	FlexTest SE; FlexTest GT	052-752-309
Instron 3340 Act Off/High to 493.08 Cable	MS to CPC	7.5m (25 ft)	FlexTest SE; FlexTest GT	052-751-204
Instron 3340 Act Off/High to 493.08 Cable	MS to CPC	15m (50 ft)	FlexTest SE; FlexTest GT	052-751-209
Instron 210 5/10/20 HPS to 493.08 Cable (Replacing 2150)	MS	7.5m (25 ft)	FlexTest SE; FlexTest GT	054-145-504
Instron 210 5/10/20 HPS to 493.08 Cable (Replacing 8500)	MS	7.5m (25 ft)	FlexTest SE; FlexTest GT	054-145-704
Instron Extensometer to MTS PT Cable Adapter	D to PT	.3m (1 ft)		100-140-617
MTS Extensometer to Instron 8500 Cable	D to PT	7.5m (25 ft)		049-751-304
Instron 133X Xhead Interlock to FT40/60/100/200 Cable	D to MS	7.5m (25 ft)	FlexTest SE; FlexTest GT	057-048-504
Instron 133X Xhead Interlock to FT40/60/100/200 Cable	D to MS	15m (50 ft)	FlexTest SE; FlexTest GT	057-048-509
Instron 133X & 851X SelfID Extensometer to FT40/60/100/200 Cable	D to RJ50	7.5m (25 ft)	FlexTest 40; 60; 100; 200	057-335-604
Instron 133X & 851X SelfID Extensometer to FT40/60/100/200 Cable	D to RJ50	15m (50 ft)	FlexTest 40; 60; 100; 200	057-335-609
Instron 133X & 851X Non-SelfID Extensometer to FT40/60/100/200 Cable	MS to RJ50	7.5m (25 ft)	FlexTest 40; 60; 100; 200	057-335-704
Instron 133X & 851X SelfID L/C to FT40/60/100/200 Cable	D to RJ50	7.5m (25 ft)	FlexTest 40; 60; 100; 200	057-335-404
Instron 133X & 851X SelfID L/C to FT40/60/100/200 Cable	D to RJ50	15m (50 ft)	FlexTest 40; 60; 100; 200	057-335-409
Instron 133X Lebow L/C to FT40/60/100/200 Cable	MS to RJ50	7.5m (25 ft)	FlexTest 40; 60; 100; 200	057-221-604
Instron 133X Lebow L/C to FT40/60/100/200 Cable	MS to RJ50	15m (50 ft)	FlexTest 40; 60; 100; 200	057-221-609
Instron 133X S/V (Single) to FT40/60/100/200 Cable	MS to RJ50	7.5m (25 ft)	FlexTest 40; 60; 100; 200	057-193-704
Instron 133X S/V (Single) to FT40/60/100/200 Cable	MS to RJ50	15m (50 ft)	FlexTest 40; 60; 100; 200	057-193-709
Instron 133X S/V (Dual) to FT40/60/100/200 Cable	(2) MS to RJ50	7.5m (25 ft)	FlexTest 40; 60; 100; 200	057-255-404
Instron 133X S/V (Dual) to FT40/60/100/200 Cable	(2) MS to RJ50	15m (50 ft)	FlexTest 40; 60; 100; 200	057-255-409
Instron 133X LVDT (2150 & 8500 w/ MS Connector) to FT40/60/100/200 Cable	MS to RJ50	7.5m (25 ft)	FlexTest 40; 60; 100; 200	057-335-504
Instron 133X LVDT (2150 & 8500 w/ MS Connector) to FT40/60/100/200 Cable	MS to RJ50	15m (50 ft)	FlexTest 40; 60; 100; 200	057-335-509
Instron 133X & 851X System Ground to FT40/60/100/200 Cable		7.5m (25 ft)	FlexTest 40; 60; 100; 200	039-709-204
Instron 133X & 851X System Ground to FT40/60/100/200 Cable		15m (50 ft)	FlexTest 40; 60; 100; 200	039-709-209
Instron 2GPM 1500PSI HPS to FT40/60/100/200		7.5m (25 ft)	FlexTest 40; 60; 100; 200	054-872-204
Instron 2GPM 1500PSI HPS to FT40/60/100/200		15m (50 ft)	FlexTest 40; 60; 100; 200	054-872-209
Instron 347X Mod 718 HPS to FT40/60/100/200		7.5m (25 ft)	FlexTest 40; 60; 100; 200	054-872-004
Instron 347X Mod 718 HPS to FT40/60/100/200		15m (50 ft)	FlexTest 40; 60; 100; 200	054-872-009
Instron 851X LF Load Rel Pres Switch to MTS Load Release Interface Box Cable	CPC to DIN	7.5m (25 ft)		057-140-404
Instron 851X LF Load Rel Pres Switch to MTS Load Release Interface Box Cable	CPC to DIN	15m (50 ft)		057-140-409
Instron 851X LF Pres Red Man Opt to MTS Load Release Interface Box Cable	CPC to DIN	7.5m (25 ft)		055-859-804
Instron 851X LF Pres Red Man Opt to MTS Load Release Interface Box Cable	CPC to DIN	15m (50 ft)		055-859-809
Instron 851X LF Load Rel Sol to MTS Load Release Interface Box Cable	CPC to DIN	7.5m (25 ft)		055-859-704
Instron 851X LF Load Rel Sol to MTS Load Release Interface Box Cable	CPC to DIN	15m (50 ft)		055-859-709
Load Release Interface Box for Instron 851X LF - Floor Standing w/ 10' Cable		3m (10 ft)		053-045-301
Load Release Interface Box for Instron 851X LF - Rack Mounted w/ 15' Cable		4.5m (15 ft)		053-045-302
Instron 851X LF Load Unit Interlock Adapter Cable	CPC to DIN	1.5m (5 ft)		053-047-201
Instron 851X LF Load Unit Interlock Adapter Cable to FT40/60/100/200		7.5m (25 ft)	FlexTest 40; 60; 100; 200	056-126-504
Instron 851X LF Load Unit Interlock Adapter Cable to FT40/60/100/200		15m (50 ft)	FlexTest 40; 60; 100; 200	056-126-509
Instron 851X S/V (Single) to FT40/60/100/200 Cable		7.5m (25 ft)	FlexTest 40; 60; 100; 200	052-752-204
Instron 851X S/V (Single) to FT40/60/100/200 Cable		15m (50 ft)	FlexTest 40; 60; 100; 200	052-752-209
Instron 851X S/V (Dual) to FT40/60/100/200 Cable		7.5m (25 ft)	FlexTest 40; 60; 100; 200	039-708-404
Instron 851X S/V (Dual) to FT40/60/100/200 Cable		15m (50 ft)	FlexTest 40; 60; 100; 200	039-708-409
Instron 851X LVDT w/ Burndy Connector to FT40/60/100/200 Cable		7.5m (25 ft)	FlexTest 40; 60; 100; 200	057-335-804
Instron 851X LVDT w/ Burndy Connector to FT40/60/100/200 Cable		15m (50 ft)	FlexTest 40; 60; 100; 200	057-335-809

MTS Maintenance Parts

Grip Parts

641.xx Seal Kits

Model	Rating	Description	Part Number
641.35	100 kN	Seal Kit/Metric (Two required)	020-718-301
641.37	500 kN	Seal Kit/Metric (Two required)	020-718-701
641.35	100 kN	Seal Kit	036-792-301
641.36	250 kN	Seal Kit	038-753-801
641.37	500 kN	Seal Kit	036-809-201
641.38	1000 kN	Seal Kit	038-753-901

Metric grip sets have a knurled ring on the main body.

646.xx Seal Kits

Model	Rating	Description	Part Number
646.10A	100 kN/22 kip	Seal Kit	038-400-501
646.10B	100 kN/22 kip	Seal Kit	042-739-101
646.25A	250 kN/55 kip	Seal Kit	038-400-701
646.25B	250 kN/55 kip	Seal Kit	042-739-201

647.xx Seal Kits (seals for upper and lower grip)

Model	Rating	Description	Temperature Range	Part Number
647.02	25 kN/5.5 kip	Seal Kit	-17/+65°C (0/+150°F)	047-810-701
647.02	25 kN/5.5 kip	Replacement Springs		010-086-754
647.02	25 kN/5.5 kip	Spring Anchors		038-529-001
647.02	25 kN/5.5 kip	Seal Kit (high temp)	-40/+175°C (-40/+350°F)	047-810-702
647.02B	25 kN/5.5 kip	Seal Kit	-40/+120°C (-40/+250°F)	056-143-501
647.02B	25 kN/5.5 kip	Seal Kit (high temp)	-40/+175°C (-40/+350°F)	056-143-502
647.10B	100 kN/22 kip	Seal Kit	-17/+65°C (0/+150°F)	047-810-901
647.10	100 kN/22 kip	Replacement Springs		010-086-752
647.10	100 kN/22 kip	Spring Anchors		038-310-501
647.10B	100 kN/22 kip	Seal Kit (high temp)	-40/+175°C (-40/+350°F)	047-810-902
647.25B	250 kN/55 kip	Seal Kit	-17/+65°C (0/+150°F)	047-810-801
647.25	250 kN/55 kip	Replacement Springs		010-086-753
647.25	250 kN/55 kip	Spring Anchors		038-310-501
647.25B	250 kN/55 kip	Seal Kit (high temp)	-40/+175°C (-40/+350°F)	047-810-802
647.50	500 kN/110 kip	Seal Kit	-17/+65°C (0/+150°F)	047-811-001
647.50	500 kN/110 kip	Replacement Springs		010-086-753
647.50	500 kN/110 kip	Spring Anchors		038-310-501
647.50	500 kN/110 kip	Seal Kit (high temp)	-40/+175°C (-40/+350°F)	047-811-002

680.xx Seal Kits

Model	Description	Part Number
680.01	Seal Kit	040-985-901

Estimated weight of each is no more than 2 kg. Each kit contains parts needed to replace all existing seals.

Electromechanical Grip Parts

Advantage Pneumatic Grip Spares Kit	Part Number
Spares Kit – Advantage Pneumatic 100 N/200 N	100-044-616
Spares Kit – Advantage Pneumatic Grip 2 kN	100-044-617
Spares Kit – Advantage Pneumatic 10 N	100-044-618
Spares Kit – Advantage Pneumatic 10 kN	100-044-619

Advantage Wedge Action Replacement Kit	Part Number
Replacement Kit Wedge Action 30 kN/50 kN	056-011-601
Replacement Kit Wedge Action 100 kN/150 kN	056-011-602

Grip Supplies and Environmental Simulation Parts

Grip Supply Spares Kit	Part Number
Kit-Spares, Grip Supply 685.10/685.22	100-109-989

653.xx Furnace Service Kit	Part Number
Heater Element Service Kit – 653.01 Furnace	056-543-201
Heater Element Service Kit – 653.02 &.03 Furnace	056-543-202
Heater Element Service Kit – 653.04 Furnace	056-543-203

MTS Maintenance Parts

Hydraulic Hoses

Pressure and Return Hoses

Fitting Size	Diameter in Inches	Length (ft/m)	Pressure Rating	Pressure Hose Part Number	Return Rating	Return Hose Part Number
-6	0.375	5/1.5	3000 psi	006-890-305	2000 psi	006-890-405
-6	0.375	10/3.048	3000 psi	006-890-310	2000 psi	006-890-410
-6	0.375	15/4.5	3000 psi	006-890-311	2000 psi	006-890-411
-6	0.375	20/6.096	3000 psi	006-890-312	2000 psi	006-890-412
-6	0.375	25/7.6	3000 psi	006-890-313	2000 psi	006-890-413
-6	0.375	30/9.144	3000 psi	006-890-314	2000 psi	006-890-414
-8	0.5	5/1.5	3000 psi	006-890-605	2000 psi	006-890-705
-8	0.5	10/3.048	3000 psi	006-890-610	2000 psi	006-890-710
-8	0.5	15/4.5	3000 psi	006-890-611	2000 psi	006-890-711
-8	0.5	20/6.096	3000 psi	006-890-612	2000 psi	006-890-712
-8	0.5	25/7.6	3000 psi	006-890-613	2000 psi	006-890-713
-8	0.5	30/9.144	3000 psi	006-890-614	2000 psi	006-890-714
-12	0.75	5/1.5	4000 psi	006-890-905	2000 psi	006-891-005
-12	0.75	10/3.048	4000 psi	006-890-910	2000 psi	006-891-010
-12	0.75	15/4.5	4000 psi	006-890-911	2000 psi	006-891-011
-12	0.75	20/6.096	4000 psi	006-890-912	2000 psi	006-891-012
-12	0.75	25/7.6	4000 psi	006-890-913	2000 psi	006-891-013
-12	0.75	30/9.144	4000 psi	006-890-914	2000 psi	006-891-014
-16	1	5/1.5	4000 psi	006-891-205	2000 psi	006-891-305
-16	1	10/3.048	4000 psi	006-891-210	2000 psi	006-891-310
-16	1	15/4.5	4000 psi	006-891-211	2000 psi	006-891-311
-16	1	20/6.096	4000 psi	006-891-212	2000 psi	006-891-312
-16	1	25/7.6	4000 psi	006-891-213	2000 psi	006-891-313
-16	1	30/9.144	4000 psi	006-891-214	2000 psi	006-891-314
-20	1.25	5/1.5	3000 psi	006-891-505	2000 psi	006-891-605
-20	1.25	10/3.048	3000 psi	006-891-510	2000 psi	006-891-610
-20	1.25	15/4.5	3000 psi	006-891-511	2000 psi	006-891-611
-20	1.25	20/6.096	3000 psi	006-891-512	2000 psi	006-891-612
-20	1.25	25/7.6	3000 psi	006-891-513	2000 psi	006-891-613
-20	1.25	30/9.144	3000 psi	006-891-514	2000 psi	006-891-614

Drain Hoses

Fitting Size	Diameter in Inches	Length (ft/m)	Pressure Rating	Part Number
-6	0.375	5/1.5	100 psi	006-890-505
-6	0.375	10/3.048	100 psi	006-890-510
-6	0.375	15/4.5	100 psi	006-890-511
-6	0.375	20/6.096	100 psi	006-890-512
-6	0.375	25/7.5	100 psi	006-890-513
-6	0.375	30/9.144	100 psi	006-890-514
-8	0.5	5/1.5	100 psi	006-890-805
-8	0.5	10/3.048	100 psi	006-890-810
-8	0.5	15/4.5	100 psi	006-890-811
-8	0.5	20/6.096	100 psi	006-890-812
-8	0.5	25/7.5	100 psi	006-890-813
-8	0.5	30/9.144	100 psi	006-890-814

Actual hoses used depend on specific equipment in the installation.

To determine desired hose size: 1) Determine servovalve and actuator manifold; 2) determine HSM; 3) determine HPU; and 4) then refer to those sections for proper fitting sizes to complete your hose selection.

MTS Maintenance Parts

Hydraulic Power Unit Parts

505.xx Filter Kits

Model	Description	Part Number
505.07	High Pressure Filter Kit (Adds High Pressure Filtration)	100-008-737
	High Pressure Element & Seal Kit	100-030-194
	High Pressure Element	100-030-007
	Return Element & Seal Kit	100-030-195
	Return Element	100-009-495
505.11	High Pressure Filter Kit (Adds High Pressure Filtration)	100-008-737
	High Pressure Element & Seal Kit	100-030-194
	High Pressure Element	100-030-007
	Return Element & Seal Kit	100-030-195
	Return Element	100-009-495
505.20/.30	High Pressure Filter Kit for 505.20 & .30	054-728-801
	Return Element	010-053-349
	Return Element & Seal Kit	100-078-099
	High Pressure Element for 505.20 & .30	011-970-652
505.60	Return Element**	**MFG prior to 2007 100-015-519
	Return Element w/ O-ring Seal**	**MFG prior to 2007 100-030-199
	Return Element w/ O-ring Seal***	***MFG in 2007 & later 100-029-989
	High Pressure Element (two required)	010-053-305
505.90	Return Element**	**MFG prior to 2007 100-015-519
	Return Element w/ O-ring Seal**	**MFG prior to 2007 100-030-199
	Return Element w/ O-ring Seal***	***MFG in 2007 & later 100-029-989
	High Pressure Element (two required)	010-053-305
505.120	Return Element**	**MFG prior to 2007 100-015-519
	Return Element w/ O-ring Seal**	**MFG prior to 2007 100-030-199
	Return Element w/ O-ring Seal***	***MFG in 2007 & later 100-029-989
	High Pressure Element (four required)	010-053-305
505.120	Return Element**	**MFG prior to 2007 100-015-519
	Return Element w/ O-ring Seal**	**MFG prior to 2007 100-030-199
	Return Element w/ O-ring Seal***	***MFG in 2007 & later 100-029-989
	High Pressure Element (four required)	010-053-305
505.180	Return Element**	**MFG prior to 2007 100-015-519
	Return Element w/ O-ring Seal**	**MFG prior to 2007 100-030-199
	Return Element w/ O-ring Seal***	***MFG in 2007 & later 100-029-989
	High Pressure Element (four required)	010-053-305

**Machines before January 2007: Clamp style filter cover. Filter part number: 100-015-519 (approx. 24.25" long).

- Kit (filter & seals): 100-030-199

***Machines from January 2007 on: Bolt on filter cover. Filter part number: 100-029-989 (includes seals) (approx. 18-25" long).

506.xx Filter Kits

Model	Description	Part Number
506.00-01	Filter Element-Main Pressure	010-088-309
506.00-02	Filter Element-Inlet Pressure **	011-068-418
All serial numbers	Filter Kit-Level 1	038-752-401
	Filter Kit-Level 2	038-094-801
	Filter Kit-Level 4	038-750-901
506.01 Serial numbers 100-470, 472-474, 481 and 482	Filter Element-Main Pressure	010-088-334
	Filter Element-Inlet Pressure **	011-129-901
	Filter Kit-Level 1	035-843-601
	Filter Kit-Level 2	031-875-301
	Filter Kit-Level 4	031-875-401
506.01 Serial numbers 471, 475-480, 484 and up	Filter Element-Main Pressure	010-088-328
	Filter Element-Inlet Pressure **	011-129-901
	Filter Kit-Level 1	038-750-301
	Filter Kit-Level 2	038-094-901
	Filter Kit-Level 4	038-751-001

*** Cleanable element. Estimated weights: No more than 2 kg on elements; no more than 10 kg on kits.

Level 1 kits contain filters and seals to perform one maintenance requirement.

Level 2 kits contain filters and seals to perform two maintenance requirements, one cleanable filter.

Level 4 kits contain filters and seals to perform four maintenance requirements, one cleanable filter.

MTS Maintenance Parts

Hydraulic Power Unit Parts

506.xx Filter Kits

Model	Description	Part Number
506.02 Serial numbers 100-545 4 in Element, Silver Bowl	Filter Element-Main Pressure	010-088-334
	Filter Element-Inlet Pressure **	011-129-901
	Filter Kit-Level 1	035-843-601
	Filter Kit-Level 2	031-875-301
	Filter Kit-Level 4	031-875-401
506.02 Serial numbers 100-545 8 in Element, Silver Bowl	Filter Element-Main Pressure	010-088-354
	Filter Element-Inlet Pressure **	011-129-901
	Filter Kit-Level 1	035-843-701
	Filter Kit-Level 2	032-845-001
	Filter Kit-Level 4	032-845-101
506.02 Serial numbers 546 and up 4 in Element, Black Bowl	Filter Element-Main Pressure	010-088-328
	Filter Element-Inlet Pressure **	011-129-901
	Filter Kit-Level 1	038-750-301
	Filter Kit-Level 2	038-094-901
	Filter Kit-Level 4	038-751-001
506.03 All serial numbers	Filter Element-Main Pressure	010-088-354
	Filter Element-Inlet Pressure **	011-129-901
	Filter Kit-Level 1	035-843-701
	Filter Kit-Level 2	032-845-001
	Filter Kit-Level 4	032-845-101
506.10/.20 All serial numbers 4 in Element	Filter Element-Main Pressure	010-088-328
	Filter Element-Inlet Pressure **	011-068-406
	Filter Kit-Level 1	035-843-801
	Filter Kit-Level 2	031-875-701
	Filter Kit-Level 4	036-911-001
506.10/.20 All serial numbers 8 in Element	Filter Element-Main Pressure	010-088-323
	Filter Element-Inlet Pressure **	011-068-406
	Filter Kit-Level 1	038-514-001
	Filter Kit-Level 2	036-911-101
	Filter Kit-Level 4	031-875-801
506.22 All serial numbers	Filter Element-Inlet Pressure **	011-068-406
	Filter Kit-Level 1	038-514-001
	Filter Kit-Level 2	036-911-101
	Filter Kit-Level 4	031-875-801

** Cleanable element. Estimated weights: No more than 2 kg on elements; no more than 10 kg on kits.

Level 1 kits contain filters and seals to perform one maintenance requirement.

Level 2 kits contain filters and seals to perform two maintenance requirements, one cleanable filter.

Level 4 kits contain filters and seals to perform four maintenance requirements, one cleanable filter.

MTS Maintenance Parts

Hydraulic Power Unit Parts

506.xx Filter Kits

Model	Description	Part Number
506.41 Serial numbers 100-186 and 193	Filter Element-Main Pressure (two required)	010-053-305
	Filter Element-Inlet Pressure	011-068-403
	Filter Element-Bypass	010-088-323
	Filter Kit-Level 1	035-843-901
	Filter Kit-Level 2	031-875-901
	Filter Kit-Level 4	031-876-001
506.41 Serial numbers 187-192, 194 and up	Filter Element-Main Pressure (two required)	010-053-305
	Filter Element-Inlet Pressure	011-402-819
	Filter Kit-Level 1	038-750-401
	Filter Kit-Level 2	038-105-201
506.51 Serial numbers 100-143	Filter Element-Main Pressure (two required)	010-053-305
	Filter Element-Inlet Pressure	011-068-403
	Filter Element-Bypass	010-088-323
	Filter Kit-Level 1	035-843-901
	Filter Kit-Level 2	031-875-901
506.51 Serial numbers 144 and up	Filter Element-Main Pressure (two required)	010-053-305
	Filter Element-Inlet Pressure	011-402-819
	Filter Kit-Level 1	038-750-401
	Filter Kit-Level 2	038-105-201
	Filter Kit-Level 4	038-751-101
Filter Element-Main Pressure	Filter Element-Main Pressure	011-951-524
	Filter Element-Inlet Pressure	011-178-619
506.61 Serial numbers 100-189, and 205	Filter Element-Main Pressure (two required)	010-053-305
	Filter Element-Inlet Pressure	011-068-403
	Filter Element-Bypass	010-088-323
	Filter Kit-Level 1	035-843-901
	Filter Kit-Level 2	031-875-901
506.61 Serial numbers 190-204, 206 and up	Filter Element-Main Pressure (two required)	010-053-305
	Filter Element-Inlet Pressure	011-402-819
	Filter Kit-Level 1	038-750-401
	Filter Kit-Level 2	038-105-201
506.61 Serial numbers 190-204, 206 and up	Filter Kit-Level 4	038-751-101

** Cleanable element. Estimated weights: No more than 2 kg on elements; no more than 10 kg on kits.

Level 1 kits contain filters and seals to perform one maintenance requirement.

Level 2 kits contain filters and seals to perform two maintenance requirements, one cleanable filter.

Level 4 kits contain filters and seals to perform four maintenance requirements, one cleanable filter.

MTS Maintenance Parts

Hydraulic Power Unit Parts

506.xx Filter Kits

Model	Description	Part Number
506.62 All serial numbers	Filter Element-Main Pressure (two required)	010-053-305
	Filter Element-Inlet Pressure	011-402-819
	Filter Kit-Level 1	038-750-401
	Filter Kit-Level 2	038-105-201
	Filter Kit-Level 4	038-751-101
506.71 Serial numbers 100-165	Filter Element-Main Pressure (four required)	010-053-305
	Filter Element-Inlet Pressure	011-068-403
	Filter Element-Inlet Pressure	011-068-412
	Filter Element-Bypass	010-088-323
	Filter Kit-Level 1	038-514-101
	Filter Kit-Level 2	032-845-201
506.71 Serial numbers 166 and up	Filter Kit-Level 4	032-845-301
	Filter Element-Main Pressure (four required)	010-053-305
	Filter Element-Inlet Pressure	011-402-817
	Filter Kit-Level 1	038-750-501
506.81 Serial numbers 100-141	Filter Kit-Level 2	038-750-801
	Filter Kit-Level 4	038-751-201
	Filter Element-Main Pressure (four required)	010-053-305
	Filter Element-Inlet Pressure	011-068-403
	Filter Element-Inlet Pressure	011-068-412
	Filter Element-Bypass	010-088-323
506.81 Serial numbers 142 and up	Filter Kit-Level 1	038-514-101
	Filter Kit-Level 2	032-845-201
	Filter Kit-Level 4	032-845-301
	Filter Element-Main Pressure (four required)	010-053-305
	Filter Element-Inlet Pressure	011-402-817
506.82/92 All serial numbers	Filter Kit-Level 1	038-750-501
	Filter Kit-Level 2	038-750-801
	Filter Kit-Level 4	038-751-201
	Filter Element-Main Pressure (four required)	010-053-305
	Filter Element-Inlet Pressure	011-402-817

** Cleanable element. Estimated weights: No more than 2 kg on elements; no more than 10 kg on kits.

Level 1 kits contain filters and seals to perform one maintenance requirement.

Level 2 kits contain filters and seals to perform two maintenance requirements, one cleanable filter.

Level 4 kits contain filters and seals to perform four maintenance requirements, one cleanable filter.

MTS Maintenance Parts

Hydraulic Power Unit Parts

510.xx Filter Kits

Model	Description	Part Number
510.10 All serial numbers	Filter Element-Main Pressure	010-088-323
	Filter Element-Inlet Pressure **	011-068-416
	Filter Kit-Level 1	038-750-601
	Filter Kit-Level 2	038-105-001
	Filter Kit-Level 4	038-751-301
510.21/.23 – Rev A & B Built through April, 1991 Top Level Assy #'s – 380821-xx; 380823-xx	Filter Element-Main Pressure	011-402-827
	Filter Element-Inlet Pressure **	011-068-417
	Filter Kit-Level 1	038-750-701
	Filter Kit-Level 2	038-105-101
	Filter Kit-Level 4	038-751-401
510.21/.23 - Rev C Built from May, 1991 – present Top Level Assy #'s – 480821-xx; 480823-xx	Filter Element-Main Pressure	011-402-827
	Filter Element-Inlet Pressure **	011-068-406
	Filter Kit-Level 1	038-750-701
	Filter Kit-Level 2	048-603-101
	Filter Kit-Level 4	048-603-201
510.30 - Rev A Built from May, 1991 – present Top Level Assy #'s – 480830-xx	Filter Element-Main Pressure	011-402-827
	Filter Element-Inlet Pressure **	011-068-406
	Filter Kit-Level 1	038-750-701
	Filter Kit-Level 2	048-603-101
	Filter Kit-Level 4	048-603-201

** Cleanable element. Estimated weights: No more than 2 kg on elements; no more than 10 kg on kits.

Level 1 kits contain filters and seals to perform one maintenance requirement.

Level 2 kits contain filters and seals to perform two maintenance requirements, one cleanable filter.

Level 4 kits contain filters and seals to perform four maintenance requirements, one cleanable filter.

515.xx Filter Kits

Model	Description	Part Number
515.04	Return Filter Kit	100-538-036
	Pressure Filter Kit	100-538-037
515.07 and 515.11	Pressure Kits	
	- High Pressure Filter Kit (3000 psi)	100-322-895
	- High Pressure Filter Kit (4000 psi)	100-322-896
	Return Kits	
	- Return Kit w/Schroeder Filter Housing	100-538-036
- Return Kit w/Parker Filter Housing	100-030-195	
<i>Note: 515.07/11 transitioned during 2021 to a Schroeder filter housing. Do physical check, or use BOM to verify</i>		
515.20/.30	High Pressure Filter Kit for 505.20 & .30	100-322-897
	Return Element (two required)	010-053-349
	High Pressure Element for 505.20 & .30	010-053-305
515.60/90/90S-1	Return Element	100-337-062
	Return Element w/ O-ring Seal	100-322-894
	High Pressure Element w/ O-ring Seal	100-322-898
	High Pressure Element (two required)	010-053-305
515.120-180/180S-1/2/3	Return Element	100-337-062
	Return Element w/ O-ring Seal	100-322-894
	High Pressure Element w/ O-ring Seal	100-322-899
	High Pressure Element (four required)	010-053-305

MTS Maintenance Parts

Hydraulic Power Unit Parts

512 and 530 Filter Elements

Model	Description	Part Number
512.01	Filter Element 5-in spin on	011-951-521
512.04	Filter Element 5-in spin on	011-951-521
530.07	Filter Element 5-in spin on	011-951-522
530.10	Filter Element 5-in spin on	011-951-521
530.20	Filter Element 8-in	010-053-349

Seal Kit for Radial Piston Pump - RKP 63

Model	Description	Part Number
504.11/.12/.21	Seal Kit RKP 63	Contact MTS

Please refer to the HPS manual for detailed information.
Contact MTS Technical Support in case of difficulties.

Filter Elements / European Standards

Model/Type	Description	Part Number
HC 9021 FUT 4H	Filter Element	010-088-302
HC 9020 FDP 4H	Filter Element	010-088-309
HC 9021 FDP 4H	Filter Element	011-402-821
HC 9600 FDP 4H	Filter Element	010-088-328
HC 9601 FDP 4H	Filter Element	010-088-361
HC 9600 FDP 8H	Filter Element	010-088-323
HC 9600 FDP 13H	Filter Element	011-402-827
HC 9600 FDP 16H	Filter Element	011-402-880
HC 9601 FDP 16H	Filter Element	011-402-883
HC 9800 FDP 8H	Filter Element	011-402-824
927 965 10BXLV 10-Micron	Filter Element	011-395-936
927 964 03BXCW 3-Micron	Filter Element	011-395-937

** Cleanable element. Estimated weights: No more than 2 kg on elements; no more than 10 kg on kits.
Level 1 kits contain filters and seals to perform one maintenance requirement.
Level 2 kits contain filters and seals to perform two maintenance requirements, one cleanable filter.
Level 4 kits contain filters and seals to perform four maintenance requirements, one cleanable filter.

Filter Bowl Seal Kits

Model/Type	Description	Part Number
SB 9020 SKH*	Seal Kit	027-001-052
SB 9600 SKH*	Seal Kit	027-001-049
SB 9800 SKH*	Seal Kit	027-001-051

Heat Exchangers

Model/Type	Description	Part Number
504.21	Heat Exchanger	027-000-353
504.22	Heat Exchanger	027-001-973

Upgrade of heat exchanger required. Contact MTS.
Each Package contains the parts needed to replace existing seals, filter elements, and accumulators.

MTS Maintenance Parts

Hydraulic Service Manifold Parts

290.xx Filter & Seal Kits

Model/Type	Description	Part Number
290.11	Filter Element-Main Pressure **	011-130-208
	Filter Kit – Level 2	038-926-201
	Seal Kit	038-926-301
290.12/.14	Filter Element-Main Pressure **	011-130-208
	Filter Element-Pilot Pressure	010-088-309
	Filter Kit – Level 1	038-802-901
	Filter Kit – Level 2	038-803-601
	Seal Kit	038-806-001
290.13	Filter Element-Main Pressure **	011-130-208
	Filter Kit – Level 2	038-926-201
	Seal Kit	038-806-001

**Cleanable element. Estimated weights: No more than 2 kg on elements; no more than 5 kg on kits.

Level 1 kit contains the paper filters and filter seals required to perform one complete filter change.

Level 2 kit contains one cleanable element, paper filters & filter seals required for two filter changes.

290.xx Filter & Seal Kits

Model/Type	Description	Part Number
290.21/.22	Filter Element-Main Pressure **	011-130-205
	Filter Element-Pilot Pressure	010-088-309
	Filter Kit – Level 1	038-802-901
	Filter Kit – Level 2	038-803-701
	Seal Kit	038-806-101
290.31	Filter Element-Main Pressure **	011-130-205
	Filter Element-Pilot Pressure	010-088-309
	Filter Kit – Level 1	038-802-901
	Filter Kit – Level 2	038-803-701
	Seal Kit	038-806-201
290.32	Filter Element-Main Pressure **	011-130-205
	Filter Element-Pilot Pressure	010-088-309
	Filter Kit – Level 1	038-802-901
	Filter Kit – Level 2	038-803-701
	Seal Kit	038-806-301
290.4X	Seal Kit – 7-in Accumulator	011-484-307

**Cleanable element. Estimated weights: No more than 2 kg on elements; no more than 5 kg on kits.

Level 1 kit contains the paper filters and filter seals required to perform one complete filter change.

Level 2 kit contains one cleanable element, paper filters & filter seals required for two filter changes.

293.xx Filter & Seal Kits

Model/Type	Description	Part Number
293.1X	Seal Kit, 1-station	052-816-601
	Seal Kit, 2-station	052-816-602
	Seal Kit, 3-station	052-816-603
	Seal Kit, 4-station	052-816-604
	Filter Kit, Main Element, 3-Micron	052-957-601
	Filter Kit, Main Element, 10-Micron	052-957-501
	Filter Kit, Pilot Pressure	052-957-701
293.22	Bowl O-ring	010-010-947
	Seal Kit, 1-station	052-816-701
	Seal Kit, 2-station	052-816-801
	Seal Kit, 3-station	052-816-802
	Seal Kit, 4-station	052-816-803
	Filter Kit, Main Element, cleanable	052-957-801
	Filter Kit, Pilot Pressure	052-957-701
293.32	Seal Kit	052-816-901
	Filter Kit, Main Element, cleanable	052-957-901
	Filter Kit, Pilot Pressure	052-957-701

Note: All Series 293 Elements are disposable, except part numbers 052-957-801 & 052-957-901.

MTS Maintenance Parts

Hydraulic Service Manifold Parts

294.xx Filter & Seal Kits

Model/Type	Description	Part Number
294.11	Filter Element-Main Pressure	010-088-302
	Filter Kit – Level 1	038-803-001
	Filter Kit – Level 2	038-803-801
	Seal Kit	038-806-401
294.12	Filter Element-Main Pressure	010-088-302
	Filter Kit – Level 1	038-803-001
	Filter Kit – Level 2	038-803-801
	Seal Kit	038-806-501

Level 1 kit contains the paper filters and filter seals required to perform one complete filter change.

Level 2 kit contains one cleanable element, paper filters, & filter seals required for two filter changes.

295.1x & 295.2x Filter & Seal Kits

Model/Type	Description	Part Number	
295.1x	Spares Kit, HPF	Filter Kit, Main Elements, 10 Micron	058-577-301
HSM	Spares Kit, PPF	Filter Kit, Pilot Pressure Elements, 3-Micron	058-577-302
	Spares Kit, Seals, Accumulator	Seal Kit, Pressure Accumulator	058-577-303
	Spares Kit, Seals, Control	Seal Kit, Pressure Accumulator	058-577-304
	Spares Kit, Seals, Control, Multi	Seal Kit, Multi-Channel Control Manifold	058-577-305
	Spares Kit, Seals, Pilot, PLD/PLE	Seal Kit, Pilot Pressure Manifold PLD/PLE	058-577-306
	295.2x	Spares Kit, HPF	Filter Kit, Main Elements, 25-Micron
HSM	Spares Kit, PPF	Filter Kit, Pilot Pressure Elements, 3-Micron	058-407-202
	Spares Kit, Seals, ACC, MFLD	Seals Kit, Accumulators and Manifolds	058-407-203

298.xx Filter & Seal Kits

Model/Type	Description	Part Number
298.10/11/12	Filter Element-Main Pressure, 10-Micron	011-395-936
	Filter Kit, Level 1, 10-Micron	044-205-201
	Filter Kit, Level 1, 3-Micron	044-205-301
298.12	Seal Kit	047-651-201
298.10/11	Seal Kit	047-651-301

Model 298 Notes: Filter Assy is an option on Series 298 Manifolds. All Series 298 Elements are disposable.

Level 1 kit contains the paper filters and filter seals required to perform one complete filter change.

Level 2 kit contains one cleanable element, paper filters & filter seals required for two filter changes.

Marotta Valve Replacement Kit

Model/Type	Part Number
24 Volt	047-792-401
110 Volt	047-792-402

Whenever possible, we recommend the purchase of replacement kits instead of the original Marotta valves.

Replacement kits provide all the components required to replace the existing Marotta valves.

Replacement kits are less expensive to purchase, less expensive to maintain, and readily available from MTS.

Installation is not included in this price. Not intended for gas use.

MTS Maintenance Parts

Filter Elements and Flushing & Shut-Off Valves

Hydraulic Fluid Filter Elements by P/N

Material Description	Part Number
Filter Element – 10 Micron*	008-725-501
Filter Element – Cotton, 10 in 5 Micron, Tin P	010-052-802
Filter Element – 10 Micron, for 506 Pumps	010-053-305
Filter Element – 10 Micron	010-053-308
Filter Element – 3 Micron 8 in Length	010-053-349
Filter Element – 4 in Large B15=75,3000 psid, 10 gp	010-088-302
Filter Element – 4 in Large B3=75,150 psid, 12 gp	010-088-309
Filter Element – 8 in Large B3=75,150 psid, 40 gp	010-088-323
Filter Element – HC 9600 FKP 4H	010-088-328
Filter Element – Dispos, 4 in B6=75,150 psid	010-088-334
Filter Element – 8 in Large B6=75,150 psid, 20 gp	010-088-354
Filter Element – Paper 40 Micron	011-068-403
Filter Element – Strainer 100 Mesh, 50 gpm*	011-068-406
Filter Element – 40 Micron	011-068-412
Filter Element – Strainer 60 Mesh, 10 gpm	011-068-416
Filter Element – Strainer 200 Mesh, 20 gpm*	011-068-417
Filter Element – Strainer 60 Mesh, 5 gpm*	011-068-418
Filter Element – 6 in Large 74 Micron, 10 gpm*	011-129-901
Filter Element – 8 in Large 74 Micron, 2000 psid*	011-130-205
Filter Element – 4 in Large 74 Micron, 2000 psid*	011-130-208
Filter Element – 19 in Large 25 Micron, 2000 psid	011-130-224
Filter Element – Strainer 60 Mesh, 100 gpm	011-178-619
Filter Element – B10=75,3000 psid, 30 gpm	011-395-936
Filter Element – B3=75,3000 psid, 30 gpm	011-395-937
Filter Element – 39 in Large B3=75,150 psid, 175	011-402-817
Filter Element – 16 in Large B3=75,150 psid, 150	011-402-819
Filter Element – 13 in Large B3=75,150 psid,	011-402-827
Filter Element – 5 in Spin On B3=75, Microgl	011-951-521
Filter Element – 5 in Spin On B11=75, Cellulo	011-951-522
Filter Element – 18 in Large B3=200, 150 psid	011-951-524
Filter Element – Criterion C64 IOP	100-248-238
Filter Element – 8 in Large B3=200, 150 psid	011-951-528

Controller Chassis Air Filter Elements by P/N

Material Description	Part Number
Guard & Filter – TestStar IIs – Model 493.01	010-087-541
Filter – FlexTest SE & FlexTest 40 – Models 493.02 & 494.04	100-057-809
Filter – FlexTest GT & TestStar IIm & FlexTest 100 – Models 493.10 [10-Slot] & 494.10	100-020-714
Filter – FlexTest GT & Aero ST – Model 493.20 [20-Slot]	100-169-943
Filter – FlexTest 60 – Model 494.06 [6-Slot]	100-168-328
Filter – FlexTest 200 – Model 494.20 [20-Slot]	100-169-890

*Cleanable element.

Estimated weights: No more than 2 kg on elements; no more than 5 kg on kits.

System Flushing Valves

Model	For Servovalve	Part Number
291.01B-01	252.2x Series	031-622-001
291.02B-01	252.3x Series	032-484-401
291.08B-01	256.0x Series	033-874-001

Port-Shut-off-Valves

Model	For Servovalve	Part Number
254.02A-01	252.2x Series	031-101-001
291.01B-01	Seal kit	049-160-701
254.02B-01	252.3x Series	006-540-801

Estimated weight of each is no more than 2 kg.

MTS Maintenance Parts

SWIFT Parts

SWIFT 20 Ultra Parts

Description	Qty needed	Part Number
Storage Case	1	100-025-776
Beam Hole Plug Assembly 20T	4	100-026-667
Beam Hole Plug Assembly 20A	4	100-019-585
Outer Label SWIFT 20T	1	100-027-373
Outer Label SWIFT 20A	1	100-019-296
Leveling Assembly – with inclinometer*	1	100-014-450
Slip Ring Assembly (with bracket and slip ring encoder)	1	100-019-727
Slip Ring Assembly (with bracket and ratcheting slip ring encoder)	1	100-052-351
Slip Ring Assembly (with bracket and slip ring encoder)	1	100-062-128

SWIFT 30 PC Parts

Description	Qty needed	Part Number
Storage Case	1	054-924-501
Flexure Covers	8	054-405-901
O-Ring Type Beam Hole Cover like SWIFT LT Assembly	4	Contact MTS
Slip Ring Bracket Assembly – with slip ring/encoder	1	100-052-353
Inner Label	1	054-286-401
Outer Label	1	054-286-201
Leveling Assembly – with inclinometer*	1	100-010-124

SWIFT 40 LT Parts

Model	QTY Needed	Part Number
Storage Case	1	055-975-401
Flexure Covers	8	054-947-301
Beam Hole Cover Assembly	4	Contact MTS
Slip Ring Bracket Assembly – with slip ring/encoder	1	100-027-993
Inner Label	1	055-235-701
Outer Label	1	055-235-801
Leveling Assembly – with inclinometer*	1	100-010-509

SWIFT 45 MT Parts

Model	QTY Needed	Part Number
Storage Case	1	100-211-561
Beam Hole Covers	16	100-203-509
Slip Ring Bracket	1	100-205-155
Slip Ring/Encoder	1	100-172-139
Outer Label	1	100-205-328
Level Bracket Ref 700-004-754	1	100-211-570
Level Bracket	1	100-211-585
Extension Assembly	1	100-219-464

MTS Maintenance Parts

SWIFT Parts

SWIFT 50 GLP Parts

Description	Qty needed	Part Number
Storage Case	1	100-162-342
Beam Hole Plug	8	100-155-050
Modified Set Screws needed for Beam Hole Plug	8	100-157-769
Spinning Output Cable with D-style Connector-25ft	1	056-997-604
SWIFT 50GLP has special low profile feedback cables	1	056-997-604
Outer Label	1	100-147-491
Leveling Assembly - with inclinometer	1	100-148-483
Encoder/Slip Ring with D-style Connector	1	100-143-325
Flat Spider Bracket	1	100-163-204
Dished-in-Spider Bracket	1	100-154-409
Anti-Rotate Hinge/Tube Assembly	1	100-149-775
Non-Spinning Connector Adapter for Slip Ring Replacement (also requires special cable 056-493-704)	1	100-166-648
Shunt Cable with D-style Connector-25ft	2	056-997-504
Modified Lug Nut-M22	10	056-984-401
Lug Nut Shim Washer	10	057-090-201

Shared Parts between ULTRA(20), PC(30) & SWIFT LT(40), & SWIFT 50GLP SWIFT 30 PC Parts

Description	Qty needed	Part Number
‡Small Oval Connector Cover on top of slip ring brkt. assy.	2/spider assembly	053-323-701
‡Encoder/Slip Ring – connector closer to spinning tire - non ratcheting**	1	055-554-001
‡Encoder/Slip Ring – ratcheting connector**	1	100-043-522
‡Shunt Cal Cover Assembly	2/spider assembly	Contact MTS
‡Bottom Extruded Aluminum Cover for Slip Ring assembly	1/spider assembly	053-324-001
‡Anti-Rotate Hinge/Tube Assembly	1	055-862-401
‡Anti-Rotate Steel Sleeve*	1	054-405-201
‡Anti-Rotate Modified Delrin Ball*	1	054-405-301
‡Spinning Output Cable – non ratcheting - 25 ft***	1	054-145-004
‡Spinning Output Cable – non ratcheting – Low Profile – 25 ft***	1	056-493-604
‡Spinning Output Cable – ratcheting - 25 ft***	1	056-221-904
‡Spinning Output Cable – ratcheting – Low Profile 25 ft***	1	056-753-804
‡Non-Spinning Ratcheting Output Cable – 50 ft***	1	054-145-106
‡Non-Spinning Ratcheting Output Cable – Low Profile – 50 ft***	1	056-493-709
Comm Cable to PC	1	051-074-101
Power to TI Box	1	054-870-906
Power to TI Box – Low Profile	1	056-494-606
Fast Blow Fuse*	1	010-052-509
‡Shunt Cal Cables – non ratcheting – 25 ft	1	054-871-004
Shunt Cal Cables – non ratcheting – Low Profile – 25 ft	1	056-493-504
‡Shunt Cal Cable – non-spinning ratcheting for use with connector housing, 50 ft	1	054-871-105
Non-Spinning Connector Adaptor for slip ring replacement	1	100-192-580
AC/DC Lab Power Supply (for up to 4 SWIFTS):	1	054-864-903
‡Lug Nut Washer for M14 or 9/16 studs	depends on vehicle	055-879-401
‡Lug Nut Washer for M12x1.5 or 1/2-20 studs	depends on vehicle	055-522-801
‡Lug Nut - M12x1.5, 1/2-20, M14x2.0 or 9/16-18 thread	depends on vehicle	545-521-1xx

Mini TI Section

Description	Qty needed	Part Number
Mini TI	1	100-182-635
Cable SWIFT 10 or 45	1	052-702-9xx
Mini Cable Adapter to SWIFT 20, 30, 40, and 50	1	100-224-052

*] Recommended spare part.

**] Typically only one of the three encoders/Slip rings are required.

***] Typically only one of the output cables are required per transducer.

‡] Recommended spare part for the Ultra(20), PC(30), & SWIFT LT(40) only. Not for use with the SWIFT50 GLP.

MTS Maintenance Parts

FlatTrac & Rolling Road Systems Parts

Flat Trac System Endless Belts

Description	Part Number
Belt-Endless, Painted, FT LTR	100-047-038
Belt-Endless, Painted, FT 1	100-064-608

Note 1: Always verify correct belt part number to specific system application.

Rolling Road System Endless Belts - Uncoated

Description	Part Number
Belt-Endless, 0.9M x 7.8M RRS	100-247-104
Belt-Endless, 1M x 5.3M RRS	Contact MTS
Belt-Endless, 1M x 10.0M RRS	Contact MTS
Belt-Endless, 1M x 7.3M RRS	Contact MTS
Belt-Endless, 1.1M x 10.0M RRS	Contact MTS
Belt-Endless, 1.1M x 5.7M x 590M RRS	100-237-053
Belt-Endless, 1.1M x 7.8M RRS	100-247-105
Belt-Endless, 2M x 3.96M RRS	Contact MTS
Belt-Endless, 2M x 7.0M RRS	Contact MTS
Belt-Endless, 2.4M x 6.695M RRS	057-374-401
Belt-Endless, 2.4M x 7.0M RRS	057-374-402
Belt-Endless, 2.4M x 8.0M RRS	057-374-403
Belt-Endless, 2.4M x 5.74M RRS	Contact MTS
Belt-Endless, 2.4M x 6.695M RRS	Contact MTS
Belt-Endless, 3.2M x 9.0M RRS	100-048-656
Belt-Endless, 3.2M HS x 9.0M RRS	Contact MTS
Belt-Endless, 6.0M x 7.3M RRS	100-223-993
Belt-Endless, 3.2M HS x 9.5M RRS	100-400-676

Note 1: Always verify correct belt part number to specific system application.

Note 2: Contact MTS for special belt coating requests.

Rolling Road System Air Bearings - Standard

Description	Part Number
AirBearing 3.0 LG Strip	100-031-076
AirBearing 6.0 LG Strip	100-014-067
AirBearing 9.0 LG Strip	100-014-068
AirBearing 12.0 LG Strip	100-014-069

Note 1: For custom system air bearings contact MTS for pricing and availability.

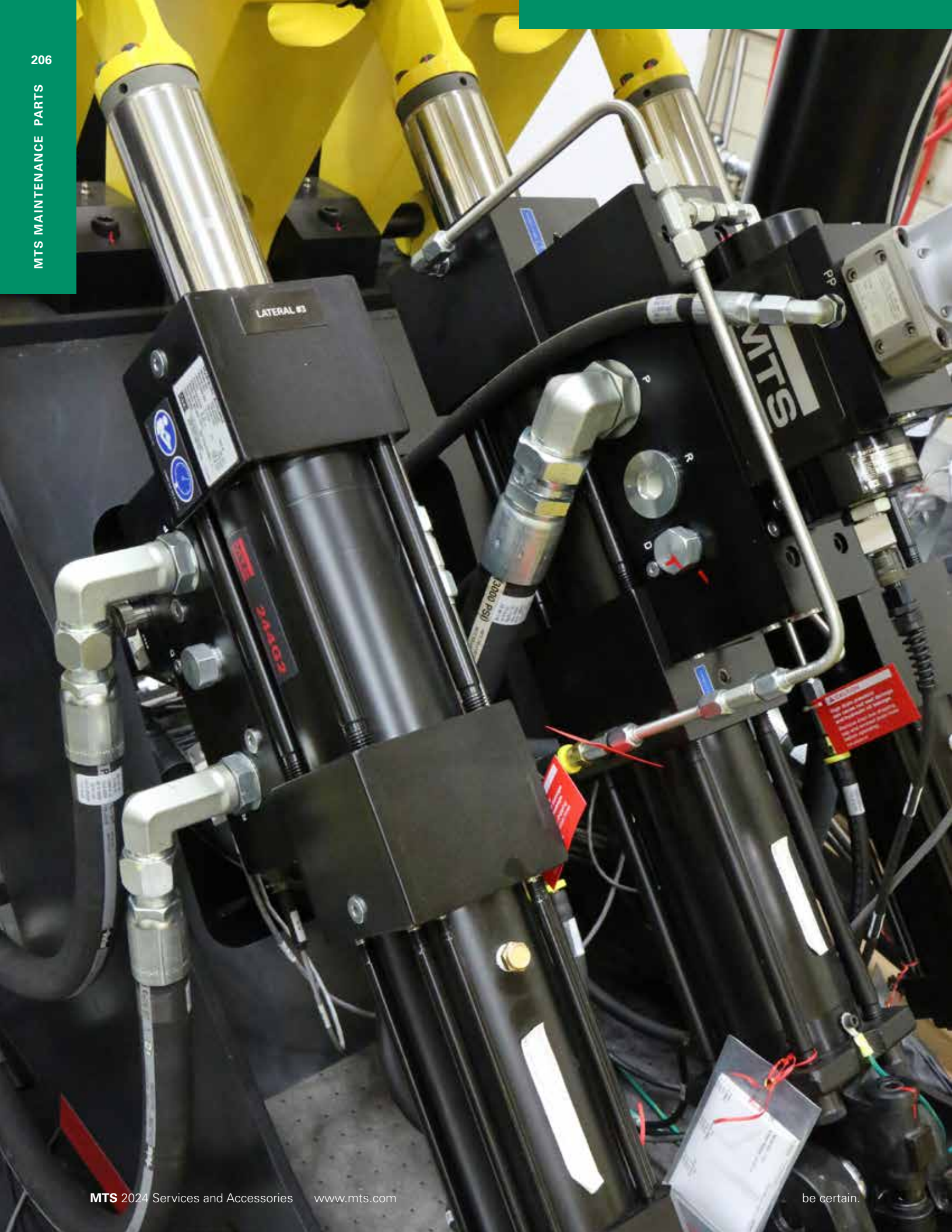

MTS Maintenance Parts

Series 329 Road Simulator Parts and Durability Systems

Overview

Series 329 Road Simulator maintenance parts kits are designed for several levels of service, from routine maintenance to repair. Replace just some of the pieces or the entire component. All kits are manufactured using the latest design features and highest quality parts for maximum performance. Most of these kits are normally stocked. Contact MTS for availability.

Component Kit

A component kit enables you to replace the wear parts of a fixture, commonly known as bushing/bearing kits. These are bushings and bearings that keep the fixture operating smoothly. When used as part of a routine maintenance program, these kits help to prolong the repeatability and life of your test rig.

Component Assembly Kit

A component assembly is designed to completely replace a given component in your test rig. This gives you a fast and convenient way to perform routine maintenance and repairs. Each component assembly comes with the appropriate bushings and bearings already installed (for attachment pins and shafts, see connecting kit). Replacing a component is simple: remove the old component and put the new one in its place.

Connecting Kit

The connecting kit is designed to replace the pieces that connect two adjacent components, commonly referred to as pin kits. These kits consist of pins, shafts, and grease fittings. These parts are not included in a component assembly or kit because they are not always needed for a repair.

Material Handling Trays

The wear parts shown in the trays below are included in the Series 329 rebuild kit. These original OEM replacement parts are used to rebuild the 11 unique structural fixture assemblies used within one MTS Series 329 4DOF corner.

Factory Maintenance

Not every Series 329 Road Simulator component is listed on the following pages. There are some components that can be serviced with the use of custom-made tools and special processes available only at an MTS facility. Please contact your MTS service specialist for parts needs not found in this catalog.

Series 329 Rebuild Program

It's almost like getting a brand new system. The Series 329 rebuild program was developed to make it efficient and economical to accomplish extensive routine maintenance during a single maintenance period. The Series 329 rebuild program will disassemble your corners at our factory and rebuild them to like-new condition. This program can be tailored to meet the maintenance requirements of your system. Please contact us for an evaluation and a discussion of these options.

MTS offers a planned approach for fast cycle times in completing complex 329 Rig overhauls either onsite or in the factory with our efficient 329 rebuild program. The two trays shown below contain all pin, bushings, bearings, and shims to completely rebuild all moving parts on one corner of 329 LT or PC. The trays are shipped stacked together in a box. The kits are compact and easily stored at the customer's site for future use if desired.



Small parts trays

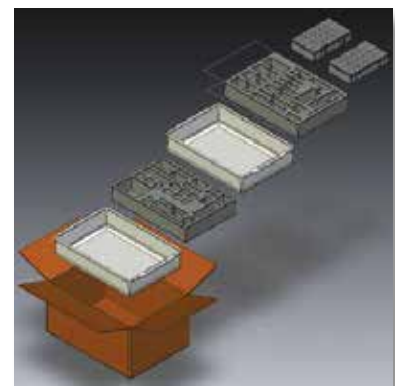

Series 329 rebuild kits help organize the many small parts needed for a successful rebuild.

MTS Maintenance Parts

329 System Parts

329 6DOF Hardware Kits for Level 2 Rebuild

Pre 2007 329 PC 6DOF REF 562040-XX

Description	Part Number
Hardware Kits-Need to be created	

Pre 2007 329 LT 6DOF REF 562045-XX

2007-09 329 PC/LT REF 571210-XX

Description	Part Number
Spindle Service ASSY 329-6D (HDWR)	056-736-651
VERT STRUT SVC ASSY-329 6DOF TUBE (HDWR)	057-460-351
SERVICE ASSY-VERT HDWR KIT, 329-6DOF LT	056-736-452
INPUT ASSY-LONG (HDWR), 329LT-6DOF SVC	056-736-751
SERVICE ASSY,329-6D PC/LT,LAT/STR (HDWR)	056-736-851

2010-Current 329 PC/LT REF 575000-XX

Description	Part Number
SPINDLE SVC ASSY 329-6D (HDWR)	056-736-651
VERT STRUT SVC ASSY-329 6DOF TUBE (HDWR)	057-460-351
SERVICE ASSY-VERT HDWR KIT, 329-6DOF LT	056-736-452
INPUT ASSY-LONG (HDWR), 329LT-6DOF SVC	056-736-751
SERVICE ASSY-LAT/STR (HDWR)329-6D PC/LT	057-460-551

MTS Maintenance Parts

Model 329 4 DOF Passenger Car Road Simulator Parts

329 Bearings

Description	Part Number
Rod End Bearing, 3/4-16, R.H. Thread, 0.750 Bore	042-798-601
Rod End Bearing, 3/4-16, L.H. Thread, 0.750 Bore	042-798-602
Rod End Bearing, 3/4-16, R.H. Thread, 0.625 Bore	042-795-401
Rod End Bearing, 1/2-20, R.H. Thread, 0.500 Bore	042-798-603

329 Load Cells

Description	Part Number
661.57x-xx Load Cell for 329 & 329LT Longitudinal (Includes attachment screws)	048-104-273
661.57x-xx Load Cell for 329 & 329LT Lateral (Includes attachment screws)	048-102-974
661.19x-xx Load Cell-Modified for 329 Brake Actuator	440396-XX

329 Actuator Seal Kits

Description	Part Number
Vertical Actuator Seal Kit for 244.20 Spcl (Static Support) This Seal Kit provides seals for both the Model 244.20 Actuator and the Static Support Option.	048-705-606
Vertical Actuator Seal Kit for 244.22 Spcl (Static Support) This Seal Kit provides seals for both the Model 244.22 Actuator and the Static Support Option.	047-785-401
Lateral Actuator Seal Kit for 244.12	008-710-047
Longitudinal Actuator Seal Kit for 244.21	008-710-048
Brake Actuator Seal Kit for 242.0x	042-065-404

Miscellaneous 329 Parts

Description	Part Number
Water Dummy, Torso ONLY	011-860-904
Water Dummy Assembly (w/valves)	045-962-001
Brake-Strut Shaft Service Kit	050-668-961
Brake-Strut Bushing/Bearing Service Kit	050-668-981
Seat Mounted Steer Robot (cables & amplifier enclosure not included)	100-107-417
Dynamic Brake Intensifier (brake fluid not included, EPR seals compatible with most brake fluids)	045-233-306
Replacement Seal Kit for Dynamic Brake Intensifier	100-110-498
Dynamic Brake Intensifier Air Inlet Filter	100-130-988
HSM Pilot Pressure Filter	052-957-701
AEROSHELL14 GREASE (tube for grease gun)	011-010-225

MTS Maintenance Parts

Model 329 4 DOF Passenger Car Road Simulator Parts

329 Structural Parts

Description	Drawing Number	Clevit P/N	Lord P/N
Spindle Adapter (Component Assembly)	1	048-102-691	048-103-091
Spindle Adapter @ Vertical Strut Bearings and Bushings (Component Kit)		048-102-681	048-103-081
Spindle Adapter @ Vertical Strut Clamp and Shaft Kit (Connecting Kit)		048-102-662	048-103-062
Spindle Adapter @ Lateral Strut Clamp and Shaft Kit (Connecting Kit)		048-102-661	048-103-061
Vertical Strut Assembly (Component Assembly)	2	048-103-191	048-103-191
Vertical Strut-Bearings (Component Kit)		048-103-181	048-103-181
Vertical Strut-Pin Kit @ Center (Connecting Kit)		048-103-161	048-103-161
Vertical Strut-Special/For Limited Clearance Applications (Component Assembly)		044-038-101	044-038-101
Longitudinal Attach Beam Assembly (Component Assembly)	3	049-071-891	049-071-691
Longitudinal Attach –Bushings & Bearings (Component Kit)		049-071-881	049-071-681
Longitudinal Attach –Triangular Cast Adapters (Connecting Kit)		049-071-871	049-071-671
Longitudinal Attach – Pin Kit @ Center (Connecting Kit)		049-071-661	049-071-661
Delta Crank Assembly (Component Assembly)	4	048-102-891	048-103-391
Delta Crank @ Vertical Strut Bushing w/Bearing (Single Bushing Only)		048-102-882	048-103-382
Delta Crank @ Vertical Struts Bushing w/Bearing (Component Kit)		048-102-881	048-103-381
Delta Crank @ Vertical Bellcrank/Bearings (Component Kit)		048-102-871	048-103-371
Delta Crank @ Vertical Bellcrank/Pin Kit (Connecting Kit)		048-102-862	048-103-362
Delta Crank @ Vertical Strut/ Pin Kit (Single Pin Only)		048-102-861	048-103-361
Brake Lever (Component Assembly)	5	048-103-491	048-103-491
Brake Lever/Bearings (Component Kit)		048-103-481	048-103-481
Brake Lever/Pin Kit @ Vertical Bellcrank (Connecting Kit)		048-103-461	048-103-461
Brake Input Strut Assembly (Component Assembly)	6	048-103-591	048-103-591
Brake Input Strut/Rod End Bearing/ 3/4"-16 R.H.		042-798-601	042-798-601
Brake Input Strut/Rod End Bearing/ 3/4"-16 L.H.		042-798-602	042-798-602
Vertical Bellcrank Assembly (Component Assembly)	7	048-103-691	048-103-691
Vertical Bellcrank & Flexure Bearings (Component Kit)		048-103-681	048-103-681
Vertical Flexure Housing (Component Assembly)		048-103-671	048-103-671
Vertical Flexure Housing/Pin Kit (Connecting Kit)		048-103-662	048-103-662
Vertical Bellcrank/Pin Kit @ Pivot (Connecting Kit)		048-103-661	048-103-661
Longitudinal Bellcrank (Component Assembly)	8	048-103-791	048-103-791
Longitudinal Strut (Component Assembly)	9	048-104-291	048-103-891
Longitudinal Strut Bearings & Bushings (Component Kit)		048-104-282	048-103-882
Longitudinal Strut Bearings (Component Kit)		048-104-281	048-103-881
Longitudinal Strut Load Cells (Connecting Kit)		048-104-273	048-103-873
Longitudinal Strut Standard Housing Assy (Component Assembly)		048-104-272	048-103-872
Longitudinal Strut Swivel Housing Assy (Component Assembly)		048-104-271	048-103-871
Longitudinal Strut/Pin Kit @ Bellcrank (Connecting Kit)		048-104-261	048-103-861

MTS Maintenance Parts

Model 329 4 DOF Passenger Car Road Simulator Parts

329 Structural Parts (continued)

Description	Drawing Number	Clevit P/N	Lord P/N
Lateral Strut (Component Assembly)	10	048-102-991	048-103-991
Lateral Strut Wrist Joint (Component Kit)		048-102-982	
Lateral Strut Bearings & Bushings (Component Kit)		048-102-981	048-103-981
Lateral Strut Bearing Housing Assy @ Spindle (Component Assembly)		048-102-975	048-103-975
Lateral Strut Load Cell (Connecting Kit)		048-102-974	048-103-974
Lateral Strut Bearings/Bushings/Wrist (Component Kit)		048-102-973	048-103-973
Lateral Strut Bushing Housing Assy @ Bellcrank (Component Assembly)		048-102-972	048-103-972
Lateral Strut Tube & Tie Rod (Connecting Kit)		048-102-971	048-103-971
Lateral Strut Pin Kit @ Spindle (Connecting Kit)		048-102-962	048-103-962
Lateral Strut Pin Kit @ Bellcrank (Connecting Kit)		048-102-961	048-103-961
Lateral Bellcrank (Component Assembly)	11	048-104-091	048-104-091

(329 4 DOF PC drawing on next page)

Component Assembly:

- Is usually the -x91 part numbers
- Involves a preassembly of parts for fast “plug & play” and to reduce customer downtime.

Connecting Kit

- Usually involves a smaller group of parts than a Component Assembly, which may or may not be preassembled.
- Focus of a connecting kit is on repair or replacement of a failed part.
- Customer uptime on a system is usually not as critical; involves system teardown to a single component level.

Component Kit

- Involves replacement of parts with a predetermined life span. Components of this nature are all bearings, bushings, and so forth.

MTS Maintenance Parts

Model 329 4 DOF Passenger Car Road Simulator Parts

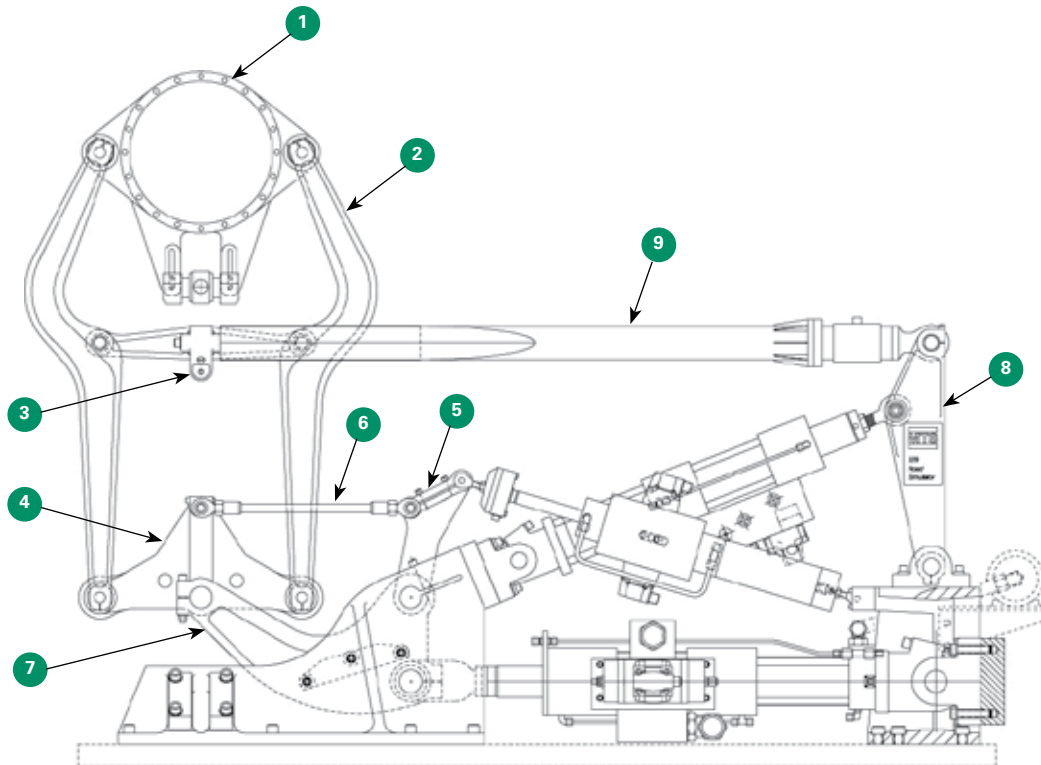

To determine which part number is correct for your Series 329 Road Simulator, you must determine if you need assemblies with Lord bushings or Clevite bushings. MTS keeps detailed records of your system to help determine which bushings you have. Make sure you discuss which bushing is correct for your system when placing your order.

Guidelines for choosing the correct bushing:

- » If you are replacing just one assembly, you should replace it with the same type of bushing that was in the original assembly.
- » If you are replacing multiple assemblies as part of a major overhaul of your system, you should consider assemblies with Clevite bushings.
- » If you decide to replace your existing Lord bushing assembly or assemblies with an assembly with Clevite bushings, you may need to adjust (reiterate) your drive files to compensate for the slightly different performance characteristics of the Clevite bushings.

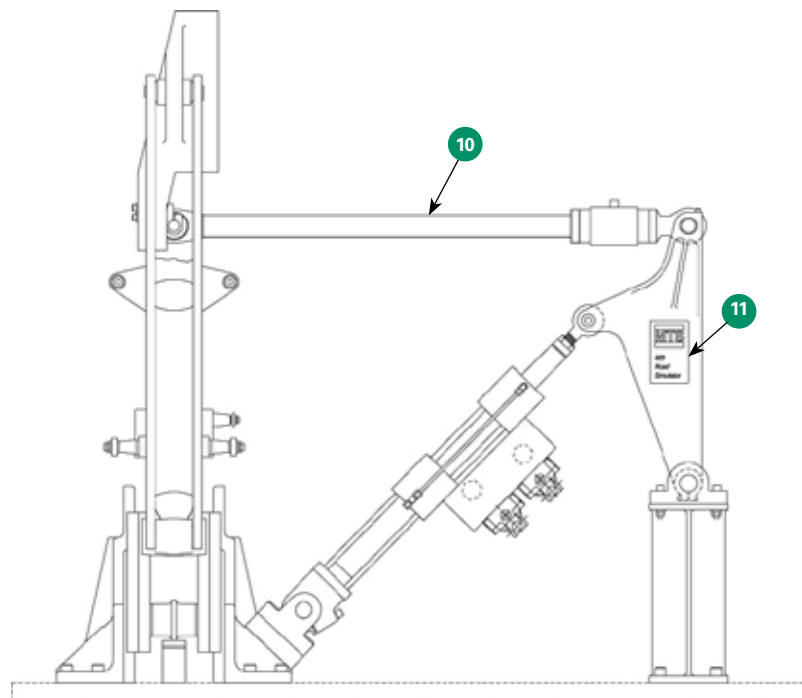

Note: Some maintenance and part replacement requires special tools to complete. MTS field service can also complete these tasks on site with the appropriate tools and expertise.

MTS Maintenance Parts

Model 329 6 DOF Road Simulator Actuator Parts

329 6 DOF Road Simulator Actuator Parts

**To determine the correct service parts locate the actuator part number on cylinder assembly.
This applies to all 329 6 DOF Passenger Car and Light Truck. Contact MTS if your actuator is not shown here.
The last two digits indicate left or right version and will typically be a -01 or -02.*

Vertical Actuator Part Number	Description	Part Number
571599-XX	LVDT	039-075-103
	3 Stage Servo Valve	033-561-002
	2 Stage Servo Valve	056-006-201
	Seal Kit	008-710-050
564342-XX	LVDT	048-821-201
	3 Stage Servo Valve	033-561-002
	2 Stage Servo Valve	056-006-201
	Seal Kit	056-079-353
571599-XX	LVDT	039-075-103
	3 Stage Servo Valve	033-561-002
	2 Stage Servo Valve	056-006-201
	Seal Kit	008-710-050
561982-XX	LVDT	048-821-201
	3 Stage Servo Valve	033-561-002
	2 Stage Servo Valve	056-006-201
	Seal Kit	048-978-504
569889-XX	LVDT	048-821-201
	3 Stage Servo Valve	033-561-002
	2 Stage Servo Valve	056-006-201
	Seal Kit	056-079-348

Longitudinal Actuator Part Numbers	Description	Part Number
564247-XX	LVDT	039-075-111
	2 Stage Servo Valve	056-006-501
	Seal Kit	008-710-048
560805-XX	LVDT	039-075-111
	3 Stage Servo Valve	033-366-501
	2 Stage Servo Valve	056-006-101
	Seal Kit	008-710-075

Lateral Actuator Part Numbers	Description	Part Number
100-063-299	LVDT	039-075-111
	2 Stage Servo Valve	056-006-501
	Seal Kit	056-079-305
100-064-331	LVDT	039-075-111
	3 Stage Servo Valve	033-366-508
	2 Stage Servo Valve	056-348-201
	Seal Kit	008-710-048

Steer Actuator Part Numbers	Description	Part Number
564234-XX	LVDT	039-075-104
	2 Stage Servo Valve	056-006-501
	Seal Kit	008-710-046
564248-XX	LVDT	039-075-104
	2 Stage Servo Valve	056-006-501
	Seal Kit	008-710-047

Brake Actuator Part Numbers	Description	Part Number
564235-XX	LVDT	039-075-104
	2 Stage Servo Valve	056-006-501
	Seal Kit	056-079-304
564324-XX	LVDT	039-075-104
	2 Stage Servo Valve	056-006-501
	Seal Kit	048-705-609

MTS Maintenance Parts

Model 329 6 DOF Passenger Car Road Simulator Parts

329 6 DOF Passenger Car Road Simulator Parts

*The following part numbers apply to 329 6DOF Passenger Car Road Simulators purchased pre December 1, 2006.

See 329 6DOF Light Truck section for purchases after this date.

Spindle Housing Assembly*	Drawing Number (P184)	Description	Part Number
329-6DOF SVC Assembly Spindle (HSG/BRG)	1	Spindle Housing, Shafts & Bearings	056-736-692

Vertical Strut Assembly*	2	Description	Part Number
Vertical Strut SVC Assembly-329-6D (Strut)		Vertical Struts, Bearings, and Bushings	056-737-092
Vertical Strut SVC Assembly-329-6D (BRG)		Vertical Strut Assembly Bearings	056-737-082
Vertical Strut SVC Assembly-329-6D (BSHG)		Vertical Strut Assembly Bushings	056-737-084
Vertical Strut SVC Assembly-329-6D (PIN)		Vertical Strut Assembly Pin Kit	056-737-072
Spherical Ball & Pin Upgrade Assembly		Updates ball and pin to include a grease zerk for lubrication of the ball joint	056-736-972

Vertical Input Assembly*	3	Description	Part Number
329-6 DOF SVC Assembly (J Crank Component Kit)		J-Cranks only	056-736-492
329-6 DOF SVC Assembly (J Crank SVC Assembly)		J-Crank Replacement Set; (one corner) no pins	056-736-491
329-6 DOF SVC Assembly (J Crank Bearing)		J-Crank Bearings and Wear Components	056-736-481
329-6 DOF SVC Assembly (Pin Kit) x		Vertical Input Assembly Pin Kit	056-736-471
329-6 DOF SVC Assembly (Flexure)		Vertical Input Flexure and Bearings/Wear Components	056-736-392
329-6 DOF SVC Assembly (Flexure Bearing)		Vertical Input Flexure Bearings	056-736-381
329-6 DOF SVC Assembly (Delta Crank)		Delta Crank and Bearings/Wear Components	056-736-291
329-6 DOF SVC Assembly (Delta Crank Bearing)		Delta Crank Bearings	056-736-281
329-6 DOF SVC Assembly (Brake)		Brake Bellcrank and Bearings/Wear Components	056-736-191
329-6 DOF SVC Assembly (Brake Bearing)		Brake Bearings	056-736-181
329-6 DOF SVC Assembly (Brake Bushing)		Brake Input Bushing	056-736-172
329-6 DOF SVC Assembly (Brake Lever)		Brake Input Links and Bearings/Wear Components	056-736-171

Longitudinal Input Assembly*	4	Description	Part Number
329-6 DOF SVC Assembly Longitudinal Input (Bellcrank and Bearing)		Longitudinal Bellcrank and Bearings/Wear Components	056-736-791
329-6 DOF SVC Assembly Longitudinal Input (Bearing)		Longitudinal Bearings and Wear Components	056-736-781
329-6 DOF SVC Assembly Longitudinal Input (Pin Kit)		Longitudinal Pin Kit	056-736-771

Lateral Input Assembly*	5	Description	Part Number
329-6 DOF SVC Assembly Lateral 1 (Bellcrank and Bearing)		Lateral 1 Bellcrank and Bearings/Wear Components	056-736-891
329-6 DOF SVC Assembly Lateral 2 (Bellcrank and Bearing)		Lateral 2 Bellcrank and Bearings/Wear Components	056-736-892
329-6 DOF SVC Assembly Lateral 3 (Bellcrank and Bearing)		Lateral 3 Bellcrank and Bearings/Wear Components	056-736-893
329-6 DOF SVC Assembly Lateral/Steer (Bearing)		Lateral 1, Lateral 2, Lateral 3 Bearings/Wear Components	056-736-881
329-6 DOF SVC Assembly Lateral/Steer (Pin Kit)		Lateral 1, Lateral 2, Lateral 3 Pin Kit	056-736-771

Longitudinal Strut Assembly*	6	Description	Part Number
Strut Assembly Longitudinal SVC Assembly (Strut)		Longitudinal Strut and End caps, Assembled	056-737-391
Strut Assembly Longitudinal SVC Assembly (Bushing)		Longitudinal Strut Bearings/Wear Components	056-737-381
Strut Assembly Longitudinal SVC Assembly (Clevis)		Longitudinal Strut Clevis and Bearings	056-737-382
Strut Assembly Longitudinal SVC Assembly (U-Joint)		Longitudinal U-Joint and Bearings	056-737-383

MTS Maintenance Parts

Model 329 6 DOF Passenger Car Road Simulator Parts

329 6 DOF Passenger Car Road Simulator Parts (continued)

Center Lateral Strut Assembly*	7	Description	Part Number
Strut Assembly Lateral LT SVC Assembly (Strut)		Lateral Strut and End Caps, Assembled	056-737-191
Strut Assembly Lateral LT SVC Assembly (Bearing)		Lateral Strut Rod-Eye and Bearings/Wear Components	056-737-181
Strut Assembly Lateral LT SVC Assembly (Bearing)		Upgrade for Lateral Input Spherical Bearing	100-178-317

Steer Strut Assembly*	8	Description	Part Number
Strut Assembly Steer SVC Assembly (Strut)		Steer Strut and End caps, Assembled	056-737-291
Strut Assembly Steer SVC Assembly (Bearing)		Steer Strut Bearings/Wear Components	056-737-281
Strut Assembly Steer SVC Assembly (HSG/Bushing)		Wrist Joint Assembly for all Horizontal Struts	056-735-761

Actuator Assemblies	Description	Part Number
Vertical		
LVDT Assembly-Closed Housing, Static Support, 7 in, 244.3	Vertical LVDT Assembly	044-965-901
Servo Valve-2.5 gpm 252.22G-01 4 Port	Two-Stage Vertical Servo Valve Assembly	056-006-201
244.3x Seal Kit 45 Kip, 1 in Cushion, STCSUPR	Vertical Actuator Seal Kit	008-710-085
Longitudinal		
LVDT Assembly Closed Housing	Longitudinal LVDT Assembly	036-738-931
Servo Valve Assembly-50 gpm 256.05A-01, 1 gpm PL	Three-Stage Longitudinal Servo Valve Assembly (includes two-stage)	Contact MTS
Servo Valve-252.xx	Two-Stage Longitudinal Servo Valve Assembly	056-006-501
Shipping Assembly-Seal Kit, 244.20, Structural	Longitudinal Actuator Seal Kit	008-710-048
Lateral		
LVDT Assembly Closed Housing	Lateral LVDT Assembly	036-738-931
Servo Valve Assembly-256.05A-005, 1/2 gpm PLT	Three-stage Lateral Servo Valve Assembly (includes two-stage)	Contact MTS
Servo Valve- 252.xx	Two-stage Lateral Servo Valve Assembly	056-006-501
Seal Kit 244.21, Structural	Lateral Actuator Seal Kit	056-079-305
Steer		
LVDT Assembly Closed Housing 244.11/12 8 in SP	Steer LVDT Assembly	036-738-821
Servo Valve-15 gpm 252.25G-01 4 Port	Steer Servo Valve Assembly	056-006-501
Seal Kit, 244.12 Structural	Steer Actuator Seal Kit	008-710-046
Brake		
LVDT Assembly Closed Housing 244.11/12 8 in SP	Brake LVDT Assembly	036-738-821
Servo Valve-15 gpm 252.25G-01 4 Port	Brake Servo Valve Assembly	056-006-501
Seal Kit, 244.10	Brake Actuator Seal Kit	056-079-304

HSM Filter Kit	Description	Part Number
Filter Element (Pilot Pressure)	8 in lg b3 = 200, 150 psid	100-216-412

Lubricant	Part Number
AEROSHELL14 GREASE (tube for grease gun)	011-010-225
KRYTOX GREASE (tube for grease gun)	100-123-981

Dynamic Brake Intensifier	Part Number
Dynamic Brake Intensifier Air Inlet Filter	100-130-988
Replacement Seal Kit for Dynamic Brake Intensifier	100-110-498

(329 6 DOF PC drawing on next page)

MTS Maintenance Parts

Model 329 6 DOF Passenger Car Road Simulator Parts

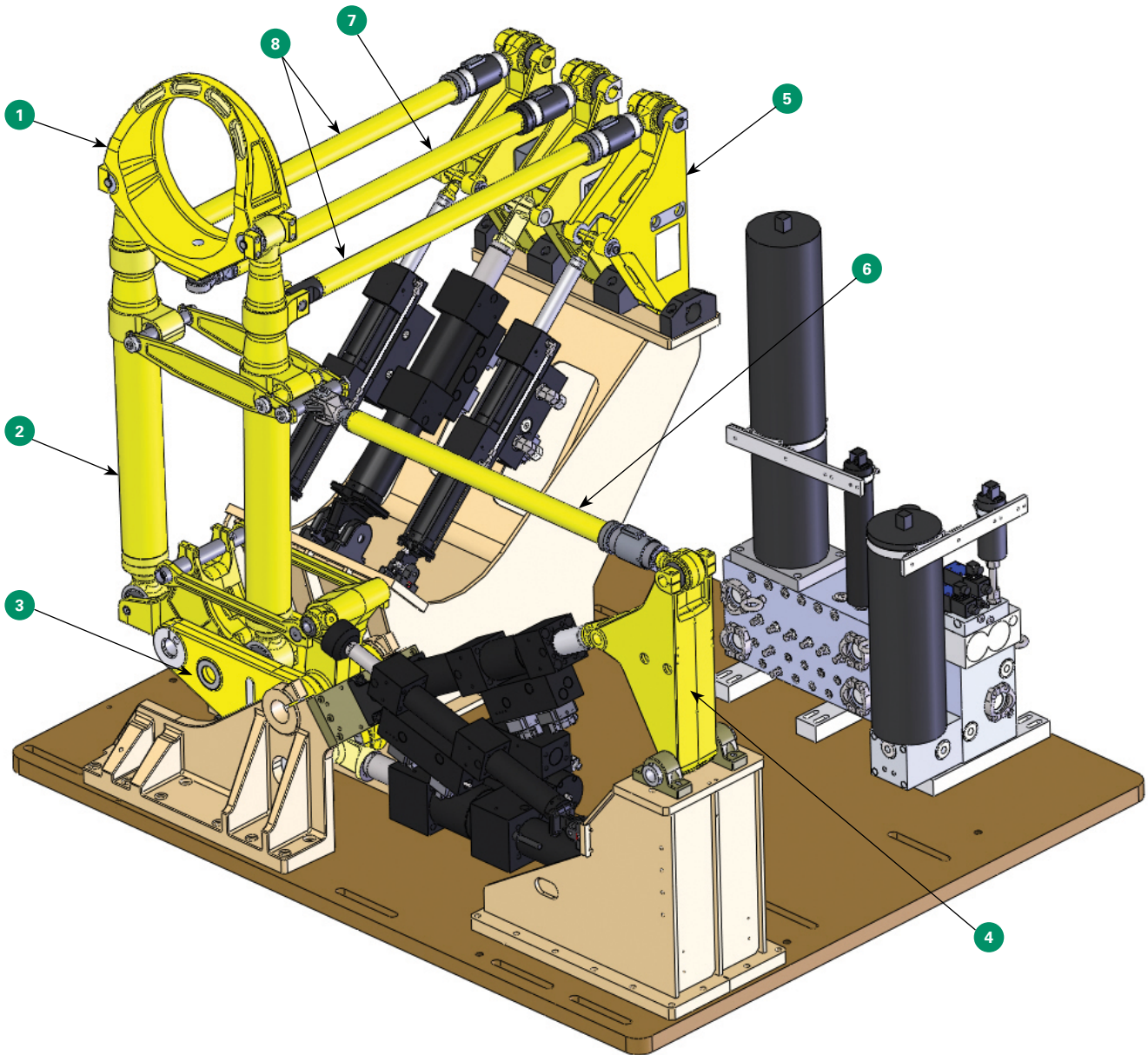

MTS Maintenance Parts

Model 329 4 DOF Light Truck Road Simulator Parts

329 4 DOF Light Truck Structural Parts

Description	Drawing Number (P186)	Quantity per corner	Part Number
LT Spindle Adapter (Component Assembly)	1	1	045-538-791
LT Tire Patch Input (Component Assembly)		1	044-453-391
LT Vertical Strut Assembly (Component Assembly)	2	2	047-419-791
LT Longitudinal Strut Assembly (Component Assembly)	3	1	045-844-491
LT Longitudinal Wrist Joint Component Assembly	4	1	045-516-791
LT Brake Strut (No-Brake option) Connecting Kit		1	044-452-391
LT Brake Housing (w/Brake option) Component Assembly	5	1	045-836-191
LT Brake Lever (Component Assembly)	6	1	044-451-591
LT Brake Lever (Component Kit)		1	044-451-581
LT Brake Link Component Assembly	7	2	044-452-491
LT Brake Link Component Kit		2	044-452-481
LT Delta Crank Component Assembly	8	1	045-324-491
LT Delta Crank Component Kit		1	045-324-481
LT Vertical J-Crank Component Assembly	9	1	045-538-891
LT Vertical J-Crank Component Kit		1	045-538-881
LT Flexure-Vert-45 Kip Connecting Kit	10	1	045-324-791
LT Flexure-Vert-45 Kip Component Kit		1	045-324-781
LT Flexure-Vert-35 Kip Connecting Kit		1	045-324-792
LT Flexure-Vert-35 Kip Component Kit		1	045-324-782
LT Flexure-Lat/Long Connecting Kit	11	2	045-324-991
LT Flexure-Lat/Long Component Kit		2	045-324-981
LT Bellcrank-Lat/Long Component Assembly	12	2	045-537-691
LT Bellcrank-Lat/Long Component Kit		2	045-537-681
LT Lateral Strut Component Assembly	13	1	045-844-291
LT Lateral Wrist Joint Service Assembly	14	1	045-516-691
LT Pillow Block Bearing-Lat/Long Connecting Kit	15	4	043-683-991

Miscellaneous	Part Number
AEROSHELL14 GREASE (tube for grease gun)	011-010-225
HSM Pilot Pressure Filter	100-216-412
Replacement Seal Kit for Dynamic Brake Intensifier	100-110-498
Dynamic Brake Intensifier Air Inlet Filter	100-130-988

(329 4 DOF LT drawing on next page)

Series 329 4 DOF LT Strut and Wrist Joint Repair

Most Series 329 4 DOF LT struts (drawing item 2,3,5 and 13) and wrist joints (drawing item 4 and 14) can be more economically repaired than buying whole new assemblies. Lead times vary.

Contact MTS for an evaluation and a quote.

MTS Maintenance Parts

Model 329 4 DOF Light Truck Road Simulator Parts

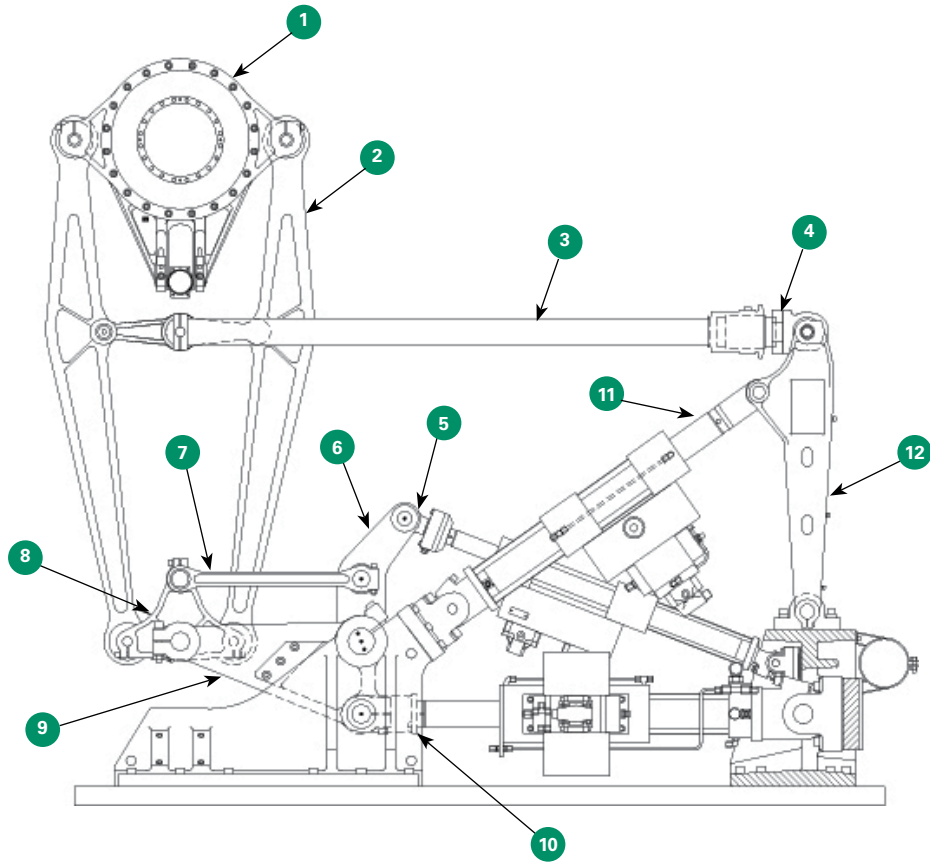

Note: It is recommended that any 329 4DOF LT bushing that is replaced to be done so at MTS. This can be part of a total system overhaul or with select components/housings being sent back for bushing replacement.

Note: The longitudinal strut (item 3) should only be disassembled if absolutely necessary. The tensioning rods surrounding each strut tube must always be replaced if taken apart. Also, it is likely that disassembly will disrupt the bond between the strut tubes and either housing end. This requires re-machining the housings, replacing the strut tubes and completing the bonding process. This must also be completed at MTS.

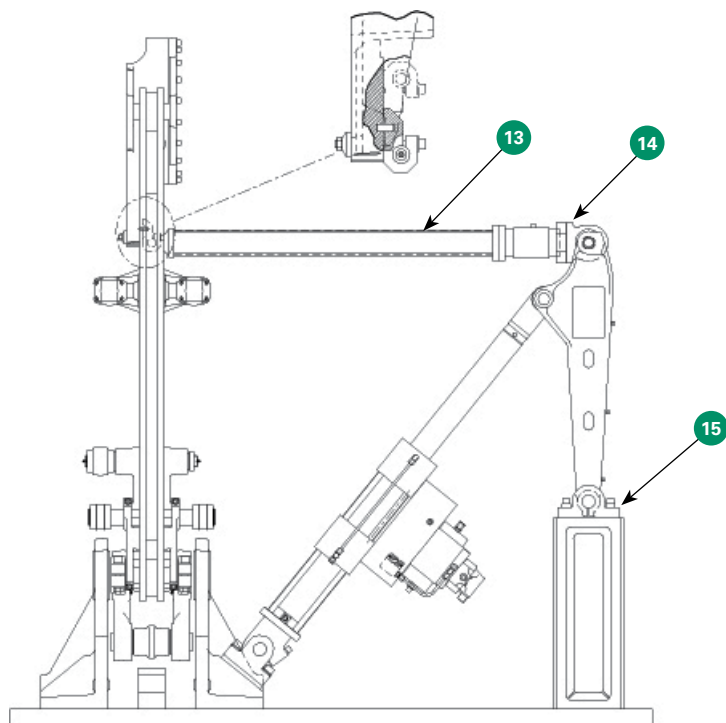

MTS Maintenance Parts

Model 329 6 DOF Light Truck Road Simulator Parts

329 6 DOF Light Truck Road Simulator Parts

The following part numbers apply to 329 6DOF Light Truck Road Simulators purchased pre September 1, 2009 and 329 6DOF Passenger Car Road Simulators (excluding) purchased between December 1, 2006 and September 1, 2009.*

Spindle Housing Assembly*	Drawing Number (P189)	Description	Part Number
329-6 DOF SVC Assembly Spindle (Housing/Bearing)	1	Spindle Housing, Shafts & Bearings	056-736-691

Vertical Strut Assembly*	2	Description	Part Number
Vertical Strut SVC Assembly-329-6D (Bearing)		Vertical Strut Assembly Bearings	057-460-382
Vertical Strut SVC Assembly-329-6D (Bushing)		Vertical Strut Assembly Bushings	057-460-384
Vertical Strut SVC Assembly-329-6D (RF/LR Strut)		Vertical Struts, Bearings, and Bushings	057-460-391
Vertical Strut SVC Assembly-329-6D (LF/RR Strut)		Vertical Struts, Bearings, and Bushings	057-460-392

Vertical Input Assembly*	3	Description	Part Number
329-6 DOF SVC Assembly (J Crank SVC Assembly)		J-Crank Replacement Set; (one corner) no pins	056-736-491
329-6 DOF SVC Assembly (J Crank Bearing)		J-Crank Bearings and Wear Components	056-736-481
329-6 DOF SVC Assembly (Pin Kit)		Vertical Input Assembly Pin Kit	056-736-471
329-6 DOF SVC Assembly (Flexure)**		Vertical Input Flexure and Bearings/Wear Components	056-736-391
329-6 DOF SVC Assembly (Flexure Bearing)		Vertical Input Flexure Bearings	056-736-381
329-6 DOF SVC Assembly (Delta Crank)		Delta Crank and Bearings/Wear Components	056-736-291
329-6 DOF SVC Assembly (Delta Crank Bearing)		Delta Crank Bearings	056-736-281
329-6 DOF SVC Assembly (Brake)		Brake Bellcrank and Bearings/Wear Components	056-736-191
329-6 DOF SVC Assembly (Brake)		Brake Bearings	056-736-181
329-6 DOF SVC Assembly (Brake Bushing)		Brake Input Bushing	056-736-172
329-6 DOF SVC Assembly (Brake Lever)		Brake Input Links and Bearings/Wear Components	056-736-171

Longitudinal Input Assembly*	4	Description	Part Number
329-6 DOF SVC Assembly Longitudinal Input (Bearing)		Longitudinal Bearings and Wear Components	056-736-781
329-6 DOF SVC Assembly Longitudinal Input (Pin Kit)		Longitudinal Pin Kit	056-736-771

Lateral Input Assembly*	5	Description	Part Number
329-6 DOF SVC Assembly Lateral 2 (Bellcrank and Bearing)		Lateral 2 Bellcrank and Bearings/Wear Components	056-736-892
329-6 DOF SVC Assembly Lateral 3 (Bellcrank and Bearing)		Lateral 3 Bellcrank and Bearings/Wear Components	056-736-893
329-6 DOF SVC Assembly Lateral/Steer (Bearing)		Lateral 1, Lateral 2, Lateral 3 Bearings/Wear Components	056-736-881
329-6 DOF SVC Assembly Lateral/Steer (Pin Kit)		Lateral 1, Lateral 2, Lateral 3 Pin Kit	056-736-871

Longitudinal Strut Assembly*	6	Description	Part Number
Strut Assembly Longitudinal SVC Assembly (U-Joint)		Longitudinal Joint Assembly with bearings/pins	100-219-013
Strut Assembly Longitudinal SVC Assembly (Pin)		Longitudinal Strut Pin Kit	056-735-772
Strut Assembly Longitudinal SVC Assembly (Bearing)			056-735-781
Strut Assembly Longitudinal SVC Assembly (Clevis)			056-735-783
Strut Assembly Longitudinal SVC Assembly (U-Joint)			056-735-783

MTS Maintenance Parts

Model 329 6 DOF Light Truck Road Simulator Parts

329 6 DOF Light Truck Road Simulator Parts (continued)

Center Lateral Strut Assembly*	7	Description	Part Number
Strut Assembly Lateral LT SVC Assembly (Strut)		Lateral Strut and End caps, Assembled	056-735-991
Strut Assembly Lateral LT SVC Assembly (Bearing)		Lateral Strut Rod-Eye and Bearings/Wear Components	056-735-981
Rod End Bearing Upgrade, 329 6DOF LT		Upgrade for Lateral Input Spherical Bearing	100-178-334

Steer Strut Assembly*	8	Description	Part Number
Strut Assembly Steer SVC Assembly (Bearing)		Steer Strut Bearings/Wear Components	056-737-281
Strut Assembly Steer SVC Assembly (Housing/Bushing)		Wrist Joint Assembly for all Horizontal Struts	056-735-761

Actuator Assemblies	Description	Part Number
LVDT Assembly-Closed Housing, Static Support, 7 in, 244.3	Vertical LVDT Assembly	045-362-001
Servo Valve Assembly-250 gpm 256.25A-02, 2.5 gpm	Three-Stage Vertical Servo Valve Assembly (includes two-stage)	033-561-002
Servo Valve-2.5 gpm 252.22G-01 4 Port	Two-Stage Vertical Servo Valve Assembly	056-006-201
244.3x Seal Kit 45 Kip, 1 in Cushion, Static Support	Vertical Actuator Seal Kit	048-978-504

Longitudinal**

LVDT Assembly Closed Housing	Longitudinal LVDT Assembly	036-738-931
Servo Valve Assembly-50 gpm 256.05A-01, 1 gpm PL	Three-stage Longitudinal Servo Valve Assembly (includes two-stage)	033-366-501
Servo Valve-252.xx	Two-stage Longitudinal Servo Valve Assembly	056-006-101
Shipping Assembly-Seal Kit, 244.20, Structural	Longitudinal Actuator Seal Kit	008-710-075

Lateral**

LVDT Assembly Closed Housing	Lateral LVDT Assembly	036-738-931
Servo Valve Assembly-256.05A-005, 1/2 gpm PLT	Three-Stage Lateral Servo Valve Assembly (includes two-stage)	033-366-508
Servo Valve- 252.xx	Two-stage Lateral Servo Valve Assembly	056-348-201
Seal Kit 244.21, Structural	Lateral Actuator Seal Kit	008-710-048

Steer**

LVDT Assembly-Closed Housing 244.11/12 8 in SP	Steer LVDT Assembly	036-738-821
Servo Valve-15 gpm 252.25G-01 4 Port	Brake Servo Valve Assembly	056-006-501
Seal Kit, 244.12 Structural	Steer Actuator Seal Kit	008-710-047

Brake**

LVDT Assembly-Closed Housing 244.11/12 8 in SP	Brake LVDT Assembly	036-738-821
Servo Valve-15 gpm 252.25G-01 4 Port	Brake Servo Valve Assembly	056-006-501
Seal Kit, 244.10	Brake Actuator Seal Kit	048-705-609

HSM Filter Kit	Description	Part Number
Filter Element (Pilot Pressure)	8 in lg b3 = 200, 150 psid	100-216-412

Lubricant	Part Number
AEROSHELL14 GREASE (tube for grease gun)	011-010-225
KRYTOX GREASE (tube for grease gun)	100-123-981

Dynamic Brake Intensifier	Part Number
Dynamic Brake Intensifier Air Inlet Filter	100-130-988
Replacement Seal Kit for Dynamic Intensifier	100-110-498

(329 6 DOF LT drawing on next page)

MTS Maintenance Parts

Model 329 6 DOF Light Truck Road Simulator Parts

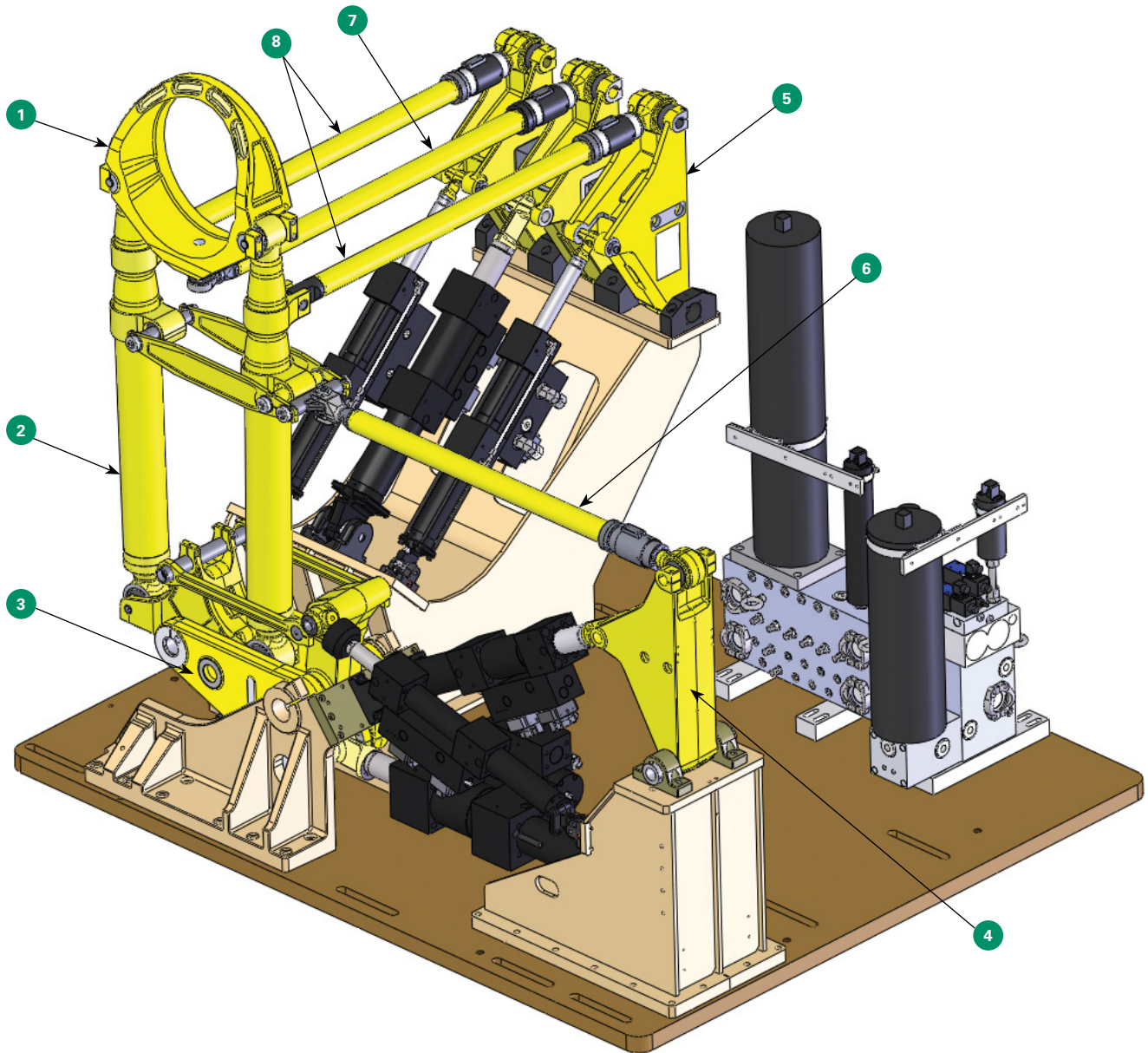

MTS Maintenance Parts

MAST Systems Parts

MAST

Model	Description	Part Number
323.10	Vert table swivels	051-107-001
323.10	Lat/long actuator rod swivel	050-043-101
323.10	Actuator base swivels	049-577-401
323.10	Strut swivel- table end	050-043-102
323.10	Strut swivel- bellcrank end	050-043-101
323.10	Pillow block bearings	048-894-802

Model	Description	Part Number
323.20	Vert table swivels	052-173-001
323.20	Lat/long actuator rod swivel	050-043-101
323.20	Actuator base swivels	049-577-401
323.20	Strut swivel- table end	051-107-002
323.20	Strut swivel- bellcrank end	050-043-101
323.20	Pillow block bearings	048-894-802

Model	Description	Part Number
323.30	Vert table swivels	051-107-001
323.30	Lat/long actuator rod swivel	050-043-101
323.30	Actuator base swivels	049-577-401
323.30	Strut swivel- table end	050-043-102
323.30	Strut swivel- bellcrank end	050-043-101
323.30	Pillow block bearings	048-894-802

Model	Description	Part Number
323.40	Vert table swivels	052-173-001
323.40	Lat/long actuator rod swivel	050-043-101
323.40	Actuator base swivels	049-577-401
323.40	Strut swivel- table end	051-107-002
323.40	Strut swivel- bellcrank end	050-043-101
323.40	Pillow block bearings	048-894-802

Model	Description	Part Number
353.10	Bearing Assy- U-Joint (STD)	100-137-817
353.10	Boot - Rolling, 3" Stroke, 353.10	100-220-297

Model	Description	Part Number
353.20	Swivel Assy-353.20-S	100-174-868
353.20	Boot - Convuluted, 8.25" Stroke, 353.20	100-291-907
353.20	Boot - Upper, Convuluted, 353.20	100-214-399
353.20	Upgrade Kit - Bellows, 353.20 Strut	100-301-438

MTS Maintenance Parts

320 Seal Kits

320.025 First Road and Small Car Systems

Description	Part Number
Actuator Seal Kit	040-262-601
Actuator Seal Kit for Environmental Systems	056-079-329
Servo valve	042-795-401

320.035 Large Car Systems

Description	Part Number
Actuator Seal Kit	040-262-601
Actuator Seal Kit for Environmental Systems	056-079-329
Servo valve	033-366-601

320.050 Light Truck Standard Performance Systems

Description	Part Number
Actuator Seal Kit	040-262-601
Actuator Seal Kit for Environmental Systems	056-079-329
Servo valve	033-366-601

320.050 Light Truck High Performance Systems

Description	Part Number
Actuator Seal Kit	040-262-601
Actuator Seal Kit for Environmental Systems	056-079-329
Servo valve	033-206-921

EXCHANGE PROGRAMS

The exchange programs provide a cost-effective turnaround option to extend the life of your test equipment. You'll receive a fully-warranted, remanufactured component to replace the worn component. A service contract and installation is required. The field service engineer will return the worn component to MTS as a core. This offer will be sold through a service contract.



Exchange Programs

Introduction	224
Just In Case™	225
Electronics	226-232
Onsite Exchange Programs	233-235
MTS Series 252 & 256 Servovalves	236
Remanufacturer Programs - Actuators	237

Exchange Programs

FlexTest Controllers/Insight Electromechanical Load Frames

PRODUCTIVITY INSURANCE FOR YOUR MTS DIGITAL CONTROLLERS



Controller Spare Kits – Just in Case

FlexTest 40, 60, 100, & 200	Part Number
Spares Kit - Just in Case, FlexTest 40 -NV350/60 w/o Handset, Basic	100-246-613
Spares Kit - Just in Case, FlexTest 40 -NV350/60 w/Handset & Accel Cards, Advanced	100-246-634
Spares Kit - Just in Case, FlexTest 40 -NV350/60—Multiple Content w/Handset, Extended	100-246-635
Spares Kit - Just in Case, FlexTest 40 -NV350/ 60—Multiple Content w/o Handset, Extended	100-246-636
Spares Kit - Just in Case, FlexTest 100 & 200—Multiple Content w/o Handset, Basic	100-200-812
Spares Kit - Just in Case, FlexTest 200 for Aero Structures	100-195-413

We make custom spares kits for the FlexTest 11m, FlexTest 40, 60, 100, & 200 Controllers and other systems. Contact your sales engineer for details.

Insight Spares Kits

New MTS Description	Part Number
Spares Kit - Insight 1K / 2K	100-187-792
Spares Kit - Insight 5K / 10K	100-187-793
Spares Kit - Insight 30K / 50K	100-187-794
Spares Kit - Insight 100K	100-187-795
Spares Kit - Insight 150K	100-187-796
Spares Kit - Insight 200K	100-187-797
Spares Kit - Insight 300K	100-187-798
Spares Kit - Insight 50K Wide	100-187-799
Spares Kit - XLT Extensometer 100R STD	100-187-800
Spares Kit - XLT Extensometer 100R Ext	100-187-801

All Insight spares kits contain both consumable and essential components that are prone to wear including: fuses, bolts, grease, switches, bellows and brushes.



Exchange Programs

Electronics

Electronic Exchange Program

The MTS electronic exchange program provides a cost-effective, quick turnaround, replacement option for electronic boards. You can purchase a fully warranted and tested product in exchange for your failed unit.

FEATURES

- » Good-as-new performance for less than replacement price
- » Shipment within 24 hours (Monday–Friday), if item is in stock
- » A fixed price for your repair
- » A 12 month warranty
- » The latest product revision levels
- » Each product is cosmetically remanufactured
- » MTS provides a convenient return shipping carton and label to make it easy for you to return the failed module to MTS.

HOW THE EXCHANGE PROGRAM WORKS

1. Call MTS and ask for Order Services.
2. You will be connected with an order specialist who will help you select the proper product. You will be required to provide a secured payment method equal to the core charge by one of the following methods:
 - » A purchase order
 - » A credit card
 - » An MTS Value Payment Plan contract number or Pay-As-You-Go Plan.
3. MTS will ship your exchange part, if it is in stock, within 24 hours.
4. Once you receive the exchange product, you must return your defective item to MTS within 30 days of initial order placement.
5. Ship the defective item in the same package in which you received the exchanged item. Make sure the Return Authorization Number (RAN) is clearly marked on the shipping labels and enclosed within the package.
6. If MTS receives your defective item within 30 days of initial order placement and if it can be remanufactured, MTS will invoice the exchange price.
7. In addition to the exchange price, if MTS does not receive your defective item within 30 days of order placement, or if it does not qualify for remanufacture, MTS will invoice the core charge. (In a warranty exchange only, a core charge would apply if the item is unreturned.)

Ordering

To place an order for either an exchange product, please call MTS and ask for Order Services.

BE PREPARED WITH THE FOLLOWING INFORMATION WHEN YOU CALL MTS

- » Your MTS site number
- » The MTS model number of the product you want to exchange or repair
- » The MTS assembly number of the product you want to repair
- » The MTS serial number of the product you want to exchange or repair
- » The MTS system in which the product is used
- » The symptoms of the problem you are experiencing
- » Your PO number or method of payment.

COMPATIBILITY

Inclusion in this catalog does not imply that a product is electrically or physically compatible with your existing equipment. Many MTS product configurations have been customized to meet specific system testing needs. If you are unsure if your part can be exchanged, contact your service engineer or the MTS Customer Care Center.

Established Systems

We attempt to repair or exchange all possible systems. However, we may not be able to repair some of our more established systems for various reasons. For these situations we will make a best effort at the time of the call. Please contact your application engineer for pricing and availability.

Exchange Programs

Electronics

Model 407

Model	Description	Exchange Part Number
407	Base Unit, Pwr Sup, Proc, PIDF, CE	407BASE-EX
407	Base Unit, Pwr Sup, Proc, PIDF, AMP, CE	407BASEAMP-EX
407.14	AC Conditioner (repair only)	
407.16	Valve Driver (repair only)	

Models 408-413 are no longer supported.

Motorola Power PC CPUs

Limited Supply (Contact your MTS application engineer)

Model	Config'd material #	Top Level #	Exchange Part Number
498.94-1	054-396-401	054-396-401 (kit only)	011-970-862-EX
498.94-1	054-396-401	054-396-402 (kit only)	011-970-862-EX
498.96-1	056-027-601	100-040-837	100-003-121-EX
498.96-1	056-027-602	100-040-837	100-003-121-EX
498.96-1	100-009-996	100-009-996	100-003-121-EX
498.96-2	056-023-701	100-040-838	011-973-553-EX
498.96-2	056-023-702	100-040-838	011-973-553-EX
498.96-2	056-023-703	100-040-838	011-973-553-EX
498.96-3	056-309-601	100-053-993	100-044-858-EX
498.96-3	056-309-602	100-053-993	100-044-858-EX
498.96-3	056-309-603	100-053-993	100-044-858-EX
498.96-5B			100-100-909-EX
498.96-5			100-074-939-EX
498.96-6			100-074-940-EX
498.96-7			100-102-106-EX
498.96-7B			057-159-301-EX

Model 497 & 498 Modules are shipped unconfigured.

Exchange Programs

Electronics

Flat-Trac II, III

Model	Description	Exchange Part Number
497.13B	AC Conditioner	100-005-333-EX
497.15B	Three-Stage Valve Driver	100-019-313-EX
498.05	Serial Port (Used with the 498.32)	011-487-360-EX
498.47	PAMUX Bus Controller	011-487-343-EX
498.55	MIOP II	046-555-501-EX
498.70	16 Channel Digital I/O	044-127-701-EX
498.00	16 Channel Digital I/O Transition	049-808-401-EX

Note: 497 modules are backward compatible for letter releases.

Flat-Trac III

Limited Supply (Contact your MTS application engineer)

Model	Description	Exchange Part Number
497.15	Three-Stage Valve Driver	047-178-601-EX
497.22A	Dual DC Conditioner	046-359-501-EX
498.32	Processor Module	011-487-365-EX
498.36	Processor Module	011-487-392-EX
498.71	GRES II	049-808-501-EX
498.00	Eight-Channel Filtered Analog Input	051-064-630-EX
498.00	Eight-Channel Filtered Analog Input	051-064-670-EX
498.00	Eight-Channel A/D Daughter Card	049-676-901-EX

RPC III

Limited Supply (Contact your MTS application engineer)

Model	Description	Exchange Part Number
498.60	DCON	043-669-201-EX
498.60B	DCON	052-736-901-EX
498.36	Processor Module	011-487-392-EX
498.37	MJME 147SA-1 Processor	011-487-372-EX
498.61	DSPAD	043-669-101-EX
498.70	16 Channel Digital I/O	044-127-701-EX

Exchange Programs

Electronics

FlexTest IIm, IIs, CTM & CTC

Limited Supply (Contact your MTS application engineer)

Model	Description	Exchange Part Number
497.13B	AC Conditioner	100-005-333-EX
497.15B	Three-Stage Valve Driver	100-019-313-EX
498.34B	Station Controller	100-048-996-EX
497.36	FlexTest Communications	046-791-101-EX
498.65	ADDA	048-077-001-EX
498.70	16 Channel Digital I/O	044-127-701-EX
498.71B	GRES III	100-111-372-EX
498.00	System Digital I/O Transition	053-112-101-EX
498.00	Serial Transition	054-170-601-EX

Note: 497 modules are backward compatible for letter releases.

FlexTest IIm, IIs, CTM & CTC

Limited Supply (Contact your MTS application engineer)

Model	Description	Exchange Part Number
497.12	DC Conditioner	045-771-801-EX
497.14	AC Conditioner	046-481-501-EX
497.15A	Three-Stage Valve Driver	047-178-601-EX
497.22A	Dual DC Conditioner	046-359-501-EX
497.26	Dual Channel Valve Driver	045-771-701-EX
497.34A	Station Controller	045-772-001-EX
498.71	GRES II	049-808-501-EX
498.71B	GRES III	054-170-401-EX
498.71C	GRES III	100-111-372-EX
498.00	Eight-Channel Filtered Analog Input	051-064-610-EX
498.00	Eight-Channel Filtered Analog Input	051-064-630-EX
498.00	Eight-Channel Filtered Analog Input	051-064-670-EX
498.00	Eight-Channel Filtered Analog Input (repair only)	051-064-690-EX
498.00	Eight-Channel A/D Daughter Card	049-676-901-EX
498.00	Eight-Channel D/A Daughter Card	047-849-602-EX

Note: 497 modules are backward compatible for letter releases (A, B, C...).

Exchange Programs

Electronics

FlexTest 40, 60, 100, & 200

Model	Description	Exchange Part Number
494.16	494.16 DUC/Valve Driver	100-174-701-EX
494.21	494.21 EL DUC	100-176-671-EX
494.44	494.44 Module	100-184-696-EX
494.47	494.47 Two-Channel UART/Encoder	100-161-906-EX
494.49	494.49 Encoder	100-170-372-EX
493.72	493.72 Digital I/O Transition SHLD	100-003-853-EX
493.73	493.73 HPU Transition Board	100-003-855-EX
493.74	493.74 HSM Transition, w/o Label	100-039-452-EX
494.74	494.74 Dual HSM w/o Label	100-169-789-EX
494.75	494.75, Analog In, No Label	057-203-101-EX
494.76	494.76, Analog Out, No Label	057-203-201-EX

Note: 497 modules are backward compatible for letter releases (A, B, C...).

FlexTest GT

Limited Supply (Contact your MTS application engineer)

Model	Description	Exchange Part Number
493.10	Power Supply Assembly – Lambda	100-031-143-EX
493.25C	Digital Universal Conditioner	100-207-810-EX
493.40	I/O Carrier Board	100-003-854-EX
493.47	High Speed Encoder Module	055-351-501-EX
493.48	Accelerometer Conditioner Module	100-011-578-EX
493.71	RS485	100-003-832-EX
493.72	Digital I/O Transition Module	100-003-853-EX
493.73	HPU Transition Board	100-003-855-EX
493.74	493.74 HSM Transition Station 1 & 2	100-039-452-EX
493.75	Analog Input BNC Transition Module, 6 Channel	100-008-984-EX
493.76	Analog Output BNC Transition Module, 6 Channel	100-008-986-EX
493.78	Accelerated Input	100-013-651-EX
498.71C	Global resource III Module	100-111-372-EX

FlexTest GT

Limited Supply (Contact your MTS application engineer)

Model	Description	Exchange Part Number
493.02	Chassis Assembly – Repair only	100-061-333-EX
493.14	Two-Stage Valve Driver	048-934-001-EX
493.15	Three-Stage Valve Driver	053-782-701-EX
493.21B	Digital Universal Conditioner	053-476-101-EX
493.25	Digital Universal Conditioner	100-033-468-EX
493.25C	Digital Universal Conditioner	100-207-810-EX
493.40	I/O Carrier Board	100-003-854-EX
493.45	Analog Input Module – 6 Channel A/D	051-904-401-EX
493.46	Analog Output Module – 6 Channel D/A	052-907-701-EX

Note: 493 modules are backward compatible for letter releases (A, B, C...), with the exception of the 493.21A.

Exchange Programs

Electronics

T/RAC & FlexTest DSC

Limited Supply (Contact your MTS application engineer)

Model	Description	Exchange Part Number
497.12	DC Conditioner	045-771-801-EX
497.14	AC Conditioner	046-481-501-EX
497.15A	Three-Stage Valve Driver	047-178-601-EX
497.15B	Three-Stage Valve Driver	100-019-313-EX
497.22A	Dual DC Conditioner	046-359-501-EX
497.26	Dual Channel Valve Driver	045-771-701-EX
497.34	Station Controller	045-772-001-EX
497.34B	Station Controller	100-048-996-EX
497.35	Analog Interface	045-223-401-EX
497.36	FlexTest Communications	046-791-101-EX

T/RAC & FlexTest DSC

Limited Supply (Contact your MTS application engineer)

Model	Description	Exchange Part Number
498.33	Processor Module	011-487-337-EX
498.42	1 Mb EPROM Memory	011-487-350-EX
498.55	MIOP II	046-555-501-EX
498.70	16 Channel Digital I/O	044-127-701-EX

Note: 497 modules are backward compatible for letter releases.

Exchange Programs

Onsite Exchange Programs

505E/515 Pump Service Kits

505E/515 Pump Service Kits have all the service parts normally needed to service a failed pump, assembled into a simple kit. The kits include the main piston pump, filters, connecting hardware and a kit for fluid analysis. These kits should be used when replacing a pump on any 515 HPU or a 505 HPU that has had a new 505 Enhanced Module installed.

505 Enhanced Module Program

The 505 Enhanced Module Replacement is a new product offering from MTS that enables customers who have existing 505G1 or 505G2 HPUs to extend the useful lives of their HPUs while gaining many of the benefits of the 515 Silentflo HPUs. The new 515 pump/motor module has been retrofitted to install seamlessly into existing 505 HPUs, without the expense of buying an entire new HPU.

ADVANTAGES OF THE 505 ENHANCED MODULE

- » These new modules are about 8% more energy efficient to operate, saving money over the long run. The retrofit 515 design incorporates motors that meet IE4 standards providing greater efficiencies with reduced energy consumption.
- » Total cost of ownership is further reduced because of the way the 515 module is designed. A splined double bearing motor to pump interface increases life expectancy while also increasing future serviceability. This design enables seamless field replacement of just the piston pump as the main wear item vs exchanging the entire module: thus, decreasing future service costs.
- » Uses our latest product revisions so obsolescence is not a concern.
- » Saves labor and downtime costs by exchanging components instead of replacing equipment.
- » Field delivery through MTS personnel.
- » Minimized downtime because many times the service can be scheduled with other onsite service activities
- » All new components are used in the manufacturing of the 505E modules.



Series 329 System Actuator Onsite Exchange

Available for 4DOF and 6DOF systems. Please consult your service sales representatives for more information.

CAPABILITY

Inclusion of a product in this catalog does not imply that it is mechanically or physically compatible with your existing equipment. Many MTS product configurations have been customized to meet specific system testing needs. Let us help you determine the compatibility required for an exchange.



329 system

Exchange Programs

Onsite Exchange Programs

Pump Service Kits

Existing HPU	Description	PUMP KIT Part Number
505.07 with enhanced module	PUMP SERVICE KIT-505.07E	058-693-901
505.11 with enhanced module	PUMP SERVICE KIT-505.11E	058-693-902
505.20 with enhanced module	PUMP SERVICE KIT-505.20E	058-693-903
505.30 with enhanced module	PUMP SERVICE KIT-505.30E	058-693-904
505 Enhanced multibay		Contact MTS
515.07 HPU	PUMP SERVICE KIT-515.07	058-693-905
515.11 HPU	PUMP SERVICE KIT-515.11	058-693-906
515.20 HPU	PUMP SERVICE KIT-515.20	058-693-907
515.30 HPU	PUMP SERVICE KIT-515.30	058-693-908
515 Multibay		Contact MTS

505.07 G1 & G2 Series

Voltage	Pressure (PSI)	Hertz	Bays	Series	505 Enhanced Module Part Number
200-208V	3000	60	Single	G1 and G2	058-560-101
200V	3000	50	Single	G1 and G2	058-560-102
220-230V	3000	50	Single	G1 and G2	058-560-103
440-480V	3000	60	Single	G1 and G2	058-560-104
380-400V	3000	60	Single	G1 and G2	058-560-105
415-440V	3000	50	Single	G1 and G2	058-560-106
575V	3000	60	Single	G1 and G2	058-560-107
220-240V	3000	60	Single	G1 and G2	058-560-108
380-400V	3000	50	Single	G1 and G2	058-560-109

505.11 G1 & G2 Series

Voltage	Pressure (PSI)	Hertz	Bays	Series	505 Enhanced Module Part Number
200-208V	3000	60	Single	G1 and G2	058-560-201
200V	3000	50	Single	G1 and G2	058-560-202
220-230V	3000	50	Single	G1 and G2	058-560-203
440-480V	3000	60	Single	G1 and G2	058-560-204
380-400V	3000	60	Single	G1 and G2	058-560-205
415-440V	3000	50	Single	G1 and G2	058-560-206
575V	3000	60	Single	G1 and G2	058-560-207
220-240V	3000	60	Single	G1 and G2	058-560-208
380-400V	3000	50	Single	G1 and G2	058-560-209

505.20 G1 & G2 Series

Voltage	Pressure (PSI)	Hertz	Bays	Series	505 Enhanced Module Part Number
200-208V	3000	60	Single	G1 and G2	058-560-301
200V	3000	50	Single	G1 and G2	058-560-302
220-230V	3000	50	Single	G1 and G2	058-560-303
440-480V	3000	60	Single	G1 and G2	058-560-304
380-400V	3000	60	Single	G1 and G2	058-560-305
415-440V	3000	50	Single	G1 and G2	058-560-306
575V	3000	60	Single	G1 and G2	058-560-307
220-240V	3000	60	Single	G1 and G2	058-560-308
380-400V	3000	50	Single	G1 and G2	058-560-309

Exchange Programs

Onsite Exchange Programs

505.30 G1 & G2 Series

Voltage	Pressure (PSI)	Hertz	Bays	Series	505 Enhanced Module Part Number
200-208V	3000	60	Single	G1 and G2	058-560-401
200V	3000	50	Single	G1 and G2	058-560-402
220-230V	3000	50	Single	G1 and G2	058-560-403
440-480V	3000	60	Single	G1 and G2	058-560-404
380-400V	3000	60	Single	G1 and G2	058-560-405
415-440V	3000	50	Single	G1 and G2	058-560-406
575V	3000	60	Single	G1 and G2	058-560-407
220-240V	3000	60	Single	G1 and G2	058-560-408
380-400V	3000	50	Single	G1 and G2	058-560-409

505 Multibay G1 & G2 Series

Voltage	Pressure (PSI)	Hertz	Bays	Series	505 Enhanced Module Part Number
440-480V	3000	60	6Bay	G1	058-735-601
380-400V	3000	60	6Bay	G1	058-735-602
415-440V	3000	50	6Bay	G1	058-735-603
575V	3000	60	6Bay	G1	058-735-604
380-400V	3000	50	6Bay	G1	058-735-605
440-480V	3000	60	6Bay	G2	058-735-606
380-400V	3000	60	6Bay	G2	058-735-607
415-440V	3000	50	6Bay	G2	058-735-608
575V	3000	60	6Bay	G2	058-735-609
380-400V	3000	50	6Bay	G2	058-735-610
440-480V	3000	60	3Bay	G1 and G2	058-735-606
380-400V	3000	60	3Bay	G1 and G2	058-735-607
415-440V	3000	50	3Bay	G1 and G2	058-735-608
575V	3000	60	3Bay	G1 and G2	058-735-609
380-400V	3000	50	3Bay	G1 and G2	058-735-610
440-480V	4000	60	6Bay	G1	058-735-611
380-400V	4000	60	6Bay	G1	058-735-612
415-440V	4000	50	6Bay	G1	058-735-613
575V	4000	60	6Bay	G1	058-735-614
380-400V	4000	50	6Bay	G1	058-735-615
440-480V	4000	60	6Bay	G2	058-735-616
380-400V	4000	60	6Bay	G2	058-735-617
415-440V	4000	50	6Bay	G2	058-735-618
575V	4000	60	6Bay	G2	058-735-619
380-400V	4000	50	6Bay	G2	058-735-620
440-480V	4000	60	3Bay	G1 and G2	058-735-616
380-400V	4000	60	3Bay	G1 and G2	058-735-617
415-440V	4000	50	3Bay	G1 and G2	058-735-618
575V	4000	60	3Bay	G1 and G2	058-735-619
380-400V	4000	50	3Bay	G1 and G2	058-735-620

Exchange Programs

MTS Series 252 & 256 Servovalves

The MTS servovalve exchange program provides a cost effective, rapid turnaround replacement option for non-functioning servovalves. You can purchase a remanufactured, tested and fully-warranted product in exchange for your used unit to ensure top quality performance of your complete system.

FEATURES

- » Good-as-new performance for less than new product replacement price
- » Shipment within 24-hours (Monday-Friday)
- » 12 Month Warranty
- » Remanufactured to stringent MTS specifications using the latest product revision levels where applicable
- » Convenient return shipping carton and label provided for easy return of the used servovalve core.

COMPATIBILITY

Inclusion of a product in this catalog does not imply that it is mechanically or physically compatible with your existing equipment. Many MTS product configurations have been customized to meet specific system testing needs. Let us help you determine the compatibility required for exchange or if functional replacement/upgrade is the best solution. MTS provides fit-form-function interchange exchange using the G-Type Model servovalves of the same 4 or 5 port configuration and flow size. The G-Type Model servovalves are completely interchangeable with the legacy C-Type Model servovalves.



EXCLUSIONS

The following types of exchanges are not supported/allowed:

- » Exchange of 1970's vintage Model A series servovalves
- » Exchange of vintage 1980's A-Series copper-body servovalves
- » Change in 4 or 5 port configuration servovalves
- » Change in servovalve flow size
- » Exchange of Series 252.5x servovalves
- » Exchange of high response (HR) servovalves
- » Repair of A or C-Type Model servovalves. (C-Type servovalves can be Exchanged for G-Type).



How the valve exchange program works

1. Contact the MTS Order Services Team to help you select the proper remanufactured exchange valve. You will be asked to provide a secured payment method to cover the value of both the remanufactured valve and the value of your used core to be returned. Payment can be secured by one of the following methods.
 - » A purchase order
 - » A credit card
 - » An MTS service plan contract number
2. MTS will ship the remanufactured exchange valve that includes the used valve core return packaging.
3. Upon receiving the exchange valve, you must return your used valve core to MTS within 30 days of order placement.
4. Ship your used valve core back to MTS using the white inner carton provided. Ensure that the Return Authorization Number (RAN) is clearly indicated on the shipping labels and enclosed within the package.
5. When MTS receives your used valve core within 30 days of order placement, your final invoice will have only the exchange valve price.
6. When MTS does not receive your used valve core within 30 days of order placement or the used core is found to not qualify for remanufacture, your final invoice will have the exchange valve price plus the core value price as set in the initial purchase order.

NOTE FOR ALL EXCHANGES

All MTS remanufactured product exchanges require a core value to be associated with the purchase. Your purchase order must explicitly include both the exchange product price plus the core value. Please consult with your order services representative to answer any questions about exchange product and related core pricing. Upon returning your good condition and qualifying used core to MTS within 30 days of issuing the purchase order, MTS will not levy the core charge and you will pay for only the remanufactured exchange product.

FACTORY REPAIR SERVICE 256.XX

1. Pilot
2. Basic cleaning/tuning/validation
3. Full rebuild

Servovalves Models 252.2x - Exchange

Model	Description	Also Applies	Exchange Part Number
252.21G-01	1 gpm, 4 Port Servovalve	252.21C-01	056-006-101-EX

Remanufacture Programs

Actuators

MTS offers you an alternative to buying new actuators or constantly repairing your existing ones. The MTS Actuator Remanufacture Program follows a strict protocol to restore the performance and reliability of your old actuators. We are so confident in the performance and quality of our remanufactured actuators that we provide the same warranty that you would receive when purchasing a new actuator.

Here's What You Get When You Choose to Remanufacture:

Your actuator will be updated to meet the newest design standards, as required. Improvements that were incorporated after your unit was built are retrofitted, bringing performance to "better than original" in many instances.

All remanufacturing work is performed in our factory to our specifications, using MTS parts. This is why we can assure that your actuator will perform as intended after the remanufacture. Components subjected to wear are resurfaced or replaced. That's how we can promise you that you'll receive the same or better service life from your remanufactured actuator.

Service Contracts Eliminate Procurement Hassle

You can include actuator remanufacturing, as well as other MTS services, on an MTS service contract. This solution saves money and time, and avoids the hassle of issuing separate purchase orders.

The Actuator Remanufacture Program covers the basic cylinder assembly.

HERE ARE THE SPECIFICS:

- » End cap bearings are replaced or resurfaced
- » Piston rods are stripped and thermal spray coated or rechromed
- » Seals are replaced with the latest design
- » Other damaged or worn components are repaired or replaced
- » Clearances are inspected and brought up to new MTS actuator specifications
- » Remanufactured units are pressure checked and performance tested

Other components such as servovalves, LVDTs, manifolds, accumulators, and swivels may be repaired or replaced at an additional charge.



Take the First Step

Restore the performance of your worn hydraulic actuators by contacting MTS about actuator remanufactures today. Call us at 1-800-328-2255 or 1-952-937-4000 or email info@mts.com for more information.

BENEFITS

- » Economical solution
- » Extended service life
- » Like-new, or better than original performance
- » MTS quality and reliability
- » Quick turnaround service for some models
- » Expedited service upon request

QUICKTURN SERVICE

At our U.S. facility, we can process your remanufacture within approximately 10 business days of actuator receipt, and then send it back to you. The following models and stroke lengths currently eligible for this service:

- » Stroke length 150 mm (6 in)
- » Stroke length 250 mm (10 in)
- » 244.11 – 15 kN (3.3 kip)
- » 244.12 – 25 kN (5.5 kip)
- » 244.20 – 67 kN (15 kip)
- » 244.21 – 50 kN (11 kip)
- » 244.22 – 100 kN (22 kip)
- » 244.23 – 150 kN (35 kip)
- » 244.31 – 250 kN (55 kip)

EXPEDITE SERVICE

MTS may be able to offer expedited service at an additional charge. Our goal is to provide you with a quality product at a reliable lead time. Please discuss this option with your Service Sales Representative.

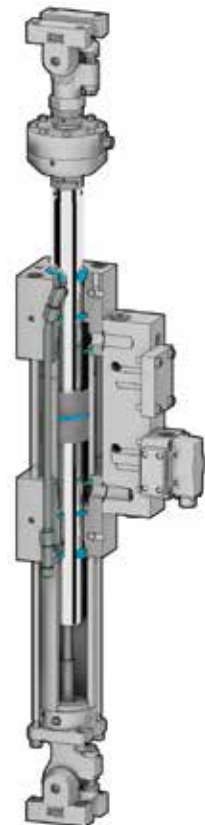

Company Locations

Regional Business Centers

THE AMERICAS

MTS Systems

14000 Technology Drive
Eden Prairie, MN 55344-2290
USA
Telephone: 952-937-4000
Toll Free: 800-328-2255
E-mail: info@mts.com
Internet: www.mts.com

EUROPE

MTS Systems France

BAT EXA 16
16/18 rue Eugène Dupuis
94046 Créteil Cedex
France
Telephone: +33-(0)1-58 43 90 00
E-mail: contact.france@mts.com

MTS Systems (Germany) GmbH

Hohentwielsteig 3
14163 Berlin
Germany
Telephone: +49-(0)30 81002-0
E-mail: euroinfo@mts.com

MTS Systems S.R.L. socio unico

Strada Pianezza 289
10151 Torino
Italy
Telephone: +39-(0)11 45175 11 sel. pass.
E-mail: mtstorino@mts.com

MTS Systems Norden AB

Datavägen 37b
SE-436 32 Askim
Sweden
Telephone: +46-(0)31-68 69 99
E-mail: norden@mts.com

MTS Systems Limited

98 Church Street,
Hunslet,
Leeds
LS102AZ
United Kingdom
Telephone: +44 (0) 113 270 8011
E-mail: mtsuksales@mts.com

ASIA/PACIFIC

MTS Japan Ltd.

Raiden Bldg. 3F 3-22-6,
Ryogoku, Sumida-ku,
Tokyo 130- 0026
Japan
Telephone: +81 3 5638 0850
E-mail: mtsj-info@mts.com

MTS Korea, Inc.

4th F, ATEC Tower, 289,
Pankyo-ro, Bundang-gu
Seongnam-si
Gyeonggi-do 13488,
Korea
Telephone: +82-31-728-1600
E-mail: mtsk-info@mts.com

MTS Systems (China) Co., Ltd.

Floor 34, Building B,
New Caohejing International
Business Center,
No.391, Guiping Road,
Xuhui District
Shanghai 200233
P.R.China
Telephone: +021-24151000
Market: +021-24151111
Sales: +021-24151188
Service: +021-24151198
E-mail: MTSC-Info@mts.com

MTS Testing Solutions Pvt Ltd.

Unit No. 201 & 202, Second Floor
Donata Radiance,
Krishna Nagar Industrial Layout,
Koramangala, Bangalore - 560029
Karnataka, India
Telephone: +91 80 46254100
Email: mts.india@mts.com

Training Centers

Americas Training Center

MTS Systems Corporation
14000 Technology Drive
Eden Prairie, MN 55344-2290
USA
Telephone: 952-937-4000
Toll Free: 800-328-2255
E-mail: info@mts.com
Internet: www.mts.com

Asia Training Center

MTS Korea, Inc.
#1007, 560 Dongtangiheung-ro
Hwaseong-si Gyeonggi-do 18469
Korea
Office Phone: +82-31-728-1600
E-mail: mtsk-info@mts.com

Europe Training Center

MTS Systems GmbH
Hohentwielsteig 3
14163 Berlin
Germany
Telephone: +49-(0)30 81002-0
E-mail: training.europe@mts.com

Shanghai Training Center

MTS Systems (China) Co., Ltd.
Building #23, No.481, Guiping Rd.
Shanghai,
China
Telephone: +86-21-2415 1000
Service: +86-21-2415 1198
E-mail: mtsctraining@mts.com

Sales & Service Organizations

NORTH AMERICA

Tech Support:

Toll Free: 1-800-328-2255
Outside US: 1-952-937-4000
E-mail: tech.support@mts.com

Canada

Telephone: 800-328-2255

Mexico

Telephone: 52-449-922-9200

United States

Telephone: 800-328-2255
1-952-937-4000

CENTRAL AND SOUTH AMERICA

Argentina

Telephone: +(54) (11) 4331-5766
or +(54) (11) 4331 4503
or +(54) (11) 4331 4504

Brazil

Telephone: +55-11-5501-5300

Chile

Telephone: +1-952-937-4027

Colombia

Telephone: +57-(1)-268-8496
ext. 103-105

Costa Rica

Telephone: +506-2256-1784

Ecuador

Telephone: +592 (2) 226-3537

Peru

Telephone: +51-1-710-4236

Venezuela

Telephone: +1-952-937-4027

EUROPE

Tech Support:

E-mail: techsupport.europe@mts.com

Belarus

DL Kinesis, LLC
37/1 Surganova St, Suite 107
220013, Minsk
Republic of Belarus
Telephone: +375 (17) 235-39-57,
+375 (33) 322-41-83 or +375 (29) 761-76-27

Belgium Wallonie (Sales – Service)

MTS Systems SAS
BAT EXA 16
16/18 rue Eugène Dupuis
94046 Créteil Cedex

France

Telephone: +33-(0)1-58 43 90 00

Belgium Flanders (Sales – Service)

Technisch Advies- en
Handelsburo J.J. Bos B.V.
Marconistraat 11
NL2809 PH Gouda
The Netherlands
Telephone: +31-(0)182-619 333

Czech Republic

JD DVORÁK, s.r.o.
V Holešovičkách 1448/14
180 00 Praha 8
Czech Republic
Telephone: +420 284 688 050

France (Sales – Service)

MTS Systems SAS
BAT EXA 16
16/18 rue Eugène Dupuis
94046 Créteil Cedex
France
Telephone: +33-(0)1-58 43 90 00

Germany, Austria, Benelux, Southeast Europe (Sales – Service)

MTS Systems (Germany) GmbH
Hohentwielsteig 3
14163 Berlin
Germany
Telephone: +49-(0)30 81002-0

Greece (Sales)

Neotek OE
P. Xystris & Co.
Measuring & Testing Systems
E. Venizelou 105, N. Smyrni 17123
Athens, Greece
Telephone: +30-210-9341533 or
+30-210-9359142

Italy (Sales – Service)

MTS Systems S.r.l. socio unico
Strada Pianezza 289
10151 Torino,
Italy
Telephone: +39-(0)11 45175 11 sel. pass.
Email: mtstorino.com

Netherlands (Sales)

Technisch Advies- en
Handelsburo J.J. Bos B.V.
Marconistraat 11
NL2809 PH Gouda
The Netherlands
Telephone: +31-(0)182-619 333

Northern Europe (Sales – Service)

MTS Systems Norden AB
Datavägen 37b
SE-436 32 Askim
Sweden
Telephone: +46-(0)31-68 69 99

Poland (Sales – Service)

Spectro-Lab
ul. Warszawska 100
05-092 Lomianki /Warszawa
Poland
Telephone: +48 (22) 675 25 67

Turkey (Sales – Service)

MEGA Danışmanlık,
Temsilcilik Dis Tic. A.S.
Uzuncayir Cad. No: 31, A Blok D: 18-19
34722 - Hasanpasa
Istanbul, Turkey
Telephone: +90-216-326-4535

United Kingdom (Sales – Service) MTS Systems Limited

98 Church Street,
Hunslet,
Leeds
LS102AZ
United Kingdom
Telephone: +44 (0) 113 270 8011
E-mail: mtsuksales@mts.com

AFRICA AND THE MIDDLE EAST

Egypt

Heliopolis
Telephone: +20-22-642-3604

Israel

Lod
Telephone: +972-73-2570000

Kuwait, Oman, Qatar, United Arab Emirates, Yemen

Saudi Arabia
Telephone: +966-54-882-4125

ASIA/PACIFIC

India

Karnataka
Telephone: +91-80-46254100

Indonesia

Jakarta
Telephone: +62-21-6251690

Japan

Nagoya
Telephone: +81-52-709-6433
Tokyo
Telephone: +81-3-5638-0850

People's Republic of China

Beijing
Telephone: +86-10-65876888
Shanghai
Telephone: +86-21-24151000
Shenzhen
Telephone: +86-755-26700399

Republic of Korea

Seongnam City
Telephone: +82-31-728-1600

Saudi Arabia, Bahrain

Al Khobar
Telephone: +966-54-882-4125

Singapore

Singapore
Telephone: +65-6778-3655

Taichung

Telephone: +886-4-2245 4700

Taipei

Telephone: +886-2-2792 2440

Taiwan

Kaohsiung
Telephone: +886-7-554-1800

AUSTRALIA AND NEW ZEALAND











Australia

Chatswood
Telephone: +61-(02) 9496-4200

New Zealand

Auckland
Telephone: +64-9-366-3999

Services & Accessories

-  Introduction
-  Services
-  Load Cells
-  Extensometers
-  Grips & Fixtures
-  Furnace & Chambers
-  Testing System Components
-  MTS Maintenance Parts
-  Exchange & Repair Programs
-  Company Locations



MTS Systems
14000 Technology Drive
Eden Prairie, Minnesota 55344-2290 USA
Toll Free: 800-328-2255
Telephone: 952-937-4000
E-mail: info@mts.com
<http://www.mts.com>

ISO 9001 CERTIFIED QMS

©2024 MTS Systems
100-688-385b English - Printed in U.S.A. - 04/2024

MTS, Bionix, Flat-Trac, FlexTest, MTS Acumen, MTS Landmark, MTS EM Extend, MTS Insight, MTS Echo, RPC, SWIFT, TestWare, Acumen, SureCoat, DuraGlide, and TestWorks are registered trademarks; Advantage, Aero-90, Elastomer Express, Just In Case, MAST, MicroProfiler, MTS Fundamental, SilentFlo, TestStar, SafeGuard, and T/RAC are trademarks of MTS Systems within the United States. These trademarks may be protected in other countries.

Android is a trademark of Google Inc.

Apple is a registered trademark of Apple, Inc., registered in the U.S. and other countries. iOS is a registered trademark of Cisco Systems, Inc.

Products or company names other than trademarks of MTS Systems are used for identification purposes only and may be trademarks of their respective owners.

All specifications are subject to change without notice. Please contact MTS for specifications critical to your application. MTS reserves the right to change products, services and prices without notice.