

# INSTRUCTION MANUAL

## NAGRA IV-SJ



code no. 20.01.004.151

MEASUREMENTS	chapter 1
SPECIFICATIONS	chapter 2
DIRECTIONS FOR USE	chapter 3
BATTERIES AND ACCUMULATORS	chapter 4
ACCESSORIES	chapter 5

KUDELSKI SA  
NAGRA Tape Recorders Manufacture  
CH-1033 Cheseaux/Lausanne  
Switzerland  
Tel (021) 91 21 21  
Telex 459 302 nagr ch



Printed in Switzerland by KUDELSKI S.A.

Edition August 1985

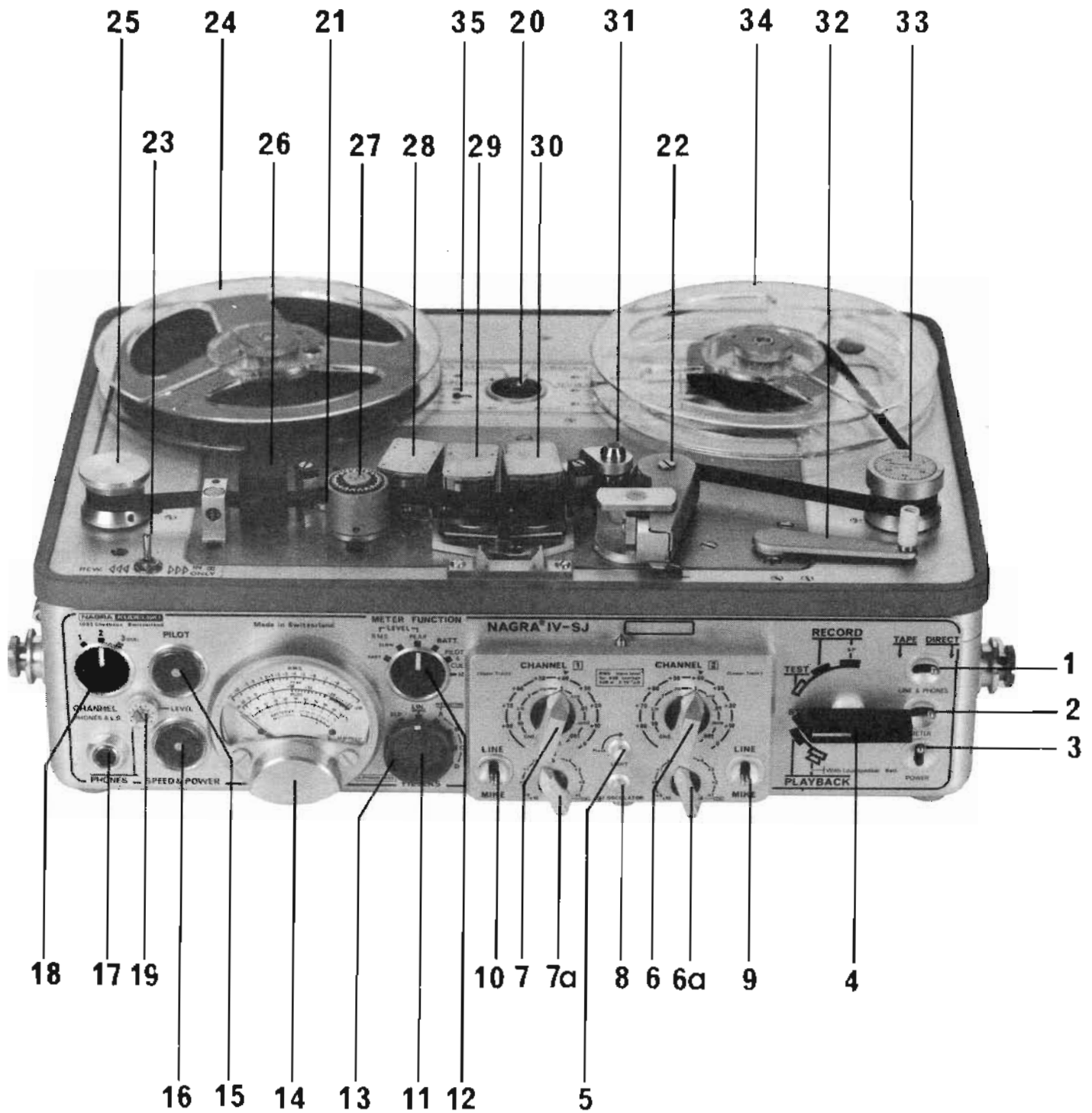
NAGRA, KUDELSKI, NEOPILOT, NEOPILOTTON,  
NAGRASTATIC, NAGRAFAX,  
sont des marques enregistrées, propriété de  
KUDELSKI S. A.  
fabrique d'enregistreurs NAGRA.



- 1 **TAPE/DIRECT, LINE & PHONES:** switching of the playback signal or of the direct signal on the line outputs, headphones and loudspeaker; switch inactive on TEST
- 2 **TAPE/DIRECT, METER:** switching of the playback signal or of the direct signal on the circuit of meter 14; this switch cannot be locked on TAPE
- 3 **POWER:** power selector switch i.e. built-in batteries or accumulators or external power supply connected to plug 48

- 4 Main function switch**  
**STOP:** recorder at a standstill  
**TEST:** power supplied to all circuits, except record and erase  
**RECORD:** power supplied to all circuits and the motor; record and erase on the 3 tracks  
**PLAYBACK:** the recorded signal can be heard on the headphones and is fed to the line outputs of connectors 41, 42, 43, 45 and 46 when switch 1 is on TAPE (or on DIRECT if the output signal is reintroduced into the direct chain, see 42)  
**PLAYBACK with Loudspeaker:** playback of tape using loudspeaker
- 5 LIGHT:** meter 14 lights up momentarily; remains illuminated when the button is turned to the right
- 6 Main attenuator CHANNEL 2:** in steps of 10 dB for channel 2, lower track
- 6a Vernier attenuator CHANNEL 2:** in steps of 1 dB for channel 2
- 7 Main attenuator CHANNEL 1:** in steps of 10 dB for channel 1, upper track
- 7a Vernier attenuator CHANNEL 1:** in steps of 1 dB for channel 1  
**NOTE:** dB scale: for the microphone inputs, in relation to the sound pressure level  $0.0002 \mu\text{bar} = 0 \text{ dB}$   
Voltage scale: effective voltage applied to the line output, which gives a reading of 0 dB on the RMS scale of meter 14
- 8 REF. OSCILLATOR:** switched on when the button is depressed, the reference oscillator supplies a +10 dB signal to the direct amplifier on each channel, after the attenuator
- 9 LINE/MIKE:** line or microphone input selector, channel 2
- 10 LINE/MIKE:** line or microphone input selector, channel 1
- 11 FILTERS:** 6—position filter selector switch for channel 1  
HP = high—pass  
LIN. = linear  
WEIGHTING A,B,C,D = weighting curves A,B,C,D
- 12 METER FUNCTION:** six—position selector switch for meter 14  
**LEVEL, RMS FAST:** on the decibel scale, RMS value of the sound level, fast characteristic, red needle for channel 1, green needle for channel 2  
**LEVEL, RMS SLOW:** the same as RMS FAST, but slow characteristic  
**LEVEL, PEAK:** on the PEAK decibel scale, peak value of the sound level, channels as above  
**BATT:** on the BATTERIES scale, battery or accumulator check, red needle: battery voltage per cell (VOLTS/CELL), green needle: voltage required by the motor, with the same reduction factor as battery voltage  
**PILOT & CUE:** green needle: on the Pilot 0 to 100% scale, overall frequency deviation caused by the pilot and CUE signals, 100% on the scale corresponding to a deviation of  $\pm 40\%$ , red needle: on the PILOT +4 to -4% scale, frequency shift, as determined by the built—*in* QFMS frequency meter, between a signal recorded or played back on the third track and an internal reference  
**Position M:** green needle: same as PILOT & CUE, red needle: on the 0 to 100% scale, current through the motor, 100% on the scale corresponding to 250 mA
- 13 FILTERS:** filter selector switch for channel 2, identical to 11
- 14 Meter:** indicates sound level and checking functions according to the position of selector switch 12
- 15 PILOT:** indicator which shows a white zone when frequency and amplitude of the pilot signal are correct
- 16 SPEED & POWER:** indicator which shows a white zone when the following three conditions are fulfilled:  
— power supply voltage higher than the maximum admissible value  
— motor regulation within the correct operating range  
— tachometric speed fluctuations not exceeding the maximum value
- 17 PHONES:** connector for mono headphones, impedance 25 to  $600\Omega$
- 18 CHANNEL, PHONE & L.S.:** channel selector for listening with headphones and loudspeaker
- 19 LEVEL, PHONES:** adjustment of the headphones volume
- 20 Tape speed selector switch**  
15 ips = 38.1 cm/s      3 3/4 ips = 9.525 cm/s  
7 1/2 ips = 19.05 cm/s      1 1/2 ips = 3.81 cm/s
- 21 BIAS:** 5—position bias selector switch
- 22 Pinch—wheel**
- 23 Fast wind switch:**
- REW.** 
-  **IN ONLY**
- rewind with main switch 4 any position except STOP, lever 32 in disengage position  
fast wind when main switch 4 on PLAYBACK with Loudspeaker
- 24 Supply reel**
- 25 Tension roller of the supply reel**
- 26 Erase head**
- 27 Stabilizer roller with 50 or 60 Hz stroboscope**
- 28 Recording head track 1 and 2**
- 29 Recording and playback head track 3**
- 30 Playback head tracks 1 and 2**
- 31 Capstan**
- 32 3—position lever** controlling the pinch—wheel and tape guides:  
— lever pulled to the left: for threading the tape (rewind possible in this position)  
— lever at  $45^\circ$  to the edge of the tape—deck: motor running, but tape not moving  
— lever pushed backwards: tape running
- 33 Tension roller of the take—up reel**
- 34 Take—up reel**
- 35 RECORDING EQUALIZATION ADJUSTEMENT**

**36 MICROPHONE CHANNEL 2:** channel 2 microphone input

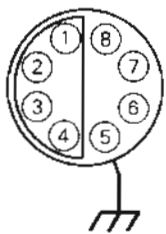

EXTERNAL VIEW OF CHASSIS CONNECTOR OR PLUG FROM THE SOLDERING SIDE

- 1 200V voltage available with built—
- 2 120V in microphone power supply
- 3 supply voltage, varies according to the type of amplifier
- 4 -10G: -10V stabilized voltage, maximum current 350 mA
- 5 chassis
- 6 preamplifier supply voltage
- 7 signal input
- 8 signal input ground

**37 MICROPHONE CHANNEL 1:** channel 1 microphone input connector, identical to 36

**38 Gain selector for channel 2 microphone amplifier,** 3 positions, +40, +60 and +80 dB

**39 Gain selector for channel 1 microphone amplifier,** identical to 38

**40 MICROPHONE TYPES:** B & K cartridge type selector

**41 CHANNEL 2:** channel 2 multiple connector

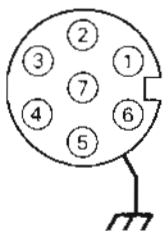

EXTERNAL VIEW OF CHASSIS CONNECTOR OR PLUG FROM THE SOLDERING SIDE

- 1 VAR. LEVEL IN: line input impedance 100k $\Omega$ , input voltage  $\geq 1$  mV
- 2 -10 G: stabilized voltage -10V
- 4 Playback output: output voltage 10 mV at 0 dB, load  $\geq 47$  k $\Omega$
- 7 ground

**42 CHANNEL 1:** channel 1 connector, identical to 41, shown with strap plug to reintroduce the playback signal into the direct chain (switch 10 must be on LINE)

**43 OUTPUTS:** line output connector

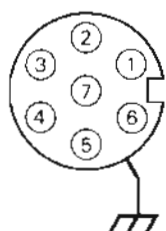

EXTERNAL VIEW OF CHASSIS CONNECTOR OR PLUG FROM THE SOLDERING SIDE

- 1 LINE OUT 2: line output, channel 2, output voltage 100 mV at 0 dB in a load greater than 10 k $\Omega$
- 2 -10G: stabilized output voltage -10V
- 3 LINE OUT 1: line output channel 1, output voltage 100 mV at 10 dB in a load greater than 10 k $\Omega$
- 4 unstabilized negative supply voltage
- 5 -10R: stabilized voltage -10V available only during recording
- 6 STOP: motor stop control terminal (connect to -10V to stop)
- 7 ground

**44 PILOT:** pilot signal input for the 3rd track

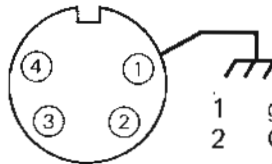

EXTERNAL VIEW OF CHASSIS CONNECTOR OR PLUG FROM THE SOLDERING SIDE

- 1 ground
- 2 Clapper: reference oscillator or crystal pilot generator control terminal
- 3 Xtal: 50 or 60 Hz internal crystal pilot generator output
- 4 PILOT IN: pilot signal input

**45 LINE OUTPUT 2:** channel 2 line output on banana jacks

**46 LINE OUTPUT 1:** channel 1 line output on banana jacks

**47 CUE:** connector for recording and playback on the third track

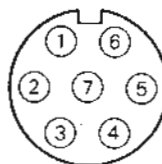

EXTERNAL VIEW OF CHASSIS CONNECTOR OR PLUG FROM THE SOLDERING SIDE

- 1 CUE IN: modulation signal input
- 2 -10G: -10V stabilized voltage
- 3 PILOT OUT: pilot signal output
- 4 -10V: stabilized voltage available only during recording
- 5 -10V FM: voltage terminal to activate the FM modulator
- 6 CUE OUT: signal output (direct or recorded)
- 7 ground

**48 POWER PACK:** connector for external power supply

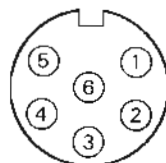

EXTERNAL VIEW OF CHASSIS CONNECTOR OR PLUG FROM THE SOLDERING SIDE

- 1 -BATT.: negative pole of the battery box
- 2 +BATT.: positive pole of the battery box and ground
- 3 STOP: motor stop control terminal (connect to -10V to stop)
- 4 SPEED CORRECTION: tape speed correction signal input
- 5 EXTERNAL -12V to -30V: 12 to 30V external power input, negative pole
- 6 -10G: -10V stabilized voltage

# INSTRUCTION MANUAL

## NAGRA IV-SJ



## Measurements

### Direct analysis of sound signals

Used solely as an amplifier the NAGRA IV-SJ is a precision sound level meter, which operates with any calibrated microphone cartridge. The sound pressure measurements must be taken in relation to the 0 dB reference level, which corresponds to a pressure of  $0.0002 \mu\text{bar}$ , i.e.  $20 \mu\text{N/m}^2$  or  $20 \mu\text{Pa}$ . This level coincides in practice with the audibility-threshold of the human ear at 1 kHz; at this frequency, the sound level can be expressed in phones, the phones value being equal to the dB value read in relation to the  $0.0002 \mu\text{bar}$  reference.

The frequency response of the human ear is not linear and depends very much on the sound level; a sound level meter must therefore include weighting filters which modify the values measured in accordance with certain criteria, so that they can be interpreted in relation to the subjective impression felt by the human ear. There are three standard weighting curves, A, B and C. Curve A is used for low and medium sound levels, which are the subject of most analyses; curves B and C relate to higher levels. Curve D relates to contour-lines of perceived noisiness, in particular with noise produced by aviation: this weighting is used for the measurement of sounds which cause annoyance in general. Curves A, B, C and D are shown after the specifications.

The sound level measured is shown on a dual galvanometer, with one needle per channel. Its measuring circuit determines the average value of the signal on RMS and its peak value on PEAK, with different dynamic characteristics in relation to the integration time. On RMS FAST integration time is 200 ms: a signal at 1 kHz lasting 200 ms gives a reading 1 dB lower than that which would correspond to the steady signal. On RMS SLOW, integration time is 500 ms and a signal lasting 500 ms gives a reading 4 dB below that which would correspond to the steady signal.

These two integration times are in accordance with

the CEI standard 179 for precision sound level meters. Naturally, any signal which is shorter than the integration time will be shown below its real value. For analysis of pulse signals or strong transients a more useful reading is obtained on PEAK, i.e. peak value with an integration time of only 5 ms. This very fast reading cannot be used because it causes visual fatigue: in order to overcome this disadvantage the measuring circuit holds the signal for about one second, thereby increasing the fall time of the needle.

### Recording and playback of the sound signals

In all cases where direct measurement is not sufficient for studying the signals picked up by the microphone, these signals can be recorded on magnetic tape and analyzed later in the laboratory. While the two tracks used for direct recording are in use, the third track can record FM signals for synchronization, a commentary, or a measuring-signal from D.C. up to 4 kHz. The three tracks thus store signals in fully-synchronized form, which is an important factor for analysis.

However, this storage is restricted to some extent due to the limitations of present magnetic tapes. These limitations concern the following characteristics in particular:

#### the response curve

Attenuation at the upper and lower extremes of the spectrum depends on the speed used. Very low frequency signals, which are difficult to play back with a small reproduce head, should be analyzed by frequency transposition.

#### distortion

This increases very rapidly as soon as the maximum recording level is exceeded, and tape saturation occurs, generating harmonic frequencies (in particular 2nd and 3rd harmonics), which falsify the analysis of the signals.

**crosstalk**

The juxtaposition of the two channels inside the recording head and the playback head produces crosstalk. This is the ratio, at a playback amplifier output, between the wanted signal and the unwanted signal from the other channel. Crosstalk increases at high frequencies.

The maximum peak level, which corresponds to a tape flux of 32 mM/mm, is reached when the measuring instrument shows +10 dB on the RMS scale and +20 dB on the PEAK scale. These two values are given in relation to the sound pressure reference level 0 dB = 20  $\mu$ Pa or 0.0002  $\mu$ bar.

On RMS the integration time of the measuring circuit is long enough not to indicate short pulses at their exact value and risk exceeding the maximum recording level, thereby saturating the tape. That is why, on RMS, the maximum level is given at +10 dB: the 10 dB lead avoids the signals with strong pulse content saturating the tape too quickly.

In all cases where the nature of a signal is not obvious it should be recorded with the measuring circuit on PEAK, which is the only way to make the peak value of very short pulses visible and to avoid their exceeding the maximum recording level.

**Frequency transposition**

Playback speed may be different from recording speed: this produces a frequency transposition of the signals recorded within the ratio of these two speeds. Since the response curve in the low frequencies is limited to 25 Hz on playback only, it is possible, if the tape transport speed is ten times faster on playback than on recording, to play back frequencies which are ten times lower. Thus, a 2.5 Hz signal recorded at 1.5 ips will have a frequency of 25 Hz if it is played back at 15 ips (transposition 1:10), and can be analyzed easily by conventional equipment. In the same way, the time needed to analyze signals which vary very slowly is reduced in the same ratio by this process. Conversely, it is possible to analyze in more detail a signal which varies rapidly by playing it back more slowly than it was recorded. However, in both cases, care must be taken that the transposition does not alter the signals in any way, taking into account the limitations of the frequency response at the speeds used.

# INSTRUCTION MANUAL

## NAGRA IV-SJ



### 2

## Specifications

### DIMENSIONS AND WEIGHT

Dimensions of the box as such with the lid closed, without knobs, feet, handle or handle mounts	12.6 x 8.8 x 4.4" – 318 x 222 x 110 mm
Overall dimensions without the removable handle	13.2 x 9.6 x 4.5" – 333 x 242 x 113 mm
Thickness of the Anticorodal sheet used for the box	.080" – 2 mm
Thickness of the tape deck	.120" – 3 mm
Empty weight, without batteries or tape	14 lbs – 6.150 kg
Weight with ordinary batteries, 5" reels and tape	16 lbs – 7.300 kg

### POWER SUPPLY

Supply voltage, direct current, positive to the ground	12 to 30 V
Current consumption	
on Test	120 mA
on Line Playback	205 mA
on Record      direct	260 mA
mic. (1 BK 2619)	465 mA
on Rapid Rewind	305 mA
Type of batteries used (12 cells)	
CEI standard	R 20
ASA standard	D and L 90
Approximate autonomy with Eveready E95 manganese dioxide alkaline batteries	
Continuous use, recording	
direct	26 hours
with mic. and 2619 preamp.	11½ hours

### MAGNETIC TAPE

Nominal width	¼" – 6.25 mm
Admissible thickness	0.5 to 2 mils – 12 to 50 µm
Maximum reel diameter with lid open	7" – 178 mm
Recording time at 7½ ips with 35 µm (1.5 mils) tape	45 min.
Maximum reel diameter with lid closed	5" – 127 mm
Recording time under the same conditions	22 min.
Rewind time with 5" reel and 35 µm (1.5 mils) tape	2 min.

### TAPE TRANSPORT

Switchable nominal speeds:

15 ips	=	38.1	cm/s
7½ ips	=	19.05	cm/s
3¾ ips	=	9.525	cm/s
1½ ips	=	3.81	cm/s

Stability of the nominal speed in relation to the temperature (from 0° to 50°C), the position of the recorder, the distribution of the tape between the reels, and the supply voltage (except for 1 1/2 ips). ±0.1%

Wow and flutter

weighted peak-to-peak value, in accordance with DIN 45 507 standard: (IEE 193–1972 / ANSIS 4.03.1972)

15 ips	±0.05% (0.07%)
7 1/2 ips	±0.07% (0.11%)
3 3/4 ips	±0.12% (0.15%)
1 1/2 ips	±0.25% (0.3%)

Starting time 3 seconds

## DIRECT RECORDING TRACKS

Amplifier chain (without microphone amplifiers)

Input impedance 100 k $\Omega$

Overall accuracy of the attenuator  $\pm 0.1$  dB ( $\pm 0.2$  dB)

Frequency response

from 2.5 Hz to 35 kHz  $\pm 0.3$  dB ( $\pm 0.5$  dB)

Input voltage for recording at Maximum Peak Level, maximum sensitivity 10 mV RMS

Maximum admissible level for 1% distortion referred to MPL +8.5 dB (+8 dB)

Signal-to-noise ratio

linear 66 dB (62 dB)

ASA A weighted 74 dB (70 dB)

Crosstalk attenuation at 1 kHz 80 dB (74 dB)

Weighting curve accuracy better than CEI 179 and CEI 537 (for exact curve see diagrams)

High pass filter

attenuation - 3 dB at 20 Hz, 12 dB per octave

## METER

PEAK indication

semi-logarithmic scale, usable from -10 to +23 dB

frequency response

from 30 Hz to 35 kHz  $\pm 0.5$  dB (1 dB)

integration time for 2 dB

below reference deviation 5 ms  $\pm 20$  %

RMS (sonometer) indication

normalised scale, usable from -10 to +12 dB

frequency response

from 10 Hz to 35 kHz  $\pm 0.5$  dB (1 dB)

from 20 Hz to 20 kHz

$\pm 0.2$  dB (0.5 dB)

FAST integration time,

200 ms for 1 dB

below reference deviation  $\pm 0.5$  dB (1 dB)

SLOW integration time,

500 ms for 4 dB

below reference deviation  $\pm 0.5$  dB (1 dB)

Reading accuracy below 0 dB ( $\pm 0.5$  dB)

above 0 dB ( $\pm 0.2$  dB)

Peak factor >5

## Record and Playback

Nominal recording level, identical to Maximum Peak Level (M.P.L.) = 320 nWb/m for NAB  
405 nWb/m for CCIR

Bias frequency 150 kHz

Bias switchable per 10% increments

Tape used for testing for NAB 3M 177  
for CCIR LPR 35 LH

Erase efficiency referred to M.P.L. 82 dB (80 dB)

Frequency response, recording at 20 dB below M.P.L.

15 ips 25 Hz to 35 kHz  $\pm 1$  dB (2 dB)

7 1/2 ips 25 Hz to 20 kHz

3 3/4 ips 25 Hz to 10 kHz  $\pm 1.5$  dB (3 dB)

\*1 1/2 ips 25 Hz to 3.5 kHz

\*recording possible from 2.5 Hz with translation to 15 ips in playback

Third harmonic distortion at M.P.L. 1% (2%)

Signal-to-noise ratio

Linear ASA A  
dB dB

15 ips - 38 cm/s NAB 58 (53) 63 (60)

CCIR 58 (55) 66 (63)

7 1/2 ips - 19 cm/s NAB 60 (56) 64 (62)

CCIR 57 (55) 63 (60)

Crosstalk attenuation

at 1 kHz (60 dB)

at 10 kHz (50 dB)

Phase shift between tracks

at 7 1/2 ips (19 cm/s) and 10 kHz  $\pm 15^\circ$  ( $\pm 20^\circ$ )

## Outputs

Output voltage at M.P.L. on 10 k $\Omega$  1 V

Output voltage for 1% distortion at 1 kHz (2.5 V)

Output voltage for 200  $\Omega$  headphones, adjustable 0 to 1 V

Built-in loudspeaker, power output of amplifier 1 W

Reference signal level RMS +10 dB  $\pm 0.2$  dB

## FM TRACK

Operating speeds, 15 and 7 1/2 ips - 38 and 19 cm/s

Input and Output centered at OVDC

Carrier frequency 17 kHz

Static linearity  $\pm 0.4$  % ( $\pm 1$  %)



Maximum frequency deviation  $\Delta f_0$   $\pm 45\%$  (40)

Frequency response  
at  $-3$  dB 0 to 4 kHz (0 to 3.5 kHz)

Signal-to-noise ratio for  
a  $\pm 20\%$  deviation 44 dB (40 dB)

Peak-to-peak input voltage for a  $\pm 40\%$  deviation

PILOT  $\pm 2.8V \pm 0.5$  dB

CUE  $\pm 2 V \pm 0.5$  dB

## OPERATING CONDITIONS

Temperature  
with manganese batteries - 4 to  $+160^\circ$  F  
-20 to  $+71^\circ$  C  
with external power -67 to  $+160^\circ$  F  
-55 to  $+71^\circ$  C

The recorder functions correctly in any position.

### Weighting curve A

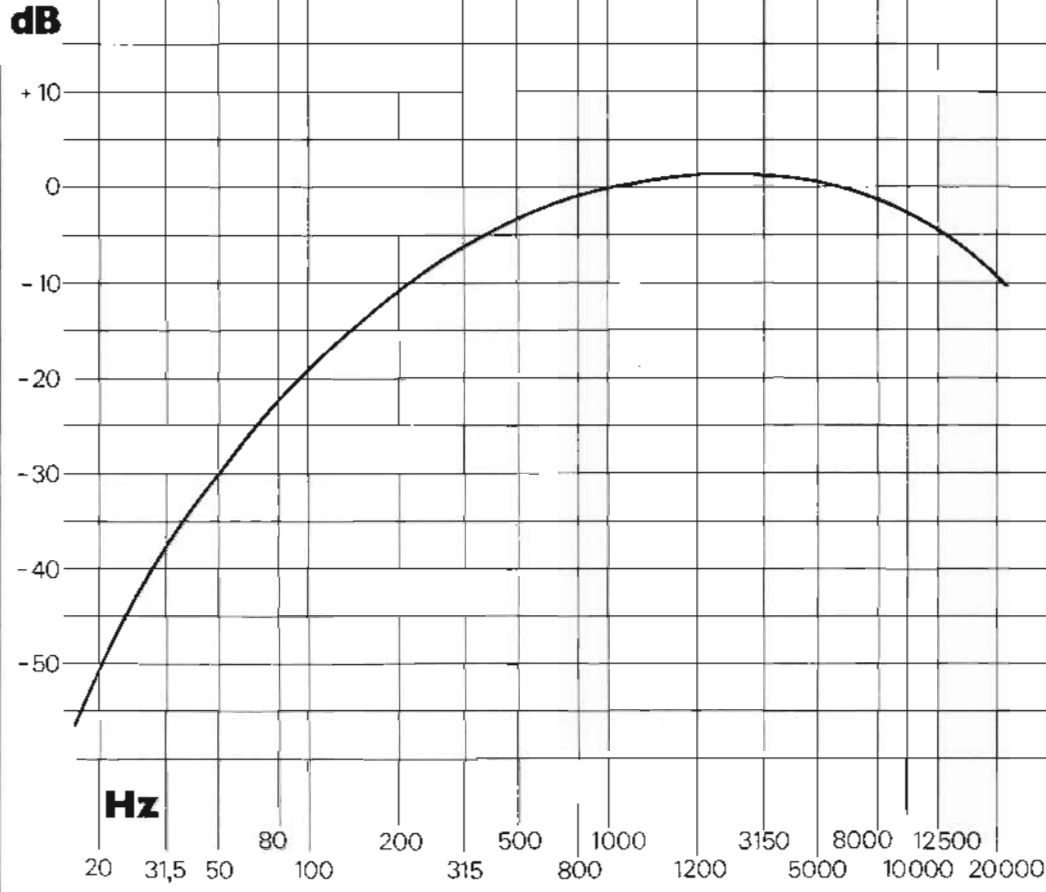

Frequency Hz	IEC Recommendation 179 Relative Response dB	Tolerance Limits dB	NAGRA IV.SJ Tolerance Limits dB
20	-50.5	±5	±3
25	-44.7	±5	±2.5
31.5	-39.4	±3	±2
40	-34.6	±3	±2
50	-30.2	±3	±2
63	-26.2	±3	±2
80	-22.5	±2	±1.5
100	-19.1	±1	±1
125	-16.1	±1	±1
160	-13.4	±1	±1
200	-10.9	±1	±1
250	- 8.6	±1	±1
315	- 6.6	±1	±1
400	- 4.8	±1	±1
500	- 3.2	±1	±1
630	- 1.9	±1	±1
800	- 0.8	±1	±1
1 000	0	±1	±1
1 250	+ 0.6	±1	±1
1 600	+ 1	±1	±1
2 000	+ 1.2	±1	±1
2 500	+ 1.3	±1	±1
3 150	+ 1.2	±1	±1
4 000	+ 1	±1	±1
5 000	+ 0.5	±1.5	±1
6 300	- 0.1	+1.5 -2	±1
8 000	- 1.1	+1.5 -3	±1.5
10 000	- 2.5	+2 -4	±1.5
12 500	- 4.3	+3 -6	±1.5
16 000	- 6.6	+3 -∞	±1.5
20 000	- 9.3	+3 -∞	±2

### Weighting curve B

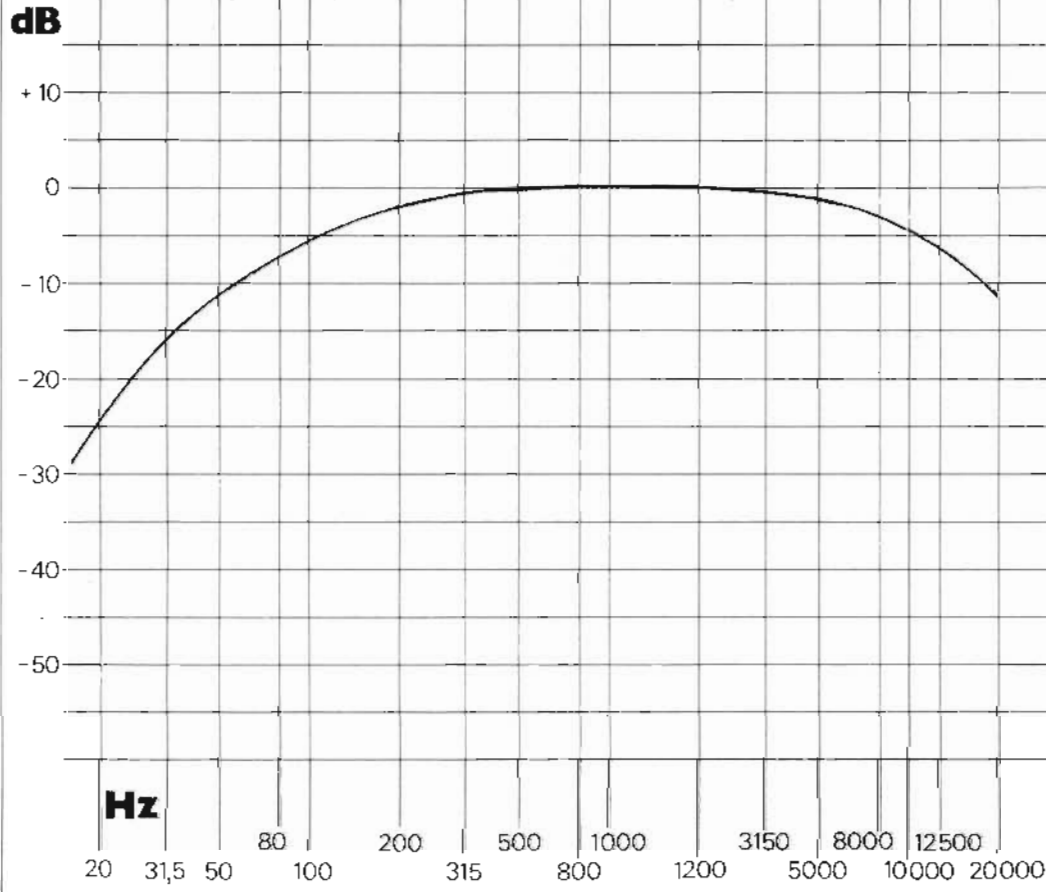

Frequency Hz	IEC Recommendation 179 Relative Response dB	Tolerance Limits dB	NAGRA IV.SJ Tolerance Limits dB
20	-24.2	±5	±2
25	-20.4	±5	±2
31.5	-17.1	±3	±2
40	-14.2	±3	±2
50	-11.6	±3	±2
63	- 9.3	±3	±2
80	- 7.4	±2	±1.5
100	- 5.6	±1	±1
125	- 4.2	±1	±1
160	- 3	±1	±1
200	- 2	±1	±1
250	- 1.3	±1	±1
315	- 0.8	±1	±1
400	- 0.5	±1	±1
500	- 0.3	±1	±1
630	- 0.1	±1	±1
800	0	±1	±1
1 000	0	±1	±1
1 250	0	±1	±1
1 600	0	±1	±1
2 000	- 0.1	±1	±1
2 500	- 0.2	±1	±1
3 150	- 0.4	±1	±1
4 000	- 0.7	±1	±1
5 000	- 1.2	±1.5	±1
6 300	- 1.9	+1.5 -2	±1
8 000	- 2.9	+1.5 -3	±1.5
10 000	- 4.4	+2 -4	±1.5
12 500	- 6.1	+3 -6	±1.5
16 000	- 8.4	+3 -∞	±1.5
20 000	- 11.1	+3 -∞	±2

## Weighting curve C



Frequency Hz	IEC Recommendation Relative Response dB	IEC Recommendation 179 Tolerance Limits dB	NAGRA IV-SJ Tolerance Limits dB
20	-6.2	±5	±1.5
25	-4.4	±5	±1
31.5	-3	±3	±1
40	-2	±3	±1
50	-1.3	±3	±1
63	-0.8	±3	±1
80	-0.5	±2	±1
100	-0.3	±1	±1
125	-0.2	±1	±1
160	-0.1	±1	±1
200	0	±1	±1
250	0	±1	±1
315	0	±1	±1
400	0	±1	±1
500	0	±1	±3
630	0	±1	±3
800	0	±1	±3
1000	0	±1	±3
1250	0	±1	±3
1600	-0.1	±1	±1
2000	-0.2	±1	±1
2500	-0.3	±1	±1
3150	-0.5	±1	±1
4000	-0.8	±1	±1
5000	-1.3	±1.5	±1
6300	-2	+1.5 -2	±1
8000	-3	+1.5 -3	±1.5
10000	-4.3	+2 -4	±1.5
12500	-6.2	+3 -6	±1.5
16000	-8.5	+3 -∞	±1.5
20000	-12	+3 -∞	±2

## Weighting curve D

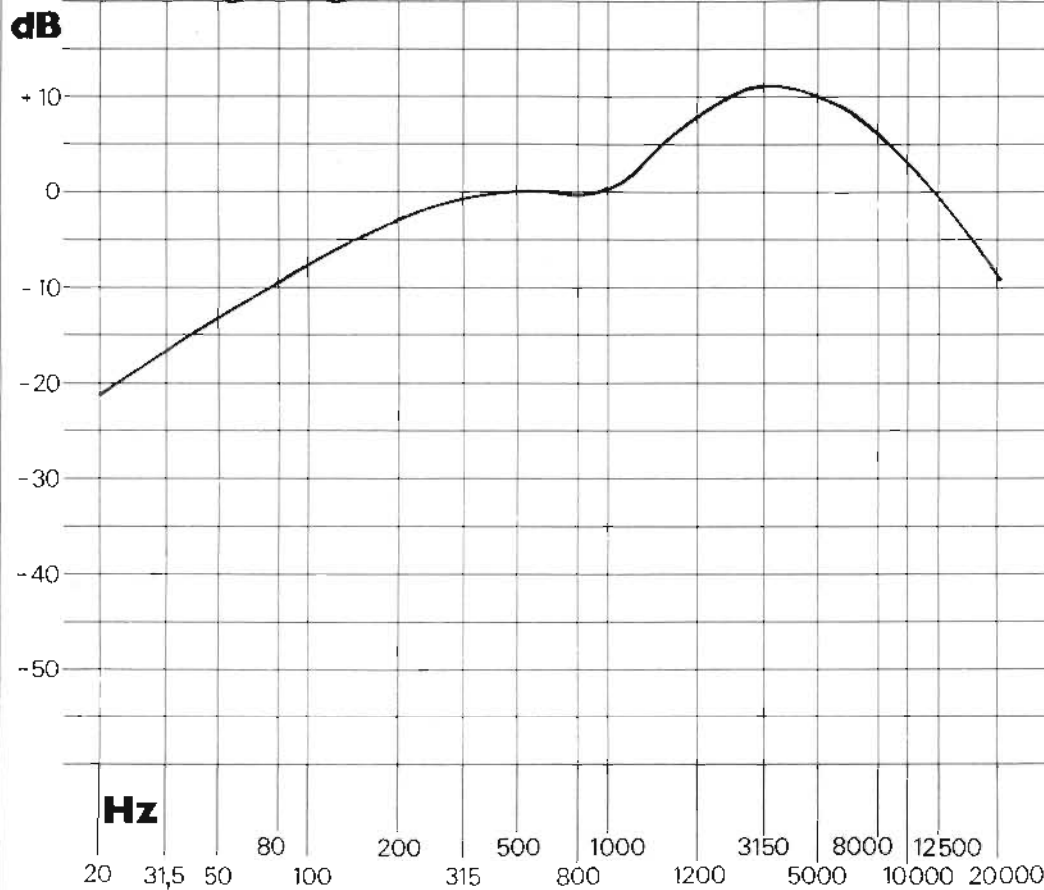

Frequency Hz	IEC Recommendation Relative Response dB	IEC Recommendation 537 Tolerance Limits (same as for iV-SJ) dB
20	-20.6	± 3.0
25	-18.7	± 2.0
31.5	-16.7	± 1.5
40	-14.7	± 1.5
50	-12.8	± 1.5
63	-10.9	± 1.5
80	-9.0	± 1.5
100	-7.2	± 1
125	-5.5	± 1
160	-4.0	± 1
200	-2.6	± 1
250	-1.6	± 1
315	-0.8	± 1
400	-0.4	± 1
500	-0.3	± 1
630	-0.5	± 1
800	-0.6	± 1
1000	0.0	± 1
1250	2.0	± 1
1600	4.9	± 1
2000	7.9	± 1
2500	10.4	± 1
3150	11.6	± 1
4000	11.1	± 1
5000	9.6	± 1.5
6300	7.6	+1.5 -2.0
8000	5.5	+1.5 -3.0
10000	3.4	-2.0 -4.0
12500	1.4	+3.0 -6.0
16000	-0.7	+3.0 -∞
20000	-2.7	+3.0 -∞

# INSTRUCTION MANUAL

## NAGRA IV-SJ



### 3 Directions for use

#### 1. BASIC EQUIPMENT

##### 1.1. Installation of Batteries or Accumulators

Select the type of battery or accumulator according to the expected working conditions for the recorder (see Section 4). Turn the recorder over so that it is resting on its lid; turn the screws marked A and remove the cover of the battery compartment. Insert the 12 cells in the position shown;

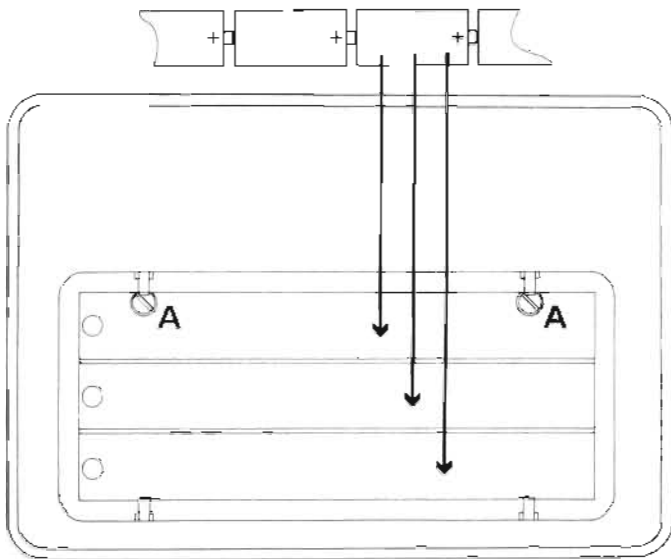

then replace the cover and secure it by turning the screws marked A. Set POWER switch 3 on **Batt.**

##### 1.2. Connection of an External D.C. Source

Connect the 12-30 V voltage source to the POWER PACK connector 48, with the negative pole to pin 5. Set POWER switch 3 on **External.**

##### 1.3. Connection of Mains Power Supply

Connect an ATN or ATN 2 mains power supply to the POWER PACK connector 48. If necessary, check the position of the voltage selector. Set POWER switch 3 on **External.**

##### 1.4. To Check the Power Supply:

Turn METER FUNCTION switch 12 to **BATT.** and main selector switch 4 to **TEST**: the red needle of meter 14 indicates on the lowest scale the unstabilized battery voltage expressed for one cell: the total voltage is therefore obtained by multiplying the meter reading by 12. The pointer at 1.25 V indicates the minimum voltage at which the manganese dioxide batteries should be recharged so that they are able to go through the discharge/charge cycle several dozen times (see Section 4). Turn main selector switch 4 back to **STOP.**

#### 2. CONNECTION OF SIGNAL SOURCES

Since the two direct recording channels are identical, instructions are given for channel 1 only, but they are also valid for channel 2.

##### 2.1. Connection of a High Level Line

The recorder can be connected to an appliance or a measuring instrument, the output voltage of which is equal to or higher than 1 mV RMS: input is direct on the main attenuator and input impedance is 100 k $\Omega$ .

The lower the output impedance of the signal source, the better the signal to noise ratio is.

The external signal source is connected to connector 42: the wiring of the corresponding plug is shown in General View II on the inside cover. Selector 10 will then be on **LINE.**

##### 2.2. Connection of a High Level Microphone or Transducer

Input identical to 2.1., but using connector 37, with selector 10 on **MIKE.** The wiring of the plug is shown in General View II: only contacts 4, 5, 7 and 8 can be used; contact 3 supplies a -10 V stabilized voltage which can feed an external pre-amplifier, if desired.

### 2.3. Connection of the QJPA Preamplifier fitted with a Brüel & Kjaer Microphone Cartridge

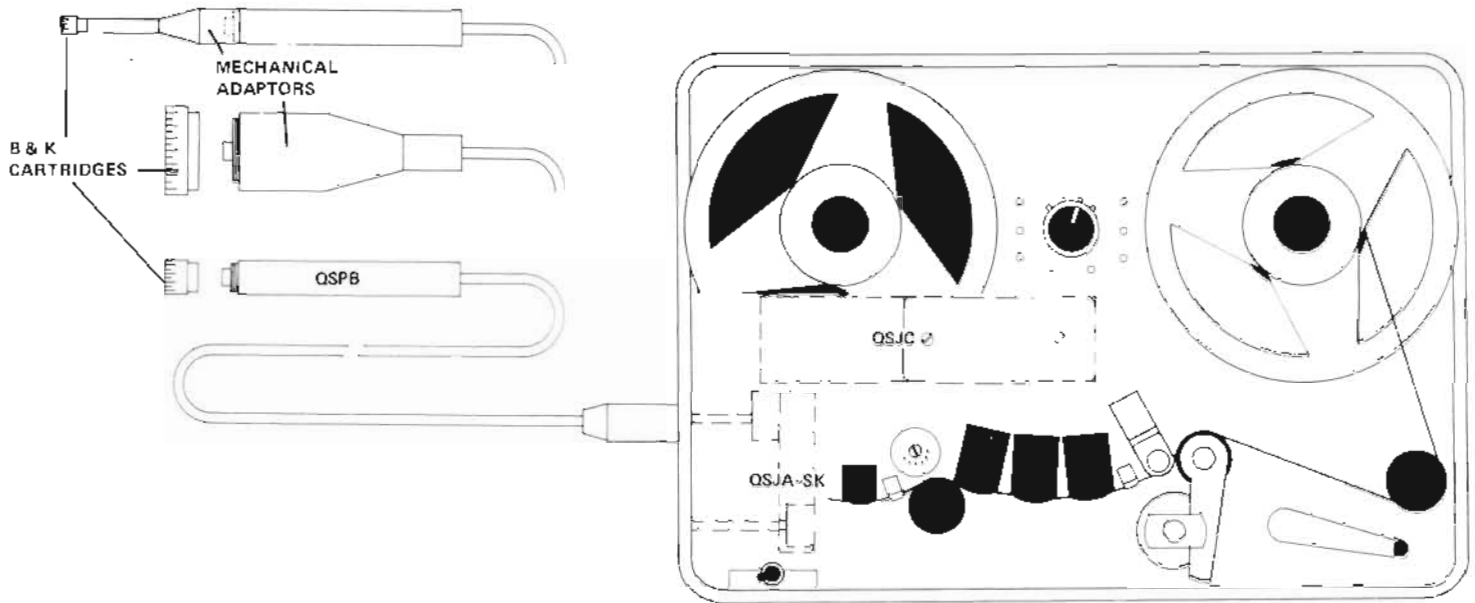

Brüel & Kjaer 1/2" 4133, 4134, 4149 and 4163 microphone cartridges screw directly onto the QJPA preamplifier, and the preamplifier output plug fits into microphone connector 37. Other cartridges can be screwed on using a mechanical adapter, i.e.

- 1": 4144, 4145, 4146 and 4161 type
- 1/4": 4135 and 4136 type
- 1/8": 4138 type.

The 25 m or 50 m. QCPA extension cable can be inserted between the output plug of the QJPA preamplifier and the microphone connector.

Set selector switch 10 on MIKE. The recorder must be fitted with the QSJA-BK microphone amplifier and the QSJC universal power supply.

#### Installation of QSJA-BK Amplifier

Lock the lid of the recorder, turn screws 50 several times and open the case to its full extent. Unscrew the connector between the microphone input wiring and the case interconnection board. Plug in and fix this connector to the microphone amplifier and secure the latter to the case interconnection board. Unscrew the level adapter board A. Carefully position the metal ground strap B and slip it under the ground comb C. The two switch spindles D should be passed through the corresponding holes in the box, then the blocking rings E threaded on. Introduce the spindle into the switches, press the rings against the ground strap and tighten them. Place the shield in position and fix it under the ground comb and under a nut screwed onto one of the two hinge fixing screws (this screw should be longer - M3x8). Reinstall the level adapter board A.

#### Installation of QSJC Power Supply

Plug in the power supply circuit and fix it with screw G to the connector. Pass a M2x6 flat head screw through from the inside of the battery box and through the bracket of the metal box, and fix with a nut.

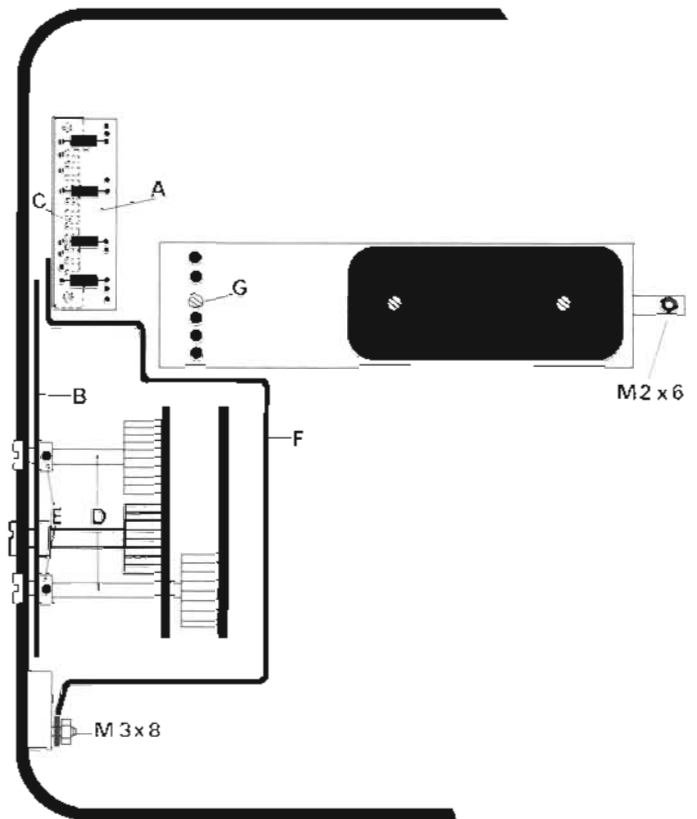

#### Signals and Voltages

Chassis connector external side or plug soldering side.

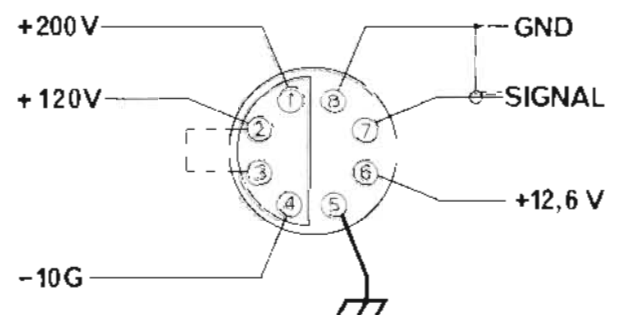

## 2.4. Connection of Brüel & Kjaer Amplifiers fitted with Brüel & Kjaer Microphone Cartridges

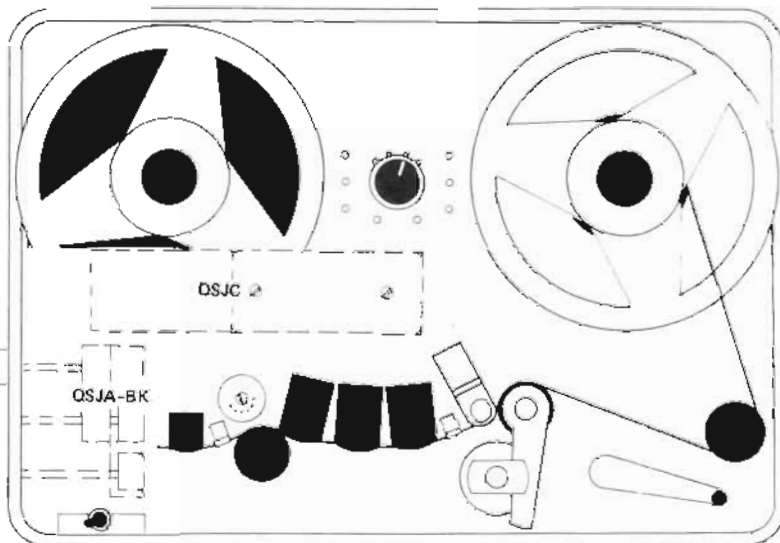
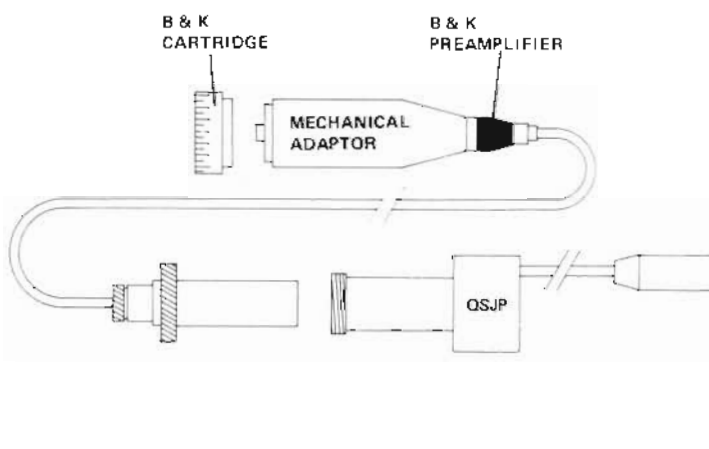

The following types of cartridges

- 1/2": 4133, 4134, 4149 and 4163
- 1": 4144, 4145, 4146 and 4161
- 1/4": 4135 and 4136
- 1/8": 4138

can be fitted to the following types of preamplifiers:

- 1", 1/2", 1/4" : 2615
- 1/2", 1/4", 1/8" : 2614
- 1", 1/2", 1/4", 1/8" : 2619
- 1" : 2627, 2612 and 2613
- 1/4", 1/8" : 2618

The cartridges can be fitted directly onto the preamplifiers when the diameters match; if they do not match, a mechanical adaptor can be used. The output plug of the preamplifier screws into the QSJP adapter and the plug of the preamplifier adapter fits into microphone connector 37: selector 10 should be on MIKE.

The recorder should be fitted with the QSJA-BK microphone amplifier and the QSJC universal power supply. These circuits can be installed as described in the preceding paragraph.

## 2.5. Connection of Sennheiser MKH 110 Measuring Microphone

The MKH 110 microphone consists of a capacitor cartridge and an electronic circuit with a low impedance output; microphone sensitivity is 2 mV/ $\mu$ bar. It should be connected to microphone connector 37 by the QCJ-MKH cable; selector 10 should be on MIKE.

The recorder should be fitted with the QSJA-MKH microphone amplifier, which also supplies the voltage for the microphone.

### Installation of QSJA-MKH Amplifier

Lock the lid of the recorder, turn screws 50 several times and open the case to its full extent. Unscrew the connector between the microphone input wiring and the case interconnection board. Plug in and fix this connector to the microphone amplifier and secure the latter to the case interconnection board. Unscrew the level adapter board. Place the shield in position and fix it under the ground comb and under a nut screwed onto one of the two hinge fixing screws (this screw should be longer - M3x8). Reinstall the level adapter board.

### Signals and Voltages

Chassis connector external side or plug soldering side

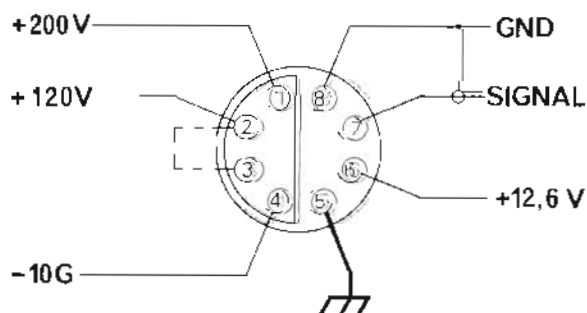

### Signals and Voltages

Chassis connector external side or plug soldering side

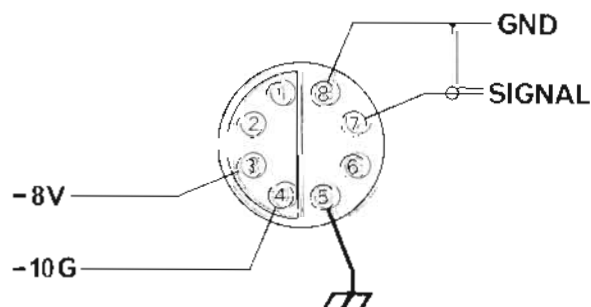

## 2.6. Connection of General Radio 1560-P42 Preamplifier fitted with a Microphone Cartridge

This preamplifier can be fitted with the same cartridges and mechanical adapters as the Brüel & Kjaer 2619 preamplifier. Its output plug fits into the input connector of the QSJP-GR adapter; the output connector of this adapter must be plugged into microphone connector 37; selector 10 should be on MIKE.

Preamplifier 1560-P42 can also be fitted with GR 1" and GR ½" ceramic microphone cartridges. When Brüel & Kjaer cartridges are being used the recorder should be fitted with the QSJA-BK amplifier and QSJC-power supply, version 2 only, which should be modified to supply the +16 V voltage required for the GENERAL RADIO preamplifier.

Version 2 of the QSJC power supply differs from version 1 (which can supply only +12 V) in the value of certain components, e.g. resistances R24 and R25:

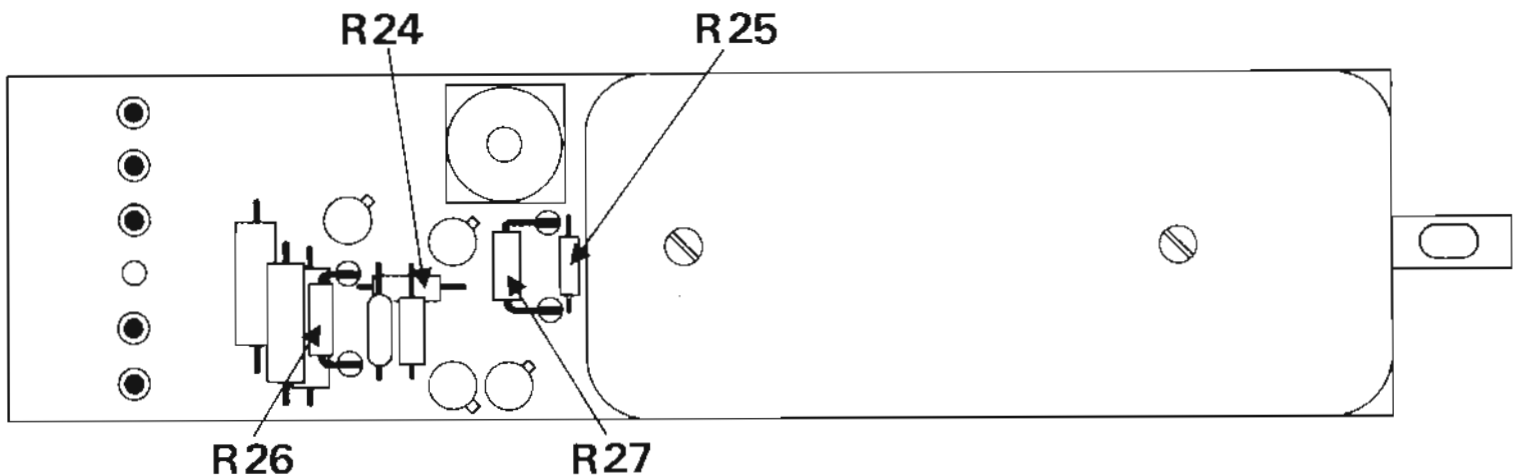

Version 1: R24 = 33 k $\Omega$ , R25 = 27 k $\Omega$   
no modification possible

Version 2: R24 = 47 k $\Omega$ , R25 = 33 k $\Omega$   
modification possible

It is not possible to transform a version 1 circuit into version 2, as the oscillator coil of the converter is different in each case.

Before modifying a version 2 circuit, it is essential to measure the negative voltage available at terminal 6 of connector CUE 47, in relation to the ground (terminal 7) with no modulation. Bridge terminals 5 and 2 and set main switch 4 on TEST; note the value of the negative voltage at terminal 6 (see paragraph 7.6 for the meaning of this value).

To obtain a +16 V voltage, remove resistance R26 (180 k $\Omega$ ), which is soldered to two pins; it is not necessary to dismantle the circuit.

After this modification has been made, the voltage available at terminal 6 of connector CUE 47 should be adjusted to the value noted before the modification was made; this can be done by adjusting

potentiometer R83 of circuit A24 (THIRD TRACK CIRCUITS). If it is impossible to obtain the value noted, replace resistance R82 of this circuit by a 10 k $\Omega$  resistance and adjustable potentiometer R83 by a 2.2 k $\Omega$  model.

### Signals and Voltages

Chassis connector external side or plug soldering side

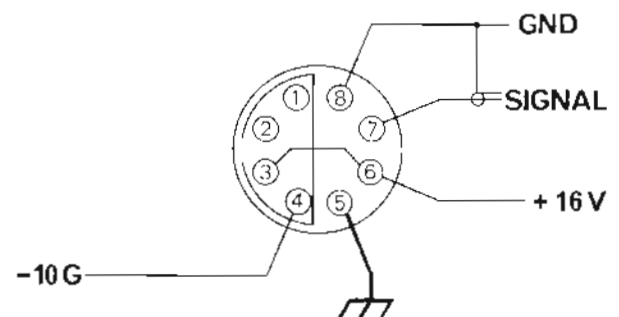

### 3. DIRECT MEASUREMENT OF SIGNALS

#### 3.1. Position of the Controls

Set switch **1** on **DIRECT**: switch **2**, which cannot be locked in position, remains on **DIRECT**. Turn main selector switch **4** to **TEST**: the circuits are then switched on and will stabilize after about 10 seconds.

#### 3.2. Selection of Measuring Circuit

Set the **METER FUNCTION** switch on one of the **LEVEL** positions:

- **RMS FAST** : average value of the signal on the **RMS** scale of meter **14**, integration time 200 ms.
- **RMS SLOW** : average value of the signal on the same scale, but integration time 500 ms.
- **PEAK**: peak value of the signal, on the **PEAK** scale of meter **14**, integration time 5 ms, with a memory circuit holding the signal for about 1 second.

The measuring circuit of the recorder should be selected in accordance with the criteria given in Section 3.

#### 3.3. Adjustment of the Monitoring Circuit

The signals can be monitored on the headphones with switch **4** in any position and with the built-in loudspeaker on **PLAYBACK with Loudspeaker** (see 6.).

The mono headphones, impedance 50 to 600  $\Omega$ , plug into jack **17**. The required channel can be selected with switch **18** and the loudness regulated by potentiometer **19**, which can be adjusted with a screwdriver.

#### 3.4. Choice of Sensitivity

##### 3.4.1. High-level Signals on the Line Input

Set selector **10** on **LINE**, turn main attenuator **7** fully to the left, or on **GND**, set vernier attenuator **7A** on **0 dB (CAL.)**.

Switch on the signal source connected to the line input. While watching meter **14**, turn main attenuator **7** to the right until the red needle makes a visible movement. Calculate the value measured as described in paragraph 3.6.1.

##### 3.4.2. High-level Signals on the Microphone Input

Same procedure as in the preceding paragraph, but with selector **10** on **MIKE**.

##### 3.4.3. Low-level Signals on the Microphone Input QSJA-BK AMPLIFIER

With selector **10** on **MIKE**, set vernier attenuator **7A** on **0 dB**.

Turn the cartridge type selector **40** to the position which corresponds to the diameter of the cartridge used. On  $\frac{1}{4}$ " the positions of gain selector **39** become +40, +60 and +90 dB, values inscribed in a circle.

Turn attenuator **7** to +20 dB and watch meter **14**. If the needle moves noticeably beyond +20 dB **PEAK** or +10 dB **RMS** turn switch **39** to +80 dB. If the needle is clearly below 0 dB, turn switch **39** to +40 dB. Calculate the value measured and take into account the restrictions described in paragraph 3.6.3.

##### QSJA-MKH AMPLIFIER

This amplifier has no gain selector or cartridge type selector. The sensitivity can be determined by main attenuator **7** only.

##### AMPLIFIER FOR GENERAL RADIO MICROPHONE

The amplifier for use with the **GENERAL RADIO** microphone is the **QSJA-BK**; please refer to the above instructions for using this amplifier.

#### 3.5. Choice of Filter

When filter selector switch **11** is on **LIN**, the frequency response of the direct chain is linear at  $\pm 0.3$  dB from 2.5 Hz to 35 kHz. Selector switch **11** should be set on one of the following positions according to the kind of measurements being taken:

**HP**: high-pass filter, attenuation 3 dB at 20 Hz, 12 dB per octave

**WEIGHTING A, B, C, D**: weighting of the frequency response as determined by international standards, the exact value of which is given at the end of the section entitled **Specifications**.

The **HP** position should be used systematically when the measurement of signals is not extended to very low frequencies: in fact, since these are inaudible, they are likely to falsify results and, in some cases, saturate the amplifiers. Furthermore, this position eliminates very low frequency noise from the cartridge itself.

The weighting positions **A, B, C** and **D** are used, in the case of noise measurement, to obtain a value corresponding to the subjective impression felt by the human ear (see Section 1).



### 3.6. Calculation of the Value Measured

#### 3.6.1. Measurement of High-level Signals by the Line Input

A 1 mV sine wave signal applied to the line input gives a reading of 0 dB on the PEAK scale or on the RMS scale, when main attenuator 7 is on 0.001 V or 0 dB.

Meter 14 is graduated in decibels only; since the value indicated by main attenuator 7 corresponds to a reading of 0 dB on the meter, the exact value of the signal – in decibels in relation to the 0 dB reference level – is obtained by adding algebraically the value shown on meter 14 to the value shown on main attenuator 7 and, when necessary, on vernier attenuator 7A. The number of decibels obtained should then be converted into a voltage ratio, and the line input voltage deducted from the 1 mV reference voltage.

It is a convention in electro-acoustics to express measurements taken at peak value in terms of the RMS value which would be given by a sine wave signal with the same peak value; the input sensitivity and the output voltage of the recorder are therefore expressed in terms of their RMS value, assuming the signals are sine wave.

On RMS, the measuring circuit of the recorder responds to the RMS value of the signal and indicates, after decibel/voltage conversion, the RMS value.

On PEAK, the measuring circuit of the recorder responds to the peak value of the signal and indicates, after decibel/voltage conversion, a value which is the RMS value of the signal only if it is a pure sine wave; the actual peak value, whatever the form of the signal, is obtained by multiplying the value indicated by 1.414.

A 1 mV RMS sine wave signal applied to the line input, with the attenuators on 0 dB, gives an identical reading on PEAK and on RMS, which is equal to 0 dB,

A signal without a well-defined form, applied to the line input, gives the following values after decibel/voltage conversion of the reading:

- on PEAK, peak value divided by 1.414
- on RMS, RMS value

The line input impedance is 100 kΩ. On the maximum sensitivity position (0 dB) there is no increase in input noise as long as the sound source impedance remains low in relation to the 100 kΩ input impedance.

Select the attenuator position for which the needle of the meter shows the closest possible value to +10 dB RMS or +20 dB PEAK, **without exceeding this limit**. The attenuator knob then indicates a decibel value which, when added to the

value shown by the needle, makes it possible to determine the voltage applied to the input, i.e. for x dB:

$$\text{input voltage in millivolts} = 10^{\frac{x}{20}}$$

Basically, vernier attenuator 7A remains on 0 dB (CAL.). With this attenuator it is possible to make a fine adjustment, if necessary, in steps of 1 dB: the value shown by its switch should be added to that of main attenuator 7.

The graduations in dB of attenuators 7 and 7A and meter 14 are also usable for relative measurements without pinpointing the reference.

#### 3.6.2. Measurement of High-level Signals by the Microphone Input

Proceed in the same way as described in the preceding paragraph, but with selector 10 on MIKE.

#### 3.6.3. Measurement of Low-level Signals by the Microphone Input

The sound level, measured in decibels, in relation to the  $2 \cdot 10^{-5}$  N/m<sup>2</sup> reference level, is equal to the algebraic sum of the values indicated by gain selector 39, main attenuator 7, vernier attenuator 7A, the reading on meter 14 and a specific correction value given according to the cartridge and amplifier circuits used.

The correction value includes, amongst other things, a correction factor  $K_0$ . This is the difference, expressed in decibels, between the sensitivity of a standard cartridge (50 mV/N/m<sup>2</sup>) and the actual sensitivity measured in the laboratory by the manufacturer. The  $K_0$  factor is given in the calibration chart issued with each Brüel & Kjaer microphone cartridge.

To facilitate the reading of meter 14 the needle should be as near as possible to the +20 dB PEAK or +10 dB RMS values, without exceeding them. If the signal is too weak when attenuator 7 is on +20 dB, turn the knob to the right; if the reading is still too low when the attenuator is on 0 dB, turn gain selector 39 from +60 dB to +40 dB. If necessary, readjust main attenuator 7.

If the signal is too strong when attenuator 7 is on +20 dB, turn its knob to the left; if the reading is still too high when the attenuator is on +40 dB (marked with an arrowhead), move gain selector 39 from +60 dB to +80 dB.

The arrowhead opposite the +40 dB position on attenuator **7** is to remind the user that certain restrictions must be observed in order to avoid saturation of the input circuits, when measurements are taken by microphone, preamplifier and amplifier.

The performance of the microphone cartridges and input amplifier circuits is restricted by the occurrence of saturation phenomena which are produced when the sound level measured becomes very high. These phenomena may be detected by a trained ear if measurements are being taken and monitored simultaneously (see 3.3.), and if the operator is not exposed acoustically to the sound source. If the phenomena pass unnoticed the measurement will be incorrect. The only sure way to avoid saturation and its consequences is to impose a limit on the attenuator which directly follows the input circuits; when the attenuator is at this limit, any sound signal which makes the needle of meter **14** deviate to the right to its fullest extent, saturates the input circuits and cannot be measured. In this case, the amplifier gain must be reduced by turning its selector from +40 dB to +60 dB or from +60 dB to +80 dB; if saturation still occurs on this position it means that the output level of the transducer used is too high. A less sensitive transducer should then be used or an attenuator inserted between the transducer and the preamplifier.

### 3.6.3.1. Limits and Corrections with the QJPA Preamplifier and QSJA-BK Amplifier

Same as below

The preamplifier gain "G" is the same as for Brüel & Kjaer 2619 preamplifier.

### 3.6.3.2. Limits and Corrections with Brüel & Kjaer Preamplifiers and the QSJA-BK Amplifier

When main attenuator **7** is opposite the reference at +40 dB, there is no risk of saturation as long as the needle of meter **14** does not move beyond +20 dB PEAK, with gain selector **39** on +40 or +60 dB; when the latter is on +80 dB (+90 dB for a ¼" cartridge), the main attenuator may be set beyond the +40 dB position as saturation then depends only on the cartridge used and the corresponding preamplifier.

With cartridge type selector **40** in the position corresponding to the cartridge used, the sound level is obtained by direct reading when the potentiometer of the QSJP adapter is adjusted to a correction value K, given in dB by the following relation:

$$K = K_0 - G - X$$

- $K_0$  = open circuit correction factor given by the manufacturer
- $G$  = preamplifier gain in relation to the type of cartridge and its mechanical adapter given by the manufacturer
- $X$  = difference between the typical sensitivity of the cartridge and the 50 mV/N/m<sup>2</sup> reference value, in accordance with the following table:

Type of cartridge	1"	½"	¼"	¼"	⅛"
			4135	4136*	4138**
X in dB	0	+12	+22	+30	+34

\*With the ¼" cartridge 4136, 8 dB must be added to the calculated value to obtain the sound level (X takes into account the adjustment range limits of the QSJP adapter).

\*\* Cartridge type selector **40** on ¼"; add 12 dB to the calculated value to obtain the sound level.

#### Example

½" cartridge 4133 with preamplifier 2619:

$K_0 = +12.2$  dB       $G = 0.4$  dB       $X = +12$  dB

Value to which the potentiometer of the QSJP adapter should be adjusted:

$$K = 12.2 + 0.4 - 12 = +0.6 \text{ dB}$$

### 3.6.3.3. Limits and Corrections with the MKH 110 Microphone and the QSJA-MKH Amplifier

The QSJA-MKH amplifier does not in any way alter the performance of the microphone and its electronic circuit; reference should be made to the sound level limits indicated by the manufacturer for saturation and background noise.

**Correction:** With the MKH 110 microphone add 60 decibels to the value set on main attenuator 7 and to the value shown by meter 14. With the MKH 110-1 microphone add 80 dB.

### 3.6.3.4. Limits and Corrections with the 1560-P42 GENERAL RADIO Amplifier

As the QSJA-BK amplifier is being used, the same limits and corrections as those given in paragraph 3.6.3.2. are valid.

The G value, which represents preamplifier gain in relation to the type of cartridge, is shown in the following table.

Type of cartridge	1/2"	1/4"
G in dB	-2.5	-6

### IMPORTANT

In all cases where there is uncertainty about the sensitivity, the K correction factor of the cartridge, or the gain of the input circuits, we recommend the use of a calibration device. This device is applied to the cartridge and produces a calibrated sound level of a precisely known value. The Brüel & Kjaer pistonphone and the acoustic calibrator produce a fixed frequency signal; with calibration equipment using an electrostatic actuator for condenser microphones it is possible to calibrate at different frequencies.

## 4. RECORDING OF SIGNALS

### 4.1. Choice of Tape

It is essential to use the type of magnetic tape for which the recorder was adjusted at the factory; it is only in this way that the values indicated in the technical specifications (Section 2) can be obtained. It is possible to use another type of tape by re-adjusting the bias, equalization and recording level.

The performance obtained may differ from the values shown in the test report issued with each recorder; it is necessary to check the results obtained with a new tape before using the recorder for taking accurate measurements.

The positions of bias selector switch 21 correspond to steps of 10%.

The length of the recording to be made is also a determining factor in choosing the tape speed. Place speed selector 20 on the position corresponding to the wanted speed; the speed can be switched while the tape is running without damaging the recorder.

### 4.3. Threading the Tape

Pull lever 32 forward to its fullest extent. Place a full reel on the left-hand spindle (24) and fix it in position with the knurled nut; place an empty reel on the right-hand spindle (34) and fix it in position. Lower the head shield. Unwind the tape slowly from the supply reel and thread it across the two tension rollers 25 and 33 to wind it onto the take-up reel; turn this reel a few times so that the tape is pulled taut.

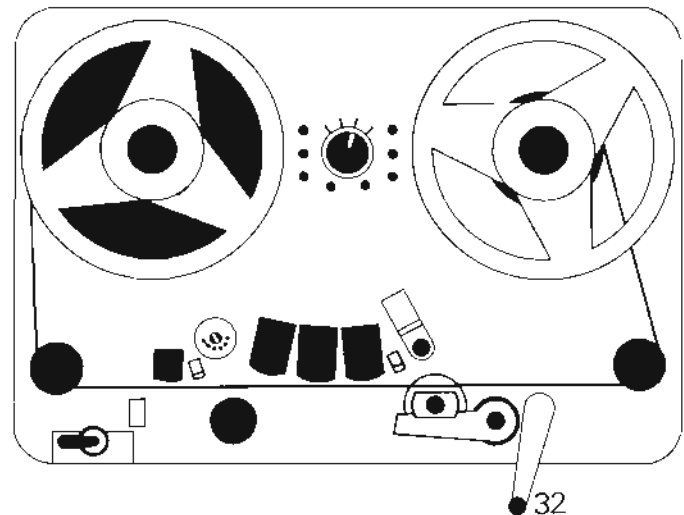

Push lever 32 backwards to its fullest extent. Raise the head shield.

### 4.2. Speed Selection

The tape speed should be selected in relation to the upper and lower limits of the frequency response:

- at 15"/s (38 cm/s) : 25 Hz to 35 kHz  $\pm 1$  dB
- at 7.5"/s (19 cm/s) : 25 Hz to 20 kHz  $\pm 1$  dB
- at 3.75"/s (9.5 cm/s) : 25 Hz to 10 kHz  $\pm 1$  dB
- at 1.5"/s (3.8 cm/s) : 25 Hz to 3.5 kHz  $\pm 1$  dB

At 1.5"/s recording is possible from 2.5 Hz, with playback by transposition (see 4.8).

When the tape speed is being selected recording equalization should also be taken into account; this is higher for low speeds and may cause tape saturation when the signal frequency is high, even if the modulometer shows the recording level to be correct (see 4.7.2. Restrictions).

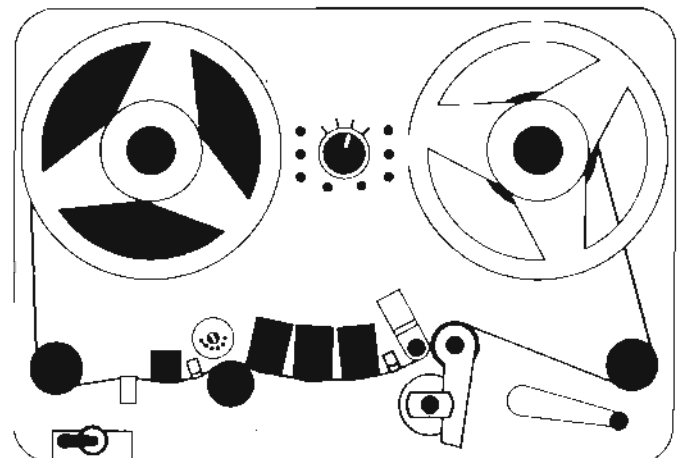

which is similar to the distribution spectrum of the spoken word and of music – was used as the basis for an inverted curve which determines the possible pre-emphasis. For the three higher speeds, emphasis and de-emphasis conform to the recorder standard (mentioned in the test report and marked on plate 51). For the 1.5" speed, which is used in particular for recording very low frequency signals to be played back by transposition at 15"/s, the emphasis has been calculated in relation to compatibility for playback at 15"/s.

The emphasizing of signals during recording in accordance with the standards has the advantage of making it possible to play back the tapes on any conventional recorder. On the other hand, this process has one disadvantage: the frequencies affected by emphasis are likely to cause tape saturation, even if the recording level indicated on meter 14 is correct. In fact, emphasis occurs in the recording amplifier, i.e. after the measuring circuit, which cannot under any circumstances indicate it.

Pre-emphasis depends on the tape speed: the lower the speed the higher the treble emphasis will be. Furthermore, the NAB standard also requires bass pre-emphasis which, however, should not exceed 6 dB at the lower limit of the recording frequency response. Treble pre-emphasis therefore predominates and, to avoid saturating the tape, high frequency signals must be recorded below the maximum recording level (+20 dB PEAK). Taking into account the difference between the NAB and CCIR standards, if a recording is made at 6 dB below the maximum level, i.e. at +14 dB PEAK, there is no risk of saturation, as long as the signal frequency is not higher than:

- 20 kHz for the 15" speed
- 14 kHz for the 7.5" speed
- 5 kHz for the 3.75" speed
- 2.5 kHz for the 1.5" speed.

Since the pre-emphasis curve shows a rise of about 6 dB per octave, it is possible to calculate the pre-emphasis value at a different frequency and deduct the recording level reduction in relation to the +20 dB maximum peak level.

#### 4.7.3. Signal-to-noise Ratio

When gain selector 39 is on +40 dB and attenuator 7 on 0, maximum amplification can be obtained. It is possible to measure signals at about +30 dB; meter 14 then shows -10 dB, which is the limit of readability. These signals are very weak, but can nevertheless be recorded as such without decreasing the signal-to-noise ratio of the cartridge and input circuits. Thus, by using a Brüel & Kjaer 4133 cartridge with its preamplifier and QSJP adapter, the weighted noise level is 30 dB; with a 40 dB signal the signal-to-noise ratio is 10 dB.

In the record/playback mode, the weighted signal-to-noise ratio is always higher than 60 dB,

which means that noise inherent to the recording is 60 dB below the maximum recording level: this level is reached when meter 14 indicates +20 dB PEAK and, as gain selector 39 is on +40 dB, the 60 dB difference brings the noise level produced during recording to 0 dB, i.e. to the  $2.10^{-5}$  N/m<sup>2</sup> reference level. For the 40 dB signal the signal-to-noise ratio would also be 40 dB, therefore clearly higher than the 10 dB signal-to-noise ratio obtained with the cartridge and the input circuits used.

In practice, while the signal of the transducer and input circuits is below 60 dB, the noise level does not increase when the signal is recorded. On the other hand, as soon as the sound level reaches 100 dB, the signal must be kept as near as possible to the maximum recording level in order to obtain the highest possible signal-to-noise ratio. To record, set main selector switch 4 on TEST; allow the circuits to stabilize for about ten seconds, then switch to RECORD: the tape begins to run.

#### 4.7.4. Tape Monitoring during Recording

When main selector 4 is on TEST, the direct signal is present at the line outputs 43 and headphones output 17 according to the position of track selector 18.

When selector 4 is on RECORD and switch 1 on DIRECT, it is again the direct signal which is present at the outputs; but, if switch 1 is on TAPE, the recorded signal is immediately played back and will be present at the line and phones outputs.

Switch 2 fulfils the same function for meter 14, which indicates the direct signal on DIRECT and the playback signal on TAPE; this switch springs back automatically to DIRECT.

TAPE/DIRECT switches 1 and 2 make it possible to check the quality of the signal during recording; any audible or visible deterioration of the signal indicates a false manoeuvre or defect.

#### 4.8. Frequency Transposition

Playback of signals recorded at a very low frequency is difficult because of the smallness of the NAGRA IV-SJ playback head and the lower limit of the frequency response of the amplifiers. To analyse signals with a frequency between 2.5 Hz and 35 Hz, set the speed selector 20 on 1.5" = 3.81 cm/s, the filter selector 11 on LIN, and meter function selector 12 on RMS SLOW; this position gives a more accurate reading than RMS FAST and PEAK, which have too rapid a characteristic.

Playback is at 15" = 38.1 cm/s in the usual way (see 6.).

## 5. REWIND AND RAPID ADVANCE

After completing a recording turn main switch 4 back to TEST; if the series of recordings and measurements is finished, turn the switch to STOP.

### 5.1. Rewind

Pull down the head shield, pull lever 32 fully to the left and place main selector switch 4 on TEST, then push switch 23 to the left onto REW.: the tape rewinds onto supply reel 24. After rewinding the tape, reset switch 23 in the vertical position, put main switch 4 on STOP and remove the reel. In the case of partial rewind, wait for the tape to stop running, push lever 32 to the right to its fullest extent and raise the head shield; the recorder is then ready for playback or to make a new recording. The tape can be rewound when main switch 4 is in any position except STOP. This means, for example, that the tape can be monitored during rewind to pinpoint the beginning of a sequence: the main selector must then be on **PLAYBACK with Loudspeaker** and the head shield must be raised before switch 23 is turned to REW.: the recorded signals, played back rapidly and backwards, are transmitted through the loudspeaker. To monitor on the headphones only, rewind with the main selector switch on **PLAYBACK**.

### 5.2. Rapid Wind

It is possible to increase the winding speed of the tape, to find a particular sequence, for example. The tape can be wound rapidly on **PLAYBACK with Loudspeaker** only: with lever 32 pushed to the right to its fullest extent, set main switch 4 on **PLAYBACK with Loudspeaker**; the tape winds at its normal speed. Flick switch 23 to the right: the tape winds rapidly. When the required spot on the tape is reached set switch 23 in the vertical position and quickly turn the main selector switch to STOP.

## 6. PLAYBACK OF RECORDED SIGNALS

### 6.1. Direct Playback

With lever 32 pushed back to the right to its fullest extent, set switch 1 on TAPE and main selector switch 4 on **PLAYBACK**. The tape begins to move and the recorded signals are present at the outputs:

**Connector 43:** 100 mV line output voltage for a recording level of 0 dB (20 dB below the maximum level indicated on PEAK); the input impedance of the accessories connected to this output must be higher than 10 k $\Omega$ .

**Banana jacks 45 and 46:** same characteristics as for connector 43.

**Multiple connectors 41 and 42:** playback output voltage 10 mV for a 0 dB recording level, on contact 4, ground on contact 7; the input impedance of accessories connected to this output must be higher than 47 k $\Omega$ .

For simultaneous monitoring on the headphones, use selector 18 to select the channel; adjust the loudness with potentiometer 19. For loudspeaker monitoring set main selector switch 4 on **PLAYBACK with Loudspeaker** and use selector 18 to select the channel; the loudness is not adjustable. Care should be taken that switch 23 is not flicked to the right, which would put the tape on rapid wind (see 5.2.).

The output level reading can be obtained by holding switch 2 on TAPE during playback; as during recording, selector 12 determines the type of reading, PEAK or RMS

### 6.2. To Reintroduce a Signal into the Direct Chain

On playback, the recorded signal can be reintroduced into the line input of the corresponding channel by screwing a strap plug onto the multiple connector (41 or 42) of the channel, which connects contacts 4 (output) and 1 (input) to each other. Input selector 9 or 10 must be on **LINE** and switch 1 on **DIRECT**. In fact, the recorded signal passes through the whole direct chain, attenuator and filter again and is present at the line outputs, connector 43 and banana jacks 45 or 46: it can therefore be attenuated and filtered a second time.

At the line output the playback level (switch 1 on TAPE) is equivalent to the level after reintroduction into the direct chain (switch 1 on **DIRECT**) when attenuator 6 or 7 is on +20 dB or 0.01 V, and vernier attenuator 6A or 7A is on 0. A signal recorded at 0 dB produces a 10 mV voltage at the output of multiple connector 41 or 42; this voltage reintroduced at the line input gives a reading of 0 dB if the attenuator is on 0.01 V.

### 6.3. Interpretation of the Recorded Signals

It is necessary to fix a reference during recording so that, when the recorded signals are analysed, the exact value of the sound level can be determined.

#### 6.3.1. Written or Recorded Reference

Before recording is begun, the position of the microphone amplifier gain selector (38 or 39), the main attenuator (6 or 7) and the vernier attenuator (6A or 7A) should be noted on the recording data sheet, or dictated on the third track using the QSCM microphone. On playback, with METER switch 2 and LINE & PHONES switch 1 on TAPE, meter 14 will indicate the same value as during recording and the output voltage will be in proportion to the meter reading. If the tape is analysed on the recorder itself, it is sufficient to add, in the usual way, the value shown by the meter to the attenuator and gain selector readings, which were taken during recording. If analysis is done with the recorder connected to external analysing equipment, the output voltage can be compared with the 0 dB references given in paragraph 6.1., thus making it possible to determine the fraction of the sound level given by the meter reading and to calibrate the equipment. Finally, if analysis is done on a recorder other than the NAGRA IV-SJ, the same fraction of the sound level will be deducted from the tape flux, the 0 dB meter reading corresponding to 32 nWb/m on the tape.

**In all cases, the position of the attenuators and that of the microphone amplifier gain selector must be known in order to determine the sound level at the time of recording.**

The accuracy of the meter reading on playback depends on the quality of the tape used; even if it is the kind of tape for which the recorder was adjusted, the difference between the reading on TAPE and on DIRECT may reach 2 dB.

#### 6.3.2. Recorded Internal Reference Signal

This method is more rapid and more accurate, but still requires written notes or commentary on the third track; it can be used to eliminate the playback level inaccuracy due to the dispersion of the characteristics of a tape of the same type. The reference generator built into the recorder applies a calibration signal to the output of the direct amplifier, without passing through the attenuators. When the microphone amplifier gain selector and the attenuators are adjusted to obtain a correct recording, the reference signal must be recorded at the beginning of the tape and note taken of the sound level to which it corresponds. This signal will be used on playback for finding the sound level again by conversion.

**Example:** the gain selector of the microphone amplifier is on +60 dB, the main attenuator on +30 dB and the vernier attenuator on 0 dB; record the reference signal: the meter shows +10 dB; the reference signal therefore corresponds to a sound level of  $60 + 30 + 10 = +100$  dB. During analysis the equipment will be calibrated at +100 dB when the reference signal is played back.

#### 6.3.3. Recorded External Signal Reference

An acoustic signal with a known sound level can be used as a reference during recording. The B & K pistonphone supplies a 250 Hz signal at 124 dB  $\pm 0.2$  dB, and the B & K calibrator a 1 kHz signal at 94 dB  $\pm 0.3$  dB.

Insert the microphone into the sound source and check the calibration of the recorder by trying to obtain a deviation on the meter between 0 and +10 dB, then record this signal noting the position of the microphone amplifier gain selector and that of the attenuators. On playback this signal will represent a reference at +124 or +94 dB.

If the signal to be analysed is at a very different sound level, after calibration has been checked, the gain selector and the attenuators must be reset in a position which allows correct recording, and the positions noted again. On playback the level of the recorded reference signal no longer corresponds to +124 or +94 dB; it should be calculated by adding the difference in decibels between the first and second reading to these values.

**Example:** the gain selector is on +80 dB, the main attenuator on +40 dB and the vernier attenuator on 0 dB; using the pistonphone, the reference signal will be indicated at +4 dB ( $80 + 40 + 0 + 4 = +124$  dB) and recorded. The signal to be analysed must be recorded with the gain selector on +60 dB, the main attenuator on +30 dB, the vernier attenuator on 0 dB, and it gives a reading of +10 dB; its level is therefore  $60 + 30 + 0 + 10 = +100$  dB.

Attenuation indication for the reference signal:

$$80 + 40 + 0 = 120 \text{ dB}$$

Attenuation indication for the signal to be analysed:

$$60 + 30 + 0 = 90 \text{ dB}$$

Difference:  $90 - 120 = -30$  dB

Apparent level of the reference signal on playback:

$$124 - 30 = +94 \text{ dB}$$

# INSTRUCTION MANUAL

## NAGRA IV-SJ

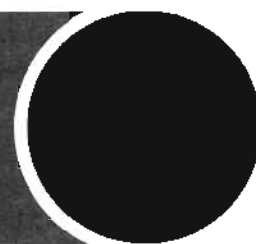

## Batteries and Accumulators

### 4

The NAGRA IV-SJ or IV-SJS has space for 12 1.5 V cells (nominal voltage). Batteries conforming to CEI (e.g. R20 type) or ASA (e.g. D or L90 type) standards are suitable; their diameter should not exceed  $1\frac{5}{16}$ " (33.5 mm) and they should be between  $2\frac{1}{32}$ " (59.5 mm) and  $2\frac{15}{32}$ " (62.5 mm) long.

The central electrode is positive and the can negative, with a few exceptions; polarity is generally shown by  $\oplus$  and  $\ominus$  signs. If the batteries do not fit securely in the box, the cells can be packed with cotton wool, which will prevent them from producing unwanted noise while the recorder is in use. If the batteries are too short and do not produce the required contact, a mechanical adapter can be fixed to the contacts when they are used consistently.

#### 1. Power Supply Voltage

New carbon-zinc batteries supply a total voltage of 18 V. The recorder will still function correctly with 12 V at 15 ips (38 cm/s) and 11 V at the three low speeds, when it is in perfect condition and working at a normal temperature. The built-in voltage stabilizer means that the functioning of the recorder does not depend on the unstabilized supply voltage, except during fast wind which is at a speed in direct proportion to the supply voltage.

#### 2. Danger of Polarity Inversion

A diode connected in parallel on the power supply will short circuit it if polarity inversion occurs. The discharge current may overheat the wiring insulation, which disintegrates and produces corrosive agents. 2.5A fuses inserted in the battery box breaks the circuit; this fuses should be replaced if the

recorder still does not work after the cells have been replaced in the correct order.

#### 3. Check on Supply Voltage and Condition of the Batteries or Accumulators

Set meter function switch 12 on BATT. and main switch 4 on RECORD. The red needle of meter 14 shows the unstabilized voltage expressed for one cell (VOLTS/CELL); the total voltage is obtained by multiplying this reading by 12. Simultaneously the green needle indicates the voltage required by the motor, with the same reduction factor; the wider the angle between the two needles, the greater the voltage reserve.

The index at 1.25 V on the scale marks the minimum voltage at which manganese dioxide batteries should be recharged so that the discharge/recharge cycle can be repeated several dozen times.

SPEED & POWER indicator 16 gives a warning signal when the recorder is in operation: it shows a white segment when voltage and speed are correct, but turns black as soon as the supply voltage falls below the minimum admissible value.

#### 4. Operating Conditions

The following data have been extracted from documentation obtained from various suppliers. The list of makes quoted here is not exclusive; the manufacturers mentioned are those which provide the most accurate and readily-available information. KUDELSKI S.A. does not accept any responsibility for the degree of accuracy of the values indicated. In general, the performance of a battery cell or accumulator depends largely on the conditions and length of storage before use. Care should therefore be taken when suppliers are selected.



## 5. Leclanché Standard Batteries (carbon-zinc)

These batteries are light, inexpensive and sold everywhere. Their capacity varies considerably, depending on how they are used: it is high with low current, but low with high current and acceptable with an average current of about 350 mA, if periods of use are interspersed with rest periods during which the cells can depolarize (e.g. 4 hours use every 24 hours). Normally the batteries can be used at temperatures from 32° F (0° C) to 122° F (+50° C), and certain special types can be used at a lower temperature. If batteries are stored at or below 68° F (+20° C) their shelf life should be more than 12 months, with remaining energy content 75 to 90%. This is reduced to three months when the storage temperature is 104° F (+40° C). Above 122° F (+50° C) batteries deteriorate rapidly. Cold storage produces excellent results and certain cells retain their full capacity if deep-frozen.

A carbon-zinc battery is considered to be completely discharged when the voltage at its terminals falls to 0.9 V with normal current flow.

## 6. Manganese Dioxide Alkaline Batteries

Of more recent design, these batteries have a higher capacity, with the same current, than carbon-zinc batteries. They can be used between 4° F (-20° C) and 158° F (+71° C) and stored for more than 24 months at 68° F (+20° C) and even for more than 12 months at 113° F (+45° C) according to MALLORY. The discharge current is constant and does not require rest periods as there is no need to depolarize. However, these batteries are about 50% heavier and cost more than the standard type. They are suitable for use when:

- the temperature is unfavourable for carbon-zinc batteries
- a long storage period is required
- the ratio of weight or volume to recording hour must be as low as possible (ease of transport and forwarding)
- the recorder is used for long uninterrupted periods
- there is high power consumption using measurement microphones and preamplifiers with a heating circuit.

Some manufacturers indicate that it is possible to recharge their manganese batteries under certain conditions; WONDER sanctions recharging their manganese batteries when their charge falls to 80% of their total capacity. Voltage per cell is then 1.25 V and this value is indicated by an arrow on the VOLTS/CELL scale of meter 14.

Recharging can be done with a maximum current equivalent to one fifteenth of the nominal capacity, i.e. 0.5 A for a 7.5 A cell; charging should be stopped when the voltage at the cell terminals reaches 1.68 to 1.7 V. It is important not to continue

charging the cells beyond this limit, thus shortening their life. A completely discharged cell can also be recharged, but only once or twice.

### Warning

WONDER recommend recharging their battery cells: MALLORY forbid it and warn the user of the danger of explosion. EVEREADY produce a special cell which can be recharged.

Before recharging manganese batteries it is absolutely essential to consult the manufacturer or supplier to make sure that the type used lends itself to this procedure.

## 7. Mercury Cells

The capacity and shelf life of these cells are greater than for manganese batteries. However, they are heavier and more expensive and they do not perform so well at low temperatures, their lower limit being 50° F (+10° C), except for certain special types.

In the majority of cases polarity is inverted - the can is the positive pole - and a mechanical adapter is required for using the batteries with a NAGRA recorder; the only known exception is WONDER Pilat which has conventional polarity. As there is a high risk of inversion, the polarity of mercury batteries should be determined very carefully.

The voltage at the terminals of mercury cells remains almost constant at 1.2 V during discharge; it is therefore impossible to estimate their remaining capacity by measuring their voltage.

## 8. Danger of Leakage

Electrical energy is liberated through a chemical reaction which fundamentally alters the constituents of the battery cell and, in particular, attacks the can. When the cell is completely discharged, it may leak a corrosive liquid which can cause serious damage to the inside of the recorder. The batteries should therefore be checked frequently; if the recorder is not going to be used for several weeks, the batteries should be removed.

Leak-proof batteries are available which almost completely eliminate the risk of leakage.

## 9. Nickel-cadmium Accumulators

The information below is again based on documentation obtained from manufacturers and is an indication only, as the evaluation criteria used are different in each case.

### Length of Life

The essential advantage of accumulators is that they have a long life. Even if only 100 charge/discharge cycles can be obtained, the cost per hour of operation is approximately one-tenth that of battery

cells. The manufacturer of NIFE accumulators estimates that 1,000 charge cycles can be obtained.

#### Temperature

Excellent performance at high or low temperatures: EVEREADY indicate: normal discharge between 4° F (-20° C) and 104° F (+40° C) and possibly up to 158° F (+71° C) for short periods. NIFE indicate use at 22° F (-30° C) and authorise storage between -40° F (-40° C) and 122° F (+50° C), but all manufacturers are agreed that storage at above 68° F (+20° C) shortens the life of accumulators.

#### Recharging

Basically, an accumulator should be recharged with a current equal to one-tenth of its nominal capacity, i.e. 0.2 A for a 2 Ah cell. The PAR charger supplies, with an ATN or ATN2 power supply, a charge of 0.25 A, sufficient for recharging a medium-capacity accumulator in 12 to 14 hours. With this current, if the charge continues after the accumulator has regained its normal capacity, there is no risk of deterioration. Some accumulators can be charged rapidly on the condition that they are completely discharged beforehand; a NIFE RC40 accumulator can thus be recharged in one hour with 4 A. In this case it is essential to stop charging as soon as the accumulator is completely recharged in order to prevent serious damage.

#### Danger of Polarity Inversion

In NAGRA recorders the 12 cells are connected in series. Any one cell which has a slightly lower capacity than the others will be the first to become completely discharged. The current from the other cells will then flow through this cell and invert its polarity, which may seriously damage it. Certain types of cell are protected against inversion: for instance, the EVEREADY C2 can take an inverse current of 200 mA for 5 hours without any ill effects. The inversion of one cell produces a total voltage reduction of about 1.2 V, i.e. 0.1 V per cell. If discharge is stopped systematically whenever the meter shows 1.1 V/cell, there is practically no risk of inversion.

#### WARNING

Well-charged accumulators must never be mixed with partly or fully discharged ones in the same recorder as this will make it difficult to estimate how long they can be used or recharged, and also increase the risk of polarity inversion. A set of 12 accumulator cells is to be considered as a single unit which should always be charged and discharged as such. If necessary, unmatched cells can be used if each one is discharged beforehand through a resistor of a few ohms or a bulb; the cells should be recharged as one unit.

#### Storage

Some manufacturers advise the storage of nickel-cadmium accumulators in a state of discharge, as a chemical reaction may shorten their life if they are left to discharge by themselves. EVEREADY advise

the following procedure for charging cells which have been left to discharge themselves: begin by accelerating the discharge with a current between one-tenth and one-half the nominal capacity in Ah, then recharge at half the normal charging current, i.e. one-twentieth of the capacity in Ah. Charging time should be between 28 and 30 hours. After this first recharging phase the total capacity cannot be reached and a second discharge/recharge cycle is necessary. By analogy NIFE accumulators will be rechargeable with 0.25 A, the normal current of the PAR charger.

In general, storage at below 70° F (+20° C) is recommended, as the cold slows down all chemical reactions. A refrigerator would seem to be the ideal storage place.

#### Danger of Explosion

Even though most cells are fitted with a safety valve to evacuate gases which may be produced inside them, there is still a risk of explosion. Three basic rules should be observed in order to eliminate this risk:

- never recharge with a current higher than one-tenth of the nominal capacity in Ah (higher than 0.35 A for NIFE, 0.25 A for LECLANCHÉ and 0.2 A for EVEREADY)
- never recharge with inverted polarity caused either by an error in connecting the cells or by spontaneous inversion (see above)
- never throw used cells into a fire.

#### 10. Length of Use according to Type of Cells Used (See table overleaf)

#### 11. Equivalent Types of Cells

Carbon-zinc batteries:

EVEREADY 1150  
WONDER (Export and Marin)  
PERTRIX 222 and 232  
LECLANCHÉ Suisse no. 800

Manganese dioxide batteries:

EVEREADY E95  
MALLORY Mn-1300  
WONDER Amiro 1.5 and Judit 1.5

Nickel-cadmium accumulators:

2-2.5 Ah: EVEREADY C2  
LECLANCHÉ 32 A 60  
3.5-4 Ah: EVEREADY NH4  
SAFT VR 4 D  
PHILIPS  
NIFE RC 40

## 12. Conclusion

Generally, since battery or accumulator cells are chosen according to the power consumption of a given recorder, the following uses are possible:

- NAGRA IV S-J plus accessories, with accumulators or with mercury or dioxide manganese batteries
- NAGRA IV S-J without accessories or NAGRA IV S-JS, possibility of using carbon-zinc battery cells.

Leak-proof battery cells are preferable. A PAR charger is recommended for recharging accumulators as they do not have to be removed from the recorder if this accessory is used.

OPERATING CONDITIONS			TOTAL LENGTH OF USE			
			4 Hours every 24 Hours		Continuous Use	
Average Current	Recorder Setting in Relation to Length of Use	Inputs and Accessories	Eveready 1150 Carbon-zinc Batteries	Eveready E95 Manganese-dioxide Batteries	Nickel-cadmium Accumulators	
					Capacity 2-2.5 Ah	Capacity 4Ah
240 mA	50% TEST/ 50% RECORD	Line input (without microphone)	10 h	25 h	9 h	17 h
310 mA	100% RECORD or Fast Wind or 50% TEST/ 50% RECORD	Line input	6 h	22 h	6.5 h	13 h
		Microphone inputs with 1 QSJA-BK amplifier 2 QJPA preamplifiers with heating				
400 mA	100% RECORD or Fast Wind	Microphone inputs with 1 QSJA-BK amplifier 2 QJPA preamplifiers with heating	4,5h	14,5h	5h	10h
460 mA	100% RECORD or Fast Wind	Microphone input with 1 B & K 2619 or 2618 preamplifier with heating, QSJP adapter and QSJA-BK microphone amplifier	3 h	11 h	4.5 h	9 h
620 mA	100% RECORD or Fast Wind	Microphone inputs with 2 B & K 2619 or 2618 preamplifiers with heating, QSJP adapters and QSJA-BK amplifier	-	5.5 h	3 h	6.5 h
765 mA	100% RECORD or Fast Wind	Microphone inputs with 2 B & K 2615 preamplifiers, QSJP adapters and QSJA-BK amplifier	-	3 h	2 h	5 h

# **INSTRUCTION MANUAL**

**NAGRA IV-SJ**



**5**

**Accessories**

# NAGRA IV.SJ

## configurator

### Synchronization

SLO	13400	Automatic speed synchronizer Synchroniseur automatique de vitesse
SLO-3	13429	Crystal pilot generator for SLO Générateur pilote à quartz pour SLO
QCLS	16300	Adapter for connecting SLO to NAGRA IV-SJ Adaptateur pour la connexion SLO NAGRA IV-SJ
QSV-2	14600	Manual speed variator Variateur manuel de vitesse
QSL5	16350	Synchronizer for NAGRA IV-SJ Synchroniseur pour NAGRA IV-SJ

### Internal electro accessories

QFMS50	06780	Frequency meter for 50 Hz pilot signal Fréquence-mètre pour signal pilote 50 Hz
QFMS60	06781	Frequency meter for 60 Hz pilot signal Fréquence-mètre pour signal pilote 60 Hz
QSGX-3	06897	Switchable crystal pilot generator 50-60 Hz Générateur pilote à quartz commutable 50-60 Hz
QSJC	01128	Universal power supply for measuring microphones Alimentation universelle pour microphones de mesure
QSJA-SK	01165	2-channel amplifier for QSPB preamplifier Amplificateur à 2 canaux pour préamplificateur QSPB
QSJA-BK	01170	2-channel amplifier for BK preamplifier Amplificateur à 2 canaux pour préamplificateur BK
QSJA-MKH	01175	2-channel amplifier for MKH 110 microphones Amplificateurs à 2 canaux pour microphones MKH 110

### Modulation

QSPB	11001	Preamplifier for BK microphone cartridges Préamplificateur pour microphone à capsule BK
QSJP	11025	Adapter for connecting BK preamplifiers to NAGRA IV-SJ Adaptateur pour connecter les préamplificateurs BK au NAGRA IV-SJ
QSJP-GR	11050	Adapter for connecting GR preamplifiers to NAGRA IV-SJ Adaptateur pour connecter les préamplificateurs GR au NAGRA IV-SJ
QJPA	11075	Preamplifier for BK measuring cartridges Préamplificateur pour capsules de mesure BK
QCJ-MKH	11902	Cable for connecting MKH 110 microphone to NAGRA IV-SJ Câble pour connecter les microphones MKH 110 au NAGRA IV-SJ
QSSF	16450	Amplifier with balanced outputs Amplificateur avec sorties flottantes
QCJE	11900	Line input cable with banana plugs Câble d'entrée ligne avec fiches banane
QCJC	11901	CUE input/output cable Câble d'entrée/sortie CUE
QSCM-2	16025	Commentary microphone with ALC Microphone de commentaire avec RAS
QSSC	16475	Synchronizer for slide projector Synchroniseur pour projecteur de diapositives

# NAGRA KUDELSKI

CH-1033 Cheseaux / Lausanne

NAGRA IV-SJ

Configurator

Modulation and synchronization

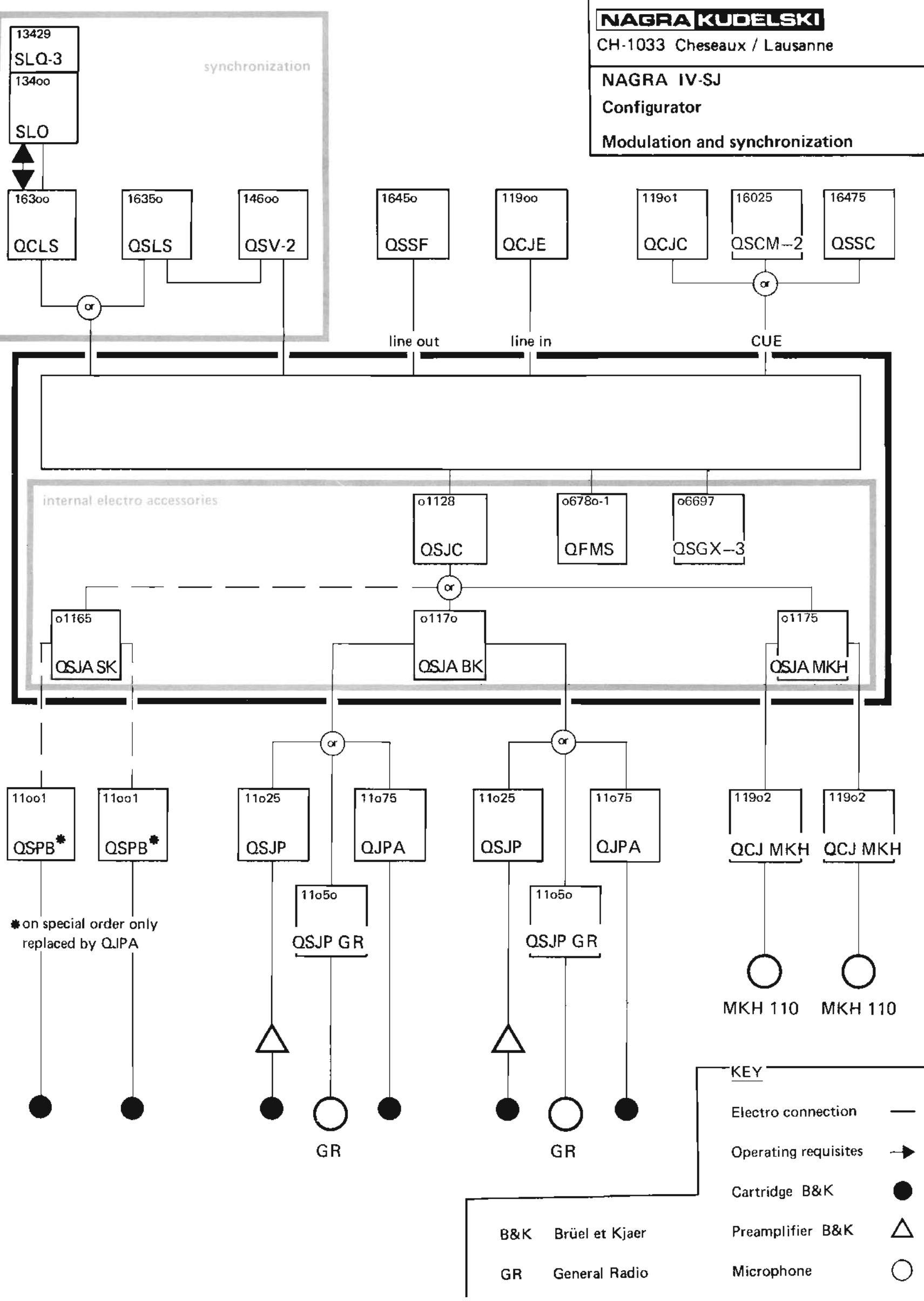

# NAGRA IV.SJ configurator

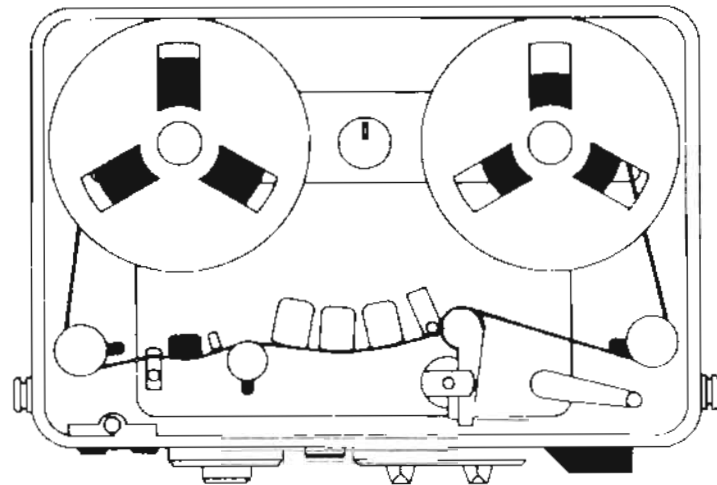

## Power supply

ATN-2	14350	Mains power supply 110-250 V with pilot signal output Alimentation secteur 110-250 V avec sortie signal pilote
QCAS	98001	Mains cable with Swiss plug Câble d'alimentation secteur avec fiche suisse
QCAW	98003	Mains cable without mains plug Câble d'alimentation secteur sans fiche secteur
PAR	13200	Charger for PA type rechargeable cells Chargeur pour accumulateurs du type PA
PPD	14150	Multiple connection box Boîte de dérivation
PD	98202	Set of 12 standard cells Jeu de 12 piles standard
PA-2.5	98251	Set of 15 rechargeable cells with extension 2.5 Ah Jeu de 15 accumulateurs avec rallonge 2.5 Ah
PA-4	98254	Set of 12 4 Ah rechargeable cells Jeu de 12 accumulateurs 4 Ah
AST	90400	Stabilized power supply for measurements Alimentation stabilisée de laboratoire

## Carrying cases

QHP	14120	Carrying handle Poignée
QHC	14125	Spare carrying strap for NAGRA IV-SJ Courroie de rechange pour porter le NAGRA IV-SJ
QHTP	99009	Standard carrying case with pocket Sacoche standard avec poche
QHTPC	99220	Leather cover for QSET Couvercle de sacoche pour QSET
QHCP	14124	Special strap for carrying a recorder equipped with a QHP handle Courroie spéciale à monter sur un appareil équipé d'une poignée QHP

## Headphones

DT 48	96239	Beyer DT 48 headphones Casque d'écoute Beyer DT 48
DT 96A	96247	Beyer DT 96A headphones Casque d'écoute Beyer DT 96A

## External electro accessories

QGB	14001	10 1/2" reel adapter Adaptateur grande bobine 267 mm
QCA	14102	Start-stop cable for remote control Câble start-stop pour commande à distance
TPBC	18907	Normal 8 mm cinespool holder Porte bobine cinéma (standard)
QGBN	14006	NAB-type hub holder Porte noyau type NAB
QGBA	14007	AEG-type hub holder Porte noyau type AEG
DSM	14700	Field monitor and amplifier Moniteur-amplificateur de reportage
IACC	17910	Removable cell compartment for DSM and IS Magasin amovible d'accumulateurs pour DSM et IS
QCAS	98001	Mains cable with Swiss-type plug Câble d'alimentation secteur avec fiche suisse
QCAW	98003	Mains cable without mains plug Câble d'alimentation secteur sans fiche secteur

## Mechanical accessories

QTIM	14650	Tape driven timer Compteur temps entraîné par la bande
QLEN	14655	Tape driven metric counter Compteur métrique entraîné par la bande
QRAC	06260	Tape cleaning blade Râcleur de bande
MAG-220	90801	Electronically-controlled degausser 220 - 240 V Démagnétiseur à commande électronique 220 - 240 V
MAG-110	90802	Electronically-controlled degausser 110 - 117 V Démagnétiseur à commande électronique 110 - 117 V
QSET	14120	Lid when using 7" reels Couvercle pour l'emploi de bobines 178 mm



# NAGRA KUDELSKI

CH-1033 Cheseaux / Lausanne

## NAGRA IV-SJ

Configurator

Power supply and accessories

14125  
QHC

96239  
DT 48

96247  
DT 96A

14120  
QHP

14124  
QHCP

99009  
QHTP

99220  
QHTP-C

90801-2  
MAG

14102  
QCA

18907  
TPBC  
14001  
QGB

14007  
QGBA

14006  
QGBN

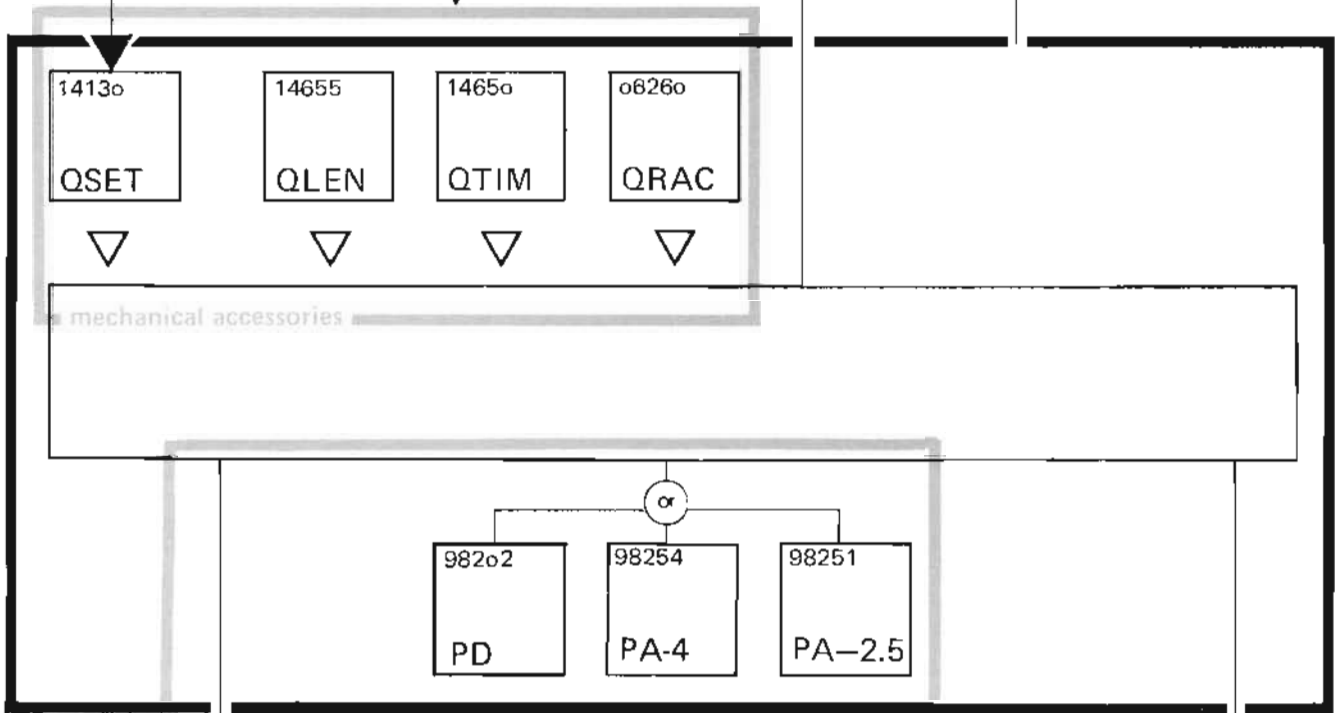

mechanical accessories

power supply

14700  
DSM

17910  
IACC

98001  
QCAS

98003  
QCAW

90400  
AST

14350  
ATN-2

98001  
QCAS

98003  
QCAW

### KEY

Electro connections —

Mechanical connections ▽

Operating requisites →



# ACCESSORIES

ACCESSOIRES  
ZUBEHÖR

## QJPA

EXTERNAL MICROPHONE PREAMPLIFIER  
FOR USE OF BRÜEL & KJÆR CARTRIDGES  
WITH NAGRA IV-SJ

Measuring preamplifier for Brüel & Kjaer condenser cartridges. Contrary to the former model (QSPB), this preamplifier is interchangeable with Brüel & Kjaer preamplifiers No. 2619, 2615, etc. Moreover, a built-in switch enables the adaptation of the used cartridge K factor, in a -2 dB to +4 dB range.

### SPECIFICATIONS

- low noise and high input impedance
- wide dynamic range for noise measurement
- usable with cartridges of different diameter
- K factor adaptation
- compact
- low power consumption

Préamplificateur de mesure pour capsules à condensateur Brüel & Kjaer. Contrairement à l'ancienne version (QSPB), ce préamplificateur est interchangeable avec les modèles Brüel & Kjaer No. 2619, 2615, etc. De plus, un réglage incorporé permet l'adaptation du facteur K de la capsule utilisée dans une plage de -2 à +4 dB.

### SPECIFICATIONS

- faible bruit et haute impédance d'entrée
- dynamique élevée pour les mesures de bruit
- utilisable pour différents diamètres de capsule
- réglage d'adaptation du facteur K
- faible encombrement
- faible consommation

Mess-Vorverstärker zur Anpassung von Brüel & Kjaer-Kondensatormikrophonkapseln. Entgegen der ehemaligen Version (QSPB) ist dieser Mess-Vorverstärker auswechselbar mit den Modellen Brüel & Kjaer Nr. 2615, 2619, u.s.w. Ueberdies erlaubt eine eingebaute Regelung die Anpassung des Faktors K der verwendeten Kapsel im Bereich von -2 bis +4 dB.

### MERKMALE

- Vorverstärker mit schwachem Rauschen und hoher Eingangsimpedanz
- Grosse Dynamik für Geräuschmessungen
- Verwendbar für verschiedene Mikrophonkapseldurchmesser
- Anpassungs - Regelung des Faktors K
- Kompakte Bauweise
- Geringer Leistungsverbrauch



The QJPA is a measurement microphone preamplifier for noise analysis using the NAGRA IV-SJ. It acts as a low noise impedance adapter and connects directly to one of the microphone inputs of the NAGRA IV-SJ recorder. The latter must compulsorily be fitted with the plug-in QSJA-BK microphone amplifier. Brüel & Kjaer 1/2" cartridges can be screwed directly onto the QJPA, while 1/8", 1/4" and 1" cartridges can be fitted with the appropriate Brüel & Kjaer adapters. The preamplifier includes a heating circuit which prevents condensation from affecting the cartridge.

The -10V power necessary for this preamplifier is directly supplied by the regulated power supply of the NAGRA. The + 200V cartridge polarisation is supplied through the QJPA by the QSJC plug-in microphone power supply, which must be set to 16V.

Le QJPA est un préamplificateur de mesure utilisé pour l'analyse des bruits avec le NAGRA IV-SJ. Il fonctionne en tant qu'adaptateur d'impédance à faible bruit et se branche directement à l'une des entrées microphone du NAGRA IV-SJ: celui-ci doit obligatoirement être équipé de l'amplificateur de microphone enfichable QSJA-BK. Les capsules à condensateur Brüel & Kjaer 1/2" se vissent directement sur le QJPA, tandis que les capsules 1/8", 1/4" et 1" peuvent être montées à l'aide des adaptateurs Brüel & Kjaer prévus à cet effet. Ce préamplificateur est doté d'un circuit de chauffage permettant d'éviter les effets de condensation à l'intérieur de la capsule.

L'alimentation -10V nécessaire au préamplificateur est directement fournie par l'alimentation régulée du NAGRA. La polarisation + 200V de la capsule est assurée à travers le QJPA par l'alimentation de microphone QSJC enfichable dans le NAGRA, qui doit préalablement être ajusté à + 16V.

Der QJPA ist ein Mess-Vorverstärker für die Geräuschanalyse mit dem NAGRA IV-SJ. Er wirkt als Impedanzadapter mit schwachem Rauschen und wird direkt an eine der Mikrofonbuchsen von NAGRA IV-SJ angeschlossen, welches obligatorisch mit dem Mikrofonverstärker QSJA-BK ausgerüstet sein muss. Die 1/2" Kondensatormikrofonkapseln Brüel & Kjaer werden direkt an den QJPA angeschraubt; die 1/8", 1/4" und 1" Kapseln können mit den für diesen Zweck von Brüel & Kjaer vorgesehenen Adaptern verwendet werden. Der Vorverstärker ist mit einer Heizung versehen, um Kondensationserscheinungen im Innern der Kapsel zu verhüten.

Die nötige Versorgung des Vorverstärkers mit -10V wird direkt von der regulierten Speisung des NAGRA zugeführt. Die + 200 V Polarisationsspannung der Mikrofonkapsel wird über den QJPA von der Mikrofonspeisung zugesichert, das auf + 16V eingestellt ist, mit welcher das NAGRA ausgerüstet sein muss.

**SPECIFICATIONS (Typical values)**

**SPECIFICATIONS (valeurs typiques)**

**TECHNISCHE DATEN (Typische Werte)**

Cartridges to be used (Brüel & Kjaer) without mechanical adapter  
 Capsules utilisables (Brüel & Kjaer) sans adaptateur mécanique  
 Anwendbare Mikrofonkapseln (Brüel & Kjaer) ohne mechanischen Adapter

1/2" Types 4133, 4134, 4149, 4163

With mechanical adaptor  
 Avec adaptateur mécanique  
 Mit mechanischem Adapter

1/8" Type 4138  
 1/4" Types 4135, 4136  
 1" Types 4144, 4145, 4146, 4161

Preamplifier gain G in relation to the type of cartridge  
 Gain G du préamplificateur en fonction du type de capsule  
 G Verstärkung des Vorverstärkers in Funktion des Kapseltypes

1"	1/2"	1/4"	1/8"
-0,1	-0,4	-1,1	-2

Input impedance  
 Impédance d'entrée  
 Eingangsimpedanz

2 GΩ/0,8 pF

Maximum allowable capacitive load  
 Charge capacitive maximale admise  
 Maximale kapazitive Last

2 nF

Power consumption, -10V of the NAGRA  
 Consommation sur l'alimentation -10V du NAGRA  
 Belastung der -10V Speisung des NAGRA

With heating  
 sans chauffage  
 ohne Heizung  
 Without heating  
 avec chauffage  
 mit Heizung

33 mA

70 mA

Frequency response \* at ± 1 dB  
 Courbe de réponse \* à ± 1 dB  
 Frequenzgang \* bei ± 1 dB

3 Hz - 35 kHz

Maximum allowable input level with 1/2" cartridge  
 Niveau maximal admissible à l'entrée avec capsule 1/2"  
 Maximaler Eingangspegel mit der Kapsel 1/2"

150 dB

**BACKGROUND NOISE**Corresponding level with  
Brüel & Kjaer cartridge

		1/2"	1"	
Potentiometer position "K"		+4 dB	+4 dB	0 dB
Linear measurement 20 Hz - 200 kHz	38 $\mu$ V	44 dB	20 dB	22 dB
Measurement weighted according to ASA A	10 $\mu$ V	32 dB	10 dB	14 dB

**BRUIT DE FOND**Niveau correspondant avec  
capsules Brüel & Kjaer

		1/2"	1"	
Position du potentiomètre "K"		+4 dB	+4 dB	0 dB
Mesure linéaire 20 Hz - 200 kHz	38 $\mu$ V	44 dB	20 dB	22 dB
Mesure pondérée selon ASA A	10 $\mu$ V	32 dB	10 dB	14 dB

**STOERSPANNUNG**Entsprechender Pegel mit  
Kapseln Brüel & Kjaer

		1/2"	1"	
"K" Potentiometer position		+4 dB	+4 dB	0 dB
Linearmessung 20 Hz - 200 kHz	38 $\mu$ V	44 dB	20 dB	22 dB
Gedämpfte Messung nach ASA A	10 $\mu$ V	32 dB	10 dB	14 dB

The QJPA preamplifier is calibrated in order to obtain an average frequency response for 1/2" and 1" cartridges (R10LF = 2,7k $\Omega$ ). It is possible, for a given measuring cartridge to better the very low frequency range by adjusting an internal element of the QJPA. In this case, the frequency response will not be as good with other cartridges.

Le QJPA est réglé de sorte à obtenir une courbe de réponse moyenne pour les capsules 1/2" et 1" (R10LF = 2,7k $\Omega$ ). Il est possible, pour une capsule de mesure donnée, d'améliorer la partie TBF du spectre en ajustant un élément interne du QJPA. Dans ce cas, la courbe de réponse sera évidemment moins bonne pour une capsule différente.

Der QJPA ist zur Verwendung von 1/2" und 1"-Kapseln für einen mittleren Frequenzgang eingestellt. (R10LF = 2,7k $\Omega$ ). Für Kapseln mit gegebenen Messwerten ist es möglich, den sehr tiefen Frequenzbereich durch Anpassung eines internen Elementes des QJPA zu verbessern. In diesem Fall wird jedoch bei Verwendung einer andern als der gemessenen Kapsel der Frequenzgang weniger gut sein.

Results obtained on a NAGRA IV-SJ with different values of R10LF comp according to the used cartridge.  
 Résultats obtenus sur un NAGRA IV-SJ avec différentes valeurs de R10LF comp suivant les capsules utilisées.  
 Auf einem NAGRA IV-SJ erhaltene Ergebnisse, bei verschiedenen Werten von R10LF comp für 1/2" und 1"-Kapseln.

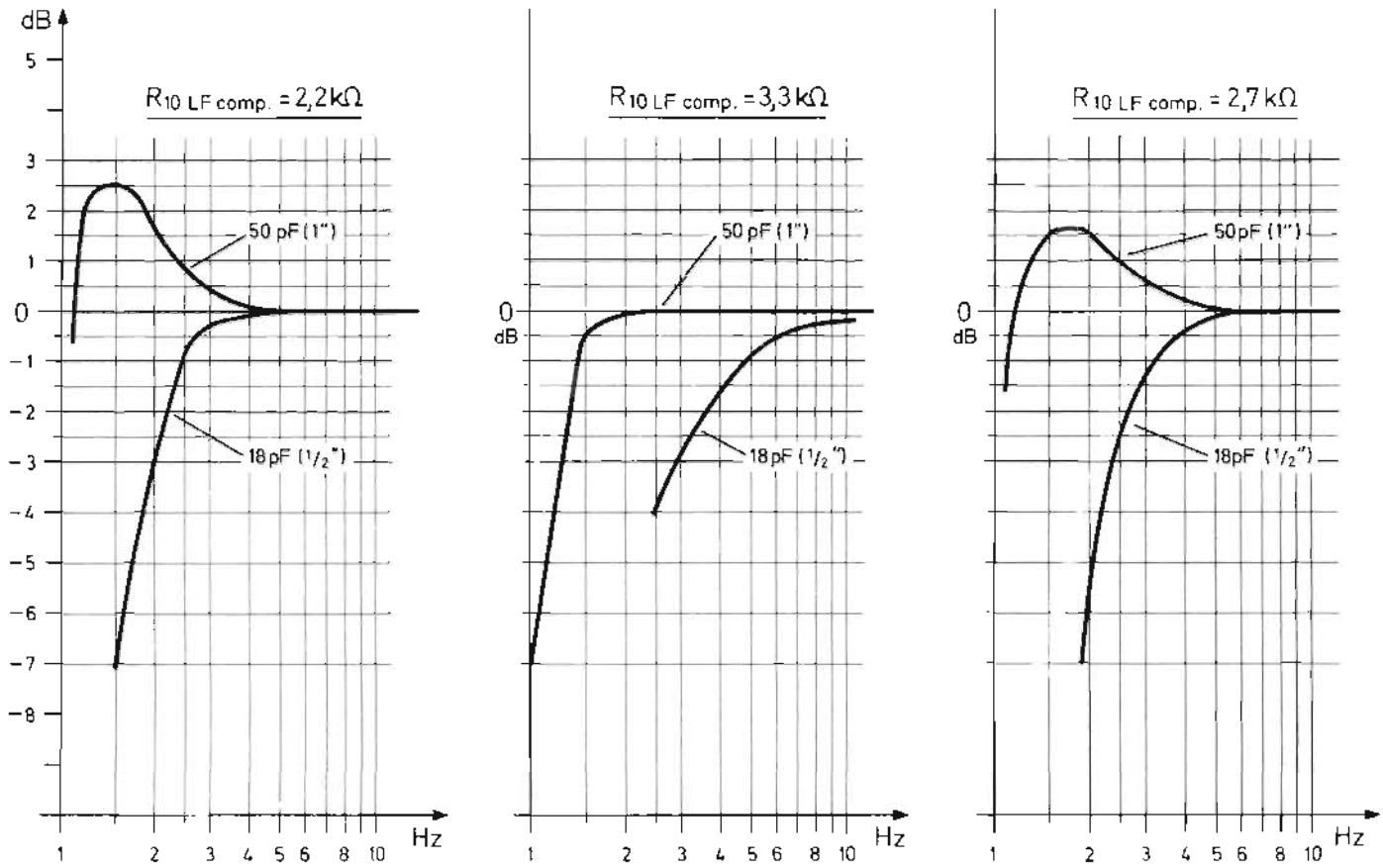

CARTRIDGE  
CAPSULE  
KAPSELN

MECHANICAL ADAPTER  
ADAPTATEUR MÉCANIQUE  
MECHANISCHE ADAPTER

PREAMPLIFIER  
PRÉAMPLIFICATEUR  
VORVERSTÄRKER

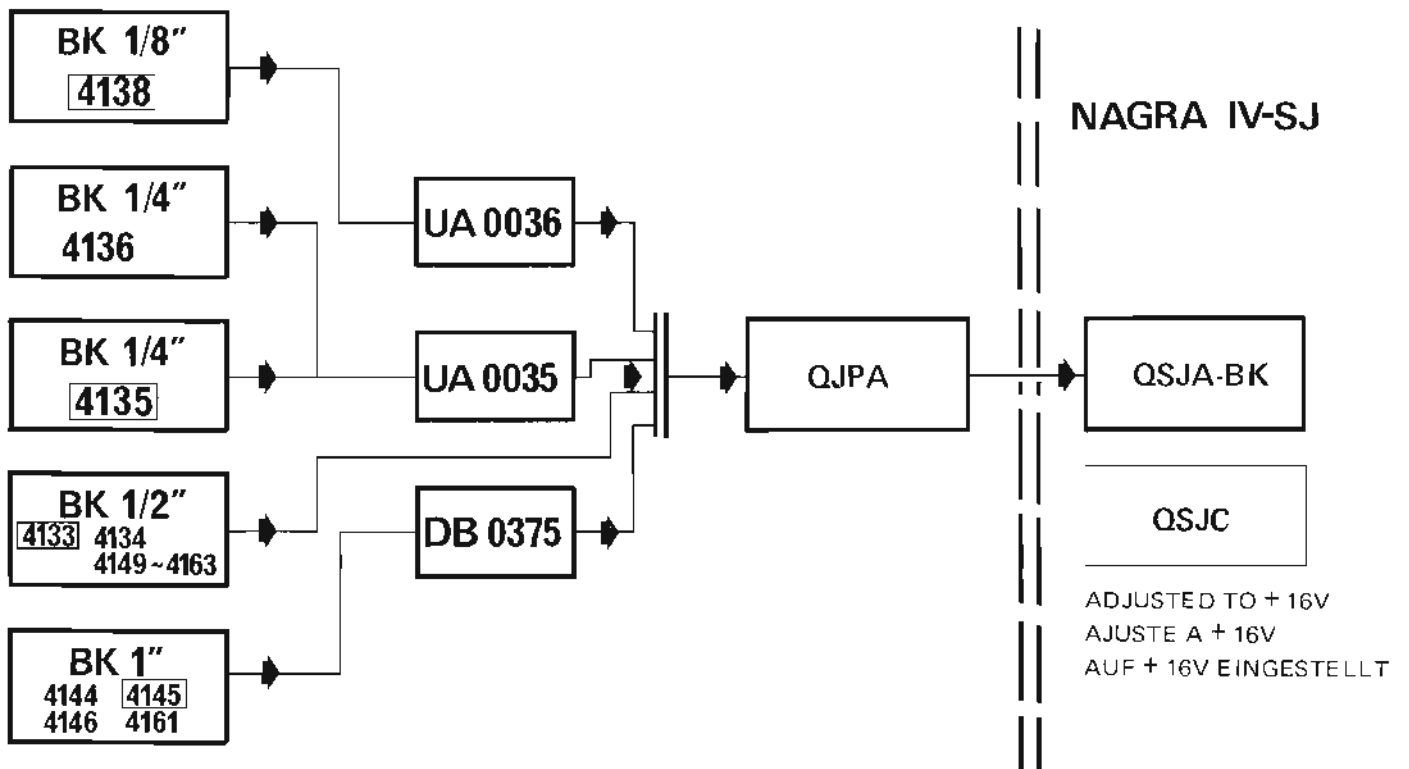

# QSJP

## Adapter for Brüel & Kjær Preamplifiers

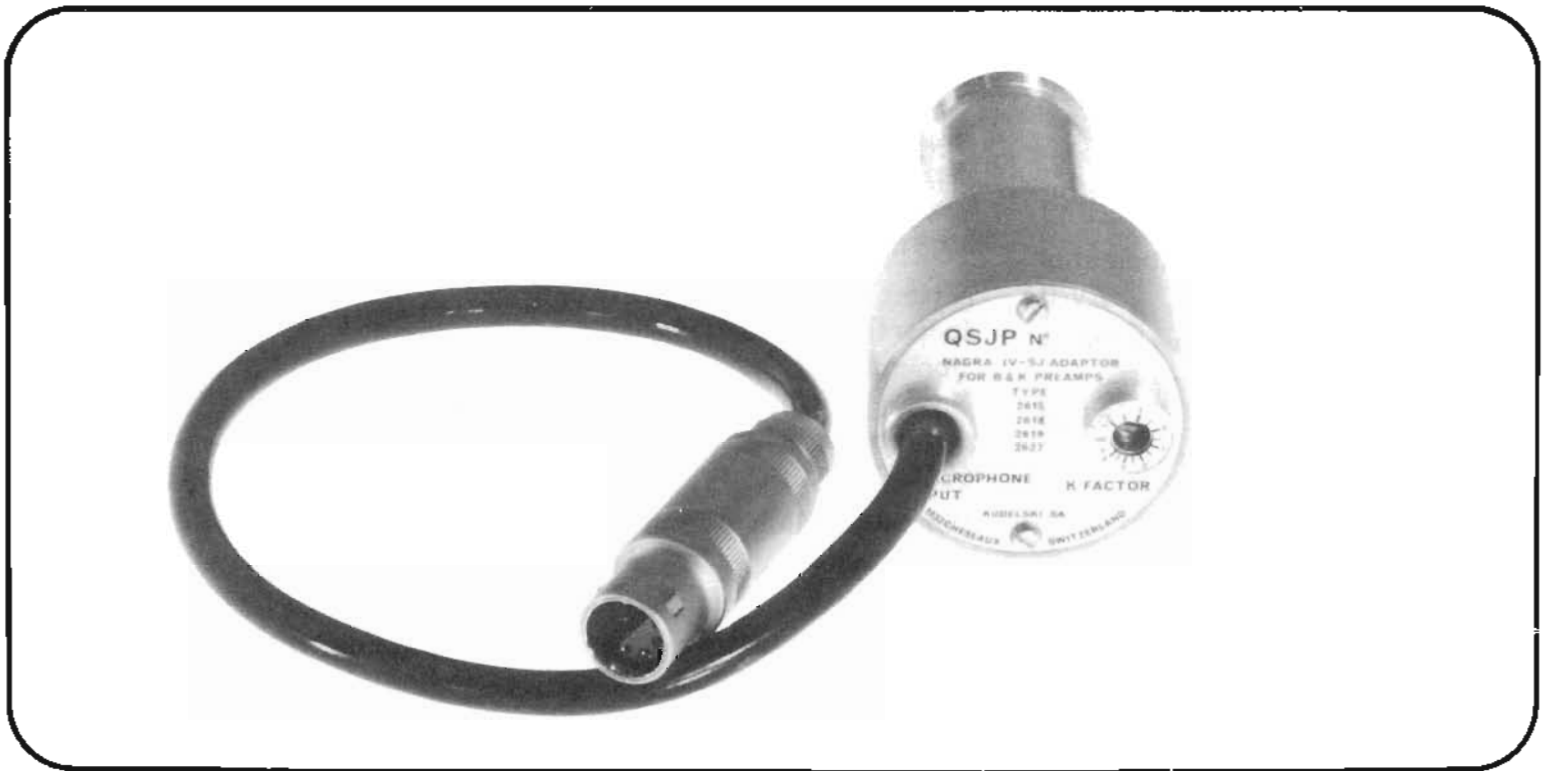

### ENGLISH

The QSJP is an external accessory for the NAGRA IV-SJ which connects the Brüel & Kjær 2619 type preamplifier, as well as the 2615 and, if desired, the 2618 and 2627, to the recorder; the latter should be equipped with the QSJA-BK microphone amplifier and the QSJC power supply.

The adapter is fitted with a plug which can be connected to a microphone input of the NAGRA and a connector corresponding to the plug of the Brüel & Kjær preamplifiers.

The K factor of the Brüel & Kjær cartridge used can be directly compensated using the potentiometer with a -2 dB to +4 dB scale.

### FRANÇAIS

Le QSJP est un accessoire externe du NAGRA IV-SJ qui permet d'utiliser le préamplificateur type 2619, ainsi que le type 2615 et, le cas échéant, les types 2618 et 2627 avec l'enregistreur. Celui-ci doit être équipé de l'amplificateur de microphone QSJA-BK et de l'alimentation QSJC.

Cet adaptateur est muni d'une fiche qui se branche à une entrée microphone du NAGRA et d'une prise correspondant à la fiche des préamplificateurs Brüel & Kjær.

Un potentiomètre gradué de -2 à +4 dB permet de compenser directement le facteur K de la capsule Brüel & Kjær utilisée.

### DEUTSCH

Der QSJP ist ein externes Zubehör zum NAGRA IV-SJ, mit welchem der Brüel & Kjær Vorverstärker Typ 2619, sowie der Typ 2615 und gegebenenfalls die Typen 2618 und 2627 an das Bandgerät anzuschliessen sind. Dieses muss mit dem Mikrophon-Verstärker QSJA-BK und der Speisung QSJC ausgerüstet sein.

Der Adapter ist versehen mit einem Stecker, passend zur Mikrophon-eingangsbuchse des Bandgerätes und mit einer Buchse passend zum Stecker des Brüel & Kjær Vorverstärker.

Ein von -2 bis +4 dB geeichtes Potentiometer ermöglicht die direkte Anpassung an den K-Faktor der verwendeten Brüel & Kjær Kapsel.

**SPECIFICATIONS (Typical Values)**

Power consumption on 120V 1.3 mA  
 Frequency response ±0.2 dB from 2.5 Hz to 35 kHz  
 Equivalent input noise  
 Measurement taken with a-QSJA-BK preamplifier, with the adjustment potentiometer set on +1 dB  
 A. linear from 20 Hz to 20 kHz  
 B. ASA A weighted

	A	B
Noise level	10 µV	4 µV
Corresponding sound level with a 1/2" cartridge, sensitivity 12.5 mV/N/m <sup>2</sup>	31 dB	23 dB
Input saturation level (potentiometer on +1 dB)		37 V <sub>eff</sub>
Corresponding sound level for a 1/2" cartridge, sensitivity 12.5 mV/N/m <sup>2</sup>		165 dB
Dimensions: 3 1/8" x 1 5/8" x 80 x 40 mm		
Weight: 4 oz - 110 g		

**SPÉCIFICATIONS**

(valeurs typiques)

Consommation sur 120 V 1,3 mA  
 Bande passante 2,5 Hz-35 kHz ±0,2 dB  
 Bruit de fond  
 Mesure effectuée avec un préamplificateur QSJA-BK, potentiomètre de réglage en position médiane (+1 dB)  
 A. mesure linéaire de 20 Hz à 20 kHz  
 B. mesure pondérée ASA A

	A	B
Tension de bruit ramenée à l'entrée	10 µV	4 µV
Niveau sonore correspondant avec une capsule 1/2" d'une sensibilité de 12,5 mV/N/m <sup>2</sup>	31 dB	23 dB
Niveau de saturation à l'entrée (potentiomètre de réglage en position médiane +1 dB)		37 V <sub>eff</sub>
Niveau sonore correspondant avec une capsule 1/2" d'une sensibilité de 12,5 mV/N/m <sup>2</sup>		165 dB
Dimensions: 80 x 40 mm		
Poids: 110 g		

**TECHNISCHE DATEN**

(Typische Werte)

Stromverbrauch 120 V 1,3 mA  
 Frequenzgang von 2,5 Hz bis 35 kHz ±0,2 dB  
 Rauschen  
 Messungen vorgenommen mit Vorverstärker QSJA-BK, Potentiometer in Mittelstellung (+1 dB)  
 A. linear von 20 Hz bis 20 kHz  
 B. ASA A bewertet

	A	B
Rauschspannung auf den Eingang bezogen	10 µV	4 µV
Entsprechender akustischer Pegel unter Verwendung einer 1/2"-Kapsel mit der Empfindlichkeit 12,5 mV/N/m <sup>2</sup>	31 dB	23 dB
Übersteuerungspegel des Eingangs (Potentiometer in Mittelstellung +1 dB)		37 V <sub>eff</sub>
Entsprechender akustischer Pegel unter Verwendung einer 1/2"-Kapsel mit der Empfindlichkeit 12,5 mV/N/m <sup>2</sup>		165 dB
Abmessungen: 80 x 40 mm		
Gewicht: 110 g		

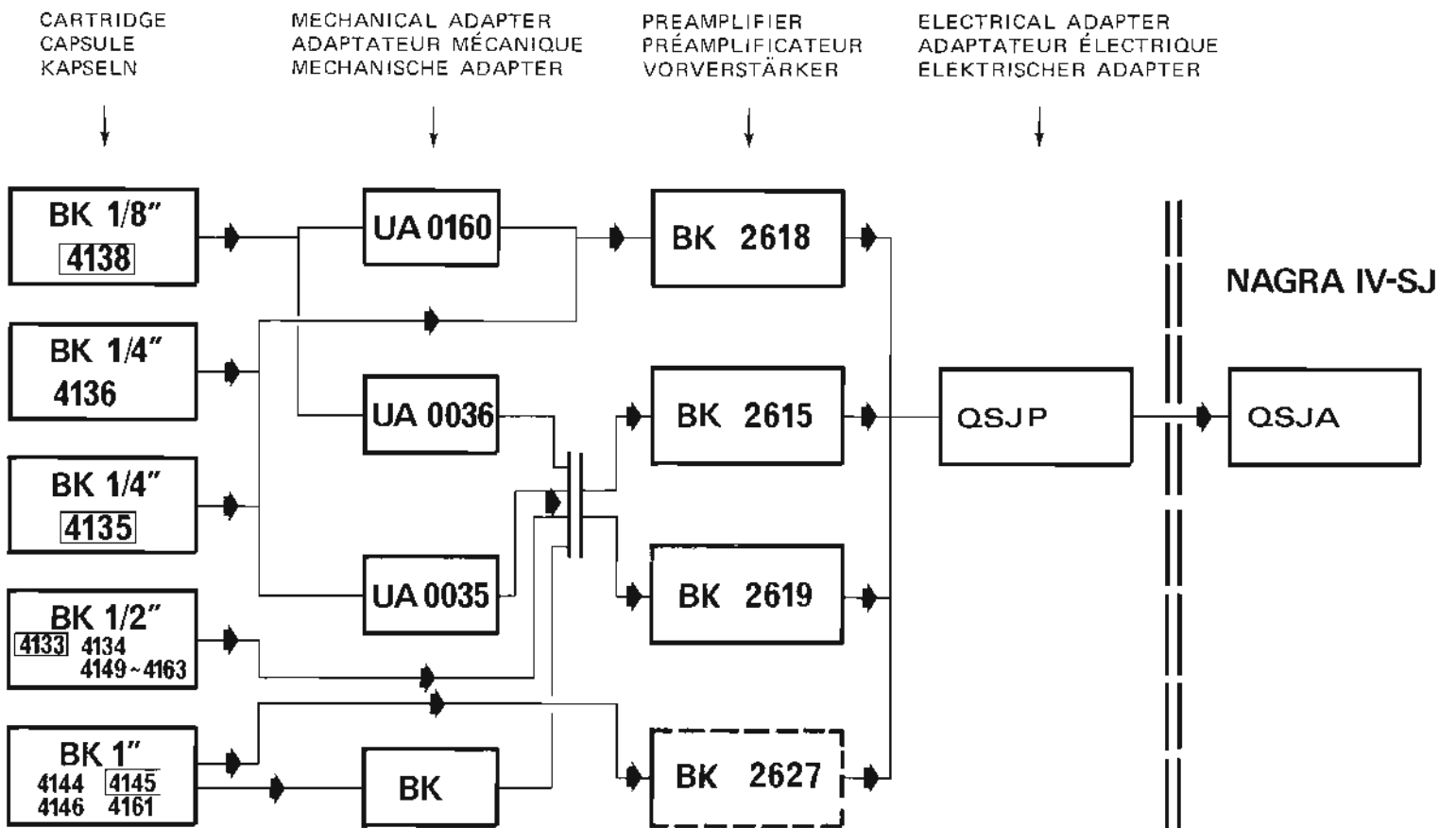

# QSJA-BK

## Microphone Amplifier Plug-in Module for NAGRA IV-SJ

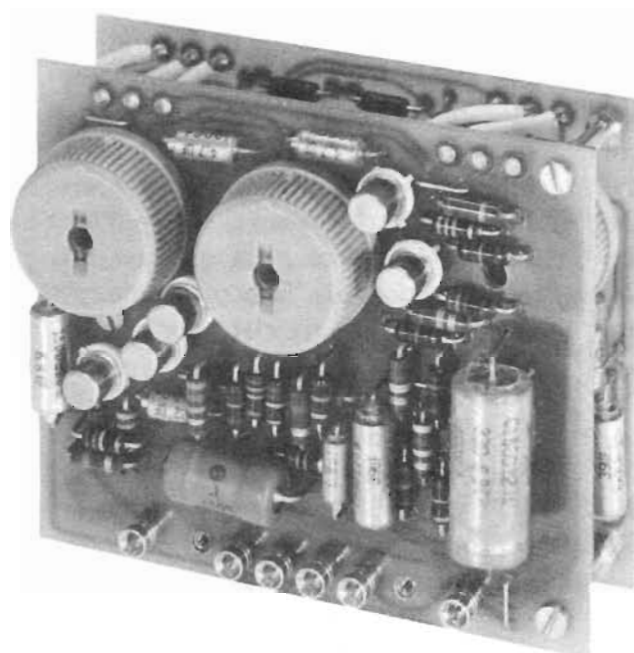

### ENGLISH

The QSJA-BK is a switchable gain amplifier, for capacitor measuring microphones, which can be plugged in inside the NAGRA. This accessory makes it possible to use Brüel & Kjaer 2619, as well as 2615 and, if desired, 2618 and 2627 type preamplifiers with the QSJP adapter, or the General Radio 1560 P42 preamplifier with the QSJP-GR adapter.

The amplifier, preamplifiers, adapters and cartridges can function only when the QSJC microphone power supply is installed in the recorder.

### FRANCAIS

Le QSJA-BK est un amplificateur à gain commutable pour microphone de mesure à condensateur, enfichable à l'intérieur du NAGRA. Cet accessoire permet d'utiliser le préamplificateur Brüel & Kjaer type 2619, ainsi que le type 2615 et, le cas échéant, les types 2618 et 2627 avec l'adaptateur QSJP, ou le préamplificateur General Radio 1560 P42 avec l'adaptateur QSJP-GR.

L'amplificateur, les préamplificateurs, adaptateurs et capsules ne peuvent fonctionner que si l'alimentation de microphone QSJC est montée à l'intérieur de l'enregistreur.

### DEUTSCH

Der QSJA-BK ist ein Verstärker mit schaltbarer Verstärkung für Kondensator-Messmikrophone und ist im Inneren des NAGRA eingesteckt. Mit diesem Zubehör können folgende Einheiten verwendet werden: Brüel & Kjaer Vorverstärker Typ 2619, sowie auch 2615 und gegebenenfalls 2618 und 2627 mit dem Adapter QSJP, oder General Radio Vorverstärker Typ 1560 P42 mit dem Adapter QSJP-GR.

Der Verstärker, die Vorverstärker, Adapter und Mikrophonkapseln werden durch die Mikrophonspeseinheit QSJC gespeist, die in das Innere des Tonbandgerätes eingesteckt wird.

The QSJA-BK amplifier has two channels with switchable sensitivity, on three positions: +40, +60 and +80 dB.

The sound level measured using the microphone is obtained by adding the setting of the amplifier gain selector to that of the attenuator and to the reading on the measuring instrument.

When the QSJA-BK amplifier is used care should be taken that the main attenuator is not set higher than the +40 dB position which is indicated by a triangular index. Beyond this position there is a risk of saturating the input stages and the microphone amplifier gain should be reduced using the three-position switch. In the +80 dB position the input level is no longer limited, except by the performance of the microphone cartridge. With a third switch, common to both channels, the gain can be selected according to the diameter of the cartridge used. The exact sound level is thus obtained direct in relation to the sensitivity of the cartridge. This is valid for the following Brüel & Kjaer cartridges:  
1/4": 4135  
1/2": 4133, 4134, 4149 and 4163  
1": 4144, 4145, 4146 and 4161.  
With the 1/4" 4136 type cartridge a correction must be made to account for its sensitivity difference.

## SPECIFICATIONS

Power consumption  
0.8 mA on -10 V  
0.3 mA on +120 V

Sensitivity of the microphone inputs for which a direct reading is obtained

1" position	50 mV/N/m <sup>2</sup>
1/2" position	12.5 mV/N/m <sup>2</sup>
1/4" position	4 mV/N/m <sup>2</sup>

Frequency response  
2.5 Hz to 35 kHz  $\pm 0.3$  dB

Attenuator accuracy  $\pm 0.2$  dB

L'amplificateur QSJA-BK possède deux canaux d'amplification dont le gain est commutable, séparément, sur trois positions: +40, +60 et +80 dB.

Le niveau sonore mesuré à l'aide du microphone s'obtient en additionnant l'indication du sélecteur de gain de l'amplificateur de microphone avec celles de l'atténuateur et de l'instrument de mesure de l'enregistreur.

En utilisant cet amplificateur, il faut veiller à ne pas dépasser la position +40 dB de l'atténuateur principal du NAGRA, position repérée par un index triangulaire. Au-delà de cette position, il y a risque de saturation des étages d'entrée, et il faut alors réduire le gain de l'amplificateur de microphone à l'aide de son commutateur à trois positions. Sur la position +80 dB, le niveau d'entrée n'est plus limité, si ce n'est que par les performances de la capsule microphonique. Un troisième sélecteur, commun aux deux canaux, commute le gain suivant le diamètre de la capsule utilisée. Le niveau sonore exact est ainsi obtenu directement, en fonction de la sensibilité de la capsule. Ceci est valable pour les capsules Brüel & Kjaer suivantes:  
1/4": 4135  
1/2": 4133, 4134, 4149 et 4163  
1": 4144, 4145, 4146 et 4161.  
Avec la capsule 1/4" type 4136, il est nécessaire d'effectuer une correction qui tient compte de sa sensibilité différente pour obtenir le niveau sonore réel.

## SPÉCIFICATIONS

Consommation  
0,8 mA sur le -10 V  
0,3 mA sur le +120 V

Sensibilité des entrées microphone pour laquelle une lecture directe est obtenue

position 1"	50 mV/N/m <sup>2</sup>
position 1/2"	12,5 mV/N/m <sup>2</sup>
position 1/4"	4 mV/N/m <sup>2</sup>

Bande passante  
2,5 Hz à 35 kHz  $\pm 0,3$  dB

Précision des atténuateurs  $\pm 0,2$  dB

Der Verstärker QSJA-BK ist zweikanalig, mit unabhängiger Verstärkungseinstellung durch je einen dreistelligen Schalter, mit den Stellungen +40, +60 und +80 dB.

Den mit dem Mikrophon gemessenen akustischen Pegel erhält man durch Addition der eingestellten Werte an diesem dreistelligen Schalter und an dem Hauptabschwächer mit dem vom Messinstrument angezeigten Wert.

Bei der Verwendung dieses Verstärkers muss darauf geachtet werden, dass die +40 dB Stellung des NAGRA-Hauptabschwächers - durch ein Dreieck gekennzeichnet - nicht überschritten wird. Bei höheren Stellungen besteht die Gefahr einer Übersteuerung der Eingangsstufe; in diesem Falle muss der Verstärkungsregler des Mikrophonverstärkers in eine andere Stellung gebracht werden. Ist die Stellung +80 dB erreicht, so ist der Eingangspegel nur noch durch die Mikrophondynamik begrenzt. Ein dritter Schalter, gemeinsam für beide Kanäle, passt die Verstärkung an den verwendeten Kapseldurchmesser an. Der richtige akustische Pegel wird somit der Kapselempfindlichkeit entsprechend, für folgende Brüel & Kjaer Kapseln direkt erhalten:  
1/4": 4135  
1/2": 4133, 4134, 4149 und 4163  
1": 4144, 4145, 4146 und 4161.  
Bei Verwendung der 1/4"-Kapsel 4136 muss die erhaltene Ablesung unter Berücksichtigung der abweichenden Kapselempfindlichkeit korrigiert werden.

## TECHNISCHE DATEN

Stromverbrauch 0,8 mA auf -10 V  
0,3 mA auf +120 V

Empfindlichkeit der Mikrophoneingänge bei denen die Ablesung direkt erhalten wird

Stellung 1"	50 mV/N/m <sup>2</sup>
Stellung 1/2"	12,5 mV/N/m <sup>2</sup>
Stellung 1/4"	4 mV/N/m <sup>2</sup>

Frequenzgang  
2,5 Hz bis 35 kHz bei  $\pm 0,3$  dB

Genauigkeit der Abschwächer  $\pm 0,2$  dB



Equivalent input noise  
 A. Linear 20 Hz to 20 kHz  
 B. ASA A weighted

	A	B
Noise level on +40 dB and 1/2" cartridge	2.5 μV	1.1 μV
Corresponding sound level with a 12.5 mV/N/m <sup>2</sup> cartridge	24 dB	17 dB

Saturation level on 1/2" position  
 C. Maximum input voltage  
 D. Corresponding sound level

	C	D
+80 dB position	28 V	165 dB
+60 dB position	0.4 V	128 dB
+40 dB position	40 mV	108 dB

Bruit de fond  
 A. mesure linéaire de 20 Hz à 20 kHz  
 B. mesure pondérée ASA A

	A	B
Tension de bruit ramenée à l'entrée, en position +40 dB et 1/2"	2,5 μV	1,1 μV
Niveau sonore correspondant avec une capsule de 12,5 mV/N/m <sup>2</sup> de sensibilité	24 dB	17 dB

Niveau de saturation en position 1/2"  
 C. tension d'entrée maximale  
 D. niveau sonore correspondant

	C	D
pos. +80 dB	28 V	165 dB
pos. +60 dB	0,4 V	128 dB
pos. +40 dB	40 mV	108 dB

Rauschen  
 A. linear von 20 Hz bis 20 kHz  
 B. ASA A bewertet

	A	B
Rauschspannung auf den Eingang bezogen, in Stellung +40 dB und 1/2" der Schalter	2,5 μV	1,1 μV
Entsprechender akustischer Pegel mit einer Kapselempfindlichkeit von 12,5 mV/N/m <sup>2</sup>	24 dB	17 dB

Übersteuerungspegel in Stellung 1/2"  
 C. maximale Spannung  
 D. Entsprechender akustischer Pegel

	C	D
St. +80 dB	28 V	165 dB
St. +60 dB	0,4 V	128 dB
St. +40 dB	40 mV	108 dB

Dimensions: 2 5/8" x 1 1/2" x 1"  
 67 x 58 x 28 mm

Weight: 3 oz – 80 g

Dimensions: 67 x 58 x 28 mm  
 Poids: 80 g

Abmessungen: 67 x 58 x 28 mm  
 Gewicht: 80 g

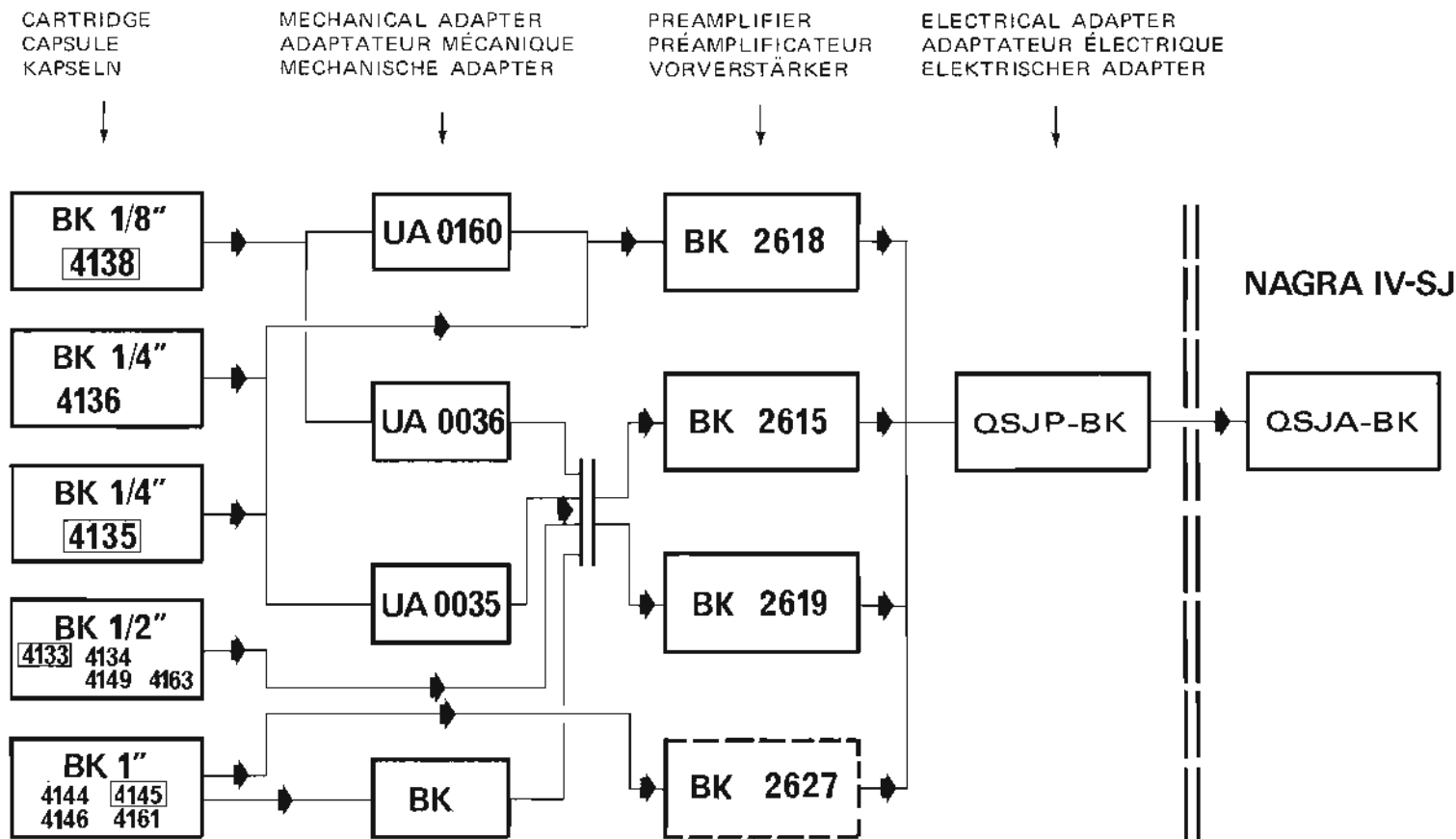

# QSJA-MKH

## Amplifier for Sennheiser MKH 110 Microphone

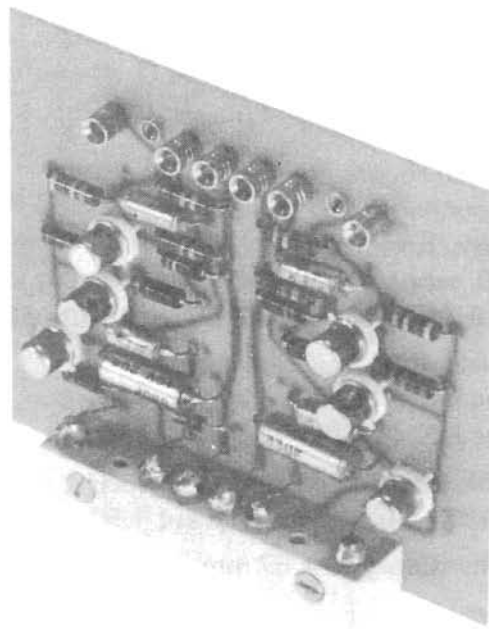

### ENGLISH

The QSJA-MKH is an amplifier which can be plugged in inside the NAGRA IV-SJ so that Sennheiser MKH 110 and 110-1 measuring microphones can be used.

This accessory has two fixed gain amplifier channels. The sound level is obtained by adding 60 dB for the MKH 110 and 80 dB for the MKH 110-1 to the readings given by the NAGRA. The amplifier also makes it possible to supply power direct to the microphone from the NAGRA without using the QSJC power supply. The dynamic of the microphone is not affected by the use of the amplifier.

### FRANÇAIS

Le QSJA-MKH est un amplificateur enfichable à l'intérieur du NAGRA IV-SJ qui permet d'utiliser les microphones de mesure Sennheiser MKH 110 et 110-1.

Cet accessoire comporte deux canaux d'amplification à gain fixe. Le niveau sonore s'obtient en ajoutant 60 dB aux indications du NAGRA pour le MKH 110 et 80 dB pour le MKH 110-1. Il permet d'autre part d'alimenter directement le microphone à partir du NAGRA sans utiliser l'alimentation QSJC. La dynamique du microphone n'est pas altérée par les performances de l'amplificateur.

### DEUTSCH

Der QSJA MKH ist ein Verstärker, im Innern des NAGRA IV-SJ einsteckbar, der für die Verwendung der Messmikrophone MKH 110 und MKH 110-1 von Sennheiser vorgesehen ist.

Dieses Zubehör enthält zwei Kanäle mit einer festen Verstärkung. Den akustischen Pegel erhält man durch Addition von 60 dB für MKH 110 und 80 dB für MKH 110-1 zur Anzeige des NAGRA Gerätes. Die Mikrophone werden mit diesem Verstärker vom NAGRA IV-SJ ohne Verwendung der Speiseeinheit QSJC gespeist. Die Dynamik des Mikrophons wird in keiner Weise vom Verstärker beeinträchtigt.

The MKH 110 preamplifier can be connected to the microphone inputs by means of the QCJ-MKH input cable.

Le microphone MKH 110 se branche à une entrée microphone à l'aide du câble QCJ-MKH.

Das Mikrofon MKH 110 wird an eine Mikrophoneingangsbuchse mittels des Kabels QCJ-MKH angeschlossen.

## SPECIFICATIONS

Current consumption unloaded  
11 mA

Current consumption with 1 microphone  
19 mA

Frequency response  
2.5 Hz–35 kHz  $\pm 0.2$  dB

Equivalent input noise  
A. linear from 20 Hz to 20 kHz  
B. ASA A weighted

	A	B
Noise level	12 $\mu$ V	7 $\mu$ V
Corresponding sound level with MKH 110 microphone, referred to $2 \cdot 10^{-5}$ N/m <sup>2</sup>	30 dB	25 dB
Saturation sound level with MKH 110	130 dB	
with MKH 110-1	150 dB	

QCJ-MKH connecting cable  
length 4½ ft – 1.50 m

Dimensions: 2¼" x 2½"  
60 x 67 mm

Weight: 1 oz – 22 g

## SPÉCIFICATIONS

Consommation à vide  
11 mA

Consommation en charge avec 1 microphone  
19 mA

Bande passante  
2,5 Hz–35 kHz  $\pm 0,2$  dB

Bruit de fond  
A. mesure linéaire de 20 Hz à 20 kHz  
B. mesure pondérée ASA A

	A	B
Tension de bruit ramenée à l'entrée de l'amplificateur	12 $\mu$ V	7 $\mu$ V
Niveau sonore correspondant avec microphone MKH 110, rapporté à $2 \cdot 10^{-5}$ N/m <sup>2</sup>	30 dB	25 dB
Niveau sonore de saturation avec MKH 110	130 dB	
avec MKH 110-1	150 dB	

Câble de raccordement QCJ-MKH  
longueur 1,50 m

Dimensions: 60 x 67 mm

Poids: 22 g

## TECHNISCHE DATEN

Stromverbrauch ohne Mikrofon  
11 mA

Stromverbrauch mit einem Mikrofon  
19 mA

Frequenzgang  
2,5 Hz bis 35 kHz bei  $\pm 0,2$  dB

Rauschen  
A. linear von 20 Hz bis 20 kHz  
B. bewertet ASA A

	A	B
Rauschspannung auf den Verstärkereingang bezogen	12 $\mu$ V	7 $\mu$ V
Entsprechender akustischer Pegel mit dem Mikrofon MKH-110, auf $2 \cdot 10^{-5}$ N/m <sup>2</sup> bezogen	30 dB	25 dB
Übersteuerungspegel mit MKH 110	130 dB	
mit MKH 110-1	150 dB	

Anschlusskabel QCJ-MKH  
Länge 1,50 m

Abmessungen: 60 x 67 mm

Gewicht: 22 g

# QSCM

## Commentary Microphone for NAGRA IV-S and IV-SJ

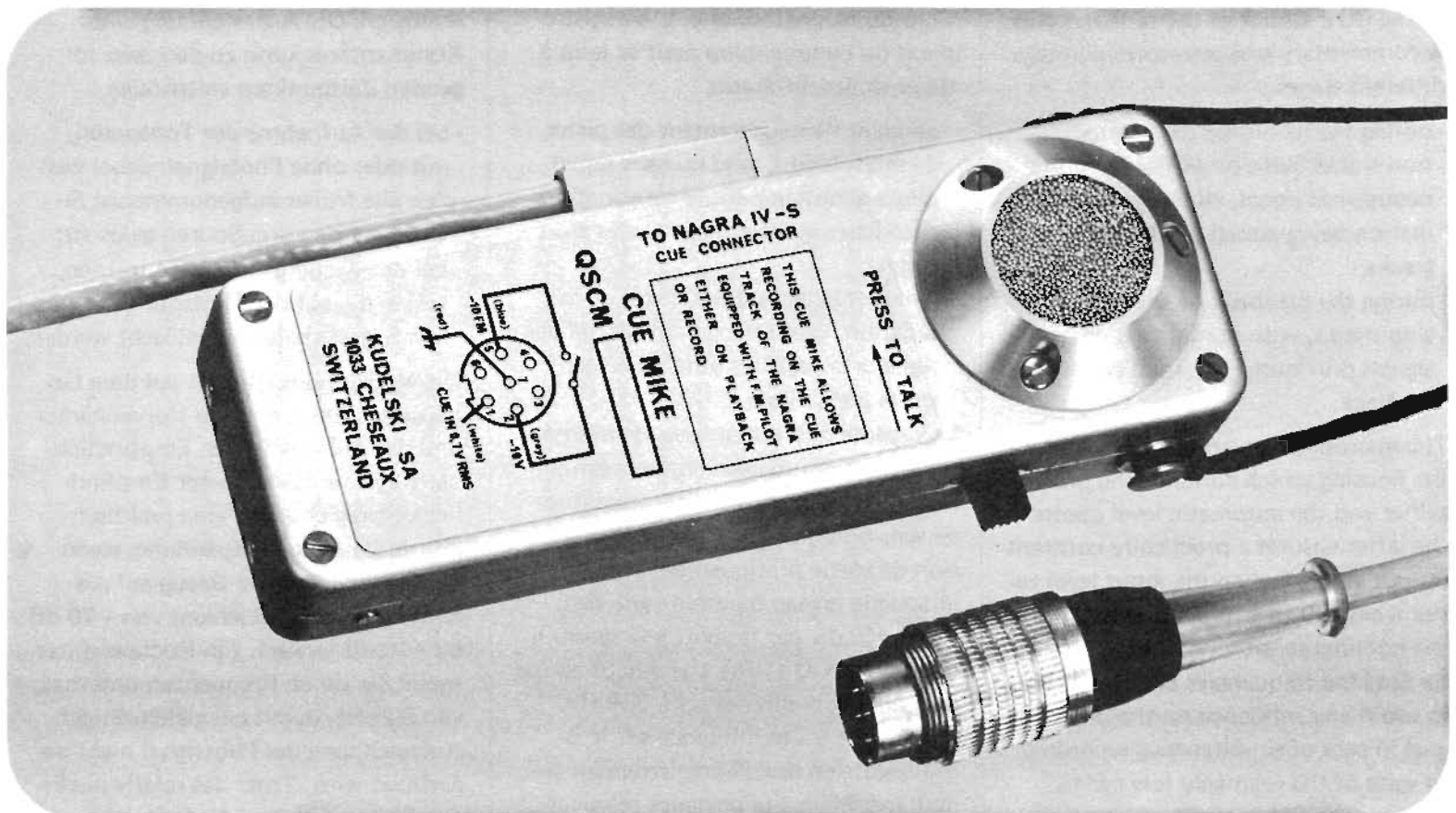

### ENGLISH

Hand microphone for recording a commentary on the pilot track of the NAGRA IV-S and IV-SJ tape recorders.

#### FEATURES

Capacitor microphone system : intelligibility of the message is heightened. Sintered bronze acoustical screen effectively protecting the diaphragm. Built-in preamplifier which gives out a strong useful signal.

Automatic level control : optimum modulation without any manual adjustment.

Filters determining a bandwidth adapted to the speech reproduction.

Operation by locking push-button.

### FRANÇAIS

Microphone manuel pour l'enregistrement d'un commentaire sur la piste pilote des magnétophones NAGRA IV-S et IV-SJ.

#### CARACTÉRISTIQUES

Capsule microphonique à condensateur : l'intelligibilité du message est accrue.

Ecran acoustique en bronze fritté, protégeant efficacement la membrane.

Préamplificateur incorporé, qui délivre un signal utile important.

Régulateur automatique de sensibilité : modulation optimale sans aucun réglage manuel.

Filtres déterminant une bande passante adaptée à la reproduction de la parole.

Mise en service par bouton-poussoir verrouillable.

### DEUTSCH

Handmikrofon für die Aufzeichnung eines gesprochenen Kommentares auf der Pilot-Spur der NAGRA Tonbandgeräte IV-S und IV-SJ.

#### MERKMALE

Kondensator-Mikrofonkapsel für eine bessere Sprachverständlichkeit. Nahbesprechungsschutz aus Sinterbronze.

Eingebauter Vorverstärker mit hohem Ausgangspegel.

Automatischer Empfindlichkeitsregler zur optimalen Aussteuerung.

Filter zur Bestimmung eines, für die Sprache geeigneten, Frequenzganges.

Ein- und Ausschalten mittels verriegelbarer Drucktaste.

The NAGRA IV-S and IV-SJ tape recorders may be fitted with a third track for the recording and playback of a pilot signal which will permit subsequent synchronization. In addition to the pilot signal, or in its place, the third track can receive a commentary for identifying the sequences recorded on the two modulation tracks, or giving directives for the setting up of these sequences; for instrumentation application, the commentary could include instructions in order to analyze the recordings.

The QSCM microphone is connected to the CUE socket of the tape recorder. A commentary can be recorded at two different stages :

- during the recording of the modulation tracks, with or without simultaneous pilot signal, all previous information being erased on the three tracks,
- during the playback of the modulation tracks, with partial erasing of the signals previously recorded on the pilot track.

The microphone system is mounted on the housing which contains the preamplifier and the automatic level control; the latter ensures a practically constant output voltage when the input level varies from -20 to +10 dB in relation to the nominal sensitivity. A high-pass filter cuts the frequencies below 250 Hz to avoid any influence on the pilot signal in case of simultaneous recording. In spite of the relatively low carrier used for the FM recording, the upper limit of the bandwidth enables excellent speech reproduction. The push-button connects the output of the preamplifier to the corresponding terminal of the Tuchel plug and turns on the FM modulator of the third track by connecting it to the tape recorder supply.

## SPECIFICATIONS

Normal output voltage with automatic level control 700 mV, determining a frequency deviation of  $\pm 20\%$   
Operating range of the automatic level control from 3 to 100  $\mu$ bar  
Stabilized supply voltage -10 V, consumption 2.5 mA  
Dimensions 4 3/4 x 1 5/8 x 1 1/8 ", cable length 4'8"  
Weight with cable and plug 7 oz

Les magnétophones NAGRA IV-S et IV-SJ disposent d'une troisième piste pour l'enregistrement et la lecture d'un signal pilote, qui permettra une synchronisation ultérieure. En plus du signal pilote, ou à sa place, la troisième piste peut recevoir un commentaire destiné à identifier les séquences enregistrées sur les deux pistes de modulation, ou à donner des directives pour le montage de ces séquences; en métrologie, le commentaire pourra comporter des instructions pour le dépouillement des enregistrements.

Le micro QSCM se branche à la prise CUE du magnétophone. L'enregistrement du commentaire peut se faire à deux stades différents :

- pendant l'enregistrement des pistes de modulation, avec ou sans signal pilote simultané, toute information antérieure étant effacée sur les trois pistes.
- pendant la lecture des pistes de modulation, avec effacement partiel des signaux enregistrés antérieurement sur la piste pilote.

La capsule microphonique est montée sur le boîtier qui contient le préamplificateur et le régulateur automatique de sensibilité; ce dernier assure une tension de sortie pratiquement constante lorsque le niveau d'entrée varie de -20 à +10 dB par rapport à la sensibilité nominale. Un filtre passe-haut coupe les fréquences inférieures à 250 Hz, pour éviter toute influence sur le signal pilote en cas d'enregistrement simultané. Malgré la porteuse relativement basse utilisée pour l'enregistrement en modulation de fréquence, la limite supérieure de la bande passante permet une excellente reproduction de la parole. Le bouton-poussoir connecte la sortie du préamplificateur à la broche correspondante de la fiche Tuchel, et met en service le modulateur FM de la troisième piste en le raccordant à l'alimentation du magnétophone.

## SPÉCIFICATIONS

Tension nominale de sortie avec réglage automatique de sensibilité 700 mV, déterminant une excursion de fréquence de  $\pm 20\%$   
Plage de régulation automatique de la sensibilité de 3 à 100  $\mu$ bar  
Tension d'alimentation stabilisée -10 V, consommation 2,5 mA  
Dimensions 120 x 40 x 28 mm, câble de 140 cm  
Poids avec câble et fiche 200 g

Für die Aufzeichnung und Wiedergabe eines zur späteren Synchronisation bestimmten Pilotsignales, steht bei den Tonbandgeräten IV-S und IV-SJ eine dritte Spur zur Verfügung. Auf dieser Spur kann, zusätzlich zum Pilotsignal oder an dessen Stelle, ein Kommentar aufgenommen werden, welcher die aufgezeichneten Sequenzen identifiziert oder für die spätere Montage bezeichnet; bei Messdaten-Aufnahmen können Anweisungen für die Auswertung aufgenommen werden.

Das QSCM-Mikrofon wird an der CUE-Buchse des Tonbandgerätes angeschlossen. Die Aufzeichnung eines Kommentares kann zu den zwei folgenden Zeitpunkten stattfinden :

- bei der Aufnahme der Tonspuren, mit oder ohne Pilotsignal; dabei werden alle früher aufgenommenen Signale auf den drei Spuren gelöscht;
- bei der Wiedergabe der Tonspuren, wobei die auf der Pilotspur vorhandenen Signale teilweise gelöscht werden.

Die Mikrophonkapsel ist auf dem Gehäuse montiert, das den Vorverstärker und den automatischen Empfindlichkeitsregler enthält. Dieser Empfindlichkeitsregler ergibt eine praktisch konstante Ausgangsspannung, wenn der Eingangspegel in Bezug auf die nominale Empfindlichkeit von -20 dB bis +10 dB variiert. Ein Hochpassfilter sperrt die tiefen Frequenzen unterhalb von 250 Hz, damit bei gleichzeitiger Aufzeichnung das Pilotsignal nicht beeinflusst wird. Trotz des relativ niedrigen Trägers bei der FM-Aufzeichnung, ist die obere Grenzfrequenz für eine ausgezeichnete Sprachwiedergabe ausreichend. Durch die Drucktaste wird der Ausgang des Vorverstärkers an den entsprechenden Anschluss der Tuchel-Buchse gelegt, und dem FM-Modulator der dritten Spur wird die Speisespannung des Tonbandgerätes zugeführt.

## TECHNISCHE DATEN

Nominale Ausgangsspannung mit automatischem Empfindlichkeitsregler 700 mV; diese Spannung ergibt einen Frequenzhub von  $\pm 20\%$ . Regelbereich des automatischen Empfindlichkeitsregler : 3 bis 100  $\mu$ bar. Stabilisierte Speisespannung -10 V, Stromverbrauch 2,5 mA  
Abmessungen 120 x 40 x 28 mm, Kabel 140 cm  
Gewicht mit Kabel und Stecker 200 g

# QSL5

## External Synchronizer for NAGRA IV-S and IV-SJ

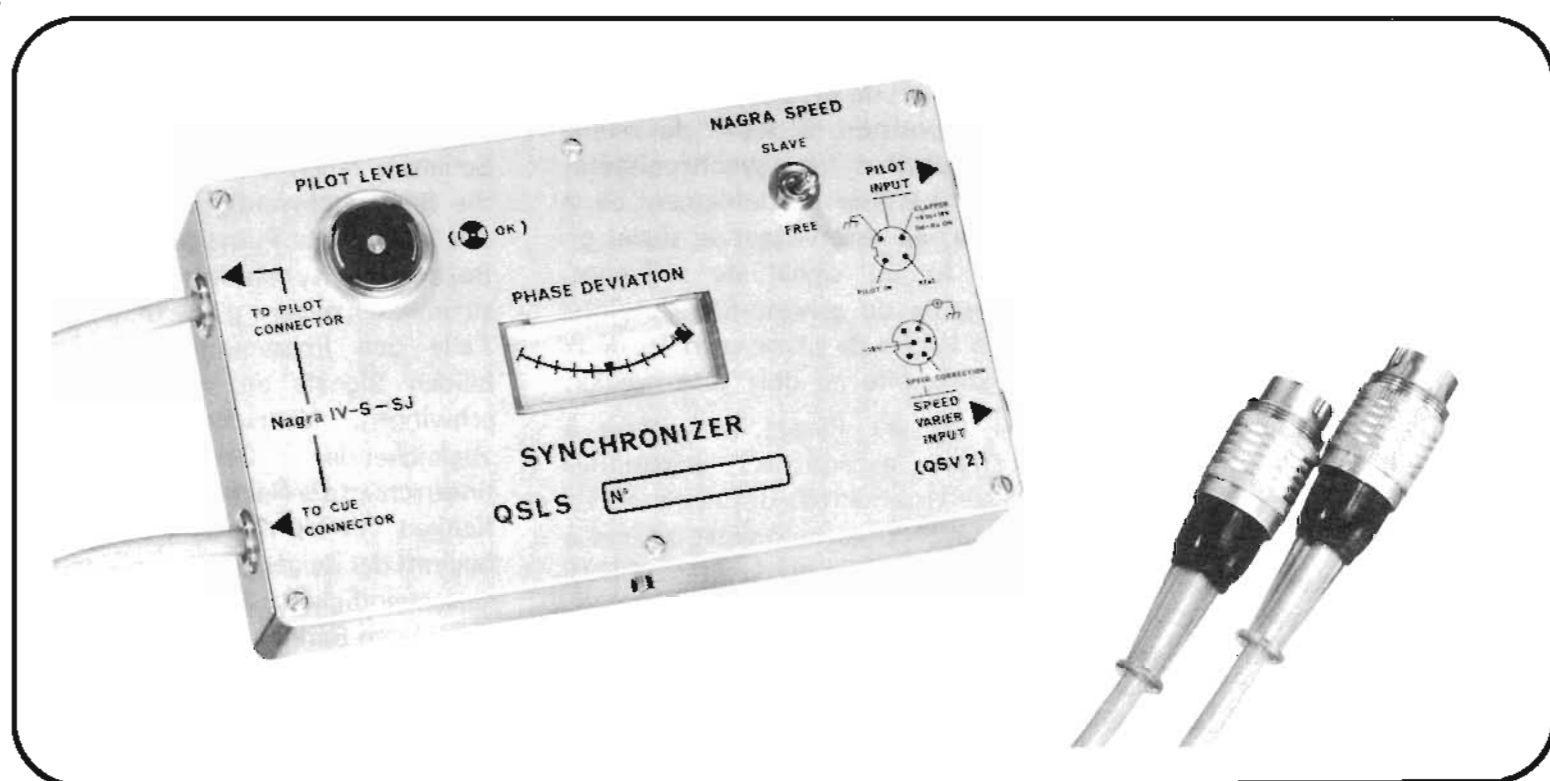

### ENGLISH

External synchronization accessory for varying the tape speed of the NAGRA to make the playback pilot signal synchronous with the pilot reference signal received by the recorder.

The QSL5 can be connected to the PILOT & CUE inputs on the right-hand side of the NAGRA IV-S or IV-SJ.

The synchronization signal must be applied to the PILOT INPUT connector which also carries the reference signal from the internal crystal pilot generator of the NAGRA; this signal can be used for synchronization. This offers the possibility of playing back the signal at the speed at which it was

### FRANÇAIS

Accessoire externe de synchronisation qui permet de modifier la vitesse de défilement du NAGRA pour rendre le signal pilote lu synchrone avec le signal pilote de référence entrant dans l'appareil.

Le QSL5 se raccorde aux prises PILOT et CUE situées sur le côté droit du NAGRA IV-S ou IV-SJ.

Le signal de synchronisation doit être introduit par la prise PILOT INPUT sur laquelle arrive également le signal de référence du générateur à quartz interne du NAGRA, qui peut être utilisé comme signal de synchronisation. Cette possibilité permet d'obtenir à la lecture un signal dont la vitesse de défilement

### DEUTSCH

Externer Synchronisator, welcher erlaubt die Bandlaufgeschwindigkeit des NAGRA-Gerätes zu verändern, um das abgetastete Pilotsignal mit einem externen Bezugssignal zu synchronisieren.

Der QSL5 wird an den Buchsen PILOT und CUE auf der rechten Seite des NAGRA IV-S und IV-SJ angeschlossen.

Das abgetastete Synchronisationssignal wird über den Stecker PILOT-INPUT eingeführt; am gleichen Stecker erscheint das Bezugssignal des im NAGRA Tonbandgerätes eingebauten Quarzgenerators. Dies ermöglicht es, das Band mit der Originalaufnahmegeschwindigkeit bei

recorded, with about 0.001% accuracy.

The QSV2 speed variator can be connected to the SPEED VARIER INPUT when it is necessary to extend the synchronization range ( $\pm 12\%$ ).

The meter gives two readings:

- if the NAGRA SPEED switch is on FREE, i.e. without speed slaving, it indicates the frequency error between the playback pilot signal frequency and that of the synchronization signal. One complete oscillation of the needle left/right/left, in two seconds, indicates a speed difference of 1%.

- if the same switch is set on SLAVE, the synchronizer adjusts the tape speed, slaving the playback pilot signal to the reference signal. The meter needle then shows the phase difference between the two signals and should not oscillate.

If the desired speed correction is beyond the slaving capability of the device ( $\pm 3\%$ ), the meter needle begins to oscillate; use of the QSV2 speed variator will extend the slaving range by  $\pm 12\%$ .

The PILOT LEVEL indicator becomes black if there is no pilot signal or it is not sufficient for good synchronization.

### Applications

- Filming on playback
- Transfer of sound recorded on a NAGRA to a film or perforated tape, facsimiles
- Correlation of signals recorded on several recorders
- Synchronous measurements etc.

### SPECIFICATIONS

Nominal synchronization range  $\pm 3\%$

Current consumption 8.8 mA

Dimensions: 5 1/2" x 3 1/4" x 1 1/4"  
140 x 82 x 30 mm

Weight: 13 oz - 360 g

égale la vitesse originale avec une précision de l'ordre de 0,001%.

La deuxième prise d'entrée SPEED VARIER INPUT est destinée à recevoir le variateur de vitesse QSV2, lorsqu'il est nécessaire d'élargir la plage de synchronisation ( $\pm 12\%$ ).

Le galvanomètre donne deux indications:

- en position FREE du commutateur NAGRA SPEED, c'est-à-dire sans asservissement de vitesse, il affiche l'écart entre la fréquence du signal pilote lu et celle du signal de synchronisation. Une oscillation complète de l'aiguille gauche/droite/gauche en deux secondes correspond à un écart de vitesse de 1%.

- en position SLAVE du même commutateur, le synchronisateur règle la vitesse de défilement de la bande, en asservissant le signal pilote lu au signal de référence. L'aiguille du galvanomètre indique alors l'écart de phase entre les deux signaux; elle ne doit plus osciller.

Au cas où l'écart de vitesse à corriger excède les possibilités d'asservissement du dispositif ( $\pm 3\%$ ), l'aiguille du galvanomètre se met à osciller; le variateur de vitesse QSV2 permet d'élargir cette plage d'asservissement de  $\pm 12\%$ .

Le voyant PILOT LEVEL devient noir si le signal pilote est absent ou insuffisant pour une bonne synchronisation.

### Applications

- Tournage en playback
- Transfert du son NAGRA sur film ou bande perforée, utilisation pour fac-similés
- Corrélation des signaux enregistrés sur plusieurs appareils
- Mesures synchrones etc.

### SPÉCIFICATIONS

Plage de synchronisation propre  $\pm 3\%$

Consommation 8,8 mA

Dimensions: 140 x 82 x 30 mm

Poids: 360 g

einer Genauigkeit von etwa 0,001% abzuspielen.

Die zweite Eingangsbuchse SPEED VARIER INPUT dient zum Anschluss des Geschwindigkeitsreglers QSV2, falls der Regelbereich auf  $\pm 12\%$  erweitert werden muss.

Das Instrument gibt zwei verschiedene Anzeigen:

- in Stellung FREE des Schalters NAGRA SPEED, das heißt ohne Geschwindigkeitsnachregelung, zeigt es den Unterschied zwischen dem abgetasteten Pilotsignal und dem Bezugssignal an. Eine volle Schwingung links/rechts/links in zwei Sekunden entspricht einem Geschwindigkeitsunterschied von 1%.

- in Stellung SLAVE des gleichen Schalters regelt der Synchronisator die Bandgeschwindigkeit, indem es das abgetastete Pilotsignal mit dem Bezugssignal synchronisiert. Der Instrumentenzeiger gibt in diesem Falle den Phasenunterschied der beiden Signale an; er darf nicht schwingen. Überschreitet der ausgleichende Geschwindigkeitsunterschied die Nachsteuerungsmöglichkeit der Vorrichtung ( $\pm 3\%$ ), so beginnt der Zeiger zu schwingen; der Geschwindigkeitsregler QSV2 erweitert diesen Bereich um  $\pm 12\%$ .

Das Schanzeichen PILOT LEVEL wird schwarz, wenn das Pilotsignal nicht vorhanden oder zu schwach für gute Synchronisation ist.

### Anwendungsbeispiele:

- Filmen in Playbackverfahren
- Überspielen des Tons vom NAGRA-Gerät auf Film, perforiertes Tonband sowie für Facsimile
- Korrelation von auf mehreren Geräten aufgezeichneten Signalen, synchrone Messungen.

### TECHNISCHE DATEN

Eigener Nachsteuerungsbereich der Synchronisation  $\pm 3\%$

Stromverbrauch 8,8 mA

Abmessungen: 140 x 82 x 30 mm

Gewicht: 360 g

# NAGRA KUDELSKI

## ATN 2

### Universal Power Supply

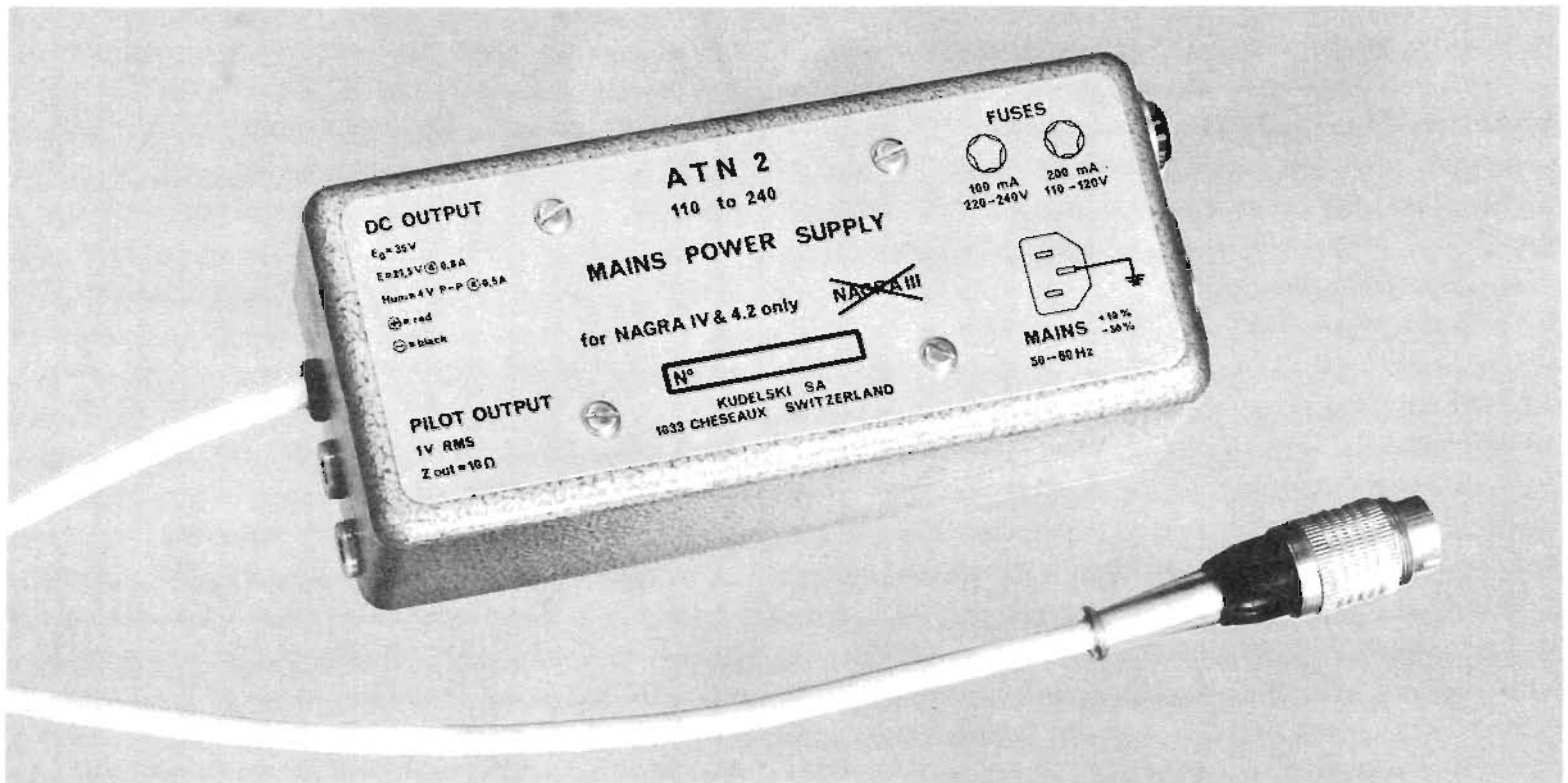

#### ENGLISH

Universal power supply unit for NAGRA III, IV, 4.2, IV-S and IV-SJ (110 to 240V, 50 or 60 Hz). Also supplies a mains frequency signal of 1V, serving as a pilot signal when operating a camera with synchronous motor from the same mains.

Secondary internally commutable for 25V (NAGRA III) or 35V (NAGRA IV, 4.2, IV-S, IV-SJ) for faster rewinding than with the former ATN.

Meets the Swiss ASE requirements and the international IEC requirements.

Supplied without cable

Dimensions 6 x 2 1/2 x 2"

Weight 2.3 lbs

#### FRANÇAIS

Alimentation secteur pour NAGRA III, IV, 4.2, IV-S et IV-SJ (110 à 240V, 50 ou 60 Hz). Cet accessoire fournit également un signal pilote de 1V à la fréquence du secteur, utilisé lors du tournage avec une caméra à moteur synchrone alimenté par le même secteur.

Secondaire à prises, connectées à l'intérieur pour 25V (NAGRA III) ou pour 35V (NAGRA IV, 4.2, IV-S et IV-SJ), avec rebobinage plus rapide qu'avec l'ancien ATN.

Appareil conforme aux prescriptions suisses ASE et internationales CEI.

Livré sans câble secteur

Dimensions 150 x 62 x 50 mm

Poids 1 kg

#### DEUTSCH

Netzgerät für NAGRA III, IV, 4.2, IV-S und IV-SJ (110 bis 240V, 50 oder 60 Hz). Dieses Zubehör liefert auch ein Pilotsignal, 1V bei Netzfrequenz, verwendbar beim Filmen mit einer Synchronmotor-Kamera, die an das gleiche Netz angeschlossen ist.

Sekundärwicklung intern umschaltbar für 25V (NAGRA III) oder 35V (NAGRA IV, 4.2, IV-S und IV-SJ) mit schnellerer Rückwicklung als beim früheren ATN-Modell.

Entspricht den schweizerischen ASE-Vorschriften und internationalen IEC-Vorschriften.

Lieferbar ohne Netzkabel

Abmessungen 150 x 62 x 50 mm

Gewicht 1 kg



# QSV2

## SPEED VARIER

QSV2 for NAGRA 4.2, IV-S and IV-SJ

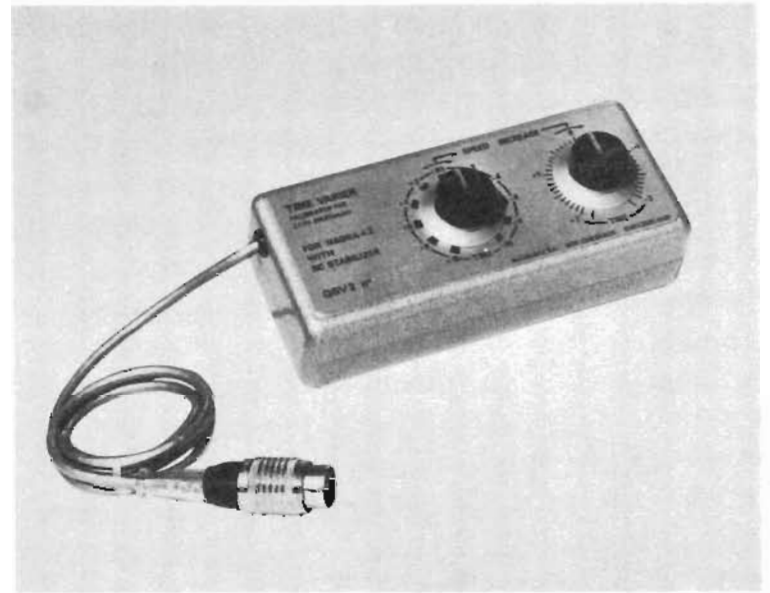

QSV 2

### ENGLISH

When connected to the Nagra, the Speed Varier allows all 3 speeds 15"/s - 7.5"/s - 3.75"/s to be varied manually up to  $\pm 12\%$

Sound transfer applications :

- To adjust the pilot signal frequency to a reference.
- To compensate for a missing pilot signal or to adjust the synchronization when the pilot signal frequency fluctuates.

Dimensions :  $5 \frac{3}{4}'' \times 2 \frac{1}{2}'' \times 1 \frac{5}{8}''$   
(142 x 62 x 38 mm)

Weight : 1 lb (0.450 kg)

### FRANÇAIS

Le variateur de vitesse permet de faire varier manuellement la vitesse de défilement du Nagra de  $\pm 12\%$

Il est utilisable à toutes les vitesses (38,1 cm/s; 19,05 cm/s; 9,525 cm/s).

Applications :

- Transfert d'un ruban dont le signal pilote provenait d'une caméra à vitesse hors tolérance.
- Transfert d'un ruban dont le signal pilote comporte des interruptions.

Dimensions : 142 x 62 x 38 mm

Poids : 0,450 kg

### DEUTSCH

Das QSV Zubehör welches am Nagra angeschlossen wird, erlaubt die 3 Band-Geschwindigkeiten (38,1 cm/s; 19,05 cm/s; 9,525 cm/s) von Hand um  $\pm 12\%$

Anwendung bei Überspielungen :

- Anpassen der Pilotton-Frequenz an die Referenz Frequenz.
- Ausgleichen schwankender oder fehlender Pilotton Signale.

Abmessungen : 142 x 62 x 38 mm

Gewicht : 0,450 kg

# MAG

## Electronically controlled degausser Démagnétiseur à commande électronique Entmagnetisierungsgerät mit elektronischer Steuerung

The MAG is an electronically controlled degausser for recorder heads and mechanical parts which are in continuous contact with the tape.

There are two versions:

MAG 90801 220 – 240 Volts mains  
MAG 90802 110 – 117 Volts mains

Le MAG est un démagnétiseur à commande électronique pour les têtes et les éléments mécaniques en contact constant avec la bande magnétique.

Il existe en deux versions:

MAG 90801 220 – 240 volts  
MAG 90802 110 – 117 volts

Das MAG ist ein elektronisch gesteuertes Entmagnetisierungsgerät für die Köpfe sowie die mechanischen Elemente welche in ständigem Kontakt mit dem Tonband sind.

Es existiert in zwei Versionen:

MAG 90801 220 – 240 Volt  
MAG 90802 110 – 117 Volt

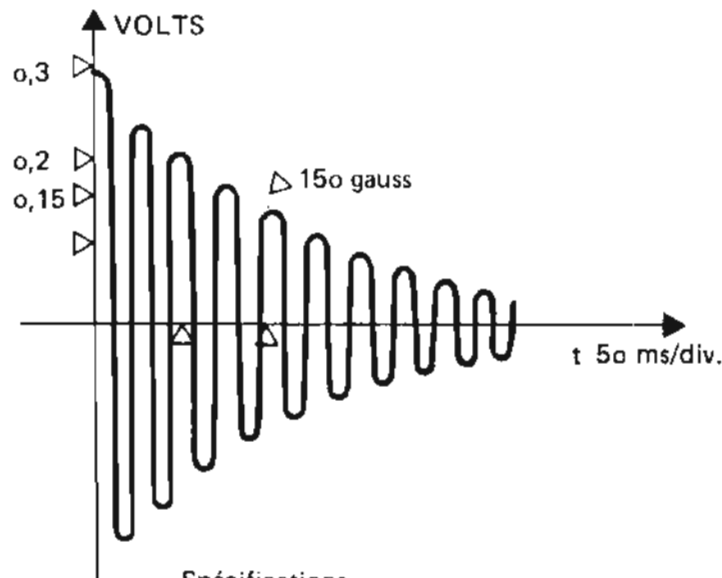

### Specifications

mains supply: 220 to 240 V  
or 110 to 117 V

no load power consumption: 10 mA  
max. power consumption:  
peak current 300 mA

max. field strength: 270 gauss  
field strength after 100 ms: 135 gauss

FST fuse standard:  
630 mA for 220 V  
1,25 A for 110 V

### Spécifications

alimentation: 220 à 240 V  
ou 110 à 117 V

consommation à vide: 10 mA  
consommation maximum:  
courant de pointe 300 mA

champ maximum: 270 gauss  
champ après 100 ms: 135 gauss

calibre des fusibles FST:  
630 mA pour 220 V  
1,25 A pour 110 V

### Technische Daten

Netzspeisung: 220 bis 240 V  
oder 110 bis 117 V

Leerlaufleistung: 10 mA  
Max. Stromaufnahme:  
Spitzenstrom 300 mA

Max. Magnetfeld: 270 gauss  
Magnetfeld nach 100 ms: 135 gauss

FST Kaliber Eichmass:  
630 mA für 220 V  
1,25 A für 110 V

## Operating instructions

It is advisable to switch the recorder off completely to prevent damage caused by the voltage induced in the heads to the amplifiers.

### Preparation:

After removing its cover plate, mains power the MAG and switching POWER "ON" place the coil on the heads or on the parts which are to be demagnetized.

### Operation:

The demagnetization switch being in the "OFF" position, throw it onto "ON": the indicator lights up and slowly goes out. When the light is off, switch back to "OFF". Repeat the operation three or four times to ensure a thorough demagnetization.

## Mode d'emploi

Le magnétophone ne doit pas être sous tension afin d'éviter que la tension induite dans les têtes n'endommage les amplificateurs.

### Mise en place:

Après avoir enlevé le couvercle, raccorde le MAG au secteur et commute l'interrupteur POWER sur "ON", placez la bobine sur les têtes ou sur les éléments à démagnétiser.

### Utilisation:

L'interrupteur DEMAGNETIZATION étant sur "OFF", le basculer sur "ON", le voyant s'allume puis s'éteint lentement. Quand il est complètement éteint, ramener l'interrupteur sur "OFF" et répéter l'opération trois ou quatre fois pour obtenir une démagnétisation complète.

## Gebrauchsanweisung

Das Tonbandgerät darf nicht unter Spannung stehen, um zu verhindern, dass die induzierte Spannung in den Köpfen die Verstärker beschädigt.

### Einbau:

Nach Abnahme des Deckels das MAG an den Sektor anschliessen und den POWER Schalter auf "ON" einstellen. Spule auf den Köpfen oder den zu entmagnetisierenden Elementen anbringen.

### Betätigung:

Den sich auf "OFF" befindenden DEMAGNETIZATION-Schalter auf Position "ON" drehen, das Anzeigelämpchen leuchtet auf und erlischt dann langsam. Sobald es komplett erloschen ist, den Schalter wieder auf Pos. "OFF" bringen und den ganzen Vorgang drei- bis viermal wiederholen um eine totale Entmagnetisierung zu erreichen.

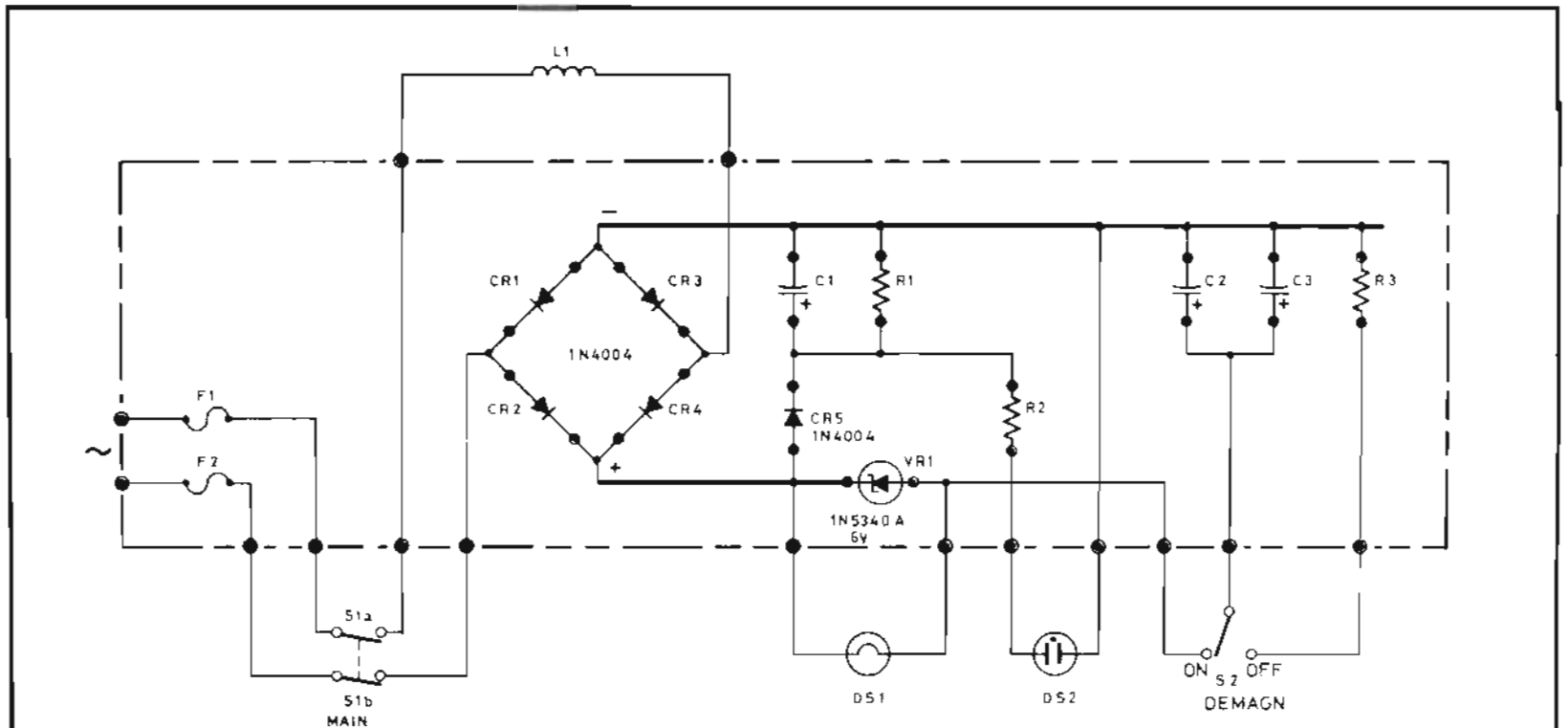
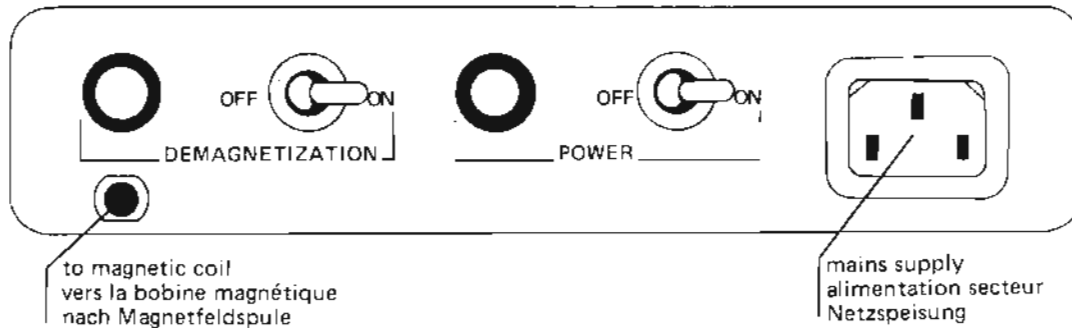

ALL RESISTORS  $\pm 5\%$

~	R1	R2	R3	C1	C2	C3	L1	F1	F2
110 V 117 V	100K 1W	0	33 $\Omega$ 10 W	25 $\mu$ F 400 V	590 $\mu$ F 200 V	590 $\mu$ F 200 V	1035 sp $\phi$ 0,4 L 3,3	1,25 A	1,25 A
220 V	100K 2W	58K 1W	100 $\Omega$ 10 W	25 $\mu$ F 400 V	290 $\mu$ F 400 V	290 $\mu$ F 400 V	2070 sp $\phi$ 0,4 L 3,3	630 mA	630 mA

CIRCUIT DIAGRAM

DEMAGNETIZER MAG

