



Owner's Manual

NanaWall SL73

Florida Hurricane Product Approved Aluminum Framed Floor Supported Folding System

This Owner's Manual contains instructions on the installation, operation, maintenance, and warranty of the NanaWall SL73 Florida Hurricane Product Approved Aluminum Framed Floor Supported Folding System. This manual is to be used by the installer for installation and is to be kept by the Owner for reference. Replacement parts can be ordered directly through NanaWall.

Installation Instructions

The installation of the SL73 System requires a working knowledge and experience in the use of tools, equipment and methods necessary for the installation of aluminum doors, windows, storefronts and/or partitions. This practice assumes a familiarity with preparing a proper and structurally sound opening, proper anchorage, waterproofing, caulking and sealing and assumes an understanding of the fundamentals of building construction that affect the installation of large aluminum door systems. These systems can be heavy. A crew of at least 2 persons is needed. Use safe lifting techniques to avoid injury and product damage.

Using an independent NanaWall Certified Installer is highly recommended. At the least, the installer should have some experience in installing NanaWall systems.

If this unit is being installed in reliance of the product's Florida product approval, please note that it has to be installed in strict conformance to installation requirements contained in the Florida Product Approval Installation Drawings that are included in Appendix A and B or could be downloaded from https://www.floridabuilding.org/pr/pr_default.aspx. The SL73 inward opening system is approved with Florida Product Approval No. FL20107.1 and is shown in Appendix A. The SL73 outward opening system is

approved with Florida Product Approval No. FL20107.2 and is shown in Appendix B.

CAUTION:

As regulations governing the use of glazed windows, doors, storefronts and/or partitions vary widely, it is the responsibility of the customer, building owner, architect, contractor and installer to insure that products selected conform to all applicable codes and regulations, including federal, state, and local. NanaWall can assume no obligation or responsibility whatsoever for failure of the customer, building owner, architect, contractor and installer to comply with all applicable laws and ordinances and safety and building codes.

The SL73 system has Florida Product Approval, but with strict limitations. Approval is limited to certain design pressures, sizes, configurations, special impact glass and glazing, installation conditions, and specific locking, and other factors. Please check carefully if your application meets all applicable limitations.

The SL73 system is shipped with all necessary components, except correct fasteners and shims. These are not provided by NanaWall and are critical to proper installation as outlined in these instructions. The correct fasteners will vary depending on the specifics for each installation.

The frame is shipped knocked down and needs to be assembled. Panels are pre-assembled with glass, ready to be attached to the installed frame. In most cases, all hinges, weather stripping, multiple locking, and standard handles are pre-attached to the panels, posts and frame components.

IMPORTANT: READ COMPLETE INSTRUCTIONS BEFORE BEGINNING INSTALLATION. INSTALL AS RECOMMENDED; OTHERWISE, THE UNIT MAY NOT FUNCTION PROPERLY AND ANY WARRANTY, WRITTEN OR IMPLIED, WILL BE VOID.

DESCRIPTION OF SUPPLIED PARTS

Check all parts carefully before assembly. Depending on the model, some of these parts may already be installed on the panels. The Product Drawings are in the small cardboard box attached to the frame components that contains hinge pins and various hardware. Inspect the elevation drawing, indicating size, configuration, and labeling of the unit ordered. Check that the sizes of the frame components, panel sizes and configurations match what was ordered according to the signed Product Drawings that show all dimensions of the system. Carefully note the information on the rough opening allowances to make sure the rough opening is prepared properly for the system to fit correctly when installed.

For orders with multiple units, do not mix and match panels and frames, even if two units are the same. Below is a list of supplied parts.

Always looking from inside.

- Left side jamb, labeled L, and right-side jamb, labeled R.
- Head (top) track, labeled O for over, and sill track, labeled U for under. (In some instances, the head jamb and sill may be in segments and will require joining in the field.)
- Pre-assembled panels. The number of panels depends on the model ordered. The sequence of labeling of panels starts from the left with the left most panel labeled Panel 1 –as viewed from the inside.
- Separate locking posts with pre-attached hinges, locking rods and handles.
- Separate running posts with pre-attached hinges and lower running carriage sets and upper guide assembly.
- Tapered pins or screws to connect the four corners of the frame.
- Corner connectors for frame corners.
- Necessary amount of hinge pins and set screws to secure the hinge pins.
- Lever handles, other handles or other entry hardware as ordered. These may be pre-attached to the panels. Panel holder – one for each swing door not attached to a side jamb.

HANDLING OF COMPONENTS

1. Upon receipt, inspect the shipment to ensure it is in good condition. Any shipment damage to crates and components inside must be photographed and reported to NanaWall immediately. Please e-mail pictures with your order number 'xxxxx' to service@nanawall.com and call the Service Dept. at 800-873-5673 ext. 256.
2. Make sure that the small cardboard box with the hinge pins and other hardware does not get lost. Please also verify the Product Drawings and Owner's Manual are in the hardware box. If these are missing, please contact NanaWall at info@nanawall.com to get this information.
3. Store in a clean and dry location and protect against defacement or damage, especially to the edges of panels, glass and all other finished surfaces. The panels and frame components are to be stored as they were shipped. Panels need to be stored on the sides and the frame components needs to be covered to protect them from damage on the project until it is installed.

PREPARATION OF THE ROUGH OPENING

All rough opening spaces and allowances shown in the drawings are meant for shimming the system to be installed perfectly plumb, level and square. For necessary clearance and shim/adjustment space, the rough opening should 3/4" wider than the unit width and 3/8" taller than the unit height of the unit ordered (check to comply with applicable codes for maximum shim space allowed, especially in high wind load areas). For Florida Product Approval, maximum shim space allowed is 3/8". It is important that the opening be the correct size.

NOTE: The outside frame height of the unit ordered is measured from the bottom of the sill and not from the finished floor. Allowance must be made in height for the portion of the sill that is below the measured opening. An important reference for the preparation of the rough opening is the finish floor height.

NOTE: The saddle sill is Florida Product approved, but with some restrictions as noted in the Notice of Approval.

It is highly recommended to install the system in a rough opening only and return all finishes to the system frame after proper installation. The shim space around the system is required. If the system is installed into the finished opening there will be space exposed around the system that will still need to be trimmed. Under no circumstances should the system be installed on compressible substrates such as Gyproc.

IMPORTANT: Because of the large opening sizes and the weight and movement of the panels, any application should take into consideration the following:

1. The structural integrity of the header is critical for proper operation. Vertical deflection of the header under full live and dead loads should be the lesser of $L/720$ th of the span and 1/4". Structural support to prevent movement due to lateral loads (both wind load and when the panels are stacked open) must also be provided. In addition, point loads supporting the head must be reinforced to prevent compression.
2. A qualified engineer or architect should be used to determine the proper construction details and header to be used in your application.
3. THE ROUGH OPENING SHOULD BE LEVEL, PLUMB, AND SQUARE AT ALL POINTS. THERE SHOULD BE NO UNEVENNESS OR BOWING. MAKE SURE THAT THE HEADER, SIDE POSTS, AND SILL ARE NOT TILTED OR TWISTED. THERE SHOULD BE NO BUMPS ON THE FLOOR. THE SIDE POSTS SHOULD BE IN THE SAME VERTICAL PLANE AND NOT OFFSET OF EACH OTHER. THE ROUGH OPENING HEADER AND SILL NEED TO BE LEVEL AND PARALLEL AND THE SIDE POSTS SHOULD BE PLUMB AND PARALLEL. A TRANSIT AND OTHER SIMILAR PRECISE MEASURING EQUIPMENT SHOULD BE USED TO VERIFY THE ROUGH OPENING IS PREPARED PROPERLY.
4. With a recessed sill, if concrete is to be poured after the installation of the unit, the sill must be securely attached to the construction. If the sill is to be cast in concrete, then an expansion gap with appropriate material has to be created next to the sill.

5. With a low profile saddle sill, there is no Florida Product Approved water rating, but some resistance to water infiltration may be achieved by installing weep holes and drain connections to the outside. Drain connections are an option that is provided by the installer or customer and not by NanaWall. Location of drain connections and flow of water is determined by others according to the surrounding conditions. See Diagram 3 for details.
6. If heavy gage all metal studs is the surrounding substrate, they must have continuous wood backing sufficient to allow for minimum 2 ½" embedment of fasteners.
7. For better performance and protection, any exterior folding system should be installed under an overhang or with other similar protection.
8. For better performance it is recommended that all dead loads such as upper levels, roof, etc. be constructed before a unit is installed to limit the deflection of the header after installation of the system.

Waterproofing and envelope details are not part of the base NanaWall installation and will be unique to each project - proper flashing, waterproofing, and envelope details around the perimeter of the opening, especially at the sill, are to be designed and completed by others. Make sure you seek proper professional advice for the appropriate construction, waterproofing, and building envelope details needed for your application and jurisdiction.

Do not install unit in structures that do not allow for proper management/drainage of moisture. Peel and stick or ice shield should be used under all bottom sills.

IMPORTANT: To avoid future problems, do not install your unit until the rough opening has been correctly prepared.

Please note that all installation methods, including anchoring the frame to the rough opening, must be in exact conformance with the Florida Product Approval Installation Drawings.

UNIT INSTALLATION

The Installation of the folding unit is described in the following categories:

A. FRAME ASSEMBLY AND INSTALLATION

B. PANELS AND FOLDING HARDWARE INSTALLATION

C. FINAL STEPS

A. FRAME ASSEMBLY AND INSTALLATION

Step A1 Preparation of the frame components

Drilling of holes for anchorage devices to connect the frame to the opening is done first. The fastener types for different substrates, minimum embedment, and minimum edge distance needs to strictly comply with the Florida Product Approval Installation Drawings that are attached as Appendix A. All fasteners should be corrosion resistant.

Additional fasteners needed that are not shown in the Florida Installation Drawings are as follows:

1. Where panels stack whether on one side of the opening or both sides, there should be extra fasteners in both the head track and sill that should be about 4" apart.
2. In units with multiple head track and sill segments, on both sides of the splice joint, it is required to put a fastener at 2" from the splice and 4" from the splice, for a total of 4 fasteners on each side of the head and sill tracks.

The recommended installation method is for fastener/attachment holes to be drilled through the polyamide thermal break in the frame components, and it is imperative to span the thermal break with a washer or screw head so the pressure of the screws is on the aluminum of the frame. The FL Product Approval Installation Drawings allows for an alternative installation method of fasteners on either side of the thermal break. Please see details for this installation method in that document. In this manual, only the recommended installation method will be discussed.

All joints require a proper sealant to keep all water and air infiltration from occurring; recommended sealants include commercial grade polyurethane, either clear or color matched.

Side jambs will be marked 'L' and 'R' for left and right as viewed from the inside. Top head tracks will be marked 'O' for 'over' and bottom sill tracks will be marked 'U' for 'under'. Note: If there are no weep holes in the sill, please check whether such holes are required and drill them if necessary. Head and sill tracks may be supplied in two or more segments that are required to be joined. Lay out the multiple segments in a line to mark out the required fastener locations. Drill all the fastener holes and then join the segments while they are on the floor using the supplied joining pieces.

At all times, use appropriate padding to protect the finish on the frame pieces. When drilling holes through the polyamide thermal break, take measures to protect the frame components from being marred by the drill chuck.

Step A2

Apply exterior grade sealant to all connection points between the frame components. The ends of the sill should be completely filled with sealant to prevent water leakage from the ends of the water channels on the sill.

Step A3

Insert the corner connectors into the head track (and into a higher weather performance (raised) sill) and into the side jamb - see Illustration A1 on page 7. See Illustration A2 on page 7 for connection of a side jamb with a low profile saddle sill.

Step A4

Connect corners with tapered brass cone pins or screws in the pre-drilled holes. Align the frame corners carefully and once the frame is squared, insert the brass cone pins in both sides at the same time into the pre-drilled holes before tapping the pins in all the way. Do not tap the pins in one at a time – alternate tapping the pins. Do not tap the brass cone pins deeper than the surface of the aluminum frame. They will not hold the joint together properly if they are too deep.

Step A5

Be sure that appropriate flashing and waterproofing around the perimeter of the opening is installed. Set the assembled frame into the rough opening at the proper position relative to the header. Make sure the direction is correct with respect to inward or outward opening.

ILL. A1
Frame Assembly of a Unit
with a Higher Weather
Performance Sill

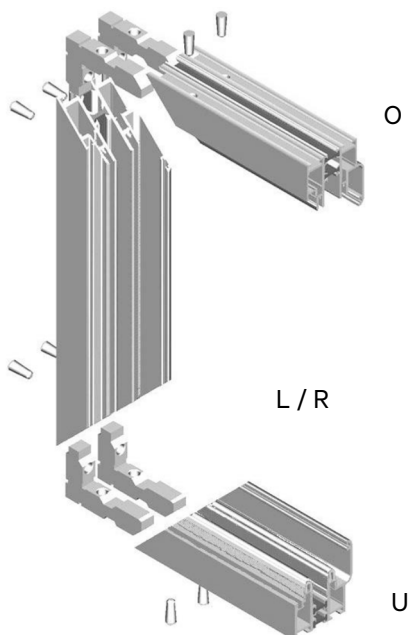

See the Florida Product Approval Installation Drawings and Diagram 1 for Suggested Installation Details. Please note that the Diagram 1 drawings are suggestions only and that these may not be suitable in all applications.

Step A6 – Selection and Use of Installation Shims

Use only hard plastic 'horseshoe' style glazier's shims. Wood shims are NOT appropriate. Shims are to be installed between the system frame and the building structure at every fastener location to keep the frame components straight, level and plumb, without any twisting.

Step A7

Stand up the assembled system frame and temporarily secure the frame to the rough opening with clamps or other aids.

Position frame in the rough opening. Use loose shim stacks at either end of the sill track to center the system frame in the opening horizontally. Check that there is sufficient shim space behind both side jambs to be able to fasten the jambs perfectly plumb and straight.

ILL. A2
Corner Connection of a
Side Jamb with a Saddle
Sill

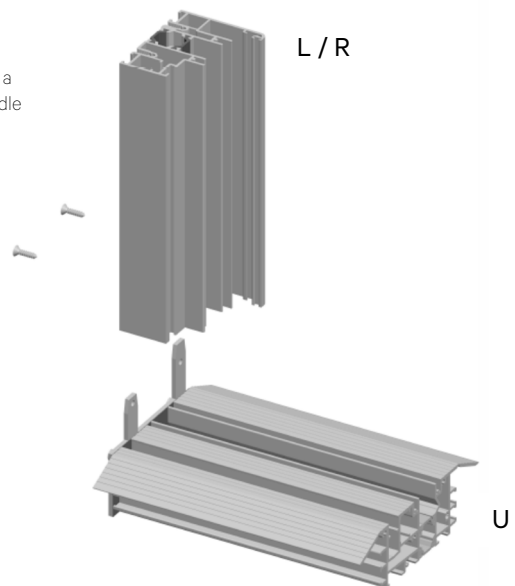
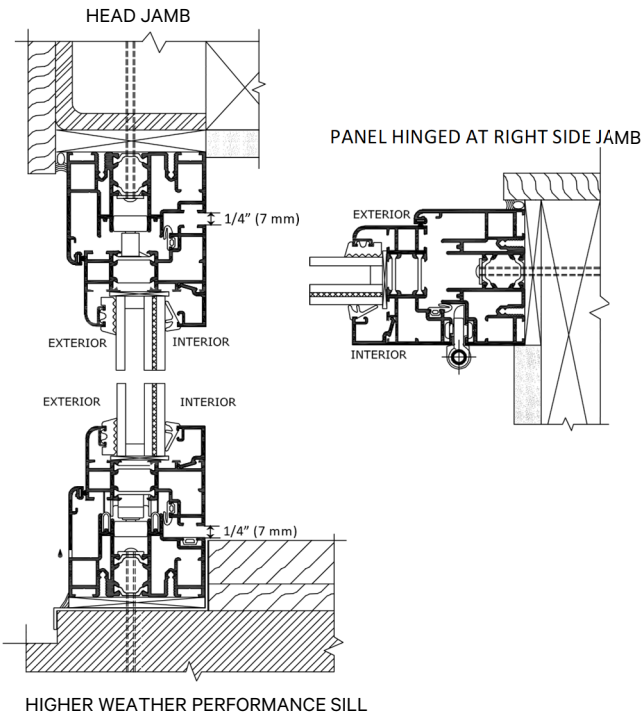

DIAGRAM 1: SL73 SUGGESTED TYPICAL INSTALLATION

Suggested Typical Installation drawings shown are very general and may not be suitable for any particular installation. Product placement, fasteners, flashing, waterproofing, sealant, trim, and other details for specific surrounding conditions must be properly designed and provided by others. Product must be installed in conformance with Dade county NOA documents.

Drawings not to scale.
Details shown are subject to change without notice.

INWARD OPENING SUGGESTED TYPICAL INSTALLATION



OUTWARD OPENING SUGGESTED TYPICAL INSTALLATION

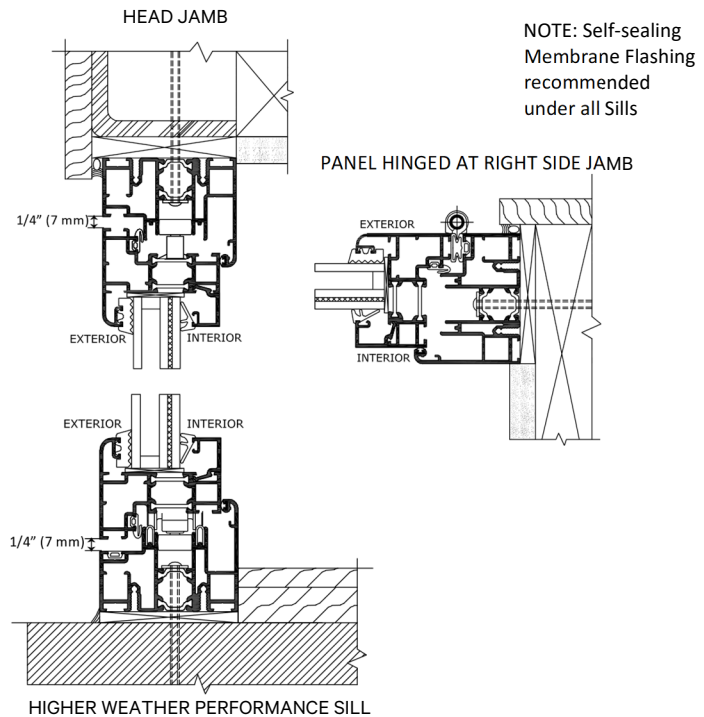

INWARD / OUTWARD OPENING SUGGESTED TYPICAL INSTALLATION (INWARD OPENING SHOWN)

LOW PROFILE SADDLE SILL - OPTION 1
(Weep holes by others necessary for water rating as lab tested)

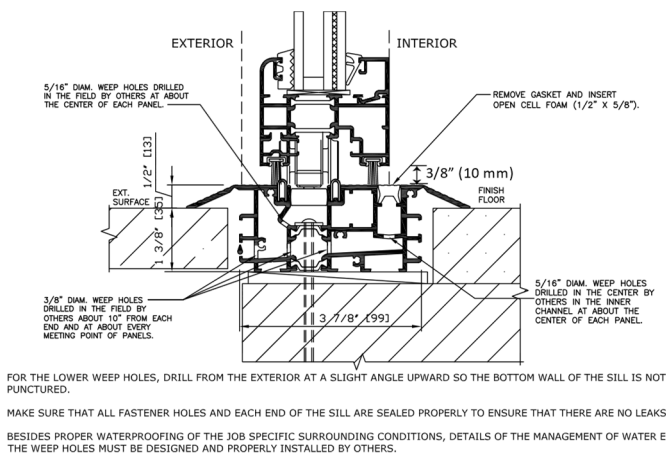

LOW PROFILE SADDLE SILL - OPTION 2
(If no water rating is needed)

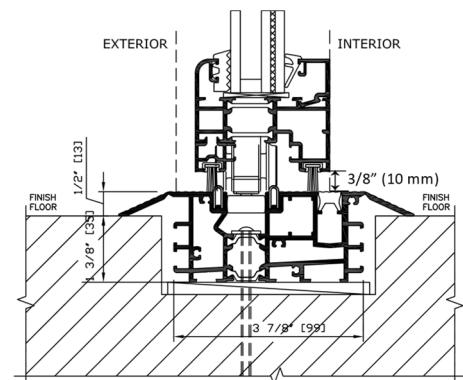

Step A8

Place shims under the sill track at every fastener location to level the sill to within +/- 1 mm. Check the elevation of the sill track in relation to the finish floor and then anchor the sill with the correct fasteners. Please note that Florida Product Approval Installation Drawings requires shim space at any point to be not more than 3/8". If there is a bigger gap between the unit and the opening, then this space must be filled by a continuous structural member.



Make sure that the screw head with washer (if any) is small enough to fit inside the slot in the middle of the head jamb and sill; otherwise, it will interfere with the rolling of the running carriages.



Use hard plastic shims only.

IMPORTANT: Make sure shims are held firmly in place by fixing screws of the frame, without bowing or twisting of any frame components. Add or remove shims if necessary, to keep frames straight, checking the frame constantly to be certain that it is level, plumb, and square. A transit, rotary laser level or other similar precise measuring equipment should be used to make these determinations.

Step A9

Check the fastened sill to make sure that it is level, and not tilted or twisted. Loosen fasteners and adjust the height of the shim stacks until the sill is at the correct elevation, and perfectly level without any tilt or twist.

Make sure that all holes drilled through the sill are properly sealed with exterior grade polyurethane sealant underneath and around the screws.

All Weep holes in the sill, if present, are not to be obstructed.

It is critical to make any necessary adjustments to level, plumb, and square before proceeding on.

Step A10

Anchor the side jambs to studs or walls in the same manner. Make sure that the jambs are plumb and straight with no twist.

Step A11

Anchor the head track through the pre-drilled holes with shims above at every fastener. Make sure that the head track is level +/- 1 mm, and without any tilt or twist.

IMPORTANT: Make sure that all the surfaces of the upper and lower tracks are clean and free of any debris, especially cuttings from drilled holes. Otherwise, some of the components on the rollers will get damaged.

B. PANELS AND FOLDING HARDWARE INSTALLATION

At least 2 people are needed to install panels. Use vacuum suction cups on cleaned glass surfaces to lift panels into place. Please do not carry or lift the panels by the frame, as it can move the frame out of its original position.

IMPORTANT: Look for glass stops to determine the interior side of a panel.

Step B1

Looking at the elevation drawing, first attach panel(s) to be hinged off side jambs by aligning the hinges and inserting the proper hinge pins. Be sure that the washers, if any, between different hinge components remain securely in place

Do not force any hinge pins. The security set screws on the hinges must be loosened with an Allen key before inserting the hinge pins, tighten them till they touch the pin and then back off a full turn. See also Illustration C1.

Step B2

Attach the properly numbered post with locking mechanism to the panel that is going to be part of a folding pair by aligning the hinges and inserting the hinge pins. Only use posts as numbered.

Step B3

Again, looking at the elevation drawing, attach the next panel needed to create a folding pair to the other side of the locking post by aligning the hinges and inserting the proper hinge pins. If necessary, place temporary blocks under the panels to assist in keeping the panels in a steady position.

Step B4

Attach the next numbered post with running carriages to the second panel of the folding pair. To facilitate, bring the running post in at an angle to set the lower running carriage on the lower track and upper guide carriage in the upper track. Attach by aligning the hinges and inserting the hinge pins.

DIAGRAM 3: SL73 EXAMPLE OF A 3 PANEL UNIT INWARD OPENING.

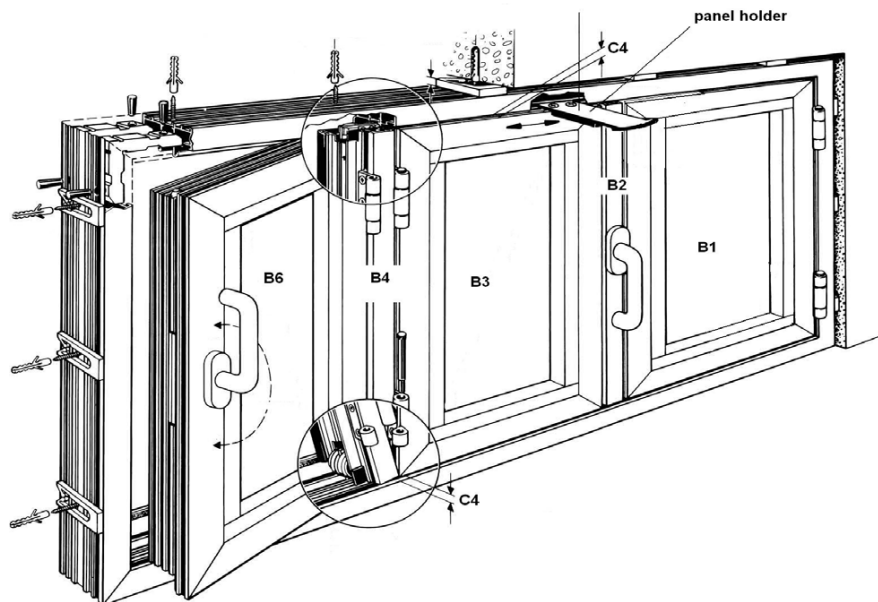

Step B5

If there are additional panels to be attached to the folding pair, close the pair by turning the handle on the locking post between them. Turning the handle 180° engages the shoot bolts in the locking post.

Step B6

Attach additional panels and posts in the same manner.

C. FINAL STEPS**Step C1**

Attach handles and other hardware that have not been pre-attached. Install the profile cylinder (if any) to the locking gear by inserting it into the lock hole and attaching the set screw through the screw hole on the gear located at the edge of the panel. Cut the set screw, if needed, so it is not longer than 1-1/2".

For outswing units, between each pair of folding panels, attach a pull handle to a hinge at the center of the unit.

Step C2

IMPORTANT: For swing panels not attached to a side jamb, attach the panel catch to the top of the upper rail of the adjacent panel. See Diagram 3. The purpose of the panel catch is that the swing panel should always be opened and secured and engaged into the panel catch before the folding panels are to be opened. Failure to install the panel catch could lead to damage to the system and will void the product warranty.

Step C3

Check operations and open the panels. Close and lock all panels into position.

Step C4

Check all horizontal joints:

Make sure the head track and sill are still level. Then along the entire width of the opening, check the spacing between the sill and each panel and the spacing between the head track and each panel. Both spaces should be about 1/4" along the entire length of the unit with the higher weather performance (raised) sill. For a unit with the low profile saddle sill, the space between the sill and each panel should be about 3/8". Please see Diagram 1 for these relevant dimensions.

Check specifically to see if the upper corner of a panel where the running carriage is located is not higher than the other corner of the panel. If it is slightly lower (not more than 1/16"), it is okay. Proper spacing is critical for proper operation of the unit.

Step C5

Check all vertical joints:

Make sure that the side jambs are still vertically straight. All vertical spacing between side jamb and panel, post and panel should be about 5/16". If necessary, the hinges can be adjusted. See Illustration C1 on page 12. Adjust across the length of the unit and at all hinges at a pivot point, not just in one place.

Step C6

The lower running carriage has an adjustment feature too. U-shaped shims of 1/16" thickness each are located above the lower running carriage. With a crowbar, carefully raise the astragal profile up and push shims out as needed to lower the panel.

ILL. C1: SL73 HINGE ADJUSTMENT

1. Security set screw (not to be used for hinge adjustment).

Hinge Adjustment

2. Loosen Phillips screws.
3. Adjust Hinge Adjustment Set screw with an Allen key as necessary.
4. Re-tighten Phillips screws.

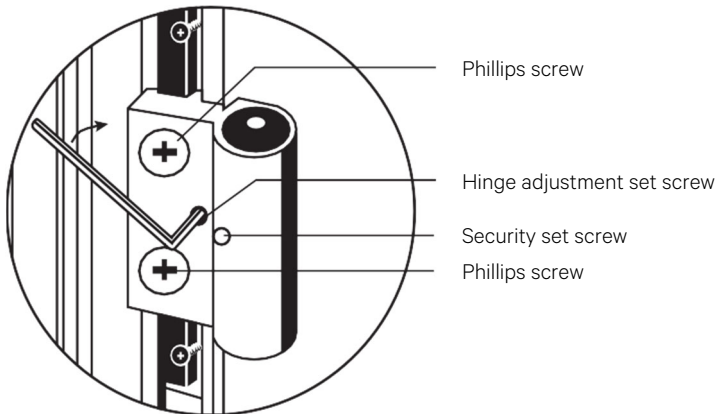
**Step C7**

Check that the system operates and functions properly. The panels should be able to be moved easily by one person without much effort (for not more than 6 panels to one side) when opening or closing and all shoot bolts should engage smoothly. If the panels do not move easily or a lot of effort is needed, the indication is that the unit is not properly installed. Correct any problems before finish trimming.

Step C8

Finish any waterproofing, flashing, trim, and sealant needed around the perimeter of the opening. Important: Make sure any weep holes in the sill are not blocked.

Step C9

Confirm that the panel catches on the swing panels are installed. To prevent uncontrolled movement of the panels when in the open position, place appropriate door holder by others as needed.

PROTECTION OF UNIT DURING CONSTRUCTION PHASE

It is important that during the construction phase the unit be kept closed, covered, and protected from damage. During this phase, a unit is often subject to the most extreme conditions from all types of construction operations that can permanently damage and destroy it. A unit can be damaged by cement splatter, tar, paint, weld splatter, falling objects, construction dust, sand blasting, etc. All temptations to use the large opening of an installed system for easy ingress and egress by tradesmen should be resisted.

GENERAL NOTES:

- THIS PRODUCT HAS BEEN TESTED, ANALYZED & APPROVED FOR DESIGN PRESSURES NOT TO EXCEED THOSE SHOWN IN THE ALLOWABLE DESIGN PRESSURE TABLE(S).
- OPENINGS, BUCKING & BUCKING FASTENERS MUST BE PROPERLY DESIGNED & INSTALLED TO TRANSFER WIND LOADS TO THE STRUCTURE BEHIND THE PRODUCT.
- ALL ANCHORS SHALL BE CAPABLE OF RESISTING TORSION CAUSED BY THE PRESSING AND SUCTION WIND LOADS IN THE WOOD USE WHEN REFERENCING THESE COMMENTS IN ACCORDANCE WITH THE GOVERNING CODE AND GOVERNING WIND VELOCITY. FOR WIND LOAD CALCULATIONS IN ACCORDANCE WITH THE FLORIDA BUILDING CODE, A DIRECTIONALITY FACTOR OF $K_d = 0.85$ MAY BE APPLIED PER THE ASCE-7 STANDARD.
- MATERIALS, INCLUDING BUT NOT LIMITED TO STEEL SCREWS, THAT COME INTO CONTACT WITH OTHER DISSIMILAR MATERIALS SHALL MEET THE REQUIREMENTS OF FLORIDA BUILDING CODE.
- TO THE BEST OF OUR KNOWLEDGE, THE PRODUCT SHOWN HEREIN IS QUALITY ASSURED BY A FLORIDA STATE APPROVED CERTIFICATION FOR THE MANUFACTURE OF BUSINESS & PROFESSIONAL REGULATION SPECIFICATIONS. THESE DRAWINGS SHOW ALL APPLICABLE ELEVATION, COMBINATION, INSTALLATION & COMPARATIVE ANALYSIS CONDITIONS AS DETERMINED THROUGH TESTING & ENGINEERING RATIONAL ANALYSIS. PRODUCT ASSEMBLY SHALL BE IN ACCORDANCE WITH THESE DRAWINGS. THE MANUFACTURER'S QUALITY ASSURANCE SPECIFICATIONS & TESTING REPORTS.
- CERTIFICATION OF THIS PRODUCT SHALL BE CONSIDERED VOID IF IT IS INSTALLED WITHOUT A BUILDING PERMIT FROM THE APPLICABLE LOCAL BUILDING DEPARTMENT OR IS INSTALLED BY ANYONE OTHER THAN A PRODUCT CONTRACTOR EXPERIENCED WITH INSTALLATIONS OF THIS TYPE OF PRODUCT.

HINGE REQUIREMENTS
 5 PER PANEL (ALL PANEL SIZES)
 PLACED APPROXIMATELY 5" & 13" FROM TOP & BOTTOM & AT MIDDLE OF PANEL

FRAME ANCHOR REQUIREMENTS TABLE

OPENING TYPE (SUBSTRATE)	MINIMUM EMBED	MINIMUM FASTENER TYPE	MINIMUM EDGE DIST.
MIN. 2X4 WOOD FRAME OR BUCK (MIN. GR. 3 & G=0.55)	1 1/4"	NO. 14 SMS OR WOOD SCREW	3/4"
MIN. 16 GA. 33 KSI METAL STUD	FULL	1/4" GR. 5 SELF TAP/DRILL SCREW	1/2"
MIN. 1/8" THK A36 STEEL	FULL	1/4" GR. 5 SELF TAP/DRILL SCREW	1/2"
MIN. 1/8" THK 6063-T5 ALUM.	FULL	1/4" GR. 5 SELF TAP/DRILL SCREW	1/2"
MIN. C-90 CMU	1 1/4"	(2) 1/4" CONCRETE SCREW	2 1/2"
MIN. 2500 PSI CONCRETE	1 1/2"	(2) 1/4" CONCRETE SCREW	2 1/2"
DOUBLE SCREW ROW			
(3) MIN. 2X6 WOOD FRAME OR BUCK (MIN. GR. 3 & G=0.55)	1 1/4"	NO. 10 SMS OR WOOD SCREW	3/4"
MIN. 16 GA. 33 KSI METAL STUD	FULL	NO. 10 GR. 5 SELF TAP/DRILL SCREW	1/2"
MIN. 1/8" THK A36 STEEL	FULL	NO. 10 GR. 5 SELF TAP/DRILL SCREW	1/2"
MIN. 1/8" THK 6063-T5 ALUM.	FULL	NO. 10 GR. 5 SELF TAP/DRILL SCREW	1/2"
MIN. C-90 CMU	1 1/4"	(2) 1/4" CONCRETE SCREW	2"
MIN. 2500 PSI CONCRETE	1 1/2"	(2) 1/4" CONCRETE SCREW	2"
(1) WHEN SINGLE SCREW ROW ANCHORING METHOD IS USED SCREWS MUST HAVE A #3/4" O.D. FLAT WASHER AT THE SCREW HEAD.			
(2) CONCRETE HEADS SHALL BE ELCO ULTRACONS (C.S.), ELCO CRETE-FLEX (S.S.), ITW RAMSEY/RED HEAD TAPCONS (C.S. OR S.S.) OR HILTI KWIK-CON II (C-S OR S.S.).			
(3) 2X6 WOOD BUCK MAY BE RIPPED DOWN TO 4 1/2" PROVIDING THAT REQ'D SCREW TO BUCK EDGE DISTANCES ARE MAINTAINED.			

FRAME SCREWS

FRAME TO OPENING FASTENER TYPE

(1) SINGLE SCREW ROW

DOUBLE SCREW ROW

ALLOWABLE DESIGN PRESSURE WITH STANDARD SILL

MAX. FRAME HEIGHT (IN.)	MAX. D.L.O. WIDTH (IN.)	ALLOWABLE PRESSURE (PSF)		
		GLASS OPTION 1, 3 & 4	GLASS OPTION 2	GLASS OPTION 5
99 5/16	31 3/8	70.0	70.0	70.0
99 5/16	28 3/8	100.0	87.4	70.0
99 5/16	25 3/8	108.2	75.8	108.2
99 5/16	22 3/8	110.0	80.0	110.0
93 5/16	31 3/8	106.4	74.5	106.0
93 5/16	28 3/8	110.0	80.0	110.0
93 5/16	25 3/8	110.0	80.0	110.0
93 5/16	22 3/8	110.0	80.0	110.0
87 5/16	31 3/8	110.0	79.6	110.0
87 5/16	28 3/8	110.0	80.0	110.0
87 5/16	25 3/8	110.0	80.0	110.0
87 5/16	22 3/8	110.0	80.0	110.0
82 5/16	31 3/8	110.0	80.0	110.0
82 5/16	28 3/8	110.0	80.0	110.0
82 5/16	25 3/8	110.0	80.0	110.0
82 5/16	22 3/8	110.0	80.0	110.0

ALLOWABLE DESIGN PRESSURE WITH ADA SILL

MAX. FRAME HEIGHT (IN.)	MAX. D.L.O. WIDTH (IN.)	ALLOWABLE PRESSURE (PSF)	
		POS.	NEG.
99 7/8	31 3/8	70.0	70.0
99 7/8	28 3/8	75.8	75.8
99 7/8	25 3/8	82.5	82.5
99 7/8	22 3/8	90.0	90.0
93 7/8	31 3/8	74.5	74.5
93 7/8	28 3/8	80.6	80.6
93 7/8	25 3/8	87.8	87.8
93 7/8	24 3/8	90.0	90.0
87 7/8	31 3/8	79.6	79.6
87 7/8	28 3/8	86.1	86.1
87 7/8	26 3/8	90.0	90.0
87 7/8	24 3/8	90.0	90.0
82 7/8	31 3/8	84.4	84.4
82 7/8	28 3/8	90.0	90.0

INTERIOR ELEVATION:
 SCALE: 1/2" = 1'-0"

(2) DIRECTION FOLDING PANELS

(4)-PANEL DOOR SHOWN. SEE SHEET 4 FOR OTHER DOOR PANEL QUANTITY CONDITIONS AND RESTRICTIONS.

SEE SHEET 7 FOR GLASS OPTIONS

FRAME SCREWS WHERE SHOWN, SEE "FRAME ANCHOR REQUIREMENTS TABLE" ON THIS SHEET FOR REQUIREMENTS (APPLICABLE TO SINGLE OR DOUBLE ROW OF SCREWS).

MIDDLE ANCHOR SHOWN AT MEETING STILE END LOCATIONS IS ONLY REQUIRED WITH SINGLE ROW ANCHOR CONDITION (N/A WITH DOUBLE ROW ANCHORS)

SEE CORNER CONSTRUCTION DESCRIPTIONS ON THIS SHEET

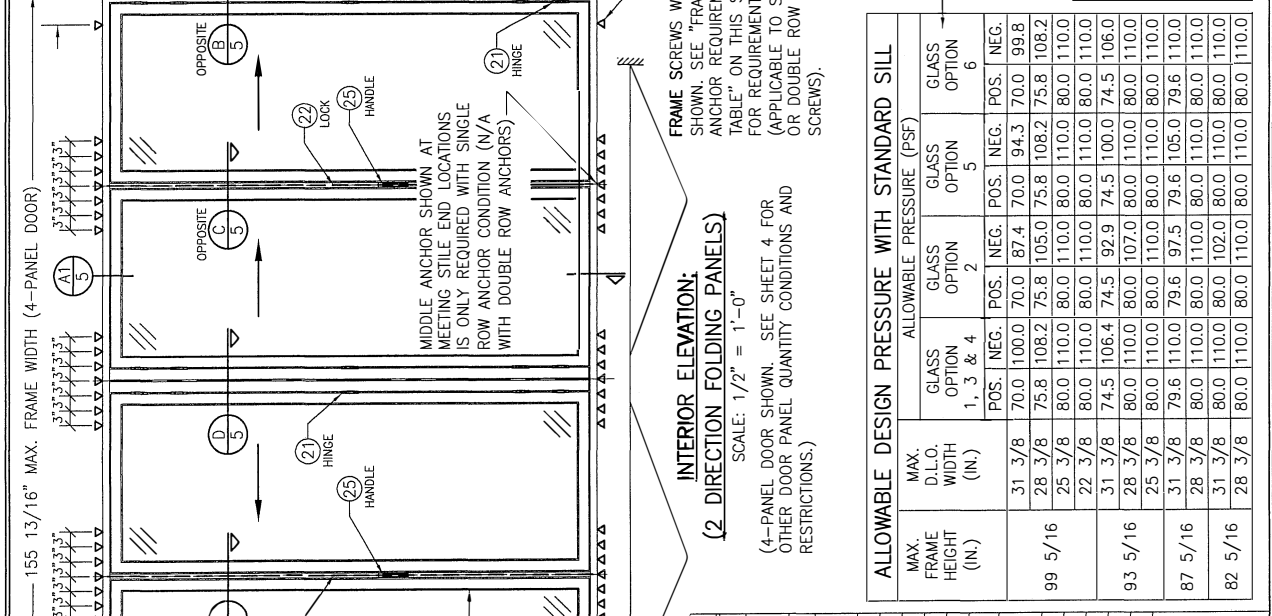

CORNER CONSTRUCTION:

FRAME WITH STANDARD RAISED SILL: MEMBERS ARE MITERED, BUTTED & JOINED VIA (2) TWO CORNER KEYS (ITEM #12) EACH CORNER KEY IS SECURED WITH (2) TWO #5/16 X 3/4 BRASS ELUSO SADDLE SILL MEMBERS ARE SQUARE CUT, BUTTED & JOINED VIA AN END CAP WITH (3) THREE 1/8" X 5/8" PHF SCREWS AT THE SILL & (2) TWO 1/8" X 5/8" PHF SCREWS AT THE VERTICAL MEMBER. CORNERS ARE SEALED WITH A CUSHION WEATHERSTRIPPING.

RAIL TO STILE: MEMBERS ARE MITERED, BUTTED & JOINED VIA (2) TWO CORNER KEYS (ITEM #13 & #14) THE CORNER KEY IS SECURED BY CRIMPING (2) TWO LEGS EACH PANEL. CORNERS ARE SEALED WITH SILICONE SEALANT.

ALLOWABLE DESIGN PRESSURE WITH STANDARD SILL

MAX. FRAME HEIGHT (IN.)	MAX. D.L.O. WIDTH (IN.)	ALLOWABLE PRESSURE (PSF)		
		GLASS OPTION 1, 3 & 4	GLASS OPTION 2	GLASS OPTION 5
99 5/16	31 3/8	70.0	70.0	70.0
99 5/16	28 3/8	100.0	87.4	70.0
99 5/16	25 3/8	108.2	75.8	108.2
99 5/16	22 3/8	110.0	80.0	110.0
93 5/16	31 3/8	106.4	74.5	106.0
93 5/16	28 3/8	110.0	80.0	110.0
93 5/16	25 3/8	110.0	80.0	110.0
93 5/16	22 3/8	110.0	80.0	110.0
87 5/16	31 3/8	110.0	79.6	110.0
87 5/16	28 3/8	110.0	80.0	110.0
87 5/16	25 3/8	110.0	80.0	110.0
87 5/16	22 3/8	110.0	80.0	110.0
82 5/16	31 3/8	110.0	80.0	110.0
82 5/16	28 3/8	110.0	80.0	110.0
82 5/16	25 3/8	110.0	80.0	110.0
82 5/16	22 3/8	110.0	80.0	110.0

ALLOWABLE DESIGN PRESSURE WITH ADA SILL

MAX. FRAME HEIGHT (IN.)	MAX. D.L.O. WIDTH (IN.)	ALLOWABLE PRESSURE (PSF)	
		POS.	NEG.
99 7/8	31 3/8	70.0	70.0
99 7/8	28 3/8	75.8	75.8
99 7/8	25 3/8	82.5	82.5
99 7/8	22 3/8	90.0	90.0
93 7/8	31 3/8	74.5	74.5
93 7/8	28 3/8	80.6	80.6
93 7/8	25 3/8	87.8	87.8
93 7/8	24 3/8	90.0	90.0
87 7/8	31 3/8	79.6	79.6
87 7/8	28 3/8	86.1	86.1
87 7/8	26 3/8	90.0	90.0
87 7/8	24 3/8	90.0	90.0
82 7/8	31 3/8	84.4	84.4
82 7/8	28 3/8	90.0	90.0

CONTRACTOR INFORMATION:

MANUFACTURER: NMA WALL SYSTEMS, INC.
 707 REDWOOD HIGHWAY
 MILL VALLEY, CA 94541
 800-873-5673

CONSULTANTS: W & S CONSULTING, P.A. (CA 6809)
 W.W. SCHAEFER ENGINEERING
 7480 150TH COURT NORTH
 PALM BEACH GARDENS, FL 33418
 PHONE: 561-744-3424

DATE: 07/12/19
 CHECKED BY: W.W.S.
 DRAWN BY: W.W.S.

NO. REVISION DESCRIPTION BY DATE

DATE: 02/19/15
 W.W.S.
 B1. UPDATE TO CURRENT STANDARDS

DATE: 10/18/11
 W.W.S.
 A1. UPDATE CONSULTANT ADDRESS

DATE: 07/12/19
 W.W.S.
 C1. CHANGE TO STATE ONLY APPROVAL

DATE: 07/12/19
 W.W.S.
 W.W.S.

DRAWING NO.: 1636
 SHEET NO.: 1 OF 8

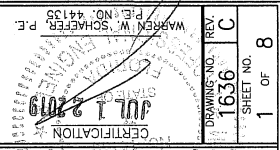

EVALUATION OF THIS PRODUCT IS BASED ON APPLICABLE STANDARDS AND/OR INFORMATION & RESULTS FROM APPLICABLE TEST REPORTS. THE FLORIDA BUILDING CODE VERSION CONSIDERED WITH THIS EVALUATION WAS THAT IN FORCE AT THE TIME OF THE EVALUATION. IN THE EVENT OF CODE VERSION CHANGES/UPDATES OR IN THE EVENT THAT NEW OR ADDITIONAL TESTING IS COMPLETED ON THIS PRODUCT, PRIOR TO STATING CODE COMPLIANCE WITH THE EVALUATION ENGINEER OF RECORD, THAT EVERYTHING SPECIFIED HERE-IN IS CURRENT WITH ALL CURRENT TESTING, CODES AND APPLICABLE STANDARDS.

DATE	11/22/08
CHECKED BY	W.W.S.
DATE	
BY	
REVISION DESCRIPTION	
NO.	

MANUFACTURER
NAMA WALL SYSTEMS, INC
 707 REDWOOD HIGHWAY
 MILL VALLEY, CA 94941
 800-873-5673

CONSULTANTS
W. W. SCHAEFER ENGINEERING & CONSULTING, P.A. (CA 6809)
 7480 150TH COURT NORTH
 PALM BEACH GARDENS, FL 33418
 PHONE: 561-744-3424

DRAWING TITLE
SL-73 IN-SWING IMPACT FOLDING PANELS

ENGINEER
WARREN W. SCHAEFER, P.E.
 P.E. NO. 44135

DATE
JUL 12 2019

DRAWING NO. **1636**
 REV. **C**

SHEET NO. **2** OF **8**

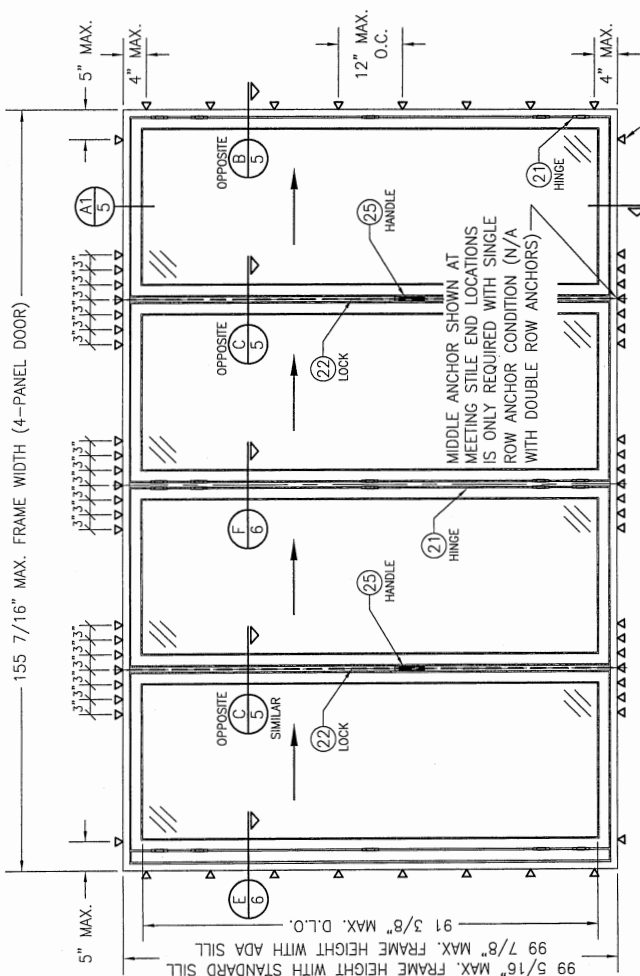
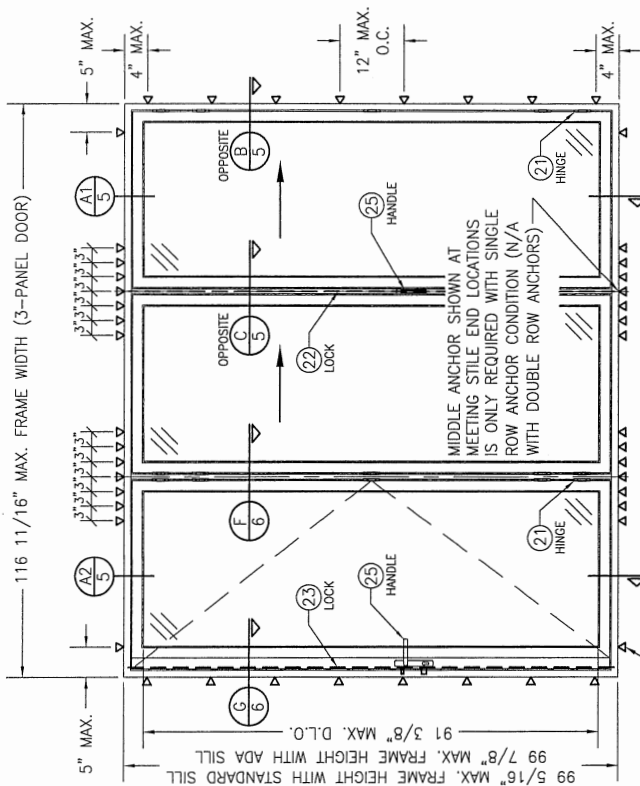

FRAME SCREWS WHERE SHOWN. SEE "FRAME ANCHOR REQUIREMENTS TABLE" ON SHEET 1 FOR REQUIREMENTS (APPLICABLE TO SINGLE OR DOUBLE ROW OF SCREWS).

**INTERIOR ELEVATION:
 (1 DIRECTION FOLDING PANELS WITH SWING PANEL
 LOCKING TO JAMB)**

SCALE: 1/2" = 1'-0"
 (ACTIVE SWING DOOR SHOWN WITH MULTI-POINT LOCK.
 DEADBOLT/FLUSH BOLT LOCK COMBINATION ALSO APPLIES)
 (3-PANEL DOOR SHOWN. SEE SHEET 4 FOR
 OTHER DOOR PANEL QUANTITY CONDITIONS AND
 RESTRICTIONS.)

**INTERIOR ELEVATION:
 (1 DIRECTION FOLDING PANELS)**

SCALE: 1/2" = 1'-0"
 (4-PANEL DOOR SHOWN. SEE SHEET 4 FOR
 OTHER DOOR PANEL QUANTITY CONDITIONS AND
 RESTRICTIONS.)

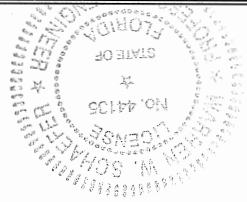

ISSUED BY:	W.W.S.
DATE:	11/22/09
FLUT:	10-A
NO.	REVISION DESCRIPTION
BY:	DATE

MANUFACTURER
 NANA WALL SYSTEMS, INC.
 707 REDWOOD HIGHWAY
 MILL VALLEY, CA 94941
 800-873-5673

DRAWING TITLE
 SL-73 IN-SWING IMPACT FOLDING PANELS

CONSULTANTS
 W. W. SCHAEFER ENGINEERING
 & CONSULTING, P.A. (CA 6809)
 7480 150TH COURT NORTH
 PALM BEACH GARDENS, FL 33418
 PHONE: 561-744-2424

CERTIFICATION
 W. W. SCHAEFER
 P.E. NO. 44138
 JUL 1 2 2019

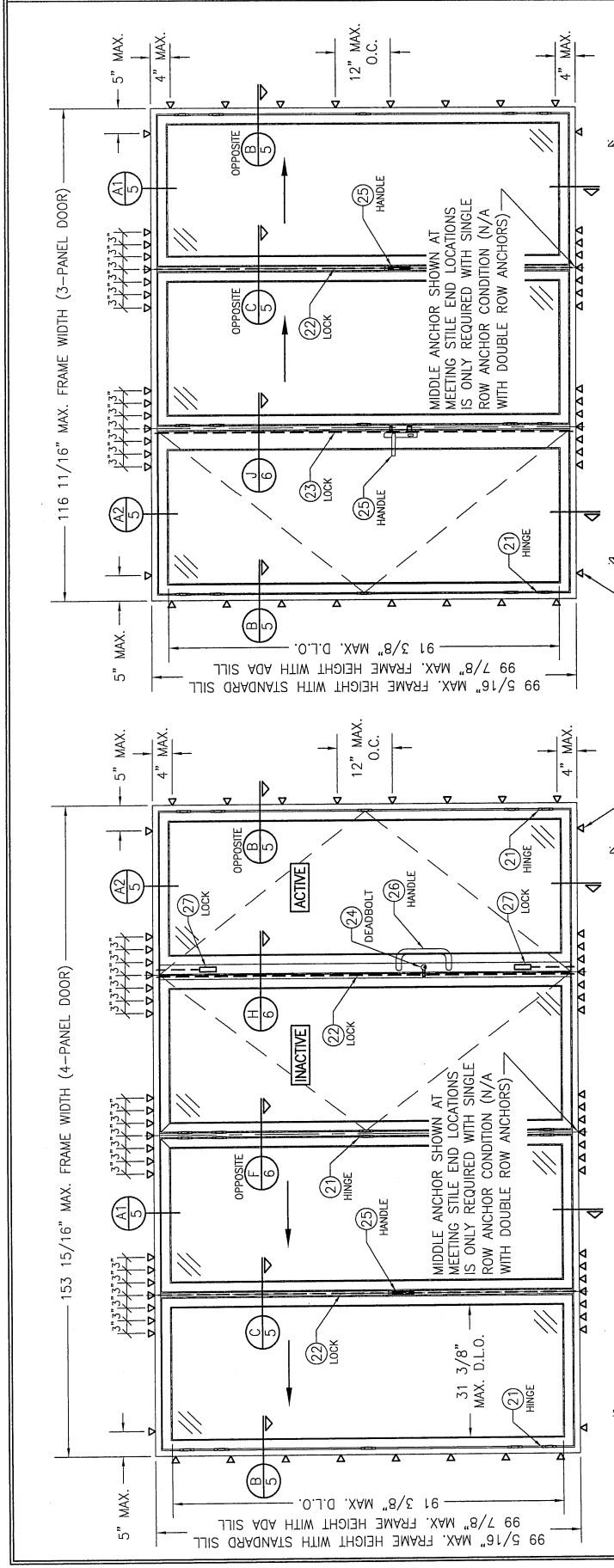

INTERIOR ELEVATION:
 (1 DIRECTION FOLDING PANELS WITH DOUBLE SWING PANELS)

SCALE: 1/2" = 1'-0"

(ACTIVE SWING DOOR SHOWN WITH DEADBOLT/FLUSH BOLT LOCK COMBINATION. MULTI-POINT LOCK ALSO APPLIES)
 (4-PANEL DOOR SHOWN. SEE SHEET 4 FOR OTHER DOOR PANEL QUANTITY CONDITIONS AND RESTRICTIONS.)

INTERIOR ELEVATION:
 (SWING PANEL LOCKING TO 1 DIRECTION FOLDING PANELS)

SCALE: 1/2" = 1'-0"

(ACTIVE SWING DOOR SHOWN WITH MULTI-POINT LOCK. DEADBOLT/FLUSH BOLT LOCK COMBINATION ALSO APPLIES)
 (3-PANEL DOOR SHOWN. SEE SHEET 4 FOR OTHER DOOR PANEL QUANTITY CONDITIONS AND RESTRICTIONS.)

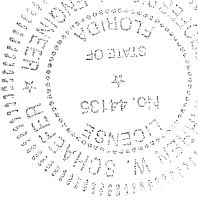

DRAWING NO.:	1636
REV.:	C
SHEET NO.:	3
OF:	8

NO.	REVISION DESCRIPTION	BY	DATE

SL-73 IN-SWING IMPACT FOLDING PANELS

MANUFACTURER
NANA WALL SYSTEMS, INC
 707 REDWOOD HIGHWAY
 MILL VALLEY, CA 94941
 800-873-5673

CONSULTANTS
W. W. SCHAFFER ENGINEERING & CONSULTING, P.A. (CA 6809)
 7480 150TH COURT NORTH
 PALM BEACH GARDENS, FL 33418
 PHONE: 561-744-3424

CERTIFICATION
APR 12 2019
 W. W. SCHAFFER, P.E.
 P.E. NO. 44138
 WARREN W. SCHAFFER, P.E.
 P.E. NO. 44138

DRAWING NO. **1636**
 SHEET NO. **4** OF **8**

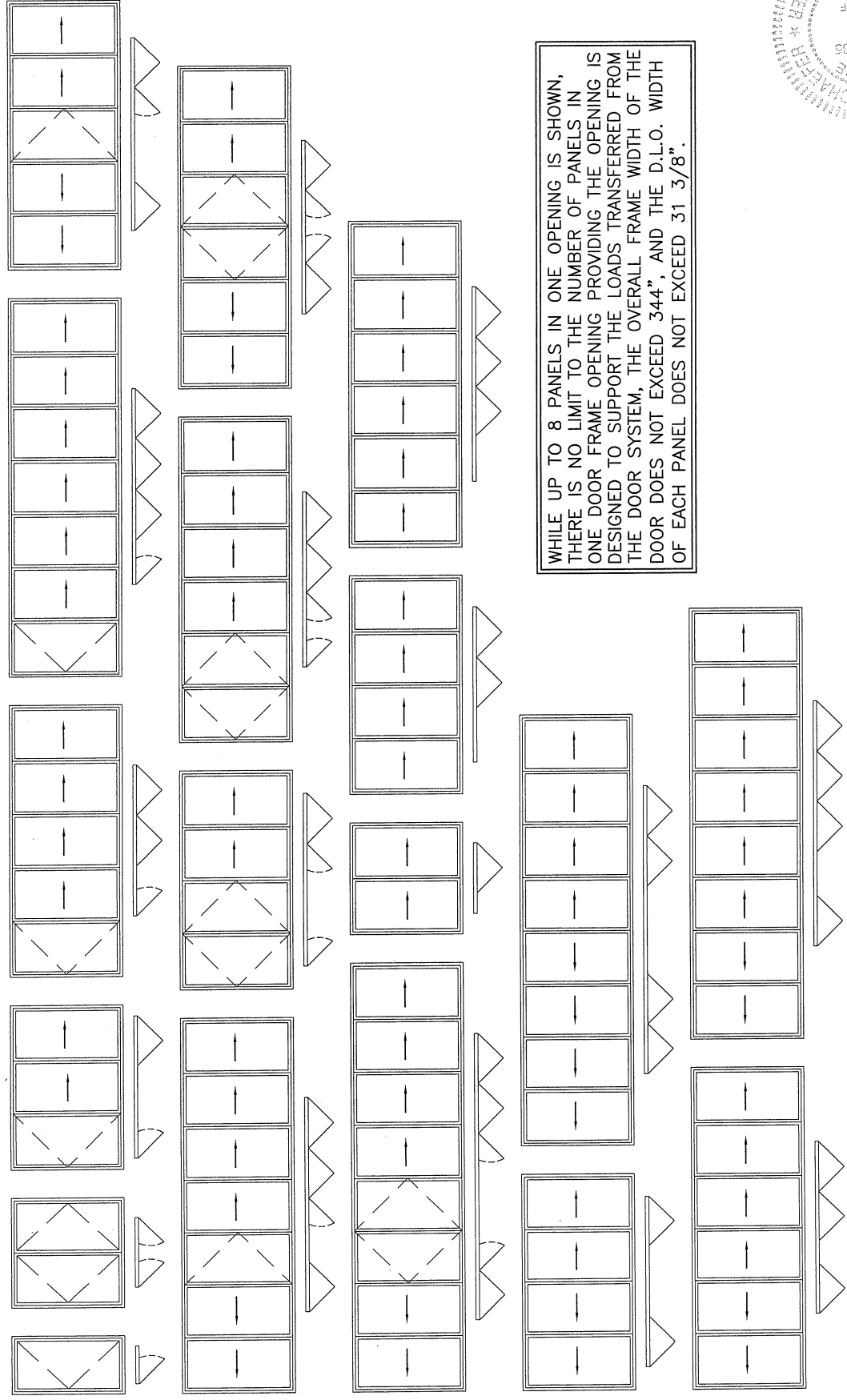

WHILE UP TO 8 PANELS IN ONE OPENING IS SHOWN, THERE IS NO LIMIT TO THE NUMBER OF PANELS IN ONE DOOR FRAME OPENING PROVIDING THE OPENING IS DESIGNED TO SUPPORT THE LOADS TRANSFERRED FROM THE DOOR SYSTEM, THE OVERALL FRAME WIDTH OF THE DOOR DOES NOT EXCEED 344", AND THE D.L.O. WIDTH OF EACH PANEL DOES NOT EXCEED 31 3/8".

CONDITIONS SHOWN ARE THE MAJORITY OF THOSE USED. OTHER CONDITIONS OF FOLDING & SWING PANELS APPLY PROVIDING THEY ARE WITHIN THE SCOPE OF THE DETAILS WITHIN THIS DRAWING.

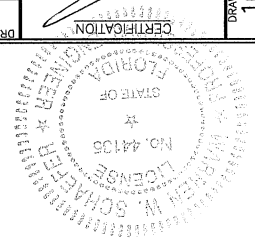

NO.	REVISION DESCRIPTION	BY	DATE

MANUFACTURER
NANA WALL SYSTEMS, INC.
 707 REDWOOD HIGHWAY
 MILL VALLEY, CA 94941
 800-873-5673

CONSULTANTS
W. W. SCHAEFER ENGINEERING & CONSULTING, P.A. (CA 6809)
 7480 150TH COURT NORTH
 PALM BEACH GARDENS, FL 33418
 PHONE: 561-744-5424

CONSULTANTS
W. W. SCHAEFER ENGINEERING & CONSULTING, P.A. (CA 6809)
 7480 150TH COURT NORTH
 PALM BEACH GARDENS, FL 33418
 PHONE: 561-744-5424

DRAWING NO. 1636
 SHEET NO. 5 OF 8

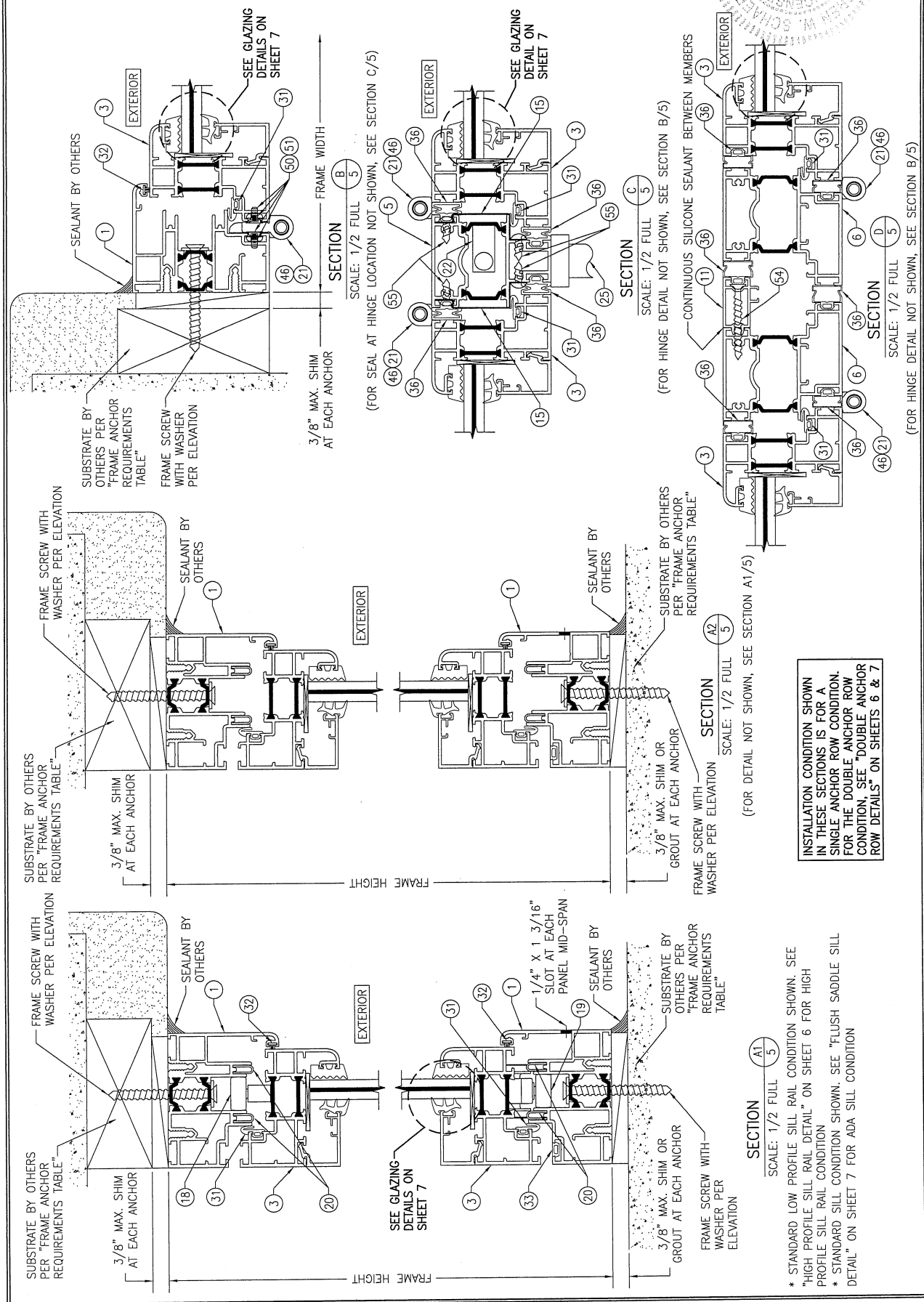

INSTALLATION CONDITION SHOWN IN THESE SECTIONS IS FOR A SINGLE ANCHOR ROW CONDITION. FOR THE DOUBLE ANCHOR ROW CONDITION, SEE "DOUBLE ANCHOR ROW DETAILS" ON SHEETS 6 & 7

* STANDARD LOW PROFILE SILL RAIL CONDITION SHOWN. SEE "HIGH PROFILE SILL RAIL DETAIL" ON SHEET 6 FOR HIGH PROFILE SILL RAIL CONDITION
 * STANDARD SILL CONDITION SHOWN. SEE "FLUSH SADDLE SILL DETAIL" ON SHEET 7 FOR ADA SILL CONDITION

SL-73 IN-SWING IMPACT FOLDING PANELS



CHECKED BY:	W.S.
DATE:	11/20/08
DESIGNED BY:	W.S.
DATE:	11/20/08
PLotted:	11/20/08
BY:	
DATE:	
NO.:	
REVISION DESCRIPTION:	

MANUFACTURER
NAMA WALL SYSTEMS, INC
 707 REDWOOD HIGHWAY
 MILL VALLEY, CA 94941
 800-873-5673

CONSULTANTS
W. W. SCHAEFER ENGINEERING & CONSULTING, P.A. (CA 6809)
 7480 150TH COURT NORTH
 PALM BEACH GARDENS, FL 33418
 PHONE: 561-744-3424

DRAWING TITLE
SL-73 IN-SWING IMPACT FOLDING PANELS

CERTIFICATION
 JUL 1 2019
 WARREN W. SCHAEFER, P.E.
 P. NO. 44135
 DRAWING NO. **1636**
 REV. **C**
 SHEET NO. **6** OF **8**

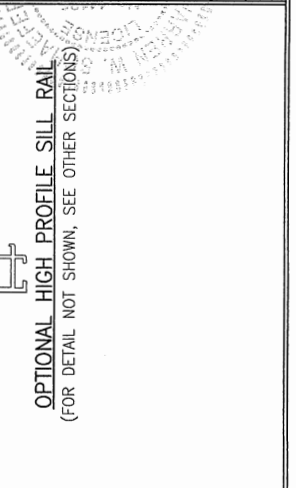
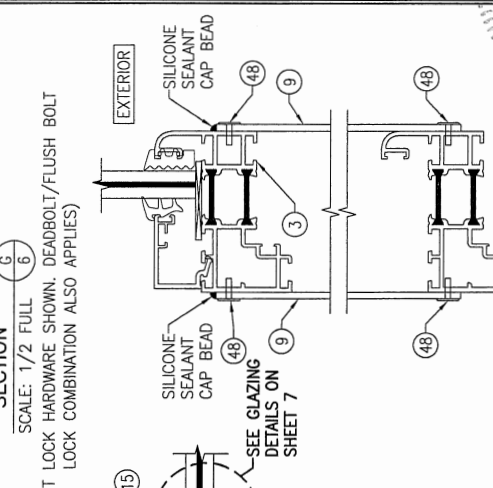
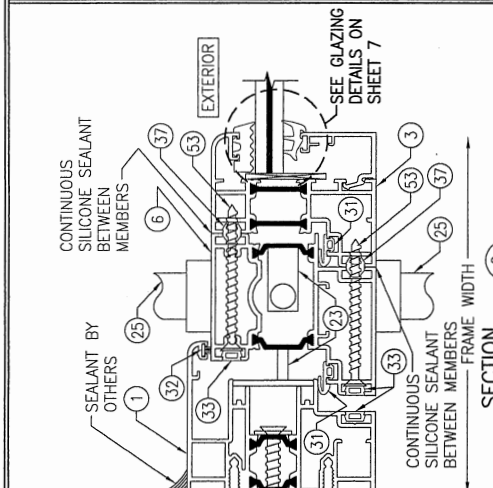
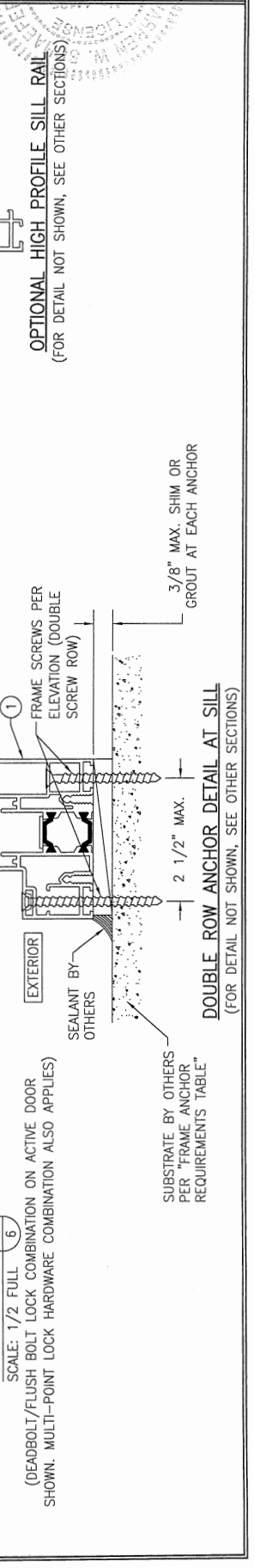
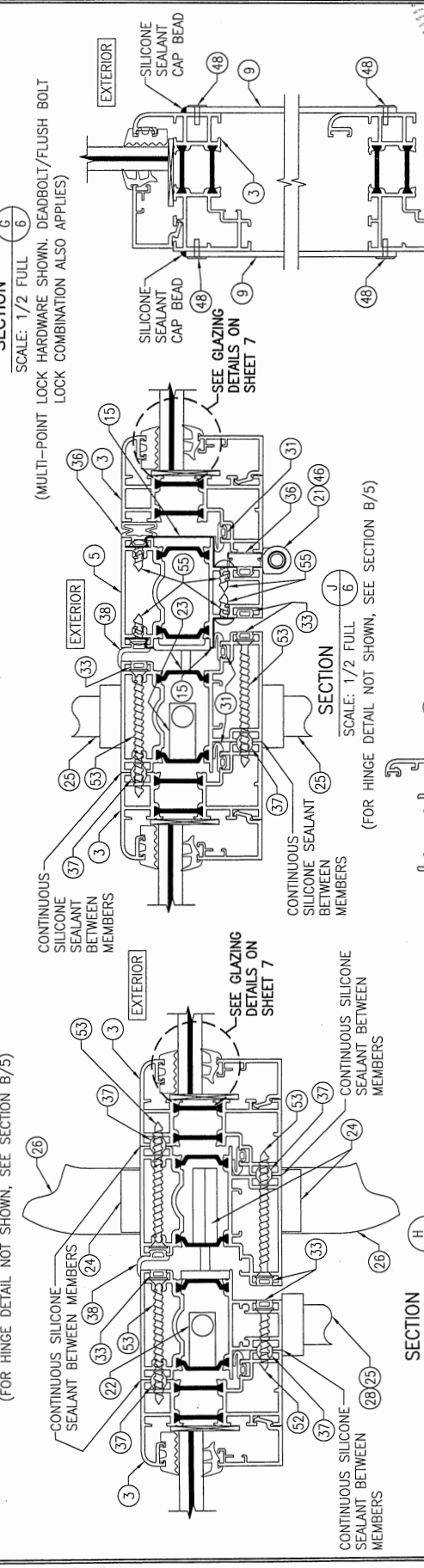
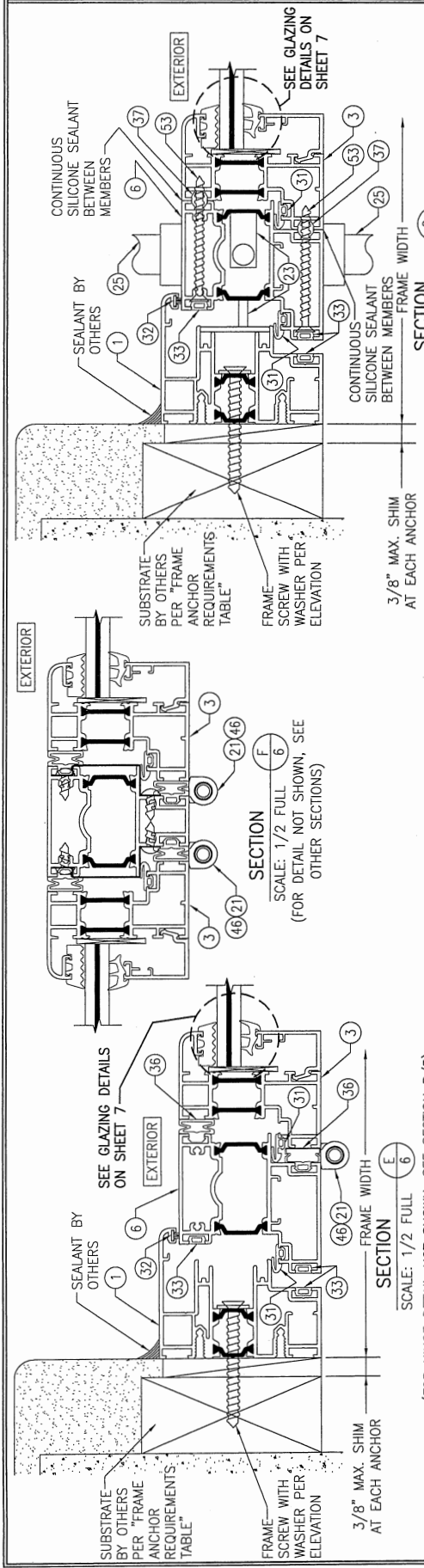

OPTIONAL HIGH PROFILE SILL RAIL
 (FOR DETAIL NOT SHOWN, SEE OTHER SECTIONS)

DOUBLE ROW ANCHOR DETAIL AT SILL
 (FOR DETAIL NOT SHOWN, SEE OTHER SECTIONS)

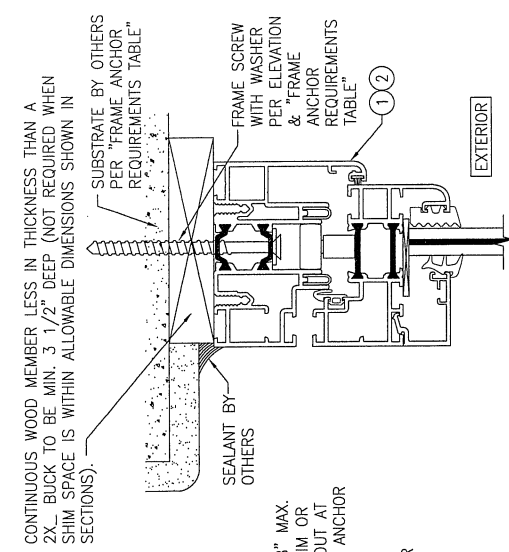
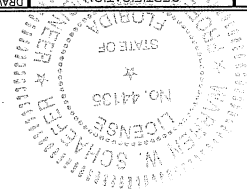

OPTIONAL DIRECT MOUNT DETAIL TO SUBSTRATE WITH SPACER
 (HEAD SECTION SHOWN. SILL & SIDES ARE INSTALLED THE SAME)
 (FOR DETAIL NOT SHOWN, SEE OTHER SECTIONS)
 (SINGLE SCREW ROW INSTALLATION SHOWN. DOUBLE SCREW ROW ALSO APPLIES)

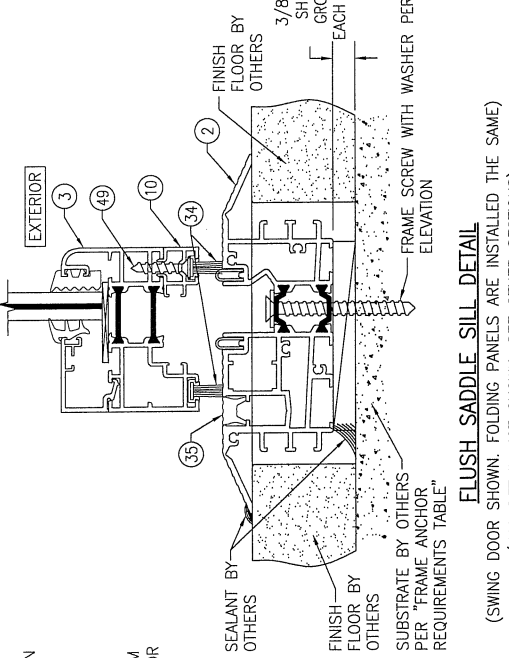

FLUSH SADDLE SILL DETAIL
 (SWING DOOR SHOWN. FOLDING PANELS ARE INSTALLED THE SAME)
 (FOR DETAIL NOT SHOWN, SEE OTHER SECTIONS)
 (DOUBLE SCREW ROW DOES NOT APPLY TO THIS DETAIL)

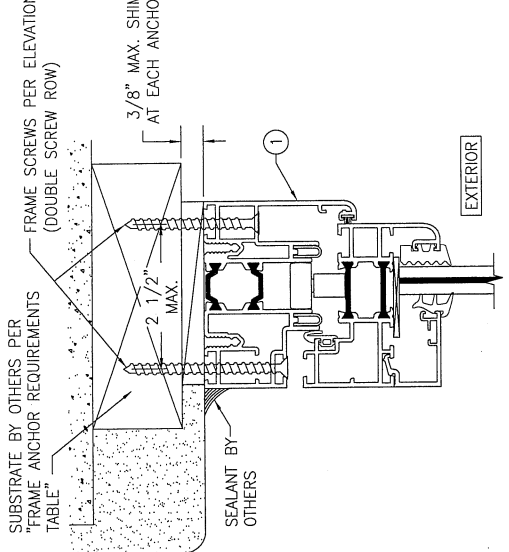

DOUBLE ROW ANCHOR DETAIL AT HEAD & SIDES
 (FOR DETAIL NOT SHOWN, SEE OTHER SECTIONS)
 (HEAD SECTION SHOWN. SIDES ARE INSTALLED THE SAME)

WHEN AN ADA/FLUSH SADDLE SILL IS USED, THESE DOORS ARE NOT APPROVED FOR USE WHERE WATER INFILTRATION RESISTANCE IS REQUIRED BY THE DOOR UNLESS UNITS ARE INSTALLED IN NON-HABITABLE AREAS WHERE THE UNIT & THE AREA ARE DESIGNED TO ACCEPT WATER INFILTRATION OR THEY ARE INSTALLED ONLY AT LOCATIONS PROTECTED BY A CANOPY OR OVERHANG WHERE-BY THE OVERHANG(OH) RATIO IS EQUAL TO OR MORE THAN 1.0 PER FBC.

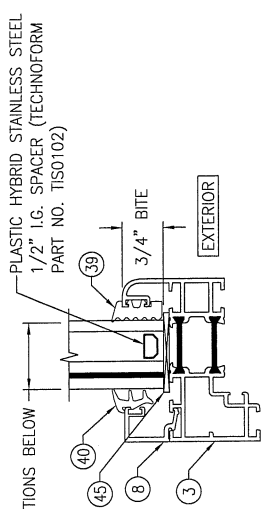

I.G. GLAZING DETAIL
GLASS OPTIONS 3, 4, 5 & 6
 GLASS OPTION 3: 1 1/8" I.G. LAMINATED GLASS (3/16" H.S./0.09 KURARAY SG/3/16" H.S. INTERIOR; 1/2" AIR SPACE; 3/16" TEMP. EXTERIOR)
 GLASS OPTION 4: 1 1/8" I.G. LAMINATED GLASS (3/16" H.S./0.09 KURARAY SG/3/16" H.S. INTERIOR; 7/16" AIR SPACE; 1/4" TEMP. EXTERIOR)
 GLASS OPTION 5: 1 1/8" I.G. LAMINATED GLASS (3/16" AN./0.09 KURARAY SG/3/16" AN. INTERIOR; 1/2" AIR SPACE; 3/16" TEMP. EXTERIOR)
 GLASS OPTION 6: 1 1/8" I.G. LAMINATED GLASS (3/16" AN./0.09 KURARAY SG/3/16" AN. INTERIOR; 7/16" AIR SPACE; 1/4" TEMP. EXTERIOR)

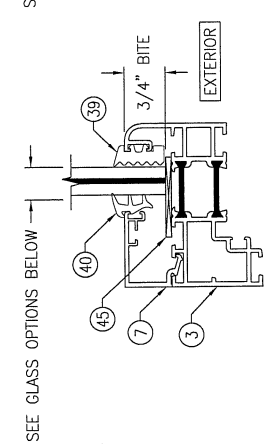

NON-I.G. GLAZING DETAIL
GLASS OPTIONS 1 & 2
 GLASS OPTION 1: 7/16" LAMINATED GLASS (3/16" H.S./0.09 KURARAY SG/3/16" H.S.)
 GLASS OPTION 2: 7/16" LAMINATED GLASS (3/16" AN./0.09 KURARAY SG/3/16" AN.)

CONTINUOUS WOOD MEMBER LESS IN THICKNESS THAN A 2X. BUCK TO BE MIN. 3 1/2" DEEP (NOT REQUIRED WHEN SHIM SPACE IS WITHIN ALLOWABLE DIMENSIONS SHOWN IN SECTIONS).

FRAME SCREWS PER ELEVATION (DOUBLE SCREW ROW)
 3/8" MAX. SHIM AT EACH ANCHOR
 2 1/2" MAX.

DATE: 11/25/08
 W.M.S. DATE: 11/25/08
 W.M.S. DATE: 11/25/08

NO.	REVISION DESCRIPTION	BY	DATE

ITEM #	ITEM DESCRIPTION	FASTENERS	MANUFACTURER/NOTES
48	1/8" RIVET	6 PER KICK PLATE	
49	NO. 8 X 1" SMS SCREW	WITHIN 4" FROM CORNERS & MAX. 16" O.C.	
50	NO. 10 X 3/8" FH S.S. MS	4 PER HINGE	
51	3/16 X 1/4 S.S. SET SCREW	4 PER HINGE	
52	NO. 8 X 1 1/4" SMS SCREW	WITHIN 4" FROM CORNERS & MAX. 16" O.C.	
53	NO. 8 X 2 3/4" SMS SCREW	WITHIN 4" FROM CORNERS & MAX. 16" O.C.	
54	NO. 8 X 1 3/4" SMS SCREW	WITHIN 4" FROM CORNERS & MAX. 16" O.C.	
55	NO. 8 X 1/2" SMS SCREW	2 PER CLIP	

MANUFACTURER
 707A WALL SYSTEMS, INC
 707 REDWOOD HIGHWAY
 MILL VALLEY, CA 94541
 800-873-5673

CONSULTANTS
 W. W. SCHAEFER ENGINEERING
 7480 150TH COURT NORTH
 PALM BEACH GARDENS, FL 33418
 PHONE: 561-744-3424
 800-873-5673

DRAWING TITLE
 SL-73 IN-SWING IMPACT FOLDING PANELS

CERTIFICATION
 JUL 12 2019
 W. W. SCHAEFER
 LICENSE NO. 44133
 DRAWING NO. 1636
 REV. C
 SHEET NO. 8 OF 8

ITEM #	ITEM DESCRIPTION	MANUFACTURER/NOTES
1	FRAME/STANDARD RAISED SILL	6063-T5 ALUMINUM
2	ADA/FLUSH SADDLE SILL	6063-T5 ALUMINUM
3	PANEL STILE /RAIL	6063-T5 ALUMINUM
5	SLIDING POST	6063-T5 ALUMINUM
6	POST	6063-T5 ALUMINUM
7	NON-I.G. GLAZING BEAD	6063-T5 ALUMINUM
8	I.G. GLAZING BEAD	6063-T5 ALUMINUM
9	KICK PLATE	6063-T5 ALUMINUM
10	STILE/RAIL EXTENSION	6063-T5 ALUMINUM
11	STILE/RAIL EXTENSION	6063-T5 ALUMINUM
12	FRAME CORNER KEY	6063-T5 ALUMINUM
13	PANEL CORNER KEY	6063-T5 ALUMINUM
14	PANEL CORNER KEY	6063-T5 ALUMINUM
15	REINFORCEMENT CLIP (4 PER POST; 2 EACH END)	S.S.
18	UPPER GUIDING TROLLEY	NEIDERHOFF OR DELLENBUSH 15-71-53-1
19	ROLLER REINFORCEMENT	WESTERFELD 15-73-78-X S.S.
20	ROLLER REINFORCEMENT	NEIDERHOFF OR DELLENBUSH 15-71-50-1
21	ROLLER REINFORCEMENT	WESTERFELD 15-73-78-X S.S.
22	ROLLER INSERT	WELSER 5-66-09
23	ROLLER INSERT	BURGHANUS 15-0-2210-190 DIECAST OR
24	ROLLER INSERT	IBW IDEAL 15-0-2227/8-120 S.S.
25	ROLLER INSERT	EURIT SRL 15-0-2001-1
26	ROLLER INSERT	VBH GMBH 15-60-27-1
27	ROLLER INSERT	VBH GMBH 15-0-210-109
28	ROLLER INSERT	AS REQ'D TO OPERATE 2 & 3-POINT LOCK
29	ROLLER INSERT	AS REQ'D WITH PUSH/PULL SWING DOORS
30	ROLLER INSERT	EURIT SRL 15-0-2001-1
31	ROLLER INSERT	WIHL, SCHLECHTENDAHL & SOHNE 15-0-218
32	WEATHERSTRIP	DURAPROOF OR TREMCO 25-0-1052-195 EPDM
33	PILE SEAL	KULLER GMBH 25-0-1065-171 POLYAMIDE
34	COVER GASKET	JAEGER GUMMI UND KUNSTSTOFF OR TREMCO 25-0-1054-195 EPDM
35	FILLER SEAL	DURAPROOF OR TREMCO 25-0-1084-155 EPDM
36	PANEL GASKET	DURAPROOF OR TREMCO 25-0-1036-195 EPDM
37	CONNECTOR	DURAPROOF OR TREMCO 25-0-1056-195 EPDM
38	PANEL GASKET	SYNCAMER GUMMI OR TREMCO 25-0-1050-195 EPDM
39	EXTERIOR GLAZING GASKET (DIUROMETER = 56)	TREMCO TX16702E EPDM
40	INTERIOR GLAZING GASKET (DIUROMETER = 70)	TREMCO 25-0-1007-X EPDM
41-43	DEBRIDGING/THERMAL BREAK	ENSINGER, INC., TECATHERM 66 GF INSULBAR POLYAMIDE
44	GLAZING SHIM	GLUSKE, PVC
45	1/2" X 3" X 1/16" THICK GLAZING TAPE	ADHERED TO EA. HINGE AS A SEAL

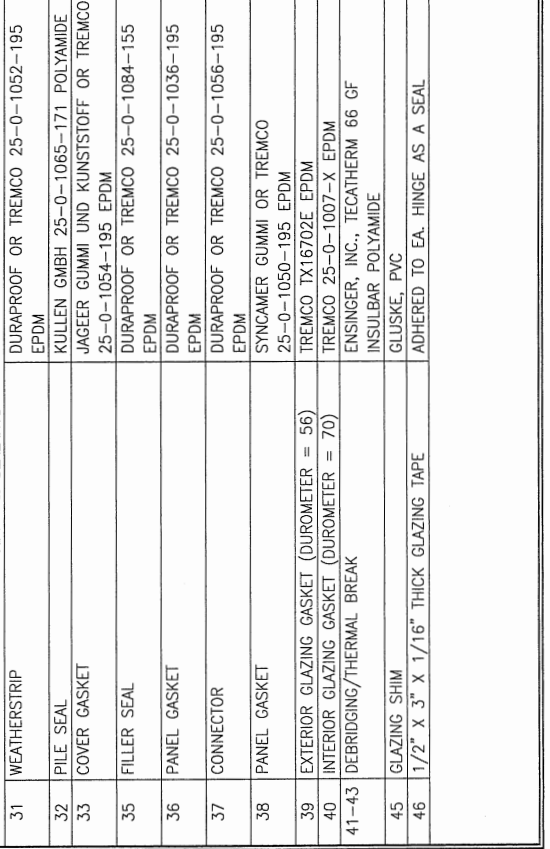
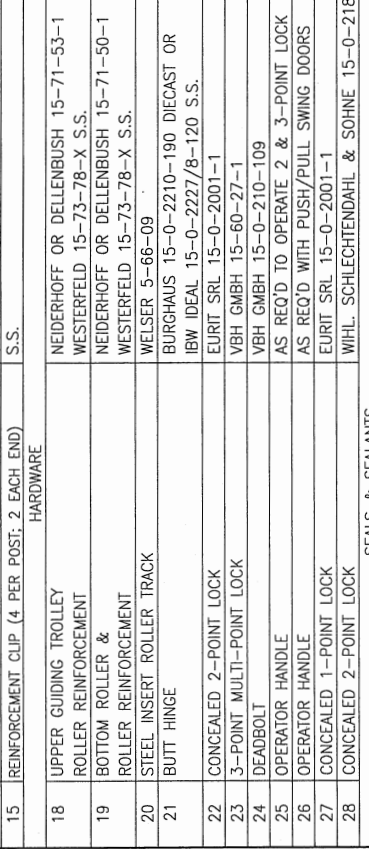

REINFORCEMENT CLIP LENGTH = 0.787

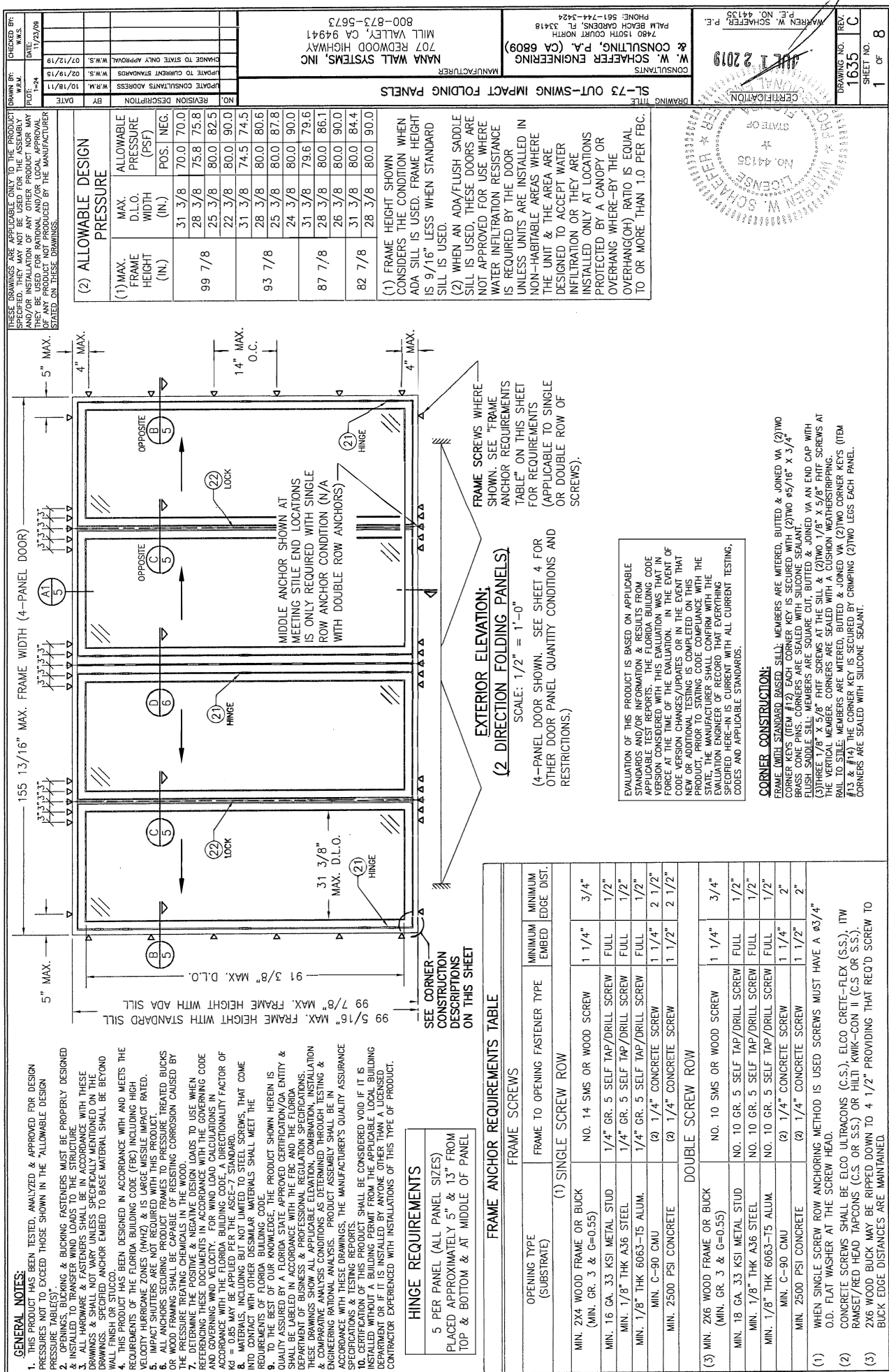

GENERAL NOTES:

- THIS PRODUCT HAS BEEN TESTED, ANALYZED & APPROVED FOR DESIGN PRESSURES NOT TO EXCEED THOSE SHOWN IN THE "ALLOWABLE DESIGN PRESSURE TABLES".
- OPENINGS, BUCKING & BUCKING FASTENERS MUST BE PROPERLY DESIGNED DRAWINGS & SHALL NOT EXCEED SPECIFICATIONS LISTED ON THE DRAWINGS.
- ALL HARDWARE & FASTENERS SHALL BE IN ACCORDANCE WITH THESE DRAWINGS. REQUIRED ANCHOR EMBED TO BASE MATERIAL SHALL BE BEYOND MINIMUM EMBED REQUIREMENTS.
- THIS PRODUCT HAS BEEN DESIGNED IN ACCORDANCE WITH AND MEETS THE REQUIREMENTS OF THE FLORIDA BUILDING CODE (FBC) INCLUDING HIGH WIND/HURRICANE ZONES (HWZ) & IS LARGE MISSILE IMPACT RATED.
- IMPACT SHUTTERS ARE NOT REQUIRED WITH THIS PRODUCT.
- ALL ANCHORS SECURING PRODUCT FRAMES TO PRESSURE TREATED BUCKS OR WOOD FRAMING SHALL BE CAPABLE OF RESISTING CORROSION CAUSED BY THE PRESSURE TREATING CHEMICALS IN THE WOOD.
- DETERMINE THE POSITIVE & NEGATIVE DESIGN LOADS TO USE WHEN REFERENCING THESE DOCUMENTS IN ACCORDANCE WITH THE GOVERNING CODE AUTHORITY IN THE FLORIDA BUILDING CODE. A CORRELATION FACTOR OF K₁ = 0.85 MAY BE APPLIED PER THE ASCE-7 STANDARD.
- MATERIALS, INCLUDING BUT NOT LIMITED TO STEEL SCREWS, THAT COME INTO CONTACT WITH OTHER DISSIMILAR MATERIALS SHALL MEET THE REQUIREMENTS OF FLORIDA BUILDING CODE.
- TO THE BEST OF OUR KNOWLEDGE, THE PRODUCT SHOWN HEREIN IS QUALITY ASSURED BY A FLORIDA STATE APPROVED CERTIFICATION/QA ENTITY & SHALL BE LABELED IN ACCORDANCE WITH THE FBC AND THE FLORIDA DEPARTMENT OF BUSINESS & PROFESSIONAL REGULATION SPECIFICATIONS. THESE SPECIFICATIONS, INCLUDING BUT NOT LIMITED TO TESTING & ENGINEERING RATIONAL ANALYSIS, PRODUCT ASSEMBLY SHALL BE IN ACCORDANCE WITH THESE DRAWINGS. THE MANUFACTURER'S QUALITY ASSURANCE SPECIFICATIONS & TESTING REPORTS.
- CERTIFICATION OF THIS PRODUCT SHALL BE CONSIDERED VOID IF IT IS INSTALLED WITHOUT A BUILDING PERMIT FROM THE APPLICABLE LOCAL BUILDING DEPARTMENT OR IF IT IS INSTALLED BY ANYONE OTHER THAN A LICENSED CONTRACTOR EXPERIENCED WITH INSTALLATIONS OF THIS TYPE OF PRODUCT.

HINGE REQUIREMENTS
5 PER PANEL (ALL PANEL SIZES) PLACED APPROXIMATELY 5" & 13" FROM TOP & BOTTOM & AT MIDDLE OF PANEL

OPENER TYPE (SUBSTRATE)	MINIMUM EMBED	MINIMUM TYPE	MINIMUM EDGE DIST.
MIN. 2x4 WOOD FRAME OR BUCK (MIN. GR. 3 & G=0.55)	1 1/4"	NO. 14 SMS OR WOOD SCREW	3/4"
MIN. 16 GA. 33 KSI METAL STUD	FULL	1/4" GR. 5 SELF TAP/DRILL SCREW	1/2"
MIN. 1/8" THK A36 STEEL	FULL	1/4" GR. 5 SELF TAP/DRILL SCREW	1/2"
MIN. 1/8" THK 6063-T5 ALUM.	FULL	1/4" GR. 5 SELF TAP/DRILL SCREW	1/2"
MIN. C-80 CMU	1 1/4"	(2) 1/4" CONCRETE SCREW	2 1/2"
MIN. 2500 PSI CONCRETE	1 1/2"	(2) 1/4" CONCRETE SCREW	2 1/2"

DOUBLE SCREW ROW

(3) MIN. 2x6 WOOD FRAME OR BUCK (MIN. GR. 3 & G=0.55)	1 1/4"	NO. 10 SMS OR WOOD SCREW	3/4"
MIN. 18 GA. 33 KSI METAL STUD	FULL	NO. 10 GR. 5 SELF TAP/DRILL SCREW	1/2"
MIN. 1/8" THK A36 STEEL	FULL	NO. 10 GR. 5 SELF TAP/DRILL SCREW	1/2"
MIN. 1/8" THK 6063-T5 ALUM.	FULL	NO. 10 GR. 5 SELF TAP/DRILL SCREW	1/2"
MIN. C-80 CMU	1 1/4"	(2) 1/4" CONCRETE SCREW	2"
MIN. 2500 PSI CONCRETE	1 1/2"	(2) 1/4" CONCRETE SCREW	2"

(1) WHEN SINGLE SCREW ROW ANCHORING METHOD IS USED SCREWS MUST HAVE A Ø3/4" O.D. FLAT WASHER AT THE SCREW HEAD.
 (2) CONCRETE SCREWS SHALL BE ELCO ULTRACONS (C.S.), ELCO CRETE-FLEX (S.S.), ITW RAMSET/RED HEADS TAPCONS (C.S. OR S.S.) OR HILTI KWIK-CON II (C.S. OR S.S.).
 (3) 2X6 WOOD BUCK MAY BE RIPPED DOWN TO 4 1/2" PROVIDING THAT REQ'D SCREW TO BUCK EDGE DISTANCES ARE MAINTAINED.

THESE DRAWINGS ARE APPLICABLE ONLY TO THE PRODUCT SPECIFIED. THEY MAY NOT BE USED FOR THE ASSEMBLY AND/OR INSTALLATION OF ANY OTHER PRODUCT NOR MAY THEY BE USED FOR NATIONAL AND/OR LOCAL APPROVALS. ANY CHANGES TO THESE DRAWINGS SHALL BE MADE AS STATED ON THESE DRAWINGS.

(2) ALLOWABLE DESIGN PRESSURE

(1) MAX. FRAME HEIGHT (IN.)	MAX. D.L.O. WIDTH (IN.)	ALLOWABLE PRESSURE (PSF)
99 7/8	31 3/8	70.0
	28 3/8	75.8
	25 3/8	80.0
	22 3/8	80.0
93 7/8	31 3/8	74.5
	28 3/8	80.0
	25 3/8	80.0
	24 3/8	80.0
87 7/8	31 3/8	79.6
	28 3/8	80.0
	26 3/8	80.0
82 7/8	31 3/8	80.0
	28 3/8	80.0

(1) FRAME HEIGHT SHOWN CONSIDERS THE CONDITION WHEN ADA SILL IS USED. FRAME HEIGHT IS 9 1/16" LESS WHEN STANDARD SILL IS USED.
 (2) WHEN AN ADA/FLUSH SADDLE SILL IS USED, THESE DOORS ARE NOT APPROVED FOR USE WHERE WATER INFILTRATION RESISTANCE IS REQUIRED BY THE DOOR UNLESS UNITS ARE INSTALLED IN NON-HABITABLE AREAS WHERE THE UNIT & THE AREA ARE DESIGNED TO ACCEPT WATER INFILTRATION OR THEY ARE INSTALLED ONLY AT LOCATIONS PROTECTED BY A CANOPY OR OVERHANG WHERE-BY THE OVERHANG(OH) RATIO IS EQUAL TO OR MORE THAN 1.0 PER FBC.

**EXTERIOR ELEVATION:
(2 DIRECTION FOLDING PANELS)**
SCALE: 1/2" = 1'-0"

(4-PANEL DOOR SHOWN. SEE SHEET 4 FOR OTHER DOOR PANEL QUANTITY CONDITIONS AND RESTRICTIONS.)

SEE CORNER CONSTRUCTION DESCRIPTIONS ON THIS SHEET

FRAME SCREWS WHERE SHOWN. SEE "FRAME ANCHOR REQUIREMENTS TABLE" ON THIS SHEET FOR REQUIREMENTS (APPLICABLE TO SINGLE OR DOUBLE ROW OF SCREWS).

EVALUATION OF THIS PRODUCT IS BASED ON APPLICABLE STANDARDS AND/OR INFORMATION & RESULTS FROM APPLICABLE TEST REPORTS. THE FLORIDA BUILDING CODE VERSION CONSIDERED WITH THIS EVALUATION. IN THE EVENT OF CODE VERSION CHANGES/UPDATES OR IN THE EVENT THAT NEW OR ADDITIONAL TESTING IS COMPLETED ON THIS PRODUCT, PRIOR TO STATING CODE COMPLIANCE WITH THE STATE, THE MANUFACTURER SHALL CONFIRM WITH THE ENGINEER. THIS EVALUATION IS CURRENT WITH ALL CURRENT SPECIFIED HERE-IN IS CURRENT WITH ALL CURRENT TESTING, CODES AND APPLICABLE STANDARDS.

CORNER CONSTRUCTION:
 FRAME (WITH STANDARD BASED SILL): MEMBERS ARE MITERED, BUTTED & JOINED VIA (2) TWO CORNER KEYS (ITEM #12) EACH CORNER KEY IS SECURED WITH (2) TWO Ø5/16" x 3 1/4" BRASS CONE PINS. CORNERS ARE SEALED WITH SILICONE SEALANT.
 FLUSH SADDLE SILL: MEMBERS ARE SQUARE CUT, BUTTED & JOINED VIA AN END CAP WITH (3) THREE 1/8" x 5/8" PHF SCREWS AT THE SILL & (2) TWO 1/8" x 5/8" PHF SCREWS AT THE VERTICAL MEMBER. CORNERS ARE SEALED WITH A CUSHION MEMBRANE STRIPPING.
 BUILT TO SILL: MEMBERS ARE MITERED, BUTTED & JOINED VIA (2) TWO CORNER KEYS (ITEM #12) & (2) TWO CORNER KEYS (ITEM #13) & (2) TWO CORNER KEYS (ITEM #14). CORNER KEYS ARE SECURED BY CRIMPING (2) TWO LEGS EACH PANEL. CORNERS ARE SEALED WITH SILICONE SEALANT.

NO.	REVISION DESCRIPTION	BY	DATE
1	ISSUE FOR CONSTRUCTION	W.S.	11/29/08
2	CHANGE TO STATE ONLY APPROVAL	W.S.	07/12/19
3	UPDATE TO CURRENT STANDARDS	W.S.	02/19/13
4	CHANGE TO STATE ONLY APPROVAL	W.S.	10/18/11

DRAWING TITLE: SL-73 OUT-SWING IMPACT FOLDING PANELS

MANUFACTURER: ZONA WALL SYSTEMS, INC
 707 REDWOOD HIGHWAY
 MILL VALLEY, CA 94941
 800-873-5673

CONSULTANTS: W. W. SCHAEFER ENGINEERING & CONSULTING, P.A. (CA 6809)
 7480 150TH COURT NORTH
 PALM BEACH GARDENS, FL 33418
 PHONE: 561-744-3424

DATE: JUL 12 2019

CERTIFICATION: W. W. SCHAEFER ENGINEERING & CONSULTING, P.A. LICENSE NO. 44138

DRAWING NO. REV. 1635 C
 SHEET NO. 1 OF 8

DATE	BY	DESCRIPTION

MANUFACTURER
NANA WALL SYSTEMS, INC.
 707 REDWOOD HIGHWAY
 MILL VALLEY, CA 94541
 800-873-5673

CONSULTANTS
W. W. SCHAEFER ENGINEERING & CONSULTING, P.A. (CA 6809)
 7480 150TH COURT NORTH
 PALM BEACH GARDENS, FL 33418
 PHONE: 561-744-3424

DRAWING NO. **1655**
 SHEET NO. **2** OF **8**
 DATE **JUL 1 2 2019**
 PROJECT: **WARREN W. SCHAEFER, P.E.**
 P.E. NO. **44135**
 LICENSE NO. **44135**
 STATE OF **FLORIDA**

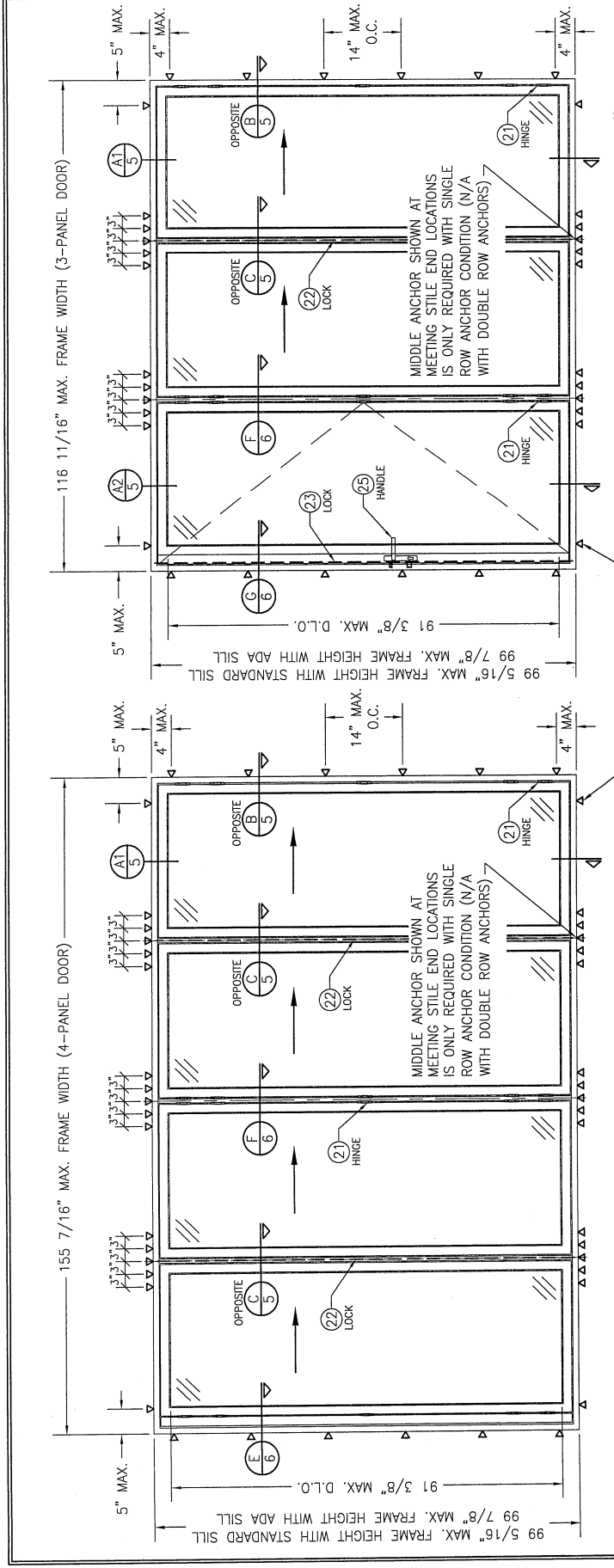

EXTERIOR ELEVATION:
 (1 DIRECTION FOLDING PANELS WITH SWING PANEL LOCKING TO JAMB)

SCALE: 1/2" = 1'-0"

(ACTIVE SWING DOOR SHOWN WITH MULTI-POINT LOCK. DEADBOLT/FLUSH BOLT LOCK COMBINATION ALSO APPLIES) (3-PANEL DOOR SHOWN. SEE SHEET 4 FOR OTHER DOOR PANEL QUANTITY CONDITIONS AND RESTRICTIONS.)

EXTERIOR ELEVATION:
 (1 DIRECTION FOLDING PANELS)

SCALE: 1/2" = 1'-0"

(4-PANEL DOOR SHOWN. SEE SHEET 4 FOR OTHER DOOR PANEL QUANTITY CONDITIONS AND RESTRICTIONS.)

FRAME SCREWS WHERE SHOWN. SEE "FRAME ANCHOR REQUIREMENTS TABLE" ON SHEET 1 FOR REQUIREMENTS (APPLICABLE TO SINGLE OR DOUBLE ROW OF SCREWS).

DRAWING TITLE: **SL-73 OUT-SWING IMPACT FOLDING PANELS**

WARREN W. SCHAEFER, P.E.

STATE OF FLORIDA

PROFESSIONAL ENGINEER

NO. 44135

WARREN W. SCHAEFER

CHECKED BY:	W.S.		
DATE:	11/22/08		
DESIGN BY:	W.S.		
DATE:			
NO.	REVISION DESCRIPTION	BY	DATE

MANUFACTURER
NANA WALL SYSTEMS, INC
 707 REDWOOD HIGHWAY
 MILL VALLEY, CA 94941
 800-873-5673

CONSULTANTS
W. W. SCHAEFER ENGINEERING & CONSULTING, P.A. (CA 6809)
 7801 150TH COURT NORTH
 PALM BEACH GARDENS, FL 33418
 PHONE: 561-744-3424

DRAWING TITLE
SL-73 OUT-SWING IMPACT FOLDING PANELS

DRAWING NO. | REV.
1635 | C

SHEET NO. | OF
3 | 8

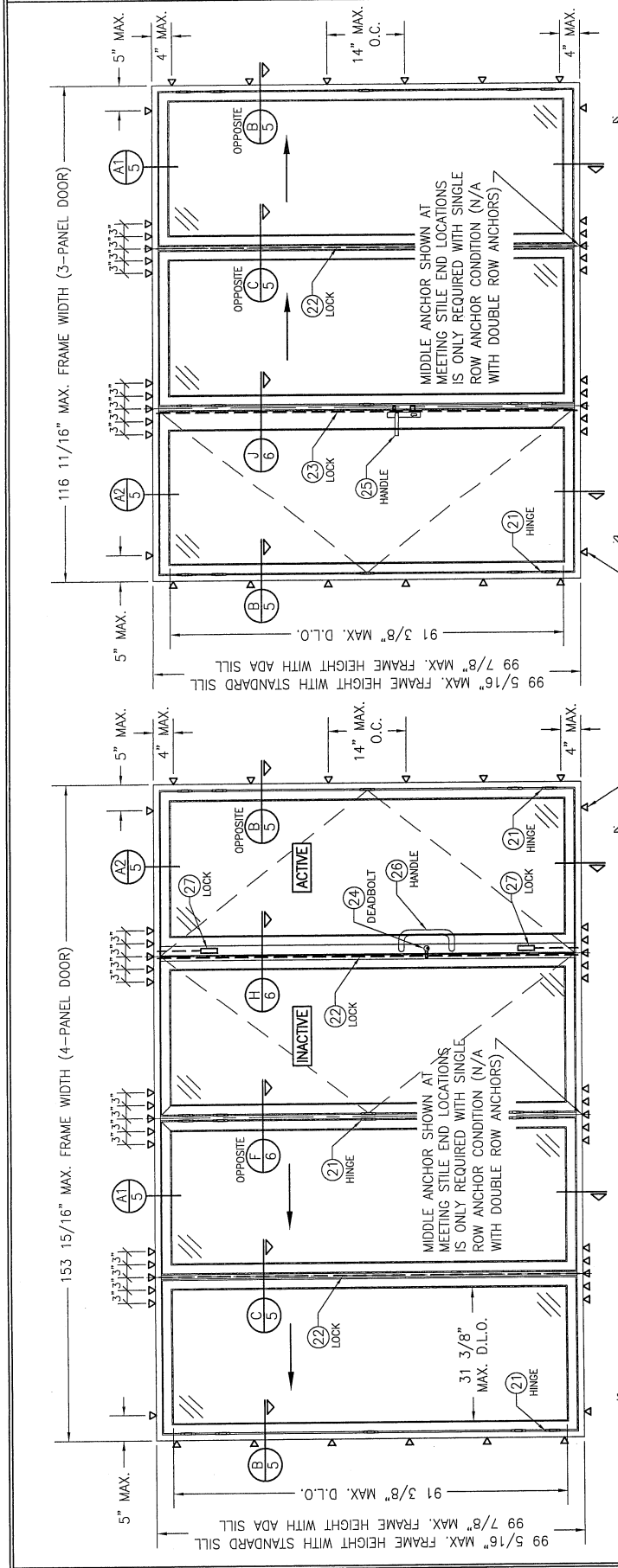

**EXTERIOR ELEVATION:
 (SWING PANEL LOCKING TO 1 DIRECTION
 FOLDING PANELS)**

SCALE: 1/2" = 1'-0"

(ACTIVE SWING DOOR SHOWN WITH MULTI-POINT LOCK.
 DEADBOLT/FLUSH BOLT LOCK COMBINATION ALSO APPLIES)
 (3-PANEL DOOR SHOWN. SEE SHEET 4 FOR
 OTHER DOOR PANEL QUANTITY CONDITIONS AND
 RESTRICTIONS.)

FRAME SCREWS WHERE
 SHOWN. SEE "FRAME
 ANCHOR REQUIREMENTS
 TABLE" ON SHEET 1 FOR
 REQUIREMENTS
 (APPLICABLE TO SINGLE
 OR DOUBLE ROW OF
 SCREWS).

**EXTERIOR ELEVATION:
 (1 DIRECTION FOLDING PANELS WITH DOUBLE SWING
 PANELS)**

SCALE: 1/2" = 1'-0"

(ACTIVE SWING DOOR SHOWN WITH DEADBOLT/FLUSH BOLT LOCK
 COMBINATION. MULTI-POINT LOCK ALSO APPLIES)
 (4-PANEL DOOR SHOWN. SEE SHEET 4 FOR
 OTHER DOOR PANEL QUANTITY CONDITIONS AND
 RESTRICTIONS.)



CHECKED BY:	W.S.
DATE:	11/23/09
DESIGNED BY:	
DATE:	
BY:	
DATE:	
REVISION DESCRIPTION:	
NO.:	

MANUFACTURER
NANA WALL SYSTEMS, INC.
 707 REDWOOD HIGHWAY
 MILL VALLEY, CA 94941
 800-873-5673

CONSULTANTS
W. W. SCHAEFER ENGINEERING & CONSULTING, P.A. (CA 6809)
 7480 150TH COURT NORTH
 PALM BEACH GARDENS, FL 33418
 PHONE: 561-744-3424

DRAWING TITLE
SL-73 OUT-SWING IMPACT FOLDING PANELS

CERTIFICATION
JUL 12 2019
 WARREN W. SCHAEFER, P.E.
 P.E. NO. 44135

DRAWING NO. **1635**
 REV. **C**
 SHEET NO. **4** OF **8**

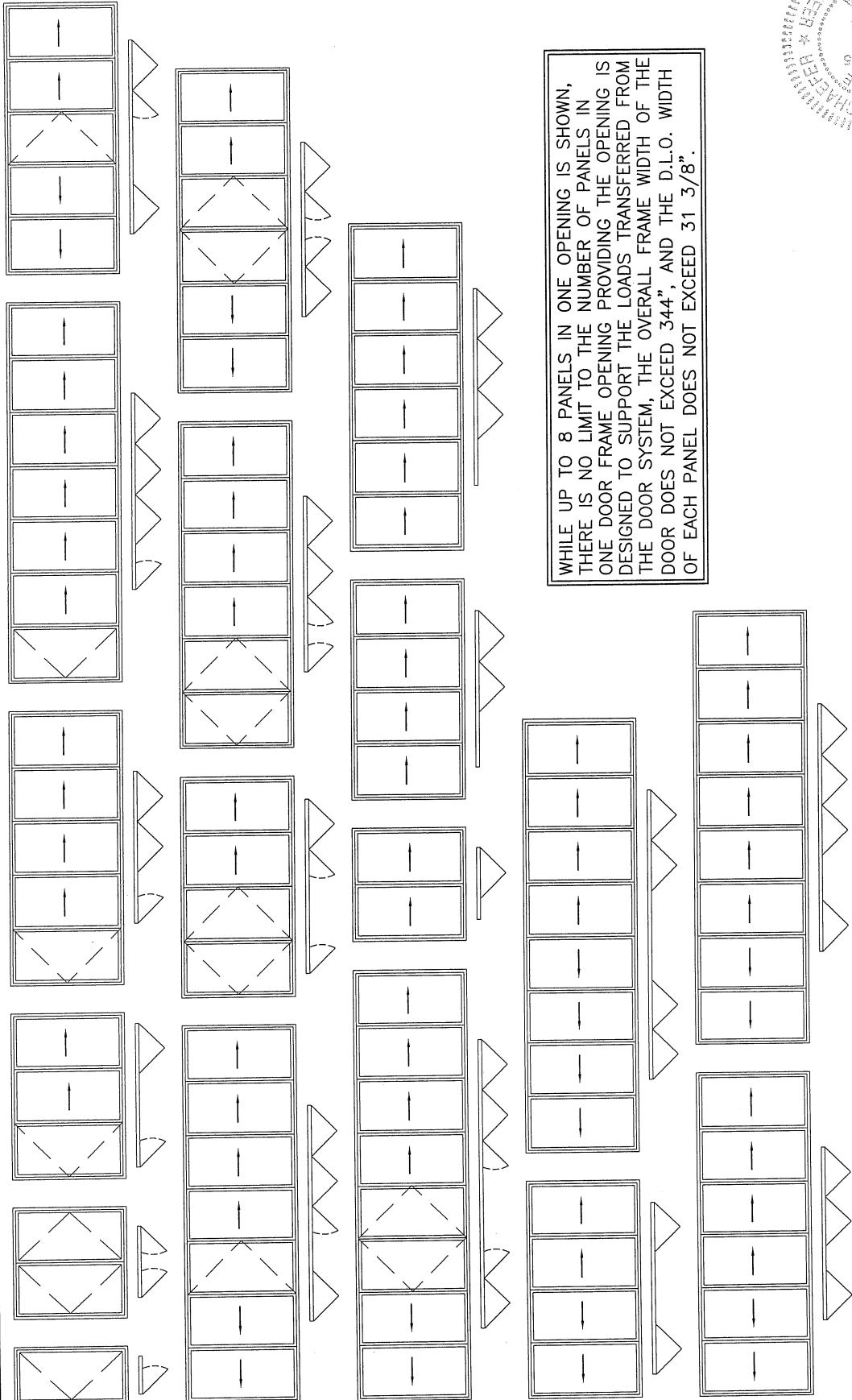

WHILE UP TO 8 PANELS IN ONE OPENING IS SHOWN, THERE IS NO LIMIT TO THE NUMBER OF PANELS IN ONE DOOR FRAME OPENING PROVIDING THE OPENING IS DESIGNED TO SUPPORT THE LOADS TRANSFERRED FROM THE DOOR SYSTEM, THE OVERALL FRAME WIDTH OF THE DOOR DOES NOT EXCEED 344", AND THE D.L.O. WIDTH OF EACH PANEL DOES NOT EXCEED 31 3/8".

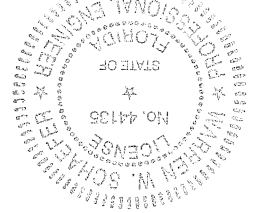

CONDITIONS SHOWN ARE THE MAJORITY OF THOSE USED; OTHER CONDITIONS OF FOLDING & SWING PANELS APPLY PROVIDING THEY ARE WITHIN THE SCOPE OF THE DETAILS WITHIN THIS DRAWING.

NO.	REVISION DESCRIPTION	BY	DATE

MANUFACTURER
NANA WALL SYSTEMS, INC
 707 REDWOOD HIGHWAY
 MILL VALLEY, CA 94941
 800-873-5673

CONSULTANTS
W. W. SCHAEFER ENGINEERING & CONSULTING, P.A. (CA 6809)
 7480 BACH GARDENS, FL 33418
 PALM BEACH GARDENS, FL 33418
 PHONE: 561-744-3424

DRAWING TITLE
SL-73 OUT-SWING IMPACT FOLDING PANELS

CERTIFICATION
 W. W. SCHAEFER, P.E.
 P.E. NO. 44130
 APR 1 2 2019

ISSUING NO. 1635
 SHEET NO. C
 5 OF 8

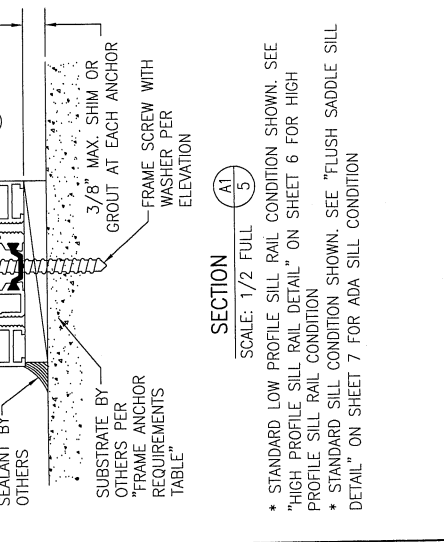
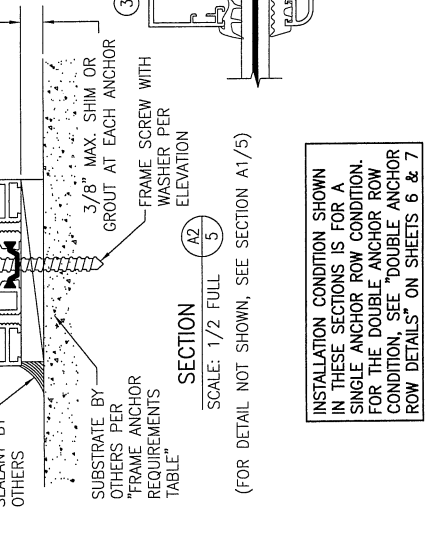
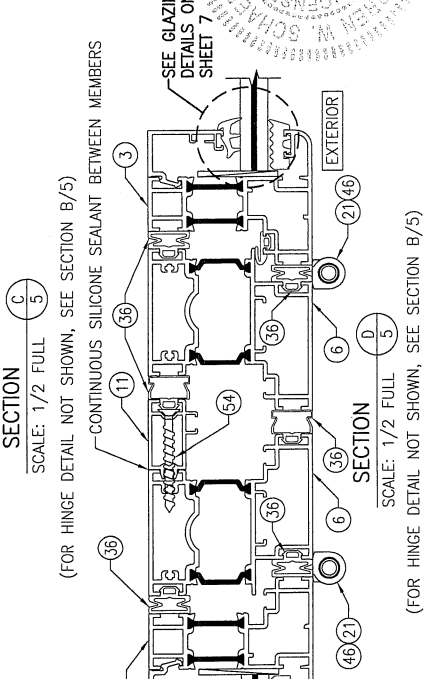
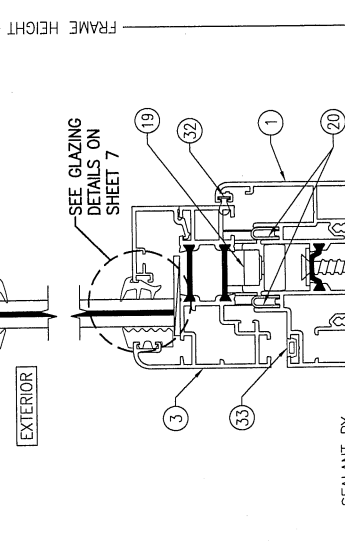
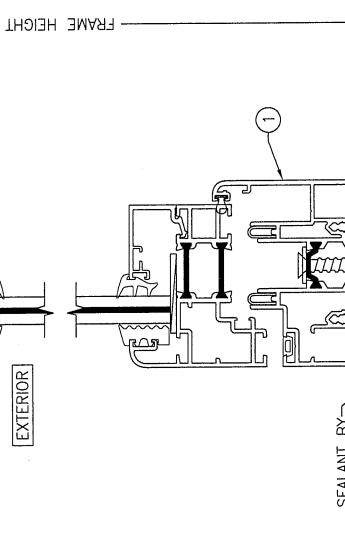
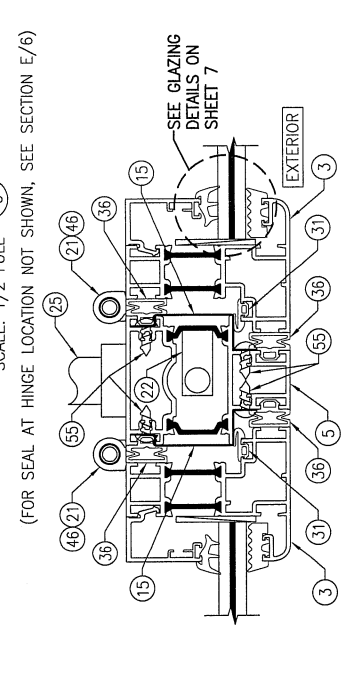
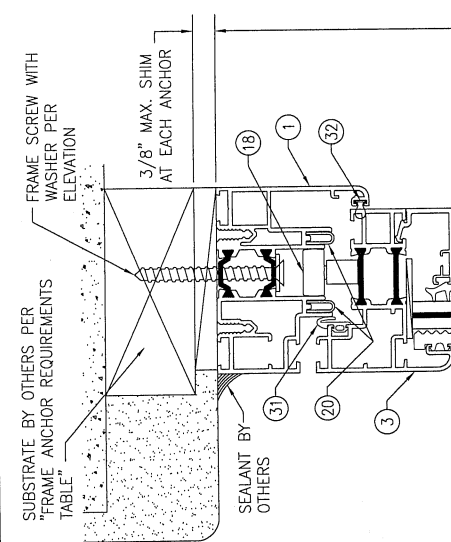
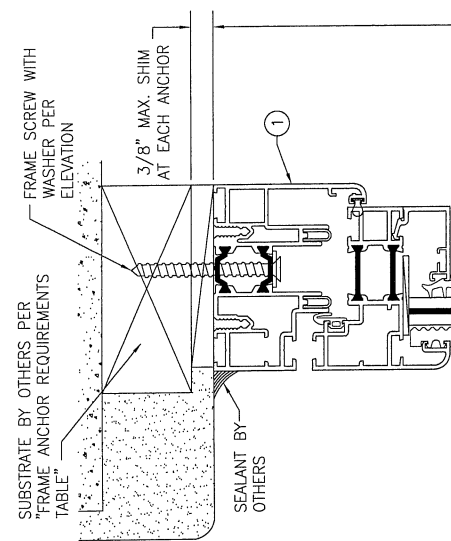
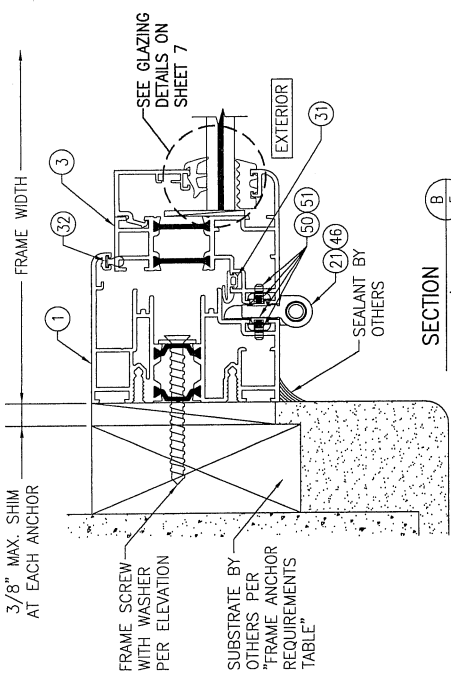

INSTALLATION CONDITION SHOWN IN THESE SECTIONS IS FOR A SINGLE ANCHOR ROW CONDITION. FOR THE DOUBLE ANCHOR ROW CONDITION, SEE "DOUBLE ANCHOR ROW DETAILS" ON SHEETS 6 & 7

* STANDARD LOW PROFILE SILL RAIL CONDITION SHOWN. SEE "HIGH PROFILE SILL RAIL DETAIL" ON SHEET 6 FOR HIGH PROFILE SILL RAIL CONDITION
 * STANDARD SILL CONDITION SHOWN. SEE "FLUSH SADDLE SILL DETAIL" ON SHEET 7 FOR ADA SILL CONDITION

NO.	REVISION DESCRIPTION	BY	DATE

CHECKED BY: W.M.S.
 DRAWN BY: W.M.S.
 DATE: 11/23/09
 PLOT: 1/2
 NANA WALL SYSTEMS, INC
 MANUFACTURER
 707 REDWOOD HIGHWAY
 MILL VALLEY, CA 94941
 800-873-5673

CONSULTANTS
 W. W. SCHAEFER ENGINEERING & CONSULTING, P.A. (CA 6809)
 2480 150TH COURT NORTH
 PALM BEACH GARDENS, FL 33418
 PHONE: 561-744-5424

DRAWING TITLE	DRAWING NO.	REV.	SHEET NO.	OF
SL-73 OUT-SWING IMPACT FOLDING PANELS	1655	C	6	8

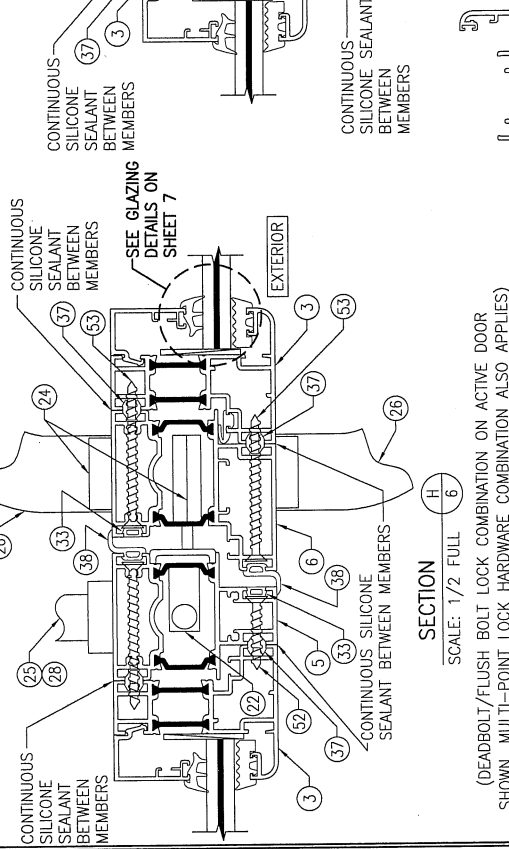
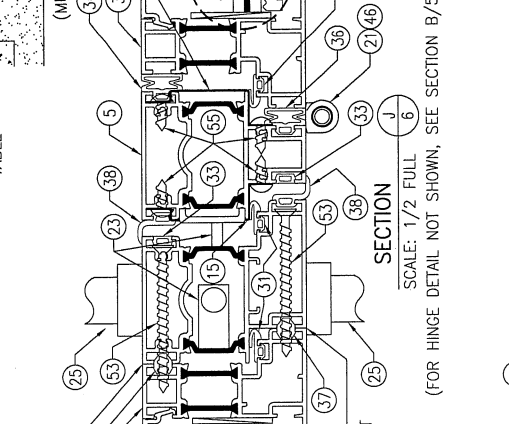
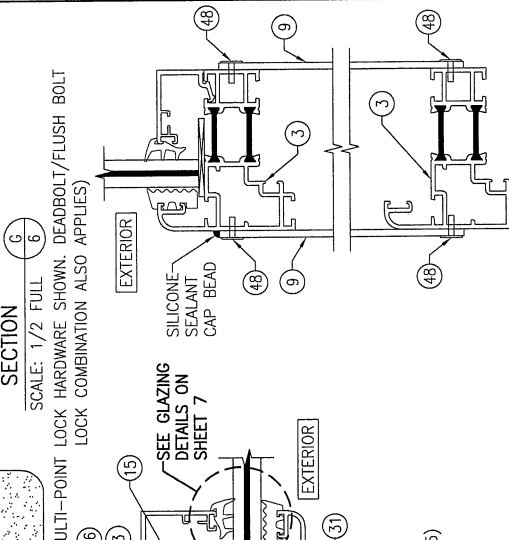
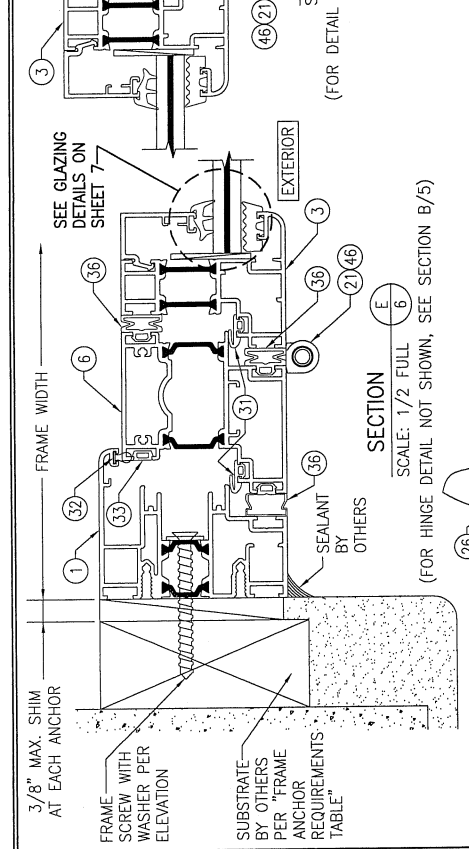
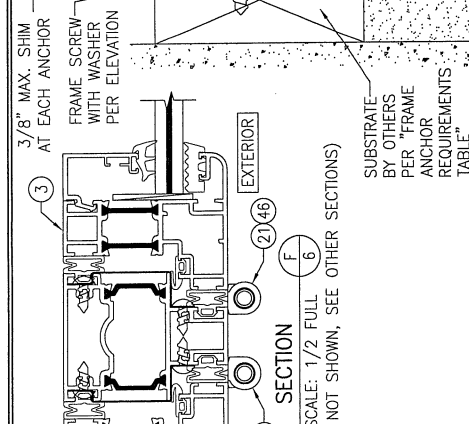
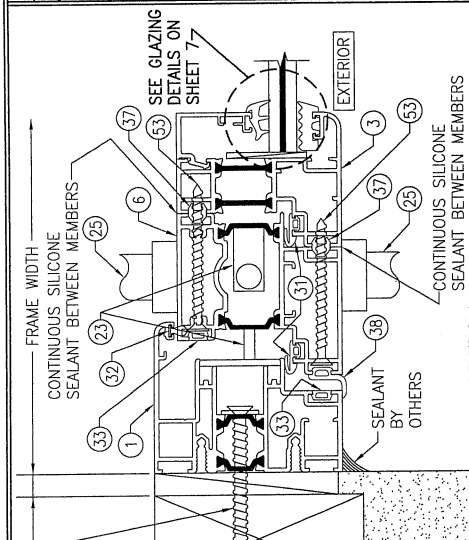

OPTIONAL HIGH PROFILE SILL RAIL
 (FOR DETAIL NOT SHOWN, SEE OTHER SECTIONS)

(DEADBOLT/FLUSH BOLT LOCK COMBINATION ON ACTIVE DOOR SHOWN. MULTI-POINT LOCK HARDWARE COMBINATION ALSO APPLIES)

(FOR HINGE DETAIL NOT SHOWN, SEE SECTION B/5)

(FOR HINGE DETAIL NOT SHOWN, SEE SECTION B/5)

(FOR DETAIL NOT SHOWN, SEE OTHER SECTIONS)

STATE OF CALIFORNIA
 PROFESSIONAL ENGINEERING
 LICENSE
 NO. 44135
 WARREN W. SCHAEFER
 P. E.
 JUL 1 2 2010
 CERTIFICATION

NO.	REVISION DESCRIPTION	BY	DATE

MANUFACTURER
NAMA WALL SYSTEMS, INC
 707 REDWOOD HIGHWAY
 MILL VALLEY, CA 94941
 800-873-5673

CONSULTANTS
W. W. SCHAEFER ENGINEERING & CONSULTING, P.A. (CA 6809)
 7480 150TH COURT NORTH
 PALM BEACH GARDENS, FL 33418
 PHONE: 561-744-3424

DRAWING TITLE
SL-73 OUT-SWING IMPACT FOLDING PANELS

CHECKED BY: WWS
 DATE: 1/23/08
 DRAWING NO.: 1635
 SHEET NO.: 7 OF 8

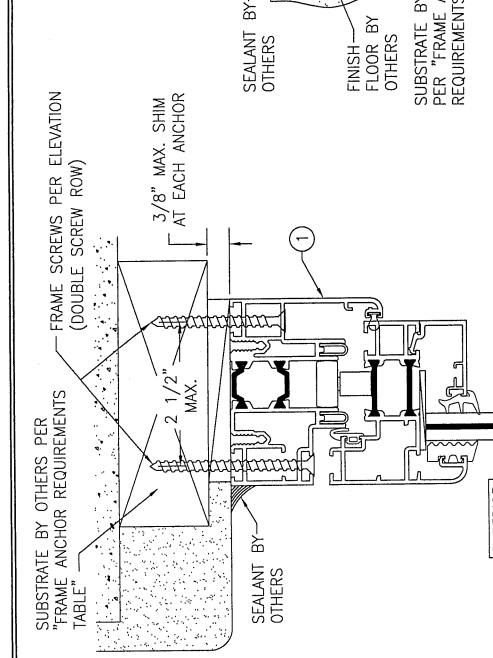
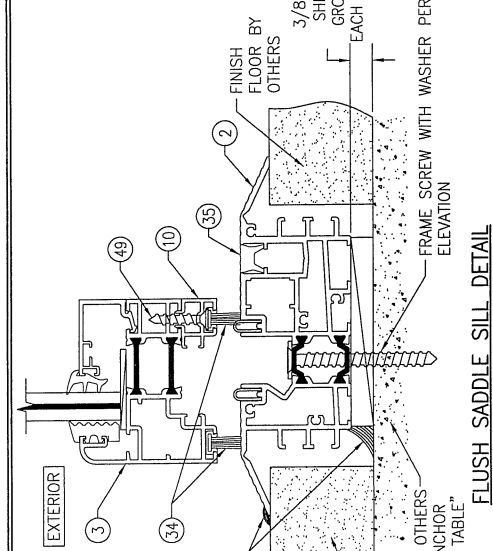
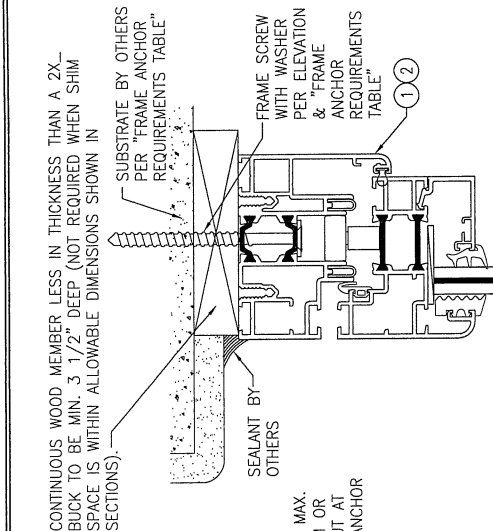

DOUBLE ROW ANCHOR DETAIL AT HEAD & SIDES
 (FOR DETAIL NOT SHOWN, SEE OTHER SECTIONS)
 (HEAD SECTION SHOWN. SIDES ARE INSTALLED THE SAME)

FLUSH SADDLE SILL DETAIL
 (SWING DOOR SHOWN. FOLDING PANELS ARE INSTALLED THE SAME)
 (FOR DETAIL NOT SHOWN, SEE OTHER SECTIONS)
 (DOUBLE SCREW ROW DOES NOT APPLY TO THIS DETAIL)

OPTIONAL DIRECT MOUNT DETAIL TO SUBSTRATE WITH SPACER
 (HEAD SECTION SHOWN. SILL & SIDES ARE INSTALLED THE SAME)
 (FOR DETAIL NOT SHOWN, SEE OTHER SECTIONS)
 (SINGLE SCREW ROW INSTALLATION SHOWN. DOUBLE SCREW ROW ALSO APPLIES)

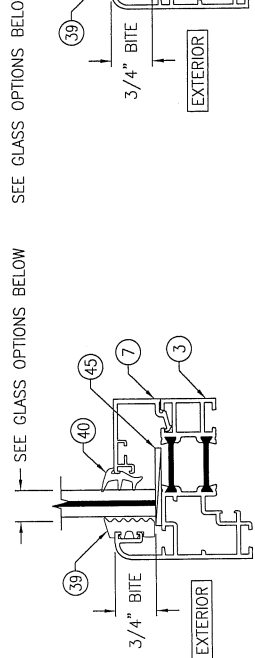
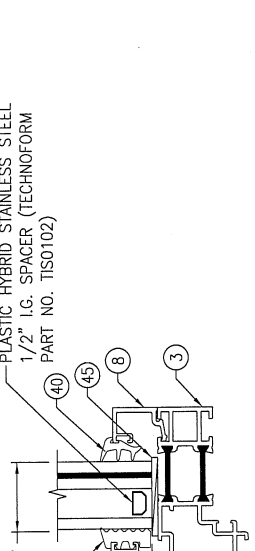

NON-I.G. GLAZING DETAIL
GLASS OPTIONS 1 & 2
 GLASS OPTION 1: 7/16" LAMINATED GLASS (3/16" H.S./0.09 KURARAY SG/3/16" H.S.)
 GLASS OPTION 2: 7/16" LAMINATED GLASS (3/16" AN./0.09 KURARAY SG/3/16" AN.)

NON-I.G. GLAZING DETAIL
GLASS OPTIONS 3, 4, 5 & 6
 GLASS OPTION 3: 1 1/8" I.G. LAMINATED GLASS (3/16" H.S./0.09 KURARAY SG/3/16" H.S. INTERIOR; 1/2" AIR SPACE; 3/16" TEMP. EXTERIOR)
 GLASS OPTION 4: 1 1/8" I.G. LAMINATED GLASS (3/16" H.S./0.09 KURARAY SG/3/16" H.S. INTERIOR; 7/16" AIR SPACE; 1/4" TEMP. EXTERIOR)
 GLASS OPTION 5: 1 1/8" I.G. LAMINATED GLASS (3/16" AN./0.09 KURARAY SG/3/16" AN. INTERIOR; 1/2" AIR SPACE; 3/16" TEMP. EXTERIOR)
 GLASS OPTION 6: 1 1/8" I.G. LAMINATED GLASS (3/16" AN./0.09 KURARAY SG/3/16" AN. INTERIOR; 7/16" AIR SPACE; 1/4" TEMP. EXTERIOR)

I.G. GLAZING DETAIL
GLASS OPTIONS 3, 4, 5 & 6
 PLASTIC HYBRID STAINLESS STEEL
 1/2" I.G. SPACER (TECHNOFORM PART NO. TIS0102)

CONTINUOUS WOOD MEMBER LESS IN THICKNESS THAN A 2X...
 BUCK TO BE MIN. 3 1/2" DEEP (NOT REQUIRED WHEN SHIM SPACE IS WITHIN ALLOWABLE DIMENSIONS SHOWN IN SECTIONS).

STATE OF CALIFORNIA
 LICENSE
 NO. 44108
 W. W. SCHAEFER, P.E.
 CERTIFICATION
 APR 2 2019

NO.	REVISION DESCRIPTION	BY	DATE

MANUFACTURER
NAMA WALL SYSTEMS, INC
 707 REDWOOD HIGHWAY
 MILL VALLEY, CA 94541
 800-873-5673

CONSULTANTS
W. W. SCHAEFER ENGINEERING & CONSULTING, P.A. (CA 6809)
 7480 150TH COURT NORTH
 PALM BEACH GARDENS, FL 33418
 PHONE: 561-744-3424

DRAWING TITLE
SL-73 OUT-SWING IMPACT FOLDING PANELS

CERTIFICATION
 W. W. SCHAEFER
 P.E. NO. 44138
 P.E. NO. 44138

DRAWING NO. 1655
 SHEET NO. 8 OF 8

ITEM #	ITEM DESCRIPTION	MANUFACTURER/NOTES
48	1/8" RIVET	6 PER KICK PLATE
49	NO. 8 X 1" SMS SCREW	WITHIN 4" FROM CORNERS & MAX. 16" O.C.
50	NO. 10 X 3/8" FH S.S. MS	4 PER HINGE
51	3/16 X 1/4 S.S. SET SCREW	4 PER HINGE
52	NO. 8 X 1 1/4" SMS SCREW	WITHIN 4" FROM CORNERS & MAX. 16" O.C.
53	NO. 8 X 2 3/4" SMS SCREW	WITHIN 4" FROM CORNERS & MAX. 16" O.C.
54	NO. 8 X 1 3/4" SMS SCREW	WITHIN 4" FROM CORNERS & MAX. 16" O.C.
55	NO. 8 X 1/2" SMS SCREW	2 PER CLIP

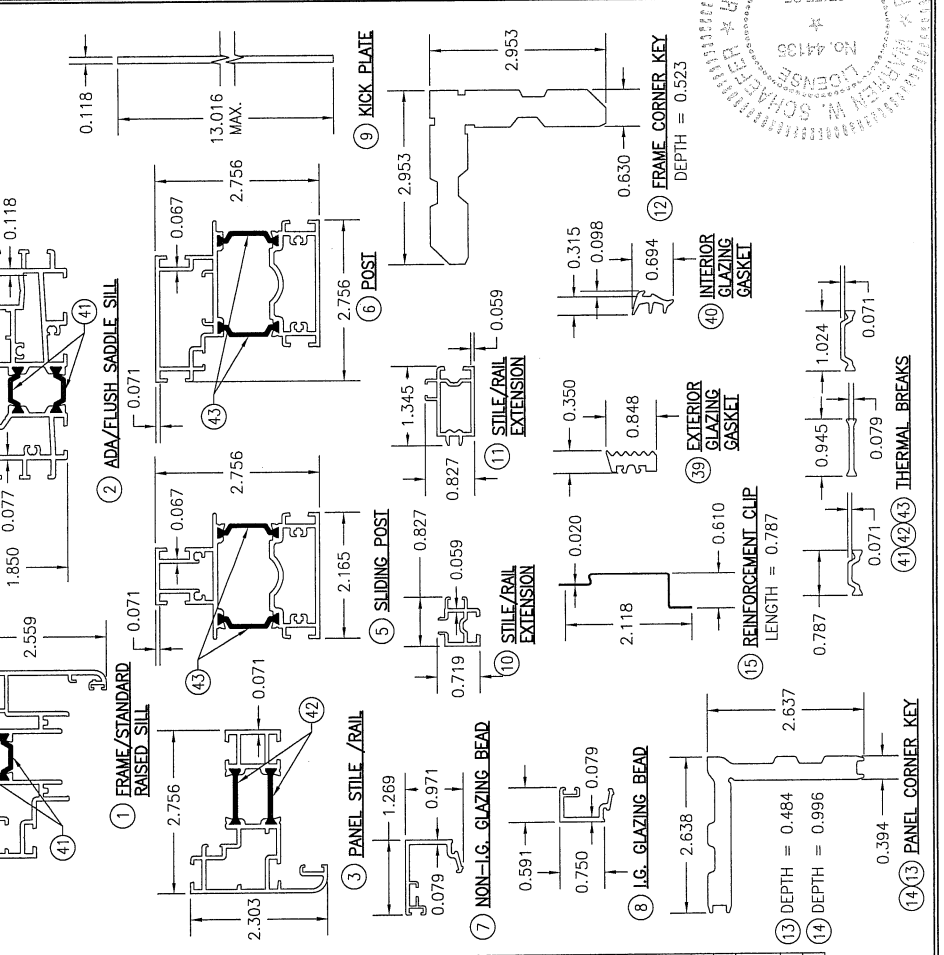

ITEM #	ITEM DESCRIPTION	MANUFACTURER/NOTES
1	FRAME/STANDARD RAISED SILL	6063-T5 ALUMINUM
2	ADA/FLUSH SADDLE SILL	6063-T5 ALUMINUM
3	PANEL STILE/RAIL	6063-T5 ALUMINUM
5	SLIDING POST	6063-T5 ALUMINUM
6	POST	6063-T5 ALUMINUM
7	NON-I.G. GLAZING BEAD	6063-T5 ALUMINUM
8	I.G. GLAZING BEAD	6063-T5 ALUMINUM
9	KICK PLATE	6063-T5 ALUMINUM
10	STILE/RAIL EXTENSION	6063-T5 ALUMINUM
11	STILE/RAIL EXTENSION	6063-T5 ALUMINUM
12	FRAME CORNER KEY	6063-T5 ALUMINUM
13	PANEL CORNER KEY	6063-T5 ALUMINUM
14	PANEL CORNER KEY	6063-T5 ALUMINUM
15	REINFORCEMENT CLIP (4 PER POST, 2 EACH END)	S.S.

ITEM #	ITEM DESCRIPTION	MANUFACTURER/NOTES
18	UPPER GUIDING TROLLEY	NEIDERHOFF OR DELLENBUSH 15-71-53-1
19	ROLLER REINFORCEMENT	WESTERFELD 15-73-78-X S.S.
20	BOTTOM ROLLER & ROLLER REINFORCEMENT	NEIDERHOFF OR DELLENBUSH 15-71-50-1
21	STEEL INSERT ROLLER TRACK	WESTERFELD 15-73-78-X S.S.
22	BUTT HINGE	WELSER 5-66-09
23	CONCEALED 2-POINT LOCK	BURGHANUS 15-0-2210-190 DIECAST OR IBW IDEAL 15-0-2227/8-120 S.S.
24	3-POINT MULTI-POINT LOCK	EURIT SRL 15-0-2001-1
25	DEADBOLT	VBH GMBH 15-60-27-1
26	OPERATOR HANDLE	VBH GMBH 15-0-210-109
27	OPERATOR HANDLE	AS REQ'D TO OPERATE 2 & 3-POINT LOCK
28	CONCEALED 1-POINT LOCK	EURIT SRL 15-0-2001-1
29	CONCEALED 2-POINT LOCK	WIHL. SCHLECHTENDAHL & SOHNE 15-0-218

ITEM #	ITEM DESCRIPTION	MANUFACTURER/NOTES
31	WEATHERSTRIP	DURAPROOF OR TREMCO 25-0-1052-195 EPDM
32	Q-LON GASKET	SCHLAGEL Q300T190 POLYETHYLENE
33	COVER GASKET	JAEGER GUMMI UND KUNSTSTOFF OR TREMCO 25-0-1054-195 EPDM
35	FILLER SEAL	DURAPROOF OR TREMCO 25-0-1084-155 EPDM
36	PANEL GASKET	DURAPROOF OR TREMCO 25-0-1036-195 EPDM
37	CONNECTOR	DURAPROOF OR TREMCO 25-0-1056-195 EPDM
38	PANEL GASKET	SYNCAMER GUMMI OR TREMCO 25-0-1050-195 EPDM
39	EXTERIOR GLAZING GASKET (DUROMETER = 56)	TREMCO TX16702E EPDM
40	INTERIOR GLAZING GASKET (DUROMETER = 70)	TREMCO 25-0-1007-X EPDM
41-43	DEBRIDGING/THERMAL BREAK	ENSINGER, INC., TECATHERM 66 GF INSULBAR POLYAMIDE
45	GLAZING SHIM	GLUSKE, PVC
46	1/2" X 3" X 1/16" THICK GLAZING TAPE	ADHERED TO EA. HINGE AS A SEAL

Operation And Maintenance Of NanaWall Products

OPERATION OF A NANAWALL FOLDING UNIT

For opening and closing the folding system, please observe the special notes on the following pages in as far as they relate to your folding system.



When operating the folding system similar to any other door, please do not place your fingers between the panels/pivot points. You may hurt them!

Do not have anyone not properly trained on operation and children operate the unit.

Do not force the system if not operating properly. Please have it repaired as soon as possible by a qualified technician.

Secure panels when in the open position to prevent uncontrolled movement, especially in windy conditions, which might cause damage and injury.

It is highly recommended that if not used, the NanaWall folding unit be kept closed as much as possible, in order to provide best security and weather resistance. When closed, please engage all locking points fully.

The correct sequence of opening and closing of panels is dependent on the configuration ordered. Panels must be opened and closed in the right order.

With a Swing Panel Attached to a Folding Pair

1. Open the swing panel a full 180° and connect to the panel catch on the adjacent panel.
2. Disengage the locking points on all the other panels.
3. Slide folding panels, starting with the pair adjacent to the swing panel.

For closing, proceed in reverse order and disconnect swing panel only after all other panels are closed in place.

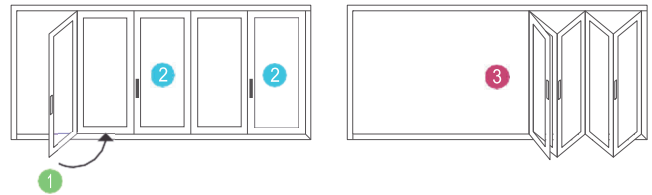

Without a Swing Panel

1. Disengage locking points on primary opening panel pair and fold it slightly.
2. Do the same with any adjacent panel pair.
3. Slide folding panels completely to the side.

For closing, proceed in reverse order.

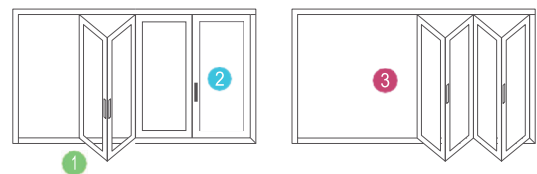

With Folding left/right FourFold or SixFold

1. Disengage locking points on primary opening panel pair and fold it slightly.
2. Do the same with any adjacent panel pair(s).
3. Slide folding panels into desired stacking position.

For closing, proceed in reverse order.

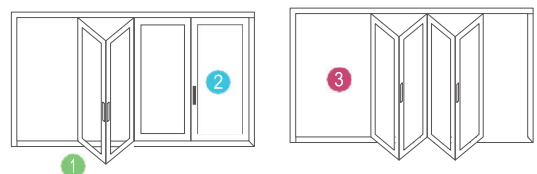

OPERATING THE SL-MULTIPOINT LOCKING ON THE PRIMARY SWING PANEL

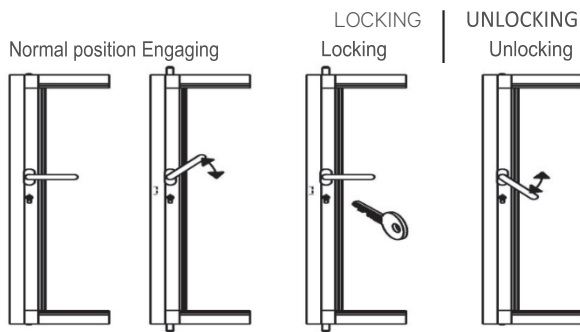

Disengaging locking points
 (Note that this is not one motion operation. Key or thumb turn must be unlocked first.)



Be sure to check that the door is locked by fully engaging the lock cylinder. The door is locked, when the handle cannot be depressed.

Engaging the locking points and locking

- Turn handle up about 45° to engage the locking points. Then let it move back into its normal position.
- Only now can it be locked with a key on the outside or a thumb turn on the inside.

Unlock and disengaging the locking points

- Unlock the lock with key or thumb turn.
- By operating the door handle downwards, the locking points at the top and the bottom are disengaged.

RECOMMENDED MAINTENANCE OF NANAWALL PRODUCTS

Some General Considerations on all Projects:

1. It is important that the product is installed correctly. A poorly installed unit will not function properly. This will cause more abnormal force or stress on the components and will lead to premature failure. When operating the unit, the panels should generally be able to be moved easily by one person (except when there are very large panels or when there are more than 6 panels folding to one side). All locking points should engage smoothly. There should be no rubbing on the floor and no binding. When the unit is closed, the reveal between panels and head jamb and between panels and sill should be consistent. There should be no daylight seen from the inside. Please have all problems corrected as soon as possible by a qualified technician.
2. From time to time, due to building movement or settlement, a unit may need to be adjusted by a qualified technician to compensate for any building change. Any adjustments needed related to building movement are not covered under the warranty.
3. It is important that a unit is operated properly. Locking points should be gently opened and closed and not forced. Panels should be opened and closed in the proper manner and sequence. See the Operation section for proper operation.
4. Periodically check for worn or damaged components and replace as soon as possible. A unit with nonworking components will subject the other components to increased stress and lead to premature failure. A unit with worn or damaged components will compromise the performance level expected for air and water infiltration, structural loading, and forced entry.
5. Periodically, inspect the sealant/caulking on the exterior perimeter of the unit. It is extremely important that the sealant/caulking remains intact and in good condition. Trim off any old, loose caulking, and seal any gaps with a good quality caulk.
6. Check that all weep holes are clean and clear of any obstructions. Remove debris and other foreign bodies which have dropped into the tracks immediately to prevent damaging the running carriages and guide trolleys. Clean all components as needed. Check gaskets for proper seating and condition. Remove dust and any deposits from these gaskets.
7. The finished aluminum or wood surface needs periodic cleaning and maintenance. Its appearance may be marred by harsh chemicals, abuse, or neglect. Frequency of cleaning depends on exposure and needs. For aluminum surfaces, generally warm soapy water should be enough. Stubborn stains and deposits may be removed with mineral spirits. For wood surfaces, superficial surface dirt can be removed by washing with water and a soft-bristled brush. Heavier accumulations can be removed with a mild solution of household detergent. For all surfaces, aggressive alkaline or acid cleaners should not be used. Excessive abrasive rubbing should be avoided. Sealants and weather stripping may be affected by strong organic solvents. Superficial damage to the aluminum surface must be touched up immediately with proper touch up paint.
8. If it is a wood product, the surface should be visually inspected every six months or earlier, depending on the exposure of the NanaWall unit. Periodically repaint or re-stain the wood as needed. Exposure to the environment will break down the finish and compromise its protective features if not refinished. See Finishing Recommendations in the Owner's Manual of the wood systems.

9. All hardware, hinges, and handles should be periodically cleaned with a soft cloth and mild cleanser. Excessive abrasive rubbing should be avoided. Please note that oil rubbed brass is a finish that will develop its own unique patina over time.
 10. About every six months, apply lubricant to all the hinges and Teflon based lubricant to all the hinges and to the running carriages and guiding trolleys.
- b. For cleaning, do not use abrasive household cleaners or materials like steel wool or hard brushes that can wear and harm finishes.
 - c. Any glass cleaner used should not be allowed to run down on any other surface.

SOME SPECIFIC SUGGESTED MAINTENANCE FOR COASTAL SALT WATER AND OTHER EXTREME ENVIRONMENTS:

Please note that the environment within one mile of a sea coast can be extremely corrosive. Products installed in this environment will typically deteriorate sooner than products installed in a less severe environment.

1. Open and close completely a unit at least once a week and inspect all surfaces.
 - a. Salt and other corrosive or abrasive materials such as sand must not be allowed to build up on any surfaces, including all hardware and sill.
 - b. The sill and head jamb tracks should be free from all dirt and debris.
 - c. There should be no standing water in the track in the sill.
 - d. All hardware should be intact and operating properly.
2. All surfaces must be cleaned with a mild detergent soap and fresh water at least every month and more frequently, if necessary.
 - a. After washing, the surface should be rinsed thoroughly with clean water and allowed to dry.
3. Any breaches in the paint coating, such as scratches, chips, or areas of abrasion, must be repaired immediately.
4. Every 3 months, thoroughly clean and dry all upper and lower rollers and all hinges. Liberally apply lubricant such as Teflon spray (no grease) on the wheels and bearings of the rollers. Lube all hinges including the hinge pin with light weight lubricating oil or Teflon spray. Do not use WD40. Silicon spray is for gaskets only. Apply silicone spray to rag and wipe down gasket.
5. As with any painted surface exposed to corrosive environments, every 6 months apply a wax to the outside of the painted panel and painted track. If the system includes corner connections make sure the wax penetrates the connection joints.

NanaWall Limited Warranty

NanaWall is pleased to provide the following warranty to the owner of NanaWall products, including the initial purchaser and all subsequent owners (“Owner”), subject to all terms and conditions stated herein. This Warranty supersedes all previous product warranties and is the exclusive statement of all commitments and rights of NanaWall with respect to its products sold on or after May 1, 2023, to be installed in the United States (excluding territories) or Canada.

NanaWall shall have no obligation to respond under this Warranty until receipt of proper notice of a claim and an opportunity to respond. Upon notice and confirmation by NanaWall of a condition covered under this Warranty, NanaWall will respond in good faith and in a timely manner as follows:

TEN YEAR COVERAGE.

For ten (10) years from the date of delivery by NanaWall (“Delivery”), NanaWall will respond as follows:

Insulated Glass. For an insulated glass unit with a permanent material obstruction of vision due to a premature failure of the glass seal, NanaWall will ship a replacement glass unit or panel.

Exception: insulated glass units for cero® are covered for five (5) years from Delivery.

Powder Coat or Baked-on Fluoropolymer Surface Finish of Aluminum Profiles. For powder coat or baked-on fluoropolymer surface finish not functioning as an Effective Surface Material (“ESM”*), NanaWall will, at its option, (1) assume reasonable costs to restore the finish using standard commercial refinishing techniques or (2) ship replacement parts. Uneven fading is not a covered condition due to environmental variables.

Exception: Products installed within two (2) miles of any coastal area or body of salt water or other harsh or corrosive environments or chemicals (“Harsh Environments”) are covered for one (1) year from Delivery, provided that the instructions in Specific Suggested Maintenance For Coastal Salt Water and Other Extreme Environments included in the Owner’s Manual for each Product and is available for review on NanaWall’s website, is properly implemented and documented.

**An ESM is a finish without (1) substantial cracking, chipping, or peeling due to the deterioration of the finish (exclusive of mechanical damage); (2) chalking in excess of a numerical rating of 8 as per ASTM D 659; or (3) fading or color changes in excess of 5 NBS units as per ASTM D 2244.*

Rollers. For a roller with material or workmanship issues that significantly impair proper operation and function, NanaWall will ship a replacement roller.

Wood and Other Remaining Components (for product installed by an independent NanaWall Certified Installer or Approved Installer*). For all remaining components of NanaWall products not otherwise addressed herein with a material or workmanship issue that substantially impairs operation and function, NanaWall will, at its option, (1) ship a replacement part or product or (2) ship any replacement part or replacement product in the same stage of fitting and/or finishing as originally supplied by NanaWall. This includes wood frame components, hinges, handles, locking mechanisms, tracks, beads, and weather-stripping.

FIVE YEAR COVERAGE.

For five (5) years from Delivery, NanaWall will respond as follows:

Laminated Glass. For a laminated glass unit with permanent material obstruction of vision due to premature delamination, NanaWall will ship a replacement glass unit or panel.

Wood and Other Remaining Components (for product NOT installed by an independent NanaWall Certified Installer or Approved Installer*). For all remaining components of NanaWall products not otherwise addressed herein with a material or workmanship issue that substantially impairs operation and function, NanaWall will ship a replacement part or product without charge in the same stage of fitting and/or finishing as originally supplied by NanaWall. This includes wood frame components, hinges, handles, locking mechanisms, tracks, and weather-stripping.

THREE YEAR COVERAGE.

For three (3) years from Delivery, NanaWall will respond as follows:

Anodized Surface Finish of Aluminum Profiles. For anodized surface finish of aluminum profile not functioning as an ESM,* NanaWall will, at its option, (1) assume reasonable costs to restore the finish on a non-compliant (non-ESM) material using standard commercial refinishing techniques or (2) ship replacement parts.

Exception: Products installed in Harsh Environments are not covered.

ONE YEAR COVERAGE.

For one (1) year from Delivery, NanaWall will respond as follows:

Screens. For a screen part (excluding the screen mesh) with a material or workmanship issue that substantially impairs the function of the screen, NanaWall will, at its option, (1) ship a replacement screen or (2) upon return by owner, repair the screen without charge.

ADDITIONAL SERVICE INFORMATION

This Warranty does not cover labor costs to remove existing parts or products, install a replacement part or product, costs to finish wood products, or the cost to repair or replace surrounding substrates, trim, or other work. Nor does it cover costs incurred due to delays or other construction costs, costs for late or damaged delivery, loss of revenue, loss of time, liquidated damages, inconvenience, or loss of use of the product or any parts or components. NanaWall reserves the right to determine whether or not a covered condition exists. If the claim is not covered under this Warranty, NanaWall may charge and collect a fee for on-site product inspections.

Any replacement part or product will be shipped to the location of original product delivery by NanaWall. Replacement products will be the closest equivalent current product and may not be an exact match to the original. Any replacement parts or any repairs are warranted for the remainder of the original limited warranty period. If providing a replacement part or product is not commercially practicable, NanaWall may elect to refund the purchase price of the affected product in full satisfaction of its obligations.

Wood. Wood components must be properly finished on all sides promptly after receipt of unit, before installation, and prior to exposure to weather. Repair or replacement of a warped wood panel or frame can be delayed by up to 12 months from date of claim to allow the wood component to adjust to local environmental conditions.

Glass. Unloading the replacement glass/panel from the delivery truck is the responsibility of the owner. Due to the weight of the product, appropriate manpower and/or equipment will be needed to unload and move the glass/panel to the location for replacement. Depending on the size of the replacement part and interior building dimensions, it may not be possible to transport the glass/panel through the interior of the building. NanaWall is not responsible for any costs associated with moving the replacement glass/panel at the delivery location.

**Whether an installer is a NanaWall Certified Installer or Approved Installer is determined by the installer's status as of the date of delivery. NanaWall maintains information regarding the installers designated as Certified Installers or Approved Installers.*

NOTICE PROCESS

Written notice of any claim under this Warranty with supporting documents such as photos or videos must be given to Nana Wall Systems, Inc. via email to service@nanawall.com or via mail to 100 Meadowcreek Drive, Corte Madera, CA 94925, promptly when discovered. A condition will not be covered under this Warranty if there is a failure to notify NanaWall in writing (1) within 7 days of receipt of the product for any defect which an ordinary inspection would reveal, (2) within a reasonable time during the warranty period after an impairment in operation and use is manifest or a hidden defect is discovered, or (3) for claims first made after expiration of the coverage period outlined in this Warranty.

DISCLAIMERS & LIMITATIONS

Any responsibility of NanaWall is contingent upon owner fulfilling its notice obligations as stated in this Warranty. The owner shall have no standing to assert a claim absent timely notice to NanaWall and an opportunity to cure. The remedies prescribed in this Warranty are the exclusive and sole remedies available to the owner who hereby waives any claim not encompassed herein. This exclusivity and waiver survive expiration of warranty coverages herein. In no event shall the liability of NanaWall or any seller of NanaWall product exceed the price paid for the product.

This Warranty is the sole and exclusive warranty for NanaWall products. **ALL OTHER WARRANTIES, EXPRESS OR IMPLIED, INCLUDING ANY WARRANTY OF MERCHANTABILITY OR FITNESS FOR A PARTICULAR PURPOSE, ARE DISCLAIMED. NANAWALL SHALL NOT BE LIABLE FOR CONSEQUENTIAL OR INCIDENTAL DAMAGES.** Some state and federal laws may not allow disclaimers of implied warranties or exclusions of incidental or consequential damages, so these limitations or exclusions may not apply to you. Where federal law prohibits disclaimer of implied warranties, the duration of any implied warranty is limited to the duration of the relevant coverage period, if less than the statutory limitation period. This Warranty gives you specific legal rights, and you may also have other rights which vary from state to state.

This Warranty may only be modified by a writing signed by an officer of NanaWall. Any action taken by NanaWall does not create a new warranty or extend the duration of the original product warranty. A failure by NanaWall to enforce a warranty provision shall not constitute a waiver barring subsequent enforcement.

EXCLUDED CONDITIONS.

This Warranty does not cover the following conditions, or any damage or issues caused in whole or part by the following:

- Improper product selection, application, storage, handling, modification, or waterproofing; Movement of surrounding substrates, including deflection of the header of more than ¼", or any other stresses on product; Improper installation, flashing, or integration into the structure; Failure to provide an adequate overhang; Failure to prevent the effects of sheeting rain or water; Failure to install proper weep holes in sill where needed, and failure to properly drain water exiting weep holes in the sill; Failure to meet code or specification requirements.
- Finishing by anyone other than NanaWall, including, but not limited to, not properly finishing all sides of wood products promptly after receipt of unit, before installation, and before exposure to weather, finishing exterior wood in dark colors, or not refinishing periodically; Discoloration of finish; Failure to immediately repair any breaches such as scratches, chips, or abrasions in any finish or aluminum profile.
- Condensation, frost, or mold caused by high interior relative humidity; Installation near swimming pools, saunas, hot tubs or other high humidity environments or sources of chlorine; Harsh chemicals such as road salt, solvents, acid, brick or mortar wash, or cleaning chemicals; Corrosion, oxidation, discoloration or tarnish on product installed in Harsh Environments.
- Normal weathering, wear and tear; Failure to follow the NanaWall operation and maintenance instructions; Failure to operate the product for more than one month; Failure to clean and maintain aluminum surfaces in accordance with AAMA 609 and 610 or not maintaining adequate cleaning records.
- Imperfections in glass that do not affect the product's structural integrity or obscure vision and cannot be detected from within 10 feet as per ASTM C 1036; Accidental or spontaneous glass breakage; Glass breakage due to thermal or other stresses, or glass with film or other coatings applied to the surface; Industry accepted bow, warp or distortion in glass and minor variations in glass color; Glass not installed as per NanaWall's instructions.

- Variations in wood grain or color; Warp within the allowable warp tolerance for wood panels per ANSI/WDMA I.S. 6-A-01; Warp that does not affect the normal functioning of the Product; Warpage on wood panels caused by leaving panels in the open position exposed to the elements or not engaging the locking points properly when in the closed position; Resin or sap bleeding from wood panels.
- Panel shrinkage or expansion caused by change in weather; Expansion or bowing of aluminum units caused by exposure to sunlight or caused by temperature difference between interior and exterior panel surfaces.
- Acts of God, falling objects, fire, accidents, external forces, extreme weather events, or other conditions beyond NanaWall's control.
- Gas fill or retention levels in insulated glass units.
- Field testing of Product; Performance of the Product in conformance to any published NanaWall testing results (e.g. air infiltration, water infiltration, structural loading, thermal and sound). Published test results measure the laboratory performance of a single sample of the product of a certain size, sill and configuration that may not be applicable to the Product being field tested. Performance during testing may vary depending upon handling, installation, use, maintenance, and time after installation. Field testing must be in compliance with AAMA 502, including water penetration testing at 2/3 of the pressure of applicable published test results.
- Products or components not supplied by NanaWall; Products that have not been paid for in full; Products ordered in larger sizes or special configurations beyond NanaWall's published specifications. Product with glass that is heavier than NanaWall specifications; Product that has been modified or altered in any manner.

NanaWall Warranty Registration

Must be filled out and returned to Nana Wall Systems, Inc., 100 Meadowcreek Drive, Corte Madera, CA 94925 within 30 days from date of purchase of the NanaWall in order for the limited warranty to become effective.

NANAWALL ORDER # _____

PROJECT NAME _____

Date of Purchase _____

Purchaser Name _____

PROPERTY OWNER

Name _____

Address _____

Telephone _____

E-mail _____

Project Address (if different from above) _____

INSTALLATION

Installer Name _____

Address _____

Telephone _____

E-mail _____

Type of project new residential restaurant shopping mall
 residential remodel office building other _____

Architect Name _____

Address _____

1. Is the installation complete? yes If yes, date completed _____

no If no, date scheduled _____

2. Have you been shown how to yes Is operation satisfying? yes no

operate your new NanaWall? no If no, why not? _____

Print Name _____

Signature _____

Date _____