

PARTS LIST AND INSTRUCTION MANUAL

FOR NC81200 CLASSES



CARPET SIZERS



N-C CARPET BINDING & EQUIPMENT CORP.

858 Summer Avenue, Newark, New Jersey 0710

Telephone (973) 481-3500 * Toll Free **(800) 526-1184**

Canada (800)336-1184 * Fax (973) 481-0839

<http://www.n-ccarpet.com> * E-mail: nccarpet1@aol.com



OILING DIAGRAM

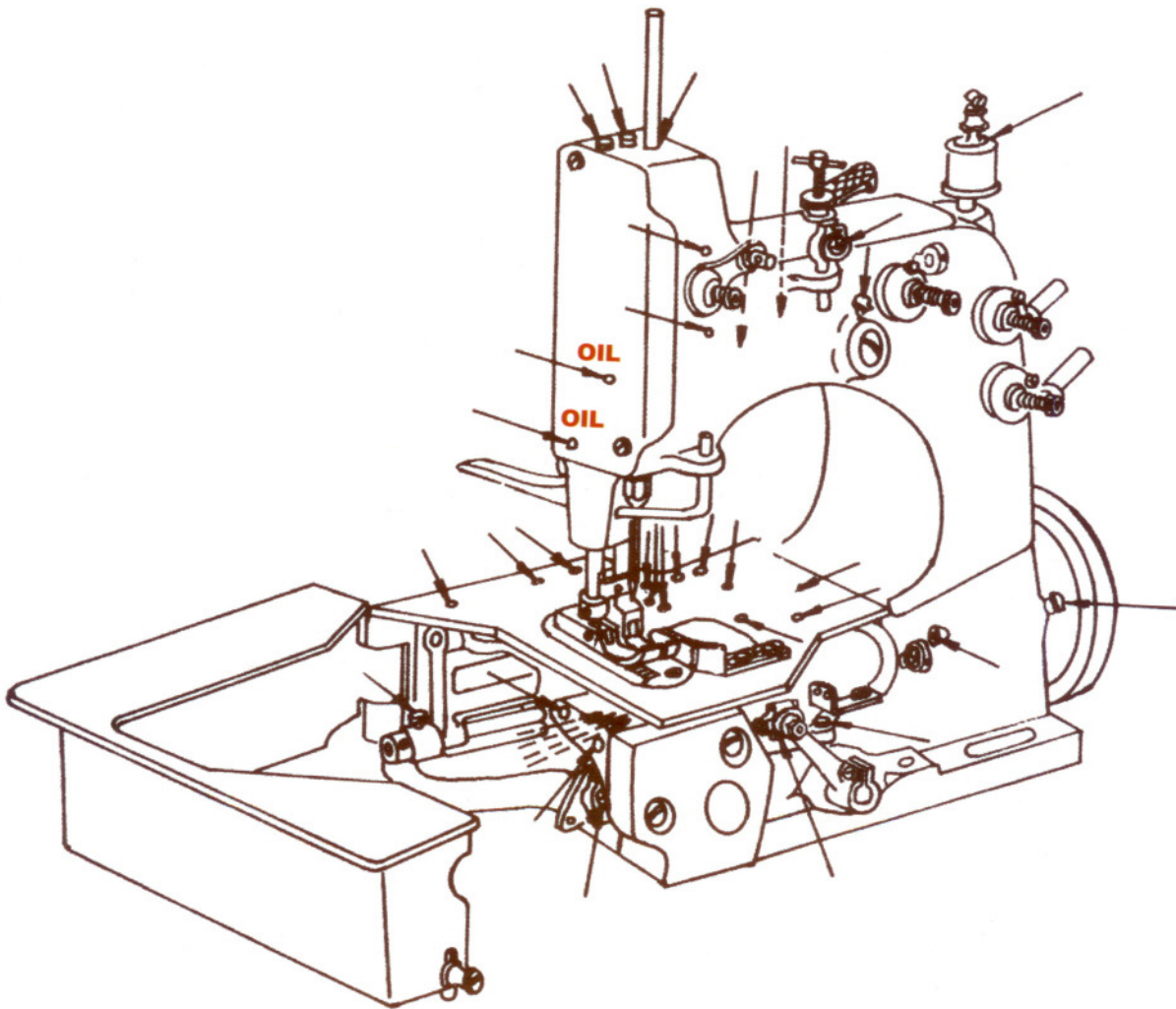
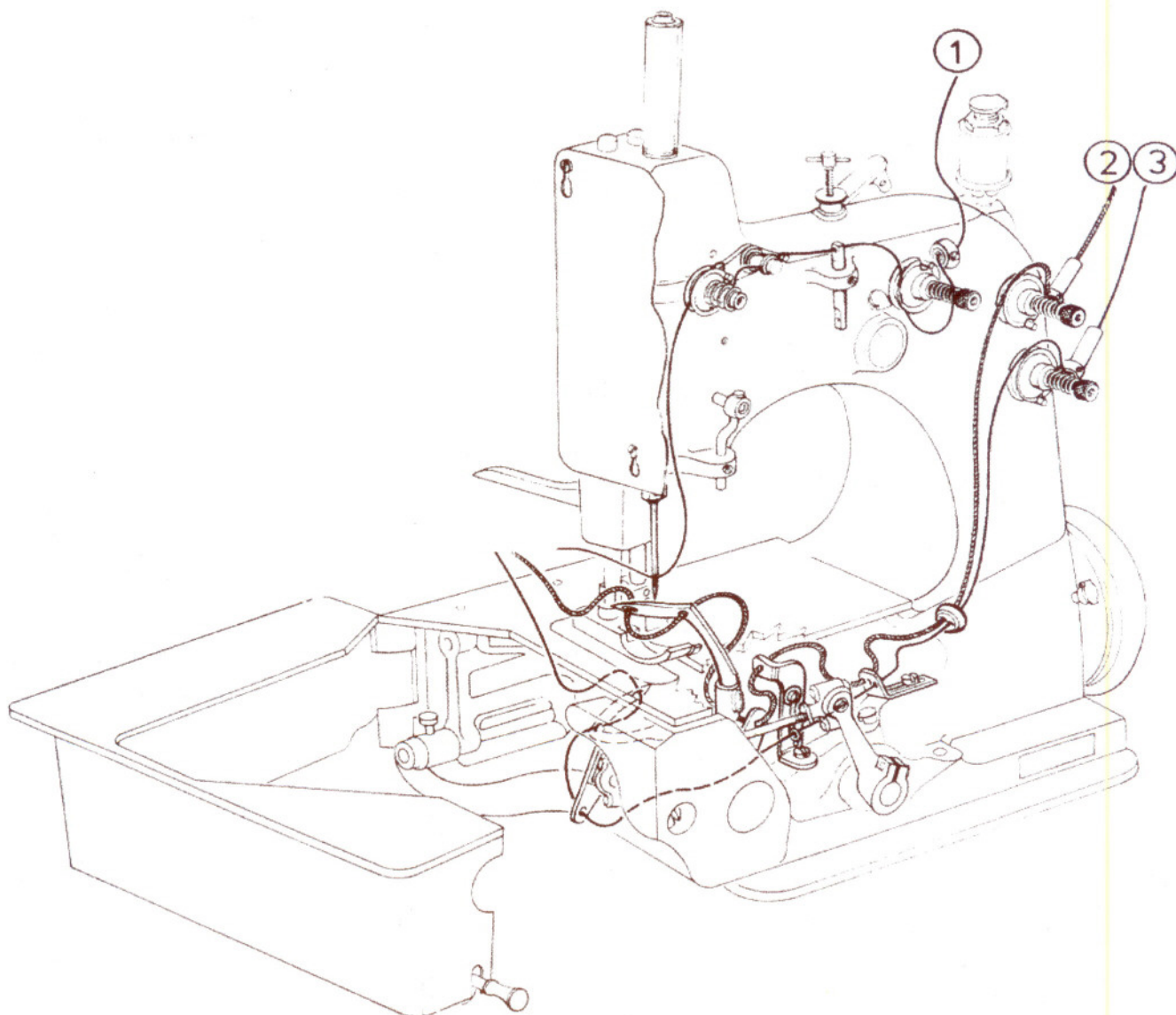

FIGURE 1



THREADING DIAGRAM

FOR NC 81200 AND 81200 TP



THREADING DIAGRAM FOR MACHINES CLASS

Utilize only Threads 16/4, 12/4, 69 Bonded Nylon

81200 AIR 2

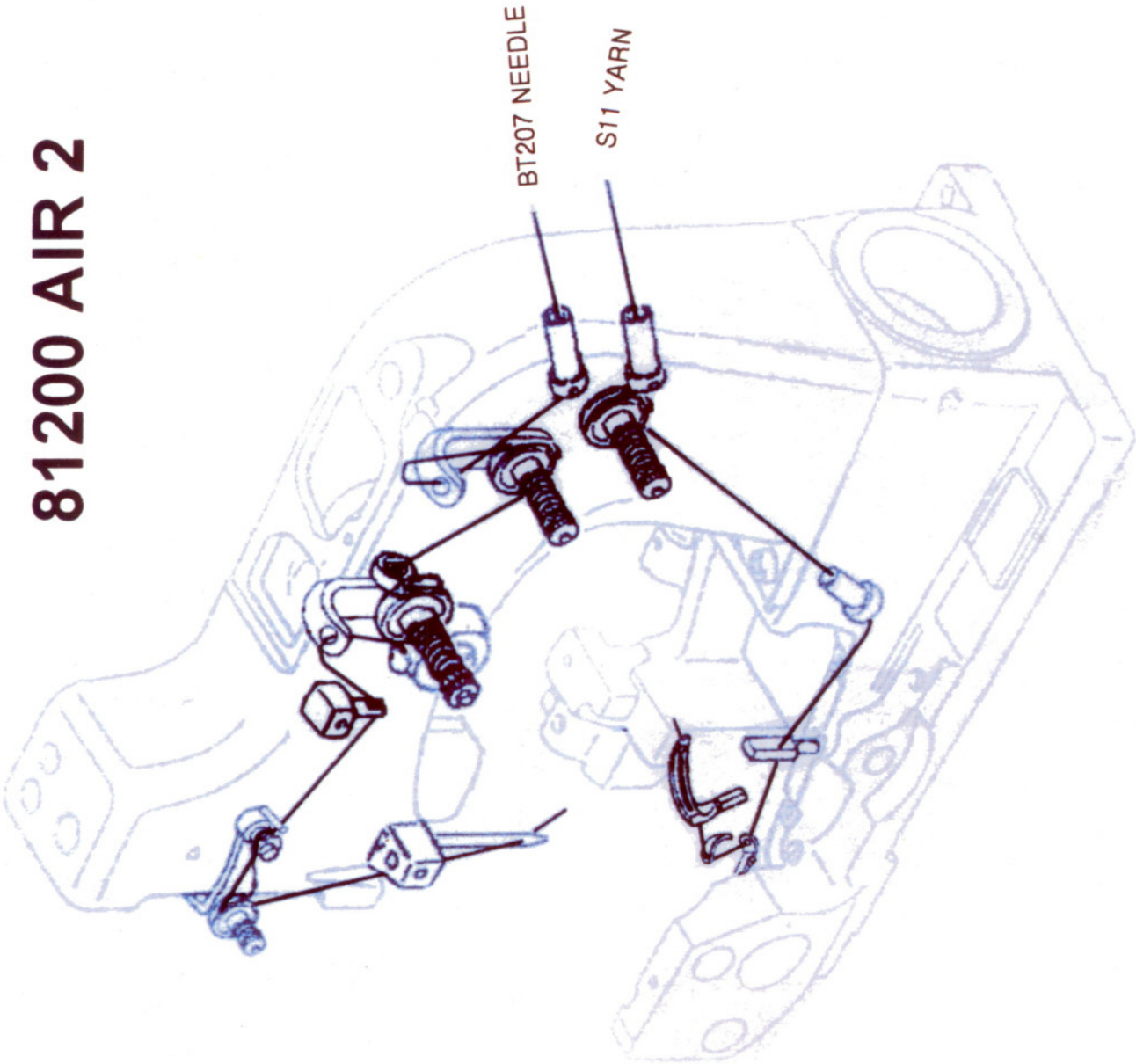

*****LIST OF PARTS FOR NC PORTABLE SERGER*****

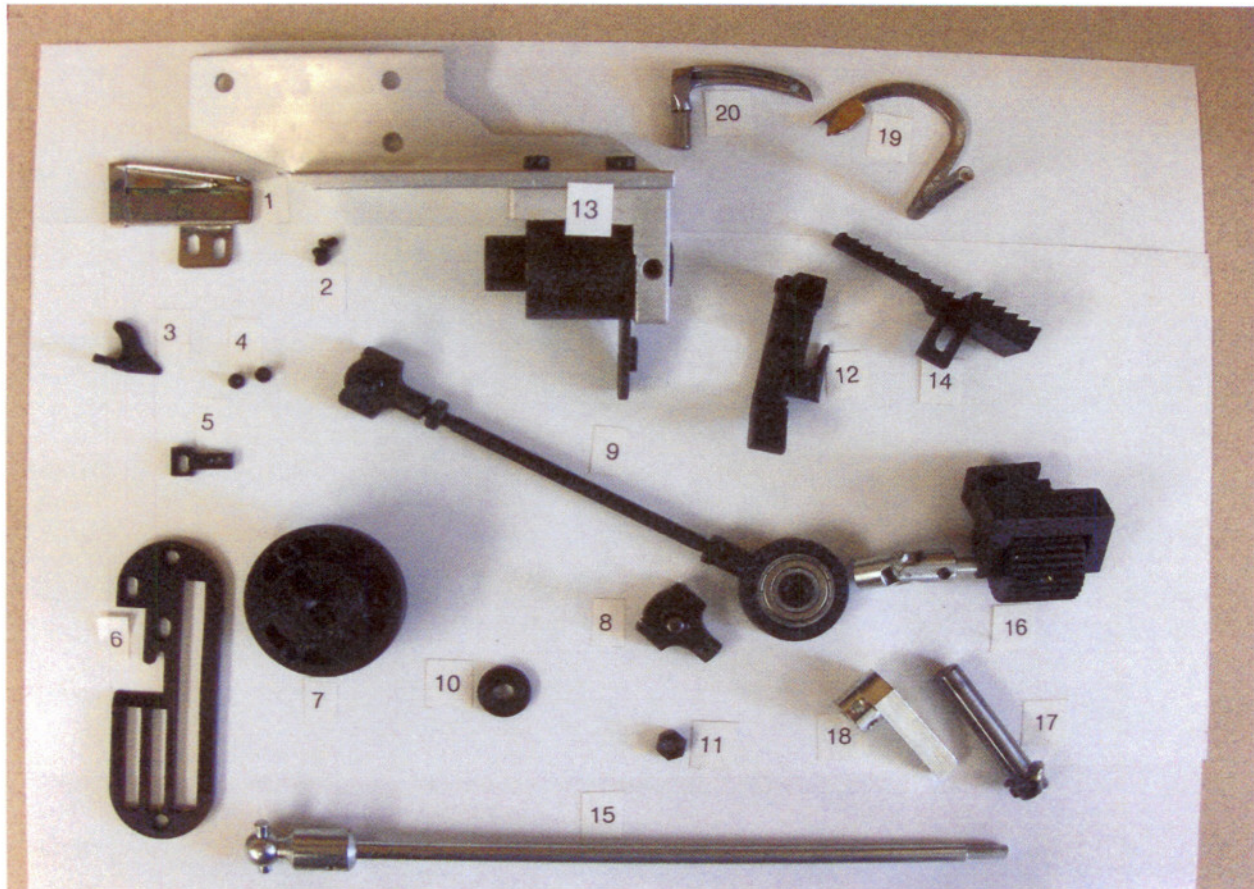

PART#	DESCRIPTIONS
1. PS7/8NSAIR	7/8" TAPE FOLDER FOR SERGER
2. 90	SCREW FOR FOLDER & HOLDER
3. NSAT	TONGUE FOR PORTABLE SERGER
4. 90	SCREW FOR TONGUE & HOLDER
5. JB1203	HOLDER FOR STITCH TONGUE
6. NSAP	NEEDLE PLATE FOR PSAIR
7. NC52921BSC	HUB COMPLETE
8. PSAIRRFBJ	BALL JOINT FOR RF & PSAIR
9. RPDA	REAR PULLER DRIVE ASSEMBLY
10. 009	WASHER FOR HUB
11. 18	NUT FOR RPDA
12. NSAF	PRESSER FOOT FOR PORT. SERGER
13. M145	CLUTCH COMPLETE WITH BASE
14. 81205AIR-F	FEED DOG FOR PSAIR
15. M111R	SHAFT FOR REAR PULLER
16. FWBASS	FEED WHEEL BRKT. ASSEMBLY COMP.
17. 81251PS	LOOPER ROCKER SHAFT
18. PSK	PF LIFTER FOR PSAIR
19. 81207WAL	BLIND WRAP AROUND LOOPER
20. 81208LE	LEFT HAND LOOPER

LIST OF PARTS FOR

81200AIR / 81200AIR-RF ,

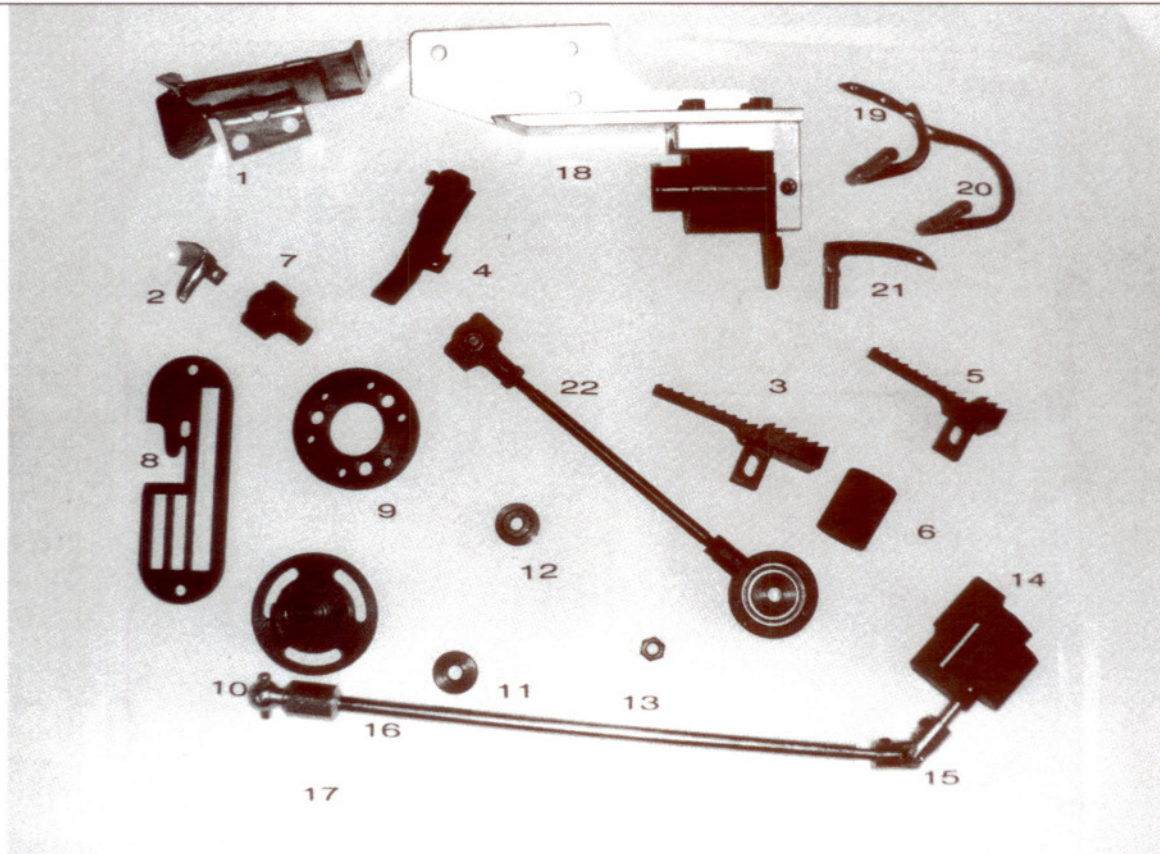

PART#	DESCRIPTIONS
1. PS7/8NS	(NEW Style Folder)
2. AIRT	(Tongue F/812000AIR & PSAIR)
3. 81205AIR-F	(Presser Dog F/AIR& PSAIR)
4. AIRFT	(Presser Foot F/AIR & PSAIR)
5. 81205A	(Feed Dog F81200Air)
6. PS506	(Feed Wheel)
7. PSAIRRFBJ	(Ball Joint FRF & PSAIR)
8. 81224C	(Needle Plate)
9. NC52921BS	(Hub F/Rear Pullers)
10. P33S	(Feed Regulator Plate W/Stud)
11. 009	(Washer)
12. 011	(Stepped Shoulder Washer)
13. 18	(Nut)
14. FWBASS	(Feed wheel Bkt Assembly F/AIR-RF/PSAIR)
15. M110NS	(Universal Joint)
16. M111r	(Shaft)
17. M111	(Joint)
18. M145	(Clutch w/Base Only)
19. 81207D3	(Upper Looper F/81200 AIR-3)
20. 81207KD	(Blind Looper F/81200 Air-2)
21. 81208D3	(Rear Puller Driver Assembly)
22. RPDA	(Rear Puller Driver Assembly)



Figure 1

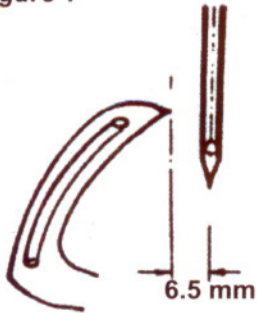

ADJUSTING THE LOOPER

For convenient access, remove the presser foot, throat plate and feed dog. Insert the looper into the looper rocker. Set the looper so that the distance from the center line of the needle to the point of the looper is 6.5 mm \approx 1/4" in the lowest position of needle bar just before moving upwards (**Fig. 1**). Then, loosen the nut at the right side of looper rocker and the ball stud till the specified dimension is obtained. As the looper moves to the right, its point should pass behind the needle as close as possible without contacting it. Adjustment can be made by loosening the fastening screws of looper rocker and replacing the looper rocker axially till this adjustment be obtained.

ADJUSTING THE SPREADER

The spreader should closely pass behind the looper and behind the needle so that its point just brushes, without deflecting them. Set the distance of 5mm \approx 13/64" between spreader and needle (**Fig. 2**). If adjustment is necessary, turn the connecting rod, as required to obtain the desired dimension.

THIS ADJUSTMENT IS FOR WRAP AROUND SERGERS ONLY.

Figure 2

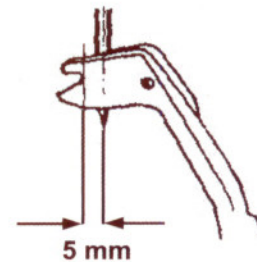
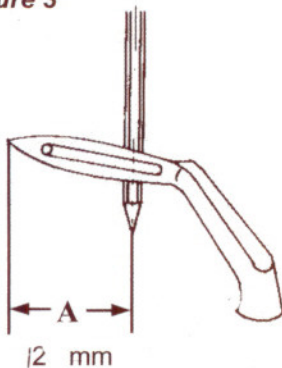

Figure 3



ADJUSTING THE UPPER LOOPER

Will be done like machines with spreader. But the distance between the needle and looper are to be adjusted like (**Fig. 3**).

THIS ADJUSTMENT IS FOR ALL 81200 CLASSES EXCEPT WRAP AROUND SERGERS.

SETTING THE NEEDLE BAR

Set the needle bar so that the top of the needle eye is even with the underside of the looper, when the looper point in its travel to the left projects 1 - 1.5 mm = 0.04 - 0.06" from the left side of the needle. If adjustment is necessary, loosen the clamping screw in the needle bar connection and move the needle bar up or down as required and retighten screw.



THREADING AND ADJUSTMENT INSTRUCTIONS

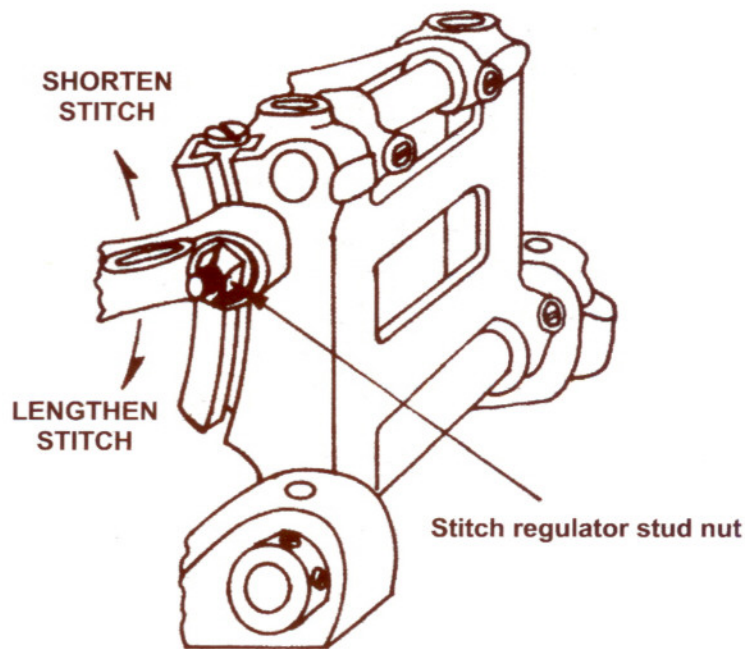

Figure 6

1. Adjust the stitch length to give the desired number of stitches per inch. This adjustment is made by loosening the stitch regulator stud nut (#HA 18 A) on the side of the feed rocker (#80233) (**Fig. 6**). Raising the feed driving arm (#80651) shortens the stitch and lowering it lengthens the stitch. After the stitch length is set, reset the rear needle guard so that it barely contacts the needle when in its most forward position of travel.
2. Regulate the pressure on the presser feet so that the springs exert a pressure sufficient to feed properly. A comparatively heavy pressure is usually required.



3. Adjust the left hand looper thread take-up (#81266 K) outward or clockwise until the left hand looper thread just tightens as the left hand looper thread comes off the right hand looper. (**CAUTION: NO LEFT HAND LOOPER THREAD SHOULD BE DRAWN FROM THE CONE AT THIS TIME.**) All the left hand looper thread should be drawn from the cone as the left hand looper moves to the end of its travel to the right.

4. The needle and the right hand looper thread tension should be set as low as possible yet high enough to give positive and consistent control to the needle and right hand looper thread. The left hand looper thread tension should be just high enough to give a beaded appearance of the lower thread at the purl or edge.

5. Make sewing test on a single thickness of rug material. If satisfactory samples are not obtained, check the following thread controls.

6. **NEEDLE THREAD CONTROL**

To pull less needle thread into the stitch, or move purl down, increase needle thread tension, or raise needle frame eyelet. Most of the needle thread should be drawn from the cone on the upstroke of the needle.

7. **RIGHT LOOPER THREAD CONTROL**

To pull more right hand looper thread into the stitch, or move purl down, reduce the right hand looper thread tension or move right hand looper thread take-up (eyelet) clockwise, being careful that the left hand looper gauge is not changed when nut (#9937) is loosened.

8. **LEFT HAND LOOPER THREAD CONTROL**

The left hand looper thread control eyelet (take-up) should be adjusted outward or clockwise until the left hand looper thread just tightens as the left hand looper thread should be drawn from the cone as the left hand looper moves to the end of its travel to the right.



PLATE NO. 1

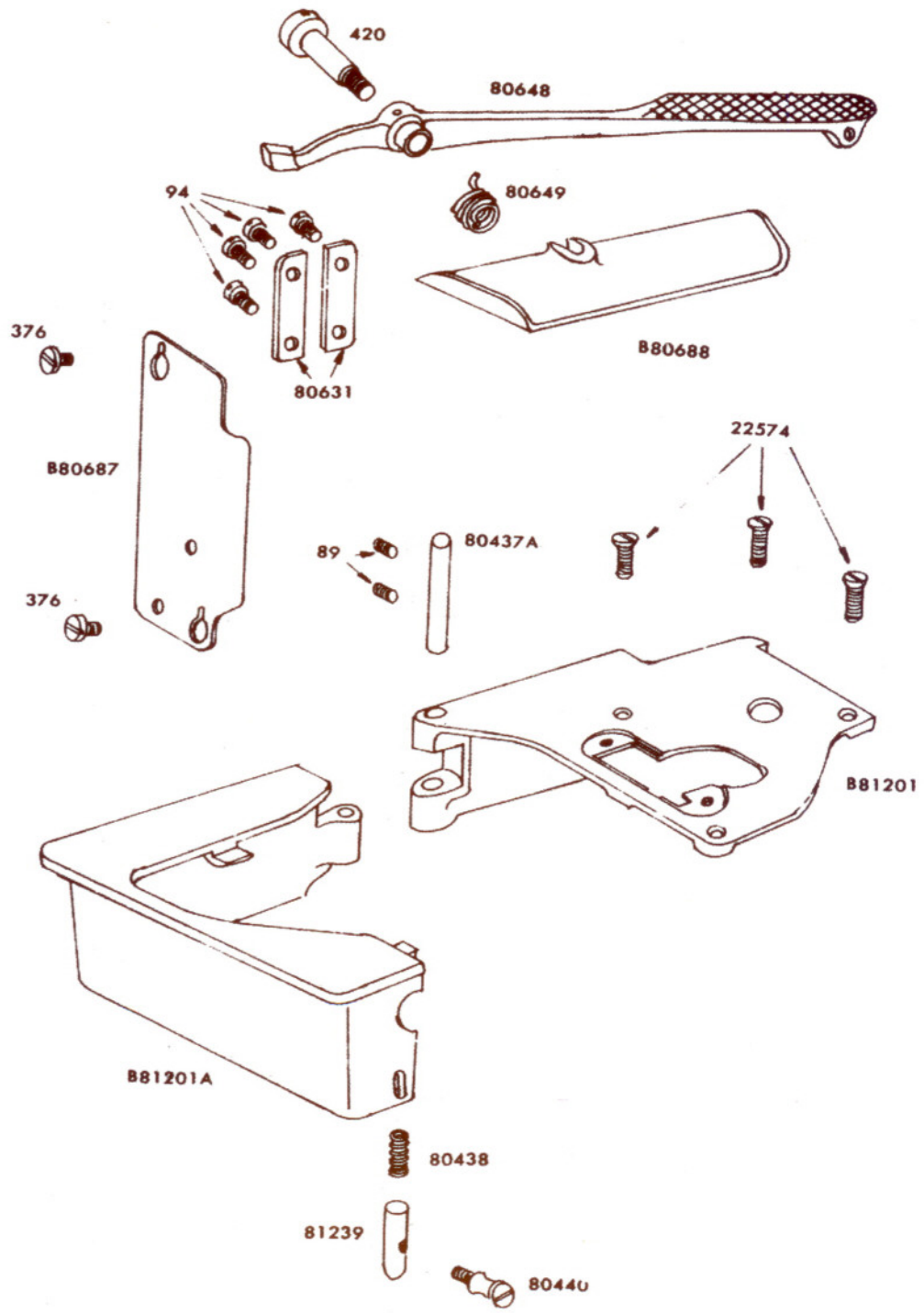



PLATE NO. 1

89	Set screw for Hinge pin	2 pcs
94	Set screw for Presser bar lifter guide plate and Looper thread guard	4 pcs
376	Screw for face plate	2 pcs
420	Lifter lever stud	1 pc
22574	Screw for Cloth plate	3 pcs
80437 A	Cloth plate swinging extension hinge pin	1 pc
80438	Spring for Locking bolt	1 pc
80440	Locking bolt knob	1 pc
80631	Presser bar lifter guide plate	2 pcs
80648	Lifter lever	1 pc
80649	Lifter lever spring	1 pc
B80687	Face plate	1 pc
B80688	Top cover	1 pc
B81201	Cloth plate	1 pc
B81201 A	Cloth plate swinging extension	1 pc
81239	Cloth plate swinging extension locking bolt	1 pc

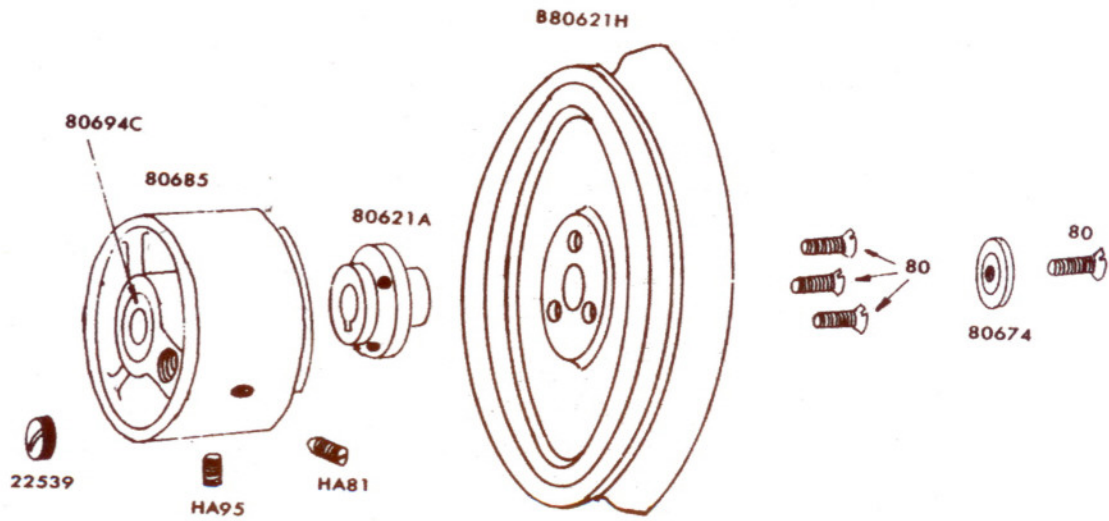
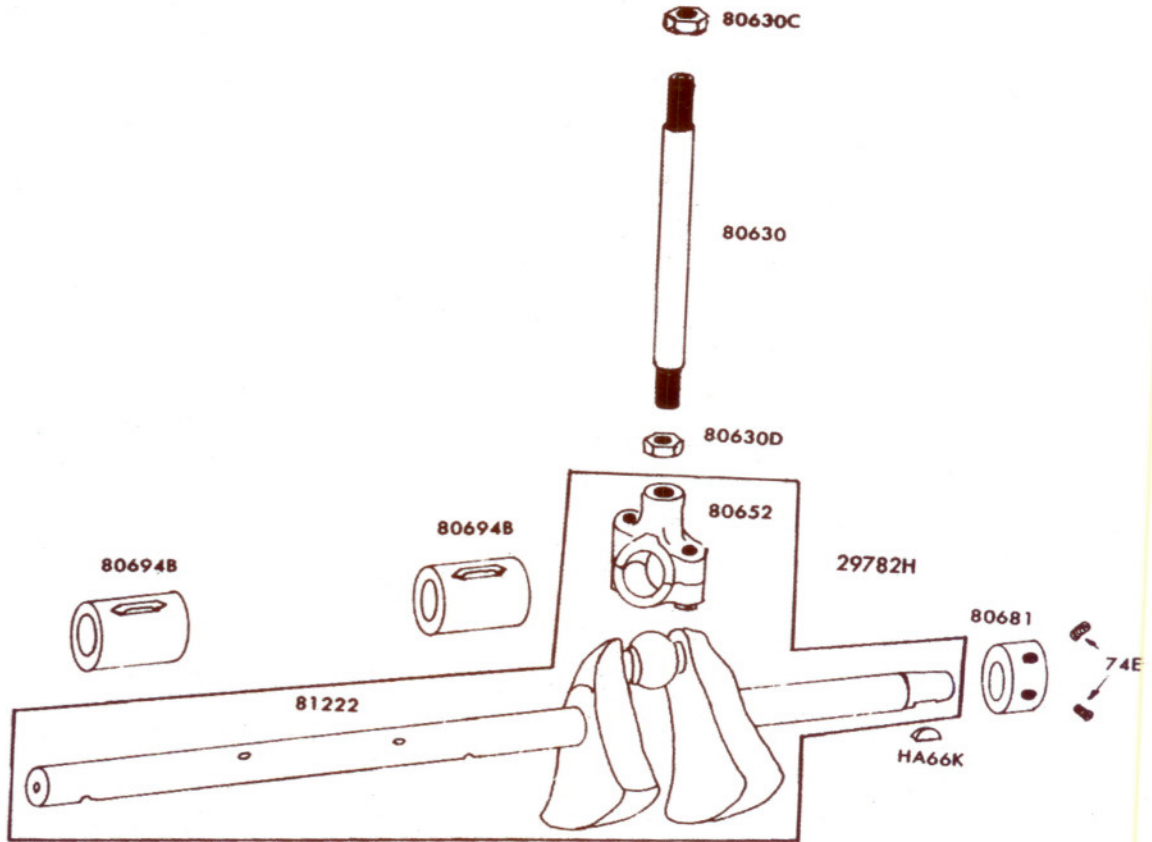



PLATE NO. 2

HA 66 K	Key for Pulley hub	1 pc
74 E	Screw for main shaft collar	2 pcs
80	Screw for wheel	4 pcs
HA 81	Spot screw for main shaft bushing housing	1 pc
HA 95	Set screw for main shaft bushing housing	1 pc
22539	Plug screw for main shaft bearing sponge hole	1 pc
29782 H	Main shaft assembly	1 pc
80621 A	Wheel hub	1 pc
880621 H	Wheel rim	1 pc
80630	Needle lever connecting rod tube	1 pc
80630 C	Needle lever connecting rod tube nut (left thread)	1 pc
80630 D	Needle lever connecting rod tube nut (right thread)	1 pc
80652	Needle lever connection bearing (lower)	1 pc
80674	Wheel hub lock washer	1 pc
80681	Main shaft collar	1 pc
80685	Main shaft bushing and housing	1 pc
80694 B	Main shaft bushing, left and middle	2 pcs
80694 C	Main shaft bushing, right	1 pc
81222	Main shaft	1 pc



PLATE NO. 3

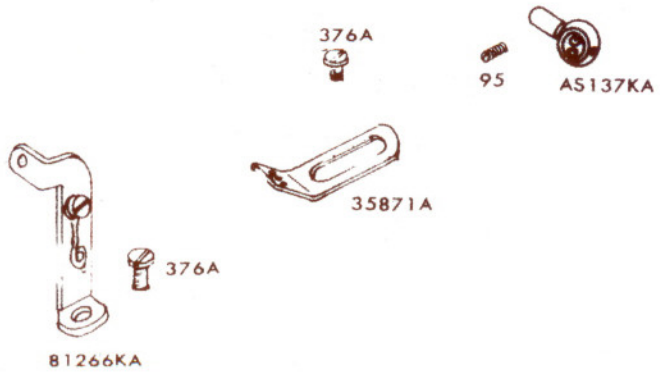
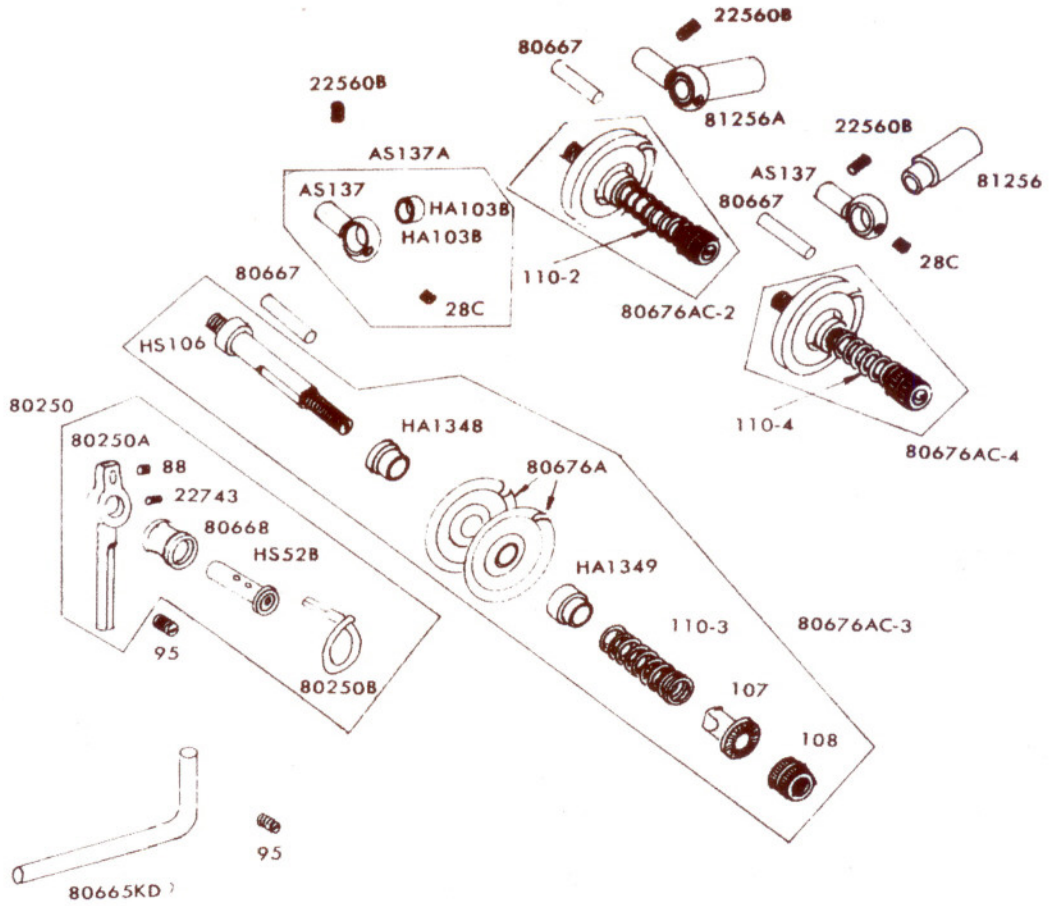



PLATE NO. 3

28 C	Set screw for frame thread eyelet	4 pcs
HS 52 B	Frame rolling thread guide axle assembly	1 pc
88	Set screw for Rolling thread guide	1 pc
95	Set screw	3 pcs
HA 103 B	Frame thread eyelet	1 pc
HS 106	Tension post	3 pcs
107	Tension spring ferrule	3 pcs
108	Tension regulating nut	3 pcs
110-2	Tension spring for right hand looper thread	1 pc
110-3	Tension spring for left hand looper thread	1 pc
110-4	Tension spring for needle thread	1 pc
AS 137	Frame thread eyelet support	4 pcs
AS 137 A	Frame thread eyelet assembly	1 pc
AS 137 KA	Base thread eyelet assembly (two thread hole)	1 pc
376 A	Looper thread guide set screw	2 pcs
HA 1348	Frame tension post ferrule, front	3 pcs
HA 1349	Frame tension post ferrule, rear	3 pcs
22560 B	Set screw for frame thread guide	3 pcs
22743	Screw for frame rolling thread guide axle	1 pc
35871 A	Base thread guide	1 pc
80250	Frame needle thread rolling thread guide assembly	1 pc
80250 A	Frame needle thread rolling thread guide support	1 pc
80250 B	Frame needle thread rolling thread guide	1 pc
80665 KD	Needle thread guide (lower)	1 pc
80667	Tension disc stop pin	3 pcs
80668	Needle thread take up rolling thread guide roller	1 pc
80676 A	Tension disc	6 pcs
80676 AC-2	Thread tension assembly for right hand looper thread	1 pc
80676 AC-3	Thread tension assembly for left hand looper thread	1 pc
80676 AC-4	Thread tension assembly for Needle thread	1 pc
81256	Frame thread eyelet	2 pcs
81256 A	Frame thread eyelet assembly	2 pcs
81266 KA	Base thread guide assembly	1 pc



PLATE NO. 4

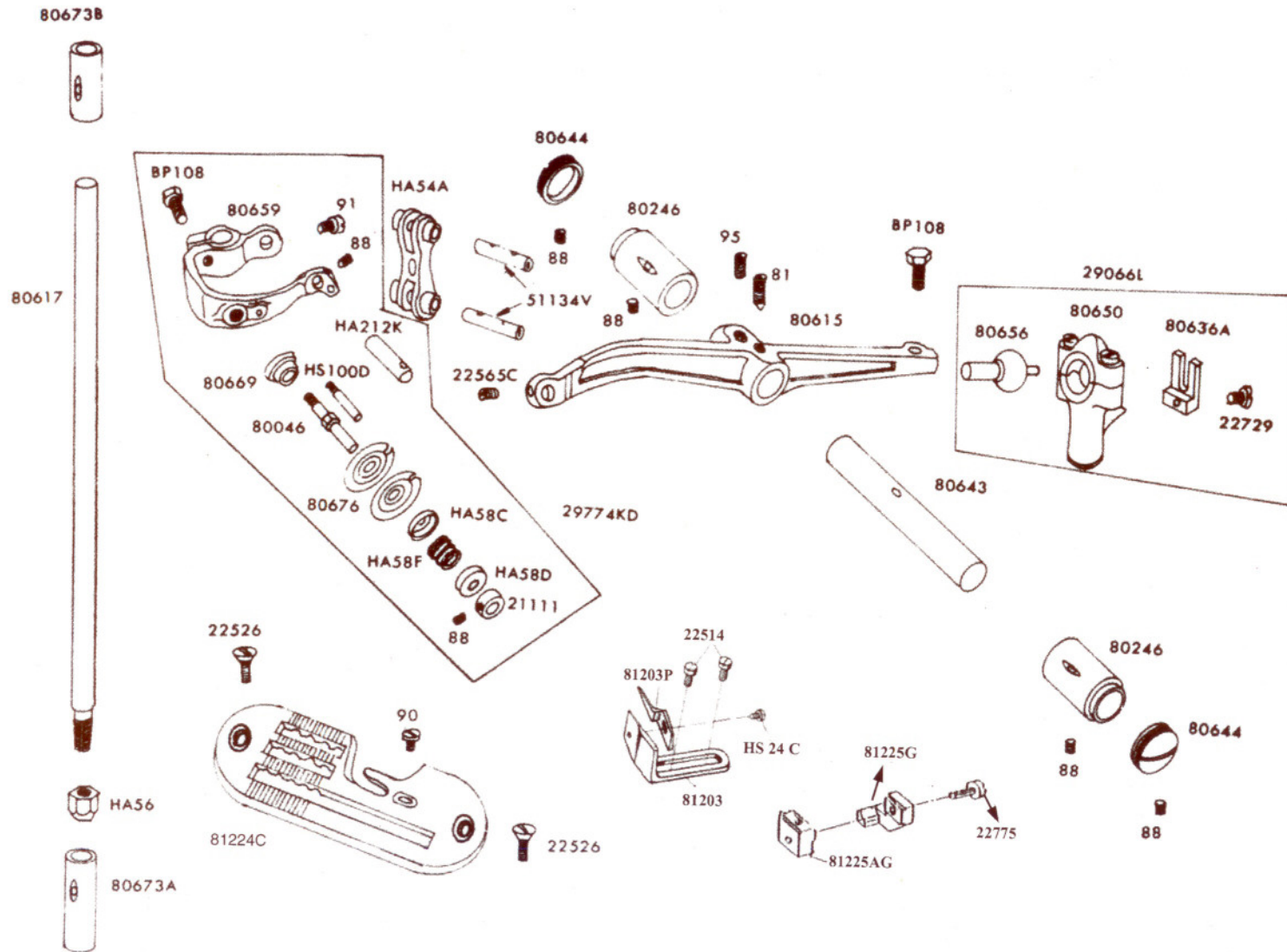



PLATE NO. 4

HA 54 A	Needle bar link	1 pc
HA 56	Needle clamp nut	1 pc
HA 58 C	Needle bar connection tension ferrule (front)	1 pc
HA 58 D	Needle bar connection tension ferrule (rear)	1 pc
HA 58 F	Needle bar connection spring	1 pc
81	Spot screw for needle lever	1 pc
88	Set screw	6 pcs
90	Screw for Needle plate needle guard	1 pc
91	Screw for Needle lever link upper pin	1 pc
95	Set screw for needle lever	1 pc
HS 100 D	Stop screw for tension disc	1 pc
BP 108	Clamp screw for needle bar connection & needle lever ball	2 pcs
HA 212 K	Thread guide for needle bar connection	1 pc
21111	Needle bar connection post collar	1 pc
22526	Screw for needle plate	2 pcs
22565 C	Screw for needle lever link lower pin	1 pc
22729	Screw for needle lever ball stud fork	1 pc
29066 L	Needle lever connecting rod upper bearing assembly	1 pc
29774 KD	Needle bar connection assembly	1 pc
51134 V	Needle lever link pin assembly	2 pcs
80046	Needle bar connection tension post	1 pc
80246	Needle lever shaft bushing	2 pcs
80615	Needle lever	1 pc
80617	Needle bar	1 pc
80636 A	Needle lever ball stud fork	1 pc
80643	Needle lever shaft	1 pc
80644	Needle lever shaft hole plug screw	2 pcs
80650	Needle lever connection bearing (upper)	1 pc
80656	Needle lever ball	1 pc
80659	Needle bar connection	1 pc
80669	Needle bar connection tension post ferrule (front)	1 pc
80673 A	Needle bar bushing (lower)	1 pc
80673 B	Needle bar bushing (upper)	1 pc
80676	Tension disc	2 pcs
81203	Cloth plate edge guide	1 pc
81203 P	Cloth plate edge guide tongue	1 pc
81224 C	Needle plate (81224C, 81224I)	1 pc
81225 G	Needle guard	1 pc
81225 AG	Front needle guard	1 pc
22775	Screw for needle guard	1 pc
22514	Screw	1 pc
HS 24 C	Screw	1 pc



PLATE NO. 5

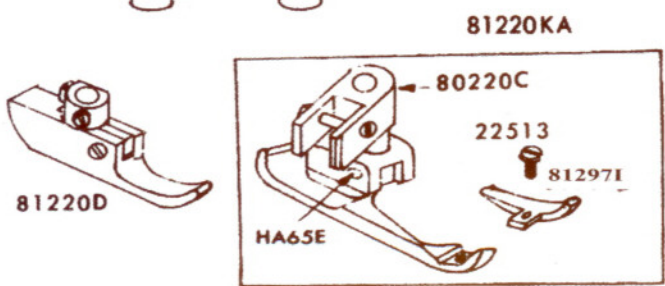
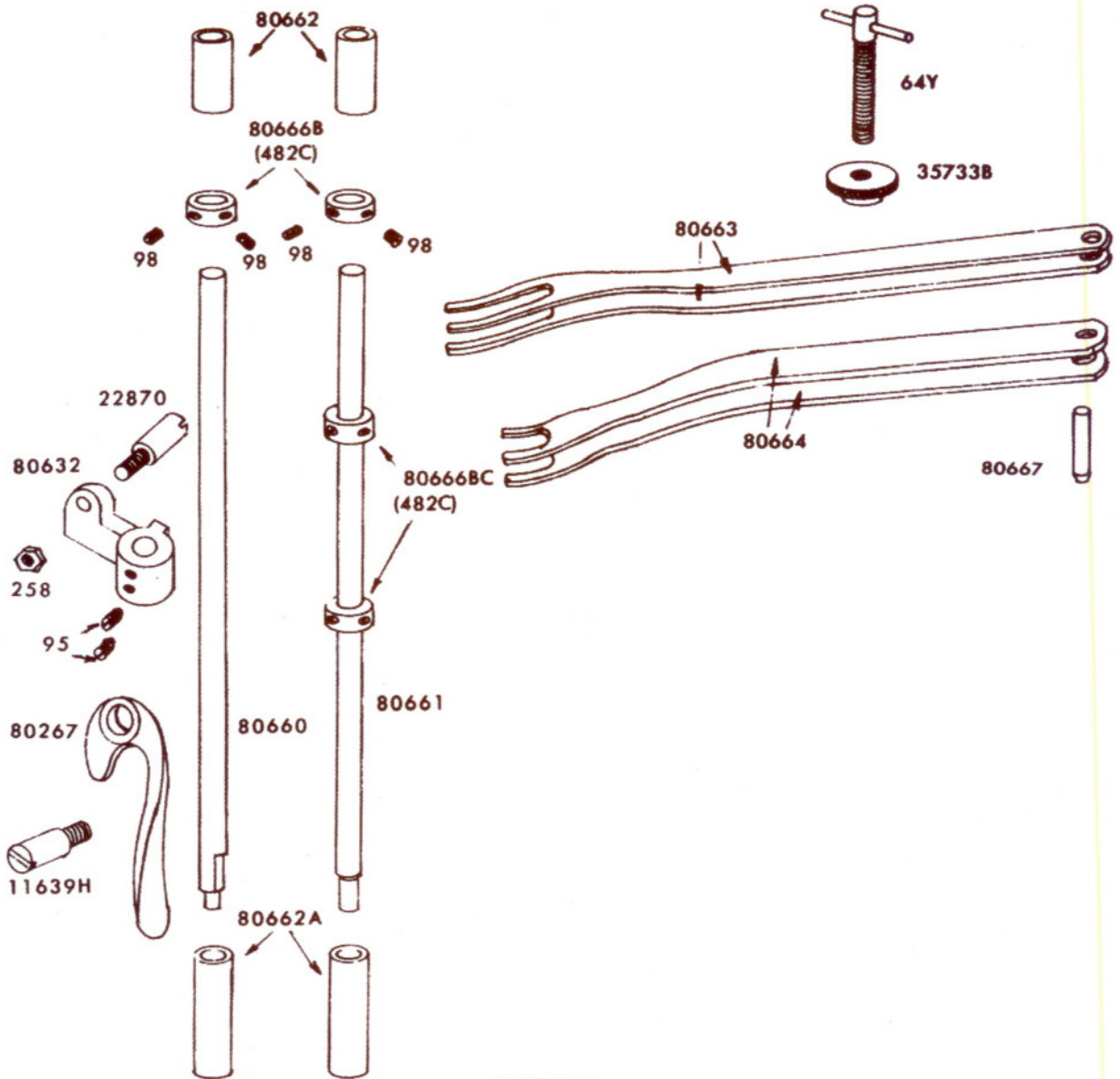



PLATE NO. 5

64 Y	Presser spring regulator screw	1 pc
HA 65 E	Hinge screw for right presser foot	1 pc
95	Set screw for presser bar lifter	2 pcs
98	Screw for presser bar collar	8 pcs
258	Nut for lifter lever screw pin	1 pc
11639 H	Hand lifter stud	1 pc
22513	Set screw for presser foot tongue	1 pc
22870	Lifter lever screw pin	1 pc
35733 B	Lock nut for presser spring regulator screw	1 pc
80220 C	Presser foot shank (right)	1 pc
80267	Hand lifter	1 pc
80632	Presser bar lifter	1 pc
80660	Presser bar (left)	1 pc
80661	Presser bar (right)	1 pc
80662	Presser bar bushing (upper)	2 pcs
80662 A	Presser bar bushing (lower)	2 pcs
80663	Presser spring (upper)	2 pcs
80664	Presser spring (lower)	2 pcs
80666 B	Presser bar collar	4 pcs
80666 BC	Presser bar collar with screw	4 pcs
80667	Presser spring pin	1 pc
81220 D	Presser foot assembly (left)	1 pc
81220 KA	Presser foot assembly (right)	1 pc
81297 I	Presser foot tongue	1 pc

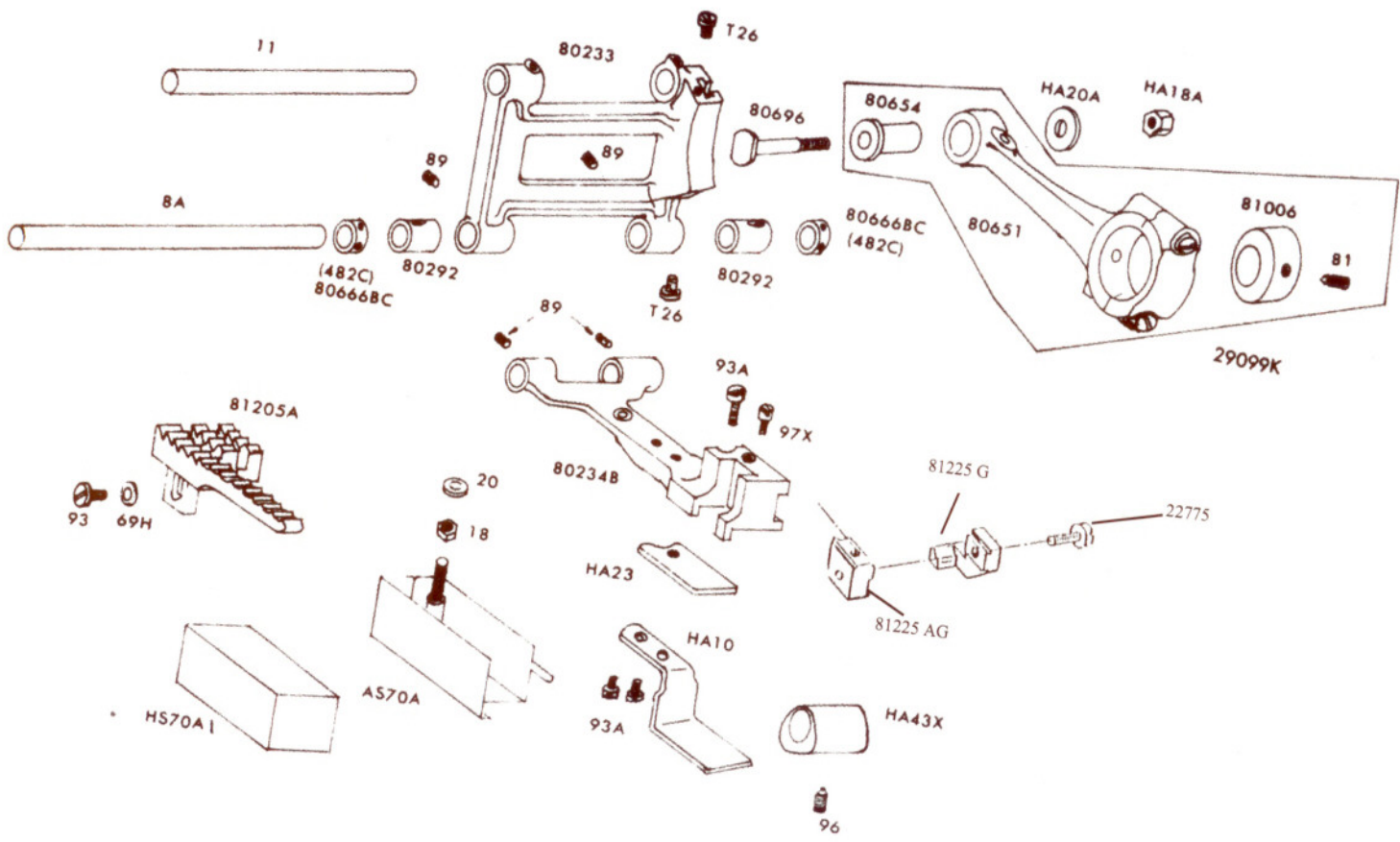

PLATE NO. 6



PLATE NO. 6

8 A	Feed rocker shaft	1 pc
HA 10	Feed bar prong	1 pc
11	Feed bar shaft	1 pc
18	Nut for feed cam oiling felt holder	1 pc
HA 18 A	Nut for stitch regulating stud	1 pc
20	Washer for feed cam oiling felt holder	1 pc
HA 20 A	Washer for stitch regulating stud	1 pc
HA 23	Feed bar shoe	1 pc
T 26	Stop screw for stitch regulating stud	2 pcs
HA 43 X	Feed lift cam	1 pc
69 H	Washer for feed dog screw	1 pc
AS 70 A	Feed cam oiling felt holder	1 pc
HS 70 A	Feed cam oiling felt	1 pc
81	Screw for feed driving eccentric	1 pc
89	Set screw for feed rocker and feed bar	4 pcs
93	Set screw for feed dog	1 pc
96	Spot screw for feed lifter cam	1 pc
97 X	Screw for supporting feed dog	1 pc
98	Screw for feed bar shaft collar	4 pcs
29099 K	Feed driving eccentric assembly	1 pc
80233	Feed rocker	1 pc
80234 B	Feed bar	1 pc
80292	Feed rocker shaft bushing	2 pcs
80651	Feed driving eccentric connection	1 pc
80654	Stitch regulating stud bushing	1 pc
80666 B	Feed rocker shaft collar	2 pcs
80666 BC	Feed rocker shaft collar with screw	2 pcs
80696	Stitch regulating stud	1 pc
81006	Feed driving eccentric	1 pc
81205 A	Feed dog	1 pc



PLATE NO. 7

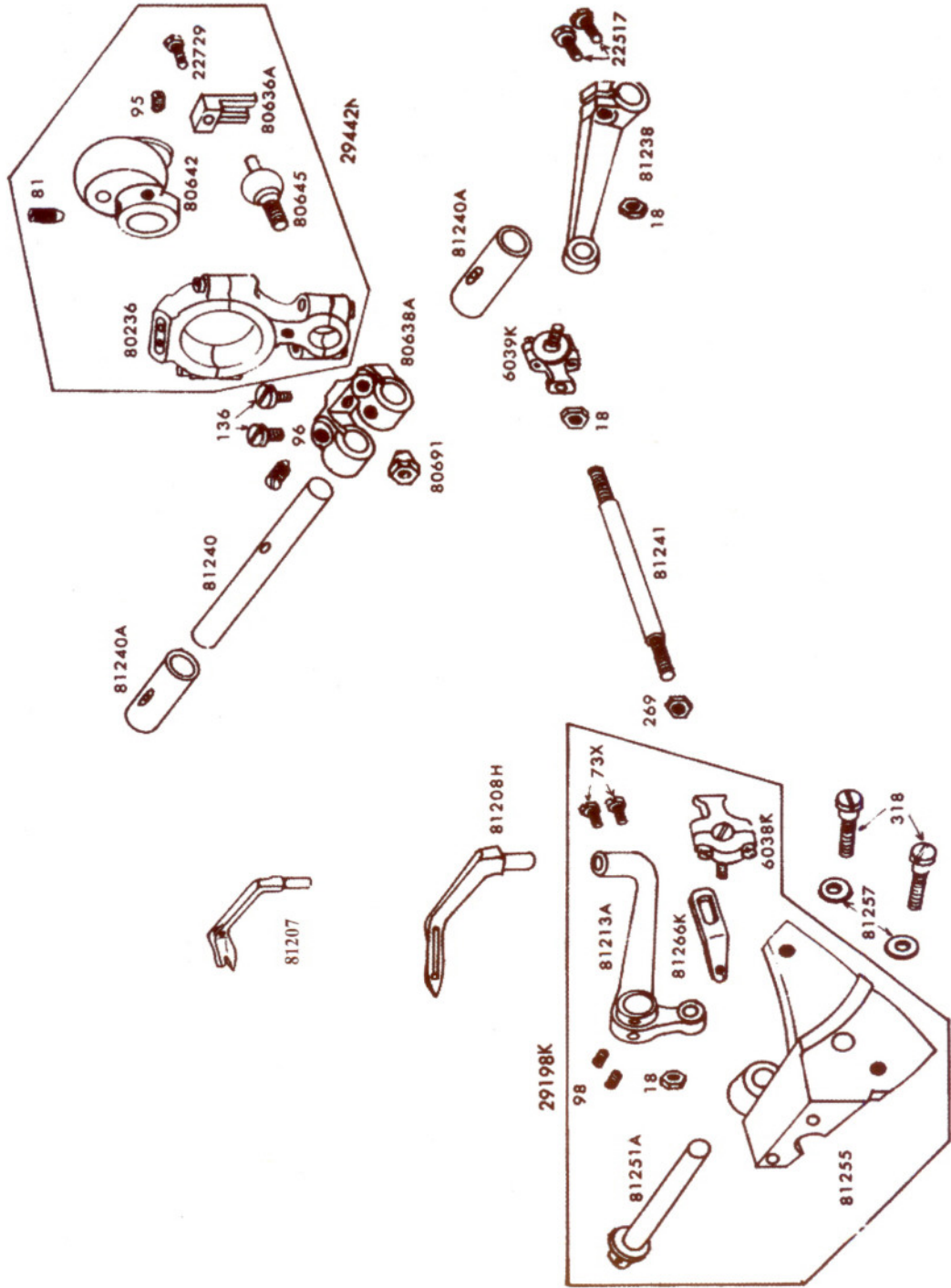



PLATE NO. 7

18	Nut for Looper drive connecting rod and Ball joint	3 pcs
HS 36 K	Looper connecting rod ball joint washer	1 pc
73 X	Set screw for Looper	2 pcs
81	Spot screw for Looper driving eccentric	1 pc
95	Set screw for Looper driving eccentric	1 pc
96	Spot screw for Looper drive lever shaft rocker	1 pc
98	Screw for Looper rocker (right hand)	2 pcs
136	Clamp screw for Looper drive lever shaft rocker	2 pcs
269	Nut for Looper drive connecting rod (left thread)	1 pc
318	Clamp screw for right hand Looper rocker shaft bearing	2 pcs
6038 K	Looper rocker connecting rod ball joint (left)	1 pc
6039 K	Looper rocker connecting rod ball joint (right)	1 pc
22517	Screw for Looper drive lever	2 pcs
22729	Screw for Looper lever ball stud fork	1 pc
29198 K	Right hand Looper rocker assembly	1 pc
29442 N	Looper drive eccentric assembly	1 pc
80236	Looper drive eccentric connecting bearing	1 pc
80636 A	Looper lever ball stud fork	1 pc
80638 A	Looper drive lever shaft rocker	1 pc
80642	Looper drive eccentric	1 pc
80645	Looper drive eccentric connection ball stud	1 pc
80691	Looper drive eccentric connection ball stud	1 pc
81207	Right hand blind Looper for wrap around machines	1 pc
81208 H	Right hand looper for plain sergers	1 pc
81213 A	Looper rocker (right hand)	1 pc
81238	Looper drive lever	1 pc
81240	Looper drive lever shaft	1 pc
81240 A	Looper drive lever shaft bushing	2 pcs
81241	Looper rocker connecting rod	1 pc
81251 A	Right hand Looper rocker shaft	1 pc
81255	Right hand Looper rocker shaft bearing	1 pc
81257	Right hand Looper rocker shaft bearing attaching screw washer	2 pcs
81266 K	Left hand Looper thread take-up	1 pc



PLATE NO. 8

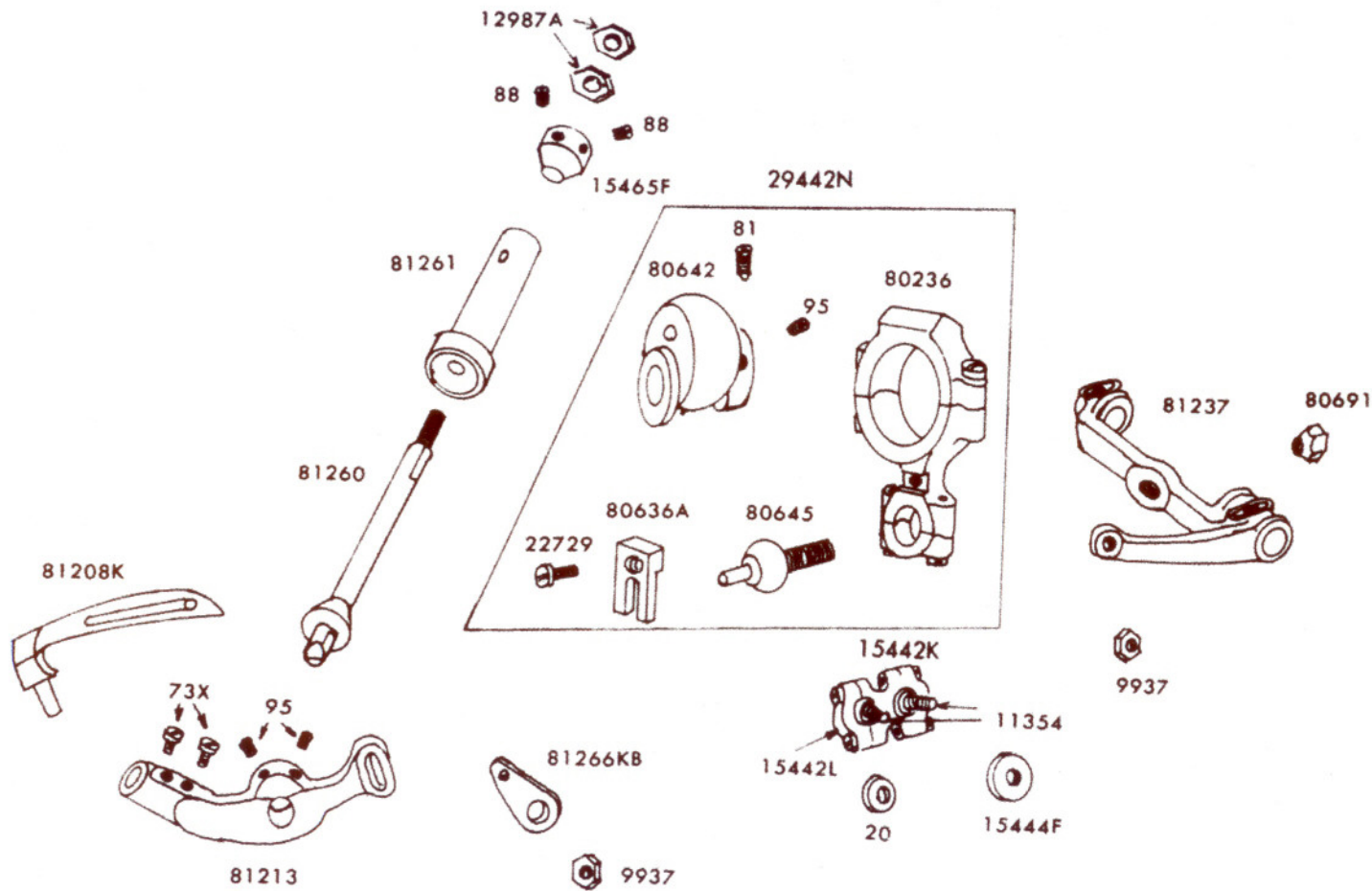



PLATE NO. 8

20	Washer for Looper Rocker double ball joint right stud	1 pc
73 X	Set screw for Looper	2 pcs
81	Spot screw for Looper driving eccentric	1 pc
88	Set screw for Looper rocker cone	2 pcs
95	Set screw for Looper driving eccentric and Looper rocker	3 pcs
9937	Nut for Looper rocker double ball joint stud	2 pcs
11354	Looper rocker double ball joint stud	2 pcs
12987 A	Check nut for Looper rocker cone stud	2 pcs
15442 K	Looper rocker double ball joint connection assembly	1 pc
15442 L	Looper rocker double ball joint connection	1 pc
15444 F	Washer for Looper rocker double ball joint left stud	1 pc
15465 F	Looper rocker cone	1 pc
22729	Screw for Looper lever ball stud fork	1 pc
29442 N	Looper driving eccentric assembly	1 pc
80236	Looper drive eccentric connecting bearing	1 pc
80636 A	Looper lever ball stud fork	1 pc
80642	Looper drive eccentric	1 pc
80645	Looper drive eccentric connection ball stud	1 pc
80691	Looper drive eccentric connection ball nut	1 pc
81208 K	Left hand Looper	1 pc
81213	Looper rocker (left hand)	1 pc
81237	Looper driving lever (left hand)	1 pc
81260	Left hand Looper rocker cone stud	1 pc
81261	Left hand Looper rocker cone stud bushing	1 pc
81266 KB	Right hand Looper thread take-up	1pc



THREAD STAND

FOR NC 81200WA/81200WAB/81200TPWA/B

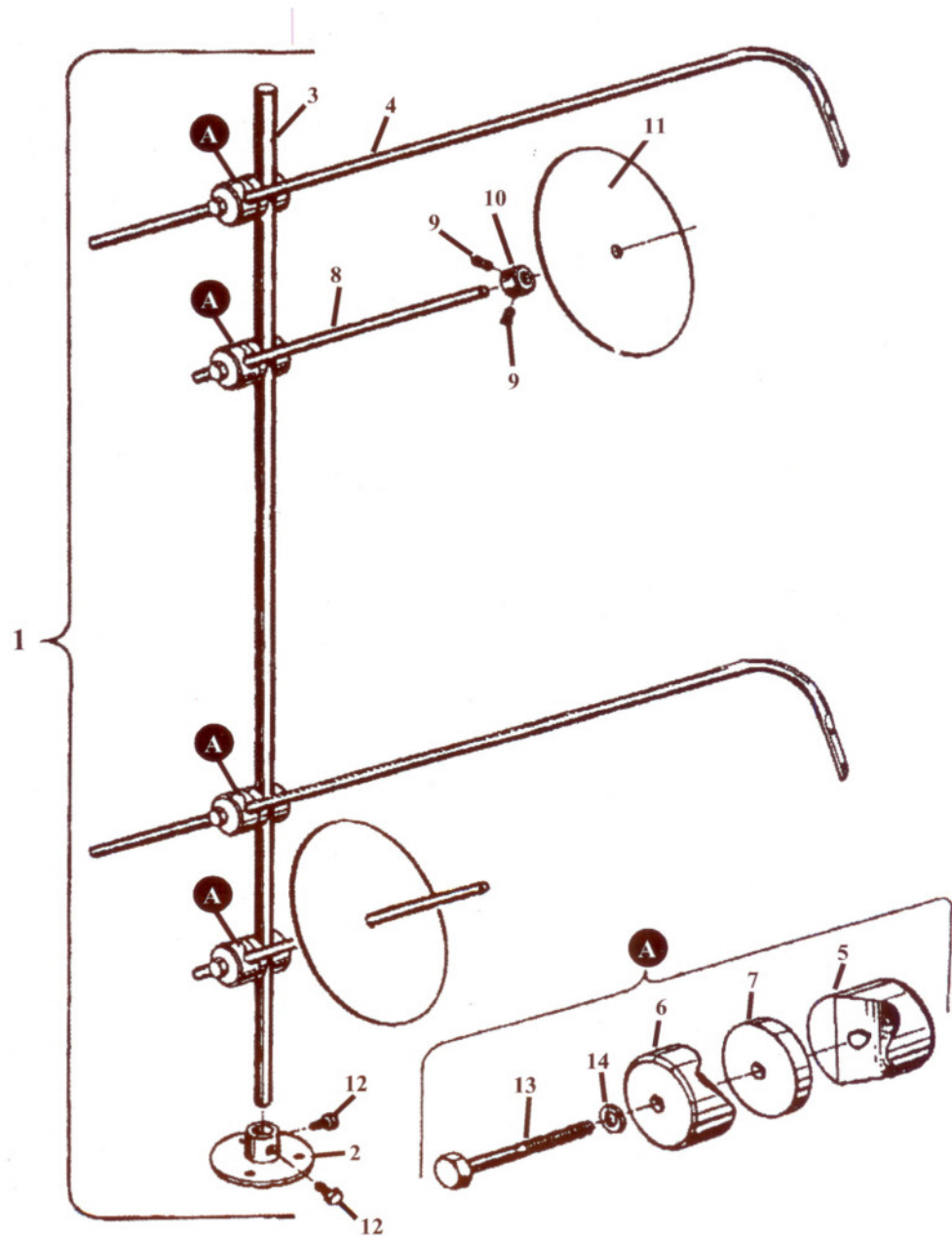



THREAD STAND

FOR STYLES NC81200/81200TP

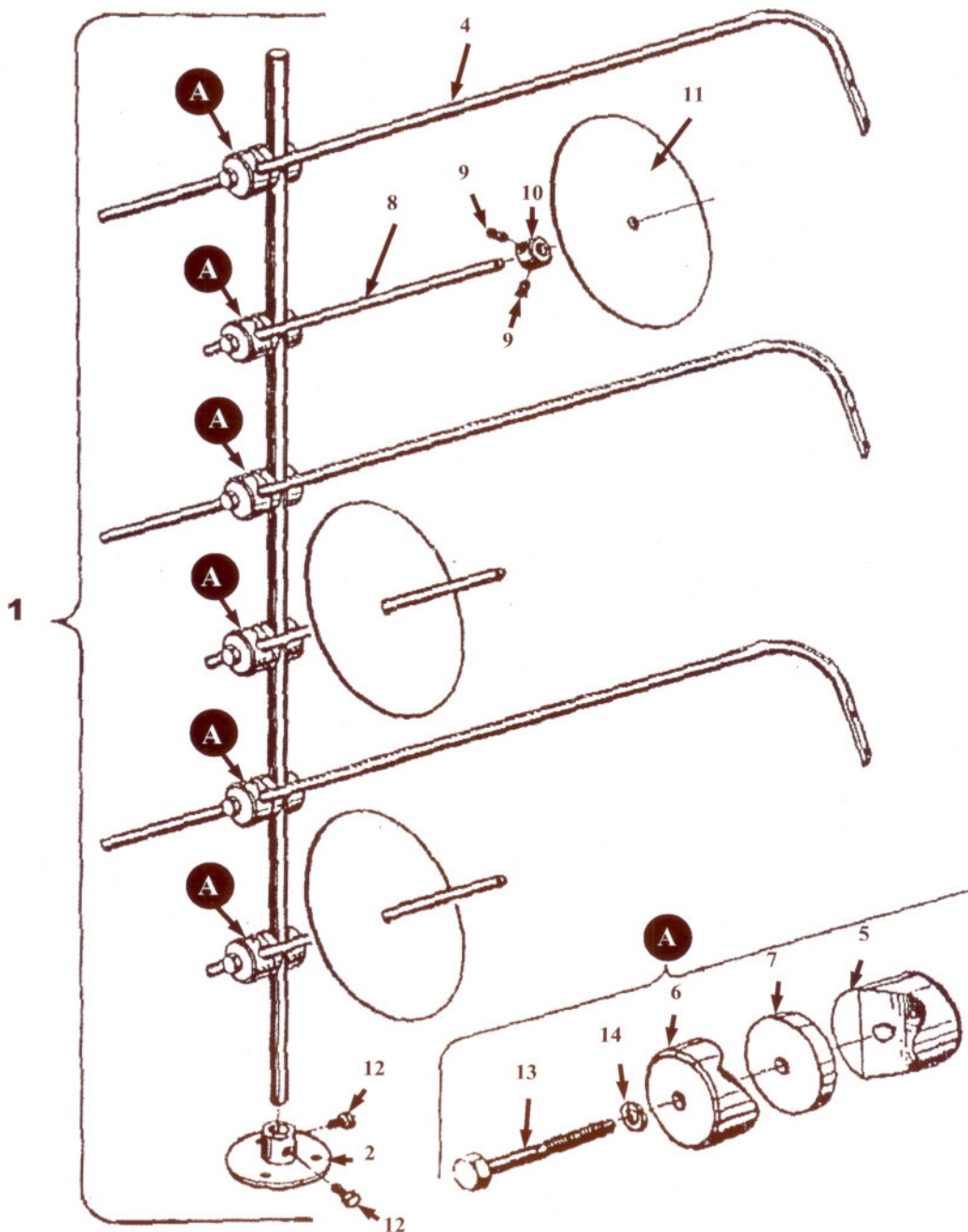

Numerical List Of Parts

PART NO.	PLATE NO.	PART NO.	PLATE NO.	PART NO.	PLATE NO.
8 A	6	91	4	6039 K	7
HA 10	6	93	6	9937	8
11	6	93 A	6	11354	8
18	6, 7	94	1	11639 H	5
HA18A	6	95	3, 4, 5, 7, 8	12987 A	8
20	6, 8	HA 95	2	15442 K	8
HA 20A	6	96	6, 7	15442 L	8
HA 23	6	97 X	6	15465 F	8
T 26	5	98	5, 6, 7	21104 B-9	9
28 C	3	HS 100 D	4	21104 B-20	9
HS 36 K	7	HA 103 B	3	21104 E	9
HA 43 X	6	HS 106	3	21104 G	9
HS 52 B	3	107	3	21104 H	9
HA 54 A	4	108	3	21104 KC	9
HA 56	4	BP 108	4	21104 KK	9
HA 58 C	4	110-2	3	21104 PD	9
HA 58 D	4	110-3	3	21111	4
HA 58 F	4	110-4	3	21114 A	9
64 Y	5	136	7	21145	9
HA 65 E	5	AS 137	3	22513	5
HA 66 K	2	AS 137 A	3	22517	7
69 H	6	AS 137 KA	3	22526	4
AS 70 A	6	HA 212 K	4	22539	2
HS 70 A	6	258	5	22560 B	3
73 X	7, 8	269	7	22565 C	4
74 E	2	318	7	22574	1
80	2	376	1	22729	4, 7, 8
81	4, 6, 7, 8	376 A	3	22743	3
HA 81	2	420	1	22870	5
88	3, 4, 8	HA 1348	3	22966 L	4
89	1, 6	HA 1349	3	29099 K	6
90	4	6038 K	7	29198 K	7

Numerical List Of Parts

PART NO.	PLATE NO.	PART NO.	PLATE NO.	PART NO.	PLATE NO.	PART NO.	PLATE NO.
29442 N	7, 8	80643	4	80685	2	81256	3
29774 KD	4	80644	4	B 80687	1	81256 A	3
29782 H	2	80645	7, 8	B 80688	1	81257	7
35733 B	5	80648	1	80691	7, 8	81260	8
35871 A	3	80649	1	80694 C	2	81261	8
51134 V	4	80650	4	80696	6	81266 K	7
80046	4	80651	6	81006	6	81266 KA	3
80220 C	5	80652	2	B 81201	1	81266 KB	8
80233	6	80654	6	B 81201 A	1	81297 KA	5
80234 B	6	80656	4	81203 KA	4		
80236	7, 8	80659	4	81203KA-1	4		
80246	4	80660	5	81203 KA-2	4		
80250	3	80661	5	81205 A	6		
80250 A	3	80662	5	81207/81208 H	7		
80250 B	3	80662 A	5	81208 K	8		
80267	5	80663	5	81213	8		
80292	6	80664	5	81213 A	7		
80437 A	1	80665 KD	3	81220 D	5		
80438	1	80666 B	5, 6	81220 KA	5		
80440	1	80666 BC	5, 6	81222	2		
80615	4	80667	3, 5	81224 K	4		
80617	4	80668	3	81225	4		
80621 A	2	80669	4	81225 K	6		
B 89621 H	2	80673 A	4	81237	8		
80630	2	80673 B	4	81238	1		
80630 C	2	80674	2	81239	1		
80630 D	2	80676	4	81240	7		
80631	1	80676 A	4	81240 A	7		
80632	5	80676 AC-2	3	81241	7		
80636 A	4, 7, 8	80676 AC-3	3	81251 A	7		
80638 A	7	80676 AC-4	3	81255	7		
80642	7, 8	80681	2	81256	3		

SERVING
THE TRADE
FOR OVER

50 YEARS

OUR ONLY BUSINESS
is designing, engineering and manufacturing
sewing machines and equipment for the carpet
industry
WORLDWIDE

ONE STEP
BOBBINLESS
BINDERS
PAT # 3, 320,910
TPB

EVERYTHING YOU NEED FOR CARPET BINDING, FRINGING, CUTTING, CARVING, INLAYS, BEVELING & SCULPTURING

ONE STEP
FRINGERS
BOBBINLESS
FTW

FOR MANUFACTURERS, WORK ROOMS AND CUSTOM DESIGNERS

PORTABLE
BINDERS
SINGLE & TWIN
PULLERS

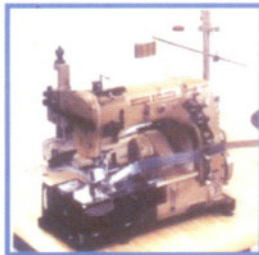

BOBBINLESS BINDER • TPB
Original one-step twin-feed
bobbinless Pat. # 3,320,910

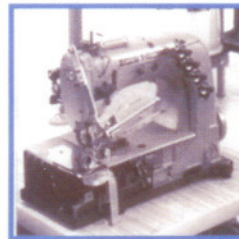

FRINGE & TAPE • FTW
Double lock stitch, one pass
bobbinless fringer.

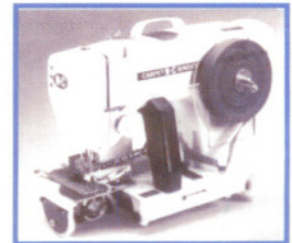

**PORTABLE BINDERS
SINGLE & TWIN PULLERS**
Binds top and bottom in one
operation. Compact, completely
self-contained. Built-in casters

HIGH SPEED
SERGERS
860 SERIES

HEAVY DUTY
SERGERS
SINGLE & TWIN
PULLERS

AIR-DRIVEN
CARVERS
MOTOR-DRIVEN

PORTABLE
BEVELERS
CUTS 30°-90°
ANGLES

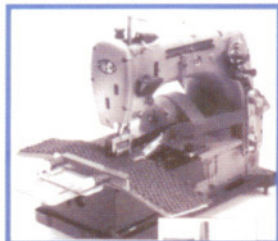

**SAMPLE & COVE BASE
BINDER SB**
Built-in puller for faster
positive feed

NC 2000 MILLENNIUM BOBBINLESS PORTABLE

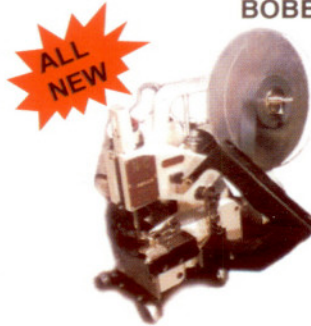

Supercharge your installation
business with the super-fast,
super-rugged and super-
profitable NC 2000. This super
fast binder doubles the speed of
bobbin-type machines and binds
thousands of linear feet with no
stopping for bobbin replacement.

PORTABLES
CUTTERS
FLOOR MODELS

BINDING TAPES
COTTON OR POLY
ACCESSORIES
CARPET FRINGE

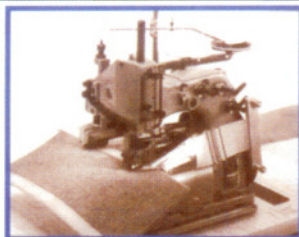

**SISAL/BERBER BINDER
81200-S**
The heavy duty binder that
binds top and bottom in one
operation. Independent heavy
duty front & back pullers.

SEND
FOR OUR
LATEST
CATALOG



SEND
FOR OUR
LATEST
CATALOG

N-C CARPET BINDING & EQUIPMENT CORP.

858 Summer Avenue, Newark, New Jersey 0710

Telephone (973) 481-3500 * Toll Free **(800) 526-1184**

Canada (800)336-1184 * Fax (973) 481-0839

http://www.n-ccarpet.com * E-mail: nccarpet1@aol.com

SEND FOR COLOR CHART