

CSX Train Derailment with Hazardous Materials
Release
Hyndman, Pennsylvania
August 2, 2017



Accident Report
NTSB/RAR-20/04
PB2020-101012



**National
Transportation
Safety Board**

Railroad Accident Report

CSX Train Derailment with Hazardous Materials Release

Hyndman, Pennsylvania

August 2, 2017



**National
Transportation
Safety Board**

490 L'Enfant Plaza, S.W.
Washington, D.C. 20594

National Transportation Safety Board. 2020. *CSX Train Derailment with Hazardous Materials Release, Hyndman, Pennsylvania, August 2, 2017*. NTSB/RAR-20/04. Washington, DC: NTSB.

Abstract: On August 2, 2017, at 4:54 a.m., local time, 33 rail cars on CSX Transportation, Inc. (CSX) train Q38831 derailed in Hyndman Borough, Bedford County, Pennsylvania. The train consisted of 5 locomotives and a total of 178 cars (128 loaded and 50 empty), including derailed cars 53 through 65. Three derailed tank cars containing hazardous materials were breached, resulting in a fire. Three homes were damaged by the derailment and subsequent fire. There was no loss of life or injuries. A 1-mile radius evacuation zone was established, which affected about 1,000 residents, and several highway-railroad grade crossings were closed. The evacuation was lifted about 12:00 p.m. on August 5. CSX reported \$1.8 million in damages for the derailed equipment and \$60,000 in damages to the track structure. Investigators determined that the probable cause of the accident was the inappropriate use of hand brakes on empty rail cars to control train speed and the placement of blocks of empty rail cars at the front of the train consist, leading to elevated longitudinal forces and increased lateral forces at the wheel-rail interface at the curve in the rail on the leading 42 cars combined with tread buildup on the 35th car, which was the first to derail. Contributing to the derailment were CSX operating practices that accepted the use of hand brakes on empty rail cars to control train speed and allowed blocks of empty rail cars to be placed at the front of the train consist. The investigators focused on the safety issues of CSX operational practices for building train consists, use of hand brakes to control train movement, and assessment and response to fires involving jacketed tank cars. As a result of the investigation, the National Transportation Safety Board makes one safety recommendation to the Federal Railroad Administration, three recommendations to CSX, one recommendation to the American Association of Railroads, and one recommendation to the Security and Emergency Response Training Center.

The National Transportation Safety Board (NTSB) is an independent federal agency dedicated to promoting aviation, railroad, highway, marine, and pipeline safety. Established in 1967, the agency is mandated by Congress through the Independent Safety Board Act of 1974, to investigate transportation accidents, determine the probable causes of the accidents, issue safety recommendations, study transportation safety issues, and evaluate the safety effectiveness of government agencies involved in transportation. The NTSB makes public its actions and decisions through accident reports, safety studies, special investigation reports, safety recommendations, and statistical reviews.

The NTSB does not assign fault or blame for an accident or incident; rather, as specified by NTSB regulation, “accident/incident investigations are fact-finding proceedings with no formal issues and no adverse parties ... and are not conducted for the purpose of determining the rights or liabilities of any person” (Title 49 *Code of Federal Regulations* section 831.4). Assignment of fault or legal liability is not relevant to the NTSB’s statutory mission to improve transportation safety by investigating accidents and incidents and issuing safety recommendations. In addition, statutory language prohibits the admission into evidence or use of any part of an NTSB report related to an accident in a civil action for damages resulting from a matter mentioned in the report (Title 49 *United States Code* section 1154(b)).

For more detailed background information on this report, visit the [NTSB investigations website](#) and search for NTSB accident ID DCA17FR011. Recent publications are available in their entirety on [the NTSB website](#). Other information about available publications also may be obtained from the website or by contacting—

**National Transportation Safety Board
Records Management Division, CIO-40
490 L’Enfant Plaza, SW
Washington, DC 20594
(800) 877-6799 or (202) 314-6551**

Copies of NTSB publications may be downloaded at no cost from the National Technical Information Service, at the [National Technical Reports Library search page](#), using product number PB2020-101012. For additional assistance, contact—

**National Technical Information Service
5301 Shawnee Rd. Alexandria, VA 22312
(800) 553-6847 or (703) 605-6000**

[NTIS website](#)

NOTE: This report was reissued on December 29, 2020, with corrections to pages 39-40 to add recommendation numbers to the recommendations listed in appendix B.

Contents

Figures.....	iii
Tables	iv
Abbreviations and Acronyms	v
Executive Summary	vii
Accident Summary.....	vii
Probable Cause.....	vii
Safety Issues.....	vii
Findings.....	viii
Recommendations.....	ix
1.Factual Information.....	1
1.1 Accident Description	1
1.2 The Accident.....	3
1.2.1 Train Q38831	3
1.2.2 Train Operations Prior to Derailment	4
1.3 Emergency Response.....	5
1.4 Operational Factors.....	9
1.4.1 First Crew.....	9
1.4.2 Relief Crew	10
1.5 Mechanical Factors	11
1.5.1 Locomotives.....	11
1.5.2 Rail Cars.....	11
1.6 Track Factors	14
1.6.1 General Characteristics	14
1.6.2 Postaccident Track Investigation	15
1.7 Hazardous Materials	17
1.7.1 Molten Asphalt Tank Car.....	18
1.7.2 Molten Sulfur Tank Car	19
1.7.3 Liquefied Petroleum Gas Tank Car	20
1.8 Supplementary Information	24
1.8.1 Emergency Response Guidance Involving LPG/Propane	24
1.8.2 Previous NTSB Investigation of LPG Tank Car Delayed Rupture	26
2.Analysis.....	28
2.1 Introduction.....	28
2.1.1 Exclusions	28
2.1.2 Safety Issues.....	28
2.2 CSX Operational Practices for Building Train Consists.....	28
2.3 Control of Train Movement.....	29
2.4 Tank Car Integrity.....	30
2.4.1 DOT-111 Tank Cars	30

2.4.2 Jacketed Pressure Tank Cars.....	31
2.5 Establishing Risk Reduction Programs.....	33
3.Conclusions.....	35
3.1 Findings.....	35
3.2 Probable Cause.....	36
4.Safety Recommendations	37
Appendix A: Investigation	38
Appendix B: Consolidated Recommendation Information.....	39
References	41

Figures

Figure 1. Location of Hyndman, Pennsylvania, and accident site.	2
Figure 2. Overhead view of derailment of CSX freight train Q38831.	3
Figure 3. Accident scene August 2, 2017, 7:45 p.m.	6
Figure 4. The shell bulge and puncture site..	8
Figure 5. Close-up view of defective intermediate air brake hose from car LW 62114.....	12
Figure 6. Closeup of wheel tread surface showing tread buildup on wheel of the 35th car.	14
Figure 7. Accident curve facing east toward direction of accident train travel.	15
Figure 8. Flange mark at point of departure of FWTX 620111 (35th car).	16
Figure 9. Diagram of a DOT-111A100W1 tank car.	18
Figure 10. UTLX643949 open bottom outlet valve.....	19
Figure 11. Burning molten sulfur released from tank car IDTX5082.	20
Figure 12. Diagram of tank car CBTX 781553 (a DOT-112J340W tank car).	21
Figure 13. CBTX 781553 with puncture location circled, August 3, 2017, 2:46 p.m.	21
Figure 14. Tank Car CBTX 781553 puncture in exterior surface, August 4, 2017.....	22
Figure 15. CTBX 781553 interior surface of shell puncture, August 5, 2017.....	23

Tables

Table 1. Most recent knowledge and skills evaluation for the first engineer.....	9
Table 2. Most recent knowledge and skills evaluation for the first conductor.	9
Table 3. Most recent knowledge and skills evaluation for the relief engineer.....	10
Table 4. Most recent knowledge and skills evaluation for the relief conductor.	10
Table 5. Derailed rail car summary.....	13
Table 6. Hazardous materials on train Q38831.....	17

Abbreviations and Acronyms

AAR	Association of American Railroads
AEI	automatic equipment identification
Amtrak	National Railroad Passenger Corporation
ASTM	American Society for Testing and Materials
BLEVE	boiling liquid expanding vapor explosion
CCB	computer-controlled brake
CFR	<i>Code of Federal Regulations</i>
CPC	Casualty Prevention Circular
CSX	CSX Transportation, Inc.
DOT	Department of Transportation
ERG	Emergency Response Guide
ETD	end-of train device
FRA	Federal Railroad Administration
LPG	liquefied petroleum gas
L/V	lateral/vertical
MP	milepost
mph	miles per hour
NTSB	National Transportation Safety Board
ORD	FRA Office of Research and Development
PHMSA	Pipeline and Hazardous Materials Safety Administration
POD	point of derailment
PRD	pressure relief device
PSCC	Public Safety Coordination Center

psi	pounds per square inch
psig	pounds per square inch, gauge
RRP	risk reduction program
SERTC	Security Emergency Response Training Center
SMS	safety management system
SPSI	Specialized Professional Services, Inc.
SSP	system safety program
TCVN	Vietnamese standard for domestic products and imported goods

Executive Summary

Accident Summary

On August 2, 2017, at 4:54 a.m., local time, 33 rail cars on CSX Transportation, Inc. (CSX) train Q38831 derailed in Hyndman Borough, Bedford County, Pennsylvania. The train consisted of 5 locomotives and a total of 178 cars (128 loaded and 50 empty), including derailed cars 53 through 65. Three derailed tank cars containing hazardous materials were breached, resulting in a fire. Three homes were damaged by the derailment and subsequent fire. There was no loss of life or injuries. A 1-mile radius evacuation zone was established, which affected about 1,000 residents, and several highway-railroad grade crossings were closed. The evacuation was lifted about 12:00 p.m. on August 5. CSX reported \$1.8 million in damages for the derailed equipment and \$60,000 in damages to the track structure.¹

Probable Cause

The National Transportation Safety Board determines the probable cause of the accident was the inappropriate use of hand brakes on empty rail cars to control train speed and the placement of blocks of empty rail cars at the front of the train consist, leading to elevated longitudinal forces and increased lateral forces at the wheel-rail interface at the curve in the rail on the leading 42 cars combined with tread buildup on the 35th car, which was the first to derail. Contributing to the derailment were CSX operating practices that accepted the use of hand brakes on empty rail cars to control train speed and allowed blocks of empty rail cars to be placed at the front of the train consist.

Safety Issues

The investigation identified the following safety issues:

- **[CSX Operational Practices for Building Train Consists.](#)** The CSX rules for building train consists address the placement of loaded rail cars ahead of blocks of empty rail cars but do not account for the placement of the empty rail cars at the front of a consist or the total tonnage behind the empty rail cars. Operational practices allowed the train consist, which was assembled with a more uniform weight distribution when it left its point of origin, to be altered during the route for purposes of time and efficiency, changing the forces exerted on empty cars. Consequently, 90 percent of the train's total tonnage was behind the lead 42 cars, resulting in excessive longitudinal and lateral forces exerted on the empty cars as the train descended the grade.

¹ For more information, see the [factual information](#) and [analysis sections](#) of this report. For detailed information about this accident investigation, see the public docket at <https://data.nts.gov/Docket/Forms/searchdocket> and search for accident number DCA17FR011.

- [Use of Hand Brakes to Control Train Movement.](#) CSX train handling rules allow the use of hand brakes to control train movement on a descending grade, and an operational decision was made to use them on a steep descending grade. Hand brakes applied to empty rail cars caused the wheels of those rail cars to overheat and build up tread. The tread buildup on the wheels of the 35th rail car compromised the ability of the wheel flange to properly negotiate the curve.
- [Assessment and Response to Fires Involving Jacketed Tank Cars.](#) Emergency response personnel were unable to perform a detailed tank car damage assessment because the jacket on the Department of Transportation (DOT)-112 tank car obscured the bulging tank shell, and the damage could not be readily observed.

Findings

- [None of the following were factors in the derailment: train crew experience and training; physical or mental impairment of the train crew due to alcohol, other impairing drugs, or fatigue; or track structure condition.](#)
- [CSX Transportation's Equipment Handling Rule 4466 does not sufficiently address excessive lateral forces that may lead to or contribute to wheel lift or other undesirable train performance outcomes.](#)
- [The application of hand brakes on empty rail cars toward the front of the consist caused the wheels of those cars to overheat and build up tread.](#)
- [The tread buildup on the wheel of the 35th rail car compromised the ability of the wheel flange to keep the wheels on the track as the train negotiated the curve, causing the derailment.](#)
- [The breach of the derailed liquefied petroleum gas tank car shell occurred during its impact with the robust body bolster frame of another derailed tank car.](#)
- [Emergency response personnel were unable to perform a detailed tank car damage assessment because the bulging tank shell was hidden under the jacket of the US Department of Transportation-112 tank car and could not be readily observed.](#)
- [An effective CSX Transportation risk reduction program or system safety program would have likely identified the risks that led to the accident and provided an opportunity to prevent the accident and mitigate risks to prevent future accidents.](#)
- [The Federal Railroad Administration's recently enacted requirement for risk reduction programs and system safety programs provides an opportunity to identify and mitigate risks to prevent future accidents.](#)
- [The Federal Railroad Administration has not provided sufficient guidance to railroads on how to develop and implement its requirements for a risk reduction program and](#)

system safety program that the railroads are due to submit to the Federal Railroad Administration for review and approval by August 16, 2021.

- The railroad industry would benefit from an industry-led effort to develop best practices and implementation guidance for risk reduction programs.

Recommendations

To the Federal Railroad Administration:

Develop and issue guidance for railroads to use in developing the risk reduction programs required to be submitted for approval by the Federal Railroad Administration. (R-20-21)

To CSX Transportation:

Revise your rules for building train consists to require that large blocks of empty cars be placed toward the end of the consist. (R-20-22)

Prohibit the use of hand brakes on empty rail cars for controlling train movement in grade territory. (R-20-23)

Incorporate lessons learned about the hazards caused by fire-exposed jacketed pressure tank cars in first responder hazardous materials training and outreach programs. (R-20-24)

To The Association of American Railroads:

Work with member railroads to develop guidance material and best practices for the development and implementation of their risk reduction programs. (R-20-25)

To the Security and Emergency Response Training Center:

Incorporate lessons learned from the Hyndman, Pennsylvania, accident about the hidden hazards caused by fire-exposed jacketed pressure tank cars in first responder hazardous materials technician and tank car specialist training programs. (R-20-26)

1. Factual Information

1.1 Accident Description

On August 2, 2017, at 4:54 a.m. local time, 33 rail cars on eastbound CSX Transportation, Inc. (CSX) train Q38831 derailed in Hyndman Borough, Bedford County, Pennsylvania. (See figures 1 and 2.)² The train consisted of 5 locomotives and a total of 178 rail cars (128 loaded and 50 empty). Three derailed tank cars containing hazardous materials were breached, resulting in a fire. Three homes were damaged by the derailment and subsequent fire. There was no loss of life or injuries. A 1-mile radius evacuation zone was established, which affected about 1,000 residents, and several highway-railroad grade crossings were closed. The evacuation was lifted about 12:00 p.m. on August 5. CSX reported \$1.8 million in damages for the derailed equipment and \$60,000 in damages to the track structure.³

² All times in this document are local time unless otherwise noted.

³ For more detailed information about this accident investigation, see the public docket at <https://data.nts.gov/Docket/Forms/searchdocket> and search for accident number DCA17FR011.

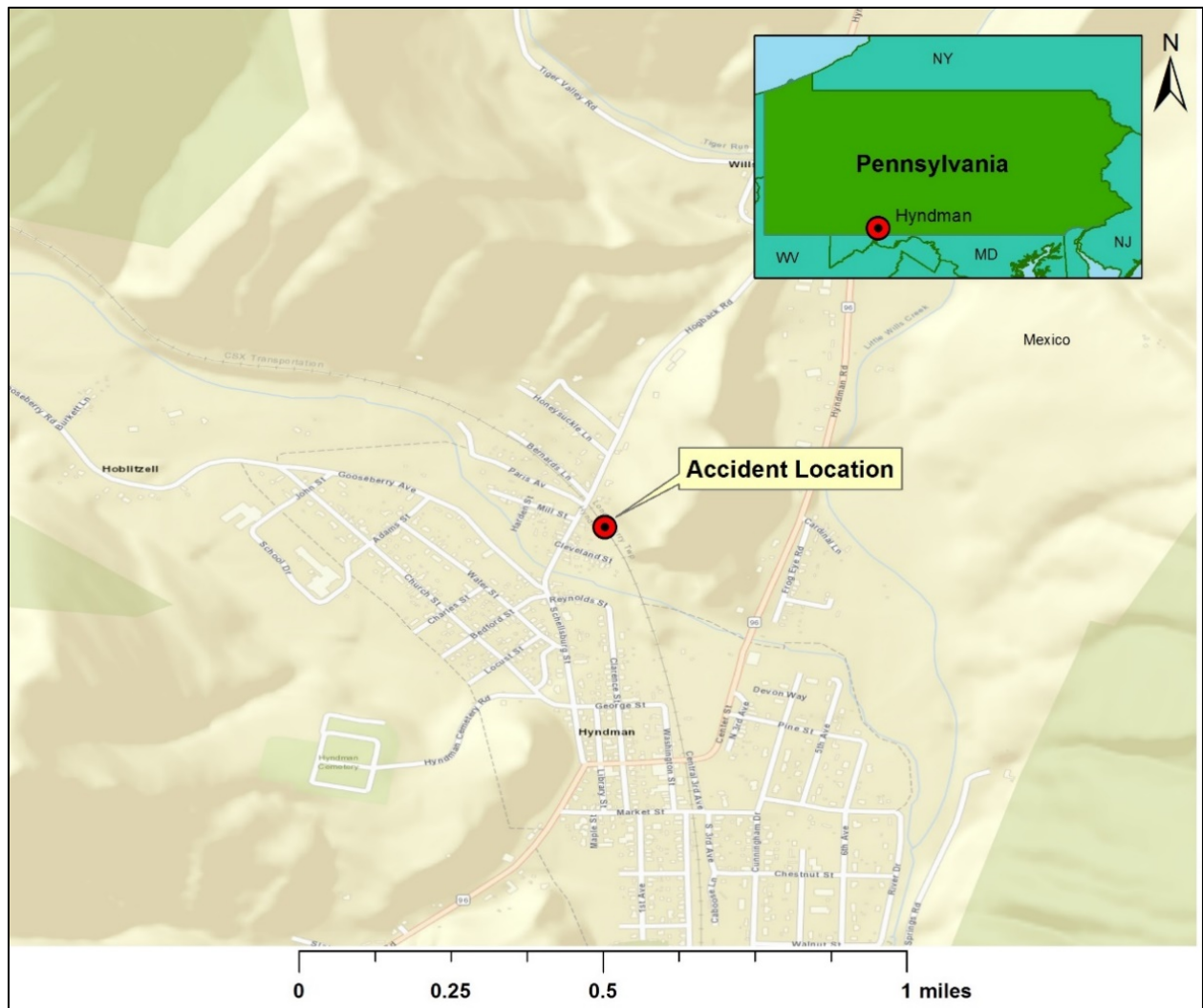

Figure 1. Location of Hyndman, Pennsylvania, and accident site.



Figure 2. Overhead view of derailment of CSX freight train Q38831. (Courtesy of CSX.)

1.2 The Accident

1.2.1 Train Q38831

Train Q38831 consisted of 5 locomotives at the front of the train (2 in tow and not being used) and 178 rail cars. It was 10,612 feet long and weighed 18,252 tons. Of the 178 rail cars, 128 were loaded and 50 were empty. Seventy of the loaded rail cars contained hazardous materials, such as propane, isobutane, denatured ethanol, undenatured ethanol, heptane, molten sulfur, sodium chlorate, and phosphoric acid. (See Section 1.7 for additional hazardous material information.)⁴ The train was classified as a Hazardous Material Key Train.⁵ All rail cars had

⁴ Refer to the Train Listing and Hazardous Material Descriptions in the public docket for this report (DCA17FR011) for additional information.

⁵ Association of American Railroads (AAR) Circular OT-55-P (CPC-1321) defines a key train as a train transporting any of the following: 1 or more car loads of spent nuclear fuel or certain types of high-level radioactive waste; 1 or more loaded tank cars of poison or toxic inhalation hazard material, anhydrous ammonia, or ammonia solutions; or 20 or more car loads (including intermodal portable tank loads) of any combination of hazardous material. Key trains are subject to speed restrictions and other operating criteria.

received a Federal Railroad Administration (FRA) Class I brake test and mechanical inspection prior to the derailment, with no defects noted.⁶

1.2.2 Train Operations Prior to Derailment

On August 1, 2017, at 1:45 p.m., a crew consisting of a locomotive engineer and a conductor departed Cumberland, Maryland, for Connellsville, Pennsylvania, to take control of the train. When the train arrived, the crew was told that it had a little “bit of flow,” but that everything else was working well.⁷ The crew received a signal indication to depart and proceeded east to Cumberland, Maryland, at 8:28 p.m. As the train descended a grade at milepost (MP) 212.2, the engineer saw from the end-of-train device (ETD) that the brake pipe pressure was increasing.⁸ Concerned that the brakes might release if they proceeded any further, the engineer applied the brakes and brought the train to a stop at 11:36 p.m.

The conductor applied hand brakes on 30 percent of the rail cars (58 rail cars) after the train came to a stop, as required by CSX operating rules.⁹ He applied the hand brakes on the first 25 rail cars of the consist, skipped the 26th through the 33rd cars because the hand brakes were located on top of the cars and not easily accessible, and applied the remaining hand brakes from cars 34 through 64.¹⁰ The conductor inspected the train and found the 159th rail car had an air leak. The engineer reported the air leak, and CSX dispatched two mechanics to fix the problem. By this time, the train crew did not have enough duty time to complete the trip, so a relief crew was dispatched to the train.

The relief crew of CSX train Q38831, which included a locomotive engineer and a conductor, went on duty at 11:59 p.m., at Cumberland, Maryland. When they reached the train, the previous crew explained they had experienced issues with the air brake and had applied 58 rail car hand brakes to secure the train. About 20 minutes after the relief crew took charge of the train, two carmen arrived and replaced a brake hose on the 159th rail car to address the air leak. After the repairs were completed, the conductor informed CSX dispatch that the train was ready to proceed and that they would release the hand brakes when they reached the bottom of the grade; CSX is the only Class I railroad that allows its engineers to use handbrakes to control a train’s downhill descent. CSX dispatch authorized the relief crew to proceed. The train departed at 4:17a.m.

The relief crew tried to pull the train down the grade with the 58 hand brakes applied. When they were unable to move, the conductor released 25 of the handbrakes, leaving 33 applied within the first 58 rail cars in the train. An airbrake minimum set was applied before the train began

⁶ Title 49 *Code of Federal Regulations (CFR)* 232.205 Class I Brake Test-Initial Terminal inspection.

⁷ *Flow* refers to the brake pipe air pressure constantly being charged, indicating that there was a leak.

⁸ With train air brakes, an increase in brake pipe air pressure releases the brakes, and a decrease activates the brakes. The *end-of-train device* (ETD) measures air pressure through the brake pipe at the end of the train.

⁹ CSX Baltimore Timetable-Airbrake and Train Handling Rule 5559: When the total brake pipe reduction exceeds 18 pounds on any eastward freight train operating Sand Patch to Hyndman, the train will be stopped. Thirty percent of hand brakes will be applied to the head end of the train to hold it on the grade during the recharge procedure.

¹⁰ A *locomotive consist* is a locomotive or combination of locomotives properly coupled for multiple unit operation and operated from a single control.

moving down the grade.¹¹ Train speed down the grade fluctuated between 20 and 30 mph. The engineer controlled the speed of the train by using dynamic braking.¹² About 1.7 miles west of Hyndman, as the train traversed a right-hand curve with a two percent descending grade, the trailing truck of the 35th rail car derailed.¹³ At 4:54 a.m., as the train entered Hyndman and the rail cars traveled over the Center Street grade crossing, several other cars derailed, and the train experienced an uncommanded emergency brake application when the brake pipe between the rail cars separated. The lead locomotive traveled another 500 feet and came to a stop just east of the grade crossing at Market Street.¹⁴

1.3 Emergency Response

At 5:06 a.m. on August 2, 2017, the CSX Public Safety Coordination Center (PSCC) notified the CSX operations section chief for emergency response of the derailment. The PSCC operator said he received multiple reports of fires and an explosion in connection with a derailment in Hyndman, Pennsylvania. The CSX operations section chief contacted the CSX primary emergency response contractor, Specialized Professional Services, Inc. (SPSI), and requested it respond. Meanwhile, the CSX incident commander initiated the company's emergency response plan to notify other CSX hazardous materials managers and contractors to respond to the accident.

At 6:01 a.m., the operations section chief was the first CSX official to arrive at the derailment scene. Firefighters from the Hyndman Volunteer Fire Department were readying fire hoses, establishing a water supply, and conducting door-to-door evacuations. The CSX operations section chief located a deputy fire chief and verbally conveyed the identity of the hazardous materials on the train. He also inquired about the safety of the train crew, and the deputy fire chief confirmed the crew was safe and had provided a paper copy of the train consist to another fire department chief. The CSX operations section chief then instructed the Hyndman fire chief to contact the PSCC for an electronic copy of the train consist.

At 6:10 a.m., the CSX operations section chief and two local firefighters entered the incident scene to assess the situation with the burning tank car. They approached the houses that were affected by derailed freight cars and verified the occupants had evacuated. At that point, they observed a large flame and pressurized gas coming out of one tank car. The CSX operations section chief telephoned the CSX incident commander and reported that a pressure car was venting and was on fire, but the hazardous material in that car was still unknown.¹⁵ The CSX incident commander directed the CSX operations section chief to make sure that everyone, including fire

¹¹ *Minimum set* refers to the position on air brake handle. The minimum set position reduces brake pipe pressure by 6 to 8 psi.

¹² *Dynamic braking* is a method of train braking that uses an electrical device called a dynamic brake that converts some of the energy developed by a moving locomotive into an effective braking force.

¹³ (a) The tonnage from the first car in the consist to the 35th car was 1,631 tons. There were 16,621 tons trailing the 35th car. The 35th car was an empty high-sided gondola and was in a block of 27 empty cars. (b) A *truck* is a complete assembly of parts that includes wheels, axles, bearings, side frames, bolster, brake rigging, and springs, all of which provide support, mobility, and guidance to a railroad car.

¹⁴ An *uncommanded emergency brake application* occurs when the brake pipe pressure rapidly decreases to 0 psi due to the hoses between the cars disconnecting because of the derailment and separation of cars.

¹⁵ A *pressure car* is a tank built to specific DOT specifications referenced in 49 *CFR* Part 179 Subparts A, B, and C. Pressure cars have only one top nozzle that serves as a manway and upon which the fittings are mounted.

department responders, evacuated the area. The CSX operations section chief recommended to fire department leadership that they move everyone as far back as possible from the incident site.

At 7:00 a.m., the CSX operations section chief identified the burning tank car as CBTX 781553, which contained liquefied petroleum gas (LPG) consisting of 100 percent odorized propane.¹⁶ CBTX 781553 had come to rest on its side during the derailment. He noted a ground fire with a blue flame, characteristic of molten sulfur, in the area surrounding CBTX 781553 and became concerned that heat from the burning molten sulfur would further increase the pressure within the LPG car. He was unable to assess the extent of the damage to the car because it was jacketed.¹⁷ (See [Section 1.7.3](#) for a description of the rail car.)

Based on these observations, the CSX operations section chief recommended to the fire chief and several of his officers that the fire department evacuate the scene. The fire chief evacuated all emergency response personnel and staged the operations from the Hyndman fire station, about 0.4 miles away from the burning propane tank car.

At 9:50 a.m., the CSX operations section chief participated in a state police helicopter overflight of the incident scene and confirmed that molten sulfur and asphalt had been released.¹⁸ Fire was seen issuing from several locations on the propane tank car, giving the appearance of multiple tank punctures. (See figure 3 for accident scene.)



Figure 3. Accident scene August 2, 2017, 7:45 p.m. (Courtesy of CSX.)

¹⁶ CBTX 781553 is technically considered a liquified petroleum gas (LPG) tank car, but it was carrying propane in this case, and is referred to as the propane tank car to distinguish it from other derailed tank cars. Propane has different properties from other LPGs.

¹⁷ A *jacket* is a metal outer shell used to contain insulating material around a tank car.

¹⁸ Overflight operations were provided with mutual aid by the Maryland State Police Aviation Division.

The incident command post was temporarily established about one-half mile from the accident site at the Hope for Hyndman Charter School and was later relocated to the Tri-State Ministry Center, about 7 miles south of Hyndman. The CSX operations section chief briefed the Pennsylvania State Police commander on his observations and discussed possible outcomes and the risks associated with the burning propane tank car. He suggested that should the tank car breach further, the risks included a larger shell tear or tank fragmentation.

The CSX incident commander, CSX operations section chief, alternate CSX operations section chief, and the SPSI emergency response contractor conducted another site entry at 12:00 p.m. to assess the situation and tank car damages. When they arrived close to the accident scene at the Schellsburg Road bridge over Willis Creek, they noticed a significant increase in volume and intensity of the sound and flames compared with their earlier observations. The CSX incident commander determined that it was necessary to assess the situation from a safer distance; however, the entry team could not get a good view of the burning propane tank car. During this time, the sound of the escaping gas continued to become noticeably louder, and the flames grew higher, suggesting to the group that conditions were changing, and the integrity of the propane tank car was in question.

The CSX responders joined a unified command with police, fire, and emergency management officials. The unified command staff consisted of the Pennsylvania State Police, Hyndman Volunteer Fire Department, Pennsylvania Department of Environmental Protection, Pennsylvania Emergency Management Agency, and CSX. The unified command decided the safest course of action was to allow the propane tank car to continue venting and burning at its own pace and to allow events to take their course without further exposing personnel to the hazard or to attempt mitigating actions. Meanwhile, responders concentrated on establishing an appropriate evacuation zone and monitoring the situation from a distance as best they could. Based on CSX's recommendation, the evacuation zone was ultimately increased to a 1-mile radius from the accident scene.

By the evening of August 3, the pressure in the propane tank car decreased as indicated by diminishing flame size. A hazardous materials team consisting of CSX and contractor personnel measured the pressure in CBTX 781553, finding about 28 psig, confirming that the pressure was considerably lower than the vapor pressure of propane under normal transportation conditions of 138 psi at 77°F. Therefore, although the tank car was not yet empty, its internal pressure had significantly reduced to the point that CSX was less concerned about the potential for further loss in tank integrity. The shell puncture became evident when CSX contractors peeled the jacket back to determine the nature of shell damage and to search for a frost line suggestive of any remaining liquid level.¹⁹ The frost line ranged from about 6 inches to 15 inches high, indicating that an estimated 2,000 to 3,000 gallons of liquid was still inside the tank. The most significant finding was the lack of a shell crack or buckled tank wall indicative of compromised structural integrity; however, the tank shell had been punctured in one location. The CSX operations section chief said

¹⁹ A *frost line* occurs when the pressure inside a tank car drops as liquid petroleum gas (LPG) is released, causing liquid inside the tank to cool. Moisture or frost will then collect on the lower part of the tank up to the liquid level if the temperature of the liquid inside the tank drops below the dew point of the surrounding air.

he noticed what appeared to be a bulge in the tank shell adjacent to the puncture. He said that by the time the shell bulge was discovered, there was almost no vapor pressure or product left in the car. Figure 4 shows the puncture covered by a square of magnetic patching material and the visible edge of the shell bulge under the exposed jacket.

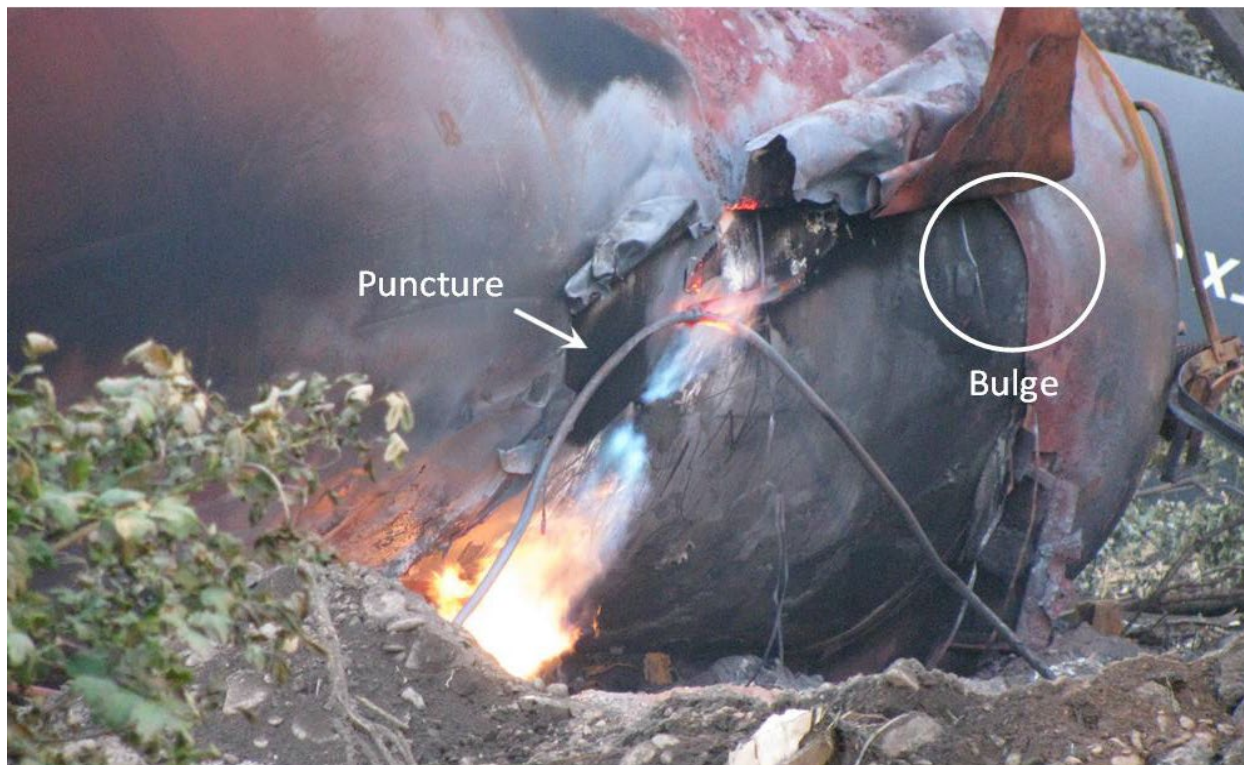

Figure 4. The shell bulge and puncture site. (Courtesy of CSX.)

When the propane tank car pressure fell to about 8 psig, CSX responders felt confident that they could manage any risks associated with moving the tank car. The CSX incident commander explained that the unified command was uncomfortable allowing the car to burn at a diminished rate for several days while keeping evacuated residents from their homes for a prolonged period. They therefore decided to roll the car upright so that the eduction line would be situated in liquid, and the vapor line was in contact with only vapor space.²⁰ Crews placed a magnetic patch over the shell puncture and excavated a pit next to the tank car to catch any propane that might spill from the shell puncture when rolling the car. When the car was rolled upright, no liquid released from the shell puncture. Crews erected a flare stack near the tank car and burned off remaining propane transferred from the tank over a period of about 12 hours. Following that, crews inerted the car with nitrogen.²¹ The propane fire was extinguished at 6:23 a.m. on Friday, August 4.

Smoke and high sulfur dioxide levels from smoldering molten sulfur fires continued to hamper access to the derailment scene for some time on August 4. Crews placed a water stream

²⁰ An *eduction line* is the pipe that runs from the liquid valve to the bottom of the tank.

²¹ Nitrogen inerting is used to purge flammable vapors in a tank and make the atmosphere oxygen deficient and nonignitable.

over the breached molten sulfur car to cause a crust to form over the material.²² The CSX crew then inerted the car with nitrogen until the sulfur fire was out.

CSX contractors conducted air monitoring until levels of sulfur dioxide were sufficiently low, in accordance with appropriate Pennsylvania Department of Health standards, to allow residents to return to the area. At 11:30 a.m. on Saturday, August 5, the unified command and state health officials agreed that the air quality was sufficiently acceptable for the evacuation to be lifted, and residents were allowed to return at noon.

1.4 Operational Factors

1.4.1 First Crew

According to records obtained from CSX, the first engineer received his most recent certification, which is required every 3 years, in December 2015.²³ He was endorsed for both the conductor and engineer positions. His most recent vision and hearing examinations were conducted in May 2015. Table 1 lists his most recent knowledge and skills examinations. The engineer had been off duty almost 17 hours prior to returning to duty on August 1, 2017.

Table 1. Most recent knowledge and skills evaluation for first engineer.

Knowledge and Skills	Completion Date
Skills Evaluation	11/17/2016
Knowledge Exam	5/11/2015
Territory Physical Characteristics Exam	5/11/2015

The first conductor received his most recent certification in December 2016. His endorsement was for the conductor position. His most recent vision and hearing examinations were conducted in April 2016. Table 2 lists his most recent knowledge and skills examinations. Like the engineer, the conductor had been off duty for almost 17 hours prior to returning to duty on August 1, 2017.

Table 2. Most recent knowledge and skills evaluation for first conductor.

Knowledge and Skills	Completion Date
Skills Evaluation*	--
Knowledge Exam	3/23/2016
Territory Physical Characteristics Exam	3/23/2016

*Skills evaluations are conducted on employees who are qualified as engineers. The conductor was not engineered qualified although some conductors are qualified as both engineers and conductors.

During the postaccident interview, the first conductor stated that although it was “legal procedures,” the engineer had confided that he did not like the loaded cars at the rear of the train, with empty cars toward the front. When the first engineer was interviewed, he stated that he

²² Molten sulfur is shipped at a temperature above its melting point of 235°F.

²³ See 49 *CFR* Part 240 Qualification and Certification of Locomotive Engineers for specific requirements.

“counted 42 empties on the head end of all that tonnage behind it...[As] s an engineer, that really stinks because it hits you a lot. It’s just—I don't like it.”²⁴

1.4.2 Relief Crew

The relief engineer received his most recent certification in December 2016. He was endorsed for both the conductor and engineer positions. His most recent vision and hearing examinations were conducted in May 2016. Table 3 lists his most recent knowledge and skills examinations. According to the relief engineer’s duty logs, he had worked on July 31 for about 12.5 hours, and was off-duty for most of August 1 before being called back on-duty at 11:59 p.m. that day. The derailment occurred a little less than 5 hours into his shift. A toxicology test administered before 11:13 a.m. August 2 was negative for alcohol and other tested drugs.²⁵

Table 3. Most recent knowledge and skills evaluation for relief engineer.

Knowledge and Skills	Completion Date
Skills Evaluation	11/17/2016
Knowledge Exam	05/11/2015
Territory Physical Characteristics Exam	05/11/2015

The relief conductor received his most recent certification in December 2015. He was endorsed for both the conductor and engineer positions. His most recent vision and hearing examinations were conducted in May 2015. Table 4 lists his most recent knowledge and skills examinations. According to the relief conductor’s duty logs, prior to going on-duty at 11:59 p.m. on August 1, he had been off since July 28, 2017. A toxicology test administered at 9:10 a.m., August 2, about 4 hours after the accident, was negative for alcohol and other tested drugs.

Table 4. Most recent knowledge and skills evaluation for relief conductor.

Knowledge and Skills	Completion Date
Skills Evaluation	11/17/2016
Knowledge Exam	5/11/2015
Territory Physical Characteristics Exam	5/11/2015

During postaccident interviews, the relief conductor stated that after the repair had been made to the brake hose on rail car 159, they called the dispatcher and told him that they planned to take the train to the bottom of the hill before releasing the handbrakes. The relief conductor stated that this was standard operating procedure in cases where the train was having problems on a hill.

²⁴ The phrase “hits you a lot” refers to longitudinal run in forces associated with the unloaded cars being pushed by the loaded cars coupled in the rear of the train during train operation associated with braking or descending grades.

²⁵ Drugs tested for included amphetamines, barbiturates, benzodiazepines, cocaine, methadone, opiates, phencyclidine, marijuana, ecstasy, and tramadol. The toxicology test report for the relief conductor did not indicate when the test was administered—only when the specimen was verified by the medical review officer.

1.5 Mechanical Factors

1.5.1 Locomotives

The train was assembled with 5 head-end locomotives (two in tow) and 136 cars in Chicago, Illinois, on July 31, 2017. Twenty-eight additional cars were added in Lordstown, Ohio, and 14 more were added in New Castle, Pennsylvania, on August 1, 2017. No distributed power was assigned to this train at the time of the derailment.²⁶

A postaccident examination of the inspection records for the on-line locomotives noted no reported defects. An on-scene inspection was also performed on the locomotives, and no issues or defects were identified.

1.5.2 Rail Cars

1.5.2.1 Preaccident Brake Inspections

Maintenance records obtained from CSX indicate that every block of rail cars on the consist had passed an FRA Class I brake test and mechanical inspection prior to being added to the train.²⁷ The first block of 74 cars and the ETD received a Class I brake test and mechanical inspection by qualified CSX mechanical department personnel in Chicago, Illinois, on July 31, 2017, with no defects noted. The second block of 62 cars received a Class I brake test and mechanical inspection by qualified Belt Railway Company mechanical department personnel in Chicago, Illinois, that same day, with no defects noted.

When the train arrived at Lordstown, Ohio, approximately 390 miles from the originating location, 28 additional empty rail cars were added to the front (head end). These 28 cars received a Class I brake test and mechanical inspection by the train crew in Lordstown, Ohio, on August 1, 2017, with no defects noted. When the train arrived at New Castle, Pennsylvania, approximately 430 miles from the originating location, 14 additional cars (six loaded and eight empty) were added behind the 8th car. These 14 cars received a Class I brake test and mechanical inspection by the train crew in New Castle, on August 1, 2017, with no defects noted. Leaving New Castle, the train consist had 178 cars, as indicated by the automatic equipment identification (AEI) wayside detector located at the east end of the yard.²⁸

Of interest to investigators was the condition of the intermediate air brake hose on the 159th rail car, the cause of the air leak that resulted in the initial train crew stopping the train at MP

²⁶ *Distributed power* is a generic term referring to the physical distribution—at intermediate points throughout the length of a train—of separate motive power groups. Such 'groups' may be single locomotives or multiple consists and are remotely controlled from the leading locomotive. This positioning allows more locomotives to pull longer trains without separation from overpowering.

²⁷ (a) A *block of rail cars* is a group of cars routed for a common destination, which is not necessarily the final destination. (b) A Class I brake test consists of tasks and requirements defined in 49 *CFR* 232.205, including air leakage testing and observation of functioning of all moving brake system parts.

²⁸ An *automatic equipment identification* (AEI) is an electronic recognition system in use with the North American railroad industry. Consisting of passive tags mounted on each side of rolling stock and active trackside readers, AEI uses radio frequency technology to identify railroad equipment while it is en route.

205.6. (See figure 5.) According to one of the mechanics who replaced the defective hose prior to the derailment, the hose that attached from the angle behind the angle cock to the train line was kinked and leaking.²⁹ The mechanic stated that the hose was “basically falling apart. You could see the internal threads.... I guess it was an older hose.”

Investigators inspected the damaged hose that was removed and found no visible signs of kinking. The hose was fitted with a coupling on one end and a pipe nipple and cap on the other. The hose was then pressurized to identify the location of the leak. The hose leaked at one end just behind the hose clamp and flange fitting. After returning the damaged hose to the Cumberland, Maryland, terminal for further testing, investigators attached the hose to the rear of a 67-car freight train. Leakage, measured by a pressure drop over time, on the train before attaching the hose at the rear was 2 psi over a span of 3 minutes in compliance with FRA minimum safety standards. After attaching and aligning air into the leaking hose, the pressure drop increased by 1 psi (to a 3-psi drop) within 3 minutes, which was within the federal threshold.³⁰



Figure 5. Close-up view of defective intermediate air brake hose removed from car LW 62114.

Investigators also examined the ETD that had been on the train and found that it also leaked air near the connection to the brake pipe hose. A brake pipe leakage test was performed with both the worn intermediate air brake hose and the ETD installed on a train with 4 locomotives and a consist of 147 cars. The test determined that the ETD and defective brake pipe hose resulted in a 2 psi drop per minute of brake pipe leakage, which was within the federal regulatory threshold.

²⁹ An *angle cock* is a special type of 1 1/4-inch valve located at both ends of the brake pipe on locomotives and rail cars and used to control admission of air to the brake pipe on individual cars. The free end is angled at 45° and is threaded to receive the air hose nipple.

³⁰ Title 49 *CFR* 232.205 states that brake pipe leakage “shall not exceed 5 psi per minute.”

1.5.2.2 Postaccident Car Investigation

After examining the wreckage investigators determined that 31 of the 33 cars that derailed had their handbrake applied.³¹ Several overheated wheels had flat spots and evidence of tread buildup.³² Table 5 summarizes the number of cars within each position group and the corresponding handbrake status.

Table 5. Derailed rail car summary.

Car Position	Number of Cars	Loaded/Empty	Number of Hand Brakes Applied	Location Added
33-42	10	Empty	9	Lordstown, PA
43-49	7	Loaded	7	Chicago, IL
50	1	Empty	1	Chicago, IL
51-57	7	Loaded	7	Chicago, IL
58	1	Empty	1	Chicago, IL
59-65	7	Loaded	6	Chicago, IL
Total Loaded	21	--	--	--
Total Empty	12	--	--	--

A rail car truck assembly with damage consistent with being derailed was discovered between the point of derailment (POD) and the location of the general pile-up. It was identified as the truck assembly from FWTX 620111 (35th car). The truck assembly was discovered 600 feet away from the resting location of FWTX 620111. There were several indications that this truck assembly had derailed prior to the general pileup. These included gouges on the bottom of the side frame (consistent with impact with the rails), damage to the inside vertical surfaces of the side frame (where the wheel made contact) and damage to the tread of the wheels (consistent with contact with the roadbed). This truck assembly was from the leading end (in the direction of movement) of FWTX 620111 on the train at the time of derailment. All the wheels of FWTX 620111 showed signs of overheating. The 1st and 3rd axles (in the direction of movement) had a reddish-brown discoloration on both the front and back of the rim, which extended more than 4 inches into the plate. These wheels also had extensive tread buildup, especially along the throat of the flange as can be seen in figure 6.

³¹ Due to the fire and damage, it could not be determined if all the derailed cars had their hand brakes applied.

³² *Tread buildup* is the accumulation of metallic material on the tread surface of a railroad wheel. The source of the metallic material is thought to be a combination of wheel and rail steel. The root cause of tread buildup is wheel slide caused by excessive brake force. Train speeds between 20 and 30 mph appear to increase tread buildup height. Tread buildup is the second most common cause of wheel-related accidents (FRA 2015).



Figure 6. Closeup of wheel tread surface showing tread buildup on wheel of the 35th car.

Investigators reviewed data from a wayside detector located less than 7 miles before the POD, which monitored axle journal bearing temperature for overheating/failure. No defects were indicated by this detector as Q38831 passed through. Investigators also reviewed 90 days of wayside wheel impact load detector data for the first 66 cars of Q38831, which included FWTX 620111 and all the cars that derailed or passed beyond the general pileup without derailling. The data showed normal readings.

1.6 Track Factors

1.6.1 General Characteristics

The accident track was part of the Keystone Subdivision, which consisted of 87.1 miles of double main track and 2.7 miles of single main track between MP 178.6 and MP 268.4 with one passing siding. The subdivision's average daily train count was 30. According to CSX documentation, the 2016 total tonnage figure for the subject track between MP 178.6 and

MP 268.4 was about 39.2 million gross tons. CSX inspected and maintained the main track on this portion of the Keystone Subdivision to FRA track safety standards for Class 3 track, which allowed for a maximum operating speed of 40 mph for freight trains and 60 mph for passenger trains.

Traveling on main track 2, the train moved through a descending grade beginning at MP 209.8 (top of grade) to MP 192.3 (train resting location). The grade is one of the steepest grades in the CSX system. At the POD (MP 193.8), the train was moving through a right-hand curve that has a permanent speed restriction of 30 mph for freight trains. (See figure 7.) As stated previously, the train had been traveling at 29 mph at the time of derailment.

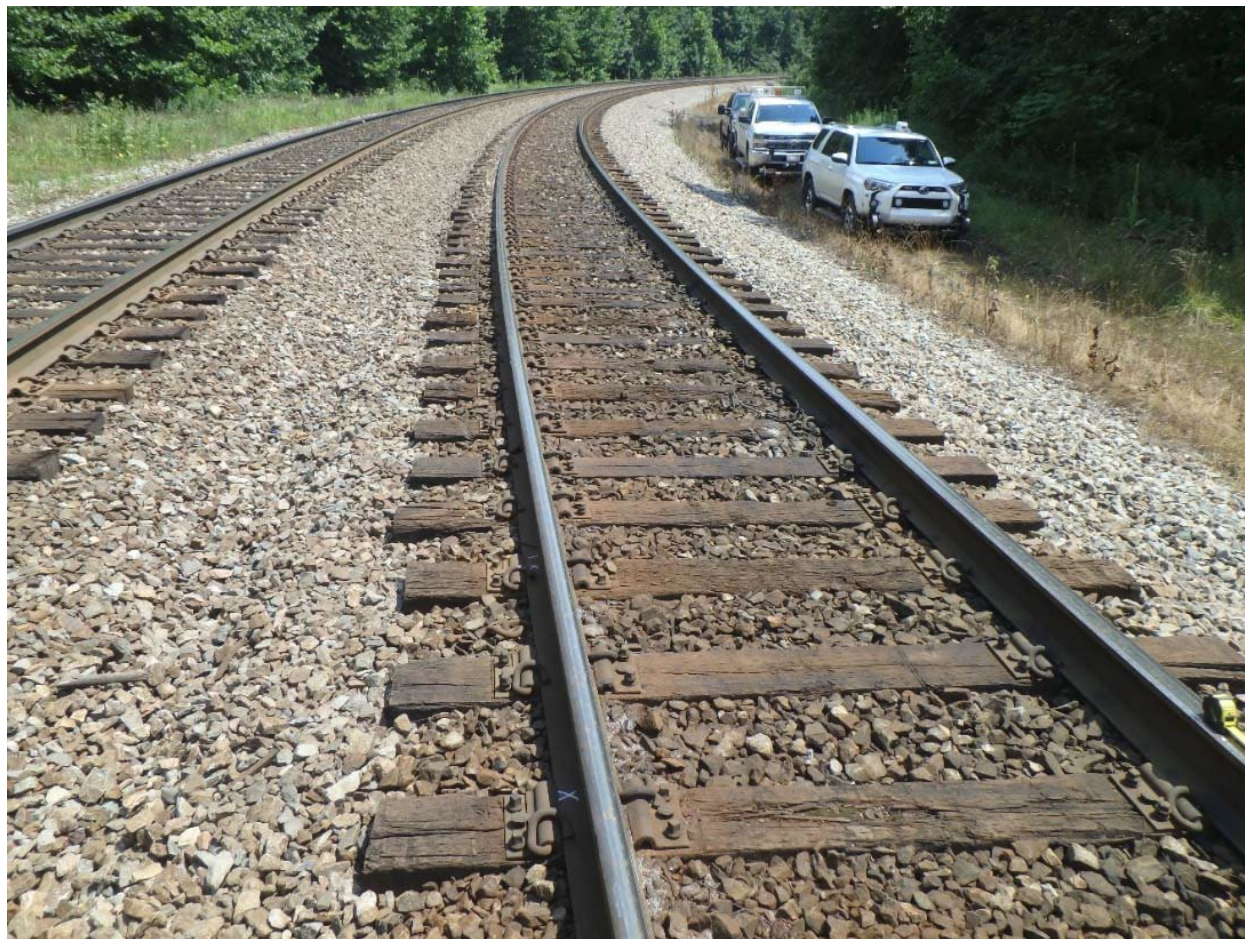

Figure 7. Accident curve facing east toward direction of accident train travel.

1.6.2 Postaccident Track Investigation

A postaccident inspection of the rail, shown in figure 8, identified the POD from a flange mark traversing over the top of the rail head of the high rail in the curve.³³ Corresponding wheel departure marks were identified across the top of the rail head of the low rail of the curve. The POD was about 1.5 miles west of the highway rail grade crossing (Old Schellsburg Road) where

³³ The *high rail* is defined as the rail in the outer radius of the track curve and the corresponding *low rail* is the inner rail in the curve radius.

the other rail cars departed the tracks. This crossing is in a left-hand curve.



Figure 8. Flange mark at point of departure of FWTX 620111 (35th car).

The postaccident inspection of the track structure found that the track alignment was uniform; the rail was lubricated; the crosstie conditions met FRA requirements, and no track surface issues were noted. The rail fasteners were in place and secure, and the ballast and drainage conditions also complied with Title 49 *Code of Federal Regulations (CFR)* Part 213 Track Safety Standards.

Inspectors found rail wear on the gage face of the high rail in the accident curve.³⁴ The amount of wear was within the maintenance limits permitted by CSX. To help reduce this rail wear, the railway industry has rail lubricators that apply lubrication to the rails as rail cars move over them. This lubricant reduces the friction at the contact point between the rails and the wheels. Investigators noted the presence of rail lubricant in the curve at the POD.

CSX records indicated that the company had performed a track geometry survey twice in 2017 preceding the accident, with the most recent survey conducted on June 13, 2017, and found

³⁴ *Rail wear* is defined as the deviation in the actual dimensions of the rail head from those of a new rail. *Gage face* refers to the side of the inner rail.

no defects. CSX also conducted an ultrasonic rail test for the Keystone Subdivision, with the most recent on July 21, 2017; no defectives rails were identified in the accident curve.

In addition to inspections by CSX, the FRA conducted a survey under its Automated Track Inspection Program on May 5, 2017. This survey included main track 2 through the accident area, with no track geometry conditions identified within 60 miles of the POD. An FRA track safety inspector also performed a regulatory track inspection on June 27, 2017. Four deviations from FRA track safety standard were identified, including a defective switch component at MP 190.2. The FRA inspector documented that CSX addressed this condition with the placement of a speed restriction.

1.7 Hazardous Materials

The train consist included 70 rail cars that contained hazardous materials. (See table 6.) Fifteen of these cars derailed and three released hazardous materials after sustaining damage:

1. Tank car UTLX643949 (46th car in the consist)—molten asphalt released from an open bottom outlet valve.³⁵
2. Tank car ITDX5082 (49th car in the consist)—molten sulfur released from two shell tears.³⁶
3. Tank car CBTX 781553 (53rd car in the consist)—propane released from a shell puncture.³⁷

Table 6. Hazardous materials on train Q38831 (derailed cars in bold italics).

Commodity	Hazard Class	Position in Train*
UN3257 Elevated Temperature Liquid	9	9, 10, 45, 46
UN1075 Isobutane	2.1	12, 13, 14
NA2448 Molten Sulfur	9	47, 48, 49, 61, 62, 63, 64, 65, 66, 84, 85, 148, 149, 150, 151
UN2448 Molten Sulfur	4.1	114, 115, 116, 117, 118, 119, 120, 121, 122, 123, 124, 125, 126, 127, 128, 129, 130, 157

³⁵ The molten asphalt was shipped at a temperature above 212°F and could be easily ignited by heat, sparks, or flames. If released, vapors could form an explosive mixture with air. The recommended initial downwind evacuation in the event of a large spill is 1,000 feet. The recommended isolation distance is 0.5 miles in all directions if the asphalt catches fire.

³⁶ The molten sulfur was shipped at an elevated temperature to keep it in a liquid state for ease of transport. When ignited, molten sulfur may release sulfur dioxide gas. It may be ignited by friction, heat, sparks, or flames, and it may burn rapidly with flare-burning effect. The recommended isolation distance for a large spill is 330 feet. If a rail car is involved in a fire, the recommended isolation distance is 0.5 miles in all directions.

³⁷ Propane is shipped as a liquefied gas under its vapor pressure. It is extremely flammable and easily ignited by heat, sparks, or flames. Its vapors are heavier than air, and a flame can flash back to the source of the leak. Containers may rupture violently and rocket under prolonged exposure to fire or heat. The recommended isolation distance is 1 mile in all directions in a scenario where a rail car containing propane is involved in fire.

Commodity	Hazard Class	Position in Train*
UN1805 Phosphoric Acid Solution	8	50, 58, 88, 112
UN1075 Liquefied Petroleum Gas	2.1	51, 52, 53, 89
UN1075 Liquefied Petroleum Gas (LPG)	2.1	90, 91, 92
UN1987 Alcohols, N.O.S.	3	75, 76, 77, 78, 79, 80, 81, 99, 100, 101, 102, 103, 104, 105, 106
UN1170 Ethyl Alcohol	3	107, 108
UN1495 Sodium Chlorate	5.1	131
UN1206 Heptane	3	168

*Derailed cars are in bold italics.

1.7.1 Molten Asphalt Tank Car

Tank car UTLX643949 carried molten asphalt and was a specification U.S. Department of Transportation (DOT)-111A100W1 tank car that was built in October 2013 and owned by Union Tank Car. The tank car had a load limit of 191,000 pounds and a tank capacity of 23,467 gallons. (See figure 9.)³⁸ The tank heads and shell were constructed of 0.4375-inch A516-70 nonnormalized steel. The tank was equipped with steam coils and covered with 4 inches of fiberglass insulation and an 11-gauge jacket. The tank car did not have head shields or a thermal protection system.

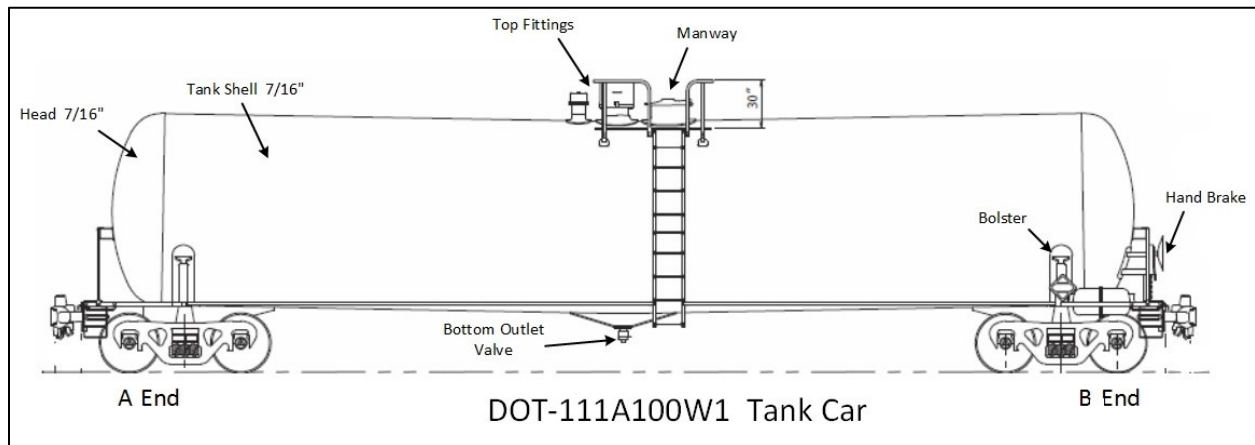

Figure 9. Diagram of a DOT-111A100W1 tank car.³⁹

The derailment left the tank car with a missing bottom outlet valve nozzle, a bent operating handle, and the ball valve in the completely open position as shown in figure 10. Most of the asphalt released through this open ball valve. The left side of the shell was also crushed with significant loss in tank volume. The entire load of about 23,000 gallons of asphalt released and pooled on the two residential properties north of Cleveland Street in Hyndman.

³⁸ A *body bolster* is a cross-beam attached to the underside of a car body near the end that contains the apparatus that supports and stabilizes the car on its trucks. This apparatus generally consists of the body center plate and a pair of body side bearings. More related technical details can be found in the public docket.

³⁹ Rail cars have an “A” end and a “B” end. The “B” end has a hand brake wheel, and the other end is the A end.



Figure 10. UTLX643949 open bottom outlet valve.

1.7.2 Molten Sulfur Tank Car

Tank car ITDX5082 was a specification DOT-111A100W1 tank car with a 13,880-gallon capacity. Trinity Tank Car, Inc. constructed the tank car in February 2001, and it was owned and maintained by Sulcom, Inc. The tank car had a load limit of 203,800 pounds, a tare weight of 59,200 pounds, and a gross rail load of 263,000 pounds.⁴⁰ The tank head and shell were both constructed of 0.4375-inch A516-70 steel. The tank had 6 inches of fiberglass insulation, steam coils, and an 11-gauge steel jacket. The tank did not have head shields or a thermal protection system.

Most of the 13,000 gallons of molten sulfur product contained in tank car IDTX5082 released and ignited. (See figure 11.) The tank car sustained a 7-foot transverse shell tear in the right center of the car. The bottom of the car sustained a 32 x 18-inch puncture midway between the bottom outlet valve and the A end.

⁴⁰ *Tare weight* is the weight of the empty car. The sum of the empty weights of the cars is the tare weight of the train.



Figure 11. Burning molten sulfur released from tank car IDTX5082.

1.7.3 Liquefied Petroleum Gas Tank Car

Tank car CBTX 781553 was a specification DOT-112J340W tank car, intended for the transportation of LPG products. Trinity Tank Car constructed the tank car in November 2013. It was owned by CIT Rail, which was responsible for periodic qualification and maintenance. It had a water capacity of 33,710 gallons, a test pressure of 340 psig, and a burst pressure rating of 850 psig. The tank heads and shells were constructed of 0.608-inch TC-128 Grade B TCVN-30F steel. The semi-ellipsoidal heads were protected with full diameter 0.5-inch thick head shields constructed of ASTM A572-50 steel. The tank was equipped with one pressure relief device with a start-to-discharge setting of 280.5 psig. It was also equipped with a thermal protection system consisting of 0.5-inch thick 4.5 lb/ft³ ceramic fiber thermal blanket and an 11-gauge steel jacket. The tank car had not been modified from its original construction configuration. (See figure 12.)

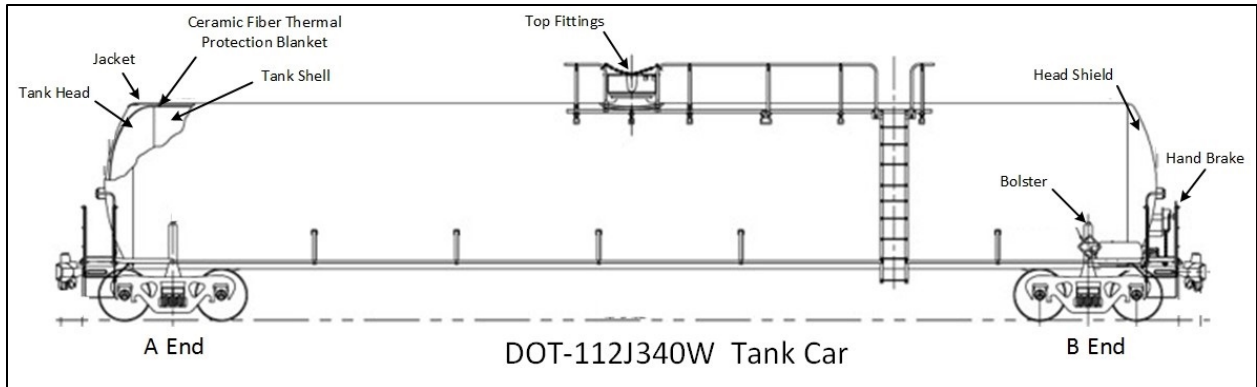

Figure 12. Diagram of tank car CBTX 781553 (a DOT-112J340W tank car).

The A end of CBTX 781553 was leading in the eastbound train consist. The car came to rest with the A end facing east, parallel to and about 2 car lengths south of the track. The bottom of the car was in contact with a pool of burning molten sulfur released from tank car ITDX5082. The car was punctured and released burning propane, with torch fires escaping from holes and gaps in the jacket at several locations the length of the car. The most vigorous flame was observed at the right A end. (See figure 13.) As the postaccident emergency response actions progressed, the fire became restricted to the A end of the car. Aerial video and visual examination of the pressure relief device did not show any evidence that it had activated.



Figure 13. CBTX 781553 with puncture location circled, August 3, 2017, 2:46 p.m.

Investigators found a shell puncture at about the 3 o'clock position on the right side of the A end in the first barrel section. (See figures 14 and 15.) The puncture measured about 3.25 inches

in length and was oriented longitudinally. The puncture was within a dent measuring about 3.5 inches deep, with evidence of sliding contact in an upward direction. The shell fracture was isolated to the impact area and did not show any visual evidence of brittle propagation. Ultrasonic gauge thickness measurements of the tank shell in this region found thinning from 0.630 inch in a nearby unaffected area to 0.537 inch at the top edge of the puncture.

Investigators removed a section of the punctured tank shell plate 1 to examine the interior surface of the puncture as shown in figure 15. Penetration into the shell became deeper toward the A end. At the A-end side of the puncture, the crack turned downward about 1/2 inch in the circumferential direction. Carbon was deposited on the interior shell surface above the breach.

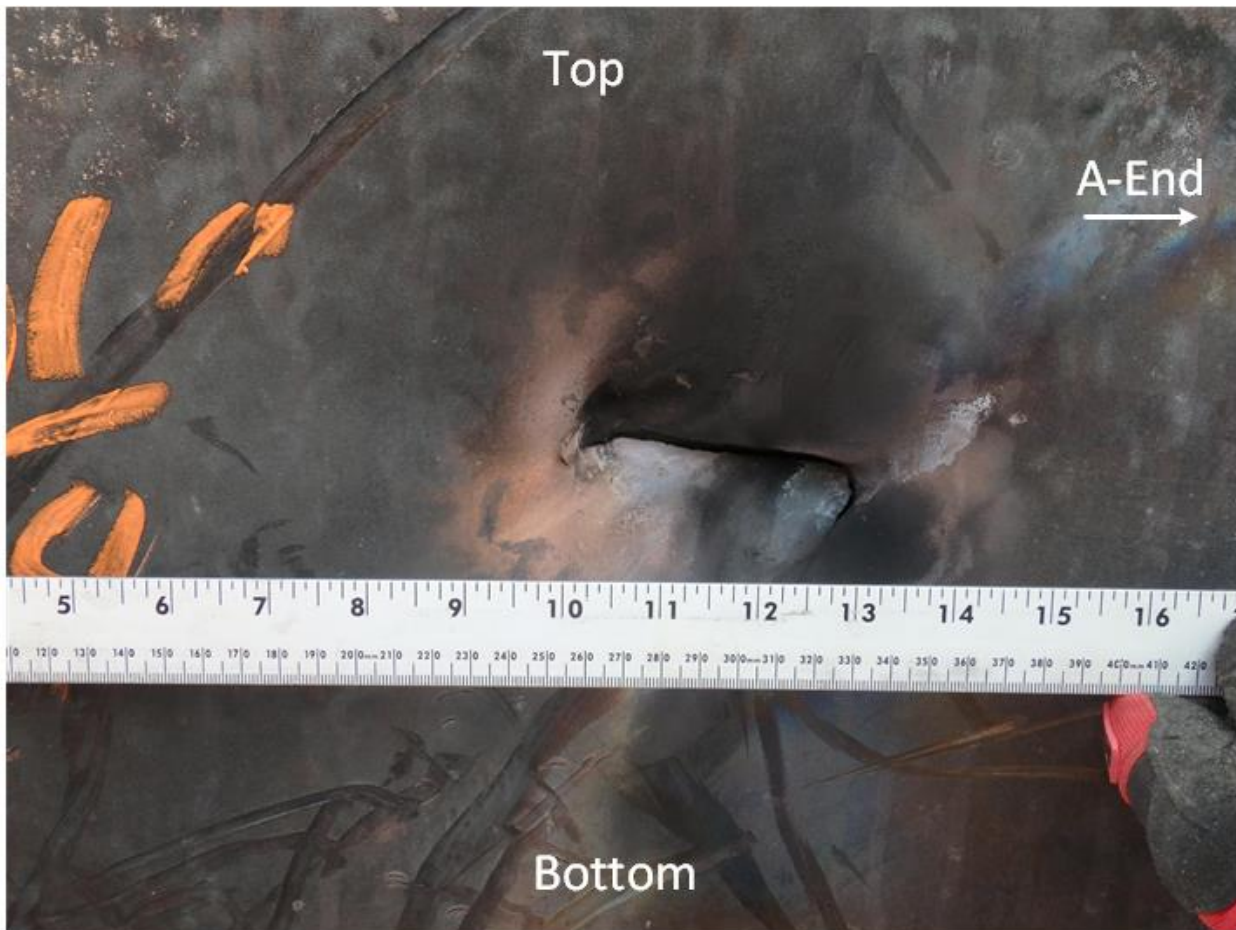

Figure 14. Tank Car CBTX 781553 puncture in exterior surface, August 4, 2017.

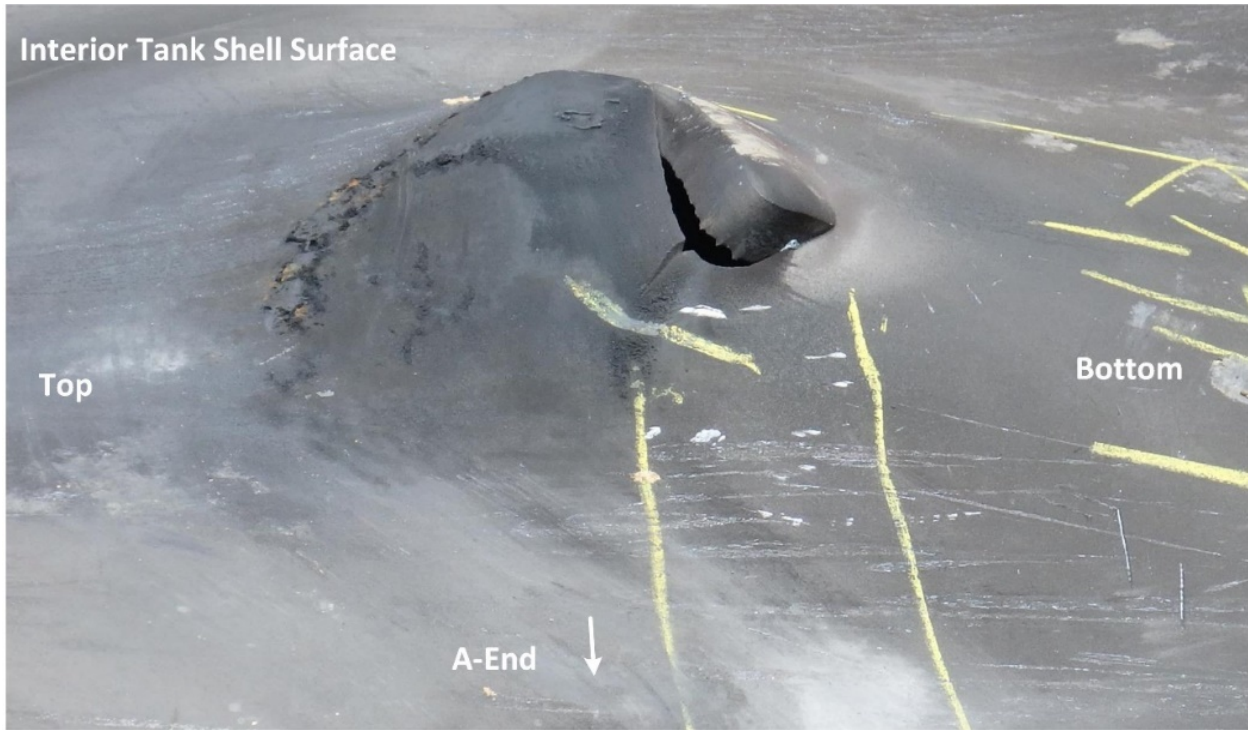

Figure 15. CTBX 781553 interior surface of shell puncture, August 5, 2017.

A shell bulge was observed closer to the A end, above the right-side body bolster in ring 1 of the tank shell. The bulge measured 27 inches in the longitudinal direction and 56 inches in the circumferential direction and protruded outward about 5 inches. (See figure 16.) Ultrasonic thickness measurements taken at about 2-inch intervals across the center of the bulge found that the shell thinned from 0.630 inches in a nearby unaffected area, to 0.436 inches at the thinnest location near the edge of the bulge. The Certificate of Construction reported a nominal shell thickness of 0.608 inches.⁴¹

⁴¹ The Certificate of Construction includes the design specification for a specific rail car.



Figure 16. CBTX 781553 tank shell coupon showing bulge profile, August 5, 2017.

1.8 Supplementary Information

1.8.1 Emergency Response Guidance Involving LPG/Propane

The NTSB identified several sources of guidance directed to emergency responders responding to accidents involving railroad pressure tank cars, including those that meet DOT-112 specifications. This guidance includes assessing damage that may be hidden from view during emergency response or wreckage clearing operations because of the presence of tank jackets or the orientation of tank cars in a derailment pileup.

1.8.1.1 Federal Railroad Administration Research

In 2002 and 2005 the FRA published reports on tank car damage assessment to evaluate the validity of recommended practices and to revise guidelines used to assess the severity of derailment damage to pressure tank cars. These guidelines are intended to avoid exposing personnel to the phenomenon of delayed tank fracture (FRA 2002, 2005). The FRA noted that although mechanisms of delayed fracture in pressure tank cars are not well documented or understood, delayed fractures have occurred and can place emergency response and wreckage clearing personnel at risk of death or injury.

The FRA noted that tank car damage assessment is inherently dangerous because of conditions such as pre-existing cracks not visible to responders, defects in material or workmanship of the tank or its welds, and jackets covering pre-existing or accident-caused damage such that it is not visible to the responders. The FRA states that it is always prudent to limit access to an accident site involving damaged compressed gas tank cars until a thorough damage assessment can be made.

The 2005 FRA report contains revised damage assessment guidelines for interpreting the seriousness of various types of damage, and states that accurate damage assessment of jacketed tank cars can only be done when the jacket and insulation or thermal protection are removed. The guidelines state that although damage to a jacket itself is of little consequence, serious jacket damage may be an indication of tank damage behind the jacket.

1.8.1.2 Association of American Railroads *Field Guide to Tank Cars*

The Association of American Railroads (AAR) *Field Guide to Tank Cars* provides information about the safety systems employed on tank cars, guidelines for initial emergency response, and tank car damage assessment (AAR 2017). The tank car damage assessment guidelines provide first responders with information for making an initial appraisal to determine what action should be taken until expert assistance is available.

Among other things, the *Field Guide* states the following:

- The most serious damage that can occur to tanks and other containers transporting compressed gases is caused by bending, denting, scoring, or gouging without resultant leaks. Time, pressure, and handling can result in delayed rupture.
- Virtually all liquefied compressed gases are shipped in tank cars that are equipped with jackets and that tank damage refers to damage to the tank itself—not the surrounding jacket.
- Each visible dent, score, or gouge must be examined. Newly exposed surfaces must be examined as adjacent cars or surrounding materials are removed, or as the tank car itself is moved.
- When fire, especially a torch-like flame, impinges on a tank, a high-volume hose stream directed at the point of flame contact may prevent dangerous heat and pressure buildup in the tank.
- Torch fires occur when a tank has been punctured or the pressure relief valve functions as well as other sources where flammable gas is burning out of the opening with strongly projecting flame. With this kind of fire, a large standoff distance is required, and unmanned monitor nozzles provide greater protection for responders than hand lines.

1.8.1.3 DOT Emergency Response Guidebook

The *Emergency Response Guidebook (ERG)* is a reference resource intended for use by first responders during the initial phase of a transportation incident involving hazardous

materials (DOT 2016).⁴² The *ERG* is primarily a guide to quickly identify the hazards of the material involved in the incident, and to protect first responders and the public during initial incident response activities.

ERG Guide No. 115 provides emergency response guidance for UN1075, the DOT placard number for propane and other flammable gases. The *ERG* states if a rail car is involved in a fire, isolate and evacuate for 1 mile in all directions. The guide recommends not to attempt to extinguish a leaking gas fire unless the leak can be stopped. For fire involving tanks, fight fires from maximum distance or use unmanned hose holders or monitor nozzles. The guide recommends that personnel withdraw immediately in case of rising sound from venting safety devices or discoloration of tank. The guide states: “ALWAYS stay away from tanks engulfed in fire.”

Furthermore, the *ERG* contains a special section with safety precautions for boiling liquid expanding vapor explosions (BLEVE). This section of the guide provides background information on BLEVEs and provides important safety-related information when confronted with situations involving LPGs. The main hazards from a propane or LPG BLEVE are fire, thermal radiation from the fire, blast, and projectiles.

For a tank car-sized tank, the BLEVE safety precautions provide estimated minimum time to failure in as little as 9 minutes based on a severe torch fire impingement on the vapor space of a tank in good condition. Tanks may fail earlier if they are damaged or corroded or may fail minutes or hours later than the minimum times provided depending on conditions. For a tank car-sized tank, the BLEVE safety precautions also suggest a minimum emergency response distance of about 1,500 feet and a preferred evacuation distance of about 7,200 feet (DOT 2016).

The guide also references a video, *BLEVE Response and Prevention*, which was produced for Transport Canada and available from its website (Birk 1995). The information contained in this video was prepared for Transport Canada, the Canadian Association of Fire Chiefs, and the Propane Gas Association of Canada, Inc., by Dr. A. M. Birk, Queen’s University, Kingston, Ontario, Canada. Topics covered in the video include BLEVE hazards and recommended safe distances for emergency responders when a fire is close to a pressured tank or tank car.

1.8.2 Previous NTSB Investigation of LPG Tank Car Delayed Rupture

On February 22, 1978, 23 tank cars of a Louisville and Nashville Railroad Company train derailed in Waverly, Tennessee. A derailed tank car containing LPG ruptured, releasing the product which ignited with explosive force (NTSB 1979). The specification DOT-112A400W tank car was not equipped with a jacket, insulation, thermal protection, or head shields.

On February 24, about 40 hours after the accident, crews raised one end of the loaded tank car, using the opposite end as a pivot to move the car from the track. As the tank car was moved, a fracture originated in the gouged girth weld and propagated in each direction from the gouge,

⁴² The 11th edition (2016) version of the *Emergency Response Guide (ERG)* was the reference source used during this accident. However, the 12th edition of the *ERG* was just released in mid-August 2020. Many sections have been revised and made easier to read. The BLEVE section in the 2020 *ERG* has been reworked into the BLEVE and Heat Induced Tear Section. This section now shows the cause and hazards of BLEVEs and heat-induced tears.

causing the tank to separate into four large pieces. Large tank fragments were propelled as far as 350 feet when the product ignited. The tank car rupture and resulting fires killed 16 people and injured 43 others.

The NTSB determined that the probable cause of the accident was the release and ignition of LPG from a tank car rupture. The rupture resulted from stress propagation of a crack, which may have developed during movement of the car for transfer of product or from increased pressure within the tank.

The NTSB accident report pointed out the need for training of all persons involved with hazardous materials accidents. The NTSB also stated that the inability of anyone at the scene to properly assess the mechanical damage sustained by the tank cars also indicated a need for additional knowledge.

Since the accident in Waverly, Tennessee, and several others that occurred in the 1960s and 1970s involving uninsulated pressure tank cars transporting hazardous materials, the DOT mandated that specification 112 and 114 tank cars carrying liquefied compressed flammable gases be equipped with shelf couplers, tank head puncture resistance systems, and thermal protection systems (*Federal Register* 1978, 30057). Modern tank cars, such as accident tank car CBTX 781553, typically have thermal protection systems that consist of a 0.5-inch thick ceramic fiber blanket shell covering, covered by an 11-gauge steel jacket.

2. Analysis

2.1 Introduction

On August 2, 2017, 33 of 178 cars derailed as CSX train Q38831 entered the borough of Hyndman, Bedford County, Pennsylvania. Fifteen of the derailed cars contained hazardous materials, and 3 were breached, resulting in the release of hazardous materials. The accident did not result in fatalities, but 1,000 residents within a 1-mile radius were ordered to evacuate on August 2 and were not permitted to return until August 5, 2017.

2.1.1 Exclusions

As a result of its investigation, the NTSB established that the following did not cause or contribute to the accident:

- *Train crew experience and training:* The relief crew was properly trained and certified to operate the train.
- *Impairment:* The results of postaccident toxicological tests performed on the relief crew were negative for alcohol and other impairing drugs.
- *Fatigue:* The work schedule suggested that the relief engineer and conductor had ample sleep opportunity prior to beginning their shift.
- *Track structure condition:* A postaccident inspection of the track structure revealed that the track in the accident area met the required maintenance and safety standards.

The NTSB concludes that none of the following were factors in the derailment: train crew experience and training; physical or mental impairment of the train crew due to alcohol, other impairing drugs, or fatigue; or track structure condition.

2.1.2 Safety Issues

The following analysis focuses on three issues identified in the investigation of the derailment in Hyndman, Pennsylvania. These issues include CSX's operational practices for building train consists ([Section 2.2](#)), the use of hand brakes for controlling train movements ([Section 2.3](#)), and assessment and response to fires involving jacketed pressure tank cars ([Section 2.4.2](#)).

2.2 CSX Operational Practices for Building Train Consists

Of the 42 cars at the head of train Q38831, 36 were empty cars with one block of 2 and one block of 4 loaded cars placed among them. Car FWTX 620111 (35th car) was in a solid block of 27 empty cars. The lead 42 cars at the head of the train were followed by a solid block of 44 loaded cars. The train was built in a manner consistent with CSX's Equipment Handling Rule 4466, which stated that solid blocks of six or more loaded cars should not be placed directly behind solid blocks

of 30 or more empty cars. The intent of this rule was to mitigate excessive lateral forces that may lead to or contribute to wheel lift or other undesirable train performance outcomes.

Although consistent with the current CSX handling rule, the lead cars were still subject to excessive lateral forces as they negotiated the curve, due to the mass of the trailing cars pushing behind them as the train descended the grade. The 42 lead cars comprised about 24 percent of the train's total cars, yet they made up only 10 percent (1,883 tons) of the train's total tonnage due to the number of empty cars. When interviewed, both the relief train crew and the prior crew expressed concerns that so many empty rail cars were at the front of the consist. Operational practices allowed the train consist, which was assembled with more uniform weight distribution when it left its point of origin in Chicago, to be altered during the route for purposes of time and efficiency, changing the forces exerted on empty cars. The NTSB Office of Research and Engineering conducted a study of the train forces leading up to this derailment. Calculations were made using the force required for the recorded motion distributed between the cars based on recorded tractive effort and brake pipe pressure with normal brake behavior, with handbrakes added.

The ratio of lateral to vertical force (L/V) is an important contributor to derailment. Lateral force is due to a combination of the force required to produce the centripetal acceleration needed to move around turns and any left or right component of coupler force. Coupler force on the first derailed car (35th car) was high at the POD. The 35th car derailed with both the fore and aft couplers under compression. Since the local cars are in a right turn at the POD, the couplers are angled to the right. This results in an outward (left) force on the rail car.

Ninety percent of the train's tonnage was behind the lead 42 cars. As a result of the trailing tonnage imparted into the lead cars because they were empty, the lead cars were more prone to derailment because of the excessive longitudinal forces present during braking in a descending grade with a curve. As discussed above, this has a significant impact on the L/V ratio. The arrangement of the consist, in combination with the tread buildup from the frictional forces exerted on the wheels, led to the initial derailment of rail car 35 followed by the derailment of 32 other rail cars as the train reached the borough of Hyndman. The NTSB concludes that CSX's Equipment Handling Rule 4466 does not sufficiently address excessive lateral forces that may lead to or contribute to wheel lift or other undesirable train performance outcomes. Therefore, the NTSB recommends CSX revise its rules for building train consists to require that large blocks of empty cars be placed toward the end of the consist.

2.3 Control of Train Movement

Before proceeding toward Cumberland, Maryland, the relief crew informed dispatch of its plan to descend the grade with all 58 handbrakes applied within the first 64 cars. When they were unable to move, the conductor released 25 of the handbrakes within the first 58 cars, leaving 33 applied. Most of the derailed cars had their handbrakes applied. (See [Section 1.2.2](#) and [Table 5](#) for further details.) Because the empty rail cars lacked sufficient mass, it is likely that the application of the handbrakes on the empty cars caused the wheels to slide on the rails, continuously pushed along by the tonnage of the trailing rail cars. Evidence collected on scene indicated that many of the wheels from these empty cars overheated as they were shoved down the descending grade.

Friction between the wheel and brake shoes, which resulted in brake fade, and friction between the wheels and the rails were the two primary sources of heat.⁴³ The extreme heat led to the accumulation of metallic material on the treads of the wheels, particularly the #3 wheel of 35th car. Built up tread is the result of the wheels sliding along the rails due to brakes being applied or other mechanical defects, and metal builds up on the surface where the wheel meets the rail (FRA 2015). This tread buildup was extensive, especially along the throat of the flange, effectively reducing the wheel flange angle and relative flange height, thereby making the train more susceptible to derailment. As the train negotiated a curve, the combination of the altered wheel profile and the excessive lateral forces on the empty rail cars led to the derailment of the 35th rail car on a worn but serviceable section of rail. The NTSB concludes that the application of hand brakes on empty rail cars toward the front of the consist caused the wheels of those cars to overheat and build up tread. The NTSB further concludes that the tread buildup on the wheel of the 35th rail car compromised the ability of the wheel flange to keep the wheels on the track as the train negotiated the curve, causing the derailment. The NTSB therefore recommends that CSX prohibit the use of hand brakes on empty rail cars for controlling train movement in grade territory.

2.4 Tank Car Integrity

2.4.1 DOT-111 Tank Cars

The breaching mechanism for UTLX643949, which carried the liquid asphalt, was a bottom outlet valve that opened when the operating handle was bent and manipulated to its open position from contact with the ground or other derailment debris. The operating handle was secured from opening with a retention pin. If force is applied to the handle, the pin is designed to break away, leaving the bottom outlet ball valve closed. However, this does not always occur because the handle can bend under load rather than break free, or its retaining pin can break because the handle itself is too robust. For new flammable liquids tank cars, this problem has been solved with alternative bottom outlet designs that call for a detachable operating handle or a sleeved handle that can decouple from the ball valve stem. The Pipeline and Hazardous Materials Safety Administration (PHMSA) has not prioritized tank car design modifications for commodities such as elevated temperature material because the risk of serious consequences is perceived to be low. While the released asphalt did not ignite or contribute to the postaccident fire, it did flow a considerable distance into adjacent residential yards damaging fruit trees and gardens.

The tank shell of molten sulfur car ITDX5082 was severely breached with angular folded tears when its shell was torn by the couplers of two other rail cars. This resulted in most of the molten sulfur contents quickly releasing to form a pool that flowed downhill and surrounded the LPG tank car CBTX 781553. DOT-111 tank cars like ITDX5082 have the minimum lading protection features authorized for tank cars in hazardous materials transportation, except that this car was equipped with a tank jacket that provided some increased puncture resistance over baseline DOT-111 tank cars. The poor fracture resistance of the 7/16-inch tank shells used in DOT-111 car construction has been well documented in NTSB investigations such as the derailment of Canadian

⁴³ Brake fade is caused by the wheels and brake shoes overheating due to excessive braking. This overheating diminishes the abrasive properties of the brake pads and wheel tread.

National Railway freight train U70691-18 and the subsequent release of hazardous materials in Cherry Valley, Illinois, on June 19, 2009 (NTSB 2012).

In coupler-to-shell impact scenarios such as the Hyndman derailment, the shape of the coupler face can result in concentrated loading forces, leading to greater puncture potential from coupler face corners and edges. Furthermore, impact angles of 45-degrees, such as apparently was the case with ITDX5082, result in significantly less energy required to puncture the shell than impacts at more oblique or narrower angles (FRA 2013). Thus, tank car ITDX5082 was subjected to a near worst-case impact scenario for the survival of the tank. The derailment speed of 20–30 mph was also well above the expected best-case coupler-to-shell puncture threshold for jacketed DOT-111 tank cars of about 12.1 mph with a 12 x 12-inch uniform-surface impactor (FRA 2014).

The breaching mechanisms observed for these two tank cars have been widely observed and cited as evidence of significant design deficiencies, particularly in recent accidents involving the transportation of crude oil and ethanol. These deficiencies have led to the adoption of a new DOT-117 tank car standard for flammable liquids, which is not required for rail transportation of less hazardous commodities such as elevated temperature asphalt and molten sulfur (PHMSA 2015).

2.4.2 Jacketed Pressure Tank Cars

LPG tank car CBTX 781553, which was the 53rd car in the consist, was most likely breached as its forward motion and the trailing consist forced it into the body bolster frame of the 49th car, tank car ITDX5082. The tank car resting positions further suggested that the derailed cars ahead of CBTX 781553 constrained the car such that it could only have passed over the B end of tank car ITDX5082 to arrive at its final resting position. The left B end shell of tank car ITDX5082 was flattened, and its body bolster structure was bent inboard against the tank by the full weight of CBTX 781553 sliding over it.

The body bolster frame is a necessarily robust steel protuberance because it is also designed to be used as a lifting point for the car. The upper part of the bolster frame consists of a thick rectangular bar that protrudes several inches outward from the tank and serves as the upper surface of the lifting point. Welded to the end of the top bolster frame structure is an outside frame piece with a rounded edge that protrudes about one inch beyond the end of the upper bolster frame member. Apart from a draft sill, coupler, and truck frames, this is the strongest structure protruding from the tank and is likely to cause damage in car-to-car impacts. The NTSB concludes that the breach of the derailed LPG tank car shell occurred during its impact with the robust body bolster frame of another derailed tank car.

Although the tank car sustained only one relatively small shell breach, released propane gas flowed under pressure in the space between the tank shell and jacket, emerging on fire in several locations on the tank and giving the appearance that the tank shell had sustained multiple breaches. Propane released from the breach in a tall flame column, reaching peak pressure during the first few hours following the derailment. At that point, emergency responders suspected the tank car might catastrophically fail and erupt into a fireball or a BLEVE and prudently expanded the initial evacuation and isolation zones.

CBTX 781553 was equipped with a jacket and ceramic fiber thermal protection and a relatively thick normalized steel tank shell. These key features likely prevented the car from rupturing during its prolonged exposure to the molten sulfur pool fire. Catastrophic pressure tank car failures and explosions have become much rarer since DOT mandated thermal protection systems for tank cars carrying flammable liquefied compressed gasses, following several fiery accidents that occurred in the 1960s and 1970s (Burke 2003).

The burning and venting propane from the tank puncture also regulated the internal tank pressure in a similar manner as a pressure relief device (PRD). This was a fortunate occurrence because the actual PRD of the overturned tank car was in contact with the liquid phase of the propane lading, compromising its ability to efficiently relieve vapor pressure. The lack of carbon residue in the pressure relief device throat or visible flame issuing from that area of the tank car suggests that the PRD never activated following the derailment. The already-venting shell breach kept the internal tank pressure from reaching the PRD start-to-discharge setting of about 280 psig and contributed to avoiding an energetic tank rupture.

The CSX emergency responders were initially unaware of a potentially hazardous tank bulge developing in the tank because the shell surface was obscured from view by the jacket and thermal protection covering. The bulge grew as the shell puncture vented propane, lowering the liquid level in the tank. The wetted tank wall heat-sink effect diminished with the growing vapor space, and the upper region of the tank shell began losing yield strength. In the region of weakened steel, the bulge was pushed outward with growing internal tank pressure. However, the coincidental venting LPG from the shell breach kept the internal pressure sufficiently in check to prevent the tank from rupturing. Video and aerial photographs of flaming gas escaping from gaps in the tank jacket near the bulge also suggest that the tank shell in this region was impinged by a torch fire.

The bulge in the tank shell did not become evident until CSX contractors finally approached the tank and removed parts of the jacket from the nearby puncture location to apply a magnetic patch. But by then, the tank car was nearly empty. Tank wall thickness measurements across the shell bulge found that the stretching resulted in a reduction of about 36 percent of its thickness. This thinning and bulging suggest that the shell surface was progressing toward the formation of a thermal tear.⁴⁴ However the bulged shell section microstructure showed no indications of precursors to imminent rupture, such as cavitation or grain boundary separation. While shell deformation would have been a clear sign that the tank was subject to breaching at any time, the tank integrity and true extent of shell damage remained unknown until shell specimens were examined in a laboratory setting. The NTSB concludes that emergency response personnel were unable to perform a detailed tank car damage assessment because the bulging tank shell was hidden under the jacket of the DOT-112 tank car and could not be readily observed.

Emergency responders evacuated residents and other nonemergency personnel to a safe distance; however, many emergency responders put themselves at risk by working perilously close to the derailment scene to hasten stabilization, even as the propane continued to burn and even though the extent of the tank car damage was unknown. As the flame began to abate, emergency

⁴⁴ A *thermal tear* forms when a tank shell subjected to fire bulges and thins in the unwetted vapor space until it ruptures, at which point an energetic fireball or BLEVE may occur.

responders may have become lulled by the apparent reduction in tank pressure. Evidence of their lowered sense of caution was observed on several occasions when personnel approached very close for reconnaissance. The incident commander suggested that the prolonged and expanded residential evacuation pressured responders to intervene by implementing a flare stack to speed emptying the tank car. Adequate emergency response guidance is available from various sources such as the *ERG*, which contains a special section on BLEVE safety precautions and links to a video describing the hazards of propane transport containers involved in fire (Birk 1995). The NTSB recommends that CSX incorporate lessons learned about the hazards caused by fire-exposed jacketed pressure tank cars in first responder hazardous materials training and outreach programs.

The Security and Emergency Response Training Center (SERTC), a subsidiary of the AAR run by the Transportation Technology Center, Inc., operates a center that trains railroad officials to safely handle accidents involving tank cars carrying hazardous materials. SERTC training is also provided to the transportation service industry, the public sector emergency response community, the chemical industry, government agencies, and emergency response contractors from all over the world. The training instructs participants on how to safely respond to railroad emergencies and bring incidents to a successful closure. SERTC hands-on tank car specialist training instructs participants about tank car hazards, designs and features, product transfer, containment methods, plugging and patching, use of special containment devices, and flaring operations. Therefore, the NTSB recommends that SERTC incorporate lessons learned from the Hyndman, Pennsylvania, accident about the hidden hazards caused by fire-exposed jacketed pressure tank cars in first responder hazardous materials technician and tank car specialist training programs.

2.5 Establishing Risk Reduction Programs

At the time of the accident, the FRA did not require that each railroad have a risk reduction program (RRP) or system safety program (SSP) in place. That changed on February 18, 2020, when the FRA published a final rule requiring Class I railroads and railroads with inadequate safety performance to submit a written railroad safety RRP to the FRA for review and approval by August 16, 2021 (FR 2020, 9262).⁴⁵ Both the first crew and relief crew members expressed concern with operating heavy loads with multiple empty rail cars in the front of the train consist. Although the train makeup was in accordance with CSX rules, NTSB has determined this rule to be insufficient to manage elevated longitudinal forces imparted on blocks of empty rail cars in the front of the train consist. An RRP would encourage employees to express safety concerns to management, and management in turn would evaluate these concerns to determine the necessary safety mitigations. At the time of the accident, CSX operating rules (practices) allowed for the accident train consist to complete its move downhill with the handbrakes applied; this action, although allowed by rule, contributed to the accident. An RRP would aim to evaluate operating rules for effectiveness and safety mitigation. The evaluation would seek to determine if any changes to the operating environment could create an adverse effect if applying the current operating rule. An effective RRP would require any adverse effects to be mitigated. Both the information reported by the train crews and the evaluation of operating rules within an RRP

⁴⁵ The FRA had published a similar rule on August 12, 2016, requiring commuter and intercity passenger railroads to implement a system safety program (SSP) (FR 2016).

framework could have provided CSX an opportunity to reduce the risk factors ultimately associated with this accident. The NTSB concludes that an effective CSX RRP or SSP would have likely identified the risks that led to the accident and provided an opportunity to prevent the accident and mitigate risks to prevent future accidents. The NTSB further concludes that the FRA's recently enacted requirement for RRPs and SSPs provides an opportunity to identify and mitigate risks to prevent future accidents.

Railroads currently use engineering standards, rules, procedures, and training as a risk mitigation strategy to comply with the minimum federal safety standards. The FRA's final rule on RRPs will require railroads to include a variety of new activities, including a risk-based hazard management program, a safety performance evaluation, safety outreach, a technology implementation plan, RRP employee/contractor training, railroad employee involvement, and internal assessment of their RRP. Both the RRP and SSP are forms of safety management systems (SMS), which the NTSB has long advocated that commercial operations in all modes of transportation (including pipeline, highway, aviation, marine, or rail) adopt.

The FRA's final rule requiring all Class I railroads to develop and implement RRPs represents a departure from the historic approach used by the FRA for oversight and safety management. For example, rather than monitoring rules compliance, an SMS approach seeks to further improve safety through identification and control of potential safety hazards that may not technically violate prescriptive FRA regulations. Transitioning to an RRP regulation will take time to mature for the FRA and industry. The FRA has traditionally had clear minimum safety standards and limited ability to examine the effectiveness of railroad safety programs for hazard identification and management. To date, the FRA has not published guidance for the industry on how to develop and implement the requirements for RRPs and SSPs. This lack of guidance on what is needed to comply with the FRA's requirements may result in different levels of RRP and SSP program development and implementation, potentially limiting the safety benefits anticipated from the FRA's RRP requirement. It is also unclear how the FRA and the industry will measure the success of the required RRPs and SSPs. The NTSB concludes that the FRA has not provided sufficient guidance to railroads on how to develop and implement its requirements for an RRP and SSP that the railroads are due to submit to the FRA for review and approval by August 16, 2021. Therefore, the NTSB recommends that the FRA develop and issue guidance for railroads to use in developing the RRPs required to be submitted for approval by the FRA.

The NTSB believes it is also important for the industry to participate in the development of standards and practices for railroads to use in developing and implementing RRPs and SSPs. The shift to implementing an SMS approach will require cultural change throughout the industry. Industry-led efforts including issuing guidance and best practices for developing SMSs in both the pipeline and aviation sectors have led to the development of effective programs in those modes of transportation.

The NTSB concludes that the railroad industry would benefit from an industry-led effort to develop best practices and implementation guidance for RRPs. Therefore, the NTSB recommends that the AAR work with member railroads to develop guidance material and best practices for the development and implementation of their RRPs.

3. Conclusions

3.1 Findings

1. None of the following were factors in the derailment: train crew experience and training; physical or mental impairment of the train crew due to alcohol, other impairing drugs, or fatigue; or track structure condition.
2. CSX Transportation's Equipment Handling Rule 4466 does not sufficiently address excessive lateral forces that may lead to or contribute to wheel lift or other undesirable train performance outcomes.
3. The application of hand brakes on empty rail cars toward the front of the consist caused the wheels of those cars to overheat and build up tread.
4. The tread buildup on the wheel of the 35th rail car compromised the ability of the wheel flange to keep the wheels on the track as the train negotiated the curve, causing the derailment.
5. The breach of the derailed liquefied petroleum gas tank car shell occurred during its impact with the robust body bolster frame of another derailed tank car.
6. Emergency response personnel were unable to perform a detailed tank car damage assessment because the bulging tank shell was hidden under the jacket of the US Department of Transportation-112 tank car and could not be readily observed.
7. An effective CSX Transportation risk reduction program or system safety program would have likely identified the risks that lead to the accident and provided an opportunity to prevent the accident and mitigate risks to prevent future accidents.
8. The Federal Railroad Administration's recently enacted requirement for risk reduction programs and system safety programs provides an opportunity to identify and mitigate risks to prevent future accidents.
9. The Federal Railroad Administration has not provided sufficient guidance to railroads on how to develop and implement its requirements for a risk reduction program and system safety plan that the railroads are due to submit to the Federal Railroad Administration for review and approval by August 16, 2021.
10. The railroad industry would benefit from an industry-led effort to develop best practices and implementation guidance for risk reduction programs.

3.2 Probable Cause

The National Transportation Safety Board determines the probable cause of the accident was the inappropriate use of hand brakes on empty rail cars to control train speed and the placement of blocks of empty rail cars at the front of the train consist, leading to elevated longitudinal forces and increased lateral forces at the wheel-rail interface at the curve in the rail on the leading 42 cars combined with tread buildup on the 35th car, which was the first to derail. Contributing to the derailment were CSX operating practices that accepted the use of hand brakes on empty rail cars to control train speed and allowed blocks of empty rail cars to be placed at the front of the train consist.

4. Safety Recommendations

As a result of this investigation, the National Transportation Safety Board makes the following new safety recommendations:

To the Federal Railroad Administration:

Develop and issue guidance for railroads to use in developing the risk reduction programs required to be submitted for approval by the Federal Railroad Administration. (R-20-21)

To CSX Transportation:

Revise your rules for building train consists to require that large blocks of empty cars be placed toward the end of the consist. (R-20-22)

Prohibit the use of hand brakes on empty rail cars for controlling train movement in grade territory. (R-20-23)

Incorporate lessons learned about the hazards caused by fire-exposed jacketed pressure tank cars in first responder hazardous materials training and outreach programs. (R-20-24)

To the Association of American Railroads:

Work with member railroads to develop guidance material and best practices for the development and implementation of their risk reduction programs. (R-20-25)

To the Security and Emergency Response Training Center:

Incorporate lessons learned from the Hyndman, Pennsylvania, accident about the hidden hazards caused by fire-exposed jacketed pressure tank cars in first responder hazardous materials technician and tank car specialist training programs. (R-20-26)

BY THE NATIONAL TRANSPORTATION SAFETY BOARD

ROBERT L. SUMWALT, III
Chairman

JENNIFER HOMENDY
Member

BRUCE LANDSBERG
Vice Chairman

MICHAEL E. GRAHAM
Member

THOMAS B. CHAPMAN
Member

Adopted: November 23, 2020

Appendix A: Investigation

The National Transportation Safety Board (NTSB) was notified on August 2, 2017, of the derailment of a CSX Transportation (CSX) 178-car train in Hyndman Borough, Pennsylvania, and the subsequent fire and release of hazardous materials. While there were no injuries or fatalities, 3 homes were destroyed, and about 1,000 residents were evacuated for 3 days. The NTSB launched an investigator-in-charge and a team to investigate track, train consist and mechanical factors, tank car integrity, railroad operations, and hazardous materials response.

The parties to the investigation include the Federal Railroad Administration; CSX Transportation; the Brotherhood of Locomotive Engineers and Trainmen; the International Association of Sheet Metal, Air, Rail and Transportation Workers; and the Pennsylvania Public Utilities Commission. Submissions were received from CSX and The Brotherhood of Locomotive Engineers and Trainmen.

Appendix B: Consolidated Recommendation Information

Title 49 *United States Code* (USC) 1117(b) requires the following information on the recommendations in this report.

For each recommendation—

- (1) a brief summary of the NTSB’s collection and analysis of the specific accident investigation information most relevant to the recommendation;
- (2) a description of the NTSB’s use of external information, including studies, reports, and experts, other than the findings of a specific accident investigation, if any were used to inform or support the recommendation, including a brief summary of the specific safety benefits and other effects identified by each study, report, or expert; and
- (3) a brief summary of any examples of actions taken by regulated entities before the publication of the safety recommendation, to the extent such actions are known to the Board, that were consistent with the recommendation.

To the Federal Railroad Administration

R-20-21

Develop and issue guidance for railroads to use in developing the risk reduction programs required to be submitted for approval by the Federal Railroad Administration.

Information that addresses the requirements of 49 USC 1117(b), as applicable, can be found in section [2.5 Establishing Risk Reduction Programs](#). Information supporting (b)(1) can be found in sections [2.2 CSX Practices for Building Train Consists](#) and [2.3 Control of Train Movement](#); (b)(2) is not applicable; (b)(3) can be found on page 51.

To CSX Transportation

R-20-22

Revise your rules for building train consists to require that large blocks of empty cars be placed toward the end of the consist.

Information that addresses the requirements of 49 USC 1117(b), as applicable, can be found in section [2.2 CSX Operational Practices for Building Train Consists](#). Information supporting (b)(1) can be found on pages 26, 41–42; (b)(2) and (b)(3) are not applicable.

R-20-23

Prohibit the use of hand brakes on empty rail cars for controlling train movement in grade territory.

Information that addresses the requirements of 49 USC 1117(b), as applicable can be found in sections [1.2.2 Train Operations Prior to Derailment](#), [1.5.2.1 Preaccident Brake Inspections](#), and [2.3 Control of Train Movement](#); Information supporting (b)(1) can be found on pages 17–19; (b)(2) and (b)(3) are not applicable.

R-20-24

Incorporate lessons learned about the hazards caused by fire-exposed jacketed pressure tank cars in first responder hazardous materials training and outreach programs.

Information that addresses the requirements of 49 USC 1117(b), as applicable, can be found in sections [1.3 Emergency Response](#), [1.7.3 Liquefied Petroleum Gas Tank Car](#), and [2.4.2 Jacketed Pressure Tank Cars](#); Information supporting (b)(1) can be found on pages 7–11, 31–5, 47–50; Information supporting (b)(2) can be found in sections [1.81 Emergency Response Guidance Involving LPG/Propane](#) and [1.8.2 Previous NTSB Investigation of LPG Tank Car Delayed Rupture](#); (b)(3) is not applicable.

To the Association of American Railroads

R-20-25

Work with member railroads to develop guidance material and best practices for the development and implementation of their risk reduction programs.

Information that addresses the requirements of 49 USC 1117(b), as applicable, can be found in section [2.5 Establishing Risk Reduction Programs](#). Information supporting (b)(1) can be found on page 52; (b)(2) and (b)(3) are not applicable.

To the Security and Emergency Response Training Center

R-20-26

Incorporate lessons learned from the Hyndman, Pennsylvania, accident about the hidden hazards caused by fire-exposed jacketed pressure tank cars in first responder hazardous materials technician and tank car specialist training programs.

Information that addresses the requirements of 49 USC 1117(b), as applicable, can be found in section [2.4.2 Tank Car Integrity](#); Information supporting (b)(1) can be found on page 50; (b)(2) and (b)(3) are not applicable.

References

- AAR (Association of American Railroads). 2016. *Recommended railroad operating practices for transportation of hazardous materials*. Circular OT55P (CPC-1321. Washington DC: AAR (issued January 19, 2016).
- . 2017. *Field Guide to Tank Cars*, 3rd Ed. Washington, DC: AAR/Bureau of Explosives.
- Birk, A.M. 1995. *Transport Canada BLEVE Response and Prevention*. Queen’s University, Kingston (Ontario), Canada: Transport Canada. Video provided on Transport Canada website at <http://www.tc.gc.ca/eng/tdg/publications-menu-1238.html>.
- Burke, R. 2003. “The Waverly Propane Explosion 25th Anniversary: What Has Changed?” *Firehouse Magazine* (January 31).
- DOT (Department of Transportation). 2016. *Emergency Response Guidebook*, 11th Ed. Washington, DC: US Department of Transportation.
- . 2020. *Emergency Response Guidebook*, 12th Ed. Washington, DC: U.S. Department of Transportation.
- FR (Federal Register)*. 1978. Vol. 43 (July 12): 30057.
- . 2015. Vol. 80 (May 8): 26644.
- . 2016. Vol. 81, no. 28 (August 12): 53850.
- . 2020. Vol. 85, no. 32 (February 18): 9262.
- FRA (Federal Railroad Administration). 2002. *Revised Railroad Tank Car Damage Assessment Guidelines for Pressure Tank Cars*. DOT/FRA/ORD-03/22. Washington, DC: US Department of Transportation, FRA.
- . 2005. *Damage Assessment of Railroad Tank Cars Involved in Accidents: Phase 1 Literature Search and Evaluation*. DOT/FRA/ORD-06/12. Washington, DC: US Department of Transportation, FRA.
- . 2013. *Detailed Puncture Analysis Tank Cars: Analysis of Different Impactor Threats and Impact Conditions*. DOT/FRA/ORD-13/17. Washington, DC: US Department of Transportation, FRA.
- . 2014. *Full-scale Shell Impact Tests of a DOT-111 Tank Car*. RR 14-29. Washington, DC: US Department of Transportation, FRA.
- . 2015. *Tread Buildup on Railroad Wheels*. DOT/FRA/ORD-15/06. Washington, DC: US Department of Transportation, FRA.

NTSB (National Transportation Safety Board). 1979. *Derailment of Louisville & Nashville Railroad Company's Train No. 584 and Subsequent Rupture of Tank Car Containing Liquefied Petroleum Gas, Waverly, Tennessee, February 22, 1978*. NTSB-RAR-79-1. Washington, DC: NTSB.

———. 2012. *Derailment of CN Freight Train U70691-18 With Subsequent Hazardous Materials Release and Fire, Cherry Valley, Illinois, June 19, 2009*. RAR-12/01. Washington, DC: NTSB.

PHMSA (Pipeline and Hazardous Materials Safety Administration). 2015. *Hazardous Materials: Enhanced Tank Car Standards and Operational Controls for High-Hazard Flammable Trains*, PHMSA Final Rule. FR 80 (May 8): 26644.