

## Design of an Efficient Turbofan Engine with Afterburners

Justin Williams<sup>1</sup> and Yawo Ezunkpe<sup>2\*</sup>

<sup>1</sup>Student, Aerospace Engineering Department, San Jose State University, 1 Washington Sq, San Jose, CA 95192, USA

<sup>2</sup>Assistant Professor, Aerospace Engineering Department, San Jose State University, 1 Washington Sq, San Jose, CA 95192, USA

### ABSTRACT

In this paper we examine ways to potentially improve the overall efficiency of a turbofan engine with afterburners. A design similar to a turbofan engine used mostly in today's general commercial aviation aircraft was considered and a study was performed on its components individually using GasTurb and MATLAB software packages. The study revealed that the pressure and the temperature are the two main parameters which affect the overall efficiency of the turbofan engine with afterburners. In addition, the study showed the validation of the analytical results numerically using MATLAB and then visually using GasTurb. Finally, GasTurb was also used to perform the analysis of the 3-D plots that allowed for a complete understanding of how the efficiency of the turbofan engine was affected. As a result, different performance values were found, and showed that a turbofan engine with an afterburner can be made more efficient by increasing the pressure and the temperature in the combustion chambers.

### Corresponding author

Yawo Ezunkpe, Assistant Professor, Aerospace Engineering Department, San Jose State University, 1 Washington Sq, San Jose, CA 95192, USA.

**Received:** August 28, 2023; **Accepted:** September 01, 2023; **Published:** September 09, 2023

**Keywords:** Efficiency, Turbofan, Afterburners, GasTurb, MATLAB

### Introduction

Many commercial aircraft are designed by gas turbine engines, which are either turbofan or turboprop. When it comes to the design of a turbofan engine, many engineers are trying to increase the efficiency of the turbofan engine without affecting the fuel consumption, performance, endurance, etc. Most modern-day commercial airplanes use a turbo fan engine because of the high thrust it produces and because of the good fuel efficiency that it has. Many turbofan engines consist of the air inlet/fan section, compressor section, combustion section, turbine section and the exhaust/nozzle section. Many modern-day designers are focusing more on the power generation of the engine. In turn, this brings to conversation on the efficiency and performance aspects of the turbofan engine while including an afterburner.

The development of the propulsion system for a turbofan engine has had a lot of complex challenges. Most of the challenges were because of its multidimensional systems. There are different propulsion systems with higher efficiency that would decrease the amount of fuel and hence the environmental impact, especially the release of CO<sub>2</sub> [1]. There are different theories that prove that the turbofan engine is one of the most fuel-efficient airplane engines that has been developed. With the state-of-art technology that we have there are different ways that the overall efficiency of the turbofan engine can be improved. One way is to use the Adaptive Cycle Engine (ACE) concept. The Adaptive Cycle Engine (ACE) concept is proven to meet the demands of the turbofan engine in terms of performance requirements. The ACE has low specific

fuel consumption in subsonic flight. The ACE model involves two different thermodynamic cycles (turbojet and turbofan) on the same system, which makes the aircraft replies to multi-purpose missions both in supersonic and subsonic flight [1]. Furthermore, since the ACE model involves a changing bypass ratio, it would be considered to have more advantages in regard to the overall efficiency, flight range and specific fuel consumption.

With all this in consideration, the main purpose of the present study is to study and improve the overall efficiency of the turbofan engine while incorporating an afterburner(s) into its engine cycle for commercial airplanes. The approach and procedures will follow the different sources included in this paper that were used to analyze and design turbofan engines. A realistic design approach for the inclusion of afterburner(s) to a turbofan engine will be discussed throughout this paper to provide more insight into the possibilities of this design.

The objective of this paper is to study and improve the overall efficiency of the turbofan engine while incorporating an afterburner(s) into its engine cycle for commercial airplanes. The main method of analysis would be done by using computer software called GasTurb. This software will be used to simulate different gas turbines' performance calculations and optimizations.

The approach that was taken was to use a gas turbine software that will analyze the performance of the turbofan engine and optimization the calculations used to design the turbofan engine. The gas turbine software named GasTurb will be used to perform the necessary analyses for this study. The first step of the analysis will be to review and develop a turbofan engine

geometry while including an afterburner. This will be done by researching a turbofan engine and its overall engine specifications. The specifications will involve the engines geometry, engine dimensions, compressor, combustor, and turbine. The different properties that would be researched are the freestream conditions (Mach Number, Temperature, Pressure) and Burner (Temperature). Furthermore, this step will help with the overall turbofan engine specifications.

The second step of the analysis is to do a steady state parametric cycle analysis for a turbofan engine while including an afterburner. The step will include a component analysis of the compressor, combustor, and turbine. Therefore, this step will help with the component analysis of the turbofan engine and afterburner.

The third step of the analysis is to do a computation analysis of the turbofan engine while integrating an afterburner using the gas turbine software; GasTurb. This step would define the computational framework of the turbofan engine. In addition to that, different simulations of the turbofan engine and the afterburner would be simulated under different constraints. Furthermore, this step will help with the computation analysis of the turbofan engine and afterburner.

### Literature Review

Before we dive into the analysis of the current work, a literature review was conducted on how to improve the overall efficiency of a turbofan engine. This was done to get a better understanding of the concept of the afterburner(s). This was also done to get a better understanding of the concept of an afterburner. Lastly, one final literature review was done. The energy and performance optimization of an Adaptive Cycle Engine for Next Generation Combat Aircraft was long considered and studied. This study looked at how the Adaptive Cycle Engine (ACE) was one of the top methods that would fulfill the many multi-mission requirements of aircraft flight. This concept dealt with the deficiencies of conventional low bypass mixed turbofan engines. This study explained how two different methods are used to optimize the overall efficiency of a turbofan engine. The first method looked at the performance and design results of the ACE model and compared it with those of fixed cycle low bypass turbofan engine by using specific fuel consumption, specific thrust, power and efficiency parameters [1].

The second method looked at the different ways the design parameters such as, the ST and SFC values of the ACE model are analyzed for double bypass mode and single by-pass mode [1]. Overall, this study provides a well-developed approach to how to optimize the overall efficiency of a turbofan engine which can be referenced for this project. Furthermore, Exergy modeling for evaluating sustainability level of a high bypass Turbofan engine was set to be used on commercial aircraft. This study presents an exergy modeling to evaluate the sustainability level of a high bypass turbofan engine used on commercial aircrafts [2].

The PW4056 model turbofan engine was used to examine its sustainability under different flight conditions. As a result, a sustainability analysis was done to improve the exergy efficiency of the engine. Furthermore, this study provides what is needed to know to optimize the overall efficiency of a turbofan engine for this paper. Also, it is very important to point out that the parametric study on exergy and NO<sub>x</sub> Metrics of turbofan engine under different design variables because this study examined the different effects of design variables on performance parameters

for turbofan engines. This study looked at the effects of the bypass ratio and turbine inlet temperatures for a turbofan engine. The parametric cycle equations regarding turbofan engines are encoded to compute performance metrics, while conducting energy analysis.

Overall, this study looked at ways to improve and to find out optimum design variables in terms of ecofriendly aircraft activities [3]. Nevertheless, Exergy and Thermo-economic Analysis of a Turbofan Engine During a Typical Commercial Flight is one of the very important concepts of this analysis. This article examined the design and improvement of energy conversion systems for a turbofan engine. The article presented an exergy-based analysis which analyzed the performance of a typical turbofan engine and its components. The analysis was meant to simulate the exergy efficiency over the entire flight cycle for commercial flight. From that the data gathered was used to model aircraft for commercial flight. Overall, this article provides exergy and thermo-economic approaches to improve the efficiency of a turbofan engine. Furthermore, An Exergy Way to Quantify Sustainability Metrics for A High Bypass Turbofan Engine is needed. This study examined a new methodology to meet the need of the growing concern of fuel efficiency for the design and operation of the turbofan engine. The new methodology is being developed here that proposes the use of exergetic metrics for mapping the exergy flows throughout high bypass turbofan engine at maximum thrust level for its sustainability assessment [4].

The engine that was used for this study had a net thrust force of 206 kN and was used in the first wide body, dual-aisle, and the largest commercial aircraft [4]. The study found that the exergetic sustainability method was an effective way to assess the sustainability of aircraft and aero engines and provides a good tool for designers, users, decision makers and researchers in green air transportation [5]. As result, it was found that the method made turbofan engines more sustainable for flight. Furthermore, this article will serve as a good reference to help improve the overall efficiency of a turbofan engine. Before the analysis was done for the current project a literature review was done involving how to improve the overall efficiency of a turbofan engine. This was done in order to get a better understanding of the concept.

Another literature review was done involving afterburner(s). This was also done to get a better understanding of the concept of an afterburner. Lastly, one final literature review was done involving the overall efficiency of the turbofan engine while incorporating an afterburner(s) into its engine cycle. The following sections summarize each literature review finds and their contribution to the project. Below is a list of the different books and articles used for the literature review.

### Overall Efficiency of a Turbofan Engine Studies

*Turbofan Engine Performances from Aviation, Thermodynamic and Environmental Perspectives*

This study examined how the JT15D turbofan engine and its main subcomponents were assessed with the aviation, energy, exergy, environmental, and sustainability analyses [5]. These different subcomponents were analyzed in order to make the turbofan engine more efficient. After the analysis it was found that the combustion chamber has minimum rates of sustainable efficiency factor, exergetic efficiency and sustainability index, while it has utmost rates of ecological and environmental effect factors, fuel exergy waste ratio, irreversibility and productivity lack ratios [6]. Finally, it was found that the combustion chamber and the

low-pressure compressor components should be optimized for better performance of the system. Overall, this study provides an approach to how to optimize the overall efficiency of a turbofan engine which can be referenced for this project.

#### *Impact of Different Fuel Usages on Thermodynamic Performances of a High Bypass Turbofan Engine Used In Commercial Aircraft*

The study examined the different impacts of fuel usages on thermodynamic performances of a high bypass turbofan engine used in commercial aircraft. The study examined the PW4056 engine to observe the different fuel effects on the thermodynamic performance of a turbofan engine [7]. The energy, exergy, and sustainability analyses were performed on this engine. All analyses that were performed started at the same dead state conditions. In order to compare the different fuel performances for this engine, nineteen thermodynamic performance metrics were adapted for the purpose of this study. The overall study serves as a good reference to help improve the overall efficiency of a turbofan engine.

#### *Turbofan Engine Health Assessment from Flight Data*

This study examines the different approaches to engine health by using wing data from an engine of a commercial short-range aircraft obtained after a year of flight time. This was done by using an on-wing data measurements that analyzed three different approaches. In order to obtain good overall efficiency of a turbofan engine, a diagnostic process was used to track any engine deterioration. By taking this approach it helps reduce any issues to the engine or the engines health while in flight. Furthermore, this study provides good information that will serve as a good reference to help improve the overall efficiency of a turbofan engine.

#### *Making Turbofan Engines More Energy Efficient*

This study examined the different ways to making a turbofan engine more energy efficient. The study reviewed the different interaction and effects of cycle pressure ratio, firing temperature, bypass ratio, and component efficiencies on installed fuel consumption [8]. Also, the different possibilities for improvements in energy efficiency with operating economics and environmental characteristics are identified and reviewed. Parametric data was constructed which showed the trade-offs in the areas of efficiency and economics. Lastly, the balance of factors in cost effective advanced turbofans is discussed. This overall study serves as a good reference to help improve the overall efficiency of a turbofan engine.

#### **Afterburner(s) Studies: Thermal Degradation of Turbine Components in a Military Turbofan**

This study looked at the failure analysis of the turbine components of the RD-33 turbofan which is operated by the Polish Air Force. The thermal and dynamic stresses of the turbofan engine was analyzed. The study explained how the design of the afterburner activation system is a significant contributor to accelerated degradation of the turbine components and premature grounding of engines [8]. It was mentioned that when the afterburner is activated, during the ignition and propagation of the flame, local overheating of the turbine components occurs and initiates their damage [9]. Furthermore, to combat this issue actions were proposed that would stop the negative impact of the afterburner. Overall, this study provides a well-developed approach to understanding how an afterburner works in regards to optimizing the overall efficiency of a turbofan engine.

#### *Afterburner*

This article gives an overview on how an afterburner works. The article examines how an afterburner is to provide a thrust increase. The article mentions that afterburning is normally achieved when

the fuel is injected into a jet pipe downstream of the turbine. It was mentioned that; the advantage of afterburning is to significantly increased thrust; the disadvantage is its very high fuel consumption and inefficiencies [10]. Furthermore, this article gives a better understanding on how an afterburner works which will help optimize the overall efficiency of a turbofan engine for this paper.

#### *Afterburners. In: Aerothermodynamics of Aircraft Engine Components.*

This book gives a general overview on how an afterburner works. This text went over the different characteristics of an afterburner. In addition to that, it explained the different flight conditions that an afterburner can be used under. The text explains the basic principles and concepts of propulsion combustion and goes over the different processes, limitations and analytical methods. Furthermore, this textbook serves as a good reference for the subject regarding afterburners.

#### *Turbofan Engine While Incorporating an Afterburner(s) (Augmented Turbofan) Into Its Engine Cycle Studies.*

#### *Propulsion and Power: An Exploration of Gas Turbine Performance Modeling*

This text addresses the preliminary design of gas turbine engines, as well as the associated performance calculations. The text mentions how thermodynamics and turbomachinery is used throughout the design process for gas turbine engines. In addition to that, the text describes the background of augmented turbofan engines and their performances. Furthermore, this text is a good reference for the subject regarding augmented turbofan engines.

#### *Developments in High-Speed Vehicle Propulsion Systems*

This study explains the different technological achievements associated to the combined cycle engines such as the augmented turbofan engine. Some of the technologies that was described were the thermal management and how the afterburner was integrated with the turbofan engine. The study gave a better understanding on how the augmented turbofan propulsion systems are developed. Overall, this study would be good reference for understanding how augmented turbofan engine is developed.

#### *Aircraft Propulsion: Cleaner, Leaner, and Greener*

This text examines the new technologies for propulsion and power, like turbofan propulsion systems. The text gave a thorough intro into the different innovations in aircraft gas turbine engines. These innovations evolved new engine concepts, and new vehicles an exploration of compressible flow with friction and heat, including a brief review of thermodynamics, isentropic process and flow, and conservation principles [11]. In addition to that, a discussion on gas turbine engine cycle analysis was given. This would in turn help with the design of the gas turbine engine cycle. Furthermore, this text provides information needed to get a better understanding on the different aircraft propulsion systems for this study.

#### *Combustion in Advanced Gas Turbine Systems*

This text looks at different design considerations in advanced gas turbine combustion chambers, combustion in industrial gas turbines, and the overall combustion cycle. The type of engine that the study was based on was the Rolls-Royce Spey engine. Discussions focus on mechanical condition, carbon-formation and exhaust smoke, system requirements, fuel oil ash deposition and corrosion, combustion-system design, performance requirements, types of primary zone, fuel injection, and combustion chamber types [12]. The text also explains subsonic flow flame holder

studies using a low-pressure simulation technique and different augmentation systems for turbofan engines. Overall, this study provides a well-developed approach to understanding how a turbofan engine can incorporate an afterburner into its engine cycle.

### Methodology/Materials and Methods

Turbofan engines have been used as a means of propulsion for airplanes for over 8 decades. In the early years of development, the turbofan engine was not as fuel-efficient as it could have been. The reason for this is because their overall pressure ratio and turbine inlet temperature were severely limited by the technology and materials available at that time. However, as technology advanced throughout the years the turbofan engine is now one of the most fuel-efficient engines ever made. The turbofan is a portion of the turbine work used to supply power to the fan. Generally, the turbofan engine is more economical and efficient than the turbojet engine. The thrust specific fuel consumption is lower for turbofans and indicates a more economical operation. The turbofan also accelerates a larger mass of air to a lower velocity than a turbojet for a higher propulsive efficiency [13]. A schematic of a turbofan engine is shown in Figure 1.

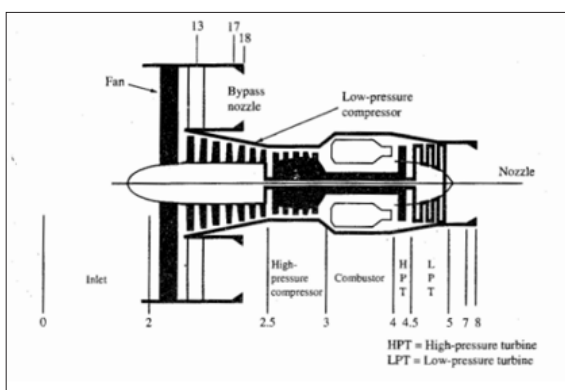

Figure 1: Schematic of a turbofan engine

The turbofan engine that will be studied for this paper is the General Electric GE90-115B shown in Figure 2. The GE90-115B was developed from a list of General Electric GE90 turbofan engines. The GE90 engines is a family of high-bypass turbofan engines built by GE-Aviation for the Boeing 777, with thrust ranging from 74,000 to 115,000 lbf (329 to 512 kN). It was first introduced in November 1995 on British Airways' 777s and is only available on the 777 [14]. In 1995, the GE90 engine debuted aboard a British Airways 777 airplane. Early GE90 engine models boasted outputs between 74,000 and 94,000 lbs. of thrust, and today it remains the world's largest turbofan engine. GE has continued to improve upon the GE90 design with larger variants such as the GE90 – 11B turbofan engine. This engine was built for Boeing's largest 777 models 777-200LR and 777-300ER. In 2005 the GE90-115B engine was selected to power the Boeing 777-300ER (2004), the Boeing 777-200LR Worldliner (2006) and the Boeing 777 Freighter airplane. The GE90-115B 115,000-lb class engine was developed to meet the requirements of longer-range Boeing 777-200LR and Boeing 777-300ER aircraft. It is considered the world's most powerful jet engine and has set many aviation records. It was developed in April of 2004 powering Air France's Boeing 777-300ER [15].



Figure 2: GE90-115B turbofan engine

### Governing Equations

There are multiple equations that govern the field of propulsion. For this paper the governing equations will be in the area of Thermodynamics, Parametric Cycle Analysis of Ideal Engines, Component Performance, Parametric Cycle Analysis of Real Engines, Engine Performance Analysis and Inlets, Nozzles, and Combustion Systems. These areas of interest were picked from the textbook Elements of Gas Turbine Propulsion by Jack D. Mattingly. The governing equations were used to design the properties for the compressor, combustor, and turbine for a turbofan engine with an afterburner. The formulas that were used for the thermodynamics of the turbofan engine design was:

The Uninstalled Thrust  $F$  with a single inlet and single exhaust

$$F = \frac{(\dot{m}_0 + \dot{m}_f)V_e + \dot{m}_0 V_0}{g_c} + (P_e + P_0)A_e$$

The Uninstalled Thrust Equation

$$F = \frac{(\dot{m}_0 + \dot{m}_f)V_e - \dot{m}_0 V_0}{g_c} \quad \text{for } P_e = P_0$$

The second performance parameter is the thrust specific fuel consumption (S and TSFC). This is the rate of fuel use by the propulsion system per unit of thrust produced. The uninstalled fuel consumption  $S$  and installed fuel consumption TSFC is written in equation form as:

$$S = \frac{\dot{m}_f}{F}$$

$$TSFC = \frac{\dot{m}_f}{T}$$

The thermal efficiency of an engine is one useful engine performance parameter. Thermal efficiency is defined as the net rate of organized energy out of the engine which is then divided by the rate of thermal energy available from the fuel in the engine. The fuel's available thermal energy is equal to the mass flow rate of the fuel times the fuel heating value.

$$\eta_T = \frac{\dot{W}_{out}}{\dot{Q}_{in}}$$

Propulsive efficiency is the ratio of the aircraft power to the power out of the engine as shown in the equation below.

$$\eta_P = \frac{TV_0}{W_{out}}$$

The next set of equations are used to solve the parametric cycle analysis for ideal engines. The cycle analysis studies the thermodynamic changes of the working fluid as it flows through the engine. The parametric cycle analysis determines the performance of engines at different flight conditions and values of design choice and design limit parameters [12]. In order to find the total/static temperature and pressure ratios of a free stream, the equations below are used.

$$\tau_r = \frac{T_{r0}}{T_0} = 1 + \frac{\gamma - 1}{2} M_0^2$$

$$\pi_r = \frac{P_{r0}}{P_0} = \left(1 + \frac{\gamma - 1}{2} M_0^2\right)^{\gamma/(\gamma - 1)}$$

Following the equations mentioned above, the rest of the paper uses equations and concepts from chapters Component Performance, Parametric Cycle Analysis of Real Engines, Engine Performance Analysis and Inlets, Nozzles, and Combustion Systems. These concepts will be used to design the properties for the compressor, combustor and turbine for a turbofan engine with an afterburner.

### Theory

The Brayton power cycle is a model used in thermodynamics. This cycle can be used for an ideal gas turbofan engine. The Brayton cycle consists of four different thermodynamic processes.

- 1) The Isentropic Compression Process (From 2 to 3)
- 2) The Constant-Pressure Heat Addition Process (From 3 to 4)
- 3) The Isentropic Expansion Process (From 4 to 9)
- 4) The Constant-Pressure Heat Rejection Process (From 9 to 2)

Figure 3 shows a pictorial example of the Brayton cycle, which includes a TS-diagram and its four different thermodynamic processes:

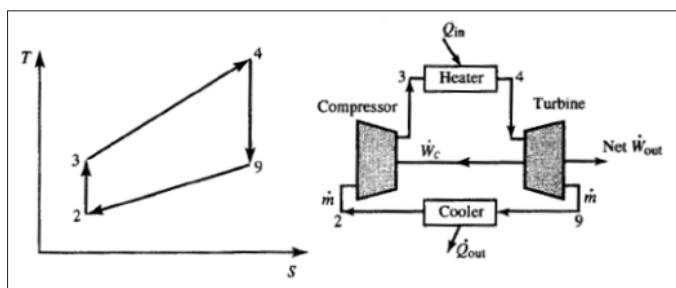

Figure 3: The Brayton cycle which includes a TS-diagram

For the Brayton cycle when the process starts and goes through the compressor and then the turbine it is considered to be reversible and adiabatic which is an isentropic process. In addition to that, when the process passes through the heater and cooler, it is considered to be the constant pressure process of the Brayton cycle. When the Brayton cycle passes through both the compressor and the turbine it is considered to be reversible and adiabatic (isentropic). For the process that goes through the heater and cooler is considered to be constant-pressure [12].

Since the engine that's going to be modeled for this paper has an afterburner, Figure 4 shows a pictorial example of the Brayton cycle with an afterburner, which includes a TS-diagram and its different thermodynamic processes.

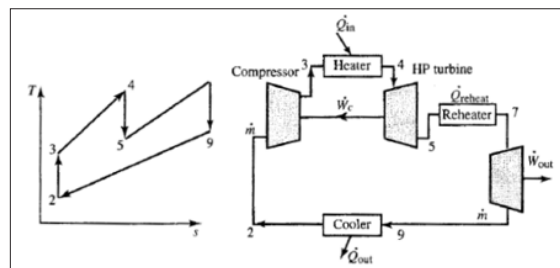

Figure 4: The Brayton cycle with an afterburner which includes a TS-diagram

Figure 4 shows the Brayton cycle with reheat. The addition of reheat to the cycle increases the specific power of the free turbine and reduces the thermal efficiency [12]. The cycle analysis studies the different thermodynamic changes of the working fluid as it flows through the engine. It is divided into two types of analysis: parametric cycle analysis and engine performance analysis. Parametric cycle analysis determines the performance of engines at different flight conditions and values of design choice and design limit parameters. Engine performance analysis determines the performance of a specific engine at all flight conditions and throttle settings [12].

The main objective of the parametric cycle analysis is to relate the engine performance parameters to the design choices, the design limitations, and the flight environment. From the parametric cycle analysis, it can easily be determined which engine type and component design characteristics best satisfy a particular need. In other words, the parametric cycle analysis will relate the engine performance parameters such as the thrust and thrust specific fuel consumption, the design choices such as the compressor pressure ratio, bypass ratio, etc. the design limitations such as the burner exit temperature, compressor exit pressure, etc. and lastly the flight environment such as the Mach number, ambient temperature, etc. From these parameters the parametric cycle analysis can determine what the engine type would be such as a turbojet or turbofan engine and the component design characteristics such as the range of the aircraft flight. Therefore, the realistic values from this cycle analysis can help design a realistic turbofan engine.

### The Steps of the Parametric Cycle Analysis Process

The general steps that would be used in order to perform a steady state parametric cycle analysis for a turbofan engine with an afterburner for mixed exhaust streams would be the steps from the engine parametric cycle analysis for a jet engine with a single inlet and single exhaust.

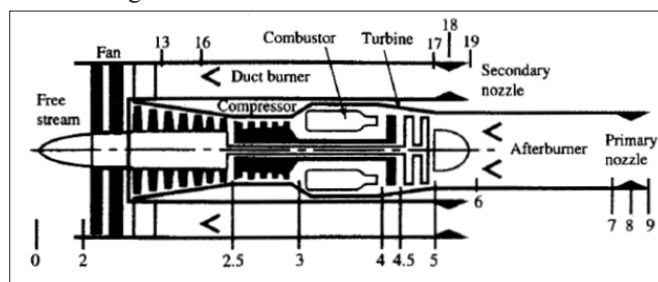

Figure 5: A gas turbine engine with station numbering used to analyze the turbofan engine flows

Furthermore, the figure above will be used as a guide to analyze the parametric cycle analysis for real engines. The next chapter of this paper will cover the analysis using the parametric cycle analysis for real engines. The equations and concepts will be used to design the properties for the compressor, combustor, and turbine for a turbofan engine with an afterburner.

## Results and Discussion

### A Parametric Cycle Analysis for a 2 Spool Mixed Turbofan Engine with an Afterburner Using GasTurb Software

This chapter of the paper will go over the process used to obtain the values for a 2-spool mixed turbofan engine with an afterburner using GasTurb as the main software package. GasTurb is a gas turbine performance calculation and optimization program. It simulates most of the gas turbine configurations in use for propulsion or for power generation. Therefore, a basic understanding of turbofan engine performance calculations was used to make best use of this software. The software was used to conduct a design point calculation using a turbofan engine with an afterburner. Also, it was used to calculate basic thermodynamics properties for a turbofan engine. Next, the software was used to calculate a gas turbine cycle using the design point calculation, the enthalpy-entropy diagram (H-S diagram), the temperature-entropy (T-S diagram) and the pressure-volume (P-V diagram). The design parametric study such as the use of conducting parametric studies, contours and design Limits. Then the off-design simulations such as the use of off-design point calculation, usage of component maps, and the usage of operating lines to view different graphs. Lastly, the design of the engine geometry was determined.

### A Parametric Cycle Analysis for a 2 Spool Mixed Turbofan Engine with an Afterburner

The 2-spool mixed turbofan engine with an afterburner design configuration will be used for this study. The input data for a 2-spool mixed turbofan engine with an afterburner were generated by the GasTurb software. The most important input design parameters are listed in Table 1 below. The parameters such as the Burner Exit Temperature and the Mixer Efficiency played an important role when it came to the overall efficiency of the turbofan engine.

**Table 1: Input Design Parameters**

Property	Unit	Value	Comment
Intake Pressure Ratio		-0.99	
No (0) or Average (1) Core dP/P		1	
Inner Fan Pressure Ratio		2.5	
Booster Map Type (0/1/2)		0	used for off design only
Outer Fan Pressure Ratio		3	
Compr. Interduct Press. Ratio		0.99	
HP Compressor Pressure Ratio		7	
Bypass Duct Pressure Ratio		0.97	
Turb. Interd. Ref. Press. Ratio		0.98	
Design Bypass Ratio		1	
Burner Exit Temperature	K	1600	
Burner Design Efficiency		0.9995	
Burner Partload Constant		1.6	used for off design only
Fuel Heating Value	MJ/kg	43.124	
Overboard Bleed	kg/s	0	
Power Offtake	kW	50	
HP Spool Mechanical Efficiency		1	
LP Spool Mechanical Efficiency		1	
Burner Pressure Ratio		0.97	
Turbine Exit Duct Press Ratio		0.98	
Hot Stream Mixer Press Ratio		0.99	
Cold Stream Mixer Press Ratio		0.99	
Mixed Stream Pressure Ratio		1	
Mixer Efficiency		0.5	
Design Mixer Mach Number		0.247	
Design Mixer Area	m <sup>2</sup>	0	

The Burner Exit Temperature is 1,600K and the Mixer Efficiency is 0.5. The ambient conditions for the turbofan engine had a Mach number of 1.5 and had flight altitude of 11,000m. The Mach number and flight altitude came from the standard atmosphere, which was used to define the inlet conditions of the turbofan engine. Alternatively, the ambient pressure and the total pressure and temperature at the engine inlet was directly specified.

The stations of the 2-spool mixed turbofan engine with an afterburner will now be examined next. The stations of the 2-spool mixed turbofan engine with an afterburner are labelled in accordance with SAE notation.

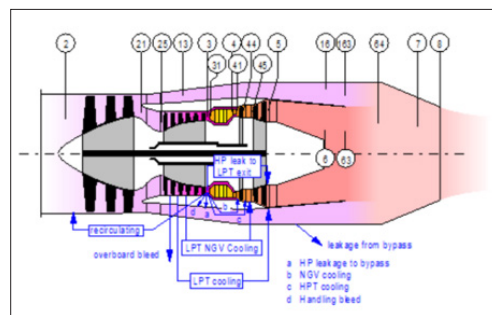

**Figure 6:** A 2-spool mixed turbofan engine with an afterburner labelled with SAE notation

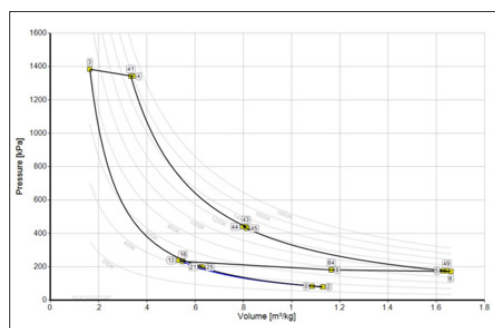

**Figure 7:** The Pressure-Volume Diagram (P-V diagram)

In this section it was demonstrated how to calculate a turbofan engine cycle and also was able to use the GasTurb the iteration functions. The concepts from this section will be used to analyze the properties for the compressor, combustor and turbine for a turbofan engine with an afterburner.

### The Off-Design Simulations for a 2 Spool Mixed Turbofan Engine with an Afterburner

This final section of the chapter will go over how the off-design simulations will be performed. To start things off, calculating a single off-design point of a turbofan engine will be done first. The next step will be to examine how GasTurb uses component maps to calculate the off-design behavior. The last step will be to calculate the turbofan engine operating line. The study will continue to use the 2-spool mixed turbofan engine with an afterburner. First, we'll look at the low-pressure compressor map and the high-pressure compressor map of the turbofan engine that was generated. Figure 8 and Figure 9 show the low- and high-pressure compressor graphs, which show the compressors efficiency and relative spool speeds as a function of the mass flow and pressure ratio.

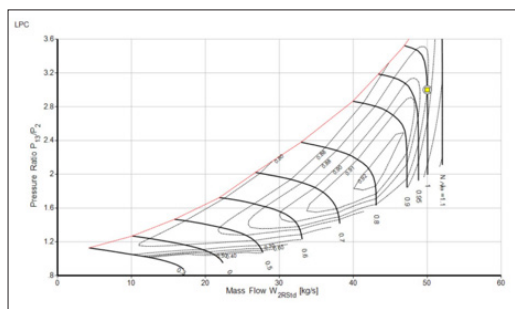

Figure 8: The Low-Pressure Compressor Graph

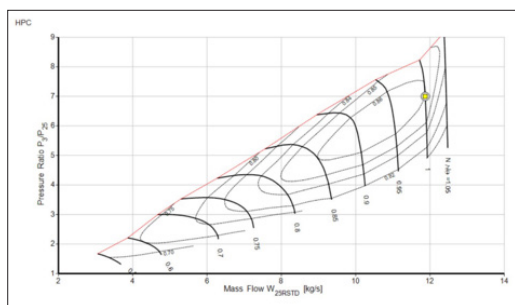

Figure 9: The High-Pressure Compressor Graph

In both figures the cycle design point is marked with a circle whilst the yellow square marks the calculated off-design operating point. As showed in the two figures, the calculated design point of this off-design point are almost identical. This is due to the fact that, the GasTurb software has already calculated the off-design input for the cycle design point of the turbofan engine. In Figure 8 above the low-pressure compressor ratio is 3, with a design compressor efficiency of 88% and a reduced mass flow of 50 kilogram per second. Also, in Figure 9 above the high-pressure compressor ratio is 7, with a design compressor efficiency of 86% and a reduced mass flow of 12 kilogram per second. This shows that the low- and high-pressure compressor maps are close in value.

In this section it was demonstrated how the off-design simulations was done GasTurb software. In addition to that, this chapter demonstrated how to calculate a turbofan engine cycle and also was able to use the GasTurb the iteration functions. Also, how the GasTurb software uses parametric study to simplify the engine design process and to help us discover relationships between design variables and performance results. The next chapter of this paper will cover the analysis done using the parametric cycle analysis for real engines. This analysis will be done using MATLAB software. The equations and concepts from this work will be used to design the properties for the compressor, combustor, and turbine for a turbofan engine with an afterburner.

**Performance Analysis of a Turbofan Engine Using MATLAB**  
 MATLAB was used to solve to model the velocity, temperature at the inlet, the pressure at the inlet, temperature of the fan, pressure of the fan, temperature of the compressor, pressure of the compressor, temperature of the high compressor and pressure of the high compressor. In addition to that, equations were set up using MATLAB for a performance analysis for a turbofan engine. Once these parameters were calculated, the results were then plotted against a range of Mach numbers. To find the results, code was used to calculate various parameters and then used to graph the results over a range of Mach numbers that ranged between Mach 0 to 5 for an ideal turbofan engine. The graphs were all created using MATLAB's built-in plotting functions. This allowed one

to view the different graphs easily.

Figure 10 shows that when starting the velocity at Mach 0 and increasing to Mach 5, the results showed that the velocity reached 19.6 m/s in a linear fashion. Figure 11 shows that when starting the velocity at Mach 0 and increasing to Mach 5, the results showed that the pressure of the fan reached  $2 \times 10^7$  Pa in an increasing fashion. Figure 12 shows that when starting the velocity at Mach 0 and increasing to Mach 5, the results showed that the pressure of the high compressor reached  $2.25 \times 10^8$  Pa in an increasing fashion. Furthermore, one can note that for each graph as the Mach number increases so does the graphs.

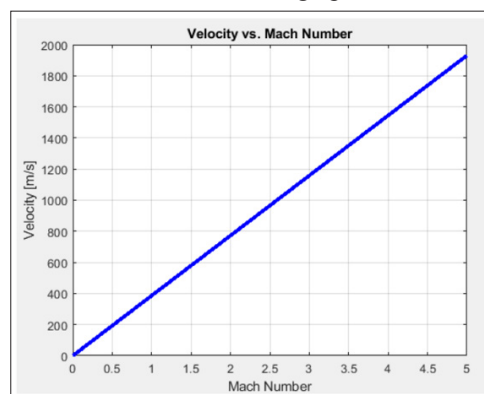

Figure 10: Velocity vs Mach Number

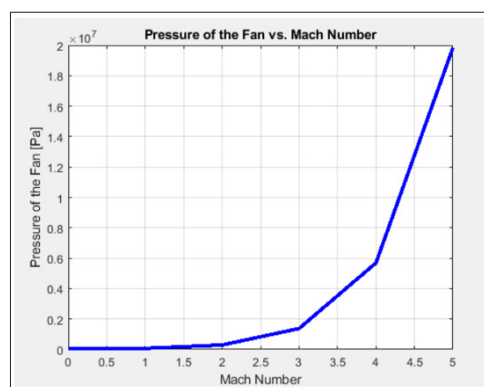

Figure 11: Pressure of the Fan vs Mach Number

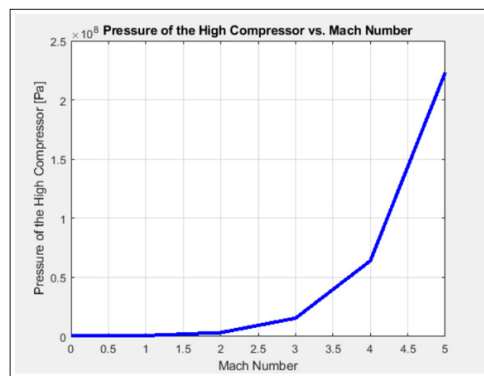

Figure 12: Pressure of the High Compressor vs Mach Number

In this section the performance analysis of a turbofan engine was demonstrated using MATLAB. In addition to that, MATLAB was successfully able to calculate various parameters and then used to graph the results over a range of Mach numbers that ranged between 0 to 5.

## Conclusions

The primary purpose of this study was to design an efficient turbofan engine that included afterburners. The modelling and simulation of the turbofan engine that included afterburners was done using GasTurb and MATLAB software packages. Since this turbofan engine was to include afterburners, it was greatly needed for the engine to be efficient. This meant that the design of the engine from its inlet to the afterburners should be designed efficiently to compress the high-speed air that would be flowing through it. Therefore, there were different simulations that were done at different Mach numbers. The Mach numbers were 0 through 5. The trends from the graphs were observed to have contour plots.

Theory states that if the pressure in the combustion chamber is high then there will be a chance for an efficient combustion process. At times there were slight discrepancies in the values calculated however, these discrepancies are possibly a result of an error in the MATLAB code. Nevertheless, this study was just a small step in designing an efficient turbofan engine with an afterburner. Building on this study, future studies can look at the numerous other combinations of mass flow rates of oxygen and other fuels. After the validation of the modelling and simulation of the turbofan engine with an afterburner, different scenarios of the turbofan engine were studied as shown in the graphs.

In the future, new turbofan engine designs will possibly require new propulsion systems. Propulsion capabilities are essential when it comes to increasing the efficiency of the turbofan engine, the durability, mission proficiency, etc. Furthermore, this project has explored a possible future propulsion system design that included an afterburner. For this to be possible, new and improved additive materials could be explored as well as the manufacturing processes and technological advances which would provide solutions to issues. A system like this could be used to replace the traditional turbofan engine propulsion systems.

## References

1. Balli O (2017) Exergy modeling for evaluating sustainability level of a high by-pass turbofan engine used on Commercial Aircrafts. *Applied Thermal Engineering* 123: 138-155.
2. Aygun H, Cilgin M E, Ekmekci I, Turan O (2020) Energy and performance optimization of an adaptive cycle engine for next generation combat aircraft. *Energy* 209: 118261.
3. Aygun H, Sheikhi M R, Kirmizi M (2022) Parametric Study on Exergy and NOx Metrics of Turbofan Engine Under Different Design Variables. *J. Energy Resour. Technol* 144: 062303.
4. Turan O (2015) An exergy way to quantify sustainability metrics for a high bypass turbofan engine. *Energy* 86: 722-736.
5. Balli O, Caliskan H (2021) Turbofan engine performances from aviation, thermodynamic and environmental perspectives. *Energy* 232: 121031.
6. Akdeniz H Y, Balli O (2022) Impact of different fuel usages on thermodynamic performances of a high bypass turbofan engine used in Commercial Aircraft. *Energy* 238: 121745.
7. Hemsworth M C, Zipkin M A (2015) Making Turbofan Engines More Energy Efficient. *Turbo Expo: Power for Land, Sea, and Air Paper* 1-13.
8. Szczepankowski A, Przynsowa R (2022) Thermal degradation of turbine components in a military turbofan. *Engineering Failure Analysis* 134: 106088.
9. Afterburner. SKYbrary Aviation Safety [https://skybrary.aero/](https://skybrary.aero/articles/afterburner)

articles/afterburner.

10. Farokhi Saeed (2021) *Aircraft Propulsion: Cleaner, Leaner, and Greener*. Wiley [https://www.google.com/books/edition/Aircraft\\_Propulsion/8QY7EAAAQBAJ?hl=en&gbpv=1&dq=augmented%2Bturbofan&pg=PA156&printsec=frontcover](https://www.google.com/books/edition/Aircraft_Propulsion/8QY7EAAAQBAJ?hl=en&gbpv=1&dq=augmented%2Bturbofan&pg=PA156&printsec=frontcover).
11. *Combustion in Advanced Gas Turbine Systems* (2014). Proceedings of an International Propulsion Symposium Held at the College of Aeronautics, Cranfield, April 1967. Elsevier Science [https://www.google.com/books/edition/Combustion\\_in\\_Advanced\\_Gas\\_Turbine\\_Syste/\\_pKjBQAQBAJ?hl=en&gbpv=1&dq=augmented%2Bturbofan&pg=PA129&printsec=frontcover](https://www.google.com/books/edition/Combustion_in_Advanced_Gas_Turbine_Syste/_pKjBQAQBAJ?hl=en&gbpv=1&dq=augmented%2Bturbofan&pg=PA129&printsec=frontcover).
12. Mattingly J D, Ohain, V H (2014) *Elements of gas turbine propulsion*, New Delhi: McGraw-Hill Education
13. General Electric GE90. *Academic Dictionaries and Encyclopedias*
14. <https://en-academic.com/dic.nsf/enwiki/244277>.
14. Ancile. Deagel <https://www.deagel.com/Propulsion%20Systems/GE90/a001376>.
15. Amir Faghri, Yuwen Zhang (2006) *Turbofan Engines - an overview*. *Transport Phenomena in Multiphase Systems* 1-106.

**Copyright:** ©2023 Yawo Ezunkpe. This is an open-access article distributed under the terms of the Creative Commons Attribution License, which permits unrestricted use, distribution, and reproduction in any medium, provided the original author and source are credited.