



DYNAMICS OF GAGING

TABLE OF CONTENTS

GAGES

	Page No.
★ Gage Definition	2
★ Thread Plug Gages	2-3
★ Thread Ring Gages	4
★ Thread Setting Plug Gages	5
★ Cylindrical Plug Gages Reversible—Taperlock—Trilock	6-7
★ Pipe Plug Gages	8
★ Pipe Ring Gages	9-10
★ Gage Recalibration	11

ENGINEERING DATA

★ See side tabs for Engineering Data ★

★ Standard System of Marking	12-14
★ Thread Plug Gage Pitch Diameters	15-17
★ Thread Ring and Setting Thread Plug Gage Pitch Diameters	18-20
★ Cylindrical Plug Gages Dimensions Reversible—Taperlock—Trilock	20-22
★ Gaging Taper Pipe Threads	23-25
★ NPT and NPTF — L1 Taper Pipe Thread Plug Gages — Dimensions	26
★ NPTF — L3 Taper Pipe Thread Plug Gages Dimensions	26
★ NPT and NPTF — L1 Taper Pipe “Thin” Thread Ring Gages — Dimensions	27
★ NPTF — L2 Taper Pipe “Thick” Thread Ring Gages — Dimensions	27
★ Basic Dimensions for Crest Check Plug Gages	28-30

WHAT IS A GAGE?

Gages are a means of measurement between two (2) specified limits which accepts or rejects parts being gaged. The most commonly used are:

THREAD PLUG

CYLINDRICAL PLUG

THREAD RING

PIPE PLUG

THREAD SETTING PLUG

PIPE RING

THREAD PLUG GAGES

Thread plug gages are used to check an internal threaded hole. The most common thread plug classifications are:

- 2B...a general purpose class of fit.
- 3B...used to check parts with "closer" tolerance requirements.
(See pages 15-17 for tolerance)



DOUBLE END THREAD PLUG GAGE
TAPERLOCK DESIGN



DOUBLE END THREAD PLUG GAGE
REVERSIBLE DESIGN

Working thread plugs are to be used in an internally threaded hole and are not to be used to check a ring gage. The part being checked is generally acceptable when the No Go work plug does not enter more than 1½ to 3 turns dependent upon customer specifications and the Go work plug freely enters the threaded hole its entire length.

Thread Plug Gages: GO = LO; NO GO = HI Thread Ring Gages: GO = HI; NO GO = LO

There are three (3) styles of working plug gages...Taperlock, Reversible and Trilock.

The taperlock style consists of a Go and/or No Go member(s). The Go member is longer than the No Go and has a chip groove (in larger sizes) which not only adds to ease of identification but also assists in clearing obstructions.

The reversible thread plug gage also consists of a Go and No Go member(s). Both members are straight and afford the gage user double the life by simply reversing the gage member(s), turning the worn portion into the handle.

The trilock design is best suited for large size thread plug gages (1½ inches and up). Consisting of a Go and/or No Go member(s), the trilock has a bolt fastening system to support the size and weight. A chip groove is provided on the Go member for ease of identification and clearing obstructions.

Proper selection of the drill and tap is required to insure that the tapped hole will meet tolerance limits. The Go member not entering the hole may be indicative of incorrect tooling, improper set-up and/or burrs. If the No Go member enters the threaded hole of the part more than three (3) turns it is possible the wrong size threading tool is being used or you have a "bell mouth" hole condition.

Gages are normally manufactured and inventoried to class "X" tolerances which refers to pitch diameter, major diameter, lead tolerances and thread angle tolerances. Class "W" tolerances which are recommended for closer product tolerances or final inspection are also available upon request. Both classifications, "X" and "W", are gage manufacturers' tolerances and not the limits. See pages 15-17 tolerances.

EXAMPLE: 1/4-20 UNC 2B plug gage...

the "X" gage makers' tolerance on the pitch diameter would be .0003 and the "W" tolerance would be .0001. The tolerance is applied (+) plus on the Go gage and (-) minus on the No Go gage.

THREAD RING GAGES

Thread ring gages are used to check an external threaded part. The most common classes of fit are:

- 2A...a general purpose class of fit and
- 3A...used to check parts with "closer" tolerance requirements.

(See pages 18-20 for tolerances.)

Other classes of fit and special pitch diameters are available upon request.

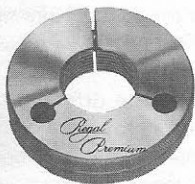

THREAD RING GAGE

The part being checked is generally acceptable when it does not enter the No Go ring gage more than 1½ to 3 turns dependent upon customer specifications. No Go ring gages have an annular groove around the outside for identification.

The Go thread ring gage checks all functional geometries of the threaded part with the exception of the major diameter. The products' thread should freely enter the Go thread ring gage for the entire length of the threaded portion.

Thread Ring Gages: GO = HI; NO GO = LO Thread Plug Gages: GO = LO; NO GO = HI

THREAD SETTING PLUG GAGES

Thread setting plugs are to be used to set ring gages only. Their purpose is setting or resetting the ring gages and determining if the ring is within tolerance. Setting plugs are not to be used to check the work piece.

To insure the ring gage is still within its tolerance after being put into use, the setting plug gage, both Go and No Go, should be used to verify accuracy. This also provides the gage user the capability to reset the ring gage as required. Generally, the setting plug is ordered at the same time as the thread ring gage and there could be a cost savings when ordering them together. Remember, the set plug gage is needed in the manufacturing and certification of the ring gage and they are matched to each other.



THREAD SETTING PLUG GAGE

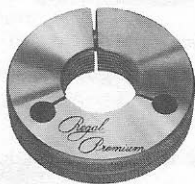

THREAD RING GAGE

In setting an adjustable thread ring gage, the sealing compound must be removed and the locking screw loosened. Turning the adjusting screw to the right enlarges the ring so that it turns freely onto the thread setting plug. Alternately adjusting the adjusting screw and tightening the locking screw, until a firm fit on the threads is achieved, is the proper method of assuring accurate adjustment.

A truncated setting plug of standard design will have

the crest of the thread truncated for half the length of the gage, unless otherwise specified, giving a full-form portion and a truncated portion. In setting thread ring gages to size, the truncated portion controls the pitch diameter and the full-form portion assures that the proper clearance is provided at the major diameter of the ring gage. The use of the full-form portion along with the truncated portion checks the flank angle of the thread gage.

CYLINDRICAL PLUG GAGES

Cylindrical plug gages, sometimes referred to as pin gages or plain plug gages, are used to check a drilled hole or the minor diameter of a threaded hole. There are three (3) basic styles of cylindrical plug gages:

REVERSIBLE (PIN)



Size Range: .015 to .760

TAPERLOCK



Size Range: .240 to 1.510

TRILOCK



Size Range: .760 to 4.510

The attraction of the reversible is that it affords the end-user the opportunity to double the wear-life of the gage by simply turning the gage around and using the other end, resulting in lower gage cost. The reversible cylindrical (pin) gage is designed for size ranges of .015 to .760.

The taperlock design is held in the handle by means of a tapered shank which provides added holding strength necessary for intermediate size ranges of .240 to 1.510.

The trilock design may be used like a reversible by simply turning the members around. A bolt fastening system is used because of size and weight. The trilock is designed for size ranges .760 to 4.510.

Double end gages are supplied with (+) plus tolerance on the Go member and (-) minus tolerance on the No Go member. Cylindrical plug gages may be furnished in four (4) tolerance classes, as follows:

Class "XX" — Very close tolerance and typically used for master gages.

Class "X" — Close tolerance for products requiring the highest grade of precision.
(Most commonly used)

Class "Y" — Larger tolerance than class "X" and used as working gages.

Class "Z" — Used as working gages for more liberal product tolerances.

When selecting gage tolerance it is a good practice to **not** exceed 10% of the product tolerance.

Following are examples of tolerance comparisons for cylindrical plug gages:

RANGE ABOVE—THRU INCH—METRIC	TOLERANCES—INCHES—MILLIMETRES			
	CLASS XX	CLASS X	CLASS Y	CLASS Z
.015" — .075" .38mm — 1.90mm	.00002 .000508	.00004 .001016	.00007 .001778	.00010 .002540
.075" — .180" 1.90mm — 4.57mm	.00002 .000508	.00004 .001016	.00004 .001778	.00010 .002540

See page 20 through 22 for dimensions and tolerance.

Handles are supplied with green caps for Go gages and red for No Go gages.

PIPE PLUG GAGES

There are three (3) basic styles of pipe plug gages:

- Straight Threaded Pipe Plug Gages
- Threaded Taper Pipe Plug Gages
- Plain Taper Pipe Plug Gages

Straight threaded pipe plug gages consist of two (2) members (Go and No Go) and follow the same gaging principles as the working thread plug gages...the part being checked is generally acceptable when the No Go member does not enter more than 1½ to 3 turns dependent upon customer specifications.

The NPT (American National Standard Taper Pipe) gage consists of one member (L-1) and is used to check an internal threaded hole. Parts being checked are generally acceptable when they come flush with the notch to plus (+) or minus (-) one turn. The L-1 plug gage checks the first four (4) threads.

NPTF (Dryseal) and ANPT (Aeronautical) thread tolerances are more closely controlled requiring an L-3 gage as well as an L-1. The L-3 checks the fifth (5), sixth (6) and seventh (7) threads.



L-1



L-3



6 STEP PLAIN TAPER PIPE PLUG

Thread Ring Gages: GO = HI; NO GO = LO Thread Plug Gages: GO = LO; NO GO = HI

The 6-step plain taper pipe plug gage, consisting of one member, checks the minor diameter of an internally threaded NPTF (Dryseal) and ANPT (Aeronautical) hole. Taper pipe plugs are used in tapered holes...both threaded and plain. In order to use the plain plug, you first must determine with the threaded plug where the hole is in relationship to basic, minimum and maximum thread.

EXAMPLE: Insert your NPTF thread plug gage into the hole. If the parts comes flush with the notch, you must use the notches marked "B" and "BT" on your 6-step plain plug gage. If you insert the NPTF threaded plug gage into the hole and the notch is one (1) turn small from being flush then use the notches marked "MN" and "MNT" on the 6-step plain plug gage. If after inserting the NPTF threaded plug gage into the hole the notch is one (1) turn large (that is, into the part deeper) from being flush, then use notches marked "MX" and "MXT" on your 6-step plain plug gage.

Remember, first determine thread depth relative to basic and minimum or maximum thread with the threaded plug gage before using the plain plug gage which would be checking the "crest" of the internal threads. For gaging taper pipe threads and basic dimensions for crest check information refer to tables and illustration on pages 23 through 30.

PIPE RING GAGES

There are two (2) basic styles of pipe ring gages...threaded and plain. Threaded ring gages are used to check external threaded parts. For taper pipe ring gages, only one (1) member is required when checking NPT (American National Standard Taper Pipe) threaded parts...L-1. Two (2) members (Go and No Go) are required for straight pipe gages.

When gaging NPT threaded parts, thread the marked side on first. Parts being checked are generally acceptable when they come flush to end of ring to plus (+) or minus (-) one turn. The L-1 thin ring gage checks the first four (4) threads.

NPTF (Dryseal) and ANPT (Aeronautical) thread tolerances are more closely controlled requiring an L-2 thick ring gage as well as an L-1 ring. The L-2 thick gage checks approximately the fifth (5), sixth (6) and seventh (7) threads.

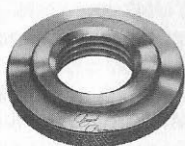

L-1 THIN



L-2 THICK

The plain ring gage is used to check the major diameter of the external thread.

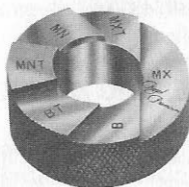

PLAIN RING GAGE

Taper pipe ring gages are used in the same manner as pipe plugs except you are now checking an external thread.

EXAMPLE: Thread the pipe ring gage on the part (marked side first). If the part comes flush with end of ring gage, you are at basic thread. Then use the plain ring gage with steps marked "B" and "BT". If the part comes one (1) turn small from being flush then you are at minimum thread. Then use the plain ring gage with steps marked "MN" and "MNT". If the part comes one (1) turn large from being flush then you are at maximum thread. You then use the plain ring gage with steps marked "MX" and "MXT".

Again, determine location with your threaded ring (basic, minimum, maximum) before using your plain crest check ring gage. Refer to pages 23 through 30 for gaging taper pipe thread and basic dimensions for crest check information.

GAGE RECALIBRATION

Providing substantial cost savings to gage users worldwide, some quality gage manufacturers offer recalibration services. Regal Cutting Tools is proud to offer such a service supplying certificates of calibration or compliance with each recalibrated gage.

ENGINEERING DATA

STANDARD SYSTEM OF MARKING REGAL CUTTING TOOLS

Tap Marking	Thread Designations	Thread Series
ACME-C	ACME-C	Acme threads, centralizing
ACME-G	ACME-G	Acme threads, general purpose (See also "STUB ACME")
AMO	AMO	American Standard microscope objective threads
NPT	ANPT	Aeronautical National Form taper pipe threads
BUTT	BUTT	Buttress Threads, pull type
PUSH-BUTT	PUSH-BUTT	Buttress Threads, push type
M	M	Metric Screw Threads—M Profile, with basic ISO 68 profile
MJ	MJ	Metric Screw Threads—MJ Profile, with rounded root of radius 0.15011P to 0.18042P
NC	NS5 IF	—Entire ferrous material range
NC	NC5 INF	—Entire nonferrous material range
NGO-RH or LH	NGO	National gas outlet threads
NGT	NGT	National gas taper threads
NH	NH	American Standard hose coupling threads of full form
NPS	NPSC	American Standard straight pipe threads in pipe couplings
NPSF	NPSF	Dryseal American Standard fuel internal straight pipe threads
NPSH	NPSH	American Standard straight hose hose coupling threads for joining to American Standard taper pipe threads

STANDARD SYSTEM OF MARKING

Continued

Tap Marking	Thread Designations	Thread Series
NPSI	NPSI	Dryseal American Standard intermediate internal straight pipe threads
NPSL	NPSL	American Standard straight pipe threads for loose fitting mechanical joints with locknuts
NPS	NPSM	American Standard straight pipe threads for free fitting mechanical joints for fixtures
NPT	NPT	American Standard taper pipe threads for general use
NPTF	NPTF	Dryseal American Standard taper pipe threads
NPTR	NPTR	American Standard taper pipe threads for railing joints
PTF SHORT	PTF—SAE SHORT	Dryseal SAE short taper pipe threads
NC	UNJC	Unified Inch Screw Thread, coarse pitch series, with rounded root of radius 0.15011P to 0.18042P. On external thread only
NF	UNJF	Unified Inch Screw Thread, fine pitch series, with rounded root of radius 0.15011P to 0.18042P. On external thread only.
NEF	UNJEF	Unified Inch Screw Thread, extra-fine pitch series, with rounded root of radius 0.15011P to 0.18042P. On external thread only
STUB ACME	STUB ACME	Stub Acme threads
STUB ACME M1	STUB ACME M1	Stub Acme Modified Form 1
STUB ACME M2	STUB ACME M2	Stub Acme Modified Form 2
N	UN	Unified Inch Screw Thread, constant-pitch series

STANDARD SYSTEM OF MARKING

Continued

Tap Marking	Thread Designations	Thread Series
NC	UNC	Unified Inch Screw Thread, coarse pitch series
NF	UNF	Unified Inch Screw Thread, fine pitch series
NEF	UNEF	Unified Inch Screw Thread, extra-fine pitch series
N	UNJ	Unified Inch Screw Thread, constant-pitch series, with rounded root of radius of 0.15011P to 0.18042P. On external thread only
NS	UNS	Unified Inch Screw Thread, special diameter pitch, or length of engagement
Tap & Die Marking	Thread Designations	BRITISH SCREW THREADS
BA	BA	British Association
BSC	BSC	British Cycle
BSF	BSF	British WHITWORTH Fine
BSW	BSW	British WHITWORTH Coarse
BSPP (OLD)	BSPP	British Straight Pipe
BSPT (OLD)	BSPT	British Taper Pipe
WHIT	WHIT	British WHITWORTH Special

THREAD PLUG GAGE PITCH DIAMETERS

Nominal Size	Go Basic All Classes All Series	UNIFIED PITCH DIAMETERS				
		No Go		X Tol. Go = +	X Lead Tol.	X ± Half Angle Tol.
		CL. 2B	CL. 3B	No Go = -		
#0-80 UNF	.0519	.0542	.0536	.0002	.0002	0°30'
#1-64 UNC	.0629	.0655	.0648	.0002	.0002	0°30'
#1-72 UNF	.0640	.0665	.0659	.0002	.0002	0°30'
#2-56 UNC	.0744	.0772	.0765	.0002	.0002	0°30'
#2-64 UNF	.0759	.0786	.0779	.0002	.0002	0°30'
#3-48 UNC	.0855	.0885	.0877	.0002	.0002	0°30'
#3-56 UNF	.0874	.0902	.0895	.0002	.0002	0°30'
#4-40 UNC	.0958	.0991	.0982	.0002	.0002	0°20'
#4-48 UNF	.0985	.1016	.1008	.0002	.0002	0°30'
#5-40 UNC	.1088	.1121	.1113	.0002	.0002	0°20'
#5-44 UNF	.1102	.1134	.1126	.0002	.0002	0°20'
#6-32 UNC	.1177	.1214	.1204	.0003	.0003	0°15'
#6-40 UNF	.1218	.1252	.1243	.0002	.0002	0°20'
#8-32 UNC	.1437	.1475	.1465	.0003	.0003	0°15'
#8-36 UNF	.1460	.1496	.1487	.0002	.0002	0°20'
#10-24 UNC	.1629	.1672	.1661	.0003	.0003	0°15'
#10-32 UNF	.1697	.1736	.1726	.0003	.0003	0°15'
#12-24 UNC	.1889	.1933	.1922	.0003	.0003	0°15'
#12-28 UNF	.1928	.1970	.1959	.0003	.0003	0°15'
#12-32 UNEF	.1957	.1998	.1988	.0003	.0003	0°15'
1/4-20 UNC	.2175	.2224	.2211	.0003	.0003	0°15'
1/4-28 UNF	.2268	.2311	.2300	.0003	.0003	0°15'
1/4-32 UNEF	.2297	.2339	.2328	.0003	.0003	0°15'
5/16-18 UNC	.2764	.2817	.2803	.0003	.0003	0°10'
5/16-24 UNF	.2854	.2902	.2890	.0003	.0003	0°15'
5/16-32 UNEF	.2922	.2964	.2953	.0003	.0003	0°15'
3/8-16 UNC	.3344	.3401	.3387	.0003	.0003	0°10'
3/8-24 UNF	.3479	.3528	.3516	.0003	.0003	0°15'
3/8-32 UNEF	.3547	.3591	.3580	.0003	.0003	0°15'
7/16-14 UNC	.3911	.3972	.3957	.0003	.0003	0°10'
7/16-20 UNF	.4050	.4104	.4091	.0003	.0003	0°15'

THREAD PLUG GAGE PITCH DIAMETERS (Continued)

Nominal Size	Go Basic All Classes All Series	UNIFIED PITCH DIAMETERS				
		No Go		X Tol. Go = + No Go = -	X Lead Tol.	X ± Half Angle Tol.
		CL. 2B	CL. 3B			
7/16-28 UNEF	.4143	.4189	.4178	.0003	.0003	0°15'
1/2-13 UNC	.4500	.4565	.4548	.0003	.0003	0°10'
1/2-20 UNF	.4675	.4731	.4717	.0003	.0003	0°15'
1/2-28 UNEF	.4768	.4816	.4804	.0003	.0003	0°15'
9/16 UNC	.5084	.5152	.5135	.0003	.0003	0°10'
9/16 UNF	.5264	.5323	.5308	.0003	.0003	0°10'
9/16-24 UNEF	.5354	.5405	.5392	.0003	.0003	0°15'
5/8-11 UNC	.5660	.5732	.5714	.0003	.0003	0°10'
5/8-18 UNF	.5889	.5949	.5934	.0003	.0003	0°10'
5/8-24 UNEF	.5979	.6031	.6018	.0003	.0003	0°15'
11/16-24 UNEF	.6604	.6656	.6643	.0003	.0003	0°15'
3/4-10 UNC	.6850	.6927	.6907	.0003	.0003	0°10'
3/4-16 UNF	.7094	.7159	.7143	.0003	.0003	0°10'
3/4-20 UNEF	.7175	.7232	.7218	.0003	.0003	0°15'
13/16-20 UNEF	.7800	.7857	.7843	.0003	.0003	0°15'
7/8-9 UNC	.8028	.8110	.8089	.0003	.0003	0°10'
7/8-14 UNF	.8286	.8356	.8339	.0003	.0003	0°10'
7/8-20 UNEF	.8425	.8482	.8468	.0003	.0003	0°15'
15/16-20 UNEF	.9050	.9109	.9094	.0003	.0003	0°15'
1"-8 UNC	.9188	.9276	.9254	.0004	.0004	0°05'
1"-12 UNF	.9459	.9535	.9516	.0003	.0003	0°10'
1"-14 UNS	.9536	.9609	.9590	.0003	.0003	0°10'
1"-20 UNEF	.9675	.9734	.9719	.0003	.0003	0°15'
1 1/16-18 UNEF	1.0315	1.0264	1.0310	.0003	.0003	0°10'
1 1/8-7 UNC	1.0322	1.0416	1.0393	.0004	.0004	0°05'
1 1/8-12 UNF	1.0709	1.0787	1.0768	.0003	.0003	0°10'
1 1/8-18 UNEF	1.0889	1.0951	1.0935	.0003	.0003	0°10'
1 3/16-18 UNEF	1.1514	1.1577	1.1561	.0003	.0003	0°10'
1 1/4-7 UNC	1.1572	1.1668	1.1644	.0004	.0004	0°05'
1 1/4-12 UNF	1.1959	1.2039	1.2019	.0003	.0003	0°10'
1 1/4-18 UNEF	1.2139	1.2202	1.2186	.0003	.0003	0°10'

THREAD PLUG GAGE PITCH DIAMETERS *(Continued)*

Nominal Size	Go Basic All Classes All Series	UNIFIED PITCH DIAMETERS				
		No Go		X Tol. Go = + No Go = -	X Lead Tol.	X \pm Half Angle Tol.
		CL. 2B	CL. 3B			
1 5/16-18 UNEF	1.2764	1.2827	1.2811	.0003	.0003	0°10'
1 3/8-6 UNC	1.2667	1.2771	1.2745	.0004	.0004	0°05'
1 3/8-12 UNF	1.3209	1.3291	1.3270	.0003	.0003	0°10'
1 3/8-18 UNEF	1.3389	1.3452	1.3436	.0003	.0003	0°10'
1 7/16-18 UNEF	1.4014	1.4079	1.4062	.0003	.0003	0°10'
1 1/2-6 UNC	1.3917	1.4022	1.3996	.0004	.0004	0°05'
1 1/2-12 UNF	1.4459	1.4542	1.4522	.0003	.0003	0°10'
1 1/2-18 UNEF	1.4639	1.4704	1.4687	.0003	.0003	0°10'

THREAD RING & SETTING THREAD PLUG GAGE PITCH DIAMETERS

Nominal Size	UNIFIED PITCH DIAMETERS				X Tol. Go = - No Go = +
	Go		No Go		
	CL. 3A	CL. 2A	CL. 2A	CL. 3A	
#0-80 UNF	.0519	.0514	.0496	.0506	.0002
#1-64 UNC	.0629	.0623	.0603	.0614	.0002
#1-72 UNF	.0640	.0634	.0615	.0626	.0002
#2-56 UNC	.0744	.0738	.0717	.0728	.0002
#2-64 UNF	.0759	.0753	.0733	.0744	.0002
#3-48 UNC	.0855	.0848	.0825	.0838	.0002
#3-56 UNF	.0874	.0867	.0845	.0858	.0002
#4-40 UNC	.0958	.0950	.0925	.0939	.0002
#4-48 UNF	.0985	.0978	.0954	.0967	.0002
#5-40 UNC	.1088	.1080	.1054	.1069	.0002
#5-44 UNF	.1102	.1095	.1070	.1082	.0002
#6-32 UNC	.1177	.1169	.1141	.1156	.0003
#6-40 UNF	.1218	.1210	.1184	.1198	.0002
#8-32 UNC	.1437	.1428	.1399	.1415	.0003
#8-36 UNF	.1460	.1452	.1424	.1439	.0002
#10-24 UNC	.1629	.1619	.1586	.1604	.0003
#10-32 UNF	.1697	.1688	.1658	.1674	.0003
#12-24 UNC	.1889	.1879	.1845	.1863	.0003
#12-28 UNF	.1928	.1918	.1886	.1904	.0003
#12-32 UNEF	.1957	.1948	.1917	.1933	.0003
1/4-20 UNC	.2175	.2164	.2127	.2147	.0003
1/4-28 UNF	.2268	.2258	.2225	.2243	.0003
1/4-32 UNEF	.2297	.2287	.2255	.2273	.0003
5/16-18 UNC	.2764	.2752	.2712	.2734	.0003
5/16-24 UNF	.2854	.2843	.2806	.2827	.0003
5/16-32 UNEF	.2922	.2912	.2880	.2898	.0003
3/8-16 UNC	.3344	.3331	.3287	.3311	.0003
3/8-24 UNF	.3479	.3468	.3430	.3450	.0003
3/8-32 UNEF	.3547	.3537	.3503	.3522	.0003
7/16-14 UNC	.3911	.3897	.3850	.3876	.0003
7/16-20 UNF	.4050	.4037	.3995	.4019	.0003
7/16-28 UNEF	.4143	.4132	.4096	.4116	.0003

THREAD RING & SETTING THREAD PLUG GAGE PITCH DIAMETERS

(Continued)

Nominal Size	UNIFIED PITCH DIAMETERS				X Tol. Go = - No Go = +
	Go		No Go		
	CL. 3A	CL. 2A	CL. 2A	CL. 3A	
1/2-13 UNC	.4500	.4485	.4435	.4463	.0003
1/2-20 UNF	.4675	.4662	.4619	.4643	.0003
1/2-28 UNEF	.4768	.4757	.4720	.4740	.0003
9/16-12 UNC	.5084	.5068	.5016	.5045	.0003
9/16-18 UNF	.5264	.5250	.5205	.5230	.0003
9/16-24 UNEF	.5354	.5342	.5303	.5325	.0003
5/8-11 UNC	.5660	.5644	.5589	.5619	.0003
5/8-18 UNF	.5889	.5875	.5828	.5854	.0003
5/8-24 UNEF	.5979	.5967	.5927	.5949	.0003
11/16-24 UNEF	.6604	.6592	.6552	.6574	.0003
3/4-10 UNC	.6850	.6832	.6773	.6806	.0003
3/4-16 UNF	.7094	.7079	.7029	.7056	.0003
3/4-20 UNEF	.7175	.7162	.7118	.7142	.0003
13/16-20 UNEF	.7800	.7787	.7743	.7767	.0003
7/8-9 UNC	.8028	.8009	.7946	.7981	.0003
7/8-14 UNF	.8286	.8270	.8216	.8245	.0003
7/8-20 UNEF	.8425	.8412	.8368	.8392	.0003
15/16-20 UNEF	.9050	.9036	.8991	.9016	.0003
1"-8 UNC	.9188	.9168	.9100	.9137	.0004
1"-12 UNF	.9459	.9441	.9382	.9415	.0003
1"-14 UNS	.9536	.9519	.9463	.9494	.0003
1"-20 UNEF	.9675	.9661	.9616	.9641	.0003
1 1/16-18 UNEF	1.0264	1.0250	1.0203	1.0228	.0003
1 1/8-7 UNC	1.0322	1.0300	1.0228	1.0268	.0004
1 1/8-12 UNF	1.0709	1.0691	1.0631	1.0664	.0003
1 1/8-18 UNEF	1.0889	1.0875	1.0828	1.0853	.0003
1 3/16-18 UNEF	1.1514	1.1499	1.1450	1.1478	.0003
1 1/4-7 UNC	1.1572	1.1550	1.1476	1.1517	.0004
1 1/4-12 UNF	1.1959	1.1941	1.1879	1.1913	.0003
1 1/4-18 UNEF	1.2139	1.2124	1.2075	1.2103	.0003
1 5/16-18 UNEF	1.2764	1.2749	1.2700	1.2728	.0003

THREAD RING & SETTING THREAD PLUG GAGE PITCH DIAMETERS

(Continued)

Nominal Size	UNIFIED PITCH DIAMETERS				X Tol. Go = - No Go = +
	Go		No Go		
	CL. 3A	CL. 2A	CL. 2A	CL. 3A	
1 3/8-6 UNC	1.2667	1.2643	1.2563	1.2607	.0004
1 3/8-12 UNF	1.3209	1.3190	1.3127	1.3162	.0003
1 3/8-18 UNEF	1.3389	1.3374	1.3325	1.3353	.0003
1 7/16-18 UNEF	1.4014	1.3999	1.3949	1.3977	.0003
1 1/2-6 UNC	1.3917	1.3893	1.3812	1.3856	.0004
1 1/2-6 UNC	1.3917	1.3893	1.3812	1.3856	.0004
1 1/2-12 UNF	1.4459	1.4440	1.4376	1.4411	.0003
1 1/2-18 UNEF	1.4639	1.4624	1.4574	1.4602	.0003

CYLINDRICAL PLUG GAGES REVERSIBLE TYPE—INCH & METRIC DIMENSIONS

Size Ranges		Tolerances (Inches)				Length Member Go/No Go	Handle No.
Inches	Millimetres	Class XX	Class X	Class Y	Class Z		
.015 - .075	.38 - 1.90	.00002	.00004	.00007	.00010	2	1W
.075 - .180	1.90 - 4.57	.00002	.00004	.00007	.00010	2	2W
.180 - .281	4.57 - 7.14	.00002	.00004	.00007	.00010	2	3W
.281 - .406	7.14 - 10.31	.00002	.00004	.00007	.00010	2	4W
.406 - .510	10.31 - 12.95	.00002	.00004	.00007	.00010	2	5W
.510 - .635	12.95 - 16.13	.00002	.00004	.00007	.00010	2	6W
.635 - .760	16.13 - 19.30	.00002	.00004	.00007	.00010	2	7W

CYLINDRICAL PLUG GAGES

TAPERLOCK DESIGN—INCH & METRIC DIMENSIONS

Size Ranges		Tolerances (Inches)			
Inches	Millimetres	Class XX	Class X	Class Y	Class Z
.240 - .365	6.10 - 9.27	.00002	.00004	.00007	.00010
.365 - .510	9.27 - 12.95	.00002	.00004	.00007	.00010
.510 - .825	12.95 - 20.95	.00002	.00004	.00007	.00010
.825 - 1.135	20.95 - 28.83	.00003	.00006	.00009	.00012
1.135 - 1.510	28.83 - 38.35	.00003	.00006	.00009	.00012

Size Ranges		Length GO Member	Length NO GO Member	Handle	
Inches	Millimetres			No.	Length
.240 - .365	6.10 - 9.27	3/4	5/16	1	2-3/4
.365 - .510	9.27 - 12.95	1	3/8	2	3
.510 - .825	12.95 - 20.95	1-1/4	1/2	3	3-1/4
.825 - 1.135	20.95 - 28.83	1-1/2	5/8	4	3-5/8
1.135 - 1.510	28.83 - 38.35	1-5/8	3/4	5	4

CYLINDRICAL PLUG GAGES TRILOCK DESIGN—INCH & METRIC DIMENSIONS

Size Ranges		Tolerances (Inches)			
Inches	Millimetres	Class XX	Class X	Class Y	Class Z
.760 - .825	19.30 - 20.95	.00002	.00004	.00007	.00010
.825 - .947	20.95 - 24.05	.00003	.00006	.00009	.00012
.947 - 1.135	24.05 - 28.83	.00003	.00006	.00009	.00012
1.135 - 1.510	28.83 - 38.35	.00003	.00006	.00009	.00012
1.510 - 2.010	38.35 - 51.05	.00004	.00008	.00012	.00016
2.010 - 2.510	51.05 - 63.75	.00004	.00008	.00012	.00016
2.510 - 3.510	63.75 - 89.15	.00005	.00010	.00015	.00020
3.510 - 4.510	89.15 - 114.55	.00005	.00010	.00015	.00020

Size Ranges		Length GO Member	Length NO GO Member	Handle	
Inches	Millimetres			No.	Length
.760 - .825	19.30 - 20.95	1-1/4	3/4	2-1/2	4
.825 - .947	20.95 - 24.05	1-1/4	3/4	2-1/2	4
.947 - 1.135	24.05 - 28.83	1-3/8	3/4	3-1/2	4
1.135 - 1.510	28.83 - 38.35	1-1/2	3/4	4-1/2	4
1.510 - 2.010	38.35 - 51.05	1-7/8	7/8	5-1/2	4-1/2
2.010 - 2.510	51.05 - 63.75	2	7/8	6	5
2.510 - 3.510	63.75 - 89.15	2	1	7	6
3.510 - 4.510	89.15 - 114.55	2-1/8	1	7	6

GAGING TAPER PIPE THREADS

APPLICATION OF GAGES: (Basic Notch Illustrated)

BASIC THREAD

When gage is screwed up with hand tight pressure and basic notch of the L-1 thread plug is flush with gaging point of fitting, (usually the face) the pitch diameter of the internal thread is at Basic Size.

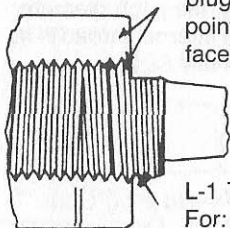

L-1 Thread Plug Gage
For: NPT, ANPT & NPTF

Basic L-1 Length

When gage is screwed up with hand tight pressure and basic notch of the L-3 thread plug is flush with gaging point of fitting, (usually the face) the pitch diameter of the internal thread is at Basic Size.

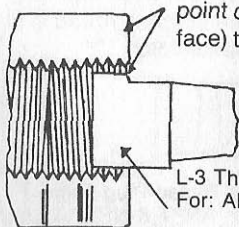

L-3 Thread Plug Gage
For: ANPT & NPTF

L-3 = 3 threads
L-3 + P = 4 threads
L-1 + L-3

Same gaging principles apply for taper pipe ring gages except you are now checking an external thread. L-2 rings are used for ANPT and NPTF.

GAGING TAPER PIPE THREADS

APPLICATION OF GAGES:

(Continued)

(Basic Notch Illustrated)

MINIMUM THREAD

When basic notch of the L-1 thread plug is one turn (small) from gaging point of fitting, the pitch diameter of the internal thread is at Minimum Size.

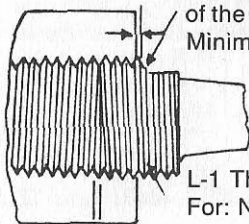

L-1 Thread Plug Gage
For: NPT, ANPT & NPTF

L-1 (—) one turn small

When basic notch of the L-3 thread plug is one turn (small) from gaging point of fitting, the pitch diameter of the internal thread is at Minimum Size.

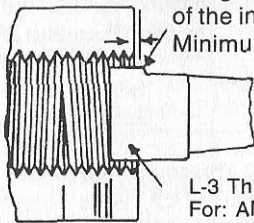

L-3 Thread Plug Gage
For: ANPT & NPTF

L-3 = 3 threads
L-3 + P = 4 threads
L-1 + L-3 (—) one turn small

Same gaging principles apply for taper pipe ring gages except you are now checking an external thread. L-2 rings are used for ANPT and NPTF.

GAGING TAPER PIPE THREADS

APPLICATION OF GAGES:

(Continued)

(Basic Notch Illustrated)

MAXIMUM THREAD

When basic notch of the L-1 thread plug is one turn (large) from gaging point of fitting, the pitch diameter of the internal thread is at Maximum Size.

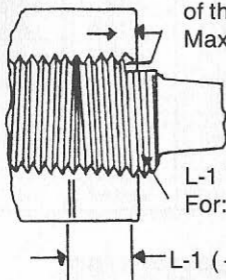

L-1 Thread Plug Gage
For: NPT, ANPT & NPTF

L-1 (+) one turn large

When basic notch of the L-3 thread plug is one turn (large) from gaging point of fitting, the pitch diameter of the internal thread is at Maximum Size.

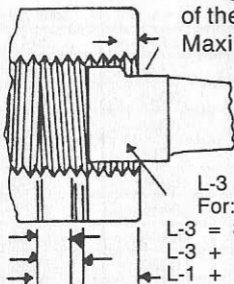

L-3 Thread Plug Gage
For: ANPT & NPTF

L-3 = 3 threads

L-3 + P = 4 threads

L-1 + L-3 (+) one turn large

Same gaging principles apply for taper pipe ring gages except you are now checking an external thread. L-2 rings are used for ANPT and NPTF.

NPT and NPTF-L1 TAPER PIPE THREAD PLUG GAGES DIMENSIONS

Size	Length L-1 to Notch	Min. Length L-2	Pitch Diam. Small End	Pitch Diam. at Gage Notch
1/16-27	.160	.26111	.27118	.28118
1/8-27	.1615	.26385	.36351	.37360
1/4-18	.2278	.40178	.47739	.49163
3/8-18	.240	.40778	.61201	.62701
1/2-14	.320	.53371	.75843	.77843
3/4-14	.339	.54571	.96768	.98887
1-11 1/2	.400	.68278	1.21363	1.23853
1 1/4-11 1/2	.420	.70678	1.55713	1.58338
1 1/2-11 1/2	.420	.72348	1.79609	1.82234
2-11 1/2	.436	.75652	2.26902	2.29627
2 1/2-8	.682	1.13750	2.71953	2.76216
3-8	.766	1.20000	3.34062	3.38850

NPTF-L3 TAPER PIPE THREAD PLUG GAGES DIMENSIONS

Size	4 Threads Long	Basic Length L-1 + L-3	Pitch Diam. Small End
1/16-27	.1482	.2711	.2642
1/8-27	.1482	.2726	.3566
1/4-18	.2222	.3945	.4670
3/8-18	.2222	.4067	.6016
1/2-14	.2857	.5343	.7451
3/4-14	.3857	.5533	.9543
1-11 1/2	.3478	.6609	1.1973
1 1/4-11 1/2	.3478	.6809	1.5408
1 1/2-11 1/2	.3478	.6809	1.7798
2-11 1/2	.3478	.6969	2.2527
2 1/2-8	.5000	1.0570	2.6961
3-8	.5000	1.1410	3.3172

NPT and NPTF-L1 TAPER PIPE "THIN" THREAD RING GAGES DIMENSIONS

Size	Length L-1	Pitch Diam. Small End	Pitch Diam. Large End	Outside Diam.
1/16-27	.160	.27118	.28118	1-1/8
1/8-27	.1615	.36351	.37360	1-1/8
1/4-18	.2278	.47739	.49163	1-3/8
3/8-18	.240	.61201	.62701	1-1/2
1/2-14	.320	.75843	.77843	1-3/4
3/4-14	.339	.96768	.98887	2
1-11 1/2	.400	1.21363	1.23853	2-1/2
1 1/4-11 1/2	.420	1.55713	1.58338	3
1 1/2-11 1/2	.420	1.79609	1.82234	3-1/4
2-11 1/2	.436	2.26902	2.29627	3-3/4
2 1/2-8	.682	2.71953	2.76216	4-1/4
3-8	.766	3.34062	3.38850	5

NPTF-L2 TAPER PIPE "THICK" THREAD RING GAGES DIMENSIONS

Size	Length L-2	Pitch Diam. Small End	Pitch Diam. Large End	Outside Diam.
1/16-27	1.26113	.27886	.28750	1-1/8
1/8-27	.26385	.37129	.38000	1-1/8
1/4-18	.40178	.48816	.50250	1-3/8
3/8-18	.40778	.62354	.63750	1-1/2
1/2-14	.53371	.77396	.79179	1-3/4
3/4-14	.54571	.98440	1.00179	2
1-11 1/2	.68278	1.23320	1.25630	2-1/2
1 1/4-11 1/2	.70678	1.57794	1.60130	3
1 1/2-11 1/2	.72348	1.81690	1.84130	3-1/4
2-11 1/2	.75652	2.29084	2.31630	3-3/4
2 1/2-8	1.13750	2.75434	2.79062	4-1/4
3-8	1.20000	3.38068	3.41562	5

CREST CHECK PLUG GAGE

(For checking NPTF threads)

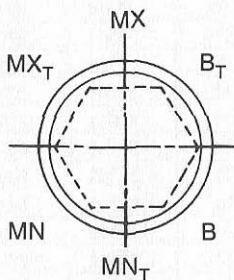

TAPER 0.0625
± 0.0005 INCH
PER INCH ON DIAMETER

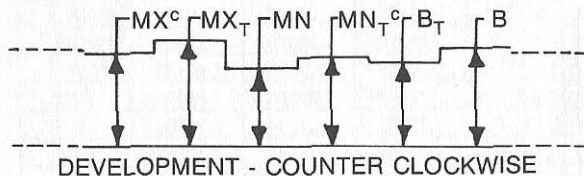
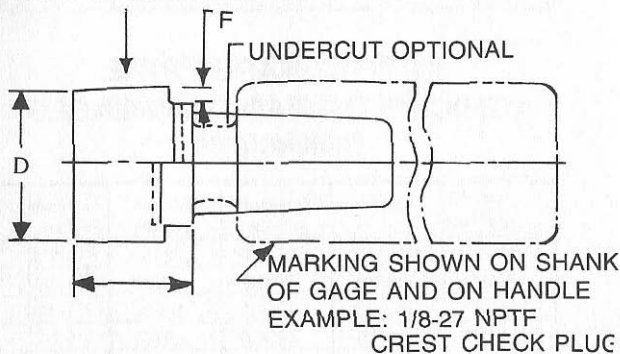

BASIC DIMENSIONS FOR CREST CHECK PLUG GAGES

Nominal Size	Minor Diameter at L ₃ Basic Thread with Maximum Truncation (D)	Basic Pipe Thread		Minimum Thread ^b	
		Minimum Truncation (B)	Maximum Truncation (B _T)	Minimum Truncation (MN)	Maximum Truncation (MN _T)
		+ 0.00015 - 0.00000	± 0.001	+ 0.000 - 0.002	± 0.001
1/16-27	0.2391	0.2154	0.2711	0.1907	0.2464
1/8-27	0.3315	0.2169	0.2726	0.1922	0.2479
1/4-18	0.4276	0.3394	0.3945	0.3024	0.3575
3/8-18	0.5622	0.3516	0.4067	0.3146	0.3697
1/2-14	0.6918	0.4794	0.5343	0.4318	0.4867
3/4-14	0.9010	0.4984	0.5533	0.4508	0.5057
1-11 1/2	1.1324	0.6052	0.6609	0.5472	0.6029
1 1/4-11 1/2	1.4759	0.6252	0.6809	0.5672	0.6229
1 1/2-11 1/2	1.7149	0.6252	0.6809	0.5672	0.6229
2-11 1/2	2.1878	0.6412	0.6969	0.5832	0.6389
2 1/2-8 ^a	2.6016	1.0050	1.0570	0.9217	0.9737
3-8 ^a	3.2227	1.0890	1.1410	1.0057	1.0577

^a Gages for sizes 2 1/2 and 3 to fit standard trilock handle.

^b The dimensions given for steps at minimum thread and maximum thread are based on 2/3 turn (0.6667p) from basic thread. Actual truncation of the product thread may be slightly less than or slightly more than the tabulated truncation limit (B1.20.3) depending upon the variance from mean size in any given range (minimum range — basic range — maximum range). Formulas are shown in Appendix C.

^c On sizes 1/16 and 1/8, the MN and MN_T dimensions are shown out of relationship on the illustration of step development.

BASIC DIMENSIONS FOR CREST CHECK PLUG GAGES

(Continued)

Nominal Size	Maximum Thread ^b		Depth of Notch (F)
	Minimum Truncation (MX)	Maximum Truncation (MX _T)	
	± 0.001	+ 0.000 - 0.002	
1/16-27	0.2401	0.2958	0.037
1/8-27	0.2416	0.2973	0.055
1/4-18	0.3764	0.4315	0.055
3/8-18	0.3886	0.4437	0.085
1/2-14	0.5270	0.5819	0.085
3/4-14	0.5460	0.6009	0.120
1-11 1/2	0.6632	0.7189	0.120
1 1/4-11 1/2	0.6832	0.7389	0.120
1 1/2-11 1/2	0.6832	0.7389	0.120
2-11 1/2	0.6992	0.7549	0.120
2 1/2-8 ^a	1.0883	1.1403	0.120
3-8 ^a	1.1723	1.2243	0.120

- ^a Gages for sizes 2 1/2 and 3 to fit standard trilock handle.
- ^b The dimensions given for steps at minimum thread and maximum thread are based on 2/3 turn (0.6667p) from basic thread. Actual truncation of the product thread may be slightly less than or slightly more than the tabulated truncation limit (B1.20.3) depending upon the variance from mean size in any given range (minimum range — basic range — maximum range). Formulas are shown in Appendix C.
- ^c On sizes 1/16 and 1/8, the MX and MN_T dimensions are shown out of relationship on the illustration of step development.