

Consultant's Guide to Park Design and Development



City of San Diego

Park & Recreation Department

January 2005

(REVISION: 5/23/05 Revised Appendix 'M'; 6/6/05 Revised Appendix 'N';

2/2/06 Added Appendix 'O'; Revised Item 2.2.17.2 page 36-37; Item J page 85, # 3, #4)

ACKNOWLEDGMENTS

City of San Diego Park and Recreation Department Director, Ted Medina

Deputy Director Community Parks I Division
Deputy Director Developed Regional Parks Division
Deputy Director Community Parks II Division
Deputy Director Open Space Division

Deputy Director Park Planning & Development Division, April Penera

City Staff

Sheila Bose, Park Planning & Development Division
Div Brasted, Developed Regional Parks Division
Tom Cartier, Public Buildings and Parks Division
Charles Daniels, Park Planning & Development Division
Hossein Motamani, Park Planning & Development
Janine Anderson, Developed Regional Parks Division
Mark Marney, Park Planning & Development Division
John Montoya, Facilities Maintenance Division
Kevin Oliver, Park Planning & Development Division
Jim Winter, Park Planning & Development Division
L. Clark Ritter, Park Planning & Development Division
Tina Huang, Park Planning & Development Division
Kelly Rodgers, Park Planning & Development Division
Todd Schmit, Park Planning & Development Division
Deborah Sharpe, Park Planning & Development Division
Robin Shifflet, Park Planning & Development Division
Alex Warner, Park Planning & Development Division
Denise Weems, Park Planning & Development Division

Consultant's Guide Update Coordinator:

Tony Bonacorsi, Park Planning & Development Division

Special Thanks:

The Park Planning & Development Division would like to extend a special 'Thank You' to the numerous individuals, organizations and City staff who helped in the update of the Consultant's Guide.

Consultant's Guide to Park Design and Development

*“We enrich lives through quality parks and programs.”
City of San Diego Park and Recreation Department's Vision Statement*

**Prepared by:
Park Planning & Development
Park and Recreation Department
202 “C” Street
San Diego, CA 92101-3860**

January 2005

TABLE OF CONTENTS

1.	INTRODUCTION	Page Number
1.1	Purpose and Application	1
1.2	Description of Changes	2
2.	PARK DESIGN STANDARDS	
2.1	Types of Recreational Parks	3
2.1.1	Resource - Based Parks	3
2.1.2	Population - Based Parks	3
2.1.3	Special Parks	4
2.2	Design Standards	4
2.2.1	Site Planning	4
2.2.2	Grading and Drainage	5
2.2.3	Paving, Walkways and Mow Curbs	6
2.2.4	Fences and Walls	7
2.2.5	Site Furniture	8
2.2.6	Multi-Purpose Courts (Basketball and Volleyball Courts)	9
2.2.7	Tennis Courts	10
2.2.8	Swimming Pools	11
2.2.9	Multi-Purpose Fields (Softball and Soccer Fields)	12
2.2.10	Playgrounds and Equipment	14
2.2.11	Comfort Stations and Recreation Centers	21
2.2.12	Parking Areas	26
2.2.13	Trash Enclosures	27
2.2.14	Signs	27
2.2.15	Trails	28
2.2.16	Irrigation	29
2.2.17	Planting	35
2.2.18	Site and Sports Lighting	38
2.2.19	Graffiti Prevention	42
3.	GRAPHIC AND DRAFTING STANDARDS	
3.1	General Development Plans (GDP)	42
3.1.1	General Requirements for all GDP Plans	42
3.1.2	General Development Plan	42
3.1.3	Building Plans and Elevations	43

	Page Number
3.1.4	Park Sign Plan and Elevation(s) 43
3.1.5	Special Site Details and Site Furniture 43
3.1.6	Project Cost Estimate 43
3.1.7	Design review Committee Presentation Requirements 44
3.2	Construction Plans 45
3.2.1	General Requirements for all Plans 46
3.2.2	Title Sheet 47
3.2.3	Grading and Drainage Plans 51
3.2.4	Layout and Construction Plans 52
3.2.5	Irrigation Plans 53
3.2.6	Planting Plans 56
3.2.7	Lighting Plans 57
3.3	As-Built Plans 58
4.	PROJECT PROCESS, SUBMITTALS AND APPROVALS
4.1	General Development Plans 58
4.2	Construction Plans 61
4.3	As-Built Plans 62
5.	APPENDICES
	Appendix 'A' Park and Recreation Board Policies: No. 1001 'Naming of Parks', No. 1011 'Graphic Presentations' and No. 1302 'Park Signs'
Appendix 'B'	Council Policy No. 200-14 'Landscape Design'
Appendix 'C'	References Cited
Appendix 'D'	Standard Symbols and Legend for Irrigation Systems
Appendix 'E'	Approved Irrigation Materials List
Appendix 'F'	Supplemental Irrigation Specifications
Appendix 'G'	Approved Manufacturers and Products List
Appendix 'H'	Crime Prevention Through Environmental Design (CPTED) Guidelines for Park Design
Appendix 'I'	Division Standards and Specification from Facilities Division
Appendix 'J'	Standard Park Details Multi-Purpose Courts Tennis Courts Multi-Purpose Fields
Appendix 'K'	Council Policy #900-14, Sustainable Building Policy
Appendix 'L'	Disapproved Play Equipment
Appendix 'M'	Joint Use Checklist
Appendix 'N'	Access Law Memorandum's 2004-01,-02,-03,-04
Appendix 'O'	Policy on Avoiding Use of Non-Native Invasive Plants in Park & Recreation Department Projects

PREFACE

The Consultant's Guide to Park Design and Development is prepared by the Park Planning & Development Division of the Park and Recreation Department. This new edition, dated January 2005, replaces the last published edition, dated November 2001. The Park and Recreation Department will update the Consultant's Guide to Park Design and Development on an as-needed basis. The Appendices, found in the back of the Guide, will be updated on a yearly basis. Copies of this document or the Appendices can be obtained by contacting the Park Planning Section at the address list below.

This is a guideline for City staff, consultants and the general public to use in the design and development of public parks. These guidelines support the City's General Plan and Policy Documents but are subject to change due to changes in local, State and Federal laws, changes in City policy or administration.

The Park and Recreation Department is dedicated to the high quality of this publication and desires to correct any errors, omissions or ambiguity. If you have any corrections, additions or suggestions that you would like to submit for consideration to be included in the next publication, please submit them in writing to:

Consultants Guide to Park Design and Development
Park Planning & Development Division of the Park and Recreation Department
City of San Diego
202 'C' Street, M.S. 35
San Diego, CA 92101

1. INTRODUCTION

1.1 PURPOSE AND APPLICATION

1.1.1 Intent

The Park and Recreation Department has developed the Consultant's Guide to establish general standards, guidelines and criteria for the design and development of parks and open spaces. The Consultant's Guide is not a substitute for professional experience. Sound judgment must be exercised in the application of the standards to specific circumstances. The standards do not preclude the use of different methods when special conditions or site specific conditions are a factor and when proper authorization is obtained.

The Park and Recreation Department encourages "partnering", the creation of a relationship between the City Project Manager and the Consultant that promotes achievement of the standards and quality parks. In this respect, City Project Managers and the Consultant are encouraged to take the time at the start of a project to identify common goals, lines of communication and a commitment to cooperative problem solving.

If a major deviation from the standards is necessary or desirable the City Project Manager should be informed by writing so that a change can be evaluated as a possible future revision to the Consultants Guide.

1.1.2 Goals

The Park and Recreation Department ensures quality parks by basing designs on the following goals:

Aesthetics: Parks should project a positive image and establish a permanent character for the community and City. Park designs should provide a sense of arrival with reference points to promote circulation. They should provide places for groups and individuals for both formal and impromptu events. They should indicate nature through seasonal changes and provide something unique, obvious, complex and simple. They should provide human and monumental scale and should be visible from a distance. Overall, a sense of place and community should be created through the design of each Park.

Function: Parks should be designed for all community members to use and enjoy the facilities. Parks must also be functionally designed for the people who maintain the facilities. The most current products and industry standards should be applied to the park's design.

Economics: Parks should be designed for the allocated budgetary considerations and to provide economical means of maintaining the park.

1.1.3 Application

The Consultant's Guide applies to all parks, rights-of-way, MADS, gas tax medians and open spaces that are to be maintained by the Park and Recreation Department or a City Maintenance Assessment District. This includes all new parks, retrofitting existing parks, (Capital Improvement Projects), parks that are built by public funds (referred to as Public Projects), parks that are built by private funds and turned over to the City (referred to as Turn-Key Project or Developer Built Project), parks that are part of a joint use agreement and parks within City open space areas.

1.1.4 Other Regulating Documents

The design of parks shall also include the standards and requirements of the cited reference documents found in Appendix 'C'. If conflicts arise between this manual and other governing documents, contact the City Project Manager for clarification.

1.2 DESCRIPTION OF CHANGES

1.2.1 General Changes

In general, the 2005 'Consultant's Guide to Park Design and Development' has been updated to meet new local, state and federal requirements. The street rights-of-way and open space landscaping standards are found in the San Diego Municipal Code - Land Development Code. All development in open spaces must meet the requirements of the Consultant's Guide and the Municipal Code. The section, "Project Process, Submittals and Approvals", has been revised to conform with the new City Council Policy #600-33, "Community Notification and Input for City Wide Park Development Projects".

1.2.2 Specific Changes

See also the Landscape Standards - Sections One through Five, a technical guide to the Municipal Code, formerly known as the Landscape Technical Manual, for additional information on Street Rights-of-Way and Open Space requirements. Check lists for joint use parks has been added see Appendix "M".

2. PARK DESIGN STANDARDS

2.1 TYPES OF RECREATIONAL PARKS

The City of San Diego provides three types of recreational parks for residents and visitors: 1) Resource-Based Parks, 2) Population-Based Parks, and 3) Special Recreational Parks. Resource-based parks serve users from the entire city and elsewhere, and are located at or centered around natural or man-made features. Beaches (Mission Bay Park), historical sites (Balboa Park), and natural canyons and water courses (Mission Trails Regional Park), are examples of this type of park. Population-based parks are intended to serve the local daily needs of residential areas. Where possible they adjoin schools in order to share facilities, and ideally are within walking distance of the residences within their service area. The City also provides other special and smaller recreational parks that are neither population-based nor resource-based; these include developed parks within open space, plazas, large and small landscaped areas, and pocket parks.

2.1.1 Resource-Based Parks

Are intended to preserve and make available to the public areas of outstanding scenic, natural, or cultural interest. They are meant to supplement the neighborhood and community parks, and they serve the entire City and its visitors rather than any one community. However, they can also function to fulfill local neighborhood and community park needs of surrounding residents.

2.1.2 Population-Based Parks

Are typically of two categories: Community Parks and Neighborhood Parks.

2.1.2.1 Community Parks: Community Parks typically serve 18,000 to 25,000 residents within approximately a 1-1/2 mile radius. Ideally they should have at least 13 useable acres if adjacent to a school or 20 useable acres if not adjacent to a school (“useable acres” is defined as being 2% or less in grade). They should provide a wide range of facilities that supplement those of the neighborhood parks and which are determined by the needs and preferences of the community. Recreation centers, athletic fields, multipurpose courts, picnic facilities, play areas, parking areas, and comfort stations, landscaping and lawn areas are standard amenities. When possible and desirable, swimming pools and tennis courts may be provided.

2.1.2.2 Neighborhood Parks: Neighborhood Parks serve a resident population of 3,500 to 5,000 persons within approximately a one half mile radius. Ideally, they should have a minimum useable area of five acres when located adjacent to a school or 10 useable acres when not adjacent to a school. The design and type of facilities should be determined by the population and use characteristics of the neighborhood. Play areas, multi-purpose fields, comfort stations, multipurpose

courts, picnic facilities, landscaping and lawn areas are typical amenities in neighborhood parks.

2.1.3 Special Parks

Special Parks are smaller than community or neighborhood parks (2 acres or smaller) and contain passive recreation activities. These parks, sometimes called ‘Pocket Parks’ or Renaissance Parks or ‘Mini-Parks’, are often built by a Developer as a condition of a Land Development Permit and then turned over to the City to maintain. Walkways, trails, benches, shade structures and small play areas are typical amenities of these parks.

2.2 DESIGN STANDARDS

The following design standards address functional and aesthetic issues for park and open space design, and are to be referenced and utilized during the formulation of General Development Plans and the final Construction Plans. (See Appendix B, Council Policy 200-14, Landscape Design Guidelines.) All parks and open space shall meet the following guidelines and regulations (the stricter rule applies): Americans with Disabilities Act (ADA) regulations; Title 24 of the California Administrative Code; American Society for Testing and Materials (ASTM) standards; Consumer Products Safety Commission (CPSC); the Greenbook Specifications for Public Works ; San Diego Municipal Code; City of San Diego Standard Drawings; Uniform Building Code (UBC) and the City of San Diego Rules and Regulations for Reclaimed Water Use, when applicable. The Design Consultant shall verify with the City Project Manager the project program, the specific size and functional requirements for the programmed facilities and the project budget prior to beginning the design process.

The design consultant has the sole responsibility to design a project in compliance with current and adopted ADA/ADAAG (Federal) and CBC (State) access law requirements. This guideline is for information only and does not relieve the design consultant of liability in any way. Failure to design in conformity by law should be remedied at consultant’s own expense. Please note that the more stringent requirements of the ADA/ADAAG or CBC shall apply to the design. It is the design consultant’s responsibility to implement the stricter standard to the project. The City will not be responsible for anything that is missed in the evaluation and plan review of the design.

2.2.1 Site Planning

Park design and site planning shall include analysis and integration of on-site and off-site features such as: bicycle and pedestrian trails, open space areas, topography, views, existing vegetation and joint-use needs of adjacent schools. Community Plans, Master or Precise Plans, General Development Plans and other City planning documents should be referenced when analyzing and evaluating the project during site planning.

2.2.2 Grading and Drainage

All park projects shall have positive drainage (drainage is to be directed away from buildings, electrical enclosures, backstops and irrigation controllers) and provide the necessary components for drainage.

2.2.2.1 Site Grading and Drainage: Shall conform to the following requirements:

<u>Use</u>	<u>Grade</u>
Paving: (Pedestrian walkways and monolithic surfaces of concrete, asphalt or unit pavers)	1.5 % min. – 4.5% max. 1.5 % max. cross slope, no exceptions. Paving outside of street rights-of-way shall meet current T-24/ADA accessibility guidelines.
Basketball and Volleyball Courts: (Multi-Purpose Paved Courts)	Drain end to end at 1%
Tennis Courts:	Drain side to side or end to end at 1 %, never allow high point at net.
Multi-Purpose Fields:	1.5 % min. - 2 % max.
Softball Fields:	1.5% for skinned and turf infields, outfield turf, provide positive drainage away from home plate in all cases.
Parking Areas: (Asphalt)	1 % min. - 4 % max. with a 4.5 % cross slope or 1.5 % where disabled access is provided, no exceptions.
Lawn Areas: (Passive recreation)	2 % min. - 20 % max.(5:1)
Shrub and Groundcover Areas:	2 % min. - 50 % max (2:1)
Mulch Areas:	2 % min. - 33 % max. (3:1)

2.2.2.2 Drainage Systems: Area drainage systems shall be designed and sized per flow requirements and engineered accordingly. For drainage which exceeds the capacity of a 6” PVC pipe, the drainage system will conform to the City’s Grading Development Regulations (Municipal Code 142.0101) and Drainage Regulations (Municipal Code 142.0201).

2.2.2.3 Storm Water Runoff and Best Management Practices: All park projects shall be designed to meet the Federal requirements of the ‘Clean Water Act’. A Best Management Practices (BMP) plan shall be prepared for all park projects in order to control the long term erosion and reduce the amount of pollutants and other sediments discharged from the project site into the storm water system. In addition, a Storm Water Pollution Prevention Plan (SWPPP) shall be prepared for the construction activity of the park when the park site is over one acre.

2.2.2.4 Finished Grade: Finish grade for lawn areas shall be 1” below walks, mow curbs or other paving, and finish grade for shrub, groundcover or mulch areas shall be 2” below.

2.2.2.5 Security: Grading and planting should be such that a police officer seated in a vehicle may observe the entire park while driving through or around it. Avoid mounds or berms that provide hiding places.

2.2.3 Paving, Walkways and Mow Curbs

2.2.3.1 Paving and Walkway Designs: Walkways are provided in all parks for functional and aesthetic purposes. Functionally, walkways should provide a connection to different parts of the park and lead to special landmarks. Walkways that provide a loop system are preferred. Primary walkways in the park shall be concrete paving without color. At park perimeter(s) and parking lots, walkways should be located to provide a logical, convenient, and aesthetic means of accessing the park. Walkways should be accessible to all users and in some areas they must be designed for emergency and maintenance vehicles. Aesthetically, walkways should be designed for the user to enjoy on and off-site views and the different amenities of the park.

2.2.3.2 Walkway Locations: Where possible provide walkways to separate lawn areas from shrub and groundcover areas to reduce edging costs.

2.2.3.3 Walkway Widths:

Primary pedestrian/ maintenance access walkways & security lighting	9’ wide (min.)
Walkways adjacent to ball field lights	12’ wide (min.)
Walkways adjacent to parking stalls without wheel stops	9’ wide (min.)

Secondary pedestrian walkways without maintenance access or security lighting 6' wide (min.)

2.2.3.4 Walkway Construction: Walkway construction and reinforcement shall be based on the soils report. Soil testing shall be provided during the design phase and recommendations shall be included in the bid documents.

2.2.3.5 Walkway Expansion Joints: Concrete walkways shall have expansion joints and score lines as shown in the Standard Drawings G-7, 9 and 10.

2.2.3.6 Decomposed Granite Walkways or Trails: May be proposed as a secondary component of a park's circulation system. These walkways shall be stabilized decomposed granite, pre-mixed by the plant at the rate recommended by the manufacturer, prior to delivery. Walkway depth and sub-base shall be based on the soils report. A weed barrier is recommended below all decomposed granite paving. Preferred walkway edging to be concrete or non-corrosive metal.

2.2.3.7 Mow Curbs: Concrete mow curbs shall be provided to separate all lawn areas from shrub or groundcover areas, to contain decomposed granite paving, under fencing, where fencing is adjacent to turf or ground cover that requires edging or mowing, as an integral component of any wall (both at the top and bottom where lawn is proposed or where it exists). Mow curb width to be 8" minimum. (See Standard Drawing L-3 for construction detailing.)

2.2.4 Fences and Walls

2.2.4.1 Fences: Parks should be designed functionally and visually as open as possible with as little fencing as possible. Fencing should only be provided for multipurpose fields or where there is a safety issue that cannot be addressed by some other means.

2.2.4.2 Tubular Steel Fencing: Used to maintain views or to be consistent with the project's design theme. All components shall be tubular steel and galvanized (free of burrs and sharp edges). Fence color to be a powder coated paint applied electrostatically.

2.2.4.3 Chain-Link Fencing: Vary in height and detailing as per the specific site use(s) and requirements. If the fence exceeds 8' in height a mid-rail will be required (see Standard Drawings M-5, M-6 & SDM-112). Specify a top and bottom rail for all chain link fences, and 9 gauge fabric before thermal coating, knuckled on top and bottom (not shown in Standard Drawings). All materials shall be free of burrs and sharp edges. Fence posts, chain link, rails and all hardware to be 'thermally-fused poly-vinyl chloride' coating (see Standard

Drawing SDM-112). Chain link fabric shall be located on the side adjacent to play or use areas.

2.2.4.4 Fence Gates: Gate openings for pedestrians shall be a minimum of 4' wide. Gate openings for maintenance vehicles shall be a minimum of 14' wide. (See Standard Drawings M-5, SDM-100, SDM-112.)

2.2.4.5 Walls: Shall be designed and located to discourage skateboarding and graffiti vandalism.

2.2.4.6 Wall Caps and Railings: All concrete block walls shall be finished with a wall cap, made of precast units that are sized for the block, or a custom cap. Retaining walls shall be installed with wall drains (see Standard Drawings C-1 through C-15). Safety railings shall be provided when walls are over 30" in height and adjacent to walkways, as necessary or required by Municipal Code.

2.2.5 Site Furniture

All parks shall have picnic tables, benches, drinking fountains, barbecues, bicycle racks, trash receptacles and other site furnishings as necessary. Types of site furniture selected shall be based on the type of park, design character, durability and maintenance. The site furnishings should compliment each other in color, materials and form. Site furniture shall be permanently secured to the concrete with dowels and epoxy or within decomposed granite paving per manufacturers recommendations.

2.2.5.1 Locations: Site furniture in lawn areas shall be spaced a minimum of 12' from other site furniture, fencing/walls, and trees/shrubs to accommodate City lawn mowers. Site furniture shall be located to avoid conflicts with irrigation systems and other park improvements.

2.2.5.2 Picnic Tables: Shall be placed on concrete pads with a 1% cross slope for drainage. Pads shall extend 4' beyond the table/bench dimensions on all sides. Some of the picnic tables should be contiguous to walkways or have walkways leading to them for disabled access. Orientation of the picnic tables adjacent to walkways shall be perpendicular to walkways to discourage skateboard activity.. One piece tables with benches are preferred.

2.2.5.3 Park Benches: Shall be placed on a concrete pad when located in lawn areas and designed and located to discourage skateboard activity. Some of the park benches should provide an area for companion seating.

2.2.5.4 Drinking Fountains: Each park shall have at least one ‘High/Low’ drinking fountain for disabled access. (See Standard Drawings SDM-107 and M-18). Fence-hung fountains may be used if a disabled access fountain has been provided elsewhere in the park. Provide a stainless steel High/Low fixture wall-hung at the comfort station or a stainless steel High/Low pedestal fixture behind the backstop.

2.2.5.5 Barbecues and Hot Coal Receptacles: Metal barbecues shall be located outside the circulation routes and installed with a concrete hot coal receptacle in a visible location. If located in lawn areas, provide a concrete pad as a mow curb.

2.2.5.6 Bicycle Racks: Shall be located on concrete paving and outside the major circulation routes.

2.2.5.7 Trash Receptacles: Concrete trash receptacles shall be square and provided with side openings or top openings per the direction of the City Project Manager. All trash receptacles shall have a protective ‘Hood’ cover.

2.2.6 Multi-Purpose Courts (Basketball and Volleyball Courts)

When possible and space permitting, basketball and volleyball courts shall be separate. When site constraints dictate. Courts can be combined into multi-purpose courts. (See Standard Details, Appendix ‘J’.)

2.2.6.1 Basketball Courts: Shall be a poured concrete surface 104’ x 70’ in dimension, with a playing area of 84’ x 50’. Court construction and reinforcing shall be based on the soils report. Rebar dowels and sleeves to be provided at all cold joints and all sleeves shall be greased. Court surface to be a non-skid surface or a medium broom finish. All striping on the playing surface shall be applied using a wear-resistant substance. (See Standard Detail A-3, Appendix ‘J’.)

2.2.6.2 Basketball Court Placement: Preferred court orientation should be along north-south axis. The minimum distance between courts when two or more courts are side by side or end to end is 10’.

2.2.6.3 Basketball Goals: Backboard shall be all steel with emulsion type undercoat, fan shaped, 6’ extensions. Rims shall be double rimmed with nylon netting nets. Pole shall be galvanized steel. (See standard Detail A-1 Appendix “J”).

2.2.6.4 Paved Volleyball Courts: Shall be a poured concrete surface 50’ x 80’ in dimension, with a playing area of 30’ x 60’. Court construction and reinforcing shall be based on the soils report. Rebar dowels and sleeves to be provided at all cold joints and all sleeves shall be greased. Court surface to be a non-skid surface

or a medium broom finish. When two courts are side by side, there should be a minimum of 10' between them. Courts placed end to end shall have a minimum distance of 15' between them. (See Standard Detail A-1, Appendix 'J'.)

2.2.6.5 Sand Volleyball Courts: Shall have a playing area of 30' x 60' with a 10' safety zone on the sides and a 15' safety zone on the ends, total area to be 50' x 90' in dimension. The sand shall be contained by a concrete curb, 8" minimum width, that is the same elevation around the perimeter of the court. The sand surfacing shall be a minimum of 12" deep. Sand shall be imported, clean, doubled washed, manufactured #20 silica sand, free of deleterious organic materials, with a "mean effective size" between .55" and .65". A subsurface drainage system shall be provided that connects to the site drainage system. Leach lines or sumps may be considered if a storm drain is not available and if approved by the City Project Manager.

2.2.6.6 Volleyball Nets and Poles: All volleyball standards shall be galvanized. The net post shall be 8' above the finish playing surface. The net shall have the cable along the top and rope along the bottom. The pole spacing shall accommodate a 32' x 3' net.

2.2.7 Tennis Courts

2.2.7.1 Tennis Court: Shall be a poured concrete surface 36' x 78', with 12' side clearance on each side, and 21' between each baseline and the fence. Court construction and reinforcing shall be based on the soils report. Score lines (saw cut) per soils report shall be provided to eliminate stress cracking in monolithic pours. Rebar dowels and sleeves to be provided at all cold joints and all sleeves shall be greased. Court surface to be a non-skid surface. The courts will have markings for both singles and doubles play. Lines shall be painted 2" wide, except for the baseline which shall be painted 4" wide. (See Standard Detail B-1, Appendix 'J'.)

2.2.7.2 Orientation and Placement: Preferred orientation should be long axis north-south (recommended 22 degrees west of north). The minimum distance between courts when two or more courts are side-to-side or end-to-end should be 12' between adjacent side lines. When two or more courts are placed side-to-side, a 12' high fence shall separate the courts by extending 24' in from the rear of the courts. Minimum distance between each end of court and fence shall be 21'.

2.2.7.3 Tennis Court Fencing: Fencing shall be 12' high with chain link fabric installed on the inside of the court. Fence posts, chain link, rails and hardware be black 'thermally-fused poly-vinyl chloride'. Fine mesh wind screening shall be

attached to the inside of the fence. Gates shall be located within the fence so as to disrupt play as little as possible. (See Standard Drawing M-17 and SDM-112.)

2.2.8 Swimming Pools

Specific facilities and site detailing to be coordinated with the Park and Recreation Department Aquatics Program, the Maintenance Staff and the City Project Manager.

2.2.8.1 Swimming Pool Requirements and Standards:

- (1) Codes and Regulations:** All new and retrofitted swimming pools shall meet current ADA requirements and State Bathing Codes. (The Design, Construction, Operation and Maintenance of Public Swimming Pools.)
- (2) Deep Water:** The deep area of the pool shall be designed to accommodate competitive swimming, water polo and synchronized swimming (25 yards by either 25 or 50 meters) with a minimum of six lanes at a minimum depth of 9'. Deep water is also required for high level instruction (lifeguard training and diving instruction). Orientation for lap lanes should be north/south, however, anchor sockets should be installed so that lane directions can be changed to allow for multiple programs in pool at one time.
- (3) Shallow Water:** The shallow area of the pool shall be designed to best serve the instructional needs of participants. Shallow areas shall be between 0" and 5' with the majority of the shallow water being in the 18" to 4' range.
- (4) First Aid Room:** Facilities shall have a separate room in which to administer first aid.
- (5) Pool Manager's Office:** Must connect to main front office area (where guests pay to enter facility) and be provided a view of the pool area.
- (6) Deck Area Lighting:** Pool deck shall be provided with sufficient lighting so that persons walking on the deck can identify hazards.
- (7) Sinks:** Men's and women's restrooms shall be equipped with sensor activated sinks to minimize contamination.
- (8) Soap Dispenser:** Provide a soap dispenser for each sink in restroom.

- (9) **Electric Hand Dryer:** Provide one electric hand dryer inside restroom for each pair of sinks. (Heat element disconnected).
- (10) **Toilet Paper Dispensers:** Provide in each restroom stall and shall be anti-theft multi-roll with two or more roll storage capacity.
- (11) **Diaper Changing Stations:** Provide one changing station in both men's and women's locker areas.
- (12) **Family Changing Room:** Provide a minimum of one family changing room, with a shower, sink, toilet and bench.
- (13) **Access Into the Pool:** A ramp or zero depth entry shall be provided into the pool.
- (14) **Spectator Seating:** A spectator seating area that is physically separated from the pool deck shall be provided.
- (15) **Class Room/ Meeting Room:** If the pool is a separate, stand-alone facility, a large meeting room shall be provided for special events, meetings, community aquatic safety training courses and staff training.
- (16) **Storage Area:** A storage area (with shelving) for pool equipment and instructional items shall be provided.
- (17) **Shade Structure:** Shall be provided on the deck area.
- (18) **Emergency/ Repair Vehicle Access:** Provide a 14' wide, double gate at the deck area for emergency and repair vehicles.

2.2.9 Multi-Purpose Fields (Softball and Soccer Fields / Turf Areas)

2.2.9.1 Multi-Purpose Fields: Shall be free of all ½" diameter or larger rock to a depth of 15", or the field shall be provided with a 15" layer of topsoil and meet the horticultural requirements per the "Greenbook" for Class "A" topsoil.

2.2.9.2 Softball Fields: Base length: 65' minimum. Foul Line distance: 250' radius minimum. Home Plate to Backstop distance: 20'. Drainage catch basins or manholes should not be located within the field of play. (See Standard Detail, Appendix 'J'.)

2.2.9.3 Field Orientation: The preferred orientation places the batter facing the pitcher in a northerly direction with a line from home plate to the pitcher's mound

not deviating more than 20 degrees east or west of north, and the first base line running in a west to east orientation. However, optimum utilization, or configuration of the site, may required deviation from the preferred orientation.

2.2.9.4 Field Drainage: The fields will typically be crowned in the center with drainage to the sides. Certain sites and field overlay situations would make this drainage pattern unacceptable. In such cases, other drainage patterns or drainage devices will be considered and approved by the City Project Manager. In all cases there will be positive drainage away from home plate.

2.2.9.5 Softball Field Infield Mix: Shall meet the following requirement:
Grain Size Distribution/ Percent Passing

<u>Sieve Size</u>	<u>Minimum</u>	<u>Maximum</u>
No. 4	100%	
No. 8	90%	100%
No. 16	85%	95%
No. 30	65%	85%
No. 50	35%	55%
No. 100	20%	35%
No. 200	10%	25%

Clay Content: Shall be between 10 -15%.

Sand Equivalent: Shall be 15 - 25%, as per test method. (Calif. 217 or ASTM D2419)

ph: Shall be 6 - 8.5

Color: Gold is preferred. Red is acceptable.

Depth of Infield Mix: 4” to 6”

2.2.9.6 Certification of the Infield Mix Requirements: Shall be furnished by the Contractor to the Resident Engineer or Project Manager at the time of project submittals. Infield areas shall not be amended with soil conditioners used for planting areas.

2.2.9.7 Infield Dust Control: Provide two quick coupler valves in the lawn area just beyond the perimeter of the infield. These valves to be at the finish grade. Additionally, provide a manually controlled system of high speed rotors at the perimeter of the infield to wet the infield evenly and quickly.

2.2.9.8 Fencing and Backstop: Refer to Standard Detail C-1 thru C-6, Appendix 'J'. Deviations from the detail require City Project Manager approval.

2.2.9.9 Access to Softball Field Lighting: Maintenance access to the lights shall be provided by concrete walkways (concrete designed for heavy equipment) or 12' wide access gates shall be provided in the fencing.

2.2.9.10 Electrical Requirements: Verify location for the electrical outlet for the use of a pitching machine with the City Project Manager. The outlet can be located in a lockable stainless steel box behind the backstop or the backstop fence or provided adjacent to the pitcher's mound in a lockable water proof box within an 8" gate valve box.

2.2.9.11 Softball Bleachers: Shall be hot dipped galvanized steel, 3 rows minimum or 5 rows typical and 15' long. Bleachers with 5 rows require a guardrail. Specify spot welding of seats and foot planks to bleacher frame (free of burrs and sharp edges). Bleachers shall be placed a maximum of 4' from the fence line of the backstop.

2.2.9.12 Soccer Fields: Preferred size is 225' x 360' with a clear zone of 9' on all sides, (soccer field size may vary depending on site constraints, confirm with the City Project Manager the actual size of the soccer field). The playing surface shall not overlay onto the skinned infield of a softball field. The field area shall be free of drainage catch basins and manholes.

2.2.9.13 Soccer Field Orientation and Placement: Preferred orientation is with the long axis north-south. Multiple fields being placed adjacent to one another shall be placed side by side. Fields may be "off-set" to facilitate field layout, but may not be end to end.

2.2.10 Playgrounds and Equipment

Playgrounds shall be designed to offer the greatest "play value" possible within the budgetary constraints and physical restrictions of the site. The play experience should challenge the users by addressing their physical, social and mental development while providing entertainment. The play environment shall be safe, durable, vandal resistant and require minimal maintenance. Playgrounds and equipment shall meet the current requirements of Americans with Disabilities Act (ADA); Consumer Product Safety Commission's (CPSC) Handbook for Public Playground Safety; and the American Society for Testing and Materials' (ASTM)(F-1487) Standard Consumer Safety Performance Specification for Playground Equipment for Public Use (F-1292), Standard Specification for

Impact Attenuation of Surface Systems Under and Around Playground Equipment and Standard Specification for Determination of Accessibility of Surface Systems Under and Around Playground Equipment (F-1951).

2.2.10.1 General Play Area Requirements:

- (1) **Play Areas:** Play areas for “preschool” children (ages 2-5 years) shall be separated from play areas for “school-age” children (ages 5-12 years).
- (2) **Play Area Hazards:** Barbecues, hot coal receptacles and plant materials with thorns or stickers, or that attract bees, or other potential hazards shall not be located adjacent to play areas. Trees are not allowed to overhang safety zones of play equipment.
- (3) **Play Area Maintenance:** Play areas with sand surfacing shall not be located adjacent to a gymnasium or recreation center to prevent tracking of sand indoors. Drinking fountains shall not be located adjacent to play areas with sand surfacing, but in close proximity.
- (4) **Disabled Access:** Current ADA requirements are now adopted federally, and though the requirements are for about a third of the equipment to be disabled accessible, the Park & Recreation Department prefers to maximize ground-level play components and to provide resilient accessible surfacing to a minimum of 50% of the play equipment.
- (5) **Seating:** Provide seating close enough to play areas for adults to supervise children. Seating shall be designed to meet ADA requirements, and shall be designed or located to discourage skateboard damage. Install outside of the play area as directed in 2.2.5 Site Furniture, and 2.2.5.3, Park Benches.

2.2.10.2 Play Area Drainage and Construction:

- (1) **Subgrade:** The play area subgrade shall be sloped to a subsurface drainage system (1.5% minimum) for all play area surfaces. Concrete sub-base for poured in place rubber surfacing shall slope at 1% minimum towards drain inlet or sump. Subgrade for concrete sub-base shall be compacted to 95% minimum.

- (2) **Subsurface Drainage Systems:** A subsurface drainage system shall be provided for all play surfaces. This system shall be designed for positive flow for the play area square footage. The drain lines shall contain a clean out before it empties into a storm drain. Leach lines or sumps may be considered if a storm drain is not available and approved by the City Project Manager. If sumps are needed, design them outside of the play area, if possible, to minimize the amount of drainage rock that infiltrates the play area in the event children dig down and pull up the filter fabric, or repairs to the play equipment requires digging.
- (3) **Play Area Containment:** New play areas of sand or engineered wood fiber shall be contained by a minimum 4' wide concrete walk with a deepened footing set at a continuous elevation. Sand shall be a minimum 4" below the adjacent paving. Engineered wood fiber may be flush, or up to 4" below adjacent paving, after settlement. The area surrounding the play area shall be graded so that runoff flows away from the play area. If the play area is contained with a wall adjacent to a turf area, the wall shall include an 8" wide concrete mow edge at the base of the wall, slope at 2% away from wall.
- (4) **Play Area Walkway:** A minimum 4' wide concrete walkway shall be provided all around play areas. At existing concrete containment curb or low wall, the walkway shall be installed with an expansion joint adjacent to the concrete containment curb or wall. Walkways shall provide a 1.5% gradient away from the play area.

2.2.10.3 Play Area Surfacing Materials: Acceptable surfacing material includes sand, engineered wood fiber, loose rubber fill or rubberized paving to a depth of 12". If both sand and engineered wood products or loose rubber fill are used in the same play area, then they shall be separated from each other by a minimum of 10' of paving or rubberized surfacing.

- (1) **Sand:** Shall be imported, clean, double washed, manufactured #20 silica sand, free of deleterious organic material, loam, clay and debris, with a "mean effective size" between 0.55" min. and 0.65" max. and a "mean uniformity coefficient" between 1.00 and 1.54. The contractor shall submit certification of the above requirement to the Resident Engineer at time of product submittals. Sand shall only be used with a filter fabric and drain system. Depth shall be 12" minimum, and shall be of a thickness sufficient to attenuate falls per ASTM F1292.

- (2) **Engineered Wood Fiber:** Shall be an energy absorbing protective surfacing manufactured for playground installations. The manufactured fibrous crushed wood product (tumbled, with blunt ends) shall consist of random sized wood fibers comprised of but not limited to soft wood such as; Ponderosa Pine, Douglas Fir, Spruce and/or White Pine. The particle size shall be between ½” and 3” in length, and not less than 3/8” in width nor 1/16” in thickness. At least 85% by volume of the manufactured wood product shall be the sizes specified. It shall be non-toxic, free of bark and organic materials, independently tested by ASTM Standard F1292, with sufficient fines to comply with ADA requirements, while maintaining Head Impact Criteria (HIC). Engineered wood fiber shall only be used with a filter fabric and drain system. Depth shall be 12” minimum, and shall be of a thickness sufficient to attenuate falls per ASTM F1292. A ramp which conforms to ADA and Title 24 requirements for disabled access shall be provided within 20’ of each entry or exit to a play structure, unless an approved bonding agent has been added.
- (3) **Loose Rubber Fill:** Shall meet the requirements of CPSC and ASTM for play areas. Color shall be brown or tan. Rubber shall be clean, with no fiber or steel radial remnants. Depth shall be of a thickness sufficient to attenuate falls per ASTM F1292. A ramp which conforms to ADA and Title 24 requirements for disabled access shall be provided.
- (4) **Interlocking Rubber Pavers:** Shall meet the requirements of CPSC and ASTM for play areas. Only pavers which have joints that will not trap sand or dirt in the process of expansion and contraction are allowed, similar or equal to Play Mattas (no known equal). Pavers may be placed on asphalt or concrete sub base, and shall be of a thickness sufficient to attenuate falls per ASTM F1292.
- (5) **Poured-in-Place Rubberized Paving:** Shall meet the requirements of CPSC and ASTM for play areas. All rubberized paving shall be installed on a concrete sub-base. Color EPDM layer shall be ½” – 5/8” thick. Buffings layer shall be of a thickness sufficient to attenuate falls per ASTM F1292. A thickened color layer shall be keyed into surface adjacent to transition to concrete pavement. 30 degree cant into adjacent sand play area shall be keyed into concrete sub-base.

2.2.10.4 General Play Equipment Criteria:

- (1) **Disapproved Play Equipment:** The following equipment is not allowed by the Park and Recreation Department: Plastic decks; decks with center

access, unless rails are placed 90 degrees to main access or circulation patterns, perforations in excess of 3/16" in decks over 30" in height, decks which are secured with self-tapping screws, climbing walls in vertical orientation on decks over 30" in height (must be canted), climbers that do not have head clearance, enclosed tunnel-slides or level tunnels (unless made of a mesh material); bubble panels; lexan or plexiglass 'windows'; sectional slides; wood components; metal slides; dark colored plastic slides in any orientation; movable digging shovel toys that do not have a safety stop; whirlers (unless equipped with brakes); see-saws with fulcrum points (springs are acceptable); pinch-type coil spring base animals; swings with heavy animal figures; half-bucket swing seats with chains to secure occupants; vinyl-clad cargo nets (except with non-slip clad, rigid horizontal bars); vinyl-clad swing chains; rigid swing seats; non-reinforced swing seats (must be slash resistant); cable components; roller slides- Recycled plastic structures are not prohibited, but should be limited to low-volume playgrounds, unless reinforced with metal bracing. (Refer to appendix 'L' for a detailed listing.)

- (2) **Substitutions:** At the time of product submittals, any substitutions of specified play equipment on construction plans must fit the designed play area and be approved by the City Project Manager and a National Playground Safety Institute (NPSI) Certified Play Ground Inspector. Shop drawings or catalog cuts are required in order to make a determination.
- (3) **Equipment Installation:** All play equipment shall be installed in accordance with the manufacturer's specifications. The Construction Documents shall specify that the play equipment shall be installed as late in the construction process as possible.
- (4) **Equipment Footings:** The tops of all play equipment footings shall be 12" below finish grade of surfacing material, with a smooth finish, except for spring animals. Spring animals shall have footing edges chamfered at 45° or rounded with a 2" minimum radius and exposed bolts cut at the nut and spot welded, and be 3" to 6" below finish grade.
- (5) **Steel or Aluminum Play Equipment:** Shall be colored by electrostatically applied powder coating or hot dipped galvanized with fused vinyl coating, minimum thickness of 5-7 mils.
- (6) **Product Availability:** Limit specification of products to those available within the United States so replacement parts are more readily available.

2.2.10.5 Safety Standards for Play Equipment:

- (1) **Modular Play Equipment:** Platforms on modular equipment shall be punched steel with 3/16" diameter holes on decks over 30" in height (to prevent fingers protruding up from below being crushed from above and minimize potential for hood drawstrings to be caught in larger deck openings at the top of slides) with non-skid surfacing and 6' maximum height. Low (<30" height) steps and transfer stations may have larger holes to aid grasping for transfer from wheelchair. Decks may be taller if the unit is fully enclosed with no potential for falls from the greater height. Do not incorporate tunnels or lexan or plexiglass windows or panels in the modules. Posts shall be 3-1/2" minimum diameter steel or aluminum, or 3-1/2" minimum recycled plastic with aluminum framing for structures built for 2-5 age; 5" minimum diameter steel or aluminum for structures built for 5-12 age users. Swings shall have 5" diameter steel or aluminum posts, or 3-1/2" diameter galvanized steel posts. Posts shall be aluminum or recycled plastic with aluminum framing within one mile of the coast or bay.
- (2) **Climbing Equipment:** Rungs or climbing bars shall be cylindrical, smooth and sized per CPSC and ASTM guidelines. Non-slip coating is acceptable. Light colors are recommended for plastic climbers (yellow or tan), even in coastal areas. Rockwall chains may be coated with non-slip heavy duty coating.
- (3) **Swing Structures:** Swings shall be free standing, with four posts minimum for stability, and not attached to composite structures. Separate age groups (2-5 and 5-12). Swiveling swing attachments which minimize chains wrapping around top bar are preferred. No more than two swings shall be hung in each bay of the support structure. Preferred surfacing below swings is manufactured wood fiber, with minimum 1" thick x 4' x 4' rubber mats, 6"-8" deep, secured with duckbill anchors. If space does not permit a 10' minimum separation between wood fiber and sand, then a combination of sand and rubberized surfacing is acceptable. Swing chains shall be 4.0 gauge galvanized steel (no vinyl coating allowed on chains).
- (4) **Swing Seats:** Swings shall be provided with seats which accommodate pre-school children (bucket seats), as well as school age children (belt seats). If space permits, specify a swing set for each age group of children. Belt and bucket seats shall be provided in different bays of the swing set. Belt seat swings shall be slash proof. Fully enclosed bucket

seats shall be molded rubber, reinforced with steel. Hard seats are not acceptable. Half bucket seats with chain restraint is not acceptable.

- (5) **Swing Safety Zones:** Provide a safety zone for the swing set equal to 2 times the height of the top rail in front and in back of the centerline of the swing, and 6' clear between the support posts and other structures. In tight spaces, the safety zones for bucket seats may be sized per ASTM and CPSC standards, with the approval of the project manager.
- (6) **Slide Structures:** Free-standing and attached slides shall be single-piece units with plastic beds. Decks at the head of slides shall have no openings in excess of 3/16" in any direction. Light colors are recommended for slide beds (yellow or tan), even in coastal areas. Install minimum 1" thick x 4' x 4' rubber mats, 6"-8" deep, secured with duckbill anchors at exit region of slides.
- (7) **Slide Ladders and Stairways:** Stairways and ladders shall have continuous handrails on both sides and be placed at a height which will allow the child to stand erect over each step.
- (8) **Slide Locations:** The preferable orientation for slides is facing north to northeast.
- (9) **Slide Safety Zones:** All slide exits shall be located in uncongested areas with a clear safety zone per ASTM and CPSC standards.
- (10) **Spring Animals:** Spring animal bodies shall be constructed of cast aluminum. Spring animals shall only be mounted on "C" spring bases or 'non-pinching' coils.
- (11) **Horizontal Ladders/ Overhead Grasp Bars:** Rungs on horizontal ladders shall be 1" to 1-1/4" o.d. galvanized steel at 11" spacing. Maximum height of horizontal ladders shall be 7' - 6". Minimum height of horizontal ladders shall be 6' - 6".
- (12) **Track Rides:** The minimum height of track rides shall be 6'-6"; the maximum height shall be 7'-6", equipped with ladders on each end.
- (13) **Safety Zones:** All safety zones set by the most current CPSC and ASTM guidelines takes precedence over all noted safety zones in this Consultant's Guideline.

- (14) **Roof Heights:** Roof heights on modular structures shall be set at a minimum 6'-6" clear height from deck or adjacent step tread.
- (15) **Signage:** A permanently mounted sign indicating age-appropriateness for each play area shall be set. Verbiage shall include that supervision is required for ages 2-5, and recommended for ages 5-12. The signage may be incorporated as a panel on a modular structure. Stickers may be applied with the initial installation to supplement permanent signage, but should not be the only means of identify age appropriateness. Stickers stating compliance with fall surfacing requirements is required upon completion of installation.

2.2.11 Comfort Stations and Recreation Centers

2.2.11.1 Requirements and Standards for all Buildings:

- (1) **Codes and Regulations:** All new and retrofitted buildings shall meet current local, State, and Federal codes and regulations, including the UBC, Municipal Code, Title 24 and ADA. (See Appendix 'G' for the approved list of manufacturers and products.)
- (2) **Green Buildings:** The building design and construction shall comply with the City Council Green Building Policy, #900-14 (5-20-2003). The Consultant shall be responsible for preparing a cost savings comparison of energy saving devices for City review using life-cycle cost analysis. The policy prescribes performance objectives of at least 22.5 % better than California Title 24 requirements, to the extent such measures are economically justified. An average pay-back period of five years shall be used as a guide for the aggregate of all energy efficiency measure included in the project. All buildings shall include infrastructure for utilities, phones, computers, etc. **(See appendix 'K'.)**
- (3) **Facilities Maintenance Division Standards:** All new and retrofitted buildings shall meet the most current Facilities Division Standards & Specifications Guidelines. Consultant shall obtain a copy from the Project Manager. (See Appendix "I")
- (4) **Specific Electrical Standards:** See Appendix 'I' for requirements.
- (5) **Doors, Windows and Hardware Standards:** See Appendix 'I' for requirements. (Note: Double doors shall have a removable center mullion at storage areas.)

- (6) **Building Colors:** Shall be selected by the Consultant and approved by the City Project Manager. Buildings in Mission Bay Park must use the approved Mission Bay Colors. (Refer to Appendix 'G.') For all buildings that are required to be 'City Tan' color, see Appendix 'G'.
- (7) **Locks, Locksets, Exit Devices and Latch Sets For All Buildings:** Shall be the product of one manufacturer and shall conform with the requirements of Federal Spec. FF-H-106A, 87 Series, for the series indicated in the schedule.
- (8) **Interchangeable Core, Cylinders and Cores:** All cylinders are "00" bitted. The Contractor shall use his own temporary construction cylinders and give the "00" bitted cylinders and two keys per cylinder to the Resident Engineer for delivery to the locksmith. The cylinders should be in a container that is marked to identify the project. After project acceptance, the City locksmith will install the keyed cylinders and hold the Contractor's construction cylinders for the Contractor to retrieve. Installation of post-construction, permanent cylinders will be by the City. The cores for SDG&E electrical rooms are installed by SDG&E.
- (9) **Exit Devices:** Flat bar style rim series shall be used with single doors or mullion only. All exit devices shall be dogged by key. Hardware by door manufacturer and automatic flush bolts are not acceptable. Check with Buildings Division Lock Shop for brand, type of cylinder and keyway required for each project specification. (See Appendix 'G'.)
- (10) **Toilets, Urinals and Sinks:** Shall be wall hung, stainless steel. Toilets and urinals shall be blow-out type with 2" diameter push button operated flush valves. Sinks shall be punched for cold and hot water (cold water only in comfort stations), with a self-closing faucet and concealed supporting arms. All toilet and sink fixtures shall be low flow with automatic water shut-off fixtures.
- (11) **Toilet Paper Dispensers:** Shall be provided in each stall and shall be anti-theft multi-roll with two or more roll storage capacity.
- (12) **Soap Dispensers:** Provide an automatic soap dispenser in each restroom.
- (13) **Electric Hand Dryer:** Provide one electric hand dryer for each pair of sinks. Remove heating element from dryer.

- (14) **Electric Room:** Shall contain the electrical meter as approved by SDG&E. Electrical meters shall not be located in the same room as the City's power distribution panels.
- (15) **Exterior Building Lights:** All exterior building lights should be surface mounted on the building. All exterior doors shall have a surface mounted light on the side or above the door.
- (16) **Recessed Ground Lights:** Lights recessed in paving or landscaping are discouraged due to potential vandalism and water damage. If the design requires recessed ground lights, then they shall be equal to Hydel fixtures.
- (17) **Electrical Outlet for Beverage Machines:** Provide (2) 110V, 20 amp outlets (provide stainless steel lockable cover, flush with wall type) on the exterior of the building for beverage machines (adjacent to each other) with the required concrete paving for disabled access. Location to be approved by the City Project Manager.

2.2.11.2 Comfort Stations: These facilities typically contain men's and women's restrooms, an electrical room for SDG&E, a plumbing chase room, a Park and Recreation storage room, a community storage room, and a concession stand room if located adjacent to sports fields. and shall include the following specific requirements:

- (1) **Building Design:** The building design and materials should harmonize with the design of the park's theme or natural character. The building shall be designed to facilitate natural air ventilation. If an exterior privacy wall is needed at the entries to the comfort station, the wall should be no larger than necessary and not L-shape. Orientation of the comfort station should face the main area of activity. The plumbing chase room shall be accessed from the exterior of the building and not from a storage room.
- (2) **Floors:** Shall be reinforced concrete floor slab and foundation. Foundations should not interfere with sewer lines. Floors shall slope to the building's drainage channel.
- (3) **Floor Drains:** Floor drains shall be a drainage channel located at the wall on which the fixtures are mounted. The drainage channel shall be continuous and have a 1% minimum slope. Outdoor showers or drinking fountains located at the beach areas may drain to a sump.

- (4) **Walls:** All walls shall be reinforced solid grouted concrete block masonry. All walls to be treated with an anti-graffiti coating inside and outside, including the ceiling of the comfort station.
- (5) **Roofs:** See Facilities Maintenance Division Standards, obtained from the Project Manager. Note: A reinforced concrete roof is preferred for ease of maintenance.
- (6) **Exterior Doors and Frames:** Frames shall be steel with heavy duty door hardware. Exterior doors to electrical or plumbing chase room shall be a single door with louvers. Exterior doors to storage rooms are preferred to be double doors with removable center mullions. Exterior doors to restrooms may be a tubular steel gate or chain link.
- (7) **Men's and Women's Signs:** Shall be precast concrete with recessed lettering and symbol. The signs shall be installed into the masonry walls. Provide signs at the entry of each restroom and on the appropriate sides of the comfort station.
- (8) **Plumbing and Electrical Conduit:** Shall be exposed and secured to the wall in a 2'-6" minimum width pipe chase. Provide one exterior loose key hose bibb at the front of the building. The plumbing and electrical pipes shall not prevent maintenance access throughout.
- (9) **Hardware:** Separate keys are required for storage rooms, electrical rooms and plumbing chases.
- (10) **Lighting:** Light fixtures shall be vandal resistant and mounted a minimum of 9' above the floor or finish grade. Interior lights shall be 26 watt PL fluorescent lighting, with at least two fixtures in each restroom. Exterior lights shall be 50 watt HPS. Interior lights shall be on a separate circuit from the exterior circuits. The switch shall be a 'selector' type with 'off-on' automatic for exterior lights. Provide lighting in the plumbing chase room. Time clock controls lighting in restroom. No switches, photocells or lighting sensors.
- (11) **Interior Masonry Walls and Floors:** Provide an epoxy sealant on the floors and mid-height to the walls around toilets.
- (12) **Interior Stall Doors and Partitions:** Shall be 3/4" stainless steel or plastic. Acceptable hardware for stalls shall be heavy duty, lever type door handles. Hardware to be approved by the City's Buildings Division lock

shop. Finish to be determined by Consultant and approved by the City Project Manager.

- (13) **Dressing Room and Showers:** Provide at beach areas only. Showers to be provided on the exterior of the building. Install at least two lights in these areas.
- (14) **Storage Rooms:** Shall be properly ventilated and protected from floor moisture. Provide a phone jack in the Park and Recreation storage room.
- (15) **Concession Stand Room:** For parks with league activities, a concession stand room shall be provided with an 100 amp electrical panel, electrical outlets, and lights in that room. Each outlet shall be on separate circuit for food equipment and future equipment. Provide water, service window and other components as determined by City Project manager.

2.2.11.3 Recreation Centers: These facilities typically contain a lobby with a reception counter, offices for at least three staff members, a gymnasium, meeting or craft rooms, kitchen (to provide warming of food only), large storage room for athletic equipment with access from outside and inside, small storage rooms for maintenance equipment, a set of restrooms near the lobby and one set in the back of the building and an electrical room.

- (1) **Building Design:** The building design, location and materials should harmonize with the park's theme or natural character. The building entry should be visible from the public street and communicate public pride. It is preferred that the parking area shall be provided on the sides of the building to maintain the view of the building entrance.
- (2) **Acoustic Insulation:** Rooms used for noisy activities shall be acoustically insulated.
- (3) **Exterior Doors:** Shall be hollow metal and provided with thresholds. Keying requirements shall be approved by the City Project Manager.
- (4) **Toilet Partitions:** Shall be non-rusting partitions with vandal resistant finish.
- (5) **Interior Lighting:** Provide vandal resistant lighting mounted at least 9' above the floor in all public areas . Lighting shall be electrical ballast type, and designed to minimize electrical energy use.

- (6) **Interior Doors and Hardware:** Shall be wide enough to allow easy installation and removal of equipment or furniture in the rooms. Double doors with exit hardware shall be used with removable center mullion. Provide standard 3' x 7' x 1-3/4" doors installed with heavy duty door hardware. Closers to be mounted with through bolts. Provide stainless steel hardware in coastal areas.
- (7) **Roofs:** Heating, ventilating and air conditioning equipment shall not be roof mounted. Roofs and exterior walls shall have thermal insulation.
- (8) **Gymnasium Rooms:** With wood floors shall not contain drinking fountains or other water sources. Minimize protrusions, including door knobs, in high speed play areas. Wall vents in these rooms should be located such that malfunctioning irrigation heads or wind driven rain cannot damage the floor. The floor design shall provide air circulation below the floor. All gymnasium floor designs shall include game striping plans.
- (9) **Gymnasium Scoreboards:** Shall have a hinged polycarbonate protective cover installed to prevent damage from balls.
- (10) **Security Alarm Systems:** Shall be specified where necessary. Consult City Project Manager for acceptable types and necessary locations.
- (11) **Fire Sprinkler System:** Shall be per applicable Building Codes.

2.2.12 Parking Areas

2.2.12.1 Parking Areas: Shall meet the City's Parking Regulations, (Municipal Code 142.0500), Title 24, Standard Drawings M-27A, 27B, M-28A, 28B and M29, and the parking ratios listed below. See 2.2.17 (5) for planting requirements for parking areas.

(1) **Parking Ratio for Neighborhood Parks:**

With Multi-Purpose Fields: Thirty (30) parking spaces per backstop are required, in addition to the five (5) spaces required per park acre.

Without Multi-Purpose Fields: Thirty (30) parking spaces are required, either on site and/or provided at the adjacent street parking.

(2) **Parking Ratio for Community Parks:**

Recreation Centers: One (1) parking space per 200 square feet of building.

Swimming Pool Facility: One (1) parking space per 175 sf of pool surface area, in addition to the parking spaces required for the recreation center.

Multi-Purpose Fields: Thirty (30) parking spaces per backstop, in addition to the parking spaces required for the recreation center.

Tennis Courts: Twelve (12) parking spaces per six courts, in addition to the parking spaces required for the recreation center. (Note: If less than six courts are provided, no additional parking is required.)

2.2.12.2 Parking Area Paving: Shall be constructed with AC pavement on CTB. Provide a pavement section on the construction plans based on R-values and the Schedule 'J' pavement recommendations of Standard Drawing SDG-113, Cul-de-sac Criteria and CBR's for parking lots. Refer to Section 203 of the Greenbook. Specify AR 8000 oil.

2.2.12.3 Parking Area Geotechnical Test: Shall be conducted to provide a paving section design for the parking lot and all vehicular access paths.

2.2.12.4 Parking Area Drive Aisles and Parking Space Dimensions: Shall meet or exceed the Land Development Code, Parking Regulations, M.C. 142.0500.

2.2.12.5 Parking Area Lot Striping: The paint utilized for striping and mark-outs shall be based on the Greenbook specifications.

2.2.12.6 Parking Areas Adjacent to Lawn Areas: To compensate for vehicular over-hang, provide wheel stops in parking spaces or provide a minimum 6' wide concrete walkway to allow operation of lawn mowers when vehicles are parked.

2.2.13 Trash Enclosures

Concrete block trash receptacle enclosures shall be located within parking lot areas. A heavy vehicle load paving section for the drive lane and the concrete apron shall be provided at the head of the enclosure. Minimum size of the concrete apron shall be sufficient to allow refuse vehicle access to the trash receptacles. Specific dimensions, location and design shall be reviewed and approved by the City Project Manager. The enclosures shall have solid steel doors or chain link doors with screening slats with locking ability.

2.2.14 Signs

All parks shall have at least one permanently installed park identification sign. (See Appendix 'A', Park and Recreation Board Policy No.1302 for the required sign elements and examples of signs.) The sign shall also be consistent with the City's corporate image policy defined in the Corporate Identity Manual. The City's seal and the Park and Recreation Department logo shall be cast bronze. The sign should harmonize with the park's theme or natural character. Signs are typically one sided and parallel to the most prominent public street, or angled if located at the intersection of two streets. The park identification sign shall have vandal resistant light fixtures.

2.2.15 Trails

Trails provide for the use of alternative modes of transportation, as well as recreational activities. The various trail components within the City of San Diego include pedestrian, bicycling and equestrian trails. Trails shall meet or exceed the requirements of the State of California, Department of Park and Recreation (Trails Handbook).

2.2.15.1 Trail Design: Shall be included where possible to provide connections to other parks, schools, and public facilities, in addition to accessing City open space areas and regional trails. User safety is of the utmost concern when locating and designing trails. Trails shall intersect each other at 90° if possible, with clear site distances. The design of trails shall include the trail width and a clear zone on either side of the trail. The trail width shall be free and clear of any horizontal or vertical obstructions (do not locate any valve boxes, vaults or drain inlets in the trail). Trails shall have a minimum overhead clearance of 12' for both built and natural features.

2.2.15.2 Trails and Motorcycle or Vehicular Access: Motorized vehicles, except for emergency vehicles, shall not be permitted on trails and shall be prevented through proper design and detailing.

2.2.15.3 Trail Surfacing: Preferred surfacing is a stabilized decomposed granite on compacted stabilized subgrade with a cross slope for drainage. Native soil/surfacing shall be compacted.

2.2.15.4 Pedestrian Trails: Shall be a 2' minimum- 6' maximum width with a 2' clear zone on each side of the trail.

2.2.15.5 Equestrian Trails: Shall be a 4' minimum - 6' maximum width with a 2' clear zone on each side.

2.2.15.6 Multi-Purpose Trails: Shall be a 6' minimum - 8' maximum width with a 2' clear zone on each side.

2.2.15.7 Safety Railing: A post and rail fence shall be provided along the side of the trail when a slope condition within 5' of either side of the trail is steeper than 2:1 or over 5' in height.

2.2.15.8 Trail Signage: All trails shall be sufficiently signed for type of use and user per the standards of the Trails Handbook.

2.2.16 Irrigation

2.2.16.1 General Requirements:

- (1) **Irrigation Design:** The irrigation system must be designed with water conservation standards and equipment. The irrigation design shall be based on accurate pressure information and produce an irrigation system which efficiently applies uniform water throughout the site. The irrigation design must also have sufficient residual pressure and flow to accommodate site conditions, field changes and unforeseen future demands as well as anticipated future demands, if it is a phased project.
- (2) **Watering Schedule:** For most parks there are two primary considerations: 1) To assure that the irrigation design will meet the time constraints of the park's required operation needs and, 2) The system must be able to apply the volume of water necessary to achieve the evapotranspiration rate (ETO) for the highest demand month within the following criteria:

4 days per week, 8 hour irrigation window, 10:00 pm to 6:00 am

For parks with active sports fields it is critical that the irrigation design is adequate to irrigate the site within the irrigation window and the recreational schedule of the sports fields. The irrigation design must be able to irrigate the complete site within one 8 hour irrigation window. This cycle must be able to apply the volume of water needed in a peak summer condition following two consecutive days of no water. A typical condition at most sport field complexes requires that the fields not receive irrigation on Friday or Saturday nights in preparation for community use on the following morning, and therefore the irrigation design must apply three days of irrigation on a single night. To carry overtime for this condition is NOT effective.

- (3) **Residual Pressure:** In developed areas the residual pressure shall be 15% and in undeveloped areas the residual pressure shall be 25% of the required operating pressure.
- (4) **Ballfield Irrigation:** Irrigation systems for ballfields shall be separated from other lawn areas of the park.
- (5) **Slope Irrigation:** Irrigation lines shall run horizontally (level and parallel to the slope contours) to reduce line drainage and pressure loss.
- (6) **Supplemental Irrigation Specifications:** The supplemental irrigation specifications, Appendix 'F', shall be implemented in the irrigation design and selection of irrigation materials, and shall be provided in the plans.

2.2.16.2 Reclaimed Water: The irrigation designer shall verify with the appropriate water district if the project requires irrigation products for reclaimed water or future reclaimed water. All reclaimed irrigation systems shall be designed per the 'Rules and Regulations for Reclaimed Water Use and Distribution within the City of San Diego' and reclaimed irrigation signs per the County Health Code.

- (1) **Markings:** All above grade irrigation equipment is required to be integral colored purple and embossed with the "Reclaimed Water - Do Not Drink" symbol on all materials, purple paint is not acceptable. Reclaimed water irrigation sprinkler heads shall have integral color purple caps.
- (2) **Cross Connection Test Station:** Shall be a cast bronze globe valve with stainless steel fittings, 3/4" female thread and shall be installed in a concrete valve box with cast iron locking lid.

2.2.16.3 Water Meter, Point of Connection and Backflow Device:

- (1) **Water Meter:** The maximum water meter size is 2". If the irrigation system requires more than a 2" service, provide an additional water meter. Provide separate meters for irrigation and domestic uses.
- (2) **Point of Connection:** The preferred location is in a shrub or groundcover planting area rather than a lawn area.
- (3) **Backflow Device:** A reduced pressure backflow preventer is mandatory per the Municipal Code. The installation is to include a stainless steel enclosure (free of burrs and sharp edges) on a concrete pad. (See Standard Drawings W-27 and W-28.)

2.2.16.4 Irrigation Controllers:

- (1) **Irrigation Systems:** Shall be controlled by an automatic electrical controller for lawn, shrub and groundcover areas.
- (2) **Controller Locations:** Shall be installed at locations approved by the City Project Manager. Preferred location is within the Park and Recreation storage room of a comfort station.
- (3) **Controller Enclosure:** All pedestal mounted irrigation controllers shall be installed in vandal resistant, weather proof, stainless steel enclosures on concrete pads. (See Standard Drawing I-17) All exterior wall mounted irrigation controllers shall be installed in a stainless steel enclosure. (See Standard Drawing I-18)
- (4) **Rain Shut Off Device:** Shall be automatic and provided for each controller.
- (5) **Switches, Phone and Electrical Service:** Irrigation controllers shall be specified to have on/off switches and electrical receptacles. A concrete pull box to loop the 110 service into before sweeping into the controller enclosure shall be provided. All new controllers shall have a phone jack installed as part of the installation for future Central Control System.

2.2.16.5 Pressure Regulating Valves: Provide a pressure regulating valve if the static pressure is over 85 psi at time of construction. The pressure regulating valve shall be in line, below grade, and within ten feet of backflow device. (See Standard Drawing SDI-104.)

2.2.16.6 Master Control Valves and Flow Sensor Devices: Provide a 'normally open' master control valve after the backflow preventer and the pressure regulator valve. It shall be wired independently and have a separate station at the controller. The flow sensor shall be located down stream of the master control valve. Install per manufacturer's recommendations. All transitions from mainline depth to valve box depth shall be accomplished by the use of 45° coupling.

2.2.16.7 Isolation Valves:

- (1) **Locations:** Provide isolation valves along the mainline at appropriate locations to divide the irrigation system into controllable units, at stub outs for future systems, prior to crossing expansive pavement, at each remote control valve or manifold and for each quick coupler.

(2) **Type of Valves:** All isolation valves shall be bronze globe valves, unless the line size is over 4", then a bronze gate valve may be used.

(3) **Globe Valves/Mainline:** For all mainline applications install line size globe valves. (See Standard Drawing SDI-102 and 103)

(4) **Globe Valves/ Remote Control Valves and Quick Couplers:** For all remote control valves or valve manifolds install a globe valve the same size as the remote control valve or the largest valve in the manifold. For quick coupler applications install a 1" globe valve. (See Standard Drawing I-33.)

2.2.16.8 Remote Control Valves: The maximum remote control valve size is 2" with a maximum flow of 80 gallons per minute. Remote control valves shall be installed in manifolds where feasible (maximum four remote control valves per globe valve). Install individual boxes for each remote control valve. In multi-purpose fields, locate remote control valves along the fence line, outside the field of play. All other remote control valves shall be located in shrub or groundcover areas where possible. (See Standard Drawings SDI-104 and I-33.) Plastic valves are not acceptable.

2.2.16.9 Quick Coupler Valves: Provide 1" locking rubber cover quick couplers with a 1" globe valve at a maximum of 150' on center. Minimum mainline size is 1-1/2" to quick coupler valve. All quick coupler valves shall be set and installed in shrub or groundcover areas, or as directed by the City Project Manager. (See Standard Drawing I-5.)

2.2.16.10 Irrigation Boxes: All irrigation boxes shall be concrete with a cast iron locking top. The preferred location for irrigation boxes is in shrub or groundcover areas adjacent to a walkways. Irrigation boxes for remote control valves shall be set parallel to each other, and perpendicular to adjacent paving or concrete curb. The contractor shall paint the identification number of the valve box on the cover. The paint shall be white or yellow 100% acrylic epoxy waterproof paint. (See Standard Drawing SDI-104.)

2.2.16.11 Irrigation Heads:

(1) **Head Coverage:** Provide head to head coverage for all lawn, shrub and groundcover irrigation heads. All heads shall be spaced at 50% of the maximum rated diameter of coverage.

(2) **Overspray:** All irrigation heads shall be installed and adjusted to avoid overspray onto buildings, walkways, play equipment, etc.

- (3) **Anti-Drain Valve/Excess Flow Valve:** Every irrigation head, regardless of change in elevation, shall have an anti-drain valve/excess flow valve installed in the riser of the head assembly. (See Standard Drawing I-1,I-2,I-3.)
- (4) **Pop-up Head Locations:** Irrigation heads in an “accessible area” or prone to vandalism, as determined by the City Project Manager, shall be pop-up heads. All heads directly adjacent to walkways, curbs, parking areas, or pedestrian accessible areas shall be pop-up heads.
- (5) **Lawn Heads:** Shall be pop-up spray heads or rotors. Pop-up spray heads shall have a 4” or 6” riser height, depending on lawn type and mow height. Pop-up rotors shall have a 4” riser height and stainless steel risers. (See Standard Drawing I-3.)
- (6) **Shrub or Groundcover Heads:** Pop-up heads shall have a 6” or 12” riser height depending on the adjacent shrubs or groundcover. (See Standard Drawing I-2.) Fixed heads shall be on a 6” - 12” high, Sch. 80 PVC risers, and provided only in areas approved by the City Project Manager. (See Standard Drawings I-1 and I-34.) Stake per detail.
- (7) **Bubblers:** Two bubblers are required for each tree per detail, in lawn areas, two bubblers per tree in shrub and ground cover areas. Bubblers shall be on a separate valve from other irrigation heads.

2.2.16.12 Trenching:

- (1) **No Sharing of Trenches:** No shared use of trenches will be allowed between various trades and for incompatible uses. Pipes shall not be installed directly over one another. (See Standard Drawings I-25 and I-26.)
- (2) **Trenching Requirements:** A minimum of 2” horizontal clearance shall be provided between parallel lines to allow for accessing all pipes.
- (3) **Pipe Bedding:** All mainline and lateral pipe shall be encased with SE 50 plaster or mortar sand. For 3” or smaller lines see Standard Drawings I-25. For 4” and larger pipes see Standard Drawings I-26.
- (4) **Mainline Pipe and Low Voltage Wire Warning Tape:** Warning tapes shall be a minimum of 3” wide and shall run continuously for the entire length of all constant pressure main line piping and low voltage wire. The

tape shall be installed in the trench 12” below finish grade. In a mainline trench, containing low voltage control wire, both trench marker tapes shall be installed side by side.

2.2.16.13 Piping:

- (1) **Water Velocity:** All systems shall be designed to operate at a water velocity not to exceed five feet per second (fps).
- (2) **Pressure Mainline Pipe:**

1-1/2” diameter shall be:	Sch. 40 PVC pipe (1-1/2” minimum size) with Sch. 40 fittings.
2” diameter and larger shall be:	Class 315 PVC pipe with Sch. 80 fittings. Fittings for 3” pipe and larger shall be solvent weld.
- (3) **Non-Pressure Lateral Pipe:** Shall be Sch. 40 PVC pipe with Sch. 80 fittings. All end runs, regardless of head type, shall be 3/4” line size minimum, or 1” if the head inlet is 1”.
- (4) **On-Grade Pipe:** On-grade piping is only allowed with City Project Manager approval. (See Standard Drawings I-19, I-20, I-23 and I-24.)

2.2.16.14 Sleeving:

- (1) **Sleeving:** Is required for all plastic irrigation pipe and electrical lines below paving. Extend sleeves a minimum of 12” beyond the paved surface above.
- (2) **Irrigation Lines:** All sleeves for irrigation lines shall be Sch. 40 PVC pipe two times the diameter of the pipe to be enclosed.
- (3) **Electrical Lines:** All sleeves for electrical lines shall be 2” Sch. 40 PVC pipe. unless the wire bundle exceeds 1” diameter, size the sleeve accordingly to achieve pipe size for the sleeve to be twice the diameter of the wire bundle.

2.2.16.15 Wiring

- (1) **Spare Control Wires:** A minimum of two (2) spare control wires shall be run along each mainline branch to the furthest valve manifold. Bundle and

tape 10' of additional wire and install in a pull box adjacent to the valve manifold. (See Standard Drawings I-15 and I-16.)

- (2) **Color Coded:** All control wires shall be color coded. (See Appendix 'F'.)
- (3) **Splices:** No splices will be allowed on runs of less than 500'. On runs of greater than 500', splices are to be made with an approved splice unit, soldered, and installed in a concrete pull box.

2.2.17 Planting

2.2.17.1 General Requirements:

- (1) **Planting Design:** Shall be appropriate for the site and climate conditions and shall aesthetically enhance the park site and the park user's experience. (See Appendix 'B', Council Policy No. 200-14 Landscape Design.)
- (2) **Plant Spacing and Locations:** All planting shall be located to permit the proper operation of irrigation systems and the effective use of mechanized maintenance equipment. Plant locations and spacing shall permit normal plant development without undue crowding or trimming. Shrubs, groundcover and vines should be spaced at one half of their mature diameter from all walkways.
- (3) **Slope Revegetation:** All existing and manufactured slopes greater than 4:1 and over 5' in vertical height shall be revegetated per the City-Wide Landscape Regulations (Municipal Code 142.0411).
- (4) **Brush Management:** All areas that require brush management shall be designed per the City-Wide Landscape Regulations (Municipal Code 142.0412).
- (5) **Parking Areas:** All parking areas shall provide a minimum of 5% of the parking area as landscape area. Within the parking area one 24" box tree shall be provided within 30' of each parking space. The required trees shall be located in a minimum of 40 square feet of landscape area. Parking areas that are adjacent to public rights-of-way shall provide a 30" high screen. Plants may be used to screen the parking area if the plants selected will provide a 30" high screen within two years. Curbs (6" minimum height) are required to protect all landscape areas within parking areas. (Municipal Code 142.0406).

- (6) **Trees:** Planted in lawn areas shall be spaced to permit the most effective use of mechanized maintenance equipment and operation of irrigation system. There shall be 12 horizontal feet between trees and other vertical objects in the park. For all trees installed in lawn areas provide a non-lawn area, 2' radius from the baseline of each tree trunk to the edge of the lawn area. The 2' non-lawn radius around the tree trunk shall have a 2" layer of mulch to prevent weed growth There shall be no mulch on crown of tree.. Dense tree groves should be excluded from lawn areas, or provide a continuous surface of bark mulch under the grove.
- (7) **Shrubs/Vines:** Ornamental shrub beds in parks and around park buildings may be provided with approval from the City Project Manager. Shrubs/vines adjacent to building walls should have a mature height that preserves visual access. Provide a 2" layer of shredded bark mulch in all shrub areas.
- (8) **Groundcover:** Shall be planted with triangular spacing at a distance that will typically ensure 100 percent coverage within one year of installation.
- (9) **Lawn:** Shall be used for passive and active recreational uses. Lawn areas should be of a size and configuration to permit the most effective use of mechanized maintenance equipment and reduce lawn edging. Small, decorative lawn areas are discouraged.
- (10) **Non-Planted Areas:** Must be covered with a 2" layer of shredded bark mulch.
- (11) **Coastal Bluffs:** Plant material used adjacent to coastal bluffs shall be native or naturalized to minimize the need for irrigation beyond initial plant establishment. Existing exotic and other plant material that requires regular irrigation should be removed and replaced with native or naturalized plant material.

2.2.17.2 Plant Selection

- (1) **Plant Selection:** Shall be those species which are considered relatively disease and pest-free and require minimal trimming to be maintained in a safe and attractive condition. The Park and Recreation Department retains the right to prohibit any plant material generally known to require excessive maintenance, because of factors such as, but not limited to, disease, pest control, troublesome root development, ultimate size and difficult growth habits. Non-native invasive plants shall not be used unless

approved by the Park and Recreation Department. Refer to Appendix O for the current list of non-native invasive plant species to avoid. Other non-native plants not listed in Appendix O may be identified by the Park and Recreation Department as invasive and not appropriate to use.

- (2) **Trees:** Shall be selected to provide a succession of growth, enhance the uniqueness of the site and provide shade and seasonal interest. To provide a succession of growth, an even mix of fast growing and slow growing trees shall be provided, i.e. mix of Acacia trees with Oak trees. To enhance the uniqueness of the site, tree species shall be selected that create a sense of place, i.e. Palm trees at beach locations or Sycamore trees for inland areas. To provide shade and seasonal interest, an even mix of evergreen and deciduous trees shall be provided.
- (3) **Drought-Tolerant or Native Plant Materials:** The use of drought tolerant or native plant material that is particularly compatible with our local environment is encouraged to promote water conservation and reduce maintenance costs.
- (4) **Lawn Species:** The preferred lawn species is one that is drought tolerant and stays green throughout the year. To meet this criteria the Park and Recreation Department prefers an 80% Perennial Rye (Pinnacle or Grandslam) and 20% Bermuda (Cheyenne or Sahara) mix. Consult with the City Project Manager for the appropriate lawn species per site conditions and use. Rate of application 10 lbs. per 1,000 square feet. Preferred sod specification is a mix of 80% Perennial Rye and 20% Bermuda, or 'Tifgreen', 'Santa Ana', 'GN-1' hybrid Bermuda.
- (5) **Non-Irrigated Seed Mixes:** All non-irrigated seed mixes shall be installed in October - February only.

2.2.17.3 Installation Criteria

- (1) **Horticultural Suitability Soil Tests:** The consultant shall obtain a horticultural suitability soil test on the site soil and incorporate the results and recommendations into the construction plans and specifications. The test results shall determine the type and rate of soil amendments, if leaching is a requirement and the post maintenance requirements.
- (2) **Tree Staking:** Trees shall be staked. (See Standard Drawings L-1 & L-2.)
- (3) **Root Barriers:** Trees located within 5' of walkways, walls, etc. shall be installed with root barriers. The root barrier shall be installed adjacent to

the walkway or wall and not around the rootball. The length of the root barrier shall be a minimum of 10' from the center of the trunk in both directions of the tree and 24" deep. Root barrier shall be made of a rib system, polyethylene material with a minimum thickness of 0.08".

- (4) **Tree Grates:** Shall have expandable center openings and they must meet current ADA requirements. (See Standard Drawing L-4.) Note: Concrete tree grates are not acceptable.
- (5) **Lawn Installation:** Seeded lawn areas shall have a germination/establishment period of 120 days prior to acceptance, and sod shall have a growth period of 90 days prior to acceptance. Germination/establishment period may be less if approved by City Project manager.

2.2.18 Site and Sports Lighting

2.2.18.1 General Design Requirements:

- (1) **Lighting Systems Specifications:** Shall be designed by a State of California licensed Electrical Engineer. All designs shall comply with the applicable City of San Diego requirements, including but not limited to, Traffic Signal and Street Lighting Requirements, Standard Specification for Public Works Construction and Title 24 Standards for 'Outdoor Lighting Design' as applicable. Light fixture and plant locations should be coordinated so that plants and trees at maturity do not obscure the lights.
- (2) **General Exterior Lighting Requirements:** Exterior lighting that is within 30 miles of Mt. Palomar Observatory shall be high-pressure sodium.
- (3) **Exterior Lighting Design:** During the design phase the Consultant shall provide to the City Project Manager, point to point drawings showing illumination levels of the playing surfaces, extending 150 feet beyond the planning surface in all directions. The point to point drawing will be used to verify the amount of spill lighting, or trespass light outside the playing area.
- (4) **Interior Lighting Design:** Interior sports lighting systems shall consider the use of tubular type skylights to minimize light use during the day. The Consultant shall evaluate gymnasium sports lighting systems including use of pulse start metal halide and multi ballast florescent fixtures.

- (5) **Interior Lighting Controls:** During the design of all lighting systems, the Consultant shall consider the merits of using occupancy sensors and lighting automatic lighting control systems to switch lights. This includes but is not limited to automatic lighting controls, day lighting controls, and programmable lighting controllers to minimize energy consumption from lighting.
- (6) **Exterior Lighting Spill and Glare Requirements:** All exterior lighting systems shall have internal reflectors to reduce light pollution. All security lighting and parking lot pole mounted lighting shall be “cut off” as defined by Illumination the Engineering Society (IES). The other exception is Sport Lighting; this type of lighting shall be 1500 watt metal halide. All lighting systems shall use internal reflectors and exterior louvers to reduce light pollution.
- (7) **Conduit:** Underground conduit improvements shall be in Schedule 40 PVC pipe, minimum size of 1”. Above ground conduit improvements shall be in galvanized rigid steel pipe. When adjacent to a sidewalk, conduit shall be installed parallel to the sidewalk, 6” beyond the edge of the sidewalk.
- (8) **Pull Boxes:** Shall be placed in the sidewalk or within concrete areas where possible. Pull boxes must be a minimum of 10’ from all drainage inlets. Pull boxes are required at each light standard when light standards are placed further than 50’ apart. Pull boxes shall be concrete with a bolt-down cover.
- (9) **Light Pole Mow Curb:** All light poles located in lawn areas shall have a concrete mow curb around the base. (See Standard Drawing L-5.)
- (10) **Light Poles and Irrigation Heads:** Light poles and irrigation head layout shall be coordinated to allow for full irrigation coverage and to avoid spraying poles.
- (11) **Anchor Bolts:** The bottom anchor bolts and nuts for all light poles shall be grout covered. Metal shrouds provided by the manufacturer shall be installed.
- (12) **Light Pole Bases:** A midjet ferrule fuse shall be provided in the base of each light pole.

- (13) **Electrical Enclosures:** All outdoor lighting facilities shall be flush mounted and installed in lockable and vandal proof enclosures.
- (14) **Maintenance:** City maintenance trucks must have access to all light poles for relamping and maintenance purposes. New lights are installed with a boom mounted on a truck. A typical truck weighs 12 tons with outriggers extending to 14'. All new paving and walkways shall be designed to provide access and support the maintenance trucks.
- (15) **Future Lighting:** The Lighting Consultant shall verify with the City's Project Manager the type of future lighting infrastructure to be provided for each project.
- (16) **Programmable Lighting Panels:** All U.P.S. and E.P.S. System and Programmable Lighting Panels shall have the following included with the Systems: All software need to change times or zones; Exterior Controller for Lighting Systems and Telephone Line Installed and Hook-up to Modem Provided in each system.

2.2.18.2 Security Lighting:

- (1) **Requirements:** All community and neighborhood parks shall be designed with security lighting along the walkways and parking areas (where possible, security lights are to be mounted on building walls). The minimum amount of lighting along all walkways and in parking areas shall be 0.5 footcandles (fc), with a uniformity rate of 6.
- (2) **Lighting Type:** The fixtures shall have a Classification of Type I or cut-off per the Illumination Engineering Societies (IES) standards. The refractor shall be U.V. stabilized, prismatic acrylic or polycarbonate. The mast-arm type shall be the slip-on type. Each fixture shall be individually switched by means of a twist-lock photocell. Lighting circuit shall be energized by means of a time clock, so that each system has the capability of being switched off at a pre-determined time.

2.2.18.3 Multi-Purpose Field and Court Lighting:

- (1) **Requirements:** Lighting shall meet the current IES standards and the skill level of the highest play activity that is being provided. The design shall be designed to use the least number of light fixtures and electrical energy required to provide the

specified lighting intensities. Spill and glare shall be minimized. Photometric data and lighting density calculations must be provided at plan check phase.

(2) Lighting Levels:

<u>Soccer:</u>	<u>Horizontal</u>	<u>Vertical</u>	<u>Uniformity</u>
Recreational	20fc	15fc	3.0 max. to min.
Amateur	30fc	25fc	2.0 max. to min.

<u>Softball:</u>			
Infield	30fc	25fc	3.0 max. to min.
Outfield	20fc	15fc	3.5 max. to min.

<u>Baseball and Little League:</u>			
Infield:	50 fc	40 fc	2.0 max. to min.
Outfield:	30 fc	25 fc	2.4 max. to min.

Note: Baseball and Little League lighting requirements are sanctioned and tested by Little League Baseball. This type of lighting requires written approval from the Park and Recreation Deputy Director.

Tennis Courts:

50 footcandles - measured at the net.

30 footcandles - measured at the baseline.

Basketball/ Volleyball Courts: If lighting is provided, light level should be evenly distributed across the courts. 30 fc min. optimum.

2.2.18.4 Tennis Court and Multi-Purpose Court Light Switches: Control of sports lighting shall be accomplished with an “on” button only, energized by a time clock and time clock shall turn lights off after set time. Verify all court lighting requirements with the City Project manager. Each tennis court shall be lighted independently. Individual “On” buttons shall be located adjacent to each tennis court. The electrical power to tennis court lighting shall be independently metered by SDG&E.

2.2.18.5 Multi-Purpose Field Light Switches: Shall be activated by means of an on-off switch located in a separate lockable (padlock) vandal resistant enclosure. The “On” switch shall be energized by a time clock. The clock shall turn the lights “Off” at a predetermined time. Lighting for each softball and soccer fields shall be on separate systems. Relay switches (contactors) of more than three poles or any other exotic switching equipment shall not be used.

2.2.18.6 Multi-Purpose Field and Court Light Pole Standards: Lighting Poles shall be a maximum height of 70'. Field lighting poles shall be located outside the fenced play areas.

2.2.19 Graffiti Prevention

2.2.19.1 Graffiti Prevention: Parks should be designed to discourage graffiti, such as the use of thorny vines or shrubs adjacent to walls.

2.2.19.2 Anti-Graffiti Material: All building walls, site walls, concrete amenities such as tables, benches, drinking fountains, etc. shall be treated with a non-sacrificial anti-graffiti material. Specify the application of two (2) coats of anti-graffiti material per manufacturer's specifications to all exposed areas.

3. GRAPHIC AND DRAFTING STANDARDS

To ensure consistency and clarity, the following graphic and drafting standards apply to all park projects. These are to be adhered to in the preparation of General Development Plans, Construction Plans and As-Built Plans. If the project requires a Discretionary Permit, the plans will need to meet the additional criteria of the Applicant's Guide to Project/Permit Applications of the Development Services Department.

3.1 GENERAL DEVELOPMENT PLANS

The General Development Plan (GDP) is the conceptual/master plan for the park's design. The GDP is used for the presentations to the advisory bodies and will be used as the exhibit on which the Construction Plans will be based. The graphics and drafting requirements for General Development Plans shall conform to Park and Recreation Board Policy No. 1011. Refer to Appendix 'A', and the following criteria listed below.

3.1.1 General Requirements for all GDP Plans

The project title shall be on all GDP plans and boards. The project title shall be "General Development Plan for , *Park Name, Community Park or Neighborhood Park*". A north arrow (pointing to the top of the page), graphic and written scale shall be provided on all plans.

3.1.2 General Development Plan

This is the development plan that clearly indicates all on-site facilities including buildings, parking areas, play areas, site furniture, lighting, landscape materials, drainage, etc. Property or limit of work lines should be shown in bold lines to

delineate the scope of work. Grading and planting information can be shown on the GDP or provided as a separate exhibit. A legend shall be provided for all symbols. Play equipment safety zones and any critical dimensions are to be included. This plan shall be rendered and colored for the advisory body presentations.

3.1.2.1 Grading: Conceptual grading shall be shown on the GDP or as a separate plan for the entire project site clearly indicating existing and proposed contours. For softball fields, the drainage away from home plate shall be shown.

3.1.2.2 Planting Design and Palette: All existing and proposed planting shall be shown on the GDP or as a separate plan. Trees shall be represented graphically with a mature canopy. The plant palette shall provide categories identifying the form and function of the plant material, such as Street Trees, Canopy Trees, Shrubs, Groundcovers, Slope Planting, etc. Typical plant species for each plant category shall be provided.

3.1.3 Building Plans and Elevations (if applicable)

When buildings are part of the park design, provide a plan showing the conceptual floor plan, roof plan and all elevations to clearly indicate the structure. This plan shall be rendered and colored for the advisory body presentations. A materials board may be required, with samples of proposed exterior materials to show true colors and textures.

3.1.4 Park Sign Plan and Elevation(s)

Provide a plan of the park sign in plan view, and all elevations clearly indicating the sign elements and materials. Indicate the proposed sign location.

3.1.5 Special Site Details and Site Furniture

Provide details, plans and elevations of any custom site elements, such as seat walls, overhead trellis structures, fencing, paving, etc. The materials and finishes should be indicated in the details along with any critical dimensions. Provide catalog cuts of all proposed manufactured site furniture, play equipment and light fixtures, etc.

3.1.6 Project Cost Estimate

A project cost estimate shall be prepared during the design of the park and finalized at the end of the General Development Plan phase. All costs shall be included in the estimate including a cost for a 90-day maintenance period and a 10% contingency.

3.1.7 Design Review Committee presentation requirements

The Design Review Committee meets on the second Wednesday of each month to review proposed projects prior to their consideration by the Park and Recreation Board. The scope of the Design Review Committee encompasses the conceptual review of design, land planning, engineering, architecture, landscape architecture, lighting and signage for proposed projects.

The purpose of this policy is to establish minimum graphic standards for use by architects, landscape architects, other consultants and staff in their presentation to the Design Review Committee..

POLICY:

1. Presentations shall be as clear and concise as possible while still describing the total scope of the project.
2. Presentation exhibits shall be of sufficient scale and size to be easily viewed from fifteen to twenty feet away. Presentation drawings shall be mounted on 30" x 40" (minimum) boards. Loose or rolled drawings are not acceptable.
3. Staff reports shall include graphic exhibits, when applicable, to be mailed and distributed to Committee members. Exhibits shall be at a size that is easily readable and clearly expresses the information presented.
4. Photographs of the site and surrounding areas are important to provide information on adjacent uses, unusual topography or unique features.
5. Presentation drawings will include but not be limited to the following (as applicable):
 - a. A location map and most recent available aerial photograph.
 - b. A site development plan clearly indicating proposed on-site facilities including buildings, parking areas, play areas, lighting, landscape materials (including plant palette), signage, drainage and utilities. This plan should be in color. Critical dimensions should be included.

- c. Building presentations will include floor plan, and all elevations necessary to clearly describe the structure. The drawings shall be colored. A perspective drawing or rendering of the facility may be submitted at the Consultant's option.
 - d. A topographic or grading plan which clearly indicates existing and proposed contours (including existing trees and caliper sizes).
 - e. Signage details shall indicate proposed materials, colors, size, locations, layout and in the font.
6. All presentation drawings shall clearly indicate which direction is northerly (orient north in an upward direction when possible).
 7. Slide and power point presentations shall be permitted within the previous defined presentation criteria at the Consultant's option.
 8. A "color board" with samples of actual proposed exterior materials to show true colors and textures is required for building presentations.
 9. Product "cut sheets" or photos may be used to describe proposed site amenities or special design features, (including but not limited to, site furnishings, light fixtures, play equipment, unique plant material, etc.), in lieu of presentation in presentation plan format.
 10. Presentations shall be limited to fifteen minutes unless determined otherwise by the Chair.
 11. Committee review and questions shall be limited to fifteen minutes unless determined otherwise by the Chair.

3.2 CONSTRUCTION PLANS

Construction Plans are the technical plans used for obtaining bids, the actual construction and the As-Built plans. These plans shall be prepared in compliance with the approved General Development Plan. All construction plans for parks shall be submitted to the City's Engineering Maps and Records section for final recording. Construction Plans shall meet the graphic and drafting standards listed below.

3.2.1 General Requirements for all Plans

3.2.1.1 Mylar Sheets: All projects shall be on City standard 'D' sheets (24" X 36"), of reproducible bond, with the Park and Recreation Department title block. Larger sheet sizes are acceptable with City Project Manager approval. The cover sheet shall be polyester drawing film (3 mil. Min., single matte)

3.2.1.2 Lettering: Shall be capitalized and no smaller than 1/8" high. The space between lines of lettering shall be not less than one-half the height of the letters. Hand drawn plans shall be done in ink or with plastic lead manufactured for use on plastic drawing film. Computer generated plans shall be ink jet plots or electrostatic plots on mylar.

3.2.1.3 Title Block: Above the title block should be 'Private Contract' or 'Public Contract', depending on the type of project. Within the title block provide the 'Project Name and Phase' (if applicable), 'Work Order' or 'Job Order Number', 'Lambert Coordinates' and 'Drawing Number'. City Contracts shall also include the Capital Improvement Program (CIP) number and Special Specification No. above the title block.

3.2.1.4 Key Map: Shall be provided on each sheet if the project contains multiple plans.

3.2.1.5 North Orientation: North arrow with scale shall be shown on each sheet. North orientation of plan shall be to the top or to the left side of the plan.

3.2.1.6 Scale of Plans: All plans shall be done at a scale no smaller than 1" = 30'. Prior City Project Manager approval is necessary if projects require a smaller scale to fit onto sheet size. If additional detail is required, a larger scale is to be utilized to provide sufficient clarity. Provide a written and graphic scale on all plans.

3.2.1.7 Limit of Work: A limit of work line shall be provided, showing the project scope of work.

3.2.1.8 Matchlines: Shall be labeled to provide adequate reference for identification and cross-indexing to other plans.

3.2.1.9 Streets: Label streets that are adjacent to the project or within the project's immediate sphere.

3.2.1.10 Professional Registration Stamp: Shall be provided on all plans, signed and dated.

3.2.1.11 Provide the following note on all plans:

Sheet Size and Scale: "If sheet size is less than 24" X 36", it is a reduced print - scale accordingly."

3.2.2 Title Sheet

Shall include but not be limited to the following:

3.2.2.1 Name of Project: Project name and the project phase, if applicable, shall be placed at the top of the Title Sheet in 48 pt. font or larger.

3.2.2.2 Vicinity Map: A vicinity map showing nearest arterial intersection, street names, north arrow and project location.

3.2.2.3 Location Map: A location map showing the project area and applicable street names, north arrow, matchlines, project limits, tract boundaries and scale.

3.2.2.4 Project Address: Provide a brief legal description and street address.

3.2.2.5 Project Directory: A project directory that lists the prime consultant and all the sub-consultants firms, addresses, phone numbers, fax numbers and e-mail if applicable.

3.2.2.6 Sheet Index: A sheet index with plans listed by Sheet No., D-Sheet No. and Sheet Title.

3.2.2.7 Right Hand Margin: The project name shall be provided on the right hand margin of the title sheet.

3.2.2.8 Survey Data: The survey data shall be provided by listing the following applicable aerial, field survey or benchmark information on the Title Sheet:

<u>Aerial Survey</u>	<u>Field Survey</u>	<u>Benchmark</u>
Party Chief:	Party Chief:	Description:
Contractor:	Date:	Location:

(Note: The latest editions of the preceding specifications and drawings should be used. Where one or more sets of specifications or drawings are applicable, the more restrictive will take precedence.)

3.2.2.13 Provide the following note on the Title Sheet:

CAUTION:

Before excavating, verify the location of underground utilities. At least two (2) working days prior to excavation, the Contractor shall request markout of underground utilities by calling the below listed regional notification center for an inquiry identification number:

Underground Service Alert (Gas, Electric, Telephone, Water, Sewer, Lighting, and TV)	800/422-4133
Irrigation Systems	619/235-1179
Irrigation Control Wire:	619/235-1179
Facilities Maintenance Division	619/236-5500

3.2.2.14 Provide the following note on the Title Sheet:

Declaration of Responsible Charge:

I hereby declare that I am the (Engineer, Landscape Architect, Architect) of Work for this project, that I have exercised responsible charge over the design of the project as defined in Section 6703 of the Business and Professions Code, and that the design is consistent with current standards.

I understand that the check of project drawings and specifications by the City of San Diego is confined to a review only and does not relieve me, as (Engineer, Landscape Architect, Architect) of Work, of my responsibilities for project design.

Name of (Engineer, Landscape Architect, Architect) License Number Date

Firm Name (Engineer, Landscape Architect, Architect)
Address
Phone Number
Fax Number
Email Address

3.2.2.15 Provide the following note on the Title Sheet:

Park Construction Inspection Stages and Inspection Team:

Park Inspection Team

- A. Site Superintendent (Contractor/Developer's Representative)
- B. Contractor(s)
- C. Resident Engineer from Field Engineering Department
- D. City Project Manager
- E. Design Consultant
- F. Park and Recreation District Manager

Park Construction Inspection Stages: (Minimum depending on project)

1. Pre-construction meeting.
2. Rough grading and drainage.
3. Irrigation mainline pressure test.
4. Wiring prior to backfilling trenches.
5. Hardscape at time of finished staking and layout.
6. Finish grading and soil preparation.
7. Irrigation coverage test.
8. Plant material (when delivered) and placement approval.
9. Play Ground Inspection, if applicable.
10. Project construction 90% complete (develop punch list and submit red-line As-Builts).
11. 90-Day Plant Maintenance Period. (This inspection to be held when the punch list items are complete, if lawn area is seeded, it is a 120-day plant maintenance period.)
12. Final walk-through, acceptance by the City. (Contractor to submit final approved As-Builts to the City.)

3.2.2.16 Provide the following note on the Title Sheet:

WATER FEES:

The City of San Diego Project Manager and the Consultant shall coordinate the following: Water and Sewer Capacity Fees and the Wet Tap Fees shall be pre-paid by the City for City contracts, the Contractor shall pay all other construction and maintenance water meter and sewer fees, and shall coordinate with the Water Utilities Department for installation of services. Allow three (3) months notice to the Water Utilities Department. For Developer-Built projects, all fees shall be paid by the Developer.

3.2.3 Grading and Drainage Plans

Shall include but not be limited to the following:

3.2.3.1 Grading Plans: Shall conform to the City's Manual for the Preparation of Land Development and Public Improvements and the Municipal Code Grading Ordinance. Grading plans shall be prepared by a professional, as licensed and allowed by the California Business and Professions Code.

3.2.3.2 Existing and Proposed Finished Grades: Shall be graphically shown on the plans with minimum two foot contours and spot elevations for the entire site and within 50 feet of the site boundaries. The plan must clearly show how the site will drain and to where. All areas of the site must have positive drainage.

3.2.3.3 Spot Elevations (existing and proposed): Shall be shown at all high points, low points, changes in gradients, changes in elevations (stairs, curbs, etc.), hardscape, corners of structures, finish floor elevations, drain locations and inverts, top and bottom of walls, and any other locations necessary to indicate the proposed grading design.

3.2.3.4 Slope Gradients: Shall be labeled as a percentage or as a ratio.

3.2.3.5 Property Lines and Off Site Grading: Clearly show property lines and indicate all off-site grading. Provide a letter of permission from the adjacent land owners for proposed off site grading.

3.2.3.6 Limit of Grading: Areas to remain undisturbed shall be indicated on the plans.

3.2.3.7 Grading and Drainage Details: Shall be provided for all details that do not conform to the City of San Diego Standard Drawings.

3.2.3.8 Grading Notes: Shall be provided on the plans.

3.2.3.8 Storm Water Pollution Prevention Plan (SWPP) Provide a Storm Water Pollution Prevention Plan (SWPPP) for all parks where the construction activity impacts one acre or more.

3.2.4 Layout and Construction Plans

Shall include but not be limited to the following:

3.2.4.1 Existing and Proposed Improvements: Walkways, paving, mow curbs, fences, walls, site furniture, multi-purpose courts and fields, play areas, buildings, parking lots, signs, trails, etc., shall be graphically located on the plans.

3.2.4.2 Horizontal Control: All proposed improvements shall be located on a horizontal control plan.

3.2.4.3 Construction Legend: Shall include all symbols used on the plan.

3.2.4.4 Site Amenities and Materials Legend: Shall include a symbol, manufacturer/model no., description of material, color, detail number, and other information, as required.

3.2.4.5 Construction Details: Shall be provided for all details that do not conform to the City of San Diego Standard Drawings.

3.2.4.6 Construction Notes: Shall be provided on the plans.

3.2.4.7 Construction Specifications: Shall be provided on the plans, or provided in a specification book with the City Project Manager approval.

3.2.4.8 Provide the following note on the Playground and Equipment Plans:

CONTRACTOR EXPERIENCE:

The contractor shall have National Playground Safety Institute (NPSI) certification for installers and in addition the installers shall be certified by the equipment manufacturer to install their equipment and surfacing. The NPSI certified

installers shall be involved in the construction of the playground at all times during construction and including preparation of the subgrade.

PLAYGROUND AUDIT / NPSI CERTIFICATION:

The Contractor shall be responsible for providing an independent third party audit of the playground area, surfacing and all play equipment. The audit shall be conducted by a NRPA/NPSI Certified Playground Safety Inspector. The audit shall determine compliance of the playground area, surfacing and all play equipment with the most current versions of accessibility and safety standards including, but not limited to, the following: Americans with Disabilities Act (ADA); Consumer Product Safety Commission (CPSC) Handbook for Public Playground Safety; the American Society for Testing and Materials (ASTM) Standard Consumer Safety Performance Specification for Playground Equipment for Public Use (F-1487) and Standard Specification for Impact Attenuation of Surface Systems Under and Around Playground Equipment (F-1292) and Standard Specification for Determination of Accessibility of Surface Systems Under and Around Playground Equipment (F-1951). The audit shall also test for actual G-Max ratings accomplished with various surface materials.

The Contractor shall be responsible for correcting any items found not to be in compliance with the above standards as a result of the audit, at no charge to the City. The Contractor shall provide to the Resident Engineer and Project Manager a signed letter stating that the playground area, surfacing and play equipment comply with all current applicable accessibility and safety standards. The letter shall include an itemized list corresponding to each audit item, describing all corrections and the date each correction was completed. If applicable, the letter may state that any equipment in question is certified by International Playground Equipment Manufacturers Association (IPEMA). (Provide manufacture’s proof of IPEMA certification.)

3.2.5 Irrigation Plans

Shall include but not be limited to the following:

3.2.5.1 Irrigation Components and Drinking Fountains: Shall be graphically shown on the plans. (See Appendix ‘D’ for approved graphic symbols)

- (1) **Point of Connection and Meter:**
Size, type of water (potable or reclaimed).

- (2) **Backflow Device:**
Size, available static pressure in PSI, and the PSI and GPM for which the system is designed.
- (3) **Controller:**
Location, number of stations, identifying letter.
- (4) **Master Control Valve and Flow Sensor**
- (5) **Pressure Regulator Valve**
- (6) **Isolation Valves**
- (7) **Remote Control Valves:**
Size, irrigation controller letter, valve station number and gpm.
- (8) **Quick Couplers and Globe Valves**
- (9) **Check Valves**
- (10) **Irrigation Heads**
- (11) **Irrigation Mainline and Size**
- (12) **Irrigation Lateral Line and Size**
- (13) **Irrigation Sleeves and Size**
- (14) **Pull Boxes**
- (15) **Rain Shut Off Switch**
- (16) **Drinking Fountains:**
Locations and water source.

- (17) **Electrical Lines:**
From electrical meter to irrigation controller only.

3.2.5.2 Irrigation Legend: Shall Include all symbols, manufacturer model number/size, description of equipment, radius, psi, gpm, detail number or standard drawing number.

3.2.5.3 Irrigation Details: Shall be provided for all details that do not conform to the City of San Diego Standard Drawings.

3.2.5.4 Water Service/Meter(s): Provide a note on the plan adjacent to the water service meter symbol that identifies the following.

- (1) **Service:** Domestic or reclaimed.
 - (2) **Water meter size and address.**
 - (3) **Installation requirements and responsibilities of the water purveyor and the Contractor.**
 - (4) **Available static water pressure at point of connection (POC).**
 - (5) **Design pressure.**

(6) Peak flow through water meter (GPM).

3.2.5.5 Pressure Loss Calculations: Provide pressure loss calculations (incorporate residual loss factor) for the system with the highest pressure requirement for each controller on a separate 8 ½” x 11” sheet of paper (submit calculations to the City Project Manager).

3.2.5.6 Irrigation Notes: Shall be provided on the plans.

3.2.5.7 Irrigation Specifications: Shall be provided on the plans or provided in a specification book with the City Project Manager approval. The ‘Supplemental Irrigation Specifications’ shall be incorporated into the design and provided on the plans. (See Appendix ‘F’.)

3.2.5.8 Reclaimed Water: The following requirements pertain to reclaimed water projects. These notes shall be included on all plans for irrigation systems using (or designed for) reclaimed water:

- (1) The installation of the reclaimed water system shall conform to the rules and regulations for the construction of reclaimed water system within the water district.
- (2) The water district shall be notified two days prior to the start of construction and each workday thereafter until completion of the project.
- (3) All on-site constant pressure reclaimed and potable water main line piping installed on this project shall be identified in accordance with the district’s regulations and the irrigation specifications.
- (4) Detectable warning tapes shall be used on all constant pressure main line piping carrying either reclaimed or potable water.
- (5) Warning tapes shall be a minimum of 3” wide and shall run continuously for the entire length of all constant pressure main line piping. The tape shall be installed in the trench 6” above the top of the pipe at the top of the sand bedding material.
- (6) Warning tape for the constant pressure reclaimed water piping shall be PURPLE in color with the words “CAUTION BURIED WATERLINE BELOW” imprinted in minimum 1” high letters, black in color. Imprinting shall be continuous and permanent.

- (7) All pressure main line piping from the reclaimed water system shall be installed to maintain 10' minimum horizontal separation from all potable water piping. Where reclaimed and potable water pressure main line piping cross, the reclaimed water piping shall be installed below the potable water piping in a PVC Class 200 pipe sleeve which extends a minimum of 5' on either side of the potable water piping. Provide a minimum vertical clearance of 6".
- (8) Contact the water district and the City of San Diego staff for this project to arrange for a coverage test and a system walk-through.
- (9) Exterior drinking fountains must be shown and called out on the reclaimed water irrigation plans. If no exterior drinking fountains are present in the design area, it must be specifically stated on the plans that none exist.

3.2.6 Planting Plans

Shall include but not be limited to the following:

3.2.6.1 Plant Symbols (trees, shrubs, vines, groundcovers, etc.): Proposed plant materials shall be graphically shown on the plans with a symbol that represents the mature size of the proposed species. Show all existing plant material that will remain on the site as a dash symbol.

3.2.6.2 Planting Legend: Shall include the symbol, quantity, size, botanical name, common name, detail number, and any special remarks such as on-center spacing, tree height and width, variety or color.

3.2.6.3 Seed Mix Information: Shall include the botanical name (s), % pure live seed, total pounds per acre, mulch, binder, fertilization and inoculation requirements. Identify if the seed mix is irrigated or non-irrigated.

3.2.6.4 Planting Details: Shall be provided for all details that do not conform to the City of San Diego Standard Drawings.

3.2.6.5 Planting Notes: Shall be provided on the plans..

3.2.6.6 Fertilization Note: Provide the following note on the plan: Maintenance 120 days seed, 90 days sod, No Stolons.

Fertilization for all Lawn Areas:

- 9-9-9 Five days after germination.
- 9-9-9 Every 21 days through acceptance of maintenance period.

21-0-0 At end of maintenance period.

Fertilization for all Trees, Shrubs and Groundcovers:

0-10-10 or 1-10-10 at 40 lbs./ 1000 square feet at 30 day intervals.

OR:

6-20-20 at 25 lbs. / 1000 square feet at 30 day intervals.

3.2.6.7 Planting Specifications: Shall be provided on the plans or provided in a specification book with the City Project Manager approval.

3.2.7 Lighting Plans

Shall include but not be limited to the following:

3.2.7.1 Proposed Lighting: All security and sports lighting shall be graphically located on the plans including all light poles, fixtures, pull boxes, transformers, and other components. Sports lighting poles shall be shown with dimensions from identified landmarks for each pole location.

3.2.7.2 Point of Connection: The service point shall be shown on the plans. If the point of connection is not within the project site, the service point shall be identified in a vicinity map detail. The San Diego Gas & Electric (SDG&E) planner and their phone number shall be identified on the plan. Any SDG&E fees shall be enumerated by an appropriate bid item.

3.2.7.3 Light Fixture Legend: Shall include symbols for poles, fixture types, conduit size, panels and utility service points.

3.2.7.4 Lighting Fixtures Schedule: Shall identify manufacturer, model number, type of fixture, voltage and wattage.

3.2.7.5 Panel Schedule: Shall designate circuits with the number of devices being served, voltage, number of phases, short circuit rating, load continues amperage, etc.

3.2.7.6 Lighting Details: Shall be provided for all details that do not conform to the City of San Diego Standard Drawings, including but not limited to, conduit, pull box installation, foundation installation and configuration of all panels.

3.2.7.7 Lighting Notes: Shall be included on the plans.

3.2.7.8 Lighting Specifications: Shall be provided on the plans or provided in a specification book with the City Project Manager approval.

3.2.7.9 Additional Sports Lighting Notes:

- (1) **Illumination Levels:** Identify on the plan the foot candle levels for each type of sports activity to be illuminated. Designate average maintained illumination levels and uniformity ratios (maximum to minimum).
- (2) **Fixture Aiming:** Identify on the plan the aiming point on the playing surface for each fixture.
- (3) **Testing:** Provide notes on the plan that the contractor is responsible for testing each sports field and for furnishing a written report to the City Project Manager indicating the testing results of the illumination levels in foot candles and uniformity ratios for each field.

3.3 AS-BUILT PLANS

As-Built Plans are the final record of what was constructed. The Design Consultant, as part of the Consultant's contract, shall be responsible for correcting the original mylar construction plans to show the as-built conditions. The Design Consultant shall obtain the original mylars and the current requirements for "Drawings: Changes and Revisions" from City's Maps and Records Section. All as-built changes noted on the red line set shall be incorporated on the mylars with water-proof ink. The drafting shall be of equal quality to the original mylars. Erase all incorrect information and add any Field Engineer's comments. Provide the word 'As-Built' in large lettering in the margin below the Title Block on all sheets changed. The original Architect, Engineer or Landscape Architect must sign the as-built sheets.

4. PROJECT PROCESS, SUBMITTALS AND APPROVALS

The project, submittals and approval processes will vary relative to the type of project and the phase of work being addressed. It is recommended that the Design Consultant meet with the City Project Manager to confirm the appropriate project process, submittals and approvals, for public or privately built parks prior to starting the project. The following outline is a typical process for park projects:

4.1 GENERAL DEVELOPMENT PLANS (GDP)

4.1.1 Project Program Meeting

The Design Consultant (Consultant) will meet with the City Project Manager and the park's District Manager to review and discuss the proposed project program and budget. The Consultant will prepare a memo to the City Project Manager summarizing the proposed project program, a project schedule and any special issues or site constraints which will affect the outcome of the design.

Submittal: Memo of Proposed Project Program and Schedule

4.1.2 Workshop #1 - Public Input of a Preferred Project Program

The City Project Manager will set up and advertise the first workshop with the officially-recognized Recreation Council (Council) or Open Space Citizen's Advisory Committee (Committee) for public input per Council Policy #600-33. The City Project Manager will prepare project information that outlines the roles of the design team and the community members, the anticipated scope of work, the project budget and funding sources and projected time schedule. The City Project Manager and Consultant will present this information and the GDP process to the Council or Committee. The Council or Committee will provide input regarding the development of a preferred project program, as well as a community priority ranking of the proposed program elements (a written questionnaire can be used to get community input at the meeting and to document what was said). This information will give the Consultant clear direction regarding community desires and will be used to develop conceptual alternatives that maintain community priorities and the project budget. The Consultant will prepare a summary report of the public input.

Submittal: Summary Report of Workshop #1, including preferred project program and priority ranking of program.

4.1.3 Conceptual Alternatives Meeting

The Consultant will prepare conceptual alternatives for review and discussion with the City Project Manager and the park's District Manager (the number of alternatives that are appropriate for the individual project will be determined by the Project Manager). These conceptual alternatives should show how the project program will be accomplished within the specific site, taking into consideration the site constraints and budget requirements. A preliminary statement of probable costs shall be developed and submitted to the City Project Manager.

Submittal: Conceptual Alternatives and Preliminary Statement of Probable Costs

4.1.4 Workshop #2 - Public Input of Conceptual Alternatives

The City Project Manager will present a summary of the preferred project program and the Consultant will present the conceptual alternatives to the Council or Committee for input. The graphics for the conceptual alternatives will need to comply with the Park and Recreation Board Policy No. 1011. (See appendix 'A'). At this second meeting, the Council or Committee will have an opportunity to review and comment on the conceptual alternatives. Community members will be allowed to: a) recommend individual elements from the conceptual alternative to be synthesized into a preferred alternative plan, or b) recommend the presented

conceptual plan that best meets the outlined project program and priorities identified in the first workshop.

Submittal: Summary Report of Workshop #2, including recommend conceptual alternative and/or recommended individual elements.

4.1.5 Preferred GDP Meeting with City Staff

The Consultant will incorporate the proposed revisions and prepare a preferred GDP and statement of probable cost for review and recommendation by the City Project Manager and the park's District Manager.

Submittal: Preferred General Development Plan based on Workshop #2. Statement of Probable Cost Estimate

4.1.6 Preliminary Meeting with Planning & Development Review Department

The City Project Manager and the lead Consultant shall meet with Planning & Development Review to determine if discretionary permits are required and to submit the proposed project for environmental review in compliance with California Environmental Quality Act (CEQA). If a discretionary permit is required, the lead Consultant will prepare the submittal application and the required plans. The lead Consultant will prepare all necessary plans for the CEQA submittal.

Submittal: Discretionary Permit and CEQA Submittal

4.1.7 Area Committee Presentation

The City Project Manager will present the project program and the Consultant will present the preferred General Development Plan to the Area Committee for a recommendation of approval.

4.1.8 Additional Advisory Committees

The City Project Manager will determine which additional advisory committees will be required based on the project type. At each these additional meetings the City Project Manager will present the project program and the Consultant will present the preferred General Development Plan. Additional Committees could include:

SCRAB – Sub-Committee for the Removal of Access Barriers

FARB – Facilities Access Review Board

HRB – Historical Resources Board

4.1.9 Design Review Committee Presentation

The City Project Manager will present the project program and the Consultant will present the preferred General Development Plan to the Design Review Committee for a recommendation of approval.

4.1.10 Park and Recreation Board or Task Force Approval

The City Project Manager will present the project and draft/final environmental document to the Board or Task Force for approval. The lead Consultant will be available to provide a presentation of the preferred GDP, if requested by the Board or Task Force.

*Submittal: Final General Development Plan(s)
Draft/Final Environmental Report*

4.1.11 Submittal of Final General Development to City Project Manager

Consultant shall submit the final General Development Plan Package and Statement of Probable Cost to the City Project Manager.

*Submittal: One full size mylar of the General Development Plan(s)
One 8 1/2" x 11" mylar of the General Development Plan (s)
A computer disc with the plans listed above in Microstation DGN or DXF format . Disc should be a single floppy or a single compact disc.*

4.2 CONSTRUCTION PLANS

4.2.1 Notice to Proceed

City Project Manager shall send a letter to the Consultant of "Notification to Proceed" and include a copy of the approved GDP and budget requirements.

4.2.2 Preparation of Plans, Specifications and Cost Estimate

Consultant shall obtain the correct mylar title block from the City Project Manager. The construction plans shall be prepared based on the approved GDP. Modification to the GDP design shall be approved by the City Project Manager.

Submittal: Any modifications to the GDP design shall be submitted in writing

4.2.3 60% Plan Check Submittal to City Project Manager

Consultant shall submit the construction plans and preliminary cost estimate to the City Project Manager at 60% completion for an in-house City plan check. The City Project Manager shall meet with the District Manager for the park for a group plan check. Plan check comments will be sent to the Consultant within 30 days of receiving the plans. Consultant shall incorporate comments into the plans.

Submittal: 60% Construction Plans

Preliminary Cost Estimate

4.2.4 90% Plan Check Submittal for Permits and Revisions

Consultant shall submit the construction plans and final cost estimate to the City Project Manager at 90% completion and to Planning & Development and Review for any required building or engineering permits. City Project Manager to review plans for conformance to the General Development Plan and to submit plans to Contract Services for a City Wide Plan Check.. Consultant to process all plan check corrections.

*Submittal: 90% Construction Plans and Specifications
Final Cost Estimate*

4.2.5 100% Submittal

Consultant to resubmit plans to the City Project Manager for final approval. The City Project Manager to submit the 100% submittal to Contract Services for public bid.

*Submittal: 100% Construction Plans and Specifications
A computer disc with the Construction Plans in Microstation DGN or DXF format . Disc should be a single floppy or a single compact disc. Consultant shall provide a Mylar cover sheet w/ bond copes for the remainder of the set.*

4.2.6 Plans Approved and Submitted to City Records

Consultant shall coordinate with the City PM, submittal of original mylars to the City Maps and Records Section.

Submittal: Original Mylars

4.3 AS-BUILT PLANS

4.3.1 As-Built Plan Requirement

Each Design Consultant shall be responsible for coordinating the completion of the as-built plans. The Design Consultant shall specify in the plans that the Contractor shall maintain a blueprint set of plans, with as-built information noted in red ink, on the site at all times during construction, and shall update information weekly.

4.3.2 Redline set of As-Built submittal to City Project Manager

Upon the completion of the park construction and prior to the maintenance period, the Contractor shall provide a redline set of as-builts to the Design Consultant and the Project Manager for review and approval. The redline set shall clearly reflect the actual locations of all above and below changes made to park amenities. Buildings and equipment such as valves and backflow preventers shall be

referenced and dimensioned from two fixed points on the site to triangulate their location to the nearest six inches (6”). The redline set shall also reflect any modification of equipment/products used that differ from the legend on the plans. Addresses for water/electrical meters shall be correctly indicated on the redline set.

Submittal: Red line set of as-builts

4.3.3 Transfer of As-Built Information onto Digital Originals

After the redline set of as-builts have been approved by the City Project Manager, the Consultant shall at their expense revise the original digital drawings indicating the changes and transfer the as-built information onto them during the maintenance period. All as-built changes shall be provided per the requirements of City Maps and Records. The Consultant shall be responsible for the accuracy of the completed as-built plans. The Design Consultant shall not receive full and final payment until the Project Manager has received and approved the full set of final As-Built mylars.

Submittal: Red line set of as-builts

4.3.4 Certification of the Final As-Builts

The original Architect, Engineer or Landscape Architect of record shall make the as-built corrections and sign the sheets. The mylars with the as-built information shall be re-submitted to City Maps and Records for recording. As-built drawings shall be completed prior to the end of the maintenance period so that two sets of drawings can be provided to the Park & Recreation Department at the time the project is accepted by the City of San Diego.

Submittal: Signed original mylars with approved as-built informatio

APPENDICES

for the Consultant's Guide to Park Design and Development

January 2005

Appendix 'A'	Park and Recreation Board Policies: No. 1001 'Naming of Parks', No. 1011 'Graphic Presentations' and No. 1302 'Park Signs'
Appendix 'B'	Council Policy No. 200-14 'Landscape Design'
Appendix 'C'	References Cited
Appendix 'D'	Standard Symbols and Legend for Irrigation Systems
Appendix 'E'	Approved Irrigation Materials List
Appendix 'F'	Supplemental Irrigation Specifications
Appendix 'G'	Approved Manufacturers and Products List
Appendix 'H'	Crime Prevention Through Environmental Design for Park Design
Appendix 'I'	Standards and Specifications Guidelines from Facilities Division
Appendix 'J'	Standard Park Details Multi-Purpose Courts Tennis Courts Multi-Purpose Fields
Appendix 'K'	Council Policy #900-14 Sustainable Building Policy
Appendix 'L'	Disapproved Play Equipment
Appendix 'M'	Joint Use Checklist
Appendix 'N'	Access Memo's 2004-01, -02, -03, -04
Appendix 'O'	Policy on Avoiding Use of Non-Native Invasive Plants in Park & Recreation Department Projects

PARK AND RECREATION BOARD POLICY NO. 1001

- SUBJECT:** Naming of Parks and Recreation Facilities
- BACKGROUND:** The public sometimes suggests that parks and recreation facilities be named after persons, living or dead.
- PURPOSE:** To provide a systematic procedure for the naming of parks and recreation facilities which will assist in their location by the citizenry, and to develop a method for the retention of names of historical or fiscal significance.
- POLICY:** As a general policy, parks and recreation facilities should be named to identify their locations. The name of the community area, the names of nearby geographic features, the names of adjacent schools and street names should be given first consideration. However, they may also be named for individuals, living or dead, who are of historical significance to the local area or who have made major financial contributions in the opinion of the appropriate recreation councils and/or other advisory bodies, Board committees and the full Board.
- SUBSTANTIATION:** Park and Recreation Board Minutes of 6/16/83 (page 2469).

PARK AND RECREATION BOARD POLICY NO. 1011

SUBJECT: Graphic Presentations for the Park and Recreation Board and Committees.

BACKGROUND: Graphic presentations showing preliminary designs of parks, park improvements, park related structures and facilities are regularly submitted for review and approval by the Board and its sub-committees. These graphic presentations are often the only occasion on which the Board will review and recommend approval of a project.

PURPOSE: The purpose of this policy is to establish a minimum graphic standard for use by architects, landscape architects, other consultants and staff for presentation to the Park and Recreation Board and Committees.

POLICY:

1. Presentations shall be as clear and simple as possible while still describing the total scope of the project.
2. Presentations shall be of sufficient scale and size to be easily viewed from fifteen to twenty feet away.
3. Presentation drawings shall be mounted on minimum sized 30" X 40" boards. Loose or rolled drawings are not acceptable.
4. Presentation drawings will include but not be limited to the following (as applicable):
 - a. A location map.
 - b. A topographic or grading plan which clearly indicates existing and proposed contours.
 - c. A development plan clearly indicating on-site facilities including buildings, parking areas, play areas, lighting, landscape materials, drainage, and utilities. This plan should be in color. Critical dimensions should be included.
 - d. Building presentations will include floor plan, all elevations to clearly describe the structure. The drawings shall be colored. A perspective drawing may be submitted at the Consultant's option.

5. Photographs of the site and the surrounding areas, if required to define unusual topography or features, are recommended.
6. All presentation drawings indicating site or general development plan shall have the north arrow pointing up.
7. Slide presentations will be permitted along with the above items at the Consultant's option.
8. A board with samples of actual proposed exterior materials to show true exterior colors and textures is required for building presentations.
9. A rendering of a facility may be present in lieu of elevations at the Consultant's option.
10. The basic purpose of the graphics is to describe and support a particular construction or planning project, rather than to sell or impress.

Substantiation:

Park and Recreation Board
Minutes of December 21, 1976
Facilities Committee Report

PARK AND RECREATION BOARD POLICY NO. 1302

No. 1302
Revised 11/15/01

- SUBJECT:** Park Signs and Recognition Media in Community, Neighborhood, and Open Space Parks
- PURPOSE:** To establish a policy and guidelines regulating design, placement and information on signs and other forms of media allowed in community, neighborhood and open space parks in order to achieve a unifying theme for signs in City of San Diego parks which strikes a balance between aesthetics and public information
- BACKGROUND:** On December 21, 1989, the Park and Recreation Board recommended that a policy be developed governing approval of signs within City parks. On February 10, 1993, the City Council approved the City Ventures pilot program which is aimed at encouraging sponsorship of park facilities and programs. The City Council also agreed that thanking sponsors through sign recognition or other forms of media placed at the site would be appropriate.
- POLICY:** It shall be the policy of the Park and Recreation Board to provide oversight for the number, wording, appearance, and size of signs and other types of media allowed in neighborhood, community and open space parks.
- For open space parks, signage shall follow this policy unless, upon recommendation from an open space park task force or other appropriate body, City Council directs otherwise.
- Signage which is significantly different from typical park signage due to format, size, or materials, shall be reviewed by the Design Review Committee to conform to standards within this policy. This includes informational and directional signs, permanent signs (Section A below), temporary signs (Section B below), and sponsorship recognition signs (Section C below). Deviations from said policy must be reviewed and approved by the Park and Recreation Board and the City Council.

A. Permanent Signs – defined as a sign installed on year-round basis.

1. Identification Signs – All parks should have at least one permanently installed identification sign.

a. Permanent identification sign(s) should be included in all new park construction plans. Existing parks which do not have identification sign(s) should systematically be retrofitted with permanent signs as funding becomes available.

b. Permanent identification signs for population-based park, shall be monument-style and constructed of durable materials, preferably concrete, no larger than fourteen (14) feet wide and four (4) feet high.

Signs should include: the name of the park; the words “The City of San Diego, Park and Recreation Department”; the City logo and the Department’s logo. Lettering on signs should be recessed. Raised or applied letters are not recommended because of vandalism and maintenance concerns.

c. Signs should be located at major entrance(s) to each park, or within a major traffic area to ensure maximum public visibility.

d. No advertising shall be permitted on the main body of the sign. However, signs informing the public of permanent park users, such as tennis clubs and senior citizen centers, may be allowed and attached to the main sign, if such affixing can be accommodated without detracting from the primary signage. Commercial advertising shall not be permitted.

2. Facility Operator Signs – Signs permitted for permanent installation may also be granted to organizations which have been issued special agreements to operate facility in City parks on a

year-round basis. Examples of such facilities are golf courses, tennis courts, snack bars and senior citizen centers. These permanent signs shall be constructed and installed in a manner that that ensures public safety and shall conform to the following guidelines

- a. Size of signs shall be appropriately sized to the purpose and under no circumstances shall exceed twenty-five (25) square feet.
- b. Signs shall be installed on buildings operated by organizations. Placement of information or directional signs may be approved at other locations within the park as may be appropriate.
- c. Wording on signs shall not infer ownership of public facilities and shall include a statement identifying the facility as “public property”.
- d. Sign color and lettering should be limited to earthtones or to colors which conform to existing park signage.
- e. Placement of any and all signs shall be determined by the Park and Recreation Director or his/her designee.
- f. Signs shall be well maintained by the organization. Graffiti or defacement shall be corrected within seven (7) days of the occurrence. The operator shall be responsible for removal of the sign at termination of the organization’s agreement with the City.
- g. Electrical signs shall not be permitted.

- B. Temporary Signs – Are defined as those of short duration, limited to three months or less, as determined by the length of activity or event.

It shall be the policy of the Park and Recreation Board to allow temporary signage to groups or organizations which wish to notify the public concerning an event or activity which will be or is being held on park grounds.

No. 1302
Revised 11/15/01
Page 4

1. Temporary signs shall be allowed under the following conditions:
 - a. A Sign Permit issued by the Park and Recreation Department has been approved.
 - b. Signs are of professional quality. Sign material shall be of durable materials consistent with the length of time the sign will be posted.
 - c. Signs will be sized appropriately for purpose and under no circumstances shall exceed a size of twenty-five(25) square feet.
 - d. Permittee shall be responsible for the installation, maintenance and removal of the sign.
 - e. Advertising shall be allowed, but shall not exceed twenty-five percent (25%) of the sign's total square footage. Any product advertising shall be approved by the Park and Recreation Director or his/her designee.
 - f. Advertising inflatables or advertising forms not covered in this policy shall be reviewed and approved by the Park and Recreation Board and its committees.

- C. Sponsorship Recognition – Defined as a sign or other type of media recognizing a sponsor of a Park and Recreation facility

or program. Sign/media shall be limited to the duration of sponsorship agreement.

1. Sponsorship recognition shall be allowed under the following conditions:
 - a. The form and duration of recognition has been approved by the Department Director of his/her designee.
 - b. Media form is of professional quality and shall be of durable materials consistent with the length of time the sign will be posted.

No. 1302
Revised 11/15/01
Page 5

- c. Media form shall be sized appropriately for purpose and under no circumstances shall exceed a size of twenty-five (25) square feet.
- d. The cost of installing, maintaining and removing the media shall be included in the sponsorship agreement.
- e. Identification of sponsor shall comprise no more than 20% of sign/media and will be limited to name and logo only.
- f. Forms of recognition not covered in this policy shall be reviewed and approved by the Park and Recreation Board and its committees.

SUBSTANTIATION:

Park and Recreation Board Minutes of December 21, 2989, Item No. 201 (page 3055).

Park and Recreation Board Minutes of May 17, 1990, Item No. 203 (page 3081).

City Manager Report 93-37 of February 3, 1993.

Park and Recreation Board Minutes of 11/15/01 (page 4).

COUNCIL POLICY 200-14, EFFECTIVE DATE 8-24-81
PARK AND RECREATION FACILITY LANDSCAPE DESIGN

BACKGROUND:

The City of San Diego has a large number of landscaped park and recreation facilities, and additional facilities will be required to serve the City's increasing population. The cost of development and maintenance of these facilities continues to rise while there is a concurrent reduction in financing available for this purpose. There is also an increased awareness of the need to promote user safety in these facilities and to conserve diminishing water and energy resources. This Council Policy provides direction for the design, or redesign, of landscaped areas which will meet community needs within the limits of available resources.

PURPOSE:

To provide policy guidance to City staff and design consultants relative to the landscape design of general park and recreation facilities.

POLICY:

It is the policy of the City Council that landscaping for new facilities, and the improvement or redevelopment of existing facilities, be designed in a manner that will assure user safety and facility function, reduce water and energy use, and reduce construction and maintenance costs through conformance with the following guidelines..

DESIGN GUIDELINES:

I. Landscaping - General

- a. High maintenance, water demanding landscaping will be limited to those areas where such improvement is essential.
- b. Each facility should be designed to retain significant existing native or naturalized plant growth, if any, consistent with intended use of the facility and the other requirements of this policy.

II. Visual Access

- a. Site grading, the location of park furnishings, structures and landscaping must permit adequate visual access into the entire site from an adjacent public thoroughfare, building or parking lot.

III. Grading - Drainage

- a. Site grading shall be accomplished in such a manner as to reduce steep grades and/or eliminate unnecessary grade changes.
- b. Adequate drainage must be provided particularly for active use areas.

IV. Irrigation Systems

- a. Irrigation systems will be automated and designed to apply water at a rate which will minimize runoff.
- b. Irrigation systems for non-turfed, but planted areas, will be operated by a controller that is independent from units that control turf area irrigation.
- c. The most effective and readily available vandal/theft resistant components will be utilized.

V. Lighting

- a. Area and parking lot lighting will be provided where ambient light from adjacent areas is inadequate for user safety and convenience.
- b. Lighting for athletic areas will be provided at a minimum level consistent with user safety and intended use.
- c. Energy efficient fixtures will be utilized.
- d. Automatic controls, with convenient manual override, will be provided.
- e. Athletic area lighting will be operated by controls which do not operate other lighting systems.

VI. Furnishings and Fixtures

- a. Avoid the use of “custom” designed park furnishings and fixtures, i.e. picnic facilities, benches, drinking fountains, lighting fixtures, play and athletic equipment, etc., except in unique and special situations.
- b. Avoid the use of wooden bollards, fences, barricades, walls, play equipment, and other “timber structures.

- c. The use of vandal resistant materials and installation methods are required.
- d. Park furnishings located in turf shall be limited in number and so spaced as to permit the effective use of mechanized maintenance equipment and the effective operation of the irrigation system.
- e. Park structures, fixtures and furnishings located in turfed areas will be provided with a concrete pad or footing flush with the adjacent turf and sufficiently wide to permit efficient turf maintenance.
- f. Locate children's play apparatus in informal groupings in non-turfed areas. Avoid the use of formalized enclosures and a sand base. Limit apparatus to basic equipment such as slides, swings and climbers.

VII. Native/Naturalized Plants

- a. The restoration of natural areas disturbed by site development with native or naturalized planting, in a manner which will require minimal maintenance, including irrigation, is encouraged, if consistent with the intended use of the facility and the other requirements of this policy.
- b. Plant material will be selected that will provide a "natural" succession of plants designed to provide initial surface stabilization followed by a permanent, long-lived plant community.

VIII. Turf

- a. Turf planting will be generally limited to areas where required for functional use.
- b. Turf areas should be of a size and configuration to permit the most effective use of mechanized maintenance equipment and reduce turf edging.
- c. Turf areas should terminate at the inside edge of perimeter walks wherever possible.
- d. Concrete mowing strips area required at the interface of turf area with shrub or groundcover planting.
- e. Athletic fields will be turfed only if they are multi-sports fields. Single use baseball fields and softball fields will not be turfed. Baseball infields will not be turfed.

IX. Trees and Shrubs

- a. Plant selection shall be limited to those species which are considered to be relatively disease and pest free, and require minimal trimming to be maintained in a safe and attractive condition.
- b. Drought-tolerant species should be utilized where practical, particularly in non-turfed areas.
- c. Planting locations and spacing will permit normal plant development without undue crowding or trimming. Plant symbols on drawings and general development plans will be in scale with the mature size of the species proposed.
- d. Trees planted in turfed areas will be spaced to permit the most effective use of mechanized maintenance equipment and operation of the irrigation system.
- e. Dense tree groves should be excluded from turfed areas. Where planted, the soil surface under such groves must be mulched with a wood chip product or equal.
- f. Shrub planting will not be permitted except where required, i.e. for safety, and to screen objectionable views.
- g. Foundation planting of park and recreation buildings is prohibited, except in unique design situations.

X. Groundcover

- a. Living groundcover will be permitted only where absolutely necessary to control surface erosion.
- b. Plant selection must be limited to low maintenance species.
- c. Drought-tolerant species should be utilized where practical.

XI. Non-Planted Areas

- a. Non-planted areas must be covered with mulch, wood chip product, decomposed granite, or other material suitable for the intended use of the area.

IMPLEMENTATION:

- I. Landscape design will conform to the guidelines listed above.
- II. General development plans for the landscaping of new facilities, or significant redevelopment of existing facilities, will be approved by the Park and Recreation Board, its appropriate subcommittees and the Public Facilities and Recreation Committee of the City Council prior to the preparation of construction documents or implementation of City force landscaping projects. The Police Department will advise the Park and Recreation Department staff relative to the public safety aspects of the proposed design.
- III. It is understood that deviation from specific sections of the guidelines due to special site conditions and/or use considerations may be required. However, such deviations must be fully justified and approved at the time of general plan approval.
- IV. Staff will assure that detailed construction documents are prepared in a manner consistent with this policy and the approved general development plan.

CROSS REFERENCE: City Charter Section 55
Municipal Code Section 63.01
Council Policy 200-5

Adopted by Resolution No. 254869 - 8-24-81

REFERENCE DOCUMENTS

Note: Consultant shall use the most current/approved edition of the Reference Documents listed below.

ADA: Americans with Disabilities Act, 1990, Americans with Disabilities Act - Accessibility Guidelines for Buildings and Facilities, (ADAAG), Federal Register/ Vol. 63, No. 8, September 2002.

ASTM: American Society For Testing and Materials, Standard Consumer Safety Performance for Playground Equipment for Public Use, , ASTM F 1487-01, Standard Specification for Determination of Accessibility of Surface Systems Under and Around Playground Equipment, February 1999, ASTM F 1951-99, Standard Specification for Impact Attenuation of Surface Systems Under and Around Playground Equipment, September 1999, ASTM F 1292-04.

Cal Trans: Manual of Traffic Controls for Construction and Maintenance Work Zones, State of California Department of Transportation, Document No. 769744, 1990.

CPSC: U.S. Consumer Products Safety Commission, Handbook for Public Playground Safety, Latest Edition www.cpsc.gov.

Greenbook: “Greenbook “- Standard Specifications for Public Works Construction 2003 Edition, 2000 Regional Supplement Amendments to “Greenbook 2003”, April 2000 and City of San Diego Supplement Amendments, Document No. 769845, July 21, 2003.

IES: Illuminating Engineering Society, Lighting Handbook Reference & Application, Chapter 21 - Sports and Recreational Area Lighting 8th Edition, 1993

Municipal Code: San Diego Municipal Code - Land Development/ Zoning Code, Chapter 11, 12, 13 and 14, City of San Diego.

Standard Drawings: City of San Diego Standard Drawings, Document No. AEC701042, filed July 21, 2004.

Title 24: Title 24 of the California Administrative Code, State of California Building Code and California State Accessibility Standards Interpretive Manual, Office of the State Architect, 2003.

Trails Handbook: Trails Handbook, State of California, Park and Recreation Department, 1998.

UBC: Uniform Building Code, California Building Code, 2001

Water Reclamation Program: Rules and Regulations for Reclaimed Water Use and Distribution within the City of San Diego, City of San Diego, April 1996.

IRRIGATION LEGEND					DETAIL
SYM	MANUFACTURER/MODEL/DESCRIPTION	PSI	GPM	RADIUS	
	<i>Consultant to describe type of heads and</i>				SD I-2 AND I-3 , I-3
	<i>assign identification numbers - special</i>				
	<i>Symbols may be used for drip and other</i>				
	<i>special heads with prior approval by</i>				
	<i>Park and Recreation Department.</i>				
	Water Meter				SD W-1 or W-2
	Pressure Regulating Valve				Similar to SD I-14
	Remote Control Valve				SD I-14
	Gate Valve w/ alternate pipe sleeve installation				SD I-13
	Globe Valve w/ alternate pipe sleeve installation				SD I-12
	Quick Coupling Valve (1" - size minimum)				SD I-5
	Automatic Controller				SD I-17 or I-18
-----	Direct Burial Control Wire (Solid Copper - Color Coded)				SD I-16
	Pull Box (Low Voltage - Locking Lid / High Voltage - Bolt Down Lid)				SD I-15
---	2" and larger Mainline - Class 315 PVC w/Sch 80 fittings or bell solvent weld for 3" and larger. 21" Below Grade (JoJ)				SD I-25 or I-26
---	1 1/2" and smaller Mainline - Sch. 40 PVC. 21" Below Grade				SD I-25
---	Lateral Lines - Sch. 40 PVC, 3/4" Minimum Size. 15" Below Grade				SD I-25
<u>G.I.</u>	Galvanized Pipe Sch. 40				SD I-20 thru I-24
	Copper Pipe Type "L"				SD I-25
	Reduced Pressure Backflow Preventer				SD W-27
	Potable Water				
P.O.C.	Point of Connection				

APPROVED IRRIGATION MATERIALS LIST

This list is updated on a yearly basis. To obtain the current list contact Park Planning, Park and Recreation Department, 619/533-4491.

NOTE: In projects that involve large open turf areas, it is recommended that the consultant use heads specifically designed for these areas, with a minimum radius of 40'. The Consultant shall confer with the City Project Manager prior to design of the irrigation system.

A. REDUCED PRESSURE BACKFLOW PREVENTERS AND ENCLOSURES:**1. Reduced Pressure Backflow Preventers**

(Assemblies shall include all necessary Test Cocks with Full Port Valves)

Febco #825Y BV; #825YAR
 Febco #880 'N' Shape
 Febco #880V Vertical
 Wilkins #575 RP
 Hershey Beeco FRP-11/6 CM Series
 Watts 009 Series; 909 Series

2. Backflow Enclosures

(Free of burs and sharp edges)

BFDI Guard Shack Stainless Steel
 VIT #SBBC - SS
 Le Meur (Stainless Steel Mesh)
 All-Spec (Stainless Steel Mesh)
 Strong Box "Smooth Touch" (Stainless Steel Mesh)

B. IRRIGATION CONTROLLERS AND ENCLOSURES:**1. Irrigation Controllers**

Irritrol MC-Plus
 Rainbird ESP (MC Series) (12-14 Stations)
 Rainmaster RME Series
 Cal Sense 2100/et-1

2. Controller Enclosures

(Stainless Steel only) 14 GA.Min
 All Spec
 La Max
 Strong Box
 Rain Man

C. PRESSURE REDUCING VALVES:
(Pilot Operated, Stainless Steel Trim)

CLA-VAL #90-01BS (1 1/4" - 3" Size)
CLA-VAL #90-01BS (4" and Larger)

(With Stainless Steel Trim for Manual and Pilot Valves)

Bailey #400
Wilkins #500
Watts 25 AUB Series

D. MASTER CONTROL VALVES:
(24 volt, Electric, Bronze, Normally Open)

Griswold 2160
Superior 3100

E. FLOW SENSORS DEVICES:

Data Industrial Flow Sensor 220P
Data Industrial Meter 600
Cal Sense FM Series

F. ISOLATION VALVES:

1. Globe Valves - 3" and Smaller Bronze

Wilkins #215
Champion #100
Buckner #22000

2. Gate Valves - 4" and Larger Cast Iron

Clow
Mueller #100-011
I.O.W.A.

3. Locking Cap for Globe/Gate Valve Sleeves

Rainbird #63100 with #2049 Key
Buckner #72

G. REMOTE CONTROL VALVES:

(24-volt Electric, Bronze, Normally Closed)

Rainbird EFB-CP Series

Superior 950-DW; 4000 (Reclaimed)

Griswold DWS and DW-PRS Series

Toro 220 Series

H. QUICK COUPLING VALVES:**1. Quick Coupling Valves - Two Piece with Locking Cover**

Rainbird #44 LRC

Buckner #25016

2. Quick Coupling Valve Keys - Single Lug

Rainbird #44K

Buckner #25011

3. Reclaimed Water Quick Coupling Valves - One Piece, Red Brass Acme -Thread with Locking Lavender Cover

Rainbird 4NP-ACME

Toro #474-44

Nelson #7645

4. Reclaimed Water Quick Coupling Valve Key - Acme-thread

Rainbird 4K-ACME

Toro #464-03

Nelson #764I.

I. IRRIGATION BOXES:**1. Remote Control Valve Boxes and Pull Boxes with Cast Iron Locking Lid**

Concrete: Brooks #3-HL

Concrete: Christy #B3-3 with B3TL

Concrete: San Diego Precast

Concrete: J & R 3HL

2. Quick Coupling Valve Boxes with Concrete Lid

Concrete: Brooks #1-RD

Concrete: Christy #F-8 with F8D

Concrete: San Diego Precast #1A

J. IRRIGATION HEADS:

1. Lawn Pop-Up Rotor Heads, Oversize - Full Circle With 50' - 60' Radius

Rainbird #41-51A SAM-RC, , Talon TA-80-FC w/S.S. Riser

Buckner #11360-06

Hunter #I-40, I-25Plus 36S (With Factory Installed Nozzles)

Toro 640, S2001

2. Lawn Pop-Up Rotor Heads, Oversize - Part Circle With 50' - 60' Radius

Rainbird #47A SAM-RC, , Talon TA-85-PC w/S.S. Riser

Hunter #I-40 ADS, I-25 Plus 36S/ADS (With Factory-installed Nozzles)

Toro 640, S2001

3. Shrub & Lawn Pop-Up Rotor Heads, Standard - Full Circle With 40' - 50' Radius

Rainbird #31A RC, Falcon w/Stainless Steel Riser,

Buckner #10060-06

Hunter # I-25 Plus 36S (With Factory-installed Nozzles)

Toro 640, S700C

4. Shrub & Lawn Pop-Up Rotor Heads, Standard - Part Circle With 40' - 50' Radius

Rainbird #37A SAM RC, Falcon w/stainless steel riser,

Buckner #10061-06 or #17061-06

Hunter # I-25 PLUS ADS (With Factory-installed Nozzles)

Toro 640, S700C

**5. Shrub & Pop-Up Rotor Heads, Undersize - Full Circle
With 30' - 40' Radius**

Rainbird #21AP RC
Buckner #11330-06
Hunter #I-20 ADS Ultra 36S (With Factory-installed Nozzles)
Toro S700C

**6. Shrub & Lawn Pop-Up Rotor Heads, Undersize - Part Circle
With 30' - 40' Radius**

Rainbird #27AP SAM RC
Buckner #11300-06 Series
Hunter #I-20 ULTRA ADS Ultra 36 S (With Factory-installed Nozzles)
Toro S700C

**7. Shrub & Lawn Pop-Up Rotor Heads, Short Range - Full or Part Circle
With 16' - 30' Radius**

Hunter I-20 Ultra ADS/36S, Stainless Steel
Toro S700C

**8. Brass Impact Rotor Heads (Riser Mount)
Oversize - Full or Part Circle With 60' - 70' Radius**

Rainbird #65 PJ ADJ-TNT
Buckner AI-103 or AI-123

Standard - Full or Part Circle With 45' - 50' Radius

Rainbird #35 PJADJ-TNT (With 3/16" Nozzle)
Buckner AI-73 BU

Undersize - Full or Part Circle With 30' - 40' Radius

Rainbird #25 BPJADJ-TNT
Buckner AI-53SB-AB

9. Shrub Fixed Spray Heads, Full or Part Circle

Rainbird PA-8S Adapter,
 Rainbird PA-8S PRS (Pressure Regulating Riser)
 Hunter #I-10
 Thompson #460 Series
 Toro #570Z with Adapter

10. Shrub Plastic Pop-Up Spray Heads, Full or Part Circle

Rainbird #1800 Series, 1800 Sam, 1800 Sam PRS,
 Rainbird 1800 with XERI-SPRAYS
 Toro #570
 Hunter "S" or "R" Type (90, 180, and 360 Degrees Only)

11. Shrub Bubblers Pressure Compensating Flood Type

Rainbird #1400 Series
 Buckner #13000 and #13001
 Hunter Pro-spray or institutional

12. Shrub Bubblers Pressure Compensating Stream Type

Rainbird #1400 Series
 Buckner #13010 Hunter PCN/PCB

K. ANTI-DRAIN/EXCESS FLOW VALVES:

Valcon #ADV-XS, #ADV
 King Brother's KBI Hunter HCV

L. PIPE AND FITTINGS:**1. Cast Iron Fittings/ Ductile Iron Fittings for Mainline (AWWA-C110) Short Body/Cement Lined**

Dayton Foundry
 Tyler Pipe and Foundry
 Leemco-Slant Bell Fittings

2. Cast Iron Joint Restraints:

Leemco

3. Polyvinyl Chloride Pipe (PVC):

EPCO

Pacific Plastic

PW Pipe

J-M Mfg.

Finn

Apache

Browline

Alertline (Reclaimed Water)

Waterwarn (Reclaimed Water)

4. Polyvinyl Chloride Pipe (PVC) Fittings:

Dura

Lasco

Sloan

Plastiline

Spears

5. Swing Joints/Height Adjusters

Dura

Toro 850 Series

Olson TSR-1

M. TRENCH MARKER TAPE:

Allen Marking Tape

Paul Potter Warning Tape, Inc. 'Alarmatape'

N. WIRE CONNECTORS: (Epoxy Filled)

Pen-Tite (Epoxy Filled)

Dri-Splice DS 100 W/DS 300 EPOXY SEALANT

O. RAIN SHUT OFF SWITCH

Hunter – Mini Click W. Sensor Guard Enclosure

WCS Rainguard

SUPPLEMENTAL IRRIGATION SPECIFICATIONS

To be incorporated into the irrigation design and added to the written irrigation specifications.

SUPPLEMENTAL IRRIGATION SPECIFICATIONS

1. **GENERAL:** ALL MATERIALS AND EQUIPMENT USED IN SPRINKLER IRRIGATION WORK SHALL BE NEW AND WITHOUT FLAWS OR DEFECTS AND OF QUALITY AND PERFORMANCE AS SPECIFIED. PRIOR TO INSTALLATION OF ANY IRRIGATION WORK, THE CONTRACTOR SHALL SUBMIT FOR APPROVAL BY THE CITY A LIST OF ALL PROPOSED MATERIALS AND EQUIPMENT. SHOULD THE CONTRACTOR PROPOSE TO USE MATERIAL(S) OR EQUIPMENT OTHER THAN THOSE AS LISTED AS “APPROVED”, THE CONTRACTOR SHALL SUBMIT IN WRITING, TO THE CITY, A REQUEST TO DEVIATE FROM THE APPROVED LIST. SAMPLES OF THE MATERIAL(S) OR EQUIPMENT SHOULD ACCOMPANY THE REQUEST TO ASSIST IN THE EVALUATION OF THE PROPOSED SUBSTITUTION. THE BURDEN OF PROOF SHALL BE BORNE BY THE CONTRACTOR.
2. **MAIN LINE PIPE CONNECTIONS:** SHALL BE MADE HORIZONTALLY PER STANDARD DRAWINGS I-28 AND I-29.
3. **PIPE THRUST BLOCKS:** ALL PRESSURE PIPE 4” AND SMALLER, POLYVINYL CHLORIDE OR ASBESTOS CEMENT, SHALL HAVE THE CORRECT SIZED CONCRETE THRUST BLOCK INSTALLED AT EVERY ABRUPT CHANGE OF ALIGNMENT; AT GLOBE OR GATE VALVES, AT TEES, ELBOWS AND CROSSES, AND AT ENDS OF PIPE RUNS; OR WHEREVER THE FIELD ENGINEER DEEMS ONE TO BE NECESSARY. THRUST BLOCKS ARE TO BE INSTALLED AS PER STANDARD DRAWINGS W-17, W-18, W-19 AND SDW-100, SIZED AS FOR 4” PIPE.
4. **PIPE SLEEVES:** SHALL BE SCH. 40 PVC, TWO TIMES THE PIPE SIZE DIAMETER, AND EXTEND 12” BEYOND EACH SIDE OF PAVEMENT. THE LETTERS “E” FOR ELECTRICAL OR “W” FOR WATER SHALL BE STAMPED OR CHISELED ON THE PAVEMENT DIRECTLY ABOVE THE SLEEVE.
5. **TRENCH MARKER TAPE FOR ALL PRESSURE PIPE:** SHALL HAVE A CONTINUOUS BLUE COLORED TRENCH MARKER METALLIC TAPE PLACED 9” – 12” BELOW FINISHED GRADE AND DIRECTLY ABOVE THE BURIED PIPE.

6. **SAND ENCASUREMENT FOR PIPES:** FOR ALL IRRIGATION PIPE, DIRECT BURIAL CONTROL WIRE AND ELECTRICAL CONDUIT SHALL BE PLASTER OR MORTAR SAND, AS PER SECTION 200 OF THE GREENBOOK, WITH A MINIMUM SAND EQUIVALENT OF 50.
7. **REMOTE CONTROL VALVE BOXES:** SHALL BE CONCRETE WITH A CAST IRON LOCKING LID. THE CONTRACTOR SHALL PAINT THE IDENTIFICATION NUMBER OF THE VALVE BOX. THE PAINT SHALL BE WHITE OR YELLOW 100% ACRYLIC EPOXY WATERPROOF PAINT. IN ADDITION, WEATHERPROOF PLASTIC IDENTIFICATION TAGS SHALL BE AFFIXED TO THE COLORED CONDUCTOR IN THE VALVE BOX.
8. **VALVE BOX LOCKING LIDS:** THE CONTRACTOR SHALL REWORK THE LOCKING TOGGLES OF THE CONCRETE VALVE BOXES BY REPLACING THE EXISTING CLEVIS PIN AND SHEET METAL CLIP WITH A MARINE-TYPE STAINLESS STEEL MACHINE BOLT AND SELF-LOCKING UNIT. APPLY OIL TO LUBRICATE AND TO PREVENT RUST.
9. **ANTI-DRAIN/EXCESS-FLOW VALVE:** SHALL BE INSTALLED UNDER EACH SPRINKLER HEAD (AS AN ANTI-GEYSER DEVICE AS WELL AS A LOW HEAD ANTI-DRAIN VALVE).
10. **ALTERNATE PIPE SLEEVE LOCKING CAP FOR VALVES:** SHALL BE PER STANDARD DRAWING I-13, HEAVY DUTY RED BRASS LOCKING CAP THREADED TO FIT 2" DIAMETER SCH. 40 PVC PIPE.
11. **MULTIPLE CONTROLLER INSTALLATIONS:** ENCLOSURES SHALL BE SIZED ACCORDINGLY. NO 110 VOLT WIRE RUNS SHALL PASS FROM CONTROLLER CABINET TO CABINET. EACH CONTROLLER SHALL HAVE A SEPARATE ELECTRICAL SERVICE THROUGH A RACEWAY. PROVIDE ONE POWER OFF-ON SWITCH FOR EACH CONTROLLER.
12. **DIRECT BURIAL CONTROL WIRES:** SHALL BE SOLID COPPER, 600 VOLT, TYPE UF, CONFORMING TO THE GREENBOOK, THE STANDARD DRAWINGS AND THE FOLLOWING WIRE COLORS AND INSTALLATION REQUIREMENTS.

NEUTRAL WIRES: WHITE (#12 AWG), DO NOT INTERCONNECT NEUTRAL WIRES BETWEEN CONTROLLERS.

PILOT WIRES: (#14 AWG), USE AS MANY AS NECESSARY.

VALVE NO.
1/19*. YELLOW

VALVE NO.
10. WHITE W/ RED STRIPE

- | | |
|---------------------------|----------------------------|
| 2/20*. ORANGE | 11. YELLOW W/ RED STRIPE |
| 3/21*. BLUE | 12. BLUE W/RED STRIPE |
| 4/22*. BLACK | 13. ORANGE W/ RED STRIPE |
| 5/23*. BROWN | 14. PURPLE W/ WHITE STRIPE |
| 6/24*. PURPLE | 15. BROWN W/ WHITE STRIPE |
| 7. YELLOW W/ BLACK STRIPE | 16. YELLOW W/ WHITE STRIPE |
| 8. ORANGE W/ BLACK STRIPE | 17. BLUE W/ WHITE STRIPE |
| 9. RED W/ BLACK STRIPE | 18. RED W/WHITE STRIPE |

SPARE WIRES: TWO (2) RED (#14 AWG) FROM FURTHEST VALVE OR MANIFOLD TO EACH CONTROLLER.

*COLORS REPEAT FOR VALVES BEYOND 18.

13. WIRE CONNECTIONS: NEUTRAL, PILOT AND SPARE WIRES SHALL BE INSTALLED WITH A 2' COILED EXCESS WIRE LENGTH AT EACH END ENCLOSURE. EACH AND EVERY WIRE SPLICE SHALL BE SOLDERED TOGETHER (USING 60-40 SOLDER), THEN ENCASED IN THE WATERPROOF EPOXY CONNECTORS. WIRE SPLICES SHALL BE MADE ONLY IN VALVE OR PULL BOXES.

14. WIRE BUNDLES: EACH INDIVIDUAL CONTROLLER CLOCK'S CONTROL WIRES SHALL BE BUNDLES AND TAPED TOGETHER WITH COLORED TAPE AT INTERVALS NOT EXCEEDING 10'. CONTROLLER IDENTIFICATION TAPE COLORS SHALL BE AS FOLLOW: (USE AS MANY AS NECESSARY).

<u>CONTROLLER</u>	<u>COLOR</u>
"A"	BLACK
"B"	RED
"C"	WHITE
"D"	BLUE
"E"	GREEN
"F"	YELLOW

15. WIRES IN PULL BOXES: SHALL BE LOOSE AND SHALL NOT COME WITHIN 3" FROM LID. BOXES SHALL BE SIZED ACCORDINGLY TO ACCOMMODATE THIS REQUIREMENT.

16. **TRENCH MARKER TAPE FOR WIRES:** ALL DIRECT BURIAL WIRES SHALL BE MARKED WITH A CONTINUOUS RED COLORED TRENCH MARKER PLASTIC TAPE PLACED 9" BELOW FINISHED GRADE AND DIRECTLY ABOVE THE BURIED WIRES. TAPE SHALL BE 3" WIDE.
17. **WIRE TESTING:** SHALL BE TESTED FOR CONTINUITY, OPEN CIRCUITS, AND UNINTENTIONAL GROUNDS PRIOR TO CONNECTING TO EQUIPMENT. ANY WIRING THAT IS DEFECTIVE SHALL BE REPLACED, AT THE CONTRACTOR'S EXPENSE.
18. **GUARANTEE:** THE CONTRACTOR'S GUARANTEE SHALL CONSIST OF SECTION 308-7 OF THE GREENBOOK AND THE FOLLOWING:

THE ENTIRE IRRIGATION SYSTEM SHALL BE GUARANTEED AGAINST DEFECTS IN MATERIALS AND WORKMANSHIP FOR A PERIOD OF ONE (1) YEAR FROM THE DATE OF ACCEPTANCE OF WORK. SHOULD THE CONTRACTOR FAIL DURING THE GUARANTEE PERIOD TO EXPEDITIOUSLY CORRECT A DEFECT UPON WRITTEN NOTIFICATION BY THE CITY, THE CITY SHALL CAUSE THE WORK TO BE CORRECTED AND BILL THE ACTUAL COSTS INCURRED TO THE CONTRACTOR. DEFECT CORRECTIONS SHALL INCLUDE THE COMPLETE RESTORATION OF EXISTING IMPROVEMENTS THAT WERE DAMAGED AS A RESULT OF THE DEFECT.
19. **AS BUILT IRRIGATION PLANS:** A REDUCED COPY OF THE APPROVED AS-BUILT IRRIGATION PLAN(S), COLOR CODED BY STATIONS AND LAMINATED IN PLASTIC, SHALL BE MOUNTED ON THE INSIDE OF EACH CONTROLLER ENCLOSURE FOR MAINTENANCE PERSONNEL AT THE TIME OF THE FINAL ACCEPTANCE.

APPROVED MANUFACTURER AND PRODUCTS LIST

This list is updated on a yearly basis. To obtain the current list contact Park Planning of the Park and Recreation Department, 619/525-8228.

A. SITE FURNITURE:

1. Picnic Tables (Prefer separate tables and benches for replacement purposes and litter collecting & tripping).

San Diego Precast Concrete

Quick Crete

Dura Art Stone

Terra Form

2. Benches

San Diego Precast Concrete

Quick Crete

Dura Art Stone

3. Drinking Fountains

Haws #3150 pedestal mounted concrete drinking fountain

Haws #1108-14, 14 gauge stainless steel drinking fountain

4. Barbecues and Ash Urns

Little Tikes

Burke

Miracle

5. Bicycle Racks

Quick Crete

Hanson

Burke

6. Trash Receptacles and Ash Urns

San Diego Precast Concrete

Quick Crete

B. MULTI-PURPOSE COURTS:

1. Basketball Court Surfacing

Sports Coat 'Play-On'

California 'Plexi-Pave'

C. MULTI-PURPOSE FIELDS:**1. Softball Bleachers**

3-seat Bleacher (no guardrails required):

Miracle

LA Steelcraft

5-seat Bleacher (with guardrails):

Miracle

LA Steelcraft

D. PLAY EQUIPMENT:**1. Play Area Surfacing**

Architect's Choice Kids Turf (manufactured wood product)

Fibar (manufactured wood product)

Playbound (poured in place rubber surfacing)

Playsafe (poured in place rubber surfacing)

Tot Turf (poured in place rubber surfacing)

Sportfield (sand filled polyethylene turf)

AM-DEX

Cushion Walk Pavers

G-Flex

Kid Tiles

Playguard

2. Play Equipment

Burke

Columbia Cascade

Gametime

Little Tikes

Landscape Structures

Miracle Recreation Equipment Company

3. Physical Fitness Equipment

Gametime

Miracle

Quality Industries, Inc.

Landscape Structures, Inc.

4. Gymnasium Scoreboards

Nevco L.E.D.

Consultants Guide to Park Design and Development - City of San Diego

5. Climbing Rocks

Boldr
 Landscape Structures, Inc
 HUNA Designs
 Rockraft Designs

E. COMFORT STATIONS AND RECREATION CENTERS:**1. Mission Bay Park Building Colors**

(All colors by Ameritone)

Wall and Trim Colors:

Dove Gray #298d
 Atoll Gray #197E
 Larkspur #261D
 Bone White #2990-8J
 Feather Gray #297F
 Stone #195d
 Nougat #W44
 Mushroom #W14

Trim Colors:

Hunter Green #181a
 Dutch Blue #262A
 Chocolate #191A
 Umber Brown #297A

2. Balboa Park Building Colors

Frazer 'Travatan' C3Y16; 1Y12; L4Y28 (for 5 gallon formula)

3. Locks, Cylinders, and Cores

Best 35H series - Mortise Locks
 Best 9K series - Cylindrical Locksets
 Best IE-64, 1 1/8" Cylinder Lengths
 Best IE7 series - Cylinder
 Best IC7 series - Core

4. Exit Hardware Devices

Sargent 80 series
 Precision Apex Series
 Dorma 9000 Series
 Von Duprin 99 Series

5. Closers

Dorma 8900
 Norton 7500

Sargent 143

6. Hinges

Stanley
McKinney
Hager

7. Toilets, Urinals and Sinks

DuraWare 2100-W-I-CN (Stainless Steel Toilets)
DuraWare 2167-W-I-FV-2898 (Stainless Steel Urinals)
DuraWare 1953-I-CSG-9-GE, single hole (Stainless Steel Sink)
Chicago 333-665 (Stainless Steel Faucet)

8. Toilet Paper Dispensers

Aslin Industries

9. Interior Masonry Wall and Floor Sealant

Desco Glazetite with ICBO approval

10. Electric Hand Dryer

World Dryer Corporation, Model #RA505 (used with buildings that do not have a plumbing chase)
Fastaire HP03 (used with buildings that do have a plumbing chase)
Electric Hand Dryer/Semi-Flush ADA approved
Fastaire #RA5E

11. Light Fixtures

Interior Lights: Lithonia LB232GEB
Lithonia 2TLB232GEB Recreation Buildings Only
Lithonia 2GT332AGEB
Halo #H274, trim #400
Kenall, shorty forty, No. 8140 (recreation building restroom wall mount)
Kenall #282 (comfort stations)

Interior/Exterior Lights: Eclipse - CMK Series 2 - 13 watt
Kenall #3714
Kenall #3826 (comfort station ceiling mounted)

Interior Comfort Station Kenall H1212C-13W TWIN -2-120
Eclipse CMK series 2-26 watt

Exterior Security Lights: Kenall #S711D-C-DB-50W-1-120
Kenall #KENALL MR 13E-SR-C-DB-50HPS-1-120

Kenall #1212 26-Watt

- 12. Electric Wall Switches**
Hubbell 1221-G
Bryant 4901-G
P&S 5021-GX
- 13. Electric Duplex Receptacles**
Hubbell #5362 (20AMP), #5262 (15AMP)
Bryant #5362 (20AMP), #5262 (15AMP)
P&S #5362 (20AMP), #5262 (15AMP)
- 14. Electric Fuses**
Bussman (low peak)
Gould (low peak)
- 15. Electric Generators and Fire Alarms**
Kohler Generator
Edwards Fire Alarm
Notify Fire Alarm
Simplex Fire Alarm
- 16. Interior Atomic Exit Signs**
ISOLITE Model#2040-70 or 2040-95 Green Background 3/8 polycarbonate cover (20 Years Life)
- 17. Electric Time Clocks**
TORK 7200ZL (Astronomical Type) no substitutions.
- 18. Gymnasium Scoreboards and Lights**
Nevco - LED type Scoreboard with polycarbonite hinged cover over scoreboard
HolopHane 400 watt MH cordcap receptacle Gymnasium light
- 19. Electrical Wire**
All Stranded copper wire only (no solid wire).

F. PLANTING:**1. Lawn Seed Mix**

Preferred Seed Mix: 10% Bermuda Shorts (Yuma/Black Jack/Sahara)
 10% 'Barclay' Perennial Rye
 60% 'Turfstar' Perennial Rye
 20% Hulled Bermuda* (Common Bermuda)
 OR
 Agrono-tec '2A Ballfield Mix'

*Hulled - April through September
 Unhulled - October through March

2. Lawn Sod Mix

Preferred Sod: Agrono-tec '2A Ballfield Mix'
 Agrono-tec 'Ballfield Mix Number 2-A'
 Pacific Sod 'Santa Ana Bermuda'*
 Pacific Sod 'Tif-Green Bermuda'*
 Pacific Sod 'GN-1 Bermuda'*

*All of these hybrid Bermuda sods that do not contain perennial rye shall be over seeded with: 'Grand Slam' or 'Turfstar' Perennial Rye, at a rate of 5 lbs./1,000 square feet.

G. SITE AND SPORTS LIGHTING:**1. Electrical Enclosures**

NEMA 3R (stainless steel)

2. Security Lighting Mast Arm (slip-on type)

American SRP
 Spaulding 'Palomar'

3. Security Lighting Time Clock

TORK 7200zl Astro Timeclock, no substitution

H. GRAFFITI PREVENTION:**1. Graffiti Prevention**

Dunn Edwards 'Ultrashield', clear with 'Okon' sealer

CRIME PREVENTION THROUGH ENVIRONMENTAL DESIGN
GUIDELINES FOR PARK DESIGN

San Diego Police Department, Community Crime Prevention Unit
 May 1999

CPTED is based on a set of four design and usage concepts that can lead to a reduction in the incidence and fear of crime, and an improvement in the quality of life. These concepts are defined briefly as follows:

- A. **Surveillance.** Involves the location and use of physical features, electrical and mechanical devices, activities, and people to maximize visibility. Creates a risk of detection for intruders and offenders, and a perception of safety for legitimate users.
- B. **Access control.** Employs people, electrical and mechanical devices, and natural measures to create a perception of risk to offenders and deny them access to targets. Also guides legitimate users safely through the environment.
- C. **Territoriality.** Uses physical features and activities to express ownership and control of the environment. Promotes neighborhood pride. Discourages presence of outsiders by delineating private and semi-private spaces, controlling the movement of people and vehicles, and making someone responsible for maintaining all spaces in the neighborhood.
- D. **Maintenance.** Allows the continued use of space for its intended purposes. Maintains the effectiveness of measures employed for surveillance, access control, and territoriality.

A. SURVEILLANCE:

Surveillance measures include (1) the design and location of physical features and electrical/mechanical devices to enhance visibility by people during normal/everyday activities, and (2) the location of people and activities to facilitate surveillance. These measures create a risk of detection for intruders and offenders, and a perception of safety for legitimate users.

1. **Lighting**

- Provide exterior lighting for visibility at night on streets, parking areas, sidewalks, pedestrian paths, possible entrapment spots, etc. to enable people to see where they are going and identify others along their route. Light should be consistent to reduce contrast between shadows and illuminated areas.
- Avoid lighting isolated areas that people should not use at night.
- Make sure that light is not blocked by trees or other landscaping.

2. Windows and Doors

- Provide two-way visibility in areas open to the public. Windows and doors should not be obstructed by signs, displays, plants, etc.
- Provide one-way visibility (from inside to outside) in areas not open to the public. Use mirrored glass or see-through curtains to maintain inside privacy. Use glare-proof glass to enable occupants of a lighted building to see out at night.
- Install peepholes for viewing people seeking entrance to secure areas.

3. Unobstructed Sight Lines

- Maintain tree canopies at least 8 ft above the ground.
- Keep shrubs trimmed to less than 3 ft except where privacy or environmental noise mitigation is a primary concern.
- Grade land where practical without substantially altering the natural terrain to provide unobstructed sight lines within the park and from adjacent streets and developed areas.
- Use open landscaping and see-through fences instead of solid walls or hedges for boundaries where privacy or environmental noise mitigation is not needed.
- Orient buildings for good visibility of park facilities.
- Orient parking spaces to provide good visibility between cars.
- Use open or see-through structures for exterior stairways, walkway railings, sitting areas, patios, parking spaces, etc.
- Eliminate possible hiding or entrapment spots along pedestrian paths.
- Install closed-circuit television (CCTV) cameras or mirrors where sight lines are obstructed.
- Provide a clear view of room interiors from room entry points.
- Install mirrors where sight lines are obstructed.
- Use streets as buffers between parks and other land development where possible.

4. Communications Systems

- Install emergency phones, alarms, or intercoms in convenient places for people to use to report intruders or suspicious activities, or to call for help.
- Post signs to show locations of emergency communications systems.

5. Indoor Facilities and Activities

- Locate high-activity rooms and areas so they can be seen by receptionists and park managers. Provide large, unobstructed windows for good visibility of interior and exterior areas.
- Locate facilities for activities that involve a few people at a time in areas of high usage and good visibility so they can benefit from the natural surveillance already in the area. These include rest rooms, elevators, stairs, pay phones, trash containers, etc.

6. Outdoor Facilities and Activities

- Include benches to provide places where people can sit and observe activities in the park. Plant trees to shade the benches.

- Locate facilities for activities that attract large numbers of people in areas of low usage and poor visibility so that users can provide surveillance of the area. These include basketball courts, ball fields, etc.
- Locate facilities for activities that involve a few people at a time in areas of high usage and good visibility so they can benefit from the natural surveillance in the area. These include pay phones, rest rooms, bike racks, parking lots, hiking or jogging trails, etc.
- Locate activities within a facility to reduce potential causes of conflict and confusion, and make individual activities easier to supervise.
- Locate paths to and from entrances and exits of building through areas that need surveillance. Use most direct route where possible.

B. ACCESS CONTROL:

Access control measures include design features and target hardening that create a perception of risk to offenders and deny them access to targets. They also guide legitimate users safely through the environment. Controls should also be established on exits to deny offenders escape opportunities.

1. Security Systems

- Consider installation of alarms, cameras, intrusion detectors, metal detectors, activity decoys, intercoms, etc. to protect and control of all entrances and exits, including garage, basement, service, loading and unloading doors, fire, roof, and attic. Make systems visible to potential intruders.
- Provide special protection for ground floor rooms.
- Install alarmed, self-locking emergency exits.

2. Doors and Windows

- Use strong locks and construction materials on all doors and windows. Avoid use of bars, if possible.
- Limit numbers of entrances and exits to buildings, parking lots, etc.
- Locate entrances and exits in areas that are under surveillance or direct supervision.
- Locate windows next to doors on hinge side, not on lock side.

3. Walls and Fences

- Make walls and fences attractive as well as durable.
- Use open fences, e.g., vertical wrought iron or decorative iron. They are preferred because they are easier to see through, harder to climb, and less susceptible to graffiti.
- Use vines, thorny plants, and other landscaping along walls to make access more difficult and prevent graffiti.

4. Signs

- Make signs legible and unambiguous. Use symbol signs where possible.
- Locate signs in strategic places.

Use signs to:

- Discourage access to dangerous areas
- Indicate opening and closing times
- Direct people to safe paths, exits, emergency assistance, means of calling for help, etc.
- Inform people how to report maintenance problems

5. Safe Paths and Common Areas

- Provide adequate light for nighttime use of paths to and from the entrances and exits of buildings, and throughout the park.
- Close or discourage nighttime use of certain paths where adequate lighting, visibility, and surveillance cannot be provided.
- Eliminate entrapment spots, e.g., dense shrubs, high walls or hedges, or alcoves, along pedestrian paths.
- Locate amenities and activities at or near entrances, exits, and major circulation paths to increase risk of detection for intruders.

6. Restraints

- Install barriers or other devices to prevent misuse of park facilities or areas, e.g., bathing in fountains, camping overnight, or violating protected open space.
- Design park amenities to discourage misuse, e.g., shape benches to be comfortable for sitting but not for sleeping, and roughen or install breaks in low walls, curbs, steps, railings, and smooth surfaces to discourage skateboarding.
- Provide designated park entries and exits to adjacent streets and areas.
- Limit numbers of entrances and exits to buildings, parking lots, etc. to those that can be kept under direct surveillance, supervision, or control.
- Install gates or other means of preventing vehicles from entering the parking lots when the park is closed.

C. TERRITORIALITY:

Territoriality measures involve the use physical features to express ownership and control of the environment, and promote neighborhood pride. They discourage the presence of outsiders by delineating private and semi-private spaces, and controlling the movement of people and vehicles.

1. Boundaries

- Define clear boundaries between public, semi-public/private, and private spaces within the park. They can be established by signs, walls and fences, gates, landscaping, sidewalks, curbs, and pavement treatment like tiles and cobblestones.

- Use boundaries to prevent conflicts between different groups, e.g., teens and seniors, so all user groups will be able to enjoy an area or facility and maintain an ownership interest in it.

2. Public Spaces

- Include display and performance areas for local artists. A beautiful environment attracts people while a barren one repels legitimate users.
- Design neighborhood parks to meet the needs of the people living in the neighborhood.
- Define uses for all areas in the park to prevent “no man’s lands” from existing.

D. MAINTENANCE:

Maintenance measures permit continued use of the space for the intended purposes. They help maintain the effectiveness of the measures employed for surveillance, access control, and territoriality.

1. Low-Maintenance Landscaping

- Use low-maintenance designs and irrigation systems, and drought-resistant plants to facilitate upkeep over time.
- Avoid use of loose rocks, bark, etc.

2. Hardening against Vandalism

- Employ design features and materials that cannot easily be vandalized, stolen or used to damage the property.
- Use graffiti-resistant paint or anti-graffiti coatings on walls, benches, light poles, signs, etc.
- Avoid blank wall facades at ground level.
- Use screens, wired glass, or other protection for light fixtures and bulbs.
- Use shiny aluminum or shatter-resistant glass for mirrors.

Standards and Specifications Guidelines from Facilities Division

Division 1 General Requirements

General Services/ Facilities Division requires review of all plans or designs for new or improvement projects to City owned Buildings and Facilities. Facilities Division would like review of project submittals before approval by design team.

Project Officer is to submit Facility Record form: REA-111 to Auditors Department after the award of project to contractor.

Identified Funding or Job Order numbers will be opened to Department 532 before any Project Walk- Thru or Inspections can take place by General Services Department.

Division 2 Site work

Division 3 Concrete

Division 4 Masonry

Division 5 Metals

Division 6 Wood and Plastics

Division 7 Thermal and Moisture Protection

Roofing:**Option 1.**

Roof material and specifications on ¼” to 3” per foot roof slope.

No gravel roofs are to be installed on any City Facility, Exterior gutters are to be used in place of internal or boxed in gutters, Flashing should be installed over the edge of the gutter and the gutter should be sloped to the down spout.

Facilities Division uses a four-ply mineral surfaced fiberglass built-up roof system. The first ply is an asphaltic base sheet that may be nailed in place or mopped in place with hot asphalt. The second ply is two layers of Glass Ply nailed or mopped in place. The final layer is one Ply of Mineral Surfaced Flex Cap sheet.

Using the glass base, start with a 12-inch wide starter piece. The following base sheet is applied full width with a 2-inch minimum lap over the preceding sheet and a minimum of 4 inch laps on the sides. All subsequent sheets will be full width with a 2-inch minimum lap.

Then using the Glass Ply, apply a 18-inch wide piece, then over that a full width piece. The following felts are to be applied full width overlapping the preceding felts by 19 inches so that at least 2 plies of felt cover the base sheet. Install each felt so that it is firmly and uniformly set, without voids into the hot asphalt.

The final layer is the Mineral Surfaced Flex Cap sheet. Prior to application, the cap sheet should be laid out on the roof and allow it to relax and flatten. Apply a mopping of hot asphalt the width of the cap sheet, and then lay the cap sheet into the hot asphalt. All subsequent courses should be applied in the same manner with a minimum of 2 inch laps on the preceding sheet and a minimum of 6 inch laps on the end laps.

- When the roof is complete there, should be 4 layers of roofing material at all locations on the roof.
- All roof jacks will be hot mopped in place
- All fasteners should be galvanized
- Asphalt should meet ASTM requirements and be applied at a minimum of 400 degrees
- All flashing and roof jacks should be minimum 24 gauge galvanized metal
- Roof drains will be cast iron or plastic with leaf strainer and minimum 3 inch outlet
- All roof mastic will meet minimum ICBO standard and contain no asbestos.
- Cant strips will be installed at 90 degree roof to wall areas
- All roof sheathing will be minimum 1/2 inch CDX plywood
- All pipes and duct work will be supported off the roof with redwood blocks
- All HVAC units will be lifted off their platforms and roofing material applied and

a minimum 24 gauge cap install on the platform, then the unit set back down.

Option 2.**Roof material and specifications on 1/4" to 3" per foot roof slope:**

Facilities Division also uses a torch down application. This system is designed to be applied with a propane torch. Dibiten is the preferred brand name of this type material. One layer of 18-pound fiberglass base sheet is installed and then a minimum one layer of Dibiten poly 4.5 granular modified bitumen membrane is torch applied with a minimum 4 inch lap and a minimum 6 inch end lap. This product should be applied according to the manufactures specifications and precautions for fire protection.

Roof material for 4 inch per foot slope and greater:

Facilities Division uses a three-tad architectural grade shingle with a minimum 25 year guarantee. Minimum 30-pound felt paper is applied on a new roof or one that has been removed and the shingles are to applied to a plywood substrate. If the shingles are to be applied over an existing shingle roof, the roof should be cleaned and any high edges of the old roof removed and then a minimum of 30-pound felt applied before the new shingles are installed. All roof shingles will be nailed with galvanized roofing nails with a minimum 7/8 inch for new roofs and 1 1/4 inch for re-roof.

Wood Shake Shingles:

Wood shake shingles are not preferred or recommended in the City but if they are to be used, Facilities Division requires that all wood the shingles be treated with a fire retardant coating and a medium grade wood shingle.

Any Questions, Please Contact Roofing Supervisor, Roy Kirby 525-8554

Division 8 Doors and Windows

1. Doors and frames
 - (A) All hollow metal doors will be 16ga exterior, 18ga interiors. Doors will be a honeycomb-core, full edge seam welded with sealed tops.
 - (B) Exterior doors that swing out should have non-removable pin type hinges.
 - (C) Double doors with panic exit devices should have a mullion between doors.
 - (D) Wood doors should be wood stave core, minimum 1 3/4 in. thick by 3-0 x 7-0.
 - (E) Door not to exceed 8-0 in height.
 - (F) Door stiles should be wide enough to accommodate heavy-duty mortise type locks.
 - (G) Steel frames (jambs) will be 14ga. galvanized exterior, 16ga. cold rolled interior. Reinforce all hinge pockets with additional hinge reinforcement straps for high traffic areas.
 - (H) Provide roof overhangs at exterior doors or recess entries for weather protection.
 - (I) Slope concrete walkways away from doors and set thresholds in mastics for exterior doorways.

2. Storefronts
 - (A) Storefronts should have minimum 4" framing and maximum size stiles.
 - (B) Storefront doors should be minimum 1 3/4 inch thick by 3'-0 by 6'-8" or 7'-0".
 - (C) Provide cylinders keyed to city wide system, (existing system is Best Access Systems)
 - (D) Doors not to exceed 8'0" in. height.

3. Windows
 - (A) Glazing for windows should be minimum 3/16" thick.
 - (B) Operable windows should have secure locking devices and be as vandal resistant as possible.
 - (C) Provide window screening for operable windows.

4. Hardware
 - (A) Locks will be ANSI 156.3 Mortise Series 1000, Grade 1 Operational and carry the approval of Federal Bureau of Prisons.
 - (B) Mortise locks will carry a standard 5 year warranty.
 - (C) Locks will have separate springs which will be internal to the lock case. Lever return springs will operate interior and exterior hubs independently. No springs will be allowed outside of door or under escutcheon or rose.
 - (D) Hubs will have roller bearing assembly.
 - (E) All strikes will have a curved lip strike.
 - (F) Deadbolts will be solid stainless steel (without internal riveted actuator), when deadbolt is extended 1", at least 2" will remain in the lock case.

- (G) All levers will be cast solid levers, hollow levers will not be allowed.
 - (H) Cylindrical lock sets may be used only on interior non-high-traffic openings. Locks will have a replaceable sheer lug which when broken will disable the lever. Clutch mechanisms will not be allowed. Locks will have 7 pin interchangeable cores. Cylindrical locks are not to be used on exterior doors.
 - (I) All locks and hardware should be 626 finish (26D) or 630 (32D) Bright chromed or painted finishes should not be used.
 - (J) All doors and hardware must meet Americans with Disabilities Act and Title 24
 - (K) Approved manufactures are Best Access Systems or Folger Adams with Best Lock.
 - (L) Panic exit devices will be Von Duprin 99, Precision Apex series or Dorma and have Best cylinders.
 - (M) Closers will be Dorma 8900 or Norton 7500 series or Sargent 351 or approved equal. All closers to have back check and be field adjusted to not more than 5 lb. opening force. Closers will be through-bolted to door and jamb if possible.
 - (N) Hinges will be Stanley, McKinney or Hager. All hinges to be Ball Bearing type 630 finish. Exterior doors that swing out will have NRP hinges. High traffic doors will be continuous types `Roton`.
 - (O) Doors in the following locations will have locks which are ANSI series 1000 Grade 1 SECURITY and Grade 1 OPERATIONAL. Locks will meet UL 437 requirements.
 - 1- rooms with narcotics
 - 2- rooms that contain an armory
 - 3- exterior doors for Police facilities
 - 4- exterior doors for Court facilities
 - 5- doors to Judges chambers
 - 6- Any exterior door which could be in a remote location or subject to high vandalism.
5. Keys and keying
- (A) All cylinders will be Best 7-pin, interchangeable core and keyed into an existing factory-registered Grand Master key System. All seven pins to be operational.
 - (B) Furnish permanent cores to City Lock shop for final installation unless provided by manufacturer.
 - (C) Temporary cores (construction cores) will be installed by Contractor for security purposes. Temporary cores will be keyed alike and interchangeable with Best cores. Cores provided by manufacturer.
 - (D) Contractor will provide to the City Lock shop copies of Control key and Operating key upon completion.
 - (E) All keys and cores will have visual key control.
 - (F) All keys will be stamped "Do Not Duplicate".
 - (G) The Electric Meter Room will have S. D. G. & E. lock installed. The cylinder to be keyed to Schlage key way VTQP AA-10. Three keys are provided with lock. All keys are to be turned over to the City of San Diego Lock shop at completion of the project. The contractor will obtain lock from any contracted S. D.G. & E. Locksmith for installation.

Any Questions, Please Contact Carpentry and Lock Supervisor,

Division 9 Finishes**Painting:**

Surface Preparation:

1. All exterior wood surfaces must be clean, firm and free of dust, grease, wax, oil, rust and other foreign matter.
2. All exterior wood will be scraped and rough edged and sanded.
3. All exterior wood will be primed with one coat of latex water base primer and two coats of finish.
4. All cracks and holes will be filled with spackle or wood putty,
5. All windows will be re glazed where glazing is missing or deteriorated.
6. All exterior wood or stucco will be painted with one coat of primer and of two coats flat or semi-gloss finish paint.
7. All doors and casing will be one coat primed and painted with two coats of finish paint.
8. Paint will be providing by Dunn Edward, Vista Paint, Frazee Paint, or ICI Paint.

Any Questions, Please call Paint Supervisor, Glenn Jones 525-8558

Division 10 Specialties**Division 11 Equipment****Division 12 Furnishings**

Division 13 Special Construction

Fire Suppression and Supervisory Systems

- 1 Fire Detection and Alarm Systems
 1. Fire Alarm Systems
 2. Smoke Detectors
 3. Heat Detectors
 4. Flame Detectors
 5. Manual Station, Bells, AMD Horns
 6. Voice Alarm Systems
 7. Radio Alarm Systems
 8. Telegraph Systems

- 2 Automatic Sprinkler Systems
 1. Wet pipe sprinkler system
 2. Dry pipe sprinkler system
 3. Deluge sprinkler system
 4. Pre-action sprinkler system

- 3 Water Spray Systems
 - 1 Foam Water Sprinkler Systems
 - 2 Standpipe and Hose Systems
 - 3 Fire Pumps
 - 4 Water Supply Systems
 - 5 Fire Hydrants
 - 6 Fixed Dry Chemical Extinguishing Systems
 - 7 Halogenated Agent Extinguishing Systems
 - 8 Carbon Dioxide Extinguishing Systems
 - 9 Portable Fire Extinguisher
 - 10 Fire Doors and Dampers

Design requirements can be found in the following codes:

National Fire Protection Association (NFPA)

OSHA

Basic Building Code (BOCA)

Standard Building Code

Uniform Building Code

Inspection Testing and Maintenance see:

NFPA Inspections, testing and, maintenance manual for details and references.

All Inspections, testing, and maintenance should have:

1. Visual Inspection
2. Test
3. Maintenance
4. Record Keeping on appropriate forms and copies of each

1	Annual	TEST + MAINTENANCE FORM
2	Semi-Annual	TEST + MAINTENANCE FORM
3	5-Year	TEST + MAINTENANCE FORM

Copies must be sent to:

1. Local Fire Marshall
2. Building Manager or Facilities Division Coordinator
3. Fire Suppression Coordinator

For their records.

Any Questions, Please call Luiz Pereira, Assistant Civil Engineer, Facilities Division at:
525-8535

Division 14 Conveying Systems/ Elevators

- 1.1 Proprietary equipment of any elevator/escalator equipment will not be allowed in City conveyance system.
- 1.2 Diagnostic Tools and Software Manual:
 - 2 Should elevator/escalator controls require special maintenance equipment or tools, the elevator contractor will provide to the City, all required diagnostic tools and all supporting software documentation required for the complete maintenance of the control and dispatch system and all related elevator/escalator parts. Periodic upgrades and/or calibrations to the diagnostic tools will be provided as required. Elevator contractors will identify and list the type and description of function of the diagnostic tool(s) and control components requiring such tools and submit to the City before acceptance of the elevator/escalator.
 - 3 Diagnostic tools, whether hand-held or built into the control system, will not require recharging or reprogramming. Should recharging, re-calibrating, reprogramming or upgrading and any repair or if replacement of the diagnostic tool should be required, the contractor will provide these services indefinitely to the City immediately upon request at no additional cost for the lifetime of the equipment.
- 1.3 Submittals: As-built wiring diagrams, operating and maintenance manuals will be provided at the machine room, and one set provided to Facilities Division. Other sets will be provided for the facility as required.
- 1.4 Door Opening and Control Device:
 1. Multiple Infrared Light Beam Electronic Sensing Device: Provide new multiple infrared light beam electronic sensing device securely and rigidly mounted on the car between the car and hoist way doors. The sensing device will have a minimum of 40 infrared beam sensors spaced evenly from the floor sill to the header jamb. When the car and hoist way doors are closing, the interruption of the light beam will cause the doors to reverse automatically to the full-open position and the doors to remain open as long as the light beams are interrupted; or, when the doors are in the open position, the interruption of the light beam will cause the doors to remain open as long as the light beams are interrupted. The time interval for the initiation of the door closing operation after light beams are reestablished will be adjustable. The sensing device will have an audible obstruction alarm which can be disabled.
 2. Nudging Action: In the event of an obstructed light beam is operated for a predetermined time interval (15 - 20 seconds) after automatic door closing has been initiated, a buzzer will sound and the doors will close with a maximum of 2.5 foot-pounds kinetic energy and at reduced speed. Timers will be adjustable.

3. Variable Timing Features: In the event the light beam is interrupted while the doors are opening or after the doors are fully open, the time that the doors remain open after the beam has been reestablished will be reduced to an adjustable time between one and two seconds, depending upon whether a landing call or a car call predominated. This time will be a minimum time that the doors remain open if the beam is interrupted and reestablished before the door is full open.

- 1.5 Provide door restrictive opening devices.
- 1.6 No equipment, wiring and conduits that are not related to the elevator will be installed in the elevator hoist way and machine room.
- 1.7 Provide one set each of vinyl-covered elevator protective pads for the elevator of the same size.
- 1.8 Provide three sets of all operational keys for the elevator.
- 1.9 Hydraulic elevators will be provided with emergency power system that will activate in the event of power failure and provide power to the hydraulic elevator and close the elevator doors, lowers the elevator to the designated landing, opens the doors allowing the passengers to exit, then close the doors leaving the elevator at rest. The elevator doors can be re-opened from inside the elevator only if necessary. Upon resumption of power the emergency lowering device will automatically reset itself and the elevator will return to normal service.
- 1.10 The elevator contractor will provide all labor, parts, materials and equipment in order to furnish a complete preventive maintenance service to regularly and systematically examine the elevator equipment and provide the necessary repair and/or replacement for the duration of one year from acceptance of elevator operation.
- 1.11 All submittals will be forwarded to:

Manny Mojica, Mechanical Engineer 525-8534
General Services/Facilities Division
M.S. 20

Division 15 Mechanical

Plumbing: All City public buildings should be designed to have minimum of 3 woman's toilets and 2 sinks. 2 men's toilets 1 or 2 urinals and 2 sinks.

Plumbing Fixtures recommended for City Designed Facilities / Comfort Stations

Toilets: Acorn wall mount Dura-Ware (with Sloan concealed flush valve include 3" push button assemble.)
 Lavatories : Acorn Dura-Ware
 Faucets: Chicago #333-665
 Urinals: Acorn (with Sloan concealed flush valve and 3" pushbutton assemble.)
 Floor drains: Zurn
 Water Regulator: Wilkins or Watts
 Flushometers: Sloan
 Drinking Fountains: Haws, High Low ADA
 Hose Bibbs: Acorn Sill Cocks
 All hardware to be stainless steel (All thread, nuts, unistrut, etc)

Plumbing Fixtures recommended for City Designed Facilities All Others

Sensor or Auto Flush Toto
 Toilets: American Standard, Kohler, Toto
 Lavatories: American Standard
 Faucets: 4" Centers, Moen (staff areas only) Public areas use Symmons S-6 self closing ADA.
 Urinals: American Standard, Kohler, Toto
 Floor Drains: Zurn
 Slop Sinks: American Standard
 Valves: Nibco full port
 Kitchen Sink Faucets Moen
 Stainless S. Sinks: Elkay ADA Type
 Water Heaters: Rudd
 Drinking Fountains: Haws, High Low ADA
 Circulating Pumps: Bell & Gosset
 Hose Bibbs: Acorn Sill Cocks
 Ball Valves: Nibco Full Port or Apollo full port type.

Rough Plumbing:

C.I. Pipe

Vents: Copper or cast iron pipe.

C.O's on every Fixture – Full size vent, install cleanout wye then reduce vent.

Shut Offs on every Branch line – Isolation valves, hot and cold with access panels.

Copper Water Lines / Type- L

All vent penetrations to have vandal proof cap on roof.

Any Questions, Please call Plumber Supervisor, Steve Anderson 525-8561

HVAC:

- 1.1.10_The HVAC crew will assist the Project Engineer during the construction phase and the final walk through as needed. The City Facilities Division HVAC representative will be in discussions with the Architect and Mechanical Consultant during the first design stages of a facility.
- 1.1.11_Only the newest models of HVAC equipment and Building Automation Systems will be used. When the designed Automation system or Mechanical Equipment is not of the newest version or design, the most recent version and model will be installed.
- 1.1.12_The Manufactures representative will provide personnel, training on the operation and maintenance of the HVAC equipment, to the City HVAC personnel.
- 1.1.13_Technical manuals for the HVAC system and components will be provided to the Facility Maintenance Division HVAC Representative.
- 1.1.14_Use of underground Chilled Water and Hot Water piping will not incorporate PVC pipe wrapped in PVC jacket. Brazed Copper pipe with PVC jacket is acceptable. Brazed joints are preferred not soft solder. Copper type L is preferred and long radius elbows.
- 1.1.15_No refrigerant lines will be installed below grade or within a concrete slab.
- 1.1.16_No HVAC (Heating, Ventilating & Air Conditioning) duct will be installed below grade or incased within a concrete slab.
- 1.1.17_All fresh air openings for HVAC system will not be located at ground level, below grade, or within 10 feet of the buildings sewer vents or storm drain venting. (per Sec. 317.6 Uniform Mechanical Code)
- 1.1.18_A/C package units installed on City roofs will be down flow type only.
- 1.1.19_All ductwork will have exterior insulation, due to previous building air quality issues.
- 1.1.20_When natural gas is available at the street, natural gas will be used for all HVAC equipment.
- 1.1.21_HVAC unit's 3 ton (36,000 BTUs) or over, will be three-phase power when available.
- 1.1.22_Facilities needing 80 Tons of Air conditioning or more will specify a hydronic system to be installed. Energy efficient design will be incorporated with variable speed pumps. Chiller compressors should be in-closed in a way as to minimize sound travel. EPAK Chillers are a good example of this. A central boiler will be used for supplying the facility heating hot water and a scroll chiller will be used for supplying the facility-chilled water system.
- 1.1.23_Floor zones will have there own temperature control and independent fan system for controlling the environment independent of neighboring zones.
- 1.1.24_Whenever possible, a scroll compressor with the maximum available warranty years offered, will be specified. When water source heat pumps are specified, a minimum of five years for the warranty on the compressor will be required.
- 1.1.25_Extended warranties (five yrs.) will be used for A/C compressors 5 ton and over.
- 1.1.26_Package units, 7 1/2 Ton or larger, will have multiple compressors or capacity unloaders for energy savings.
- 1.1.27_All refrigerators will be free standing, no built in units or combination units.
- 1.1.28_All temperature controls in gyms must be incased or covered by a metal guard box.

- 1.1.29_VAV System's 5 ton and over, will be either chilled water or multiple compressor system, with an adequate airflow bypass. A static bypass damper sensor will be used when a bypass damper is used in a multizone vav system application.
- 1.1.30_HVAC systems will use a Grasslin 365-day time clock, or it's equivalent, with battery back up. Features to include Holiday and Daylight Savings Programming. This type of Time clock should be used if a Building Automation System is not installed.
- 1.1.31_Safe and unobstructed access to all HVAC equipment will be provided, for maintenance & repair purposes. Equipment above ceilings should have clear access to all panels and filter removal. Equipment on roofs or equipment areas will have the needed clearance to remove filters and access all panels for service and repair.
- 1.1.32_Manufacturers minimum clearances will be met, for installation of all equipment.
- 1.1.33_All control wire colors will conform to the equipments color schedule or mechanical wiring diagrams.
- 1.1.34_All terminal blocks and termination points, of the control wiring, will be labeled and identified as to match the submitted drawings & schematics.
- 1.1.35_Only standard sized filters such as Eco-Air E-35 or C-35 2-inch pleated type filters will be used and installed for efficiency.
- 1.1.36_All air filters, and water strainers, will be installed, to maintain easy access for maintenance purposes. If equipment, such as air handlers, fan coils, split systems or heat pumps are installed above ceiling, the use of a T-bar filter housing should be used. The need to remove ceiling tiles to access filters should be avoided.
- 1.1.37_The City of San DIEGO HVAC Shop personnel, for compatibility of existing Building Management System control will identify standardization of the Energy Management Systems or Building Automation Systems. Example: Trane Voyager package roof tops with a Trane Building Automation system interfacing with the Trane A/C units.
- 1.1.38_There will be 100% compatibility between the Building Automation system and the HVAC equipment. No specialized interfacing between equipment and controls will be used to communicate between the HVAC Equipment and Building Automation System. Avoid the use of Lonworks, or any other device, which is needed to make one control system communicate with another. This creates two or more separate control systems within one building. Example, Johnson Controls Metasys as workstation and air handler control, which communicates to McQuay Open Protocol panel which, communicates with Lonworks to communicate with Heat Pumps and Chiller. This is a three party control system.
- 1.1.39_The Building Automation System must have the capability to perform demand limiting from the factory and will be able to receive information from a pulse meter supplied by the Utilities Company.
- 1.1.40_When a P.C. is specified to accompany the Building Automation System, it should be of the latest technology, not a Dumb Terminal, and have a local distributor for warranty purposes to maintain the computer.
- 1.1.41_All Building Automation Systems will be able to, from the factory, dial out alarms to a remote printer at the Cities HVAC Shop, via a dedicated phone line and page City personnel via the City paging system. The Contractor will supply the proper modem, specified by the Building Automation Systems Manufacturer.

- 1.1.42_The Building Automation System software will be Windows compatible, preferably Windows 2000. O.S.2 Operating systems are not acceptable. Compatible communication software program preferred by the manufacturer, such as Pro Comm Plus or Hyper Terminal in Windows. The automation system must communicate with the Cities HVAC Shop monitoring system site. (PC's, Laptops and alarm Printer)
- 1.1.43_The Use of Software for a graphical application on a local PC is acceptable but must not require a specialized security key connected to any PC or LAN devices.
- 1.1.44_Specialized software or security cards or chips should not be used or be needed due to extra expense to the City. The local operating system PC should be an off the shelf type product and current within its design year of start up. No special built PC should be accepted. A local printer will be supplied for the use of system alarms and user login printing.
- 1.1.45_The control system should be completely independent in operation and not dependant of other devices within its DDC network. If a loss of communication occurs with the LAN, the individual units should resume normal occupied operation with its last known set points.
- 1.1.46_Building Automation System will be stand-alone. Equipment end devices will not be dependent of a PC to receive Time of Day Schedule, Holidays or On-Off control. Equipment should be able to start without needing personnel to turn something on in the event of a power failure.
- 1.1.47_Building Automation System end devices controlling equipment such as Fans and Pumps must have Hand-Off-Auto capability.
- 1.1.48_Water and Air Flow switches if used in equipment must be approved by equipment manufacture. These devices must also be compatible with Building Automation System.
- 1.1.49_Local PC must be equipped to accomplish a full back-up of PC.

Any Questions, Please Contact HVAC Supervisor, Calvin Yeldell 525-8537

Ken Jordan, Senior Refrigeration Mech.,
General Services, Facilities Division
(619)525-8519

Division 16 Electrical**PART 1****1 P.V.C.**

- 1.1.1 All conduits in the ground will be P.V.C. schedule #40, (minimum) 3/4 inch or larger in diameter.
- 1.1.2 All P.V.C. will be buried below ground level and NEVER be in a concrete slab or concrete floor.
- 1.1.3 All stub-ups in P.V.C. will be changed to E.M.T. in walls. Exceptions are outside block walls can be P.V.C.. No flexible conduit will be used.

1.2 E.M.T. Conduit

- 1.2.1 All wiring inside the building will be in E.M.T. conduit.
- 1.2.2 All E.M.T. connector, coupling, and other fittings will be non- cast steel compression type.
- 1.2.3 No BX or MC cables allowed.

1.3 Rigid Conduit

- 1.3.1 All conduit exposed on salt air to be PVC coated.
- 1.3.2 All conduit exposed below 4 feet of finish grade on walls.

1.4 Flexible Steel Conduit

- 1.4.1 Only on motor connection and fixture tails, not over 6 feet in length.

1.5 Boxes

- 1.5.1 Any exposed wiring device box will be cast iron only. No cast aluminum.
- 1.5.2 All exterior light fixture junction boxes will be cast iron only. No cast aluminum.
- 1.5.3 All outside outlets will be in a recessed stainless steel box with a flush, lockable cover and a 20 G.F.I. receptacle. (Cole TL310)
- 1.5.4 Inside wiring device boxes and junction boxes will be at least 4" square by 1 1/8 inch deep.

1.5.5 Electrical, phone, and data floor boxes will be brass type (RFB style Walker) with tamper – proof screw cap only. All brass covers will be flush with the floor. Floor monuments are not acceptable.

1.5.6 Flat wiring will not be used.

Wire

1.6.1 All wiring will be stranded, copper THHN type, including all #12 A.W. wire.

1.6.2 Minimum wiring size will be #12 A.W.C. stranded. EXCEPT for control circuits will be #14 A.W.C. stranded wire. NO SOLID WIRE

1.6.3 One neutral for every one circuit pulled. No sharing on neutral wires anymore.

Marking and Names Plates

1.7.1 Name plates: Furnish and install a minimum size of 1" high and 3" wide by 3/32" thick matte white (for normal power) and red (for emergency power) laminated phenolic nameplates with 1/4" white characters engraved in the plastic for all items of electrical equipment including, but not limited to switchboards, panel boards, automatic transfer switches, motor control centers, feeder circuit breakers, relays, time switches, disconnect switches, exposed pull or junction boxes, and all control equipment. Name plates will be attached with 2 cadmium-plated screws. Adhesive attachment will not be acceptable. Punch strip tape type name plates with card holders in any form are prohibited.

1.7.2 Provide wire marker on each conductor in electrical panel pull box, outlet, and junction box. This includes all disconnects and connections. *If more than one neutral conductor is present, mark each related circuit and panel number.

1.7.3 Label outside of all cover plates of wiring devices and junction boxes with circuit and panel number. Each branch circuit device cover plate will be labeled (engraved or silk screen) to indicate the branch circuit and panel number. Devices will include, but not be limited to, the following: toggle switches, dimmer switches and receptacle.

Grounding

1.8.1 All raceways will include a full size green insulated ground wire terminated at each outlet box, device enclosure, etc. and connected back at the panel boards, switchboard or cabinet on the appropriate ground bus.

1.8.2 The green insulated ground (bond) wire will be spliced together within the outlet box. A green insulated bonding jumper will be provided from the splice to the box body. Attachment to the box body will be provided using a tapped #10-32 x 3/8" screw minimum. A green insulated bonding jumper will be provided from the splice to the receptacle ground screw even with self grounding receptacles.

Devices and Cover Plates

1.9.1 Wall switches - 20 AMP 120v/277v Specify:

- A. Hubbell 1221-G
- B. Bryant 1221-G
- C. P&S 1221-G

1.9.2 Duplex Receptacle - 15 AMP - 20 AMP 120v/277v Specify:

- A. Hubbell - (20 AMP) #5362
- B. Bryant - (20 AMP) #5362
- C. P&S - (20 AMP) #5362ALA
- D. Leviton - (20 AMP) # 16362

1.9.3 All devices are to have clamp style side/ back connections for stranded wire only.

1.9.4 All receptacles and switches on emergency power will be RED.

PART 2**2.1.0 Hand Dryers**

2.1 Install at least one hand dryer 2000 watt in each restroom. City Standard is the World Hand Dryer. Pipe chase use Fastair thru the wall units.

2.2.0 Exit Signs

2.2.1 All exit signs will be Atomic 20 year life with polycarbonate lens. City Standard is Permex exit sign.

2.2.2 L.E.D. exit signs are good, but the battery only last 3 to 5 years.

2.3.0 Emergency Battery Systems

2.3.1 Batteries shall be 10 year full warranty (not to be pro-rated) or independent battery pack. (i.e. Dual-light)

2.4.0 Low Voltage System for Title 24

2.4.1 Avoid low voltage programmable systems (i.e., Malcolm X. Library). If a system must be installed use it for only large rooms over 5000 feet, in all other areas use normal switching. Use Tork Time clock 7200KL. Also, all software manuals and training to program the system must be given to Facilities Division Electrician no later than on final walk thru. Brand name system Neel.

PART 3**3.1.0 Light Fixtures**

3.1.1 Reduce the number of decorative and display light fixtures where possible.

- 3.1.2 Light fixtures will be high quality, long lasting, brand name, Energy Efficient and made in the U.S.A., with easy to replace lamps. The number of different types of fixtures must be kept to a minimum and the ease of re-lamping must be a major consideration in fixture selection.
- 3.1.3 Standard 4 foot fluorescent fixtures are most desirable in the general area.
- 3.1.4 Metal Halide, indirect light fixtures are great in high ceiling areas.
- 3.1.5 Recessed floor cans with P.L. lamps are good in restrooms.
- 3.1.6 Do not use low voltage light fixtures.

3.2.0 Outside Light Fixtures

- 3.2.1 All outside light fixtures will have polycarbonate lenses, vandal resistant screws. City Standard is Kenall 5010, 3826.
- 3.2.2 Install light fixtures for library sign, book drop and all outside door openings.
- 3.2.3 Wall mounted light fixtures will be used for general outside area for security and safety.
- 3.2.4 Libraries will be well lit inside and out.
- 3.2.5 Avoid small light fixtures in steps, use pole or wall lights.
- 3.2.6 Avoid tree lights that are mounted above the ground (i.e., Pacific Beach Library).
- 3.2.7 Avoid in ground lights (i.e., Mira Mesa Library). If it is necessary use only brand name City Standard Hydrel.
- 3.2.8 Avoid low voltage light fixtures.
- 3.2.9 Heavy duty mounting will be needed for all outside light fixtures.
- 3.2.10 Parking lot pole light are necessary in all parking lots.
- 3.2.11 We encourage wall mounted light fixtures on the building.
- 3.2.12 All exterior building lighting will have separate circuits from exterior pole lighting.

3.3.0 Time Clocks

- 3.3.1 All time clocks will be City Standard Tork 7200kl. Astronical, 40 amp contact.
- 3.3.2 Lighting contractor will be necessary if more than 2 circuits for outside lights. Install hand, off, automatic switch for testing during the day for outside lights.
- 3.3.3 Do not install programmable time clock (problem with different clocks).
- 3.3.4 Inside lights will be on lighting contractor controlled by separate time clock or switches.

3.4.0 Lamps

- 3.4.1 Provide a spare case of lamps for every type used, including M.H., incandescent, H.P.S., L.P.S. and fluorescent lamps. Provide no later than final walk thru.
- 3.4.2 Avoid incandescent lamp.
- 3.4.3 Low pressure sodium lamp are use only in parking lot lights.
- 3.4.4 When possible install 130 volt lamps
- 3.4.5 Standardize with 4 foot fluorescent energy 35 watt cool white T-8 lamps.
- 3.4.6 Use brand name electronic ballast, 5 year warranty.
- 3.4.7 Reduce the number of decorative and display lamps.
- 3.4.8 Provide fixture location that allows easy lamp replacement, this is a major problem.
- 3.4.9 Brand name lamps are a must.
- 3.4.10 Outside lamps will be high pressure sodium, (general lighting) fluorescent (signs) and metal halide (for security).

PART 4**4.1.0 Conduits, Raceways and Boxes**

- 4.1.1 All Flexible conduit will have a green ground wire. It will only be used for motor connections, fixture tails, or used in existing walls (6" or less). Non-metallic or sealite will be used in damp locations and machinery rooms.

- 4.1.2 Conduit run above suspended ceilings will be supported from the building structure independently and will be run with sufficient clearance from the ceiling system to permit the tiles to be removed and to allow full access to the space above.
- 4.1.3 Roof top conduits (rigid steel) will be neatly grouped and installed parallel to the building lines. Support conduit on minimum 2" x 4" redwood sleepers at minimum 5' spacing.
- 4.1.4 Home runs will be a minimum of 3/4" conduit. 1/2" can be used to supply a single termination (e.g., conduit going from switch box to single light fixture).
- 4.1.5 Junction and Switch boxes shall be a minimum of 4" square in size and a minimum of 2-5/8" deep.

4.2.0 Wires And Conductors

- 4.2.1 All insulation in AWG sizes 10 and below will be impregnated with color according to the following:

	<u>480/277 volts</u>	<u>208/120 volts</u>
Phase A	Brown	Black
Phase B	Orange	Red
Phase C	Yellow	Blue
Neutral	Gray	White
Ground	Green	Green

Where color other than black is not an integral part of insulation use 3M No. 35 tapes in the same color code to identify both ends of conductors No. 8 and larger. Use other colors as required to identify control or other special circuits. Ground conductor will have green insulation for 1/0 or smaller conductors, green tapes on other colors of insulation are NOT acceptable.

4.3.1 Light fixtures commonly used by the City of San Diego:

- 4.3.2 Indoor/Outdoor
1. Gym light fixture- Holophane 400w- Glass- prsl 400MH, 12DD WG212B CDP.L5.15.3P
 2. Compact fluorescent - Eclipse 26 watt CMK series
 3. Ceiling mount fluorescent - Kenall, No. S1212LPMW132MB120
- 4.3.3 Outdoor Security Lighting
1. High pressure sodium (HPS) - Kenall, "Millieum" 50 watt, minimum
 2. High pressure sodium (HPS) - Kenall, 50 watt, minimum
 3. In ground - Hydrel Only (Tree lights)

4.4.0 Switchgear and Electrical Panels

- 4.4.1 A. Supply 10% spare breaker space in all panels and copper bus.

- B. Provide 10% more ampacity for electric panel above calculated load requirements.
- C. Provide on 3/4 inch conduit for each three spares or spaces in all flush mounted power or lighting panel boards. Route conduit to accessible space above the ceiling.
- D. All panels will have bolt on breaker, copper buss, and full size neutral-ground bar.
- E. Main Switch and all circuit breakers will be supplied with a name plate adjacent to each device as specified under Marking and Name plates.
- F. Fusible Switches: (heavy duty) switches, with fuses of classes and current ratings indicated. See Section Fuses for specifications. Where current limiting fuses are indicated, provide switches with non-interchangeable feature suitable only for current limiting type fuses. Each fusible disconnect switch will be equipped with a blown fuse indicator module.

4.4.2 Fuses

- A. Fuses will be class ARK rejection type.
- B. Fuses serving motor loads will be dual element with a minimum time delay of 10 seconds at 500 percent rating. Fuses will be current limiting time delay type with interrupting capacity of 200,000 ampere RMS symmetrical minimum.
- C. Fuses will be Bussman or Gould Alow peak, only.
Provide spare fuses in the amount of ten percent of each size and type installed, but not less than three; delivered to the Owner upon final acceptance of the project. Provide and install fuse cabinet in the electrical room for storing these extra fuses.

4.4.3 Transformers :

- A. Attach incoming and outgoing conduits to the transformer case with approximately 18 inches of flexible conduit to reduce noise transmission. Provide separate grounding jumper when using flexible conduit.
- B. Maintain a minimum of 1'-0" free air space between transformer and walls.
- C. All transformers will have name plates showing its rating, circuit number it is fed from and panel it is feeding.
- D. Install transformers on seismic style vibration isolator pads (feet).

4.4.4 Generators, Motors, Controllers and Fire Alarms

- A. Generator KW rating must be at least 10% more than calculated load for future use requirements. Kohler generators only. Documentation and repair manuals will be supplied.
- B. Motors will be energy efficient with sealed bearings.
- C. Programmable logic controller (PLC): The contractor will furnish, to the City a licensed copy of the software for the PLC and all files and hard copies of the ladder logic with reference documentation.
- D. Fire Alarms: Use only Edwards, Notify, or Simplex fire alarms.

PART 5**Designs, Submittals and Final Walk-Thru****5.1 Design**

The architects' electrical engineer must consult with the City of San Diego's Facilities Division personnel during the design phase and through out the project. The City staff has developed standards that must be incorporated into the plans and specifications. Please route thru General Services/ Facilities Division, Electrical Crew. Kurt Hoeger M.S. 20, Phone 525-8524.

5.2 Submittals

All electrical submittals will be reviewed thru Facilities Division Electrical crew. All comments will be in writing within five days. This is very important to us in Maintenance so that we get the item that is equal or spec. out. Especially light fixture, switches, recept. and electrical equipment.

5.3 Final Walk Thru

All manuals and training on all electrical system will be done at this time, which includes, but not limited to: testing of emergency systems, time clocks, lights, and exhaust fans. Provide one set of blue prints, spec book, and submittals.

5.4 Manual and Documentation

The Contractor will furnish operation and maintenance manuals for each electrical system and for each piece of equipment. The complete manual, bound in hardback binders, or and approved equivalent will be provided to the Owner's Representative. The number of copies will be as indicated in Division 1. One manual will be furnished prior to the time that the system or equipment tests are performed to the electrical shop:

City of San Diego
General Services / Facilities Division
Electrical Crew, Suite A, Bldg. 38
San Diego, CA 92102

The remaining manuals will be furnished before the contract is completed. The following identification will be inscribed on the cover; the words OPERATING AND MAINTENANCE MANUAL, the name and location of the building, the name of the Contractor, and the contract number.

The manual will include the names, address, and the telephone numbers of each Subcontractor installing equipment and systems, and of the local representatives for each item of equipment and each system. The manual will have a table of contents and be assembled to conform to the table of contents with tab sheets placed before instructions covering each subject. The

instruction sheets will be legible with large sheets of drawings folded in. The manual will include, but not limited to, the following:

- A. System layout showing components.
- B. Devices and controls.
- C. Wiring and control diagrams showing operation and control of each component.
- D. Sequence of operation describing start-up, operation, and shutdown.
- E. Functional description of the principal system components.
- F. Installation instructions.
- G. Maintenance and overhaul instructions.
- H. Lubrication schedule including type, grade, temperature range, and frequency.
- I. Safety precautions, diagrams and illustrations.

Training:

User staff and maintenance personnel will be thoroughly trained (minimum of 4 hours) in the use of each system or major piece of equipment installed. This training will be provided as a part of the Contractors bid to supply the system or equipment. Additional training requirements, will be as specified in the subsequent sections of Division 16.

It will be the responsibility of the Contractor to provide equipment with the proper electrical characteristics for the electrical service provided. All necessary electrical components to provide a complete system will be furnished.

Any Questions, Please Contact Kurt Hoeger, Electrician Supervisor at 525-8524.

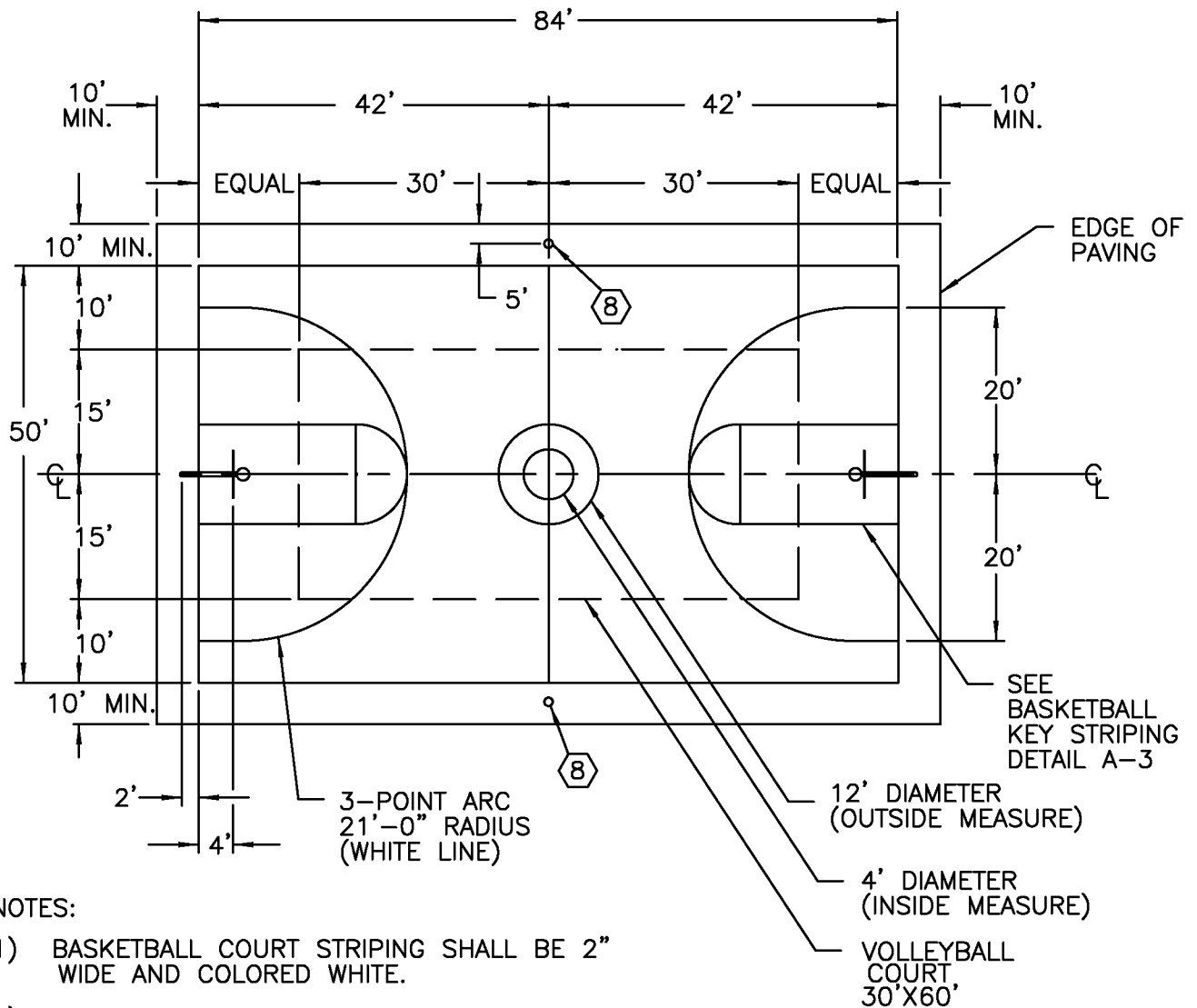

NOTES:

- 1) BASKETBALL COURT STRIPING SHALL BE 2" WIDE AND COLORED WHITE.
 - 2) VOLLEYBALL COURT STRIPING SHALL BE 1-1/2" WIDE AND COLORED YELLOW (COURTLINES ARE SHOWN DASHED FOR CLARITY ONLY).
 - 3) DIMENSIONS ARE TO THE OUTSIDE EDGE OF THE LINES UNLESS INDICATED OTHERWISE.
 - 4) THE WHITE LINE SHALL DOMINATE WHERE WHITE AND OTHER COLORED LINES INTERSECT.
 - 5) CONTRACTOR SHALL BE RESPONSIBLE FOR COURT LAYOUTS.
 - 6) BASKETBALL GOAL POSTS SHALL BE SET 2' BEYOND BASELINE WITH 6' EXTENSIONS. RIM HEIGHT SHALL BE 10' ABOVE FINISH SURFACE OF COURT.
 - 7) SEE COLOR COATING DETAIL A-2 FOR COLORS.
- (8) PROVIDE VOLLEYBALL POST SLEEVES IF COURTS ARE MULTI-PURPOSE, (2) PLACES.

MULTI-PURPOSE COURT STRIPING PLAN (BASKETBALL/VOLLEYBALL)

PLAN VIEW

SCALE: NONE

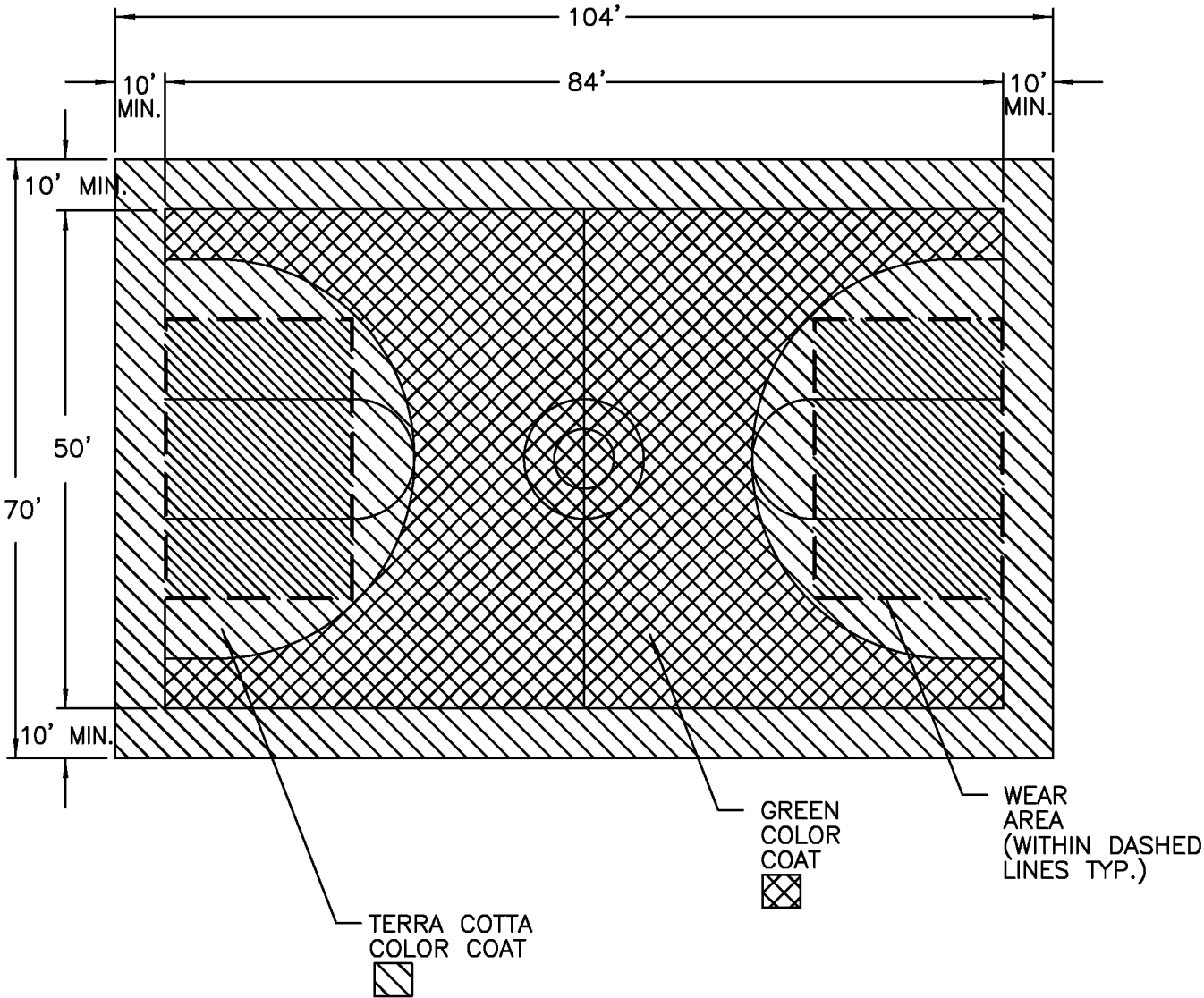

- 1) WEAR AREA TO RECEIVE ADDITIONAL COAT OF COURT SURFACING.
- 2) TERRA COTTA COLOR COAT EXTEND TO EDGES OF PAVING UNLESS OTHERWISE NOTED.

MULTI-PURPOSE COURT COLOR COATING
PLAN VIEW SCALE: NONE

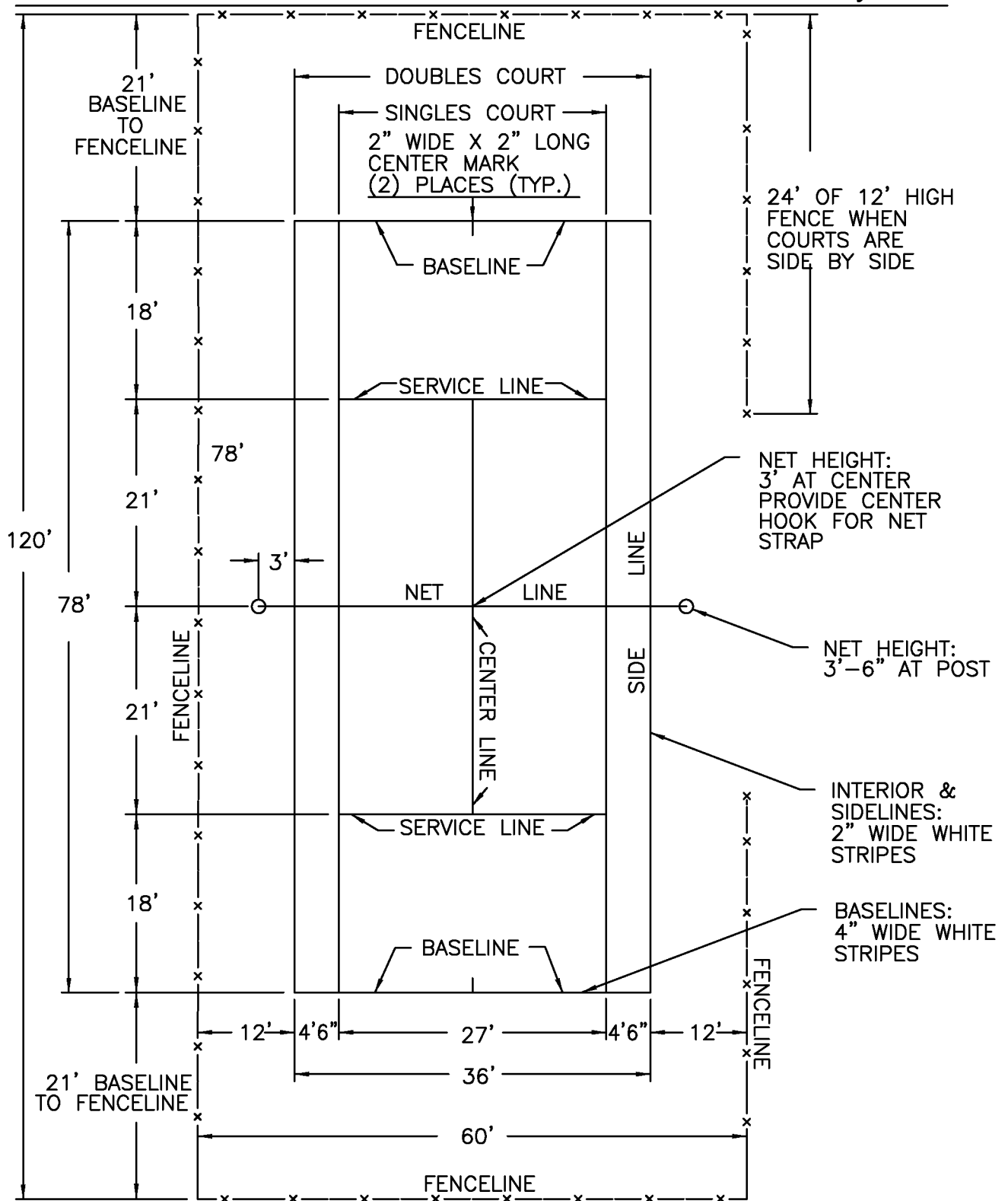

NOTES:

- 1) TENNIS COURT STRIPING SHALL BE COLORED WHITE. DIMENSIONS ARE TO OUTSIDE EDGE OF THE LINES UNLESS INDICATED OTHERWISE.
- 2) CONTRACTOR SHALL BE RESPONSIBLE FOR COURT LAYOUT.
- 3) SEE COLOR COATING DETAIL B-2 FOR COLORS.

TENNIS COURT STRIPING PLAN
PLAN VIEW SCALE: NONE

FENCING NOTES:

- 1) GATES SHALL HAVE STOP PLATES AND WELDED LATCHING.
- 2) ALL CHAIN LINK FENCE FABRIC SHALL BE 9-GAUGE WIRE, 2" MESH GALVANIZED.
- 3) ALL CHAIN LINK FENCE FABRIC, POSTS, RAILS, AND FITTINGS, EXCEPT BACKSTOP, SHALL BE BLACK VINYL COATED.
- 4) ALL CHAIN LINK FENCE SHALL HAVE A TOP AND BOTTOM RAIL.
CHAIN LINK FENCE SHALL BE CONSTRUCTED WITH A MID-RAIL IF TALLER THAN 8'.
- 5) ALL CHAIN LINK FABRIC SHALL BE MOUNTED ON THE SIDE OF THE POSTS TOWARD THE PLAYING FIELD.
- 6) ALL FENCE POSTS, BRACES, AND RAILS SHALL CONSIST OF NEW GALVANIZED PIPE MANUFACTURED IN ACCORDANCE WITH A.S.T.M. DESIGNATION A-120 AND SHALL BE THE FOLLOWING SIZES AND WEIGHTS BELOW:

FENCES 72" HIGH AND OVER:

POST LOCATION	NOMINAL DIA. IN.	OUTSIDE DIA. IN.	INSIDE DIA. IN.	WT. PER FOOT LBS.
END AND CORNER	2-1/2	2.875	2.469	5.79
LINE POSTS	2	2.375	2.067	3.65
BRACES & RAILS	1-1/4	1.660	1.380	2.27

FENCES LESS THAN 72" HIGH:

POST LOCATION	NOMINAL DIA. IN.	OUTSIDE DIA. IN.	INSIDE DIA. IN.	WT. PER FOOT-LBS.
END AND CORNER	2	2.375	2.067	2.65
LINE POSTS	1-1/4	1.900	1.610	2.72
BRACES & RAILS	1-1/4	1.660	1.380	2.27

- 7) ALL HARDWARE, TENSION WIRE, TIE WIRE, TRUSS RODS, AND GATES, SHALL CONFORM TO THE APPLICABLE PARTS OF STANDARD DRAWINGS SDM-100, SDM-112, M-5, M-6, M-17, SECTIONS 206-6 AND 304 OF THE STANDARD SPECIFICATIONS FOR PUBLIC WORKS CONSTRUCTION ("GREENBOOK").
- 8) ALL NUTS SHALL BE CUT TWO (2) THREADS ABOVE THE NUT AND PEEN ENDS.

BACK STOP NOTES:

- 1) WHERE BACKSTOP ABUTS ANOTHER CHAIN LINK FENCE, THE BACKSTOP SHALL BE PART OF THAT FENCE.
- 2) ALL UPRIGHT POSTS AND HORIZONTAL RAILS SHALL BE 2" NOMINAL DIAMETER GALVANIZED IRON WELDED (5/16" BEAD) ALL AROUND AT EVERY JOINT.
- 3) ALL MEMBERS OF THE TOP (ARCHES AND BRACES) SHALL BE 1-1/2" NOMINAL DIAMETER GALVANIZED IRON PIPE WELDED (5/16" BEAD) ALL AROUND AT EVERY JOINT.
- 4) CHAIN LINK FABRIC SHALL BE 9-GUAGE STEEL WIRE GALVANIZED AFTER FABRICATION, EXCEPT THAT THE LOWER 4' OF THE BACKSTOP SHALL BE 6-GUAGE STEEL WIRE GALVANIZED AFTER FABRICATION. ALL CHAIN LINK FABRIC SHALL BE 2" MESH.
- 5) CHAIN LINK FABRIC SHALL BE MOUNTED ON THE INSIDE OF THE BACKSTOP.
- 6) ALL WELDED JOINTS SHALL BE WIRE BRUSHED CLEAN AND PAINTED WITH TWO (2) COATS OF ZINC OXIDE PAINT ("GALVALOY" OR APPROVED EQUIVALENT).
- 7) ALL NUTS SHALL BE CUT TWO (2) THREADS ABOVE THE NUT AND PEEN ENDS.
- 8) ALL WOOD TO BE DOUGLAS FIR "SELECT" WITH NO KNOTS, SPLITS, OR SAP POCKETS. BOARDS SHALL BE STRAIGHT AND TRUE.
- 9) ALL WOOD SHALL BE TREATED WITH A ONE (1) MINUTE DIP OF CWF-UV, FLOOD MANUFACTURER OR EQUAL.
- 10) ALL ANGLE IRON SHALL BE GALVANIZED.
- 11) ALL CONCRETE SHALL BE PER THE SOILS REPORT.
- 12) BOTTOM RAIL OF BACKSTOP SHALL BE A MAXIMUM OF 1" ABOVE FINISH GRADE.
- 13) BATTER BOARDS SHALL COVER INSIDE OF CONCRETE SLAB AND EXTEND INTO FINISH GRADE OF INFIELD SOIL MIX.

2"X10"X20' RECYCLED PLASTIC OR GALVANIZED
STEEL BENCH. USE VANDAL RESISTANT BOLTS
OR SPOT WELD.

NOTE: FOR RECYCLED PLASTIC BENCHES
POST SPACING SHALL BE ENGINEERED

8' HIGH FENCE PER
SDRSD SDM-112

12' HIGH FENCE
PER SDRSD SDM-112

INFIELD
PLAY
AREA

CONCRETE
PAVING PER
SOILS REPORT

1-1/2" GALV
IRON PIPE.
6'-4" ON
CENTER
(4) TOTAL
PER BENCH.

FENCE
FOOTING PER
SDRSD SDM-112

FENCE FOOTING
PER SDRSD SDM-112

PLAYERS BENCH

SECTION VIEW

SCALE: NONE

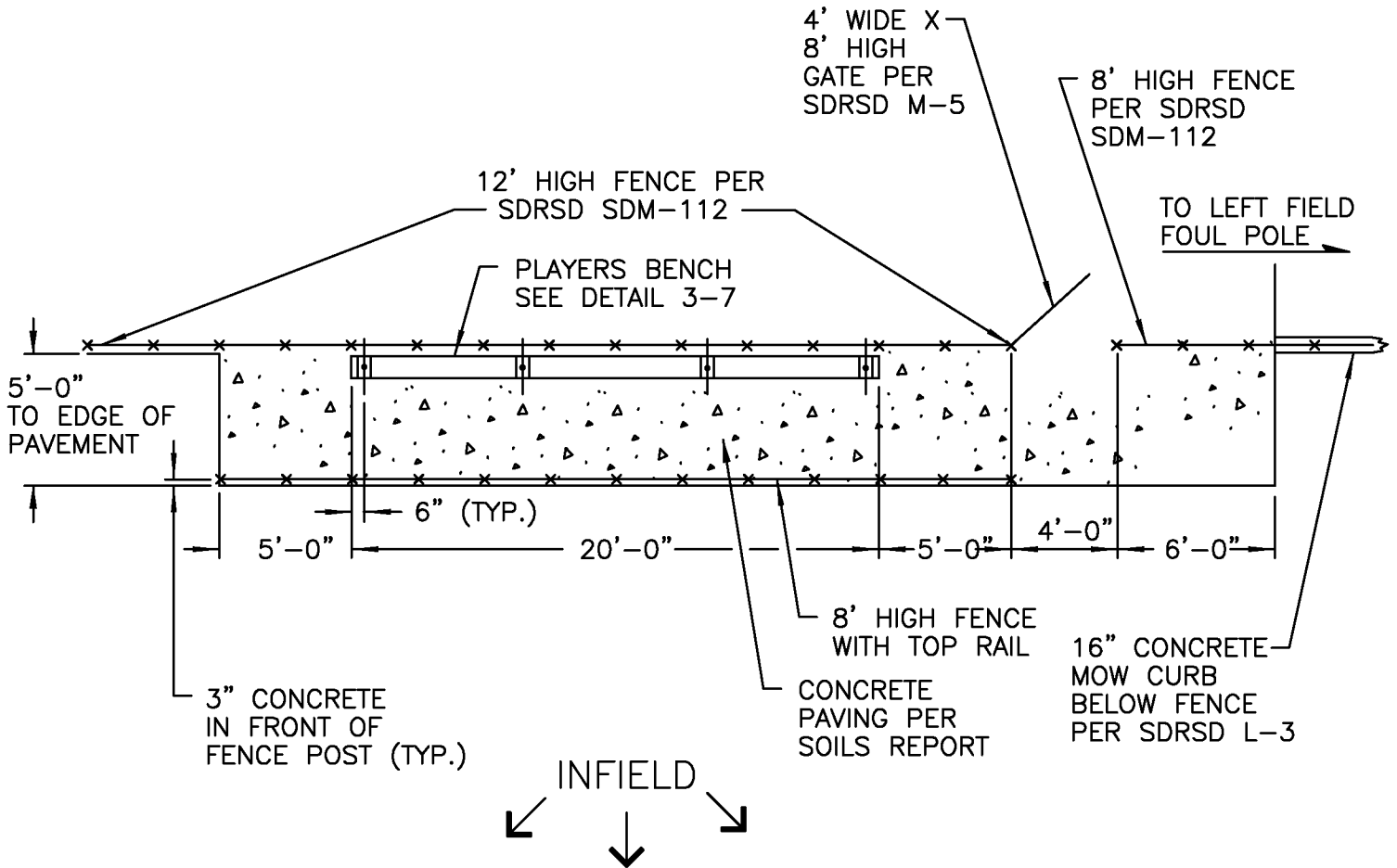

NOTE:

- 1) SEE FENCING NOTES.
- 2) DETAIL SHOWN ABOVE INDICATES "VISITORS" DUGOUT, THIRD BASE SIDE. THE "HOME" TEAM DUGOUT, FIRST BASE SIDE, IS A MIRROR IMAGE.

DUGOUT
PLAN VIEW SCALE: NONE

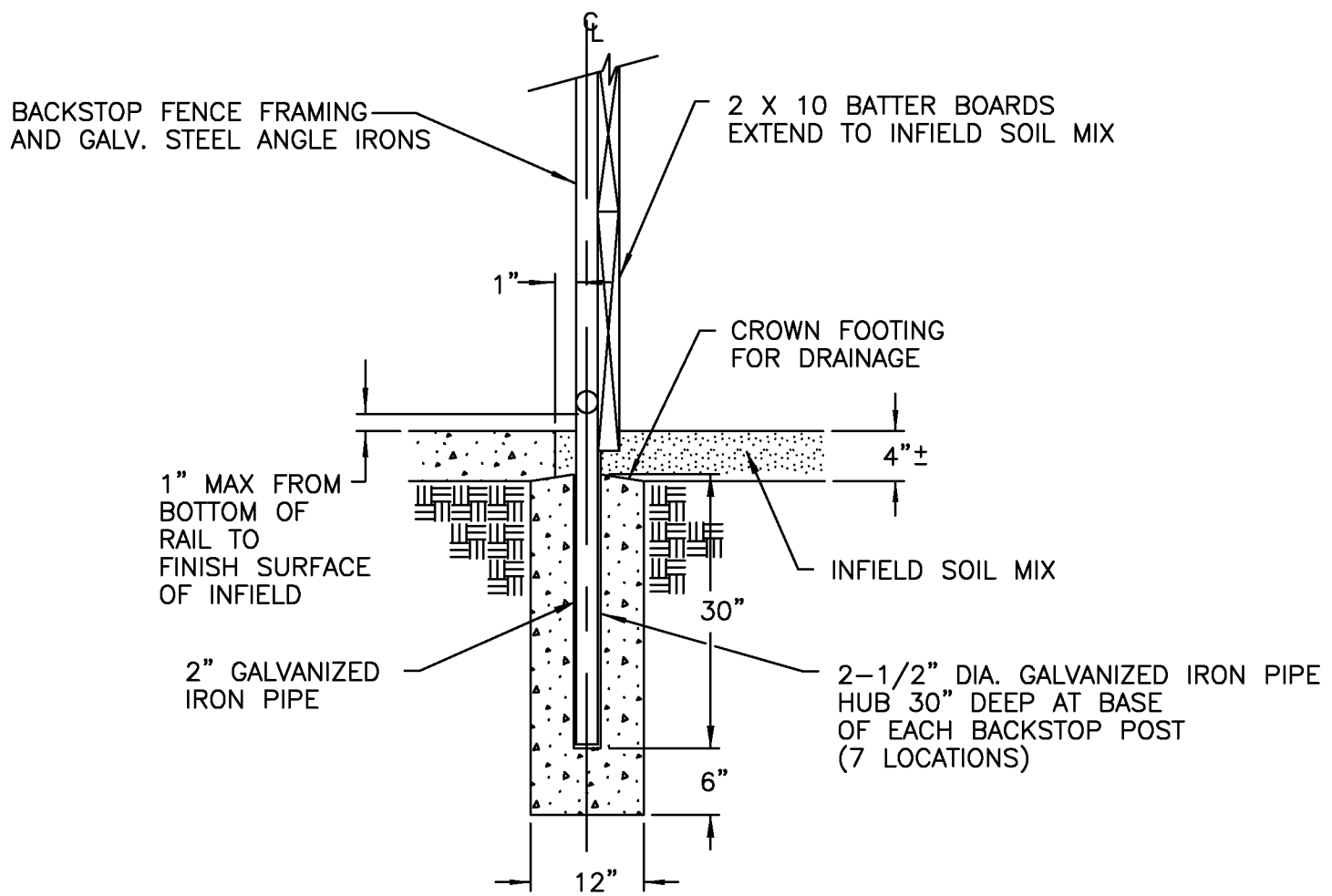

BATTER BOARD AT BACKSTOP
SECTION VIEW SCALE: NONE

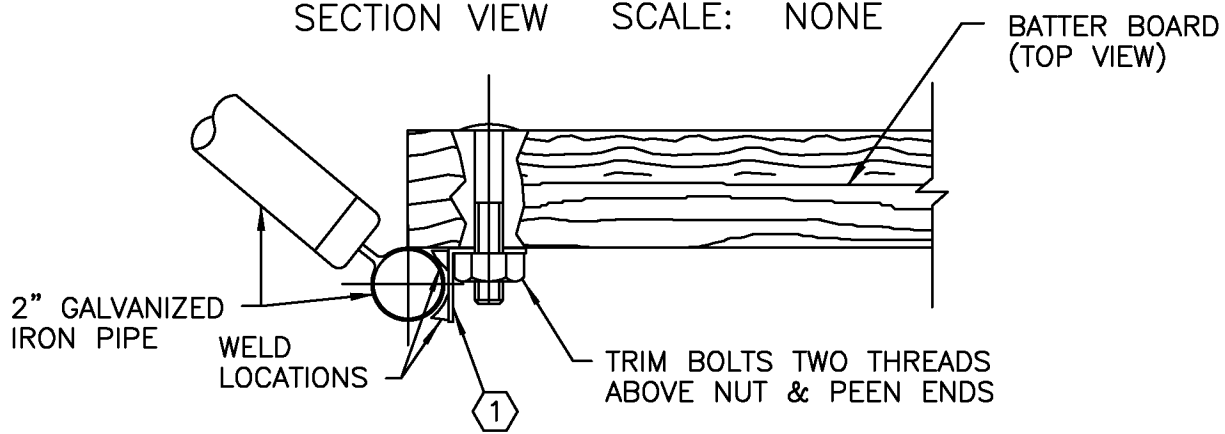

NOTE:

- ① 2" X 1-1/2" X 4' GALVANIZED ANGLE IRON, WELD TO PIPE. SECURE 2 X 10 BATTER BOARDS TO ANGLE IRON WITH TWO (2) 1/2" X 3" LONG CARRIAGE BOLTS AT EACH LOCATION.

BATTER BOARD AT BACKSTOP
PLAN VIEW SCALE: NONE

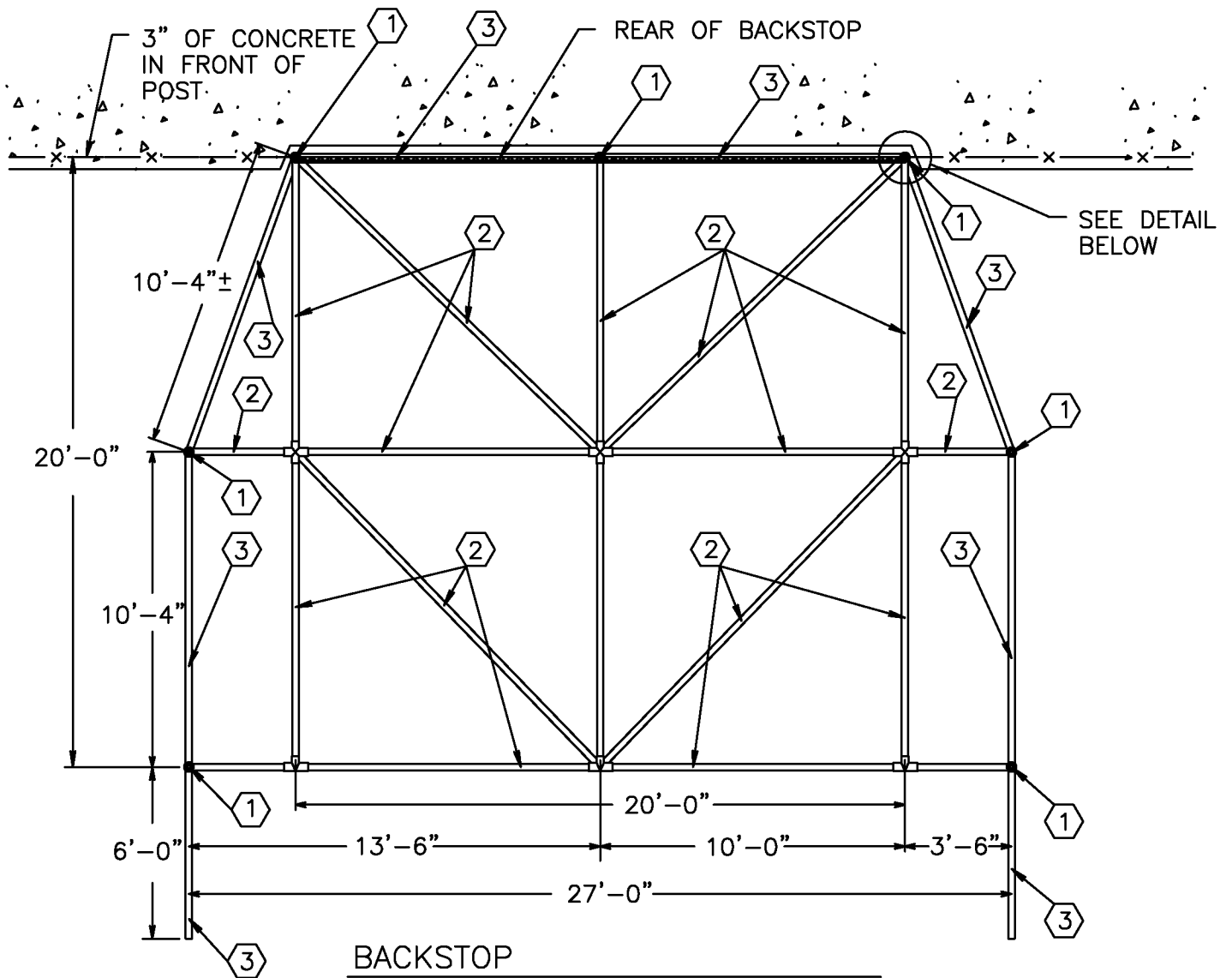

BACKSTOP
TOP VIEW SCALE: NONE

NOTES:

1) SEE BACKSTOP NOTES.

① 2-1/2" GALVANIZED IRON PIPE HUBS 30" DEEP AT BASE OF EACH POST (TOTAL 7) WITH CONCRETE FOOTING, SEE DETAIL 3-5.

② 1-1/2" GALVANIZED IRON PIPE (TYP.).

③ 2" GALVANIZED IRON PIPE (TYP.).

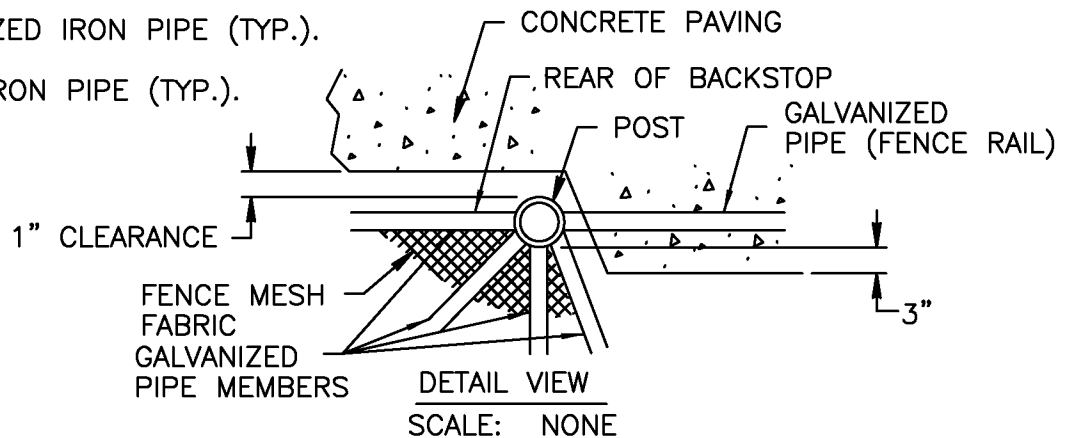

DETAIL VIEW
SCALE: NONE

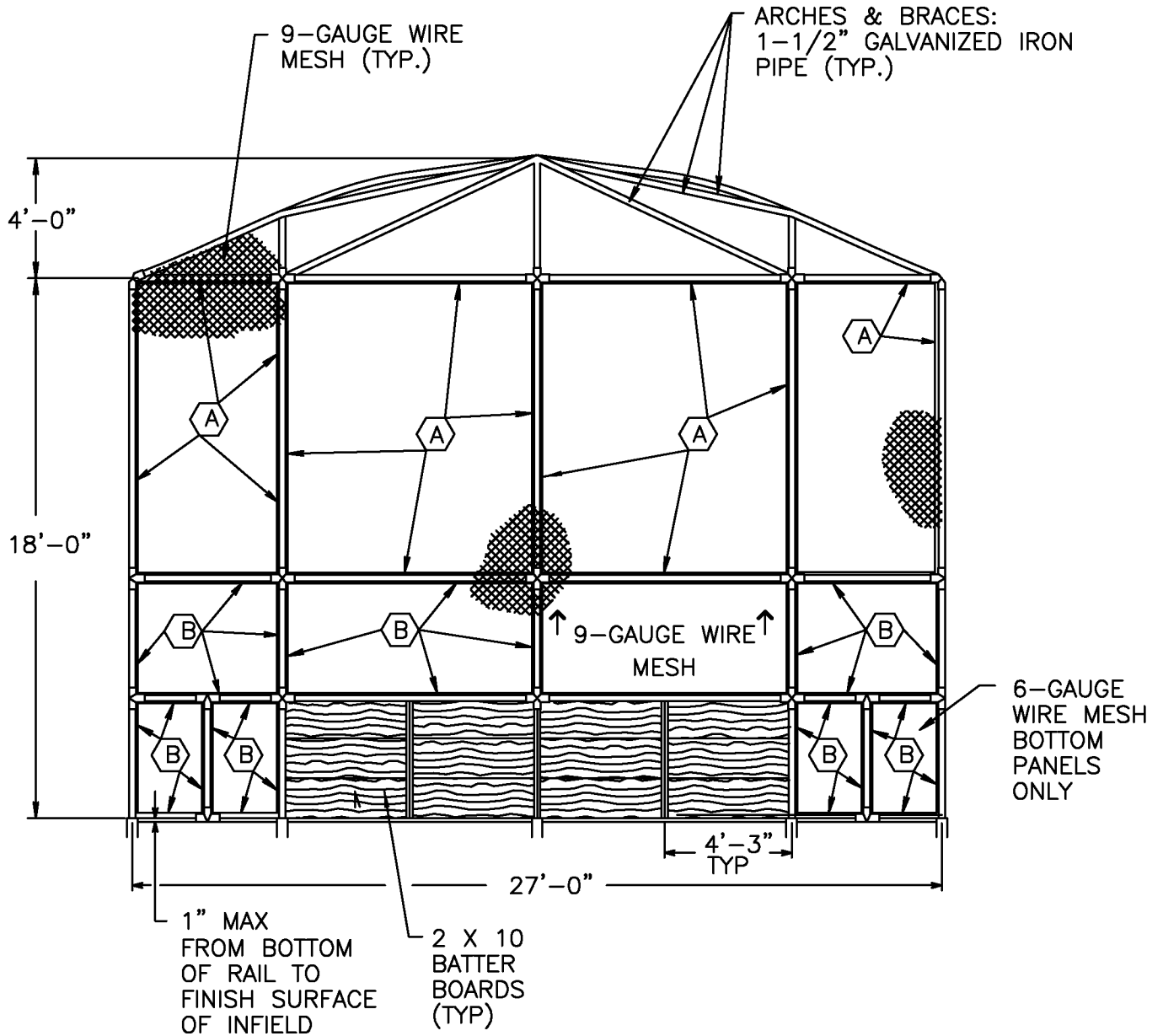

NOTES:

- 1) ALL PIPE FRAME TO BE 2" GALVANIZED IRON PIPE, EXCEPT AS NOTED ABOVE.
- 2) SEE BACKSTOP NOTES.

- (A) 3/4" X 3/16" TENSION BAR WITH 1" X 14-GAUGE BANDS 12" ON CENTER (TYP.).
- (B) 3/4" X 3/16" TENSION BAR WITH 1" X 14-GAUGE BANDS 8" ON CENTER (TYP.).

BACKSTOP
REAR ELEVATION SCALE: NONE

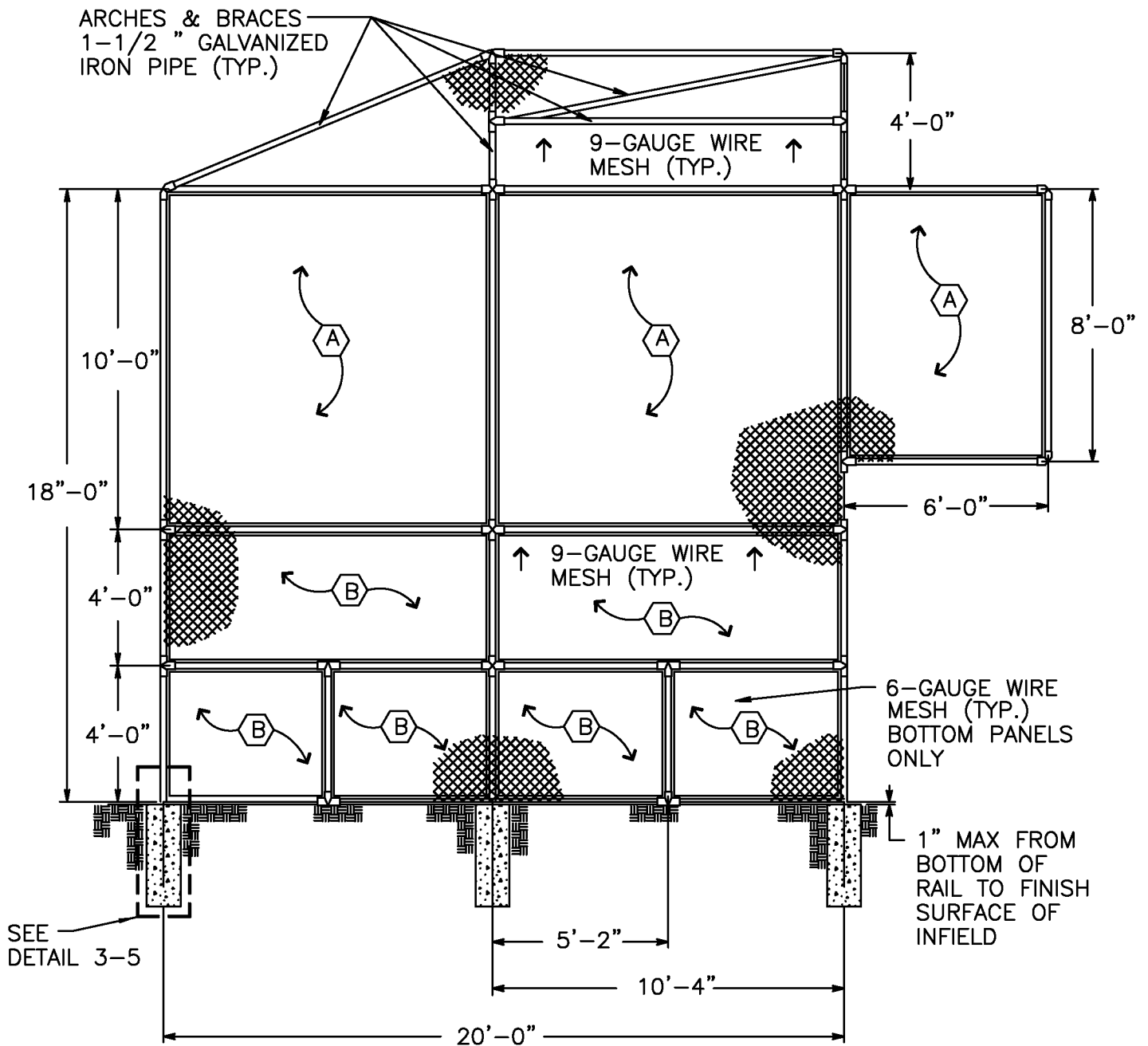

NOTES:

- 1) ALL PIPE FRAME TO BE 2" GALVANIZED IRON PIPE, EXCEPT AS NOTED ABOVE.
- 2) SEE BACKSTOP NOTES.

(A) 3/4" X 3/16" TENSION BAR WITH 1" X 14-GAUGE BANDS 12" ON CENTER (TYP.).

(B) 3/4" X 3/16" TENSION BAR WITH 1" X 14-GAUGE BANDS 8" ON CENTER (TYP.).

BACKSTOP
SIDE ELEVATION SCALE: NONE

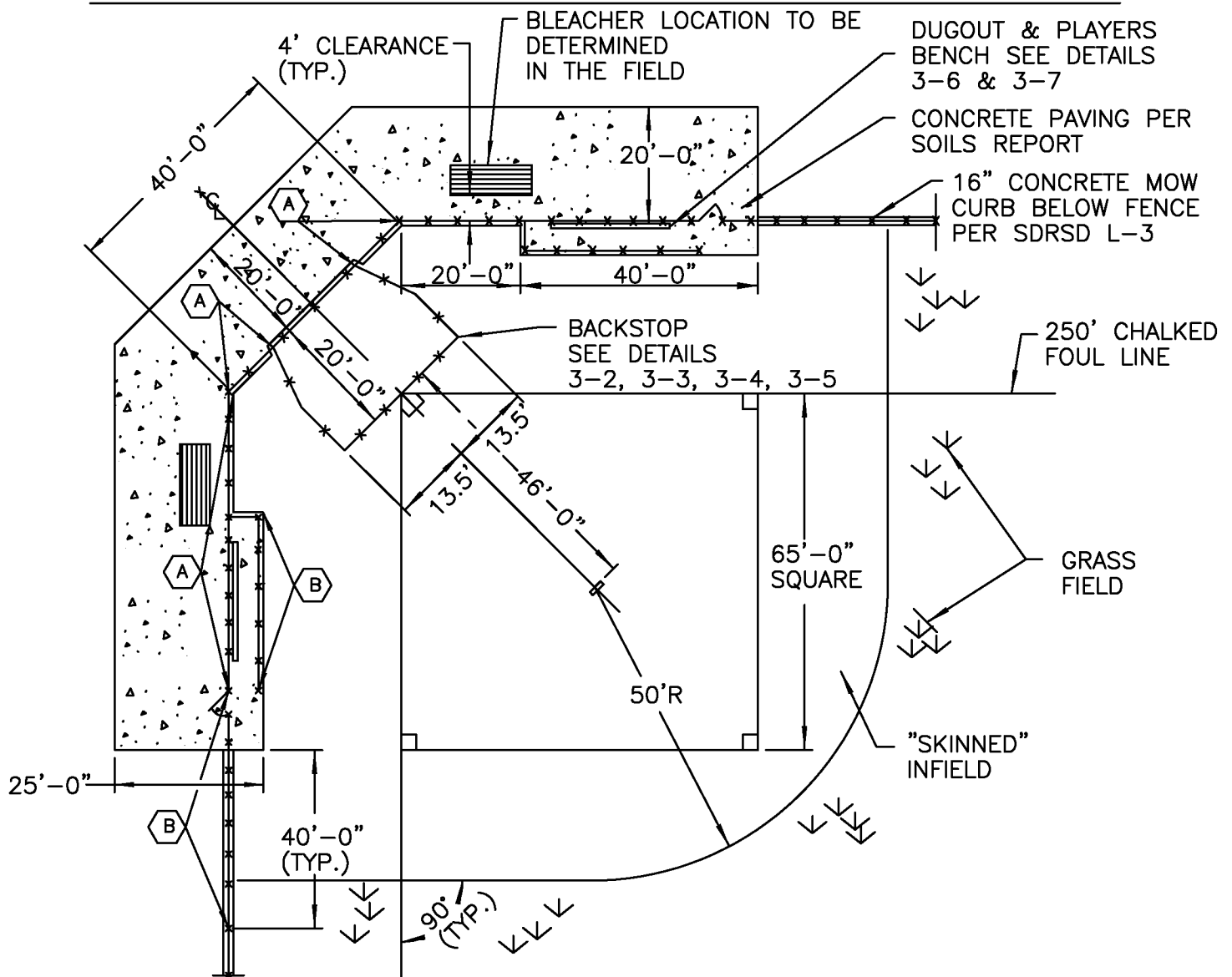

NOTES:

- 1) BACKSTOP AREA IS SYMMETRICAL ABOUT THE CENTER LINE, EXCEPT AS NOTED ABOVE.
- 2) DIMENSIONS ARE TO CENTER LINE OF FENCE POSTS.
- 3) CONTRACTOR SHALL INSTALL HOME PLATE AND PLACE GUINEAS AT BASE LOCATIONS FOR FUTURE BASES (BASES BY OTHERS).
- 4) TIE BACKSTOP IN AS PART OF FENCE, SEE BACKSTOP NOTES.
- 5) SEE FENCING NOTES.

(A) 12' HIGH BLACK VINYL CHAIN LINK FENCE AND POSTS PER SDRSD SDM-112.

(B) 8' HIGH BLACK VINYL CHAIN LINK FENCE AND POSTS PER SDRSD SDM-112.

SOFTBALL FIELD
PLAN VIEW SCALE: NONE

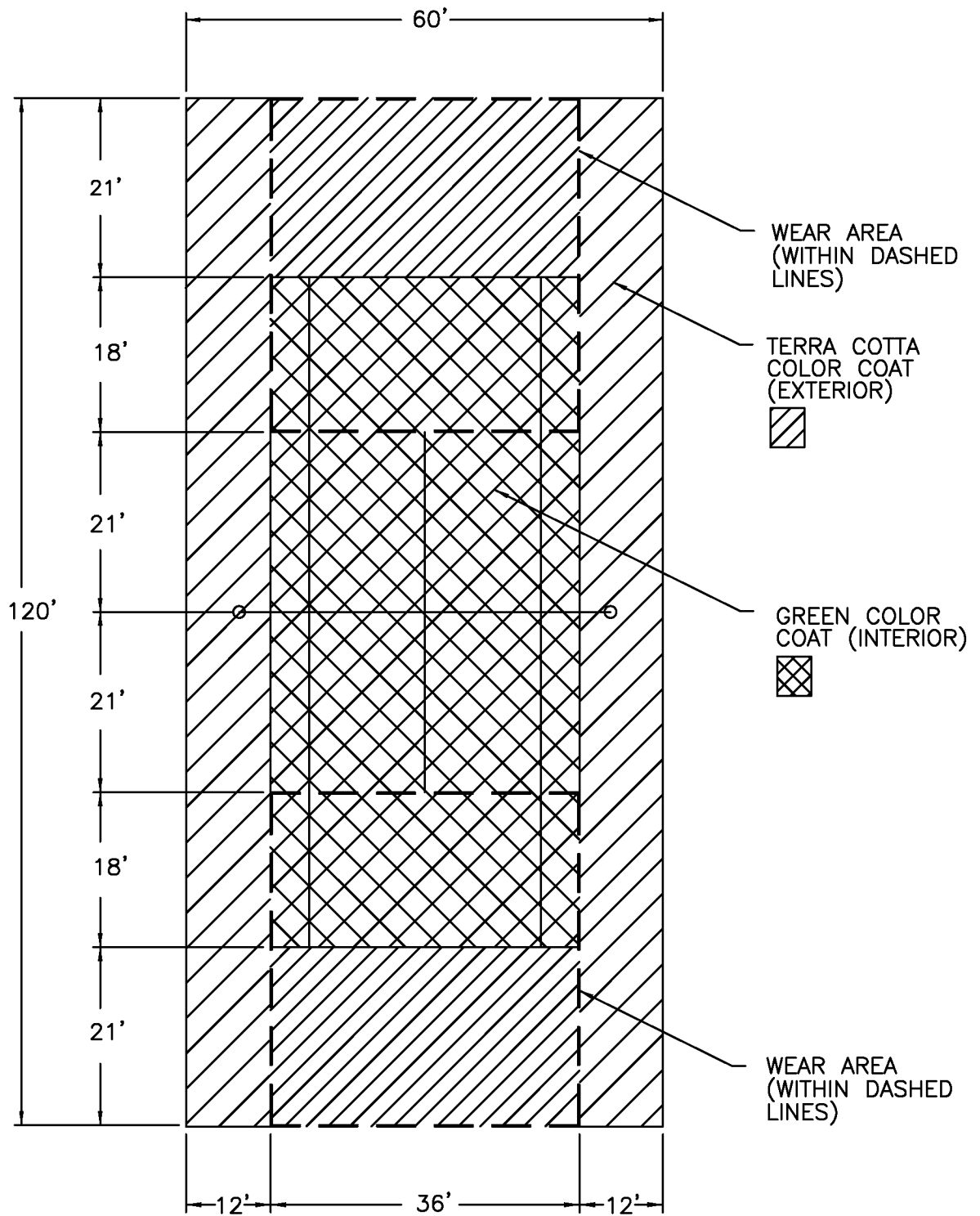

NOTE:

- 1) WEAR AREA TO RECEIVE ADDITIONAL COLOR COAT OF COURT SURFACING PER SPECIFICATIONS.

TENNIS COURT COLOR COATING
PLAN VIEW SCALE: NONE

CITY OF SAN DIEGO, CALIFORNIA**COUNCIL POLICY**

SUBJECT: SUSTAINABLE BUILDING POLICY

POLICY NO.: 900-14

EFFECTIVE DATE: May 20, 2003

BACKGROUND:

Existing buildings and the building development industry consume nearly half of the total energy used in the United States. The City of San Diego's commitment to become increasingly efficient with resources, including energy, water, and materials associated with construction projects, is demonstrated in Council Policy 900-14 "Green Building Policy" adopted in 1997, Council Policy 900-16 "Community Energy Partnership," adopted in 2000, and the updated Council Policy 900-14 "Sustainable Buildings Expedite Program" adopted in 2001.

On April 16, 2002, the Mayor and City Council adopted CMR 02-060 which requires City projects to achieve the U.S. Green Building Council's LEED silver standard for all new buildings and major renovations over 5,000 square feet. This places San Diego among the most progressive cities in the nation in terms of sustainable building policies.

As a participant in the International Council for Local Environmental Initiatives (ICLEI) Cities for Climate Protection Program, as a Charter member in the California Climate Action Registry and as an active member of the U.S. Green Building Council, the City of San Diego is committed to reducing greenhouse gas emissions by implementing more sustainable practices, including green building technologies.

PURPOSE:

The purpose of this policy is to reassert the City's commitment to green building practices in City facilities, and to provide leadership and guidance in promoting, facilitating, and instituting such practices in the community.

POLICY:

The following principles will be required for all newly constructed facilities and major building renovation projects for City facilities:

LEED (Leadership in Energy and Environmental Design):

Consultants Guide to Park Design and Development - City of San Diego

The LEED (Leadership in Energy and Environmental Design) Green Building Rating System is a voluntary, consensus-based national standard for developing high-performance, sustainable buildings. Members of the U.S. Green Building Council representing all segments of the building industry developed LEED and continue to contribute to its evolution.

The City of San Diego is committed to achieving LEED “Silver” Level Certification for all new City facilities and major building renovation projects over 5,000 square feet.

SUSTAINABLE BUILDING MEASURES:

In addition to achieving LEED “Silver” Level Certification, Council Policy 900-14 encourages the following sustainable building measures for all newly constructed facilities and major renovation projects regardless of square footage:

1. Design and construct mechanical and electrical systems to achieve the maximum energy efficiency achievable with current technology. Consultants shall use computer modeling programs, (Energy Pro) to analyze the effects of various design options and select the set of options producing the most efficient integrated design. Energy efficiency measures shall be selected to achieve energy efficiencies at least 22.51% better than California’s Title 24.2001 standards for both new construction and major renovation projects.
2. Incorporate self-generation using renewable technologies to reduce environmental impacts associated with fossil fuel energy use. Newly constructed City facilities shall generate a minimum of 10%, with a goal of 20% from renewable technologies (e.g., photovoltaic, wind and fuel cells).
3. Eliminate the use of CFC based refrigerants in newly constructed facilities and major building renovations and retrofits for all heating, ventilation, air conditioning and refrigerant-based building systems.
4. Incorporate additional commissioning and measurement and verification procedures as outlined by LEED 2.0 Rating System, Energy and Atmospheres, credit 3 and credit 5 for all projects over 20,000 sq. ft.
5. Reduce the quantity of indoor air contaminants that are odorous or potentially materials will include adhesives, paints, coatings carpet systems, composite wood and agri-fiber products.
6. In order to maximize energy efficiency measures within these requirements, projects will combine energy efficiency measures requiring longer payback periods, with measures requiring shorter payback periods to determine the overall project period.
7. Comply with the storm water development requirements in the Storm Water Management and Discharge Control Ordinance (Municipal Code § 43.03), and the City’s grading and drainage regulations and implementing documents (MC § 142.01 and 142.02, respectively).

In addition to achieving the minimum sustainable building measure this Council Policy encourages the following measures be incorporated into newly constructed facilities and major renovation projects whenever possible:

1. Use high efficiency irrigation technology, drought tolerant native plants and recycled site water to reduce potable water for irrigation by 50%. Additionally, building water consumption should be reduced by 30%.
2. Limit disruption of natural water flows and minimize storm water runoff by minimizing building footprints and other impervious areas, increasing on-site infiltration, preserving and/or restoring natural drainage systems, and reducing contaminants introduced into San Diego's bays, beaches and the ocean.
3. Facilitate the reduction of waste generated by building occupants that is hauled to and disposed of in landfills. Provide an easily accessible area that serves the entire building and is dedicated to the separation, collection and storage of materials for recycling. Recycling should include paper, glass, plastic and metals at a minimum.
4. Incorporate building products that have recycled content reducing the impacts resulting from the extraction of new materials. Newly constructed City facilities shall have a minimum of 25% of building materials that contain in aggregate, a minimum weighted average of 20% post consumer recycled content materials.
5. Reduce the use and depletion of finite raw and long-cycle renewable materials by replacing them with rapidly renewable materials. Newly constructed City facilities should consider incorporating rapidly renewable building materials for 5% of the total building materials.
6. Establish minimum indoor air quality (IAQ) performance to prevent the development of indoor air quality problems in buildings, maintaining the health and well being of the occupants. Newly constructed City facilities will comply with IAQ by conforming to ASHRAE 62-1999.
7. City buildings will be designed to take the maximum advantage of passive and natural sources of heat, cooling, ventilation and light.

The Environmental Services Department, Energy Conservation and Management Division has been designated by this Council Policy as the clearing authority for issues relating to energy for the City of San Diego. The Energy Conservation and Management Division will enter into a Memorandum of Understanding with those City Departments who design, renovate and build new city owned facilities to insure all new City facilities reflect the intent of Council Policy 900-14.

PRIVATE-SECTOR/INCENTIVES:

It shall be the policy of the City Council to expedite the ministerial process for projects which meet the following criteria:

1. Residential projects that provide 50% of their projected total energy use utilizing renewable energy resources, (e.g., photovoltaic, wind and fuel cells).
2. Commercial and industrial projects that provide 30% of their projected total energy use utilizing renewable energy resources, (e.g., photovoltaic, wind and fuel cells).
3. Residential and commercial and industrial projects that exceed the State of California Title 24 energy requirements by:
 - a. 15% better than California's Title 24.2001 for Residential Buildings.
 - b. 10% better than California's Title 24.2001 for Commercial and Industrial Buildings.

It shall be the policy of the City Council to expedite the discretionary process for projects which meet the following criteria:

1. Incorporate the U.S. Green Building Council, Leadership in Energy and Environmental Design (LEED) 2.0 Rating System "Silver" Level Certification for commercial development projects.
2. Incorporate self-generation through renewable technologies (e.g., photovoltaic, wind and fuel cells) to reduce environmental impacts associated with fossil fuel energy use for commercial and industrial projects generating a minimum of 30% or more of the designed energy consumption from renewable technologies such as photovoltaic, wind and fuel cells.
3. Residential discretionary projects of 4 units or more within urbanized communities as defined in the Progress Guide and General Plan that provide 50% of their projected total energy use utilizing renewable energy resources.

HEALTH AND RESOURCE CONSERVATION:

1. Projects will be designed to avoid inflicting permanent adverse impact on the natural state of the air, land and water, by using resources and methods that minimize pollution and waste, and do not cause permanent damage to the earth, including erosion.
2. Projects will include innovative strategies and technologies such as porous paving to conserve water, reduce effluent and run-off, thus recharging the water table.
3. When feasible, native plants will be used in landscaping to reduce pesticide, fertilizer, and water usage.

4. Buildings will be constructed and operated using materials, methods, mechanical contamination by carcinogens, volatile organic compounds, fungi, molds, bacteria, and other known toxins.
5. Projects will be planned to minimize waste through the use of a variety of strategies such as: a) reuse of materials or the highest practical recycled content; b) raw materials derived from sustainable or renewable sources; c) materials and products ensuring long life/durability and recyclability; d) materials requiring the minimum of energy and rare resources to produce and use; and e) materials requiring the least amount of energy to transport to the job site.

OUTREACH / EDUCATION:

1. An education and outreach effort will be implemented to make the community aware of the benefits of “Green Building” practices.
2. The City will sponsor a recognition program for innovative Green Building projects implemented in the public as well as private sector in an effort to encourage and recognize outstanding environmental protection and energy conservation projects.

IMPLEMENTATION:

The City will seek cooperation with other governmental agencies, public interest organizations, and the private sector to promote, facilitate, and implement Green Building and energy efficiency in the community.

LEGISLATION:

The City will support State and Federal legislation that promotes or allows sustainable development, conservation of natural resources, and energy efficiency technology.

REFERENCES:

Related existing Council Policies: 400-11,
Water Conservation Techniques 400-12,
Water Reclamation/Reuse 900-02, Energy
Conservation and Management 900-06,
Solid Waste Recycling

HISTORY:

Adopted by Resolution R-289457 11/18/1997, Amended by Resolution
R-295074 06/19/2001, Amended by Resolution R-298000 05/20/2003

CRITERIA FOR PLAYGROUND EQUIPMENT
DISAPPROVED EQUIPMENT

Park Planning, Park and Recreation Department
Revised 2004

Manufacturer	Component
All	Tunnels (slides or level)
All	Plexiglass or lexan bubble or window panels
All	Metal mesh roofs
All	Multiple piece spiral slide
All	Web or cargo net climbers with vinyl-coated chain, or cable-core rope
All	Vinyl-coated swing chains
Burke	Genesis line
Burke	Spiral Climber
Burke	Mirror Panel
Burke	Steering Wheel with Window
Burke	Pipe Slide
Burke	Carousel
Burke	Rock-N-Rides
Burke	Little Digger
Gametime	KidTime line
Gametime	Pentes Play line
Gametime	Expanded metal decks with vinyl coating
Gametime	Piston Panel
Gametime	RaceTime, Mini-Bus, Fire Engine and Rescue 911 panels
Gametime	Wavy Mirror Panel; Flat Mirror Panel; Flat Window Panel; Paint Time Panel
Gametime	Bannister Rails
Gametime	Bucket Seat for swings

Manufacturer	Component
Gametime	Rubber spring riders
Gametime	Handi-Swing Seat and PowerScape HandiSwing
Gametime	Scrambler Whirl
Landscape Structures	Ribbon Slide
Landscape Structures	Maze Tilt Table
Landscape Structures	Permalene Spring Riders
Landscape Structures	Mirror Panel; Slant Window; Gear Panel; Ball Maze Panel
Landscape Structures	PlayOdyssey Roof
Little Tikes	Climbing Net
Little Tikes	Curved Climbing Wall
Little Tikes	Cargo Bridge
Little Tikes	Suspension Bridge
Little Tikes	Bannister Rails
Little Tikes	Mirror and Bubble Panels
Little Tikes	7-Station Play
Little Tikes	Duraglide Swing Seat
Miracle	Expanded Metal Decks with vinyl coating
Miracle	Miratherm
Miracle	Stainless Steel (multiple-section) Slide
Miracle	Clock Panel
Miracle	Mirror; Bus/Truck/Flyer Panels
Miracle	Wall with Seat
Miracle	Tot Seat #297 w/ chain
Miracle	Therapeutic Seat
Miracle	Paint Easel Panel
Miracle	Sloped Double Rail
Miracle	Pony Express, Mustang Whirl, Junior Whirl, Lifetime Whirl, Apollo Whirl, Galaxy Whirl
Playworld Systems	Bannister Slide

Manufacturer	Component
Playworld Systems	Clock Activity Panel
Playworld Systems	Driver Panel
Playworld Systems	Shifting Sands, Wavy Maze and Pachinko Panels
Playworld Systems	Aluminum Spiral Slide
Playworld Systems	Bubble and Look-Down Panels and Barriers
Playworld Systems	Accessible Swing Seat
Playworld Systems	Adult Rigid Swing Seat
Playworld Systems	See-saw
Playworld Systems	Reinforced Rubber Swing Seat
Playworld Systems	Modular Wood System
Playworld Systems	High Density Plastic Spring Riders
Playworld Systems	SkyTowers System

**PARK AND RECREATION DEPARTMENT
PARK PLANNING AND DEVELOPMENT**

JOINT USE CHECKLIST

The list below serves as a resource for the design of joint use areas. While the items included are not exhaustive, they will aid in the design of joint use areas and allow the City quicker reviews/plan checks if they are accommodated. Please note that each joint use site is different and this checklist is for reference only. Each site is unique and requirements listed may apply to some joint use sites and not to others.

The criteria below are based upon a Memorandum of Understanding (MOU) dated December 31, 2002, entered into with the San Diego Unified School District. The same logic should be used, in general, for other joint use ventures as well.

1. General Plan Standard Information

- a. Joint use sites are considered similar in nature to neighborhood parks with respect to service radii. A radius of ½ mile is ideal. Joint use sites are to be for active play and, do not have to be, but are preferably for programming purposes (services 18,000-25,000 persons).

2. Joint Use Field Size Criteria

- a. The SDUSD should strive to meet our standards of 2.0 acres of turf as a standard configuration for multi-purpose play.
- b. If 2.0 acres cannot be achieved, the SDUSD should strive to meet as close to 2.0 acres as possible. The City will evaluate proposed joint use sites of between 1.5 acres and 2.0 acres of turf on a case by case basis.
 - i. Enhanced levels of service will be credited per the MOU; however, is discouraged as a solution for acreage deficit due to current and anticipated future budget constraints.
- c. Less than 1.5 acres simply does not provide the City with enough playing surface to rest the field, rotate the use of the users, etc. resulting in an unsuccessful product for the public.
 - i. If a minimum of 1.5 acres of turf as a standard configuration for multipurpose play cannot be achieved, then artificial turf should be provided.

3. Public Input Process:

- a. City project manager should take joint use area project to the appropriate Recreation Council for input.
 - i. The need for programmed use should be investigated.
- b. When a Recreation Council does not exist, City project manager should go to the recognized Planning Group for that area.
- c. Area Committee may be required if the project exceeds \$1,000,000.
- d. DRC is optional (recommended if you have a complicated site).
- e. FARB and SCRAB are optional (recommended if you have a complicated site).
- f. Park and Recreation Board are not required.

4. Joint Use Limits/Boundaries

- a. Provide clear delineation of the joint use area on plans.
- b. The City does not generally accept the following for maintenance in a joint use agreement (JUA) unless agreed to by the Deputy Director:
 - 1) 2:1 slopes
 - 2) Trees
 - 3) Shrub areas and associated groundcovers
 - 4) Planting mulch
 - 5) Lawn areas that exceed 5:1, are segmented from the main field area or that require hand mowing
 - 6) Stairs (case by case basis)
 - 7) Walls
 - 8) Retaining walls
 - 9) Railings
 - 10) Arbors/Trellis'
 - 11) Ball walls
 - 12) Enhanced paving
 - 13) Climbing walls
 - 14) Performance or stage areas/amphitheatres and associated walkways
 - 15) Play equipment and surfacing (case by case basis)
 - 16) Decomposed granite
 - 17) Asphalt (other than parking lots to be included in the JUA)
 - 18) Black top for play (case by case basis)
 - 19) Site furnishings, such as benches, picnic tables, bleachers, etc.
 - 20) Other amenities on site unless agreed to

5. Restrooms

- a. Per the MOU between the City and the District, dated December 31, 2002, The SDUSD was to provide a restroom facility for use by joint use users. The restroom can be located within the joint use field or within a School District building, as long as it's accessible to the public after school hours and on weekends.
- b. If the SDUSD does not participate in the MOU and does not intend to provide a restroom for Prop MM projects, have them bid the project with water, sewer and electrical hook-ups. If funds can be found, the City may wish to fund a pre-fab restroom at that time or in the future.
- c. Providing an area for a portable may be acceptable. If this is an option, a concrete pad for the portable will need to be provided within 20' of vehicular access due to cleaning access requirements. It will also need to be placed in an area compliant with ADA/Title 24 (accessible path of travel provided to the unit). The portable itself will also need to be an ADA/Title 24 model.

6. Site Layout

- a. Maximize the flat field area as much as possible. 2 acres, minimum size for joint use areas.
 - 1) Areas 2 acres and over will require standard maintenance procedures.
 - 2) Areas 1.5 to 2.0 acres will require artificial turf or enhanced maintenance standards.
 - 3) Areas less than 1.5 acres should be artificial turf or not pursued.
- b. Provide maximum 2% slope for multi-purpose joint use field areas.
- c. Provide a 12' access gate to allow mowing equipment in and out easily from the street.
- d. Provide a concrete approach to the access gate from a major street to gain access to the joint use area. This includes access for vehicles.
- e. Provide pedestrian gates (4' wide, minimum) in joint use areas next to City parks or other open space so users can pass between one area and the other. Accessible routes should be considered where possible.
- f. Provide a 16" wide mowcurb under all new fencing where fencing is adjacent to the turfed joint use field area. Mowcurbs with no fencing within the joint use area should be 8" wide. See SDRSD L-3.

7. Materials

- a. Provide concrete walks within the joint use area. Asphalt and decomposed granite are not acceptable.

8. Hard Court Areas

- a. Provide concrete hard court areas, if included in the joint use area. Asphalt is not preferred and will only be accepted on a case by case basis by Deputy Director.

9. Parking

- a. Per the MOU between the District and the City, dated December 31, 2002, inclusion of parking lots in joint use agreements is evaluated on a case-by-case basis depending on off-street parking availability and recreational programs proposed for the site.
- b. If parking is included in the Joint Use area, provide ADA/Title 24 access from the joint use parking lot to the joint use field area.

10. Site Amenities

- a. Provide a free standing drinking fountain (ADA/Title 24 compliant), accessible by those using the joint use fields during non-school hours and on weekends, if one is not accessible on the school buildings.
- b. Reconfigure fencing in the joint use area to allow for access to school drinking fountains, if possible.

11. Planting (When Negotiated)

- a. Utilize the City of San Diego Regional Standard Drawings for the joint use field details.
- b. Provide bubblers and a 2' radius of no turf around any trees in the joint use area. . For all trees installed in lawn areas provide a non-lawn area, 2' radius from the baseline of each tree trunk to the edge of the lawn area. The 2' non-lawn radius around the tree trunk shall have a 2" layer of mulch to prevent weed growth, there shall be no mulch on crown of tree.. All bubblers shall be on a separate remote control valve, two (2) per tree.
- c. Provide hydroseed mix '2A' per the *Consultant's Guide to Park Design and Development* for the joint use area.
- d. Provide a simple plant palette, with only a few species that will be easy to maintain.
- e. Any negotiated tree planting in the joint use area will need to be guaranteed and maintained by the District for 3 years. Trees must be healthy and established at time of turn-over to City for maintenance.
- f. No slopes shall be included in the joint use area. City will not maintain slopes surrounding the joint use site (neither irrigation nor planting on slopes).

12. Irrigation

- a. Utilize the City of San Diego Regional Standard Drawings and Green Book for the joint use field details.
- b. Utilize the *Consultant's Guide to Park Design and Development* for the joint use field irrigation equipment legend, as all the equipment must be on the approved irrigation materials list.

- c. Provide quick couplers with globe valves at a maximum distance of 150 feet on center for the field area. See the *Consultant's Guide to Park Design and Development*.
- d. Provide a separate water meter and controller for the joint use area, separate from the school's system. The electricity for the controller is usually supplied by the District. Ensure that this is accommodated on plans.
- e. Locate controller in joint use area in an easily accessible location within the joint use area, but outside of the irrigation spray zone.
- f. Provide a high flow shut-off assembly in the controller area.
- g. Install mainlines at 21" depth and laterals at 15" depth in the joint use area.
- h. Utilize globe valves, not gate valves. Install globe valves per SDRSD I-13 with alternate pipe sleeve installation.
- i. The backflow preventer will require a stainless steel enclosure free of burrs and sharp edges on a concrete pad. Reference SDRSD W-27 and W-28.
- j. Irrigation boxes shall be concrete with a hinged cast iron locking top.
- k. Ensure two spare wires are run for irrigation, minimum.
- l. Provide a receptacle and plug for the controller in the enclosure box so controller can be unplugged to work on it if required. Or, provide an electrical breaker for the controller. Either must be accessible to City staff during evening and weekend hours so the controller can be shut off if required.
- m. Ensure that all change in directions for mainline in the joint use area utilize an isolation valve.
- n. Complete irrigation and planting sheets for construction documents and for as-builts separately from District sheets for clarity.
- o. Provide 6" high pop-ups in the joint use area where possible pending manufacturer, stainless steel if available.
- p. The system must be able to apply the volume of water necessary to achieve the evapotranspiration rate (ETO) of the highest demand month within the following criteria: 4 days per week, 8 hour irrigation window, 10 pm – 6 am. This may mean that the system may need to be sized to accommodate 2 valves running at once.

13. Soil

- a. Per the *Consultant's Guide*, the field shall be free of all ½" diameter or larger rock to a depth of 15". This can be achieved by two means:
 - The field can be provided with a 15" layer of Class 'A' topsoil free of rocks; or
 - The field can be grated free of the rocks for the top 15" and the soil amended for the top 15" as approved.

Note on plans how this will be achieved.

14. Accessibility

- a. If a new parking lot is included, provide wheel chair path of travel from the parking lot to the joint use area.
- b. In all cases, an accessible route from the adjacent public right of way or public transportation stop to the joint use area is required.
- c. Be sure to consider the school fencing plan and coordinate which ones are open in off school hours and on joint use hours.
- d. Improvements must be consistent with the requirements of state and federal law for disabled access, including the California Government Code section 4450, et. seq. the California Building Code in the California Code of Regulations at Title 24, the Americans with Disabilities Act, and the Americans with Disabilities Act Accessibility Guidelines.

15. Miscellaneous

- a. The *Consultant's Guide* lists inspection stages and team members for the joint use area. Ensure these are included on the plans for the joint use area. City staff must be present numerous times during construction to ensure compliance with our standards.
- b. Add City of San Diego supplemental irrigation specs. to the plans (Appendix 'F' of the *Consultant's Guide*).

16. Not Allowed in Joint Use Facilities

- a. Off leash dogs.
- b. Alcohol use.

The Appendix contains: Access Memo 2004-01,

Access Memo2004-02,

Access Memo 2004-03,

Access Memo 2004-04.

The referenced Memos contain City of San Diego Standard Drawings and other References to Accessibility Standards. The user of this Guide is aware that the most recent approved Drawings and/or Standards shall apply.

The following drawings are part of Access Memo 2004-03:

SDG – 130 Truncated Dome Detail

SDG – 132 Curb Ramps Type A & B

SDG – 133 Curb Ramp Type A-1 & B-1

SDG – 134 Curb Ramp Type C

SDG – 136 Curb Ramp Type D

SDG – 137 General Notes for Curb Ramps

We have put in a reference to their location (City of San Diego Standard Drawings Document No. AEC701042).

There is a link to this document on the City Web Site:

<http://www.sandiego.gov/engineering-cip/services/consultcontract/edocref/standarddraw.shtml>

Follow this link to General Surface Improvements Chapter.

Consultant shall confer with City of San Diego Project Manager prior to implementation.

CITY OF SAN DIEGO
MEMORANDUM



DATE: February 19, 2004
TO: City Departments and City Facility Managers
FROM: Frank Belock, City Engineer
Tina Christiansen, Development Services Director
Linda Woodbury, Disability Services Coordinator
SUBJECT: Accessibility Design Standards for City Owned or Leased Facilities

The City is committed to having its buildings accessible to all individuals. This memorandum sets forth the City's first set of recommendations to be used for the new construction and alterations of City owned or leased facilities. It should be used by all City departments and incorporated in all City contracts for new construction, alteration, and addition projects in any City-owned or leased facilities.

As part of the City's ongoing efforts to ensure compliance with the State and Federal accessibility laws¹, a technical group of City staff, known as the City's Access Law Technical Group (Technical Group), has been formed to review areas of conflict or confusion and recommend policies. When a recommendation, such as those listed here, is specified, it is to be followed in new construction, alterations, and additions, unless the Deputy Director and the Technical Group determine that to follow such a recommendation is impracticable either structurally or economically.

A reference to a specific code section is a reminder of current legal requirements, whereas a recommendation sets forth a goal which exceeds minimum legal requirements. The recommendations set forth here are in bold.

I. **Sanitary Facilities - (Multiple Accommodations, Single-Occupancy Toilets and Family Stalls):**

1. **General:**

All sanitary facilities shall be designed per the most current accessibility

¹ The California Building Code (CBC) and Americans with Disabilities Act (ADA), respectively.

ORIGINAL

regulations of the CBC and the ADA/ADAAG adopted at the time of submittal for a building permit review.

2. Urinals:

Grab bars are recommended on each side of urinals (please see attached diagram). Where urinals are provided, install at least one accessible urinal with a 24" long (min.) and 1½" diameter grab bar vertically placed on each side of the fixture. The top of the grab bars shall not exceed 48" as measured from the finish floor (based on maximum forward reach height requirement per CBC 1118B.5 and ADAAG 4.2.5). An accessible urinal shall have a clear floor space of 30" by 48" in front of the fixture to allow a forward approach (CBC 111B.9.4 and ADAAG 4.22.5). All grab bars shall comply with CBC 1115B.8 and ADAAG 4.26.

3. Accessible Stalls within Multiple Accommodation Restrooms:

- a. Provide the International Symbol of Accessibility (ISA) on the center of a stall/partition door mounted at 5'-0" max. from the finish floor to the centerline of the sign (height per CBC 1117B.5.7 and ADAAG 4.30.6). The ISA shall consist of a white figure on a blue background. The blue shall be equal to Color No. 15090 in Federal Standard 595b (CBC 1117B.5.8.1.1)
- b. Install a "Loop Handle" on the inside and outside of a stall/compartement door immediately below the latch. The latch should be a flip-over style, sliding, or other hardware not requiring the user to grasp or twist. Center the opening hardware approximately between 30" and 44" above the finish floor (CBC 1133B.2.5.2 and ADAAG 4.13.9).

The "Loop Handle" is recommended over a "U-Shaped Handle", but either is allowed per CBC 1115B.7.1.4 and ADAAG 4.13.9.

4. Single-Accommodation and Family Unit Restrooms:

- a. General - For single user portable toilet or bathing units clustered at a single location, at least 5% but no less than one accessible toilet unit or bathing unit shall be installed at each cluster whenever typical inaccessible units are provided. Accessible units shall be identified by the International Symbol of Accessibility. ADAAG 4.1.2(6)
- b. **A 3' 0" wide and 7'0" high door is recommended.** Although a clear width of 32" minimum door width is allowed by CBC 1133B.2.2 and ADAAG 4.13.5, we recommend installing a minimum 3'0" wide and 7'0" high entry door (CBC 1133B.2.2). The effort to operate the door shall be

ORIGINAL

within the allowed 5-pound pressure (CBC 1133B.2.5 and ADAAG 4.13.11(2)) with a privacy latch (push button-lever release) (ADAAG 4.1.6(e)).

II. Library Facilities, Recreation Centers, and Senior Centers (including facilities where there is a high usage by senior citizens and/or persons with disabilities) are **recommended to install power-assisted doors when they are constructed.**

1. General:

Construction of all facilities (new construction, alteration, and addition) shall be designed per the most current accessibility regulations of the CBC and the ADA/ADAAG adopted at the time of the submittal for a building permit review.

2. Doors:

Power-assisted doors are recommended for the main entry. Construct all facilities (new construction, alteration, and addition) with at least one power-assisted door(s) at the main entry. All new doors must comply with the most current accessibility regulations of the CBC and the ADA/ADAAG adopted at the time of the submittal for a building permit review.

These recommendations are specific to urinal grab bars, accessible toilet compartment doors, and power-assisted doors. The overall design is required to comply with the ADA/ADAAG, the CBC, and other governing laws and regulations adopted at the time of the submittal for a building permit review.

Frank Belock
City Engineer

Tina Christiansen
Development Services Director

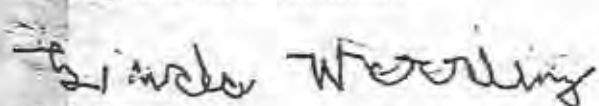
Linda Woodbury
Disability Services Coordinator

ORIGINAL

CITY OF SAN DIEGO
MEMORANDUM

DATE: October 14, 2004

TO: City Departments and City Facility Managers

FROM: Patti Boekamp, Engineering and Capital Projects Acting Director
Gary Halbert, Development Services Acting Director
Linda Woodbury, Disability Services Coordinator

SUBJECT: Forward and Side Reach Range Limits Standards for City Owned and Leased Facilities

This memorandum sets forth the City's recommendations to be used in the new construction, alteration, and/or addition of City owned or leased facilities and public way. These recommendations should be incorporated in all City contracts for new construction, alteration, and addition projects.

As part of the City's ongoing efforts to ensure compliance with the State and Federal accessibility laws¹, the City's Access Law Technical Group² is releasing this memorandum of recommendations on forward and side reach range limits standards that shall be applied to all building elements such as coat hooks, lockers, controls, operating mechanisms, and other operable parts designed for use by the public and staff in all City owned and leased facilities. When a recommendation is specified, it is to be followed in new construction, alterations, and additions to all City-owned and leased facilities unless, the Deputy Director and the Access Law Technical Group officially determine that to follow such a recommendation is impracticable either structurally or economically.

A reference to a specific code section is a reminder of current legal requirements, whereas a recommendation sets forth a goal which exceeds minimum legal requirements. The recommendations set forth here are in bold italics.

I. Forward Reach Range Limits

A. Existing Requirements:

If the clear floor space allows only forward approach to an object, the maximum height forward reach allowed shall be 48 inches. The minimum low forward reach height shall be 15 inches. If the high forward reach is over an obstruction and the depth of the obstruction is less than 20 inches, then the maximum high forward reach allowed shall be 48 inches. If the high forward reach is over an obstruction and the

¹ The California Building Code Title 24 Disabled Access Regulations (CBC Title 24) and the Americans with Disabilities Act (ADA)/Americans with Disabilities Act Accessibility Guidelines (ADAAG), respectively.

² Access Law Technical Group is a technical group of City staff formed to develop accessibility standards for construction (which may exceed minimum requirements), develop policies on accessible design, and provide resolution on unclear areas of accessibility requirements.

depth of the obstruction is 20 to 25 inches, then the maximum high forward reach allowed shall be 44 inches. CBC 1118B.5

If the clear floor space only allows forward approach to an object, the maximum high forward reach allowed shall be 48 inches. The minimum low forward reach is 15 inches. ADAAG 4.2.5

The maximum level forward reach over an obstruction with knee space below is 25 inches. When the obstruction is less than 20 inches deep, the maximum high forward reach is 48 inches. When the obstruction projects 20 to 25 inches, the maximum high forward reach is 44 inches. ADAAG 4.2.5

B. Recommendation:

1. *Where a forward reach is unobstructed:*

- a. *High Forward Reach: The preferred height is 44 inches above finish floor or ground, and 48 inches is the maximum. See Figure 308.2.1 below and draft 2004 ADAAG 308.2.*
- b. *Low Forward Reach: The preferred height is 18 inches above finish floor or ground, and 15 inches is the minimum. See Figure 308.2.1 below and draft 2004 ADAAG 308.2.*

Where such building elements are designed for use primarily by children, refer to ADAAG's Children's Reach Range Table

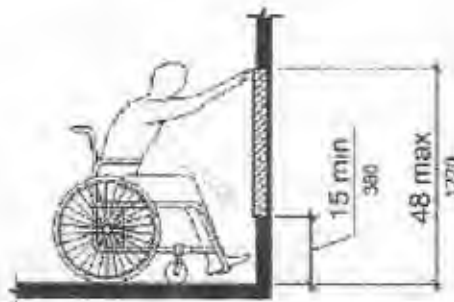

Figure 308.2.1
Unobstructed Forward Reach

2. *Where a high forward reach is over an obstruction, the clear floor space should extend beneath the element for a distance not less than the required reach depth over the obstruction.*
 - a. *Where the reach depth is 20 inches maximum: The preferred height is 44 inches above finish floor or ground, and 48 inches is the maximum. See Figure 308.2.2 below and draft 2004 ADAAG 308.2.*
 - b. *Where the reach depth exceeds 20 inches: The preferred height is 42 inches, and 44 inches is the maximum above finish floor or ground; and, the reach depth should be 25 inches maximum. See Figure 308.2.2 below and draft 2004 ADAAG 308.2.*

Where such building elements are designed for use primarily by children, refer to ADAAG's Children's Reach Range Table.

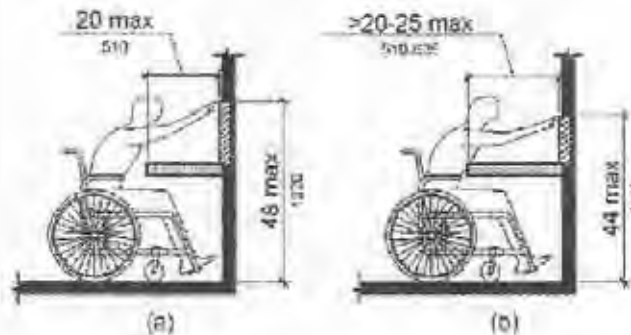

Figure 308.2.2
Obstructed High Forward Reach

II. Side Reach Range Limits:

A. Existing Requirements:

If the clear floor space allows parallel approach by a person in a wheelchair, the maximum high side reach allowed shall be 54 inches and the low side reach shall be no less than 9 inches above the floor. If the side reach is over an obstruction, the maximum high reach shall be 46 inches. CBC 1118B.6

If the clear floor space allows parallel approach by a person in a wheelchair, the maximum high side reach allowed shall be 54 inches and the low side reach shall be no less than 9 inches above the floor. ADAAG 4.2.6

If the depth of the obstruction is 24 inches and the maximum height of the obstruction is 34 inches, the maximum high side reach over the obstruction is 46 inches. ADAAG 4.2.6

B. Recommendation:

1. *Where a side reach is unobstructed:*

- a. *High Side Reach: The preferred height is 44 inches above finish floor or ground where 48 inches is the maximum. See Figure 308.3.1 below and draft 2004 ADAAG 308.3.1.*
- b. *Low Side Reach: The preferred height is 18 inches above finish floor or ground where 15 inches is the minimum. See Figure 308.3.1 below and draft 2004 ADAAG 308.3.1.*

EXCEPTIONS: 1. An obstruction shall be permitted between the clear floor or ground space and the element where the depth of the obstruction is 10 inches maximum; 2. Operable parts of fuel dispensers shall be permitted to be 54 inches maximum measured from the surface of the vehicular way where fuel dispensers are installed on existing curbs - Draft 2004 ADAAG 308.3.1.

Where such building elements are designed for use primarily by children, refer to ADAAG's Children's Reach Range Table.

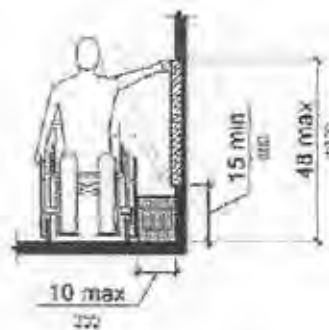

Figure 308.3.1
Unobstructed Side Reach

2. *Where a high side reach is over an obstruction, the height of the obstruction should be 34 inches maximum and the depth of the obstruction should be 24 inches maximum.*
 - a. *High Side Reach: The preferred height is 44 inches above finish floor or ground where 48 inches is the maximum for a reach depth of 10 inches maximum. See Figure 308.3.2 below and draft 2004 ADAAG 308.3.2.*
 - b. *Where the reach depth exceeds 10 inches: The preferred high side reach height is 42 inches above finish floor or ground where 46 inches is the maximum for a reach depth of 24 inches maximum. See Figure 308.3.2 below and draft 2004 ADAAG 308.3.2.*

EXCEPTIONS: 1. The top of washing machines and clothes dryers shall be permitted to be 36 inches maximum above the finish floor; 2. Operable parts of fuel dispensers shall be permitted to be 54 inches maximum measured from the surface of the vehicular way where fuel dispensers are installed on existing curbs - Draft 2004 ADAAG 308.3.2.

Where such building elements are designed for use primarily by children, refer to ADAAG's Children's Reach Range Table.

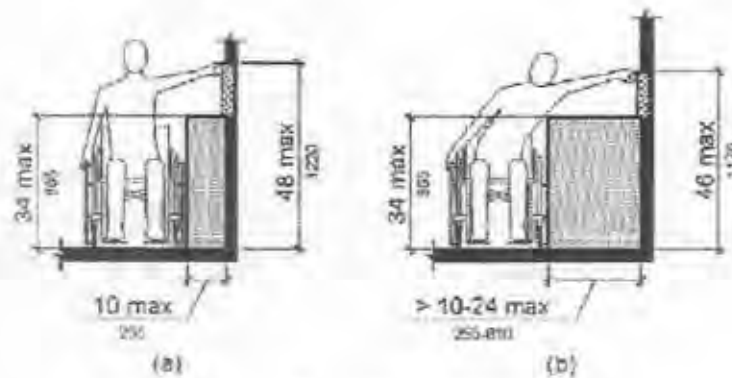

Figure 308.3.2
Obstructed High Side Reach

City Departments and City Facility Managers

October 14, 2004

Page 6

These recommendations are specific to forward and side reach range limit standards only. The overall design is required to comply with the access laws and other governing laws, regulations and City policies adopted at the time of the submittal for a building permit review.



Patti Boekamp

Engineering and Capital Projects Acting Director

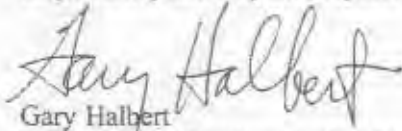

Gary Halbert

Development Services Acting Director

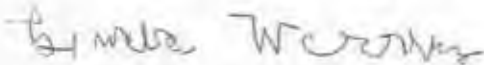

Linda Woodbury

Disability Services Coordinator

CITY OF SAN DIEGO
MEMORANDUM

DATE: June 28, 2004
TO: City Departments and City Facility Managers
FROM: Patti Boekamp, Engineering and Capital Projects Acting Director
Gary Halbert, Development Services Acting Director
Linda Woodbury, Disability Services Coordinator
SUBJECT: Implementation of Truncated Domes on Curb Ramps

The City is committed to having its public rights-of-way accessible to all individuals. This memorandum sets forth the City's policy on truncated domes on curb ramps and shall be used in the new construction and alterations of City owned or leased facilities and public rights-of-way. This policy should be incorporated in all City contracts for new construction, alteration, and addition projects.

As part of the City's ongoing efforts to ensure compliance with the State and Federal accessibility laws¹, the City's Access Law Technical Group formed the Curb Ramp Committee to review areas of conflict or confusion and recommend policies on curb ramps, including the issue of truncated domes. This committee's work culminated in the issuance of new City standard drawings for curb ramps. These new City standard drawings comply with the federal requirement that curb ramps include truncated domes. Please refer to the attached Manager's Report, dated May 27, 2004, for the background information regarding truncated domes. The implementation and policy are set forth below in bold italics.

I. Curb Ramp - (New Construction and Alteration):

1. Implementation:

The new City standard curb ramp drawings are complete and have been signed as of June 14, 2004. Accordingly, all new construction or alteration projects that include or trigger curb ramps shall use truncated domes, as required in the new City standard curb ramp drawings and consistent with the implementation detailed herein.

A. *Public Projects*

¹ The California Building Code (CBC) and Americans with Disabilities Act (ADA)/Americans with Disabilities Act Accessibility Guidelines (ADAAG), respectively.



THE CITY OF SAN DIEGO
MANAGER'S REPORT

DATE ISSUED: May 27, 2004

REPORT NO. 04-116

ATTENTION: Honorable Mayor and City Council

SUBJECT: Implementation of Truncated Domes

SUMMARY

THIS IS AN INFORMATION ITEM ONLY. NO ACTION IS REQUIRED ON THE PART OF THE COMMITTEE OR THE CITY COUNCIL.

BACKGROUND

The Americans with Disabilities Act (ADA) requires detectable warnings (truncated domes) on hazardous vehicular ways, transit platform edges, and curb ramps. This provision was originally adopted in 1991, but a suspension was imposed for detectable warning devices at curb ramps to conduct research on the performance of their detectability. The Department of Justice (DOJ) continued the suspension through July 26, 2001. The research determined that designs such as grooves and exposed aggregate, some of which are in the current City's standard design for curb ramps, were not detectable in the sidewalk and roadway environment because of similarities to other surface textures and defects. According to the research, truncated domes have a unique design that can be detected underfoot and with a cane. The research concluded that these other surfaces are not considered ADA equivalent and therefore, do not comply with the ADA requirements. Thus, truncated domes were determined to be the only acceptable detectable warning, under the ADA (See diagram above).

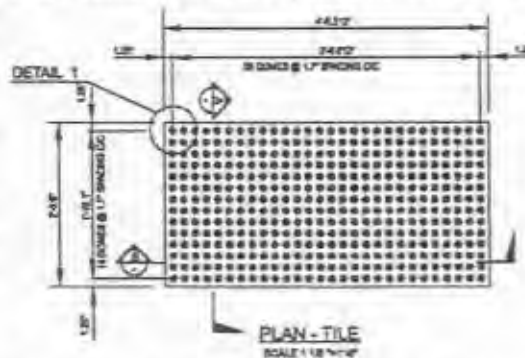

California requirements differ from the federal standards. The California Building Code [CBC] requires detectable warnings such as a half-inch lip beveled at 45 degrees as a detectable way-finding edge for persons with visual impairment, slip-resistant contrasting finish and a 12-inch grooved border at the level surface of the sidewalk. Truncated domes as a detectable warning are required only when the curb ramp slope is flatter than 1:15 (i.e. 1 inch vertical for every 15 inches horizontal) or 6.7% slope.

DISCUSSION

Due to the difference between the state and federal law regarding acceptable detectable warnings and questions about whether truncated domes provided greater accessibility and usability for our community, the City decided to solicit feedback from our communities before making a final design decision. This approach was similar to the one taken by the City of Denver, Colorado.

In our follow-up conversations with the City of Denver, we learned that Denver abandoned their approach as they were told that federal funding they were to receive may be withheld if they do not comply. Additionally, at various seminars attended by staff, representatives of the Access Board, an independent Federal agency appointed by the President of the United States responsible for developing and enforcing the accessibility standards of the ADA, have reiterated the federal government's position that truncated domes must now be used. Accordingly, many jurisdictions including the following California cities and agencies have fully implemented truncated domes on their curb ramps by making it a requirement of both public and private projects: The California Department of Transportation (Caltrans), Cities of Los Angeles, Marin, Oakland, Sacramento San Francisco, San Jose, San Rafael, Roseville, and Marin County.

The U.S. Department of Transportation's Federal Highway Authority Board and the State's Department of Transportation have both sent memorandums to cities that all curb ramp construction and alteration projects must incorporate the truncated domes found in the draft Americans with Disabilities Act Accessibility Guidelines [ADAAG] for public rights-of-way. See U.S. Department of Transportation Memorandum dated May 6, 2002, as Attachment 1. A typical design standard is depicted hereto.



The revised standard curb ramp standard and specifications will be released for immediate distribution when they are approved by the Citywide Access Law Technical

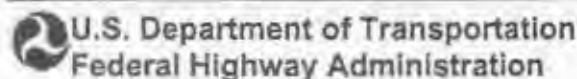

Memorandum

Subject: INFORMATION: ADAAG Detectable Warnings
(Truncated Domes)

Date: May 6, 2002

From: (Original signed by)
Dwight A. Horne
Director, Office of Program Administration

In reply, refer to: HIPA-20

To: Resource Center Managers
Division Administrators
Federal Lands Highway Division Engineers

Recently a number of questions have been raised by people from various agencies concerning the use of detectable warnings, specifically truncated domes, when constructing or altering curb ramps. Truncated domes are the standard design requirement for detectable warnings for determining the boundary between the sidewalk and street by people with visual disabilities.

The Department of Justice (DOJ) is the lead agency that oversees the Americans with Disabilities Act (ADA)(1990). The U.S. Access Board develops the minimum design standards for complying with the ADA. The Department of Transportation is a designated agency responsible for enforcing the standards and implementing regulations of the ADA's Title II (State and Local Government Services). The Federal Highway Administration (FHWA) is the enforcement authority for overseeing pedestrian discrimination issues under the Title II implementing regulations.

Detectable warnings were required in 1991 by the Americans with Disabilities Act Accessible Guideline (ADAAG) (regulatory standards) for hazardous vehicular ways, transit platform edges, and curb ramps. A suspension was placed on requiring detectable warnings at curb ramps and hazardous vehicular ways, but not for transit platform edges. The reason for the suspension was to conduct research on the performance of their detectability. The DOJ continued the suspension through July 26, 2001, which allowed 10 years for conducting research. The research determined that other designs used in place of truncated domes such as grooves, striations, and exposed aggregate, were not detectable in the sidewalk and roadway environment because of the similarities to other surface textures and defects. Truncated domes have a unique design that can be detected underfoot and with a cane, and other surfaces are not considered ADA equivalent and therefore do not comply with the ADA requirements.

The DOJ had the option of allowing the suspension to expire on July 26, 2001 or publish a Federal Register Notice to continue the suspension. They decided to let the suspension expire. Consequently, since July 26, 2001 detectable warnings are again required. FHWA is obligated to enforce the requirements, and State and local governments are required to apply the minimum design standards when constructing and altering pedestrian facilities, though we encourage higher than minimum standards where possible.

The original ADA design standard for truncated domes is found in ADAAG (4.29.2). After the research was conducted, a new design recommendation was made for the dimension and placement of the domes on curb ramps. Both FHWA and the U.S. Access Board are encouraging the use of the new design over the original. Information on the recommended design and other useful information are included in the attachment.

Attachment

Information on Detectable Warnings (truncated domes)

Detectable warnings are an Americans with Disabilities Act (ADA) requirement in the current Americans with Disabilities Act Accessibility Guidelines (ADAAG) for the use of detecting the boundary between the sidewalk and the street. The original requirement in ADAAG was suspended for a time to conduct further research. Research was conducted, and the suspension of the requirement was lifted on July 26, 2001, and are now required when constructing and altering curb ramps. Truncated domes are the only detectable warnings allowed by ADAAG. Grooves, exposed aggregate, and other designs intended for use as detectable warning are too similar to pavement textures, cracks and joints and are not considered equivalent facilitation. Truncated domes are a unique design and have proven to be the most detectable surface.

Where to find information on detectable warnings:

Where to find the regulation on the suspension and requirement:

The US Department of Justice website, www.usdoj.gov/crt/ada/detwarn.htm, or visit the US Access Board's website, www.access-board.gov, click on "publications," go to "facilities," go to "Detectable Warnings: Final Rule"

Where to find the design and application requirement in ADAAG:

Visit the US Access Board's website, www.access-board.gov, click on "publications," go to "facilities," go to "ADA Accessibility Guidelines (ADAAG)" -the provision is in 4.7.7 under Curb Ramps

Where to find technical information and a list of manufactures:

Visit the US Access Board's website, www.access-board.gov, click on "publications," go to "Public Rights-of-Way," go to *Detectable Warnings: Synthesis of US and International Practice*

Where to find the recommended design for curb ramps:

Visit the US Access Board's website, www.access-board.gov, click on "publications," go to "Public Rights-of-Way," go to *Building A True Community: Accessible Public Rights-of-Ways*, sections X02.5.6.2 through X02.5.7.3. After a number of years of research there is a new recommended design for detectable warning/truncated dome. Both the US Access Board and FHWA recommend the new design pattern and application over the original ADAAG design. FHWA's *Designing Sidewalks and Trails for Access, Part II, Best Practices Design Guide* has comparable information to the Building A True Community report. At the time the FHWA *Designing Sidewalks and Trails for Access*, went to print, the suspension had not been lifted, so the text in Chapter 6 does not mention that detectable warnings are required.

Web Site Guidelines Directory

To provide Feedback, Suggestions or Comments for this page contact John C. Fegan at john.fegan@fhwa.dot.gov.

- 1) *Design phase: public projects in the design phase (schematic, design development, or construction document) shall comply with the new City standard curb ramp drawings.*
- 2) *Contracts processing phase: public projects in the contracts processing phase shall comply with the new City standard curb ramp drawings.*
- 3) *Bidding phase but not awarded (out to bid): public projects which are out to bid, but not yet awarded, shall comply with the new City standard curb ramp drawings.*
- 4) *Contract awarded but ramps not constructed: those public projects for which the contract has been awarded but the ramps have not yet been constructed are strongly encouraged to use the new City standard curb ramp drawings. The decision of whether to use the new standard curb ramp drawings will be made on a case-by-case basis depending on various factors, including: available funding, willingness of contractor to negotiate a fair price, and nature of project (is it integral to the project – i.e. sidewalk project). If agreeing on a price presents a challenge, consider exploring time and materials for a few curb ramps to determine the price. If the contractor is not willing to negotiate a fair price, then look at the contract to determine whether there is a “deductive change order” provision, and whether there is a unit price for the curb ramps, as another avenue to achieve the installation of curb ramps consistent with the new City standards.*
- 5) *Ramps constructed but not yet accepted: if the curb ramp is otherwise compliant (only missing truncated domes), then defer the ramp(s) to the Transition Plan Update.*
- 6) *Ramps constructed and accepted: defer to the Transition Plan Update.*

B. Private Projects:

- 1) *Plan check/review phase: private projects in plan check/review phase shall comply with the new City standard curb ramp drawings.*
- 2) *Permitted, but not built: DSD is sending a “Notice” to the industry informing them to comply with the new standard curb*

ramp drawings

2. General:

Newly constructed or altered streets, roads, and highways must contain curb ramps or other sloped areas at any intersection having curbs or other barriers to entry from a street level pedestrian walkway.

28 Code of Federal Regulations § 35.151(e)(1).

Newly constructed or altered street level pedestrian walkways must contain curb ramps or other sloped areas at intersections to streets, roads, or highways.

28 Code of Federal Regulations §35.151(e)(2).

A curb ramp shall be provided wherever an accessible route crosses a curb – ADAAG 4.7.1.

Curb ramps shall be constructed at each corner of street intersections and where a pedestrian way crosses a curb. The preferred and recommended location for curb ramps is in the center of the crosswalk of each street corner. Where it is necessary to locate a curb ramp in the center of the curb return and the street surfaces are marked to identify pedestrian crosswalks, the lower end of the curb ramp shall terminate within such crosswalk areas – 2001 CBC 1127B.5.1.

3. Detectable Warnings:

A curb ramp shall have a detectable warning complying with ADAAG 4.29.2. ADAAG 4.7.7.

Detectable warnings shall consist of raised truncated domes, ADAAG 4.29.2.

A curb ramp shall have a detectable warning . . . when the ramp slope is less than 1 unit vertical to 15 units horizontal. Detectable warnings shall consist of raised truncated domes. 2001 CBC 1127B.5.8.

Curb ramps shall be designed consistent with the new City standard drawings for curb ramps, which include truncated domes. Truncated domes are required by the Americans with Disabilities Act Accessibility Guidelines. The new design is consistent with the recommendation by the U.S. Department of Transportation Federal Highway Administration (FHWA) and the U.S. Access Board. Federal Yellow shall be used for the truncated domes, unless there is a compelling reason otherwise, which is approved by the Access Law Technical Group.

This policy is specific to curb ramps only. The overall street and sidewalk design is required to comply with the ADA/ADAAG, the CBC, and other governing laws and regulations adopted at the time of submittal for a building permit review or design of the public right-of-way project.

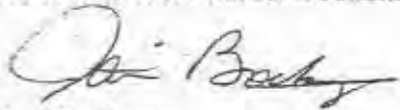

Patti Boekamp
Engineering and Capital Projects Acting Director

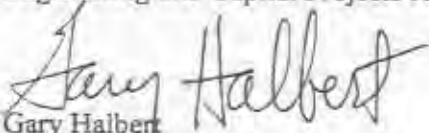

Gary Halbert
Development Services Acting Director

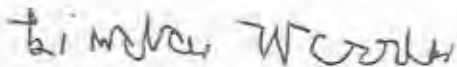

Linda Woodbury
Disability Services Coordinator

- Attachments:
1. City Manager's Report
 2. Information: ADAAG Detectable Warnings (Truncated Domes)/US Dept. of Transportation Memorandum, May 6, 2002
 3. New City of San Diego Standard Curb Ramp Drawings

CITY OF SAN DIEGO
M E M O R A N D U M

DATE: December 21, 2004

TO: City Departments and City Facility Managers

FROM: Patti Boekamp, Engineering and Capital Projects Director
Gary Halbert, Development Services Director
Linda Woodbury, Disability Services Coordinator

SUBJECT: Accessible Standards on Cross Slope, Running Slope, and Pedestrian Ramp Design for City-Owned and Leased Facilities

This memorandum sets forth the City's recommendations to be used in the new construction, alteration, and/or addition of City-owned or leased facilities including the public right-of-way. These recommendations should be incorporated in all City contracts for new construction, alteration, and addition projects as appropriate.

As part of the City's ongoing efforts to ensure compliance with the State and Federal accessibility laws¹, the City's Access Law Technical Group² is releasing this memorandum of recommendations to address certain issues pertaining to accessible routes of travel. When a recommendation is specified, it is to be followed in new construction, alterations, and additions to all City-owned and leased facilities unless, the Deputy Director and the Access Law Technical Group officially determine that to follow such a recommendation is impracticable to implement.

Please note this memorandum does not address curb ramps. Refer to Access Law Memorandum 2004-03 for City policy on curb ramp design and construction. Curb ramps and pedestrian ramps are often used interchangeably to refer to the ramps found at street corners. The precise name for this type of ramp, however, is a curb ramp. Pedestrian ramps are those which are paved walkways with a running slope steeper than 5.0% and integrated with landings and handrails.

A reference to a specific code section is a recitation of current legal requirements, whereas a recommendation sets forth a goal that exceeds minimum legal requirements. The recommendations set forth here are in bold italics.

Walks and Sidewalks at Accessible Routes

Cross Slope

¹ The California Building Code (CBC) and Americans with Disabilities Act (ADA)/Americans with Disabilities Act Accessibility Guidelines (ADAAG), respectively.

² Access Law Technical Group - a technical group of City staff formed to develop accessibility standards for construction (which may exceed minimum requirements), develop policies on accessible design, and provide resolution on unclear areas of accessibility requirements.

A. Existing Requirements

Cross Slope is the slope that is perpendicular to the direction of travel – 2001 CBC 1102B and ADAAG 3.5.

Surface cross slopes shall not exceed ¼ inch per foot except when the enforcing agency finds that due to local conditions it creates an unreasonable hardship³, the cross slope shall be increased to a maximum of one-half inch per foot (4.0%) for distances not to exceed 20 feet – 2001 CBC 1133B.7.1.3 Exception.

B. Recommendation:

In order to accommodate construction tolerances and variations in field conditions, the cross slope at paved walking surfaces that are part of an accessible route⁴ should have a maximum cross slope of 1.5% (1:66) gradient. This includes stabilized decomposed granite paved walking surfaces and sidewalks along the public right-of-way.

2. Running Slope

A. Existing Requirements:

1. Running Slope is the slope that is parallel to the direction of travel – 2001 CBC 219 and ADAAG 3.5.
2. Slope in the direction of travel shall not exceed 1:20 gradient (5.0%) – 2001 CBC 1133B.7.3 and ADAAG 4.3.7.
3. Any part of an accessible route with a slope greater than 1:20 gradient (5.0%) shall be considered a ramp and shall comply with ADAAG 4.8 – ADAAG 4.8.1.
4. Continuous common surface along the accessible route shall not be interrupted. All walks with continuous gradient shall have level areas at least 5 feet in length at intervals of at least every 400 feet – 2001 CBC 1133B.7.6.

³ Unreasonable Hardship is defined in the CBC as follows: Unreasonable hardship exists when the enforcing agency finds that compliance with the building standard would make the specific work of the project affected by the building standard unfeasible, based on an overall evaluation of the following factors: a. The cost of providing access; b. The cost of all construction contemplated; c. The impact of proposed improvements on financial feasibility of the project; d. The nature of the accessibility which would be gained or lost; e. The nature of the use of the facility under construction and its availability to persons with disabilities. The details of any finding of unreasonable hardship shall be recorded and entered in the files of the enforcing agency. 24 California Code of Regulations Section 222. Situations involving an application for unreasonable hardship should first be discussed with a team member of the Technical Group. Final determinations of unreasonable hardship are made by the building official.

⁴ Accessible Route is defined in the ADAAG as a continuous unobstructed path connecting all accessible elements and spaces of a building or facility. Exterior accessible routes may include parking access aisles, curb ramps, crosswalks at vehicular ways, walks, ramps, and lifts.

5. If an accessible route has less than 60 inches clear width, then passing spaces at least 60 inches by 60 inches shall be located at reasonable intervals not to exceed 200 feet. A T-intersection of two corridors or walks is an acceptable passing place – ADAAG 4.3.4.
6. The grade of the pedestrian access route within a sidewalk shall not exceed the grade established for the adjacent roadway - Draft ADAAG for Public Rights-of-Way Section 1103.5

EXCEPTION: The running slope of a pedestrian access route shall be permitted to be steeper than the grade of the adjacent roadway, provided that the pedestrian access route is less than 1:20, or complies with Draft ADAAG for Public Rights-of-Way Section 405.

B. Recommendation:

In order to accommodate construction tolerances and variations in field conditions, the running slope at paved walking surfaces that are part of an accessible route should not exceed 4.5% (1:22) gradient.

II. Pedestrian Ramp

Existing Requirements:

- A.
 1. Any path of travel shall be considered a ramp if its slope is greater than a foot rise in 20 feet of horizontal run (1:20 gradient, or 5.0%). The least possible slope shall be used for any ramp – 2001 CBC 11335.5.1.
 2. The maximum slope of a ramp that serves any exit way, provides access for persons with physical disabilities or is in the path of travel shall be 1 foot rise in 12 feet of horizontal run (8.33% gradient) – 2001 CBC 1133B.5.3.
 3. The cross slope of ramp surfaces shall be no greater than 1 unit vertical in 50 units horizontal (2.0% slope) – 2001 CBC 1133B.5.3.1.
- B.
 1. Any part of an accessible route with a slope greater than 1:20 (5.0%) shall be considered a ramp and shall comply with 4.8 – ADAAG 4.8.1
 2. The least possible slope shall be used for any ramp. The maximum slope of a ramp in new construction shall be 1:12 (8.33%). The maximum rise for any run shall be 30 inches. Curb ramps and ramps to be constructed on existing sites or in existing buildings or facilities may have slopes and rises as allowed in 4.1.6(3)(a) if space limitations prohibit the use of a 1:12 (8.33%) slope or less – ADAAG 4.8.2.

3. The cross slope of ramp surfaces shall be no greater than 1:50 (2.0%). Ramp surfaces shall comply with 4.5 – ADAAG 4.8.6.

C. Recommendation:

1. *The least possible slope should be used for a pedestrian ramp without exceeding the maximum running slope of 6.67% (1:15) gradient.*
2. *If site conditions restrict the use of 6.67% (1:15) gradient or less, then the running slope of the pedestrian ramp(s) should not exceed 8.33% (1:12) gradient.*

These recommendations are specific to cross slope, running slope, and pedestrian ramp only. The overall design of the project are still required to comply with the CBC, the ADA/ADAAG, the City of San Diego Standard Drawings, and other governing laws, regulations and policies adopted at the time of the submittal of the project for a building or engineering permit review. In cases where certain accessibility design regulations and policies may have conflicts of standards, the stricter standard shall apply to the project.



Patti Boekamp
Engineering and Capital Projects Director

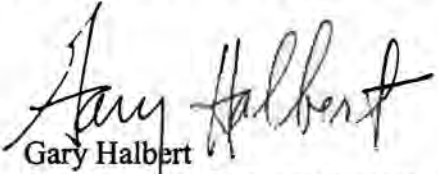

Gary Halbert
Development Services Director

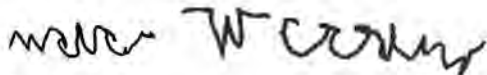

Linda Woodbury
Disability Services Coordinator

CITY OF SAN DIEGO
MEMORANDUM

DATE: December 14, 2005

TO: Park Planning and Development Division Project Managers and Maintenance Assessment District Grounds Maintenance Managers

FROM: Ann Hix, Deputy Director, Park and Recreation Department Open Space Division
April Pendera, Deputy Director, Park and Recreation Department, Park Planning and Development Division

SUBJECT: Policy on Avoiding Use of Non-Native Invasive Plants in Park & Recreation Department Projects

PARK AND RECREATION DEPARTMENT POLICY

All future Park and Recreation Department projects, whether upgrades to existing facilities or new construction, should avoid the use of any of the Most Invasive non-native plants species listed in the attached *Invasive Ornamental Plant Guide* in any landscape, and should avoid the use of any of the Moderately Invasive non-native species in landscapes located on parcels adjacent to open space and/or Multi-Habitat Planning Area (MHPA) lands.

Most Invasive Plants: It is important to avoid the use of the Most Invasive species in **any** landscape because it has been documented that they may become established in open space lands from distant plantings. This is because plant seeds or spores can spread long distances through wind, water, or other carriers to reach open space.

Moderately Invasive Plants: Moderately invasive species should be avoided in landscapes located on parcels adjacent to publicly-owned open space lands or open space easements, or the Multi-Habitat Planning Area (MHPA). The *Invasive Ornamental Plan Guide* identifies habitats in which a plant species from this list may be invasive.

Exceptions: While every attempt should be made to substitute alternative, non-invasive plant species for those invasive species listed, in certain unique situations, such as, but not limited to, historic and/or significant landscapes which are not located adjacent to open space or MHPA lands, it may be appropriate to selectively use plant species identified in the Most Invasive and Moderately Invasive plant lists. In those specific instances, a justification letter approved by the Deputy Director of the appropriate Park and Recreation Department Division must be written and placed in the project file.

EXPLANATION

We are experiencing an invasion of non-native plants in over 70% of our 24,000+ acres of open space, which crowd out native plants and reduce the quality of habitats. Removing these non-natives once established is an expensive, time-consuming, and often not very successful process. Additionally, it is important that the Park and Recreation Department lead by example, comply with the City's Multiple Species Conservation Program (MSCP), and be a good steward to the open space lands we manage and the MHPA preserve our parks are often adjacent to.

The City's MSCP Subarea Plan, Section 1.4.3 Land Use Adjacency Guidelines, states that adjacency issues must "be addressed, on a project by project basis, during either the planning (new development) or management (new and existing development) stages to minimize impacts and maintain the function of the MHPA.....No invasive non-native plant species shall be introduced into areas adjacent to the MHPA."

Recently, the San Diego Chapters of the California Native Plant Society and the American Society of Landscape Architects worked together to develop the attached *Invasive Ornamental Plant Guide*. The guide is a good resource for explaining characteristics of invasive plants and how they impact native plants, and provides a matrix list of Most Invasive and Moderately Invasive plant species that should be used either not at all, or, only in certain locations. We have included the matrix list as an attachment; however, we encourage staff to explore the website to learn more about invasive plant species and about the *Invasive Ornamental Plant Guide* <http://www.asla-sandiego.org/content/plantguide.html>. We have also ordered copies of the California Invasive Plant Council *Don't Plant a Pest* brochures for distribution to interested staff and the public. This brochure is a good visual and informative guide to what native or non-invasive plants can be used to replace species on the *Invasive Ornamental Plant Guide* matrix list. The brochure can also be accessed on the internet at the following web site <http://www.cal-ipc.org/dpp/planttypes.php?region=socal>.

If you have general policy questions, feel free to contact Ann at 619-533-6721. For more specific or technical questions, contact the following Open Space staff: Josh Garcia, Natural Resources Manager, at 619-533-6713; or Paul Kilburg, Open Space Lands Coordinator, at 619-533-6739.



Ann Hix
Deputy Director
Open Space Division

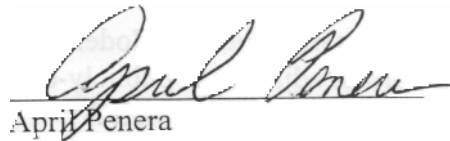

April Penner
April Penner
Deputy Director
Park Planning & Development Division