

# Quality knows no compromise

Components and  
standard products  
catalog 2019



# Table of contents

## I Mechanics

---

### Belt Weighers

MULTIBELT® Single-Idler Belt Weighers	5
MULTIBELT® Multi-Idler Belt Weighers	9
Speed Sensor FGA 20RSLE	13
Speed Sensor FGA 30R2	15
Correction system for Scales with variable Weigher Inclination	17
Recommendations for the Installation Planning of Belt Weighers	19

### Solids Flow Meters

MULTISTREAM® B Solids Flow Meter	23
MULTISTREAM® G Solids Flow Meter	27

### Volumetric Feeder

Volumetric Feeders AccuRate Series	31
ProFlex® C500 / C3000 / C6000 Volumetric Feeder	39

### Platform Scales

Platform Scales DVC/DVM	43
DPW Pallet Scales	47

### Load Cells

Ring-Torsion Load Cells RTB	49
Compact Ring-Torsion Load Cells RTN	53
Load Cells VBB and Load Cell Mounts VEB	57
VDW Self-Centering Pressure Load Cell	61

## **Load Cells Mounts**

SENSiQ® Elastomer Mount (SEM)	65
SENSiQ® Secure Mount (SSM)	69
SENSiQ® Secure Mount PLUS (SSM PLUS)	77
SENSiQ® Pendulum Mount (SPM)	81
Load Cells VBB and Load Cell Mounts VEB	85
SENSiQ® Fixed Mount (SFM)	89
SENSiQ® Fixed Mount PLUS (SFM PLUS)	91
Accessories for SENSiQ® Mounts	95
Engineering and design rules for hopper scales with SENSiQ®	99

## **Weighing Sensors**

Weighbeam DWB 11.5t - 25t	107
SENSiQ® Weighbeam WB 40t - 600t	111
Measuring Eye, DMA Type	119

## **II Electronics**

---

INTECONT® Satus, Indicator for Beltscales	123
INTECONT® Tersus - Mass flow rate measurement	127
DISOCONT® Tersus Measurement, Control and Supervisory System	132
Weighing Indicator DISOMAT Parvus	136
DISOMAT® Satus Weighing Transmitter	140
Disomat® Opus Weight Indicators	144
DISOMAT® Opus - ZEUS Weighbridge	148
DISOMAT® Tersus weighing terminal	150
DISOMAT® Tersus - Unit Load Handling Scale	157
DISOMAT® Tersus - Crane scale	159
DISOMAT® Tersus - Filling Scale	161
DISOMAT® Tersus - Discharge Scale	165
DISOMAT® Tersus - ZEUS Road Weighbridge	169
DISOMAT® Tersus – JASON Road Weighbridge	171
DISOMAT® Tersus - HERMES Dynamic Axle Load Scales	173
A/D Converter DISOBOX® Plus	175

Display and Operator Panels VOP 280xx/VFG 28000, Keyboard VTT 28000	179
---	-----

Display and Operating Panels VOP 28090/VFG 28090 ATEX 2GD Keyboard VTT 28090 ATEX 2GD	183
--	-----

### **III Software**

---

DISOVIEW E - The Legal-for-trade Scale Window for Windows PCs	187
---	-----

DISOSAVE Legal-For-Trade Memory	191
---------------------------------	-----

Modbus OPC Server VPC 28004	193
-----------------------------	-----

Communication Modules for PCS 7, TIA and STEP 7 to SIEMENS Controllers	195
---	-----

### **IV Accessories**

---

The wireless way to your scale – Bluetooth radio modules	199
--	-----

VFM 28000 Radio Module	201
------------------------	-----

Secondary- and Large-size Display Units	203
---	-----

DISOPRINT VPR 20150 Flat Bed Printer	207
--------------------------------------	-----

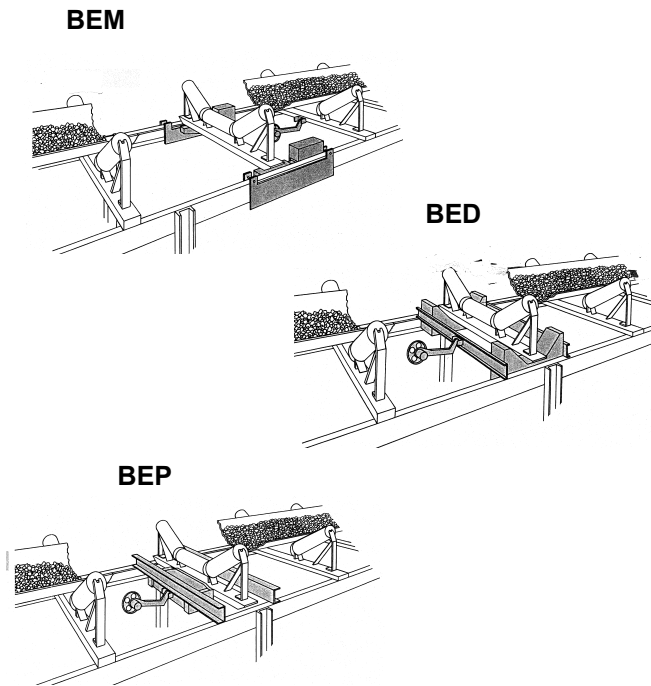
Scale Simulators, Types DISOTEST 11 and VWZ 20410	209
---	-----

Terminal Boxes Types VAK and VKK for Sensors	211
--	-----

Measuring, Data and Control Cables	215
------------------------------------	-----



## MULTIBELT® Single-Idler Belt Weighers



- Continuous bulk solids measurement in belt conveyor systems
- Suitable for flow rates up to 15,000 t/h
- Accuracy up to  $\pm 0.5\%$
- Also legal-for-trade-version
- Simple and quick installation
- Type BEM – designed modularly, suitable for any belt width
- Types BEP/BED – weighing platforms, suitable for IEC belt widths
- Suitable for use in ATEX explosion-zones

### Application

Single-Idler Belt Weighers are used for continuous acquisition of flow rates and totalized amounts. They are especially designed for integration into continuously operating belt conveyors enabling accuracies of up to  $\pm 0.5\%$  to be achieved. They can be employed for a whole variety of tasks:

- Throughput and consumption measurement in production plants
- Accountability of stored and retrieved amounts
- Load limit alarm
- Batching, in load-out stations
- Legal-for-trade weighing
- Prefeeder control.

Their rugged design ensures a high-degree of reliability and availability.

We have the right Belt Weigher for every Belt Conveyor. For Multi-Idler Belt Weighers designed for higher accuracies, see separate Spec Sheet BV-D2050.

### Construction

The standard single-idler belt weigher comprises:

- Weighing module or platform for accommodating user's idler set
- Overload-protected load cell(s) with high degree of protection
- Cable junction box for connection of sensors, and
- All fixing elements required for mounting.

For speed measurement, various speed transducers e.g. friction wheel tachometers, are available as options.

### Operating Principle

Belt Weighers are used to measure continuous material flows of varying amounts.

Load cells acquire the weight of load on particular belt sections. A speed transducer measures the belt speed.

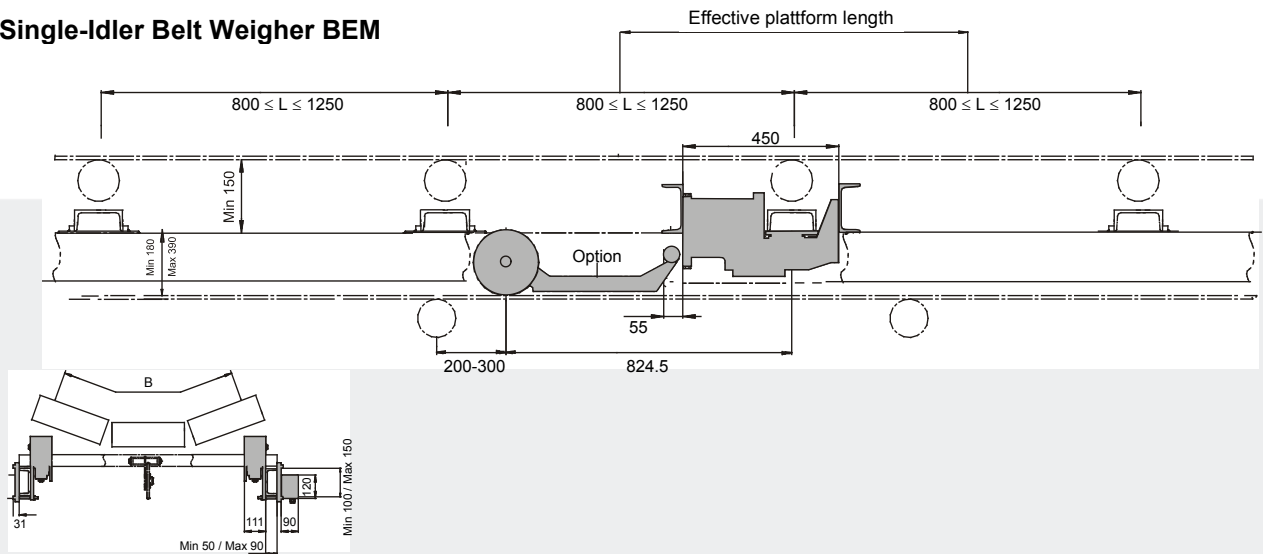
The product of these two variables is the current flow rate. Integration of flow rate determines the totalized amount of material.

If belt weighers are not equipped with speed measurement system, belt speed is not acquired. In the secases, weighing electronics use the constant speed value set by parameter.

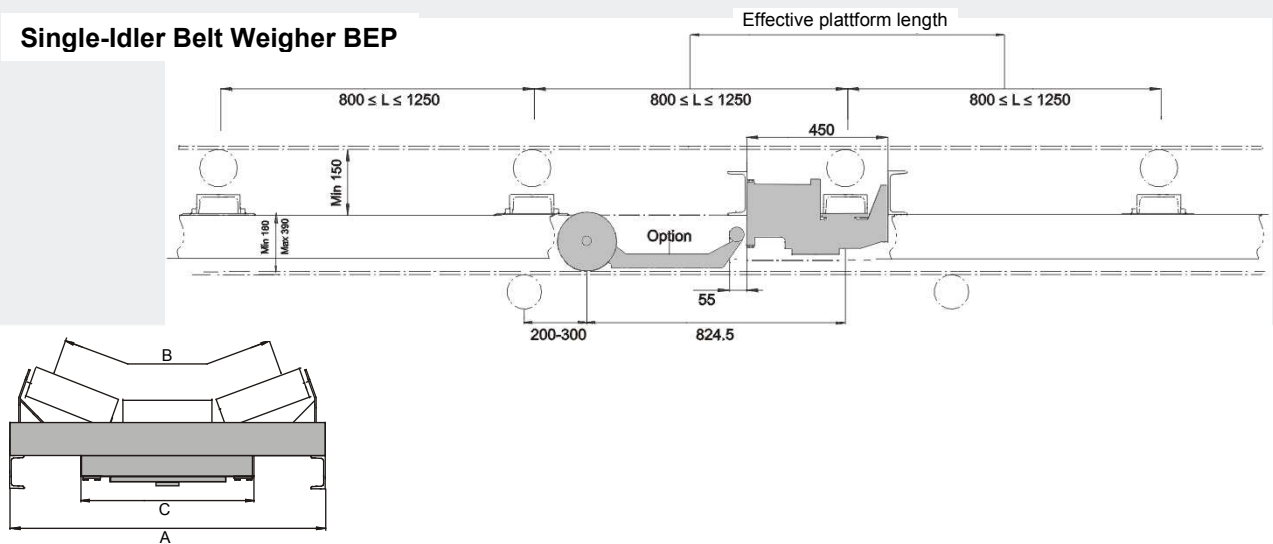
However, this method can adversely affect the accuracy.

Dimensions [mm]

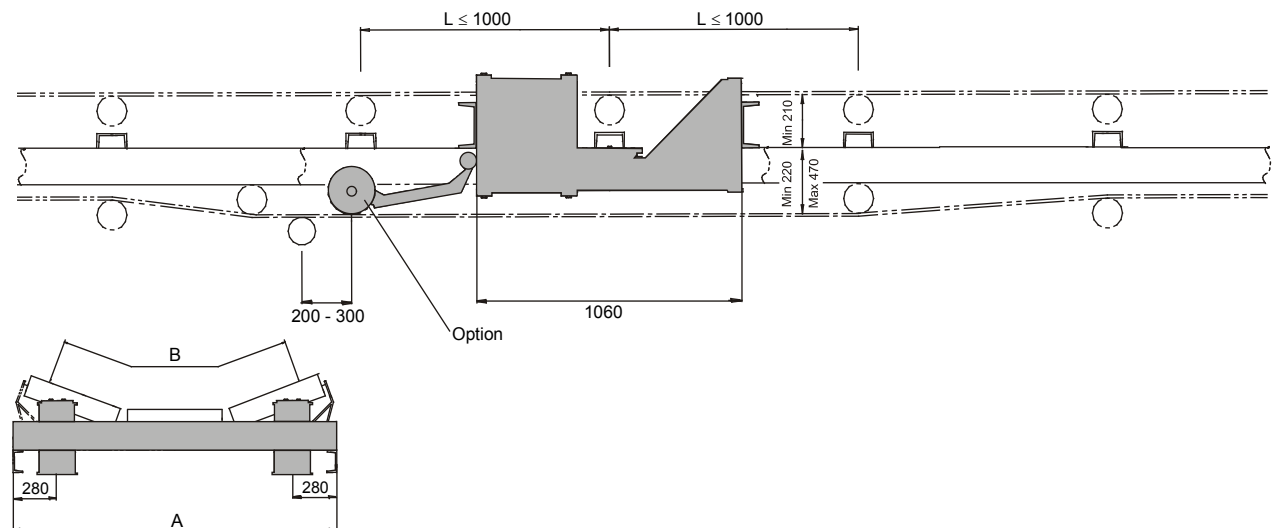
Single-Idler Belt Weigher BEM



Single-Idler Belt Weigher BEP



Single-Idler Belt Weigher BED



## Dimensions [mm]

MULTIBELT	Dimensions [mm]										
<b>BEM</b>	Measure B Belt width	400	500	650	800	1000	1200	1400			
	Measure A	700	800	950	1150	1350	1600	1800			
<b>BEP</b>	Measure B Belt width	400	500	650	800	1000	1200	1400			
	Measure C	440	440	440	740	740	740	740			
<b>BED</b>	Measure A								2050	2250	2500
	Measure B Belt width								1600	1800	2000

## Technical Data

MULTIBELT Single-Idler Belt Weighers	Accuracy without speed measurement system only achievable at constant speed	Flow rate	Weight	Belt Speed	Belt Rise
<b>BEM</b>	±1,0 % of nominal flow rate	to ca. 4.000 t/h	≈ 60 kg	to ca. 6 m/s	~ 20° (No relative material movement)
<b>BEP</b>	±0,5 % of nominal flow rate	to ca. 6.000 t/h	≈ 100 kg		
	±1,0 % of actual flow rate				
<b>BED</b>	±0,5 % of nominal flow rate	to ca. 15.000 t/h	≈ 300 kg		
	±1,0 % of actual flow rate				

### Accuracy

Specified accuracies refer either to nominal (maximum) flow rate or to the corresponding actual flow rate in the range of 20 to 100 %.

Specified accuracies assume that the variant is installed in a suitable belt conveyor and that the measuring station is installed and calibrated in accordance with our installation and calibration instructions.

For optimum planning-in of your belt weigher(s), see Spec Sheet BVR2220 'Recommendations for ensure proper functioning and high accuracy'.

### Special Requirements

Should you have special requirements, e.g.

- Legal-for-trade variants
- Belt speed out of specified range
- Meter for varying belt angle
- Prefeeder control
- Flow rates exceeding 15,000 t/h
- Higher accuracies
- Special belt widths
- Special belt conveyors, please let us know.

### Ordering Data

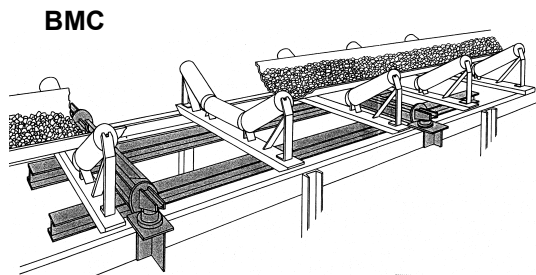
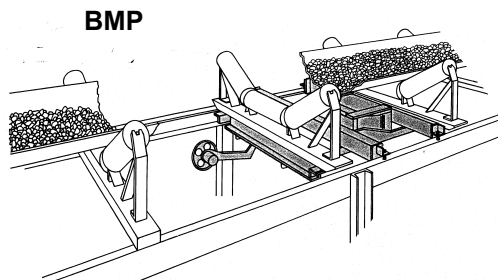
For us to be able to handle your order smoothly and quickly, please let us have the data below in addition to the ordering number:

- Belt width [mm]
- Flow rate [t/h]
- Belt rise [°]
- Belt speed [m/s]
- Accuracy [%]
- Nominal flow rate ( )
- Actual flow rate ( )

Single-Idler Belt Weigher Variants
<b>BEM 400 - 1400</b> Belt weigher of modular design, belt widths from 400 - 1400 mm
<b>BEP 400 - 1400</b> Belt weigher with weighing platform, IEC-belt widths from 400 - 1400 mm
<b>BED 1600 - 2000</b> Belt weigher with weighing platform, IEC-belt widths from 1600 - 2000 mm

Options
<b>FGA 24 A</b> – Speed measurement system, Namur switch with perforated disc
<b>FGA 20 RSLE</b> - Speed measurement system for belt speeds up to 3.5 m/s; friction wheel with rocker and support
<b>FGA 30 R2</b> - Speed measurement system for belt speeds up to 3.5 m/s; friction wheel, enclosed casing, rocker and support
<b>FGA 30 R2 K</b> - Speed measurement system for belt speeds from 3.5 m/s onward, with coupling for connection to shaft end
<b>FGA 53 K</b> - Speed measurement system for belt speeds from 0.1 m/s onward, with coupling for connection to shaft end

## MULTIBELT® Multi-Idler Belt Weighers



- Continuous bulk solids measurement in belt conveyor systems
- Suitable for flow rates up to 20,000 t/h
- Accuracy up to  $\pm 0.25\%$
- Also legal-for-trade-version
- Suitable for IEC belt widths
- Suitable for use in ATEX explosion-zones

### Application

Multi-Idler Belt Weighers are used for continuous acquisition of flow rates and totalized amounts. They are especially designed for integration into continuously operating belt conveyors and enable accuracies of up to  $\pm 0.25\%$  to be achieved. They can be employed for a whole variety of tasks:

- Throughput and consumption measurement in production plants
- Accountability of stored and retrieved amounts
- Load limit alarm
- Batching, in load-out stations
- Legal-for-trade weighing
- Prefeeder control.

Their rugged design ensures a high degree of reliability and availability.

Our product range is as varied as the demands of our customers. For Single-Idler Belt Weighers, see separate Spec Sheet BV-D 2049.

### Construction

The standard Multi-Idler belt weigher comprises:

- Weighing platform for accommodating user's idler sets
- Overload-protected load cell(s) with high degree of protection
- Cable junction box for connection of sensors, and
- All fixing elements required for mounting.

For speed measurement, various speed transducers e.g. friction wheel tachometers, are available as options.

### Operating Principle

Belt Weighers are used to acquire continuous material flows of varying amounts.

Load cells acquire the weight of load on particular belt sections.

The longer the belt section is, the less the measuring result is affected by external influences.

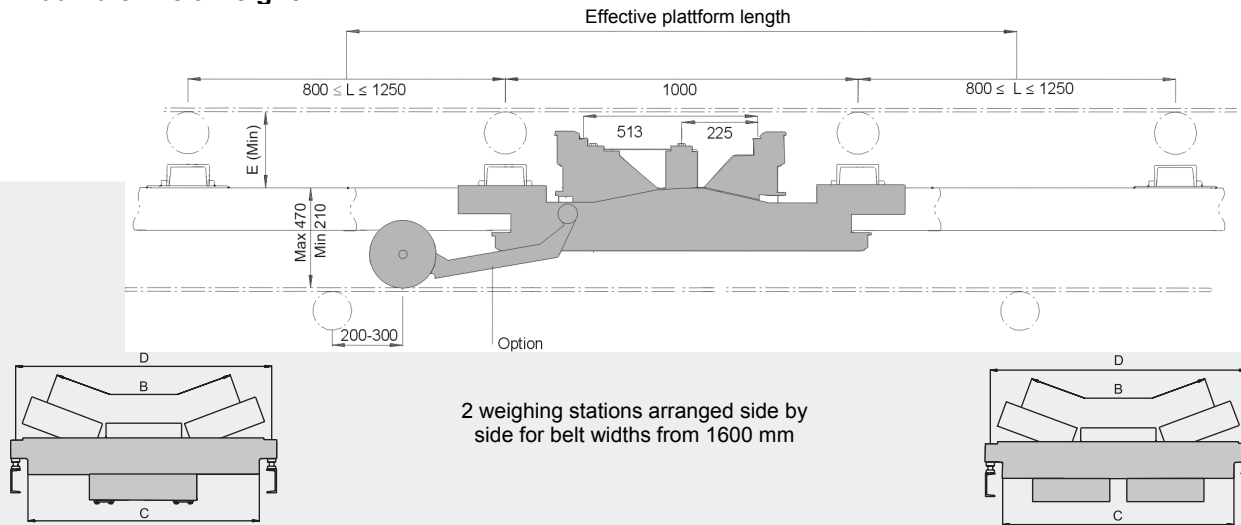
In addition to belt load acquired by load cells, belt speed is measured by a speed transducer.

The product of these two variables is the current flow rate.

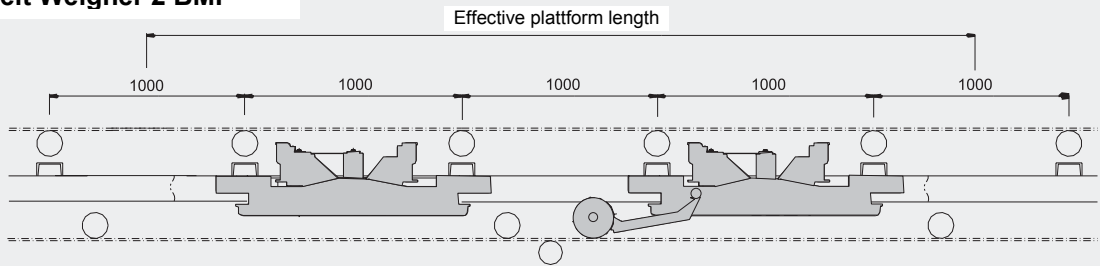
Integration of flow rate determines the totalized amount of material

**Dimensions [mm]**

**Dual-Idler Belt Weigher BMP**

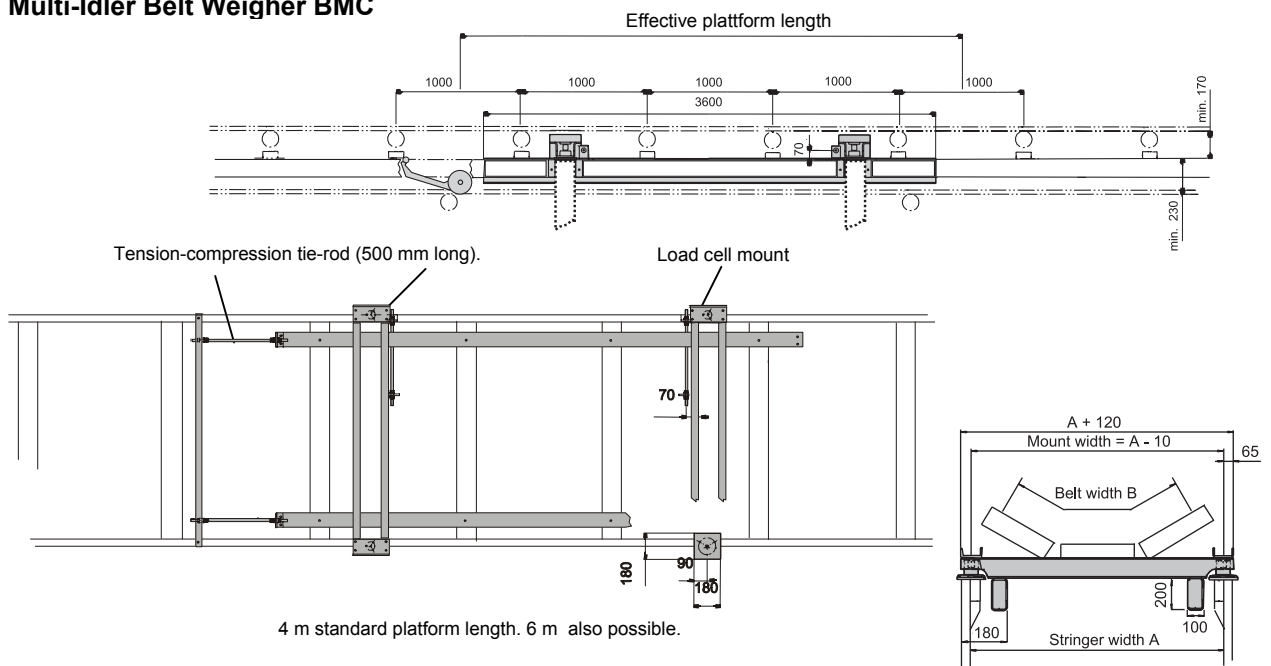


**Dual-Idler Belt Weigher 2 BMP**



2 BMP weighing stations arranged one after the other to achieve higher accuracies  
(Weighing station dimensions are the same as those of the BMP weighing stations)

**Multi-Idler Belt Weigher BMC**



## Dimensions [mm]

MULTIBELT	Dimensions [mm]									
<b>BMP</b>	Measure B Belt width	500	650	800	1000	1200	1400	1600 <sup>1)</sup>	1800 <sup>1)</sup>	2000 <sup>1)</sup>
	Measure C	616	766	966	1166	1416	1616	1880	2080	2330
	Measure D	740	890	1090	1290	1540	1740	1990	2190	2440
	Measure E	120	120	120	120	120	160			
<b>2 BMP</b>	Measure B Belt width	500	650	800	1000	1200	1400			
	Measure C	616	766	966	1166	1416	1616			
	Measure D	740	890	1090	1290	1540	1740			
	Measure E	120	120	120	120	120	160			
<b>BMC</b>	Measure A	800	950	1150	1350	1600	1800	2050	2250	2500
	Measure B Belt width	500	650	800	1000	1200	1400	1600	1800	2000

<sup>1)</sup> 2 weighing stations side by side

## Technical Data

MULTIBELT Multi-Idler Belt Weighers	Accuracy without speed measurement system only achievable at constant speed	Flow rate	Weight	Belt Speed	Belt Rise
<b>BMP</b>	±0.25 % of nominal flow rate	to ca. 15,000 t/h	≈ 200 kg to 1400 mm belt width	to ca. 6 m/s (Preferential range)	~ 20° (No relative material movement)
	±0.5 % of actual flow rate		≈ 400 kg to 1600 mm belt width		
<b>2 BMP</b>	±0.25 % of actual flow rate	to ca. 15,000 t/h	≈ 400 kg		
<b>BMC</b>	±0.25 % of actual flow rate	to ca. 20,000 t/h	≈ 380 - 480 kg		

### Accuracy

Specified accuracies refer either to nominal (maximum) flow rate or to the corresponding actual flow rate in the range of 20 to 100 %.

The accuracy specified for the 2 BMP / BMC types refers to corresponding actual flow rate in the range of 30 to 100 %.

Specified accuracies assume that the variant is installed in a suitable belt conveyor and that the measuring station is installed and calibrated in accordance with our installation and calibration instructions.

For optimum planning-in of your belt weigher(s), see Spec Sheet BVR2220 'Recommendations for ensure proper functioning and high accuracy'.

### Special Requirements

Should you have special requirements, e.g.

- Legal-for-trade variants
  - Belt speed out of specified range
  - Meter for varying belt angle
  - Prefeeder control
  - Special belt widths
  - Special belt conveyors,
- please let us know.

### Ordering Data

For us to be able to handle your order smoothly and quickly, please let us have the data below in addition to the ordering number:

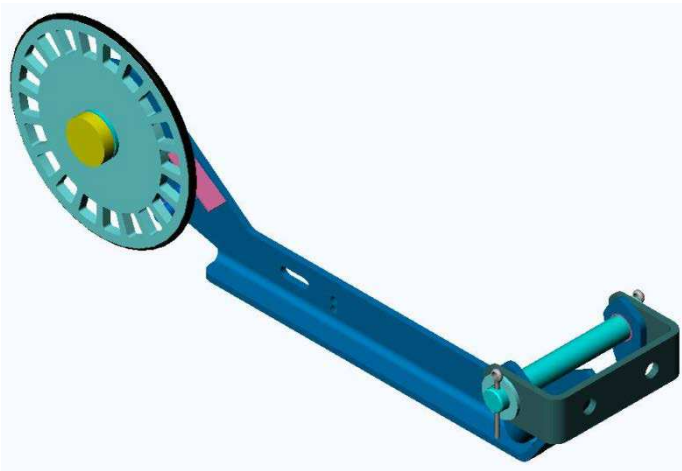
- Belt width [mm]
- Flow rate [t/h]
- Belt rise [°]
- Belt speed [m/s]
- Accuracy [%]
- Nominal flow rate ( )
- Actual flow rate ( )



<b>Multi-Idler Belt Weigher Variants</b>
<b>BMP 500 - 2000</b> Belt weigher with weighing platform, IEC belt widths from 500 to 2000 mm
<b>2 BMP 500 - 1400</b> Belt weigher with weighing platform, IEC belt widths from 500 to 1400 mm
<b>BMC 500 - 2000</b> Belt weigher with weighing platform, IEC belt widths from 500 to 2000 mm

<b>Options</b>
<b>FGA 24 A</b> – Speed measurement system, Namur switch with perforated disc
<b>FGA 20 RSLE</b> - Speed measurement system; friction wheel with rocker and support
<b>FGA 20 RSLE-VA</b> - Speed measurement system for belt speeds up to 3.5 m/s; friction wheel with rocker and support in stainless steel design
<b>FGA 30 R2</b> - Speed measurement system for belt speeds up to 3.5 m/s; friction wheel, enclosed casing, rocker and support
<b>FGA 53 K</b> - Speed measurement system for belt speeds from 3.5 m/s onward, with coupling for connection to shaft end

## Speed Sensor FGA 20RSLE



- **Cost-efficient integration**
- **High reliability**
- **Maintenance-free storage and sealings**
- **Easy handling**
- **Completely made of galvanized steel or stainless steel**
- **Legal-for-trade variant for MULTIBELT®-type belt weighers**
- **ATEX optional category 2GD (zones 21, 22, 1 or 2)**

### Application

The FGA 20RSLE speed sensors are designed for measuring the belt speed of belt conveyor systems.

They are used as optional equipment for MULTIBELT®-type belt weighers.

A customized speed sensor can be used in ATEX zones 21, 22, 1 or 2.

### Design

The speed sensor consists of a rocker that can be pivoted around an axis. The axis is mounted in a bracket that is attached to the machine (belt conveyor) to be monitored. The measuring wheel is attached to this rocker and runs slip-free on the belt to be measured. The belt speed is measured as a frequency signal through windows in the measuring wheel and with one or two (legal-for-trade) proximity sensor/s and processed using an evaluation device.

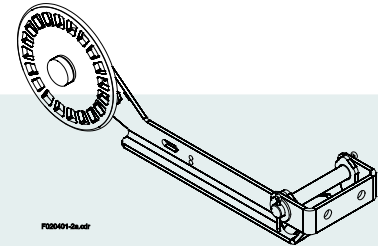
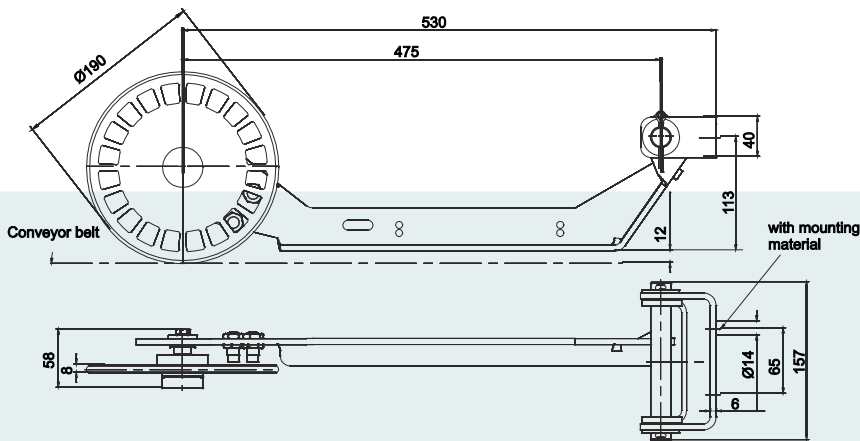
The FGA 20RSLE speed sensor is manufactured entirely of a highly corrosion-resistant galvanized steel and in the ATEX – certified model made of 1.4301 stainless steel.

### Function

The pulse wheel runs on the interior of the empty, returning belt of a belt feeder system with a rubber ring. Under its own weight, the wheel is friction-locked against the belt and is made to rotate by the belt movement. The non-slip motion means that the wheel circumferential velocity corresponds to the belt speed.

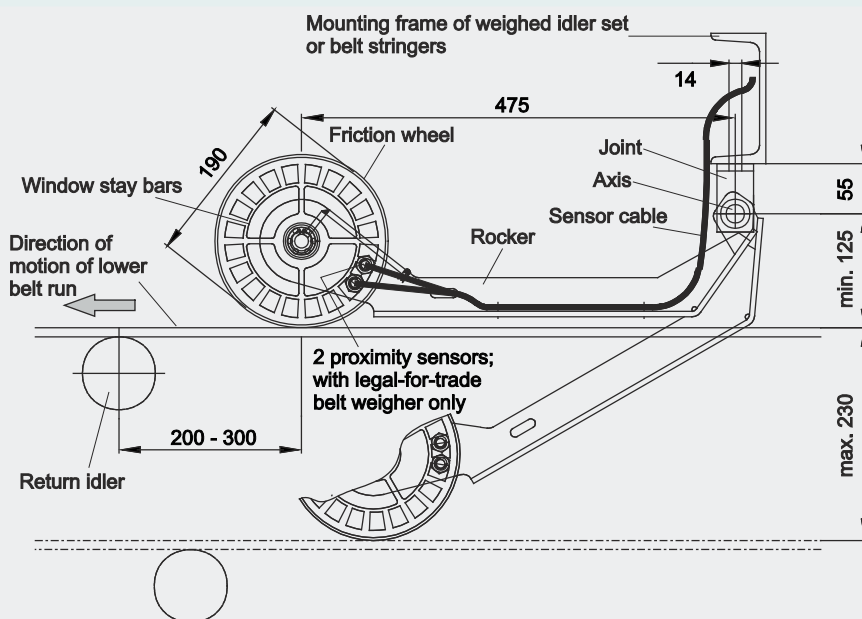
The rotational speed of the wheel is registered by a sensor that records the speed by means of transmitting a signal through an alternating series of windows and bars, recording a frequency that corresponds to the belt speed of the belt conveyor system. This frequency is transmitted to the evaluation electronics where it is analyzed.

### Dimensions [mm]



Operating temperature	-20 °C ... +50 °C
Operating temperature, ATEX	-20 °C ... +50 °C
Belt speed	< 3.5 m/s
Pulses	20 pulses per revolution = 33.5 pulses per meter of belt
Output signal	Namur
Weight	4.55 kg
Legal-for-trade type	2 proximity sensors
ATEX (option)	Zone 21, 22, 1 or 2

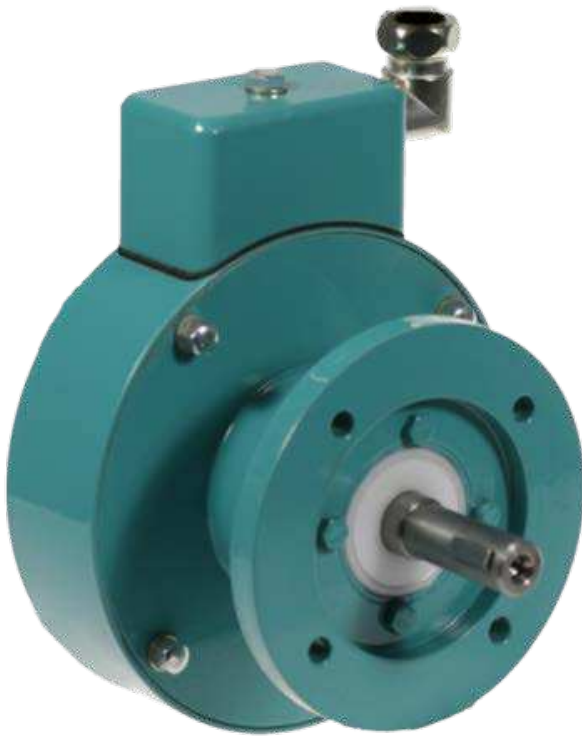
### Installation of the FGA 20RSLE



### Schenck Process Europe GmbH

Pallaswiesenstr. 100  
 64293 Darmstadt, Germany  
 T +49 6151 1531-0  
 F +49 6151 1531-66  
 sales@schenckprocess.com  
 www.schenckprocess.com

## Speed Sensor FGA 30R2



- High degree of reliability
- Robust design
- Maintenance-free storage and seals
- Made completely from steel
- Legal-for-trade variant for MULTIBELT-type belt weighers
- Designed for operation with friction wheel and rocker
- Drive system with coupling available
- Successor to the FGA 30R with identical connection dimensions
- ATEX optional category 2GD (Zone 21, 22, 1 or 2)

### Application

FGA 30R2 speed sensors are designed for measuring the belt speed of belt conveyor systems. They are used as optional equipment for MULTIBELT®-type belt weighers. A customized speed sensor can be used in ATEX zones 21, 22, 1 or 2.

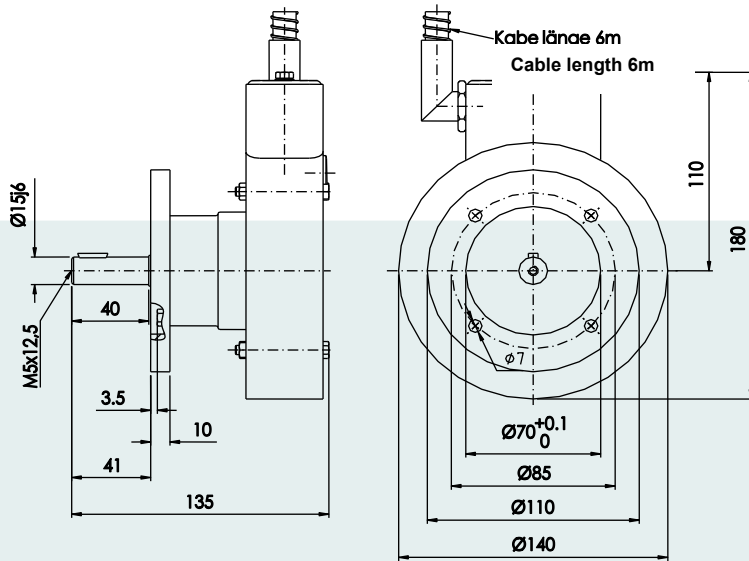
### Equipment

The speed sensor consists of a housing with an internal impulse wheel mounted on a drive shaft. The angular velocity of the shaft is measured as a frequency signal through windows in the measuring wheel and with one or two (legal-for-trade) proximity sensor/s and processed using an evaluation device. The FGA 30R2 speed sensor is made entirely of steel with a powder-coated surface. The FGA 30R2 can be fitted with a rocker and a friction wheel for use as a friction wheel speedometer for registering the speed of the returning belt. Alternatively, with a coupling the FGA 30R2 can be run by e.g. the tail pulley of a belt feeder system.

### Function

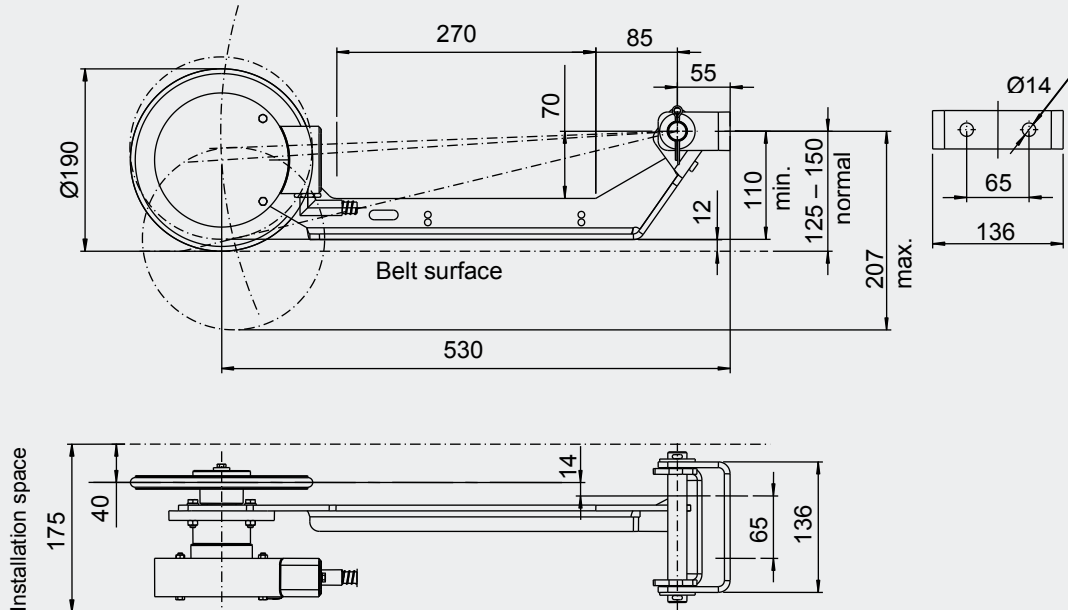
If operated as a friction wheel speedometer:  
The friction wheel runs on the interior of the empty, returning belt of a belt feeder system with a rubber ring. Under its own weight, the wheel is friction-locked against the belt and is made to rotate by the belt movement. The non-slip motion means that the wheel circumferential velocity corresponds to the belt speed. The rotational speed of the wheel is registered by a sensor that records the speed by means of transmitting a signal through an alternating series of windows and bars, recording a frequency that corresponds to the belt speed of the belt feeder system. This frequency is transmitted to the evaluation electronics where it is analyzed.

## Dimensions [mm]



Operational temperature	-25 °C ... +60 °C
Operational temperature, ATEX	-25 °C ... +60 °C
Belt speed	< 5 m/s
Max. rotational speed	3000 min <sup>-1</sup>
Pulses	30 Pulses/revolution
Output signal	Namur
Weight	3,2 kg
Standard design	1 Proximity sensor
Legal for trade design	2 Proximity sensors
ATEX (option)	Zone 21, 22, 1 or 2

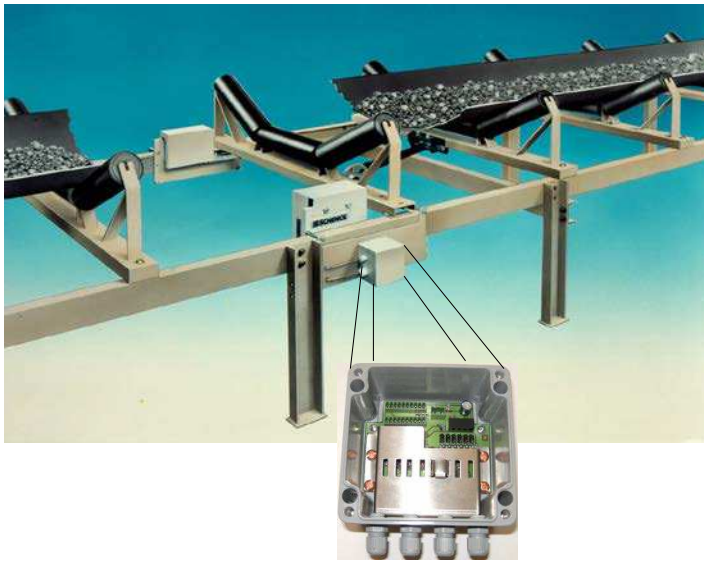
## Installation situation



## Schenck Process Europe GmbH

Pallaswiesenstr. 100  
 64293 Darmstadt, Germany  
 Phone: +49 6151 1531-0  
 Fax: +49 6151 1531-66  
 sales@schenckprocess.com  
 www.schenckprocess.com

## Correction system for Scales with variable Weigher Inclination



- Suited for any scales such as belt weighers
- Inclination correction: to  $\pm 29^\circ$
- Robust structure, IP65

### Application

The inclination correction system VME 28061 is used for correcting the measuring signal of a weighing unit if the inclination is variable. It is preferred for use with belt weighers.

### Structure

The device measures the inclination electronically and in accordance with the inclination corrects the signal of the load cell. It is installed in an IP65 enclosure. The device is mounted at a location with the same inclination as the scale to be corrected. The system is roughly aligned at the scale. Fine tuning is done electronically.

### Function

An inclined scale only measures a weight of the mass to be measured that is reduced by the cosine of the angle. The VME 28061 corrects this fault on the electrical output of a strain gauge load cell. The correct functions are not depending upon the load cell model and number nor the design of the electronic measuring unit as long as the electronic supplies the load cell with max. 12 V.

### Uncorrected readings of inclined scales

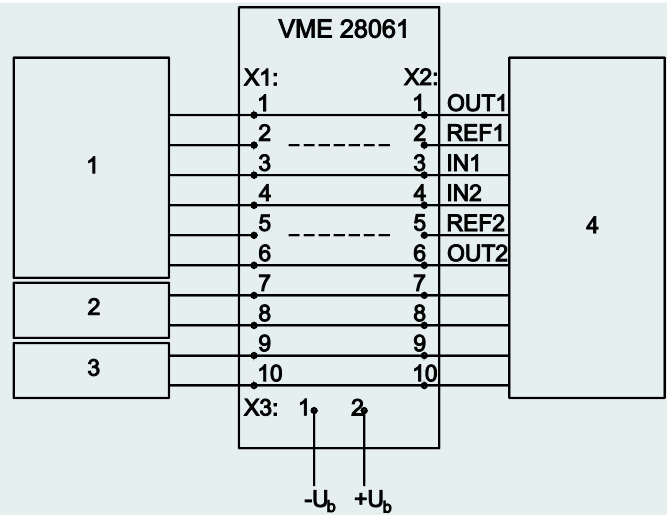
Inclination	Reading error
2,5°	-0,1 %
5,0°	-0,4 %
10,0°	-1,5 %
15,0°	-3,4 %
20,0°	-6,0 %

Note:  
If the scale inclines with no corrective mechanism this will falsify the dead load measurement. This also will cause absolute measuring errors when determining the payload.

### Technical Specifications

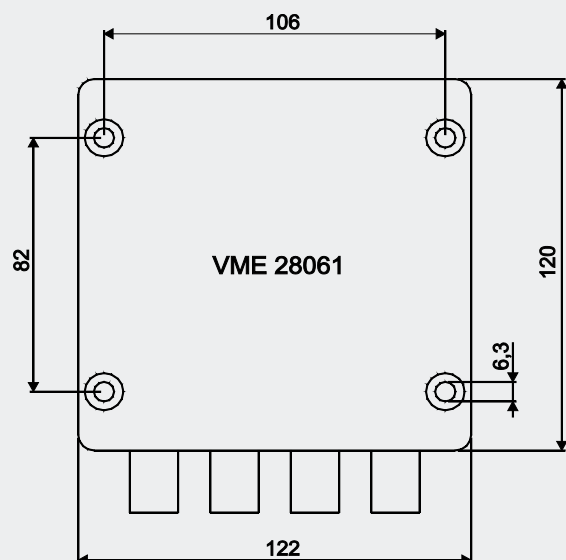
Inclination range	-29° ... +29° from the horizontal in exactly one plane of inclination
Residual correction error in the operating temperature range	<0.05 % of the load cell measured reading
Power supply	18 ... 36 VDC (isolation is realised in the VME 28061)
Load cell supply voltage	12 Vpp AC or DC max.
Operating temperature range	-25 °C ... +60 °C Avoid direct sunlight
Storage temperature range	-40 °C ... +80 °C
Signal wire cable cross-section	Max. 1.5 mm <sup>2</sup>
Supply voltage cable cross-section	Max. 2.5 mm <sup>2</sup>
Protection class	IP65
Dimensions W x H x D [mm] (cable inlets not considered)	122 x 120 x 90
Weight	1500 g
Approbatation	CE

### Example of how to connect VME 28061



1	Load cell
2	Tachometer 1
3	Tachometer 2
4	Control electronics

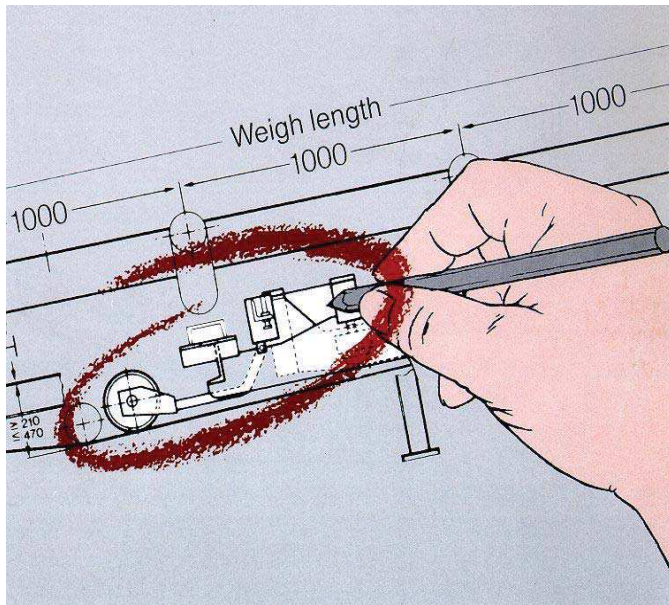
### Dimension



**Schenck Process GmbH**  
Pallaswiesenstr. 100  
64293 Darmstadt, Germany  
T +49 6151 1531-1216  
F +49 6151 1531-1172  
sales@schenckprocess.com  
www.schenckprocess.com



## Recommendations for the Installation Planning of Belt Weighers



### 10 rules to ensure proper functioning and high accuracy

Strict observation of the following rules is essential with a view to minimizing factors which might adversely affect the functioning and measuring accuracy of the belt weigher, and which originate from the weigher environment.

For maximum accuracy (related to the actual value), rules 4, 5 and 9 are of particular importance. The measuring stations themselves are of rugged design, and resistant to torsion.

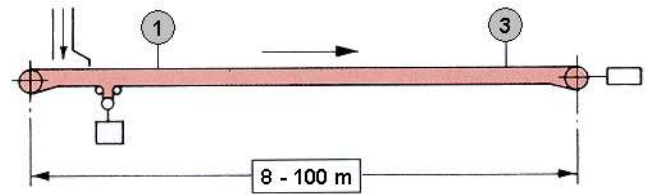
Detailed instructions for installation and alignment are given in our installation, calibration and commissioning instructions

# 1

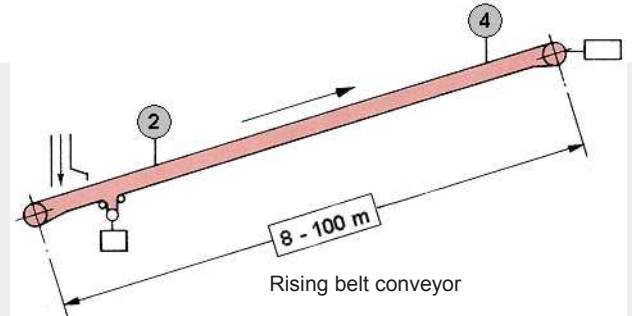
## Install the belt weigher in a straight belt section

The adjacent illustrations show a number of typical locations of belt weighers for different conveyor belt arrangements.

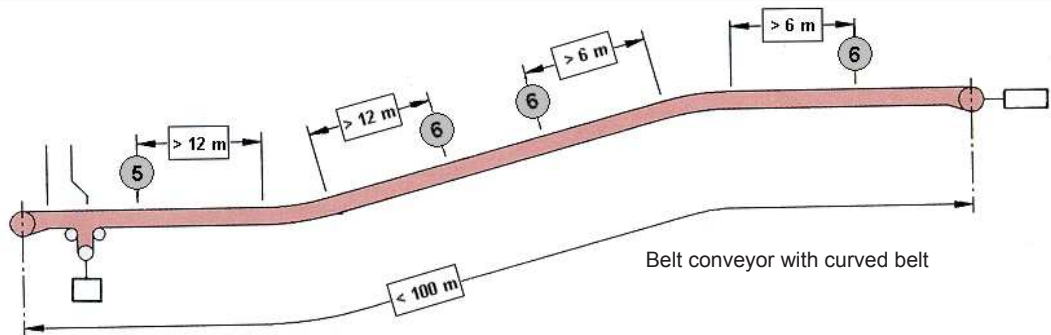
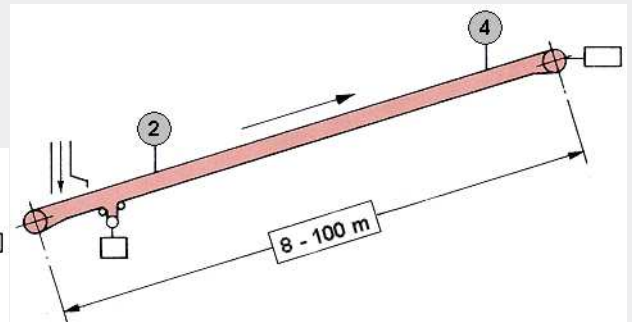
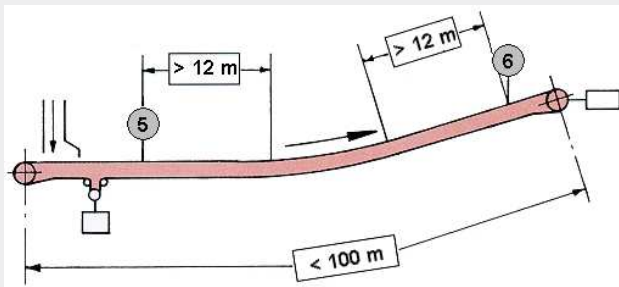
The numbers in the circles represent a rating scale (from 1 = to be preferred to 6 = unfavourable), characterizing the influence of the place of installation on the accuracy of the belt weigher.



Horizontal belt conveyor



Rising belt conveyor



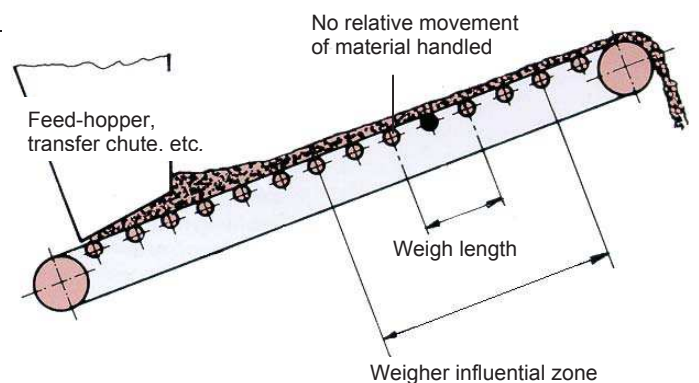
Belt conveyor with curved belt

# 2

The angle of inclination of the belt must be such that there is **no relative movement of the material handled**.

# 3

Install the belt weigher sufficiently far away from the hopper to ensure that the bulk solids flow has settled and there is no relative movement of the material.



# 4

Observe minimum distance of the belt weigher from the belt drum in the troughed belt.

$L_Y$  = troughing or flattening-out

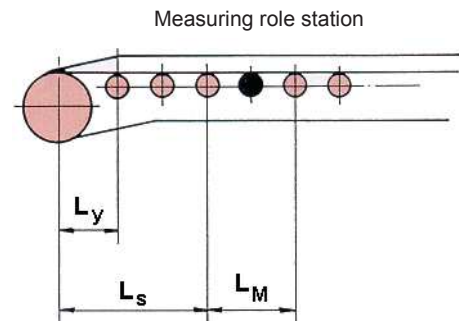
$L_S$  = safety distance

$L_M$  = weigh length

Rules:

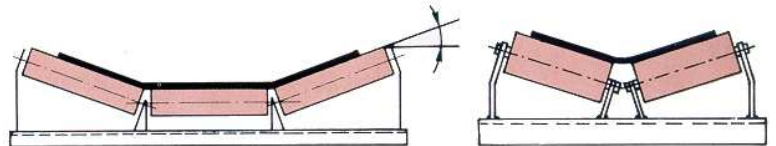
For 3-section idler sets  $L_S = 2.5 \times L_Y$

for V-shaped conveyors  $L_S = 4 \times L_Y$



# 5

Accuracy is influenced by troughing.



# 6

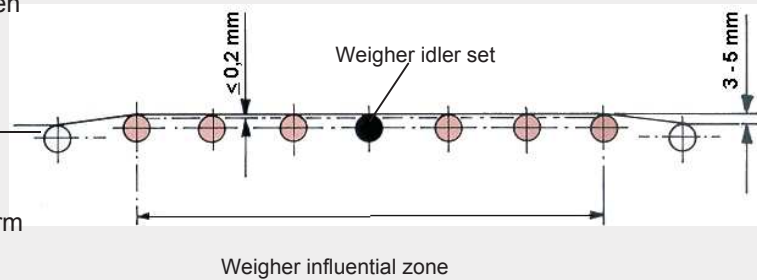
Ensure that the weigher is fully and constantly troughed in the weigher influential zone (3 approach and 3 retreat idlers)..

0 bis 20° GOOD  
up to 30° ADEQUATE  
up to 45° SUITABLE for measuring accuracies of  $\pm 1\%$  and  $\pm 2\%$  relative to the nominal feed rate

SUITABLE for measuring accuracies of  $\pm 1\%$  und  $\pm 2\%$  relative to the nominal feed rate

# 7

Accurately align all idler sets the weigher influential zone. Idler sets with offset idlers (as seen from above) may affect measuring accuracy. Carrying idlers out-of-round is max. 0.2 mm..

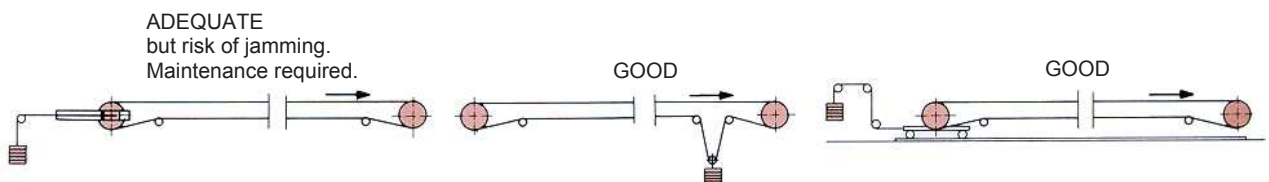


# 8

Belt stringers in the weigher influential zone must be stable, and the foundation must be firm and safe from sinking.

# 9

A weight take-up unit must be provided.



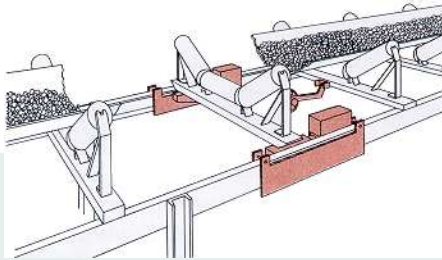
# 10

Take suitable precautions to protect the equipment against wind, moisture and extreme variations of temperature.

### Please note:

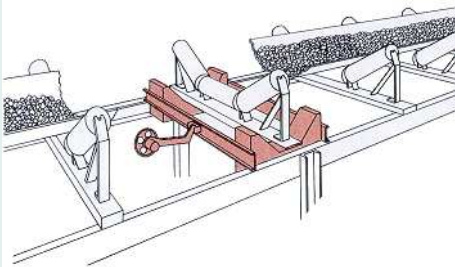
- The accuracies specified by us are only valid if the weighers are serviced, maintained, and calibrated as instructed, and installed in accordance with these recommendations for the installation planning of belt weighers.
- In the case of legal-for-trade belt weighers, the pertinent local weights and measures regulations must also be observed.
- The accuracy of belt weighers without speed transducer (without v-measurement) varies as a function of the fluctuation in belt speed.
- Proof of accuracy is obtained by performing check measurements with material.
- The quantity used in the mesungen mit Material. check must be at least 10 % of the hourly totalized quantity at nominal feed rate ( $I_{nom}$ ), and one belt circuit must have been completed.
- Before installation of belt weighers, check to see that site can easily be accessed.

## The Right Belt Weigher for Every Belt Conveyor



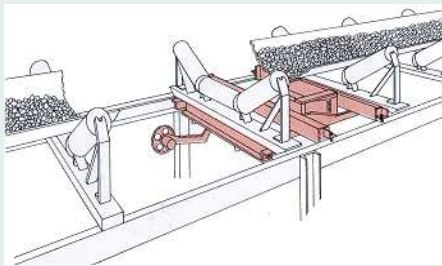
### Single-idler belt weigher type BEM

Achievable accuracy:  $\pm 1 \%$   
 Maximum feed rate: approx. 4.000 t/h  
 Range of belt widths: 400 – 1.400 mm



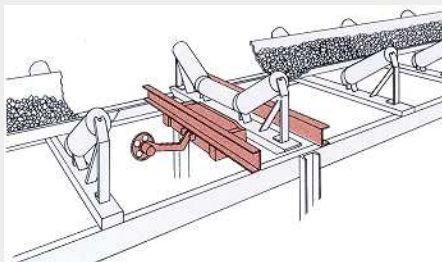
### Single-idler belt weigher type BED

Achievable accuracy:  $\pm 0,5 \%$   
 Maximum feed rate: approx. 15.000 t/h  
 Range of belt widths: 1.600 – 2.000 mm



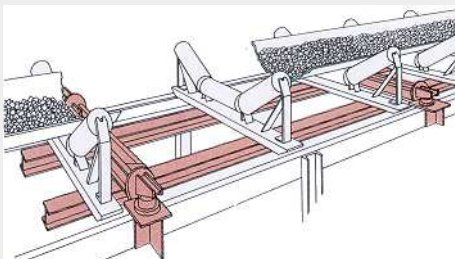
### Multi-idler belt weigher type BMP

Achievable accuracy:  $\pm 0,25 \%$   
 Maximum feed rate: approx. 15.000 t/h  
 Range of belt widths: 500 – 2.000 mm



### Single-idler belt weigher type BEP

Achievable accuracy:  $\pm 0,5 \%$   
 Maximum feed rate: approx. 6.000 t/h  
 Range of belt widths: 400 – 1.400 mm



### Multi-idler belt weigher type BMC

Achievable accuracy:  $\pm 0,25 \%$   
 Maximum feed rate: approx. 20.000 t/h  
 Range of belt widths: 500 – 2.000 mm

Higher belt widths available upon request



## MULTISTREAM® B Solids Flow Meter



- Flow rate measurement according to the impact plate principle
- Compact design - no loss of headroom due to additional chutes
- Cost effective, simple integration - offset-free arrangement of inlet and outlet
- Dust-tight stainless steel housing
- Weighing electronics can be integrated in the mechanical system

### Application

MULTISTREAM B Solids Flow Meters are designed as enclosed in-line measuring systems for continuous acquisition of flow rates and totalized amounts. With flow rates up to 100 t/h, or max. 80 m<sup>3</sup>/h, these measuring systems can be used for

- flow rate and consumption measurement
- totalization and
- batching

of pulverized to granular materials with a grain size of up to 30 mm. Equipped with a controllable pre-feeder, MULTISTREAM B is also available for use as a feed system, upon request.

Its inlet/outlet arrangement without offset makes this measuring system specially suitable for economical integration into existing production plants.

### Construction

The standard equipment of MULTISTREAM B Solids Flow Meters comprises:

- Stainless steel housing
- Impact plate
- Load cell
- Integrated electronic box

Designed as a complete module for local operation, the ECOCONT weighing electronics can be easily accommodated in the box which is integrated in the measuring system. Of course, it is also possible to install the weighing electronics outside of the measuring system, e.g. in the control cabinet.

### Functions

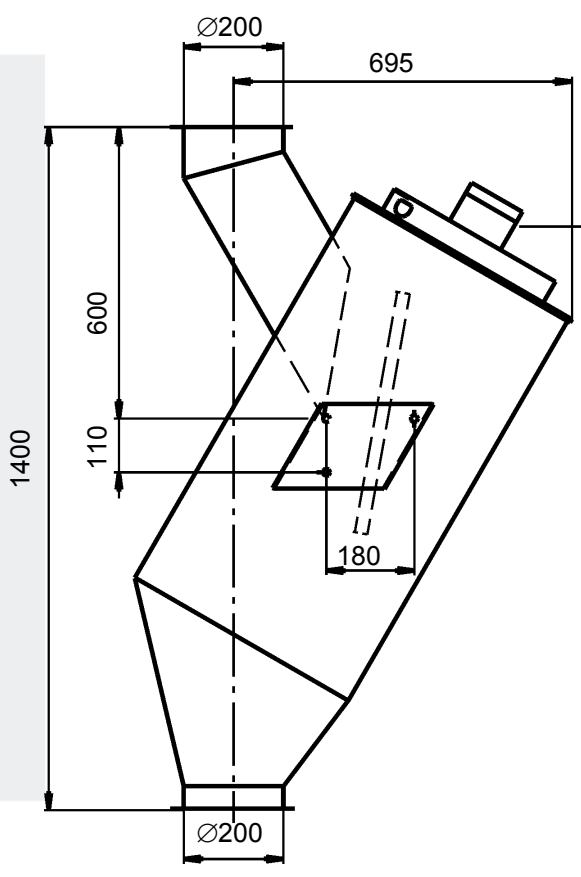
Measuring systems operating according to the impact plate principle acquire the flow rate by means of a reactive force.

Guided by the inlet pipe, the material stream hits the impact plate mounted at a defined angle of inclination. The load cell and the weighing electronics acquire the horizontal component of the reactive force. Material build-ups do not affect the measuring result. Reproducible conditions of material feed, e.g. height and speed of fall or angle of impact, provide for highest accuracies.

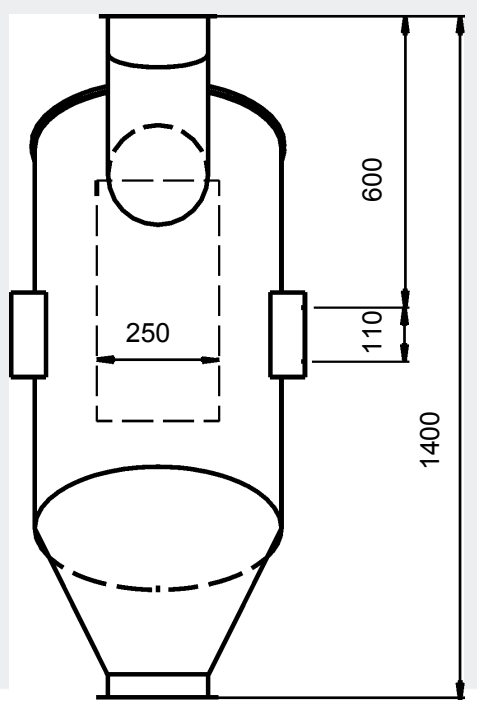
If higher accuracies are required, check measurements are necessary which allow the measuring system to be calibrated without interrupting material flow. Requiring a presilo to be weighed, this additional equipment is available upon request.

Dimensions [mm]

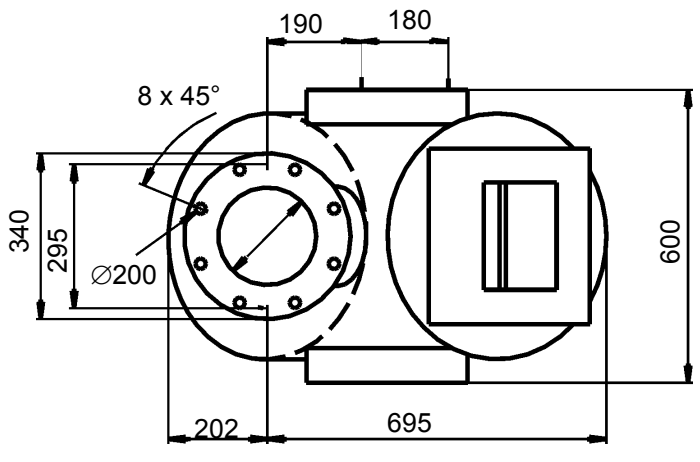
MULTISTREAM B80 Solids Flow Meter



Electronic housing



Top View



**Technical Data**

	<b>MULTISTREAM B80 Solids Flow Meters</b>
Flow rate	min. 1 t/h – max. 80 m <sup>3</sup> /h (100 t/h)
Accuracy	±2 % of nominal flow rate
Measuring range	1 : 5
Operating pressure	-25 mbar to 50 mbar
Inlet/outlet flange dimensions (DIN)	200 mm / 200 mm
Weight	50 kg
Ambient temperature	-30 °C to +60 °C
Material temperature	max. 70 °C
Bulk density	min. 0,4 t/m <sup>3</sup>
Grain size	max. 10 mm (single grain up to 30 mm)
Flow properties	pulverized to granular, non sticky

**Accuracy**

Stated accuracy relates to maximum (nominal) flow rate in the range of 20 % - 100 % (measuring range 1:5) under the following conditions:

- Constant material properties (flow behaviour, moisture, temperature, grain size)
- System installed and calibrated in accordance with our Installation and Calibration Instructions

**Additional Requirements**

Should you have additional requirements like:

- higher accuracy
  - use as a feeding system
- dust or gas explosion proof design, we kindly ask for a separate request.

**Order Data**

To be able to process your order smoothly and quickly, please remember to indicate order numbers complete with data below:

<b>Material Data</b>	
Bulk density .....	[t/m <sup>3</sup> ]
Material.....	
<b>Flow Rate Range</b>	
From .....	[t/h]
To .....	[t/h]



Variant	Order No.
MULTISTREAM B80, Solids Flow Meter, max. 80 m <sup>3</sup> /h	F018320.01

Documentation	Order No.
MULTISTREAM B80 Service Manual	BVH2030
German	D707380.01
English	D707381.01
French	D707382.01

One set of documentation is supplied as standard. Should you need additional copies, please order separately. Remember to indicate desired language version.

## MULTISTREAM® G Solids Flow Meter



- Flow rate measurement on the deflection chute principle
- Dust-tight housing
- Compact design
- Cost effective, simple integration

### Application

MULTISTREAM® G Solids Flow Meters are designed as enclosed in-line measuring systems for continuous acquisition of flow rates from 4 t/h to 1000 t/h (max. 1250 m³/h).

These measuring systems can be used for

- flow rate and consumption measurement
- totalization and
- batching

of pulverized to granular materials with a grain size of up to 30 mm. Equipped with a controllable pre-feeder,

MULTISTREAM® G is also available for use as a feed system, upon request.

Thanks to its enclosed, rugged design, this measuring system is the answer to limited space and enclosed conveyor routes.

### Construction

The standard equipment of MULTISTREAM® G Solids Flow Meters comprises:

- Sheet metal housing,
- Guide and measuring chutes,
- Load cell,
- Measuring force transmission to load cell arranged outside of material room,
- Cable junction box.

The load cell arranged outside of material room, measuring system can be used at material temperatures of up to 100° C.

Higher temperature ranges are available, upon request.

### Function

The deflection chute measuring system acquires the flow rate by using a reactive force.

Via guide chute, the material is leveled out, settled, then guided to the curved measuring/ deflection chute, free from shocks.

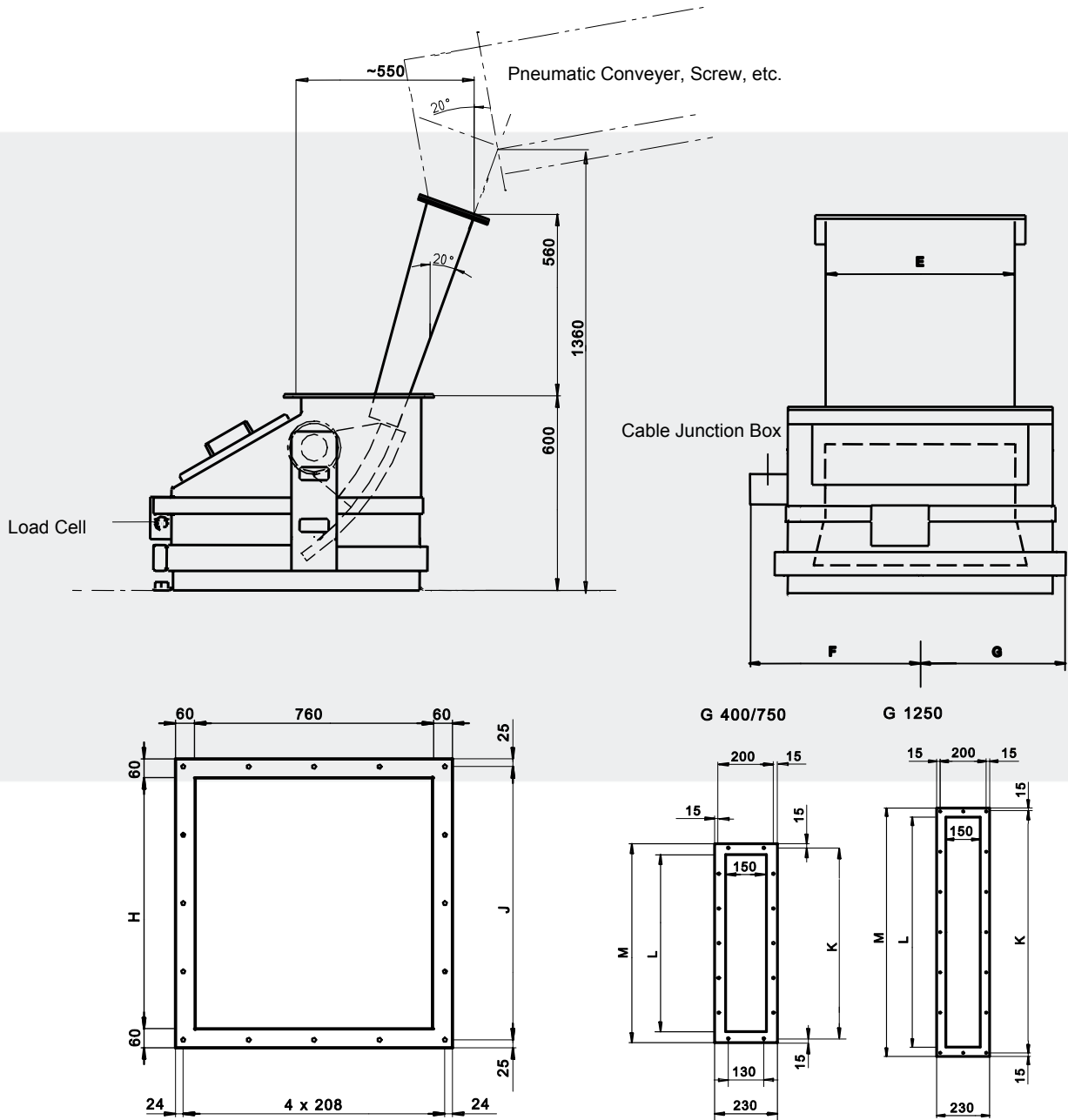
On the measuring chute the material is accelerated in radial direction. The resulting reactive force is acquired by the load cell.

If higher accuracies are required, check measurements are necessary which allow the measuring system to be calibrated without interrupting material flow.

Requiring presilo to be weighed, this additional equipment is available upon request.

Dimensions [mm]

MULTISTREAM® G Solids Flow Meter



Variant	Sizes [mm]							
	E	F	G	H	J	K	M	L
G 400	400	470	380	550	2 x 310	3 x 150	480	400
G 750	650	593	505	800	4 x 217,5	4 x 127,5	730	650
G 1250	1000	770	680	1150	5 x 244	6 x 175	1080	1000

## Technical Data

<b>MULTISTREAM® Solids Flow Meters</b>			
<b>Variant</b>	<b>G 400</b>	<b>G 750</b>	<b>G 1250</b>
<b>Flow rate</b>	min. 4 t/h – max. 400 m <sup>3</sup> /h (max. 1000 t/h)	min. 16 t/h – max. 750 m <sup>3</sup> /h (max. 1000 t/h)	min. 40 t/h – max. 1250 m <sup>3</sup> /h (max. 1000 t/h)
<b>Accuracy</b>	± 2% of nominal flow rate		
<b>Measuring range</b>	1 : 5		
<b>Operating pressure</b>	- 2 mbar to - 8 mbar, Variation ± 2 mbar		
<b>Weight</b>	155 kg	250 kg	390 kg
<b>Ambient temperature</b>	-30°C to +60°C		
<b>Material temperature</b>	max. 100° ( optional 200° ) Celsius		
<b>Bulk density</b>	min. 0,4 t/m <sup>3</sup>		
<b>Grain size</b>	max. 10 mm (single grain up to 30 mm)		
<b>Flow properties</b>	pulverized to granular, non-sticky		

### Accuracy

Stated accuracy relates to maximum (nominal) flow rate in the range of 20 -100% (measuring range 1:5) under the following conditions:

- Constant material properties (flow behaviour, moisture, temperature, grain size)

System installed and calibrated in accordance with our Installation and Calibration Instructions.

### Additional Requirements

Should you have additional requirements like:

- abrasive material,
- Ex applications,
- material temperatures > 100° C,
- higher accuracy or
- use as a feeding system,

we kindly ask for a separate request.

### Order Data

To be able to process your order smoothly and quickly, please remember to indicate order numbers complete with data below:

#### Material Data

Bulk density ..... [t/m<sup>3</sup>]

Material.....

#### Flow Rate Range

From ..... [t/h]

To ..... [t/h]

Variant	Order No.
MULTISTREAM® G, Solids Flow Meter	
G 400, max. 400 m³/h	F021140.01
G 750, max. 750 m³/h	F021140.02
G 1250, max. 1250 m³/h	F021140.03

Documentation	Order No.
MULTISTREAM® G Operating and Service Manual	
German	D707380.01
English	D707381.01
French	D707382.01

One set of documentation is supplied as standard. Should you need additional copies, please order separately. Remember to indicate desired language version.

## Volumetric Feeders, AccuRate Series



- Volumetric feeding of bulk solids
- Feeding without internal agitation
- Gentle material conditioning
- Economical and simple integration
- Compact design

### Application

Feeders of the AccuRate series are a special economical solution for volumetric feeding of bulk solids.

With a feed rate range of 0.1 l/h to 8,000 l/h, these feed systems can be used for:

- continuous feeding
- batching and
- blending

of materials with up to 10 mm grain size.

No matter whether materials or additives are fed into the process, extruders or compounders, or a blend requires to be formed, feeders of the AccuRate series offer the right solution for almost any application.

Their simple, compact design does not only ensure easy service and maintenance but also economical integration into existing production plants.

### Features

The AccuRate basic feeder comes with the following features:

- Housing (rugged welded structure) of stainless steel, with easily removable side panels
- Flexible hopper of (FDA-approved) TUFLEX vinyl
- “Massaging” paddle system
- Discharge unit (helix and nozzle in stainless steel)
- Vertical discharge head
- Protective grid
- DC or AC drive for helix and paddle (joint or separate)

For DC-drives, a wide choice of controllers is available.

Feed rate and agitation setpoints can be entered via potentiometer, with or without display, for continuous or batch mode. External presetting via analog signal input is also possible.

For optimum adaption of the feed system to the application, beside the basic feeder, a wide choice of feed equipment and accessories is available.

### Function

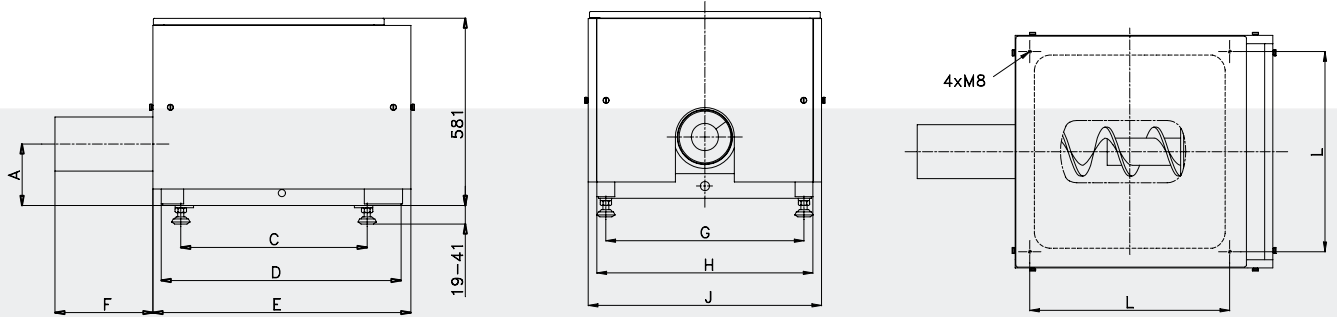
Volumetric AccuRate feeders operate according to the “flexible-wall principle” introduced by Schenck-AccuRate more than 30 years ago.

Instead of the usual internal agitators, all feeders are fitted with two external paddles that gently massage the molded hopper. This ensures a continuous, even flow of material into the helix with a uniform bulk density.

This avoids bridging and material build-up. Additionally, the flexible-wall principle ensures a constantly high filling degree of the helix.

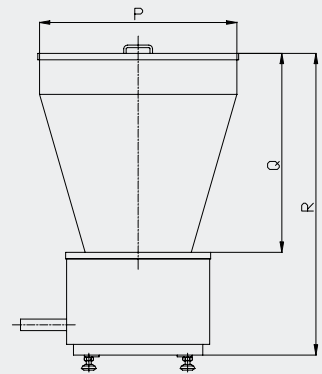
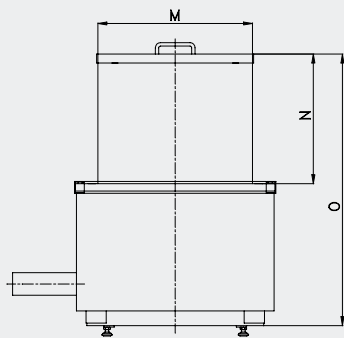
## Dimensions

### AccuRate Feeder



### AccuRate Feeder

Fitted With Extension Hopper

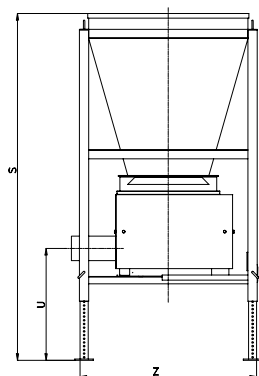


28 l hopper for Series 300  
70/140 l hopper for Series 600  
140/280 l hopper for Series 900

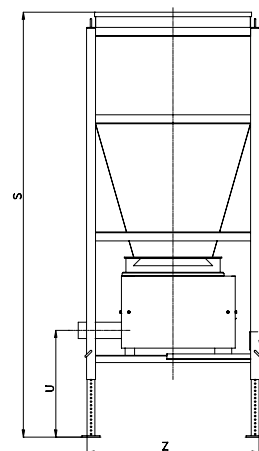
280 l hopper for Series 600  
425 l hopper for Series 900

### AccuRate Feeder

Free Standing Hopper



560 l hopper



1420 l hopper



Feeder	Size [mm]									
	A	B	C	D	E	F*)	G	H	J	L
<b>Series 300</b>	86	305	295	330	386	102	267	330	368	305
<b>Series 600</b>	117	400	381	499	552	178	442	499	552	465
<b>Series 900</b>	176	593	470	750	801	305	616	672	725	622

\*) Standard size; other lengths available as an option

Hopper - Fitted	Size [mm]					
	M	N	O	P	Q	R
Series 300 28 liters	283	362	664			
Series 600 - 70 liters - 140 liters - 280 liters	432 432	362 718	762 1118	762	1118	1168
Series 900 - 140 liters - 280 liters - 425 liters	584 584	413 870	1006 1463	914	672	1265

Hopper – Free Standing	Size [mm]		
	S	U	Z
Series 600 - 560 liters 1420 liters	2020, 2325, 2360, 2935 2604, 2909, 3213, 3519	587, 892, 1197, 1502	1220 1220
Series 900 - 560 liters - 1420 liters	2020, 2325, 2360, 2935 2604, 2909, 3213, 3519	557, 762, 1067, 1372	1220 1220

## Technical Data

### AccuRate Feeders

Series	300	600	900
Maximum feed rate	~0.1 l/h – 105 l/h	1 l/h – 1.300 l/h	30 l/h – 8.000 l/h
Setting range	1 : 50		
Flexible hopper capacity - without extension hopper	9 dm <sup>3</sup>	25 dm <sup>3</sup>	75 dm <sup>3</sup>
Helix diameter - available	Ø 6, 10, 13, 19, 25 mm	Ø 13, 19, 25, 35, 45, 57 mm	Ø 57, 76, 102 mm
Helix standard length - from feeder front	102 mm	178 mm	305 mm
Maximum helix extension	~ 300 mm	~ 1.220 mm	~ 1.220 mm
Drive motor	0.09 kW DC 0.09 kW AC	0.18 kW DC 0.18 kW AC	0.55 kW DC 1.1 / 1.5 kW AC
Motor protected to	IP 54		
Supply voltage	230 V (AC)	230 V (AC)	230 V / 400 V (AC)
Weight	~ 30 kg	~ 65 kg	~ 145 kg
Ambient temperature	- 20°C bis + 40°C		
Material temperature	max. 80°C		
Bulk density	$\gamma \sim 0.1 - 3 \text{ kg/l}$		
Grain size	up to 10 mm		
Flow properties	free flowing to sluggish		

#### Accuracy

The normal accuracy achieved with AccuRate feeders is between  $\pm 1.5$  and 2.5% of setpoint.

#### Additional Requirements

The variants and options described in this brochure are only a small part of the AccuRate feeders program. Should you have specific needs, e.g. for:

- special hopper designs for the food and pharmaceutical industries
- dust-tight connection to BIG-BAG stations
- extension hoppers for manual bag discharge

... please tell us your requirements.

#### Order Data

To be able to process your order smoothly and quickly, please let us know the application data below.

#### Material Data

Material.....  
 Material density..... [kg/l]  
 Grain size..... [mm]  
 Flow properties.....

#### Feed Rate Range

from ..... [kg/h]  
 to ..... [kg/h]

#### Drive Design

AC drive

DC drive

#### Extension Hopper

Volume ..... [l]

Should you order an option which requires size or length to be indicated, please specify in your order.

## AccuRate Feeders – Series 300

### Basic Variants

#### Basic variants,

including discharge unit (helix and nozzle) in standard design (diameter depending on feed rate)

- DC drive (0.09 kW) including power controller with digital potentiometer in stainless steel housing
- AC drive (0.09 kW for 3 x 230V) without drive control

### Variants

#### Dual drive

Separate drive motor to be used with sluggish materials, big extension hoppers, big feed rate range (> 5:1) and helix extended to > 50% of standard length

- DC version – separate DC drive and extended control
- AC version – separate AC drive

#### Quick-disconnect system,

for easy exchange of flexible hopper in case of frequent cleaning or product change

#### Food/pharmaceutical industries design (to FDA and USDA)

With sealed bearings, ground welds, polished helix, flexible (white) hopper and quick-disconnect system

### Control Options for DC motors

#### Control with Potentiometer

#### Display and Touchpad Potentiometer

#### Wall-mounting housing for control system

IP65 in carbon steel painted or stainless steel

#### Analog input, 4-20 mA / 0-10V

Feeder control via external setpoint

#### Batch timer, for setting of batching time, volumetric mode

#### Remote start/stop contact

### Feed Unit/ Tube Options (length and size to be indicated in your order)

#### Additional discharge unit (helix and nozzle),

for extension of feed rate range in particular standard length (Series300: 102 mm) diameter in accordance with desired feed rate extension

#### Helix and nozzle extension, to max. 300 mm

Stainless steel; length (from feeder front) to be specified in your order

#### Nozzle support with Series 300, we recommend support for stainless steel downturn.

#### Side nozzle discharge, for flushing material, to improve feeding constancy

#### Outlet shut-off gate, pneumatically actuated, suitable for batching

#### Stainless steel Dust Elbow (in place of vinyl)

### Extension Hoppers, Stainless Steel

28 liters

## AccuRate Feeders – Series 600

### Basic Variants

#### Basic variants,

including discharge unit (helix and nozzle) in standard design (diameter depending on feed rate)

- DC drive (0.18 kW) including power controller with digital potentiometer in stainless steel housing
- AC drive (0.18 kW for 3 x 230V) without drive control

### Variants

#### Dual drive

Separate drive motor to be used with sluggish materials, big extension hoppers, big feed rate range (> 5:1) and helix extended to > 50% of standard length

- DC version – separate DC drive and extended control
- AC version – separate AC drive

#### Quick-disconnect system,

for easy exchange of flexible hopper in case of frequent cleaning or product change

#### Food/pharmaceutical industries design (to FDA and USDA)

With sealed bearings, ground welds, polished helix, flexible (white) hopper and quick-disconnect system

### Control Options for DC motors

#### Control with Potentiometer

#### Display and Touchpad Potentiometer

#### Wall-mounting housing for control system

IP65 in carbon steel painted or stainless steel

#### Analog input, 4-20 mA / 0-10V

Feeder control via external setpoint

#### Batch timer, for setting of batching time, volumetric mode

#### Remote start/stop contact

### Feed Unit/ Tube Options (length and size to be indicated in your order)

#### Additional discharge unit (helix and nozzle),

for extension of feed rate range in particular standard length (Series 600: 178 mm) diameter in accordance with desired feed rate extension

#### Helix and nozzle extension, to max. 1220 mm

Stainless steel; length (from feeder front) to be specified in your order

#### Nozzle support with Series 600, we recommend min. 300 mm length or if a stainless steel dust elbow is used.

#### Side nozzle discharge, for flushing material, to improve feeding constancy

#### Outlet shut-off gate, pneumatically actuated, suitable for batching

#### Stainless steel Dust Elbow (in place of vinyl)

### Extension Hoppers, Stainless Steel

70 liters; fitted onto feeder

140 liters; fitted onto feeder

280 liters; fitted onto feeder

560 liters; free standing

1420 liters; free standing

## AccuRate Feeders – Series 900

<b>Basic Variants</b>
<b>Basic variants,</b> including discharge unit (helix and nozzle) in standard design (diameter depending on feed rate) <ul style="list-style-type: none"><li>▪ DC drive (0.55 kW) including power controller with digital potentiometer in stainless steel housing</li><li>▪ AC drive (1.1 / 1.5 kW for 3 x 230V or 3 x 400V) without drive control</li></ul>
<b>Variants</b>
<b>Dual drive</b> Separate drive motor to be used with sluggish materials, big extension hoppers, big feed rate range (> 5:1) and helix extended to > 50% of standard length <ul style="list-style-type: none"><li>▪ DC version – separate DC drive and extended control</li><li>▪ AC version – separate AC drive</li></ul>
<b>Quick-disconnect system,</b> for easy exchange of flexible hopper in case of frequent cleaning or product change
<b>Food/pharmaceutical industries design</b> (to FDA and USDA) With sealed bearings, ground welds, polished helix, flexible (white) hopper and quick-disconnect system
<b>Control Options for DC motors</b>
<b>Control with Potentiometer</b>
<b>Display and Touchpad Potentiometer</b>
<b>Wall-mounting housing for control system</b> IP65 in carbon steel painted or stainless steel
<b>Analog input, 4-20 mA / 0-10V</b> Feeder control via external setpoint
<b>Batch timer,</b> for setting of batching time, volumetric mode
<b>Remote start/stop contact</b>
<b>Feed Unit/ Tube Options</b> (length and size to be indicated in your order)
<b>Additional discharge unit</b> (helix and nozzle), for extension of feed rate range in particular standard length (Series 900: 305 mm) diameter in accordance with desired feed rate extension
<b>Helix and nozzle extension,</b> to max. 1220 mm Stainless steel; length (from feeder front) to be specified in your order
<b>Nozzle support with Series 900,</b> we recommend min. 400 mm length or if a stainless steel dust elbow is used.
<b>Side nozzle discharge,</b> for flushing material, to improve feeding constancy
<b>Outlet shut-off gate,</b> pneumatically actuated, suitable for batching
<b>Stainless steel Dust Elbow</b> (in place of vinyl)
<b>Extension Hoppers, Stainless Steel</b> 140 liters; fitted onto feeder 280 liters; fitted onto feeder 425 liters; fitted onto feeder 560 liters; free standing 1420 liters; free standing

### Theoretical Federates

All mentioned feed rates are theoretical feed rates based on a filling efficiency of 100 %. In practice the filling efficiency can be reduced by 20 – 30 %, depending on material properties and application.

Open Helix [l/hr]														
Helix O.D. [mm]	Pitch [mm]	Sizes by Series			Helix Speed [rpm]									
		300	600	900	1	10	20	40	60	80	100	120	140	160
13	6,5				0,0374	0,374	0,748	1,50	2,24	2,99	3,74	4,49	5,24	5,98
13	13				0,0784	0,784	1,57	3,14	4,71	6,27	7,8	9,4	11,0	12,5
19	9,5				0,133	1,33	2,65	5,31	7,96	10,6	13,3	15,9	18,6	21,2
19	19				0,296	2,96	5,91	11,8	17,7	23,6	29,6	35,5	41,4	47,3
25	12,5				0,303	3,03	6,06	12,1	18,2	24,3	30,3	36,4	42,5	48,5
25	25				0,689	6,89	13,8	27,6	41,4	55,1	68,9	82,7	96,5	110
35	17,5				0,850	8,50	17,0	34,0	51,0	68,0	85,0	102	119	136
35	35				1,85	18,5	37,1	74,1	111	148	185	222	259	296
44	22				1,83	18,3	36,6	73,1	110	146	183	219	256	293
44	44				3,90	39,0	77,9	156	234	312	390	468	546	624
57	28,5				4,04	40,4	80,8	162	242	323	404	485	566	646
57	57				8,46	84,6	169	338	507	677	846	1015	1184	1353
76	38				9,26	92,6	185	371	556	741	926	1112	1297	1482
76	76				19,7	197	394	788	1181	1575	1969	2363	2756	3150
102	102				50,4	504	1007	2015	3022	4029	5036	6044	7051	8058

Helix With Center Rod [l/hr]														
Helix O.D. [mm]	Pitch [mm]	Sizes by Series			Helix Speed [rpm]									
		300	600	900	1	10	20	40	60	80	100	120	140	160
6	6				0,0067	0,0677	0,135	0,271	0,406	0,541	0,677	0,812	0,948	1,08
10	10				0,0188	0,188	0,375	0,750	1,13	1,50	1,88	2,25	2,63	3,00
13	6,5				0,0253	0,253	0,507	1,01	1,52	2,03	2,53	3,04	3,55	4,05
13	13				0,0543	0,543	1,09	2,17	3,26	4,34	5,4	6,5	7,6	8,7
19	9,5				0,060	0,60	1,21	2,41	3,62	4,8	6,0	7,2	8,4	9,6
19	19				0,151	1,51	3,02	6,0	9,1	12,1	15,1	18,1	21,1	24,1
25	12,5				0,249	2,49	4,97	9,9	14,9	19,9	24,9	29,8	34,8	39,8
25	25				0,580	5,80	11,6	23,2	34,8	46,4	58,0	69,6	81,2	93
35	17,5				0,698	6,98	14,0	27,9	41,9	55,8	69,8	84	98	112
35	35				1,55	15,5	31,0	61,9	93	124	155	186	217	248
44	22				1,45	14,5	29,0	57,9	87	116	145	174	203	232
44	44				3,14	31,4	62,7	125	188	251	314	376	439	502
57	28,5				2,69	26,9	53,8	108	161	215	269	323	376	430
57	57				5,74	57,4	115	230	345	459	574	689	804	919
76	38				8,11	81,1	162	324	486	648	811	973	1135	1297
76	76				17,4	174	347	695	1042	1390	1737	2085	2432	2779
102	102				44,5	445	890	1781	2671	3562	4452	5343	6233	7124

## ProFlex® C500 / C3000 / C6000 Volumetric Feeder



- Volumetric feeder system for powders and granules
- Fast, easy disassembly for cleaning the feeder and changing products
- Asymmetric design allows for a compact, in pairs arrangement of up to 8 feeder stations
- Flexible feed hopper with external agitation
- Control electronics available for the feeder

### Properties

The ProFlex C feeder system is used for continuous volumetric feeding of bulk materials such as powders and granules.

The ProFlex C has been designed specially to meet the demands of your flexible processes: the components can be easily disassembled, the feed unit changed and the feeder cleaned using one tool only.

The asymmetric design of the ProFlex C allows for a compact, in pairs arrangement of up to 8 feeder stations. Discharge side orientation can be swapped in a few simple steps at any time.

The ProFlex C is available in three different sizes and can be equipped with a range of extension hoppers, helix and helix with center rod for adaptation to the characteristics of the bulk materials and to the required feed rate.

### Design

The ProFlex C uses the principle of external agitation: An external drive agitates the wear-resistant elastomer feed hopper, producing a gentle material flow and a constant fill level in the discharge unit.

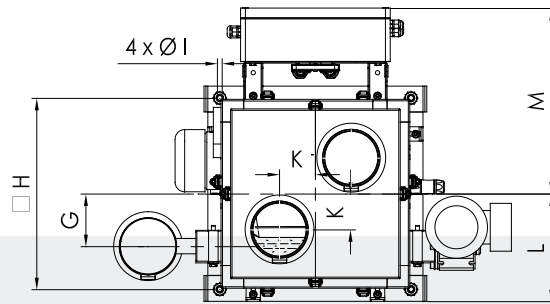
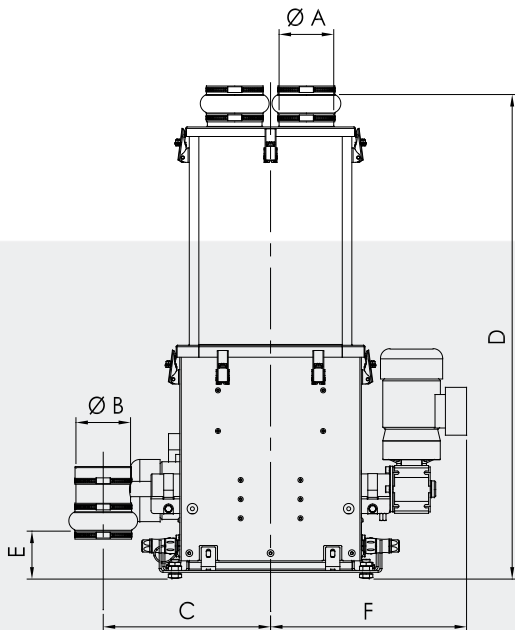
The special geometry of the ProFlex C discharge nozzle generates a low-pulse discharge at low screw rotational speeds.

One particular characteristic of the ProFlex C is its robust construction.

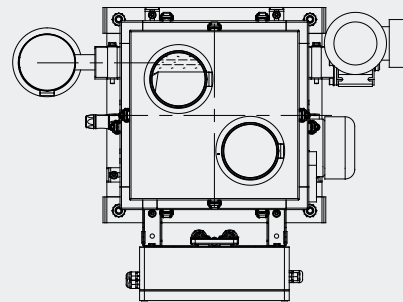
There is a range of electronic components to choose from, in order to best match the feeder to the respective application. From junction boxes to complete electronic controls.

You can choose the elements to match your needs and requirements.

## Dimensions



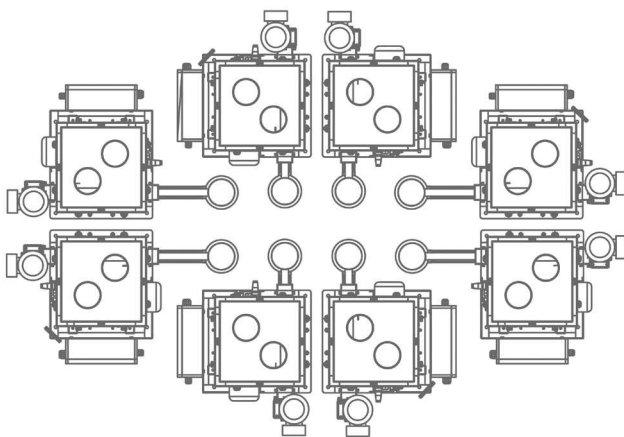
Left-handed variant



Right-handed variant

Extension hopper		Dimensions [mm]												
		A	B	C		D	E	F	G	H	I	K	L	M
				Discharge short	Discharge long									
<b>C500</b>	50 l	114.3	114.3	350	500	1013	100	410	110	400	10	75	225	388
<b>C3000</b>	100 l	168.3	139.7	450	650	1265	146	531	150	550	12	100	303	463
	150 l	168.3	139.7	450	650	1515	146	531	150	550	12	100	303	463
<b>C6000</b>	200 l	168.3	168.3	600	800	1432	145	649	180	680	12	100	365	521
	400 l	168.3	168.3	600	800	2032	145	649	180	680	12	100	365	521

## Multiple-Feeder Arrangements



8-fold view



In pairs arrangement of two ProFlex C devices



## Theoretical Feed Rates

All feed rates are theoretical nominal feed rates with 100 % screw fill levels. Actual feed rates may be up to 20 % ... 30 % lower in practice, depending on the bulk material and the application.

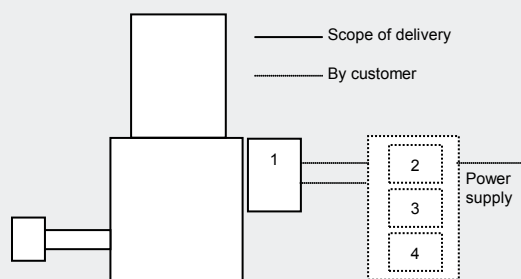
Installation size	Bulk materials	Conveying unit type	Inner diameter [mm]	Feed rate [dm <sup>3</sup> /h] (200 min <sup>-1</sup> )
<b>C500</b>	Powder	Helix 19 x 9.5	21.8	26
		Helix 19 x 19	21.8	58
		Helix 25 x 12.5	28	58
		Helix 25 x 25	28	132
		Helix 35 x 17.5	38.4	174
		Helix 35 x 35	38.4	375
		Helix 44 x 22	47.8	358
		Helix 44 x 44	47.8	759
	Granules	Helix 19 x 19	28	101
		Helix 25 x 25	38.4	249
		Helix 35 x 17.5	47.8	261
		Helix 35 x 35	47.8	544
	Powder, Flushing	Helix with center rod 19 x 9.5	21.8	17
		Helix with center rod 19 x 19	21.8	41
		Helix with center rod 25 x 12.5	28	47
		Helix with center rod 25 x 25	28	109
Helix with center rod 35 x 17.5		38.4	137	
Helix with center rod 35 x 35		38.4	301	
Helix with center rod 44 x 22		47.8	275	
Helix with center rod 44 x 44		47.8	593	
<b>C3000</b>	Powder	Helix 35 x 17.5	38.4	174
		Helix 35 x 35	38.4	375
		Helix 44 x 22	47.8	358
		Helix 44 x 44	47.8	759
		Helix 57 x 28.5	60.3	768
		Helix 57 x 57	60.3	1640
		Helix 76 x 38	79.3	1824
		Helix 76 x 76	79.3	3891
	Granules	Helix 35 x 17.5	47.8	261
		Helix 35 x 35	47.8	544
		Helix 44 x 22	60.3	533
		Helix 44 x 44	60.3	1098
		Helix 57 x 28.5	79.3	1188
	Powder, Flushing	Helix 57 x 57	79.3	2455
		Helix with center rod 35 x 17.5	38.4	137
		Helix with center rod 35 x 35	38.4	301
Helix with center rod 44 x 22		47.8	275	
Helix with center rod 44 x 44		47.8	593	
Helix with center rod 57 x 28.5		60.3	638	
Helix with center rod 57 x 57		60.3	1380	
Helix with center rod 76 x 38		79.3	1600	
<b>C6000</b>	Powder	Helix 57 x 28.5	60.3	768
		Helix 57 x 57	60.3	1640
		Helix 76 x 38	79.3	1824
		Helix 76 x 76	79.3	3891
		Helix 89 x 44.5	97.6	2983
		Helix 89 x 89	97.6	6302
		Helix 102 x 51	110.3	4466
		Helix 102 x 102	110.3	9463
	Granules	Helix 57 x 28.5	79.3	1188
		Helix 57 x 57	79.3	2455
		Helix 76 x 38	97.6	2375
		Helix 76 x 76	97.6	4933
		Helix 89 x 44.5	110.3	3572
		Helix 89 x 89	110.3	7397
	Powder, Flushing	Helix with center rod 57 x 28.5	60.3	638
		Helix with center rod 57 x 57	60.3	1380
Helix with center rod 76 x 38		79.3	1600	
Helix with center rod 76 x 76		79.3	3444	
Helix with center rod 89 x 44.5		97.6	2654	
Helix with center rod 89 x 89		97.6	5645	
Helix with center rod 102 x 51		110.3	3974	
Helix with center rod 102 x 102		110.3	8479	

## Technical Data

Installation Size		C500	C3000	C6000
Max. feed rate		759 dm <sup>3</sup> /h	3891 dm <sup>3</sup> /h	9463 dm <sup>3</sup> /h
Adjustment range		1 : 20	1 : 20	1 : 20
Available discharge unit diameters	Single helix Single screw	19 / 25 / 35 / 44 mm	35 / 44 / 57 / 76 mm	57 / 76 / 89 / 102 mm
	Twin shaft	22 mm	-	-
Discharge length from center of feeder		350 / 500 mm	450 / 650 mm	600 / 800 mm
Extension hopper		50 dm <sup>3</sup>	100 / 150 dm <sup>3</sup>	200/400 dm <sup>3</sup>
Feed Hopper		EPDM / 20 dm <sup>3</sup>	PUR / 60 dm <sup>3</sup>	PUR / 100 dm <sup>3</sup>
Weight, empty		about 70 kg	ca. 170 kg	about 220 kg
Motor protection class		IP55		
Connection voltage		230/400 VAC 3-phase (110/230 VAC 1-phase on request)		
Ambient temperature		-20 °C ... +50 °C		
Bulk solids temperature		-30 °C ... +50 °C (higher available on request)		
Bulk material density		0.3 ... 1.2 kg/dm <sup>3</sup> (higher available on request)		
Grain size		up to 5 mm		
Flow properties		free flowing to slightly sluggish		
Components in contact with the bulk material		Stainless steel 1.4301		

## ProFlex C Electrical System Variants

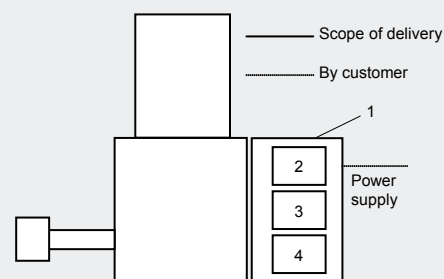
### Junction box



1 – Junction box/housing 2 – Frequency convertor (helix drive) 3 – Set point presetting 4 – Motor Start/Stop (agitation drive)

Both drives come factory wired with a junction box. Electrical supply and control will be provided on site.

### Mechatronic



This feeder comes completely factory cabled. The electrical components are included in the order and will be matched to suit each other. Manual/Auto mode switch included. Start/Stop and set point entry via the integrated touchpad (manual), or via contact and 4 ... 20 mA analogue signal provided by customer (auto).

**Schenck Process GmbH**  
Pallaswiesenstr. 100  
64293 Darmstadt, Germany  
T +49 6151 1531 0  
F +49 6151 1531 66  
sales@schenckprocess.com  
www.schenckprocess.com

## Platform Scales DVC/DVM



- **Flat construction**
- **Rugged and maintenance-free**
- **High-quality design**
- **Wide range of accessories**
- **Legal-for-trade as commercial scale, Class III**
- **Hazardous area variants (option)**

### Application

Thanks to their flat, rugged and maintenance-friendly design, the DVM platform scales are perfectly suitable for use in virtually any industry.

The DVC line has more complex engineering meaning it offers a wider spectrum of designs and accessories.

High-quality design (optionally electropolished, stainless steel up to grade 316L), easy cleaning (removable load plate) and a wide range of accessories qualify the scales for use in sophisticated applications, e. g. in the chemical and food industries.

### Construction

- 10 sizes from 400 x 300 mm to 2000 x 1500 mm
- Removable load plate
- Material S235JRGZ powder-coated (median grey, RAL 7040) or stainless steel 304L up to size 800 x 600 mm load plate 304L on standard
- Option: load plate 316L (DVC) electropolished, surface roughness <3 µm
- Option: complete scale in 316L (DVC), electropolished, surface roughness <3 µm
- Floor-mounted variant with 4 adjustable feet
- Option: foundation frame for pit-mounted variant
- Legal-for-trade variant for 3000 d or multi-range 2 x 3000 d

- Hazardous area variants (DVC) for:
  - Gas-Ex Zone 1 (ATEX) in protection class Ex-i
  - Gas-Ex Zone 2 (ATEX)
  - Dust-Ex Zones 21 and 22 (ATEX)
- Wide range of accessories, e. g.
  - Tear-drop load plate
  - Ball-shaped load plate
  - Roller train
  - Drive-on ramps
  - Mounting supports
  - Bottom fixation

Further special variants are available and will be offered to you upon request.

We will be pleased to suggest a complete scale configured to your requirements, e.g. DVC/DVM platform scale complete with DISOMAT weighing electronics, printer, displays and other accessories.

### Available combinations of scale size and rated capacities

Size [mm]	Weighing range [kg]					
	60	150	300	600	1500	3000
400 x 300	X					
500 x 400	X	X				
650 x 500	X	X	X			
800 x 600	X	X	X			
1000 x 800				X	X	X
1000 x 1000				X	X	X
1250 x 1000				X	X	X
1500 x 1250				X	X	X
1500 x 1500				X	X	X
2000 x 1500				X	X	X

**View of scales up to size 500 x 400 mm**  
(with S235JRGZ variant up to 650 x 500 mm)

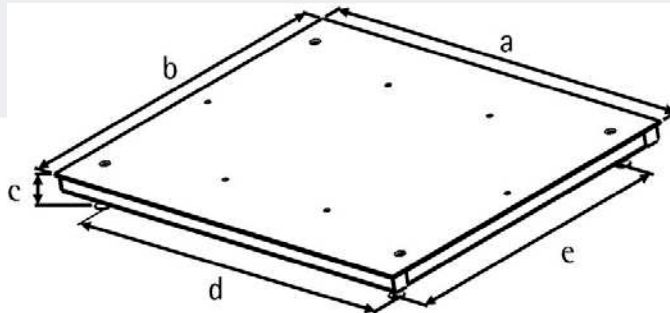


**View of scales up to size 650 x 500 mm**  
(with S235JRGZ variant up to 800 x 600 mm)



Load plate of 304L on standard.

### Dimensions and load limits



Support  
feet diameter: 80 mm  
Adjusting range: 5 mm

Size [mm] (a x b)	Height DVC [mm] (c)	Height DVM [mm] (c)	Support spacing [mm] (d x e)	Cable length [m]	Dead weight [kg]	Strength		
						Mid [kg]	Side [kg]	Corner [kg]
400 x 300	94 (**:101)	96	344 x 244	1,5	11	130	85	45
500 x 400	96 (**:104)	110	443 x 343	1,5	18	300	200	100
650 x 500 *)	145	142	530 x 434	3	20	600	400	200
650 x 500 **)	90	140	550 x 400	3	20	450	300	150
800 x 600 *)	145	142	680 x 534	3	35	1200	800	400
800 x 600 **)	90	140	700 x 500	3	35	900	600	300
1000 x 800	90	100	804 x 604	6	140	4500	3000	1500
1000 x 1000	90	100	804 x 804	6	160	4500	3000	1500
1250 x 1000	90	100	1054 x 804	6	185	4500	3000	1500
1500 x 1250	90	100	1304 x 1054	6	270	4500	3000	1500
1500 x 1500	90	100	1304 x 1304	6	305	4500	3000	1500
2000 x 1500	100	100	1804 x 1304	6	425	4500	3000	1500

\*) S235JRGZ

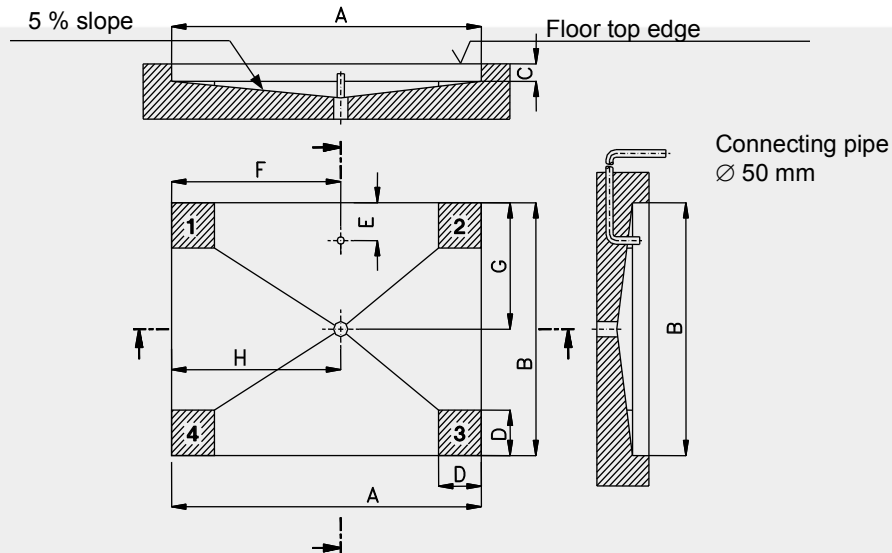
\*\*) Stainless steel

## Foundation Frame

For mounting the DVC/DVM scales in a pit, appropriate foundation frames are available. These frames have the job of perfectly bordering the edge of the foundation pit. The frames for the DVC line also provide centering and metallic mounting surfaces for the adjustment bases of this platform scale.

That reduces the demands made of evenness and strength of the pit floor. All you have to do is install the foundation frame in the prepared pit and fill the residual gap with concrete. For further details, please see the installation instructions given in Service Manual BV-H2224.

## Dimensions of user's pit



**Note:** Dimensions [mm] H, G (dewatering) and E, F (cable inlet) are useful suggestions and can be varied in case of need.

Platform size	Foundation frame inner dimensions	Pit inner dimensions (A x B)	Pit depth (C)	Mounting surface (D)	Correction sheets	E	F	G	H
800 x 600 *)	814 x 614	970 x 770	160	220	150 x 150	200	485	560	485
800 x 600 **)	814 x 614	950 x 750	105	250	200 x 200	175	475	570	475
1000 x 1000	1014 x 1014	1150 x 1150	105	300	250 x 250	250	800	575	575
1250 x 1000	1264 x 1014	1400 x 1150	105	300	250 x 250	250	800	575	575
1500 x 1250	1514 x 1264	1650 x 1400	105	300	250 x 250	450	1100	700	700
1500 x 1500	1514 x 1514	1650 x 1650	105	300	250 x 250	480	1200	825	825
2000 x 1500	2014 x 1514	2170 x 1670	115	300	300 x 300	250	1185	835	1185

\*) S235JRGZ

\*\*\*) Stainless steel

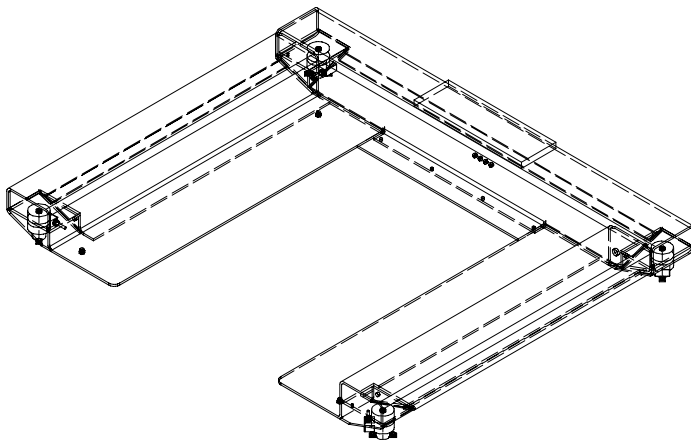
## Available preference sizes (Reduced range of products supplied with DVM models)

Size [mm]	Material	Rated Capacity [kg]	Quality	Ordering no.
Platform scales				
800 x 600	S235JRGZ	300	C3	V020526.B01
1000 x 1000	S235JRGZ	600	C3	V020526.B02
1250 x 1000	S235JRGZ	600	C3	V020526.B03
1000 x 1000	S235JRGZ	1500	C3	V020526.B04
1250 x 1000	S235JRGZ	1500	C3	V020526.B05
1500 x 1250	S235JRGZ	1500	C3	V020526.B06
1500 x 1500	S235JRGZ	1500	C3	V020526.B07
2000 x 1500	S235JRGZ	1500	C3	V020526.B08
1000 x 1000	S235JRGZ	3000	C3	V020526.B09
1250 x 1000	S235JRGZ	3000	C3	V020526.B10
1500 x 1250	S235JRGZ	3000	C3	V020526.B11
1500 x 1500	S235JRGZ	3000	C3	V020526.B12
2000 x 1500	S235JRGZ	3000	C3	V020526.B13

Size [mm]	Material	Rated Capacity [kg]	Quality	Ordering no.
Platform scales				
800 x 600	304L	300	C3	V020538.B01
1000 x 1000	304L	600	C3	V020538.B02
1250 x 1000	304L	600	C3	V020538.B03
1000 x 1000	304L	1500	C3	V020538.B04
1250 x 1000	304L	1500	C3	V020538.B05
1500 x 1250	304L	1500	C3	V020538.B06
1500 x 1500	304L	1500	C3	V020538.B07
2000 x 1500	304L	1500	C3	V020538.B08
1000 x 1000	304L	3000	C3	V020538.B09
1250 x 1000	304L	3000	C3	V020538.B10
1500 x 1250	304L	3000	C3	V020538.B11
1500 x 1500	304L	3000	C3	V020538.B12
2000 x 1500	304L	3000	C3	V020538.B13
Platform scales Ex-i Zone 1				
800 x 600	304L	300	C3	V020546.B01
1000 x 1000	304L	600	C3	V020546.B02
1250 x 1000	304L	600	C3	V020546.B03
1000 x 1000	304L	1500	C3	V020546.B04
1250 x 1000	304L	1500	C3	V020546.B05
1500 x 1250	304L	1500	C3	V020546.B06
1500 x 1500	304L	1500	C3	V020546.B07
2000 x 1500	304L	1500	C3	V020546.B08
1000 x 1000	304L	3000	C3	V020546.B09
1250 x 1000	304L	3000	C3	V020546.B10
1500 x 1250	304L	3000	C3	V020546.B11
1500 x 1500	304L	3000	C3	V020546.B12
2000 x 1500	304L	3000	C3	V020546.B13
Foundation frame				
800 x 600	S235JRGZ			V020567.B01
1000 x 1000	S235JRGZ			V020567.B02
1250 x 1000	S235JRGZ			V020567.B03
1500 x 1250	S235JRGZ			V020567.B04
1500 x 1500	S235JRGZ			V020567.B05
2000 x 1500	S235JRGZ			V020567.B06
Foundation frame				
800 x 600	304L			V020575.B01
1000 x 1000	304L			V020575.B02
1250 x 1000	304L			V020575.B03
1500 x 1250	304L			V020575.B04
1500 x 1500	304L			V020575.B05
2000 x 1500	304L			V020575.B06
Small scales				
400 x 500	304L	60	C3	V020576.B01
400 x 500	304L-Exi	60	C3	V020577.B01

Further sizes and accessories available upon request.

## DPW Pallet Scales



- **Low access height for Hand-Pallet-Truck**
- **Robust and Maintenance-Free**
- **High Quality Manufacture**
- **Available in AISI 316Ti Stainless steel**
- **Extensive Range of Accessories**
- **Legal-for-Trade as a Class III Trade Scales**
- **Also Available as an ATEX Design**

### Applications

The robust and maintenance-free design of DPW Pallet Scales makes them suitable for applications in almost all areas of industry.

Paired with the appropriate scales electronics from the DISOMAT family they can also be used as a self-acting scales for automatic gravimetric filling of big bags.

The high-quality design of the scales, the easy access for cleaning and the extensive range of accessories also allow them to be used in exacting applications such as the chemicals industry and for the manufacture of foodstuffs.

### Design

- **2 Sizes:** 1080 mm x 1250 mm and 1350 mm x 1250 mm
- **Material:**
  - Powder-coated steel 37 (as per DIN 4753, RAL 7040 medium grey),
  - Stainless steel 1.4301 (AISI 304),
  - Stainless steel 1.4571 (AISI 316Ti).
- **Legal-for-Trade design** for 3000d or multi-range 2 x 3000d
- **Optional explosion hazard design** for explosion hazard zone combinations
  - ATEX Zone 1 and 21
  - ATEX Zone 2 and 22

- The DPW Pallet Scales use the robust, tried-and-tested RTN load cells.

Big bag filling stations can be simply constructed on top of the pallet scales.

We are happy to offer further special designs that meet your particular demands.

And of course we can create a complete scales system for you consisting of a DPW Pallet Scales, DISOMAT® control and evaluation electronics and further accessories such as a printer, display, etc...

### Technical Specifications

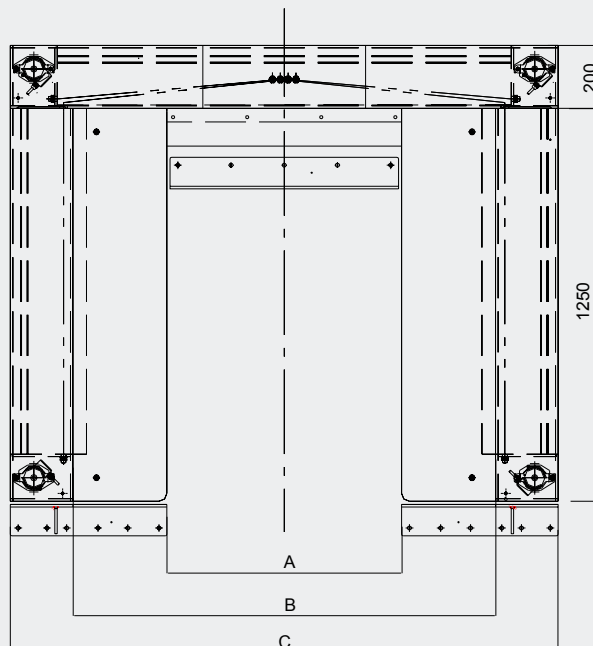
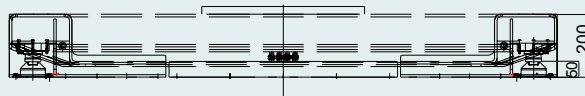
Load-carrying capacity: max. 2 000 kg  
 Possible Weighing ranges: 4 – 600 kg / 0.2 kg  
 or 10 – 1 500 kg / 0.5 kg  
 or 20 – 2 000 kg / 1 kg  
 or multi-range or multi-interval scales

DPW Pallet Scales are available in two sizes

Size	I	II
Placement area	1 080 x 1 250 mm	1 350 x 1 250 mm
for pallets	800 x 600 mm	1 200 x 1 000 mm
	1 000 x 800 mm	1 200 x 1 200 mm
	1 200 x 800 mm	
A	620	740
B	1080	1350
C	1480	1750

Material: St37, Stainless steel AISI 304 1.4301 – AISI 316Ti 1.4571  
 Weight: approx. 250 kg

2 sizes with respect to the drive-in width





# RTB

## Ring torsion load cell

- Legal-for-trade design according to OIML
- High accuracy, even for very small application areas (for legal-for-trade applications up to at least 15 %)
- Low power consumption due to high input impedance of 1100  $\Omega$
- ATEX/IECEX approval for category 1GD (intrinsically safe to operate) or 3GD (not intrinsically safe)
- Protection class IP68



### Application

The load cell as transducer converts the mechanical input variable force proportionally into the electronic output variable voltage.

The specific model of the ring torsion load cell offers the user specific advantages:

- The extremely small frame size simplifies the use in almost all weighing device applications
- The robust construction allows problem-free transport, installation and operation, also under rough ambient conditions (disturbance forces, temperature)

### Construction

- Hermetically sealed encapsulation through laser welding and glass-metal implementation (IP68)
- Corrosion protection through the use of stainless steel

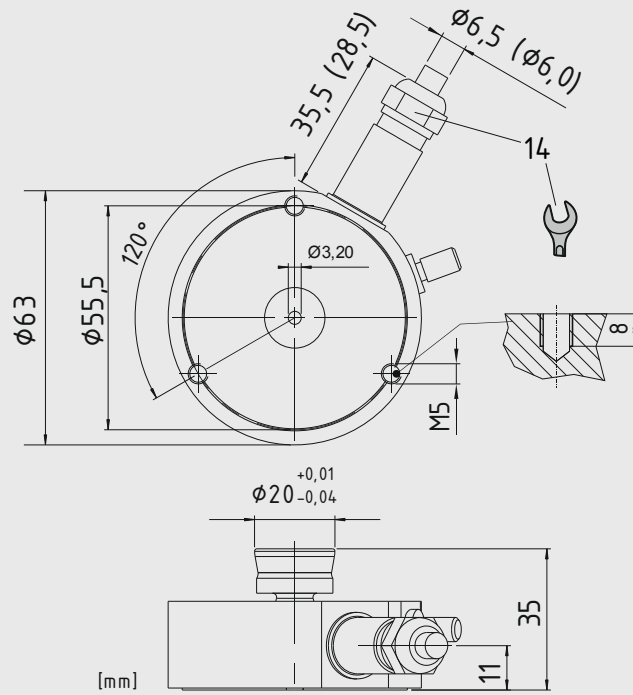
- All electrical components are located inside the load cell and thus are optimally protected
- The high quality and robust connecting cable is guided radially into the load cell
- Mechanically compatible with the RTK type series

### Function

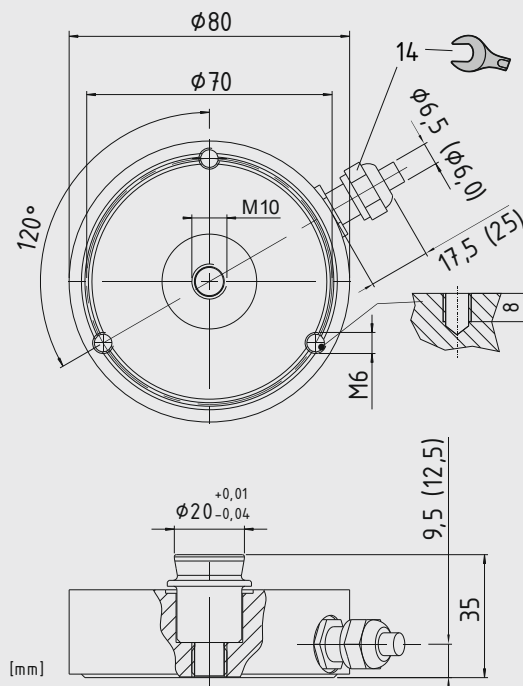
- High reproducibility
- High long-term stability and therefore consistently high accuracy permanently
- Extremely small measured value influence as a result of lateral forces
- High functional safety, even with frequently unavoidable impact loads and constraining forces, as well as with electrical interferences
- Torque-free force input/output as a result of the direct, vertical power train

## Dimensions

### RTB 0.13 t



### RTB 0.25 t / 0.5 t



## Technical Data

Nominal load	E <sub>max</sub>	0.13 t	0.25 t	0.5 t	—	
Accuracy class		C3	C3	C3	C5	Ref
Nominal characteristic value	C <sub>n</sub>	1 mV/V ±0.1 mV/V	1.75 mV/V ±0.2 mV/V	2 mV/V ±0.1 mV/V		—
Combined error	F <sub>comb</sub>	±0.023 %	±0.023 %	±0.0140 %		C <sub>n</sub>
Dead load return after load (30 min)	F <sub>dr</sub>	±0.0167 %	±0.0167 %	±0.0083 %		C <sub>n</sub>
Creepage under load (30 min)	F <sub>cr</sub>	±0.012 %	±0.0245 %	±0.0123 %		C <sub>n</sub> , B <sub>tn</sub>
Hysteresis		±0.017 %	±0.0167 %	±0.0083 %		C <sub>n</sub> , B <sub>tn</sub>
Temperature coefficient of the zero signal per 10 K	TK <sub>0</sub>	±0.008 % —	±0.014 % ±0.007 %	±0.009 %		C <sub>n</sub> , B <sub>tn</sub> Option MR
Temperature coefficient of the characteristic value per 10 K	TK <sub>c</sub>	±0.008 %	±0.01 %	±0.005 %		C <sub>n</sub> , B <sub>tn</sub>
Max. permissible number of legal-for-trade scale intervals	n <sub>LC</sub>	3000	3000		5000	—
Smallest scale interval	V <sub>min</sub>	E <sub>max</sub> /17500 —	E <sub>max</sub> /10000 E <sub>max</sub> /20000	E <sub>max</sub> /17500		Standard Option MR
Minimum application range	B <sub>amin</sub>	17 % —	30 % 15 %	40 %		E <sub>max</sub> Option MR
max. application range	B <sub>amax</sub>	100 %			E <sub>max</sub>	
Maximum capacity *	L <sub>I</sub>	150 %			E <sub>max</sub>	
Max. lateral load **	L <sub>q</sub>	20 %			E <sub>max</sub>	
Input resistance	R <sub>e</sub>	1260 Ω ±100 Ω	1100 Ω ±100 Ω	1100 Ω ±100 Ω		—
Output resistance	R <sub>a</sub>	1020 Ω ±0.5 Ω	1025 Ω ±25 Ω	1025 Ω ±25 Ω		—
Zero Signal	S <sub>0</sub>	1 %	1.5 %	1 %		C <sub>n</sub>
Supply voltage	U <sub>s</sub>	max. 30 V (recommended: 5 V – 15 V)			—	
Nominal temperature	B <sub>tn</sub>	-10 °C - +40 °C			—	
Operating temperature range	B <sub>tu</sub>	-30 °C - +70 °C		-35 °C - +70 °C		—
Storage temperature range	—	-50 °C - +90 °C		-50 °C - +90 °C		—
Protection class	—	IP68			—	
Cable Specification	—	Length of cable 5 m, Shield insulated by the housing (0.13 t), and connected with the housing (0.25 t – 0.50 t)			—	
Connection assignment	—	Input + 82: pink / Output + 28: brown		Input - 81: gray / Output - 27: white		—
Material	—	Stainless steel			—	
Corrosion protection	—	See resistance table DDP8 483			—	
Recommended tightening torque for the fastening bolts	—	8 Nm	12 – 14 Nm		—	
ATEX approval	—	Only operate intrinsically safely:		II 1G Ex ia IIC T4 Ga II 1D Ex ia IIIC T73°C Da		—
		Not operated intrinsically safely:		II 3G Ex nA IIC T4 Gc II 3D Ex tc IIIC T63°C DC		—

\* Permissible vibrational loading as defined by DIN 50100: 70 % E<sub>max</sub>. Peak loading values may **not** exceed E<sub>max</sub>.

\*\* In combination with elastomer bearings, SEM must be observed that the reset force of the elastomer bearings already represents a transverse force.

## Order Numbers

Design	Accuracy class	
	C3	C5
[t]		
0.13	V041085.B01	—
0.25	V041086.B01	—
0.50	V041087.B01	V041087.B05
0.25 MR	V041086.B07	—
0.50 MR	V041087.B07	—
<b>Order numbers model ATEX/IECEX II 1G Ex ia IIC T4 Ga/ II 1D Ex ia IIIC T73°C Da/            II 3G Ex nA IIC T4 Gc/ II 3D Ex tc IIIC T63°C DC*</b>		
0.13	V041085.B11	—
0.25	V041086.B11	—
0.50	V041087.B11	V041087.B15

**\*Which range, 1GD or 3GD, the load cell is used for, must be marked on the identification plate. For category 1GD or 2GD, the load cell must be connected intrinsically safe.**

**Installation accessories:**

SENSiQ™ Secure Mount SSM, SENSiQ™ Elastomer Mount SEM



## Ring-Torsion Load Cells RTN



- OIML approved as suitable for trade use (up to 5000 d and 7500 d in case of multi-divisional scales)
- High accuracy, even for very small utilisation ranges (down to 15 % in case of trade use according to OIML)
- High output signal and, thus, high-resolution of useful signal range
- Low power consumption allows realisation of multi-scale systems with simple evaluation electronics
- Use in hazardous zone with protection class Ex ia IIC T4 Gb / Ex ia IIIC T125 °C Db or protection class Ex nA IIC T4 Gc / Ex tb IIIC T125 °C Db
- Protection class IP68

### Application

Acting as a transducer, the load cell converts the mechanical input signal, the load, proportionally into the electrical output voltage.

The consistent optimization of the ringtorsion load cells offers additional advantages:

- The extremely low headroom simplifies the use in almost all weighing applications
- The sturdy design enables easy transport, installation, and operation, even under very harsh environmental conditions (e.g. aggressive media, interfering forces, or extreme temperatures)

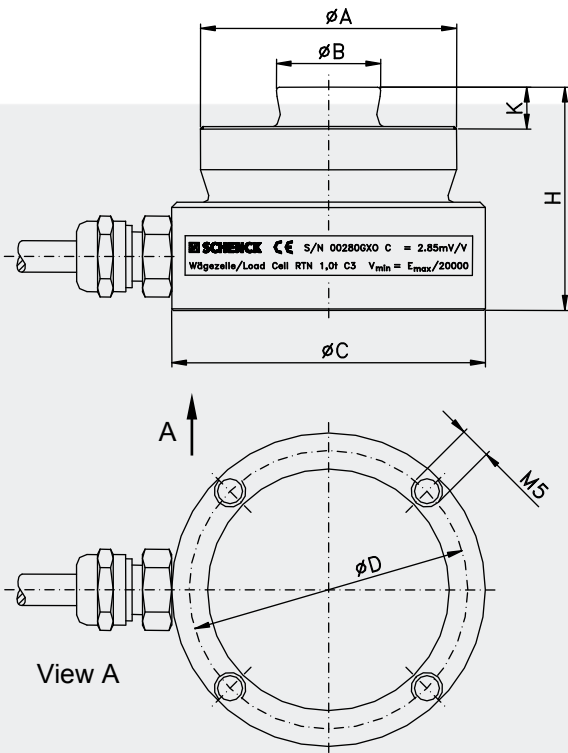
### Construction

- Hermetically sealed due to laser welding; protection class IP68
- High corrosion protection due to the use of electrolytically polished stainless steel
- All electrical components are inside the load cell and are thus optimally protected
- The high-quality, sturdy connection cable is lead radially into the load cell
- The RTN load cells are compatible with earlier ring-torsion load cells if our adapter kits are used

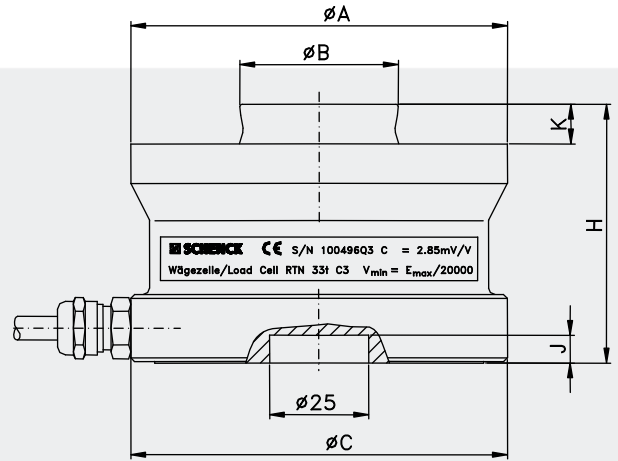
### Functions

- High measuring sensitivity
- High repeatability
- High long-term stability and, thus, continuing and consistently high accuracy
- Minimal effect on accuracy by side forces
- High reliability and availability, even in case of unavoidable shock loads, constraining forces or electrical interferences
- Integral excessive voltage protection
- Moment-free load input/output due to direct, vertical force flow

### RTN 1 t – 4.7 t



### RTN 10 t - 470 t



### Technical Data

Rated Capacity $E_{max}$ t	Safe-Load-Limit $L_1$ t	Breaking Load $L_d$ t	Nominal displacement $h_n$ mm	Dead weight kg
1	1.7	4	0.13	0.6
2.2	4	9	0.12	0.6
4.7	8	19	0.12	0.7
10	17	40	0.17	1.2
15	28	60	0.18	1.3
22	38	90	0.21	1.3
33	58	130	0.25	2.1
47	80	190	0.33	4.3
68	120	270	0.35	4.8
100	170	400	0.45	7.0
150	250	600	0.57	8.6
220	380	900	0.67	22.0
330	580	1200	0.85	29.0
470	700	1500	1.00	50.0

### Dimensions

Type	Dimensions (mm)						
RTN	A	B	C	D	H	K	J
1 t	49	20	60	53	43	7.5	-
2.2 t	49	20	60	53	43	7.5	-
4.7 t	49	20	60	53	43	7.5	-
10 t	73	30	75	-	50	6.5	7
15 t	75	30	75	-	50	6.5	7
22 t	75	30	75	-	50	6.5	7
33 t	95	40	95	-	65	10	7
47 t	130	60	130	-	75	14	7
68 t	130	60	130	-	85	14	7
100 t	150	70	150	-	90	16	7
150 t	150	70	150	-	100	16	7
220 t	225	100	225	-	130	24	10
330 t	225	100	225	-	145	24	10
470 t	270	120	270	-	170	28	10

Admissible static side load  $L_q = 0.5 (E_{max} - 0.8 L_z)$ , but no higher than  $L_{qmax} = 0.3 E_{max}$ ;  $E_{max}$  = rated capacity;

$L_z$  = load in measuring direction

Admissible dynamic load to DIN 50100: 70 %  $E_{max}$ . Dynamic load value must not exceed  $E_{max}$ .

## Technical Data

<b>Rated capacity</b>	$E_{max}$	<b>1 t – 470 t</b>		<b>1 t – 100 t</b>	
<b>Accuracy class</b>		0.05	C3	C5 / C4 Mi 7.5	Reference
<b>Sensitivity</b>	$C_n$	2.85 mV/V $\pm$ 2.85 $\mu$ V/V			
<b>Combined error</b>	$F_{comb}$	0.05 %	0.02 %	0.01 %	$C_n$
<b>Minimum dead load output return</b>	$F_{dr}$	$\pm$ 0.03 %	$\pm$ 0.016 %	$\pm$ 0.006 %	$C_n$
<b>Creep (30 m)</b>	$F_{cr}$	$\pm$ 0.04 %	$\pm$ 0.024 %	$\pm$ 0.009 %	$C_n$
<b>Temperature effect on zero sensitivity per 10 K</b>	$TK_0$	$\pm$ 0.03 % $\pm$ 0.05 %	$\pm$ 0.007 % $\pm$ 0.02 %	$\pm$ 0.0058 % $\pm$ 0.02 %	$C_n, B_{tn}$ $C_n, B_{tu}$
<b>Temperature effect on sensitivity per 10 K</b>	$TK_c$	$\pm$ 0.05 % $\pm$ 0.07 %	$\pm$ 0.008 % $\pm$ 0.02 %	$\pm$ 0.0062 % $\pm$ 0.02 %	$C_n, B_{tn}$ $C_n, B_{tu}$
<b>Maximum number of scale intervalls</b>	$n_{LC}$		3000	5000	
<b>For multi-divisional scales</b>	Z			7500	
<b>Minimum load cell verification intervall</b>	$V_{min}$		$E_{max}/20000$	$E_{max}/24000$	
<b>Max. utilisation range</b>	$B_{amax}$	$B_{amax} = E_{max}$			
<b>Input resistance</b>	$R_e$	4450 $\Omega$ $\pm$ 100 $\Omega$			$T_r$
<b>Output resistance</b>	$R_a$	4010 $\Omega$ $\pm$ 2 $\Omega$	4010 $\Omega$ $\pm$ 0.5 $\Omega$		$T_r$
<b>Zero signal</b>	$S_0$	$\pm$ 1 %			$C_n$
<b>Max. supply voltage</b>	$U_{smax}$	60 V			
<b>Nominal temperature range</b>	$B_{tn}$	-10 °C ... +40 °C			
<b>Service temperature range Explosion-proof design</b>	$B_{tu}$	-40 °C ... +80 °C, Option to +110 °C *) -30 °C ... +70 °C			
<b>Reference temperature</b>	$T_r$	22 °C			
<b>Storage temperature range</b>	$B_{ts}$	-50 °C ... +85 °C			
<b>Protection class Explosion-proof design</b>		IP68, 1 m / 100 h; (Option 110 °C: IP66) IP67			
<b>Cable specification</b>		TPE (grey) $\varnothing$ 6.5 mm, silicone and halogen free, -30 °C to +150 °C, Length 5 m for RTN 1 t - 15 t and RTN 150 t - 470 t Length 15 m for RTN 22 t - 100 t			
<b>Colour code</b>		Black: input + / blue: input - Red: output + / white: output - Yellow: screening			
<b>Material</b>		Stainless steel			
<b>Corrosion protection</b>		see Spec Sheet DDP8483 "Chemical resistance of RT Load Cells"			

\*) Optional feature 110 °C not possible in combination with C5 or ATEX

**Order No.**

Variants	Accuracy class		
	0.05	C3	C5 / C4 Mi 7.5
RTN 1 t	D726173.04	D726173.02	D726173.10
RTN 2.2 t	D726174.04	D726174.02	D726174.10
RTN 4.7 t	D726175.04	D726175.02	D726175.10
RTN 10 t	D726176.04	D726176.02	D726176.10
RTN 15 t	D726177.04	D726177.02	D726177.10
RTN 22 t	D724781.04	D724781.02	D724781.10
RTN 33 t	D724754.04	D724754.02	D724754.10
RTN 47 t	D724782.04	D724782.02	D724782.10
RTN 68 t	D724783.04	D724783.02	D724783.10
RTN 100 t	D724784.04	D724784.02	D724784.10
RTN 150 t	D726178.04	D726178.02	
RTN 220 t	D726179.04	D726179.02	
RTN 330 t	D726180.04	D726180.02	
RTN 470 t	D726181.04	D726181.02	

**Optional feature ATEX/IECEX approval**

Intrinsically safe ATEX explosion-proof design category 2GD and IECEx EPL Gb, Db

Gas-Ex II 2G Ex ia IIC T4 Gb (Zone 1)

Dust-Ex II 2D Ex ia IIIC T125 °C Db, IP67 (Zone 21)

Warning: The verification of intrinsically safe circuit must be verified. New barriers are provided in particular for new systems. The verifications of intrinsically safe circuit are available for all load cells and barriers.

Accuracy class		
0.05 2GD	C3 2GD	C5 / C4 MI 7,5 2GD
Variant .82	Variant .81	Variant .83

Load cells marked as intrinsically safe - Ex "i" - are also operated intrinsically safely irrespective of the zone.

Non intrinsically safe ATEX explosion-proof design category 2D, 3G and IECEx EPL Db, Gc

Gas-Ex II 3G Ex nA IIC T4 Gc (Zone 2)

Dust-Ex II 2D Ex tb IIIC T125 °C Db, IP67 (Zone 21)

Accuracy class		
0.05 2D3G	C3 2D3G	C5 / C4 MI 7,5 2D3G
Variant .86	Variant .85	Variant .87

**Example for ordering:** 47 t, accuracy class C3, ATEX category 2D, 3G. Typ RTN 47 t C3 2D, 3G ...;  
Order No. D724782.85

Option	Accessories
<ul style="list-style-type: none"> <li>■ Variant for service temperature range of up to 110 °C</li> <li>■ Customized cable length</li> <li>■ Special corrosion protection</li> <li>■ Protection class IP69K</li> <li>■ Cable resistant to gnawing rodents</li> <li>■ Mounting holes</li> </ul>	<ul style="list-style-type: none"> <li>SENSiQ™ Elastomer Mount (SEM)</li> <li>SENSiQ™ Secure Mount (SSM)</li> <li>SENSiQ™ Pendulum Mount (SPM)</li> <li>SENSiQ™ Fixed Mount (SFM)</li> </ul>

**Schenck Process Europe GmbH**

Pallaswiesenstr. 100

64293 Darmstadt, Germany

Phone: +49 6151 1531 0

Fax: +49 6151 1531 66

sales@schenckprocess.com

www.schenckprocess.com



## Load Cells VBB and Load Cell Mounts VEB



- **Highest accuracies (up to 6000 increments to OIML R60)**
- **Hermetically sealed due to laser welding (IP68)**
- **Use in hazardous zone with protection class  
Ex ia IIC T4 Gb / Ex ia IIIC T125 °C Db  
or protection class  
Ex nA IIC T4 Gc / Ex tb IIIC T125 °C Db**
- **Optimized for parallel connection through perfect calibration**
- **6-wire circuit**
- **100 % stainless steel**

### Application

Load cells of the VBB type are designed to convert the mechanical input signal, the load, proportionally into the electrical output voltage.

Combined with the corresponding VEB elastomer mounts, they are very suitable for use with platform, batching, and hopper scales. Their compact design simplifies the integration in any existing construction.

The rugged design of the load cells and mounts ensures reliable operation even in severe environments.

### Construction

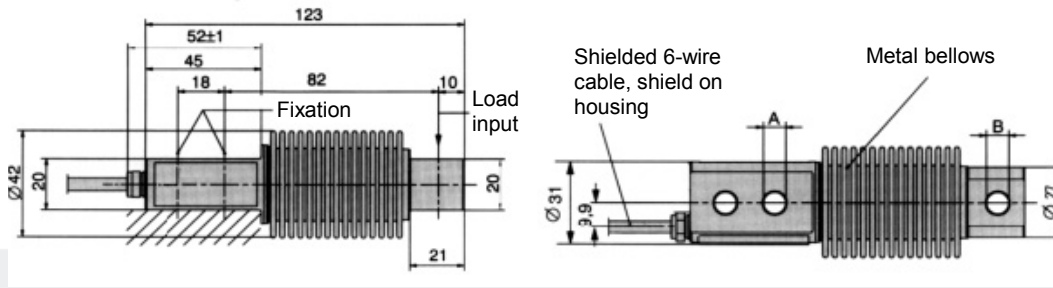
Entirely made of stainless steel and hermetically sealed by laser welding, the VBB load cells are connected by using a high-quality shielded 6-wire PVC cable.

The 6-wire circuit provides for a measuring signal which is insensitive to connecting cables of different lengths.

### Functions

- High calibrating accuracy, thus, optimal prerequisites for the parallel connection of load cells
- High degree of measuring signals repeatability
- Damping of side forces through the elastomer mount
- Self-centering after side load
- Minimal effect on accuracy by side forces

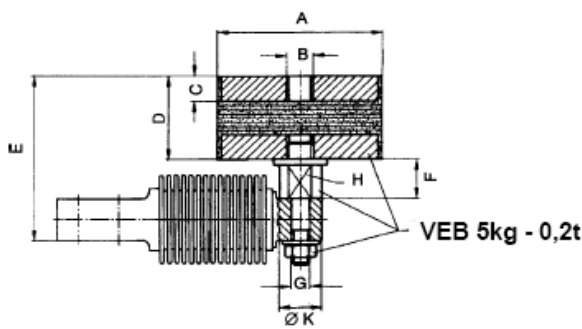
### VBB Load Cells 5 kg – 0.5 t



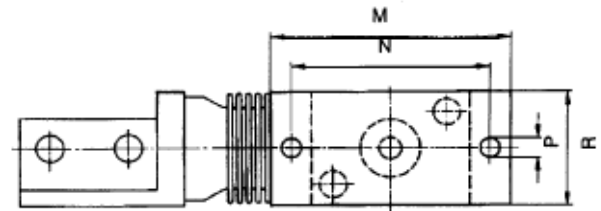
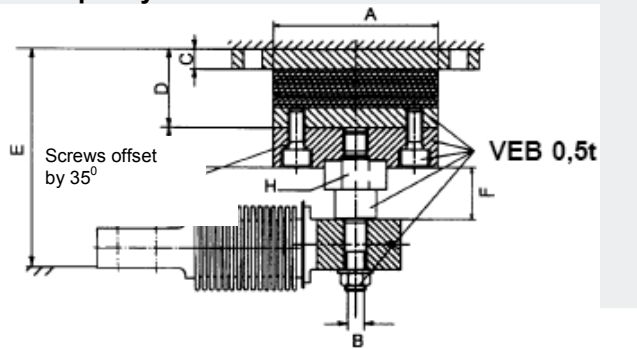
Variant	Dimensions (mm)	
	A	B
VBB 5 kg – 0.2 t	8.2	8.2
VBB 0.5 t	10.5	11.1

### VEB Elastomer Mount 5 kg – 0.5 t for VBB Load Cells

#### Capacities 5 kg – 0.2 t



#### Capacity 0.5 t



Elastomer mount correct mounting position

### Dimensions (mm)

Elastomer mount	A	B	C	D	E	F	G	H	K	L	M	N	P	R	F <sub>R</sub> *	S <sub>max</sub> **
VEB 5 kg – 0.2 t	75	M12	12	40	79 ±1,3	18.5	M8	SW 17	19	-	-	-	-	-	163	3
VEB 0.5 t	80	M10	10	39	105 <sup>+2,1</sup> <sub>-2,2</sub>	26	-	SW 27	-	20	120	100	9	60	400	4.5

\* F<sub>R</sub> Restoring force in N with 1 mm lateral displacement

\*\* S<sub>max.</sub>, in mm, maximum adm. lateral displacement if loaded with rated capacity

## Technical Data

Rated capacity	$E_{max}$	5 kg – 0.5 t				
Accuracy class		D1	C3*	C4**	C6***	Reference
Nominal characteristic value	$C_n$	2 mV/V +20 $\mu$ V/V; -2 $\mu$ V/V	2 mV/V $\pm$ 1 $\mu$ V/V			
Combined error	$F_{comb}$	0.05 %	0.02 %	0.013 %	0.01 %	$C_n$
Zero signal return after loading (30 min)	$F_{dr}$	$\pm$ 0.049 %	$\pm$ 0.016 %	$\pm$ 0.012 %	$\pm$ 0.008 %	$C_n$
Creep error during stress (30 min)	$F_{cr}$	$\pm$ 0.049 %	$\pm$ 0.016 %	$\pm$ 0.012 %	$\pm$ 0.008 %	$C_n$
Temperature coefficient of zero signal	$TK_0$	$\pm$ 0.05 %/10 K	$\pm$ 0.0125 %/10 K	$\pm$ 0.009 %/10 K	$\pm$ 0.009 %/10 K	$C_n$ B $B_{tn}$
Temperature coefficient of characteristic value	$TK_c$	$\pm$ 0.05 %/10 K	$\pm$ 0.008 %/10 K	$\pm$ 0.007 %/10 K	$\pm$ 0.004 %/10 K	$C_n$ B $B_{tn}$
Maximum number of increments in certified applications	$n_{LC}$	1000	3000	4000	6000	
Min. scale interval	$V_{min}$	0.036 %	0.009 %	0.0066 %	0.0066 %	$E_{max}$
Minimum utilisation rate	$B_{amin}$	36 %	27 %	26 %	39 %	$E_{max}$
Maximum utilisation rate	$B_{amax}$	$B_{amax} = E_{max}$				
Input resistance	$R_e$	350 $\Omega$ - 480 $\Omega$				$t_r$
Output resistance	$R_a$	356 $\Omega$ $\pm$ 0.2 $\Omega$	356 $\Omega$ $\pm$ 0.12 $\Omega$			$t_r$
Zero signal	$S_0$	$\pm$ 1 %				$C_n$
Maximum supply voltage	$U_{smax}$	18 V				
Nominal temperature range	$B_{tn}$	-10 $^{\circ}$ C ... +40 $^{\circ}$ C				
Service temperature range Explosion-proof design	$B_{tu}$	-40 $^{\circ}$ C ... +70 $^{\circ}$ C -30 $^{\circ}$ C ... +70 $^{\circ}$ C				
Reference temperature	$t_r$	23 $^{\circ}$ C				
Storage temperature range	$B_{ts}$	-50 $^{\circ}$ C ... +85 $^{\circ}$ C				
Safe load limit	$E_L$	150 %				$C_n$
Breaking load	$E_D$	300 %				$C_n$
Displacement **** at rated capacity		0.25 mm 5 kg	0.3 mm 10 - 100 kg	0.4 mm 200 kg	0.6 mm 500 kg	
Protection class Explosion-proof design		IP68 (tightened test conditions: 1 m water gauge; 100 h) IP67				
Cable specification		3 m PVC cable, 6 wires, shielded, shield on housing				
Colour code		black: input - / blue : input + / black/yellow: shield red : output - / white : output + grey : sensor - / green : sensor +				
Corrosion protection		Stainless steel				

\*: Quality C3 available for nominal loads  $\geq$  10 kg only

\*\* : Quality C4 available for nominal loads  $\geq$  20 kg only

\*\*\*: Quality C6 available for nominal loads  $\geq$  50 kg only

\*\*\*\*: Please adjust the overload stops to nominal displacement +0.05 mm (unloaded scale)

Variants Load Cells	Order No.	Ex-Variants Load Cells	Order No. 2GD	Order No. 2D/3G
VBB 5 kg D1	D 725 417.01			
VBB 10 kg D1	D 725 417.02			
VBB 10 kg C3	D 725 419.02	VBB 10 kg C3 „Ex“	D 725 419.32	D 725 419.42
VBB 20 kg D1	D 725 417.03			
VBB 20 kg C3	D 725 419.03	VBB 20 kg C3 „Ex“	D 725 419.33	D 725 419.43
VBB 50 kg D1	D 725 417.04			
VBB 50 kg C3	D 725 419.04	VBB 50 kg C3 „Ex“	D 725 419.34	D 725 419.44
VBB 0.1 t D1	D 725 409.01	VBB 0,1 t D1 „Ex“	D 725 409.61	D 725 409.41
VBB 0.1 t C3	D 725 409.04	VBB 0,1 t C3 „Ex“	D 725 409.64	D 725 409.44
VBB 0.1 t C4	D 726 370.01	VBB 0,1 t C4 „Ex“	D 726 370.31	D 726 370.41
VBB 0.2 t D1	D 725 409.02	VBB 0,2 t D1 „Ex“	D 725 409.62	D 725 409.42
VBB 0.2 t C3	D 725 409.05	VBB 0,2 t C3 „Ex“	D 725 409.65	D 725 409.45
VBB 0.2 t C4	D 726 370.02	VBB 0,2 t C4 „Ex“	D 726 370.32	D 726 370.42
VBB 0.2 t C6	D 726 370.04	VBB 0,2 t C6 „Ex“	D 726 370.34	D 726 370.44
VBB 0.5 t D1	D 725 409.03	VBB 0,5 t D1 „Ex“	D 725 409.63	D 725 409.43
VBB 0.5 t C3	D 725 409.06	VBB 0,5 t C3 „Ex“	D 725 409.66	D 725 409.46
VBB 0.5 t C4	D 726 370.03	VBB 0,5 t C4 „Ex“	D 726 370.33	D 726 370.43

Variants Elastomer Mounts	Order No.
VEB 5 kg – 0.2 t	D 725 408.01
VEB 0.5 t	D 725 408.02

Example for ordering:

Rated Capacity 0.2 t, Accuracy Class C6: Variant VBB 0.2 t C6 – Ordering Number D726 370.04

Additional versions available upon request.

#### Optional feature ATEX/IECEX approval

Intrinsically safe ATEX explosion-proof design category 2GD and IECEx EPL Gb, Db

Gas-Ex II 2G Ex ia IIC T4 Gb (Zone 1)

Dust-Ex II 2D Ex ia IIIC T125 °C Db, IP67 (Zone 21)

Load cells marked as intrinsically safe - Ex "i" - are also operated intrinsically safely irrespective of the zone.

Warning: The verification of intrinsically safe circuit must be verified. New barriers are provided in particular for new systems. The verifications of intrinsically safe circuit are available for all load cells and barriers.

Non intrinsically safe ATEX explosion-proof design category 2D, 3G and IECEx EPL Db, Gc

Gas-Ex II 3G Ex nA IIC T4 Gc (Zone 2)

Dust-Ex II 2D Ex tb IIIC T125 °C Db, IP67 (Zone 21)

#### Schenck Process GmbH

Pallaswiesenstr. 100

64293 Darmstadt, Germany

Phone: +49 6151 1531 0

Fax: +49 6151 1531 66

sales@schenckprocess.com

www.schenckprocess.com

## VDW Self-Centering Pressure Load Cell



- Legal for Trade Use Pressure Load Cell, Optimized for Use in Vehicle Scales
- Self-Straightening Function
- Simple Installation and Orientation thanks to Matching Accessories
- Comparison of Characteristic Value and Output Impedance Simplifies Corner-Load Comparison in Multiple-Cell Scales
- Excellent Protection Against Electromagnetic Influences thanks to an Optimized Screening Concept
- Integrated Over-Voltage Protection
- Laser-Welded, Protection Class IP 68 1m/100hr; IP69K

### Application

Acting as a measuring transducer, the load cell converts the mechanical input variable load into the electrical output variable voltage.

The VDW has been consistently optimized for use in vehicle scales. :

- The design of the cell as a self-straightening stabilizer link keeps transverse forces away from it, even if the bridge is displaced horizontally to a large degree.
- The design allows for a rapid and cost-effective assembly of the cell with no expensive mounting parts.
- Matching accessories and fitting aids simplify installation.

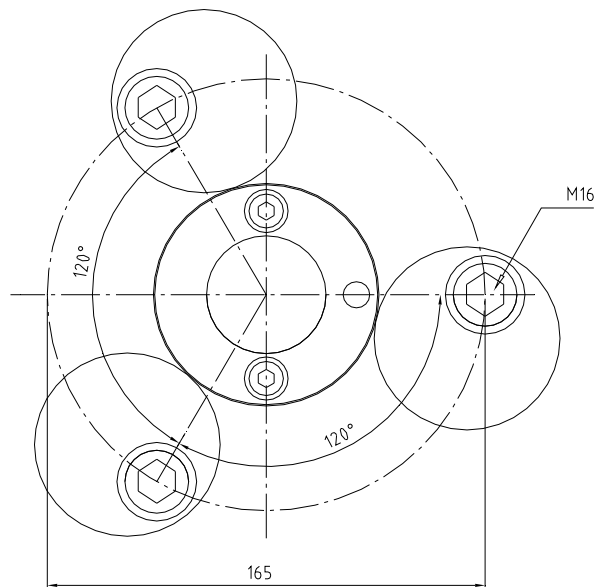
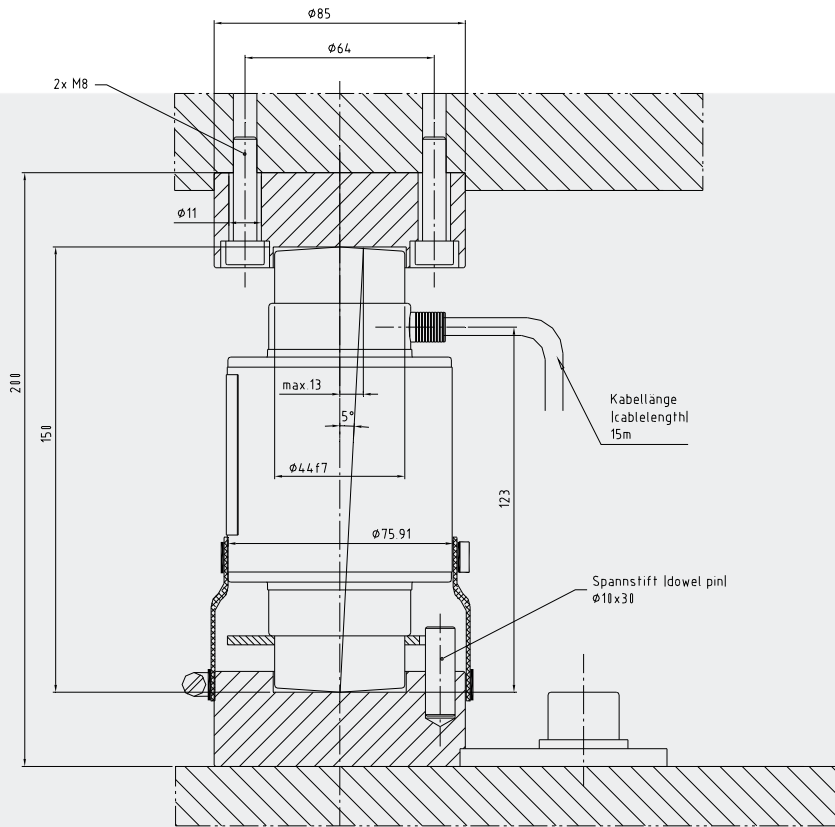
### Construction

- Hermetically sealed thanks to the laser-welding (IP68)
- High corrosion protection thanks to the use of rustproof materials - incl. high-grade steel cable screw connections
- Built-in over-voltage protection
- All electrical components are located in the interior of the load cell and are thus optimally protected.
- Laser-welded, protection class IP 68 1m immersion depth /100hr, or IP69K ( steam jet cleaning )

### Function

- High measuring sensitivity
- High reproducibility
- High long term stability and thus continuously high accuracy over time.
- Characteristic value and output impedance of the VDW are compared to each other such that the corner-load comparison for a multiple-cell scales generally becomes redundant
- The optimized screening concept (no conductible connection from cable screen to load cell body) gives excellent protection against electromagnetic influences..

Dimensions:



## Technical Data

<b>Rated Capacity</b>	<b>E<sub>max</sub></b>	<b>33t / 44t</b>	Reference
<b>Accuracy Class:</b>		C3	
<b>Nominal Characteristic Value</b>	C <sub>n</sub>	2.2 mV/V ± 0.5% *)	
<b>Combined Errors</b>	F <sub>comb</sub>	0.02 %	C <sub>n</sub>
<b>Zero-Signal Return After Loading (30m)</b>	F <sub>dr</sub>	± 0.12 %	C <sub>n</sub>
<b>Creeping Under Load (30 min)</b>	F <sub>cr</sub>	± 0.017 %	C <sub>n</sub>
<b>Temperature Coefficient of the Zero Signal per 10 K</b>	TK <sub>0</sub>	± 0.014 % ± 0.04 %	C <sub>n</sub> , B <sub>tn</sub> C <sub>n</sub> , B <sub>tu</sub>
<b>Temperature Coefficient of the Characteristic Value per 10 K</b>	TK <sub>c</sub>	± 0.008 % ± 0.025 %	C <sub>n</sub> , B <sub>tn</sub> C <sub>n</sub> , B <sub>tu</sub>
<b>Max. Permissible Number of Legal for Trade Scale Intervals</b>	n <sub>LC</sub>	3000	
<b>Smallest Scale Interval</b>	V <sub>min</sub>	E <sub>max</sub> /10000	
<b>Max. Application Area</b>	B <sub>amax</sub>	B <sub>amax</sub> = E <sub>max</sub>	
<b>Input Resistance</b>	R <sub>e</sub>	700 Ω ± 3%	T <sub>r</sub>
<b>Output Resistance</b>	R <sub>a</sub>	706 Ω ± 0.5% *)	T <sub>r</sub>
<b>Zero Signal</b>	S <sub>0</sub>	± 1%	C <sub>n</sub>
<b>Max. Supply Voltage</b>	U <sub>smax</sub>	12V +10%	
<b>Nominal Temperature Range</b>	B <sub>tn</sub>	-10°C to +40°C	
<b>Operating Temperature Range</b>	B <sub>tu</sub>	-30°C to +70°C	
<b>Storage Temperature Range</b>	B <sub>ts</sub>	-50°C to +85°C	
<b>Permissible Angle Error</b>	α	5°	
<b>Permissible Horizontal Displacement</b>	S <sub>max</sub>	13mm	
<b>Restoring Force</b>	F <sub>r</sub>	0.76% / 0.94% per mm displacement	E
<b>Nominal Measuring Displacement</b>		0.8mm / 0.9mm	E <sub>max</sub>
<b>Limit Load</b>	E <sub>l</sub>	45t / 60t	
<b>Breaking Load</b>	L <sub>d</sub>	100t / 125t	
<b>Vibrational Loading (as per DIN 50100)</b>		70% E <sub>max</sub> . Peak load may not exceed the load E <sub>max</sub>	
<b>Protection Class</b>		IP 68 (1m; 100hr); IP 69K	
<b>Cable Specification</b>		TPE (grey) Ø 5,3mm, silicone- and halogen-free, -30°C to +120°C; length 15m	
<b>Connection Assignment</b>		black: input + / blue: input - grey: sense + / green: sense - red: output + / white: output -	
<b>Material</b>		Stainless steel	
<b>Weight including pressure pieces</b>		4.7 kg	

\*) Characteristic value and output impedance of the VDW are compared to each other such that the corner-load comparison for a multiple-cell scales generally becomes redundant - assuming that the mechanics of the scales can guarantee a clean, reproducible load distribution across the sensors.

### Order Numbers

Design	Material number
VDW 33t, C3 without mounting parts	V080434.B01
VDW 44t, C3 without mounting parts	V080434.B02
Set of mounting parts (2 thrust pieces) for load cell VDW	V080494.B01

**Schenck Process GmbH**  
Pallaswiesenstr. 100  
64293 Darmstadt, Germany  
Phone: +49 6151 1531-1216  
Fax: +49 6151 1531-1172  
sales@schenckprocess.com  
www.schenckprocess.com



## SENSiQ™ Elastomer Mount (SEM) Elastomer Mount for SENSiQ™ RTN/RTB 0.25 t ... 470 t Load Cell



- Self-centering
- Cushions dynamic loads
- Stable to shear forces
- Simple, robust and flat construction
- High resistance to environmental conditions and chemicals
- Easy to assemble
- Maintenance-free

### Application

For technical measurements the elastomer bearing provides ideal load application to Schenck Process ring torsion load cells.

It is used for all industrial scales such as e.g. bin weighers, roller table scales, crane scales and road weighbridges.

### Construction

The Elastomer Mount consists of the pressure piece for load application, the elastomer for self-centering and the base plate for dissipating the load into the supporting construction.

The lateral play must be limited depending on the application. Similarly a lifting restraint should be fitted to prevent lifting.

### Function

The weight to be measured is applied to the load cell by means of the pressure piece. The design means that the vertical deflection is extremely small and proportional to the load.

Any lateral forces deform the elastomer in a parallel manner. It automatically will center itself as soon as the lateral force ceases.

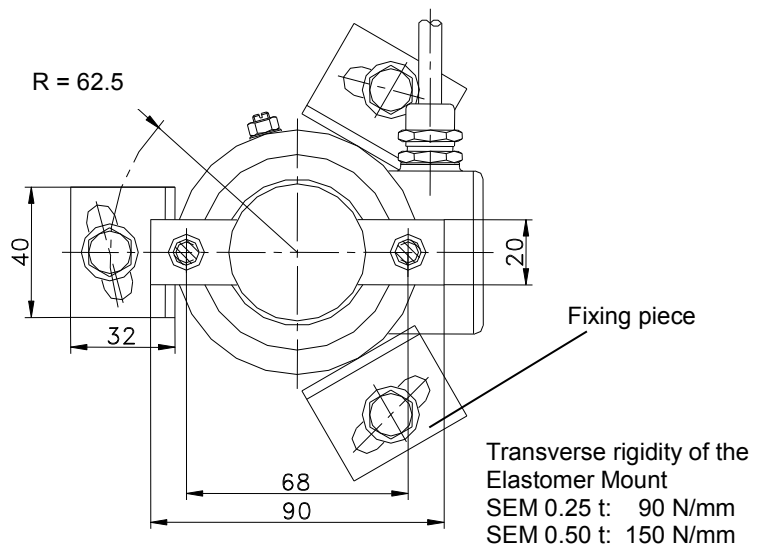
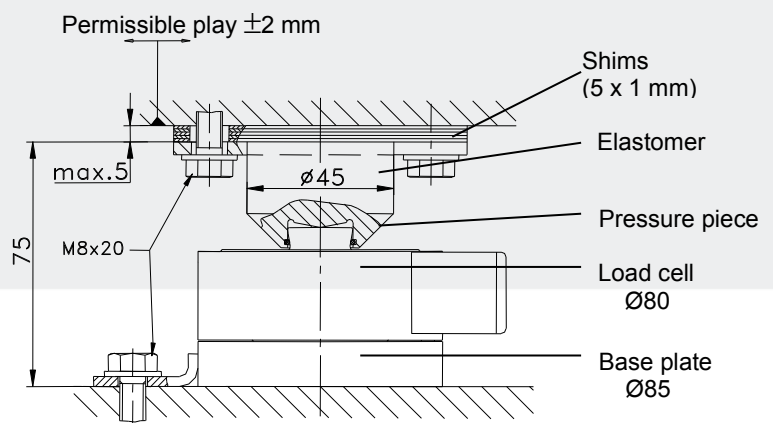
A load distribution plate above the pressure piece may be necessary depending on the permissible bearing pressure of the load pick-up. This should always be checked for a transition from steel to concrete.

### Important Notice:

A non-reproducible application of force into the load cell may occur when lifting and re-applying the load application elements, causing measuring errors in the scales overall. The Elastomer Mount therefore may never completely be unloaded. The minimum pre-load should be large enough so that there always is a non-positive connection between the load cell and the pressure piece or base plate.

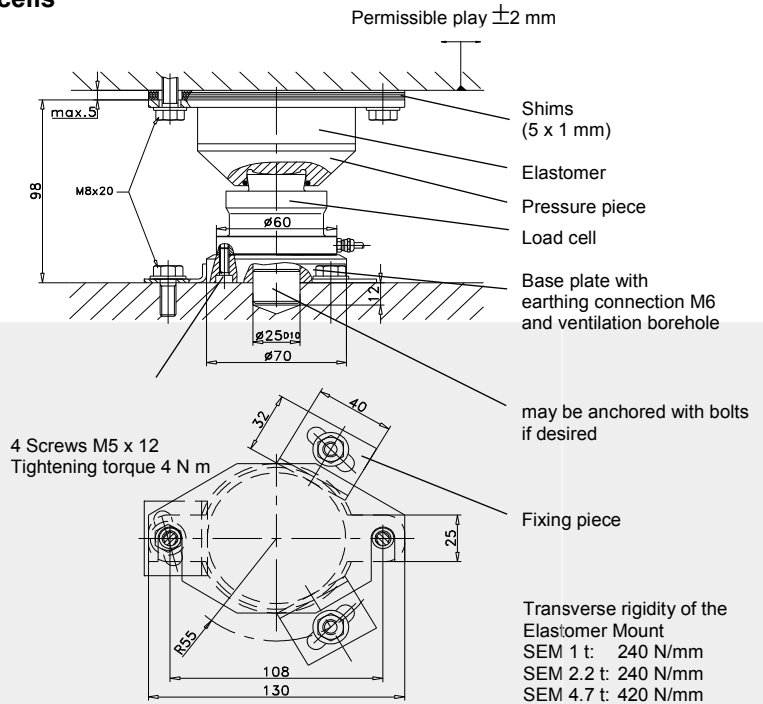
### Elastomer Mount SEM 0.25 t ... 0.50 t for RTB load cells

- the elastomer is located above the pressure piece
- the pressure piece is bolted or pinned to the connecting structure by means of two straps on the side
- height compensation (max. 5 mm) is performed using shims
- the bearing is aligned using by moving the base plate that is secured using the fixing pieces to be pinned or bolted on.



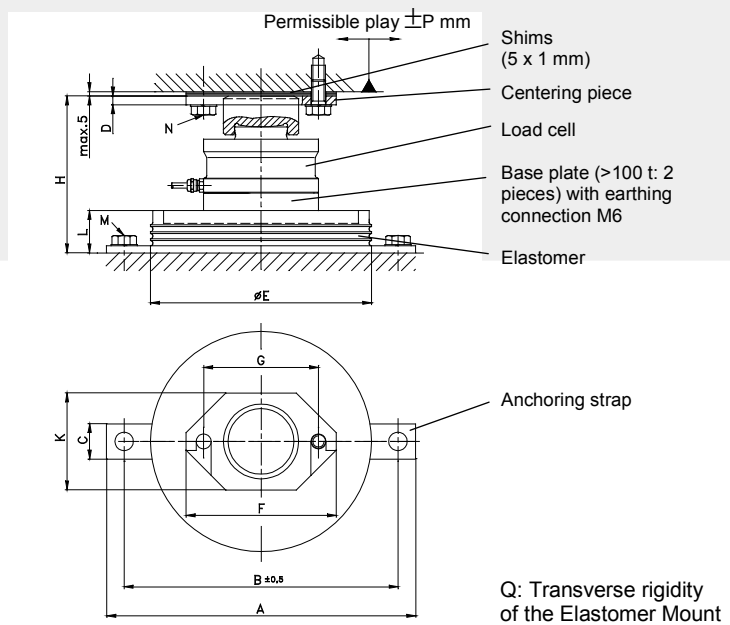
### Elastomer Mount SEM 1 t ... 4.7 t for RTN load cells

- the elastomer is located above the pressure piece
- the pressure piece is bolted or pinned to the connecting structure by means of two straps on the side
- height compensation (max. 5 mm) is performed using shims
- the SEM is aligned using by moving the base plate that is secured using the fixing pieces to be pinned or bolted on
- it also may be anchored using a centering bolt.
- The head and base of the Elastomer Mount can directly be connected to the connecting structure by bolting them to it. By using the optionale weld-on plates, there is no need to drill and thread the connecting structure. The weld-on plates are welded onto the construction after the load receptor has been aligned. They then hold the bearing with their tap holes. The weld-on plates for the load range 1 t ... 4.7 t can be used above and/or below the SEM. The additional height will be 15 mm each.



### Elastomer Mount SEM 10 t ... 470 t for RTN load cells

- the elastomer is located beneath the load cell
- the pressure piece is secured using a centering piece that is bolted or pinned to the connecting structure
- height compensation (max. 5 mm) is performed using shims
- the SEM is aligned using by moving the elastomer that is secured using straps to be pinned or bolted on
- the head and base of the Elastomer Mount can directly be connected to the connecting structure by bolting them to it. By using the optionale weld-on plates, there is no need to drill and thread the connecting structure. The Elastomer Mount is welded directly to the lower side of the bearing. Additional construction height of the weld-on plate:
  - SEM 10 t ... 22 t: 20 mm
  - SEM 33 t: 25 mm
  - Other nominal loads are available on request



Type SEM	Dimensions (mm)													
	A	B	C	D	E	S	G	H	K	L	M	N	P	Q
10-22	190	170	25	6	135	90	68	130	60	41	M10x25	M10x25	6	1.4
33	280	250	30	6	175	120	90	168	80	56	M12x25	M12x25	6	1.7
47	350	310	40	10	250	170	130	198	110	63	M16x30	M16x30	6	3.1
68	350	310	40	10	250	170	130	220	110	63	M16x30	M16x30	6	3.1
100	400	360	40	10	300	180	140	239	130	68	M16x30	M16x30	6	4.3
150	510	460	50	10	400	180	140	320	130	81	M20x45	M16x30	8	6.8
220	560	510	50	12	450	260	200	373	180	81	M20x45	M20x45	8	8.7
330	680	620	60	12	550	260	200	427	180	96	M24x40	M24x40	10	7.3
470	780	720	60	12	650	320	240	520	220	115	M24x40	M24x40	13	7.7

## Technical Data

Type	SEM		SEM		SEM	
Nominal load	0.25 t ... 0.50 t		1 t ... 100 t		150 t ... 470 t	
Weight (including load cell)	SEM 0.25 ... 0.50 2.8 kg		SEM 1 ... 4.7 2.9 kg	SEM 10 ... 22 5.3 kg	SEM 150 120 kg	SEM 220 170 kg
			SEM 33 14 kg	SEM 47 26 kg	SEM 330 250 kg	SEM 470 410 kg
	Standard SEM		SEM for Extended Temperature Range			
Materials	SEM 0.25 t ... 4.7 t	SEM 10 t ... 470 t	SEM 0.25 t ... 4.7 t	SEM 10 t ... 470 t		
Metal parts	entirely of stainless steel	S235 galvanized	entirely of stainless steel	S355 galvanized		
Elastomer	Neoprene (CR)	Neoprene (CR)	Silicone (VMQ)	Silicone (VMQ)		
			other materials are available refer to data sheet DDP8483			
Nominal temperature (restricted by the load cell)	-10 °C ... +40 °C		-10 °C ... +40 °C			
Service temperature (restricted by the load cell)	-30 °C ... +100 °C		-50 °C ... +110 °C			
Compression stroke	approx. ≤ 0.8 mm at nominal load					
max. permissible inclination of the substructure	0.2°					
max. permissible angle between upper and lower connecting structure	0.6°					

Standard SEM				SEM with silicone (VMQ)			
Model/Order numbers				Model/Order numbers			
SEM 0.25	V041386.B01	SEM 33	D 725575.02	SEM 1/2.2	D 726185.11	SEM 100	D 725575.25
SEM 0.50	V041387.B01	SEM 47	D 725575.03	SEM 4.7	D 726185.12	SEM 150	D 726186.11
SEM 1	D 726185.01	SEM 68	D 725575.04	SEM 10 ... 22	D 725575.20	SEM 220	D 726186.12
SEM 2.2	D 726185.01	SEM 100	D 725575.05	SEM 10 ... 22	D 725575.21*)	SEM 330	D 726186.13
SEM 4.7	D 726185.02	SEM 150	D 726186.01	SEM 33	D 725575.22	SEM 470	D 726186.14
SEM 10 ... 22	D 725575.10	SEM 220	D 726186.02	SEM 47	D 725575.23		
SEM 10 ... 22	D 725575.11*)	SEM 330	D 726186.03	SEM 68	D 725575.24		
		SEM 470	D 726186.04				

\*) Metal parts made of stainless steel

(Load cell not included in delivery)

Optional weld-on plates available, refer to data sheet BV-D2228

Other nominal loads and materials available on request.

Also available:

- SENSiQ™ Secure Mount 0.25 t ... 470 t (BV-D2083)
- SENSiQ™ Secure Mount PLUS 10 t ... 330 t (BV-D2444)
- SENSiQ™ Pendulum Mount 1 t ... 100 t (BV-D2025)
- SENSiQ™ Fixed Mount 1 t ... 470 t (BV-D2182)
- SENSiQ™ Fixed Mount PLUS 10 t ... 330 t (BV-D2442)

### Schenck Process Europe GmbH

Pallaswiesenstr. 100  
64293 Darmstadt, Germany  
Phone: +49 6151 1531-0  
Fax: +49 6151 1531-66  
sales@schenckprocess.com  
www.schenckprocess.com

## SENSiQ™ Secure Mount (SSM)

Bearing unit for SENSiQ™ Ring-Torsion Load Cells RTN/RTB 0.25 t ... 470 t



- Complete load cell bearing with horizontal reset function and built-in shock absorber element
- Horizontal limit stop and lift locks
- Absorbs up to 20 % of the nominal load along the horizontal axis and prevents lifting
- Legal-for-trade
- Safety without shunt forces
- High resistance to environmental conditions and chemicals
- Maintenance-free
- Pre-centered at the factory
- Design and manufacturing certified after DIN EN 1090-2 EXC 2

### Application

The SENSiQ Secure Mount ensures an optimal application of force to Schenck Process SENSiQ Ring-Torsion Load Cells.

They are deployed as bearing units (Secure Mount and Elastomer Mount) in industrial scales such as e.g. bin weighers, hopper scales, tank scales and mixed-mode scales and guarantee reliable and secure weighing.

### Equipment

The SENSiQ Secure Mount bearings consist of a load application unit, a fixed limit stop at right angles to the direction of free movement, an adjustable lift-lock and the SENSiQ Elastomer Mount that guarantees horizontal self-centering of the SENSiQ Secure Mount.

Adjustable screws are used to set the tolerance for the lift lock.

The tolerance also can be checked easily in installations with little free space.

The tolerance for the horizontal limit stop does not need to be adjusted.

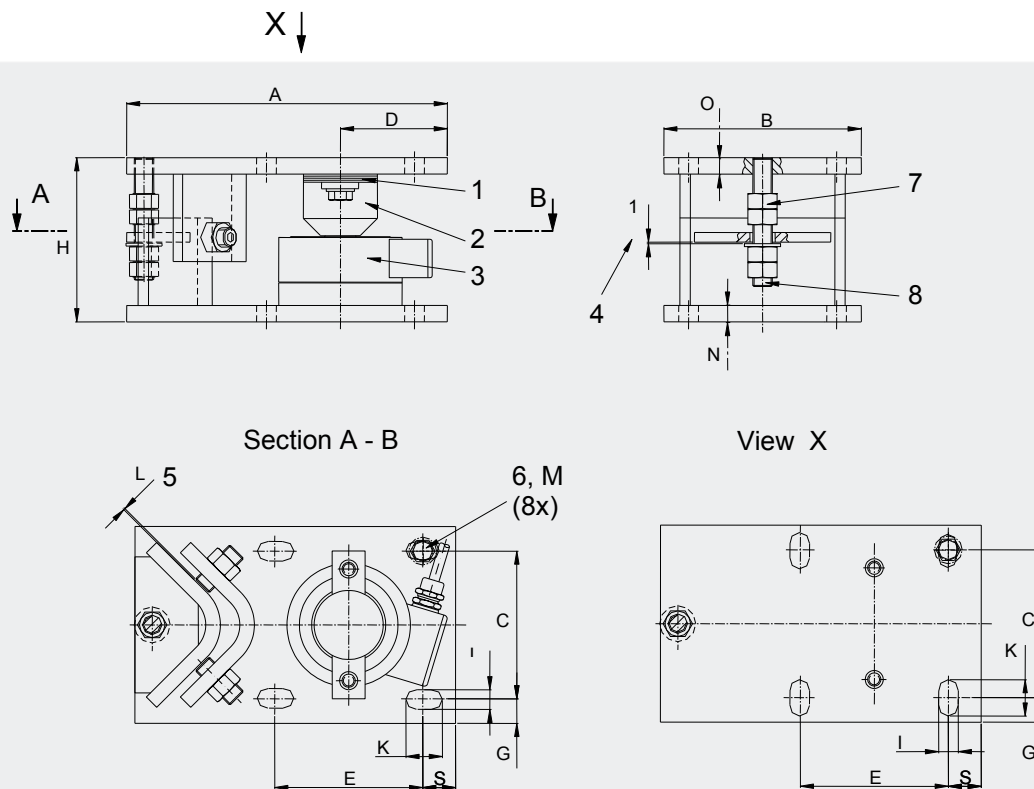
With respect to the installation height the dimensions are compatible with the predecessor generation of VKN bearings. The installation surface on the supporting structure is considerably smaller.

### Function

The weight to be measured is applied to the load cell by means of the pressure piece and transmitted to the elastomer. Depending on the model type its vertical deflection is extremely low and is proportional to the load. Any lateral forces deform the elastomer in a parallel manner. It automatically will center itself as soon as the lateral force ceases.

The horizontal limit stop restricts the freedom of movement of the bearing. The lift lock prevents the entire structure from tipping over. A control arm is not required, which eases considerably the installation and adjustment and helps to prevent errors.

## SENSiQ Secure Mount for load cells 0.25 t ... 33 t



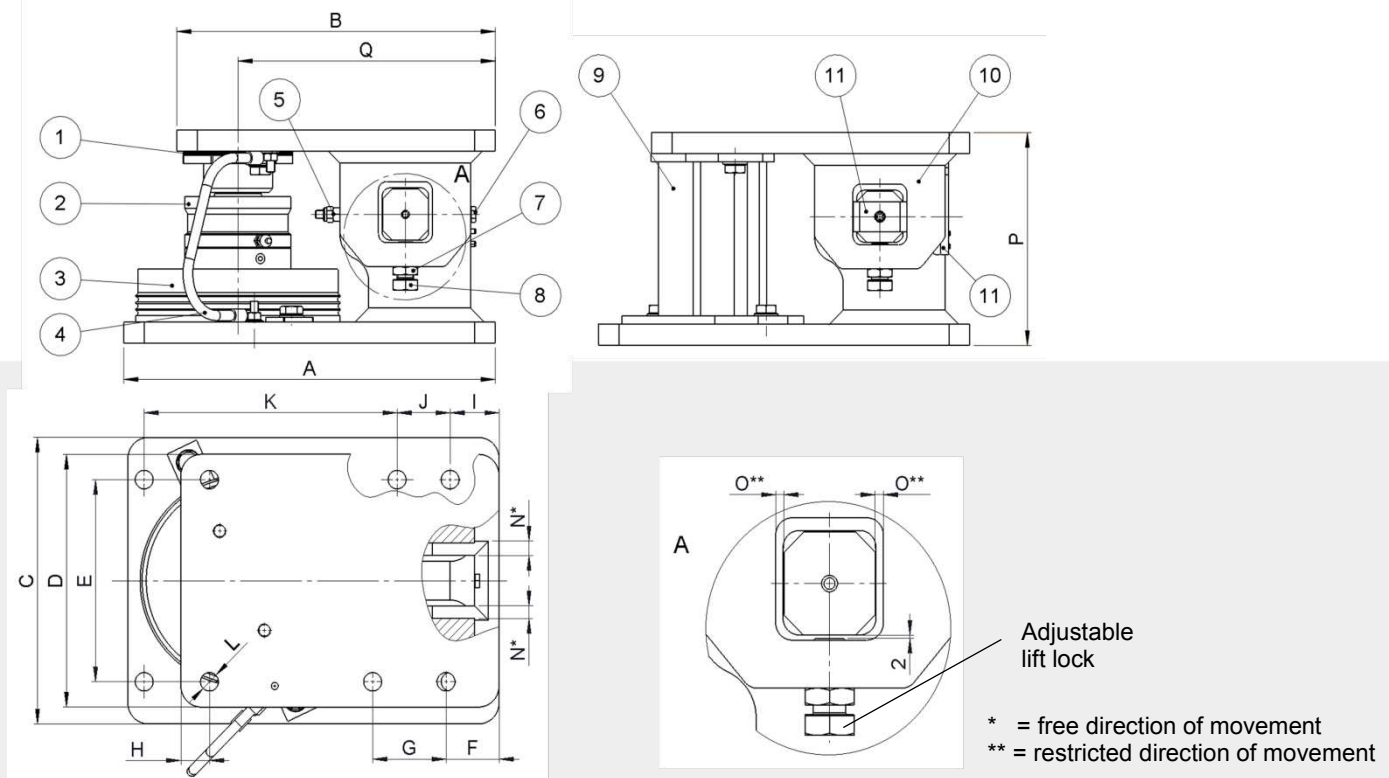
Ref.	Model designation
1	Leveling plates are enclosed, suitable for adjustment of heights up to 5 mm
2	SENSiQ™ Elastomer Mount, for nominal loads of 10 t upwards the elastomer is located beneath the load cell
3	SENSiQ™ RTN/RTB
4	Set a 1 mm tolerance for the lift lock
5	Adjust the pendulum limit stop with play L
6	On-site fastening screw and plate, see dimension M (8x)
7	After on-site assembly screw the transport securing device nuts approx. 10 mm upwards and again lock them
8	If assembling on a workshop or on-site, the bolts should be aligned centrally to the borehole

### Dimensions in mm

Type	A	B	C	D	E	S	G	H*	I	K	L	M	N	O	max. horizontal force kN	max. vertical force (lift force) kN
0.25 t ... 0.5 t for RTB	195	120	90	65	90	20	15	100 <sub>-5</sub>	12	12	1	M 8	10	10	0.5	0.7
1 t ... 4.7 t for RTN	200	140	100	60	100	15	20	115 <sub>-5</sub>	15	20	1	M 12	8	10	5	7
10 t ... 22 t for RTN	235	180	140	90	140	20	20	155 <sub>-5</sub>	18	22	1.5	M 16	10	10	22	33
33 t for RTN	340	250	200	135	200	35	25	197 <sub>-5</sub>	22	26	2	M 20	12	12	33	50

\* max. height with leveling plates

## SENSiQ Secure Mount for load cells 47 t ... 470 t



Ref.	Model designation
1	Leveling plates are enclosed, suitable for adjustment of heights up to 5 mm
2	SENSiQ™ RTN
3	SENSiQ™ Elastomer Mount
4	Grounding conductor
5	Locknuts
6	Snap screws
7	Counternut (lift lock)
8	Adjustment screw (lift lock)
9	After assembly the transport support is replaced by items 2 and 3. <b>Caution:</b> The transport support has not been dimensioned for loading with the nominal load or for receiving horizontal forces.
10	Limit stop unit
11	Centering plates for transport and installation

### Dimensions in mm

Type	A	B	C	D	E	F	G <sup>3</sup>	H	I <sup>3</sup>	J <sup>3</sup>	K <sup>3</sup>	L <sup>2</sup>	N	O	P <sup>1</sup>	Q <sup>4</sup>	max. horizontal force kN	max. vertical force (lift force) kN	Max. vertical loading of transport supports t
47 t	455	390	340	300	240	65	90	35	60	65	310	M20	15	5	253 <sub>-5</sub>	315	94	94	25
68 t	500	435	340	300	240	65	-	35	-	-	-	M20	15	5	275 <sub>-5</sub>	360	136	136	25
100 t	580	520	390	340	290	45	-	45	-	-	-	M20	15	5	304 <sub>-5</sub>	420	200	200	35
150 t	740	680	460	460	340	45	-	45	-	-	-	M24	20	7	395 <sub>-5</sub>	520	300	300	45
220 t	850	770	480	460	380	40	-	40	-	-	-	M24	20	7	468 <sub>-5</sub>	600	440	440	45
330 t	1040	910	580	460	390	70	-	70	-	-	-	M24	20	9	553 <sub>-5</sub>	740	660	660	45
470 t	1240	1100	680	470	400	70	-	70	-	-	-	M24	30	10	645 <sub>-5</sub>	890	940	940	45

1 Max. height with leveling plates

2 Screws and threads to be used in the connecting structure, for assistance during assembly only

3 Clearance holes (K, I, J) on lower plate and central holes (G) on upper plate are present only for nominal loads of 47 t

4 Midpoint of the load cell

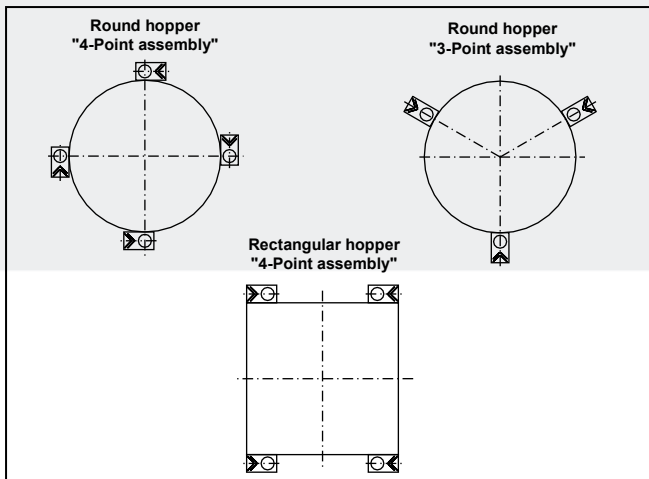
The SENSiQ™ Secure Mount PLUS with maximum permissible horizontal and vertical loads of up to 40 % of the nominal load is available for greater loads of 10 t up to 330 t. Refer to data sheet BV-D2444. Separate measures must be implemented for the horizontal limit stops and the lift lock for loads beyond these specifications.

**Important information:**

The connecting surfaces for the bearings must be planar and metallically bright. The difference in height in the area of the contact surface may not exceed 0.2 mm. Painted surfaces are not suited for mounting the SENSiQ Secure Mount.

A non-repeatable transmission of force may occur when raising/resetting the load cell load application elements, causing measuring errors in the scales. For this reason the load cell in the SENSiQ Secure Mount may never be completely load-free. The minimum preload should be calculated so that when in operation a permanent friction connection always connects the load cell with the pressure piece or the bearing base plate.

**Arrangement of the bearings 0.25 t ... 33 t**



**Please Strictly Observe!**

The bearing arrangements shown take only weighing-related technical factors into consideration.

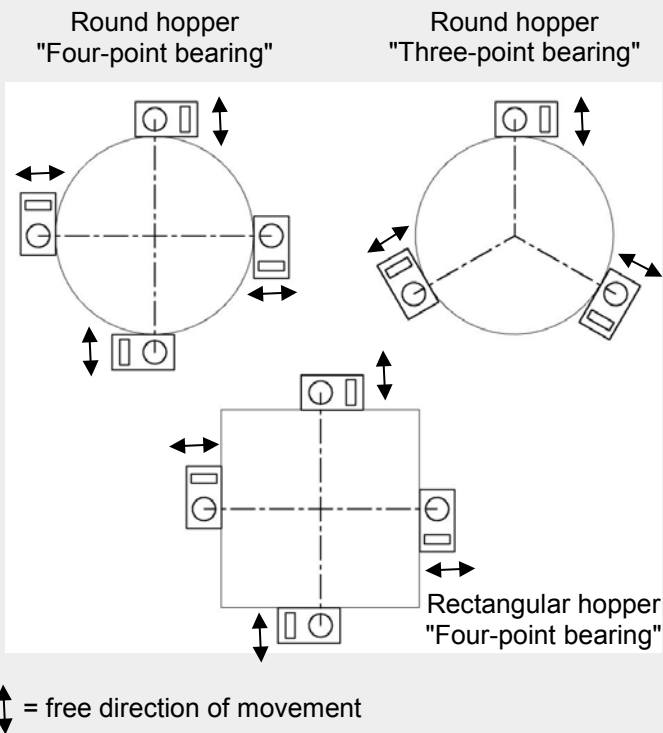
The operator/plant constructor must check and verify the structural safety and stability.

The direction of the temperature-dependent expansion must correspond to the free direction of movement of the SENSiQ Secure Mount.

SENSiQ Secure Mount 0.25 t ... 33 t generally are bolted to the connecting structure.



## Arrangement of the bearings 47 t ... 470 t



### Please Strictly Observe!

The bearing arrangements shown take only weighing-related technical factors into consideration.

The operator/plant constructor must check and verify the structural safety and stability.

The direction of the temperature-dependent expansion must correspond to the free direction of movement of the SENSiQ Secure Mount.

For round hoppers the SENSiQ Secure Mount 47 t ... 470 t is designed for a minimum diameter of 3000 mm.

SENSiQ Secure Mount 47 t can be bolted or welded to the connecting structure.

SENSiQ Secure Mount 68 t ... 470 t can be affixed to the connecting structure by weld only.

## Technical data

Available nominal load	0.25 t ... 33 t		47 t ... 470 t	
Weight (including load cell)	0.25 ... 0.5 t	8.5 kg	47 t	118 kg
	1 ... 4.7 t	12.3 kg	68 t	128 kg
	10 ... 22 t	19 kg	100 t	197 kg
	33 t	42 kg	150 t	391 kg
			220 t	540 kg
			330 t	953 kg
			470 t	1412 kg
Elastomer material  Optional (on request, refer also to data sheet BV-D2044 and DDP8483)	Neoprene (polychloroprene rubber)  FKM (fluorine rubber), SBR (styrene-butadiene rubber), EPDM (ethylene propylene diene monomer rubber), VMQ (silicone), NR (natural rubber),			
Steel parts material 0.25 t ... 22 t 33 t 47 t ... 470 t	1.4301 1.0038 (S235JRG2) 1.0577+N (S355J2G4+N)			
Height Compensation	up to 5 mm			
Deflection (under nominal load)	approx. 0.8 mm			
Max. permissible inclination of the substructure	0.2°			
Max. permissible angle between the upper and lower connecting structures	0.6°			
Nominal temperature range (restricted by load cell)	-10 °C ... +40 °C			
Operating temperature range (restricted by load cell and material)	-30 °C ... +80 °C			
(with special elastomer mounting and special RTN, refer to data sheets BV-D2044 and BV-D2019)	-40 °C ... +110 °C			

**SENSiQ Secure Mount complete with SENSiQ Elastomer Mount, without load cell**

<b>Variants</b>	<b>Order Number</b>
0.25 t	V041091.B01
0.50 t	V041092.B01
1 ... 2.2 t	D 731186.01
4.7 t	D 731186.02
10 ... 22 t	D 731353.01
33 t	D 731415.01
47 t	V654503.B01
68 t	V654503.B11
100 t	V654503.B21
150 t	V654503.B31
220 t	V654503.B41
330 t	V654503.B51
470 t	V654503.B61
Accessories	Thermal protection plate, splash water protection, weld-on plates See BV-D2228

Please contact us for further information on the SENSiQ Secure Mount and ask for the manual and the detailed planning-in drawings if needed.



SENSiQ™ Secure Mount PLUS  
10 t... 330 t  
BV-D2444



SENSiQ™ Elastomer Mount  
0.25 t... 470 t  
BV-D2044



Ring-torsion load cell RTN  
1 t... 470 t  
BV-D2019



SENSiQ™ Pendulum Mount  
1 t... 100 t  
BV-D2025



SENSiQ™ Fixed Mount  
1 t... 470 t  
BV-D2182



SENSiQ™ Fixed Mount PLUS  
10 t... 330 t  
BV-D2442

## SENSiQ™ Secure Mount PLUS (SSM PLUS)

Limit Stop Unit for SENSiQ™ Elastomer Mount for Nominal Loads between 10 t ... 330 t



- Significantly greater stability compared to normal SENSiQ™ Secure Mounts
- Absorbs 40 % of the rated load along the horizontal axis and prevents lifting
- Legal-for-trade
- Design and manufacturing certified after DIN EN 1090-2 EXC 2
- Safety without shunt forces
- Simple and robust construction
- Highly stable against environmental influences and chemicals
- Maintenance-free
- Pre-centered at the factory

### Application

The SENSiQ Secure Mount PLUS is a limit stop and lift-lock used with the SENSiQ™ Elastomer Mount for increased stability.

It is used for industrial scales such as e.g. bin weighers, hopper scales, tank scales and mixed-mode scales and guarantee reliable and secure weighing.

### Equipment

The SENSiQ Secure Mount PLUS consists of a specially reinforced limit stop along a horizontal axis. The structure is freely moveable along the other axis. Furthermore there is a specially reinforced lift lock.

Adjustable screws are used to set the tolerance for the horizontal limit and the lift lock.

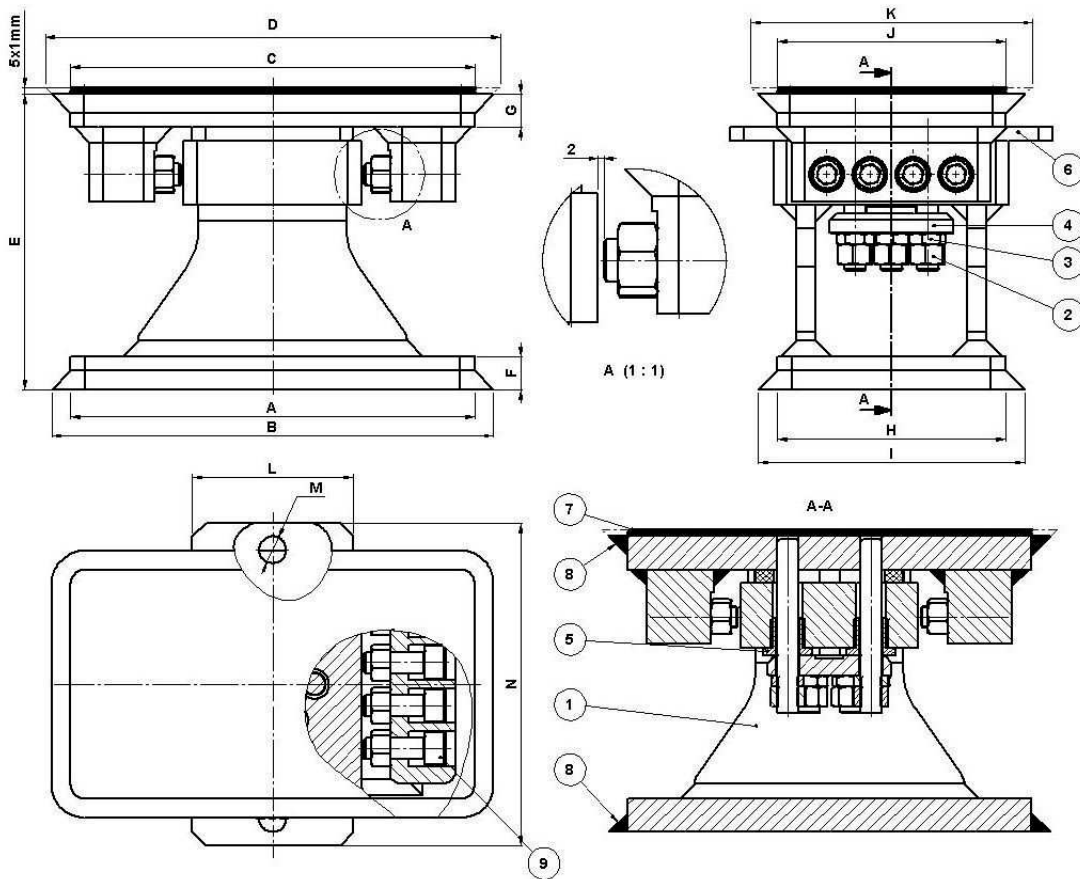
The tolerance also can be adjusted and checked easily in installations with little free space.

In order to compensate for differences in height of SENSiQ Elastomer Mounts, they must be combined with weld-on plates.

### Function

The horizontal limit stop restricts the freedom of movement of the bearing along a horizontal axis. The lift lock prevents the entire structure from tipping over. A control arm is not required, which eases considerably the installation and adjustment and helps to prevent errors.

## Limit stop unit for SENSIQ™ RTN load cells



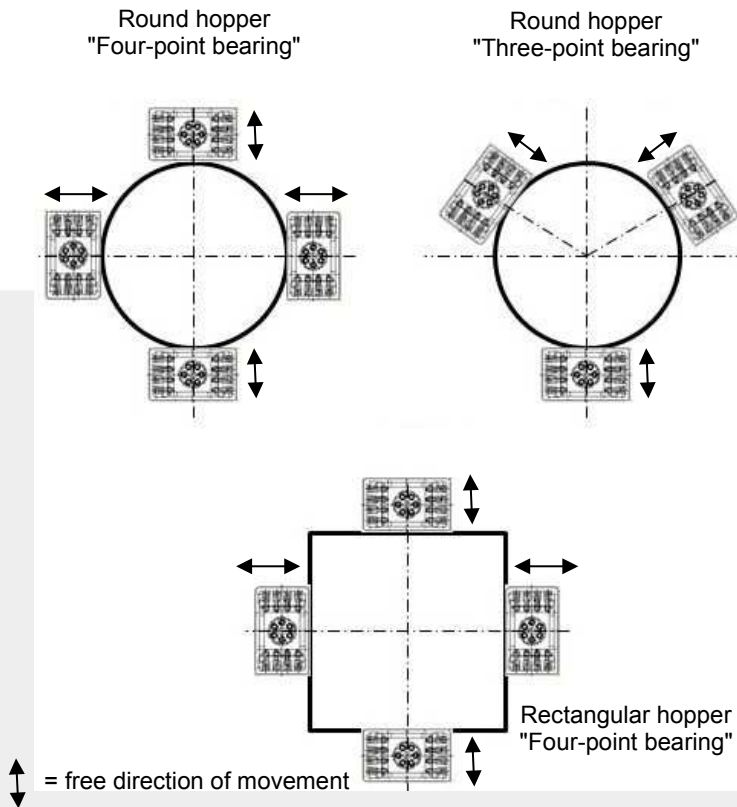
Ref.	Model designation
1	Side panel
2	Lock nut
3	Hexagon nut
4	Compression plate
5	Centering bush
6	Spacer plate
7	Leveling plates are enclosed, suitable for adjustment of heights up to 5 mm
8	Construction site welding seam
9	Stop Screw

### Dimensions

Type	A mm	B mm	C mm	D mm	E* mm	F mm	G mm	H mm	I mm	J mm	K mm	L mm	M	N mm
10 t ... 22 t	250	280	250	290	185	20	20	150	180	150	190	108	M12	220
33 t	300	322	300	340	220	25	25	170	200	170	210	132	M16	240
47 t	370	400	370	410	270	30	35	200	230	200	240	162	M16	280
68 t	440	470	440	480	295	40	40	240	270	240	280	184	M20	320
100 t	550	580	550	590	335	40	50	300	330	300	340	234	M24	400
150 t	650	680	650	690	410	60	60	350	380	350	390	264	M30	440
220 t	800	830	800	840	470	60	70	440	470	440	480	350	M36	560
330 t	1000	1030	1000	1070	525	80	80	550	580	550	620	456	M48	680

\* Height if using SENSIQ Elastomer Mount with 5 shims and a weld-on plate.

## Bearing points arrangement for the SENSiQ Secure Mount PLUS 10 t ... 330 t



**Please Strictly Observe!**

The bearing arrangements shown take only weighing-related technical factors into consideration.

The operator/plant constructor must check and verify the structural safety and stability.

The direction of the temperature-dependent expansion must correspond to the free direction of movement of the SENSiQ Secure Mount PLUS.

### Important information:

The connecting surfaces for the bearings must be planar and metallically bright. The difference in height in the area of the contact surface may not exceed 0.2 mm. Painted surfaces are not suited for mounting the SENSiQ Secure Mount PLUS.

### Technical Data

Available nominal load	10 t ... 330 t	
Weight (including load cell)	10 t ... 22 t	23.1 kg
	33 t	42.4 kg
	47 t	78.1 kg
	68 t	118.9 kg
	100 t	218.2 kg
	150 t	389.3 kg
	220 t	679.2 kg
	330 t	1251 kg
Material	S235	
Height Compensation	5 mm	
Max. permissible inclination of the substructure	0.2°	
Max. permissible angle between the upper and lower connecting structures	0.6°	
Nominal temperature range (restricted by load cell)	-10 °C ... +40 °C	
Operating temperature range (restricted by load cell and limit by material)	-30 °C ... +80 °C	

SENSiQ Secure Mount PLUS			Permissible maximum forces	
	with SENSiQ Elastomer Mount and weld-on plate	without SENSiQ Elastomer Mount and without weld-on plate	max. horizontal force	max. vertical force (lift force)
Variants	Order Number	Order Number	kN	kN
10 t ... 22 t	V555055.B03	V555055.B02	88	88
33 t	V555063.B03	V555063.B02	132	132
47 t	V554145.B03	V554145.B02	188	188
68 t	V554775.B03	V554775.B02	272	272
100 t	V554152.B03	V554152.B02	400	400
150 t	V555070.B03	V555070.B02	600	600
220 t	V555077.B03	V555077.B02	880	880
330 t	V555085.B03	V555085.B02	1320	1320
Accessories	Thermal protection plate, splash water protection, weld-on plates			

Separate measures must be implemented if the loads that act on the horizontal limit stops and the lifting lock are impermissibly high.

**The following products also are available**



SENSiQ™ Pendulum Mount  
1 t ... 100 t  
BV-D2025



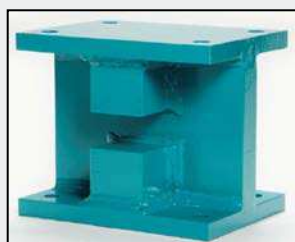
SENSiQ™ Elastomer Mount  
0.25 t ... 470 t  
BV-D2044



SENSiQ™ Secure Mount  
0.25 t ... 470 t  
BV-D2083



Ring-Torsion Load Cells  
RTN 1 t ... 470 t  
BV-D2019



SENSiQ™ Fixed Mount  
1 t ... 470 t  
BV-D2182



SENSiQ™ Fixed Mount PLUS  
10 t ... 330 t  
BV-D2442

Please contact us for further information on the SENSiQ Secure Mount PLUS and ask for the manual and the detailed planning-in drawings if required.

**Schenck Process Europe GmbH**

Pallaswiesenstr. 100  
64293 Darmstadt, Germany  
T +49 6151 1531 - 0  
F +49 6151 1531 - 66  
sales@schenckprocess.com  
www.schenckprocess.com



## SENSiQ™ Pendulum Mount (SPM)

### Self-Aligning Mount for Load Cell SENSiQ™ RTN 1 t ... 470 t



- Capable of the highest measuring accuracy
- Legal-for-trade
- Extremely robust (stainless steel)
- Self-centering
- Easy to assemble and maintenance-free

#### Application

The pendulum mount was designed for perfect interaction with the RTN load cell.

It is used in situations with extremely rough ambient conditions but where a long life cycle and the highest measuring accuracy are required.

Typical applications are vehicle scales and binweighers.

#### Construction

A complete Pendulum Mount consists of a pendulum pressure piece, a pressure piece and a centering piece of shims for height compensation.

The load cell is located either directly on the connecting structure or on an optional base plate.

The base plate ensures an ideal installation surface if the floor is uneven.

#### Function

The weight to be measured is applied to the load cell by means of the pressure piece via the pendulum pressure piece.

The pendulum pressure piece prevents disturbance transverse forces from being applied to the load cell.

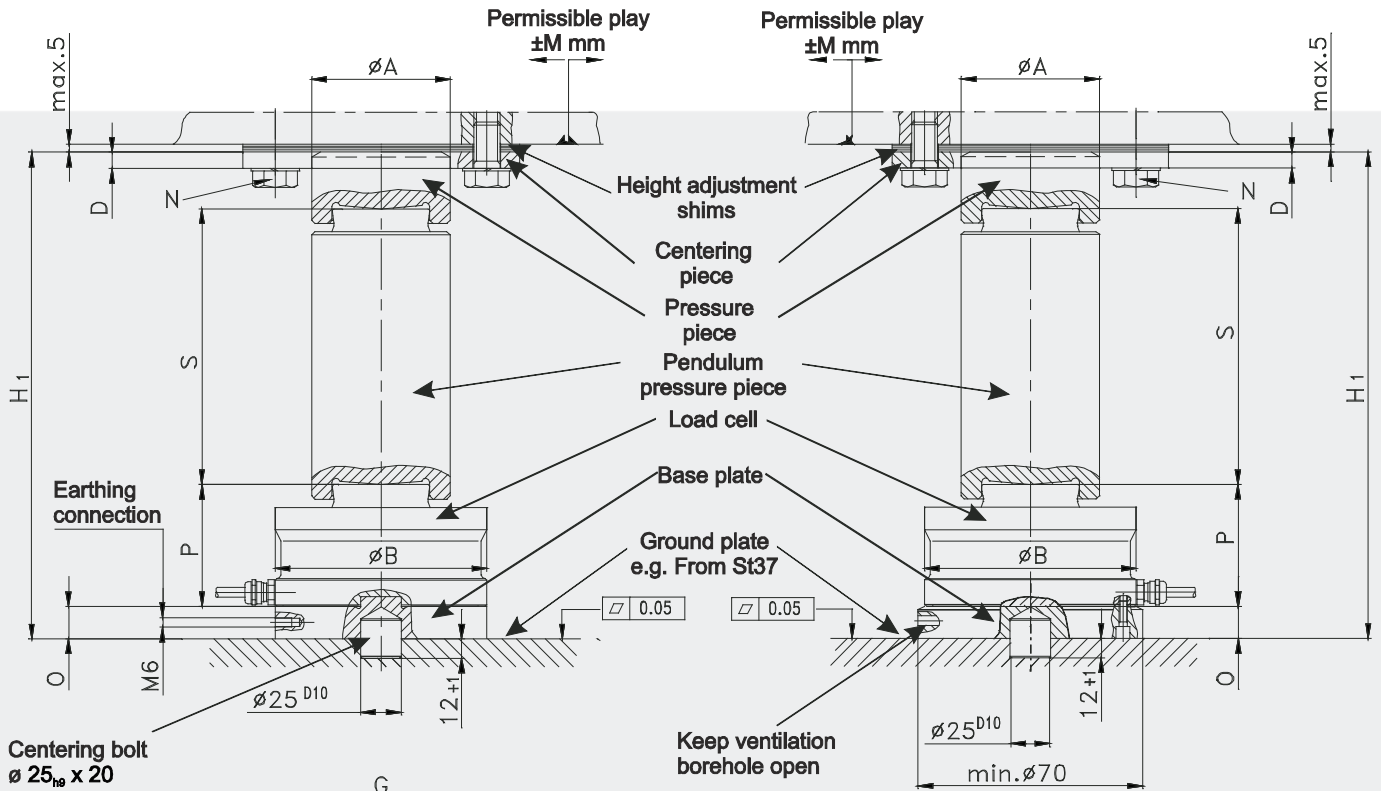
The self-centering effect of the bearing returns automatically the scales to the home position after each deflection.

Depending on the installation situation the pendulum may require limit stops.

## Dimensions

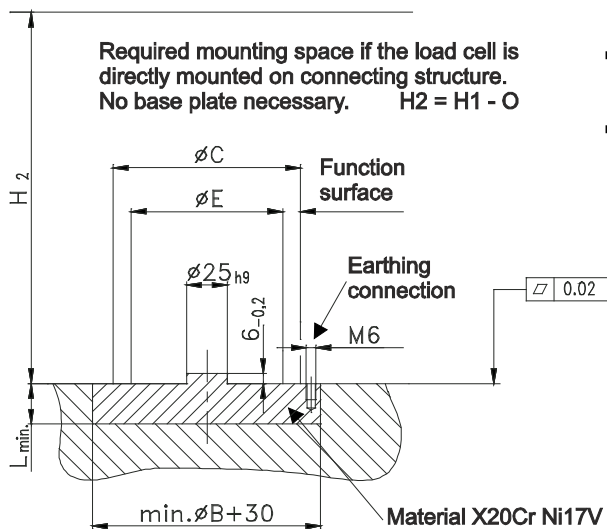
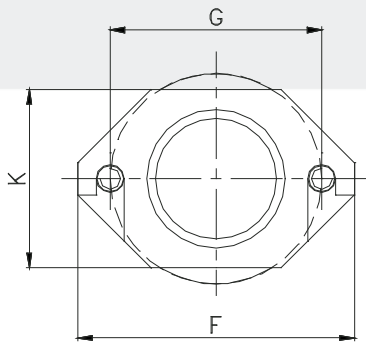
SPM 10 t ... 470 t

SPM 1 t ... 4.7 t



Centering bolt  
 $\varnothing 25_{h8} \times 20$

Keep ventilation  
 borehole open



- The pressure piece is secured using a centering piece that is bolted to the connecting structure.
- Height compensation (maximum 5 mm) is performed using leveling shims.
- The load cell is centered using a spigot ( $\varnothing 25$  mm).
- The optional base plate is centered using a bolt ( $\varnothing 25$  mm, included in delivery).
- An earthing connection must be provided on the ground plate of the connecting structure (see the planning-in drawings).

## Dimensions

Nominal load [t]	Dimensions [mm]															
	A	B	C	D	E	F	G	H <sub>1</sub>	H <sub>2</sub>	K	L	M	N	O	P	S
1	35	60		4		90	68	128		60		3.5	M8x20	15	43	56
2.2	35	60		4		90	68	128		60		3.5	M8x20	15	43	56
4.7	35	60		4		90	68	145		60		3.5	M8x20	15	43	73
10	45	75	80	4	62	90	68	165	145	60	20	3.5	M10x20	20	50	76
15	45	75	80	4	62	90	68	175	155	60	20	4	M10x20	20	50	86
22	45	75	80	4	62	90	68	229	209	60	20	7	M10x25	20	50	140
33	58	95	100	6	78	120	90	272	252	80	25	7	M12x25	20	65	160
47	85	130	140	10	110	170	130	295	270	110	35	6	M16x30	25	75	160
68	85	130	140	10	110	170	130	337	300	110	40	7	M16x30	37	85	180
100	100	150	160	10	129	180	140	371	331	130	45	8	M16x30	40	90	200
150	100	150	160	10	130	180	140	405	365	30	80	9	M16x30	40	100	224
220	135	225	230	12	190	260	200	474	429	180	96	10	M20x40	45	130	240
330	135	225	230	12	190	260	200	554	504	180	116	11	M24x50	50	145	300
470	160	270	275	12	230	320	240	667	603	220	138	12	M24x50	64	170	360

Custom heights are available on request.

## Technical Data

Nominal load [t]	Weight with load cell [kg]	Weight of base plate [kg]
1	1.1	0.3
2.2	1.1	0.3
4.7	1.4	0.3
10	2.5	0.7
15	2.7	0.7
22	3.7	0.7
33	6.3	1.1
47	14.0	2.7
68	15.4	3.8
100	22.3	5.4
150	34 *)	
220	77 *)	
330	112 *)	
470	160 *)	
Material	Stainless steel	
Height compensation	max. 5 mm	

\*) Overall weight with load cell and base plate

Variants	Order number without base plate	Order number with base plate	Variants	Order number without base plate	Order number with base plate
<b>SPM 1 t</b>	D 725565.16	D 725565.11	<b>SPM 47 t</b>	D 725565.08	D 725565.03
<b>SPM 2.2 t</b>	D 725565.17	D 725565.12	<b>SPM 68 t</b>	D 725565.09	D 725565.04
<b>SPM 4.7 t</b>	D 725565.18	D 725565.13	<b>SPM 100 t</b>	D 725565.10	D 725565.05
<b>SPM 10 t</b>	D 725565.19	D 725565.14	<b>SPM 150 t</b>	-	D 726616.01
<b>SPM 15 t</b>	D 725565.20	D 725565.15	<b>SPM 220 t</b>	-	D 726616.02
<b>SPM 22 t</b>	D 725565.06	D 725565.01	<b>SPM 330 t</b>	-	D 726616.03
<b>SPM 33 t</b>	D 725565.07	D 725565.02	<b>SPM 470 t</b>	-	D 726616.04

No load cells are included in the SPM delivery and must be ordered separately.



SENSiQ™ Secure Mount  
0.25 t ... 470 t  
BV-D2083



SENSiQ™ Elastomer Mount  
0.25 t ... 470 t  
BV-D2044



Ring-Torsion Load Cell  
RTN 1 t ... 470 t  
BV-D2019



SENSiQ™ Secure Mount PLUS  
10 t ... 330 t  
BV-D2444



SENSiQ™ Fixed Mount  
1 t ... 470 t  
BV-D2182



SENSiQ™ Fixed Mount PLUS  
10 t ... 330 t  
BV-D2442

**Schenck Process Europe GmbH**  
 Pallaswiesenstr. 100  
 64293 Darmstadt, Germany  
 T +49 6151 1531-0  
 F +49 6151 1531-66  
 sales@schenckprocess.com  
 www.schenckprocess.com

## Load Cells VBB and Load Cell Mounts VEB



- **Highest accuracies (up to 6000 increments to OIML R60)**
- **Hermetically sealed due to laser welding (IP68)**
- **Use in hazardous zone with protection class  
Ex ia IIC T4 Gb / Ex ia IIIC T125 °C Db  
or protection class  
Ex nA IIC T4 Gc / Ex tb IIIC T125 °C Db**
- **Optimized for parallel connection through perfect calibration**
- **6-wire circuit**
- **100 % stainless steel**

### Application

Load cells of the VBB type are designed to convert the mechanical input signal, the load, proportionally into the electrical output voltage.

Combined with the corresponding VEB elastomer mounts, they are very suitable for use with platform, batching, and hopper scales. Their compact design simplifies the integration in any existing construction.

The rugged design of the load cells and mounts ensures reliable operation even in severe environments.

### Construction

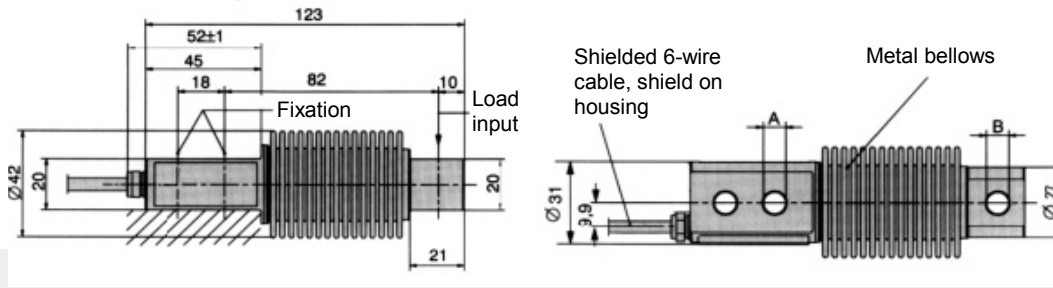
Entirely made of stainless steel and hermetically sealed by laser welding, the VBB load cells are connected by using a high-quality shielded 6-wire PVC cable.

The 6-wire circuit provides for a measuring signal which is insensitive to connecting cables of different lengths.

### Functions

- High calibrating accuracy, thus, optimal prerequisites for the parallel connection of load cells
- High degree of measuring signals repeatability
- Damping of side forces through the elastomer mount
- Self-centering after side load
- Minimal effect on accuracy by side forces

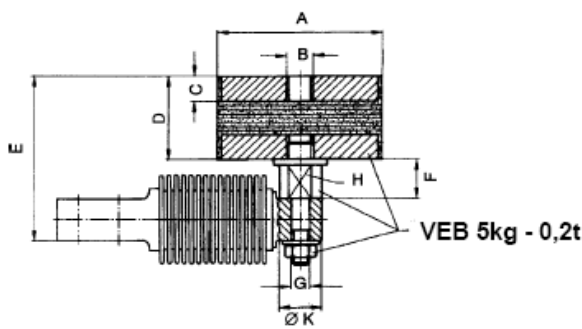
### VBB Load Cells 5 kg – 0.5 t



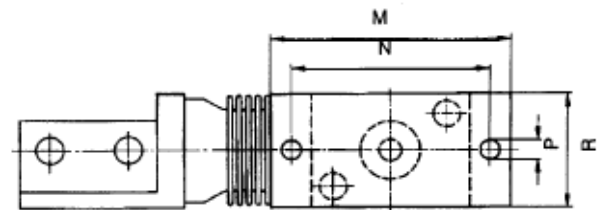
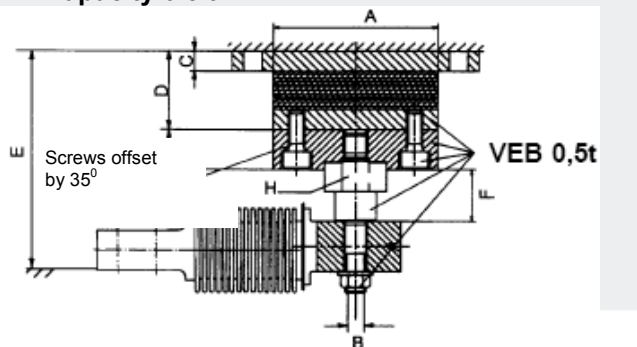
Variant	Dimensions (mm)	
	A	B
VBB 5 kg – 0.2 t	8.2	8.2
VBB 0.5 t	10.5	11.1

### VEB Elastomer Mount 5 kg – 0.5 t for VBB Load Cells

#### Capacities 5 kg – 0.2 t



#### Capacity 0.5 t



Elastomer mount correct mounting position

#### Dimensions (mm)

Elastomer mount	A	B	C	D	E	F	G	H	K	L	M	N	P	R	F <sub>R</sub> *	S <sub>max</sub> **
VEB 5 kg – 0.2 t	75	M12	12	40	79 ±1,3	18.5	M8	SW 17	19	-	-	-	-	-	163	3
VEB 0.5 t	80	M10	10	39	105 <sup>+2,1</sup> <sub>-2,2</sub>	26	-	SW 27	-	20	120	100	9	60	400	4.5

\* F<sub>R</sub> Restoring force in N with 1 mm lateral displacement

\*\* S<sub>max.</sub>, in mm, maximum adm. lateral displacement if loaded with rated capacity

## Technical Data

Rated capacity	$E_{max}$	5 kg – 0.5 t				
Accuracy class		D1	C3*	C4**	C6***	Reference
Nominal characteristic value	$C_n$	2 mV/V +20 $\mu$ V/V; -2 $\mu$ V/V	2 mV/V $\pm$ 1 $\mu$ V/V			
Combined error	$F_{comb}$	0.05 %	0.02 %	0.013 %	0.01 %	$C_n$
Zero signal return after loading (30 min)	$F_{dr}$	$\pm$ 0.049 %	$\pm$ 0.016 %	$\pm$ 0.012 %	$\pm$ 0.008 %	$C_n$
Creep error during stress (30 min)	$F_{cr}$	$\pm$ 0.049 %	$\pm$ 0.016 %	$\pm$ 0.012 %	$\pm$ 0.008 %	$C_n$
Temperature coefficient of zero signal	$TK_0$	$\pm$ 0.05 %/10 K	$\pm$ 0.0125 %/10 K	$\pm$ 0.009 %/10 K	$\pm$ 0.009 %/10 K	$C_n$ B $B_{tn}$
Temperature coefficient of characteristic value	$TK_c$	$\pm$ 0.05 %/10 K	$\pm$ 0.008 %/10 K	$\pm$ 0.007 %/10 K	$\pm$ 0.004 %/10 K	$C_n$ B $B_{tn}$
Maximum number of increments in certified applications	$n_{LC}$	1000	3000	4000	6000	
Min. scale interval	$V_{min}$	0.036 %	0.009 %	0.0066 %	0.0066 %	$E_{max}$
Minimum utilisation rate	$B_{amin}$	36 %	27 %	26 %	39 %	$E_{max}$
Maximum utilisation rate	$B_{amax}$	$B_{amax} = E_{max}$				
Input resistance	$R_e$	350 $\Omega$ - 480 $\Omega$				$t_r$
Output resistance	$R_a$	356 $\Omega$ $\pm$ 0.2 $\Omega$	356 $\Omega$ $\pm$ 0.12 $\Omega$			$t_r$
Zero signal	$S_0$	$\pm$ 1 %				$C_n$
Maximum supply voltage	$U_{smax}$	18 V				
Nominal temperature range	$B_{tn}$	-10 $^{\circ}$ C ... +40 $^{\circ}$ C				
Service temperature range Explosion-proof design	$B_{tu}$	-40 $^{\circ}$ C ... +70 $^{\circ}$ C -30 $^{\circ}$ C ... +70 $^{\circ}$ C				
Reference temperature	$t_r$	23 $^{\circ}$ C				
Storage temperature range	$B_{ts}$	-50 $^{\circ}$ C ... +85 $^{\circ}$ C				
Safe load limit	$E_L$	150 %				$C_n$
Breaking load	$E_D$	300 %				$C_n$
Displacement **** at rated capacity		0.25 mm	0.3 mm	0.4 mm	0.6 mm	
		5 kg	10 - 100 kg	200 kg	500 kg	
Protection class Explosion-proof design		IP68 (tightened test conditions: 1 m water gauge; 100 h) IP67				
Cable specification		3 m PVC cable, 6 wires, shielded, shield on housing				
Colour code		black: input - / blue : input + / black/yellow: shield red : output - / white : output + grey : sensor - / green : sensor +				
Corrosion protection		Stainless steel				

\*: Quality C3 available for nominal loads  $\geq$  10 kg only

\*\* : Quality C4 available for nominal loads  $\geq$  20 kg only

\*\*\*: Quality C6 available for nominal loads  $\geq$  50 kg only

\*\*\*\*: Please adjust the overload stops to nominal displacement +0.05 mm (unloaded scale)

Variants Load Cells	Order No.	Ex-Variants Load Cells	Order No. 2GD	Order No. 2D/3G
VBB 5 kg D1	D 725 417.01			
VBB 10 kg D1	D 725 417.02			
VBB 10 kg C3	D 725 419.02	VBB 10 kg C3 „Ex“	D 725 419.32	D 725 419.42
VBB 20 kg D1	D 725 417.03			
VBB 20 kg C3	D 725 419.03	VBB 20 kg C3 „Ex“	D 725 419.33	D 725 419.43
VBB 50 kg D1	D 725 417.04			
VBB 50 kg C3	D 725 419.04	VBB 50 kg C3 „Ex“	D 725 419.34	D 725 419.44
VBB 0.1 t D1	D 725 409.01	VBB 0,1 t D1 „Ex“	D 725 409.61	D 725 409.41
VBB 0.1 t C3	D 725 409.04	VBB 0,1 t C3 „Ex“	D 725 409.64	D 725 409.44
VBB 0.1 t C4	D 726 370.01	VBB 0,1 t C4 „Ex“	D 726 370.31	D 726 370.41
VBB 0.2 t D1	D 725 409.02	VBB 0,2 t D1 „Ex“	D 725 409.62	D 725 409.42
VBB 0.2 t C3	D 725 409.05	VBB 0,2 t C3 „Ex“	D 725 409.65	D 725 409.45
VBB 0.2 t C4	D 726 370.02	VBB 0,2 t C4 „Ex“	D 726 370.32	D 726 370.42
VBB 0.2 t C6	D 726 370.04	VBB 0,2 t C6 „Ex“	D 726 370.34	D 726 370.44
VBB 0.5 t D1	D 725 409.03	VBB 0,5 t D1 „Ex“	D 725 409.63	D 725 409.43
VBB 0.5 t C3	D 725 409.06	VBB 0,5 t C3 „Ex“	D 725 409.66	D 725 409.46
VBB 0.5 t C4	D 726 370.03	VBB 0,5 t C4 „Ex“	D 726 370.33	D 726 370.43

Variants Elastomer Mounts	Order No.
VEB 5 kg – 0.2 t	D 725 408.01
VEB 0.5 t	D 725 408.02

Example for ordering:

Rated Capacity 0.2 t, Accuracy Class C6: Variant VBB 0.2 t C6 – Ordering Number D726 370.04

Additional versions available upon request.

#### Optional feature ATEX/IECEx approval

Intrinsically safe ATEX explosion-proof design category 2GD and IECEx EPL Gb, Db

Gas-Ex II 2G Ex ia IIC T4 Gb (Zone 1)

Dust-Ex II 2D Ex ia IIIC T125 °C Db, IP67 (Zone 21)

Load cells marked as intrinsically safe - Ex "i" - are also operated intrinsically safely irrespective of the zone.

Warning: The verification of intrinsically safe circuit must be verified. New barriers are provided in particular for new systems. The verifications of intrinsically safe circuit are available for all load cells and barriers.

Non intrinsically safe ATEX explosion-proof design category 2D, 3G and IECEx EPL Db, Gc

Gas-Ex II 3G Ex nA IIC T4 Gc (Zone 2)

Dust-Ex II 2D Ex tb IIIC T125 °C Db, IP67 (Zone 21)

#### Schenck Process GmbH

Pallaswiesenstr. 100

64293 Darmstadt, Germany

Phone: +49 6151 1531 0

Fax: +49 6151 1531 66

sales@schenckprocess.com

www.schenckprocess.com



## SENSiQ™ Fixed Mount (SFM)

Pivot for load cell applications with nominal loads from 1 t ... 470 t



- Simple, rugged and flat design
- Dimensions compatible to Elastomer Mount SEM and Secure Mount SSM
- Minimal reaction to lateral forces
- Ease of installation
- Stainless steel (SFM 1 t ... 22 t) or S235 (SFM 33 t ... 470 t)
- Design and manufacturing certified after DIN EN 1090-2 EXC 2

### Application

Fixed Mount are designed for simple weighing tasks, e.g. hopper level measurement.

Combined with one or two load cells (partial load measurement), the Fixed Mount offer a favourably priced but sufficiently accurate solution, particularly for applications with a defined centre of gravity, e.g. hoppers with liquid contents.

### Construction

The Fixed Mount consists of a double T girder reinforced with ribs. The reinforcement ribs ensure a defined bending zone and increase the resistance to lateral forces, so that normally no additional tie-rods are required.

The Fixed Mount of the SFM type is dimensionally compatible with the SEM Elastomer Mounts, so that no height adjustment is necessary when the two types of mount are combined.

The mounts can be adjusted in height with the use of shims by max. 5 mm (SFM 470 shims by max. 10 mm).

When using in combination with the Secure Mount SSM the height adjustment of the SFM is provided via optional compensation plates.

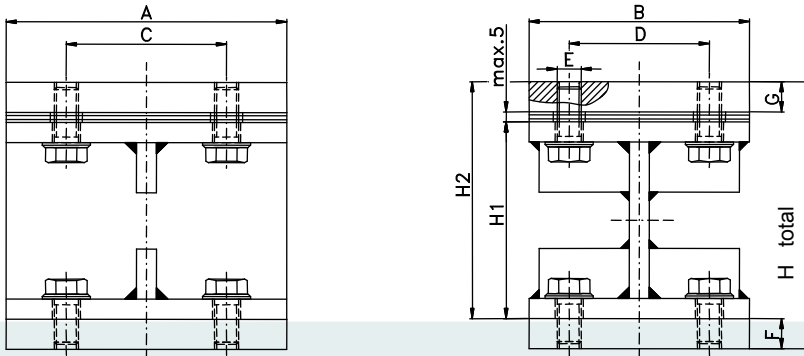
Normally, the SFM mounts are welded to the existing construction. Connecting surfaces without shims can also be screwed on.

### Function

The deflection for measurement of load cell and mount causes a restoring force in the bending zone of the Fixed Mount, acting on load cell but being compensated upon calibration. Depending on the point of application, significant weighing errors can be produced through horizontal forces acting vertically to the tilting line. Therefore it is essential that the Fixed Mount be mounted on a common tilting line as shown in the installation drawings.

The load distribution between Fixed Mount and load cells highly depends on the symmetry of the load carrier/hopper and the horizontal forces (wind, pipe connections, agitator), particularly in the case of 4 support points. In contrast to a full load measurement using load cells, these forces have the potential to cause a significantly higher weighing error.

## Fixed Mount 1 t ... 470 t



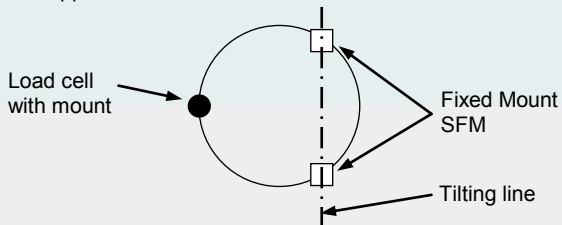
### Dimensions

Type	Nominal load [t]	Weight [kg]	A	B	C	D	E	H1	H2	H total	F	G	Q1=Q2 [k N]
VFN 4,7	1 ... 4,7	9	140	110	80	70	M12	98	113 + 5	128 + 5	15	15	5
VFN 22	10 ... 22	27	250	140	150	90	M16	130	150 + 5	170 + 5	20	20	22
VFN 33	33	46	270	180	180	110	M20	168	193 + 5	218 + 5	25	25	33
VFN 47	47	47	270	180	180	110	M20	168	198 + 5	248 + 5	50	30	47
VFN 68	68	94	300	270	180	180	M24	220	245 + 5	270 + 5	25	25	68
VFN 100	100	113	300	270	180	180	M24	220	240 + 5	300 + 5	60	20	100
VFN 150	150	176	380	280	300	190	M24	320	355 + 5	390 + 5	35	35	150
VFN 220	220	251	450	300	330	200	M30	373	418 + 5	463 + 5	45	45	220
VFN 330	330	400	500	350	380	220	M36	425	475 + 5	545 + 5	60	60	330
VFN 470	470	835	630	450	450	280	M42	455	515+10	635+10	120	60	470

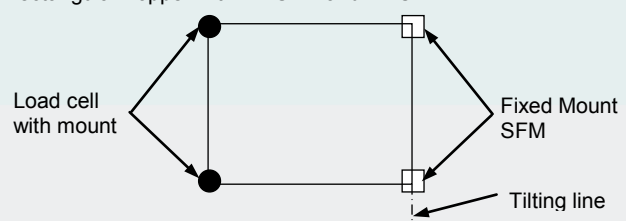
- Weight in kg including all shims
- Total height H2/H up to max. 5 mm (10 mm at 470 t) exactly like SSM and SEM, adjustable in height using intermediate plates
- Q1 max. lateral force parallel to tilting line
- Q2 max. lateral force vertical to tilting line

### Support point arrangement

Round hopper with 2 x SFM and 1 LC



Rectangular hopper with 2 x SFM and 2 LC



### Items supplied (SFM complete with 5 mm shims; SFM 470 10 mm)

Type	Ordering no. SFM height just like SEM *)	including weld-on plates	Height	Ordering no. SFM height just like SSM **)	including weld-on plates	Shims
VFN 4,7	V021894.B02	-	H1	V021894.B01	above	H2
VFN 22	V021837.B02	-	H1	V021837.B01	above	H2
VFN 33	V021776.B02	-	H1	V021776.B01	above	H2
VFN 47	V021995.B02	above	H2	V021995.B01	above and down	H total
VFN 68	V021974.B02	-	H1	V021974.B01	above and down	H total
VFN 100	V021777.B02	above	H2	V021777.B01	above and down	H total
VFN 150	V022583.B02	-	H1	V022583.B01	above and down	H total
VFN 220	V022592.B02	-	H1	V022592.B01	above and down	H total
VFN 330	V038093.B03	-	H1	V038093.B07	above and down	H total
VFN 470	V049185.B02	above	H2	V049185.B04	above and down	H total

\*) see data sheet BV-D2044

\*\*) see data sheet BV-D2083

**Schenck Process GmbH**  
Pallaswiesenstr. 100  
64293 Darmstadt, Germany  
T +49 6151 1531-0  
F +49 6151 1531-66  
sales@schenckprocess.com  
www.schenckprocess.com

### Also available:

- SENSiQ™ Secure Mount 0,25 t ... 470 t (BV-D2083)
- SENSiQ™ Secure Mount PLUS 10 t ... 330 t (BV-D2444)
- SENSiQ™ Pendulum Mount 1 t ... 100 t (BV-D2025)
- SENSiQ™ Elastomer Mount 0,25 t ... 470 t (BV-D2044)
- SENSiQ™ Fixed Mount PLUS 10 t ... 330 t (BV-D2442)

## SENSiQ™ Fixed Mount PLUS (SFM PLUS)

Fixed bearing for load cell applications for nominal loads from 10 t ... 330 t



- **Simple and robust construction, even more stable than the normal SENSiQ™ Fixed Mount**
- **Stable against shear forces up to 40 % of the nominal load**
- **Height dimension is compatible with the SENSiQ™ Secure Mount PLUS**
- **Easy to assemble**
- **Design and manufacturing certified after DIN EN 1090-2 EXC 2**
- **Material: S235, painted**

### Application

SENSiQ Fixed Mount PLUS is used for uncomplicated weighing tasks, such as e.g. fill level measuring systems.

In combination with one or two load cells (partial-load measurement) this represents a cost-efficient solution sufficiently accurate for many situations.

In particular this applies to applications with a defined center of gravity, such as hoppers with fluid contents.

### Equipment

The SENSiQ Fixed Mount PLUS consists of a double T-beam with reinforcing ribs. The reinforcing ribs create a defined bending zone and a greater stability against shear forces so that additional pinning of the hopper or the supporting beam is in many cases no longer required.

The SENSiQ Fixed Mount PLUS are higher than the SENSiQ™ Elastomer Mount so shims will be required if they are used in combination. No compensation is required if used in combination with the SENSiQ Secure Mount PLUS.

Additionally the height of the bearings can be adjusted with the used of shims by up to 5 mm.

The SENSiQ Fixed Mount PLUS are welded directly on both sides to the steel frame construction.

### Function

The measuring displacement from the load cell and the load cell bearing generates in the bending zone of the SENSiQ Fixed Mount PLUS a return force that acts on the load cell that can be compensated for during adjustment.

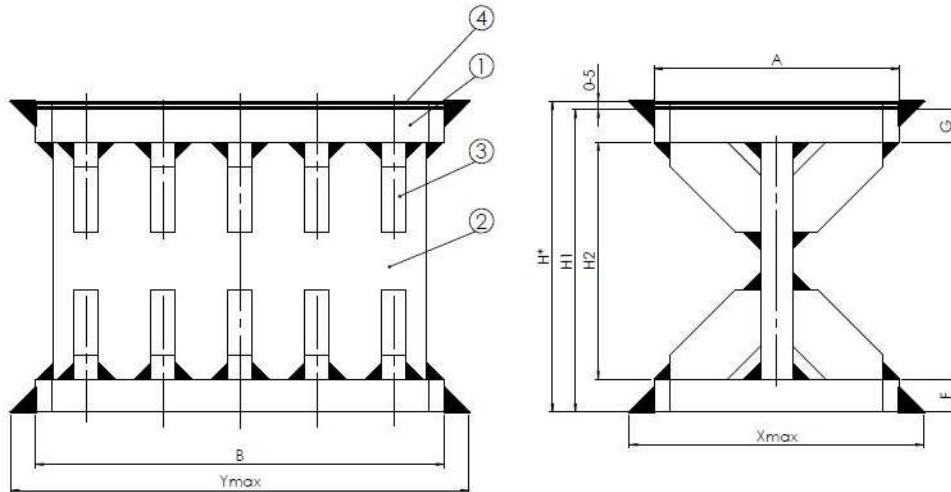
Depending on the point of contact, larger weighing errors can arise due to horizontal forces acting perpendicular to the tilting horizon.

Therefore it is essential that multiple SENSiQ Fixed Mount PLUS must be installed with a common tilting horizon (see the planning-in drawings).

The load distribution between the SENSiQ Fixed Mount PLUS and the load cells depends on the symmetry of the load carriers/hoppers, the location of the bulk material center of gravity and the horizontal forces (wind loads, pipe connections, agitators), in particular if there are 4 supporting points.

As opposed to a full-load measurement using load cells, influencing factors of this kind can cause significantly greater weighing errors.

## SENSiQ Fixed Mount PLUS 10 t ... 330 t



Ref.	Model Designation
1	Plate
2	Center plate
3	Rib
4	Leveling plates are enclosed, suitable for adjustment of heights up to 5 mm

### Dimensions

Nominal load t	A mm	B mm	F mm	G mm	H* mm	H1 mm	H2 mm	Xmax mm	Ymax mm	Max. shear force kN
10 ... 22	150	250	20	20	190	185	145	180	280	88
33	170	300	20	20	225	220	180	200	330	132
47	200	370	20	20	275	270	230	230	400	188
68	240	440	30	30	300	295	235	270	470	272
100	300	550	35	35	340	335	265	330	580	400
150	350	650	40	40	415	410	330	380	680	600
220	440	800	50	50	475	470	370	470	830	880
330	550	1000	60	60	530	525	405	580	1030	1320

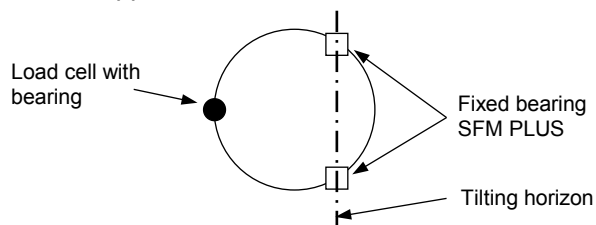
\* Max. height using shims

### Important Information

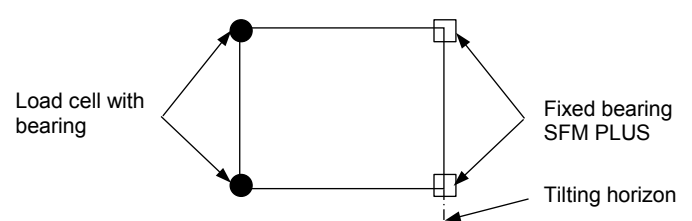
The connecting surfaces for the bearings must be planar and metallically bright. Painted surfaces are not suited for mounting the SENSiQ Fixed Mount.

### Arrangement of supporting points

Round hopper with 2 x SFM and 1 LC



Rectangular hopper with 2 x SFM and 2 LCs



## Technical Data

Available nominal load		10 t ... 330 t
Weight	10 t ... 22 t	25 kg
	33 t	38 kg
	47 t	65 kg
	68 t	99 kg
	100 t	176 kg
	150 t	296 kg
	220 t	515 kg
	330 t	976 kg
Material		S235JR
Height compensation		5 mm
Operating temperature range Caution: Take into account specifications of SENSiQ Elastomer Mount and load cell.		-30 °C ... +110 °C

### SENSiQ Fixed Mount PLUS (without load cell or weld-on plate)

Variants	Order number
10 t ... 22 t	V554135.B02
33 t	V554136.B02
47 t	V554137.B02
68 t	V554138.B02
100 t	V554139.B02
150 t	V554140.B02
220 t	V554141.B02
330 t	V554142.B02

Please contact us for further information on the SENSiQ Fixed Mount PLUS and ask for the manual and the detailed planning-in drawings if required.

The following products also are available



SENSiQ™ Fixed Mount  
1 t ... 470 t  
BV-D2182



SENSiQ™ Secure Mount PLUS  
10 t ... 330 t  
BV-D2444



SENSiQ™ Elastomer Mount  
0.25 t ... 470 t  
BV-D2044



Ring-Torsion Load Cells  
RTN 1 t ... 470 t  
BV-D2019



SENSiQ™ Secure Mount  
0.25 t ... 470 t  
BV-D2083

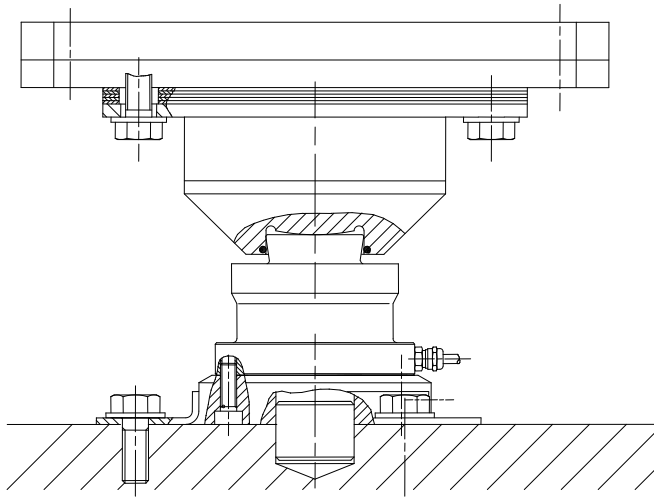


SENSiQ™ Pendulum Mount  
1 t ... 100 t  
BV-D2025

**Schenck Process Europe GmbH**

Pallaswiesenstr. 100  
64293 Darmstadt, Germany  
T +49 6151 1531-0  
F +49 6151 1531-66  
sales@schenckprocess.com  
www.schenckprocess.com

## Accessories for load cell mount SENSiQ Secure Mount SSM and SENSiQ Elastomer Mount SEM



- Heat insulation plates
- Weld-on plates
- Dimensionally compatible with mounts SSM and SEM
- Heat insulation plates protect the load cells and extend the application range
- Weld-on plates simplify installation
- Can also be used for height leveling

### Application

**Heat insulation plates** prevent heat transfer from a load carrier, e.g. a hot hopper, to the load cells via the mount elements.

In this way, errors of measurements caused by inadmissibly high temperatures or thermal gradients can be prevented.

The load cell's application range is extended.

**Weld-on plates** simplify installation of the load cell mounts. There is no necessity to make precise fastening borings above and below the mount or to correct them during installation. Weld-on plates can also be used for height leveling, e.g. when retrofitting. Heat insulation and weld-on plates can be combined.

### Construction

Heat insulation plates consist of several layers of insulating material which are separated by thin steel plates to improve load distribution. The predefined packs extend the load cells' application temperature range to 150 °C.

Heat insulation plates with different dimensions are also available on request for different ambient conditions.

The weld-on plates are designed thus that they can be combined with both SENSiQ Secure Mount SSM and SENSiQ Elastomer Mount SEM.

### Function

The heat insulation plates installed above the mount prevent heat conduction from the load carrier into the load cells via the load reception elements.

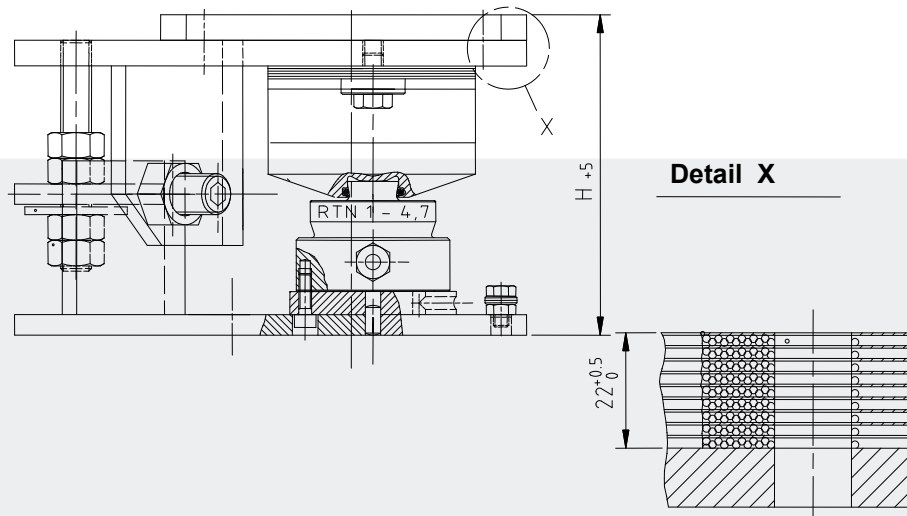
On the one hand, inadmissibly high temperatures which might in the worst case cause permanent damage to the load cell are kept away from the load cell and on the other, temperature gradients at the load cell are avoided which may impair accuracy.

Nominal and service temperature ranges of the load cells are thus extended.

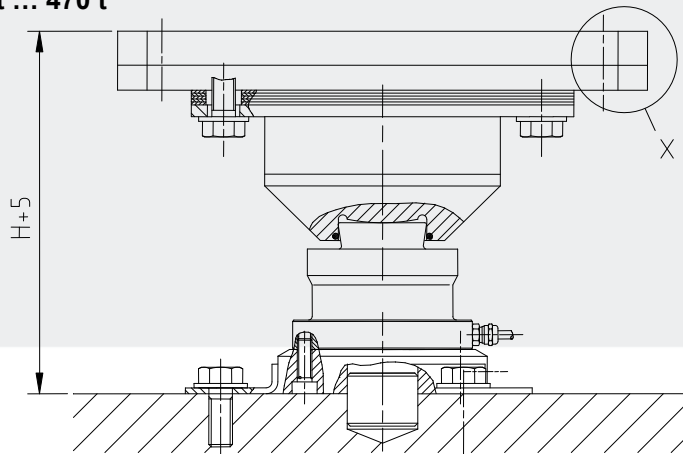


## Standard variants of heat insulation plates

### Example: SSM 1 t ... 4.7 t



### Example: SEM 1 t ... 470 t



## Technical Data

Type	Material of metal parts	Height	Overall height H + 5	Material number
SEM 1 t ... 4.7 t	1.4301	34	132	D733119.01
SEM 10 t ... 22 t	1.4301	34	164	D733119.02
SEM 33 t	S235, galvanised	34	202	D733119.03
SEM 47 t	S235, galvanised	62	260	V081425.B01
SEM 68 t	S235, galvanised	72	292	V081425.B02
SEM 100 t	S235, galvanised	82	321	V081425.B03
SEM 150 t	S235, galvanised	97	417	V081425.B04
SEM 220 t	S235, galvanised	112	485	V081425.B05
SEM 330 t	S235, galvanised	132	559	V081425.B06
SEM 470 t	S235, galvanised	157	677	V081425.B07
SSM 1 t ... 4.7 t	1.4301	22	138	V020696.B01
SSM 10 t ... 22 t	1.4301	22	172	V020696.B02
SSM 33 t	S235, galvanised	22	214	V020696.B05
SSM 47 t	S235, galvanised	52	305	V024275.B01

Heat insulation plates are as a rule installed above the bearings.

Heat insulation plates for SSM >47 t are available upon request. But then the horizontal load capacity and lifting force is reduced.



### Temperature range

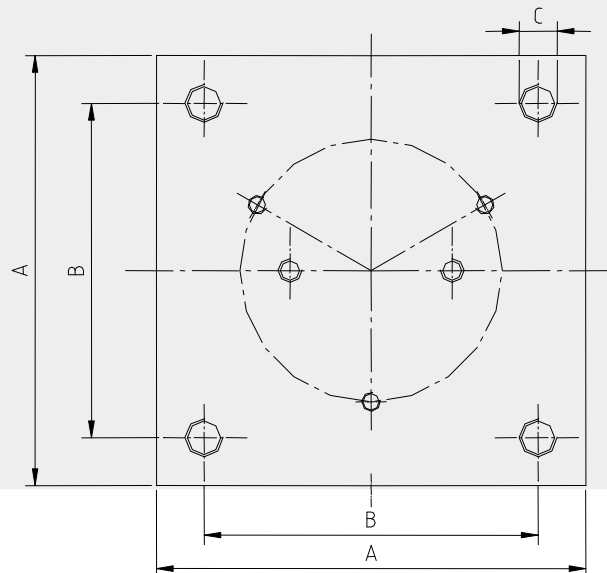
- Up to a container temperature of 80 °C, heat insulation plates are not necessary.
- The setup shown with single heat insulation is suitable for temperature of up to 150 °C.
- At higher temperatures special solutions are available upon request.

### Notice

Load transmission must be without force bypass over the entire temperature range.

This means: Limit stops and lift-off protection must have sufficient play despite thermal expansion.

### Standard variants of the weld-on plates



### Technical Data

Type	Material	Height	A	B	C	Material number
SEM / SSM 1 t ... 4.7 t	1.4301	15	140	100	M 12	D733120.06
SEM / SSM 1 t ... 4.7 t	S235, galvanised	15	140	100	M 12	D733120.01
SEM / SSM 10 t ... 22 t	1.4301	20	180	140	M 16	D733120.04
SEM / SSM 10 t ... 22 t	S235, galvanised	20	180	140	M 16	D733120.02
SEM / SSM 33 t	S235, galvanised	25	240	200	M 20	D733120.03

In combination with SSM, the weld-on plates can be used above and below the mount. With elastomer mounts SEM this can only be done in the load area of 1 t ... 4.7 t.

With SEM mounts of 10 t and up, weld-on plates can only be used above the mount; if necessary the elastomer at the bottom is welded directly.

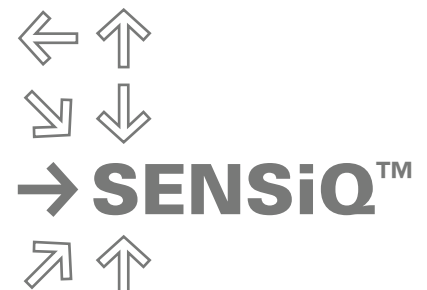
Designs for other nominal loads or with different thickness are available on request.

**Schenck Process GmbH**  
Pallaswiesenstr. 100  
64293 Darmstadt, Germany  
T +49 6151 1531-0  
F +49 6151 1531-66  
sales@schenckprocess.com  
www.schenckprocess.com

## Engineering and design rules for hopper scales with **SENSiQ™**



- ❖ **Defining hopper scales**
- ❖ **Dimensioning hopper scales**
- ❖ **Selecting load cell mounts**
- ❖ **Ambient influences and shunt forces**
- ❖ **Hopper scale accuracy**



# Rules to ensure proper operation and high accuracy

## 1) Defining hopper scales



### **Net weight acquisition systems mounted on load cells and load application elements, e.g. tanks, silos, reactors, mixers, agitator hoppers.**

The more closely these rules are observed, the lower the local influences on operation and accuracy.

The choice of the right mechanical components for the particular application, proper installation and consideration of environmental conditions, e.g. piping connectors, wind loads and process sequence, are of particular importance to accuracy.

Our installation and commissioning instructions as well as the relevant spec sheets detail use, configuration and functions. If hoppers are subjected to shunt forces from existing piping connections, pay particular attention to the rules stated under Item 4.

Proper scale dimensioning requires the following details:

- ❖ Weighing range
- ❖ Required resolution
- ❖ Required accuracy (legal-for-trade?)
- ❖ Number of load points (load cells)
- ❖ Dead load (hopper's own weight)
- ❖ Asymmetric load
- ❖ Dynamic loads
- ❖ Wind loads

## 2) Dimensioning hopper scales

The load cell rated capacity needed is calculated using the following formula:

$$\text{L/C rated capacity} = \frac{(\text{weighing range} + \text{tare load}) * \text{safety factor}}{\text{number of support points}}$$

To acquire load cell output signal/digit (Ua/d):

$$\text{Ua/d} = \frac{\text{weighing range} * \text{sensitivity} * \text{supply voltage} * 1000}{\text{number of L/Cs} * \text{load cell rated capacity} * \text{resolution}}$$



With 3 load points, factor in at least 25% for safety. With 4 support points, as a rule of thumb, use 3 load points. In the worst case scenario, if the construction is very rigid, the load can even act on just 2 support points.

Select the next largest available load cell rated capacity and relevant quality using the relevant spec sheet.

With legal-for-trade scales, ensure minimum load cell utilization in accordance with spec sheet.

Minimum utilization = weighing range: total of load cells rated capacities (with SENSiQ™ RT load cells at least 15 %).

With non-legal-for-trade scales, depending on duty and application, 5 % load cell utilization will suffice.

Observe minimum input signal of evaluation electronics provided.

### Example:

<b>Weighing range:</b>	<b>15 t</b>	<b>Result: 4.275 μV/d</b>
<b>Sensitivity:</b>	<b>2.85 mV/V</b>	
<b>Supply voltage:</b>	<b>12 V</b>	
<b>Number of load cells:</b>	<b>4</b>	
<b>Load cell rated capacity:</b>	<b>10 t (SENSiQ™ RTN C3)</b>	
<b>Resolution:</b>	<b>3000 digits (5 kg increment value)</b>	

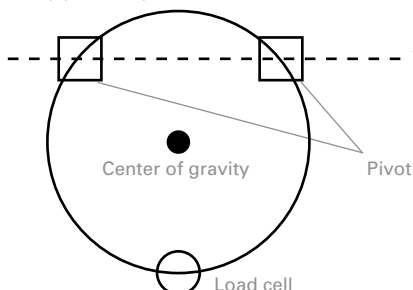
When using pivots (partial load measurement), first determine the load on every weighing support point.

Then establish load cell output signal as described above.

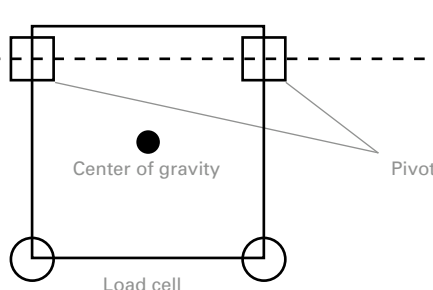
The achievable accuracy depends on the material used (solids, liquids; see Item 3, SENSiQ™ fixed mounts (SFM)).

### 3 load distribution examples

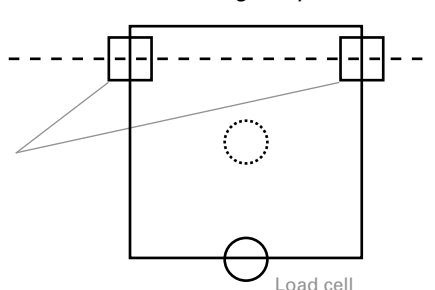
A) Round hopper  
(1/3 each)



B) Square hopper  
(1/4 each)

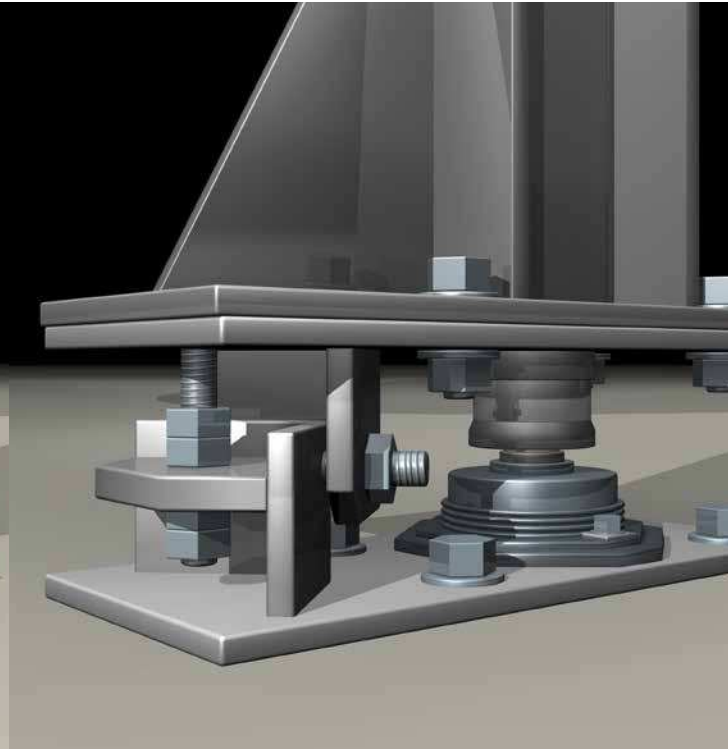
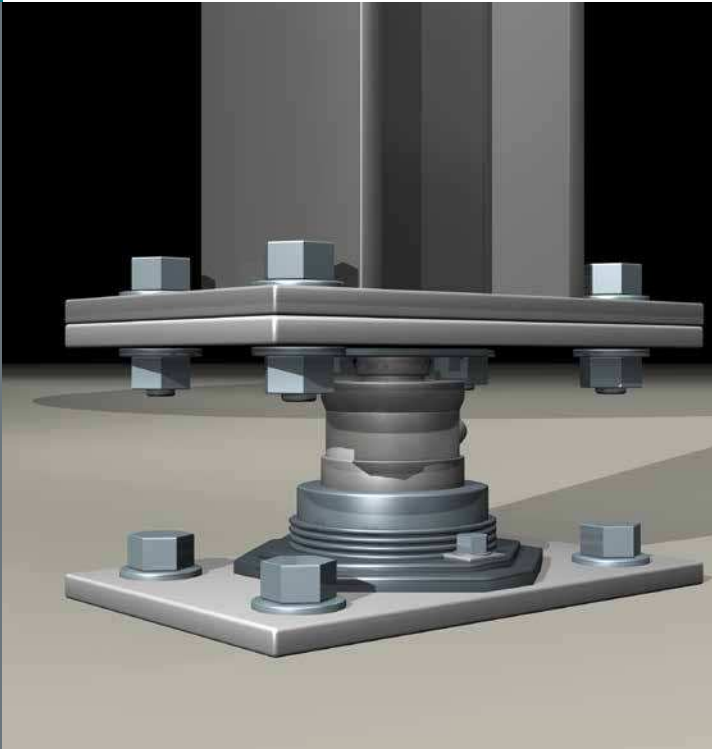
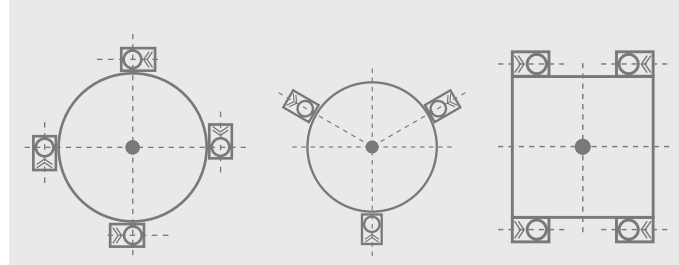


C) Square hopper  
(center of gravity undefined)



### 3) Selecting load cell mount

Select load cell mounts depending on application and accuracy requirements



#### **SENSiQ™ elastomer mount (SEM)**

Typical applications: hopper scales, roller table scales, crane scales and road weighbridges.

Self-centering and resistant to lateral forces. Insensitive to max.  $0.6^\circ = 10 \text{ mm/m}$  inclination of support structure. Service-friendly and maintenance-free. Observe lateral stiffness of elastomer (differs depending on rated capacity) (the admissible lateral force on load cells must not be exceeded at nominal hopper deflection).

Limit stops and lift-off protection have to be provided by user.

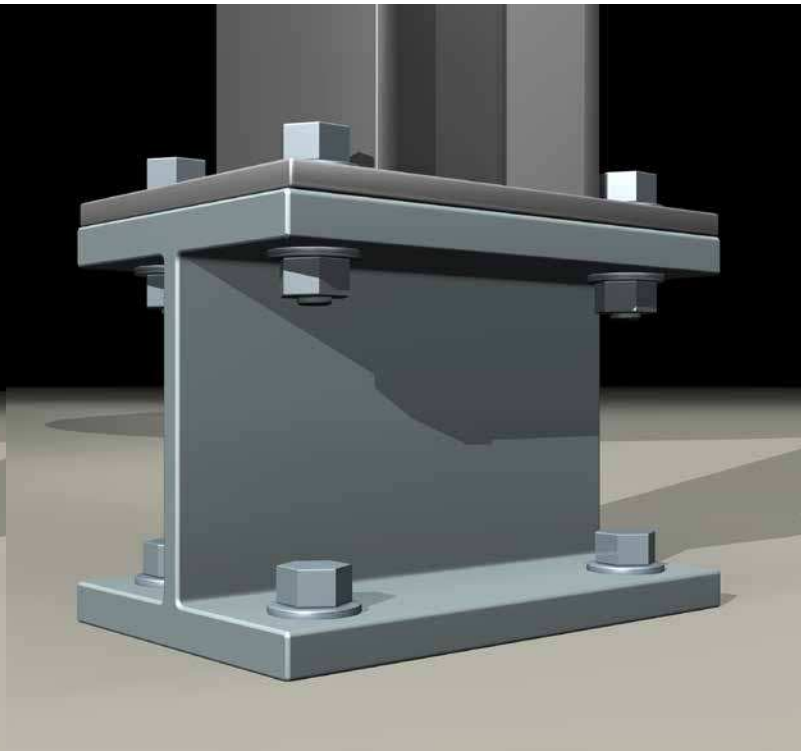
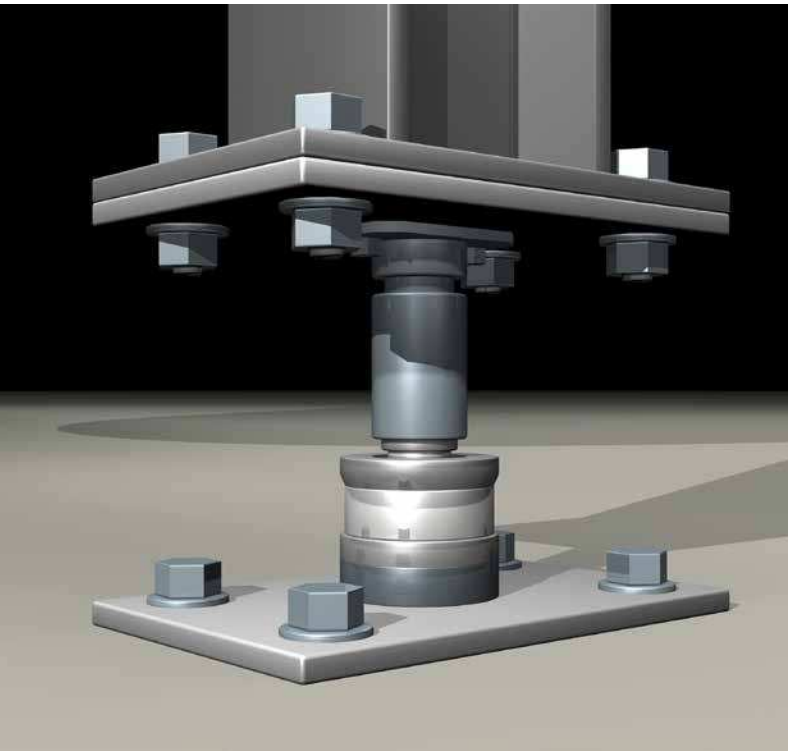
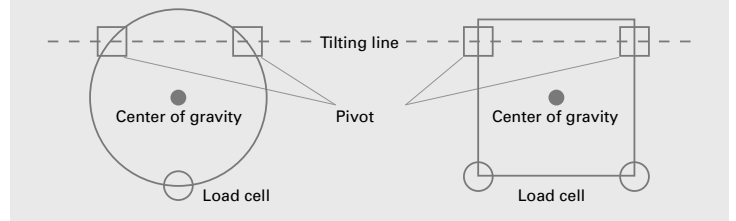
More information can be found in spec sheet BVD-2044.

#### **SENSiQ™ secure mount (SSM)**

Typical applications: hopper, silo, tank, and mixer scales. Extended SENSiQ™ elastomer mount complete with head and foot plates, integrated limit stops and lift-off protection. Up to and including rated capacity of 33 t, the maximum horizontal force is 10% of the rated capacity of the mount and maximum vertical lift-off force is 15% of rated capacity of the mount. With a rated capacity of 47 t or higher, the maximum horizontal force and vertical force preventing lift-off is 20 % of the rated capacity of the mount. For applications with higher horizontal and lift-off loads, use the SENSiQ™ safety mount PLUS with a maximum horizontal and lift-off capacity of 40 % of the rated capacity of the mount for rated capacities of between 10 t and 220 t.

If the loads on limit stops and lift-off protection are even higher, take additional actions (e.g. fit external bumpers and external lift-off protection). Strictly observe specified arrangement (see sketch).

More information can be found in spec sheets BVD-2083, BVD2443 and BVD2444.



### **SENSiQ™ pendulum mount (SPM)**

Typical applications: hopper and vehicle scales. Designed for extremely rugged environments. Suitable for maximum measuring accuracy. Self-centering, maximum admissible inclination of existing connecting surface  $0.6^\circ = 10 \text{ mm/m}$ .

Smaller spring deflection compared with SENSiQ™ SEM/SSM as there is no elastomer mount.

Pendulum limit stops and lift-off protection have to be provided by user.

More information can be found in spec sheet BVD-2025.

### **SENSiQ™ fixed mount (SFM)**

Typical applications: for simple weighing tasks on hopper scales with  $\geq 5 \text{ t}$  weighing range, e.g. level measuring systems, equipped with one or two load cells (partial measurement). Simple, rugged, flat design, resistant to lateral forces. Sufficient accuracy with defined center of gravity, e.g. for liquid hoppers. Dimensions compatible with SENSiQ™ secure or elastomer Mounts.

Installation on common tilting line. Typical accuracies (in relation to full scale value) without influence of the immediate environment:

$\geq \pm 0.5 \%$  with liquids

$\geq \pm 1 \%$  with solids

Maximum lateral force in any horizontal direction may be 10 % of the rated capacity of the mount. For higher lateral forces, the SENSiQ™ fixed mount PLUS with a maximum admissible lateral force of 40 % of the rated capacity of the mount is available for rated capacities of between 10 t and 220 t.

More information can be found in spec sheets BVD-2182 and BVD2442.

Load distribution depends on load carrier / hopper symmetry and horizontal forces (wind load, agitator, pipe connections). In contrast to a full load measurement using load cells, these forces may cause considerably greater measuring errors depending on the application point and effective direction.



## 4) Ambient influences and shunt forces



❖ **Appropriate measures during planning and design can minimize, or eliminate, shunt forces.**

### **Shunt forces**

The load to be determined may only be applied via defined support points. If partial loads bypass the defined support points (shunt forces), measuring errors will result.

### **Shunt forces may occur if:**

- ❖ the load receptor makes contact with the permanent construction (foundation, frame, support structure)
- ❖ pipes and other connections to the scale (e.g. agitator cable) in direction of load cell load are too rigid
- ❖ limit stops are improperly mounted/adjusted or blocked by grime, material residues or corrosion
- ❖ compensators are too rigid or grimed (particularly through material residues with bellows-type compensators)

## **Examples of how to avoid shunt forces**

### **Fig. 1**

Free flanged inlet connection, if necessary, with labyrinth ring / cover.

### **Fig. 2**

Horizontal supply line sufficiently long to avoid faults resulting from pipe deformation.

Important: Never support supply line near hopper.

**Rule of thumb:  $L = 30 \times \text{pipe diameter}$**

Always support pipes on scale platform.

### **Fig. 3**

If pressure (or underpressure) is present on hoppers, ensure identical compensator diameter!

### **Fig. 4**

Fit compensators or flexible hoses to ensure flexibility of extremely rigid lines with large diameters. Dimension "L" can be halved using a pipe loop (also for Fig. 2).

- ❖ Ensure sufficient pipe bend length  
Design pipe bend horizontally
- ❖ Mount support on the side away from the hopper only
- ❖ If pipes are very thick, the dual compensators shown considerably reduce shunt forces.



Fig. 1



Fig. 2



Fig. 3



Fig. 4



#### Additional considerations:

Provide venting for cooling/heating jacket. Note level to which hopper heater is filled.

Consider operating state (pressure, temperature, heating).

- ❖ Reactor and piping pressures cause weighing errors via pipe cross-section.

Remedy: Provide pressure compensation, operate at zero-pressure.

Mount pipes horizontally

- ❖ Note heating of pipes through internal medium or radiating heat.

Typical pipe elongation:  $0.1 \text{ mm}/10^\circ \text{ C} \times \text{length}$

Irregular warming can cause the pipe to behave like a bimetal thus generating additional bending forces.

#### Environmental influences through heat, moisture

- ❖ Protect load cells from direct insolation and drafts.

Remedy: Provide insulating jacket or enclosure.

- ❖ Avoid thermal gradients (heat discharge from hopper via load cells).

Remedy: Provide heat insulating plates.

- ❖ Protect load cell cable from mechanical damage (rodents) and moisture.

Remedy: Run load cell cable in protective tubes.

#### Design/installation considerations

- ❖ Design platform construction with sufficient stiffness.

- ❖ Ensure deflection  $L/1000$

- ❖ Run pipes and mount compensators horizontally.

- ❖ Compensate vertical lines as gently as possible.

- ❖ Provide potential equalization between load cell housing and evaluation electronics.

Use existing mechanical construction or provide PE line.

- ❖ Connect weigh hopper to ground of user construction using flexible connector.

- ❖ Design load cell output lines horizontally, plane parallel and sufficiently rigid.

- ❖ To avoid mechanical stresses from thermal expansion, always use genuine Schenck Process parts (foot plate and load cells of same material).

- ❖ To be able to calibrate and verify your scale, ensure that standard weights of at least 20% of its rated capacity can be applied.

(This is the prerequisite for legal-for-trade applications).

## 5) Hopper scale accuracy

The main requirement for attaining the desired scale weighing accuracy is selecting the right load cell rated capacity and quality.

### Decisive parameters:

- ❖ Characteristic deviation (non-linearity and hysteresis)
- ❖ Temperature dependencies of zero signal and characteristic
- ❖ Resolution
- ❖ Measurement value creep
- ❖ Repeatability

With hopper scales, the achievable system accuracy is essentially determined by the ambient influences and process sequence.

### Key words:

- ❖ Accurate mounting of supports.
- ❖ Repeatability influenced by pipes, compensators and other connections.
- ❖ Stiffness of mounting platform.
- ❖ Agitator vibrations, center of gravity displacement

With legal-for-trade weighing systems, use load cells of minimum quality C3, and evaluation electronics approved for trade use.

If scale is properly configured in accordance with the instructions provided in these documents, the (legal-for-trade) system accuracy will be comfortably below 0.1%.

With non-legal-for-trade weighing systems, when using SENSiQ™ RT load cells with 0.05% accuracy and proper installation in conjunction with Schenck Process evaluation electronics, 0.1% system accuracy can be achieved.

These accuracies are obtained through input of all scale parameters, i.e. by "theoretical calibration" without application of weights.

### Schenck Process will be glad to back you up with:

- ❖ **Advice**
- ❖ **Engineering**
- ❖ **Design**
- ❖ **Service**
- ❖ **Checks**

## Weighbeam DWB 11.5 ... 25t



- Simple and economical installation through direct screwing onto the connecting structure
- Transmission of high interferential forces and moments at minimal impact on measurement value
- Extremely low headroom
- Designed for rugged environment
- Suitable for construction of service free scales
- Option: HT-type for service temperature up to 120°C

### Application

- Silo and hopper scales
- Crane scales
- Rail weighbridges
- Scrap bucket, roller train, and tundish scales
- Platform scales

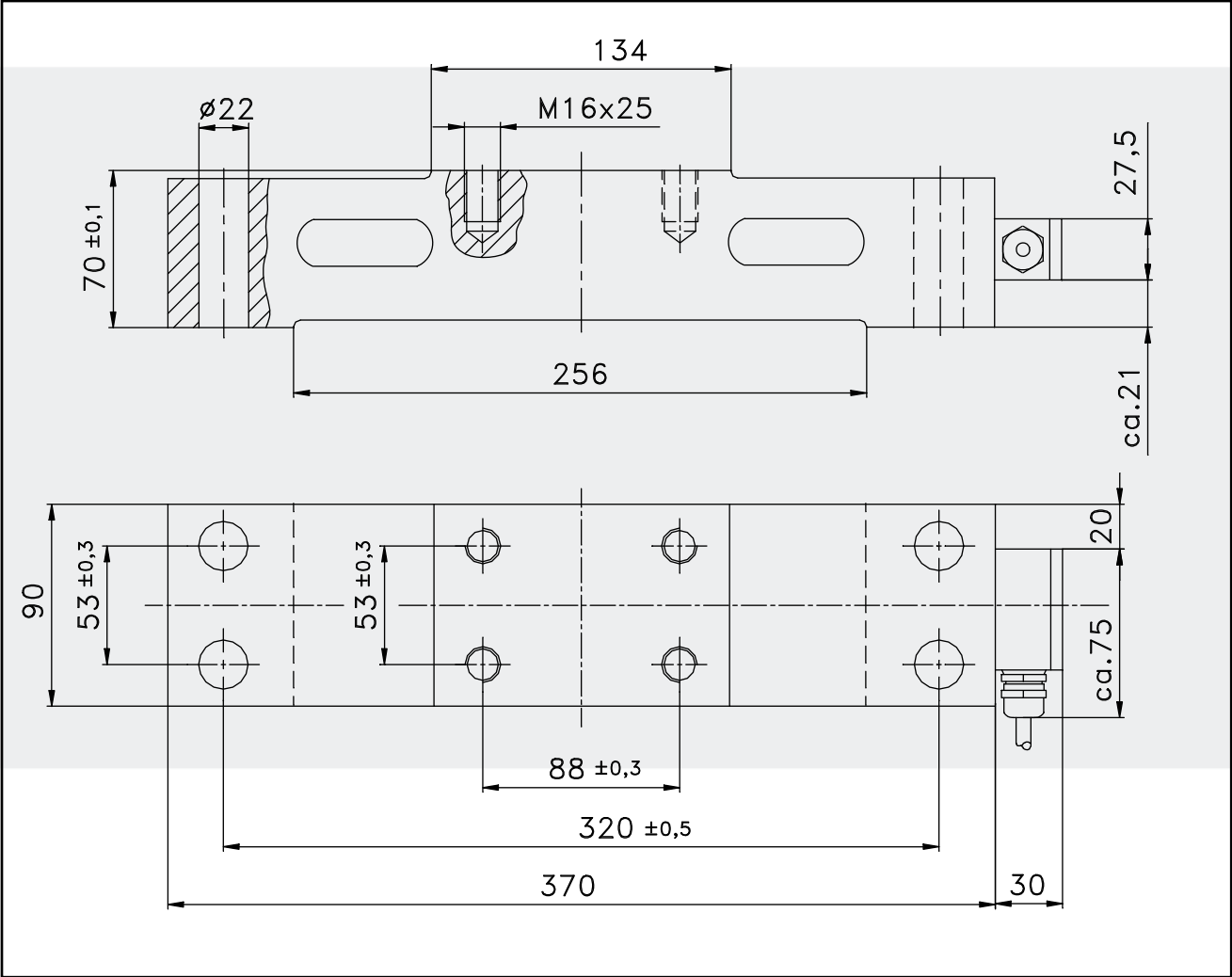
### Construction

- Low and compact design
- Galvanized surface
- Protected to IP 67

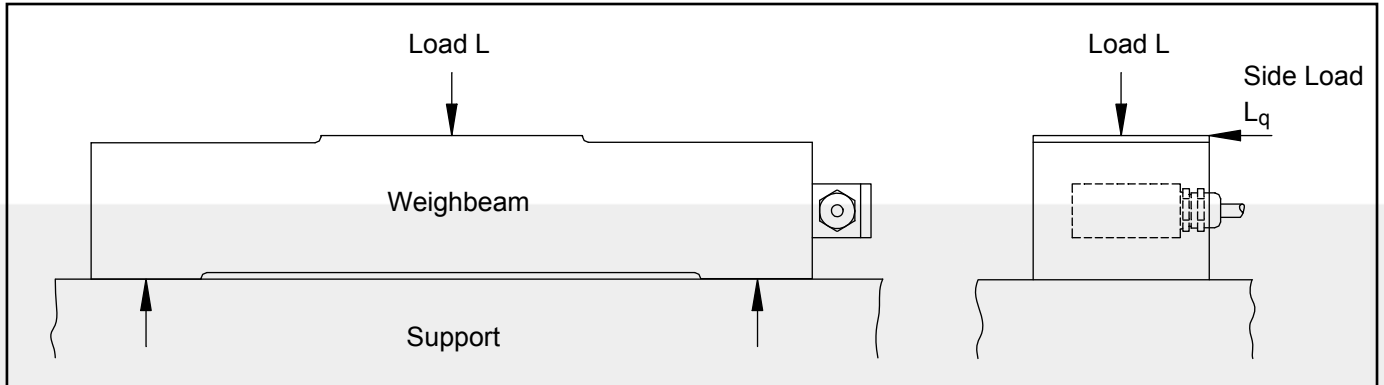
### Function

- High degree of reliability and availability
- Virtually impervious to shock loads and unavoidable side forces
- No need for additional tie-rods and hold-downs

Mounting Dimensions



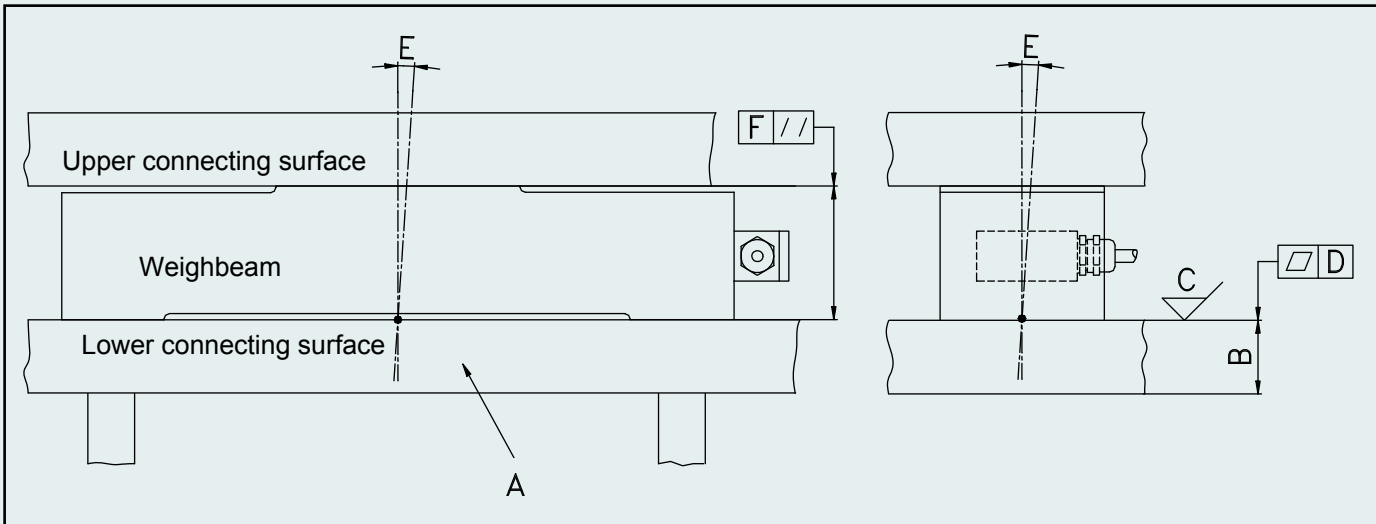
## Operating Principle



## Technical Data

		DWB 11.5 t	DWB 15 t	DWB 25 t	Reference
Rated capacity	$L_n$	11.5 t	15 t	25 t	
Limit load (with $L_q = 0.15 \times L_n$ )	$L_l$	23 t	26 t	35 t	
Rupture load (with $L_q = 0.15 \times L_n$ )	$L_d$	35 t	38 t	40 t	
Max. admissible side load	$L_{qmax}$	15 t	18 t	25 t	
Sensitivity	$C_n$	0.90 mV/V	1.16 mV/V	1.40 mV/V	$L_n$
Combined error	$F_{comb}$	± 0.3 %			$C_n$
Creep (30 m)	$F_{cr}$	± 0.05 %			$C_n$
Input resistance	$R_e$	378 Ω	378 Ω	756 Ω	$T_r$
Output resistance	$R_a$	350 Ω	350 Ω	700 Ω	$T_r$
Ref. supply voltage	$U_{sref}$	10V			
Max. supply voltage	$U_{smax}$	18V	18V	36V	
Nominal temperature range	$B_{tn}$	- 10°C to + 40°C			
Service temperature range	$B_{tu}$	- 15°C to + 80°C (HT quality + 120°C)			
Reference temperature	$T_r$	+ 22°C			
Storage temperature range	$B_{ts}$	- 30°C to + 85°C ( HT quality + 120°C)			
Temperature effect on zero signal	$TK_o$	± 0.1% / 10K ( HT quality: ± 0.05%)			$C_n$ in $B_{tu}$
Temperature effect on sensitivity	$TK_c$	± 0.07% / 10K ( HT quality: ± 0.05%)			
Dead weight	$m_e$	18kg	18kg	18kg	
Corrosion protection		hot dip galvanized			
Protection class		IP 67			
Cable specification		silicone RAL 7000 (grey) Ø 6.5mm x 15m – 30°C to + 150°C			
Colour code		black : input + (82) / blue : input - (81) red : output + (28) / white : output - (27) green-yellow : screening			

## Contact surfaces quality requirements



- Material "A":  
Usually, construction steel of a minimum quality S355 is used
- Plate thickness "B":  
Plate thickness depends on total construction stiffness. Connecting surfaces plate thickness must be at least 40% of weighbeam height
- Surface quality "C":  
The requisite mean rough value of connecting surfaces is around 6.3µm
- Planeness "D":  
The maximum admissible tolerance of each contact surface is 0.05 mm
- Angular error to vertical axle "E":  
The connecting surface angle may differ from the vertical axle in both planes of view by max.  $\pm 2^\circ$
- Plane parallelity "F":  
The upper and lower connecting surfaces to the weighbeam must be plane parallel to minimum 0.1 mm

Variants	Order No.
DWB 11.5 t	D 703 100.01
DWB 15 t	D 703 100.02
DWB 25 t	D 704 280.03

### Options:

HT quality for service temperature up to 120°C

Variants	Order No.
DWB 11.5 t HT	D 703 100.04
DWB 25 t HT	D 704 280.05

# SENSiQ<sup>®</sup> Weighbeam

## WB 40 t ... 600 t

- The original, proven over more than 30 years, optimized to the latest state of technology
- Expanded to an operating temperature from -40 °C ... 180 °C
- High precision with a maximum combined error of  $\pm 0.07\%$  across the entire temperature range
- Extremely robust and maintenance-free, IP68
- 6-wire circuit
- Integrated sensor for temperature monitoring and compensation, and integrated overvoltage protection
- Separate installation of the connecting cable through plug connection on the Weighbeam, also available as hinged plug outlet



### Application

- Ladle turret scale
- Ladle transfer car
- Scrap basket, roller and tundish scales
- Silo and bin weighers

### Function

- Simple and cost-effective installation through direct bolted joint with the connecting structure without moving parts
- No additional straps or hold down bolts required
- High functional safety and availability, even with frequently unavoidable impact loads and constraining forces

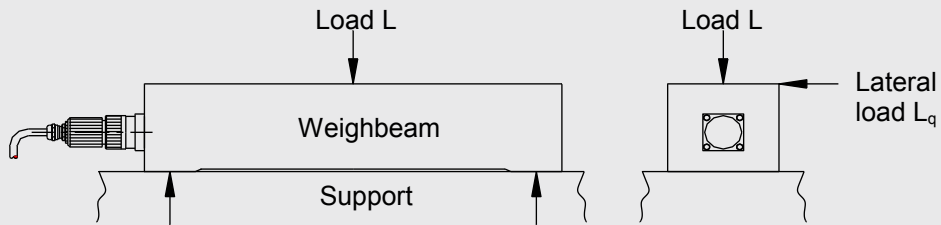
### Construction

- Compact, flat design
- From WB 50 t: Fit head for form-locking take-up of lateral forces
- Plug connection, also available as hinged plug outlet
- For maintenance-free scales operated under harsh conditions
- Transfer of high disturbance forces and torques with minimum measuring value interference
- High long-term stability
- High reproducibility
- Separate installation of Weighbeam and connecting cable possible
- Cable change without problems

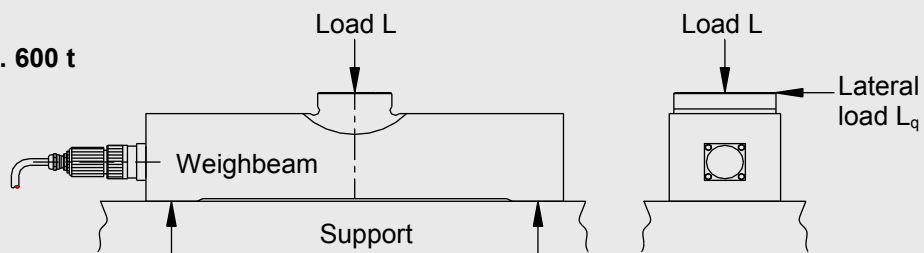
## Operating Principle

### WB 40 t ... 600 t

WB 40 t

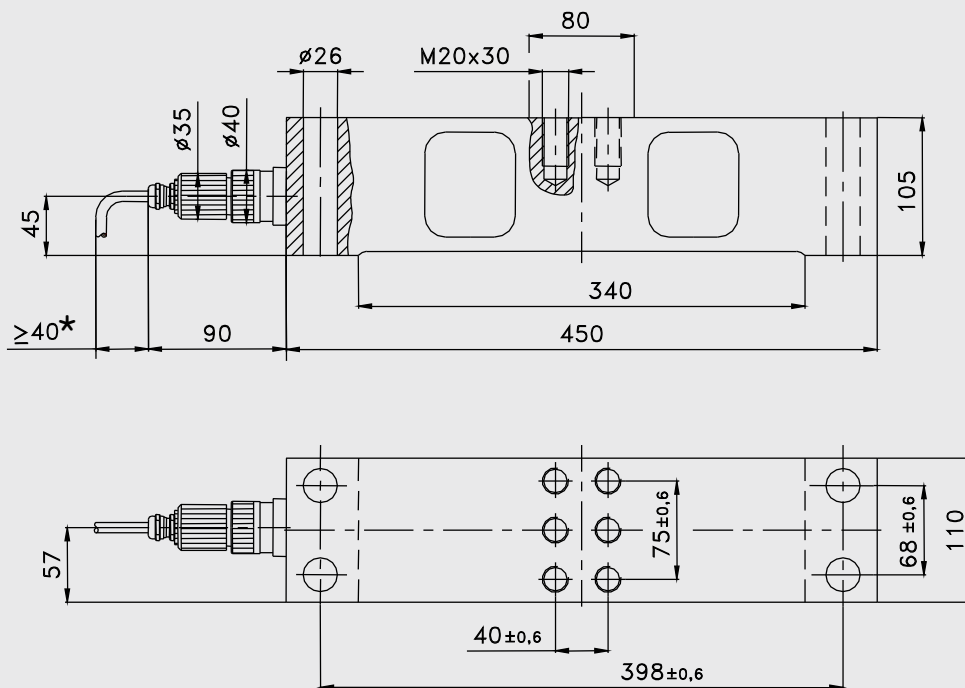


WB 50 t ... 600 t



## Installation dimensions

### WB 40 t

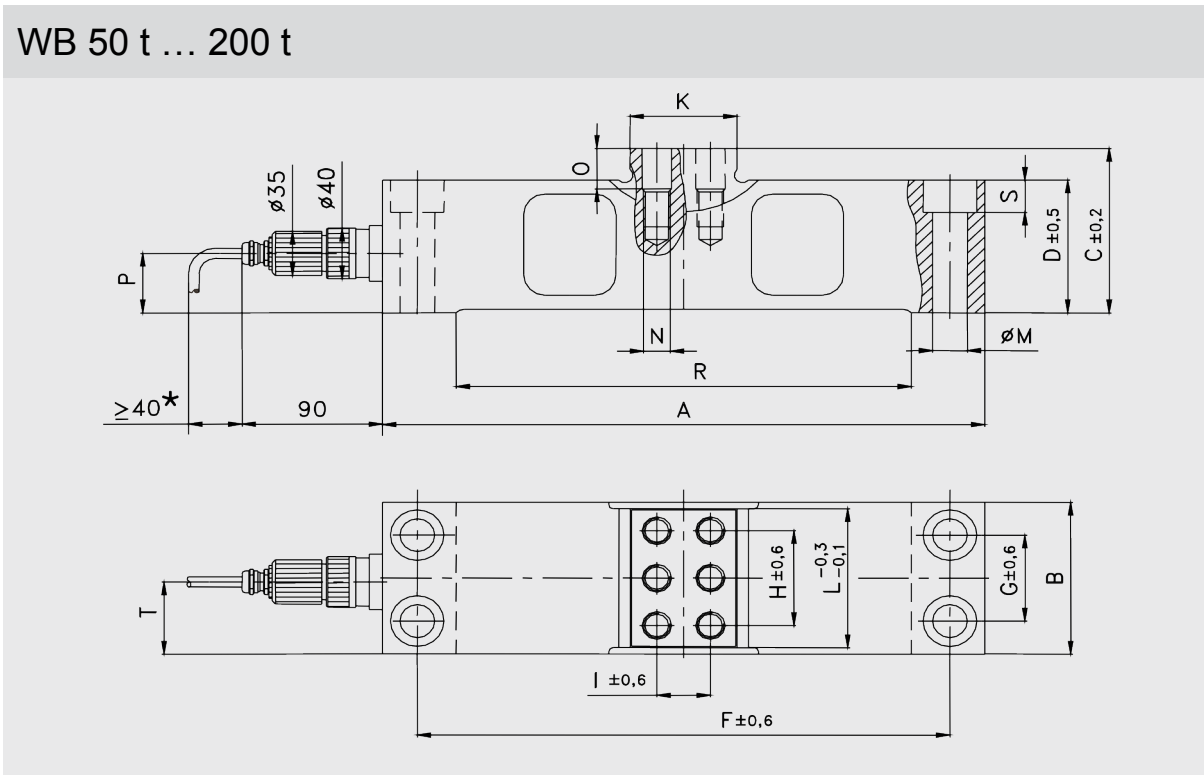


\* Another 15 mm are needed for isolating the plug connection.



## Fitting dimension when connecting with a straight plug connection

WB 50 t ... 200 t



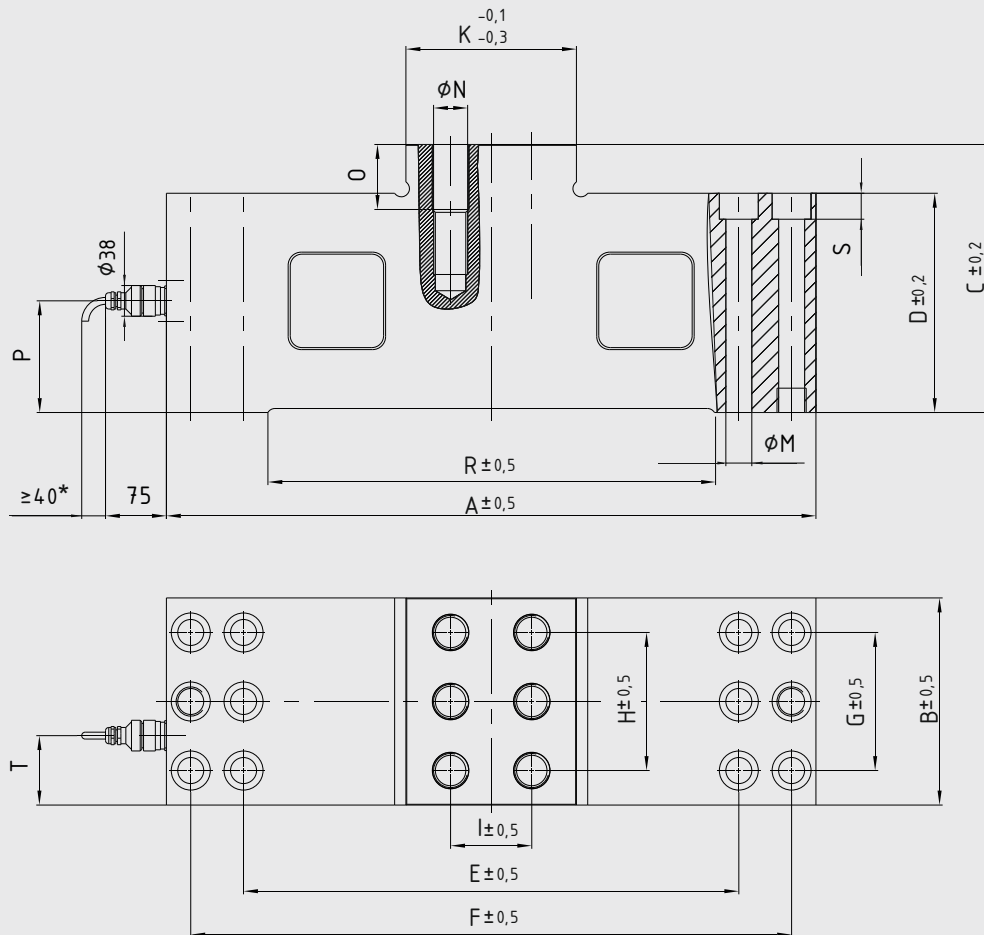
\* Another 15 mm are needed for isolating the plug connection.

[mm]

Design	A	B	C	D	F	G	H	I	K	L	M(**)	N	O	P	R	S	T
WB 50 t	450	120	130	105	398	68	75	40	80	110	26 (M24)	M20 x 30	32	45	340	25.5	57
WB 100 t	500	140	143	118	444	80	90	44	90	130	30 (M27)	M24 x 36	38	54	370	28.5	63
WB 150 t	560	160	158	133	500	94	102	44	90	150	33 (M30)	M24 x 36	38	66	410	32	69
WB 200 t	620	180	175	150	560	114	110	44	90	160	33 (M30)	M24 x 40	40	75	450	32	76

(\*\*) Screw size

## WB 600 t



\* Another 15 mm are needed for isolating the plug connection.

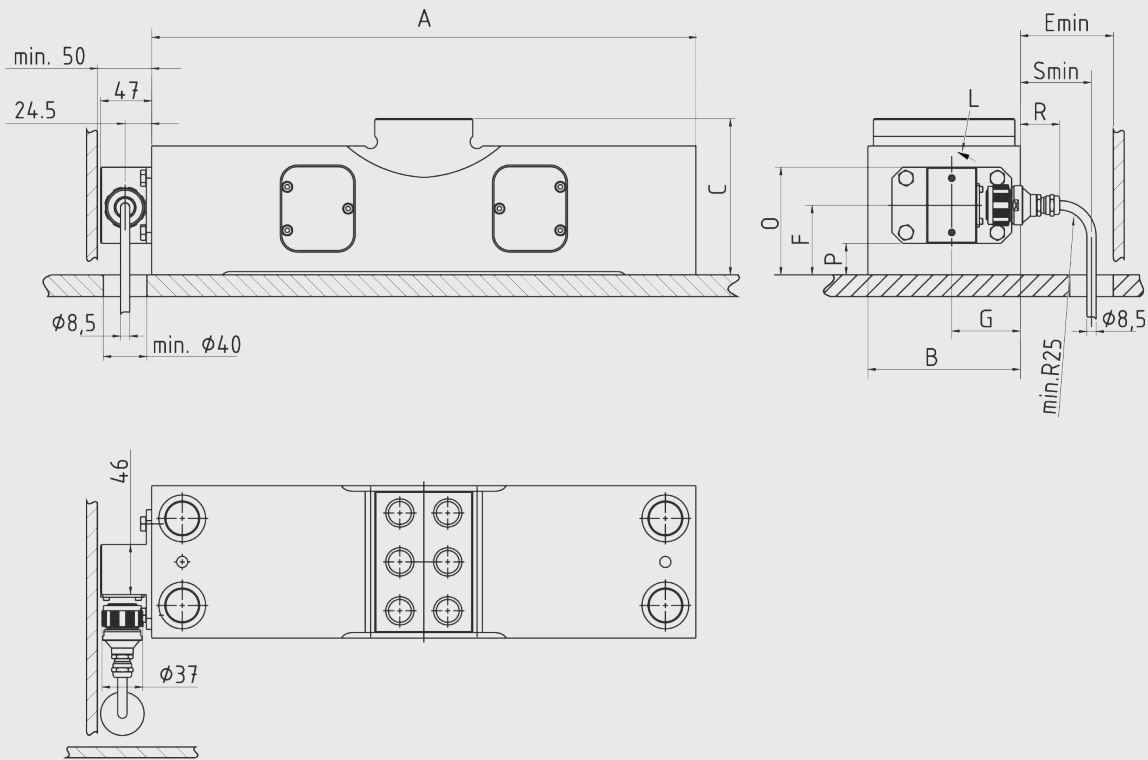
[mm]

Design	A	B	C	D	E	F	G	H	I	K	M (**)	N	O	P	R	S	T
WB 600 t	800	255	330	270	610	740	170	170	100	210	32 (M30)	M42 x 80	80	137.5	550	32	85.5

(\*\*) Screw size

## Fitting dimension when connecting with hinged plug connection

### WB 40 t ... 600 t



Design	A	B	C	E	S	G	L *)	O	R	S	P
WB 40 t	450	110	105	96	45	57	0°/180°	80	47	76	10
WB 50 t	450	120	130	91	45	57	0°/180°	80	42	71	10
WB 100 t	500	140	143	85	54	63	0°/180°	89	36	65	19
WB 150 t	560	160	158	79	66	69	0°/180°	101	30	59	31
WB 200 t	620	180	175	74	75	76	0°/180°	110	25	54	40
WB 600 t	800	255	330	64	137.5	85.5	0°/180°	172.5	15	44	102.5

- \*) Cable outlet possible on both sides.  
 0°: Cable outlet on the right  
 180°: Cable outlet on the left  
 Standard: Cable outlet on the right

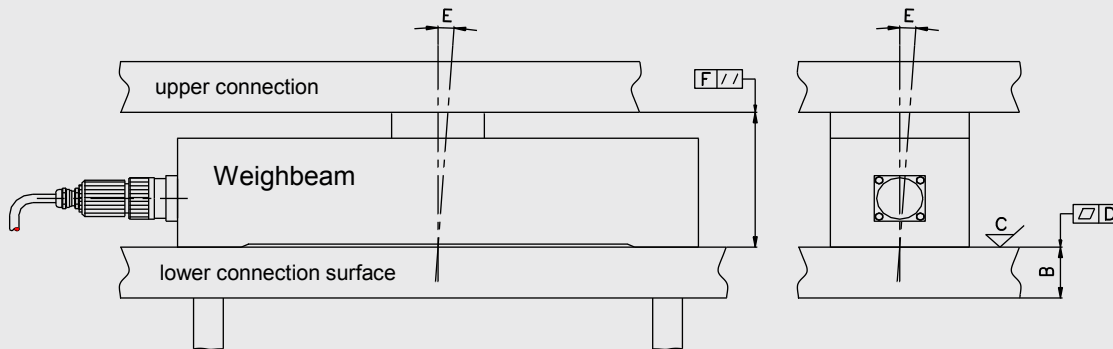
## Technical Data

		WB 40 t	WB 50 t	WB 100 t	WB 150 t	WB 200 t	WB 600 t	Ref
Nominal load	$E_{max}$	40 t	50 t	100 t	150 t	200 t	600 t	
Limit load (with $L_q = 0.15 \times L_l$ ) Limit load = max. safe load	$L_l$	100 t	120 t	210 t	290 t	360 t	1000 t	
Breaking load (with $L_q = 0.15 \times L_d$ )	$L_d$	160 t	200 t	350 t	480 t	600 t	1200 t	
Max. permitted lateral load	$L_{q,max}$	40 t	50 t	85 t	120 t	150 t	400 t	
Nominal characteristic value	$C_n$	0.95 mV / V	1.08 mV / V	1.38 mV / V	1.57 mV / V	1.63 mV / V	1.40 mV/V	$E_{max}$
Compound error	$F_{comb}$	$\pm 0.1 \% *$	$\pm 0.07 \% *$				$0.1 \% *$	$C_n$
Creepage under load (30 min)	$F_{cr}$	$\pm 0.05 \%$						$C_n$
Input resistance	$R_e$	694 $\Omega \pm 8 \Omega$						$T_r$
Output resistance	$R_a$	700 $\Omega \pm 4 \Omega$						$T_r$
Ref- supply voltage	$U_{sref}$	10 V						
Max. supply voltage	$U_{smax}$	36 V						
Nominal temperature	$B_{tn}$	-10 °C ... +100 °C						
Operating temperature (and storage temperature range)	$B_{tu}$	-40 °C ... +180 °C						
Temperature	$T_r$	+22 °C						
Temperature coefficient of the zero signal	$TK_o$	$\pm 0.05 \% / 10 K *$						$C_n$ in $B_{tu}$
Temperature coefficient of the characteristic value	$TK_c$	$\pm 0.03 \% / 10 K *$						
Self-weight	$m_e$	39 kg	40 kg	55 kg	85 kg	120 kg	400 kg	
Surface		galvanized,						
Protection class		IP68						
Cable specification		<p>The Weighbeam has a 200 mm connection cable with plug connection. A separate, shielded cable (<math>\varnothing 8.5 \text{ mm} \times 15 \text{ m}</math>) is also supplied with suitable plug socket.</p> <p>The following applies to the cable: Silicon cable, bend radius: <math>&gt; 40 \text{ mm}</math>; temperature range: <math>-50 \text{ °C} \dots +180 \text{ °C}</math></p>						
Cable connection allocation		<p>Black: input + (82)                      Blue: Input - (81) Red: Output + (28)                      White: Output - (27) Yellow: sense + (82.1)                      Green: sense - (81.1)</p> <p>Black/yellow: shielding Purple/brown: temperature sensor Pt100</p> <p>(Not connected sense line – lines have to be insulated)</p>						

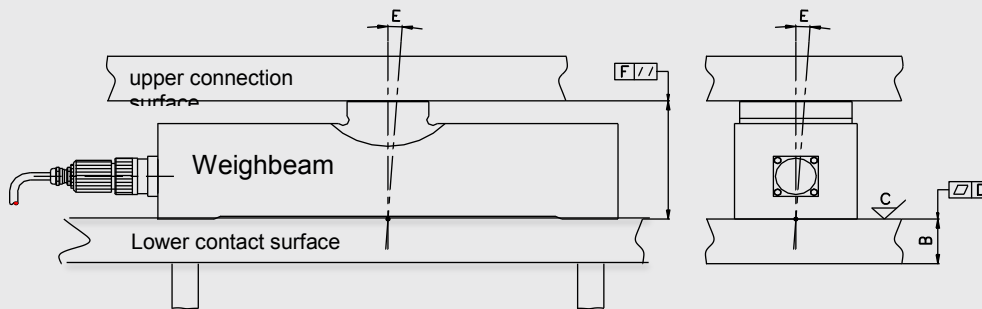
\*) in isothermic state

## Requirements of the Quality of both Contact Surfaces

### WB 40 t



### WB 50 t ... 600 t



- **Material selection "A"**: Construction steel is used of at least S355 grade must be used.
- **Operating thickness "B"**: This depends on the stiffness of the overall construction. The operating thickness of the connect surfaces must be at least 40% of the the weighbeam height.
- **Surface quality "C"**: The average peak-to-valley height required of the contact surfaces is 6.3  $\mu\text{m}$ .
- **Flatness "D"**: The maximum permissible flatness tolerance of each contact surface is 0.05 mm.
- **Angle error to the vertical axis "E"**: The permitted maximum value for the angle deviation of the contact surface to the vertical axis is  $\pm 2^\circ$  in both planes.
- **Plane parallelism "F"**: The upper and lower contact surfaces to the weighbeam must be plan parallel to each other within at least 0.1 mm.

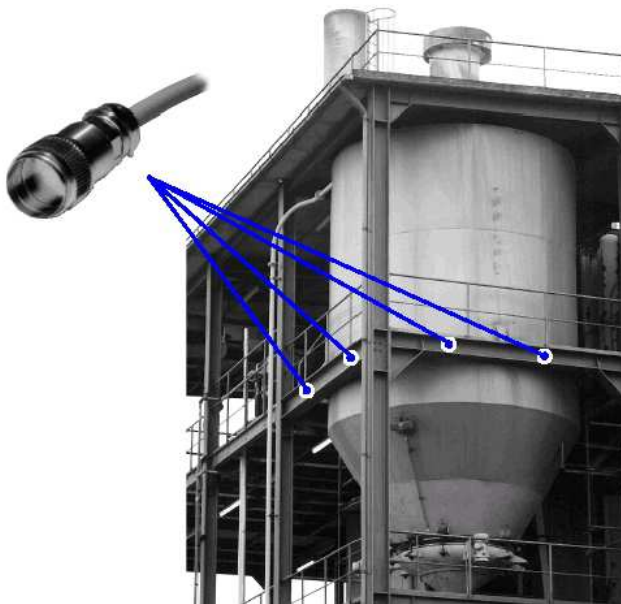
## Order Numbers

Design	Order number with straight plug outlet (see drawing above)	Order number with lateral plug outlet on the right (cf. page 5) *)
WB 40 t	V711375.B03	V758596.B01
WB 50 t	V711375.B13	V758596.B11
WB 100 t	V711375.B23	V758596.B21
WB 150 t	V711375.B33	V758596.B31
WB 200 t	V711375.B43	V758596.B41
WB 600 t	V711375.B53	V758596.B51
<u>Spare part:</u> Connecting cable 15 m with plug connection	V090162.B01	—

\*) Plug outlet in the other direction possible on request



## Measuring Eye, DMA Type



- **Compact sensor for measuring forces and masses**
- **Same sensor geometry for all load ranges**
- **Maintenance-free**
- **Hermetically sealed design, protection class IP68**
- **High corrosion protection through use of stainless steel**
- **Easy retrofit of existing silo structures**
- **No contact between sensor and material to be weighed**
- **ATEX categories**  
 II 2G Ex ib IIC T6 Gb,  
 II 2D Ex tb IIIC T85 °C Db  
 II 3G Ex nA IIC T6 Gc
- **IECEX**

### Application

The DMA measuring eye has been particularly designed for use as low-priced hopper level measuring system.

With very little effort it can be retrofitted into existing structures permitting gravimetric level measurement.

Other possible applications are, for instance, pre-assembled measuring supports or beams as well as threshold messages for cranes.

### Construction

The DMA measuring eye is made of stainless steel. The knurled pressing-in area on circumference transmits the deformations of the supporting structure to a web equipped with strain gauges.

Measuring body and cable outlet are connected by laser welding which produces a hermetical sealing effect.

### Function

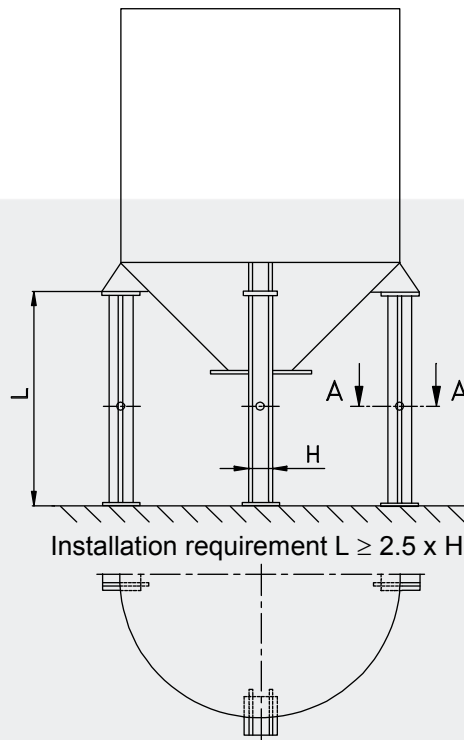
The DMA measuring eye is pressed into the supporting structure of the construction to be weighed.

When the supporting structure is loaded, the resulting deformations generate a voltage change proportional to applied load.

**The following types of measuring eyes are available**

- **DMA-V:**  
Standard measuring eye with complete strain gauge full bridge
- **DMA-H:**  
Special variant with strain gauge half bridge (if more than 4 measuring eyes/system are used)
- **DMA-V-ÜS:**  
Measuring eye with complete strain gauge full bridge and additional overvoltage protection, e.g. for use in railway tracks
- DMA-V, DMA-V-ÜS and DMA-H are also available as **ATEX and IECEx version**

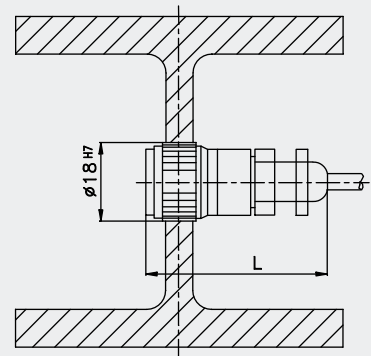
**Typical applications**



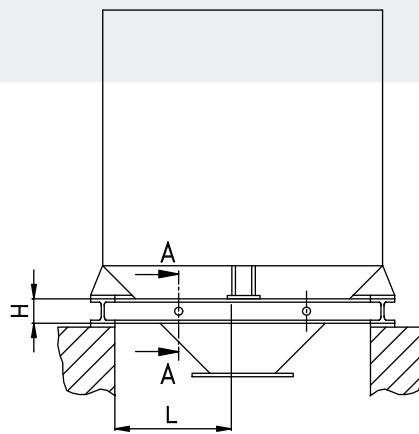
**Normal force measurement**

Measuring eye mounted on vertical silo supports

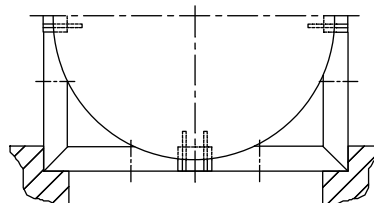
**Section A-A**



Variant	L
DMA-V DMA-H	46
DMA-V-ÜS	62
DMA-V-Ex DMA-H-Ex	71



Installation requirement  $L \geq 1.5 \times H$



**Lateral force measurement**

Measuring eye mounted on horizontal silo supports



## Technical Data

The technical data apply to one DMA-V measuring eye or a pair of DMA-H measuring eyes (combined to form a Wheatstone bridge).

		DMA-V or 2x DMA-H		ATEX-Variant
Measuring principle		Normal force measurement	Lateral force measurement	
Required rated stress	$\sigma, \tau$	$\sigma \geq 30 \text{ N/mm}^2$	$\tau \geq 15 \text{ N/mm}^2$	$\sigma, \tau$ , see left side
Sensitivity at required rated stress	$C_n$	$\geq 0.3 \text{ mV/V}$		
Input resistance	$R_e$	380 $\Omega$		1060 $\Omega$
Output resistance	$R_a$	350 $\Omega$		1000 $\Omega$
Ref. supply voltage	$U_{sref.}$	10 V		
Max. supply voltage	$U_{smax.}$	12 V		
Rated temperature range	$B_{tn}$	-10 °C ... +40 °C		
Service temperature range	$B_{tu}$	-30 °C ... +80 °C	-20 °C ... +60 °C	
Storage temperature range	$B_{ts}$	-40 °C ... +85 °C		
Zero signal temperature coefficient	$TK_o$	$< 1.5 \mu\text{V} / \text{V} / 10 \text{ K}$		
Material		Stainless steel		
Weight with cable		0.6 kg		
Protection class		IP68 (laser-welded)		
Cable standard		PVC cable $\varnothing 5.4 \text{ mm} \times 15 \text{ m} / -30 \text{ °C} \dots +85 \text{ °C}$		
Cable Ex		TPE cable $\varnothing 6,5 \text{ mm} \times 15 \text{ m} / -40 \text{ °C} \dots +120 \text{ °C}$		
Connection assignment		Black: input + 82	/	blue: input - 81
		Red: output + 28	/	white: output - 27
		Black-yellow: screen		

System and switching accuracies depend on several factors, e.g. hopper geometry, installation site and measuring task. Typically, system accuracies of  $\pm 0.5 \%$  for lateral force measurement and  $\pm 1.5 \%$  for normal force measurement can be obtained. The switching accuracies for preset fill levels (setpoints) are approx.  $\pm 0.2 \%$  (each related to full scale).

These accuracies require highly qualified engineering and proper and workmanlike installation.

## Projection notes

To determine whether an existing hopper can be retrofitted with Schenck Process measuring eyes, calculate the rated stress as under:

- **Normal force measurement (required rated stress  $\sigma \geq 30 \text{ N/mm}^2$ )**

$$\text{Rated stress } \sigma \text{ in } [\text{N/mm}^2] = \frac{(\text{Mass of hopper contents in } [\text{kg}]) \times 10}{(\text{Number of supports}) \times (\text{supports cross-sectional area in } [\text{mm}^2])}$$

- **Lateral force measurement (required rated stress  $\tau \geq 15 \text{ N/mm}^2$ )**

$$\text{Rated stress } \tau \text{ in } [\text{N/mm}^2] = \frac{(\text{Mass of hopper contents in } [\text{kg}]) \times 10}{(\text{Number of cross members}) \times 2 \times (\text{cross member area in } [\text{mm}^2])}$$

Variants	Ordering No.
<b>DMA-V</b> Measuring eye with strain gauge full bridge	D 705 336.01
<b>DMA-V-Ex (intrinsically safe)</b> <b>II 2G Ex ib IIC T6 Gb</b> Measuring eye with strain gauge full bridge for use in ATEX/IECEX	D 724 987.02
<b>DMA-V-Ex (not intrinsically safe)</b> <b>II 3G Ex nA IIC T6 Gc and II 2D Ex tb IIIC T85 °C Db</b> Measuring eye with strain gauge full bridge for use in ATEX/IECEX	D 724 987.03
<b>DMA-V-ÜS</b> Measuring eye with strain gauge full bridge for use in railway tracks	D 705 336.08
<b>DMA-V-ÜS-Ex (intrinsically safe)</b> <b>II 2G Ex ib IIC T6 Gb</b> Measuring eye with strain gauge full bridge for use in ATEX/IECEX and overvoltage protection	D 724 987.10
<b>DMA-V-ÜS-Ex (not intrinsically safe)</b> <b>II 3G Ex nA IIC T6 Gc and II 2D Ex tb IIIC T85 °C Db</b> Measuring eye with strain gauge full bridge for use in ATEX/IECEX and overvoltage protection	D 724 987.11
<b>DMA-H</b> Measuring eye with strain gauge half bridge	D 705 226.01
<b>DMA-H-Ex (intrinsically safe)</b> <b>II 2G Ex ib IIC T6 Gb</b> Measuring eye with strain gauge half bridge for use in ATEX/IECEX	D 724 988.01
<b>DMA-H-Ex (not intrinsically safe)</b> <b>II 3G Ex nA IIC T6 Gc and II 2D Ex tb IIIC T85 °C Db</b> Measuring eye with strain gauge half bridge for use in ATEX/IECEX	D 724 988.03
<b>DMA-V, 0.1 mm oversize</b> Spare part for exchanged DMA-V	V030174.B01
<b>DMA-V-ÜS for MULTIRAIL, 0.1 mm oversize</b> Spare part for exchanged DMA-V-ÜS	V030174.B03
<b>DMA-H, 0.1 mm oversize</b> Spare part for exchanged DMA-H	V030174.B02
<b>DMA-V-Ex, 0.1 mm oversize (intrinsically safe)</b> <b>II 2G Ex ib IIC T6 Gb</b> Spare part for exchanged DMA-V-Ex	V030174.B04
<b>DMA-V-Ex, 0.1 mm oversize (not intrinsically safe)</b> <b>II 3G Ex nA IIC T6 Gc and II 2D Ex tb IIIC T85 °C Db</b> Spare part for exchanged DMA-V-Ex	V030174.B05
Mounting kit for pressing-in measuring eyes	D 705 046.01
<b>Suitable for junction box</b> , refer to data sheet BV-D2121	
Closing device to protect measuring eyes against mechanical damage (not for type DMA-V-ÜS)	D 705 968.01
Manual DK1 206 DE, German Manual DK1 206 GB, English Manual DK1 206 FR, French Manual DK1 206 RU, Russian	D 707 200.01 D 707 204.01 D 707 200.02

## INTECONT® Satus, Indicator for Beltscales



- Clear text operator guidance on back lighting LCD display
- Stainless steel housing – at a high protection class
- Table-top or wall mounting
- Various fieldbuses
- Ethernet interface, can also be used for configuration
- All components can be exchanged without recalibration

### Application

The indicator INTECONT Satus is designed for applications using stand-alone belt weigher MULTIBELT® with on-site electronics.

By focusing primarily on the necessities the INTECONT Satus represents a very attractive, simple and modern device on the market.

### Equipment and functionality

The indicator for beltscales INTECONT Satus VKG 20790 has a standard stainless steel console shaped case in protection class IP65 that is suited for table-top and wall mounting.

The indicator has an easily readable back lighting LCD display for showing measured values with clear text operator guidance. Data is keyed in via flexible membrane keyboard with 6 keys.

All INTECONT Satus parameters can be configured very easy by using the PC program EasyServe.

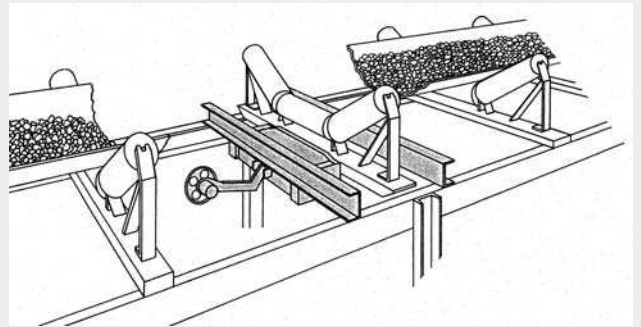
The parameters are stored using the load cell dongle technology and therefore are available even after replacement of the main board.

Since Ethernet is increasingly becoming the communication standard even in industry, INTECONT Satus has a standard 10/100 Mbaud network connection. Also the well-established Modbus.

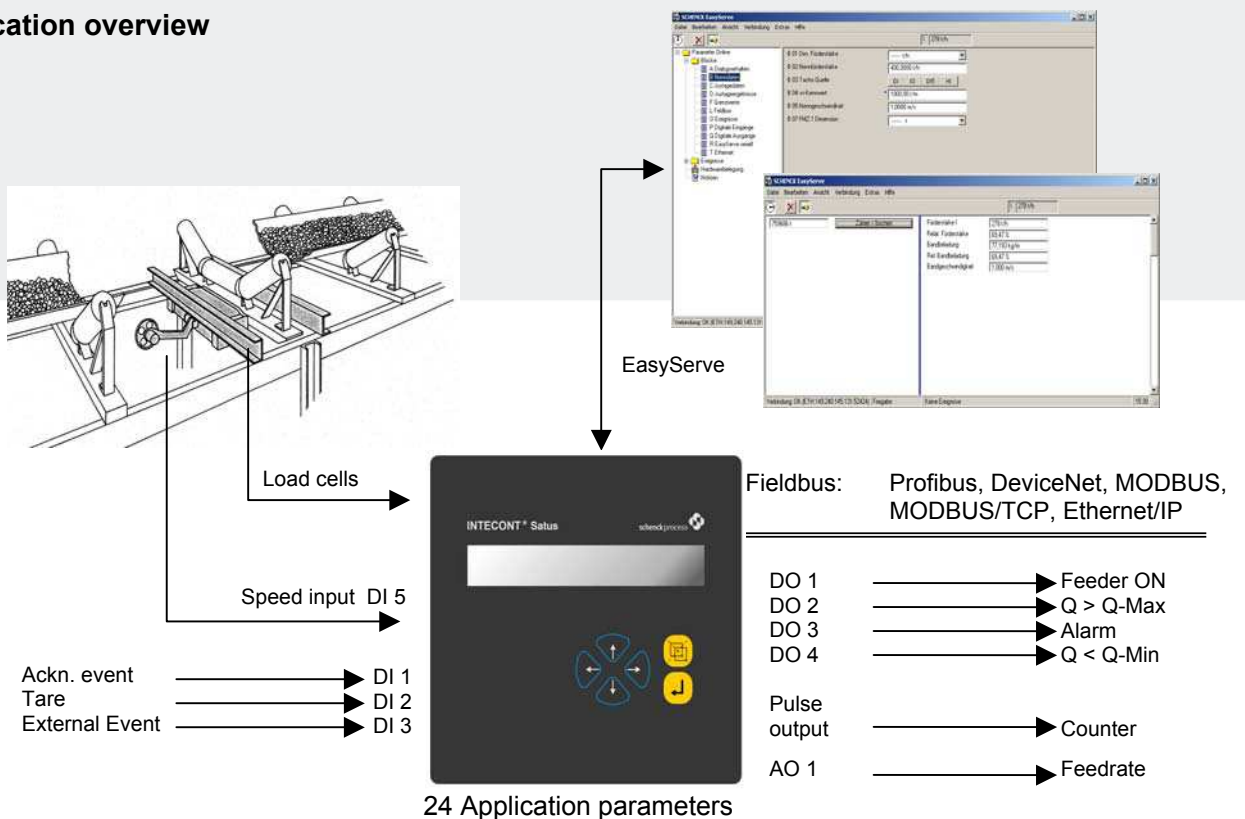
Optional fieldbus protocols for Profibus DP-V0, DeviceNet, Ethernet MODBUS/TCP and Ethernet/IP are available.

## Belt weigher application

- On site assembly possible
- Simple and easy commissioning
- Automatic measuring of bulk solids flow
- Totalizing counter
- Belt load monitoring
- Zero-drop-out (no totalizing if belt load is too low, empty belt)



## Application overview

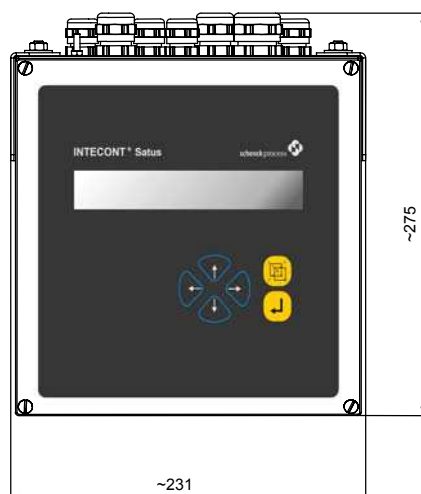


## INTECONT Satus

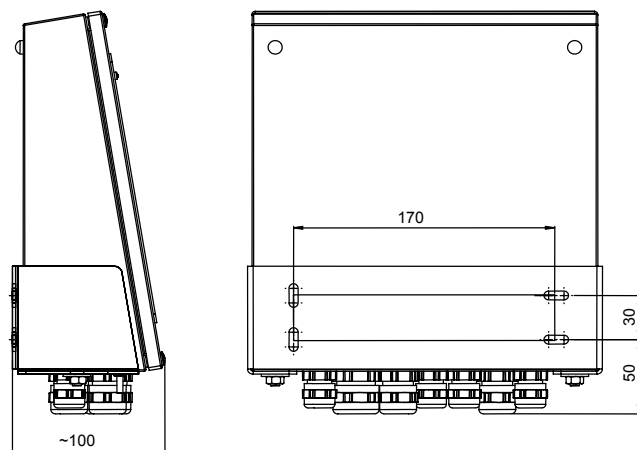
- Stainless steel housing with a high protection class
- All connections are tied up to special functions
- All components can be exchanged without reverification
- Functionality self explaining: simple and easy commissioning
- Minimized complexity: only necessary parameters have to be adapted
- 6 keys sufficient for data input and control
- Preloaded menu languages: German, English, French, Spanish, Italian
- PC-based service program EasyServe; to be connected serial or via Ethernet
- Serial connections on board: MODBUS; Ethernet with MODBUS/TCP protocol
- Optional fieldbus protocols: Profibus DP-V0; DeviceNet; Ethernet with protocol Ethernet/IP



### Table-top mounting



### Wall mounting



## Technical data

<b>View</b>	LCD back lighting. 1 cell 20 characters. Characters 12 mm high	
<b>Keyboard</b>	6 keys	
<b>Supply voltage</b>	85 - 240 VAC, 50 - 60 Hz, max. 10 VA, Variant 24 VDC	
<b>Housing</b>	Stainless steel 1.4301, deep drawn, IP65	
<b>Temperature range</b>	Service temperature: -30 °C ... +60 °C	
<b>Measuring circuit</b>	Supply voltage:	5 V alternating current supply
	Range:	-20 mV ... +20 mV;
	Load cell impedance:	R min 47 Ω
	Cable length:	max. 1000 m
<b>Units</b>	kg, t, lb; kg/h, t/h, lb/h;	
<b>Taring</b>	to be started via digital input or keyboard	
<b>Belt monitoring</b>	zero-drop-out; Belt load > max / < min	
<b>Binary inputs</b>	3 x Optocoupler, 18 - 36 VDC, typ. 5 mA	<b>assigned signal</b>
		Ack. event
		Tare
		External event
	1 x NAMUR, max. 5 V, 0,04 - 3000 Hz	Tacho input
<b>Binary outputs</b>	4 x relay, 230 VAC, max. 60 W	Running
		Belt load Q > Max
		Alarm
		Belt load Q < Min
<b>Pulse output</b>	Optocoupler, 18 - 36 VDC, max. 50 mA / 10 Hz	Totalizing counter pulses
<b>Analog output</b>	0(4)-20 mA, 12 Bit, max. imp. 500 Ω	Feedrate
<b>Serial connections</b>	Interface 1: RS 232	EasyServe
	Interface 2: RS 232	- not used -
	Interface 3: RS 485, 2/4-wire	MODBUS Fieldbus
	Ethernet	MODBUS/TCP Fieldbus
<b>Optional</b>	PROFIBUS DPV0, DeviceNet, Ethernet/IP	

## Equipment supplied

Systems	Type	Material number
INTECONT® Satus, Stainless steel housing IP65	VKG 20790	V040007.B11
INTECONT® Satus with Profibus Fieldbus card	VKG 20792	V060127.B11
INTECONT® Satus with DeviceNet Fieldbus card	VKG 20793	V060128.B11
INTECONT® Satus with Ethernet/IP Interface	VKG 20795	V060129.B11
INTECONT® Satus, Stainless steel housing IP65, 24 VDC	VKG 20796	V084590.B11
INTECONT® Satus with Profibus Fieldbus card, 24 VDC	VKG 20797	V084720.B01
INTECONT® Satus with DeviceNet Fieldbus card, 24 VDC	VKG 20798	V084721.B01
INTECONT® Satus with Ethernet/IP Interface, 24 VDC	VKG 20799	V084722.B01
<b>Options</b>		
Profibus Fieldbus card	VPB 8020	V054033.B01
DeviceNet Fieldbus card	VCB 8020	V081906.B01
Ethernet/IP activating	VET 20700	V040035.B01
<b>Spare parts</b>		
Load cell plug (dongle)	VDO 20700	V040013.B01
<b>EasyServe</b>		
Software (CD)	VPC 20150	E144541.01
Cable for EasyServe, 9p/3p		V052410.B01

# INTECONT<sup>®</sup> Tersus

## Mass flow rate measurement

- Maximum reliability
- Legal-for-trade ability accuracy
- Automated commissioning and adjustment
- Cost-effective compact system



### Application

The INTECONT<sup>®</sup> Tersus control electronics are used specifically in technical weighing tasks in continuous process sequences.

It is conceived for recording highly accurate bulk solids flows.

#### Application

- MULTIBELT<sup>®</sup> belt weighers (also able for legal-for-trade)
- MULTISTREAM<sup>®</sup> solids flow meters
- MULTICOR<sup>®</sup> coriolis mass flow meters

Custom models are for applications in explosion hazard areas.

The control electronics is primarily for cases where the operator needs convenient and comprehensive display, control and monitoring functions in the electronics themselves - in addition to the basic technical measuring functions.

Proven industrial quality guarantees a long lifetime and high levels of accuracy.

### Equipment

The electronics are supplied as a front-of-panel unit or with a wall-mounted housing for installation on site. The controls are

operated using ergonomic menus – divided into operation and service functions. Measured values and additional information are available from the colored LCD display.

Fitted with the corresponding communication module, the INTECONT<sup>®</sup> Tersus connects optimally via fieldbuses to automation structures. The Ethernet network connection is included in the standard features.

### Function

The functions of the INTECONT<sup>®</sup> Tersus differ depending on the scale type. However, the standard features are always the same:

- Device accuracy for weighing tasks better than 0.05 %
- Manual and/or automatic zeroing
- Rough/fine controls for precise backlash
- High electromagnetic compatibility
- Galvanically separated exits
- Feed quantity impulses
- Power fail safe data storage device
- Integrated diagnostic and self-test functions
- Dialog language in German, English, Italian, Spanish and French or other loadable languages, including Chinese or Russian (Cyrillic)



- Factory settings for easy, quick connection
- Automatic adjustment programs, self-starting taring
- Maintenance-interval input with signalisation
- Status, event, adjustment and quantity protocols
- Simulation operation for test and learning purposes possible

### Scale-specific functions

The actual feedrate is calculated corresponding to the mechanics used:

- Belt load and belt speed for belt weighers
- Reaction force for solids flow meters
- Direct mass current measurement using coriolis force for mass flow meters

Alongside the extensive standard features, the following scale-specific characteristic features are realized:

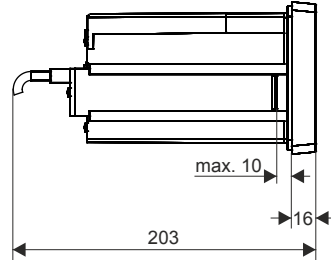
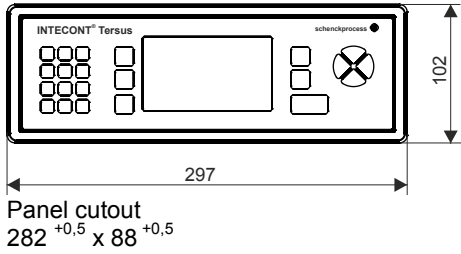
- Belt weighers
  - Precise belt speed measurement
  - Belt influence compensation (BIC)
  - Monitoring of the belt creep and belt loop creep
  - Movement of the weighing at the discharge point
  - Legal-for-trade ability Eichfähigkeit (please request separately)
- Solids flow meters
  - Adjustment to different measuring chute characteristic curves
- Coriolis mass flow meters
  - Precise rotational speed and torque measurement

## Technical data

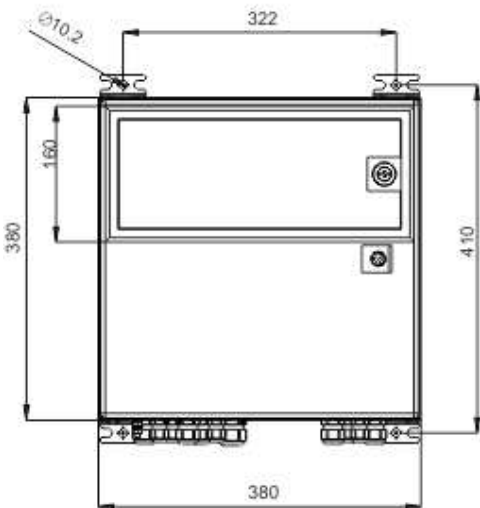
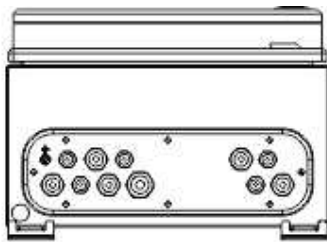
<b>Display</b>	LCD graphic display with adjustable brightness
<b>Keyboard</b>	22 buttons
<b>Supply voltage</b>	24 VDC +50 % / -25 %, max. 20 VA
<b>Temperature range</b>	Operation temperature: Standard device: -25 °C ... +60 °C Able for legal-for-trade and ATEX device: -20 °C ... +40 °C Storage temperature (all devices): -40 °C ... +80 °C
<b>Scales connection</b>	Power supply: 12 V alternating voltage Load cell impedance: $R_{min.}$ 80 $\Omega$ Cable length: max. 1000 m
<b>Housing</b>	Operating panel rack model IP54, optional bracket for IP65 Protect keyboard and display against longer, direct sunlight.
<b>Binary inputs</b>	5 x optocouplers 18 ... 36 VDC, type 5 mA 1 x NAMUR and 1 x NAMUR/voltage 0.04 ... 3,000 Hz
<b>Binary outputs</b>	8 x relays, max. 230 V, 8 A ohm / 1 A inductive
<b>Impulse output</b>	1 optocoupler for totalizing counter 24 V, 0.1 A, max. 10 Hz
<b>Analog outputs</b>	2 x 0(4) ... 20 mA, load max. 500 $\Omega$ , galvanically isolated
<b>Analog input</b>	Current 0(4) ... 20 mA, input impedance 100 $\Omega$ , galvanically separated, or voltage 0 ... 10 V
<b>Serial interfaces</b>	Interface 1: EasyServe / Interface 2: Printer / Interface 3: Large display
<b>Power supply VNT0650 internal (optional)</b>	85 ... 264 VAC / 24 VDC
<b>Fieldbus (optional)</b>	Can be selected from: Modbus-RTU, PROFIBUS DP, DeviceNet, Modbus-TCP, EtherNet/IP, PROFINET IO
<b>Analog signal card (optional) VEA0451</b>	2 Analog outputs 0(4) ... 20 mA, load max. 500 $\Omega$ , galvanically isolated, common potential 2 analog inputs 0(4) ... 20 mA, input impedance 100 $\Omega$ galvanically isolated, common potential
<b>ATEX</b>	Optional approval for use in explosive atmosphere (zone 22) at front



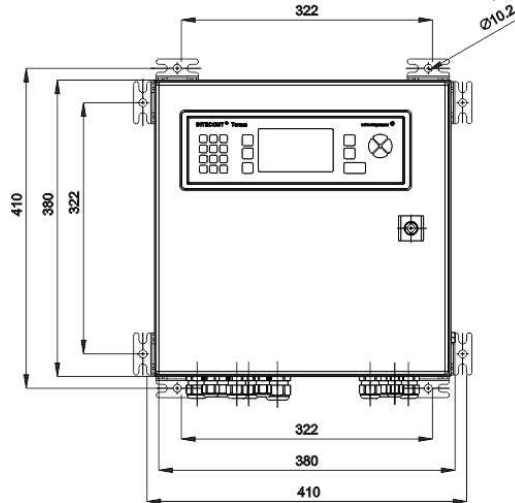
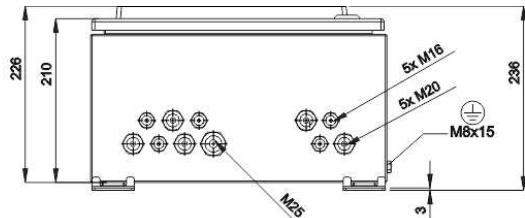
Front-of-panel unit



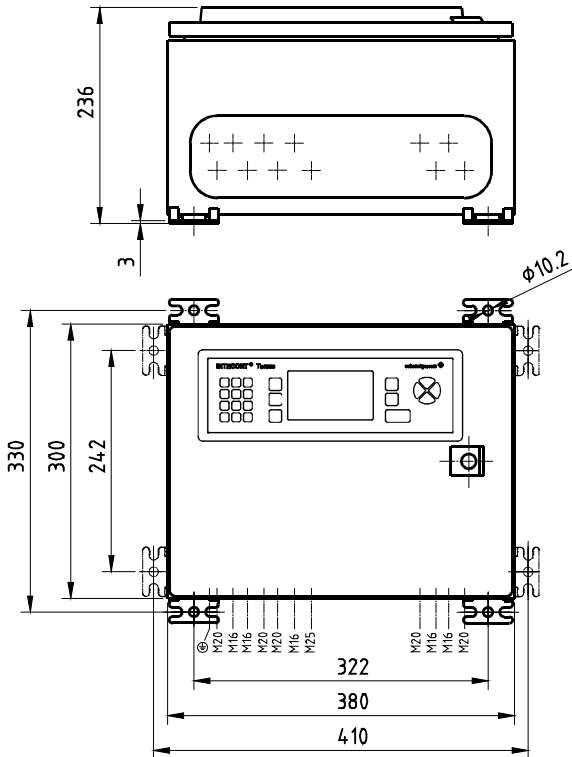
Wall-mounted housing with inspection window



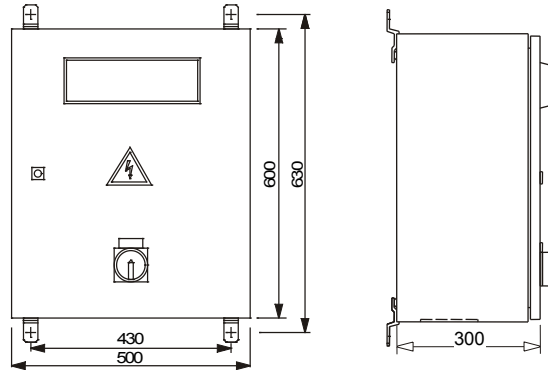
Stainless steel housing (Ex-zone 22)



### Wall-mounted housing standard



### Wall-mounted housing for expansions



## Type code

ITE:	aa.	bb.	cc.	dd.	ee.	ff
Product name	Software	Housing	Fieldbus	Input/output extension	Power supply	Proximity sensors supply
INTECONT® Tersus						
	BW: Belt weigher BWLFT: Legal-for-trade belt weigher MC: Coriolis mass flow meter IF: MULTISTREAM solids flow meter					
	EG: Panel mount unit EG3D: Panel mount unit for frontal installation in EX zone 22					
	0: Standard Modbus TCP SS: Modbus-RTU PB: PROFIBUS DP PN: PROFINET IO CB: DeviceNet EI: EtherNet/IP					
	0: No extension EA: Extension VEA0451					
	0: No internal power supply NT: Internal power supply VNT0650					
	No specification: Standard [3G] [3D] Ex-i: Ex-i-supply for sensors in EX zone 2 or 22					

## Extensions, accessories

<b>Wall-mounted housing</b>	Wall-mounted housing IP65 incl. power supply 85 ... 264 VAC / 24 VDC Optional lockable window available for the display and keyboard or in a stainless steel version
<b>Power supply, external, desk-top model</b>	85 ... 264 VAC / 24 VDC
<b>Event printer</b>	Printer with serial RS232 interface and system cable
<b>Large display</b>	Selectable from: VLD 20100 (LED, 100 mm); VLZ 20045 (LCD, 45 mm); VLZ 20100 (LCD, 100 mm)
<b>Control cabinets and device frames</b>	Control cabinets and device frames for multiple INTECONT® Tersus with or without infeed

## Accessories

Description	Type	Material number
Fieldbuscommunication modules		
Modbus-RTU	VSS 28020	V081902.B01
PROFIBUS DP (Slave)	VPB 28020	V081901.B01
DeviceNet	VCB 28020	V081903.B01
EtherNet/IP activation	VET 20700	V040035.B01
PROFINET IO (Slave)	VPN 28020	V097103.B01
Further Options		
Installed power supply	VNT0650	V082050.B01
Analog signal card with 2 analog inputs and 2 analog outputs	VEA 20451	V054098.B01
Operating panel installation kit for protection class IP65 for device front		V082039.B01
Service software		
EasyServe	VPC 20150	E144541.01
Large displays		
Large 5-digit display, LED, 100 mm digit height	VLD 20100	V090252.B01
Large 6-digit display, LCD, 45 mm digit height	VLZ 20045	V067304.B01
Large 5-digit display, LCD, 100 mm digit height	VLZ 20100	V066611.B01



## DISOCONT® Tersus Measurement, Control and Supervisory System



- Tailored by modules as needed
- Product line for MechaTronic scales; a synthesis of mechanics, electrics and software
- Installation close to feeder in field enclosure or in control cabinet
- Reduced engineering planning and wiring costs
- Commissioning and diagnostics supported by graphics
- Optimal communication structures because of modular fieldbus technology
- Wireless access for service

### Application

DISOCONT Tersus is a system in modular design for controlling of continuous weighing and feeding applications. It is used wherever bulk solids flow has to be measured, fed or batched with the use of

- Loss-in-weight feeders (measuring/feeding)
- Weighfeeders
- Mass flow meters and feeders
- Solids flow meters and feeders
- Belt weighers
- Screw feeder
- Weighing hoppers

The DISOCONT Tersus - electronics are preferably integrated locally into the scale mechanics. So self-contained function units will be created - the MechaTronic scales - which offers numerous advantages:

- Reduced engineering because of minimal number of interfaces; only one unit has to be planned in
- No control cubicle
- Reduced cabling; only power and data cables have to be run

- At a glance - easy service because of the combination of mechanics and electronics

For special applications the DISOCONT Tersus-electronics may be conventionally installed in a control cubicle. Via the Ethernet interface included in the standard or equipped with a suitable fieldbus interface DISOCONT Tersus fits optimal into automation structures in the plant.

### Equipment

The DISOCONT Tersus electronics consist of a system unit VCU and multiple optional expansion units. Its modular design enables the requisite units to be combined for a specific application, at a most cost effective price.

- Central unit VCU for all measurement and control functions with interface to operator panels and extension units
- EasyServe-PC-program for commissioning and service

- Fieldbus communication modules plugged into system unit for transfer of all relevant data to the user's control and scale control system
- Additional VCU-unit for conventional connection to user's control system and expanded control of the scale environment
- Operator panel with graphical display and touch for operation of the scale and/or parameterization
- Integrated web server for service access
- Group control unit-operation, survey and control of scale groups, as shown in separate spec sheet
- Access via LAN, WLAN and Bluetooth

The internal DISOCONT Tersus communication bus permits a flexible arrangement of the units, locally or in cabinets. All modules can be replaced with no need for recalibration and reconfiguration.

The System includes housing options for installation at site and in control cubicles.

## Technical features for all weighing and feeding systems

- System accuracy for scales better than 0,05 % (DIN EN 61143-1); Resolution of the weight signal: 24 million parts
- galvanically isolated inputs/ outputs
- power fail save data storage
- factory presettings for easy and quick commissioning
- various languages loadable/ transferrable
- status, event, calibration, and batch reports
- Batch control with adaptive cut-off curve
- Integrated diagnostics and self testing functions (SPC)
- Simulation mode for testing and learning

### Functions

DISOCONT Tersus is designed to acquire the actual feed rate [kg/h, t/h] via

- belt load and belt speed for belt weighers MULTIBELT
- changes in weight of material in weigh hopper per unit of time for loss-in-weight feeders
- reactive force for solids flow meters MULTISTREAM
- direct mass flow measurement using the Coriolis force for mass flow meters MULTICOR
- the load of the feeding screw with automatic calibration via a check hopper for screw feeders type MultiFlex

With **feeding** applications, the control deviation is acquired by feed rate set/actual comparison. Depending on type of scale, DISOCONT Tersus routes a control signal to

- speed-controlled weighfeeder drive or the drive of the feed helix
- controllable loss-in-weight feeder discharge unit
- controllable solids and mass flow feeders' prefeeders

The control circuit exactly controls the actual feed rate for conformity with setpoint.

In batching mode, DISOCONT Tersus feeds a preset amount of material and automatically stops feeding at the end of a batch. System uses batch results for automatic self optimization.

### Scale Specific Functions

Depending on the software loaded for the different types of scales and feeders, the following functions are available:

- With belt weighers and weighfeeders:
  - Accurate belt speed measurement
  - Belt run monitoring
  - Shifting of control for weighing/feeding to point of discharge
  - Belt influence compensation (BIC)
  - Complete control of scales peripheral devices

- Auto-calibration (automatic calibration programs), self-starting taring
- Block control with weighfeeders leads to constant belt load realized by pre-feeder control
- On Stream calibration
- With solids flow meters and feeders:
  - Adaption to different measuring chute characteristics
  - Manual and automatic zeroing
  - On Stream calibration
- With mass flow meters and feeders:
  - Accurate speed and torque measurement
  - Manual and automatic zeroing
  - Highly constant feeding
  - On Stream calibration
- With Loss-in-Weight feeders (measuring and feeding):
  - Adaptive FUZZY interference peak elimination
  - Automatic correction of material flow properties during filling
  - Highly constant feeding
  - sets of parameters for quick adaptation on different bulk solids
  - Setup programs for fast change of bulk material
- With Sequential batching:
  - Sequence of up to 10 material types
  - Adaptive feed control
- With Screw feeders:
  - Individual measurement of up to three load points
  - Feeding with high constancy
  - On Stream calibration

## DISOCONT Tersus Component-Overview

Type hardware	Functions
<b>VCU 20100</b>	Central control electronic, minimum 1 x per system Optional extension via up to 2 additional VCU
<b>VAI 20100</b>	Extension by one analogue input channel
<b>VAO 20100</b>	Extension by one analogue output channel 0(4) ... 20 mA
<b>VAO 20103</b>	Extension by one analogue output channel 0 ... 10 V
<b>VME 20102</b>	Extension by one load cell interface channel
<b>VFG 20103/ VFG 20104</b>	VCU for field housing
<b>VEG 20100</b>	VCU for cabinet enclosure
<b>VHM 20100</b>	Operator panel for control panel mounting with supply by VCU 20100
<b>VHM 20101</b>	Operator panel for control panel mounting with separate power supply
<b>VHM 20110</b>	Handheld operator panel with cable
<b>VHM 20121</b>	Wireless handheld operator panel
<b>VPB 28020</b>	PROFIBUS Interface
<b>VPN 28020</b>	PROFINET IO Interface
<b>VSS 28020</b>	Modbus Interface
<b>VCB 28020</b>	DeviceNet Interface
<b>VPC 20150</b>	Service-Software EasyServe for PC
<b>VMO or VLG</b>	Optional local motor control unit
	Bluetooth Adapter for the VCU

Type Software for VCU 20100	Functions
<b>VBW 20170</b>	Beltweighers MULTIBELT
<b>VWF 20170</b>	Weighfeeders MULTIDOS
<b>VLW 20170</b>	Loss-in-Weight Feeder MechaTron, ProFlex, PureFeed
<b>VIF 20170</b>	Solids flow meters and feeders MUTISTREAM
<b>VMC 20170</b>	Mass flow meters and feeders MULTICOR
<b>VBC 20170</b>	Multi ingredient batch feeding
<b>VSF 20170</b>	MULTIFLEX screw feeder
<b>VIO 20170</b>	Input/output extension unit VCU

Optional control of a group of scales in accordance with the separate data sheet DISOCONT Master running in separate process computer hardware.

## Technical Data

### DISOCONT Tersus System unit VCU 20100

<b>Standard Inputs*)</b>	Load cell input ±6 V, $R_i > 87 \Omega$ , 2 NAMUR-Inputs 0.03 ... 3000 Hz for speed or belt sensor, flap limit switches, 5 Isolated, digital inputs 24 V, 20 mA, save isolation
<b>Optional Inputs*)</b>	Additional load cell input Up to 2 analogue input channels 0(4) ... 20 mA / 0 ... 10 V
<b>Standard Outputs*)</b>	1 isolated analogue output 0(4) mA ... 20 mA, max. 11 V, 6 relay outputs 230 V / 1 A save isolation, 1 relay output 230 V / 1 A with base isolation, Open collector output for external totalizer 30 VDC / 50 mA
<b>Optional Outputs *)</b>	Up to 2 analogue outputs 0(4) ... 20 mA or 0 ... 10 V
<b>Serial interfaces</b>	4 Ethernet RJ45 Interface for operator panel local bus Interface for extension units VCU Connection EasyServe RS232 Optional: 1 x Fieldbus plug in module
<b>Power supply</b>	24 VDC ±20 %; 110 V ... 230 V -20 % +10 % 50 Hz or 60 Hz; 35 W
<b>Ambient temperature</b>	-25 °C ... +50 °C outside of the housing
<b>Protection class</b>	IP20
<b>Approbation</b>	CE; In preparation: UL, ATEX

\*) Logical signals are freely configured for physical in-/outputs.

### Field housing VFG 20103 or 20104 for VCU 20100

<b>Material</b>	Fibre enforced plastics
<b>Dimensions [mm]</b>	260 x 160 x 90
<b>Protection classes</b>	Protection class IP65 (IEC 60529), NEMA4-Typ

### Control Cubicle Housing VEG 20100 for VCU 20100

<b>Material</b>	Stainless steel
<b>Dimensions [mm]</b>	250 x 146 x 98 For installing an DIN top-hat-rail or for wall mounting
<b>Protection classes</b>	IP20 (IEC 60529)

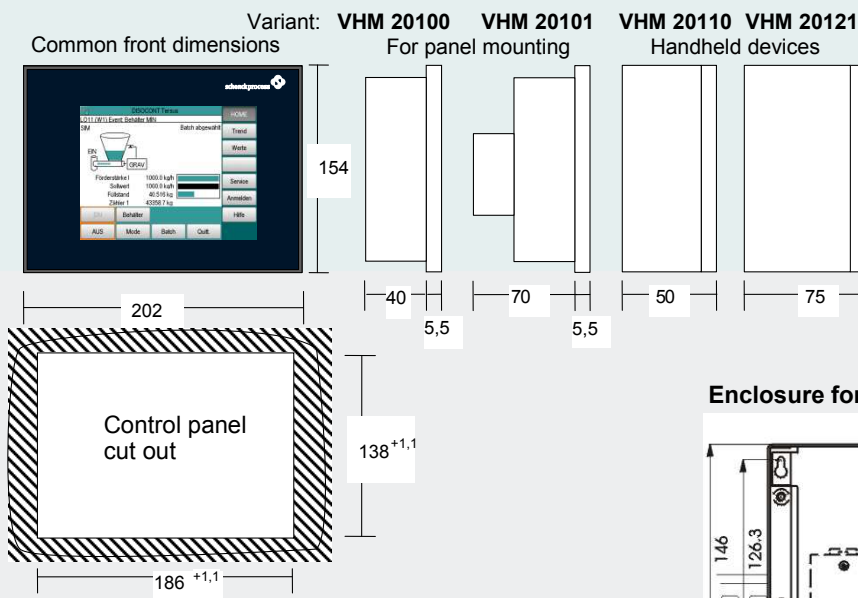
### DISOCONT Tersus operator panel VHM

VHM	20100	20101	20110	20121
Display [mm]	TFT colour display 115 x 89			
Input	Touch for pen and glove operation			
Power supply	24 VDC 4 W	110 ... 230 VAC, 10 W	24 VDC 4 W	Battery, charger 110 ... 230 VAC 10 W
Ambient temperature	-15 °C ... +50 °C			
Dimensions [mm] W x H	202 x 154			
Depth [mm]	45,5	75,5	50	75
Protection class front back	IP65 IP20	IP65 IP20	IP65	IP65
Interfaces	Ethernet RJ45 and local bus			
Approbation	CE Optional: UL, ATEX			

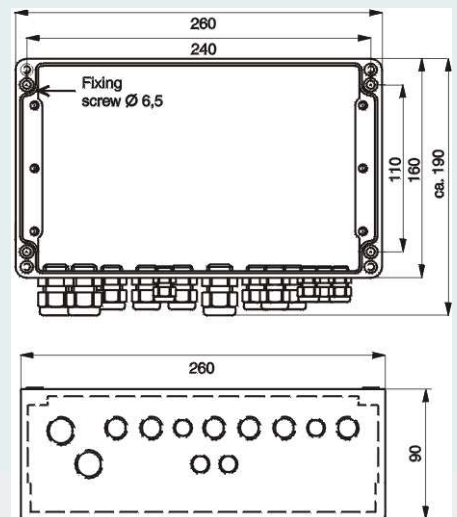
### Option Fieldbus- interfaces to plant control

Quantity	Maximum one in main-VCU
Type	PROFIBUS DP-V2 PROFINET IO Ethernet Modbus-TCP EtherNet/IP DeviceNet Modbus RS232/RS422/RS485
Data	All process variables All parameters and configuration Via web server: Logged process data

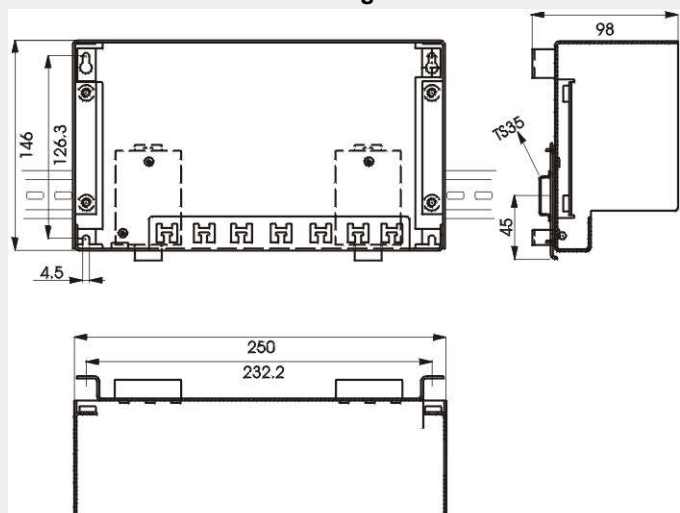
### Dimensions of the DISOCONT Tersus Operator Panel versions



### Field housing VFG 20103/20104



### Enclosure for cabinet mounting VEG 20100





## Weighing Indicator DISOMAT Parvus



- Simple weighing indicator for displaying weights
- Panel mounted unit with high protection class IP65
- Stainless steel face frame
- Backlit LCD display
- Cleartext operator guidance
- Configurable using DISOPLAN service tool (PC based)
- Threshold value contacts
- Analog output

### Application

The DISOMAT Parvus is an evaluation device for simple, non legal-for-trade scales. It offers the operator a clear weight display layout and a keypad for basic scale functions.

Typical applications for the device are:

- Bin weigher
- Platform scale
- Other applications of similar complexity

### Construction

The DISOMAT Parvus VEG 21100 is designed as a panel unit for flush mounting in control panels, control cabinet doors or in the front of control housings. The mounting frame is stainless steel, the rear seal conforms to protection class IP65.

The device is operated by means of a membrane keypad with 9 clearly laid out keys.

Spring terminals are used for the electrical connections – power is supplied via a pluggable block (protection against contact).

### Function

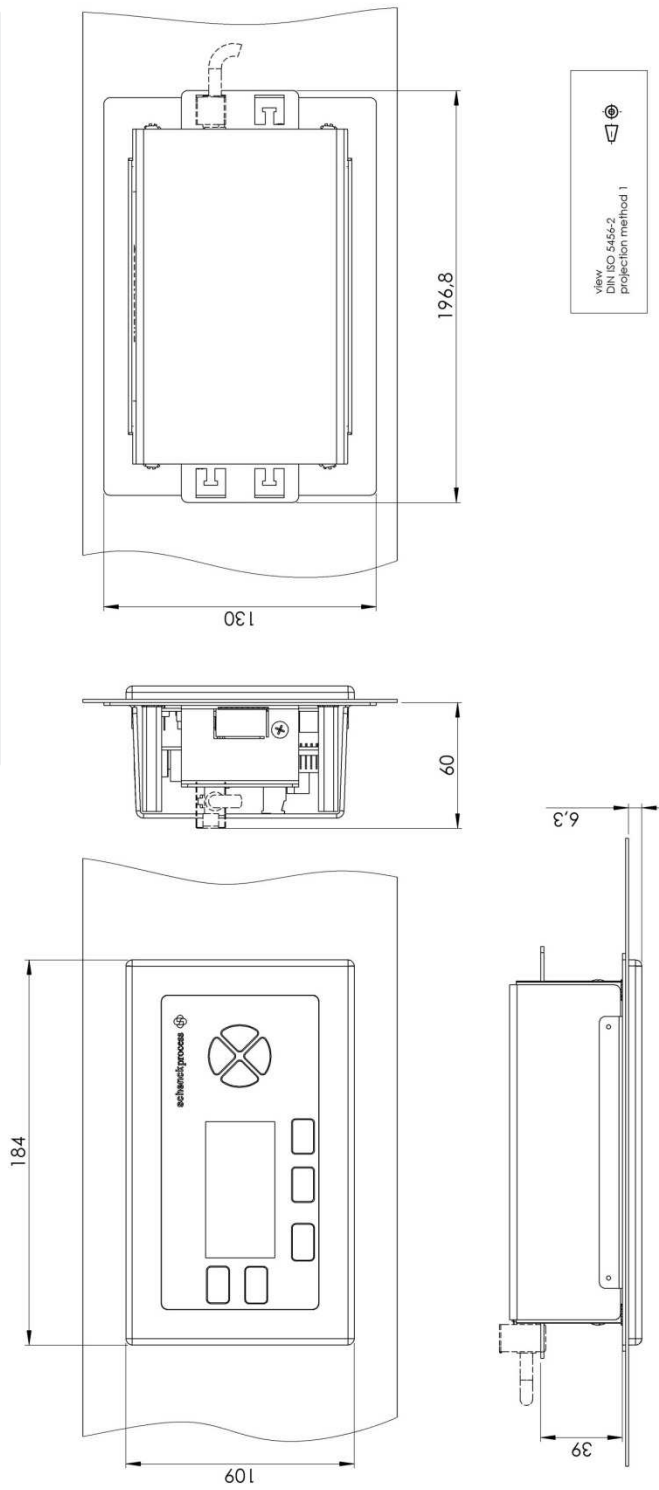
The DISOMAT Parvus is used to indicate and display weight values. Weighing functions such as setting and clearing tares or zeroing can directly be carried out using the keypad.

Other available functions are:

- Two threshold value contacts (relays), e.g. for hopper fill-level monitoring
- Two binary inputs for device control as an alternative to the keypad
- Analog output for outputting weight values
- Serial interfaces for controlling a second display. The cyclical output also can be used for serial transmission of weight values e.g. to a PLC.



## Panel Mounted Unit VEG 21100



## Technical Data

Display	Graphics-capable backlit LCD, 64 mm x 32 mm, 128 x 64 pixels
Keypad	Flexible membrane keypad, 9 keys
Supply voltage	85 ... 250 VAC 50 ... 60 Hz max. 5 VA
Temperature range	Service temperature: -20 °C ... +50 °C Storage temperature: -40 °C ... +80 °C
Measuring channels	1
Load cell supply	5 VAC
Input signal	0 ... 15 mV
Sensitivity	0.8 µV/d
Unit	kg, g, t, lb, N, kN, LT, TN
Increment value	1, 2, 5, etc. adjustable from 0.001 ... 1000
Taring	Up to 100 % of the weighing range
Zeroing system	Max. 20 % adjustable automatic zero point tracking 0.5 d/s, selectable automatic zeroing option
Linearity error	< 0.1 ‰ / 10 K
Zero point stability $TK_0$	< 0.8 µV / 10 K corresponds to 0.06 ‰ / 10 K
Range stability, $TK_c$	< 0.06 ‰ / 10 K
Accuracy $F_{comb}$	< 0.15 ‰ / 10 K
Load cell impedance	Min. 47 Ω (corresponds to 8 x 350 Ω load cells or > 20 RT load cells of 4000 Ω each)
Time	Software, unbuffered, no date
Housing (VKG model)	1.4301, protection class IP65, for panel flush mounting dimensions (W x H x D) [mm]: 185 x 110 x 70 panel cutout [mm] 160 x 90
Binary Inputs	2 x Optocouplers, 18 ... 36 VDC, type 5 mA
Binary outputs	2 x relays, 230 VAC, max. 60 W
Analog output	1 x 0(4) ... 20 mA, 12 Bit, max. load 500 Ω
Serial interfaces	3 Interfaces: interface 1: RS232 interface 2: RS232 (reserved for DISOPLAN) interface 3: RS485-2-wire max. baud rate: 115 kbaud
Secondary display procedures	DTA, DDP8861, DDP8850

**Order Numbers**

	<b>Material Number</b>
DISOMAT Parvus panel mounted unit VEG 21100, Stainless steel face, power supply 85 ... 250 VAC	V090000.B01

## DISOMAT® Satus Weighing Transmitter



- Digital Weighing Transmitter
  - Level Control
  - Single-Component Feed Control System
  - System-Compatible with Fieldbus, Serial Interface, Analog Output and Binary Inputs and Outputs
  - Ethernet Connection
  - Comfortable commissioning with the DISOPLAN Program
  - Four 230 VAC Relay Outputs
  - Three Binary Inputs
  - Optional Weight Display
- Model Designed for Connecting Scales in Hazardous Areas**

### Application

The DISOMAT Satus weighing transmitter is a reasonably priced solution for many basic weighing tasks.

Its fieldbus, serial interface and analog output make it suitable for scales not operated on-site which are connected to higher-order electronic data processing and PLC systems. The optional display also allows on-site monitoring of weight values.

Typical Applications for the DISOMAT Satus are:

- Weight sensor for weight control and bin level measurement. Serial or analog transmission of data to an electronic data processing or PLC system
- Monitoring of containers' fill levels, indicating MIN and MAX values via parallel contacts
- Single-component feed process (GIW or LIW operation)

### Design

The VSE 20900 basic board comprises the following functions:

- Measuring circuit with A/D conversion
- 4 relay outputs safety separated
- 3 binary inputs, galvanically free
- 1 analog output
- 3 serial interfaces
- Ethernet connection (10/100 MBaud)
- Extension connector for fieldbus module (PROFIBUS/DeviceNet/Ethernet/IP)

The following functions can be executed using expansion cards:

- PROFIBUS coupling
- DeviceNet coupling
- Display, 3 1/2 digits, 10 mm digit height, for weight monitoring
- 3 push-buttons for controlling scales functions

The basic board is slotted into a 19" sub-rack as a plug-in board. The device is powered either by 24 VDC or by optional 115/230 VAC power supply modules.

Weighing sensors and display devices in category 2G (zone 1) are connected using the optional barrier sets. The barrier sets are inserted directly into the 19" slots.

## Communication

With up to three serial interfaces, the DISOMAT Satus is fully equipped to exchange data with its environment.

For example,

- Configuration
- Serial display
- Data Processing

may be connected in parallel. Two of the interfaces are RS232 interfaces.

The third (RS485-2/4-wired) is specially suited to communication within the bus and over longer distances.

In control systems the Ethernet connector (10/100 MBaud) is operated using the Modbus-TCP protocol.

Alternatively, HTML pages stored in the device may be called up using a standard web browser. The device can also be configured via the Ethernet interface.

Furthermore, the standard fieldbus systems

- PROFIBUS DP-V0 and
- DeviceNet
- Ethernet/IP

can be connected via matching optional coupling modules.

## Parallel Signal Exchange

The DISOMAT Satus is equipped with the following inputs and outputs for control tasks:

- Three 24 V optical couplers. The inputs can be used to control the feed process (Start/Stop/Abort) or to use the basic scales functions (set/clear Tare/zero setting).
- Four relay outputs for limit value monitoring, status messages or for controlling the filling/discharge operation, naturally also suitable for 230 VAC.

It is also equipped with a 12 Bit analog output that can e.g. transmit weight or material flow to a PLC or display. The analog output can also be used for direct control of suitable feed units.

## Engineering

In spite of its reasonable price, the DISOMAT Satus has enormous processing power. The 32-Bit ARM controller has sufficient power reserves for fast weighing-processes, simultaneous operation of the various interfaces and for future applications.

## Configuration

The PC program DISOPLAN is used to configure the DISOMAT Satus. It allows you to

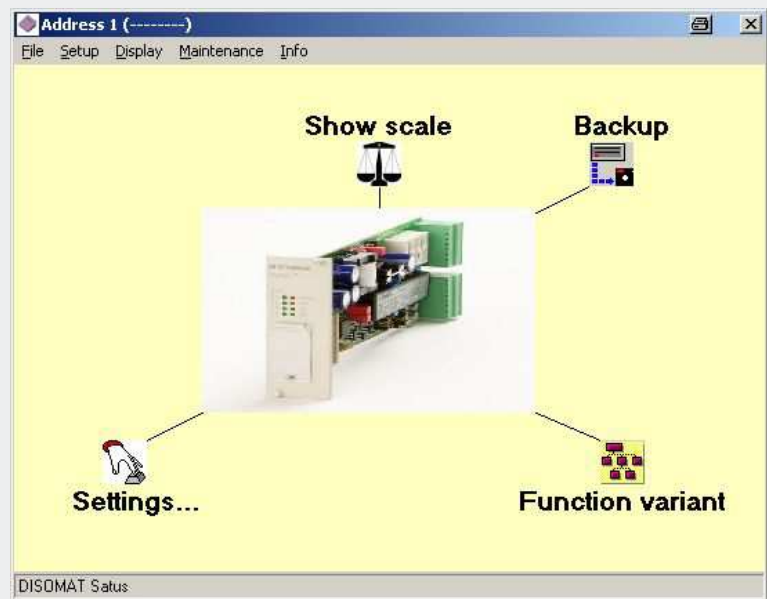
- set all device parameters
- adjust the device
- record and display weight curves
- readout the complete device configuration (backup)
- restore stored data in a DISOMAT (restore). This allows e.g. a replacement device to be prepared at short notice.

## Feed Functions

The DISOMAT Satus feed functions can be adjusted within a wide range making them suitable for a multitude of tasks.

Regardless of material, setting the feed primarily involves setting the feed process, i.e.

- Time monitoring (charging/refilling/emptying)
- Optimization
- Multiple feeds (set point > maximum scales-load)
- Automatic/manual functions



All parameter and calibration data are stored in the device, secured against power failure. The real-time clock will run for at least seven days without a power supply.

## Functions

Alongside the basic scales functions such as

- Tare setting/clearing
- Zero setting

the DISOMAT Satus also has a range of other functionalities.

To use these, one of the device's 'function variants' is activated. This opens an application-specific configuration menu in DISOPLAN in which the device's inputs and outputs can be assigned the corresponding signal.

The following different functions can be activated:

- Weighing transmitter (weighing/limit-value monitoring/data transmission)
- Filling scales/discharge scales (single-component feed process)

Additionally, two product-dependent material datasets may be administered.

These data may contain e.g.

- Pre-contact and main contacts
  - Controlling variable in full feed and dribble feed (analog-controlled feed operation)
  - Parameters for tolerance check
- Multiple-component feeds may also be implemented in conjunction with a higher-order control system that provides the respective component data and set points.

## Dongel Concept

The DISOMAT Satus also makes use of the tried-and-tested 'Intelligent Dongle' concept:

All of the scale's relevant calibration and adjustment data are stored in the dongle. As all the devices are calibrated ex factory, the electronic components can be exchanged at any time in case of a defect. Once the dongle is attached, the scales are configured and adjusted correctly.

**Casing**  
**19" VNG0900 Sub-Rack**  
 (Fig.1)

Suitable for control cubicles which are accessible from the rear or which have a pivoting frame.  
 The VNG0900 has room for 10 main cards.  
 Each of the following require one slot:

- VSE 20900  
DISOMAT Satus circuit board
- VXB 20900/20910  
Explosion protective circuit
- VNT 209xx  
power supply unit for 115/230 VAC
- blank front panel
- The weighing transmitter model VSE 20910 with display requires **two** slots

The optional bus cards require no additional slots.

Protection class at the frontside: IP20  
 Approx. weight (fitted): 10 kg

**Dimensions:**

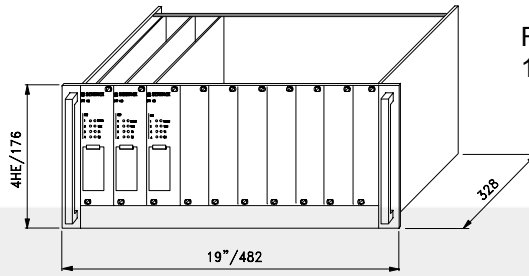
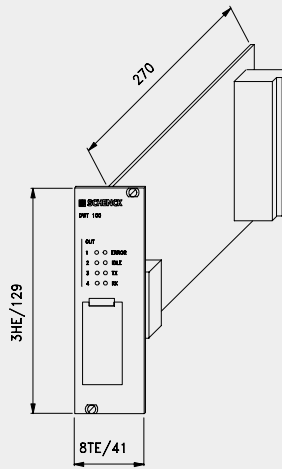
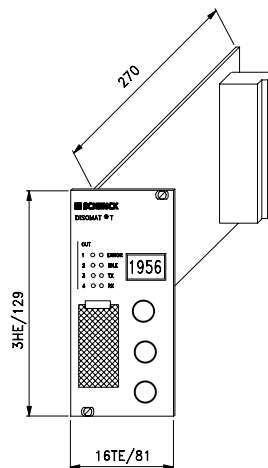


Fig.1  
 19" VNG0900 Sub-Rack



VSE 20900 Weighing Transmitter  
 The following components have equal dimensions:  
 - explosion protective circuit VXB 209xx  
 - power supply unit VNT 209xx



VSE 20910 Weighing Transmitter  
 The optional version  
 - with 3,5 digits display (digit height 10 mm),  
 and three function buttons  
 - occupies two slots in the plug-in board.

**Technical Data:**

The supply voltage for 19" VFE 20900 unit	18 ... 36 VDC
Power consumption	max. 10 VA
Temperature range	Service temperature: -30 °C ... +60 °C Storage temperature: -40 °C ... +80 °C
Measuring channels	1
Load cell supply	5 V alternating voltage supply
Input signal	0 ... 15 mV
Sensitivity	0.7 µV/d
Accuracy	Linearity error: <0,05 ‰ Zero setting stability, TK <sub>0</sub> : <1,0 µV / 10 K corresponds: <0,07 ‰ / 10 K related to max. Input signal Zero setting stability TK <sub>c</sub> : <0,1 ‰ / 10 K Compound error, F <sub>comb</sub> : <0,2 ‰ / 10 K
unit	kg, g, t, lb, N, kN
Increment value	1, 2 and 5 etc. adjustable from 0.01 ... 5,000
Taring	To 100 % of the weighing range
Load cell impedance:	min. 47 Ω (corresponds to 8 x 350 Ω - load cell or >20 Ring Torsion load cells à 4,000 Ω)
Date/Time	Real-time clock (RTC), Power-failure backup min. 7 days
Housing (VSE model)	19" cassette, 3HE, 8TE
Binary inputs	3 x optical-couplers, 18 ... 36 VDC, 5 mA typically Fourth input available for optional use
Binary output	4 x relays, 230 VAC, max. 60 W
Analog output	1 x 0(4) - 20 mA, 12 Bit, max. load 500 Ω, maximum permitted external load reduced to 250 Ω if optional DISOMAT Satus display is used. Use of VXB safety barriers also reduces permitted impedance of analog output.
Serial interfaces:	3 interfaces for electronic data processing or second display Interfaces 1 and 2: RS232 Interface 3: RS485-2/4 wired; max. baud rate: 38,400
Data processing protocols	Siemens 3964R S5 (RK512) Schenck standard protocols DDP8672 Schenck poll protocols DDP8785 Modbus
Secondary display protocols:	DTA DDP 8861 DDP 8850
Ethernet interface	10/100 MBaud, on-board Modbus-TCP protocol

<b>Options</b>	
Fieldbus	PROFIBUS DP-V0 DeviceNet Ethernet/IP
Power supply unit	VNT 20901 for 230 VAC, -15 % ... +10 % One power supply unit supplies up to 9 VSE 20900 main boards with fieldbus option
Explosion protection	Explosion protective circuit VXB 209xx for connection of electrical equipment in zone 1 (ATEX II 2G) card incl. front plate in same dimensions as VSE 20900 main boards Explosion protection class "intrinsically safe" for: - load cell connection - serial interface for second display - analog output for second display - binary input for two contacts <b>Warning:</b> If connecting the analog output in the hazardous area, the maximum external load through the barrier's series resistance is reduced by approx. 300 Ω.
Display	Displays for analog output and serial interface, fully integrable into device. WARNING: The use of the analog displays reduces the permitted external load of the analog output by 250 Ω. This option may not be combined with the connection of the analog output in the ex-area.
Configuration software	DISOPLAN VPL 20430 for Windows NT/2000/XP/7

**Equipment Supplied:**

V052188.B01	DISOMAT Satus VSE 20900 circuit board incl. front plate
V052188.B02	DISOMAT Satus VSE 20901 circuit board incl. front plate; with mounted PROFIBUS option
V053903.B01	DISOMAT Satus VSE 20910 circuit board incl. front plate, with integrated LED weight display
V055346.B01	VNG0900 19" rack
V053978.B01	Power supply unit VNT 20901 230 VAC, for up to 9 VSE 209xx
V068489.B01	VXB 20901 safety barriers for RTN/RTB/VBB/PWS load cells in potentially hazardous area of ATEX category 2G
V068493.B01	VXB 20911 safety barrier for RTK/DMA weigh cells
V053917.B02	PROFIBUS installation set for DISOMAT SATUS
V053918.B02	DeviceNet Satus installation set
V029764.B01	DISOPLAN VPL 20430 configuration software

## DISOMAT® Opus Weight Indicators



- Legal for trade weighing indicator for a wide variety of applications
- Stainless steel - at a high protection class for table-top and wall mounting
- Top-hat rail design
- Panel installation version
- Built-in legal-for-trade memory (optional)
- Fieldbus interface
- Ethernet interface, can also be used for configuration
- USB cable for optional α/n PC keyboard
- All components can be exchanged without re-verification
- For hazardous areas according to ATEX category 3D

### Application

The DISOMAT Opus weighing indicator is perfectly suited to all applications where weights are recorded, displayed and printed legal-for-trade. Results can be transferred to master systems for further processing.

DISOMAT Opus is also excellently suited to simple control jobs in process applications with its complete equipment of interfaces.

This indicator fits easily into data processing and control systems with its extensive communication options, regardless of whether it's PLC or PC.

Some typical applications are:

- Platform scales without major control jobs
- Bin weighers (fill level control and fill or discharge weighing)
- Simple road weigh bridges and crane scales
- Applications as weight transducers for PC-based weighing and data processing systems (such as truck scales)

### Equipment

DISOMAT Opus is available in three versions:

- The basic DISOMAT Opus mini VKG 20710 has a serial interface and an analog output
- The expanded DISOMAT Opus maxi design, VKG 20700 also has
  - More serial interfaces
  - Binary I/O
  - A wide range of communication capabilities

Both indicators have a standard stainless steel console shaped case in protection class IP65 that is suited for table-top and wall mounting (cable outlet downward with wall mounting).

These indicators have an easily readable back lighting LCD display for showing weight with clear text operator guidance. Data is keyed in via flexible membrane keyboard with 9 or 21 keys.

Beyond that, there is the

- VEG 20720 design for top-hat rail assembly in the control cabinet – also legal for trade and including a display

- VEG 20700, panel installation unit for installing into a control panel

These instruments also have extensive standard interface equipment that makes it suitable both for control and communication applications.

All instruments – including those with a keyboard – can be conveniently configured and calibrated via the DISOPLAN PC program.

Since Ethernet is increasingly becoming the communication standard even in industry, Opus maxi and the top-hat rail unit have a standard equipment 100 MBaud network connection.

The following options are available

- Legal for trade data memory
- Remote PC keyboard (only with the Opus maxi)
- Fieldbus cards and network cards
- DISOMAT Opus maxi VKG: ATEX category 3D



## Communication

With as many as three serial interfaces, DISOMAT Opus is excellently equipped for exchanging data with its environment.

- For example,
- Printer
  - Large display
  - Data processing

can be connected at the same time. Two of the interfaces are designed as RS232. The third (RS485-2/4-wire) is especially suited to communication on the bus and at greater distances.

The Ethernet connector (10/100 MBaud) is operated in the control systems via the Modbus-TCP protocol. Optionally, protocol EtherNet/IP is available as well. Another alternative is calling up HTML pages stored in the instrument via a standard web browser. The instrument can also be configured via the Ethernet connector.

Beyond this fieldbus systems and networks can be connected via optional communication modules.

## Parallel signal interchange

For control jobs, DISOMAT Opus has the following parallel inputs and outputs (except Opus mini):

- 4 optocoupler inputs 24 V
- 4 relay outputs, suited for 230 VAC to switch a traffic light

Beyond this, all instruments (including the mini) have a 12 Bit analog output that can transfer weight or material flow to a PLC or display.

## Operation and Settings

Standard DISOMAT operation is in German and English. All operator guidance is carried out and data is entered in clear text.

You can easily load other operating languages into the instrument via the PC-assisted DISOPLAN configuration program (WINDOWS program) (Italian, French, Dutch, Polish, Slovakian, Slovenian, Spanish, Czech, Hungarian and Russian are presently available. Other languages are available at request).

DISOPLAN also allows:

- setting all instrument parameters
- calibrating the instrument
- conveniently configuring the print pattern
- read-out and display of weight signals
- reading out the complete instrument configuration (backup)
- restoring stored data into a DISOMAT. This means a substitute can be prepared at short notice

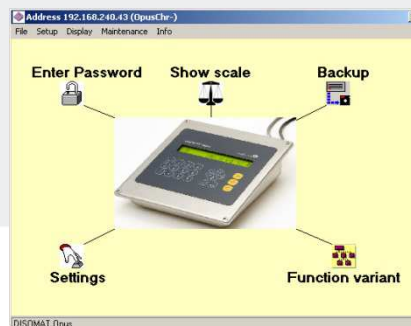
All parameter and calibration data are stored power failure safe in the instrument. The real-time clock runs at least 7 days without a power supply.

## Functions

Beyond the basic scale functions such as

- Acquire and clear tare
- Set to zero
- Print

DISOMAT Opus can also carry out a series of other functionalities.



To use them, one of the 'function variants' in the instrument is activated. This puts DISOMAT into a configuration for specific applications that both allocates the essential actions to the six function keys and assigns the inputs and outputs of the instrument to the matching signals.

The following function variants can be activated:

- Cargo scale (weighing/ printing/balancing)
- Filling scale (single component butchering)
- Discharge scale (single component butchering)
- Crane Scale
- Road Weighbridge

## Print-out

Variable print pattern formatting allows you to freely lay out your weighing report. You can e. g. print out the following along with the weight data:

- the date and time
- Serial no.
- Balance totals
- the number of balanced weighings
- 5 strings with as many as 25 digits
- 3 stored texts with 26 characters each

You can conveniently format the print-out in the DISOPLAN program. The user arranges all of the printing elements the way they should appear on the print-out later. You no longer have to spend a lot of time keying in control sequences and the like.

## Legal-for trade memory

The optional built-in legal-for-trade memory releases the user from the necessity of creating and archiving legal for trade vouchers on paper.

## Equipment

In spite of its low price, DISOMAT Opus has enormous processing performance. The 32 Bit ARM controller also has sufficient power reserves for fast weighing processes, simultaneous operation of various interfaces and also for future applications.

## Our dongle strategy

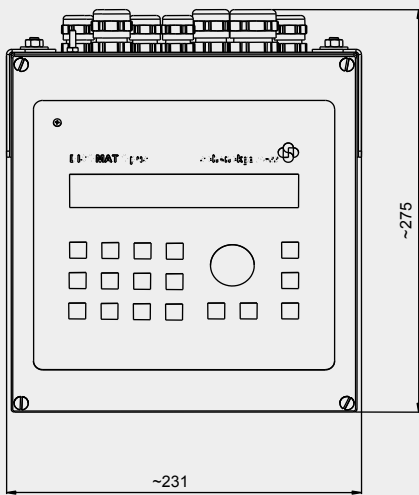
Our proven strategy of the intelligent load cell connector (dongle) is also used in DISOMAT Opus: all of the scale's relevant setting and calibration data are stored in the dongle. Since all of our instruments are calibrated at the factory for identical sensitivity, you can interchange the electronic equipment at any time if there is a defect. After attaching the dongle, the scale is correctly configured **and calibrated again**. This means that even legal for trade scales do not have to be recalibrated or reverified.

## Pattern approval

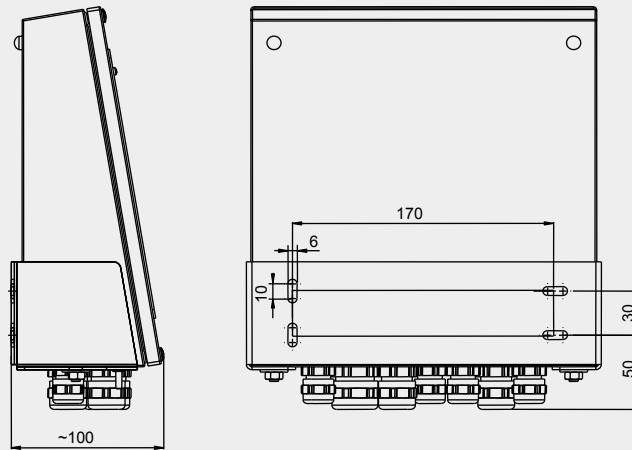
DISOMAT Opus is approved for non-automatic scales (throughout the European Union), with a maximum of 6,000 digits or as a multi-range/ multi-interval scale with as many as 3 x 4,000 digits. Together with the maximum resolution of 0.6  $\mu$ V / increment, this instrument is well equipped for demanding jobs such as with a high preload.

The dimensioned drawing of DISOMAT Opus VKG mini/maxi

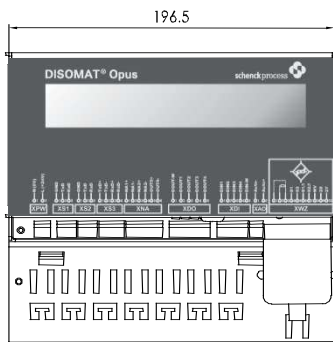
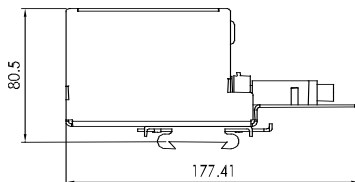
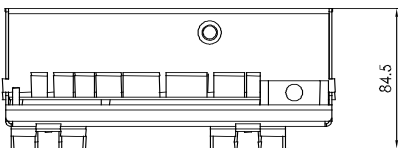
Tabletop mounting



Wall mounting



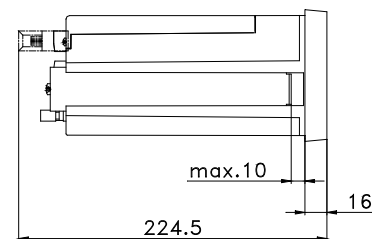
The dimensioned drawing of DISOMAT Opus VEG 20720



Dimensional drawing  
DISOMAT Opus VEG 20700 and  
VEG 20750



Panel cut-out  
282 + 0,5 x 88 + 0,5 [mm]



## Technical Data

Display	LCD back lighting. 1 row 20 characters. Characters 12 mm high
Keyboard	Flexible membrane keyboard Opus maxi, VKG 20700: 21 keys Opus mini, VKG 20710: 9 keys Opus flush mounting, VEG 20700: 21 keys VEG 20720 top-hat rail module: no keyboard
Supply voltage for VKG/VEG 20700/710 desk-top/wall units	85 ... 250 VAC, 50 ... 60 Hz, max. 10 VA
Supply voltage for VEG 20720 top-hat rail unit	12 ... 36 VDC
Temperature range	Service temperature: -30 °C to +60 °C (legal for trade: -20 °C to +40 °C) Storage temperature: -40 °C to +80 °C
Electro-magnetic environment	E2 (OIML D11)
Measuring channels	1
Load cell supply	5 V alternating current supply
Input signal	0 ... 15 mV
Sensitivity	0.6 $\mu$ V / d
Unit	kg, g, t, lb, N, kN
Increment value	1, 2 and 5, etc. adjustable from 0.01 ... 5000
Number of digits	Legal-for-trade operation: max. 6000 d Multi-range scale 3 x 4000 d Multi-interval scale 3 x 4000 d No limitation to resolution in non legal-for-trade operation
Taring	To 100 % of the weighing range
Zero setting device	Can be set max. 20 % Automatic zero tracking 0.5 d/s, can be selected; automatic zero setting can be selected
Linearity error	<0.05 ‰ / 10 K
Zero point stability, TK <sub>0</sub>	<0.6 $\mu$ V / 10 K corresponds to 0.04 ‰ / 10 K
Range stability, TK <sub>c</sub>	<0.04 ‰ / 10 K
Accuracy, F <sub>comb</sub>	<0.1 ‰ / 10 K
Load cell impedance	Min. 47 $\Omega$ (equalling 8 x 350 $\Omega$ load cell or > 20 RT load cells per 4000 $\Omega$ )
Date/Time	Real-time clock (RTC), Back-up time at least 7 days
Housing (VKG model)	Stainless steel 1.4301; Protection class IP65, suitable for desk-top and wall mounting
Binary inputs*	4 x optocoupler, 18 ... 36 VDC, type 5 mA
Binary outputs*	4 x relay, 230 VAC, max. 60 W; 1 x optocoupler, 18 ... 36 VDC, max. 100 mA
Analog output	1 x 0(4) ... 20 mA, 12 Bit, max. load 500 $\Omega$

Serial interfaces	3 interfaces for the printer, data processing or secondary display Interface 1: RS232 Interface 2: RS232 * Interface 3: RS485-2/4-wire * max. Baud rate: 38400
Data processing procedures	Siemens 3964R S5 (RK512) Schenck standard procedure DDP8672 Schenck poll procedure DDP8785 Modbus
Secondary display procedures:	DTA DDP8861 DDP8850
Ethernet interface *	10/100 MBaud, on board, Protocol Modbus-TCP
USB interface *	On board, for PC keyboard
Fieldbus (optional)	PROFIBUS DP-V0 PROFINET IO CC-B DeviceNet EtherNet/IP Modbus-TCP
Other options	PC keyboard (USB) * Legal-for trade memory

\* Only VKG 20700 (Opus maxi) top-hat rail version VEG 20720 and panel installation unit VEG 20700.

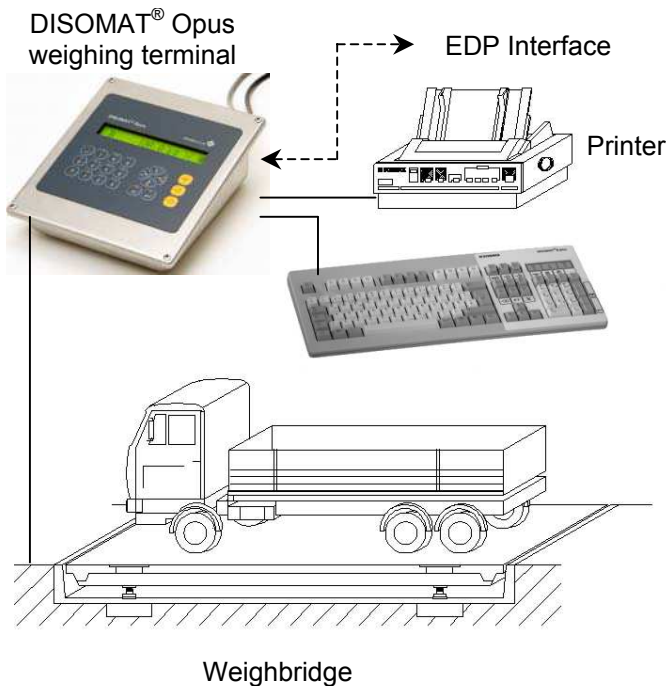
## Equipment supplied

V040000.B11	DISOMAT Opus maxi, VKG 20700, Stainless steel unit IP65
V040001.B11	DISOMAT Opus mini, VKG 20710, Stainless steel unit IP65
V040003.B11	DISOMAT Opus maxi, VKG 20740, Stainless steel unit IP65, 24 VDC supply
V040002.B01	DISOMAT Opus top-hat rail unit, VEG 20720
V063320.B01	DISOMAT Opus, Panel installation unit VEG 20700
V063321.B01	DISOMAT Opus, Panel installation unit VEG 20750, 24 VDC supply
V081990.B01	DISOMAT Opus maxi, stainless steel unit for ATEX category 3D, main supply
V095580.B01	DISOMAT Opus maxi, stainless steel unit for ATEX category 3D, 24 VDC supply
V535499.B01	PROFINET kit, VPN 28020 for VKG
V054033.B01	PROFIBUS DP kit, VPB 28020 for VKG
V081906.B01	DeviceNet kit, VCB 28020 for VKG
V081908.B01	PROFIBUS DP kit, VPB 28020 for VEG 20700
V081909.B01	DeviceNet kit, VCB 28020 for VEG 20700
V064721.B06	Procedure EtherNet/IP
V040045.B01	Remote PC keyboard (USB), German key assignment
V040045.B02	Remote PC keyboard (USB), English key assignment
V040026.B01	Legal-for-trade memory VMM 20407

## Schenck Process Europe GmbH

Pallaswiesenstr. 100  
64293 Darmstadt, Germany  
Phone: +49 6151 1531-0  
Fax: +49 6151 1531-66  
sales@schenckprocess.com  
www.schenckprocess.com

## DISOMAT® Opus - ZEUS Weighbridge



- **DISOMAT® Opus Road/Rail Weighbridge application package**
- **Easy operation**
- **Legal-for-trade measurement value transducer for use in PC controlled scale workplaces**
- **Integrable legal-for-trade memory**
- **Separate strike-key keyboard for alphanumeric input**
- **Also suitable for use as static rail weighing system**

### Application

This application program ZEUS provides DISOMAT® Opus with the basic functionality of a road or rail weigh-bridge.

The weights acquired on incoming and outgoing vehicle during first and second weighing are used to determine the NET weight of load.

Single weighing operations can also be performed.

For every single vehicle, a data record is prepared and transferred to the connected printer via printer interface.

In addition, DISOMAT Opus is excellently suitable for use as legal-for-trade measurement value transducer for scale control via PC.

Connected with an EDP system, DISOMAT Opus offers a convenient backup mode.

### Construction

The ZEUS application package is a component of the software of DISOMAT Opus. It is activated after you acquire the license.

If desired, the known scale and calibration parameters can also be set by SCHENCK.

DISOMAT Opus ZEUS comes with separate strike-key keyboard and suitable printer complete with connecting cable.

In place of the printer, ZEUS can also be equipped with integrated legal-for-trade memory.

### Function

#### First-/ Second Weighing

The vehicle is weighed upon plant entrance.

The weight is put into intermediate storage under the truck license or wagon number.

First weighing data are transferred to printer interface or registered in the legal-for-trade memory.

The outgoing vehicle is weighed again. The stored weight is identified using the truck or wagon number.

The difference in weight equals the material amount loaded or unloaded in plant.

When a printer is connected, the weights from first and second weighing are finally printed out on the weighing certificate including the calculated net weight (see below).

Querying the vehicle number / wagon number and sort number can be suppressed by configuration for simple applications that have to be done quickly. The data record of first weighing is maintained as long as possible even after second weighing. This makes it possible to repeat second weighing, for instance if there is an overload. If first weighing is done for the vehicle again or if the first-weighings file is full, the data record is deleted.

### Single Weighing

Vehicle is weighed once-only; TARE weight of load can be entered in manual, for system to acquire the NET weight.

### Weighing Using Fixed Tare Weight

This mode is designed to acquire the weight of load using the acquired totals weight and the stored empty weight of the vehicle.

### File Update Functions

These functions let you Delete / Edit / Print the contents of:

- Materials file
- Vehicle file
- Fixed tare file

### Function of Printer (if present)

- Printout of acquired weights
- Printout of stored data contents

### Files

- First weighings file for storage of 99 input weighings
- Fixed tare file for storage of 25 empty weights of known vehicles
- Materials file for storage of 25 material types

### Summating Function

The total amount of a certain material type loaded/unloaded is acquired and can be displayed and printed out at any time.

### Signal Control

Designed for control of input/output signals existing or supplied, with the following functions:

- When vehicle drives onto scale, entrance and exit are closed (RED signal).
- If weighing is complete, exit signal turns GREEN.
- If scale is totally relieved, entrance signal also turns GREEN and scale is ready for next weighing operation.
- Signal system can be connected to the device direct using an external control system.

### Weigh slip output on printer, if any

Date	Time	Cons no.	Mem. no.	Truck no.	Material no.	Material name	Weight of load on scale	Stored first weight	NET weight
04.10.01	14:27	0021	06	DA-DB 2344	01	Sand	<8,42 t>	B	
04.10.01	14:27	0022	06	DA-DB 2344	01	Sand	<20,92 t>	B	
								<8,42 t>	B
									12,50 t
Weigher									

Variant	Ordering Nr.
DISOMAT Opus Maxi, VKG 20700 Zeus, Stainless steel unit IP65 for desk-top or wall installation with an activated Zeus 'road weigh bridge' application package, remote keyboard, printer cable and operating manual.	V040081.B01 (de) V040081.B02 (gb)
DISOMAT Opus Maxi, VKG 20700 Zeus, as above, but with VMM 20700 legal-for-trade memory, no printer cable.	V040080.B01 (de) V040080.B02 (gb)
Activation for Zeus 'road weigh bridge' application package.	V040079.B01

Options
Secondary- and Large-size Display Units as per technical data sheet BV-D2003
Signal System BV-D2296
Gate System BV-D2298



# DISOMAT® Tersus

## Weighing electronics

- A weighing terminal with all the equipment
- Clear operator guidance on colored, graphical LCD display
- Built-in Ethernet port
- 4 built-in USB Ports
- Connection for industrial fieldbuses
- Bluetooth interface (optional)
- Built-in legal-for-trade memory (optional)
- Remote α/n swivel keyboard (optional)
- Modular and expandable I/O
- Also available with two measuring channels



You can also have the option of activating its configuration as a vehicle scale (inbound/outbound scale) or a crane scale with collective load memory.

Furthermore, you can adapt the functionality of the DISOMAT® Tersus to virtually any weighing job by adapting the links between the logical function blocks.

You can do either this by using the convenient DISOPLAN PC program (a graphic interface) or directly on the device. This makes it easy and cost-effective to adapt the terminal locally without major programming effort.

In the optional two-channel measuring instrument design, the DISOMAT® Tersus can also be used for operating twin-unit road weigh bridges or two-trolley cranes with a separate overload indicator, or more you can simultaneously monitor the levels of two bins. You can even carry out to feeding processes at once.

### Equipment

The weight is displayed permanently on the backlit, color display in QVGA (320 x 240 dots) format, also while the operator makes entries in the 7-line

### Application

The compact DISOMAT® Tersus weighing terminal is ideal for use in a wide range of weighing applications, regardless of whether you're focusing on operating scales or data processing systems, controlling processes or communicating with on-site systems. The device has four predefined configurations as function variants stored for typical applications that can be easily called up:

These function variants

- Cargo scales
- Crane scales
- Filling scales
- Discharge Scales

They offer the user a proven scope of functions adapted to each individual application including the option of adapting the weigh terminal to the special requirements of his scale.

dialog field of the display or during status messages.

For instance, this might be information on the progress of feeding in progress (a block diagram), on the position of the inputs or outputs or help for operating the terminal.

A special mode ("the telephone alphabets") can also be used to key in  $\alpha$ -characters via keyboard. There is also the option of a remote raised keyboard to make it more convenient to key in inputs, particularly for frequent text inputs.

A second, independent control terminal can be added at any time with a second DISOMAT® Tersus in the mirror' configuration.

You can use a total of 8 binary inputs and 12 binary outputs for controlling the scale and DISOMAT® Tersus. An analog I/A module (two input/to outputs) can also be added.

You can adapt the functionality of the inputs/outputs by linking the function blocks in broad limits to the application's requirements. The number of binary inputs/outputs can be expanded as required with upgrade modules.

Three serial interfaces enable you to connect peripheral units such as printers and remote displays while connecting up data with the data processing or PLC unit. If necessary, another serial interface can be retrofitted.

There are coupling modules available that can be retrofitted for coupling the most common industrial fieldbus systems (PROFIBUS DeviceNet) – and the Ethernet interface (100 MBaud) is even standard terminal equipment.

The DISOMAT® Tersus has 4 built-in USB ports for connecting up the external keyboard, a legal-four-trade memory and a printer.

The DISOMAT® Tersus measuring equipment has extremely high resolution and outstanding measuring speed featuring great reserves even for the most difficult weighing applications, such as scales with minor load cell utilization, scales whose load sensor is in the explosive range, and for fast filling processes. Even extreme temperature demands are no problem for this terminal – the rated temperature range extends from -30 °C ... +60 °C.

The scale specifications (including the calibration data) are stored in the connecting plug of the load cell cable (dongle). If there is a fault, any component in the terminal can be replaced without having to recalibrate or reverify it.

Together with its modular design, this keeps downtimes and repair expenditures on the terminal to a minimum.

The available housing designs

- Desk-top model
- Panel mount unit
- Stainless steel unit
- Field device
- and 19" rack

They offer the right packaging for practically every environment.

### Operation and Settings

The standard DISOMAT® operating languages are German and English.

You can easily load other operating languages into the device via the PC-assisted DISOPLAN parametrizing and configuration program (WINDOWS program) (Italian, Spanish, French, Polish, Czech, Hungarian and Russian are currently available. Other languages are available on request).

DISOPLAN also allows:

- the graphic configuration of the function blocks
- set all instrument parameters
- adjust the terminal
- easily format printed vouchers
- Recording weight curves
- Reading out the entire terminal configuration (back-up)
- Restoring the saved data to a DISOMAT® Tersus (Restore). This allows e.g. a replacement device to be prepared at short notice. Together with the dongle concept, a short down time can be guaranteed if there is a fault while at the same time guaranteeing minimal spare parts stocks

DISOPLAN communicates with the DISOMAT® either

- serially
- via Ethernet
- or via Bluetooth (optional)

All parameter and adjustment data are stored in the terminal to protect them from power failure. The real-time clock runs for at least 7 more days.

### **Print**

Variable print pattern formatting allows you to freely lay out your weighing report.

You can graphically configure the printed vouchers in DISOPLAN (direct preview).

You can print out the following along with weight data:

- Date and Time
- Serial no.
- Balance totals
- The number of balanced weighings
- 5 strings up to 25 digits
- 3 saved texts
- each with 26 characters

The arrangement of printing elements is defined in a format and you can store 6 different formats.



They offer the right packaging for virtually every environment.  
 The available housing designs for DISOMAT® Tersus

**VTG 20450 table-top terminal**



Protection class: IP54,  
 Plastic,  
 10 cable inlets including supply connections and load cell cables  
 Weight: 3.7 kg

**Panel mount unit VEG 20450**



Protection class: Front IP54, otherwise IP20,  
 Plastic,  
 Panel cutout 138.5 mm x 282 mm  
 Weight: 3.5 kg

**19" rack VNG 20450**



with panel mount unit VEG 20450  
 Depth 197 mm + 25 mm for connecting cable  
 Protection class: Front IP54 otherwise IP20  
 Weight: 7.5 kg

**Crane/field device VFG 20450**



with panel mount unit VEG 20450,  
 Sheet steel,  
 Protection class: IP54,  
 Weight 11 kg  
 \* Bezel with front frame: 236 mm

**Stainless steel unit VKG 20450**



Table-top mounting  
 Protection class: IP65  
 Weight: 5 kg  
 The VKG 20450 can also be mounted on the wall with the attached holder.  
 (cable outlets below)

## Technical Data

<b>Display</b>	Color LCD, 240 x 320 pixels, 120 mm x 90 mm, Weight display 22 mm digit height,
<b>Keyboard</b>	Membrane keyboard with 33 multiple-function keys, 12 of which are configurable function keys
<b>Supply voltage</b>	85 ... 250 VAC, 47 ... 63 Hz 24 VDC (18 ... 36 VDC)
<b>Power consumption</b>	max. 20 VA
<b>Temperature range</b>	Operating temperature: -30 °C ... +60 °C able for legal-for-trade: -30 °C ... +40 °C
<b>Electromagnetic ambient conditions</b>	E2 (OIML D11)
<b>Input signal</b>	0 ... 35 mV
<b>Sensitivity</b>	0.4 µV/d
<b>Scan rate</b>	132 measurements/s
<b>Increment value</b>	1, 2, 5, etc. adjustable from 0.01 ... 5000
<b>Unit</b>	kg, g, t, lb, N, kN
<b>Number of digits</b>	Legal-for-trade operation: max. 8000 d Multi-range scale 3 x 4000 d Multi-interval scale 3 x 4000 d
<b>Taring</b>	Up to 100 % of the weighing range
<b>Zeroing system</b>	Can be set to a max. 20 % Automatic zero point lag 0.5 d/s, can be switched off
<b>Filter</b>	Network-synchronous noise-signal suppression Interference signals $\geq 100$ dB Common mode rejection $\geq 110$ dB Software filter, filter time 0 ... 10 s
<b>Linearity error</b>	$< 0.025$ ‰
<b>Zero point stability, TK<sub>0</sub></b>	$< 0.4$ µV / 10 K corresponds to 0.012 ‰ / 10 K
<b>Range stability, TK<sub>c</sub></b>	$< 0.03$ ‰ / 10 K
<b>Accuracy, F<sub>comb</sub></b>	$< 0.05$ ‰ / 10 K
<b>Date/time:</b>	Real-time clock, back-up time min. 7 days
<b>Load cell impedance</b>	At least 43 Ω (corresponds to 8 x 350 Ω - load cell or > 20 RT load cells @ 4000 Ω)

	also valid as minimum total impedance for two-channel terminals (such as 2 x 4 x 350 Ω)
<b>Load cell supply</b>	12 V alternating voltage supply
<b>Binary inputs</b>	8 inputs, indirect coupled, securely isolated, 18 ... 36 VDC Auxiliary 24 V supply for controlling the inputs (max. 150 mA)
<b>Binary outputs</b>	12 outputs, electrically isolated, securely isolated (relay), passive. Load capacity 24 VDC/VAC max. 500 mA, 90 ... 250 VAC max. 300 mA.  The refresh rate of the outputs in the 'fast comparator' function is 132 x per second
<b>Serial interfaces</b>	3 interfaces for printer, DP or secondary display S1 and S2: convertible to  RS232 RS422/485-4-wire RS485-2-wire  The change can be made using software (no jumpers) S3: RS232 fixed, using Bluetooth as an option max. baud rate for all interfaces: 38400 Baud
<b>Data processing procedures</b>	Siemens 3964R S5 (RK512) Modbus Standard Schenck DDP 8672 procedure Schenck DDP 8785 poll procedure
<b>Secondary display procedures::</b>	DTA DDP8861 DDP8850
<b>Ethernet</b>	10/100BASE-T, full duplex-compatible
<b>USB ports</b>	4 x USB 2.0 Host (Master)

## Options

<b>Second measurement input</b>	such as for scales with switching and network switching
<b>Remote PC swivel keyboard</b>	VTT 28000 (USB)
<b>Data input via barcode scanner</b>	on request
<b>Legal-for-trade ability VMM20450 data memory for weigh data as a substitute for check printer</b>	Memory capacity min. 256 MB for typically 3 m. weighing operations
<b>Expansion card VEA 20451</b>	2 outputs, 0(4) ... 20 mA, Max load 500 Ω

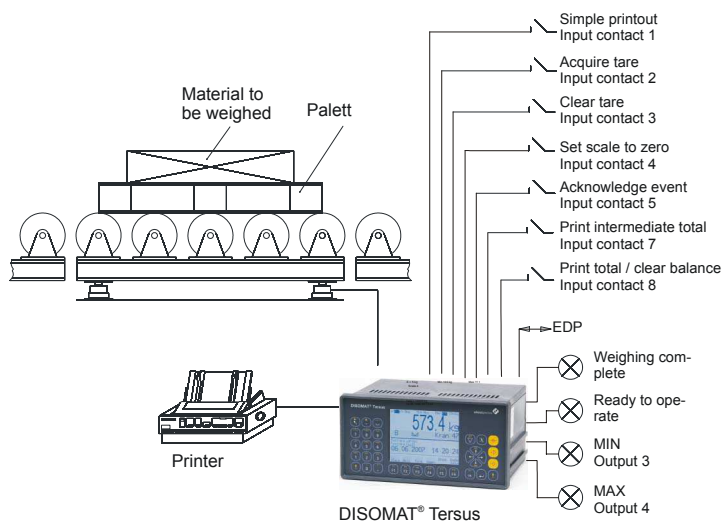
	<p>Resolution: 10,000 parts</p> <p>Refresh rate: 10/s</p> <p>2 inputs 0(4) ... 20 mA, and 0 ... 10 V</p> <p>Linearity &lt;0.15 ‰</p> <p>Zero-point stability: &lt;0.25 ‰/10 K</p> <p>Range stability: &lt;0.25 ‰/10 K</p> <p>Additionally: two binary outputs open collector 24 VDC, galvanically free, max. 200 mA</p>
<b>Option card serial</b>	1 additional serial interface RS 232 / RS 485-2 / RS 485-4
<b>Fieldbus card PROFIBUS</b>	Protocol PROFIBUS DP and DP-V1
<b>Fieldbus card PROFINET I/O</b>	Protocol PROFINET IO Conformance Class B
<b>Fieldbus card DeviceNet</b>	
<b>Bluetooth module (serial interface S3)</b>	Class 1 or 2 module, maximum transmission link 100 (15) m
<b>Radio data transmission</b>	For printing data or data processing connection
<b>I/O extensions</b>	Binary inputs/outputs (max. additional 16 inputs or 16 outputs) Added analog output
The matching barrier subassemblies for connecting intrinsically safe weighing platforms and operating units in the ATEX 2G category (zone 1)	
Other options or customised functions for your applications at request	



<http://www.schenckprocess.com/contact>

## DISOMAT® Tersus - Unit Load Handling Scale

### Unit Load Handling Scale (Example: Roller Train Scale)



- **Function variant for platform, roller train and special platform scales**
- **Weighing sequence control via keyboard, input contacts or EDP interface or fieldbus**
- **Variable print pattern formatting using 3 existing print patterns**
- **10 fixed tare memories**

### Application

The Unit Load Handling Scale function variant provides all functions required for DISOMAT® Tersus to control a platform, roller train or special platform scale.

### Construction

Permanently stored in DISOMAT® Tersus, the linkage can be loaded by the user and changed to suit his specific requirements.

Individual functions, operating instructions, function block plan and parameter table are detailed in the Operating Manual.

If required, setting can be made by Schenck Process with known scale and calibration parameters as well as requisite function block parameters, such as MIN/MAX thresholds, being adapted accordingly.

The user or Schenck Process can easily change the standard variant.

### Function

When unit loads are weighed, hopper or pallet weights as tare can be deducted from Gross weight.

The weighing result can be printed on a weigh slip or output as list report. Balancing takes place automatically after each printout. It can also be registered in the optional legal for trade memory.

Depending on Tare status, Gross or Net weights are balanced, with balance comprising the cumulative totals weight and the number of weighing operations performed. Balance can be displayed and printed.

### Weighing sequences

- Gross weighing
- Gross/Net weighing with automatic taring
- Net weighing while keying in manual tare
- Net weighing with selection of stored tare value

### Function keys

- Acquire tare
- Clear tare
- Key in tare
- Select fixed tare
- Set to zero
- Enter string
- Print single weight
- Print intermediate total
- Print total / clear balance
- Repeat printing
- Test functions

### Input contact assignment

- 1: Single printout
- 2: Acquire tare
- 3: Clear tare
- 4: Set to zero
- 5: Acknowledge event
- 6: n / a
- 7: Print intermediate total
- 8: Print total / clear balance

### Output contact assignment

- 1: Weighing complete
- 2: Ready
- 3: Min contact
- 4: Max contact

### Printing

Single printout is preset with print pattern 1; totals printout, with print pattern 3.

**Assignment of print pattern to function key can be changed at will, e.g. single printout key can also be assigned print pattern 2.**

The variable print pattern formatting gives the user the freedom to design his own weighing report. Defaults are as follows:

Print pattern 1:

- 1 head line and 1 line for weigh data. A string with product data of up to 30 digits can be entered for each printout. This string remains stored until being overwritten. After each printout a form feed is effected.

Print pattern 2:

- 1 line for weigh data. String can be entered and remains stored until being overwritten. After each printout a line feed is effected

Print pattern 3:

- 1 line for totals printout without string.

### EDP communication

For DISOMAT® Tersus, the following EDP transmission protocols are available:

- Schenck standard protocol (DDP 8672)
- Schenck poll protocol (DDP 8785)
- Siemens 3964 R
- Siemens 3964 R for SIMATIC S5 / S7
- Modbus

DISOMAT® Tersus caters for a fixed set of commands that can be addressed by the EDP programmer, if required.

Eligible commands, messages and protocols are detailed in the Manual "Data communication"

The EDP commands most frequently used are listed below.

### Typical EDP commands:

- Tare
- Clear tare
- Preset tare value
- Set to zero
- Request single weight
- Request weight at standstill
- Request cyclic weight
- Request balance
- Clear cumulative total
- Preset string
- Print patterns 1, 2, 3
- Print with copy to EDP

### Fieldbuses

In addition to the serial EDP interfacing, DISOMAT Tersus Unit Load Handling Scale can also be controlled using commercial industrial fieldbus systems.

For details, please see System Manual BV-H 2334 and Data communications Manual BV-H 2359.

**Schenck Process GmbH**  
Pallaswiesenstr. 100  
64293 Darmstadt, Germany  
Phone: +49 6151 1531-1216  
Fax: +49 6151 1531-1172  
sales@schenckprocess.com  
www.schenckprocess.com

#### Example

**Single printout** (print pattern 1):

Date	Time	No.	Cons. (String)	Weight
25.02.00	10:45:00	123	1234567890	<123,5kg>B <24,0kg>T <99,5kg>Net

**Single printout list** (print pattern 2):

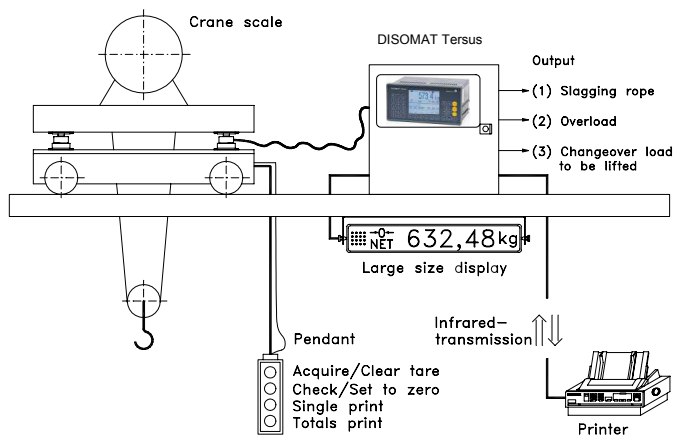
25.02.00	10:45:00	123	1234567890	<99,5kg>Net
25.02.00	10:47:00	124	1234567890	<100,0kg>Net

25.02.00	11:55:00	150	1234567890	<99,5kg>B
25.02.00	12:10:00	151	1234567890	<99,0kg>B
25.02.00	12:25:00	152	1234567890	<100,5kg>Net

**totals printout** (print pattern 3):

25.02.00	12:30:00	30		3001,5kg SU
----------	----------	----	--	-------------

## DISOMAT® Tersus - Crane Scale



- Crane Scale application package
- Control of weighing functions via crane pendant keys
- Variable print pattern formatting
- Slack rope and overload reporting contacts
- Data transmission to the printer or data processing unit by infrared link or radio (optional)
- Collective load memory (optional)
- Legal-for-trade data storage (optional)
- Two-measuring-channel variant for dual-trolley cranes

### Application

The Crane Scale function variant provides all functions required for DISOMAT® Tersus to control a crane scale from crane cabin or ground station.

### Construction

Permanently stored in the DISOMAT® B EPROM, linkage can be loaded by user and changed to suit his specific requirements.

Individual functions, operating instructions, function block diagram and parameter table are detailed in the Operating Manual.

If required, setting can be made by Schenck with known scale and calibration parameters as well as requisite function block parameters, such as MIN/MAX thresholds, being adapted accordingly.

### Function

All weighing functions can be triggered via input contacts from keys on pendant or via radio transmission.

Cab controlled crane scales are operated direct from DISOMAT® Tersus keyboard.

Before weighing start, the weight of auxiliaries can be tared off.

The weighing result can be printed in form of a list. The printing process is shown on the large display.

To avoid double printing, no new print job is accepted before scale has been unloaded.

It automatically balances every time it prints out while totaling the gross or net weight depending upon the tare status. The balance contains the total weight and number of weighings balanced.

The optional collective load memory (LKS) totals the load of the hoist and the system uses the collective load and other specific plant data to calculate the anticipated remaining hoist life. You can call up the remaining life on the unit display and large display.



### Input/Output Contacts

[values in brackets optional]

#### Inputs

- Acquire / Clear Tare
- Set to Zero / Test / Acknowledge Error
- Weigh and Print
- [Print Total]
- [Scale 1 Hoist Active]
- [Scale 2 Hoist Active]

#### Outputs

- Slack rope (Gross < 0)
- Overload (Scale 1)
- Change Over Load To Be Lifted Scale 1 (higher lifting capacity)
- Ready
- [Slack rope Scale 2]
- [Overload Scale 2]
- [Change Over Load To Be Lifted Scale 2]
- [Overload Total (Scales 1+2)]

#### Function Keys

- Acquire tare
- Clear tare
- Display tare
- Key-in tare
- Set to zero
- Enter string
- Print single weight
- Print total / reset balance
- Repeat printing
- Test functions

#### Options

- Printer
- Large-size displays
- Legal-for-trade memory
- Data transmission
- Bus interfaces
- Collective load memory
- Second measuring channel

Print Pattern (sample default setting, easy to change on device)

#### Single Printout:

Date	Time	No.	Cons. (String)	Weight
23.04.01	12:10:00	151		<99,0kg>B
23.04.01	12:25:00	152		<100,5kg>Net

With cab controlled crane scales, you can enter a product data string for each printout.

String remains stored until being overwritten.

#### Single Printout With String:

Date	Time	No.	Cons. (String)	Weight
23.04.01	12:10:00	151	333-247-A	<99,0kg>B
23.04.01	12:25:00	152	333-247-A	<100,5kg>Net

#### Totals Printout:

23.04.01	12:30:00	30		3001,5kg SU
----------	----------	----	--	-------------

#### Variants (Examples)

DISOMAT® Tersus panel-mounting unit in field housing 1 measuring point, no infrared, no collective load memory
DISOMAT® Tersus panel-mounting unit in field housing 1 measuring point, infrared, no collective load memory
DISOMAT® Tersus panel-mounting unit in field housing 1 measuring point, no infrared, collective load memory
DISOMAT® Tersus panel-mounting unit in field housing 1 measuring point, infrared, collective load memory
DISOMAT® Tersus panel-mounting unit in field housing 2 measuring points, no infrared, no collective load memory
DISOMAT® Tersus panel-mounting unit in field housing 2 measuring points, infrared, no collective load memory
DISOMAT® Tersus panel-mounting unit in field housing 2 measuring points, no infrared, collective load memory
DISOMAT® Tersus panel-mounting unit in field housing 2 measuring points, infrared, collective load memory
DISOMAT® Tersus stainless steel unit 1 measuring point, infrared, collective load memory
DISOMAT® Tersus stainless steel unit 2 measuring points, infrared, collective load memory

#### All variants include

- Mounting tools for field housing
- Large size display with mounting tools
- Documentation ( including all wiring diagrams)
- Setting of scale parameters
- Parametrisation of collective load memory, if any.

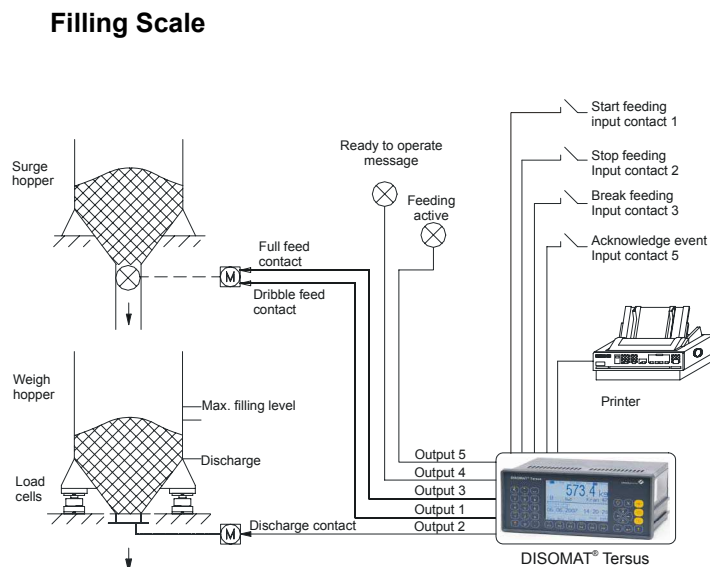
Further configurations available upon request. For more information on DISOMAT® Tersus Crane Scale, see Manual BV-H2133AA.

### Schenck Process GmbH

Pallaswiesenstr. 100  
64293 Darmstadt, Germany  
Phone: +49 6151 1531-1216  
Fax: +49 6151 1531-1172  
sales@schenckprocess.com  
www.schenckprocess.com



## DISOMAT® Tersus - Filling Scale



- **Function variant for fill feed into scale hoppers or containers on platform scales**
- **Feeding with full and dribble feed**
- **Automatic tolerance check and tracking optimization**
- **Control of weighing sequence via keyboard, input contacts or EDP interface or fieldbus**
- **Weighing report and totals printout**
- **10 fixed tare memories for containers with residual contents**
- **10 parameter records for materials with different feed properties**

### Application

The filling Scale function variant provides all functions required for the DISOMAT Tersus to realize a single-ingredient feed control: Set/act comparison in full feed and dribble feed, material flow monitoring, tolerance check and tracking optimization.

### Equipment

Permanently stored in the DISOMAT Tersus, the linkage can be loaded by the user and changed to suit his specific requirements. Individual functions, operating instructions, function block plan and parameter table are detailed in the Operating Manual.

If required, setting can be made by Schenck with known scale and calibration parameters, as well as dosing parameters being adapted accordingly.

For materials with varying properties, 10 selectable parameter records (materials files) are available.

### Functions

The filling scale is designed to feed liquids or bulk solids into hoppers or fill them into containers. Filling is in two speeds, by full feed and dribble feed, to setpoint. You can also trigger feed units with an analog interface (such as discharge screws). The amount fed is checked for tolerance and made up, if necessary. Overfill is reported by a message. For optimization of feed process, pre-act and main contact are tracked. After each aborted or completed batch, weigh data are automatically printed and totalised. Accumulation contains cumulative total of NET weights and number of totalised batches. Accumulation can be displayed and printed.

## Weighing Sequences

- Fill weighing
- Fill weighing with discharge
- Multiple fill weighings with discharge

## Function keys

- Acquire Tare
- Clear Tare
- Start
- Stop
- Abort
- Print intermediate total
- Print total and clear cumulative total
- Print Repeat
- Select Material / Enter Set-point
- Set to Zero
- Test Functions

## Other Menu Tree Functions

- Enter String
- Key-in Tare
- Select Fixed Tare
- Single Printout
- Settings

## Input Contact Assignment

- 1: Start
- 2: Stop
- 3: Abort
- 4: N.C.
- 5: Acknowledge event

## Output Contact Assignment

- 1: Full Feed
- 2: Dribble Feed
- 3: Discharge
- 4: Ready
- 5: Feeding active
- 5: N.C.

## Printing

Single printout is preset with Print Pattern 2; totals printout, with Print Pattern 3. Assignment of print pattern to function key can be changed e.g. Single Printout key can also be assigned Print Pattern 1.

The variable print pattern formatting gives the user the possibility to design his own weighing reports. Defaults are as follows:

## Print Pattern 1:

One head line and one line for weigh data. A string with product data of up to 30 digits can be entered for each printout. This string remains stored until being overwritten. After each printout a form feed is effected.

## Print Pattern 2:

One line for weigh data. String can be entered and remains stored until being overwritten. After each printout a line feed is effected.

## Print Pattern 3:

One line for totals printout without string.

Print Pattern						
<b>Single Printout</b> (Print Pattern 1):						
Date	Time	Cons. No.	(Weigh Data)	Weight		
25.02.00	10:45:00	123	1234567890	<123.5kg>B	<24.0kg>T	<99.5kg>Net
<b>Single Printout List</b> (Print Pattern 2):						
25.02.00	10:45:00	123	1234567890	<99.5kg>Net		
25.02.00	10:47:00	124	1234567890	<100.0kg>Net		
.						
25.02.00	11:55:00	150	1234567890	<99.5kg>B		
25.02.00	12:10:00	151	1234567890	<99.0kg>B		
25.02.00	12:25:00	152	1234567890	<100.5kg>Net		
<b>Totals Printout</b> (Print Pattern 3):						
25.02.00	12:30:00	30		3001.5kg SU		

## EDP communication

For DISOMAT Tersus, the following EDP transmission procedures are available:

- SCHENCK Standard Protocol (DDP 8672)
- SCHENCK Poll Protocol (DDP 8785)
- SIEMENS 3964 R (DDP 8782)
- SIEMENS 3964 R for SIMATIC S5/S7

Disomat Tersus caters for a fixed set of commands that can be addressed by the EDP programmer, if required. Eligible commands, messages and procedures are detailed in the Data Communication Manual. The EDP commands most frequently used are listed below.

### Typical EDP commands:

- Tare
- Clear tare
- Preset tare value
- Set to zero
- Request single weight
- Request weight at standstill
- Request cyclic weight
- Request cumulative total
- Clear cumulative total
- Preset string
- Print patterns 1, 2, 3
- Print with copy to EDP

## Response messages by DISOMAT Tersus

- Message is processed
- Command executed
- Command executed, send data to EDP

## Messages Initiated by DISOMAT Tersus

- Feeding complete
- Feeding interrupted
- Weight at standstill
- Cyclic weight
- Taring complete
- Zeroing complete
- On the "Print With EDP Copy" command, DISOMAT Tersus acknowledges successful printout in form of a message that can widely be configured at will.

## Fieldbuses

In addition to the serial EDP interfacing, DISOMAT Tersus Discharge Scale can also be controlled using the most frequent fieldbus systems.

- Modbus
- Profibus DP-V0
- Device Net
- Modbus -TCP (via Ethernet)

For details, see System Manual BV-H2334 and Data Communication Manual BV-H2359.

## Flexibility

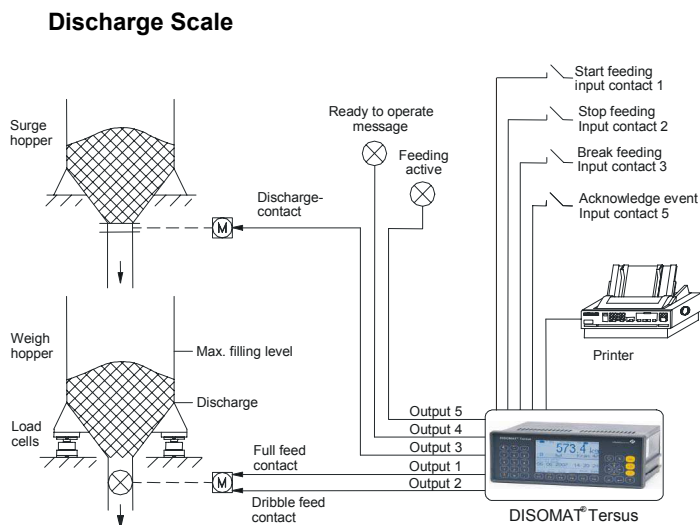
Although the Filling Scale function has been set and supplied, the logical function block system can be used to the full extent. The filling scale can be matched to new requirements or replaced by a totally different function. This can be performed using the DISOMAT Tersus keyboard or, even more convenient, on PC using the DISOPLAN software tool.

## Variants

DISOMAT Tersus Weighing Terminal  
see Spec Sheet BV-D2273GB



## DISOMAT® Tersus - Discharge Scale



- **Function variant for discharge feed from weigh hoppers**
- **Feeding by full and dribble feed**
- **Automatic tolerance check and tracking optimization**
- **Weighing sequence control via keyboard, input contacts or EDP interface or fieldbus**
- **Weighing report and totals printout**
- **10 parameter records for materials with different feed properties**
- **Legal-for-trade dynamic weighing of rail vehicles**

### Application

The discharge scale functional variant gives DISOMAT Tersus the functionality of one-component feeding control: Set/act comparison in full feed and dribble feed, material flow monitoring, tolerance check and tracking optimization.

### Equipment

Permanently stored in the DISOMAT Tersus, the linkage can be loaded by the user and changed to suit his specific requirements.

Individual functions, operating instructions, function block plan and parameter table are detailed in the Operating Manual.

If required, setting can be made by Schenck with known scale and calibration parameters as well as requisite feed parameters.

For materials with varying properties, 10 selectable parameter records (materials files) are available.

### Functions

The discharge scale is designed to feed liquids or bulk solids out of hoppers into containers. Discharge is in two speeds, by full feed and dribble feed, to set point. You can also trigger feed units with an analog interface (such as discharge screws). The amount fed is checked for tolerance and made up, if necessary. Overfill is reported by a message.

After each aborted or completed feed operation, weigh data are automatically printed and balanced. The balance contains the cumulative total of NET weights and the total number of NET weighings performed. The balance can be displayed and printed.

## Weighing Sequences

- Discharge weighing
- Discharge weighing with refill
- Multiple discharge weighings with refilling

## Function keys

- Acquire Tare
- Clear Tare
- Display Tare
- Start
- Stop
- Abort
- Print intermediate total
- Print Total / Clear Balance Memory
- Print Repeat
- Select Material / Enter Set-point
- Set to Zero
- Test Functions

## Other Menu Tree Functions

- Enter String
- Key-in Tare
- Select Fixed Tare
- Single Printout
- Settings

## Input Contact Assignment

- 1: Start
- 2: Stop
- 3: Abort
- 4: N.C.
- 5: Acknowledge event

## Output Contact Assignment

- 1: Full Feed
- 2: Dribble Feed
- 3: Refilling
- 4: Ready
- 5: Feeding active
- 6: N.C.

## Printing

Single printout is preset with Print Pattern 2; totals printout, with Print Pattern 3. Assignment of print pattern to function key can be changed at will, e.g. Single Printout key can also be assigned Print Pattern 1.

The variable print pattern formatting gives the users the possibility to design their own weighing reports. Defaults are as follows:

## Print Pattern 1:

One head line and one line for weigh data. A string with product data of up to 30 digits can be entered for each printout. This string remains stored until being overwritten. After each printout a form feed is effected.

## Print Pattern 2:

One line for weigh data. String can be entered and remains stored until being overwritten. After each printout a line feed is effected.

## Print Pattern 3:

1 line for totals printout without string.

### Print Pattern

#### Single Printout (Print Pattern 1):

Date	Time	Cons. (Weigh No.)	Weight Data
25.02.00	10:45:00	123	1234567890 <123.5kg>B <24.0kg>T <99.5kg>Net

#### Single Printout List (Print Pattern 2):

25.02.00	10:45:00	123	1234567890 <99.5kg>Net
25.02.00	10:47:00	124	1234567890 <100.0kg>Net
..			
25.02.00	11:55:00	150	1234567890 <99.5kg>B
25.02.00	12:10:00	151	1234567890 <99.0kg>B
25.02.00	12:25:00	152	1234567890 <100.5kg>Net

#### Totals Printout (Print Pattern 3):

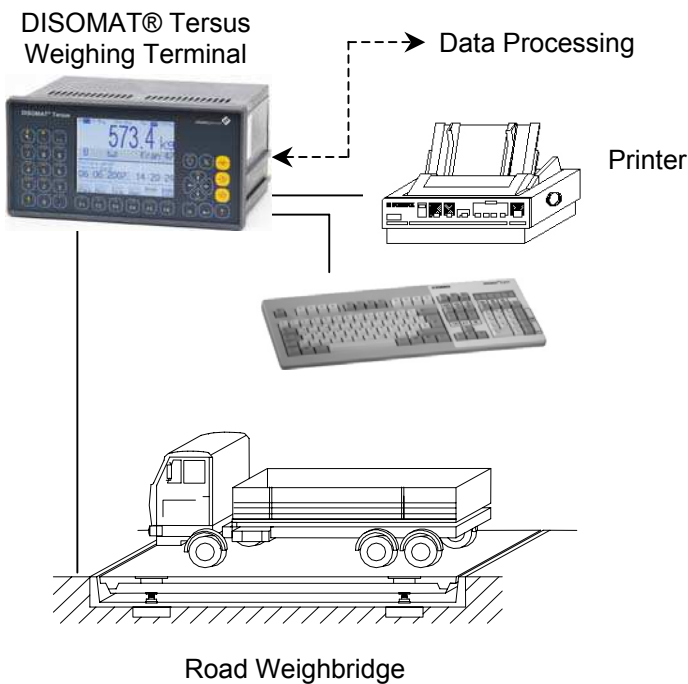
25.02.00	12:30:00	30	3001.5kg SU
----------	----------	----	-------------

<p><b>EDP Communication</b></p> <p>For DISOMAT Tersus, the following EDP transmission procedures are available:</p> <ul style="list-style-type: none"> <li>- SCHENCK Standard procedures (DDP 8 672)</li> <li>- SCHENCK Poll procedures (DDP 8 785)</li> <li>- SIEMENS 3964 R (DDP 8 782)</li> <li>- SIEMENS 3964 R for SIMATIC S5/S7</li> </ul> <p>DISOMAT Tersus caters for a fixed set of commands that can be addressed by the EDP programmer, if required. Eligible commands, messages and protocols are detailed in the Data Communication Manual.</p> <p>The EDP commands most frequently used are listed below.</p> <p><b>Typical EDP commands:</b></p> <ul style="list-style-type: none"> <li>- Tare</li> <li>- Clear tare</li> <li>- Preset tare value</li> <li>- Set to zero</li> <li>- Request single weight</li> <li>- Request weight at standstill</li> <li>- Request cyclic weight</li> <li>- Request balance total</li> <li>- Clear cumulative total</li> <li>- Preset string</li> <li>- Print patterns 1, 2, 3</li> <li>- Print with copy to EDP</li> </ul>	<p><b>Response messages by DISOMAT Tersus</b></p> <ul style="list-style-type: none"> <li>- Message is processed</li> <li>- Command executed</li> <li>- Command executed, send data to EDP</li> </ul> <p><b>Messages Initiated by DISOMAT Tersus</b></p> <ul style="list-style-type: none"> <li>- Feeding complete</li> <li>- Feeding interrupted</li> <li>- Weight at standstill</li> <li>- Cyclic weight</li> <li>- Taring complete</li> <li>- Zeroing complete</li> <li>- On the "Print With EDP Copy" command, DISOMAT Tersus acknowledges successful printout in form of a message that can widely be configured at will.</li> </ul> <p><b>Fieldbuses</b></p> <p>In addition to the serial EDP interfacing, DISOMAT Tersus Discharge Scale can also be controlled using the most frequent fieldbus systems.</p> <ul style="list-style-type: none"> <li>- Modbus</li> <li>- Profibus DP-V0</li> <li>- Device Net</li> <li>- Modbus -TCP (via Ethernet)</li> </ul> <p>For details, see System Manual BV-H 2334 and Data Communication Manual BV-H 2359.</p>	<p><b>Flexibility</b></p> <p>Although the Discharge Scale function has been set and supplied, the logical function block system can be used to the full extent. The discharge scale can be matched to new requirements or replaced by a totally different function. This can be performed using the DISOMAT Tersus keyboard or, even more convenient, on PC using the DISOPLAN software tool.</p> <p><b>Variants</b></p> <p>For DISOMAT Tersus Weighing Terminal, see Data Sheet BV-D2273GB.</p>
--	---	--





## DISOMAT® Tersus - ZEUS Road Weighbridge



- **DISOMAT® Tersus Road Weighbridge Applications Package**
- **Easy Operation**
- **Legal-for-trade Transducer with PC Controlled Scales-Workstations**
- **Integrable Legal-For-Trade Memory**
- **Remote Swivel Keyboard for Alphanumeric Input**
- **Model with Two Measuring Channels Available for Twin Scales**
- **Can also be Used for Static Rail Weighbridges**

### Applications

The ZEUS program gives the DISOMAT® Tersus the standard functionalities of a road or rail weighbridge.

The net weight of the cargo is calculated from the difference between the weight of the vehicle measured at entrance and exit (first and second weighings).

Single weighings may also be performed.

A data set is created for each vehicle and forwarded to a connected printer via the printer interface.

The DISOMAT Tersus can also be used as a legal-for-trade transducer for scales operation per PC.

If a computer is connected, the DISOMAT still has an easy-to-use backup operation.

### Design

The ZEUS applications package can be activated in every DISOMAT Tersus by entering an activation code. The parameters may be set by the operator.

The weighing and calibration parameters can be set by Schenck Process, if desired.

The remote swivel-keyboard and a suitable printer and connecting cable are supplied with the DISOMAT Tersus ZEUS complete package.

ZEUS can also be run with an integrated legal-for-trade memory instead of a printer.

ZEUS can also be used with twin scales in the model with two measuring channels.

### Function

#### First / Second Weighing

The vehicle is weighed when it enters the site.

The weight is stored temporarily under the licence plate number or the rail car number.

In the process, the first-weighing data is transmitted to the printer interface.

The vehicle is weighed again when leaving the site.

The stored weight is identified using the vehicle's licence plate number or the number of the rail car.

The difference in weight thus determined is equivalent to the weight of the goods loaded or unloaded on-site.

If connected to a printer, the weigh bill printed will show the results of the initial weighing, the second weighing and the net weight determined (see below).

### Single weighing

The vehicle is only weighed once; the tare weight of the vehicle can be entered manually so that the system can calculate the net weight.

### Weighing Using Fixed Tare Weight

Used to determine the weight of cargo based on the overall vehicle weight ascertained and the stored empty weight.

### File Maintenance Functions

For deleting / altering / printing the contents of:

- Materials files
- Vehicle files
- Fixed-tare files

### Print Functions

(with printer connected)

- Printing the weights calculated
- Printing the data stored

### Files

- First-weighing file for storing 99 initial weighings
- Fixed-tare file for storing empty-weights of 25 known vehicles

### Sample weigh bill with connected printer

Date	Time	Seq. No.	Carrier No.	Licence No.	Material - No.	Material Name	Weight on the scales	Stored 1st weight	Net weight
04.10.01	14:27	0021	06	DA-DB 2344	01	Sand	8.42 t	B	
04.10.01	14:27	0022	06	DA-DB 2344	01	Sand	20.92 t	B	
								8.42 t	B
									12.50 t

Design	Order number
Complete Package: DISOMAT® Tersus ZEUS, VTG 20450 desktop device with road weighbridge program, remote swivel-keyboard, DISOPRINT 332 printer, 1 ZEUS weighing forms package, operating manual	V054083.B01
Or: Package as described above, with a printer cable but no printer	V054083.B02
Or: Package as described above, with VMM 20450 legal-for-trade memory but no printer	V054083.B03

### Weigher

#### Options

Secondary- and Large-size Display Units as per technical data sheet BV-D2003

Stoptlights system BV-D2296

Gates System BV-D2298

Two measuring-channels model available on request

- Materials file for storing the weight of 25 materials

### Totaling Function

**The amount of each material weighed is measured and can be displayed and printed at will.**

### Stoptlights Control

Used to control on-site or (optionally) delivered

Entrance / exit stoptlights with the following functionality:

- When a vehicle enters, entrance and exit are closed (red signal).
- Once weighing is complete, a green exit signal is given.
- Once the scales are completely relieved, the entrance signal also turns green and the scales are ready for next weighing operation.
- The stoptlight can be connected directly to the device without the need for an external control unit.

### DISOBOX External A/D Converter

Optionally, up to two external legal-for-trade DISOBOX A/D convertors can be connected to the DISOMATs. If so, they would replace the internal measuring channels. In this 'mechatronic' design, the A/D convertors are located directly on the scales, ie. beneath the weighbridge. Data is communicated serially and thus also safe from disruptions over longer distances.

### Second Operating Station

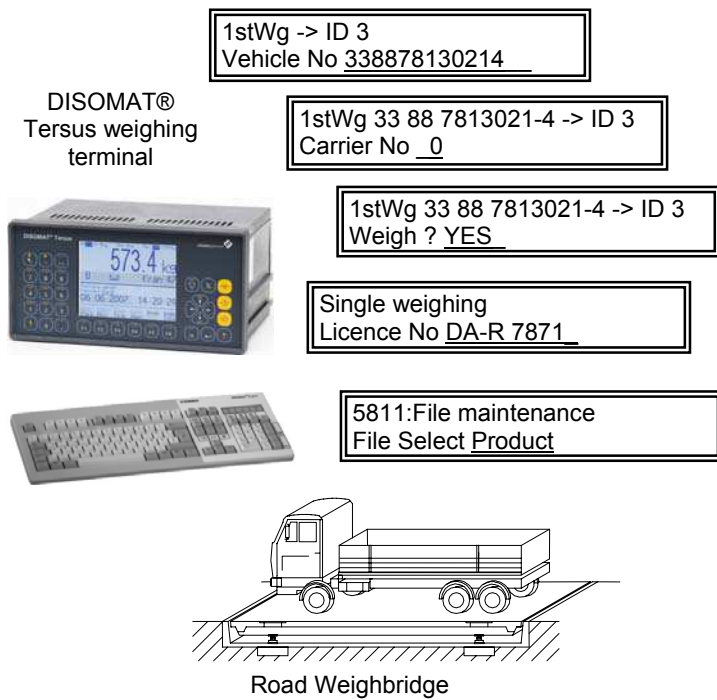
A second DISOMAT® Tersus can be used as a second, removable operating station ('mirror device').

This function is available in every DISOMAT Tersus housing variant. The operator has an identical display and keyboard to the main device, also with the remote alpha-keyboard, if desired. Printer, computer connection etc. can also be controlled using the second operating station rather than the main device, if desired.

### Schenck Process GmbH

Pallaswiesenstr. 100  
Darmstadt, Germany 64293  
Phone: +49 6151 1531-1216  
Fax: +49 6151 1531-1172  
sales@schenckprocess.com  
www.schenckprocess.com

## DISOMAT® Tersus – JASON Road Weighbridge



- **DISOMAT® Tersus Road and Rail Weighbridges Applications Package**
- **Comprehensive File Functions**
- **Flexible Configuration**
- **Easy Operation**
- **Integrable Legal-For-Trade Memory**
- **Removable Swivel Keyboard for Alphanumeric Input**
- **Model with Two Measuring Channels Available for Twin Scales**

### Application

The JASON application program enables the DISOMAT® Tersus to operate road weighbridges whose requirements exceed simple inbound and outbound weighings. It can therefore be used as a substitute for simple PC solutions.

JASON determines and records the weight of goods loaded onto or unloaded from vehicles (lorries, cars or rail vehicles).

The weight is calculated in one of the following ways:

- by weighing the vehicle in the loaded and unloaded state (first / second weighing)
- by weighing the loaded vehicle and comparing this weight to the empty weight, weighed at an earlier moment and stored permanently (weighing with a fixed tare weight).
- by weighing the loaded vehicle and comparing this weight to the empty weight, which is entered manually (single weighing).

Weigh-related data are recorded, administered and logged with the freely configurable file management.

### Equipment

JASON is loaded into the DISOMAT Tersus instead of the standard program. It expands the DISOMAT Tersus's standard functionalities.

The parameters can be set by the operator.

The weighing and calibration parameters can be set by Schenck, if desired.

The removable swivel-keyboard and a suitable printer and connecting cable are supplied with the DISOMAT Tersus JASON.

JASON can also be run with an integrated legal-for-trade memory instead of a printer.

JASON can also be used with twin scales in the model with two measuring-channels.

### Function

#### First / second weighing

The lorry is weighed when it enters the site.

Depending on the configuration, a number of different, weighing-related data are also recorded (see 'File Management').

The weight of the lorry is stored temporarily under its licence plate number and, if desired, printed.

The lorry is weighed again when leaving the site.

The stored weight is identified using the lorry licence plate number.

Depending on the configuration, the data acquired on the initial weighing can be altered or supplemented.

The difference in weight thus calculated is equivalent to the weight of the goods loaded or unloaded on-site.

If connected to a printer, the weigh bill printed will show the results of the initial weighing, the second weighing and the net weight calculated along with any supplementary data recorded (see below).

### Single weighing

The lorry is only weighed once; the tare weight of the lorry can be entered manually so that the system can calculate the net weight.

### Weighing Using Fixed Tare Weight

Used to determine the weight of cargo based on the overall lorry weight ascertained and the stored lorry tare weight.

The size of the input field for the licence plate (14 digits) means JASON can be used with **static weighbridges**.

### Print Functions

(with printer connected)

- Printing the weights calculated
- Printing the data stored
- Content and format of the weigh bill can be configured on-site within wide limits.
- The printout after the first weighing can be deselected. If this option is chosen, a legal-for-trade memory must be installed to record the result of the first weighing.

### Files

The use and size of different files for weighing processes can be changed.

JASON recognizes files for:

- Customers (max. 200)  
Name / Street / City / Telephone (20 digits each)
- Suppliers (max. 200)  
Name / Street / City / Telephone (20 digits each)

- Carriers (max. 50)  
Name (20 digits)
- Products (max. 100)  
Name (20 digits)
- Fixed tare weighings (max. 200)
- First weighings (max. 250)

### File Maintenance Functions

For deleting / altering / printing file contents

### Totaling Function

Three (parallel) accounts are kept for each product. Each of these accounts can be printed and deleted individually.

### Stoplights Control

Used to control on-site or (optionally) supplied entrance / exit stoplights, with the following functionality:

- When a vehicle enters, entrance and exit are closed (red signal).
- Once weighing is complete, green exit signal is given.
- Once the scales are completely relieved, the entrance signal also turns green and the scales are ready for next weighing operation.
- The stoplight can be connected directly to the device without the need for an external control unit.

### Communication with a Computer

JASON was designed as a stand-alone application (operation directly at the device).

Standard weighing functions can be carried out using the computer interface, such as:

- Query weight
- Set / clear tare
- Print / store weight

In this case, weighing processes and file management are carried out in the computer system. JASON allows manual backup operation.

### A/D Converter DISOBOX

Optionally, up to two external legal-for-trade DISOBOX A/D converters can be connected to the DISOMAT. If so, they would replace the internal measuring channels. In this 'mechatronic' design, the A/D converters are located directly on the scales, ie. beneath the weighbridge. Data is communicated serially and thus also safe from disruptions over longer distances.

### Second Operating Station

A second DISOMAT Tersus can be used as a second, remote operating station ('mirror device').

This function is available in every DISOMAT Tersus housing variant. The operator has an identical display and keyboard to the main device, also with the removable alpha-keyboard, if desired.

Printer, computer connection etc. can also be controlled using the second operating station rather than the main device, if desired.

Design	Order number
Complete Package: DISOMAT® Tersus JASON, VTG 20450 desktop device with road weighbridge application program and remote swivel keyboard, no printer.	On request
Or: Package as described above, with an additional integrated VMM 20450 legal-for-trade memory (128MB = approx. 3 Mio. weighings).	On request
Or: Package as described above, with no legal-for-trade memory but with a DISOPRINT 331 printer.	On request

Options
Secondary- and Large-size Display Units as per technical data sheet BV-D2003
Stoplights system BV-D2296
Gates System BV-D2298

Two measuring-channels model and other configurations available on request

### Schenck Process GmbH

Pallaswiesenstr. 100  
Darmstadt, Germany 64293  
T +49 6151 1531-1216  
F +49 6151 1531-1172  
sales@schenckprocess.com  
www.schenckprocess.com



## DISOMAT<sup>®</sup> Tersus — HERMES Dynamic Axle Load Scales



- **Dynamic Weighing of Road Vehicles**
- **Automatic, Operator-Free Weighing with no Need to Alight or Stop**
- **Monitoring of Axle Loads and Overall Loads While Crossing**
- **Calculation of Weight and Speed Regardless of Drive-Through Direction**
- **Axle Loads and Speed Displayed on an Interactive Terminal**
- **Stoptlights System for Controlling Vehicles**
- **Variable Print Formatting**

### Application

Hermes is a dynamic Weighing system for weighing road vehicles axles. The axle load scales are ideal for situations where there is, for example, insufficient space to install vehicle scales and if the scales are not required to perform further calculations. Whereas a vehicle on a static axle loads scales must come to a full stop, the dynamic scales can weigh vehicles as they drive slowly across. The weight is calculated by automatically adding the axle loads. The calculated data can be recorded onto a printer or an electronic storage medium. Alternatively, the system can also be connected to an on-site computer system via a number of possible interfaces.

### Equipment

The system is supplied with the DISOMAT<sup>®</sup> Tersus weighing electronics and the software package for HERMES. The weighing system attached to the scales can filter interfering factors out with the use of a number of variable parameters and can also determine vehicle speed in addition to the weight. The maximum vehicle speed can be up to 13 km/h. The accuracy depends heavily on the road holding in front of and behind the weighbridge. The results are influenced by the construction (axle suspension, suspension characteristics) of the vehicles to be weighed, as they are not positioned entirely on the scales.

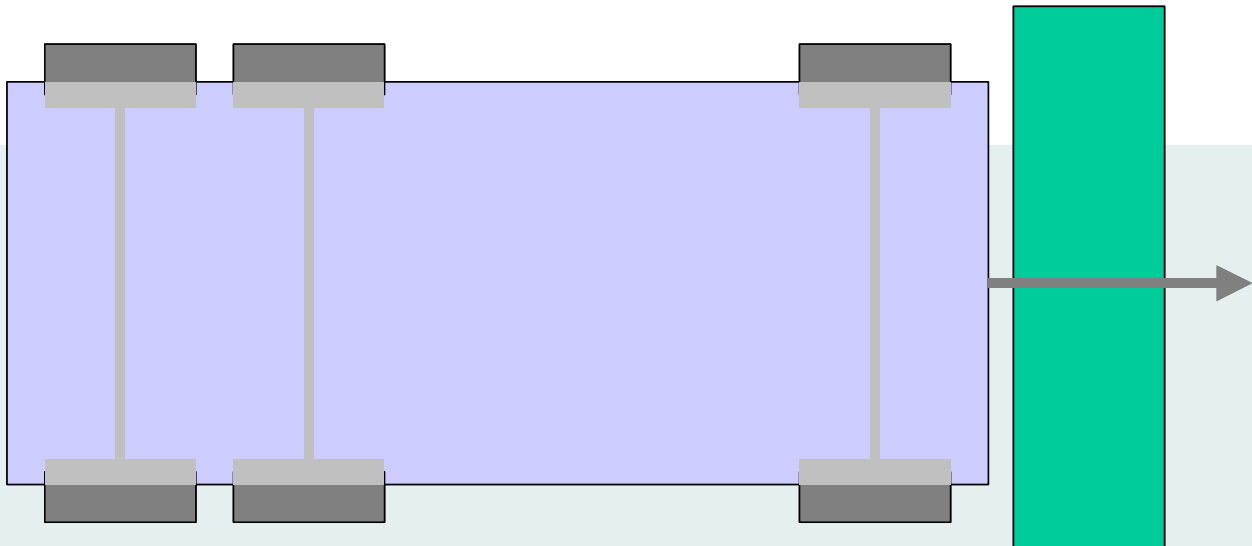
### Function

HERMES comprises the basic functions:

- Calculation, monitoring and display of axle loads and overall loads
- Input of the vehicle license number
- Contact settings for "Ready", "Weighing Valid", "Weighing Invalid", "Too Heavy"
- Calculation of speed
- Calculation of weight, regardless of the direction of travel
- Drive-through controlled by a stoptlights system

Further features that may be selected:

- Fully automatic weighing process (automatic, operator-free weighing with no need to alight or stop)
- Connection to a computer/PDA system



### Technical Data

Installation length of the dynamic scales	Bridge length may be adjusted in the software program
Weighing range per axle	Model 15 t - 20 t
Weighing operation	Dynamic
Weighing accuracy	The axle-load weighing accuracy depends on the local conditions of the scales, in particular on the even surfaces in front of and behind the scales.
Scales' speed range	2 to 13 km/h

**Schenck Process GmbH**  
 Pallaswiesenstr. 100  
 64293 Darmstadt, Germany  
 Phone: +49 6151 1531-1216  
 Fax: +49 6151 1531-1172  
 sales@schenckprocess.com  
 www.schenckprocess.com

## A/D Converter DISOBX® Plus



- **Local weighing electronics IP66**
- **One measuring channel per load cell**
- **Can monitor individual load cells**
- **Electronic corner adjustment**
- **Digital transmission of measured values**
- **Fieldbus connection**
- **All components can be replaced without requiring or reverification recalibration**
- **Can be combined optimally with Schenck Process weighing electronics, legal-for-trade PC programs or standard PLCs**

### Application

The Schenck Process DISOBX Plus is a multi-channel, on-site analog-digital converter unit.

The output signal of each load cell connected is digitized separately.

This allows the measuring voltage of each individual load cell to be accessed at any time – for many applications an invaluable advantage:

- in commissioning (analysis of dead weight distribution, electronic corner adjustment)
- in operation (analysis of the load distribution on the scales, load cell monitoring)
- and in case of a fault (rapid identification of the components affected)

The digital transmission through a standard fieldbus system is fast, fail-safe and easy to project.

These features make the DISOBX Plus an ideal data recording and control unit for weighing systems – in combination either with Schenck Process DISOMAT® series weighing terminals, or with PC-based weighing systems or PLC controllers.

Typical applications are:

- Road weighbridges
- Bin weighers
- Security relevant overload control systems as per EN ISO 13849

However, the integrated scales functions also enable the device to be operated as a multi-channel scale indicator for, for example, a series of simple bin weighers.

### Equipment

The DISOBX Plus has up to 8 measuring channels (model-dependent). One load cell can be connected to each channel. The fact that each individual signal can be accessed individually allows each load point to be calibrated separately (electronic corner adjustment) without requiring the box to be opened, without plugging, soldering, ...

Each channel has its own high-resolution analog/digital converter (not a multiplexer). This makes the DISOBX Plus also suitable for measuring and controlling fast sequences – e.g. of feeds.

The integrated I/O signals allow direct control of time-critical signals such as an overload shutdown by bypassing the connected control systems.

The individual load cell signals can also be accessed separately during operation, in order to e.g. monitor the sensors or, in case of a fault, to localize quickly the source of the fault.

Integrated diagnostics functions in the DISOBOX Plus allow automatic monitoring of the load cell zero-point and the load distribution on the scales.

Individual measuring channels can be bundled together to form a maximum of eight independent groups. Each group corresponds to a complete, legal-for-trade scales, with:

- Filtering of the weight values
- Status determination (idle, ...)
- Tare memory
- Zeroing
- Multi-range / multi-interval function (3 ranges)
- Zero tracking
- ...

### Communication

All measured values (channel values and scales weights) can be transmitted on to higher-level systems through the serial interface.

The optional cards available allow adaptation to all standard industry communication systems. Available at this point in time are:

- PROFIBUS DP-V0, data width 256 Byte, max. data transfer rate 12 Mbaud
- DeviceNet

The Modbus-RTU protocol can be connected via the internal serial interfaces directly.

The following protocols are supported by the permanently installed Ethernet interface

- Modbus-TCP
- UDP
- EtherNet/IP (optional)

The Ethernet interface can also be used to configure the device.

Key advantages of communication via Ethernet are the ability to use existing network infrastructures, the high data transfer rate and parallel access of multiple partners to a device (e.g. to make a diagnosis during normal system operation). (External access via internet can of course be restricted as desired or disabled completely by introducing the appropriate privileges).

The DISOBOX Plus serial interfaces are not reserved for communication with the plant control system. Other peripheral devices can also be connected, such as:

- Serial I/O expansion
- Second display or large display
- Printer

### Inputs/Outputs

The DISOBOX Plus inputs and outputs (6 inputs/6 outputs, 24 VDC) also allow direct, local process control, in the form of overload messages, feed contacts or release signals.

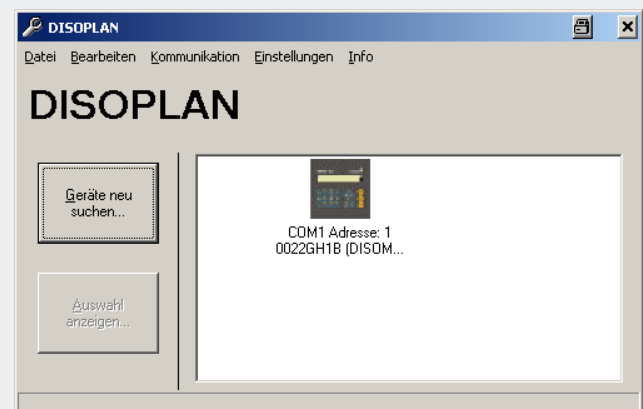
### Configuration/Calibration

Used in combination with Schenck Process systems (DISOMAT, PC programs, DISOVIEW X), configuration and calibration are usually performed using the connected master. The configuration program DISOPLAN® is used for comprehensive configurations or if the DISOBOX is used in conjunction with third-party systems. It allows access to all parameters for the complete calibration and can indicate weight values if required.

Furthermore, the complete status of a DISOBOX Plus can be read out (backup) and loaded (restore) into a similar device or a replacement if necessary.

DISOPLAN runs on the platforms Windows 7, 8 and 10. It communicates with the DISOBOXes either:

- Point-to-point
- Via an RS485 bus
- Via Ethernet



### Legal-for-Trade Verification

The DISOBOX Plus has EU certification as a legal-for-trade weighing system, both as an A/D converter in combination with a DISOMAT Tersus or the Schenck Process PC software DISOVIEW X or as a stand-alone scales, for instance in combination with a suitable display and operating console.

The certification allows that in case of a fault the complete active electronics can be replaced without the need for adjustment or a re-calibration – all adjustment and calibration parameters are stored in a non-volatile memory in the passive part of the system. Together with the DISOPLAN backup/restore function, this allows downtimes to be avoided effectively.

The system's sealing concept, with no jumpers, normally allows it to keep the DISOBOX always closed. Parameterization and adjustments are made through the serial interface, the legal-for-trade protection is performed by a change counter for the relevant parameter. This removes the risk dirt or moisture entering the electronics during maintenance or calibration.



## DISOVIEW X

Many data-intensive weighing applications, such as road weighbridges or batching systems, today use a PC as a high-performance and comfortable operator guidance – usually in combination with conventional weighing electronics to implement the legal-for-trade display and the data storage.

The combination of DISOBOX Plus with the legal-for-trade scales program DISOVIEW X opens up a range of new possibilities.

- The DISOBOX is located on-site at the scales
- Data is transmitted digitally to the PC interference-free
- There are no additional devices next to the PC to cause interference
- DISOVIEW X displays the legal-for-trade, comfortable and flexible scales directly on the PC monitor
- The DISOVIEW X application interface allows simple access from the operator program to the data and the scales functions

DISOVIEW X can display any number of legal-for-trade scales.



## Accessories

The DISOBOX Plus is powered by a nominal 24 VDC (permissible range 18 - 36 V). This power will often be available on-site.

However, up to three DISOBOXes can be supplied by the VNT 20410 supplementary power supply unit. The VNT 20410 can also convert a serial RS232 interface (PC COM) to RS485. This allows a DISOBOX to be located at a distance of 300 m away.

There is also a scales simulator to test the hardware and the process flow, the VWZ 21000, with which up to 8 load cells can be simulated individually.

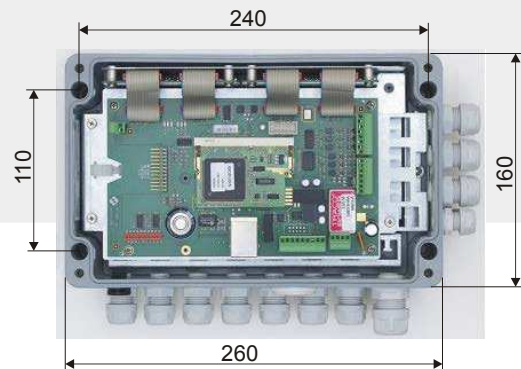
DISOBOX Plus units with integrated overvoltage protection for the load cell connections as an optional extra are also available.

## Non-Standard Applications

In addition to the weighing applications already described, the DISOBOX can also provide solutions to tasks that cannot be solved using conventional weighing electronics.

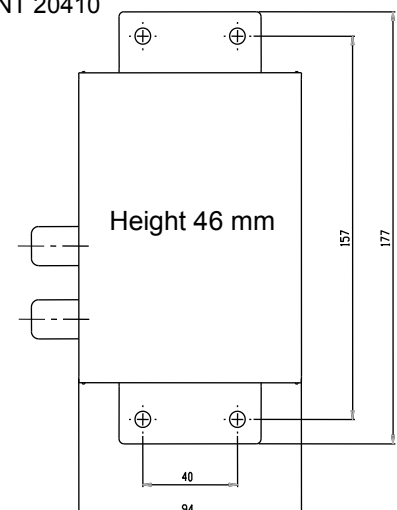
- If one does without the individual load cell monitoring option, a group of load cells can be attached to each measuring channel instead (attention must be paid to the overall impedance).
  - In this case, a DISOBOX Plus can measure the weight of up to eight scales (e.g. surge hoppers) and transmit the data to a control system.
  - The fact that each measuring channel can be configured individually means that the DISOBOX Plus allows scales to be constructed with load cells of differing rated capacities or sensitivities, e.g. for systems with greatly differing loads at the individual points of support.
  - This feature allows, for example, the repair of systems with load cells that are no longer available. Instead of having to completely re-equip the scales with new sensors, now the defective load cell can simply be replaced (any restrictions that may apply due to the permissible combination of load cells used must be considered in legal-for-trade systems).
- The DISOBOX Plus is installed in the place of the previous junction box. In many cases even the old measurement cable for serial data transmission can be retained. This can turn a necessary repair into an attractive upgrade.

- Plastic housing



Height: 90 mm Mounting material supplied

- Stainless steel housing: 300 x 200 x 121 mm (L x W x H), fastened with 4 clips, hole distance 330 x 144 mm, max. bolt diameter 10 mm
- Power supply unit VNT 20410





## Technical Data

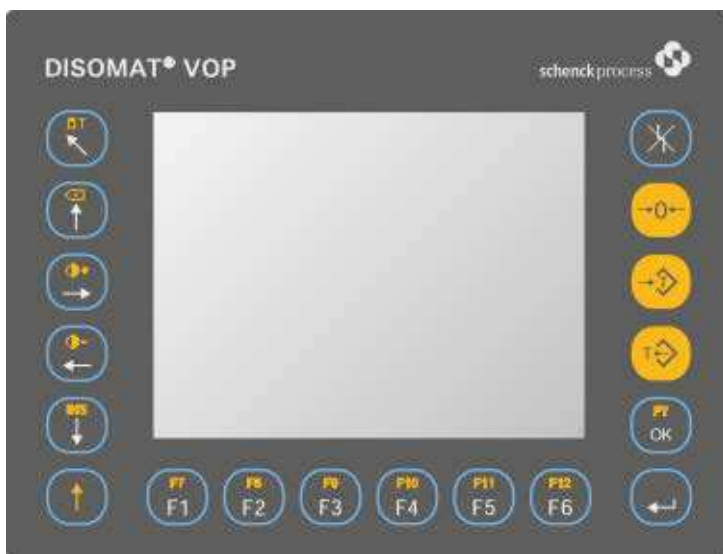
Date	Value
Processor	ARM-9 high-performance controller
RAM	32 MB
Flash	8 MB
EEPROM	16 kB
Clock	Real-time clock, 2 weeks back-up time
Display	None
Keyboard	None
On-site housing	Plastic, plastic cable screw connections, protection class IP66, impact-resistance 7 Joule.
Optional	Stainless steel 1.4301, brass screw connections
No. of measuring channels	4 to 8, model dependant
Load cell power supply	5 VAC
Load cell impedance per channel	44 ... 4000 Ω
Total impedance	>44 Ω
Input signal per channel	0 ... 19 mV
Scan rate	132/s per measuring channel
Connections	4- or 6-wire
Scales	max. 8, the measuring channels can be freely assigned to the scales
Minimal signal voltage	$0.5 \mu\text{V}/d * \sqrt{n}$ n: number of measuring channels per scales
Number of digits in legal-for-trade operation	$N \leq 10,000 d$
Multi-range-/ Multi-interval scales	3 ranges, with each $N \leq 8,000 d$ $E_{\text{max.}} / d_{\text{min.}} \leq 15,000 d$
Linearity error	<0.05 ‰
Zero point stability, $Tk_0$	<0.6 μV / 10 K <0.03 ‰ / 10 K with reference to the max. input voltage
Range error, $Tk_c$	<0.03 ‰ / 10 K
Combined error $F_{\text{comb}}$	<0.08 ‰ / 10 K
Supply voltage	24 VDC (18 ... 36 V)
Power requirement	max. 5 W
Temperature range	Service temperature: -30 °C to +60 °C (legal for trade: -30 °C to +50 °C) Storage temperature: -30 °C to +60 °C
Electro-magnetic environment	E2 (OIML D11)
Binary outputs	6 x 24 VDC isolated, max. 100 mA 2 x 3 each with common root
Inputs	6 x 24 VDC isolated, with common root
Serial port	S1: RS485-2-wire DC isolated S2: RS485-2-wire DC coupled S3: RS232 DC coupled 9,600 ... 115,000 Baud
Ethernet interface	Full duplex 100 MBaud
USB interface	1 x USB 2.0 Host
Fieldbus protocol	Modbus, Modbus-TCP
Optional	PROFIBUS PROFINET I/O DeviceNet EtherNet/IP

Equipment Supplied	Type	Material Nr.
<b>Basic Units</b>		
DISOBOX base unit, A/D converter unit with 8 measuring channels	VME 21080	V081000.B01
DISOBOX base unit, A/D converter unit with 4 measuring channels	VME 21040	V081001.B01
DISOBOX, A/D converter unit with 8 measuring channels for ATEX category 3D	VME 21080-3D	V081100.B01
DISOBOX, A/D converter unit with 4 measuring channels for ATEX category 3D	VME 21040-3D	V081101.B01
DISOBOX, A/D converter unit with 8 measuring channels for ATEX category 2D	VME 21080-2D	V081102.B01
DISOBOX basic unit, A/D converter unit with 8 measuring channels and overvoltage protection for the load cell connections	VME 21081	V081003.B01
DISOBOX basic unit, A/D converter unit with 4 measuring channels and overvoltage protection for the load cell connections	VME 21041	V081004.B01
DISOBOX basic unit, A/D converter unit with 8 measuring channels, stainless steel housing	VME 21084	V081005.B01
DISOBOX basic unit, A/D converter unit with 4 measuring channels, stainless steel housing	VME 21044	V081006.B01
<b>Bus Cards</b>		
Optional PROFIBUS, mounted and wired	VPB 28020	V081904.B01
Optional PROFINET, mounted and wired	VPN 28020	V533496.B01
Optional DeviceNet, mounted and wired	VCB 28020	V081906.B01
Optional interface expansion, mounted and wired	VSS 28020	V081905.B01
<b>Analog I/O</b>		
Analog Input	VAI 20100	V078800.B01
Analog Output 0 - 20 mA, max. 11 V	VAO 20100	V078801.B01
Analog Output 0 - 10 V, max. 50 mA	VAO 20101	V078802.B01
<b>Accessories</b>		
Power supply unit/ serial adapter IP20	VNT 20410	V028209.B01
Load cell simulator, 8 channel	VWZ 21000	V081029.B01
DISOPLAN	VPL 20430	V029764.B01
Grounding angle for fitting the PEL connections of the load cells		V035403.B01

### Schenck Process Europe GmbH

Pallaswiesenstr. 100  
64293 Darmstadt, Germany  
T +49 6151 1531-0  
F +49 6151 1531-66  
sales@schenckprocess.com  
www.schenckprocess.com

## Display and Operator Panels VOP 280xx/VFG 28000 Keyboard VTT 28000



- **Display and Operating Terminal for DISOMAT®/DISOBOX®**
- **As a Front-of-Panel, Table, Hand-Held or Field Device**
- **Contrast-Rich LCD Display, Suitable for Daylight**
- **Built-In Keyboard**
- **Enlarged Keyboard (Optional)**
- **Protection Class IP65**
- **Approved for Legal-for-Trade Operation**

### Application

The equipment of the VOP 28000/ VFG 28000/VTT 28000 series is used as display and control terminals for the weighing terminals of the DISOMAT® and DISOBOX® types. The VOP is the main - Legal-for-trade - display of a DISOBOX® Plus. Its built-in flexible membrane keyboard allows you the entire range of scale operation.

The VOP is used as a remote second control terminal on a DISOMAT® Tersus 'its mirror'. This makes it possible to visualise and operate the scale from a second work station.

Applications could be e.g.:

- Alternating operator's workplaces
- Operated by the set-up man and plant operator
- Mounting the terminal in a remote control room

The VOP can also be used as a secondary display for all DISOMAT® and DISOBOX® units (including older types) without an operating unit (DTA mode).

### Construction

VOP equipment is available as:

- Front-of-panel unit (Frontal IP65/NEMA 4X)
- A portable plastic unit with a cable (IP65) or with a storage battery and Bluetooth connection
- Stainless steel unit for desktop- or wall-mounting (IP65)
- Stainless steel field unit for wall-mounting incl. VTT 28000 keyboard and additional operating buttons.

The backlit, transfective LCD display in QVGA format (320 x 240 pixels) ensures excellent legibility both indoors and outdoors in full sunlight.

The devices can be supplied either with 24 VDC or mains voltage. The auxiliary voltage of a DISOMAT® Tersus can be used directly as a power supply. A serial RS485 connection is available as the interfaces to the weighing electronics – another option is using the permanently integrated Ethernet connection.

The integrated USB connection allows the use of a PC keyboard.

### Function

The screen of the VOP shows a 1:1 copy of the display of a DISOMAT® Tersus in its mirror function. This is why using the unit as a second control terminal does not require the operator to change habits in any way.

In this operating mode, the buttons on the VOP function parallel to those of the main unit because the button symbols were kept identical. You key in numbers with the 12 function keys and you can overlay help wherever needed.

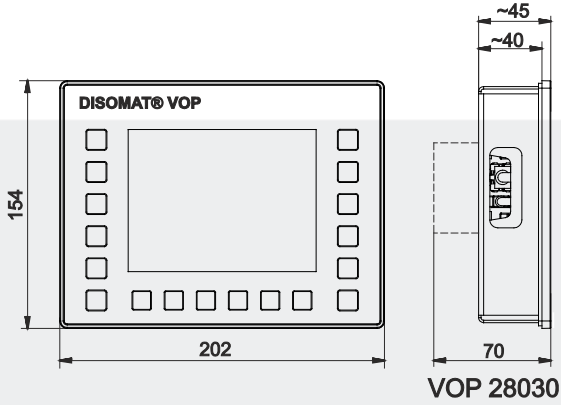
If numerical inputs frequently are required we recommend the use of the optional keyboard VTT 28000 with numerical 10-digit block (identical dimensions to VOP). Occasional α-entries also are possible using the VTT.

A standard off-the-shelf USB keyboard of any kind can be used for more comprehensive text entries.

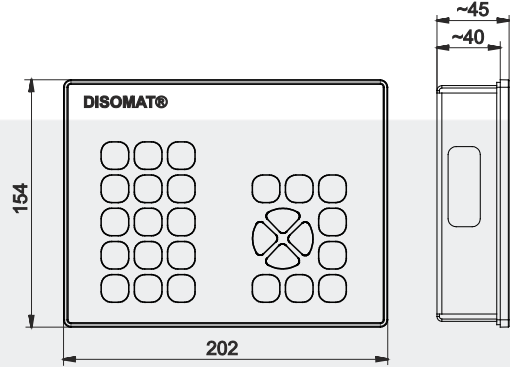
It shows the weight of a DISOMAT® unit in large letters in the secondary display operating mode although no input is possible. This operating mode can also be combined with other DISOMAT® units.

**Dimensional Drawings [mm]**

**Front-of-Panel Unit VOP 28000/28030**

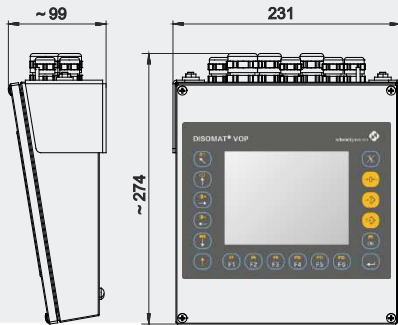


**Keyboard VTT 28000**

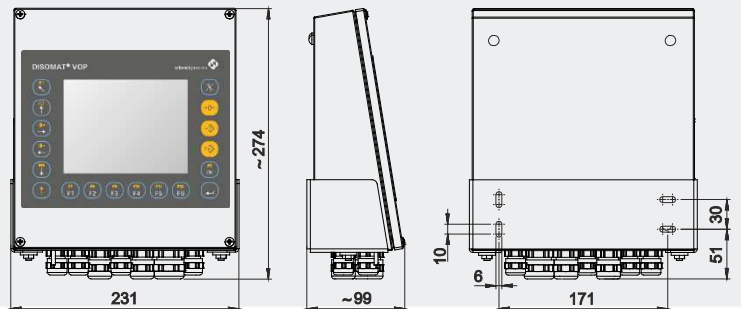


**VOP 28040**

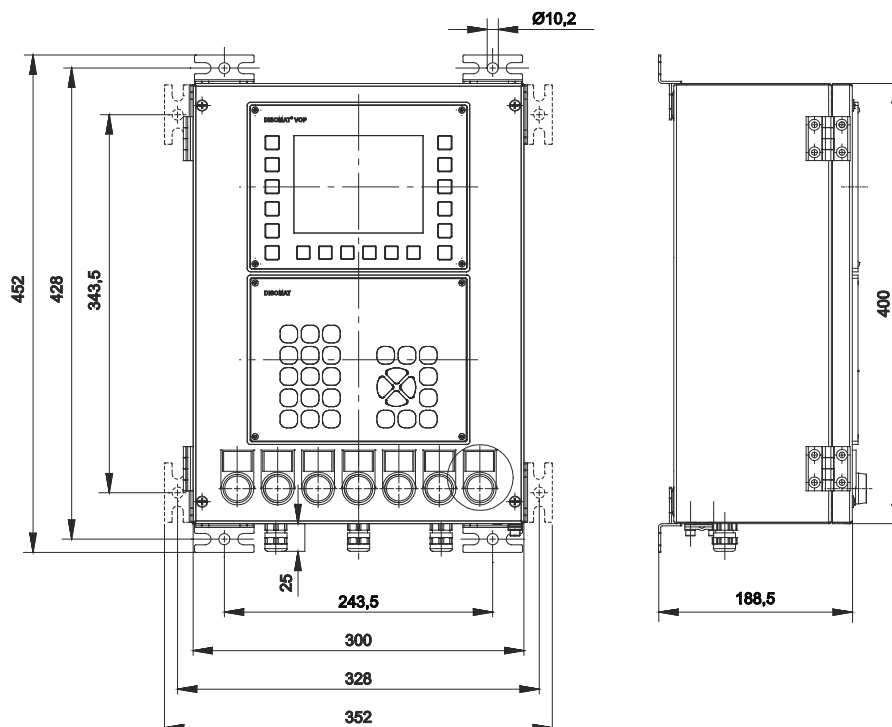
**Desktop**



**Wall-Mounting**



**Field Device VFG 28000**



## Technical Data

### Front-of-Panel Unit VOP 28000, VOP 28030/Hand-Held Unit VOP 28010

External dimensions [mm] Width x Height x Depth	202 x 154 x 45 <sup>+5</sup>
Panel cutout [mm] as per DIN IEC 61554	186 <sup>+1.1</sup> x 138 <sup>+1.1</sup> ; Panel thickness max. 5
Hand-Held unit Width x Height x Depth [mm] Weight	202 x 154 x 50 1.5 kg
with power supply unit VOP 28030 [mm]	202 x 154 x 70
Display	5.7" LCD with graphics capabilities, 320 x 240 pixels (QVGA), transfective
Keyboard	Membrane keyboard, 18 keys of which 12 are configurable function keys
Interfaces	1 x Ethernet RJ45 (10/100 MBaud, protocol Modbus-TCP) 1 x RS485-2-wire for communication over greater distances 1 x RS232 for external PC keyboard (or TTL for DTT 20) 1 x USB (for external PC keyboard)
Supply voltage	24 VDC (Range: 18 ... 36 VDC); VOP 28030: 85 ... 264 VAC, 47 ... 63 Hz
Protection class: Front-of-panel unit Hand-held unit	Front: IP65, NEMA 4X; Rear: IP20 IP65
Temperature ranges	Operating temperature: -20 °C ... +60 °C Legal-for-trade: -10 °C ... +40 °C

### Keyboard VTT 28000

External dimensions [mm] Width x Height x Depth	202 x 154 x 45 <sup>+5</sup>
Panel cutout [mm] as per DIN IEC 61554	186 <sup>+1.1</sup> x 138 <sup>+1.1</sup> ; Panel thickness max. 5
Display	No display
Keyboard	Membrane keyboard, 27 keys
Interfaces	1 x RS232 for the connection to VOP
Cable	Front-of-panel version: 1 m cable permanent plug connection to the VOP
Supply voltage	Supply is sourced from the VOP
Protection class	Front: IP65, NEMA 4X Rear: IP20
Operating temperature	-20 °C ... +60 °C

### Desktop or Wall Mounting VOP 28040

External dimensions [mm] Width x Height x Depth	231 x 99 x 274
Display	5.7" LCD with graphics capabilities, 320 x 240 pixels (QVGA), transfective
Keyboard	Membrane keyboard, 18 keys of which 12 are configurable function keys
Interfaces	1 x Ethernet RJ45 (10/100 MBaud, protocol Modbus-TCP) 1 x RS485-2-wire for communication over greater distances 1 x RS232 for external PC keyboard (or TTL for DTT 20) 1 x USB (for external PC keyboard)
Supply voltage	85 ... 264 VAC, 47 ... 63 Hz; Alternatively: 24 VDC (Range: 18 ... 36 VDC)
Protection class	IP65, NEMA 4X
Operating temperature	-20 °C ... 60 °C

### Field Unit VFG 28000

External dimensions [mm] Width x Height x Depth	352 x 452 x 188.5
Display	5.7" LCD with graphics capabilities, 320 x 240 pixels (QVGA), transfective
Keyboard	Membrane keyboard, 18 and 27 keys of which 12 are configurable function keys
Interfaces	1 x Ethernet RJ45 (10/100 MBaud, protocol Modbus-TCP) 1 x RS485-2-wire for communication over greater distances 1 x RS232 for external PC keyboard (or TTL for DTT 20) 1 x USB (for external PC keyboard)
Control button	7 x Functions, individually configurable
Supply voltage	24 VDC (Range: 18 ... 36 VDC); VOP 28030: 85 ... 264 VAC, 47 ... 63 Hz
Protection class	All sides: IP65, NEMA 4X
Operating temperature	-20 °C ... 60 °C

### Order Numbers

Design	Material Number
VOP 28000 display and operating unit, front-of-panel unit, plastic front frame, 24 VDC	V078510.B01
VOP 28030 display and operating unit, front-of-panel unit, plastic front frame, 85 ... 264 VAC	V078513.B01
VOP 28010 display and operating unit, hand-held unit (mobile version), plastic housing, 24 VDC	V078511.B01
VOP 28040 display and operating unit, desktop or wall-mounted, incl. wall bracket, stainless steel housing, 85 ... 264 VAC	V078514.B01
VOP 28040-3D display and operating unit, ATEX category 3D (Zone 22), desktop or wall-mounted, incl. wall bracket, stainless steel housing, 85 ... 264 VAC	V078529.B01
Keyboard VTT 28000	V081929.B01
VFG 28000 display and operating unit, field unit, stainless steel, incl. VOP 28000, VTT 28000 and 7 operating buttons	V577415.B01
VFG 28000 display and operating unit, field unit, stainless steel, incl. VOP 28030, VTT 28000 and 7 operating buttons	On request

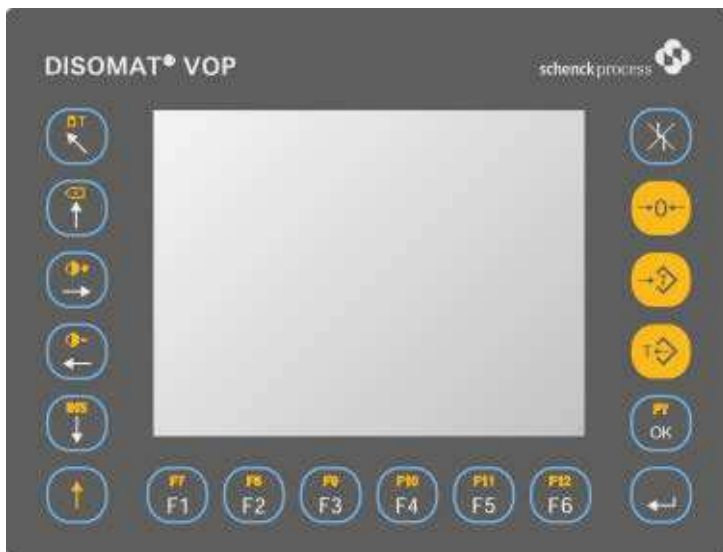
VOP/VTT 28090 2GD display and operating unit for use in explosion-hazard areas, see data sheet BV-D2422.

### Schenck Process Europe GmbH

Pallaswiesenstr. 100  
64293 Darmstadt, Germany  
Phone: +49 6151 1531-0  
Fax: +49 6151 1531-66  
sales@schcnckprocess.com  
www.schenckprocess.com



## Display and Operating Panels VOP 28090/VFG 28090 ATEX 2GD Keyboard VTT 28090 ATEX 2GD



- **Display and Operating Terminal for DISOMAT®/DISOBOX®**
- **Suitable for Explosion-Hazard Environments defined by ATEX Category 2 GD (Zone 1 or 21)**
- **Front-of-Panel or Field Device**
- **Built-in Keyboard**
- **Enlarged Keyboard (Optional)**
- **Protection Class IP65**
- **Approved for Legal-for-Trade Operation**

### Application

Operation in explosion-hazard areas. The equipment of the VOP 28090/VFG 28090/VTT 28090 series is used as display and control terminals for the weighing electronics of the DISOMAT® and DISOBOX® types.

The control electronics itself is installed in the safe area. This creates a second operating station in the safe area for one DISOMAT® Tersus. For the DISOBOX® Plus the VOP is the (legal-for-trade) main operating station.

For all DISOMAT® and DISOBOX® devices (including older types) the VOP also can be used in the explosion-hazard area as a secondary display with no operating functions (DTA mode).

### Construction

VOP equipment is available as:

- Front-of-panel unit (frontal IP65/NEMA 4X)
- Stainless steel field device for wall-mounting incl. VTT 28090 keyboard and additional operating buttons.

The backlit, transfective LCD display in QVGA format (320 x 240 pixels) ensures excellent legibility.

The devices can be supplied with 24 VDC ±10 %. A serial RS485 connection is available as the interface to the weighing terminal.

A big advantage of the VOP 28090 is the protection class used, 'encapsulation' (Ex m). It allows the device to be connected in an explosion-hazard area WITHOUT requiring safety barriers or switch amplifiers.

### Function

The screen of the VOP shows a 1:1 copy of the display of a DISOMAT® Tersus in its mirror function. Thus the user does not need to learn to use a new device.

In this operating mode, the buttons on the VOP function parallel to those of the main unit because the button symbols were kept identical. You key in numbers with the 12 function keys and you can overlay help wherever needed.

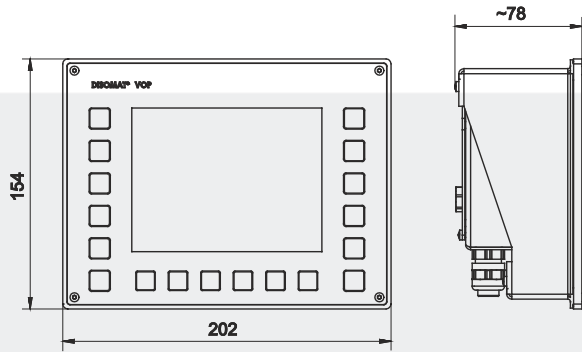
If numerical inputs frequently are required we recommend the use of the optional keyboard VTT 28090 with numerical 10-digit block (identical dimensions to VOP). Occasional α-entries also are possible using the VTT.

It shows the weight of a DISOMAT® unit in large letters in the 'secondary display' operating mode although no input is possible. This operating mode can also be combined with older DISOMAT® units.

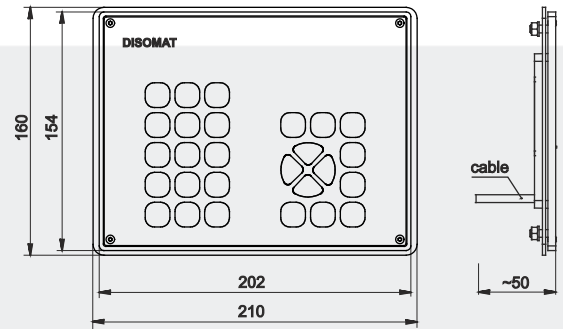
The large buttons of the field device can be assigned flexibly to the device functions.

## Dimensional Drawings [mm]

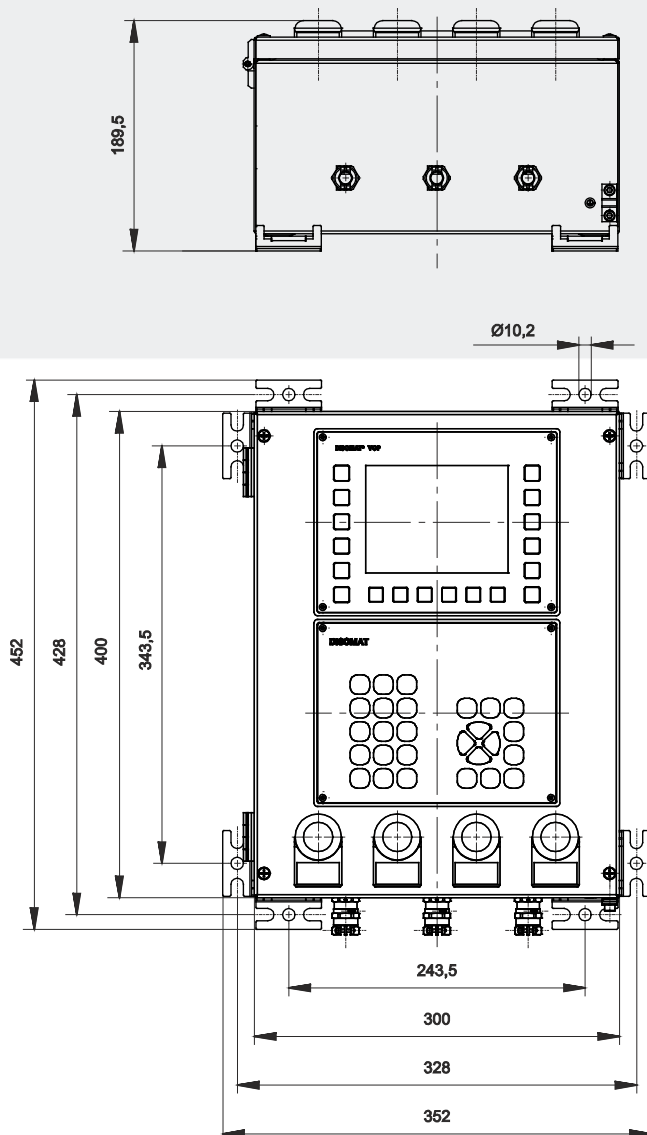
### Front-of-Panel Unit VOP 28090



### Keyboard VTT 28090



### Field Device VFG 28090





## Technical Data

### Front-of-Panel Unit VOP 28090

External dimensions [mm] Width x Height x Depth	202 x 154 x 78 <sup>+5</sup>
Panel cutout [mm] as per DIN IEC 61554	186 <sup>+1.1</sup> x 138 <sup>+1.1</sup> ; Panel thickness max. 5
Display	5.7", 320 x 240 pixels (QVGA), transfective
Keyboard	Membrane keyboard, 18 keys
Interfaces	1 x RS485-2/4-wire for communicating over longer distances (increased safety, Ex-e) 1 x serial for external keyboard (intrinsically safe, ex i) 7 x parallel for external operating buttons (intrinsically safe, ex i)
Supply voltage	Rated voltage 24 VDC $\pm$ 10 %; typically 3 W
Protection class	Front: IP65, NEMA 4X Rear: IP65
Operating temperature range	-20 °C ... +60 °C

### Keyboard VTT 28090

External dimensions [mm] Width x Height x Depth	210 x 160 x 50
Panel cutout [mm] as per DIN IEC 61554	186 <sup>+1.1</sup> x 138 <sup>+1.1</sup> ; Panel thickness max. 5
Display	No display
Keyboard	Membrane keyboard, 27 keys
Interfaces	1 x serial for the connection to VOP, intrinsically safe
Cable	Front-of-panel version: 1 m cable permanent plug connection to the VOP
Supply voltage	Supply is sourced from the VOP
Protection class	Front: IP65, NEMA 4X Rear: IP20
Operating temperature range	-20 °C ... +60 °C

### Field Device VFG 28090

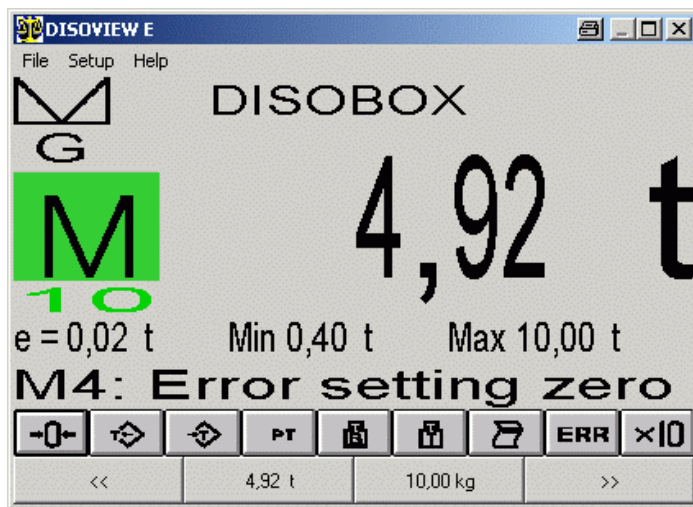
External dimensions [mm] Width x Height x Depth	300 x 400 x 190
Display	5.7", 320 x 240 pixels (QVGA), transfective
Keyboard	Membrane keyboard, 18 and 27 keys
Control button	4 x Functions, individually configurable
Interfaces	1 x RS485-2/4-wire for communicating over longer distances (increased safety, Ex-e)
Supply voltage	Rated voltage 24 VDC $\pm$ 10 %; typically 3 W
Protection class	All sides: IP65, NEMA 4X
Operating temperature range	-20 °C ... +60 °C

## Order Numbers

Design	Material Number
VOP 28090 ATEX 2GD display and operating unit, front-of-panel unit, stainless steel, 24 VDC	V097000.B01
Keyboard VTT 28090 ATEX 2GD	V097001.B01
VFG 28090 ATEX 2GD display and operating unit field device, stainless steel, incl. VOP 28090 and VTT 28090	V559477.B01

VOP/VFG 28000 display and operating unit and VTT 28000 keyboard for use in safe areas, see data sheet BV-D2396.

## DISOVIEW E - The Legal-for-trade Scale Window for Windows PCs



- Legal-for-trade weight display on standard Windows PCs
- Twin-unit functionality
- Legal-for-trade printout
- Convenient print pattern definition
- Network capability
- Intelligent parameter storage concept
- Application interface
- Optional integration of DISOSAVE legal-for-trade memory

### Application

Today, numerous weighing applications ask for a convenient and standardised operator environment and/or access to big memory areas, often distributed in network.

Standard PCs normally operating under Windows are the solution of choice.

Weight displays on such systems are normally designed as non-legal-for-trade secondary displays, so that the main display of a legal-for-trade weighing electronics should be in operator's view.

DISOVIEW E enables the legal-for-trade weight display function to be integrated into a standard PC with no need for a visible secondary display.

### Function

DISOVIEW E is designed to realise a legal-for-trade weight display on a standard Windows PC. The indicated weight can stem from a connected weighing electronics of the DISOMAT type (display function).

In this case, DISOVIEW E can compute and represent the total of various single weights (twin-unit scale function).

Alternatively, DISOVIEW E can receive the measuring signal from local A/D converter modules of the DISOBOX<sup>®</sup> type, and process them to form legal-for-trade weight values.

Up to 16 scales (operating in single or group mode) can be managed and represented.

DISOVIEW E lets your control the displayed scale (Acquire/Clear Tare, Zero Set), and print the weight legal-for-trade.

Combined with DISOBOX<sup>®</sup> units, DISOVIEW E offers convenient support upon parameterisation and calibration:

- individual parameterisation of single measuring channels (of every load cell)
- electronic corner adjustment
- dead load calibration
- range calibration

Integral diagnostic functions enable single load cell signals to be analysed during operation, so that errors and defects can be detected and localised early.

An application interface allows DISOVIEW E to be integrated in complex EDP systems.

Optionally, the legal-for-trade data can be stored in the DISOSAVE legal-for-trade memory and called up at any time for check and/or evaluation.

### Weight Window (Fig. 1)

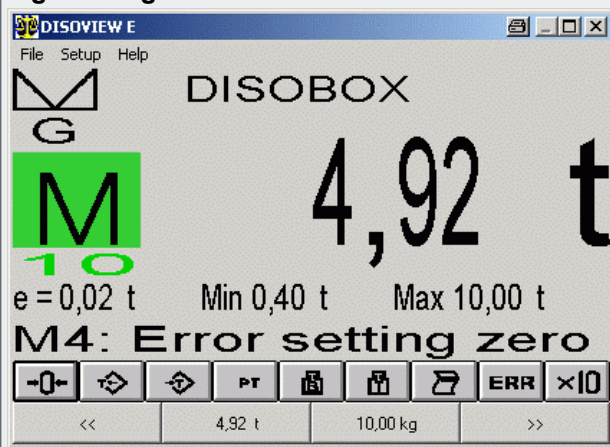
The DISOVIEW E main window represents the weight of the displayed scale complete with further information, e.g. taring status.

The button bar below the weight serves for control of displayed scale.

The lower part of the window lets you see the weights of the residual scales not represented on display. Just click on a weight, and the main display shows the selected scale.

The size of the weight window can be varied to a wide extent. However, it cannot be shifted out of visible screen area nor overlapped by other applications.

**Fig. 1: Weight Window**



### Configuration Window

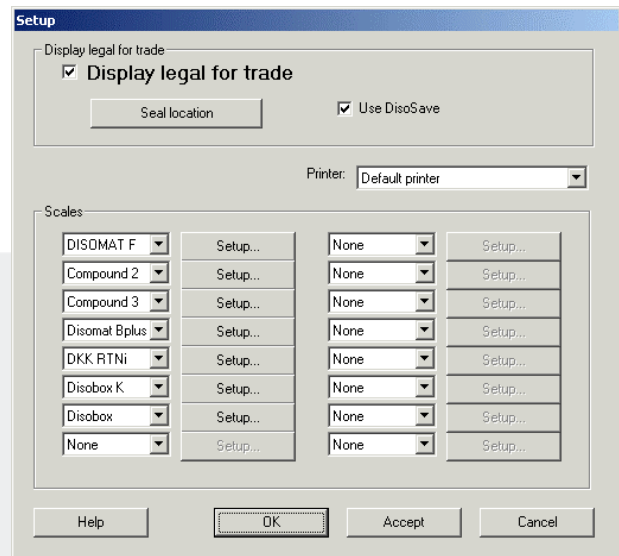
For each of the 16 eligible scales, the configuration dialog (Fig. 2) lets you determine the device to be used for display and/or computation of weights, as well as the device type.

At present, the following scale types are available:

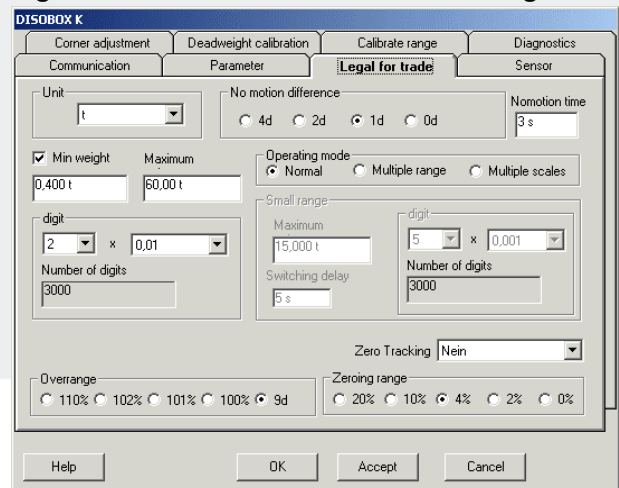
- DISOMAT® B plus / DISOMAT® OPUS
- Twin-unit scale with two platforms
- Combined scale with three platforms
- DISOBX® local A/D converter unit

The type-specific detail images (Fig. 3) let you enter the residual data.

**Fig. 2: Configuration Window**

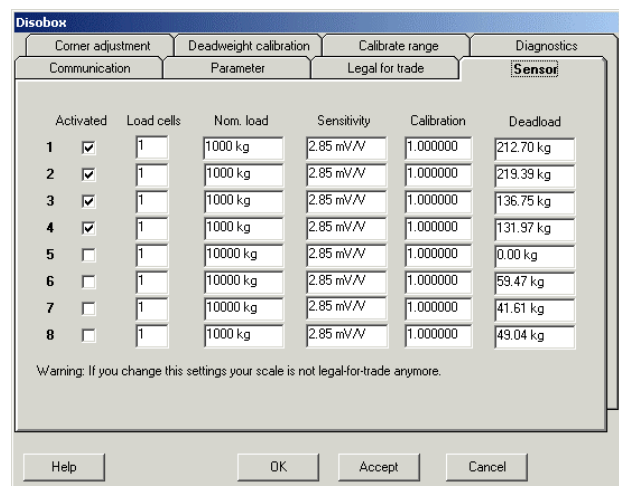


**Fig. 3: Calibration Parameters Detail Image**



### Special Configurations for DISOBX® (Fig. 4-6)

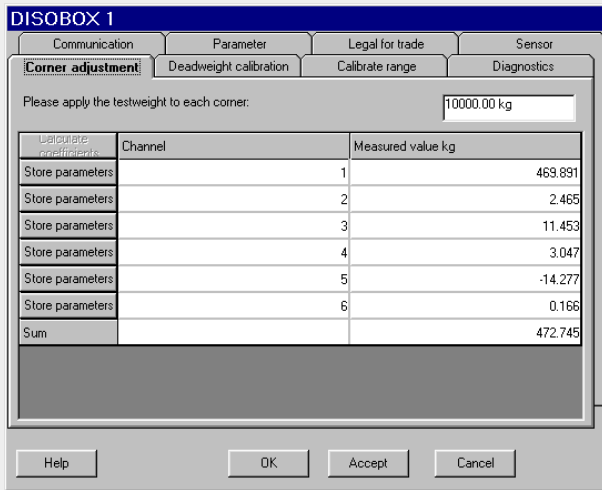
**Fig. 4: Configuration of Load Cell on a DISOBX® Scale**



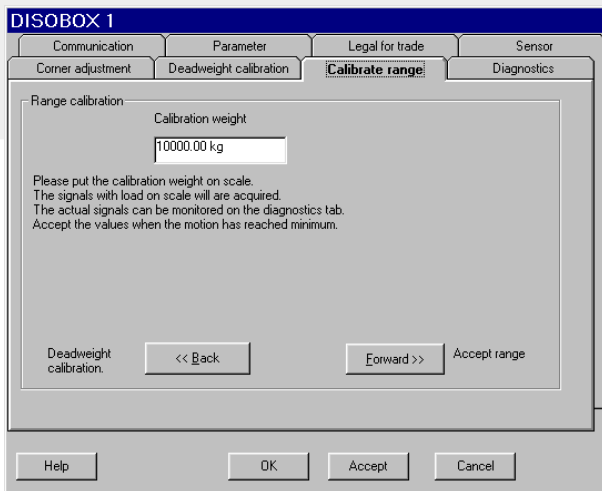
Since every measuring channel is configured individually, basic combinations of various load cells can be formed.

One DISOBOX® allows multiple scales to be operated provided that all scale load cells are connected to the same DISOBOX® unit.

**Fig. 5: Corner Adjustment and Diagnostic Screen for a Scale of DISOBOX®**



**Fig. 6: Range Calibration of a Scale of DISOBOX®**

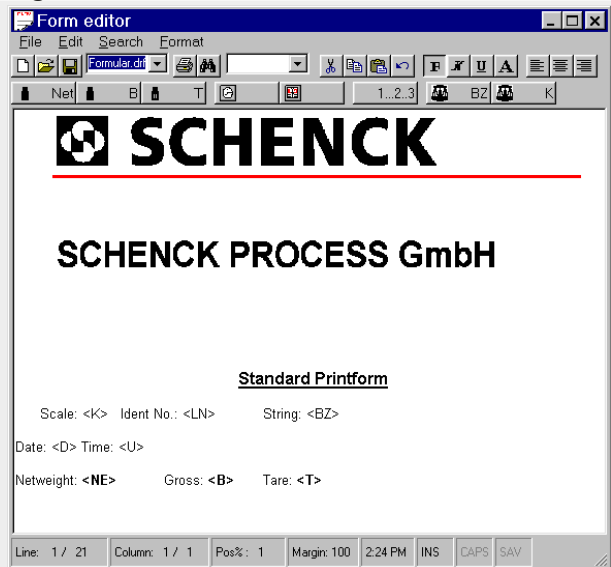


**Form Editor (Fig. 7)**

The form editor lets you design the print pattern for every scale in accordance with your requirements.

Wildcards for different print variables (weight, date, attribute, ...) can be graphically combined to form a print pattern (company logo). The latter is subsequently completed with current values and printed.

**Fig. 7: Form Editor**



**Data Saving Concept**

All DISOVIEW E parameters are stored in PC in a protected file.

This parameter record also includes types and serial numbers of connected devices.

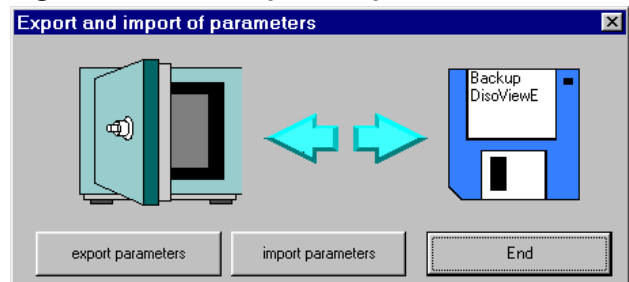
Upon start-up, program checks data record and connected devices. If no error is detected, DISOVIEW E goes to legal-for-trade mode. If data record is faulty or connected devices are not found, program goes to non-legal-for-trade mode. Legal-for-trade weighing and printing is not possible any longer.

This data saving concept enables the complete parameter record to be exported (backup)

(Fig. 8). If required, data record can be imported into another PC using DISOVIEW E.

Simply connect the proper devices, and legal-for-trade weighing is possible. Thanks to this concept, your PC can be exchanged easily, e.g. in case of defect.

**Fig. 8: Parameter Export / Import**



**Network Mode**

A special mechanism for communication between DISOVIEW E and connected scales lets you transport the weigh data through local networks, i.e. the PC the scales are connected to via serial interface needs not be the one DISOVIEW E uses to represent the data legal-for-trade. (Legal-for-trade regulations, e.g. scale display in operator's view, still have to be respected.)

**Variants**

V015516.B01	DISOVIEW E programm package: Installation CD for Windows XP/NT/2000 Manual in German language.
-------------	---

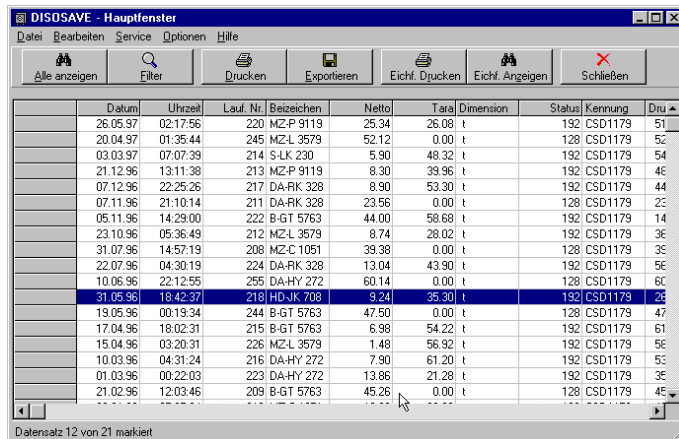
**Special Configurations**

Special configurations of DISOVIEW E are possible, for instance:

- simultaneous representation of weight on multiple PCs, or
- interfacing of scale via Ethernet.

Please ask us for an individual solution, we will gladly provide you with a suggestion.

## DISOSAVE Legal-For-Trade Memory



Datum	Uhrzeit	Lauf. Nr.	Bezeichnung	Netto	Tara	Dimension	Status	Kennung	Dru
26.05.97	02:17:56	220	MZ-P 9119	25.34	26.08	t	192	CSD1179	51
20.04.97	01:35:44	245	MZ-L 3579	52.12	0.00	t	128	CSD1179	52
03.03.97	07:07:39	214	S-LK 230	5.90	48.32	t	192	CSD1179	54
21.12.96	13:11:38	213	MZ-P 9119	8.30	39.96	t	192	CSD1179	46
07.12.96	22:25:26	217	DA-RK 328	8.90	53.30	t	192	CSD1179	44
07.11.96	21:10:14	211	DA-RK 328	23.56	0.00	t	128	CSD1179	22
05.11.96	14:29:00	222	B-GT 5763	44.00	58.68	t	192	CSD1179	14
23.10.96	05:36:49	212	MZ-L 3579	8.74	28.02	t	192	CSD1179	36
31.07.96	14:57:19	208	MZ-C 1051	39.38	0.00	t	128	CSD1179	35
22.07.96	04:30:19	224	DA-RK 328	13.04	43.90	t	192	CSD1179	56
10.06.96	22:12:55	255	DA-HY 272	60.14	0.00	t	128	CSD1179	60
31.05.96	18:42:37	219	HD-JK 706	9.24	65.30	t	192	CSD1179	63
19.05.96	00:19:34	244	B-GT 5763	47.50	0.00	t	128	CSD1179	47
17.04.96	18:02:31	215	B-GT 5763	6.98	54.22	t	192	CSD1179	61
15.04.96	03:20:31	226	MZ-L 3579	1.48	56.92	t	192	CSD1179	58
10.03.96	04:31:24	216	DA-HY 272	7.90	61.20	t	192	CSD1179	53
01.03.96	00:22:03	223	DA-HY 272	13.86	21.28	t	192	CSD1179	38
21.02.96	12:03:46	209	B-GT 5763	45.26	0.00	t	128	CSD1179	45

- Legal-for-trade data storage on standard PC
- Replacement of redundant printer
- Convenient evaluation of data stored

### Application

The DISOSAVE legal-for-trade memory program offers the user the following functions:

- Legal-for-trade storage of weigh data on PC hard disk
- Legal-for-trade display and printout of values stored.

No special measures have to be taken on PC.

DISOSAVE has the EU approval for legal-for-trade data storage. This type of storage provides a high degree of safety where loss or falsification of data is concerned. The combination of standard PC + DISOSAVE establishes the legal-for-trade data memory on the user PC.

### Construction

PC program for WINDOWS NT/XP/2000 designed for legal-for-trade storage of weighing results. Supplied in the form of a CD for installation of the program on a normal PC, complete with WINDOWS help documentation and copying protection.

### Function

#### Legal-for-trade storage of weighing results with DISOSAVE

From the user's view, the storage of weighing results with DISOSAVE does not differ in any respect from the legal-for-trade printout on paper.

The legal-for-trade memory performs the function of the redundant printer (however, it is totally free from maintenance; no paper or ribbon to be changed; no paper jam).

Data storage can be triggered either via an application program on the PC, using Active-X Control VPC 20002, or on the DISOMAT by simple operation of the Print key. DISOMAT can be configured for paper printout or legal-for-trade storage with DISOSAVE.

You can also operate the two output media in parallel.

#### Display / Evaluation of Values Stored

In addition to safe and convenient storage of weighing results, DISOSAVE offers additional functions for display and evaluation of stored data.



The following functions are available:

- Display complete legal-for-trade memory

Screen shows total number of inputs sorted by date/time of storage. Every data record comprises date, time, consecutive number, scale identification, attributes, net and tare values, and formatted print string.

- Display selected inputs

Using the filter function, you can visualize selected inputs stored, e.g. :

- Date
- Time
- Consecutive number
- Strings included in attributes
- Strings included in print string

On the right you can see a sample screen showing all 1996 inputs filtered by Darmstadt vehicles (-DA attribute).

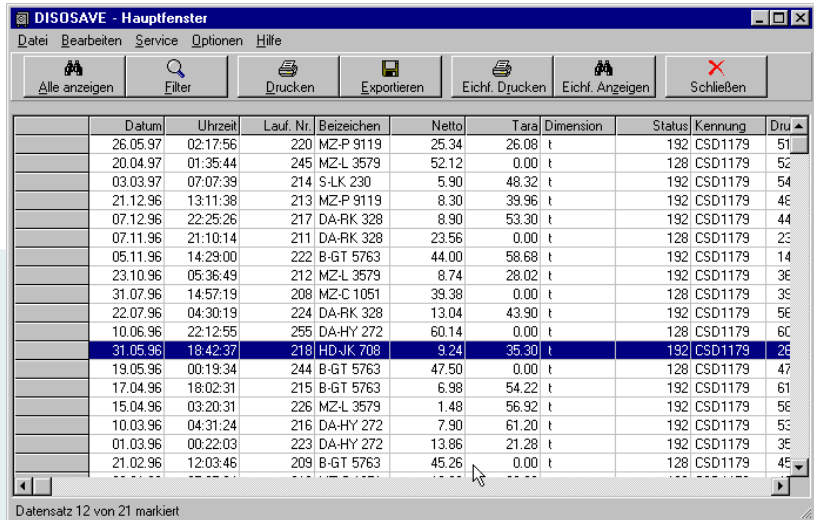
The values represented on screen (possibly pre-selected via filter function) can be printed on a printer connected to PC. You can also mark a data block by mouse operation and print this partial record. In the same way, you can export data into other applications in form of an ASCII file.

DISOSAVE can be parametrized such that older data records stored are automatically deleted upon program start or after user's acknowledgement. Storage time can be set at will. However, the 3-month minimum period required in accordance with weights and measures regulations is ensured in all cases.

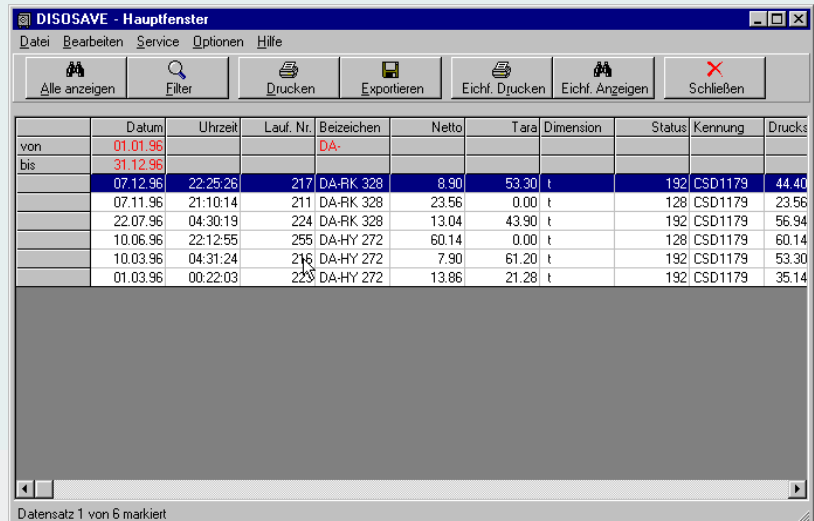
## Report

The Report function allows the data stored legal-for-trade to be recorded daily in form of an ASCII file for non-legal-for-trade evaluation and further processing with the use of other programs.

A new file is generated daily and includes all data acquired this very day.



Datum	Uhrzeit	Lauf. Nr.	Beizeichen	Netto	Tara	Dimension	Status	Kennung	Dru
26.05.97	02:17:56	220	MZ-P 9119	25.34	26.08	t	192	CSD1179	51
20.04.97	01:35:44	245	MZ-L 3579	52.12	0.00	t	128	CSD1179	52
03.03.97	07:07:39	214	S-LK 230	5.90	48.32	t	192	CSD1179	54
21.12.96	13:11:38	213	MZ-P 9119	8.30	39.96	t	128	CSD1179	46
07.12.96	22:25:26	217	DA-RK 328	8.90	53.30	t	192	CSD1179	44
07.11.96	21:10:14	211	DA-RK 328	23.56	0.00	t	128	CSD1179	23
05.11.96	14:29:00	222	B-GT 5763	44.00	58.68	t	192	CSD1179	14
23.10.96	05:36:49	212	MZ-L 3579	8.74	28.02	t	192	CSD1179	36
31.07.96	14:57:19	208	MZ-C 1051	39.38	0.00	t	192	CSD1179	35
22.07.96	04:30:19	224	DA-RK 328	13.04	43.90	t	192	CSD1179	56
10.06.96	22:12:55	255	DA-HY 272	60.14	0.00	t	128	CSD1179	60
31.05.96	18:42:37	218	HD-JK 708	9.24	35.30	t	192	CSD1179	26
19.05.96	00:19:34	244	B-GT 5763	47.50	0.00	t	128	CSD1179	47
17.04.96	18:02:31	215	B-GT 5763	6.98	54.22	t	192	CSD1179	61
15.04.96	03:20:31	226	MZ-L 3579	1.48	56.92	t	192	CSD1179	58
10.03.96	04:31:24	216	DA-HY 272	7.90	61.20	t	192	CSD1179	53
01.03.96	00:22:03	223	DA-HY 272	13.86	21.28	t	192	CSD1179	35
21.02.96	12:03:46	209	B-GT 5763	45.26	0.00	t	128	CSD1179	45



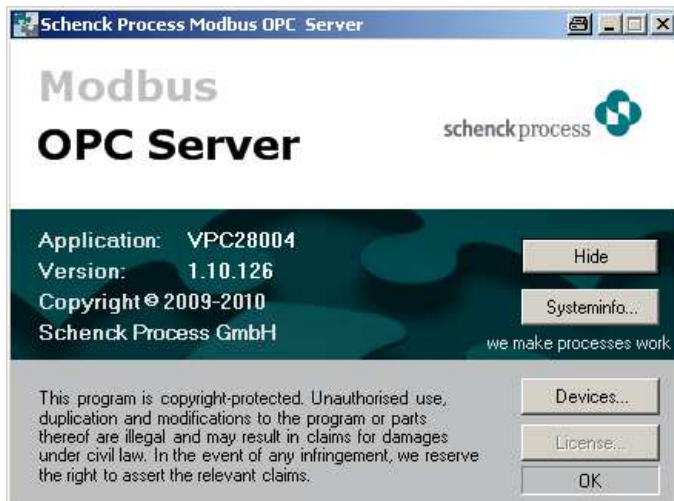
Datum	Uhrzeit	Lauf. Nr.	Beizeichen	Netto	Tara	Dimension	Status	Kennung	Drucks
von	01.01.96		DA-						
bis	31.12.96								
07.12.96	22:25:26	217	DA-RK 328	8.90	53.30	t	192	CSD1179	44.40
07.11.96	21:10:14	211	DA-RK 328	23.56	0.00	t	128	CSD1179	23.56
22.07.96	04:30:19	224	DA-RK 328	13.04	43.90	t	192	CSD1179	56.94
10.06.96	22:12:55	255	DA-HY 272	60.14	0.00	t	128	CSD1179	60.14
10.03.96	04:31:24	216	DA-HY 272	7.90	61.20	t	192	CSD1179	53.30
01.03.96	00:22:03	223	DA-HY 272	13.86	21.28	t	192	CSD1179	35.14

Variant	Ordering No.
<b>DISOSAVE PC Program Package VPC 2006</b> replacing the redundant printer required in accordance with the weights and measures regulations, and designed for: <ul style="list-style-type: none"> <li>▪ Legal-for-trade storage of DISOMAT weighing electronic of results or legal-for-trade viewing, evaluation and printing of results on PC scales-programm DISOVIEW E, VPC20100.</li> </ul> Operable under WINDOWS NT/XP/2000. Comprising: <ul style="list-style-type: none"> <li>▪ CD for installation of DISOSAVE on PC</li> <li>▪ Active-X communication driver VPC 20002</li> <li>▪ Multilingual WINDOWS Help file</li> <li>▪ Program copying protection (LPT dongle)</li> </ul>	D 707 340.02

All information is given without obligation. All specifications are subject to change.



## Modbus OPC Server VPC 28004



- OPC Server for weighing terminals
- Fast and simple access to process data of the terminals
- Write and read access
- Connection to the terminal through Ethernet or through serial interface

### Application

In the automation segment, OPC (= *OLE for Process Control*) has established itself as the standard. OPC enables the cross-manufacturer communication between devices without the expansive and error-prone implementation of protocols and without exact knowledge of the memory places.

The Schenck Process Modbus OPC Server implements this idea consistently. It permits access to the process data of the DISOMAT / DISOBOX / DISOCONT / INTECONT equipment of each OPC-capable application (OPC client). Access is achieved through logical names and independent of the selected physical transmission method (Ethernet or serial).

### Structure

The Modbus OPC Server will be installed on the PC, which also runs the application software and which wants to access the data.

Other OPC client computers can also use this Modbus OPC Server, because OPC is configurable for remote access.

The server realizes a proxy (=substitute) of the scale(s). The application treats this as if the scale would be part of the PC.

The physical connection of the terminals is provided serial (through a COM port of the computer) or through Ethernet (network access).

### Function

The Modbus OPC Server permits read access for the most important process variable of the connected devices. This is possible through a single query and also through cyclical access (e.g. for weight and status values).

The setting of values is also possible (e.g. tare weights or print texts).

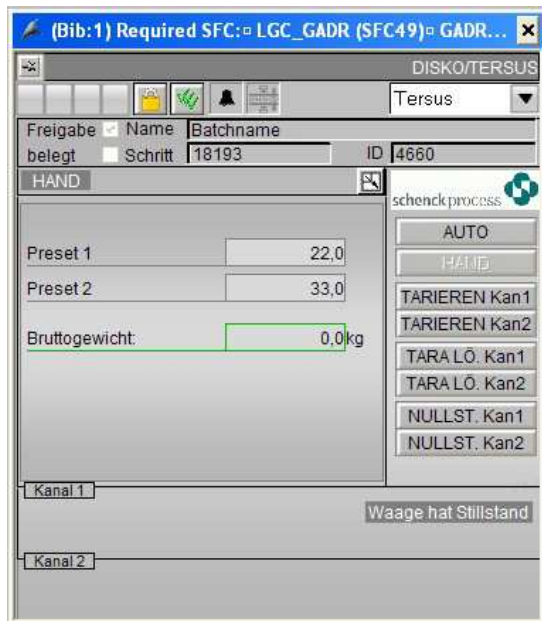
### Technical Data

Operating Systems	Windows 2000 SP4 Windows XP SP 3 Windows 7
Other system requirements	NET Framework 2.0 SP1
OPC Specifications	Data Access specifications V1.0a, V2.05 and V3.0
Communication protocols	Ethernet (MODBUS/TCP) Serial (MODBUS RTU)
Documentation	Online help

### Order numbers

Type	Description	Material Number
VPC 28004	Modbus OPC Server for Schenck Process weighing terminals DISOMAT Tersus DISOMAT Opus DISOMAT Satus DISOBOX Plus (INTECONT Opus) (INTECONT Satus) (DISOCONT Tersus)  Delivery on CD	V095231.B01

## Communication Modules for PCS 7, TIA and STEP 7 to SIEMENS Controllers



Faceplate: DISOMAT Tersus

- Simple, rapid connection of the scales to SIMATIC controllers
- Complete communication modules for PCS 7, TIA and STEP 7
- The programmer can parameterize the existing modules at any time
- PCS 7 modules have faceplates to visualize the weighing data
- Compatible with PCS 7 release 8
- The scales is portrayed in the system as a SIEMENS component (in Hardware configuration)
- Easy editing of statuses and commands for setpoints and measured values
- No complicated programming required for fieldbus communication
- All scales values are directly available as binary or numerical values

### Applications

Many of the Schenck Process weighing electronic systems are coupled with SIEMENS controllers from the SIMATIC S7 series. This coupling is often implemented by the customer or on their behalf. PROFIBUS or PROFINET are used as a medium of communication. This often involves significant effort and furthermore the same solution is often re-implemented by different programmers. With the aid of the communication modules the weighing electronics can be integrated into automation systems with little effort.

### Structure

The use of PCS 7 modules, the TIA library or the STEP 7 library means that the customer or the supplier of the control system no longer needs to program the PROFIBUS/PROFINET connection to the weighing electronics themselves.

The communication details remain concealed from the PLC programmer. The programmer needs only to specify the data and parameters desired at the moment of configuration. Both the PCS 7 modules and the TIA and STEP 7 libraries support all of the fieldbus-capable Schenck Process weighing electronics.

### Function

**PCS 7 modules**  
Each of the PCS 7 modules has a 'Faceplate' that shows the most important weighing data in a PCS 7 graphical display.

Furthermore, the module uses the WinCC detection system integrated into the PCS 7.

A module from the TIA or STEP 7 libraries should be used for implementation in a SCADA solution.

## TIA library, STEP 7 library

Today, many installations are realized using SIEMENS SIMATIC S7 systems and programmed in TIA or STEP 7.

The STEP 7 library is a collection of routines for the SIMATIC S7-300 and 400 series that implement access from the control program via PROFIBUS/PROFINET to scales data or the transfer of commands and setpoints to the weighing electronics.

There is a corresponding module for the TIA portal for newer series S7-1200/1500 controllers. In this case communication ought to be carried out using PROFINET.

Expansions for editing statuses and commands and for setpoints and measured values can be easily implemented in a familiar programming environment.

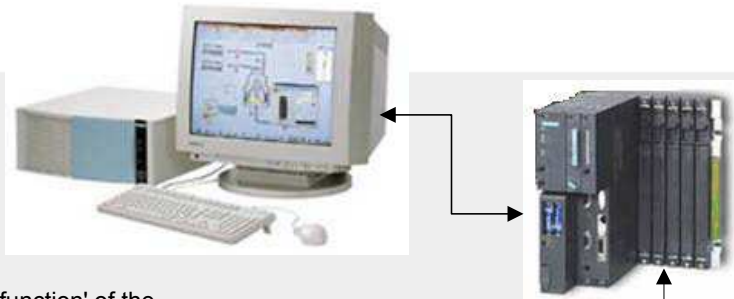
Main difference to the PCS 7 modules:

The STEP 7 library routines do **not** have faceplates or WinCC messages.

The graphical visualization of a module shows inputs (commands, setpoints, etc.) in the left-hand column and status bits and measured values in the right-hand column.

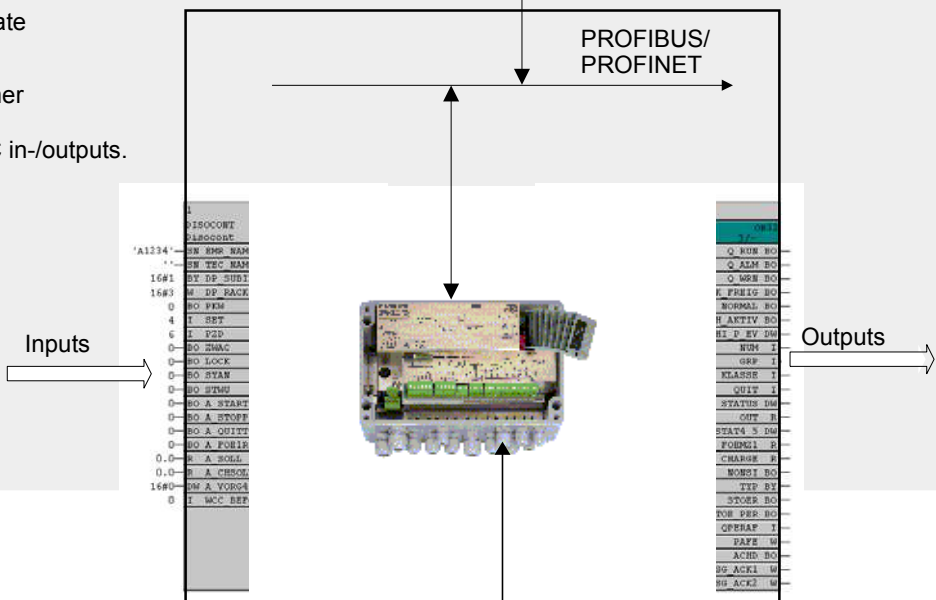
SCALE		DISCO_P7 (Bib:1)	
		0B32	
		6/5	
16#200	DEVICE	Q_TXTTKE	16#0
16#200	ADDR_OUT	Q_TXT4	16#0
16#0	DP_SUBID	Q_FKB	16#0
4	CONF_TXT	STATUS	16#C00
4	CONF_ID	ST_UFLOW	0
16#0	TXITKE	ST_OFLOW	0
16#0	TXIBLK4	ST_TARAE	0
16#0	FKB	ST_NULL	0
16#0	COMMAND	ST_UNGLT	0
16#0000	DP_ID_V1	ST_TARAG	0
16#0004	DP_ID_V2	ST_STILL	1
16#0	A_PRES1	ST_INIT	0
16#0	A_PRES2	SID1	16#3004
16#0	HMI_V1_D	GROSS	63.53467
16#0	HMI_V2_D	GROSS_D1	
0	HMI_COM	VALUE1	16#0
0	HMI_COM0	VALUE2	16#C00
0	ZWAC	VALUE3	16#0
0	SVAN	VALUE4	16#42E2300
0	STWU	VALUE5	16#0
0	CSF	VALUE6	16#0
0	A_TARE	VALUE7	16#0
0	A_TARE5	VALUE8	16#0
0	A_SEIZ	NUM	0
0	A_QUIT	CLASS	0
		QDP_SUBI	16#1
		QDP_RACK	16#F
		QDP_BAST	8189
		ACHD	0
		NONSI	0
		FAILURE	0
		FAIL_UER	0
		FAIL_PER	0
		OPERAF	0
		PAFE	16#0
		MSG_ACK1	16#FFFF

# Example: SIEMENS PCS 7 system with DISOCONT Tersus



'Substitute function' of the PCS 7 module:  
It conceals the subordinate communication.

The controller programmer can use directly the DISOCONT Tersus CFC in-/outputs.



**Manuals for PCS 7 modules:**

**VPD 28001**

DISOCONT	BV-H2155AA
DISOMAT T	BV-H2156AA
DISOMAT T plus	BV-H2197AA
INTECONT PLUS	BV-H2245AA
DISOBOX	BV-H2323AA

**VPD 28002/VPD 28004**

DISCO P7	BV-H2483AA
CONTI_P7	BV-H2427AA
DP-V1	BV-H2466AA

**Manual for STEP 7 library:**

VSP 28004	BV-H2473
-----------	----------

The **PROFIBUS Data** can be found in:

DISOCONT	BV-H2100 and BV-H2102
DISOCONT Tersus	BV-H2448
DISOMAT Tersus, Opus, Satus	BV-H2359
DISOBOX, DISOBOX Plus	BV-H2359
INTECONT PLUS	BV-H2220
INTECONT Opus, Satus	BV-H2220
INTECONT Tersus	BV-H2474

**Equipment Supplied**

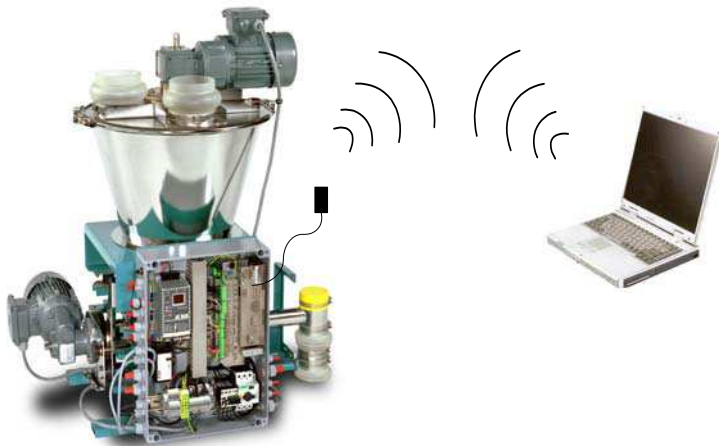
Program and manual with 1 cd in stock

Type	Description	Material number
VPD 28001	PCS 7 module for coupling to SIEMENS PCS 7 for DISOMAT B plus, DISOMAT T, DISOMAT T plus, DISOBOX, INTECONT PLUS and DISOCONT	D707319.03
VPD 28002	CFC module <b>DISCO_P7</b> for coupling to SIEMENS PCS 7 version 6.1 for DISOMAT Tersus, DISOMAT Opus, DISOMAT Satus	V079799.B01
VPD 28004	CFC modules for coupling to SIEMENS PCS 7 version 7 and 8: CFC module <b>DISCO_P7</b> for DISOMAT Tersus, DISOMAT Opus, DISOMAT Satus and DISOBOX Plus CFC module <b>CONTI_P7</b> for INTECONT Tersus, INTECONT Opus, INTECONT Satus and DISOCONT Tersus add-on module for <b>DP_V1</b>	V594374.B01
VSP 28000	STEP 7 library for DISOMAT B plus, DISOMAT T, DISOMAT T plus, DISOBOX, INTECONT PLUS and DISOCONT	V047816.B01
VSP 28004 VTA 28001	TIA and STEP 7 libraries: <b>DISCO_S7</b> for DISOMAT Tersus, DISOMAT Opus and DISOMAT Satus <b>CONTI_P7</b> for INTECONT Tersus, INTECONT Opus, INTECONT Satus and DISOCONT Tersus add-on module for <b>DP_V1</b>	V594373.B01

**Schenck Process Europe GmbH**

Pallaswiesenstrasse 100  
 Darmstadt, Germany 64293  
 T +49 6151 1531-0  
 F +49 6151 1531-66  
 sales@schenckprocess.com  
 www.schenckprocess.com

## The wireless way to your scale – Bluetooth radio modules



- **Wireless configuration of your weighing electronic systems**
- **Replace cables by a radio link**
- **Perfect access via EasyServe or DISOPLAN**
- **Wireless service bus to several electronic systems**
- **Configuration from a "safe distance" with greater convenience in a clean environment**

### Application

These modules enable you to parameterise and configure all weighing electronic systems without requiring a serial interconnecting cable.

The modules can be used for units of the DISOCONT<sup>®</sup>, INTECONT<sup>®</sup>, DISOMAT<sup>®</sup>, and DISOBOX<sup>®</sup> families.

This enables the operation of the service tool in a clean environment.

Using these modules on several DISOCONT<sup>®</sup> feeders replaces the service bus.

### Equipment

The Bluetooth function modules are only intended for use for service and start-up work with weighing controllers.

There are different modules with ranges up to 100 m (Bluetooth class 1) and 30 m (Bluetooth class 2).

The class 1 Bluetooth module has an external antenna while the class 2 module has a built-in antenna.

DISOMAT<sup>®</sup> Tersus has an optional internal Bluetooth communication module (class 1) plugged directly into the mainboard.

The 2-meter connecting cable allows to placement where it is best for the radio link.

Both modules are select to IP65.

The modules are fastened with two external straps. Built-in LEDs provide information on status and data transmission.

### Function

The communication to the weighing controller is realized via serial interface. The module is powered up through the weighing controller except with DISOMAT<sup>®</sup> Opus INTECONT<sup>®</sup> Opus or INTECONT<sup>®</sup> Satus, where an extra power supply unit is needed.

The product's primary purpose is for service and start-up. The Bluetooth module is initially not yet suited for loading programs into the weighing controller.



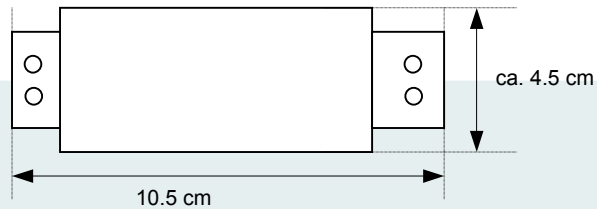
### Technical Data



**Class 1 Module  
VBT 28001**



**Class 2 Module  
VBT 28002**



	Width [cm]	Length [cm]	Height [cm]
Class 1 Module VBT 28001	4.5	10.5	4.5
Class 2 Module VBT 28002	4.5	10.5	3

Power supply	24 VDC, 15 mA
The length of the power cable	2 m
Protection class	
Class 1 Module VBT 28001	IP20
Class 2 Module VBT 28002	IP65
Grouting compound	BECTRON <sup>®</sup> PB 3251

Order information	Order number
Class 1 Module VBT 28001	V049491.B01
Class 2 Module VBT 28002	V053992.B01
Manual	BV-H2314
Bluetooth USB Adapter for PC	V041176.B01
9-pole plug, SUB-D (needed for DISOMAT B plus and DISOMAT Satus)	V035913.B01
VBT 20450 Bluetooth Module for internal installation in DISOMAT Tersus	V039998.B21



## VFM 28000 Radio Module



- Radio modem substitute for cable connections between scales system components or between scales and plant system
- RF modems, broadcast-license free Europe-wide Frequency band: 869 MHz
- Radio range 250 m (with clear line of sight)
- Multi-channel compliant
- Bluetooth radio module (class 1) range 100 m
- Protection class IP65
- Approved for legal-for-trade operation

### Application

The VFM 28000 radio module is used as a substitute for cable connections in situations in which installation of cables would be unnecessarily expensive, if cables could be easily damaged or if cables cannot be used.

Typical applications are:

- Coupling of weighing electronics to a crane crossbeam (replacing a cable drum or a trailing cable installation)
- Connections between mobile plant components, containers free to move to a degree, or operating panels in vehicles
- Connections over long distances between plant components, in particular across open spaces
- Communication between a DISOMAT and a mirror device or a VOP display device or communication with a DISOBOX (with the RF modules only)
- Control of a large display or a printer

Combined with the DISOMAT and DISOBOX series analysis devices, the VFM modems are also certified for the transfer of legal-for-trade data.

As radio frequency modems the VFM devices require no broadcast licenses anywhere in Europe – national legislation must be referred to outside Europe.

The Bluetooth version can be used worldwide.

BV-D2403GB

### Design

A housing with a high protection class forms the basic unit of all VFM modules. This basic unit contains the power supply and the serial interfaces. Without any further modules, this basis unit can be used as a power source for 24 V devices or as an RS232 ↔ RS422 interface converter.

Additional HF modules will result in RF radio modules with a frequency of 869 MHz and ranges of 250 m, or class 1 Bluetooth modems with ranges of 100 m.

The Bluetooth modules have an internal antenna whereas the RF modules are supplied with a suitable antenna with a magnetic base (1.5 m cable).

The Bluetooth modules can be used in pairs. However, if e.g. connected to a PC, they can also be connected individually with another Bluetooth partner (e.g. USB-BT).

In many applications the VFM can also provide power to connected 24 VDC devices (large format displays, operating units, weighing electronics).

### Function

In the simplest configuration the VFM modules are used in pairs as a replacement for a serial interface. For serial baud rates of up to 9600 a route can be established without further configuration.

Higher baud rates and parallel routes can be operated, but the devices must be reconfigured. The configuration software is supplied with the DISOMAT documentation software.

We recommend consulting Schenck Process beforehand if dealing with such a situation.

Multi-point connections can also be established, such as the addressing of several analog-digital converters via one master. In these cases also the concept should be discussed in advance.

The ranges given in the technical data apply to open spaces only and only if there is a direct line of sight between the modems. Under more complex operating conditions – such as indoors in halls – we recommend performing measurements before selecting the required equipment.

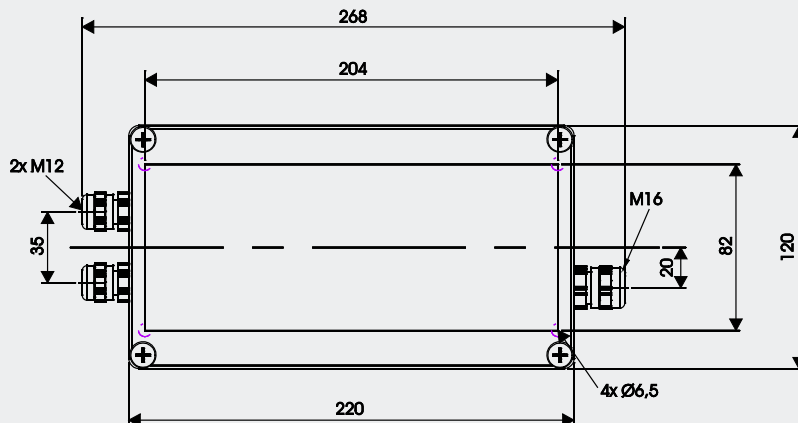
### Technical Data

External dimensions L x W x H [mm]	220 x 120 x 91
Interfaces	1 x RS422-4-wire for communication over longer distances 1 x RS232 Can be operated as an RS232 ↔ RS422 converter
Supply voltage DC	24 VDC (range: 18 ... 36 VDC); typically 10 W
Max. data rate (HF side)	38,400 Baud (LR design: 19,200 Baud)
Supply voltage AC	85 ... 264 VAC
Protection class	IP65, NEMA 4X
Operating temperature range	-20 °C ... 60 °C

### Order Numbers

Type	Description	Material Number
VFM 28000 Basic unit	Suitable as a 100 ... 240 VAC → 24 VDC, 10 W power supply and as an RS232 ↔ RS422 inter- face converter	V081931.B01
VFM 28000 BT	Bluetooth radio module class 1; range 100 m	V081932.B01
VFM 28000 RF	Short range radio module, 869 MHz, 50 mW, range 250 m	V081933.B01

### Dimension Diagram with Mounting Holes Indicated



**Schenck Process GmbH**  
Pallaswiesenstr. 100  
Darmstadt, Germany 64293  
Phone: +49 6151 1531-0  
Fax: +49 6151 1531-66  
sales@schenckprocess.com  
www.schenckprocess.com

## Secondary- and Large-size Display Units



- High contrast, easily-readable display
- Rugged industrial design
- Protection type as far as IP65
- Temperature range to  $-30\text{ °C}$  ...  $+60\text{ °C}$
- Legal-for-trade

### Application

The digital display units are designed for large-size display of weight values. They are used on all industrial weighing systems which require the weight to be read from long distances, e.g. crane scales, scales for racking systems, road weigh-bridges.

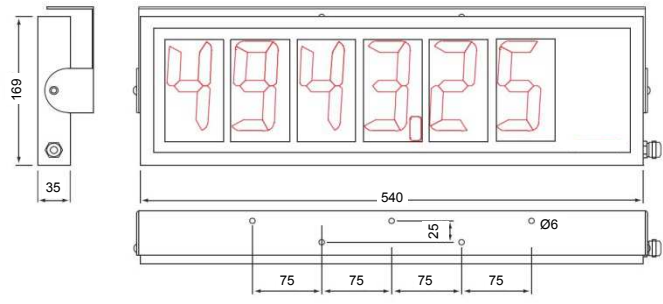
### Equipment

The display uses either LED- or LCD-technology, depending on type. The swivel housings are fixed with mounting brackets.

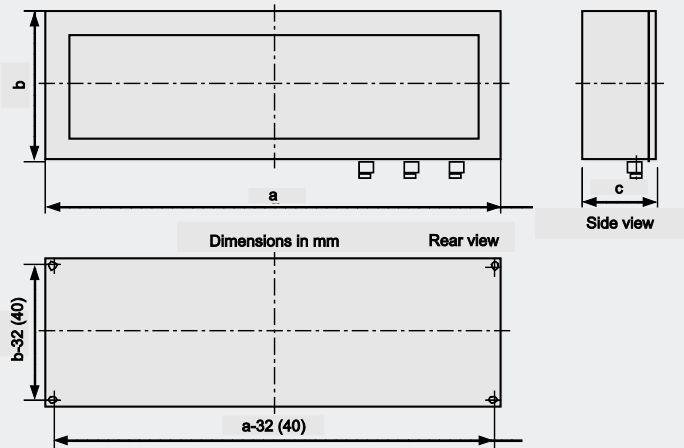
### Functions

Display of the weight value with additional symbols for sign, unit and operating status.

## Display dimensions



VLZ 20100

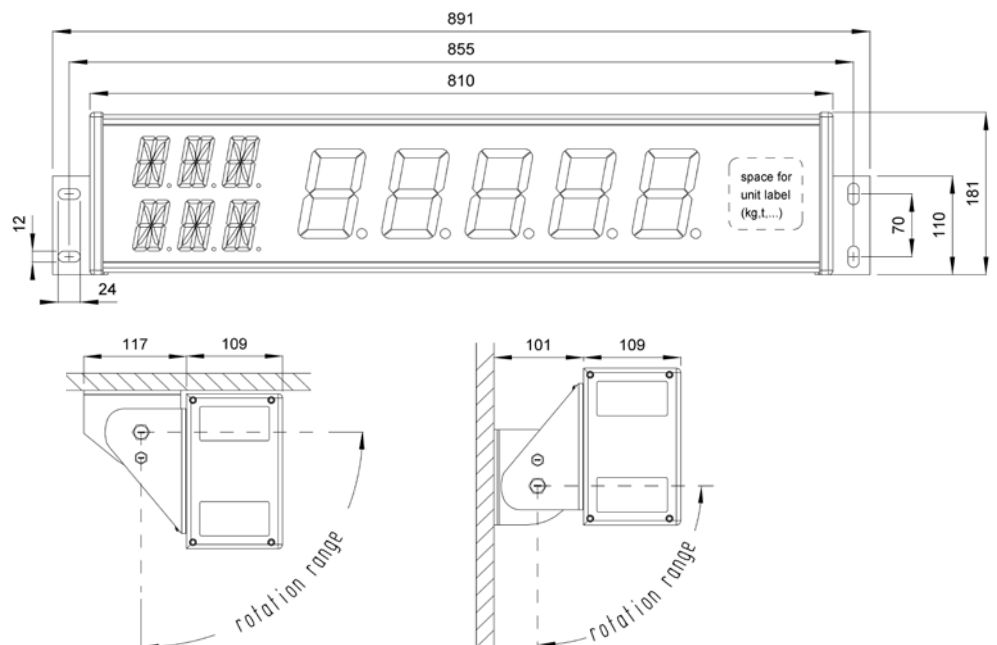


DLS 160-250

Dimensions in brackets apply to variants with 160 and 250 mm digit height.

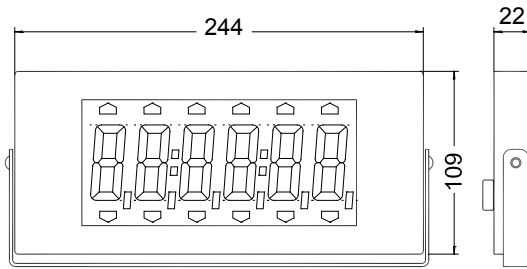
Dimensions [mm]	a	b	c
DLS 160	1100	300	145
DLS 250	1730	400	165

VLD 20100

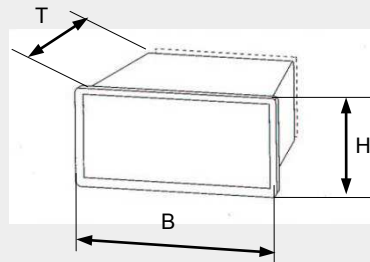
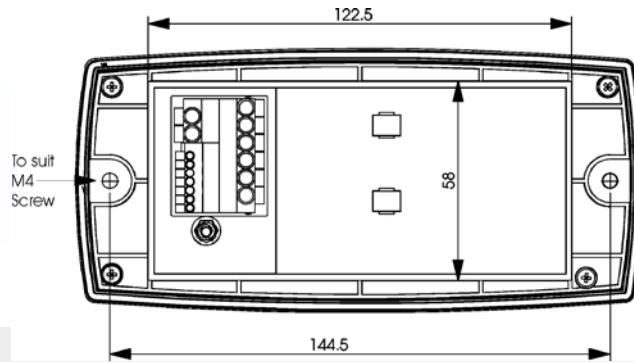




**VLZ 20045**



**VAG 20200-D**

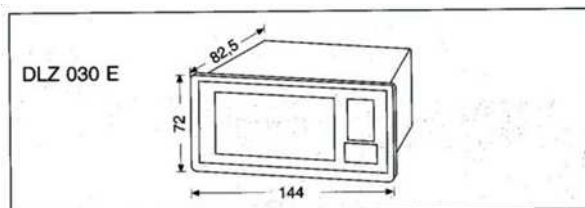


Dimensions [mm]	B	H	T	Cut-out
VLZ 20151	96	48	115	92 x 45
VLZ 20250	144	72	72	138 x 68

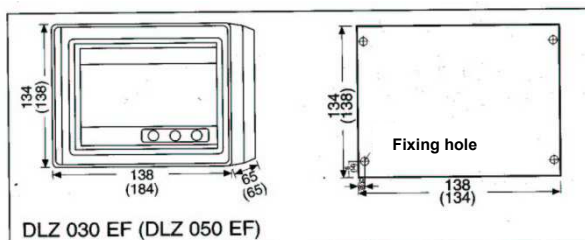
**VLZ 20151  
VLZ 20250**



**DLZ 030 E**



**DLZ 030 EF  
DLZ 050 EF**



## Technical Data

	VLD 20100	DLS 160	DLS 250	VLZ 20100	VLZ 20045
Display principle	LED	LED		LCD	
Display colour	Red	Red		Black, white backlight	Black, amber backlight
Number of digits	5	5		5	6
Digit height [mm]	100	160	250	100	45
Unit	g, kg, t (Adhesive symbols)	g, kg, t		g, kg, t, lb	----
Status display	Zero, tare, net	Zero, tare, net, no-motion		Zero, tare, net	----
Reading distance	40 m	60 m	100 m	40 m	15 m
Protection type	IP54	IP54		IP65	
Temperature range	-20 °C ... +45 °C	0 °C ... +55 °C		-30 °C ... +60 °C	-10 °C - +60 °C
Legal-for-trade	Yes	Yes		Yes	No
Mounting variant	Floor, wall and ceiling mounting	Floor, wall and ceiling mounting		Wall or ceiling mounting	
Weight approx.	7.4 kg	21 kg	40 kg	4.5 kg	0.8 kg
Swivel-mounted	Yes	No, bracket for swivel- mounting available as option		Yes	
Data interface	RS423, RS232	RS232		RS232, RS485, TTY 20 mA	
Power supply	100 ... 240 VAC (47 ... 63 Hz); max. 40 W	230 VAC +15/-10 % (47 ... 63 Hz)		24 VDC, 100 mA	24 VDC, 60 mA
Max. cable length approx.	100 m	100 m		600 m	
Order No.	V090252.B01	E909054.02/04		V066611.B01	V067304.B01

	VLZ 20151	VLZ 20250	DLS 030E / DLZ 030EF / DLZ 050EF	VAG 20200-D
Display principle	LED, 7-Segment		LCD	LCD
Colour	Red		Black	Black
Number of digits	6	5	4	6
Digit height [mm]	14	25	30 / 30 / 50	20
Unit	g, kg, t		Selectable	kg, t, lb
Protection type	IP40, optional IP65	IP40	IP40 / IP65 / IP65	IP54 front
Temperature range	0 °C ... 60 °C		-10 °C ... 50 °C / 65 °C / T5	-10 °C ... +50 °C
Legal-for-trade	No	No	No	Yes
Explosion-proof design	No		Ex ib IIC T6 for ATEX Zone 1	No
Mounting variant	Panel-mounting		Panel-mounting/filed housing/filed housing	Panel-mounting
Data interface	RS232, RS422 / RS485 / TTY 20 mA		Analog 4 ... 20 mA	RS232
Power supply	16 ... 30 VDC, 230 VAC optional		---	12 ... 24 VDC
Max. cable length approx.	100 m		750 m	15 m
Order No.	V036225. B01/B02	E054593.01	E909034.01 / E909034.02 / E909033.01	V070449.B01

## DISOPRINT VPR 20150 Flat Bed Printer



- Printing of cut sheets and weigh cards
- Easy and convenient insertion of forms through print table open on three sides
- Compact and rugged design for industrial use

### Application

DISOPRINT VPR 20150 Flat Bed Printer is designed especially for printing of cut sheets, form sets and weigh cards.

It is approved as printers for legal-for-trade scales, with DISOPRINT VPR 20150 as local printer.

### Equipment

Printer parameters are set menu-controlled via function keys. One ribbon cassette is supplied.

### Function

Paper infeed is automatic, with forward/reverse retention. Characters can be represented both horizontally and vertically. To enable left area of wide form sets to be printed, print pattern can be turned by 180°. Line feed is automatic.

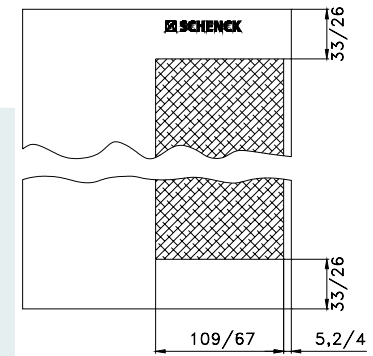
### Technical Data

	DISOPRINT VPR 20150
Print Speed:	2.1 lines/s
Line spacing:	settable
Characters height:	settable
Number of characters:	35 char/line; normal PICA 42 char/line; compressed 27 char/line; elongated
Copies:	1 original, 2 copies, Paper thickness: 0.09 - 0.35 mm
<b>Paper Specification:</b> Form size:	min: h = 80 mm x w = 70 mm max: 182 mm x 257 mm
Page feed:	forward and reverse
Interfaces:	RS 232 C/V24 and Centronics
Power supply:	24 VDC
Power Consumption:	15 VA
Operating temperature:	+5°C to +40°C
Storage temperature:	-10°C to +50°C
Dimensions w x h x d:	180 x 101.5 x 190.5 mm
Weight:	1,6 kg
Print area:	width: 67 mm, length: variable

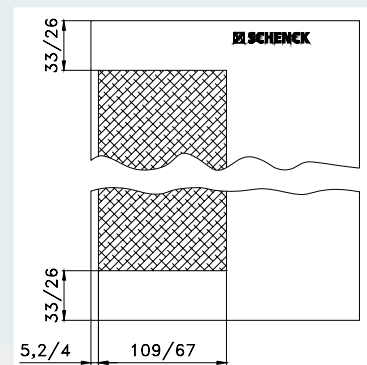
Variant	Order Number
DISOPRINT VPR 20150 Flat bed printer with matrix print head for printing cut sheets complete with 24 VDC power supply	D 713 193.01
Option	Order Number
Power supply for DISOPRINT VPR 20150 230 VAC	3691.918

### Printed Area:

DISOPRINT VPR 20150



DISOPRINT VPR 20150

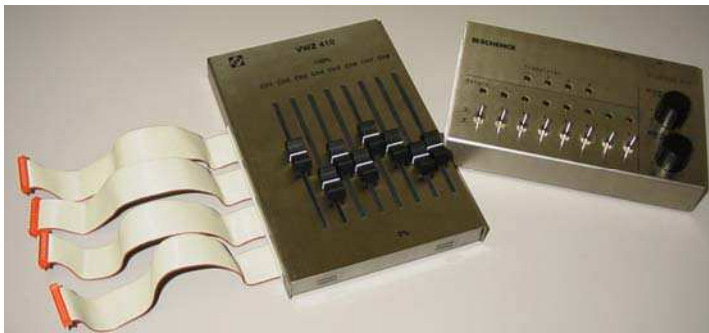


### Sample Print

17.09.01 09:08 33
<2252kg> Net
Signature:



## Scale Simulators, Types DISOTEST 11 and VWZ 20410



- Simulation of 2 complete scales, or 8 single load cells
- Presetting of input signals
- Display of output signals
- Compatible with all DISOMAT weighing electronics
- Designed for functional testing of system and testing of configuration outside the plant

### Application

Designed to simulate all peripherals of the weighing electronics, Scale Simulators DISOTEST 11 and VWZ 20410 enable a measuring system to be tested outside the plant without disruption to normal operations.

Furthermore, settings and/or configured sequences can be tested and optimised outside the plant.

### Equipment

DISOTEST 11 simulates max.

- 2 scales
- 8 binary inputs
- 12 binary outputs.

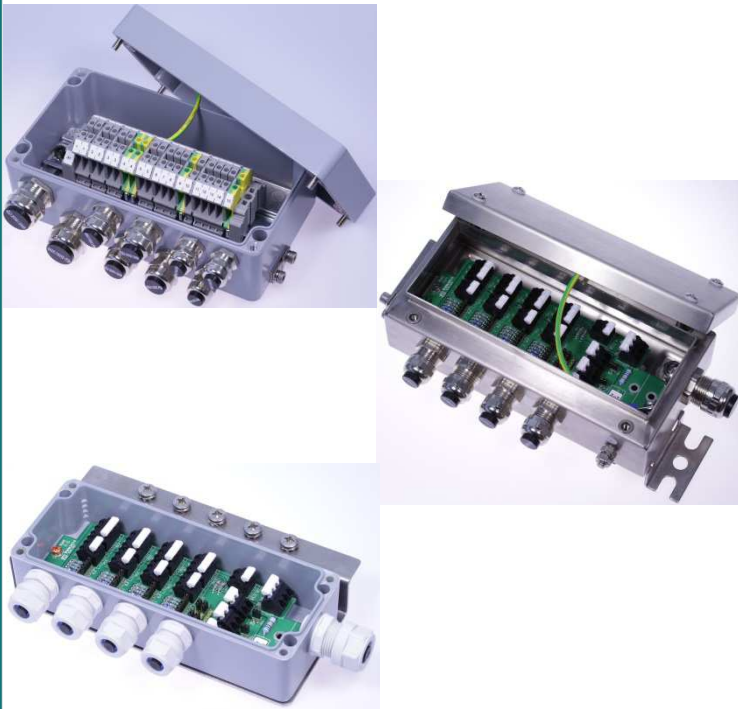
Using adapter cables, the base unit is adjusted to the different DISOMAT variants.

VWZ 20410 is designed to simulate up to 8 load cells for the local A/D converter unit, the so-called DISOBOX.

### Equipment Supplied:

K002807.01	Scale Simulator DISOTEST 11, base unit
K002816.01	Cable 2 for DISOTEST 11, for simulation of scale on DISOMAT T, B, C
K002820.01	Cable 6 for DISOTEST 11, for simulation of DISOMAT T inputs/outputs
D739126.01	Cable 11 for DISOTEST 11, for simulation of scale on DISOMAT B plus or DISOMAT Tersus (max. 2 connectable to one DISOMAT)
D739127.01	Cable 12 for DISOTEST 11, for simulation of DISOMAT B plus inputs/outputs
V032070.B01	Cable 13 for DISOTEST 11, for simulation of scale on DISOMAT B plus Ex
V032071.B01	Cable 14 for DISOTEST 11, for simulation of DISOMAT B plus Ex inputs/outputs
V040060.B01	Cable 15 for DISOTEST 11, for simulation of scale on DISOMAT Opus/Satus
V040061.B01	Cable 16 for DISOTEST 11, for simulation of DISOMAT Opus inputs/outputs
V054061.B01	Cable 17 for DISOTEST 11, for simulation of DISOMAT Tersus inputs/outputs
V024383.B01	Load Cell Simulator VWZ 20410 for DISOBOX A/D converter

## Terminal Boxes Types VAK and VKK for Sensors



- Easy to install
- Different variants for extension or summation of load cell cables
- Suitable for use in hazardous areas and severe environments
- Highly resistant to aggressive media
- Optional overvoltage protection

### Application

The **cable boxes**, types VKK 280x1, are designed for extension of the load cell connecting cable.

The **cable summation boxes**, types VKK 280x6, VKK 280x4 and VKK 280x8, are designed for interconnecting the load cells of a scale.

In case of high demands on weighing accuracy, the built-in series resistors can be used for corner adjustment.

Thanks to the plug-in jumpers balancing is especially easy and time saving.

Depending on the application, the **junction boxes** type VAK can be used for mere extension of the load cell connecting cable and other sensor lines, but also for summation of the signals of multiple load cells (without corner adjustment).

### Design

The VAK/VKK terminal boxes are made of aluminium diecast, polyester or stainless steel.

For easy mounting within the terminal box, all cable connections are screwed in place or clamped.

Polyester cases are equipped with plastic cable screw connections, aluminium and steel cases are equipped with bronze screw connections - steel ones are available as an option.

### Performance

As cable summation box, types VKK 280x4 are available for 4 load cells, types VKK 280x6 for 6 load cells and VKK 280x8 for 8 load cells.

The terminal boxes are universally applicable. For high temperatures or used in explosion hazard environments (up to approx. +100 °C – with use of appropriate cable and special cable glands 150 °C are possible), housings are made of aluminium.

If the terminal box is exposed to aggressive media or mounted in severe environments, polyester housings are preferred.

The stainless steel housings are suitable for both application areas.

Load cells both with 4- and 6-wire cable can be connected.

All terminal boxes VKK are equipped with potential-equalization rail for correct connection of the potential-equalization lines.

All boxes guarantee that the correct cable screen connection has been made.

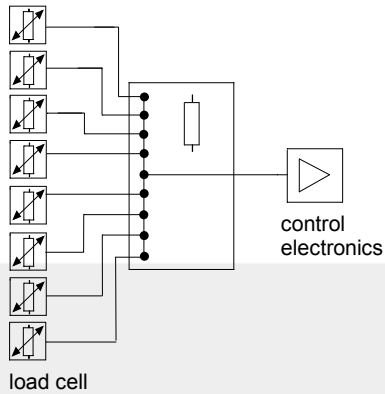
Terminal boxes for use in explosion hazard areas of category 2G/2D remain available.

Variant	Order No. Standard Design	Order No. Model ATEX 2G, 2D	IECEX *)	EAC *)
<b>VKK 28001</b> Cable box, polyester housing, spring terminals	V053956.B01	-	-	-
<b>VKK 28011</b> Cable box, aluminium housing, spring terminals	V053957.B01	V595989.B01	X	-
<b>VKK 28021</b> Cable box, stainless steel housing, spring terminals	V053958.B01	V649087.B01	X	-
<b>VKK 28004</b> Cable summation box for max. 4 load cells, polyester housing, spring terminals	V053953.B01	-	-	-
<b>VKK 28014</b> Cable summation box for max. 4 load cells, aluminium housing, spring terminals	V053954.B01	V595988.B01	X	-
<b>VKK 28024</b> Cable summation box for max. 4 load cells, stainless steel housing, spring terminals	V053955.B01	V512515.B01	X	-
<b>VKK 28006</b> Cable summation box for max. 6 load cells, polyester housing, spring terminals	V076863.B01	-	-	-
<b>VKK 28016</b> Cable summation box for max. 6 load cells, aluminium housing, spring terminals	-	V649089.B01	X	-
<b>VKK 28026</b> Cable summation box for max. 6 load cells, stainless steel housing, spring terminals	-	V649085.B01	X	-
<b>VKK 28008</b> Cable summation box for max. 8 load cells, polyester housing, integrated overvoltage protection, screw terminals	V041675.B01	-		
<b>VKK 28018</b> Cable summation box for max. 8 load cells, aluminium housing, screw terminals	-	V649086.B01	X	-
<b>VKK 28028</b> Cable summation box for max. 8 load cells, stainless steel housing, screw terminals	-	V649088.B01	X	-
<b>VBS 28011</b> Overvoltage protection module with aluminium housing, to protect the load cell resp. the control electronics	V053969.B01	V053969.B51 (only 2D)	-	-
<b>VAK 28040</b> Junction box with 14 terminals, extension 1 load cell + 2 sensors or 2 load cells without corner adjustment, polyester housing	V029901.B01	-	-	-
<b>VAK 28040-2GD</b> Junction box with 14 terminals, extension 1 load cell + 2 sensors or 2 load cells without corner adjustment, aluminium housing	-	V583197.B01	X	X
<b>VAK 28040-2GD-SS</b> Junction box with 14 terminals, extension 1 load cell + 2 sensors or 2 load cells without corner adjustment, stainless steel housing	-	V653900.B01	X	X
<b>VAK 28080</b> Junction box with 18 terminals, 4 load cell + 2 sensors (without corner adjustment), polyester housing	V583558.B01	-	-	-
<b>VAK 28080-2GD</b> Junction box with 18 terminals, 4 load cell + 2 sensors (without corner adjustment), aluminium housing	-	V580943.B01	X	X
<b>VAK 28080-2GD-SS</b> Junction box with 18 terminals, 4 load cell + 2 sensors (without corner adjustment), stainless steel housing	-	V654495.B01	X	X
<b>VAK 28051</b> Junction box with 16 terminals for the connection of motors, polyester housing	V583561.B01	-	-	-
<b>VAK 28051-2GD</b> Junction box with 16 terminals for the connection of motors, aluminium housing	-	V580776.B01	X	X
<b>VAK 28051</b> Junction box with 16 terminals for the connection of motors, stainless steel housing	-	V654496.B01	X	X
<b>VAK 20120</b> Junction box with 15 terminals for the connection of motors, incl. the motor protective switch, polyester housing	F217763.03 **)	-	-	-
<b>VAK 20120-2GD</b> Junction box with 15 terminals for the connection of motors, incl. the motor protective switch, aluminium housing	-	V657753.B01 (only 2D) **)	X	X
**) This order number refers to the standard terminal box with no motor protection. The motor protection is included on an order-specific basis.			*) X = available - = not available	

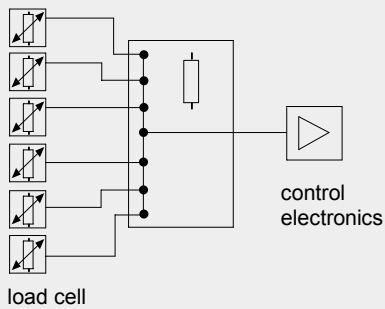
## Options

<b>DBS6</b> Overvoltage protection module for retrofit of a VKK 28006	D707465.01
<b>VBS001</b> Overvoltage protection module without housing (printed circuit board)	V039944.B01

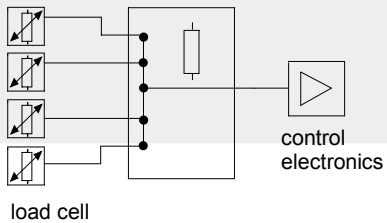
**VKK 280x8**



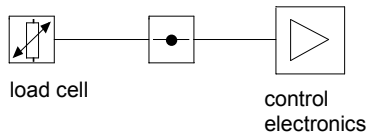
**VKK 280x6**



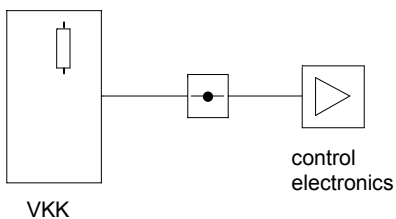
**VKK 280x4**



**VKK 280x1**

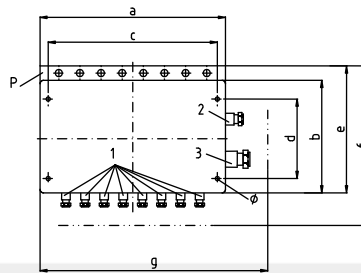


**VBS 28011**

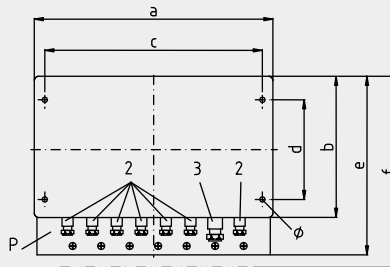


In combination of cable summation boxes with overvoltage protection (VKK 28006 with DBS6; VKK 28008) one VBS module is used close to the control electronics (max. 1 m).  
In all other cases a 2<sup>nd</sup> VBS module is required close to the VKK!

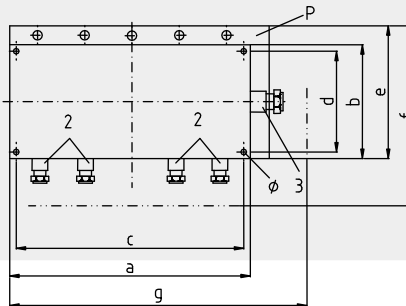
**VKK 28008 / 28018 / 28028**



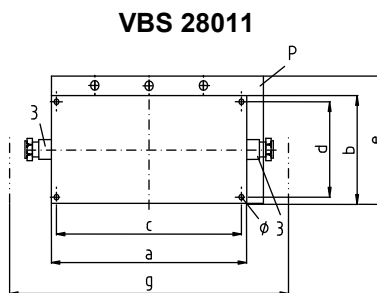
**VKK 28006 / 28016 / 28026**



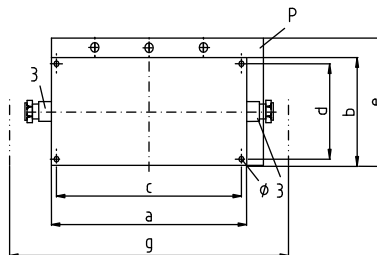
**VKK 28004 / 28014 / 28024**



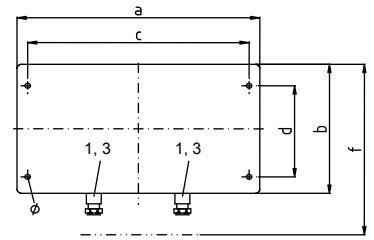
**VKK 28001 / 28011 / 28021**



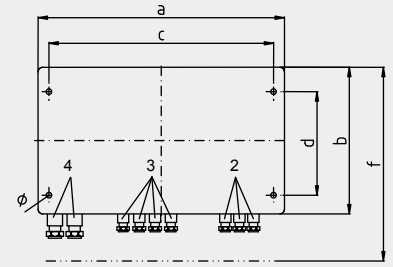
**VBS 28011**



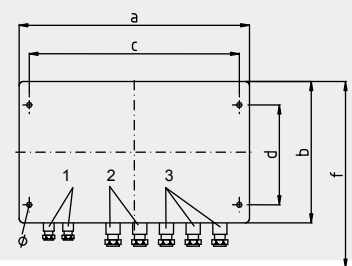
**VAK 28040**



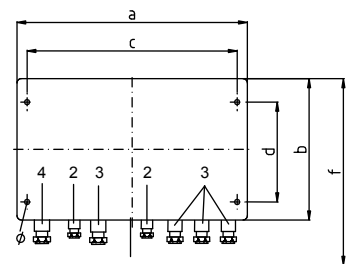
**VAK 28051**



**VAK 28080**



**VAK 20120**



P = potential-equalization rail    Ø = fixing bore

**Cable inlet**

1 = M12	Cable Ø 2	- 7.5 mm
2 = M16	Cable Ø 4	- 11 mm
3 = M20	Cable Ø 5	- 14 mm
4 = M25	Cable Ø 11	- 20 mm

Dimensions [mm]									
Typ	a	b	c	d	e	f	g	Height	Ø
VKK 28001	190	75	178	45	105	-	310	60	4.5
VKK 28011 VBS 28011	175	80	163	52	105	-	295	60	4.8
VKK 28021	200	100	229*	43.5*	-	-	320	75	10
VKK 28004	190	75	178	45	105	160	250	60	4.5
VKK 28014	175	80	163	52	105	165	235	60	4.8
VKK 28024	200	100	229*	43.5*	-	160	260	75	10
VKK 28006 VKK 28016	260	160	240	110	210	220	-	90	6.5
VKK 28026	260	160	290	103.5	210	260	314	91	10
VKK 28008 VKK 28018	260	160	240	110	210	270	320	90	6.5
VKK 28028	260	160	240	110	210	220	340	91	10
VAK 28040-(2GD)	122	120	106	82	-	180	-	90	6.3
VAK 28040-2GD-SS	150	150	180*	93.5*	-	200	-	95	10
VAK 28080-(2GD) VAK 28051-(2GD)	220	120	204	82	-	180	-	91	6
VAK 28080-2GD-SS VAK 28051-2GD-SS	260	160	290	103.5	--	210	314	91	10
VAK 20120-(2GD)	260	160	240	110	-	220	-	90	6.3

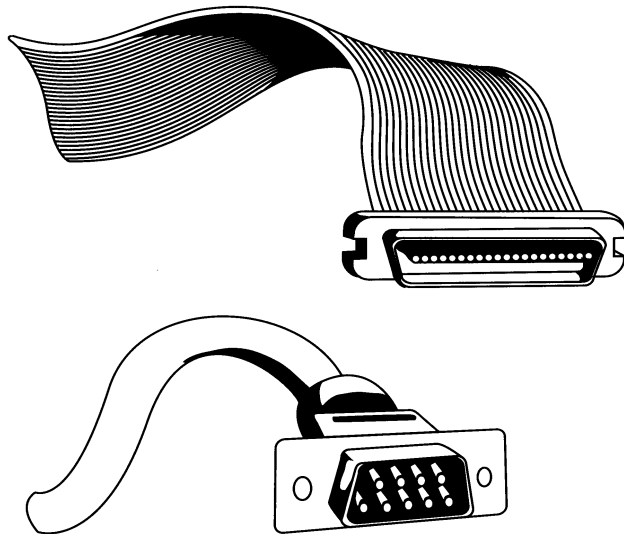
\*) This stainless steel housing has only 2 (instead of 4) fixing holes.

Further technical data	
Protection class	IP66 IP68 available on request
Permissible ambient temperature	Polyester housing, non-ATEX -20 °C ... +100 °C Aluminium housing and stainless steel housing: non-ATEX: -40 °C ... +100 °C available on request: -40 °C ... +150 °C ATEX: -30 °C ... +60 °C
Impact-resistance of the housing	7 Joule
Housing material information	
Polyester	glass fiber reinforced, thermoset polyester RAL 7000 (ATEX RAL 9011) Flammability: self-extinguishing, UL 94 V-0; Cable screw connections: Plastic
Aluminium	DIN EN 1706 EN AC-AISi12(Fe), powder-coated RAL 7001; Brass screw connections
Stainless steel	1.4301, polished (standard variants)
Stainless steel	1.4404, polished (ATEX variants)
Brass screw connections; Versions with stainless steel screw connections are available upon request.	

### Schenck Process Europe GmbH

Pallaswiesenstr. 100  
64293 Darmstadt, Germany  
T +49 6151 1531-0  
F +49 6151 1531-66  
sales@schenckprocess.com  
www.schenckprocess.com

## Measuring, Data and Control Cables



- Precisely tuned to devices
- Screened against electrical interference fields
- Perfectly isolated
- Hardly inflammable

### Application

- Cables interconnecting the electronic scale components have a decisive influence on reliability and availability of these components.
- The use of interconnection cables must not reduce the electromagnetic compatibility (EMC) of single devices. Device protection has to be retained on cable inlets as well.

### Construction

- The load cell, data and control cables selected here are tuned to the weighing components:  
  
Screening and stranding in pairs protect cables from electromagnetic interference and electrical disturbances.

### Function

- The cables are designed in accordance with international safety standards, especially with respect to hazardous area applications. In addition, they are hardly inflammable and non-ageing.
- Defined outer diameters and ageing stability ensure a high degree of protection and tight sealing of cable inlets.
- The cables ensure stable and accurate signal transmission even over great distances.
- High insulation resistance and 6-conductor technology provide long-term accuracy.



**Technical Data**

Cable (Cores x Cross Section)	Application	Outer Diameter [mm]	Weight per 100 m [kg]	Ordering Number
Measuring cable 1 x 2 x 0.5 mm <sup>2</sup> + 2 x 2 x 0.25 mm <sup>2</sup> . Shielded in pairs and totally shielded	Standard measuring cable for connection of load cells for discontinuous weighing systems (DISOMAT) Temperature range: moved -5 ... +70 °C rigid installation -20 ... +70 °C	9	11.3	Standard gray V085231.B01
				Blue, for intrinsically safe circuits V087819.B01
Measuring and sensor cable 5 x 2 x 0.5 mm <sup>2</sup>	Standard measuring cable for connection of load cells for continuous weighing systems. In addition, a speed sensor can be connected.	12	20	3849.059
Measuring cable 7 x 0.5 mm <sup>2</sup> , screened	Measuring cable for trailing cable installation and energy chains min. 80 mm bending radius Ozone- and UV-resistant For use in energy chains: max. trailing distance 20 m max. trailing speed 10 m/s Temperature range: moved -25 ... +80 °C at rest -40 ... +80 °C	10.7	16	V063682.B01
Measuring cable 7 x 0.5 mm <sup>2</sup> , screened	Strain-relieved measuring cable for cable drum, tensile strength 300 N Temperature range: moved -25 ... +80 °C at rest -40 ... +80 °C	9.8	15.8	3849.711
Measuring cable 4 x 2 x 0.5 mm <sup>2</sup> , screened	Silicone cable for ambient temperatures -65 °C ... +180 °C and fixed installation. (Supply only in certain lengths)	9.3	14	V080372.B01 (50 m) V080372.B02 (100 m)
Measuring and data cable 4 x 2 x 0.23 mm <sup>2</sup> , shielded in pairs and totally shielded	Connection of DISOMAT DT display and control terminal to the DISOMAT weighing electronics. Also suitable for load-cell connection Temperature range: moved -5 ... +70 °C rigid installation -20 ... +70 °C	8	7.5	3849.009
Measuring and data cable 3 x 2 x 0.23 mm <sup>2</sup> , screened	Universal data or fieldbus cable for medium-speed bus systems; CAN, PROFIBUS to 0.5 MBit/s, or other serial connections. Also suitable for load-cell connection (length max. 100 m).	6.8	5.7	3849.306
Fieldbus cable for DeviceNet and Local Bus 2 x 0.33 mm <sup>2</sup> + 2 x 0.2 mm <sup>2</sup> , screened	Special cable for DeviceNet fieldbus and Local Bus with DISOCONT (thin cable)	7		3849.074
Fieldbus cable for PROFIBUS 2 x 0.64 mm <sup>2</sup> , screened	Special cable for PROFIBUS DP up to 12 MBit/s	7.7	2.5	3849.219
Data cable, 2 x 2 x 0.14 mm <sup>2</sup> , screened	Universal data cable for serial connection of displays and printers	6	3.8	3849.420
Control cable 12 x 0.22 mm <sup>2</sup> , screened	Connection of binary inputs and outputs	9	10.6	3849.010
Control cable 14 x 0.25 mm <sup>2</sup> , screened	Connection of binary inputs and outputs, e. g. for connection to VLG	8	6.5	3849.073



Schenck Process Europe GmbH  
Pallaswiesenstr. 100  
64293 Darmstadt, Germany  
T +49 61 51-15 31 - 0  
F +49 61 51-15 31 - 66  
sales@schenckprocess.com  
[www.schenckprocess.com](http://www.schenckprocess.com)

Austria  
Schenck Process Austria GmbH  
IZ NÖ Süd,  
Objekt M27/I, Straße 2  
2351 Wr. Neudorf, Austria  
T +43 (0) 2236 660355-0  
F +43 (0) 2236 660355-793  
office.pat@schenckprocess.com

Spain  
Schenck Process Ibérica, S.A.  
C/San Severo, 30  
Barajas Park  
28042 Madrid, Spain  
T +34 91 7 46 19 80  
F +34 91 3 29 60 10  
info@schenck.es

France  
Schenck Process France SAS  
Le Tourillon  
430, rue Denis Papin  
13100 Aix en Provence, France  
T +33 4 42 97 65 40  
info.fr@schenckprocess.com

Ukraine  
Schenck Process Ukraine TOW  
120/4, Kazachya St.  
03022 Kiev, Ukraine  
T +380 44 4 90 26 96  
F +380 44 4 90 26 97  
sales-ua@schenckprocess.com.ua

Poland  
Schenck Process Polska Sp. z o.o.  
ul. Annopol 4 A  
03-236 Warszawa, Poland  
T +48 22 6 65 40 11  
F +48 22 6 65 40 27  
info.pl@schenckprocess.com

United Kingdom  
Schenck Process UK Ltd.  
Unit 3 Alpha Court, Capitol Park  
Thorne, DN8 5TZ, United Kingdom  
T +44 (0) 1302 321 313  
F +44 (0) 1302 554 400  
enquiries@schenckprocess.co.uk

Russian Federation  
OOO Schenck Process RUS  
105082 Moscow  
ul.Bakuninskaja 71/10, Russian  
Federation  
T +7 495 981 12 68  
F +7 495 981 12 68  
mail@schenckprocess.ru

## THINK GLOBAL – ACT LOCAL

When you connect with Schenck Process, you also connect with our locations around the globe. Thinking globally and acting locally isn't a call from a central telephone support centre, it's a team nearby guiding and planning everything for you – from optimizing processes to developing customized solutions.

