



STEM LESSON PLANS



TEACHING GUIDE
UNIT 1: AERODYNAMICS
UNIT 2: ENERGY
NEW LESSONS!

Dear Teacher,

Science is all around us!

STEM is serious business on a NASCAR racetrack, where race cars can reach speeds of more than 200 miles per hour. The **NASCAR Acceleration Nation** program brings STEM skills to life in the classroom with two units full of fun, hands-on experiments that teach students in grades 5–7 about key scientific principles.

- **UNIT 1—Aerodynamics:** Five interactive lessons about **aero balance** and the key aerodynamic principles known as **drag, downforce, and drafting**. Plus a brand-new online car engineering simulation at scholastic.com/nascarspeed.
- **UNIT 2—Energy:** Three engaging lessons that demonstrate how **potential energy, kinetic energy, and friction** influence NASCAR and the world around us.

Ready to teach your students all about the science of speed? Buckle up, and let's go!

CONTENTS

UNIT 1: AERODYNAMICS

Learning Outcomes.....	1
Pre-Assessment.....	2

LESSON 1: DRAG

Lesson Plan 1: Drag.....	3
Assembly Sheet A.....	4
Activity Sheet 1: Drag.....	5
Resource Sheet A.....	6
Resource Sheet B.....	7

LESSON 2: DOWNFORCE

Lesson Plan 2: Downforce.....	8
Assembly Sheet B.....	9
Activity Sheet 2: Downforce.....	10
Resource Sheet C.....	11

LESSON 3: AERO BALANCE

Lesson Plan 3: Aero Balance.....	12
Activity Sheet 3: Aero Balance.....	13

LESSON 4: ENGINEERING AERO BALANCE

Lesson Plan 4: Engineering Aero Balance.....	14
Activity Sheet 4: Engineering Aero Balance.....	15

LESSON 5: DRAFTING

Lesson Plan 5: Drafting	16
Activity Sheet 5: Drafting	17

LESSON 6: AIRFLOW

Lesson Plan 6: Airflow	18
Activity Sheet 6: Airflow	19
Post-Assessment.....	20
Core Concepts and Skills Spotlight	21

UNIT 2: ENERGY AND NASCAR

Learning Outcomes.....	22
Pre-Assessment.....	23

LESSON 1: POTENTIAL ENERGY

Lesson Plan 1: Potential Energy.....	24
Activity Sheet 1A: Potential Energy.....	25
Activity Sheet 1B: Potential Energy.....	26

LESSON 2: KINETIC ENERGY

Lesson Plan 2: Kinetic Energy.....	27
Activity Sheet 2: Kinetic Energy.....	28

LESSON 3: ENERGY AND SPEED

Lesson Plan 3: Energy and Speed....	29
Activity Sheet 3: Energy and Speed...	30

LESSON 4: FRICTION AND ENERGY

Lesson Plan 4: Friction and Energy	31
Activity Sheet 4: Friction and Energy....	32
Post-Assessment.....	33
Core Concepts and Skills Spotlight.....	back cover

UNIT 1

ENGINEERING FOR SPEED

DRAG • DOWNFORCE • DRAFTING • AERO BALANCE

★ **AERODYNAMICS LEARNING OUTCOMES** ★

LESSON 1: DRAG START YOUR ENGINES

At the end of Lesson 1, students will be able to:

1. Define the science of aerodynamics
2. Explain how drag influences moving objects
3. Identify the elements of a race car that create drag

LESSON 2: DOWNFORCE UNDER PRESSURE

At the end of Lesson 2, students will be able to:

1. Explain how air pressure influences moving objects
2. Identify how the speed of air determines the amount of pressure moving air exerts
3. Determine which combinations of air pressure create downforce and lift

LESSON 4: ENGINEERING AERO BALANCE KEEP IT BALANCED

At the end of Lesson 4, students will be able to:

1. Identify factors that affect a race car's aerodynamic balance
2. Provide solutions to fix an aerodynamically imbalanced race car

LESSON 5: DRAFTING GAME CHANGER

At the end of Lesson 5, students will be able to:

1. Define the strategy of drafting
2. Explain how aerodynamics principles help drafting cars move faster

LESSON 3: AERO BALANCE BALANCE IN ACTION

At the end of Lesson 3, students will be able to:

1. Define aerodynamic balance
2. Explain why aerodynamic balance is important to race car engineers

NEW ONLINE SIMULATION



Go digital with the new **Design + Drive Simulation**. Students will be able to apply aerodynamics principles to design, then drive their own race cars at [scholastic.com/nascarspeed!](https://www.scholastic.com/nascarspeed/)

BEFORE YOU BEGIN Have students complete the pre-assessment on page 2.

PRE-ASSESSMENT ANSWER KEY 1. C; 2. B; 3. A; 4. C; 5. A; 6. A; 7. B; 8. B; 9. E; 10. D

NAME _____

DO YOU KNOW THE SCIENCE OF SPEED?

This unit is about aerodynamics and how it influences force, momentum, and speed.
Share what you know about the science of speed.

- 1 **What does the science of aerodynamics study?**
 - A The weight of objects
 - B The speed and flight of objects
 - C The movement of air
 - D The sound of air
- 2 **What are three key aerodynamics principles?**
 - A Drag, height, and acceleration
 - B Drag, downforce, and drafting
 - C Acceleration, downforce, and motion
 - D Acceleration, height, and motion
- 3 **What word describes a force that slows an object when air pushes against it?**
 - A Drag
 - B Downforce
 - C Drafting
 - D Deceleration
- 4 **What aerodynamics force is used to create both lift and downforce?**
 - A Air speed
 - B Air pressure
 - C Both A and B
 - D Neither A nor B
- 5 **A race car is aerodynamically balanced when there is balanced force on:**
 - A The front and back wheels
 - B The spoiler and the roof
 - C The splitter and the rear bumper
 - D None of the above
- 6 **True or false? Downforce is the opposite of lift.**
 - A True
 - B False
- 7 **True or false? Aerodynamic balance is complicated, which makes it impossible for engineers to use it to improve a race car's performance.**
 - A True
 - B False
- 8 **Drafting happens when:**
 - A Two or more race cars accelerate next to each other with inches between them.
 - B Two or more race cars line up, one behind the other, with inches between them.
 - C Two or more race cars tap the bumpers of the cars in front of them.
 - D None of the above
- 9 **The goal of adaptations to NASCAR race cars is:**
 - A To prevent race cars from flipping over or lifting.
 - B To provide more downforce to improve tire traction.
 - C To force high-pressure air over the car to make sure it "sticks" to the track.
 - D To create more contact between the tires and the track.
 - E All of the above
- 10 **Why is the science of aerodynamics important to racing?**
 - A Aerodynamics helps improve the safety of the race cars, keeping them on the track.
 - B Aerodynamics enhances the speed of the race cars, helping drivers zoom past the competition.
 - C Aerodynamics helps improve the performance of the cars, keeping them running smoothly and consistently.
 - D All of the above

LESSON PLAN 1: DRAG

START YOUR ENGINES

TIME REQUIRED 1½ hours, plus time for optional extension activity

MATERIALS Recycled or reused paper (2 sheets), race car templates (1 per student), card stock (1 sheet per student), scissors, tape, markers, wheels (4 per student), axles (2 per student), index cards (1 per student), ruler, plastic straw (1 per student). *Note: Test that the axles fit in the opening of the straws before the lesson. After the Drag activity, save the leftover piece of straw and the card stock for Lesson 2.*

ACTIVITY AND RESOURCE SHEETS Assembly Sheet A, Activity Sheet 1: Drag, Resource Sheet A, Resource Sheet B.

Download additional sheets as needed at scholastic.com/nascarspeed.

VIDEOS View *Aerodynamics on the Racetrack* and *Drag* at scholastic.com/nascarspeed.

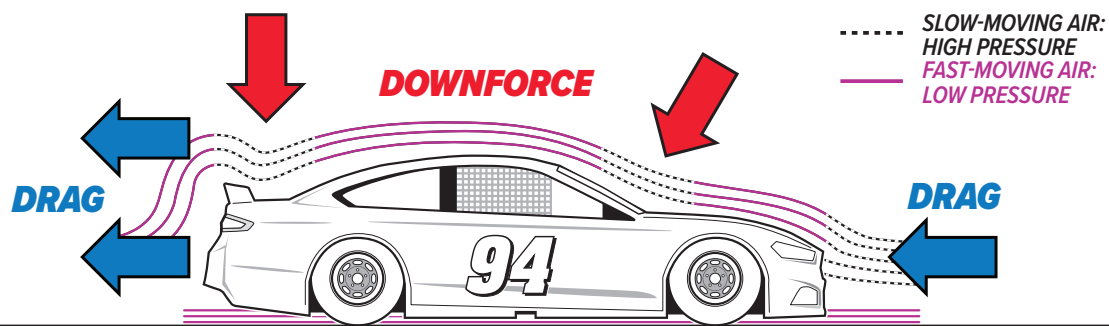

What is the science of aerodynamics?

Introduce **aerodynamics**—the study of the movement of air, specifically how it flows around objects such as cars and airplanes. Explain that NASCAR engineers study aerodynamics to improve the speed and safety of race cars.

Show the Video

Introduce the unit by showing students *Aerodynamics on the Racetrack* at scholastic.com/nascarspeed.



How does the science of aerodynamics work?

1. Call on three volunteers. Have one student drop a flat sheet of paper from about 3 feet up, while another times how long it takes to hit the floor.
2. Have the third volunteer crumple the paper into a ball and repeat the experiment. Ask students to explain what happened. Note that the object's shape affected how it moved through the air. The flat sheet of paper met resistance and moved slowly. Crumpling the paper into a ball reduced its surface area and caused it to drop more quickly to the ground.

3. Explain that aerodynamics doesn't apply only to objects. Ask students if they can think of sports in which people might bend to give their bodies less surface area or spread their bodies to make more surface area. You may show images of downhill skiers and speed skaters (smaller surface area); skydivers and hang gliders (larger surface area). Ask: *Why might speed be desired in some sports and moving more slowly be desired in others?*



What is drag?

1. Point out that NASCAR engineers not only make cars super fast—they also make them safer. Explain that **drag**, or air resistance, is a force that occurs when air pushes against an object as it moves, slowing it down.

Show the Video

Show students *Drag* at scholastic.com/nascarspeed.

2. Pair students into pit crews of two. Hand out the car templates, *Assembly Sheet A*, and *Activity Sheet 1: Drag*. Have students assemble the cars and complete the experiment. You can print out more car templates as

needed using the template provided at scholastic.com/nascarspeed.

3. Hand out *Resource Sheet A* to support groups in answering the Conclusions questions. To wrap up, explain that much like the index card in the experiment, the spoilers on NASCAR race cars create drag to slow them down and make them safer to operate.

EXTENSION: PIT CREW CHALLENGE



How does a race car's design make it more aerodynamic?

1. Give each group a copy of *Resource Sheet B*. Instruct students to read the introduction, then mark three areas where air moves slowly around the car with an "S" for slow-moving air; and mark three areas where air moves quickly around the car with an "F" for fast-moving air.

ANSWER KEY

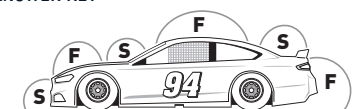

2. To wrap up, challenge each group to write an explanation of how one of the features labeled on *Resource Sheet A* increases or decreases drag.

BUILD A RACE CAR

GATHER YOUR MATERIALS

Car template, plastic straw, scissors, ruler, four round candies with holes in their centers, tape, markers



BEFORE YOU BEGIN Color or personalize your race car.

STEP 1

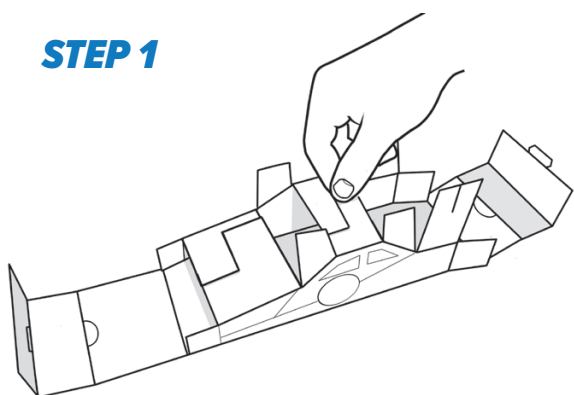

Flip the car over. Fold up the sides and connect the tabs using the split ends.

STEP 2

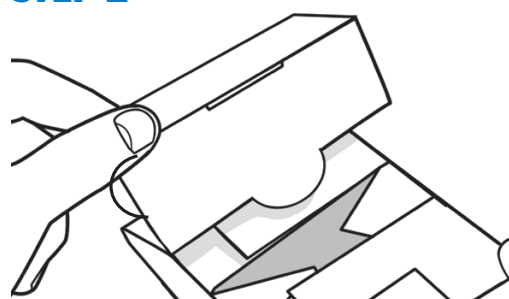

Fold up the front and the back of the car to cover all the tabs. Secure the hood and trunk by tucking the semicircles into the front and back openings.

STEP 3

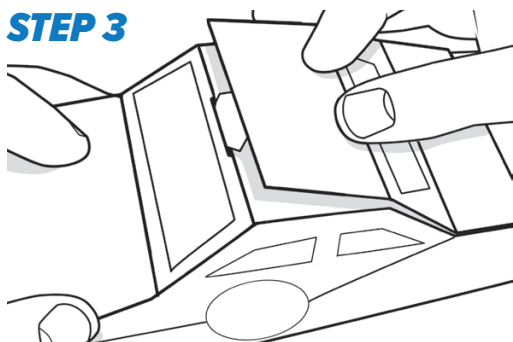

Connect the front and back of the car by sliding the top tab into the top slot. Reinforce the roof of your car with tape.

STEP 4

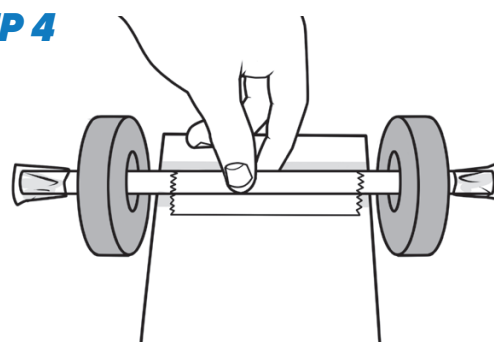

Cut two 3-inch pieces from the plastic straw. *(Note: Save the final piece of straw for the Lesson 2 experiment.)* Flip the car over and tape the straw pieces along the guidelines on the bottom of the car.

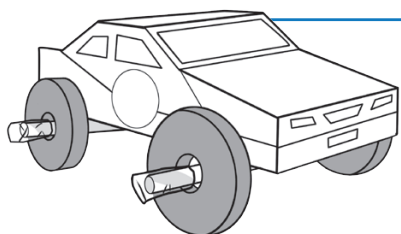

COMPLETE YOUR CAR

Thread a candy over each straw end. Fold a small piece of tape over the end of each straw to keep the candies in place. *(Note: The tape shouldn't prevent the candies from spinning.)* **Now your car is ready to roll.**

NAME _____

START YOUR ENGINES

What limits how fast a race car can go?

One factor is **drag**—a slowing force created when air pushes against an object. Try this activity to test how drag affects motion.

PROCEDURE

- 1 Fold up both edges of a sheet of card stock. Lift one end of the card stock onto a stack of books to form a ramp.
- 2 Place your car at the top of your ramp so that it rolls forward. Measure the distance it travels. Repeat for a second test run. Record both results.
- 3 Tape an index card to the back of your car so that it sticks up above the car's roof. Repeat Step 2 again for two more test runs. Record the results of both runs.

GATHER YOUR MATERIALS

Completed car, ruler, tape, index card, card stock

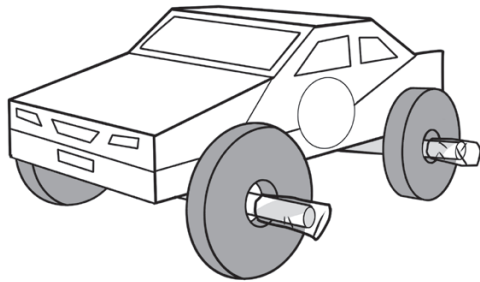
DISTANCE TRAVELED
RACE CAR WITHOUT INDEX CARD

Test Run 1

Test Run 2

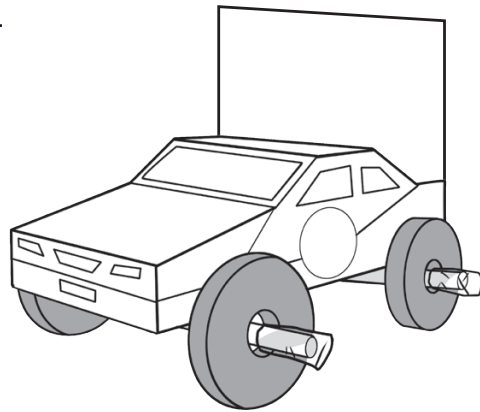

DISTANCE TRAVELED
RACE CAR WITH INDEX CARD

Test Run 1

Test Run 2

CONCLUSIONS

Answer these questions on a separate sheet of paper.

- 1 Which car went farther? Explain why you think this happened.
- 2 How did adding the index card affect the car's drag?
- 3 Why might NASCAR engineers modify race cars to create the type of drag your race car experienced? Look at *Resource Sheet A* for clues.

RACE CAR ADAPTATIONS

Each racing season, NASCAR sets rules that determine the shape and weight of its cars. Check out some NASCAR race car features and learn how they influence safety, speed, and racing aerodynamics.

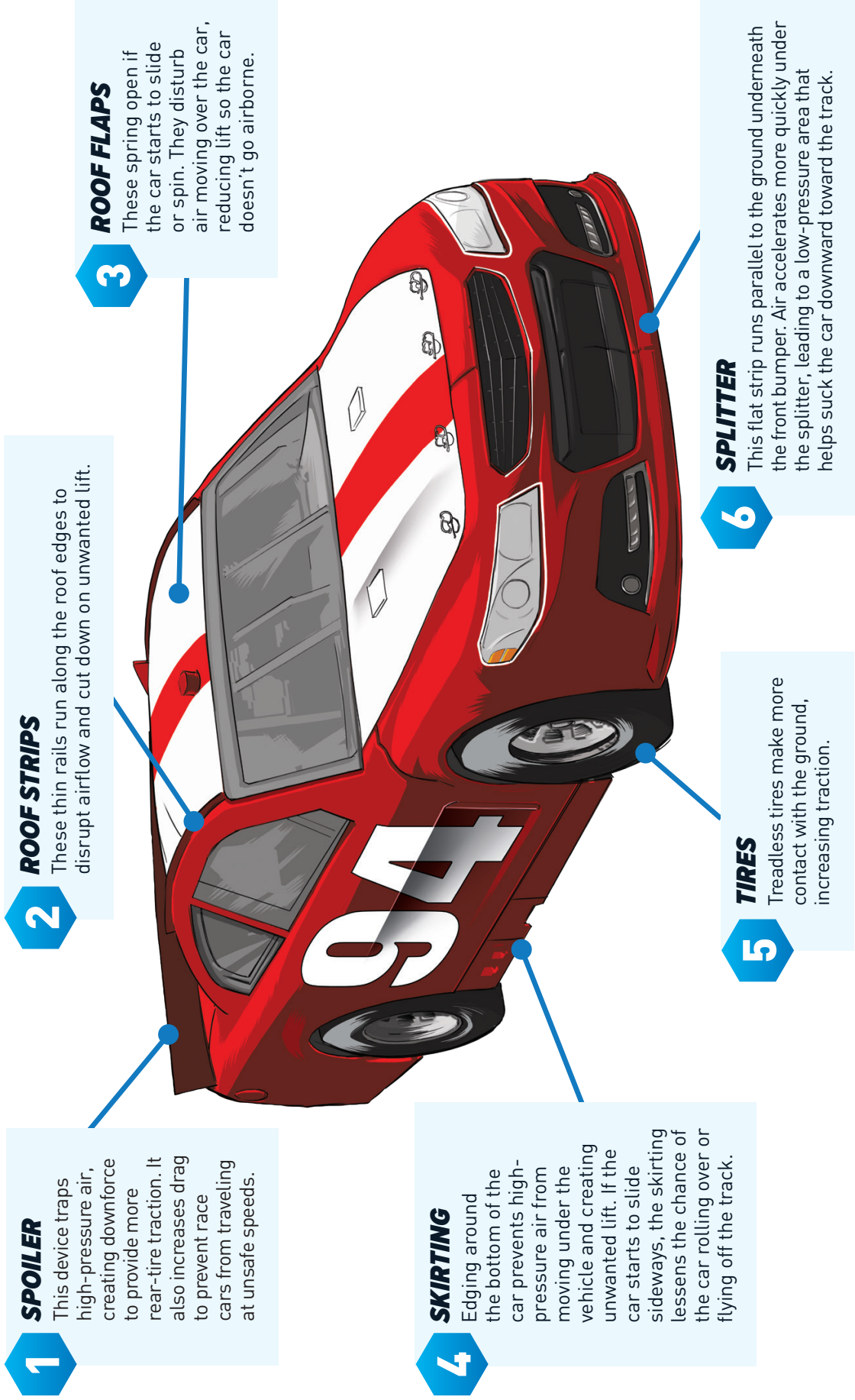

1 SPOILER
This device traps high-pressure air, creating downforce to provide more rear-tire traction. It also increases drag to prevent race cars from traveling at unsafe speeds.

2 ROOF STRIPS
These thin rails run along the roof edges to disrupt airflow and cut down on unwanted lift.

3 ROOF FLAPS
These spring open if the car starts to slide or spin. They disturb air moving over the car, reducing lift so the car doesn't go airborne.

4 SKIRTING
Edging around the bottom of the car prevents high-pressure air from moving under the vehicle and creating unwanted lift. If the car starts to slide sideways, the skirting lessens the chance of the car rolling over or flying off the track.

5 TIRES
Treadless tires make more contact with the ground, increasing traction.

6 SPLITTER
This flat strip runs parallel to the ground underneath the front bumper. Air accelerates more quickly under the splitter, leading to a low-pressure area that helps suck the car downward toward the track.

RACE CAR AIRFLOW

The way air flows around a NASCAR race car determines how much pressure the car is under. Pressure is measured by PSI, which means pounds per square inch. Areas that allow the air to flow quickly experience low pressure. Areas where the air gets trapped and flows slowly experience high pressure.

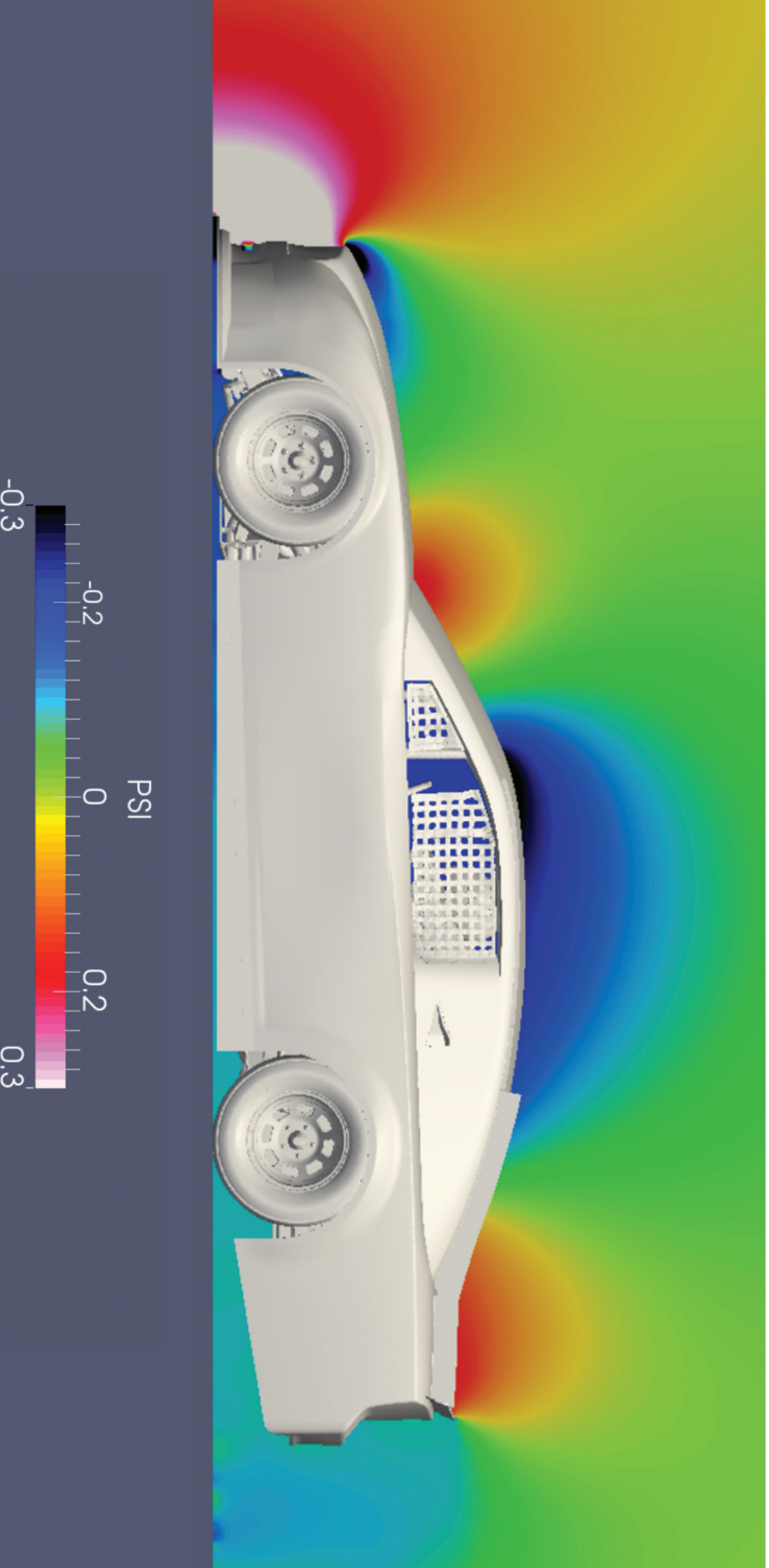

Use the color bar above to identify the areas of the car that experience the highest pressure and the lowest pressure.

LESSON PLAN 2: DOWNFORCE UNDER PRESSURE

TIME REQUIRED 45 minutes, plus optional extension activity

MATERIALS Recycled or reused paper (1 sheet per student), straws (1 per student), spools (1 per student), index cards (1 per student), card stock (1 sheet per student), rulers, scissors, pencils, markers, completed cars. *Note: Students will need one whole straw, plus the piece of straw left over from Lesson 1. Students will reuse the card stock from Lesson 1.*

ACTIVITY AND RESOURCE SHEETS Assembly Sheet B, Activity Sheet 2: Downforce, Resource Sheet A, Resource Sheet C (optional). **Download additional sheets as needed at scholastic.com/nascarspeed.**



How are the aerodynamics of racing and flight similar?

1. Explain that because NASCAR race cars can reach speeds of more than 200 miles per hour, they rely on air pressure and special race car adaptations to stick to the track. Air pressure—a key element of aerodynamics—is a force caused by the weight of air molecules pushing against an object's surface.
2. Fast-moving air causes low air pressure, and slow-moving air creates high air pressure. **Downforce** is created when high pressure pushes down on an object from above and there is low pressure below. **Lift**—the opposite of downforce—is created when there is low pressure above an object and high pressure below.
3. Downforce pushes NASCAR race cars downward so they stay on the track. Lift pushes the wings of airplanes upward so that the planes fly.



How does air pressure cause an object to rise or fall?

1. To demonstrate how air pressure works, have each student hold the short end of a sheet of paper with his or her hands pointing up. The paper should curve down over the back of his or her hands. Tell the students to blow forcefully over the curve of the paper. What happens? *(Faster-moving air over the top of the paper creates lower pressure above in contrast to higher pressure below. That creates lift, causing the paper to rise.)*

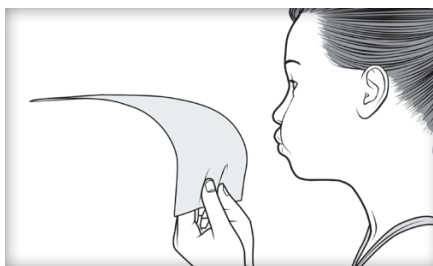

2. Next have students fold 1-inch flaps along the two shorter edges of the paper. Have them turn the paper over and fold two more 1-inch flaps along those same edges. Finally, have them set the paper on a tabletop so that there is a gap between the paper and the table. Ask them to blow forcefully through the gap. What happens? *(Faster-moving air below the paper creates an area of low pressure. The high pressure above pushes downward, creating downforce and causing the paper to sag.)*

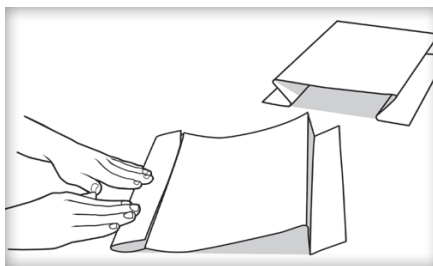

What is the relationship between air speed and air pressure?

1. Pass out *Assembly Sheet B*, *Activity Sheet 2: Downforce*, and experiment materials. Have pit crews complete the experiment. If students have trouble, make sure the straws are not taped at an angle and the top of the spool is completely covered.

2. After groups complete the Conclusions questions, challenge them to think of other objects that rely on lift or downforce to operate. *(Answer Key: Experiment: fast/low; slow/high; low/fast; high/slow; low/high/lift. Race car: slow/high; fast/low; high/slow; low/fast; high/low/downforce.)*

EXTENSION: PIT CREW CHALLENGE



How do race car modifications influence downforce on the vehicle?

1. Pass out copies of *Resource Sheet A*. Point out the race car's splitter and skirting. Explain that these adaptations enhance the car's downforce by directing fast-moving air underneath it (splitter) and preventing slow-moving air from slipping underneath its sides (skirting).
2. Pass out card stock, scissors, and the completed cars from Lesson 1. Have pit crews use *Resource Sheet A* to guide them in adding spoilers, splitters, and other features to their cars. After they have adapted their race cars, ask students to write two or three paragraphs explaining:
 - how the speed of airflow creates air pressure, drag, and downforce
 - how a race car's spoiler increases drag and creates downforce
 - how a race car's splitter and skirting help keep the car on the track

You may choose to share *Resource Sheet C* with students for a visual illustration of where race cars experience air pressure.

PRESSURE-TEST SPOOL

GATHER YOUR MATERIALS

Standard spool of thread, plastic straw, scissors, ruler, index card, tape, hole punch

STEP 1

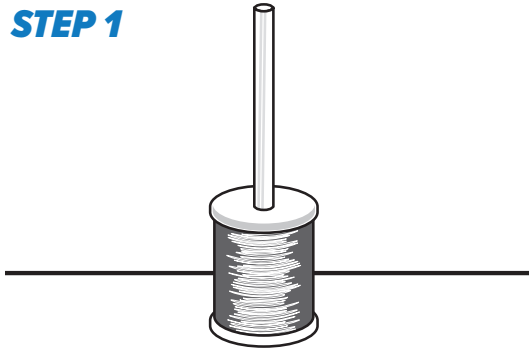

Place the spool on a flat surface and insert the leftover straw from the race car experiments into the center hole. Tape the straw to the top of the spool. Make sure that any openings on the top of the spool are completely covered.

STEP 2

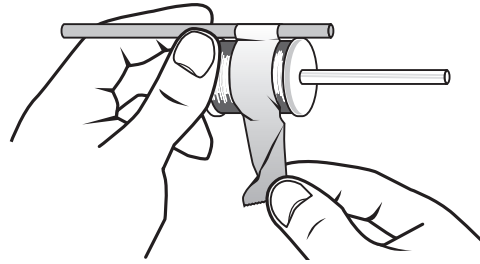

Cut a straw in half. Hold the spool sideways. Align one half of the straw to the side of the spool and tape it in place so that the straw sticks out from the bottom of the spool.

STEP 3

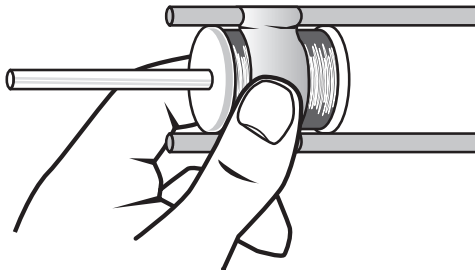

Flip the spool over and tape the second straw in place.

STEP 4

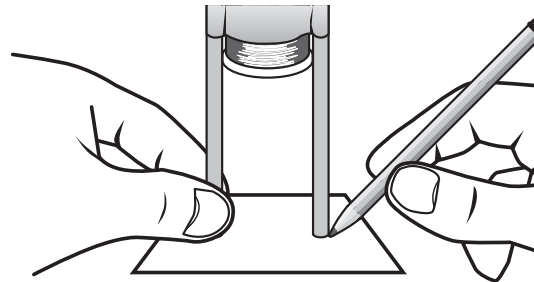

Cut a 2-inch-by-2-inch square from the index card. Stand the spool over the cut card and trace the shape of the straws on the card.

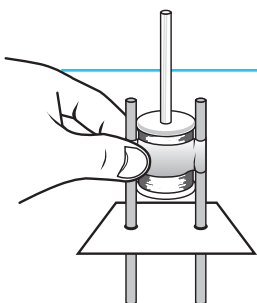

COMPLETE YOUR PRESSURE TESTER

Punch two holes in the card where you have marked them. The holes must be larger than the straws to allow the card to easily slide down the straws when you're not holding it in place. Thread the paper onto the straws. Make the holes larger as needed. **Your pressure-test spool is now complete!**

NAME _____

UNDER PRESSURE

How do NASCAR race cars stay on the track?

Race cars are designed to force air to flow faster underneath them than over the top. The low pressure below the car sucks it down toward the track. At the same time, high-pressure air pushes down on the car from above. Try this experiment to demonstrate how air pressure shifts can cause an object to stick to a surface.

PROCEDURE

- 1 Thread the index card on the straws and hold it against the bottom of the spool.
- 2 Blow strongly through the straw and let go of the card. How long can you keep the card suspended?

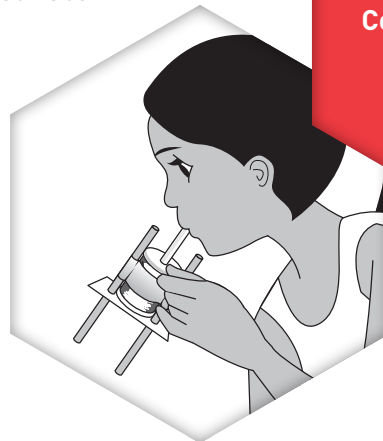

GATHER YOUR MATERIALS:
Completed pressure-test spool with index card

CONCLUSIONS

Lift or downforce? Fill in the blanks below to explain how fast- and slow-moving air create low and high air pressure, which lead to lift or downforce on an object.

EXPERIMENT

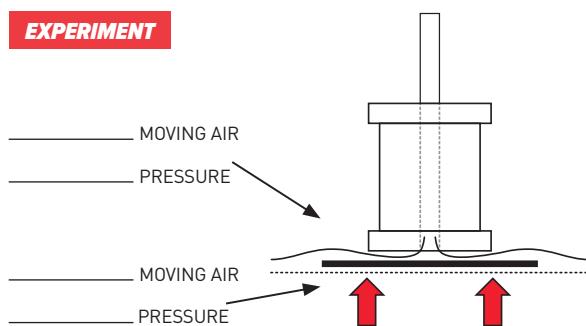

The _____ air pressure above the card was caused by _____ moving air. The _____ air pressure below the card was caused by _____ moving air. The combination of _____ air pressure above and _____ air pressure below creates _____.

RACE CAR

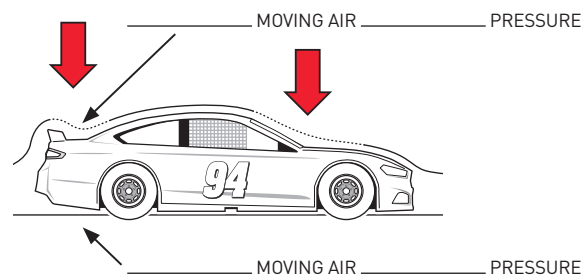

The _____ air pressure pushing downward above the front and back of the car is caused by _____ moving air. The _____ air pressure below the car is caused by _____ moving air. The combination of _____ air pressure above and _____ air pressure below creates _____.

RESOURCE SHEET C

A FOCUS ON AIR PRESSURE

Take a look at the image below to discover exactly where a NASCAR race car experiences pressure. The areas of high PSI are the areas of the race car that receive the most downforce. As the higher amounts of pounds per square inch push down on the race car, it experiences more traction and sticks to the track.

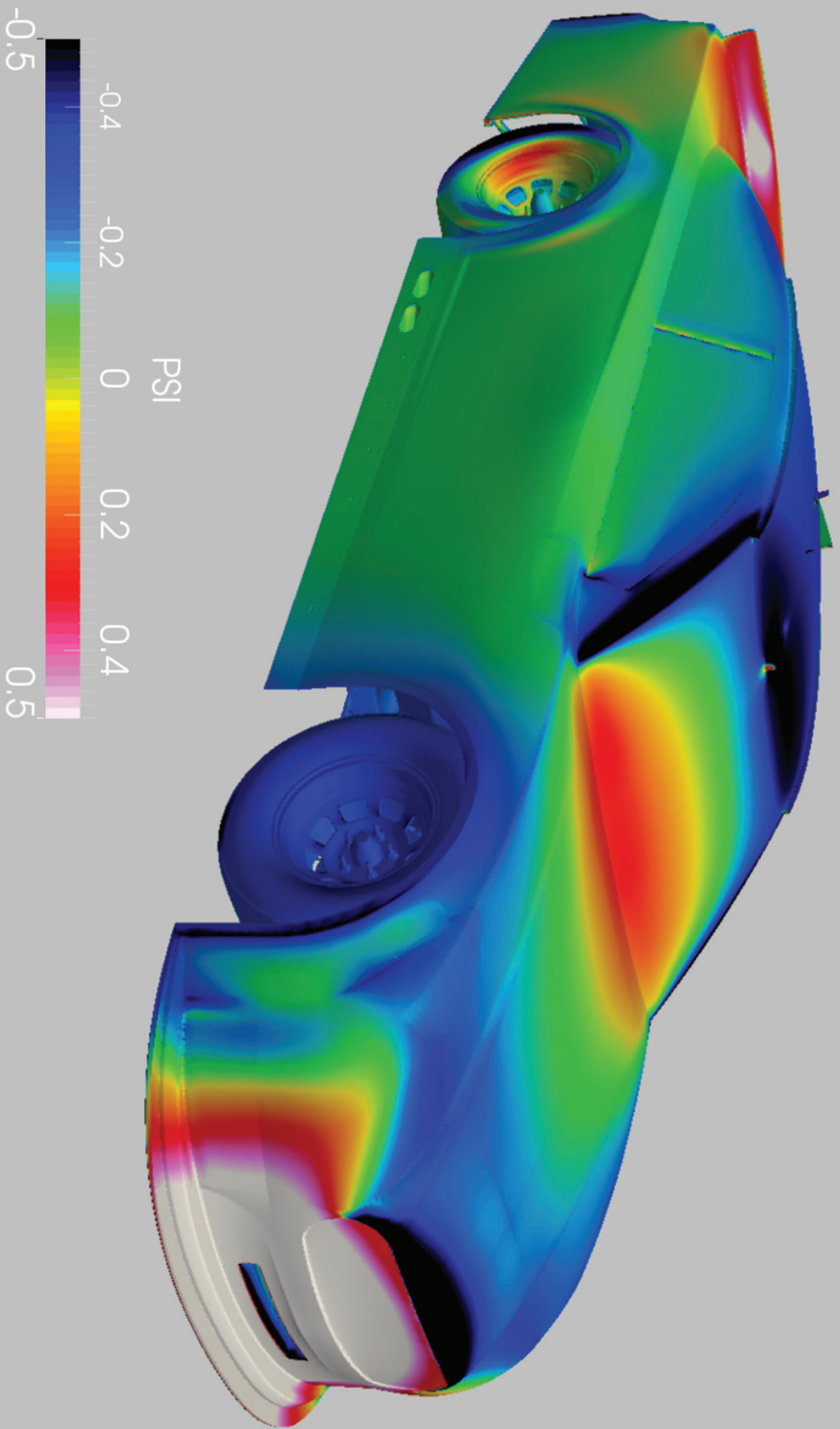

LESSON PLAN 3: AERO BALANCE

BALANCE IN ACTION

TIME REQUIRED 45 minutes, additional time may be required to build model cars

MATERIALS Assembled race cars from Lesson 1

ACTIVITY AND RESOURCE SHEETS Assembly Sheet A and Car Template (as needed), Resource Sheet B, Activity Sheet 3: Aero Balance. [Download additional sheets as needed at scholastic.com/nascarspeed.](http://scholastic.com/nascarspeed)



What is aerodynamic balance?

1. Ask a volunteer to define **downforce**. (Downforce is the downward force on a vehicle caused by air pressure differences.) Review *Resource Sheet B* and the areas of high pressure air around a race car. Ask students to identify areas of high pressure (the front and back of the car, as well as at the crease of the windshield).
2. Introduce **aerodynamic balance**, or **aero balance**—the pattern of downforce on a vehicle. Explain that the downforce—or high pressure pushing down on a car—can have different amounts of pressure. Ask volunteers to suggest ways that imbalance, or more downforce in one area, might affect a car. (Answers may include making the vehicle flip, spin, or tilt.)



Why is aerodynamic balance important on the racetrack?

1. Explain that NASCAR engineers work hard to manage the aerodynamic balance between the front and back of the vehicle. When the downforce at the front of the car is well balanced with the downforce at the back, then the car is easier and safer to drive.
2. Introduce the concept of **grip**. Grip between a race car's tires and the road helps the car to steer. Point out that race cars come in contact with the track at four different points (each tire). The downforce on race cars creates pressure on the tires, which in turn creates grip. One of the main goals of aerodynamic balance is to make sure there is balanced grip across the car's four tires.
3. Explain that aerodynamic balance helps keep cars level on the track as they are racing. Place a model car on a tabletop where all the students can see it. Explain that you will now demonstrate how grip impacts a race car's steering. Apply gentle pressure to the car's hood. Make sure students note how the car's back wheels lose contact when pressure is applied to the

front of the car. Then apply pressure to the back of the car. Make sure students note that now the car's front wheels lose contact due to the pressure applied to the back of the car.

4. Introduce the terms **oversteer** and **understeer**. Greater downforce at the front of the car is called oversteer, which causes the car's rear tires to lose grip while the front tires retain traction. On the other hand, understeer or "push" occurs when greater downforce at the back of the car causes the rear tires to retain grip while the front tires lose traction.

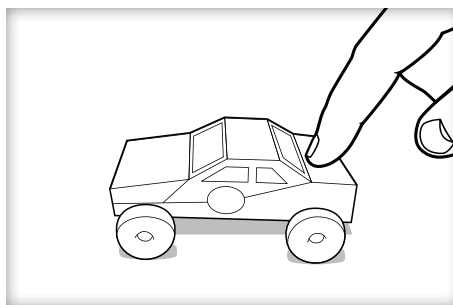
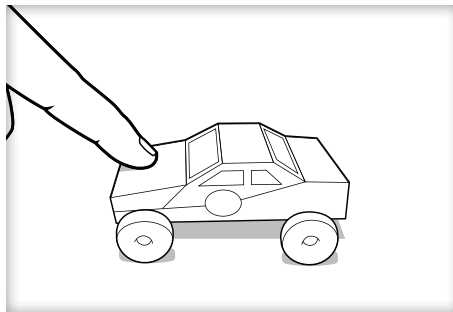

What are the effects of poor aerodynamic balance?

1. Tell students they will use their model cars to observe aerodynamic balance firsthand.
2. Distribute *Activity Sheet 3: Aero Balance*, and review instructions with students. If students need help understanding how to manipulate the car, you may repeat parts of the demonstration from Step 3 in the MOVE section above.

EXTENSION: PIT CREW CHALLENGE



What happens to race cars when they understeer and oversteer?

1. Tell students to conduct online research (using videos and text) to learn more about oversteer and understeer.
2. Have students form small groups and tell them that they'll be hand-printing small books. Ask student groups to fold standard 8.5" x 11" sheets of paper into halves twice to yield four evenly shaped squares (eight pages total). Instruct them to cut the paper into squares and staple their books along the edge for "binding." Offer the class additional sheets of paper as needed.
3. Ask students to work together to craft their own informational books that demonstrate and explain understeer and oversteer. In text and illustrations, have students explain what oversteer and understeer are—what is the result of each, why it happens, and what it looks like. Allow groups to determine exactly how their books will look and how much text and how many illustrations they'll use.



Visit scholastic.com/nascarspeed for an online interactive simulation that will allow students to apply aerodynamics principles to design, then drive their own race cars!

NAME _____

OBSERVING AERO BALANCE

How does aero balance affect a car? Greater or lesser **downforce** in one part of a race car can make it aerodynamically imbalanced. In this activity, the pressure of your fingers will stand in for aerodynamic downforce. Try the experiment with your model car to gather observations about how differences in downforce affect steering.

PROCEDURE

- 1 Place the index finger of one hand on the front hood of the car. Place the index finger of your other hand on the rear of the car, near the spoiler.
- 2 Adjust the amount of force you apply downward and attempt to roll the car forward and steer it left and right.
- 3 Record detailed observations about the ease or difficulty of steering in the chart below.

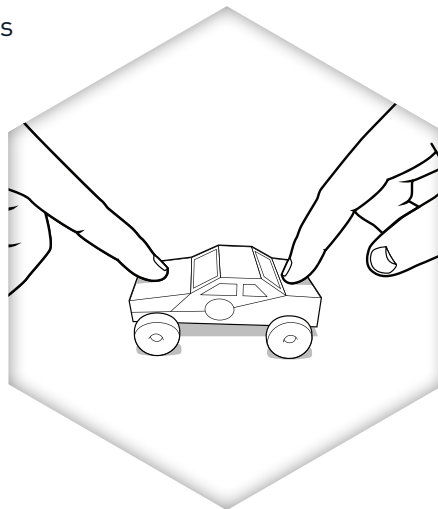

DATA

		Small amount of force	
		Front	Back
Large amount of force	Front		
	Back		

CONCLUSIONS

Answer these questions on a separate sheet of paper.

- 1 Which combination of forces made the car easiest to steer? Which combinations made it difficult to steer the car?
- 2 Based on your observations, why is aero balance important to race car performance and safety?
- 3 Based on your observations, what effect did downward force have on **grip**?

KEEP IT BALANCED

TIME REQUIRED 1 hour

MATERIALS 1 sheet of paper, small weights such as paper clips or coins, assembled race cars from Lesson 1, card stock

ACTIVITY AND RESOURCE SHEETS Resource Sheet A (for reference), Activity Sheet 4: Engineering Aero Balance.

Download additional sheets as needed at scholastic.com/nascarspeed.



How does design affect a car's aerodynamic balance?

1. Recall and review the race car adaptations that NASCAR engineers use to influence aerodynamics during races (*Resource Sheet A*). Discuss the fact that the fine-tuning of these parts, with minor adjustments to size, shape, material, or position, affects the balance of aerodynamic forces acting on a vehicle.
2. Have students consider who makes these adaptations. Explain that many people are involved in the design, development, and adaptation of race cars. The life of a race car begins in a workshop. The shop foreperson plans and manages diverse jobs to get the car created and assembled. Different kinds of engineers and other car experts work together in the workshop to build the cars that will race on the track. Mechanical engineers develop new tools and engines as well as design race car adaptations, while test engineers review those adaptations in special research centers. Manufacturers bring the adaptations to life, and the pit crew engineers make additional changes to the adaptations, which occur right on the track! All of these careers rely on math and science to determine how to best adapt cars for optimal aerodynamics, safety, and speed.



How does the force of weight affect a vehicle's balance?

1. Explain that air pressure works like additional weight on a vehicle. The aerodynamic forces that exert pressure on cars are even stronger at higher speeds. Tell students that by studying how aerodynamic forces influence a race car's balance, engineers make decisions about the mechanical forces they will manipulate on the race car.

2. Reinforce the downforce demonstration from Lesson 2: Downforce (MOVE: Step 2). To prepare for the demonstration, have students fold 1-inch flaps along the two shorter edges of the paper, then have them turn the paper over in order to fold two more 1-inch flaps along those same edges. Have them blow air beneath the paper and remind them that slow-moving air above the paper creates high pressure, and fast-moving air below the paper creates low pressure, the combination of which causes the paper to sag.
3. Next have students add weights, such as paper clips or coins, on top of the folded paper. Ask them to describe what they notice. The weights have the same effect on the paper as aerodynamic forces—both forces cause the paper to sag. Just as altering airflow changes the balance of the paper, moving weights changes the balance of the paper.

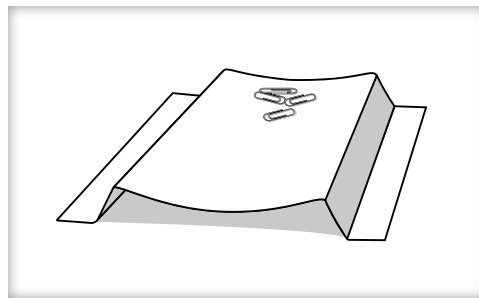

How does weight distribution affect a vehicle?

1. Remind students that imbalanced forces can affect steering, and race car engineers achieve mechanical balance through weight distribution. Challenge students to come up with an experiment to test the effect of mechanical balance on a moving car.
2. Have students form pairs or small groups. Distribute *Activity Sheet 4: Engineering Aero Balance*. Go over instructions with the class, and have students complete the activity.

3. Review the results of the experiment as a class. There may or may not have been an observable effect. Ask: Were you surprised by the results? Why? How is this model like a race car? How is it different? How might your results apply to NASCAR, and why might they not? Depending on factors such as the angle of their ramp, students may observe that back-heavy cars traveled farther than others. However, potential energy plays a role in the ramp test, which is one key difference between this model and real race cars—which race on a flatter track.

EXTENSION: PIT CREW CHALLENGE



How could you test the effects of balance on a real-life race car?

Have students form small groups. Tell them they will write a proposal for an experiment to test the effects of balance on race car performance in the real world. Reports should include: A) a description of the race car; B) a list of materials or facilities that they will need; C) basic steps of the experiment; and D) an explanation of the data they intend to collect.



Visit scholastic.com/nascarspeed for an online interactive simulation that will allow students to apply aerodynamics principles to design, then drive their own race cars!

NAME _____

BALANCING BACKWARDS AND FORWARDS

Does weight distribution affect the performance of a race car? Follow the basic steps of the experiment described below to try to answer the question.

PROCEDURE

- 1 Decide the cases you will test:
 - How can you add weight to model cars to test if weight distribution has an effect?
 - What types of weights will you use?
 - How many different weight distributions will you compare?
- 2 Decide if you will test one or two cars at a time. You can choose to send two cars down a ramp at the same time, or test them one at a time.
- 3 Set up cars with weights attached. Prop up your ramp on a book or two, and lay your measuring tape at the bottom.
- 4 Now run your experiment and record your results on a separate sheet of paper.

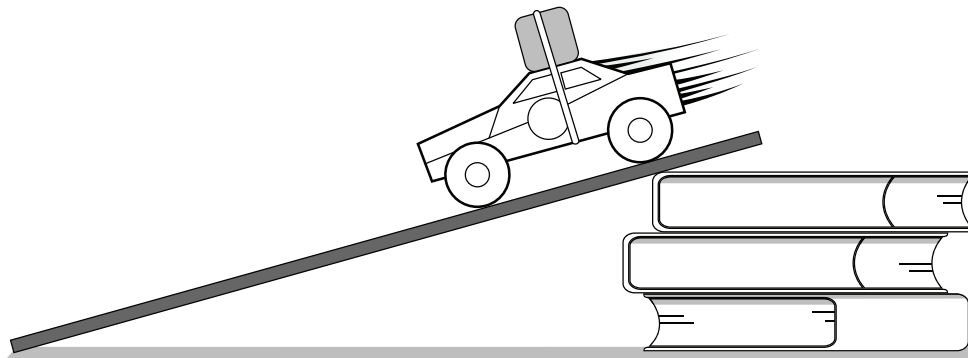

CONCLUSIONS

- 1 Was there an effect? Analyze your results to look for a pattern. Why do you think there was or was not a difference?
- 2 Like many experiments, these results rely on a model. How do you think balance affects real race cars?

LESSON PLAN 5: DRAFTING

GAME CHANGER

TIME REQUIRED 40 minutes

MATERIALS Recycled or reused drawing paper, poster board or butcher paper, tape, scissors, markers

ACTIVITY AND RESOURCE SHEETS Activity Sheet 5: Drafting, Resource Sheet A.

Download additional sheets as needed at scholastic.com/nascarspeed.

VIDEO View *The Art of Drafting* at scholastic.com/nascarspeed.

LEXILE SCORE 930L

DRAFTING STAGE 1:

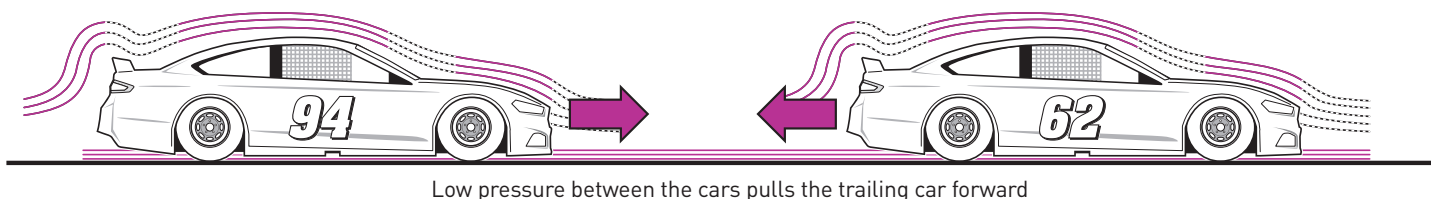

DRAFTING STAGE 2:

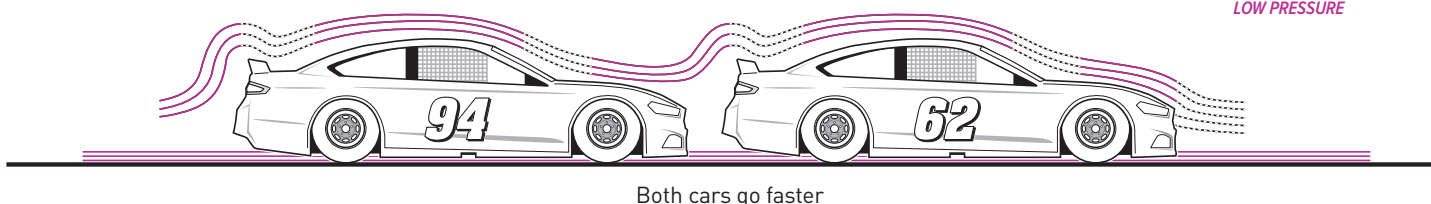

What is drafting?

1. Explain to students that, in addition to the NASCAR race car adaptations we've discussed, drivers use a technique called **drafting** to gain a boost in speed on the track. Drafting is a driving strategy where race cars improve the performance of their vehicles by closely lining up one behind the other.

Video Connection

Show students the *Drafting* video at scholastic.com/nascarspeed.

2. Explain that the science behind drafting relies on **Bernoulli's principle**. When race cars draft, the leading car blocks the air, creating

an area of low pressure behind it. The low pressure pulls the trailing car forward toward the leading car. This pushes the high-pressure air over the lead car's spoiler, reducing its drag. The result allows both cars to go a few miles per hour faster. Project the above diagram to demonstrate the aerodynamics of drafting to students.

3. Hand out *Activity Sheet 5: Drafting*, where students will read a passage about the history of drafting, followed by questions to assess their reading comprehension. (Answers: 1. C; 2. A; 3. D; 4. *It looks like two or more cars trailing each other with just inches between them*; 5. *"The more cars that are grouped in a drafting formation, the faster they all will go."*)

EXTENSION: PIT CREW CHALLENGE



How does drafting help cars travel faster?

1. Provide pit crews with poster board or butcher paper, tape, scissors, markers, and *Resource Sheet A*.
2. Instruct them to draw and cut out race cars to make a poster that includes:
 - a racetrack with three or more race cars
 - examples of drag, downforce, and drafting
 - arrows that show how air pressure acts on race cars
 - labels demonstrating spoilers, splitters, and other adaptations

NAME _____

⚡ GAME CHANGER ⚡

Winning a NASCAR race requires more than a super-speedy car. Drivers also use a strategy called **drafting** to get ahead on the track. Read the passage below to learn about the technique's accidental discovery. Then answer the questions on the right.

THE DISCOVERY OF DRAFTING



In 1960, race car driver Junior Johnson was gearing up for the second-ever Daytona 500 race. But he realized he had a problem: His car was much slower than those of the top contenders in the race.

During a practice run, Johnson noticed that when he pulled up close behind a faster car his vehicle sped up, too. By the final lap of his run, he'd built up enough speed to overtake the other car. Johnson had discovered drafting.

Drafting occurs when a car lines up right behind the car in front of it, with just inches between their bumpers. Leading cars block the flow of air, creating an area of low pressure behind them. This area acts like a vacuum, sucking the trailing cars forward. The trailing cars push high-pressure air over the leading cars' spoilers, reducing their drag and also giving them a boost. The more cars that are grouped in a drafting formation, the faster they all will go.

Using the drafting tactic, Johnson won the Daytona 500 even though his car wasn't the fastest on the track. Today, drafting is a common strategy in NASCAR races.

1 What was the central idea of the text?

- A** Drafting is a common strategy used in NASCAR races.
- B** Drafting was first used by accident.
- C** By driving close behind other cars, race cars can move faster.
- D** A car doesn't have to be the fastest to win a race.

2 The purpose of the third paragraph is to:

- A** Explain the science of how drafting works.
- B** Describe the first time that drafting was used in NASCAR.
- C** Detail how drafting has changed in the last 40 years.
- D** List the pros and cons of drafting.

3 What is a synonym for the word *tactic*?

- A** ability **C** idea
- B** formation **D** strategy

4 Describe what a drafting formation looks like.

5 Which statement in the text supports the idea that multiple drivers can benefit from drafting?

LESSON PLAN 6: AIRFLOW

TUNNEL TESTING

TIME REQUIRED 1 hour, plus time for optional extension activity

MATERIALS Assembled race cars from Lesson 1, small fan, straws, string, scissors, ruler, masking tape, pencil, paper

ACTIVITY AND RESOURCE SHEETS Activity Sheet 6: Airflow, Resource Sheet B.

Download additional sheets as needed at scholastic.com/nascarspeed.

LEXILE SCORE 1060L



How do engineers test the aerodynamics of race cars?

1. Ask students how they think NASCAR engineers test race car performance considering that race cars travel around racetracks at high speeds. After students volunteer guesses, explain that engineers build special testing environments to simulate racetrack conditions.
2. Hand out *Activity Sheet 3: Airflow*, which contains a reading passage about the use of wind tunnels to test drag and downforce. Read the introduction together as a class. Before students read the passage, challenge them to think about what they've already learned about aerodynamics and make connections with their own drag and downforce experiments as they gather information from and form opinions about the text.



What does wind tunnel testing tell engineers about aerodynamics?

1. On your whiteboard or chalkboard write the following questions. Tell students to record their answers to these questions on a separate sheet of paper as they read the passage.
 - What predictions can you make about the passage based on the title?
 - What questions come to mind as you read?
 - What do you picture in your mind as you read?
 - Does the text make you think about anything you've already learned?
 - Are there any words in the text that you don't know?

2. Instruct students to answer the questions on the sheet to assess their reading comprehension. (Answers: 1. A wind tunnel is a large, narrow room with powerful fans at one end, which blow air over an object, such as a race car, placed inside the tunnel. 2. Engineers use wind tunnels to study race cars' aerodynamics and improve their performance. 3. NASCAR designers use wind tunnels to learn about different forces and pressures on a car. 4. They might alter the car's body to give it a more aerodynamic shape. Or engineers might change the angle of a car's spoiler to increase downforce.)

Show Video

After completing the activity sheet, show students a video of a real wind tunnel used to test NASCAR race cars: youtu.be/i0ixLwD8CRc. Prompt students to compare how information is presented visually in the video versus the reading passage. Does the video help them better understand what they just read?



How can engineers view airflow in a wind tunnel?

1. Explain that streamers are another way engineers determine how air flows around objects in a wind tunnel. Separate students into groups and provide them with a straw and a 4-inch piece of string. Have groups tape one end of the string to one end of the straw to create their own streamers.
2. Set up a fan on a table and mark a distance 2 feet away with a piece of masking tape. Have students place the car the team built in Lesson 1 on the piece of tape facing the fan. Turn the fan to a medium setting and make sure it is positioned so air is blowing at the car. Tell one group member to hold the straw and place the end of the streamer on different points of the

car, such as the front, sides, back, and top. The direction in which the string moves shows the direction that air is moving over the car's surface. If the string is straight, the airflow is steady—a sign of an aerodynamic design. The opposite is true if the string whips around wildly.

3. Instruct students to draw a simple sketch of their car and label it with arrows to show which way air is flowing in different spots. Also have them label where the airflow is smooth and where it is turbulent.

EXTENSION: PIT CREW CHALLENGE



What other testing facilities and mechanisms do engineers use to test car performance?

Explain that wind tunnels are just one type of testing that race cars undergo. Have students team up to research race car testing facilities. Instruct students to compile lists of the types of testing race cars undergo at specific testing facilities and/or test tracks. Have the groups use their lists to build their dream testing facilities. Groups should prepare profiles of their facilities. Their profiles should include the name and location of their facility; descriptions of all the testing mechanisms at the facility; a description of the test track, including its length, the number of curves, elevation of banking, etc.; and an illustration of what the facility looks like.

AFTER THE UNIT Once you have finished all six lessons, have students complete the post-assessment and compare their responses to the pre-assessment.

POST-ASSESSMENT ANSWER KEY

1. B; 2. D; 3. A; 4. B; 5. B; 6. A; 7. D; 8. B; 9. D; 10. A

NAME _____

TUNNEL TESTING

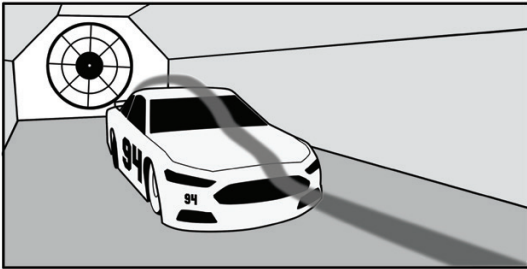

A NASCAR race car goes through extensive testing before it ever hits the track. Engineers want to know how forces such as drag and downforce will affect a race car’s performance. Read the passage below to find out how engineers study race car aerodynamics using a **wind tunnel**. Then answer the questions on the right in complete sentences.

ENGINEERING WIND

Engineers study aerodynamics to improve race cars’ speed and safety, but that’s not an easy thing to do while a race car is hurtling more than 200 miles per hour around a track. Engineers need the car to stay put while they gather information on how air flows around it. To do that, they place a stationary race car inside a wind tunnel.

A wind tunnel is a large, narrow room with powerful fans at one end. NASCAR engineers release smoke into the tunnel while the fans blow air over the race car to make the air movements around the vehicle visible. High-tech sensors collect data about the forces the race car experiences in the tunnel.

Wind-tunnel tests help engineers identify important changes to build better race cars. They might alter the car’s body to give it a more aerodynamic shape, which can reduce drag and boost a car’s speed. Or engineers might change the angle of a car’s spoiler to increase downforce, which would help a car grip the track better. Both changes would improve the airflow around the race car and allow it to go faster.

1 In your own words, explain how a wind tunnel works.

2 What is the main idea of this passage?

3 Give one key detail in the second paragraph that supports the passage’s main idea.

4 Explain how engineers use the data they collect in a wind tunnel to improve a race car’s design.

NAME _____

WHAT DID YOU LEARN ABOUT THE SCIENCE OF SPEED?

You just completed a unit about aerodynamics and its influence on an object's speed. Share what you have learned about aerodynamics.

1 The science of aerodynamics studies:

- A** How fast a car or plane can move.
- B** The movement of air.
- C** How objects can change the air.
- D** The weight of objects.

2 What are three key aerodynamics principles?

- A** Drag, distance, and downforce
- B** Drafting, distance, and drag
- C** Drag, downforce, and dynamics
- D** Drag, downforce, and drafting

3 Drag occurs when:

- A** Air pushes against an object.
- B** Air enters an object.
- C** Air avoids an object.
- D** None of the above

4 Poor aerodynamic balance will make a race car:

- A** Faster.
- B** Difficult to steer.
- C** Better at drafting.
- D** None of the above

5 True or false? Fast-moving air creates high air pressure.

- A** True **B** False

6 True or false? When two cars draft, the area of low pressure behind the first car sucks the second car forward, causing it to move even faster.

- A** True **B** False

7 Aerodynamic balance is affected by:

- A** Race car adaptations to improve aerodynamics.
- B** Added weight in the vehicle
- C** Downforces.
- D** All of the above

8 The flaps on race cars that create drag:

- A** Help the cars move faster.
- B** Slow the cars down to better control their speed.
- C** Help the cars increase speed during drafting.
- D** All of the above

9 Downforce is important to NASCAR race cars because:

- A** It helps the cars move faster.
- B** It makes it safer to speed around turns.
- C** It helps the cars "stick" to the track.
- D** All of the above

10 In the world of NASCAR racing aerodynamics, engineers:

- A** Create car adaptations that help improve the safety and speed of race cars.
- B** Design helmets that help the drivers focus better when driving.
- C** Invent car adaptations that make the cars heavier and safer.
- D** Develop adaptations that enhance the communication between the car and the driver.

CORE CONCEPTS AND SKILLS SPOTLIGHT

NEXT GENERATION SCIENCE STANDARDS

Unit 1—Aerodynamics covers overarching concepts and skills relevant to a range of principles that can be easily applied to your state’s science and reading standards.

DISCIPLINARY CORE IDEAS: PHYSICAL SCIENCE

Matter and Its Interactions

- ▶ A model showing that gases are made from matter particles that are too small to see and are moving freely around in space can explain many observations, including the inflation and shape of a balloon and the effects of air on larger particles or objects.

Related Standard:

Develop a model to describe that matter is made of particles too small to be seen.

Motion and Stability: Forces and Interactions

- ▶ The sum of an object is determined by the sum of the forces acting on it; if the total force on the object is not zero, its motion will change. For any given object, a larger force causes a larger change in motion.

Related Standard:

Plan an investigation to provide evidence that the change in an object’s motion depends on the sum of the forces on the object and the mass of the object.

SCIENCE AND ENGINEERING PRACTICES

Planning and Carrying Out Investigations

- ▶ Conduct an investigation and/or evaluate and/or revise the experimental design to produce data to serve as the basis for evidence that meets the goals of the investigation.

Developing and Using Models

- ▶ Develop and/or use a model to predict and/or describe phenomena.

Constructing Explanations and Designing Solutions

- ▶ Construct an explanation using models or representations.

Engaging in Argument From Evidence

- ▶ Construct, use, and/or present an oral and written argument supported by empirical evidence and scientific reasoning to support or refute an explanation or a model for a phenomenon or a solution to a problem.

Obtaining, Evaluating, and Communicating Information

- ▶ Communicate scientific and/or technical information (e.g., about a proposed object, tool, process, system) in writing and/or through oral presentations.

Source: NGSS Lead States. *Next Generation Science Standards: For States, By States*. Washington, DC: The National Academies Press.

COMMON CORE READING STANDARDS

ENGLISH LANGUAGE ARTS: READING INFORMATIONAL TEXT

Key Ideas and Details

- ▶ Determine central idea of a text and draw inferences by citing textual evidence and analyses of key individuals, events, or ideas.

Craft and Structure

- ▶ Determine meaning of words, phrases, and sentences in the context of their significance to the passage.

Source: Common Core State Standards Initiative.

UNIT 2

ENERGY AND NASCAR

POTENTIAL ENERGY • KINETIC ENERGY FRICTION & ENERGY

★ ENERGY AND NASCAR LEARNING OUTCOMES ★

LESSON 1: POTENTIAL ENERGY HIDDEN ENERGY

At the end of Lesson 1, students will be able to:

1. Define potential energy
2. List the four main types of potential energy
3. Identify forces that influence potential energy

LESSON 2: KINETIC ENERGY ENERGY IN MOTION

At the end of Lesson 2, students will be able to:

1. Define kinetic energy
2. Identify forces that influence kinetic energy
3. Describe the relationship between potential and kinetic energy

LESSON 3: ENERGY AND SPEED UNDER THE HOOD

At the end of Lesson 3, students will be able to:

1. Explain the connection between potential energy and kinetic energy
2. Explain how NASCAR engines work

LESSON 4: FRICTION AND ENERGY A DYNAMIC DUO

At the end of Lesson 4, students will be able to:

1. Define friction
2. Describe the relationship between friction and speed
3. Describe the relationship between friction and race car safety



NEW ONLINE SIMULATION

Go digital with the new **Design + Drive Simulation**. Students will be able to apply aerodynamics principles to design, then drive their own race cars at [scholastic.com/nascarspeed!](https://scholastic.com/nascarspeed/)

BEFORE YOU BEGIN Have students complete the pre-assessment on page 23. Save the pre-assessments until the end of the unit to measure the growth in student knowledge.

PRE-ASSESSMENT ANSWER KEY 1. C; 2. B; 3. D; 4. B; 5. A; 6. A; 7. C; 8. D; 9. D; 10. D

NAME _____

WHAT DO YOU KNOW ABOUT ENERGY?

This unit is all about energy. Share what you know about how energy works.

- 1 **What is potential energy?**
 - A How fast an object can move
 - B The force that makes an object move
 - C The unused energy stored in an unmoving object
 - D All of the above
- 2 **The potential energy of a car at the top of a ramp is affected by:**
 - A The car's shape.
 - B The height of the ramp.
 - C The car's speed.
 - D The length of the ramp
- 3 **The force of gravity _____**
 - A pushes objects away from Earth.
 - B slows objects down.
 - C causes objects to be pulled in two different directions.
 - D pulls objects downward toward Earth.
- 4 **True or false? Two objects with the same mass sitting at different heights have the same potential energy.**
 - A True
 - B False
- 5 **What is kinetic energy?**
 - A The energy of an object in motion
 - B The energy in machines
 - C The energy stored in unmoving objects
 - D None of the above
- 6 **True or false? You can influence an object's kinetic energy by changing its mass.**
 - A True
 - B False
- 7 **What are two factors in kinetic energy?**
 - A Height and gravity
 - B Gravity and speed
 - C Speed and mass
 - D Mass and height
- 8 **What is friction?**
 - A An oppositional force
 - B The resistance that one surface experiences when moving over another
 - C The pull of gravity
 - D Both A and B
 - E None of the above
- 9 **What type of energy is created when two surfaces rub against each other?**
 - A Light
 - B Heat
 - C Sound
 - D All of the above
- 10 **Why are the rules of energy important to racing?**
 - A Because potential and kinetic energy help determine how quickly a race car will go
 - B Because potential and kinetic energy help determine how much fuel a race car will need to complete a race
 - C Because adjusting the factors that contribute to potential and kinetic energy can help a race car go faster
 - D All of the above

LESSON PLAN 1: POTENTIAL ENERGY

HIDDEN ENERGY

TIME REQUIRED 1 hour

MATERIALS Small marble, large marble, Ping-Pong ball, golf ball, large pan, flour, yardstick

ACTIVITY AND RESOURCE SHEETS Activity Sheets 1A and 1B: Potential Energy



What is potential energy?

1. Introduce the concept of potential energy—energy that is stored due to an object’s position or condition. Explain that the word “potential” means having the ability to do something. Therefore, potential energy is energy that has not yet been used.
2. To illustrate the concept of potential energy, ask students to imagine a race car sitting on the top of a steep banking. (See the BUILD section of Lesson 2: Kinetic Energy for a description of racetrack bankings.) Tell students that in this position the car is loaded with a specific type of potential energy, called **gravitational potential energy**. Explain that when an object, like a race car, is far above the ground, a force called **gravity** pulls it downward toward Earth’s surface.



What affects the amount of potential energy an object has?

1. Explain that the potential energy of an object is measured by its ability to exert a specific amount of force for a particular distance. There are three factors that determine how much **gravitational potential energy** an object has: gravity, height, and mass. Gravity is constant, but differences in an object’s mass and height can increase or decrease the amount of potential energy the object has.
2. To demonstrate, set a small marble on the floor of your classroom. Ask students if the marble has potential energy in its current state. (No, because there’s no distance for gravity to pull it toward Earth.) Raise the marble about one foot in the air. Ask whether it now has any potential energy. (Yes.)

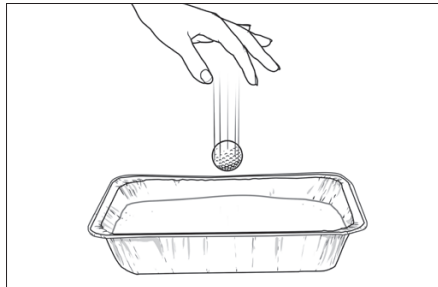

3. Drop the marble into a large pan filled with a few inches of flour. Gently remove it from the pan and have a volunteer measure the width of the impact crater left in the flour. Climb on a chair and drop the marble from a height of about seven feet. Measure the new impact crater. Repeat the experiment with the large marble, the Ping-Pong ball, and the golf ball. Have students take notes throughout the experiment. After the demonstration is complete, ask them to draw conclusions about how mass and height impact the amount of potential energy an object has.



What types of potential energy exist?

1. Hand out *Activity Sheet 1A: Potential Energy*. Tell students that gravitational potential energy is just one type of potential energy. Have them complete the activity to learn about three other forms.
2. Now that students understand potential energy’s different forms, have them imagine a race car sitting in position on the starting grid before the start of a NASCAR race. Ask: *What forms of potential energy might the car have before it starts moving?*
3. Explain that cars use **electric potential energy** to operate. When a driver starts the car, the battery releases a jolt of electricity to power parts inside the

car. The fuel in the car’s gas tank holds **chemical potential energy**. When the fuel burns, it undergoes a chemical reaction that unleashes energy to power the car’s engine and propel the vehicle around the track. Batteries are unique because they hold energy in chemical form, but they release electric energy! (Fun fact: NASCAR race cars use Sunoco Green E15 as fuel. Just like a car, the human body relies on chemical potential energy stored in another type of fuel—food. By breaking down food, our bodies get the energy they need to survive.)

4. Describe how a race car also has a suspension system between its wheels and its base. This system contains flexible springs that store **elastic potential energy**. This type of energy—also called mechanical energy—is energy stored in an object due to its tension. When the car hits a bump in the road, the springs absorb the impact by compressing. Then they stretch to release the stored energy, pushing the tire back against the road. This helps prevent the car’s wheels from losing their grip on the track.

EXTENSION: PIT CREW CHALLENGE



How do we identify the different types of potential energy around us?

Divide students into groups, and hand out *Activity Sheet 1B: Potential Energy*. Tell students to study the scenes on the sheet and search for examples of potential energy. See which group can identify the most objects with stored energy. Answer key: **Chemical:** snacks in box in stands, gas, battery, race car, blimp; **Gravitational:** tire raised, food raised overhead, man holding flag, man climbing ladder; **Electric:** lamppost, lights in the viewing boxes, television camera; **Elastic:** muscles, tires, air compressor.

NAME _____

POTENTIAL ALL AROUND US

DIRECTIONS Read about four types of potential energy in the chart below. Then write down as many examples of each that you can think of. One is already done for you.

GRAVITATIONAL energy stored in an object due to its height.

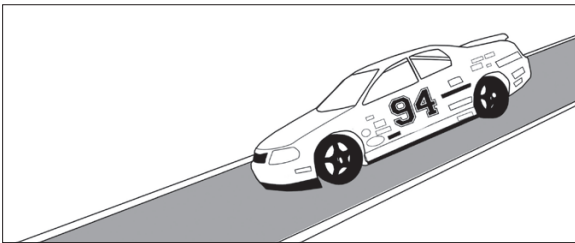

UNITS OF MEASURE joules

Examples a race car coming off a bank,

CHEMICAL energy stored in chemicals.

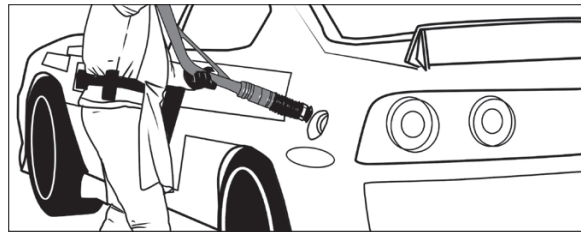

UNITS OF MEASURE calories (food), joules, horsepower-hours (vehicles)

Examples burning fuel inside a race car's engine, _____

ELASTIC energy stored in an object that can be stretched or squeezed.



UNITS OF MEASURE joules

Examples the springs that make up a race car's suspension system, _____

ELECTRIC energy stored as electricity.

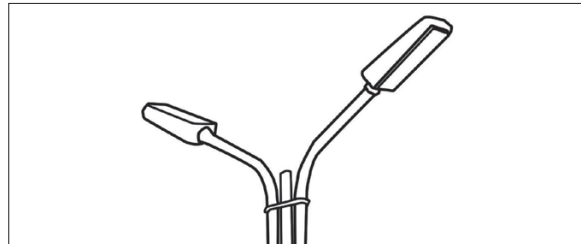

UNITS OF MEASURE volts

Examples the wires in a lamppost, _____

A DAY AT A NASCAR RACE

DIRECTIONS A day at the racetrack is full of potential energy. Look at the scenes below on race day and find examples of the four main types of potential energy. How many examples can you find?

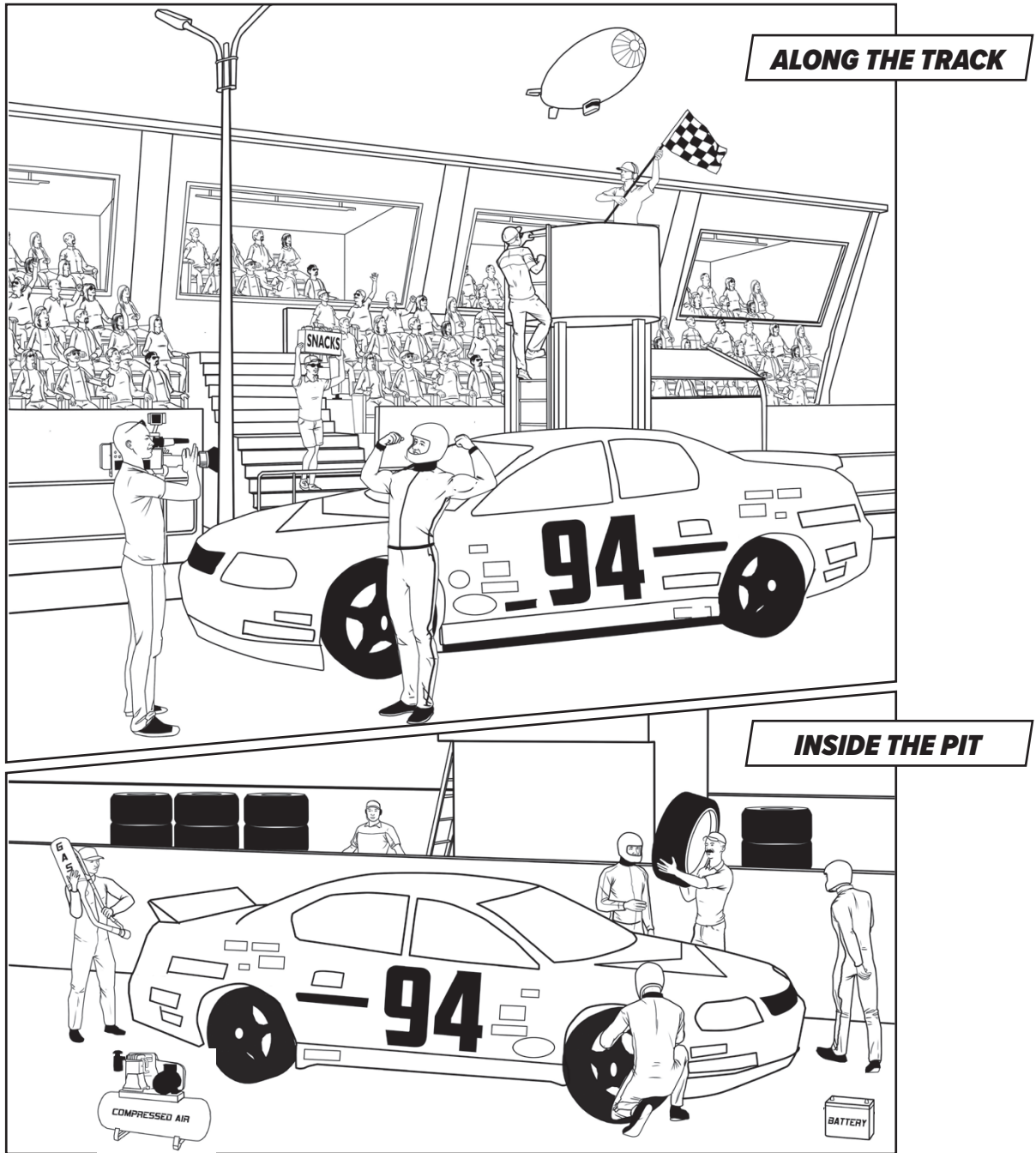

- 1 Chemical: _____
- 2 Gravitational: _____
- 3 Electric: _____
- 4 Elastic: _____

LESSON PLAN 2: KINETIC ENERGY

ENERGY IN MOTION

TIME REQUIRED 1 hour

MATERIALS String, heavy and light objects (such as a pencil and a pack of index cards), paper cup, masking tape, ruler, textbooks, cardboard, toy car or completed car from

Unit 1: Aerodynamics

ACTIVITY SHEETS Activity Sheet 2: Kinetic Energy



What is kinetic energy?

Have students consider what happens to potential energy when it's released from its stored state. Explain that energy can't be created or destroyed, but it does change from one form to another. Potential energy is often converted into another type of energy called kinetic energy. Kinetic energy is the energy of motion. Kinetic energy can also transform back into potential energy. For example, you'd use kinetic energy to lift a ball to the top of a ramp. That energy would be stored in the ball as potential energy.



What factors affect kinetic energy?

1. Explain that there are two factors that affect how much kinetic energy a moving object will have: mass and speed. Have students complete this demonstration to learn how mass influences an object's kinetic energy.
2. Select a light object (such as a pencil) and a heavy object (such as a pack of index cards). Tie a string around each object, leaving a 3-foot-long piece attached. Have a student volunteer hold the light object in his or her right hand 3 feet above the ground. He or she should hold the other end of the string in his or her left hand so it is stretched horizontally. Have another student place a paper cup on the floor just under the first student's left hand, and mark the spot on the floor with a piece of masking tape. Tell the first student to let go of the object so it swings and collides with the paper cup (it may take a few tries to hit the cup). Have your other volunteer measure the distance the paper cup

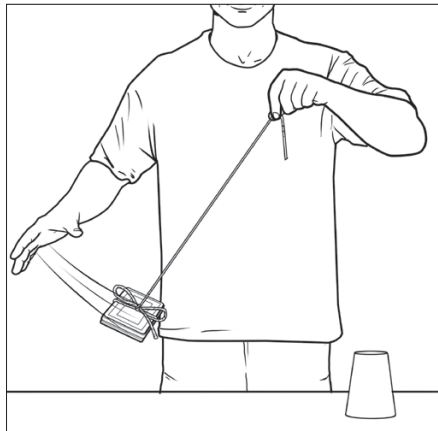

moved after the swinging object struck it.

3. Repeat the process with the heavier object. Students will observe that the heavier object made more of an impact than the lighter one, moving the cup farther away. This is because the heavier object had a greater kinetic energy.



How can potential energy become kinetic energy?

1. Reveal that race cars don't just go forward and side to side as they pass each other on the racetrack, they also go up! NASCAR racetracks aren't completely flat. On turns, the tracks are actually tilted. The highest racetrack banking is tilted a steep 33 degrees at the Talladega Super Speedway.
2. Racetrack bankings help drivers maintain grip as they whip around corners. The steeper bankings also create more potential energy in the race cars because the cars are raised higher in the air. When drivers come off a banking and onto the flat portion of the track, they have more speed as the potential energy transforms into kinetic energy.
3. Explain that NASCAR engineers consider the height of a racetrack's

banking when considering how cars will perform. Remind students that three factors affect how much gravitational potential energy the race car has at the top of a racetrack's banking: the height of the banking, the car's mass, and the force of gravity. Given the fact that mass impacts kinetic energy, all race cars must weigh 3,300 pounds (without a driver). Having identical masses makes sure the cars are competitively equal. NASCAR enforces these rules by inspecting each car before and after each race. (If you have not explored aerodynamics with your class, refer to **Unit 1: Aerodynamics** to learn how NASCAR drivers and engineers use science to create more speed on the track.)

4. Tell students they will team up to test how potential energy turns into kinetic energy. Hand out *Activity Sheet 2: Kinetic Energy* and the experiment materials. After groups have completed the experiment, have them present their results and discuss as a class.

EXTENSION: PIT CREW CHALLENGE



How does kinetic energy influence NASCAR engineers' choices?

Explain that NASCAR engineers spend a lot of time thinking about kinetic energy for both race car performance and safety. Divide students into teams, and tell them to put on their make-believe "engineer caps." They'll need to imagine all the parts of a NASCAR race from start to finish—that includes designing cars and tracks, installing safety protections for drivers and fans, understanding how vehicles will perform while racing and when making pit stops, and even things that could possibly go wrong during a competition. Have students create a list of the roles kinetic energy plays in each stage of racing.

NAME _____

RAMP IT UP

DIRECTIONS Try this experiment to see how changing a car's potential energy changes its kinetic energy.

PREDICT Will a car racing down a ramp travel a shorter or greater distance if you raise the ramp's height? _____

GATHER YOUR MATERIALS:

Books, cardboard, toy car or completed car from Unit 1: Aerodynamics, tape, ruler

PROCEDURE

- 1 Use books and cardboard to make a ramp. Use tape to secure both ends of the ramp to the books and floor.
- 2 Measure the height of the ramp. Record the height under "Run 1" in the table below.
- 3 Place your car at the top of the ramp. Release the car. Once it stops moving, use the ruler to measure how far it rolled from the end of the ramp.
- 4 Add two textbooks to raise the height of your ramp. Then repeat steps 2 and 3.

DATA

	Ramp Height	Distance Car Rolled
Run 1		
Run 2		

CONCLUSIONS

Answer these questions on a separate sheet of paper.

- 1 What happened when you raised the height of the ramp? Was your prediction correct?
- 2 Did raising the ramp's height give the car more or less potential energy? Explain your answer.
- 3 Did the car in Run 1 or 2 end up with more kinetic energy? How could you tell?

LESSON PLAN 3: ENERGY AND SPEED

UNDER THE HOOD

TIME REQUIRED 1 hour, plus time for optional extension activity

MATERIALS Completed race cars from the **Aerodynamics** unit, straws, balloons, rubber bands, tape, scissors, index cards

ACTIVITY AND RESOURCE SHEETS Activity Sheet 3: Energy and Speed

Download additional sheets as needed at scholastic.com/nascarspeed.

LEXILE SCORE 1050L



How are potential and kinetic energy connected?

1. Read the following description to your class: "My hands tightly grip the steering wheel. My ears are filled with the loud roar from the engine. I feel my body pushed back into my seat. A crowd of people whips past my window." Ask students if they can guess which activity you are describing. (*Driving a race car.*)
2. Show students a picture of a roller coaster. Ask them to explain what's going on in the image. What clues let them know what's taking place? Have them recall the idea of **potential energy** (stored energy) and **kinetic energy** (energy of motion). Ask them how these concepts relate to what's going on in the picture. (*A roller coaster gains potential energy as it reaches the peak of each track. It's converted to kinetic energy as the roller coaster plunges downward.*)
3. Explain that in these two activities, students practiced making inferences. They used prior knowledge, evidence, and reasoning to make connections and draw conclusions.



Why are speed limits important for NASCAR safety?

1. State that making inferences is an important skill to have when reading texts. It helps students "read between the lines" and identify ideas that are not directly stated.
2. Hand out *Activity Sheet 3: Energy and Speed*, where students will read a passage about NASCAR's safety measures to reduce high-speed crashes. After reading the passage,

have them answer the reading comprehension questions on the sheet, which require them to make inferences about the text. They'll also be asked to explain how they came to their conclusions. (*Answers: 1. Fuel. 2. The flow of fuel into the car's engine is reduced. 3. No one has been able to beat Bill Elliott's record speed since restrictor plates were introduced. 4. A high-speed crash in 1987. 5. To ensure that no team has an unfair advantage over another and to make sure the teams do not tamper with the plates to go faster.*)

3. Prompt students to discuss in pairs their responses to the activity sheet's questions. Ask students to share real-world examples other than race car engines during which potential energy is converted to kinetic energy.



How does limiting potential energy reduce kinetic energy?

1. In previous lessons and in the reading passage, students learned that the fuel in a race car's gas tank holds chemical potential energy. When the fuel burns, it undergoes a chemical reaction that unleashes energy to power the car's engine and propel the vehicle forward.
2. Pass out a straw, balloon, and rubber band to each pit crew. Instruct teams to insert the straw into the mouth of the balloon and wrap a rubber band around the balloon's neck so it makes an airtight seal. Tell pit crews to tape the straw lengthwise to the top of their completed cars from **Unit 1: Aerodynamics**. The balloon end of the straw should point toward the front of each car.
3. Place a piece of tape on the floor to act as a starting line. Have students blow into the open end of their straws to inflate their balloons until they measure 4 inches wide, and then pinch the end of the straw so the air can't escape. Have pit crews place their cars on the line and, on your signal, release the ends of the straws. Discuss what happened as a

class. How did the balloon-powered race cars convert potential energy into kinetic energy?

4. Have each crew cut a hole $\frac{1}{8}$ of an inch wide in the center of an index card. Fit the neck of the balloon through the hole, then reattach the balloon to the straw and retape it to the car. Have students inflate their balloons to 4 inches and race their cars again. How did the index card act like a NASCAR restrictor plate? How did it affect how far each car rolled?

EXTENSION: PIT CREW CHALLENGE



What is race car driver Bill Elliott known for?

1. Have students think about the *Activity Sheet 3: Energy and Speed* story on NASCAR race car driver Bill Elliott. Now retired, Elliott holds a number of championship titles that include two victories in the Daytona 500, the 500-mile-long NASCAR race in Daytona Beach, FL. But he's best known for the enormous speed record he set in 1987 in at the Winston 500 in Alabama.
2. Encourage students to form small groups to prepare a piece of journalism about Bill Elliott. Ask them to conduct some research and to use *Activity Sheet 3: Energy and Speed* to prepare a script for a radio news story. The scope of the script can be subjective—encourage students to be creative. They can write a straight, informational piece or pretend to intersperse newsreel audio from the day of the Winston 500—as if they're including moments from the original historical event to build their report. Teams may want to conduct an imagined interview with Elliott's son, Chase, who's also a NASCAR race car driver, to gather his thoughts on his dad's record. Each student on the team can be assigned different roles, such as editor, researcher, and broadcast journalist, and students should be prepared to read their reports aloud when they've finished.



NAME _____

⚡ UNDER THE HOOD ⚡

NASCAR race cars are superfast—but there’s a limiting factor to their speed. For safety reasons, NASCAR officials have reduced just how fast race cars can go. Read the passage below to find out how this happened. Then answer the associated questions.

SPEED LIMIT

In 1987, Bill Elliott set the NASCAR speed record. His race car reached 212 miles per hour while qualifying for the Winston 500 at the Talladega Superspeedway in Alabama. Why has no other racer topped this feat since?



BILL ELLIOTT

During the actual 1987 Winston 500, the car of another driver named Bobby Allison went airborne and crashed into a fence at 210 mph. After that, NASCAR put safety measures in place to prevent similar high-speed crashes.

In 1988, NASCAR began to require the use of restrictor plates on all race cars during superspeedway races. A restrictor plate is a square piece of aluminum with four holes drilled into it. Each hole is about the size of a quarter. The plate reduces the flow of air and fuel into a car’s engine. With less fuel to burn, the cars go slower.

All teams must have identical restrictor plates at the start of a race. NASCAR distributes them before the race and collects them when it is over. Some people believe that without restrictor plates, NASCAR racers could go more than 220 mph. In fact, one car tested at Talladega without a restrictor plate reached a speed of 228 mph, exceeding Bill Elliott’s record by 16 mph.

For each question, provide an answer and an explanation of how you arrived at your response.

- 1 What is the source of potential energy in a race car’s engine?

- 2 What happens to the source of potential energy when a restrictor plate is added to the race car?

- 3 How can you infer that restrictor plates work to slow race cars?

- 4 What prompted NASCAR to use restrictor plates at superspeedways?

- 5 Why do NASCAR officials give all teams identical restrictor plates at the start of a race and collect them at the end?

Photo: © RacingOne/ISC Images & Archives/Getty Images.

LESSON PLAN 4: FRICTION AND ENERGY

A DYNAMIC DUO

TIME REQUIRED 1 hour

MATERIALS Cardboard, toy car or completed car from **Unit 1: Aerodynamics**, tape measures or rulers, tape, books, various surfaces (such as tinfoil, fine sandpaper, rough sandpaper, waxed paper, carpet)

ACTIVITY SHEET Activity Sheet 4: Friction and Energy



How are kinetic energy and friction related?

1. Ask students to define friction—the resistance that one surface experiences when moving over another. For example, as a spinning tire rolls over a racetrack, the tire’s surface catches against the road, creating friction that improves traction and helps race cars gain speed and increase grip. Grip, which is another word for friction, helps race cars stay on the track, even when navigating turns at high speeds.

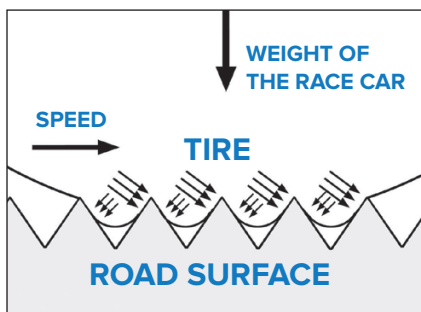

2. At NASCAR, car tires, the race car’s aerodynamics, and the surface of the roads are all fine-tuned to ensure the race cars make solid contact with the ground. NASCAR tires are smoother than the tires on everyday vehicles. This allows more surface area on the tire to be in contact with the track. This smooth surface area provides greater grip at higher speeds, keeping race cars safe on the track. In addition, NASCAR tracks are made of specific surfaces, such as asphalt or concrete, which help tire friction and performance. Rougher surfaces increase friction, while smoother surfaces allow objects to slide more easily over them.
3. While friction can increase safety in race cars, it can cause problems, too.

Due to a race car’s high speed, there is a lot of friction where the tires rub against the road. The friction takes some of the race car’s kinetic energy and converts it into heat energy. As a result, the race car’s tires become very hot and can eventually fall apart. This is why race car teams change tires multiple times during a race.



What type of energy is created by friction?

1. Demonstrate how friction is heat energy by having students rub their hands together. Point out that the more vigorously they rub them, the warmer their hands will become. Any two surfaces that rub together will create heat.
2. Point out that friction depends on a force pushing two surfaces together. For example, when you rub your hands together, the more force you apply, the more friction and heat you will create. If there is no force, there is no contact; therefore, there is no friction.



What types of surfaces create the most friction?

1. Distribute *Activity Sheet 4: Friction and Energy* and tell students that they will build a high-friction racetrack to demonstrate the effects of friction on a rolling car. Point out that any contact between atoms or molecules that are moving against each other will create friction. Rough surfaces have more matter exposed than smooth surfaces—more nooks and crannies—and this can create more available spots for possible friction.

2. After the discussion, have students create a cause-and-effect chart that analyzes the impact of friction on their experiment and have them explain the effects of friction on kinetic energy.

EXTENSION: PIT CREW CHALLENGE



How can we diminish friction?

Explain that race car engineers study friction to improve the speed of race cars. They work to diminish friction so the cars can move quickly, but they don’t want to get rid of friction altogether, because friction allows the cars to slow down and stop. Divide students into problem-solving teams and give them the task of brainstorming ways to remove friction from their daily lives. Their lists should include sources of friction around them and an explanation of how removing that friction would make their lives better. If they need idea prompts, share this list of everyday items that experience friction: car tires, skateboard wheels, train tracks, revolving doors, zippers. Have groups present their recommendations to the class.

AFTER THE UNIT Once you have finished all three lessons, have students complete the post-assessment and compare their responses to the pre-assessment.

POST-ASSESSMENT ANSWER KEY

1. B; 2. D; 3. D; 4. B; 5. B; 6. C; 7. A; 8. A; 9. B; 10. D

BONUS ENERGY LESSON ONLINE AT
scholastic.com/nascarspeed

NAME _____

THE FORCE OF FRICTION

Friction helps a race car's tires better grip the track, allowing it to surge ahead at high speeds. But friction can work against objects too, slowing them down.

Friction is the resistance that happens between surfaces that are moving against each other. You can't often see friction, but it's all around us. Use this experiment to create friction, measure it, and analyze its impacts.

PROCEDURE

- 1 Build a simple incline to roll your car down. Put one end of your cardboard on a stack of books. In front of the ramp, clear a racetrack for the car to travel. Curl the bottom of the ramp so the car's impact with the floor is as gentle as possible.
- 2 For your first test run, place your car at the top of the ramp and release the car. When it stops rolling, measure how far it traveled across the floor from the bottom of the ramp. Record your data in the chart on the right.
- 3 Before your next test run, list the surfaces you will test on the blanks in the chart. Then place the first surface you will test at the bottom of your ramp. Release your car from the top of your ramp. Measure how far the car travels when it rolls over your first surface. Follow these same steps to test your two other surfaces. Record your data.

GATHER YOUR MATERIALS

Cardboard, toy car, completed car from Unit 1: Aerodynamics, ruler, tape, books, three different surfaces such as sandpaper, tinfoil, waxed paper, and carpet

DATA	
Surface	Distance
Floor	
Surface 1 _____	
Surface 2 _____	
Surface 3 _____	

CONCLUSIONS

Answer these questions on a separate sheet of paper.

- 1 What causes friction? Which surfaces caused the most friction and which surfaces caused the least friction?
- 2 How did you witness friction in this experiment? What piece of data was evidence of friction?
- 3 In your own words, summarize how friction affects a moving object's kinetic energy.

NAME _____

WHAT DID YOU LEARN ABOUT HOW ENERGY WORKS?

Share what you know about the influence of energy on the objects in the world around us.

- 1** The energy stored in an object due to its position or condition is known as _____.

 - A** kinetic energy
 - B** potential energy
 - C** friction
 - D** all of the above
- 2** Mass, gravity, and height are the variables that shape _____.

 - A** speed
 - B** friction
 - C** kinetic energy
 - D** potential energy
- 3** Increasing an object's _____ will increase its potential energy.

 - A** girth
 - B** force
 - C** width
 - D** mass
- 4** Imagine two objects of the same mass sitting on a bookshelf. If you take one of them and move it to a lower shelf, you have _____.

 - A** increased its potential energy
 - B** decreased its potential energy
 - C** caused no change in its potential energy
 - D** removed all energy from the object
- 5** The energy of an object in motion is known as _____.

 - A** potential energy
 - B** kinetic energy
 - C** mechanical energy
 - D** nuclear energy
- 6** Speed and _____ are the factors that affect kinetic energy.

 - A** height
 - B** gravity
 - C** mass
 - D** temperature
- 7** True or false? Imagine a delivery truck is driving down the road and suddenly it loses half of its load. The truck's kinetic energy has decreased.

 - A** True
 - B** False
- 8** The resistance that occurs when one surface rubs against another is called _____.

 - A** friction
 - B** free energy
 - C** gravity
 - D** acceleration
- 9** A race car's brake rotors often glow red because friction generates _____.

 - A** kinetic energy
 - B** heat
 - C** potential energy
 - D** acceleration
- 10** Knowing about potential and kinetic energy helps race car engineers _____.

 - A** understand how the two are related
 - B** design cars that go faster
 - C** reduce the effects of friction
 - D** all of the above

CORE CONCEPTS AND SKILLS SPOTLIGHT

NEXT GENERATION SCIENCE STANDARDS

Unit 2's Energy and NASCAR covers overarching concepts and skills relevant to a range of principles that can be easily applied to your state's science and reading standards.

DISCIPLINARY CORE IDEAS: PHYSICAL SCIENCE

Motion and Stability: Forces and Interactions

- ▶ The gravitational force of Earth acting on an object near Earth's surface pulls that object toward the planet's center.

Related Standard:

Support an argument that the gravitational force exerted by Earth on objects is directed down.

- ▶ The sum of an object is determined by the sum of the forces acting on it; if the total force on the object is not zero, its motion will change. For any given object, a larger force causes a larger change in motion.

Related Standard:

Plan an investigation to provide evidence that the change in an object's motion depends on the sum of the forces on the object and the mass of the object.

Energy

- ▶ Motion energy is properly called kinetic energy; it is proportional to the mass of the moving object and grows with the square of its speed.

Related Standard:

Construct and interpret graphical displays of data to describe the relationship of kinetic energy to the mass of an object and to the speed of an object.

- ▶ A system of objects may also contain stored (potential) energy, depending on their relative positions.

Related Standard:

Develop a model to describe that when the arrangement of objects interacting at a distance changes, different amounts of potential energy are stored in the system.

SCIENCE AND ENGINEERING PRACTICES

Planning and Carrying Out Investigations

- ▶ Plan and conduct an investigation collaboratively to produce data to serve as the basis for evidence, using fair tests in which variables are controlled and the number of trials considered.
- ▶ Make observations and/or measurements to produce data to serve as the basis for evidence for an explanation of a phenomenon or test a design solution.

Engaging in Argument From Evidence

- ▶ Construct, use, and/or present an oral and written argument supported by empirical evidence and scientific reasoning to support or refute an explanation or a model for a phenomenon or a solution to a problem.

Constructing Explanations and Designing Solutions

- ▶ Construct an explanation of observed relationships.

Obtaining, Evaluating, and Communicating Information

- ▶ Communicate scientific and/or technical information orally and/or in written formats, including various forms of media as well as tables, diagrams, and charts.

Source: NGSS Lead States. *Next Generation Science Standards: For States, By States*. Washington, DC: The National Academies Press.

COMMON CORE READING STANDARDS

ENGLISH LANGUAGE ARTS: READING INFORMATIONAL TEXT

Key Ideas and Details

- ▶ Determine central idea of a text and draw inferences by citing textual evidence and analyses of key individuals, events, or ideas.

Craft and Structure

- ▶ Determine meaning of words, phrases, and sentences in the context of their significance to the passage.

Source: Common Core State Standards Initiative.