

SEATTLE PARKS AND RECREATION

Soft Surface Trails Management Plan



Seattle
Parks & Recreation

healthy people healthy environment strong communities

MAY 2017

*Supporting
Recreation,
Enhancing
Public Health,
Connecting
Neighborhoods*



SEATTLE PARKS AND RECREATION

Soft Surface Trails Management Plan

OCTOBER 2017

Seattle Parks and Recreation Natural Resource Unit

Jon Jainga, Manager
Chukundi Salisbury, Trail Coordinator

Consultants

Maggi Johnson, Johnson+Southerland
Curt Warber, Parametrix



Seattle
Parks & Recreation

healthy people healthy environment strong communities



TABLE OF CONTENTS

TABLE OF CONTENTS

- Introduction 1
- 1. Roles and Resources 7
- 2. Trail Guidelines and Standards 17
- 3. Signage Guidelines 21
- 4. Level of Service Guidelines 25
- 5. Application Process for Trail Projects. 27
- 6. Application Process for Signage Projects 35
- 7. Appendices
 - A. Performance Management Initiative Response A-1
 - B. Trail Application Approval Criteria. B-1
 - C. Signage Application Approval Criteria C-1
 - D. Trail Standards D-1
 - E. Trail Best Management Practices E-1
 - F. Signage Standards. F-1

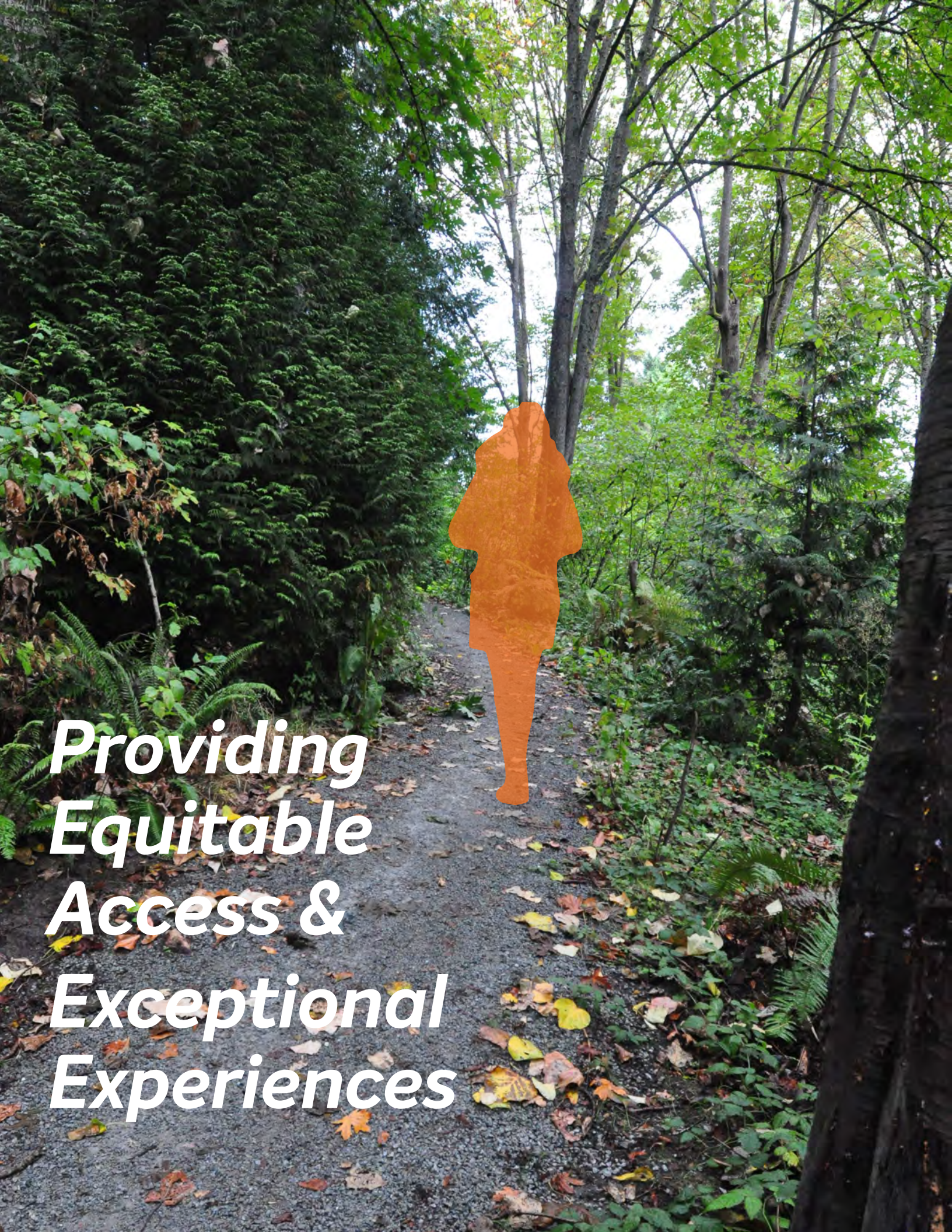

***Providing
Equitable
Access &
Exceptional
Experiences***

Introduction: Sustaining and Improving Seattle's Soft Surface Trail System

Trails are for getting outside and renewing body and spirit; for appreciating nature; for experiencing solitude or companionship; for getting from one place to another; for recreation or challenge. In addition to health and recreation benefits, trails are an important part of Seattle's quality of life and help make our city a desirable place to live. Trails provide access for all sorts of people to experience, enjoy and learn about nature.

Seattle Parks and Recreation (SPR) has about 90 miles of soft surface (unpaved) trails in its parks and public green spaces. Many of these trails are exceptionally popular, supporting well over 100,000 trips annually. Other trails are less busy, but provide access from a neighborhood to a school, transit stop, p-patch or natural area.

Soft surface trails are critical infrastructure for Seattle's parks. They provide access to our best natural places and connect neighborhoods to vital community resources. Without trails to provide access, the most cherished natural places in Seattle's parks would be off limits.

Although the soft surface trails system is well-used and appreciated, large sections of the system are in poor condition and the system as a whole may be in decline. There is increasing demand from neighborhood groups for trails; simultaneously, trails are being closed to public use due to lack of maintenance resources. There are also concerns with the equity of the trail system, both in the need to improve accessibility for a diversity of trail users and to provide more equitable distribution of trails and trail maintenance throughout the City.

The Seattle Trails Vision Plan 2020 (2011) included a vision for the trail system that recognizes the value of the trails system and captures the aspirations of trail system stakeholders and the SPR staff:

The Seattle Parks and Recreation soft-surface trails system will be well-used, optimally maintained, and highly connected to the broader non-motorized transportation network. The trails will provide environmentally sustainable access to the City's forested parklands and natural landscapes with amenities and programming to enhance the experiences, health, and safety of all people.

The Soft Surface Trails Management Plan is intended to be a tool with a series of actionable strategies to realize that vision. It describes a strategy that will enable SPR to manage its soft-surface trails more efficiently and effectively and improve outcomes as prioritized by SPR's Performance Management Initiative (PMI): Healthy People, Healthy Environment and Strong Communities (see expanded response to PMI challenges in the appendix).

The Soft Surface Trails Management Plan (SSTMP) summarizes current trail conditions, management resources and needs; articulates SPR's goals and recommendations for management of our soft surface trail system; and provides guidance for citizens and City staff who are maintaining existing trails or contemplating new trails.

The SSTMP focuses on soft surface recreational trails within SPR's parks and green spaces. The City of Seattle has several documents dealing with paved paths and sidewalks, including bike and pedestrian master plans. These cover sidewalks and multi-use recreational paths such as the Burke-Gilman which are critical to transportation as well as recreation. Seattle Parks is also working on a Comprehensive Trail Master Plan which will cover all types of trails. The SSTMP will become a complementary component of the Comprehensive Trail Master Plan.

The current soft surface trail system has been developed through years of effort by SPR, non-governmental organization (NGO) partners such as the Youth Green Corps and volunteers. Each of these groups will continue to play critical roles in a strategy to sustainably maintain trails currently in place and enhance the system with new and upgraded trail facilities. The SSTMP focuses on the delivery of key goals for the trail system:

Goal 1: Access to Nature in Seattle's Parks.

Performance indicators:

- Trails are well-sited, well-designed and bring people close to the natural resources in our parks.
- Trails complement, rather than damage, the natural resources in our parks.

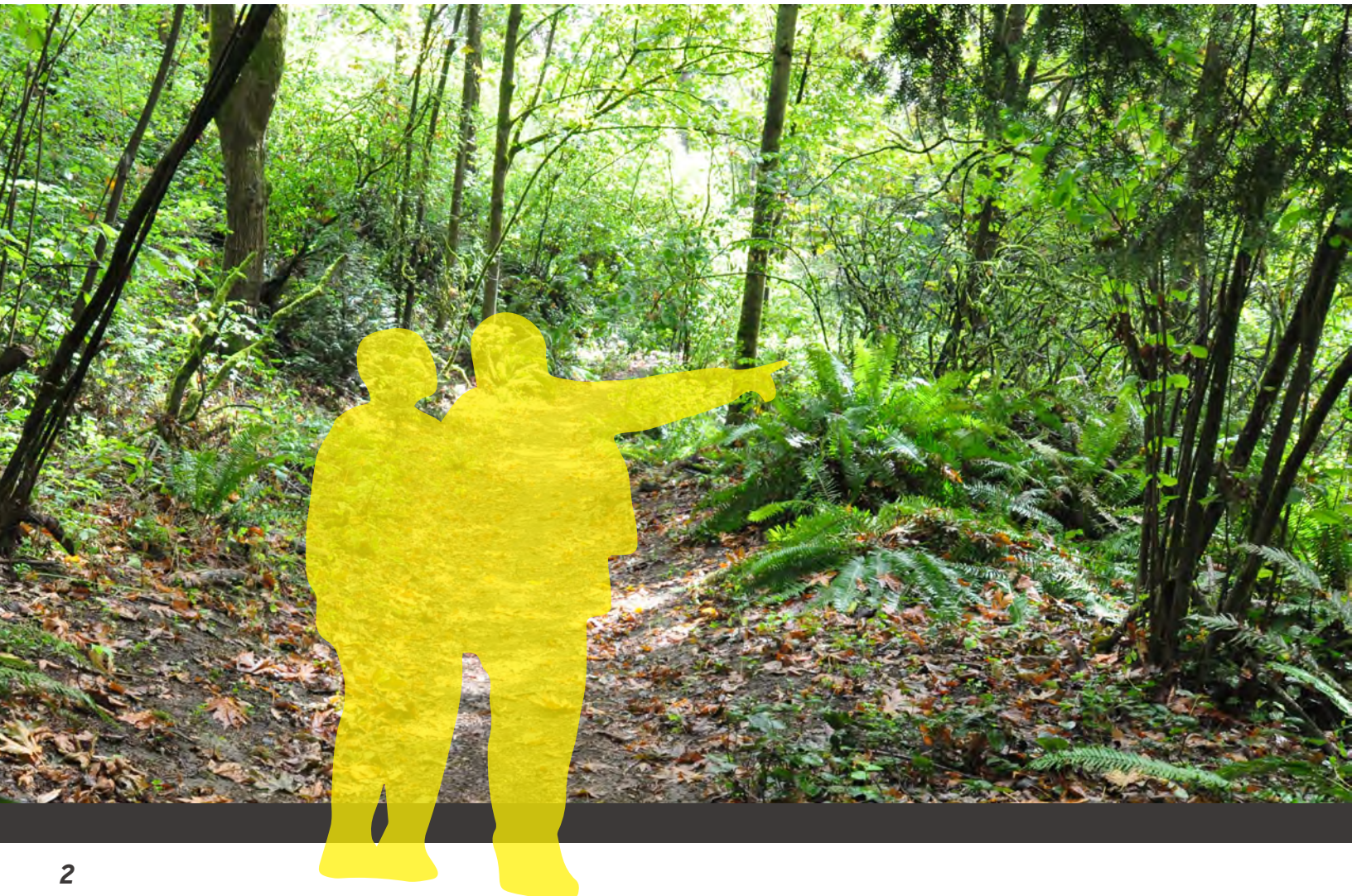

Goal 2: Safety

Performance indicators:

- Trails meet maintenance standards including regular inspection, identification of hazards, and hazard reduction.
- Trails are built to trail standards including vegetation management to maintain sight lines.
- Trailheads have signage encouraging positive public use of trails and sufficient wayfinding signage so users feel comfortable finding their way.

Goal 3: Equity

Performance indicators

- Trail Management meets the intent of SPR's Race and Social Justice Initiative and RSJI Outcomes, Strategies and Actions (ROSA) goals.
- New trail development prioritizes underserved areas of the City.
- New trail development prioritizes making pedestrian connections between neighborhood destinations.
- New Trail development is coordinated with Seattle's Pedestrian Master Plan, the Comprehensive Trail Plan (under development) and Seattle Neighborhood Greenways Plan.
- All parks and green spaces that have trails include at least one "primary trail" providing access for a wide range of users.
- The trail system includes a range of trail types to serve
- people with a wide range of abilities and interests.
- The trail system includes accessible trails.

Goal 4: User Experience

Performance indicators

- System-wide information is provided for predictability, accessibility, user choice, and to avoid confusion.
- Volunteer Opportunities are available for people with a wide range of abilities and experience and to provide access to learning about and enjoying nature in an urban setting.
- Development and maintenance of trails system is responsive to stakeholder input.
- Information and programming is available to introduce people with a wide range of abilities and experience to Seattle's green spaces and trail system and to provide opportunities for learning about and enjoying urban nature

Goal 5: Environmental Sustainability

Performance indicators

- New trails are located, designed, and constructed to minimize impacts to environmentally critical areas (ECA's) and other sensitive areas and avoid long-term impacts to soils, drainage, vegetation and wildlife.

- Drainage features including culverts, water bars and ditches are maintained and functional.
- Trail segments showing consistent evidence of environmental impact (e.g. erosion, interrupted drainage channels, impacts to sensitive vegetation or wildlife habitat) are reconstructed, removed or relocated.

Goal 6: Volunteer engagement

Performance indicators

- Volunteer opportunities are available to allow engagement and contribution.
- NGO partnerships are maintained and enhanced.
- The Trail Program includes active outreach to underrepresented communities, with an emphasis on youth engagement.

Goal 7: Efficient and Effective Maintenance

Performance indicators

- Management system is in place to track maintenance effort and results.
- Trails are regularly inspected and maintained to meet adopted level of service standards.
- No primary trail is closed for longer than six months due to need for emergency repairs.



Overview of the Plan

The strategy for delivering these goals is developed in the following sections of this document:

1. Roles and Resources

Directed internally to SPR Administration and staff, this section proposes an organizational realignment to consolidate resources and responsibilities for management of the trail system into the NRU Trails Unit and to add resources for managing soft-surface trails.

2. Trail Guidelines

This section provides updated and expanded definitions and typology of trails that are part of the soft-surface trail system hierarchy. Trail design standards for each trail type are located in the appendix.

3. Signage Guidelines

This section provides updated and expanded guidelines and typology for signage associated with trails. Standards for each type of sign are located in the appendix.

4. Level of Service Goals

The SSTMP includes a set of performance standards for the trail system to clarify expectations for maintenance and construction and allow effective monitoring of the overall condition of the trail system measured against the goals for the system.

5. Application/Approval Process for Trail Projects

This section outlines an application/approval process for any party interested in proposing a trail project on SPR property. Trail projects requiring an application include new trails or major renovations. Trail projects may be initiated by community members, partner organizations or City agencies. Expanded application information and approval criteria are included in the appendix.

6. Application/Approval Process for Trail-related Signage Projects

This section outlines an application/approval process for any party interested in proposing a trail-related signage project on SPR property. Signage projects may be initiated by community members, partner organizations or City agencies. Expanded application information and approval criteria are included in the appendix.



***Growing
internal
capacity &
broadening
partnerships***

1: Roles and Resources

The primary purpose in completing this Management Plan is to develop a strategy to adequately maintain the soft surface trails system. System-wide data tracking trail conditions is not up-to-date or complete enough to be useful (the same shortfall in staffing resources that has led to a challenge in adequately maintaining the trail system has also resulted in inadequate condition inventories), however there is clear evidence that trails are not being maintained to standard and that the trail inventory is declining due to inadequate maintenance rather than growing to meet demand.

A core recommendation of the SSTMP includes a realignment of resources within SPR to manage the trails system as a unified critical asset for the public and to adequately maintain the trail system for safety, equitable access, and enjoyment.

Development of the Soft Surface Trail System

SPR is currently responsible for about 90 miles of soft surface trails—trails that are not paved with asphalt or concrete and are usually associated with the more natural areas of our parks. The current system was developed through a variety of methods:

- In some cases, especially in the larger parks, the trails system was constructed as part of the initial design and construction of the park.
- Many trails were developed informally, when “desire paths” created by users began to be systematically maintained and improved.
- Many trail miles in the system have been developed through community-based volunteer efforts, often supported by grant funding.
- Efforts to restore natural areas—including removal of invasive plant species, planting native species, and general cleanup—have raised awareness of these often overlooked park properties, and have resulted in an interest in improved access.

Currently, the Trails Unit has no funds for building trails, aside from coordinating and supervising efforts by community-based volunteer groups who have brought in additional funding for specific trail projects. And since the current trail system exceeds the Trails Unit’s capacity for maintenance, the only new trails being built have been sponsored by community groups with fundraising and volunteer capacity for both construction and maintenance of the new trails.

Prior to 1999, some trails in bigger parks were maintained by local park staff, but maintenance and repair of trails throughout the system was not a high priority and many trails became impassable and unsafe. In 1999, SPR’s Trails Unit was established in the Natural Resources Unit (NRU) with one staff person working with volunteers. A second staff person was hired in 2001. Since its inception, the three primary program activities have included:

- Inventory and assess the condition of all SPR trails;
- Develop trail construction and maintenance standards; and
- Implement trail restoration projects.

Maintenance Responsibilities and Capabilities

Responsibility for maintenance of the trails system is decentralized within SPR. Some trails in bigger parks are maintained by local District or Regional Park staff. However, no District staff are assigned primarily to trail maintenance; it is a low priority activity compared to other tasks and only takes place sporadically. Time tracking data for 2015 indicates that District employee time spent on trail maintenance added up to about 1 FTE. The Trails Unit, with its staff of 2 FTE, attempts to address the rest of the system by organizing trail projects that are carried out primarily by volunteer work parties and hired non-profit labor, achieving about 5-8 miles of trail maintenance per year. Incidental and routine maintenance can generally be completed by staff without specialized training, however many of the regular maintenance needs for the trail system require familiarity with trail standards and best practices for maintaining elements such as culverts, drainage channels, and water bars (*see sidebar*).

Trails Unit staff estimate that a trail can last indefinitely without deteriorating to a point that it needs major maintenance (very labor intensive), if it gets routine maintenance (much less labor intensive) every 1-4 years. For the entire 90-plus miles of trail system to receive routine maintenance at this rate would require maintaining at least 22.5 miles per year. Currently, the Trails Program achieves about 5-8 miles of trail maintenance per year (Routine and Major Maintenance combined).

One of the biggest issues in maintaining our trails is that by not providing adequate routine maintenance, trails degrade to the point that they need major maintenance. Doing major maintenance to keep trails from closing takes time away from doing routine maintenance, so even more trails fall into the major maintenance category. Current staffing and resources can't stretch to deal with the backlog, so some trails become unsafe and must be closed. In fact, we are losing trail mileage at a time when the City is growing and the demand for trails is rising.

A more efficient system, if we could first bring all trails up to standard, would be to have enough staff and resources to do routine maintenance on all trails every 1-4 years. If SPR were able to keep up with routine maintenance on all of its trails, the need for labor-intensive major maintenance should drop-off drastically.

Another ongoing issue is that no capital improvement funds are allocated for replacement of grant-funded soft-surface trail projects. This is an issue especially in projects including bridges, stairs or other capital-intensive wood structures. While all new trail projects incur ongoing maintenance costs, wood structures are particularly expensive as they rot and need to be replaced approximately every 10-15 years.

To improve the effectiveness and efficiency of SPR's soft-surface trail management, the SSTMP recommends centralizing responsibility and oversight for soft surface trail management in the NRU Trails Unit, increasing staffing and resources for trail maintenance and expanded volunteer coordination, allocating replacement funds for trails and structures and allocating resources for better needs and performance tracking to facilitate future data-based efficiency improvements.

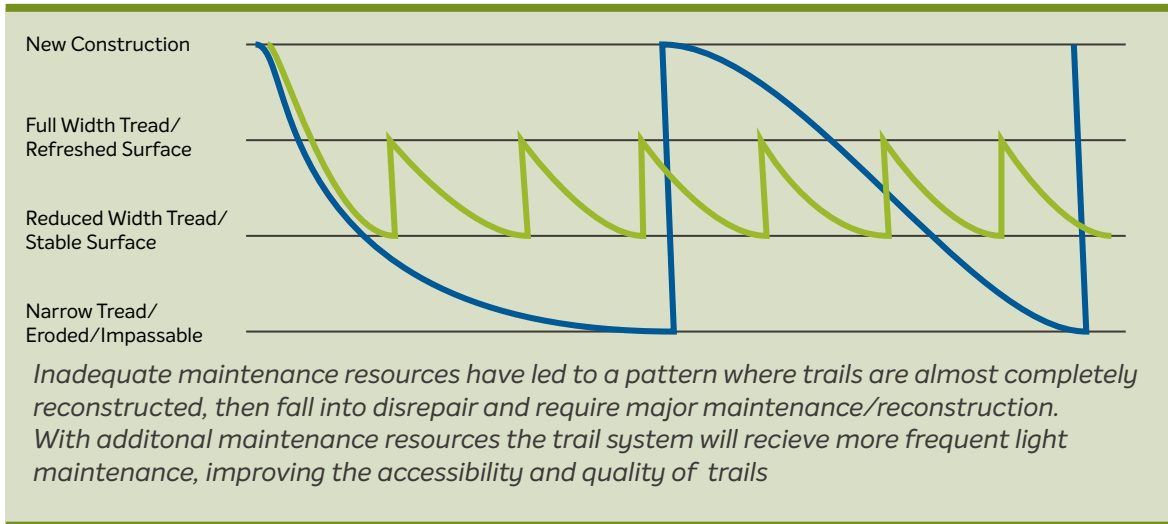

Figure 1- Periodic major maintenance vs. frequent minor maintenance

The Role of Volunteers and NGO Partners

The current trail system is the legacy of many thousands of hours of volunteer work. Volunteers will continue to play a vital role in the ongoing maintenance and expansion of trails in Seattle Parks. In some parks, volunteers have transformed the experience for visitors, offering exceptional access and maintaining trails at a high standard. In many parks volunteers have been able to obtain grants to fund new trails and critical trail improvements. The Trails Unit's emphasis on working with volunteer and community partners has leveraged the capabilities of its 2 staff members, created strong relationships between Parks and community members, provided skill-building opportunities and given volunteers an opportunity to enjoy the woods while serving their community.

However, volunteers have not provided the consistent, organized workforce necessary to meet development and maintenance goals for the trail system citywide. Some volunteers want to enjoy a day in the woods with friends, but may lack the physical ability or motivation to complete trail maintenance tasks, and some do not work in a way that is compliant with SPR's best management practices (BMP's) for trail maintenance. All work parties require supervision and coordination. Often, community members are inspired to become trail volunteers for the park or greenspace in their own neighborhood or would prefer to build a trail rather than do routine maintenance, which means that the Trail Program can't use them flexibly for needs throughout the system.

The pathway to a sustainable future for trails in Seattle's parks includes maintaining the existing volunteer system with support from NGO partners. However, it also requires a shift that supplements volunteers who are motivated to work in their favorite park with a pool of volunteers motivated by trail work citywide, who can be mobilized to meet the most pressing needs within the system.

Recommendations for aligning roles and resources to support the trails system

The most pressing issue for Seattle’s soft surface trail system is that the current staffing, resources and organization of the Trails Program is resulting in an uneven distribution of care, where some localized trail systems with strong volunteer support or committed park maintenance staff are exceptionally well-maintained, while at the same time there is increasing backlog of trails needing major maintenance resulting in trail closures. To improve administration, better address maintenance and keep the trail system growing rather than shrinking, the management plan proposes to:

1. Centralize management of the soft surface trail system in the Natural Resources Unit Trails Group (with additional staff and funding resources, see below). Resource Maintenance District staff will still have a role in day to day trail maintenance such as litter pick-up or emergency tasks, routine and major maintenance of all trails will be the responsibility of the Trails Unit. Any proposals for new trail-related projects in park facilities by any party (including other Park departments or community groups) need to be reviewed and approved by the Trails Unit prior to implementation.
2. Increase staffing. To achieve maintenance goals and to begin addressing the backlog of deferred maintenance, NRU staff estimate that the Trails Unit needs to increase from the current 2 FTE by a minimum of 5 FTE, for a total of 7 FTE, including the Trail Coordinator, Senior Forest Maintenance Worker, 4 Maintenance

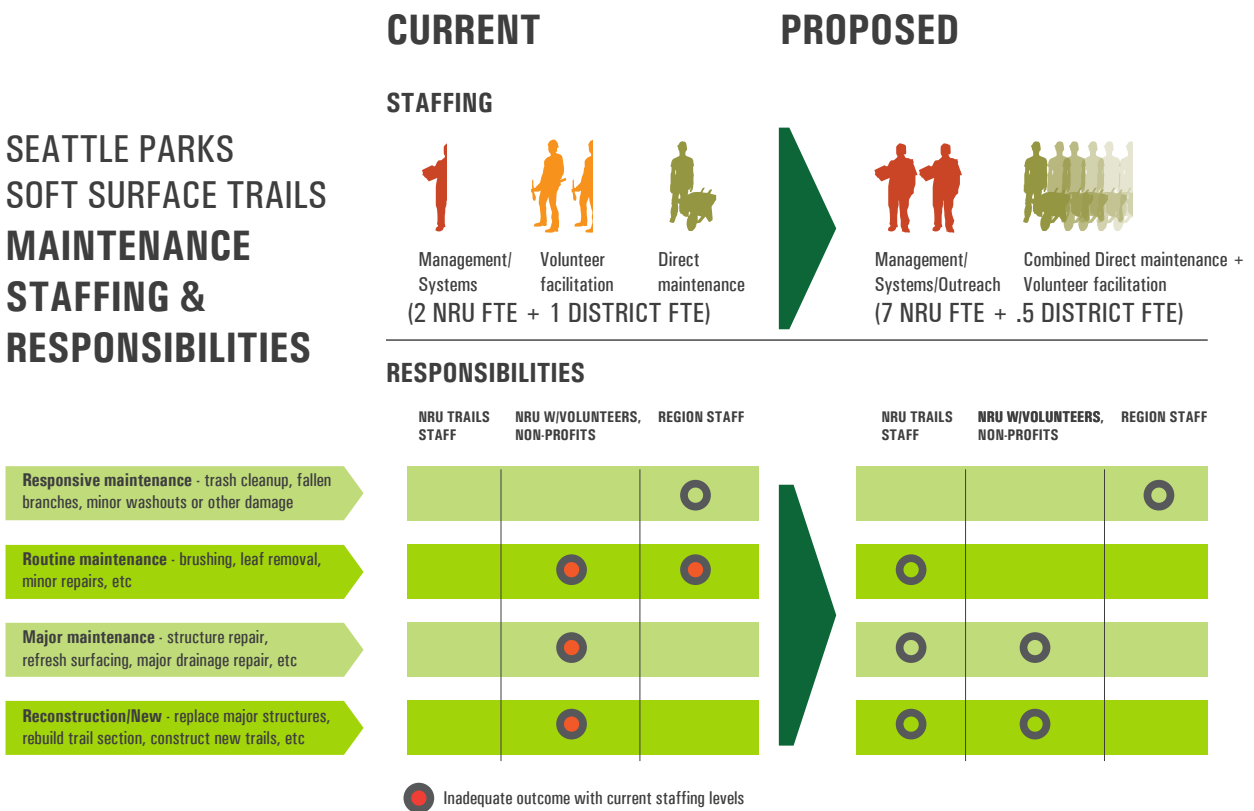

Figure 2- Existing and Proposed Staffing for soft Surface Trail Management

Laborers, a half-time Recreational Leader and a half-time Assistant Management Systems Analyst:

- i. Trail Coordinator (existing position – 1 FTE). The Trail Coordinator will continue to administer the Trails Program; plan projects and work schedules; do preliminary reviews and approvals of trail project proposals and guide applicants through the application/review process; update GIS mapping, facilitate engagement with the public and NGO participants the Trails Program; supervise staff, manage the budget, set performance goals, evaluate staff, and monitor compliance with the Trails Unit principles and goals. Based on the proposed program, the Trail Coordinator position would also likely be changed to a different job classification to reflect increased management responsibilities.
- ii. Lead Forest Maintenance Worker (existing position – 1 FTE). The Lead Forest Maintenance Worker will assist the Coordinator; train and supervise Maintenance Laborers; train, coordinate and facilitate projects with volunteers and NGOs; and carry out trail construction and maintenance.
- iii. Maintenance Laborers (new position – 4FTE). The primary responsibility of Maintenance Laborers will be trail maintenance, although they will also assist in training, facilitating and supervising volunteers and NGO laborers.
- iv. Recreational Leader (new position – .5 FTE). The Recreational Leader will be responsible for programming activities on trails, for instance for unskilled volunteer groups, so that NRU/volunteer interactions can focus more on education and experience when appropriate.
- v. Assistant Management Systems Analyst (new position – .5 FTE). The Assistant Management Systems Analyst will work with City administration on modifying the time-tracking system to insure that adequately fine-grained information is being collected for the Trails Unit to improve staffing needs forecasts and utilization standards. The Assistant Management Systems Analyst will also assist with reporting Trails Program outcomes and GIS mapping as well as maintaining trail accessibility information on the SPR website and coordinating with the Seattle Trails App for better communication of trail information with the public.

In addition to completing more miles of maintenance themselves, additional staff will enable the Trails Unit to expand support of Trail Stewards and facilitate additional volunteer and non-profit work parties.

3. Increase funding and equipment. To support additional staff, the Trails Unit will need additional tools, machinery, vehicles and materials. However, the budget for non-profit contractors may be reduced as Trails Unit staff take over maintenance work.
4. Increase participation by volunteer and NGO partners. Additional staff will make it possible to coordinate, train and supervise additional volunteers. Partner with the Seattle Trails Alliance to develop a pool of volunteers interested in working on trail projects City-wide.
5. Allocate capital replacement funds for new trail projects so that predictable expenses such as bridge or stair replacements are anticipated.

**SEATTLE PARKS
SOFT SURFACE TRAILS
TRAILS PROGRAM FUNDING**

	CURRENT	PROPOSED
ANNUAL BUDGET	\$325,000	\$1.6 MILLION
STAFFING	TRAILS COORDINATOR (1 FTE) LEAD FOREST MAINTENANCE WORKER (1 FTE)	TRAILS PROGRAM LEAD (1 FTE) LEAD FOREST MAINTENANCE WORKER (1 FTE) 4 MAINTENANCE LABORERS (4 FTE) RECREATION LEADER (.25 FTE) ASST. MANAGEMENT SYSTEMS ANALYST (.5 FTE)
VOLUNTEERS+ NEIGHBORHOOD GROUPS	4 TRAIL STEWARDS FOREST STEWARDS INDIVIDUAL GROUPS	30+ TRAIL STEWARDS FOREST STEWARDS INDIVIDUAL GROUPS
RECREATION PROGRAMMING	NO PROGRAMMING MAPS POSTED ONLINE	REC & HEALTH THEME MAPS MONTHLY REC & HEALTH EVENTS REC COORDINATION WEB COORDINATION
LEVEL OF SERVICE MONITORING	LIMITED/INACCURATE TRACKING OF MAINTENANCE AND TRAIL CONDITIONS	SYSTEMATIC MAINTENANCE TRACKING PROVIDES IMPROVED MANAGEMENT INFORMATION FOR NEEDS FORECASTING AND LEVEL OF SERVICE MONITORING
EVENTS	150 VOLUNTEER DRIVEN EVENTS 12 DISTRICT PROJECTS	400+ VOLUNTEER DRIVEN EVENTS 50 DISTRICT PROJECTS
TRAIL SYSTEM EXPANSION	NEW TRAILS ONLY WITH OUTSIDE FUNDING NO CAPACITY TO MAINTAIN NEW TRAILS	SUPPORT UNFUNDED COMMUNITY TRAILS IMPLEMENT NEW PLANS TO MEET NEEDS
INVENTORY	YEARLY UPDATE WITH MAPS	CONTINUOUS UPDATE VIA APPS+ FUTURE TECHNOLOGY
EQUIPMENT & EXPENSES	1 TRUCK 1 TRAILER 1 IBEX MATERIALS: \$25K CONTRACTING: \$20K	3 TRUCKS (1 SMALL SUPERVISOR) 2 TRAILERS 2 IBEX/1 DINGO/1PW MATERIALS: \$100K CONTRACTING: \$200K CAPITAL BUDGET: \$500K

Figure 3- Current and Proposed Trails Program Funding

6. Improve recordkeeping so the Trail Program can be assessed and improved in the future based on data. In the SPR's time-tracking system, provide more categories within "trails" to differentiate time spent on major maintenance from minor maintenance, planning, inspecting, training, transportation and time spent engaging with the public. Institute a system for keeping track of time spent by skilled volunteers, unskilled volunteers and non-profits along with their accomplishments. In GIS record-keeping, show annual accomplishments including miles inspected, major maintenance, minor maintenance and keep track of miles completed by volunteers versus staff alone.
7. Improve communication of trail standards, maintenance goals and responsibilities to employees throughout the Park system as well as to volunteers and NGO participants.



How do other cities compare?

The process for developing the SSTMP included comparison of Seattle's trails program with other nearby cities. The cities of Bellevue and Portland have similar sized trail systems as Seattle's.

Seattle Parks

Total Trail Miles	92 miles
Trail surfacing and standards	With our typical 4' wide, crushed rock trails and substantial details for stairs, footbridges and other trail appurtenances, Seattle has prioritized a robust trail standard that feels comfortable, safe and accessible to a wide variety of people and is also very durable. This trail design should have reasonably low routine maintenance requirements, but if routine maintenance doesn't happen for several years, the trail tread may need extensive repair to restore it to standard, which is major maintenance and very labor intensive.
Budget and Staffing Levels	Seattle's 2016 Trails budget of \$350,000 for 92 miles of trail comes out to about \$0.72 per linear foot. This supports 2 FTE and includes a contracting and materials budget of \$50,000. The 2 FTE leverage their resources by spending most of their time facilitating volunteers and non-profits who actually do most of the trail work. SPR district staff also complete some trail maintenance; the total hours logged as trail maintenance throughout the system adds up to approximately 1 FTE.

Of these 3 cities, Seattle's Trail Program is the only one reporting that it is losing trails due to lack of maintenance.

SEATTLE - 112 MILES

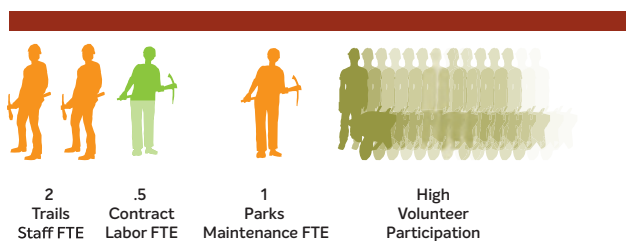

BELLEVUE- 96 MILES

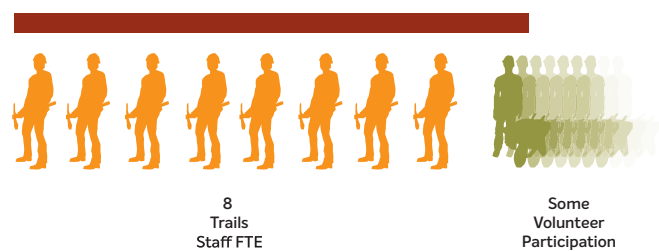

Figure 4- Comparing Seattle Parks Trails Programs with Peer Communities

Although the three cities have widely different goals and standards for their trail systems and sufficient data is not available to make any comparison “apples to apples”, looking at our neighbors yields some helpful insights.

Bellevue Parks

97 miles

Bellevue’s standard for wood-chip surfaced trails responds to aesthetic and environmental values but provides less accessibility. Also, the mulch can be extremely high maintenance in moist environments when it breaks down, requiring removal and replacement every few years.

Bellevue’s trail system is funded with an annual budget of \$3 per linear foot, approximately \$1.5 million, and supports 8 FTE in the trail program to maintain 97 miles of trail. This budget is supplemented by grants and allows Bellevue to maintain their trails to a labor-intensive mulch trail standard with minimal help from volunteers, outside groups or City employees outside of the trails program. Bellevue manages its entire trail system out of one office as a single asset.

Portland Parks

180 miles

Portland’s trail standards include more miles that look like Forest Service hiking trails with a mineral surface tread that can be quite narrow and have step/bridge/etc. details that are less robust than ours. Routine maintenance for Portland trails is likely similar to Seattle’s, but they probably do not spend much time on what we would call major maintenance.

Portland employs 2 FTE to maintain 180 miles of trail. Trails throughout the City are maintained primarily by these 2 trail program employees. Portland uses volunteers on a limited basis both as a supplement to staff and to provide youth training opportunities. As described above, many of Portland’s trails are maintained as primitive trails similar to the trails found in National Forest settings. Portland also manages its trail system as a single asset.

PORTLAND- 180 MILES

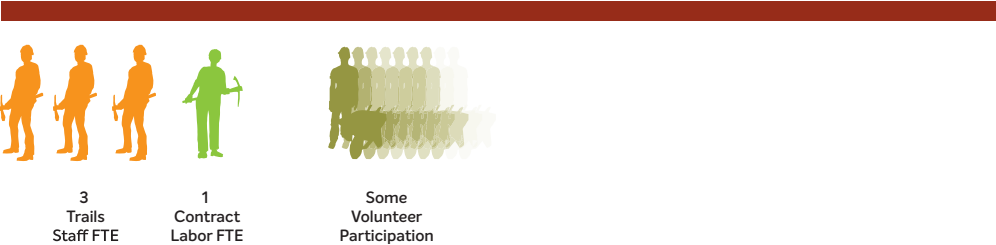



Consistent Construction and Maintenance

2: TRAIL GUIDELINES AND STANDARDS

Trail standards are intended to promote consistency throughout the trails system, improve predictability for users, and ensure that trails in the system are maintainable. SPR has developed a robust set of trail construction standards and best management practices (BMP's) for maintaining trails. The current hierarchy of trails (the trail hierarchy currently in use has not been officially adopted) includes the following trail categories (*see trail hierarchy, p.xx*):

- multi-purpose,
- primary,
- secondary and
- temporary (or illegitimate)

These different trail types differ primarily in width, connectivity, access, and proximity to major access points. The current trail standards were designed to provide a sense of comfort and safety for a wide variety of users and durable construction that requires minimal maintenance.

While the current trail hierarchy includes a variety of trail widths, the preferred standard for most trails has been the “Primary Trail”, a 4’ wide crushed rock trail with a 2’ zone to either side where vegetation is kept below 2’ in height. The standards also address stairs, footbridges, and other typical trail appurtenances. The even tread and open sight-lines along the trail contribute to the sense of comfort and safety. The durable crushed rock does not need regular replacement like a woodchip or mulch trail. The crushed rock can also meet accessibility criteria. The 4’ width with additional maintained edges means it would take several years for vegetation to grow in and close off the trail. In general, narrower trails and trails with less durable tread materials require more frequent maintenance.

Some community members and volunteers have expressed a preference for trails that are narrower or more challenging, similar to Forest Service style hiking trails on a mineral surface tread and trails that tolerate obstacles such as fallen logs. This type of “primitive trail” standard has been approved for some trails in Seward Park. At the same time, SPR has few trails that can be considered accessible to people in wheelchairs or with strollers and has not adopted an accessible trail standard.

One reason for the Trail Unit’s preference for the 4’ Primary Trail standard is that it is perceived to be the most durable and manageable trail type, and therefore most compatible with current staffing and budget resources. If the recommendations of this report are adopted, the capacity of the Trails Unit to maintain a more complex hierarchy of trails may be increased, allowing consideration of a wider range of trail types to accommodate a wider range of abilities and interests.

Recommendations for Trail Guidelines and Standards:

- Keep SPR’s current trail standards and BMP’s intact for trail types currently in the trail hierarchy.
- Expand the trail hierarchy to include an SPR Accessible Trail and maintainable Primitive Trail.
- Develop standards for an SPR Accessible Trail and a Primitive Trail.

TRAIL SYSTEM MAINTENANCE NEEDS

A sustainable trail system requires a spectrum of maintenance operations:

- 1. Incidental. Occasional attention for small items such as picking up litter on an as-needed basis.*
- 2. Routine. Activities such as raking, weeding and brushing that need to take place every 1-3 years, depending on the trail. Routine maintenance includes blowing or raking leaves, dirt and other compostable material that has fallen or drifted onto the trail tread; weeding back vegetation encroaching into the tread; cleaning out water bars and ditches; brushing alongside the trail and maintaining trail side slopes. Routine maintenance is relatively light work that can be carried out by unskilled workers or volunteers with supervision, coordination and direction. How frequently a trail needs routine maintenance usually depends on environmental conditions. A trail in a wet location with aggressive vegetation alongside or a trail traversing a steep slope that sheds debris onto the trail may need routine maintenance every year. A well-used trail in a flat, dry location may get by without routine maintenance for a year or two.*
- 3. Major. Major maintenance and/or trail replacement is what needs to happen when a trail has not received adequate routine maintenance. For instance, if the drainage ditch and culvert has become completely full of sediment and water is flowing over the trail, significant work is needed to clean it out and get it flowing again. If a portion of the trail has washed away due to the blockage, a new trail bed may need to be established. If a trail is disappearing due to the accumulation of organic materials in the tread and vegetation is encroaching from the sides and growing in the tread, significant work maybe required for weeding and cleaning out the tread and providing replacement crushed rock. Major maintenance is often very heavy work and requires skilled supervision.*
- 4. Wood replacement. There are many wood structures in our trails, including stairs, handrails and bridges, and smaller structures such as water bars and turnpikes. These rot and need replacement every 10-15 years.*
- 5. Catastrophic. Maintenance responding to a onetime event such as a tree falling on a trail or a major event such as a creek washing out a portion of a trail.*

Figure 5–System Maintenance Needs

Trail Classification Hierarchy with Siting and Maintenance Goals

Class	Description	Surface	Width	Example		
PAVED TRAILS (for reference only)						
1	On-street trail or spur section, of which a considerable portion is within DOPAR jurisdiction. Typically, a cross-jurisdictional bicycle or walking route. Route is published and/or signed.	Paved (asphalt or concrete)	5' min, may vary	Cheshiahud Trail?		
2	Multi-use trail, cross-jurisdictional. Uses include walking, jogging, skating, bicycling. Urban and includes street crossings although vehicular access is limited to service vehicles.	Paved	8' min	Burke Gilman, Alki Blvd.		
3	Multi-use trail, park. Uses include walking, jogging, skating, bicycling and service access. Contained within a park, vehicular access limited to service vehicles.	Paved	8' min	Seward Park Shoreline Loop		
4	Walkway, contained within a park.	Paved	5' min, may vary	Almost any developed park		
SOFT-SURFACE TRAILS					SITING GOALS	MAINTENANCE GOALS
5	Multi-purpose trail. Service vehicles allowed. Contained within a park. Vehicles limited to service access.	Crushed rock	8'-12'	Carkeek Park	Located primarily where service access is needed.	Tread is responsibility of NRU Heavy Equipment Crew. Vegetation responsibility of Trails Program. <ul style="list-style-type: none"> • Inspection: 1x / year • Routine Maintenance: 1x / 1-4 years • Major Maintenance: NA • Wood Replacement: NA
6	Primary trail. No vehicle access. Contained within a park.	Crushed rock	4'	Most developed trails within parks or greenspaces.	Most existing and new trails should be primary trails providing comfortable walking access for most people and maintained to standard. Soft surface trails of any type are to be provided only when meeting trail approval criteria. Goal is for each park or greenspace to provide at least 1 primary trail, prioritizing an accessible trail if possible.	<ul style="list-style-type: none"> • Inspection: 1x / year • Routine Maintenance: 1x / 1-4 years • Major Maintenance: rare • Wood Replacement: 1x / 10-15 years
7	Accessible trail. A primary or multi-purpose trail that also meets SPR Accessible Trails Guidelines (in development).	Crushed rock	4'	Seward Park Scarp Trail	Where getting to a trail on an accessible route is possible (via accessible walkway, sidewalk or adjacent parking) and proposed trail can meet siting criteria, the goal is for each park and greenspace to have at least 1 accessible trail.	<ul style="list-style-type: none"> • Inspection: 1x / year • Routine Maintenance: 1x / year • Major Maintenance: rare • Wood Replacement: 1x / 10-15 years
8	Secondary trail. No vehicle access. Contained within a park. Usually associated with a Class 6 or 7 Primary or Accessible Trail	Crushed rock	2' - 4'	Schmitz Park	Where desired by a community and approved as part of a comprehensive trail plan for a park or greenspace, secondary trails that are narrower and have a lower maintenance priority than primary trails are allowed.	<ul style="list-style-type: none"> • Inspection: 1x / year • Routine Maintenance: 1x / 1-4 years • Major Maintenance: rare • Wood Replacement: 1x / 10-15 years
9	Primitive trail. Pedestrian only, no vehicle access. Contained within a park along with Class 6 or 7 Primary or Accessible trails. Allows some obstacles, such as a log that can be stepped over.	Mineral soil	1' min	Seward Park Rustic Trail	Where desired by a community and approved as part of a comprehensive trail plan for a park or greenspace, primitive trails that may be challenging and have a very low maintenance priority are allowed.	<ul style="list-style-type: none"> • Inspection: 1x / 2-3 years • Routine Maintenance: rare* • Major Maintenance: rare* • Wood Replacement: 1x / 10-15 years <p>*Maintenance only for major dis-functions on as-needed basis</p>
11	Temporary or illegitimate trail. Temporary trails include those developed as part of restoration projects. Illegitimate trails include short cuts such as private points of access and user-created trails in inappropriate locations and are not considered part of the trail system.	varies	NA	Many short cuts through the Parks trail system as well as restoration trails.	Illegitimate trails should be evaluated for alternative solutions to desire paths. Maintenance and removal as necessary to prevent damage to resources.	Dealing with these trails is a lower priority than maintenance of trails in the system. Maintenance as needed to prevent damage to resources.

Figure 6- Trail Hierarchy and Maintenance Goals

3: SIGNAGE GUIDELINES

Many of our trails have signage. A rules sign is typical at a park entry and many trailheads also have a welcome sign, kiosk or wayfinding post. Some parks also have additional wayfinding signage or interpretive signage along trails. SPR's existing policies, guidelines and standards cover all types of signs and kiosks, including trail-related signage. The SSTMP proposes to supplement these guidelines, considering trail-related kiosks and signage as a family of features that occur in relationship to each other and would benefit from additional coordination and design consistency. SPR's existing sign policies are an umbrella over these supplemental guidelines and standards, including the statement:

In general, the signage plan shall be developed in a manner that allows Parks users to easily navigate the site/facility, but minimize the number of signs needed. Signage must be clear, consistent, easy to recognize, and appropriately placed. Signs shall be coordinated in a manner that prevents visual clutter and minimizes proliferation of signs within parks (Design Standard 10430-01).

Trail signs present a number of management issues. They are frequent targets of vandalism. SPR's current signage standards are designed in part to minimize characteristics that seem to attract vandalism such as large surfaces and location in less-frequented areas. They are also designed to be durable and to streamline sign replacement by having consistent materials and components that are easily replicated. However, the current standards for some signage types are out of date in terms of materials technology. Signage for welcome, rules and wayfinding often create an uncoordinated clutter at trailheads. There is no standard for signage addressing accessibility of trails. In the past, without a centralized management and review policy, community groups have implemented unique signs that don't necessarily achieve SPR goals. There is a lack of clarity about when signs are required, when they are optional and when it would be better not to have a sign at all.

The SSTMP proposes guidelines for trail-related signage and communication, especially at trailheads addressing the following goals:

- **Inclusiveness.** To make a wide variety of users feel welcome by making trailheads evident and communicating through SPR branding that these trails are open for public use.
- **Appropriateness.** To provide signage only where it is needed and is complementary to the environment.
- **Accessibility.** To make it possible for all users to find their way with clarity and ease and for users with special needs to assess for themselves which trails they can use.
- **Quality and sustainability.** To maintain trail signage in good condition and to have reasonably consistent standards for signage enabling easy maintenance and replacement of signs when needed.

Recommendations for Signage Guidelines and Standards:

- Establish an application process for new trail-related signage (see Section 6) including guidelines for required and optional signs and providing clarity on criteria for signage approval.
- Adopt new standards for signage (see Appendix F) addressing the following functions:
 - a. Identity.
 - b. Trailhead Information (including accessibility)
 - c. Rules
 - d. Interpretation
 - e. Wayfinding
 - f. Community communication





RIDGELINE TRAIL **JUDKINS PARK**

TRAIL LENGTH: 1.0 MILE

TRAIL CONDITIONS

- 1. Paved surface
- 2. Suitable for all ages
- 3. Accessible
- 4. ADA compliant
- 5. ADA accessible
- 6. ADA accessible
- 7. ADA accessible

Follow the Ridgeline Trail to visit nature lovers, enjoy bird watching in an open meadow and pass by a small wetland. The trail ends at NE USM Street in the Midtown neighborhood.

This park is yours to enjoy as in all parks, the following activities are NOT allowed:

- ALCOHOL CONSUMPTION
- SMOKING (including e-cigarettes)
- DRUGS AND RECREATIONAL DRUGS
- DRUGS
- DRUGS

Leash Pets
Obey Scoop Law

Call 911 to report illegal activity

DATE: 10.12.2019



*Improving
Quality &
Consistency
of Trail
Maintenance*

4: LEVEL OF SERVICE GUIDELINES

While SPR has established trail maintenance BMP's, there are no guidelines for frequency of maintenance to support the goal of maintaining the entire trail system so that it is safe, stable and provides the intended experience for trail users. Establishing expectations for trail maintenance frequency and outcomes will provide a framework for the Trails Unit to use for project planning, staffing and budget projections.

Recommendations for Level of Service Standards:

While maintenance needs may vary between different facilities depending on specific site conditions, adoption of the following maintenance intervals are expected to meet maintenance needs for the system:

- SPR accessible, multi-purpose, primary and secondary trails are inspected once per year. Primitive and temporary trails are inspected every 2-3 years.
- Accessible trails receive routine maintenance once per year to insure that they continue to meet the SPR accessible trails standard (under development).
- Multi-purpose, primary and secondary trails receive routine maintenance every 1-3 years, depending on inspection results. High use trails are prioritized for annual maintenance if needed.
- Primitive trails have no scheduled maintenance. Maintenance to address specific issues, such as a puddle in a trail, may be provided on an as-needed basis at the discretion of the Trail Coordinator.
- Temporary trails that are part of a restoration project sponsored by any group other than the Trails Program are monitored occasionally to ensure that they are in active use for the restoration project or that the sponsoring group is actively removing/restoring the trail.
- Illegitimate trails are monitored occasionally to ensure that they are not causing damage to resources.

Soft Surface Trails Level of Service (LOS) Goals

SOFT-SURFACE TRAILS			LEVEL OF SERVICE GOALS
5	Multi-purpose trail.	Crushed rock	Tread is responsibility of NRU Heavy Equipment Crew. Vegetation responsibility of Trails Program. <ul style="list-style-type: none"> • Inspection: 1x / year • Routine Maintenance: 1x / 1-4 years
6	Primary trail.	Crushed rock	<ul style="list-style-type: none"> • Inspection: 1x / year • Routine Maintenance: 1x / 1-4 years • Major Maintenance: rare • Wood Replacement: 1x / 10-15 years
7	Accessible trail.	Crushed rock	<ul style="list-style-type: none"> • Inspection: 1x / year • Routine Maintenance: 1x / year • Major Maintenance: rare • Wood Replacement: 1x / 10-15 years
8	Secondary trail.	Crushed rock	<ul style="list-style-type: none"> • Inspection: 1x / year • Routine Maintenance: 1x / 1-4 years • Major Maintenance: rare • Wood Replacement: 1x / 10-15 years
9	Primitive trail.	Mineral soil	<ul style="list-style-type: none"> • Inspection: 1x / 2-3 years • Routine Maintenance: rare (as needed) • Major Maintenance: rare (as needed) • Wood Replacement: 1x / 10-15 years
10	Temporary or illegitimate trail.	varies	INSPECTION Dealing with these trails is a lower priority than maintenance of trails in the system. Maintenance as needed to prevent damage to resources.

Figure 8- Trail Level of Service Goals



*Growing the
Trail System*

5: APPLICATION PROCESS FOR TRAIL PROJECTS

Since the establishment of the NRU Trails Unit, the majority of new soft surface trails developed in Seattle's parks and green spaces have been initiated by community groups or NGO's. Over this period there has been significant ambiguity over the process for proposing, approving, or rejecting new trails or trail features such as stairs, bridges and signage.

There is a strong need to clarify a process for review of proposals for new trails on Seattle Park property. A standardized process for review will set appropriate expectations, provide a predictable pathway for applicants to follow, and protect the City's interest in providing safe, sustainable facilities on valued park land. The process needs to include evaluation of impacts to Environmentally Critical Areas (ECA's) and other sensitive resources, ensure that trail projects are well designed, and demonstrate that projects will minimize and mitigate impacts.

SPR has an established project review process that will continue to be followed for new trail projects, but will be supplemented by an early review with the NRU trails group. The current process includes two elements that will be maintained in the proposed revised process. First, the standard SPR ProView process, which is used to ensure broad department-wide input on proposed projects will be required for all soft-surface trail proposals. Second, the existing interdepartmental/interagency grant application review process will remain in place for certain types of grants.

To ensure adequate review of proposed trail projects, the SSTMP supplements the current review process with a new, formal early review stage intended to identify important concerns or missed opportunities prior to community groups or other outside applicants seeking funding or other resources for projects.

Recommendations for Application/Approval Process for Trail Projects:

- The proposed process includes a two step review process. The first review begins with the NRU Trails Program, and also includes review by SPR planning and development. This Level 1 review requires a fairly simple application. If approved for further review, the applicant will be required to provide more complete design and environmental information for a Level 2 review process.
- Community groups, NGO's, other City agencies or SPR departments desiring to propose a new trail or a major renovation of an existing trail (including trail-related elements such as signage, steps, bridges etc.) must coordinate with the Trails Unit as a first step in the process. This early coordination is intended to share ideas for a trail project, and includes preparation of a basic application to provide an overview of the project. The application/approval process, described in more detail below, requires early contact between the applicant and NRU Trails Unit, and encourages ongoing coordination. Applicants bring proposals to the Trails Program with a fairly simple application package for Level 1 Review. Coordination with the Trails Unit may provide guidance for improving applications prior to continuing review with SPR planning and development. If approved for further

consideration following the Level 1 Review, Level 2 Review will require a more extensive application package and requirements for community engagement and support.

- All projects will be evaluated based on the following criteria (see Appendix B for an expanded discussion of criteria and considerations for approval):
 - a. Need (Connectivity, uniqueness, community support, equity)
 - b. Environment (Compatibility with natural and historic resources)
 - c. Resources (Availability of capital and maintenance resources)
 - d. Design (Appropriate, compliance with standards, durable & maintainable)
 - e. Schedule

These criteria initially provide an overview of considerations that should be addressed in the location and character of a trail project. They are also a guide for discussion with Trails Program staff. To be approved, trail project proposals need to meet minimum criteria in all 5 categories.

Trail Application Process

All applicants considering a trail project are urged to coordinate with the Trails Program as early as possible, since projects are more likely to be successful with a collaborative process between applicants and reviewers.

Level 1 Review

Level 1 Review is a preliminary vetting of a trail proposal.

Required application materials:

- Location map, showing where the proposed trail or project elements will be located.
- Narrative, including
 1. Identification and contact information of the applicant
 2. Description of the proposal and key elements (trail, signage, furnishings?)
 3. Description of how the proposal meets Trail Project Approval Criteria (See Appendix B for Trail Project Approval Criteria). For a Level 1 review, the primary focus for the applicant is Section A – Need and any key components of the proposal that can help address Section D – Resources, including volunteer commitments and funding sources. It is understood that the applicant may have not yet completed in depth site analysis or design, however, any preliminary information they can provide addressing other Trail Project Approval Criteria will be helpful to reviewers.

Trail Unit staff will review the application materials and, at their discretion, meet with the applicant to review the proposal on site. They will provide a preliminary evaluation focused on criteria that could elevate the project to high priority (e.g. if there is a very high need for the project) or that could disqualify the project (e.g. if the proposal is clearly not compatible with natural or historic resources or if there are no funding sources available for building the project).

Following their review, the NRU Trails Unit forwards the proposal to SPR planning and development with comments and a recommendation. Planning and development makes the final recommendation for the proposal, with potential outcomes described below.

Possible outcomes of a Level 1 Review:

High-priority approval. Proposal is clearly a high priority and upon preliminary review appears to be feasible (feasibility is defined as meeting Environment and Resources criteria, including identification of funding and maintenance resources). The Trails Program will lead further Environment and Resources analyses to verify feasibility and will lead the project development process with appropriate community and City involvement. The NRU Trails Unit Level 1 approval is preliminary, and would be finalized through the SPR project evaluation system, including a review by SPR's Proview committee.

Conditional Approval. Further development, by the applicant, of the proposal for a Level 2 Review is merited. Trails Program staff will advise the applicant on any issues and opportunities identified during the Level 1 review needing to be addressed in addition to the Level 2 application requirements. These may include consultation and preparation of materials by professionals such as landscape architects, structural engineers and geotechnical engineers or they may include commitments of volunteer hours, staffing, funding or ongoing maintenance by the applicant.

In some cases, especially for larger parks and parks with an established system of multiple trails, proposals for new trails may require completion of a park-specific Trail Master Plan to illustrate the relationship of the proposed trail and other potential future trails to the existing trail system and other park features. Proposals for new trails must also consider the ongoing maintenance of the new facility. In some cases approval of a trail proposal may require a maintenance agreement clarifying the roles and responsibilities of SPR staff and external stakeholders or other City agencies. The NRU Trails Unit Level 1 conditional approval is preliminary. Review of the application would be finalized through the SPR project evaluation system, including a review by SPR's Proview committee, in the Level 2 review.

Disqualified. Proposal is clearly low priority or not compatible with natural or historic resources or there are no capital or maintenance resources available (Does not meet Need, Environment or Resources criteria).

Level 2 Review

Level 2 Review is an in-depth evaluation by SPR's ProView committee. Materials required for Level 2 Trail Project Application include:

1. Drawing set, including:
 - a. Location map
 - b. Scaled plan showing trail project area of impact including layout, topography, Environmentally Critical Areas (ECA's) property lines, grading, compliance with standards, construction impacts, restoration plan and construction stormwater management plan
 - c. Construction details for trails and appurtenances showing compliance with standards
2. Additional documents that may be required:
 - a. Comprehensive trail plan for entire park or facility
 - b. Design and details for any proposed elements not meeting standards
 - c. Signage Plan (if project includes a trail head or any proposed signage. A comprehensive signage plan for the entire park facility is required for projects proposing wayfinding or interpretive signage)
 - d. Geotechnical report
 - e. Structural engineering report
 - f. Stormwater management plan
 - g. Drainage plan
 - h. SEPA review
3. Narrative, including
 - a. Identification and contact information of the applicant
 - b. Description of the proposal and all elements such as the trail, signage and furnishings
 - c. Description of how the proposal meets Trail Project Approval Criteria

In some cases, the applicant may be required to provide a Comprehensive Trail Plan that addresses all existing and proposed trails within the park that their proposal is intended for. The plan does not need to be complex, but does need to show the relationship of the proposed project to the rest of the trail system and with other resources and facilities in the park. Any costs associated with preparing the plan are the responsibility of the applicant. If the proposed project includes signage, the Signage Plan (see Signage Section) may be folded into the Comprehensive Trail Plan.

Preparation of a Comprehensive Trail Plan is more likely to be required when:

- The proposed project is in a large or heavily-used park
- The park already includes trails
- Trails are proposed to be developed and maintained as either Secondary or

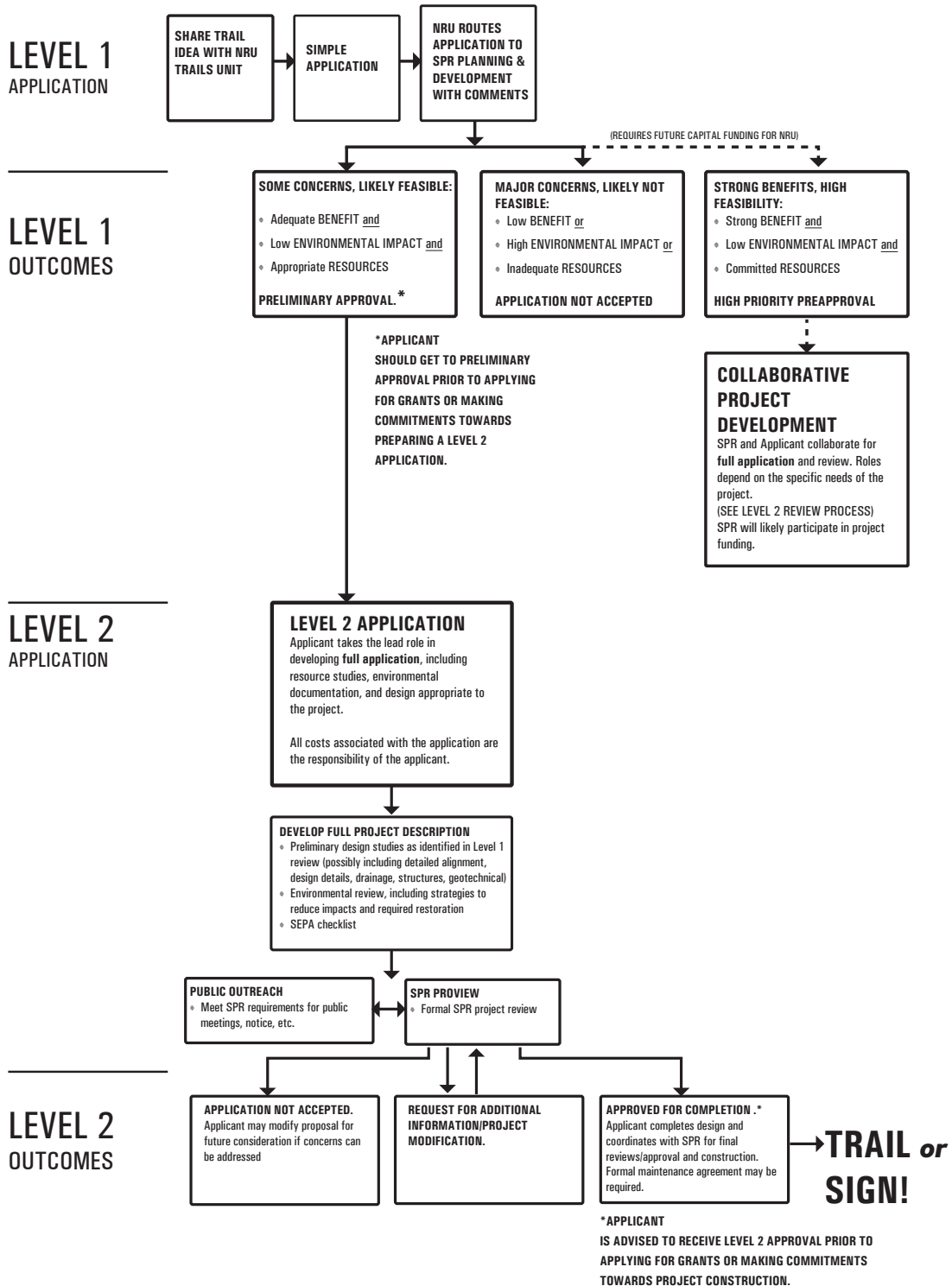

Figure 9- Soft Surface Trail Project and Signage Review Process

Primitive trails rather than to the Primary trail design standard

- The proposed trail is part of a longer-term project that might include multiple phases, or
- The project may be controversial

The Comprehensive Trail Plan includes:

1. An accurate map showing:
 - a. existing and proposed trails in the park
 - b. Park entry points
 - c. Major park features or destinations
 - d. Location of Environmentally Critical Areas (ECA's, including streams, wetlands and steep slopes) and of major geographic features (such as a bluff or ravine)
 - e. Accessible parking, trails, or other accessible park features
 - f. Locations where major structures (for examples stairways or bridges across streams) would be necessary
2. A narrative describing the existing trail system (including trail classifications) and how the proposed project relates to the existing system and facilities in the park. It should describe how the proposed project provides a needed element that is not redundant of existing elements.

Possible outcomes of a Level 2 Review:

Approval. Trails Program staff will work with the applicant to develop a work plan and schedule along with finalizing any agreements for commitments of volunteer hours, staffing, funding or ongoing maintenance.

Conditional Approval. Further information is needed. Applicant must resubmit package with additional technical analysis, materials, design revisions or community commitments as requested by Trails Program staff.

Disqualified. Proposal is not compatible with natural or historic resources, is incorrectly sited or does not complement the rest of the trail system within the park, does not demonstrate adequate community support or there are no capital or maintenance resources available (Does not meet Need, Environment, Design or Availability criteria).

Historic Landmark or Olmsted Park Additional Review:

If the proposed trail or sign project is in an Olmsted Park or Boulevard or on a site that is or has an historic landmark, the application will receive additional scrutiny during the SPR Proview review for appropriateness to the historic landscape context and compliance with SPR standards for Olmsted Parks. Projects associated with historic landmarks will also be reviewed by the Landmarks Board. Additionally, SPR may instruct the applicant to present the project to Friends of Seattle's Olmsted Parks for review.

Multi-jurisdictional Trail Additional Review:

Many trail projects extend beyond SPR property. SPR is working to develop agreements with Seattle Department of Transportation and Seattle Public Utility that will simplify the process for approving multi-jurisdictional projects. Until that time, applicants may need to coordinate with all applicable landowners and should anticipate a more complex review process if their project requires approvals by other agencies in addition to SPR.



***Protecting
& Enhancing
Seattle's
Natural and
Cultural
Heritage***



Enhanced Information & Compatibility



6: APPLICATION PROCESS FOR SIGNAGE PROJECTS

As described earlier, signage associated with the soft surface trail system meets several functional needs. When properly designed and located, signs:

- provide wayfinding information,
- help trail users understand the character and level of physical challenge associated with a trail,
- communicate regulatory and behavioral expectations, and
- provide interpretive information about the trail's setting.

However, balanced against the benefits signs can provide there is also the concern that too many signs can cause visual clutter and overwhelm visitors with too much information. The SSTMP includes a goal of providing consistent sign information at trailheads, improving the consistency for use of regulatory signage, and allowing some additional interpretive signs to enhance the visitor experience. In order to meet these goals, signs may be required as part of projects for new or enhanced trails. Also, community groups or other stakeholders may propose projects to add new signs to existing trails.

A standardized process for review of trail proposals will set appropriate expectations, provide a predictable pathway for applicants to follow, and protect the City's interest in providing maintainable signage meeting its goals for inclusiveness, appropriateness, accessibility, quality and sustainability. The process for reviewing and approving signs is similar to the process for reviewing trail projects, including a required early review by the NRU Trails Unit, followed by review through the SPR ProView process.

Recommendations for Application/Approval Process for Signage Projects:

1. Community groups, NGO's, other City agencies or SPR departments desiring to propose new trail-related signage must prepare an application for review by the Trails Unit and SPR ProView. The application/approval process encourages early and ongoing coordination. The signage application/approval process is essentially the same as the trail application/approval process, except that the required application materials differ. Applications for trails and signs on the same site may be combined. Applicants may bring proposals to the Trails Program with a fairly simple application package for Level 1 Review. Applicants proceeding to Level 2 Review must bring a more extensive application package and clear a higher bar for community engagement and support.
2. All signage projects will be evaluated based on the following criteria (see Appendix C for expanded criteria and considerations for approval):
 - a. Compliance with requirements and standards
 - b. Appropriateness to park facility and signage context
 - c. Location

- d. Design and Content
- e. Durability and Maintainability
- f. Community support

These criteria initially provide an overview of considerations that should be addressed in the location and character of a trail project. They are also a guide for discussion with Trails Program staff. To be approved, signage project proposals need to meet minimum criteria in all categories.

- 3. The application process includes a route for potential approval of non-standard signage. Applications for non-standard signage need to demonstrate how they are compliant with the signage goals and criteria and must demonstrate compelling need for an exception to the standards. Applicants requesting non-standard signs should anticipate an extensive review process.

Signage Application Process

All applicants considering a trail-related signage project are urged to coordinate with the Trails Program as early as possible. Projects are more likely to be successful with a collaborative process between applicants and reviewers. Any party proposing signage associated with a trail must submit a Signage Proposal to the Trails Program for review and approval. Trail projects, especially proposals for new trails, may be required to include trailhead information signs as part of the project. Signage-only projects may also be required to provide trailhead signs at the discretion of SPR, even if the intent of the project is focused on interpretive or regulatory signage.

Required signs include:

- Rainbow sign (for trail projects, a rainbow sign is only required if the trailhead is the main entry to the park and is requested by SPR).
- Basic Trailhead Information. Trailhead information signs occur only at trailheads and include the park name, the trail name and information about trail conditions and accessibility. It also includes rules including the hours that the park is open and a standard list of rules regarding behavior, substances, dogs and bicycles.

Optional signs and elements include:

- Identity Element. An additional Identity Element with the name of the park facility as part of a more natural or ceremonial gesture, such as a large engraved stone or a gateway, may be proposed. The Identity element must include the name of the park facility and the SPR logo. There is no standard for optional Identity Elements.
- Enhanced or Major Trailhead Display. An enhanced or major trailhead display including a kiosk or larger support may be proposed for interpretive information or event postings related to the park facility, such as trail work parties in addition to the Basic Trailhead Information.
- Interpretive Sign. Interpretive signage may be proposed
- Wayfinding Post. Wayfinding Posts may be proposed.
- Trailside Reminder Signs. Trailside Reminder signs may be proposed

Standard and Non-standard signs

All required signs and all optional signs (except the identity element) have associated design standards (see Appendices C and F for sign standards). All proposed signage, even if meeting the standards, must be included in a Signage Proposal. Non-standard signage may be proposed but will receive additional scrutiny to ensure that the alternate approach responds appropriately to the goals and approval criteria, including use of the SPR logo. The Trails Program may approve alternative signage with certain provisos, such as provision of replacement signs for use if originals are damaged. Any signs installed as a result of community proposals become the property of SPR, and applicants should understand that signs may be removed at SPR's discretion if they wear out, are damaged or cause other operational concerns.

Level 1 Review

Level 1 Review is a preliminary vetting of a signage proposal by Trails Unit staff followed by preliminary review through the ProView process. Applicants must coordinate the application with the Trails Unit, who will provide comments on the project prior to ProView review. Applicants may work collaboratively with the Trails Unit to resolve concerns and improve their proposal prior to ProView review.

All proposals need to include:

- Map of entire park facility showing locations of proposed signage
- Enlarged scaled plan showing approximate locations of proposed signs showing property lines, trail, any existing signage and existing features such street right-of-ways and major vegetation.
- Identification of signage types.
- Description and illustration of proposed content.
- Narrative describing need for the signage and community support

Potential Outcomes of Level 1 Review

Approval. Trails Unit staff will work with the applicant to develop a work plan and schedule along with finalizing any agreements for commitments of volunteer hours, staffing, funding or ongoing maintenance. The NRU Trails Unit Level 1 approval is preliminary and would be finalized through the SPR project evaluation system including a review by SPR's Proview committee.

Conditional Approval. Further information is needed. Applicant must resubmit package for Level 2 Review with additional per Level 2 Review application requirements and as requested by Trails Program staff. Conditional approval by the NRU Trails Unit is preliminary. Review of the application would be finalized through the SPR project evaluation system, including a review by SPR's Proview committee in the Level 2 review.

Disqualified. Proposal does not meet signage approval criteria.

Level 2 Review

Level 2 Review is an in-depth evaluation by SPR's Proview committee. Materials required for Level 2 Signage Project Application include:

- Map of entire park facility showing locations of proposed signage
- Enlarged scaled plan of proposed sign locations showing property lines, trail, any existing signage and existing features such as street right-of-ways and major vegetation. Plan should show sign locations dimensioned on plan and sign orientation.
- Construction details of signage showing the SPR standards, any modifications proposed, graphic layout including text (including font and font size) and illustrations.
- Narrative describing need for the signage and community support

Optional signage proposals must also include:

- Inventory and plan of existing signage throughout the park, showing locations, quantity, type and materials used.
- Expanded narrative describing commitment of resources for building and maintaining the signage and a proposed schedule.
- For interpretive signs, narrative describing widespread community support for the proposed content.

Potential outcomes of a Level 2 Signage Proposal review

Preliminary approval. Final approval pending agreement with Trails Program showing schedule, required inspections, etc., Upon final approval and construction,

- a. For any standard signage with unique content, such as trailhead information or wayfinding posts, the applicant is to provide graphic templates to be kept on file at the Trails Unit, in case of replacement.
- b. For any optional signage, such as interpretive signs, the Trails Unit may request that the applicant provide duplicate replacement panels, and/or agree to maintain, repair or replace the signage within 6 months of damage, and/or agree that the Trails Program may remove a sign if they have already replaced it once with provided replacement panels or if it is not repaired or replaced promptly by the applicant.

Requests for revisions or additional information

Disqualified. Proposal does not meet signage approval criteria.

APPENDICES

Appendix A—Performance Management Initiative Response

How does Soft Surface Trails Management Plan measure up with Seattle Parks & Recreation's Performance Management Initiative?

Outcome	Objective	How SSTMP Measures Up
Healthy People	01 Provide quality programs	A safe and accessible trail system will provide opportunities for walking, running, studying and enjoying nature. The new trail evaluation tool will help in meeting public demand for new trails.
	04 Increase awareness	Improved trailhead signage and on-line tools for trail information will increase public awareness of the trails system.
Healthy Environment	01 Prolong the life and usefulness of facilities	New maintenance guidelines and recommendations for centralized trail management will result in safe, usable trails that last longer.
	02 Preserve, expand and reclaim park property	Better trail maintenance and tools for providing new trails opens up more park property to public use.
	03 Provide safe, welcoming and accessible facilities	Better trail maintenance, better trailhead information and online trail information and accessible trails will make the system safer and more welcoming and accessible.
	04 Steward and environmentally sustainable parks system	Better trail maintenance reduces the materials and effort needed to restore deteriorated trails and results fewer social trails and other off-trail impacts.
Strong Communities	01 Connect the public with a diversity of opportunities	A better maintained and expanded trail system provides the public to enjoy nature and to make connections between neighborhoods.
	02 Improve access and reduce barriers	The new trail evaluation tool will prioritize underserved communities. Adoption of ABA trail guidelines for at least one trail per facility, along with better trailhead and online information will improve accessibility of trails.
	04 Encourage community engagement and volunteerism	Trails are already a focus of community engagement and volunteerism. The TMP recommends a more strategic approach to providing opportunities for engagement.
Continual Improvement	01 Positive public experiences	A better maintained and more accessible trail system with better trailhead information will improve the public experience of trails.
	02 Efficient & effective operations	Centralization of trails management, establishment of maintenance guidelines, better communication of standards and collection of data will make trail management more efficient and effective and bring Seattle's trail management on par with other cities.
	03 Equitable access	The new trail evaluation tool will prioritize underserved communities. Adoption of ABA trail guidelines for at least one trail per facility, along with better trailhead and online information will improve accessibility of trails.
	04 Sustainable urban environment	A robust trail system makes urban living more sustainable by providing outlets for people who live in tight urban spaces to enjoy nature. Better trail maintenance reduces the materials and effort needed to restore deteriorated trails and results fewer social trails and other off-trail impacts.
	05 Proud & supported employees	Establishing maintenance guidelines, improving communication of standards and providing the management tools and resources needed will enable employees to do a good job and feel supported.

Appendix B–Trail Application Approval Criteria

As described in Section 5 of the SSTMP document, reviewers will use the following criteria for both the Level 1 preliminary review and the Level 2 in-depth review. Reviewers will evaluate the project in each category. To be approved, a project must be satisfactory in every category.

Evaluation Criteria for Trail Projects

Please provide a short narrative for each of the criteria below. Groups outside of Seattle Parks and Recreation are encouraged to coordinate with the **NRU Trails Unit** prior to preparing an application for a trail project.

Criteria 1 – NEED

- Does the proposed project provide a **missing link** in an existing trail system?
- Does the proposed trail located in a **neighborhood underserved** by access to useable open space? Is the trail near a **school, community destination, recreation facility, or transit**?
- Is the route already used as an **informal trail**?
Describe why and level of use.
- Does the proposed trail provide **access** not offered by other trails in this Park or Greenspace?
- Does the proposed trail create a desirable **non-motorized link** between neighborhoods or to transit facilities?
- Is the proposed project **accessible** per the SPR accessible trails standard and the trails Program criteria for accessible trails?
- Is this project **supported by the local community**—how well and why?
How has the applicant engaged the community for its input?
Does the input represent a diverse cross-section of the community?
*Does the project contribute to **SPR equity goals**?*
- What are **community objections** to the project?

Criteria 2 – COMPATIBILITY WITH NATURAL AND HISTORICAL RESOURCES

- Can the project be built to standard with minimum **slope and vegetation impacts**?
Show cross section at steepest section of trail. Trails Program staff may require geotechnical analysis.
- How does the project impact **drainage patterns and water resources**?
How does the design avoid or mitigate any impacts?
- Does the project impact a **significant wildlife habitat**?
- Does the project impact any **other unique or unusual resource**
(such as vegetation, topography, archeology, or Olmsted park)?
- Is the proposed project in an **Environmental Critical Area** or ECA setback?
- How does the project design minimize impacts to habitat, unique or unusual resources and ECA's? (Habitat information from groups such as Audubon may be used to supplement and potentially strengthen an application.)
- What unavoidable impacts will the project and its use have on habitat, unique or unusual resources and ECA's?
- Is a **SEPA checklist** required for this project? Has it been provided?

Evaluation Criteria for Trail Projects—Page 2

Criteria 3 – RESOURCES

- Does the applicant have **resources to design and/or build** the proposed project?
Or, if applicant can not meet need, does the Trails Program have resources to design and/or build the proposed project?
Is this project high enough priority to qualify for Trails Program capital resources?
- Has the applicant provided a **viable maintenance plan** and commitment?
Or, if applicant can not meet need, does Trails Program have adequate resources available to maintain proposed project?

Criteria 4 – DESIGN

- Does the proposed trail or trail element appear to be **located correctly**?
Have alternate routes or locations been considered?
- Are **trailheads** located in appropriate pedestrian environments, near parking areas, or near public transit?
- How close is the trail to **neighboring properties**, residences or buildings?
- Does the trail design respond appropriately to **slopes, natural and historical resources**?
- Does the proposal require trail **structures** (bridges, stairs, turnpikes etc.)?
Do structures comply with SPR standards?
- Does the project propose structures or design **not compliant with SPR standards**?
Is there a compelling reason to accept these non-compliant elements?
Have they been designed professionally (e.g., structures designed by structural engineer)?
How well do they meet Trails Program principles?

Criteria 5 – SCHEDULE

- Is construction **schedule appropriate** (seasonality) and compatible with Trails Program availability for coaching, supervision (if needed), other support and inspections?

Appendix C – Signage Approval Criteria

As described in Section 6 of the SSTMP document, reviewers will use the following criteria for review of proposed sign projects. Reviewers will evaluate the project in each category. To be approved, a project must be satisfactory in every category.

Evaluation Criteria for Sign Projects

Please provide a short narrative for each of the criteria below. Groups outside of Seattle Parks and Recreation are encouraged to coordinate with the **NRU Trails Unit** prior to preparing an application for a sign project.

Criteria 1 – COMPLIANCE WITH REQUIREMENTS AND STANDARDS

- Has the proposal included **required signs** (for example trailhead and rules signs)?
- Do the proposed signs comply with SPR design **standards and guidelines**?

Criteria 2 – APPROPRIATENESS TO PARK FACILITY AND SIGNAGE CONTEXT

- For optional signage, would the proposed signs lead to **sign clutter**?
- Is required **wayfinding signage** included in the proposal?

Criteria 3 – LOCATION

- Are signs **appropriately located** in terms of property lines, relationship to approach and parking and visibility?
- Are signs located where they will be most useful and cause the least impact on resources?
- For signs with a lot of information (trailhead, kiosks and interpretive signs), are they sited so that users can read them without blocking a busy trail?
- Is the trail designated **accessible**?
Do trailhead signs, kiosks and interpretive sign locations should meet SPR accessible trail standards?

Criteria 4 – DESIGN AND CONTENT

- Is the **content accurate** and does it connect the viewer to the resource?
- Are interpretive signs **interesting and engaging**?
Is the sign so compelling that it will result in people learning or interacting with their environment?
Is the content well-written and relevant?
Are graphics engaging, informative, and of a high quality?
- Does the style of the sign **complement other signs in the park**?

Evaluation Criteria for Sign Projects–Page 2

Criteria 5 –DURABILITY AND MAINTAINABILITY

- Are there any **public safety concerns** with the design?

Criteria 6 –COMMUNITY SUPPORT

- Has the applicant done adequate **community outreach**?
- Is there **community support** for the signs and their content?
- Has the applicant reached out to likely interested **subject area groups** (such as Seattle Audubon, Friends of Seattle Olmsted Parks)?
- Has the applicant reached out to **diverse nearby community groups** (for example Refugee Women’s Alliance, Boys and Girls Club, local schools) to demonstrate support of people from a variety backgrounds, genders, ages and ethnicities to achieve inclusiveness and equity goals?

Criteria 7 –RESOURCES

- Does the applicant have **resources** to design and/or build the proposed project?
Or, Does the Trails Program have resources to design and/or build the proposed project?
- Are resources available to repair or replace the signs if vandalized or when they need replacement? How are those funds secured and made available to the NRU Trails Program?

Appendix D–Trail Standards



**** DRAFT ****
TRAIL
CONSTRUCTION & MAINTENANCE
STANDARDS

NOVEMBER 2000

- 1. TRAIL HIERARCHY/CLASSIFICATIONS**
- 2. TRAIL CONSTRUCTION SPECS**
- 3. TRAIL MAINTAINENCE GUIDELINE**
- 4. CONSTRUCTION DRAWINGS**
- 5. ILLUSTRATIONS**

COMMENTS / QUESTIONS:

CHUKUNDI SALISBURY
SEATTLE DPR - TRAILS PROGRAM COORDINATOR
1600 SOUTH DAKOTA STREET
SEATTLE, WA 98108
(206) 684-4122 VOICE
(206) 684-4126 FAX
CHUKUNDI.SALISBURY@CI.SEATTLE.WA.US

PART 1 - GENERAL

1.01 Description

The work of this section is limited to the restoration of disturbance resulting from all construction activities related to the installation of the sanitary sewer line. This work includes, but may not be limited to:

- Clearing and Removal of Existing Vegetation
- Stockpiling of Native Organic Material
- Grading of Disturbed Areas
- Construction of Trails and Related Appurtenances
- Drainage
- Soil Reconditioning
- Planting
- Mulching
- Warranty

1.02 Related Sections

Coordinate the work of this Section with that of all other Sections of the Contract.

1.03 Definitions

The following definitions may apply to this Specification Section only:

“Disturbance” refers to any negative impact to the project site caused by the execution of the Contract, including, but not necessarily limited to, access, excavation, exploration, hauling, staging, stockpiling, or survey.

“Mechanical Damage” refers to damage caused by unnatural physical forces, including vandalism, inappropriate handling, or damage occurring over time as a result of poor materials or workmanship.

“Plant Schedule” refers to the lists of plants associated with the restoration work of this Contract. Schedules are provided for planting in wet sites and dry sites.

“Trail Stationing Plan” refers to the spreadsheet formatted stationing plan associated with the restoration work of the Contract identifying specific improvements or restoration measures by type and location.

1.04 Quality Assurance

A. Reference Standards

The following standards are considered part of these specifications.

- American Association of Nurserymen
- “American Standard for Nursery Stock, ANSI Z 60.1”, latest edition.

B. Inspections

1. On-Going inspection and observation by the City of Seattle Department of Parks and Recreation (DPR) of the work in progress will be coordinated through the Project Engineer.
2. Plant Material

Upon approval of purchase order and Vendor, paragraph 1.03.C below, ship plants to project site staging area for inspection and approval by DPR. Remove from the site any plant material not accepted by the inspector immediately. Alternatively, arrange for inspection at the Vendors location, if within 20 miles of the Seattle City limits, within 24 hours of anticipated shipping.
3. Refer to paragraph 3.09 for Inspections required by Warranty.
4. Comply with the requirements of other inspections that may be identified elsewhere in these specifications.

C. Submittals

Provide for DPR approval a copy of all purchase orders for plant material, including the name, address, and telephone number of the Vendor. Do not ship plant material until approved. Approval of purchase order and vendor does not constitute acceptance of plant material.

D. Field Changes

Field Changes may be instituted by DPR, to the extent that the over-all value of the work is not substantially changed. In the event of a substantial change to the scope of work, as determined by agreement between the Contractor and the Owner, a Change Order will be negotiated.

E. Work Force

Work Force to be utilized for Planting, paragraph 3.07, shall be experienced in the planting of native species and be approved by DPR prior to mobilization.

PART 2 - PRODUCTS

2.01 Native Organic Material

Native Organic Material refers to that material encountered within the limits of disturbance, including haul and access routes, that consists of naturally occurring decomposed vegetation. This material does not include waste from clearing, logs, branches over 2" in diameter or over 5 feet in

length. Native Organic Material, for the purposes of this Section, includes topsoil and composted leaves, sticks, and twigs, which when stockpiled may result in a mixture of those elements.

2.02 Native Mineral Soil

Where described in this Section, Native Mineral Soil refers to that soil encountered during clearing and excavation that contains little or no Native Organic Material. Native Mineral Soil, for the purposes of this Section, includes clay, silt, sand, gravel, and rock in such a combination as to provide adequate drainage with a minimum of visible voids.

2.03 Imported Trail Construction Materials

A. Trail Surfacing

Trail Surfacing shall be 5/8" Minus Crushed Rock, crushed ledge rock or talus with no naturally occurring faces. Particle gradation as follows:

<u>Sieve</u>	<u>% Passing</u>
5/8"	90-100
1/4"	55-75
#40	8-24
#200	5-15

B. Lumber

Materials specified in this Section are for Footbridges under 20' in length, Waterbars, Turnpike sections, and Step construction only. Refer to City of Seattle Engineering Department Standards and Details for lumber associated with all other wood construction associated with this Contract.

All lumber for work of this section shall be LP-22, #2 Structural.

C. Fasteners

1. All plate-type and stamped fasteners shall be 16 gauge hot dipped galvanized steel or as approved by DPR prior to installation.
2. All other fasteners and connectors, i.e., nails, screws, and bolt assemblies, shall be galvanized steel, sized per details or as appropriate for the task.
3. Reinforcing Bars used as anchor pins for wood-on-grade construction shall be #4 deformed.

2.04 Drainage

- A. Culvert Pipe shall be 12" I.D. corrugated PVC, double-wall re-core, smooth interior wall, or approved equivalent.

- B. Rock for Rock Spillway and Rock Lined Sump shall be granite, largest face generally flat, weathered or shot, and minimum size 1/2 cubic foot.

2.05 Soil Conditioning and Planting Backfill

- A. Native Organic Material as described in this Section, paragraphs 2.01, above.
- B. Moisture Retention Agent shall be an Hydrophilic Acrylic Copolymer, "Soil Moist" by JRM Chemical, Cleveland, Ohio, or equal.
- C. Planting Backfill shall be a thoroughly blended mixture of existing soil, Moisture Retention Agent at the manufacturers recommended rate, and Native Organic Material.

2.06 Plant Material

- A. Provide only those plant species identified on the Schedules. Where specific cultivars or varieties are not identified, provide only the species as indicated. Do not provide cultivars or varieties.
- B. Size
 - 1. Meet or exceed the standards for plant size per container as described in "American Standard for Nursery Stock, ANSI Z 60.1".
 - 2. Provide trees and shrubs at the sizes indicated on the schedules. In the event of unavailability, provide one size smaller at a documented credit to the Owner, or alternatively, one size larger at no additional cost to the Owner.
 - 3. Provide groundcovers at the size indicated on the schedules. In the event of unavailability, provide one size smaller at a documented credit to the Owner.
- C. Quality
 - 1. Meet or exceed the standards for plant quality as described in "American Standard for Nursery Stock, ANSI Z 60.1".
 - 2. Plant Material shall be healthy, vigorous, and sound upon inspection and acceptance. There shall be no evidence of insect infestation including eggs, insects, or feeding damage. There shall be evidence of mechanical damage such as broken branches, root balls, or bruising of foliage.
 - 3. Plant material shall have been grown and held in conditions similar to those expected for the species.

2.07 Mulch

Mulch and Erosion Control Blanket shall be clean, unbound Wood Excelsior, supplied in bales.

PART 3 - EXECUTION

3.01 Clearing

- A. In general, clear only that vegetation that is immediately threatened by activity associated with the work of this Contract.
- B. Remove no deciduous trees over 3" in trunk diameter measured 4 feet above ground level and no coniferous trees measuring over 5' above ground level without prior approval of DPR. Obtain approval by flagging trees proposed for removal prior to coordinating a review by DPR. Anticipate the alignment far enough ahead to allow for alternate routing in the event proposals for tree removal are rejected by DPR.
- C. Where overhead clearance requirements necessitate the pruning or limbing of tree branches over 3" in diameter at that point where the cut is to be made, obtain approval through the same procedure identified above in paragraph 3.01.B.
- D. Refer to the construction details associated with the trail work for additional clearing requirements.
- E. Remove thoroughly from the Project Site all material cleared. Alternatively, chip all material mechanically and disperse equally to both sides of the Project alignment.

3.02 Stockpiling of Native Organic Material

- A. Refer to the above paragraph 2.01, for a description of Native Organic Material.
- B. Excavate by scraping the upper soil profiles to collect the material. Work in such a manner as to accumulate a minimum of Native Mineral Soil.
- C. Stockpile Native Organic Material (Organic Material) in a linear "berm" along both outer edges of disturbance. In the event that excavated Native Mineral Soil (Mineral Soil) requires such room as to make stockpiling the Organic Material on both sides of the disturbed area impractical, stockpile the Mineral Soil on the up-slope side of the disturbed area. Areas receiving stockpiles will be considered disturbed areas.
- D. Stockpile Organic Material loosely. Do not compress or compact stockpiles beyond the natural compression of the material to achieve a steeper angle of repose.

3.03 Grading

- A. General
 - 1. Grading of disturbed areas within the limits of DPR jurisdiction falls within two categories. Grading taking place beneath areas to receive trails on grade and their associated appurtenances, referred to as "Traffic Areas", grading taking place beneath

areas to receive elevated trail structures such as footbridges and bridges, and grading taking place along areas to receive Plantings, referred to as "Non-Traffic Areas".

2. On average, the rough grade of all areas within the limits of disturbance shall transition smoothly into the adjacent existing undisturbed grades. Exceptions are those areas on the up-slope side, which are scheduled to receive parallel ditches.
- B. Traffic Areas
1. All Traffic Areas shall be rough graded with clean Native Mineral Soil containing a minimum of contaminating organic material.
 2. Areas scheduled to receive a Standard Trail Section;
 - a. Shall be graded with a side slope draining either inward to a parallel drainage ditch or outward down-slope at between 2 and 5 percent.
 - b. Shall be compacted to the greatest density supportable by the surrounding soils and slopes.
 3. Areas scheduled to receive Turnpike and/or Water-bars;
 - a. Shall be graded flat, or no more than 2% across in any direction.
 - b. Shall be compacted to the greatest density supportable by the surrounding soils and slopes.
 4. Areas scheduled to receive Drainage improvements;
 - a. Shall occur only as excavations into undisturbed soil.
 - b. Shall be graded in lateral section per the drawings and in profile such that they result in positive the designed out-fall.
- C. Non-Traffic Areas
1. All Non-Traffic Areas shall be rough graded with either Native Mineral Soil or a combination of Native Mineral Soil and Native Organic Material (Organic Material). Minimize use of stockpiled Organic Material and do not use Organic Material occurring outside the limits of disturbance.
 2. Areas scheduled to receive Elevated Trail Structures;
 - a. Shall be graded;
 - i. To smoothly transition into adjacent existing grades.

- ii. To drain along pre-existing flow lines. Where directed, reconstructed flow-lines shall be reinforced with imported rock, as associated with drainage work, and as defined in paragraph 2.04.B, above.
- b. Shall be compacted to the greatest density supportable by the surrounding soils and slopes.
- 3. Areas scheduled to receive Plantings;
 - a. Shall be graded to smoothly transition into adjacent existing grades.
 - b. Shall be compacted to such an extent as to prevent excessive erosion but not to such an extent as to inhibit infiltration or percolation of surface water into the soil. Generally, 70% of maximum density at 15% moisture by weight.

3.04 Trail Construction

A. General

- 1. Work of this Section consists of all services, labor, equipment, and materials necessary to construct the trail system described in the Trail Stationing Plan. This includes construction of Standard Trail Section, Water Bars, Turnpike Section, Steps, and Footbridges under 20' in length.
- 2. The Trail Stationing Plan has been developed to meet the existing topography, soil conditions, and apparent hydrology of the Project Site. If, in the course of construction of the Sewer Interceptor, substantial changes are made to any of these existing characteristics, it will become necessary to alter, in the field, the Trail Stationing Plan. The current schedule of construction details associated with this work and described below will be used to adapt the plan to actual conditions. Refer to paragraph 1.03.D.
- 3. Prior to performing the work of this section, verify the condition of the rough grade as being in conformance with the above paragraphs 3.03.A.2 and 3.03.B. Obtain Engineer approval of conditions as adequate to proceed.
- 4. Provide clean, uncontaminated surfaces.

B. Standard Trail Section

- 1. Generally, Standard Trail Section consists of a 36" (standard) or 72" (wide section) wide trail tread on grade.
- 2. Import and place Trail Surfacing in a single lift to the dimensions specified in the details. Provide sufficient material to insure a full 3" depth following compaction.
- 3. Compaction

- a. Perform compaction only under suitable conditions. Do not compact excessively wet or dry material or when the sub-grade soils are excessively wet or dry. Allow materials to dry or add clean water as necessary to achieve optimum moisture.
- b. Mechanically compact the Trail Surfacing to the maximum density supportable by the underlying soils.

C. Turnpike

1. Generally, Turnpike shall consist of a 36" (standard) or 72" (wide section) wide trail tread on grade, retained by 4"x4"x8' LP-22 timbers pinned to the sub-grade with 24" of #4 deformed reinforcing bar, 3 bars per timber.
2. Layout and set bottom of retaining timbers flush to, or up to 1/2" below, compacted sub-grade, end to end with no gaps between timbers. Stagger joints on opposing sides of tread where practical. Miter ends of timbers equally where trail alignment turns.
3. Pre-drill timbers 3/8", to accept reinforcing bar pins, at 12" from each end and at center. Set 24" - #4 reinforcing bar pins into stable soil to a depth of 3/4" below the top of retaining timber.
4. Import and place, in one lift, sufficient Trail Surfacing to provide an average depth of 4" following compaction, with a crown of 1" above top of retaining timbers.
5. Compaction per 3.04.B.3, above.

D. Water Bars

1. Generally, Water Bars are intended to both divert surface water off the trail and stabilize Trail Surfacing. Construct Water Bars of 4"x4" LP-22 timbers pinned to the sub-grade with 24" - #4 deformed reinforcing bar, 2 bars per timber. Install Trail Surfacing, as for Standard Trail Section, paragraph 3.04.B above.
2. Locate timbers flush to the prepared sub-grade, spaced per the Trail Stationing Plan. Where formal drainage ditching is scheduled, set timbers to divert surface run-off into these ditches. Where no formal drainage work is associated with the Water Bars, set the timbers to divert surface run-off generally down-slope.
3. Pre-drill timbers perpendicular to the prevailing slope 3/8", to accept 24" - #4 reinforcing bar pins, at 6" from each end. Set reinforcing bar pins into stable soil to a depth of 1" below top of timber.

E. Steps

1. Generally, Steps are constructed of 6"x6" LP-22 timbers arranged in a "crib-work" fashion, each riser consisting of 2 sides and a leading edge, stacked and staggered to

fit the slope to the tolerances indicated in the drawings. Individual timbers are fastened with 30" - #4 deformed reinforcing bars as indicated below.

2. Begin all Step construction at the bottom of the slope by excavating a stable, flat bench slightly larger than the design dimensions of the Step. Mechanically compact this bench to the maximum density supportable by the soils present, assuming optimum moisture content per paragraph 3.04.B.3 above.
3. Arrange the timbers per the drawing, with the leading edge timber spanning the full width of the Steps. Length of the sides of the crib-work will vary depending on the slope. Provide sufficient length for the next Steps sides to overlap a minimum of 12".
4. Pre-drill timbers plumb 3/8", to accept 30" - #4 reinforcing bar pins, as follows;
 - a. For leading edge timbers, at 2 places, 4" from each end.
 - b. For side timbers, at 4" from exposed ends.
 - i. If tread will be longer than 24", one place centered between exposed end and leading edge of the next riser.
 - ii. If last riser at top of steps, 3 places, 12" on center beginning 4" from each end.

Set pins into stable earth to a depth of 3/4" below top of each timber.

5. Backfill each Step as it is constructed by importing sufficient Trail Surfacing in a single lift, to completely fill the crib-work upon compaction per 3.04.B.3, above.
6. Begin construction of successive risers directly atop the preceding riser, using the drilling and pinning procedure, paragraph 3.04.E.4 above, to secure the overlapped portions of the riser below.
7. Backfill the sides of the completed Steps with Native Mineral Soil to a point 2" below the bottom of the leading edge timber of each step.

F. Footbridges and Railings

1. Generally, Footbridges are wooden structures constructed with either post-and-beam construction for sections over 14" above grade or mud-sill construction for sections under 14" above grade. Sections more than 30" above grade require a handrail. All timbers, lumber, and fasteners are per paragraphs 2.03.B and 2.03.C above, sized per the details or as appropriate for the task.
2. Refer to other Specifications of this project for details regarding installation of Sewer Interceptor supported by Footbridges or Boardwalks.

3. At the Contractors option, all construction of Footbridges under 20' in total length associated with this project may be of the post-and-beam construction technique described for Footbridges over 14" above grade, or per details provided for Boardwalks or Footbridges over 20' in overall length.
4. Construct all Footbridge components plumb and level, with the exception of extreme ends, which may transition at up to, but no more than, a 5% slope down to the successive or proceeding trail detail.

3.05 Drainage

A. General

1. Work of this Section consists of all services, labor, equipment, and materials necessary to construct the Drainage work associated with the trail system described in the Trail Stationing Plan. This includes construction of Drainage Dips, Drainage Ditches, Rock-Lined Sumps, Culverts, Leadoff Ditches, and associated Rock Spillways.
2. The Trail Stationing Plan has been developed to meet the existing topography, soil conditions, and apparent hydrology of the Project Site. If, in the course of construction of the Sewer Interceptor, substantial changes are made to any of these existing characteristics, it will become necessary to alter, in the field, the Trail Stationing Plan. The current schedule of construction details associated with this work and described below will be used to adapt the plan to actual conditions. Refer to paragraph 1.03.D.
3. Verify that the condition of areas scheduled to receive drainage work is consistent with the requirements of paragraph 3.03.B.4 above. Obtain Engineer approval of conditions as adequate to proceed.

B. Drainage Dips

Where directed by the Trail Stationing Plan to install a Drainage Dip, refer to the detail and provide the necessary grading alteration to the specified trail construction detail, paragraph 3.04, above. Each Drainage Dip shall collect and divert surface run-off down-slope to an associated Rock Spillway, paragraph 3.05.G, below.

C. Drainage Ditches

1. Where indicated on the Trail Stationing Plan, Drainage Ditch refers to a surface run-off interceptor trench that runs parallel to and up-slope from the trail and perpendicular to the prevailing slope
2. Where directed by the Trail Stationing Plan, excavate Drainage Ditches to the dimensions indicated in the details. Provide ditch bottoms that slope positively to the associated outlet.

3. Where Drainage Ditches slope at greater than 1' vertically in 12' for more than 30', provide a 6"x6" timber check-dam across the bottom of the ditch, embedded 12" into each side, 10' spacing. Secure the timber check-dam as for Water Bars, paragraph 3.04.D.3 above, except 12" from each end.

D. Rock-Lined Sump

Where directed by the Trail Stationing Plan to install a Culvert associated with a Drainage Ditch, install on the up-slope side of the trail or trail structure a Rock-Lined Sump (Sump) as follows;

1. Identify the intersection point of the flow-line of the culvert and the flow-line of the associated ditch to be drained. At the point of intersection, excavate sufficient undisturbed Native Mineral Soil to allow the excavation to be tightly lined with Rock, per paragraph 2.04.B above, leaving a sump approximately 1 foot deep below bottom of ditch invert of Culvert with a capacity of 2 cubic feet. Dimensions for Sump should be approx. 1'-5 square or 1'-7 diameter.
2. Beginning with the bottom of the Sump and working up to the bottom of the associated Drainage Ditch, line the Sump with Rock. Rock should fit tightly, with no gaps over 2" in any dimension. Provide additional Rock across the bottom of the Drainage Ditch which over-hangs the Sump 1" to protect the Sump walls from out-wash.
3. Pack joints in the bottom of the Sump with 5/8" Minus Crushed Rock per paragraph 2.03.A.

E. Culvert

1. Generally, Culverts occur either at the apparent low-point of a Drainage Ditch or as a surface water run-off outlet along flat, wet runs of trail. If for reasons defined in paragraph 3.04.A.2, the Trail Stationing Plan identifies a location as scheduled to receive a Culvert that does not appear to meet this criteria, notify the Engineer and obtain specific direction before proceeding with the work.
3. Culverts have, normally associated with them, the following additional elements;
 - a. Rock-Lined Sump, paragraph 3.05.D, above.
 - b. Leadoff Ditch, paragraph 3.05.F, below.
 - c. Rock spillway, paragraph 3.05.G, below.
2. Install Culverts as follows;
 - a. Generally perpendicular to trail, sloping to drain down-slope.
 - b. Extend Culvert 12" beyond edge of trail up-slope or 4" into Sump

- c. Extend Culvert 12" beyond edge of trail down-slope
- d. Invert of pipe at inlet shall be either
 - i. Flush with finish grade at Culverts not associated with Drainage Ditches.
 - ii. At 6" below bottom of Drainage Ditch.
- e. Minimum cover over Culvert shall be 6".
- f. Invert of Culvert out-fall shall be sufficiently lower than the inlet to provide adequate flow, generally 2-5%.
- g. Where the existing slope permits, construct a Rock Spillway at the out-fall of the Culvert.
- h. Where the existing slope would otherwise inhibit discharge of the out-fall, construct a Lead-off Ditch, paragraph 3.05.F

F. Lead-off Ditch

- 1. Construct a Leadoff Ditch where directed by the Trail Stationing Plan or where the elevation of the out-fall of a Culvert would otherwise be below existing grade.
- 2. Leadoff ditches shall have a flat bottom 8" in width shall be a minimum 12" in depth, depth increasing as necessary to provide a 2% slope to a point where natural grade allows for discharge. Leadoff Ditches shall be excavated into previously undisturbed earth.
- 3. At the out-fall point of all Leadoff Ditches, provide a Rock Spillway, paragraph 3.05.G.

G. Rock Spillway

Install Rock Spillways (Spillway) at the out-fall point of all drainage structures as follows;

- 1. Use only imported rock, which complies with paragraph 2.04.B of this specification.
- 2. Extend the Spillway the width or diameter of the drainage structure discharge to each side of the discharge point and 3 times that dimension down-slope. Slope the Spillway to drain a minimum 2% or to conform to the existing slope. Embed the Rock so that only the top plane is exposed, butting all joints as tightly as possible. Pack all resulting joints with 5/8" Minus Crushed Rock complying to paragraph 2.03.A.

3.06 Soil Reconditioning

A. General

The intent of the work of this section is to provide a complex soil profile and finished grade for planting that is more conducive to the survival of native plant species scheduled for restorative planting. All areas of disturbance, generally those consisting of exposed mineral soils unless otherwise directed by the Engineer, shall receive Soil Reconditioning.

B. Identify the limits of disturbance remaining following the work of paragraphs 3.03, 3.04 and 3.05. Verify that the condition of rough grades encountered is in compliance with paragraph 3.03.C, as appropriate for the specific location. Obtain Engineer approval of the conditions as adequate to proceed before commencing the work.

C. Distribute equally all stockpiled Native Organic Material over the disturbed areas identified above. Incorporate this material into the top 2" of the sub-grade soil. Roll or otherwise lightly compact the resulting surfaces to form a consistent mat.

3.07 Planting

A. General

1. All areas of disturbance not occupied by drainage, trail on-grade, or related appurtenance, shall receive Planting, including areas beneath Bridges, Boardwalks, or Footbridges.
2. Refer to the Trail Stationing Plan for identification of areas to receive plant material from each of the two Plant Schedules. Calculate the total area associated with each Plant Schedule, and provide a copy of the purchase order to the Engineer for approval, per paragraph 1.03.C.
3. Provide and maintain stationing stakes indicating limits of planting for each schedule.
4. Planting activity is to take place between October 1st and December 1st only.
5. Prior to commencing planting activity, obtain approval of the plant material per paragraph 1.03.B.2.

B. Shipping and Handling

1. Plant material received on-site showing evidence of mishandling such as tightly bound or broken branches, crushed or misshapen containers or root-balls, or stripped, crushed, or severely bruised foliage will be rejected and must be removed from the project site immediately.
2. Plant material shall be transported to the planting location with extreme care and attention. Do not handle plant material by any means other than fully supporting the container or root-ball. Previously accepted plant material showing evidence of

mishandling, such as broken branches or loose root-balls will be rejected and must be removed from the site immediately.

C. Tree Location

Stake for DPR approval the locations of individual trees. Locate in a natural, random pattern. Alternatively, provide DPR with stakes pre-marked by species and in the specified quantities for placement within 48 hours of receipt.

D. Preparation and Planting

1. Excavate planting pit approximately one and one half times as deep as the root mass provided with the plant and twice as wide.

2. Planting Backfill

To the excavated soil, thoroughly incorporate the manufacturers recommended rate for Moisture Retention Agent and the Native Organic Material found at the surface of the pit.

3. Backfill the planting pit with sufficient Planting Backfill to result in the plant root crown being flush with the surrounding grade.
4. Gently disturb the root ball of the plant manually, to loosen tightly wound or matted roots.
5. Set the plant plumb in the planting pit and backfill with Planting Backfill. By hand, compact the backfill to eliminate air pockets.
6. Where practical, water plants thoroughly.

3.08 Mulching

Provide a uniform 2" layer of unbound Wood Excelsior Erosion Control Blanket over all disturbed areas not covered by trail on-grade or drainage appurtenances.

3.09 Warranty

- A. Prior to Contract Closeout, coordinate a punch-list walk-through with the Engineer and DPR.
- B. Correct any punch list items to the standards established by the Trail Stationing Plan, Plant Schedules, details, and this Specification. Upon satisfying the requirements of the punch list, request DPR acceptance of the work as substantially complete.
- C. Warranty the materials and workmanship for a period of one year from date of DPR acceptance as substantially complete, as follows;

1. At 6 months, coordinate an inspection of the condition of the work and correct, in a timely manner, any damage or failure as follows;
 - a. For plant material, replace 100% of trees and shrubs and 50% of groundcovers showing significant sign of decline as determined by DPR. Exclusion to this warranty is allowed for obvious mechanical damage due to vandalism or natural processes.
 - b. For Drainage work and Trails or Trail Appurtenances, repair and/or replace any defects which may have occurred other than obvious mechanical damage due to vandalism.

 2. At the one year anniversary, coordinate an inspection of the condition of the work and correct, in a timely manner, any damage or failure as follows;
 - a. For plant material, replace 50% of trees and shrubs showing significant sign of decline as determined by DPR. Exclusion to this warranty is allowed for obvious mechanical damage due to vandalism or natural processes.
 - b. For Drainage work and Trails or Trail Appurtenances, repair and/or replace any defects which may have occurred other than obvious mechanical damage due to vandalism.
- D. Upon satisfaction of the requirements of the inspections at 6 months and one year, obtain DPR approval of the work as physically complete.

END OF SECTION

NOTES

Trail Maintenance Standards

Maintaining the Trail Travel Corridor

In order to provide safe and enjoyable hiking experiences year round, all trails should be free of obstructions and brushed out to a height and width of 8 feet. To accomplish this, vegetation and other elements of the urban forests (e.g.: down trees, rocks, debris piles) should be removed from all trail areas if they encroach into the trail travelway.

With a hand pruner, saw, lopper, or weed whip, cut out the vegetation (or other trail obstruction) within 3 feet of the center of the trail. Vegetation over 18" tall should always be cut flush with the ground (take out the whole plant) or at the point where a branch connects to its mother branch or trunk. Removing the whole plant, or at least an entire limb, is best because "stobs" (the exposed cuts on plant limbs) pose a danger to future trail users, and often sprout new "branchlets" out into the trail corridor. Most importantly, removal of entire plants or limbs means that as trail maintainers, we do not have to recut the same plant year after year.

*Stubs
OR
Healing
cuts
NISA TERM.*

Summary: Trails should be brushed to 8 feet high and 6 feet wide. All material removed should be safely scattered off trail, down slope, and away from trail structures.

Note: Vegetation which is not growing over the trail tread and is under 18 inches high, does not need to be removed. Also, if a trail is located on a relatively steep slope, vegetation on the uphill side of a trail should be brushed back an additional foot while the vegetation on the downhill slope can remain flush to the trail tread. This encourages hikers to use the more stable uphill portion of the trail tread.

Maintaining the Trail Backslope

Trails, which are located on sloping terrain (as opposed to trails in relatively flat areas), should not have a backslope in excess of 45 degrees. Steep backslopes force hikers away from the more durable inside (uphill) edge of the trail, and force them to use the outer edge (or shoulder) of the trail where tread material erodes quickly.

With a hoe, Polaski, or pick madox, loosen all material needing to be excavated from the backslope and remove it

with a shovel. In most cases, vegetation and other forest debris will have to be removed before excavation can begin.

Summary: The backslope of all trails should be maintained at an angle less than 45 degrees. All material removed while maintaining the proper backslope should be safely scattered well off trail, down slope, and away from trail structures.

Maintaining the Trail Tread

All major trails should have a tread at least 4 feet wide, free of any tripping or stumbling hazards (such as exposed roots, rocks, and logs), and consist of hard packed mineral soil, gravel, or crushed rock. Trail tread should be uniformly smooth and slightly out-sloped (about 5 degrees), or crowned. Out-sloping the trail means grading the trail tread so it is lower nearest the outer (and down hill) edge of the trail and highest at the trail's inner (or uphill) edge. A crowned trail means the trail tread is highest in the trail's center, and gently slopes downward towards the outer edges of the trail. Trail tread, which is crowned or outsloped, encourages surface water to drain off trail (sideways) rather than down the trail. Water, which is allowed to run down the trail causes erosion and will increase the amount of maintenance a trail, will need over time. Lastly, all plant life growing on the trail tread (including moss, grass, flowers, weeds, etc) should be removed, and standing water or muddy areas should be eliminated.

With a Polaski, pick madox, or hoe, remove all roots, rocks, logs, or other tripping/stumbling hazard from the trail tread. Tread hazards should be chopped or dig out to a depth of 6 inches and the resulting hole filled with mineral soil, gravel, or crushed rock. Always tamp the worked area with a Mcload or tamper to compact the new material consistent with the overall tread.

To create a trail tread that drains well (as described above), use a Polaski, pick madox, hoe, or shovel to move material from one area of the tread to another to create a proper trail outslope or crown. Compact all material with a Mcload or tamper.

To eliminate mud puddles or areas of standing water, use a shovel or Mcload to remove all muddy soil and moisture from the trail tread. Once all moisture and mud is removed, fill in the resulting depression with mineral soil, gravel, or Crushed rock, and re-establish the trail's outslope or

crown. Tamp down all tread material with a Mcload or Tamper.

In areas where the trail has expanded so the tread is more than 3 feet wide, move nearby forest materials (such as plants, leaves, sticks, old logs, and large rocks) into the trail so the tread is brought back to the appropriate size. (Note that any items put within reach of the trail must be firmly in place and resistant to rocking or tipping.) If the trail in question is on a slope, always cover the downhill portion of the tread so as to retain the upper 3 feet of tread.

Summary: Trail tread should always be 3 feet wide, smooth, hazard free, free of standing water and mud, properly sloped for effective surface water runoff, and consist of hard packed mineral soil, gravel, or crushed rock.

Maintaining Drainage Structures

Water bars, drain ditches, and culverts should always be clean, clear, and properly sloped to eliminate tread erosion, on trail standing water, and the creation of mud puddles. All drainage structures made of wood, plastic, or similar materials should be firmly in place, resistant to prying, and free of rot or other damage.

Drain Ditches: Use a Polaski, madox, Mcload, hoe, or shovel to maintain drainage ditches to a depth and width of one foot. Most importantly, eliminate ditch walls, which are greater than 50 degrees. The walls of all drain ditches should be angled less than 50 degrees to reduce and eliminate dirt or other forest debris from sloughing off the walls and into the ditch. Any nearby logs, rocks, or sticks should be moved well away from the ditch to allow the trail maintainer easy access, and any plant life growing in the ditch should be removed.

Water Bars: Use Polaski, madox, Mcload, hoe, or shovel to remove all debris and excess dirt from the uphill edge of Water Bar. A slight depression should be maintained along the upper edge of the water bar to facilitate collection and diversion of surface water from the trail. Maintain the water bar's leadoff ditch at its downhill end consistent with a standard drain ditch (as described above). The trail tread on the downhill or "downtread" edge of the waterbar should be flush with (or slightly higher than) the top of the water bar, while the upper edge, or "uptread" part of the waterbar (the one nearest where the water flows) should be slightly lower and packed

with gravel so as to prevent water from under cutting the waterbar.

Culverts: Use a shovel blade, shovel handle, or a post hole digger to scrape out any material from inside the culvert. Culverts should be completely free of debris and plant life at all times. Catch basins of culverts should be dug out to at least 4 inches lower than the bottom of the culvert. Deep catch basins allow sediments in the runoff to settle out and ensure that water traveling through the culvert is fast flowing and clear. Like drain ditches, catch basins should have sloped walls no greater than 50 degrees and should be free of plant life, debris, sticks, etc.. The downslope opening of the culvert should also be free of obstructions and should be maintained as a drainage ditch. If possible, the downslope opening of the culvert should be two inches higher than the bottom of the drain ditch to prevent water from backing up into the culvert.

Summary: culverts, water bars, and drainage ditches should be maintained to allow maximum trail drainage and prevent water from flowing onto the trail. If materials are damaged, rotten, or easily kicked out of place, the structure should be replaced.

NOTES

NOTES

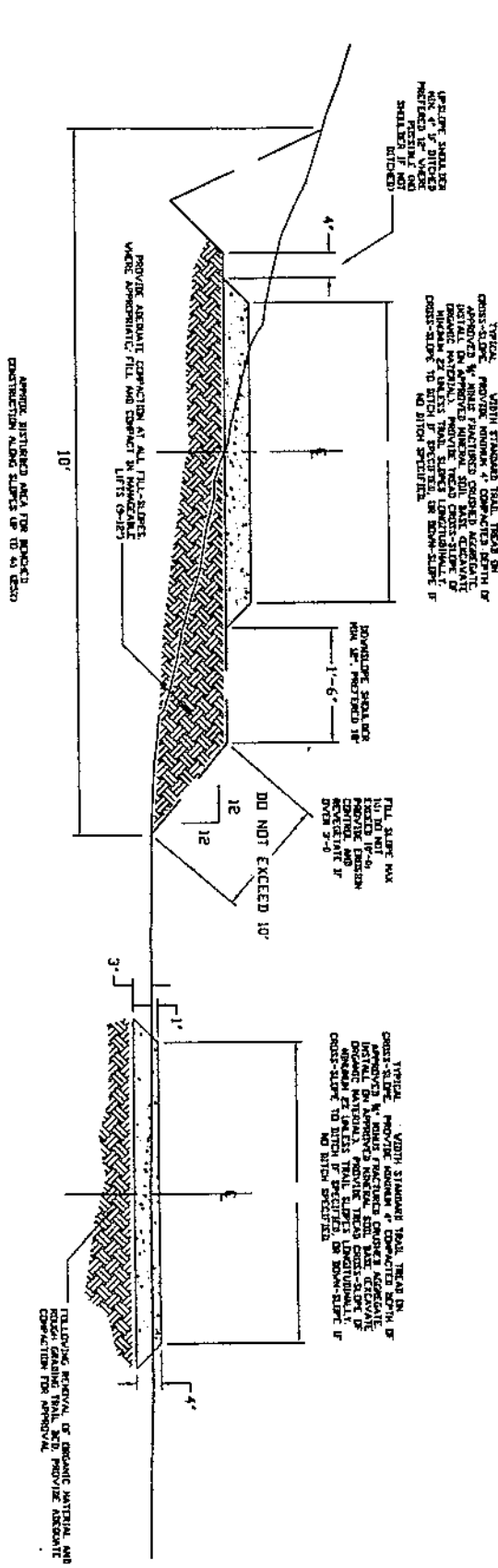

NOTES:

1. ALL TRAIL CONSTRUCTION SHALL INCLUDE STANDARD CLEARING LIMITS AS FOLLOWS: BRUSH AND BRANCHES ABOVE 36" ABOVE GROUND LEVEL SHALL BE REMOVED TO A HT. OF 8'-0" WITHIN 3'-0" ALL VEGETATION BELOW 36" HT SHALL BE CUT BACK TO THE WIDTH OF THE TRAIL. FALLEN LOGS SHALL BE CUT FLUSH AT THE EDGE OF THE TRAIL.
2. FOLLOWING CLEARING WITHIN THE DESIGNED TRAIL CORRIDOR, REMOVE ALL ROOTS AND ORGANIC DEBRIS TO A DEPTH OF 6" PRIOR TO IMPORTING TREAD AGGREGATE. ESTABLISH DESIGN CROSS-SLOPE IN SUBGRADE MATERIALS.
3. IMPORT TREAD AGGREGATE FOLLOWING DEPARTMENTAL APPROVAL OF PREPARED TRAIL BED. TRAIL AGGREGATE SHALL BE 3/4" MINUS CRUSHED ROCK UNLESS OTHERWISE SPECIFIED. PLACE MATERIAL UNIFORMLY, PROVIDING FULL DESIGN WIDTH ACROSS SURFACE. TAPER EDGES AT A 45° ANGLE INTO THE SUBGRADE, LEAVING APPROX. 1" OF TREAD ABOVE GRADE. WHERE POSSIBLE, PROVIDE COMPLETE MECHANICAL COMPACTION, WHERE THIS IS IMPRACTICAL OR IMPOSSIBLE, COMPACT BY HAND WITH AN APPROPRIATELY WEIGHTED IMPLEMENT.
4. FOLLOWING IMPORT AND PLACEMENT OF TREAD AGGREGATE AND CONSTRUCTION OF DRAINAGE ELEMENTS OR OTHER SPECIFIED TRAIL COMPONENTS, PERFORM SITE RESTORATION AND REVEGETATION AS DIRECTED BY THE DESIGNATED REPRESENTATIVE OF THE DEPARTMENT OF PARKS AND RECREATION.

02895.01A

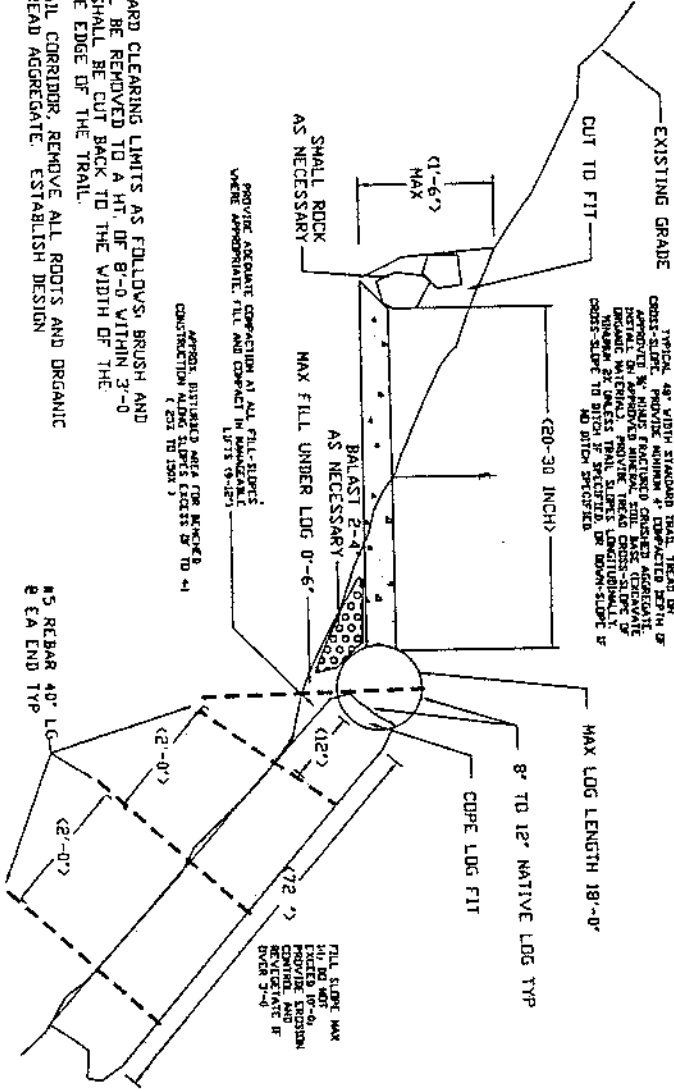
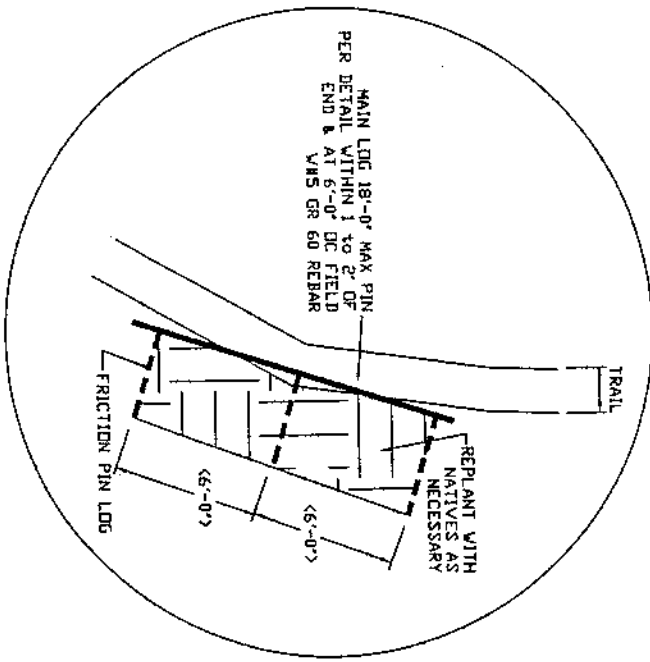

- NOTES:**
1. ALL TRAIL CONSTRUCTION SHALL INCLUDE STANDARD CLEARING LIMITS AS FOLLOWS: BRUSH AND BRANCHES ABOVE 36" ABOVE GROUND LEVEL SHALL BE REMOVED TO A HT. OF 8'-0" WITHIN 3'-0" OF THE TRAIL. ALL VEGETATION BELOW 36" HT. SHALL BE CUT BACK TO THE WIDTH OF THE TRAIL. FALLEN LOGS SHALL BE CUT FLUSH AT THE EDGE OF THE TRAIL.
 2. FOLLOWING CLEARING WITHIN THE DESIGNED TRAIL CORRIDOR, REMOVE ALL ROOTS AND ORGANIC DEBRIS TO A DEPTH OF 6" PRIOR TO IMPORTING TREAD AGGREGATE. ESTABLISH DESIGN CROSS-SLOPE IN SUBGRADE MATERIALS.
 3. IMPORT TREAD AGGREGATE FOLLOWING DEPARTMENTAL APPROVAL OF PREPARED TRAIL BED. TRAIL AGGREGATE SHALL BE ¾" MINUS CRUSHED ROCK UNLESS OTHERWISE SPECIFIED. PLACE MATERIAL UNIFORMLY, PROVIDING FULL DESIGN WIDTH ACROSS SURFACE. TAPER EDGES AT A 45° ANGLE INTO THE SUBGRADE. LEAVING APPROX. 1" OF TREAD ABOVE GRADE. WHERE POSSIBLE, PROVIDE COMPLETE MECHANICAL COMPACTATION. WHERE THIS IS IMPRACTICAL OR IMPOSSIBLE, COMPACT BY HAND WITH AN APPROPRIATELY WEIGHTED IMPLEMENT.
 4. FOLLOWING IMPORT AND PLACEMENT OF TREAD AGGREGATE AND CONSTRUCTION OF DRAINAGE ELEMENTS OR OTHER SPECIFIED TRAIL COMPONENTS, PERFORM SITE RESTORATION AND REVEGETATION AS DIRECTED BY THE DESIGNATED REPRESENTATIVE OF THE DEPARTMENT OF PARKS AND RECREATION.

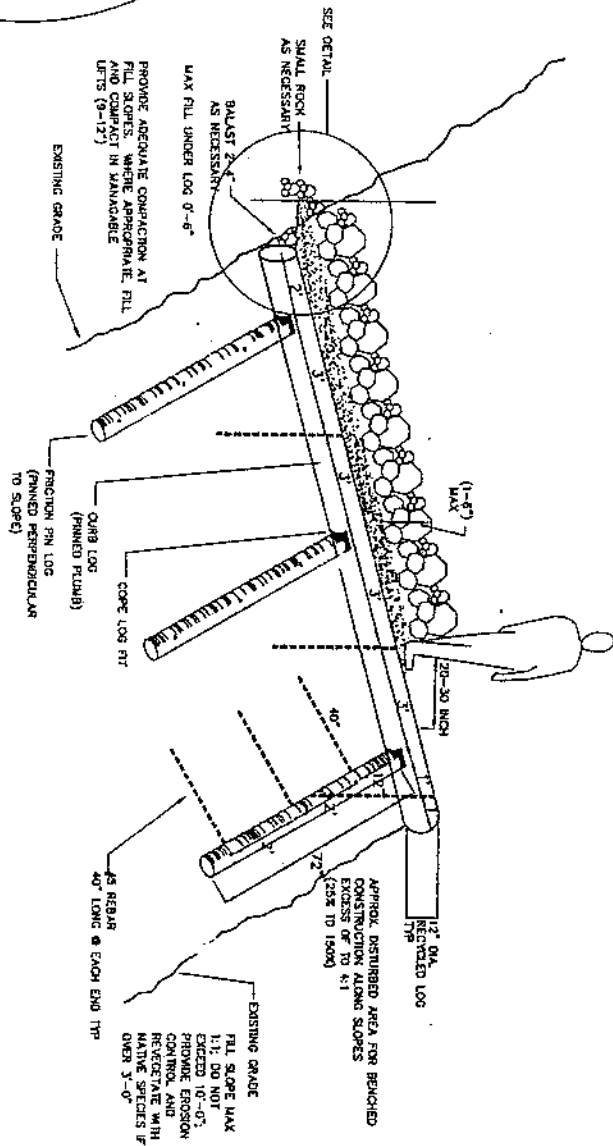
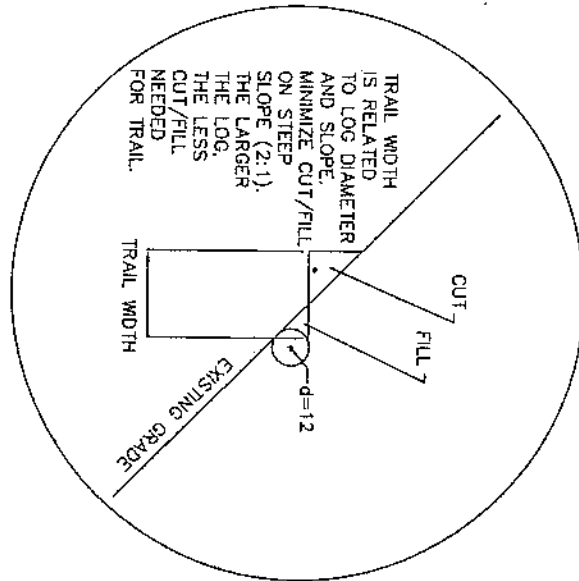

NOTES:
 THIS DETAIL TO BE USED ONLY WITH AUTHORIZATION OF TRAIL ENGINEER.
 TYPICAL 48" WHEEL STANDARD TRAIL (NARROW AS FIELD CONDITIONS NECESSITATE) HEAD ON CROSS-SLOPE. PROVIDE MINIMUM 4" COMPACTED ASPHALT OR APPROVED EQUIVALENT MINERAL SIK BAZE (EXCAVATE ORGANIC MATERIAL). PROVIDE TREAD CROSS-SLOPE OF MINIMUM 2% UNLESS TRAIL SLOPES LONGITUDINALLY. CROSS-SLOPE TO OUTER IF SLOPED, OR DOWN-SLOPE IF NO OTHER SPECIFIED.
 TRAIL CROSS SLOPE TO EQUAL 2% IN ALL INSTANCES. TREAD RIGIDITY SHOULD NOT EXCEED 1.6.

02895.03	Std. Detail #	City of Seattle Department of Parks and Recreation Facilities Maintenance and Development Division Engineering & Design Unit 800 Maynard Ave. S., Seattle 98134	Approved, Park Engineer: _____	Last Revision: _____
		FRICION-PIN LOG DETAIL		Std. Detail #
			NO SCALE	02895.03

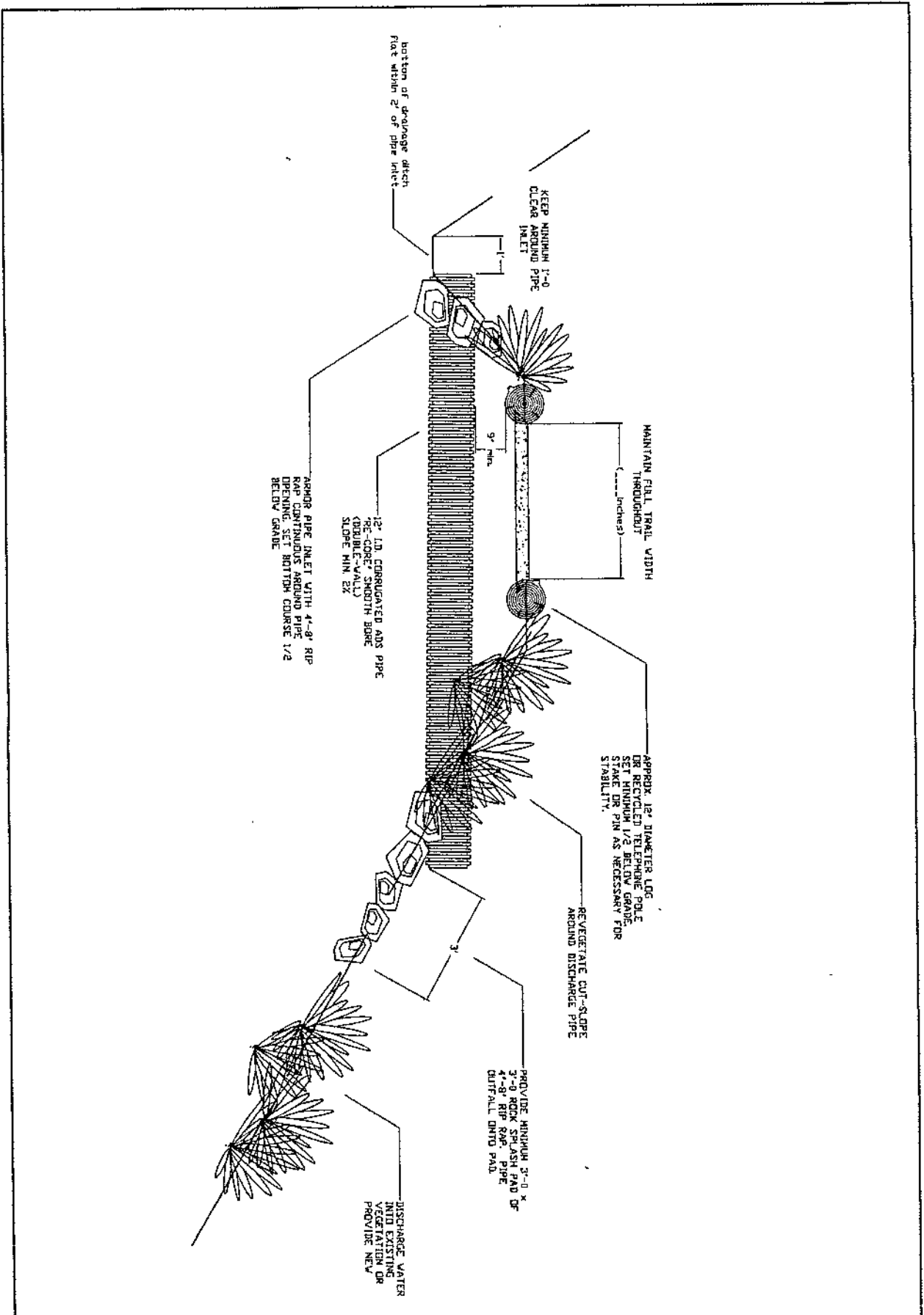

02895.02

City of Seattle
 Department of Parks and Recreation
 Facilities Maintenance and Development Division
 Engineering & Design Unit
 800 Maynard Ave. S., Seattle 98134

Approved, Park Engineer: _____ Last Revision: _____

TURNPIKE & CULVERT W/ SPLASH PAD
 NOSCALE

Std. Detail #
 02895.02

- NOTES:
1. MAINTAIN THOROUGH COMPACTION TO EDGE OF ADJACENT FIXED SURFACE.
 2. PROVIDE A MINIMUM 12" FLUSH TO ADJACENT FIXED SURFACE PRIOR TO TRANSITIONING SLOPE.

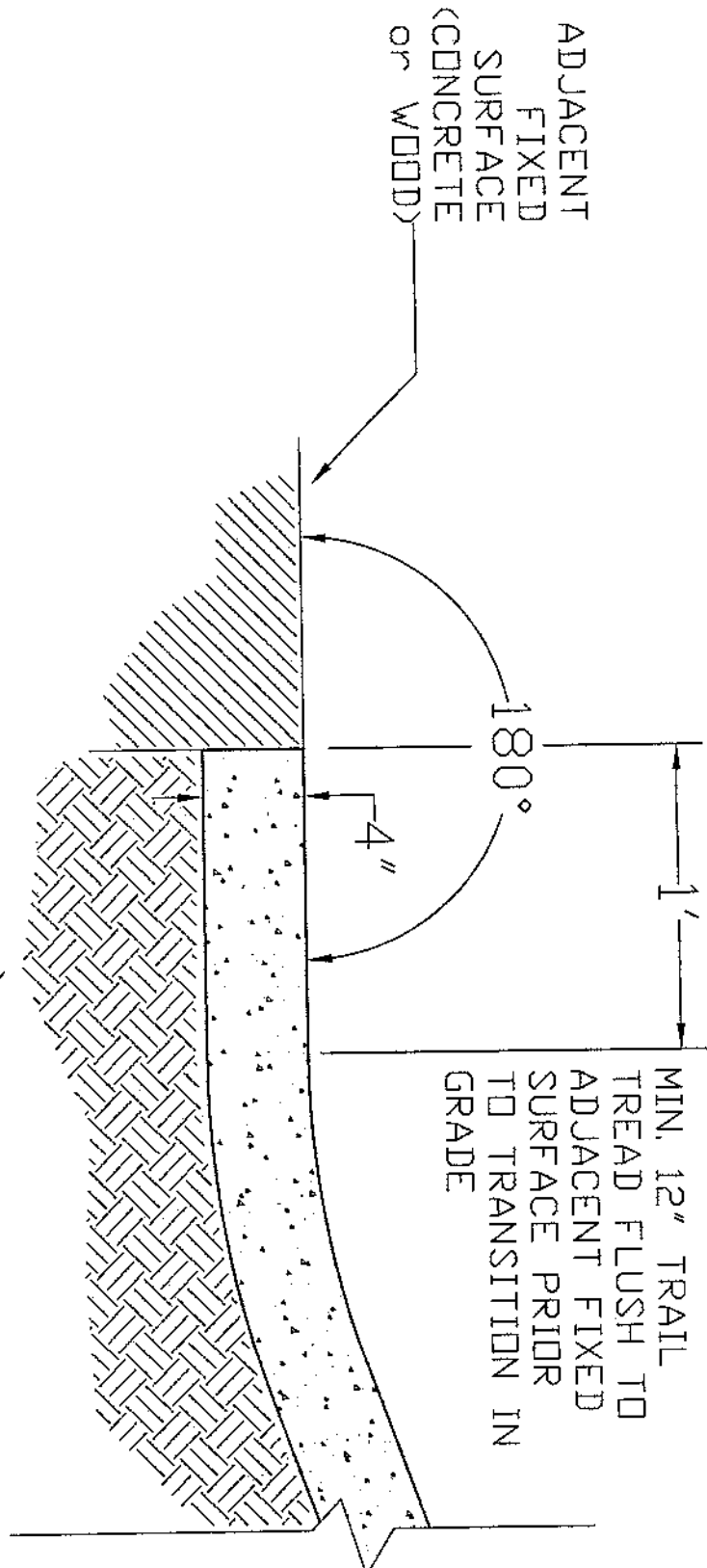

02895.04	City of Seattle Department of Parks and Recreation Facilities Maintenance and Development Division Engineering & Design Unit 800 Maynard Ave. S., Seattle 98134	Approved, Park Engineer: _____	Last Revision: _____
		TRANSITION TO ADJACENT FIXED SURFACE	
		NO SCALE	02895.04

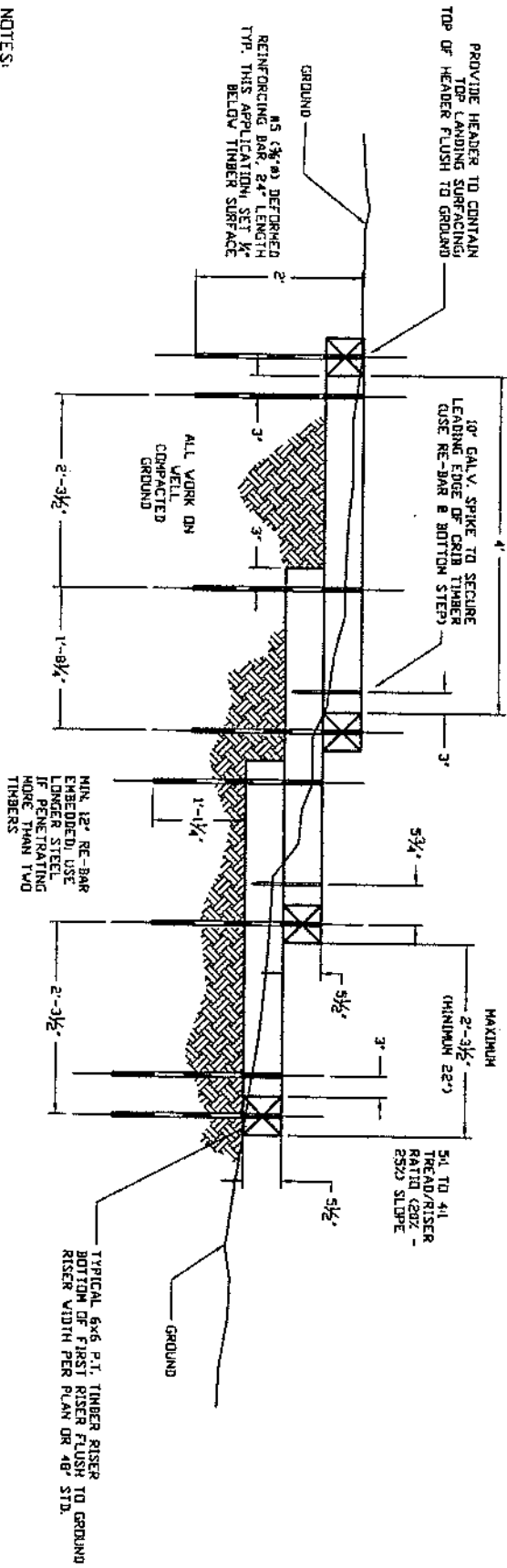

- NOTES:
1. USE THIS DETAIL WHERE AVERAGE GROUND SLOPE IS 20-25%, BUT DOES NOT EXCEED 30% FOR MORE THAN 10 LF.
 2. ALL TIMBER SHALL BE PRESSURE TREATED LP-22 OR APPROVED EQUAL. TREAT ALL CUT ENDS AND DRILLED HOLES ON SITE. USE ONLY 4x6 OR 6x6 FOR THIS DETAIL.
 3. PREPARE ALL SUBGRADE SURFACES PRIOR TO DRILLING TIMBERS FOR STEEL PINS. ADJUST DRILL-POINTS TO ALLOW FOR SUBGRADE OBSTRUCTIONS SUCH AS ROCKS. COMPACT ALL SUBGRADE SURFACES TO RECEIVE TIMBERS.
 4. ALL HORIZONTAL DIMENSIONS GIVEN ABOVE ASSUME 5:1 (20%) GRADE. ADJUST AS NECESSARY TO ACCOMMODATE GRADES UP TO 4:1 (25%).
 5. BACKFILL ALL TIMBER GRUBS WITH 5 #4 COMPACTED DEPTH 3/4" MINUS CRUSHED AGGREGATE, COMPACT FINISHED GRADE FLUSH TO TOP OF TIMBER CRIB.
 6. REFER TO APPROPRIATE DETAILS FOR SLOPES LESS THAN 5:1 (20%), SEE WATER BARS OR GREATER THAN 4:1 (25%), SEE STEPS #1 - 24).

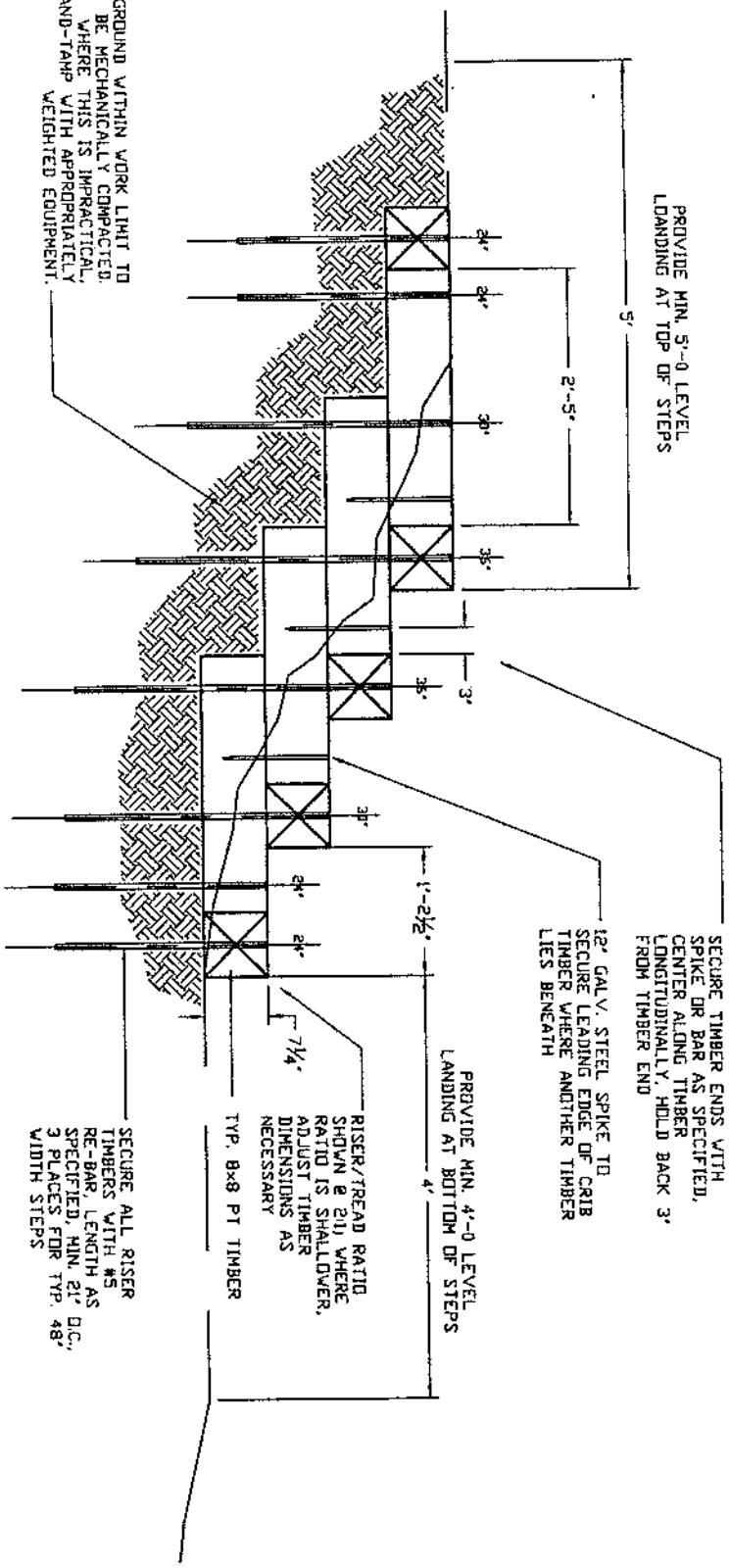

ALL GROUND WITHIN WORK LIMIT TO BE MECHANICALLY COMPACTED, WHERE THIS IS IMPRACTICAL, HAND-TAMP WITH APPROPRIATELY WEIGHTED EQUIPMENT.

NOTES:

1. USE THIS DETAIL WHERE AVERAGE GROUND SLOPE IS 25-50%, BUT DOES NOT EXCEED 65% FOR MORE THAN 10 LF.
2. ALL TIMBER SHALL BE PRESSURE TREATED LP-22 OR APPROVED EQUAL. TREAT ALL CUT ENDS AND DRILLED HOLES ON SITE. USE ONLY 6x8 FOR THIS DETAIL.
3. PREPARE ALL SUBGRADE SURFACES PRIOR TO DRILLING TIMBERS FOR STEEL PINS. ADJUST DRILL-POINTS TO ALLOW FOR SUBGRADE OBSTRUCTIONS SUCH AS ROCKS. COMPACT ALL SUBGRADE SURFACES TO RECEIVE TIMBERS.
4. ALL HORIZONTAL DIMENSIONS GIVEN ABOVE ASSUME 2:1 (50%) GRADE. ADJUST AS NECESSARY TO ACCOMMODATE SHALLOWER GRADES TO 4:1 (25%).
5. BACKFILL ALL TIMBER CRIBS W/MIN. 6" COMPACTED DEPTH ¾" MINUS CRUSHED AGGREGATE, COMPACT FINISHED GRADE FLUSH TO TOP OF TIMBER CRIB.
6. REFER TO APPROPRIATE DETAILS FOR SLOPES LESS THAN 4:1 (10-20%, SEE WATER BARS, 20-25% SEE 6x6 STEPS) OR GREATER THAN 2:1 (50%, SEE OPEN TREAD LADDER STEPS).

02895.06 Std. Detail #	City of Seattle Department of Parks and Recreation Facilities Maintenance and Development Division Engineering & Design Unit 600 Maynard Ave. S., Seattle 98134	Approved, Park Engineer: _____ Last Revision: _____	Std. Detail # 02895.06
	TIMBER STEPS 4:1 - 2:1 PRESSURE TREATED 6X6 CONSTRUCTION		

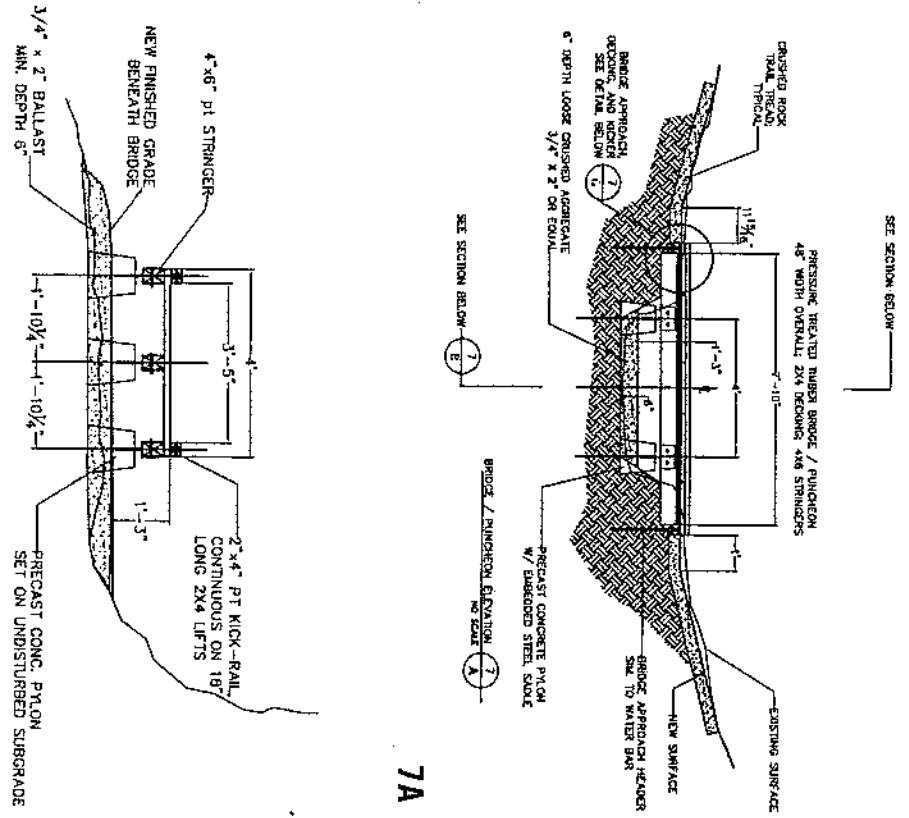

7A

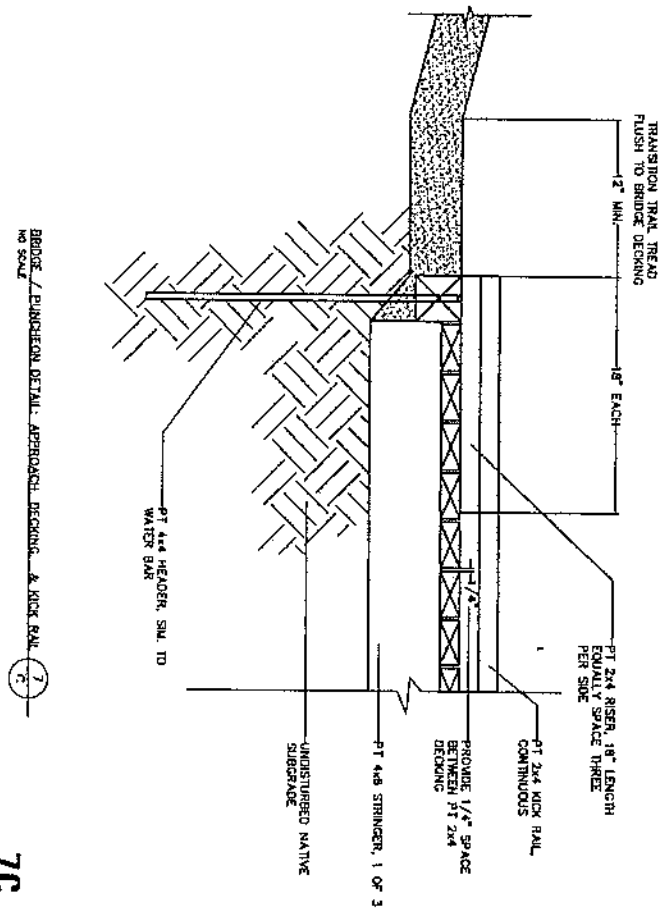

7C

7B

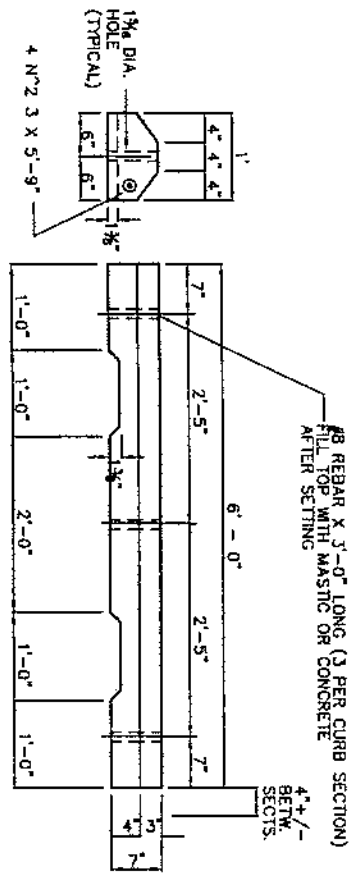
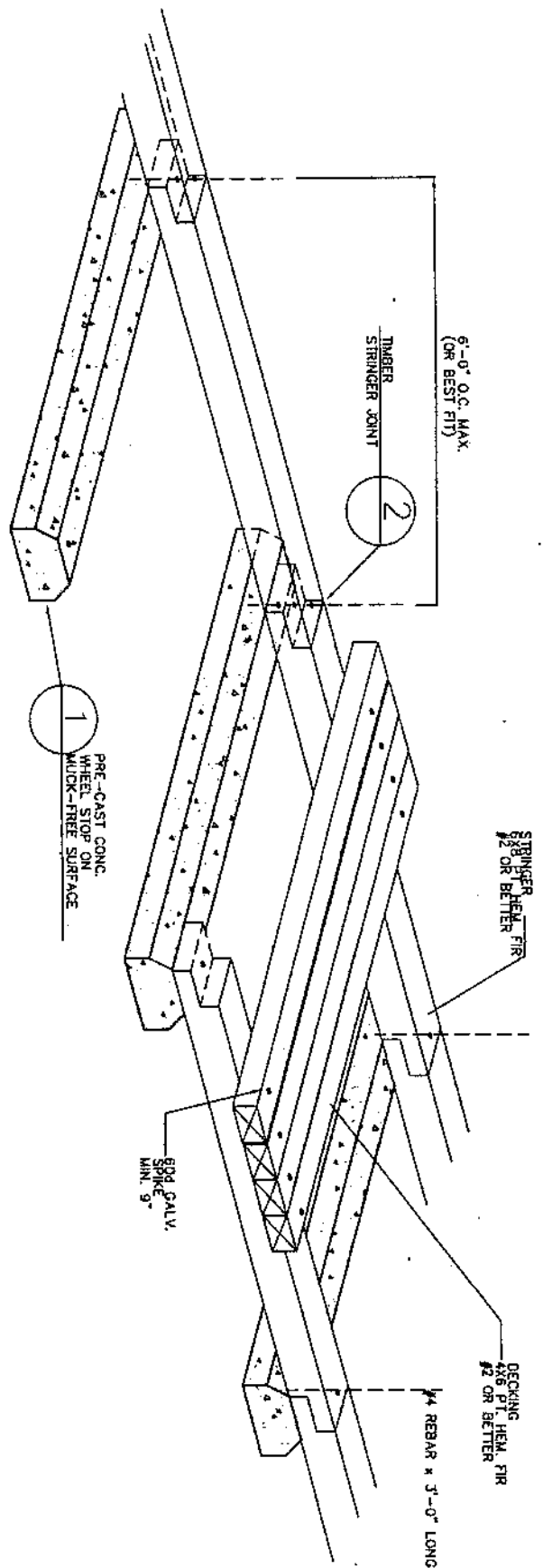

NOTES:
AVAILABLE FROM RENTON CONCRETE PRODUCTS
OR UTILITY VAIL CO.

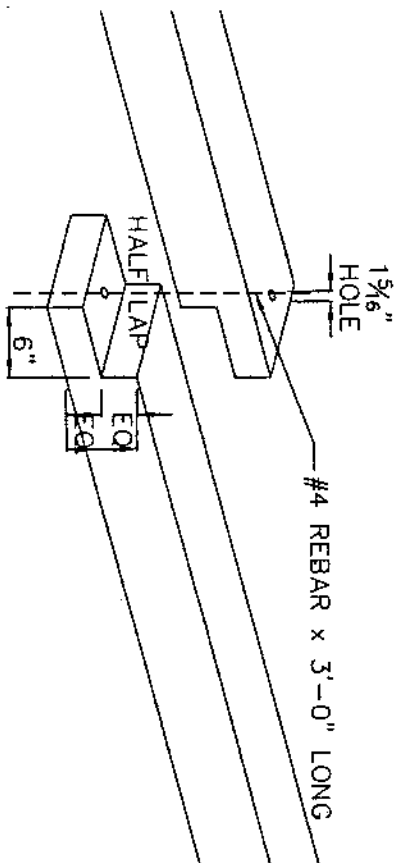

1 PRECAST CONC. CURB DETAIL

2 TIMBER STRINGER JOINT DETAIL

02895.08

City of Seattle
Department of Parks and Recreation
Facilities Maintenance and Development Division
Engineering & Design Unit
800 Maynard Ave. S., Seattle 98134

Approved, Park Engineer: _____

Last Revision: _____

PUNCHEON/MUD-SILL DETAIL

Std. Detail #

02895.08

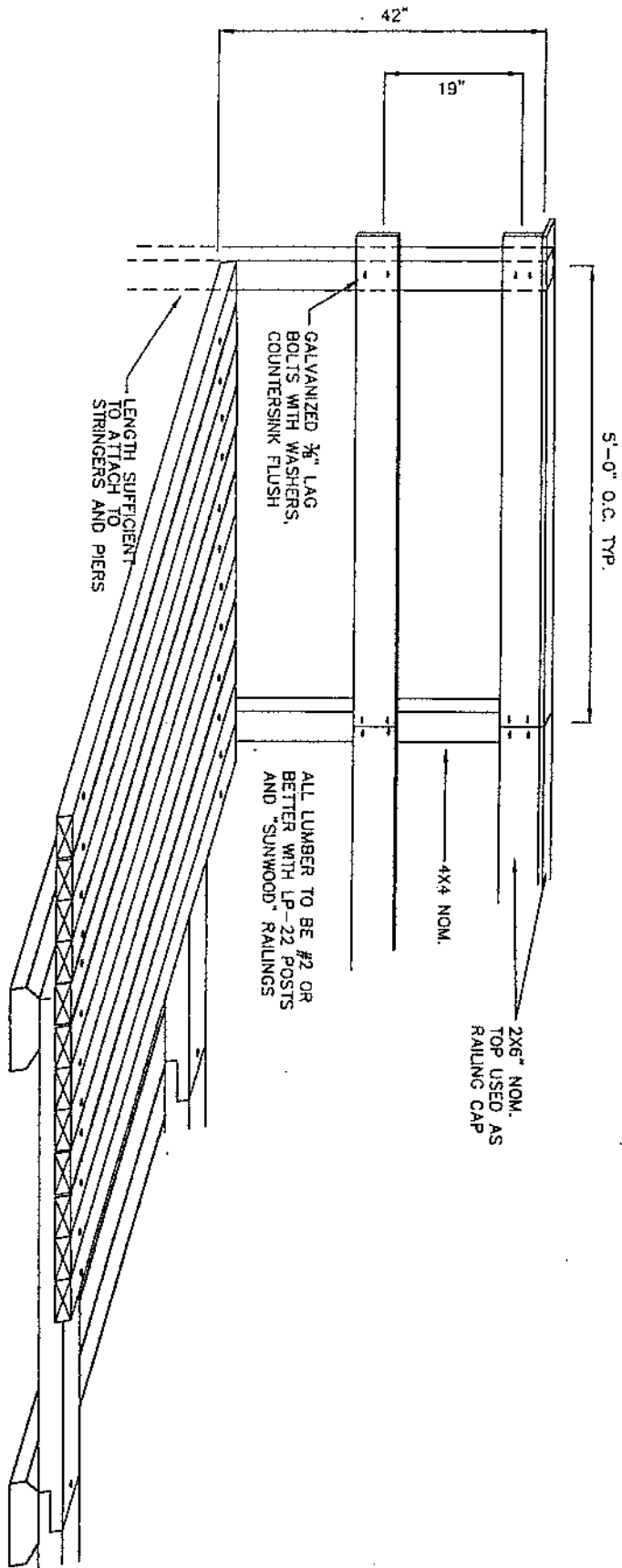

02895.09

Std. Detail #

City of Seattle
 Department of Parks and Recreation
 Facilities Maintenance and Development Division
 Engineering & Design Unit
 800 Maynard Ave. S., Seattle 98134

Approved, Park Engineer:

Last Revision:

RAILING DETAIL

Std. Detail #

NO SCALE

02895.09

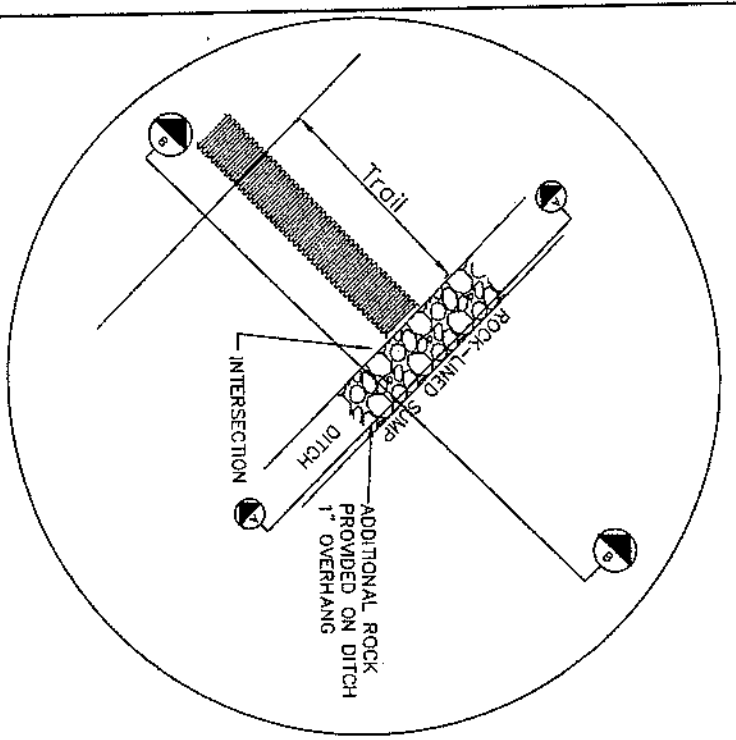

NOTES:

A ROCK-LINED SUMP IS A FEATURE USED IN ASSOCIATION WITH A CULVERT TO TRAP SILT AND OTHER SOLIDS BEFORE THEY ENTER THE CULVERT. WHEN DIRECTED BY DRAINAGE DITCH, INSTALL A CULVERT APPROXIMATELY 1' DEEP BELOW BOTTOM OF DITCH INVERT ON THE TRAIL OR TRAIL STRUCTURE. A ROCK-LINED SUMP AS FOLLOWS:

1. IDENTIFY THE INTERSECTION POINT OF THE FLOW-LINE OF THE CULVERT AND THE FLOW-LINE OF THE ASSOCIATED DITCH TO BE DRAINAGE. AT THE POINT OF INTERSECTION, EXCAVATE SUFFICIENT UNDISTURBED NATIVE MATERIAL SOIL TO ALLOW THE EXCAVATION TO BE TIGHTLY LINED WITH ROCK. ROCK SHOULD FIT TIGHTLY WITH NO GAPS OVER 2" IN ANY DIMENSION. PROVIDE ADDITIONAL ROCK ACROSS THE BOTTOM OF THE DRAINAGE DITCH WHICH OVER-HANGS THE SUMP 1' TO PROTECT THE SUMP WALLS FROM OUTFLOW.
2. BEGINNING WITH THE BOTTOM OF THE SUMP AND WORKING UP TO THE BOTTOM OF THE ASSOCIATED DRAINAGE DITCH, LINE THE SUMP WITH ROCK. ROCK SHOULD FIT TIGHTLY WITH NO GAPS OVER 2" IN ANY DIMENSION. PROVIDE ADDITIONAL ROCK ACROSS THE BOTTOM OF THE DRAINAGE DITCH WHICH OVER-HANGS THE SUMP 1' TO PROTECT THE SUMP WALLS FROM OUTFLOW.
3. BACK JOINTS IN THE BOTTOM OF THE SUMP WITH 5/8" MINUS CRUSHED ROCK.

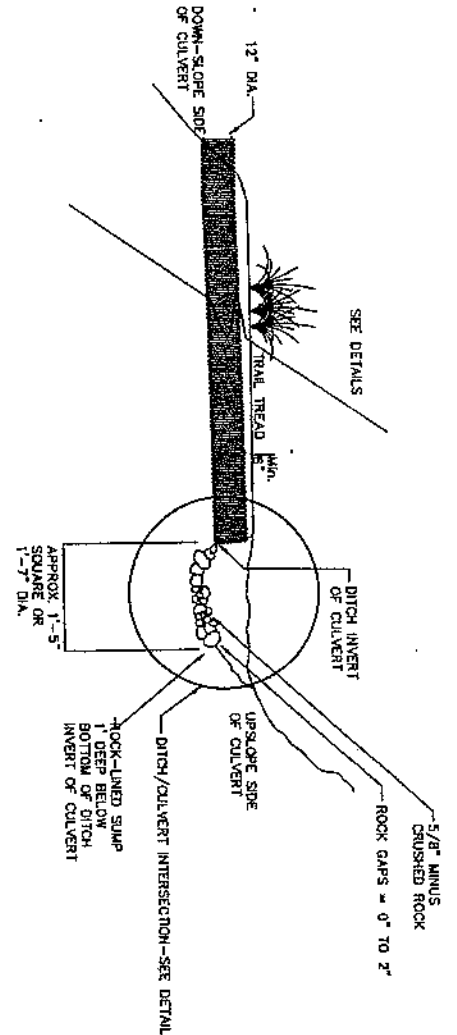

SECTION B-B

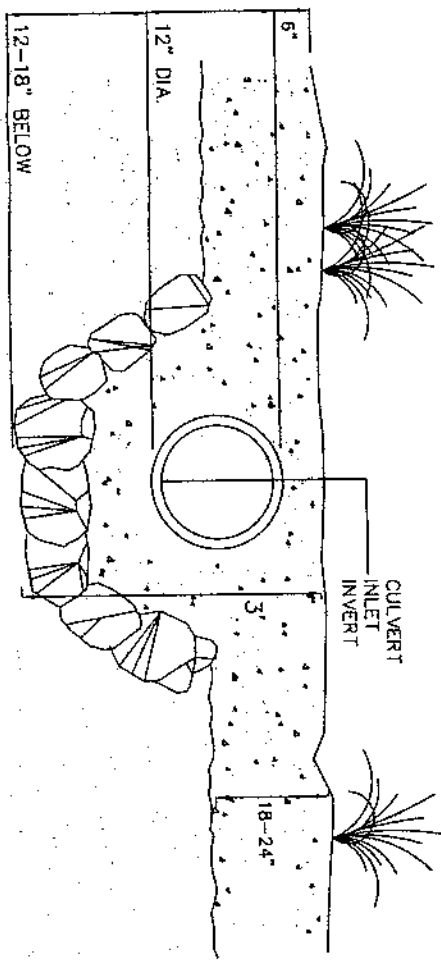

SECTION A-A

02895.10

City of Seattle
 Department of Parks and Recreation
 Facilities Maintenance and Development Division
 Engineering & Design Unit
 800 Moynard Ave. S., Seattle 98134

Approved, Park Engineer: _____

Last Revision: _____

ROCK-LINED SUMP DETAIL

NO SCALE

Std. Detail #

02895.10

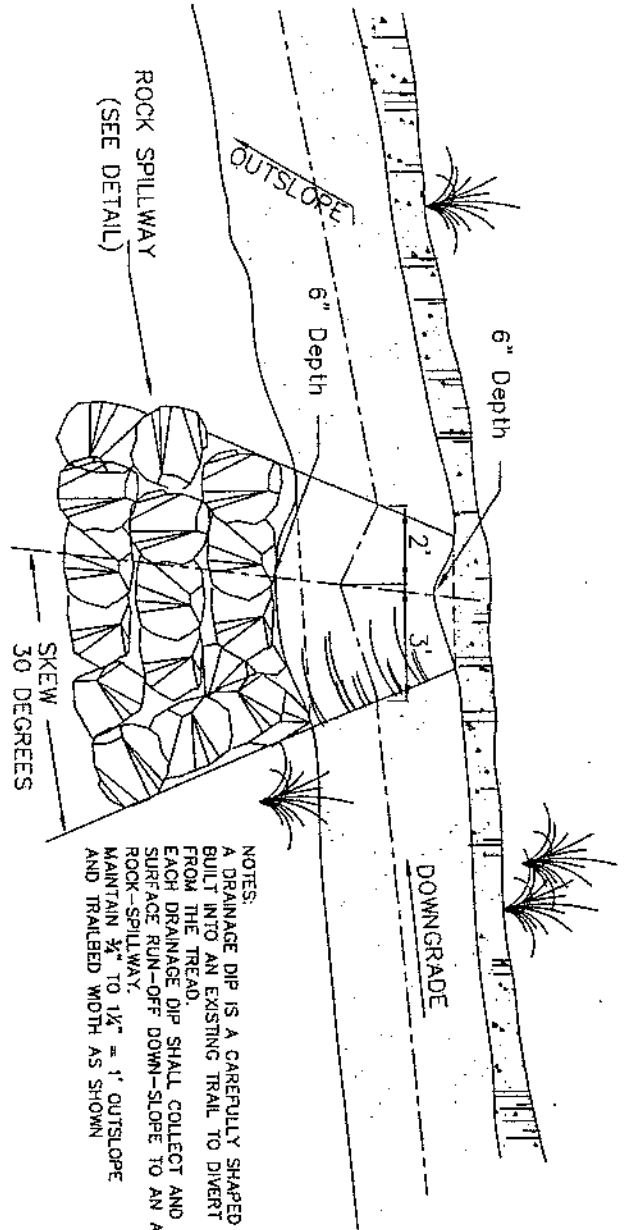
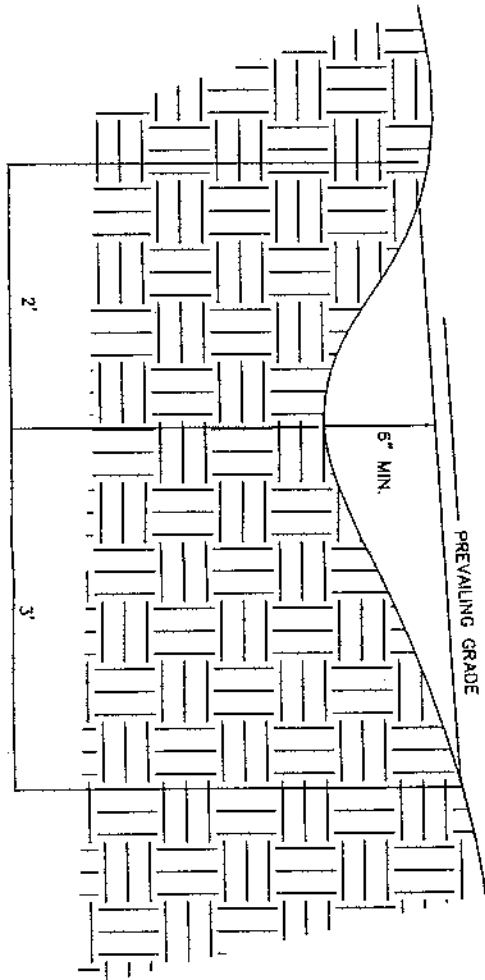

NOTES:
 A DRAINAGE DIP IS A CAREFULLY SHAPED DEPRESSION BUILT INTO AN EXISTING TRAIL TO DIVERT WATER FROM THE TREAD.
 EACH DRAINAGE DIP SHALL COLLECT AND DIVERT SURFACE RUN-OFF DOWN-SLOPE TO AN ASSOCIATED ROCK-SPILLWAY.
 MAINTAIN $\frac{3}{4}$ " TO $1\frac{1}{2}$ " = 1' OUTSLOPE AND TRAILBED WIDTH AS SHOWN

02895.11

Std. Detail #

City of Seattle
 Department of Parks and Recreation
 Facilities Maintenance and Development Division
 Engineering & Design Unit
 800 Maynard Ave. S., Seattle 98134

Approved, Park Engineer: _____

Last Revision: _____

DRAINAGE DIP DETAIL

NO SCALE

Std. Detail #

02895.11

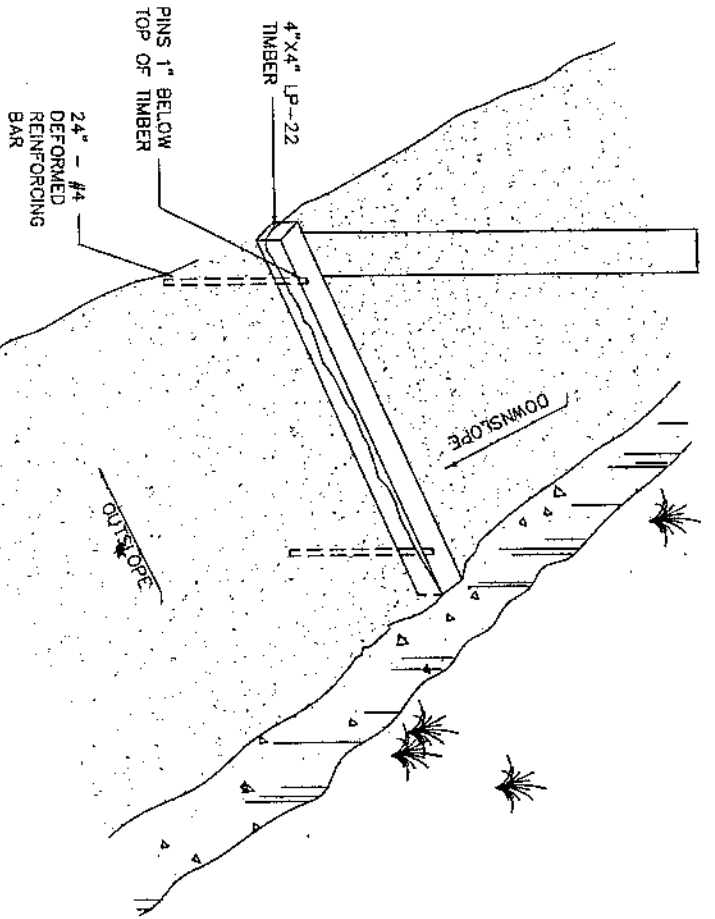
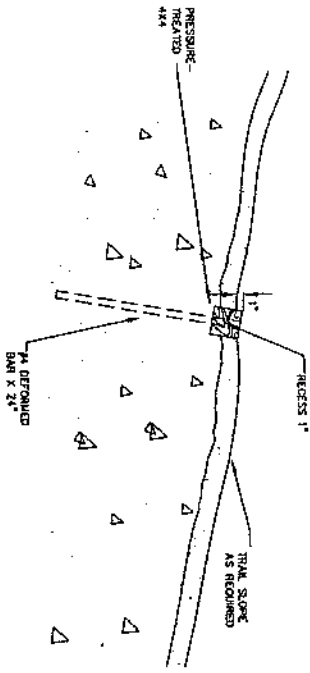
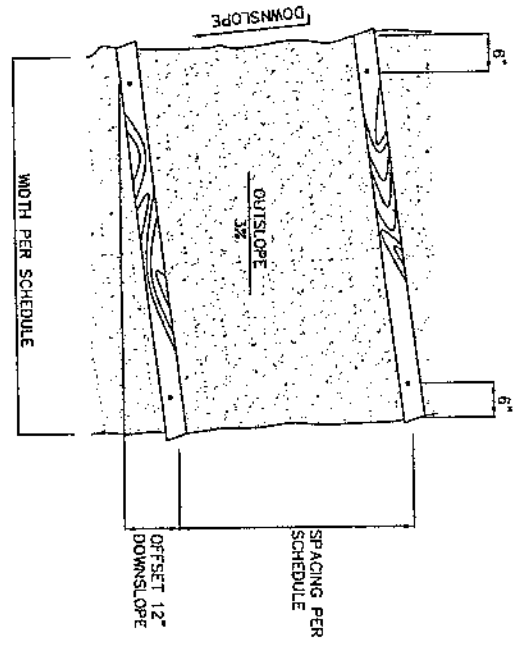

- NOTES:
1. CONSTRUCT WATER BARS OF 4"X4" LP-22 TIMBERS PINNED TO THE SUBGRADE WITH 24" - #4 DEFORMED REINFORCING BAR, 2 BARS PER TIMBER. INSTALL TRAIL SURFACING AS FOR STANDARD TRAIL SECTION.
 2. LOCATE TIMBERS FLUSH TO THE PREPARED SUBGRADE, SPACED PER THE TRAIL STATIONING PLAN, WHERE FORMAL DRAINAGE DITCHING IS SCHEDULED, SET TIMBERS TO DIVERT SURFACE RUN-OFF INTO THESE DITCHES. WHERE NO FORMAL DRAINAGE WORK IS ASSOCIATED WITH THE WATER BARS, SET THE TIMBERS TO DIVERT SURFACE RUN-OFF GENERALLY DOWN-SLOPE.
 3. PREDRILL TIMBERS PERPENDICULAR TO THE PREVAILING SLOPE 3/8" TO ACCEPT 24" - #4 REINFORCING BAR PINS, AT 6" FROM EACH END, SET REINFORCING BAR PINS INTO STABLE SOIL TO A DEPTH OF 1" BELOW TOP OF TIMBER.

02895.12

Std. Detail #

City of Seattle
 Department of Parks and Recreation
 Facilities Maintenance and Development Division
 Engineering & Design Unit
 800 Maynard Ave. S., Seattle 98134

Approved, Park Engineer:

Last Revision:

WATERBAR DETAIL

Std. Detail #

NO SCALE

02895.12

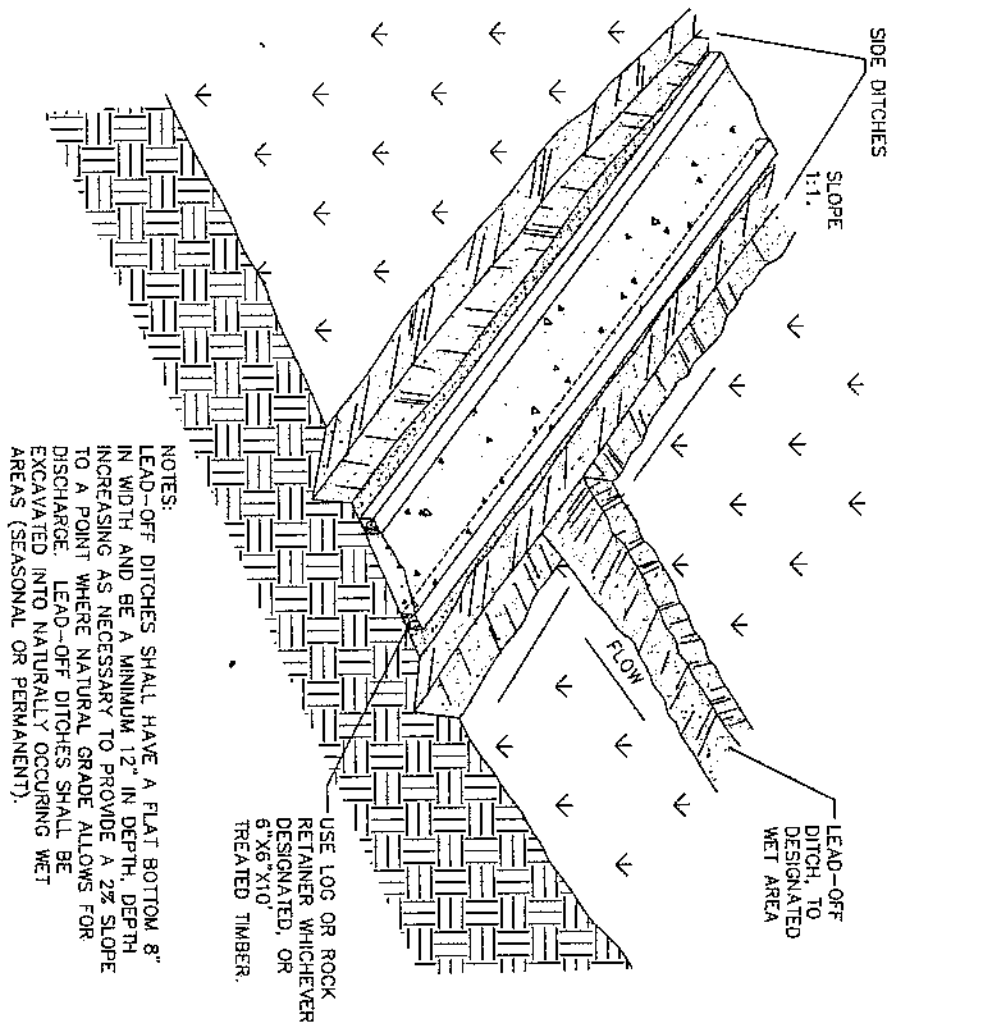

NOTES:
 LEAD-OFF DITCHES SHALL HAVE A FLAT BOTTOM 8" IN WIDTH AND BE A MINIMUM 12" IN DEPTH. DEPTH INCREASING AS NECESSARY TO PROVIDE A 2% SLOPE TO A POINT WHERE NATURAL GRADE ALLOWS FOR DISCHARGE. LEAD-OFF DITCHES SHALL BE EXCAVATED INTO NATURALLY OCCURRING WET AREAS (SEASONAL OR PERMANENT).

USE LOG OR ROCK RETAINER WHICHEVER DESIGNATED, OR 6"x6"x10' TREATED TIMBER.

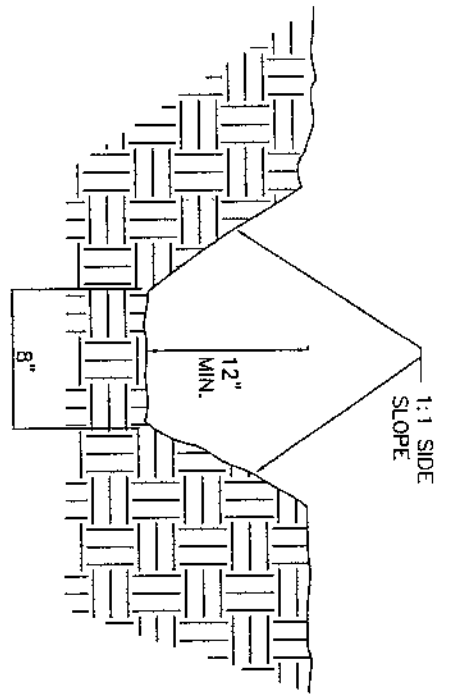

LEAD-OFF DITCH

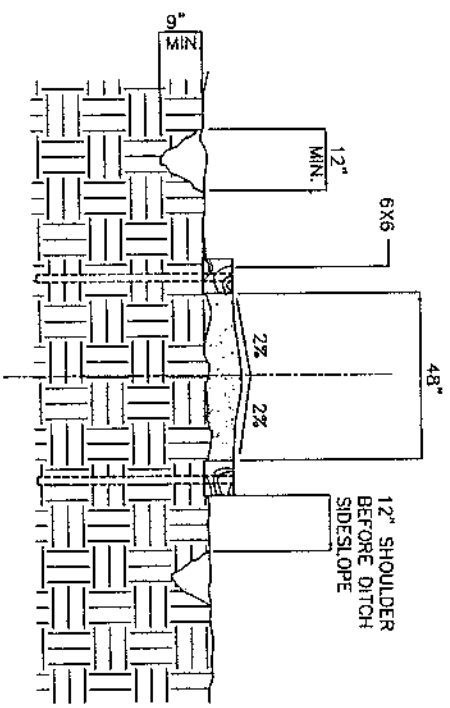

SIDE DITCHES

02895.13	Std. Detail #	City of Seattle Department of Parks and Recreation Facilities Maintenance and Development Division Engineering & Design Unit 800 Maynard Ave. S., Seattle 98134	Approved, Park Engineer: _____	Last Revision: _____
		SIDE AND LEAD OFF DITCHES W/TURMPIKE NO SCALE	Std. Detail # 02895.13	

NOTES

27

NOTES

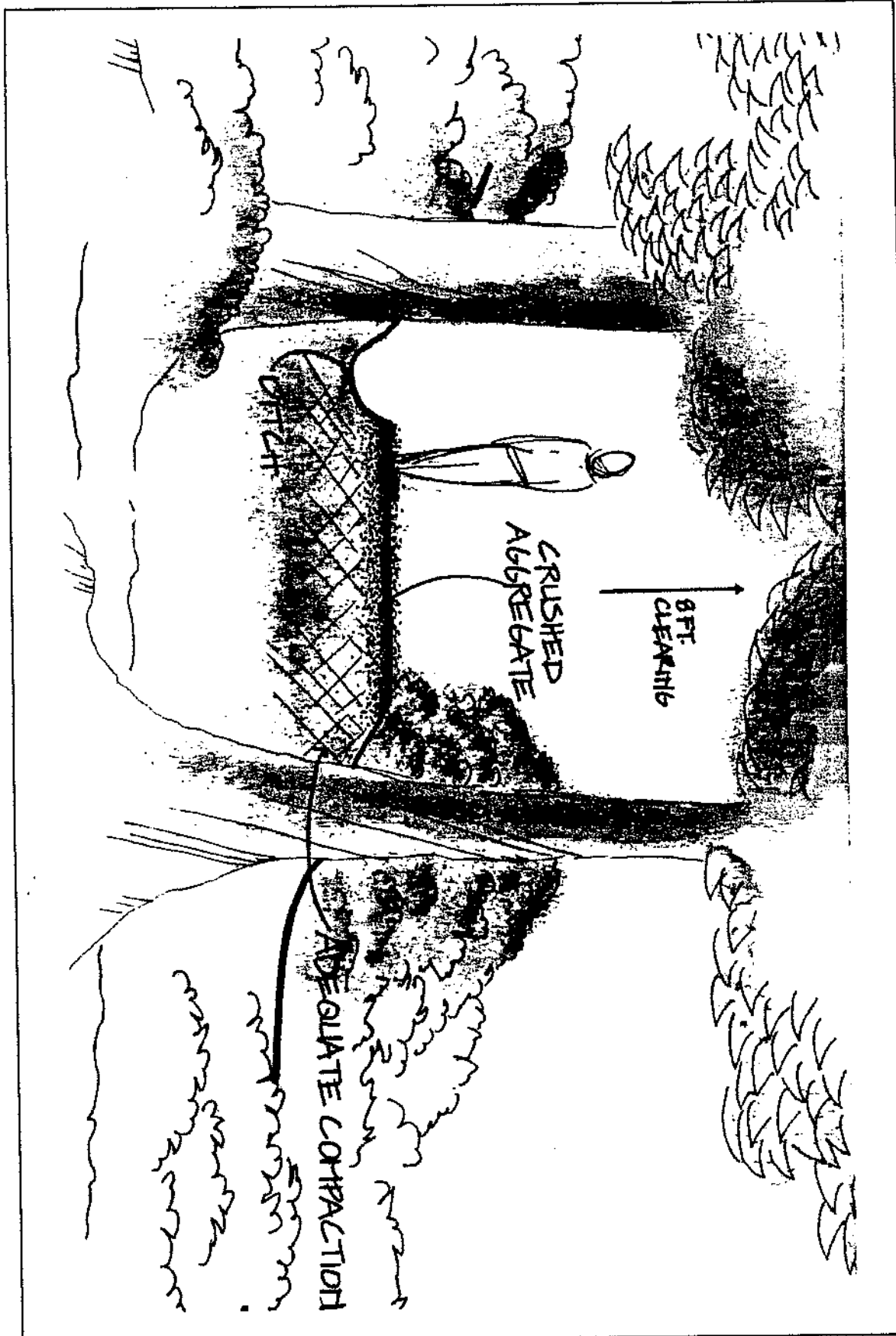

Std. Detail # City of Seattle Department of Parks and Recreation Facilities Maintenance and Development Division Engineering & Design Unit 800 Maynard Ave. S., Seattle 98134	Approved, Park Engineer: _____	Last Revision: _____
	STANDARD TRAIL SKETCH	

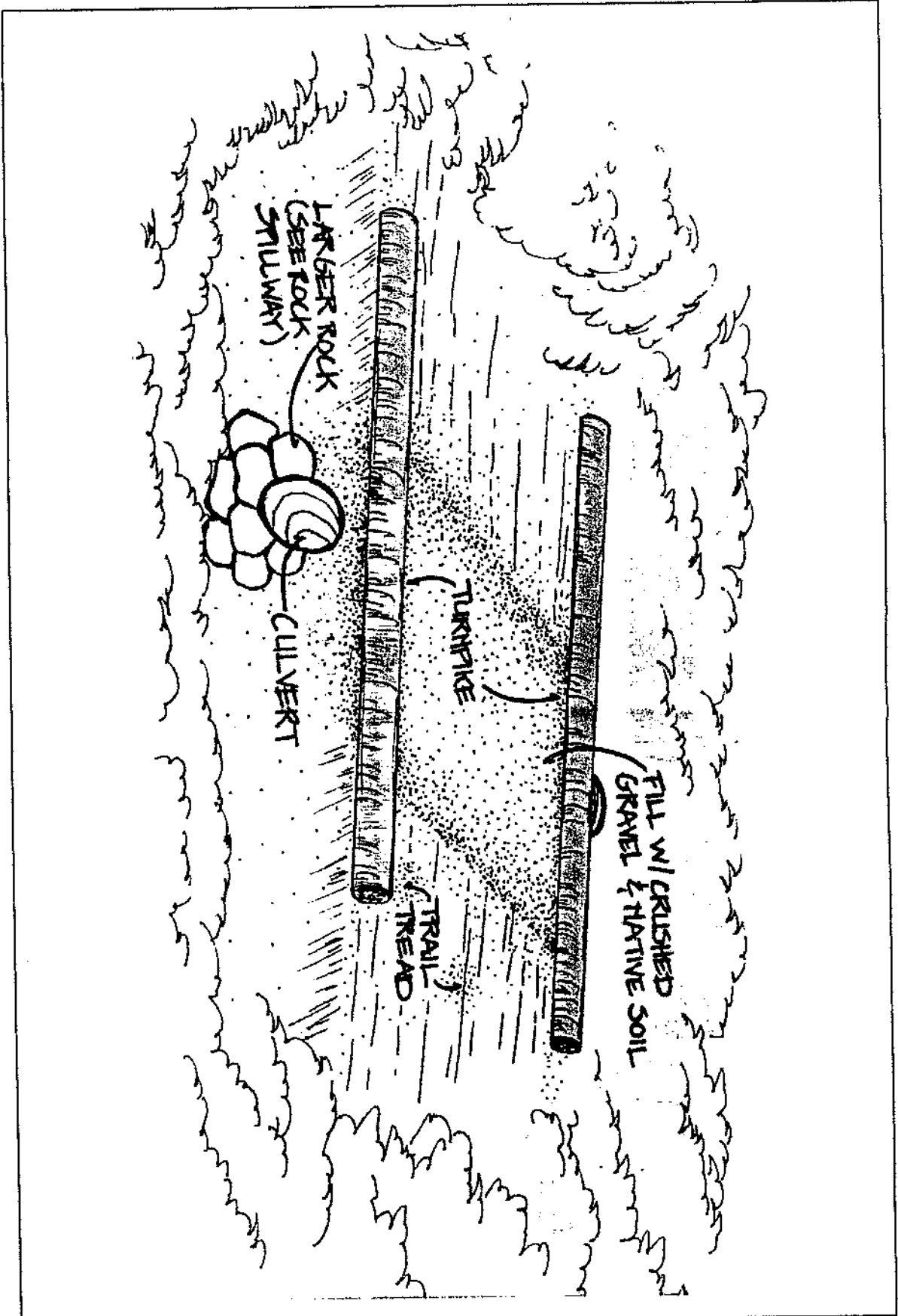

City of Seattle
 Department of Parks and Recreation
 Facilities Maintenance and Development Division
 Engineering & Design Unit
 800 Maynard Ave. S., Seattle 98134

Approved, Park Engineer: _____

Last Revision: _____

TURNPIKE & CULVERT SKETCH

Std. Detail # _____

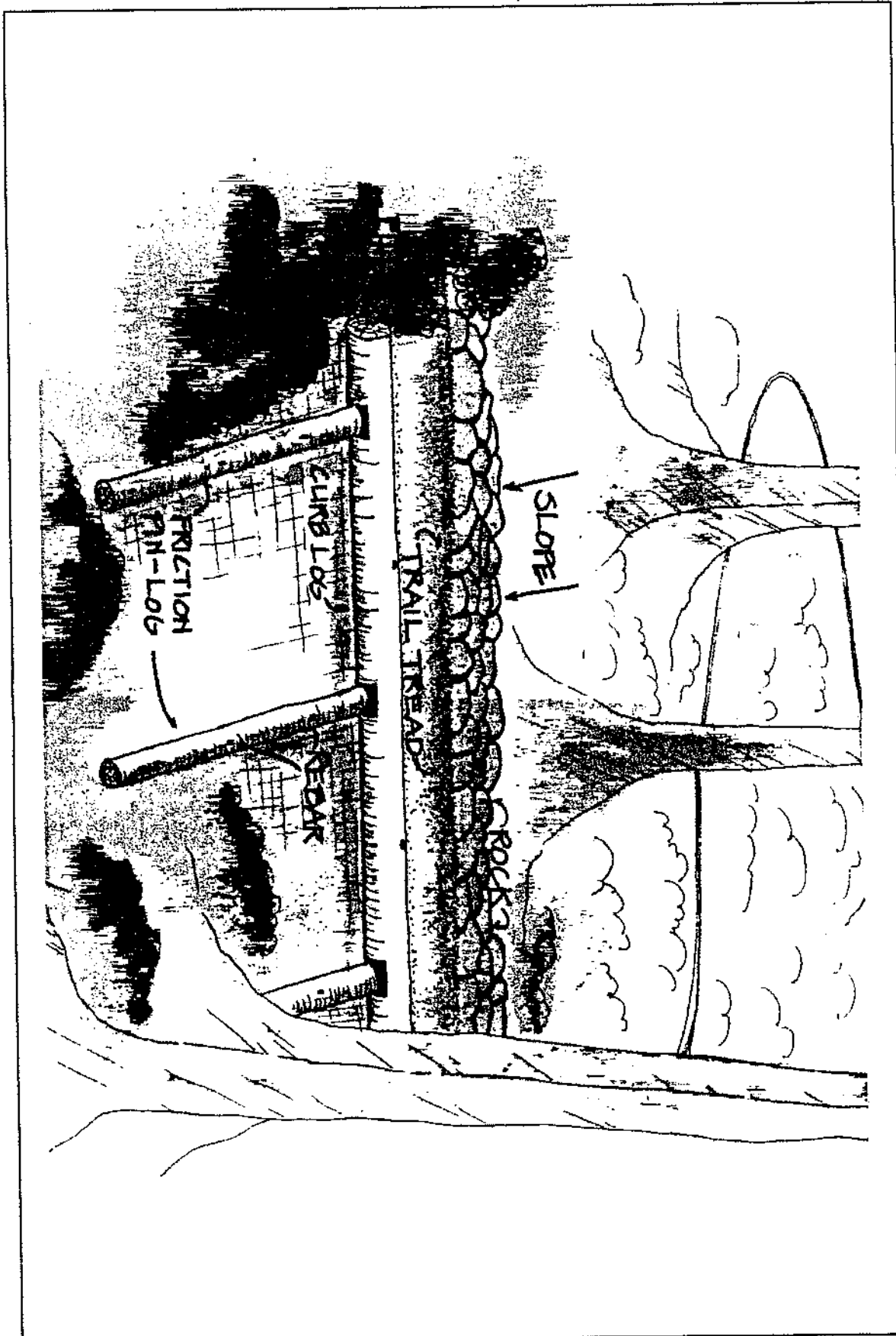

Std. Detail # City of Seattle Department of Parks and Recreation Facilities Maintenance and Development Division Engineering & Design Unit 800 Maynard Ave. S., Seattle 98134	Approved, Park Engineer: _____ Last Revision: _____
	FRICITION PIN LOG SKETCH

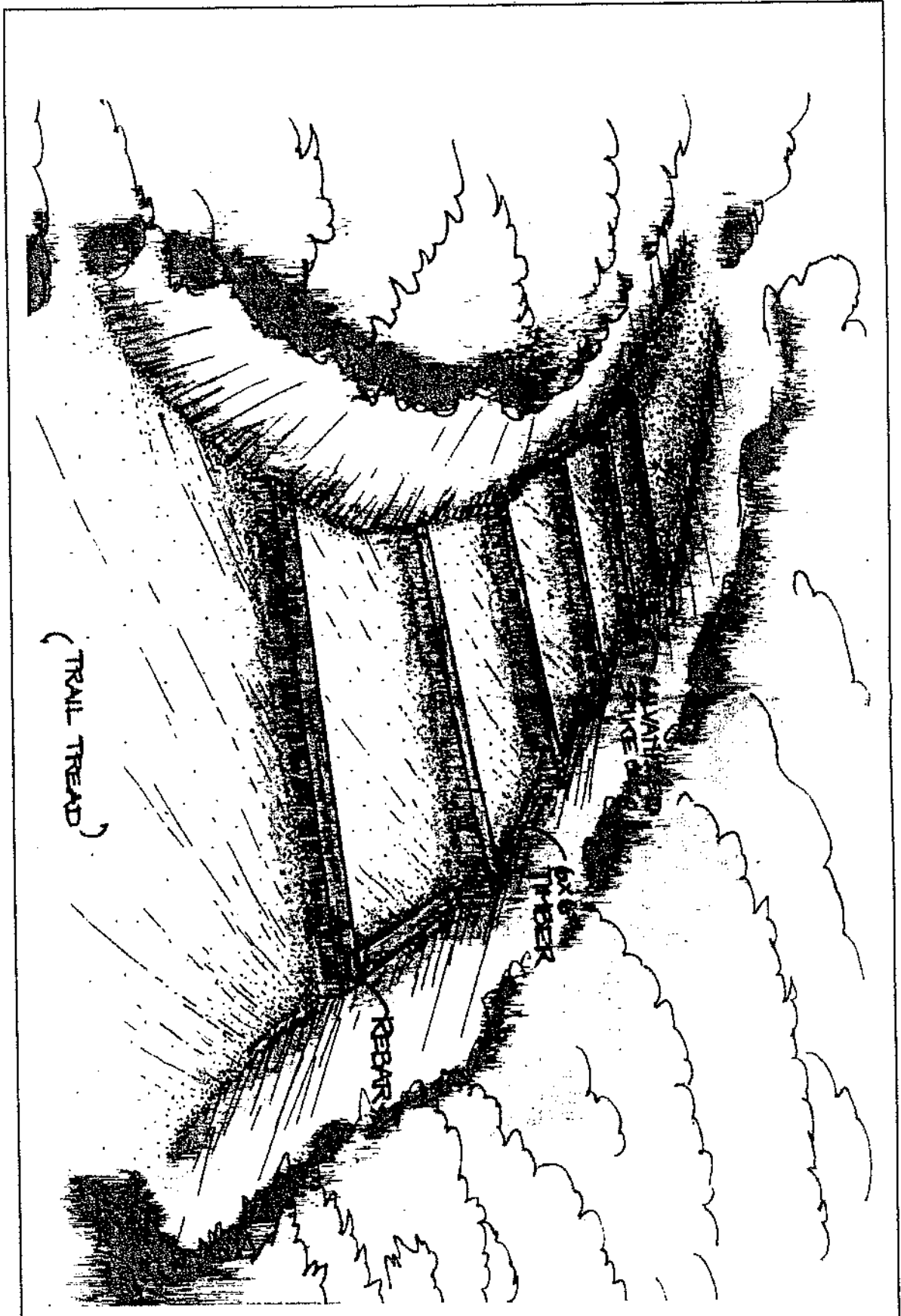

Std. Detail #	City of Seattle Department of Parks and Recreation Facilities Maintenance and Development Division Engineering & Design Unit 800 Maynard Ave. S., Seattle 98134	Approved, Park Engineer: _____	Last Revision: _____
		TIMBER STEPS 5:1 - 4:1 SKETCH	
			Std. Detail #

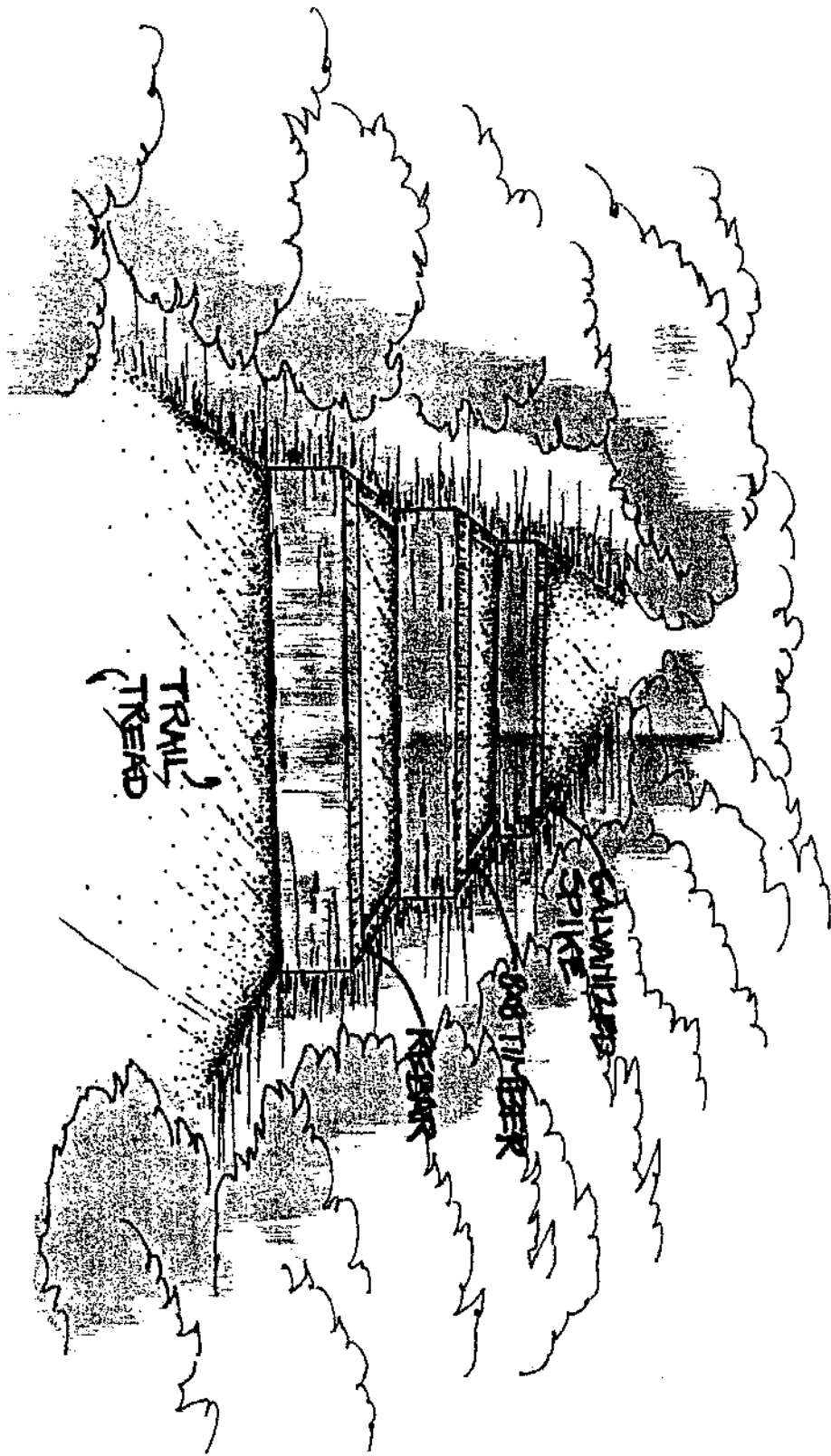

Std. Detail #	City of Seattle Department of Parks and Recreation Facilities Maintenance and Development Division Engineering & Design Unit 800 Moynard Ave. S., Seattle 98134	Approved, Park Engineer: _____ ROCK-LINED SUMP SKETCH	Last Revision: _____ Std. Detail #
---------------	---	---	---

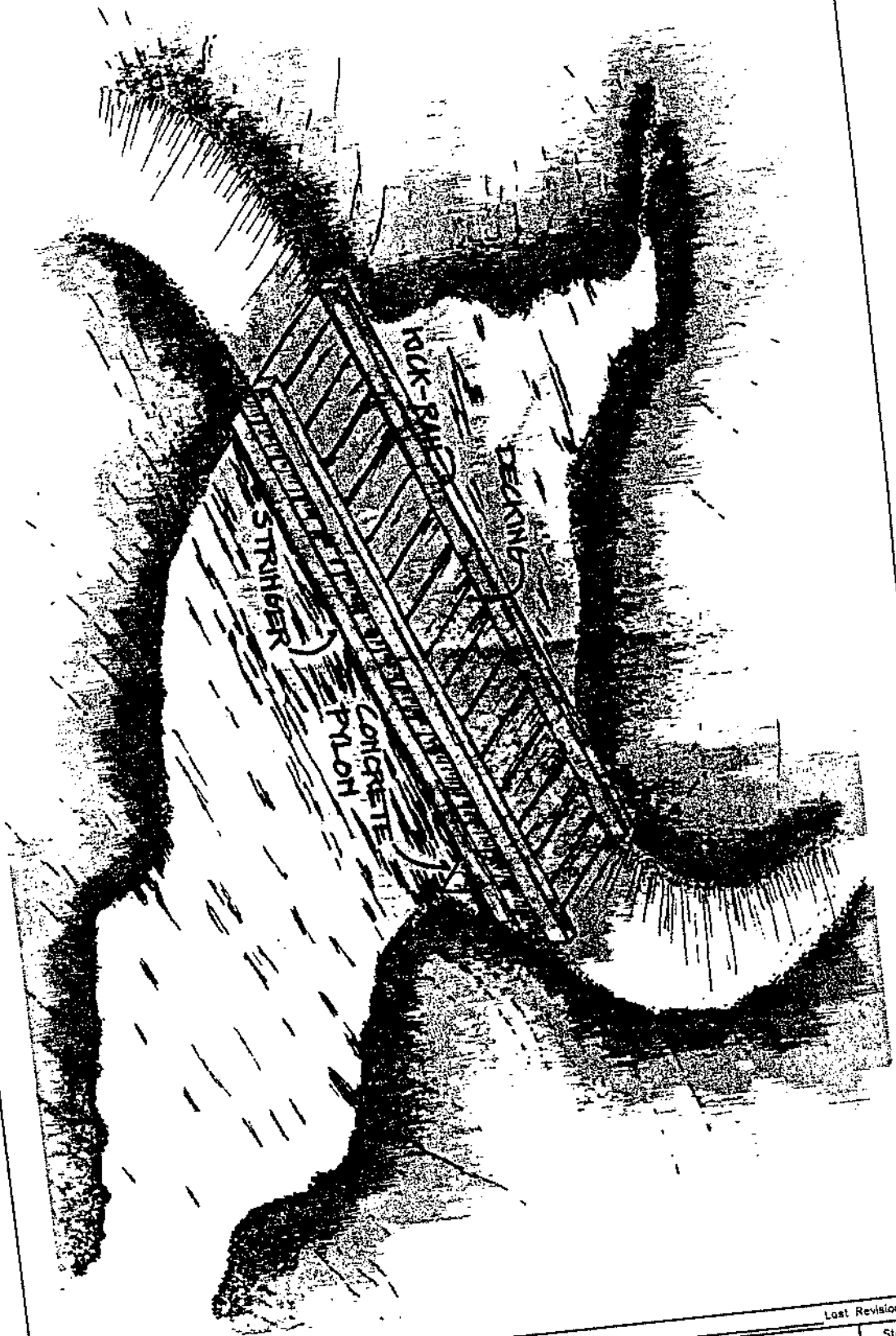

Std. Detail #	City of Seattle Department of Parks and Recreation Facilities Maintenance and Development Division Engineering & Design Unit 800 Maynard Ave. S., Seattle 98134	Approved, Park Engineer:	Last Revision:
		BRIDGE/PUNCHEON SKETCH	

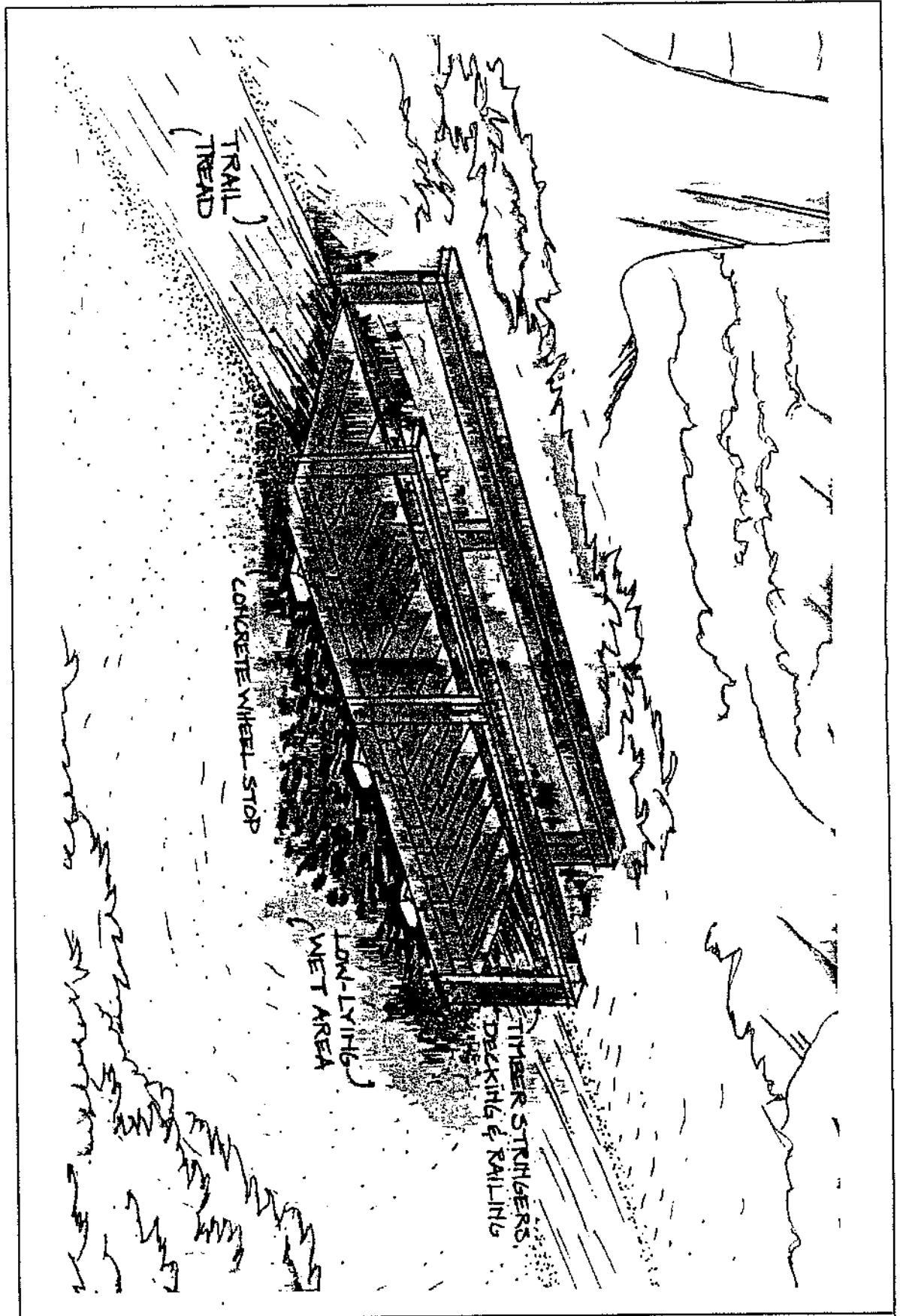

Std. Detail # _____
 City of Seattle
 Department of Parks and Recreation
 Facilities Maintenance and Development Division
 Engineering & Design Unit
 800 Maynard Ave. S., Seattle 98134

Approved, Park Engineer: _____
 Last Revision: _____
MUDSILL SKETCH
 Std. Detail # _____

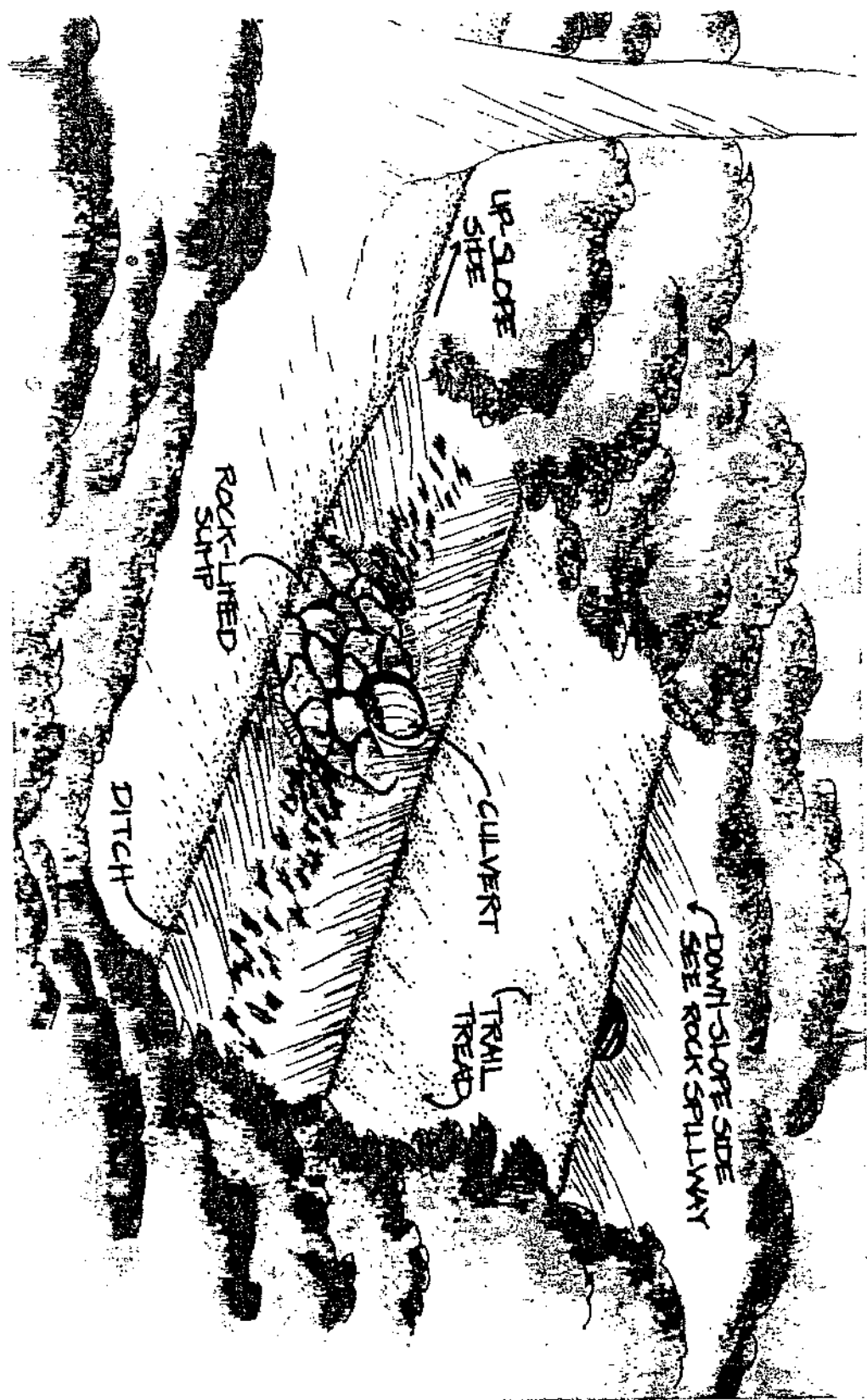

City of Seattle
 Department of Parks and Recreation
 Facilities Maintenance and Development Division
 Engineering & Design Unit
 800 Maynard Ave. S., Seattle 98134

Approved, Park Engineer: _____ Last Revision: _____

ROCK-LINED SUMP SKETCH

Std. Detail # _____

Std. Detail # _____

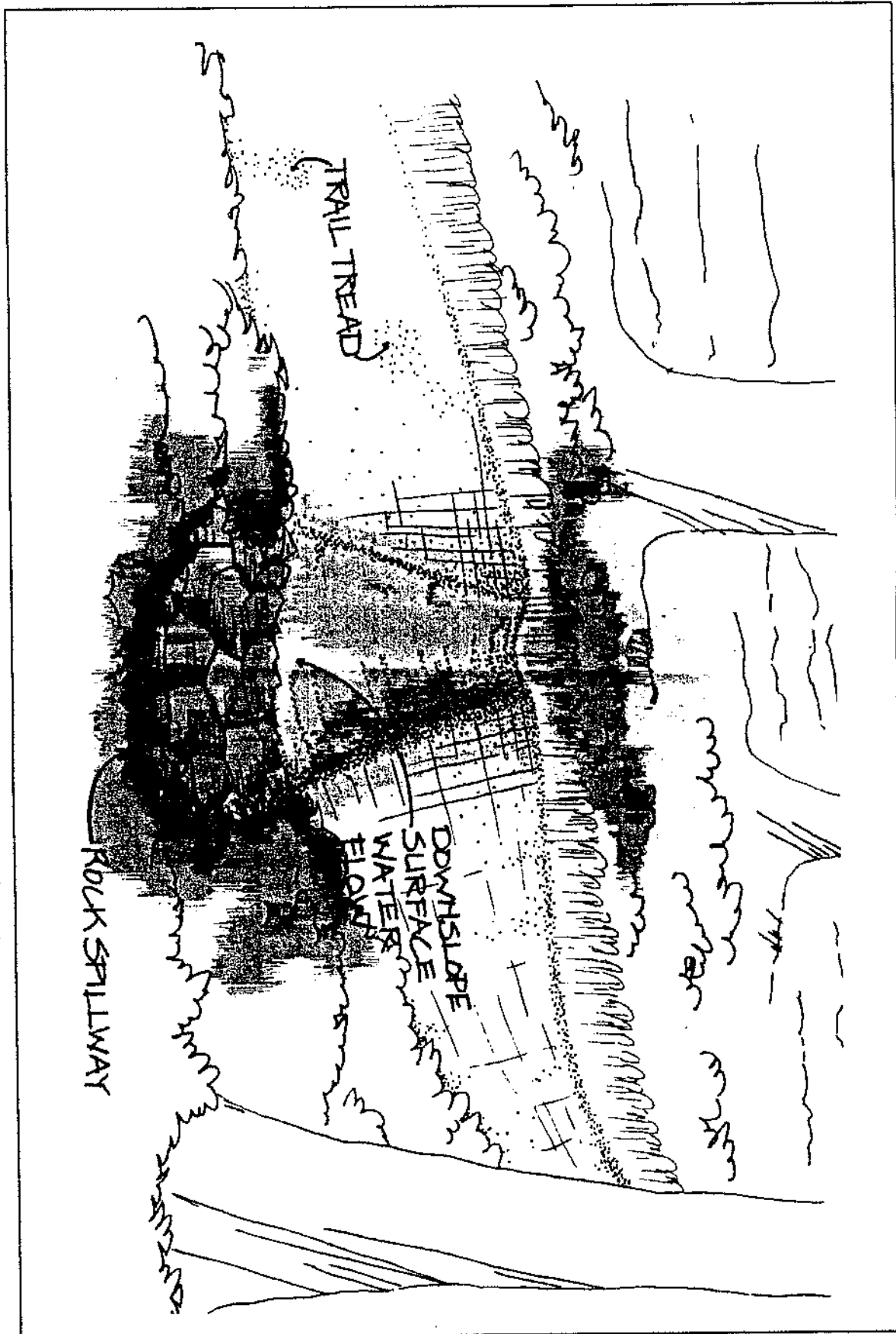

City of Seattle
 Department of Parks and Recreation
 Facilities Maintenance and Development Division
 Engineering & Design Unit
 800 Maynard Ave. S., Seattle 98134

Approved, Park Engineer: _____

Last Revision: _____

DRAINAGE DIP SKETCH

Std. Detail # _____

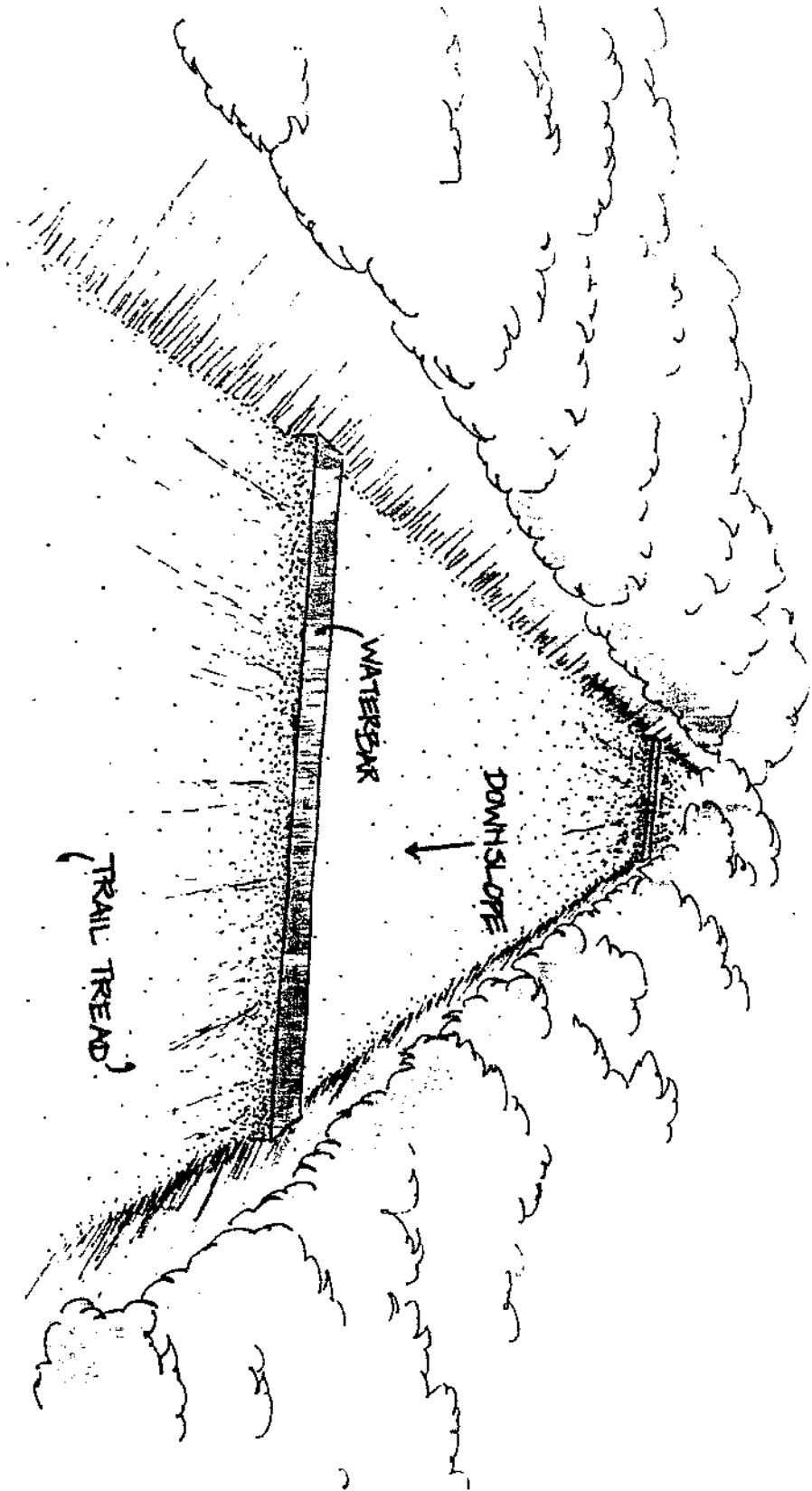

City of Seattle
Department of Parks and Recreation
Facilities Maintenance and Development Division
Engineering & Design Unit
800 Maynard Ave. S., Seattle 98134

Approved, Park Engineer: _____
Last Revision: _____

WATERBAR SKETCH

Std. Detail #

Std. Detail #



City of Seattle
 Department of Parks and Recreation
 Facilities Maintenance and Development Division
 Engineering & Design Unit
 800 Maynard Ave. S., Seattle 98134

Approved, Park Engineer: _____ Last Revision: _____

WATER BAR SKETCH

Std. Detail #

Std. Detail #

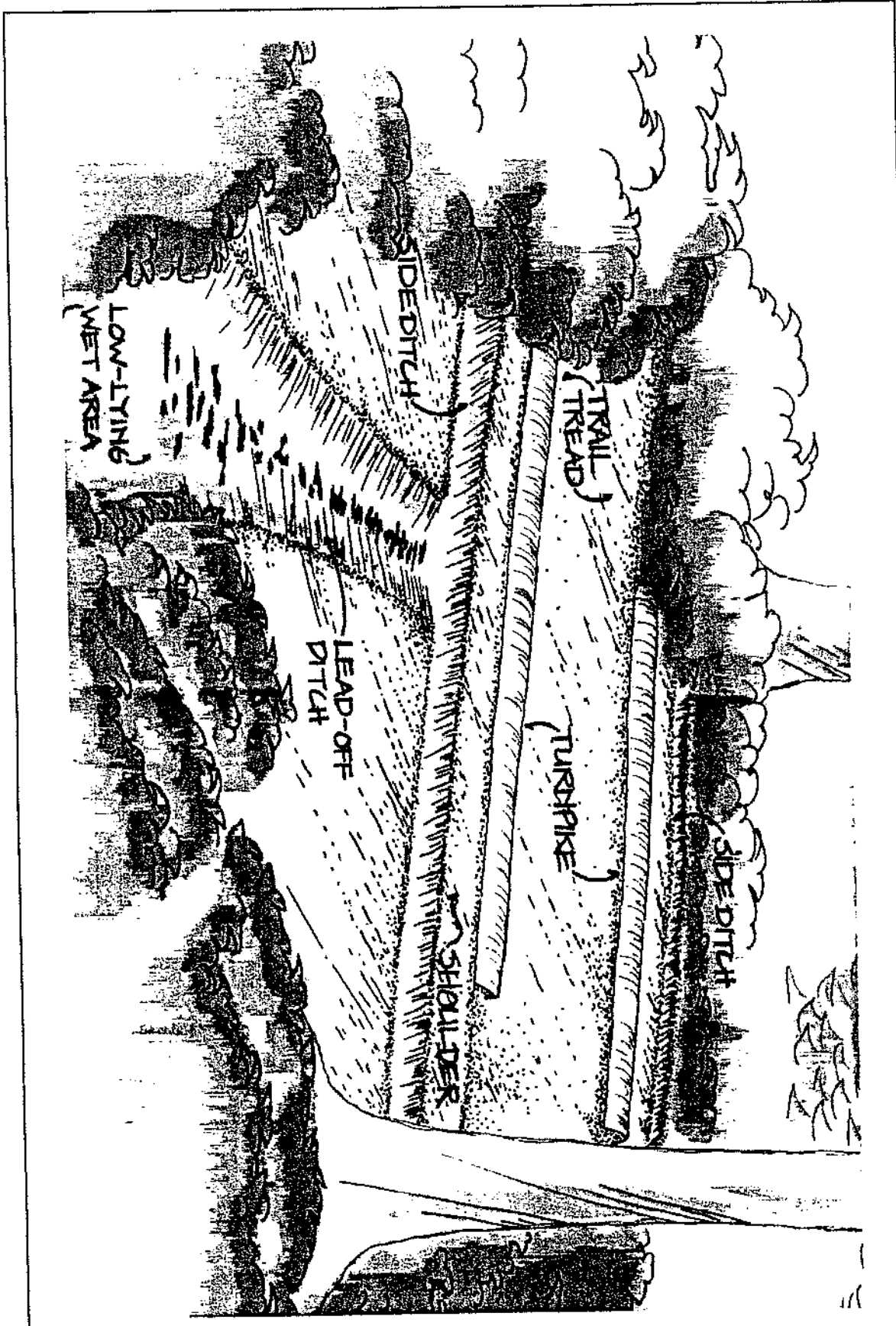

City of Seattle
 Department of Parks and Recreation
 Facilities Maintenance and Development Division
 Engineering & Design Unit
 800 Maynard Ave. S., Seattle 98134

Approved, Park Engineer: _____ Last Revision: _____

LEAD-OFF & SIDE DITCH SKETCH

Std. Detail #

NOTES

Appendix E–Trail Best Management Practices

Definition of Resource



The Seattle Park system contains more than 4200 acres of natural area or greenspaces. Natural areas are characterized as being largely undeveloped landscapes, thickly vegetated with native plant communities and used primarily for passive recreation. Natural areas are also considered to have limited or minimal human disturbance and support habitat for plants, mammals, reptiles, birds, insects, amphibians and sometimes fish in an urban setting. In contrast, developed parks have formal landscapes and include active recreation for sports.

There are many diverse types of “natural area”. For example, more than 8 miles of urban creeks and wetlands are contained in over 760 acres of park-owned watershed. The park system has more than 21 miles of lake and saltwater shoreline. Seward Park and Schmitz Preserve together protect more than 180 acres of old-growth forest. Other park natural area sites contain evergreen and deciduous forest, grasslands, beaches and sand dune areas. Natural areas can be found within developed parks, special gardens and environmental learning centers. Parks identified as natural areas include greenbelts, beaches, ridges, viewpoints, preserves, and ravines.

Natural areas constitute a rich tapestry of natural environments and ecosystems that only recently have begun to receive the management attention they deserve. Thoughtful management of park natural areas is essential to ensuring the quality of life enjoyed by Seattle residents and to sustain biodiversity in the urban environment.

9.1 Goal Statement

Our goal is to develop a sustainable resource that protects, optimizes, enhances and increases our natural environments. These environments will provide opportunities for observing and enjoying urban wildlife, engaging in environmental education and participating in restoration activities.

Our maintenance programs will incorporate staff expertise, and adaptive management strategies based on the best available science in Pacific Northwest ecosystem, wildlife and vegetation management. We will create vegetation management plans for individual forested areas and parks, in order to standardize our planning, design and maintenance activities. We will strive to enhance public safety, optimize tree canopy, improve our trail system and ecosystem health and manage green infrastructure assets effectively in all natural areas.

9.2 Definitions

Class "A" noxious weeds: Class A noxious weeds are non-native species with a limited distribution in Washington State. Preventing new infestations and eradicating existing infestations is a high priority in managing these weeds.

ecological weeds: any weed such as English ivy or Himalayan blackberry that threatens the balance within an ecosystem.

environmentally critical areas: are areas determined by the City's Department of Construction and Land Use (DCLU) to be particularly environmentally critical. These areas include steep slopes and wetlands.

forests: these natural areas are undeveloped landscapes that do not fall into any of the classifications above. Forests contain tall and predominantly woody vegetation.

marine reserve: A marine reserve is any stretch of beach or water that is protected, preventing over harvesting of shellfish and damage to local marine habitat.

meadows: Non-forested areas having 25% or less tree cover. Meadows include the following sub-classifications: sparsely vegetated, grassland forbs, shrub savannah, shrubland, and tree savannah.

natural areas: Any City-owned property with critical environmental resources. Natural areas shelter native ecosystems and wildlife habitat. These sensitive areas and habitats include nearly all classifications in the City's Regulations for Environmentally Critical Areas or ECAs. Natural areas fall into a number of categories, which include steep slopes and slide prone areas. For this BMP manual, these resource assets are divided into three major groups:

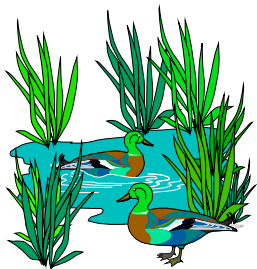

- forests
- meadows
- wetlands, riparian corridors, shorelines and aquatic habitats

riparian corridors: wetland and terrestrial areas within the influence area of the adjacent stream. Technically they are defined as:

... all areas within 100 feet measured horizontally from the top of the bank, or if that cannot be determined, from the ordinary high water mark of the watercourse and water body, or a 100-year flood plain as mapped by FEMA, as regulated by the Seattle Floodplain Development ordinance, whichever is greater.

9. Natural Areas

shoreline and aquatic habitats: areas affected by the hydrology of a water body (pond, lake, sound). The area 200 feet landward of water is the shoreline zone. Shorelines include several sub classifications:

- estuarine – brackish water between 0.5 and 30 parts per thousand (ppt)
- lacustrine – mostly open water
- marine – salt water of greater than 30 ppt
- palustrine – includes open water and emergent habitats, including freshwater wetlands (see "wetlands" definition above).
- riverine – same as riparian corridor (see "riparian corridors" above)

social trail: a trail within any natural area formed by casual use rather than design.

wetlands: those areas inundated or saturated by ground or surface water at a frequency and duration sufficient to support, and under normal circumstances do support, a prevalence of vegetation typically adapted for life in saturated soil conditions.

Vegetation Management Plan: A plan for the long-term restoration, renovation and care of the vegetation within the boundaries of a particular park .

Volunteer Steward/Docent: A citizen volunteer who donates their time to work on specific activities for public education or maintenance programs. Examples include Wetland Steward, Beach Naturalist, and Adopt-an-Area.

9.3 Policies and guidelines

ANSI A300-1995 for Tree Care Operations-Tree, Shrub and Other Woody Plant Maintenance-Standards Practices. 1995. American National Standards Institute.

City of Seattle Greenbelt Ordinance No. 111568, 9.

City of Seattle Regulations for Environmentally Critical Areas. 1992, amended 1994, 2004.

Construction Best Management Practices Manual. City of Seattle.

Council Resolution 28653 Greenspaces Policy 1993.

Director's Rule 3-94. 1994. Seattle Department of Planning and Development.

The Mayor's Environmental Action Agenda: The EAA presents the City's goals and creates a framework for integrated City departmental environmental action. It addresses water conservation through mandates for increased energy and water efficiency of City buildings and facilities. The City has a continuing commitment to an aggressive water conservation program, including incentives for water efficient irrigation system development. (URL)

Public Involvement Policy for Proposals to Acquire Property, Initiate Funded Capital Projects, or Make Changes to a Park or Facility. 1999. Seattle Department of Parks and Recreation.

Seattle Department of Parks and Recreation Tree Management, Maintenance, Pruning And/Or Removal Policy, Number 060-P 5.6.1, June 1, 2001

Sustainable Infrastructure Initiative (SII): The SII a component of the Mayor's Environmental Action Agenda. It encourages application of innovative approaches that provide basic services in ways that are resource-efficient and environmentally responsible through a variety of incentive programs. Sustainable design encompasses the following broad topics:

- efficient management of energy and water resources
- management of material resources and waste
- restoration and protection of environmental quality
- enhancement and protection of health and indoor environmental quality
- reinforcement of natural systems
- analysis of the life cycle costs and benefits of materials and methods

Trails Classification Hierarchy: This document describes types of trails, different materials used, typical locations and construction standards

Tree-Pruning Guidelines. 1995. International Society of Arboriculture.

Urban Wildlife and Habitat Management Plan. 1994. Seattle Department of Parks and Recreation.

SMC 18.12.030 Definitions -- Rules of construction (leash length):
Domestic pets can potentially cause more damage than people. Dogs and cats can destroy

9. Natural Areas

vegetation and kill or maim wildlife. Pets in parks must be on an 8 foot leash except for designated off-leash areas or other permitted activities.

(Link)

Viewpoint Policy(from Tree Policy) Number 060-P 5.6.1, 4.8: Views from designated public view parks and viewpoints will be preserved through maintenance and management of parks vegetation in front of or below the viewpoint. (see appendix XX for list)

City of Seattle Park Code Section 18.12.070, Subchapter II: protects resource assets from vandalism, graffiti or removal from parks. All living and non-living resources found in natural areas are the property of the City of Seattle. Cutting trees, collecting or removing plant material, branches or wood, shells or rocks, harassing wildlife and gathering firewood are all prohibited.

9.4 Planning and Design

All persons and entities planning, designing, or overseeing construction and installation projects in natural areas will consult with staff directly responsible for maintenance and management of these areas prior to and during every phase of the process. Such projects include but are not limited to: Forest Restoration, Invasive Removal, Habitat Rehabilitation, Plant Installations, Trails work and Interpretive/Educational Program fieldwork projects of any kind.

Natural areas planning and design BMPs will provide guidance for the maintenance, enhancement and expansion of existing plant communities, wildlife features and structural assets within designated areas. Habitat needs of native vegetation and wildlife will be considered when developing long-term maintenance, restoration or other planning documents. As such, landscape design and vegetation management planning shall consider natural ecological cycles of succession and disturbance whenever and wherever possible.

Design and planning will also accommodate human uses such as recreation, accessibility, movement and stewardship. When resources are available, it is important to add environmental education through development of Interpretive program areas. Educated park users are much more likely to preserve and protect a site and use it with care.

Planning and design BMPs will be incorporated into crew projects and renovations as well as Capital projects. Planning and design is divided into a number of steps and include, but are not limited to the following topics. Use this checklist to plan project work in natural areas.

Planning and Development Checklist for Natural Areas	
1	Refer to existing Vegetation Management Plans to develop design and management goals
2	Set goals with SPR staff directly responsible for the site's maintenance and management and community stakeholders/constituencies
3	Inventory the site's natural resources and human-use patterns
4	Analyze where site resources are not achieving intended goals
5	Define a scope of planning work based the Vegetation Management Plans and staff/public constituency input
6	Develop recommended strategies for correcting deficiencies. Set priorities according to both natural resource, pest management and human-use issues
7	Present these recommendations to the general public for comment. Modify them as necessary.

Critical Design Considerations

The following design considerations preserve the aesthetic and environmental value of natural areas.

Designated Environmentally Critical Areas/ Steep Slopes

See page XXX in this BMP for more information.

Vegetation Management

SPR has over 50 completed Vegetation Management Plans (VMPs), written to guide the growth, development, and maintenance of specific parks, sites within parks and selected open spaces. These plans provide references for historical information, and outline the SPR design and resource management goals and objectives for each particular site that must be followed. The planning associated with each VMP includes a public involvement process. Each process brings together stakeholder groups representing the diversity of interests associated with each park space. The outcome of each process is intended to direct the actions of the governing bodies (City of Seattle Departments, Metro King County, etc...) and individuals (Community Stewards, Groups, NGOs) that manage park sites. VMPs are available through the Urban Forestry Program. A complete plan must include the following:

9. Natural Areas

- ✚ Site Inventory and Assessment including maps which illustrate existing topography, vegetation, trails and other pertinent natural and recreational resources or constructed features.
- ✚ Proposed Tree Work Inventory (*pruning or removal*) having been conducted by hazard analysis or in the specific case of City Designated, SEPA exempted viewpoints, through view interruption analysis as well as hazard analysis. Only in the case of such designated SEPA exempted viewpoints shall view interruption be considered as reason for removing trees designated as significant by SMC within natural areas.
- ✚ Plant Community Protection and Enhancement Strategies with plant species, size and location and any necessary erosion control/slope stabilization methods.
- ✚ Public involvement plan, if applicable, in compliance with DPR Public Involvement Policies and Procedures.
- ✚ Maintenance plan which includes necessary tasks, frequency, and resources. Such tasks shall include replacement and infill planting, seasonal irrigation needs, integrated pest management including invasive plant control and periodic weeding, annual mulching, and occasional pruning.

Interpretive Program Areas

Special attention needs to be paid to maintaining the integrity of Interpretive Program Areas (IPAs). These areas are historically used for naturalist programs explaining the site's notable and special plants, animals, birds, reptiles and amphibians, geology, ecology and natural history. Work with naturalists to develop goals, objectives to develop, enhance and preserve a high quality of habitat in these specific sites. A list of interpretive sites should be available for each natural area or park with an explanation of appropriate maintenance procedures and tasks. See the Appendices for current IPAs.

Boundary Delineation and Inspection

- A registered surveyor from the Department should locate City-owned boundaries. Indistinct boundaries should be signed with labeled, white fiberglass boundary stakes or by other visible and durable means by the surveyor.
- City property boundaries should be inspected annually. An inspection tool is a geographic positioning system (GPS) attached to a data logger. The data logger can be used to track typical boundary issues such as tree liabilities or non-park uses.
- Sensitive area boundaries such as riparian corridors and wetlands should be clearly located on City maps. This requirement goes beyond that of the City Critical Areas Inventory, which does not identify all "sensitive areas."

Capital improvement Signage

Public information signage is installed prior to and throughout the duration of a capital project. This sign is specified as a 2-by-3-foot temporary sign with customized text to inform park users of specific aspects of a project and provides contact information for the project manager.

Plant Selection

In restoration projects, plant selection should reflect native forest succession stage at a site. Species will typically be native plants appropriate to the site. Planting plans will be designed to protect and enhance existing wildlife habitat characteristics, as well as, where applicable, provide safe and sensible access to or movement through a site. Plant selection will consider site ecology (soil composition, moisture, available light, exposure, topography and in the case of a hill, the aspect and degree of slope). Refer to applicable BMPs for Trails, Viewpoints, and VMPs as well as the specific maintenance regime and potential for disturbance (human and otherwise) at a site for the most appropriate plant community selection.

Overhead and Underground Utility Infrastructure

Select or preserve trees and shrubs that at their mature sizes will allow required clearances for overhead utilities such as electric and telephone wires. If existing trees or shrubs require line clearance, contact the Senior Urban Forester or Forestry Crew Chief.

Contact "Dial-Before-You-Dig" **and Parks In-House Locate** at least two weeks prior to beginning of project to locate underground utilities to ensure they are not damaged during construction. Confirm that utilities have been located through a visual inspection of site..

Stormwater Management and Drainage Systems

Each site has unique hydrological characteristics. Preserving a site's natural hydrology preserves the integrity of its other resources. Staff directly responsible for maintenance and management of a site need to be aware of all drainage structures within the site. External sources of stormwater may be mitigated by detention before they enter the natural system. Site features that concentrate flow such as trails and roads should be built to re-disperse flows, if possible.

A project may include the construction of check dams, culverts, and bioswales and sediment ponds to improve water and habitat quality. Consult with the Parks Engineer, Parks Property Management and/or SPU before proceeding with a construction or maintenance project involving modification of or installation of

drainage structures and for proper procedures for private property drainage onto park sites.

Site improvements should work with the existing natural drainage patterns and maintain moisture levels that sustain plant growth.

Illegal Drainage

Storm water coming into Parks land from outside sources can cause major erosion problems. Staff will notify the SPU ‘Storm water and Drainage Hotline’ when they find At-Grade Drainpipes entering Parks lands or terminating at Parks property.

Parks personnel should not attempt to correct an erosion problem resulting from outside drainage. Staff will file an incident report with SPU, as follows.

DO: File an Incident Report with SPU:

- SPU maintains a ‘Storm water and Drainage’ hotline. 206-684-3000

DO NOT: Perform any work related to the drainpipe or storm water coming from it:

- Stop! Do not do anything! File an incident report with SPU (see above).
- Do not alter the existing drainage system.
- Do not redirect storm water flow either at the drainpipe’s terminus or within the park.
- Do not install any structure designed to alter the flow of storm water – such as check dams or water bars.

Once notified, a field crew will be dispatched by SPU to assess the situation. It may be unnecessary to compensate for the off-site drainage depending on their determination. If in fact remediation is required, any of the above tasks may apply. If this is the case, all work will be performed 1) only after SPU has made a determination and 2) in consultation with representatives from SPU

Resource Inventory

A qualified botanist, horticulturist or urban forester shall supervise landscape inventory. Management units are generally defined by vegetation, soils,

hydrology, topography, and aspect and site history. SPR prefers that all data is collected digitally or translated into ESRI's ArcView 3.3 or ArcGIS 9.0 file format.

A resource inventory shall be compiled into a written report that includes both a social and a natural history of the resource. The following table shows you where to find information.

9. Natural Areas

Sources for Resource Inventory Information		
Site Boundaries	The best tool for approximating boundary locations is our Geographic Information System (GIS). Aerial photos can be superimposed on property boundary files to locate right-of-way or park limits.	
Site Description & History	Several sources can give you this data: DPR or DON Community Planning documents and the Special Collections Library at the UW are good places to start.	
Parks Department	Start with SPR's Property Management and Real Estate Section. Or try plan and site files at the Facilities Maintenance and Development Division.	206-684-7031
Department of Transportation	For street right-of-way projects and for general property maps, visit the City's engineering records vault.	206-684-5132
City Archives	City Archives contain much historical information, including old aerial photos and newspaper articles. Be sure to look for the Sherwood documents for park sites. Copies are also available in the Seattle Public Library's Northwest Collection.	206-684-8353
Staff historians	City staff can give you detailed information on site history. Get in touch with a Crew Chief or a Senior Gardener who maintains the site.	
Community historians	Seek out long-time residents through your community council or Neighborhood Service Center or local historical societies. They can probably give you some unique oral history.	
Public Utilities ' GIS	The GIS system maps critical areas (e.g., steep slopes).	
Vegetation management plans	link	
Trails	Existing trail maps (link)	
Interpretive Program Areas	Existing lists	

Signage

Standards currently used for natural areas:

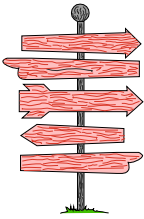

- 9 **Open Space Rainbow Sign.** This is a variation on the standard SPR rainbow sign that signifies the main access point for an open space site.
- 10 **CIP Project Sign.** This is an approximately 2-by-3-foot temporary sign with customized text to inform park users of specific aspects of a project.
- 11 **Kiosk.** This is a large-format glazed bulletin board in a shelter for posting current information and seasonal interest items for park users. In each location, determine a responsible person for information management.
- 12 **Trail Directional Sign.** This is a 1-by-1-foot post-mounted plaque that directs trail users to various destinations within a park.
- 13 **Interpretive Environmental Education Sign.** These are customized signs in various formats that provide specific information on natural resource topics. They are typically porcelain enamel, etched stainless steel, coated, or otherwise constructed to resist vandalism.
- 14 **Regulatory Sign.** These include but are not limited to Parks Code information, dogs on-leash, no bicycles, and no dumping signs. These should be combined with other permanent signs where possible to minimize sign clutter.

General Maintenance Practices

Maintenance activity in natural areas should sustain or increase habitat value and enhance habitat features whenever and wherever possible. The goal of routine maintenance in natural areas is to conserve and enhance water, soil and wildlife resources in or expected in a given habitat and balance these needs with recreational or educational activities.

Staff will consider the impacts of maintenance to natural cycles of succession, disturbance and wildlife habitat needs. For example, dead or declining trees in a natural area may create opportunities for standing snags, nurse logs and brush piles. Aquatic features like pools or in stream woody debris are maintained even if doing so decreases drainage. Every effort should be taken to retain or increase available enhancement resources on a given site.

Maintenance strategies are specific to a feature or a function and include educational programming, social and environmental objectives. Specific maintenance features include but are not limited to: (1) viewpoints, (2) wetlands

(3) trails and (4) Interpretive Program Areas (see section 2, maintenance activities, page XX).

Maintenance Activities

1. Inspection



Natural and sensitive areas in urban environments require routine monitoring of the following:

- Public use, such as high impact, vandalism, graffiti or illegal activity
- Public safety, such as hazard trees, police and fire access
- Natural processes such slides, erosion, drainage
- Silt or debris loading and drainage of wetlands, ponds and streams
- Presence of invasive plants
- Water quality and upstream impacts
- Dog or other pet impacts to turf, trails and wetlands

2. Interpretive Program Areas

Special attention needs to be paid to maintaining the integrity of Interpretive Program Areas (IPAs). These areas are historically used for naturalist programs explaining the site's notable and special plants, animals, birds, reptiles and amphibians, geology, ecology and natural history. Staff will work with naturalists to develop goals, objectives and specific maintenance tasks lists to enhance and preserve a high quality of habitat in these specific sites. A list of interpretive sites should be developed for each natural area or park with an explanation of appropriate maintenance procedures and tasks. Examples of these areas are the Wolf Tree Interpretive Trail and Spider Meadow in Discovery Park (see Appendices on current IPAs for more information)

3. Viewpoints

Seattle Parks maintains designated viewpoints throughout the city. The goal for vegetation at viewpoints will be to convert view-blocking vegetation to lower growing species that will not require long-term pruning, in conjunction with goals for wildlife habitat, aesthetics, and site engineering and erosion control. Seattle Parks does not maintain private views (Refer to Viewpoint Plan and Tree Policy).

4. Stormwater Management Activities

Whenever work is undertaken, consideration should be given to reducing runoff and reducing soil particles/contaminants from leaving a site in order to protect water quality and aquatic habitat. The most cost effective way to control erosion and sedimentation is to use good housekeeping practices. Limit exposing soils in maintenance or project work. Identify the drains and drainages in a work site; isolate, cover and protect them if needed. Soil particles or other pollutants should be kept from entering water bodies or becoming air-borne. Examples of work where stormwater management is critical are pruning projects, crew projects, irrigation, clearing and grading, ditch excavation, excavation, and planting. Depending on the activity, the some or all of the following BMPs apply:

- Protect and minimize disturbed areas
- Use low impact, least destructive strategies to accomplish the work task
- Reduce runoff from equipment and tools cleanup and periodic maintenance
- Consider runoff potential from debris disposal or staging areas
- Have a spill prevention and erosion control plan

5. Parks Drainage Infrastructure

Existing drainage systems should be maintained according to the preventive maintenance schedule and specifications. SPR resource crews are responsible for routinely cleaning catch basins, culverts, and other drainage structures.

Drainage features should be inspected as necessary or at least annually in late November or early December to ensure proper function throughout the rainy season. Leaves and other organic debris, garbage and excess sediment should be removed to allow unrestricted flow and optimal storage volume. This organic debris should be properly disposed of. If removed from roadway drains, it must be taken to the landfill, but if from stream drains or other drains, this material can be safely used in landscapes or composted.

6. Signage

Staff directly responsible for maintenance and management of a site are responsible for vegetation management adjacent to signage. All signs should be clearly visible to the intended audience. Parks facilities maintenance staff are responsible for maintenance and replacement of signs. Signs should be cleaned of algae and dirt at least once per year (For examples of signage see Appendix #).

7. Waste Management

Natural areas are subject to litter and dumping activity. Park visitors are less likely to or dump or litter if a site is clean, and appears well-maintained. Maintenance activities shall discourage this activity through these routine tasks:

- Weekly to semi-monthly inspection of trailheads and street ends
- Quick response clean-up when incidents are reported
- Inspection of dumped materials to identify the perpetrator
- Involvement of Hazmat specialists when unknown chemicals are detected
- Incident reports in all cases
- Management of encampments

8. Homeless encampments

- Areas of known homeless encampments should be frequently inspected, and the debris removed to minimize the potential for negative habitat and vegetation impacts, biohazards, wildfires and public safety.
- Obvious social trails to encampment areas can be mitigated in 2 ways: 1) Eliminating or blocking trails with hawthorn trees, roses or other thorny brush, large logs 5-10 feet long on the trail but extending wider than the trail and 2) Creating or rerouting legitimate trails near encampments areas for public access. This latter method reduces the hidden aspect of encampments and encourages vacation of the area by campers.
- Encampment sites should be restored to forest or pre-encampment condition, if feasible. Consult the senior Urban Forester or VMPs for information on vegetation characteristics of a site.
- Seattle Police Department can assist in the eviction of homeless encampments. Contact your local precinct for more information.

9. Maintenance Resources

- The Seattle Conservation Corps and the Natural Area crew are available to assist through the Work Order System for certain maintenance tasks in natural areas.

10. Permits

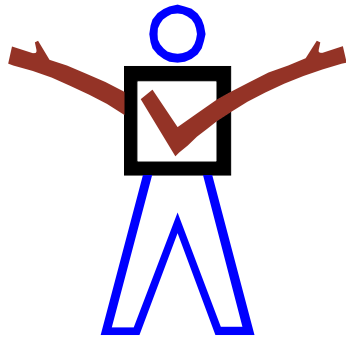

The Department of Planning and Development (DPD, formerly DCLU) regulates activities related to land use and construction. Most Parks maintenance activities do not fall into this category. General maintenance activities such as invasive removal and hazard tree removal are exempt from permitting. Parks is considered a Best Manager of these areas as long as Best Management Practices are followed. This is especially important in Environmental Critical Areas. Vegetation and tree removal occurring in ECAs should conform to the basic themes presented in the following statement:

SMC 25.09.320 Vegetation and tree removal permit in environmentally critical areas.

- A. Removal, clearing or any action detrimental to trees or vegetation within wetlands, wetland buffers and riparian corridor buffers is prohibited unless the Director has given prior approval to a restoration plan pursuant to buffer restoration, reduction, exemption, or exception provisions contained in this chapter.
- B. Removal, clearing or any action detrimental to trees (including, but not limited to, tree-topping) or vegetation within land-slide-prone, steep-slope, and fish and wildlife habitat areas shall require a permit from the Director when any of the following thresholds are exceeded:
 1. Any tree of six (6) inch caliper or greater, measured three (3) feet above the ground; or
 2. Any combination of trees over one and one-half (1.5) inch caliper, measured three (3) feet above the ground, which total a cross-section area greater than twenty-eight (28) square inches or equivalent to a tree cross-section of six (6) inches; or
 3. Any other combination of trees and other vegetation covering an area of seven hundred and fifty (750) square feet or more.
- D. A vegetation and tree removal permit shall not be required when the Director determines there is an emergency that threatens the public health, safety and welfare.

1. Environmentally critical areas.(SMC 25.05.908)

- Landslide-prone areas, including, but not limited to, known landslide areas, potential landslide areas, and steep slopes of forty (40) percent average slope or greater;

Certain activities are not allowable on steep slopes. Others can be performed but with additional safety, techniques or precautions applied. Timing is important to steep slopes work, no soil disrupting work is allowed during the wet season (November – April).

- Riparian corridors

The following buffer widths have been established by the city (SMC 25.09.140)

9. Natural Areas

Class A Riparian Corridor Buffers; Fifty Feet (50')

Class B Riparian Corridor Buffers; Twenty-five feet (25').

If vegetation within the buffer is generally in a natural state that prevents erosion, protects water quality, and provides a diverse habitat, the retention of the buffer's existing vegetation is required.

- Wetlands

Regulated wetlands have a Fifty feet (50') buffer. The same principles apply to wetland buffers as apply to riparian corridor buffers.

- Fish and wildlife habitat conservation areas.

These are areas designated as critical to the life cycle of Species of Local Importance such as Bald Eagle, Blue Heron and certain species of Salmon. The major theme in such areas is to *preserve integrity* and *minimize intrusion* (SMC 25.09.200).

2. Erosion Control – every effort and precaution is required to reduce erosion during construction and maintenance activities

Major maintenance, repair, strengthening or other operations that require substantial disturbance require notification of or permitting from DPD. Permits in stream corridors may also require a hydraulic permit application to the Washington State Department of Fish and Wildlife.

Activities in these areas performed will conform to the following (update as in Policies):

- DPD's current Environmentally Critical Areas Regulations (SMC 25.09).
- DPD's Best Management Practices for Construction Erosion and Sedimentation Control Plans (1993)
- Environmentally Critical Areas Interdepartmental Standard Operating Procedure (1994).

Seasonal Task Schedule

Many grounds maintenance activities need to be scheduled at certain times throughout the year, based on habitat considerations or ecosystem impacts. The following tasks.

WINTER – January through March

- ☛ Invasive plants: Holly is removed during the winter. Once nesting season begins (date needed) we stop cutting on the holly.
- ☛ Mowing: Mowing and trimming along roads, sidewalks, and trails stops from mid March to mid July, due to ground bird nesting. Other work tasks in these areas must be completed before mid- March.

SPRING – April through June

- ☛ Mowing: Mowing and trimming along roads, sidewalks, and trails stops from mid March to mid July, due to ground bird nesting. Other work tasks must be completed before mid- March.

SUMMER – July through September

- ☛ Mowing: Mowing and trimming along roads, sidewalks, and trails stops from mid March to mid July, due to ground bird nesting.
- ☛ New plantings: Newly planted native plants are watered approximately once every two weeks during the summer of the first year. The second year the plants are watered about once per month. This all varies depending on the species and location of the plant. Monitor for occasional water needs in the third summer.
- ☛ Invasive plants: Invasive plants are to be removed, herbicide, or both as soon as discovered. The most prevalent weeds are: garlic mustard, Daphne, clematis, and hogweed. Other invasives that are must be monitored are thistle, poison hemlock, Japanese knotweed, and reed canary grass. Invasive trees that need to be removed, such as red hawthorn, holly, and sycamore maple are removed late in the summer as to not disturb nesting birds.

FALL – October through December

- ☛ General tasks: Winter is our time to do trail work, crew projects, and sheet mulching.
- ☛ Leaf removal: From the last week in October to mid December leaves are blown off roads, sidewalks, and trails. Leaves are not removed. All leaves should be blown into the woods or if blown onto mowed grass areas, mulched.
- ☛ New Plantings: Native plants should be planted during fall and winter. Winter and spring rains will water the new plants and encourage root growth and establishment by the beginning of growing season.
- ☛ Storm cleanup: In winter there are wind storms that bring down trees. All trees down in woods are left where they fall except when across trails and roads. Trees across trails are cut and tossed into the woods. Alder is cut up and taken to Daybreak Star or other facilities for their various cooking, ceremonial or program fires.
- ☛ Invasive plants – Red hawthorn- We try to remove as much of this as early in the fall as possible, before the leaves have fallen for positive identification. Vegetation along roads, sidewalks, and trails is cut back during this time. Scott’s broom is best removed by pulling when the ground is soft. So any time from late fall through spring (except when the ground is frozen.) . Cut down and sheet mulch with cardboard and chips in areas

with blackberries, Monitor for one year for resprouting blackberries before re-vegetating the site.

- ☛ **Planting plans:** All areas of revegetation are planned a year in advance. Submit native plant restoration planting plans to the Urban Forester and plant lists to the nursery for the following year.

14.5 Integrated Pest Management in Natural Areas

Natural areas are dynamic ecosystems that respond to natural processes of disturbance and succession, including fluctuating insect and fungal organism populations. As such, these natural processes will typically be allowed to occur with minimal intervention. Specific strategies to suppress or remove the threat of invasive and noxious vegetation invasion, or pest issues of public health and safety will be part of routine maintenance.

An overriding principle of Integrated Pest Management (IPM) is the maintenance of healthy plant communities. In natural areas, cultural or manual controls will be the preferred over chemical pesticides. Natural area IPM will include the highest tolerance for pests, expecting that ecosystem dynamics will in most cases control these organisms without specific intervention.

The City of Seattle requires that pesticide use be reduced in all landscapes. In natural area as in all parks, integrated pest management (IPM) strategies will be practiced only when pest suppression or control is necessary. Please refer to the Integrated Pest Management BMP for IPM process and more information.

Specific Pest Tolerance Thresholds

PEST	THRESHOLD
Noxious weeds	Will not be tolerated and will be controlled when found.
Invasive plants	Are generally not tolerated, as they represent a threat to biodiversity. Invasive plants will be controlled in conjunction with ecosystem restoration efforts in these environments.

Weeds	Weeds will be considered habitat and as such will be tolerated, EXCEPT in demonstration gardens and where weed presence presents a threat to a particularly valuable landscape asset such as a Heritage tree.
Insects	<p>Native insect habitat will be encouraged. Insects that pose a risk to landscape asset health (such as gypsy moth), may be tolerated or controlled based on the specific asset.</p> <p>Insects that pose a risk to public health and safety (such as hornets) may be controlled or suppressed ONLY in certain circumstances, where they are located in close proximity to human activity. Mosquito management will be performed according to the City’s West Nile Virus response and IPM plan (insert link).</p>
Diseases	Will generally be tolerated. Specific control or suppression may be necessary to ensure the health of particularly valuable landscape assets.

Pest Management Strategies

Weed Control

In certain circumstances, invasive, noxious or other weedy plants will need suppression or control to preserve assets or establish native restoration sites.

Obnoxious weeds especially are a major problem in natural areas. Parks staff will contain the spread of such plant species and reduce the size and spread of current populations. Obnoxious weeds include the following:

9. Natural Areas

PLANT NAME	SCIENTIFIC NAME	MAJOR ISSUE	CONTROL METHOD
Himalayan Blackberry	<i>Rubus discolor</i>	Wide-spread Disrupts native systems	Manual removal Mechanical removal Mulching Herbicide
Cut-leaf Blackberry (<i>evergreen</i>) (<i>lace-leaf</i>)	<i>Rubus laciniatus</i>	Wide-spread Disrupts native systems	Manual removal Mechanical removal Mulching Herbicide
English Ivy	<i>Hedera Helix vars.</i>	Regenerates in shade Disrupts native systems	Manual Removal Mechanical Removal Mulching
English Laurel	<i>Prunus laurocerasus</i>	Regenerates in shade Disrupts native systems	Manual Removal Herbicide
English Holly	<i>Ilex aquilifolium</i>	Regenerates in shade Disrupts native systems	Manual Removal Herbicide
Black Locust	<i>Robinia pseudoacacia</i>	Nitrogen-fixer Alleopathic	Manual Removal Herbicide
Norway Maple	<i>Acer platanoides</i>	Generates in shade	Manual Removal Herbicide
Walnut	<i>Juglans nigra</i>	Alleopathic	Manual Removal Herbicide
Horsechestnut	<i>Aesculus spp.</i>	Readily naturalizes Regenerates in shade	Manual Removal Herbicide

The following are preferred strategies for IPM of weedy plants:

- **Manual removal** by cutting, digging or pulling
- **Shading out** by increasing the number of plants or planting over the weedy species. This is most useful in restoration.
- **Timed mowing.** Carefully timed mowing before seed set can effectively reduce weed seed sources. Frequent mowing can eliminate blackberry and other woody species.
- **Mulching.** Mulching around the base of plantings is widely accepted as a horticultural practice for water conservation, soil temperature moderation ,

soil fertility and weed control. In most instances, composted wood chips, organic composts or onsite recycle leaf litter are adequate materials. Replace mulch every 2 years or as needed.

- ❖ Mulches should be inspected at delivery. Mulches should be free of weed materials. Avoid wood chips from diseased trees.
 - ❖ Mulch should be between 2 to 4 inches deep for best results. Mulch should not touch tree trunks or plant stems.
 - ❖ Biodegradable materials such as cardboard can also be installed over restoration areas or plants either alone or in conjunction with mulching. Non- biodegradable materials such as black cloth or synthetic fiber landscape cloth can also be used, but shall be removed before planting.
- **Limited herbicide applications** may be allowed ONLY for noxious weeds, invasive plants or restoration sites (See “**Herbicide Use**” for more detail).

Woody Brush Control

The control of woody brush like blackberries, Scot’s broom and poison oak is very important in certain park locations. If not controlled, woody brush can overtake forest and grassland environments, eliminating vital habitat opportunities. Suppression and control measures for woody brush include the following:

- **Manual or mechanical removal** using hand tools or gas-powered equipment.
- **Limited herbicide applications** with Tier 2 products such as glyphosate products (Roundup Pro®) or triclopyr products (Garlon 4®) can be employed when hand removal, mulching or other measures are not possible or have failed. Spot applications are preferred whenever possible although area applications may be employed, especially for poison oak where handling by humans is dangerous. Any area applications will be limited to the exact area of infestation to eliminate or minimize off-target effects.



Stump Re-Sprouting Control

When desired for restoration, the following methods for controlling the re-sprouting of stumps are allowed:

- **Mechanical removed or grinding** can be used if the location is not within an environmentally critical area or is otherwise inaccessible.
- **Limited herbicide applications:** The re-sprouting of stumps can also be controlled by painting newly cut stump surfaces or sucker growth with the

9. Natural Areas

herbicides Roundup Pro® (for some species) or Garlon 4®. Limit the application of the selected herbicide to the stump surface only.

- **Herbicide application strategies:** Cut down the tree and apply the herbicide to the cut stump with a brush or wick applicator. An alternative method is drilling a hole into the stump of the cut down tree and pouring the herbicide into the hole, taking care not to apply to adjacent vegetation or on soils.
- **Monitoring:** The cut trees should be monitored for at least one year after. Occasionally, the stump will sprout and the suckers will need to be cut again and the herbicide applied to the cut suckers. If in contact with the soil, low branches of shrubs such as holly or laurel will take root and produce another tree. When removing the holly, pull up on the lower branches to make sure they are not in the soil. Laurel branches and stumps will sprout again if left in contact with the soil.
- **Disposal:** All cut material can be left on site with the exception of laurel.
- **Conservation:** If there are a great many of these trees in an area, don't remove them all at one time. Do it over a period of time as you are replacing them with other native trees and shrubs. This way one does not displace all the wildlife that has come to use the trees for shelter and nesting. And also, do not remove the trees when birds are nesting (from mid March to the end of August.)



Invasive Plant Control

Invasive plants have invaded many of the City's natural areas and landscapes, radically changing pre-existing ecosystems. Attaining long-term control of invasive plants is essential to recovery and preservation of the City's natural ecosystems.

Timing of invasive plant removal is most critical in natural areas as it affects habitat and life cycles of birds, amphibians, fish and animals. Be sure to understand and limit habitat impacts as part of any chosen strategy before beginning control or suppression measures. See page XX of this BMP for more information.

Invasive plants and noxious weeds control shall follow the Best Management Practices for individual weed species established by the *King County Noxious Weed Program*. Except in the case of Class A weeds, the goal is suppression of weed populations to below threshold, or damage causing levels, as determined collaboratively by Horticulture and Operations staff. Eradication of certain ecological weeds such as blackberry or ivy is a challenge as there are limited resources available for control. However, controlling spread of the problem and eradication in certain priority locations are SPR goals.



Reestablishing a native plant community as quickly as possible following the removal of invasive plants is critical to successful forest restoration. Native plants shall be planted densely and mulched to suppress weedy plants and promote establishment.

Control or suppression strategies may include any or all of the following:

- Mowing in large areas that are totally infested. Areas that are interspersed with invasive plants require more selective procedures such as manual removal.
- Heavy equipment or manual removal can be used on firm soils, but on either steep or saturated soil, use techniques that will minimize site and slope disturbance.
- Consider biological controls
- Where cultural, mechanical or manual removal is neither possible nor practical but control is essential, careful and selective use of an approved herbicide is permitted. The list of approved herbicides is limited to Roundup Pro®, Aquamaster, Rodeo®, Surflan or Garlon 4®. For more detail see “**Herbicide Use**”, below.

Herbicide Use

The use of herbicides in any natural environment must be carefully considered. Herbicides will be used for weed control in natural areas ONLY when other control measures have been tried and have failed or when past practice strongly indicates that control of the weed pest can ONLY be achieved through the use of a herbicide. The following are SPR herbicide use practices:

- Cut and stem treatment (daubing or painting) is the preferred choice for natural area management as it limits the off-target impacts.
- Certain invasive plants are difficult to treat and control in their mature form. If possible, remove existing growth manually or mechanically. Wait for new growth to become established, and then treat with the appropriate and approved herbicide.
- Herbicides approved for use in natural areas are limited to products containing glyphosate (Roundup Pro®, Rodeo®, Aquamaster or Garlon 4®). Surflan may be used in limited areas for garlic mustard seed germination control.
- **Aquatic weeds may be treated with certain other products ONLY by permit with the Washington State Department of Ecology. Any strategy or project to treat aquatic plants MUST be pre-approved by the Resource Conservation Coordinator.**



Insects

Management of insect pests will be limited to ecological management and habitat enhancement for the purposes of encouraging ecological conditions favoring healthy plant communities, populations of pest predators or other natural controls, except for cases involving public health and safety.

Insects like the European and Asian gypsy moth and the Citrus and Asian long-horned beetles can potentially devastate Seattle's urban forest. City of Seattle departments will cooperate with state and federal agencies in their monitoring and control programs to prevent the introduction of these pests.

Examples of insect pests that may be suppressed under certain public health and safety conditions are:

- Mosquitoes ONLY for West Nile virus suppression ([Link](#))
- Hornet and wasp nests ONLY when nest presence is next to a trail or in a highly visited area, such as a playground.

Wildlife



Urban wildlife such as mountain beavers, beavers, opossums, raccoons, waterfowl and other species are highly desirable and enjoyable part of the natural area recreational experience. SPR encourages the enhancement of native wildlife habitat in all parks, and maintenance activities in natural parks shall include activities to sustain these habitats for native birds, mammals, amphibians and reptiles. Parks staff will generally tolerate most animal or bird activity in natural areas. If control of wildlife is needed, SPR will work with the most appropriated City (Animal Control) or State (Department of Wildlife) agency to assess and develop strategies for maintaining a sustainable, non-damaging population level.

(Link: Bibliography Reference to Russell Link's books: [Living with Wildlife in the PNW](#) and [Gardening for Wildlife in the PNW](#))

Plant Diseases

Even native forests can have serious disease problems. Root rots are the most serious, often killing significant trees, but other problems can occur. Staff should be aware of symptoms of diseases most likely to infect native plants, and determine a strategy for suppression or control as needed, following all IPM procedures.

Important plant diseases are *Phytophthora* and *Armillaria* root rots which commonly affect forest plants. Staff directly responsible for maintenance should routinely monitor for symptoms of these diseases.

Critical Asset Management

Certain assets require specific BMPs that address detailed management strategies for these resources, as follows.

14.6 Forests

The following BMPs guide best practice for forest cover, canopy regrowth, erosion control, steep slopes, organic debris and fire prevention.

Planning by and far is the most important part of forest maintenance. Good planning develops strategies for restoring an area that are both realistic and feasible. It is important to set goals that are attainable and will successfully restore areas to stable native systems. This being said, Long-Term Sustainability is the primary goal of all restoration efforts. To achieve this, it is necessary to actively involve the community in restoration activities. Sustainable restoration will require after-care including periodic maintenance and monitoring. These long-term activities are suitable activities for community driven efforts. Therefore, every attempt will be made to foster community involvement in long-term care. This should be done during all phases of design.

9.6.1 Design

The primary objectives of Forest restoration design are

- 1) Maximize upper canopy cover**
- 2) Maintain plant species diversity**
- 3) Protect and enhance wildlife habitat**
- 4) Support recreational and community activities**

The following principles of stewardship are established to provide guidance to all parks staff. Actual implementation of these principles will vary from park to park based on neighborhood social, environmental and ecological characteristics.

PRINCIPLES OF GOOD LAND STEWARDSHIP

- Be realistic, don't take on more projects than can be completed
- Foster involvement through constituencies, partnerships and leveraged opportunities
- Assure success by involving community and special interest groups
- Ensure success by establishing dedicated community-based long-term care

9. Natural Areas

- Do not work in new restoration sites during nesting times of the year
- Do not remove all vegetation from an area at once – remove it in blocks over time
- Replant vegetation at a size & density capable of replacing what was removed within 4 years
- Maintain new plantings in a manner and frequency that assures survival

9.6.2 Construction and restoration in forests

Restoration as a process takes at least 4 years and is divided into 4 major phases. These phases are further elaborated on in the Greenbelts and Natural Areas Vegetative Management Plan (due to be released in 2005). In general all restoration projects will contain these 4 phases:

PHASES:

- **Planning,**
- **Site Prep/ Installation,**
- **Intensive Maintenance,**
- **Long-term Maintenance.**

Additionally, the following guidelines will be followed for plant selection and placement:

- Plant installations shall consider and incorporate existing adjacent plant community composition when and wherever possible.
- Trees and large woody shrubs shall be planted so that they do not impact trails and access paths. Large trees and shrubs should be planted at least 10 feet from trail edges or access path edges, except for Interpretive Program Areas. For all required planting setbacks, see trails section page#.
- All trees greater than 6 inches that are removed shall be replaced at a 3:1 ratio based on diameter at breast height (DBH). Contact the Senior Urban Forester for guidance.

The following chart presents the general parameters, tasks and work load involved in a typical restoration project.

GENERAL RESTORATION TASK LIST AND WORK SCHEDULE

ACTION: REFORESTATION	MONTH													
	PARAMETERS			J	F	M	A	M	J	J	A	S	O	N
Community Enthusiasm	minimal			lots			lots			some				
Birds Nesting/ Rearing	no			yes			yes			no				
Most Common Weather	wet / cold			wet / warm			dry / warm			wet/ cool				
STAGES	J	F	M	A	M	J	J	A	S	O	N	D		
PHASE 1 - <i>Planning</i> ¹														
PHASE 2 - <i>Site Prep</i>	<input checked="" type="checkbox"/>	<input checked="" type="checkbox"/>									<input checked="" type="checkbox"/>	<input checked="" type="checkbox"/>		
<i>Installation</i>														
PHASE 3 - <i>Intensive</i> (Year 1) <i>Maintenance</i>	↔	↔	↔	↔	↔	↔	●	●	●	●	↔	↔		
(Year 2)			↔	↔	↔		●	●	●		↔	↔		
(Year 3)			↔	↔			●	●			↔			
PHASE 4 - <i>Long-term Care</i>			↔	↔				●		↔	↔			

~ Adapted from the 'Three Year Establishment Care Calendar' first developed for Magnuson Park, found in: *Sandpoint Magnuson Vegetative Management Plan (2000)*

KEY

	Develop work plans (at least 4 months in advance of project dates)
	Advertise, build constituencies
<input checked="" type="checkbox"/>	Follow standard procedure, i.e.: fill out appropriate forms
	Plant

¹ Parks with current VMPs have gone through a large part of the planning process. However, there may be a need to define the scope of the project, required materials, workforce, leverage/ partnering opportunities, project duration, specific intensive maintenance protocols and long-term care strategies. When doing this, the specific VMP developed for that area will be used as the primary resource and guide.

9. Natural Areas

	Water
---	-------



9.6.3 Maintenance









In general, maintenance activities associated with restoration can be summarized as follows:

GENERAL MAINTENANCE SCHEDULE:

	MONTH											
	J	F	M	A	M	J	J	A	S	O	N	D
community enthusiasm	minimal			lots			lots			some		
Birds nesting/ rearing	no			yes			yes			no		
most common weather	wet / cold			wet / warm			dry / warm			wet/ cool		
INITIAL INVASIVE REMOVAL	☺💧			⊘			☹			☺💧		
FOLLOW UP REMOVAL & WEEDING	☺💧			☺			☺			☺💧		
PLANTING	☺💧			☹			☠			☺💧		
MULCHING	☺💧			☺			☺			☺💧		
WATERING				!			!!!					
MONITORING				☑						☑		
MAINTAINANCE	↔			↔			↔			↔		

KEY

	Plan for task during this time
	Schedule task during this time
	repeat as necessary

	Ok to do in wet conditions
	Avoid at All Costs during this time
	Worst time to perform task
	Ok time to perform task
	Best time to perform task
	Essential activity during this time
	Consider performing this activity during this time
	If task has not already been performed by this time, immediate action is required
	Under No Circumstance Even Consider It during this time

Vegetative Cover

Healthy vegetation cover is important for erosion control, habitat, and invasive weed control.

- Except in features that cannot function with vegetative cover (e.g. trails, cliff habitats), vegetation will be preserved and enhanced to maximize its functional value.
- Wherever possible, enhance the conditions that are favorable to desirable vegetation and inhibit undesirable vegetation.
- Limit disturbance and changes to site conditions to prevent loss of plant biomass

Invasive Plant Management

Invasive removal is just one step in the multi-stepped, multi-year process of restoration - refer to 9.6.2 - Construction and Restoration in Forests. Invasive plants should be removed and replaced with appropriate native vegetation where feasible. The scale and scope of an invasive removal strategy or project should always consider funding and labor resources available. These guidelines apply:

- Remove vegetation systematically to limit habitat impacts, especially for nesting birds or aquatic organisms.
- Leave no bare ground where weeds and invasives can reinfest. Plan restoration of the site as part of the IPM strategy.
- Do not remove invasives from an area unless the site can be restored within 3 months. In the case where restoration within that time is not feasible and the invasives must be removed, the site should be mulched with cardboard, landscape cloth or other material and wood chips to a depth of 4 inches and/or wood chips alone.

Canopy Regeneration

Except for grassland/meadow habitats, tree canopy is an integral part of the natural ecosystem. Use the following BMPs to encourage canopy growth:

- Where canopy is fragmented or absent, new plantings should anticipate natural succession in native conditions. In general, Pacific Northwest forests proceed from a pioneer deciduous forest to a predominantly conifer forest.
- While management practices should emulate natural succession, for practical reasons, successional stages may be accelerated, retarded or staggered. For example, you might create canopy gaps to stimulate tree growth in the under story at a particular site.

Vegetation Management Controls Erosion

- **Bare park** land, should be carefully evaluated and the appropriate vegetation established.
- If **bare earth** is evident, it should, at a minimum, have a layer of organic mulch applied to buffer the soil until the appropriate vegetation can be established.
- **Management decisions** should reflect the principles of plant succession leading to a multi-layered canopy, which provides the ultimate buffer to erosion.
- **Natural accumulations of leaf litter** and other organic materials should be left undisturbed whenever possible.
- All streams should be buffered from **excessive runoff** and erosion by a comprehensive watershed study followed by appropriate corrective measures and maintenance.
- **Biofiltration of hard surface runoff** water should be attempted whenever possible. Managing for healthy plant communities is a big element in the prevention of erosion. The grass in a forest can provide adequate erosion buffering provided it is healthy and vital.

Steep Slopes

- ❖ Slide areas, or areas suspected of being slide-prone, will be evaluated by the Parks Engineer before restoration is initiated.

- ❖ Work in identified Steep Slopes areas should be done in accordance with recommended standard operating procedures (SOPs) as specified by the city. Strategies can be developed to help maintain or even improve slope stability
- ❖ Stability of the slope shall be maintained during all phases of installation and prior to completion of all projects. Stability is defined by the city as ‘to possess permanent characteristics, either naturally or by manmade improvements, which can be shown to have sufficient resistance to forces normally expected to occur, and those forces which may occur as a result of a one (1) in one-hundred (100) year event (*Environmental Critical Area (ECA) Code Definitions (SMC 25.09.420)*).
- ❖ Removing vegetation from the ground layer should be minimized, and plantings should be stabilized with appropriate bioengineering techniques (e.g. netting, wattling, hydro mulching, etc.)
- ❖ Storm water runoff must be prevented from saturating or loading steep slopes. The appropriate drainage system should be in place and adequately maintained to intercept runoff flows before reaching the slope. See "Stormwater Management" above under Section X5, Slide Areas

Organic Debris

It is important to maintain available nutrients and minerals on-site in natural areas. Plants and trees depend on rotting vegetative material because our soils tend to be nutrient poor. For this reason, organic debris from maintenance practices will remain on site, as long as it does not interfere with other landscape functions. Types of interference include blocking trails, forming unstable cornices, diverting drainages, smothering desirable vegetation, or having a high tendency to re-root or sprout from debris piles. Wherever possible, use the following BMPs:

- All trees down in woods are left where they fall except when across trails and roads. Trees across trails are cut and put into the woods.
- Leave uncut branches and logs in place to restrict traffic into natural areas.
- Stabilize logs to prevent sliding or rolling.
- Remove invasive species from the site.

Pruning and Hazard Trees

Pruning shall be limited to hazard mitigation, such as dead limbs overhanging trails. Dead trees that do not pose a threat of falling and causing damage to

9. Natural Areas

persons or structures shall be left in place intact to provide habitat and large woody debris within the forest.

Pruning debris from other areas within the park can also be used to enhance habitat by placing within the forest .

Trees in natural areas that are identified as hazards should be evaluated for habitat potential and converted to snag, log or other habitat feature if site conditions warrant.

Fire Prevention

A healthy, diverse plant community is fire resistant, but woody plant debris must be managed in any urban landscape. The following BMPs encourage fire prevention in natural areas:

- Large piles of dead, woody plant debris should not be accumulated near parks structures.
- Maintain transitions to developed landscapes to provide interruptions to the normal path that fires usually travel. This practice creates a more defensible landscape.²
- Hydrants should be located along the edge of natural areas to provide immediate access for firefighting.
- Service roads into large woodland tracts should be maintained to allow access to Fire Department tanker trucks.
- Large woodland tracts with high fire potential should be studied for possible development of service roads.

9.8 Wetlands & Drainage Systems

For years, park maintenance has focused on conserving trees and plants. Today we recognize that water environments are an equally important resource . Seattle parks contain more than 1000 acres of wetlands, including lakes, streams, , riparian corridors, shorelines, rivers and other aquatic habitat. This section describes the BMPs for managing water environments in Seattle Parks.

Wetland of Exceptional Value	means and refers to wetlands with the following values: 1. Rare or unique species listed by the federal or State government as endangered or threatened and needing special protection; 2. Presence of plants or group of plants that occur infrequently in the
------------------------------	---

² DNR publication on Fire Defensible Landscaping

	Seattle or Puget Sound region; 3. Habitat diversity; 4. Sensitivity to disturbance; and 5. Difficulty in replacement of ecological functions unique to Seattle. <i>- Environmental Critical Area (ECA) Code Definitions (SMC 25.09.420)</i>
Degraded Wetland	"Degraded wetland" means and refers to those wetlands which have been altered or damaged by past human activities and/or biologically diminished by invasive, non-native plants so that the natural Biofiltration and habitat values have been rendered inefficient or nonfunctional. <i>- Environmental Critical Area (ECA) Code Definitions (SMC 25.09.420)</i>

9.8.1 Design

All wetland projects will be designed and developed by qualified professionals.

Structures

Structures are constructed features—check dams, water bars, sediment pool, boardwalks, bridges, or stairs—built to mitigate urban impact on sensitive areas.

- Treated materials should be AQC and Plastic. Alternative materials shall be approved during design review.
- Structures should neither interfere with nor dominate natural processes.
- Structures are intended to endure extreme exposures, including unstable ground and constant wetness. Staff should monitor structures as necessary to prevent hazards and degradation.

9.8.2 Construction and renovation in wetlands

In order to avoid alteration of ecosystem function, wetland construction should not be undertaken by maintenance staff. Capital projects will be the only method of renovation within wetland areas. Special consideration to protection of critical habitat shall be mandatory in construction on shorelines, beaches and nearshore aquatic habitat (See Construction Site Management for more details, page #.).

Wetlands will be carefully monitored and managed during construction to prevent loss of the facility and/or adverse environmental impacts. Parks' Planning and Development Staff will be responsible for renovation or other large scale projects in wetlands. Strategies include the following:

9. Natural Areas

- Erosion control
- Materials replenishment
- Large woody debris retention
- Monitoring and inspection
- Routine cleaning

9.8.3 Maintenance

All maintenance in wetlands should be done with least environmental impacts.

Invasive Plant Management

Invasive plants should be removed and replaced with appropriate native vegetation where feasible. The scale and scope of an invasive removal strategy or project should always consider funding and labor resources available. These guidelines apply:

- Remove vegetation systematically to limit habitat impacts, especially for nesting birds or aquatic organisms.
- Leave no bare ground where weeds and invasives can reinfest. Plan restoration of the site as part of the IPM strategy.
- Do not remove invasives from an area unless the site can be restored within 3 months. In the case where restoration within that time is not feasible and the invasives must be removed, the site should be mulched with cardboard, landscape cloth or other material and wood chips to a depth of 4 inches and/or wood chips alone.

Inter-Agency Water Quality Monitoring (Janet will send more agencies)

Agencies that manage City-owned open spaces cooperate with many jurisdictions to preserve and improve water quality. These other agencies include:

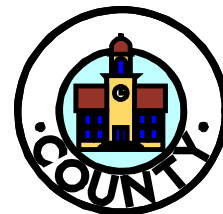

How to Coordinate with Other Agencies

Agency	Type of Coordination
Department of Planning and Development (DPD)	<ul style="list-style-type: none"> Advise them through standard operating procedures of projects that may substantially impact environmentally critical areas. DPD must participate in any review process for projects in watersheds that drain through City property
Seattle Public Utilities (SPU)	Monitor water quality and streambed conditions to document the effects of management practices and development on water quality.
Washington State Department of Fish and Wildlife (DFW).	Obtain a Hydraulic Permit for any project that might impact a fish-supporting watercourse.
Seattle-King County Department of Health(Eileen Hennessy)	Water Quality monitoring for human health
King County Freshwater Assessment Group BEACH Program Jonathon Frodge	Beach Water quality program



Buffers

Tri County Pesticide Use Guidelines, which the City of Seattle follows, impose a 25 foot buffer from all water bodies and wetlands within which the use of pesticides is strongly discouraged. If there is a need for use within this buffer zone, extra precautions and care are required to absolutely keep pesticides out of the water.

Salmon protection ruling by the U.S. District Court for the Western District of Washington imposed a 20 yard or 60 foot buffer zones restricting use of more than 30 pesticide active ingredients along streams supporting threatened and endangered salmon. Special conditions are in place for certain other pest control issues. See Appendix XX, page XXX for detailed information.

9.9 Meadows and Grasslands

The following BMPs guide best practice for grassland vegetative cover, meadow preservation, meadow restoration, habitat preservation, and fire prevention.

9.9.1 Design

To be developed

9.9.2 Construction and renovation in meadows and grasslands

Design or restoration of a meadow should consider the following:

- **Hydrologic Study of the Site.** Available moisture is the determining factor in appropriate plant selection.
- **Soil Study.** Many native plants require specific soil requirements to succeed.
- **Existing Vegetation.** The site should be assessed for desirable species as well as undesirable species. A small test plot can also help determine the potential weed seed bank in the soil profile. A thorough inventory of existing species can provide valuable information for selection of appropriate species.
- **Natural Succession.** Whenever possible, attempt to emulate the natural succession process by initially introducing primarily pioneering plant species and gradually expanding into later successional species as cultural conditions allow.

9.9.3 Maintenance

Mowing or brush removal should be done to suppress brush, which can invade grasslands and change the plant community, altering habitat quality. Scheduling and timing should minimize impacts with wildlife nesting and habitation, typically after August 1st.

One mowing every 2 to 3 years may be sufficient for woody brush control. Firebreak areas may require frequent mowing to maintain. Mowing heights should be approximately 4 to 5 inches or as determined by species composition. Preserve native herbaceous plants such as wildflowers or bulbs.

Grassland Vegetative Cover

Healthy vegetative cover is important for erosion control, habitat, and noxious weed control.

- **Grasses.** Most urban meadow sites are previously disturbed sites resulting in growth of primarily exotic grasses. Once established, these exotic species should be accepted as the primary component of the vegetative cover.
- **Native Meadow Plants.** Preservation of native plants should be attempted whenever possible.
- **Wet Meadows.** Many meadow areas in this region remain in a saturated condition for 6 months or more. Avoiding significant maintenance activities during this period is recommended. Preservation and introduction of appropriate native plants into these sites will help ensure a healthy vegetative cover.

Preservation

To preserve a grassland, wet meadow, or perennial meadow in the Pacific Northwest requires an ongoing maintenance program.

- **Disturbance.** Avoid creating holes in the vegetative cover because it will open opportunities for noxious weeds to invade.
- **Meadow Succession.** The natural evolutionary process of forest/meadow succession will eventually colonize meadow areas with shrubs and trees. The management of this process will have a major impact on the character and longevity of the meadow. The desired character of a meadow area should be defined. The meadow should be managed to prevent establishment of exotic trees and shrubs. Depending on the desired character of the meadow, all, some, or none of the native plants attempting to colonize the site can be retained.
- **Weed and Brush Control.** Scotch broom and other noxious weeds colonize many meadow areas, especially if the vegetative cover is weak or not intact. If invasive brush is a minor problem, hand grubbing or spot spraying with a broadleaf herbicide are both options. When invasive brush is a major problem, it may be necessary to mow the meadow on an annual basis. Mowing should be timed to avoid disturbing wildlife. Spring should be avoided to allow protection for ground nesting birds. The site should be monitored for other wildlife activity before mowing occurs. Mowing should also be done before seed set of the targeted species. Mowing heights should be a minimum of 6 inches high to prevent excessive grass clippings and to minimize exposing bare ground.

Wildlife Habitat

The management practices of meadow areas should reflect the goal of preserving and enhancing desirable wildlife species.

- **Maintenance Activities.** Maintenance activities should be evaluated as to their impact on wildlife and appropriate decisions made.
- **Enhancements.** Many desirable species can be attracted by enhancements such as nesting boxes, brush piles, rock piles, stumps, snags, and specific plants.

Fire Prevention

Wildfire prevention is an important aspect of meadow management. The following items should be considered when managing or creating a grassland.

- **Fuel Loading.** How much fuel does the site contain and what is the potential for an uncontrolled burn?
- **Site Geography.** Does the grassland connect to woodlands, structures, or other valued assets?
- **Fire Breaks.** Grassland areas should have established firebreaks. These breaks divide grassland and woodland areas from homes, park structures, or any other potentially flammable area. The firebreaks should be at least 25 feet wide and should be mowed frequently enough to prevent any buildup of dead grass. Closely mowed swaths and service roads can function as fire breaks. Plan the firebreaks to contain a grass fire to grasslands only.
- **Irrigation.** If a site has an irrigation system, it may be necessary to occasionally activate the system to dampen the potential fuel.
- **Mowing.** Site conditions should be monitored for the above items. Summer or fall mowing could be recommended if conditions indicate.

9.10 Beaches and Shorelines

Beaches and shorelines are considered Environmentally Critical Areas and as such need special considerations to protect both terrestrial, fresh water and marine habitats, with a special emphasis on protecting salmon habitat. PR manages 24 miles of shorelines on Lake Washington, Lake Union, Lake Washington Ship Canal, Green Lake, Bitter Lake and Puget Sound., including 9 swimming beaches.

SPR has several beaches that include designated Marine Reserves on nine miles of Puget Sound shorelines. A marine reserve is any stretch of beach or water that is protected. No collection of organisms, rocks or other features is allowed. Designated these areas on six beaches within the Seattle Parks system will prevent over harvesting of shellfish and damage to local marine habitat. Protecting even limited areas of beach and water gives marine life the chance to reproduce safely and creates nurseries for marine life.

Marine reserves are established within portions of the following beach areas:

Carkeek Park

Golden Gardens Park

Discovery Park

South Alki/Richey Viewpoint

Schmitz Viewpoint

Lincoln Park

Mee-Kwa-Mooks Park

9.10.1 Design

The unstable nature of shorelines requires that beaches be carefully engineered to prevent loss of the facility or adverse environmental impacts such as those from park users. Beach engineering includes importing sand and cobble, armoring, and installing geotextiles to reduce erosion. Jetties, seawalls and other retention structures are ineffective shoreline management.

Shoreline and Bank Stability

Armoring a shoreline should consider the least impact necessary to achieve reasonable stability.

- Traditional use of riprap should be limited to severe exposed sites. Softer treatments, such as log placement and plantings, are preferred where feasible.
- Shoreline improvements and interpretive features should be used to direct usage and interpret non-traditional treatments. Seasonal variations in water (lake or stream) level require additional engineering.

9.10.2 Construction and renovation of beaches and shorelines

Beach construction should not be undertaken by maintenance staff. Capital projects will be the only method of renovation on beaches. Special consideration to protection of critical habitat shall be mandatory in construction on shorelines and beaches, especially in marine reserves (See Construction Site Management for more details, page #.).

Beaches will be carefully monitored and managed during construction to prevent loss of the facility and/or adverse environmental impacts. Parks' Planning and Development Staff will be responsible for renovation or other large scale maintenance of beaches. Strategies include the following:

- sand and cobble replenishment
- driftwood retention
- periodic inspection by divers
- routine sand raking and cleaning

9.10.3 Maintenance

Routine maintenance procedures shall include protection of critical land and water habitat during work tasks. Litter and debris shall be promptly removed from beaches on a daily basis. Do not remove vegetation, animals, rocks or other features from beaches or otherwise disturb beach features. If such features must be disturbed during maintenance, return them back to the place where they were found. Stay out of water areas if possible. Fill any holes that are dug.

Preserve native vegetation and native habitats. Control invasive vegetation and noxious weeds (see IPM, page #). If vegetation management requires plant removal, stage and remove carefully to avoid unnecessary impacts to beaches.

Monitor for wildlife damage or impacts.

Certain projects or maintenance tasks may require permits to execute. Call PPD staff to assess the need for permits.

9.11 Trails

It is the vision of Seattle Parks and Recreation to manage a trail system that provides inviting and safe year round access in parks and natural areas for people of all abilities that is aesthetically and functionally integrated into the surrounding landscape, that promotes the protection of our natural resources and is linked to other Departmental and Citywide environmental stewardship opportunities. SPR has over 65 miles of established trails, with several more miles existing in green belts and natural areas. In general the trails described in this section are permeable or soft surface trails. These trails are not to be confused with the larger asphalt trails that also exist in the form of the Burke Gilman Trail and others. Although many of the trails that exist are maintained by a variety of entities and volunteers, it is important that there is a consistent standard in the maintenance of these areas. The BMPs described in this section are meant to for all trail stewards as a guide.

9.11.1 Design

User Access/Control

Access path guideline: This document clearly defines access paths and usage, and is contained in Vegetation management plans, the trails hierarchy or other documents. A study of predominant use patterns should determine the best way to define access from trails, shorelines, and service roads. These routes should then be developed and maintained using the BMP for trails.

9. Natural Areas

Trail Classification Hierarchy City of Seattle Department of Parks and Recreation October 30, 2000

Below are eight classifications describing the hierarchy of trails within the jurisdiction of the City of Seattle.

Class	Description	Min.-Max. width	Ex
I.	On-Street Trail, or spur section, of which a considerable portion is within Parks and Recreation jurisdiction. Typically a cross-jurisdictional bicycle or walking route. Route is published and/or signed.	5'-0 min., may vary	Ce
II.	Paved multi-use trail. Surfacing either concrete or asphalt. Uses including walking, jogging, skating, bicycling. Cross-jurisdictional, urban, includes street crossings although vehicular access is limited to service vehicles.	8'-0 min.	Bu
III.	Paved multi-use trail. Surfacing either concrete or asphalt. Uses including walking, jogging, skating, bicycling and service access. Contained within a Park, vehicular access limited to service vehicles.	8'-0 min.	Se
IV.	Paved Pedestrian-only walking path contained within a Park.	5'-0 min., may vary	Al
V.	Soft Surface Multi-purpose trail. Crushed rock paving. Primarily walking, service access, limited bicycle use. Contained within a Park, vehicular access limited to service vehicles.	8'-0 min., 12'-0 max.	Ca
VI.	Arterial Walking Trail. Crushed rock paving. Pedestrian only, no vehicle access. Contained within a Park.	4'-0 min., 8'-0 max.	M "u
VII.	Secondary Walking Trail. Improved mineral soil or crushed rock paving. Pedestrian only, usually associated with a Class VI arterial trail. Should reconnect back to arterial, developed area, or terminate at a destination of some significance. Lowest legitimate level of development within the Park system.	2'-0 min., 4'-0 max.	Fa Pa
VIII.	Dirt Track. Illegitimate path or underdeveloped class VI or VII trail awaiting improvement. Illegitimate paths may include private points of access or those in very wet or steep areas typically deemed inappropriate for continued maintenance or future development.	as narrow as 1'-0	Ma sy

9.11.2 Construction and renovation of trails

PART 1 - GENERAL

1.01 Description

The work of this section is limited to the restoration of disturbance resulting from all activities related to the restoration or new construction of trails in Seattle Parks. This work includes, but may not be limited to:

- Clearing and Removal of Existing Invasive Vegetation
- Stockpiling of salvaged Native Plants
- Stockpiling of Native Organic Material

Grading of Disturbed Areas
Construction of Trails and Related Appurtenances
Drainage
Soil Reconditioning
Planting
Mulching
Warranty

1.02 Related Sections

Coordinate the work of this Section with that of all other Sections of the Contract.

1.03 Definitions

The following definitions may apply to this Specification Section only:

“Disturbance” refers to any negative impact to the project site caused by the execution of the Contract, including, but not necessarily limited to, access, excavation, exploration, hauling, staging, stockpiling, or survey.

“Mechanical Damage” refers to damage caused by unnatural physical forces, including vandalism, inappropriate handling, or damage occurring over time as a result of poor materials or workmanship.

“Plant Schedule” refers to the Native Plant Associations: Plant Palettes for Trail Restoration Work, a list of plants associated with the restoration work of this Contract. Schedules are provided for planting in 4 differing cultural conditions.

“Trail Stationing Plan” refers to the spreadsheet formatted stationing plan associated with the restoration work of the Contract identifying specific improvements or restoration measures by type and location.

1.04 Quality Assurance

A. Reference Standards

The following standards are considered part of these specifications.

American Association of Nurserymen
“American Standard for Nursery Stock, ANSI Z 60.1”, latest edition.

B. Inspections

1. On-Going inspection and observation by the City of Seattle Department of Parks and Recreation (DPR) of the work in progress will be coordinated through the Project Manager.

2. Plant Material

9. Natural Areas

Upon approval of purchase order and Vendor, paragraph 1.03.C below, ship plants to project site staging area for inspection and approval by DPR. Remove from the site any plant material not accepted by the inspector immediately. Alternatively, arrange for inspection at the Vendors location, if within 20 miles of the Seattle City limits, within 24 hours of anticipated shipping.

3. Refer to paragraph 3.09 for Inspections required by Warranty.
4. Comply with the requirements of other inspections that may be identified elsewhere in these specifications.

C. Submittals

Provide for DPR approval a copy of all purchase orders for plant material, including the name, address, and telephone number of the Vendor. Do not ship plant material until approved. Approval of purchase order and vendor does not constitute acceptance of plant material.

D. Field Changes

Field Changes may be instituted by DPR, to the extent that the over-all value of the work is not substantially changed. In the event of a substantial change to the scope of work, as determined by agreement between the Contractor and the Owner, a Change Order will be negotiated.

E. Work Force

Work Force to be utilized for Planting, paragraph 3.07, shall be experienced in the planting of native species and be approved by DPR prior to mobilization.

PART 2 - PRODUCTS

2.01 Native Organic Material

Native Organic Material refers to that material encountered within the limits of disturbance, including haul and access routes that consists of naturally occurring decomposed vegetation. This material does not include waste from clearing, logs, branches over 2" in diameter or over 5 feet in length. Native Organic Material, for the purposes of this Section, includes topsoil and composted leaves, sticks, and twigs, which when stockpiled may result in a mixture of those elements.

2.02 Native Mineral Soil

Where described in this Section, Native Mineral Soil refers to that soil encountered during clearing and excavation that contains little or no Native Organic Material. Native Mineral Soil, for the purposes of this Section, includes clay, silt, sand, gravel, and rock in such a combination as to provide adequate drainage with a minimum of visible voids.

2.03 Native Plants

As described in **Appendix A**, Native Plants refer to those species growing native in western Washington state.

2.04 Imported Trail Construction Materials

A. Trail Surfacing

Trail Surfacing shall be 5/8” Minus Crushed Rock, crushed ledge rock or talus with no naturally occurring faces. Particle gradation as follows:

<u>Sieve</u>	<u>% Passing</u>
5/8”	90-100
1/4”	55-75
#40	8-24
#200	5-15

B. Lumber

Materials specified in this Section are for Footbridges under 20’ in length, Water bars, Turnpike sections, and Step construction only. Refer to City of Seattle Department of Design, Construction and Land Use Standards and Details for lumber associated with all other wood construction associated with this Contract.

All lumber for work of this section shall be Pressure Treated ACQ Lumber, #2 Structural.

C. Fasteners

1. All plate-type and stamped fasteners shall be 16 gauge hot dipped galvanized steel or as approved by DPR prior to installation.
2. All other fasteners and connectors, i.e., nails, screws, and bolt assemblies, shall be galvanized steel, sized per details or as appropriate for the task.

9. Natural Areas

3. Reinforcing Bars used as anchor pins for wood-on-grade construction shall be #4 deformed.

2.05 Drainage

- A. Culvert Pipe shall be 12" I.D. corrugated PVC, double-wall re-core, smooth interior wall, or approved equivalent.
- B. Rock for Rock Spillway and Rock Lined Sump shall be granite, largest face generally flat, weathered or shot, and minimum size 1/2 cubic foot.

2.06 Soil Conditioning and Planting Backfill

- A. Native Organic Material as described in this Section, paragraphs 2.01, above.
- B. Moisture Retention Agent shall be an Hydrophilic Acrylic Copolymer, "Soil Moist" by JRM Chemical, Cleveland, Ohio, or equal.
- C. Planting Backfill shall be a thoroughly blended mixture of existing soil, Moisture Retention Agent at the manufacturers recommended rate, and Native Organic Material.

2.07 Plant Material

A. Provide only those plant species identified on the Schedules and listed in **Appendix A**, Native Plant Associations: Plant Palettes for Trail Restoration Work. Where specific cultivars or varieties are not identified, provide only the species as indicated. Do not provide cultivars or varieties.

B. Size

1. Meet or exceed the standards for plant size per container as described in "American Standard for Nursery Stock, ANSI Z 60.1".
2. Provide trees and shrubs at the sizes indicated on the schedules. In the event of unavailability, provide one size smaller at a documented credit to the Owner, or alternatively, one size larger at no additional cost to the Owner.
3. Provide groundcovers at the size indicated on the schedules. In the event of unavailability, provide one size smaller at a documented credit to the Owner.

C. Quality

1. Meet or exceed the standards for plant quality as described in "American Standard for Nursery Stock, ANSI Z 60.1".

2. Plant Material shall be healthy, vigorous, and sound upon inspection and acceptance. There shall be no evidence of insect infestation including eggs, insects, or feeding damage. There shall be evidence of mechanical damage such as broken branches, root balls, or bruising of foliage.

3. Plant material shall have been grown and held in conditions similar to those expected for the species.

2.08 Mulch

Mulch shall be DPR wood chips or Erosion Control Blanket, unbound Wood Excelsior, supplied in bales.

PART 3 - EXECUTION

3.01 Clearing

- A. In general, clear only that vegetation that is immediately threatened by activity associated with the work of this Contract.
 - B. Remove no deciduous trees over 3” in trunk diameter measured 4 feet above ground level and no coniferous trees measuring over 5’ above ground level without prior approval of DPR. Obtain approval by flagging trees proposed for removal prior to coordinating a review by DPR. Anticipate the alignment far enough ahead to allow for alternate routing in the event proposals for tree removal are rejected by DPR.
 - C. Where overhead clearance requirements necessitate the pruning or limbing of tree branches over 3” in diameter at that point where the cut is to be made, obtain approval through the same procedure identified above in paragraph 3.01.B.
 - D. Refer to the construction details associated with the trail work for additional clearing requirements.
 - E. Remove thoroughly from the Project Site all material cleared. Alternatively, chip all material mechanically and disperse equally to both sides of the Project alignment.
-

F. Leave Downed Woody Debris (DWD) to decompose in natural areas.

3.02 Stockpiling of Native Organic Material and Salvaged Native Plants

9. Natural Areas

- A. Refer to the above paragraph 2.01, for a description of Native Organic Material.
 - B. Excavate by scraping the upper soil profiles to collect the material. Work in such a manner as to accumulate a minimum of Native Mineral Soil.
 - C. Stockpile Native Organic Material (Organic Material) in a linear “berm” along both outer edges of disturbance. In the event that excavated Native Mineral Soil (Mineral Soil) requires such room as to make stockpiling the Organic Material on both sides of the disturbed area impractical, stockpile the Mineral Soil on the up-slope side of the disturbed area. Areas receiving stockpiles will be considered disturbed areas.
 - D. Stockpile Organic Material loosely. Do not compress or compact stockpiles beyond the natural compression of the material to achieve a steeper angle of repose.
-
- E. Carefully dig up root ball of native plants identified by Urban Forester and place in 1 gallon containers for future replanting. Store pots in wood chip mulch and insure adequate irrigation for duration of trail construction.

3.03 Grading

- A. General
 - 1. Grading of disturbed areas within the limits of DPR jurisdiction falls within two categories. Grading taking place beneath areas to receive trails on grade and their associated appurtenances, referred to as “Traffic Areas”, grading taking place beneath areas to receive elevated trail structures such as footbridges and bridges, and grading taking place along areas to receive Plantings, referred to as “Non-Traffic Areas”.
 - 2. On average, the rough grade of all areas within the limits of disturbance shall transition smoothly into the adjacent existing undisturbed grades. Exceptions are those areas on the up-slope side, which are scheduled to receive parallel ditches.
- B. Traffic Areas
 - 1. All Traffic Areas shall be rough graded with clean Native Mineral Soil containing a minimum of contaminating organic material.
 - 2. Areas scheduled to receive a Standard Trail Section;

- a. Shall be graded with a side slope draining either inward to a parallel drainage ditch or outward down-slope at between 2 and 5 percent.
 - b. Shall be compacted to the greatest density supportable by the surrounding soils and slopes.
3. Areas scheduled to receive Turnpike and/or Water-bars;
- a. Shall be graded flat, or no more than 2% across in any direction.
 - b. Shall be compacted to the greatest density supportable by the surrounding soils and slopes.
4. Areas scheduled to receive Drainage improvements;
- a. Shall occur only as excavations into undisturbed soil.
 - b. Shall be graded in lateral section per the drawings and in profile such that they result in a positive designed out-fall.

C. Non-Traffic Areas

1. All Non-Traffic Areas shall be rough graded with either Native Mineral Soil or a combination of Native Mineral Soil and Native Organic Material (Organic Material). Minimize use of stockpiled Organic Material and do not use Organic Material occurring outside the limits of disturbance.
2. Areas scheduled to receive Elevated Trail Structures;
- a. Shall be graded;
 - i. To smoothly transition into adjacent existing grades.
 - ii. To drain along pre-existing flow lines. Where directed, reconstructed flow-lines shall be reinforced with imported rock, as associated with drainage work, and as defined in paragraph 2.04.B, above.
 - b. Shall be compacted to the greatest density supportable by the surrounding soils and slopes.
3. Areas scheduled to receive Plantings;
- a. Shall be graded to smoothly transition into adjacent existing grades.

9. Natural Areas

- b. Shall be compacted to such an extent as to prevent excessive erosion but not to such an extent as to inhibit infiltration or percolation of surface water into the soil. Generally, 70% of maximum density at 15% moisture by weight.

3.04 Trail Construction

A. General

1. Work of this Section consists of all services, labor, equipment, and materials necessary to construct the trail system described in the Trail Stationing Plan. This includes construction of Standard Trail Section, Water Bars, Turnpike Section, Steps, and Footbridges under 20' in length.
2. The Trail Stationing Plan has been developed to meet the existing topography, soil conditions, and apparent hydrology of the Project Site. If, in the course of construction, substantial changes are made to any of these existing characteristics, it will become necessary to alter, in the field, the Trail Stationing Plan. The current schedule of construction details associated with this work and described below will be used to adapt the plan to actual conditions. Refer to paragraph 1.03.D.
3. Prior to performing the work of this section, verify the condition of the rough grade as being in conformance with the above paragraphs 3.03.A.2 and 3.03.B. Obtain Urban Forester approval of conditions as adequate to proceed.
4. Provide clean, uncontaminated surfaces.

B. Standard Trail Section

1. Generally, Standard Trail Section consists of a 48" (standard) or 72" (wide section) wide trail tread on grade.
2. Import and place Trail Surfacing in a single lift to the dimensions specified in the details. Provide sufficient material to insure a full 3" depth following compaction.
3. Compaction
 - a. Perform compaction only under suitable conditions. Do not compact excessively wet or dry material or when the sub-grade soils are excessively wet or dry. Allow materials to dry or add clean water as necessary to achieve optimum moisture.

- b. Mechanically compact the Trail Surfacing to the maximum density supportable by the underlying soils.

C. Turnpike

1. Generally, Turnpike shall consist of a 48" (standard) or 72" (wide section) wide trail tread on grade, retained by 8"x 8" Pressure Treated ACQ timbers pinned to the sub-grade with 24" of #4 deformed reinforcing bar, 3 bars per timber.
2. Layout and set bottom of retaining timbers flush to, or up to 1/2" below, compacted sub-grade, end to end with no gaps between timbers. Stagger joints on opposing sides of tread where practical. Miter ends of timbers equally where trail alignment turns.
3. Pre-drill timbers 3/8", to accept reinforcing bar pins, at 12" from each end and at center. Set 24" - #4 reinforcing bar pins into stable soil to a depth of 3/4" below the top of retaining timber.
4. Import and place, in one lift, sufficient Trail Surfacing to provide an average depth of 4" following compaction, with a crown of 1" above top of retaining timbers.
5. Compaction per 3.04.B.3, above.

D. Water Bars

1. Generally, Water Bars are intended to both divert surface water off the trail and stabilize Trail Surfacing. Construct Water Bars of 6"x6" Pressure Treated ACQ timbers pinned to the sub-grade with 24" - #4 deformed reinforcing bar, 2 bars per timber. Install Trail Surfacing, as for Standard Trail Section, paragraph 3.04.B above.
2. Locate timbers flush to the prepared sub-grade, spaced per the Trail Stationing Plan. Where formal drainage ditching is scheduled, set timbers to divert surface run-off into these ditches. Where no formal drainage work is associated with the Water Bars, set the timbers to divert surface run-off generally down-slope.
3. Pre-drill timbers perpendicular to the prevailing slope 3/8", to accept 24" - #4 reinforcing bar pins, at 6" from each end. Set reinforcing bar pins into stable soil to a depth of 1" below top of timber.

E. Timber Steps

9. Natural Areas

1. Generally, Steps are constructed of 6"x6" LP-22 timbers arranged in a "crib-work" fashion, each riser consisting of 2 sides and a leading edge, stacked and staggered to fit the slope to the tolerances indicated in the drawings. Individual timbers are fastened with 30" - #4 deformed reinforcing bars as indicated below.
2. Begin all Step construction at the bottom of the slope by excavating a stable, flat bench slightly larger than the design dimensions of the Step. Mechanically compact this bench to the maximum density supportable by the soils present, assuming optimum moisture content per paragraph 3.04.B.3 above.
3. Arrange the timbers per the drawing, with the leading edge timber spanning the full width of the Steps. Length of the sides of the crib-work will vary depending on the slope. Provide sufficient length for the next Steps sides to overlap a minimum of 12".
4. Pre-drill timbers plumb 3/8", to accept 30" - #4 reinforcing bar pins, as follows;
 - a. For leading edge timbers, at 2 places, 4" from each end.
 - b. For side timbers, at 4" from exposed ends.
 - i. If tread will be longer than 24", one place centered between exposed end and leading edge of the next riser.
 - ii. If last riser at top of steps, 3 places, 12" on center beginning 4" from each end.

Set pins into stable earth to a depth of 3/4" below top of each timber.
5. Backfill each Step as it is constructed by importing sufficient Trail Surfacing in a single lift, to completely fill the crib-work upon compaction per 3.04.B.3, above.
6. Begin construction of successive risers directly atop the preceding riser, using the drilling and pinning procedure, paragraph 3.04.E.4 above, to secure the overlapped portions of the riser below.
7. Backfill the sides of the completed Steps with Native Mineral Soil to a point 2" below the bottom of the leading edge timber of each step.

F. Puncheons and Railings

1. Generally, Puncheons are wooden structures constructed with either post-and-beam construction for sections over 14” above grade or mud-sill construction for sections under 14” above grade. Sections more than 30” above grade require a handrail. All timbers lumber, and fasteners are per paragraphs 2.03.B and 2.03.C above, sized per the details or as appropriate for the task.
2. Refer to other Specifications of this project for details regarding installation of Sewer Interceptor supported by Puncheons or Boardwalks.
3. At the Contractors option, all construction of Puncheons under 20’ in total length associated with this project may be of the post-and-beam construction technique described for Footbridges over 14” above grade, or per details provided for Boardwalks or Footbridges over 20’ in overall length.
4. Construct all Puncheons components plumb and level, with the exception of extreme ends, which may transition at up to, but no more than, a 5% slope down to the successive or proceeding trail detail.

3.05 Drainage

A. General

1. Work of this Section consists of all services, labor, equipment, and materials necessary to construct the Drainage work associated with the trail system described in the Trail Stationing Plan. This includes construction of Drainage Dips, Drainage Ditches, Rock-Lined Sumps, Culverts, Leadoff Ditches, and associated Rock Spillways.
2. The Trail Stationing Plan has been developed to meet the existing topography, soil conditions, and apparent hydrology of the Project Site. If, in the course of construction, substantial changes are made to any of these existing characteristics, it will become necessary to alter, in the field, the Trail Stationing Plan. The current schedule of construction details associated with this work and described below will be used to adapt the plan to actual conditions. Refer to paragraph 1.03.D.
3. Verify that the condition of areas scheduled to receive drainage work is consistent with the requirements of paragraph 3.03.B.4 above. Obtain Engineer approval of conditions as adequate to proceed.

9. Natural Areas

B. Drainage Dips

Where directed by the Trail Stationing Plan to install a Drainage Dip, refer to the detail and provide the necessary grading alteration to the specified trail construction detail, paragraph 3.04, above. Each Drainage Dip shall collect and divert surface run-off down-slope to an associated Rock Spillway, paragraph 3.05.G, below.

C. Drainage Ditches

1. Where indicated on the Trail Stationing Plan, Drainage Ditch refers to a surface run-off interceptor trench that runs parallel to and up-slope from the trail and perpendicular to the prevailing slope
2. Where directed by the Trail Stationing Plan, excavate Drainage Ditches to the dimensions indicated in the details. Provide ditch bottoms that slope positively to the associated outlet.
3. Where Drainage Ditches slope at greater than 1' vertically in 12' for more than 30', provide a 6"x6" timber check-dam across the bottom of the ditch, embedded 12" into each side, 10' spacing. Secure the timber check-dam as for Water Bars, paragraph 3.04.D.3 above, except 12" from each end.

D. Rock-Lined Sump

Where directed by the Trail Stationing Plan to install a Culvert associated with a Drainage Ditch, install on the up-slope side of the trail or trail structure a Rock-Lined Sump (Sump) as follows;

1. Identify the intersection point of the flow-line of the culvert and the flow-line of the associated ditch to be drained. At the point of intersection, excavate sufficient undisturbed Native Mineral Soil to allow the excavation to be tightly lined with Rock, per paragraph 2.04.B above, leaving a sump approximately 1 foot deep below bottom of ditch invert of Culvert with a capacity of 2 cubic feet. Dimensions for Sump should be approx. 1'-5 square or 1'-7 diameter.
2. Beginning with the bottom of the Sump and working up to the bottom of the associated Drainage Ditch, line the Sump with Rock. Rock should fit tightly, with no gaps over 2" in any dimension. Provide additional Rock across the bottom of the Drainage Ditch which over-hangs the Sump 1" to protect the Sump walls from out-wash.
3. Pack joints in the bottom of the Sump with 5/8" Minus Crushed Rock per paragraph 2.03.A.

E. Culvert

1. Generally, Culverts occur either at the apparent low-point of a Drainage Ditch or as a surface water run-off outlet along flat, wet runs of trail. If for reasons defined in paragraph 3.04.A.2, the Trail Stationing Plan identifies a location as scheduled to receive a Culvert that does not appear to meet this criteria, notify the Project Manager and obtain specific direction before proceeding with the work.

3. Culverts have, normally associated with them, the following additional elements;
 - a. Rock-Lined Sump, paragraph 3.05.D, above.
 - b. Leadoff Ditch, paragraph 3.05.F, below.
 - c. Rock spillway, paragraph 3.05.G, below.

2. Install Culverts as follows;
 - a. Generally perpendicular to trail, sloping to drain down-slope.
 - b. Extend Culvert 12” beyond edge of trail up-slope or 4” into Sump
 - c. Extend Culvert 12” beyond edge of trail down-slope
 - d. Invert of pipe at inlet shall be either
 - i. Flush with finish grade at Culverts not associated with Drainage Ditches.
 - ii. At 6” below bottom of Drainage Ditch.
 - e. Minimum cover over Culvert shall be 6”.
 - f. Invert of Culvert out-fall shall be sufficiently lower than the inlet to provide adequate flow, generally 2-5%.
 - g. Where the existing slope permits, construct a Rock Spillway at the out-fall of the Culvert.
 - h. Where the existing slope would otherwise inhibit discharge of the out-fall, construct a Lead-off Ditch, paragraph 3.05.F

F. Lead-off Ditch

9. Natural Areas

1. Construct a Leadoff Ditch where directed by the Trail Stationing Plan or where the elevation of the out-fall of a Culvert would otherwise be below existing grade.
2. Leadoff ditches shall have a flat bottom 8" in width shall be a minimum 12" in depth, depth increasing as necessary to provide a 2% slope to a point where natural grade allows for discharge. Leadoff Ditches shall be excavated into previously undisturbed earth.
3. At the out-fall point of all Leadoff Ditches, provide a Rock Spillway, paragraph 3.05.G.

G. Rock Spillway (no detail for this in drawings)

Install Rock Spillways (Spillway) at the out-fall point of all drainage structures as follows;

1. Use only imported rock, which complies with paragraph 2.04.B of this specification.
2. Extend the Spillway the width or diameter of the drainage structure discharge to each side of the discharge point and 3 times that dimension down-slope. Slope the Spillway to drain a minimum 2% or to conform to the existing slope. Embed the Rock so that only the top plane is exposed, butting all joints as tightly as possible. Pack all resulting joints with 5/8" Minus Crushed Rock complying with paragraph 2.03.A.

3.06 Soil Reconditioning

A. General

The intent of the work of this section is to provide a complex soil profile and finished grade for planting that is more conducive to the survival of native plant species scheduled for restorative planting. All areas of disturbance, generally those consisting of exposed mineral soils unless otherwise directed by the Urban Forester, shall receive Soil Reconditioning.

- B. Identify the limits of disturbance remaining following the work of paragraphs 3.03, 3.04 and 3.05. Verify that the condition of rough grades encountered is in compliance with paragraph 3.03.C, as appropriate for the specific location. Obtain Urban Forester approval of the conditions as adequate to proceed before commencing the work.
- C. Distribute equally all stockpiled Native Organic Material over the disturbed areas identified above. Incorporate this material into the top 2" of the sub-grade soil. Roll or otherwise lightly compact the resulting surfaces to form a consistent mat.

3.07 Planting

A. General

1. All areas of disturbance not occupied by drainage, trail on-grade, or related appurtenance, shall receive Planting, including areas beneath Bridges, Boardwalks, or Puncheons.
2. Refer to the Trail Stationing Plan for identification of areas to receive plant material from each of the four Plant Schedules. Calculate the total area associated with each Plant Schedule, and provide a copy of the purchase order to the Urban Forester for approval, per paragraph 1.03.C.
3. Provide and maintain stationing stakes indicating limits of planting for each schedule.
4. Planting activity is to take place between October 1st and December 1st only, unless site conditions warrant otherwise or authorized by Urban Forester.
5. Prior to commencing planting activity, obtain approval of the plant material per paragraph 1.03.B.2.

B. Shipping and Handling

1. Plant material received on-site showing evidence of mishandling such as tightly bound or broken branches, crushed or misshapen containers or root-balls, or stripped, crushed, or severely bruised foliage will be rejected and must be removed from the project site immediately.
2. Plant material shall be transported to the planting location with extreme care and attention. Do not handle plant material by any means other than fully supporting the container or root-ball. Previously accepted plant material showing evidence of mishandling, such as broken branches or loose root-balls will be rejected and must be removed from the site immediately.

C. Tree Location

Stake for DPR approval the locations of individual trees. Locate in a natural, random pattern. Alternatively, provide DPR with stakes pre-marked by species and in the specified quantities for placement within 48 hours of receipt.

D. Preparation and Planting

1. Excavate planting pit approximately one and one half times as deep as the root mass provided with the plant and twice as wide.

9. Natural Areas

2. Planting Backfill

To the excavated soil, thoroughly incorporate the manufacturers recommended rate for Moisture Retention Agent and the Native Organic Material found at the surface of the pit.

4. Gently disturb the root ball of the plant manually; loosen or cut tightly wound or matted roots.

5. Set the plant plumb in the planting pit on a small mound of soil, spreading roots out, and add Planting Backfill. By hand, compact the backfill to eliminate air pockets.

6. Sufficient Planting Backfill should result in the plant root crown being flush or slightly above, the surrounding grade.

6. Where practical, water plants thoroughly.

3.08 Mulching

Provide 4" wood chip mulch , or alternately, a uniform 2" layer of unbound Wood Excelsior Erosion Control Blanket over all disturbed areas not covered by trail on-grade or drainage appurtenances.

3.09 Warranty

- A. Prior to Project Closeout, coordinate a punch-list walk-through with the Urban Forester and DPR.
- B. Correct any punch list items to the standards established by the Trail Stationing Plan, Plant Schedules, details, and this Specification. Upon satisfying the requirements of the punch list, request DPR acceptance of the work as substantially complete.
- C. Warranty the materials and workmanship for a period of one year from date of DPR acceptance as substantially complete, as follows;
 - 1. At 6 months, coordinate an inspection of the condition of the work and correct, in a timely manner, any damage or failure as follows;
 - a. For plant material, replace 100% of trees and shrubs and 50% of groundcovers showing significant sign of decline as determined by DPR. Exclusion to this warranty is allowed for obvious mechanical damage due to vandalism or natural processes.
 - b. For Drainage work and Trails or Trail Appurtenances, repair and/or replace any defects

which may have occurred other than obvious mechanical damage due to vandalism.

2. At the one year anniversary, coordinate an inspection of the condition of the work and correct, in a timely manner, any damage or failure as follows;
 - a. For plant material, replace 50% of trees and shrubs showing significant sign of decline as determined by DPR. Exclusion to this warranty is allowed for obvious mechanical damage due to vandalism or natural processes.
 - b. For Drainage work and Trails or Trail Appurtenances, repair and/or replace any defects which may have occurred other than obvious mechanical damage due to vandalism.
- D. Upon satisfaction of the requirements of the inspections at 6 months and one year, obtain DPR approval of the work as physically complete.

END OF SECTION

APPENDIX A

NATIVE PLANT ASSOCIATIONS: *Plant Palettes for Trail Restoration Work*

Adapted from “*Grow your Own Native Landscape*” by Michael Leigh, Native Plant Salvage Project; Cooperative Extension; WSU/Thurston County

The following plant lists are species recommended for trail-side planting. There are 4 different groups specified for varying conditions. Each group is further divided as follows:

Zone A -3 feet adjacent to the trail - plant no species greater that 3’high x 2’ spread

Zone B - 5 feet on each side of trail - plant no species with greater than 5’ spread

Note: species in bold face are considered hardiest for trailside use.

1. DEEP SHADE/ MOIST SOILS

Ground Covers: *(plant in Zone A – 3ft. on each side of trail)*

lady fern (*Athyrium filix-feminina*)

salal (*Gaultheria shallon*)

sword fern (*Polystichum munitum*)

Bunchberry (*Cornus unalaschkensis*), deer fern (*Blechnum spicant*), false Solomon’s seal (*Maianthemum racemose ssp ampexicaulis*), foam flower (*Tiarella trifoliata*), Pacific bleeding heart (*Dicentra formosa*), Piggy back plant (*Tolmeia menziesii*), redwood oxalis (*Oxalis oregana*), snowberry (*Symphoricarpos albus*), wild strawberry (*Fragaria spp.*)

Tree & Shrub Understory: *(plant in Zone B – 5 ft. on each side of trail)*

low Oregon Grape (*Berberis/mahonia nervosa*)

red huckleberry - on stumps & logs (*Vaccinium parvifolium*)

red osier dogwood (*Cornus sericea ssp. occidentalis*)

red elderberry (*Sambucus racemose ssp. Pubens var. arborescens*)

evergreen huckleberry (*Vaccinium ovatum*), vine maple (*Acer circinatum*).

Canopy: *(plant in Zone C - furthest from trail, or not at all)*

*Western Hemlock (*Tsuga heterophylla*), Western Redcedar (*Thuja plicata*), Cascara (*Rhamnus purshiana*), Douglas fir (*Pseudotsuga menziesii*)*

2. PARTIAL SHADE/ WELL-DRAINED SOILS

Ground Covers: *(plant in Zone A – 3’ on each side of trail)*

sword fern (*Polystichum munitum*)

trailing yellow violet (*Viola sermpervirens*)

Twinflower (*Linnaea borealis* ssp. *Longiflora*), deerfoot vanilla-leaf (*Achlys triphylla* ssp. *Triphylla*), western trillium (*Trillium ovatum* ssp. *Ovatum*)

Tree & Shrub Understory: (plant in Zone B – 5' on each side of trail)

bald hip rose (*Rosa Gymnocarpa* var. *gymnocarpa*)

indian plum (*oemlaria cerasiformis*)

low Oregon Grape (*Berberis nervosa*)

oceanspray (*Holodiscus discolor*)

red huckleberry (*Vaccinium parvifolium*), on stumps and logs

salal (*Gaultheria shallon*)

beaked hazelnut (*Corlylus cornuta* var. *californica*), evergreen huckleberry (*Vaccinium ovatum*), mock orange (*Philadelphus lewisii* var. *gordonianus*), western serviceberry (*Amelanchier alnifolia* var. *humptulipensis* or var. *semiintegrifolia*), red-flowering currant (*Ribes sanguineum* var. *sanguineum*), vine maple (*Acer cincinatum*) (

Canopy: (plant in Zone C - furthest from trail or not at all)

Bitter cherry (*Prunus emarginata* var. *mollis*); Douglas fir (*Pseudotsuga menziesii*); Western Redcedar (*Thuja plicata*); Grand fir (*Abies grandis*); high bush cranberry (*Viburnum edule*)

3. SUN/ MOIST SOILS

Ground Covers: (plant in Zone A– 3' on each side of trail)

lady fern (*Athyrium filix-femina*)

sword fern (*Polystichum munitum*)

false lily-of-the-valley (*Maianthemum dilatatum*), Pacific bleeding-heart (*Dicentra formosa* ssp. *formosa*), Sawbeak sedge (*Carex stipata*), small-fruited bulrush (*Scirpus microcarpus*), **violets (*Viola* species)**

Tree & Shrub Understory: (plant in Zone B – 5' on each side of trail)

pacific willow (*Salix lucida* ssp. *Lasiandra*)

red-osier dogwood (*Cornus sericea* ssp. *Occidentalis*)

Sitka willow (*Salix sitchensis*)

thimbleberry (*Rubus parviflorus* var. *Parviflorus*)

black twinberry (*Lonicera involucrata* var. *involucrata*), clustered wild rose (*Rosa pisocarpa*), Nootka rose (*Rosa nutkana* var. *muriculata* or var.

9. Natural Areas

nutkana), **Pacific** ninebark (*Physocarpus capitatus*), vine maple (*Acer circinatum*)

Canopy: (plant in Zone C - furthest from trail or not at all)

Big leaf maple (*Acer macrophyllum*), bitter cherry (*Prunus emarginata* var. *mollis*), black cottonwood (*Populus basamifera* ssp. *Trichocarpa*), black hawthorn (*Crataegus suksdorfii*); common chokecherry (*Prunus virginiana* var. *demissa*), Pacific crabapple (*Malus fusca*), red alder (*Alnus rubra*)

4. SUN/ WELL-DRAINED SOILS

Ground Covers: (plant in Zone A – 3' on each side of trail)

sword fern (*Polystichum munitum*)

kinnikinnick (*Arctostaphylos uva-ursi*), coastal strawberry (*Fragaria chiloensis*), twinflower (*Linnaea borealis*), sedum (*Sedum*), lupine (*Lupinus polyphyllus*), Cardwell's penstemon (*Penstemon cardwellii*)

Tree & Shrub Understory: (plant in Zone B – 5' on each side of trail)

bald hip rose (*Rosa gymnocarpa*)

evergreen huckleberry (*Vaccinium ovatum* var. *ovatum*)

indian-plum (*emleria cerasiformis*)

oceanspray (*Holodiscus discolor*)

red-flowering currant (*Ribes sanguineum* var. *sanguineum*)

salal (*Gaultheria shallon*) snowbrush (*Ceanothus velutinus* var. *hookeri*)

blue elderberry (*Sambucus cerulea* var. *cerulea*), hairy manzanita (*Arctostaphylos columbiana* ssp. *Columbiana*), mock orange (*Philadelphus lewisii* var. *gordonianus*), western serviceberry (*Amelanchier alnifolia* var. *humptulipensis* or var. *semiintegrifolia*), red huckleberry (*Vaccinium parvifolium*, on stumps and logs), vine maple (*Acer circinatum*), (orange honeysuckle (*Lonicera ciliosa*))

Canopy: (plant in Zone C - furthest from trail or not at all)

bitter cherry (*Prunus emarginata* var. *mollis*), common chokecherry (*Prunus virginiana* var. *demissa*), Douglas fir (*Pseudotsuga menziesii*), grand fir (*Abies grandis*), Pacific Shore pine (*Pinus contorta*); beaked hazel (*Corylus cornuta* var. *californica*)



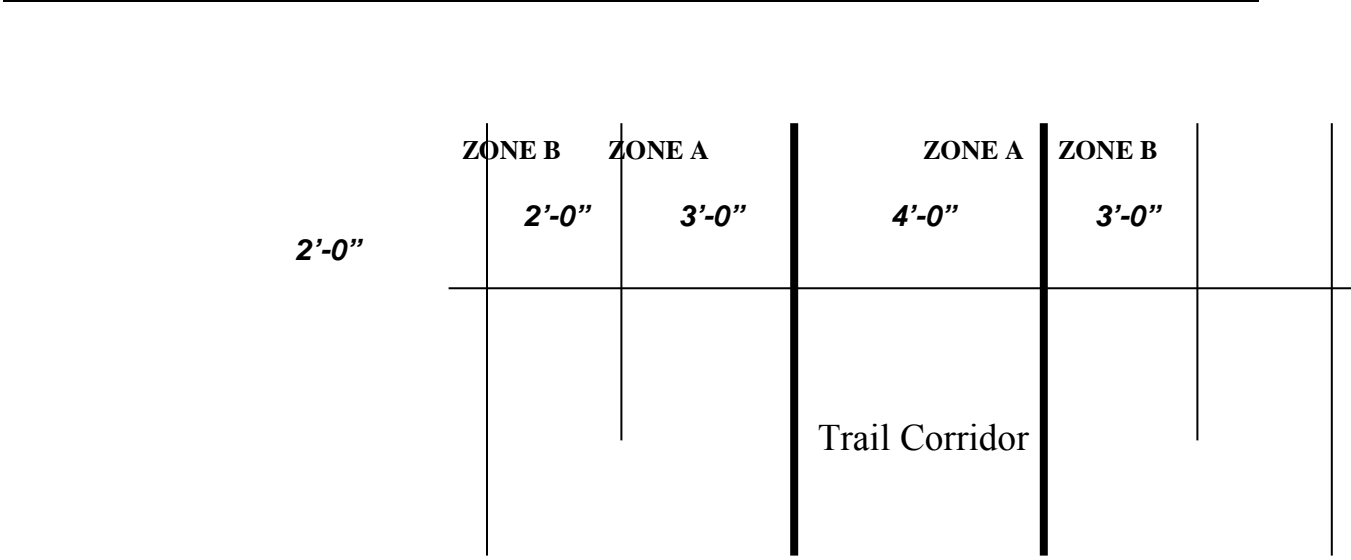

TYPICAL TRAIL PLAN

nts

9.11.3 Maintenance

The maintenance of trails hinges on the construction and maintenance of proper drainage systems along trails. See "Drainage" above. Trail surfaces can be composed of bare mineral soil, wood chips, or crushed gravel. The existing surface can be maintained by adding the same material that is already there. Do not mix surface treatments. Restrict access or close any excessive and redundant social trails using barriers and plantings.

Trail Maintenance Standards

Maintaining the Trail Travel Corridor

In order to provide safe and enjoyable hiking experiences year round, all trails should be free of obstructions and brushed out to a height and width of 8 feet. To accomplish this, vegetation and other elements of the urban forests (e.g.: down trees, rocks, debris piles) should be removed from all trail areas if they encroach into the trail travel way.

- Trails should be brushed to 8 feet high and 6 feet wide. All material removed should be safely scattered off trail, down slope, and away from trail structures.
- Vegetation which is not growing over the trail tread *and* is less than 18 inches high does not need to be removed.
- On steep slopes, vegetation on the uphill side of a trail should be brushed back an additional foot while the vegetation on the downhill slope can remain flush to the trail tread. This encourages hikers to use the more stable uphill portion of the trail tread.
- With a hand pruner, saw, lopper, or weed whip, cut out the vegetation (or other trail obstruction) within 3 feet of the center of the trail.
- Vegetation over 18" tall should always be cut flush with the ground (take out the whole plant) or at the point where a branch connects to its mother branch or trunk. Removing the whole plant, or at least an entire limb, is best because “stubs” (the exposed cuts on plant limbs) pose a danger to future trail users, and often sprout new “branchlets” out into the trail corridor. Pruning this way insures that the plants do not have to be recut year after year.

Maintaining the Trail Backslope

Trails, which are located on sloping terrain (as apposed to trails in relatively flat areas), should not have a backslope in excess of 45 degrees. Steep backslopes force hikers away from the more durable inside (uphill) edge of the trail, and force them to use the outer edge (or shoulder) of the trail where tread material erodes quickly.

- With a Hoe, Pulaski, or Pick Mattock, loosen all material needing to be excavated from the backslope and remove it with a shovel. In most cases, vegetation and other forest debris will have to be removed before excavation can begin.
- The backslope of all trails should be maintained at an angle less than 45 degrees.
- All material removed while maintaining the proper backslope should be safely scattered well off trail, down slope, and away from trail structures.

Maintaining the Trail Tread

Trail tread should always be 4 feet wide, smooth, hazard free, free of standing water and mud, properly graded for effective surface water runoff, and consist of hard packed mineral soil, gravel, or crushed rock.

- Trail tread should be uniformly smooth and slightly out-sloped (about 5 degrees), or crowned. Out-sloping the trail means grading the trail tread so it is lower nearest the outer (and down hill) edge of the trail and highest at the trail's inner (or uphill) edge.
- A crowned trail means the trail tread is highest in the trail's center, and gently slopes downward towards the outer edges of the trail. Trail tread, which is crowned or outsloped, encourages surface water to drain off trail (sideways) rather than down the trail. Water, which is allowed to run down the trail causes erosion and will increase the amount of maintenance a trail, will need over time.
- All plant life growing on the trail tread (including moss, grass, flowers, weeds, etc) should be removed, and standing water or muddy areas should be eliminated.
- With a Pulaski, Pick Mattock, or Hoe, remove all roots, rocks, logs, or other tripping/stumbling hazard from the trail tread.
- Tread hazards should be chopped or dig out to a depth of 6 inches and the resulting hole filled with mineral soil, gravel, or crushed rock. Always tamp the worked area with a McLeod or tamper to compact the new material consistent with the overall tread.
- To create a trail tread that drains well (as described above), use a Pulaski, Pick Mattock, Hoe, or shovel to move material from one area of the tread to another to create a proper trail outslope or crown. Compact all material with a McLeod or tamper. Use a Smart level to ensure a slope of 2-5%.
- To eliminate mud puddles or areas of standing water, use a shovel or McLeod to remove all muddy soil and moisture from the trail tread. Once all moisture and mud is removed, fill in the resulting depression with mineral soil, gravel, or Crushed

9. Natural Areas

rock, and re-establish the trail's outslope or crown. Tamp down all tread material with a McLeod or Tamper.

- In areas where the trail has expanded so the tread is more than 3 feet wide, move nearby forest materials (such as plants, leaves, sticks, old logs, and large rocks) into the trail so the tread is brought back to the appropriate size.
- Any items put within reach of the trail must be firmly in place and resistant to rocking or tipping.) If the trail in question is on a slope, always cover the downhill portion of the tread so as to retain the upper 4 feet of tread.

Maintaining Timber Steps, Board Walks, Puncheon, Footbridges

- Use a shovel blade to scrape out any material from the wood. Stairs and wooden structures should be completely free of debris and plant life at all times.
- The shovel blade can also be used to test the integrity of the wood and to check for rot. For puncheon and Footbridges be sure to check the sills or supports for level and integrity.
- Using a small sledge drive any exposed re-bar back into the structure to avoid tripping hazards.

Maintaining Rockwalls

- By hand, check the rockwall for loose components and use smaller rock to fill in eroded areas.

Maintaining Drainage Structures

Water bars, drain ditches, and culverts should always be clean, clear, and properly sloped to eliminate tread erosion, on trail standing water, and the creation of mud puddles. Culverts, water bars, and drainage

ditches should be maintained to allow maximum trail drainage and prevent water from flowing onto the trail. If materials are damaged, rotten, or easily kicked out of place, the structure should be replaced.

All drainage structures made of wood, plastic, or similar materials should be firmly in place, resistant to prying, and free of rot or other damage

Drain Ditches

- Use a Pulaski, Mattock, McLeod, Hoe, or shovel to maintain drainage ditches to a depth and width of one foot. Most importantly, eliminate ditch walls, which are greater than 50 degrees. The walls of all drain ditches should be angled less than 50 degrees to reduce and eliminate dirt or other forest debris from sloughing off the walls and into the ditch. Any nearby logs, rocks, or sticks should be moved well away from the ditch to allow the trail Maintenance Staff easy access, and any plant life growing in the ditch should be removed.

Water Bars

- Use Pulaski, Mattock, McLeod, Hoe, or shovel to remove all debris and excess dirt from the uphill edge of Water Bar. A slight depression should be maintained along the upper edge of the water bar to facilitate collection and diversion of surface water from the trail. Maintain the water bar's leadoff ditch at its downhill end consistent with a standard drain ditch (as described above). The trail tread on the downhill or "downtread" edge of the water bar should be flush with (or slightly higher than) the top of the water bar, while the upper edge, or "uptread" part of the water bar (the one nearest where the water flows) should be slightly lower and packed with gravel so as to prevent water from under cutting the water bar.

Culverts

- Use a shovel blade, shovel handle, or a post hole digger to scrape out any material from inside the culvert. Culverts should be completely free of debris and plant life at all times. Catch basins of culverts should be dug out to at least 4 inches lower than the bottom of the culvert. Deep catch basins allow sediments in the runoff to settle out and ensure that water traveling through the culvert is fast flowing and clear. Like drain ditches, catch basins should have sloped walls no greater than 50 degrees and should be

free of plant life, debris, sticks, etc... The downslope opening of the culvert should also be free of obstructions and should be maintained as a drainage ditch. If possible, the downslope opening of the culvert should be two inches higher than the bottom of the drain ditch to prevent water from backing up into the culvert.

9.12 Training



:

- Natural Areas BMP Overview
- Stormwater management
- Arboricultural technology and techniques
- Integrated pest management and invasive plant control techniques
- Stream protection and regulations

Appendices

- Tree Policy
- Viewpoints List
- Interpretive Program Areas

F–Signage Standards

