

# Isoclad

All panel cores - one panel supplier



# Isoclad

## Introduction



Based on a single site in the North East but delivering nationally since 1978, Isoclad are one of the major manufacturers of insulated panels and ancillaries in the UK.

Totally committed to fulfil any design requirements you may have, we offer an extensive range of panel cores, including Mineral Fibre, PIR, EPS and XPS. Combining the cores with the facing of your choice we can assure your build not only has structural strength, and superior thermal insulation, but also a visually pleasant, consistent finish.

To complement the wide range of panels we also stock fixings, flashings and ceiling suspensions, making Isoclad the ideal 'one stop shop' for complete panelling systems. With us you need only one enquiry, one order, one delivery and one invoice. Easy!

Understanding that, 'waiting time can be wasted time' we organise our delivery times to suit your site/production needs. We are able to offer a next day delivery for ancillaries and 3 to 5 days for panels.

Next day panel delivery is available on request.

### Certification

Isoclad hold a comprehensive portfolio of fire testing accreditations and assessments, including approvals from the Loss Prevention Certification Board (LPCB) and Warrington Fire. All our products are manufactured to comply with the requirements of ISO 9001 standards.

We are active in helping to develop construction industry standards and continually seek to develop our product range and look into new, even more environmentally friendly, production methods.

By bringing together our laminating capacity and engineering know how we have developed new products. In January 2010 Isoclad became the first large scale panel manufacturer to offer built in enhanced security features within insulated panels. The upgraded core includes multiple layers. This enhanced panel is certificated by the Loss Prevention Board to LPS 1175 SR4 and is ideal for environments where high value assets and goods are stored where security is paramount.

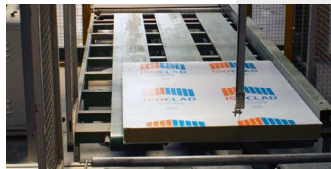

Approved for UK Government Use,  
for details contact CPNI



European Ballistic Standard  
EN1063 - BR2 (NSR), BR3 (SR)  
BR5 (NSR), BR6 (NSR)



# Meet the Team at Isoclad - Here to help

## Administration Team



**Sara, Donna & Jasmin**



## Technical



**Holly Yeaman**  
Architectural Technician

## Sales Team



**Andy Palmer**  
Technical Sales Manager  
M: 07801 588672



**Emma Bryson**  
Sales Office Manager



**Emma Symington**  
Sales Co-ordinator

## Securiclad



**Claire Sales**  
Business Development

## Manufacturing and Production



**Carl Lowson**  
Manufacturing Manager



**Steve Ellis**  
Production Planner



**Neil Kipling**  
Production Planner

## Financial Control



**Melanie Heslop**  
Accounts Manager

## Management



**Mike McColl**  
Managing Director

**Isoclad Ltd**  
T: 0191 258 5052  
E: [sales@isoclad.co.uk](mailto:sales@isoclad.co.uk)

[www.isoclad.co.uk](http://www.isoclad.co.uk)

# Products

## Panel Properties

- Environmentally Friendly
- Visually Identical Finish
- Fast Construction
- Sound Proof
- Air Tight Structures
- No / Low Heat Loss
- Complete Systems
- Chemically Resistant
- Weather Resistant
- Structural Strength
- Design Flexibility
- Thermal Performance

## Panels

Isoclad manufacture a range of insulated and fire-resisting panels which can be used for wall systems, horizontally or vertically and ceilings.

All panels are manufactured to an ISO 9001 quality assurance system.

The Isoclad composite panel is produced on a continuous lamination machine and consists of a 'core' of thermally efficient insulant which is bonded between prestressed galvanised steel faces.

The complete 'sandwich composite' process gives the panel its structurally impressive free spanning characteristics and makes it suitable for both internal and external applications.

Isoclad panels are a versatile composite insulated panel system, particularly suited for temperature-controlled applications e.g. chill and cold stores as well as distribution centres, firewall applications, data centres, clean rooms and the pharmaceutical industry.



## Core Properties

Core Properties	Firestop	PIR	EPS	XPS	Securiclad
<b>FIRE</b>	Excellent	Good	-	-	Excellent
<b>Water</b>	Good	Excellent	Good	Excellent	Good
<b>Thermal Insulation</b>	Fair	Excellent	Good	Good	Fair
<b>Environmental</b>	Excellent	Excellent	Excellent	Excellent	Excellent



## The insulated fire rated panel system

The **Firestop** panel has a Mineral Fibre\* (European fire classification Class A1 rated) core and due to its superior fire ratings and non-combustibility is especially suitable for high fire risk locations, such as bakeries, any area where cooking is prevalent or fire walls to comply with Building Regulations.

The non combustibility of Mineral Fibre combined with the steel facings give **Firestop** panels a Class '0' rating and according to the new European classifications for reaction to fire, a Class A2.

Additional classification in relation to smoke production is s1 and flaming droplets/particles is d0.

### Firestop 10 (Fstop10)

Lightweight fire rated non-combustible wall panels designed for internal linings and partitions for general industrial applications and high risk environments.

**Fstop10** has a density of 100kg and is suitable for low to medium height walls.

### Firestop 12 (Fstop12)

Stronger and more durable fire rated non-combustible panel primarily for use in internal and external applications where longer spans and greater loads and improved fire performance ratings need to be attained.

**Fstop12** has a density of 125kg and is suited to longer wall spans and ceiling panels.

\* Mineral Fibre insulant comprises of mineral rock fibres bonded together with thermo setting resins to form the insulant materials.

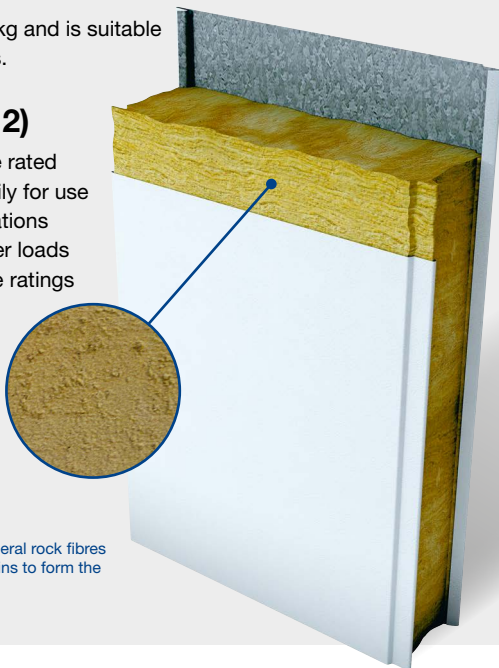

## The multi-purpose insulated panel system for any environment

The PIR panel has a Polyisocyanurate core. Manufactured from MDI Polyols and blowing agent (ODP Zero + GWP less than 5) to produce highly crosslinked polymers. This closed cell foam has an excellent thermal performance, good shear and tensile strength and is very lightweight. These benefits make our panels ideal for freezers, chill store and areas of high humidity.

### PIR

Lightweight fire rated non-combustible panels designed for internal linings and partitions for general industrial applications and low temperature environments.

PIR has a density of 40kg fully cured sanded and de-dusted, square and flat full boards of specified thickness.

Slab production allows a much greater array of thickness, a superior surface flatness (+/-0.5mm). As our PIR block is fully cured prior to processing, there can be no shrinkage or expansion of the material inside the panel, a phenomenon common with injected panels.

\*PIR is manufactured from a mixture of Polyol and MDI and a number of additives to produce highly cross-linked polymers with a closed cell structure

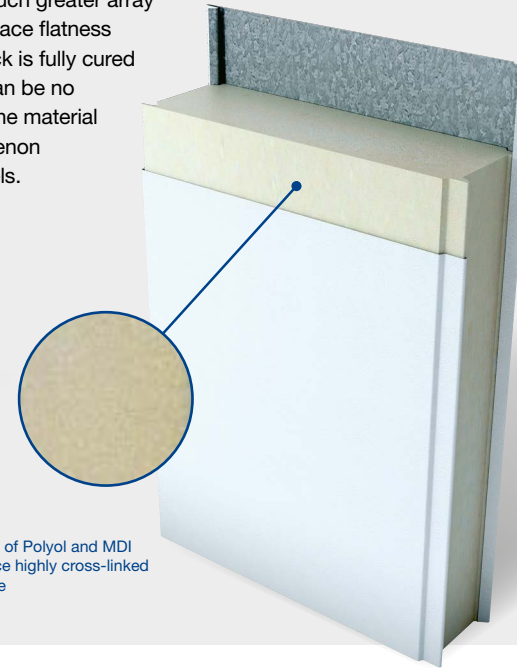

**Isoclad Ltd**  
T: 0191 258 5052  
E: sales@isoclad.co.uk

[www.isoclad.co.uk](http://www.isoclad.co.uk)

# Isoclad EPS

Expanded Polystyrene

## The multi purpose panel for temporary or cost effective containment

The main benefits of Isoclad EPS panels are its weight, strength and cost effectiveness, making it most suitable for areas such as stand alone cold and chill stores, areas of high moisture and low/no fire risk.

Polystyrene is one of the most cost effective lightweight rigid insulation materials available.

With a thickness Dependant on the application, Isoclad fabricate using 'brick build' standard density ( $15\text{kg/m}^3$ ) but also higher density ( $20\text{kg/m}^3$ ) foam panels.

Both grades contain a flame retardant additive (FRA) which restricts the extent of burn when tested to BS4735:1974 and will self extinguish if the source of the fire is removed.

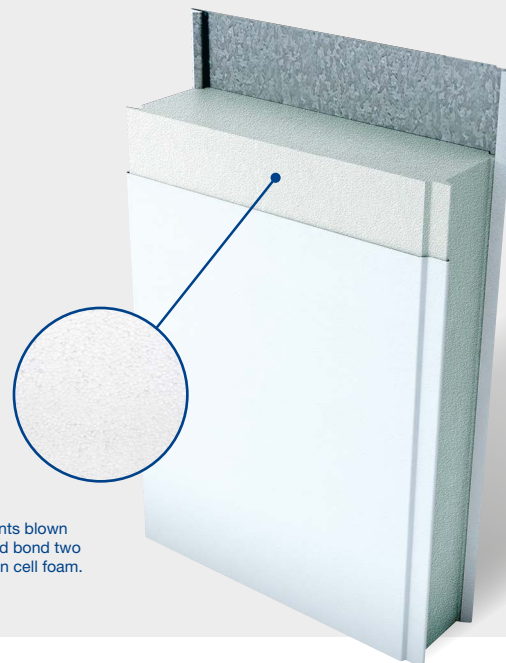

\*EPS is based on crude oil components blown using pentane to increase volume and bond two components together to form an open cell foam.

# Isoclad XPS

Extruded Polystyrene - Styrofoam

## The highly insulated and strong panel system

Extruded polystyrene is based on the same raw materials as expanded polystyrene but due to its manufacturing method, it has superior strength and higher humidity resistance.

Styrofoam panels are ideal for blast freezers and areas with high moisture applications, or where increased impact resistance is required.

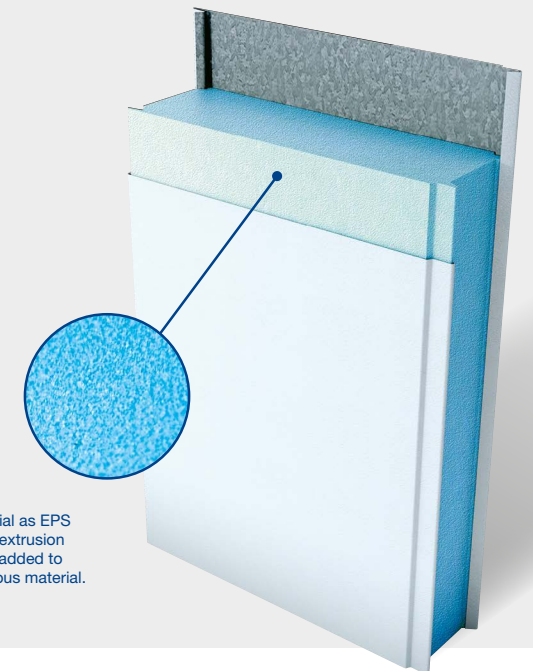

\*XPS is based on the same raw material as EPS and is manufactured by a continuous extrusion process, in which blowing agents are added to produce a rigid closed cell, homogenous material.

## The Carbon 'Negative' Option

In response to environmental concerns we developed an OSB faced mineral wool core 'SIPS' panel, as an alternative to the traditional PU 'SIPS' panel. Our non-combustible panel offers a carbon negative, walling solution to which a variety of weatherproofing options can be added externally. Our MW spline system eliminates cold bridging and aids quick installation with no parts other than three fixings required. All OSB is sourced from responsible certified forests.

## Dimensions

- A standard SIPS width is 1220mm
- Non standard panels widths below 220mm are available on request
- Thickness range from 100mm up to 300mm on request
- Panel lengths can be manufactured to any length up to 6250mm long restricted only by transport and handling constraints
- Panels are joined together using the standard interlocking rebate and spline joint system to form a continuous wall



\*11mm OSB3 is laminated to mineral wool (conroc12) core using 2 part polyurethane adhesive.

**Isoclad Ltd**  
T: 0191 258 5052  
E: [sales@isoclad.co.uk](mailto:sales@isoclad.co.uk)

[www.isoclad.co.uk](http://www.isoclad.co.uk)

# Securiclād

High security wall, ceiling and floor panels for the construction of secure environments. Rated to LPS 1175 SR4

Securiclād



Approved for UK Government Use,  
for details contact CPNI



LPS1175 SR3 and SR4  
Modular Security Enclosure and  
Partitioning System



Certificate number 142a.  
Approved for LPS1208  
and en13501



European Ballistic Standard  
EN1063 - BR2 (NSR), BR3 (SR)  
BR5 (NSR), BR6 (NSR)

The Securiclād panel system was developed by Isoclād in response to specifier, end user and authority demand for a product which provides the versatility of standard composite panels, but which achieves higher levels of security.

The product has been exhaustively tested by the Loss Prevention Certification Board and achieves LPS1175 Security Rating 4. Securiclād is also approved for use by HM Government.



Available with a choice of core types to satisfy fire rating and insulation requirements, the product is pre-finished (with a range of colours available) therefore negating the need for any 'wet trade' requirements.

A range of compatible door and ancillary products are also available to complement the system and the panels may be used for both internal and external applications.

Like our existing composite panels, Securiclād offers a method of construction that is significantly quicker and easier to install than conventional building methods.

To ensure compliance with Securiclād's approved certification, all installations must adhere to the details provided in our Construction Manual.

Securiclād offers:

- **Fully certified system**
- **Pre-finished product, no 'wet trade' requirement**
- **Bespoke manufacture- minimal waste**
- **Quick installation time**
- **Suitable for internal and external use**
- **Excellent fire ratings**

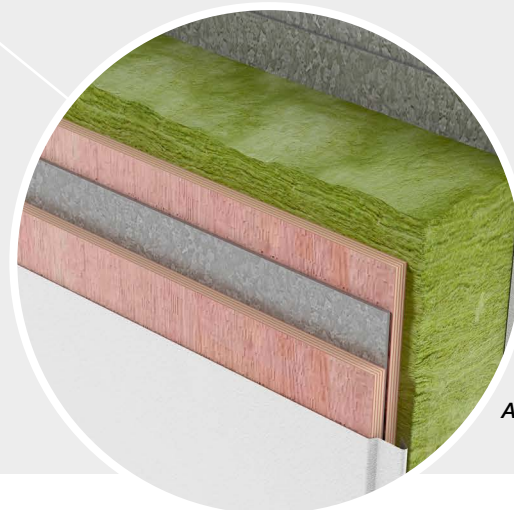

Anticutting Material





## Excellent Product Performance

Securiclad has proven to be a cost effective, secure solution in a wide range of applications. Whether offering a 'stand-alone' modular construction, upgrading an existing building or acting as a secure partition; Securiclad provides the answer in a variety of business sectors.

Comprehensive technical assistance is available and lead times are unrivalled in the industry. Please contact the Sales Department with your enquiries in relation to Securiclad - Our market leading, security rated composite panel.



**Securiclad** can be used in:

- Data Centres
- Secure Cargo Areas
- Pharmaceutical Environments
- Financial Institutions
- Hospitals
- Local Authorities
- Radiological Rooms
- Cash Handling Facilities
- Document Storage
- Personal Security/ Safe Room
- High Value Asset Storage

**Securiclad Ltd**  
T: 0191 258 5052  
E: sales@isoclad.co.uk

[www.securiclad.co.uk](http://www.securiclad.co.uk)

# Panel Joints

Isoclad manufacture panels with two types of joints: Standard Intaloc and Secret Fix.

The steel edge itself is roll formed to create the male/female inter-locking joint which gives the assembled system its superb strength characteristics.

The joint allows application of site applied mastic or silicone to the female edge, creating an effective vapour or food safe hygienic seal which does not protrude beyond the face of the panel

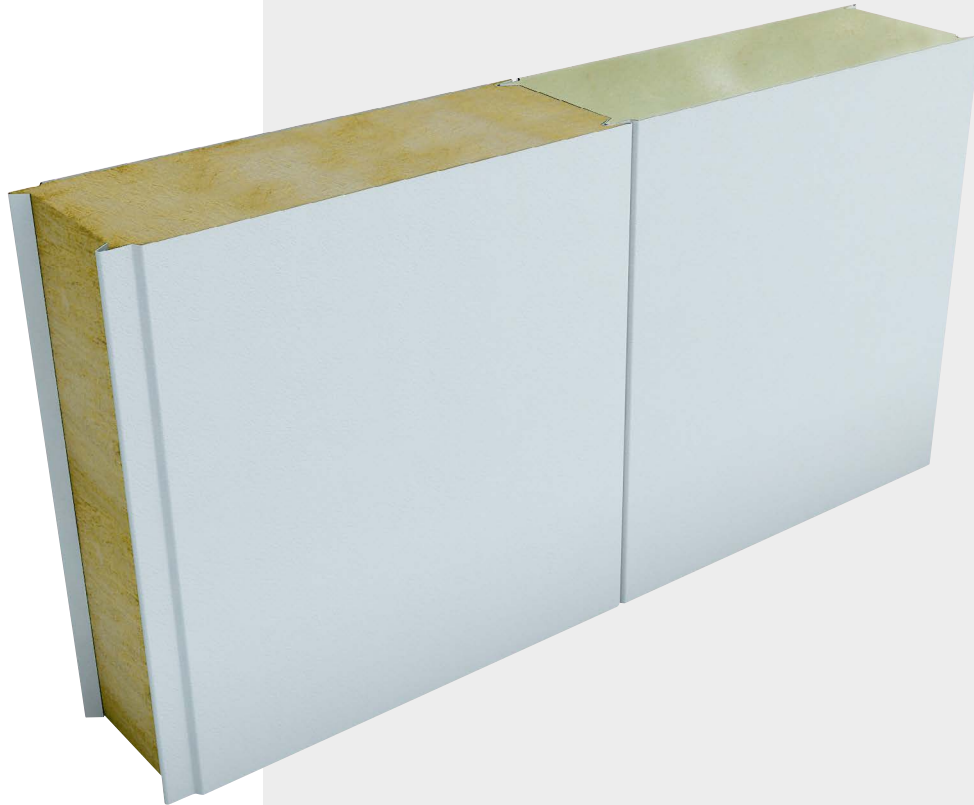

## External/Internal facing finishes

We offer a complete range of facings available in 0.5mm and 0.7mm hot dipped galvanized substrate with the following pre-coated finishes.

### External

HP200	PVF2	HPS ULTRA
Colour coat leathergrain, A 200 micron PVC paint system with leathergrain emboss, available in various colours	Colour coat smooth 27 micron poly vinyl di fluoride stoved fluorocarbon, available in various colours	Colour coat Scintilla, organic coated 200 microns Scintilla, emboss of 40 microns. Available in various colours

### Internal

WFSL	Polyester	Primer
120 micron thick White Food Safe Laminate for internal hygienic areas	Standard white 25 micron painting system consisting of primer and polyester finish. Other colours upon request.	7 micron coat of epoxy paint

## Panel Dimensions

**Width:** Standard panel width 1190mm

Non standard panel width down to 900mm can be accommodated by arrangement

**Thickness:** Range from 40mm up to 300mm

**Length:** We can manufacture panels to any length; the only restrictions being the transport and handling constraints.

## Joint Detail

Roll formed to create the male/female inter-locking joint.

### Intaloc

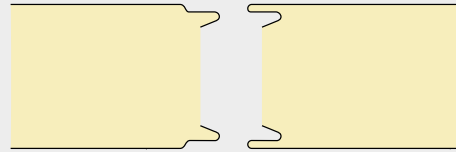

### Secret Fix

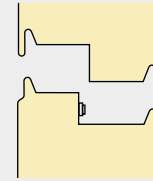

## Profiles (NOT TO SCALE)

### Flat

Laminated panel produces a much flatter surface than other manufacturing methods, but 'optical' flatness is not assured; some shadowing might be evident in certain lighting situations.

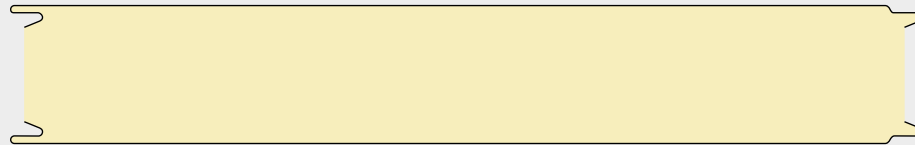

### V-Rib

(Pitch 200mm - 5 per panel)

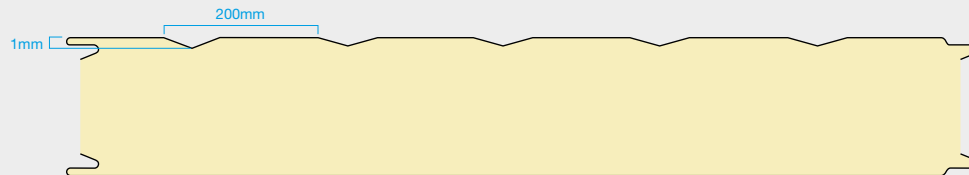

### Castellation

(Pitch 100mm)

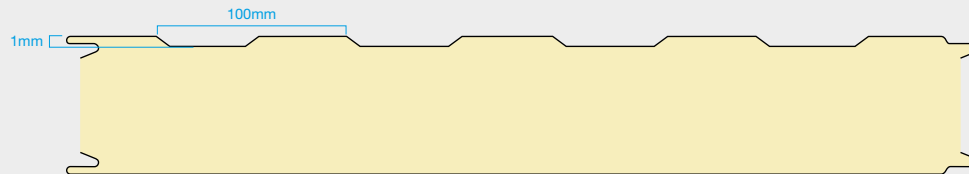

### Micro rib

(Pitch 30mm - 1 side only)

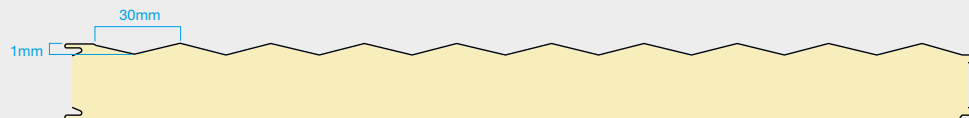

**Isoclad Ltd**  
 T: 0191 258 5052  
 E: sales@isoclad.co.uk

[www.isoclad.co.uk](http://www.isoclad.co.uk)

# Resistance

To increase the performance of our panels we are continually developing our products, making sure we always meet the latest legislative requirements, building control regulations and insurance company needs.

Newly developed products undergo thorough in-house testing and we also carry out regular fire tests in established testing centres, such as BRE-Watford and Warrington Fire.



## Thermal Resistance

Different cores give panels different thermal resistances making some panels more suitable for fire applications, such as bakeries, and others more suitable for chill or freeze related applications, such as cold stores and indoor ski slopes.

We are the only major UK LPCB approved manufacturer of the full range of panel cores (Mineral Fibre and PIR) and therefore uniquely positioned to give totally unbiased advice on panel applications.

If in doubt specifiers should refer to their insurance provider or the latest IACSC guide to ascertain the correct core material according to risk.

All Isoclad panels are produced in accordance with Building Regulation requirements and meet the highest thermal resistance standards. Different requirements can be met by the correct selection of core type and thicknesses

## Fire Resistance

Fire resistance is measured in terms of:

**Integrity** – the ability of a system to stop the penetration of hot gases and flames

**Insulation** – the ability of a system to reduce the temperature rise on the unexposed side of the fire and therefore prevent fire spread through radiated heat.

## Fire Ratings & Maximum Unsupported Spans

Isoclad Firestop panels used in a wall application will provide equal fire performance from both sides i.e. symmetrical fire performance and require NO additional components in order to achieve the excellent ratings shown in the following tables opposite.

When considering the fire resistance of a panel system it is important to refer to both integrity and insulation.

## Vertical

### Fire Ratings & Maximum Recommended Span

Panel	Thickness (mm)	Fire Resistance (mins)		Max Unsupported Span (m)	
		Integrity	Insulation	LPS 1208	BS476 Part 22
<b>Firestop10 Walls (Stitched)</b>	100 - 200	240	60	7.50	6.9 - 9.5
<b>Firestop10 Walls (Unstitched)</b>	75	30	30	3.00	-
	100 - 125	30	30	5.50	6.9 - 7.9
	100	60	60	4.00	6.9
	125	60	60	4.65	7.9
	150 - 200	60	60	5.50	8.8 - 9.5
	150	90	90	4.00	8.8
	175	90	90	4.35	9.3
	200	90	90	5.00	9.5
<b>Firestop12 Walls (Stitched)</b>	150	219	178	-	11
<b>Firestop12 Walls (Unstitched)</b>	75	30	30	3.00	-
	75	60	60	3.00	-
	100 - 200	30	30	7.50	9.3 - 12.0
	100 - 200	60	60	6.00	9.3 - 12.0
	100	90	90	4.00	9.3
	125	90	90	5.00	10.2
	150 - 200	90	90	5.50	11.0
	150	120	120	4.50	11.0
	175	120	120	5.25	11.7
	200	120	120	5.50	12.0
<b>PIR Walls (Stitched)</b>	100	46	41	3.00	-
	150	30	30	6.00	-
	150	60	30	4.00	-

## Horizontal

### Fire Ratings & Maximum Recommended Span

Panel	Thickness (mm)	Fire Resistance (mins)		Max Unsupported Span (m)	
		Integrity	Insulation	LPS 1208	BS476 Part 22
<b>Firestop10 Walls (Stitched)</b>	100 - 200	240	60	7.50	-
<b>Firestop 10 Walls</b>	100 - 200	30	30	6.00	6.9 - 8.0
	100 - 200	60	60	4.35	6.9 - 8.0

## Ceilings

### Fire Ratings & Maximum Recommended Span

Panel	Thickness (mm)	Fire Resistance (mins)		Max Unsupported Span (m)	
		Integrity	Insulation	LPS 1208	BS476 Part 22
<b>Firestop 12 Ceilings</b>	100 - 125	30	30	6.0	-
	150 - 200	30	30	7.5	-
	100 - 125	60	60	4.4	-
	150 - 200	60	60	6.0	-
	150 - 200	90	90	4.7	-
	150 - 200	120	120	4.1	-
<b>PIR Ceilings</b>	150	82	50	3.40	-

## Securiclad

### Fire Ratings & Maximum Recommended Span

Panel	Thickness (mm)	Fire Resistance (mins)		Max Unsupported Span (m)	
		Integrity	Insulation	LPS 1208	BS476 Part 22
<b>Securiclad Walls 142a/09(08)</b>	100	30	30	6.00	-
	100	60	60	5.20	-
	100	240	90	4.00	-
<b>Securiclad Ceilings</b>	100	30	30	6.00	-
	100	60	60	4.10	-



LPS1175 SR3 and SR4  
Modular Security Enclosure and  
Partitioning System



Certificate number 142a.  
Approved for LPS1208  
and en13501

bre

**Isoclad Ltd**  
T: 0191 258 5052  
E: sales@isoclad.co.uk

[www.isoclad.co.uk](http://www.isoclad.co.uk)

# Technical Specification

Notes :

- 1) Tables are Derived from CERAM Laboratory Test Data Ref (QT18518/2/JB) Carried out in January 2012. Copyright © 2010 Isoclad
- 2) Load Tables show Unfactored Loads and are based on an elastic deformation limit of Span / 200
- 3) Span data based on 0.5kN/m<sup>2</sup> uniformly distributed load (NOTE other manufacturers may quote a lower figures of 0.25)
- 4) Reference should be made to BS EN 14509 2006 - Self Supporting Double Skin, Metal Faced Insulation Panels where appropriate.
- 5) Loads refer to lateral applied wind loads, where panels are quoted as ceiling panels, suitable allowance has been considered for self weight.



## Structural Walls

Maximum Recommended Span (m)

Core Thickness	50	75	100	125	150	175	200
Firestop 10	5.1	6.0	6.9	7.9	8.8	9.3	9.5
Firestop 12	7.8	8.4	9.3	10.2	11.0	11.7	12.5
PIR	5.8	7.9	10.0	10.4	10.8	11.3	11.8
OSB/OSB	6.7	7.5	8.4	9.0	-	-	-

## Structural Ceilings

Maximum Recommended Span (m)

Core Thickness	50	75	100	125	150	175	200
Firestop 12	4.8	5.4	6.0	7.0	7.5	7.9	8.2
PIR	4.4	5.2	6.0	6.7	7.5	8.3	9.2
OSB/OSB	4.7	5.5	6.4	7.2	8.0	-	-

## Panel Weight Kg/m<sup>2</sup>

Core Thickness	40	50	75	100	125	150	175	200
Firestop 10	-	13.9	16.8	19.6	22.5	25.4	28.3	31.1
Firestop 12	-	14.9	18.3	21.6	25.0	28.4	31.8	-
PIR	9.7	10.0	11.0	11.9	12.9	13.8	14.8	15.7
Polystyrene	8.7	8.8	9.2	9.5	9.9	10.2	10.6	10.9

Panel Weights in kg/m<sup>2</sup> based on 0.5 thickness steel  
Add 1.1 kg/m<sup>2</sup> for ceiling or 0.7 panels

NB. Securiclad technical information is available on a separate brochure

## Thermal Properties

Insulation Materials	Thermal Conductivity W/m <sup>2</sup> c	40	50	75	100	125	150	175	200
<b>Firestop 10</b>	0.040	-	0.80	0.53	0.40	0.32	0.27	0.23	0.20
<b>Firestop 12</b>	0.042	-	0.84	0.56	0.42	0.34	0.28	0.24	-
<b>PIR</b>	0.022	0.55	0.44	0.29	0.22	0.18	0.15	0.13	0.11
<b>Styrofoam</b>	0.028	-	0.56	0.37	0.28	-	0.19	-	0.14
<b>Polystyrene</b>	0.038	0.95	0.76	0.76	0.38	-	0.25	0.22	0.19



**Isoclad Ltd**  
 T: 0191 258 5052  
 E: sales@isoclad.co.uk

[www.isoclad.co.uk](http://www.isoclad.co.uk)

# Handling & Maintenance

Isoclad recommends the use of approved types of mechanical handling equipment when dealing with composite panels. Using appropriate lifting devices can improve the efficiency and reduce the losses due to damage.



## Off-Loading

Isoclad panels will generally arrive on site packs. The packs should be off-loaded on arrival by mechanical means i.e. side loader/fold truck or crane. Care should be taken to avoid damage from use of inappropriate equipment.

If the packs are longer than 4 metres, it is recommended that a properly designed and fabricated lifting beam is used. It is important that if a lifting beam is used, it should carry an authentic test certificate and display the safe working load (S.W.L) in accordance with safety regulations as applicable



## Forklift Offload

When unloading the panels the forks should be set at their maximum distance apart and located centrally. It is important that the panels do not come into contact with the mast uprights of the forklift as damage could occur.

Panel stacks should be offloaded one pack at a time and then placed on even ground ensuring stacks of panels are stable at all times.

The unopened panel stacks should be positioned so as to minimise any movement of individual panels from the stack to the point of installation.



## Crane Offload

When offloading the panels, care must be taken not to damage their edges. To help protect the edges of the panels from sling damage, spreader beams and adequate lifting slings should be used.

When using suction lifting equipment, as soon as the panels are lifted from the stack they should be rotated 90° into a vertical orientation to prevent any damage to the panel face.



## Site Storage

When insulation material is stored outdoors it must be protected from rain and stacked off the ground and on a flat slope to allow water to drain. Panels should not be stacked more than 2.5m high and should allow adequate access between stacks and ensure they are stable at all times.

Bearers should be evenly spaced and if stacked (no more than 2 high) should be positioned inline with bearers on pack below.



## Cutting

Any cutting of apertures in a composite panel will reduce its structural strength. This reduction can only be determined by comprehensive testing of the panels after cutting and it will be significantly influenced by the size and position of the apertures as well as the method of cutting.

Any site operative involved in cutting panels should wear personal protective equipment (PPE) i.e. goggles, ear protection and dust mask.

When cutting an aperture in a panel it is essential that the tool used minimises the dynamic tension/ compression forces applied to the panel. A fine toothed tungsten jigsaw or skill (circular) saw is such a tool whereas an angle grinder is inappropriate.

Care should be taken when cutting panels with combustible cores to avoid heat build up which could present an ignition hazard.





## Cleaning

Provided it is done properly, cleaning can enhance the performance and longevity of the panelling.

Frequency of cleaning is determined by the application, i.e. in areas with only processor-packed food, continual cleaning is not necessary. However in food preparation or pharmaceutical areas the surface should normally be cleaned daily with appropriate types of cleaners.

Walls can be washed down with fresh water from a hose or a bucket. A solution of fresh water and non aggressive detergent may be used to remove heavy deposits, followed by a fresh water rinse. The maximum water temperature for pressure hose cleaning is 70°C with maximum pressure of 6900kpa.

Stubborn oil or grease stains can be removed with white spirit on a soft cloth followed immediately by a fresh water rinse.

Over-cleaning or scrubbing can do more harm than good. Steam cleaning can also cause problems if the surface temperature of the panels exceeds 60°C.



## Stain Resistance

The products of combustion in the exhaust fumes of site vehicles or in the fumes of gas fire space heaters (e.g. propane) may stain the panel surfaces. Fork lift truck engines or petrol driven electrical generators (often used when cold stores are being built) can generate these fumes.

Staining can occur even when the coating is covered by a protective film. Although coatings are formulated to resist this, contractors must take precautions to prevent such staining.



## Durability & Repair

The durability of Isoclad panels can be prolonged if adequate maintenance and regular inspection is carried out.

Isoclad panels have a very good resistance to chemicals. However there are exceptions e.g. certain organic solvents such as aromatics, ketoses and chlorinated hydrocarbons.

When the substrate steel sheet is punctured or scratched it must be repaired immediately by a qualified repair specialist. The life of the panel if not treated will diminish significantly and corrosion may occur.

### Corrosion Resistance

- After cleaning the panel must be rinsed thoroughly with fresh water, otherwise corrosion will start quickly at the edges or in any scratches which have been exposed to cleaning fluid.
- Continuously wet cut edges must be avoided.
- The durability of the product is prolonged if it is regularly inspected and maintained

Slight scuffs or scratches are best left untreated unless they are down to the substrate. In this case they should be repaired with a standard touch up paint. It should be considered that touch up paints, over time, could change colour, therefore the touch up area should be as small as possible.

**Isoclad Ltd**  
T: 0191 258 5052  
E: [sales@isoclad.co.uk](mailto:sales@isoclad.co.uk)

[www.isoclad.co.uk](http://www.isoclad.co.uk)

# Ancillaries

In addition to manufacturing structural panels Isoclad offers a complete range of ancillary flashing items, all manufactured at our North Shields site.

Our guillotine and press are capable of making most flashings up to 3000 mm long; including plain or powder coated galvanised flashings.

All colours of standard flashings are available on request.

All our flashings are made from the same steel as our panels to guarantee a perfect colour match.







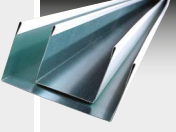

We can also supply a wide variety of sheet material cut to size from coil.

## Flashings

To ensure our flashings are produced to the highest quality standards we only use full prime steel, as used in our panel manufacturing. By doing this we can guarantee a perfect colour and material match for the end application.

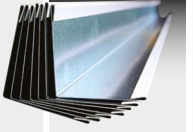
Always striving for the best and the quickest service we are able to offer a quick turnaround; for smaller orders even a next day on site delivery. On request, we can manufacture any shaped profiles.

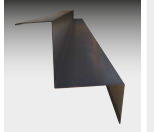
\* Standard length 3m. Up to 4m can be accommodated

<p>Channel</p> 	<p>WPC/Plain Galvanised Channel</p> 	<p>Internal Angle</p> 	<p>WPC/Plain Galvanised Angle 2mm Int/Ext</p> 	<p>External Angle</p> 	<p>Flat Cover Strip</p> 	<p>Custom Shaped Flashings</p> 	<p>Top Hat Shaped Flashings</p> 
<p>Stock 50x 52 x 50 50 x 77 x 50 50 x 102 x 50 50 x 127 x 50 50 x 152 x 50</p>	<p>Stock 50 x 52 x 50 50 x 102 x 50</p>	<p>Stock 50 x 50</p>	<p>Stock 100 x 50 125 x 50 150 x 50</p>	<p>Stock 50 x 50 50 x 100 50 x 150 100 x 100</p>	<p>Stock 100 mm 150 mm</p>		

Plus other sizes and flashings on request

## Sheet Material

Our customised steel sheet material is manufactured from the same high quality steel used on our panels and it comes in a broad range of colours.

Sizes:

**Maximum width - 1250 mm**

**Standard length - 3000 mm**

Longer lengths also available on request. Thickness - Dependant on application

The most common applications for our sheet material are:

- Column covers
- Ornamental and decorative cladding
- Over cladding existing panels

Description	Thickness mm
Colour Coat HPS200 Ultra	0.7
Colour Coat PDVF / PVF2	0.7
Colour Coat LG/Leathergrain/ Plastisol/HP200	0.5 / 0.7
White Polyester	0.5
Primer / Backer	0.5 / 0.7
White Food Safe Laminate	0.5 / 0.7
Galvanised Steel (Plain or Powder Coated)	1.6 / 2 / 3

## Fixing and Sealants

When installing fire rated panels, Isoclad recommend the use of intumescent mastic. This provides an effective vapour seal, while its formulation allows for expansion to close the joint, thus providing greater fire protection in the event of a fire.

Rivets and Tek screws are commonly used to fix accessory flashings and base channel items. In certain fire applications, additional steel rivets may be required to stitch the overlapping longitudinal edges of the panel.

Other items and sizes available on request.

Silicone (White)	25/box
Intumescent Mastic	20/box
Rivets 4.8 Aluminium Plain	per 500
Rivets 4.8 Aluminium White	per 500
Rivets 4.8 Steel Plain	per 500
Rivets 4.8 Steel White	per 500
Rivets 4.8 Stainless Steel	per 500
Aluminium Angle WPC	50 x 50mm (5m) or 150 x 50mm (3m)
Aluminium Backing Angle	4000mm long
Plastic radius Corner Flexi Edge	4000mm long
Plastic radius Corner Rigid	4000mm long
3 Way corners (to suit flexi edge)	
Ceiling Suspension Kits	
XPS (Flooring Grade) 2500 x 600mm	50 or 75mm
Bolder Fixings 60mm	EACH

**Isoclad Ltd**  
 T: 0191 258 5052  
 E: sales@isoclad.co.uk

[www.isoclad.co.uk](http://www.isoclad.co.uk)

# Ceiling Suspension Systems

Isoclad manufacture their own inverted top hat details which are supplied with the complete range of 'Unistrut' fixings and fastenings.

The ceiling suspensions we manufacture are easy to install and fully certified by Lloyds Testing. Test certificates available on request.



Isoclad ceiling suspensions are manufactured from 2mm galvanised steel. Testing conducted by Lloyds British plc has proven they can carry a load up to 300kg/m. Supplied in kit form (Please provide quantity and size of run for our staff to calculate which kit is required).

## Top Hat Kit

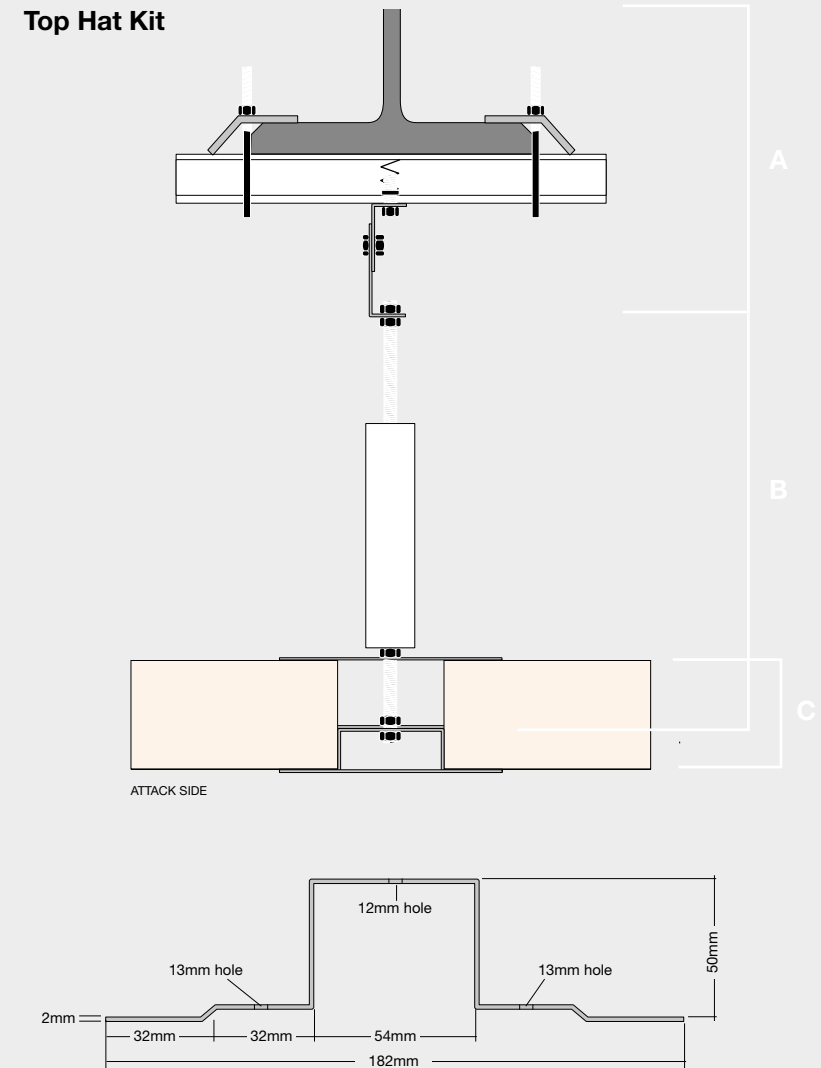

# Breakdown of kits available

## A. Swivel Assembly

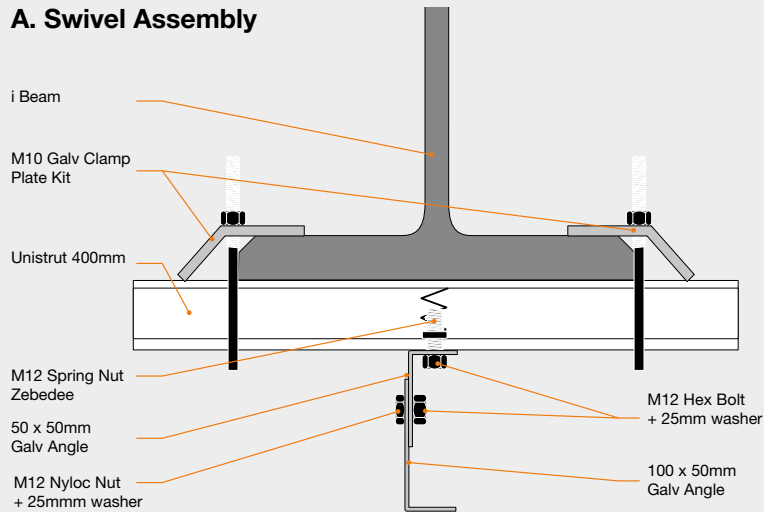

## B. Drop Rod Assembly

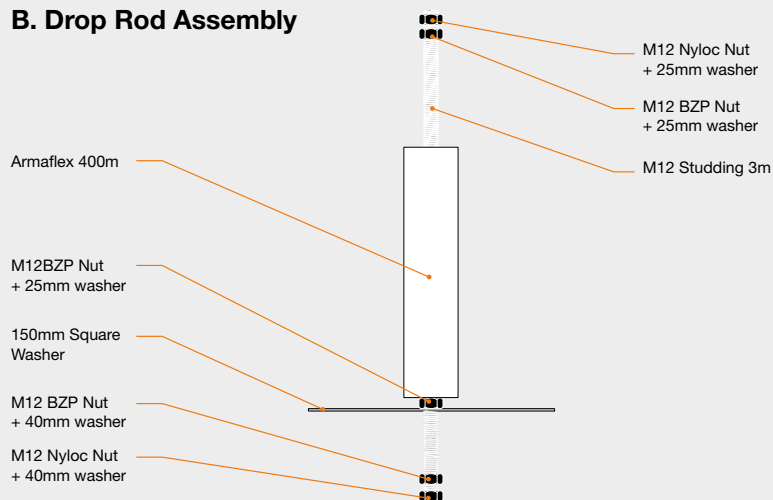

When installed Mineral Fibre and PIR ceiling panels offer a limited walk-on facility, however this is suitable for intermittent personnel use only and panels should not be used as a working platform.

Overloading should be avoided at all times and personnel should not gather in groups greater than two on any single panel, particularly adjacent to apertures which must be suitably framed and supported. Jumping and bouncing should also be avoided.

In areas subject to frequent use and access areas, Youngman type boards and catwalks should be used as walkways.

Ancillary equipment i.e. pipes, refrigeration equipment, ductwork, etc. should not be supported by the panels; the support should be taken from the building structure. Installation of equipment is not allowed on unprotected panels.

## C. Top Hat Assembly

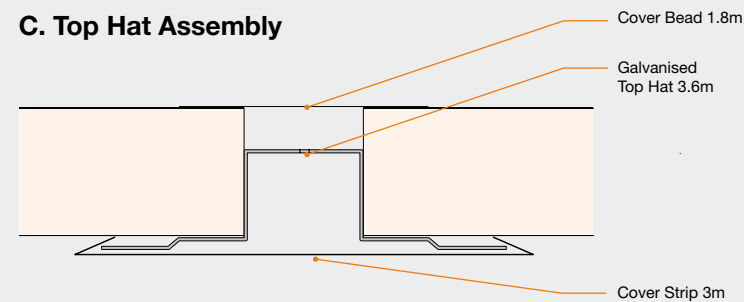

## D. Connection Assembly

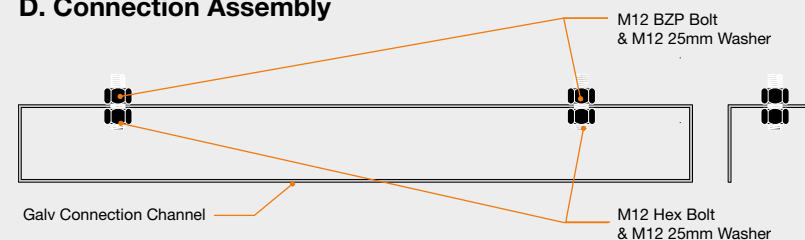

**Material: 2mm Z280 Galv**  
**Finish: Mill / Uncoated**  
**Length: 3600 mm**  
**Drawing No: Iso103 Rev1**

**Isoclad Ltd**  
**T: 0191 258 5052**  
**E: sales@isoclad.co.uk**

[www.isoclad.co.uk](http://www.isoclad.co.uk)

# Installation Guide

The following factors should be considered when installing panels:

The sealants between joints are of the appropriate type and have good adhesion to the coating of the panel.

There should be no gaps in the silicone on any joints.

Details are correctly designed, especially at joints between floors and walls.



Check floor is level then mark out the site to the dimensions shown on the relevant drawing using a chalk line.

Galvanised metal floor channels are fixed to the floor surface at 600 mm centres using an appropriate fixing system i.e. a Rawl bolt or Hilti hammer fixings. These channels will form the base into which the panels will sit.

Apply continuous bead of sealant to base of channels.

**Kerb Wall Base to Floor Detail**

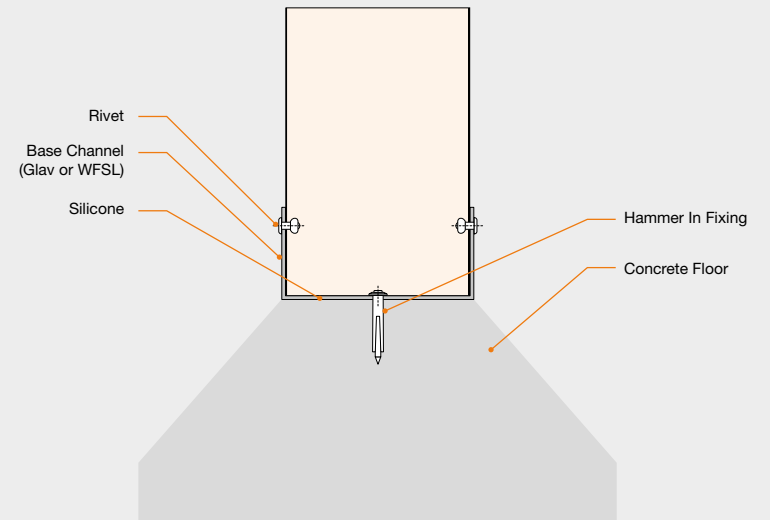

**Typical Wall to Floor Detail**

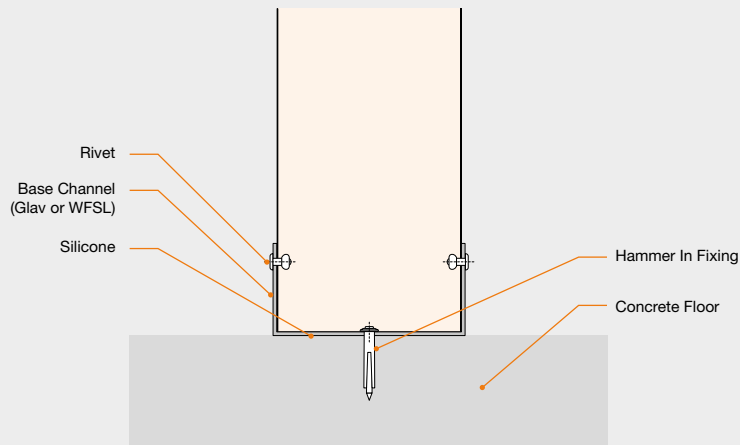

**Coldstore Wall to Floor Detail**

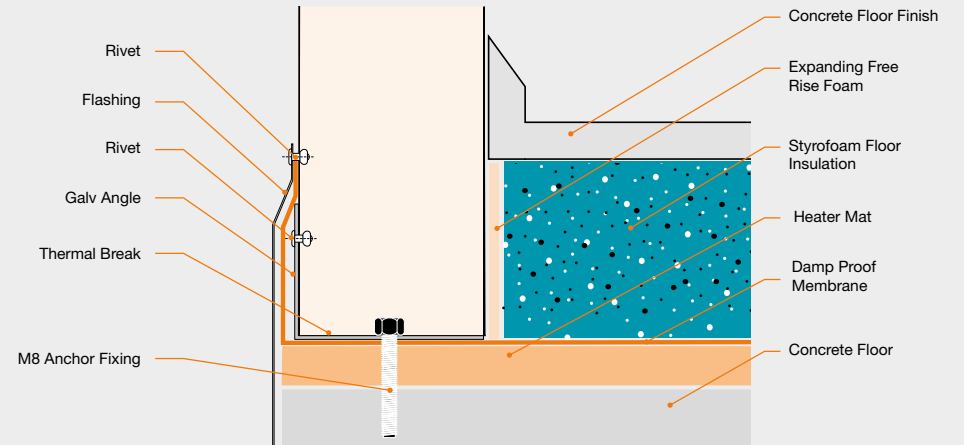

**Typical Partition 1 (Joint Chiller Wall/Ceiling)**

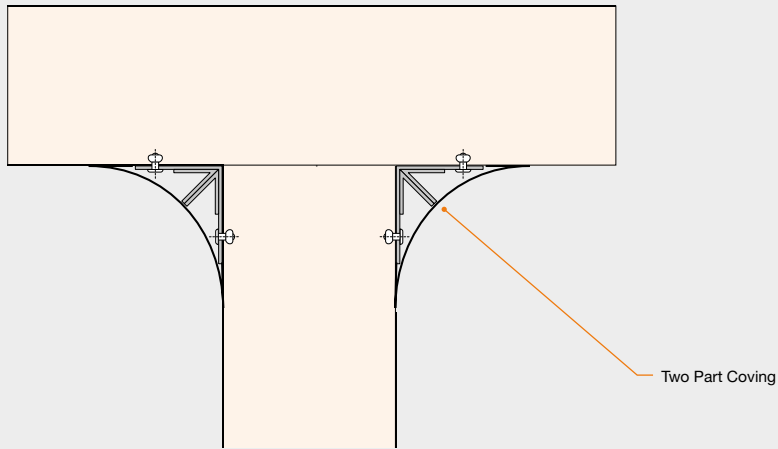

**Typical Partition 3 (Joint Freezer Wall / Ceiling)**

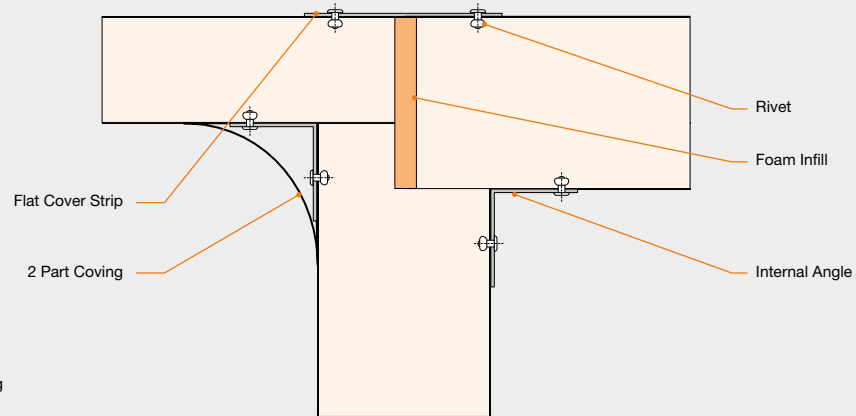

**Typical Partition 2 (Chillroom - Freezer Wall/Ceiling)**

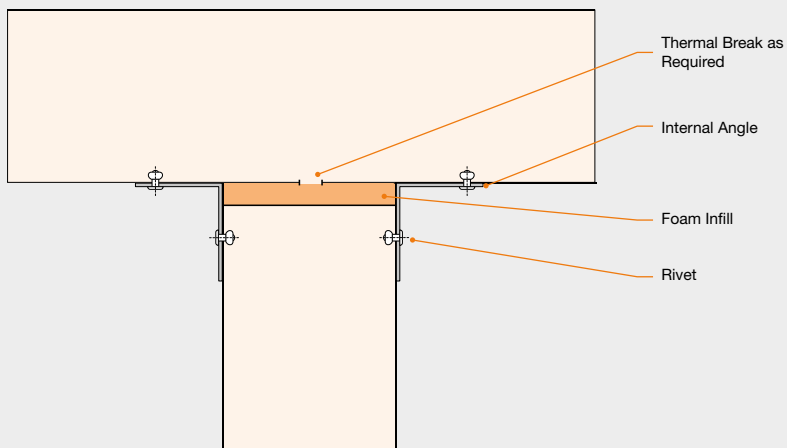

**Ceiling Joint Detail**

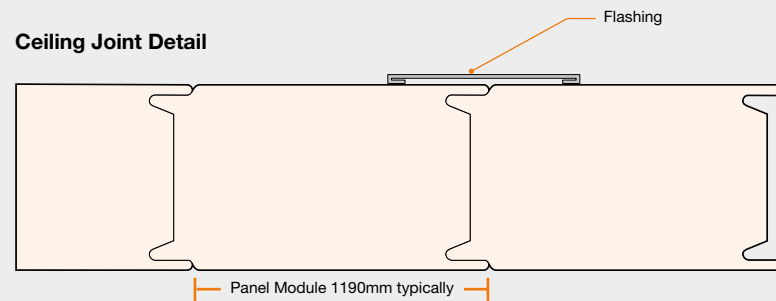

Where the structure is self supporting, two wall panels are mechanically fixed together to form a corner unit. The corner unit is positioned into the floor channel or angle and extended across the full length of the proposed rear wall and returned by one panel to match the opposite corner, thus forming a "U" shape.

A ceiling panel is then lifted into position to tie the structure together. The means of lifting this panel into position are dependant upon site conditions, but where possible a forklift with appropriately sized lifting bars or suction lifting machine should be used. This process will then continue by the repeated erection of two wall panels and one ceiling panel for the full length of the room until the front wall is reached. At this point the remaining wall panels will be erected.

**Isoclad Ltd**  
 T: 0191 258 5052  
 E: sales@isoclad.co.uk

[www.isoclad.co.uk](http://www.isoclad.co.uk)

# Installation Guide



All corners of the enclosure should be trimmed with flashings and riveted in place to tie in wall to ceiling corners and wall to wall corners. Isoclad recommend fixing flashings to panels at 300 mm centres.

All panel to panel joints should be sealed using a one part foodsafe silicone or intumescent mastic which is applied by a manual hand application unit.

Before total enclosure of the room is achieved the position of all doors, windows and product apertures are to be marked and cut. Installation guides for doors/hatches and windows will arrive on site wrapped up with the specific door or window type packaging.

All panels should be plumb and level; wall panels that are not plumb will have an adverse effect on the door operating properly.

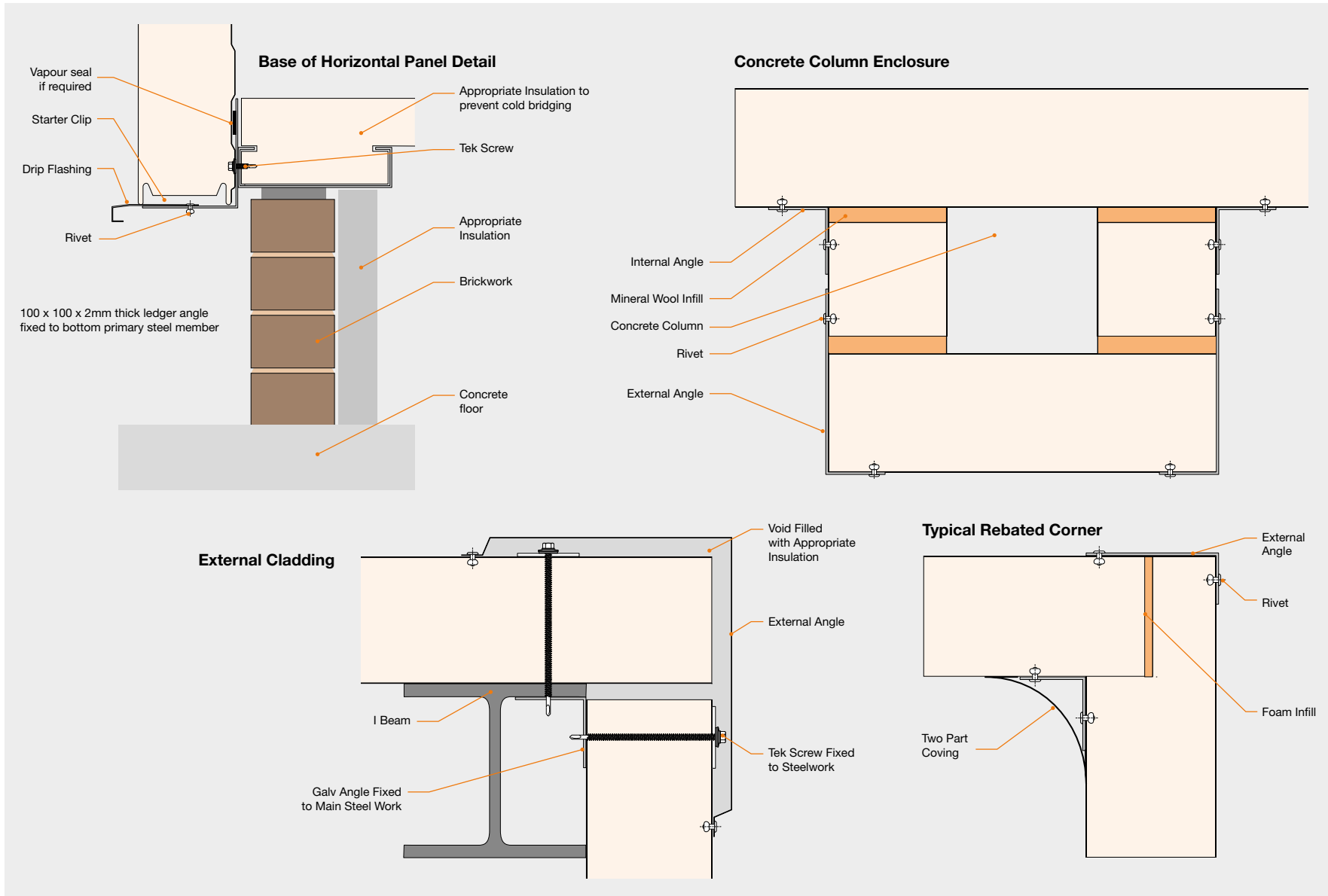



**Typical Steel Fixing 1**

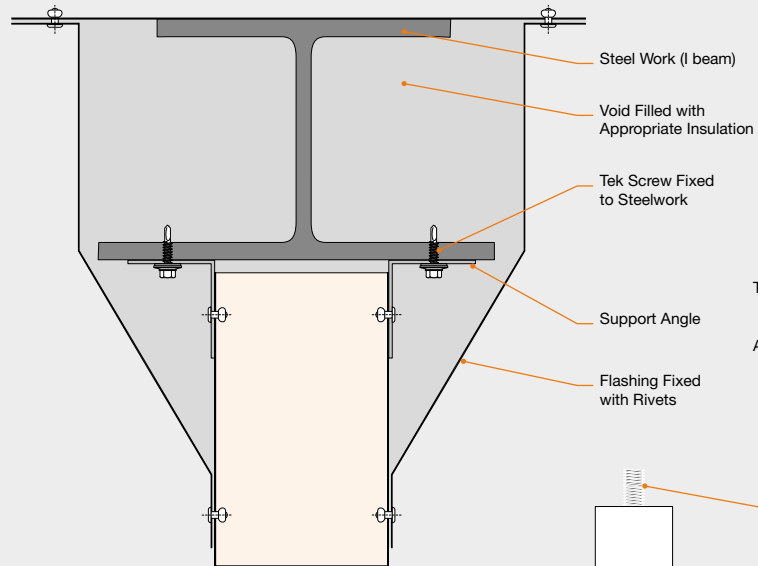

**Typical Steel Fixing 2**

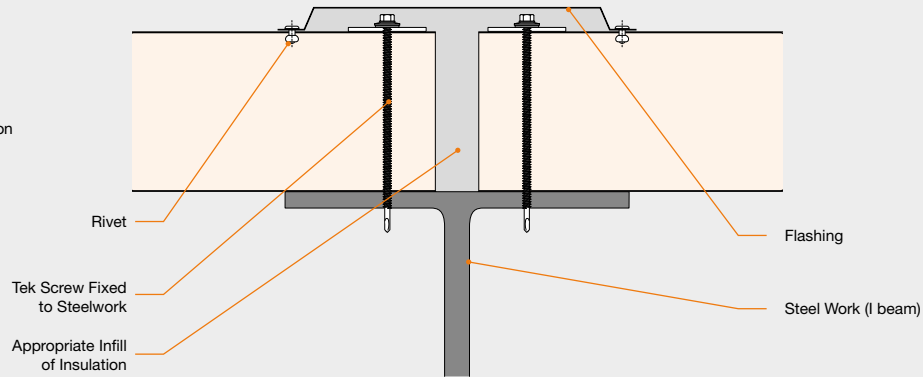

**Wall to Ceiling Detail - Coldstore**

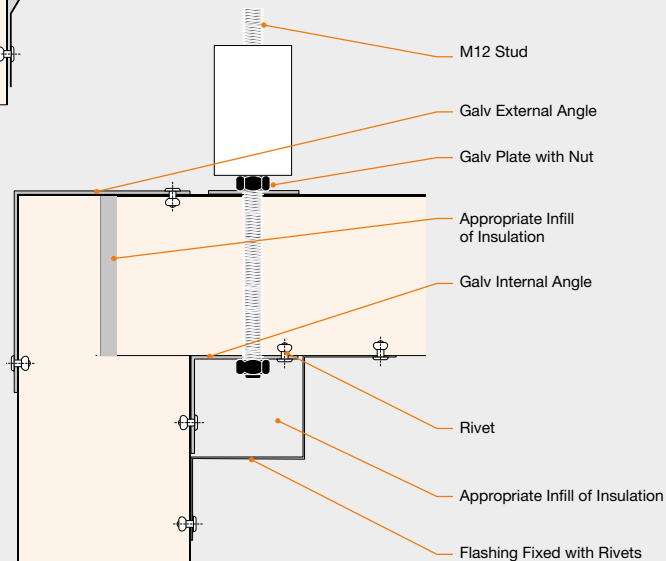

**Wall to Ceiling Detail - Chill**

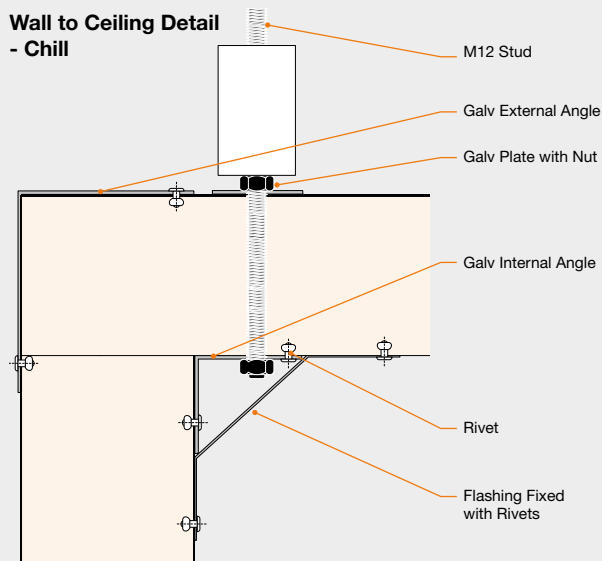

Where the structure is to be supported by a secondary top hat suspension system, the suspension system should be installed before ceilings or wall panels are installed.

Fix top hat suspension system at 300 mm centres and pack voids with appropriate insulation.

**Note**  
The illustrations shown are 'Typical' installations drawings and should be used for guidance only

Please contact Isoclad directly should you require specific application detail or clarification on anything shown

**Isoclad Ltd**  
T: 0191 258 5052  
E: sales@isoclad.co.uk

[www.isoclad.co.uk](http://www.isoclad.co.uk)

# Services

## Applications

- Internal Partitions
- Chill Stores
- Food Processing Industry
- Temporary Accommodation
- Mobile Shelters
- Petrol Station Kiosks
- Decontamination Units
- Clean Rooms
- Pharmaceutical Rooms
- Fire Walls
- Data Centres
- Modular Buildings
- Acoustic Booths
- Security Rated Walls/Ceilings
- Floor Deck Systems
- SIPS Panels

At Isoclad we offer a user-friendly professional service and will provide continuous advice and support at any stage of your build to ensure your project runs smoothly and on time.

Where possible we will advise you on all necessary technical details and specifications and ensure that the supplied products will match your needs, and help you achieve your design requirements in a practical and most efficient manner. We have a number of unique products for specialist application.

## Offline Cutting

To reduce installation time and also site wastage we have introduced a new off line cutting service.

Dependant on the required dimensions we can cut apertures and foil liners in any desired size or shape.



H&V apertures in ceilings

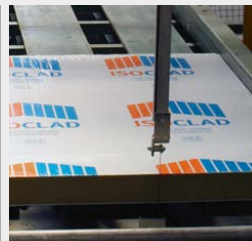

Panels cut to width



Foil lined ceiling apertures



Plywood lined non combustible panel



Floor deck system used at Weston Super-Mare Pier

## Offline Laminating

As an addition to our standard composite panel range, Isoclad offers a customised offline laminating service.

With the availability of this service you will no longer have to think within the 'usual constraints' associated with composite panels. Think plywood inside the core, stainless bonded to the surface, glasbord to the bottom of panels.

Maximum width available is 1250mm. Maximum length is only restricted by handling constraints.

As this is a customised service please contact Isoclad to discuss your requirements and we will be happy to provide you with a quotation.

Materials bonded to date include: Mineral Fibre, Styrofoam, Polyisocyanurate, Polystyrene, Plasterboard, Glasbord, various types of wood (Marine Ply, Chipboard and OSB) and also steel to Plywood, MDF and Chipboard.

Decorative steel finishes, available on request, specific to office and other work space environments from wallpaper finish, woodgrain to marble finish.

# Environmental Policy

Over the past decade global warming effects have got stronger and stronger forcing individuals and companies to finally recognise the negative influence that irresponsible behaviour can have upon our environment.

There are many ways in which we all can influence and prevent pollution. At Isoclad we are committed to play our part and have started to reduce, reuse and recycle as much as possible.

Working together with our suppliers and customers, wherever technically feasible, we concentrate on using materials made from part-recycled goods and reducing packaging and waste as much as possible.

To reduce our carbon footprint even further we have developed a 'Going Green' strategy which we continually monitor and improve in order to make sure product standards comply with relevant environmental standards and requirements, such as ISO 14001 which we are in the process of obtaining.

Split in four main sections the strategy covers all the life cycles of a product, from sourcing raw materials to production, distribution and end of life, and involves not only the manufacture site but also our offices.

## Incoming Goods

Over the last three years we have reduced the amount of packaging we use by 25% and are committed to continuously reduce this waste stream over the next few years. When possible we source our raw materials from suppliers who operate in an environmentally friendly manner and who are geographically local.

Our steel supplier is a major partner in ULCOS, Ultra Low CO2 Steel making.

They have invested heavily in reducing CO2 emissions produced from production steel.

By using partially recycled raw materials we are reducing the amount of energy that would have been used in making it from new, as well as reducing the amount of waste deposited at landfills throughout the UK. Our steel contains 25% recycled material, our Mineral Fibre 14% and PIR 20%.

## Production

To reduce the amount of waste on our site we buy all the materials in at the correct size for each particular contract.

The minimal production waste is sorted, compressed and then sent off for recycling and only where no alternative exists it is sent to a landfill.

Options for panels at the end of building life are developing rapidly. All Isoclad cores have been CFC free ODP Zero rated since 1997.

This significantly reduces the complexity and core of panel recycling where necessary.

In addition to normal commercially available re-use or recycling option Isoclad is currently developing a recycling/re-use service.

Depending on site and panel conditions Isoclad will accept redundant panels.

These panels will be offered for re-sale to suitable applications or the steel recycled and cores used as packaging material.

Details available on request.

## Distribution

We reuse 30% of the incoming packaging materials when despatching our own finished products.

As the only UK based manufacturer to offer a variety of cores to LPC standards, customers can reduce the number of deliveries to site where small amounts of different cores are required.

## End of Life

Options for end of life are developing rapidly.

Steel is obviously 100% recyclable. Shredder plants can be used to recycle the steel content of Isoclad panels; these plants are located around various parts of the UK.

Mineral Fibre is 100% recyclable. Technology is available at present to shred and separate Mineral Fibre and steel to allow recovery of both materials.

Isoclad is the first manufacturer to offer a 'return for re-use or re-cycle' option.

Subject to site survey panels can be returned for temporary storage, pending re-sale or dismantling after which the core is re-used as packaging and steel recycled.

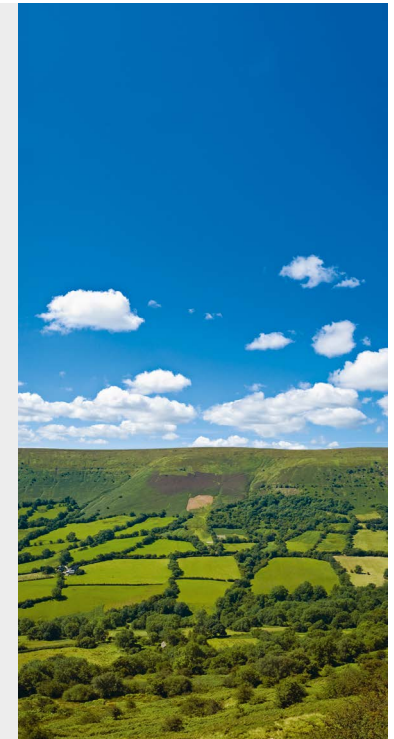

**Isoclad Ltd**  
 T: 0191 258 5052  
 E: sales@isoclad.co.uk

[www.isoclad.co.uk](http://www.isoclad.co.uk)

**Disclaimer**

While Isoclاد can give advice regarding suitability for end use it remains the responsibility of the client/architect/specifier to ensure the panels are selected and installed according to the latest regulations and fire safety requirements and that they are suitable for their intended use.

March 2015

**Isoclاد**

All panel cores - one panel supplier

**Isoclاد Ltd**

10 Alder Road, West Chirton North Industrial Estate,  
North Shields, Tyne & Wear NE29 8SD. UK

Tel: +44 (0) 191 258 5052

Email: [sales@isoclاد.co.uk](mailto:sales@isoclاد.co.uk)

**[www.isoclاد.co.uk](http://www.isoclاد.co.uk)**

