

SRAM



SRAM, LLC WARRANTY

EXTENT OF LIMITED WARRANTY

SRAM warrants its products to be free from defects in materials or workmanship for a period of two years after original purchase. This warranty only applies to the original owner and is not transferable. Claims under this warranty must be made through the retailer where the bicycle or the SRAM component was purchased. Original proof of purchase is required.

LOCAL LAW

This warranty statement gives the customer specific legal rights. The customer may also have other rights which vary from state to state (USA), from province to province (Canada), and from country to country elsewhere in the world.

To the extent that this warranty statement is inconsistent with the local law, this warranty shall be deemed modified to be consistent with such law, under such local law, certain disclaimers and limitations of this warranty statement may apply to the customer. For example, some states in the United States of America, as well as some governments outside of the United States (including provinces in Canada) may:

- a. Preclude the disclaimers and limitations of this warranty statement from limiting the statutory rights of the consumer (e.g. United Kingdom).
- b. Otherwise restrict the ability of a manufacturer to enforce such disclaimers or limitations.

LIMITATIONS OF LIABILITY

To the extent allowed by local law, except for the obligations specifically set forth in this warranty statement, in no event shall SRAM or its third party suppliers be liable for direct, indirect, special, incidental, or consequential damages.

LIMITATIONS OF WARRANTY

This warranty does not apply to products that have been incorrectly installed and/or adjusted according to the respective SRAM technical installation manual. The SRAM installation manuals can be found online at www.sram.com, www.RockShox.com, or www.avidbike.com.

This warranty does not apply to damage to the product caused by a crash, impact, abuse of the product, non-compliance with manufacturers specifications of usage or any other circumstances in which the product has been subjected to forces or loads beyond its design.

This warranty does not apply when the product has been modified.

This warranty does not apply when the serial number or production code has been deliberately altered, defaced or removed.

This warranty does not apply to normal wear and tear. Wear and tear parts are subject to damage as a result of normal use, failure to service according to SRAM recommendations and/or riding or installation in conditions or applications other than recommended.

Wear and tear parts are identified as:

- Dust seals
- Bushings
- Air sealing o-rings
- Glide rings
- Rubber moving parts
- Foam rings
- Rear shock mounting hardware and main seals
- Upper tubes (stanchions)
- Stripped threads/bolts (aluminium, titanium, magnesium or steel)
- Brake sleeves
- Brake pads
- Chains
- Sprockets
- Cassettes
- Shifter and brake cables (inner and outer)
- Handlebar grips
- Shifter grips
- Jockey wheels
- Disc brake rotors
- Wheel braking surfaces
- Bottomout pads
- Bearings
- Bearing races
- Pawls
- Transmission gears
- Tools

This warranty shall not cover damages caused by the use of parts of different manufacturers.

This warranty shall not cover damages caused by the use of parts that are not compatible, suitable and/or authorised by SRAM for use with SRAM components.

This warranty shall not cover damages resulting from commercial (rental) use.

© Copyright SRAM, LLC 2009

For exploded diagram and part number information, please refer to the Spare Parts Catalog available on our website at www.sram.com.

For order information, please contact your local SRAM distributor or dealer.

Information contained in this publication is subject to change at any time without prior notice. For the latest technical information, please visit our website at www.sram.com.

Your product's appearance may differ from the pictures/diagrams contained in this catalog.

Product names used in this document may be trademarks or registered trademarks of others.

2010

SRAM®

Technical Manual

TABLE OF CONTENTS

RED / FORCE / RIVAL · REAR DERAILLEURS	6
TECHNICAL DATA / ASSEMBLY REQUIREMENTS.....	6
ASSEMBLY.....	7
RED / FORCE / RIVAL · FRONT DERAILLEURS	9
TECHNICAL DATA / ASSEMBLY REQUIREMENTS.....	9
ASSEMBLY.....	11
RED / FORCE / RIVAL · DOUBLE TAP SHIFTERS	13
TECHNICAL DATA / ASSEMBLY REQUIREMENTS.....	13
ASSEMBLY.....	13
USE.....	14
DOUBLE TAP FLAT BAR SHIFTERS	15
TECHNICAL DATA / ASSEMBLY.....	15
USE / MAINTENANCE.....	17
TT SHIFTERS	18
TECHNICAL DATA / ASSEMBLY REQUIREMENTS.....	18
ASSEMBLY.....	18
1090-R2C TT SHIFTERS	20
USE / MAINTENANCE.....	20
TT BRAKE LEVERS	22
TECHNICAL DATA / ASSEMBLY REQUIREMENTS.....	22
ASSEMBLY.....	22
RED / FORCE / RIVAL · CRANKSETS W/ GXP BOTTOM BRACKET	23
TECHNICAL DATA / ASSEMBLY REQUIREMENTS.....	23
ASSEMBLY.....	23
MAINTENANCE.....	25
BB30 CRANKSET	26
TECHNICAL DATA / ASSEMBLY REQUIREMENTS.....	26
ASSEMBLY.....	26
PRESSFIT GXP BOTTOM BRACKET	29
ASSEMBLY.....	29
ASSEMBLY / MAINTENANCE.....	31
BB30 TO BSA BOTTOM BRACKET ADAPTER	32
ASSEMBLY.....	32
REMOVAL.....	33
RED / FORCE / RIVAL · DUAL PIVOT ROAD CALIPERS	34
TECHNICAL DATA / ASSEMBLY REQUIREMENTS.....	34
ASSEMBLY.....	34
CASSETTES · 10 SPEED ROAD	36
TECHNICAL DATA / ASSEMBLY REQUIREMENTS.....	36
ASSEMBLY.....	37
POWER CHAINS · 10 SPEED ROAD	38
TECHNICAL DATA / ASSEMBLY REQUIREMENTS.....	38
ASSEMBLY.....	39
X.0 / X-9 / X-7 / X-5 / X-4 / X-3 / 3.0 · REAR DERAILLEURS	40
TECHNICAL DATA / ASSEMBLY REQUIREMENTS.....	40
ASSEMBLY REQUIREMENTS.....	41
ASSEMBLY.....	42
X.0 · REAR DERAILLEURS	44
MAINTENANCE.....	44
X-9 / X-7 / 3.0 · HIGH CLAMP FRONT DERAILLEURS	46
TECHNICAL DATA / ASSEMBLY REQUIREMENTS.....	46
ASSEMBLY / MAINTENANCE.....	47
X-9 / X-7 / X-5 · LOW CLAMP FRONT DERAILLEURS	49
TECHNICAL DATA / ASSEMBLY REQUIREMENTS.....	49
ASSEMBLY.....	50
X.0 / X-9 · TRIGGER SHIFTERS	52
TECHNICAL DATA / ASSEMBLY REQUIREMENTS.....	52
ASSEMBLY.....	52
USE / MAINTENANCE.....	53
X-7 / X-5 / X-4 / X-3 / VIA / ATTACK / ROCKET · TRIGGER SHIFTERS	54
TECHNICAL DATA.....	54
ASSEMBLY.....	55
MAINTENANCE.....	56
X.0 / X-9 / X-7 / ROCKET / ATTACK · TWIST SHIFTERS	57
TECHNICAL DATA / ASSEMBLY REQUIREMENTS.....	57
ASSEMBLY / MAINTENANCE.....	58
X-5 / CENTERA · TWIST SHIFTERS	60
TECHNICAL DATA / ASSEMBLY REQUIREMENTS.....	60
ASSEMBLY.....	61
X-4 / MRX PRO · TWIST SHIFTERS	62
TECHNICAL DATA / ASSEMBLY REQUIREMENTS.....	62
ASSEMBLY / MAINTENANCE.....	63

3.0 COMP / MRX COMP · TWIST SHIFTERS	64
TECHNICAL DATA / ASSEMBLY REQUIREMENTS.....	64
ASSEMBLY / MAINTENANCE.....	65
3.0 PLUS / 3.0 / MRX PLUS / MRX · TWIST SHIFTERS	66
TECHNICAL DATA / ASSEMBLY REQUIREMENTS.....	66
ASSEMBLY / MAINTENANCE.....	67
CASSETTES · MTB / ROAD	68
TECHNICAL DATA / ASSEMBLY REQUIREMENTS.....	68
ASSEMBLY / MAINTENANCE.....	70
POWER CHAINS · MTB / ROAD	71
TECHNICAL DATA / ASSEMBLY REQUIREMENTS.....	71
ASSEMBLY / MAINTENANCE.....	73
SRAM HUBS.....	75
ANATOMY.....	75
DISASSEMBLY.....	77
ASSEMBLY.....	80
DISASSEMBLY.....	85
REPLACE BEARINGS.....	87
SPOKE INSTALLATION.....	91
SRAM WHEELS	92
PARTS PREPARATION.....	92
INSTALLATION.....	94

RED / FORCE / RIVAL · REAR DERAILLEURS

TECHNICAL DATA / ASSEMBLY REQUIREMENTS

	Red	Force	Rival
Speeds	10	10	10
Shifter Compatibility	SRAM Double Tap shifters (Red / Force / Rival) / SRAM TT Shifters		
Cogsets	SRAM 10 speed and other 10 speed Shimano® cogsets (largest Cog maximum 28 teeth)		
Chains	SRAM 10 speed Power Chains and Shimano® 10 speed chains		
Cranks / Chainrings	10 speed compatible, 53-39 / 52-38 / 52-36 / 50-34 / 50-36 / 48-34 / 46-38		
Cable & Housing	High quality 1.1 mm shifting cable and 4 or 5 mm compressionless housing, high quality, with non-sealed end caps of maximum diameter 5.8 mm and maximum length 16 mm		
Total	33 T	33 T	33 T
Max Sprocket	28 T	28 T	28 T
Min Sprocket	11 T	11 T	11 T
Front Difference	16 T	16 T	16 T
Parallelogram Spring	Titanium	Steel	Steel
Pulleys	Ceramic cartridge bearing	Cartridge bearing	Cartridge bearing
Direct Mount	Yes	Yes	Yes
B-Knuckle	Forged Aluminum	Forged Aluminum	Aluminum
Outer Link	Forged Aluminum	Forged Aluminum	Aluminum
Inner Link	Carbon	Magnesium	Aluminum
Outer Cage	Carbon	Carbon	Aluminum
Inner Cage	Carbon	Aluminum	Aluminum
Hanger Bolt	Aluminum	Aluminum	Aluminum

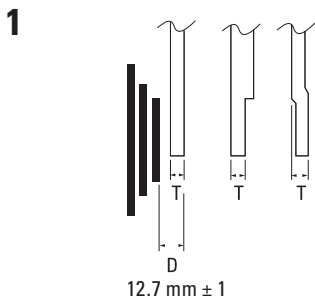

DERAILLEUR ANATOMY

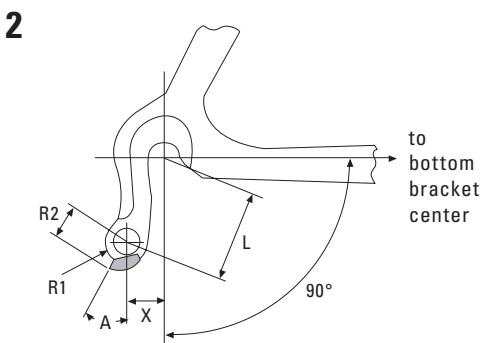
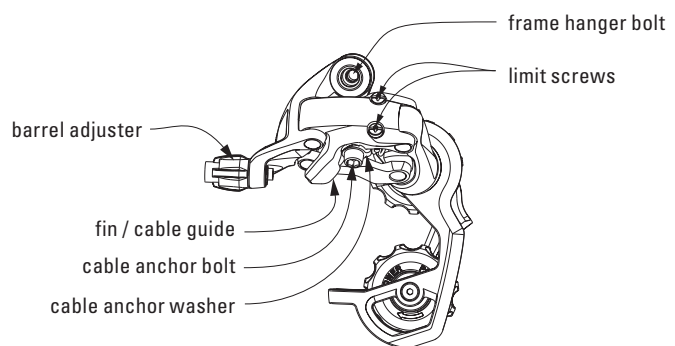

FRAME DIMENSIONS

(Figure 1 and Figure 2)

For optimal rear derailleur performance, the recommended rear derailleur hanger length (L) should be 26 – 28 mm.

L	X	A	R1	R2	T
26	6 - 10	30° - 35	8.5 max	11.5 - 12.5	7 - 8
28	8 - 10	30° - 35	8.5 max	11.5 - 12.55	7 - 8

Chainstay length ≥ 405 mm

RED / FORCE / RIVAL · REAR DERAILLEURS ASSEMBLY

1

5 mm
8 – 10 N·m
70 – 85 in·lb

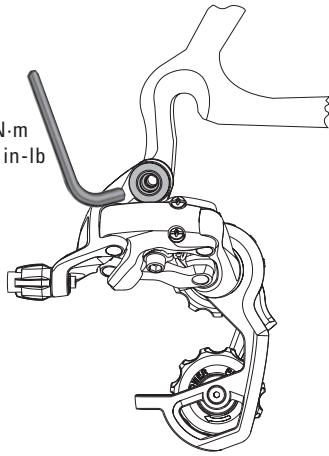

2

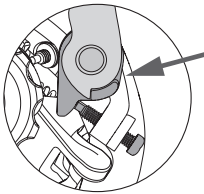

3

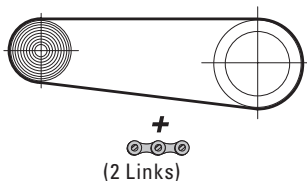

4

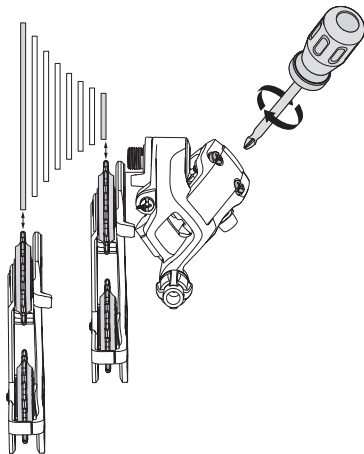

ASSEMBLY



ADVICE

Check the rear derailleur hanger alignment. A bent rear derailleur hanger will result in inaccurate index shifting.

- Attach the rear derailleur to the frame's rear derailleur hanger using a 5 mm hex wrench (**Figure 1**).
- Check that the b-adjust washer tab is clear of the rear derailleur dropout tab (**Figure 2**).
- Tighten the 5 mm hex hanger bolt to 8 – 10 N·m (70–85 in·lb) (**Figure 1**).

CHAIN LENGTH

- Bypassing the rear derailleur, run the chain around the largest cog/large chainring combination (**Figure 3**).
- Add 2 link or 1 link + connection link to this length for proper chain length.

LIMIT SCREWS ADJUSTMENT

- View the rear derailleur and pulleys from behind the rear of the bicycle (**Figure 4**).
- Turn the limit screw marked 'H' on the outer link of the derailleur to align the upper guide pulley center with the outboard edge of the smallest cog (**Figure 4**).
- While turning the crank, push the rear derailleur towards the larger cogs by hand.
- Align the upper guide pulley under the largest cog, center to center, by turning the limit screw marked 'L' on the outer link (**Figure 4**).

CHAIN GAP ADJUSTMENT

Chain gap is the distance between the upper guide pulley and the cog the chain is riding on. Optimal chain gap is small enough to allow quick, efficient shifts to and from any cog, but large enough to allow smooth shifts to and from the largest cog.

- Shift the chain to the small chain ring.
- Check the chain gap between the tip of the smallest cog and the tip of the upper guide pulley. While turning the crank, push the rear derailleur by hand to the largest cog and check the chain gap in this position. (**Figure 5**).
- Using a screw driver, turn the b-adjust screw until the minimum chain gap in either position equals approximately 6 mm.



ADVICE

Setting the chain gap at this point of your installation may be considered a rough estimate. Precision index shifting may require small changes of the b-adjustment while setting the proper cable tension.

Do not use the b-adjust screw to adjust the rear derailleur to act as a chain-tensioning device or to prevent chain suck. This increases the chain gap causing poor shifting performance.

INDEX SHIFTING ADJUSTMENT

- Attach the rear derailleur to the frame's rear derailleur hanger using a 5 mm hex wrench (**Figure 1**).
- Check that the chain and the rear derailleur are in the smallest cog position.
- Cut the rear piece of cable housing. Make sure that it is not too short or long (**Figure 6**).
- Make sure the shifter cable is fully released (hardest (highest) gear at rear shifter).
- Turn the rear derailleur barrel adjuster clockwise fully into the derailleur, then back it off 1 full turn.
- Feed the rear shifter cable through the rear derailleur cable housing, stops and cable guides.
- Thread the cable through the rear derailleur barrel adjuster and around the cable guide on the fin (**Figure 6**).
- Pull the cable tight and position it under the cable anchor washer.
- Tighten the 5 mm hex cable anchor bolt to 4 – 5 N·m (35 – 45 in·lb).
- Rapidly shift the chain and derailleur up and down the cassette several times. If the cable slips repeat the two former steps.
- Shift the chain to the smallest cog.
- While pedaling, move the shifter up one detent.
 - If the chain hesitates or does not shift to the second cog, increase the cable tension by turning the derailleur barrel adjuster counterclockwise.
 - If the chain shifts beyond the second cog, decrease the cable tension by turning the derailleur barrel adjuster clockwise.
- Repeat the two former steps until shifting and cable tension is accurate.
- While turning the crank, shift the chain up and down the cassette and chain rings several times to ensure that your derailleur is indexing smoothly.

RED / FORCE / RIVAL · REAR DERAILLEURS ASSEMBLY

5

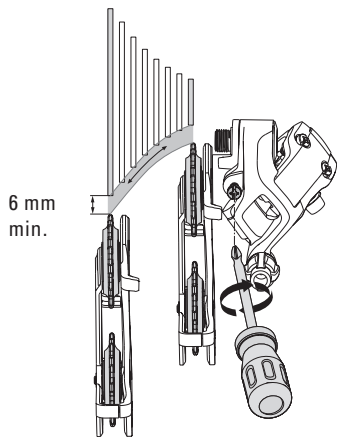

6

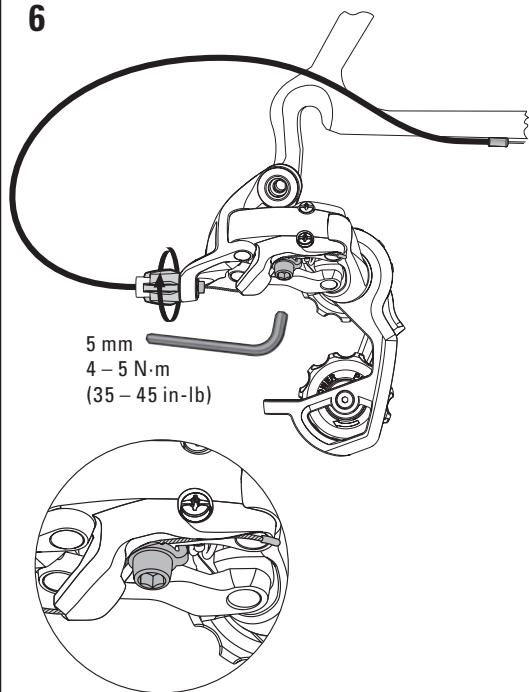

7

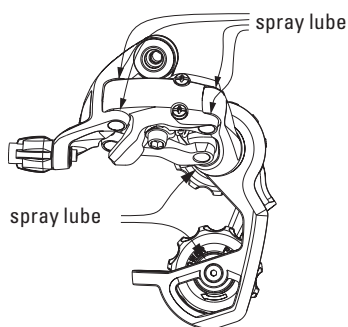

MAINTENANCE

Wipe out debris from the interior of cage plates and parallelogram linkage. Brush the derailleur with clean or soapy water. Rinse the derailleur with clean water and let air dry. Do NOT use a pressure washer.



ATTENTION

Red: The ceramic pulley bearings require regular maintenance. Re-grease bearings using SKF LGHP2 grease after 100 hrs of use in dry conditions or immediately following any significant exposure to water (riding in heavy rain, water crossings). Use a sharp pick to carefully remove the black rubber seal from one side of the bearing (Figure 2), clean the bearing thoroughly and repack with a quality waterproof grease, then replace the rubber seal by pressing it into place.



TROUBLESHOOTING

Problem	Cause	Remedy
Chain jumps from smallest sprocket to frame dropout.	High gear limit screw is not adjusted properly.	Turn in screw H until the guide pulley is aligned with the smallest sprocket.
Difficult or impossible to shift chain onto smallest sprocket.	High gear limit screw is not adjusted properly	Unscrew screw H until the guide pulley is aligned with the smallest sprocket.
Chain jumps over largest sprocket and falls between the spokes and largest sprocket or inner cage plate scrapes on spokes.	Low gear limit screw is not adjusted properly. Rear derailleur or derailleur hanger is bent.	Turn in screw L until the guide pulley is aligned with the largest sprocket. Straighten or replace.
Delayed shifting.	Clearance between guide pulley / sprocket is too large.	Adjust b-adjust screw by rotating counterclockwise.
Rough shifting behavior.	Clearance between guide pulley / sprocket is too small.	Adjust b-adjust screw by rotating clockwise.
Shifts more gears onto smaller sprockets than intended	Shift cable insufficiently tensioned.	Turn barrel adjuster on the shifter counterclockwise.
Delayed shifting onto larger sprocket	Shift cable insufficiently tensioned.	Turn barrel adjuster on the shifter clockwise.
Delayed shifting onto smaller sprocket	Shift cable is too tight. Excessive cable friction, pinched or poorly routed cable.	Lubricate or replace cable and housing. Check for excessive bending of cable housing.

RED / FORCE / RIVAL · FRONT DERAILLEURS

TECHNICAL DATA / ASSEMBLY REQUIREMENTS

	Red	Force	Rival
Braze-on	Yes	Yes	Yes
31.8 mm	Yes	Yes	Yes
34.9 mm	Yes	Yes	Yes
Rear Compatibility	10 speed	10 speed	10 speed
Shifter Compatibility	SRAM Double Tap Shifters / SRAM TT Shifters		
Cogsets	SRAM 10 speed and 10 speed Shimano® cogsets (largest cog - 28 teeth)		
Chains	SRAM 10 speed Power Chains and Shimano® 10 speed chains		
Cranks / Chainrings	10 speed compatible, 53-39 / 52-38 / 52-36 / 50-34 / 50-36 / 48-34 / 46-38		
Cable and Housing	High quality 1.1 mm shifting cable and 4 or 5 mm compressionless housing, high quality, with non-sealed end caps of maximum diameter 5.8 mm and maximum length 16 mm		
Max. Tooth Difference	16 T	16 T	16 T
Cable Routing	Bottom Pull	Bottom Pull	Bottom Pull
Chainstay Angle	61 – 66°	61 – 66°	61 – 66°
Mount Type	Down Swing	Down Swing	Down Swing
Chainline	44.5 mm	44.5 mm	44.5 mm
Band Material	Forged Aluminum	Forged Aluminum	Forged Aluminum
Outer Link	Forged Aluminum	Forged Aluminum	Aluminum
Inner Link	Aluminum	Forged Aluminum	Aluminum
Chain Cage	Hardened Titanium	Steel Chrome Plated	Steel Chrome Plated

1

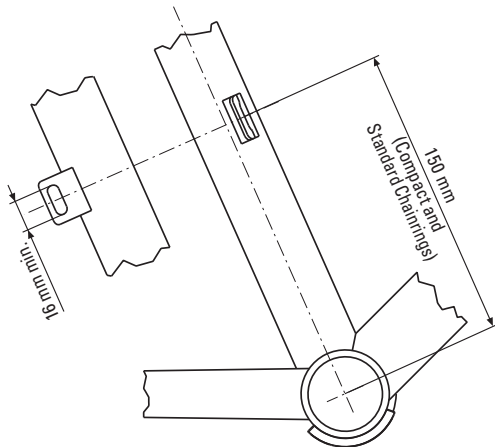

BRAZE-ON FRAME DEFINITIONS

(see Figure 1)

The contact surface of the braze-on boss should be aligned parallel with the centerline of the seat tube.

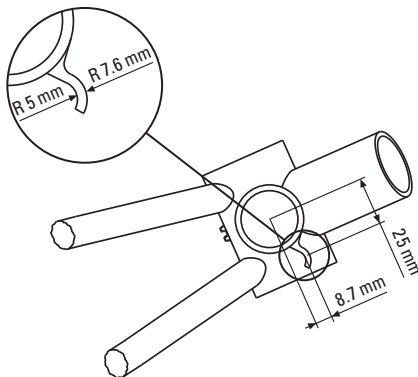

RED / FORCE / RIVAL · FRONT DERAILLEURS

TECHNICAL DATA / ASSEMBLY REQUIREMENTS

2

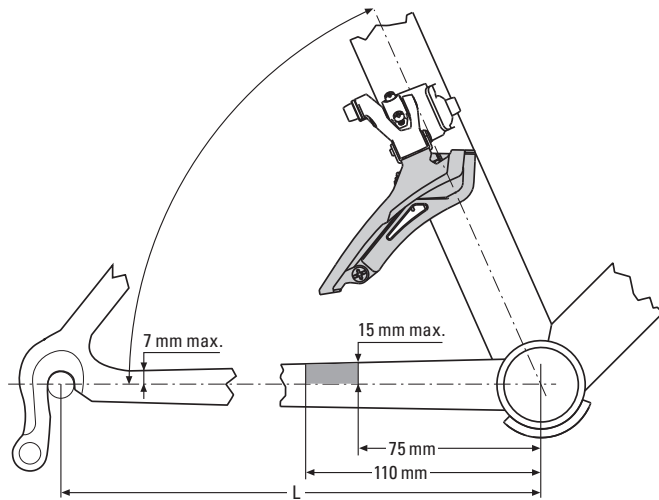

Frame Dimensions

(see **Figure 2**)

The seat tube should be positioned in the center of the bottom bracket shell.

Length of chainstay:

- Road L > 405 mm.
- Rear frame alignment must be symmetrical.

Chainstay angle:

= 61° – 66°.

Chainline:

44.5 mm.

(Measurement from the center of the bracket to the center of the two chainrings.)

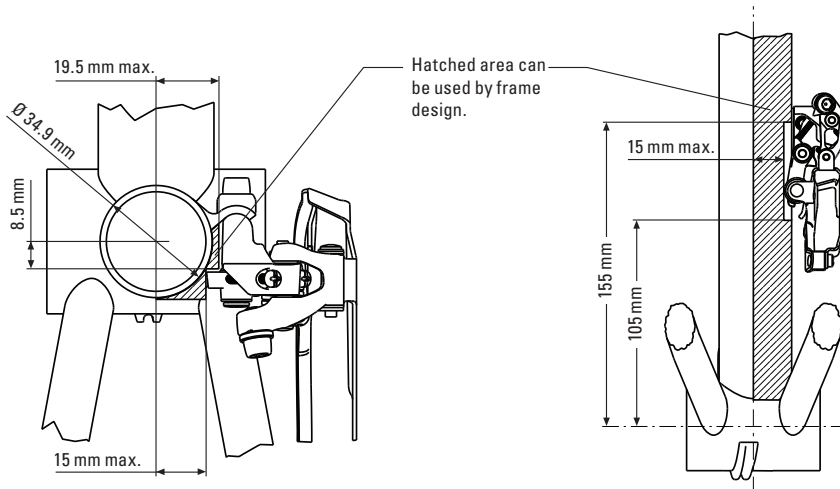

3

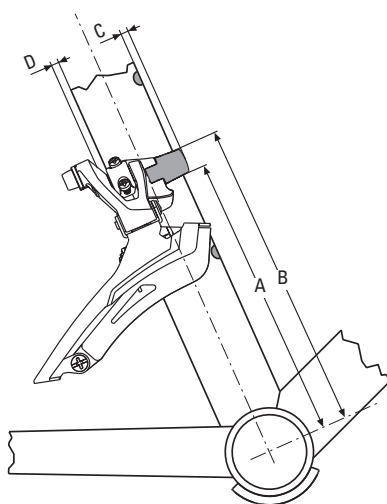

NECESSARY CLEARANCE FOR CLAMP VERSION

(see **Figure 3**)

Be sure to leave enough clearance between bottle cage holes and clamp location.

NECESSARY CLEARANCE see Figure 2					
Large Chainring		48 T	50 T	52 T	53 T
Clamp band position	A	135 mm	139 mm	143 mm	145 mm
	B	152 mm	156 mm	160 mm	162 mm
Clamp Version		Red	Force / Rival		
Necessary clearance	C	9 mm	4 mm		
	D	1 mm	4 mm		

RED / FORCE / RIVAL · FRONT DERAILLEURS ASSEMBLY

1

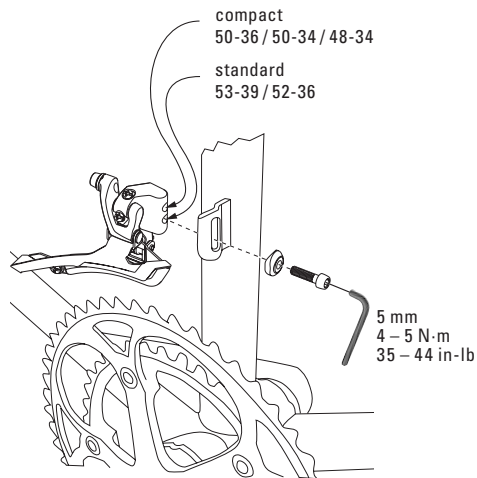

2

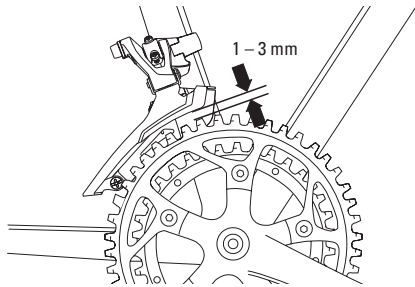

3

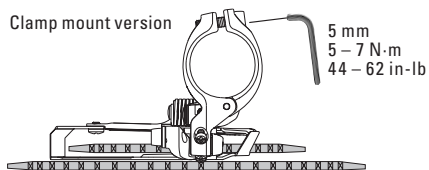

4

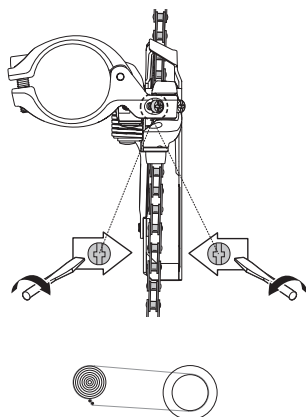

ASSEMBLY

- Red / Force / Rival braze-on mount version (see **Figure 1**): Use upper thread for compact chainrings (50-36 / 50-34 / 48-34) or lower thread for standard chainrings (53-39 / 52-36).
- Red / Force / Rival clamp mount version (see **Figure 2**): Lightly clamp the front derailleur to the seat tube.
- Adjust the position along the seat tube so that clearance between the front derailleur cage and the large chainring is 1 – 3 mm (**Figure 2**).
- At the same time, align the front derailleur cage outerplate to be parallel with the chainrings (**Figure 3**).
- Red braze-on mount version: Tighten 5 mm hex clamp bolt to 5 – 7 N·m (44 – 62 in·lb).
- Force / Rival braze-on mount version: Tighten 5 mm hex clamp bolt to 4 – 5 N·m (35 – 44 in·lb).
- Force / Rival clamp mount version: Tighten 5 mm hex clamp bolt to 3 – 4 N·m (27 – 35 in·lb).

LOW LIMIT ADJUSTMENT

- (see **Figure 4**)
- Place the chain on the largest rear cog and the small front chainring.
 - Adjust the low limit screw (**Figure 4**) so that the chain is positioned close to the inner cage plate without actually touching it (clearance between the front derailleur cage inner plate and the chain is 0.5 – 1 mm).

CONNECTING CABLE

- Check that the chain and the front derailleur are in the small chainring position.
- Make sure the shifter cable is fully released (easiest (lowest) gear for front shifter).
- Turn the barrel adjuster on the frame fully into the housing, then turn 1 full turn back.

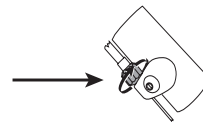

- Feed the front shifter cable through the cable housing and stops. Route cable through a cable guide beneath the bottom bracket.
- Run the cable under the cable anchor washer and hold taut (**Figure 4**).
- Tighten the 5 mm hex cable anchor bolt to 5 N·m (44 in·lb).
- Shift the chain up and down the chainrings several times to take out initial slack in the cable.
- If necessary, re-tension the cable and tighten cable anchor bolt.

HIGH LIMIT ADJUSTMENT

- (see **Figure 6**)
- Set the chain to the smallest rear cog and the large front chainring.
 - Adjust the high limit screw so that clearance between the front derailleur cage outer plate and the chain is 0.5 – 1 mm.

RED / FORCE / RIVAL · FRONT DERAILLEURS ASSEMBLY

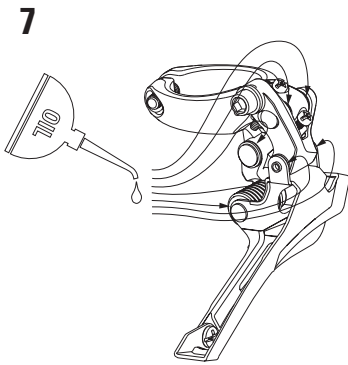
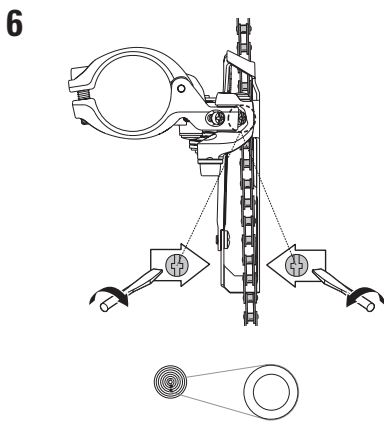
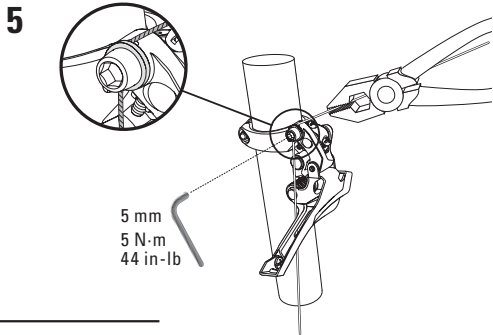

INDEX SHIFTING ADJUSTMENT

(see **Figure 8**)

Adjust the front shifter cable barrel adjuster to ensure the front derailleur contacts the high limit screw when the shifter is indexed to the large chainring position. Shift to and from the large chainring with the chain on several different rear cogs. If shifting performance is not acceptable, re-check the cage alignment (**Figure 3**) and limit screw adjustments (**Figure 4** and **6**), then repeat index shifting adjustment.

ADVICE
Avoid using extreme gear combinations as these combinations cause noise and excessive wear!

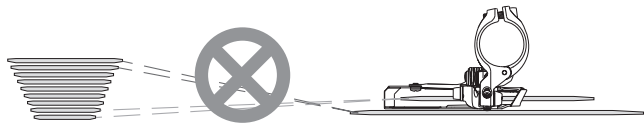

TROUBLESHOOTING

Problem	Cause	Remedy
Shifter actuated, chain fails to change chainring.	Shift cable incorrectly clamped.	Check shift cable and correct as necessary (cable clamp; cable housing stops; cable recess in shifter; cable tension).
	High / low limit screw poorly adjusted.	Correct limit screws.
	Clearance between cage and large chainring is too large / small.	Correct position (1 – 3 mm).
Chain falls over large / small chainring.	High / low limit screw poorly adjusted.	Correct limit screws.
Force required to actuate gears is too high.	Excessive cable friction, pinched or poorly routed cable.	Lubricate or replace cable and housing. Check for excessive bending of cable housing.
Crank collides with front derailleur.	High gear limit screw incorrectly adjusted.	Correct high limit screw.
	Cage not parallel with chainring.	Correct the front derailleur position.

RED / FORCE / RIVAL · DOUBLE TAP SHIFTERS

TECHNICAL DATA / ASSEMBLY REQUIREMENTS

	Red	Force	Rival
Version	Double Tap Shifter		Double Tap Shifter
Shifter Type	Front	Rear	Front
Speeds	2	10	2
Derailleur	SRAM Red / Force / Rival		
Crankset	SRAM Red / Force / Rival		
Brakes	SRAM Red / Force / Rival Dual Pivot Road calipers, Avid Shorty 4/6 cantilevers, Avid BB7 Road and most common road caliper brakes		
Shifter Cable	High quality 1.1 mm shifting cable and 4 or 5 mm compressionless housing, high quality, with non-sealed end caps of maximum diameter 5.8 mm and maximum length 16 mm.		
Brake Cable	1.6 mm high quality brake cable with road-style cable end and brake cable housing with end caps.		
Cable Pull/Release	Double Tap	Double Tap	Double Tap
Cable	GORE™ Coated Stainless Steel	PTFE Coated Stainless Steel	Stainless Steel
Reach Adjust	Brake and Shift Lever	Brake and Shift Lever	Brake and Shift Lever
Gear Indication	None	None	None
Barrel Adjuster	None	None	None
Clamping Diameter	22.1 – 22.3 mm	22.1 – 22.3 mm	22.1 – 22.3 mm

RED / FORCE / RIVAL · DOUBLE TAP SHIFTERS

ASSEMBLY

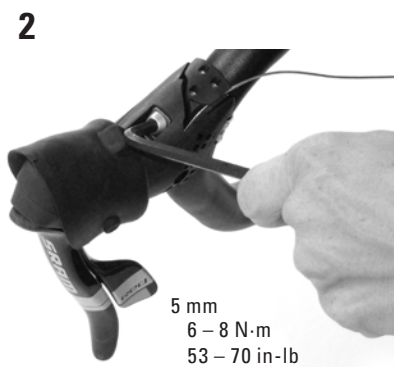

Assembly

- Flip hood cover by hand. Slide shifter onto handlebar (**Figure 1**). Tighten the 5 mm hex clamp bolt to 6 – 8 N·m (53 – 70 in·lb) (**Figure 2**).
- Feed the shifter cables through the cable housings and stops. Make sure the shifter cable is fully released (easiest (lowest) gear for front shifter or the hardest (highest) gear for rear shifter).
- Choose the one shift cable exit which fits best for your handlebar cable routing (**Figure 3**). There is no need to disassemble the shifter. Seat the housing ferrules in the stops. Feed the shift cable into the cable housing end cap using a pick to guide the cable.
- Make sure the shifter cable is fully released (easiest (lowest) gear for front shifter or the hardest (highest) gear for rear shifter).
- Replace hood cover.
- Actuate brake lever. Make sure the countersunk side of the hole is visible. Feed the new cable through the cable holder, cable housing and cable stops. Pull the cable snug. Make sure that the cable end is firmly seated in the cable holder (**Figure 4**).
- Attach the front/rear shifter cable to the front/rear derailleur and adjust indexing per derailleur instructions. Attach the front/rear brake cable to the front/rear brake and adjust per brake instructions.



CAUTION

Always check the front and rear brake levers for proper operation.



RED / FORCE / RIVAL · DOUBLE TAP SHIFTERS USE

1

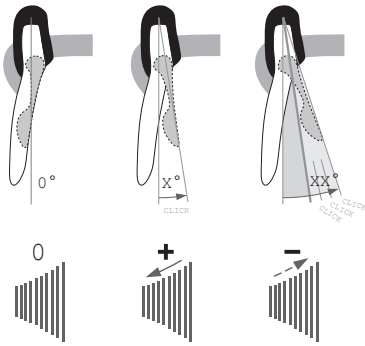

2



3



4



USE

SHIFTER

- Move the small shift lever inward slightly and an upshift to a harder (higher) gear is initiated (**Figure 1**). Push the same lever farther inward and you're shifting up to three shifts to easier (lower) gears (**Figure 1**).

The shifters also offer specific operations:

- Upshifting while sprinting:

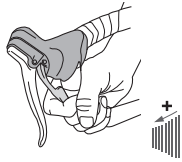

- Shifting from the hoods:

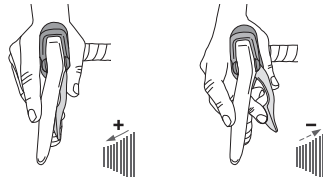

- Shifting from the drops:

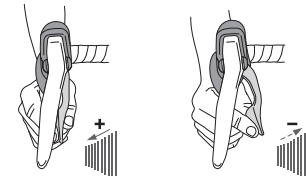

- The left hand shifter offers a trim function for the front derailleur to avoid chain rub in extreme positions. From the small chainring position, the first shift changes to the large chainring position. From the large chainring position, a slight release changes to the large chainring trim position. Alternately, a big release changes to the small chainring position.

BRAKE LEVER

⚠ CAUTION

Always check the front and rear brake levers for proper operation!

REACH ADJUST

Set the reach adjust on the shift lever first then adjust the brake lever until the brake lever bumper just touches the shift lever. This will ensure the brake lever does not interfere with the return action of the shift lever.

- Move the shift lever inboard to expose the reach adjust cam. (**Figure 2**)
- Push the cam in and turn counterclockwise to move the shift lever closer to the handlebar. It may be helpful to use a pick. The shift lever has 6 different adjustment positions.
- Pull back hood cover by hand. (**Figure 3**)
- Use the small 3mm hex bolt to set the reach adjust of the brake lever. Turn the bolt clockwise to move the brake lever closer to the handlebar until the brake lever bumper just touches the shift lever. (**Figure 4**)



CAUTION

Always check the front and rear brake levers for proper operation!

DOUBLE TAP FLAT BAR SHIFTERS

TECHNICAL DATA / ASSEMBLY

Version	Double Tap Flat Bar Shifter			
Shifter Type	Front		Rear	
Speeds	2	3	10	9
Derailleur	SRAM Red / Force / Rival	SRAM and Shimano®	SRAM Red / Force / Rival	SRAM 9 Speed (1:1 Actuation Ratio)
Shifter Cable	High quality 1.1 mm shifting cable and 4 or 5 mm compressionless housing, high quality, with non-sealed end caps of maximum diameter 5.8 mm and maximum length 16 mm.			
Brake Cable	1.6 mm high quality brake cable with road-style cable end and brake cable housing with end caps.			
Cable Pull/Release	Double Tap			
Cable	Proprietary Stainless Steel			
Reach Adjust	Brake and Shift Lever			
Gear Indication	Window			
Barrel Adjuster	Indexing			
Clamping Diameter	22.1 – 22.3 mm			

DOUBLE TAP FLAT BAR SHIFTERS

ASSEMBLY

1



INSTALLATION

- Slide shifter onto handlebar, and then slide on brake lever. Slide the handlebar grip onto the handlebar (**Figure 1**).



CAUTION

Never use lubricants or solvents to install handlebar grips. Handlebar grips provide an axial safety function. For this reason, they should be mounted in such a way as to make sure they do not slip off the handlebar.

- Choose the best shifter and brake lever position for your ergonomic needs.

2

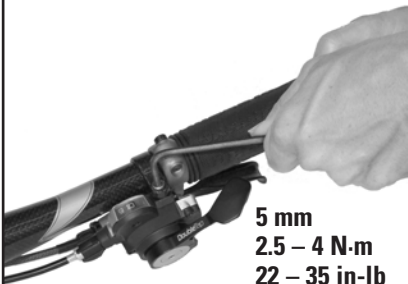

5 mm
2.5 – 4 N·m
22 – 35 in·lb

- Tighten the 5 mm hex clamp bolt to 2.5 – 4 N·m (22 – 35 in·lb) (**Figure 2**).

- Tighten the brake lever clamp bolt to the manufacturer's recommended torque specification.

- Feed the cable through the cable housing and stops. Make sure the shifter is in the fully released position (lowest gear position (front shifter) or the highest gear number (rear shifter)).

- Attach the front/rear shifter cable to the front/rear derailleur.

- Adjust indexing per derailleur instructions.



CAUTION

Always check the front and rear brake levers for proper operation. If there is interference between a shifter and a brake lever, rotate one out of the way. Check for proper brake lever operation again!

DOUBLE TAP FLAT BAR SHIFTERS

USE / MAINTENANCE

3



3 mm
2.5 – 4 N·m
22 – 35 in·lb

4

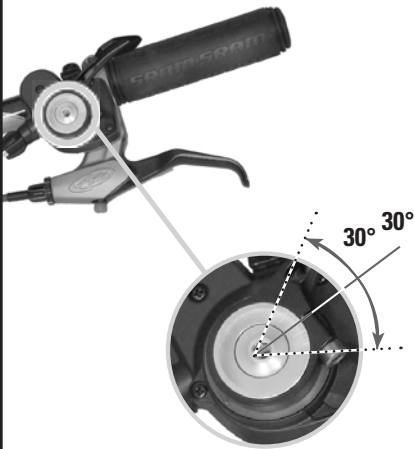

30° 30°

USE

- Push the shift lever inward slightly and an upshift to a harder (higher) gear is initiated. Push the same lever farther inward and you're shifting up to three shifts to easier (lower) gears.

10 SPEED ONLY: The left hand shifter offers a trim function for the front derailleur to avoid chain rub in extreme positions. The lever has three positions: small chainring, trim, and large chainring. From the small chainring position, a short throw changes to the trim position, a long throw changes to the large chainring position. From the trim position, a short throw releases to the small chainring, and a long throw shifts to the large chainring position. From the large chainring position, a short throw shifts to the trim position. A second short throw will shift to the small chainring position.

SHIFT LEVER ORIENTATION

- Use a 4 mm hex wrench to loosen the shift lever angle adjustment screw (Figure 3).
- Position the shift lever using the angle markings as a guide (Figure 4).
- Use a 4 mm hex wrench to torque the shift lever angle adjustment screw to 22 in·lb (2.5 N·m).

CABLE CHANGE

ADVICE

Leave the shifter on the handlebar.

- The shifter does not need to be opened.
- Use only new, high quality cable and compressionless cable housing with end caps.
- Line-up the shifter in gear position "1" (front shifter) or the highest gear number (rear shifter).
- Detach the cable from the derailleur.
- Cut the cable off 6" (15 cm) from the shifter barrel adjuster. Discard the old cable and cable housing.
- Carefully unscrew cable change cap from cable entry with a screwdriver (Figure 5).
- Push cable out of the cable entry with rotating movement (Figure 6).
- Feed the new cable through the cable entry and out of the barrel adjuster (Figure 7). It may be helpful to remove the barrel adjuster for better visibility.
- Replace cable change cap.
- Feed the cable through the new cable housing and cable stops.
- Attach the cable to the derailleur and adjust indexing per derailleur instructions.

MAINTENANCE

ADVICE

Clean the shifter using only water and mild soap.

These shifters are nearly maintenance free. For any questions regarding methods of disassembly or maintenance, please contact your qualified local dealer.

5



6



7



ROAD BRAKE LEVERS USE / MAINTENANCE

1

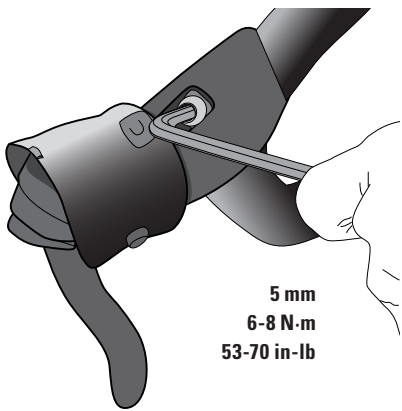
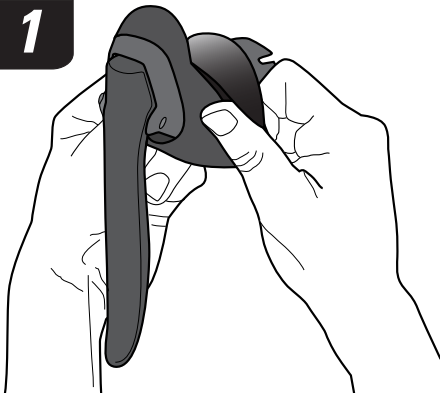

2

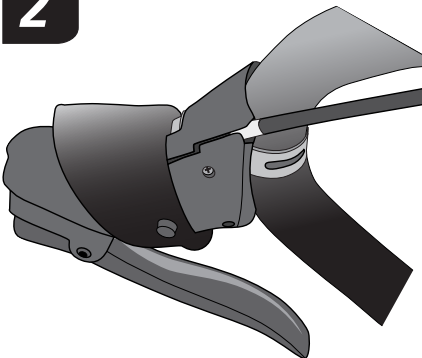

6

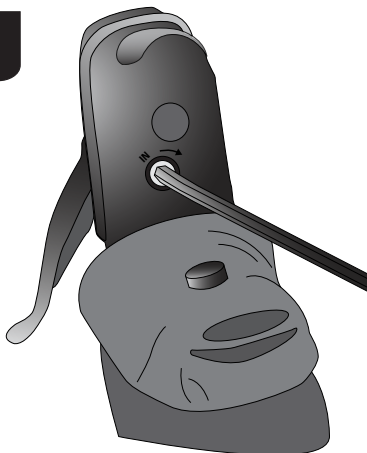

COMPATIBILITY

SRAM Road Brake Levers are designed for use with:

- Brakes: SRAM Red / Force / Rival Dual Pivot Road calipers, Avid Shorty 4/6 cantilevers, Avid BB7 Road and most common road caliper brakes
- Brake cable: 1.6 mm high quality brake cable with road-style cable end and brake cable housing with end caps

TOOLS AND SUPPLIES

- Safety glasses
- Grease
- 3 and 5 mm hex wrenches
- Torque wrench

INSTALLATION

- 1 Flip hood cover forward by hand. Slide brake lever onto handlebar. Torque the 5 mm hex clamp bolt to 6-8 N-m (53-70 in-lb).
- 2 Seat the housing ferrules in the stops inside the brake lever. Feed the brake cable through the brake cable holder so the cable head rests in the counterbore, which is just on one side of the cable anchor.
- 3 Replace hood cover. Be sure that all keys in hood cover are properly engaged with the hood (not pictured).
- 4 Attach the front/rear brake cable to the front/rear brake caliper and adjust per brake manufacturer's instructions (not pictured).



CAUTION

Always check the front and rear brake levers for proper operation.

REACH ADJUST

SRAM brake levers can be adjusted to various reach settings.

- 5 Pull back hood cover by hand (not pictured).
- 6 Use the small 3mm hex bolt to set the reach adjust of the brake lever. Turn the bolt clockwise to move the brake lever closer to the handlebar.

CHANGE OF BRAKE CABLE



ADVICE

Use only new, high quality brake cable with road-style cable end and brake cable housing with end caps.

- 7 Detach the cable from the brake caliper (not pictured).
- 8 Actuate brake lever and push out the brake cable.



ADVICE

We recommend applying a small amount of grease onto the countersunk side (a, Fig. 8) and the pivot points (b, Fig.8) of the brake cable holder.

- 9 Actuate brake lever. Make sure the countersunk side of the hole is visible. Feed the new cable through the cable holder, cable housing and cable stops (not pictured).
- 10 Pull the cable snug. Make sure that the cable nipple is firmly seated in the cable holder. Attach the cable to the brake caliper and adjust according to brake caliper manufacturer's instructions (not pictured).

MAINTENANCE

Clean the brake lever using only water and mild soap. These brake levers are nearly maintenance free. For any questions regarding methods of disassembly or maintenance, please contact your qualified local dealer.

8

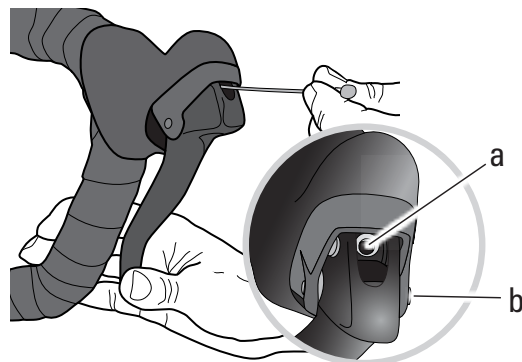

TT SHIFTERS

TECHNICAL DATA / ASSEMBLY REQUIREMENTS

Version	Time Trial Shifter	Time Trial Shifter
Shifter Type	Front (Friction)	Rear (Index)
Speeds	2	10
Deraillieur	SRAM Red / Force / Rival	
Crankset	SRAM Red / Force / Rival	
Shifter Cable	High quality 1.1 mm shifting cable and 4 or 5 mm compressionless housing, high quality, with non-sealed end caps of maximum diameter 5.8 mm and maximum length 16 mm.	
Bar Inner Diameter	19.2 - 22.5 mm / Minimum depth 35 mm	
Cable	PTFE Coated Stainless Steel	PTFE Coated Stainless Steel
Gear Indication	None	None
Barrel Adjuster	None	None

TT SHIFTERS

ASSEMBLY

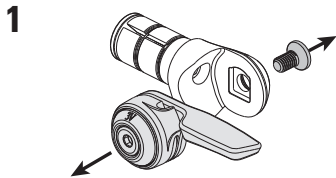

ASSEMBLY



ADVICE

Make sure cable housing length is sufficient to allow for extreme turning angles as well as adjustable handlebars and stems.

· Remove the 4 mm housing screw to separate the shifter assembly from the housing (**Figure 1**).

note: the shifter assembly will come off as one piece with no loose parts.

· Push the housing into the handlebar extension until it stops (**Figure 2**).

· Tighten the 5 mm internal clamp screw to 8 N·m (70 in·lb) (**Figure 3**).

· **Front shifter lever only:** When engaged in the big chain ring, the front shifter lever is designed to remain parallel to the ground for three different handlebar positions. The front shifter lever can be set to a “position stop angle” that corresponds to 0°, 30°, or 60° handlebar positions (**Figure 4**).

note: the front shifter lever is pre-set from the factory at a 0° position stop angle.

important: the orientation of the position stop washer is **critical** to the function of the shifter lever. Refer to the illustrations above for proper setup of the chosen position stop angle.

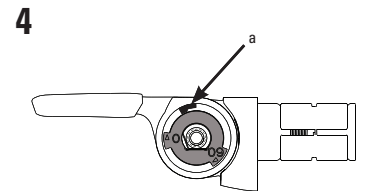
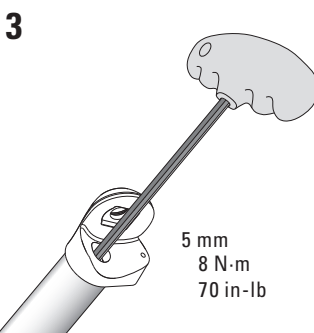
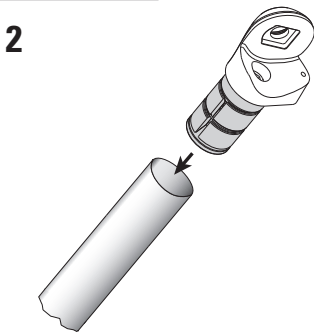

0° Position Stop Angle

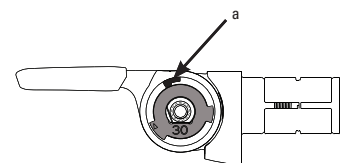

30° Position Stop Angle

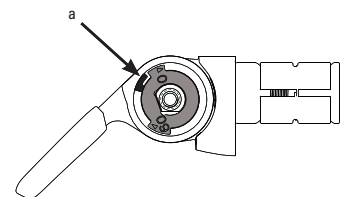

60° Position Stop Angle

TT SHIFTERS ASSEMBLY

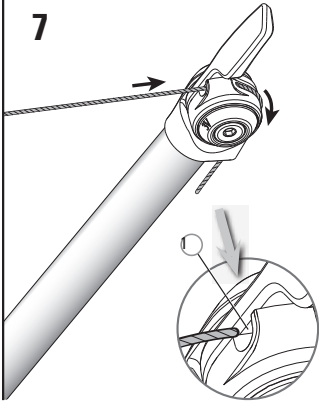
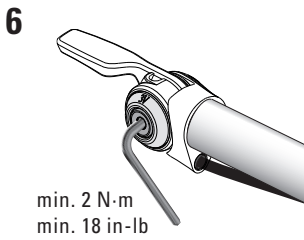
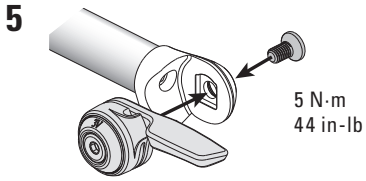

· Fit the shifter assembly back onto the housing and tighten the 4 mm housing screw to 5 N·m (44 in-lb) (**Figure 5**).

· **Front shifter lever only:** torque the friction adjust screw on the front shifter lever to 2 N·m (18 in-lb) minimum (**Figure 6**).

note: to increase the feedback felt at the front shifter lever, you can increase the torque of the friction adjust screw.

· Feed the new cable through the cable entry (1) and out the shifter (**Figure 7**).

· Feed the new cable through the cable housing and cable stops.

· Pull the cable snug. Make sure that the cable head is firmly seated in the cable holder.

· Attach the cable to the derailleur and adjust indexing per derailleur instructions.

1090-R2C TT SHIFTERS USE / MAINTENANCE

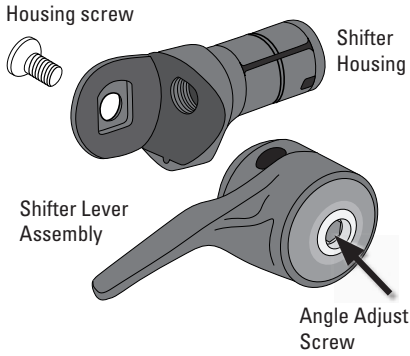

1

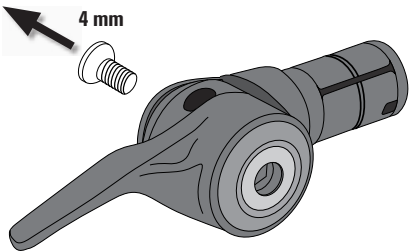

2

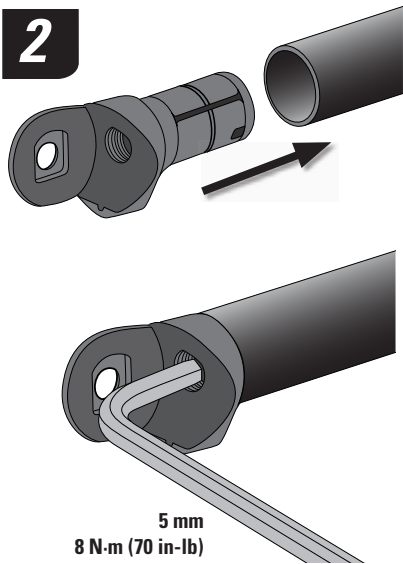

3

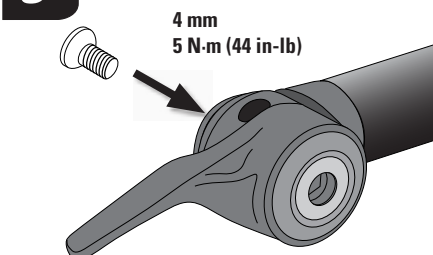

COMPATIBILITY

SRAM 1090-R2C 'Return to Center' TT Shifters are designed for use with:

- SRAM RED™ / FORCE™ / RIVAL™ front derailleurs
- SRAM RED / FORCE / RIVAL rear derailleurs
- High quality 1.1 mm shifter cable and 4 or 5 mm compression-less housing with non-sealed ferrules of 5.8 mm maximum diameter (maximum length of 16 mm)

TOOLS AND SUPPLIES

- Safety glasses
- 4 mm, 5 mm hex wrenches
- Torque wrench

INSTALLATION

- 1 Remove the 4 mm shifter housing screw to separate the shifter lever assembly from the shifter housing.



IMPORTANT

The shifter lever assembly will come off as one piece with no loose parts.

- 2 Push the shifter housing into the handlebar extension until it stops. Tighten the 5 mm internal clamp screw to 8 N-m (70 in-lb).

- 3 Re-install the shifter lever assembly on the shifter housing. Tighten the 4 mm shifter housing screw to 5 N-m (44 in-lb).

ANGLE ADJUSTMENT

The SRAM 1090-R2C shift levers allow you to start your shift from your most aerodynamic position. After your shift, the shifter automatically returns to the starting 'center' position.

To change the center position of the shifter levers, follow these steps:

- 4 Loosen but **do not remove** the 5 mm angle adjust screw.



IMPORTANT

Do not remove the 5 mm angle adjust screw. Removing the angle adjust screw will disassemble the shifter.

- 5 Position the shifter lever at an aerodynamic angle that is comfortable for you.

- 6 Tighten the 5 mm angle adjust screw to 9 N-m (80 in-lb).

4

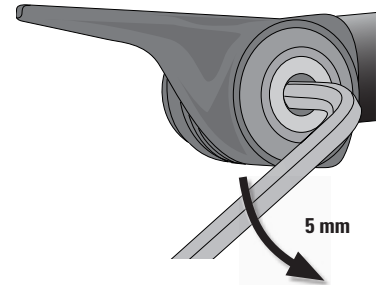

5

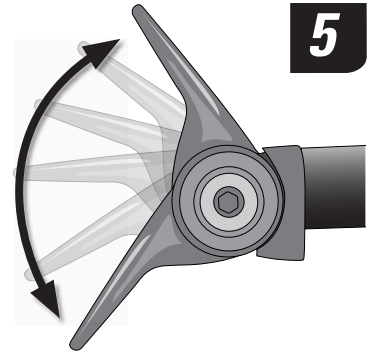

6

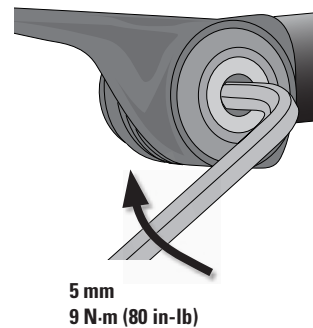

1090-R2C TT SHIFTERS USE / MAINTENANCE

8

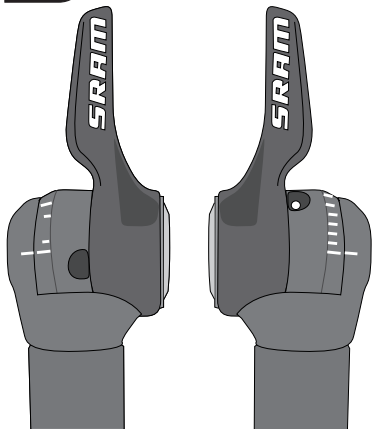

CABLE INSTALLATION

7 Measure and cut shifter housing. Ensure housing is long enough for full handlebar movement. Install ferrules on housing, then install into shifter cable stop and frame or aero bar cable stops (not pictured).

8 Actuate the rear shifter lever to move the shifter to the **highest** gear position. Actuate the front shifter lever to move the shifter to the **lowest** gear position.

9 Pass the new cable through the cable entry port (a) and out of the shifter through the cable housing and cable stops.

10 Attach the cable to the derailleur and adjust indexing according to the derailleur manufacturer's instructions (not pictured).

MAINTENANCE



IMPORTANT

Clean the shifter using only water and mild soap. These shifters are nearly maintenance free. For any questions regarding methods of disassembly or maintenance, please contact your qualified local dealer.

9

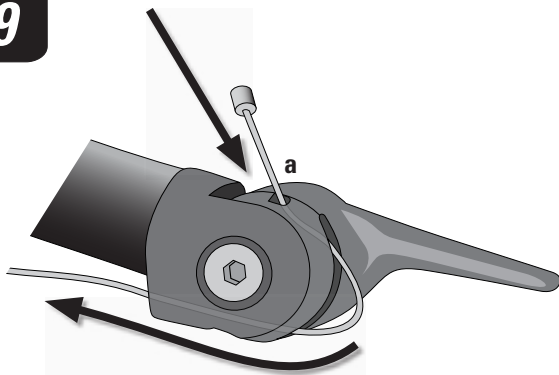

TT BRAKE LEVERS

TECHNICAL DATA / ASSEMBLY REQUIREMENTS

Version	Time Trial Brake Lever	
Brake Lever	Left	Right
Lever Size	5-Finger	5-Finger
Brake Compatibility	SRAM Red / Force / Rival Dual Pivot Road calipers, Avid Shorty 4/6 cantilevers, Avid BB7 Road and most common road caliper brakes	
Brake Cable	1.6 mm high quality brake cable with road-style cable end and brake cable housing with end caps	
Bar Inner Diameter	19.2 - 22.5 mm / Minimum depth 39 mm	
Reach Adjust	No	No
Pivot Bushing	POM	POM
Housing	Grilon Composite	Grilon Composite
Lever	Carbon Composite	Carbon Composite

TT BRAKE LEVERS

ASSEMBLY

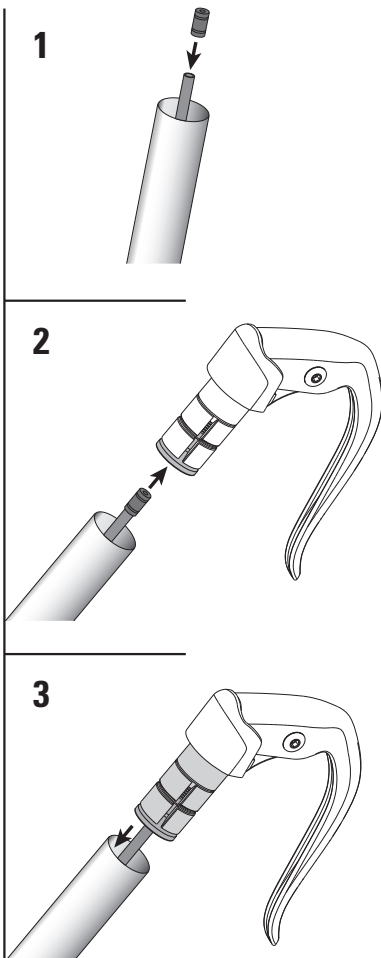

ASSEMBLY

- Push the cable housing end cap onto the brake cable housing (**Figure 1**).
- Insert the end of the brake cable housing into the brake lever bottom side (**Figure 2**).
- Push the brake lever onto the handlebar (**Figure 3**).
- Tighten the brake lever. 5 mm Allen wrench, torque 8 N·m (70 in·lb) (**Figure 4**).
- Pull the brake handle toward the handlebar and make sure the countersunk side of the hole is visible (1). Feed the new cable through the cable holder (2), cable housing and cable stops (**Figure 5**).
- Pull the cable snug. Make sure that the cable end is firmly seated in the cable holder.
- Follow the brake manufacturer's instructions when mounting the brake cable and adjusting the brakes.

CAUTION
 Before riding, always check that all brake system components are functioning properly.
 Check and correct the brake cable tension after each handle change to ensure good brake performance.

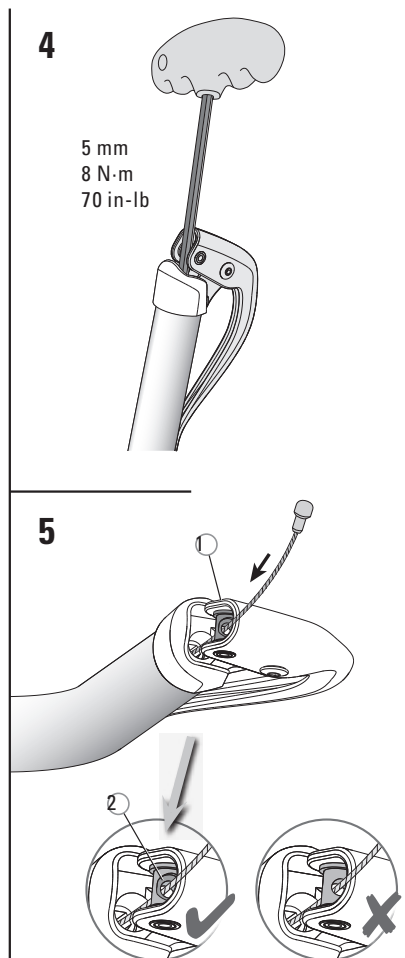

RED / FORCE / RIVAL · CRANKSETS W/ GXP BOTTOM BRACKET

TECHNICAL DATA / ASSEMBLY REQUIREMENTS

	Red	Red Compact	Force	Force Compact	Rival	Rival Compact
Bottom Bracket Type	GXP External Bearing		GXP External Bearing		GXP External Bearing	
Bottom Bracket Thread	BSA or Italian		BSA or Italian		BSA or Italian	
Bolt Circle Diameter	130 mm	110 mm	130 mm	110 mm	130 mm	110 mm
Chainring Ratio	53 / 39 T	50 / 34 T	53 / 39 T	50 / 34 - 50 / 36 T	53 / 39 T	50 / 34 - 50 / 36 T
Chains	Only compat. with SRAM 10 speed chains		SRAM 10 speed chains and Shimano® 10 speed chains			
Chainline	44.5 mm		44.5 mm		44.5 mm	
Minimum Chainstay	405 mm		405 mm		405 mm	
Crank Lengths	165 / 167.5 / 170 / 172.5 / 175 / 177.5		170 / 172.5 / 175		165 / 170 / 172.5 / 175 / 177.5 / 180	
Bearing	Ceramic Sealed Cartridge Bearing		Sealed Cartridge Bearing		Sealed Cartridge Bearing	
Bottom Bracket Cup	Forged Alloy		Forged Alloy		Forged Alloy	
Crank Arm	Carbon Fiber		Carbon Fiber		AL 6066 Aluminum	
Chainring	7075-T6 Aluminum		7075-T6 Aluminum		7075-T6 Aluminum	
Chainring Bolts	7075-T6 Aluminum		7075-T6 Aluminum		7075-T6 Aluminum	

Cranksets are only compatible with GXP bottom brackets and Powerglide chainrings by Truvativ.

RED / FORCE / RIVAL · CRANKSETS W/ GXP BOTTOM BRACKET

ASSEMBLY

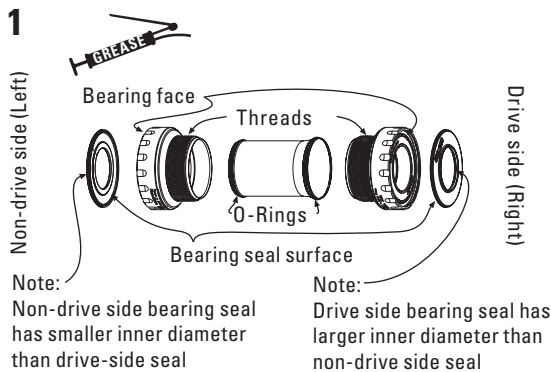

NECESSARY TOOLS

- Torque wrench
- 8 mm hex, 16 mm (5/8") hex
- Bottom Bracket installation tool (Truvativ GXP tool, Park™ BBT9 or equivalent)

Supplies:
· Grease

PARTS PREPARATION

- Prepare the frame's bottom bracket shell threads are clean and undamaged, there should be no paint or dirt present. Have your bottom bracket shell chased and faced by your bike shop for best results. Check to make sure the threads of your GXP bottom bracket match the threads in the bottom bracket shell of your frame.

ASSEMBLY

- Grease frame threads (**Figure 4**). Thread the prepared bottom bracket into the drive side (right side) of the frame (counterclockwise to tighten English (BSA) thread or clockwise to tighten Italian thread) until the flange bottoms against the frame shell face. Torque to 34 – 41 N-m (301 – 363 in-lb) using a torque wrench. Refer to **Figure 4**.
- Grease frame threads (**Figure 5**). Thread the prepared left adapter cup into the non-drive side (left side) of the frame (Clockwise to tighten) until the flange bottoms against

- Prepare the bottom bracket as shown in **Figure 1**. It may be necessary to remove the drive side seal from the spindle. Both seals should be pressed into place so that the outer lip seats firmly in the bottom bracket cup groove. Apply grease to the surfaces shown in **Figure 1**.

- Prepare the crank spindle:
 - Apply grease to splines (**1, Figure 2**)
 - Apply grease to crankbolt threads (**2, Figure 2**)
 - Apply grease to spindle bearing race surfaces (**3, Figure 2**)

- Prepare the self extracting crank bolt: Apply grease to the surfaces shown in **Figure 3**.

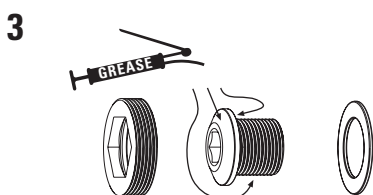
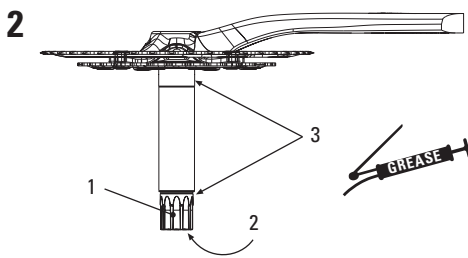

- Grease the frame shell face. Torque the left adapter cup to 34 – 41 N-m (301 – 363 in-lb) using a torque wrench.

- Grease the inner bearing races as shown in **Figure 6**. Slide the right crankarm and spindle assembly through the bottom bracket until the left side splines come through the left side bottom bracket cup, and the spindle stops.

- If the crank bolt assembly has not been assembled yet, assemble it and torque as shown in **Figure 7**. Use a 16 mm hex (5/8") and torque wrench to install self

RED / FORCE / RIVAL · CRANKSETS W/ GXP BOTTOM BRACKET ASSEMBLY

4

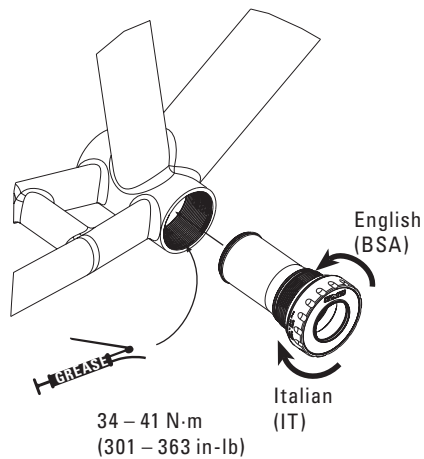

extractor and torque to 12 – 15 N·m (106 – 133 in-lb).

- Assemble the left crankarm onto the bottom bracket spindle using an 8 mm hex and torque wrench and torque to 48 – 54 N·m (425 – 478 in-lb) as shown in **Figure 8**.

- Check the assembly for play by rocking the crank arms back and forth away from frame. If the crank moves, tighten crank arm bolt until no play is detected. If maximum torque of 54 N·m (478 in-lb) has been achieved, remove the crank arm from the spindle, apply additional grease and repeat installation procedures until play is eliminated.

- Grease the pedal threads, assemble and tighten the pedals to the crankarms with 31 – 34 N·m (274 – 301 in-lb). Use the included pedal washers (1, **Figure 8**) if the pedal contact surface is not flat and smooth.

CAUTION
Drivetrain side is right hand pedal-thread. Non drive side is left hand pedal-thread.

ADVICE
If creaking of the assembly occurs, check that all parts were torqued to specification, and grease is liberally applied on all surfaces noted. Also check chainring bolts (8 – 9 N·m / 80 – 90 in-lb) and pedals are installed with proper lubrication and torque.

GXP seals are designed to prevent contamination and therefore must rub against their sealing surfaces. New GXP seals will feel stiff upon initial installation. This is normal. With use the seals will wear-in and loosen up.

5

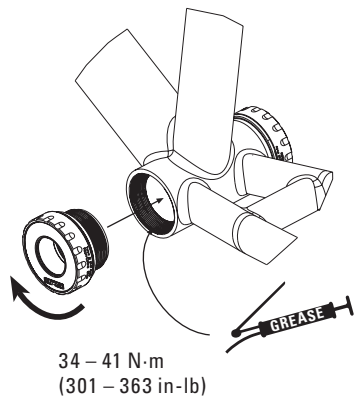

6

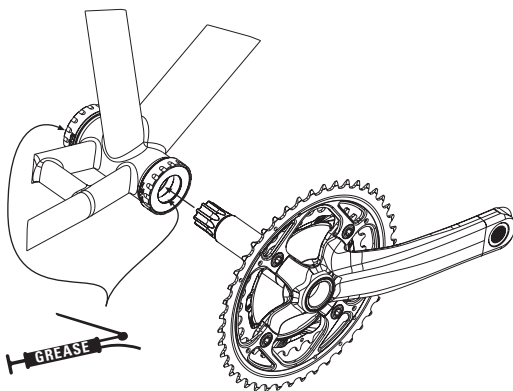

7

16 mm (5/8")
12 – 15 N·m
106 – 133 in-lb

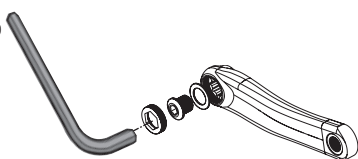

8

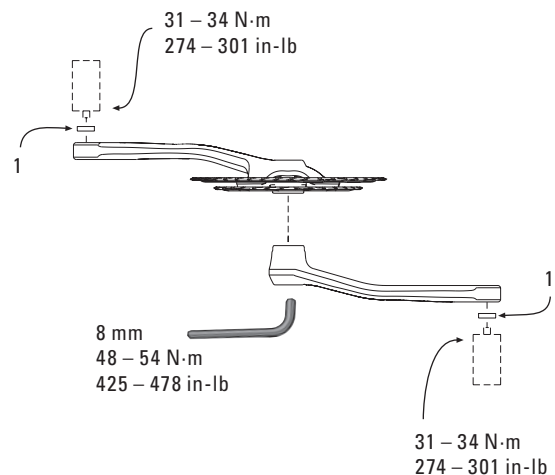

RED / FORCE / RIVAL · CRANKSETS W/ GXP BOTTOM BRACKET MAINTENANCE

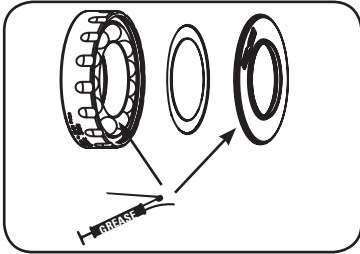

MAINTENANCE



ADVICE

- Red: The ceramic bottom bracket bearings require regular maintenance. Re-grease bearings using SKF LGHP2 grease after 100 hours of use in dry conditions or immediately following any significant exposure to water (riding in heavy rain, water crossings).
- Remove crankarms according to manufacturer's instructions.
 - Using a pick, carefully remove external seals from the face of bottom bracket, and rubber bearing seal from the face of bearing.
 - Load SKF LGHP 2 grease into syringe. Apply grease, ensuring that bearings are completely covered, including between bearings.
 - Press the rubber bearing seal back into place.
 - Apply light coating of grease to the inside surface of the external seal. Press external seals into place so that the outer lip seats firmly in bottom bracket cup groove.
 - Wipe away any excess grease with a clean cloth.
 - Re-install crankarms according to manufacturer's instructions.

BB30 CRANKSET

TECHNICAL DATA / ASSEMBLY REQUIREMENTS

BB30 Crankset	
Bottom Bracket Type	GXP External Bearing
Bottom Bracket Thread	N/A
Bolt Circle Diameter	130 mm 110 mm
Chainring Ratio	53 / 39 T 50 / 34 T
Chains	Only compatible with SRAM 10 speed chains
Chainline	44.5 mm
Minimum Chainstay	405 mm
Crank Lengths	170 / 175 / 177.5
Bearing	BB30 Standard Sealed Cartridge Bearing
Bottom Bracket Cup	N/A
Crank Arm	Carbon Fiber
Chainring	7075-T6 Aluminum
Chainring Bolts	7075-T6 Aluminum

BB30 CRANKSET

ASSEMBLY

ANATOMY

- | | |
|----------------------------|------------------------------------|
| 1 Non-Drive Side Crank Arm | 5 BB30 Bearing |
| 2 Wave Washer | 6 Retaining Clip |
| 3 Spacers | 7 Bottom Bracket Shell |
| 4 Bearing Shield | 8 Drive Side Crank Arm and Spindle |

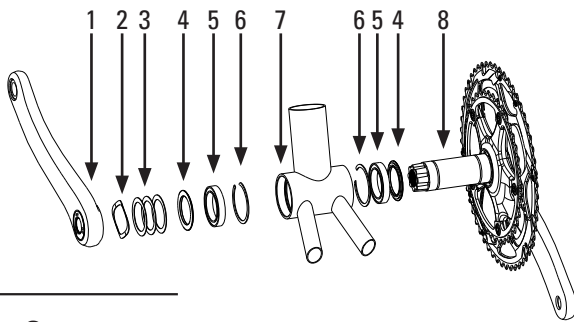

2

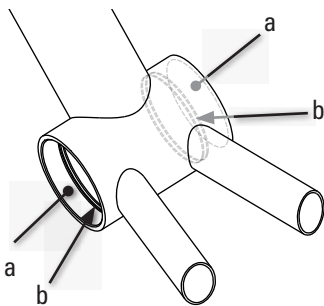

NECESSARY TOOLS

Installation:

- Safety Glasses
- 30 mm Bearing Installation Tool #00-6415-032-020
- 10 mm hex
- Torque wrench
- Headset Press (Park Tool Co. © HHP-2 or equivalent)
- Grease

Removal:

- 30 mm Bearing Removal Tool #00-6415-032-030
- 10 mm Hex
- Flat Bladed Screwdriver
- Rubber Mallet
- Drift Tool

PARTS PREPARATION

- Ensure that bottom bracket shell is clean and free of metal chips, dirt and excess paint.
- Apply a thin layer of grease to the inside surface of the bottom bracket shell (a) and the bottom bracket grooves (b).



ADVICE

It is not necessary to face or machine the bottom bracket shell to use the BB30 system.

BB30 CRANKSET ASSEMBLY

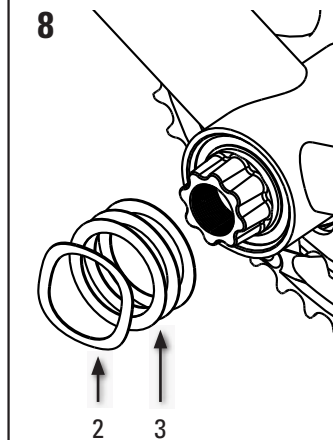
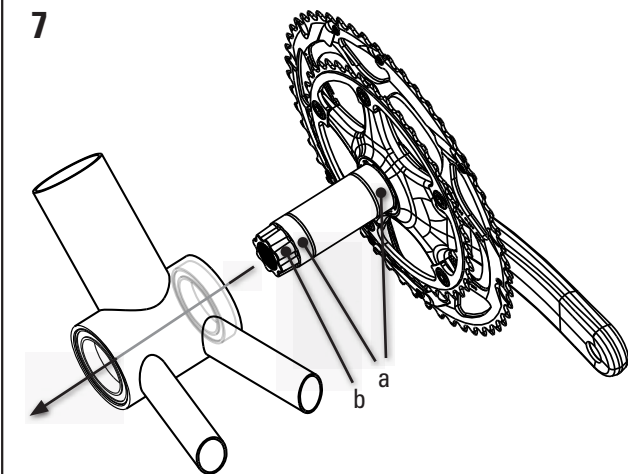
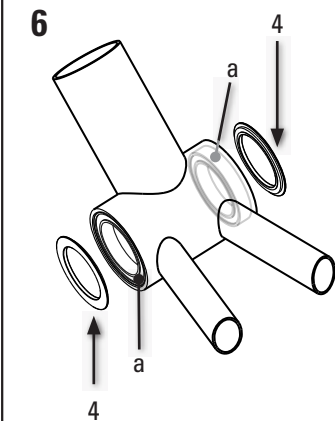
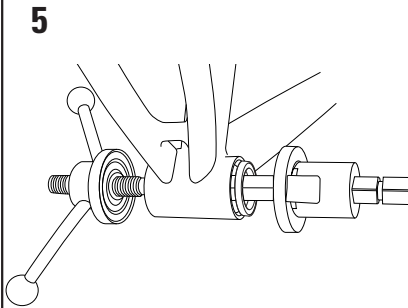
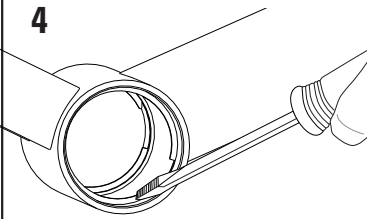

INSTALLATION

⚠ WARNING

Wear eye protection during the installation process. The BB30 retaining clips have sharp edges and can cause serious eye injury if they spring from bottom bracket during installation.

- Using a small flat blade screwdriver, gently install the square end of the retaining clip into the bottom bracket groove, then work the retaining clip into the groove until it is fully seated in the groove. Ensure retaining clip is fully seated in groove. Repeat for opposite side.

- Using a headset press, press the drive side bearing into bottom bracket shell until butted against the retaining clip. Repeat process for non-drive side bearing. Consult your headset press manufacturer's instructions for proper use of the headset press.

⚠ CAUTION

Attempting to install both bearings simultaneously can damage the bearings and/or frame.

- Apply a thin layer of grease to outer bearing surfaces (a). Place bearing shields over bearings with tiered surfaces facing inward toward the bearings.

- Apply light grease to spindle (a) and spindle splines (b). Gently and completely insert the drive side crank and spindle assembly through the installed BB30 bearings.

- Install plastic spacers and wave spring washer over spindle on non-drive side of bottom bracket.

BB30 CRANKSET ASSEMBLY

9

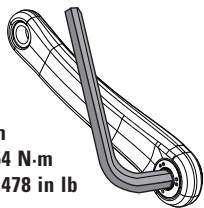

10 mm
48 – 54 N·m
425 – 478 in lb

10

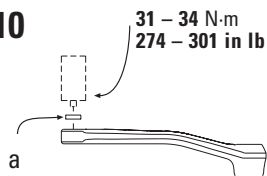

31 – 34 N·m
274 – 301 in lb

11

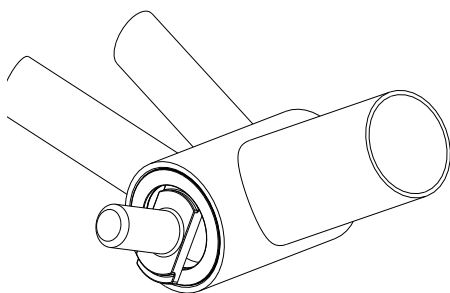

12

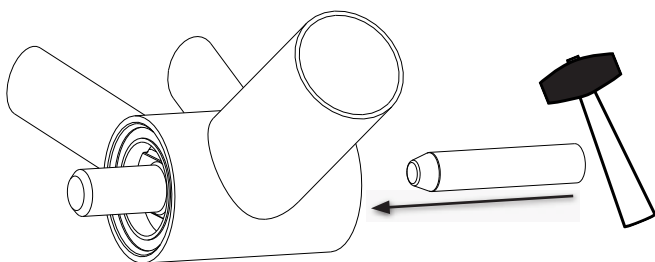

- Apply a thin layer of grease to the threads of non-drive side crank arm. Place the non-drive side crank arm on the spindle and use a 10 mm hex to tighten the crank bolt to 48-54 N·m (425-478 in-lb).

ADVICE

Wave washer on non-drive side should be compressed but not flattened when crank bolt is at full torque. Adjustments to the number of plastic spacers used may be required.

ADVICE

Do not attempt to remove self-extracting crank bolt from the non-drive side crankarm. Doing so may damage your crankset.

PEDAL INSTALLATION

- Grease pedal threads, install included pedal washers (a), and tighten the pedals to the crank arms with 31 - 34 N·m (274 - 301 in lb).

ATTENTION

Drive side is right hand pedal-threading. Non-drive side is left hand pedal-threading.

MAINTENANCE

Use only water and a mild soap to clean crankset and bottom bracket. Do NOT use a pressure washer.

REMOVAL

WARNING

Wear eye protection during the installation process. The BB30 retaining clips have sharp edges and can cause serious eye injury if they spring from bottom bracket during installation.

- Using a 10 mm hex, remove non-drive side crank arm from the spindle with self extracting crank bolt (not pictured).
- Remove drive side crankarm and spindle from the bottom bracket. It may be necessary to use a rubber mallet to gently tap the spindle toward the frame to free it (not pictured).
- Tilt BB30 removal tool inward and position so that it is seated on the inside face of the bearing.
- Insert a driver (punch or drift) from the opposite side and place it against the back of the BB30 removal tool. Using a rubber mallet, lightly tap the BB30 removal tool until bearing is removed from the bottom bracket shell. Repeat for other side.

NOTE: do not re-install removed bearings. Always replace with new bearings.

Removal of the retaining clips is unnecessary for bearing replacement unless the retaining clips are damaged. The damaged retaining clip can be removed by using a flat bladed screwdriver to lift the notched section of the retaining clip out of the bottom bracket groove and guiding the retaining clip out of the bottom bracket groove (not pictured).

PRESSFIT GXP BOTTOM BRACKET ASSEMBLY

ANATOMY

1. Non-Drive Side Crank Arm
2. Non-Drive Side Bearing Shield
3. Non-Drive Side Bottom Bracket Cup
4. Bottom Bracket Shell
5. Drive Side Spacer - MTB only
6. Drive Side Bearing Shield
7. Drive Side Bottom Bracket Cup
8. Wave Washer
9. Drive Side Crank Arm and Spindle

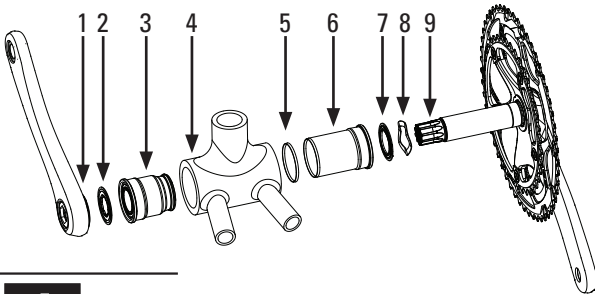

1

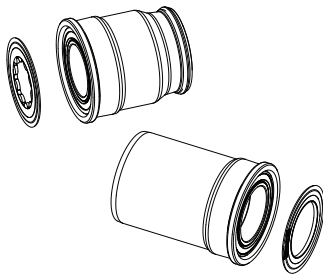

2

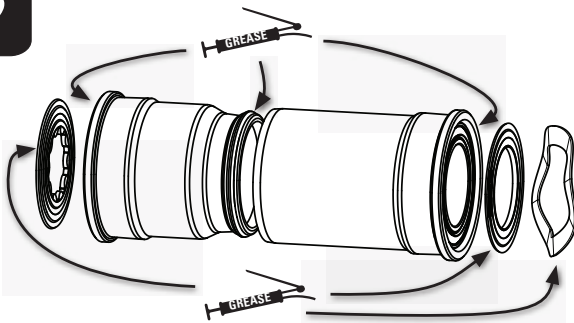

3

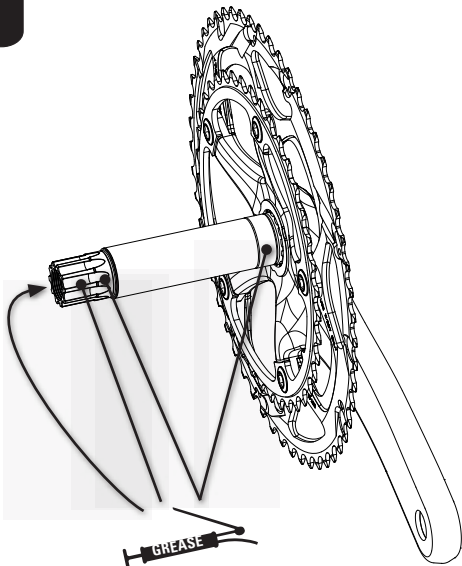

IMPORTANT

To ensure that your PressFit GXP ROAD or MTB Bottom Bracket performs properly and to help make your riding experience more enjoyable and trouble-free, we highly recommend that you have it installed by a qualified bicycle mechanic. Installation of the adapter does not have to be permanent. However, removal of the adapter can damage the cups and bearings. Do not re-use the adapter after removal from the frame shell. The adapter will only work in undamaged frames in good condition. The adapter must NOT be used as a way to repair frames with damaged press fit bottom bracket shells. Improper use, installation or removal of the adapter will void your warranty and can void the warranty for your frame.

COMPATIBILITY

PressFit GXP ROAD Bottom Bracket: enables the use of SRAM and Truvativ GXP road double cranksets in frames designed with sleeveless (PressFit) bottom bracket shells of 86.5 mm width, and 41 mm diameter.

PressFit GXP MTB Bottom Bracket: enables the use of SRAM and Truvativ GXP MTB triple cranksets in frames designed with sleeveless (PressFit) bottom bracket shells of 89.5 mm or 92 mm width, and 41 mm diameter.

TOOLS

Installation

- Safety glasses
- 8 mm, 16 mm (5/8") hex
- Torque wrench
- Headset Press (Park Tool™ HHP-2 or equivalent)
- Grease
- Pick

PREPARE PARTS

1 Carefully remove the bearing shields from the bottom bracket cups. You may need to use a pick to free the shields from the bottom bracket cups.

2 Apply grease to the bottom bracket surfaces as indicated.

3 Generously apply grease to the the crank spindle as indicated.

PRESSFIT GXP BOTTOM BRACKET ASSEMBLY

4

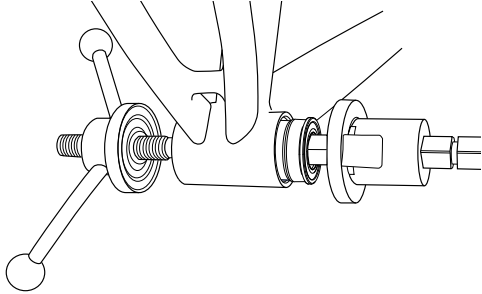

5

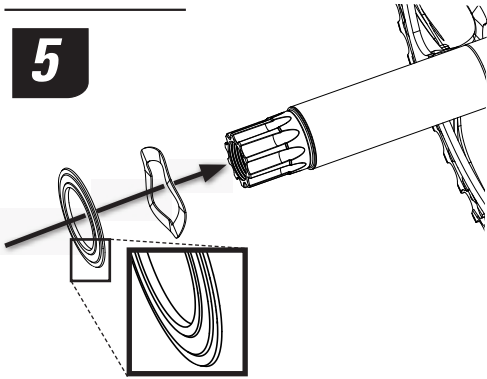

6

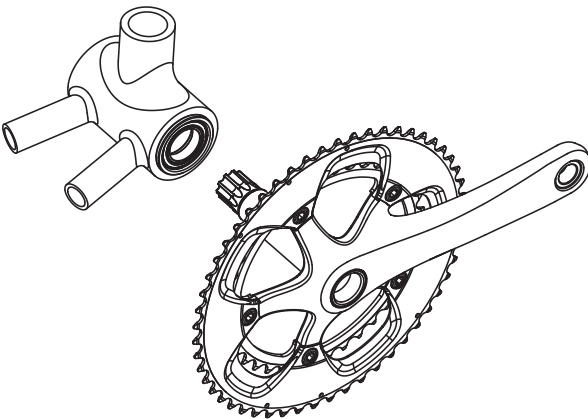

INSTALLATION



ATTENTION

Bearing shields must be removed from the bottom bracket cups prior to installation (step 1).



ATTENTION

For PressFit GXP MTB bottom brackets only: If the bottom bracket shell width is 89.5 mm wide, install the 2.5 mm spacer between the drive side cup and frame. No spacer is required for a bottom bracket shell width of 92 mm.

4

Using a headset press, press the drive side bottom bracket cup into bottom bracket shell until bottom bracket cup flange is fully seated against bottom bracket shell. Repeat process for non-drive side bottom bracket cup. Consult your headset press manufacturer's instructions for proper operation of the headset press.

Identification of non-drive side bottom bracket cup:	
PressFit GXP ROAD:	O-Ring
PressFit GXP MTB:	

5

Install the wave washer and then the drive side bearing shield onto the spindle, making sure the bearing shield is oriented correctly. The stepped lip on the bearing shield should face the bottom bracket shell.



ADVICE

The drive side bearing shield inner diameter has a circular design. The non-drive side bearing shield inner diameter has a "flower" like design.

6

Gently and completely insert the drive side crank assembly spindle through the bottom bracket cups until the non-drive side splines come through the non-drive side bottom bracket cup, and the spindle stops.

7

Install the non-drive side bearing shield onto the spindle, making sure the bearing shield is oriented correctly. The stepped lip on the bearing shield should face the bottom bracket shell (not pictured).

PRESSFIT GXP BOTTOM BRACKET ASSEMBLY / MAINTENANCE

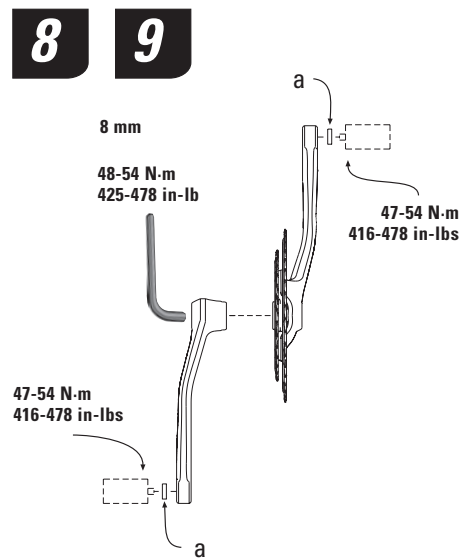

- 8** Apply grease to the threads of non-drive side crank bolt. Place the non-drive side crank arm on the spindle and use a 8 mm hex to torque the crank bolt to 48-54 N-m (425-478 in-lb).

Check the assembly for play by rocking the crank arms back and forth away from frame. If the crank moves, tighten crank arm bolt until no play is detected. If maximum torque of 54 N-m (478 in-lb) has been achieved, remove the crank arm from the spindle, apply additional grease and repeat installation procedures until play is eliminated.

PEDAL INSTALLATION

- 9** Grease the pedal threads and install the included pedal washers (a, Figure 9). Thread the pedals into the crankarms, and torque to 47-54 N-m (416-478 in-lb).

ADVICE

The drive side is right hand pedal-thread. Non-drive side is left hand pedal-thread.

MAINTENANCE

Important: use only water and a mild soap to clean crankset and bottom bracket. Do NOT use a pressure washer.

ADVICE

If creaking of the assembly occurs, check that all parts are torqued to specification, and grease is liberally applied on all surfaces noted. Verify that chainring bolts are torqued to 8-9 N-m (80-90 in-lb). If creaking continues, consult your local Truvativ dealer for assistance.

ATTENTION

Bearings require regular maintenance. Re-grease bearings after 100 hours of use in dry conditions or immediately following any significant exposure to water; such as riding in heavy rain or through water crossings.

REMOVAL

- 10** Use the self-extracting crank bolt assembly or crank puller (if applicable) to remove the non-drive side crank arm. Use a rubber mallet to gently tap the end of the crank spindle towards the frame, and slide it out of the bottom bracket. Remove the bearing shields from the bottom bracket cups (not pictured).

The bottom bracket should be removed by applying force on the internal adapter cup wall (not the bearing) (not pictured).

BB30 TO BSA BOTTOM BRACKET ADAPTER ASSEMBLY

IMPORTANT

To ensure that your BB30 Adapter To BSA performs properly and to help make your riding experience more enjoyable and trouble-free, we highly recommend that you have it installed by a qualified bicycle mechanic. The adapter will only work in undamaged frames in good condition. The adapter must NOT be used as a way to repair frames with damaged bottom bracket shells. Improper use, installation or removal of the adapter will void your warranty and can void the warranty for your frame.

COMPATIBILITY

The BB30 Adapter To BSA enables the use of 68 mm English threaded bottom brackets or 73 mm English threaded bottom brackets with spacers in frames designed with 68 mm BB30 bottom bracket shells.

TOOLS

INSTALLATION

- Safety glasses
- Mild non-abrasive degreaser
- Loctite™ 609 (included with adapter)
- Headset Press (Park Tool® HHP-2 or equivalent)
- BB30 Adapter To BSA installation tools (included with adapter)

REMOVAL

- Safety glasses
- Mild non-abrasive degreaser
- Headset Press (Park Tool® HHP-2 or equivalent)
- BB30 Adapter To BSA removal tools
- Pick

PREPARE FRAME



ATTENTION

BB30 Adapter To BSA can only be used in 68mm wide frame shells that comply with BB30 machining specifications.



1 If a BB30 crankset is already installed in the frame, remove the crankset according to the manufacturer's instructions. Be sure to remove the BB30 bearings and retaining clips.



2 Using a mild, non-abrasive degreaser, thoroughly clean the bottom bracket shell, taking care to remove all grease.



ATTENTION

Do not use any abrasive cleansers or otherwise mar/scratch either the adapter outer surface or the bottom bracket shell inner surface. Damage to either surface can lead to a weak bonding and adapter slippage.

INSTALLATION



3 Apply Loctite™ 609 to the adapter outer mating surfaces, making sure they are completely coated.



4 Using a headset press and included adapter installation tools, install the adapter with the double-grooved surface oriented on the drive side of the frame. Press adapter into frame until drive side edge of adapter is flush with drive side face of bottom bracket shell. Remove headset press and adapter installation tools and wipe off any visible Loctite™ from the frame, adapter, and tools.



5 Allow Loctite to cure for a minimum of 12 hours at 22 deg C (72 deg F) before installing bottom bracket.



ATTENTION

Do not chase or face the bottom bracket adapter. Ensure there is no Loctite on the adapter threads prior to bottom bracket installation.



6 Install the appropriate English bottom bracket (68 mm without spacers or 73 mm with a 2.5 mm spacer on each side) according to the manufacturer's instructions.

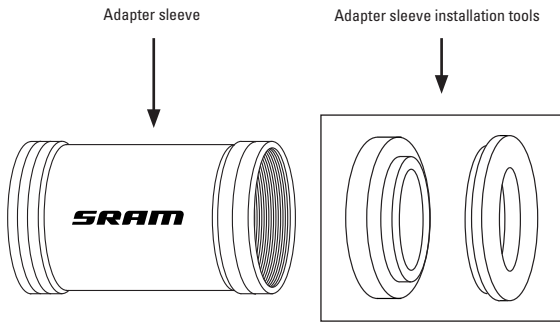

3

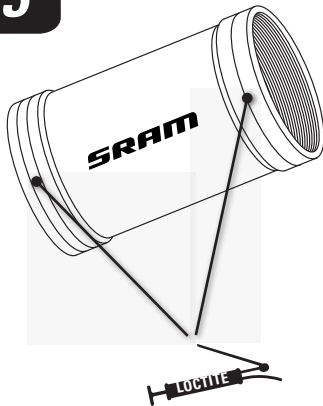

4

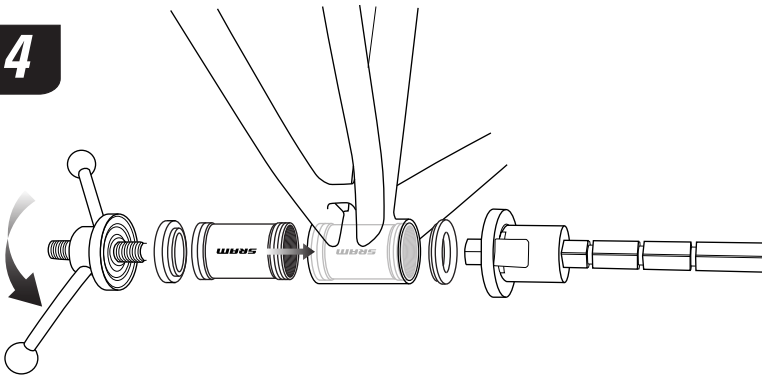

BB30 TO BSA BOTTOM BRACKET ADAPTER REMOVAL

7

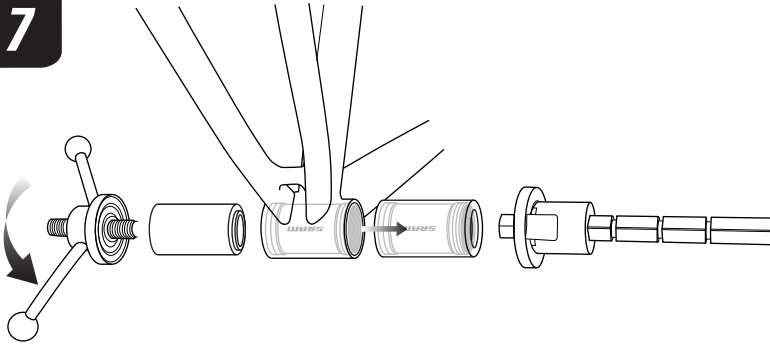

REMOVAL



WARNING

Carbon bottom bracket shells: Installation of the bottom bracket adapter into a carbon bottom bracket shell is permanent. The adapter cannot be removed. Removal will damage the adapter and bicycle frame.

Non-carbon bottom bracket shells: Installation of the bottom bracket adapter into a non-carbon bottom bracket shell is not permanent. However, repeated installation and removal of the adapter will damage both the adapter and the bicycle frame and is not recommended.

7

Use a headset press and adapter removal tools to push out the adapter.

8

Using a small pick and mild, non-abrasive degreaser, thoroughly clean the bottom bracket shell, taking care to remove all Loctite™.

RED / FORCE / RIVAL · DUAL PIVOT ROAD CALIPERS

TECHNICAL DATA / ASSEMBLY REQUIREMENTS

Version	Red		Force		Rival	
	Front	Rear	Front	Rear	Front	Rear
Brake Levers	SRAM Red / Force / Rival Double Tap shifters					
Brake Cable	1.6 mm high quality brake cable with road-style cable end and brake cable housing with end caps					
Brake Pad	Exchangeable		Exchangeable		Exchangeable	
Quick Release	Yes		Yes		Yes	
Barrel Adjuster	Yes		Yes		Yes	
Pivot Bolt	Titanium		Titanium		Stainless Steel	
Arms	Cold Forged Aluminum		Cold Forged Aluminum		Cold Forged Aluminum	

RED / FORCE / RIVAL · DUAL PIVOT ROAD CALIPERS

ASSEMBLY

1

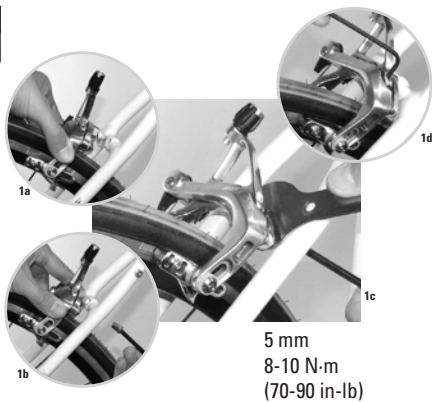

2

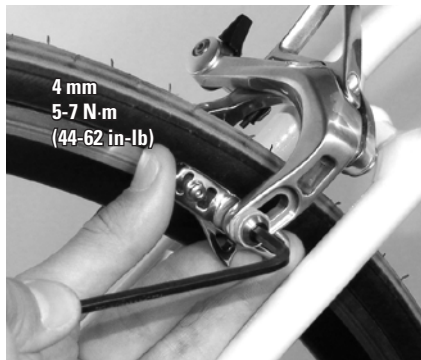

3

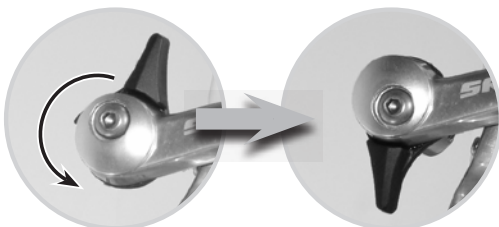

IMPORTANT

To ensure that your dual pivot road calipers perform properly and to help make your riding experience more enjoyable and trouble-free, we highly recommend that you have them installed by a qualified bicycle mechanic. For SRAM brake lever information please consult the Integrated Brake Shifter user manual.



CAUTION

Brakes are a safety-critical item on a bicycle. Improper set-up or use of brakes can result in loss of control or an accident leading to a severe injury.

It is your responsibility to learn and understand proper braking techniques. Consult the user manual for your bicycle and a professional bike dealer.

Practice your riding and braking techniques on a flat and level surface prior to aggressive riding.

The effectiveness of braking is dependent on many conditions over which SRAM has no control. These include the speed of the bicycle, type and condition of the riding surface, braking lever force, proper installation and maintenance of brakes, cables, levers, brake pads, the condition of the bike, weight of the rider, braking technique, weather, and a variety of other factors. Remember, it takes longer to stop in wet conditions.

SRAM brakes and levers are not intended for use on any motorized bicycle or vehicle. Any such use could result in serious personal injury.

Inspect your brakes regularly for damage, and always inspect them thoroughly after any crash or severe impact. If you detect damage, please have your brakes inspected by a professional bike dealer.



IMPORTANT

SRAM's standard road brake pads are optimized for aluminum rims. If used with ceramic coated or carbon rims use brake pads specifically suited for these rim materials and inspect them often as they may wear quickly. When the grooves on your brake pads disappear, they are worn and need to be replaced with new brake pads.

INSTALLATION

1

Install the brake caliper.

Red/Force (pictured): Install the brake caliper and hand tighten the mounting nut (fig. 1a, b). Use a 13 mm wrench to approximately center the brake caliper on the rim (fig. 1c). Hold the brake caliper in position, then tighten the mounting nut with a 5 mm hex wrench to 8-10 N·m (70-90 in·lb). Turn the brake pad centering bolt with a 3 mm hex until the brake caliper is precisely centered on the rim (fig. 1d).

Rival (not pictured): Install the brake caliper and hold it so it is approximately centered on the wheel. Use a 5 mm hex wrench and tighten the mounting nut to 8-10 N·m (70-90 in·lb).

2

Position the brake pads.

Use a 4 mm hex wrench to adjust the brake pad position along the rim. Toe-in, the angle of contact between the pad and the rim, can also be adjusted to optimize braking feel and performance. Tighten the brake pad bolt to 5-7 N·m (44-62 in·lb).

3

Rotate the quick release lever to the closed position.

RED / FORCE / RIVAL · DUAL PIVOT ROAD CALIPERS ASSEMBLY

4



4

Connect the brake cable.

Place the cable in the groove of the cable clamp washer. Squeeze the brake caliper by hand until each brake pad is 1-1.5 mm from the rim. Use a 5 mm hex wrench and tighten the cable clamp bolt to 6-8 N·m (53-70 in·lb). Turn the barrel adjuster on the brake caliper to reset the brake pad clearance to 1-1.5 mm from the rim.

5

Adjust spring tension - Red/Force only:

The spring tension on the brake caliper can be adjusted to your preference. Bicycles with complicated cable routing may experience increased cable friction and will require higher spring tension for proper function of the brake caliper. Turn the spring tension adjustment screw clockwise to increase spring tension.

6

Center the brake pads - Rival only:

Use a 5 mm hex wrench to slightly loosen the brake caliper mounting nut. Use a 12 mm open ended wrench to precisely center the brake to the rim. Re-tighten the brake caliper mounting nut to 8-10 N·m (70-90 in·lb).

7

Inspect brake function.

Squeeze brake lever hard 10 times to check that everything is operating correctly, then re-check the brake pad position and clearance to the rim.

BRAKE PAD REPLACEMENT

8

Replace the brake pads.

When the grooves on your brake pads disappear, they are worn and need to be replaced with new brake pads. Remove the brake pad fixing bolt with a 2 mm hex wrench. Slide the old pads out of the holders and replace with new pads. Install the brake pad fixing bolt and tighten to 0.5-1.0 N·m (4.5-9.0 in·lb).

Note: Both the brake pads and holders are marked left or right. Be sure to install the brake pads on the correct side.

5



6



8

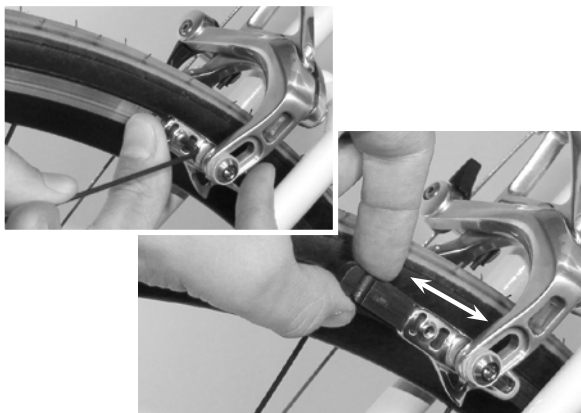

MAINTENANCE

Use only water and a mild soap to clean the brake calipers. Do NOT use a pressure washer.

When the grooves on your brake pads disappear, they are worn and need to be replaced with new brake pads.

CASSETTES · 10 SPEED ROAD

TECHNICAL DATA / ASSEMBLY REQUIREMENTS

OG 1090	
Application	Road
Technology	Open Glide
Ratio	11-23 / 11-25 / 11-26 / 11-28
Speeds	10
Chains	SRAM 10 speed Power Chains and Shimano® 10 speed chains
Hubs	Any hub with Shimano® compatible driver body (not compatible with Shimano® DURA-ACE deep-spline 10 speed cassette bodies)
Cogs	11/12/13/14/15/16/17/19/21/23 11/12/13/14/15/17/19/21/23/25 11/12/13/14/15/17/19/21/23/26 11/12/13/14/15/17/19/22/25/28
Lockring Torque	40 N·m
Cog Material	Chromium Molybdenum steel, heat treated
Spider	N/A
Lockring	Aluminum, anodized
Rivets	N/A
Finish	Electroless nickel / anodized back plate and lockring

OG 1070	
Application	Road
Technology	Open Glide
Ratio	11-23, 11-25, 11-26, 11-28, 12-25, 12-26, 12-27
Speeds	10
Chains	SRAM 10 speed Power Chains and Shimano® 10 speed chains
Hubs	Any hub with Shimano® compatible driver body (not compatible with Shimano® DURA-ACE deep-spline 10 speed cassette bodies)
Cogs	11/12/13/14/15/16/17/19/21/23 11/12/13/14/15/17/19/21/23/25 11/12/13/14/15/17/19/21/23/26 11/12/13/14/15/17/19/22/25/28 12/13/14/15/16/17/19/21/23/25 12/13/14/15/16/17/19/21/23/26 12/13/14/15/16/17/19/21/24/27
Lockring Torque	40 N·m
Cog Material	Heat treated steel
Spider	Aluminum 6061
Lockring	Aluminum, anodized
Rivets	Stainless steel
Finish	Pearl Ni-Chrome plated

CASSETTES · 10 SPEED ROAD ASSEMBLY

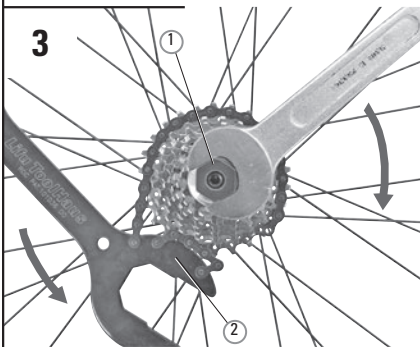
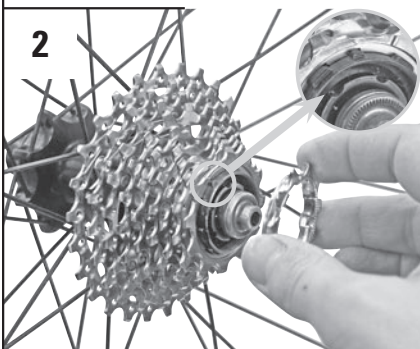
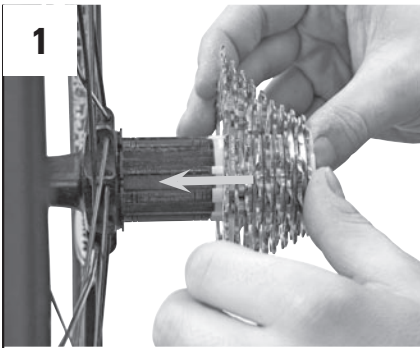

ASSEMBLY

The sprockets are arranged on a plastic support (Speedloader).

- Remove the transportation lock.
- Versions with sprockets with 11 teeth: Remove the locking from the front and the sprocket with 11 teeth from the back of the Speedloader.
- Versions with sprockets with 12 teeth: Remove the locking from the Speedloader.
- Align the spline patterns of the Speedloader with the driver of the hub and press the Speedloader against the driver (**Figure 1**).
- Check your driver body for damage caused by previous cassettes. Carefully remove any burrs before installation.
- Push the cassette from the Speedloader onto the driver of the hub.



ADVICE

The thin aluminum tube captured inside the OG-1090 cassette between the cogs and the red aluminum backing plate is designed to have a small amount of movement before installation. After installation, the aluminum tube is squeezed between the cogs and backing plate and forms a water-tight seal. The tube also provides structural reinforcement to the entire cassette - do not remove!

- Only versions with sprockets with 11 teeth: Position the sprocket with 11 teeth on the driver (**Figure 2**).
- Screw the locking into the driver. Use a mounting tool (**1, Figure 3**) (Park Tool® FR-5 or Shimano®) and a chain wrench (**2, Figure 3**). Tightening torque 40 N·m (350 in·lb) (**Figure 3**).



ADVICE

Be careful not to damage the thread of the locking by tilting.

After installing the rear wheel adjust the rear derailleur per derailleur instructions.

POWER CHAINS · 10 SPEED ROAD

TECHNICAL DATA / ASSEMBLY REQUIREMENTS

	PC 1090R	PC 1090	PC 1070	PC 1050	PC 1030
Application	Road	Road	Road	Road	Road
Max. Number of Sprockets	10 only	10 only	10 only	10 only	10 only
Compatibility Front	Truvativ / HG / EXA-Drive	Truvativ / HG / EXA-Drive	Truvativ / HG / EXA-Drive	Truvativ / HG / EXA-Drive	Truvativ / HG / EXA-Drive
Compatibility Rear	SRAM OG / HG / EXA-Drive	SRAM OG / HG / EXA-Drive	SRAM OG / HG / EXA-Drive	SRAM OG / HG / EXA-Drive	SRAM OG / HG / EXA-Drive
Dimensions	1/2" x 11/128"	1/2" x 11/128"	1/2" x 11/128"	1/2" x 11/128"	1/2" x 11/128"
Length	5.87 mm	5.87 mm	5.87 mm	5.95 mm	5.95 mm
Riveting	Cylindrical	Cylindrical	Cylindrical	Flat Cylindrical	Flat Cylindrical
Chrome Hardened	Yes	Yes	Yes	Yes	Yes
Push Power	2000 N / 450 lbs.	2000 N / 450 lbs.	2000 N / 450 lbs.	2000 N / 450 lbs.	2000 N / 450 lbs.
Min. Tensile Strength	9000 N / 2023 lbs.	9000 N / 2023 lbs.	9000 N / 2023 lbs.	9000 N / 2023 lbs.	9000 N / 2023 lbs.
External Pin Plate	Silver / Nickel Plated	Silver / Nickel Plated	Silver / Nickel Plated	Silver / Nickel Plated	Silver / Nickel Plated
Internal Pin Plate	Silver / Nickel Plated	Silver / Nickel Plated	Grey	Silver / Nickel Plated	Grey
Connecting Method ¹	Power Lock 10 Speeds	Power Lock 10 Speeds	Power Lock 10 Speeds	Power Lock 10 Speeds	Power Lock 10 Speeds

¹ **Caution:** Connecting method: with Power Lock only (no pin)!

POWER CHAINS · 10 SPEED ROAD ASSEMBLY

1

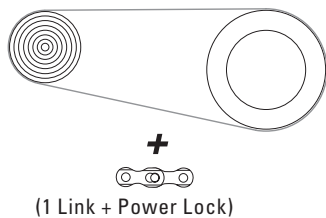

PC 1090R / PC 1090 /
PC 1070 / PC 1050 / PC 1030
(1/2" X 11/128")

CHAIN LENGTH:

(A chain tool will be required to shorten the chain.)

- Replacing a worn chain:
Measure the worn chain and shorten the new chain to the same length.
- Initial assembly:
Shorten the chain to the length specified by the derailleur manufacturer.
SRAM derailleurs:
place the chain over largest front chainwheel and largest rear sprocket and add 1 link + Power Lock (**Figure 1**).

OPENING

Once the Power Lock is installed it can only be removed by means of a Chain tool.

CAUTION

Power Lock is for one-time use only!

Always use a new Power Lock when fitting a new chain.

Failure to shorten the chain properly or to lock it exactly into place may cause damage to the chain and eventually total chain failure, material damage or the rider to fall off his bicycle resulting in injury.

Worn sprockets should also be replaced when a new chain is fitted.

2

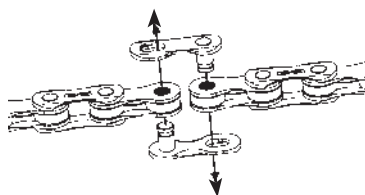

CLOSING CHAIN WITH POWER LOCK

CAUTION

Use Power Lock only with SRAM chains!
Use only Power Lock to close 10 speed chains (no Pin)!

Use only Power Lock (black coloured) for PC 1090R, PC 1090, PC 1070, PC 1050, PC 1030 to avoid material damage or the rider to fall off his bicycle resulting in injury.

3

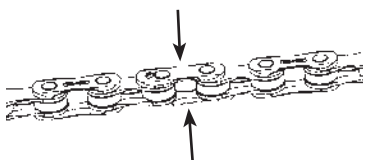

- Fit chain, insert both halves of the Power Lock into the chain ends (**Figure 2**) and bring the ends together (**Figure 3**) on the bottom side of the drivetrain (no tension side).

4



- Pull chain apart until you feel some resistance (**Figure 4**).
- Rotate the chain so the Power Lock is positioned on the top side of the drivetrain (**Figure 5**).
- Pedal forward while holding bike firmly in place (**Figure 5**) until you hear click sound. The Power Lock is now in place and safely closed.

5

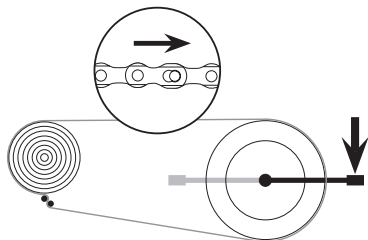

X.0 / X-9 / X-7 / X-5 / X-4 / X-3 / 3.0 · REAR DERAILLEURS

TECHNICAL DATA / ASSEMBLY REQUIREMENTS

	X.0	X-9			X-7		X-5		
Speeds	9/8	9/8			9/8		9/8		
Shifter Compatibility	SRAM 1:1 Actuation Ratio 9/8 speed shifters								
Cogsets and Chains	SRAM/ HG 9/8 speed								
Chainrings	22-32-42/44, 24-34-46, 26-36-46/48								
Total	45 T	37 T	30 T	45 T	37 T	45 T	37 T	45 T	37 T
Cage Length	Long	Medium	Short	Long	Medium	Long	Medium	Long	Medium
Max Sprocket	34 T								
Min Sprocket	11 T								
Front Difference	22 T								
Parallelogram Spring	Titanium			Steel			Steel		Steel
Pulleys	Cartridge bearing, stainless			Cartridge bearing, bushing, hardend			Bushing, hardend		Bushing
Direct Mount	Yes								
Cable and Housing	1.1 or 1.2 mm high quality cables, 4 or 5 mm compressionless cable housing with end cap / maximum diameter of 5.8 mm								
B-Knuckle	Forged Aluminum 7075 T6			Forged Aluminum 6061 T6			Aluminum		Aluminum
Outer Link	Forged Aluminum			Aluminum die-cast/ Painted			Aluminum die-cast/ Painted		Aluminum
Inner Link	Aluminum CNC machined			Aluminum CNC machined			Steel / E-coat		Steel / E-coat
Outer Cage	Carbon Composite			Stamped AL/ Anodized			Stamped AL/ Anodized		Steel / E-coat
Inner Cage	Forged Aluminum 7075 T6			Stamped AL/ Anodized			Steel		Steel
Hanger Bolt	Aluminum / Anodized			Aluminum / Anodized			Aluminum / Anodized		Steel

	X-4	X-3		3.0
Speeds	8/7	8/7		8/7
Shifter Compatibility	SRAM 1:1 8/7spd shifters			
Cogsets and Chains	SRAM/ HG 8/7 speed			
Chainrings				
Total	45 T	37 T		45 T
Cage Length	Long	Medium	Long	Medium
Max Sprocket	34T			
Min Sprocket	11T			
Front Difference	22T			
Parallelogram Spring	Steel			Steel
Pulleys	Bushing		Bushing	Bushing
Direct Mount	Yes			
Cable and Housing	1.1 or 1.2 mm high quality cables, 4 or 5 mm compressionless cable housing with end cap / maximum diameter of 5.8 mm			
B-Knuckle	Aluminum		Composite	Composite
Outer Link	Zinc Alloy		Composite	Composite
Inner Link	Composite		Steel	Steel
Outer Cage	Steel / E-coat		Steel / E-coat	Steel / E-coat
Inner Cage	Steel		Composite	Composite
Hanger Bolt	Steel		Steel	Steel

X.0/X-9/X-7/X-5/X-4/X-3/3.0 · REAR DERAILLEURS ASSEMBLY REQUIREMENTS

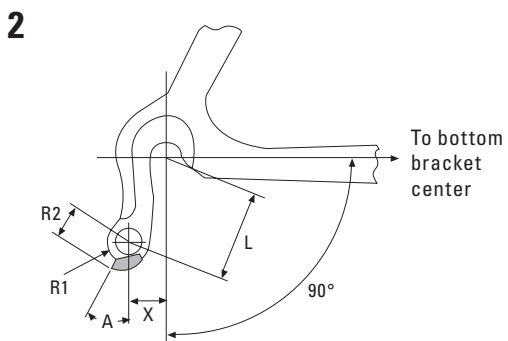
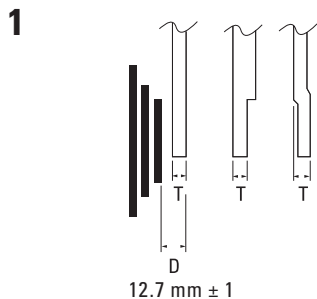

DERAILLEUR ANATOMY

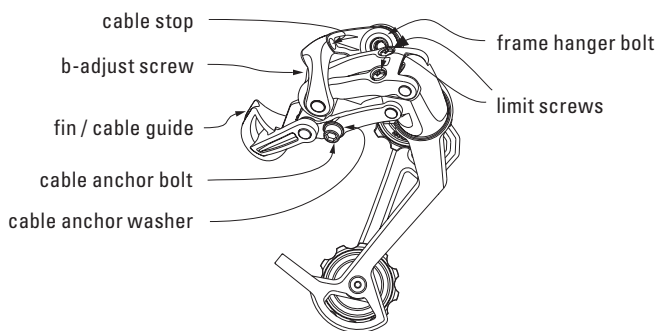

Frame Dimensions (see **Figure 1** and **2**)

· For optimal 1:1 Actuation Ratio rear derailleur performance, the recommended rear derailleur hanger length (L) should be 28 – 30 mm.

· For a given L, use the chart below to determine other 1:1 Actuation Ratio rear derailleur hanger specifications.

L	X	A	R1	R2	T
28	6 - 10	25° - 30°	8.5 max	11.5 - 13.5	7 - 8
30	7.5 - 10	25° - 30°	8.5 max	11.5 - 13.5	7 - 8

X.0 / X-9 / X-7 / X-5 / X-4 / X-3 / 3.0 · REAR DERAILLEURS ASSEMBLY

1

5 mm
8 – 10 N·m
70 – 85 in·lb

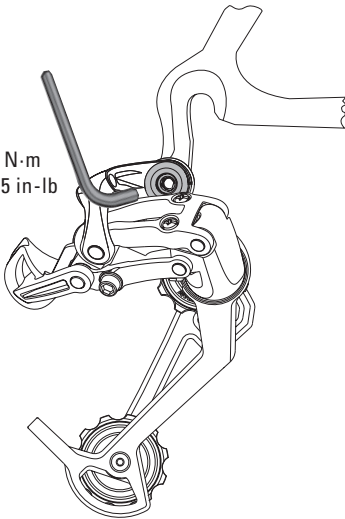

ASSEMBLY



ADVICE

Check the rear derailleur hanger alignment. A bent rear derailleur hanger will result in inaccurate index shifting. Outboard side impacts are the most common causes of this type of damage.

- Attach the rear derailleur to the frame's rear derailleur hanger using a 5 mm hex wrench (**Figure 1**).

- Check that the b-adjust washer tab (b-adjust screw) is clear of the rear derailleur dropout tab (**Figure 2**).

- Tighten the 5 mm hex hanger bolt to 8 – 10 N·m (70–85 in·lb) (**Figure 1**).

CHAIN LENGTH

A properly measured chain will prevent damage in case of accidentally shifting to the largest chain ring and cog combination. This type of accidental shifting may cause harmful binding or seizure of the chain and potentially cause severe damage.

- Bypassing the rear derailleur, run the chain around the largest cog/large chainring combination (**Figure 3**).

- For rear suspension frames, position the rear suspension for the greatest chain length required.

- Add 2 LINKS or 1 link + Connecting Link to this length for proper chain length.

LIMIT SCREWS ADJUSTMENT

- View the rear derailleur and pulleys from behind the rear of the bicycle (**Figure 4**).

- Turn the limit screw marked 'H' on the outer link of the derailleur to align the upper guide pulley center with the outboard edge of the smallest cog – clockwise moves the guide pulley inboard towards the wheel.

- While turning the crank, push the rear derailleur towards the larger cogs by hand.

- Align the upper guide pulley under the largest cog, center to center, by turning the limit screw marked 'L' on the outer link – clockwise moves the guide pulley outboard away from the spokes.

CHAIN GAP ADJUSTMENT

Chain gap is the distance between the upper guide pulley and the cog the chain is riding on. Optimal chain gap is small enough to allow quick, efficient shifts to and from any cog, but large enough to allow smooth shifts to and from the largest cog.

- Shift chain to the small chain ring.

- While turning the crank, push the rear derailleur inboard by hand to the largest cog.

- Hold the derailleur in this position while making the following adjustment.

- Using a 2.5 or 3 mm hex (screw driver for X-5), turn the b-adjust screw until the chain gap equals approximately 6 mm ($\frac{1}{4}$ ") from tip of the cog to tip of upper guide pulley (**Figure 5**).

- Turn the b-adjust screw clockwise to increase the chain gap.

- Turn the b-adjust screw counterclockwise to decrease the chain gap.



ADVICE

Bicycles equipped with an 11-28 cassette may require you to set the chain gap at the smallest cog. This is due to the shallow angle of the cassette in relation to the steeper movement of the 9 speed rear derailleur.

It is best to measure the rear piece of cable housing between the frame and derailleur after the chain gap is determined. See figure and chart for recommended lengths.

Do not use the b-adjust screw to adjust the rear derailleur to act as a chain-tensioning device or to prevent chain suck. This increases the chain gap causing poor shifting performance.

INDEX SHIFTING ADJUSTMENT

- Check that the chain and the rear derailleur are in the smallest cog position.

- Measure and cut the rear piece of cable housing. Make sure that it is not too short or long (**see figure and chart**).

- Rotate the rear shifter until the largest number and gear indication tab/dash line up.

- Turn the rear shifter barrel adjust clockwise fully into the shifter, then turn counterclockwise 1 full turn.

- Feed the rear shifter cable through the rear derailleur cable housing, stops and cable guides.

- Feed the rear derailleur cable through the rear derailleur-housing stop and through the cable guide on the fin.

- Pull the cable tight and position it under the cable anchor washer (**Figure 6**).

- Tighten the 5 mm hex cable anchor bolt to 4 – 5 N·m (35 – 45 in·lb).

- Rapidly shift the chain and derailleur up and down the cassette several times. If the cable slips repeat the two former steps.

- Shift the chain to the smallest cog.

2

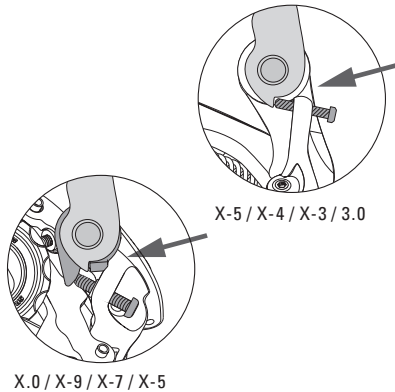

3

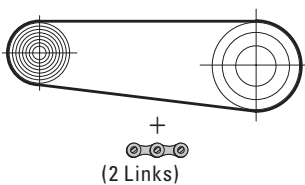

4

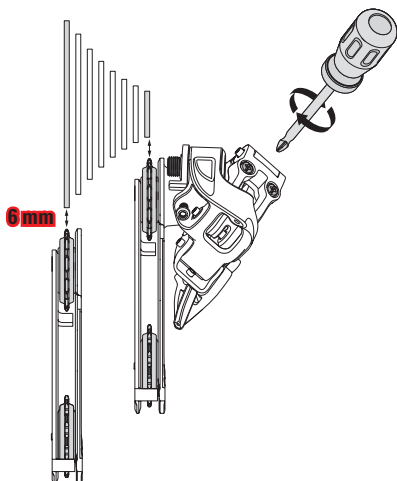

X.0 / X-9 / X-7 / X-5 / X-4 / X-3 / 3.0 · REAR DERAILLEURS ASSEMBLY

5

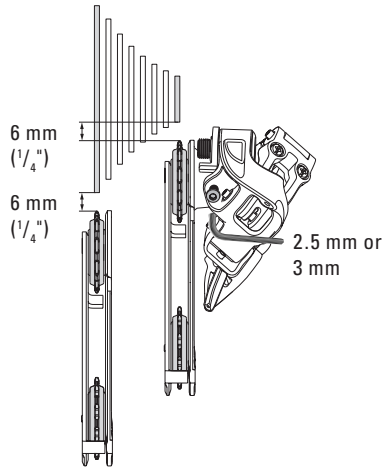

- While pedaling, move the shifter up one detent.
 - If the chain hesitates or does not shift to the second cog, increase the cable tension by turning the shifter barrel adjuster counterclockwise.
 - If the chain shifts beyond the second cog, decrease the cable tension by turning the shifter barrel adjuster clockwise.

- Repeat the two former steps until shifting and cable tension is accurate.
- While turning the crank, shift the chain up and down the cassette and chain rings several times to ensure that your derailleur is indexing smoothly.

Chart / length of cable housings

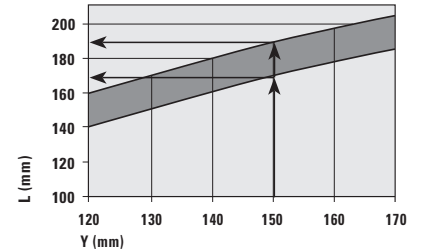
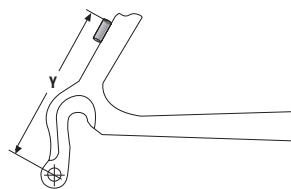
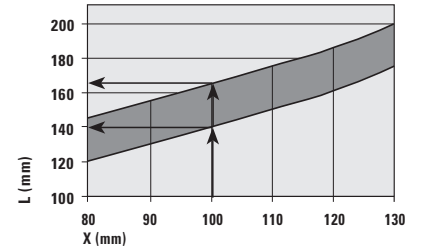
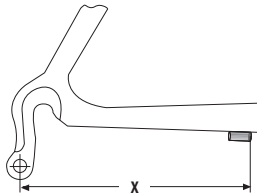

Example:
Distance Y = 150 mm → cable housing length L = 165 – 190 mm.

Caution:
It is imperative to respect the values for the correct length of cable housing.

6

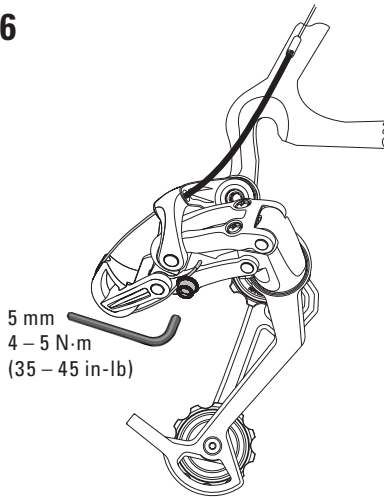

5 mm
4 – 5 N·m
(35 – 45 in·lb)

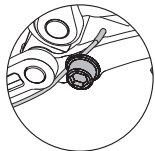

X.0 / X-9
X-5

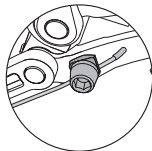

X-7 / X-5
X-4 / X-3 / 3.0

7

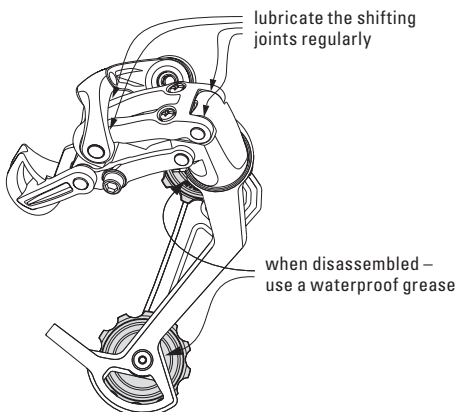

TROUBLESHOOTING

Problem	Cause	Remedy
Chain jumps from smallest sprocket to frame dropout.	High gear limit screw is not adjusted properly.	Turn in screw H until the guide pulley is aligned with the smallest sprocket.
Difficult or impossible to shift chain onto smallest sprocket.	High gear limit screw is not adjusted properly.	Unscrew screw H until the guide pulley is aligned with the smallest sprocket.
Chain jumps over largest sprocket and falls between the spokes and largest sprocket or inner cage plate scrapes on spokes.	Low gear limit screw is not adjusted properly.	Turn in screw L until the guide pulley is aligned with the largest sprocket.
	Rear derailleur or derailleur hanger is bent.	Straighten or replace.
Delayed shifting.	Clearance between guide pulley / sprocket is too large.	Adjust b-adjust screw by rotating counterclockwise.
Rough shifting behavior.	Clearance between guide pulley / sprocket is too small.	Adjust b-adjust screw by rotating clockwise.
Shifts more gears onto smaller sprockets than intended.	Shift cable insufficiently tensioned.	Turn barrel adjuster on the shifter counterclockwise.
Delayed shifting onto larger sprocket.	Shift cable insufficiently tensioned.	Turn barrel adjuster on the shifter counterclockwise.
Delayed shifting onto smaller sprocket.	Shift cable is too tight.	Turn barrel adjuster on the shifter clockwise.
	Excessive cable friction, pinched or poorly routed cable.	Lubricate or replace cable and housing. Check for excessive bending of cable housing.

X.0 · REAR DERAILLEURS MAINTENANCE

1



2



3



PULLEY MAINTENANCE



ADVICE

X.0 pulleys use stainless steel balls and races for exceptional durability and corrosion resistance. When riding in wet, muddy, sandy or dusty conditions, periodic maintenance will insure a very long service life.

- Remove the pulleywheel screws (1, **Figure 1**) using a 3 mm allen key. Make sure to fully engage the key in the 3 mm hex hole.
- Remove the aluminum covers (2) from both sides of the pulleywheels.
- Clean all parts carefully and give the bearings a spin to make sure they run smoothly. If not, use a sharp pick to carefully remove the black rubber seal from one side of the bearing (**Figure 2**), clean the bearing thoroughly and repack with a quality waterproof grease, then replace the rubber seal by pressing it into place.
- When assembling the covers to the pulleywheel, fill the gap between bearing and covers with a quality waterproof grease.

· Tightening torque of the pulleywheel screws is 2.5 N·m.

· If pulleys or bearings are damaged, replace with new SRAM X.0 pulleys, which come with new bearings and aluminum covers.

CAGE PIVOT MAINTENANCE / CAGE SPRING TENSION ADJUSTMENT



CAUTION

Wear safety glasses while disassembling and reassembling the derailleur cage spring.

- Hold the cage in an extended position so you can reach the cage stop screw on the outside of the cage (**Figure 3**).



ADVICE

Disassembly and assembly of the cage stop screw are easier if you have assistance.

- Use a 2.5 mm wrench to remove the cage stop screw (**Figure 3**).

· Now carefully and slowly let the cage unwind to relieve spring tension.

· Remove the cage and spring. The cage must be rotated to the position shown in **Figure 4** to remove it from the derailleur body.

· Clean thoroughly the shaft, cage plate, derailleur body and spring.

· Re-grease the shaft, spring tab and spring supports with a quality waterproof grease.

· Reinstall the spring and cage (**Figure 5**). There are several cavities in the derailleur body, but only one is designed for installing the spring tab. Be certain to use the correct cavity.



ADVICE

X.0 cage plates have 2 mounting holes (**Figure 6**). The lowest spring tension position offers ideal tension for all around XC riding. Higher spring tension holes are only recommended after extensive use has reduced the spring's stiffness.

· Wind the cage counterclockwise to tension the spring. The cage can not be fully installed into the derailleur body until the cage is at the same position as when it was originally removed (**Figure 4**).

· After the cage is fully installed in the derailleur body, continue to rotate the cage counterclockwise until you can access the cage stop screw hole.

· A helping hand holding the cage makes the installation of the 2.5 mm stop screw easier (**Figure 3**). Tightening torque of the cage stop is 1.5 N·m (13 in·lb).

X.0 · REAR DERAILLEURS MAINTENANCE

4



5



6

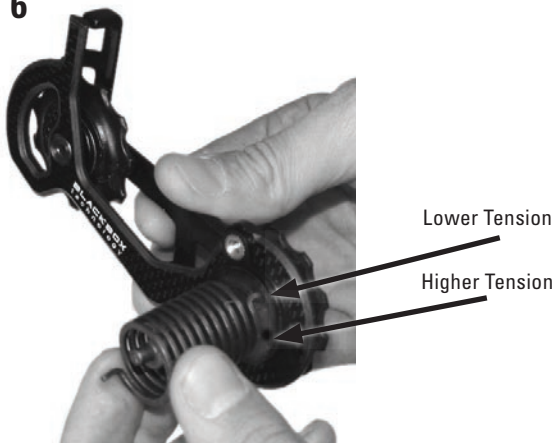

TROUBLESHOOTING

Problem	Cause	Remedy
Chain jumps from smallest sprocket to frame dropout.	High gear limit screw is not adjusted properly.	Turn in screw H until the guide pulley is aligned with the smallest sprocket.
Difficult or impossible to shift chain onto smallest sprocket.	High gear limit screw is not adjusted properly.	Unscrew screw H until the guide pulley is aligned with the smallest sprocket.
Chain jumps over largest sprocket and falls between the spokes and largest sprocket or inner cage plate scrapes on spokes.	Low gear limit screw is not adjusted properly.	Turn in screw L until the guide pulley is aligned with the largest sprocket.
	Rear derailleur or derailleur hanger is bent.	Straighten or replace.
Delayed shifting.	Clearance between guide pulley / sprocket is too large.	Adjust b-adjust screw by rotating counterclockwise.
Rough shifting behavior.	Clearance between guide pulley / sprocket is too small.	Adjust b-adjust screw by rotating clockwise.
Shifts more gears onto smaller sprockets than intended.	Shift cable insufficiently tensioned.	Turn barrel adjuster on the shifter counterclockwise.
Delayed shifting onto larger sprocket.	Shift cable insufficiently tensioned.	Turn barrel adjuster on the shifter counterclockwise.
Delayed shifting onto smaller sprocket.	Shift cable is too tight.	Turn barrel adjuster on the shifter clockwise.
	Excessive cable friction, pinched or poorly routed cable.	Lubricate or replace cable and housing. Check for excessive bending of cable housing.

X-9 / X-7 / 3.0 · HIGH CLAMP FRONT DERAILLEURS

TECHNICAL DATA / ASSEMBLY REQUIREMENTS

	X-9 High Clamp	X-7 High Clamp	3.0
28.6 mm	—	with band adaptor	with band adaptor
31.8 mm	original	with band adaptor	with band adaptor
34.9 mm	original	original	original
Rear Compatibility	9 speed	9 speed	8 speed / 7 speed
Index Compatible	Yes	Yes	Yes
Total Capacity	22 T	22 T	20 T
Top-Middle Min. Capacity	Minimum 12 T	Minimum 12 T	Minimum 10 T
Top Gear Teeth	44 T or 48 T	44 T or 48 T	42 T or 48 T
Cable Routing	Top Pull Type	Bottom Pull Type	Twin Pull Type (Top and Bottom Pull)
Chainstay Angle	66 – 69°	66 – 69°	66 – 69°
Mount Type	High Clamp	High Clamp	High Clamp
Chain Line	47.5 – 51 mm	47.5 – 51 mm	47.5 – 51 mm
Band Material	Aluminum, forged	Aluminum	Steel
Outer Link	Aluminum	Aluminum	Steel
Inner Link	Aluminum	Aluminum	Steel
Link Bushing	Outer Sealed	Outer Sealed	Bushing
Chain Cage	Steel Chrome Plated	Steel Chrome Plated	Steel Chrome Plated
Color	Silver, polished	Silver or black painted	Black

1

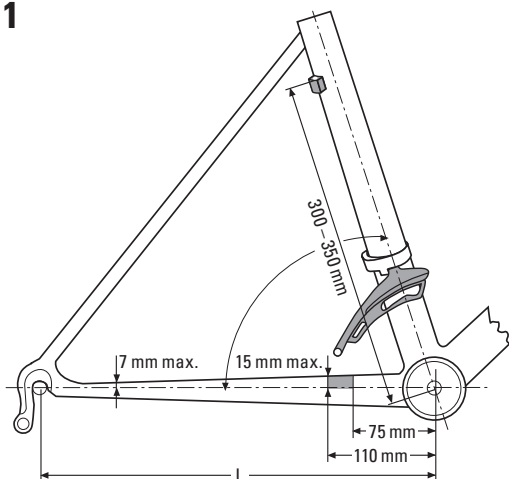

FRAME DIMENSIONS

(see Figure 1)

- For Top Pull version: upper cable stop should be positioned 300 – 350 mm above bottom bracket center.

- The seat tube should be positioned in the center of the bottom bracket shell.

Length of chainstay:

- MTB/Trekking L > 420 mm.

- Rear frame alignment must be symmetrical.

Chainstay angle:
= 66° – 69°.

Chainline:

47.5 – 51 mm.
(Measurement from the center of the bracket to the center of middle chainring).

2

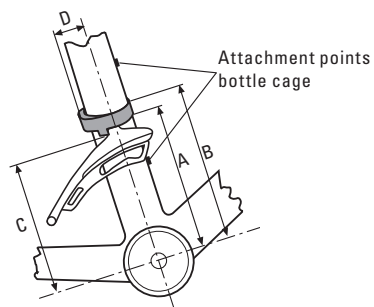

NECESSARY CLEARANCE

(see Figure 2)

Be sure to leave enough clearance between bottle cage holes and clamp location.

NECESSARY CLEARANCE

see Figure 2

		X-9 High Clamp 44T	X-9 High Clamp 48T	X-7 High Clamp 44T
Clamp position	A	130 mm	135 mm	130 mm
	B	152 mm	157 mm	152 mm
	C	100 mm	105 mm	100 mm
Tire clearance	D	22 mm (Top Pull) / 36 mm (Bottom Pull)		38 mm

		X-7 High Clamp 48T	3.0 42T	3.0 48T
Clamp position	A	135mm	114 mm	119 mm
	B	157 mm	128 mm	133 mm
	C	105 mm	107 mm	112 mm
Tire clearance	D	38 mm	43 mm	43 mm

X-9/X-7/3.0 · HIGH CLAMP FRONT DERAILLEURS ASSEMBLY / MAINTENANCE

1

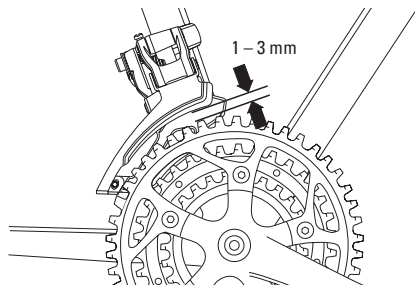

ASSEMBLY

- Attach the front derailleur to the seat tube.
- Adjust the position along the seat tube so that clearance between the front derailleur cage and the large chainring is 1 – 3 mm (**Figure 1**).

At the same time, align the front derailleur cage outerplate to be parallel with the chainrings (**Figure 2**).

- Tighten the 5 mm hex clamp bolt to 5 – 7 N·m (44 – 62 in·lb) for X-9/X-7 or 8 N·m (70 in·lb) for 3.0.

LOW LIMIT ADJUSTMENT

(see **Figure 3**)

- Place the chain on the largest rear cog and the smallest front chainring.
- Adjust the low limit screw (**Figure 3**) so that the chain is positioned close to the inner cage plate without actually touching it.

CONNECTING CABLE

- Check that the chain and the front derailleur are in the smallest chainring position.

- Place the front shifter in gear position '1'.

- Turn the front shifter barrel adjuster clockwise fully into the shifter, then turn counterclockwise 1 full turn.

- Feed the front shifter cable through the cable housing and stops.

- Run the cable under the cable anchor washer and hold taut.

– Top pull (**Figure 4**).

– Bottom pull (**Figure 5**).

- Tighten the 5 mm hex cable anchor bolt to 5 N·m (44 in·lb).

- Shift the chain up and down the chainrings several times to take out initial slack in the cable.

- If necessary re-tension the cable and tighten cable anchor bolt.

HIGH LIMIT ADJUSTMENT

(see **Figure 6**)

- Set the chain to the smallest rear cog and the largest front chainring.

- Adjust the high limit screw so that clearance between the front derailleur cage outer plate and the chain is 0 – 0.5 mm.

INDEX SHIFTING ADJUSTMENT

(see **Figure 7**)

Shift the chain onto the largest rear sprocket and middle chainring – if the chain scrapes against the inner cage plate, turn the adjusting barrel on the shifter clockwise until the chain shifts smoothly and free of obstruction.

2

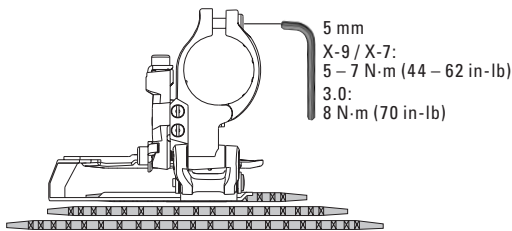

3

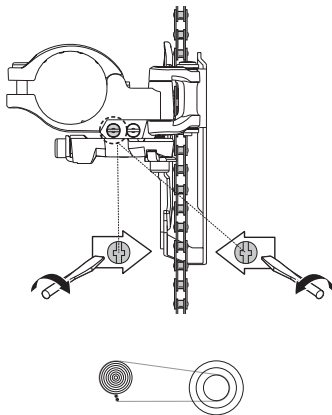

4

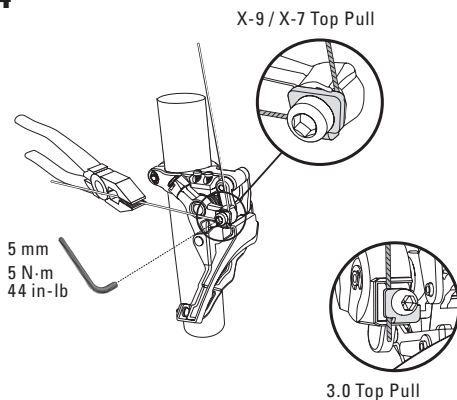

X-9 / X-7 / 3.0 · HIGH CLAMP FRONT DERAILLEURS ASSEMBLY / MAINTENANCE

5

5 mm
5 N·m
44 in·lb

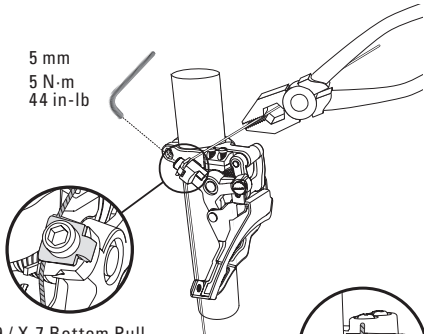

X-9 / X-7 Bottom Pull

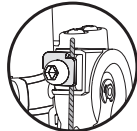

3.0 Bottom Pull

6

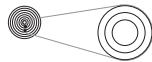
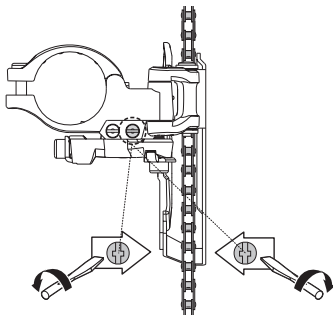

7

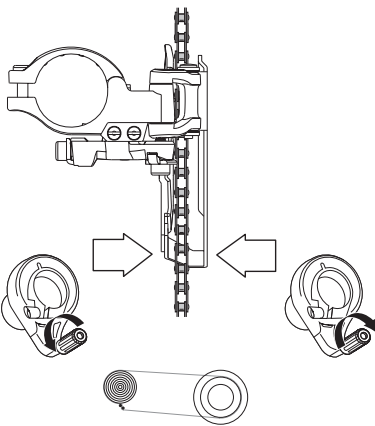

8

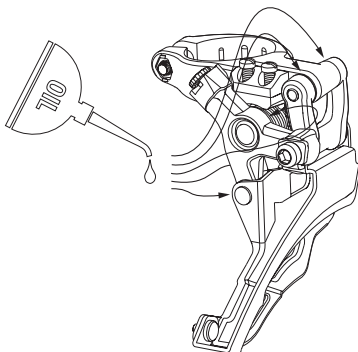

ADVICE

Avoid using extreme gear combinations as these combinations cause noise and excessive wear!



MAINTENANCE

- Do not use solvents or corrosive materials to clean the components.
- Lubricate the shifting joints regularly (Figure 8).
- Grease any cable guides (e.g. beneath the bottom bracket).

TROUBLESHOOTING

Problem	Cause	Remedy
Shifter actuated, chain fails to change chainring.	Shift cable incorrectly clamped.	Check shift cable and correct as necessary (cable clamp; cable housing stops; cable recess in shifter; cable tension).
	High / low limit screw poorly adjusted.	Correct limit screws
	Clearance between cage and large chainring is too big / small.	Correct position (1 - 3mm).
Chain falls over large / small chainring.	High / low limit screw poorly adjusted.	Lubricate or replace cable and housing. Check for excessive bending of cable housing.
Force required to actuate gears is too high.	Excessive cable friction, pinched or poorly routed cable.	Correct high limit screw.
Crank collides with front derailleur.		Correct the front derailleur position.

X-9 / X-7 / X-5 · LOW CLAMP FRONT DERAILLEURS

TECHNICAL DATA / ASSEMBLY REQUIREMENTS

	X-9 Low Clamp	X-7 Low Clamp	3.0
28.6 mm	—	—	—
31.8 mm	original	with band adaptor	with band adaptor
34.9 mm	original	original	original
Rear Compatibility	9 speed	9 speed	9 speed
Index Compatible	Yes	Yes	Yes
Total Capacity	22 T	22 T	22 T
Top-Middle Min. Capacity	Minimum 12 T	Minimum 12 T	Minimum 12 T
Top Gear Teeth	44 T or 48 T	44 T or 48 T	44 T or 48 T
Cable Routing	Top Pull Type	Bottom Pull Type	Twin Pull Type (Top and Bottom Pull)
Chainstay Angle	66 – 69°	66 – 69°	66 – 69°
Mount Type	Low Clamp	Low Clamp	Low Clamp
Chain Line	51 mm	47.5 – 51 mm	47.5 – 51 mm
Band Material	Aluminum, forged	Aluminum	Aluminum
Outer Link	Steel	Steel	Steel
Inner Link	Aluminum, forged	Aluminum	Aluminum
Link Bushing	Outer Sealed	Outer Sealed	Outer Sealed
Chain Cage	Steel Chrome Plated	Steel Chrome Plated	Steel Chrome Plated
Color	Polished and clear coated	Silver or black painted	Silver or black painted

1

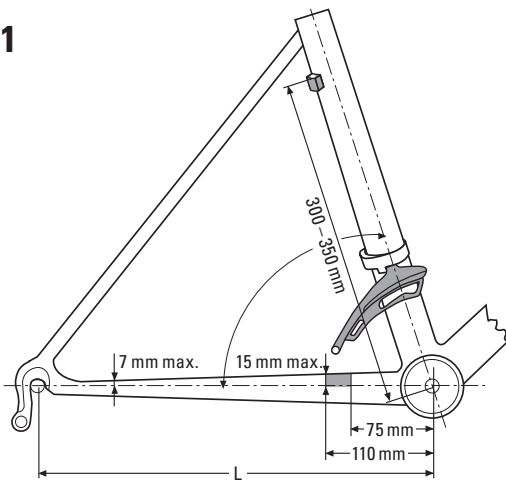

FRAME DIMENSIONS

(see Figure 1)

- For Top Pull version: upper cable stop should be positioned 300 – 350 mm above bottom bracket center.

- The seat tube should be positioned in the center of the bottom bracket shell.

Length of chainstay:

- MTB/Trekking L > 420 mm.

- Rear frame alignment must be symmetrical.

Chainstay angle:
= 66° – 69°.

Chainline:

X-9: 51 mm / X-7 and X-5: 47.5 – 51 mm
(Measurement from the center of the bracket to the center of middle chainring).

2

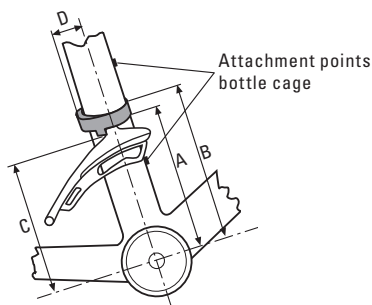

NECESSARY CLEARANCE

(see Figure 2)

Be sure to leave enough clearance between bottle cage holes and clamp location.

NECESSARY CLEARANCE see Figure 2

		X-9 Low Clamp 44T	X-9 Low Clamp 48T	X-7 Low Clamp 44T
Clamp position	A	69 mm	74 mm	69 mm
	B	86 mm	91 mm	86 mm
	C	71 mm	76 mm	69 mm
Tire clearance	D	42 mm	42 mm	43 mm

		X-7 Low Clamp 48T	X-5 Low Clamp 44T	X-5 Low Clamp 48T
Clamp position	A	74 mm	69 mm	74 mm
	B	91 mm	86 mm	91 mm
	C	74 mm	69 mm	74 mm
Tire clearance	D	43 mm	43 mm	43 mm

X-9/X-7/X-5 · LOW CLAMP FRONT DERAILLEURS ASSEMBLY

1

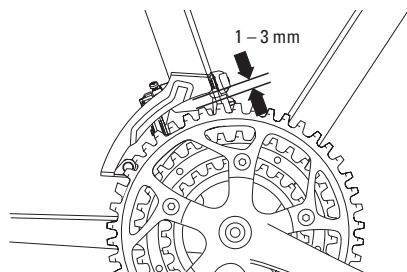

2

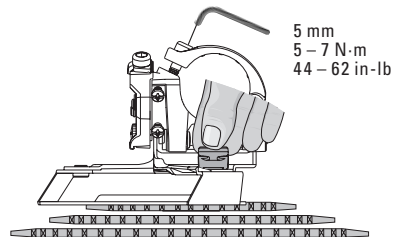

3

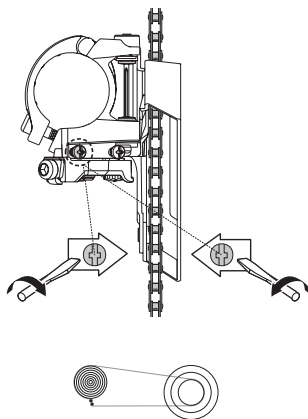

4

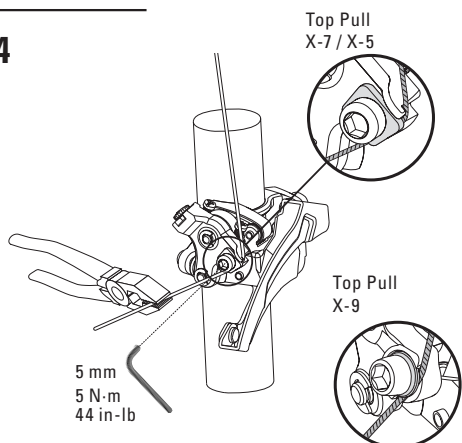

ASSEMBLY

- Attach the front derailleur to the seat tube.
- Adjust the position along the seat tube so that clearance between the front derailleur cage and the large chainring is 1 – 3 mm (**Figure 1**).

At the same time, align the front derailleur cage outerplate to be parallel with the chainrings (**Figure 2**).

- Tighten the 5 mm hex clamp bolt to 5 – 7 N·m (44 – 62 in·lb).
- Remove the mounting aid (piece of plastic – **Figure 2**).

LOW LIMIT ADJUSTMENT

(see **Figure 3**)

- Place the chain on the largest rear cog and the smallest front chainring.
- Adjust the low limit screw (**Figure 3**) so that the chain is positioned close to the inner cage plate without actually touching it.

CONNECTING CABLE

- Check that the chain and the front derailleur are in the smallest chainring position.
- Place the front shifter in gear position '1'.
- Turn the front shifter barrel adjuster clockwise fully into the shifter, then turn counterclockwise 1 full turn.
- Feed the front shifter cable through the cable housing and stops.
- Run the cable under the cable anchor washer and hold taut.
 - Top pull (**Figure 4**).
 - Bottom pull (**Figure 5**).
- Tighten the 5 mm hex cable anchor bolt to 5 N·m (44 in·lb).
- Shift the chain up and down the chainrings several times to take out initial slack in the cable.
- If necessary re-tension the cable and tighten cable anchor bolt.

HIGH LIMIT ADJUSTMENT

(see **Figure 6**)

- Set the chain to the smallest rear cog and the largest front chainring.
- Adjust the high limit screw so that clearance between the front derailleur cage outer plate and the chain is 0 – 0.5 mm.

INDEX SHIFTING ADJUSTMENT

(see **Figure 7**)

Shift the chain onto the largest rear sprocket and middle chainring – if the chain scrapes against the inner cage plate, turn the adjusting barrel on the shifter clockwise until the chain shifts smoothly and free of obstruction.

X-9 / X-7 / X-5 · LOW CLAMP FRONT DERAILLEURS ASSEMBLY

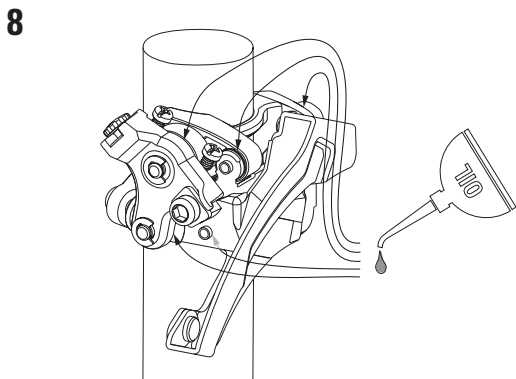
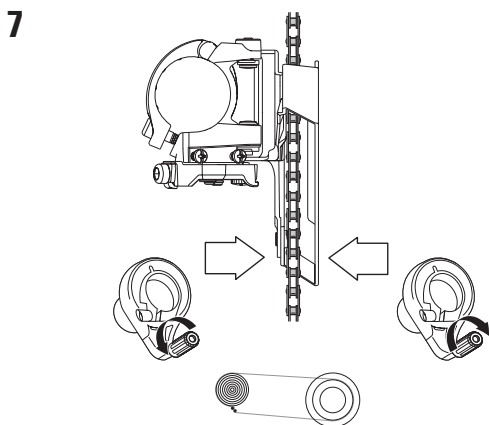
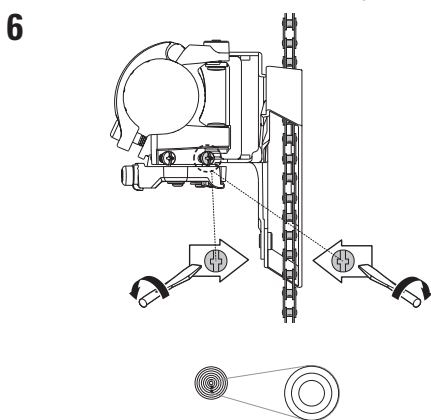
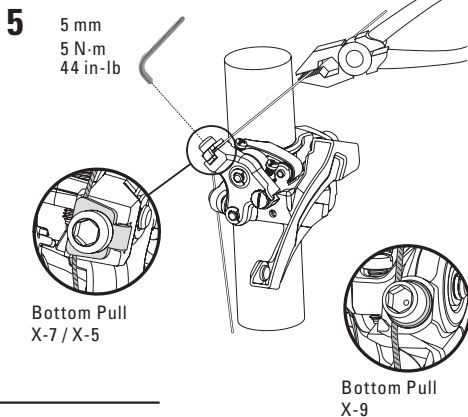

ADVICE
Avoid using extreme gear combinations as these combinations cause noise and excessive wear!



TROUBLESHOOTING

Problem	Cause	Remedy
Shifter actuated, chain fails to change chainring.	Shift cable incorrectly clamped.	Check shift cable and correct as necessary (cable clamp; cable housing stops; cable recess in shifter; cable tension).
	High / low limit screw poorly adjusted.	Correct limit screws
	Clearance between cage and large chainring is too big / small.	Correct position (1 - 3mm).
Chain falls over large / small chainring.	High / low limit screw poorly adjusted.	Lubricate or replace cable and housing. Check for excessive bending of cable housing.
Force required to actuate gears is too high.	Excessive cable friction, pinched or poorly routed cable.	Correct high limit screw.
Crank collides with front derailleur.		Correct the front derailleur position.

X.0 / X-9 · TRIGGER SHIFTERS

TECHNICAL DATA / ASSEMBLY REQUIREMENTS

	X.0		X-9	
Shifter Type	Front/Index	Rear 1:1 Actuation Ratio	Front/Index	Rear 1:1 Actuation Ratio
Speeds	3	9	3	9
Derailleur	SRAM & Shimano	SRAM 1:1 Actuation Ratio	SRAM & Shimano	SRAM 1:1 Actuation Ratio
Crankset	Triple Indexed		Triple Indexed	
Cable Pull Release	Zero Loss Technology		Zero Loss Technology	
Cable	PTFE Coated Stainless Steel		PTFE Coated Stainless Steel	
Gear Indication	None			
Barrel Adjuster	Indexing, Composite		Indexing, Composite	
Clamping Diameter	22.1 – 22.3 mm		22.1 – 22.3 mm	

CABLE HOUSING

- Use only new high quality cable and compressionless cable housing with end caps.
- When choosing cable housing lengths, be sure to allow enough housing for an extreme turn of the handlebars in both directions.
- Note also, that different stem lengths and cable stop positions effects cable housing length.

SHIFTER ANATOMY

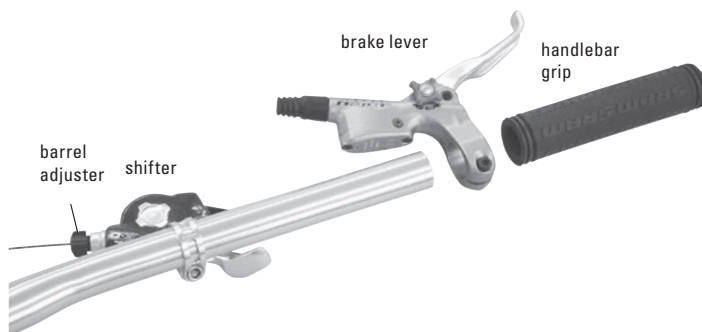

X.0 / X-9 · TRIGGER SHIFTERS

ASSEMBLY

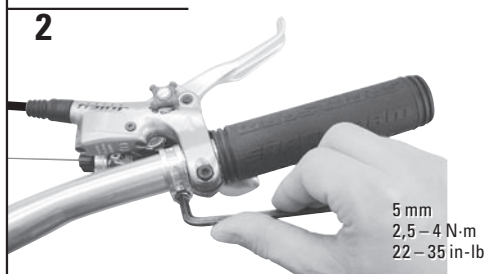
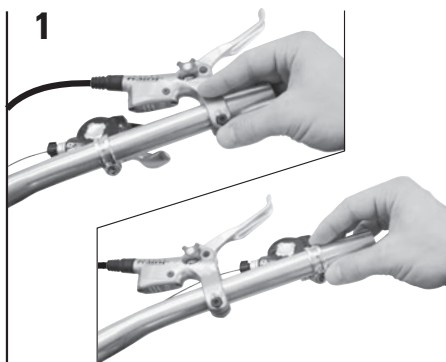

ASSEMBLY

- Slide shifter and brake lever onto handlebar. Either component can be mounted first, depending on personal preference (**Figure 1**).

- Slide the handlebar grip onto the handlebar.



CAUTION

Never use lubricants or solvents to install handlebar grips. Handlebar grips provide safety function. For this reason, they should be mounted in such a way as to make sure they do not slip off handlebar!

- Choose the best position for your ergonomic needs. Tighten the 5 mm hex clamp bolt to 2.5 – 4 N·m (22 – 35 in·lb) (**Figure 2**).

- Feed the cable through the cable housing and stops. Make sure the shifter is in fully released position (lowest gear position (front shifter) or the highest gear number (rear shifter)).

- Attach the front/rear shifter cable to the front/rear derailleur.

- Adjust indexing per derailleur instructions.



CAUTION

Always check the front and rear brake levers for proper operation.

If there is interference between a shifter and a brake lever, rotate one out of the way.

Check for proper brake lever operation again!

X.0 / X-9 · TRIGGER SHIFTERS USE / MAINTENANCE

3

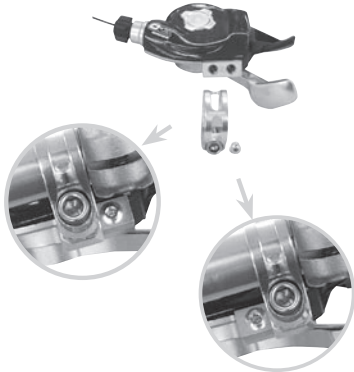

4

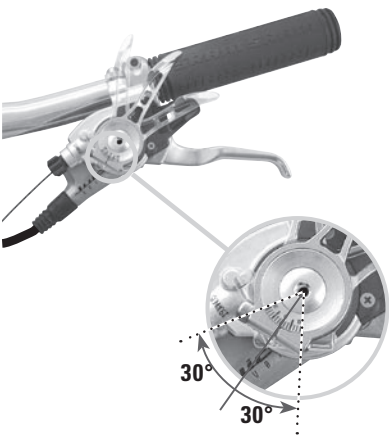

5

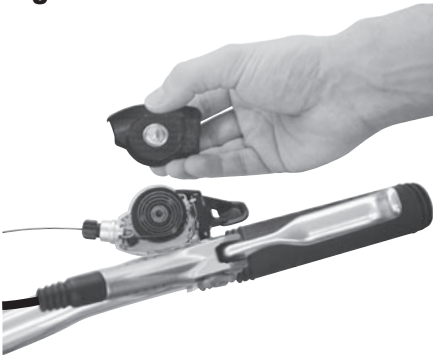

6

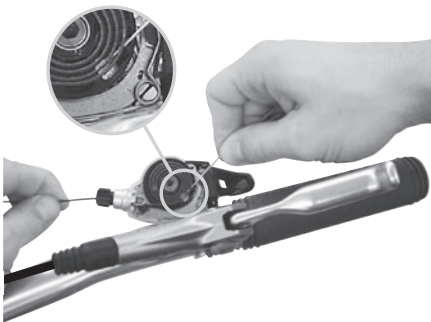

USE



CAUTION

Always check the front and rear brake levers for proper operation.

If there is interference between a shifter and a brake lever, rotate one out of the way.

Check for proper brake lever operation again!

The shifter offers the following adjustments:

- Shifter can be installed on handlebar inside and outside of brake (**Figure 1**).
- Clamp can be installed in two positions on shifter housing (**Figure 3**). Tighten the 5 mm hex clamp bolt to 2.5 – 4 N·m (22 – 35 in·lb).

X.0 only: Aluminum lever orientation is infinitely adjustable (**Figure 4**).

CABLE CHANGE



ADVICE

Use only new high quality cable and compressionless cable housing with endcaps.

- Make sure the shifter is in fully released position (lowest gear position (front shifter) or the highest gear number (rear shifter)).
- Detach the cable from the derailleur.
- Cut the cable off 6" (15 cm) from the shifter barrel adjuster. Discard the old cable and cable housing.
- Remove cover by unscrewing the top cap by hand (**Figure 5**).
- Remove cable. It may be helpful to use a pick (**Figure 6**).
- Feed the new cable through the cable entry and out of the barrel adjuster.
- Replace cover.
- Feed the cable through the new cable housing and cable stops.
- Attach the cable to the derailleur and adjust indexing per derailleur instructions.

MAINTENANCE

Clean the shifter using only water and mild soap.

X-7 / X-5 / X-4 / X-3 / VIA / ATTACK / ROCKET - TRIGGER SHIFTERS

TECHNICAL DATA

	X-7		X-5	
Shifter Type	Front/Index	Rear 1:1 Actuation Ratio	Front/Index	Rear 1:1 Actuation Ratio
Speeds	3	9	3	9
Derailleur	SRAM & Shimano	SRAM 1:1 Actuation Ratio	SRAM & Shimano	SRAM 1:1 Actuation Ratio
Crankset	Triple Indexed		Triple Indexed	
Cable Pull Release	Impulse Technology		Impulse Technology	
Cable	Stainless Steel	Stainless Steel	Stainless Steel	
Gear Indication	Window			
Barrel Adjuster	Indexing, Aluminum		Indexing	
Clamping Diameter	22.1 – 22.3 mm		22.1 – 22.3 mm	

	X-4		X-3	
Shifter Type	Front/Index	Rear 1:1 Actuation Ratio	Front/Index	Rear 1:1 Actuation Ratio
Speeds	3	8	3	7
Derailleur	SRAM & Shimano	SRAM 1:1 Actuation Ratio	SRAM & Shimano	SRAM 1:1 Actuation Ratio
Crankset	Triple Indexed		Triple Indexed	
Cable Pull Release	Impulse Technology		Impulse Technology	
Cable	Standard		Standard	
Gear Indication	Window		Window	
Barrel Adjuster	Indexing		Indexing	
Clamping Diameter	22.1 – 22.3 mm		22.1 – 22.3 mm	

	Via	
Shifter Type	Front/Index	Rear 1:1 Actuation Ratio
Speeds	3	8
Derailleur	SRAM & Shimano	SRAM 1:1 Actuation Ratio
Crankset	Triple Indexed	
Cable Pull Release	Impulse Technology	
Cable	Standard	
Gear Indication	Window	
Barrel Adjuster	Indexing	
Clamping Diameter	22.1 – 22.3 mm	

	Attack		Rocket	
Shifter Type	Front/Index	Rear 2:1 Actuation Ratio	Front/Index	Rear 2:1 Actuation Ratio
Speeds	3	9/8	3	8/7
Derailleur	SRAM & Shimano	Shimano	SRAM & Shimano	Shimano
Crankset	Triple Indexed		Triple Indexed	
Cable Pull Release	Impulse Technology		Impulse Technology	
Cable	Stainless Steel		Stainless Steel	
Gear Indication	Window		Window	
Barrel Adjuster	Indexing		Indexing	
Clamping Diameter	22.1 – 22.3 mm		22.1 – 22.3 mm	

CABLE HOUSING

- Use only new high quality cable and compressionless cable housing with end caps.
- When choosing cable housing lengths, be sure to allow enough housing for an extreme turn of the handlebars in both directions.
- Note also, that different stem lengths and cable stop positions effects cable housing length.

X-7 / X-5 / X-4 / X-3 / VIA / ATTACK / ROCKET · TRIGGER SHIFTERS ASSEMBLY

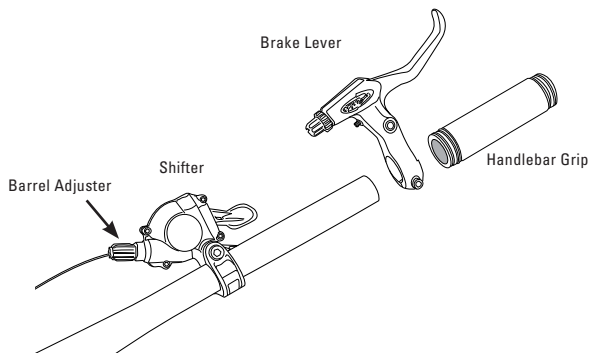

1

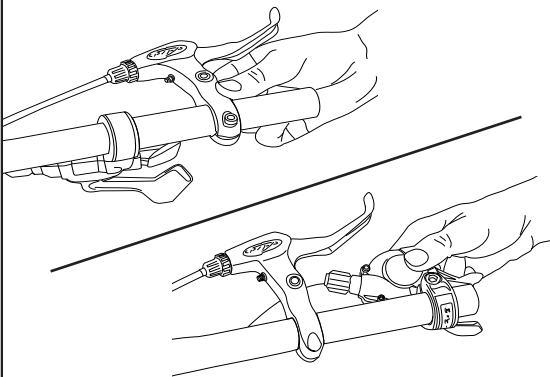

2

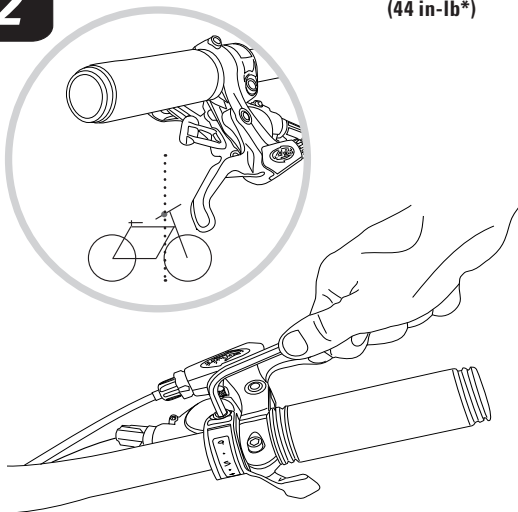

5 mm
5 N·m*
(44 in·lb*)

COMPATIBILITY

SRAM X-7 / X-5 / X-4 / X-3 / Via rear shifters are designed for use with:

» Rear derailleurs: SRAM X-0 / X-9 / X-7 / SX5 / X-5 / SX4 / X4 / 3.0 (1:1 Actuation Ratio)

SRAM Attack / Rocket rear shifters are designed for use with:

» Rear derailleurs: Shimano® (2:1 Actuation Ratio)

SRAM X-7 / X-5 / X-4 / X-3 / Attack / Rocket / Via front shifters are designed for use with:

» Front derailleurs: SRAM and Shimano® Slide shifter and brake lever onto handlebar.

Either component can be mounted first, depending on your ergonomic needs.

INSTALLATION

1 Slide the handlebar grip onto the handlebar.

x7 ONLY: X7 Trigger Shifters are Matchmaker compatible. Refer to Matchmaker instructions for installation.

CAUTION

Never use lubricants or solvents to install handlebar grips. Handlebar grips provide an axial safety function. For this reason, they should be mounted in such a way as to make sure they do not slip off the handlebar.

2 Position the shifter as you wish.

We recommend that the surface of the smaller shift lever is vertical. Tighten the 5 mm hex clamp bolt to 5 N·m (44 in·lb).

***x7 ONLY:** Tighten the 5 mm hex clamp bolt to 2.5-4.0 N·m (22-35 in·lb).

» Feed the cable through the cable housing and stops. Make sure the shifter is in gear position "1" (front shifter) or the highest gear number (rear shifter).

» Attach the front/rear shifter cable to the front/rear derailleur.

» Adjust indexing per derailleur instructions.

USE

CAUTION

Always check the front and rear brake levers for proper operation. If there is interference between a shifter and a brake lever, rotate one out of the way. Check for proper brake lever operation again!

X-7 / X-5 / X-4 / X-3 / VIA / ATTACK / ROCKET · TRIGGER SHIFTERS MAINTENANCE

3

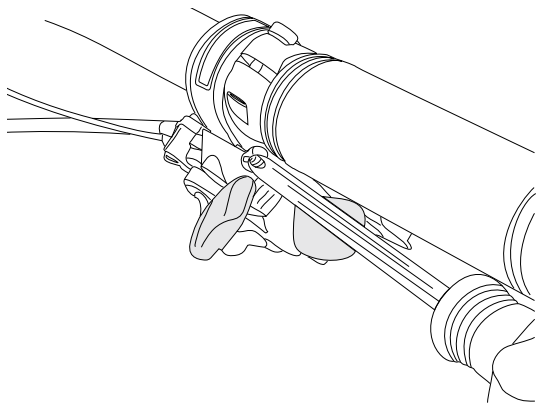

4

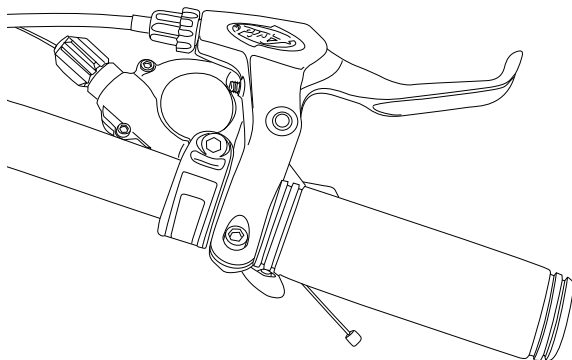

5

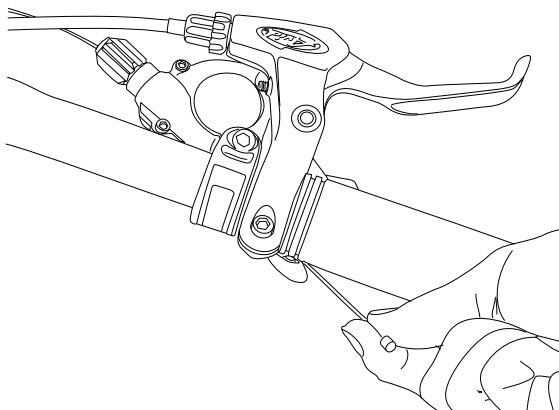

MAINTENANCE



ADVICE

Clean the shifter using only water and mild soap. These shifters are nearly maintenance free. For any questions regarding methods of disassembly or maintenance, please contact your qualified local dealer.

CABLE CHANGE



ADVICE

The shifter does not need to be opened.

- » Use only new, high quality cable and compressionless cable housing with end caps.
- » Line-up the shifter in gear position "1" (front shifter) or the highest gear number (rear shifter).
- » Detach the cable from the derailleur.
- » Cut the cable off 6" (15 cm) from the shifter barrel adjuster. Discard the old cable and cable housing.

3

Carefully unscrew cable change cap from cable entry with a screwdriver.

x7 ONLY: Pull back cable change cover (screwdriver not required).

4

Push cable out of the cable entry with rotating movement.

5

Feed the new cable through the cable entry and out of the barrel adjuster.

It may be helpful to remove the barrel adjuster for better visibility.

- » Replace cable change cap or cover.
- » Feed the cable through the new cable housing and cable stops.
- » Attach the cable to the derailleur and adjust indexing per derailleur instructions.

X.0 / X-9 / X-7 / ROCKET / ATTACK · TWIST SHIFTERS

TECHNICAL DATA / ASSEMBLY REQUIREMENTS

	X.0			X-9	
Version	Shorty			Shorty	
Shifter Type	Front / Micro adjust	Front / Index	Rear 1:1 Actuation Ratio	Front / Micro adjust	Front / Index
Speeds	3		9 8	3	
Derailleur	SRAM & Shimano		SRAM 1:1 Actuation Ratio	SRAM & Shimano	
Crankset	Triple Indexed	Triple Indexed		Triple Indexed	
Cable Pull Release	SRS			SRS	
Cable	Stainless Steel	Stainless Steel	PTFE Coated Stainless Steel	Stainless Steel	
Gear Indication	Window			Window	
Barrel Adjuster	Indexing			Indexing	
Clamping Diameter	22.1 – 22.3 mm			22.1 – 22.3 mm	
Shifter Length	70 mm			70 mm	

	X-9		X-7		Rocket	
Version	Shorty		Shorty		Shorty	
Shifter Type	Rear 1:1 Actuation Ratio		Front / Micro adjust	Front / Index	Rear 1:1 Actuation Ratio	Front / Micro adjust
Speeds	9 8		3	9 8		
Derailleur	SRAM 1:1 Actuation Ratio		SRAM & Shimano	SRAM & Shimano	SRAM 1:1 Actuation Ratio	SRAM & Shimano
Crankset			Triple Indexed	Triple Indexed	Triple Indexed	
Cable Pull Release	SRS		SRS		SRS	
Cable	Stainless Steel		Stainless Steel		Stainless Steel	
Gear Indication	Window		Window		Window	
Barrel Adjuster	Indexing		Indexing		Indexing	
Clamping Diameter	22.1 – 22.3 mm		22.1 – 22.3 mm		22.1 – 22.3 mm	
Shifter Length	70 mm		70 mm		70 mm	

	Rocket			Attack		
Version	Shorty			Shorty		
Shifter Type	Front / Index	Rear 2:1 Actuation Ratio		Front / Micro adjust	Front / Index	Rear 2:1 Actuation Ratio
Speeds	3	9	8		3	9 8
Derailleur	SRAM & Shimano	Shimano		SRAM & Shimano	SRAM & Shimano	Shimano
Crankset	Triple Indexed			Triple Indexed		
Cable Pull Release	SRS			SRS		
Cable	Stainless Steel			Stainless Steel		
Gear Indication	Window			Window		
Barrel Adjuster	Indexing			Indexing		
Clamping Diameter	22.1 – 22.3 mm			22.1 – 22.3 mm		
Shifter Length	70 mm			70 mm		

CABLE HOUSING

- Use only new high quality cable and compressionless cable housing with end caps.
- When choosing cable housing lengths, be sure to allow enough housing for an extreme turn of the handlebars in both directions.
- Note also, that different stem lengths and cable stop positions effects cable housing length.

X.0 / X-9 / X-7 / ROCKET / ATTACK · TWIST SHIFTERS

ASSEMBLY / MAINTENANCE

1

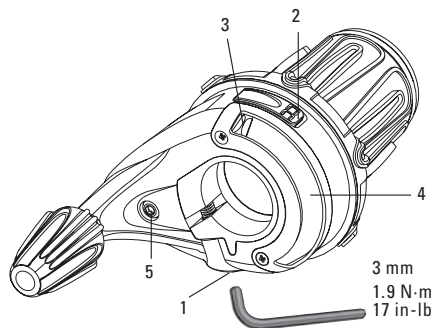

SHIFTER ANATOMY

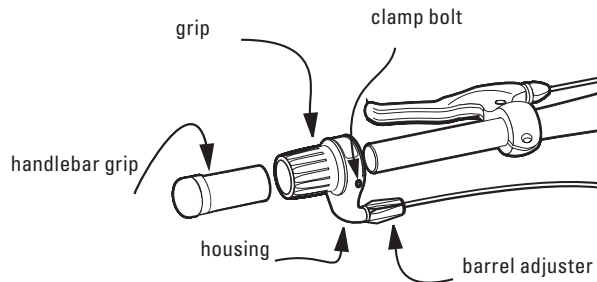

2

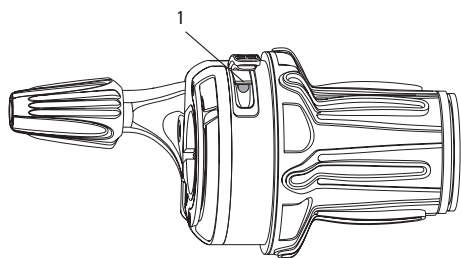

ASSEMBLY

Front and Rear:

- Slide the shifter onto the handlebar.
- If necessary, move the brake lever to allow for shifter and handlebar grip.
- Bar end users – don't forget to leave room for the bar end.
- Rotate the shifter until the barrel adjuster is beneath (but out of the way of) the brake lever.
- Tighten the 3 mm hex clamp bolt (1, **Figure 1**) to 1.9 N·m (17 in-lb).
- Slide the handlebar grip onto the handlebar.



CAUTION

Never use lubricants or solvents to install handlebar grips. Handlebar grips provide safety function. For this reason, they should be mounted in such a way as to make sure they do not slip off handlebar!

- Feed the cable through the cable housing and stops.
- Attach cable to the derailleur.
- Adjust indexing per derailleur instruction.



CAUTION

Always check the front and rear brake levers for proper operation.

If there is interference between shifters and brake levers, re-adjust lever and shifter placement.

Check again for proper operation!

3

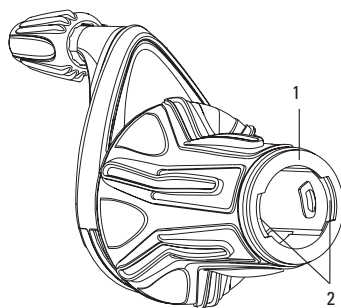

4

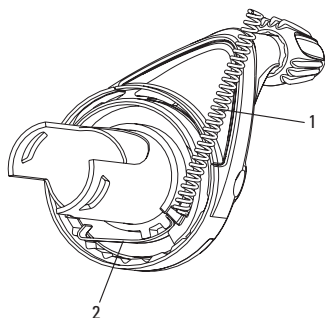

CABLE CHANGE



ADVICE

Leave the shifter on the handlebar.

No need to move other components. The shifter does not need to be opened.

Use only new high quality cable and compressionless cable housing with end caps.

Front and Rear:

- Detach the cable from the derailleur.
- Cut cable off 15 cm (6") from shifter barrel adjuster. Discard old cable and cable housing.
- From the edge (2, **Figure 1**), pull open the cable change hatch. The hinge of the hatch should remain attached to the shifter.
- Rotate the shifter fully in the cable release direction (3, **Figure 1**). (Gear "1" on the front shifter or HIGHEST gear number on the rear shifter.)
- Look for cable head entry (**Figure 2**).
- Using a small flat head screw driver, push back the tab (1, **Figure 2**) covering the cable head.
- Push cable up/out of the shifter and discard.
- Feed the new cable through the cable entry and out the barrel adjuster.
- Pull cable snug to seat cable head under tab.
- Replace cable change hatch.
- Feed the cable through the new cable housing and frame stops.
- Attach cable to the derailleur.
- Adjust indexing per derailleur instruction.

X.0 / X-9 / X-7 / ROCKET / ATTACK · TWIST SHIFTERS ASSEMBLY / MAINTENANCE

5

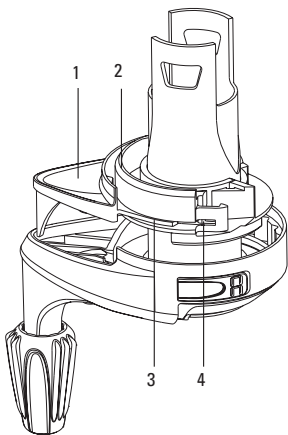

6

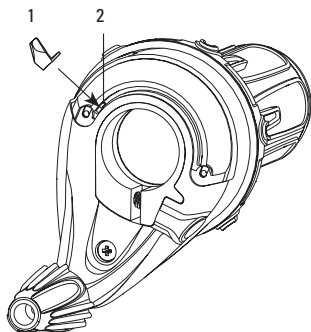

GRIP REPLACEMENT



ADVICE

Do not remove the triangular housing cover to make the change.

Removal:

- Rotate the shifter fully in the cable release direction (3, Figure 1). (Gear "1" on the front shifter or HIGHEST gear number on the rear shifter.)
- Using a 3 mm hex wrench (1, Figure 1), remove shifter from the handlebar.
- While holding shifter housing and grip together in one hand, remove axial fixture ring (1, Figure 3) by squeezing together housing tabs (2, Figure 3).
- While pushing/rotating the grip lightly forward (release direction), slowly move the grip outward away from housing.
 - Pulling the grip quickly may cause the coil spring (1, Figure 4) to move out of position.

Replacement:

- Replace front end of coil spring (1, Figure 4) on to tab in groove if necessary.
- While sliding grip up towards the housing, align spring tab so that it catches the open end of the coil spring.
- Rotate grip forward slightly compressing the coil spring and engage grip and tab into the housing.
- Replace axial fixture ring (1, Figure 3) over housing tabs (2, Figure 3).

INTERNAL CLEANING



ADVICE

When shifting performance is compromised, try replacing the cable and housing before you disassemble the shifter for cleaning.

Disassembly:

- Follow "Grip Replacement / Removal".
- Remove lens cover (4, Figure 1).
- Remove gear indicator needle (3, Figure 1) by pulling straight out.
- Remove the spool's coil spring (1, Figure 4).
- Using small pliers, pull leaf spring (2, Figure 4) straight out. Take note of the shape of the spring so that you can replace it in the correct direction.
- Remove housing cover screw (5, Figure 1). Slide housing cover (1, Figure 5) and spool (2, Figure 5) out at the same time being careful not to break the tab (3, Figure 5) on the cover.
- Clean all parts with soapy water only.
- Using only Grip Shift Jonnisnot, grease housing tube, detentes and cable track at housing bend.

Reassembly:

- Slip tab (3, Figure 5) on housing cover into groove (4, Figure 5) on spool.
- Slide spool and cover into housing and install cover screw (5, Figure 1).
- Place leaf spring (2, Figure 4) into spool. Push down slightly on opposite end of spring, then seat spring completely into spool and housing.
- Follow "Grip Replacement / Replacement".
- Rotate shifter to full release position.
- Install gear indication needle (1, Figure 6) in slot (2, Figure 6).
- Replace gear indicator lens (4, Figure 1) and screws.
- Install shifter on to bars and check for proper function.

X-5 / CENTERA · TWIST SHIFTERS

TECHNICAL DATA / ASSEMBLY REQUIREMENTS

Version	X-5			
Shifter Type	Shorty			
Speeds	Front / Micro adjust	Front / Index	Rear 1:1 Actuation Ratio	Rear 1:1 Actuation Ratio
Derailleur	SRAM & Shimano		SRAM 1:1 Actuation Ratio	8
Crankset	Triple Indexed			
Cable Pull Release	FFS		Standard	
Cable	Die Drawn Steel			
Gear Indication	Printed			
Barrel Adjuster	Indexing			
Clamping Diameter	22.1 – 22.3 mm			
Shifter Length	65 mm			

Version	Centera			
Shifter Type	Shorty			
Speeds	Front / Micro adjust	Front / Index	Rear 2:1 Actuation Ratio	Rear 2:1 Actuation Ratio
Derailleur	SRAM & Shimano		Shimano	8
Crankset	Triple Indexed			
Cable Pull Release	FFS		Standard	
Cable	Die Drawn Steel			
Gear Indication	Printed			
Barrel Adjuster	Indexing			
Clamping Diameter	22.1 – 22.3 mm			
Shifter Length	65 mm			

SHIFTER ANATOMY

- Use only new high quality cable and compressionless cable housing with end caps.
- When choosing cable housing lengths, be sure to allow enough housing for an extreme turn of the handlebars in both directions.
- Note also, that different stem lengths and cable stop positions effects cable housing length.

SHIFTER ANATOMY

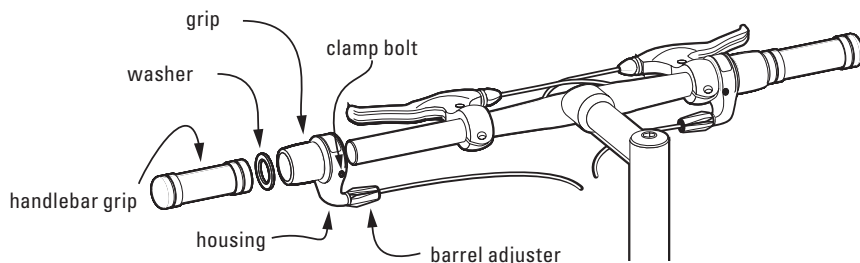

X-5 / CENTERA · TWIST SHIFTERS ASSEMBLY

1

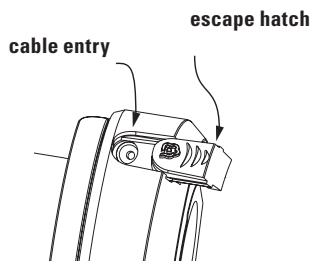

ASSEMBLY

Front and Rear:

- Slide the shifter onto the handlebar.
- If necessary, move the brake lever to allow for shifter and handlebar grip.

– Bar end users – don't forget to leave room for the bar end.

- Rotate the shifter until the barrel adjuster is beneath (but out of the way of) the brake lever.

- Tighten the 3 mm hex clamp bolt to 1.9 N·m (17 in-lb).

- Slide the plastic washer onto the handlebar.

- Slide the handlebar grip onto the handlebar.

- Feed the cable through the cable housing and stops.
- Attach the shifter cable to the derailleur.
- Adjust indexing per derailleur instructions.

CAUTION :
Always check the front and rear brake levers for proper operation.
If there is interference between shifters and brake levers, re-adjust lever and shifter placement.
Check again for proper operation.

2

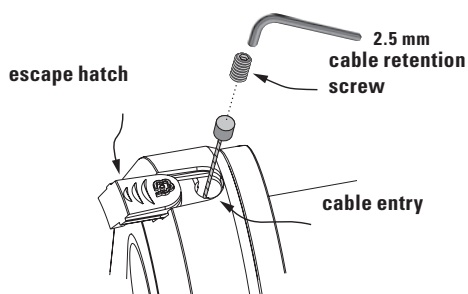

CAUTION
Never use lubricants or solvents to install handlebar grips. Handlebar grips provide safety function. For this reason, they should be mounted in such a way as to make sure they do not slip off handlebar!

3

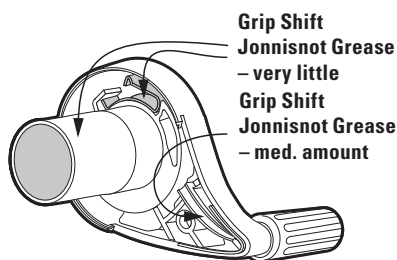
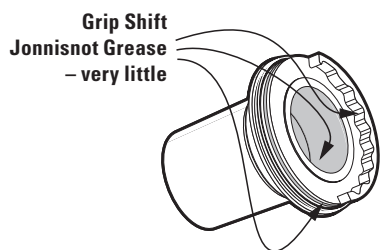

X-4 / MRX PRO · TWIST SHIFTERS

TECHNICAL DATA / ASSEMBLY REQUIREMENTS

	X-4				
Version	Half Pipe				
Shifter Type	Front / Micro adjust	Front / Index	Rear 1:1 Actuation Ratio		
Speeds		3	9	8	7
Derailleur	SRAM & Shimano		SRAM 1:1 Actuation Ratio		
Crankset	Triple Indexed				
Cable Pull Release	SRS				
Cable	Die Drawn Steel				
Gear Indication	Window				
Barrel Adjuster	Indexing				
Clamping Diameter	22.1 – 22.3 mm				
Shifter Length	86 mm				

	MRX Pro							
Version	Half Pipe							
Shifter Type	Front / Micro adjust	Front / Index	Rear 2:1 Actuation Ratio			Shimano Rapid Rise		
Speeds		3	9	8	7	9	8	7
Derailleur	SRAM & Shimano		Shimano		Shimano Rapid Rise			
Crankset	Triple Indexed							
Cable Pull Release	SRS							
Cable	Die Drawn Steel							
Gear Indication	Window							
Barrel Adjuster	Indexing							
Clamping Diameter	22.1 – 22.3 mm							
Shifter Length	86 mm							

CABLE HOUSING

- Use only new high quality cable and compressionless cable housing with end caps.
- When choosing cable housing lengths, be sure to allow enough housing for an extreme turn of the handlebars in both directions.
- Note also, that different stem lengths and cable stop positions effects cable housing length.

Shifter Anatomy

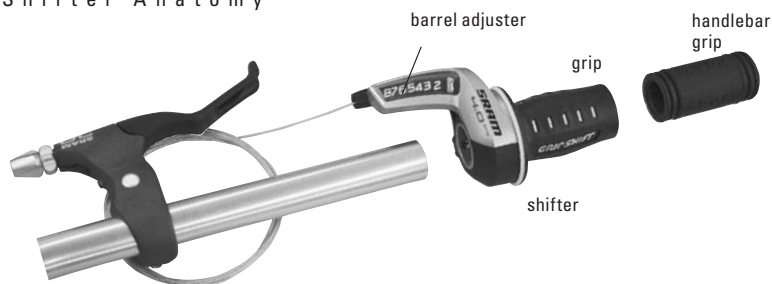

X-4 / MRX PRO · TWIST SHIFTERS ASSEMBLY / MAINTENANCE

1

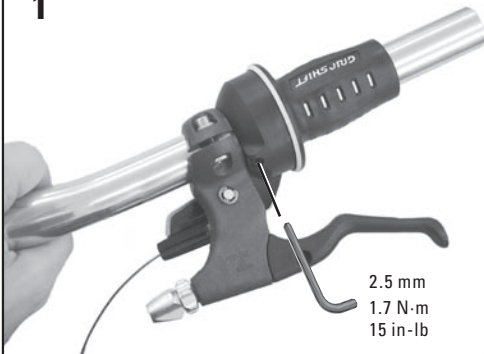

2

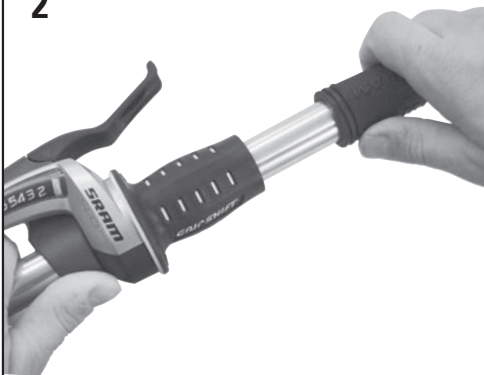

3

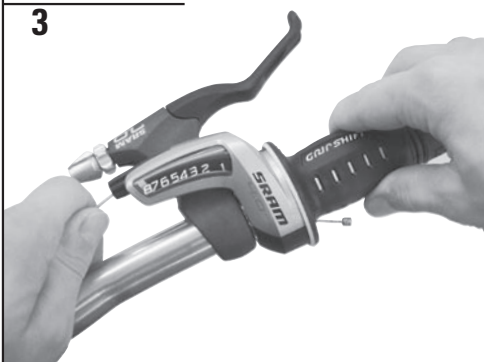

4



ASSEMBLY

Front and Rear:

- Slide the shifter onto the handlebar.
- If necessary, move the brake lever to allow for shifter and handlebar grip.
- Bar end users – don't forget to leave room for the bar end.
- Rotate the shifter until the barrel adjuster is above (but out of the way of) the brake lever and the gear indication is clearly visible from the riding position.
- Tighten the 2.5 mm hex clamp bolt (**Figure 1**) to 1.7 N·m (15 in-lb).
- Slide the handlebar grip onto bar (**Figure 2**).

CAUTION

Never use lubricants or solvents to install handlebar grips. Handlebar grips provide safety function. For this reason, they should be mounted in such a way as to make sure they do not slip off handlebar!

- Feed the cable through the cable housing and frame stops.
- Attach cable to the derailleur.
- Adjust indexing per derailleur instructions.

CAUTION

Not recommended for use on thin walled aluminum handlebars such as Hyperlite® type handlebars or Carbon handlebars.

CAUTION

Always check the front and rear brake levers for proper operation.

If there is interference between shifters and brake levers, re-adjust lever and shifter placement.

Check again for proper operation!

CABLE CHANGE



ADVICE

Leave the shifter on the handlebar.

No need to move other components. The shifter does not need to be opened.

Use only new high quality cable and compressionless cable housing with endcaps.

- Detach the cable from the derailleur.
- Cut the cable off 6" (15 cm) from the shifter barrel adjuster.
- Discard the old cable and cable housing.
- Line up the "1" (front) or HIGHEST gear number (rear) mark with the indicator mark (MRX Pro Shimano Rapid Rise® Gear number "1" for front and rear). Look for the cable entry.
- Push cable up/out of the shifter and discard (**Figure 3**).
- Feed the new cable through the cable entry and out the barrel adjuster (**Figure 4**).
- Pull the cable snug.
- Feed the cable through the new cable housing and stops.
- Attach the cable to the derailleur and adjust indexing per the derailleur instructions.

MAINTENANCE

Clean all shifter parts using only water and mild soap.

3.0 COMP / MRX COMP · TWIST SHIFTERS

TECHNICAL DATA / ASSEMBLY REQUIREMENTS

	3.0 Comp				
Version	Shorty				
Shifter Type	Front / Micro adjust	Front / Index	Rear 1:1 Actuation Ratio		
Speeds		3	8	7	6
Derailleur	SRAM & Shimano		SRAM 1:1 Actuation Ratio		
Crankset	Triple Indexed				
Cable Pull Release	SRS				
Cable	Standard Steel				
Gear Indication	Printed				
Barrel Adjuster	Friction				
Clamping Diameter	22.1 – 22.3 mm				
Shifter Length	67 mm				

	MRX Comp								
Version	Shorty								
Shifter Type	Front / Micro adjust	Front / Index	Rear 2:1 Actuation Ratio			Rear Shimano Rapid Rise			
Speeds		3	9	8	7	9	8	7	
Derailleur	SRAM & Shimano		Shimano			Shimano Rapid Rise			
Crankset	Triple Indexed								
Cable Pull Release	SRS								
Cable	Standard Steel								
Gear Indication	Printed								
Barrel Adjuster	Friction								
Clamping Diameter	22.1 – 22.3 mm								
Shifter Length	67 mm								

CABLE HOUSING

- Use only new high quality cable and compressionless cable housing with end caps.
- When choosing cable housing lengths, be sure to allow enough housing for an extreme turn of the handlebars in both directions.
- Note also, that different stem lengths and cable stop positions effects cable housing length.

SHIFTER ANATOMY

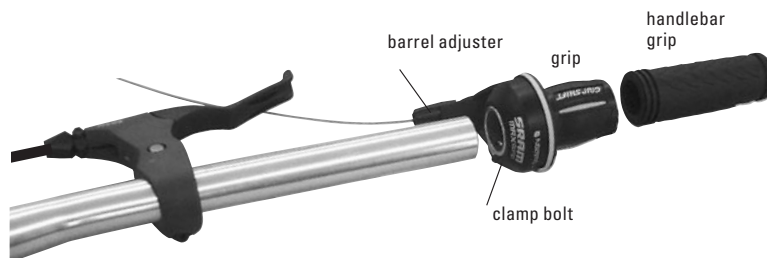

3.0 COMP / MRX COMP · TWIST SHIFTERS ASSEMBLY / MAINTENANCE

1



2

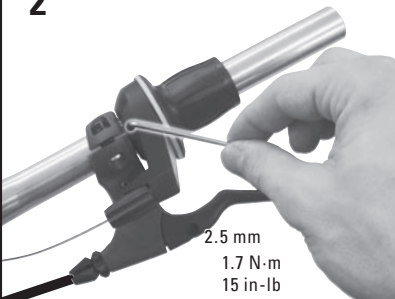

3



4



5



ASSEMBLY

- Slide the shifter onto the handlebar (**Figure 1**).
- If necessary, move the brake lever to allow for shifter and stationary grip.
- Bar end users – don't forget to leave room for the bar end.
- Rotate the shifter until the barrel adjuster is beneath (but out of the way of) the brake lever.
- Tighten the 2.5 mm hex clamp bolt (**Figure 2**) to 1.7 N·m (15 in-lb).
- Slide the stationary grip onto the handlebar (**Figure 3**).



CAUTION

Never use lubricants or solvents to install handlebar grips. Handlebar grips provide safety function. For this reason, they should be mounted in such a way as to make sure they do not slip off handlebar!

- Feed the cable through the cable housing and frame stops.
- Attach cable to the derailleur.
- Adjust indexing per derailleur instructions.



CAUTION

Not recommended for use on thin walled aluminum handlebars such as Hyperlite® type handlebars or Carbon handlebars.



CAUTION

Always check the front and rear brake levers for proper operation.

If there is interference between shifters and brake levers, re-adjust lever and shifter placement.

Check again for proper operation

CABLE CHANGE



ADVICE

Leave the shifter on the handlebar.

No need to move other components. The shifter does not need to be opened.

Use only new high quality cable and compressionless cable housing with endcaps.

- Detach the cable from the derailleur.
- Cut the cable off 6" (15 cm) from the shifter barrel adjuster.
- Discard the old cable and cable housing.
- Line up the "1" (front) or HIGHEST gear number (rear) mark with the indicator mark (MRX Pro Shimano Rapid Rise® Gear number "1" for front and rear). Look for the cable entry.
- Push cable up/out of the shifter and discard (**Figure 4**).
- Feed the new cable through the cable entry and out the barrel adjuster (**Figure 5**).
- Pull the cable snug.
- Feed the cable through the new cable housing and stops.
- Attach the cable to the derailleur and adjust indexing per the derailleur instructions.

MAINTENANCE

Clean the shifter using only water and mild soap.

3.0 PLUS / 3.0 / MRX PLUS / MRX · TWIST SHIFTERS

TECHNICAL DATA / ASSEMBLY REQUIREMENTS

3.0 Plus Half Pipe / 3.0 Shorty

Version	3.0 Plus	3.0	3.0 Plus	3.0	3.0 Plus	3.0	3.0 Plus	3.0
Shifter Type	Front / Micro adjust		Front / Index		Rear 1:1 Actuation Ratio		Rear 1:1 Actuation Ratio	
Speeds			3		8		7	
Derailleur	SRAM & Shimano				SRAM 1:1 Actuation Ratio			
Crankset	Triple Indexed							
Cable Pull Release	FFS				Standard			
Cable	Die Drawn Steel							
Gear Indication	Printed							
Barrel Adjuster	Indexing							
Clamping Diameter	22.1 – 22.3 mm							
Shifter Length	96 mm	64 mm	96 mm	64 mm	96 mm	64 mm	96 mm	64 mm

MRX Plus Half Pipe

Version	Half Pipe							
Shifter Type	Front / Micro adjust		Front / Index		Rear 2:1 Actuation Ratio		Rear Shimano Rapid Rise	
Speeds			3		8		7	
Derailleur	SRAM & Shimano				Shimano		Shimano Rapid Rise	
Crankset	Triple Indexed							
Cable Pull Release	FFS direct				Standard			
Cable	Die Drawn Steel							
Gear Indication	Printed							
Barrel Adjuster	Indexing							
Clamping Diameter	22.1 – 22.3 mm							
Shifter Length	96 mm							

MRX

Version	Shorty							
Shifter Type	Front / Micro adjust		Front / Index		Rear 2:1 Actuation Ratio		Rear Shimano Rapid Rise	
Speeds			3		8		7	
Derailleur	SRAM & Shimano				Shimano		Shimano Rapid Rise	
Crankset	Triple Indexed							
Cable Pull Release	FFS direct				Standard			
Cable	Die Drawn Steel							
Gear Indication	Printed							
Barrel Adjuster	Indexing							
Clamping Diameter	22.1 – 22.3 mm							
Shifter Length	64 mm							

- Use only new high quality cable and compressionless cable housing with end caps.
- When choosing cable housing lengths, be sure to allow enough housing for an extreme turn of the handlebars in both directions.
- Note also, that different stem lengths and cable stop positions effects cable housing length.

SHIFTER ANATOMY

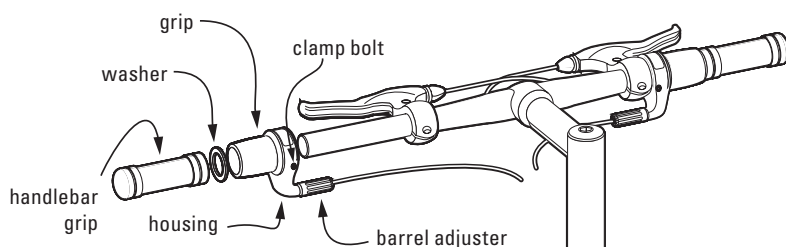

3.0 COMP / MRX COMP · TWIST SHIFTERS

ASSEMBLY / MAINTENANCE

1

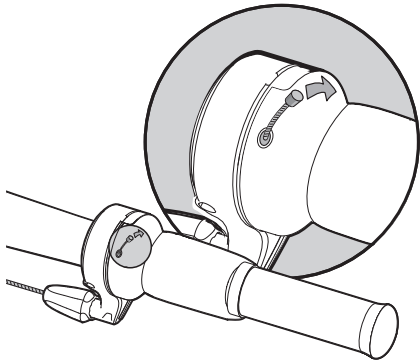

ASSEMBLY

Front and Rear:

- Slide the shifter onto the handlebar.
- If necessary, move the brake lever to allow for shifter and handlebar grip.
- Bar end users – don't forget to leave room for the bar end.
- Rotate the shifter until the barrel adjuster is beneath (but out of the way of) the brake lever.

- Tighten the 2.5 mm hex clamp bolt to 1.7 N-m (15 in-lb).
- Slide the plastic washer onto the handlebar.
- Slide the handlebar grip onto bar.

CAUTION

Never use lubricants or solvents to install handlebar grips. Handlebar grips provide safety function. For this reason, they should be mounted in such a way as to make sure they do not slip off handlebar!

- Feed the cable through the cable housing and frame stops.
- Attach cable to the derailleur.
- Adjust indexing per derailleur instructions.

CAUTION

Not recommended for use on thin walled aluminum handlebars such as Hyperlite® type handlebars or carbon handlebars.

CAUTION

Always check the front and rear brake levers for proper operation.

If there is interference between shifters and brake levers, re-adjust lever and shifter placement.

Check again for proper operation.

CABLE CHANGE



ADVICE

- Leave the shifter on the handlebar.
- No need to move other components. The shifter does not need to be opened.
- Use only new high quality cable and compressionless cable housing with endcaps.

3.0 Plus / MRX Plus: Figure 1

3.0 / MRX: Figure 2

- Detach the cable from the derailleur.
- Cut the cable off 15 cm (6") from shifter barrel adjuster. Discard old cable and cable housing.
- Rotate the shifter until the cable entry is visible.
- 3.0 / MRX only: Carefully peel back the corner of the grip cover shown in **Figure 2**. Use your fingernail or a small screwdriver.
- Remove and discard the rest of the old cable.
- Feed the new cable through the cable entry in the grip and out through the barrel adjuster.
- Feed the cable through the new cable housing and stops.
- Attach the cable to the derailleur and adjust indexing per derailleur instruction.

MAINTENANCE

- Clean all shifter parts using only water and mild soap.
- Use only Grip Shift Jonnisnot Grease for any shifter lubrication.
- After proper cleaning relubricate the areas shown in **Figure 3**.

2

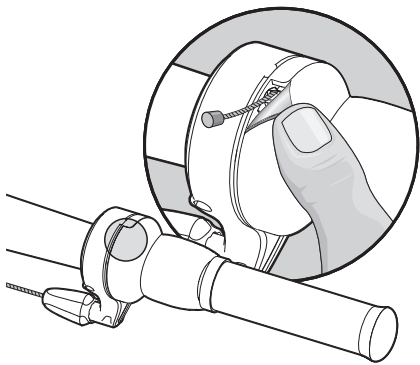

3

Grip Shift Jonnisnot Grease
– very little

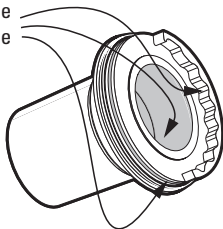

Grip Shift Jonnisnot Grease
– very little

Grip Shift Jonnisnot Grease
– med. amount

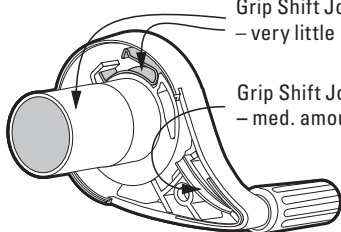

CASSETTES · MTB / ROAD

TECHNICAL DATA / ASSEMBLY REQUIREMENTS

	PG 990		PG 980	
Application	MTB		MTB	
Technology	Power Glide II		Power Glide II	
Largest Cog	34 T	32 T	34 T	32 T
Speeds	9		9	
Chains	SRAM / 9 speed index			
Hubs	9 / 8 speed HG			
Cogs	11/13/15/17/21/23/26/30/34	11/12/14/16/18/21/24/28/32	11/13/15/17/21/23/26/30/34	11/12/14/16/18/21/24/28/32
Lockring Torque	40 N·m			
Cog Material	SAPH 440 steel			
Spider Material	Aluminum, forged		Aluminum	
Lockring Material	Aluminum, anodized		Chrome Plated, Satin	
Rivet Material	Stainless Steel			
Finish	Pearl Ni-Chrome Plated			

	PG 970				
Application	MTB	MTB	Road	Road	Road
Technology	Power Glide II				
Largest Cog	34 T	32 T	26 T	23 T	23 T
Speeds	9				
Chains	SRAM / 9 speed index				
Hubs	9 / 8 speed HG				
Cogs	11/13/15/17/20/23/26/30/34	11/12/14/16/18/21/24/28/32	12/13/14/15/17/19/21/23/26	12/13/14/15/16/17/19/21/23	11/12/13/14/15/17/19/21/23
Lockring Torque	40 N·m				
Cog Material	SAPH 440 steel				
Spider Material	Chrome Plated, Satin		Aluminum, anodized		
Lockring Material	Aluminum, anodized		Chrome Plated, Satin		
Rivet Material	Steel / Zinc Coat				
Finish	Chrome Plated, Satin		Ni-Chrome Plated		

	PG 970		PG 950		
Application	Road	MTB	MTB	Road	Road
Technology	Power Glide II				
Largest Cog	21 T	34 T	32 T	26 T	26 T
Speeds	9				
Chains	SRAM / 9 speed index				
Hubs	9 / 8 speed HG				
Cogs	11/12/13/14/15/16/17/19/21	11/13/15/17/20/23/26/30/34	11/12/14/16/18/21/24/28/32	12/13/14/15/17/19/21/23/26	11/12/13/15/17/19/21/23/26
Lockring Torque	40 N·m				
Cog Material	SAPH 440 steel	Steel	Steel	SAPH 440 steel	SAPH 440 steel
Lockring Material	Aluminum, anodized	Forged Steel			
Screw Material	Steel / Zinc Coat				
Finish	Chrome Plated, Satin		Ni-Chrome Plated		

CASSETTES · MTB / ROAD

TECHNICAL DATA / ASSEMBLY REQUIREMENTS

	PG 950	
Application	Road	Road
Technology	Power Glide II	
Largest Cog	28 T	23 T
Speeds	9	
Chains	SRAM / 9 speed index	
Hubs	9 / 8 speed HG	
Cogs	11/12/13/14/16/18/21/24/28	12/13/14/15/16/17/19/21/23
Lockring Torque	40 N·m	
Cog Material	SAPH 440 steel	
Lockring Material	Forged steel	
Screw Material	Steel / Zinc Coat	
Finish	Ni-Chrome Plated	

	PG 950				
Application	MTB	MTB	MTB	Road	Road
Technology	Power Glide II				
Largest Cog	32 T	30 T	28 T	26 T	23 T
Speeds	8				
Chains	SRAM / 8 speed index				
Hubs	9 / 8 speed HG				
Cogs	11/12/14/16/18/21/26/32	11/13/15/17/20/23/26/30	11/12/14/16/18/21/24/28	12/13/15/17/19/21/23/26	12/13/14/15/17/19/21/23
Lockring Torque	40 N·m				
Cog Material	SAPH 440 steel				
Lockring Material	Forged steel				
Screw Material	Steel / Zinc Coat				
Finish	Ni-Chrome Plated				

	PG 830 / PG 820			PG 730
Application	MTB	MTB	MTB	MTB
Technology	Power Glide II			
Largest Cog	32 T	30 T	28 T	32 T
Speeds	8			7
Chains	SRAM / 8 speed index			SRAM / 8 speed index
Hubs	9 / 8 speed HG			
Cogs	11/12/14/16/18/21/26/32	11/13/15/17/20/23/26/30	11/12/14/16/18/21/24/28	12/14/16/18/21/26/32
Lockring Torque	40 N·m			
Cog Material	Steel			
Lockring Material	Forged steel			
Screw Material	Steel / Zinc Coat			
Finish	PG 830: Ni-Chrome Plated / PG 820: Black Phosphate			Ni-Chrome Plated

CASSETTES · MTB / ROAD ASSEMBLY / MAINTENANCE

1

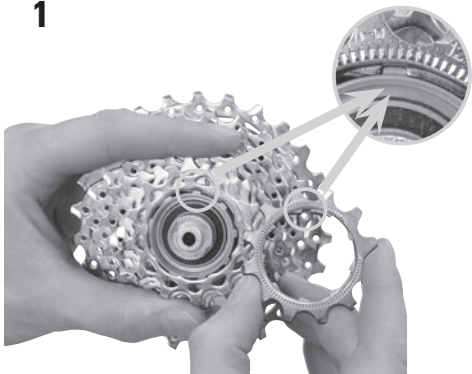

ASSEMBLY

- Position the cassette cluster and individual sprockets on the cassette body by aligning the spline pattern (**Figure 1**).
- Screw the lockring in to the cassette body and tighten it to 40 N·m (350 in·lb) by using a cassette tool (**1, Figure 2**) like the Park Tool® FR-5 or Shimano® and a chain wrench (**2, Figure 2**).
- Adjust the rear derailleur according to the installation advice from the derailleur manufacturer.



ADVICE

Due to the optimized stability of the rear wheel, there is less space between the right spoke flange and the cassette. This means that not all spoke protector discs available on the market will fit. Please carry out a trial assembly run before specifying spoke protector discs (spoke protector discs must not rub against the cassette).

MAINTENANCE



ADVICE

The only maintenance necessary on the cassette is to replace worn sprockets.

If the chain jumps repeatedly on a sprocket with correct derailleur setting it might be sufficient to replace only the chain.

If the new chain also jumps on the sprocket the sprocket is worn out and should be replaced.

Always put on a new chain when you replace worn sprockets.

To replace the sprocket do as follows:

- Remove the lockring by using cassette tool (**1, Figure 3**) and a chain wrench (**2, Figure 3**) to hold the cassette.
- Disassemble the sprocket cluster by unscrewing the small bolt on the back of the cassette.
- Replace worn or damaged sprocket and re-assemble sprockets and spacers in the correct order and re-install the bolt.
- Make sure that all the splines on the cogs are aligned to each other and the cassette body pattern.
- Tighten the cassette with 40 N·m (350 in·lb) (see **ASSEMBLY**).

1

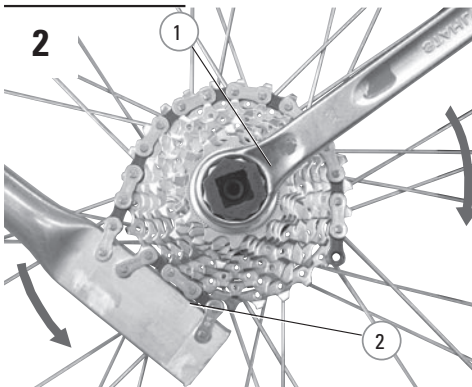

3

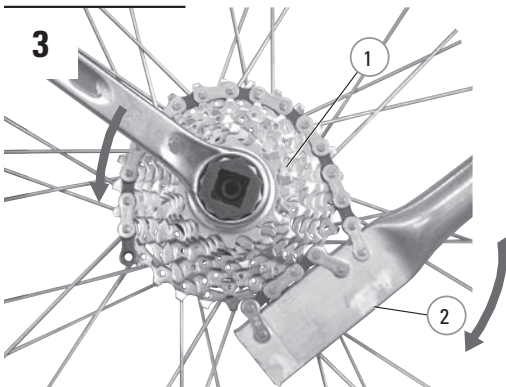

POWER CHAINS · MTB / ROAD

TECHNICAL DATA / ASSEMBLY REQUIREMENTS

	PC 991	PC 991 Hollow Pin	PC 991 Cross Step	PC 971	PC 951
Application	MTB / Road				
Max. Number of Sprockets	9 only				
Compatibility Front	Truvativ / HG / EXA-Drive				
Compatibility Rear	HG / PG / EXA-Drive				
Dimensions	1/2" x 11/128"				
Length	6.65 mm	6.35 mm	6.65 mm	6.65 mm	6.65 mm
Riveting	Step	Cylindrical	Cross Step	Step	Step
Chrome Hardened	Yes				
Push Power	2000 N / 450 lbs.	2000 N / 450 lbs.	2500 N / 562 lbs.	2000 N / 450 lbs.	2000 N / 450 lbs.
Min. Tensile Strength	9000 N / 2023 lbs.				
External Pin Plate	Nickel Plated				Grey
Internal Pin Plate	Nickel Plated			Grey	Grey
Connecting Method ¹	Power Link Gold or Pin	Power Link Gold	Power Link Gold	Power Link Gold or Pin	Power Link Gold or Pin

¹ Caution: Hollow Pin and Cross Step chains connecting method: with Power Link only (no pin)!

	PC 890	PC 870	PC 850	PC 830 Saltshaker	PC 830
Application	MTB / Road				
Max. Number of Sprockets	Maximum 8				
Compatibility Front	HG / IG / PG / EXA-Drive			HG / IG / EXA-Drive	
Compatibility Rear	HG / HG-I / IG / PG / EXA-Drive				
Dimensions	1/2" x 3/32"				
Length	7 mm				
Riveting	Step				
Chrome Hardened	Yes			No	
Push Power	2000 N / 450 lbs.			1300 N / 292 lbs.	1500 N / 340 lbs.
Min. Tensile Strength	9000 N / 2023 lbs.				
External Pin Plate	Silver / Nickel Plated		Grey / Polished	Light Grey	Grey / Polished
Internal Pin Plate	Silver / Nickel Plated	Grey / Polished	Grey / Polished	Light Grey	Grey / Polished
Connecting Method ¹	Power Link Silver	Power Link Silver or Pin		Power Link SS2 or Pin	Power Link Silver or Pin

POWER CHAINS · MTB / ROAD

TECHNICAL DATA / ASSEMBLY REQUIREMENTS

	PC 10 Saltshaker	PC 10	PC 10C
Application	MTB		
Max. Number of Sprockets	Maximum 7		
Compatibility Front	Single / HG		
Compatibility Rear	Single / HG		
Dimensions	1/2" x 3/32"		
Length	6.9 mm	7.1 mm	
Riveting	Step		
Chrome Hardened	No		
Push Power	1000 N / 225 lbs.		
Min. Tensile Strength	9000 N / 2023 lbs.		
External Pin Plate	Light Grey	Brown	Light Grey
Internal Pin Plate	Light Grey	Brown	Light Grey
Connecting Method	Power Link SS1 or Pin	Power Link Grey or Pin	Pin only

	PC 1 Saltshaker	PC 1 Ni	PC 1
Application	Gear Hubs		
Max. Number of Sprockets	1		
Compatibility Front	Single		
Compatibility Rear	Single		
Dimensions	1/2" x 1/8"		
Length	7.8 mm	8.9 mm	
Riveting	Step	V Shape	
Chrome Hardened	No		
Push Power	800 N / 180 lbs.		
Min. Tensile Strength	9000 N / 2023 lbs.		
External Pin Plate	Light Grey	Silver / Nickel Plated	Brown
Internal Pin Plate	Light Grey	Silver / Nickel Plated	Brown
Connecting Method	Snap Lock or Pin	Snap Lock, 3pcs Connection Link or Pin	

POWER CHAINS · MTB / ROAD ASSEMBLY / MAINTENANCE

1

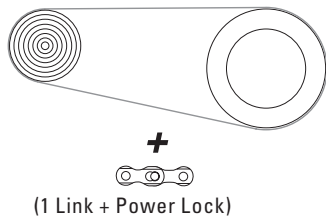

2

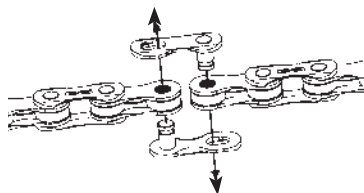

3

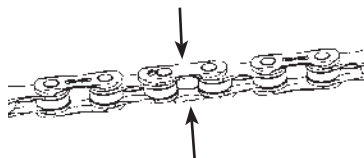

4

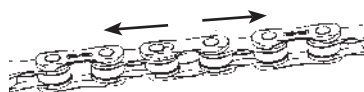

5

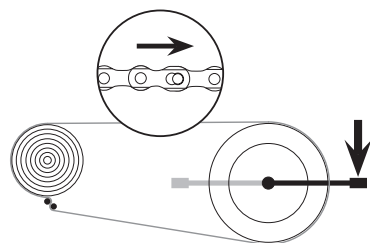

6

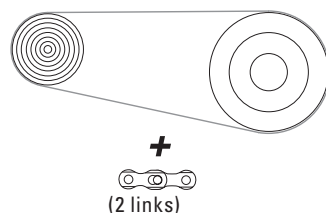

**PC 1090R / PC 1090 /
PC 1070 / PC 1050 / PC 1030**
(1/2" X 11/128")

Chain length:
(A chain tool will be required to shorten the chain.)

Replacing a worn chain:
· Measure the worn chain and shorten the new to the same length.

Initial assembly:
· Shorten the chain to the length specified by the derailleur manufacturer.

SRAM derailleurs:
· Place the chain over largest front chainwheel and largest rear sprocket and add 1 link + Power Lock (Figure 1).

CLOSING CHAIN WITH POWER LOCK

CAUTION
Use Power Lock only with SRAM chains!

Use only Power Lock to close 10 speed chains (no Pin)!

Use only Power Lock (black coloured) for PC 1090R, PC 1090, PC 1070, PC 1050, PC 1030 to avoid material damage or the rider falling from the bicycle resulting in injury.

· Fit chain, insert both halves of the Power Lock into the chain ends (Figure 2) and bring the ends together (Figure 3) on the bottom side of the drivetrain (no tension side).

· Pull chain apart until you feel some resistance (Figure 4).

· Rotate the chain so the Power Lock is positioned on the top side of the drivetrain (Figure 5).

· Pedal forward while holding bike firmly in place (Figure 5) until you hear click sound. The Power Lock is now in place and safely closed.

Opening:
Once the Power Lock is installed it can only be removed by means of a Chain tool.

CAUTION
Power Lock is for one-time use only!
Always use a new Power Lock when fitting a new chain.

Failure to shorten the chain properly or to lock it exactly into place may cause damage to the chain and eventually total chain failure, material damage, or the rider falling from the bicycle resulting in injury.

Worn sprockets should also be replaced when a new chain is fitted.

**PC 991 / PC 971 / PC 951 / PC 890 /
PC 870 / PC 850 / PC 830 / PC 10**
(1/2" X 3/32" AND 1/2" X 11/128")

Chain length:
(A chain tool will be required to shorten the chain.)

Replacing a worn chain:
· Measure the worn chain and shorten the new to the same length.

Initial assembly:
· Shorten the chain to the length specified by the derailleur manufacturer.

SRAM derailleurs:
· Place the chain over largest front chainwheel and largest rear sprocket (Figure 6). For rear suspension frame, position the rear suspension for the greatest chain length required.

· Add 2 links or 1 link + Power Link (Figure 6).

CLOSING CHAIN WITH POWER LOCK

CAUTION
Use Power Link only with SRAM chains!

Use only Power Link to close Hollow Pin chains and Cross Step chains (no Pin)!

Use only as specified, to avoid material damage or the rider to fall off his bicycle resulting in injury:

Power Link Gold (gold coloured):
for PC 991 Hollow Pin, PC 991 Cross Step, PC 991, PC 971, PC 951

Power Link Silver (silver coloured):
for PC 890, PC 870, PC 850, PC 830

Power Link SS2 (light grey coloured):
for PC 830 Saltshaker

Power Link SS1 (light grey coloured):
for PC 10 Saltshaker

Power Link Grey (grey coloured):
for PC 10

Closing:
· Fit chain, bring the ends together and insert both halves of the Power Link into the chain ends. (Figure 2)

· Press both halves of the Power Link together (Figure 3) and lock in place by pulling the chain apart. (Figure 4)

Opening:
Press both plates of the Power Link together (Figure 3) while sliding the chain ends together (unlock). Remove the two halves of the link from the chain ends.

POWER CHAINS · MTB / ROAD ASSEMBLY / MAINTENANCE

7

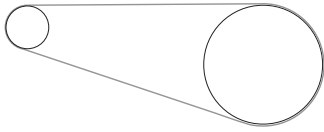

8



9

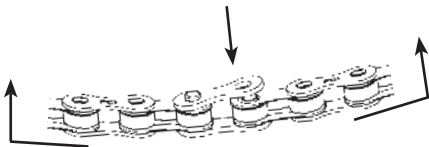

10

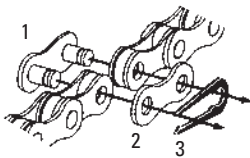

11

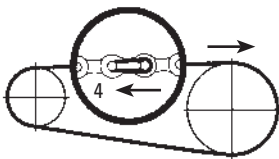

12

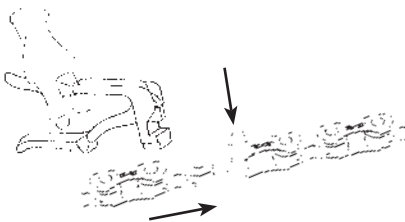

⚠ CAUTION

Always use a new Power Link when fitting a new chain.

Failure to shorten the chain properly or to lock it exactly into place may cause damage to the chain and eventually total chain failure, material damage, or the rider falling from the bicycle resulting in injury.

Worn sprockets should also be replaced when a new chain is fitted.

CLOSING STANDARD VERSION WITH CLAMPING PIN

Fit chain, bring the two ends together and press pin through with assembly tool (Figure 12). The pin must extend by the same amount at both outer plates. It must be possible to move the connecting link slightly.

PC 1 (1/2" X 1/8")

Chain length:

(A chain tool will be required to shorten the chain.)

Replacing a worn chain:

- Measure the worn chain and shorten the new to the same length.

Initial assembly:

- Shorten the chain to the length specified by the drivetrain manufacturer.

SRAM components:

- Place the chain over front chainwheel and rear sprocket (Figure 7). For rear suspension frame, position the rear suspension for the greatest chain length required.

CLOSING CHAIN WITH SNAP LOCK

CAUTION:

Use Snap Lock only with SRAM chains!

- Fit the shortened chain, bring the ends together and connect with the Snap Lock. Place the outer plate on one pin (Figure 8).

- Gently flex the chain until the outside connector plate snaps into position over the second pin (Figure 9).

⚠ CAUTION

Make sure plate is fully seated in the pin channel and plates are parallel to each other.

If movement of the connector plate is noticed a new Snap Lock must be used.

Snap Lock is for one-time use only!

Always use a new Snap Lock when fitting a new chain.

Failure to shorten the chain properly or to lock it exactly into place may cause damage to the chain and eventually total chain failure, material damage, or the rider falling from the bicycle resulting in injury.

Worn sprockets should also be replaced when a new chain is fitted.

CLOSING CHAIN WITH 3 PIECE CONNECTION LINK

- Fit the shortened chain, bring the two ends together and connect with the chain lock. The chain lock consists of an outer plate with pins (1, Figure 10), an outer plate (2, Figure 10) and a retaining spring (3, Figure 10).

- Insert outer plate with pins (1, Figure 10) into the chain ends, attach outer plate (2, Figure 10) and press chain lock together (1+2).

- Attach retaining spring (3, Figure 10) with the closed end of the retaining ring pointing in the direction of chain travel (Figure 10).

- Slide retaining spring in the direction of arrow (4, Figure 11) to engage it in the grooves in the pins.

CLOSING STANDARD VERSION WITH CLAMPING PIN

Fit chain, bring the two ends together and press pin (Figure 12) through with assembly tool. The pin must extend by the same amount at both outer plates. It must be possible to move the connecting link slightly.

MAINTENANCE

- Clean dirty chains before oiling. Do not use any acidic agents. Cleaning agent must be rinsed off after a few minutes with water. Apply oil after chain is completely dried.

- Regular lubrication will extend the chain's service life. Apply oil to the chain links rollers and allow to work in.

SRAM HUBS ANATOMY

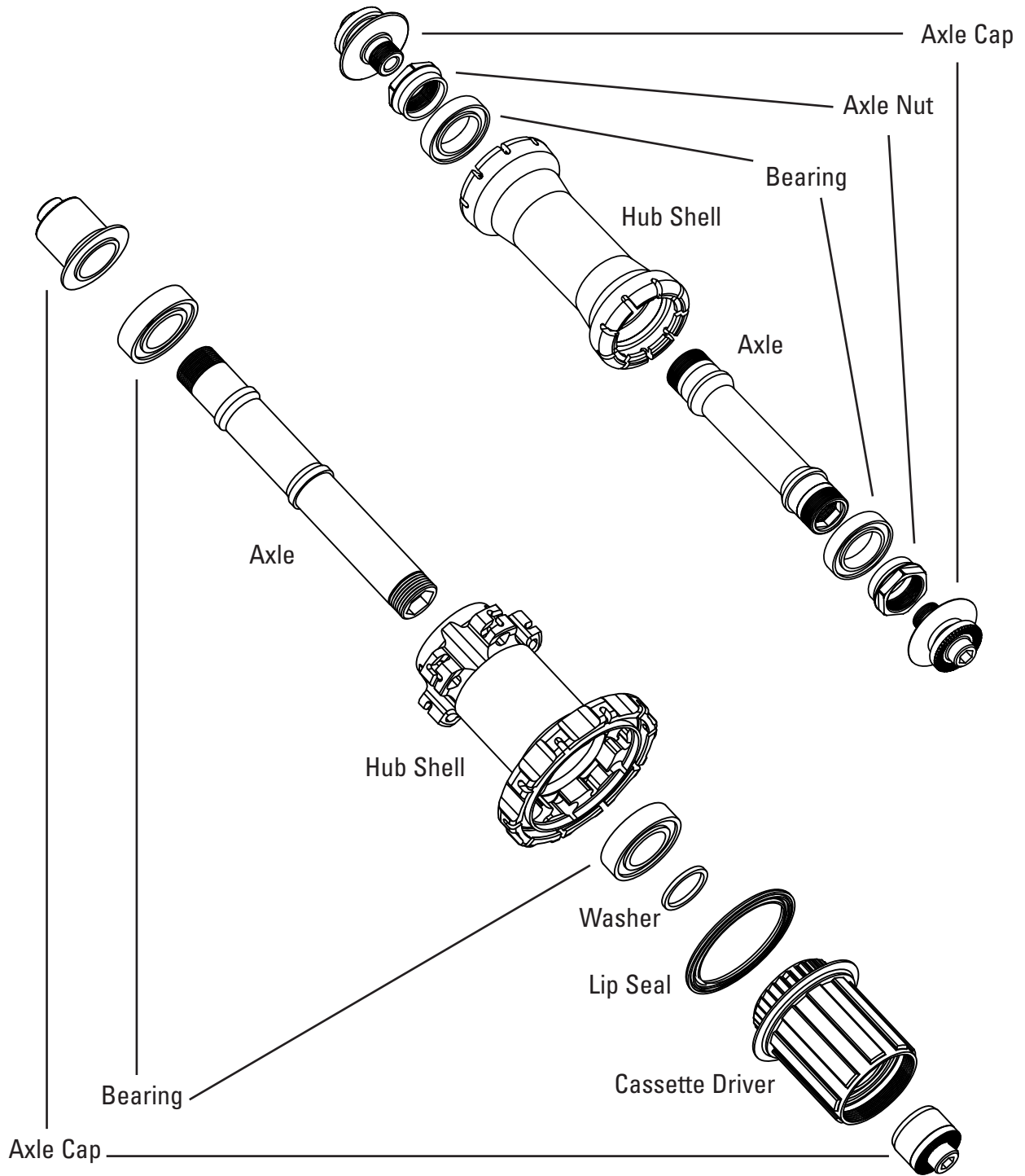

SRAM HUBS ANATOMY

INTRODUCTION

This service guide covers SRAM hub maintenance and spoke replacement. Spoke tensioning is NOT included in this manual. To service your hubs you will need the following tools and replacement parts:

TOOLS

Safety glasses	Torque wrench
(2) 5 mm hex wrenches	Drift tool
10 hex wrench	Rubber or plastic mallet
17 mm socket wrench	Grease
6 mm socket driver	SRAM hub tools (see diagram)

REPLACEMENT PARTS

Front and rear hub bearings
Leaf springs
Pawls



Bearing Service Tool
Base



Bearing Service Tool
Insert

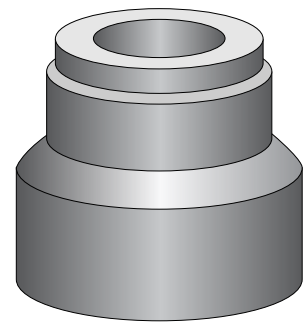

Bearing Service Tool
Cap

SRAM HUBS DISASSEMBLY

REAR HUB SERVICE

If your spokes or rim are damaged you can remove the hub from the wheel to make servicing your hub easier. Using a sharp pair of metal snips, cut the spokes, remove the hub from the wheel, then remove the spoke ends from the hub (not pictured). If your rim is damaged, send it back to SRAM from warranty review.

DISASSEMBLY

1 Insert a 5 mm hex wrench into both axle caps, and turn the wrenches counter-clockwise (as viewed from the axle end) to break loose one axle cap and fully remove.

1

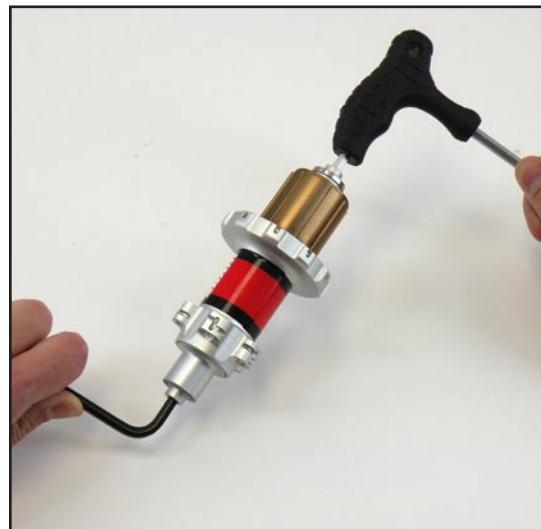

2 Insert a 10 mm hex into the exposed end of the axle, and use a 5 mm hex to remove the remaining axle cap.

2



3 Pull cassette body off by hand.

3



SRAM HUBS DISASSEMBLY

- 4** Place the drive-side face of the hub shell into the large inset in the Bearing Service Tool Base. Use a rubber mallet to firmly tap out the axle/bearing assembly. Set aside the axle/bearing assembly.
Important: A small washer is installed on the drive side of the axle near the bearing. If this washer falls off during axle removal set it aside for re-installation.

- 5** Turn hub over and insert the non-drive side end of the hub into the large hole in the Bearing Service Tool Base. Use a drift type tool to tap out other bearing.

- 6** Turn the Bearing Service Tool Base over, insert the non-drive side end of the axle/bearing assembly through the small hole. Use a mallet to gently tap the bearing and washer off of the axle. Set the washer aside for re-installation.

4



5



6

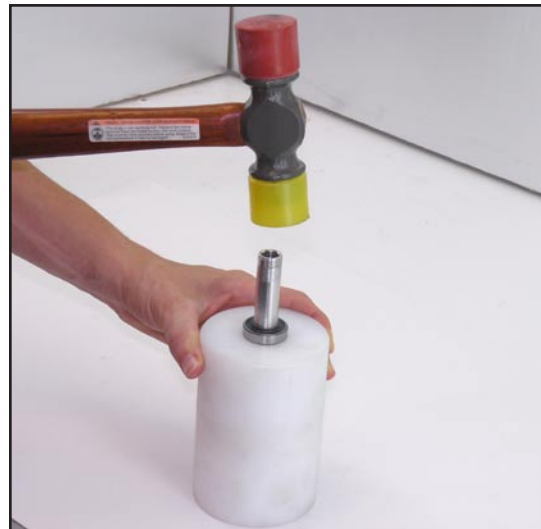

SRAM HUBS DISASSEMBLY

- 7** Use a pick to carefully remove the lip seal from the drive-side end of the hub.

7



- 8** Use your fingers or a pick to carefully remove the pawls and leaf springs. Inspect the pawls and leaf springs for signs of damage or wear. If any of the pawls or leaf springs exhibit signs of wear or damage, replace **all** of them. Otherwise, clean any grease on the pawls and leaf springs with a clean rag.

8



SRAM HUBS ASSEMBLY

ASSEMBLY

1 Install leaf springs into the pawl slots. Use a pick to compress each leaf spring as you insert the pawl into the pawl slot.

1

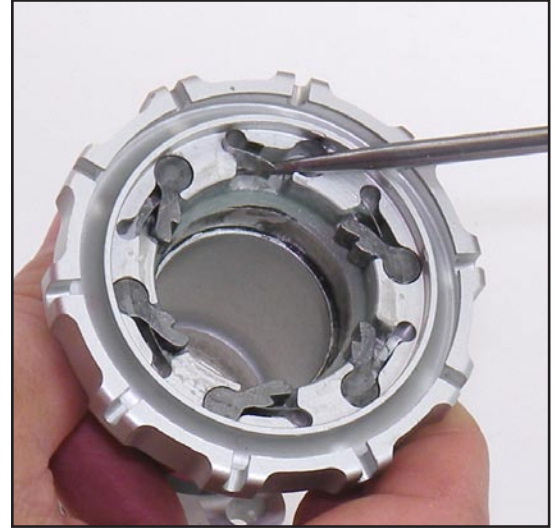

2 Apply a light coat of grease to the pawls.

2



3 Press the lip seal, with the notched side of the lip seal facing the hub, into the drive-side of the hub.

3



SRAM HUBS ASSEMBLY

- 4** Apply a light coat of grease to the hub lip seal and cassette driver ratchet ring.



- 5** Orient the Bearing Service Tool Base with the small hole facing up. Place the new bearing over the hole in the Bearing Service Tool Base, and insert the long end of the axle through the bearing. Use a mallet to gently tap the axle through the bearing until it seats in place.



SRAM HUBS ASSEMBLY

6 Install the Bearing Service Tool Insert, with the hole facing up, into the Bearing Service Tool Base.

6



7 Place the axle bearing assembly into the Bearing Service Tool Insert so that the bearing rests on the Insert.

7



8 Slide the hub, drive side down, over the axle/bearing assembly. Insert the second Bearing Service Tool Insert into the hub. Use a rubber or plastic mallet to gently but firmly tap bearing into place until it is seated against shoulder inside the hub.

8



SRAM HUBS ASSEMBLY

9 Remove the Bearing Service Tool Insert from the hub. Insert a new bearing into the non-drive side of the hub.

9



10 Hold the Bearing Service Tool Insert against the bearing. Use a rubber or plastic mallet to gently but firmly tap the bearing into place until it is seated against the shoulder inside the hub.

10



11 Grease and re-install the washer onto the drive side of the axle.
Important: The washer is critical to hub performance. The hub will not operate properly without the washer installed.

11



SRAM HUBS ASSEMBLY

- 12** Slide the driver body onto the axle until it is fully seated.
Note: The driver body has a floating sleeve that can become off-set during hub disassembly. If this occurs, use your finger to re-align and center the sleeve.

12



- 13** Hand tighten the flared axle cap and the standard axle cap onto the non-drive side and drive side of the hub respectively. Use a 5 mm hex wrench on one axle cap and a 5 mm torque wrench on the other and simultaneously torque both axle caps to 9 N-m (80 in-lbs).

13

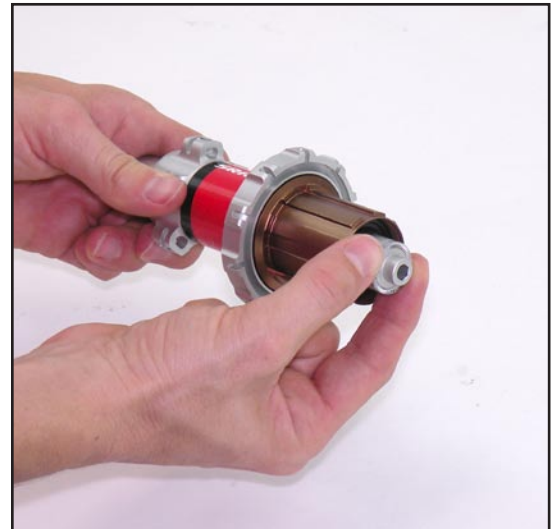

SRAM HUBS DISASSEMBLY

FRONT HUB SERVICE

If your spokes or rim are damaged you can remove the hub from the wheel to make servicing your hub easier. Using a sharp pair of metal snips, cut the spokes, remove the hub from the wheel, then remove the spoke ends from the hub (not pictured). If your rim is damaged, send it back to SRAM from warranty review.

DISASSEMBLY

1 Using two 5 mm hex wrenches on the axle caps, turn the wrenches counter-clockwise (as viewed from the axle end) to break loose one of the axle caps and fully remove.

1



2 Insert a 10 mm hex wrench into one end of the axle, and use a 5 mm hex to remove the other axle cap.

2



3 Position a 17 mm socket onto one end of the axle, and use a 10 mm hex to remove one of the axle nuts. Repeat this process to remove the other axle nut.

3



SRAM HUBS DISASSEMBLY

4 Place one end of the hub over the large hole in the Bearing Service Tool Base. Insert a 6 mm socket driver into the hub so that the driver rests on the axle.



5 Use a rubber or plastic mallet to gently but firmly tap the axle/bearing assembly out of the hub.



6 Turn the Bearing Service Tool Base over and insert the short end of the axle into the small hole so that the bearing is sitting on top of the tool. Use a rubber or plastic mallet to gently tap bearing off of the axle.



SRAM HUBS REPLACE BEARINGS

- 7 Turn the hub over and insert the other end of the hub into the Bearing Service Tool Base. Use a drift type tool to tap out other bearing.

7

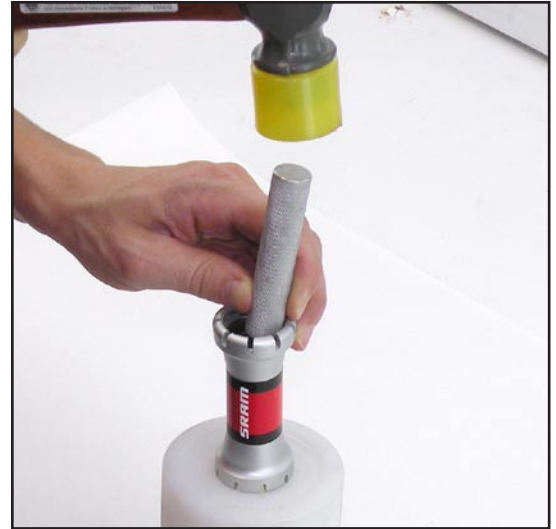

REPLACE BEARINGS

- 1 Insert a new bearing into one end of the hub.

1



- 2 Place the narrow end of the Bearing Service Tool Cap into the hub so that it contacts the bearing.

2



SRAM HUBS REPLACE BEARINGS

3 Place the Bearing Service Tool Insert into the open end of the Bearing Service Tool Cap. Use a rubber or plastic mallet to gently but firmly tap bearing into place until it is seated against shoulder inside the hub.

3



4 Place the wide end of the Bearing Service Tool Cap on a flat surface. Place the other new bearing on top of the tool and insert one end of the axle into the bearing. Use a rubber or plastic mallet to gently but firmly tap the axle into the bearing until it is fully seated against the axle shoulder.

4

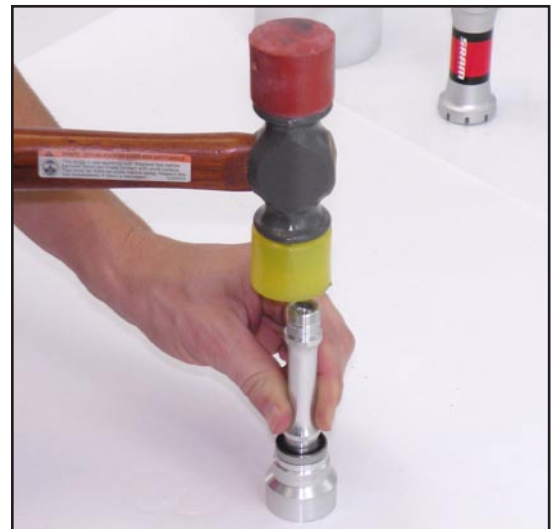

5 Remove the hub from the Bearing Service Tool Cap, and place the end of the hub with previously installed bearing onto the narrow end of the Bearing Service Tool Cap.

5



SRAM HUBS REPLACE BEARINGS

6 Insert the axle/bearing assembly into the hub until the axle threads clear the installed hub bearing.

6



7 Place the narrow end of the Bearing Service Tool Cap into the hub so that it contacts the bearing.

7



8 Place the Bearing Service Tool Insert into the open end of the Bearing Service Tool Cap. Use a rubber or plastic mallet to gently but firmly tap bearing into place until it is fully seated against the shoulder inside the hub.

8



SRAM HUBS REPLACE BEARINGS

9 Use a 10 mm hex and 17 mm socket and install the axle nuts, with the stepped side of the nut inward, onto the hub. Simultaneously torque to 9 N·m (80 in-lbs) each side.

9



10 Use a 5 mm hex and 5 mm hex driver to install the axle caps. Simultaneously torque to 9 N·m (80 in-lbs) each side.

10



SRAM HUBS

SPOKE INSTALLATION

SPOKE INSTALLATION

This portion of the SRAM Hub Service Guide covers spoke replacement. Spoke tensioning is NOT included in this manual.

SRAM S-40

Front Wheel			Rear Wheel		
Spoke Count	Spoke Length	Lacing Pattern	Spoke Count	Spoke Length	Lacing Pattern
18	276 mm	Radial	10	Drive Side: 260 mm	Radial
			10	Non-Drive Side: 288 mm	2 Cross

SRAM S-60

Front Wheel			Rear Wheel		
Spoke Count	Spoke Length	Lacing Pattern	Spoke Count	Spoke Length	Lacing Pattern
18	260 mm	Radial	10	Drive Side: 246 mm	Radial
			10	Non-Drive Side: 272 mm	2 Cross

SRAM S-80

Front Wheel			Rear Wheel		
Spoke Count	Spoke Length	Lacing Pattern	Spoke Count	Spoke Length	Lacing Pattern
18	236 mm	Radial	10	Drive Side: 220 mm	Radial
			10	Non-Drive Side: 248 mm	2 Cross

WHEEL BUILD NOTES

1. Coat the threads of the spokes with a lightweight oil. Dab off excess.
2. Orient the wheel so that the bar code label is down, and the driver of the hub is up.
3. The **non-drive side of the rear wheel** is a 2-cross lacing pattern.
4. During the wheel build process it is important to pre-stress the wheel to ensure proper seating of spokes in both the hub and the rim.
5. Tension **rear wheel drive side spokes** to a measurement of 17 on the Park TM-1 tool. Tension other spokes for proper dish and trueness.
6. Torque axle caps to 9 N·m (80 in·lb).

SRAM WHEELS

PARTS PREPARATION

This manual contains important information about the safe operation and maintenance of your wheels. To ensure that your SRAM wheels perform properly, we urge you to follow our recommendations to help make your riding experience more enjoyable and trouble-free.

IMPORTANT CONSUMER SAFETY INFORMATION

Riding a bike with an improperly installed wheel can allow the wheel to move or disengage from the bicycle, causing damage to the bicycle, and serious injury or death to the rider. Your wheels must be properly mounted to the bicycle frame. Misalignment can result in problems with shifting and bike handling. If the wheel is not securely mounted in the dropouts, it may come out when the bike is ridden, possibly causing injury or death to the rider. It is essential that you:

- Ensure that your axle, dropouts, and quick release mechanisms are clean and free of dirt or debris.
- Ask your dealer to help you understand how to properly secure your wheels using the quick release mechanism.
- Apply the correct techniques when installing your wheels. Make sure four or more threads are engaged in the quick release adjusting nut when it is closed.
- Never ride your bicycle unless you are sure your wheels are installed properly, and are secure.

COMPATIBILITY

SRAM wheelsets are only compatible with Presta valve tubes.
SRAM wheels are only compatible with SRAM and Shimano® freehubs.

PARTS PREPARATION

INSTALL VALVE EXTENSIONS

Your wheels are supplied with valve extensions matched to the depth of the rim.

Valve extenders are available in three different lengths:

- 33 mm for S40 wheels
- 48 mm for S60 wheels
- 74 mm for S80 wheels

Note: Install valve extensions **before** mounting tires.

1. Remove the plastic Presta valve cap and metal lockring. Fully unscrew the valve locknut.
2. Starting at the end of the valve, wrap plumber's tape (PTFE tape) clockwise around the end of the valve so that the tape extends over both the narrow valve cap threads and the wider valve body. Make sure that the tape does not stretch over the air opening at the end of the valve.
NOTE: plumber's tape comes in several thicknesses. If thinner tape is used, more than one layer may be needed to seal the valve properly.
3. Using a 3 mm hex wrench inserted into the valve extension, thread the valve extension onto the end of the valve and tighten.
NOTE: plumber's tape should be replaced each time the valve extension is removed.

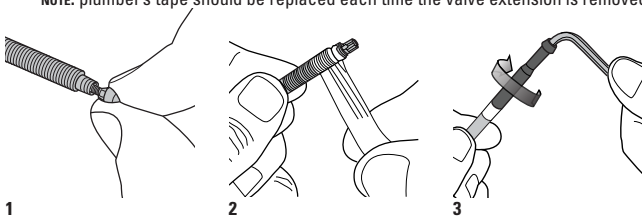

SRAM WHEELS

PARTS PREPARATION

INSTALLING RIM TAPE

Note: you must use a thin plastic or thin fabric rim strip for proper performance. We recommend using our own SRAM rim tape: a durable, yet thin, woven tape, specifically designed to work with our rims. Do not use Velox® or a similarly thick cloth rim strip.

4. Align the valve hole in the rim strip with the valve hole in the wheel rim.
5. Stretch the rim strip around the rim. Make sure the rim strip is centered on the tire bed all the way around the rim.
Important: make sure all of the spoke holes are fully covered by the rim strip. Double check that the rim strip valve hole is still aligned with the valve hole in the rim.

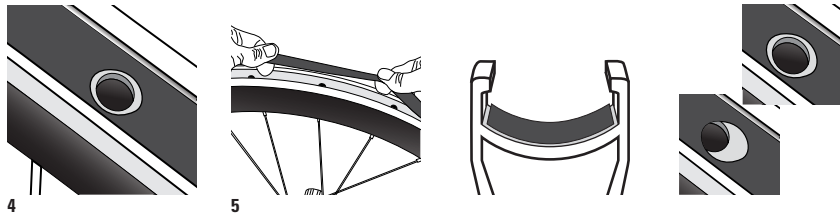

INSTALLING TIRES

6. Mount one tire bead onto the rim using your hands. If tire bead will not seat by hand, carefully use a plastic tire lever to seat the tire bead.
Note: check your tires for directional arrows printed on the sidewalls to indicate rotation of wheel. Not all tires have directional arrows. Install the tire with the manufacturer's logo near the rim valve hole. This will allow you to quickly find the cause of a puncture
7. Inflate tube enough to just hold its shape (not pictured).
8. Install the tube valve into rim valve hole and align valve so it is perpendicular to the rim. Install the rest of the tube between the tire and the rim making sure the tube does not get twisted or bunched.
9. Install second bead onto the rim using your hands. If tire bead will not seat by hand, carefully use a plastic tire lever to finish mounting the tire. Be careful to avoid pinching the inner tube against the rim.
10. Inflate the tire to low pressure. Inspect both sides of rim for proper tire seating and for any sign of the inner tube sticking out. Re-install if necessary.
11. Inflate the tire to full pressure. There should be no hops or side-to-side movement in the tire when it is rotating (not pictured).
Note: SRAM wheels are rated to a maximum of 125 psi (8,6 Bar).

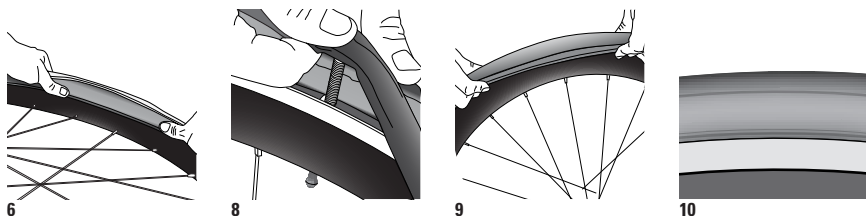

ASSEMBLING AND INSTALLING THE QUICK RELEASE

12. Unthread the adjusting nut from the end of the quick release skewer and remove the tension spring closest to the adjusting nut.
13. Slide the quick release skewer shaft through the hub axle. Re-install the tension spring with the narrow end toward the hub axle and thread the adjusting nut a few turns onto the skewer.
Note: if your tires have directional arrows, take note of the direction of rotation, and install your quick releases with the quick release levers on the non-drive side of the bicycle.

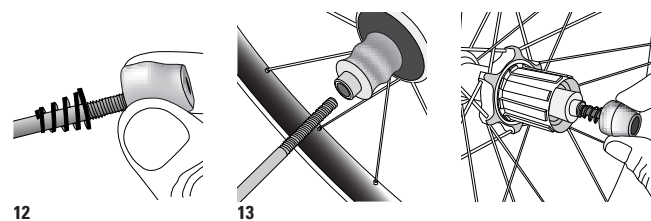

SRAM WHEELS INSTALLATION

INSTALLATION

INSTALLING THE WHEELS ON THE BIKE

Important: the wheel axle must be fully engaged in the dropout.

Front Wheel

14. Check that the quick release skewer lever is in the open position. Check that the brake quick release mechanism is open (not pictured).
15. Install the front wheel between dropouts with quick release lever positioned on the non-drive side of the bike. Check that the wheel axle is fully seated in the fork dropouts and clear of any safety tabs.
NOTE: if your front tire has directional arrows, take note of the direction of rotation and install so that the quick release lever is on the non-drive side of the bicycle, and the tire rotates in the proper direction.
16. Close the quick release half way, with the quick release lever parallel to the hub axle.
17. Tighten the quick release adjusting nut so that it contacts the dropout. When closing the lever, tension should be felt when the quick release lever is in the horizontal position (90 degrees to the fork), but you should still be able to reach the fully closed position (90 degrees to the hub axle). The quick release lever should leave a clear impression on your hand. If the quick release lever does not leave a clear imprint on your hand, tension is insufficient. To increase tension, open the quick release lever and tighten the quick release adjusting nut in small increments until proper tension is achieved. When closed, the quick release lever should be positioned just behind the non-drive side fork leg. Reposition the lever as necessary to achieve this orientation.

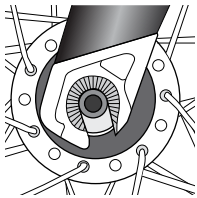

15

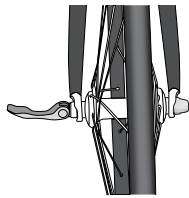

16

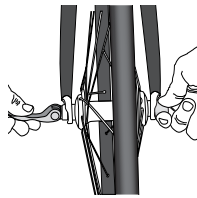

17

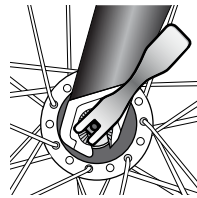

Rear Wheel

18. Check that the quick release skewer lever is in the open position. Check that the brake quick release mechanism is open (not pictured).
19. Shift the derailleur and chain to the highest (smallest) gear (not pictured).
20. Pull back and down on the rear derailleur to open chain and install the cassette between upper and lower sections of chain so that the chain wraps around the smallest cog.
21. Check that the wheel axle is fully seated in the fork dropouts (not pictured).
22. Close the quick release half way, with the quick release lever parallel to the hub axle (not pictured).
23. Tighten the quick release adjusting nut so that it contacts the dropout. When closing the lever, tension should be felt when the quick release lever is in the horizontal position (parallel to the ground), but you should still be able to reach the fully closed position (90 degrees to the hub axle). The quick release lever should leave a clear impression on your hand. If the quick release lever does not leave a clear imprint on your hand, tension is insufficient. To increase tension, open the quick release lever and tighten the quick release adjusting nut in small increments until proper tension is achieved. When closed, the quick release lever should be positioned between the seat stay and chain stay. Reposition the lever as necessary to achieve this orientation.

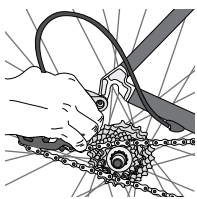

20

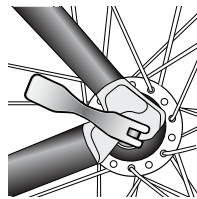

23

FINAL INSPECTION

24. Close the front brake quick-release mechanism. View front wheel centering in fork. The wheel should be centered between fork blades. If the wheel is not centered between the fork blades, open the quick release, make sure the wheel axle is fully seated in the fork dropouts, and close the quick release (see step 17). Inspect brake pad alignment and centering by closing and opening pads with brake lever. If brake pads are not centered to wheel, see your brake manufacturer's instructions. If wheel fails to adequately center in the fork, you should consult your SRAM dealer or professional bicycle mechanic.
25. Close the rear brake quick-release mechanism. View centering of the wheel between chainstays and seatstays. If the wheel is not centered between the chainstays and/or seatstays, open the quick release, make sure the wheel axle is fully seated in the dropouts, and close the quick release (see step 23). If brake pads are not adequately centered to wheel, see your brake manufacturer's instructions. If further attempts to align the wheel fail to adequately center it in the frame, you should consult your SRAM dealer or professional bicycle mechanic.

BRAKE PADS for CLINCHER WHEELSETS

For optimum performance, we recommend using SRAM standard brake pads.

TIRE PRESSURE

We rate our clincher rims at 125 psi (8,6 Bar) MAX for safety and increased tire life.

CARE AND CLEANING

Any cleaner that will not affect epoxy resins is acceptable for your rims. Acetone or denatured alcohol work well on the rims but will damage the decals, so be careful when using.

COPYRIGHT

All content included in this catalog, including but not limited to text, graphics or images is copyrighted as a collective work under the United States and other copyright laws, and is the property of SRAM Corporation. Copyright 2009, SRAM Corporation. ALL RIGHTS RESERVED. Any other use, including but not limited to the reproduction, distribution, display or transmission of this content of this catalog is strictly prohibited. Other names of products and companies mentioned in this catalog may be the trademarks of their respective owners.

All information and specifications in this catalog are subject to change without notice.

The following are trademarks or registered trademarks of SRAM Corporation in the United States and other countries:

SRAM, RockShox, Avid, Truvativ, 1:1, Grip Shift, Torpedo, U-Turn, Bar, BoXXer, Pike, SID, Reba, BlackBox, Climb It Control, Tullio, Juicy, Single Digit, Speed Dial, Arch Rival, Black Ops, Flak Jacket, Full Metal Jacket, Hussefelt, Holzfeller, Luftalarm, Stylo, Firex, IsoFlow, Touro, Giga Pipe, FiveD, Isis Drive (design), Wavo, X.0, X-9, X-7, 5.0, 4.0, 3.0, X-5, SX5, 1:1 Actuation Ratio, TRX, Attack, Rocket, SRAM Rocket, Centera, MRX, PowerChain, PowerGlide, PowerLink, PowerLock, SaltShaker, Impulse Technology, Thumbs Up, Zero Loss Travel, C3 Composite, Zero Loss Travel, Cable Cradle, StraightShot, Uni-Lever, Quick View, i-LIGHT, i-BRAKE, i-MOTION, i-MOTION 3, i-MOTION 9, Sparc, S7, P5, T3, DualDrive, TwinDrive, Bandix, Force, Rival, DoubleTap, HCT, OCT, Exact Actuation, Mission Control, 2-Step, Maxle, Maxle 360, Solo Air, Dual Air, TurnKey, IsoLite, IsoLite Cushion, Air U-Turn, Rear Maxle, PopLoc, PopLoc Dual, PopLoc Adjust, PushLoc, Ario, Pearl, MC, Argyle, Domain, Totem, Lyrik, revelation, Recon, Tora, Dart, Code, Ultimate, Shorty, Force Vector Alignment, BB5, BB7, FR5, Boxguide, Shiftguide, Engineering the shift, XR, Team, LE, 3D, XR 3D, Team 3D, Rouleur, Team BMX, Racing XR, Racing Team, Racing Junior, Ruktion, Noir, Blaze, 5D, X-Flow, Elita, Power Spline, GXP, Giga X Pipe, ISIS, Overdrive, Square LE, Howitzer, Beyond Performance and Innovative Bicycle Components.

WORLD HEADQUARTERS

SRAM, LLC
1333 N. Kingsbury, 4th Floor
Chicago, Illinois 60642
United States of America
Phone: +1-312-664-8800
Fax: +1-312-664-8826
E-mail: sramusa@sram.com

ASIAN HEADQUARTERS

SRAM Taiwan
No. 1598-8 Chung Shan Road
Shen Kang Hsiang, Taichung
County 429 Taiwan R.O.C.
Phone: +886-4-2561-3678
Fax: +886-4-2561-3686
E-mail: sramasia@sram.com

EUROPEAN HEADQUARTERS

SRAM Europe
Basicweg 12-D
3821 BR Amersfoort
The Netherlands
Phone: +31-33-450-6060
Fax: +31-33-457-0200
E-mail: srameurope@sram.com