

# CATALOGUE ELECTRIC PUMPS AND BOOSTERS

50Hz



# A LEADER IN WATER TECHNOLOGY

The Pentair Water Group is one of the world's leading companies for the engineering and manufacture of innovative products and systems suitable for all situations requiring the treatment, transportation and storage of water. The activity and success of the Group is based on values such as constant improvement, the continuous development of new products, high performance, competence, business ethics and market leadership. Pentair employees share personal values such as accountability, respect for others and the environment and a candid and practical work style. Strong customer relations and high quality standards mean that Pentair Water is ranked amongst the leading producers of water treatment technology and instruments.

## **SAFE, CLEAN WATER**

Providing clean, safe water to an ever-growing portion of the population is the Pentair Water Mission: a proven organization works to efficiently serve our customers through production plants located in every corner of the world, and through specialized sales and marketing networks.



## **ELECTRIC PUMPS**

Vertical and horizontal centrifugal pumps; submersible pumps for domestic, commercial, agricultural and industrial use; pumps for the drainage of clear and waste water; pressure booster units and fire-fighting systems, pumps for heating and air conditioning systems.



## **WATER TREATMENT**

Residential, commercial and industrial water conditioning control valves; fibreglass wound expansion tanks and vessels; water storage tanks.



## **FILTRATION**

Industrial, residential and commercial filtration systems; filter cartridges, components for the filtration of household water, pumps for mobile homes and boats, and pumps and accessories for industrial and food industry applications.



## **POOL & SPA**

A complete range of pool/spa equipment and accessories: filters, pumps, heating and lighting systems and cleaning accessories; dosing and control systems, and products and accessories for fountains and ponds.

# WATER ENERGY WE PUT ENERGY INTO YOUR WATER

The Sta-Rite brand exists since 1934 and is sold in over 100 countries worldwide. In Europe, Pentair already produces a wide range of Sta-Rite swimming pool pumps and cleaners for its pool division, which have gained a reputation for quality and durability. The new European Sta-Rite line for residential water supply and water disposal will be manufactured in Italy/Pisa.



## **FIRE-FIGHTING AND PRESSURIZATION SYSTEMS**

Vertical and horizontal centrifugal pumps. Complete systems for the transfer and pressurization of water. Fire-fighting systems.



## **ELECTRIC PUMPS FOR RESIDENTIAL USE**

Submersible pumps, self-priming pumps, multistage centrifugal pumps and compact pumping systems for domestic water supply, irrigation and the re-utilization of harvested rainwater.



## **ELECTRIC DRAINAGE PUMPS**

Pumps for the transfer of clear, dirty, waste water and sewage. Pumps for numerous applications (water in basins, tanks, pumping stations etc.)



## **ELECTRIC PUMPS FOR OPEN AND DRILLED WELLS**

Submersible pumps for irrigation and pumping underground waters.

# THE PISA PLANT BECOMES 100% GREEN.



Thanks to the development of a sophisticated photovoltaic system on the rooftop of the building, the Pentair Water plant in Pisa has become the first plant to produce **100% of the energy needed for its production activities.**

4100 solar panels that generate up to **1,280,000 kWh** each year have been installed on a surface area of 11,000 m<sup>2</sup>.

One of the greatest advantages includes a reduction of CO<sub>2</sub> emissions equal to **678 ton/year**. Our customers can rest assured

that products developed in the Pentair Water plant in Pisa are completely made using renewable energy.

The remarkable results achieved by the installation of the solar panels can be seen in real time on the various screens located throughout the plant.

All activities performed at the plant in Pisa are continuously improved, aiming towards maximum energy savings and minimum environmental impact.

In light of the initiatives undertaken and future plans, we can certainly say that Pentair Water is a leader in the management of its business, characterized by:

- Maximum environmental friendliness
- Maximum energy savings
- Improved safety conditions for workers
- Maximum respect for health

# INDEX

## 1. PUMPS WITH ELECTRONIC FREQUENCY CONVERTER

PRODUCT	DESCRIPTION	PAGE
MULTI EVO-E	MULTISTAGE CENTRIFUGAL PUMPS WITH INVERTER	10
MULTI EVO-E P	MULTISTAGE CENTRIFUGAL PUMPS WITH INVERTER	18
CPS10/JET	PUMP JET COMPLETE WITH INVERTER	25
CPS10/DHR	PUMP DHR COMPLETE WITH INVERTER	26
CPS10/DHI	PUMP DHI COMPLETE WITH INVERTER	27
CPS10/MULTINOX-VE+	PUMP MULTINOX-VE+ COMPLETE WITH INVERTER	28
CPS10/PVM	PUMP PVM COMPLETE WITH INVERTER	30
CPS3-10/MULTINOX-VE+	PUMP MULTINOX-VE+ COMPLETE WITH INVERTER	38
CPS3-10/PVM	PUMP PVM COMPLETE WITH INVERTER	40

## 2. SURFACE PUMPS

PRODUCT	DESCRIPTION	PAGE
JET	CAST IRON SELF-PRIMING CENTRIFUGAL PUMPS	57
JETINOX	STAINLESS STEEL SELF-PRIMING CENTRIFUGAL PUMPS	61
MULTI EVO-A	SELF-PRIMING MULTISTAGE CENTRIFUGAL PUMPS	64
MULTI EVO	MULTISTAGE CENTRIFUGAL PUMPS	72
DHR	HORIZONTAL MULTISTAGE CENTRIFUGAL PUMPS	80
DHI	AISI 316 HORIZONTAL MULTISTAGE CENTRIFUGAL PUMPS	87
MULTI EVO-SP	MULTISTAGE CENTRIFUGAL PUMPS - SPECIAL	90
SWIMMEY	SELF-PRIMING PUMPS FOR POOLS WITH PRE-FILTER	94
CM	SINGLE STAGE HORIZONTAL CENTRIFUGAL PUMPS	96
CB	TWO-STAGE HORIZONTAL CENTRIFUGAL PUMPS	98
SSCX	SINGLE STAGE CENTRIFUGAL PUMPS MADE OF STAINLESS STEEL AISI 304	100
MULTINOX-VE +	VERTICAL MULTISTAGE CENTRIFUGAL PUMPS	103
PVM	VERTICAL MULTISTAGE CENTRIFUGAL PUMPS	111
PVMI	VERTICAL MULTISTAGE CENTRIFUGAL PUMPS	111
PVMX	VERTICAL MULTISTAGE CENTRIFUGAL PUMPS	111
NRM	MONOBLOC NORMALISED CENTRIFUGAL PUMPS - 2 AND 4 POLES	144
PGA-DELTA OIL	PUMPS FOR DIESEL TRANSFER	161

# INDEX

## 3. PUMPS FOR OPEN AND DRILLED WELLS

PRODUCT	DESCRIPTION	PAGE
PRATIKA	MULTISTAGE SUBMERSIBLE PUMP	158
DOMINATOR 4 PLUS	MONOBLOC MULTISTAGE 4" SUBMERSED PUMPS	160
DOMINATOR 5	MONOBLOC MULTISTAGE 5" SUBMERSED PUMPS MADE OF STAINLESS STEEL AISI 304	163
DOMINATOR 5 RW	MULTISTAGE SUBMERSIBLE PUMP	166
SCM 4 PLUS	4" MULTISTAGE CENTRIFUGAL SUBMERSED PUMPS	170
4" MOTORS	ELECTRIC MOTORS FOR 4" SUBMERSED PUMPS	178
VERSAILLES	SUBMERSIBLE PUMPS FOR FOUNTAINS AND WATER GAMES	179
ACCESSORIES	CABLES AND FITTINGS	180

## 4. PRESSURE BOOSTER SETS

PRODUCT	DESCRIPTION	PAGE
FP/MULTI EVO-A	PUMPS WITH ELECTRONIC CONTROL AND PROTECTION DEVICE	183
AUTOJET	PUMPS WITH ELECTRONIC CONTROL AND PROTECTION DEVICE	187
WP/MULTI EVO-A	PRESSURE BOOSTER SET WITH HORIZONTAL PRESSURE TANK	189
WATERPRESS	PRESSURE BOOSTER SET WITH HORIZONTAL PRESSURE TANK	193
EASY20/MULTI EVO	PRESSURE BOOSTER SET WITH TWO PUMPS - PRESSURE SWITCH CONTROL	199
EASYBOOST	RESIDENTIAL - PRESSURE BOOSTER SET WITH PRESSURE SWITCH CONTROL	207
PRESSOMAT	PRESSURE BOOSTER SET WITH PRESSURE SWITCH CONTROL	223
CPS20	PRESSURE BOOSTER SET WITH TWO VARIABLE SPEED PUMPS	239
VARIO 1-20/MULTI EVO-E	PRESSURE BOOSTERS WITH TWO VARIABLE SPEED PUMPS	243
VARIO 1-20/MULTI EVO-E P	PRESSURE BOOSTERS WITH TWO VARIABLE SPEED PUMPS	251
VARIO 1-20	PRESSURE BOOSTER SET WITH TWO VARIABLE SPEED PUMPS	257
VARIO 3-20	THREE-PHASE PRESSURE BOOSTER SET WITH TWO VARIABLE SPEED PUMPS	267
VARIO 3-30	THREE-PHASE PRESSURE BOOSTER SET WITH THREE VARIABLE SPEED PUMPS	285

## 5. ACCESSORIES

PRODUCT	DESCRIPTION	PAGE
VSD	ELECTRONIC FREQUENCY CONVERTER	307
FLUSSCONTROL	ELECTRONIC PRESSURE REGULATOR FOR SINGLE-PHASE PUMPS	311
CONTROL PANELS	CONTROL PANELS	312
PRESSURE TANKS	PRESSURE TANKS	318
ACCESSORIES	ACCESSORIES AND FILTERS	320

# SECTION 1

## PUMPS WITH ELECTRONIC FREQUENCY CONVERTER



**MULTI EVO-E**  
MULTISTAGE CENTRIFUGAL PUMPS WITH  
INVERTER

PAG. 9



**CPS10/MULTINOX-VE+**  
PUMP MULTINOX-VE+ COMPLETE  
WITH INVERTER

PAG. 27



**MULTI EVO-E P**  
MULTISTAGE CENTRIFUGAL PUMPS WITH  
INVERTER

PAG. 17



**CPS10/PVM**  
PUMP PVM COMPLETE  
WITH INVERTER

PAG. 29



**CPS10/JET**  
PUMP JET COMPLETE  
WITH INVERTER

PAG. 24



**CPS3-10/MULTINOX-VE+**  
PUMP MULTINOX-VE+ COMPLETE  
WITH INVERTER

PAG. 35



**CPS10/DHR**  
PUMP DHR COMPLETE  
WITH INVERTER

PAG. 25



**CPS3-10/PVM**  
PUMP PVM COMPLETE  
WITH INVERTER

PAG. 39



**CPS10/DHI**  
PUMP DHI COMPLETE  
WITH INVERTER

PAG. 26



## CPS ELECTRONIC FREQUENCY CONVERTER

Easy to install, Low power consumption, Compact size

---

CPS is an electronic device designed to vary the frequency of a pump. It is incorporated directly on the motor to enable control of the speed to provide the utility with a constant pressure even in the event of changes in water demands. CPS is a compact, essential, reliable solution and it is easy to use; designed also to offer great comfort and benefits in applications in irrigation, greenhouses, light industries, fountains and water games.

The system consists of a pump and an electronic control system (inverter) which allows to keep the pressure constant in the system, reducing or increasing the speed of rotation of the pump. When the system pressure falls below the set threshold, the module starts up the pump to restore the set point pressure; the pump rotation speed

varies according to water demand and therefore increases speed on requests for increased quantities, through to the maximum setting. If the water demand is lower, the speed of the pump will be reduced until the minimum speed set has been reached, after which, if the pressure does not continue to drop (that is more water demands) the pump will stop (Stand By) until a new cycle is started.



### APPLICATIONS

---

- Pressurization systems
- Water supply
- Industry
- Construction
- Washes

### PROTECTION DEVICES

---

- Dry running
- Overcurrent
- Overtemperature of electronic devices
- Frost protection via external device

### TECHNICAL SPECIFICATIONS

---

- Supply voltage: inverter 1x230 Vac  $\pm$  10 %
- Inverter output voltage: 3x230 Vac  $\pm$  10 %
- Maximum rated power: 2.4 Kw
- Input frequency: 50/60 Hz + 3%
- Output maximum rated power: 8 Amp
- Degree of protection IP55 (if installed on motors with a degree of protection IP55 or above)
- Ambient temperature from +0°C to +40°C
- Waveform: sinusoidal
- Input filter complying with EMC directive
- Pressure transmitter 0 - 5 Volt - 0 - 10 Bar 0 - 20 Bar depending on the model of pump
- Set-point 2
- Serial interface connectivity RS 485
- Optional contacts 3 (external set-point, alarm, system inhibition)

# CPS

## ELECTRONIC FREQUENCY CONVERTER

### VERSIONS AVAILABLE

VERTICAL	HORIZONTAL	SELF PRIMING
CPS10 MULTINOX VE+ 4	CPS10/DHI 2	Multi EVO-E P 3
CPS10 MULTINOX VE+ 6	CPS10/DHI 4	Multi EVO-E P 5
CPS10 MULTINOX VE+ 8	CPS10/DHR 4	CPS10/JET 1000
CPS10 PVM 1	CPS10/DHR 9	
CPS10 PVM 3	CPS10/DHR 9	
CPS10 PVM 5	Multi EVO-E 3	
CPS10 PVM 10	Multi EVO-E 5	
	Multi EVO-E 8	

### CONTROL PANEL

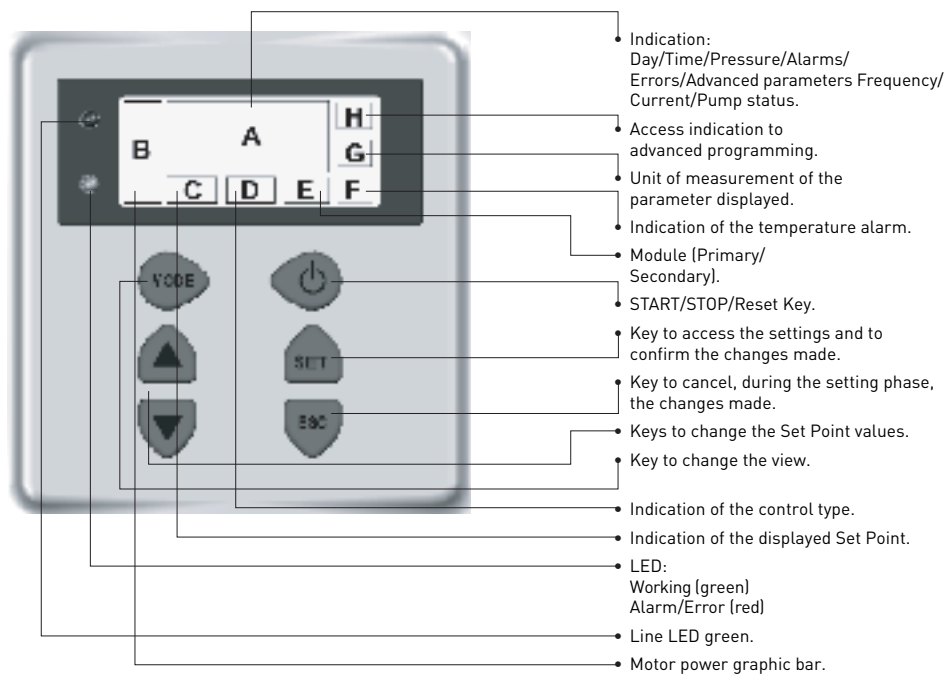

- Backlight display (switches off automatically after a reset time and can be turned on again by pressing any key)

## MULTI EVO-E MULTISTAGE CENTRIFUGAL PUMPS WITH INVERTER

The system consists of a multi-stage centrifugal horizontal pump Multi EVO-E and an electronic control system (inverter) which allows to keep the pressure constant in the system, reducing or increasing the speed of rotation of the pump.

All models are certified for use with drinking water (ACS and DM174)

### ADVANTAGES

The series Multi EVO-E pumps feature the following advantages:

- High reliability - thanks to the durable and innovative design
- Silent - more comfort for the user thanks to its silent operation
- Compact shape
- Many possible uses for the residential market
- Excellent priming ability



### SPECIFICATIONS:

#### PUMP

- Hydraulic performance according to ISO 9906:2012 - Grade 3B
- Type of liquid: clean water without suspended solids or abrasive material
- Maximum temperature of the liquid 50°C
- Maximum operating pressure 8 bar
- Maximum intake height recommended 6m with foot valve

#### MOTOR

- Closed, air ventilated (TEFC)
- 2 poles, 50 Hz (n=2850 rpm)
- IE3 three-phase AC (P2 ≥ 0.75 kW)
- Protection level: IP55
- Insulation class: F
- Maximum ambient temperature 40°C
- Single-phase power supply



### APPLICATIONS

- Pressurising and supply
- Irrigation
- Use of rainwater
- Washing systems



# MULTI EVO-E

## MULTISTAGE CENTRIFUGAL PUMPS WITH INVERTER

### CONSTRUCTION FEATURES

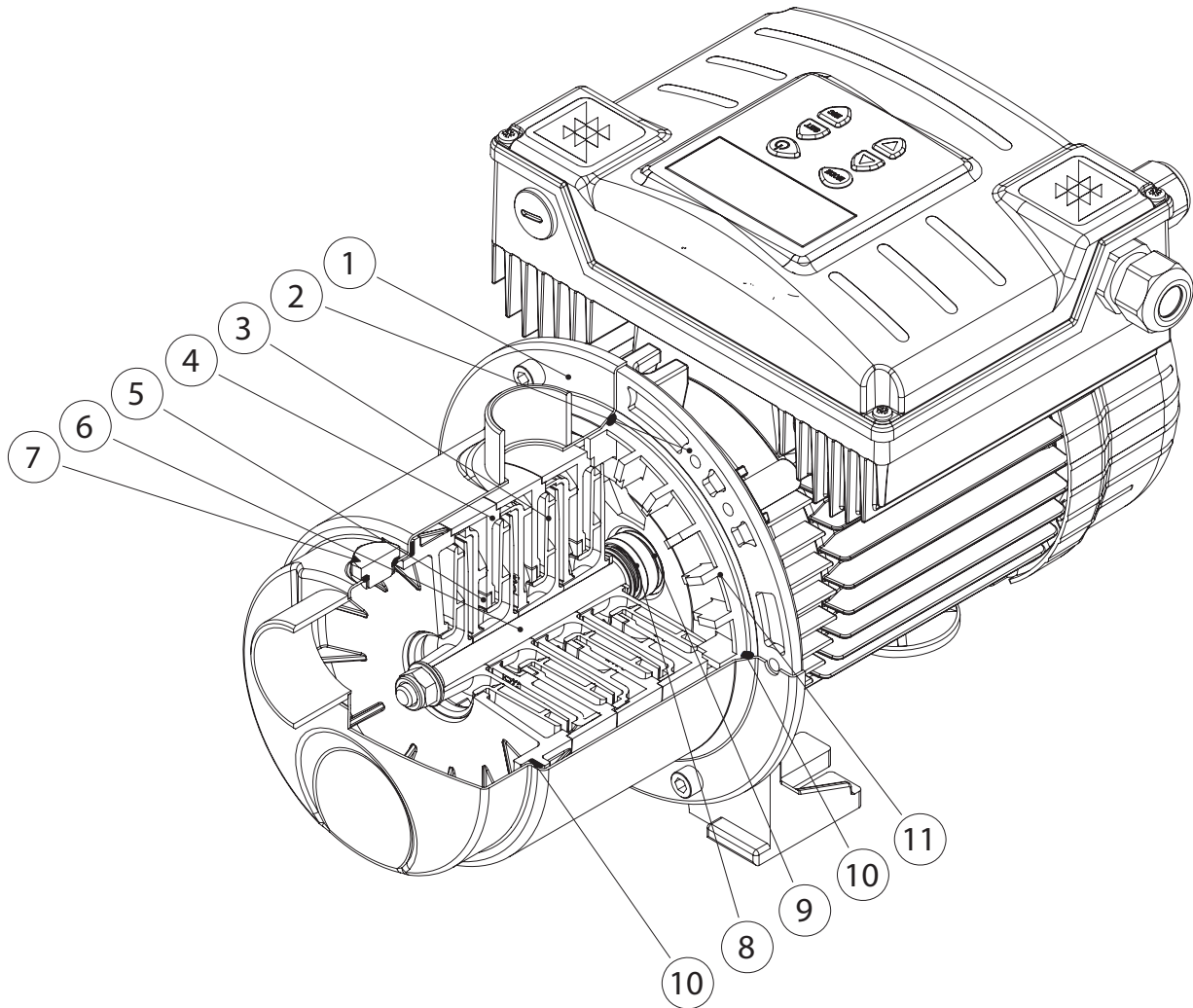

### TABLE OF MATERIALS

Ref.	Component	Material
1	Pump body	Stainless steel Europe: EN10088-1 X5CrNi18-10 (1.4301) USA: AISI 304
2	Motor casing	Die-cast aluminium
3	Impeller	PPG reinforced with fibreglass
4	Diffuser	PPG reinforced with fibreglass
5	Wear ring	PTFE
6	Shaft (hydraulic part)	Stainless steel Europe: EN10088-1 X5CrNi18-10 (1.4301) USA: AISI 304
7	Inlet / outlet caps	Stainless steel Europe: EN10088-1 X8CrNiS18-9 (1.4305) USA: AISI 303
8	Mechanical seal	Carbon graphite / NBR / SS Europe: EN10088-1 X5CrNi18-10 (1.4301) USA: AISI 304
9	Counterface	Ceramic / NBR
10	Gaskets	NBR 70 Shore A
11	Seal holder plate	PPG reinforced with fibreglass

# MULTI EVO-E 3

## MULTISTAGE CENTRIFUGAL PUMPS WITH INVERTER

### HYDRAULIC PERFORMANCE

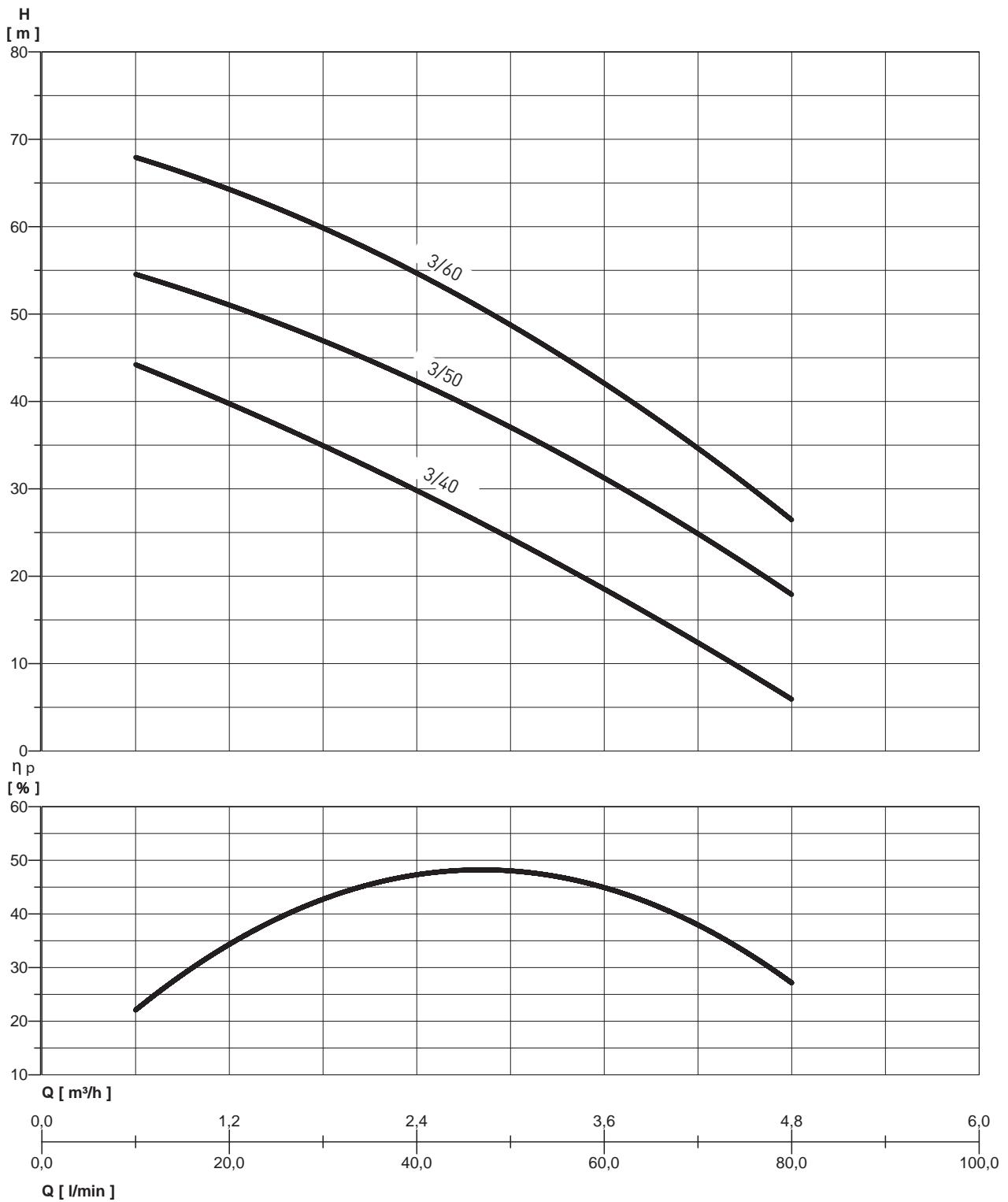

# MULTI EVO-E 3

## MULTISTAGE CENTRIFUGAL PUMPS WITH INVERTER

### PERFORMANCE TABLE

MODEL	Nominal power (P2)		Absorbed power (P1)		VOLT. (V)	In (A)	0	l/min	10	20	30	40	50	60	80
	HP	kW	HP	kW											
MULTI EVO-E 3-40	0,74	0,55	1,1	0,8	1 ~ 230	5,3	total head in water col- umn metres	44	40	35	30	24	18,5	6	
MULTI EVO-E 3-50	1	0,75	1,34	1	1 ~ 230	7		54,5	51	47	42,5	37	31	18	
MULTI EVO-E 3-60	1,27	0,95	1,8	1,35	1 ~ 230	8,7		68	64	60	55	48,5	42	26,5	

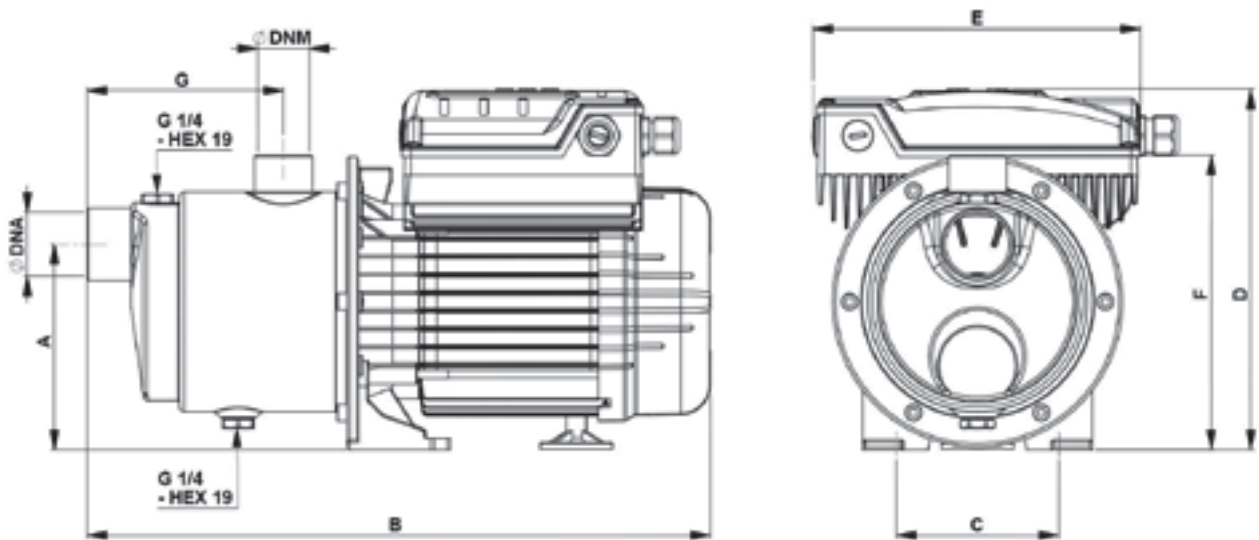

### OVERALL DIMENSIONS AND WEIGHTS

MODEL	Dimensions mm.										WEIGHTS (Kg)
	A	B	C	D	E	F	G	DNA	DNM		
MULTI EVO-E 3-40	129	360	100	211	198	180	116	1"	1"	10	
MULTI EVO-E 3-50	129	377	100	220	198	180	116	1"	1"	12,1	
MULTI EVO-E 3-60	129	377	100	220	198	180	116	1"	1"	13,4	

# MULTI EVO-E 5

## MULTISTAGE CENTRIFUGAL PUMPS WITH INVERTER

### HYDRAULIC PERFORMANCE

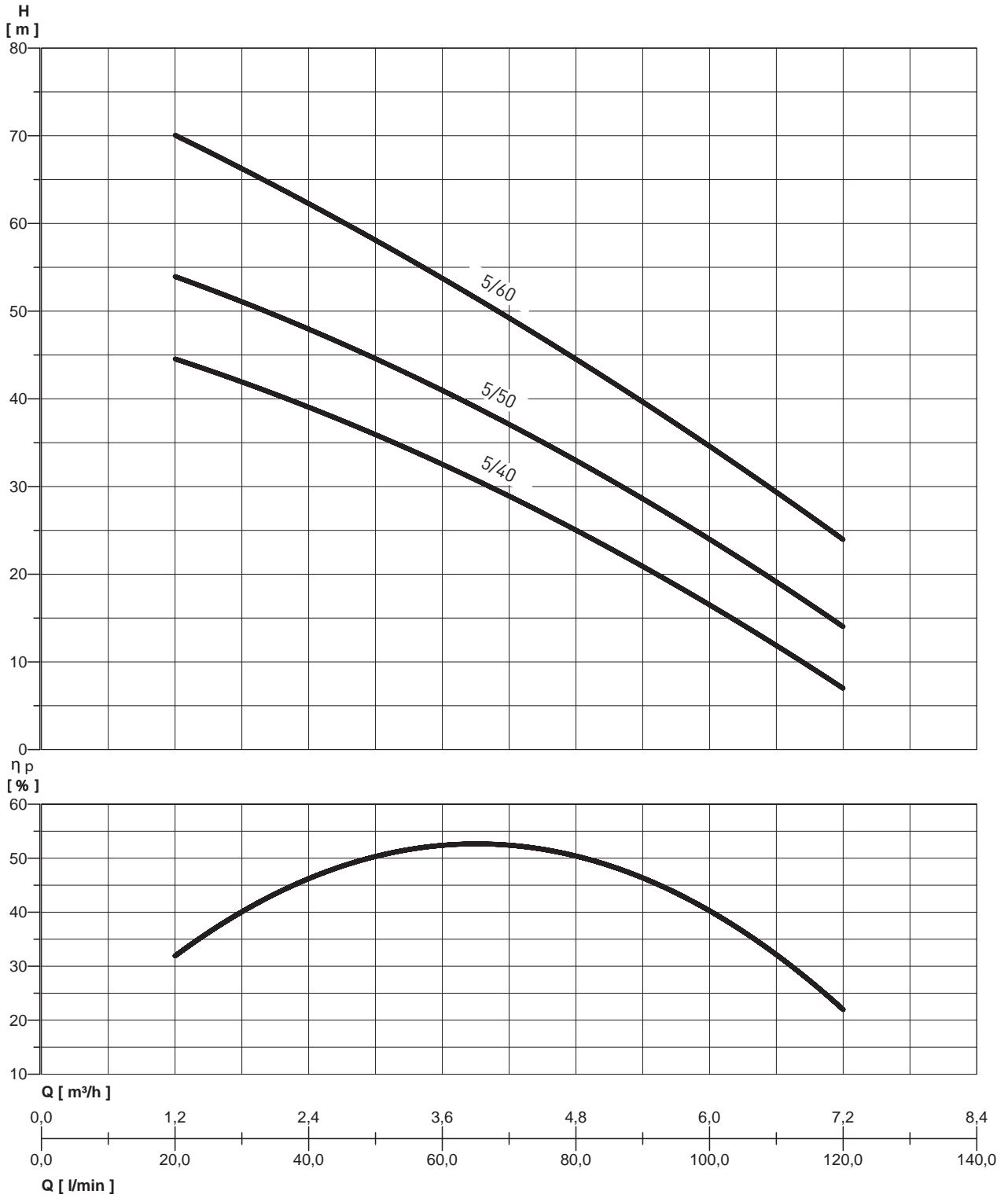

# MULTI EVO-E 5

## MULTISTAGE CENTRIFUGAL PUMPS WITH INVERTER

### PERFORMANCE TABLE

MODEL	Nominal power (P2)		Absorbed power (P1)		VOLT. (V)	In (A)	0	l/min m <sup>3</sup> /h	20	30	40	50	60	80	100	120
	HP	kW	HP	kW					total head in water column metres	1,2	1,8	2,4	3	3,6	4,8	6
MULTI EVO-E 5-40	1	0,75	1,34	1	1 ~ 230	7		44,5	42	39	36	32,5	25	16,5	7	
MULTI EVO-E 5-50	1,2	0,9	1,68	1,25	1 ~ 230	8,5		54	51	48	44,5	41	33	24	14	
MULTI EVO-E 5-60	1,74	1,3	2,4	1,8	1 ~ 230	11,5		70	66,5	62	58	54	44,5	34,5	24	

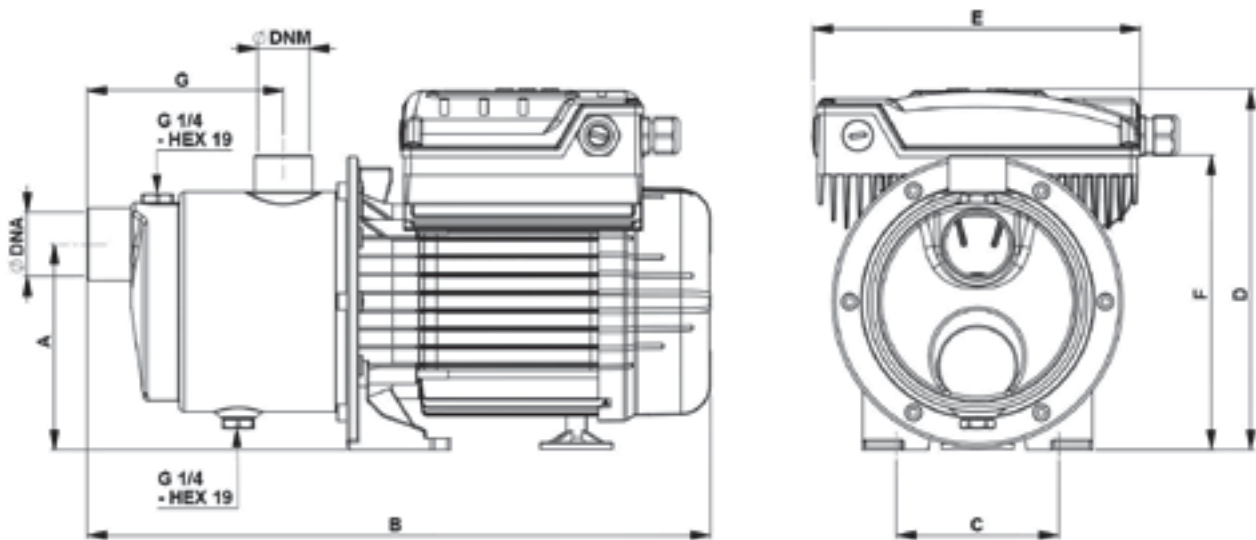

### OVERALL DIMENSIONS AND WEIGHTS

MODEL	Dimensions mm.										WEIGHTS (Kg)
	A	B	C	D	E	F	G	DNA	DNM		
MULTI EVO-E 5-40 M	125	380	100	220	198	180	119	1 1/4	1"	12,2	
MULTI EVO-E 5-50 M	125	380	100	220	198	180	119	1 1/4	1"	13	
MULTI EVO-E 5-60 M	125	413	100	230	198	180	119	1 1/4	1"	14,5	



# MULTI EVO-E 8

## MULTISTAGE CENTRIFUGAL PUMPS WITH INVERTER

### HYDRAULIC PERFORMANCE

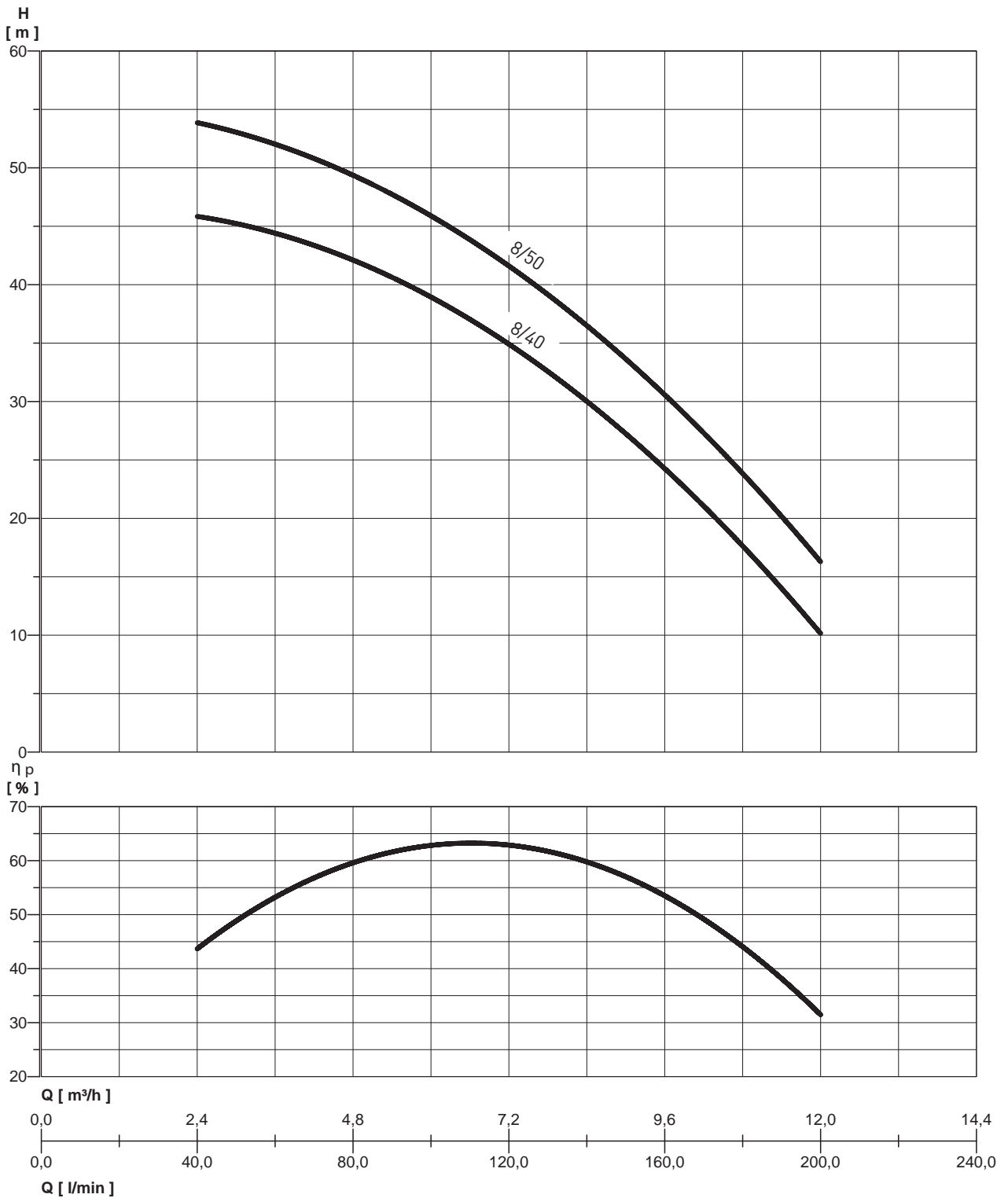

# MULTI EVO-E 8

## MULTISTAGE CENTRIFUGAL PUMPS WITH INVERTER

### PERFORMANCE TABLE

MODEL	Nominal power (P2)		Absorbed power (P1)		VOLT. (V)	In (A)	0												
	HP	kW	HP	kW				l/min	40	50	60	80	100	120	140	160	180	200	
								m <sup>3</sup> /h	2,4	3	3,6	4,8	6	7,2	8,4	9,6	10,8	12	
MULTI EVO-E 8-40	1,6	1,2	2,15	1,7	1 - 230	11	Total head in water column metres	46	45	44,5	42	39	35	30	24	18	10		
MULTI EVO-E 8-50	1,9	1,4	2,7	2	1 - 230	13		54	53	52	49	46	42	36,5	30,5	23,5	16,5		

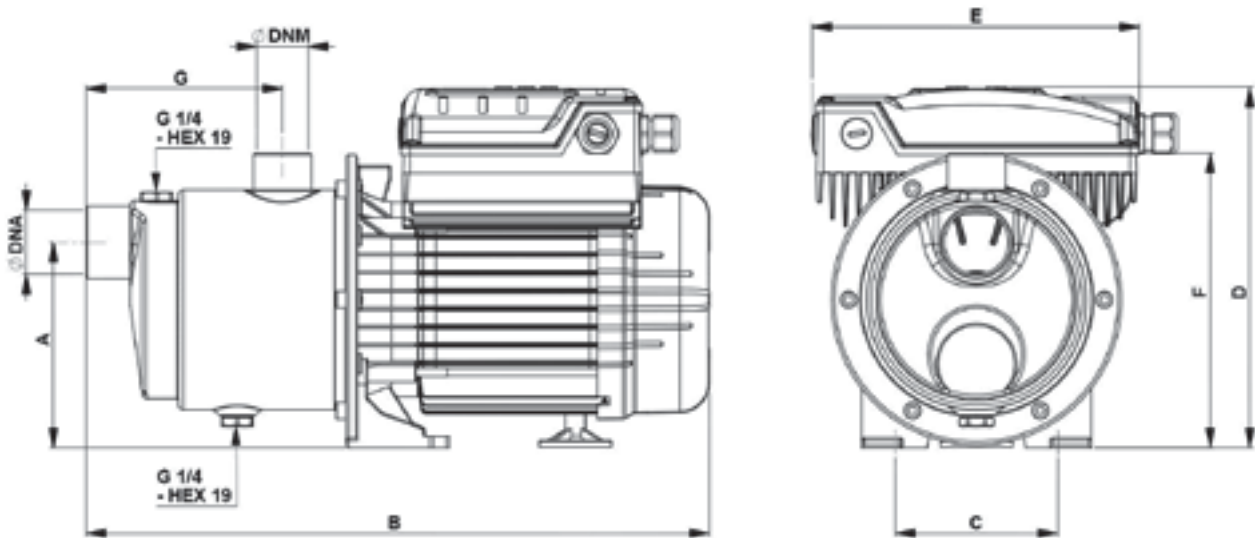

### OVERALL DIMENSIONS AND WEIGHTS

MODEL	Dimensions mm.										WEIGHTS (Kg)
	A	B	C	D	E	F	G	DNA	DNM		
MULTI EVO-E 8-40 M	125	430	100	230	198	187	137	1"1/4	1"1/4	15	
MULTI EVO-E 8-50 M	125	430	100	230	198	187	137	1"1/4	1"1/4	16,7	

## MULTI EVO-E P

### CENTRIFUGAL MULTISTAGE ELECTRIC PUMPS WITH INVERTER

The system is composed of a Multi EVO horizontal multistage electric centrifugal pump with plastic casing and a CPS electronic control system (inverter), which allows the pressure to be maintained constant in the system, reducing or increasing the electric pump motor rotation speed.

#### ADVANTAGES

Electric pumps in the Multi EVO-E P series offer the following advantages:

- High-level reliability - thanks to the resistant and innovative design
- Silent operation - improved user comfort thanks to its silent operation
- Compact form
- Wide range of performance levels for the residential market.
- Excellent priming capacity.

#### SPECIFICATIONS:

##### PUMP

- Hydraulic performance in compliance with ISO 9906:2012 - Grade 3B
- Type of liquid: clean water with no suspended solids or abrasive material
- Maximum liquid temperature 50°C
- Maximum operating pressure 7 bar
- Maximum recommended suction height 6m with foot valve

##### MOTOR

- Enclosed, air ventilated (TEFC)
- 2 poles, 50 Hz (n=2850 rpm)
- IE3 three-phase AC (P2 ≥ 0.75 kW)
- Protection class: IP55
- Insulation class: F
- Maximum room temperature 40°C
- Single phase power supply



#### APPLICATIONS

- Pressurization and supply
- Irrigation
- Re-utilization of rainwater
- Cleaning systems



# MULTI EVO-E P

## CENTRIFUGAL MULTISTAGE ELECTRIC PUMPS WITH INVERTER

### CONSTRUCTION FEATURES

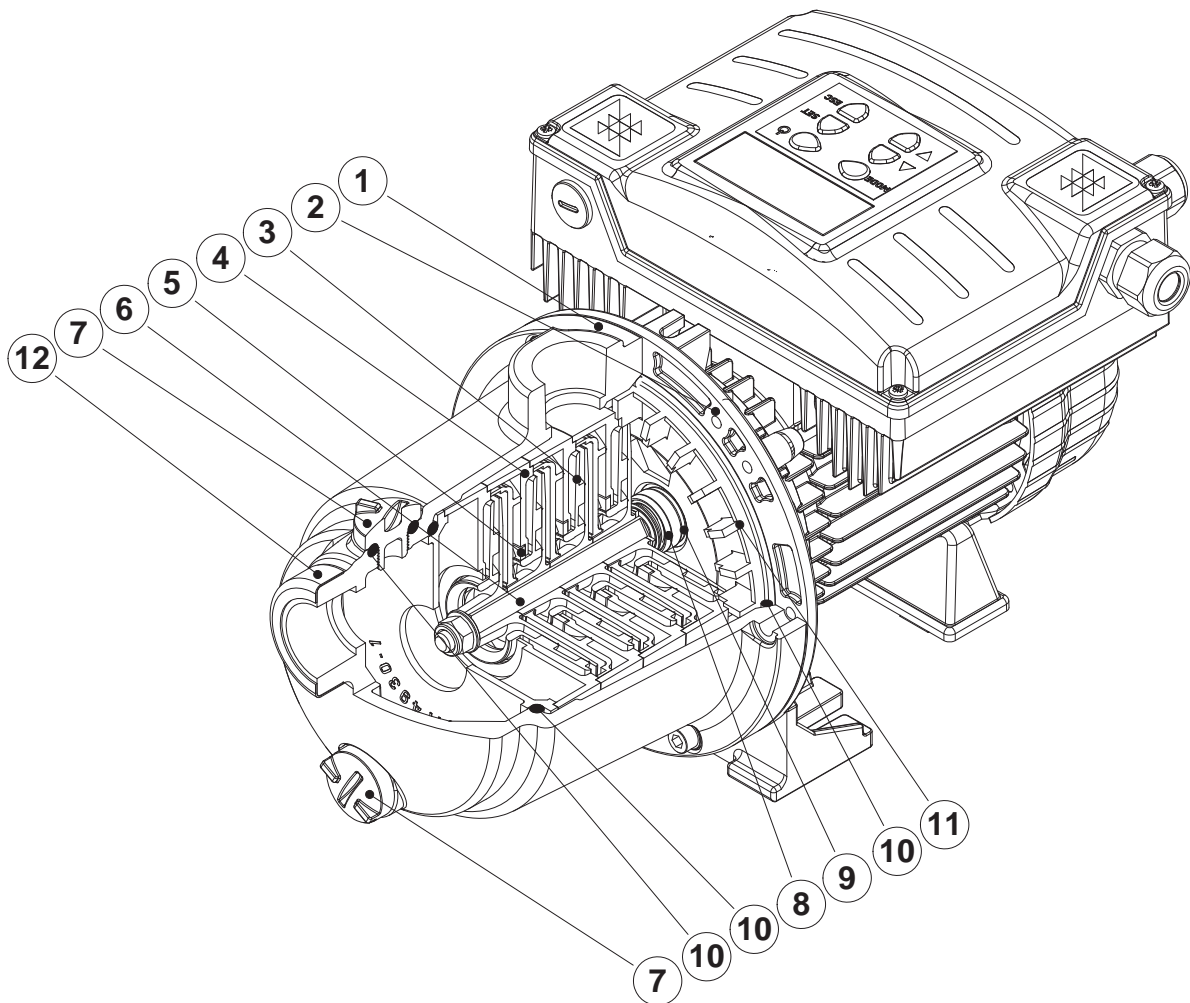

### TABLE OF MATERIALS

Ref.	Component	Material
1	Pump body	Fibreglass reinforced PP
2	Motor casing	Die-cast aluminium
3	Impeller	Fibreglass reinforced PPO
4	Diffuser	Fibreglass reinforced PPO
5	Wear ring	PTFE
6	Shaft (hydraulic part)	Stainless steel Europe: EN10088-1 X5CrNi18-10 (1.4301) USA: AISI 304
7	Inlet / outlet caps	Polyamide 6.6
8	Mechanical seal	Carbon graphite / NBR / SS Europe: EN10088-1 X5CrNi18-10 (1.4301) USA: AISI 304
9	Counterface	Ceramic / NBR
10	Gaskets	NBR 70 Shore A
11	Seal holder plate	Fibreglass reinforced PPO
12	Reinforcement ring	Stainless steel Europe: EN10088-1 X5CrNi18-10 (1.4301) USA: AISI 304

# MULTI EVO-E 3 P

## CENTRIFUGAL MULTISTAGE ELECTRIC PUMPS WITH INVERTER

### HYDRAULIC PERFORMANCE

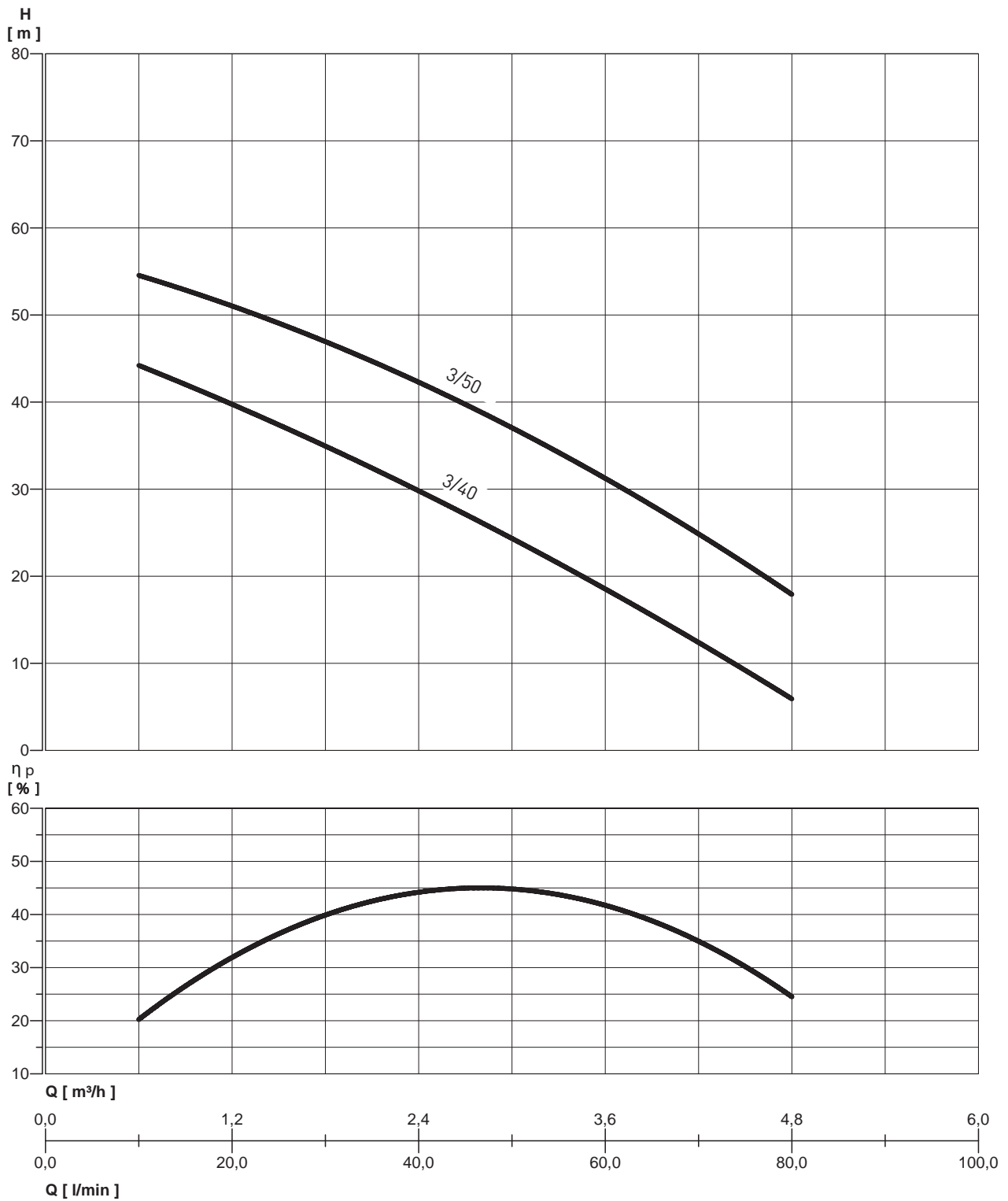

# MULTI EVO-E 3 P

## CENTRIFUGAL MULTISTAGE ELECTRIC PUMPS WITH INVERTER

### PERFORMANCE TABLE

MODEL	Nominal power (P2)		Absorbed power (P1)		Voltage (V)	In (A)	0	l/min	10	20	30	40	50	60	80
	HP	kW	HP	kW											
Multi EVO-E 3-40 P	0,74	0,55	1,1	0,8	1 ~ 230	5,3	total head in metres water column	44	40	35	30	24	18,5	6	
Multi EVO-E 3-50 P	0,94	0,7	1,34	1	1 ~ 230	7		54,5	51	47	42,5	37	31	18	

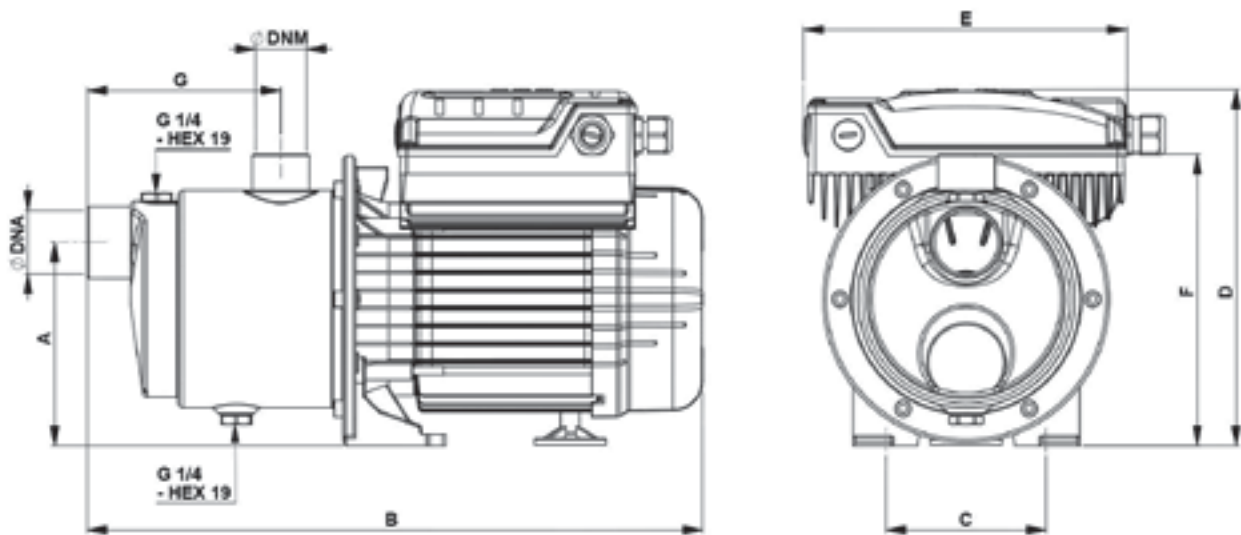

### OVERALL DIMENSIONS AND WEIGHTS

MODEL	Dimensions mm.										Weight (Kg)
	A	B	C	D	E	F	G	DNA	DNM		
Multi EVO-E 3-40 P	123	373	99	211	198	182	137	1"	1"	9,8	
Multi EVO-E 3-50 P	123	392	99	220	198	182	137	1"	1"	11,8	

# MULTI EVO-E 5 P

## CENTRIFUGAL MULTISTAGE ELECTRIC PUMPS WITH INVERTER

### HYDRAULIC PERFORMANCE

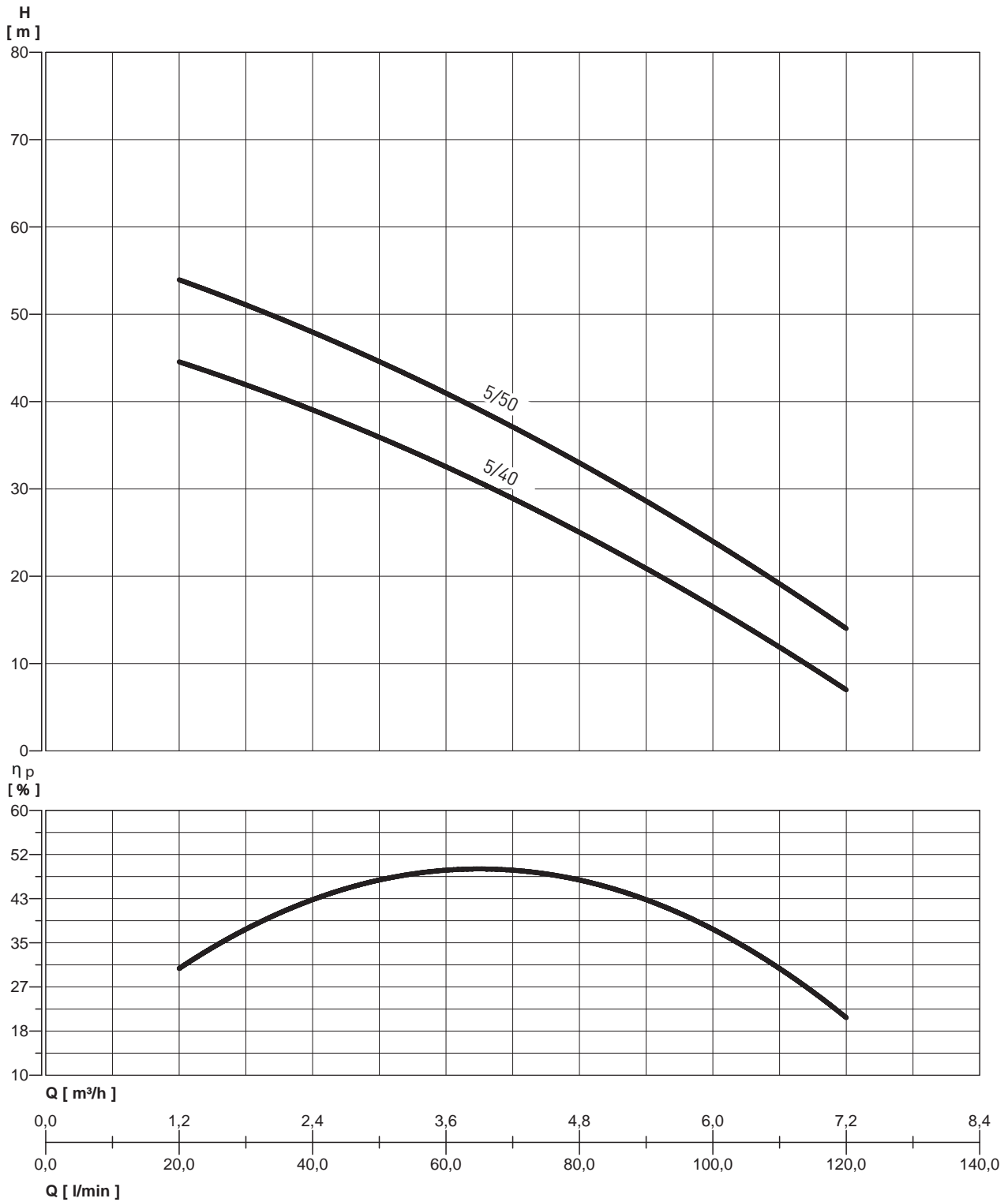

# MULTI EVO-E 5 P

## CENTRIFUGAL MULTISTAGE ELECTRIC PUMPS WITH INVERTER

### PERFORMANCE TABLE

MODEL	Nominal power (P2)		Absorbed power (P1)		Voltage (V)	In (A)	0	l/min m <sup>3</sup> /h	20	30	40	50	60	80	100	120
	HP	kW	HP	kW					1,2	1,8	2,4	3	3,6	4,8	6	7,2
Multi EVO-E 5-40 P	0,94	0,7	1,34	1	1 ~ 230	7	total head in metres water column	44,5	42	39	36	32,5	25	16,5	7	
Multi EVO-E 5-50 P	1,2	0,9	1,68	1,25	1 ~ 230	8,5		54	51	48	44,5	41	33	24	14	

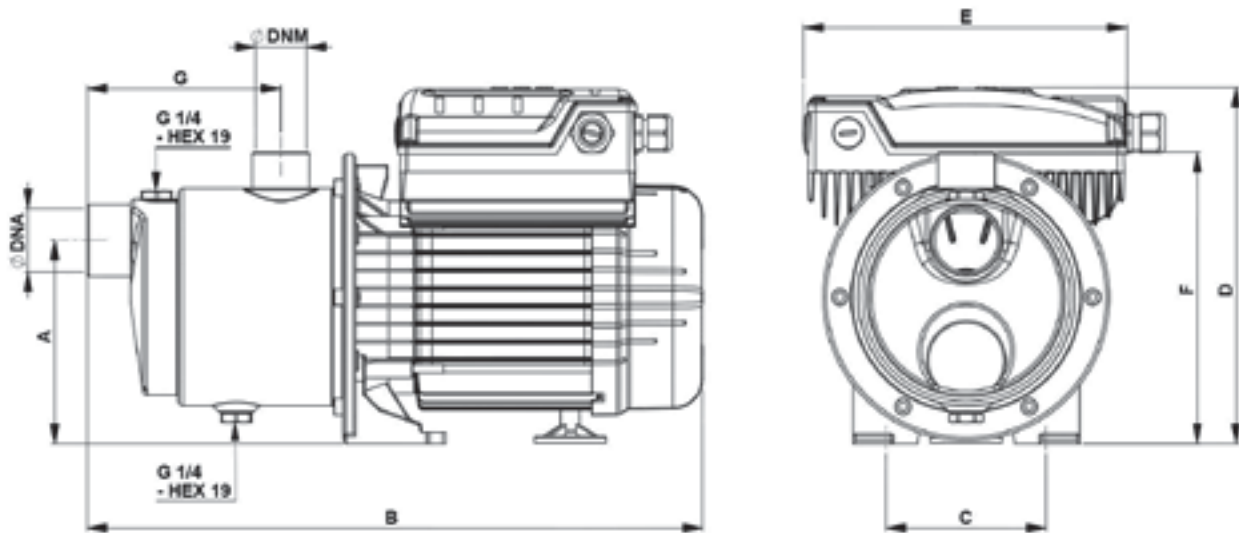

### OVERALL DIMENSIONS AND WEIGHTS

MODEL	Dimensions mm.										Weight (Kg)
	A	B	C	D	E	F	G	DNA	DNM		
Multi EVO-E 5-40 P	123	392	99	220	198	182	137	1"	1"	11,9	
Multi EVO-E 5-50 P	123	392	99	220	198	182	137	1"	1"	12,7	





# CPS10/JET

## ELECTRONIC FREQUENCY CONVERTER

### HYDRAULIC PERFORMANCE

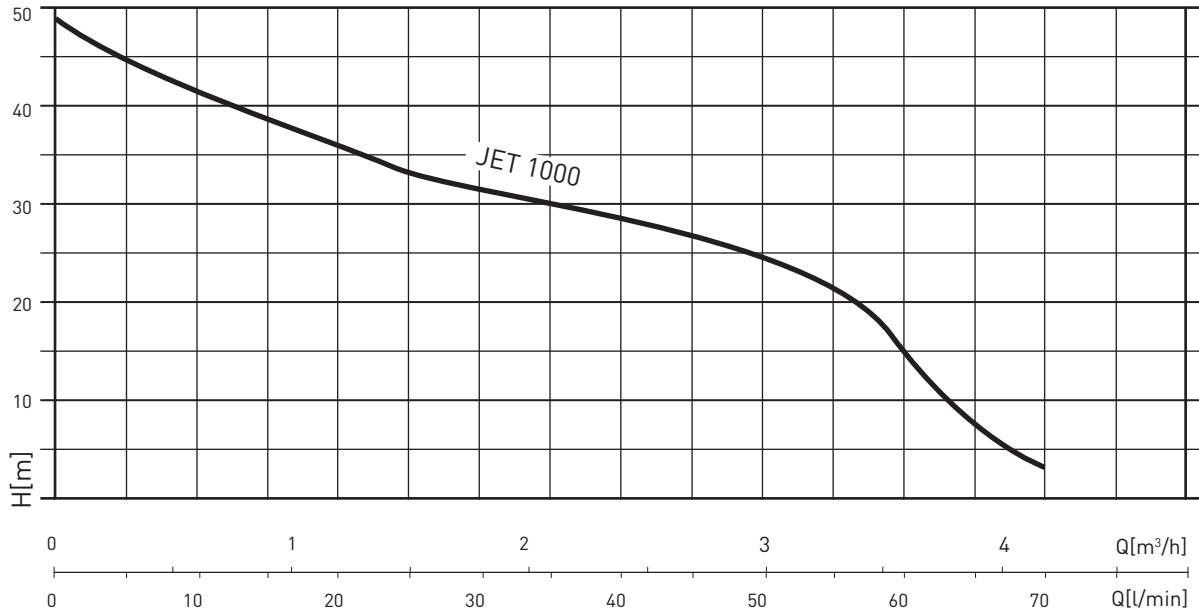

### PERFORMANCE TABLE

MODEL	P2		VOLT. (V)	In (A)	0	Q								
	HP	kW				l/min	0	5	20	30	40	50	60	70
CPS10/JET 1000	1,36	1	1 ~ 230	6,5	m.c.w.	49	45	36	32	28	25	15	3	
						m³/h	0	0,3	1,2	1,8	2,4	3	3,6	4,2

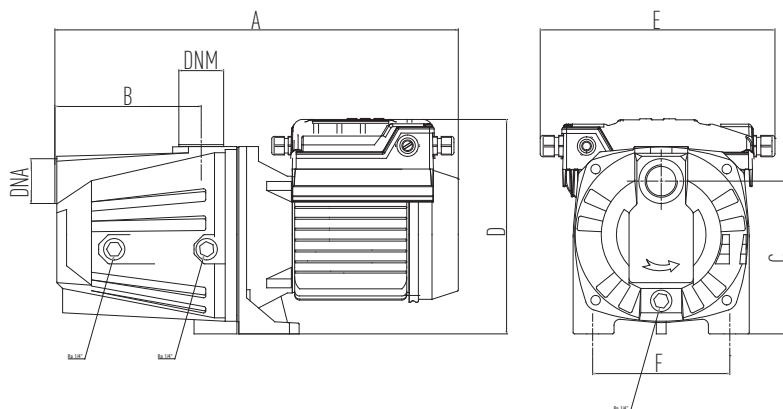

### OVERALL DIMENSIONS AND WEIGHTS

MODEL	Dimensions mm.							WEIGHT Kg
	A	B	C	D	E	DNA	DNM	
CPS10/JET 1000	400	147	160	260	195	1"	1"	20,8

# CPS10/DHR

## ELECTRONIC FREQUENCY CONVERTER

### HYDRAULIC PERFORMANCE

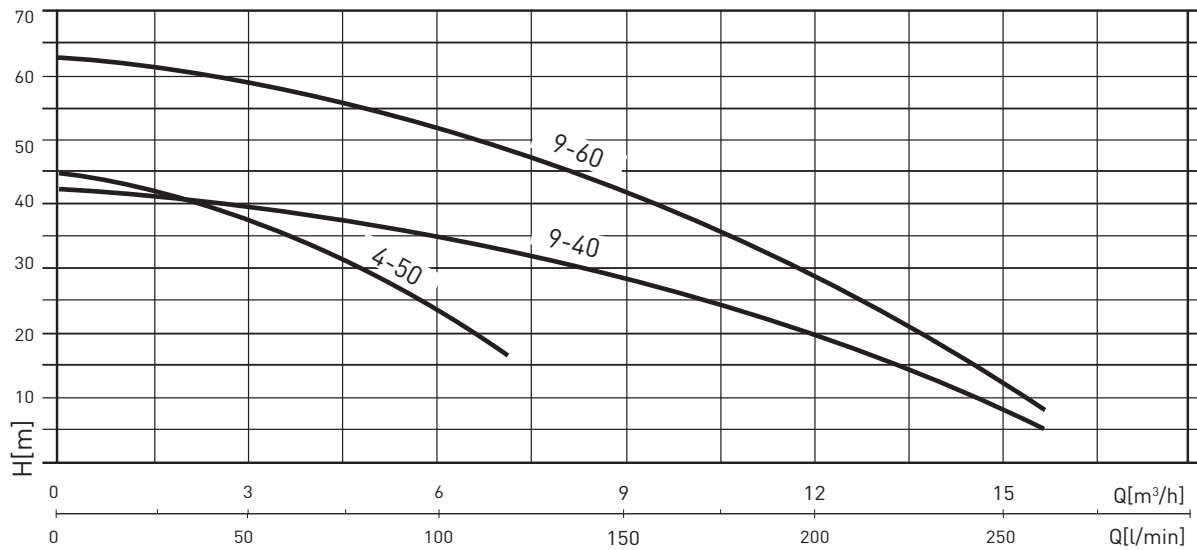

### PERFORMANCE TABLE

MODEL	P2		VOLT. (V)	In (A)	Q	m.c.w.										
	HP	kW				0	40	60	80	100	120	160	200	240	260	
						l/min	0	40	60	80	100	120	160	200	240	260
CPS10/DHR 4-50	1,5	0,9	1 ~ 230	9,1		m³/h	0	2,4	3,6	4,8	6	7,2	9,6	12	14,4	15,6
CPS10/DHR 9-40	1,74	1,3	1 ~ 230	12,5			44	39	35	30	24	17				
CPS10/DHR 9-60	2,4	1,8	1 ~ 230	15,8			41,5	40	39	38	35	33	27	19	10	5
							62	60	58	56	52	49	40	29	14	6

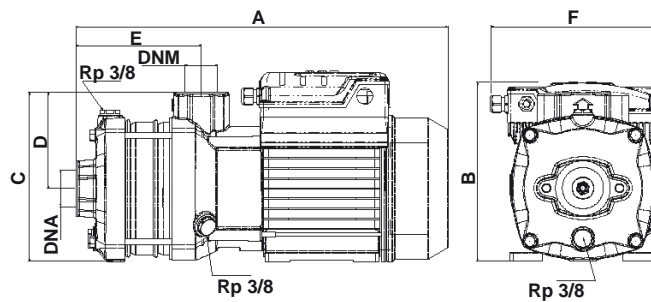

### OVERALL DIMENSIONS AND WEIGHTS

MODEL	Dimensions mm.								WEIGHT Kg
	A	B	C	D	E	F	DNA	DNM	
CPS10/DHR 4-50	445	225	155	65	190	232	1" 1/4	1"	18
CPS10/DHR 9-40	408	215	185	105	137	232	1" 1/4	1" 1/4	21,1
CPS10/DHR 9-60	468	215	185	105	198	232	1" 1/2	1" 1/4	26

# CPS10/DHI

## ELECTRONIC FREQUENCY CONVERTER

### HYDRAULIC PERFORMANCE

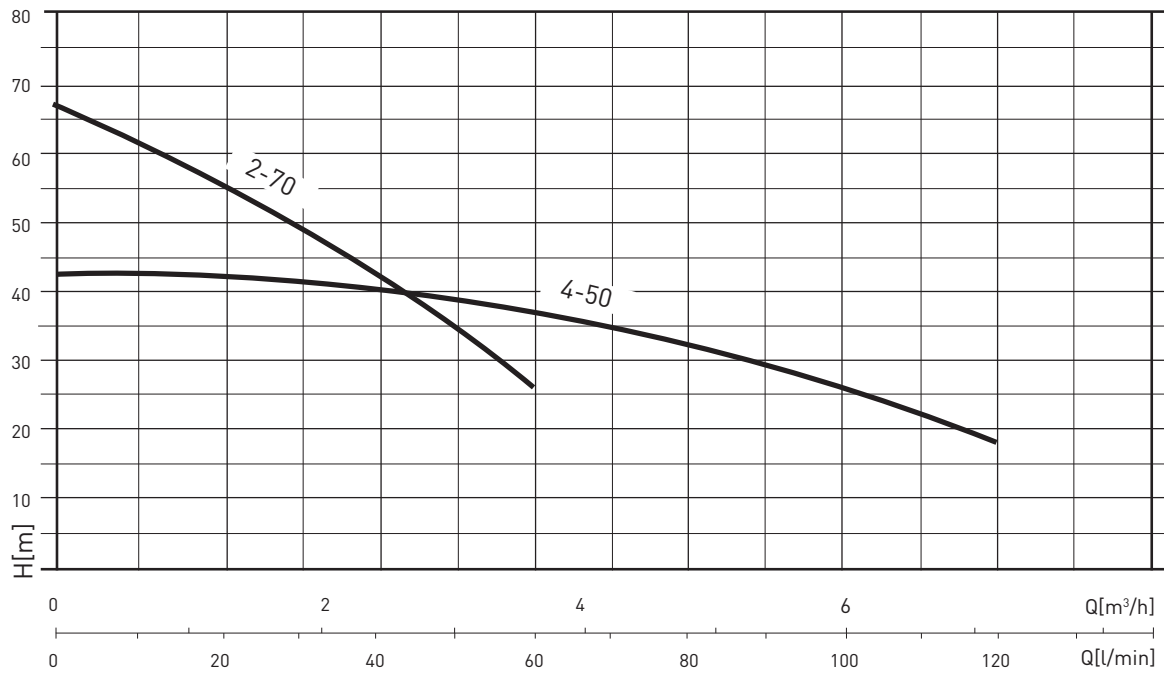

### PERFORMANCE TABLE

MODEL	P2		VOLT. (V)	In (A)	0	Q										
	HP	kW				l/min	0	10	20	30	40	50	60	80	100	120
						m³/h	0	0,6	1,2	1,8	2,4	3	3,6	4,8	6	7,2
CPS10/DHI 2-70	1,25	0,9	1 ~ 230	10,6			68	63	57	50	43	35	26			
CPS10/DHI 4-50	1,25	0,9	1 ~ 230	10,6	m.c.w.		43				42	39	36	33	27	18

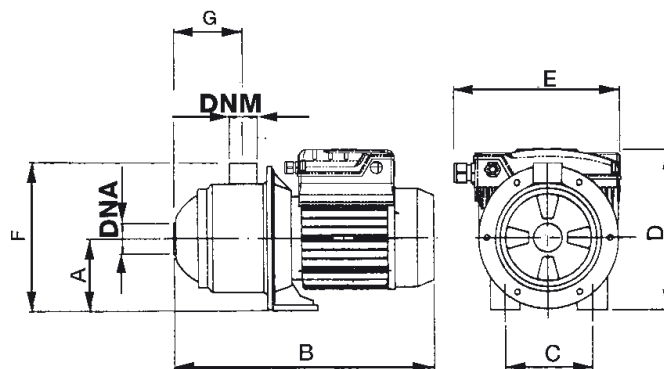

### OVERALL DIMENSIONS AND WEIGHTS

MODEL	Dimensions mm.									Weight (Kg)
	A	B	C	D	E	F	G	DNA	DNM	
CPS10/DHI 2-70	105	460	141	245	232	235	135	1" 1/4	1" 1/4	17,4
CPS10/DHI 4-50	105	460	141	245	232	235	135	1" 1/4	1" 1/4	17,4

# CPS10 MULTINOX VE+

## ELECTRONIC FREQUENCY CONVERTER



### HYDRAULIC PERFORMANCE

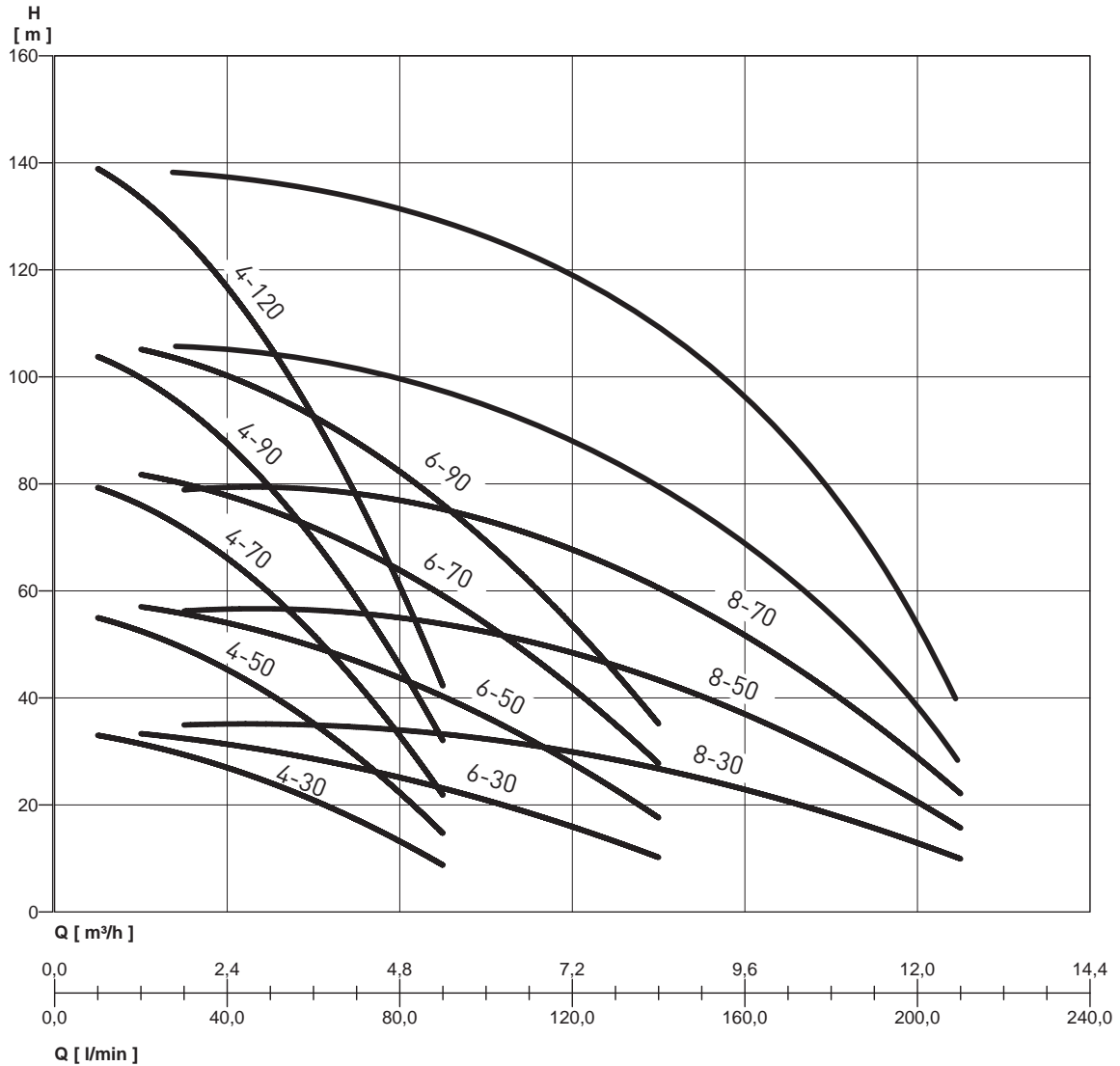

MEI ≥ 0.1 - Reference MEI ≥ 0.70 - The information on the reference efficiency is available at the address: [www.europump.org/efficiencycharts](http://www.europump.org/efficiencycharts)  
For the efficiency data see the PUMPS of the series MULTINOX-VE+

### PERFORMANCE TABLE

MODEL	P2		VOLT. (V)	In (A)	0	l/min																
	HP	kW				10	20	30	40	50	60	70	80	90	100	120	140	150	180	210		
						m³/h	0,6	1,2	2	2,4	3	3,6	4,2	5	5,4	6	7,2	8,4	9	11	13	
CPS10 MULTINOX VE+ 4-30	0,68	0,5	1 ~ 230	4,4		33	31	30	27	24	21	17	13	9								
CPS10 MULTINOX VE+ 4-50	1,1	0,84	1 ~ 230	6,71		55	52	50	45	41	35	29	22	15								
CPS10 MULTINOX VE+ 4-70	1,6	1,17	1 ~ 230	9,39		79	76	72	67	59	51	43	33	22								
CPS10 MULTINOX VE+ 4-90	2	1,5	1 ~ 230	12,08		104	99	95	88	79	69	59	46	32								
CPS10 MULTINOX VE+ 4-120	3	2	1 ~ 230	16,3		138	134	127	117	105	92	78	60	43								
CPS10 MULTINOX VE+ 6-30	0,9	0,67	1 ~ 230	5,95	m.c.w.	34	32	31	30	28	27	26	23	21	16	10						
CPS10 MULTINOX VE+ 6-50	1,5	1,1	1 ~ 230	9,02		58	56	53	51	49	47	44	41	37	28	17						
CPS10 MULTINOX VE+ 6-70	2	1,5	1 ~ 230	13,82		83	80	77	74	71	68	64	60	55	42	27						
CPS10 MULTINOX VE+ 6-90	3	2	1 ~ 230	15,75		107	103	99	95	92	87	83	77	71	54	34						
CPS10 MULTINOX VE+ 8-30	1,35	1	1 ~ 230	8,7			35	35	35	35	35	34	33	32	30	27	25	18	10			
CPS10 MULTINOX VE+ 8-50	2	1,5	1 ~ 230	14,4			57	57	56	56	56	54	53	52	50	45	40	28	16			
CPS10 MULTINOX VE+ 8-70	2,5	1,9	1 ~ 230	15,5			80	80	79	78	78	76	74	72	70	63	56	40	22			

# CPS10 MULTINOX VE+

## ELECTRONIC FREQUENCY CONVERTER

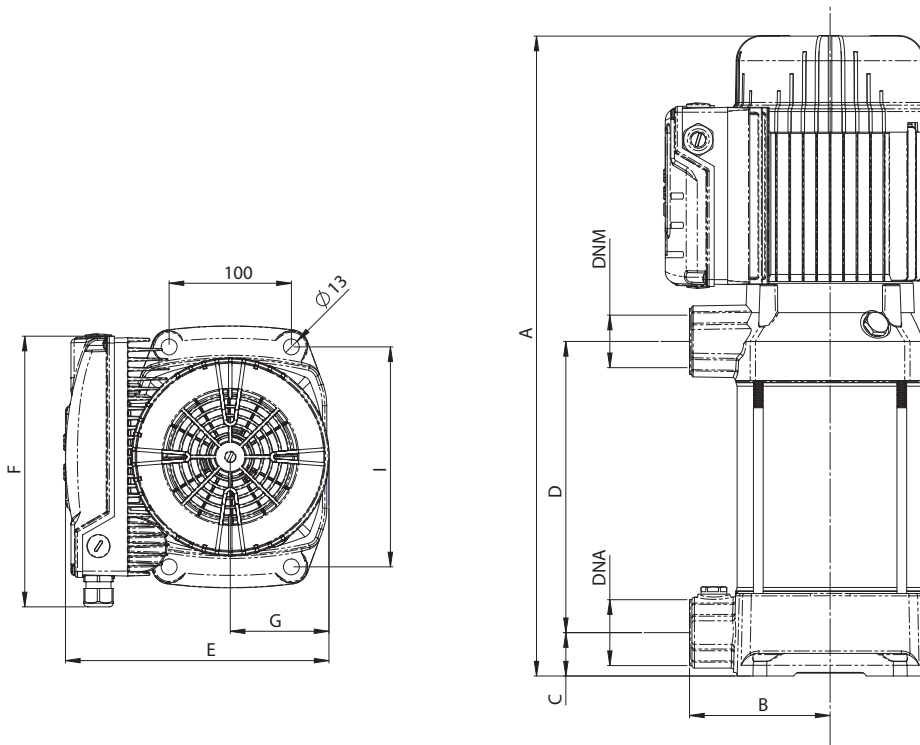

### OVERALL DIMENSIONS AND WEIGHTS

MODEL	Dimensions mm.										WEIGHT Kg
	A	B	C	D	E	F	G	I	DNA	DNM	
CPS10 MULTINOX VE+ 4-30	416	115	35	130	213	220	80	180	1" 1/4	1" 1/4	21
CPS10 MULTINOX VE+ 4-50	470	115	35	184	213	220	80	180	1" 1/4	1" 1/4	25
CPS10 MULTINOX VE+ 4-70	524	115	35	238	213	220	80	180	1" 1/4	1" 1/4	29
CPS10 MULTINOX VE+ 4-90	578	115	35	292	213	220	80	180	1" 1/4	1" 1/4	30
CPS10 MULTINOX VE+ 4-120	660	115	35	373	213	220	80	180	1" 1/4	1" 1/4	32
CPS10 MULTINOX VE+ 6-30	416	115	35	130	213	220	80	180	1" 1/4	1" 1/4	21
CPS10 MULTINOX VE+ 6-50	470	115	35	184	213	220	80	180	1" 1/4	1" 1/4	25
CPS10 MULTINOX VE+ 6-70	524	115	35	238	213	220	80	180	1" 1/4	1" 1/4	29
CPS10 MULTINOX VE+ 6-90	578	115	35	292	213	220	80	180	1" 1/4	1" 1/4	30
CPS10 MULTINOX VE+ 8-30	416	115	35	130	213	220	80	180	1" 1/4	1" 1/4	21
CPS10 MULTINOX VE+ 8-50	470	115	35	184	213	220	80	180	1" 1/4	1" 1/4	25
CPS10 MULTINOX VE+ 8-70	524	115	35	373	213	220	80	180	1" 1/4	1" 1/4	41

# CPS10 PVM

## ELECTRONIC FREQUENCY CONVERTER



### HYDRAULIC PERFORMANCE

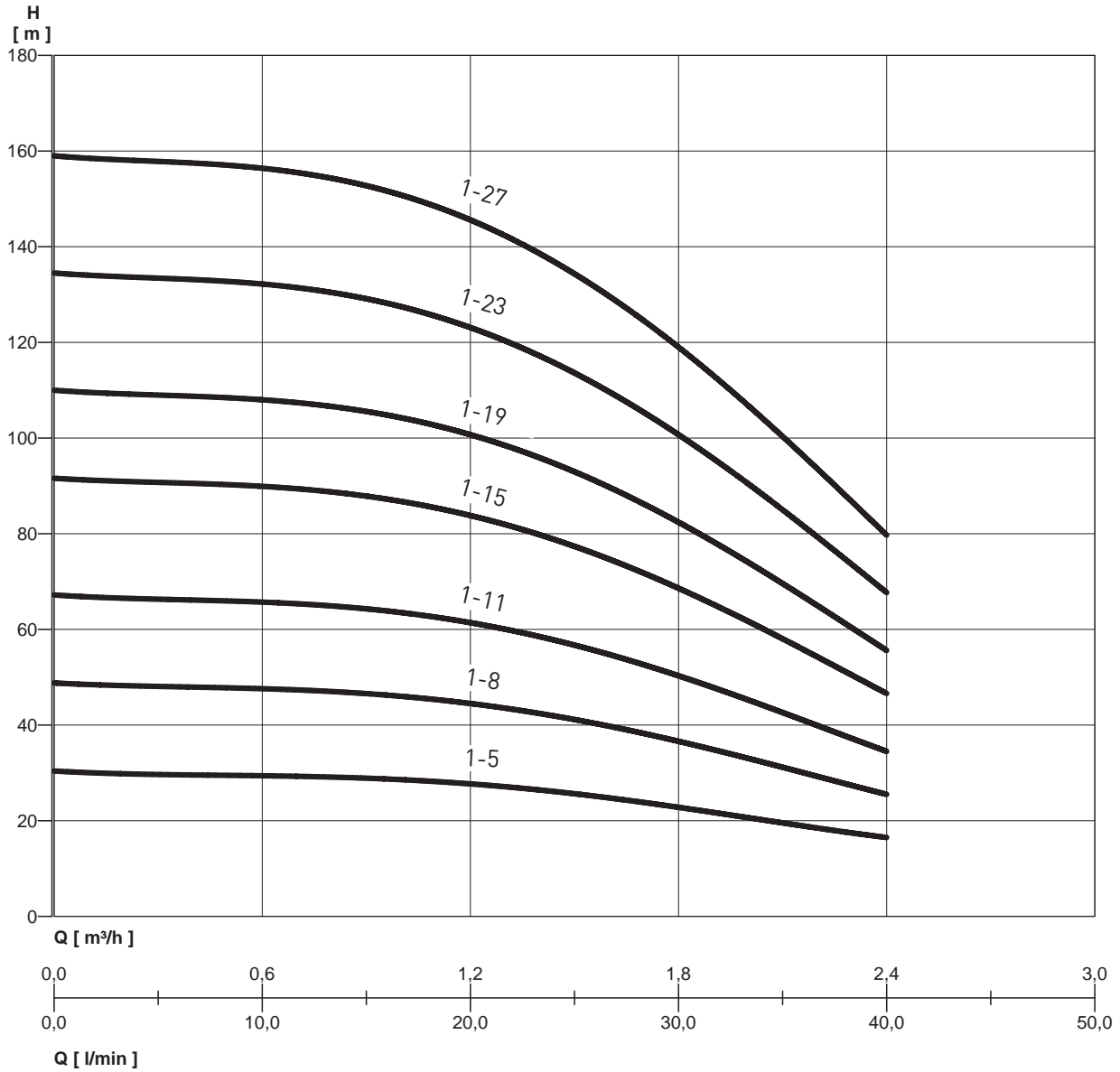

MEI ≥ 0.4 - Reference MEI ≥ 0.70 - The information on the reference efficiency is available at the address: [www.europump.org/efficiencycharts](http://www.europump.org/efficiencycharts)  
For the efficiency data see the PUMPS of the series PVM

### PERFORMANCE TABLE

MODEL	P2		VOLT. (V)	In (A)	Q	m.c.w.				
	HP	kW				0	10	20	30	40
						0	0,6	1,2	1,8	2,4
CPS10 PVM 1-5	0,5	0,4	1 ~ 230	2,7		30,4	29,4	22,7	22,8	16,5
CPS10 PVM 1-8	0,8	0,6	1 ~ 230	4,1		48,8	47,6	44,5	36,6	25,5
CPS10 PVM 1-11	0,8	0,6	1 ~ 230	4,4		67,2	65,7	61,4	50,3	34,5
CPS10 PVM 1-15	1	0,8	1 ~ 230	5,8		91,6	89,9	83,8	68,6	46,6
CPS10 PVM 1-19	1,5	1,1	1 ~ 230	7,4		110	108	101	82,4	55,6
CPS10 PVM 1-23	1,5	1,1	1 ~ 230	8,3		135	132	123	101	67,7
CPS10 PVM 1-27	2	1,5	1 ~ 230	9,9		159	156	146	119	79,7

# CPS10 PVM

## ELECTRONIC FREQUENCY CONVERTER

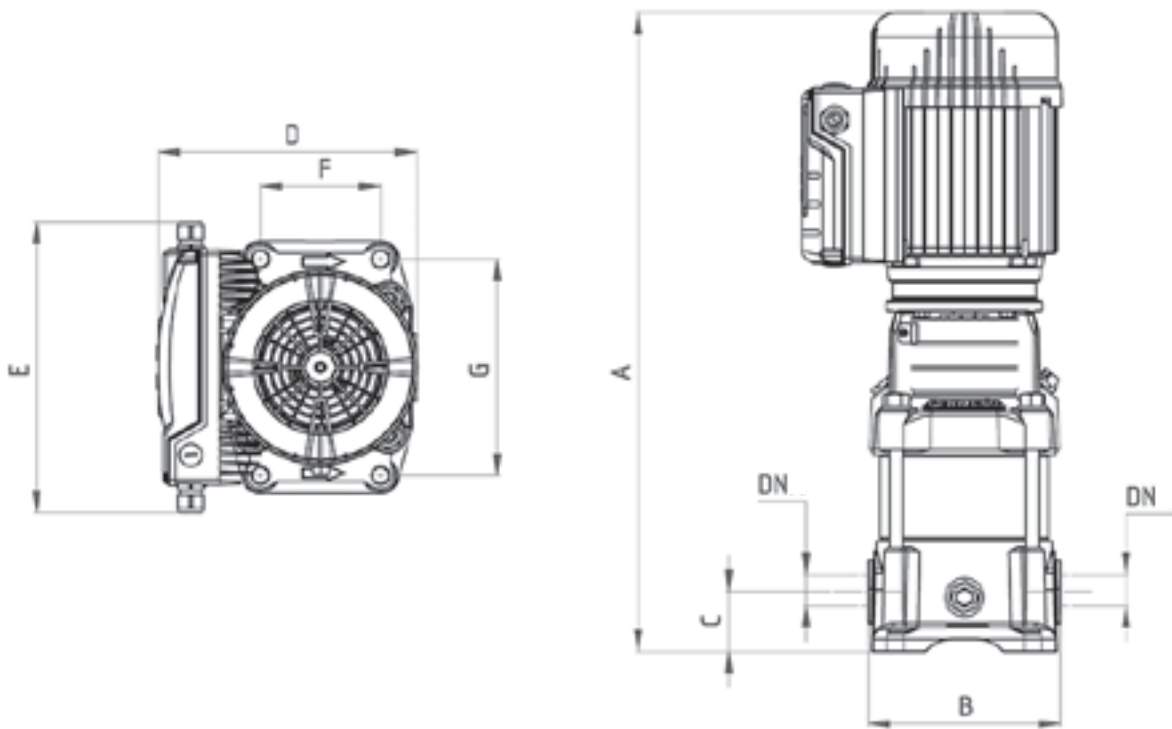

### OVERALL DIMENSIONS AND WEIGHTS

MODEL	Dimensions mm.								WEIGHT Kg
	A	B	C	D	E	F	G	DN	
CPS10 PVM 1-5	510	250	75	135	232	100	180	DN 25/DN 32	29
CPS10 PVM 1-8	564	250	75	135	232	100	180	DN 25/DN 32	31
CPS10 PVM 1-11	618	250	75	135	232	100	180	DN 25/DN 32	32
CPS10 PVM 1-15	736	250	75	135	232	100	180	DN 25/DN 32	36
CPS10 PVM 1-19	808	250	75	135	232	100	180	DN 25/DN 32	38
CPS10 PVM 1-23	880	250	75	135	232	100	180	DN 25/DN 32	40
CPS10 PVM 1-27	1024	250	75	135	232	100	180	DN 25/DN 32	50



# CPS10 PVM

## ELECTRONIC FREQUENCY CONVERTER



### HYDRAULIC PERFORMANCE

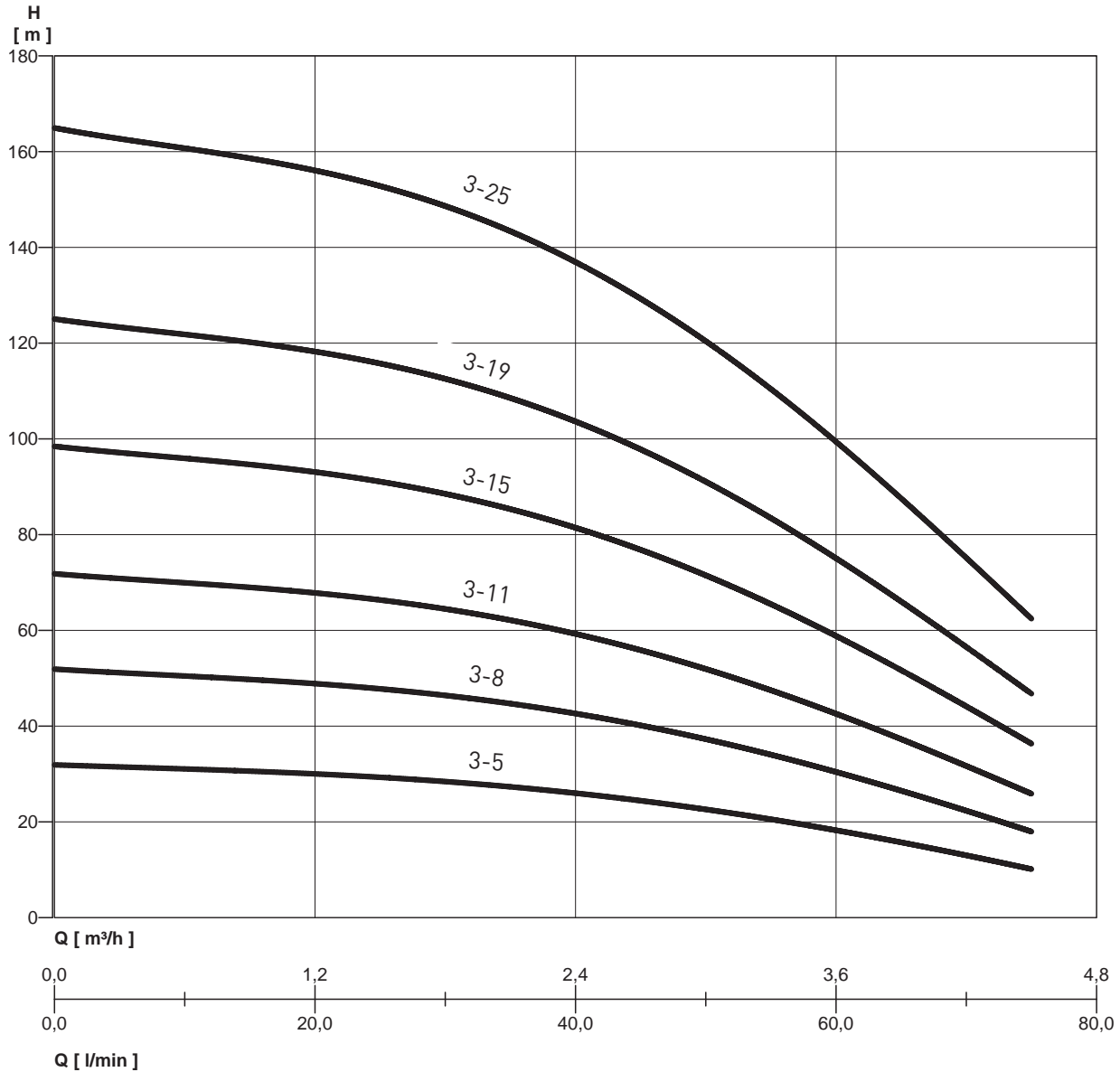

MEI ≥ 0.4 - Reference MEI ≥ 0.70 - The information on the reference efficiency is available at the address: [www.europump.org/efficiencycharts](http://www.europump.org/efficiencycharts)  
For the efficiency data see the PUMPS of the series PVM

### PERFORMANCE TABLE

MODEL	P2		VOLT. (V)	In (A)	Q	Flow Rate (l/min)										
	HP	kW				0	10	20	30	40	50	60	70	75		
						0	0,6	1,2	1,8	2,4	3,0	3,6	4,2	4,5		
CPS10 PVM 3-5	0,5	0,4	1 ~ 230	3	m.c.w.	31,9	31,1	30	28,3	26,2	22,6	18	13,3	10		
CPS10 PVM 3-8	1	0,8	1 ~ 230	4,8		51,9	50,5	48,9	46,2	42,9	37,3	30,1	22,7	17,8		
CPS10 PVM 3-11	1,5	1,1	1 ~ 230	6,6		71,8	70	67,9	64,1	59,6	52,1	42,1	32,1	25,7		
CPS10 PVM 3-15	1,5	1,1	1 ~ 230	9		98,4	96	93,2	88	81,9	71,7	58,2	44,7	36,1		
CPS10 PVM 3-19	2	1,5	1 ~ 230	11		125	121,9	118	111,9	104	91,3	74,3	57,2	46,5		
CPS10 PVM 3-25	3	2,2	1 ~ 230	15		165	160,8	156	147,8	138	120,8	98,4	76	62,1		

# CPS10 PVM

## ELECTRONIC FREQUENCY CONVERTER

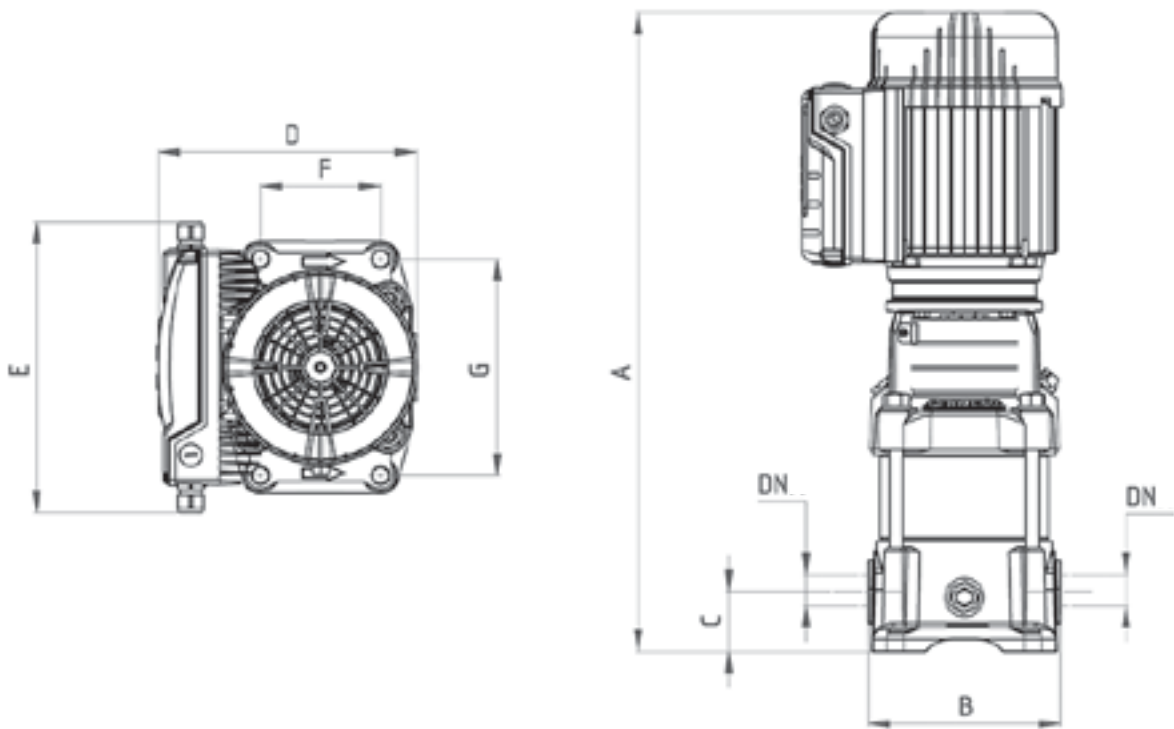

### OVERALL DIMENSIONS AND WEIGHTS

MODEL	Dimensions mm.								WEIGHT Kg
	A	B	C	D	E	F	G	DN	
CPS10 PVM 3-5	510	510	510	510	510	510	510	DN 25/DN 32	29
CPS10 PVM 3-8	610	610	610	610	610	610	610	DN 25/DN 32	33
CPS10 PVM 3-11	664	664	664	664	664	664	664	DN 25/DN 32	35
CPS10 PVM 3-15	736	736	736	736	736	736	736	DN 25/DN 32	37
CPS10 PVM 3-19	880	880	880	880	880	880	880	DN 25/DN 32	47
CPS10 PVM 3-25	988	988	988	988	988	988	988	DN 25/DN 32	52

# CPS10 PVM

## ELECTRONIC FREQUENCY CONVERTER



### HYDRAULIC PERFORMANCE

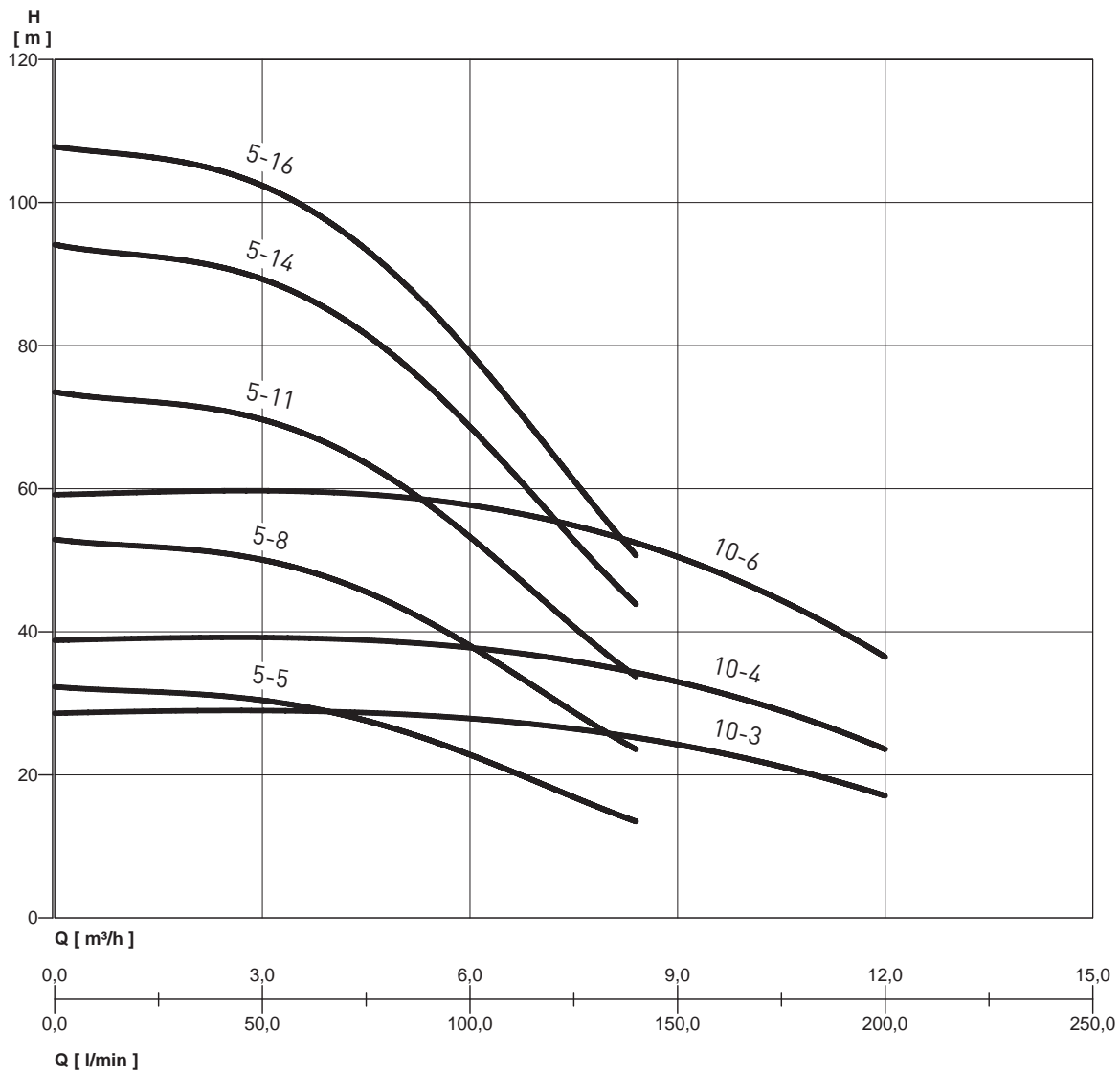

MEI ≥ 0.4 - Reference MEI > 0.70 - The information on the reference efficiency is available at the address: [www.europump.org/efficiencycharts](http://www.europump.org/efficiencycharts)  
For the efficiency data see the PUMPS of the series PVM

### PERFORMANCE TABLE

MODEL	P2		VOLT. (V)	In (A)	Q	m.c.w.									
	HP	kW				l/min	0	40	60	80	100	120	140		
						m³/h	0	2,4	3,6	4,8	6	7,2	8,4		
CPS10 PVM 5-5	1	0,75	1 - 230	5,4	m.c.w.	32,3	31,1	29,4	26,8	22,9	18	13,5			
CPS10 PVM 5-8	1,5	1,1	1 - 230	8,7		52,9	51,1	48,5	44,3	38,2	30,5	23,6			
CPS10 PVM 5-11	3	2,2	1 - 230	12,0		73,5	71,1	67,5	61,8	53,5	43	33,8			
CPS10 PVM 5-14	3	2,2	1 - 230	15,2		94,1	91,1	86,6	79,4	68,9	55,8	43,9			
CPS10 PVM 5-16	3	2,2	1 - 230	17,4		108	104,5	99,3	91	79,1	64,7	50,7			
MODEL	P2		VOLT. (V)	In (A)	Q	m.c.w.									
	HP	kW				l/min	0	25	50	75	100	125	150	175	200
						m³/h	0	1,5	3	4,5	6	7,5	9	10,5	12
CPS10 PVM 10-3	1,5	1,1	1 - 230	2,4	m.c.w.	28,6	28,9	29	28,7	27,8	26,4	24,4	21	17,1	
CPS10 PVM 10-4	2	1,5	1 - 230	3,2		38,8	39,1	39,2	38,9	37,7	35,8	33,2	28,8	23,6	
CPS10 PVM 10-6	3	2,2	1 - 230	4,8		59,2	59,4	59,8	59,4	57,5	54,7	50,8	44,2	36,5	

# CPS10 PVM

## ELECTRONIC FREQUENCY CONVERTER

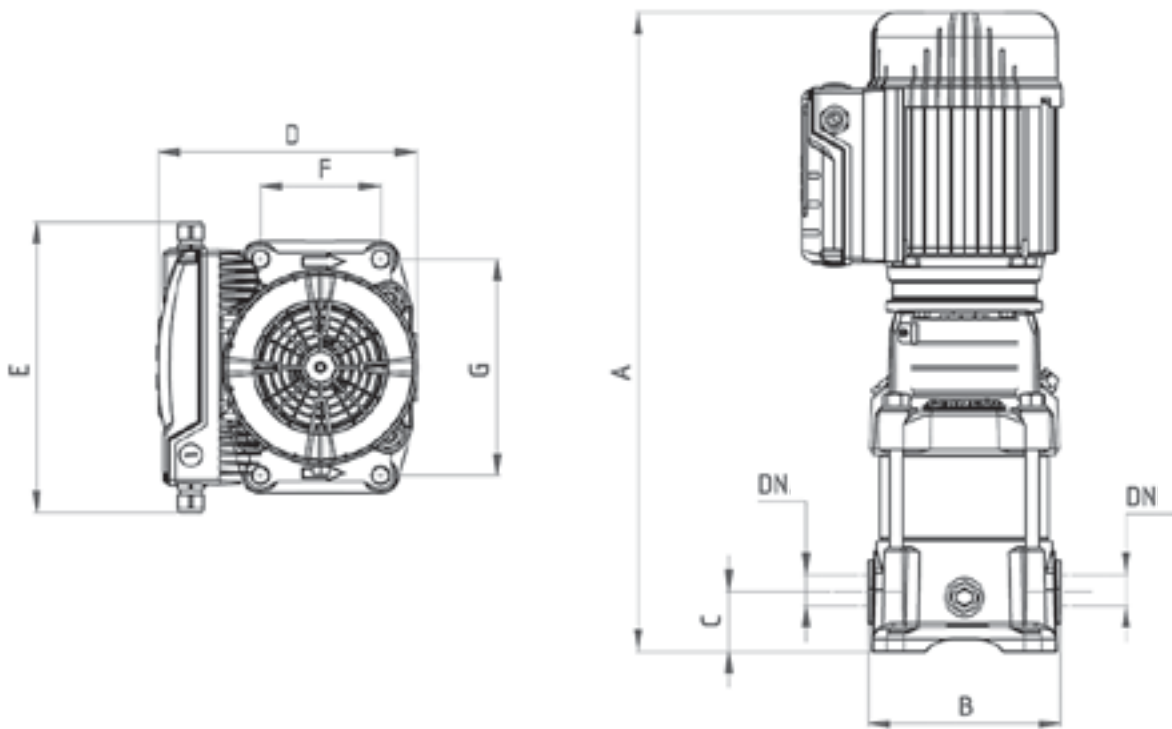

### OVERALL DIMENSIONS AND WEIGHTS

MODEL	Dimensions mm.								WEIGHT Kg
	A	B	C	D	E	F	G	DN	
CPS10 PVM 5-5	601	250	75	135	232	100	180	DN 25/DN 32	32
CPS10 PVM 5-8	682	250	75	135	232	100	180	DN 25/DN 32	35
CPS10 PVM 5-11	835	250	75	135	232	100	180	DN 25/DN 32	48
CPS10 PVM 5-14	916	250	75	135	232	100	180	DN 25/DN 32	50
CPS10 PVM 5-16	970	250	75	135	232	100	180	DN 25/DN 32	51
CPS10 PVM 10-3	612	280	80	160	232	130	215	DN 40	45
CPS10 PVM 10-4	714	280	80	160	232	130	215	DN 40	55
CPS10 PVM 10-6	774	280	80	160	232	130	215	DN 40	60

## CPS3-10

### THREE-PHASE ELECTRONIC FREQUENCY CONVERTER

Easy to install, Low power consumption, Compact size

CPS 3-10 is an electronic device capable of changing the frequency of a pump. Integrated directly on the motor, it allows to adjust its speed so as to supply the same pressure at all times, even when the water demand changes. CPS represents a compact, essential and reliable solution which is easy to use; designed to offer great comfort and benefits in various applications such as: irrigation, pressurization and water transfer, residential, commercial and industrial uses. The CPS range is characterised by a simple and elegant design with a backlight graphic display which informs the user of the operating parameters in real time.

The operating principle is simple and effective. The CPS powers the electric motor of the pump on which it is mounted and, by means of a feedback system that uses a pressure transducer, it changes the supply frequency of the electric motor depending on the water demand in order to keep the output pressure of the pump constant, the value

of which is set on the device (set point). CPS ensures high levels of efficiency and greater flexibility in performance, ensuring a high energy saving and making the use of other control devices unnecessary. The range offers a host of functions:

- Pressure measurement with the possibility to manage 2 independent levels adjustable by means of a time added internally or with an external connection;
- Start and stop;
- Internal clock;
- Calculation of the speed of the motor;
- Protection against dry running;
- Over and under current protection;
- Over and under voltage protection.



#### APPLICATIONS

- Pressurization systems
- Water supply
- Industry
- Construction
- Washes

#### PROTECTION DEVICES

- Dry running
- Overcurrent
- Overtemperature of electronic devices
- Inhibition of the system via external contact

#### TECHNICAL SPECIFICATIONS

- Supply voltage: inverter 3x380 - 3x500 Vac  $\pm$  10% sinusoidal 50/60 Hz
- Inverter output VOLT.: 3x400 Vac  $\pm$  10 %
- Maximum rated power: 11 kW
- Input frequency: 50/60 Hz + 3%
- Output maximum rated power: 20 A
- Degree of protection IP55 (if installed on motors with a degree of protection IP55 or above)
- Ambient temperature from +0°C to +50°C
- Waveform: sinusoidal
- Input filter complying with EMC directive
- Pressure transmitter 0 - 5 Volt - 0 - 10

Bar 0 - 20 Bar depending on the model of pump

- Set-point 2
- Serial interface connectivity RS 485
- Optional contacts 3 (external set-point, alarm, system inhibition)

# CPS3-10

## THREE-PHASE ELECTRONIC FREQUENCY CONVERTER

### VERSIONS AVAILABLE

VERTICAL
CPS3-10 MULTINOX VE+ 4
CPS3-10 MULTINOX VE+ 6
CPS3-10 MULTINOX VE+ 8
CPS3-10 PVM 1
CPS3-10 PVM 3
CPS3-10 PVM 5
CPS3-10 PVM 10
CPS3-10 PVM 15
CPS3-10 PVM 20
CPS3-10 PVM 32

### CONTROL PANEL

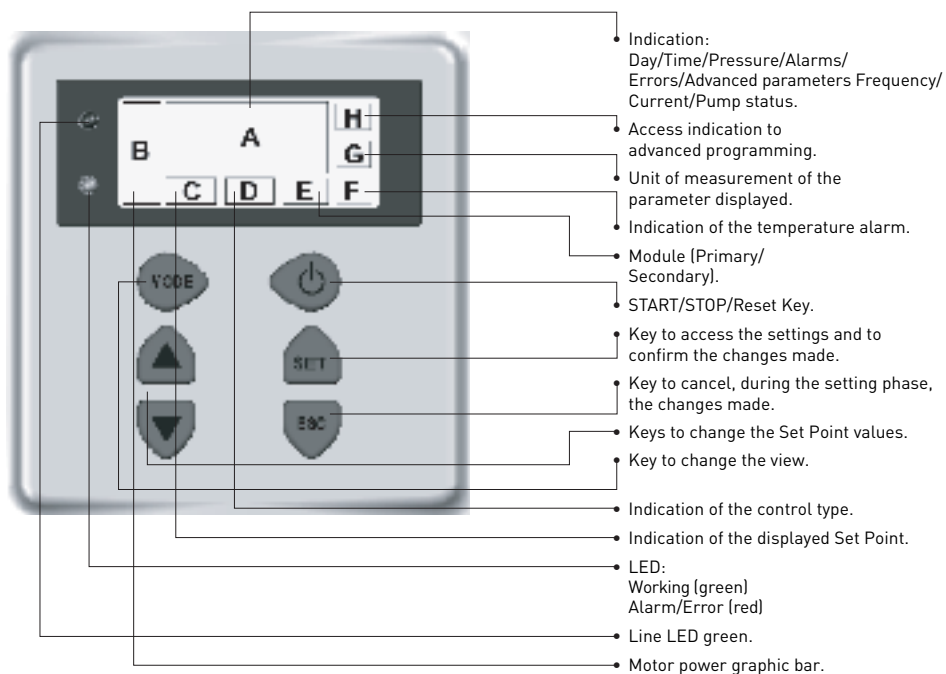

- Backlight display (switches off automatically after a reset time and can be turned on again by pressing any key)

# CPS3-10 MULTINOX VE + THREE-PHASE ELECTRONIC FREQUENCY CONVERTER

## HYDRAULIC PERFORMANCE

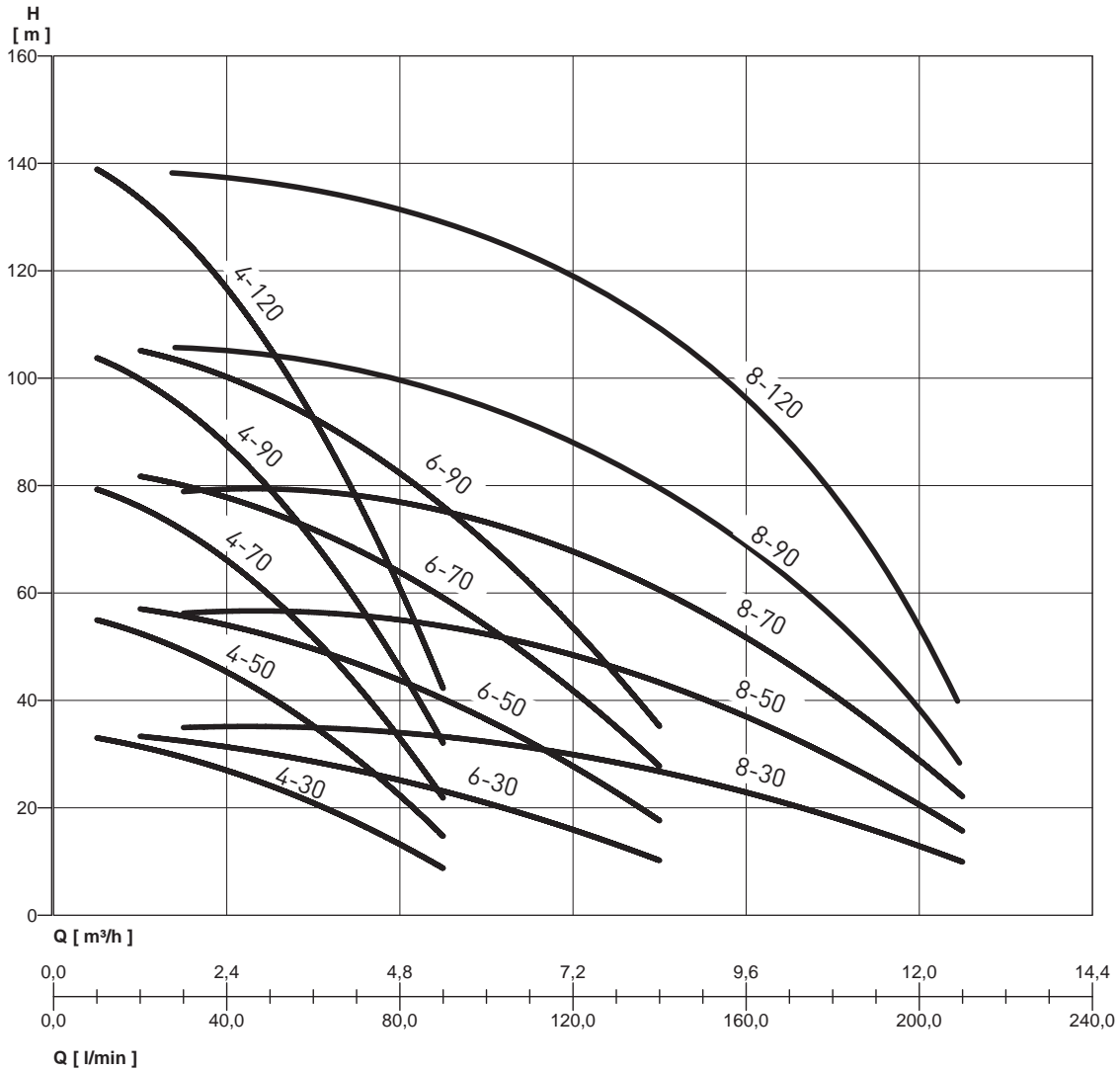

MODEL	P2		VOLT. (V)	In (A)	Q	m.c.w.																
	HP	kW				l/min	10	20	30	40	50	60	70	80	90	100	120	140	150	180	210	
						m³/h	0,6	1,2	2	2,4	3	3,6	4,2	5	5,4	6	7,2	8,4	9	11	13	
CPS3-10 MULTINOX VE+ 4-30	0,68	0,5	3 ~ 400	2,54		33	31	30	27	24	21	17	13	9								
CPS3-10 MULTINOX VE+ 4-50	1,1	0,84	3 ~ 400	3,90		55	52	50	45	41	35	29	22	15								
CPS3-10 MULTINOX VE+ 4-70	1,6	1,17	3 ~ 400	5,46		79	76	72	67	59	51	43	33	22								
CPS3-10 MULTINOX VE+ 4-90	2	1,5	3 ~ 400	7,22		104	99	95	88	79	69	59	46	32								
CPS3-10 MULTINOX VE+ 4-120	3	2	3 ~ 400	9,42		138	134	127	117	105	92	78	60	43								
CPS3-10 MULTINOX VE+ 6-30	0,9	0,67	3 ~ 400	3,58		34	32	31	30	28	27	26	23	21	16	10						
CPS3-10 MULTINOX VE+ 6-50	1,5	1,1	3 ~ 400	5,26		58	56	53	51	49	47	44	41	37	28	17						
CPS3-10 MULTINOX VE+ 6-70	2	1,5	3 ~ 400	8,21		83	80	77	74	71	68	64	60	55	42	27						
CPS3-10 MULTINOX VE+ 6-90	3	2	3 ~ 400	9,13		107	103	99	95	92	87	83	77	71	54	34						
CPS10 MULTINOX VE+ 8-30	1,35	1	3 ~ 400	2,60		35	35	35	35	35	35	34	33	32	30	27	25	18	10			
CPS10 MULTINOX VE+ 8-50	2	1,5	3 ~ 400	4,33		57	57	56	56	56	54	53	52	50	45	40	28	16				
CPS10 MULTINOX VE+ 8-70	2,5	1,9	3 ~ 400	6,13		80	80	79	78	78	76	74	72	70	63	56	40	22				
CPS3-10 MULTINOX VE+ 8-90	4	3	3 ~ 400	9,7		104	104	104	103	103	101	98	94	90	82	73	52	29				
CPS3-10 MULTINOX VE+ 8-120	5,5	4	3 ~ 400	12,3		139	139	139	138	138	135	131	126	120	109	98	70	38				

# CPS3-10 MULTINOX VE+

## THREE-PHASE ELECTRONIC FREQUENCY CONVERTER

### PERFORMANCE TABLE

FIG. 1

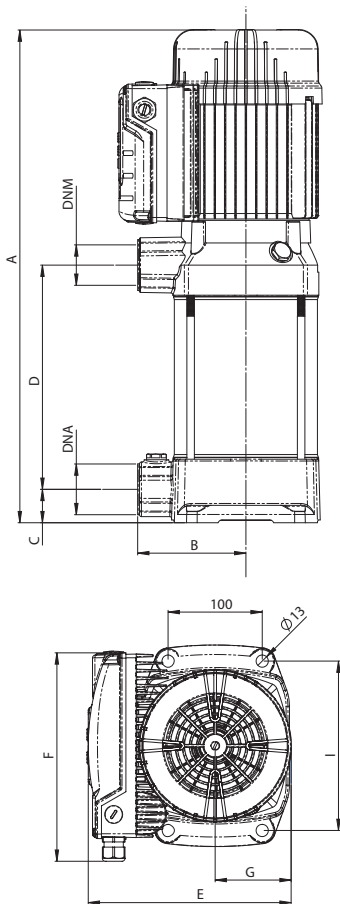
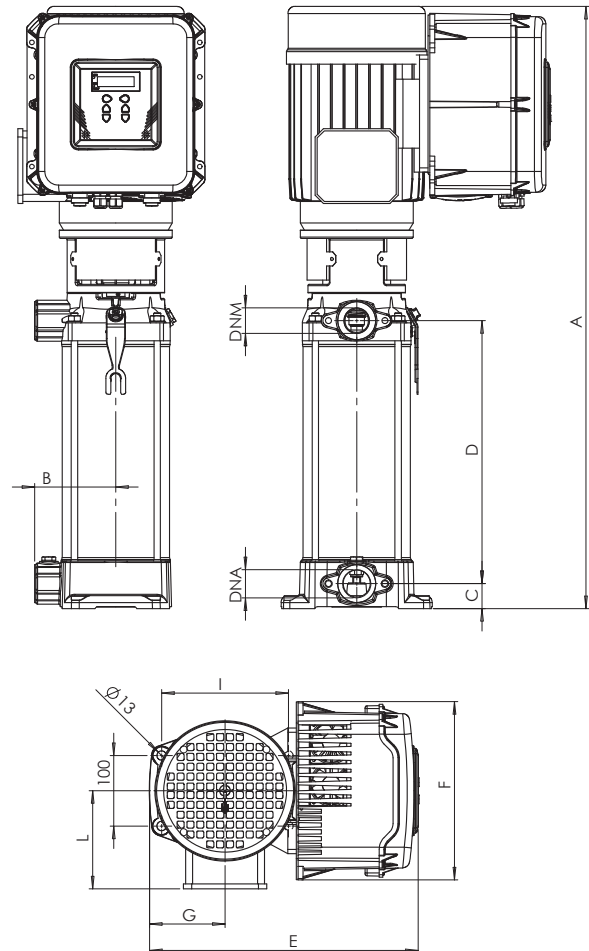

FIG. 2



### OVERALL DIMENSIONS AND WEIGHTS

MODEL	FIG.	Dimensions mm.											WEIGHT Kg
		A	B	C	D	E	F	G	I	L	DNA	DNM	
CPS3-10 MULTINOX VE+ 4-30	1	416	115	35	130	213	220	80	180	-	1" 1/4	1" 1/4	21
CPS3-10 MULTINOX VE+ 4-50	1	470	115	35	184	213	220	80	180	-	1" 1/4	1" 1/4	25
CPS3-10 MULTINOX VE+ 4-70	1	524	115	35	238	213	220	80	180	-	1" 1/4	1" 1/4	29
CPS3-10 MULTINOX VE+ 4-90	1	578	115	35	292	213	220	80	180	-	1" 1/4	1" 1/4	30
CPS3-10 MULTINOX VE+ 4-120	1	660	115	35	373	213	220	80	180	-	1" 1/4	1" 1/4	32
CPS3-10 MULTINOX VE+ 6-30	1	416	115	35	130	213	220	80	180	-	1" 1/4	1" 1/4	21
CPS3-10 MULTINOX VE+ 6-50	1	470	115	35	184	213	220	80	180	-	1" 1/4	1" 1/4	25
CPS3-10 MULTINOX VE+ 6-70	1	524	115	35	238	213	220	80	180	-	1" 1/4	1" 1/4	29
CPS3-10 MULTINOX VE+ 6-90	1	578	115	35	292	213	220	80	180	-	1" 1/4	1" 1/4	30
CPS3-10 MULTINOX VE+ 8-30	1	416	115	35	130	213	220	80	180	-	1" 1/4	1" 1/4	21
CPS3-10 MULTINOX VE+ 8-50	1	470	115	35	184	213	220	80	180	-	1" 1/4	1" 1/4	25
CPS3-10 MULTINOX VE+ 8-70	1	524	115	35	373	213	220	80	180	-	1" 1/4	1" 1/4	41
CPS3-10 MULTINOX VE+ 8-90	2	730	115	35	292	370	253	105	180	140	1" 1/4	1" 1/4	42
CPS3-10 MULTINOX VE+ 8-120	2	855	115	35	373	380	253	105	180	145	1" 1/4	1" 1/4	45



# CPS 3-10 PVM

## THREE-PHASE ELECTRONIC FREQUENCY CONVERTER

### HYDRAULIC PERFORMANCE

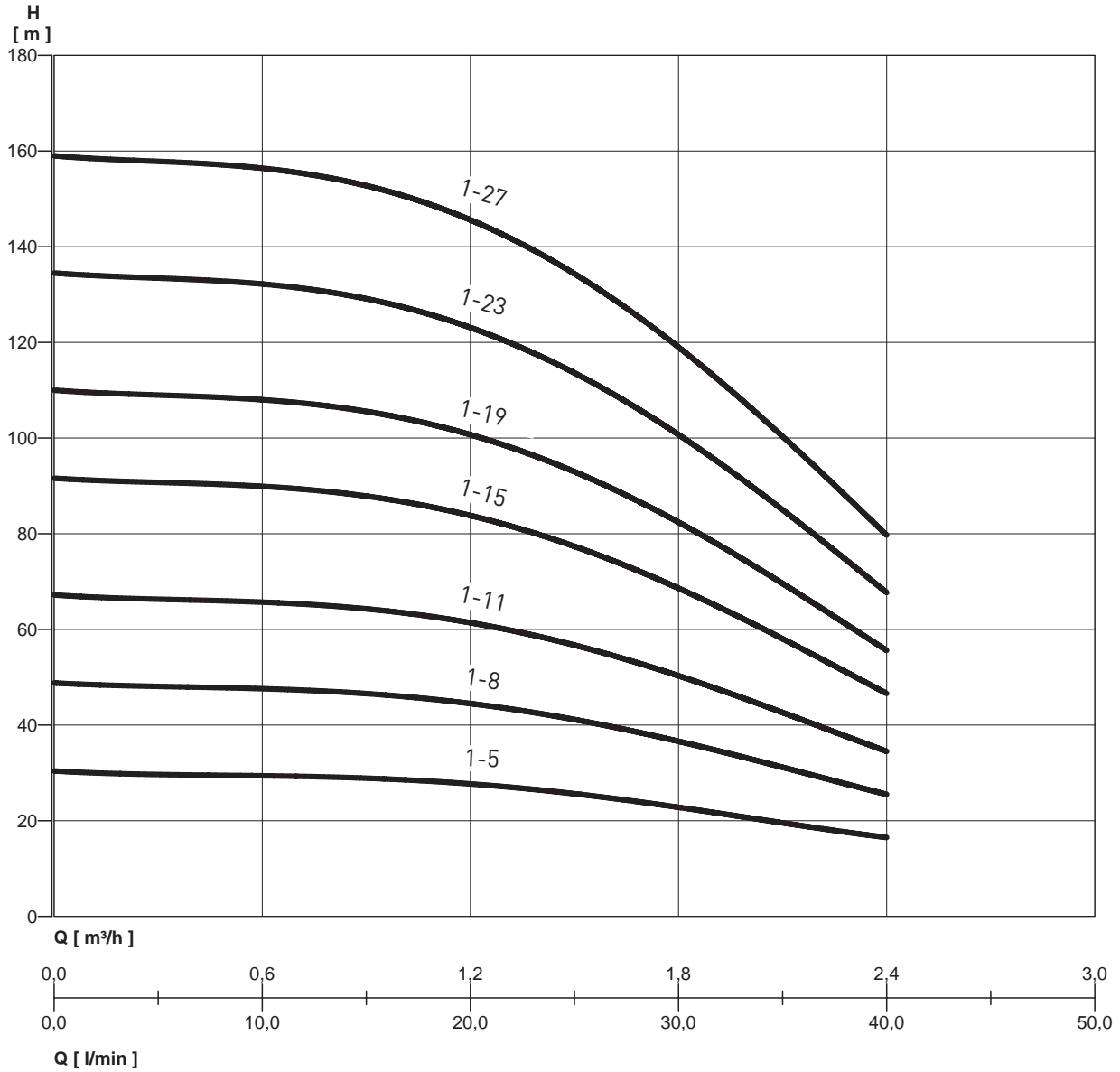

MEI ≥ 0.4 - Reference MEI ≥ 0.70 - The information on the reference efficiency is available at the address: [www.europump.org/efficiencycharts](http://www.europump.org/efficiencycharts)  
For the efficiency data see the PUMPS of the series PVM

# CPS 3-10 PVM

## THREE-PHASE ELECTRONIC FREQUENCY CONVERTER

### PERFORMANCE TABLE

MODEL	P2		VOLT. (V)	In (A)	Q	l/min	0	10	20	30	40
	HP	kW					0	0,6	1,2	1,8	2,4
CPS3-10 PVM 1-5 F	0,5	0,37	3 - 400	1,5	m.c.w.		30,4	29,4	22,7	22,8	16,5
CPS3-10 PVM 1-8 F	0,75	0,55	3 - 400	2,3		48,8	47,6	44,5	36,6	25,5	
CPS3-10 PVM 1-11 F	0,75	0,55	3 - 400	3,2		67,2	65,7	61,4	50,3	34,5	
CPS3-10 PVM 1-15 F	1	0,75	3 - 400	4,4		91,6	89,9	83,8	68,6	46,6	
CPS3-10 PVM 1-19 F	1,5	1,1	3 - 400	5,5		110	108	100,7	82,4	55,6	
CPS3-10 PVM 1-23 F	1,5	1,1	3 - 400	6,7		134,5	132,2	123,1	100,7	67,7	
CPS3-10 PVM 1-27 F	2	1,5	3 - 400	7,8		159	156,4	145,6	119	79,7	

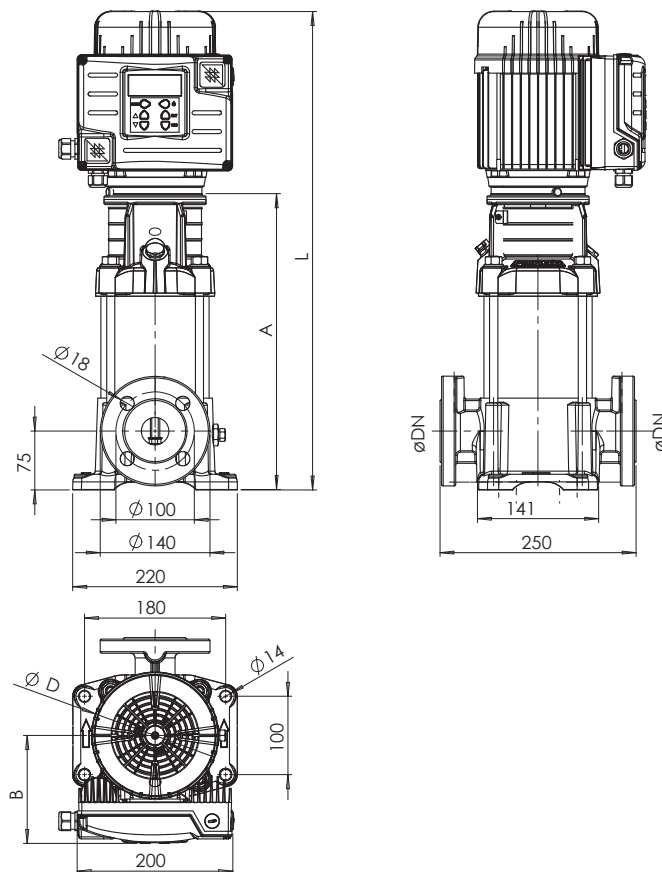

### OVERALL DIMENSIONS AND WEIGHTS

MODEL	Dimensions mm.									WEIGHT Kg
	A	B	C	D	E	F	G	DN		
CPS3-10 PVM 1-5 F	510	250	75	135	232	100	180	DN 25/DN 32	29	
CPS3-10 PVM 1-8 F	564	250	75	135	232	100	180	DN 25/DN 32	31	
CPS3-10 PVM 1-11 F	618	250	75	135	232	100	180	DN 25/DN 32	32	
CPS3-10 PVM 1-15 F	736	250	75	135	232	100	180	DN 25/DN 32	36	
CPS3-10 PVM 1-19 F	808	250	75	135	232	100	180	DN 25/DN 32	38	
CPS3-10 PVM 1-23 F	880	250	75	135	232	100	180	DN 25/DN 32	40	
CPS3-10 PVM 1-27 F	1024	250	75	135	232	100	180	DN 25/DN 32	50	

# CPS 3-10 PVM

## THREE-PHASE ELECTRONIC FREQUENCY CONVERTER

### HYDRAULIC PERFORMANCE

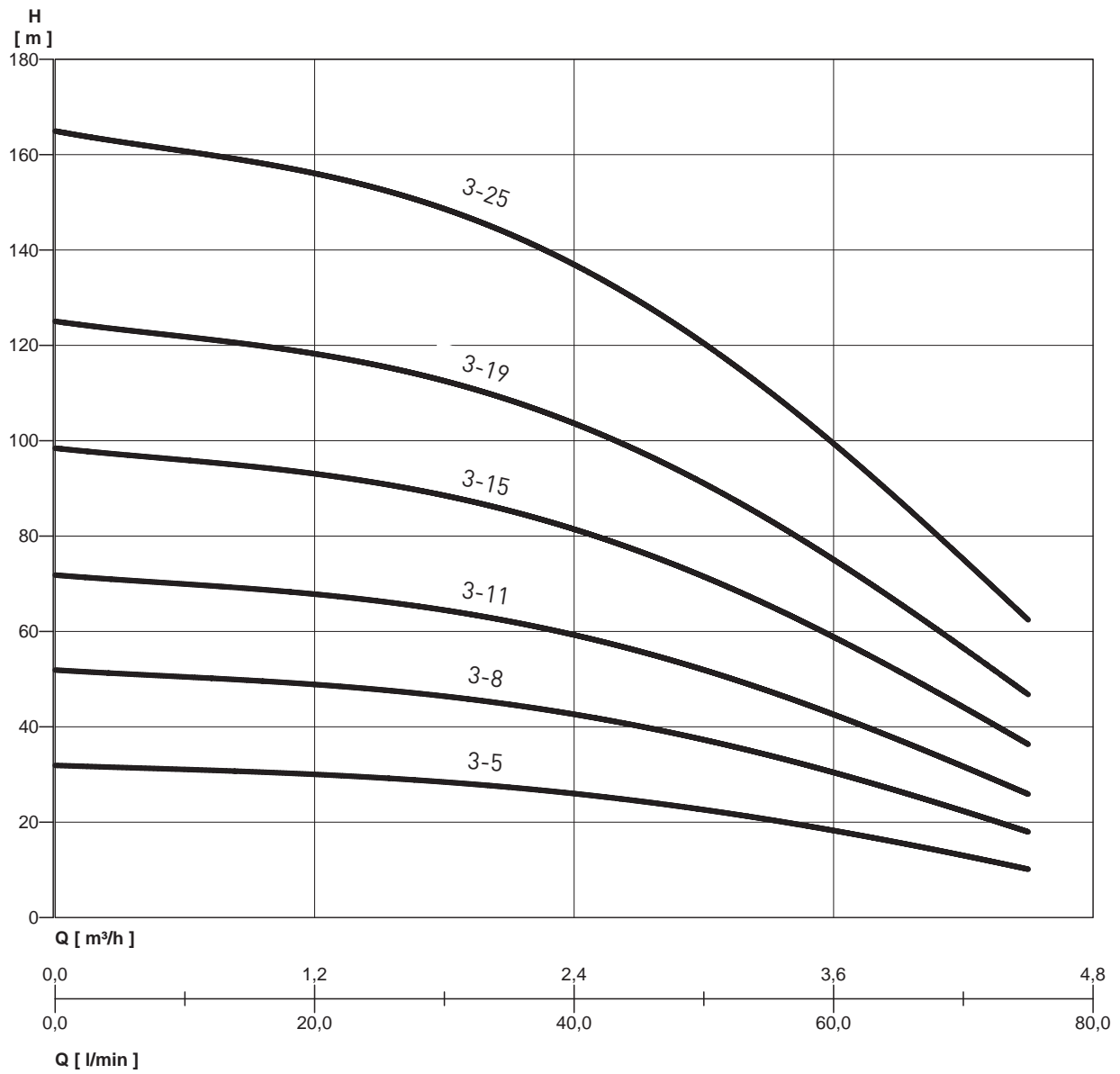

MEI ≥ 0.4 - Reference MEI ≥ 0.70 - The information on the reference efficiency is available at the address: [www.europump.org/efficiencycharts](http://www.europump.org/efficiencycharts)  
For the efficiency data see the PUMPS of the series PVM

# CPS 3-10 PVM

## THREE-PHASE ELECTRONIC FREQUENCY CONVERTER

### PERFORMANCE TABLE

MODEL	P2		VOLT. (V)	In (A)	Q	l/min	0	20	40	60	75
	HP	kW					0	1,2	2,4	3,6	4,5
CPS3-10 PVM 3-5 F	0,5	0,37	3 - 400	0,9	m.c.w.		31,9	30	26,2	18	10
CPS3-10 PVM 3-8 F	1	0,75	3 - 400	1,45		51,9	48,9	42,9	30,1	17,8	
CPS3-10 PVM 3-11 F	1	0,75	3 - 400	2		71,8	67,9	59,6	42,1	25,7	
CPS3-10 PVM 3-15 F	1,5	1,1	3 - 400	2,7		98,4	93,2	81,9	58,2	36,1	
CPS3-10 PVM 3-19 F	2	1,5	3 - 400	3,4		125	118,4	104,2	74,3	46,5	
CPS3-10 PVM 3-25 F	3	2,2	3 - 400	4,5		164,9	156,3	137,6	98,4	62,1	

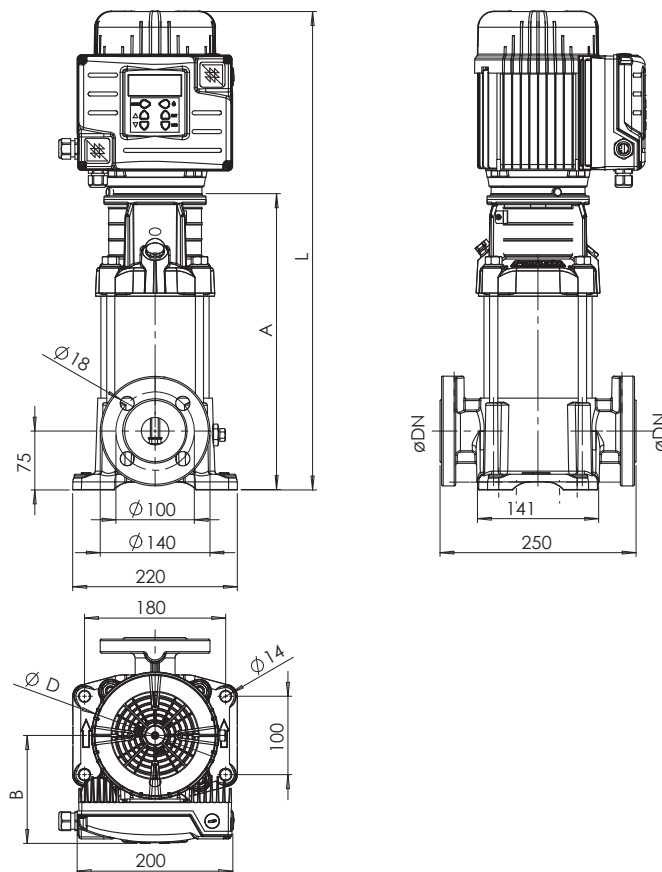

### OVERALL DIMENSIONS AND WEIGHTS

MODEL	Dimensions mm.								WEIGHT Kg
	A	B	C	D	E	F	G	DN	
CPS3-10 PVM 3-5 F	510	510	510	510	510	510	510	DN 25/DN 32	29
CPS3-10 PVM 3-8 F	610	610	610	610	610	610	610	DN 25/DN 32	33
CPS3-10 PVM 3-11 F	664	664	664	664	664	664	664	DN 25/DN 32	35
CPS3-10 PVM 3-15 F	736	736	736	736	736	736	736	DN 25/DN 32	37
CPS3-10 PVM 3-19 F	880	880	880	880	880	880	880	DN 25/DN 32	47
CPS3-10 PVM 3-25 F	988	988	988	988	988	988	988	DN 25/DN 32	52

# CPS 3-10 PVM

## THREE-PHASE ELECTRONIC FREQUENCY CONVERTER

### HYDRAULIC PERFORMANCE

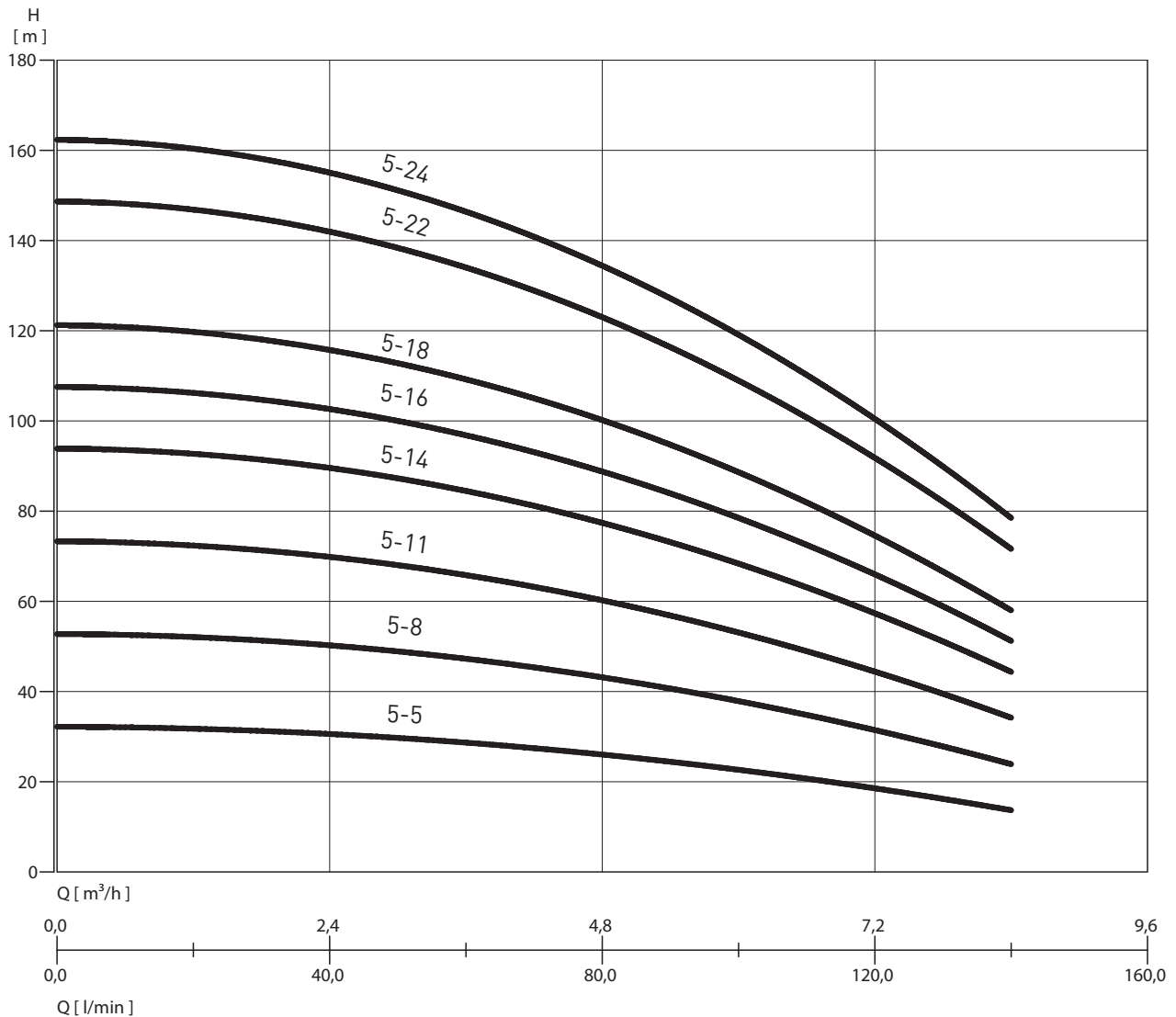

### PERFORMANCE TABLE

MODEL	P2		VOLT. (V)	In (A)	Q	m.c.w.					
	HP	kW				l/min	0	50	75	100	125
						0	3	4,5	6	7,5	8,4
CPS3-10 PVM 5-5 F	1	0,75	3 ~ 400	1,7		32,3	29,4	26,8	22,9	17,5	13,5
CPS3-10 PVM 5-8 F	1,5	1,1	3 ~ 400	2,7		52,9	48,5	44,3	38,2	29,9	23,6
CPS3-10 PVM 5-11 F	3	2,2	3 ~ 400	3,7		73,5	67,5	61,8	53,5	42,3	33,8
CPS3-10 PVM 5-14 F	3	2,2	3 ~ 400	4,8		94,1	86,6	79,4	68,9	54,6	43,9
CPS3-10 PVM 5-16 F	3	2,2	3 ~ 400	5,4		107,8	99,3	91	79,1	62,9	50,7
CPS3-10 PVM 5-18 F	4	3	3 ~ 400	6,1		121,5	112	102,7	89,3	71,1	57,4
CPS3-10 PVM 5-22 F	5,5	4	3 ~ 400	7,5		149	137,4	126,1	109,7	87,6	70,9
CPS3-10 PVM 5-24 F	5,5	4	3 ~ 400	8,2		162,7	150,1	137,8	119,9	95,9	77,7

# CPS 3-10 PVM

## THREE-PHASE ELECTRONIC FREQUENCY CONVERTER

FIG. 1

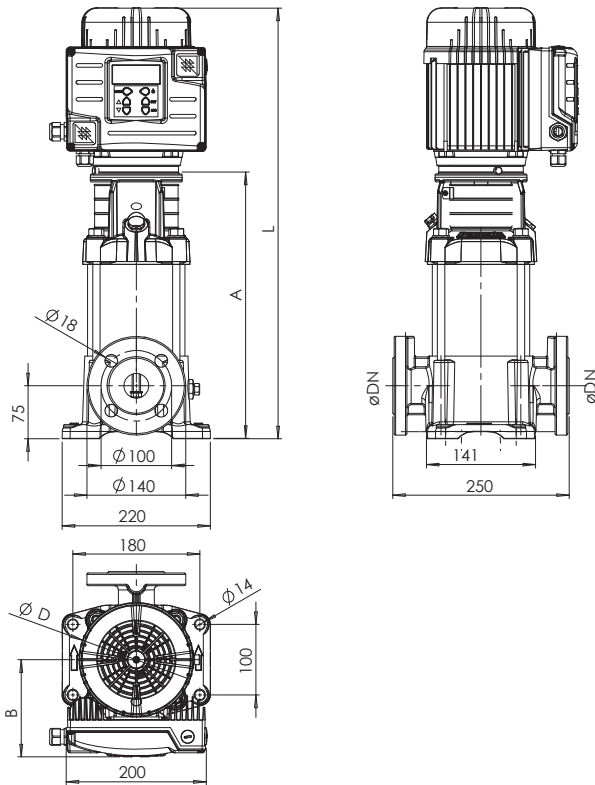
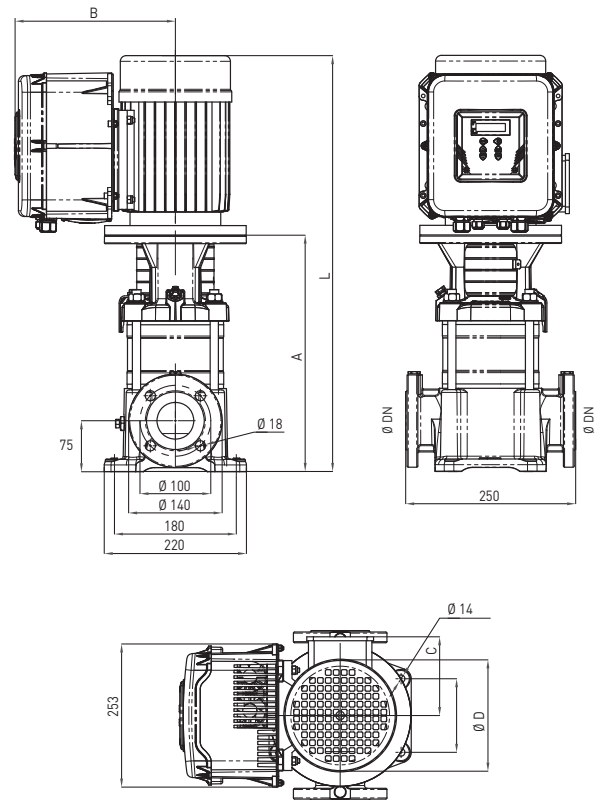

FIG. 2



### OVERALL DIMENSIONS AND WEIGHTS

MODEL	Fig.	Dimensions mm.						WEIGHT Kg
		A	B	C	D	L	DN	
CPS3-10 PVM 5-5 F	1	366	132	-	141	601	DN 32	32
CPS3-10 PVM 5-8 F	1	447	132	-	141	682	DN 32	35
CPS3-10 PVM 5-11 F	1	544	155	-	180	811	DN 32	48
CPS3-10 PVM 5-14 F	1	625	155	-	180	892	DN 32	50
CPS3-10 PVM 5-16 F	1	679	155	-	180	946	DN 32	51
CPS3-10 PVM 5-18 F	2	737	274	145	196	1058	DN 32	59
CPS3-10 PVM 5-22 F	2	845	286	161	225	1173	DN 32	65
CPS3-10 PVM 5-24 F	2	899	286	161	225	1227	DN 32	66

# CPS 3-10 PVM

## THREE-PHASE ELECTRONIC FREQUENCY CONVERTER

### HYDRAULIC PERFORMANCE

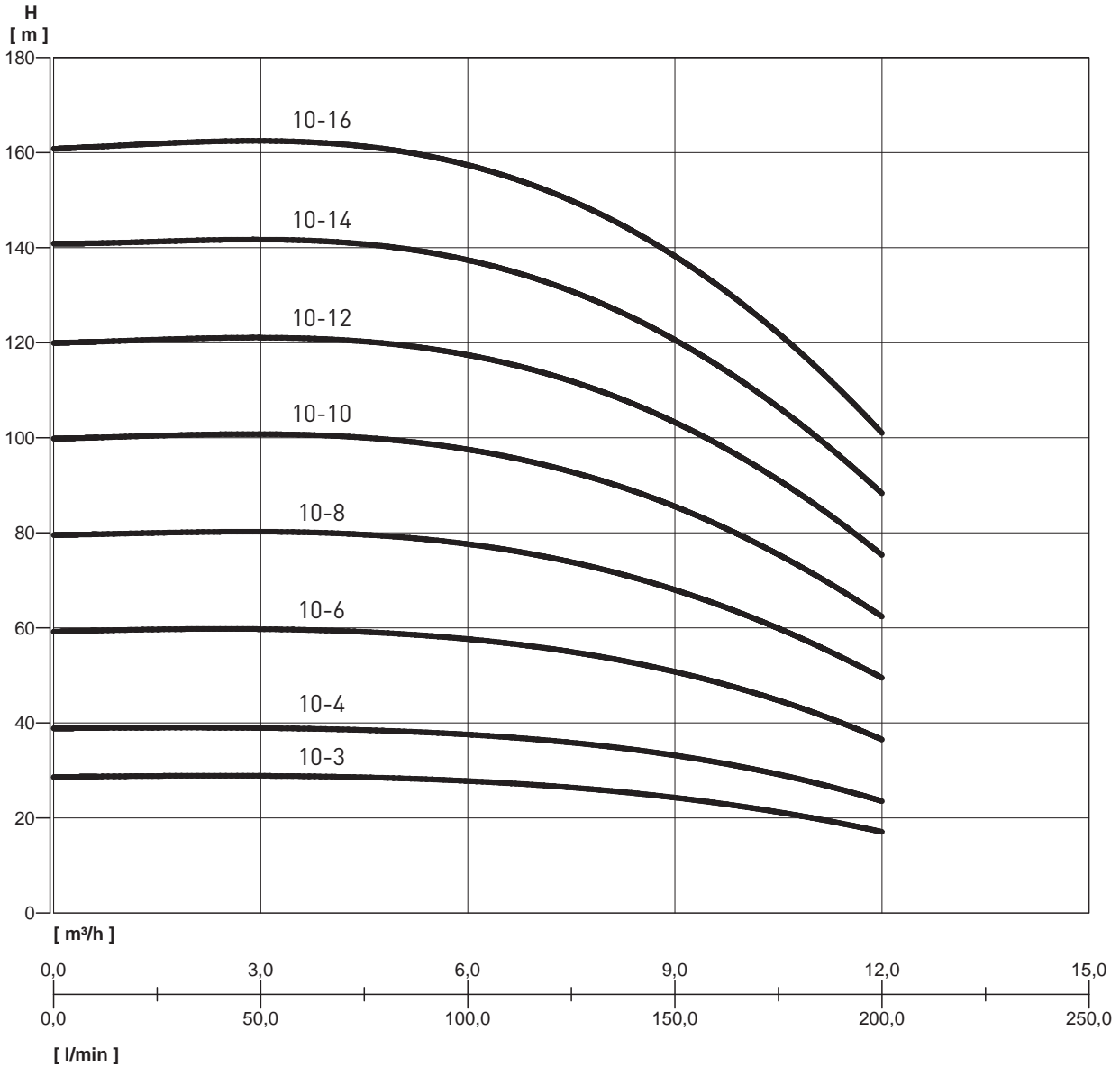

### PERFORMANCE TABLE

MODEL	P2		VOLT. (V)	In (A)	Q	Flow Rate										
	HP	kW				l/min	0	25	50	75	100	125	150	175	200	
						m³/h	0	1,5	3	4,5	6	7,5	9	10,5	12	
CPS3-10 PVM 10-3 F	1,5	1,1	3 ~ 400	2,4	m.c.w.	28,6	28,8	29	28,4	27,8	26,4	24,4	21,1	17,1		
CPS3-10 PVM 10-4 F	2	1,5	3 ~ 400	3,2		38,8	39	39,2	38	37,7	36	33,2	29	23,6		
CPS3-10 PVM 10-6 F	3	2,2	3 ~ 400	4,8		59,2	59,6	59,8	59,2	57,5	55	50,8	44,7	36,5		
CPS3-10 PVM 10-8	4	3	3 ~ 400	6,4		79,6	79,8	80,3	79,9	77,4	73,6	68,4	59,7	49,5		
CPS3-10 PVM 10-10	5,5	4	3 ~ 400	8		99,9	100,1	101	100,3	97,2	92,6	86	75,2	62,4		
CPS3-10 PVM 10-12	5,5	4	3 ~ 400	9,6		120	120,5	121	120,8	117	111,5	104	90,7	75,4		
CPS3-10 PVM 10-14	7,5	5,5	3 ~ 400	11		141	140,8	142	141,2	137	130,4	121,2	106,2	88,3		
CPS3-10 PVM 10-16	7,5	5,5	3 ~ 400	13		161	161,2	163	161,7	157	149,3	139	121,7	101		

# CPS 3-10 PVM

## THREE-PHASE ELECTRONIC FREQUENCY CONVERTER

FIG. 1

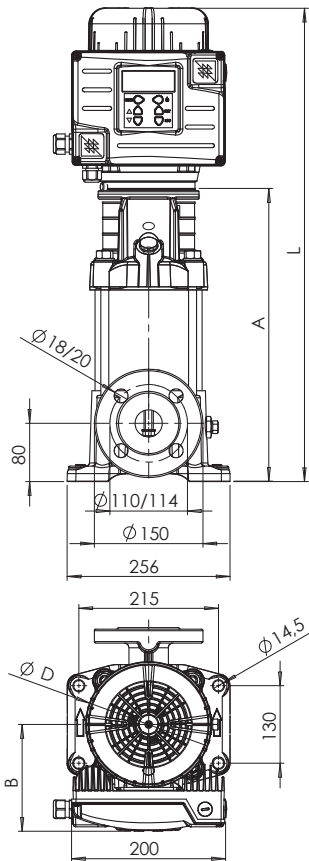
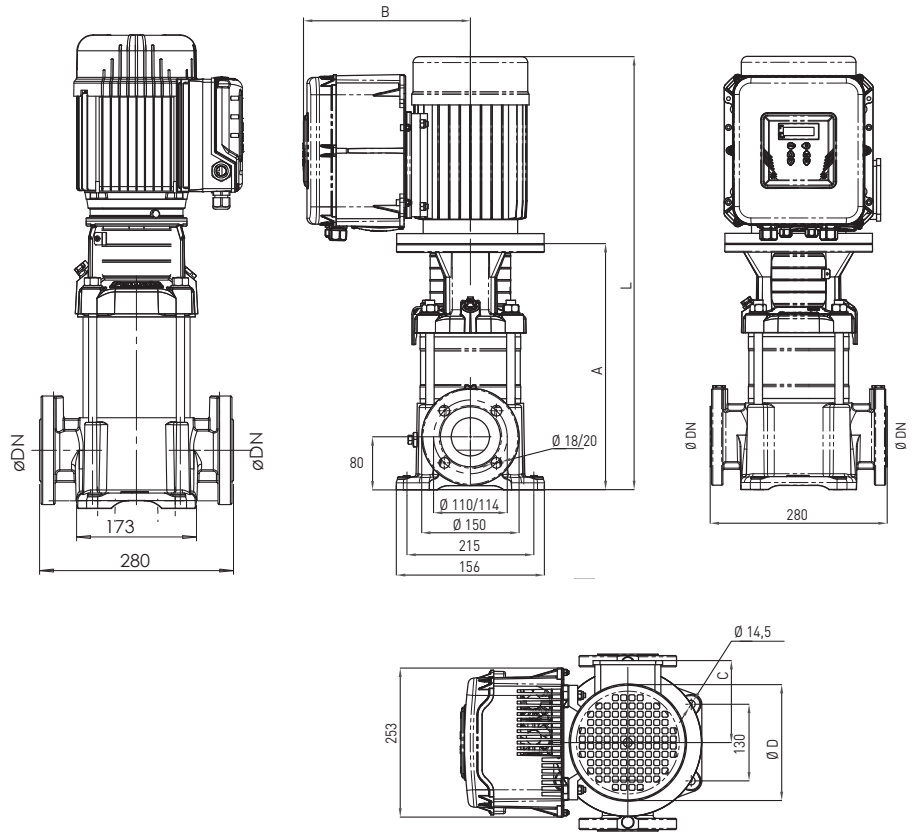

FIG. 2



### OVERALL DIMENSIONS AND WEIGHTS

MODEL	Fig.	Dimensions mm.						WEIGHT Kg
		A	B	C	D	L	DN	
CPS3-10 PVM 10-3 F	1	377	132	-	141	612	DN 40	45
CPS3-10 PVM 10-4 F	1	423	155	-	180	690	DN 40	55
CPS3-10 PVM 10-6 F	1	483	155	-	180	750	DN 40	60
CPS3-10 PVM 10-8 F	2	548	274	145	196	869	DN 40	70
CPS3-10 PVM 10-10 F	2	608	286	161	225	936	DN 40	75
CPS3-10 PVM 10-12 F	2	668	286	161	225	996	DN 40	77
CPS3-10 PVM 10-14 F	2	760	306	195	248	1125	DN 40	109
CPS3-10 PVM 10-16 F	2	820	306	195	248	1185	DN 40	111



# CPS 3-10 PVM

## THREE-PHASE ELECTRONIC FREQUENCY CONVERTER

### HYDRAULIC PERFORMANCE

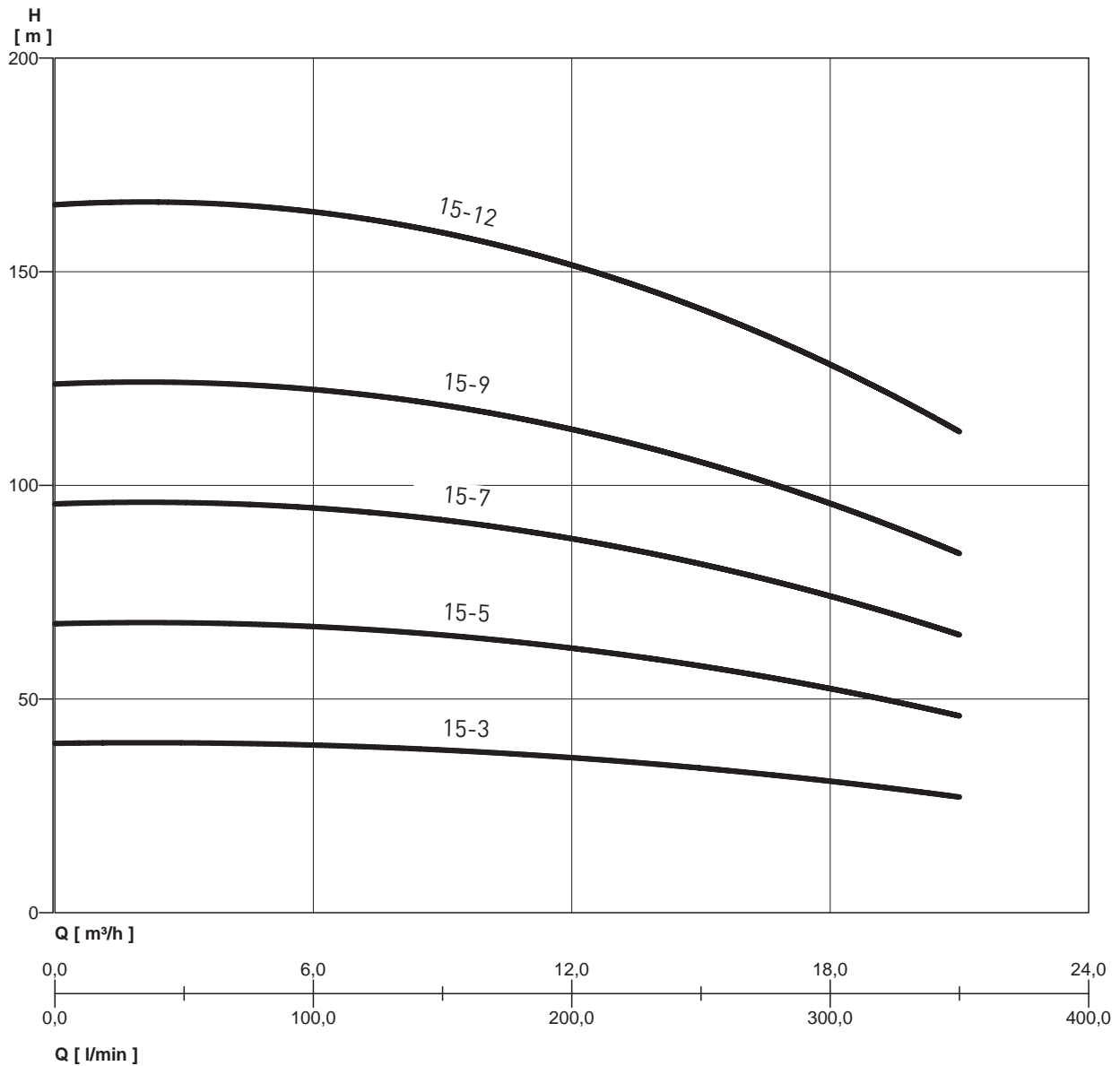

MEI ≥ 0.4 - Reference MEI ≥ 0.70 - The information on the reference efficiency is available at the address: [www.europump.org/efficiencycharts](http://www.europump.org/efficiencycharts)  
For the efficiency data see the PUMPS of the series PVM

### PERFORMANCE TABLE

MODEL	P2		VOLT. (V)	In (A)	0	Q								
	HP	kW				l/min	0	50	100	150	200	250	300	350
						m³/h	0	3	6	9	12	15	18	21
CPS3-10 PVM 15-3	4	3	3 ~ 400	5,1	m.c.w.	39,8	39,6	39,2	37,8	36,3	34,1	31	26,8	
CPS3-10 PVM 15-5	5,5	4	3 ~ 400	8,5		68	67,4	66,9	64,7	62	58,1	52,7	45,7	
CPS3-10 PVM 15-7	7,5	5,5	3 ~ 400	12		96,2	95,3	94,7	91,6	87,7	82	74,4	64,6	
CPS3-10 PVM 15-9	10	7,5	3 ~ 400	15		124	123,2	122,4	118	113	106	96	83,6	
CPS3-10 PVM 15-12	15	11	3 ~ 400	20		167	165	163,9	159	152	142	129	112	

# CPS 3-10 PVM

## THREE-PHASE ELECTRONIC FREQUENCY CONVERTER

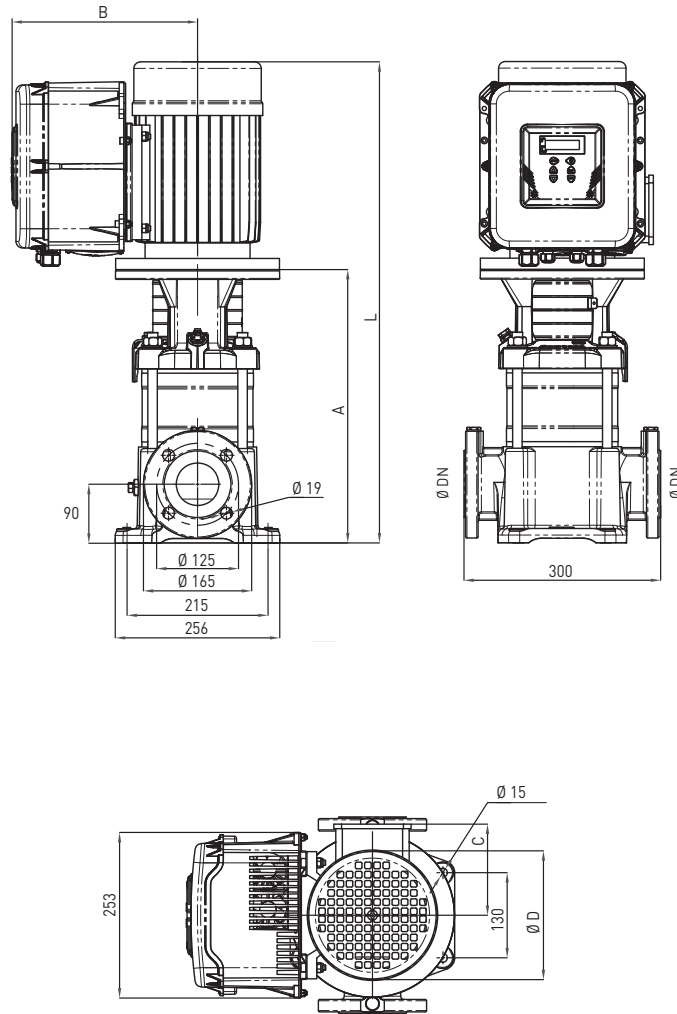

### OVERALL DIMENSIONS AND WEIGHTS

MODEL	Dimensions mm.						WEIGHT Kg
	A	B	C	D	L	DN	
CPS3-10 PVM 15-3	465	274	145	196	786	DN 50	70
CPS3-10 PVM 15-5	555	286	161	225	883	DN 50	76
CPS3-10 PVM 15-7	677	306	195	248	1042	DN 50	109
CPS3-10 PVM 15-9	767	306	195	248	1152	DN 50	118
CPS3-10 PVM 15-12	979	334	238	317	1477	DN 50	158

# CPS 3-10 PVM

## THREE-PHASE ELECTRONIC FREQUENCY CONVERTER

### HYDRAULIC PERFORMANCE

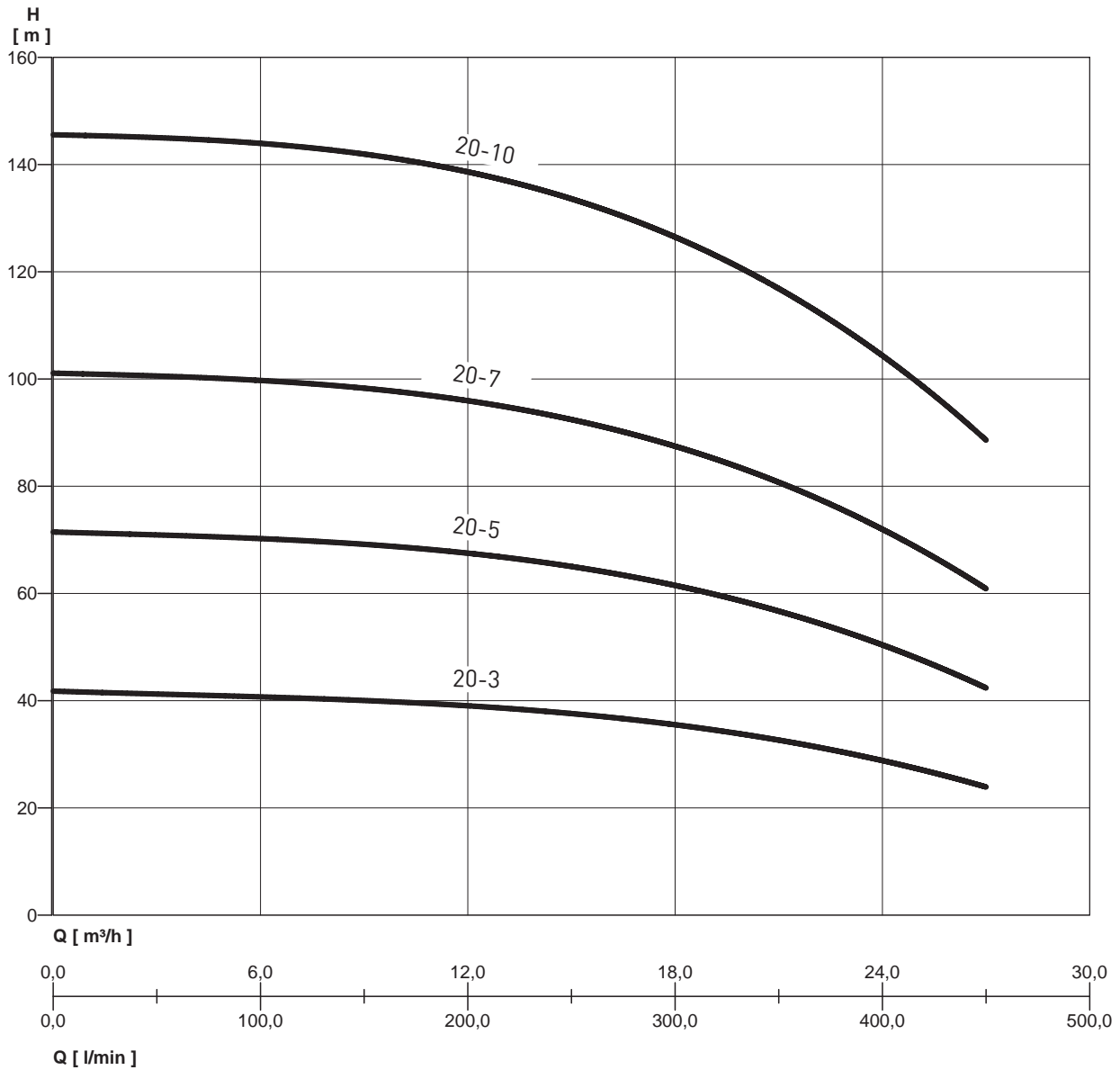

MEI ≥ 0.4 - Reference MEI ≥ 0.70 - The information on the reference efficiency is available at the address: [www.europump.org/efficiencycharts](http://www.europump.org/efficiencycharts)  
For the efficiency data see the PUMPS of the series PVM

### PERFORMANCE TABLE

MODEL	P2		VOLT. (V)	In (A)	Q	l/min									
	HP	kW				0	50	100	150	200	250	300	350	400	450
						m³/h									
						0	3	6	9	12	15	18	21	24	27
CPS3-10 PVM 20-3	5,5	4	3 ~ 400	8,5	m.c.w.	41,8	41,2	40,8	39,9	39,1	37,5	35,6	33	29,3	24,1
CPS3-10 PVM 20-5	7,5	5,5	3 ~ 400	11,9		71,6	70,7	70,3	69	67,7	64,9	61,7	57,2	52,4	42,8
CPS3-10 PVM 20-7	10	7,5	3 ~ 400	15,3		101	100,3	99,7	98	96,3	92,4	87,7	81,3	74,6	61,5
CPS3-10 PVM 20-10	15	11	3 ~ 400	20,4		146	144,6	144	141,6	139	133,6	127	117,6	106	89,5

# CPS 3-10 PVM

## THREE-PHASE ELECTRONIC FREQUENCY CONVERTER

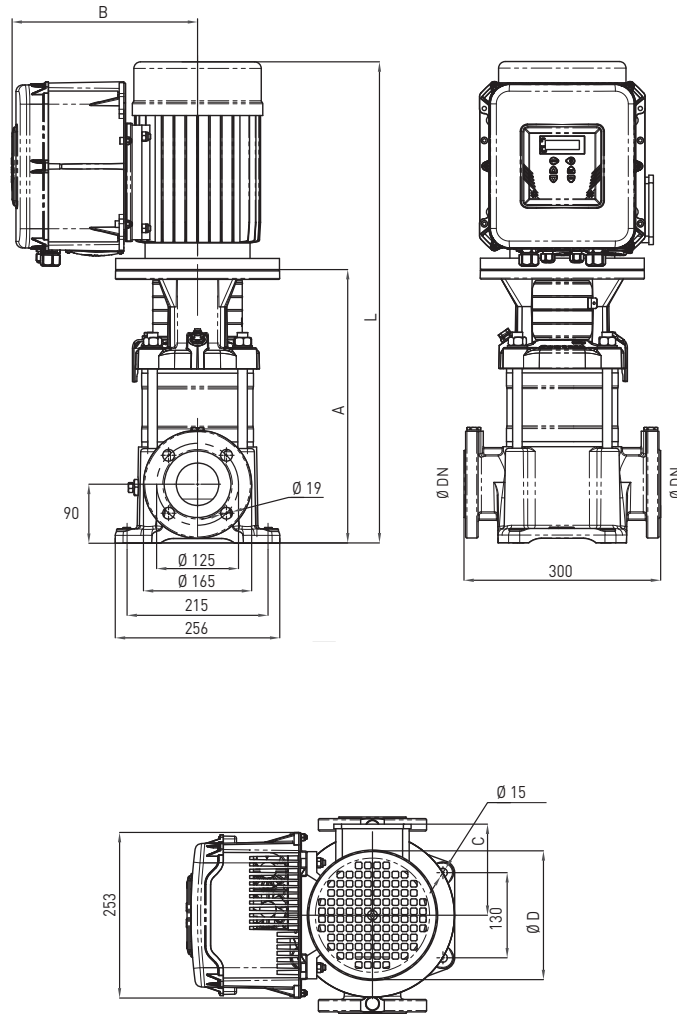

### OVERALL DIMENSIONS AND WEIGHTS

MODEL	Dimensions mm.						WEIGHT Kg
	A	B	C	D	L	DN	
CPS3-10 PVM 20-3	465	286	161	225	793	DN 50	73
CPS3-10 PVM 20-5	587	306	195	248	952	DN 50	106
CPS3-10 PVM 20-7	677	306	195	248	1062	DN 50	115
CPS3-10 PVM 20-10	889	334	238	317	1387	DN 50	155

# CPS 3-10 PVM

## THREE-PHASE ELECTRONIC FREQUENCY CONVERTER

### HYDRAULIC PERFORMANCE

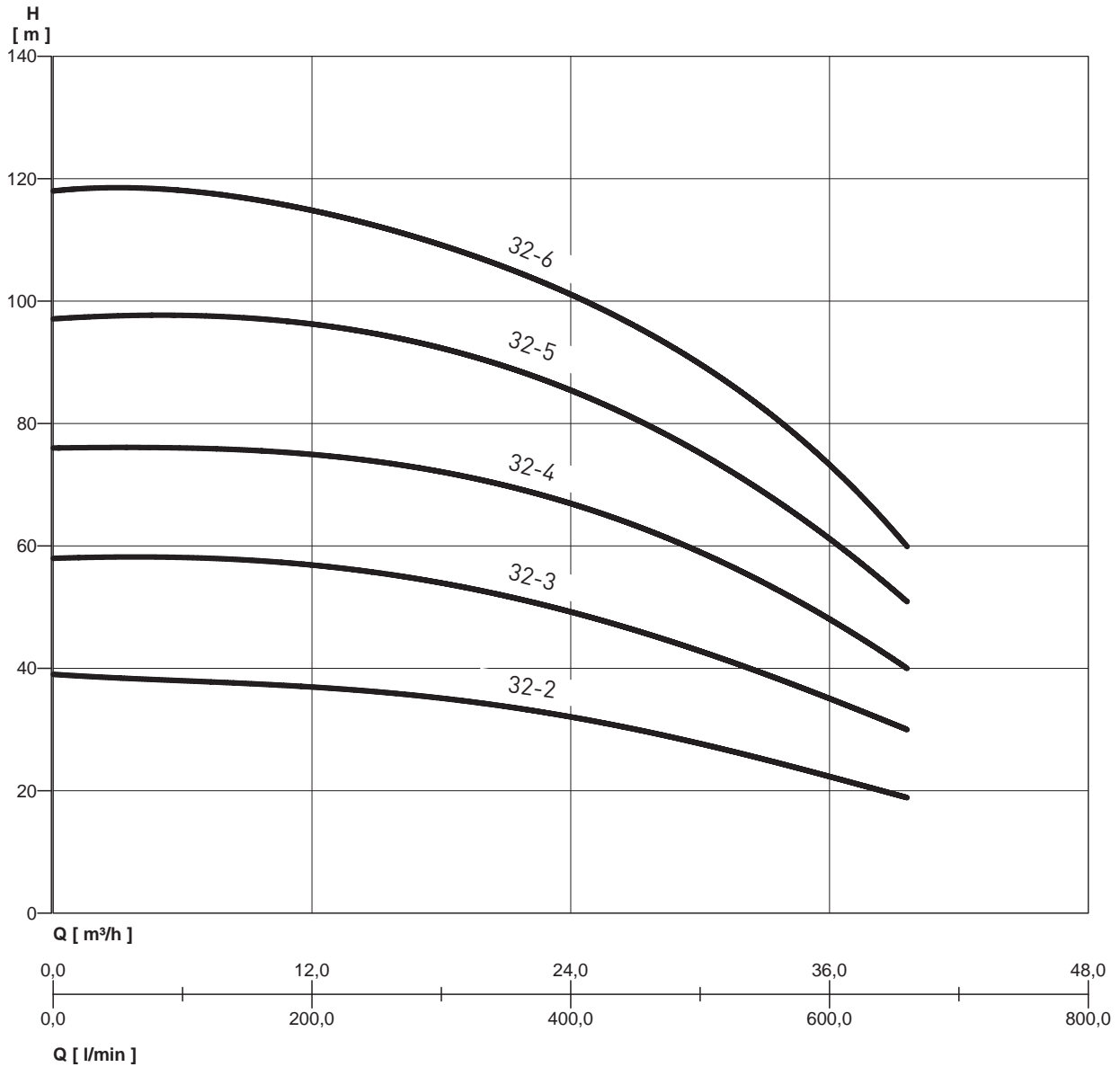

MEI ≥ 0.4 - Reference MEI ≥ 0.70 - The information on the reference efficiency is available at the address: [www.europump.org/efficiencycharts](http://www.europump.org/efficiencycharts)  
For the efficiency data see the PUMPS of the series PVM

### PERFORMANCE TABLE

MODEL	P2		VOLT. (V)	In (A)	0	m.c.w.								
	HP	kW				l/min	0	100	200	300	400	500	600	660
						m³/h	0	6	12	18	24	30	36	39,6
CPS3-10 PVM 32-2	5,5	4	3 ~ 400	7,1			39,2	38	37,7	36,2	33,8	29,8	24,2	19
CPS3-10 PVM 32-3	7,5	5,5	3 ~ 400	10,7			58,7	58	57,4	55	51,5	45,5	37,2	30
CPS3-10 PVM 32-4	10	7,5	3 ~ 400	14,3			78,2	76	77,1	73,9	69,2	61,2	50,3	40
CPS3-10 PVM 32-5	15	11	3 ~ 400	17,8			97,8	98	96,8	92,7	86,8	76,9	63,3	51
CPS3-10 PVM 32-6	15	11	3 ~ 400	21,4			117	118	117	112	105	92,6	76,3	60

# CPS 3-10 PVM

## THREE-PHASE ELECTRONIC FREQUENCY CONVERTER

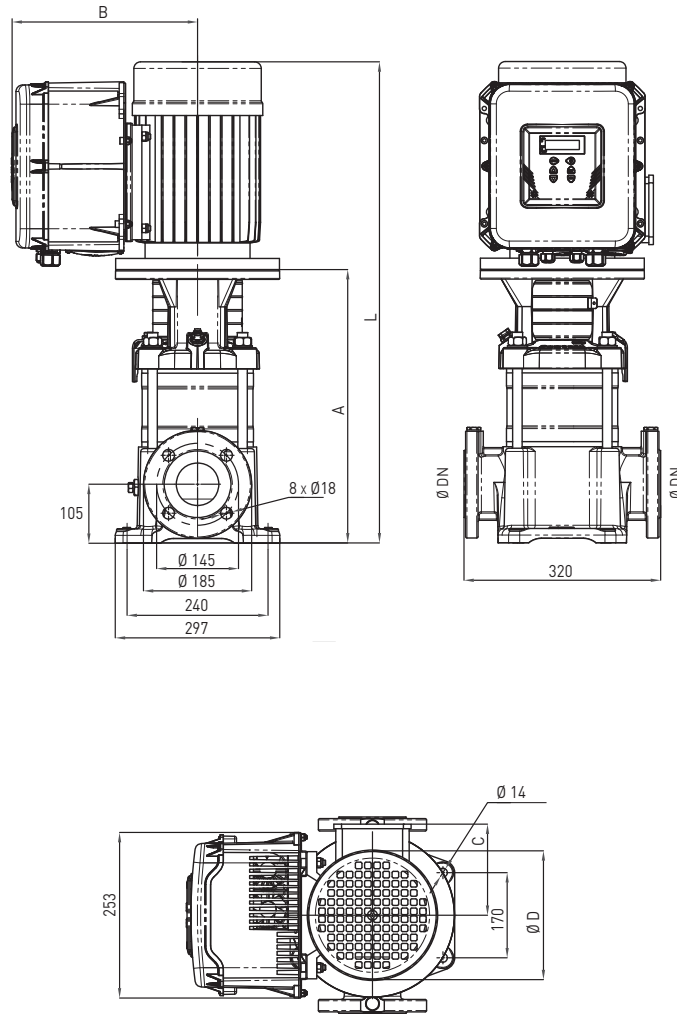

### OVERALL DIMENSIONS AND WEIGHTS

MODEL	Dimensions mm.						WEIGHT Kg
	A	B	C	D	L	DN	
CPS3-10 PVM 32-2	574	286	161	225	902	DN 65	93
CPS3-10 PVM 32-3	644	306	195	248	1009	DN 65	115
CPS3-10 PVM 32-4	714	306	195	248	1099	DN 65	125
CPS3-10 PVM 32-5	894	334	238	317	1392	DN 65	168
CPS3-10 PVM 32-6	964	334	238	317	1462	DN 65	171

# SECTION 2

## SURFACE PUMPS



### JET

CAST IRON SELF-PRIMING CENTRIFUGAL PUMPS

PAG. 54



### CB

TWO-STAGE HORIZONTAL CENTRIFUGAL PUMPS

PAG. 94



### JETINOX

STAINLESS STEEL SELF-PRIMING CENTRIFUGAL PUMPS

PAG. 58



### SSCX

SINGLE STAGE CENTRIFUGAL PUMPS MADE OF STAINLESS STEEL AISI 304

PAG. 96



### MULTI EVO - A

SELF-PRIMING MULTISTAGE CENTRIFUGAL PUMPS

PAG. 61



### MULTINOX-VE+

VERTICAL MULTISTAGE CENTRIFUGAL PUMPS

PAG. 98



### MULTI EVO

MULTISTAGE CENTRIFUGAL PUMPS

PAG. 69



### PVM

VERTICAL MULTISTAGE CENTRIFUGAL PUMPS

PAG. 105



### DHR

HORIZONTAL MULTISTAGE CENTRIFUGAL PUMPS

PAG. 77



### PVMI

VERTICAL MULTISTAGE CENTRIFUGAL PUMPS

PAG. 105



### DHI

AISI 316 HORIZONTAL MULTISTAGE CENTRIFUGAL PUMPS

PAG. 83



### PVMX

VERTICAL MULTISTAGE CENTRIFUGAL PUMPS

PAG. 105



### MULTI EVO-SP

MULTISTAGE CENTRIFUGAL PUMPS - SPECIAL

PAG. 86



### NRM

MONOBLOC NORMALISED CENTRIFUGAL PUMPS - 2 AND 4 POLES

PAG. 138



### SWIMMEY

SELF-PRIMING PUMPS FOR POOLS WITH PRE-FILTER

PAG. 90



### PGA-DELTA OIL

PUMPS FOR DIESEL TRANSFER

PAG. 155



### CM

SINGLE STAGE HORIZONTAL CENTRIFUGAL PUMPS

PAG. 96

## ACCESSORIES

PAG. 306

# JET

## CAST IRON SELF-PRIMING PUMPS

Sturdy, self-priming, large intake capacity

The self-priming pumps in the JET range combine the advantages and practical features of centrifugal pumps with the functionality of self-priming pumps. The Venturi pipe system on these pumps guarantees optimal hydraulic performance and impressive suction capacity, maintaining priming even in the presence of air or gas bubbles trapped in the water.

### MOTOR

- Closed, ventilated from exterior.
- Protection rating IP 44.
- Insulation class F.
- Single phase power supply with permanently activated capacitor and thermal cutout protection incorporated in the motor winding.
- Three phase power supply with external protection to be fitted by the user.
- Rotation speed 2850 rpm.
- Continuous duty.

### APPLICATIONS

- Lifting and distribution of water in domestic systems in continuous or intermittent operation.
- Pressurization systems.
- Washing, garden irrigation, supply to fountains, transfers.
- Lifting from wells or tanks.

### USAGE DATA

- Type of liquid: clean water without suspended solid bodies or abrasive material.
- Maximum temperature of the liquid 50°C.
- Maximum recommended suction height 8 m with foot valve.
- Maximum operating pressure: 6 bar. (10 bar for mod. 100 - 160)



## TABLE OF MATERIALS

Component	Material	
	NEW JET	JET
1 Pump body	Cast iron EN GJL 200	Cast iron EN GJL 200
2 Motor casing	Aluminium	Cast iron EN GJL 200
3 Impellers	Technopolymer with stainless steel shim ring X5 CrNi 1810 (AISI 304 )	Technopolymer models 600-800-1000 Moulded brass alloy models 100-160-800-1000
4 Diffuser-Venturi tube-nozzle	Monobloc group Technopolymer	Technopolymer
5 Motor shaft	Stainless steel X 12 CrNiS 1809 (AISI 416)	Stainless steel X 12 CrNiS 1809(AISI 416)
6 Mechanical seal	Graphite	Graphite
7 Counterface	Ceramic	Ceramic
8 Gaskets	NBR 70 shore	NBR 70 shore



# JET

## CAST IRON SELF-PRIMING PUMPS

### HYDRAULIC PERFORMANCE

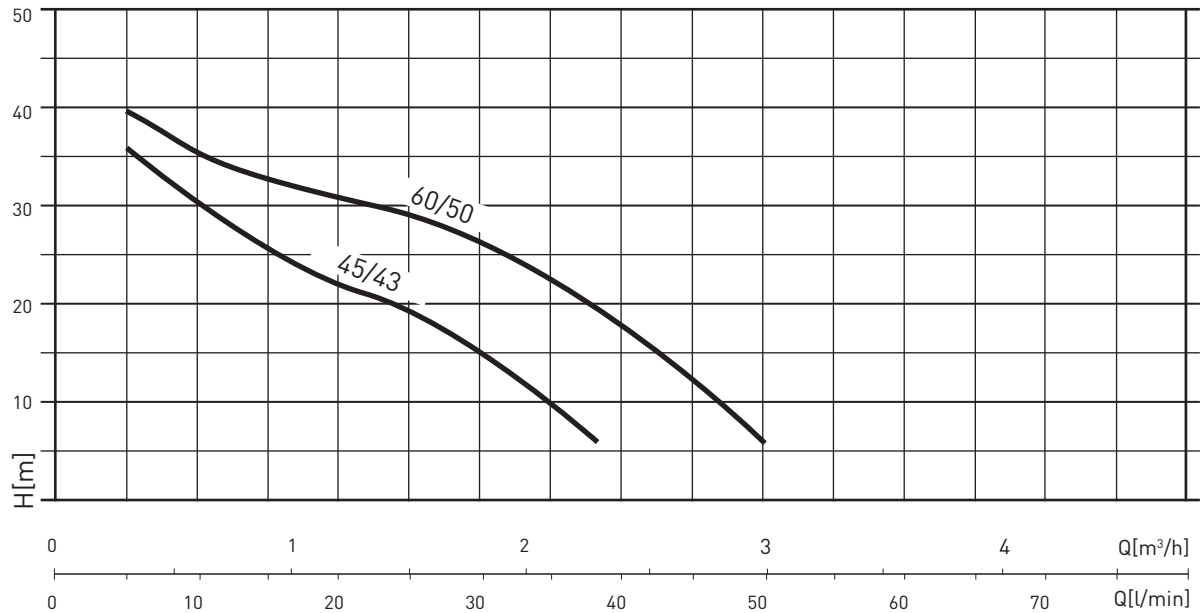

### PERFORMANCE TABLE

MODEL	Motor power (P2)		Motor power (P1)		VOLT. (V)	I <sub>n</sub> (A)	μF	Q	Q [l/min]					
	HP	kW	HP	kW					0	10	20	30	40	50
NEWJET 45/43 M	0,5	0,37	0,8	0,6	1-230	3	8	m.c.w.	43	30	23	16	1	
NEWJET 60/50 M	0,75	0,35	1,1	0,8	1-230	4	12,5	m.c.w.	43	36	31	26	18	6

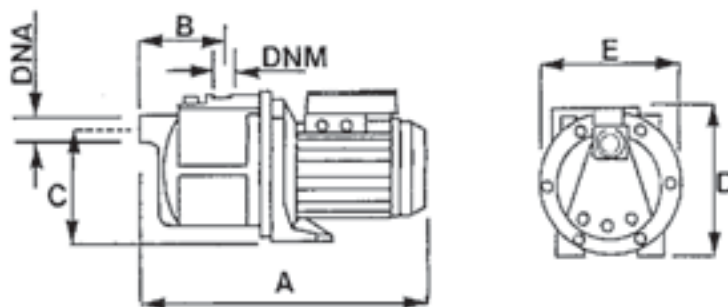

### OVERALL DIMENSIONS AND WEIGHTS

MODEL	Dimensions mm.							WEIGHT (Kg)
	A	B	C	D	E	DNA	DNM	
NEWJET 45/43	351	93	130	180	174	1"	1"	8,2
NEWJET 60/50	351	93	130	180	174	1"	1"	9

# JET

## CAST IRON SELF-PRIMING PUMPS

### HYDRAULIC PERFORMANCE

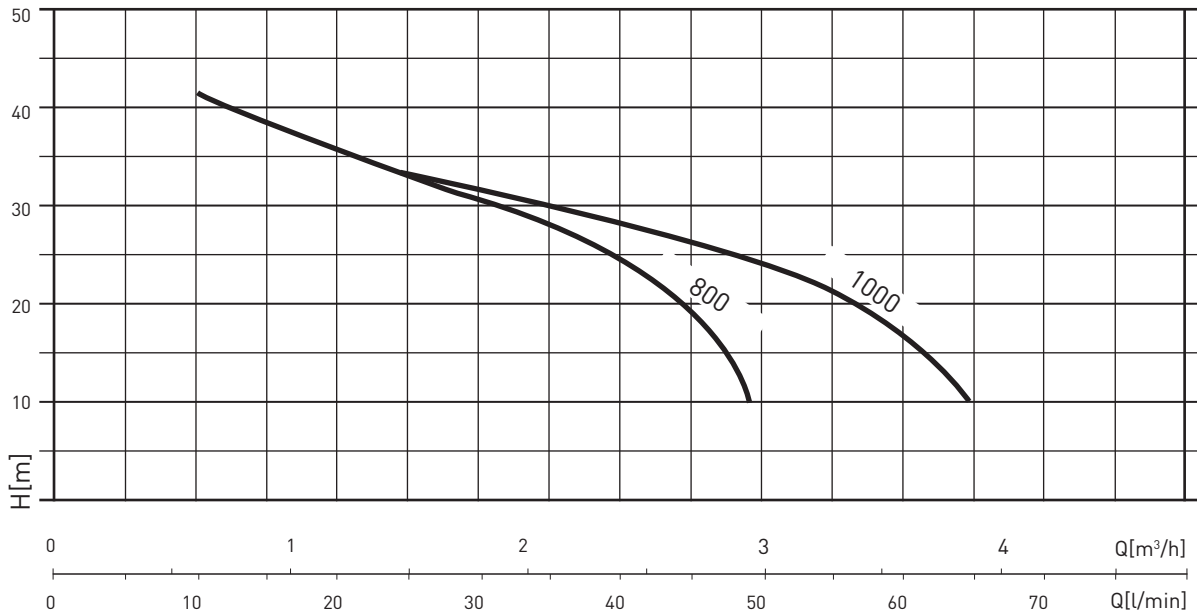

### PERFORMANCE TABLE

MODEL	Motor power (P2)		Motor power (P1)		VOLT. (V)	I <sub>n</sub> (A)	μF	Q	Flow rate							
	HP	kW	HP	kW					l/min	5	20	30	40	50	60	70
								m.c.w.	0,3	1,2	1,8	2,4	3	3,6	4,2	
JET 800 M JET 800 T	1	0,75	1,3	1	1 - 230 3 - 230/400	4,5 3,6-2,1	12,5	m.c.w.	44	36	31	27	7			
JET 1000 M JET 1000 T	1,36	1	1,5	1,1	1 - 230 3 - 230/400	5 3,8-2,2	16		45	36	32	28	25	15	3	

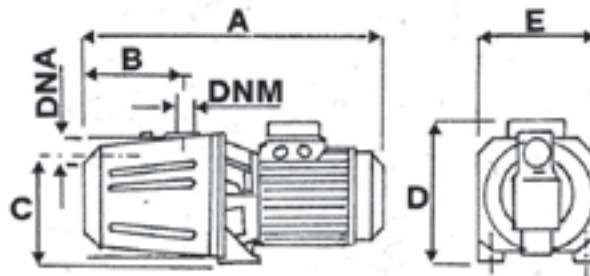

### OVERALL DIMENSIONS AND WEIGHTS

MODEL	Dimensions mm.							WEIGHT (Kg)
	A	B	C	D	E	DNA	DNM	
JET 800	400	147	160	190	182	1"	1"	14,2
JET 1000	425	147	160	190	182	1"	1"	16,8

# JET

## CAST IRON SELF-PRIMING PUMPS

### HYDRAULIC PERFORMANCE

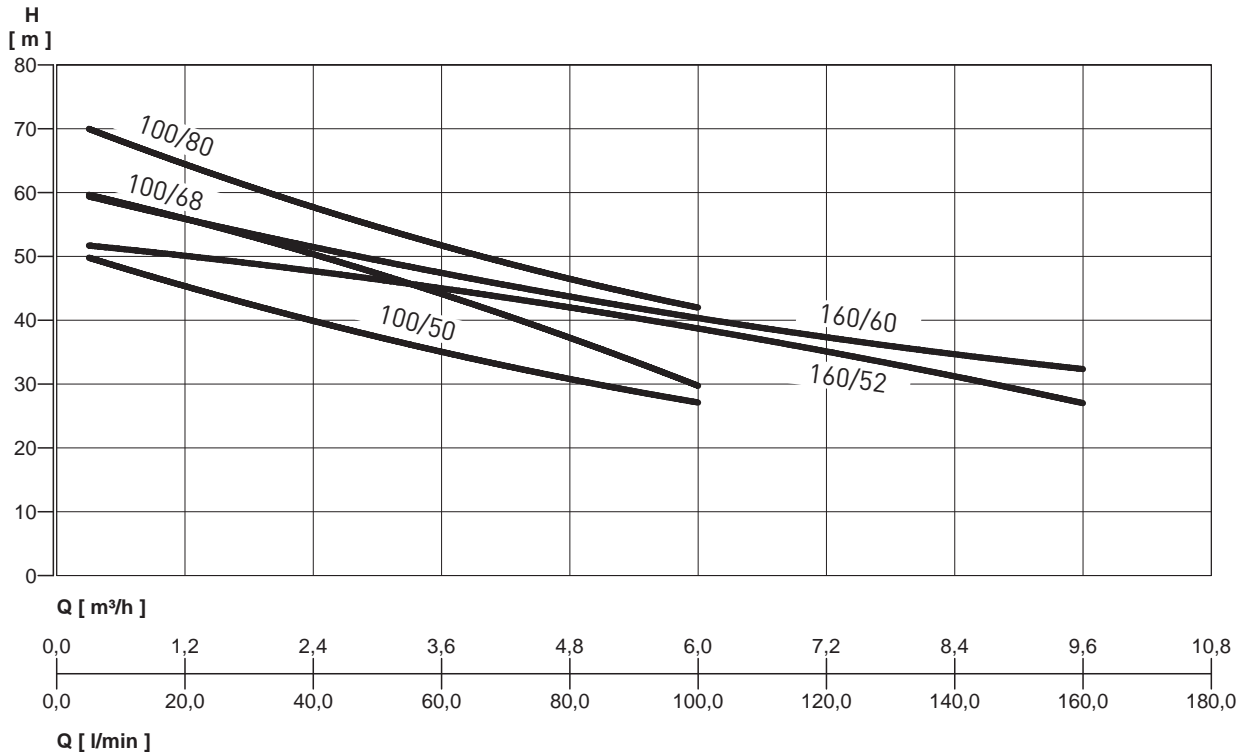

### PERFORMANCE TABLE

MODEL	Motor power (P2)		Motor power (P1)		VOLT. (V)	In (A)	μF	Q	m.c.w.									
	HP	kW	HP	kW					l/min	5	20	40	60	80	100	130	160	
									m³/h	0,3	1,2	2,4	3,6	4,8	6	7,8	9,6	
JET 100/50 M	1,5	1,1	2,2	1,7	1 ~ 230	8,1	35	m.c.w.	50	45	40	35	31	27				
JET 100/50 T			2,4	1,8	3 ~ 230/400	5,5-3,2												
JET 100/68 M	2	1,5	2,8	2,1	1 ~ 230	9,8	60		55,5	49	47,5	34,5	30,5					
JET 100/68 T			2,4	2,8	3 ~ 230/400	5,5-3,2												
JET 100/80 T	3	2,2	3,5	2,6	3 ~ 230/400	8,1-4,7	70		64,3	58	51,5	46,5	42					
JET 160/52 M	2	1,5	3,1	2,3	1 ~ 230	10,5	40		52	49,5	48	45	42	38,7	33,2	27		
JET 160/52 T			2,8	2,1	3 ~ 230/400	6,9-4,0												
JET 160/60 T	3	2,2	3,5	2,6	3 ~ 230/400	8,1-4,7	59		55,6	53	47	43,4	40	36	32,5			

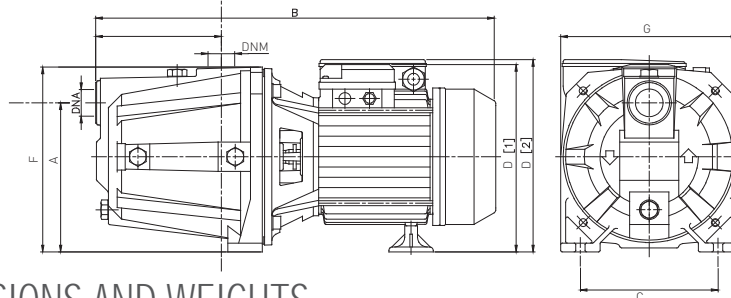

### OVERALL DIMENSIONS AND WEIGHTS

MODEL	Dimensions mm.										WEIGHT (Kg)
	A	B	C	D	E	F	G	DNA	DNM		
JET 100/50	170	508	180	247	220	223	157	1" 1/2	1"	25,5	
JET 100/68 - 160/52	170	508	180	247	220	223	157	1" 1/2	1"	26,6	
JET 100/80 - 160/60	170	508	180		220	223	157	1" 1/2	1"	28,1	

# JETINOX

## STAINLESS STEEL SELF-PRIMING PUMPS

Self-priming, high intake capacity

The self-priming pumps in the JETINOX range combine the advantages and practical features of centrifugal pumps with the functionality of self-priming pumps, as well as quality performance. The Venturi pipe system on these pumps guarantees optimal hydraulic performance and impressive suction capacity, maintaining priming even in the presence of air or gas bubbles trapped in the water.

### MOTOR

- Closed, ventilated from exterior.
- Protection rating IP 44.
- Insulation class F.
- Single phase power supply with permanently activated capacitor.
- Thermal cutout protection incorporated in motor winding.
- Rotation speed 2850 rpm.
- Continuous duty.

### APPLICATIONS

- Lifting and distribution of water in domestic systems, with continuous or intermittent duty.
- Pressure booster systems.
- Washing, irrigation of vegetable gardens, supply to fountains, transfers.
- Lifting from wells or cisterns.

### USAGE DATA

- Type of liquid: clean water without suspended solid bodies or abrasive material.
- Maximum liquid temperature: 50°C.
- Maximum recommended suction height: 8 m with foot valve.
- Maximum operating pressure: 6 bar.



## TABLE OF MATERIALS

Component	Material
1 Pump body	Stainless steel X5 CrNi 1810 (AISI 304)
2 Motor casing	Die-cast aluminium
3 Impeller	Technopolymer with stainless steel shim ring
4 Diffuser monobloc group Venturi tube-nozzle	Technopolymer
5 Shaft	Stainless steel X 12 CrNiS 1809 (AISI 416)
6 Mechanical seal	Graphite
7 Counterface	Ceramic
8 Seal holder plate	Technopolymer (series 45-60-70) Stainless steel X5 CrNi 1810 (AISI 304) series 90
9 Gaskets	NBR 70 Shore

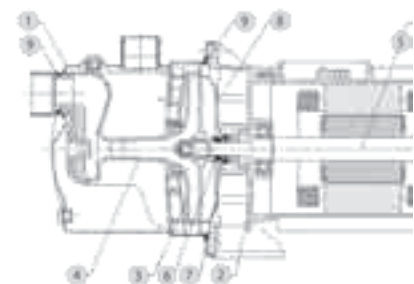

# JETINOX

## STAINLESS STEEL SELF-PRIMING PUMPS

### HYDRAULIC PERFORMANCE

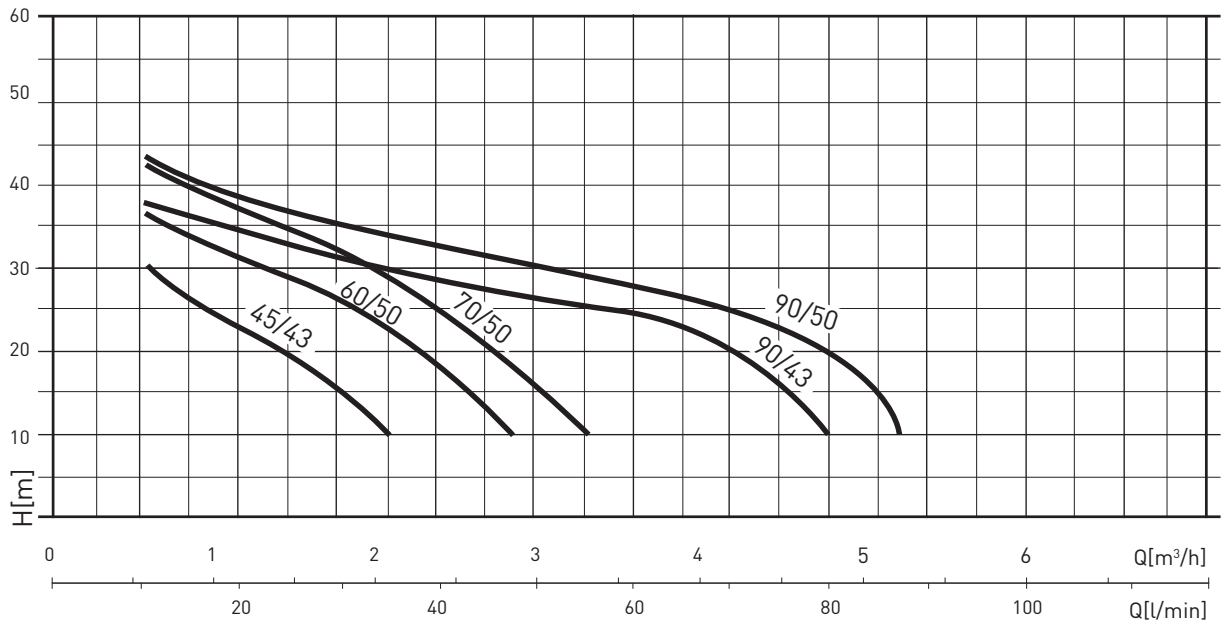

### PERFORMANCE TABLE

MODEL	Motor power (P2)		Motor power (P1)		VOLT. (V)	I <sub>n</sub> (A)	μF	Q	l/min										
	HP	kW	HP	kW					0	10	20	30	40	50	60	70	80		
JETINOX 45/43 M	0,5	0,37	0,8	0,6	1-230	3	8	0	43	30	23	16	1						
JETINOX 60/50 M	0,75	0,55	1,1	0,8	1-230	4	12,5	0	46	36	31	26	18	6					
JETINOX 70/50 M	0,95	0,7	1,36	1,0	1-230	4,5	16	0	48	42,5	37,5	32	25	16,5	7				
JETINOX 90/43 M	1,0	0,75	1,8	1,3	1-230	6,5	20	0	43	38	34	32	29	27	25	21	10		
JETINOX 90/50 M	1,2	0,9	2	1,5	1-230	7	25	0	50	42	39	37	33	30	27	25	20		
JETINOX 60/50 C*	0,75	0,55	1,10	0,8	1-230	4	12,5	0	46	36	31	26	18	6					
JETINOX 70/50 C*	0,95	0,7	1,36	1,0	1-230	4,5	16	0	48	42,5	37,5	32	25	16,5	7				
JETINOX 90/43 C*	1,0	0,75	1,80	1,3	1-230	6,5	20	0	43	38	34	32	29	27	25	21	10		
JETINOX 90/50 C*	1,2	0,9	2	1,5	1-230	7	25	0	50	42	39	37	33	30	27	25	20		

\* Version complete with handle, cable and schuko plug

# JETINOX

## STAINLESS STEEL SELF-PRIMING PUMPS

### OVERALL DIMENSIONS AND WEIGHTS

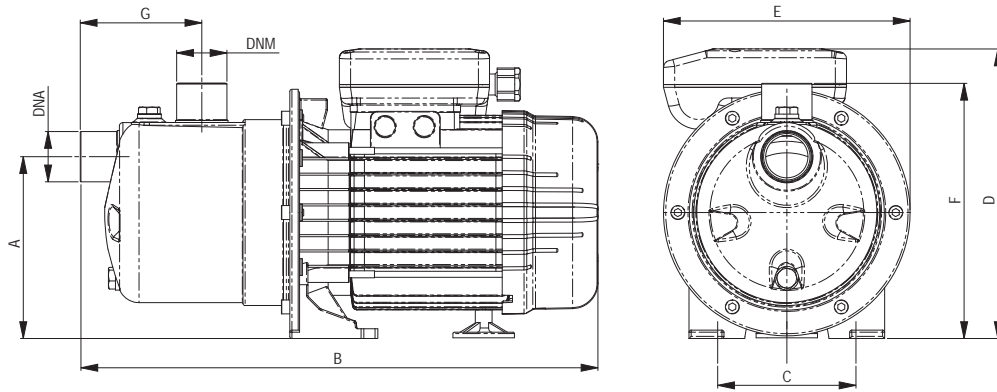

VERSION C

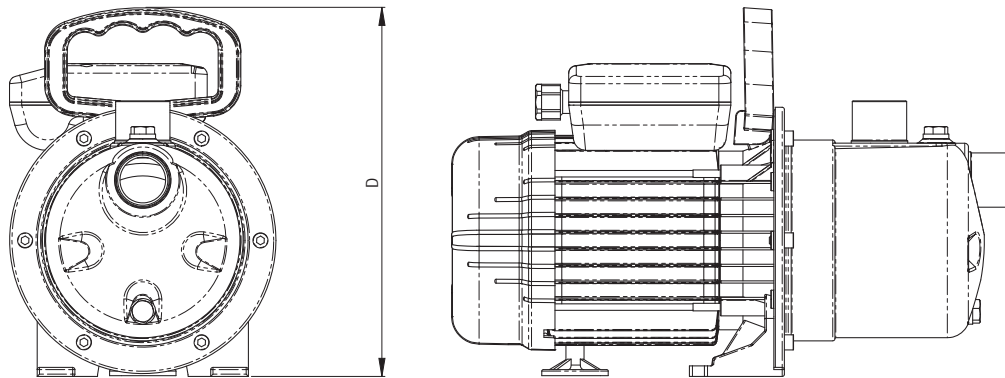

### OVERALL DIMENSIONS AND WEIGHTS

MODEL	Dimensions mm.									WEIGHT (Kg)
	A	B	C	D	E	F	G	DNA	DNM	
JETINOX 45/43	130	352	100	199	177	185	87	1" F	1" F	4,7
JETINOX 60/50	130	370	100	207	177	185	87	1" F	1" F	8,2
JETINOX 60/50 C*	130	370	100	245	177	185	87	1" F	1" F	8,2
JETINOX 70/50	143	351	100	207	177	200	76	1" F	1" F	9,5
JETINOX 70/50 C*	143	351	100	245	177	200	76	1" F	1" F	9,5
JETINOX 90/43	158	395	141	207	205	214	98	1" 1/4 M	1" F	11
JETINOX 90/43 C*	158	395	141	275	205	214	98	1" 1/4 M	1" F	11
JETINOX 90/50	158	425	141	230	218	214	98	1" 1/4 M	1" F	13
JETINOX 90/50 C*	158	425	141	275	218	214	98	1" 1/4 M	1" F	13

\* Version complete with handle, cable and schuko plug

# MULTI EVO-A

## SELF-PRIMING MULTISTAGE CENTRIFUGAL PUMPS

Multi EVO-A is a self-priming multi-stage centrifugal horizontal pump with an inlet with axial thread and an outlet with radial thread. The innovative, high efficiency hydraulic system is connected to a motor of the latest generation with a mechanical seal.

All models are certified for use with drinking water (ACS and DM174)

### ADVANTAGES

The Multi EVO series pumps feature the following advantages:

- High reliability - thanks to the durable and innovative design
- Silent - more comfort for the user thanks to its silent operation
- Compact shape
- Many possible uses for the residential market
- Excellent priming ability

### SPECIFICATIONS:

#### PUMP

- Hydraulic performance according to ISO 9906:2012 - Grade 3B
- Type of liquid: clean water without suspended solids or abrasive material
- Maximum temperature of the liquid 50°C
- Maximum operating pressure 8 bar

#### MOTOR

- Closed, air ventilated (TEFC)
- 2 poles, 50 Hz (n=2850 rpm)
- IE3 three-phase AC (P2 ≥ 0.75 kW)
- Protection level: IP55
- Insulation class: F
- Maximum ambient temperature 40°C
- Single-phase power supply with capacitor permanently on and thermal protection built into the motor casing.

### APPLICATIONS

- Pressurising and supply
- Irrigation



### SELF-PRIMING CAPACITY

H20, T = 20°C,  
Pa = 1000 hPa (mbar)  
H3 = vertical section

H2 (m)	H3 (m) minimum							
	3-40	3-50	3-60	5-40	5-50	5-60	8-40	8-50
2	0.15	0.15	0.15	0.15	0.15	0.15	0.25	0.3
4	0.15	0.15	0.35	0.15	0.15	0.35	0.25	0.6
6	0.15	0.15	0.55	0.15	0.15	0.65	0.3	
8	0.55	0.35	0.55	0.45	0.55	0.65	0.65	

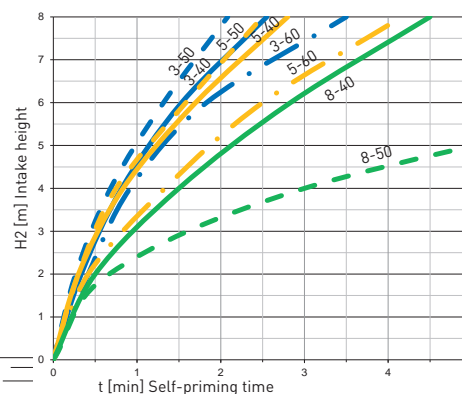
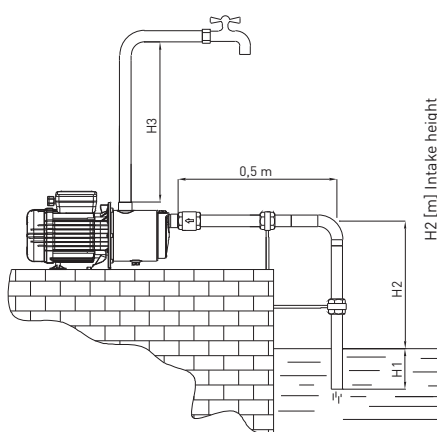

- Use of rainwater
- Washing systems



# MULTI EVO-A

## SELF-PRIMING MULTISTAGE CENTRIFUGAL PUMPS

### CONSTRUCTION FEATURES

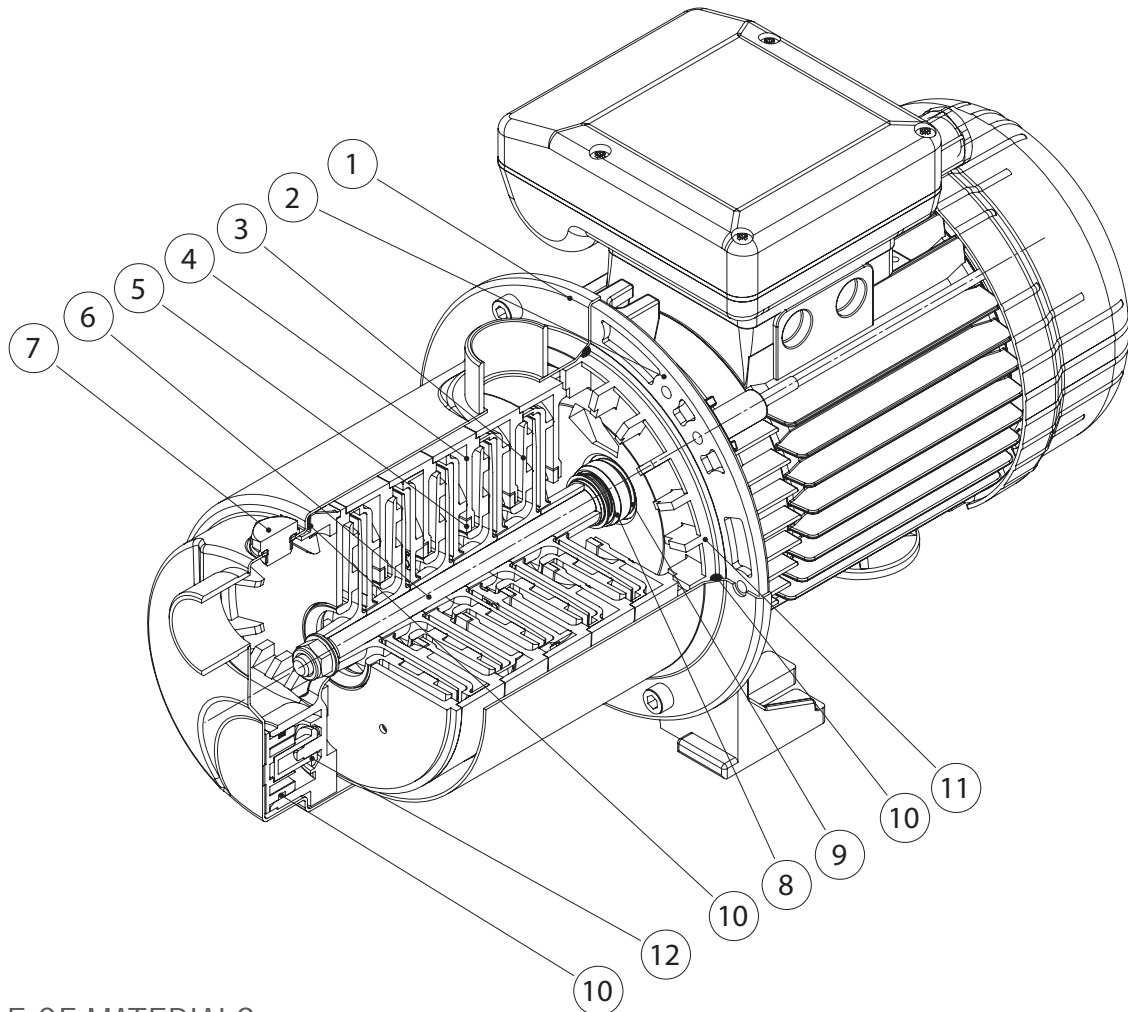

### TABLE OF MATERIALS

Ref.	Component	Material
1	Pump body	Stainless steel Europe: EN10088-1 X5CrNi18-10 (1.4301) USA: AISI 304
2	Motor casing	Die-cast aluminium
3	Impeller	PPO reinforced with fibreglass
4	Diffuser	PPO reinforced with fibreglass
5	Wear ring	PTFE
6	Shaft (hydraulic part)	Stainless steel Europe: EN10088-1 X5CrNi18-10 (1.4301) USA: AISI 304
7	Inlet / outlet caps	Stainless steel Europe: EN10088-1 X8CrNiS18-9 (1.4305) USA: AISI 303
8	Mechanical seal	Carbon graphite / NBR / SS Europe: EN10088-1 X5CrNi18-10 (1.4301) USA: AISI 304
9	Counterface	Ceramic / NBR
10	Gaskets	NBR 70 Shore A
11	Seal holder plate	PPO reinforced with fibreglass
12	Priming valve	PPO reinforced with fibreglass



# MULTI EVO-A 3

## SELF-PRIMING MULTISTAGE CENTRIFUGAL PUMPS

### HYDRAULIC PERFORMANCE

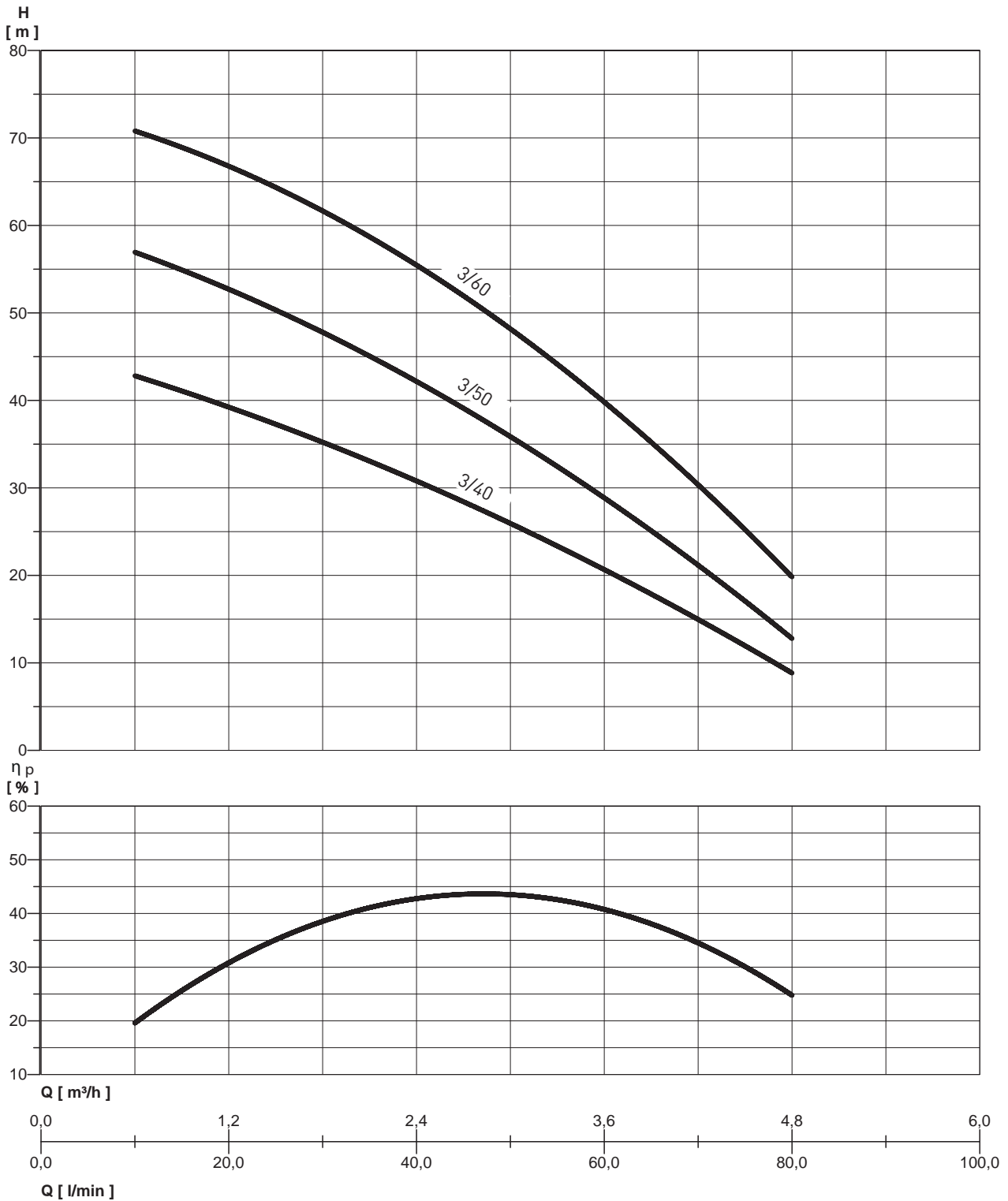

# MULTI EVO-A 3

## SELF-PRIMING MULTISTAGE CENTRIFUGAL PUMPS

### PERFORMANCE TABLE

MODEL	Nominal power (P2)		Absorbed power (P1)		VOLT. (V)	In (A)	µF	0	total head in water column metres							
	HP	kW	HP	kW					l/min	10	20	30	40	50	60	80
									m <sup>3</sup> /h	0,6	1,2	1,8	2,4	3	3,6	4,8
MULTI EVO-A 3-40 M	0,68	0,51	1,1	0,8	1 ~ 230	3,7	12,5									
MULTI EVO-A 3-40 M-C *	0,68	0,51	1,1	0,8	1 ~ 230	3,7	12,5		42,5	39,5	35,5	31	25,5	20,5	9	
MULTI EVO-A 3-40 T	0,71	0,53	1,05	0,78	3 ~ 230/400	2,7 / 1,55	--									
MULTI EVO-A 3-50 M	0,94	0,7	1,34	1	1 ~ 230	4,4	16		56,5	53	48,5	42	35,5	28,6	13	
MULTI EVO-A 3-50 T	0,94	0,7	1,34	1	3 ~ 230/400	3,3 / 1,9	--									
MULTI EVO-A 3-60 M	1,2	0,9	1,68	1,25	1 ~ 230	5,7	20		70,5	67	62	55,5	48	39,5	20	
MULTI EVO-A 3-60 T	1,1	0,82	1,57	1,17	3 ~ 230/400	3,5 - 2	--									

\* Version with cable, handle and schuko plug.

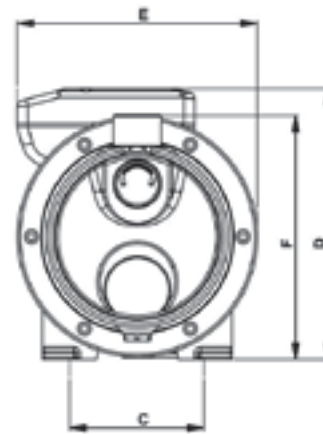
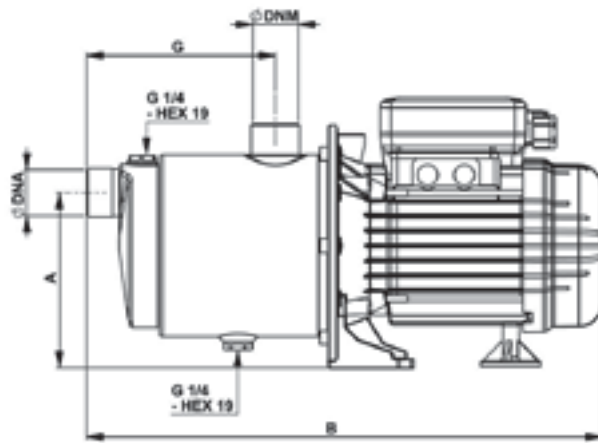

VERSION C

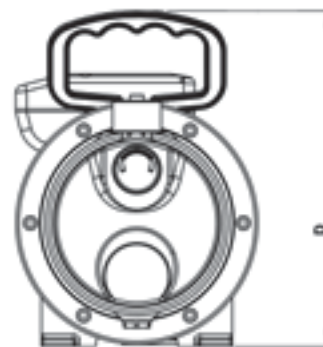
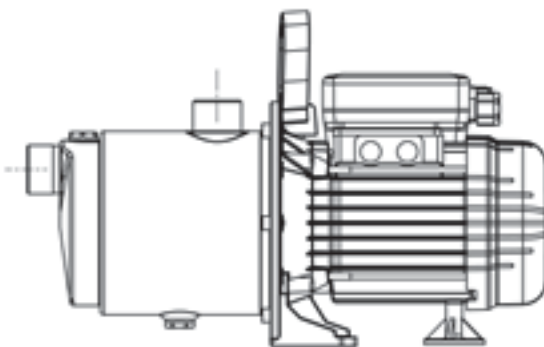

### OVERALL DIMENSIONS AND WEIGHTS

MODEL	Dimensions mm.									WEIGHTS (Kg)
	A	B	C	D	E	F	G	DNA	DNM	
MULTI EVO-A 3-40 M	129	380	100	199	177	180	139	1"	1"	7,3
MULTI EVO-A 3-40 T	129	380	100	199	177	180	139	1"	1"	7,3
MULTI EVO-A 3-40 M-C*	129	380	100	245	177	180	139	1"	1"	7,6
MULTI EVO-A 3-50 M	129	422	100	207	177	180	162	1"	1"	9,3
MULTI EVO-A 3-50 T	129	422	100	207	177	180	162	1"	1"	9,3
MULTI EVO-A 3-60 M	129	422	100	207	177	180	162	1"	1"	10,8
MULTI EVO-A 3-60 T	129	422	100	207	177	180	162	1"	1"	10,8

\* Version with cable, handle and schuko plug.

# MULTI EVO-A 5

## SELF-PRIMING MULTISTAGE CENTRIFUGAL PUMPS

### HYDRAULIC PERFORMANCE

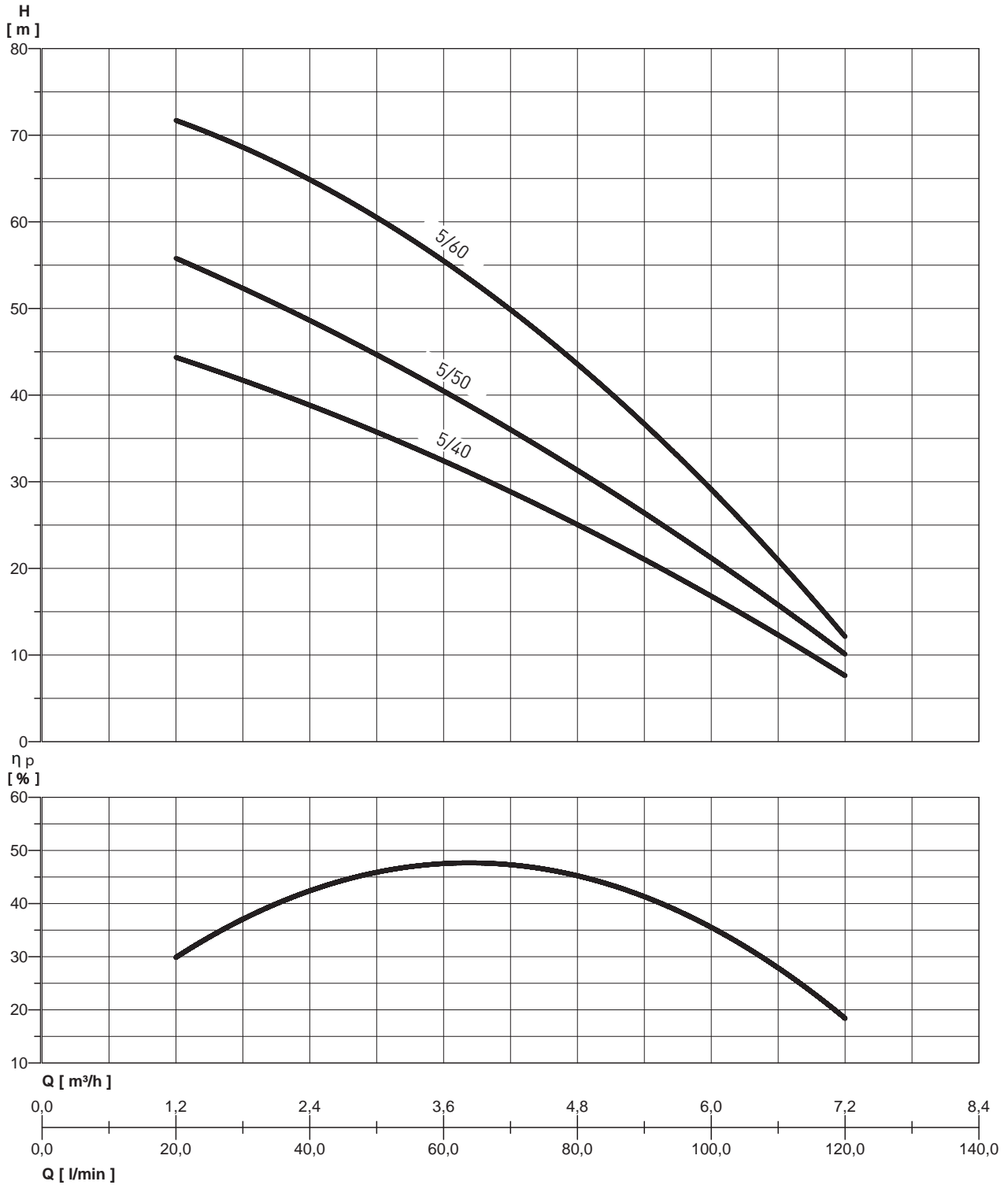

# MULTI EVO-A 5

## SELF-PRIMING MULTISTAGE CENTRIFUGAL PUMPS

### PERFORMANCE TABLE

MODEL	Nominal power (P2)		Absorbed power (P1)		VOLT. (V)	In (A)	µF	Q	Flow rate									
	HP	kW	HP	kW					l/min	20	30	40	50	60	80	100	120	
									m³/h	1,2	1,8	2,4	3	3,6	4,8	6	7,2	
MULTI EVO-A 5-40 M	1	0,75	1,5	1,1	1 ~ 230	4,7	16											
MULTI EVO-A 5-40 T	1	0,75	1,5	1,1	3 ~ 230/400	3,4 / 2	--											
MULTI EVO-A 5-50 M	1,27	0,95	1,8	1,35	1 ~ 230	6,2	20											
MULTI EVO-A 5-50 M-C*	1,27	0,95	1,8	1,35	1 ~ 230	6,2	20											
MULTI EVO-A 5-50 T	1,2	0,9	1,68	1,25	3 ~ 230/400	3,7 / 2,1	--											
MULTI EVO-A 5-60 M	1,6	1,2	2,2	1,65	1 ~ 230	7,5	31,5											
MULTI EVO-A 5-60 T	1,6	1,2	2,1	1,57	3 ~ 230/400	5,3 / 3,1	--											

total head in water column metres	Flow rate							
	1,2	1,8	2,4	3	3,6	4,8	6	7,2
	44,5	41,5	39	35,5	32,5	25	17	7,5
	56	52	48,5	45	40,5	31	21,5	10
	71,5	68,5	65	61	55,5	43,5	28,5	12,5

\* Version with cable, handle and schuko plug.

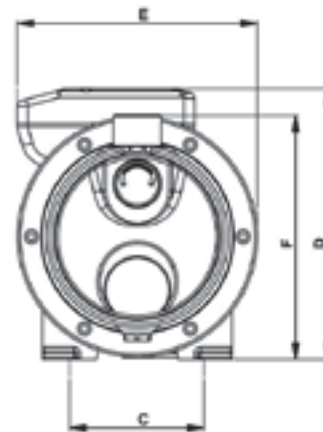
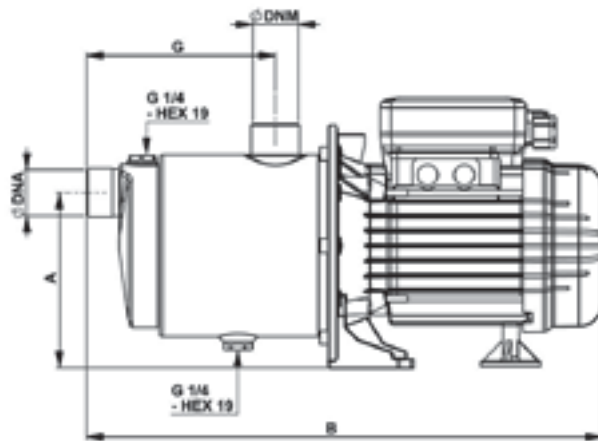

VERSION C

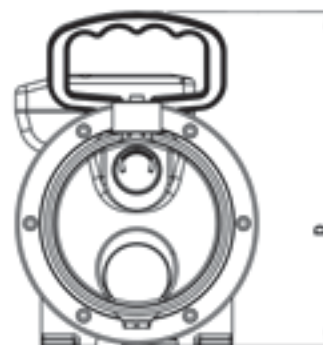
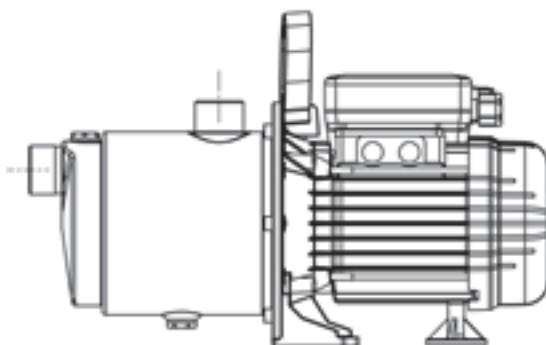

### OVERALL DIMENSIONS AND WEIGHTS

MODEL	Dimensions mm.										WEIGHTS (Kg)
	A	B	C	D	E	F	G	DNA	DNM		
MULTI EVO-A 5-40 M	129	400	100	207	177	180	139	1"	1"	9	
MULTI EVO-A 5-40 T	129	400	100	207	177	180	139	1"	1"	9	
MULTI EVO-A 5-50 M	129	422	100	207	177	180	162	1"	1"	10,6	
MULTI EVO-A 5-50 T	129	422	100	207	177	180	162	1"	1"	10,6	
MULTI EVO-A 5-50 M-C*	129	422	100	245	177	180	162	1"	1"	11	
MULTI EVO-A 5-60 M	129	457	100	215	203	180	162	1"	1"	13,5	
MULTI EVO-A 5-60 T	129	457	100	215	177	180	162	1"	1"	13,5	

\* Version with cable, handle and schuko plug.

# MULTI EVO-A 8

## SELF-PRIMING MULTISTAGE CENTRIFUGAL PUMPS

### HYDRAULIC PERFORMANCE

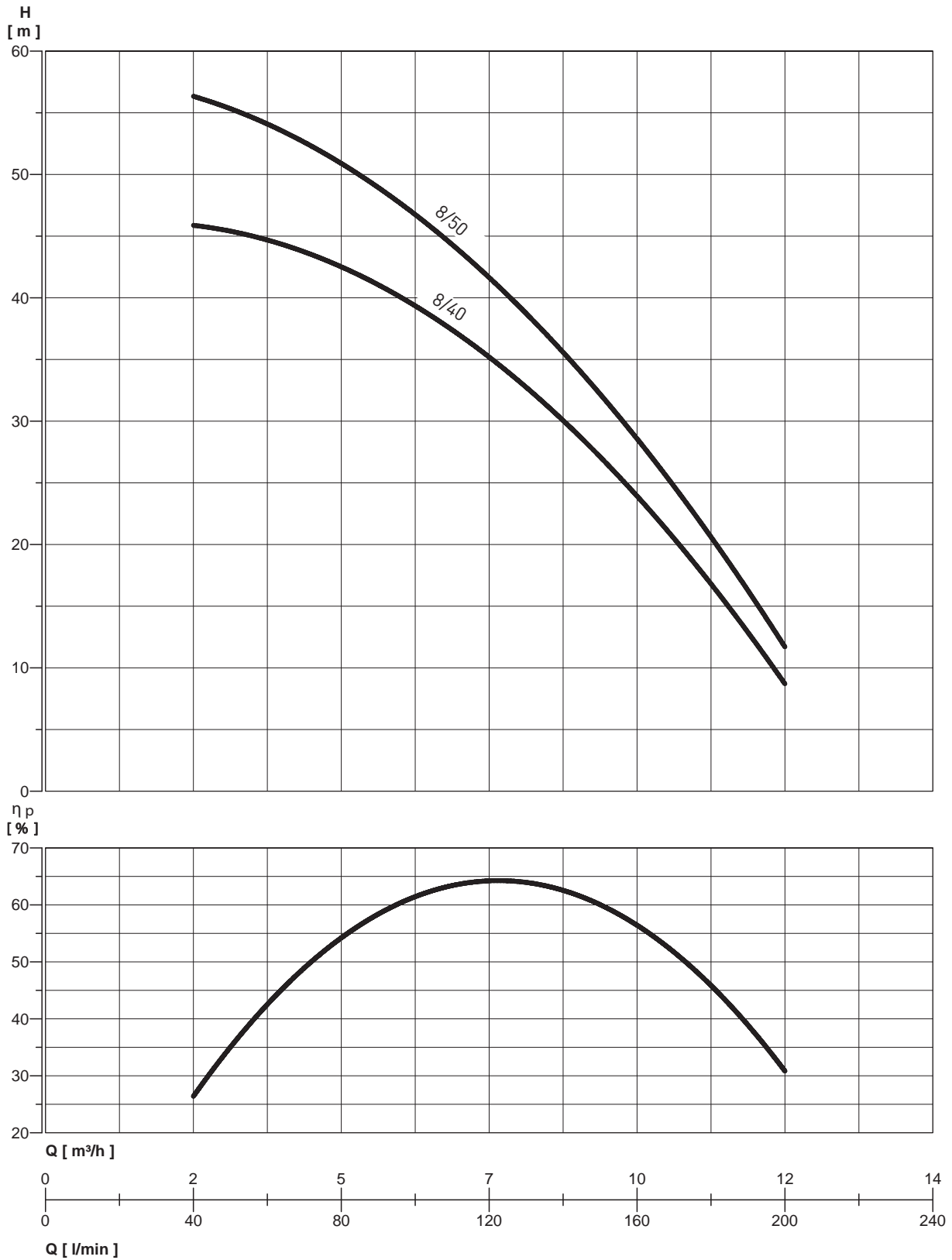

# MULTI EVO-A 8

## SELF-PRIMING MULTISTAGE CENTRIFUGAL PUMPS

### PERFORMANCE TABLE

MODEL	Nominal power (P2)		Absorbed power (P1)		VOLT. (V)	In (A)	µF	Q	total head in water column metres											
	HP	kW	HP	kW					l/min	40	50	60	80	100	120	140	160	180	200	
									m <sup>3</sup> /h	2,4	3	3,6	4,8	6	7,2	8,4	9,6	10,8	12	
MULTI EVO-A 8-40 M	1,6	1,2	2,23	1,66	1~230	7,7	31,5													
MULTI EVO-A 8-40 T	1,6	1,18	2	1,5	3~230/400	5-2,95	--		46	46	45	42	40	36	30	24	17	9		
MULTI EVO-A 8-50 M	1,9	1,4	2,7	2	1~230	9	35													
MULTI EVO-A 8-50 T	1,9	1,4	2,6	1,95	3~230/400	6,7-4	--		56,5	55	54	51	47	42	36	28	21	12		

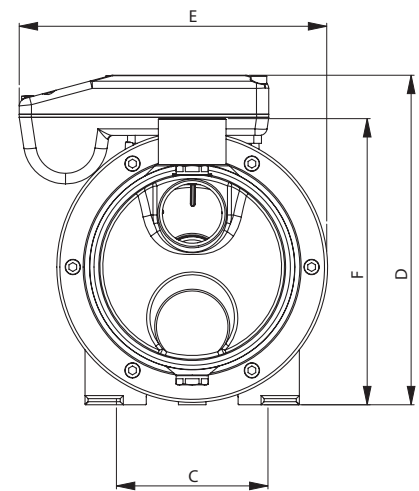
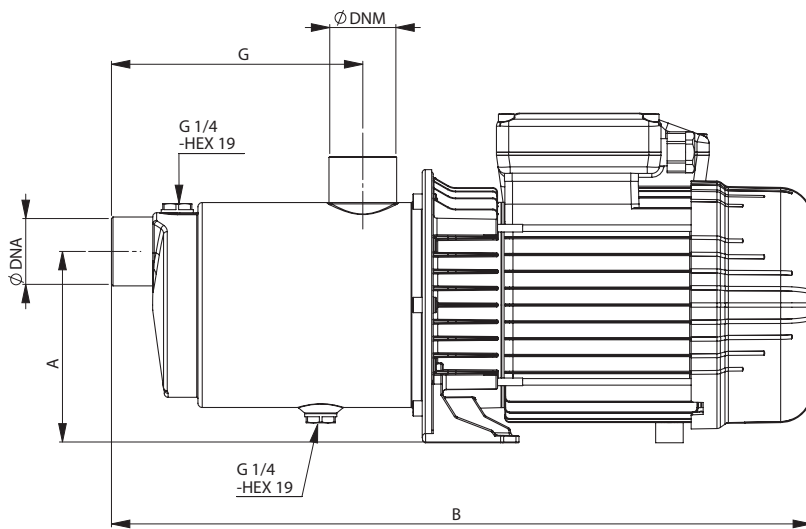

### OVERALL DIMENSIONS AND WEIGHTS

MODEL	Dimensions mm.									WEIGHTS
	A	B	C	D	E	F	G	DNA	DNM	(Kg)
MULTI EVO-A 8-40 M	125	457	100	215	203	187	164	1" 1/4	1" 1/4	13,5
MULTI EVO-A 8-40 T	125	457	100	215	177	187	164	1" 1/4	1" 1/4	13,5
MULTI EVO-A 8-50 M	125	457	100	215	203	187	164	1" 1/4	1" 1/4	14,5
MULTI EVO-A 8-50 T	125	457	100	215	177	187	164	1" 1/4	1" 1/4	14,5

## MULTI EVO

### MULTISTAGE CENTRIFUGAL PUMPS

Multi EVO-A is a multi-stage centrifugal horizontal pump with an inlet with axial thread and an outlet with radial thread. The innovative, high efficiency hydraulic system is connected to a motor of the latest generation with a mechanical seal.

All models are certified for use with drinking water (ACS and DM174)

#### ADVANTAGES

The Multi EVO series pumps feature the following advantages:

- Low energy consumption thanks to the highly efficient hydraulic system
- High efficiency
- High reliability - thanks to the durable and innovative design
- Silent - more comfort for the user thanks to its silent operation
- Compact shape
- Wide range



#### SPECIFICATIONS:

##### PUMP

- Hydraulic performance according to ISO 9906:2012 - Grade 3B
- Type of liquid: clean water without suspended solids or abrasive material
- Maximum temperature of the liquid 50°C
- Maximum operating pressure 8 bar
- Maximum intake height recommended 6m with foot valve

##### MOTOR

- Closed, air ventilated (TEFC)
- 2 poles, 50 Hz (n=2850 rpm)
- IE3 three-phase AC (P2 ≥ 0.75 kW)
- Protection level: IP55
- Insulation class: F
- Maximum ambient temperature 40°C
- Single-phase power supply with capacitor permanently on and thermal protection built into the motor casing.



#### APPLICATIONS

- Pressurising and supply
- Irrigation
- Use of rainwater
- Washing systems



# MULTI EVO

## MULTISTAGE CENTRIFUGAL PUMPS

### CONSTRUCTION FEATURES

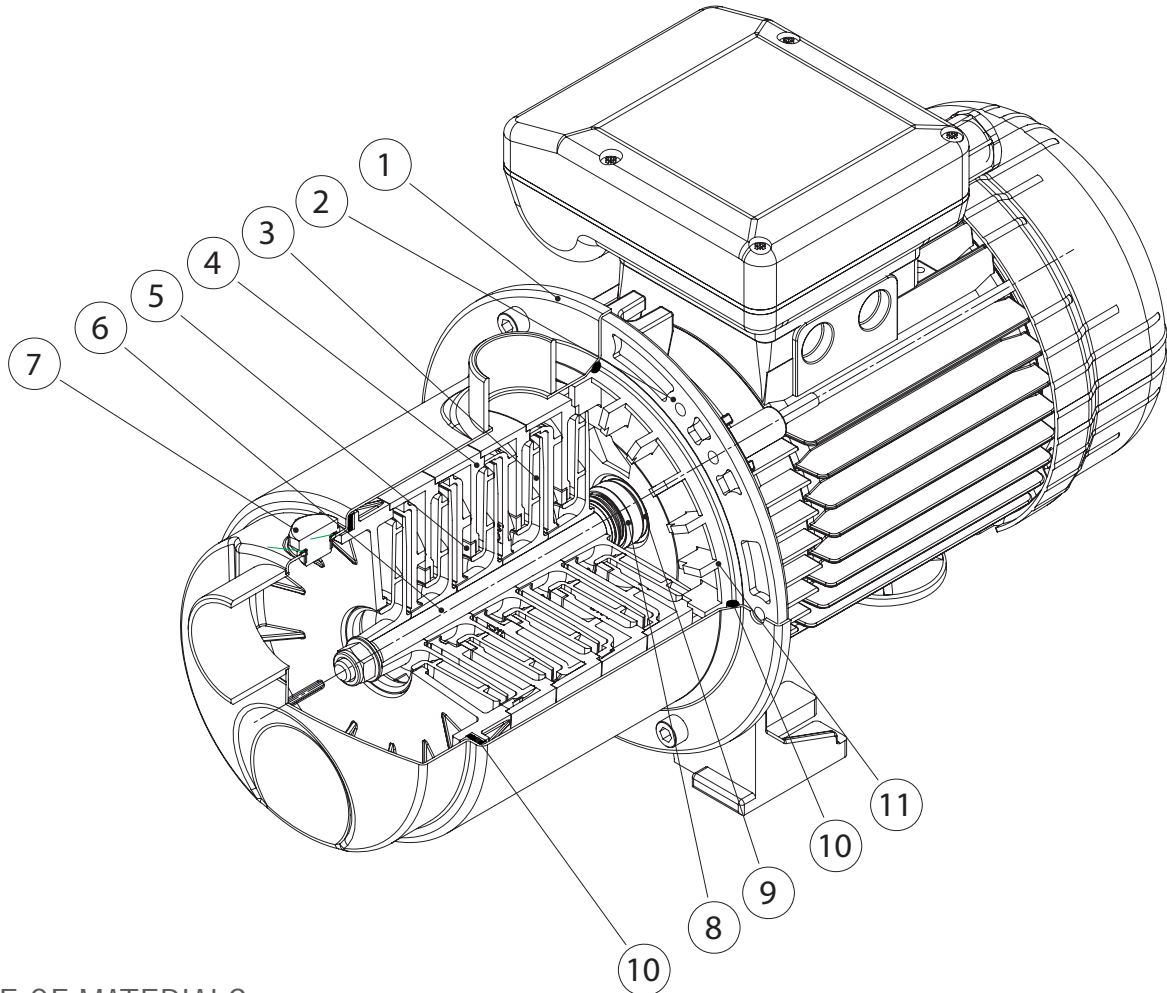

### TABLE OF MATERIALS

Ref.	Component	Material
1	Pump body	Stainless steel Europe: EN10088-1 X5CrNi18-10 (1.4301) USA: AISI 304
2	Motor casing	Die-cast aluminium
3	Impeller	PPO reinforced with fibreglass
4	Diffuser	PPO reinforced with fibreglass
5	Wear ring	PTFE
6	Shaft (hydraulic part)	Stainless steel Europe: EN10088-1 X5CrNi18-10 (1.4301) USA: AISI 304
7	Inlet / outlet caps	Stainless steel Europe: EN10088-1 X8CrNiS18-9 (1.4305) USA: AISI 303
8	Mechanical seal	Carbon graphite / NBR / SS Europe: EN10088-1 X5CrNi18-10 (1.4301) USA: AISI 304
9	Counterface	Ceramic / NBR
10	Gaskets	NBR 70 Shore A
11	Seal holder plate	PPO reinforced with fibreglass



# MULTI EVO 3

## MULTISTAGE CENTRIFUGAL PUMPS

### HYDRAULIC PERFORMANCE

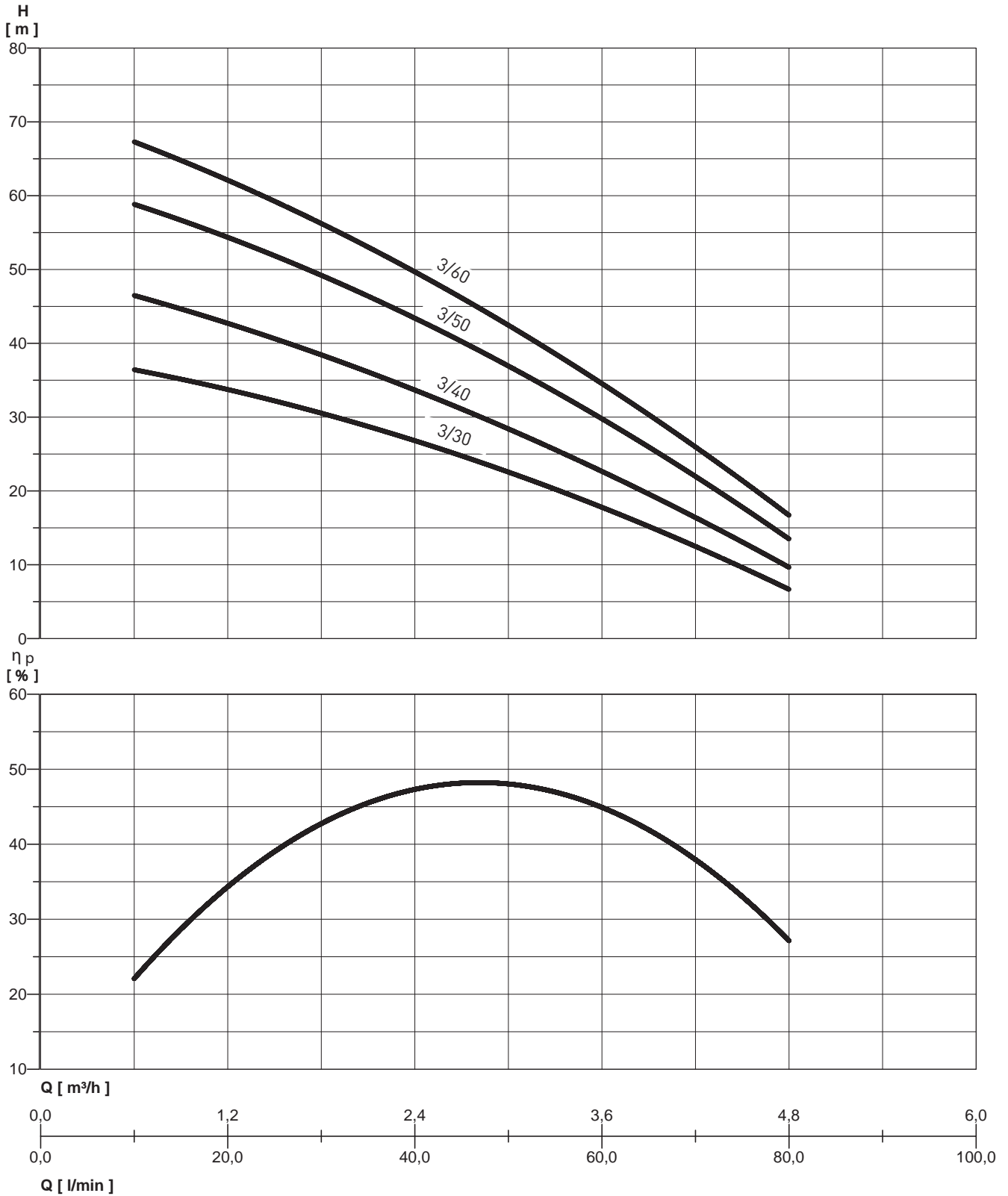

# MULTI EVO 3

## MULTISTAGE CENTRIFUGAL PUMPS

### PERFORMANCE TABLE

MODEL	Nominal power (P2)		Absorbed power (P1)		VOLT. (V)	In (A)	μF	0	total head in water column metres							
	HP	kW	HP	kW					l/min	10	20	30	40	50	60	80
									m <sup>3</sup> /h	0,6	1,2	1,8	2,4	3	3,6	4,8
MULTI EVO 3-30 M	0,54	0,4	0,87	0,65	1-230	2,95	12,5			36	34	31	27	22,5	17	7
MULTI EVO 3-30 T	0,54	0,4	0,87	0,65	3-230/400	2,3/1,3	--									
MULTI EVO 3-40 M	0,74	0,55	1,1	0,8	1-230	3,7	12,5			46	43	39	34	28	22	10
MULTI EVO 3-40 T	0,71	0,53	1,05	0,78	3-230/400	2,7/1,55	--									
MULTI EVO 3-50 M	0,94	0,7	1,34	1	1-230	4,4	16			58	55	50	44	36	29	14
MULTI EVO 3-50 T	0,94	0,7	1,34	1	3-230/400	3,3/1,9	--									
MULTI EVO 3-60 M	1,2	0,9	1,68	1,25	1-230	5,8	20			67	62	57	50	42	34	17
MULTI EVO 3-60 T	1,1	0,82	1,57	1,17	3-230/400	3,5/2	--									

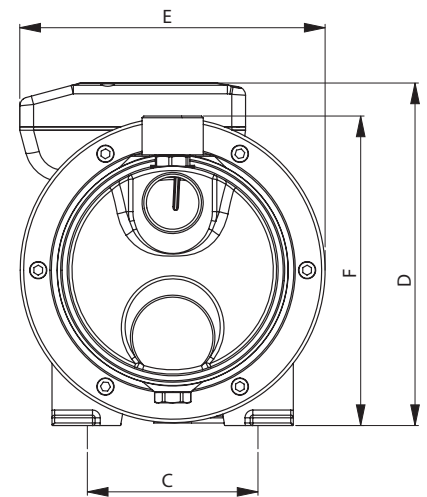
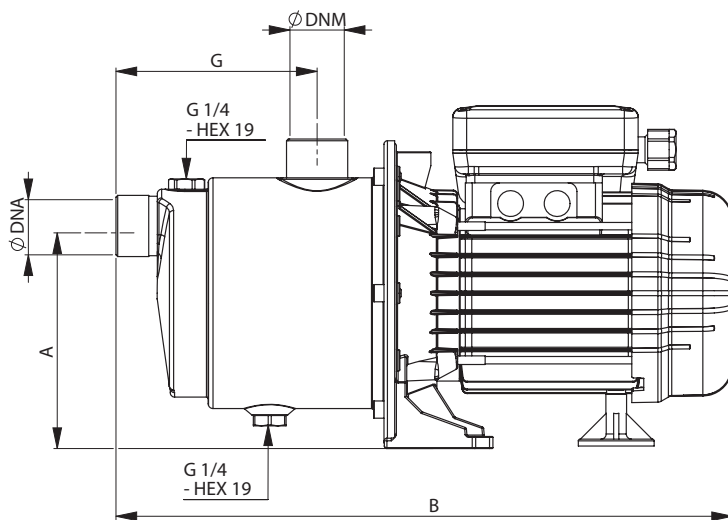

### OVERALL DIMENSIONS AND WEIGHTS

MODEL	Dimensions mm.										WEIGHTS (Kg)
	A	B	C	D	E	F	G	DNA	DNM		
MULTI EVO 3-30 M	129	356	100	199	177	180	116	1"	1"	6,7	
MULTI EVO 3-30 T	129	356	100	199	177	180	116	1"	1"	6,7	
MULTI EVO 3-40 M	129	356	100	199	177	180	116	1"	1"	7,1	
MULTI EVO 3-40 T	129	356	100	199	177	180	116	1"	1"	7,1	
MULTI EVO 3-50 M	129	400	100	207	177	180	139	1"	1"	9,1	
MULTI EVO 3-50 T	129	400	100	207	177	180	139	1"	1"	9,1	
MULTI EVO 3-60 M	129	422	100	207	177	180	161	1"	1"	10,8	
MULTI EVO 3-60 T	129	422	100	207	177	180	161	1"	1"	10,8	

# MULTI EVO 5

## MULTISTAGE CENTRIFUGAL PUMPS

### HYDRAULIC PERFORMANCE

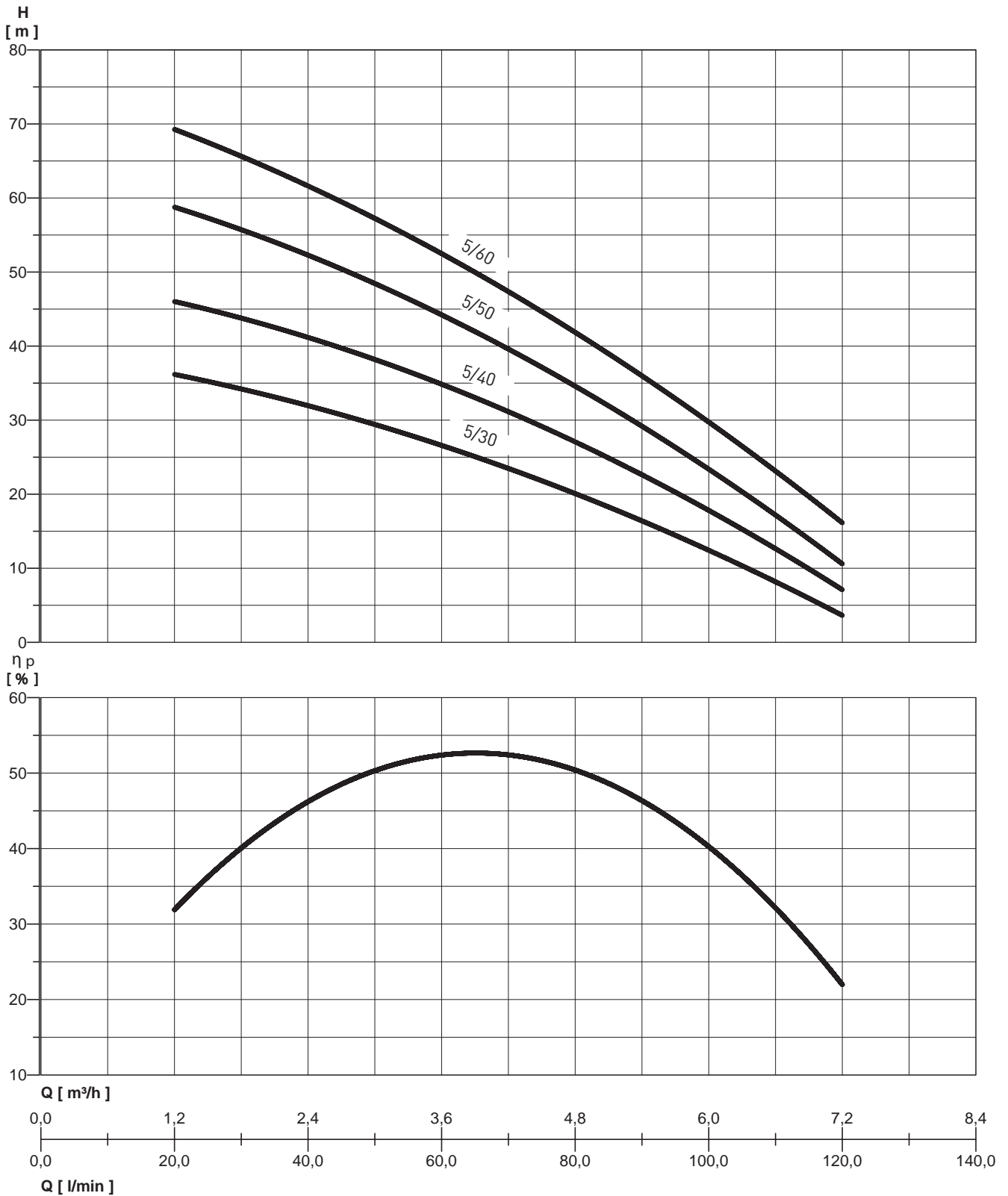

# MULTI EVO 5

## MULTISTAGE CENTRIFUGAL PUMPS

### PERFORMANCE TABLE

MODEL	Nominal power (P2)		Absorbed power (P1)		VOLT. (V)	In (A)	μF	0	total head in water column metres									
	HP	kW	HP	kW					l/min	20	30	40	50	60	80	100	120	
									m <sup>3</sup> /h	1,2	1,8	2,4	3	3,6	4,8	6	7,2	
MULTI EVO 5-30 M	0,75	0,55	1,1	0,8	1-230	3,7	12,5											
MULTI EVO 5-30 T	0,71	0,53	1,05	0,78	3-230/400	2,7 / 1,55	--			36	34	32	30	27	19,5	12	4	
MULTI EVO 5-40 M	1	0,75	1,5	1,1	1-230	4,7	16											
MULTI EVO 5-40 T	1	0,75	1,5	1,1	3-230/400	3,5 / 2	--			46	44	41	38	35	27	18	7	
MULTI EVO 5-50 M	1,27	0,95	1,8	1,35	1-230	6,2	20											
MULTI EVO 5-50 T	1,2	0,9	1,68	1,25	3-230/400	3,7 / 2,1	--			58	56	53	49	44	34	23	11	
MULTI EVO 5-60 M	1,6	1,2	2,2	1,65	1-230	7,5	31,5											
MULTI EVO 5-60 T	1,6	1,2	2,1	1,57	3-230/400	5,3 / 3,1	--			69	66	62	57	52	42	30	16	

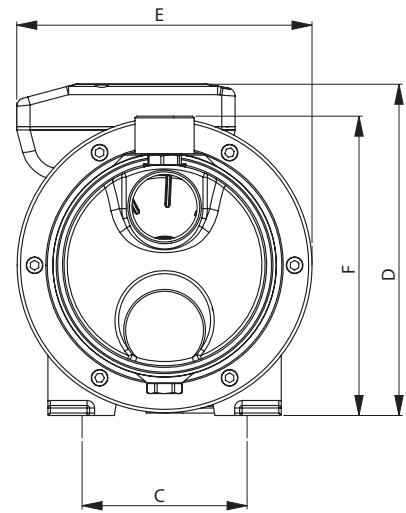
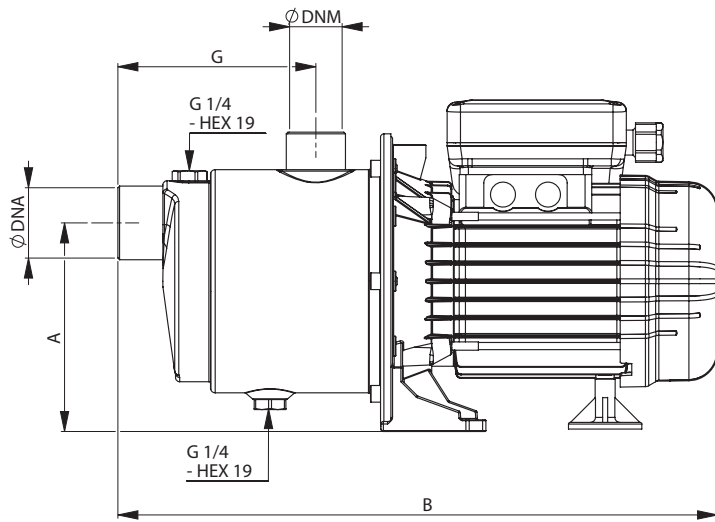

### OVERALL DIMENSIONS AND WEIGHTS

MODEL	Dimensions mm.									WEIGHTS (Kg)
	A	B	C	D	E	F	G	DNA	DNM	
MULTI EVO 5-30 M	125	360	100	199	177	180	119	1" 1/4	1"	7,1
MULTI EVO 5-30 T	125	360	100	199	177	180	119	1" 1/4	1"	7,1
MULTI EVO 5-40 M	125	380	100	207	177	180	119	1" 1/4	1"	8,8
MULTI EVO 5-40 T	125	380	100	207	177	180	119	1" 1/4	1"	8,8
MULTI EVO 5-50 M	125	402	100	207	177	180	142	1" 1/4	1"	10,4
MULTI EVO 5-50 T	125	402	100	207	177	180	142	1" 1/4	1"	10,4
MULTI EVO 5-60 M	125	457	100	215	203	180	164	1" 1/4	1"	13,5
MULTI EVO 5-60 T	125	457	100	215	177	180	164	1" 1/4	1"	13,5

# MULTI EVO 8

## MULTISTAGE CENTRIFUGAL PUMPS

### HYDRAULIC PERFORMANCE

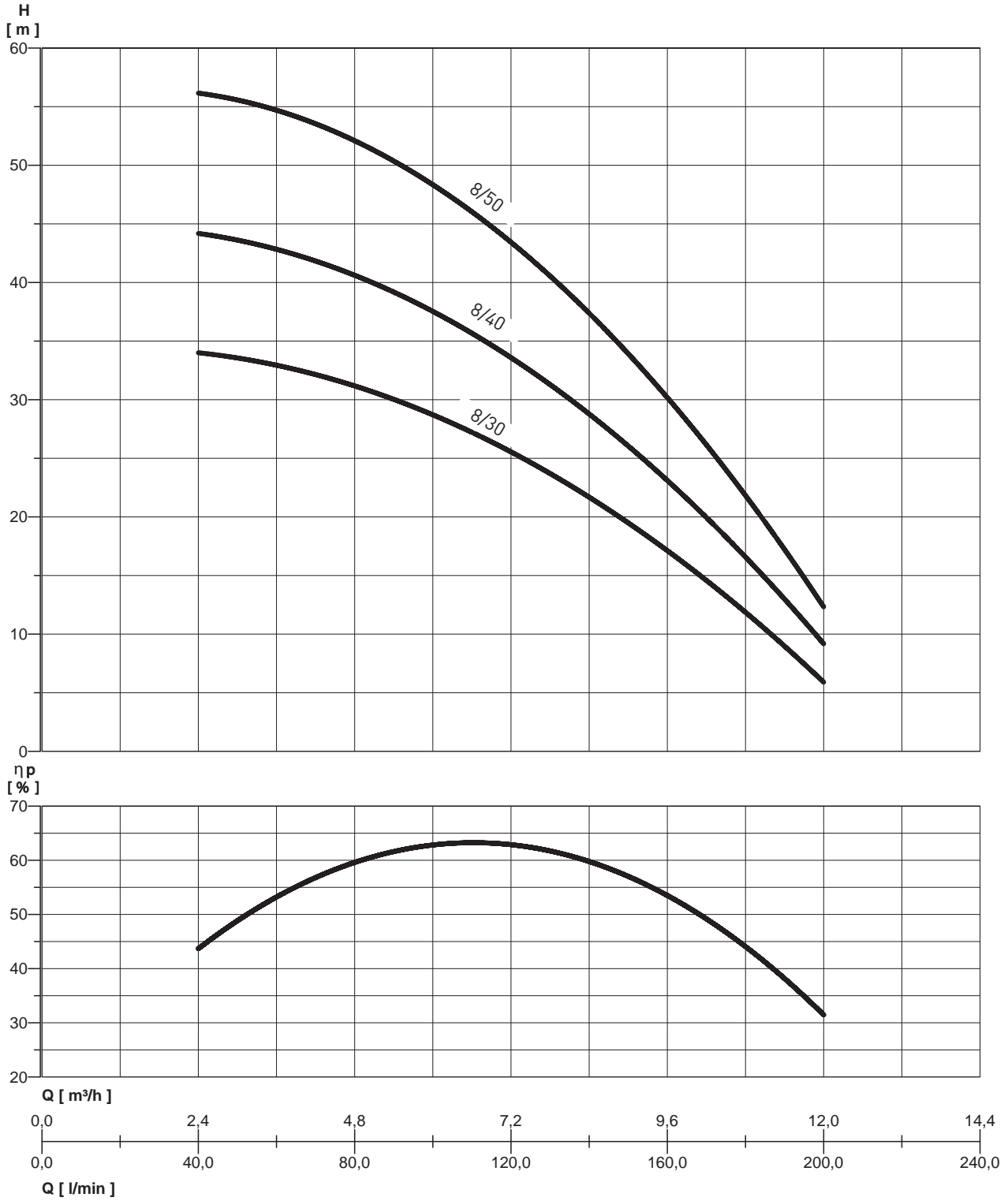

# MULTI EVO 8

## MULTISTAGE CENTRIFUGAL PUMPS

### PERFORMANCE TABLE

MODEL	Nominal power (P2)		Absorbed power (P1)		VOLT. (V)	In (A)	µF	0	total head in water column metres										
	HP	kW	HP	kW					l/min	40	60	80	100	120	140	160	180	200	
									m³/h	2,4	3,6	4,8	6	7,2	8,4	9,6	10,8	12	
MULTI EVO 8-30 M	1,2	0,9	1,7	1,28	1~230	5,9	20												
MULTI EVO 8-30 T	1,2	0,9	1,6	1,2	3~230/400	3,7 / 2,1	--		34	33,5	31	29	25,5	22	16,5	12	6		
MULTI EVO 8-40 M	1,6	1,2	2,23	1,66	1~230	7,7	31,5												
MULTI EVO 8-40 T	1,6	1,18	2	1,5	3~230/400	5 / 2,95	--		44,5	42,5	40,5	37,5	34	29	23	16	9,5		
MULTI EVO 8-50 M	1,9	1,4	2,7	2	1~230	9	35												
MULTI EVO 8-50 T	1,9	1,4	2,6	1,95	3~230/400	6,7 / 4	--		56,5	54,5	51,5	48,5	44	37,5	30	21,5	12,5		

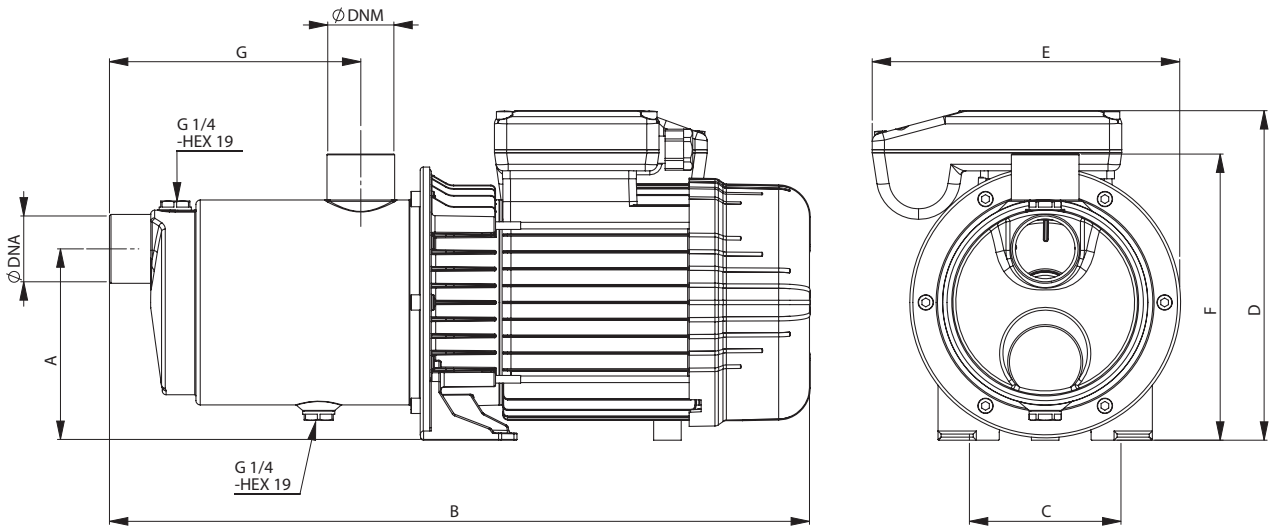

### OVERALL DIMENSIONS AND WEIGHTS

MODEL	Dimensions mm.									Weights (Kg)
	A	B	C	D	E	F	G	DNA	DNM	
MULTI EVO 8-30 M	125	398	100	207	177	187	137	1 1/4	1 1/4	10,5
MULTI EVO 8-30 T	125	398	100	207	177	187	137	1 1/4	1 1/4	10,5
MULTI EVO 8-40 M	125	430	100	215	203	187	137	1 1/4	1 1/4	13,4
MULTI EVO 8-40 T	125	430	100	215	177	187	137	1 1/4	1 1/4	13,4
MULTI EVO 8-50 M	125	457	100	215	203	187	164	1 1/4	1 1/4	14,5
MULTI EVO 8-50 T	125	457	100	215	177	187	164	1 1/4	1 1/4	14,5

## DHR

### MULTISTAGE CENTRIFUGAL PUMPS

Low energy consumption, Extremely silent, Impellers and diffusers made of stainless steel AISI 304, Threaded ports set for oval fittings (range DHR 9)

The DHR series pumps are horizontal centrifugal pumps, not self-priming. All the rotating parts that come into contact with the pumped liquid are made of stainless steel AISI 304.

#### USAGE DATA

- Type of liquid: clean water without suspended solids or abrasive material.
- Maximum temperature of the liquid 90°C.
- Maximum ambient temperature 50° C
- Maximum recommended intake height: 6 m with foot valve (with temperature of the liquid at 50° C)
- Maximum operating pressure: 10 bar (with temp. of liquid 50°C) 6 bar (with temp. of liquid 90°C)

#### APPLICATIONS

- Lifting and distribution of water in domestic systems in continuous or intermittent operation.
- Pressurization systems.
- Washing, irrigation, gardens, fountains.

#### MOTOR

- Closed, ventilated from exterior.
- Degree of protection IP 54.
- Insulation class F.
- Single-phase power supply with capacitor permanently on and thermal protection built into the motor casing.
- Three-phase power supply with external protection provided by the user.
- Speed of rotation 2850 rpm.
- Continuous service.
- Maximum ambient temperature 50°C

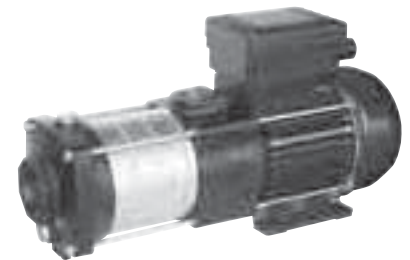
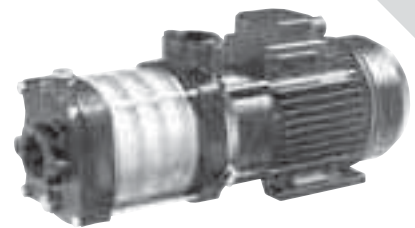

## TABLE OF MATERIALS

Component	Material
1 Intake and supply flange	Cast iron GJL 200 (ASTM Class 35)
2 Motor body	Cast aluminium
3 Impellers	Stainless steel X5CrNi18-10 (AISI 304)
4 Diffusers:	Stainless steel X5CrNi18-10 (AISI 304)
5 Sleeve	Stainless steel X5CrNi18-10 (AISI 304)
6 Shaft (part in contact with water)	Stainless steel X5CrNi18-10 (AISI 304)
7 Gaskets	NBR
8 Mechanical seal	Ceramic / Graphite / NBR

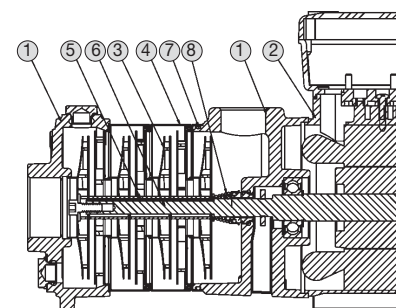

# DHR 2 - DHR 4

## MULTISTAGE CENTRIFUGAL PUMPS

### HYDRAULIC PERFORMANCE

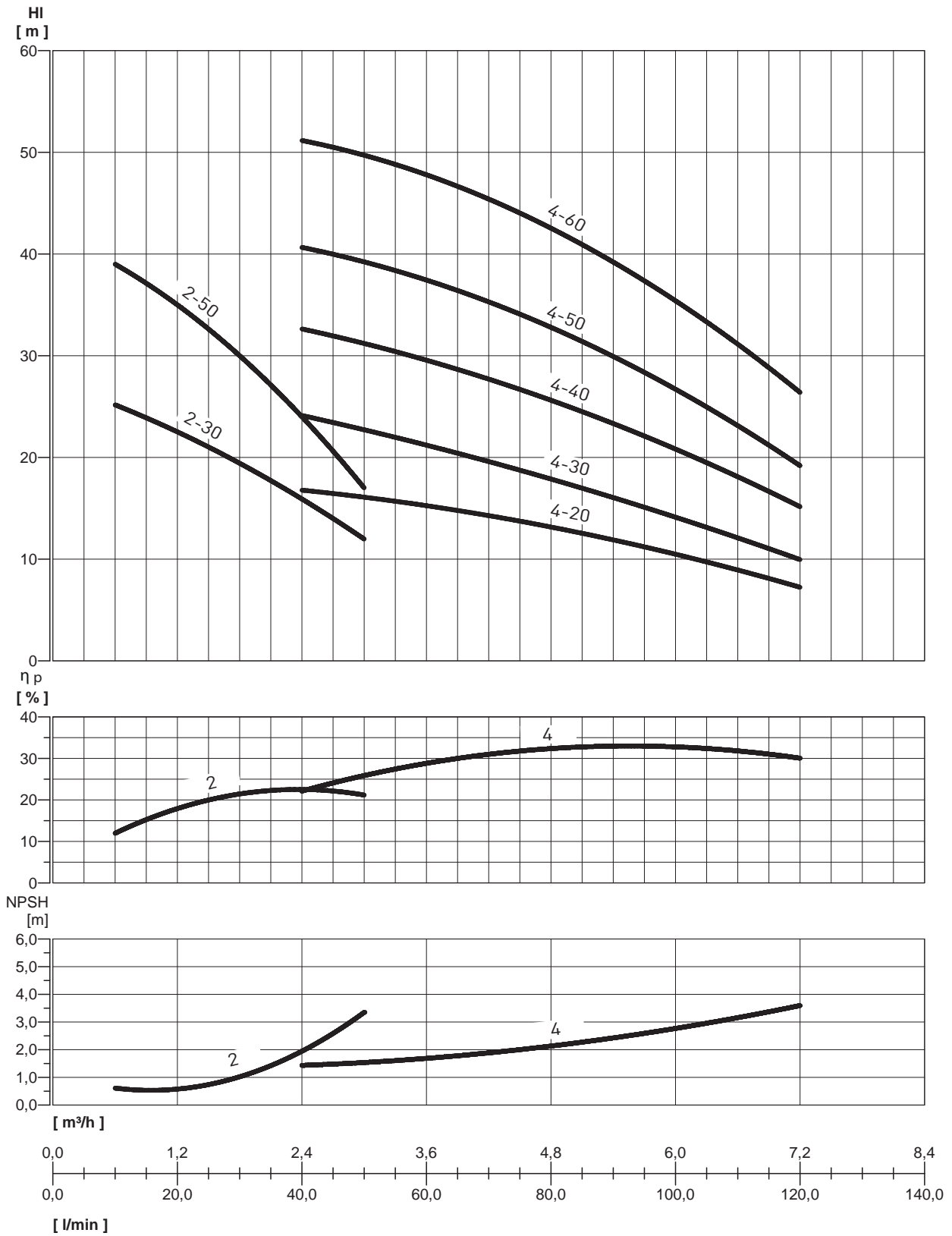



# DHR 2 - DHR 4

## MULTISTAGE CENTRIFUGAL PUMPS

### PERFORMANCE TABLE

MODEL	Nominal power (P2)		Absorbed power (P1)		VOLT. (V)	In (A)	μF.	0	L/min	10	20	30	40	50
	HP	kW	HP	kW					m³/h	0,6	1,2	1,8	2,4	3
DHR 2-30 M	0,40	0,30	0,7	0,52	1 ~ 230	2,6	12,5	m.c.w.		25	23	19	16	12
DHR 2-30 T	0,40	0,30	0,67	0,50	3 ~ 230/400	1,9-1,1	-			25	23	19	16	12
DHR 2-50 M	0,67	0,50	1	0,75	1 ~ 230	3,5	12,5			39	35	30	24	17
DHR 2-50 T	0,67	0,50	1	0,75	3 ~ 230/400	2,5-1,8	-			39	35	30	24	17

MODEL	Nominal power (P2)		Absorbed power (P1)		VOLT. (V)	In (A)	μF.	0	L/min	40	50	60	80	100	120
	HP	kW	HP	kW					m³/h	2,4	3	3,6	4,8	6	7,2
DHR 4-20 M	0,50	0,37	0,75	0,55	1 ~ 230	2,7	12,5	m.c.w.		17	16	15	13	11	7
DHR 4-20 T	0,50	0,37	0,78	0,58	3 ~ 230/400	2,1-1,2	-			17	16	15	13	11	7
DHR 4-30 M	0,67	0,50	1,10	0,80	1 ~ 230	3,7	12,5			24	23	21	18	14	10
DHR 4-30 T	0,67	0,50	1	0,75	3 ~ 230/400	2,5-1,4	-			24	23	21	18	14	10
DHR 4-40 M	0,94	0,70	1,34	1	1 ~ 230	4,5	16			33	31	29	26	21	15
DHR 4-40 T	0,94	0,70	1,34	1	3 ~ 230/400	3,2-1,9	-			33	31	29	26	21	15
DHR 4-50 M	1,20	0,90	1,68	1,25	1 ~ 230	5,8	20			41	39	37	33	27	19
DHR 4-50 T	1,20	0,90	1,55	1,15	3 ~ 230/400	3,4-2	-			41	39	37	33	27	19
DHR 4-60 M	1,6	1,2	2	1,5	1 ~ 230	7	31,5			52	49	47	43	36	26
DHR 4-60 T	1,6	1,2	2	1,5	3 ~ 230/400	5,4-3,1	-			52	49	47	43	36	26

# DHR 2 - DHR 4

## MULTISTAGE CENTRIFUGAL PUMPS

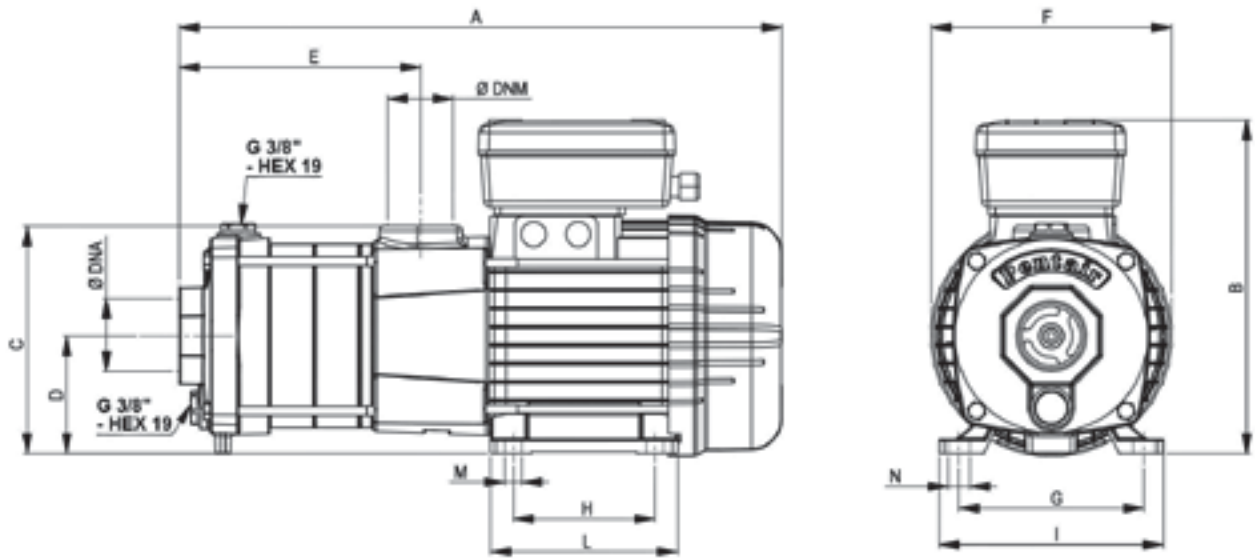

### OVERALL DIMENSIONS AND WEIGHTS

MODEL	Dimensions in mm.														WEIGHT (Kg)
	A	B	C	D	E	F	G	H	I	L	M	N	DNA	DNM	
DHR 2-30 M	326	205	137,5	71	105	142	112	90	135	112	7,5	12	1"	1"	10,2
DHR 2-30 T	326	190	137,5	71	105	142	112	90	135	112	7,5	12	1"	1"	
DHR 2-50 M	362	205	137,5	71	141	142	112	90	135	112	7,5	12	1"	1"	11,5
DHR 2-50 T	362	190	137,5	71	141	142	112	90	135	112	7,5	12	1"	1"	
DHR 4-20 M	339	205	137,5	71	119	142	112	90	135	112	7,5	12	1" 1/4	1"	10,5
DHR 4-20 T	339	190	137,5	71	119	142	112	90	135	112	7,5	12	1" 1/4	1"	
DHR 4-30 M	339	205	137,5	71	119	142	112	90	135	112	7,5	12	1" 1/4	1"	10,7
DHR 4-30 T	339	190	137,5	71	119	142	112	90	135	112	7,5	12	1" 1/4	1"	
DHR 4-40 M	366	205	137,5	71	146	142	112	90	135	112	7,5	12	1" 1/4	1"	12
DHR 4-40 T	366	190	137,5	71	146	142	112	90	135	112	7,5	12	1" 1/4	1"	
DHR 4-50 M	394	205	137,5	71	173	142	112	90	135	112	7,5	12	1" 1/4	1"	13,9
DHR 4-50 T	394	190	137,5	71	173	142	112	90	135	112	7,5	12	1" 1/4	1"	
DHR 4-60 M	445	230	149	80	200	160	125	100	153	125	9	13	1" 1/4	1"	17
DHR 4-60 T	445	209	149	80	200	160	125	100	153	125	9	13	1" 1/4	1"	

# DHR 9

## MULTISTAGE CENTRIFUGAL PUMPS

### HYDRAULIC PERFORMANCE

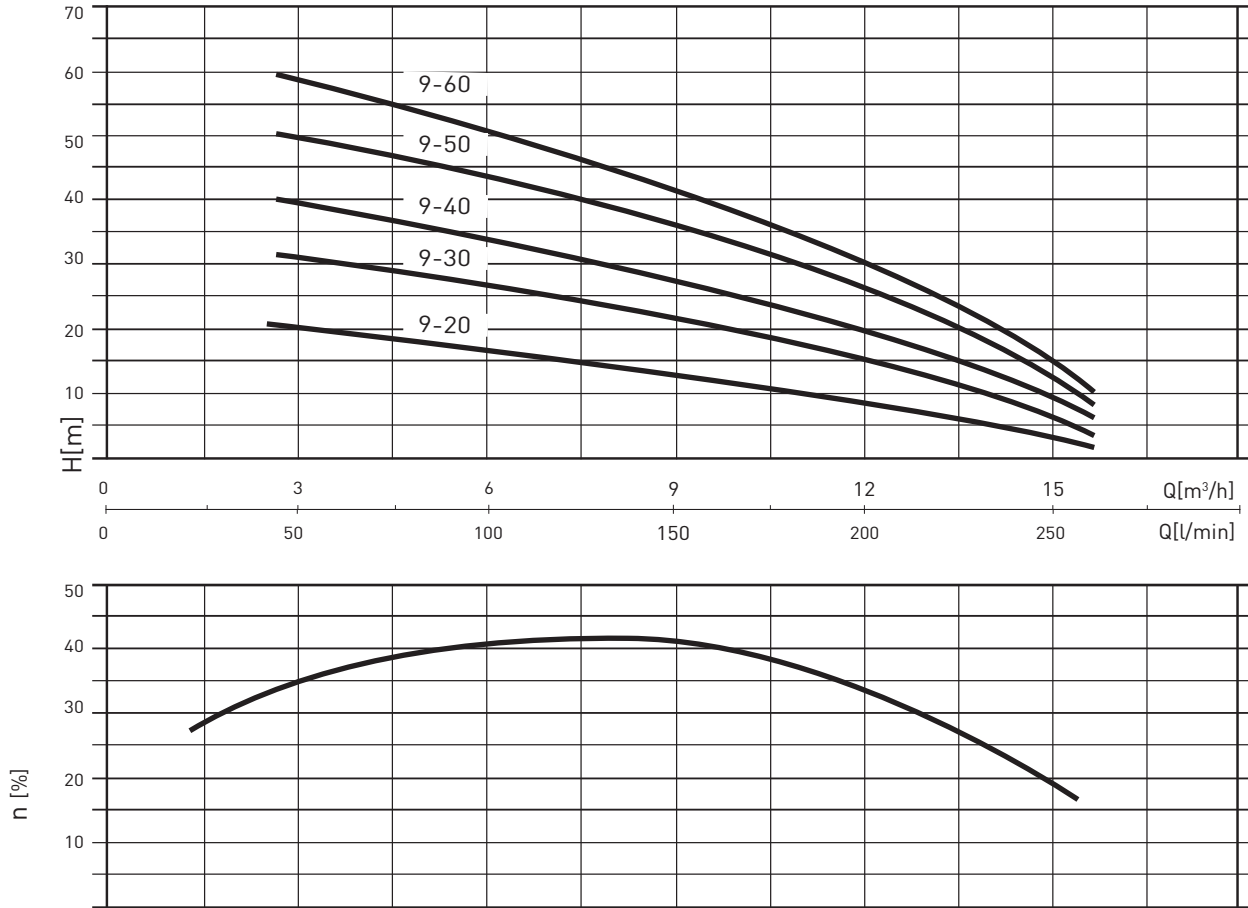

### PERFORMANCE TABLE

MODEL	Nominal power (P2)		Absorbed power (P1)		VOLT. (V)	In (A)	μF.	Q	m.c.w.							
	HP	kW	HP	kW					l/min	40	80	120	160	200	240	260
									m³/h	2,4	4,8	7,2	9,6	12	14,4	15,6
DHR 9-20 M	0,87	0,65	1,34	1	1 ~ 230	4,5	20		20	19	16	13	9	5	3	
DHR 9-20 T	0,87	0,65	1,21	0,9	3 ~ 230/400	3 - 1,7			20	19	16	13	9	5	3	
DHR 9-30 M	1,27	0,95	1,88	1,4	1 ~ 230	6	25		31	29	26	21	16	9	5	
DHR 9-30 T	1,27	0,95	1,81	1,35	3 ~ 230/400	4,4 - 2,5			31	29	26	21	16	9	5	
DHR 9-40 M	1,74	1,3	2,41	1,8	1 ~ 230	8	31,5		40	38	33	27	19	10	5	
DHR 9-40 T	1,74	1,3	2,15	1,6	3 ~ 230/400	5,3 - 3			40	38	33	27	19	10	5	
DHR 9-50 M	2,15	1,6	2,95	2,2	1 ~ 230	10	35		51	49	43	36	26	14	6	
DHR 9-50 T	2,15	1,6	2,68	2	3 ~ 230/400	6,1 - 3,5			51	49	43	36	26	14	6	
DHR 9-60 T	2,55	1,9	3,35	2,5	3 ~ 230/400	7,9 - 4,5			60	56	49	40	29	14	6	

# DHR 9

## MULTISTAGE CENTRIFUGAL PUMPS

### OVERALL DIMENSIONS AND WEIGHTS

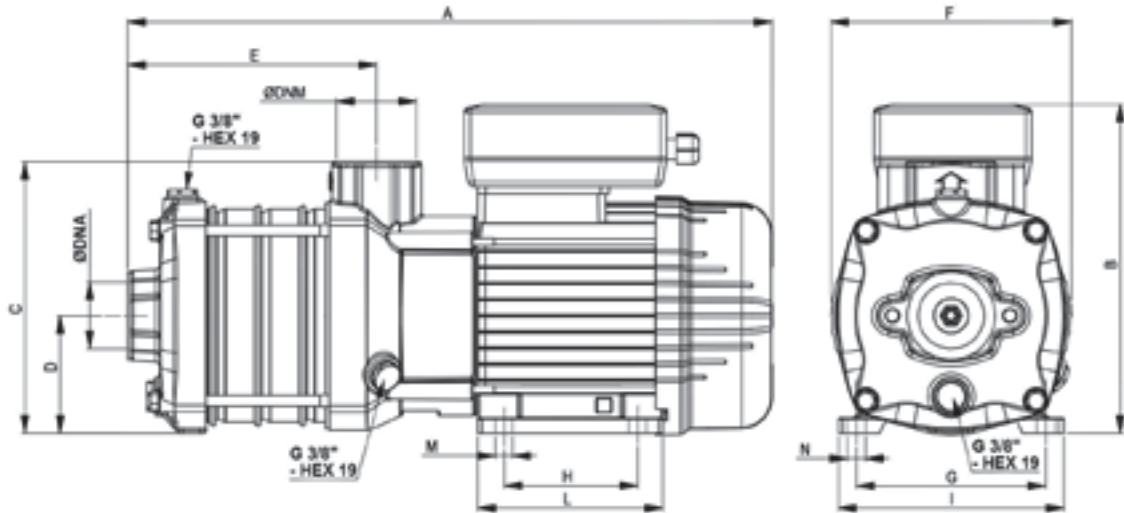

### OVERALL DIMENSIONS AND WEIGHTS

MODEL	Dimensions in mm.														WEIGHT (Kg)
	A	B	C	D	E	F	G	H	I	L	M	N	DNA	DNM	
DHR 9-20 M	378	227	185	80	107	160	125	100	153	125	9	13	1" ½	1" ¼	19,2
DHR 9-20 T	378	196	185	80	107	160	125	100	153	125	9	13	1" ½	1" ¼	17,5
DHR 9-30 M	378	227	185	80	107	160	125	100	153	125	9	13	1" ½	1" ¼	20,0
DHR 9-30 T	378	196	185	80	107	160	125	100	153	125	9	13	1" ½	1" ¼	19,1
DHR 9-40 M	408	227	185	80	137	160	125	100	153	125	9	13	1" ½	1" ¼	21,5
DHR 9-40 T	408	196	185	80	137	160	125	100	153	125	9	13	1" ½	1" ¼	20,1
DHR 9-50 M	438	227	185	80	168	160	125	100	153	125	9	13	1" ½	1" ¼	23,7
DHR 9-50 T	438	196	185	80	168	160	125	100	153	125	9	13	1" ½	1" ¼	22,0
DHR 9-60 T	468	196	185	80	198	160	125	100	153	125	9	13	1" ½	1" ¼	24,0

## DHI

### MULTISTAGE CENTRIFUGAL PUMPS MADE OF STAINLESS STEEL AISI 316

The DHI series horizontal multi-stage centrifugal pumps have the following advantages: high hydraulic performance regarding pressure and capacity. Minimum consumption of electricity. Extremely silent operation.

#### USAGE DATA

- Type of liquid: clean water without suspended solids or abrasive material.
- Maximum temperature of the liquid 90°C.
- Max recommended suction height 6 m with foot valve (with max. temperature of the liquid at 50° C)
- Maximum operating pressure 10 bar. (with temp. of liquid 50°C) 6 bar (with temp. of liquid 90°C)

#### APPLICATIONS

- Handling of aggressive liquids.
- Lifting and distribution of water in domestic systems in continuous or intermittent operation.
- Pressurization systems.
- Washing, irrigation, gardens, fountains.

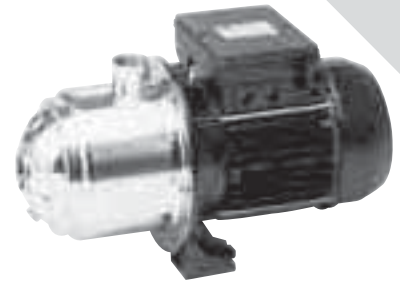

#### MOTOR

- Asynchronous motor
- Closed, ventilated from outside.
- Degree of protection IP 55.
- Insulation class F.
- Single phase power supply with permanently activated capacitor and thermal cutout protection incorporated in the motor winding.
- Three-phase power supply with external protection provided by the user.
- Speed of rotation 2850 rpm.
- Continuous service.

### TABLE OF MATERIALS

Component	Material
1 Pump body	Stainless steel X CrNiMo 17-12-03 (AISI 316)
2 Motor casing	Die-cast aluminium
3 Impeller	Stainless steel X CrNiMo 17-12-03 (AISI 316)
4 Intermediate chamber	Stainless steel X CrNiMo 17-12-03 (AISI 316)
5 Motor shaft	Stainless steel X CrNiMo 17-12-03 (AISI 316)
6 Mechanical seal	Graphite
7 Counterface	Ceramic
8 Seal-holding flange	Stainless steel X CrNiMo 17-12-03 (AISI 316)
Gaskets	EPDM

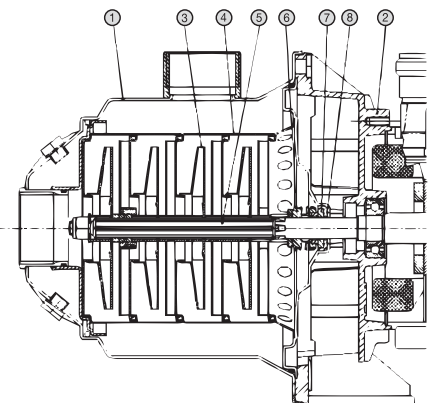

# DHI 2 - DHI 4

## MULTISTAGE CENTRIFUGAL PUMPS MADE OF STAINLESS STEEL AISI 316

### HYDRAULIC PERFORMANCE

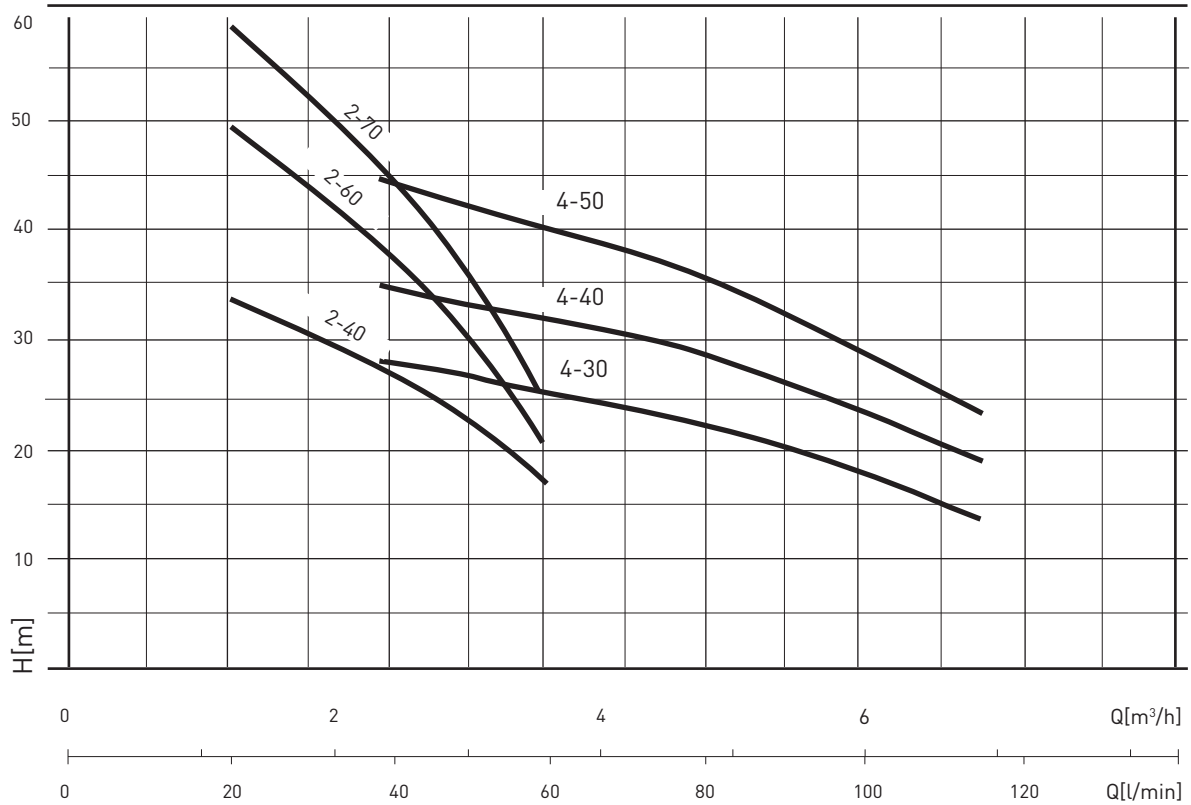

### PERFORMANCE TABLE

MODEL	Motor power (P2)		Absorbed power (P1)		VOLT. (V)	In (A)	μF.	Q	Q							
	HP	kW	HP	kW					l/min	10	20	30	40	50	60	
									m³/h	0,6	1,2	1,8	2,4	3	3,6	
DHI 2-40 M	0,5	0,4	0,9	0,7	1 - 230	3,2	12,5	m.c.w.	36	34	31	27	22	17		
DHI 2-40 T	0,5	0,4	0,9	0,7	3 - 230/400	2,3 - 1,4	-		36	34	31	27	22	17		
DHI 2-60 M	0,8	0,6	1,2	0,9	1 - 230	4,1	16		53	49	43	37	30	21		
DHI 2-60 T	0,8	0,6	1,2	0,9	3 - 230/400	3 - 1,8	-		53	49	43	37	30	21		
DHI 2-70 M	1	0,78	1,5	1,1	1 - 230	5,2	20		63	58	52	44	36	26		
DHI 2-70 T	1	0,78	1,36	1	3 - 230/400	3 - 1,8	-		63	58	52	44	36	26		

MODEL	Motor power (P2)		Absorbed power (P1)		VOLT. (V)	In (A)	μF.	Q	Q							
	HP	kW	HP	kW					l/min	40	50	60	80	100	120	
									m³/h	2,4	3	3,6	4,8	6	7,2	
DHI 4-30 M	0,67	0,5	1,1	0,8	1 - 230	3,6	12,5	m.c.w.	27	26	25	22	18	14		
DHI 4-30 T	0,67	0,5	1,1	0,8	3 - 230/400	2,9 - 1,7	-		27	26	25	22	18	14		
DHI 4-40 M	0,94	0,7	1,36	1	1 - 230	4,4	16		35	33	32	28	24	18		
DHI 4-40 T	0,94	0,7	1,36	1	3 - 230/400	3,3 - 2	-		35	33	32	28	24	18		
DHI 4-50 M	1,2	0,9	1,68	1,25	1 - 230	5,8	20		44	42	40	36	30	23		
DHI 4-50 T	1,2	0,9	1,6	1,2	3 - 230/400	3,3 - 2	-		44	42	40	36	30	23		

## DHI 2 - DHI 4

MULTISTAGE CENTRIFUGAL PUMPS MADE OF STAINLESS STEEL AISI 316

### OVERALL DIMENSIONS AND WEIGHTS

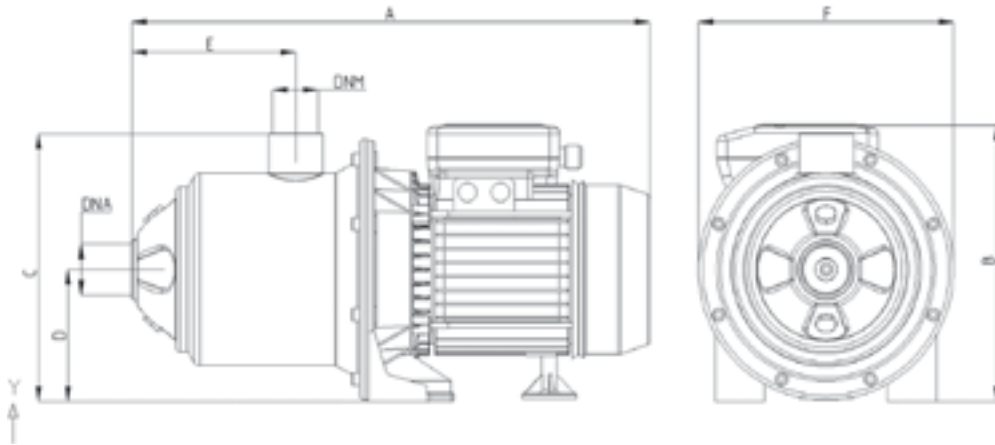

### OVERALL DIMENSIONS AND WEIGHTS

MODEL	Dimensions in mm.								WEIGHT (Kg)
	A	B	C	D	E	F	DNA	DNM	
DHI 2-40	368	220	213,5	105	80	208	1" 1/4	1" 1/4	11
DHI 2-60	396	220	213,5	105	108	208	1" 1/4	1" 1/4	11,7
DHI 2-70	422	220	213,5	105	134	208	1" 1/4	1" 1/4	14,1
DHI 4-30	368	220	213,5	105	80	208	1" 1/4	1" 1/4	11,3
DHI 4-40	396	220	213,5	105	108	208	1" 1/4	1" 1/4	12,1
DHI 4-50	422	220	213,5	105	134	208	1" 1/4	1" 1/4	14

## MULTI EVO-SP MULTISTAGE CENTRIFUGAL PUMPS - SPECIAL



Multi EVO-SP is a multi-stage centrifugal horizontal pump with an inlet with axial thread and an outlet with radial thread. The innovative, high efficiency hydraulic system is connected to a motor of the latest generation with a mechanical seal. Particularly suitable for the pumping of sea water and pool water.

### ADVANTAGES

The Multi EVO-SP series pumps feature the following advantages:

- Strong and resistant to salt water, it is the perfect partner for all pool cleaning devices
- High reliability - thanks to the durable and innovative design
- Silent - more comfort for the user thanks to its silent operation
- Compact shape



### SPECIFICATIONS:

#### PUMP

- Hydraulic performance according to ISO 9906:2012 - Grade 3B
- Type of liquid: clean water without suspended solids or abrasive material
- Maximum temperature of the liquid 50°C
- Maximum operating pressure 7 bar
- Maximum intake height recommended 6m with foot valve

#### MOTOR

- Closed, air ventilated (TEFC)
- 2 poles, 50 Hz (n=2850 rpm)
- IE3 three-phase AC (P2 ≥ 0.75 kW)
- Protection level: IP55
- Insulation class: F
- Single-phase power supply with capacitor permanently on and thermal protection built into the motor casing.



### APPLICATIONS

- Pressurising and supply
- Irrigation
- Cleaning of pools with chlorinated water
- Cleaning of pools with sea water
- Pumping of aggressive liquids (compatibly with the type of materials)





# MULTI EVO-SP

## MULTISTAGE CENTRIFUGAL PUMPS - SPECIAL

### CONSTRUCTION FEATURES

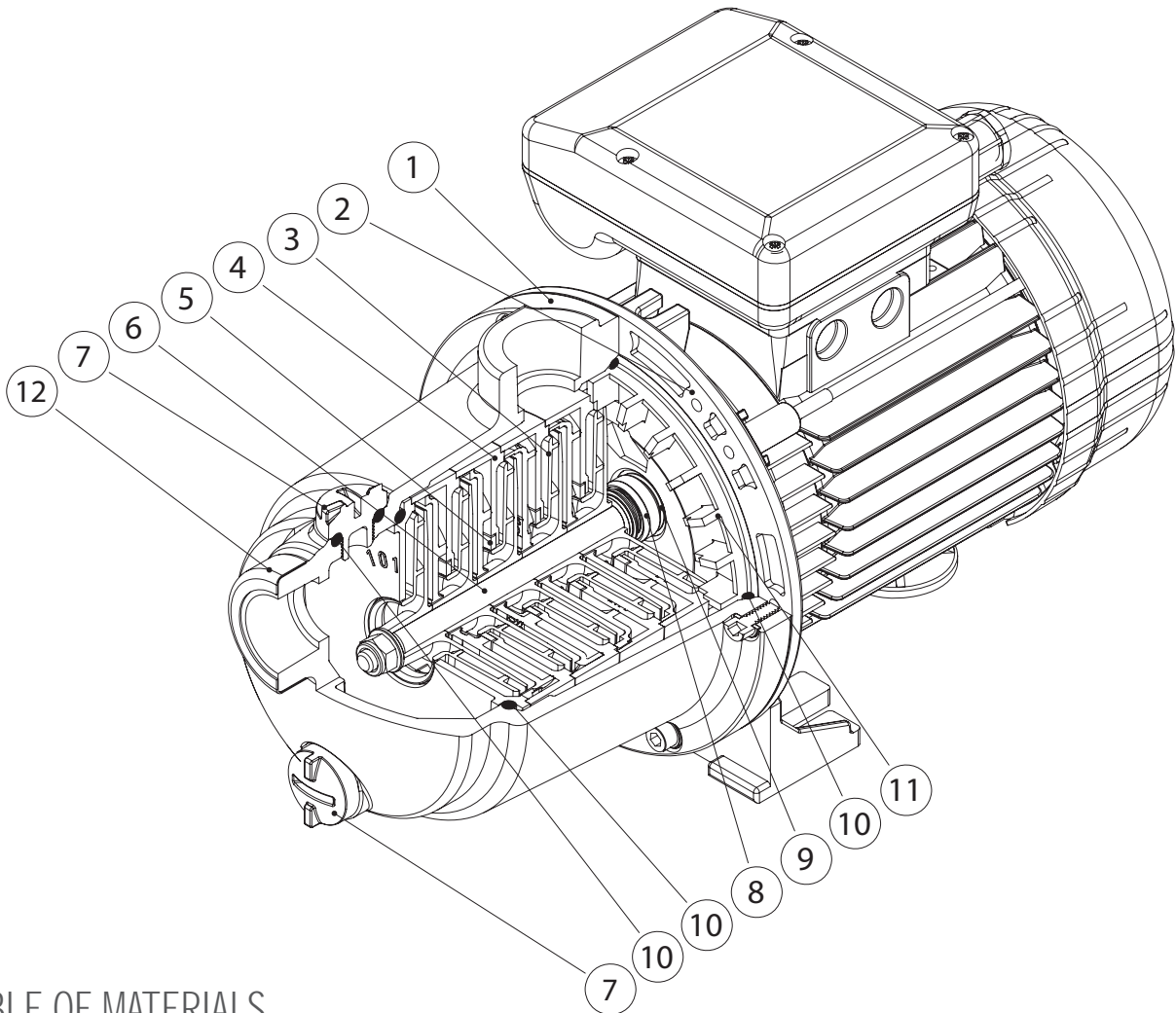

### TABLE OF MATERIALS

Ref.	Component	Material
1	Pump body	PPO reinforced with fibreglass
2	Motor casing	Die-cast aluminium
3	Impeller	PPO reinforced with fibreglass
4	Diffuser	PPO reinforced with fibreglass
5	Wear ring	PTFE
6	Shaft (hydraulic part)	Stainless steel Europe: EN10088-1 X2CrNiMo17-12-2 (1.4404) USA: AISI 316
7	Inlet / outlet caps	Polyamide 6.6
8	Mechanical seal	Carbon graphite / NBR / SS Europe: EN10088-1 X2CrNiMo17-12-2 (1.4404) USA: AISI 316
9	Counterface	Ceramic / NBR
10	Gaskets	NBR 70 Shore A
11	Seal holder plate	PPO reinforced with fibreglass
12	Reinforcing ring	Stainless steel Europe: EN10088-1 X5CrNi18-10 (1.4301) USA: AISI 304

# MULTI EVO-SP 3 - 5

## MULTISTAGE CENTRIFUGAL PUMPS - SPECIAL

### HYDRAULIC PERFORMANCE

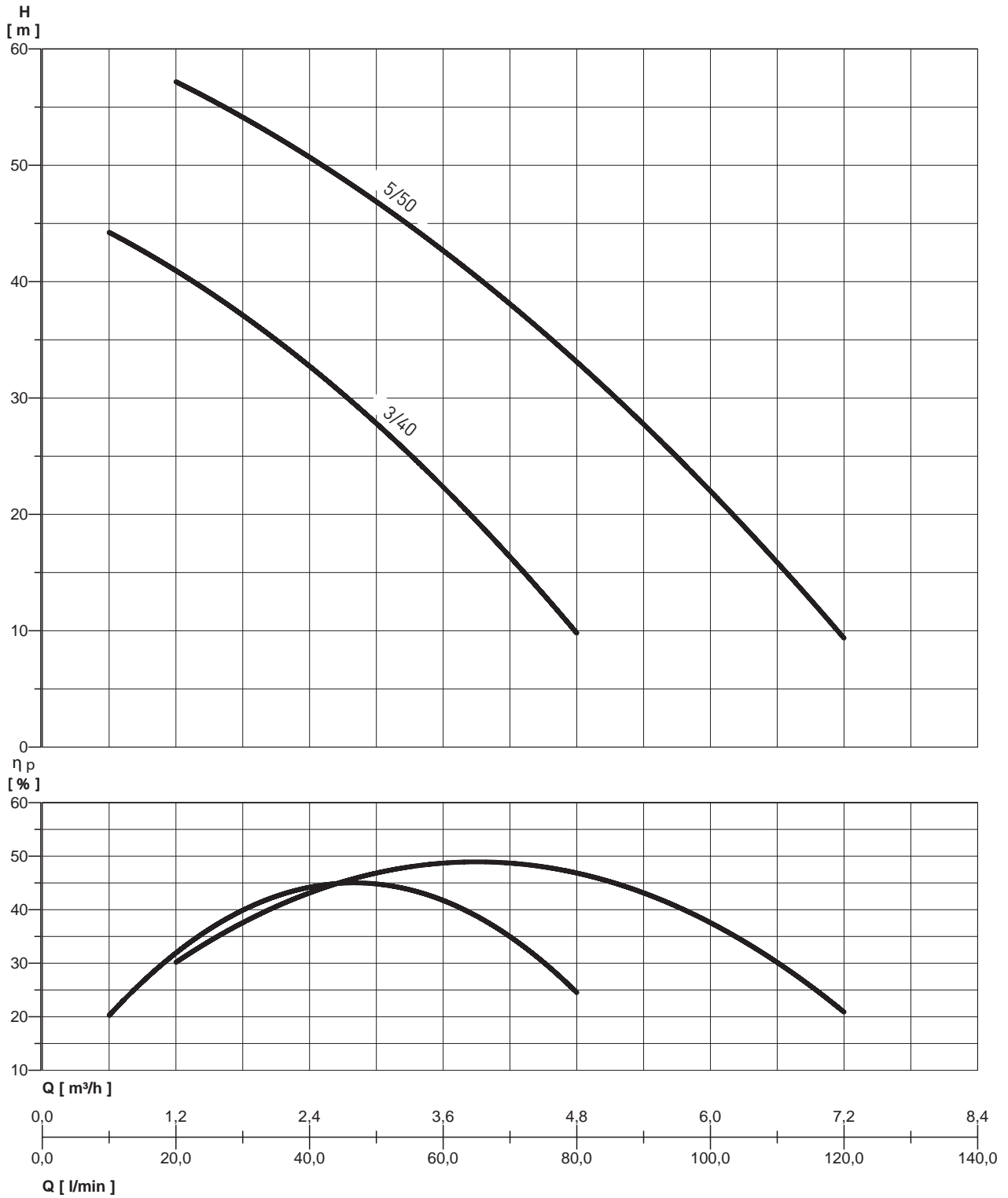

# MULTI EVO-SP 3 - 5

## MULTISTAGE CENTRIFUGAL PUMPS - SPECIAL

### PERFORMANCE TABLE

MODEL	Nominal power (P2)		Absorbed power (P1)		VOLT. (V)	In (A)	µF	0	total head in water column metres									
	HP	kW	HP	kW					l/min	10	20	30	40	50	60	80	100	120
									m³/h	0,6	1,2	1,8	2,4	3	3,6	4,8	6	7,2
MULTI EVO-SP 3-40 M	0,74	0,55	1,1	0,8	1~230	3,7	12,5			44	41	37,5	33	27,5	22	10		
MULTI EVO-SP 3-40 T	0,71	0,53	1,05	0,78	3~230/400	2,7 / 1,55	--											
MULTI EVO-SP 5-50 M	1,27	0,95	1,8	1,35	1~230	6,2	20											
MULTI EVO-SP 5-50 T	1,2	0,9	1,68	1,25	3~230/400	3,8 / 2,2	--			57	54	51	47	43	32,5	22	9,5	

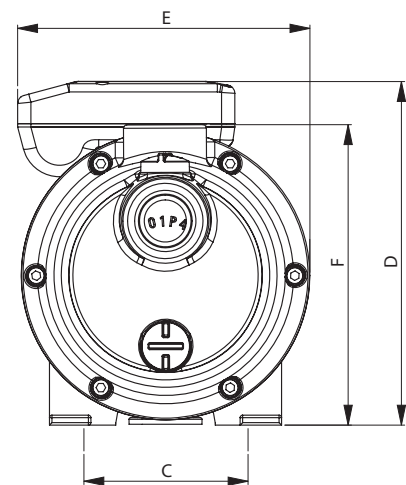
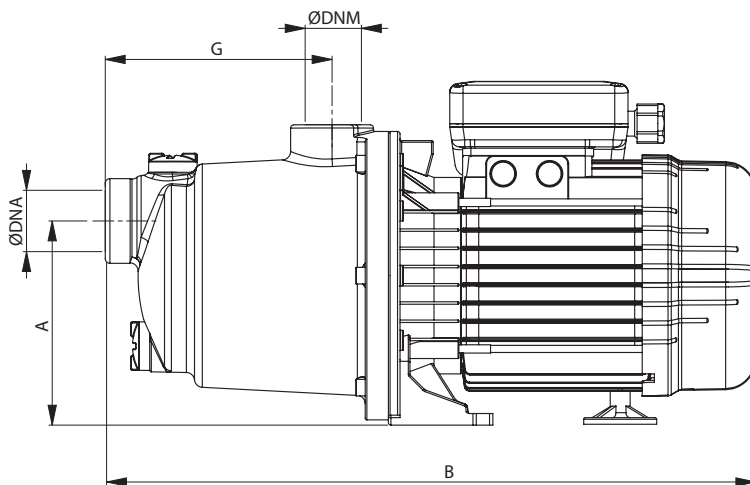

### OVERALL DIMENSIONS AND WEIGHTS

MODEL	Dimensions mm.									WEIGHTS (Kg)
	A	B	C	D	E	F	G	DNA	DNM	
MULTI EVO-SP 3-40 M	123	373	99	199	177	182	137	1"	1"	6,9
MULTI EVO-SP 3-40 T	123	373	99	199	177	182	137	1"	1"	6,9
MULTI EVO-SP 5-50 M	123	392	99	207	177	182	137	1"	1"	10,1
MULTI EVO-SP 5-50 T	123	392	99	207	177	182	137	1"	1"	10,1

## SWIMMEY

### SELF-PRIMING PUMPS FOR POOLS WITH PRE-FILTER

The SWIMMEY series pumps are designed to achieve maximum reliability regarding filtering in the recirculation of water treated with chlorine.



#### MOTOR

- Closed, ventilated from outside.
- Degree of protection IP X5
- Insulation class F
- Single-phase power supply with capacitor permanently on and thermal protection built into the motor casing.
- Three-phase power supply with external protection provided by the user.
- Self-lubricating ball bearings.
- Speed of rotation 2850 rpm.
- Suitable for continuous use.

#### USAGE DATA

- Type of liquid: swimming pool water treated with chlorine.
- Maximum temperature of the liquid 40°C.
- Maximum operating pressure: 2.5 bar.
- Maximum recommended suction height: 3 m with foot valve.

#### APPLICATIONS

- Recirculation and filtration of water for swimming pools and basins.

## TABLE OF MATERIALS

Component	Material
Pump body	ABS
Pre-filter	ABS
Fittings (intake and supply)	ABS/PVC
Basket (large inspected via cover with screws)	Polyethylene HD
Impeller	Made of fibreglass reinforced Lexan (resistant to sand abrasion)
Diffuser	Made of fibreglass reinforced Lexan (resistant to sand abrasion)
Mechanical seal	Graphite
Counterface	Ceramic
Shaft	in stainless steel with insulating element
Supporting base	Polypropylene
Filter cover	in Lexan with Teflon treated O-Ring

# SWIMMEY

## SELF-PRIMING PUMPS FOR POOLS WITH PRE-FILTER

### HYDRAULIC PERFORMANCE

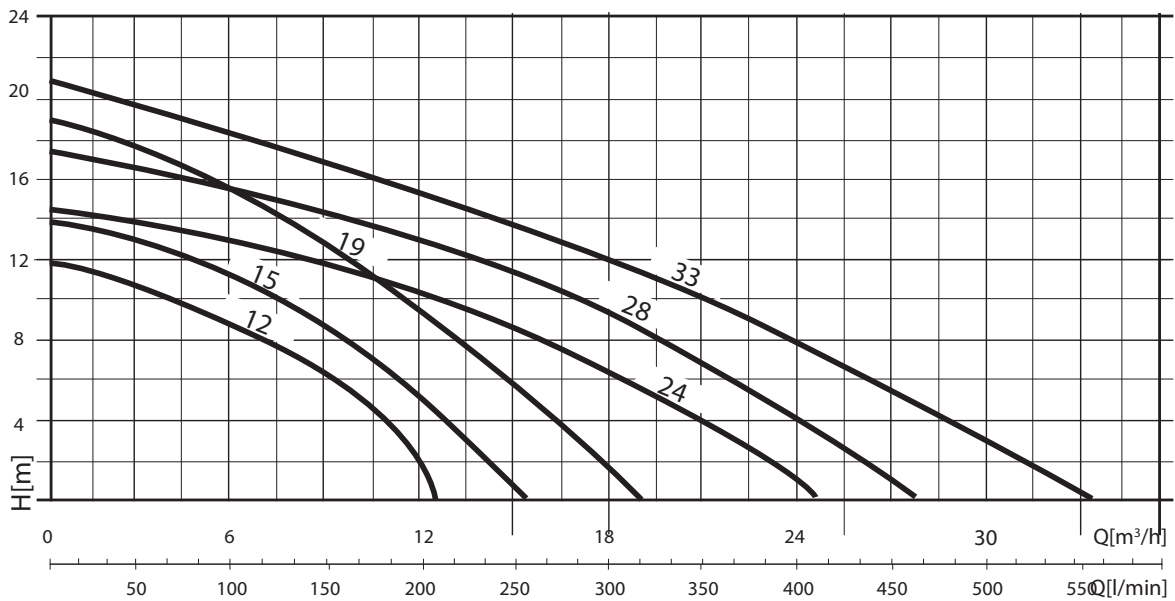

### PERFORMANCE TABLE

MODEL	Motor power (P2)		Motor power (P1)		VOLT. (V)	In (A)	μF	Q	m.c.w.								
	HP	kW	HP	kW					100	150	200	300	350	400	450	500	
									6	9	12	18	21	24	27	30	
SWIMMEY 12 M SWIMMEY 12 T	0,5	0,37	0,75	0,55	1 ~ 230 3 ~ 400	2,5 1,7-1	10		9	6	2						
SWIMMEY 15 M SWIMMEY 15 T	0,75	0,5	0,9	0,7	1 ~ 230 3 ~ 400	3 2,2-1,3	10		11	8,5	4,5						
SWIMMEY 19 M SWIMMEY 19 T	1	0,75	1,5	1,1	1 ~ 230 3 ~ 400	5 3,3-1,9	20		15,5	13	10	1,5					
SWIMMEY 24 M SWIMMEY 24 T	1	0,75	1,5	1,1	1 ~ 230 3 ~ 400	4,8 3-1,7	20		13	12	10,5	6	4	0,5			
SWIMMEY 28 M SWIMMEY 28 T	1,5	1,13	2	1,5	1 ~ 230 3 ~ 400	7 4,1-2,4	30		15,5	14,5	13	9	7	4,5	1,5		
SWIMMEY 33 M SWIMMEY 33 T	2	1,5	2,55	1,9	1 ~ 230 3 ~ 400	8,5 6-3,6	35		18,5	17	15,5	12	10,5	8	6	3,5	

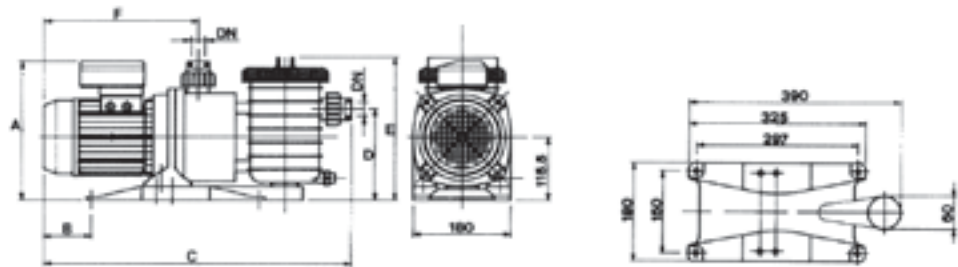

### OVERALL DIMENSIONS AND WEIGHTS

MODEL	Dimensions in mm.							WEIGHT (Kg)
	A	B	C	D	E	F	DN	
SWIMMEY 12	293	210	582	180	280	318	50	8
SWIMMEY 15	293	210	582	180	280	318	50	8,5
SWIMMEY 19	293	210	610	180	280	318	50	10,2
SWIMMEY 24	293	210	610	180	280	318	50	11
SWIMMEY 28	293	210	635	180	280	318	50	13
SWIMMEY 33	293	210	635	180	280	318	50	14,5

## CM

### HORIZONTAL CENTRIFUGAL PUMPS

---

Highly reliable, sturdy, high hydraulic performance

The CM series of single impeller centrifugal pumps are silent with optimal hydraulic performance.

#### APPLICATIONS

---

- Lifting from wells for irrigation.
- Pressurization systems.
- Autoclaves for homes.
- Washing.

#### USAGE DATA

---

- Type of liquid: clear or slightly turbid non-abrasive water.
- Maximum temperature of the liquid 90°C (model CM 90/22 50°C).
- Maximum suction height recommended 5 m with foot valve.
- Maximum operating pressure: 6 bar for models HP 0.5. 8 bar for models HP 1 - 1.5 - 2.

#### MOTOR

---

- Closed, ventilated from outside.
- Degree of protection IP 44
- Insulation class F
- Single-phase power supply with capacitor permanently on and thermal protection built into the motor casing.
- Three-phase power supply with external protection provided by the user.
- Speed of rotation 2850 rpm.
- Continuous service.



## TABLE OF MATERIALS

---

Component	Material
Pump body	Cast iron EN GJL 200
Motor casing	Cast iron EN GJL 200
Impeller	Brass (CM 90/22 in technopolymer)
Motor shaft	Stainless steel X 12 CrNiS 1809 (AISI 416)
Mechanical seal	Graphite
Counterface	Ceramic
Gaskets	NBR 70 shore

# CM

## HORIZONTAL CENTRIFUGAL PUMPS

### HYDRAULIC PERFORMANCE

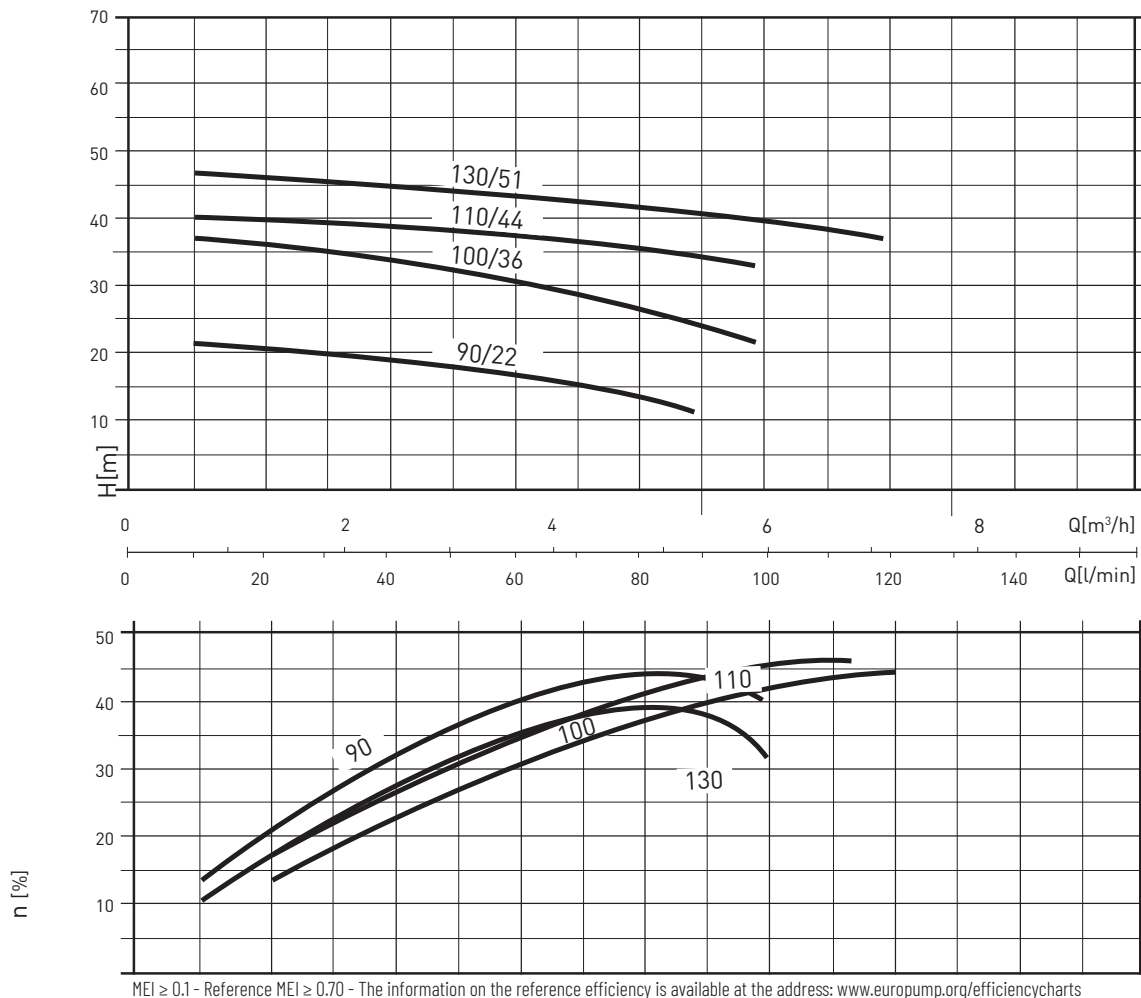

### PERFORMANCE TABLE

MODEL	Motor power (P2)		Motor power (P1)		VOLT. (V)	I <sub>n</sub> (A)	μF	0	m.c.a. / m.c.w.						
	HP	kW	HP	kW					l/min	10	30	50	80	100	120
									m³/h	0.6	1.8	3	4.8	6	7.2
CM 90/22 M* CM 90/22 T*	0.5	0.35	1	0.75	1 ~ 230 3 ~ 230/400	3.6 2.4-1.4	12.5		22	20	18	13			
CM 100/36 M CM 100/36 T	1	0.75	1.7	1.25	1 ~ 230 3 ~ 230/400	5.5 3.8-2.2	20		35	33	31	26	22		
CM 110/44 M CM 110/44 T	1.5	1.1	2.3	1.7	1 ~ 230 3 ~ 230/400	8 5.5-3.2	35		41	40	39	36	34		
CM 130/51 M CM 130/51 T	2	1.5	3.2	2.4	1 ~ 230 3 ~ 230/400	10.3 6.9-4.0	40		47	46	45	42	40	38	

\* Technopolymer impeller

### OVERALL DIMENSIONS AND WEIGHTS

MODEL	Dimensions mm.										WEIGHTS (Kg)
	A	B	C	D	E	F	H1	H2	DNA	DNM	
CM 90/22	75	43	267	150	110	160	82	202	1"	1"	6.5
CM 100/36	82	44	310	180	140	185	107	242	1"	1"	11
CM 110/44	88	45	350	194	155	200	100	252	1 1/4"	1"	20
CM 130/51	88	45	361	220	180	225	115	285	1 1/4"	1"	23

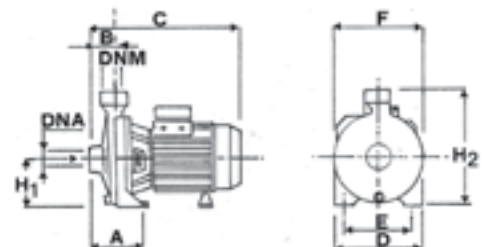

## CB TWO-STAGE CENTRIFUGAL PUMPS

### High hydraulic performance

The two opposite impellers with balanced axial thrust allow for high efficiency, making them particularly suitable for civil and industrial use, autoclave units, etc.

#### APPLICATIONS

- Pressurization systems.
- Small irrigation.
- Handling of non-aggressive liquids
- Washing systems

#### USAGE DATA

- Type of liquid: clear or slightly turbid non-abrasive water.
- Maximum temperature of the liquid  
40°C for 0.55 - 0.75 kW 90°C for 1.1 - 4.0 kW
- Maximum suction height recommended  
5 m with foot valve.
- Maximum operating pressure: 6 bar for models kW 0.55 - 0.75 10 bar for models kW 1.1 - 4

#### MOTOR

- Closed, ventilated from outside.
- Degree of protection IP 44
- Insulation class F
- Single-phase power supply with capacitor permanently on and thermal protection built into the motor casing.
- Three-phase power supply with external protection provided by the user.



## TABLE OF MATERIALS

Component	Material
Pump body	Cast iron EN GJL 200
Motor casing	Aluminium for models : kW 0.55 - 1.00 Cast iron for the rest of the range
Impeller	Technopolymer for models : kW 0.55 - 0.75 brass for the rest of the range
Intermediate disk	Cast iron
Motor shaft	AISI 303 for models : kW 1.1 - 1.5 - 2.2 AISI 304 for models : kW 3.0 - 4.0 AISI 416 for models : kW 0.55 - 0.75
Mechanical seal	Graphite
Counterface	Ceramic
Seal-holding disk	AISI 304 for models : kW 0.55 - 0.75 Cast iron for the rest of the range
Gaskets	NBR



# CB

## TWO-STAGE CENTRIFUGAL PUMPS

### HYDRAULIC PERFORMANCE

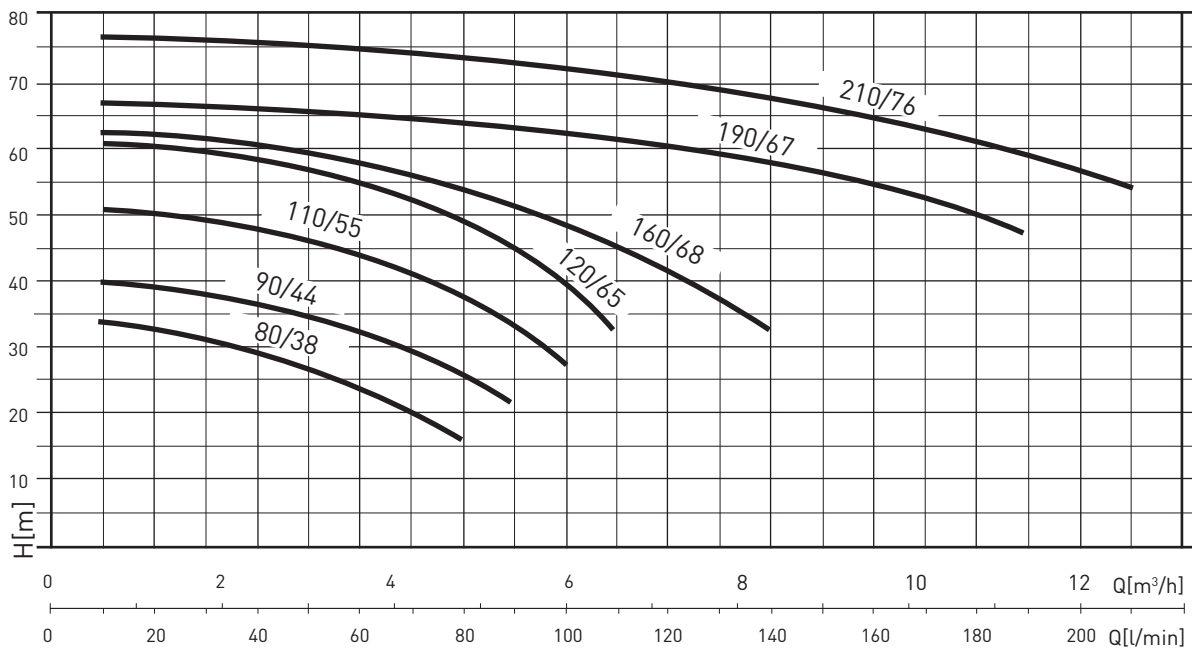

### PERFORMANCE TABLE

MODEL	Motor power (P2)		Motor power (P1)		VOLT. (V)	In (A)	μF	Q	m.c.w.												
	HP	kW	HP	kW					l/min	20	40	50	80	90	100	110	140	170	190	210	
									m³/h	1,2	2,4	3,0	4,8	5,4	6,0	6,6	8,4	9,6	10,8	12,0	
CB 80/38 M CB 80/38 T	0,75	0,55	1,5 1,4	1,1 1,1	1 ~ 230 3 ~ 220/380	5 3,4-2,0	1,6		33	30,2	27,9	17									
CB 90/44 M CB 90/44 T	1	0,74	1,9 1,2	1,4 0,9	1 ~ 230 3 ~ 230/400	6,1 2,9-1,7	20		39,5	37	35,2	27	21								
CB 110/55 M CB 110/55 T	1,5	1,1	2,5 2,4	1,9 1,8	1 ~ 230 3 ~ 230/400	8,6 5,5-3,2	35		50,8	48,8	47,1	38,4	33,4	27,5							
CB 120/65 M CB 120/65	2	1,5	3,2 2,8	2,4 2,1	1 ~ 230 3 ~ 230/400	10,8 6,9-4,0	40		60,5	58,6	56,9	49,8	46,5	40,3	32,5						
CB 160/68 T	3	2,2	3,5	2,6	3 ~ 230/400	8,1-4,7			60,5	59,3	54,1	51,6	48,4	44,6	32						
CB 190/67 T	4	3	5,5	4,1	3 ~ 230/400	12,5-7,2			67	64,8	63,9	62,5	62	58	53,5						
CB 210/76 T	5	4	6,1	4,6	3 ~ 230/400	15,1-8,7			76,5	73,9	72,9	71,8	70,5	66,8	62	58,3	54				

### OVERALL DIMENSIONS AND WEIGHTS

MODEL	Dimensions mm.										WEIGHT (Kg)
	A	B	C	D	E	F	H1	H2	DNA	DNM	
CB 80/38	58	73	336	180	140	183	97	227	1"	1"	13,5
CB 90/44	58	73	336	180	140	183	97	227	1"	1"	15
CB 110/55	66	86	394	195	155	209	110	265	1 1/4"	1"	25
CB 120/65	66	86	410	195	155	209	110	265	1 1/4"	1"	27
CB 160/68	66	86	410	195	155	194	110	265	1 1/4"	1"	27
CB 190/67	72	96	467	230	180	228	133	309	1 1/2"	1 1/4"	42,5
CB 210/76	72	96	467	230	180	228	133	309	1 1/2"	1 1/4"	46,3

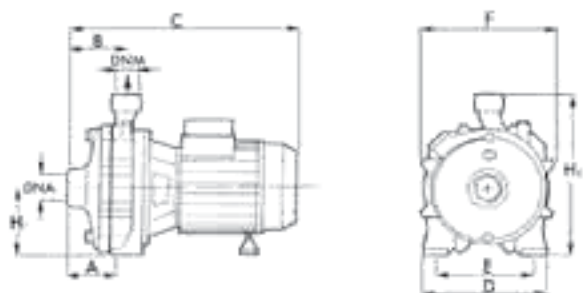

## SSCX

### SINGLE STAGE MONOBLOC CENTRIFUGAL PUMPS WITH AXIAL INTAKE AND RADIAL SUPPLY

Stainless steel 304 impeller and diffuser, high hydraulic performance, very reliable

The horizontal single stage centrifugal pumps of the series SSCX are made of stainless steel AISI 304 with an asynchronous motor, 2 poles, self-ventilated. Recommended to pump clean water and chemically non-aggressive liquids in the domestic, agricultural and industrial sectors.

#### APPLICATIONS

- Pressurization systems
- Irrigation
- Conveyance of water and non-aggressive liquids
- Gardening

#### VERSIONS

- Standard: mechanical seal in graphite/ceramic and seals in MBR
- Special: mechanical seal in silicon carbide/silicon carbide and Viton seals

#### USAGE DATA

- Type of liquid: water or chemically non-aggressive liquid, clean, without suspended solids.
- Maximum temperature of the liquid 90°C.
- Maximum operating pressure: 8 bar (PN8)

#### MOTOR

- Closed, ventilated from outside
- Degree of protection IP 55
- Insulation class F
- Single-phase power supply with capacitor permanently on and thermal protection built into the motor casing
- Three-phase power supply with protection provided by the user.
- Speed of rotation 2850 rpm
- Continuous service.



## TABLE OF MATERIALS

Component	Material
1 Pump body	Stainless steel X5 CrNi 18-10 EN1.4301 (AISI 304)
2 Motor casing	Aluminium AISI 12 UNI 5076
3 Seal-holding bottom plate	Stainless steel X5 CrNi 18-10 EN1.4301 (AISI 304)
4 Impeller	Stainless steel X5 CrNi 18-10 EN1.4301 (AISI 304)
5 Shaft (hydraulic part)	Stainless steel X5 CrNi 18-10 EN1.4301 (AISI 304)
6 Mechanical seal (rotating part)	Graphite or silicon carbide
7 Counterface (fixed part)	Ceramic or silicon carbide
8 Gaskets	NBR 70Shore or Viton

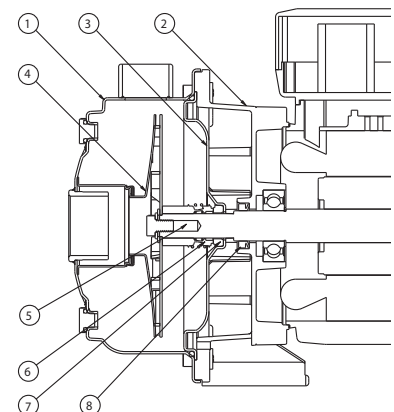

# SSCX

## SINGLE STAGE MONOBLOC CENTRIFUGAL PUMPS WITH AXIAL INTAKE AND RADIAL SUPPLY

### HYDRAULIC PERFORMANCE

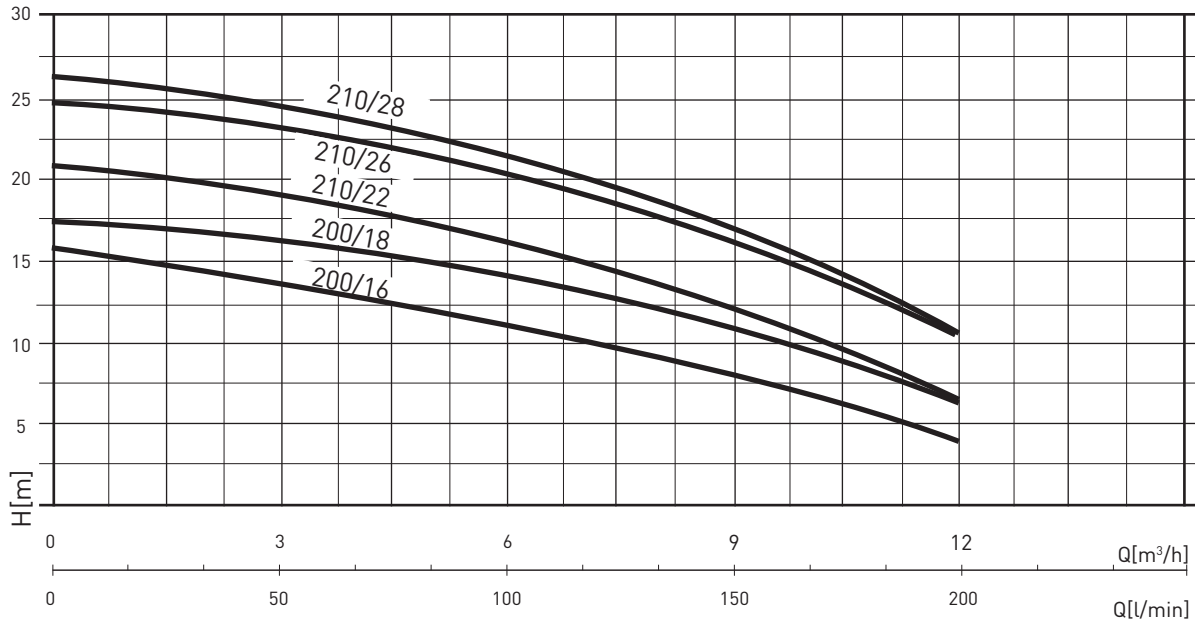

### PERFORMANCE TABLE

MODEL	Motor power (P2)		Motor power (P1)		VOLT. (V)	In (A)	μF	Q	m.c.w.							
	HP	kW	HP	kW					0	20	40	80	120	160	200	
								l/min	0	20	40	80	120	160	200	
								m³/h	0	1,2	2,4	4,8	7,2	9,6	12	
SSCX 200/16M SSCX 200/16T	0,75	0,55	1	0,75	1 - 230 3 - 230/400	3,5 3,1-1,8	12,5 -		16	14,5	14	12,5	9,5	6,5	4	
SSCX 200/18M SSCX 200/18T	1	0,75	1,2	0,9	1 - 230 3 - 230/400	4 3,1-1,8	16 -		18	17	16	15	13	10,5	6	
SSCX 210/22M SSCX 210/22T	1,15	0,85	1,5	1,1	1 - 230 3 - 230/400	4,9 3,8-2,2	25 -		21,5	20	19	17	15	11	6	
SSCX 210/26M SSCX 210/26T	1,35	1	1,9	1,4	1 - 230 3 - 230/400	6,7 5-2,9	25 -		25,5	24	23	21,5	19	15,5	10	
SSCX 210/28M SSCX 210/28T	1,5	1,1	2,1	1,55	1 - 230 3 - 230/400	7,3 5,6-3,2	25 -		27	25,5	24,5	23	19,5	16	10	

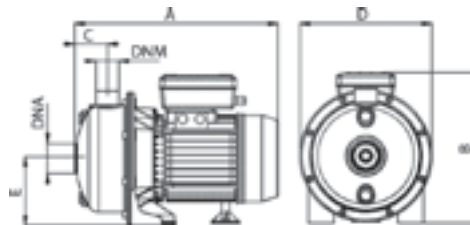

### OVERALL DIMENSIONS AND WEIGHTS

MODEL	Dimensions mm.							WEIGHT (Kg)
	A	B	C	D	E	DNA	DNM	
SSCX 200/16	320	240	50,5	210	105	1" 1/4	1"	8,7
SSCX 200/18	320	240	50,5	210	105	1" 1/4	1"	9,5
SSCX 210/22	350	250	50,5	210	105	1" 1/4	1"	12,1
SSCX 210/26	350	250	50,5	210	105	1" 1/4	1"	13,6
SSCX 210/28	350	250	50,5	210	105	1" 1/4	1"	13,8

# MULTINOX-VE+

## VERTICAL MULTISTAGE CENTRIFUGAL PUMPS

High hydraulic efficiency, strong and resistant

The MULTINOX-VE+ series vertical multi-stage centrifugal pumps are particularly suitable for the realization of lifting units, especially in the cases where high efficiency and silence are required, with compact dimensions.

### USAGE DATA

- Type of liquid: clean water without suspended solids or abrasive material.
- Maximum temperature of the liquid 50°C.
- Maximum suction height recommended 6 m with foot valve.
- Maximum operating pressure: 9 bar
- 12 bar (version MULTINOX-VE+ 4-90 e 6-90)
- 16 bar (version MULTINOX-VE+ 4-120)
- 20 bar (version MULTINOX-VE+ 8-90 e 8-120)

### APPLICATIONS

- Lifting and distribution of water in domestic systems in continuous or intermittent operation.
- Pressurization systems.
- Fire prevention systems.
- Washing, irrigation, gardens, fountains.

### MOTOR

- Closed, ventilated from outside.
- Degree of protection:  
IP44: MULTINOX-VE+ 8-30 a 8-70.  
IP55: MULTINOX-VE+ 8-90 e 8-120
- Insulation class F.
- Motor efficiency:  
IE2: MULTINOX-VE+ 8-30 a 8-70  
IE3: MULTINOX-VE+ 8-90 e 8-120.
- Single-phase power supply with capacitor permanently on and thermal protection built into the motor casing.
- Three-phase power supply with external protection provided by the user.
- Speed of rotation 2850 rpm.
- Continuous service.



## TABLE OF MATERIALS

Component	Material
1 Sleeve (pump body)	Stainless steel EN 10088-1- X5 CrNi 1810 (AISI 304)
2 Intake flange	Cast iron EN GJL 200
3 Impellers	Technopolymer
4 Diffusers:	Technopolymer
5 Shaft (hydraulic part)	Stainless steel EN 10088-1- X5 CrNi 1810 (AISI 304)
6 Mechanical seal	Graphite/Silicon Carbide for MULTINOX-VE+ 8-90 and 8-120
7 Counterface	Aluminium Oxide / Graphite for MULTINOX-VE+ 8-90 and 8-120
8 Gaskets	Nitrile-Butadiene Rubber (NBR)
9 Motor support supply flange	Cast iron EN GJL 200
10 Motor bell	Cast iron EN GJL 200
11 Motor coupling	Aluminium alloy

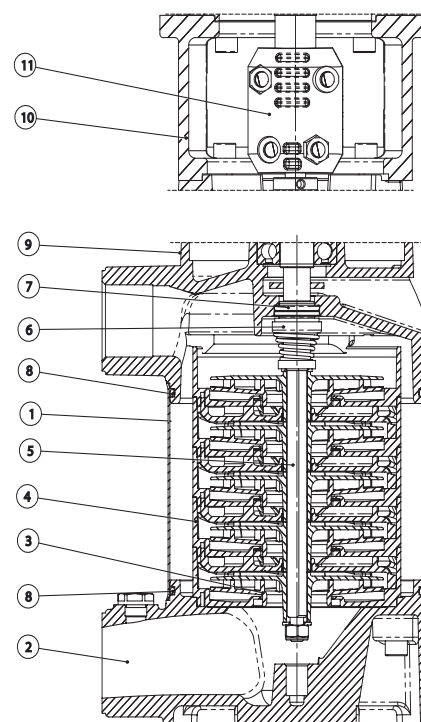

# MULTINOX-VE+

## VERTICAL MULTISTAGE CENTRIFUGAL PUMPS

### HYDRAULIC PERFORMANCE

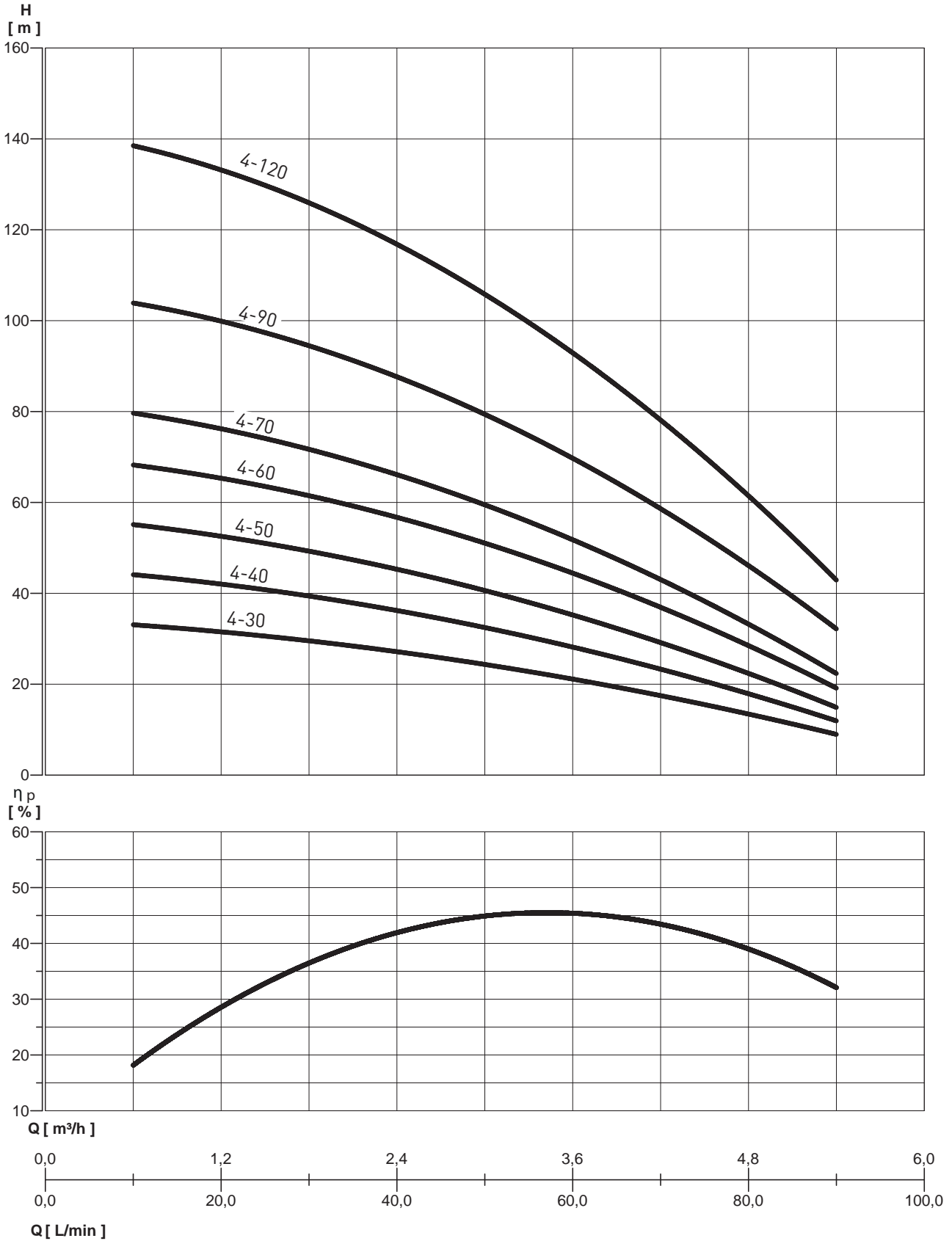

Hydraulic performance in accordance with ISO 9906:2012 - Curves at 2900 rpm

MEI ≥ 0.4 - Reference MEI ≥ 0.70 - The information on the reference efficiency is available at the address: [www.europump.org/efficiencycharts](http://www.europump.org/efficiencycharts)

# MULTINOX-VE+

## VERTICAL MULTISTAGE CENTRIFUGAL PUMPS

### PERFORMANCE TABLE

MODEL	Motor power (P2)		Motor power (P1)		VOLT. (V)	In (A)	μF	0	m.c.w.							
	HP	kW	HP	kW					l/min	10	30	40	50	60	70	90
									m³/h	0,6	1,8	2,4	3	3,6	4,2	5,4
MULTINOX VE+ 4-30 M MULTINOX VE+ 4-30 T	0,68	0,5	1,2 1	0,86 0,73	1-230 3-230/400	3,6 2,6-1,5	20		33	30	27	24	21	17	9	
MULTINOX VE+ 4-40 M MULTINOX VE+ 4-40 T	0,91	0,67	1,4 1,3	1 0,97	1-230 3-230/400	4,4 3,1-1,8	20		44	40	36	32	28	23	12	
MULTINOX VE+ 4-50 M MULTINOX VE+ 4-50 T	1,1	0,84	1,8 1,6	1,3 1,16	1-230 3-230/400	5,3 4-2,3	20		55	50	45	41	35	29	15	
MULTINOX VE+ 4-60 M MULTINOX VE+ 4-60 T	1,4	1	2 1,9	1,5 1,4	1-230 3-230/400	6,6 4,3-2,5	25		68	62	57	51	44	37	19	
MULTINOX VE+ 4-70 M MULTINOX VE+ 4-70 T	1,6	1,17	2,4 2,3	1,8 1,7	1-230 3-230/400	7,7 5-2,8	25		79	72	67	59	51	43	22	
MULTINOX VE+ 4-90 T	2	1,5	2,6	1,9	3-230/400	7,1-4			104	95	88	79	69	59	32	
MULTINOX VE+ 4-120 T	3	2	3,7	2,7	3-230/400	8,5-4,8			138	127	117	105	92	78	43	

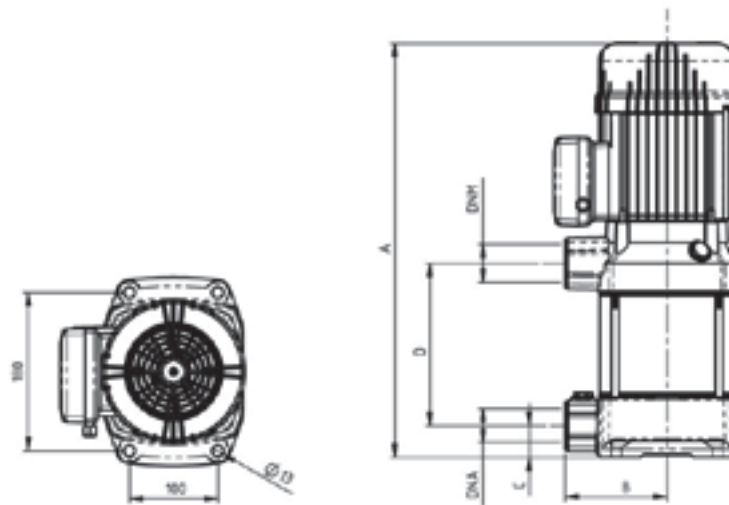

### OVERALL DIMENSIONS AND WEIGHTS

MODEL	Dimensions (mm)						WEIGHT (Kg)
	A	B	C	D	DNA	DNM	
MULTINOX VE+ 4-30	416	115	35	130	1" 1/4	1" 1/4	19
MULTINOX VE+ 4-40	443	115	35	157	1" 1/4	1" 1/4	21
MULTINOX VE+ 4-50	470	115	35	184	1" 1/4	1" 1/4	23
MULTINOX VE+ 4-60	497	115	35	211	1" 1/4	1" 1/4	25
MULTINOX VE+ 4-70	524	115	35	238	1" 1/4	1" 1/4	27
MULTINOX VE+ 4-90	578	115	35	292	1" 1/4	1" 1/4	28
MULTINOX VE+ 4-120	660	115	35	373	1" 1/4	1" 1/4	30

# MULTINOX-VE+

## VERTICAL MULTISTAGE CENTRIFUGAL PUMPS

### HYDRAULIC PERFORMANCE

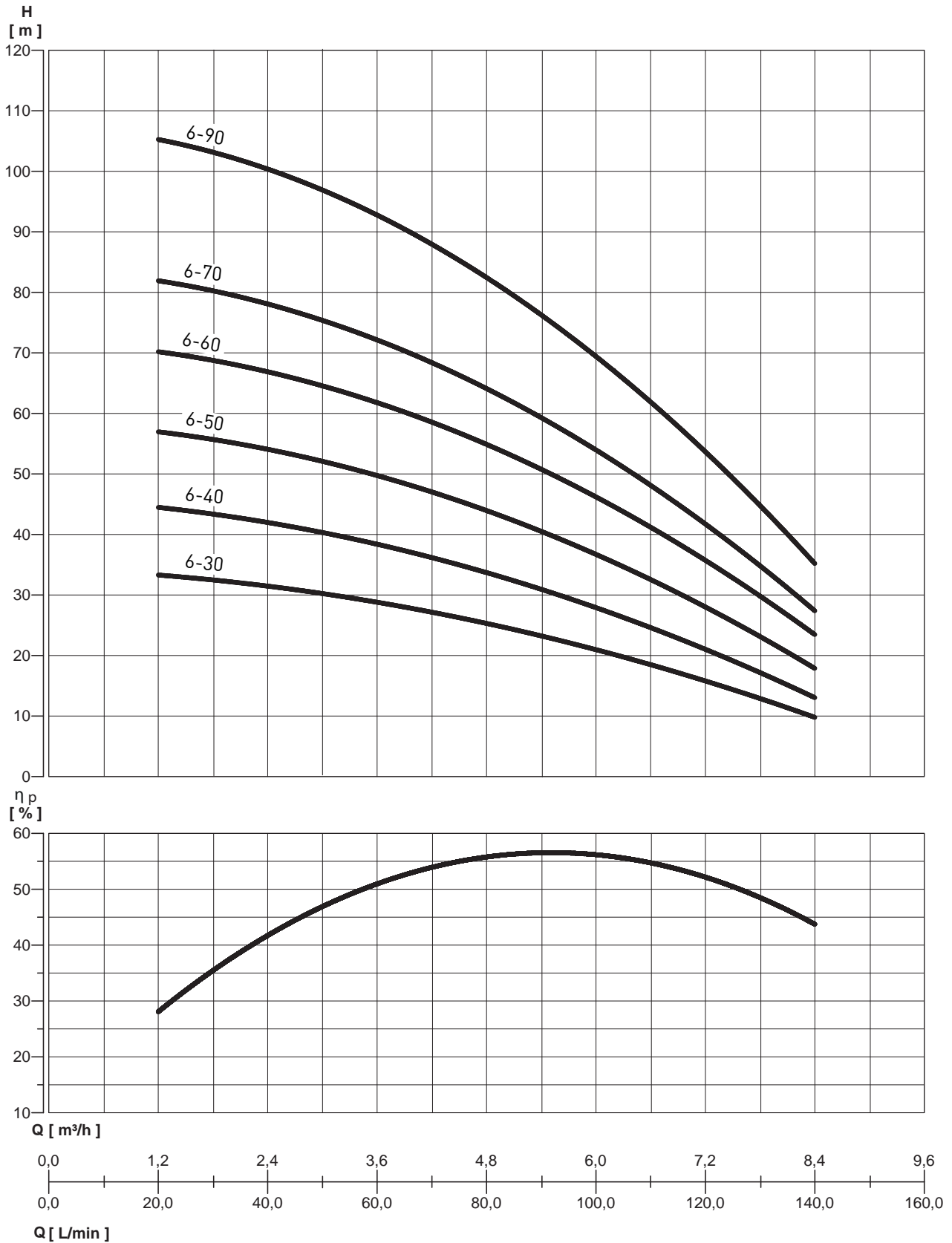

Hydraulic performance in accordance with ISO 9906:2012 - Curves at 2900 rpm

MEI ≥ 0.7 - Reference MEI ≥ 0.70 - The information on the reference efficiency is available at the address: [www.europump.org/efficiencycharts](http://www.europump.org/efficiencycharts)

# MULTINOX-VE+

## VERTICAL MULTISTAGE CENTRIFUGAL PUMPS

### PERFORMANCE TABLE

MODEL	Motor power (P2)		Motor power (P1)		VOLT. (V)	In (A)	µF	Q	m.c.w.							
	HP	kW	HP	kW					l/min	20	40	60	80	100	120	140
									m³/h	1,2	2,4	3,6	4,8	6	7,2	8,4
MULTINOX VE+ 6-30 M MULTINOX VE+ 6-30 T	0,9	0,67	1,4 1,3	1 0,97	1 - 230 3 ~ 230/400	4,4 3,1-1,8	20		34	31	28	26	21	16	10	
MULTINOX VE+ 6-40 M MULTINOX VE+ 6-40 T	1,2	0,9	1,9 1,6	1,36 1,2	1 - 230 3 ~ 230/400	6,4 2,3-4	25		45	41	38	34	28	21	13	
MULTINOX VE+ 6-50 M MULTINOX VE+ 6-50 T	1,50	1,1	2,2 1,9	1,6 1,4	1 - 230 3 ~ 230/400	7 4,7-2,6	35	m.c.w.	58	53	49	44	37	28	17	
MULTINOX VE+ 6-60 M MULTINOX VE+ 6-60 T	1,8	1,3	2,6 2,3	1,9 1,7	1 - 230 3 ~ 230/400	8 5,3-3	35		71	66	61	55	47	36	23	
MULTINOX VE+ 6-70 T	2	1,5	2,7	2	3 ~ 230/400	7,2-3,8			83	77	71	64	55	42	27	
MULTINOX VE+ 6-90 T	3	2	3,5	2,6	3 ~ 230/400	8,2-4,5			107	99	92	83	71	54	34	

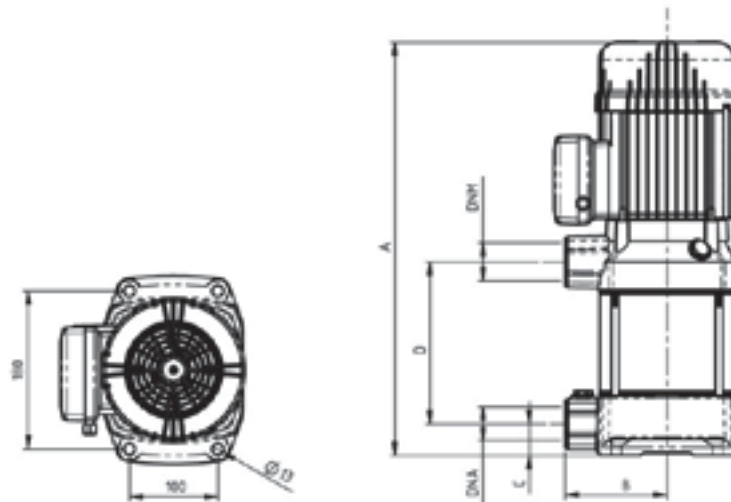

### OVERALL DIMENSIONS AND WEIGHTS

MODEL	Dimensions (mm)						WEIGHT (Kg)
	A	B	C	D	DNA	DNM	
MULTINOX VE+ 6-30	416	115	35	130	1" 1/4	1" 1/4	19
MULTINOX VE+ 6-40	443	115	35	157	1" 1/4	1" 1/4	21
MULTINOX VE+ 6-50	470	115	35	184	1" 1/4	1" 1/4	23
MULTINOX VE+ 6-60	497	115	35	211	1" 1/4	1" 1/4	25
MULTINOX VE+ 6-70	524	115	35	238	1" 1/4	1" 1/4	27
MULTINOX VE+ 6-90	578	115	35	292	1" 1/4	1" 1/4	28



# MULTINOX-VE+

## VERTICAL MULTISTAGE CENTRIFUGAL PUMPS

### HYDRAULIC PERFORMANCE

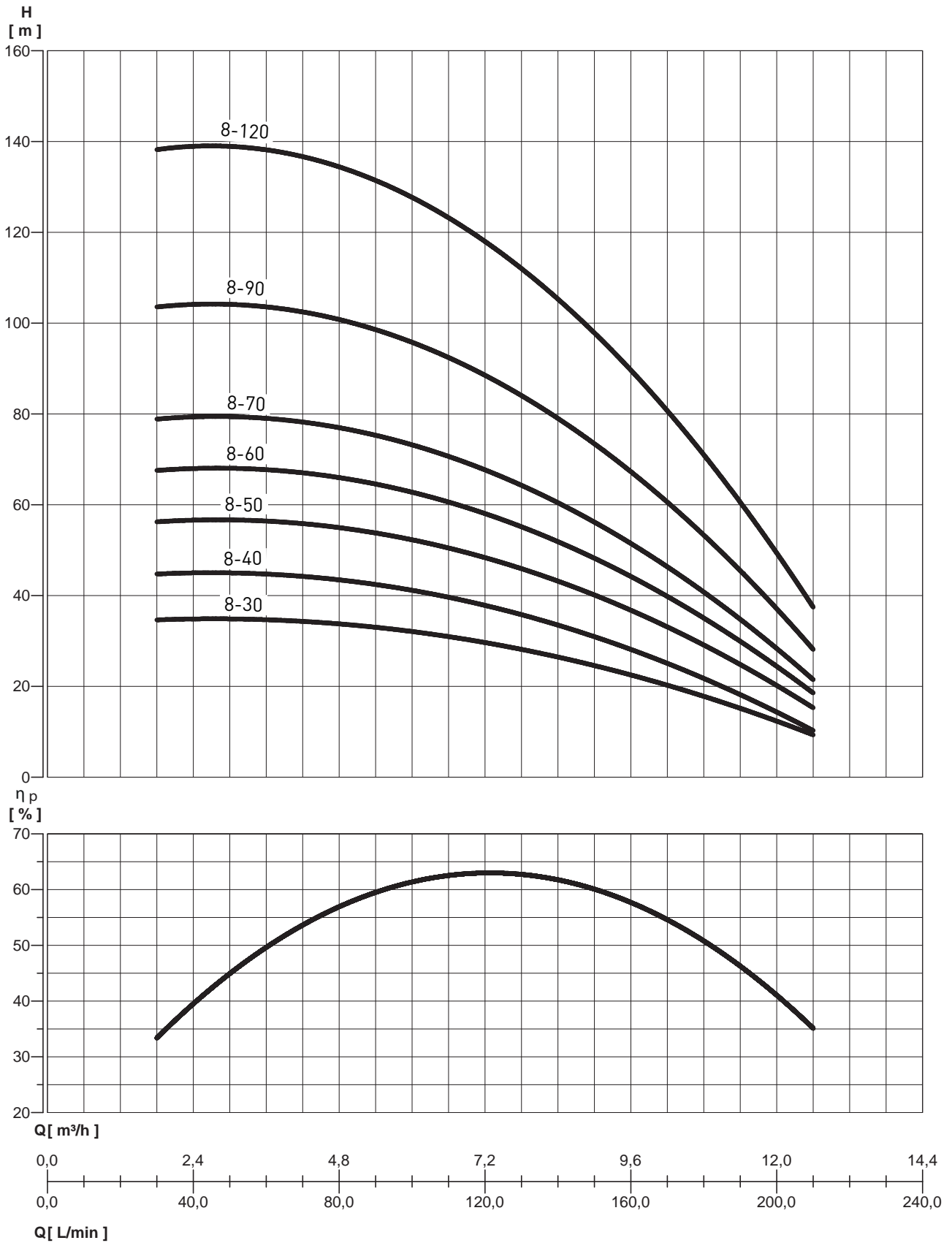

Hydraulic performance in accordance with ISO 9906:2012 - Curves at 2900 rpm

MEI ≥ 0.7 - Reference MEI ≥ 0.70 - The information on the reference efficiency is available at the address: [www.europump.org/efficiencycharts](http://www.europump.org/efficiencycharts)

# MULTINOX-VE+

## VERTICAL MULTISTAGE CENTRIFUGAL PUMPS

### PERFORMANCE TABLE

MODEL	Motor power (P2)		Motor power (P1)		VOLT. (V)	In (A)	μF	Q	l/min	30	60	90	120	150	180	210
	HP	kW	HP	kW						m³/h	1,8	3,6	5,4	7,2	9	10,8
MULTINOX VE+ 8-30 M MULTINOX VE+ 8-30 T	1,35	1	1,9	1,4	1 - 230 3 - 230/400	6,3 4-2,3	20	m.c.w.		35	35	33	30	25	18	10
MULTINOX VE+ 8-40 M MULTINOX VE+ 8-40 T	1,6	1,2	2,3	1,7	1 - 230 3 - 230/400	7,8 5,7-3,3	25		45	44	42	39	32	20	11	
MULTINOX VE+ 8-50 M MULTINOX VE+ 8-50 T	2	1,5	3	2,2	1 - 230 3 - 230/400	9,5 6-3,7	35		57	56	53	50	40	28	16	
MULTINOX VE+ 8-60 T	2,3	1,7	3,3	2,4	3 - 230/400	6,7-4,7			68	67	64	60	48	34	19	
MULTINOX VE+ 8-70 T	2,5	1,9	3,4	2,5	3 - 230/400	7-4,9			80	78	74	70	56	40	22	
MULTINOX VE+ 8-90 T	4	3	4,4	3,2	3 - 230/400	10,2-5,9			104	103	98	90	73	52	29	
MULTINOX VE+ 8-120 T	5,5	4	6,2	4,6	3 - 230/400	13,5-7,6			139	138	131	120	98	70	38	

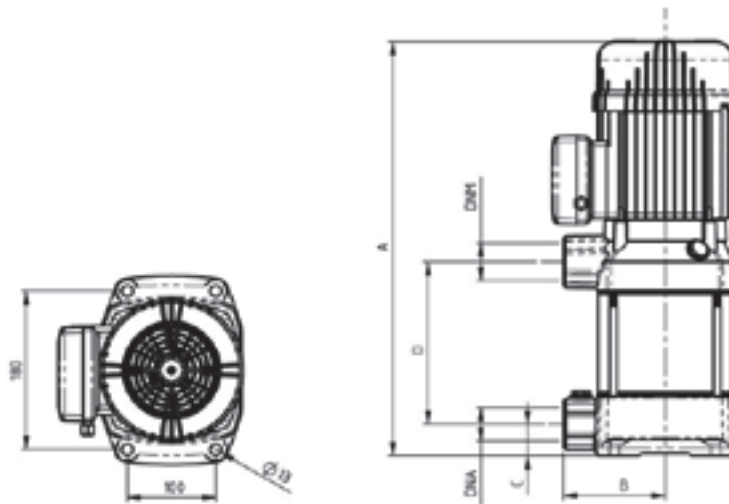

### OVERALL DIMENSIONS AND WEIGHTS

MODEL	Dimensions (mm)						WEIGHT (Kg)
	A	B	C	D	DNA	DNM	
MULTINOX VE+ 8-30	416	115	35	130	1" 1/4	1" 1/4	19
MULTINOX VE+ 8-40	443	115	35	157	1" 1/4	1" 1/4	21
MULTINOX VE+ 8-50	470	115	35	184	1" 1/4	1" 1/4	23
MULTINOX VE+ 8-60	497	115	35	211	1" 1/4	1" 1/4	25
MULTINOX VE+ 8-70	524	115	35	238	1" 1/4	1" 1/4	27
MULTINOX VE+ 8-90	730	115	35	292	1" 1/4	1" 1/4	36
MULTINOX VE+ 8-120	855	115	35	373	1" 1/4	1" 1/4	39

# PVM/PVMI/PVMX

## VERTICAL MULTISTAGE CENTRIFUGAL PUMPS

High hydraulic efficiency, motor designed according to EN regulations

PVM, PVMI and PVMX are non self-priming vertical multi-stage pumps, with Victaulic or flanged fittings with inlets and outlets of the same size.

Construction of stages with impellers, chambers and outlet in stainless steel. Pump cardan shaft and motor shaft are directly coupled according to IEC standard.

All pumps are equipped with high

efficiency motors (IE3) and a cartridge-type mechanical seal for easy maintenance.

PVM, PVMI and PVMX pumps are available in different sizes and number of stages to provide the required flow and pressure.



### APPLICATIONS

- Water supply
- Pressurization systems
- Water treatment/filtration
- Irrigation
- High pressure washing
- Liquid transfer
- Fire protection systems
- Boiler feed

### IDENTIFICATION CODE

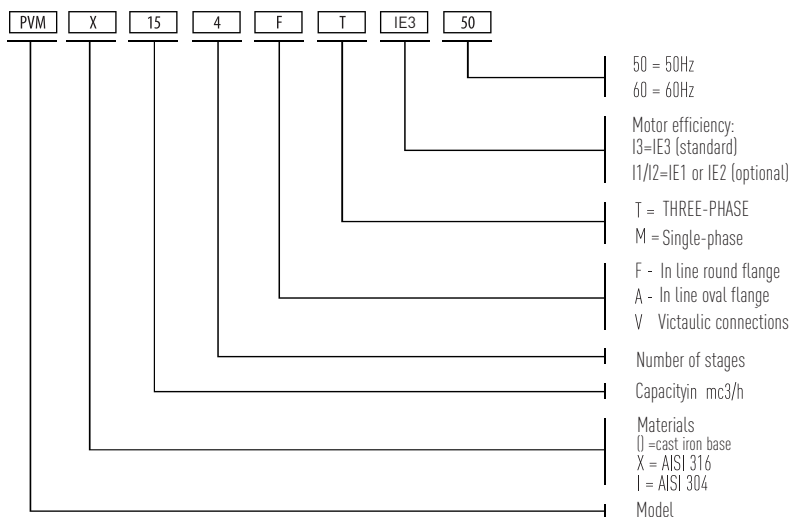

# PVM/PVMI/PVMX

## VERTICAL MULTISTAGE CENTRIFUGAL PUMPS

### PERFORMANCE TABLE

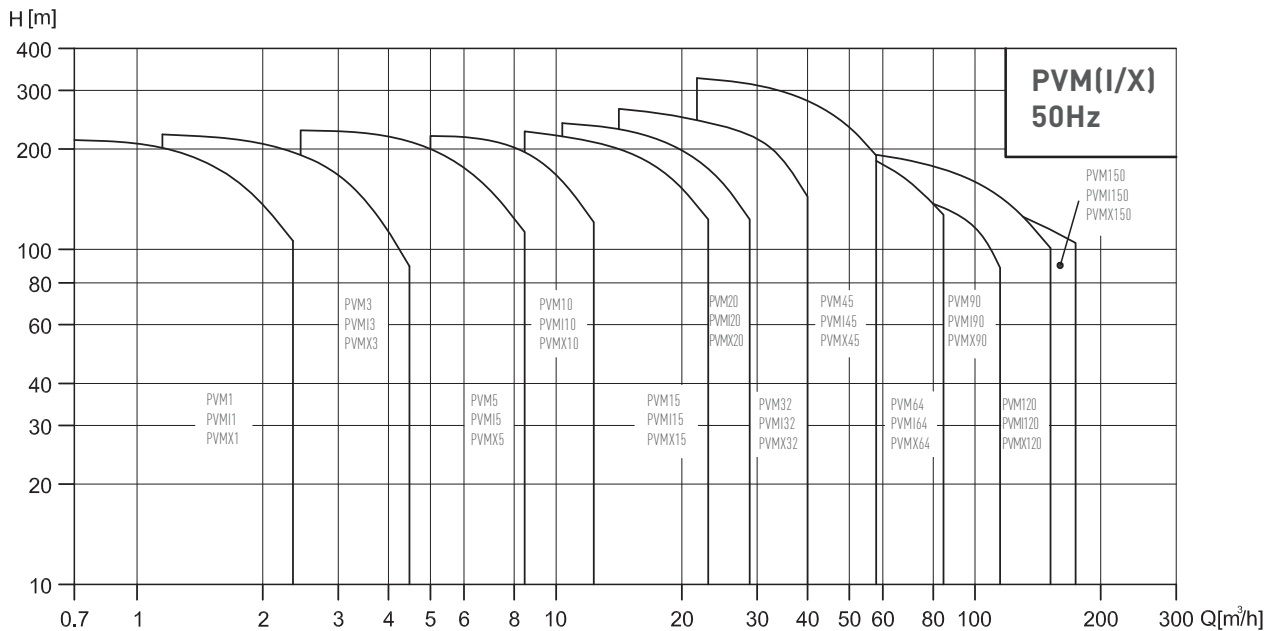

### MOTOR

- Asynchronous electric motor with integrated stator and external ventilation
- The main dimensions conform to DIN and IEC regulations
- Energy efficiency: IE3
- Insulation class F
- Protection level IP55
- Maximum ambient temperature 50°C
- Speed of rotation 2900 rpm

TYPE OF MOTOR - 2 POLES				RATED CURRENT IN [A]	
[HP]	[KW]	Flange	Frame	3~230V	3~400V
0.5	0.37	B14	71	1.9	1.1
0.75	0.55		71	2.7	1.6
1	0.75		80	3.5	2.1
1.5	1.1		80	4.5	2.6
2	1.5		90S	5.2	3.0
3	2.2		90L	8.0	4.6
4	3		100L	9.7	5.6
5.5	4		112M	12.2	7.0
7.5	5.5		132S	10.0	5.8
10	7.5		132S	13.1	7.6
15	11	B5	160M	19.7	11.4
20	15		160M	26.7	15.5
25	18.5		160L	33.0	19.1
30	22		180M	40.8	23.7
40	30		200L	52.8	30.6
50	37		200L	65.6	38
60	45		225M	82.4	47.8
75	55		250M	93.6	54.3
100	75		280S	123.1	71.4

\* The rated current values indicated refer to the standard motor configuration. For details, contact Pentair in your country.

# PVM/PVMI/PVMX

## VERTICAL MULTISTAGE CENTRIFUGAL PUMPS

### PRODUCT DATA

50Hz	PVM, PVMI, PVMX					
Rated flow (m <sup>3</sup> /h)	1	3	5	10	15	20
Range of flow rate (m <sup>3</sup> /h)	0.7-2.4	1.2-4.5	2.5-8.5	5-13	8.5-23.5	10.5-29
Max. pressure (bar)	21.5	23	24	21.5	23	24.3
Temperature of fluid	from -15°C to +120°C					
Motor power (kW)	0.37-2.2	0.37-3	0.37-5.5	0.37-7.5	1.1-15	1.1-18.5
<b>Version</b>						
PVM: cast iron and stainless steel EN 1.4301/AISI 304	•	•	•	•	•	•
PVMI: stainless steel EN 1.4301/AISI 304	•	•	•	•	•	•
PVMX: stainless steel EN 1.4401/AISI 316	•	•	•	•	•	•
<b>Motor</b>						
Network connection 1- (V/Hz) Permitted VOLT. range ± 10%	220-240 V 50 Hz					
Network connection 3- (V/Hz) Permitted VOLT. range ± 10%	0.37-7.5 kW 220-240/380-415 V 50 Hz 11 kW 380-415 V 50 Hz					
Insulation class	F					
Protection class	IP 55					
Ambient temperature	50°C					
<b>PVM pipe connection</b>						
Flange	DN 25/DN 32	DN 25/DN 32	DN 25/DN 32	DN 40	DN 50	DN 50
<b>PVMI/PVMX pipe connection</b>						
Flange	DN 25/DN 32	DN 25/DN 32	DN 25/DN 32	DN 40	DN 50	DN 50
Victaulic connection	R1"¼ DN32	R1"¼ DN32	R1"¼ DN32	R2 DN50	R2 DN50	R2 DN50
<b>Mechanical seals</b>						
SiC/SiC	Standard					
<b>Gaskets</b>						
EPDM	Standard					

# PVM/PVMI/PVMX

## VERTICAL MULTISTAGE CENTRIFUGAL PUMPS

### PRODUCT DATA

50Hz	PVM, PVMI, PVMX					
Rated flow (m <sup>3</sup> /h)	32	45	64	90	120	150
Range of flow rate (m <sup>3</sup> /h)	15-40	22-58	30-85	45-120	60-160	75-180
Max. pressure (bar)	27.5	33	21.8	20	20.4	18.7
Temperature of fluid	from -15°C to +120°C					
Motor power (kW)	1.5-30	3-45	4-45	5.5-45	11-75	11-75
Version						
PVM: cast iron and stainless steel EN 1.4301/AISI 304	.	.	.	.	.	.
PVMI: stainless steel EN 1.4301/AISI 304	.	.	.	.	.	.
PVMX: stainless steel EN 1.4401/AISI 316	.	.	.	.	.	.
Motor						
Network connection 1- (V/Hz) Permitted VOLT. range ± 10%	220-240 V 50 Hz					
Network connection 3- (V/Hz) Permitted VOLT. range ± 10%	0.37-7.5 kW 220-240/380-415 V 50 Hz 11 kW 380-415 V 50 Hz					
Insulation class	F					
Protection class	IP 55					
Ambient temperature	50°C					
PVM pipe connection						
Flange	DN 65	DN 80	DN 100	DN 100	DN 125	DN 125
PVMI/PVMX pipe connection						
Flange	DN 65	DN 80	DN 100	DN 100	DN 125	DN 125
Victaulic connection	N/D	N/D	N/D	N/D	N/D	N/D
Mechanical seals						
SiC/SiC	Standard					
Gaskets						
EPDM	Standard					

# PVM/PVMI/PVMX

## VERTICAL MULTISTAGE CENTRIFUGAL PUMPS

### MAXIMUM OPERATING AND INPUT PRESSURES

STAGES	MAXIMUM OPERATING PRESSURE	STAGES	MAXIMUM INPUT PRESSURE
<b>PVM-I-X 1</b>			
2-36	25 bar.	2-36	10 bar.
<b>PVM-I-X 3</b>			
2-36	25 bar.	2-29	10 bar.
		31-36	15 bar.
<b>PVM-I-X 5</b>			
2-36	25 bar.	2-16	10 bar.
		18-36	15 bar.
<b>PVM-I-X 10</b>			
1-16	16 bar.	1-6	8 bar.
17-22	25 bar.	7-22	10 bar.
<b>PVM-I-X 15</b>			
1-10	16 bar.	1-3	8 bar.
12-17	25 bar.	4-17	10 bar.
<b>PVM-I-X 20</b>			
1-10	16 bar.	1-3	8 bar.
12-17	25 bar.	4-17	10 bar.
<b>PVM-I-X 32</b>			
(1-1)-7	16 bar.	(1-1)-4	4 bar.
(8-2)-14	30 bar.	(5-2)-10	10 bar.
		(11-2)-14	15 bar.
<b>PVM-I-X 45</b>			
(1-1)-5	16 bar.	(1-1)-2	4 bar.
(6-2)-11	30 bar.	(3-2)-5	10 bar.
(12-2)-(13-2)	33 bar.	(6-2)-(13-2)	15 bar.
<b>PVM-I-X 64</b>			
(1-1)-5	16 bar.	(1-1)-(2-2)	4 bar.
(6-2)-(8-1)	30 bar.	(2-1)-(4-2)	10 bar.
		(4-1)-(8-1)	15 bar.
<b>PVM-I-X 90</b>			
(1-1)-4	16 bar.	(1-1)-1	4 bar.
(5-2)-6	30 bar.	(2-1)-(3-2)	10 bar.
		3-6	15 bar.
<b>PVM-I-X 120</b>			
1-7	30 bar.	1-(2-1)	10 bar.
		2-(5-1)	15 bar.
		(6-1)-7	20 bar.
<b>PVM-I-X 150</b>			
(1-1)-6	30 bar.	(1-1)-1	10 bar.
		(2-1)-(4-2)	15 bar.
		(5-2)-6	20 bar.

\* Rule Input pressure + pressure against a closed valve < Max. Operating pressure

# PVM/PVMI/PVMX

## VERTICAL MULTISTAGE CENTRIFUGAL PUMPS

### PUMP STRUCTURE

ITEM	NAME	MATERIAL	PVM 1, 3, 5, 10, 15, 20	PVMI 1, 3, 5, 10, 15, 20	PVMX 1, 3, 5, 10, 15, 20
36	Head of the pump	Cast iron	EN-GJL-200 ; ASTM 25B	EN-GJS-450-10 ; ASTM 65-45-12	EN-GJS-450-10 ; ASTM 65-45-12
56	Pump head cover	Stainless steel	N/D	1.4301 ; AISI 304	1.4401 ; AISI 316
18	Impeller	Stainless steel	1.4301 ; AISI 304	1.4301 ; AISI 304	1.4401 ; AISI 316
37	Shaft	Stainless steel	1.4057 ; AISI 431	1.4057 ; AISI 431	1.4401 ; AISI 316
48	Outer sleeve	Stainless steel	1.4301 ; AISI 304	1.4301 ; AISI 304	1.4401 ; AISI 316
82	O-ring for outer sleeve	EPDM	-	-	-
12	Chamber	Stainless steel	1.4301 ; AISI 304	1.4301 ; AISI 304	1.4401 ; AISI 316
24	Collar	PTFE	-	-	-
59	Base	Cast iron	EN-GJL-200 ; ASTM 25B	N/D	N/D
		Stainless steel	N/D	1.4301 ; AISI 304	1.4401 ; AISI 316
62	Base plate	Cast iron	N/D	EN-GJL-200 ; ASTM 25B	EN-GJL-200 ; ASTM 25B
44	Fitting	Fe-Cu-C	SINT C11 ; MPIF FC0525	SINT C11 ; MPIF FC0525	SINT C11 ; MPIF FC0525
57	Mechanical seal	Type of Cartridge	-	-	-

**PVM - 1, 3, 5, 10, 15, 20**

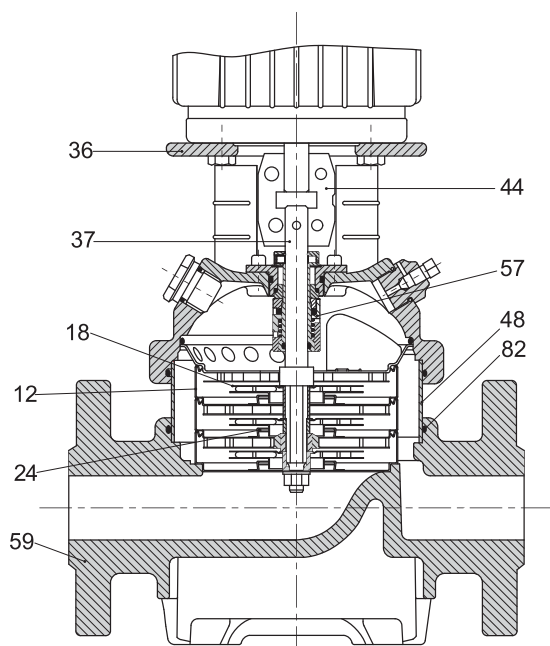

**PVMI / X - 1, 3, 5, 10, 15, 20**

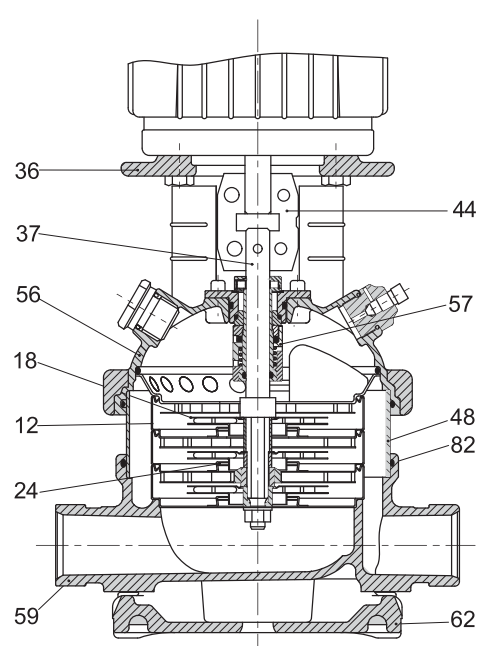



# PVM/PVMI/PVMX

## VERTICAL MULTISTAGE CENTRIFUGAL PUMPS

### PUMP STRUCTURE

ITEM	NAME	MATERIAL	PVM 32, 45, 64, 90	PVMI 32, 45, 64, 90	PVMX 32, 45, 64, 90
36	Head of the pump	Cast iron	EN-GJL-250 ; ASTM 35B	N/D	N/D
		Stainless steel	N/D	1.4301 ; AISI 304	1.4401 ; AISI 316
53	Motor bracket	Stainless steel	EN-GJL-250 ; ASTM 35B	EN-GJL-250 ; ASTM 35B	EN-GJL-250 ; ASTM 35B
18	Impeller	Stainless steel	1.4301 ; AISI 304	1.4301 ; AISI 304	1.4401 ; AISI 316
37	Shaft	Stainless steel	1.4057 ; AISI 431	1.4057 ; AISI 431	1.4401 ; AISI 316
48	Outer sleeve	Stainless steel	1.4301 ; AISI 304	1.4301 ; AISI 304	1.4401 ; AISI 316
82	O-ring for outer sleeve	EPDM	-	-	-
12	Chamber	Stainless steel	1.4301 ; AISI 304	1.4301 ; AISI 304	1.4401 ; AISI 316
24	Collar	Carbon fiber + POB + PTFE	-	-	-
59	Base	Cast iron	EN-GJL-250 ; ASTM 35B	N/D	N/D
		Stainless steel	N/D	1.4301 ; AISI 304	1.4401 ; AISI 316
62	Base plate	Cast iron	N/D	EN-GJL-250 ; ASTM 35B	EN-GJL-250 ; ASTM 35B
57	Mechanical seal	Type of Cartridge	-	-	-
14	Ring of bearing	-	Bronze	POB + graphite + PTFE	-
42	Ring of lower bearing	Tungsten carbide / tungsten carbide	-	-	-

**PVM - 32, 45, 64, 90**

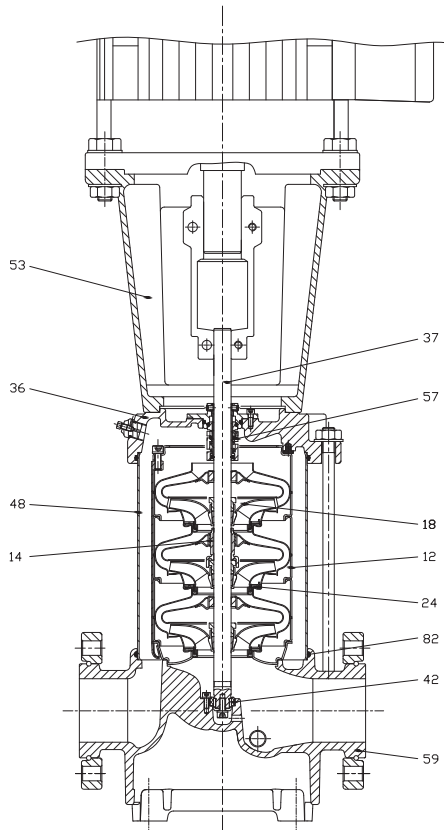

**PVMI / X - 32, 45, 64, 90**

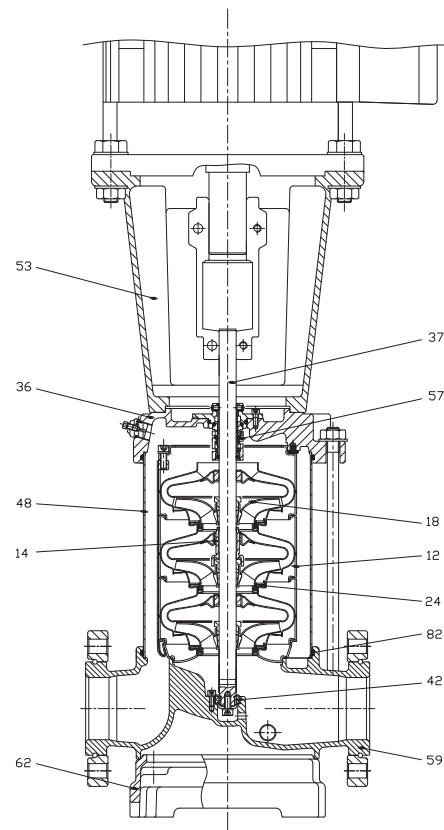

# PVM/PVMI/PVMX

## VERTICAL MULTISTAGE CENTRIFUGAL PUMPS

### PUMP STRUCTURE

ITEM	NAME	MATERIAL	PVM 120, 150	PVMI 120, 150	PVMX 120, 150
36	Head of the pump	Cast iron	EN-GJL-250 ; ASTM 35B	N/D	N/D
		Stainless steel	N/D	1.4301 ; AISI 304	1.4401 ; AISI 316
53	Motor support (15HP-60HP)	Cast iron	EN-GJL-250 ; ASTM 35B	EN-GJL-250 ; ASTM 35B	EN-GJL-250 ; ASTM 35B
	Motor support (75HP-100HP)	Cast iron	EN-GJS-450-10 ; ASTM 65-45-12	EN-GJS-450-10 ; ASTM 65-45-12	EN-GJS-450-10 ; ASTM 65-45-12
17	Ring of bearing	PTFE	-	-	-
18	Impeller	Stainless steel	1.4301 ; AISI 304	1.4301 ; AISI 304	1.4401 ; AISI 316
37	Shaft	Stainless steel	1.4057 ; AISI 431	1.4057 ; AISI 431	1.4401 ; AISI 316
48	Outer sleeve	Stainless steel	1.4301 ; AISI 304	1.4301 ; AISI 304	1.4401 ; AISI 316
82	O-ring for outer sleeve	EPDM	-	-	-
12	Chamber	Stainless steel	1.4301 ; AISI 304	1.4301 ; AISI 304	1.4401 ; AISI 316
24	Collar	PTFE	-	-	-
59	Base	Cast iron	EN-GJL-250 ; ASTM 35B	N/D	N/D
		Stainless steel	N/D	1.4301 ; AISI 304	1.4401 ; AISI 316
62	Base plate	Cast iron	N/D	EN-GJS-450-10 ; ASTM 65-45-12	-
62A	Base plate	Cast iron	N/D	EN-GJS-450-10 ; ASTM 65-45-12	-
57	Mechanical seal	Type of Cartridge	EN-GJS-450-10 ; ASTM 65-45-12	-	-
14	Ring of bearing	-	Bronze	POB + graphite + PTFE	-
42	Ring of lower bearing	Tungsten carbide / tungsten carbide	-	-	-

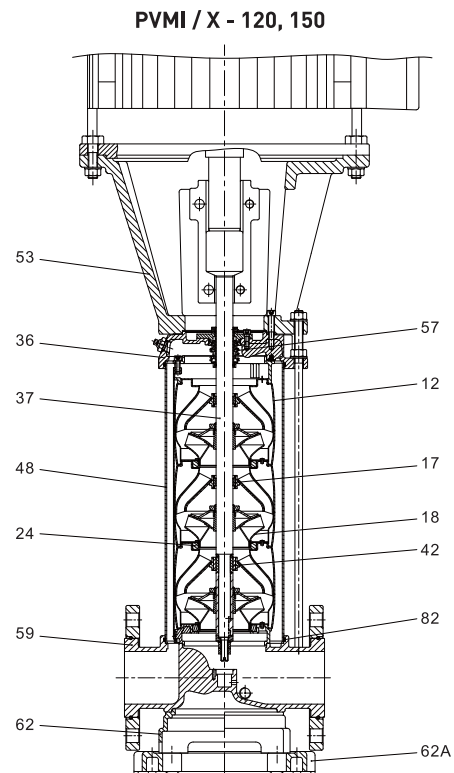
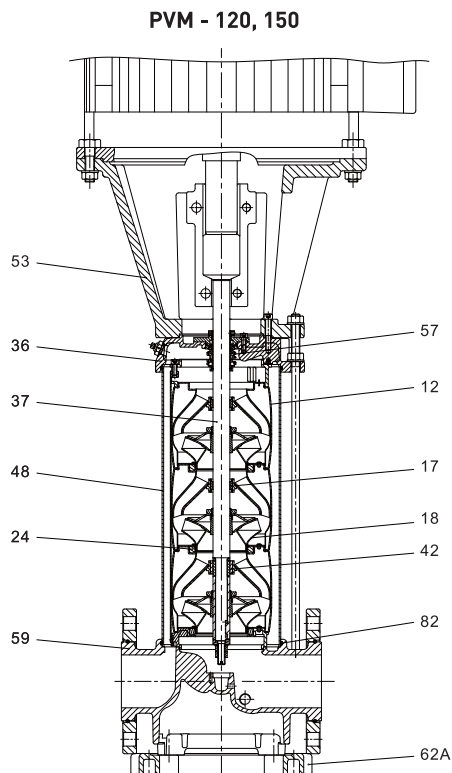

# PVM/PVMI/PVMX

## VERTICAL MULTISTAGE CENTRIFUGAL PUMPS

### OVERALL DIMENSIONS AND WEIGHTS

TYPE OF PUMP	MOTOR		PVM					PVMI - PVMX							
			Dimensions [ mm ]				Net weights [ kg ]	Dimensions [ mm ]						Net weights [ kg ]	
	P <sub>2</sub>		DIN flange		D1	D2		DIN Flange	Victaulic		DIN flange		D1	D2	Victaulic
	[ HP ]	[ KW ]	H1	H2			H1		H2	H1	H2				
PVM1-2	0.5	0.37	279	474	141	115	23.4	257	452	282	477	141	115	19.3	20.2
PVM1-3	0.5	0.37	279	474	141	115	23.4	257	452	282	477	141	115	19.3	20.3
PVM1-4	0.5	0.37	297	492	141	115	23.8	275	470	300	495	141	115	19.7	20.6
PVM1-5	0.5	0.37	315	510	141	115	24.2	293	488	318	513	141	115	20.1	21.0
PVM1-6	0.5	0.37	333	528	141	115	24.5	311	506	336	531	141	115	20.4	21.4
PVM1-7	0.5	0.37	351	546	141	115	24.9	329	524	354	549	141	115	20.8	21.7
PVM1-8	0.75	0.55	369	564	141	115	25.8	347	542	372	567	141	115	21.7	22.6
PVM1-9	0.75	0.55	387	582	141	115	26.1	365	560	390	585	141	115	22.0	23.0
PVM1-10	0.75	0.55	405	600	141	115	26.5	383	578	408	603	141	115	22.4	23.3
PVM1-11	0.75	0.55	423	618	141	115	26.9	401	596	426	621	141	115	22.8	23.7
PVM1-12	1.0	0.75	447	682	141	115	29.4	425	660	450	685	141	115	25.2	26.1
PVM1-13	1.0	0.75	465	700	141	115	29.8	443	678	468	703	141	115	25.6	26.5
PVM1-15	1.0	0.75	501	736	141	115	30.5	479	714	504	739	141	115	26.3	27.2
PVM1-17	1.5	1.1	537	772	141	115	32.3	515	750	540	775	141	115	28.1	29.1
PVM1-19	1.5	1.1	573	808	141	115	33.1	551	786	576	811	141	115	28.8	29.8
PVM1-21	1.5	1.1	609	844	141	115	33.8	587	822	612	847	141	115	29.6	30.6
PVM1-23	1.5	1.1	645	880	141	115	34.6	623	858	648	883	141	115	30.4	31.3
PVM1-25	2.0	1.5	697	964	180	138	44.0	675	942	700	991	180	138	39.8	40.8
PVM1-27	2.0	1.5	733	1000	180	138	44.8	711	978	736	1027	180	138	40.6	41.5
PVM1-30	2.0	1.5	787	1054	180	138	45.9	765	1032	790	1081	180	138	41.7	42.6
PVM1-33	3.0	2.2	841	1108	180	138	49.9	819	1086	844	1135	180	138	45.6	46.6
PVM1-36	3.0	2.2	895	1162	180	138	51.0	873	1140	898	1189	180	138	46.7	47.7

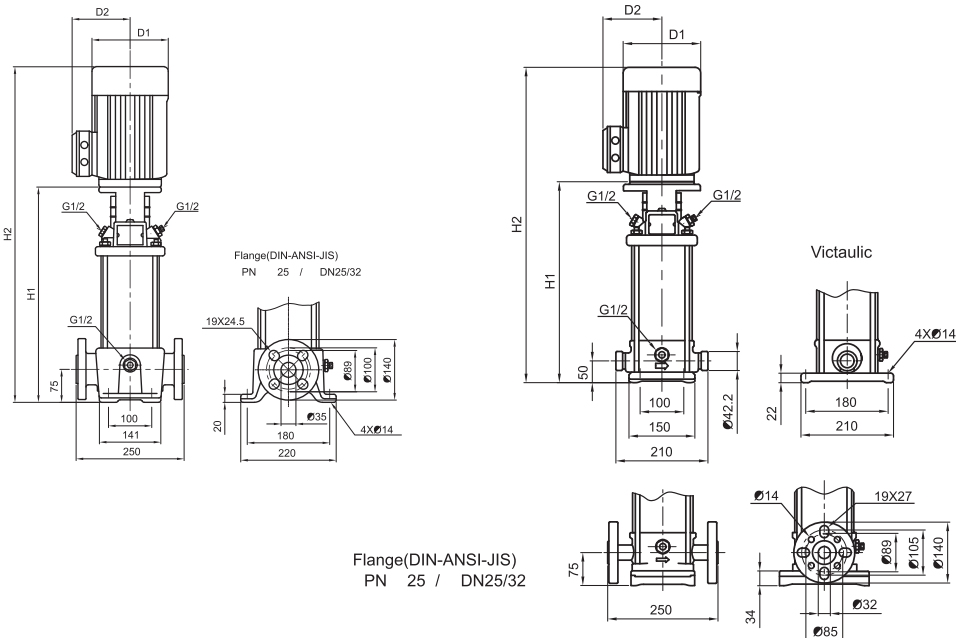

# PVM/PVMI/PVMX 1

## VERTICAL MULTISTAGE CENTRIFUGAL PUMPS

### HYDRAULIC PERFORMANCE

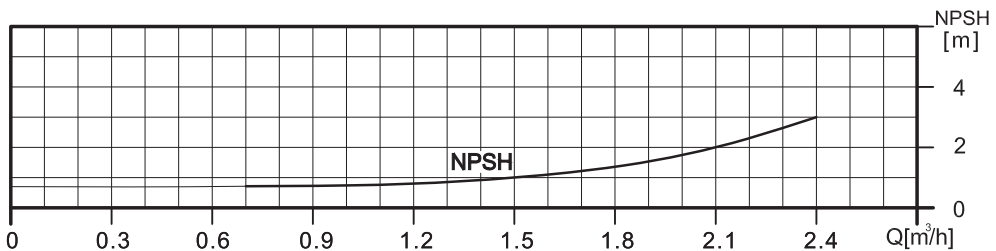
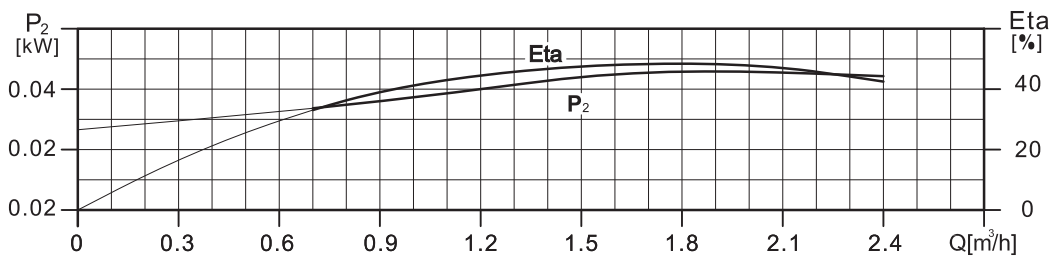
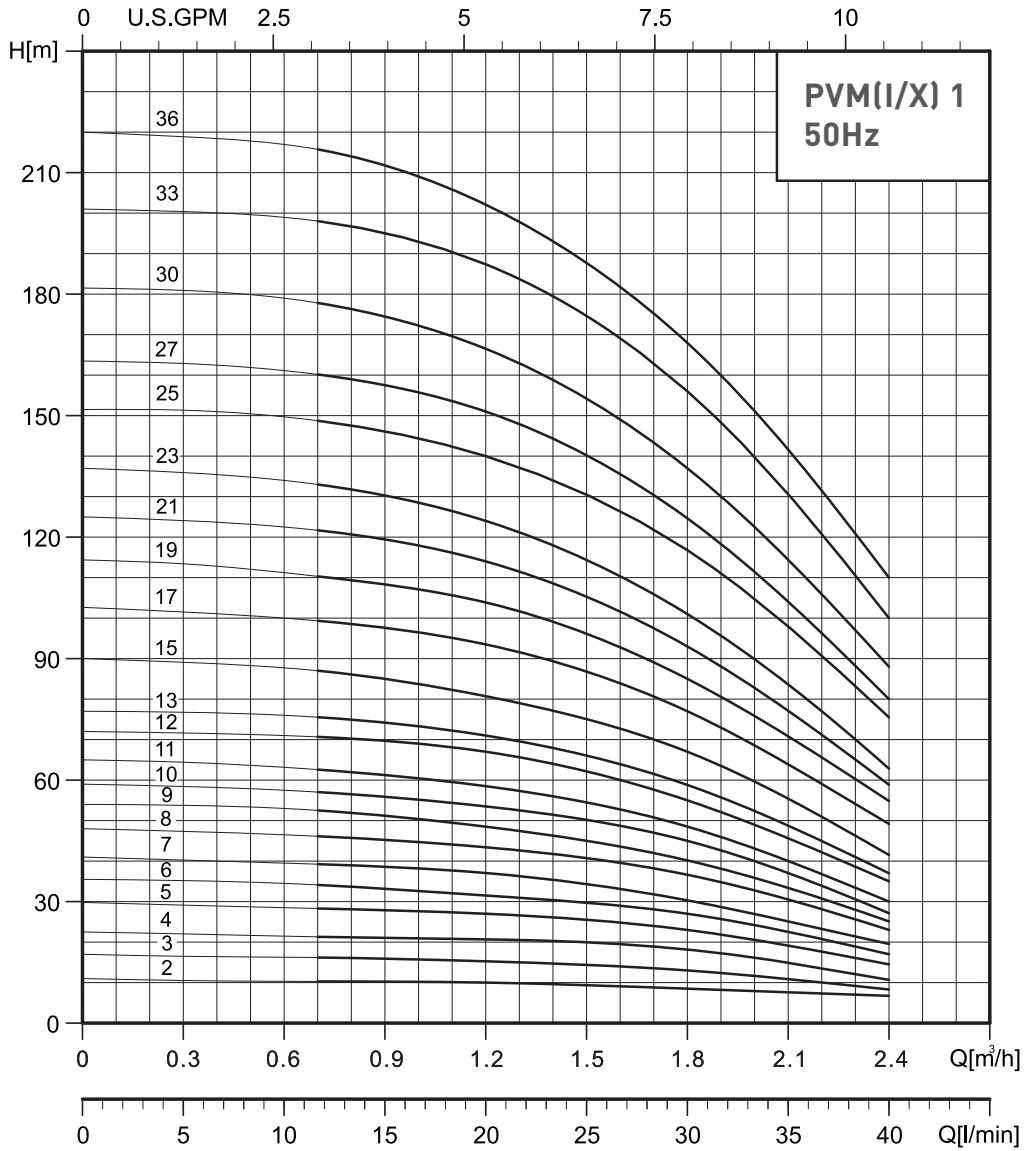

Head and NPSH values valid for water with density  $\rho = 1.0 \text{ Kg / dm}^3$  at  $20^\circ \text{C}$

PVM(I/X) 1

2900 rpm

50 Hz

ISO 9906 - Annex A

MEI  $\geq 0.4$  - Reference MEI  $\geq 0.70$  - The information on the reference efficiency is available at the address: [www.europump.org/efficiencycharts](http://www.europump.org/efficiencycharts)

# PVM/PVMI/PVMX 3

## VERTICAL MULTISTAGE CENTRIFUGAL PUMPS

### OVERALL DIMENSIONS AND WEIGHTS

TYPE OF PUMP	MOTOR		PVM						PVMI - PVMX							
			Dimensions [mm]				Net weights [kg]	Dimensions [mm]				Net weights [kg]				
	P <sub>2</sub>		DIN flange		D1	D2		DIN Flange	Victaulic		DIN flange		D1	D2	Victaulic	DIN flange
	[HP]	[KW]	H1	H2			H1		H2	H1	H2	H1				
PVM 3-2	0.5	0.37	279	474	141	115	23.4	257	452	282	477	141	115	19.3	20.2	
PVM 3-3	0.5	0.37	279	474	141	115	23.4	257	452	282	477	141	115	19.3	20.3	
PVM 3-4	0.5	0.37	297	492	141	115	23.8	275	470	300	495	141	115	19.7	20.6	
PVM 3-5	0.5	0.37	315	510	141	115	24.2	293	488	318	513	141	115	20.1	21.0	
PVM 3-6	0.75	0.55	333	528	141	115	25.0	311	506	336	531	141	115	20.9	21.9	
PVM 3-7	0.75	0.55	351	546	141	115	25.4	329	524	354	549	141	115	21.3	22.2	
PVM 3-8	1.0	0.75	375	610	141	115	27.9	353	588	378	613	141	115	23.7	24.6	
PVM 3-9	1.0	0.75	393	628	141	115	28.3	371	606	396	631	141	115	24.0	25.0	
PVM 3-10	1.0	0.75	411	646	141	115	28.7	389	624	414	649	141	115	24.4	25.4	
PVM 3-11	1.5	1.1	429	664	141	115	30.2	407	642	432	667	141	115	25.9	26.9	
PVM 3-12	1.5	1.1	447	682	141	115	30.5	425	660	450	685	141	115	26.3	27.2	
PVM 3-13	1.5	1.1	465	700	141	115	30.9	443	678	468	703	141	115	26.7	27.6	
PVM 3-15	1.5	1.1	501	736	141	115	31.6	479	714	504	739	141	115	27.4	28.3	
PVM 3-17	2.0	1.5	553	820	180	138	41.0	531	798	180	138	177	141	36.9	37.8	
PVM 3-19	2.0	1.5	589	856	180	138	41.8	567	834	180	138	177	141	37.6	38.5	
PVM 3-21	3.0	2.2	625	892	180	138	45.3	603	870	180	138	177	141	41.2	42.1	
PVM 3-23	3.0	2.2	661	928	180	138	46.1	639	906	180	138	177	141	41.9	42.9	
PVM 3-25	3.0	2.2	697	964	180	138	46.8	675	942	180	138	177	141	42.6	43.6	
PVM 3-27	3.0	2.2	733	1000	180	138	47.6	711	978	180	138	177	141	43.4	44.3	
PVM 3-29	3.0	2.2	769	1036	180	138	48.3	747	1014	180	138	177	141	44.1	45.1	
PVM 3-31	4.0	3.0	809	1130	194	145	56.6	787	1108	194	145	197	147	52.0	53.0	
PVM 3-33	4.0	3.0	845	1166	194	145	57.4	823	1144	194	145	197	147	52.8	53.7	
PVM 3-36	4.0	3.0	899	1220	194	145	58.5	877	1198	194	145	197	147	53.9	54.8	

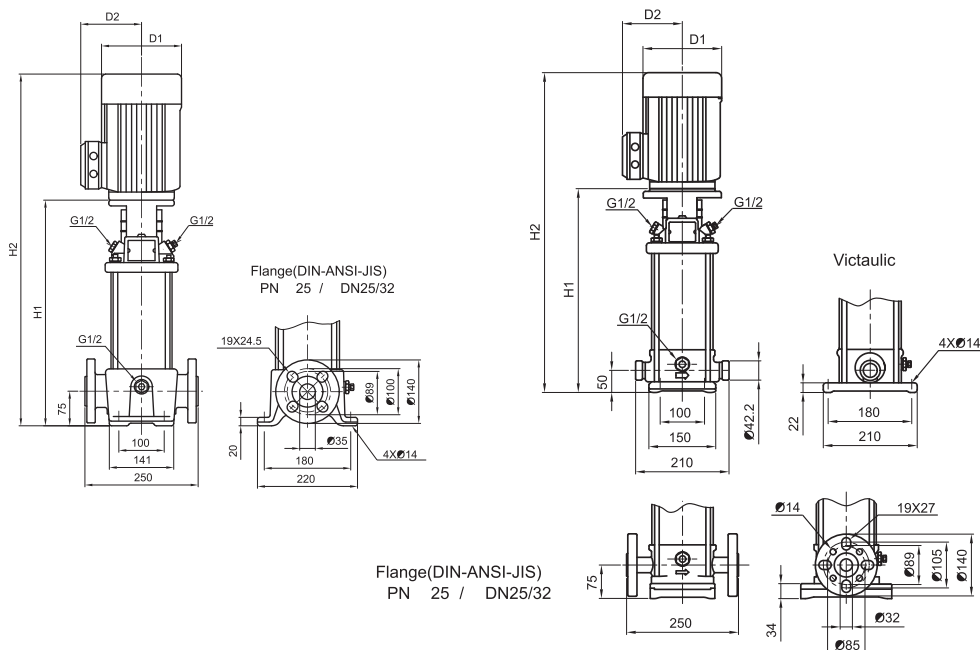

# PVM/PVMI/PVMX 3

## VERTICAL MULTISTAGE CENTRIFUGAL PUMPS

### HYDRAULIC PERFORMANCE

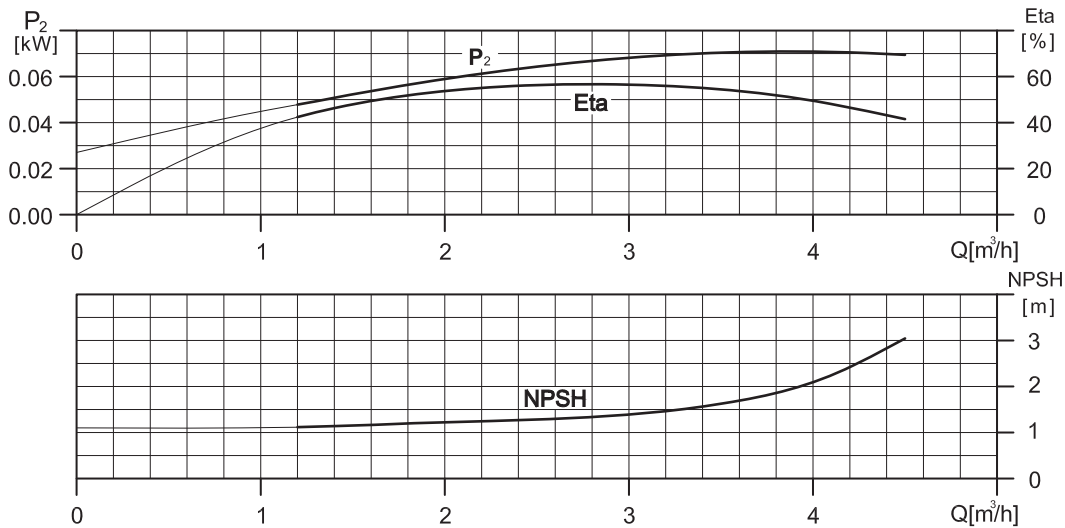
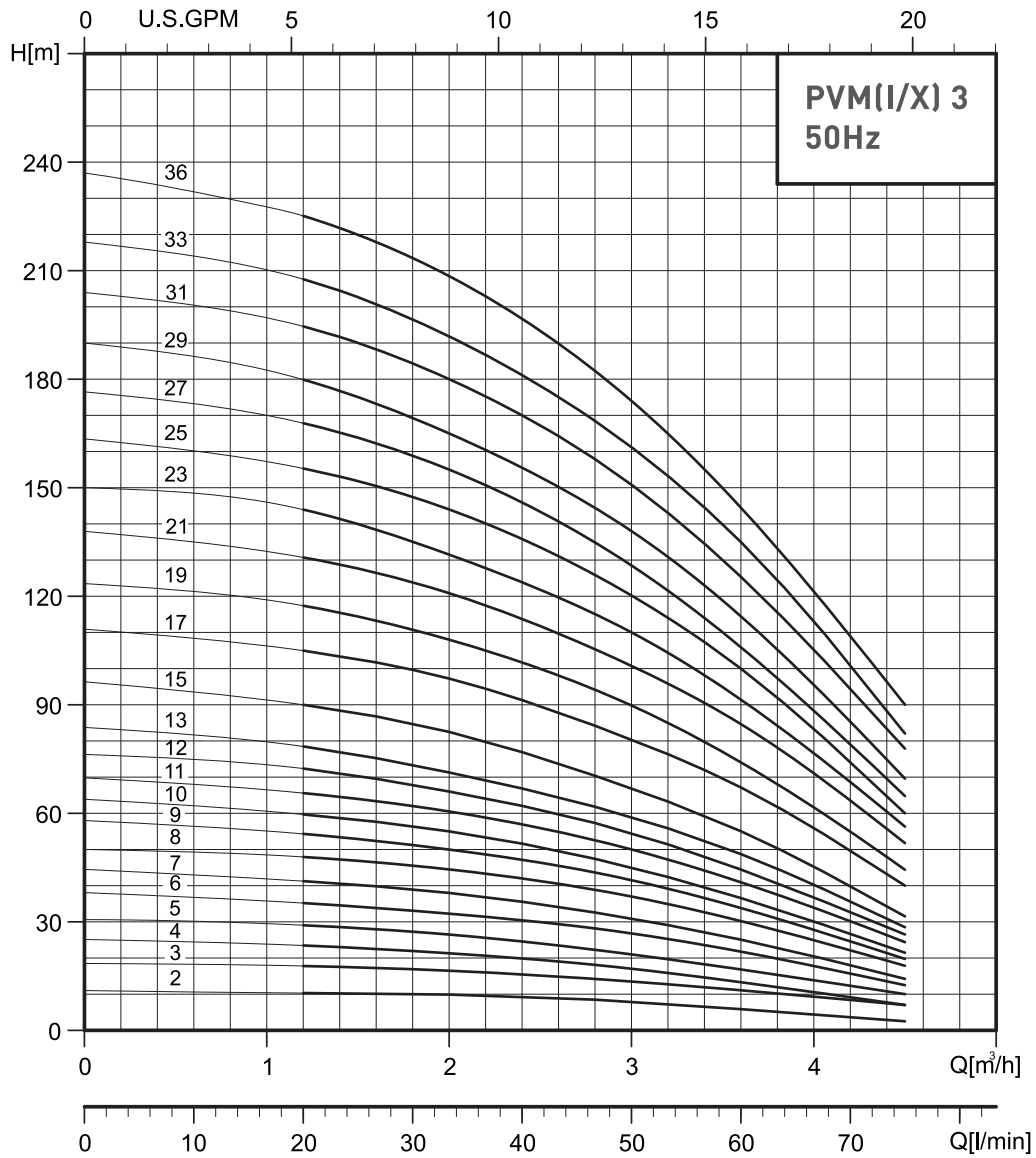

Head and NPSH values valid for water with density  $\rho = 1.0 \text{ Kg / dm}^3$  at  $20^\circ \text{C}$

PVM(I/X) 3

2900 rpm

50 Hz

ISO 9906 - Annex A

MEI  $\geq 0.4$  - Reference MEI  $\geq 0.70$  - The information on the reference efficiency is available at the address: [www.europump.org/efficiencycharts](http://www.europump.org/efficiencycharts)

# PVM/PVMI/PVMX 5

## VERTICAL MULTISTAGE CENTRIFUGAL PUMPS

### OVERALL DIMENSIONS AND WEIGHTS

TYPE OF PUMP	MOTOR		PVM						PVMI - PVMX								
			Dimensions [mm]					Net weights [kg]	Dimensions [mm]						Net weights [kg]		
	P <sub>2</sub>		DIN flange		D1	D2	D3		DIN Flange	Victaulic		DIN flange		D1	D2	D3	Victaulic
	[HP]	[KW]	H1	H2				H1		H2	H1	H2					
PVM 5-2	0.5	0.37	279	474	141	115	—	23.3	257	452	282	477	141	115	—	19.2	20.1
PVM 5-3	0.75	0.55	306	501	141	115	—	24.2	284	479	309	504	141	115	—	20.3	21.2
PVM 5-4	0.75	0.55	333	528	141	115	—	24.8	311	506	336	531	141	115	—	20.8	21.8
PVM 5-5	1.0	0.75	366	601	141	115	—	27.4	344	579	369	604	141	115	—	23.4	24.3
PVM 5-6	1.5	1.1	393	628	141	115	—	29.1	371	606	396	631	141	115	—	25.1	26.0
PVM 5-7	1.5	1.1	420	655	141	115	—	29.6	398	633	423	658	141	115	—	25.6	26.5
PVM 5-8	1.5	1.1	447	682	141	115	—	30.1	425	660	450	685	141	115	—	26.1	27.1
PVM 5-9	2.0	1.5	490	757	180	138	—	39.3	468	759	493	760	180	138	—	35.4	36.4
PVM 5-10	2.0	1.5	517	784	180	138	—	39.9	495	786	520	787	180	138	—	36.0	36.9
PVM 5-11	3.0	2.2	544	811	180	138	—	43.2	522	813	547	814	180	138	—	39.3	40.3
PVM 5-12	3.0	2.2	571	838	180	138	—	43.7	549	840	574	841	180	138	—	39.9	40.8
PVM 5-13	3.0	2.2	598	865	180	138	—	44.2	576	867	601	868	180	138	—	40.4	41.4
PVM 5-14	3.0	2.2	625	892	180	138	—	44.8	603	894	628	895	180	138	—	41.0	41.9
PVM 5-15	3.0	2.2	652	919	180	138	—	45.2	630	921	655	922	180	138	—	41.5	42.5
PVM 5-16	3.0	2.2	679	946	180	138	—	45.8	657	948	682	949	180	138	—	42.1	43.0
PVM 5-18	4.0	3.0	737	1058	194	145	—	54.3	715	1031	740	1061	194	145	—	50.3	51.3
PVM 5-20	4.0	3.0	791	1112	194	145	—	55.5	769	1085	794	1115	194	145	—	51.6	52.5
PVM 5-22	5.5	4.0	845	1173	225	160	—	59.8	823	1149	848	1176	225	160	—	55.8	56.8
PVM 5-24	5.5	4.0	899	1227	225	160	—	60.8	877	1203	902	1230	225	160	—	56.9	57.8
PVM 5-26	5.5	4.0	953	1281	225	160	—	62.7	931	1257	956	1284	225	160	—	58.0	58.9
PVM 5-29	5.5	4.0	1034	1362	225	160	—	64.6	1012	1338	1037	1365	225	160	—	59.7	60.6
PVM 5-32	7.5	5.5	1145	1510	248	194	300	90.1	1123	1485	1148	1513	248	194	300	84.9	85.8
PVM 5-36	7.5	5.5	1253	1618	248	194	300	92.6	1231	1593	1256	1621	248	194	300	87.1	88.1

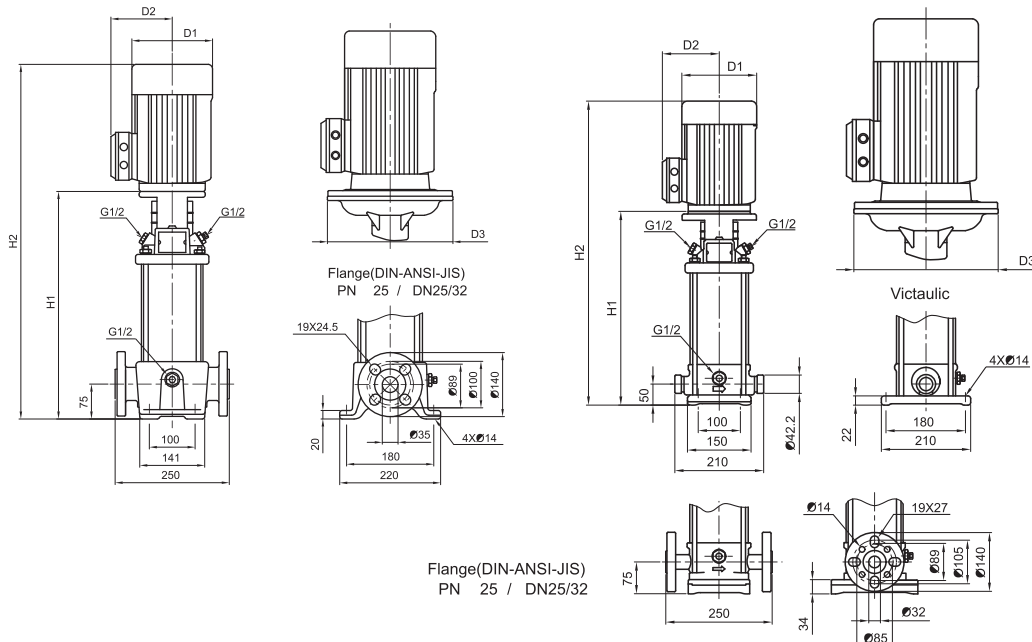

# PVM/PVMI/PVMX 5

## VERTICAL MULTISTAGE CENTRIFUGAL PUMPS

### HYDRAULIC PERFORMANCE

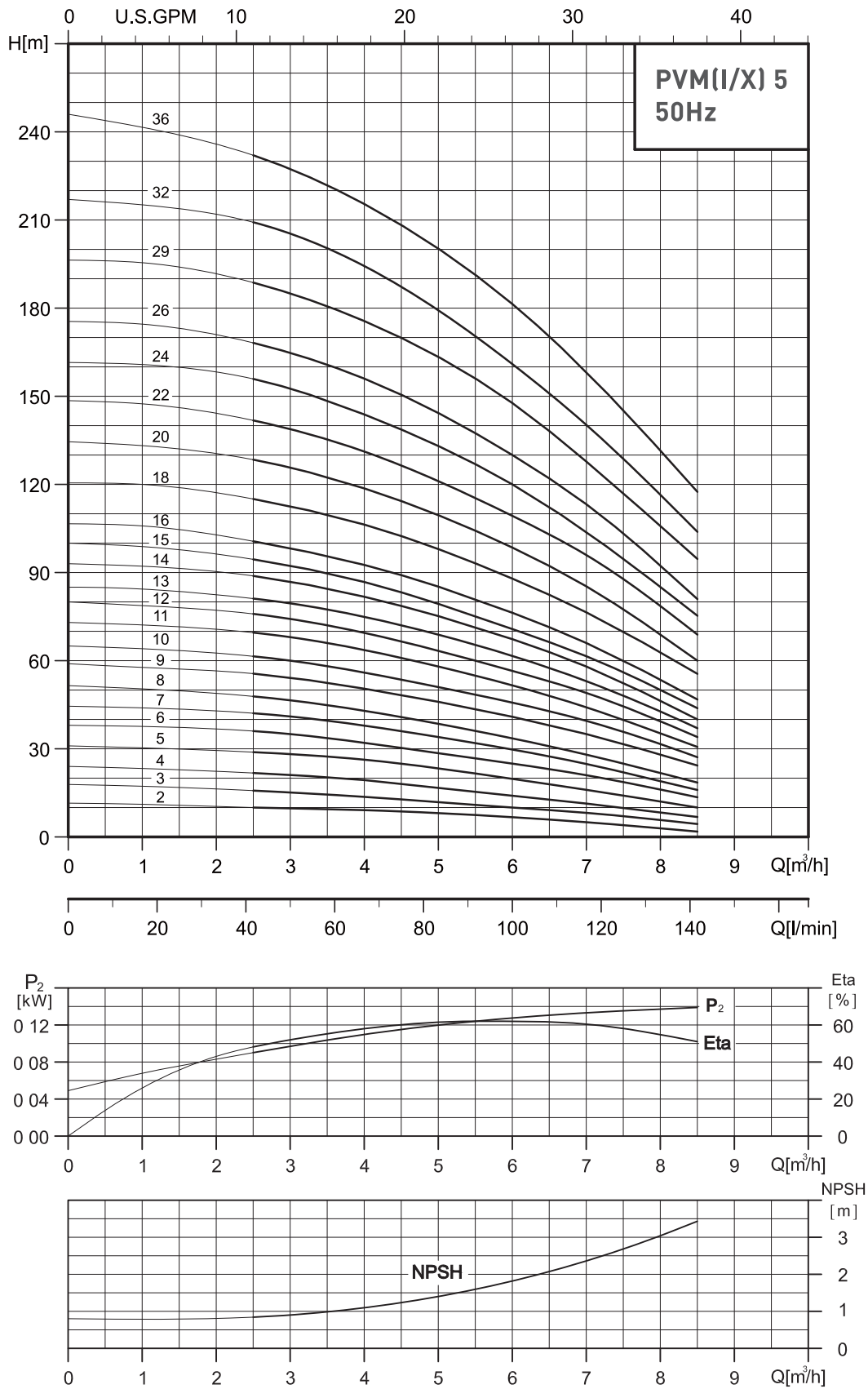

Head and NPSH values valid for water with density  $\rho = 1.0 \text{ Kg / dm}^3$  at  $20^\circ \text{C}$

PVM(I/X) 5

2900 rpm

50 Hz

ISO 9906 - Annex A

MEI  $\geq 0.4$  - Reference MEI  $\geq 0.70$  - The information on the reference efficiency is available at the address: [www.europump.org/efficiencycharts](http://www.europump.org/efficiencycharts)



# PVM/PVMI/PVMX 10

## VERTICAL MULTISTAGE CENTRIFUGAL PUMPS

### OVERALL DIMENSIONS AND WEIGHTS

TYPE OF PUMP	MOTOR		PVM						PVMI - PVMX								
			Dimensions [mm]					Net weights [kg]	Dimensions [mm]						Net weights [kg]		
	P <sub>2</sub>		DIN flange		D1	D2	D3		DIN Flange	Victaulic		DIN flange		D1	D2	D3	Victaulic
	[HP]	[KW]	H1	H2				H1		H2	H1	H2	H1				
PVM 10-1	0.5	0.37	343	538	141	115	—	35.9	353	548	353	548	141	115	—	31.6	31.4
PVM 10-2	1	0.8	347	582	141	115	—	38.2	357	592	357	592	141	115	—	34.3	34.2
PVM 10-3	1.5	1.1	377	612	141	115	—	40.3	387	622	387	622	141	115	—	36.4	36.3
PVM 10-4	2	1.5	423	690	180	138	—	50.1	433	724	433	700	180	138	—	46.1	46.0
PVM 10-5	3	2.2	453	720	180	138	—	53.9	463	754	463	730	180	138	—	50.0	49.8
PVM 10-6	3	2.2	483	750	180	138	—	55.0	493	784	493	760	180	138	—	51.0	50.8
PVM 10-7	4	3	518	839	194	145	—	63.8	528	844	528	849	194	145	—	59.1	58.9
PVM 10-8	4	3	548	869	194	145	—	64.9	558	874	558	879	194	145	—	60.1	60.0
PVM 10-9	4	3	578	899	194	145	—	65.9	588	904	588	909	194	145	—	61.1	61.0
PVM 10-10	5.5	4	608	936	225	160	—	70.3	618	944	618	946	225	160	—	65.6	65.4
PVM 10-12	5.5	4	668	996	225	160	—	72.4	678	1004	678	1006	225	160	—	67.6	67.5
PVM 10-14	7.5	5.5	760	1125	248	194	300	104.1	770	1132	770	1135	248	194	300	100.4	100.3
PVM 10-16	7.5	5.5	820	1185	248	194	300	106.2	830	1192	830	1195	248	194	300	102.5	102.4
PVM 10-18	10	7.5	880	1265	248	194	300	113.6	890	1288	890	1275	248	194	300	110.9	110.8
PVM 10-20	10	7.5	940	1325	248	194	300	116.7	950	1348	950	1335	248	194	300	113.0	112.8
PVM 10-22	10	7.5	1000	1385	248	194	300	118.8	1010	1408	1010	1395	248	194	300	115.1	114.9

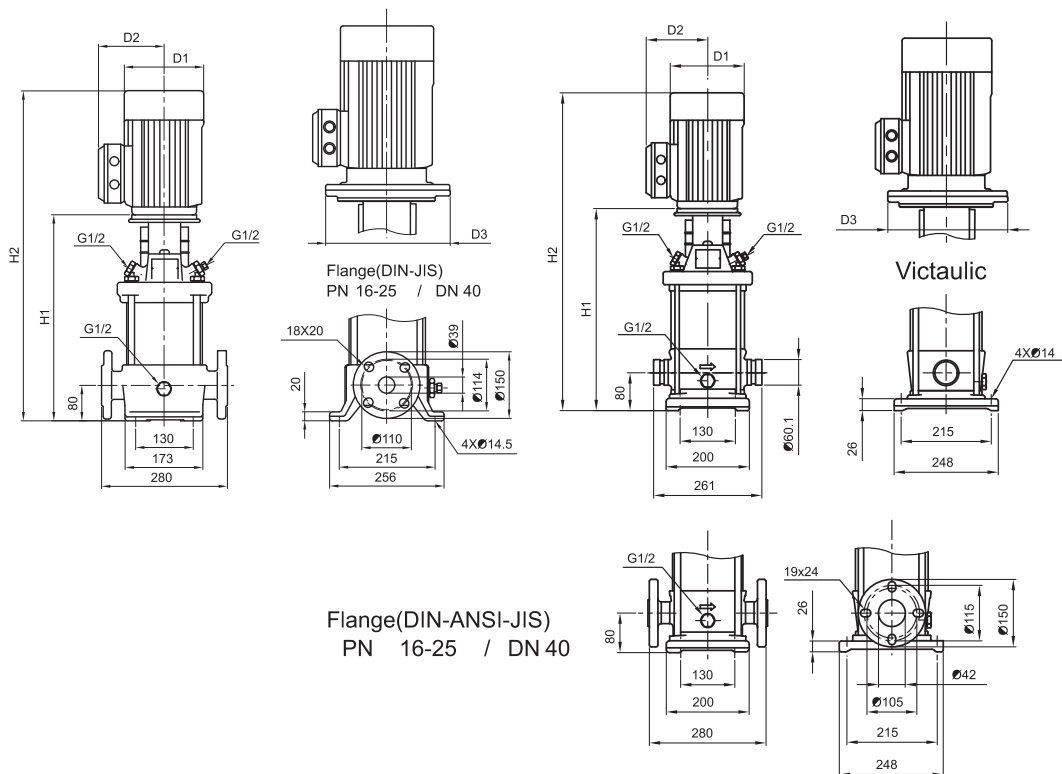

# PVM/PVMI/PVMX 10

## VERTICAL MULTISTAGE CENTRIFUGAL PUMPS

### HYDRAULIC PERFORMANCE

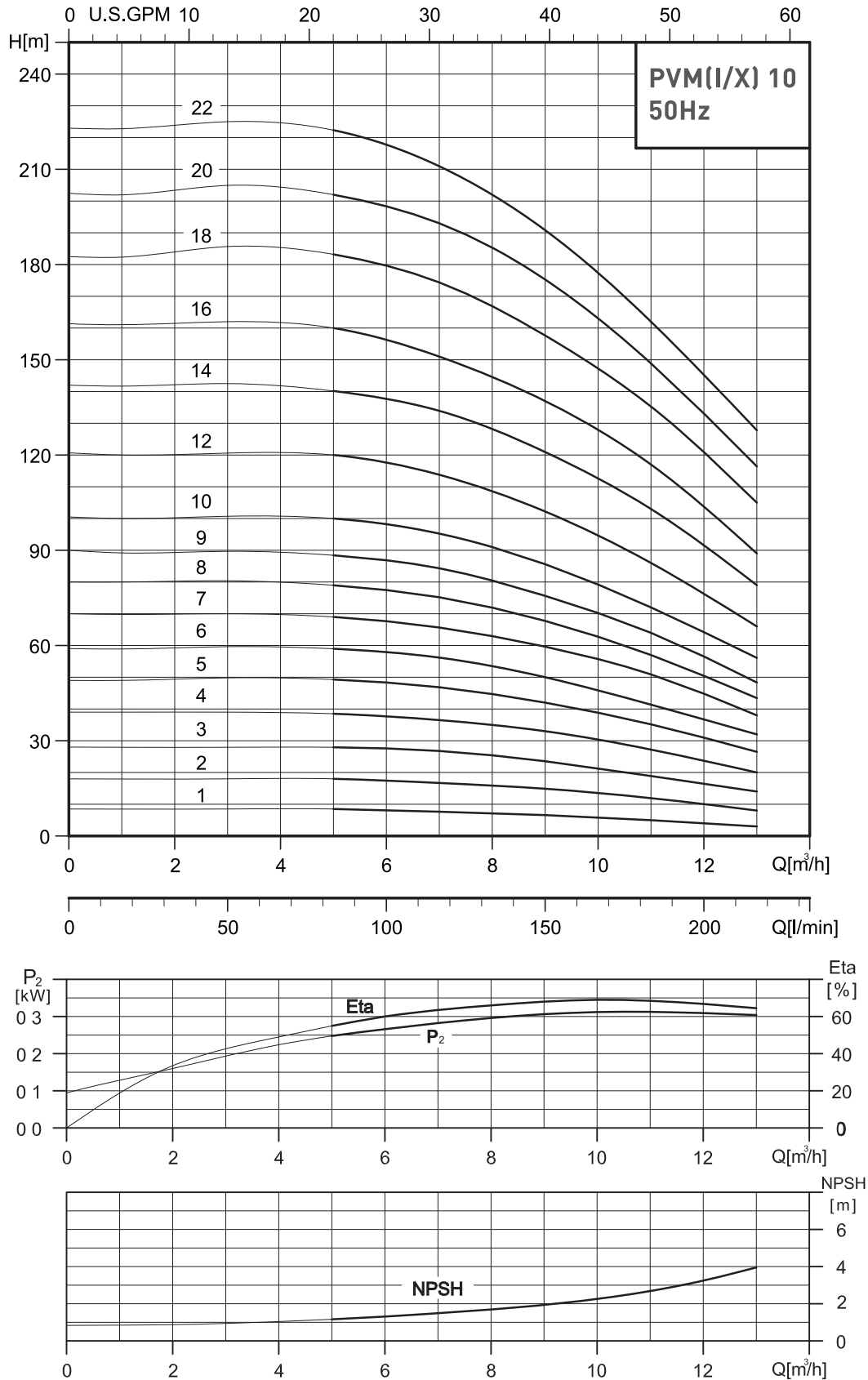

Head and NPSH values valid for water with density  $\rho = 1.0 \text{ Kg / dm}^3$  at  $20^\circ \text{C}$

PVM(I/X) 10

2900 rpm

50 Hz

ISO 9906 - Annex A

MEI  $\geq 0.4$  - Reference MEI  $\geq 0.70$  - The information on the reference efficiency is available at the address: [www.europump.org/efficiencycharts](http://www.europump.org/efficiencycharts)

# PVM/PVMI/PVMX 15

## VERTICAL MULTISTAGE CENTRIFUGAL PUMPS

### OVERALL DIMENSIONS AND WEIGHTS

TYPE OF PUMP	MOTOR		PVM							PVMI - PVMX							
			Dimensions [mm]						Net weights [kg]	Dimensions [mm]						Net weights [kg]	
	P <sub>2</sub>		DIN flange		D1	D2	D3	DIN Flange		Victaulic		DIN flange		D1	D2	D3	Victaulic
	[HP]	[KW]	H1	H2					H1	H2	H1	H2					
PVM 15-1	1.5	1.1	400	635	141	115	—	43.8	387	622	397	632	141	115	—	36.0	36.6
PVM 15-2	3	2.2	415	682	180	138	—	55.7	403	694	413	680	180	138	—	47.7	48.3
PVM 15-3	4	3	465	786	194	145	—	64.9	453	769	463	784	194	145	—	56.1	56.7
PVM 15-4	5.5	4	510	838	225	160	—	69.7	498	824	508	836	225	160	—	61.0	61.6
PVM 15-5	5.5	4	555	883	225	160	—	71.2	543	869	553	881	225	160	—	62.4	63.0
PVM 15-6	7.5	5.5	632	997	248	194	300	102.3	620	982	630	995	248	194	300	94.6	95.3
PVM 15-7	7.5	5.5	677	1042	248	194	300	103.8	665	1027	675	1040	248	194	300	96.1	96.7
PVM 15-8	10	7.5	722	1107	248	194	300	111.8	710	1108	720	1105	248	194	300	104.1	104.7
PVM 15-9	10	7.5	767	1152	248	194	300	113.3	755	1153	765	1150	248	194	300	105.6	106.2
PVM 15-10	15	11	889	1387	317	238	350	150.0	877	1382	887	1385	317	238	350	142.7	143.3
PVM 15-12	15	11	979	1477	317	238	350	153.0	967	1472	977	1475	317	238	350	145.5	146.2
PVM 15-14	15	11	1069	1567	317	238	350	156.3	1057	1562	1067	1565	317	238	350	148.5	149.1
PVM 15-17	20	15	1204	1702	317	238	350	171.5	1192	1702	1202	1700	317	238	350	162.9	163.5

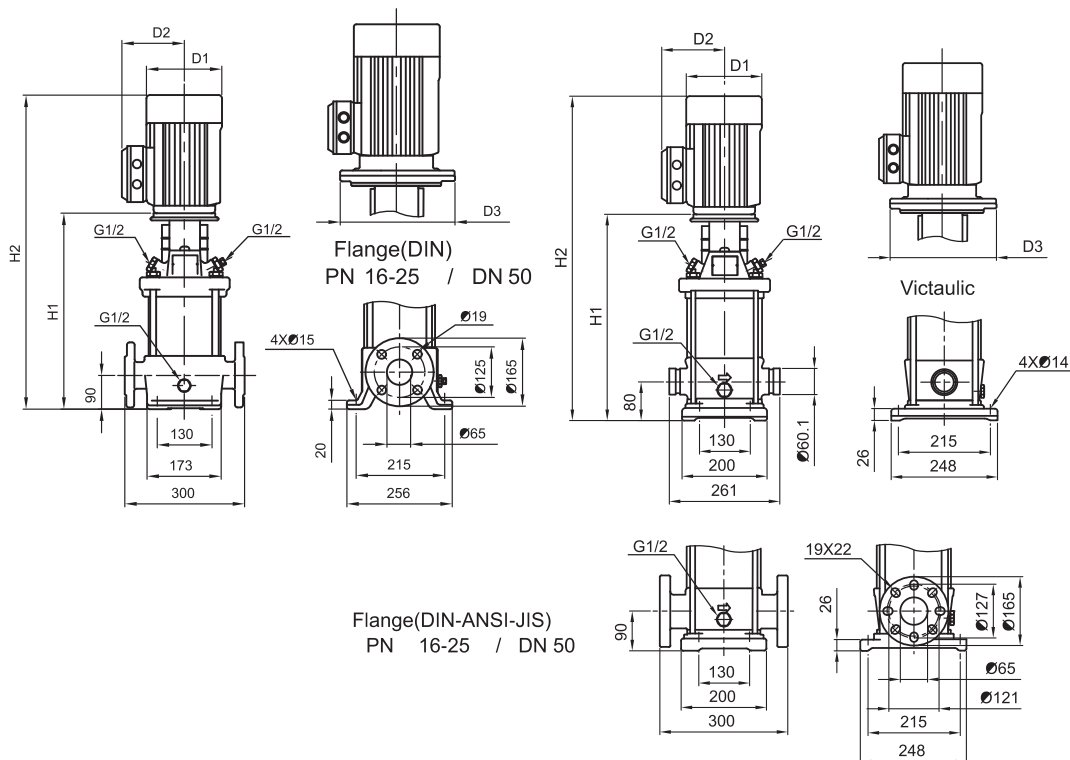

# PVM/PVMI/PVMX 15

## VERTICAL MULTISTAGE CENTRIFUGAL PUMPS

### HYDRAULIC PERFORMANCE

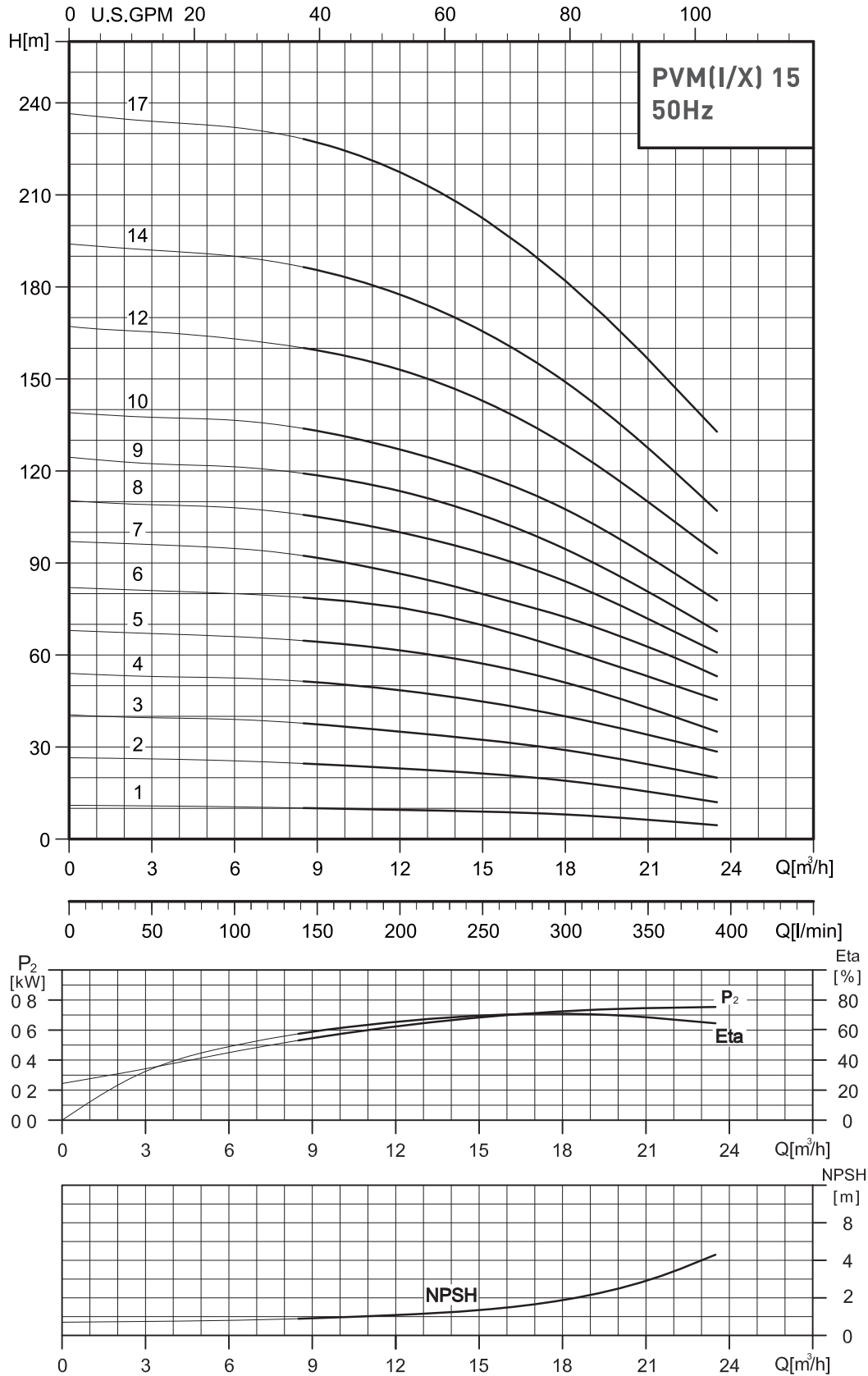

Head and NPSH values valid for water with density  $\rho = 1.0 \text{ Kg / dm}^3$  at  $20^\circ \text{C}$

PVM(I/X) 15

2900 rpm

50 Hz

ISO 9906 - Annex A

MEI  $\geq 0.4$  - Reference MEI  $\geq 0.70$  - The information on the reference efficiency is available at the address: [www.europump.org/efficiencycharts](http://www.europump.org/efficiencycharts)

# PVM/PVMI/PVMX 20

## VERTICAL MULTISTAGE CENTRIFUGAL PUMPS

### OVERALL DIMENSIONS AND WEIGHTS

TYPE OF PUMP	MOTOR		PVM						PVMI - PVMX								
			Dimensions [mm]					Net weight [kg]	Dimensions [mm]						Net weight [kg]		
	P <sub>2</sub>		DIN flange		D1	D2	D3		DIN Flange	Victaulic		DIN flange		D1	D2	D3	Victaulic
	[HP]	[KW]	H1	H2				H1		H2	H1	H2					
PVM 20-1	1.5	1.1	400	636	141	115	—	43.9	387	623	397	632	141	115	—	36.0	36.6
PVM 20-2	3	2.2	415	682	180	138	—	55.7	403	696	413	680	180	138	—	47.7	48.3
PVM 20-3	5.5	4	465	793	225	160	—	68.3	453	783	463	791	225	160	—	59.5	60.2
PVM 20-4	7.5	5.5	542	907	248	194	300	99.4	530	898	540	905	248	194	300	91.7	92.3
PVM 20-5	7.5	5.5	587	952	248	194	300	100.8	575	943	585	950	248	194	300	93.2	93.8
PVM 20-6	10	7.5	632	1017	248	194	300	108.6	620	1026	630	1015	248	194	300	100.9	101.6
PVM 20-7	10	7.5	677	1062	248	194	300	110.1	665	1071	675	1060	248	194	300	102.4	103.0
PVM 20-8	15	11	799	1297	317	238	350	147.1	787	1303	797	1295	317	238	350	139.7	140.3
PVM 20-10	15	11	889	1387	317	238	350	150.0	877	1393	887	1385	317	238	350	142.7	143.3
PVM 20-12	20	15	979	1477	317	238	350	163.1	967	1492	977	1475	317	238	350	155.7	156.3
PVM 20-14	20	15	1069	1567	317	238	350	166.0	1057	1582	1067	1565	317	238	350	158.6	159.2
PVM 20-17	25	18.5	1204	1746	317	238	350	195.4	1192	1761	1202	1744	317	238	350	187.8	188.5

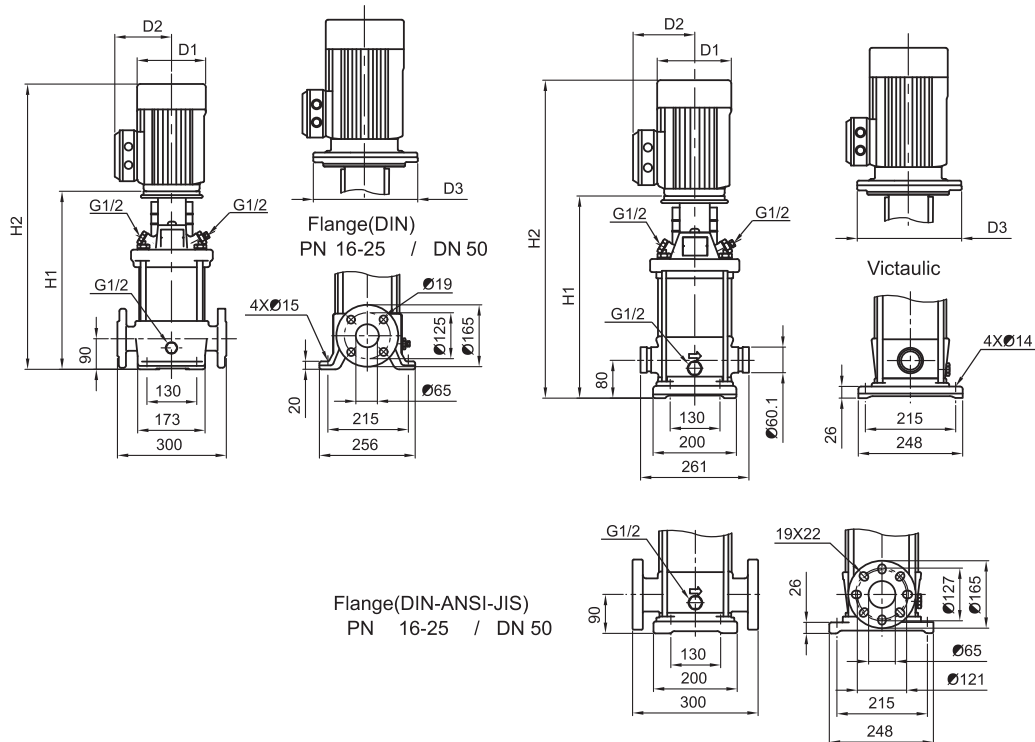

# PVM/PVMI/PVMX 20

## VERTICAL MULTISTAGE CENTRIFUGAL PUMPS

### HYDRAULIC PERFORMANCE

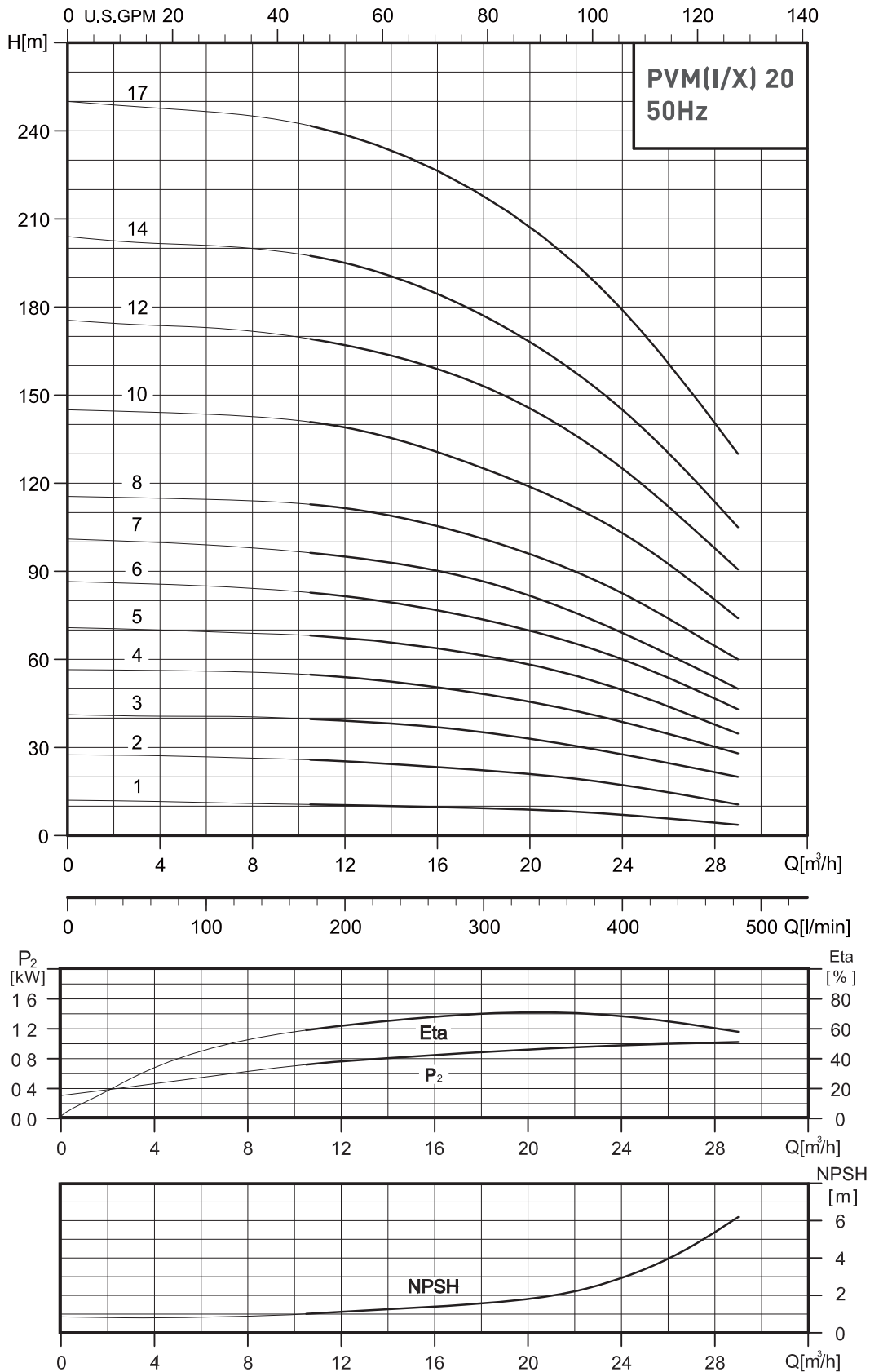

Head and NPSH values valid for water with density  $\rho = 1.0 \text{ Kg / dm}^3$  at  $20^\circ \text{C}$

PVM(I/X) 20

2900 rpm

50 Hz

ISO 9906 - Annex A

MEI  $\geq 0.4$  - Reference MEI  $\geq 0.70$  - The information on the reference efficiency is available at the address: [www.europump.org/efficiencycharts](http://www.europump.org/efficiencycharts)

# PVM/PVMI/PVMX 32

## VERTICAL MULTISTAGE CENTRIFUGAL PUMPS

### OVERALL DIMENSIONS AND WEIGHTS

TYPE OF PUMP	MOTOR		PVM						PVMI - PVMX					
			Dimensions [mm]					Net weight [kg]	Dimensions [mm]					Net weight [kg]
	P <sub>2</sub>		DIN flange		D1	D2	D3		DIN Flange	DIN flange		D1	D2	
	[HP]	[KW]	H1	H2				H1		H2				
PVM 32-1-1	2	1.5	504	771	180	138	280	71.5	504	269	180	138	280	66.5
PVM 32-1	3	2.2	504	771	180	138	280	74.3	504	269	180	138	280	69.3
PVM 32-2-2	4	3	574	895	194	145	280	84.2	574	895	194	145	280	79.1
PVM 32-2	5.5	4	574	902	225	160	280	87.6	574	902	225	160	280	82.5
PVM 32-3-2	7.5	5.5	644	1009	248	194	300	110.2	644	1009	248	194	300	105.1
PVM 32-3	7.5	5.5	644	1009	248	194	300	110.2	644	1009	248	194	300	105.1
PVM 32-4-2	10	7.5	714	1099	248	194	300	119.5	714	1099	248	194	300	114.5
PVM 32-4	10	7.5	714	1099	248	194	300	119.5	714	1099	248	194	300	114.6
PVM 32-5-2	15	11	894	1392	317	238	350	163.3	894	1392	317	238	350	158.2
PVM 32-5	15	11	894	1392	317	238	350	163.3	894	1392	317	238	350	158.3
PVM 32-6-2	15	11	964	1462	317	238	350	166.3	964	1462	317	238	350	161.3
PVM 32-6	15	11	964	1462	317	238	350	166.3	964	1462	317	238	350	161.4
PVM 32-7-2	20	15	1034	1532	317	238	350	179.5	1034	1532	317	238	350	174.6
PVM 32-7	20	15	1034	1532	317	238	350	179.5	1034	1532	317	238	350	174.6
PVM 32-8-2	20	15	1104	1602	317	238	350	182.6	1104	1602	317	238	350	177.9
PVM 32-8	20	15	1104	1602	317	238	350	182.6	1104	1602	317	238	350	177.9
PVM 32-9-2	25	18.5	1174	1716	317	238	350	210.6	1174	1716	317	238	350	205.5
PVM 32-9	25	18.5	1174	1716	317	238	350	210.6	1174	1716	317	238	350	205.6
PVM 32-10-2	25	18.5	1244	1786	317	238	350	212.7	1244	1786	317	238	350	208.1
PVM 32-10	25	18.5	1244	1786	317	238	350	213.7	1244	1786	317	238	350	208.2
PVM 32-11-2	30	22	1314	1894	358	265	350	258.8	1314	1894	358	265	350	253.6
PVM 32-11	30	22	1314	1894	358	265	350	258.8	1314	1894	358	265	350	253.6
PVM 32-12-2	30	22	1384	1964	358	265	350	260.8	1384	1964	358	265	350	256.3
PVM 32-12	30	22	1384	1964	358	265	350	260.8	1384	1964	358	265	350	256.3
PVM 32-13-2	40	30	1454	2114	420	295	400	328.2	1454	2114	420	295	400	323.6
PVM 32-13	40	30	1454	2114	420	295	400	328.2	1454	2114	420	295	400	323.6
PVM 32-14-2	40	30	1524	2184	420	295	400	331.3	1524	2184	420	295	400	326.3
PVM 32-14	40	30	1524	2184	420	295	400	331.3	1524	2184	420	295	400	326.3

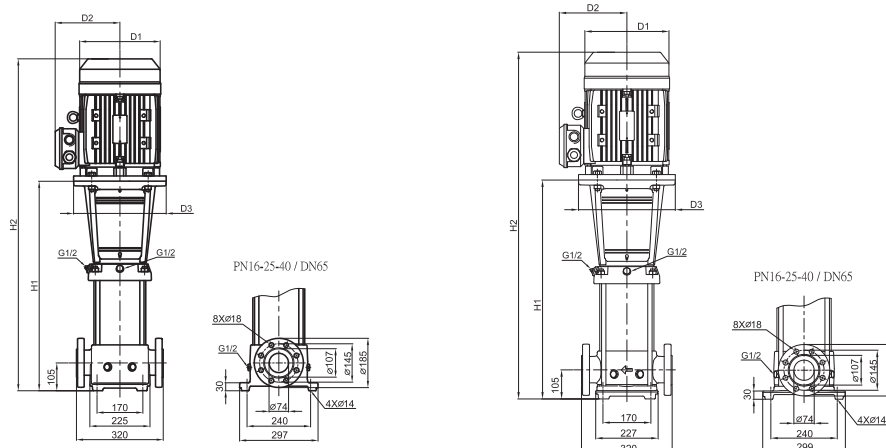

# PVM/PVMI/PVMX 32

## VERTICAL MULTISTAGE CENTRIFUGAL PUMPS

### HYDRAULIC PERFORMANCE

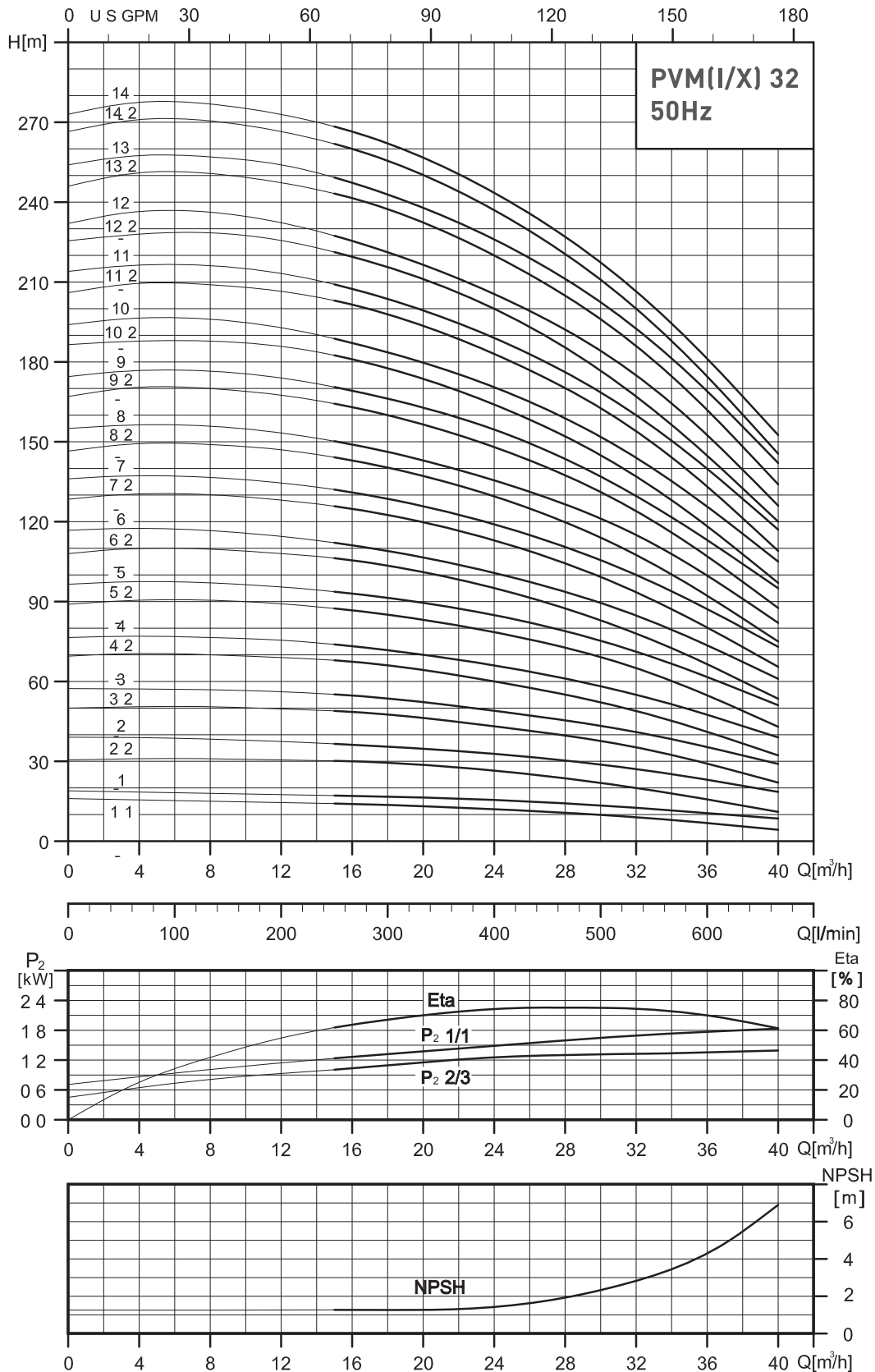

Head and NPSH values valid for water with density  $\rho = 1.0 \text{ Kg / dm}^3$  at  $20^\circ \text{C}$

PVM(I/X) 32

2900 rpm

50 Hz

ISO 9906 - Annex A

MEI  $\geq 0.4$  - Reference MEI  $\geq 0.70$  - The information on the reference efficiency is available at the address: [www.europump.org/efficiencycharts](http://www.europump.org/efficiencycharts)



# PVM/PVMI/PVMX 45

## VERTICAL MULTISTAGE CENTRIFUGAL PUMPS

### OVERALL DIMENSIONS AND WEIGHTS

TYPE OF PUMP	MOTOR		PVM						PVMI - PVMX					
			Dimensions [ mm ]				Net weight [ kg ]	Dimensions [ mm ]				Net weight [ kg ]		
	P <sub>2</sub>		DIN flange		D1	D2		D3	DIN Flange	DIN flange			D1	D2
	[ HP ]	[ KW ]	H1	H2			H1			H2				
PVM 45-1-1	4	3	560	324	194	145	280	91.7	559	880	194	145	280	82.9
PVM 45-1	5.5	4	560	889	160	225	280	95.1	559	887	160	225	280	86.3
PVM 45-2-2	7.5	5.5	640	1006	248	194	300	118.3	639	1004	248	194	300	109.5
PVM 45-2	10	7.5	640	1026	248	194	300	124.6	639	1024	248	194	300	115.8
PVM 45-3-2	15	11	830	1329	317	238	350	169.0	829	1327	317	238	350	160.2
PVM 45-3	15	11	830	1329	317	238	350	169.0	829	1327	317	238	350	160.2
PVM 45-4-2	20	15	910	1409	317	238	350	182.9	909	1407	317	238	350	174.1
PVM 45-4	20	15	910	1409	317	238	350	182.9	909	1407	317	238	350	174.1
PVM 45-5-2	25	18.5	990	1533	317	238	350	211.6	989	1531	317	238	350	202.8
PVM 45-5	25	18.5	990	1533	317	238	350	211.6	989	1531	317	238	350	202.8
PVM 45-6-2	30	22	1070	1650	358	265	350	258.1	1069	1649	358	265	350	249.3
PVM 45-6	30	22	1070	1650	358	265	350	258.1	1069	1649	358	265	350	249.3
PVM 45-7-2	40	30	1150	1810	420	295	400	326.4	1149	1809	420	295	400	317.7
PVM 45-7	40	30	1150	1810	420	295	400	326.5	1149	1809	420	295	400	317.7
PVM 45-8-2	40	30	1230	1890	420	295	400	330.2	1229	1889	420	295	400	321.4
PVM 45-8	40	30	1230	1890	420	295	400	331.3	1229	1889	420	295	400	321.5
PVM 45-9-2	40	30	1310	1970	420	295	400	334.0	1309	1969	420	295	400	325.2
PVM 45-9	50	37	1310	1970	420	295	400	347.0	1309	1969	420	295	400	338.2
PVM 45-10-2	50	37	1390	2050	420	295	400	350.7	1389	2049	420	295	400	341.9
PVM 45-10	50	37	1390	2050	420	295	400	350.7	1389	2049	420	295	400	341.9
PVM 45-11-2	60	45	1470	2160	470	325	450	412.5	1469	2159	470	325	450	403.7
PVM 45-11	60	45	1470	2160	470	325	450	412.5	1469	2159	470	325	450	403.7
PVM 45-12-2	60	45	1550	2240	470	325	450	416.2	1549	2239	470	325	450	407.4
PVM 45-12	60	45	1550	2240	470	325	450	416.2	1549	2239	470	325	450	407.4
PVM 45-13-2	60	45	1630	2320	470	325	450	419.9	1629	2319	470	325	450	411.1

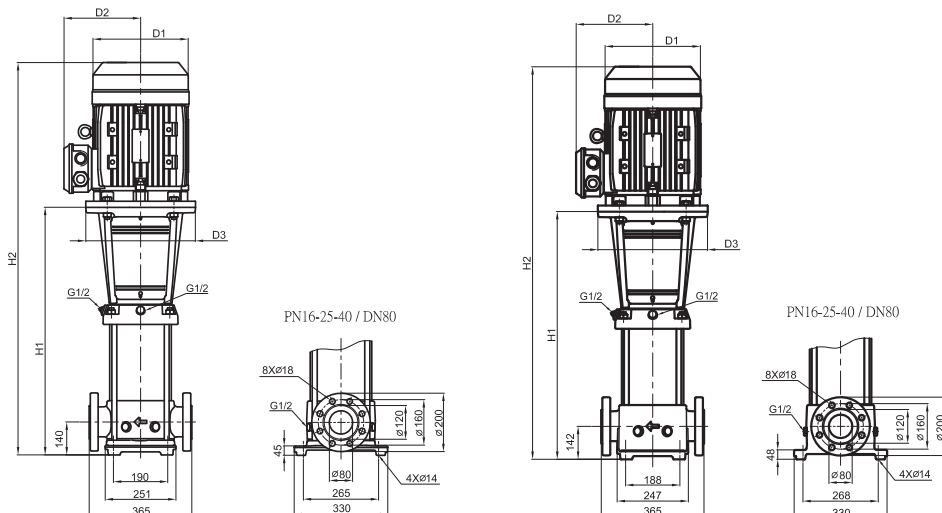

# PVM/PVMI/PVMX 45

## VERTICAL MULTISTAGE CENTRIFUGAL PUMPS

### HYDRAULIC PERFORMANCE

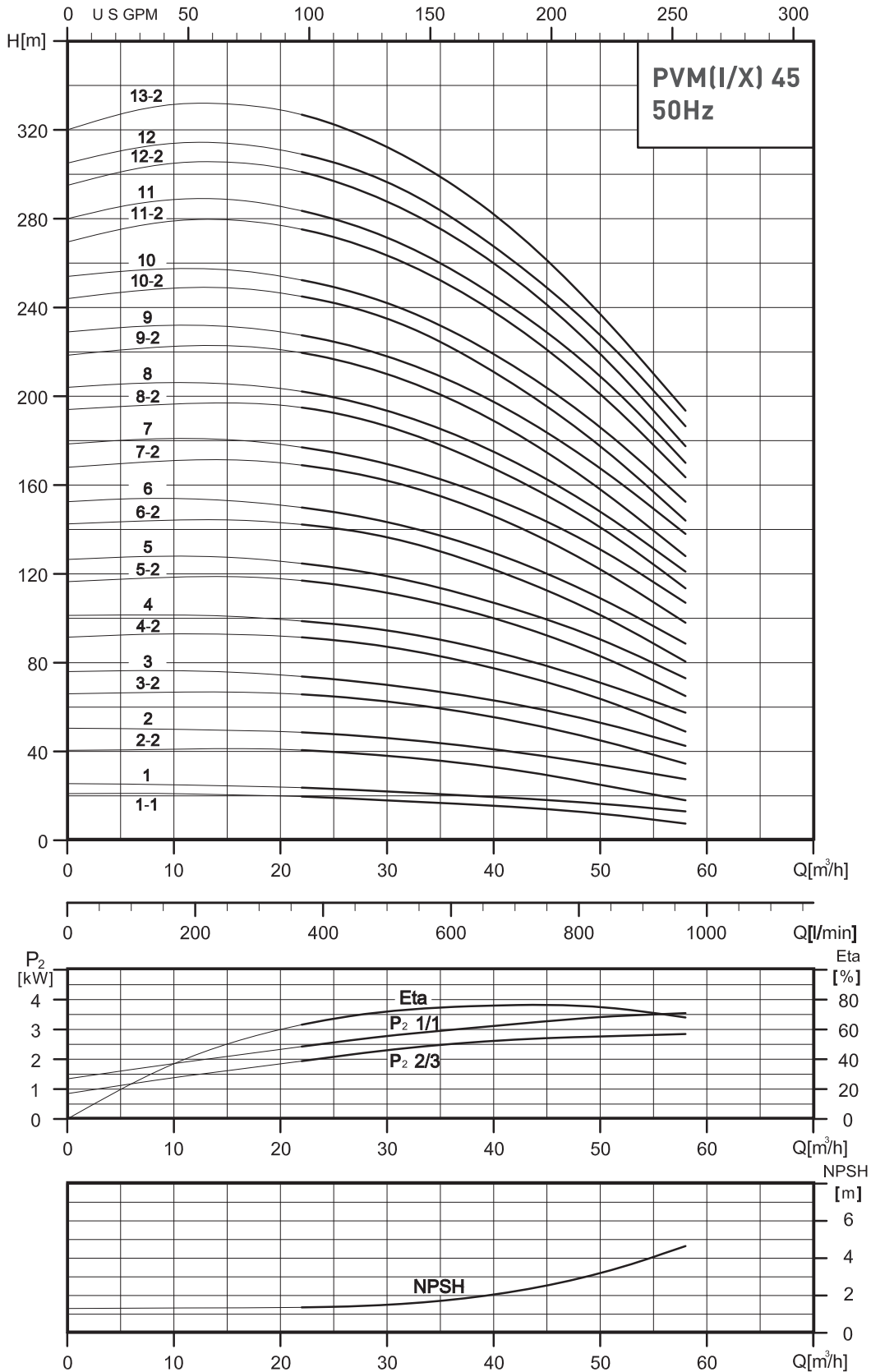

Head and NPSH values valid for water with density  $\rho = 1.0 \text{ Kg / dm}^3$  at  $20^\circ \text{C}$

PVM(I/X) 45

2900 rpm

50 Hz

ISO 9906 - Annex A

MEI  $\geq 0.4$  - Reference MEI  $\geq 0.70$  - The information on the reference efficiency is available at the address: [www.europump.org/efficiencycharts](http://www.europump.org/efficiencycharts)

# PVM/PVMI/PVMX 64

## VERTICAL MULTISTAGE CENTRIFUGAL PUMPS

### OVERALL DIMENSIONS AND WEIGHTS

TYPE OF PUMP	MOTOR		PVM						PVMI - PVMX					
			Dimensions [mm]					Net weight [kg]	Dimensions [mm]				Net weight [kg]	
	P <sub>2</sub>		DIN flange		D1	D2	D3		DIN Flange	DIN flange		D1		D2
	[HP]	[KW]	H1	H2				H1		H2				
PVM 64-1-1	5.5	4	563	891	225	160	280	88.9	563	891	225	160	280	81.8
PVM 64-1	7.5	5.5	563	928	248	194	300	108.3	563	928	248	194	300	101.3
PVM 64-2-2	10	7.5	646	1031	248	194	300	118.7	646	1031	248	194	300	111.7
PVM 64-2-1	15	11	756	1254	317	238	350	159.3	756	1254	317	238	350	152.3
PVM 64-2	15	11	756	1254	317	238	350	159.3	756	1254	317	238	350	152.3
PVM 64-3-2	20	15	838	1336	317	238	350	174.0	838	1336	317	238	350	166.5
PVM 64-3-1	20	15	838	1336	317	238	350	174.0	838	1336	317	238	350	166.5
PVM 64-3	25	18.5	838	1380	317	238	350	198.9	838	1380	317	238	350	191.4
PVM 64-4-2	25	18.5	920	1463	317	238	350	202.9	920	1463	317	238	350	195.4
PVM 64-4-1	30	22	920	1500	358	265	350	245.7	920	1500	358	265	350	238.1
PVM 64-4	30	22	920	1500	358	265	350	245.7	920	1500	358	265	350	238.1
PVM 64-5-2	40	30	1003	1663	420	295	400	314.3	1003	1663	420	295	400	306.7
PVM 64-5-1	40	30	1003	1663	420	295	400	314.3	1003	1663	420	295	400	306.7
PVM 64-5	40	30	1003	1663	420	295	400	314.3	1003	1663	420	295	400	306.7
PVM 64-6-2	40	30	1086	1746	420	295	400	318.2	1086	1746	420	295	400	310.7
PVM 64-6-1	50	37	1086	1746	420	295	400	331.2	1086	1746	420	295	400	323.7
PVM 64-6	50	37	1086	1746	420	295	400	331.2	1086	1746	420	295	400	323.7
PVM 64-7-2	50	37	1168	1828	420	295	400	335.3	1168	1828	420	295	400	327.7
PVM 64-7-1	50	37	1168	1828	420	295	400	335.3	1168	1828	420	295	400	327.7
PVM 64-7	60	45	1172	1862	470	325	450	393.4	1172	1862	470	325	450	385.8
PVM 64-8-2	60	45	1254	1944	470	325	450	397.5	1254	1944	470	325	450	390.0
PVM 64-8-1	60	45	1254	1944	470	325	450	397.5	1254	1944	470	325	450	390.0

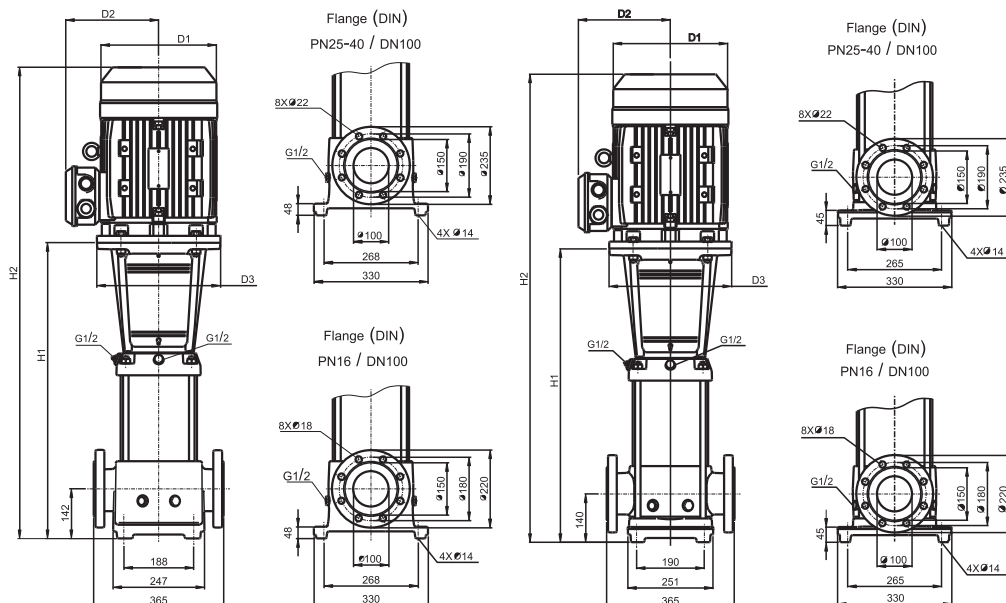

# PVM/PVMI/PVMX 64

## VERTICAL MULTISTAGE CENTRIFUGAL PUMPS

### HYDRAULIC PERFORMANCE

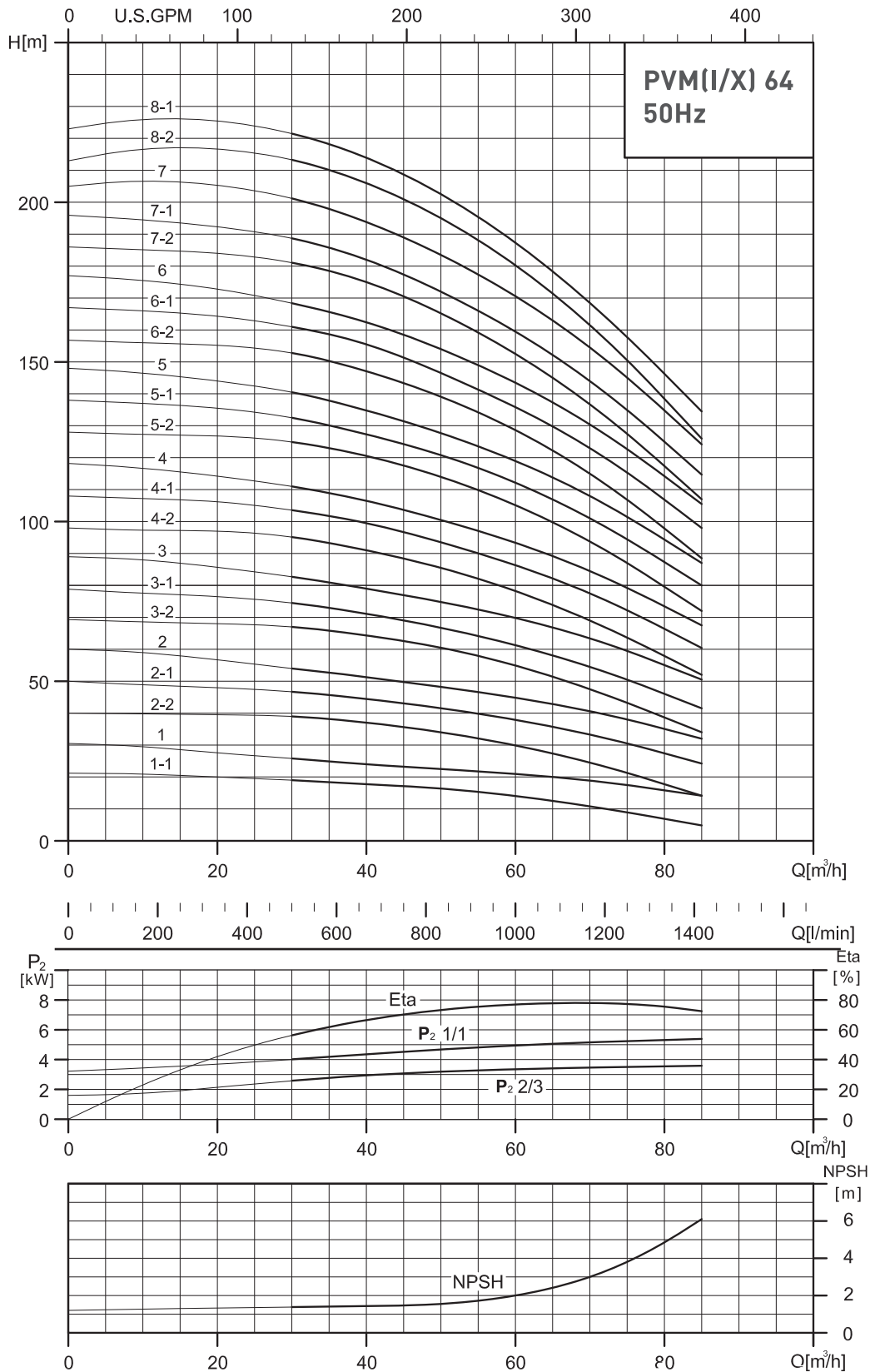

Head and NPSH values valid for water with density  $\rho = 1.0 \text{ Kg / dm}^3$  at  $20^\circ \text{ C}$

PVM(I/X) 64

2900 rpm

50 Hz

ISO 9906 - Annex A

MEI  $\geq 0.4$  - Reference MEI  $\geq 0.70$  - The information on the reference efficiency is available at the address: [www.europump.org/efficiencycharts](http://www.europump.org/efficiencycharts)

# PVM/PVMI/PVMX 90

## VERTICAL MULTISTAGE CENTRIFUGAL PUMPS

### OVERALL DIMENSIONS AND WEIGHTS

TYPE OF PUMP	MOTOR		PVM						PVMI - PVMX					
			Dimensions [mm]					Net weight [kg]	Dimensions [mm]				Net weight [kg]	
	P <sub>2</sub>		DIN flange		D1	D2	D3		DIN Flange	DIN flange		D1		D2
	[HP]	[KW]	H1	H2				H1		H2				
PVM 90-1-1	7.5	5.5	572	937	248	194	300	122.2	576	941	248	194	300	112.1
PVM 90-1	10	7.5	572	957	248	194	300	128.5	576	961	248	194	300	118.4
PVM 90-2-2	15	11.0	774	1272	317	298	350	174.4	778	1276	317	298	350	164.2
PVM 90-2	20	15.0	774	1272	317	298	350	184.5	778	1276	317	298	350	174.3
PVM 90-3-2	25	18.5	866	1408	317	298	350	214.7	870	1412	317	298	350	204.4
PVM 90-3	30	22.0	866	1446	358	265	350	257.5	870	1450	358	265	350	247.2
PVM 90-4-2	40	30.0	958	1618	420	295	400	327.3	962	1622	420	295	400	316.9
PVM 90-4	40	30.0	958	1618	420	295	400	327.3	962	1622	420	295	400	316.9
PVM 90-5-2	50	37.0	1050	1710	420	295	400	346.9	1054	1714	420	295	400	336.9
PVM 90-5	50	37.0	1050	1710	420	295	400	346.9	1054	1714	420	295	400	337.0
PVM 90-6-2	60	45.0	1142	1832	470	325	450	410.2	1146	1836	470	325	450	400.0
PVM 90-6	60	45.0	1142	1832	470	325	450	410.3	1146	1836	470	325	450	400.1

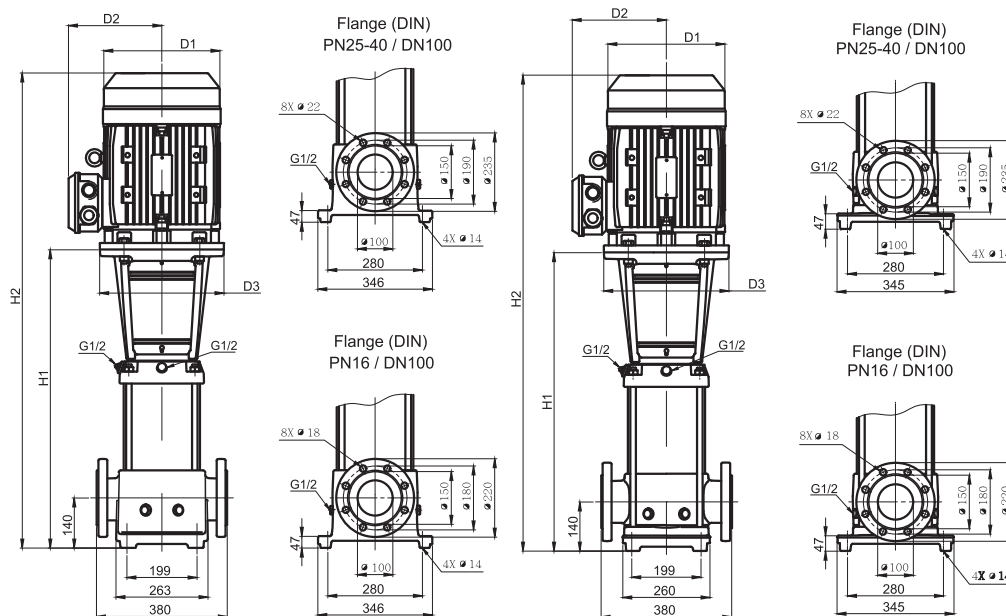

# PVM/PVMI/PVMX 90

## VERTICAL MULTISTAGE CENTRIFUGAL PUMPS

### HYDRAULIC PERFORMANCE

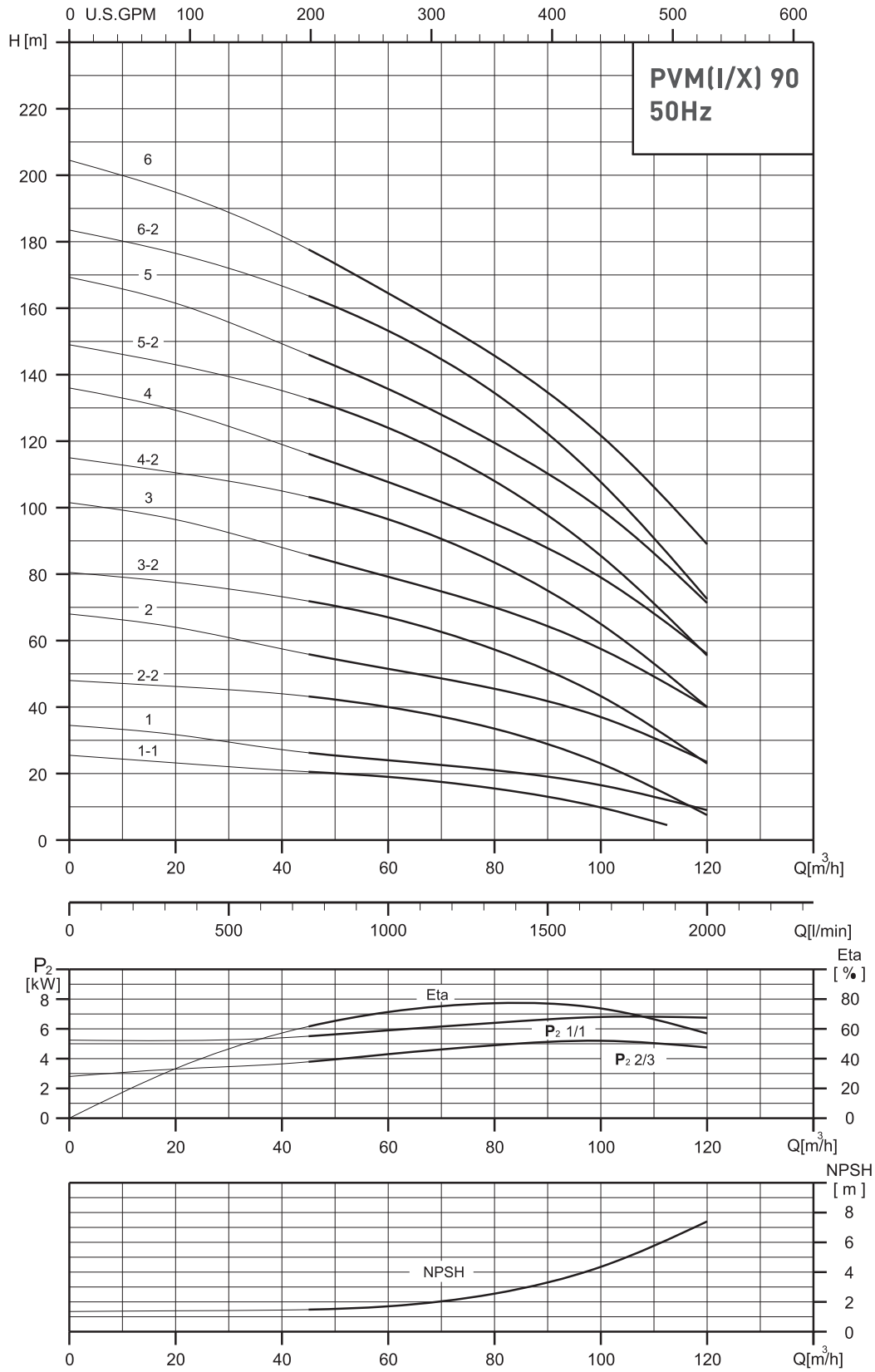

Head and NPSH values valid for water with density  $\rho = 1.0 \text{ Kg} / \text{dm}^3$  at  $20^\circ \text{C}$

PVM(I/X) 90

2900 rpm

50 Hz

ISO 9906 - Annex A

MEI  $\geq 0.4$  - Reference MEI  $\geq 0.70$  - The information on the reference efficiency is available at the address: [www.europump.org/efficiencycharts](http://www.europump.org/efficiencycharts)

# PVM/PVMI/PVMX 120

## VERTICAL MULTISTAGE CENTRIFUGAL PUMPS

### OVERALL DIMENSIONS AND WEIGHTS

TYPE OF PUMP	MOTOR		PVM							PVMI - PVMX						
			Dimensions [ mm ]						Net weight [ kg ]	Dimensions [ mm ]						Net weight [ kg ]
	P <sub>2</sub>		DIN flange			D1	D2	D3		DIN Flange	DIN flange			D1	D2	
	[ HP ]	[ KW ]	H1	H2	H3				H1		H2	H3				
PVM 120-1	15	11	834.0	498	1332	317	238	350	200.1	837.0	498	1335	317	238	350	184.3
PVM 120-2-1	25	18.5	989.5	542	1532	317	238	350	245.1	992.5	542	1535	317	238	350	229.5
PVM 120-2	30	22.0	989.5	580	1569.5	358	265	350	291.8	992.5	580	1572.5	358	265	350	276.1
PVM 120-3	40	30.0	1145.0	660	1805.0	420	295	400	362.5	1149.0	660	1809.0	420	295	400	346.9
PVM 120-4-1	50	37.0	1300.5	660	1960.5	420	295	400	385.5	1303.5	660	1963.5	420	295	400	370.1
PVM 120-5-1	60	45.0	1460.0	690	2150.0	470	325	450	453.6	1463.0	690	2153.0	470	325	450	438.3
PVM 120-6-1	75	55.0	1641.5	770	2411.5	510	355	550	578.8	1644.5	770	2414.5	510	355	550	563.8
PVM 120-7	100	75.0	1797.0	845	2642.0	580	410	550	751.4	1800.0	845	2645.0	580	410	550	736.5

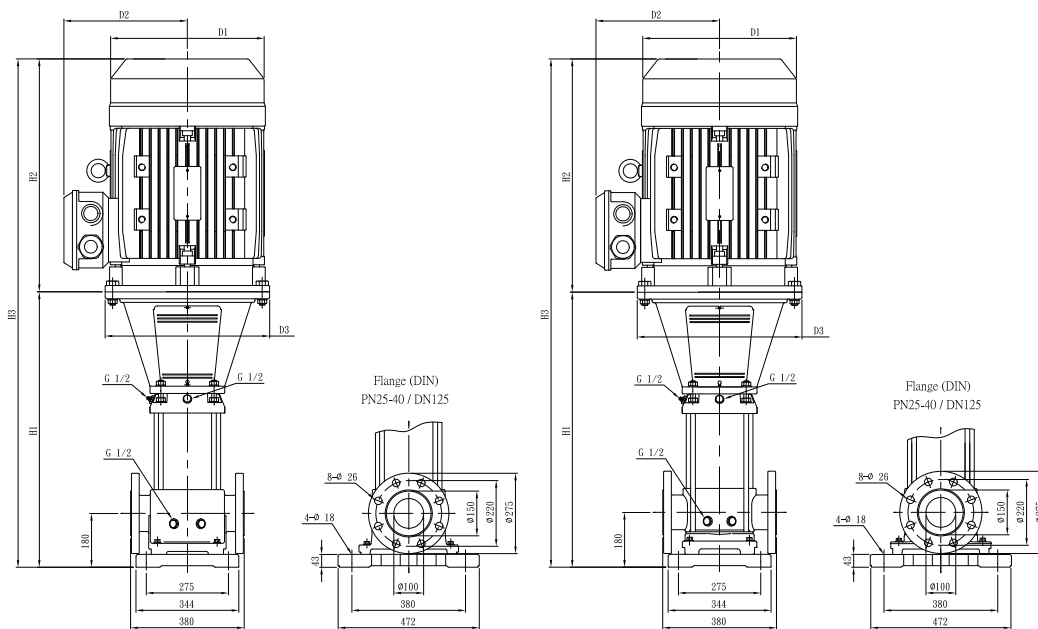

# PVM/PVMI/PVMX 120

## VERTICAL MULTISTAGE CENTRIFUGAL PUMPS

### HYDRAULIC PERFORMANCE

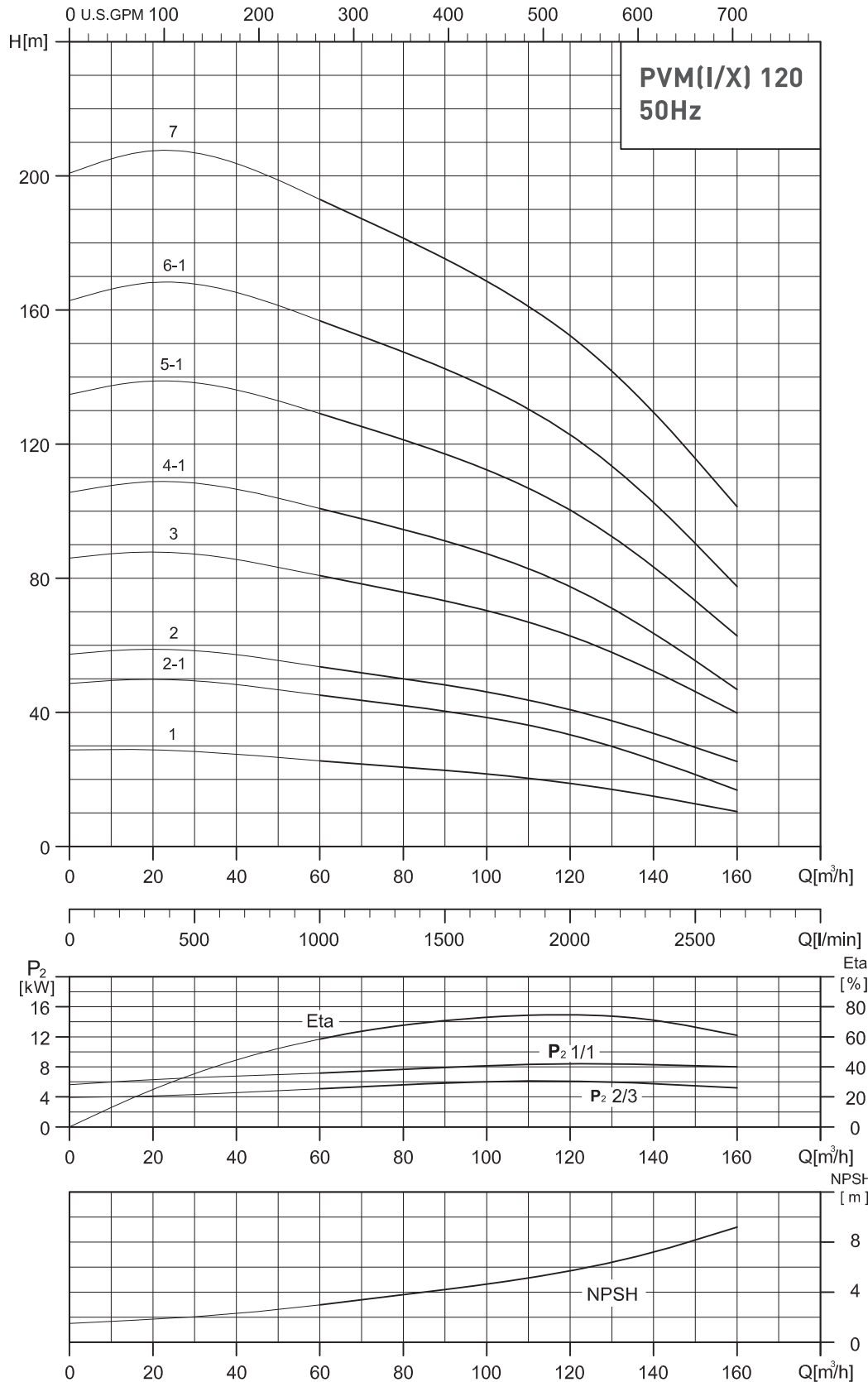

Head and NPSH values valid for water with density  $\rho = 1.0 \text{ Kg} / \text{dm}^3$  at  $20^\circ \text{C}$

PVM(I/X) 120

2900 rpm

50 Hz

ISO 9906 - Annex A

MEI  $\geq 0.4$  - Reference MEI  $\geq 0.70$  - The information on the reference efficiency is available at the address: [www.europump.org/efficiencycharts](http://www.europump.org/efficiencycharts)



# PVM/PVMI/PVMX 150

## VERTICAL MULTISTAGE CENTRIFUGAL PUMPS

### OVERALL DIMENSIONS AND WEIGHTS

TYPE OF PUMP	MOTOR		PVM							PVMI - PVMX						
			Dimensions [mm]						Net weight [kg]	Dimensions [mm]						Net weight [kg]
	P <sub>2</sub>		DIN flange			D1	D2	D3		DIN Flange	DIN flange			D1	D2	
	[HP]	[KW]	H1	H2	H3				H1		H2	H3				
PVM 150-1-1	15	11	834.0	498	1332	317	238	350	200.0	837	498	1335	317	238	350	173.4
PVM 150-1	20	15	834.0	542	1376	317	238	350	210.1	837	542	1379	317	238	350	183.5
PVM 150-2-1	30	22.0	989.5	580	1569.5	358	265	350	287.8	992.5	580	1572.5	358	265	350	271.6
PVM 150-3-2	40	30.0	1145.0	660	1805.0	420	295	400	362.3	1148	660	1808	420	295	400	346.2
PVM 150-3	50	37.0	1145.0	660	1805.0	420	295	400	375.4	1148	660	1808	420	295	400	359.2
PVM 150-4-1	60	45.0	1304.5	690	1994.5	470	325	450	443.4	1307.5	690	1997.5	470	325	450	427.4
PVM 150-5-2	75	55.0	1486.0	770	2256.0	510	355	550	568.7	1489	770	2259	510	355	550	552.8
PVM 150-6	100	75.0	1641.5	845	2486.5	580	410	550	741.0	1644.5	845	2489.5	580	410	550	725.5

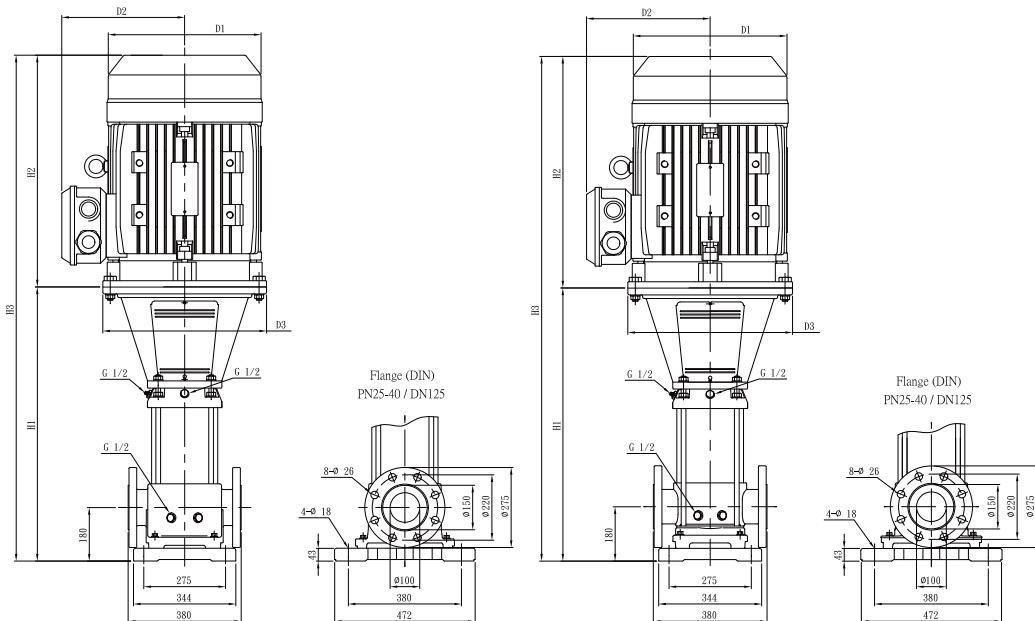

# PVM/PVMI/PVMX 150

## VERTICAL MULTISTAGE CENTRIFUGAL PUMPS

### HYDRAULIC PERFORMANCE

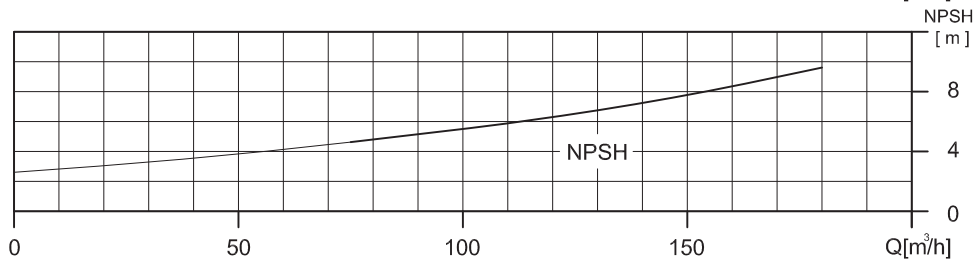
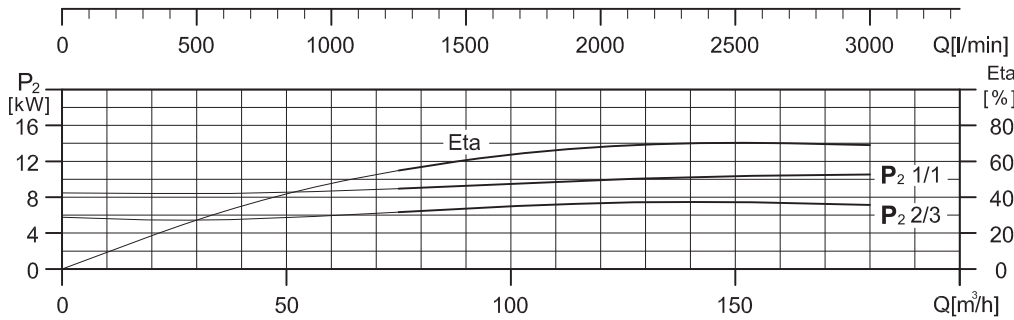
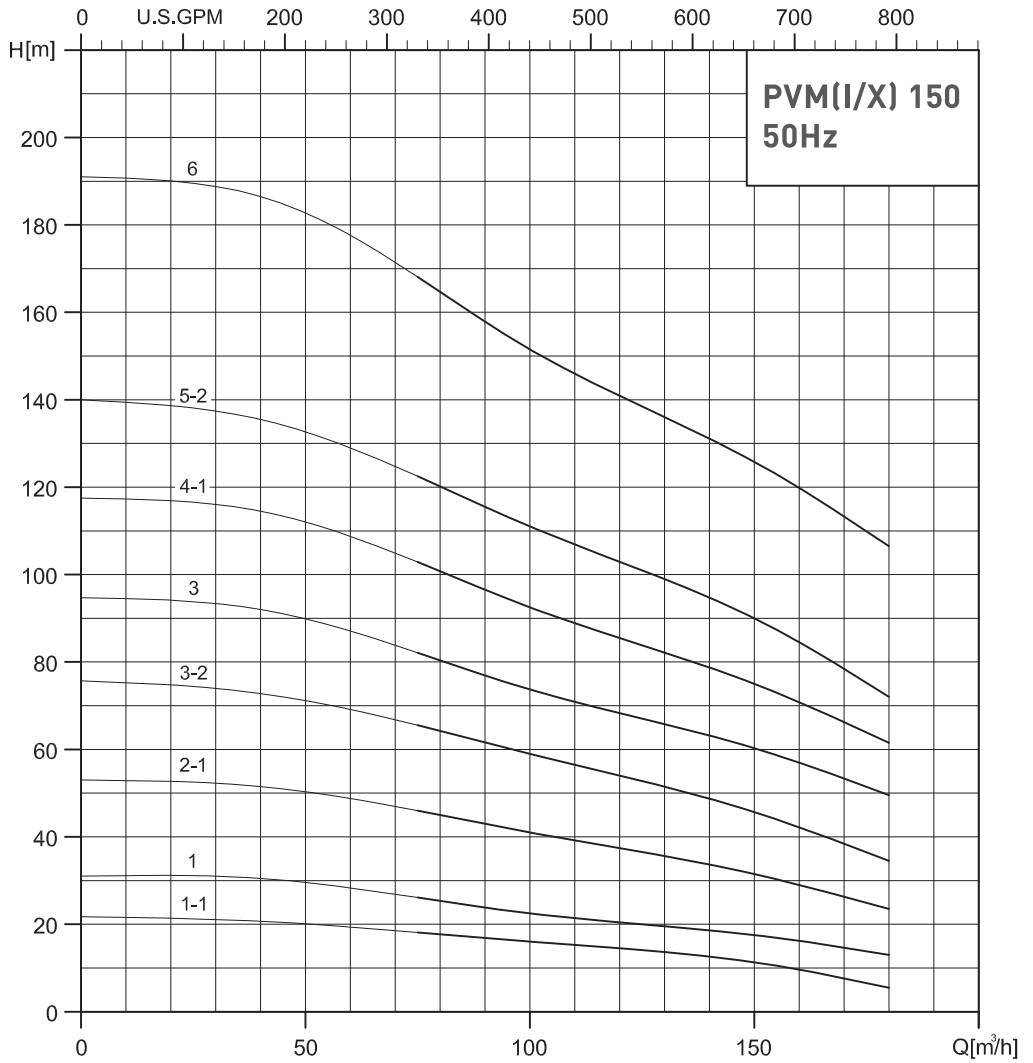

Head and NPSH values valid for water with density  $\rho = 1.0 \text{ Kg / dm}^3$  at  $20^\circ \text{C}$

PVM(I/X) 150

2900 rpm

50 Hz

ISO 9906 - Annex A

MEI  $\geq 0.4$  - Reference MEI  $\geq 0.70$  - The information on the reference efficiency is available at the address: [www.europump.org/efficiencycharts](http://www.europump.org/efficiencycharts)

# PVM/PVMI/PVMX ACCESSORIES

## CIRCULAR COUNTERFLANGES

COD. Steel	COD. AISI 304	COD. AISI 316	DESCR.	Mater.	Ext	Int	N° Holes	D Holes	hole B Thread	PN	STANDARD
ZA010970	ZA011050	ZA011130	C.FLG DN25 PN25	STEEL / AISI 304 / AISI 316	115	85	4	14	DN25	25	UNI EN 1092-1
ZA010980	ZA011060	ZA011140	C.FLG DN32 PN25		140	100	4	18	DN32	25	UNI EN 1092-1
ZA010990	ZA011070	ZA011150	C.FLG DN40 PN25		150	110	4	18	DN40	25	UNI EN 1092-1
ZA011000	ZA011080	ZA011160	C.FLG DN50 PN25		165	125	4	18	DN50	25	UNI EN 1092-1
ZA011010	ZA011090	ZA011170	C.FLG DN65 PN25		185	145	8	18	DN65	25	UNI EN 1092-1
ZA011020	ZA011100	ZA011180	C.FLG DN80 PN25		200	160	8	18	DN80	25	UNI EN 1092-1
ZA011030	ZA011110	ZA011190	C.FLG DN100 PN16		220	180	8	18	DN100	16	UNI EN 1092-1
ZA011040	ZA011120	ZA011200	C.FLG DN100 PN25		235	190	8	22	DN100	25	UNI EN 1092-1



Pair of circular flanges complete with bolts and seals

## VICTAULIC FITTINGS

COD.	DESCRIPTION	Pump	Material	Pressure PN	Dimensions			CONNECTION
					X	Y	Z	
ZA011210	Victaulic CPLG 1'-1/4"	PVMI 1/3/5	AISI 304	80	68	117	45	1" 1/4
ZA011220	Victaulic CPLG 2"	PVMI 10/15/20		70	87	133	48	2"
ZA011230	Victaulic CPLG 1'-1/4"	PVMX 1/3/5	AISI 316	80	68	117	45	1" 1/4
ZA011240	Victaulic CPLG 2"	PVMX 10/15/20		70	87	133	48	2"



VICTAULIC fitting

Note: A set includes two coupling halves, a gasket, nuts and bolts



## NRM

### MONOBLOC NORMALISED CENTRIFUGAL PUMPS (2 AND 4 POLES)

Sturdy and resistant, wide range, high hydraulic performance

The PUMPS of the series NRM are single stage monobloc pumps with the hydraulic part-motor connection via a bell, with the pump body made in accordance with standard EN733/ DIN24255.

The pumps can be installed in all positions, except in the position with the inlet facing upwards.

#### APPLICATIONS

- Heating and cooling systems
- Collection of water from lakes, rivers, wells
- Irrigation systems using rain
- Water supply systems, fire fighting systems, pressurization systems.

#### MOTOR

- Induction, closed, ventilated
- Degree of protection: IP 55
- Insulation: class F
- Constructive shape: B3/B5
- Speed of rotation:
- NRM4 1450 rpm
- NRM2 2900 rpm
- Three-phase motor efficiency class:  
IE2 from 0.75 kW  
IE3 from 7.5 kW

#### USAGE DATA

- Type of liquid: non-aggressive, non-explosive, free of solid particles and fibres.
- Hot water for heating.
- Coolants.
- Maximum ambient temperature: 40°C
- Temperature of pumped liquid -10°C +130°C
- Maximum operating pressure 10 bar



## TABLE OF MATERIALS

Component	Material
1 Pump body	Cast iron EN GJL 200
2 Motor casing	Cast iron EN GJL 200
3 Impeller	Cast iron EN GJL 200 Aisi 304 on request
4 Shaft	AISI 420 Stainless Steel
5 Mechanical seal	Silicon carbide / Silicon carbide / NBR

# NRM2

## MONOBLOC NORMALISED CENTRIFUGAL PUMPS (2 AND 4 POLES)

### HYDRAULIC PERFORMANCE

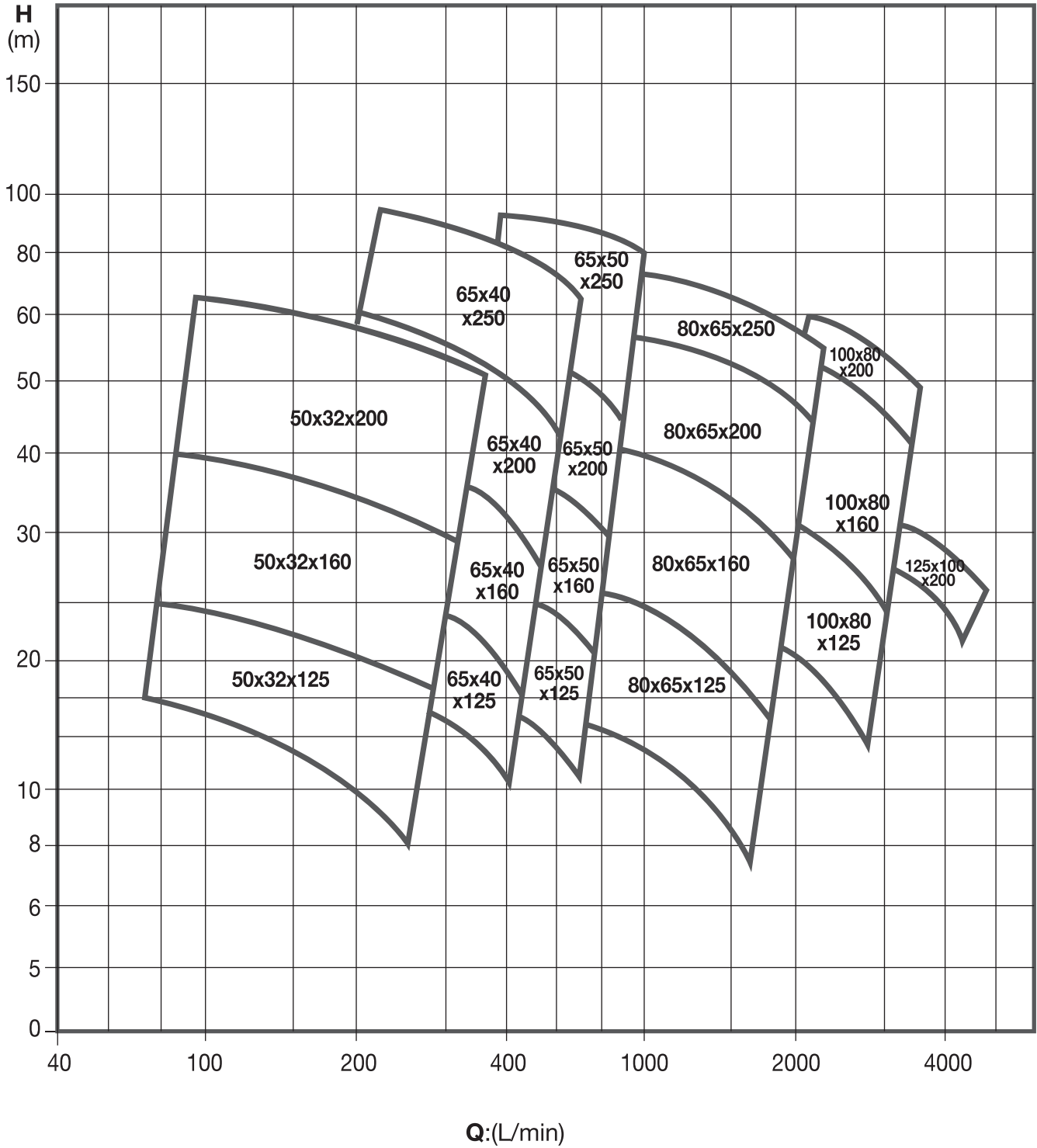

# NRM2 50x32

## MONOBLOC NORMALISED CENTRIFUGAL PUMPS (2 AND 4 POLES)

### PERFORMANCE TABLE

MOD.	P2		VOLT. (V)	In (A)	Q	Q													
	HP	kW				l/min	100	125	150	175	200	225	250	275	300	350	400		
						m³/h	6	7.5	9	10.5	12	13.5	15	16.5	18	21	24		
NRM2 50x32x125C	1	0.75	230/400	1.7	m.c.a. / m.c.w.	15.5	14.5	13.5	12.4	11.5	10.3	9	7.5	6					
NRM2 50x32x125B	1.5	1.1	230/400	2.5		20.5	20	19	18	17	16	15	13.5	11.5	7.5				
NRM2 50X32X125A	2	1.5	230/400	3.4		24.5	24	23.5	23	22	21	20	18.5	16.5	13				
NRM2 50X32X160C	3	2.2	230/400	4.4		28.5	28	27.5	26.5	25.5	24	23	21.5	20	15				
NRM2 50X32X160B	4	3	230/400	5.9		33.5	33	32.5	32	31	30	29	27.5	26	22.5				
NRM2 50X32X160A	4	3	230/400	5.9		38	37.5	37	36	35	34	33	31.5	30	26.5				
NRM2 50X32X200C	5.5	4	230/400	7.8		47	46.5	46	45	44	43	42	41	39.5	37.5	35			
NRM2 50X32X200C	5.5		400/690	7.8															
NRM2 50X32X200B	7.5	5.5	230/400	10.4		55	54.5	54	53.5	53	52	51	49.5	48	45	42			
NRM2 50X32X200B			400/690	10.4															
NRM2 50X32X200A	10	7.5	230/400	14.2		62	61.5	61	60	59.2	58.5	57.5	56.4	55	52.5	49			
NRM2 50X32X200A			400/690	14.2															

MEI ≥ 0.1 - Reference MEI ≥ 0.70 - The information on the reference efficiency is available at the address: [www.europump.org/efficiencycharts](http://www.europump.org/efficiencycharts)  
For efficiency characteristics see [www.starite.it](http://www.starite.it)

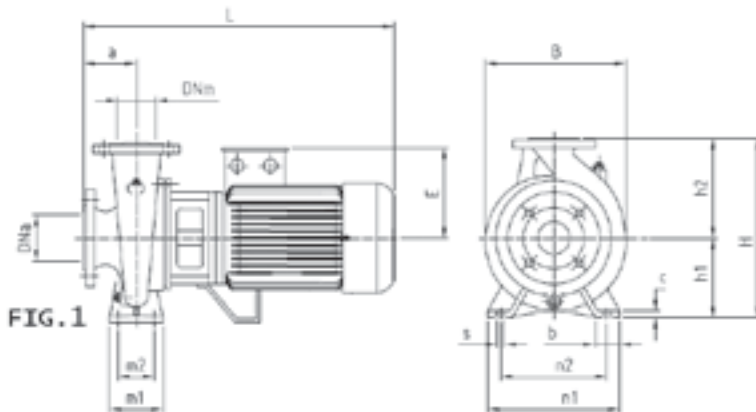

"Flange UNI PN16"					
DN	a1	b1	c1	d1	e1
32	78	100	140	4	18
50	102	125	165	4	18

### OVERALL DIMENSIONS AND WEIGHTS

MOD.	Motor	DNm	DNa	Dimensions mm.														weight (Kg)	
		PN16 mm	PN16 mm	Fig.	a	h1	h2	b	m1	m2	n1	n2	s	C	W	L~	B		H
NRM2 50x32x125C	71	32	50	1	80	112	140	50	100	70	190	140	14	12	-	421	200	252	23.3
NRM2 50x32x125B	80	32	50	1	80	112	140	50	100	70	190	140	14	12	-	421	200	252	23.6
NRM2 50X32X125A	80	32	50	1	80	112	140	50	100	70	190	140	14	12	-	421	200	252	25.9
NRM2 50X32X160C	80	32	50	1	80	132	160	50	100	70	240	190	14	12	-	426	240	292	31
NRM2 50X32X160B	100	32	50	1	80	132	160	50	100	70	240	190	14	12	-	495	240	292	36.5
NRM2 50X32X160A	100	32	50	1	80	132	160	50	100	70	240	190	14	12	-	495	240	292	38.5
NRM2 50X32X200C	100	32	50	1	80	160	180	50	100	70	240	190	14	12	-	495	240	340	46.9
NRM2 50X32X200B	112	32	50	1	80	160	180	50	100	70	240	190	14	12	-	517	240	340	51.1
NRM2 50X32X200A	112	32	50	1	80	160	180	50	100	70	240	190	14	12	-	539	240	340	59.6

# NRM2 65x40

## MONOBLOC NORMALISED CENTRIFUGAL PUMPS (2 AND 4 POLES)

### PERFORMANCE TABLE

MOD.	P2		VOLT. (V)	In (A)	0	l/min	250	275	300	350	400	450	500	550	600	650	700	
	HP	kW					m³/h	15	16.5	18	21	24	27	30	33	36	39	42
NRM2 65X40X125C	2	1.5	230/400	3.4	m.c.a. / m.c.w.	15.5	15.3	15	14.1	13	11.8	10.5	9	7				
NRM2 65X40X125B	3	2.2	230/400	4.4		19	18.8	18.5	17.5	16.5	15.5	14.5	13	10.5				
NRM2 65X40X125A	4	3	230/400	5.9		24.5	24.3	24	23.5	23	22	20.5	19	17				
NRM2 65X40X160B	4	3	230/400	5.9		30	29.5	29	28	26.5	25	23	20.5	18				
NRM2 65X40X160A	5.5	4	230/400	7.8		36.5	36	35.5	34.5	33.5	32.5	31	29	27				
NRM2 65X40X160A			400/690	7.8														
NRM2 65X40X200C	7.5	5.5	230/400	10.4		45.3	44.8	44	43	41.5	39	37	34	31				
NRM2 65X40X200C			400/690	10.4														
NRM2 65X40X200B	10	7.5	230/400	14.2		51	50.5	50	49	47.5	45	42.5	40	37				
NRM2 65X40X200B			400/690	14.2														
NRM2 65X40X200A	10	7.5	230/400	14.2		56.5	56	55.5	54.5	53	51	49	47	44				
NRM2 65X40X200A			400/690	14.2														
NRM2 65X40X250D	15	11	230/400	19.8		69	68.5	68	66.5	65	63	61	59	57	54			
NRM2 65X40X250D			400/690	19.8														
NRM2 65X40X250C	20	15	400/690	27		77	76.5	76	74.5	73	71	69	67	65	62.5	60		
NRM2 65X40X250B			400/690	27													90	89.8

MEI ≥ 0.1 - Reference MEI ≥ 0.70 - The information on the reference efficiency is available at the address: [www.europump.org/efficiencycharts](http://www.europump.org/efficiencycharts)  
For efficiency characteristics see [www.starite.it](http://www.starite.it)

"Flange UNI PN16"					
DN	a1	b1	c1	d1	e1
40	83	110	150	4	18
65	122	145	185	4	18

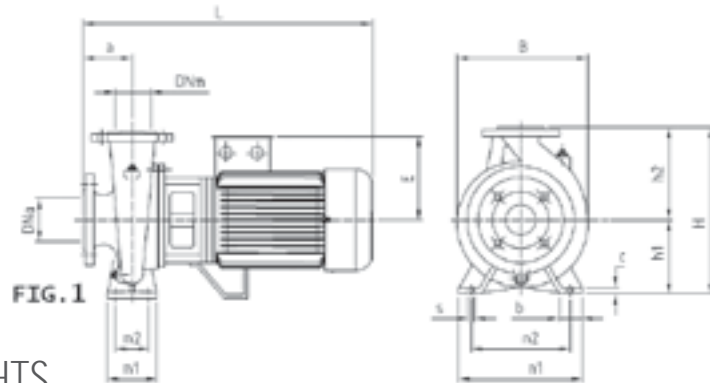

### OVERALL DIMENSIONS AND WEIGHTS

MOD.	Motor	DNm	DNa	Dimensions mm.														WEIGHTS (Kg)	
		PN16 mm	PN16 mm	Fig.	a	h1	h2	b	m1	m2	n1	n2	s	C	W	L~	B		H
NRM2 65X40X125C	80	40	65	1	80	112	140	50	100	70	240	140	14	12	-	421	215	252	26.9
NRM2 65X40X125B	90	40	65	1	80	112	140	50	100	70	210	140	14	12	-	426	215	252	28
NRM2 65X40X125A	100	40	65	1	80	112	140	50	100	70	210	140	14	12	-	495	215	252	33.5
NRM2 65X40X160B	100	40	65	1	80	132	160	50	100	70	240	190	14	12	-	495	270	292	33.5
NRM2 65X40X160A	100	40	65	1	80	132	160	50	100	70	240	190	14	12	-	495	280	292	43.1
NRM2 65X40X200C	112	40	65	1	100	160	180	50	100	70	265	190	14	12	-	537	270	340	47.9
NRM2 65X40X200B	112	40	65	1	100	160	180	50	100	70	265	190	14	12	-	559	270	340	55.4
NRM2 65X40X200A	132	40	65	1	100	160	180	50	100	70	265	190	14	12	-	559	270	340	60.6
NRM2 65X40X250D	132	40	65	1	100	180	225	65	125	95	320	250	14	12	-	654	315	405	82.5
NRM2 65X40X250C	132	40	65	1	100	180	225	65	125	95	320	250	14	12	-	705	315	405	87
NRM2 65X40X250B	132	40	65	1	100	180	225	65	125	95	320	250	14	12	-	705	315	405	94

# NRM2 65x50

## MONOBLOC NORMALISED CENTRIFUGAL PUMPS (2 AND 4 POLES)

### PERFORMANCE TABLE

MOD.	P2		VOLT. (V)	In (A)	Q	l/min	400	450	500	550	600	650	700	750	800	900	1000	
	HP	kW																
NRM2 65X50X125C	3	2.2	230/400	4.4	m.c.a. / m.c.w.	17	16.5	16	15.5	15	14	13	12	11	9			
NRM2 65X50X125B	4	3	230/400	5.9		21	20.5	20	19.5	19	18.3	17.5	16.8	16	14	12		
NRM2 65X50X125A	5.5	4	230/400	7.8		25.5	25.3	25	24.5	24	23.5	23	22.5	21.5	20	18		
NRM2 65X50X125A			400/690	7.8														
NRM2 65X50X160B	7.5	5.5	230/400	10.4		32.5	32	31.5	31	30.5	30	29.5	29	28	26	23.5		
NRM2 65X50X160B			400/690	10.4														
NRM2 65X50X160A	10	7.5	230/400	14.2		37	36.5	36	35.5	35	34.5	34	33.5	32.5	31	29		
NRM2 65X50X160A			400/690	14.2														
NRM2 65X50X200B	15	11	230/400	19.8		51	50.5	50	49	48	47	45.5	44.5	43	39.5	37		
NRM2 65X50X200B			400/690	19.8														
NRM2 65X50X200A	20	15	400/690	27		58	57.5	57	56	55	54	53	51.5	50	46.5	42.5		
NRM2 65X50X250D	20	15	400/690	27		72	71	70	69	68	67	66	64.5	63	60	56		
NRM2 65X50X250C	25	18.5	400/690	33.3		80.5	80	79.5	78.5	77.5	76.5	75.5	74.5	73.5	71	67.5		
NRM2 65X50X250B	30	22	400/690	38.6		92	91.8	91.5	91	90	89	88	87	86	83	80		

MEI ≥ 0.1 - Reference MEI ≥ 0.70 - The information on the reference efficiency is available at the address: [www.europump.org/efficiencycharts](http://www.europump.org/efficiencycharts)  
For efficiency characteristics see [www.starite.it](http://www.starite.it)

"Flange UNI PN16"					
DN	a1	b1	c1	d1	e1
50	102	125	165	4	18
65	122	145	185	4	18

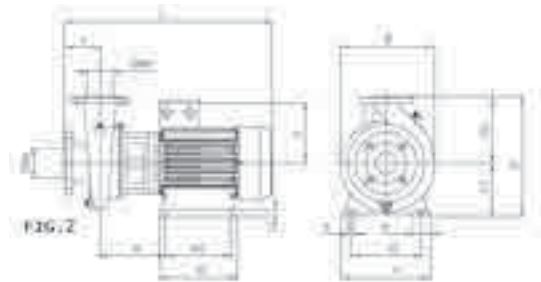
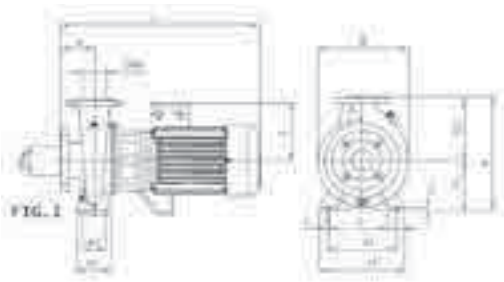

### OVERALL DIMENSIONS AND WEIGHTS

MOD.	Motor	DNm	DNa	Dimensions mm.														WEIGHTS (Kg)	
		PN16 mm	PN16 mm	Fig.	a	h1	h2	b	m1	m2	n1	n2	s	C	W	L~	B		H
NRM2 65X50X125C	90	50	65	1	100	132	160	50	100	70	240	190	14	12	-	446	245	292	34.5
NRM2 65X50X125B	100	50	65	1	100	132	160	50	100	70	240	190	14	12	-	515	270	292	40
NRM2 65X50X125A	100	50	65	1	100	132	160	50	100	70	240	190	14	12	-	515	280	292	44.1
NRM2 65X50X160B	112	50	65	1	100	160	180	50	100	70	265	212	14	12	-	537	270	340	53.4
NRM2 65X50X160A	112	50	65	1	100	160	180	50	100	70	265	212	14	12	-	559	270	340	58.1
NRM2 65X50X200B	132	50	65	1	100	160	200	50	100	70	265	212	14	12	-	654	285	360	73.5
NRM2 65X50X200A	132	50	65	1	100	160	200	50	100	70	265	212	14	12	-	705	285	360	77
NRM2 65X50X250D	132	50	65	1	100	180	225	50	100	70	265	212	14	12	-	705	320	405	95
NRM2 65X50X250C	160	50	65	2	100	180	225	76	420	370	320	254	14	20	210	802	320	405	146
NRM2 65X50X250B	160	50	65	2	100	180	225	76	420	370	320	254	14	20	210	802	320	405	167



# NRM2 80x65

## MONOBLOC NORMALISED CENTRIFUGAL PUMPS (2 AND 4 POLES)

### PERFORMANCE TABLE

MOD.	P2		VOLT. (V)	In (A)	0	m.c.a. / m.c.w.																				
	HP	kW				l/min	600	650	700	750	800	900	1000	1250	1500	1750	2000	2250								
						m <sup>3</sup> /h	36	39	42	45	48	54	60	75	90	105	120	135								
NRM2 80X65X125C	5.5	4	230/400	7.8	m.c.a. / m.c.w.	17.5	17.3	17	16.5	16	15.5	14.5	12	9												
NRM2 80X65X125C			400/690	7.8																						
NRM2 80X65X125B	7.5	5.5	230/400	10.4		21	20.8	20.6	20.3	20	19.5	19	17	14.5	11											
NRM2 80X65X125B			400/690	10.4																						
NRM2 80X65X125A	10	7.5	230/400	14.2		25	24.8	24.6	24.3	24	23.5	23	21.5	19	16											
NRM2 80X65X125A			400/690	14.2																						
NRM2 80X65X160C	15	11	230/400	19.8													30.5	30.3	30	29.5	29	26.5	24	20.5	16	
NRM2 80X65X160C			400/690	19.8																						
NRM2 80X65X160B	20	15	400/690	27													36.5	36.3	36	35.5	34.5	33	30	27	23	19
NRM2 80X65X160A			400/690	27																						
NRM2 80X65X200D	20	15	400/690	27													44	43.5	43	41.5	39	35.5	31.5			
NRM2 80X65X200C			400/690	33.3																						
NRM2 80X65X200B	30	22	400/690	38.6													51	50	49.5	48.5	46.5	43.5	39.5	35		
NRM2 80X65X200B			400/690	38.6																						
NRM2 80X65X250D	30	22	400/690	38.6													57	56.5	56	55	53.5	51	48	42.5		
NRM2 80X65X250D			400/690	38.6																						

MEI ≥ 0.1 - Reference MEI ≥ 0.70 - The information on the reference efficiency is available at the address: [www.europump.org/efficiencycharts](http://www.europump.org/efficiencycharts)  
For efficiency characteristics see [www.starite.it](http://www.starite.it)

"Flange UNI PN16"					
DN	a1	b1	c1	d1	e1
65	122	145	185	4	18
80	138	160	200	8	18

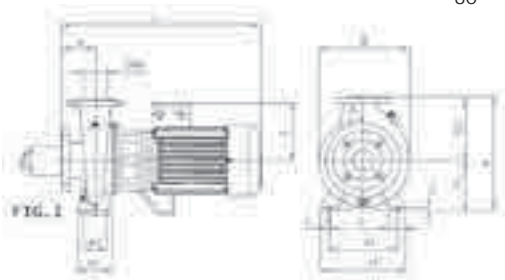

### OVERALL DIMENSIONS AND WEIGHTS

MOD.	Motor	DNm	DNa	Dimensions mm.															WEIGHTS (Kg)
		PN16 mm	PN16 mm	Fig.	a	h1	h2	b	m1	m2	n1	n2	s	C	W	L~	B	H	
NRM2 80X65X125C	100	65	80	1	100	160	180	65	125	95	280	212	14	14	-	515	280	340	44.9
NRM2 80X65X125B	112	65	80	1	100	160	180	65	125	95	280	212	14	14	-	537	280	340	47.1
NRM2 80X65X125A	112	65	80	1	100	160	180	65	125	95	280	212	14	14	-	559	280	340	57.6
NRM2 80X65X160C	132	65	80	1	100	160	200	65	125	95	280	212	14	14	-	654	280	360	75.5
NRM2 80X65X160B	132	65	80	1	100	160	200	65	125	95	280	212	14	14	-	705	280	360	79
NRM2 80X65X160A	132	65	80	1	100	160	200	65	125	95	280	212	14	14	-	705	280	360	85
NRM2 80X65X200D	132	65	80	1	100	180	225	65	125	95	280	212	14	14	-	705	330	405	89.5
NRM2 80X65X200C	160	65	80	2	100	180	225	65	420	370	320	254	14	20	210	802	330	405	140
NRM2 80X65X200B	160	65	80	2	100	180	225	65	420	370	320	254	14	20	210	802	330	405	144
NRM2 80X65X250D	160	65	80	2	100	180	250	65	420	370	320	254	14	20	222	814	365	430	172

# NRM2 100x80

## MONOBLOC NORMALISED CENTRIFUGAL PUMPS (2 AND 4 POLES)

### PERFORMANCE TABLE

MOD.	P2		VOLT. (V)	In (A)	0	l/min m <sup>3</sup> /h	1000	1250	1500	1750	2000	2250	2500	2750	3000									
	HP	kW					60	75	90	105	120	135	150	165	180									
NRM2 100X80X160D	15	11	230/400	19.8	m.c.a. / m.c.w.	24	23	22	21	19.5	18	16.5	15											
NRM2 100X80X160D			400/690	19.8																				
NRM2 100X80X160C	20	15	400/690	27										28.5	28	27	26	24.5	23	21.5	20	18.5		
NRM2 100X80X160B	20	15	400/690	27										34	33.3	32.5	31.8	31	29	27.5	26	24.5		
NRM2 100X80X200D	25	18.5	400/690	33.3										42	41	40	38.5	37	35	33	30.5			
NRM2 100X80X200C	30	22	400/690	38.6										47	46.5	45.5	44.5	43	41	39	37			

MEI ≥ 0.1 - Reference MEI ≥ 0.70 - The information on the reference efficiency is available at the address: [www.europump.org/efficiencycharts](http://www.europump.org/efficiencycharts)  
For efficiency characteristics see [www.starite.it](http://www.starite.it)

"Flange UNI PN16"					
DN	a1	b1	c1	d1	e1
80	138	160	200	8	18
100	158	180	220	8	18

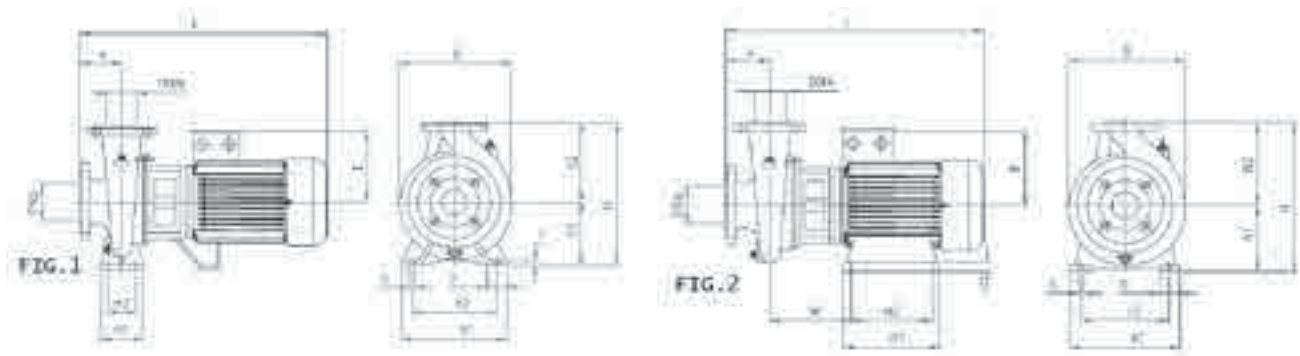

### OVERALL DIMENSIONS AND WEIGHTS

MOD.	Motor	DNm	DNa	Dimensions mm.															weight (Kg)
		PN16 mm	PN16 mm	Fig.	a	h1	h2	b	m1	m2	n1	n2	s	C	W	L ~	B	H	
NRM2 100X80X160D	132	80	100	1	125	180	225	65	125	95	320	250	14	14	-	679	315	405	79.5
NRM2 100X80X160C	132	80	100	1	125	180	225	65	125	95	320	250	14	14	-	730	315	405	83.5
NRM2 100X80X160B	132	80	100	1	125	180	225	65	125	95	320	250	14	14	-	730	315	405	90.5
NRM2 100X80X200D	160	80	100	2	125	180	250	65	420	370	320	254	14	20	222	839	360	430	150
NRM2 100X80X200C	160	80	100	2	125	180	250	65	420	370	320	254	14	20	222	839	360	430	192

# NRM2 125x100

## MONOBLOC NORMALISED CENTRIFUGAL PUMPS (2 AND 4 POLES)

### PERFORMANCE TABLE

MOD.	P2		VOLT. (V)	In (A)	0	l/min	1000	1250	1500	1750	2000	2250	2500	2750	3000	3500	4000
	HP	kW				m <sup>3</sup> /h	60	75	90	105	120	135	150	165	180	210	240
NRM2 125x100x200D	30	22	400/690	38.6	m.c.a. / m.c.w				39	38	37	36	34.5	33	31.5	28	24

MEI ≥ 0.1 - Reference MEI ≥ 0.70 - The information on the reference efficiency is available at the address: [www.europump.org/efficiencycharts](http://www.europump.org/efficiencycharts)  
For efficiency characteristics see [www.starite.it](http://www.starite.it)

"Flange UNI PN16"					
DN	a1	b1	c1	d1	e1
100	158	180	220	8	18
125	188	210	250	8	18

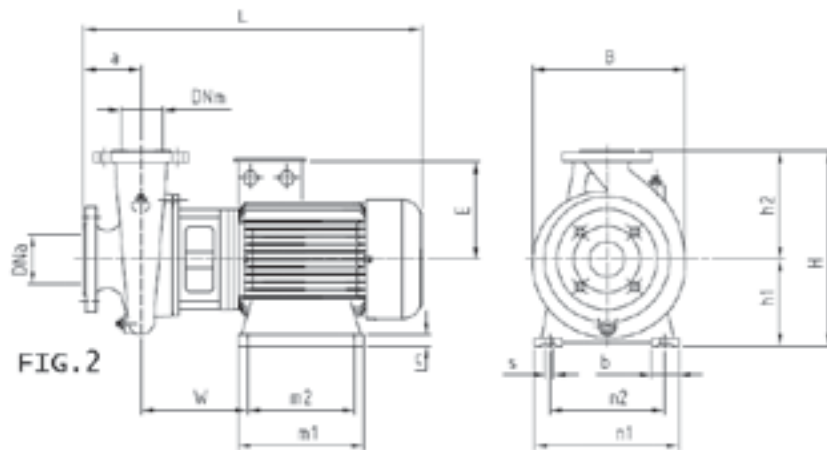

### OVERALL DIMENSIONS AND WEIGHTS

MOD.	Motor	DNm	DNa	Dimensions mm.														WEIGHTS (Kg)	
		PN16 mm	PN16 mm	Fig.	a	h1	h2	b	m1	m2	n1	n2	s	C	W	L~	B		H
NRM2 125x100x200D	160	100	125	2	125	180	280	65	420	370	320	254	14	20	222	839	380	460	160

# NRM4

## MONOBLOC NORMALISED CENTRIFUGAL PUMPS (2 AND 4 POLES)

### HYDRAULIC PERFORMANCE

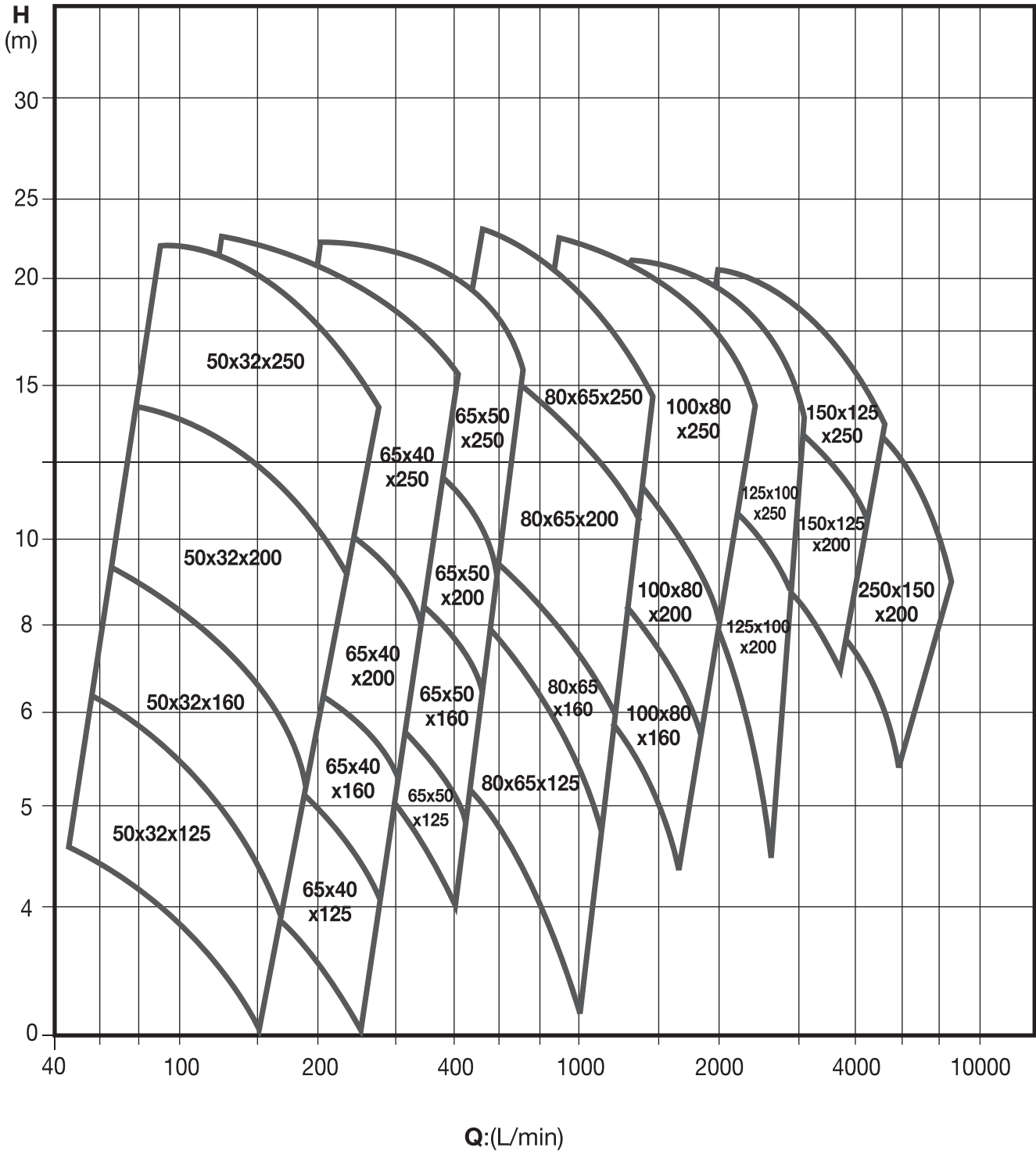

# NRM4 50x32

## MONOBLOC NORMALISED CENTRIFUGAL PUMPS (2 AND 4 POLES)

### PERFORMANCE TABLE

MOD.	P2		VOLT. (V)	In (A)	0	m.c.a. / m.c.w.												
	HP	kW				l/min	50	75	100	125	150	175	200	225	250	275	300	
						m <sup>3</sup> /h	3	4.5	6	7.5	9	10.5	12	13.5	15	16.5	18	
NRM4 50x32x125Y	0.33	0.25	230/400	0.9		4.4	4	3.5	3	2.2								
NRM4 50x32x125X	0.33	0.25	230/400	0.9		6.2	6	5.8	5.2	4.5	3.9	3						
NRM4 50x32x160X	0.5	0.37	230/400	1.2		9.4	9.2	8.9	8.3	7.7	6.9	5.8	4.7					
NRM4 50x32x200Y	1	0.75	230/400	1.8		13	12.8	12.4	11.9	11.3	10.6	9.8	9	8	7	6		
NRM4 50x32x200X	1.5	1.1	230/400	2.5		14.5	14.3	13.8	13.3	12.7	11.8	10.9	10	9	8			

MEI ≥ 0.1 - Reference MEI ≥ 0.70 - The information on the reference efficiency is available at the address: [www.europump.org/efficiencycharts](http://www.europump.org/efficiencycharts)  
For efficiency characteristics see [www.tarite.it](http://www.tarite.it)

"Flange UNI PN16"					
DN	a1	b1	c1	d1	e1
32	78	100	140	4	18
50	102	125	165	4	18

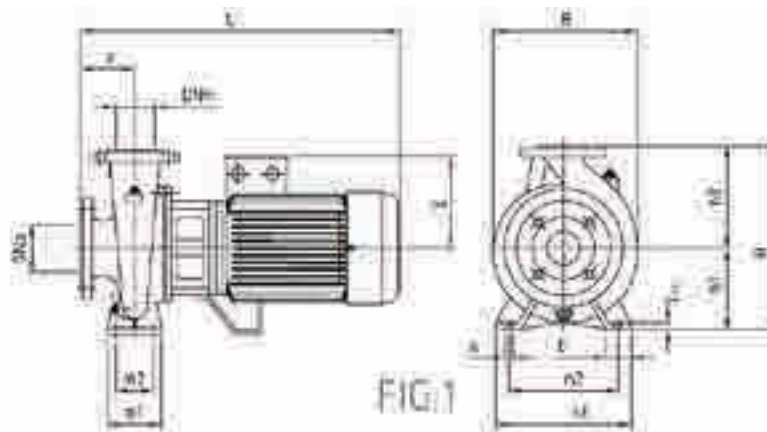

### OVERALL DIMENSIONS AND WEIGHTS

MOD.	Motor	DNm	DNa	Dimensions mm.															WEIGHTS (Kg)
		PN16 mm	PN16 mm	Fig.	a	b	c	m1	m2	n1	n2	s	h1	h2	H	B	L~	E~	
NRM4 50x32x125Y	71	32	50	1	80	50	12	100	70	190	140	14	112	140	252	205	405	110	19.5
NRM4 50x32x125X	71	32	50	1	80	50	12	100	70	190	140	14	112	140	252	205	405	110	19.5
NRM4 50x32x160X	71	32	50	1	80	50	12	100	70	240	190	14	132	160	292	240	405	110	23
NRM4 50x32x200Y	80	32	50	1	80	50	12	100	70	240	190	14	160	180	340	255	421	129	31.7
NRM4 50x32x200X	90	32	50	1	80	50	12	100	70	240	190	14	160	180	340	255	456	138	36.8

# NRM4 65x40

## MONOBLOC NORMALISED CENTRIFUGAL PUMPS (2 AND 4 POLES)

### PERFORMANCE TABLE

MOD.	P2		VOLT. (V)	In (A)	0	l/min	100	125	150	175	200	225	250	275	300	350	400	
	HP	kW				m <sup>3</sup> /h	6	7.5	9	10.5	12	13.5	15	16.5	18	21	24	
NRM4 65x40x125Y	0.33	0.25	230/400	0.9	m.c.a. / m.c.w.	4.6	4.5	4.3	4.1	3.9	3.6	3.3	2.9	2.4				
NRM4 65x40x125X	0.5	0.37	230/400	1.2		6.3	6.2	6.1	6	5.8	5.5	5.2	4.9	4.4	3			
NRM4 65x40x160X	0.75	0.55	230/400	1.7		8.8	8.6	8.3	8	7.7	7.3	6.9	6.4	5.9	4.5			
NRM4 65x40x200Y	1.5	1.1	230/400	2.5		12.7	12.5	12.1	11.7	11.2	10.7	10.1	9.3	8.5	7			
NRM4 65x40x200X	1.5	1.1	230/400	2.5		14.2	14	13.8	13.4	13	12.5	11.8	11	10.2	8.3	6		
NRM4 65x40x250Y	2	1.5	230/400	3.4		18.3	18	17.7	17.4	17	16.6	16.2	15.6	15	13.7	12		
NRM4 65x40x250X	3	2.2	230/400	5.1		22.5	22.3	22	21.7	21.4	21	20.5	20	19.5	18.5	17		

MEI ≥ 0.1 - Reference MEI ≥ 0.70 - The information on the reference efficiency is available at the address: [www.europump.org/efficiencycharts](http://www.europump.org/efficiencycharts)  
For efficiency characteristics see [www.starite.it](http://www.starite.it)

"Flange UNI PN16"					
DN	a1	b1	c1	d1	e1
40	88	110	150	4	18
65	122	145	185	4	18

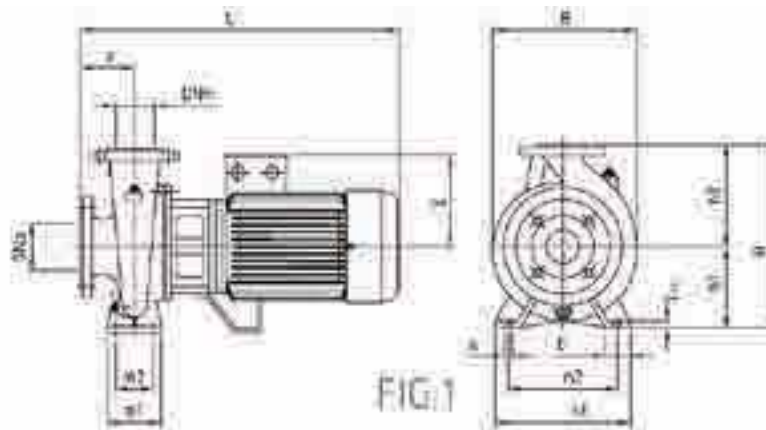

### OVERALL DIMENSIONS AND WEIGHTS

MOD.	Motor	DNm	DNa	Dimensions mm.															WEIGHTS (Kg)
		PN16 mm	PN16 mm	Fig.	a	b	c	m1	m2	n1	n2	s	h1	h2	H	B	L~	E~	
NRM4 65x40x125Y	71	40	65	1	80	50	12	100	70	210	160	14	112	140	252	230	405	110	20.5
NRM4 65x40x125X	71	40	65	1	80	50	12	100	70	210	160	14	112	140	252	230	405	110	21.5
NRM4 65x40x160X	71	40	65	1	80	50	12	100	70	240	190	14	132	160	292	230	405	110	25
NRM4 65x40x200Y	90	40	65	1	100	50	12	100	70	265	212	14	160	180	340	285	476	138	39.9
NRM4 65x40x200X	90	40	65	1	100	50	12	100	70	265	212	14	160	180	340	242	476	138	39.9
NRM4 65x40x250Y	90	40	65	1	100	65	12	125	95	320	250	14	180	225	405	325	476	138	49.4
NRM4 65x40x250X	100	40	65	1	100	65	12	125	95	320	250	14	180	225	405	325	415	145	56.9

# NRM4 65x50

## MONOBLOC NORMALISED CENTRIFUGAL PUMPS (2 AND 4 POLES)

### PERFORMANCE TABLE

MOD.	P2		VOLT. (V)	In (A)	0	l/min	150	175	200	225	250	275	300	350	400	450	500	550	600	650	700	
	HP	kW					9	10.5	12	13.5	15	16.5	18	21	24	27	30	33	36	39	42	
NRM4 65x50x125Y	0.5	0.37	230/400	1.2		5.3	5.3	5.2	5.1	5	4.9	4.8	4.5	4.1	3.6	3						
NRM4 65x50x125X	0.75	0.55	230/400	1.7		6.4	6.3	6.2	6.1	6	5.9	5.8	5.5	5.2	4.9	4.4						
NRM4 65x50x160Y	1	0.75	230/400	1.8	m.c.a. / m.c.w.			8.2	8	7.9	7.8	7.7	7.4	7.1	6.6	5.8	5	4				
NRM4 65x50x160X	1.5	1.1	230/400	2.5				9	8.9	8.8	8.7	8.6	8.4	8.1	7.7	7.2	6.5	5.5				
NRM4 65x50x200Y	1.5	1.1	230/400	2.5				12.4	12.2	12	11.8	11.5	10.8	10	9	8	7	5.8				
NRM4 65x50x200X	2	1.5	230/400	3.4				14.3	14.2	14.1	14	13.7	13	12.3	11.3	10.2	9.1	7.8	6.4	5		
NRM4 65x50x250Y	3	2.2	230/400	5.1				18.5	18.3	18.1	17.8	17.5	17	16.2	15.5	14.5	13.5	12.5	11.2	10		
NRM4 65x50x250X	4	3	230/400	6.5				22.5	22.4	22.3	22.2	22	21.5	20.9	20.2	19.4	18.5	17.5	16.3	15		

MEI ≥ 0.1 - Reference MEI ≥ 0.70 - The information on the reference efficiency is available at the address: [www.europump.org/efficiencycharts](http://www.europump.org/efficiencycharts)  
For efficiency characteristics see [www.starite.it](http://www.starite.it)

"Flange UNI PN16"					
DN	a1	b1	c1	d1	e1
50	102	125	165	4	18
65	122	145	185	4	18

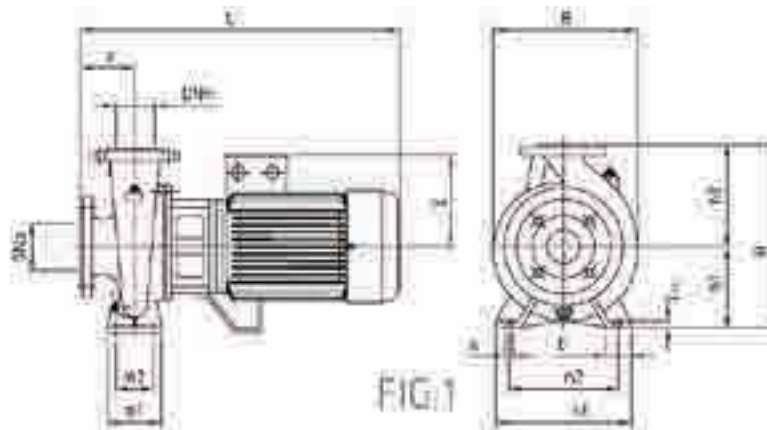

### OVERALL DIMENSIONS AND WEIGHTS

MOD.	Motor	DNm	DNa	Dimensions mm.															WEIGHTS (Kg)
		PN16 mm	PN16 mm	Fig.	a	b	c	m1	m2	n1	n2	s	h1	h2	H	B	L~	E~	
NRM4 65x50x125Y	71	50	65	1	100	50	12	100	70	240	190	14	132	160	292	246	425	110	25
NRM4 65x50x125X	71	50	65	1	100	50	12	100	70	240	190	14	132	160	292	246	425	110	26
NRM4 65x50x160Y	80	50	65	1	100	50	12	100	70	265	212	14	160	180	340	269	441	129	33.7
NRM4 65x50x160X	90	50	65	1	100	50	12	100	70	265	212	14	160	180	340	269	476	138	38.8
NRM4 65x50x200Y	90	50	65	1	100	50	12	100	70	265	250	14	160	200	360	285	476	138	41.9
NRM4 65x50x200X	90	50	65	1	100	50	12	100	70	265	212	14	160	200	360	285	476	138	41.9
NRM4 65x50x250Y	100	50	65	1	100	65	14	125	95	320	250	14	180	225	405	333	415	145	59.9
NRM4 65x50x250X	100	50	65	1	100	65	14	125	95	320	250	14	180	225	405	333	515	145	67

# NRM4 80x65

## MONOBLOC NORMALISED CENTRIFUGAL PUMPS (2 AND 4 POLES)

### PERFORMANCE TABLE

MOD.	P2		VOLT. (V)	In (A)	0	m.c.a. / m.c.w.																
	HP	kW				l/min	300	350	400	450	500	550	600	700	800	900	1000	1100	1200	1300	1400	
						m <sup>3</sup> /h	18	21	24	27	30	33	36	42	48	54	60	66	72	78	84	
NRM4 80x65x125X	1	0.75	230/400	1.8		5.8	5.7	5.6	5.5	5.3	5.1	4.9	4.5	4								
NRM4 80x65x160Y	1.5	1.1	230/400	2.5		8.6	8.5	8.4	8.3	8.2	8.1	8	7.5	6.8	6	5						
NRM4 80x65x160X	2	1.5	230/400	3.4		10.2	10.1	10	9.9	9.8	9.6	9.4	9	8.5	7.7							
NRM4 80x65x200Y	3	2.2	230/400	5.1				12.5	12.4	12.3	12.2	12.1	11.7	11.1	10.5	9.6	8.5					
NRM4 80x65x200X	4	3	230/400	6.5						15.2	15.1	15	14.6	14.3	13.6	12.8	12	11				
NRM4 80x65x250Y	5.5	4	230/400	8.5									19.1	18.4	17.5	16.5	15.5	14	12.5	10.5		
NRM4 80x65x250Y			400/690	8.5					19.5	19.3												
NRM4 80x65x250X	7.5	5.5	230/400	10.8																		
NRM4 80x65x250X			400/690	10.8					23	22.8	22.6	22.2	21.4	20.6	19.7	18.7	17.5	16	14			

MEI ≥ 0.1 - Reference MEI ≥ 0.70 - The information on the reference efficiency is available at the address: [www.europump.org/efficiencycharts](http://www.europump.org/efficiencycharts)  
For efficiency characteristics see [www.starite.it](http://www.starite.it)

"Flange UNI PN16"					
DN	a1	b1	c1	d1	e1
65	122	145	185	4	18
80	138	160	200	8	18

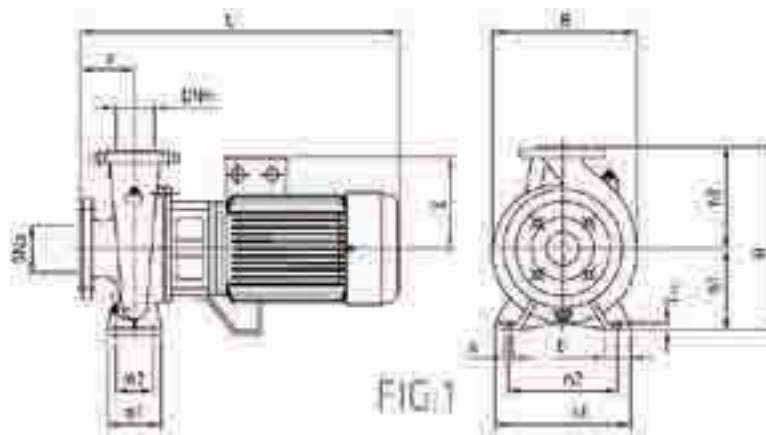

### OVERALL DIMENSIONS AND WEIGHTS

MOD.	Motor	DNm	DNa	Dimensions mm.														WEIGHTS (Kg)	
		PN16 mm	PN16 mm	Fig.	a	b	c	m1	m2	n1	n2	s	h1	h2	H	B	L~		E~
NRM4 80x65x125X	80	65	80	1	100	65	12	125	95	280	212	14	160	180	340	286	445	118	32
NRM4 80x65x160Y	90	65	80	1	100	65	12	125	95	280	212	14	160	200	360	288	485	149	37.5
NRM4 80x65x160X	90	65	80	1	100	65	12	125	95	280	212	14	160	200	360	288	485	149	40
NRM4 80x65x200Y	100	65	80	1	100	65	14	125	95	320	250	14	180	225	405	328	525	159	51
NRM4 80x65x200X	100	65	80	1	100	65	14	125	95	320	250	14	180	225	405	328	525	159	57
NRM4 80x65x250Y	112	65	80	1	100	80	14	160	120	360	280	14	200	250	450	365	535	159	80
NRM4 80x65x250X	132	65	80	1	100	80	14	160	120	360	280	14	200	250	450	365	640	184	90



# NRM4 100x80

## MONOBLOC NORMALISED CENTRIFUGAL PUMPS (2 AND 4 POLES)

### PERFORMANCE TABLE

MOD.	P2		VOLT. (V)	In (A)	0	l/min m <sup>3</sup> /h	600	650	700	800	900	1000	1100	1200	1300	1400	1500	1750	2000	2250	
	HP	kW					36	39	42	48	54	60	66	72	78	84	90	105	120	135	
NRM4 100x80x160Y	2	1.5	230/400	3.4	m.c.a. / m.c.w.	7.7	7.6	7.5	7.3	7	6.7	6.4	6.1	5.8	5.4	5					
NRM4 100x80x160X	3	2.2	230/400	5.1		9.7	9.6	9.5	9.3	9	8.8	8.5	8.2	7.9	7.5	7.1	6				
NRM4 100x80x200Y	4	3	230/400	6.5		12	11.9	11.8	11.5	11.3	11	10.5	10	9.5	9	8.5	7				
NRM4 100x80x200X	5.5	4	230/400	8.5		14.5	14.4	14.2	14	13.8	13.5	13.1	12.7	12.2	11.6	11	9	6.5			
NRM4 100x80x200X			400/690	8.5																	
NRM4 100x80x250Y	7.5	5.5	230/400	10.8						19	18.5	18	17.5	17	16.5	16	14	12			
NRM4 100x80x250Y			400/690	10.8																	
NRM4 100x80x250X	10	7.5	230/400	14.4						22	21.9	21.7	21.2	20.8	20.5	20	18.5	16.8	14.5		
NRM4 100x80x250X			400/690	14.4																	

MEI ≥ 0.1 - Reference MEI ≥ 0.70 - The information on the reference efficiency is available at the address: [www.europump.org/efficiencycharts](http://www.europump.org/efficiencycharts)  
For efficiency characteristics see [www.starite.it](http://www.starite.it)

"Flange UNI PN16"					
DN	a1	b1	c1	d1	e1
80	138	160	200	8	18
100	158	180	220	8	18

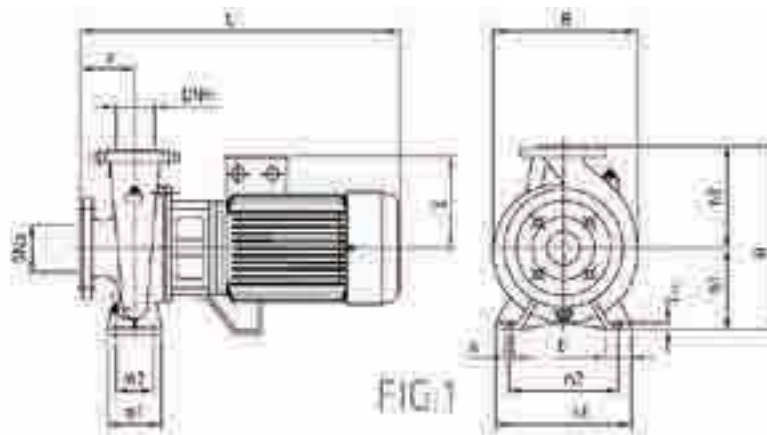

### OVERALL DIMENSIONS AND WEIGHTS

MOD.	Motor	DNm	DNa	Dimensions mm.															WEIGHTS (Kg)
		PN16 mm	PN16 mm	Fig.	a	b	c	m1	m2	n1	n2	s	h1	h2	H	B	L~	E~	
NRM4 100x80x160Y	90	80	100	1	125	65	14	125	95	320	250	14	180	225	405	330	501	138	46.9
NRM4 100x80x160X	100	80	100	1	125	65	14	125	95	320	250	14	180	225	405	330	440	145	53.9
NRM4 100x80x200Y	100	80	100	1	125	65	12	125	95	345	280	14	180	250	430	355	552	145	70
NRM4 100x80x200X	112	80	100	1	125	65	12	125	95	345	280	14	180	250	430	355	574	160	81.9
NRM4 100x80x250Y	132	80	100	1	125	80	14	160	120	400	315	18	200	280	480	400	631	194	113.1
NRM4 100x80x250X	132	80	100	1	125	80	14	160	120	400	315	18	200	280	480	400	671	194	127

# NRM4 125x100

## MONOBLOC NORMALISED CENTRIFUGAL PUMPS (2 AND 4 POLES)

### PERFORMANCE TABLE

MOD.	P2		VOLT. (V)	In (A)	0																
	HP	kW				l/min	900	1000	1100	1200	1300	1400	1500	1750	2000	2250	2500	2750	3000		
						m <sup>3</sup> /h	54	60	66	72	78	84	90	105	120	135	150	165	180		
NRM4 125x100x200Y	5.5	4	230/400	8.5	m.c.a. / m.c.w.	12.4	12.2	12	11.8	11.6	11.4	11.2	10.3	9.3	8.2	6.8	4.8				
NRM4 125x100x200Y			400/690	8.5																	
NRM4 125x100x200X	7.5	5.5	230/400	10.8		14.5	14.4	14.2	14	13.8	13.6	13.4	12.8	12	11	10	8.5				
NRM4 125x100x200X			400/690	10.8																	
NRM4 125x100x250Y	10	7.5	230/400	14.4																	
NRM4 125x100x250Y			400/690	14.4		19.5	19.3	19.1	18.9	18.7	18.5	17.5	16.5	15.2	14	12					
NRM4 125x100x250X	15	11	230/400	22																	
NRM4 125x100x250X			400/690	22		22	21.9	21.8	21.7	21.6	21.3	20.5	19.6	18.5	17	15	13				

MEI ≥ 0.1 - Reference MEI ≥ 0.70 - The information on the reference efficiency is available at the address: [www.europump.org/efficiencycharts](http://www.europump.org/efficiencycharts)  
For efficiency characteristics see [www.starite.it](http://www.starite.it)

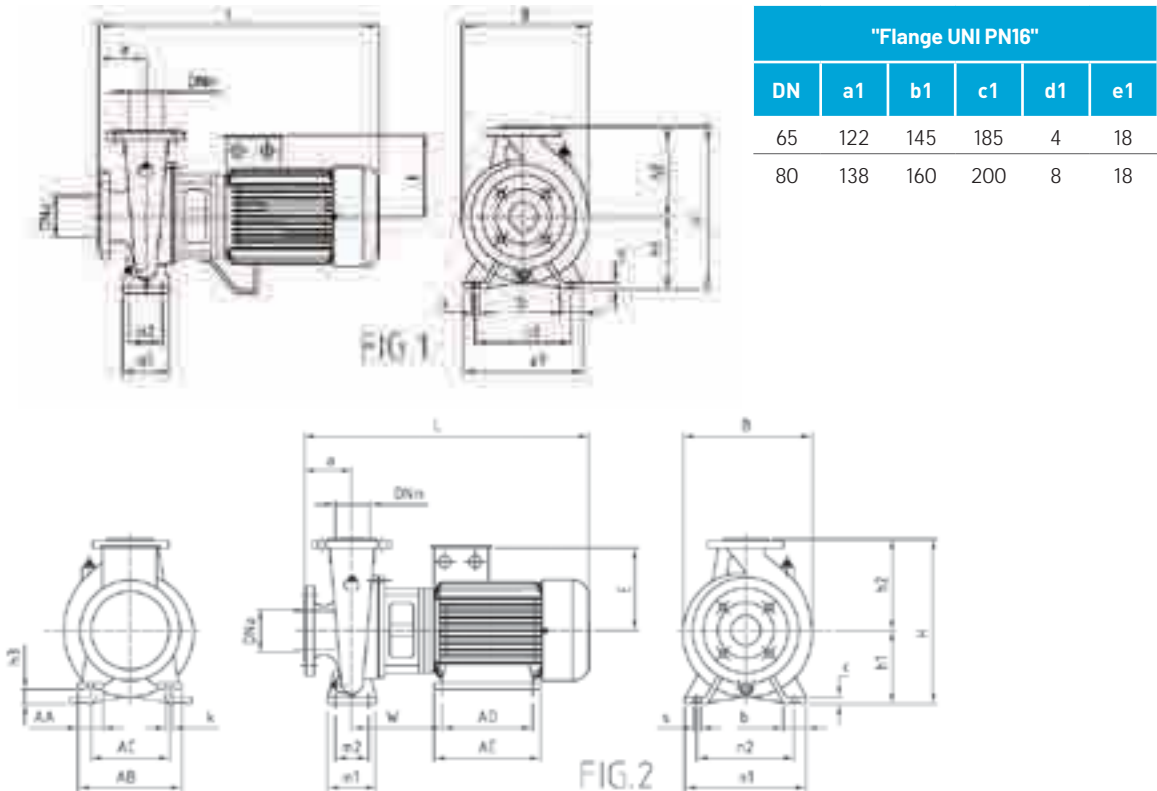

### OVERALL DIMENSIONS AND WEIGHTS

MOD.	Motor	DNm	DNa	Dimensions mm.																							Net weight [kg]		
		PN16 mm	PN16 mm	Fig.	a	b	c	m1	m2	n1	n2	s	h1	h2	h3	H	AA	AB	AC	AD	AE	k	W	B	L~	E~			
NRM4 125x100x200Y	112	100	125	1	125	80	14	160	120	360	280	18	200	280	-	480	-	-	-	-	-	-	-	-	-	385	574	160	79.9
NRM4 125x100x200X	132	100	125	1	125	80	14	160	120	360	280	18	200	280	-	480	-	-	-	-	-	-	-	-	-	385	631	194	107.1
NRM4 125x100x250Y	132	100	125	1	140	80	14	160	120	400	315	18	225	280	-	505	-	-	-	-	-	-	-	-	-	420	686	194	126
NRM4 125x100x250X	160	100	125	2	140	80	14	160	120	400	315	18	225	280	65	505	76	320	254	210	270	14	191	420	779	238	161		

# NRM4 150x125

## MONOBLOC NORMALISED CENTRIFUGAL PUMPS (2 AND 4 POLES)

### PERFORMANCE TABLE

MOD.	P2		VOLT. (V)	In (A)	0	l/min	1800	2000	2500	3000	3500	4000	4500	5000	
	HP	kW													
NRM4 150x125x200W	7.5	5.5	400/690	10.8	m.c.a. / m.c.w.	10.4	10.2	9.4	8.3	6.8					
NRM4 150x125x200Z	10	7.5	400/690	14.4		11.6	11.5	10.9	9.9	8.6	7				
NRM4 150x125x200Y	10	7.5	400/690	14.4		13	12.8	12.3	11.6	10.5	9.1	7.5			
NRM4 150x125x200X	15	11	400/690	22		14.3	14.2	13.8	13.2	12.3	11.1	9.6	8		
NRM4 150x125x250Z	15	11	400/690	22		17	16.6	15.7	14.4	12.6					
NRM4 150x125x250Y	20	15	400/690	29		19.8	19	18	16.6	15					
NRM4 150x125x250X	20	15	400/690	29		20.8	19.7	18.6	17	15.2	13.2				

MEI ≥ 0.1 - Reference MEI ≥ 0.70 - The information on the reference efficiency is available at the address: [www.europump.org/efficiencycharts](http://www.europump.org/efficiencycharts)  
For efficiency characteristics see [www.starite.it](http://www.starite.it)

"Flange UNI PN16"					
DN	a1	b1	c1	d1	e1
65	122	145	185	4	18
80	138	160	200	8	18

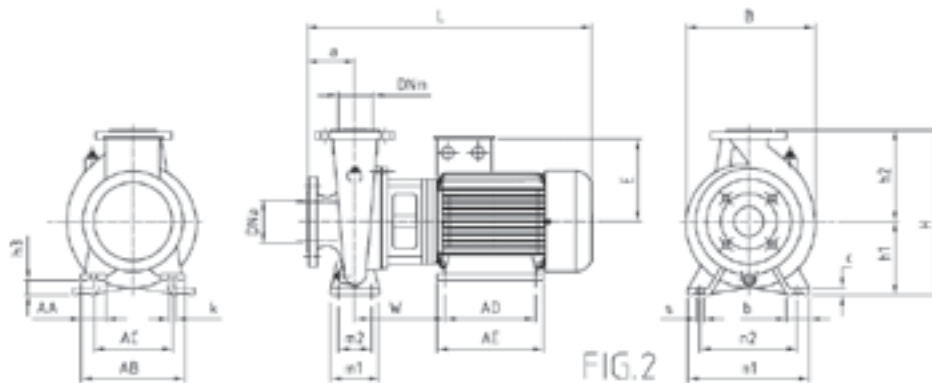

### OVERALL DIMENSIONS AND WEIGHTS

MOD.	Motor	DNm	DNa	Dimensions mm.																	Net weight [kg]						
		PN16 mm	PN16 mm	Fig.	a	b	c	m1	m2	n1	n2	s	h1	h2	h3	H	AA	AB	AC	AD		AE	k	W	B	L	E
NRM4 150x125x200W	132	125	150	2	140	80	14	160	120	400	315	18	250	280	118	565	59	256	216	140	180	12	230	470	657	194	137.1
NRM4 150x125x200Z	132	125	150	2	140	80	14	160	120	400	315	18	250	315	118	565	59	256	216	178	218	12	241	470	697	194	148
NRM4 150x125x200Y	132	125	150	2	140	80	14	160	120	400	315	18	250	315	118	565	59	256	216	178	218	12	241	470	697	194	155
NRM4 150x125x200X	160	125	150	2	140	80	14	160	120	400	315	18	250	315	90	565	76	320	254	210	270	14	241	470	790	238	187
NRM4 150x125x250Z	160	125	150	2	140	80	16	160	120	400	315	18	250	355	90	605	76	320	254	210	270	14	260	470	790	238	197.5
NRM4 150x125x250Y	160	125	150	2	140	80	16	160	120	400	315	18	250	355	90	605	76	320	254	254	310	14	260	470	854	238	205
NRM4 150x125x250X	160	125	150	2	140	80	16	160	120	400	315	18	250	355	90	605	76	320	254	254	310	14	280	470	854	238	205

# NRM4 200x150

## MONOBLOC NORMALISED CENTRIFUGAL PUMPS (2 AND 4 POLES)

### PERFORMANCE TABLE

MOD.	P2		VOLT. (V)	In (A)	Q	l/min	2500	3000	3500	4000	4500	5000	5500	6000	6500	
	HP	kW				m <sup>3</sup> /h	150	180	210	240	270	300	330	360	390	
NRM4 200x150x200W	7.5	5.5	400/690	14.4	m.c.a. / m.c.w.	10.4	9.7	8.9	7.9	6.7	5.5					
NRM4 200x150x200Z	15	11	400/690	22		11.5	10.9	10.2	9.3	8.3	7	5.8				
NRM4 200x150x200Y	15	11	400/690	22			13.3	12.6	12	11.1	10.1	9	7.6			
NRM4 200x150x200X	20	15	400/690	29			14.5	14	13.2	12.5	11.6	10.6	9.4	8		

MEI ≥ 0.1 - Reference MEI ≥ 0.70 - The information on the reference efficiency is available at the address: [www.europump.org/efficiencycharts](http://www.europump.org/efficiencycharts)  
For efficiency characteristics see [www.starite.it](http://www.starite.it)

"Flange UNI PN16"					
DN	a1	b1	c1	d1	e1
65	122	145	185	4	18
80	138	160	200	8	18

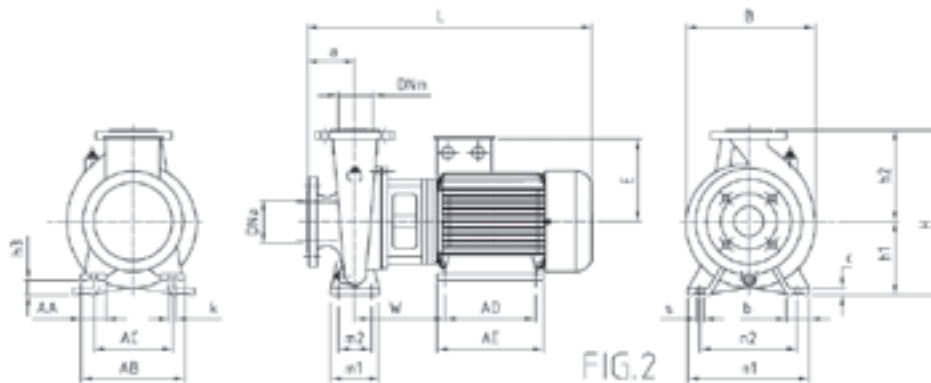

### OVERALL DIMENSIONS AND WEIGHTS

MOD.	Motor	DNm	DNa	Dimensions mm.																Net weight [kg]							
		PN16 mm	PN16 mm	Fig.	a	b	c	m1	m2	n1	n2	s	h1	h2	h3	H	AA	AB	AC		AD	AE	k	W	B	L	E~
NRM4 200x150x200W	132	150	200	2	160	100	22	200	155	550	450	24	280	400	148	680	59	256	216	178	218	12	280	550	717	194	181
NRM4 200x150x200Z	160	150	200	2	160	100	22	200	155	550	450	24	280	400	120	680	76	320	254	210	270	14	241	550	810	238	210.5
NRM4 200x150x200Y	160	150	200	2	160	100	22	200	155	550	450	24	280	400	120	680	76	320	254	210	270	14	260	550	810	238	218
NRM4 200x150x200X	160	150	200	2	160	100	22	200	155	550	450	24	280	400	120	680	76	320	254	254	310	14	260	550	874	238	220

## P.G.A. - DELTA OIL

### SELF-PRIMING LIQUID RING PUMPS SPECIFIC FOR DIESEL TRANSFER

The pumps of the series PGA are particularly suitable for diesel transfer. Available in the version complete with power cable, switch and handle. Equipped with a safety tube for the discharge of any leakage.

#### APPLICATIONS

- Realization of distributionboosters.
- For diesel transfer on farms.
- Soil processing machines.
- Small pumping stations.

#### MOTOR

- Closed, ventilated from outside.
- Degree of protection IP 44
- Insulation class F
- Single-phase power supply with capacitor permanently on and thermal protection built into the motor casing.
- Three-phase power supply with external protection
- provided by the user.
- Speed of rotation 2850 rpm.
- Continuous service.

#### USAGE DATA

- Type of liquid: diesel.
- Maximum temperature of the liquid 50°C.
- Maximum intake height recommended 5 m with foot valve.
- Maximum operating pressure 6 bar.



## TABLE OF MATERIALS

Component	Material
Pump body	Cast iron ENGJL 200
Motor casing	Cast iron ENGJL 200
Impeller with wings	Brass
Motor shaft	Stainless steel X 12 CrNiS 1809 (AISI 416)
Mechanical seal	Graphite
Counterface	Ceramic
Gaskets	NBR 70 shore

# P.G.A. - DELTA OIL

## SELF-PRIMING LIQUID RING PUMPS SPECIFIC FOR DIESEL TRANSFER

### HYDRAULIC PERFORMANCE

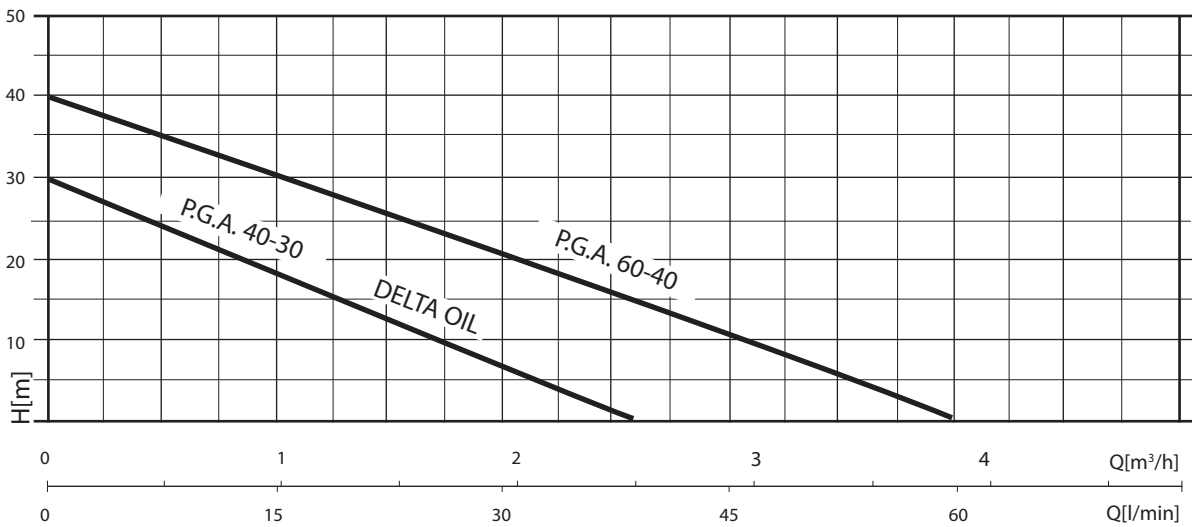

### PERFORMANCE TABLE

MODEL	Motor power (P2)		Motor power (P1)		VOLT. (V)	I <sub>n</sub> (A)	μF	Q	m.c.w.							
	HP	kW	HP	kW					l/min	5	10	15	25	35	45	60
									0	0,3	0,6	0,9	1,5	2,1	2,7	3,6
PGA 40 - 30 M PGA 40 - 30 T	0,6	0,45	0,75	0,55	1 - 230 3 - 230/400	2,7 1,6-0,9	8			28	23	18	13	5		
PGA 60 - 40 M PGA 60 - 40 T	0,8	0,6	1,2	0,9	1 - 230 3 - 230/400	4,5 2,7-1,6	12,5			39	34	32	25	18	12	12
DELTA OIL	0,6	0,45	0,75	0,55	1 - 230	2,7	8			28	23	18	13	5		

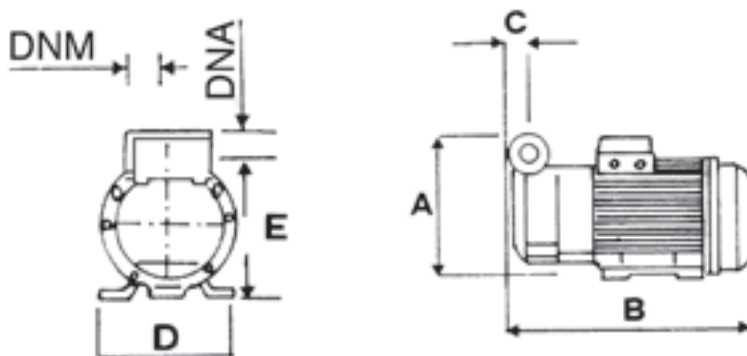

### OVERALL DIMENSIONS AND WEIGHTS

MODEL	Dimensions in mm.							WEIGHT (Kg)
	A	B	C	D	E	DNA	DNM	
PGA 40 - 30	141	255	20	120	119	3/4"	3/4"	6,2
PGA 60 - 40	148	260	24	120	123	1"	1"	8
DELTA OIL	141	255	20	120	119	3/4"	3/4"	7

# SECTION 3

## PUMPS FOR OPEN AND DRILLED WELLS



**PRATIKA**  
MULTISTAGE SUBMERSIBLE PUMP

PAG. 158



**SCM 4 PLUS**  
4" MULTISTAGE CENTRIFUGAL  
SUBMERSED PUMPS

PAG. 170



**DOMINATOR 4 PLUS**  
MONOBLOC MULTISTAGE 4" SUBMERSED  
PUMPS

PAG. 160



**MOTORI 4"**  
ELECTRIC MOTORS FOR 4" SUBMERSED  
PUMPS

PAG. 178



**DOMINATOR 5**  
MONOBLOC MULTISTAGE 5" SUBMERSED  
PUMPS MADE OF STAINLESS STEEL AISI 304

PAG. 163



**CABLES AND FITTINGS**

PAG. 179



**DOMINATOR 5 RW**  
MULTISTAGE SUBMERSIBLE PUMP

PAG. 166



**VERSAILLES**  
ELECTRIC MOTORS FOR 4" SUBMERSED  
PUMPS

PAG. 180

## ACCESSORIES

PAG. 306

## PRATIKA

### MULTISTAGE CENTRIFUGAL SUBMERSIBLE PUMP FOR CLEAR WATER

Ø 32 mm elbow fitting hose supplied, Automatic version with float switch.

PRATIKA submersible pumps are ready to use and install in traditional wells, water deposits, collection tanks, fresh water courses, lakes etc.

#### APPLICATIONS

- Lifting of water from traditional wells.
- Installations in tanks inside homes for the pressurization of domestic systems for drinking water.
- Small automatic systems for garden irrigation.
- Surface irrigation.

#### USAGE DATA

- Type of liquid: clean water without suspended solids or abrasive material.
- Maximum temperature of the liquid 40°C.
- Maximum immersion under the water level 10m.

#### MOTOR

- Dry running.
- Degree of protection IP 68
- Insulation class F.
- Single-phase power supply with capacitor always on.
- Thermal protection built into the motor casing.
- Cable connection chamber completely insulated.
- Self-lubricating ball bearings.
- Speed of rotation 2850 rpm.
- Suitable for continuous use.



### TABLE OF MATERIALS

Component	Material
1 Pump body	Stainless steel X5 CrNi 1810 (AISI 304)
2 Air inlet grille	Stainless steel X5 CrNi 1810 (AISI 304)
3 Air inlet base	Stainless steel X5 CrNi 1810 (AISI 304)
4 Supply cable	15 m H07 RN-F with Schuko plug
5 Shaft (hydraulic part)	Stainless steel X5 CrNi 1810 (AISI 304) with ceramic bushing in the points of wear of the seals.
6 Mechanical seal	Graphite
6 Counterface	Ceramic
6 Lip seal	In rubber NBR 70
8 Impellers	Technopolymer
9 Diffusers	Technopolymer

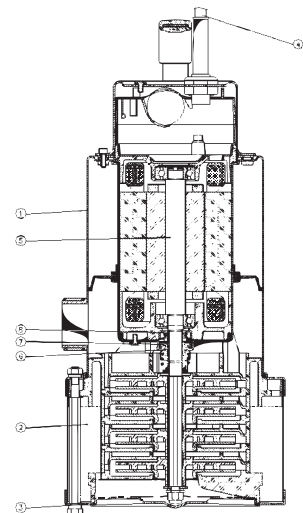



# PRATIKA

## MULTISTAGE CENTRIFUGAL SUBMERSIBLE PUMP FOR CLEAR WATER

### HYDRAULIC PERFORMANCE

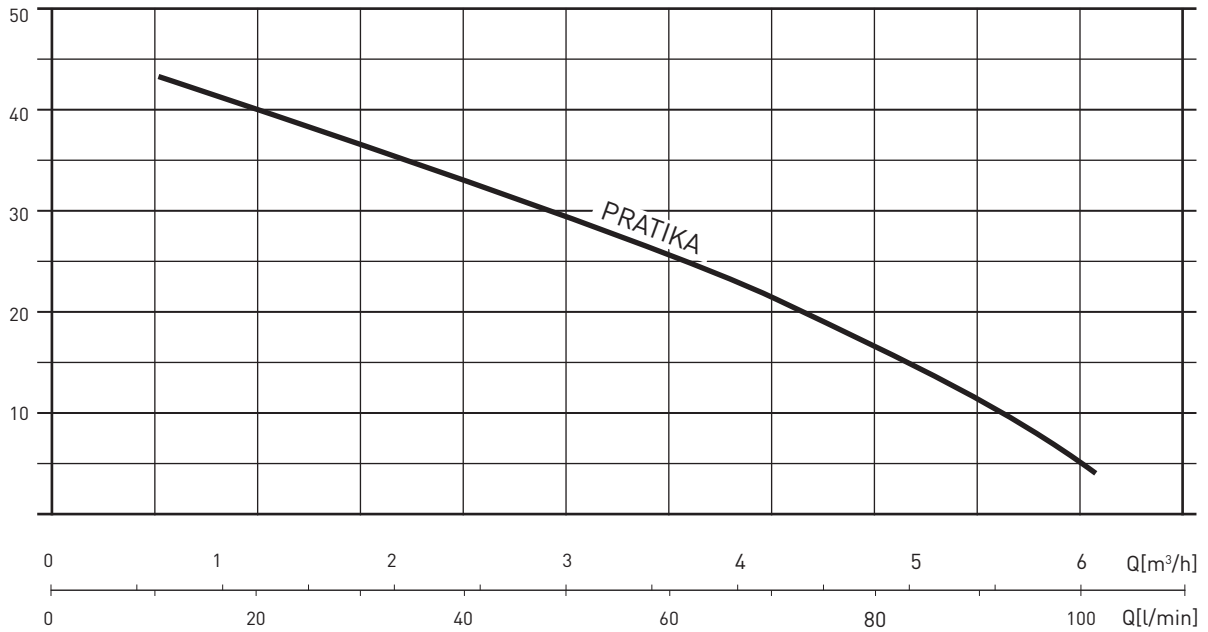

### PERFORMANCE TABLE

MODEL	Motor power (P2)		Motor power (P1)		VOLT. (V)	I <sub>n</sub> (A)	μF	Stadi	0	Q								
	HP	kW	HP	kW						l/min	0	20	40	60	80	100		
PRATIKA - MAN																		
PRATIKA - AUT	1,1	0,8	1,6	1,2	1 - 230	5	16	4	m.c.w.	46	39	31	23	12	3			

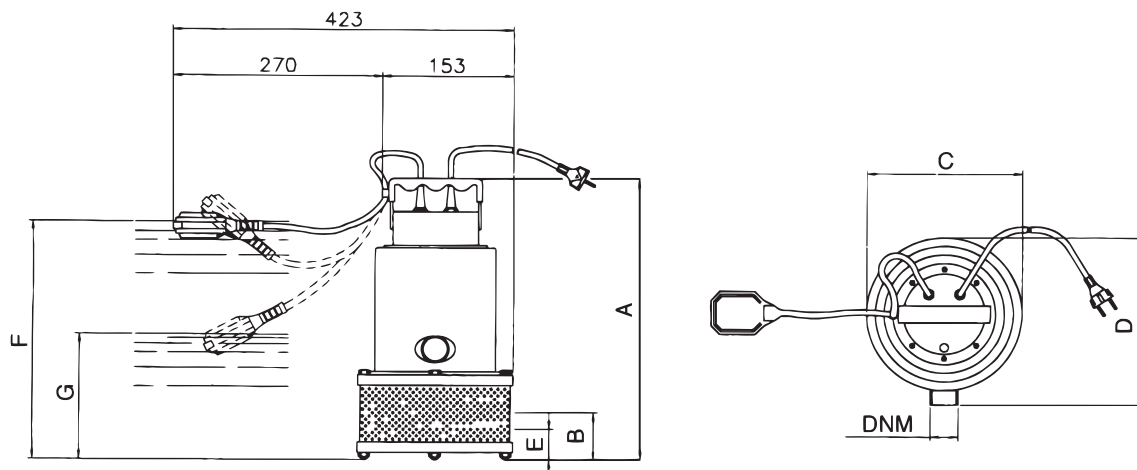

### OVERALL DIMENSIONS AND WEIGHTS

MODEL	Dimensions mm.									WEIGHT (Kg)
	A	B	Ø C	D	Minimum drying level E*	Start F*	Stop G*	Free passage	DNM	
PRATIKA	406	162	178	182	50/60	490	260	Ø1,5	1" 1/4	9



# DOMINATOR 4 PLUS

## MULTISTAGE CENTRIFUGAL SUBMERSIBLE PUMP FOR CLEAR WATER Ø 4"

Double mechanical seal, hydraulic system particularly resistant to the corrosive action of sand, integrated non-return valve

DOMINATOR 4 Plus submersible pumps with double mechanical seal are suitable for installations in traditional wells, water deposits, collection tanks, clear watercourses, lakes, etc. Nylon suspension rope (20m) included.

### APPLICATIONS

- Lifting of water from traditional wells.
- Installations in tanks inside homes for the pressurization of systems.
- Small automatic systems for garden irrigation.
- Surface irrigation.

### USAGE DATA

- Type of liquid: clean water without suspended solids or abrasive material.

- Maximum temperature of the liquid 40°C.
- Maximum immersion under the water level 17 m.

### MOTOR

- Dry motor with stainless steel body cooled by pumped liquid.
- Degree of protection IP 68
- Insulation class F.
- Single-phase power supply with capacitor always on.
- Thermal protection built into the motor casing.
- Cable connection chamber completely insulated.
- Self-lubricating ball bearings.
- Speed of rotation 2850 rpm.
- Suitable for continuous use.



## TABLE OF MATERIALS

Component	Material
1 Non-return valve	Thermoplastic with NBR o-ring integrated
2 Pump body	Stainless steel Europe: EN10088-1 X 5 CrNi 1810 (1.4301) Usa: AISI 304
3 Mechanical seal - oil chamber fixed part	Aluminium oxide / NBR
4 Mechanical seal - oil chamber rotating part	Stainless steel Europe: EN10088-1 X 5 CrNi 1810 (1.4301) Usa: AISI 304 / NBR / Resin-impregnated carbon graphite
5 Mechanical seal - fixed part	Aluminium oxide / NBR
6 Mechanical seal - rotating part	Stainless steel Europe: EN10088-1 X 2 CrNiMo 17-12-2 (1.4404) USA: AISI 316 / NBR / Carbon graphite
7 Motor shaft	Immersed part - Europe: EN10088-1 X 8 CrNiS 18-9 (1.4305) USA: AISI 303/ Motor side - carbon steel
8 Diffuser cap	Polycarbonate with stainless steel insert Europe: EN10088-1 X 5 CrNi 1810 Usa: AISI 304 (1.4301)
9 Diffuser	Polycarbonate with ceramic insert
10 Impeller	Acetal resin
11 Bushing	Stainless steel Europe: EN10088-1 X 8 CrNiS 18-9 (1.4305) USA: AISI 303 with ceramic coating
12 Bearing	Self-lubricating Nylatron®
13 Intake filter	Stainless steel Europe: EN10088-1 X 6 Cr 17 (1.4016) USA: AISI 430
14 Base	PPO - Noryl™ GFN 2
- Supply cable	Type H07 RN-F - length 20 m
-	Thrust ring in each stage

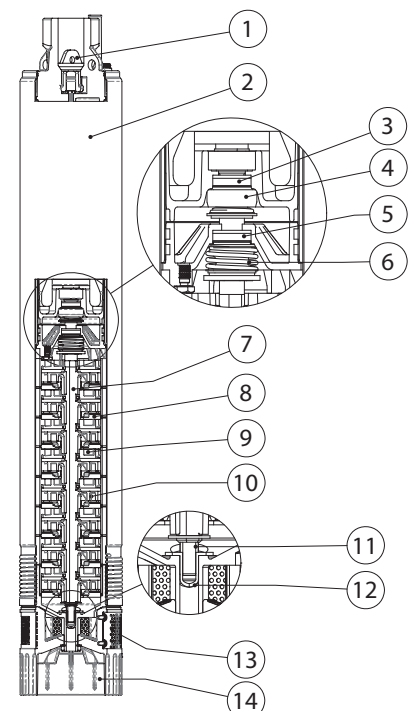

# DOMINATOR 4 PLUS

MULTISTAGE CENTRIFUGAL SUBMERSIBLE PUMP FOR CLEAR WATER Ø 4"

## HYDRAULIC PERFORMANCE

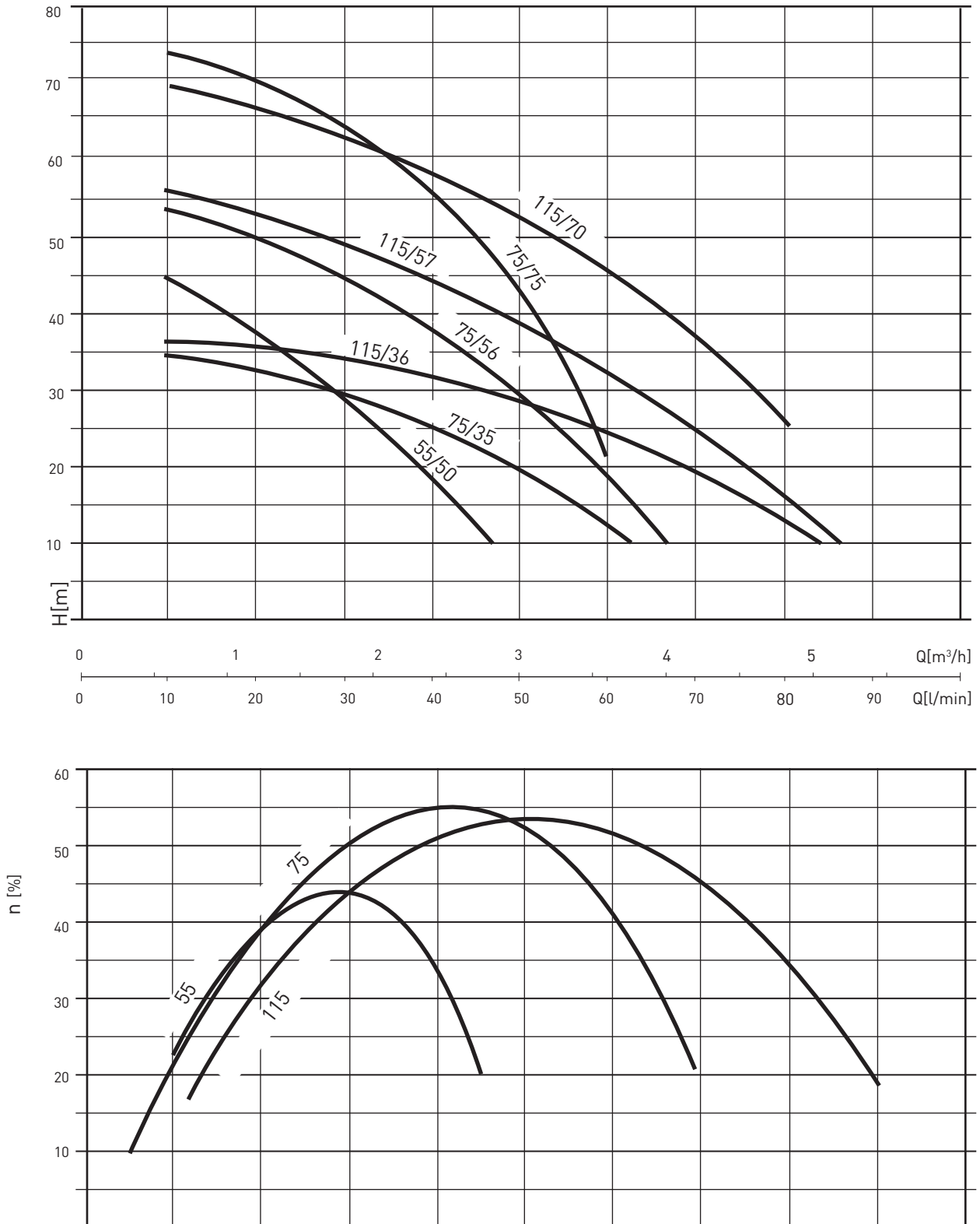

MEI  $\geq 0.4$  - Reference MEI  $\geq 0.70$  - The information on the reference efficiency is available at the address: [www.europump.org/efficiencycharts](http://www.europump.org/efficiencycharts)

# DOMINATOR 4 PLUS

## MULTISTAGE CENTRIFUGAL SUBMERSIBLE PUMP FOR CLEAR WATER Ø 4"

### PERFORMANCE TABLE

MODEL	Motor power (P2)		Motor power (P1)		VOLT. (V)	In (A)	µF	Stadi Stages	Ø	m.c.w.				
	HP	kW	HP	kW						l/min	0	20	40	60
										0	1,2	2,4	3,6	4,8
DOMINATOR 4 PLUS 55/50 M	0,75	0,56	1,1	0,8	1 ~ 230	3,8	16	6		50	38,7	17		
DOMINATOR 4 PLUS 75/35 M	0,50	0,35	0,80	0,60	1 ~ 230	3	12,5	5		35	33	26	11	
DOMINATOR 4 PLUS 75/56 M	0,80	0,60	1	0,75	1 ~ 230	3,3	16	8		56	48,9	38,1	19	
DOMINATOR 4 PLUS 75/75 M	0,95	0,7	1,5	1,1	1 ~ 230	5	20	11		75	70	53	21,6	
DOMINATOR 4 PLUS 115/36 M	0,55	0,40	1	0,75	1 ~ 230	3,5	12,5	5		36	35	32	25	13
DOMINATOR 4 PLUS 115/57 M	1	0,8	1,50	1,10	1 ~ 230	5	16	8		57	52	44,4	31,5	16,6
DOMINATOR 4 PLUS 115/70 M	1,1	0,8	1,8	1,3	1 ~ 230	6	20	10		70	65	59	45,4	27



### OVERALL DIMENSIONS AND WEIGHTS

MODEL	Dimensions mm.				WEIGHT (Kg)
	A	Ø C	Free passage	DNM	
DOMINATOR 4 PLUS 55/50 M	549	98	2 mm	1"1/4	10,4
DOMINATOR 4 PLUS 75/35 M	560	98	2 mm	1"1/4	10,2
DOMINATOR 4 PLUS 75/56 M	643	98	2 mm	1"1/4	10,8
DOMINATOR 4 PLUS 75/75 M	760	98	2 mm	1"1/4	12,5
DOMINATOR 4 PLUS 115/36 M	560	98	2 mm	1"1/4	10,2
DOMINATOR 4 PLUS 115/57 M	643	98	2 mm	1"1/4	10,8
DOMINATOR 4 PLUS 115/70 M	732	98	2 mm	1"1/4	12,5

# DOMINATOR 5"

## MULTISTAGE CENTRIFUGAL SUBMERSIBLE PUMP FOR CLEAR WATER

Completely in Stainless steel

DOMINATOR 5" submersible pumps are ready to use and install in traditional wells, water deposits, collection tanks, fresh water courses, lakes etc. Automatic version equipped with float switch.

### APPLICATIONS

- Lifting of water from traditional wells.
- Installations in tanks inside homes for the pressurization of domestic systems for drinking water.
- Small automatic systems for garden irrigation.
- Surface irrigation.

### USAGE DATA

- Type of liquid: clean water without suspended solids or abrasive material.
- Maximum temperature of the liquid 40°C.
- Maximum immersion under the water level 17 m.

### MOTOR

- Dry motor with stainless steel body cooled by pumped liquid.
- Degree of protection IP 68
- Insulation class F.
- Single-phase power supply with capacitor always on.
- Thermal protection built into the motor casing.
- Cable connection chamber completely insulated.
- Self-lubricating ball bearings.
- Speed of rotation 2850 rpm.
- Suitable for continuous use.



## TABLE OF MATERIALS

Component		Material
1	Pump body	Stainless steel X5 CrNi 1810 (AISI 304)
2	Air inlet grille	Stainless steel X5 CrNi 1810 (AISI 304)
3	Impellers	Stainless steel X5 CrNi 1810 (AISI 304)
4	Diffusers	Stainless steel X5 CrNi 1810 (AISI 304)
5	Spacer	Stainless steel X5 CrNi 1810 (AISI 304)
6	Motor shaft	Stainless steel X5 CrNi 1810 (AISI 304)
7	Supply cable	20 m H07 RN-F with plug
8	Mechanical seal	Graphite
9	Counterface	Aluminium oxide

Lubricated in oil chamber

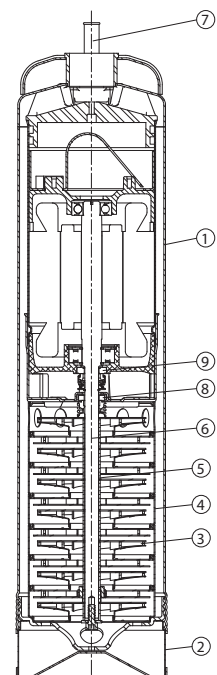

# DOMINATOR 5"

## MULTISTAGE CENTRIFUGAL SUBMERSIBLE PUMP FOR CLEAR WATER

### HYDRAULIC PERFORMANCE

---

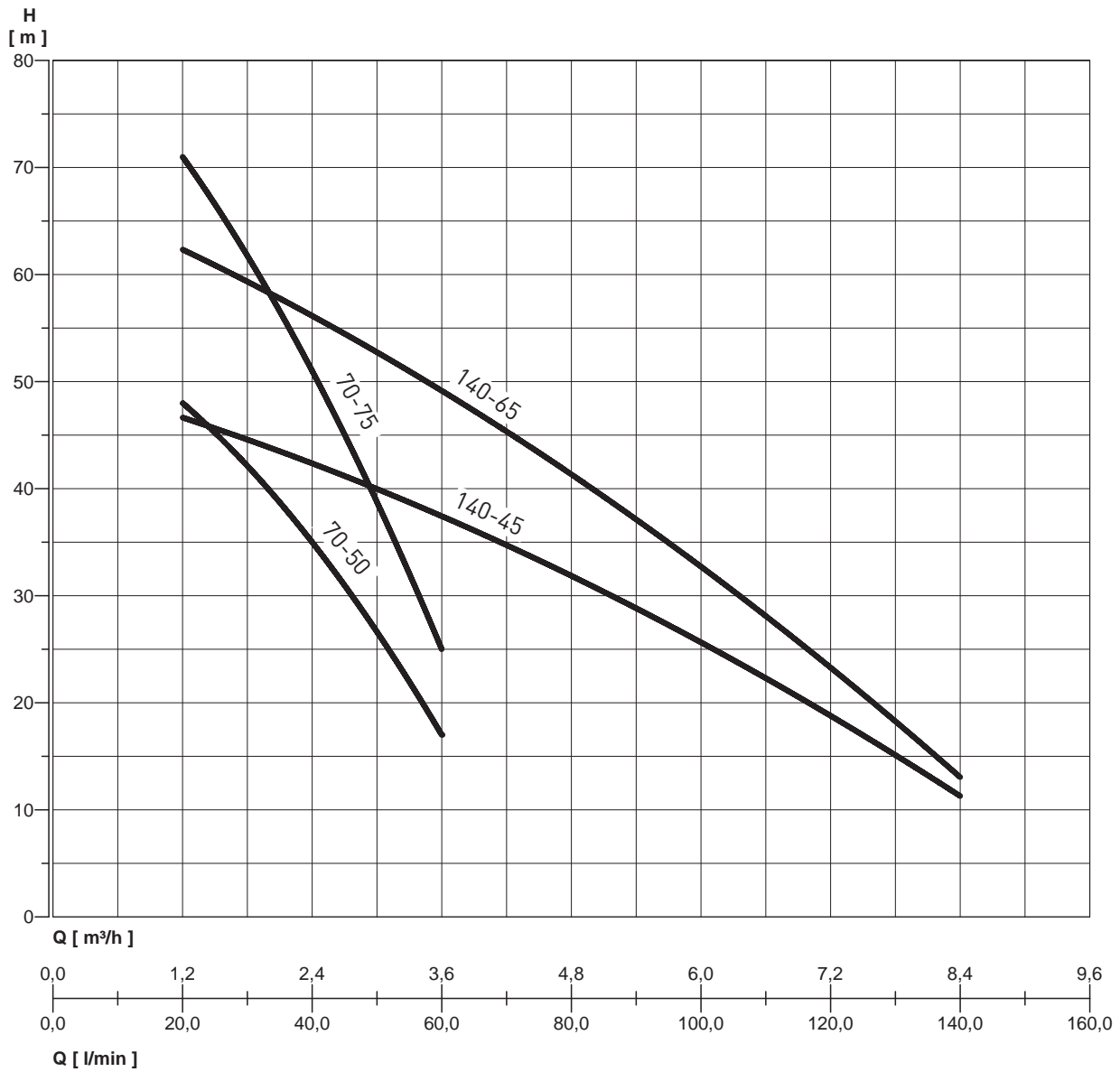

# DOMINATOR 5"

## MULTISTAGE CENTRIFUGAL SUBMERSIBLE PUMP FOR CLEAR WATER

### PERFORMANCE TABLE

MODEL	Motor power (P2)		Motor power (P1)		VOLT. (V)	In (A)	µF	Stges	0	m.c.w.								
	HP	kW	HP	kW						l/min	0	20	40	60	80	100	120	140
										m <sup>3</sup> /h	0	1,2	2,4	3,6	4,8	6	7,2	8,4
DOMINATOR 5" 70/50B M					1 - 230	4	16											
DOMINATOR 5" 70/50B MAUT					1 - 230	4	16											
DOMINATOR 5" 70/50B T	0,8	0,6	1,2	0,9	3 - 400	1,8	-	6		55	48	35	17					
DOMINATOR 5" 70/50B T					3 - 230	3	-											
DOMINATOR 5" 70/75B M					1 - 230	6	20											
DOMINATOR 5" 70/75B MAUT					1 - 230	6	20											
DOMINATOR 5" 70/75B T	1,2	0,9	1,7	1,3	3 - 400	2,1	-	9		78	71	51	25					
DOMINATOR 5" 70/75B T					3 - 230	3,7	-											
DOMINATOR 5" 140/45B M					1 - 230	5,5	16											
DOMINATOR 5" 140/45B MAUT					1 - 230	5,5	16											
DOMINATOR 5" 140/45B T	1,1	0,8	1,6	1,2	3 - 400	2,2	-	5		50	47	42	37	32	26	19	11	
DOMINATOR 5" 140/45B T					3 - 230	3,8	-											
DOMINATOR 5" 140/65B M					1 - 230	7,2	20											
DOMINATOR 5" 140/65B MAUT					1 - 230	7,2	20											
DOMINATOR 5" 140/65B T	1,5	1,1	2,1	1,6	3 - 400	2,5	-	7		68	63	55	49	42	33	23	13	
DOMINATOR 5" 140/65B T					3 - 230	4,4	-											

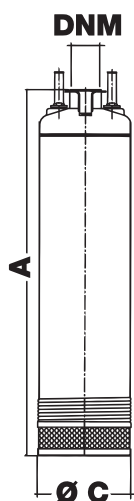

### OVERALL DIMENSIONS AND WEIGHTS

MODEL	Dimensions mm.				WEIGHT (Kg)
	A	D C	Free passage	DNM	
D 5" - 70/50	475	132	2 mm	1"1/4	13.7
D 5" - 70/75	530	132	2 mm	1"1/4	15.5
D 5" - 140/45	495	132	2 mm	1"1/4	14.2
D 5" - 140/65	550	132	2 mm	1"1/4	15.8

## DOMINATOR 5 RW Pack MULTISTAGE SUBMERSIBLE PUMP

100% Stainless steel

DOMINATOR 5 RW Pack is a system consisting of a multi-stage submersible centrifugal pump complete with an on/off device, intake tube, floating filter and 20 m of nylon rope.

Ready to use for applications using rain water.

### USAGE DATA

- Type of liquid: clean water without suspended solids or abrasive material
- Maximum temperature of the liquid 40°C
- Maximum immersion under the water level 17 m.

### MOTOR

- Dry motor with body in stainless steel cooled by the pumped liquid.
- Degree of protection IP 68
- Insulation class F
- Single-phase power supply with capacitor always on.
- Thermal protection built into the motor casing.
- Cable connection chamber completely insulated.
- Self-lubricating ball bearings.
- Speed of rotation 2850 rpm.
- Suitable for continuous use.

### APPLICATIONS

- Lifting of water from wells and rainwater collection tanks
- Small automatic systems for garden irrigation
- Rainwater recovery systems
- Surface irrigation





# DOMINATOR 5 RW Pack

## MULTISTAGE SUBMERSIBLE PUMP

### CONSTRUCTION FEATURES

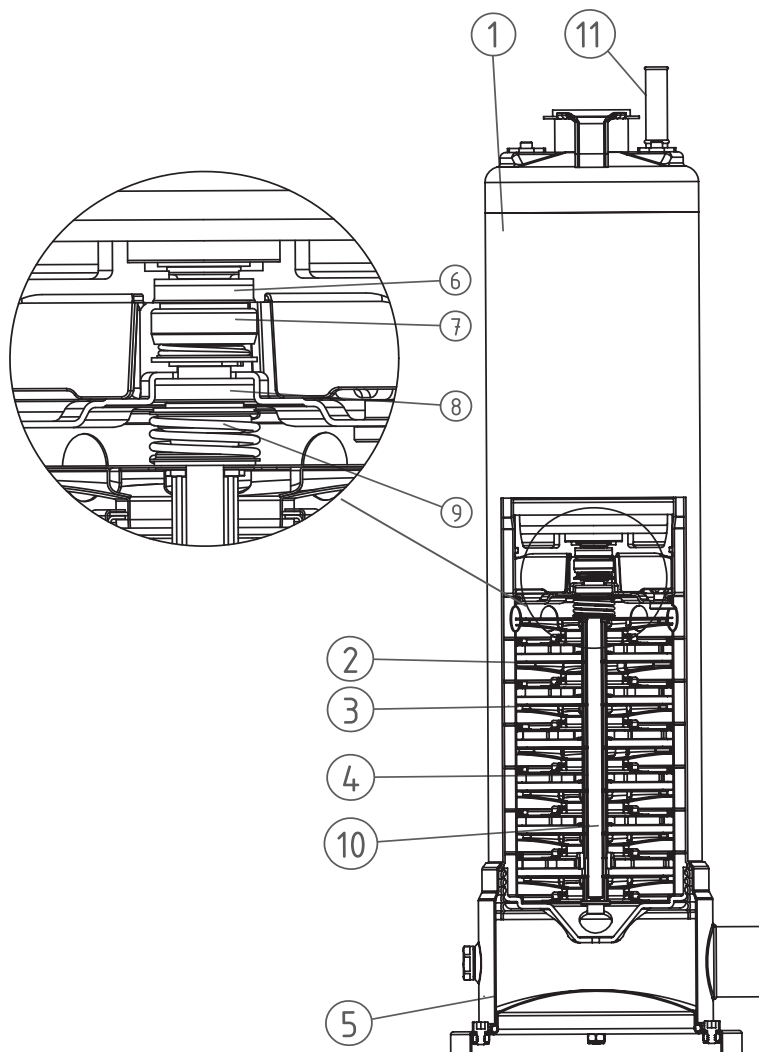

### TABLE OF MATERIALS

Component	Material
1 Pump body	Stainless steel Europe: EN 10088-1 X5CrNi18-10 (1.4301) - USA: AISI 304
2 Impellers	Stainless steel Europe: EN 10088-1 X5CrNi18-10 (1.4301) - USA: AISI 304
3 Diffusers	Stainless steel Europe: EN 10088-1 X5CrNi18-10 (1.4301) - USA: AISI 304
4 Spacer	Stainless steel Europe: EN 10088-1 X5CrNi18-10 (1.4301) - USA: AISI 304
5 Base	Stainless steel Europe: EN 10088-1 X5CrNi18-10 (1.4301) - USA: AISI 304
6 Mechanical seal oil chamber - fixed part	Aluminium oxide / NBR
7 Mechanical seal - rotary part oil chamber	Stainless steel Europe: EN 10088-1 X5CrNi18-10 (1.4301) - USA: AISI 304 / NBR / Resin-impregnated graphite
8 Mechanical seal - fixed part	Aluminium oxide / NBR
9 Mechanical seal - rotating part	Stainless steel Europe: EN 10088-1 X2CrNiMo17-12-2 (1.4404) - USA: AISI 316L / NBR / Graphite
10 Motor shaft	Part in contact with the liquid - Stainless steel Europe: EN 10088-1 X5CrNi18-10 (1.4301)/ USA: AISI 304 Motor side - Graphite
11 Supply cable	Type H07 RN-F - Length 20 m

# DOMINATOR 5 RW Pack

## MULTISTAGE SUBMERSIBLE PUMP

### HYDRAULIC PERFORMANCE

---

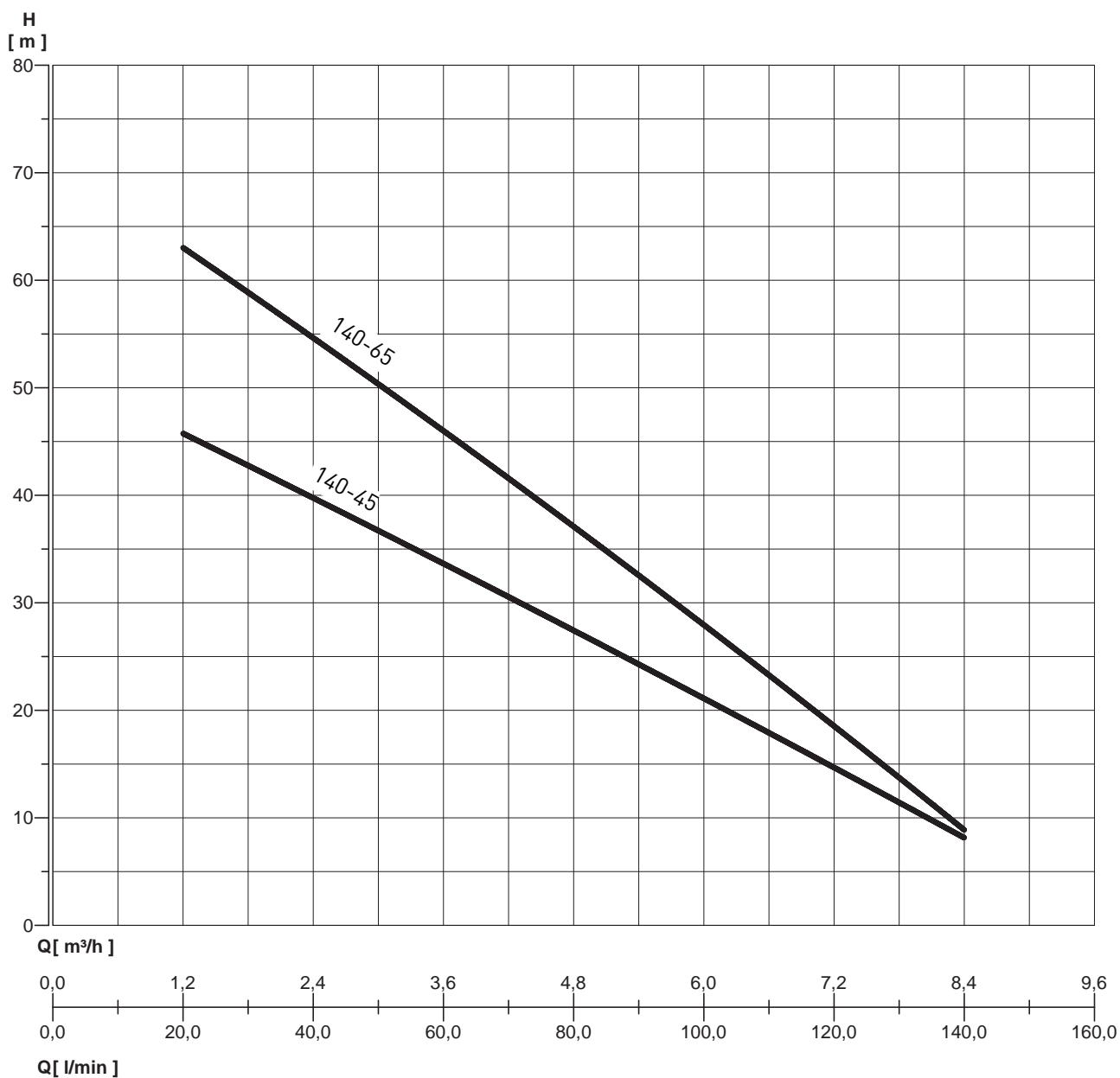

# DOMINATOR 5 RW Pack

## MULTISTAGE SUBMERSIBLE PUMP

### PERFORMANCE TABLE

MODEL	Motor power (P2)		Motor power (P1)		VOLT. (V)	In (A)	µF	Stadi	Ø	m.c.w.							
	HP	kW	HP	kW						l/min	20	40	60	80	100	120	140
										m³/h	1,2	2,4	3,6	4,8	6	7,2	8,4
DOMINATOR 5 140/45B M RW Pack	1,2	0,9	1,8	1,3	1~230	6	16	5		47	38	33	28	22	15	7,5	
DOMINATOR 5 140/65B M RW Pack	1,6	1,2	2,2	1,7	1~230	7,7	20	7		63	55	45	38	28	19	9	

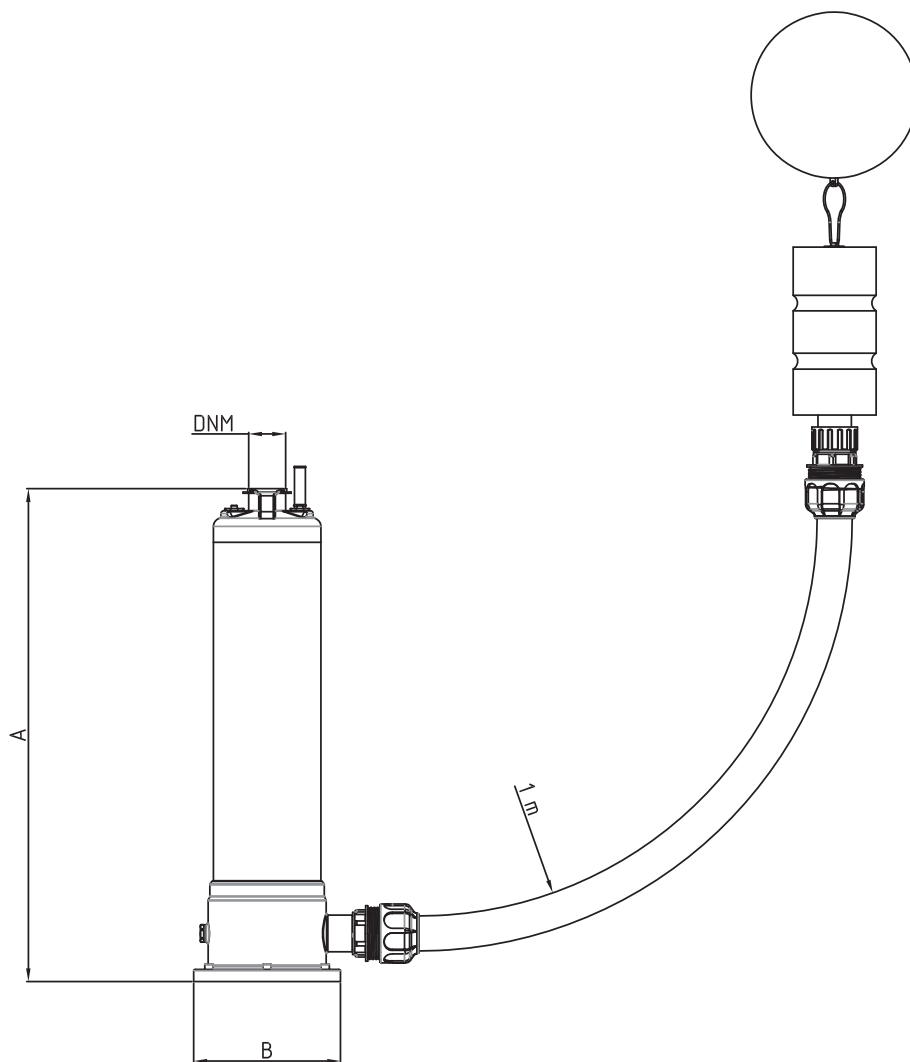

### OVERALL DIMENSIONS AND WEIGHTS

MODEL	Dimensions (mm)				WEIGHT (kg)
	A	Ø B	DNM	Passaggio libero	
DOMINATOR 5 140/45B M RW Pack	540	176,5	1"1/4 femmina	2	20,4
DOMINATOR 5 140/65B M RW Pack	594	176,5	1"1/4 femmina	2	22



## SCM 4 PLUS

### 4" MULTISTAGE CENTRIFUGAL SUBMERSED PUMPS COMPLETE WITH MOTOR

Maximum rigidity and resistance to water hammer, strong resistance to the abrasive action of sand, excellent hydraulic efficiency

SCM 4 PLUS submersible pumps consist of a multi-stage pumping unit directly coupled to a submersed motor. Particularly suitable for lifting from deep wells with  $\varnothing$  4" (100 mm).

#### APPLICATIONS

- Lifting of water from boreholes.
- Automatic systems for garden irrigation.
- Irrigation for agricultural use.
- Aqueducts for drinking water.
- Lifting and supply of tanks and pressurization autoclaves, for civil and industrial systems.

#### USAGE DATA

- Type of liquid: clean, non-aggressive, non-explosive, free of solid particles.
- Maximum temperature of the liquid 35°C.
- Max. start-ups per hour: 30.
- Motor protection with thermal relay provided by the user.

#### MOTOR

- Submersed 4" motor.
- Special resin impregnated sealed stator.
- Thrust bearings and bushings cooled with water.
- Extractable power cable about 1.75 m in length.
- Cooling in non-polluting water.
- Flange NEMA 4"
- Degree of protection IP 68
- Insulation class B.
- Speed of rotation 2850 rpm.
- Special mechanical gasket with sand-proof protection.



## TABLE OF MATERIALS

Component	Material
1 Outlet	Stainless steel X5 CrNi1810 (AISI 304) casting
2 Intake flange	Stainless steel X5 CrNi1810 (AISI 304) casting
3 Pump body	Stainless steel X5 CrNi 1810 (AISI 304)
4 Non-return valve	Stainless steel X5 CrNi 1810 (AISI 304)
5 Cable protection conduit	Stainless steel X5 CrNi 1810 (Aisi 304)
6 Filter	Stainless steel X5 CrNi 1810 (Aisi 304)
7 Impellers	Acetal resin
8 Diffuser	Polycarbonate with ceramic insert at point of wear
9 Diffuser cap	Polycarbonate with ceramic insert at point of wear
10 Motor shaft	Hexagonal in stainless steel X10 CrNiS1809 (AISI 303) with ceramic insert at point of wear
11 Self-lubricating supply bearing	Polyamide molybdenum disulfide
-	Thrust ring in each stage

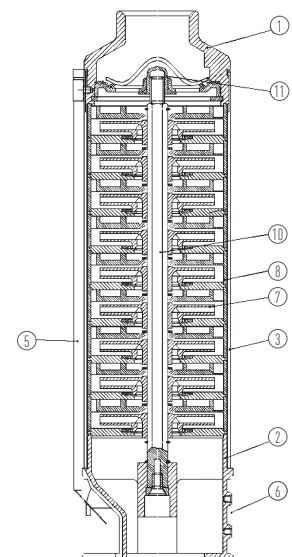

# SCM 4 PLUS

## 4" MULTISTAGE CENTRIFUGAL SUBMERSED PUMPS COMPLETE WITH MOTOR



Outlet made of stainless steel AISI 304 casting with a double inner conical profile with a stainless steel non-return valve and a double slot for a safety cable.

### ADVANTAGES:

It eliminates the load losses offering maximum rigidity and great resistance to water hammers, thus protecting the pump.

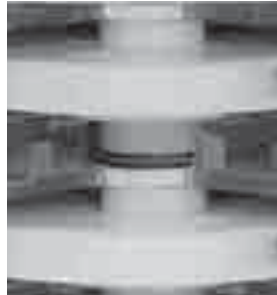

Floating impeller with stainless steel inlet moulded with a diffuser cover. Thrust bearing inserted between the hub of the impeller and the diffuser consisting of 1 ceramic ring moulded with the diffuser and a free graphite ring. "International Patent"

### ADVANTAGES:

This extraordinary technological innovation determines a great increase of the yield as well as high resistance to the abrasive action of sand and to dry running.



Shaft guide bearing made with a self-lubricating closed bushing in polyamide molybdenum disulfide and shaft in stainless steel with ceramic insert at the point of wear.

### ADVANTAGES:

It increases the life of the pump - protection against dry running - great resistance to sand.



Motor support and inlet made of stainless steel AISI 304 casting rigidly welded to the external sleeve made of stainless steel. Stainless steel intake grille

### ADVANTAGES:

It eliminates the load losses offering maximum rigidity and great resistance to water hammers, thus protecting the pump.



# SCM 4 PLUS

## 4" MULTISTAGE CENTRIFUGAL SUBMERSED PUMPS COMPLETE WITH MOTOR

TABLE TO CALCULATE THE LENGTH OF THE PUMPS

MODEL	A Total length mm	B Total length mm	C Total length mm	DNM	L Package length mm	Total weight (kg)
SCM 4 PLUS 40/57 M	584	250	334		610	11.8
SCM 4 PLUS 40/57 T	569	235	334		610	10.8
SCM 4 PLUS 40/90 M	711	265	446		800	14
SCM 4 PLUS 40/90 T	696	250	446		800	12.7
SCM 4 PLUS 40/120 M	853	295	558		960	16.1
SCM 4 PLUS 40/120 T	823	265	558		960	14.9
SCM 4 PLUS 40/185 M	1122	340	782		1330	19.2
SCM 4 PLUS 40/185 T	1077	295	782		1120	17.9
SCM 4 PLUS 40/240 M	1358	375	983		1580	22.2
SCM 4 PLUS 40/240 T	1323	340	983		1330	20.8
SCM 4 PLUS 55/50 M	517	250	267		610	11.3
SCM 4 PLUS 55/50 T	502	235	267		610	10.3
SCM 4 PLUS 55/80 M	622	265	357		800	13.1
SCM 4 PLUS 55/80 T	607	250	357		800	11.8
SCM 4 PLUS 55/105 M	696	295	401		800	14.9
SCM 4 PLUS 55/105 T	666	265	401		800	13.7
SCM 4 PLUS 55/160 M	875	340	535		960	17.3
SCM 4 PLUS 55/160 T	830	295	535		960	16
SCM 4 PLUS 55/200 M	1045	375	670		1120	19.8
SCM 4 PLUS 55/200 T	1010	340	670		1120	18.4
SCM 4 PLUS 55/300 T	1336	375	961		1580	22.3
SCM 4 PLUS 75/40 M	553	250	303	1 1/4	610	11.2
SCM 4 PLUS 75/40 T	538	235	303		610	10.2
SCM 4 PLUS 75/56 M	625	265	360		800	12.9
SCM 4 PLUS 75/56 T	610	250	360		800	11.6
SCM 4 PLUS 75/75 M	740	295	445		800	14.8
SCM 4 PLUS 75/75 T	710	265	445		800	13.6
SCM 4 PLUS 75/110 M	928	340	588		960	17.1
SCM 4 PLUS 75/110 T	883	295	588		960	15.8
SCM 4 PLUS 75/140 M	1077	375	702		1120	19.4
SCM 4 PLUS 75/140 T	1042	340	702		1120	18
SCM 4 PLUS 75/210 T	1391	375	1016		1580	21.5
SCM 4 PLUS 115/30 M	496	250	246		610	11
SCM 4 PLUS 115/30 T	481	235	246		610	10
SCM 4 PLUS 115/50 M	596	265	331		610	12.8
SCM 4 PLUS 115/50 T	581	250	331		610	11.5
SCM 4 PLUS 115/65 M	683	295	388		800	14.4
SCM 4 PLUS 115/65 T	653	265	388		800	13.2
SCM 4 PLUS 115/95 M	842	340	502		960	16.6
SCM 4 PLUS 115/95 T	797	295	502		960	15.3
SCM 4 PLUS 115/122 M	992	375	617		1120	18.8
SCM 4 PLUS 115/122 T	957	340	617		960	17.4
SCM 4 PLUS 115/185 T	1221	375	846		1330	20.8
SCM 4 PLUS 115/245 T	1582	480	1102		1870	25
SCM 4 PLUS 150/42 M	648	295	353		800	14
SCM 4 PLUS 150/42 T	618	265	353		800	12.8
SCM 4 PLUS 150/64 M	803	340	463		960	16.1
SCM 4 PLUS 150/64 T	758	295	463		800	14.8
SCM 4 PLUS 150/84 M	948	375	573		960	18.3
SCM 4 PLUS 150/84 T	913	340	573	2"	960	16.9
SCM 4 PLUS 150/120 T	1161	375	786		1330	20.1
SCM 4 PLUS 150/170 T	1523	480	1043		1580	24.2
SCM 4 PLUS 150/200 T	1781	555	1226		1870	33.1
SCM 4 PLUS 150/300 T	2378	675	1703		2590	42.3

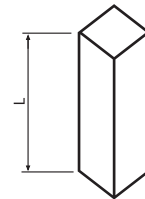
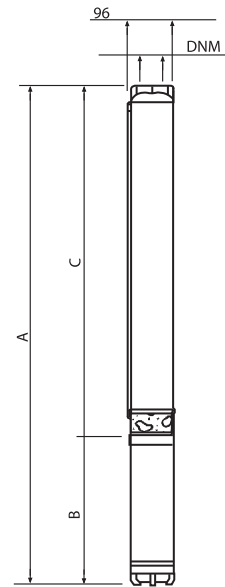

# SCM 4 PLUS

## 4" MULTISTAGE CENTRIFUGAL SUBMERSED PUMPS COMPLETE WITH MOTOR

### HYDRAULIC PERFORMANCE

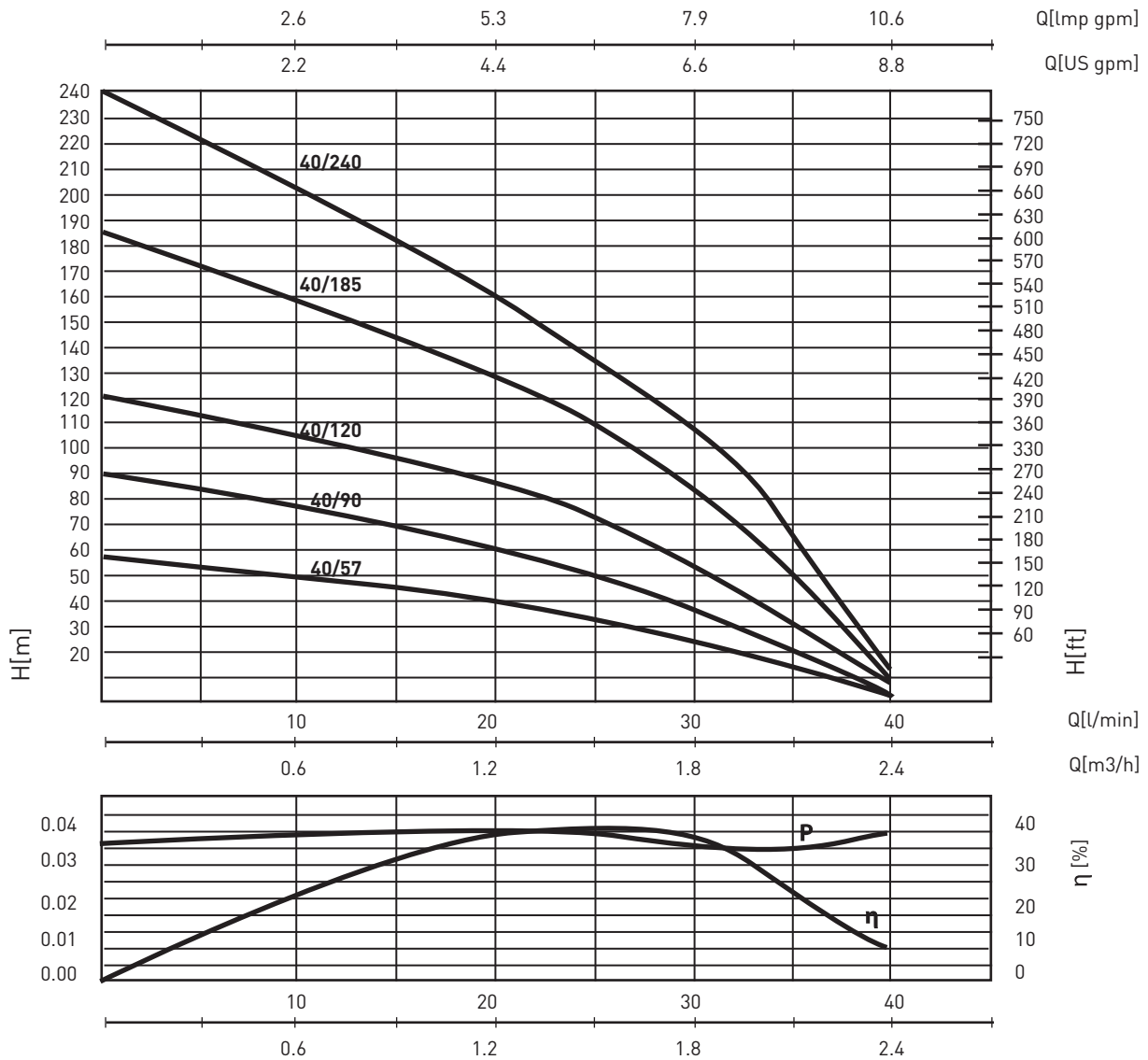

The power curve refers to the shaft power per stage,  $\eta_p$  % indicates the hydraulic yield of the pump

MEI  $\geq$  0.4 - Reference MEI  $\geq$  0.70 - The information on the reference efficiency is available at the address: [www.europump.org/efficiencycharts](http://www.europump.org/efficiencycharts)

### PERFORMANCE TABLE

MODEL	N° Stages	Motor power (P2)		VOLT. (V)	In (A)	$\mu$ F	0	l/min	10	20	30	40	$\sigma$ DNM
		HP	kW										
SCM 4 PLUS-40/57 M SCM 4 PLUS-40/57 T	9	0.5	0.37	1 ~ 230 3 ~ 400	3.4 1.2	16	m.c.a. / m.c.w.	49	41	26	3	1 1/4	
SCM 4 PLUS-40/90 M SCM 4 PLUS-40/90 T	14	0.75	0.55	1 ~ 230 3 ~ 400	4.4 1.7	20		76	64	40	4		
SCM 4 PLUS-40/120 M SCM 4 PLUS-40/120 T	19	1	0.75	1 ~ 230 3 ~ 400	5.9 2.2	30		104	86	55	7		
SCM 4 PLUS-40/185 M SCM 4 PLUS-40/185 T	29	1.5	1.1	1 ~ 230 3 ~ 400	7.8 3	40		158	130	85	10		
SCM 4 PLUS-40/240 M SCM 4 PLUS-40/240 T	38	2	1.5	1 ~ 230 3 ~ 400	10.2 4	50		205	160	110	12		

# SCM 4 PLUS 55

## 4" MULTISTAGE CENTRIFUGAL SUBMERSED PUMPS COMPLETE WITH MOTOR

### HYDRAULIC PERFORMANCE

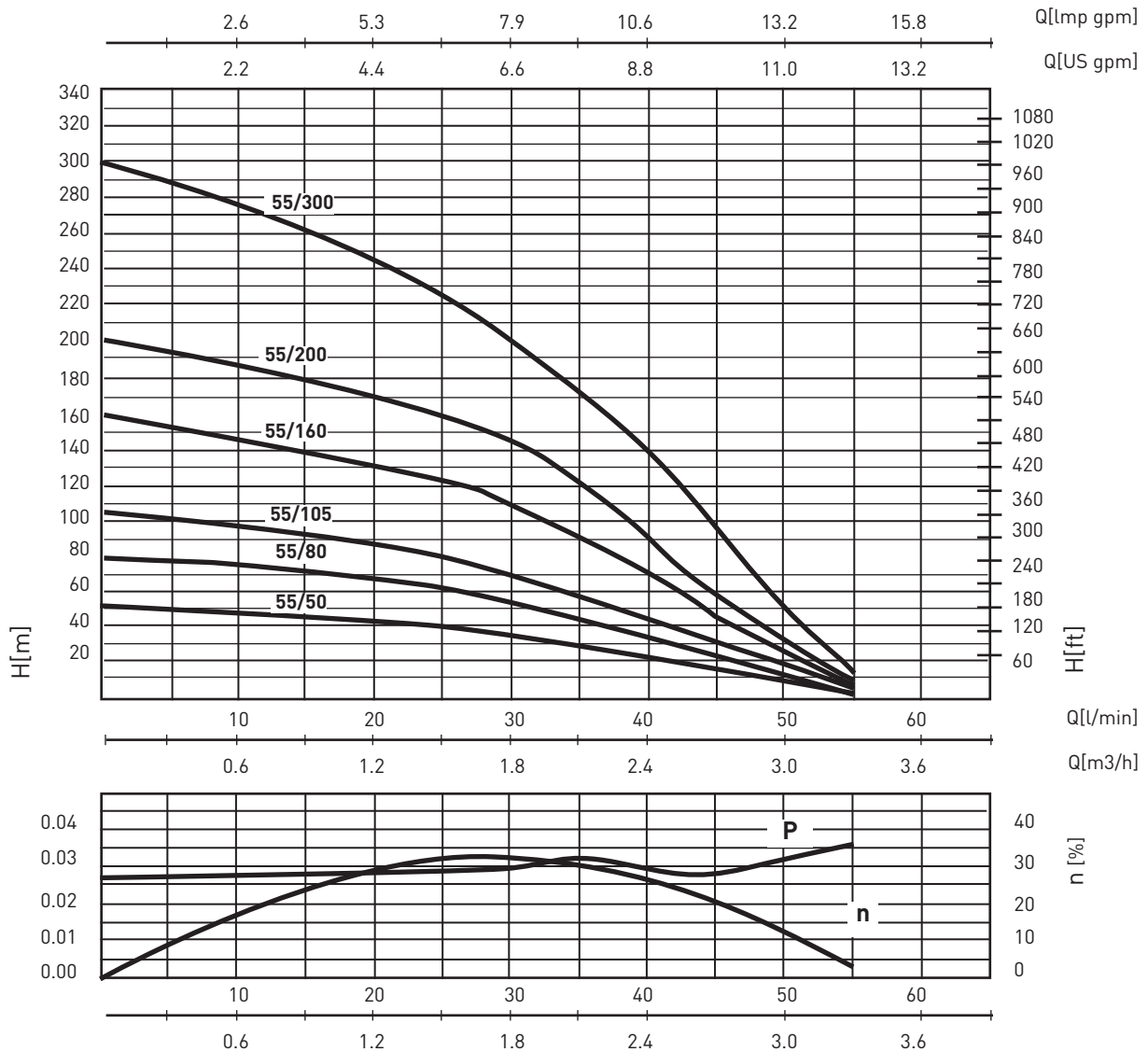

The power curve refers to the shaft power per stage.  $\eta_p$  % indicates the hydraulic yield of the pump

MEI  $\geq$  0.4 - Reference MEI  $\geq$  0.70 - The information on the reference efficiency is available at the address: [www.europump.org/efficiencycharts](http://www.europump.org/efficiencycharts)

### PERFORMANCE TABLE

MODEL	N° Stages	Motor power (P2)		VOLT. (V)	I <sub>n</sub> (A)	μF.	0	Q					Ø DN <sub>M</sub>		
		HP	kW					l/min	10	20	30	40		50	
								m³/h	0.6	1.2	1.8	2.4	3		
SCM 4 PLUS-55/50 M	6	0.5	0.37	1 ~ 230	3.4	16			47	42	36	23	8	1"1/4	
SCM 4 PLUS-55/50 T									3 ~ 400	1.2					
SCM 4 PLUS-55/80 M	10	0.75	0.55	1 ~ 230	4.4	20			75	66	55	35	12		
SCM 4 PLUS-55/80 T									3 ~ 400	1.7					
SCM 4 PLUS-55/105 M	12	1	0.75	1 ~ 230	5.9	30			98	87	72	46	12		
SCM 4 PLUS-55/105 T									3 ~ 400	2.2					
SCM 4 PLUS-55/160 M	18	1.5	1.1	1 ~ 230	7.8	40			145	132	110	70	24		
SCM 4 PLUS-55/160 T									3 ~ 400	3					
SCM 4 PLUS-55/200 M	24	2	1.5	1 ~ 230	10.2	50			187	169	145	90	30		
SCM 4 PLUS-55/200 T									3 ~ 400	4					
SCM 4 PLUS-55/300 T	37	3	2.2	3 ~ 400	5.6				278	244	200	140	50		



# SCM 4 PLUS 75

## 4" MULTISTAGE CENTRIFUGAL SUBMERSED PUMPS COMPLETE WITH MOTOR

### HYDRAULIC PERFORMANCE

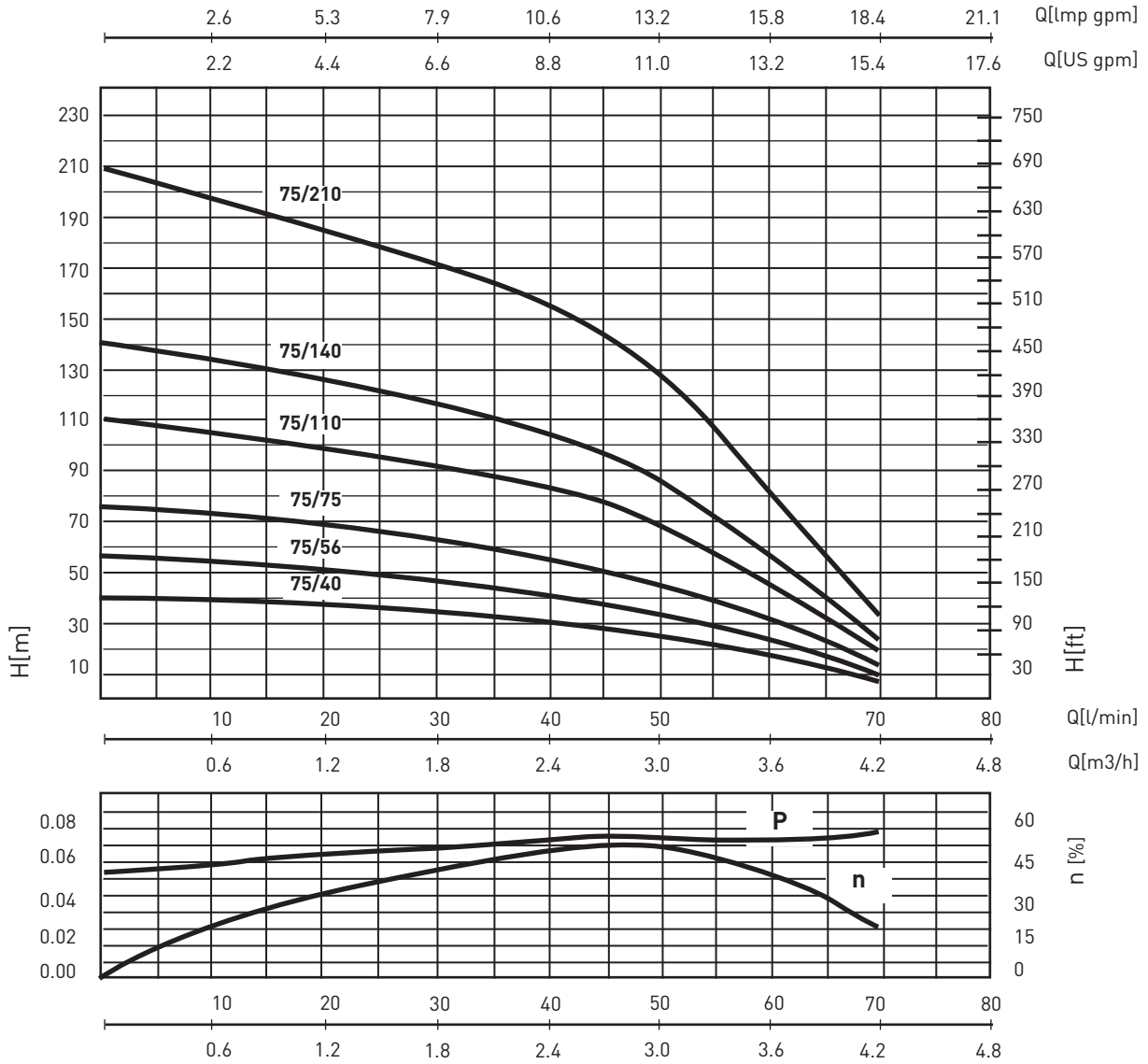

The power curve refers to the shaft power per stage.  $\eta_p$  % indicates the hydraulic yield of the pump

MEI  $\geq$  0.4 - Reference MEI  $\geq$  0.70 - The information on the reference efficiency is available at the address: [www.europump.org/efficiencycharts](http://www.europump.org/efficiencycharts)

### PERFORMANCE TABLE

MODEL	N° Stages	Motor power (P2)		VOLT. (V)	I <sub>n</sub> (A)	μF.	Q	l/min					Ø DN <sub>M</sub>
		HP	kW					20	30	40	50	60	
								m³/h					
								1.2	1.8	2.4	3	3.6	
SCM 4 PLUS-75/40 M	6	0.5	0.37	1 - 230	3.4	16	m.c.a. / m.c.w.	36	33	28	23	15	1"1/4
SCM 4 PLUS-75/40 T				3 - 400	1.2								
SCM 4 PLUS-75/56 M	8	0.75	0.55	1 - 230	4.4	20		50	45	40	32	21	
SCM 4 PLUS-75/56 T				3 - 400	1.7								
SCM 4 PLUS-75/75 M	11	1	0.75	1 - 230	5.9	30		67	62	55	45	30	
SCM 4 PLUS-75/75 T				3 - 400	2.2								
SCM 4 PLUS-75/75 T				3 - 230	3.8								
SCM 4 PLUS-75/110 M	16	1.5	1.1	1 - 230	7.8	40		100	92	82	68	44	
SCM 4 PLUS-75/110 T				3 - 400	3								
SCM 4 PLUS-75/140 M	20	2	1.5	1 - 230	10.2	50		127	116	105	86	57	
SCM 4 PLUS-75/140 T				3 - 400	4								
SCM 4 PLUS-75/210 T	30	3	2.2	3 - 400	5.6			186	170	155	130	80	

# SCM 4 PLUS 115

## 4" MULTISTAGE CENTRIFUGAL SUBMERSED PUMPS COMPLETE WITH MOTOR

### HYDRAULIC PERFORMANCE

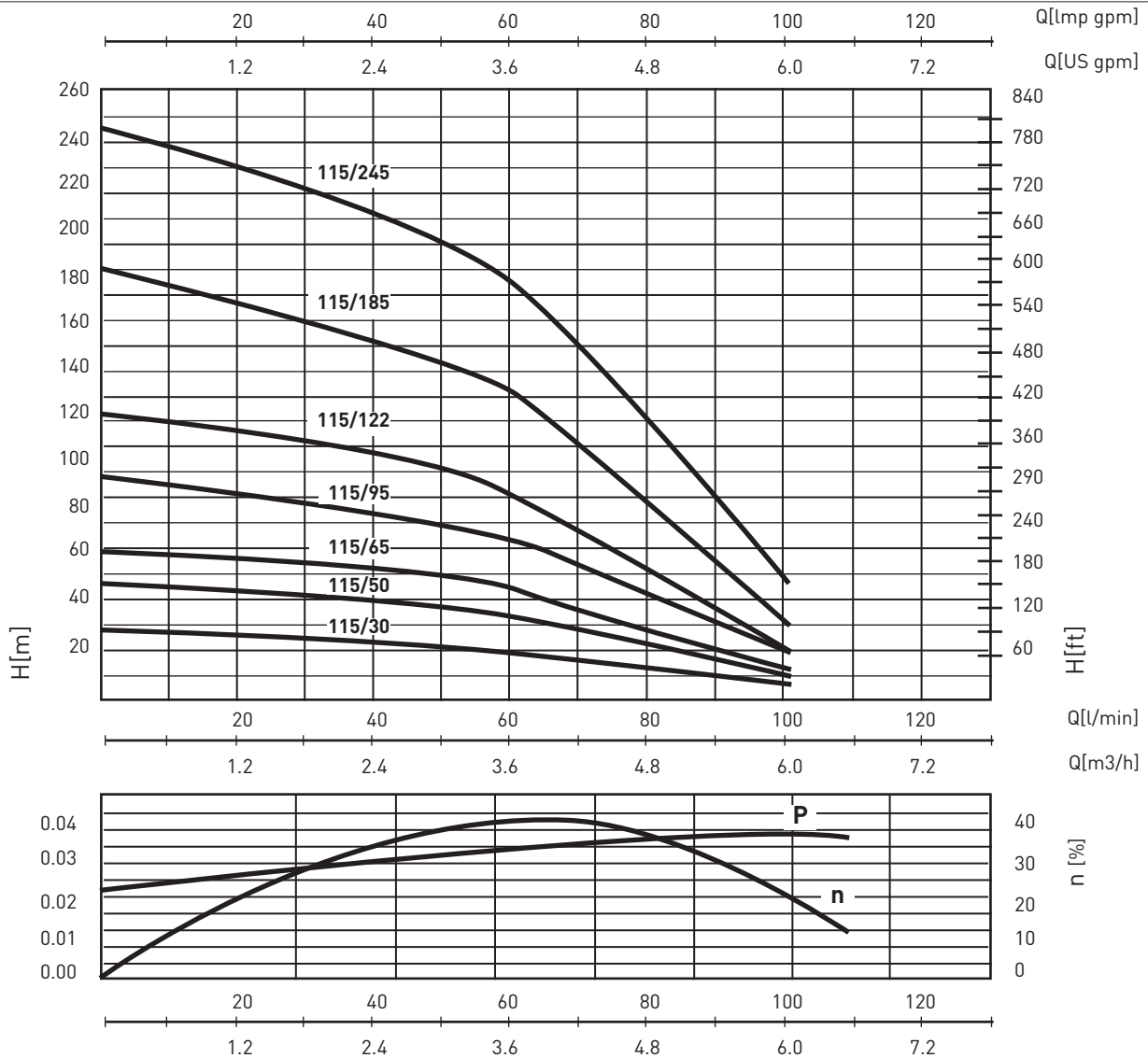

The power curve refers to the shaft power per stage  $n_p$  % indicates the hydraulic yield of the pump  
 MEI  $\geq 0.4$  - Reference MEI  $\geq 0.70$  - The information on the reference efficiency is available at the address: [www.europump.org/efficiencycharts](http://www.europump.org/efficiencycharts)

### PERFORMANCE TABLE

MODEL	N° Stages	Motor power (P2)		VOLT. (V)	In (A)	$\mu$ F.	0	Q							$\sigma$ DNM	
		HP	kW					l/min	30	40	50	60	80	90		100
								m³/h	1.8	2.4	3	3.6	4.8	5.4	6	
SCM 4 PLUS-115/30 M	4	0.5	0.37	1 - 230	3.4	16		26	24	22	20	13	9	6.4	1"1/4	
SCM 4 PLUS-115/30 T				3 - 400	1.2											
SCM 4 PLUS-115/50 M	7	0.75	0.55	1 - 230	4.4	20		46	43	40	36	23	16	10		
SCM 4 PLUS-115/50 T				3 - 400	1.7											
SCM 4 PLUS-115/65 M	9	1	0.75	1 - 230	5.9	30		58	55	51	46	29	20	11		
SCM 4 PLUS-115/65 T				3 - 400	2.2											
SCM 4 PLUS-115/65 T				3 - 230	3.8											
SCM 4 PLUS-115/95 M	13	1.5	1.1	1 - 230	7.8	40		83	80	74	67	43	30	18		
SCM 4 PLUS-115/95 T				3 - 400	3											
SCM 4 PLUS-115/95 T				3 - 230	5.2											
SCM 4 PLUS-115/122 M	17	2	1.5	1 - 230	10.2	50		109	106	98	88	55	38	21		
SCM 4 PLUS-115/122 T				3 - 400	4											
SCM 4 PLUS-115/185 T	24	3	2.2	3 - 400	5.6			160	153	143	130	85	58	31		
SCM 4 PLUS-115/245 T	33	4	3	3 - 400	7.5			218	210	198	179	118	84	47		

# SCM 4 PLUS 150

## 4" MULTISTAGE CENTRIFUGAL SUBMERSED PUMPS COMPLETE WITH MOTOR

### HYDRAULIC PERFORMANCE

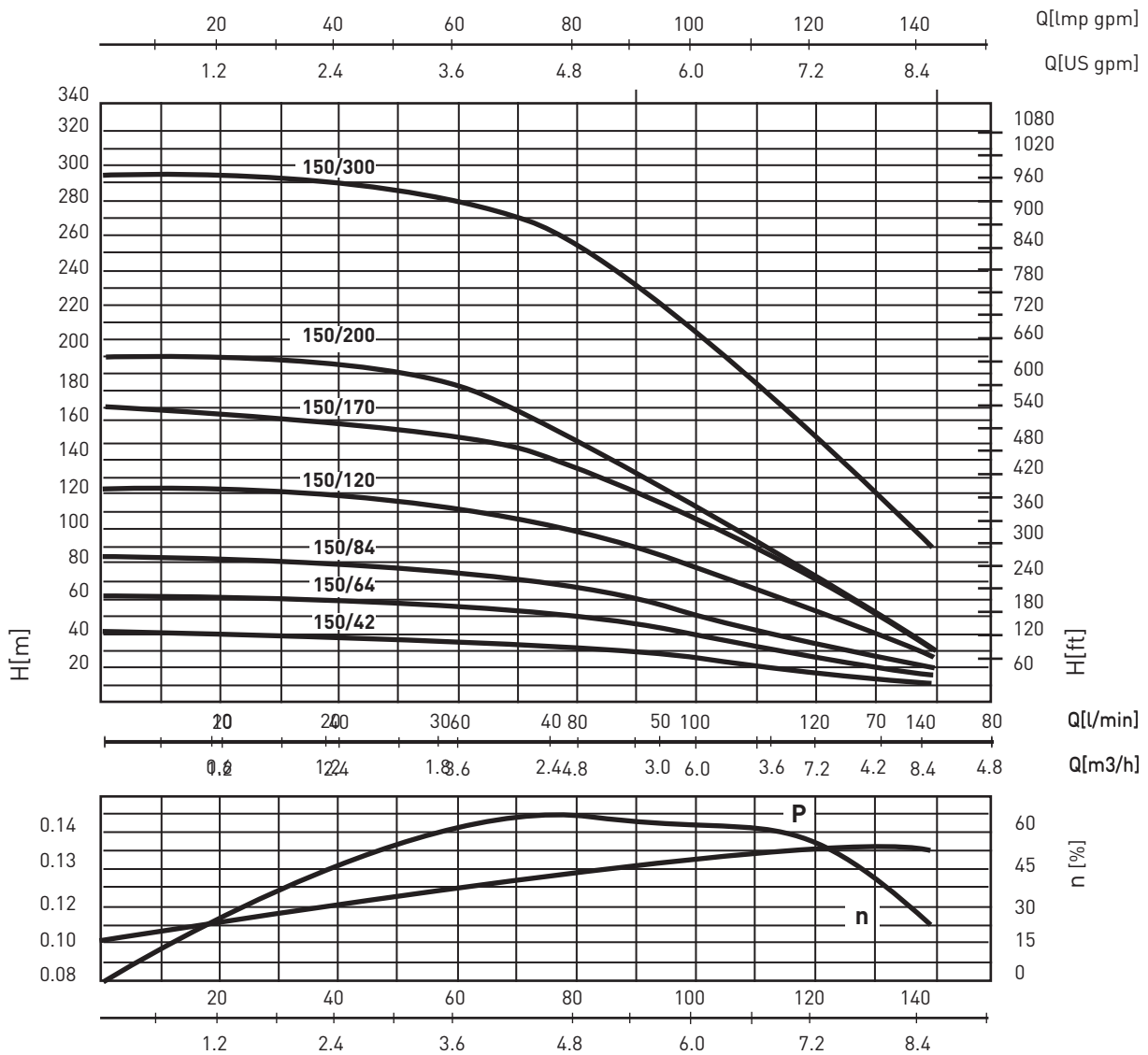

The power curve refers to the shaft power per stage  $\eta_p$  % indicates the hydraulic yield of the pump

MEI  $\geq 0.4$  - Reference MEI  $\geq 0.70$  - The information on the reference efficiency is available at the address: [www.europump.org/efficiencycharts](http://www.europump.org/efficiencycharts)

### PERFORMANCE TABLE

MODEL	N° Stages	Motor power (P2)		VOLT. (V)	In (A)	$\mu$ F.	Q	Q							$\sigma$ DNM
		HP	kW					l/min	40	50	60	80	100	120	
SCM 4 PLUS-150/42 M	6	1	0.75	1 - 230	5.9	30	m.c.a. / m.c.w.	38	37	36	33	26	17	10	2"
SCM 4 PLUS-150/42 T				3 - 400	2.2										
SCM 4 PLUS-150/42 T				3 - 230	3.8										
SCM 4 PLUS-150/64 M	9	1.5	1.1	1 - 230	7.8	40		59	58	57	50	39	27	15	
SCM 4 PLUS-150/64 T				3 - 400	3										
SCM 4 PLUS-150/64 T				3 - 230	5.2										
SCM 4 PLUS-150/84 M	12	2	1.5	1 - 230	10.2	50		80	78	75	64	50	34	20	
SCM 4 PLUS-150/84 T				3 - 400	4										
SCM 4 PLUS-150/84 T				3 - 230	6.9										
SCM 4 PLUS-150/120 T	17	3	2.2	3 - 400	5.6	116		113	108	96	77	53	26		
SCM 4 PLUS-150/170 T	24	4	3	3 - 400	7.5	160		157	152	134	106	69	30		
SCM 4 PLUS-150/200 T	29	5.5	4	3 - 400	10.1	191		188	179	152	112	71	32		
SCM 4 PLUS-150/300 T	42	7.5	5.5	3 - 400	13.6	292		290	285	252	210	155	82		

# 4" MOTORS

## ELECTRIC MOTORS Ø 4" FOR SUBMERSED PUMPS

4" SINGLE PHASE

Code	Model	V	Axial thrust N	kW	Hp	In A	I start A	RPM	CosØ	Ts/Tn	EFF %	C run µF	Weight KG	H mm	Length of cable mt
222P0590	4ESM kW0.37/Hp 0.5 1-230V 50Hz	1-230	1500	0.37	0.5	3.4	11	2850	0.91	0.65	58	16	6.8	250	1.75
222P0600	4ESM kW0.55/Hp 0.75 1-230V 50Hz	1-230	1500	0.55	0.75	4.4	16.6	2840	0.92	0.63	62	20	8.1	265	1.75
222P0610	4ESM kW0.75/Hp 11-230V 50Hz	1-230	1500	0.75	1	5.9	19.8	2860	0.94	0.62	65	30	10.6	295	1.75
222P0620	4ESM kW1.1/Hp 1.5 1-230V 50Hz	1-230	3000	1	1.5	7.8	29.5	2850	0.94	0.62	66	40	11.2	340	1.75
222P0630	4ESM kW1.5/Hp 2 1-230V 50Hz	1-230	3000	1.5	2	10.2	36.4	2850	0.95	0.61	68	50	14	375	1.75

4" THREE-PHASE

Code	Model	V	Axial thrust N	kW	Hp	In A	I start A	RPM	CosØ	Ts/Tn	EFF %	Weight KG	H mm	Length of cable mt
221P1190	4ESM kW0.37/Hp 0.5 3-400V 50Hz	3-400	1500	0.37	0.5	1.2	5.1	2840	0.73	2.1	63	5.8	235	1.75
221P1200	4ESM kW0.55/Hp 0.75 3-400V 50Hz	3-400	1500	0.55	0.75	1.7	6.5	2840	0.73	2	64	7	250	1.75
221P1210	4ESM kW0.75/Hp 13-230V 50Hz	3-230	1500	0.75	1	3.8	15.9	2840	0.75	1.9	67	8.3	265	1.75
221P1220	4ESM kW0.75/Hp 13-400V 50Hz	3-400	1500	0.75	1	2.2	9.2	2840	0.75	1.9	67	8.3	265	1.75
221P1230	4ESM kW1.1/Hp 1.5 3-230V 50Hz	3-230	1500	1.1	1.5	5.2	24.6	2840	0.76	2.3	71	10.9	295	1.75
221P1240	4ESM kW1.1/Hp 1.5 3-400V 50Hz	3-400	3000	1.1	1.5	3	14.2	2840	0.76	2.3	71	10.9	295	1.75
221P1360	4ESM kW1.5/Hp 2 3-230V 50Hz	3-230	3000	1.5	2	6.9	32	2830	0.78	2.1	72	11.4	340	1.75
221P1250	4ESM kW1.5/Hp 2 3-400V 50Hz	3-400	3000	1.5	2	4	18.5	2830	0.78	2.1	72	11.4	340	1.75
221P1260	4ESM kW2.2/Hp 3 3-400V 50Hz	3-400	3000	2.2	3	5.6	26.5	2830	0.79	2.4	74	14.2	375	2.5
221P1270	4ESM kW3/Hp 4 3-400V 50Hz	3-400	6500	3	4	7.5	34.3	2830	0.79	2.2	76	18.3	480	2.5
221P1280	4ESM kW4/Hp 5.5 3-400V 50Hz	3-400	6500	4	5.5	10.1	44	2840	0.77	2.3	75	23.4	555	2.5
221P1290	4ESM kW5.5/Hp 7.5 3-400V 50Hz	3-400	6500	5.5	7.5	13.6	62	2840	0.8	2.2	76	29.4	675	4

# 4" MOTORS

## CHOOSING THE ELECTRIC CABLE FOR SUBMERSED PUMPS



Motor 4ESM	HP	kW	CABLE SECTION (mm <sup>2</sup> )					
			4X1	4X1.5	4X2.5	4X4	4X6	4X10
SINGLE-PHASE 230V/50HZ	0.5	0.37	50	75	125			
	0.75	0.55	38	57	65	152		
	1	0.75	30	45	75	120	174	
	1.5	1.1	22	33	53	85	127	210
	2	1.5		23	38	63	92	154
	3	2.2			28	45	67	112
THREE-PHASE 400V/50HZ	0.5	0.37	240					
	0.75	0.55	164	246				
	1	0.75	133	200	333			
	1.5	1.1	97	146	244	390		
	2	1.5	72	109	180	290	435	
	3	2.2	51	78	130	207	310	516
	4	3	41	62	104	167	250	416
	5.5	4	31	46	77	124	186	310
	7.5	5.5		33	56	90	135	225
THREE-PHASE 230V/50HZ	0.5	0.37	90	135				
	0.75	0.55	60	90	150	240		
	1	0.75	47	71	118	190		
	1.5	1.1	35	52	87	140	210	
	2	1.5	26	40	66	106	160	266
	3	2.2		29	48	76	115	191
	4	3			37	60	90	150
	5.5	4			27	44	66	110
	7.5	5.5				32	48	80

## CABLES AND FITTINGS



ZA000420	CABLE 4X1	NEOPRENE CABLE H07 RNF 4 1 SQ.MM WIRES
ZA000430	CABLE 4X1.5	NEOPRENE CABLE H07 RNF 4 1.5 SQ.MM WIRES
ZA000440	CABLE 4X2.5	NEOPRENE CABLE H07 RNF 4 2.5 SQ.MM WIRES
ZA000450	CABLE 4X4	NEOPRENE CABLE H07 RNF 4 4 SQ.MM WIRES
ZA000460	CABLE 4X6	NEOPRENE CABLE H07 RNF 4 6 SQ.MM WIRES
ZA000470	CABLE 4X10	NEOPRENE CABLE H07 RNF 4 10 SQ.MM WIRES

ZA003370	JOINT KIT 2.5	KIT FOR HEAT SHRINK JOINTS FOR CABLES UP TO 4 X 2.5
ZA003390	JOINT KIT 6	KIT FOR HEAT SHRINK JOINTS FOR CABLES UP TO 4 X 6
ZA003380	JOINT KIT 10	KIT FOR CASTING RESIN JOINTS FOR CABLES UP TO 4X10
ZA009410	JOINT 2.5	HEAT SHRINK JOINT 1 - 2.5 sq.mm
ZA009430	JOINT 6	HEAT SHRINK JOINT 4 - 6 sq.mm
ZA009450	JOINT 10	CASTING RESIN JOINT UP TO 4 X 10 sq.mm

# VERSAILLES

## SUBMERSIBLE PUMPS FOR FOUNTAINS AND WATER FEATURES

The pumps of the VERSAILLES series have been designed for fountains, water features and waterfalls in water gardens.

### USAGE DATA

- Type of liquid: clear water without solids.
- Maximum temperature of the liquid 40°C.
- Maximum immersion under the water level 7m.
- Free passage of solids 1.5 mm.
- For water games with smaller passages insert the sponge filter in the hydraulic part (optional).

### MOTOR

- Dry motor with stainless steel body
- Degree of protection IP 68
- Insulation class F
- Single-phase power supply with capacitor always on.
- Thermal protection built into the motor casing.
- Cable connection chamber completely insulated.
- Self-lubricating ball bearings.
- Speed of rotation 2850 rpm.
- Suitable for continuous use.

### APPLICATIONS

- Installation of fountains, water features, waterfalls in water parks.

### OPTIONAL ACCESSORIES

- Vulcano: water game with water jets at three levels.
- Geyser: water game with one adjustable bubbling jet of water.
- Bell: water game in the shape of a bell, adjustable.
- Filters: spongy material, passages smaller than 1.5 mm to be used for all water games.



VULCANO



GEYSER



BELL



### TABLE OF MATERIALS

Component	Material
Air inlet grille	Stainless steel X 5 CrNiS 1810 (AISI 304)
Base	Stainless steel X 5 CrNiS 1810 (AISI 304)
Pump body	Stainless steel X 5 CrNiS 1810 (AISI 304)
Impeller	Stainless steel X5 CrNi 1810 (AISI 304) casting
Supply cable	10m H07 RN-F with plug
Seal	Double fixed seal in rubber NBR 70 with special V-ring sand guard
Motor shaft	Stainless steel X 12 CrS 13 (AISI 416) with ceramic insert at the points of wear of the seal
Reducer 1" F	Plastic material

# VERSAILLES

## SUBMERSIBLE PUMPS FOR FOUNTAINS AND WATER GAMES

### HYDRAULIC PERFORMANCE

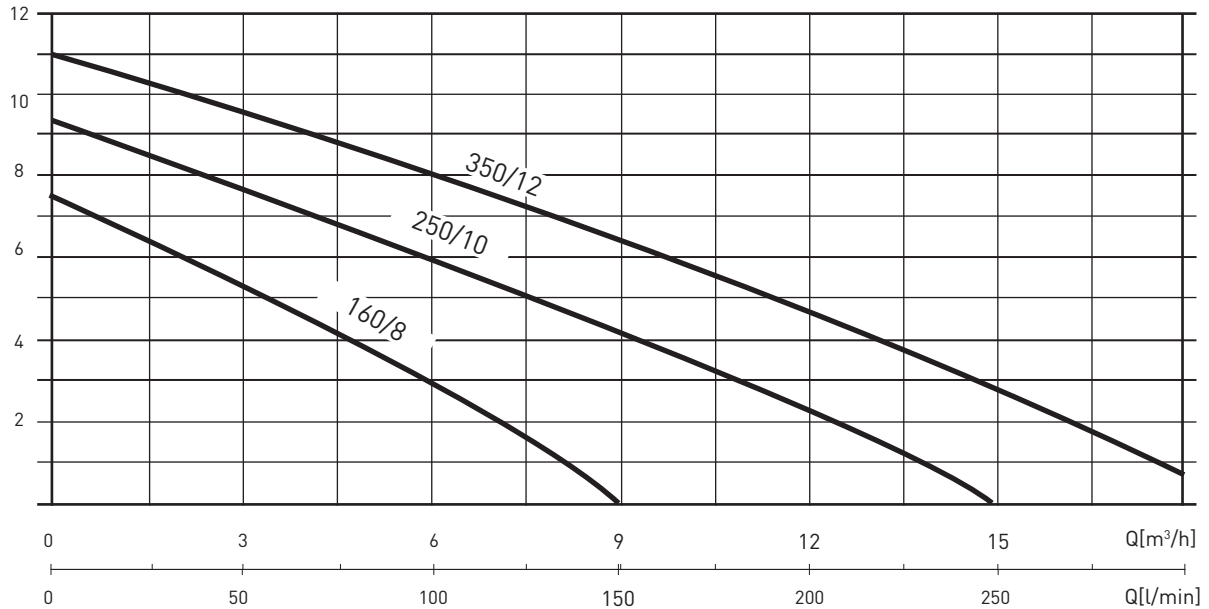

MODEL	Motor power (P2)		Motor power (P1)		VOLT (V)	In (A)	μF	Q l/min	Diameter and height of water games in cm		
	HP	kW	HP	kW					VULCANO	GAISER	CAMPANA
VERSAILLES 160/8	0,5	0,37	0,6	0,45	1-230	2,2	8		Ø 180 - H 360	Ø 20 - H 110	Ø 90 - H 45
VERSAILLES 250/10	0,75	0,5	0,9	0,7	1-230	4,5	10	m.c.w.	Ø 200 - H 420	Ø 30 - H 180	Ø 95 - H 45
VERSAILLES 350/12	1,1	0,8	1,6	1,2	1-230	5,1	16		Ø 200 - H 480	Ø 50 - H 230	Ø 100 - H 45

VULCANO  
GAISER  
CAMPANA

FILTER 1 FOR MOD. 80/7 - 160/8  
FILTER 2 FOR MOD. 250/10 - 350/12

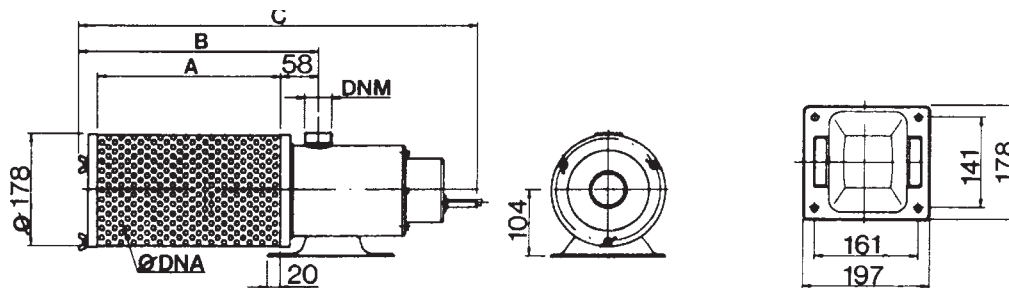

### OVERALL DIMENSIONS AND WEIGHTS

MODEL	Dimensions mm.					WEIGHT (Kg)
	A	B	C	P.L.	DNM	
VERSAILLES 160/8	144	231	425	Ø 1,5	1" 1/4	7
VERSAILLES 250/10	285	372	620	Ø 1,5	1" 1/4	7,8
VERSAILLES 350/12	285	372	620	Ø 1,5	1" 1/4	9,3

# SECTION 4

## PRESSURE BOOSTER SET



**FP/MULTI EVO-A**  
PUMPS WITH ELECTRONIC CONTROL AND PROTECTION DEVICE

PAG. 183



**CPS20**  
PRESSURE BOOSTER SET WITH TWO VARIABLE SPEED PUMPS

PAG. 239



**AUTOJET**  
PUMPS WITH ELECTRONIC CONTROL AND PROTECTION DEVICE

PAG. 187



**VARIO 1-20/Multi EVO-E**  
PRESSURE BOOSTER SET WITH TWO VARIABLE SPEED PUMPS

PAG. 243



**WP/MULTI EVO-A**  
PRESSURE BOOSTER SET WITH HORIZONTAL STAINLESS STEEL PRESSURE TANK

PAG. 189



**VARIO 1-20/Multi EVO-E P**  
PRESSURE BOOSTER SET WITH TWO VARIABLE SPEED PUMPS

PAG. 251



**WATERPRESS**  
PRESSURE BOOSTER SET WITH HORIZONTAL PRESSURE TANK

PAG. 193



**VARIO 1-20**  
PRESSURE BOOSTER SET WITH TWO VARIABLE SPEED PUMPS

PAG. 257



**EASY20/MULTI EVO**  
PRESSURE BOOSTER SET WITH TWO PUMPS - PRESSURE SWITCH CONTROL

PAG. 199



**VARIO 3-20**  
THREE-PHASE PRESSURE BOOSTER SET WITH TWO VARIABLE SPEED PUMPS

PAG. 267

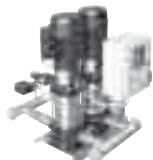

**EASYBOOST**  
RESIDENTIAL - PRESSURE BOOSTER SET WITH PRESSURE SWITCH CONTROL

PAG. 207

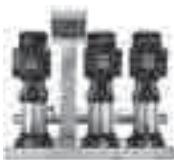

**VARIO 3-30**  
THREE-PHASE PRESSURE BOOSTER SET WITH THREE VARIABLE SPEED PUMPS

PAG. 285

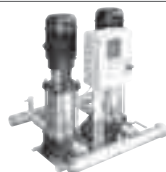

**PRESSOMAT**  
INDUSTRIAL - PRESSURE BOOSTER SET WITH PRESSURE SWITCH CONTROL

PAG. 223

## ACCESSORIES

PAG. 306



## FP/MULTI EVO-A PUMPS WITH ELECTRONIC CONTROL AND PROTECTION DEVICE

High hydraulic performance

Automatic unit to increase the pressure in the domestic water system. Consisting of a single phase pump like **Multi EVO-A** and of the electronic device FLUSSCONTROL BASIC, which controls the automatic operation of the pump and protects it in case of a lack of water. It comes assembled, wired, ready for

installation and use.

- High hydraulic performance regarding pressure and capacity
- Minimum consumption of electricity.
- Extremely silent operation.



### ADVANTAGES

- Reduces water hammers
- Replaces the traditional system of the expansion module
- Requires no maintenance
- Protection in case of a lack of water
- Very easy to install and ready for use (Plug & Play).

### SPECIFICATIONS:

#### PUMP

- Type of liquid: clean water without suspended solids or abrasive material
- Maximum temperature of the liquid 50°C
- Maximum recommended intake height: 6 m with bottom valve.
- Maximum operating pressure 8 bar

#### MOTOR

- Closed, ventilated from outside (TEFC)
- 2 poles, 50 Hz (n=2850 rpm)
- Degree of protection IP 55
- Insulation class F
- Single-phase power supply with capacitor permanently on and thermal protection built into the motor casing.
- Three-phase power supply with external protection provided by the user.



### APPLICATIONS

- Lifting and distribution of water in domestic systems
- Pressurization systems
- Irrigation
- Washing systems
- Recovery of rainwater



# FP/MULTI EVO-A

## PUMPS WITH ELECTRONIC CONTROL AND PROTECTION DEVICE

### CONSTRUCTION FEATURES

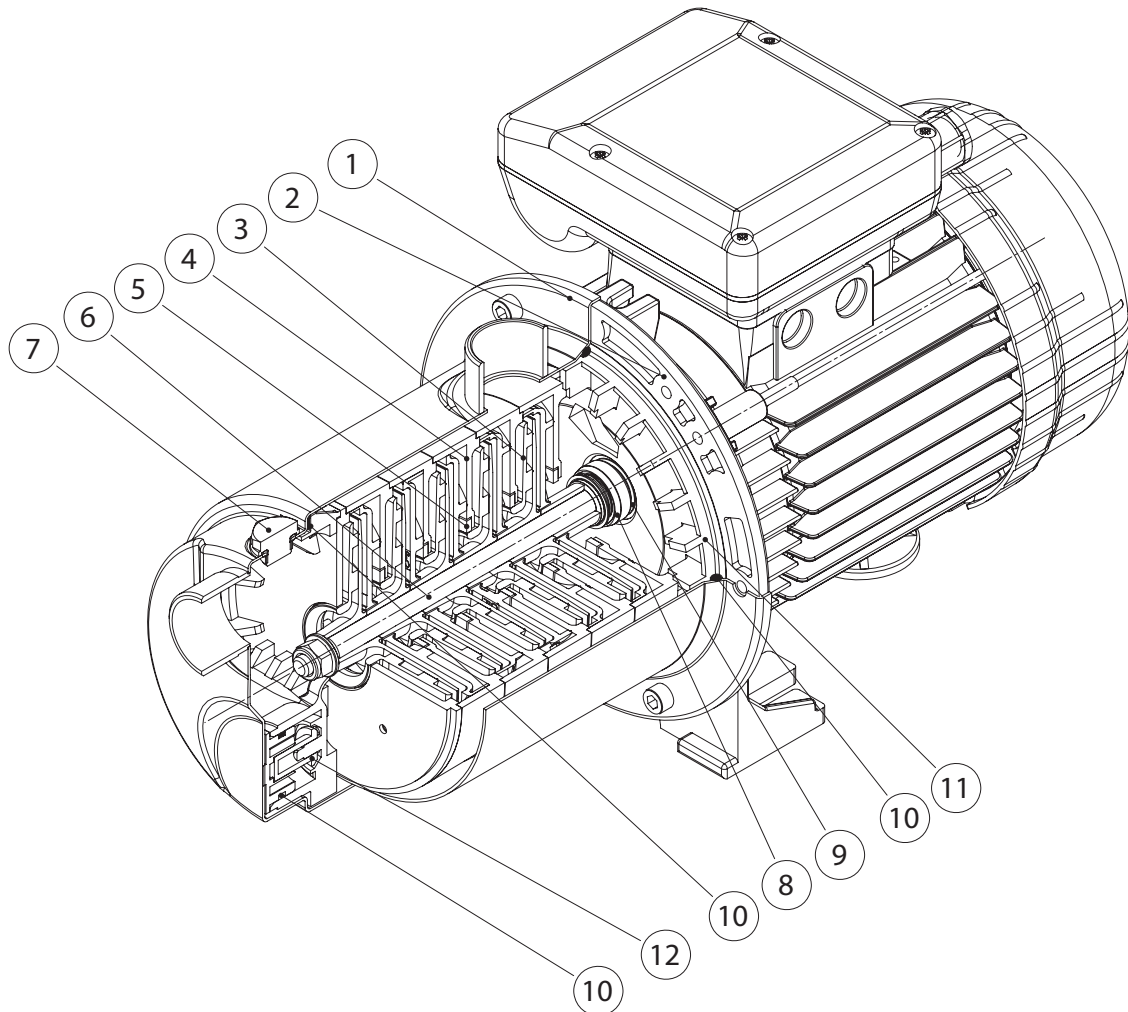

### TABLE OF MATERIALS

Ref.	Component	Material
1	Pump body	Stainless steel Europe: EN10088-1 X5CrNi18-10 (1.4301) USA: AISI 304
2	Motor casing	Die-cast aluminium
3	Impeller	PPO reinforced with fibreglass
4	Diffuser	PPO reinforced with fibreglass
5	Wear ring	PTFE
6	Shaft (hydraulic part)	Stainless steel Europe: EN10088-1 X5CrNi18-10 (1.4301) USA: AISI 304
7	Inlet / outlet caps	Stainless steel Europe: EN10088-1 X8CrNiS18-9 (1.4305) USA: AISI 303
8	Mechanical seal	Carbon graphite / NBR / SS Europe: EN10088-1 X5CrNi18-10 (1.4301) USA: AISI 304
9	Counterface	Ceramic / NBR
10	Gaskets	NBR 70 Shore A
11	Seal holder plate	PPO reinforced with fibreglass
12	Priming valve	PPO reinforced with fibreglass

# FP/MULTI EVO-A 3 - 5

## PUMPS WITH ELECTRONIC CONTROL AND PROTECTION DEVICE

### HYDRAULIC PERFORMANCE

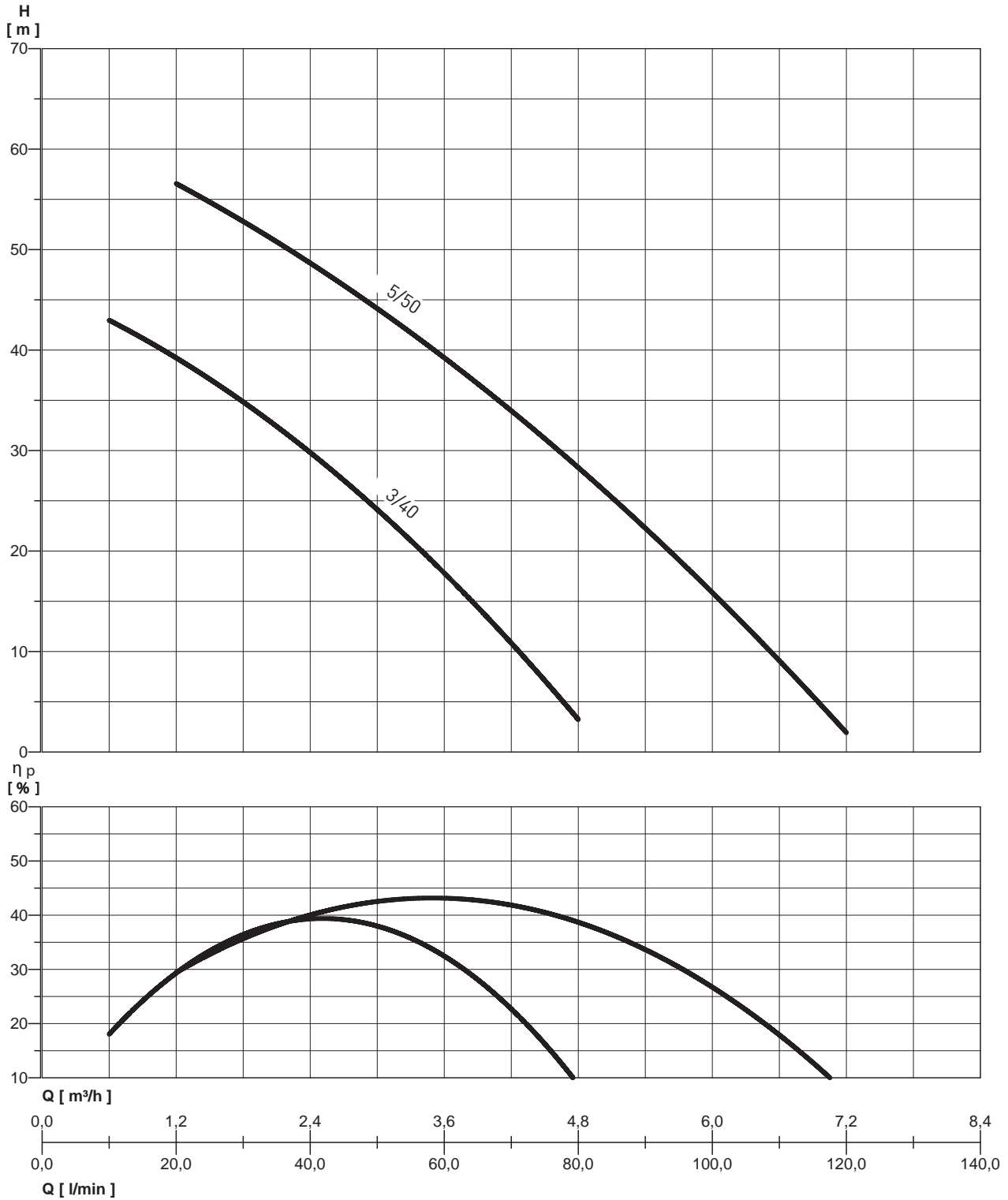

# FP/MULTI EVO-A 3 - 5

## PUMPS WITH ELECTRONIC CONTROL AND PROTECTION DEVICE

### PERFORMANCE TABLE

MODEL	Nominal power (P2)		Absorbed power (P1)		VOLT. (V)	In (A)	μF	0	Total head in water column metres									
	HP	kW	HP	kW					l/min	10	20	30	40	50	60	80	100	120
									0,6	1,2	1,8	2,4	3	3,6	4,8	6	7,2	
FP/MULTI EVO-A 3-40 M	0,74	0,55	1,1	0,8	1 - 230	3,7	12,5		42,5	39,5	35,5	30	23,5	17,5	3,5			
FP/MULTI EVO-A 5-50 M	1,27	0,95	1,8	1,35	1 - 230	6,2	20			56	53	49	44,5	39,5	28	15	2,5	

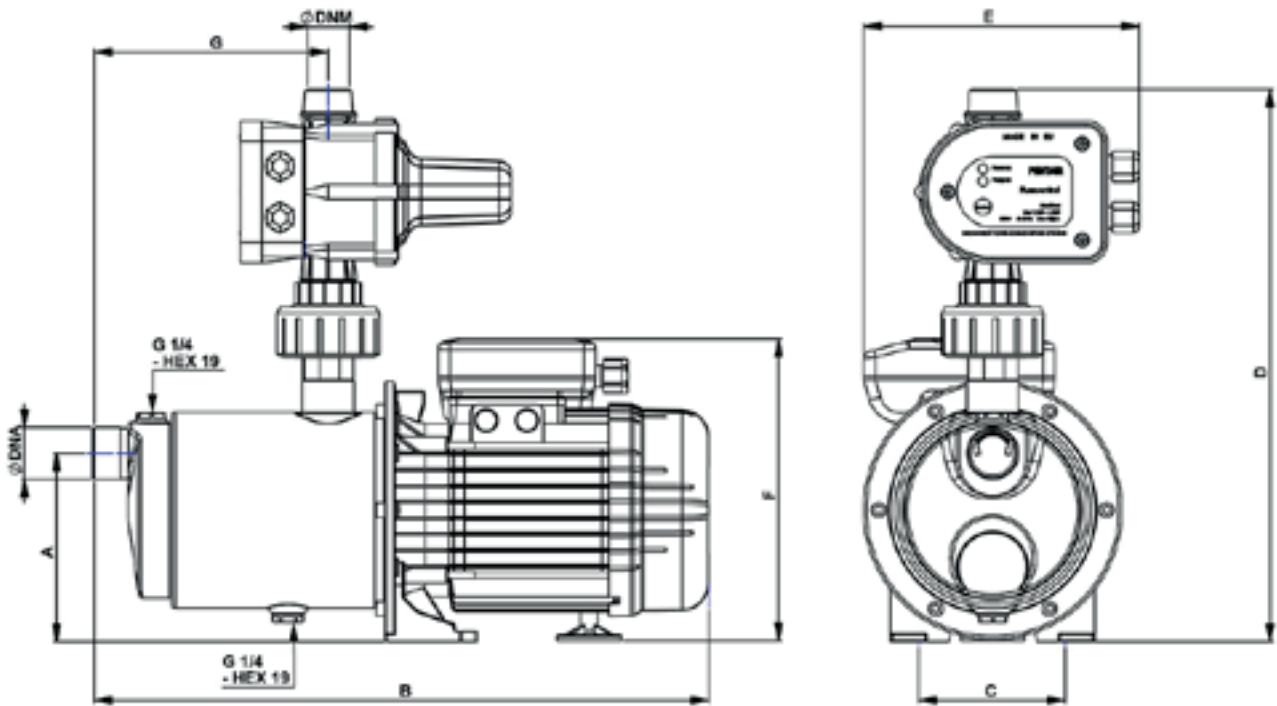

### OVERALL DIMENSIONS AND WEIGHTS

MODEL	Dimensions mm.									WEIGHT (Kg)
	A	B	C	D	E	F	G	DNA	DNM	
FP/MULTI EVO-A 3-40 M	129	380	100	380	190	199	139	1"	1"	8,5
FP/MULTI EVO-A 5-50 M	129	422	100	380	190	207	162	1"	1"	11,8

## AUTOJET

### PUMPS WITH ELECTRONIC CONTROL AND PROTECTION DEVICE

Automatic unit to increase the pressure in the domestic water system. Consisting of a single phase pump like Jetinox and of the electronic device FLUSSCONTROL BASIC, which controls the automatic operation of the pump and protects it in case of a lack of water. It comes assembled, wired, ready for installation and use.

#### APPLICATIONS

- Lifting and distribution of water in domestic systems
- Pressurization systems.
- Washing and irrigation.

#### ADVANTAGES

- Reduces water hammer effect
- Replaces traditional expansion tank system
- Maintenance free
- Protection in event of water supply failure
- Simple to install
- Pressure remains constant during supply

#### MOTOR

- Closed, ventilated from outside.
- Degree of protection IP 44.
- Insulation class F.
- Single-phase power supply with capacitor always on.
- Thermal protection built into the motor casing.
- Speed of rotation 2850 rpm.
- Continuous service.

#### CONSTRUCTION FEATURES

- Flusscontrol Basic:
- Maximum pressure 8 bar
- Maximum temperature 40°C
- Power cable 1.5 m H07 RN-F with plug.

#### USAGE DATA

- Type of liquid: clean water without suspended solids or abrasive material.
- Maximum temperature of the liquid 40°C.
- Maximum recommended intake height: 8 m with bottom valve.
- Maximum operating pressure: 6 bar.



## TABLE OF MATERIALS

Component	Material
1 Pump body	Stainless steel X5 CrNi 1810 (AISI 304)
2 Motor casing	Die-cast aluminium
3 Impeller	Technopolymer with stainless steel shim ring
4 Diffuser monobloc group Venturi tube-nozzle	Technopolymer
5 Shaft	Stainless steel X 12 CrNiS 1809 (AISI 416)
6 Mechanical seal	Graphite
7 Counterface	Ceramic
8 Seal holder plate	Technopolymer (series 45-60-70) Stainless steel X5 CrNi 1810 (AISI 304) series 90
9 Gaskets	NBR 70 Shore

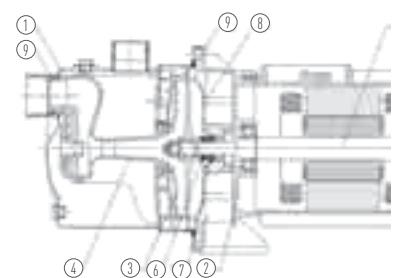

# AUTOJET

## PUMPS WITH ELECTRONIC CONTROL AND PROTECTION DEVICE

### HYDRAULIC PERFORMANCE

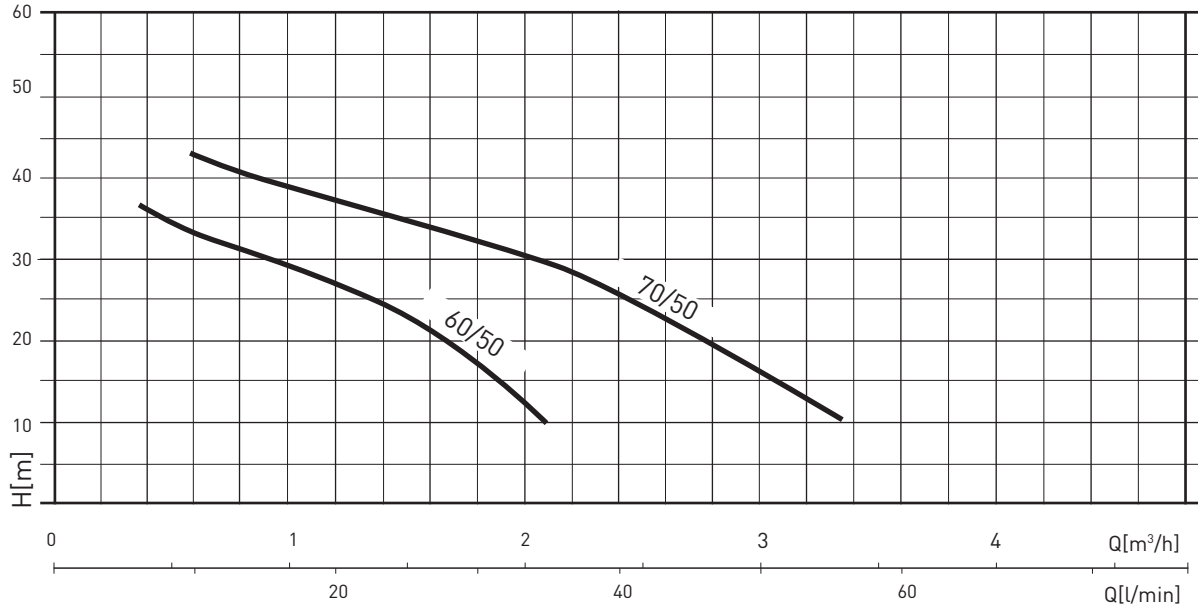

### PERFORMANCE TABLE

MODEL	Motor power (P2)		Motor power (P1)		VOLT (V)	In (A)	$\mu$ F	0	m.c.w.							
	HP	kW	HP	kW					l/min	0	10	20	30	40	50	60
									m³/h	0	0,6	1,2	1,8	2,4	3	3,6
AUTOJET 60/50	0,75	0,55	1,10	0,8	1 - 230	4	12,5		46	36	31	26	18	6		
AUTOJET 70/50	0,95	0,7	1,36	1,0	1 - 230	4,5	16		48	42,5	37,5	32	25	16,5	7	

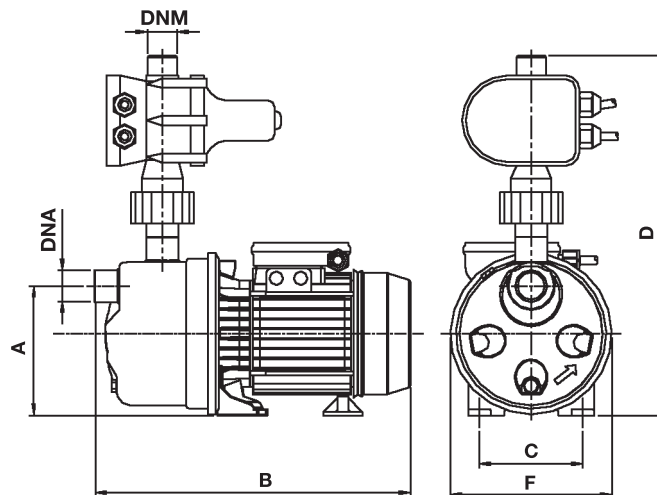

### OVERALL DIMENSIONS AND WEIGHTS

MODEL	Dimensions mm.							WEIGHT (Kg)
	A	B	C	D	E	DNA	DNM	
AUTOJET 60/50	140	374	99	391	194	1" F	1" M	9,4
AUTOJET 70/50	144	351	99	397	195	1" F	1" M	10,7

# WP/MULTI EVO-A PRESSURE BOOSTER SET WITH HORIZONTAL STAINLESS STEEL PRESSURE TANK

The Pressure booster set WATERPRESS are made with self-priming multi-stage centrifugal pumps **Multi EVO-A**. They are supplied wired, complete with a 24 l or 50 l expansion module, ready for installation and use. All models are certified for use with drinking water (ACS).

## ADVANTAGES

- Reduces water hammers
- Ideal as a water supply system in the building
- Ready to use
- Reduction of the starting frequency with the 50 l tank
- Very easy to install

## CONSTRUCTION FEATURES

- Electromechanical pressure switch (max 6 bar) set at: min 2 ÷ max 3 bar.
- Pump start-up pressure adjustable from 1.5 to 3 bar
- Pressure gauge (6 bar).
- 5-way moulded brass plated connector.
- Expansion tanks:
  - 50 l expansion tank in painted steel (models WP / Multi EVO-A 3-40 M-50l and WP / Multi EVO-A 5-50 M-50 l).
  - 24 l expansion tank in painted steel (model WP / Multi EVO-A 3-40 M).
  - 24 l expansion tank in painted steel (model WP / Multi EVO-A 5-50 M-SS).
- Tuboflex hydraulic connection.
- Power cable 1.5 m H05 RN-P with plug

## SPECIFICATIONS:

### PUMP

- Type of liquid: clean water without suspended solids or abrasive material
- Maximum temperature of the liquid 50°C
- Maximum intake height 8 m with pump installed correctly
- Maximum operating pressure 8 bar

### MOTOR

- Closed, ventilated from outside (TEFC)
- 2 poles, 50 Hz (n=2850 rpm)
- Degree of protection IP 55
- Insulation class F
- Single-phase power supply with capacitor permanently on and thermal protection built into the motor casing.
- Three-phase power supply with external protection provided by the user.



## APPLICATIONS

- Lifting and distribution of water in domestic systems
- Pressurization systems
- Irrigation
- Washing systems



# WP/MULTI EVO-A

## PRESSURE BOOSTER SET WITH HORIZONTAL STAINLESS STEEL PRESSURE TANK

### CONSTRUCTION FEATURES

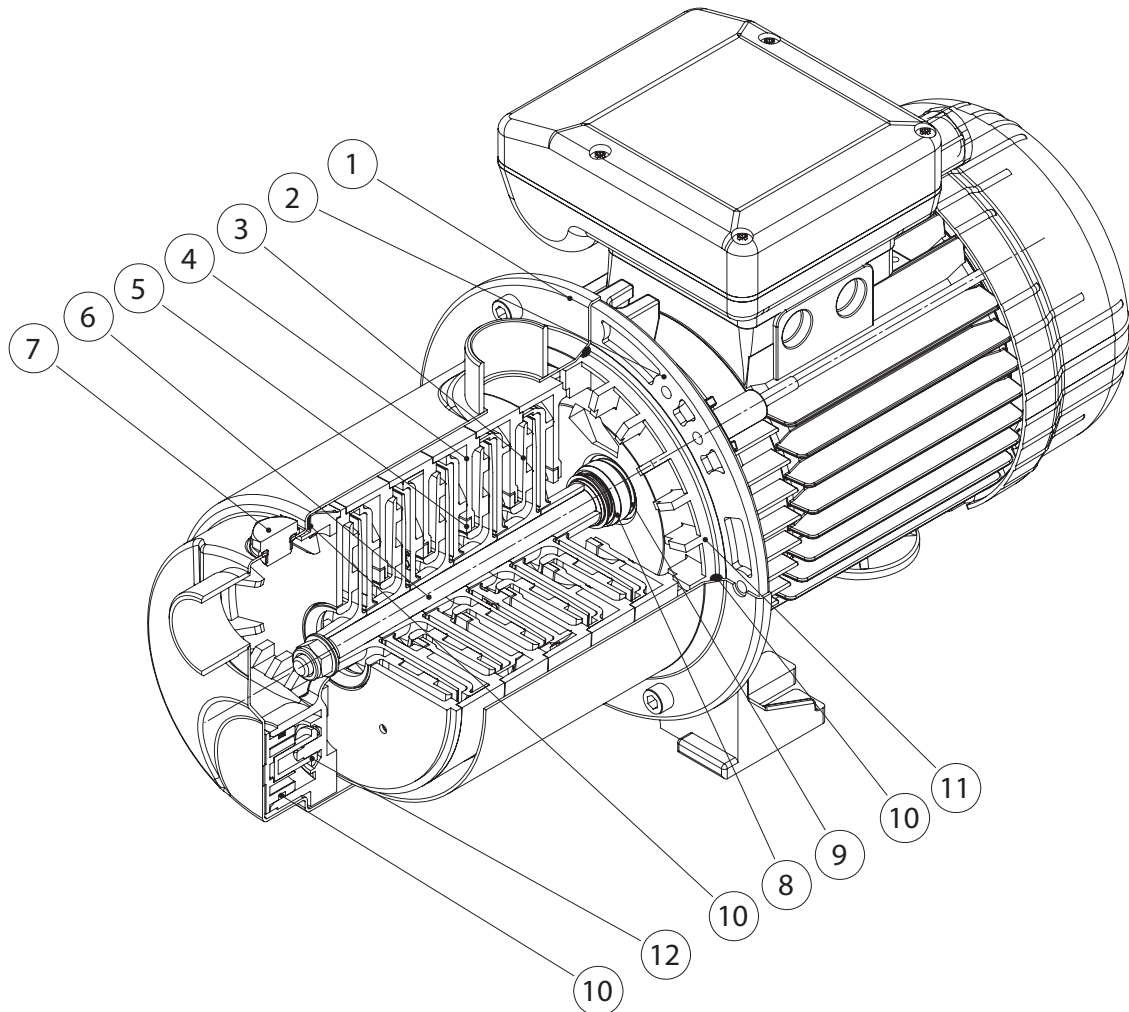

### TABLE OF MATERIALS

Ref.	Component	Material
1	Pump body	Stainless steel Europe: EN10088-1 X5CrNi18-10 (1.4301) USA: AISI 304
2	Motor casing	Die-cast aluminium
3	Impeller	PPO reinforced with fibreglass
4	Diffuser	PPO reinforced with fibreglass
5	Wear ring	PTFE
6	Shaft (hydraulic part)	Stainless steel Europe: EN10088-1 X5CrNi18-10 (1.4301) USA: AISI 304
7	Inlet / outlet caps	Stainless steel Europe: EN10088-1 X8CrNiS18-9 (1.4305) USA: AISI 303
8	Mechanical seal	Carbon graphite / NBR / SS Europe: EN10088-1 X5CrNi18-10 (1.4301) USA: AISI 304
9	Counterface	Ceramic / NBR
10	Gaskets	NBR 70 Shore A
11	Seal holder plate	PPO reinforced with fibreglass
12	Priming valve	PPO reinforced with fibreglass



# WP/MULTI EVO-A 5

PRESSURE BOOSTER SET WITH HORIZONTAL STAINLESS STEEL PRESSURE TANK

## HYDRAULIC PERFORMANCE

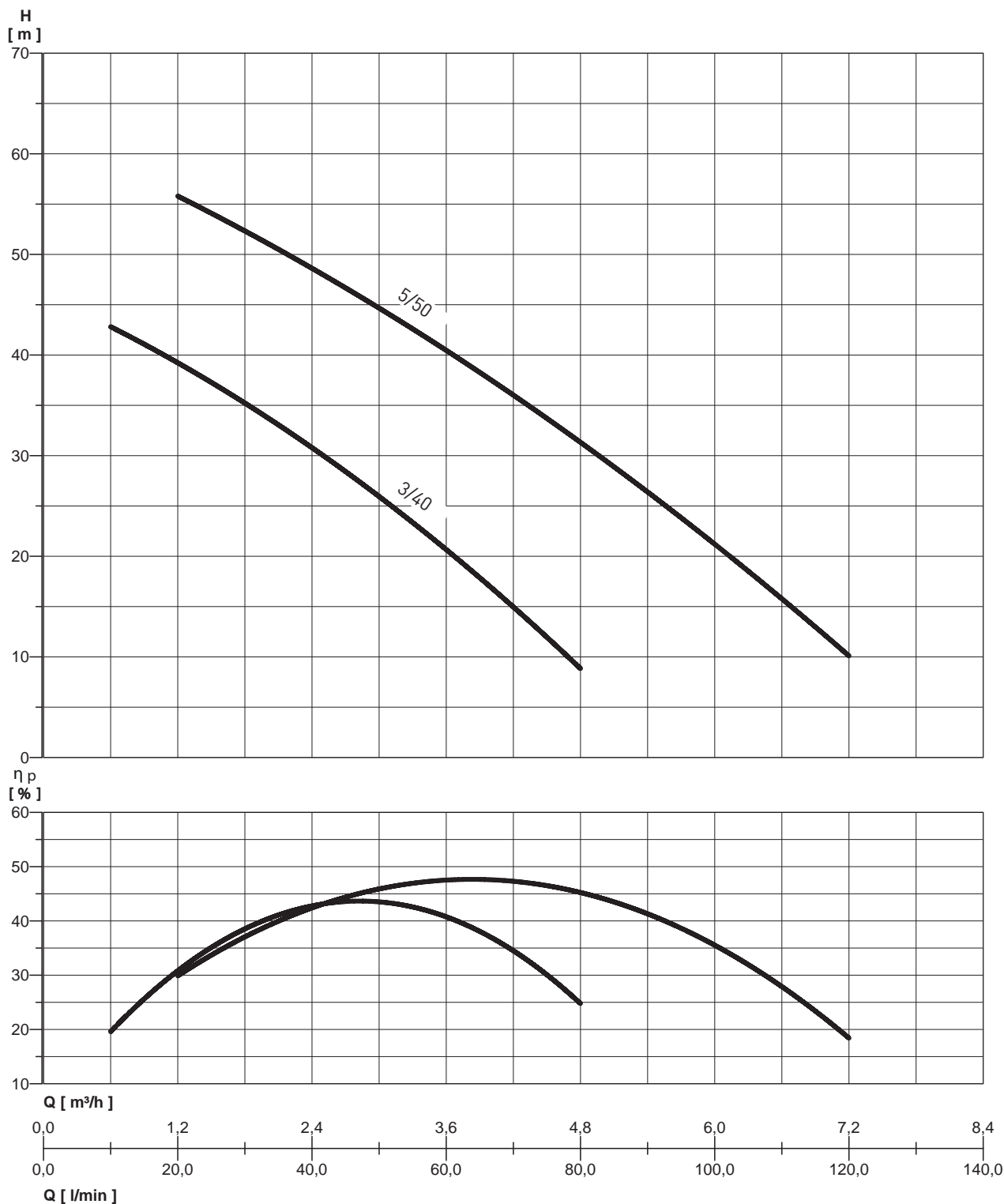

# WP/MULTI EVO-A 5

## PRESSURE BOOSTER SET WITH HORIZONTAL STAINLESS STEEL PRESSURE TANK

### PERFORMANCE TABLE

MODEL	Nominal power (P2)		Absorbed power (P1)		VOLT (V)	In (A)	μF	0	total head in water column metres										
	HP	kW	HP	kW					l/min	10	20	30	40	50	60	80	100	120	
									m³/h	0,6	1,2	1,8	2,4	3	3,6	4,8	6	7,2	
WP / MULTI EVO-A 3-40 M	0,67	0,5	1,1	0,8	1-230	3,7	12,5			42,5	39,5	35,5	31	25,5	20,5	9			
WP / MULTI EVO-A 3-40 M-50I	0,67	0,5	1,1	0,8	1-230	3,7	12,5												
WP / MULTI EVO-A 5-50 M-SS	1,34	1	1,8	1,35	1-230	6,2	20												
WP / MULTI EVO-A 5-50 M-50I	1,34	1	1,8	1,35	1-230	6,2	20			56	52	48,5	45	40,5	31	21,5	10		

24 l

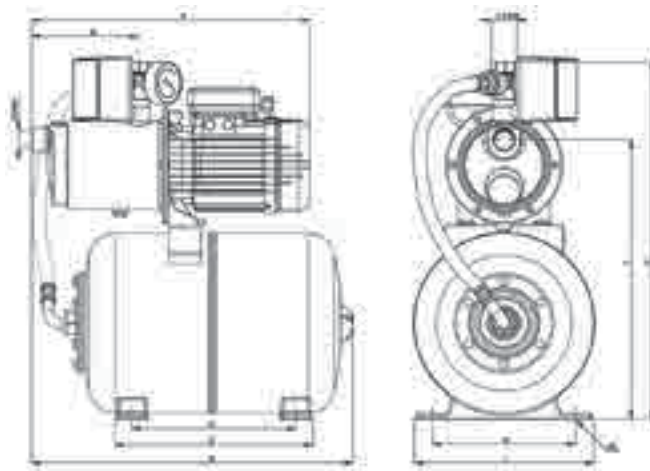

50 l

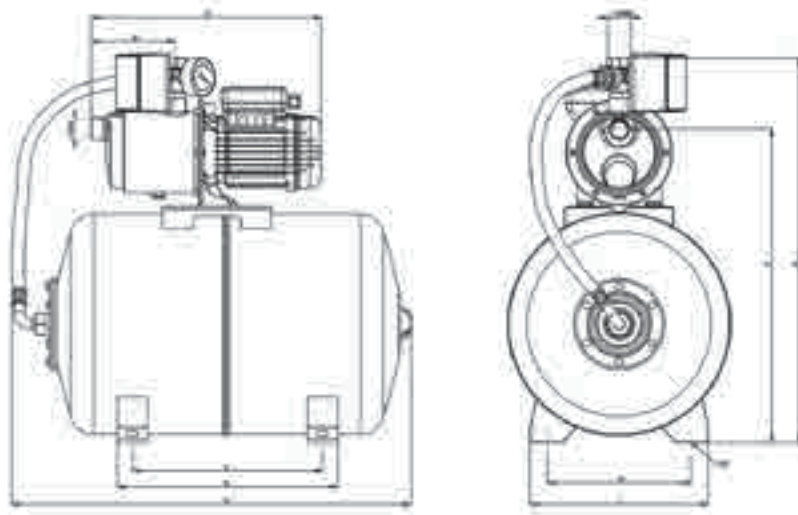

### OVERALL DIMENSIONS AND WEIGHTS

MODEL	Dimensions mm.												WEIGHT (Kg)
	A	B	C	D	E	F	G	H	I	L	DNA	DNM	
WP / MULTI EVO-A 3-40 M	380	139	245	295	495	410	530	190	240	9	1"	1"	13,6
WP / MULTI EVO-A 3-40 M-50I	380	139	315	365	660	520	640	242	295	9	1"	1"	18
WP / MULTI EVO-A 5-50 M-SS	422	162	248	300	490	435	540	218	272	11	1"	1"	14
WP / MULTI EVO-A 5-50 M-50I	422	162	215	365	660	520	640	242	295	9	1"	1"	20,5

## WATERPRESS

### PRESSURE BOOSTER SET WITH 24 LT HORIZONTAL PRESSURE TANK

The pressure booster set WATERPRESS are made with self-priming multi-stage centrifugal pumps of the JET series. They are supplied wired, complete with a 24 lt pressure tank, ready for installation and use.

#### APPLICATIONS

- Lifting and distribution of water in domestic systems
- Pressurization systems and irrigation.

#### CONSTRUCTION FEATURES

- Pressure switch (max 6 bar) set at: min 2 ÷ max 3 bar.
- Pressure gauge (6 bar).
- 3-way moulded brass plated connector (model Waterpress 70/50).
- 24 lt expansion tank in painted steel with interchangeable rubber membrane for food.
- Tuboflex hydraulic connection.
- Power cable 1.5 m H05 RN-F with plug

#### USAGE DATA

- Type of liquid: clean water without suspended solids or abrasive material.
- Maximum temperature of the liquid 50°C.
- Maximum intake height recommended 8 m with foot valve.
- Maximum operating pressure: 6 bar.

#### MOTOR

- Closed, ventilated from outside.
- Degree of protection IP 44.
- Insulation class F.
- Single-phase power supply with capacitor always on.
- Thermal protection built into the motor casing.
- Speed of rotation 2850 rpm.
- Continuous service.



## TABLE OF MATERIALS

Component	Material	
	WATERPRESS 40/40 - 60/50	WATERPRESS 70/50
Pump body	Cast iron EN GJL 200	Cast iron EN GJL 200
Motor casing	Aluminium	Cast iron EN GJL 200
Impellers	Technopolymer with stainless steel shim ring X5 CrNi 1810 (AISI 304)	Technopolymer
Diffuser-Venturi tube-nozzle	Monobloc group Technopolymer	Technopolymer
Motor shaft	Stainless steel X5 CrNi 1810 (AISI 304)	Stainless steel X5 CrNi 1810 (AISI 304)
Mechanical seal	Graphite	Graphite
Counterface	Ceramic	Ceramic
Gaskets	NBR 70 shore	NBR 70 shore

# WATERPRESS

## PRESSURE BOOSTER SET WITH 24 LT HORIZONTAL PRESSURE TANK

### HYDRAULIC PERFORMANCE

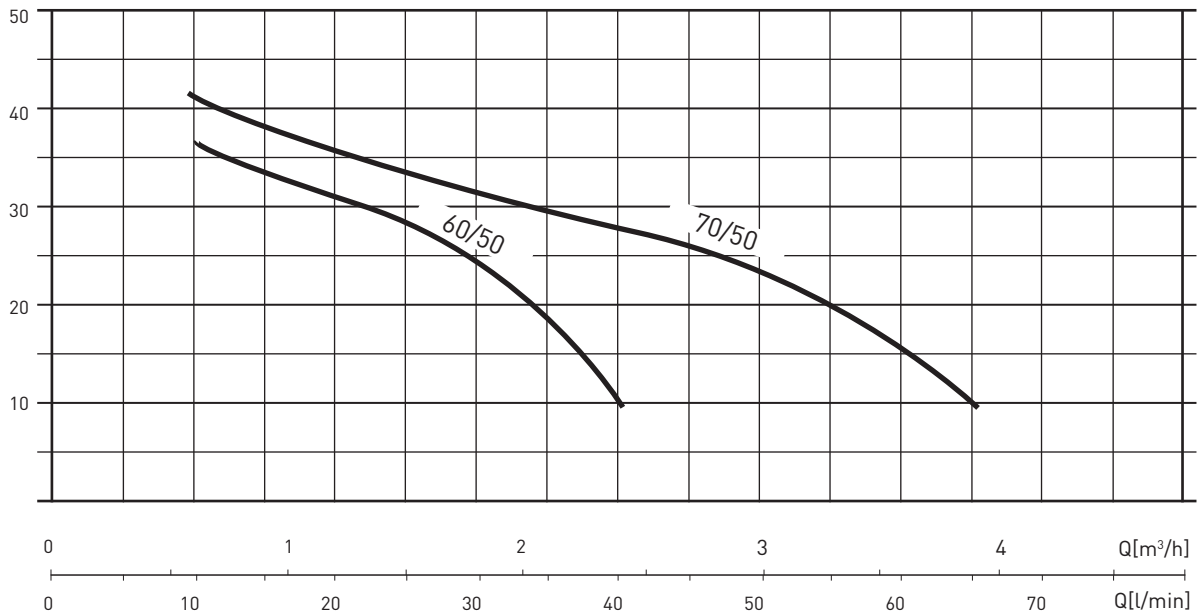

### PERFORMANCE TABLE

MODEL	Motor power (P2)		Motor power (P1)		VOLT (V)	In (A)	μF	Q	Flow rate (Q)							
	HP	kW	HP	kW					l/min	0	10	20	30	40	50	60
								m³/h	0	0,3	1,2	1,8	2,4	3	3,6	4,2
WATERPRESS 60/50	0,75	0,55	1,1	0,80	1~230	4	10	m.c.w.	46	36	31	24	9	4		
WATERPRESS 70/50	1,36	1	1,5	1,1	1~230	5	16	m.c.w.	49	41	36	32	28	25	15	3

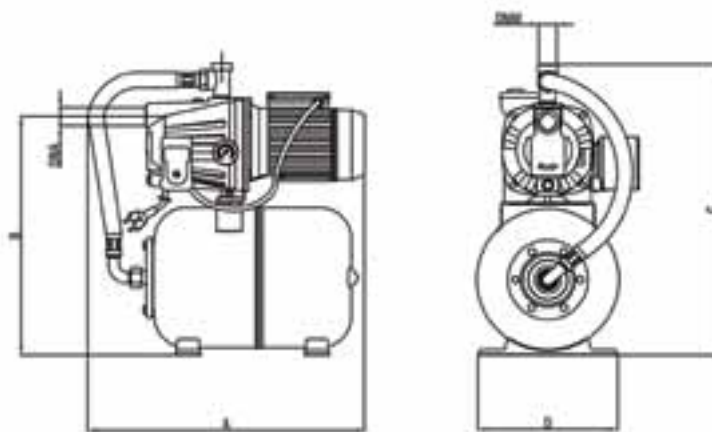

### OVERALL DIMENSIONS AND WEIGHTS

MODEL	Dimensions mm.						WEIGHT (Kg)
	A	B	C	D	DNA	DNM	
WATERPRESS 60/50	510	430	470	260	1" F	1" F	14,5
WATERPRESS 70/50	520	460	550	315	1" F	1" F	22,3

## WATERPRESS INOX

### PRESSURE BOOSTER SET WITH 24 LT HORIZONTAL PRESSURE TANK

The Pressure booster set WATERPRESS INOX are made with a JETINOX type pump. They are supplied wired, complete with a 24 lt expansion tank, ready for installation and use.

#### APPLICATIONS

- Lifting and distribution of water in domestic systems
- Pressurization systems.
- Washing and irrigation.

#### CONSTRUCTION FEATURES

- Pressure switch (max 6 bar) set at: min 2 ÷ max 3 bar.
- Pressure gauge (6 bar).
- 5-way moulded brass plated connector.
- 24 lt expansion module in painted steel with interchangeable rubber membrane for food.
- Tuboflex hydraulic connection.
- Power cable 1.5 m H05 RN-F with plug

#### USAGE DATA

- Type of liquid: clean water without suspended solids or abrasive material.
- Maximum temperature of the liquid 50°C.
- Maximum intake height recommended 8 m with foot valve.
- Maximum operating pressure: 6 bar.

#### MOTOR

- Closed, ventilated from outside.
- Degree of protection IP 44.
- Insulation class F.
- Single-phase power supply with capacitor always on.
- Thermal protection built into the motor casing.
- Speed of rotation 2850 rpm.
- Continuous service.



## TABLE OF MATERIALS

Component	Material
	WP INOX 70/50
Pump body	Stainless steel X5 CrNi 1810 (Aisi 304)
Motor casing	Die-cast aluminium
Impellers	Technopolymer with stainless steel shim ring
Diffuser-Venturi tube-nozzle	Technopolymer
Shaft	Stainless steel X 12 CrNiS 1809 (AISI 416)
Mechanical seal	Graphite
Counterface	Ceramic
Gaskets	NBR 70 shore

# WATERPRESS INOX

## PRESSURE BOOSTER SET WITH 24 LT HORIZONTAL PRESSURE TANK

### HYDRAULIC PERFORMANCE

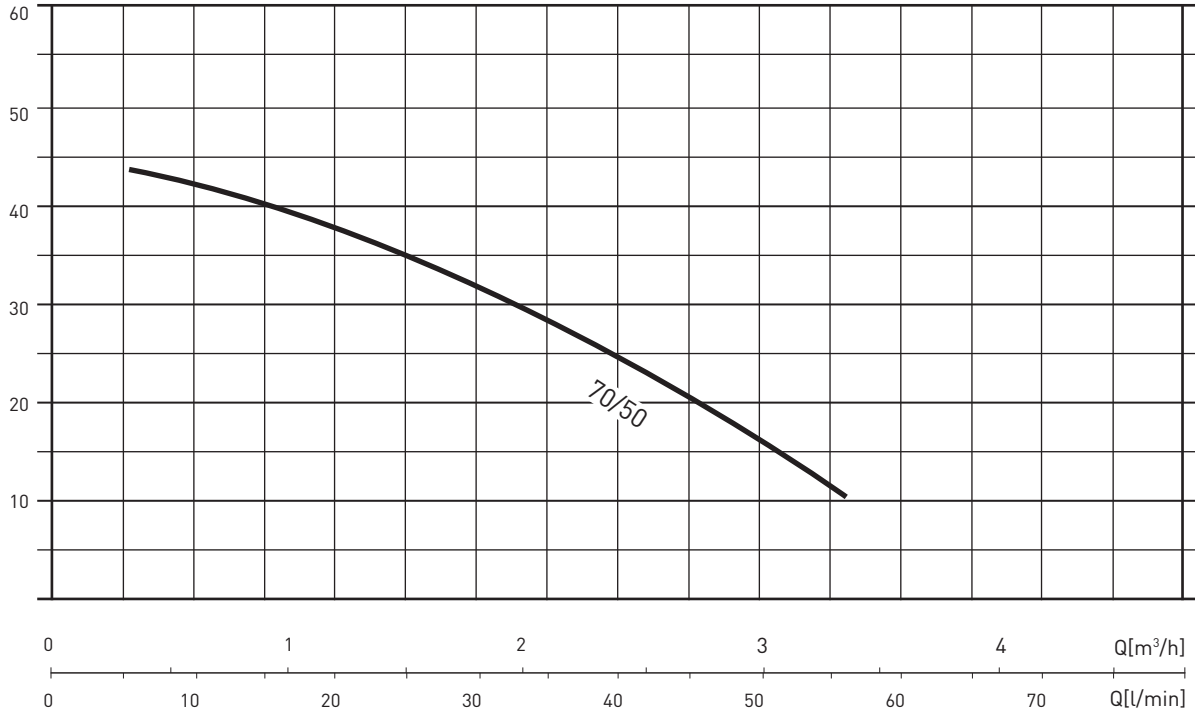

### PERFORMANCE TABLE

MODEL	Motor power (P2)		Motor power (P1)		VOLT (V)	In (A)	µF	Q	Flow rate								
	HP	kW	HP	kW					l/min	0	20	40	60	80			
WP INOX 70/50	0,95	0,7	1,36	1,0	1 - 230	4,5	16	m.c.w.	48	37,5	25	7					
									m³/h	0	1,2	2,4	3,6	4,8			

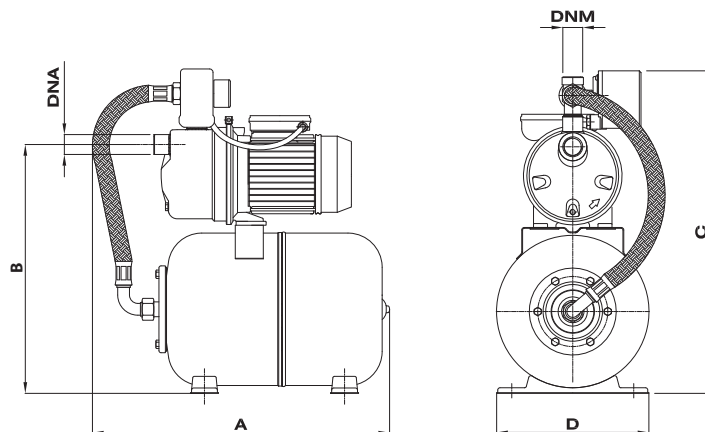

### OVERALL DIMENSIONS AND WEIGHTS

MODEL	Dimensions mm.						WEIGHT (Kg)
	A	B	C	D	DNA	DNM	
WATERPRESS INOX 70/50	520	445	565	260	1" F	1" F	13,8

## WATERPRESS SUPERINOX

### PRESSURE BOOSTER SET WITH 24 LT HORIZONTAL PRESSURE TANK

The Pressure booster set WATERPRESS SUPERINOX are made with a JETINOX self-priming centrifugal pump. They are supplied wired and complete with a stainless steel pressure tank.

#### APPLICATIONS

- Lifting and distribution of water in domestic systems
- Pressurization systems.
- Washing and irrigation.

#### CONSTRUCTION FEATURES

- Pressure switch (max 6 bar) set at: min 2 ÷ max 3 bar.
- Pressure gauge (6 bar).
- 5-way moulded brass plated connector.
- 24 Lt pressure tank in stainless steel with interchangeable rubber membrane for food.
- Tuboflex hydraulic connection.
- Power cable 1.5 m H05 RN-F with plug

#### USAGE DATA

- Type of liquid: clean water without suspended solids or abrasive material.
- Maximum temperature of the liquid 50°C.
- Maximum intake height recommended with foot valve. 8 m WP Superinox 60/50
- Maximum operating pressure: 6 m WP Superinox 60/50

#### MOTOR

- Closed, ventilated from outside.
- Degree of protection IP 44.
- Insulation class F.
- Single-phase power supply with capacitor always on.
- Thermal protection built into the motor casing.
- Speed of rotation 2850 rpm.
- Continuous service.



## TABLE OF MATERIALS

Component	Material
	WP SUPERINOX 60/50
Pump body	Stainless steel X5 CrNi 1810 (AISI 304)
Motor casing	Die-cast aluminium
Impellers	Technopolymer with stainless steel shim ring
Diffuser-Venturi tube-nozzle	Technopolymer
Shaft	Stainless steel X12 CrNiS 1809 (AISI 416)
Mechanical seal	Graphite
Counterface	Ceramic
Seal holder plate	Technopolymer
Gaskets	NBR 70 shore

# WATERPRESS SUPERINOX

## PRESSURE BOOSTER SET WITH 24 LT HORIZONTAL PRESSURE TANK

### HYDRAULIC PERFORMANCE

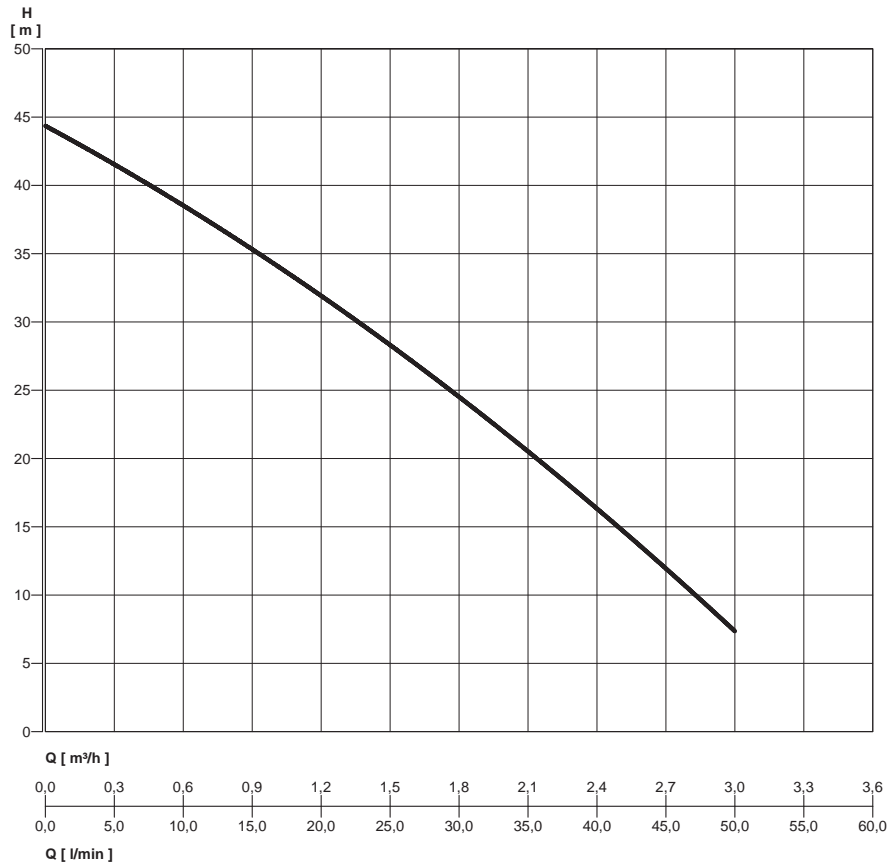

### PERFORMANCE TABLE

MODEL	Motor power (P2)		Motor power (P1)		VOLT (V)	In (A)	μF	0	I/min	10	20	30	40	50
	HP	kW	HP	kW					m³/h	0	0,6	1,2	1,8	2,4
WP SUPERINOX 60/50 C JET	0,75	0,55	1,1	0,8	1 ~ 230	4	12,5	m.c.w.	46	36	31	26	18	6

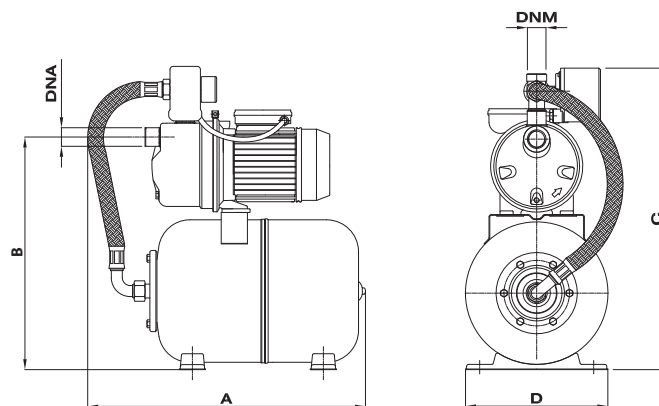

### OVERALL DIMENSIONS AND WEIGHTS

MODEL	Dimensions mm.						WEIGHT (Kg)
	A	B	C	D	DNA	DNM	
WP SUPERINOX 60/50 C	530	425	550	280	1" F	1" F	11,2



# EASY20/MULTI EVO

## PRESSURE BOOSTER SET WITH TWO PUMPS WITH PRESSURE SWITCH CONTROL

Compact, Sturdy, high hydraulic efficiency

They are booster set for the automatic pressurization of water distribution systems with single phase power supply consisting of: 2 pumps, electrical panel, base, intake and delivery manifolds, pressure switches, pressure gauge and check valve in supply.

### DESCRIPTION OF OPERATION

The pumps are controlled by two pressure switches with adjustable settings, via an electrical panel with an electronic board for:

- the sequential start-up of the pumps
- the inversion of the start-up order
- the settings for protection against dry running
- timer (adjustable from 0 to 180»)

When the network pressure reaches the value for the closing of the electrical contact of pressure switch n.1, a pump starts. If the pressure continues to drop, once the value of the closing pressure

of the second pressure switch has been reached, the other pump starts. When the value of the network pressure increases, the pressure switches open their contact causing the relative pump to stop. At the end of each cycle, the automatic inverter changes the starting order of the pumps (once pressure switch n.1 is associated to pump n.1; in the next cycle to pump n.2).

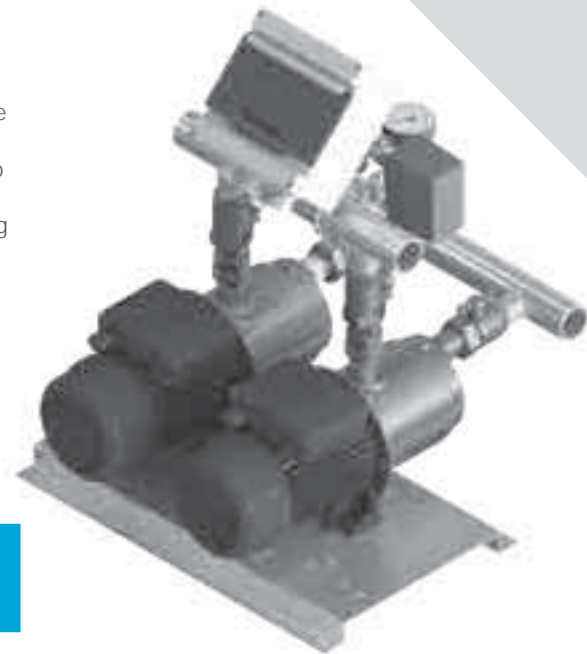

USAGE DATA	MULTIEVO
Maximum capacity (m <sup>3</sup> /h)	21
Maximum head (m.c.a.)	70
Maximum operating pressure	8 bar
Power supply VOLT.	1 ~ 230 / 3-400 V
Frequency	50 Hz
Degree of protection of control panel	IP55
Degree of protection of pump	IP55
Ambient temperature	40°C
Number of pumps	2



### APPLICATIONS

- Lifting and distribution of water in domestic systems
- Pressurization systems
- Irrigation
- Washing systems



# EASY20/MULTI EVO

## PRESSURE BOOSTER SET WITH TWO PUMPS WITH PRESSURE SWITCH CONTROL

### CONSTRUCTION FEATURES

---

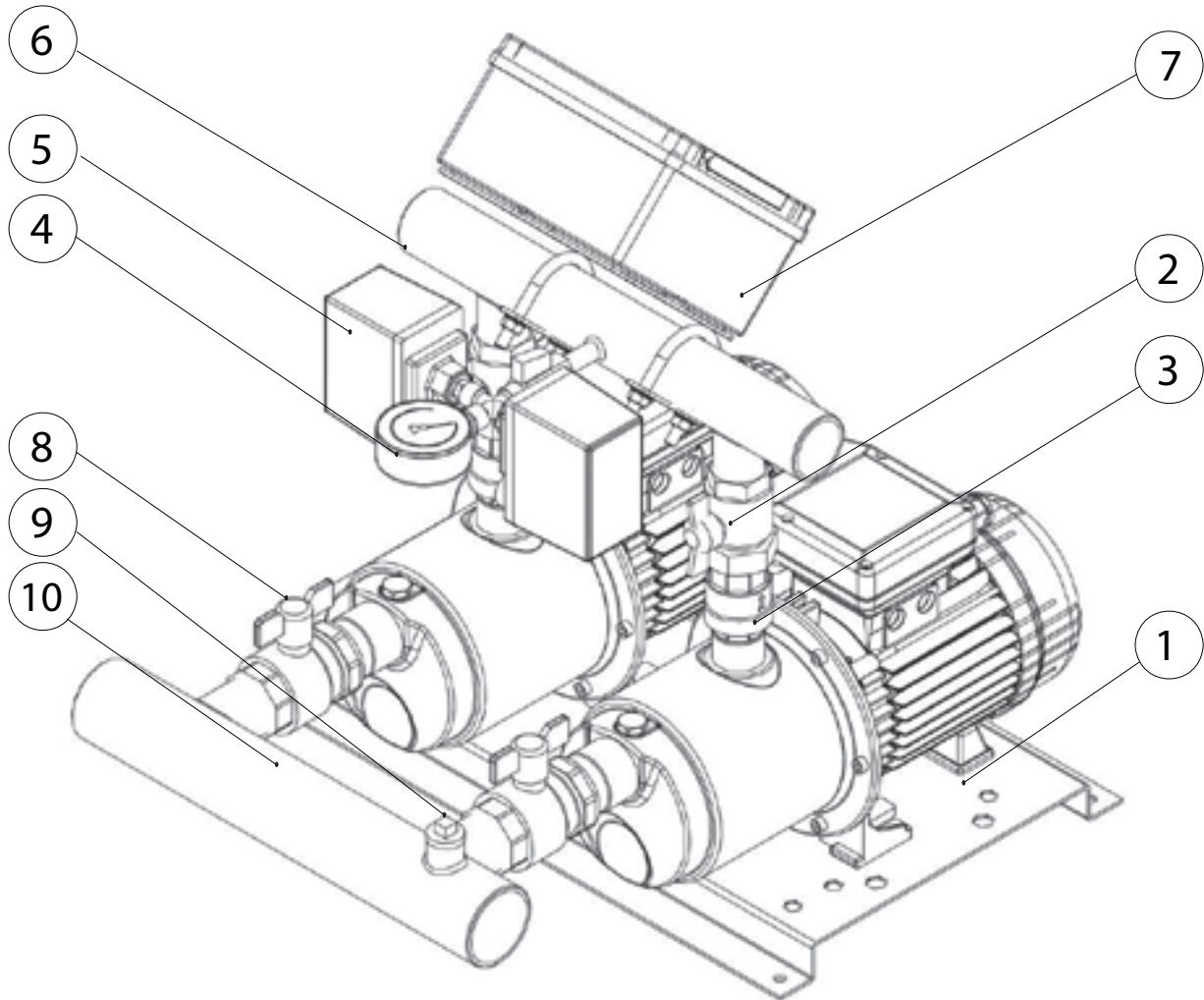

---

#### BASE

- 1. Base in galvanized metal

---

#### DELIVERY MANIFOLD

- 2. n. 2 brass ball valves
- 3. n. 2 check valves
- 4. n. 1 pressure gauges
- 5. n. 2 pressure switches
- 6. n. 1 galvanized steel manifold
- 7. n. 1 electrical panel

---

#### SUCTION MANIFOLD

- 8. n. 2 brass ball valves
- 9. n. 1 sleeve for water load
- 10. n. 1 galvanized steel manifold

# EASY20/MULTI EVO 3

PRESSURE BOOSTER SET WITH TWO PUMPS WITH PRESSURE SWITCH CONTROL

## HYDRAULIC PERFORMANCE

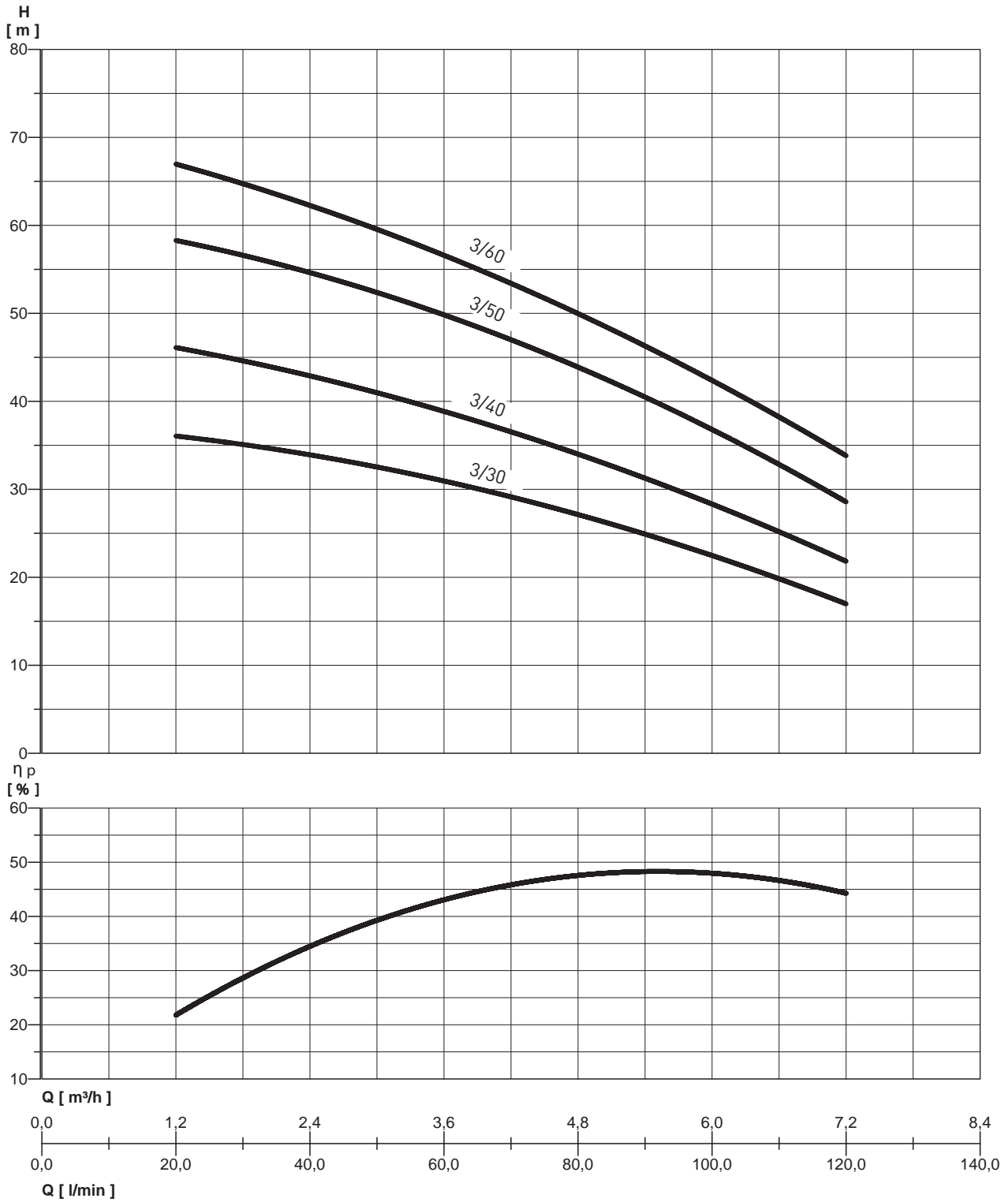

# EASY20/MULTI EVO 3

## PRESSURE BOOSTER SET WITH TWO PUMPS WITH PRESSURE SWITCH CONTROL

### PERFORMANCE TABLE

MODEL	Absorbed power (P1) kW	VOLT. (V)	0	l/min	20	40	60	80	100	120
				m <sup>3</sup> /h	1,2	2,4	3,6	4,8	6	7,2
EASY20/MULTI EVO 3-30 M-GI	2 x 0,65	1 ~ 230	total head in water column metres	36	34	31	27	22,5	17	
EASY20/MULTI EVO 3-30 T-GI	2 x 0,65	3 ~ 400		46	43	39	34	28	22	
EASY20/MULTI EVO 3-40 M-GI	2 x 0,8	1 ~ 230		58	55	50	44	36	29	
EASY20/MULTI EVO 3-40 T-GI	2 x 0,78	3 ~ 400		67	62	57	50	42	34	
EASY20/MULTI EVO 3-50 M-GI	2 x 1	1 ~ 230								
EASY20/MULTI EVO 3-50 T-GI	2 x 1	3 ~ 400								
EASY20/MULTI EVO 3-60 M-GI	2 x 1,25	1 ~ 230								
EASY20/MULTI EVO 3-60 T-GI	2 x 1,17	3 ~ 400								

For VOLT. values, see the data of the reference pump

#### Single-phase

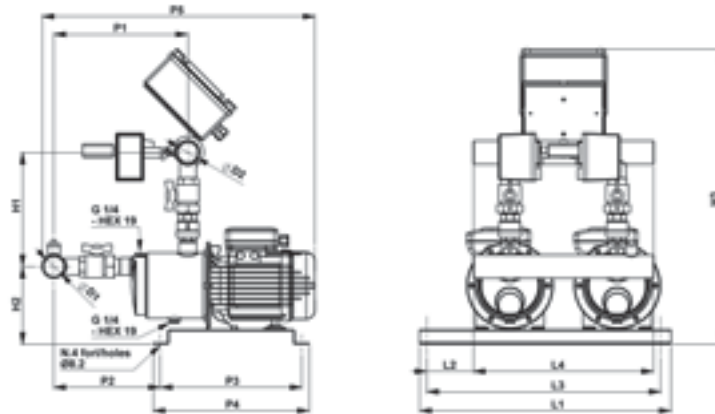

#### Three-phase

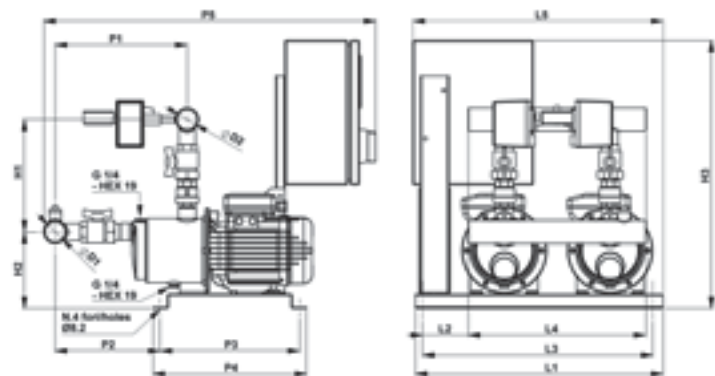

### OVERALL DIMENSIONS AND WEIGHTS

MODEL	Dimensions mm.															WEIGHT (Kg)
	L1	L2	L3	L4	L5	P1	P2	P3	P4	P5	H1	H2	H3	DNA	DNM	
EASY20/MULTI EVO 3-30 M-GI	515	95	485	370	x	255	196	290	320	525	235	160	605	1"1/2	1"1/2	31
EASY20/MULTI EVO 3-30 T-GI	515	95	485	370	520	255	196	290	320	670	235	160	560	1"1/2	1"1/2	37
EASY20/MULTI EVO 3-40 M-GI	515	95	485	370	x	255	196	290	320	525	235	160	605	1"1/2	1"1/2	32
EASY20/MULTI EVO 3-40 T-GI	515	95	485	370	520	255	196	290	320	670	235	160	560	1"1/2	1"1/2	38
EASY20/MULTI EVO 3-50 M-GI	515	95	485	370	x	275	216	290	320	560	235	160	605	1"1/2	1"1/2	36
EASY20/MULTI EVO 3-50 T-GI	515	95	485	370	520	275	216	290	320	690	235	160	560	1"1/2	1"1/2	42
EASY20/MULTI EVO 3-60 M-GI	515	95	485	370	x	297	238	290	320	580	235	160	605	1"1/2	1"1/2	39,5
EASY20/MULTI EVO 3-60 T-GI	515	95	485	370	520	297	238	290	320	715	235	160	560	1"1/2	1"1/2	45,5

# EASY20/MULTI EVO 5

PRESSURE BOOSTER SET WITH TWO PUMPS WITH PRESSURE SWITCH CONTROL

## HYDRAULIC PERFORMANCE

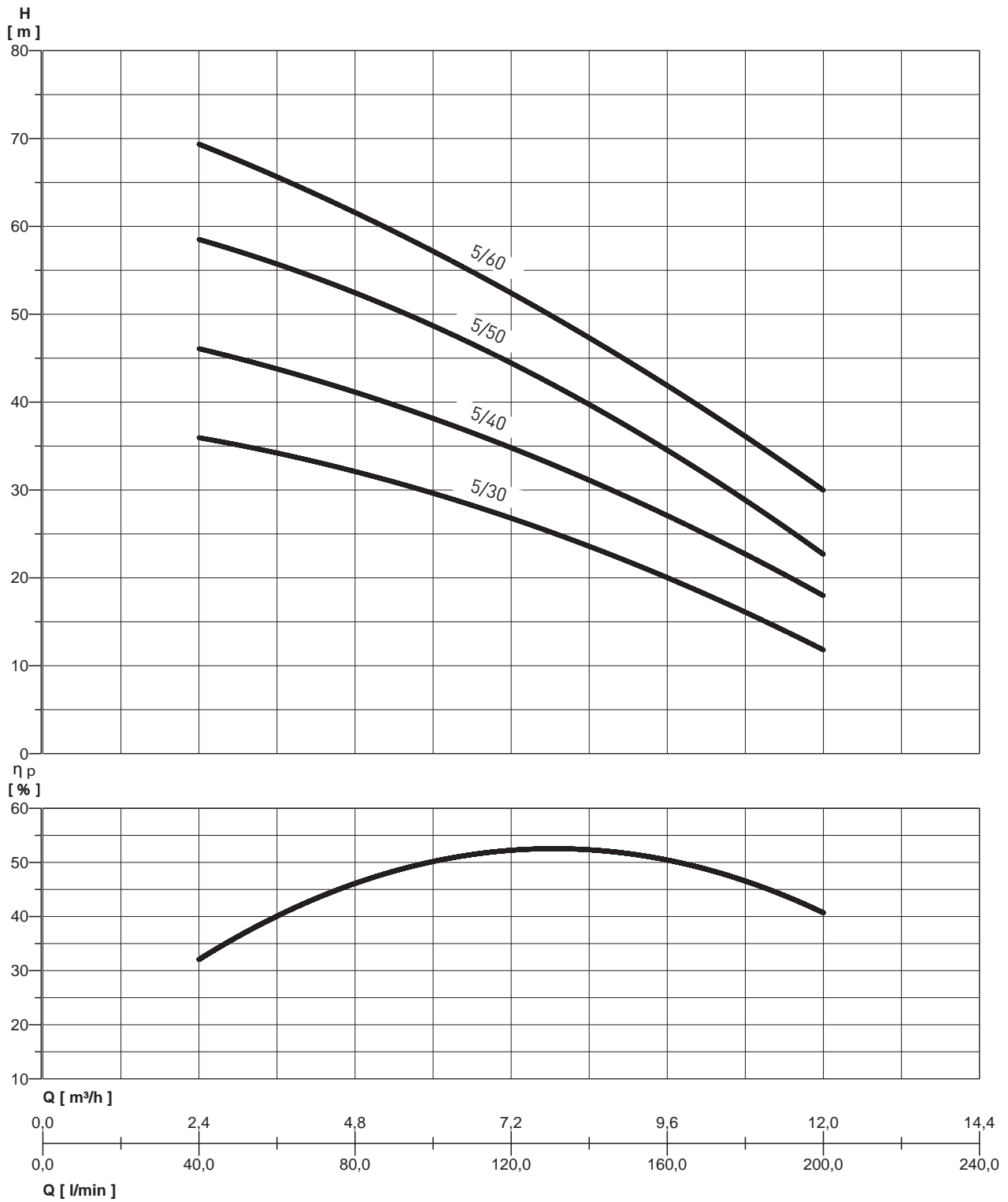

# EASY20/MULTI EVO 5

## PRESSURE BOOSTER SET WITH TWO PUMPS WITH PRESSURE SWITCH CONTROL

### PERFORMANCE TABLE

MODEL	Absorbed power (P1) kW	VOLT. (V)	0	l/min	40	60	80	100	120	160	200
				m <sup>3</sup> /h	2,4	3,6	4,8	6	7,2	9,6	12
EASY20/MULTI EVO 5-30 M-GI	2 x 0,8	1 ~ 230	total head in water column metres	36	34	32	30	27	19,5	12	
EASY20/MULTI EVO 5-30 T-GI	2 x 0,78	3 ~ 400		46	44	41	38	35	27	18	
EASY20/MULTI EVO 5-40 M-GI	2 x 1,1	1 ~ 230		58	56	53	49	44	34	23	
EASY20/MULTI EVO 5-40 T-GI	2 x 1,1	3 ~ 400		69	66	62	57	52	42	30	
EASY20/MULTI EVO 5-50 M-GI	2 x 1,35	1 ~ 230									
EASY20/MULTI EVO 5-50 T-GI	2 x 1,25	3 ~ 400									
EASY20/MULTI EVO 5-60 M-GI	2 x 1,65	1 ~ 230									
EASY20/MULTI EVO 5-60 T-GI	2 x 1,57	3 ~ 400									

For VOLT. values, see the data of the reference pump

#### Single-phase

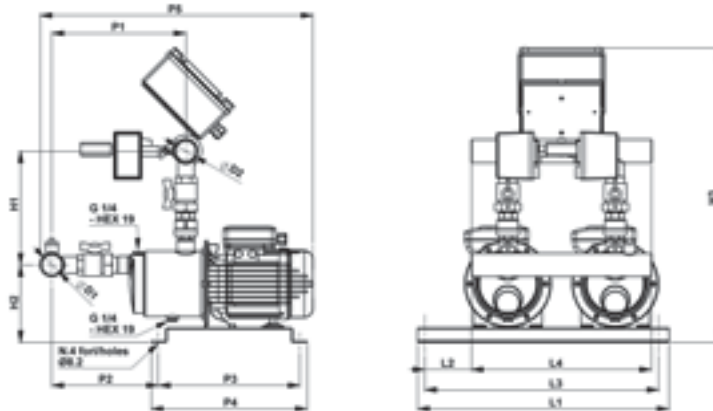

#### Three-phase

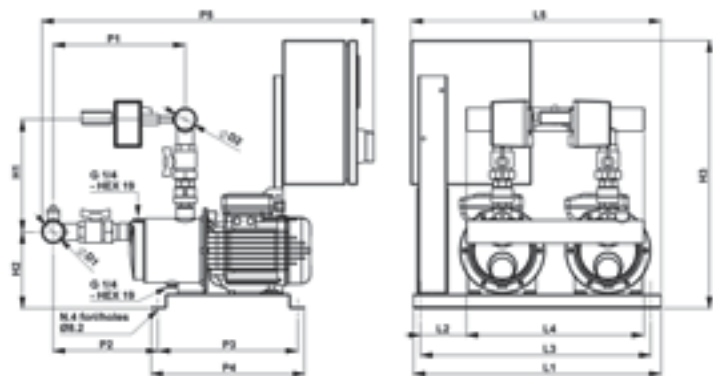

### OVERALL DIMENSIONS AND WEIGHTS

MODEL	Dimensions mm.																WEIGHT (Kg)
	L1	L2	L3	L4	L5	P1	P2	P3	P4	P5	H1	H2	H3	DNA	DNM		
EASY20/MULTI EVO 5-30 M-GI	515	95	485	370	x	275	222	290	320	550	240	155	605	2"	1 1/2"	33,5	
EASY20/MULTI EVO 5-30 T-GI	515	95	485	370	520	275	222	290	320	695	240	155	560	2"	1 1/2"	39,5	
EASY20/MULTI EVO 5-40 M-GI	515	95	485	370	x	275	222	290	320	560	240	155	605	2"	1 1/2"	37	
EASY20/MULTI EVO 5-40 T-GI	515	95	485	370	520	275	222	290	320	695	240	155	560	2"	1 1/2"	43	
EASY20/MULTI EVO 5-50 M-GI	515	95	485	370	x	300	247	290	320	590	240	155	605	2"	1 1/2"	40	
EASY20/MULTI EVO 5-50 T-GI	515	95	485	370	520	300	247	290	320	695	240	155	560	2"	1 1/2"	46	
EASY20/MULTI EVO 5-60 M-GI	515	95	485	370	x	320	267	290	320	645	240	155	605	2"	1 1/2"	46	
EASY20/MULTI EVO 5-60 T-GI	515	95	485	370	520	320	267	290	320	745	240	155	560	2"	1 1/2"	52	

# EASY20/MULTI EVO 8

PRESSURE BOOSTER SET WITH TWO PUMPS WITH PRESSURE SWITCH CONTROL

## HYDRAULIC PERFORMANCE

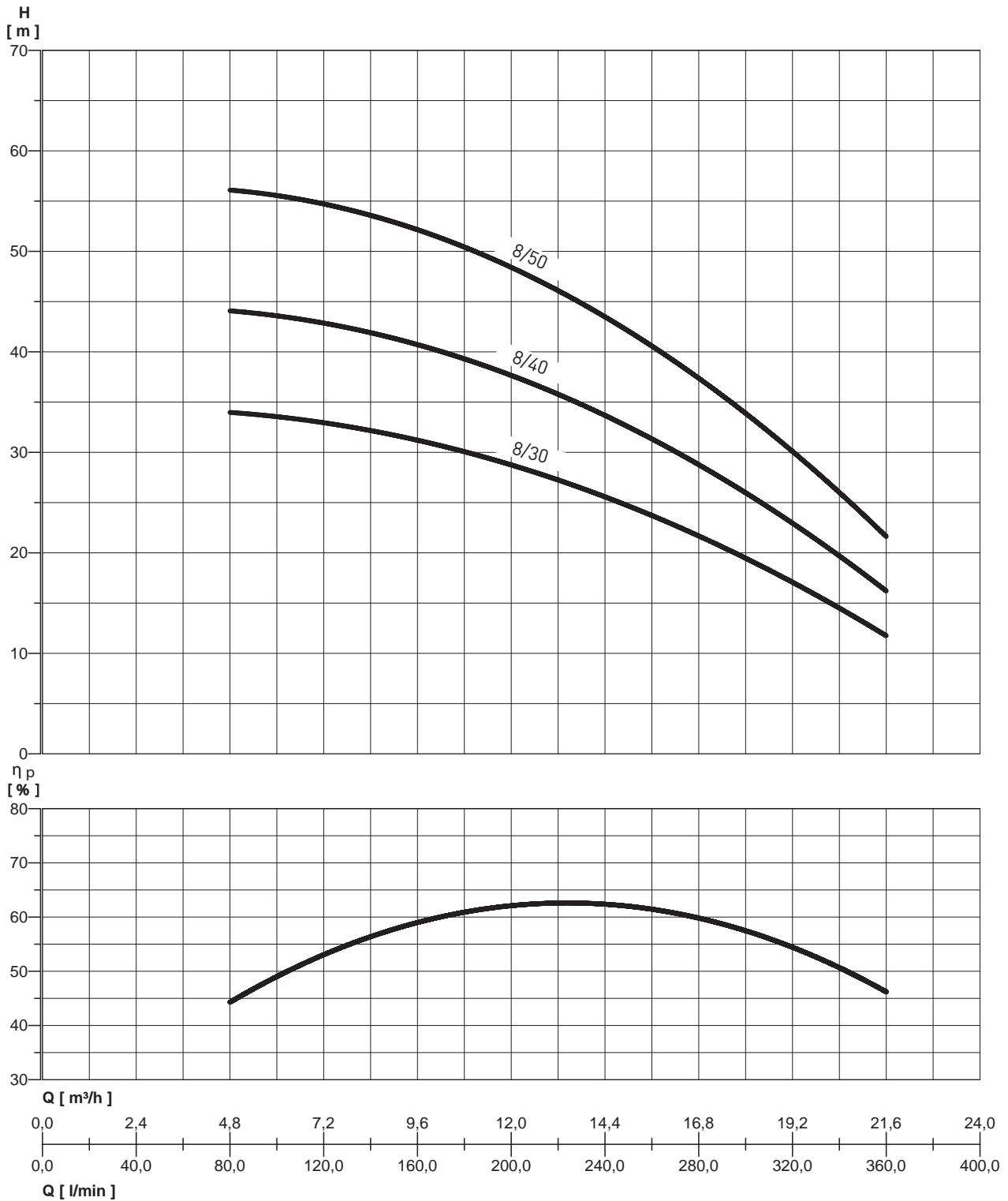

# EASY20/MULTI EVO 8

## PRESSURE BOOSTER SET WITH TWO PUMPS WITH PRESSURE SWITCH CONTROL

### PERFORMANCE TABLE

MODEL	Absorbed power (P1) kW	VOLT. (V)	0	total head in water column metres									
				l/min	80	100	120	160	200	240	280	320	360
				m <sup>3</sup> /h	4,8	6	7,2	9,6	12	14,4	16,8	19,2	21,6
EASY20/MULTI EVO 8-30 M-GI	2 x 1,28	1 ~ 230			34	33,5	33	31	29	25,5	22	16,5	12
EASY20/MULTI EVO 8-30 T-GI	2 x 1,2	3 ~ 400											
EASY20/MULTI EVO 8-40 M-GI	2 x 1,66	1 ~ 230			44,5	43,5	42,5	40,5	37,5	34	29	23	16
EASY20/MULTI EVO 8-40 T-GI	2 x 1,5	3 ~ 400											
EASY20/MULTI EVO 8-50 M-GI	2 x 2	1 ~ 230			56,5	55,5	54,5	51,5	48,5	44,0	37,5	30,0	21,5
EASY20/MULTI EVO 8-50 T-GI	2 x 1,95	3 ~ 400											

For VOLT. values, see the data of the reference pump

### Single-phase

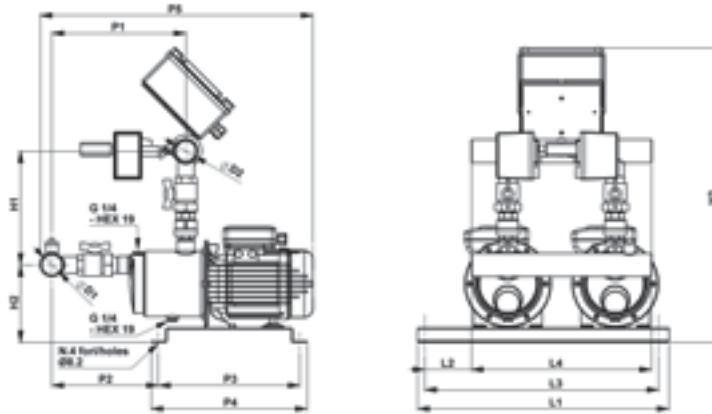

### Three-phase

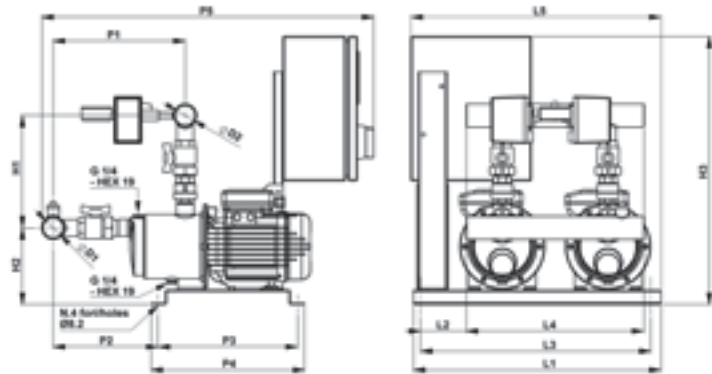

### OVERALL DIMENSIONS AND WEIGHTS

MODEL	Dimensions mm.															WEIGHT (Kg)
	L1	L2	L3	L4	L5	P1	P2	P3	P4	P5	H1	H2	H3	DNA	DNM	
EASY20/MULTI EVO 8-30 M-GI	515	95	485	370	x	296	240	290	320	585	292	155	660	2"	2"	42
EASY20/MULTI EVO 8-30 T-GI	515	95	485	370	520	296	240	290	320	718	292	155	560	2"	2"	48
EASY20/MULTI EVO 8-40 M-GI	515	95	485	370	x	296	240	290	320	620	292	155	660	2"	2"	48
EASY20/MULTI EVO 8-40 T-GI	515	95	485	370	520	296	240	290	320	718	292	155	560	2"	2"	54
EASY20/MULTI EVO 8-50 M-GI	515	95	485	370	x	325	275	290	320	645	292	155	660	2"	2"	50
EASY20/MULTI EVO 8-50 T-GI	515	95	485	370	520	325	275	290	320	745	292	155	560	2"	2"	56



## EASYBOOST

### RESIDENTIAL - PRESSURE BOOSTER SET WITH PRESSURE SWITCH CONTROL

Compact, Sturdy, high hydraulic efficiency, reliable

They are booster set for the automatic pressurization of water distribution systems with single phase power supply consisting of: 2 pumps, electrical panel, base, intake and delivery manifolds, pressure switches, pressure gauge and check valve in supply.

#### DESCRIPTION OF OPERATION

The pumps are controlled by two pressure switches with adjustable settings, via an electrical panel with an electronic board for:

- the sequential start-up of the pumps
- the inversion of the start-up order
- the settings for protection against dry running
- timer (adjustable from 0 to 180")

When the mains pressure reaches the value for the closing of the electrical contact of pressure switch n.1, a pump starts. If the pressure continues to drop, once the value of the closing pressure of the second pressure switch has been reached, the other pump starts. When the value of the network pressure increases, the pressure switches open their contact causing the relative pump to stop. At the end of each cycle, the automatic inverter changes the starting order of the pumps (once pressure switch n.1 is associated to pump n.1; in the next cycle to pump n.2).

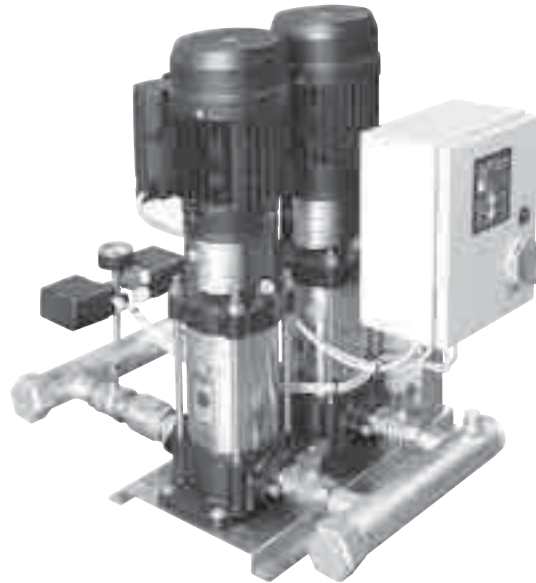

NUMBER OF PUMPS		MAXIMUM CAPACITY	
Main	Pilot	L/min	m <sup>3</sup> /h
2	-	from 200 to 480	from 12 to 28.8

# EASYBOOST

## PRESSURE BOOSTER SET WITH PRESSURE SWITCH CONTROL

### USAGE DATA

USAGE DATA	CB	DHR	MULTINOX VE +	PVM
Maximum capacity (m <sup>3</sup> /h)	16.8	28.8	25.2	17
Maximum head (m.c.a.)	60.5	63	140	110
Maximum operating pressure	9 bar	10 bar	14 bar	16 bar
Power supply VOLT.	1 ~ 230 / 3~400 V			
Frequency	50 Hz			
Degree of protection of control panel	IP55	IP54	IP55	IP54
Degree of protection of pump	IP44	IP55	IP44	IP55
Ambient temperature	40° C	50° C	50° C	50° C

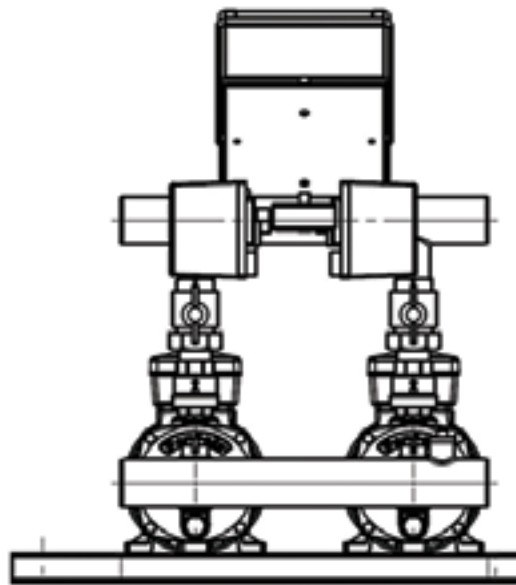

#### PUMP

- n. 2 CB - Bi-rotating centrifugal horizontal axis
- n. 2 MULTINOX VE+ - Multicellular centrifugal vertical axis
- n. 2 DHR - Multicellular centrifugal vertical axis
- n. 2 PVM - Multicellular centrifugal vertical axis

#### SUCTION MANIFOLD

- n. 2 brass ball valves
- n. 1 sleeve for water load

#### DELIVERY MANIFOLD

- n. 2 brass ball valves
- n. 2 check valves
- n. 1 pressure gauge
- n. 2 pressure switches

#### BASE

- In galvanized metal

# EASYBOOST

## PRESSURE BOOSTER SET WITH PRESSURE SWITCH CONTROL

### SINGLE PHASE ELECTRICAL PANEL

---

#### ELECTRICAL PANEL

---

- Box in plastic material IP65
- Fuses
- Multifunctional electronic board with integrated transformer for the auxiliary circuit
- Start-up relay for each pump
- Protection against overload provided by the electronic board
- Trimmer to adjust the delay time from 0 to 180 seconds, after the opening of the contact of the pressure switch (for each pump)

#### MAIN FUNCTIONS

---

- Cyclic inversion of the start-up order of the pumps after each cycle end.
- ON/OFF control of the level of the tank or the pressure of the supply duct by means of a float switch or a different differential pressure switch.
- Adjustable timer for the pumps

#### SIGNALS AND CONTROLS

---

- Manual - Automatic button
- ON/OFF buttons for each pump
- LED indicating the presence of power
- LED indicating pump in operation
- LED indicating low level in the collection tank or pressure insufficient in the Suction manifold
- LEDs indicating manual or automatic operation
- BMS with contacts for each pump: pump on and overload

#### EXTRENAL CONTROL DEVICES

---

- Two adjustable differential pressure switches ON/OFF

#### EXTRENAL CONTROL DEVICES

---

- ON/OFF float switch, located in the water collection tank, or
- Reverse pressure switch inserted in the water supply duct (aqueduct)



# EASYBOOST

## PRESSURE BOOSTER SET WITH PRESSURE SWITCH CONTROL

### THREE-PHASE ELECTRICAL PANEL

---

#### **ELECTRICAL PANEL**

- Metal box IP54
- Main switch
- Electronic board
- Fuses and contactors for each pump
- Protection against overload provided by the electronic board
- Transformer with fuses for the auxiliary circuit

#### **MAIN FUNCTIONS**

- Cyclic inversion of the start-up order of the pumps after each cycle end.
- ON/OFF control of the level of the tank or the pressure of the supply duct by means of a float switch or a different differential pressure switch.
- Timer of the last pump settable from 0 to 180 seconds, after the opening of the pressure switch operation contact.

#### **SIGNALS AND CONTROLS**

- M-O-T button (Manual - 0 - Automatic)
- ON/OFF buttons for each pump
- LED indicating the presence of power
- LED indicating pump in operation
- LED indicating low level in the collection tank or pressure insufficient in the Suction manifold
- LED indicating overload
- LEDs indicating manual or automatic operation
- BMS with contacts for each pump: pump on, overload and no water alarm
- Communication RS232/RS485

#### **EXTRENAL CONTROL DEVICES**

- Two adjustable differential pressure switches ON/OFF

#### **EXTRENAL CONTROL DEVICES**

- ON/OFF float switch, located in the water collection tank, or
- Reverse pressure switch inserted in the water supply duct (aqueduct)



# EASYBOOST - CB

## PRESSURE BOOSTER SET WITH PRESSURE SWITCH CONTROL

### HYDRAULIC PERFORMANCE

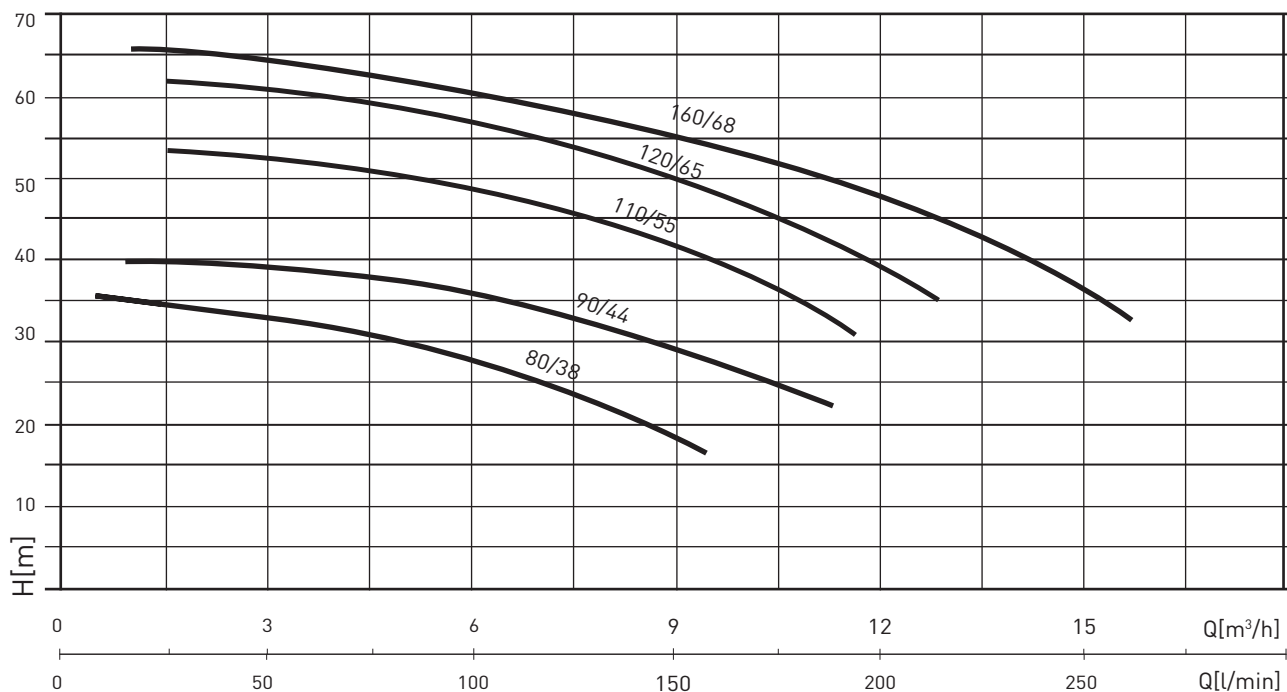

### PERFORMANCE TABLE

MODEL	kW	VOLT. (V)	l/min	40	80	100	160	180	200	220	280
				m³/h	2,4	4,8	6	9,6	10,8	12	13,2
EASY20/CB 80/38	2x0,55	1 - 230 3 - 400	m.c.w.	33	30	28	17				
EASY20/CB 90/44	2x0,74	1 - 230 3 - 400		40	37	35	27	21			
EASY20/CB 110/55	2x1,1	1 - 230 3 - 400		51	49	47	38	33	28		
EASY20/CB 120/65	2x1,5	1 - 230 3 - 400		61	59	57	50	47	40	33	
EASY20/CB 160/68	2x2,20	3 - 400			61	59	54	52	49	45	32

For VOLT values, see the data of the reference pump

# EASYBOOST - CB

## PRESSURE BOOSTER SET WITH PRESSURE SWITCH CONTROL

### OVERALL DIMENSIONS AND WEIGHTS

#### SINGLE PHASE

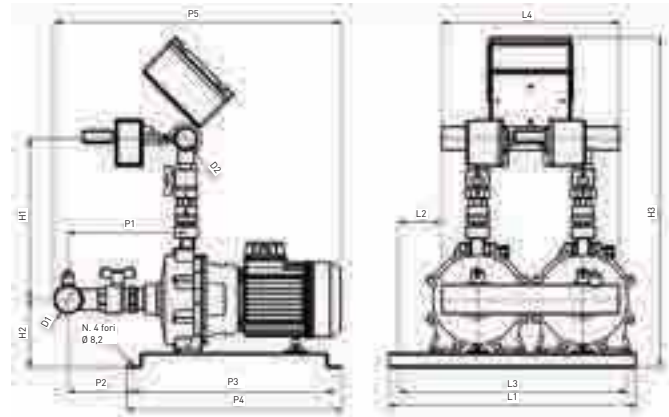

#### THREE PHASE

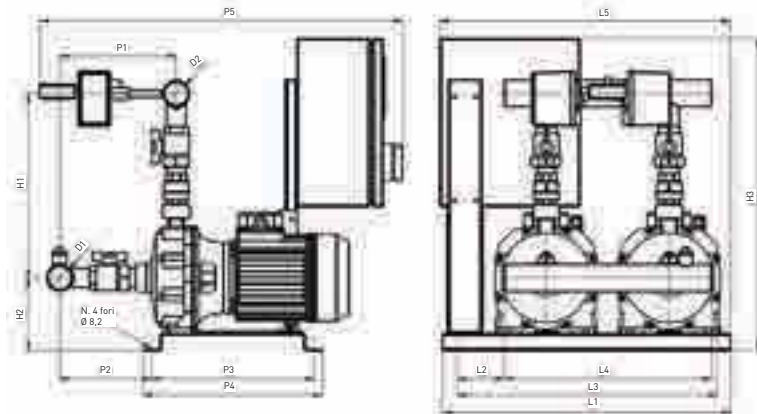

### OVERALL DIMENSIONS AND WEIGHTS

MODEL	Dimensions mm.															WEIGHT (Kg)	
	L1	L2	L3	L4	L5	P1	P2	P3	P4	P5	H1	H2	H3	D1	D2	220V	400V
EASY20/CB 80/38M-GI	515	95	485	370	X	209	165	290	320	542	328	130	671	1-1/2"	1-1/2"	34	40
EASY20/CB 80/38T-GI	515	95	485	370	520	209	165	290	320	652	328	130	560	1-1/2"	1-1/2"	34	40
EASY20/CB 90/44M-GI	515	95	485	370	X	209	165	290	320	542	328	130	671	1-1/2"	1-1/2"	42	48
EASY20/CB 90/44T-GI	515	95	485	370	520	209	165	290	320	652	328	130	560	1-1/2"	1-1/2"	42	48
EASY20/CB 110/55M-GI	515	95	485	370	X	246	135	420	450	600	335	142	690	2"	1-1/2"	62	68
EASY20/CB 110/55T-GI	515	95	485	370	520	246	135	420	450	758	335	142	560	2"	1-1/2"	62	68
EASY20/CB 120/65M-GI	515	95	485	370	X	246	135	420	450	600	335	142	690	2"	1-1/2"		70
EASY20/CB 120/65T-GI	515	95	485	370	520	246	135	420	450	758	335	142	560	2"	1-1/2"		70
EASY20/CB 160/68T-GI	515	95	485	370	520	246	135	420	450	758	335	142	560	2"	1-1/2"	63	69

# EASYBOOST - DHR 2/4

SINGLE PHASE AND THREE-PHASE PRESSURE BOOSTER SET WITH PRESSURE SWITCH CONTROL

## HYDRAULIC PERFORMANCE

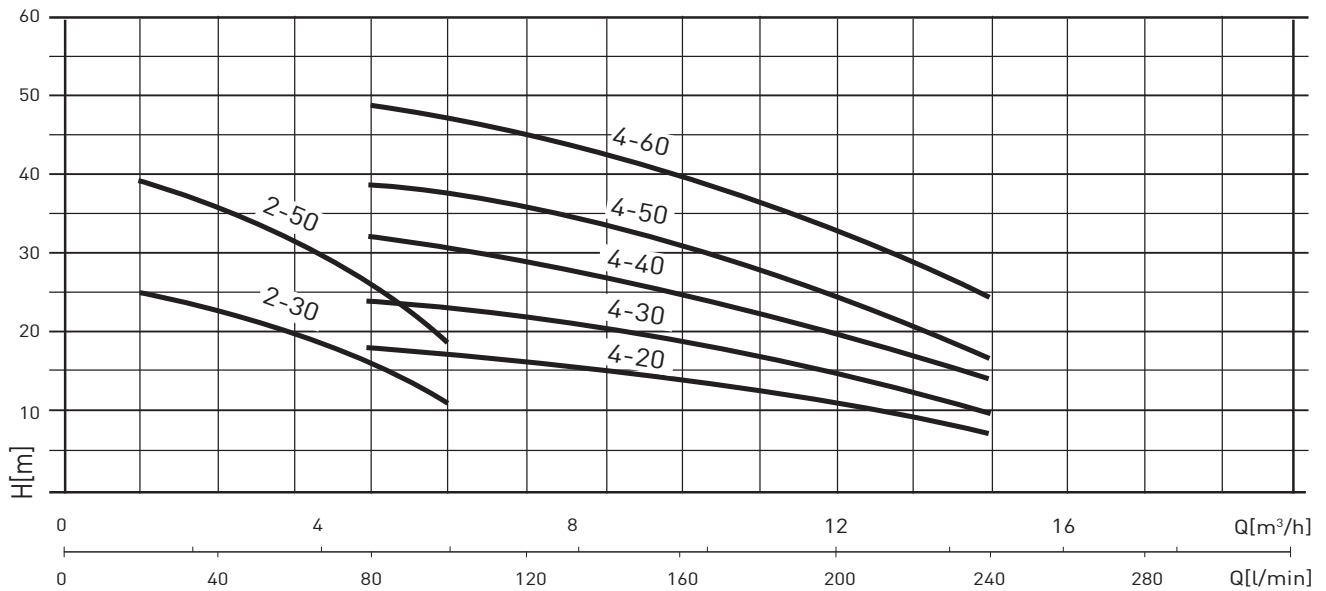

## PERFORMANCE TABLE

MODEL	kW	VOLT. (V)	l/min m³ / h	20	60	80	100	160	200	240
				1,2	3,6	4,8	6	9,6	12	14,4
EASY20/DHR 2-30	2x0,30	1 ~ 230	m.c.w.	25	19	16	12			
		3 ~ 400								
EASY20/DHR 2-50	2x0,50	1 ~ 230	m.c.w.	39	30	23	16			
		3 ~ 400								
EASY20/DHR 4-20	2x0,37	1 ~ 230	m.c.w.			17	16	13	11	7
		3 ~ 400								
EASY20/DHR 4-30	2x0,5	1 ~ 230	m.c.w.			24	23	18	14	10
		3 ~ 400								
EASY20/DHR 4-40	2x0,70	1 ~ 230	m.c.w.			32	30	25	20	14
		3 ~ 400								
EASY20/DHR 4-50	2x0,90	1 ~ 230	m.c.w.			39	38	31	25	17
		3 ~ 400								
EASY20/DHR 4-60	2x1,2	1 ~ 230	m.c.w.			49	47	41	34	25
		3 ~ 400								

For VOLT. values, see the data of the reference pump

# EASYBOOST - DHR 2/4

SINGLE PHASE AND THREE-PHASE PRESSURE BOOSTER SET WITH PRESSURE SWITCH CONTROL

## OVERALL DIMENSIONS AND WEIGHTS

**SINGLE PHASE - DHR 2**

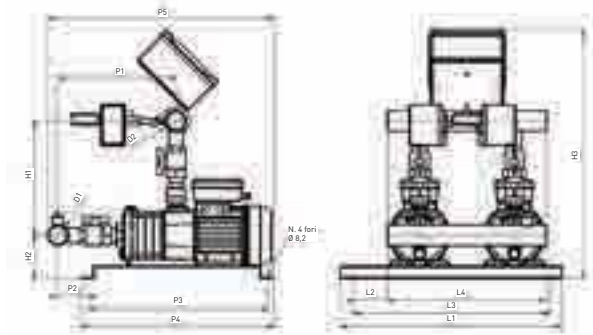

**THREE PHASE - DHR 2**

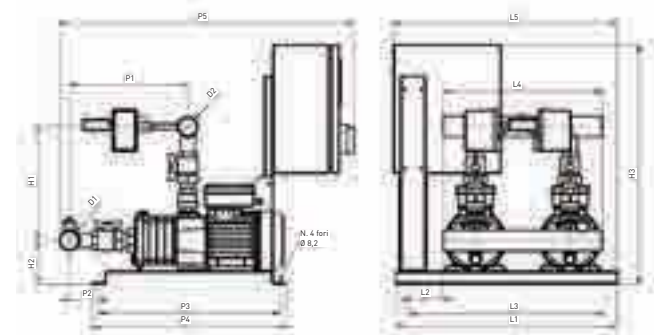

**SINGLE PHASE - DHR 4**

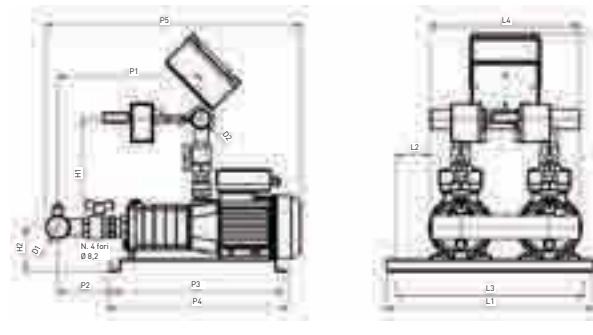

**THREE PHASE - DHR 4**

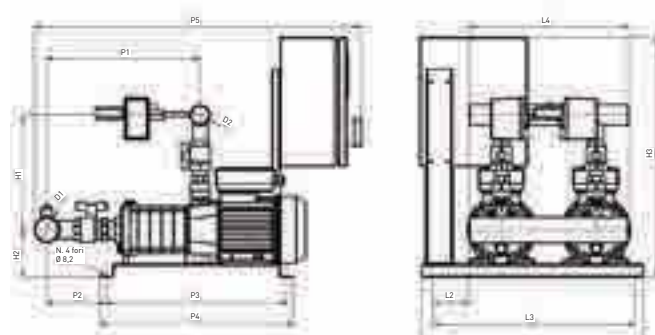

## OVERALL DIMENSIONS AND WEIGHTS

MODEL	Dimensions mm.														WEIGHT (Kg)		
	L1	L2	L3	L4	L5	P1	P2	P3	P4	P5	H1	H2	H3	D1	D2	230V	400V
EASY20/DHR 2-30M-GI	515	95	485	370	X	239	35	420	450	493	265	100	578	1-1/2"	1-1/2"	32	38
EASY20/DHR 2-30T-GI	515	95	485	370	520	239	35	420	450	651	265	100	560	1-1/2"	1-1/2"	32	38
EASY20/DHR 2-50M-GI	515	95	485	370	X	275	68	420	450	527	265	100	578	1-1/2"	1-1/2"	35	41
EASY20/DHR 2-50T-GI	515	95	485	370	520	275	68	420	450	685	265	100	560	1-1/2"	1-1/2"	35	41
EASY20/DHR 4-20M-GI	515	95	485	370	X	276	69	420	450	505	265	100	580	2"	1-1/2"	34	40
EASY20/DHR 4-20T-GI	515	95	485	370	520	276	69	420	450	687	265	100	560	2"	1-1/2"	34	40
EASY20/DHR 4-30M-GI	515	95	485	370	X	276	69	420	450	505	265	100	580	2"	1-1/2"	34	40
EASY20/DHR 4-30T-GI	515	95	485	370	520	276	69	420	450	687	265	100	560	2"	1-1/2"	34	40
EASY20/DHR 4-40M-GI	515	95	485	370	X	303	96	420	450	531	265	100	580	2"	1-1/2"	36	42
EASY20/DHR 4-40T-GI	515	95	485	370	520	303	96	420	450	714	265	100	560	2"	1-1/2"	36	42
EASY20/DHR 4-50M-GI	515	95	485	370	X	330	123	420	450	558	265	100	580	2"	1-1/2"	40	46
EASY20/DHR 4-50T-GI	515	95	485	370	520	330	123	420	450	740	265	100	560	2"	1-1/2"	40	46
EASY20/DHR 4-60M-GI	515	95	485	370	X	357	138	420	450	632	267	110	590	2"	1-1/2"	46	52
EASY20/DHR 4-60T-GI	515	95	485	370	520	357	138	420	450	762	267	110	560	2"	1-1/2"	46	52



# EASYBOOST - DHR 9

PRESSURE BOOSTER SET WITH PRESSURE SWITCH CONTROL

## HYDRAULIC PERFORMANCE

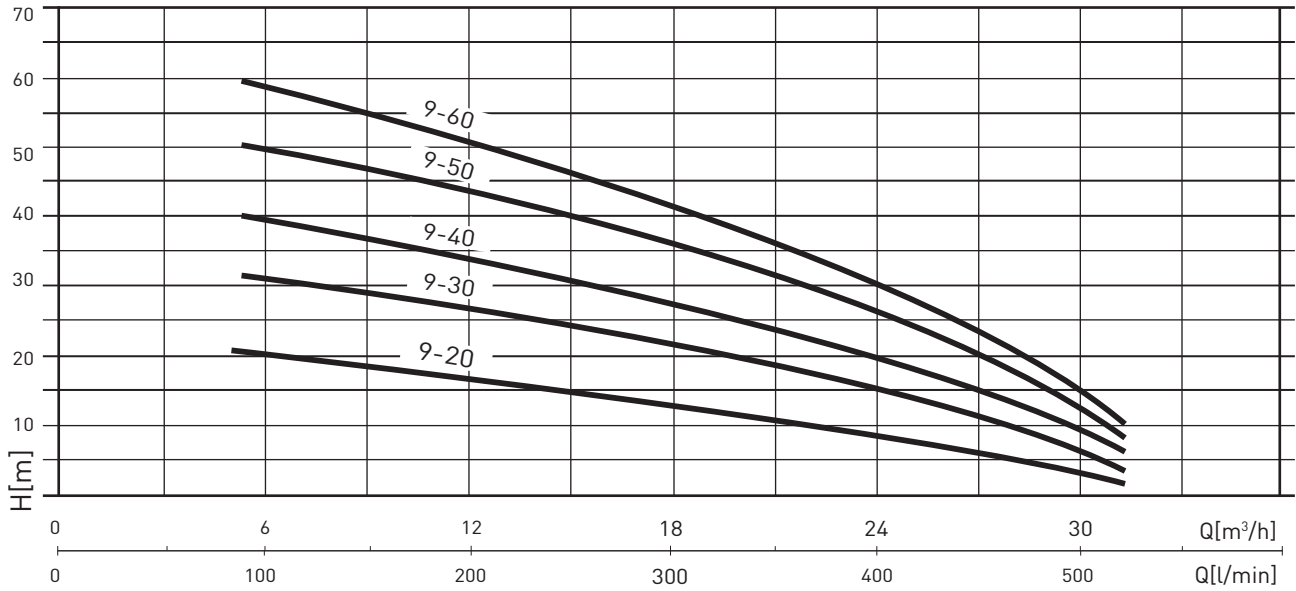

## PERFORMANCE TABLE

MODEL	kW	VOLT. (V)	l/min	80	160	240	320	400	480
			m³ / h	4,8	9,6	14,4	19,2	24	28,8
EASY20/DHR 9-20	2x0,65	1 - 230	m.c.w.	20	19	16	13	9	5
		3 - 400							
EASY20/DHR 9-30	2x0,95	1 - 230		31	29	26	21	16	9
		3 - 400							
EASY20/DHR 9-40	2x1,3	1 - 230		40	38	33	27	19	10
		3 - 400							
EASY20/DHR 9-50	2x1,6	1 - 230	51	49	43	36	26	14	
		3 - 400							
EASY20/DHR 9-60	2x1,9	1 - 230	60	56	49	40	29	14	
		3 - 400							

For VOLT. values, see the data of the reference pump

# EASYBOOST - DHR 9

PRESSURE BOOSTER SET WITH PRESSURE SWITCH CONTROL

## OVERALL DIMENSIONS AND WEIGHTS

### SINGLE PHASE

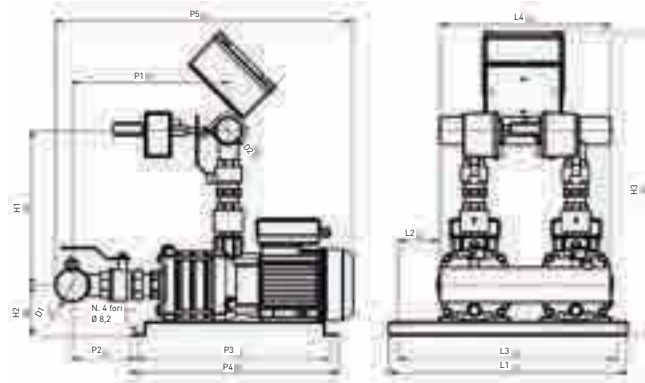

### THREE PHASE

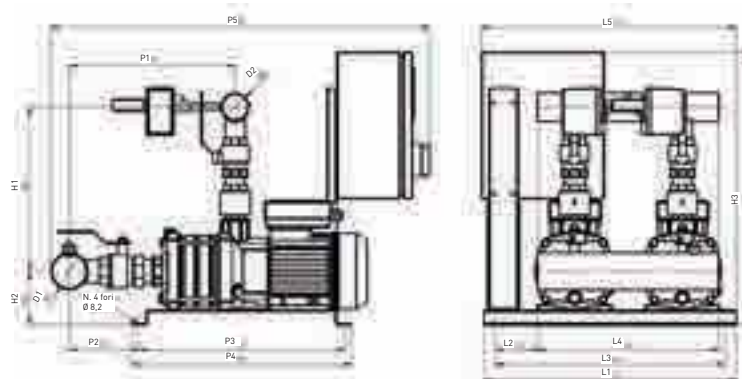

## OVERALL DIMENSIONS AND WEIGHTS

MODEL	Dimensions mm.															WEIGHT (Kg)
	L1	L2	L3	L4	L5	P1	P2	P3	P4	P5	H1	H2	H3	D1	D2	
EASY20/DHR 9-20M-GI	515	95	485	370	X	280	82	420	450	588	110	335	660	2-1/2"	2"	54
EASY20/DHR 9-20T-GI	515	95	485	370	520	280	82	420	450	713	110	335	560	2-1/2"	2"	54
EASY20/DHR 9-30M-GI	515	95	485	370	X	280	82	420	450	588	110	335	660	2-1/2"	2"	55
EASY20/DHR 9-30T-GI	515	95	485	370	520	280	82	420	450	713	110	335	560	2-1/2"	2"	55
EASY20/DHR 9-40M-GI	515	95	485	370	X	310	112	420	450	618	110	335	660	2-1/2"	2"	57
EASY20/DHR 9-40T-GI	515	95	485	370	520	310	112	420	450	743	110	335	560	2-1/2"	2"	57
EASY20/DHR 9-50M-GI	515	95	485	370	X	340	142	420	450	648	110	335	660	2-1/2"	2"	62
EASY20/DHR 9-50T-GI	515	95	485	370	520	340	142	420	450	773	110	335	560	2-1/2"	2"	62
EASY20/DHR 9-60T-GI	515	95	485	370	520	370	172	420	450	803	110	335	560	2-1/2"	2"	65

# EASYBOOST 20 MULTINOX VE +

PRESSURE BOOSTER SET WITH PRESSURE SWITCH CONTROL

## HYDRAULIC PERFORMANCE

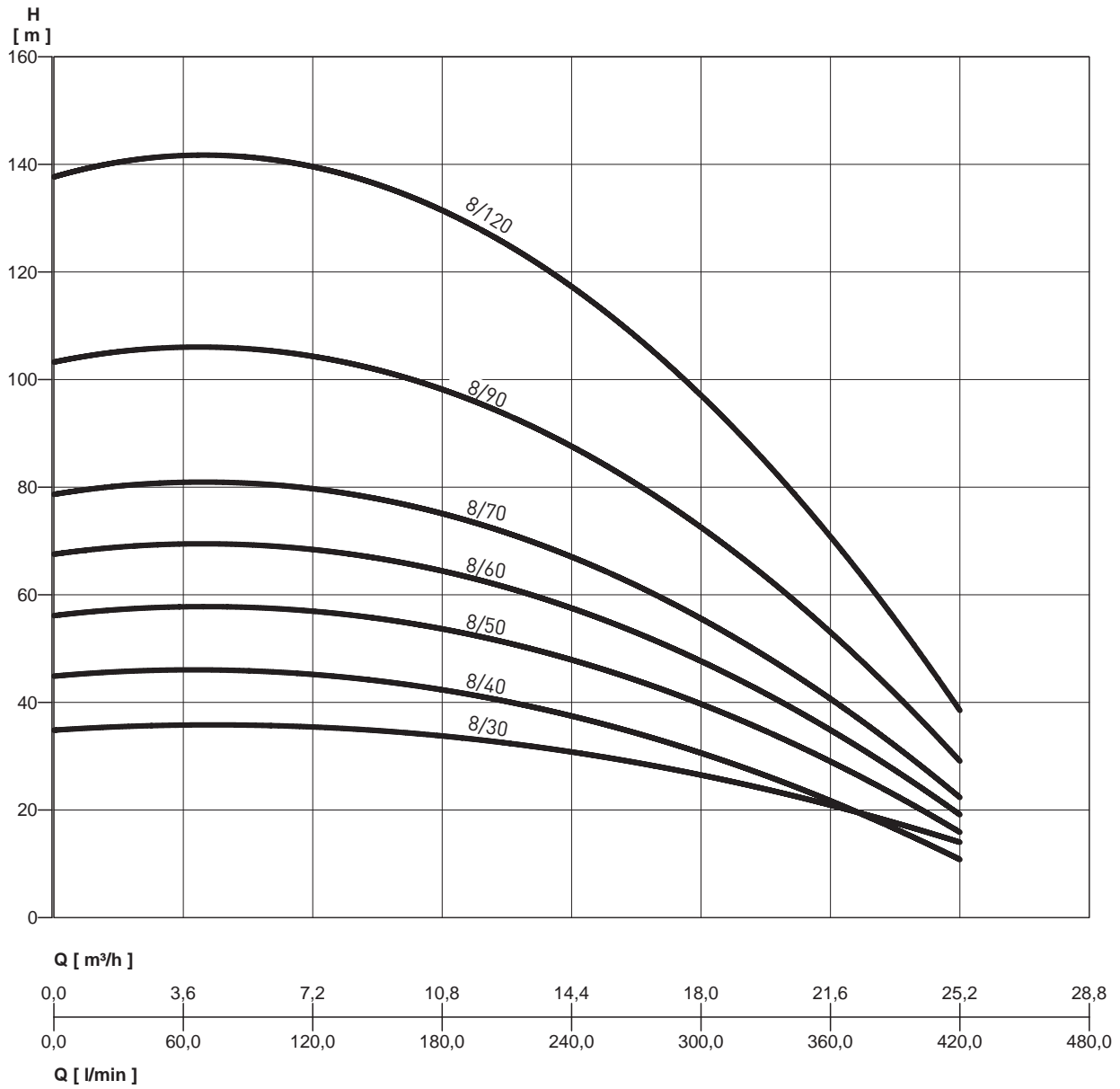

## PERFORMANCE TABLE

MODEL	P2	VOLT. (V)	l/min m³/h	0	60	120	180	240	300	360	420
	kW			0	3,6	7,2	10,8	14,4	18	21,6	25,2
EASY20 MULTINOX VE+ 8-30	2x1	1 ~ 230 3 ~ 400	m.c.w.	36	35	35	33	30	25	28	10
EASY20 MULTINOX VE+ 8-40	2x1,2	1 ~ 230 3 ~ 400		46	45	44	42	39	32	20	11
EASY20 MULTINOX VE+ 8-50	2x1,5	1 ~ 230 3 ~ 400		57	57	56	53	50	40	28	16
EASY20 MULTINOX VE+ 8-60	2x1,7	3 ~ 400		69	68	67	64	60	48	34	19
EASY20 MULTINOX VE+ 8-70	2x1,9	3 ~ 400		80	80	78	74	70	56	40	22
EASY20 MULTINOX VE+ 8-90	2x3	3 ~ 400		105	104	103	98	90	73	52	29
EASY20 MULTINOX VE+ 8-120	2x4	3 ~ 400		140	139	138	131	120	98	70	38

For VOLT. values, see the data of the reference pump

# EASYBOOST 20 MULTINOX VE +

## PRESSURE BOOSTER SET WITH PRESSURE SWITCH CONTROL

### OVERALL DIMENSIONS AND WEIGHTS

#### SINGLE PHASE

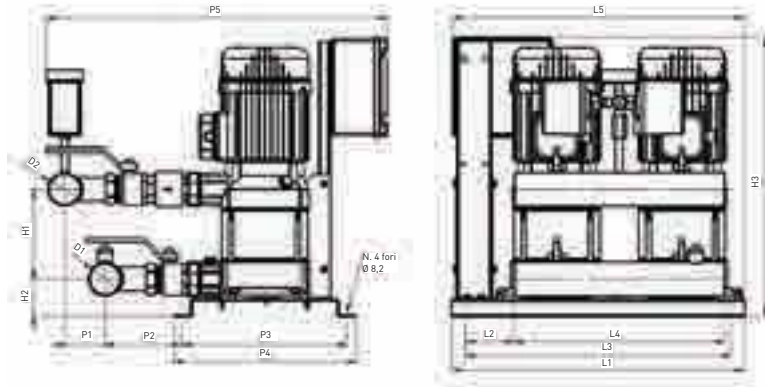

#### THREE PHASE

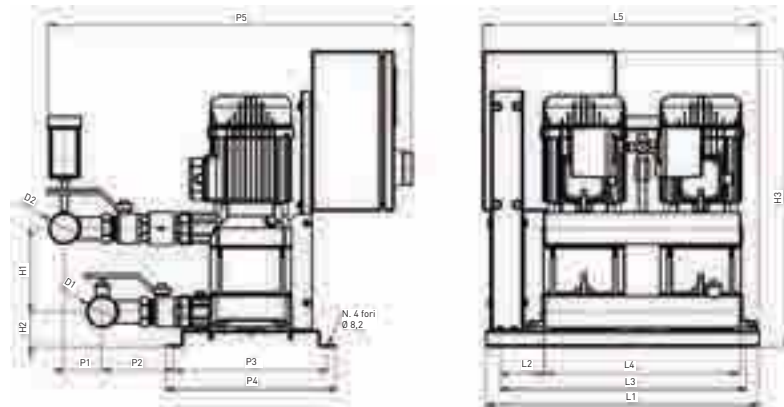

### OVERALL DIMENSIONS AND WEIGHTS

MODEL	Dimensions mm.														WEIGHT (Kg)	
	L1	L2	L3	L4	L5	P1	P2	P3	P4	P5	H1	H2	H3	D1		D2
EASY20 MULTINOX VE+ 8-30 M	515	95	485	370	520	71	138	290	320	675	130	64	510	2"	2"	69
EASY20 MULTINOX VE+ 8-30 T	515	95	485	370	520	71	138	290	320	690	130	64	560	2"	2"	75
EASY20 MULTINOX VE+ 8-40 M	515	95	485	370	520	71	138	290	320	675	157	64	510	2"	2"	73
EASY20 MULTINOX VE+ 8-40 T	515	95	485	370	520	71	138	290	320	690	157	64	560	2"	2"	79
EASY20 MULTINOX VE+ 8-50 M	515	95	485	370	520	71	138	290	320	675	184	64	510	2"	2"	77
EASY20 MULTINOX VE+ 8-50 T	515	95	485	370	520	71	138	290	320	690	184	64	560	2"	2"	83
EASY20 MULTINOX VE+ 8-60 T	515	95	485	370	520	71	138	290	320	690	211	64	560	2"	2"	87
EASY20 MULTINOX VE+ 8-70 T	515	95	485	370	520	71	138	290	320	690	238	64	560	2"	2"	91
EASY20 MULTINOX VE+ 8-90 T	515	95	485	370	520	71	138	290	320	690	292	64	750	2"	2"	109
EASY20 MULTINOX VE+ 8-120 T	515	95	485	370	520	71	138	290	320	690	292	64	750	2"	2"	115

# EASYBOOST 20 PVM

PRESSURE BOOSTER SET WITH PRESSURE SWITCH CONTROL

## HYDRAULIC PERFORMANCE

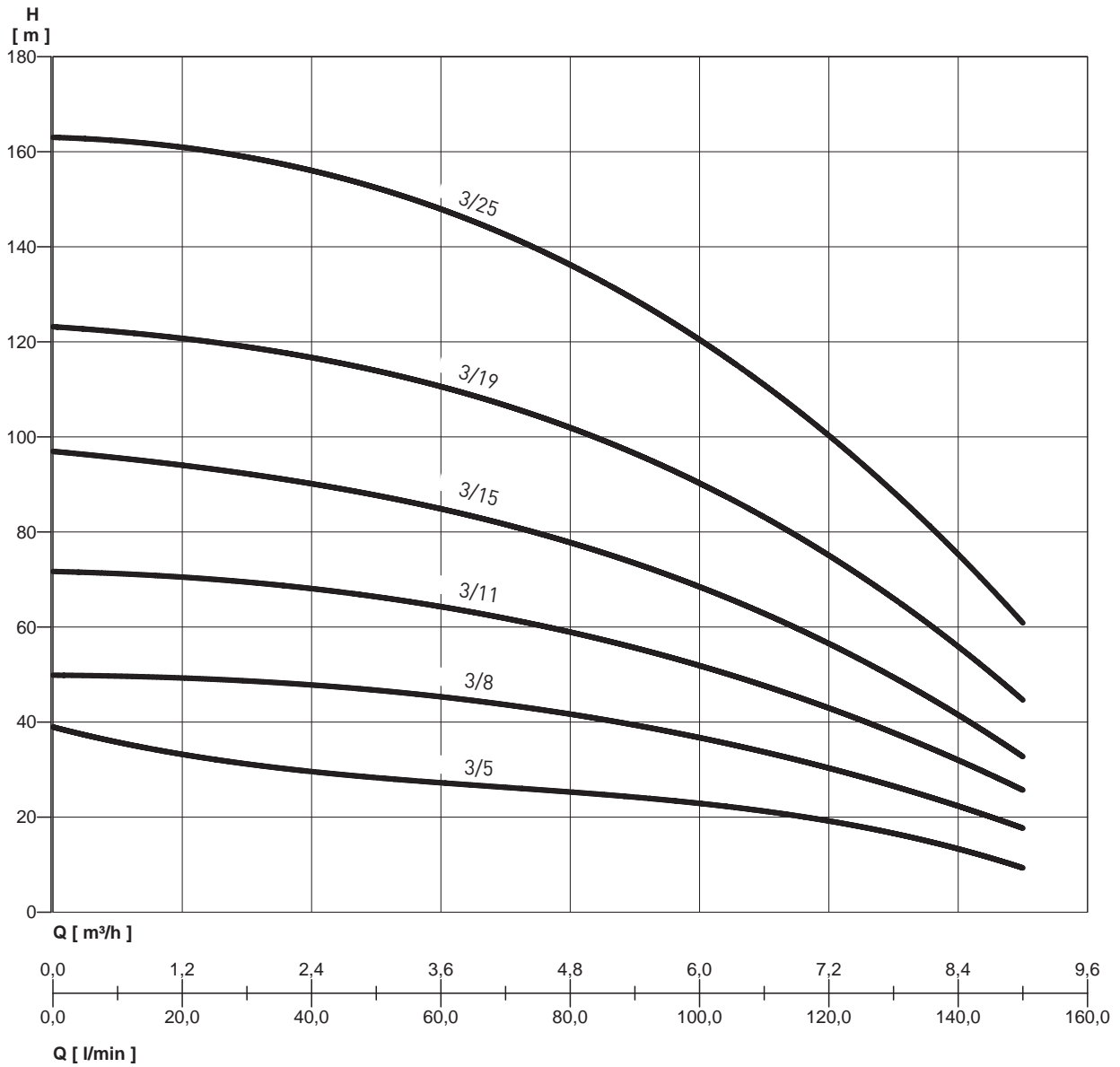

# EASYBOOST 20 PVM

## PRESSURE BOOSTER SET WITH PRESSURE SWITCH CONTROL

### PERFORMANCE TABLE

MODEL	P2	VOLT. (V)	l/min m <sup>3</sup> /h	0	20	40	60	80	100	120	140	150
	kW			0	1,2	2,4	3,6	4,8	6,0	7,2	8,4	9,0
EASY20 PVM 3-5	2x0,37	1 ~ 230 3 ~ 400	m.c.w.	40	31	30	28	26	23	18	13	10
EASY20 PVM 3-8	2x0,75	1 ~ 230 3 ~ 400		50	49	48	45	42	37	30	22	18
EASY20 PVM 3-11	2x1,1	1 ~ 230 3 ~ 400		72	70	68	64	60	52	42	32	26
EASY20 PVM 3-15	2x1,1	1 ~ 230 3 ~ 400		97	94	90	85	78	68	57	41	33
EASY20 PVM 3-19	2x1,5	1 ~ 230 3 ~ 400		123	121	117	110	102	90	76	55	45
EASY20 PVM 3-25	2x2,2	3 ~ 400		165	157	156	150	138	120	98	75	62

For VOLT. values, see the data of the reference pump

#### SINGLE PHASE

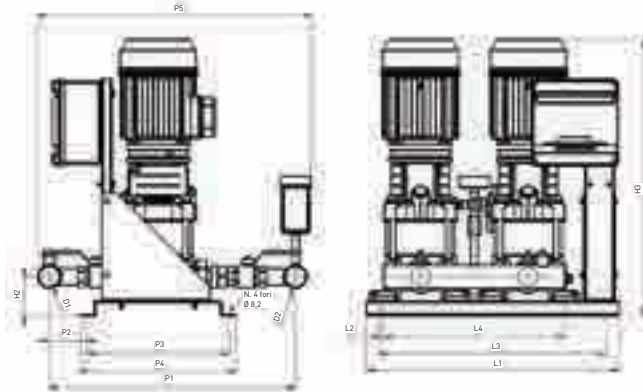

#### THREE PHASE

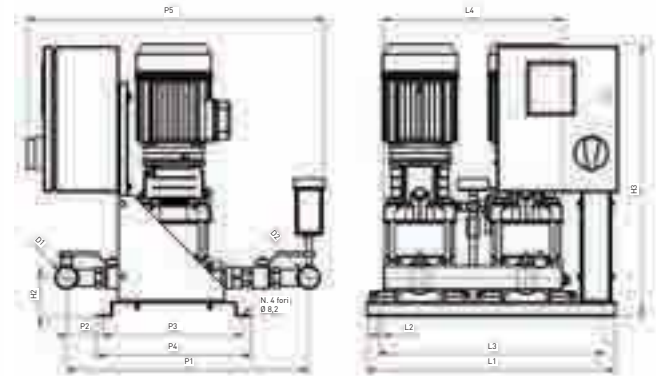

### OVERALL DIMENSIONS AND WEIGHTS

MODEL	Dimensions mm.													WEIGHT (Kg)
	L1	L2	L3	L4	P1	P2	P3	P4	P5	H2	H3	D1	D2	
EASY20 PVM 3-5 M	515	95	485	370	508	80	290	320	562	80	510	1"1/2	1"1/2	64
EASY20 PVM 3-5 T	515	95	485	370	508	80	290	320	620	80	560	1"1/2	1"1/2	74
EASY20 PVM 3-8 M	515	95	485	370	508	80	290	320	562	80	510	1"1/2	1"1/2	74
EASY20 PVM 3-8 T	515	95	485	370	508	80	290	320	620	80	560	1"1/2	1"1/2	80
EASY20 PVM 3-11 M	515	95	485	370	508	80	290	320	562	80	580	1"1/2	1"1/2	90
EASY20 PVM 3-11 T	515	95	485	370	508	80	290	320	620	80	690	1"1/2	1"1/2	96
EASY20 PVM 3-15 M	515	95	485	370	508	80	290	320	562	80	655	1"1/2	1"1/2	94
EASY20 PVM 3-15 T	515	95	485	370	508	80	290	320	620	80	655	1"1/2	1"1/2	100
EASY20 PVM 3-19 M	515	95	485	370	508	80	290	320	562	80	775	1"1/2	1"1/2	108
EASY20 PVM 3-19 T	515	95	485	370	508	80	290	320	620	80	775	1"1/2	1"1/2	114
EASY20 PVM 3-25 T	515	95	485	370	508	80	290	320	620	80	825	1"1/2	1"1/2	130

# EASYBOOST 20 PVM

PRESSURE BOOSTER SET WITH PRESSURE SWITCH CONTROL

## HYDRAULIC PERFORMANCE

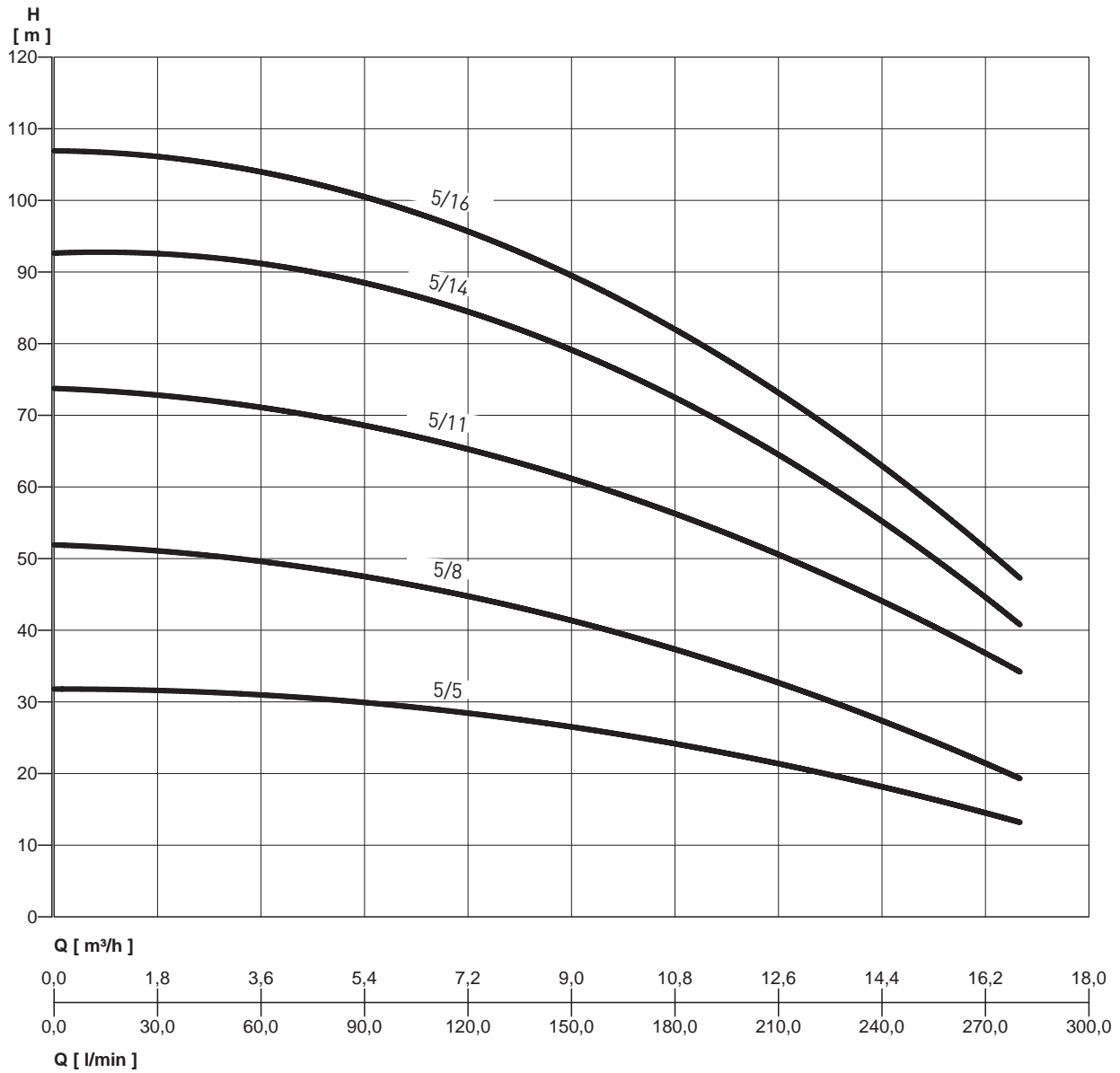

# EASYBOOST 20 PVM

PRESSURE BOOSTER SET WITH PRESSURE SWITCH CONTROL

## PERFORMANCE TABLE

MODEL	P2	VOLT. (V)	l/min	0	80	120	160	200	240	280
	kW			m <sup>3</sup> /h	0	4,8	7,2	9,6	12	14,4
EASY20 PVM 5-5	2x0,75	1 - 230 3 - 400	m.c.w.	32	30	28	26	23	18	13
EASY20 PVM 5-8	2x1,1	1 - 230 3 - 400		52	48	45	40	34	28	19
EASY20 PVM 5-11	2x2,2	3 - 400		74	69	65	60	53	44	34
EASY20 PVM 5-14	2x2,2	3 - 400		93	89	84	77	68	56	40
EASY20 PVM 5-16	2x2,2	3 - 400		107	102	95	87	77	63	47

For VOLT. values, see the data of the reference pump

### SINGLE PHASE

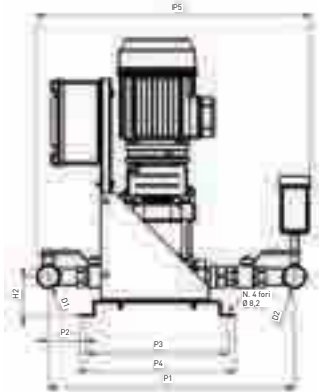

### THREE PHASE

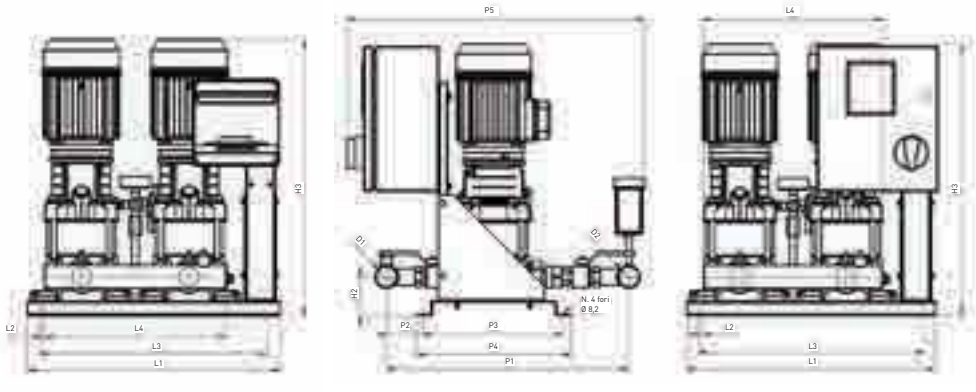

## OVERALL DIMENSIONS AND WEIGHTS

MODEL	Dimensions mm.													WEIGHT (Kg)
	L1	L2	L3	L4	P1	P2	P3	P4	P5	H2	H3	D1	D2	
EASY20 PVM 5-5 M	515	95	485	370	622	115	290	320	628	80	510	2"	2"	60
EASY20 PVM 5-5 T	515	95	485	370	622	115	290	320	697	80	560	2"	2"	70
EASY20 PVM 5-8 M	515	95	485	370	622	115	290	320	628	80	620	2"	2"	72
EASY20 PVM 5-8 T	515	95	485	370	622	115	290	320	697	80	620	2"	2"	80
EASY20 PVM 5-11 T	515	95	485	370	622	115	290	320	697	80	720	2"	2"	88
EASY20 PVM 5-14 T	515	95	485	370	622	115	290	320	697	80	765	2"	2"	100
EASY20 PVM 5-16 T	515	95	485	370	622	115	290	320	697	80	825	2"	2"	104



## PRESSOMAT

### PRESSURE BOOSTER SET WITH PRESSURE SWITCH CONTROL

High hydraulic efficiency, sturdy, piping in stainless steel AISI 304

These are automatic pressure booster set for the pressurization of distribution networks with single phase and three-phase power supply.

The pumps are controlled by two differential pressure switches with adjustable settings, via an electrical panel with an analogue electronic board for:

- the sequential start-up of the pumps
- the inversion of the start-up order
- timer settable from 0 to 180», only for the three-phase version
- protection against dry running

When the network pressure reaches the value for the closing of the electrical contact of pressure switch n.1, a pump starts.

If the pressure continues to fall, when the closing value of the second pressure switch is reached, the second pump is started up.

When the value of the network pressure increases, the pressure switches open their contact causing the relative pump to stop.

At the end of each cycle, the automatic inverter changes the starting order of the pumps (once pressure switch n.1 is associated to pump n.1; in the next cycle to pump n.2).

If the two pressure switches close at the same time, the electronic board will delay the start-up of the second pump avoiding abrupt changes in pressure and the overload of the power supply.

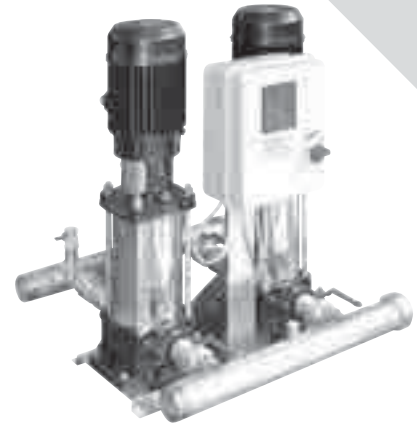

NUMBER OF PUMPS		MAXIMUM CAPACITY	
Main	Pilot	l/min	m <sup>3</sup> /h
2	-	1320	80

#### MATERIAL

USAGE DATA	PVM 3	PVM 5	PVM 10	PVM 15	PVM 20	PVM 32
Maximum capacity (m <sup>3</sup> /h)	9	17	26	47	58	80
Maximum head (m.c.a.)	160	160	160	125	145	120
Maximum operating pressure	16 bar					
Power supply VOLT	1 ~ 230 / 3~400 V			3~400 V		
Ambient temperature	50° C					
Degree of protection of pump	IP55					
Degree of protection of electrical panel	IP54					

# PRESSOMAT

## PRESSURE BOOSTER SET WITH PRESSURE SWITCH CONTROL

### PUMP

- n. 2 PVM
- Centrifugal, multicellular, vertical axis

### SUCTION MANIFOLD

In steel AISI 304 with:

- n. 2 brass ball valves
- n. 2 check valves
- n. 1 sleeve for water load

### BASE

- In galvanized metal
- Galvanized steel profiles

### DELIVERY MANIFOLD

In steel AISI 304 with:

- n. 2 brass ball valves
- n. 1 pressure gauge
- n. 2 differential pressure switches

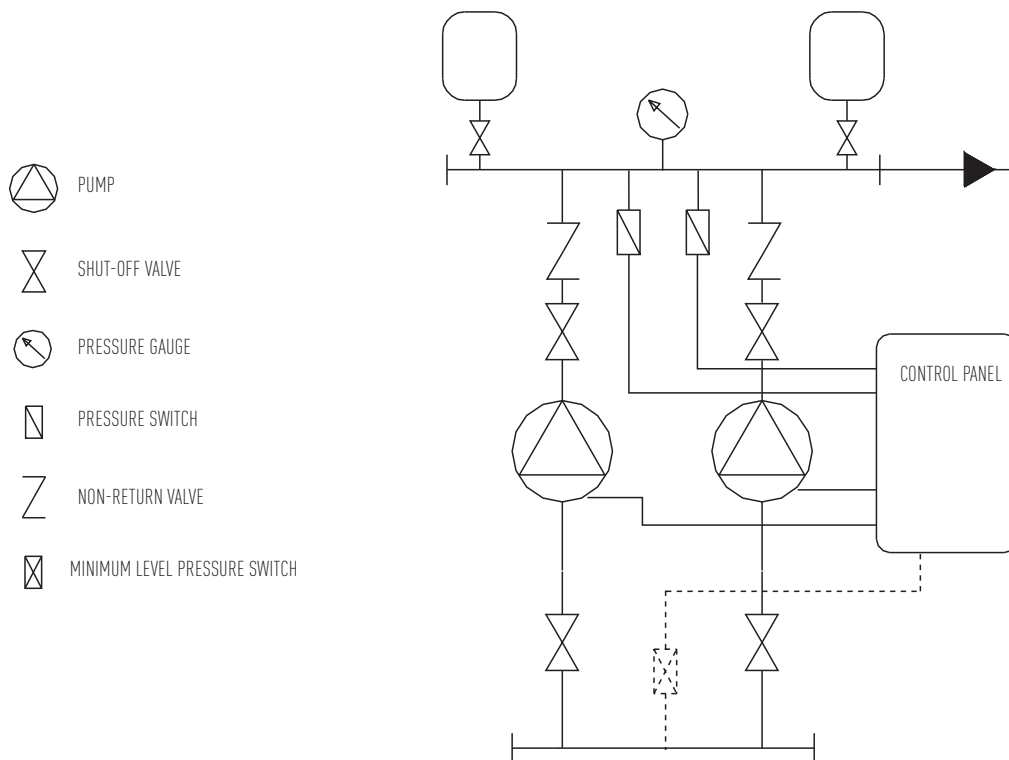
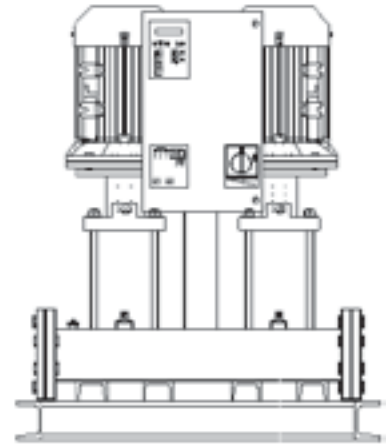

# PRESSOMAT

## PRESSURE BOOSTER SET WITH PRESSURE SWITCH CONTROL

### SINGLE PHASE ELECTRICAL PANEL

---

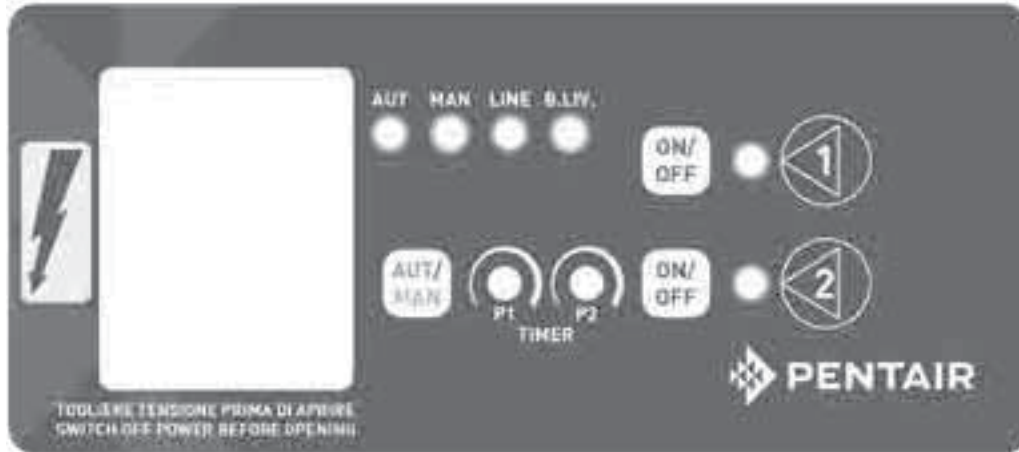

#### ELECTRICAL PANEL

- Box in plastic material IP55
- Main circuit breaker
- Electronic control panel with manual - automatic buttons for each pump
- SML electronic board
- Pump start-up relay

#### MAIN FUNCTIONS

- Cyclic inversion of the start-up order of the pumps after each cycle end.
- ON/OFF control of the level of the tank or the pressure of the supply duct by means of a float switch or a different differential pressure switch.

#### SIGNALS AND CONTROLS

- LED indicating the presence of power.
- LED indicating the low water level in the tank or an insufficient pressure in the supply duct (aqueduct).
- LED indicating the operation of each pump.

#### EXTRENAL CONTROL DEVICES

- Two adjustable differential pressure switches ON/OFF

#### EXTRENAL CONTROL DEVICES

- ON/OFF float switch, located in the water collection tank, or
- Reverse pressure switch inserted in the water supply duct (aqueduct)

# PRESSOMAT

## PRESSURE BOOSTER SET WITH PRESSURE SWITCH CONTROL

### THREE-PHASE ELECTRICAL PANEL

---



#### **ELECTRICAL PANEL**

---

- Box in metal IP54
- Main switch
- Keyboard with electronic board SA
- Fuses, contactor and thermal relay for each pump
- Transformer with fuses for the auxiliary circuit
- M-O-T switch for each pump
- Star-delta starter for motors above 7.5 kW

#### **MAIN FUNCTIONS**

---

- Cyclic inversion of the start-up order of the pumps after each cycle end.
- ON/OFF control of the level of the tank or the pressure of the supply duct by means of a float switch or a different differential pressure switch.
- Timer of the pumps settable from 0 to 180 seconds, after the opening of the pressure switch operation contact.

#### **SIGNALS AND CONTROLS**

---

- LED indicating the presence of power.
- LED indicating the low water level in the tank or an insufficient pressure in the supply duct (aqueduct).
- LED indicating the operation of each pump.
- LED indicating that one of the two thermal relays has tripped because of an overload.
- LED indicating manual or automatic operation.
- Buttons to select manual or automatic control.
- Buttons to start or stop each pump (manual operation).

#### **EXTRENAL CONTROL DEVICES**

---

- Two adjustable differential pressure switches ON/OFF

#### **EXTRENAL CONTROL DEVICES**

---

- ON/OFF float switch, located in the water collection tank, or
- 3 electrodes for the electronic control of the level of the tank, or
- Reverse pressure switch inserted in the water supply duct (aqueduct)

# PMS20 PVM - PMD20 PVM

PRESSURE BOOSTER SET WITH PRESSURE SWITCH CONTROL

## HYDRAULIC PERFORMANCE

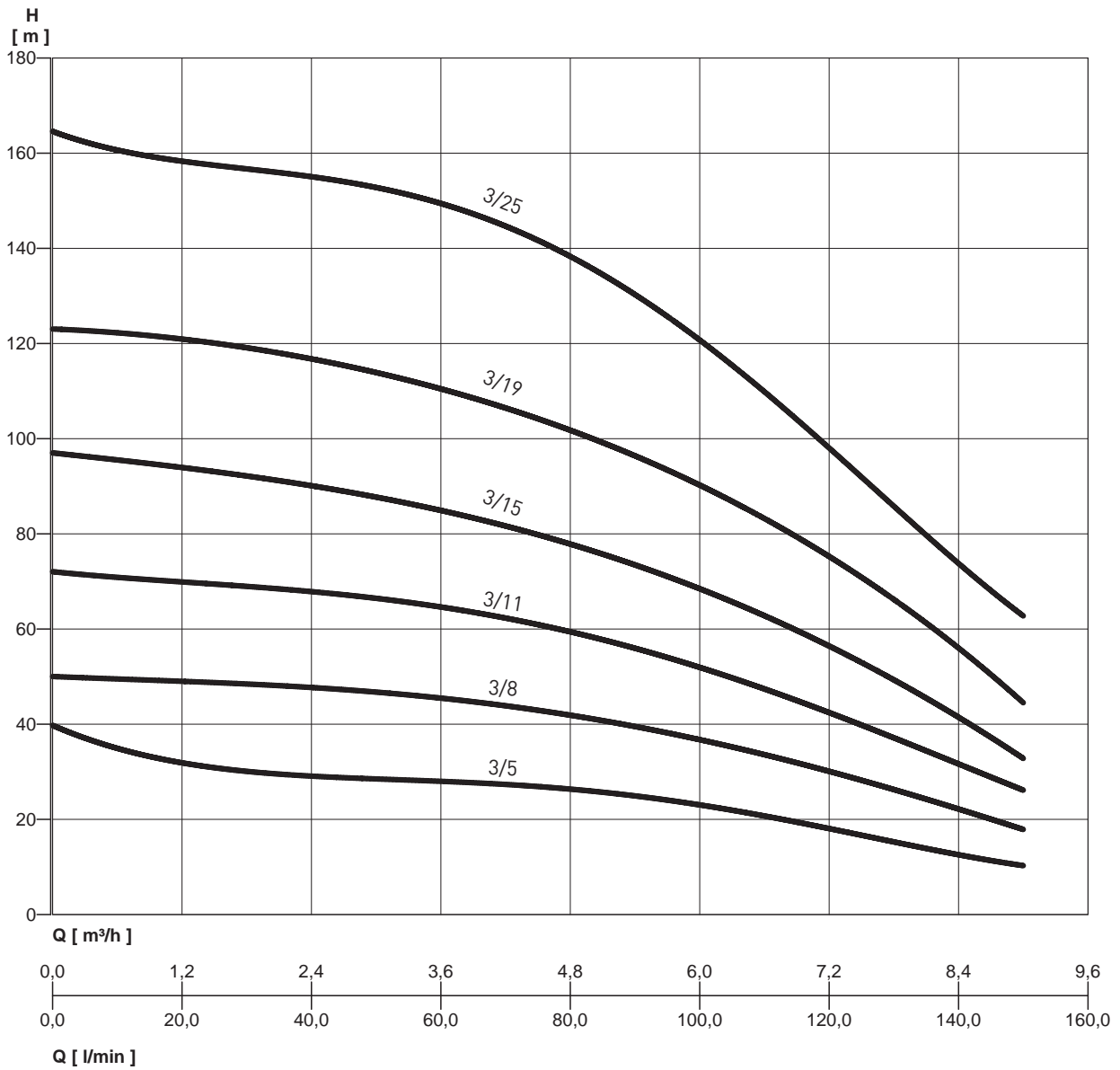

# PMS20 PVM - PMD20 PVM

## PRESSURE BOOSTER SET WITH PRESSURE SWITCH CONTROL

### PERFORMANCE TABLE

MODEL	P2	VOLT. (V)	0	l/min	0	20	40	60	80	100	120	140	150
	kW				0	1	2	4	5	6	7	8	9
PMS20 PVM 3-5 PMD20 PVM 3-5	2x0.37	1 ~ 230 3 ~ 400	m.c.w.		40	31	30	28	26	23	18	13	10
PMS20 PVM 3-5 PMD20 PVM 3-8	2x0.75	1 ~ 230 3 ~ 400			50	49	48	45	42	37	30	22	18
PMS20 PVM 3-11 PMD20 PVM 3-11	2x1.1	1 ~ 230 3 ~ 400			72	70	68	64	60	52	42	32	26
PMS20 PVM 3-15 PMD20 PVM 3-15	2x1.1	1 ~ 230 3 ~ 400			97	94	90	85	78	68	57	41	33
PMS20 PVM 3-19 PMD20 PVM 3-19	2x1.5	1 ~ 230 3 ~ 400			123	121	117	110	102	90	76	55	45
PMD20 PVM 3-25	2x2.2	3 ~ 400			165	157	156	150	138	120	98	75	62

For VOLT values, see the data of the reference pump

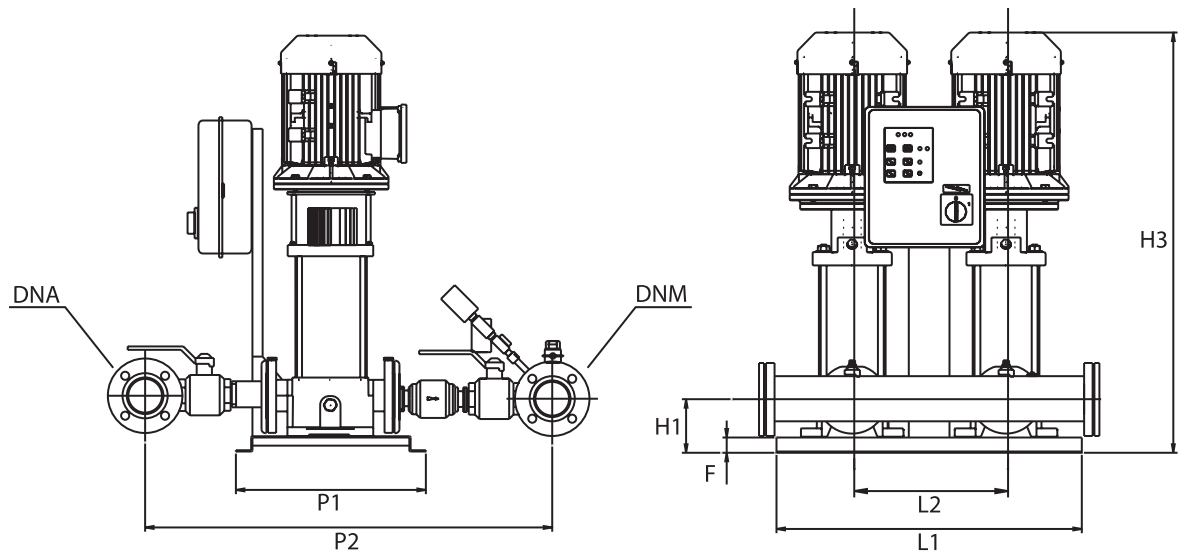

### OVERALL DIMENSIONS AND WEIGHTS

MODEL	Dimensions in mm.										WEIGHT (Kg)
	L1	P1	P2	H1	H2	H3	DNA	DNM	F	L2	
PMS20 PVM 3-5	600	320	620	80	775	510	2"	2"	30	370	62
PMD20 PVM 3-5	600	320	620	80	775	510	2"	2"	30	370	72
PMS20 PVM 3-8	600	320	620	80	775	610	2"	2"	30	370	68
PMD20 PVM 3-8	600	320	620	80	775	610	2"	2"	30	370	74
PMS20 PVM 3-11	600	320	620	80	775	664	2"	2"	30	370	74
PMD20 PVM 3-11	600	320	620	80	775	664	2"	2"	30	370	80
PMS20 PVM 3-15	600	320	620	80	775	736	2"	2"	30	370	89
PMD20 PVM 3-15	600	320	620	80	775	736	2"	2"	30	370	95
PMS20 PVM 3-19	600	320	620	80	775	880	2"	2"	30	370	100
PMD20 PVM 3-19	600	320	620	80	775	880	2"	2"	30	370	106
PMD20 PVM 3-25	600	320	620	80	775	988	2"	2"	30	370	122

# PMS20 PVM - PMD20 PVM

PRESSURE BOOSTER SET WITH PRESSURE SWITCH CONTROL

## HYDRAULIC PERFORMANCE

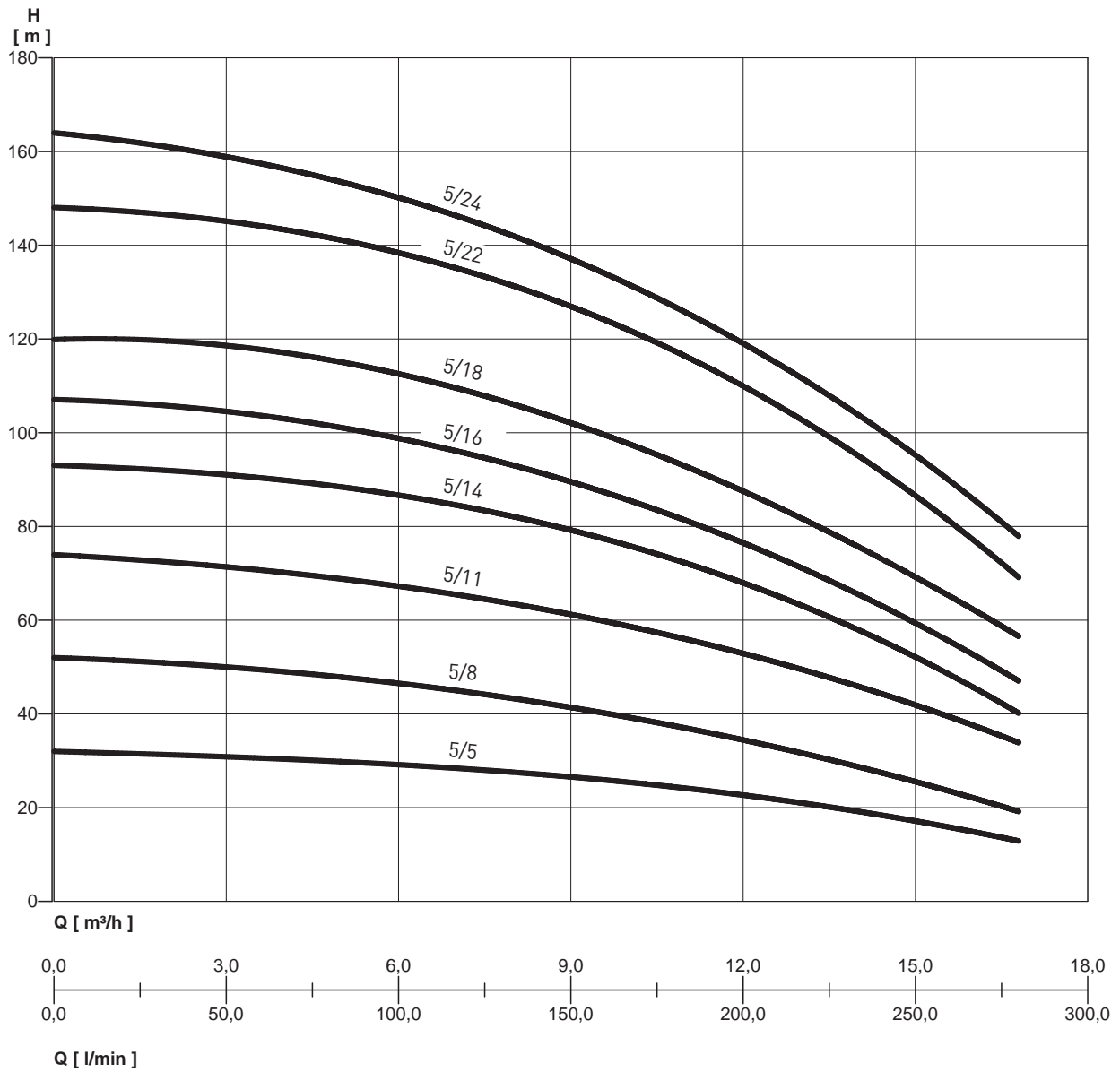

# PMD20 PVM

## PRESSURE BOOSTER SET WITH PRESSURE SWITCH CONTROL

### PERFORMANCE TABLE

MODEL	P2	VOLT. (V)	0	l/min	0	80	120	160	200	240	280
	kW			m <sup>3</sup> /h	0	4,8	7,2	9,6	12	14,4	16,8
PMS20 PVM 5-5 PMD20 PVM 5-5	2x0.75	1 - 230 3 - 400	m.c.w.	32	30	28	26	23	18	13	
PMS20 PVM 5-8 PMD20 PVM 5-8	2x1.1	1 - 230 3 - 400		52	48	45	40	34	28	19	
PMD20 PVM 5-11	2x2.2	3 - 400		74	69	65	60	53	44	34	
PMD20 PVM 5-14	2x2.2	3 - 400		93	89	84	77	68	56	40	
PMD20 PVM 5-16	2x2.2	3 - 400		107	102	95	87	77	63	47	
PMD20 PVM 5-18	2x3	3 - 400		120	115	109	100	88	72	57	
PMD20 PVM 5-22	2x4	3 - 400		148	142	134	124	110	92	69	
PMD20 PVM 5-24	2x4	3 - 400		164	154	146	133	120	100	78	

For VOLT values, see the data of the reference pump

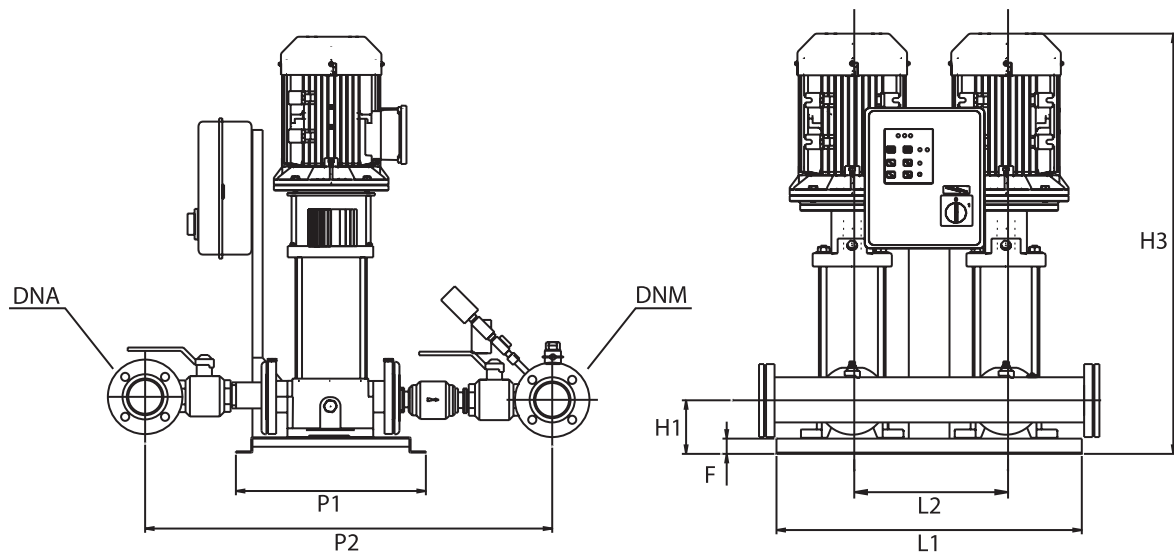

### OVERALL DIMENSIONS AND WEIGHTS

MODEL	Dimensions mm.										WEIGHT (Kg)
	L1	P1	P2	H1	H2	H3	DNA	DNM	F	L2	
PMS20 PVM 5-5	600	320	620	80	775	601	2"	2"	30	370	62
PMD20 PVM 5-5	600	320	620	80	775	601	2"	2"	30	370	72
PMS20 PVM 5-8	600	320	620	80	775	682	2"	2"	30	370	70
PMD20 PVM 5-8	600	320	620	80	775	682	2"	2"	30	370	78
PMD20 PVM 5-11	600	320	620	80	775	835	2"	2"	30	370	83
PMD20 PVM 5-14	600	320	620	80	775	916	2"	2"	30	370	90
PMD20 PVM 5-16	600	320	620	80	775	970	2"	2"	30	370	95
PMD20 PVM 5-18	600	320	620	80	775	1053	2"	2"	30	370	100
PMD20 PVM 5-22	600	320	620	80	775	1171	2"	2"	30	370	110
PMD20 PVM 5-24	600	320	620	80	775	1225	2"	2"	30	370	115



# PMS20 PVM - PMD20 PVM

PRESSURE BOOSTER SET WITH PRESSURE SWITCH CONTROL

## HYDRAULIC PERFORMANCE

---

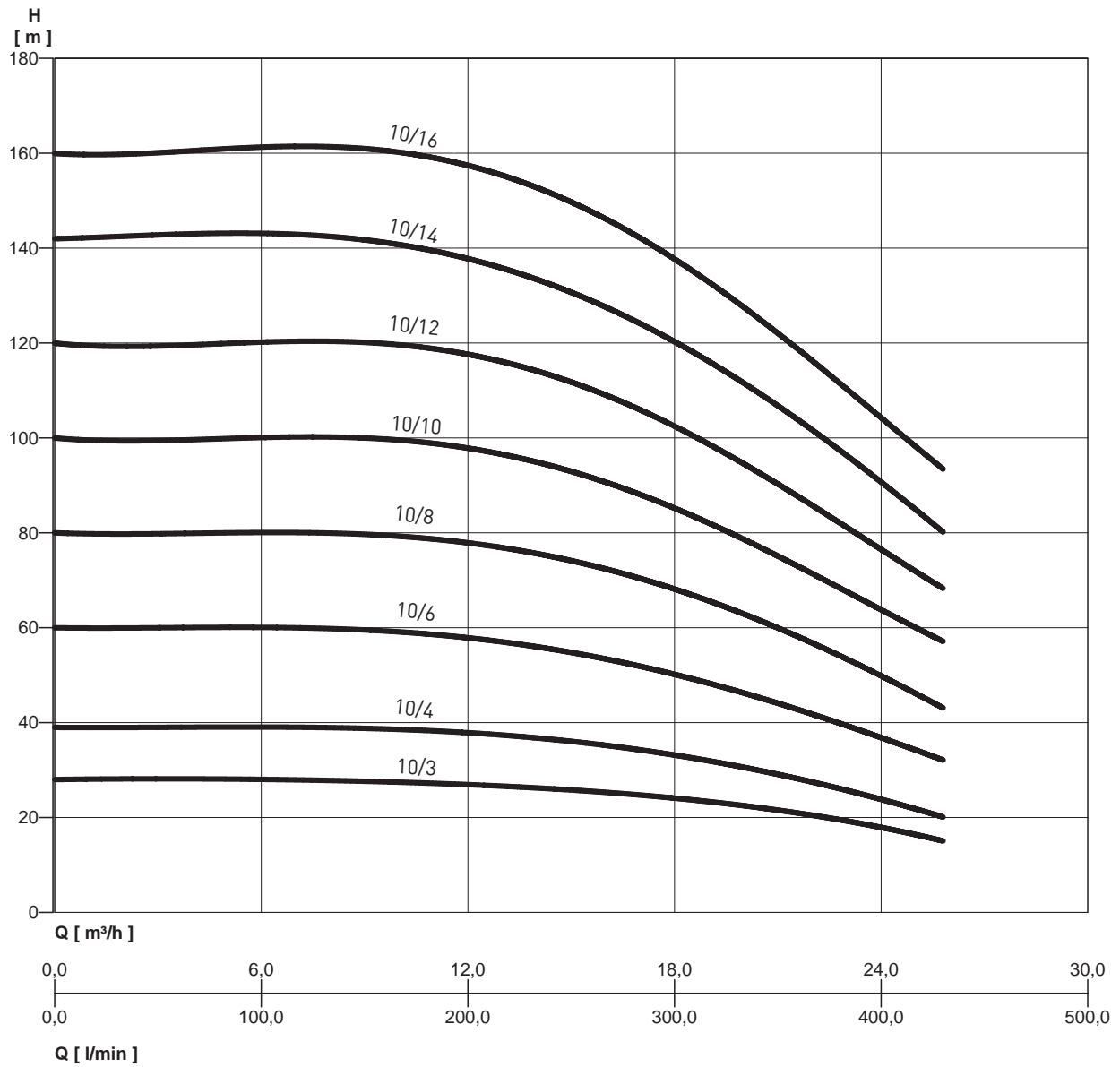

# PMS20 PVM - PMD20 PVM

## PRESSURE BOOSTER SET WITH PRESSURE SWITCH CONTROL

### PERFORMANCE TABLE

MODEL	P2	VOLT. (V)	0	l/min	0	100	200	300	400	430
	kW			m <sup>3</sup> /h	0	6	12	18	24	26
PMS20 PVM 10-3 PMD20 PVM 10-3	2x1.1	1 ~ 230 3 ~ 400	m.c.w.	28	28	27	24	18	15	
PMS20 PVM 10-4 PMD20 PVM 10-4	2x1.5	1 ~ 230 3 ~ 400		39	39	38	33	24	20	
PMD20 PVM 10-6	2x2.2	3 ~ 400		60	60	58	50	37	32	
PMD20 PVM 10-8	2x3	3 ~ 400		80	80	78	68	50	43	
PMD20 PVM 10-10	2x4	3 ~ 400		100	100	98	85	64	57	
PMD20 PVM 10-12	2x4	3 ~ 400		120	120	118	102	77	68	
PMD20 PVM 10-14	2x5.5	3 ~ 400		142	143	138	120	91	80	
PMD20 PVM 10-16	2x5.5	3 ~ 400		160	161	158	137	105	93	

For VOLT values, see the data of the reference pump

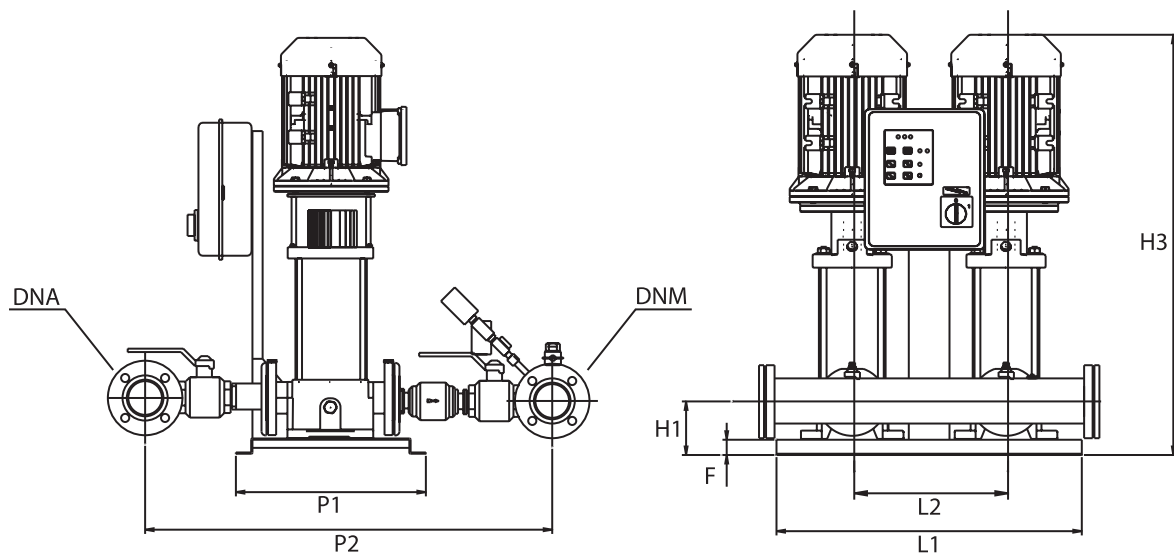

### OVERALL DIMENSIONS AND WEIGHTS

MODEL	Dimensions mm.										WEIGHT (Kg)
	L1	P1	P2	H1	H2	H3	DNA	DNM	F	L2	
PMS20 PVM 10-3	620	320	720	120	775	612	2" 1/2	2" 1/2	30	370	116
PMD20 PVM 10-3	620	320	720	120	775	612	2" 1/2	2" 1/2	30	370	106
PMS20 PVM 10-4	620	320	720	120	775	714	2" 1/2	2" 1/2	30	370	126
PMD20 PVM 10-4	620	320	720	120	775	714	2" 1/2	2" 1/2	30	370	114
PMD20 PVM 10-6	620	320	720	120	775	774	2" 1/2	2" 1/2	30	370	120
PMD20 PVM 10-8	680	320	720	120	775	864	2" 1/2	2" 1/2	30	370	136
PMD20 PVM 10-10	680	320	720	120	775	934	2" 1/2	2" 1/2	30	370	146
PMD20 PVM 10-12	680	320	720	120	775	994	2" 1/2	2" 1/2	30	370	160
PMD20 PVM 10-14	680	320	720	120	775	1122	2" 1/2	2" 1/2	30	370	170
PMD20 PVM 10-16	680	320	720	120	775	1182	2" 1/2	2" 1/2	30	370	180

# PMD20 PVM

PRESSURE BOOSTER SET WITH PRESSURE SWITCH CONTROL

## HYDRAULIC PERFORMANCE

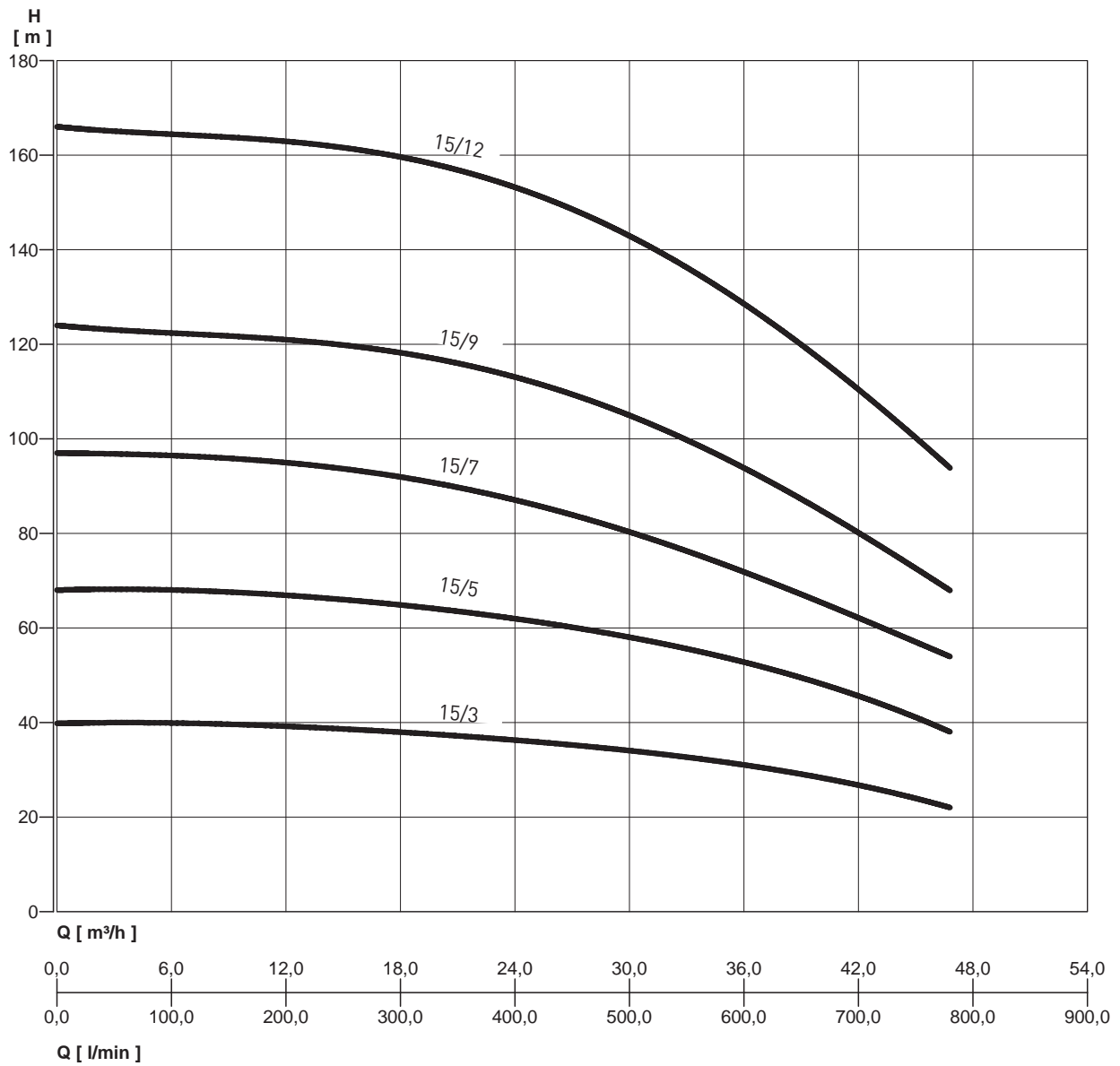

# PMD20 PVM

## PRESSURE BOOSTER SET WITH PRESSURE SWITCH CONTROL

### PERFORMANCE TABLE

MODEL	P2	VOLT. (V)	0	l/min	0	200	400	600	700	780
	kW			m <sup>3</sup> /h	0	12	24	36	42	47
PMD20 PVM 15-3	2x3	3 ~ 400	m.c.w.	39,8	39,2	36,3	31	26,8	22	
PMD20 PVM 15-5	2x4	3 ~ 400		68	66,9	62	52,7	45,7	38	
PMD20 PVM 15-7	2x5.5	3 ~ 400		97	95	87	72	62	54	
PMD20 PVM 15-9	2x7.5	3 ~ 400		124	121	113	94	80	68	
PMY20 PVM 15-12	2x11	3 ~ 400		166	163	153	129	110	94	

For VOLT values, see the data of the reference pump

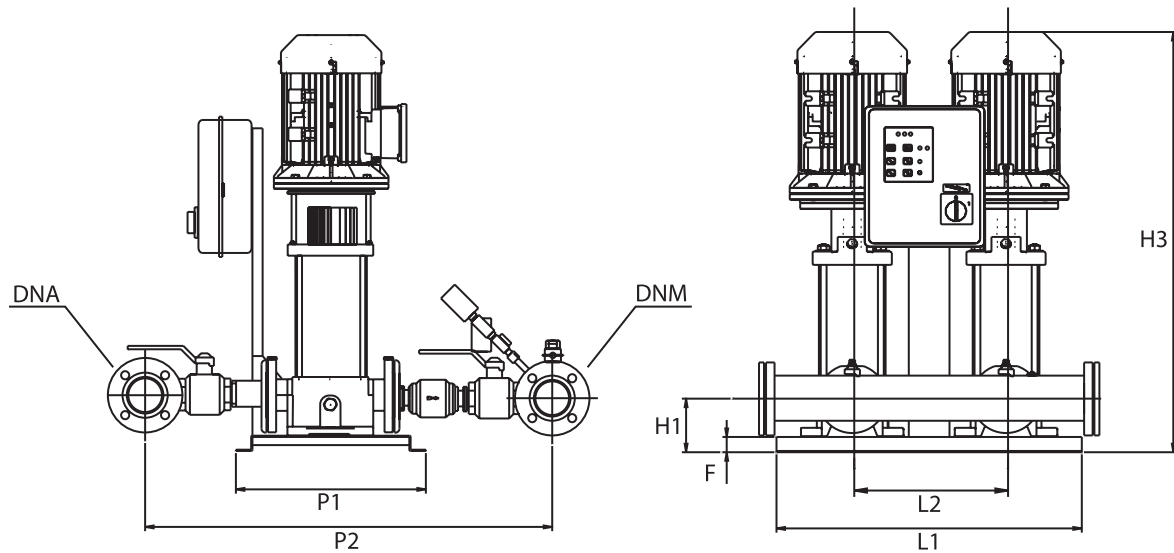

### OVERALL DIMENSIONS AND WEIGHTS

MODEL	Dimensions mm.									WEIGHT (Kg)
	L1	P1	P2	H1	H3	DNA	DNM	F	L2	
PMD20 PVM 15-3	620	380	860	120	781	3"	2" 1/2	30	370	175
PMD20 PVM 15-5	620	380	860	120	881	3"	2" 1/2	30	370	200
PMD20 PVM 15-7	620	380	860	120	1039	3"	2" 1/2	30	370	220
PMD20 PVM 15-9	620	380	860	120	1165	3"	2" 1/2	30	370	250
PMY20 PVM 15-12	620	380	860	120	1484	3"	2" 1/2	30	370	270

# PMD20 PVM

PRESSURE BOOSTER SET WITH PRESSURE SWITCH CONTROL

## HYDRAULIC PERFORMANCE

---

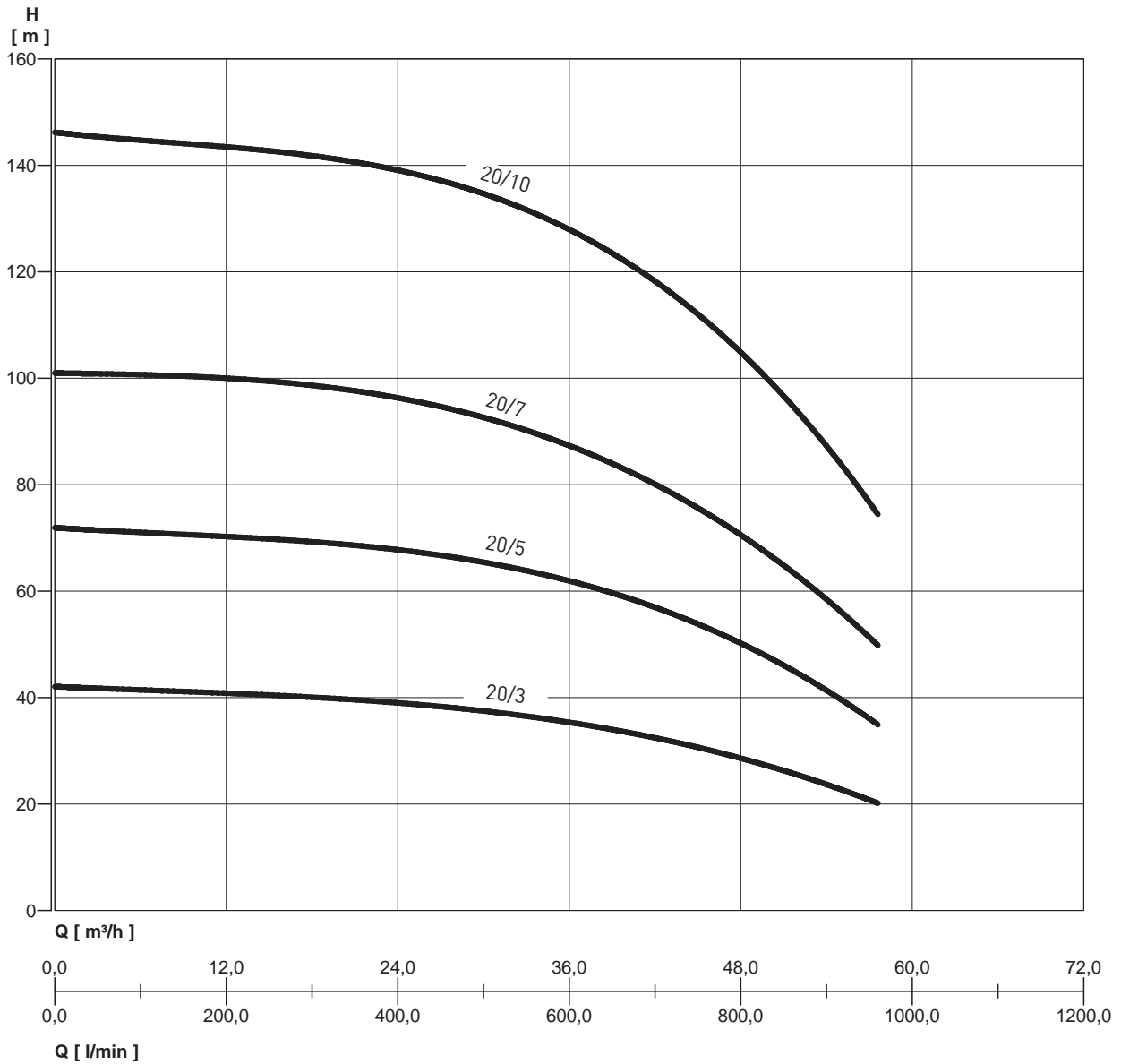

# PMD20 PVM

## PRESSURE BOOSTER SET WITH PRESSURE SWITCH CONTROL

### PERFORMANCE TABLE

MODEL	P2	VOLT. (V)	Q	I/min	0	200	400	600	800	960
	kW			m <sup>3</sup> /h	0	12	24	36	48	57,6
PMD20 PVM 20-3	2x4	3 ~ 400	M.C.W.		42	41	39	35	29	20
PMD20 PVM 20-5	2x5.5	3 ~ 400		72	70	68	62	50	35	
PMD20 PVM 20-7	2x7.5	3 ~ 400		101	100	96	88	70	50	
PMY20 PVM 20-10	2x11	3 ~ 400		146	144	139	127	106	74	

For VOLT values, see the data of the reference pump

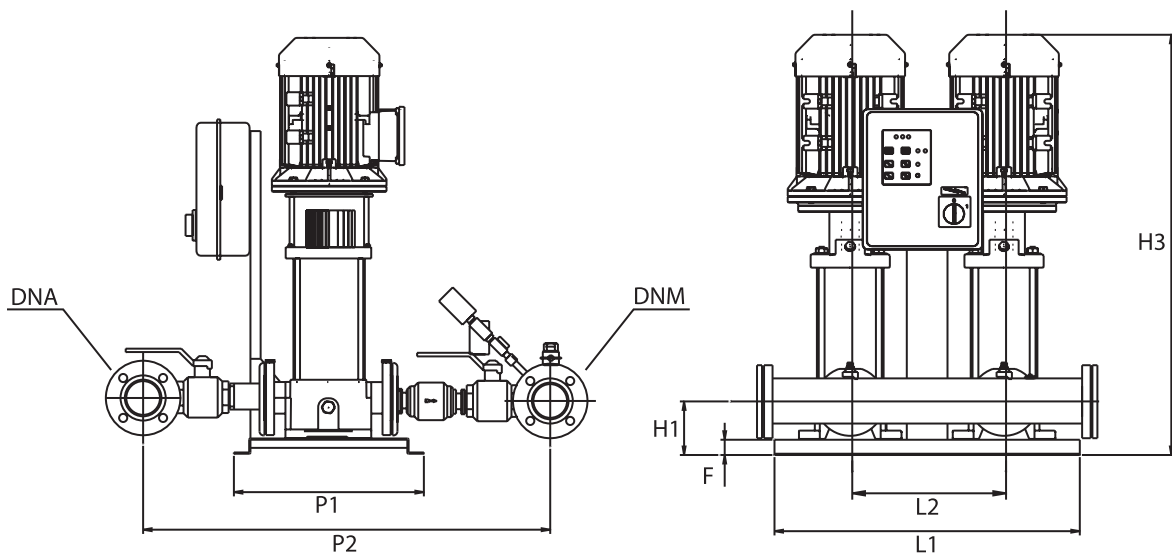

### OVERALL DIMENSIONS AND WEIGHTS

MODEL	Dimensions mm.									WEIGHT (Kg)
	L1	P1	P2	H1	H3	DNA	DNM	F	L2	
PMD20 PVM 20-3	620	380	860	120	795	3"	2" 1/2	30	370	181
PMD20 PVM 20-5	620	380	860	120	955	3"	2" 1/2	30	370	220
PMD20 PVM 20-7	620	380	860	180	1083	3"	2" 1/2	30	370	232
PMY20 PVM 20-10	620	380	860	180	1405	3"	2" 1/2	30	370	260

# PMD20 PVM

PRESSURE BOOSTER SET WITH PRESSURE SWITCH CONTROL

## HYDRAULIC PERFORMANCE

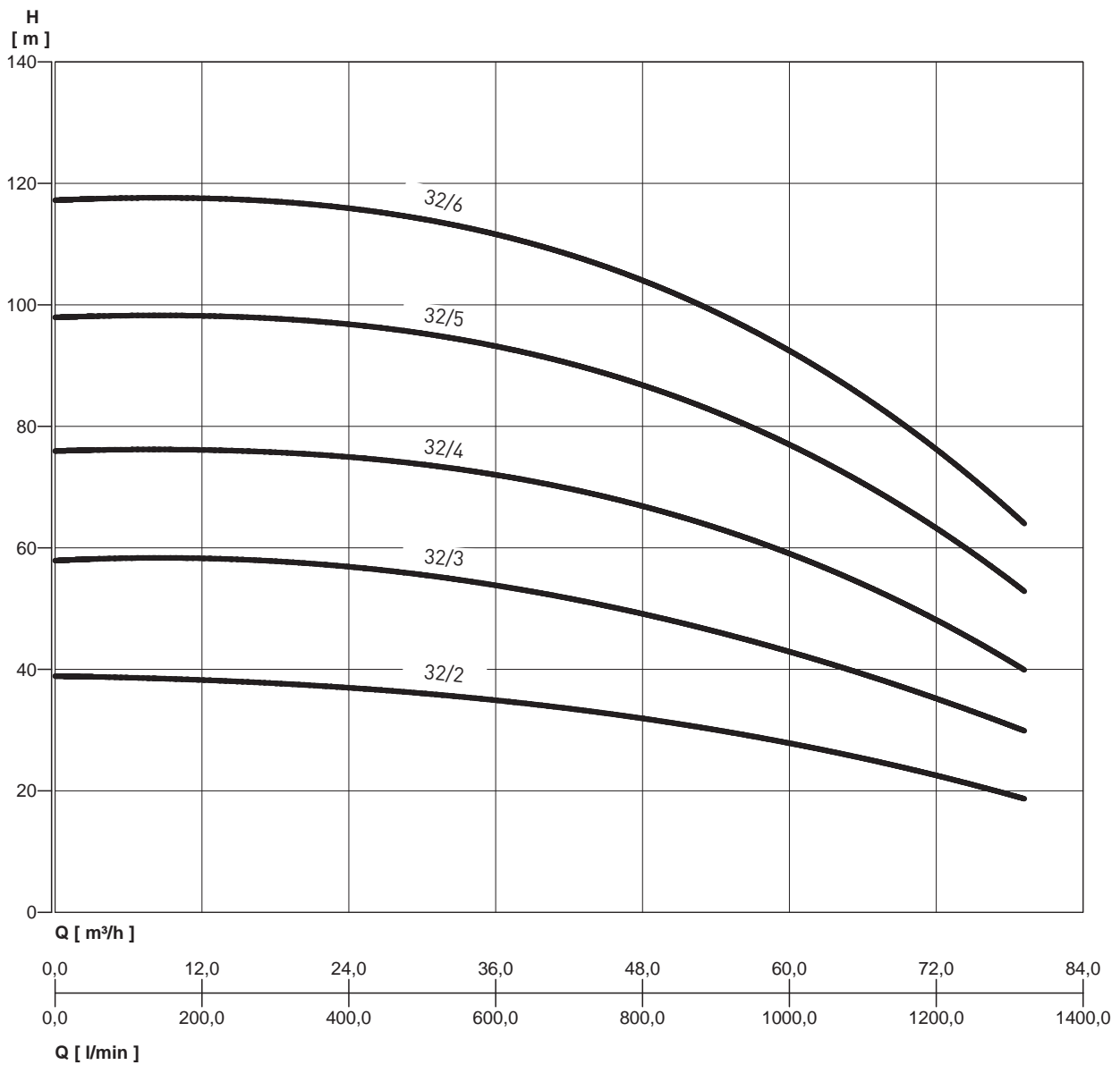

# PMD20 PVM

## PRESSURE BOOSTER SET WITH PRESSURE SWITCH CONTROL

### PERFORMANCE TABLE

MODEL	P2	VOLT. (V)	Q	m.c.w.								
	kW			l/min	0	200	400	600	800	1000	1200	1320
				m <sup>3</sup> /h	0	12	24	36	48	60	72	79,2
PMD20 PVM 32-2	2x4	3 ~ 400			39	38	37	35	32	28	22	19
PMD20 PVM 32-3	2x5.5	3 ~ 400			58	58	57	54	49	43	35	30
PMD20 PVM 32-4	2x7.5	3 ~ 400			76	76	75	72	67	59	48	40
PMY20 PVM 32-5	2x11	3 ~ 400			98	98	97	93	87	77	63	53
PMY20 PVM 32-6	2x11	3 ~ 400			117	118	116	111	104	93	76	64

For VOLT values, see the data of the reference pump

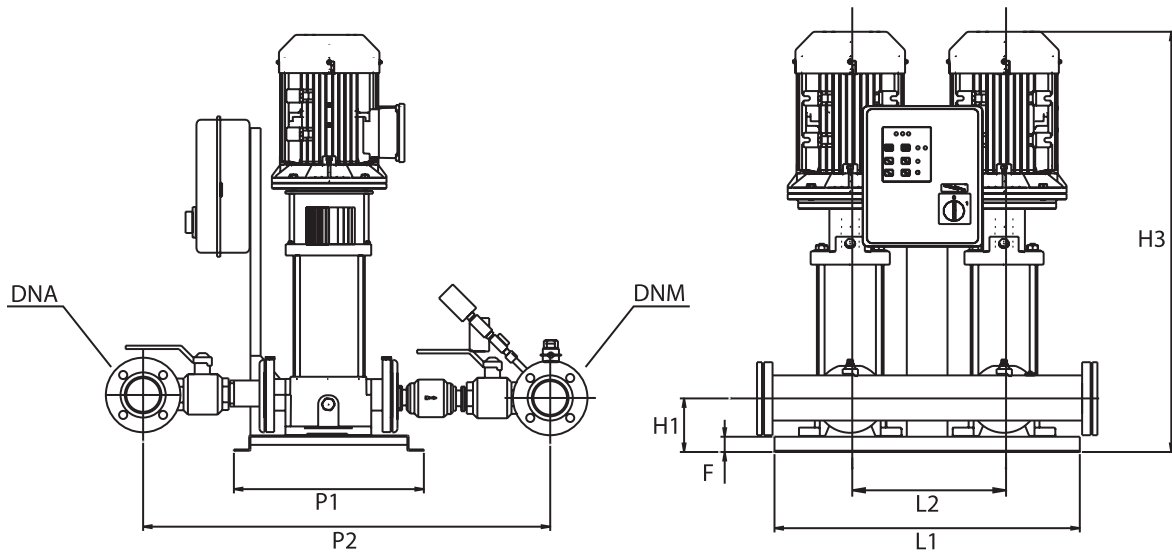

### OVERALL DIMENSIONS AND WEIGHTS

MODEL	Dimensions mm.									WEIGHT (Kg)
	L1	P1	P2	H1	H3	DNA	DNM	F	L2	
PMD20 PVM 32-2	860	700	1060	230	900	4"	3"	80	440	330
PMD20 PVM 32-3	860	700	1060	230	1006	4"	3"	80	440	350
PMD20 PVM 32-4	860	700	1060	230	1112	4"	3"	80	440	370
PMY20 PVM 32-5	860	700	1060	230	1399	4"	3"	80	440	390
PMY20 PVM 32-6	860	700	1060	230	1469	4"	3"	80	440	410



## CPS20

### PRESSURE BOOSTER SET WITH TWO VARIABLE SPEED PUMPS

The new series of variable speed pressurization booster set CPS20 represents a reliable solution which is easy to use, for residential and industrial applications. The system involves the installation in parallel of two inverters integrated directly on the motor of each pump installed. The two frequency converters communicate and alternate the starting order of each work cycle, always keeping the pressure constant in the distribution system.

#### APPLICATIONS

- Lifting and distribution of water in domestic systems
- Pressurization systems
- Irrigation
- Industry
- Washes

#### TECHNICAL CHARACTERISTICS

- Supply voltage: inverter 1x230 Vac  $\pm$  10 %.
- Inverter output voltage: 3x230 Vac  $\pm$  10 %
- Maximum rated power: 2x2.4 kW
- Input frequency: 50/60 Hz + 3%
- Output maximum rated power: 8 Amp
- Degree of protection: IP54-DHR ; IP-44 JET, JETINOX
- Maximum temperature + 50°C
- Input filter complying with EMC directive
- Pressure transducer 0 - 5 Volt - 0 - 10 Bar
- Serial interface connectivity RS 485
- Optional contacts 3 (external set-point, alarm, system inhibition)

#### BASE

- In galvanized metal complete with rubber isolated pads

#### SUCTION MANIFOLD

- In galvanized steel with:
- N.2 brass ball valves

#### DELIVERY MANIFOLD

- In galvanized steel with:
- N.2 brass ball valves
  - N.1 pressure gauge
  - N.2 pressure sensors

Protection electrical panel with circuit breakers



TYPE	MODEL	kW (P2)	Q1 l/m	Q2 l/m	H1 m	H2 m
HORIZONTAL	CPS20 JET 1000	2x1	10	140	42	20
	CPS20 JETINOX 90/50	2x0.9	20	160	44	3
	CPS20 DHR 2-50	2x0.5	20	100	25	12
	CPS20 DHR 4-50	2x0.7	80	240	39	17
	CPS20 DHR 4-60	2x1.1	80	240	49	25
	CPS20 DHR 9-40	2x1.3	80	480	40	10
	CPS20 DHR 9-60	2x1.9	804	80	60	14

# CPS20

## PRESSURE BOOSTER SET WITH TWO VARIABLE SPEED PUMPS

### CONTROL PANEL

---

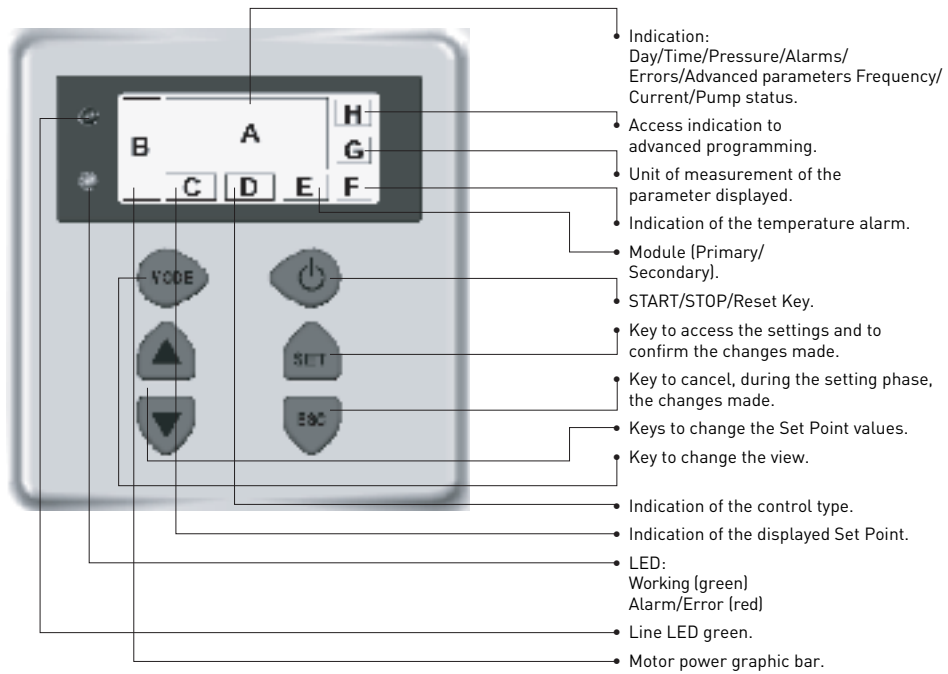

- Backlight display (switches off automatically after a pre-set time and can be turned on again by pressing any key)

# CPS20 JET - JETINOX

PRESSURE BOOSTER SET WITH TWO VARIABLE SPEED PUMPS

## HYDRAULIC PERFORMANCE

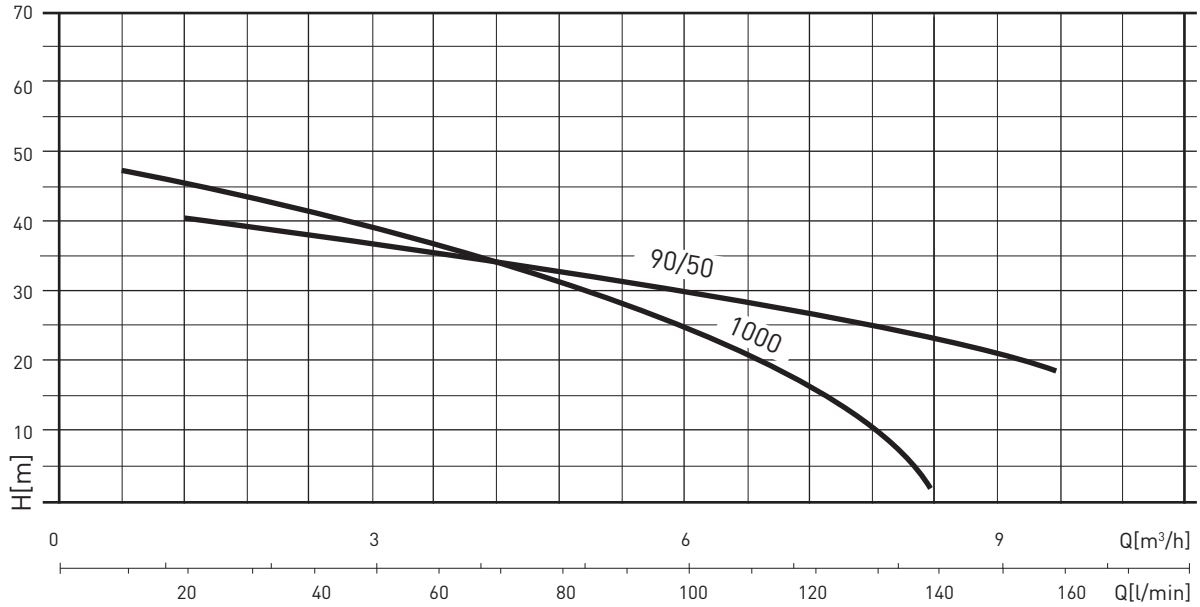

## PERFORMANCE TABLE

MODEL	P1		VOLT. (V)	In (A)	Q	Q										
	HP	kW				l/min	20	40	60	80	100	120	140	160		
CPS20-JETINOX90/50	2x2	2x1,5	1 - 230	2x9	m.c.w.											
CPS20- JET 1000	2x1,5	2x1,1	1 - 230	2x7,7			42	39	37	33	30	27	25	20		
							44	41	37	32	25	15	3			

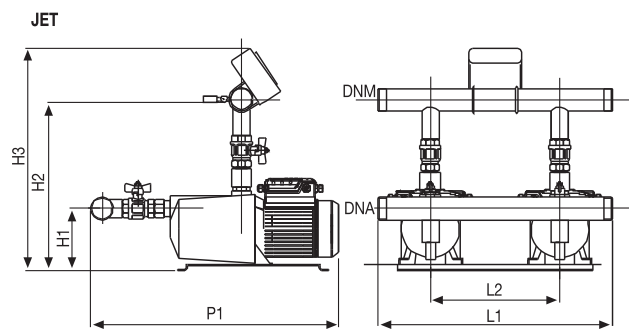
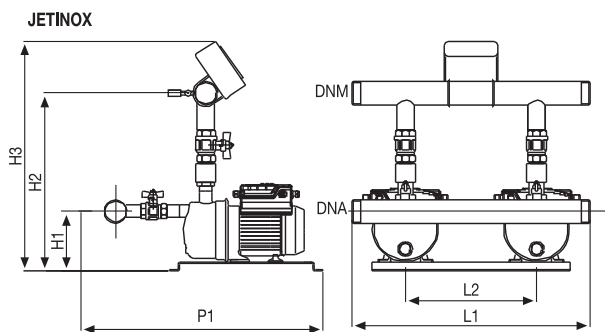

## OVERALL DIMENSIONS AND WEIGHTS

MODEL	Dimensions mm.									WEIGHT Kg
	L1	L2	H1	H2	H3	P1	DNA	DNM		
CPS20 JETINOX 90/50	540	310	188	443	648	590	2"	1 1/2"	70	
CPS20 JET 1000	670	370	190	420	625	620	2"	2"	65	

# CPS20 DHR

## PRESSURE BOOSTER SET WITH TWO VARIABLE SPEED PUMPS

### HYDRAULIC PERFORMANCE

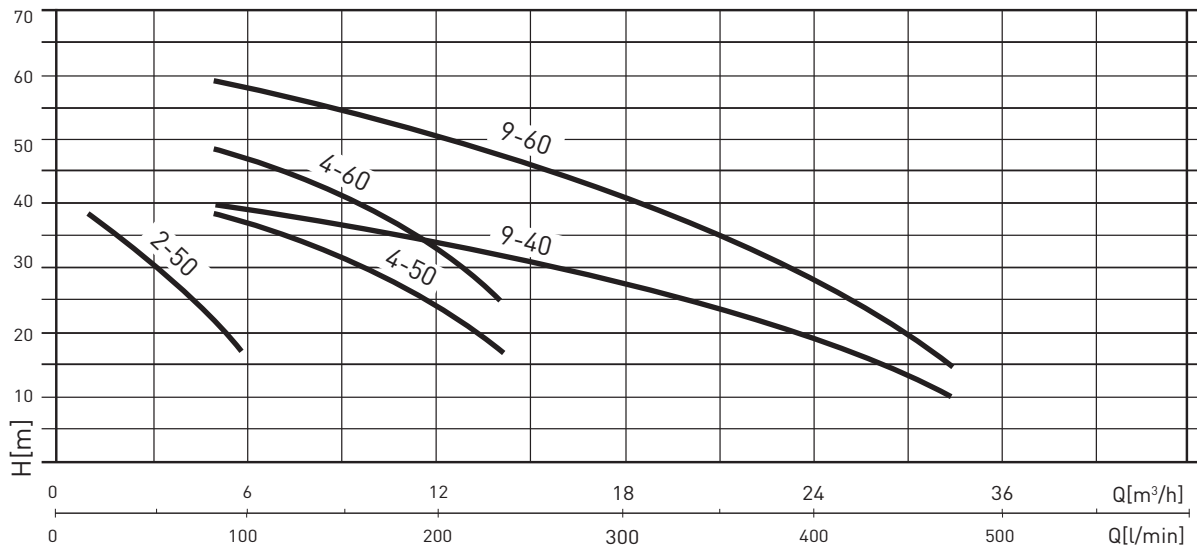

### PERFORMANCE TABLE

MODEL	P1		VOLT. (V)	In (A)	0	m.c.w.															
	HP	kW				l/min	20	40	60	80	100	120	160	200	240	320	400	480			
						0	1,2	2,4	3,6	4,8	6,0	7,2	9,6	12,0	14,4	19,2	24,0	28,8			
CPS20/DHR 2-50	2x1	2x1,0	1 - 230	2x5,5		39	35	30	23	17											
CPS20/DHR 4-50	2x1,7	2x1,1	1 - 230	2x10,6					39	38	35	31	25	17							
CPS20/DHR 4-60	2x2,15	2x1,1	1 - 230	2x9,5					49	47	45	41	34	25							
CPS20/DHR 9-40	2x2,15	2x1,1	1 - 230	2x9,5					40	39	38	38	35	33	27	19	10				
CPS20/DHR 9-60	2x3,35	2x2,2	1 - 230	2x15,8					60	58	57	56	53	49	40	29	14				

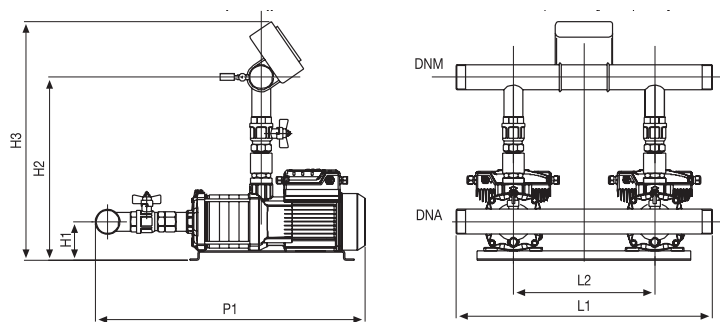

### OVERALL DIMENSIONS AND WEIGHTS

MODEL	Dimensions mm.									WEIGHT Kg
	L1	L2	H1	H2	H3	P1	DNA	DNM		
CPS20/DHR 2-50	540	310	100	365	572	525	2"1/2	1"1/2	57	
CPS20/DHR 4-50	540	310	100	365	572	587	2"	1"1/2	62	
CPS20/DHR 4-60	540	310	110	377	585	640	2"	1"1/2	68	
CPS20/DHR 9-40	670	370	110	445	660	610	2"1/2	2"	77	
CPS20/DHR 9-60	670	370	110	445	660	670	2"1/2	2"	89	

## VARIO 1-20/MULTI EVO-E PRESSURE BOOSTER SET WITH TWO VARIABLE SPEED PUMPS

Compact, Sturdy, high hydraulic efficiency

The new series of variable speed pressurization boosters VARIO 1-20 represents a reliable solution which is easy to use, for residential and industrial applications. The system involves the installation in parallel of two inverters integrated directly on the motor of each pump installed. The two frequency converters communicate and alternate the starting order of each work cycle, always keeping the pressure constant in the distribution system.

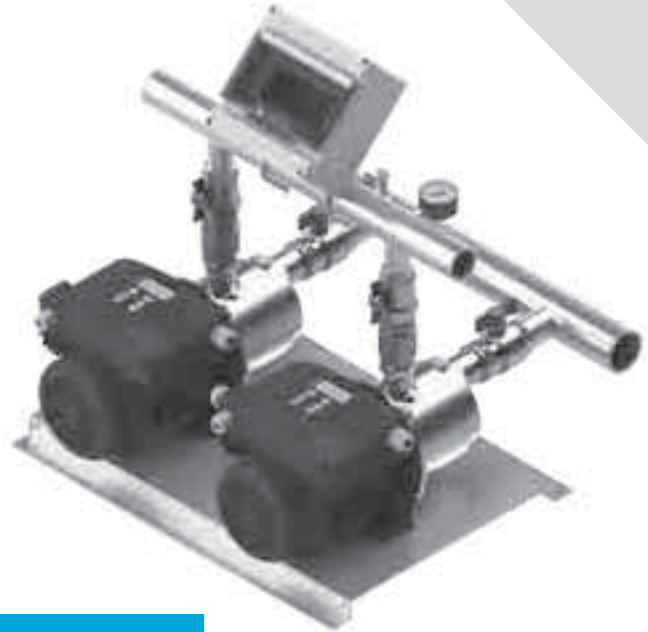

USAGE DATA	MULTIEVO
Maximum capacity (m <sup>3</sup> /h)	21
Maximum head (m.c.a.)	70
Maximum operating pressure	8 bar
Power supply VOLT.:	1 - 230 V
Frequency	50 Hz
Degree of protection of control panel	IP55
Degree of protection of pump	IP55
Ambient temperature	40°C
Number of pumps	2



### APPLICATIONS

- Lifting and distribution of water in domestic systems
- Pressurization systems
- Irrigation
- Washing systems



# VARIO 1-20/MULTI EVO-E

## PRESSURE BOOSTER SET WITH TWO VARIABLE SPEED PUMPS

### CONTROL PANEL

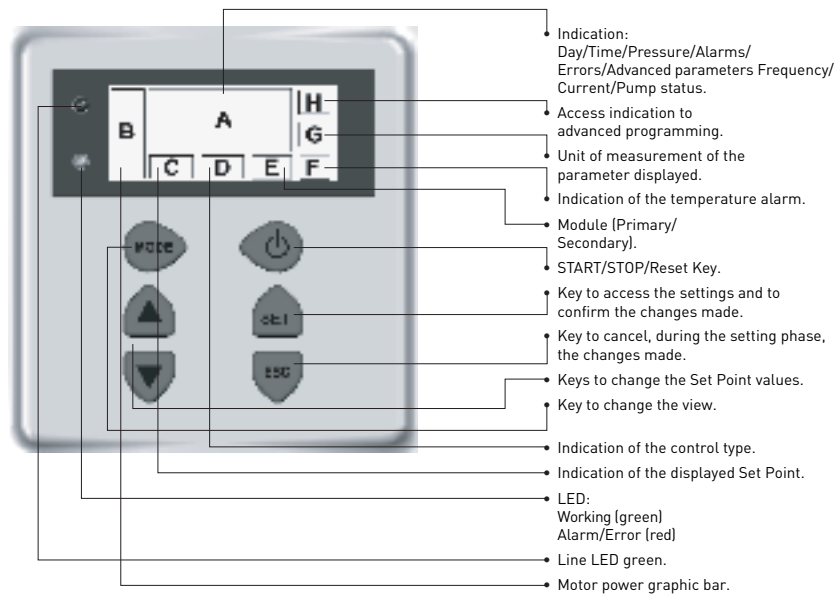

- Backlight display (switches off automatically after a reset time and can be turned on again by pressing any key)

### CONSTRUCTION FEATURES

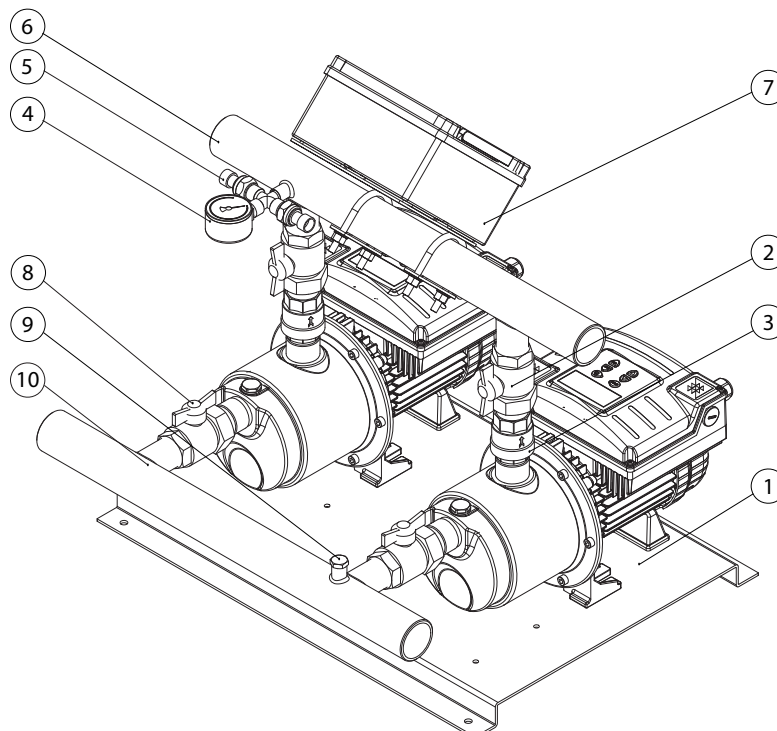

#### BASE

1. Base in galvanized metal complete with rubber isolated pads

#### DELIVERY MANIFOLD

- 2. n. 2 brass ball valves
- 3. n. 2 check valves
- 4. n. 1 pressure gauges
- 5. n. 2 pressure sensors
- 6. n. 1 galvanized steel manifold
- 7. n. 1 protection electrical panel with circuit breakers

#### SUCTION MANIFOLD

- 8. n. 2 brass ball valves
- 9. n. 1 sleeve for water load
- 10. n. 1 galvanized steel manifold

# VARIO 1-20/MULTI EVO-E

PRESSURE BOOSTER SET WITH TWO VARIABLE SPEED PUMPS

## HYDRAULIC PERFORMANCE

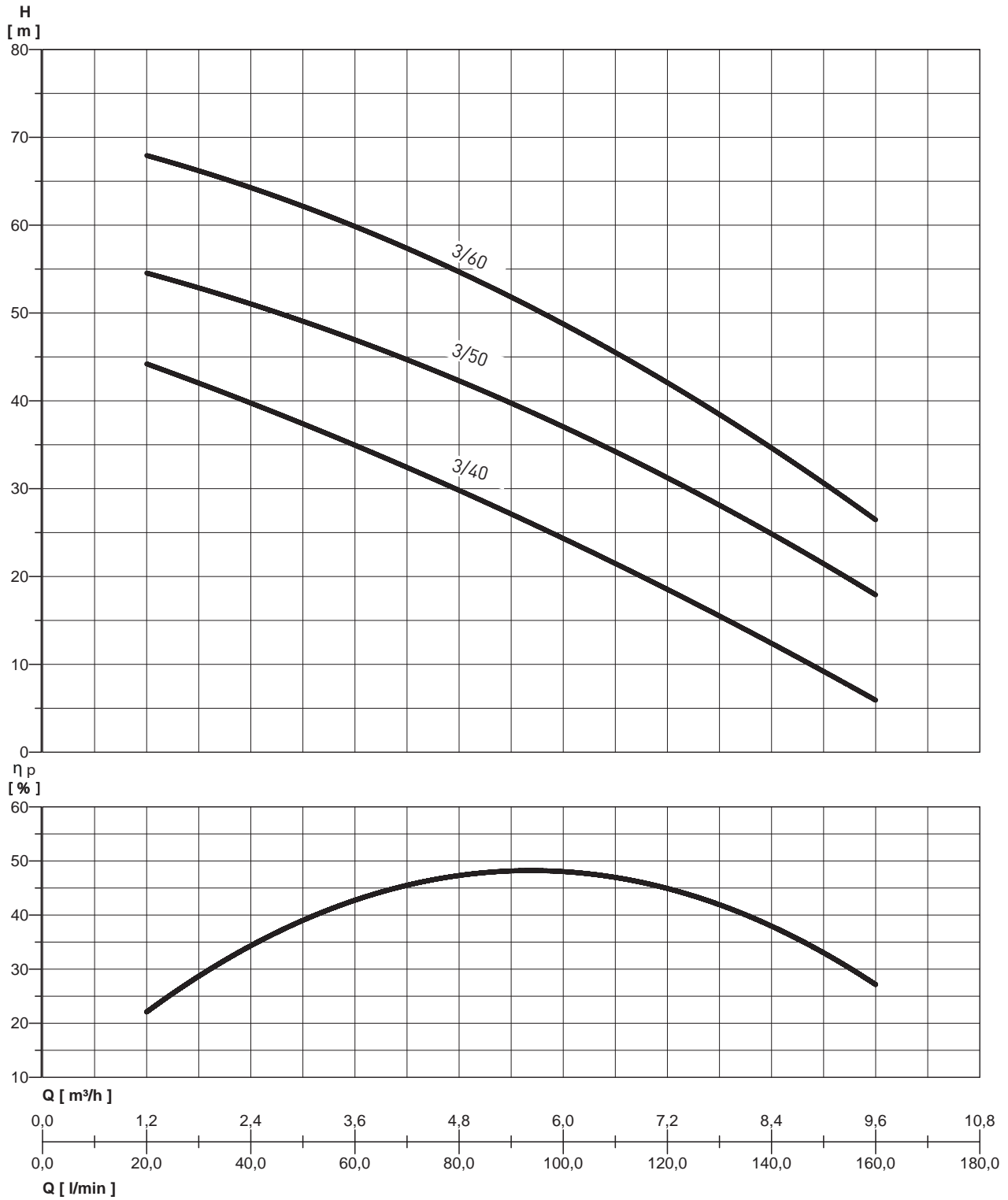

# VARIO 1-20/MULTI EVO-E 3

## PRESSURE BOOSTER SET WITH TWO VARIABLE SPEED PUMPS

### PERFORMANCE TABLE

MODEL	Absorbed power (P1) kW	VOLT. (V)	In (A)	0								
					l/min	20	40	60	80	100	120	160
					m <sup>3</sup> /h	1,2	2,4	3,6	4,8	6	7,2	9,6
VARIO1-20/MULTI EVO-E 3-40	2 x 0,8	1 - 230	2 x 5,3	total head in water column metres	44	40	35	30	24	18,5	6	
VARIO1-20/MULTI EVO-E 3-50	2 x 1	1 - 230	2 x 7		54,5	51	47	42,5	37	31	18	
VARIO1-20/MULTI EVO-E 3-60	2 x 1,35	1 - 230	2 x 8,7		68	64	60	55	48,5	42	26,5	

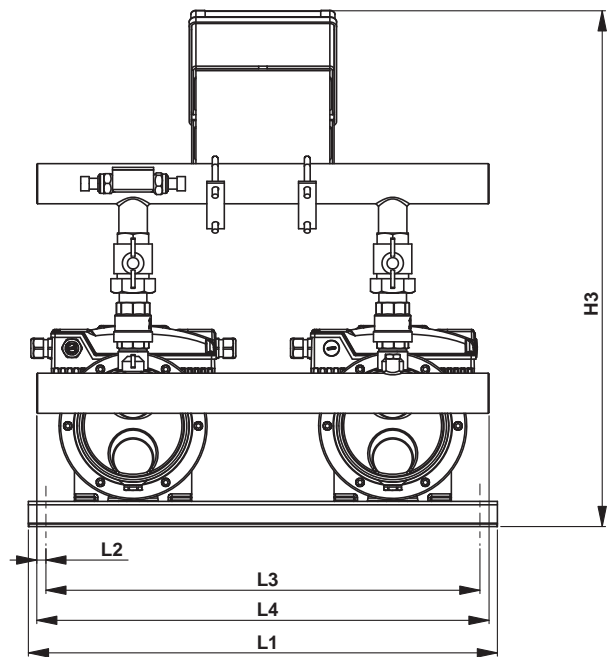
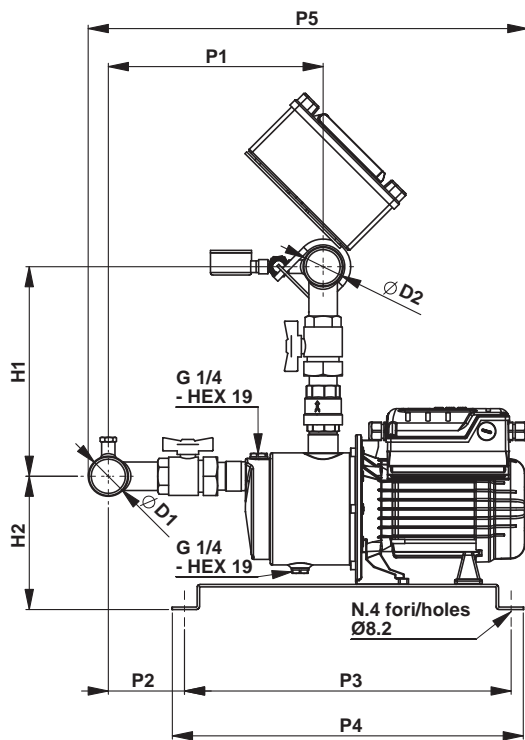

### OVERALL DIMENSIONS AND WEIGHTS

MODEL	Dimensions mm.														WEIGHT (Kg)
	L1	L2	L3	L4	P1	P2	P3	P4	P5	H1	H2	H3	ØD1	ØD2	
VARIO1-20/MULTI EVO-E 3-40	560	15	510	540	257	91	390	420	523	250	160	615	1"1/2	1"1/2	45,6
VARIO1-20/MULTI EVO-E 3-50	560	15	510	540	280	113	390	420	567	250	160	615	1"1/2	1"1/2	49,6
VARIO1-20/MULTI EVO-E 3-60	560	15	510	540	302	136	390	420	589	250	160	615	1"1/2	1"1/2	53



# VARIO 1-20/MULTI EVO-E 5

PRESSURE BOOSTER SET WITH TWO VARIABLE SPEED PUMPS

## HYDRAULIC PERFORMANCE

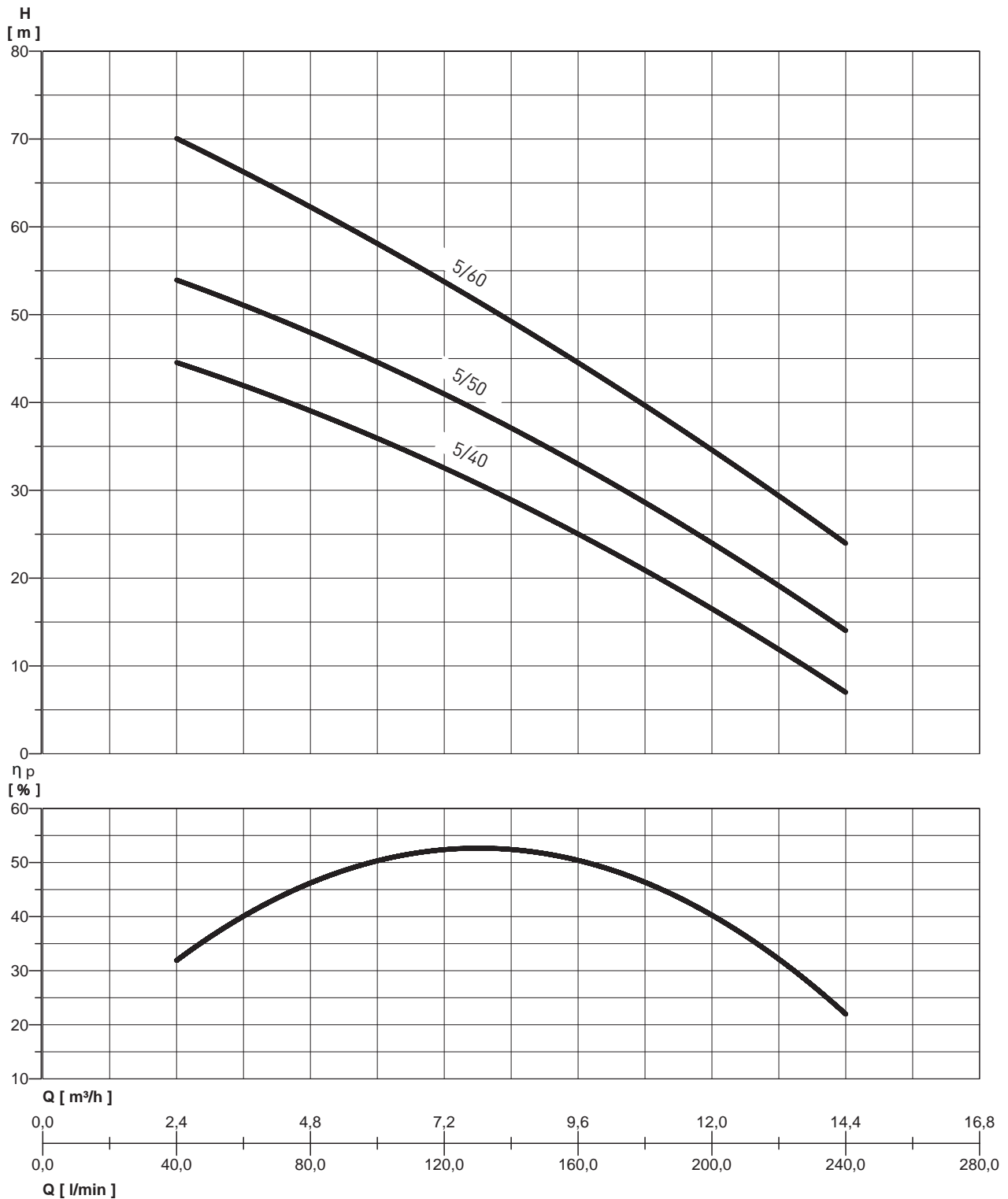

# VARIO 1-20/MULTI EVO-E 5

## PRESSURE BOOSTER SET WITH TWO VARIABLE SPEED PUMPS

### PERFORMANCE TABLE

MODEL	Absorbed power (P1) kW	VOLT. (V)	In (A)	0									
					l/min	40	60	80	100	120	160	200	240
					m <sup>3</sup> /h	2,4	3,6	4,8	6	7,2	9,6	12	14,4
VARIO1-20/MULTI EVO-E 5-40	2 x 1	1 - 230	2 x 7	total head in water column metres	44,5	42	39	36	32,5	25	16,5	7	
VARIO1-20/MULTI EVO-E 5-50	2 x 1,25	1 - 230	2 x 8,5		54	51	48	44,5	41	33	24	14	
VARIO1-20/MULTI EVO-E 5-60	2 x 1,8	1 - 230	2 x 11,5		70	66,5	62	58	54	44,5	34,5	24	

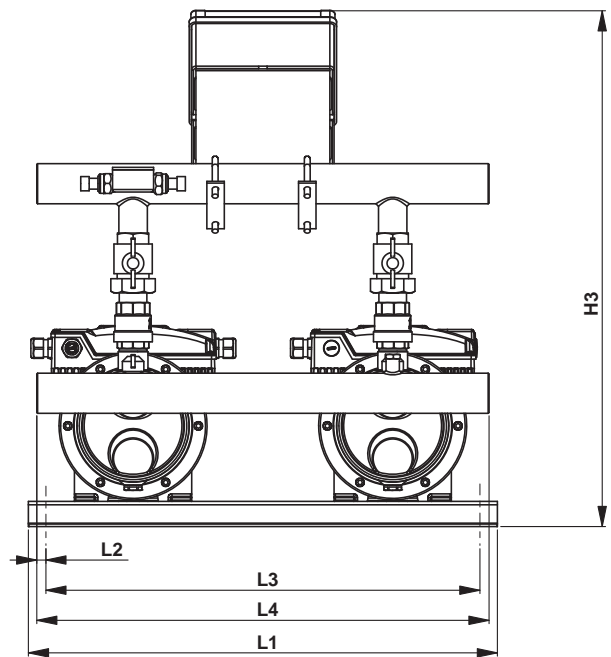
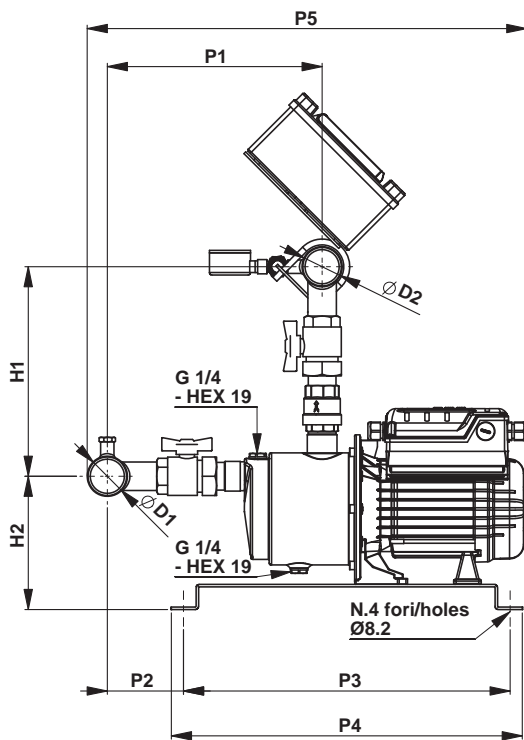

### OVERALL DIMENSIONS AND WEIGHTS

MODEL	Dimensions mm.														WEIGHT (Kg)
	L1	L2	L3	L4	P1	P2	P3	P4	P5	H1	H2	H3	ØD1	ØD2	
VARIO1-20/MULTI EVO-E 5-40	560	15	510	540	283	119	390	420	574	255	155	615	2"	1 1/2"	49
VARIO1-20/MULTI EVO-E 5-50	560	15	510	540	305	141	390	420	596	255	155	615	2"	1 1/2"	52,2
VARIO1-20/MULTI EVO-E 5-60	560	15	510	540	327	163	390	420	653	255	155	615	2"	1 1/2"	56,4

# VARIO 1-20/MULTI EVO-E 8

PRESSURE BOOSTER SET WITH TWO VARIABLE SPEED PUMPS

## HYDRAULIC PERFORMANCE

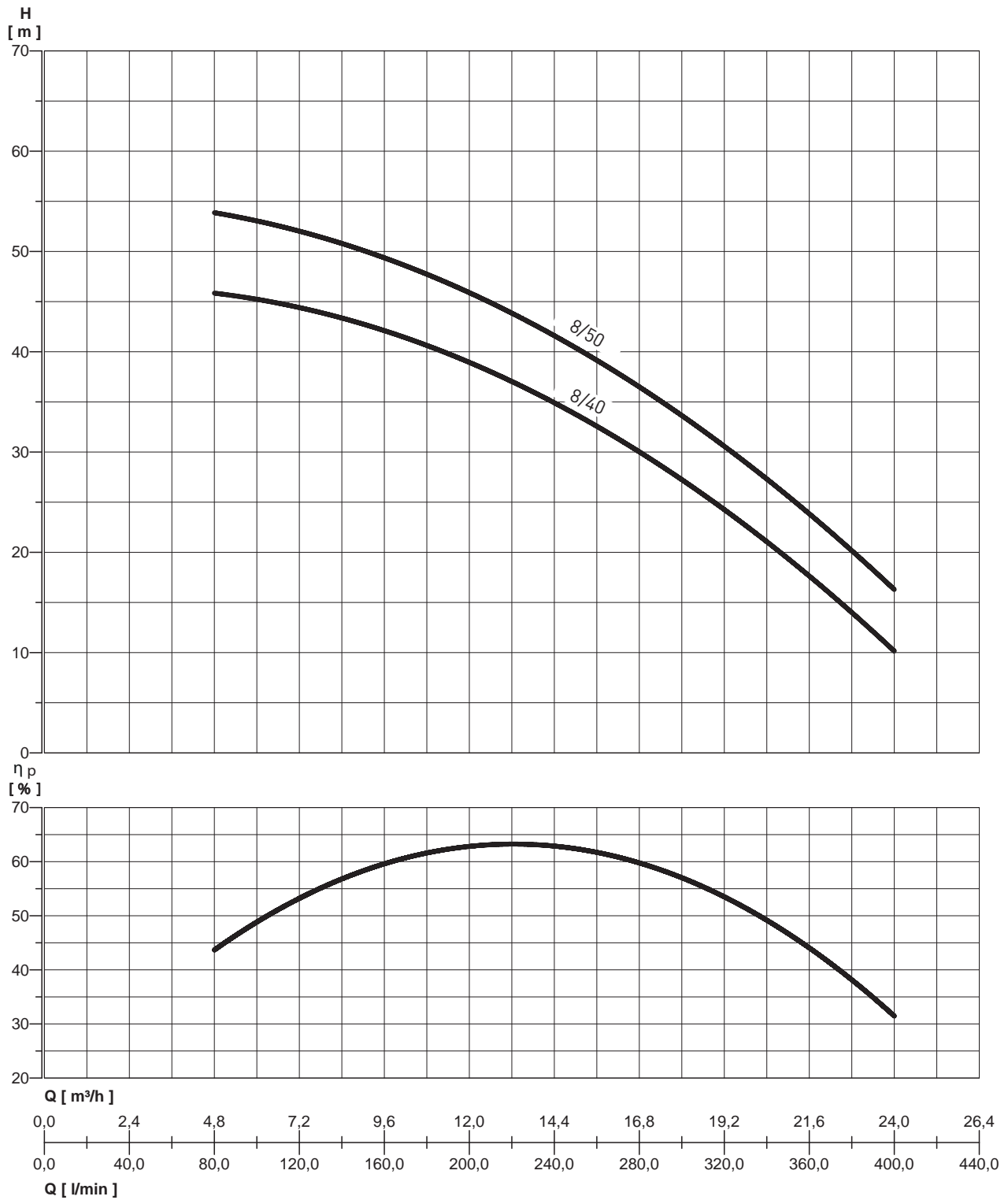

# VARIO 1-20/MULTI EVO-E 8

## PRESSURE BOOSTER SET WITH TWO VARIABLE SPEED PUMPS

### PERFORMANCE TABLE

MODEL	Absorbed power (P1) kW	VOLT. (V)	In (A)	0											
					l/min	80	100	120	160	200	240	280	320	360	400
VARIO1-20/MULTI EVO-E 8-40	2 x 1,6	1-230	2 x 10,2		4,8	6	7,2	9,6	12	14,4	16,8	19,2	21,6	24	
VARIO1-20/MULTI EVO-E 8-50	2 x 2	1-230	2 x 12,5	total head in water column metres	46	45	44,5	42	39	35	30	24	18	10	
					54	53	52	49	46	42	36,5	30,5	23,5	16,5	

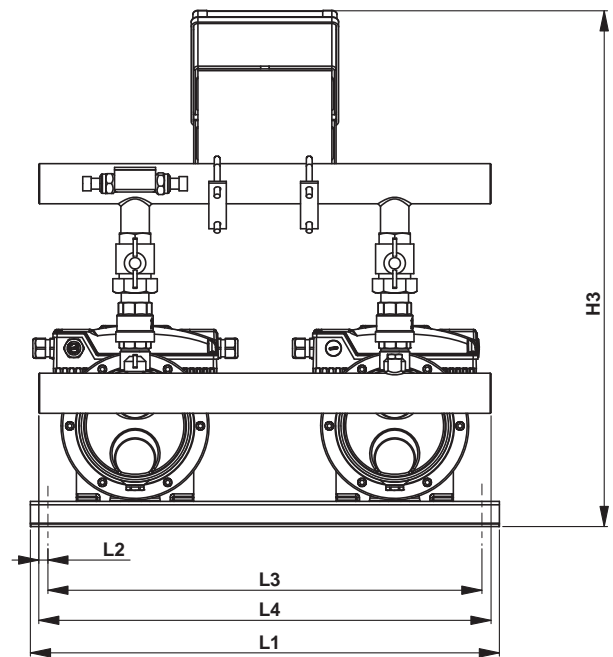
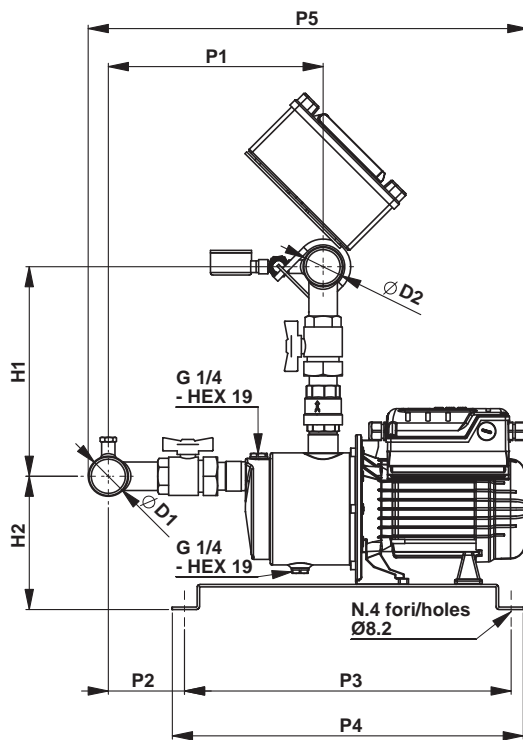

### OVERALL DIMENSIONS AND WEIGHTS

MODEL	Dimensions mm.														WEIGHT (Kg)
	L1	L2	L3	L4	P1	P2	P3	P4	P5	H1	H2	H3	ØD1	ØD2	
VARIO1-20/MULTI EVO-E 8-40	560	15	510	540	300	136	390	420	623	300	155	660	2"	2"	58
VARIO1-20/MULTI EVO-E 8-50	560	15	510	540	327	163	390	420	653	300	155	660	2"	2"	60,2

## VARIO 1-20/MULTI EVO-E P PRESSURE BOOSTER UNIT WITH TWO VARIABLE SPEED PUMPS

Compact, Robust, High hydraulic performance

The new series of VARIO 1-20 variable speed pressurization units represent a reliable, easy-to-use solution in residential and commercial applications. The system consists in the parallel installation of two inverters, incorporated directly onto the motor of each installed electric pump. The two frequency converters communicate and alternate the starting order of each operating cycle, maintaining a constant pressure in the distribution system.



USE DATA	VARIO 1-20/MULTI EVO-E P
Maximum flow (m <sup>3</sup> /h)	14,4
Maximum head (m.c.a.)	60
Maximum operating pressure	7 bar
Power supply voltage	1 - 230 V
Frequency	50 Hz
Protection class control board	IP55
Protection class electric pump	IP55
Room temperature	40°C
Number of pumps	2



### APPLICATIONS

- Lifts and distributes water in domestic systems
- Pressurization systems
- Irrigation
- Cleaning systems



# VARIO 1-20/MULTI EVO-E P

## PRESSURE BOOSTER UNIT WITH TWO VARIABLE SPEED ELECTRIC PUMPS

### DESIGN FEATURES

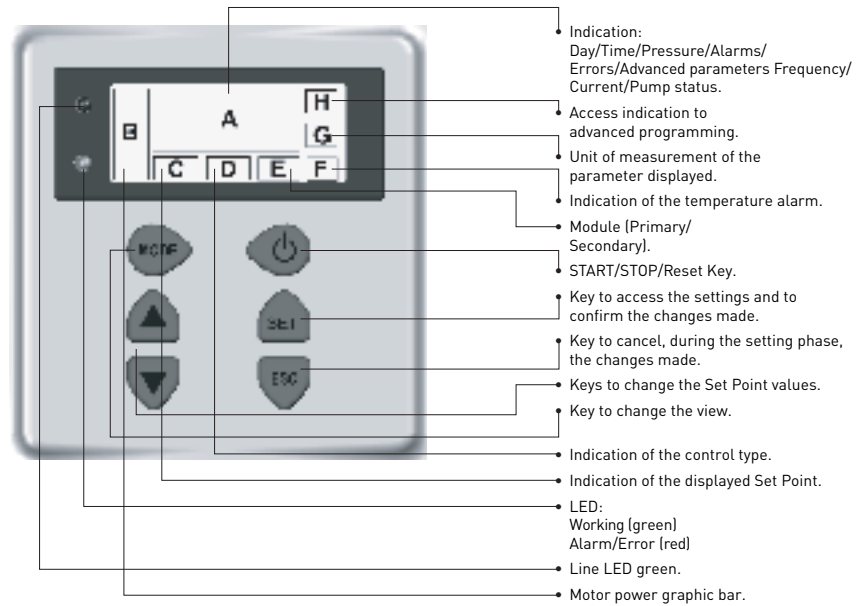

- Backlight display (switches off automatically after a reset time and can be turned on again by pressing any key)

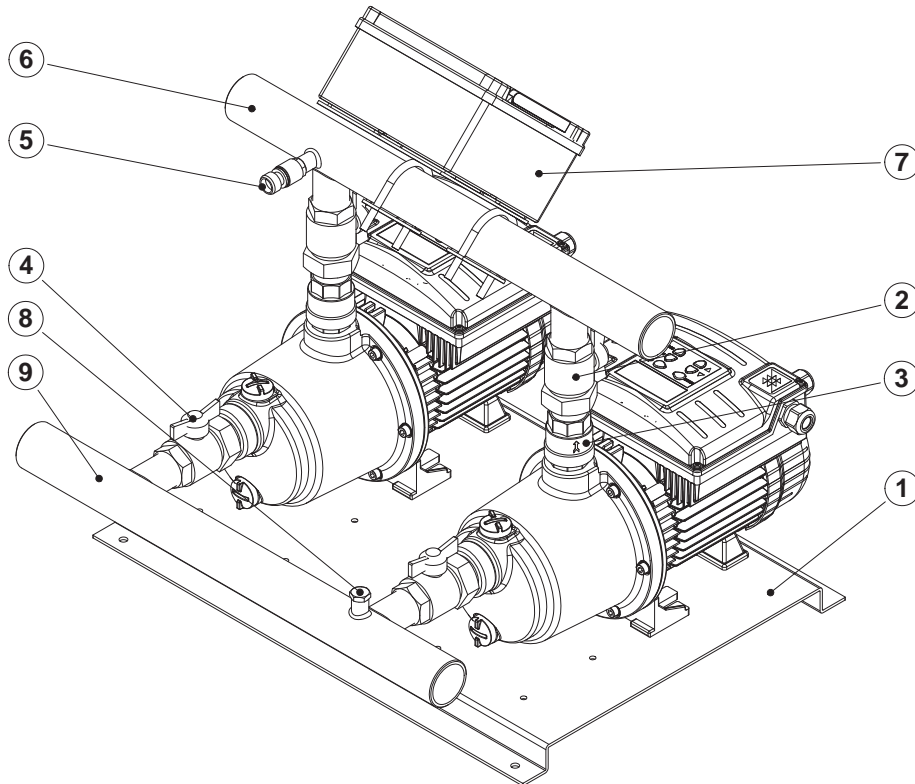

#### BASE

1. Base in zinc-coated sheet metal

#### OUTLET MANIFOLD

2. no. 2 brass ball valves
3. no. 2 retainer valves
5. no. 1 pressure sensors
6. no. 1 manifold in zinc-coated steel
7. no. 1 power board with thermal magnetic circuit breaker protection

#### INTAKE MANIFOLD

4. no. 2 brass ball valves
8. no. 1 water intake sleeve
9. no. 1 manifold in zinc-coated steel

# VARIO 1-20/MULTI EVO-E 3 P

PRESSURE BOOSTER UNIT WITH TWO VARIABLE SPEED ELECTRIC PUMPS

## HYDRAULIC PERFORMANCE

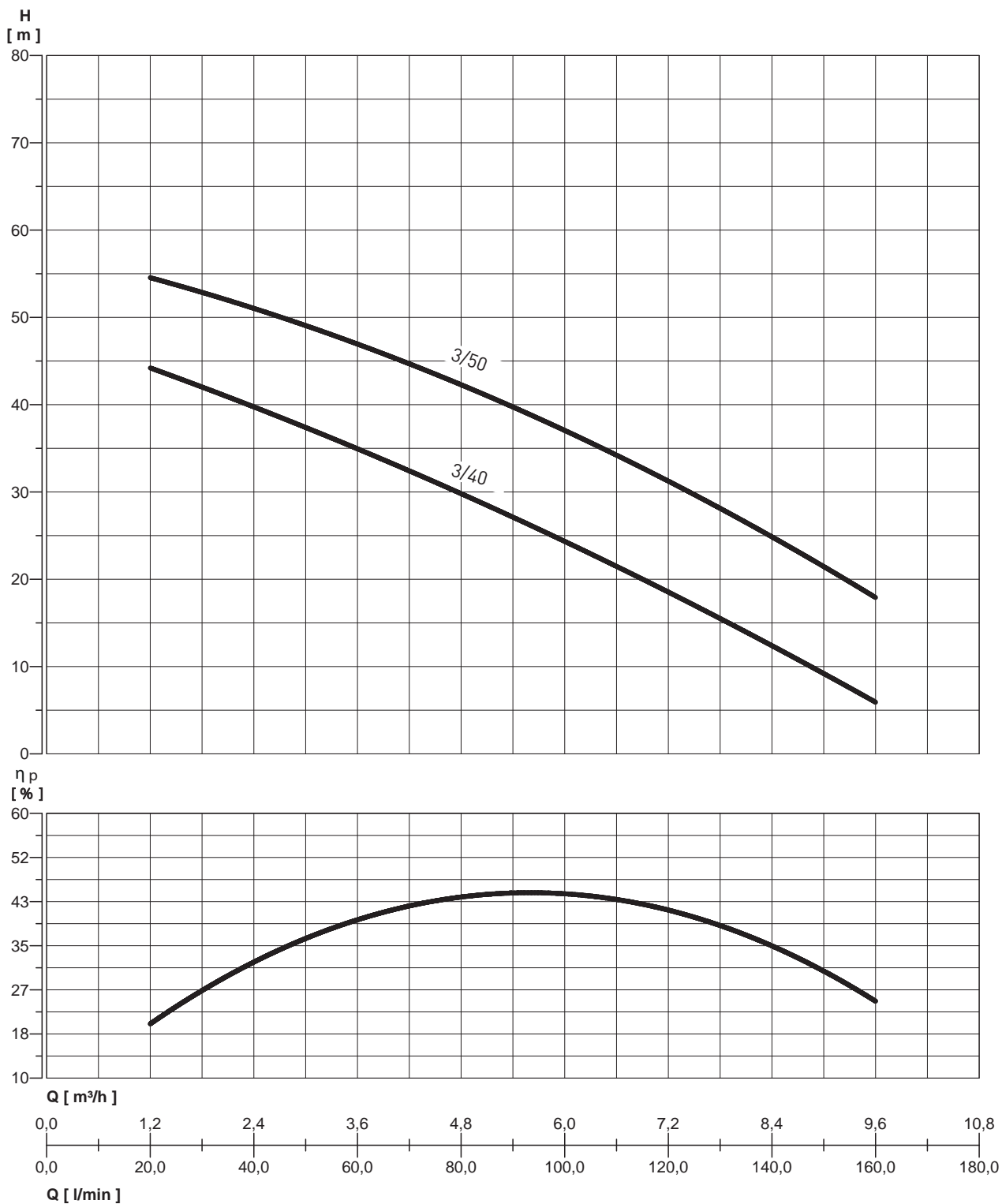

# VARIO 1-20/MULTI EVO-E 3 P

PRESSURE BOOSTER UNIT WITH TWO VARIABLE SPEED ELECTRIC PUMPS

## PERFORMANCE TABLE

MODEL	Absorbed power (P1) kW	VOLT. (V)	In (A)	0	total head in water column mm metres													
					l/min	20	40	60	80	100	120	160						
VARIO1-20/MULTI EVO-E 3-40 P	2 x 0,8	1 - 230	2 x 5,3		1,2	2,4	3,6	4,8	6	7,2	9,6	44	40	35	30	24	18,5	6
VARIO1-20/MULTI EVO-E 3-50 P	2 x 1	1 - 230	2 x 7									54,5	51	47	42,5	37	31	18

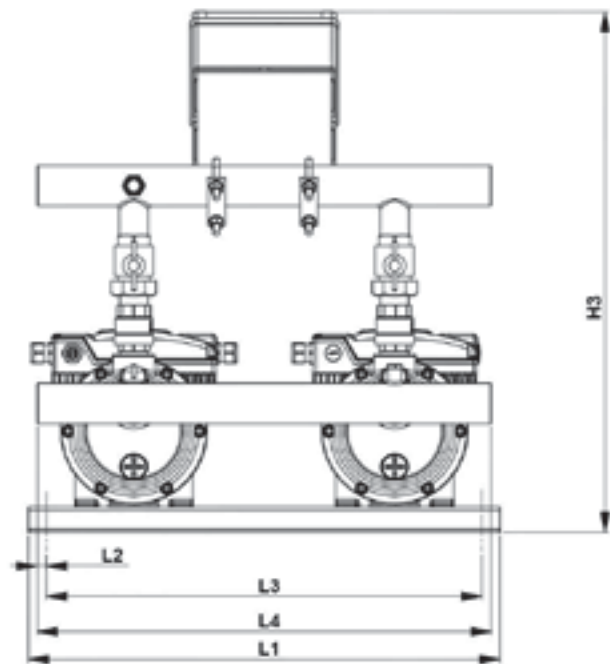
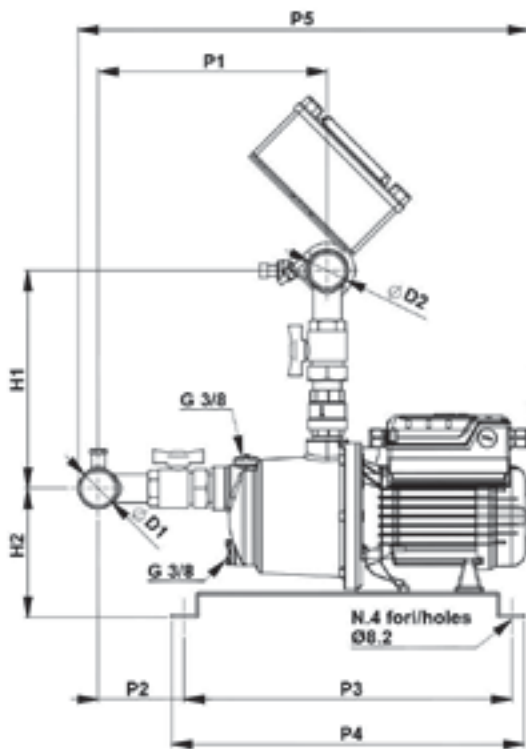

## OVERALL DIMENSIONS AND WEIGHTS

MODEL	Dimensions mm.														WEIGHT (Kg)
	L1	L2	L3	L4	P1	P2	P3	P4	P5	H1	H2	H3	ØD1	ØD2	
VARIO1-20/MULTI EVO-E 3-40 P	560	15	510	540	272	102	390	420	535	260	153	615	1"1/2	1"1/2	44,6
VARIO1-20/MULTI EVO-E 3-50 P	560	15	510	540	272	102	390	420	552	260	153	615	1"1/2	1"1/2	48,6



# VARIO 1-20/MULTI EVO-E 5 P

PRESSURE BOOSTER UNIT WITH TWO VARIABLE SPEED ELECTRIC PUMPS

## HYDRAULIC PERFORMANCE

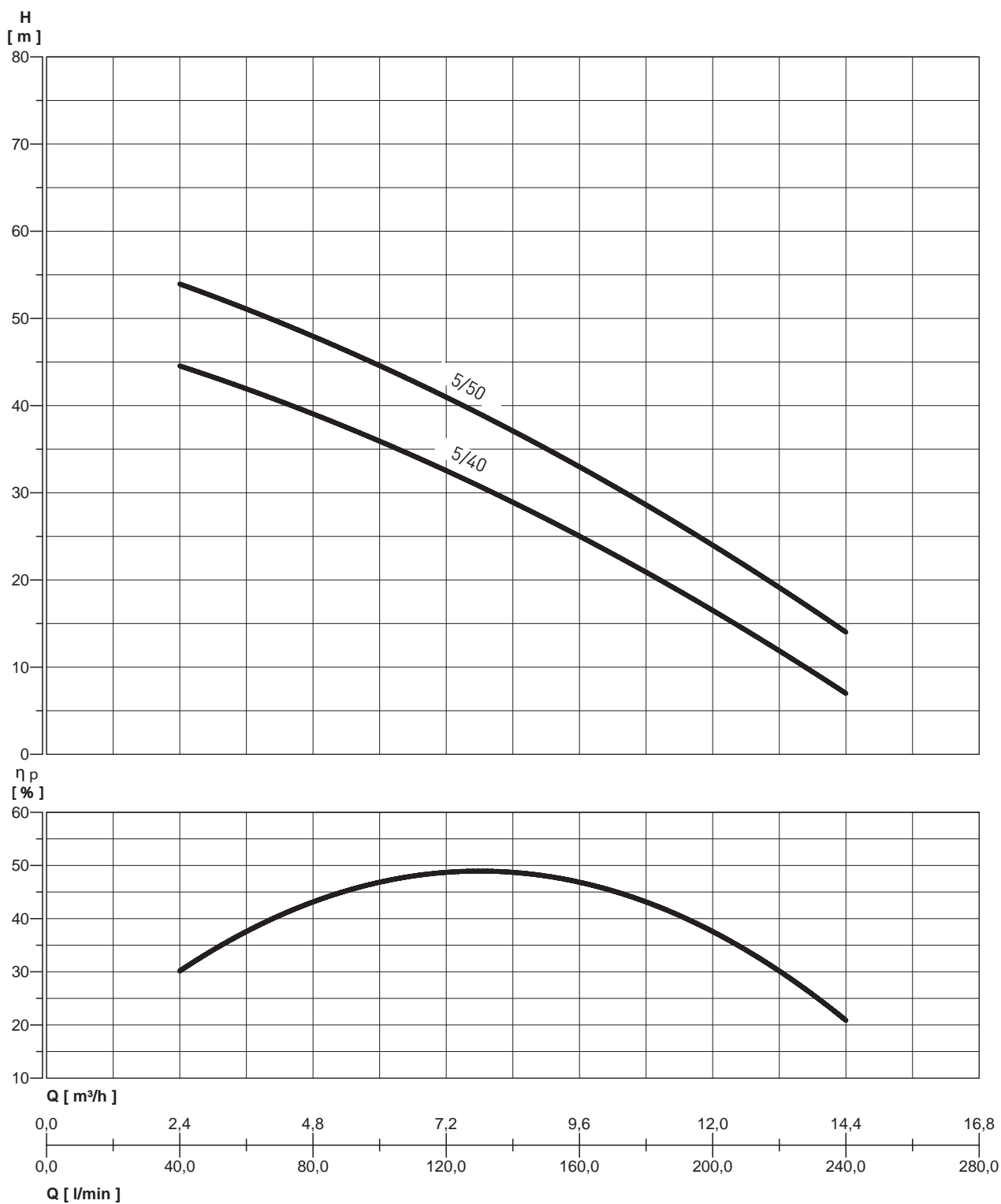

# VARIO 1-20/MULTI EVO-E 5 P

PRESSURE BOOSTER UNIT WITH TWO VARIABLE SPEED ELECTRIC PUMPS

## PERFORMANCE TABLE

MODEL	Absorbed power (P1) kW	VOLT. (V)	In (A)	0	l/min	40	60	80	100	120	160	200	240
					m <sup>3</sup> /h	2,4	3,6	4,8	6	7,2	9,6	12	14,4
VARIO1-20/MULTI EVO-E 5-40 P	2 x 1	1 - 230	2 x 7	total head in water column metres	44,5	42	39	36	32,5	25	16,5	7	
VARIO1-20/MULTI EVO-E 5-50 P	2 x 1,25	1 - 230	2 x 8,5		54	51	48	44,5	41	33	24	14	

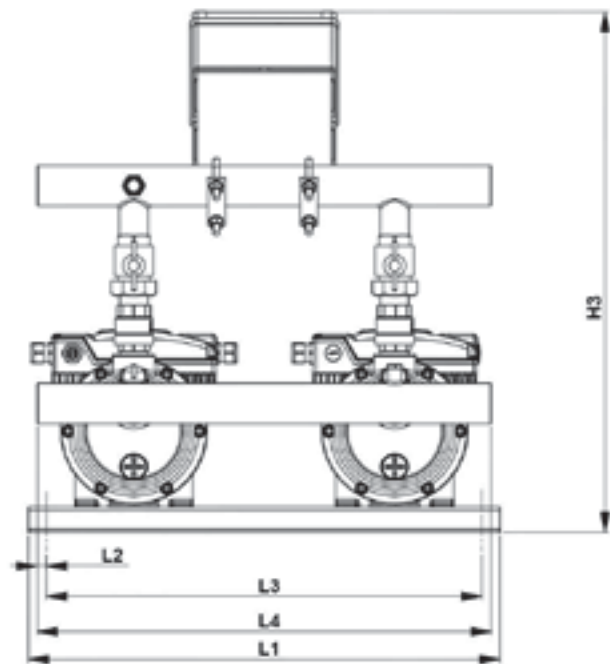
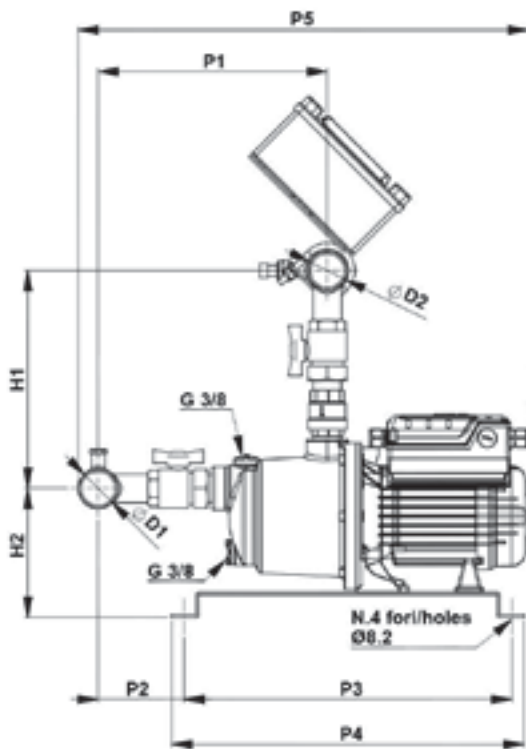

## OVERALL DIMENSIONS AND WEIGHTS

MODEL	Dimensions mm.														WEIGHT (Kg)
	L1	L2	L3	L4	P1	P2	P3	P4	P5	H1	H2	H3	ØD1	ØD2	
VARIO1-20/MULTI EVO-E 5-40 P	560	15	510	540	272	102	390	420	552	260	153	615	1 1/2	1 1/2	48,6
VARIO1-20/MULTI EVO-E 5-50 P	560	15	510	540	272	102	390	420	552	260	153	615	1 1/2	1 1/2	51,2

## VARIO 1-20

### PRESSURE BOOSTER SET WITH TWO VARIABLE SPEED PUMPS

The new series of variable speed pressurization booster set VARIO 1-20 represents a reliable solution which is easy to use, for residential and industrial applications. The system involves the installation in parallel of two inverters integrated directly on the motor of each pump installed. The two frequency converters communicate and alternate the starting order of each work cycle, always keeping the pressure constant in the distribution system.

#### APPLICATIONS

- Lifting and distribution of water in domestic systems
- Pressurization systems
- Irrigation
- Industry
- Washes

#### BASE

- in galvanized metal complete with rubber isolated pads

#### SUCTION MANIFOLD

in galvanized steel with:

- N.2 brass ball valves

#### TECHNICAL CHARACTERISTICS

- Supply voltage: inverter 1x230 Vac  $\pm$  10%.
- Inverter output voltage: 3x230 Vac  $\pm$  10 %
- Maximum rated power: 2x2.4 kW
- Input frequency: 50/60 Hz + 3%
- Output maximum rated power: 8 Amp
- Degree of protection: IP55 MULTINOX VE+ / PVM
- Maximum temperature + 50°C
- Input filter complying with EMC directive
- Pressure transducer 0 - 5 Volt - 0 - 10 Bar
- Serial interface connectivity RS 485
- Optional contacts 3 (external set-point, alarm, system inhibition)

#### DELIVERY MANIFOLD

in galvanized steel with:

- N.2 brass ball valves
- N.1 pressure gauge
- N.2 pressure sensors

Protection electrical panel with circuit breakers



USAGE DATA	MULTINOX-VE+	PVM 1	PVM 3	PVM 5	PVM 10
Maximum capacity (m <sup>3</sup> /h)	25.2	4.8	9	17	26
Maximum head (m.c.a.)	80	160	160	110	60
Maximum operating pressure	14 bar			16 bar	
Power supply VOLT.:			1-230 V		
Ambient temperature			50° C		
Degree of protection of pump	IP44			IP55	
Degree of protection of electrical panel			IP54		

# VARIO 1-20

## PRESSURE BOOSTER SET WITH TWO VARIABLE SPEED PUMPS

### CONTROL PANEL

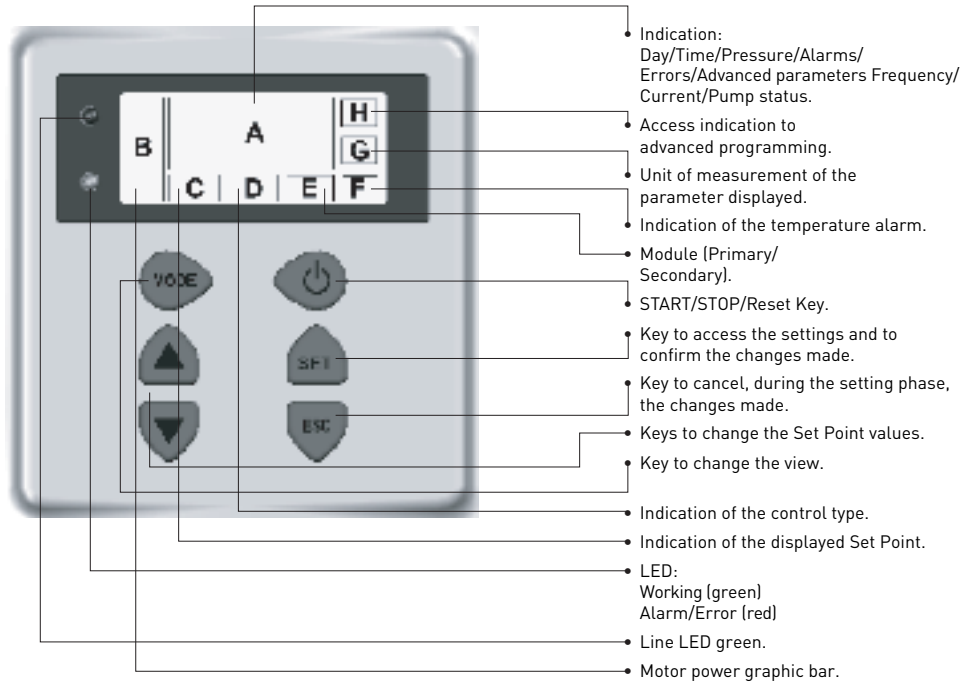

- Backlight display (switches off automatically after a reset time and can be turned on again by pressing any key)

# VARIO 1-20 MULTINOX VE +

PRESSURE BOOSTER SET WITH TWO VARIABLE SPEED PUMPS

## HYDRAULIC PERFORMANCE

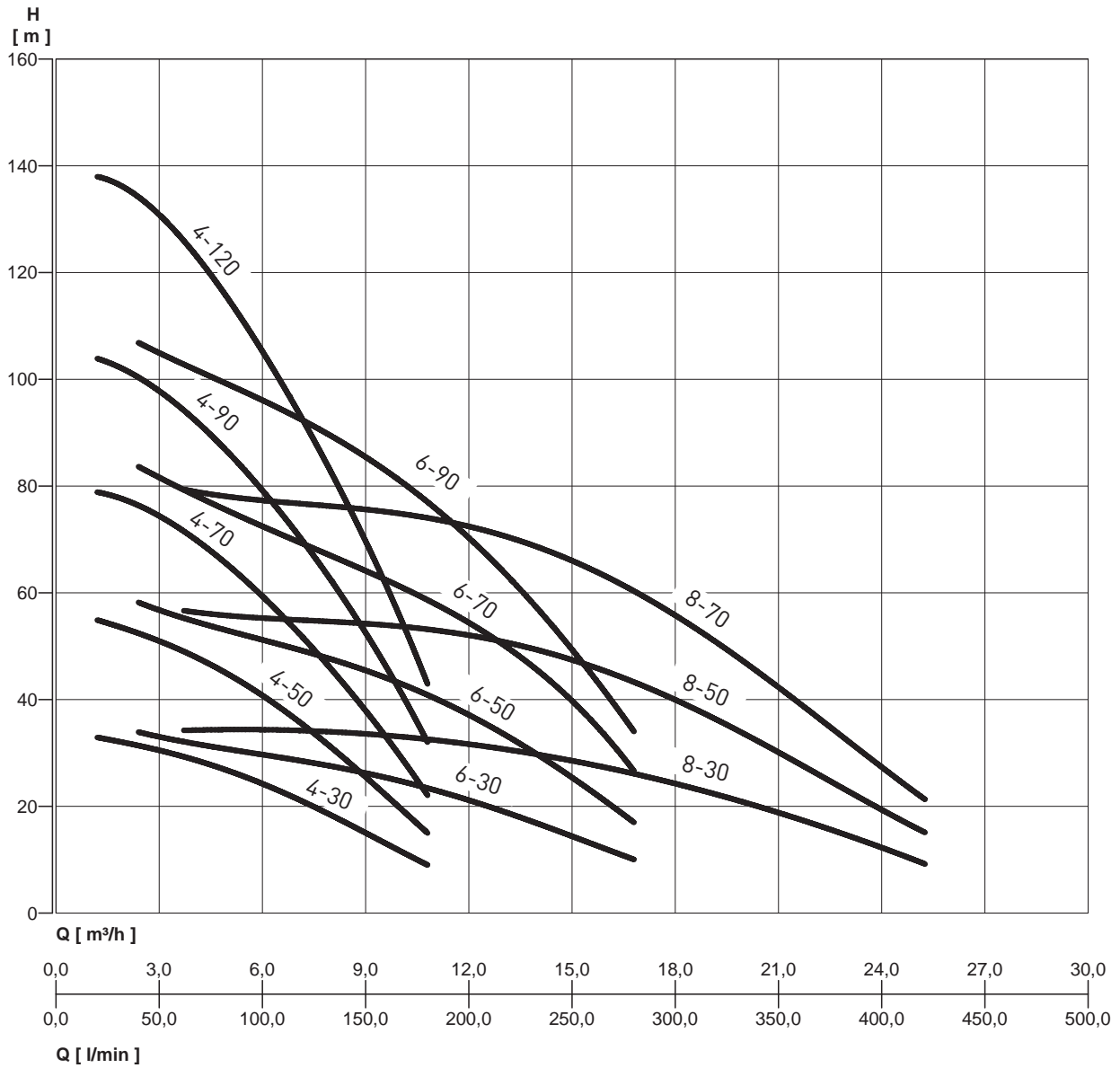

# VARIO 1-20 MULTINOX VE +

## PRESSURE BOOSTER SET WITH TWO VARIABLE SPEED PUMPS

### PERFORMANCE TABLE

MODEL	P2	VOLT. (V)	In (A)	Q	m.c.w.																
	kW				l/min	20	40	60	80	100	120	140	160	180	200	240	280	300	360	420	
					m <sup>3</sup> /h	1,2	2,4	3,6	4,8	6	7,2	8,4	9,6	10,8	12	14,4	16,8	18	21,6	25,2	
VARIO1-20 MULTINOX VE+ 4-30	2x0,5	1 ~ 230	2x4.4		33	31	30	27	24	21	17	13	9								
VARIO1-20 MULTINOX VE+ 4-50	2x0,84	1 ~ 230	2x6.71		55	52	50	45	41	35	29	22	15								
VARIO1-20 MULTINOX VE+ 4-70	2x1,17	1 ~ 230	2x9.39		79	76	72	67	59	51	43	33	22								
VARIO1-20 MULTINOX VE+ 4-90	2x1,5	1 ~ 230	2x12,08		104	100	95	88	79	69	59	46	32								
VARIO1-20 MULTINOX VE+ 4-120	2x2	1 ~ 230	2x16,3		138	134	127	117	105	92	78	61	43								
VARIO1-20 MULTINOX VE+ 6-30	2x0,67	1 ~ 230	2x5.95		34	32	31	30	28	27	26	23	21	16	10						
VARIO1-20 MULTINOX VE+ 6-50	2x1,1	1 ~ 230	2x9.02		58	56	53	51	49	47	44	41	37	28	17						
VARIO1-20 MULTINOX VE+ 6-70	2x1,5	1 ~ 230	2x13,82		83	80	77	76	61	68	64	59	55	42	27						
VARIO1-20 MULTINOX VE+ 6-90	2x2	1 ~ 230	2x15,75		107	103	99	97	92	88	83	76	71	54	34						
VARIO1-20 MULTINOX VE+ 8-30	2x1	1 ~ 230	2x8.7					35	35	35	35	34	33	32	30	27	25	18	10		
VARIO1-20 MULTINOX VE+ 8-50	2x1,5	1 ~ 230	2x14.4					57	57	56	56	54	53	52	50	45	40	28	16		
VARIO1-20 MULTINOX VE+ 8-70	2x1,9	1 ~ 230	2x15,5					80	79	78	78	77	75	74	73	70	60	56	40	22	

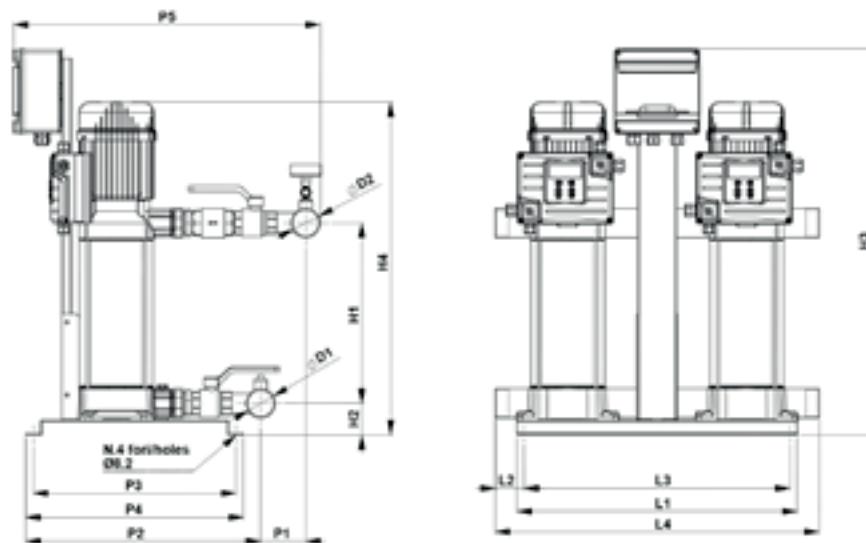

### OVERALL DIMENSIONS AND WEIGHTS

MODEL	Dimensions mm.															WEIGHT Kg
	L1	L2	L3	L4	P1	P2	P3	P4	P5	H1	H2	H3	H4	OD1	OD2	
VARIO1-20 MULTINOX VE+ 4-30	580	70	530	670	90	485	420	450	635	130	65	800	446	2"	2"	71
VARIO1-20 MULTINOX VE+ 4-50	580	70	530	670	90	485	420	450	635	184	65	800	500	2"	2"	79
VARIO1-20 MULTINOX VE+ 4-70	580	70	530	670	90	485	420	450	635	238	65	800	554	2"	2"	87
VARIO1-20 MULTINOX VE+ 4-90	580	70	530	670	90	485	420	450	635	292	65	800	608	2"	2"	89
VARIO1-20 MULTINOX VE+ 4-120	580	70	530	670	90	485	420	450	635	373	65	800	690	2"	2"	93
VARIO1-20 MULTINOX VE+ 6-30	580	70	530	670	90	485	420	450	635	130	65	800	446	2"	2"	71
VARIO1-20 MULTINOX VE+ 6-50	580	70	530	670	90	485	420	450	635	184	65	800	500	2"	2"	79
VARIO1-20 MULTINOX VE+ 6-70	580	70	530	670	90	485	420	450	635	238	65	800	554	2"	2"	87
VARIO1-20 MULTINOX VE+ 6-90	580	70	530	670	90	485	420	450	635	292	65	800	608	2"	2"	89
VARIO1-20 MULTINOX VE+ 8-30	580	70	530	670	90	485	420	450	635	130	65	800	446	2"	2"	71
VARIO1-20 MULTINOX VE+ 8-50	580	70	530	670	90	485	420	450	635	184	65	800	500	2"	2"	79
VARIO1-20 MULTINOX VE+ 8-70	580	70	530	670	90	485	420	450	635	238	65	800	554	2"	2"	87

# VARIO 1-20 PVM

PRESSURE BOOSTER SET WITH TWO VARIABLE SPEED PUMPS

## HYDRAULIC PERFORMANCE

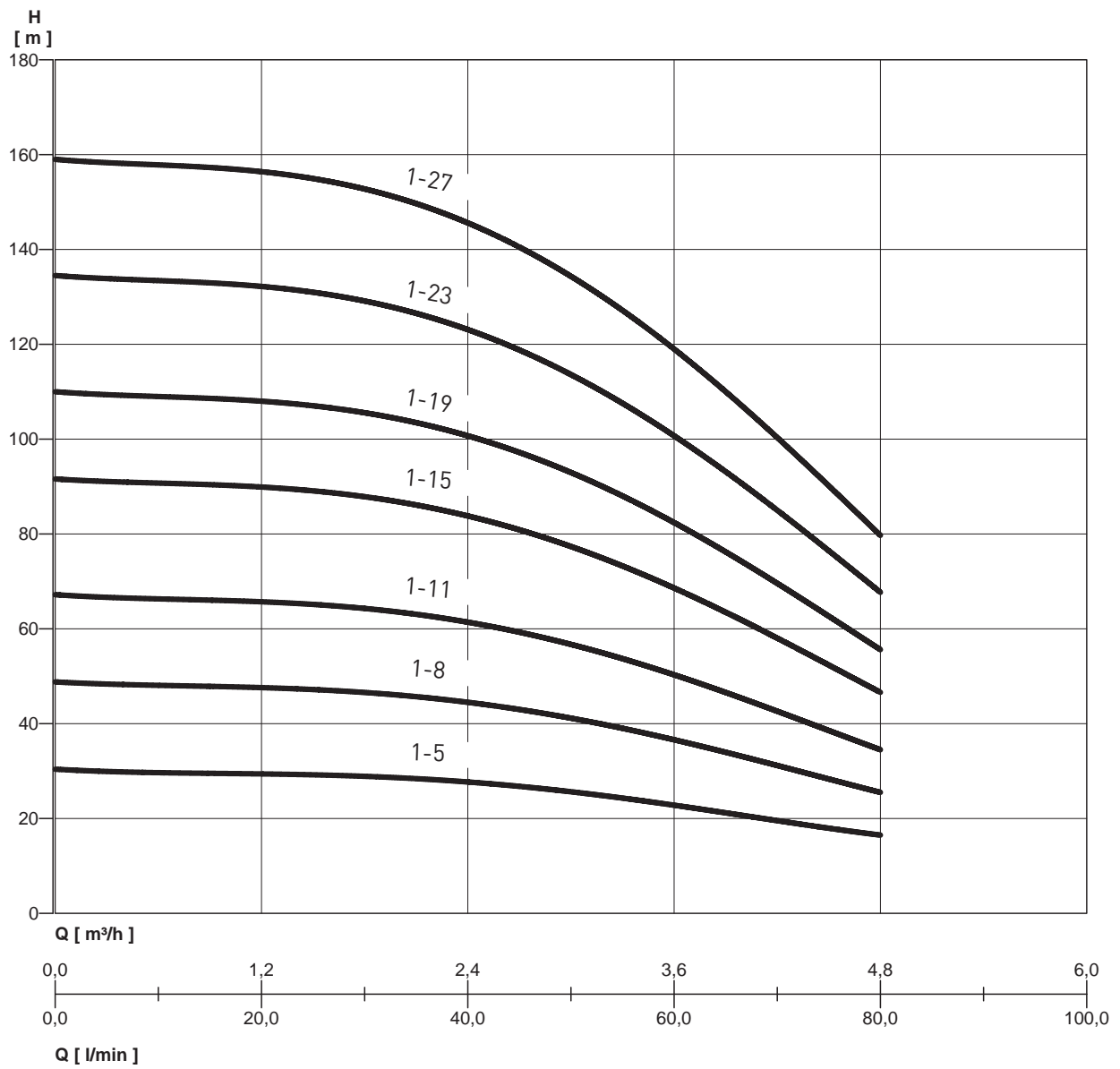

# VARIO 1-20 PVM

## PRESSURE BOOSTER SET WITH TWO VARIABLE SPEED PUMPS

### PERFORMANCE TABLE

MODEL	P2	VOLT. (V)	In (A)	0	l/min	0	20	40	60	80
	kW				m <sup>3</sup> /h	0	1,2	2,4	3,6	4,8
VARIO1-20 PVM 1-5 F	2x0,37	1 ~ 230	2x2,7	m.c.w.	30,4	29,4	27,7	22,8	16,5	
VARIO1-20 PVM 1-8 F	2x0,55	1 ~ 230	2x4,1		48,8	47,6	44,5	36,6	25,5	
VARIO1-20 PVM 1-11 F	2x0,55	1 ~ 230	2x4,4		67,2	65,7	61,4	50,3	34,5	
VARIO1-20 PVM 1-15 F	2x0,75	1 ~ 230	2x5,8		91,6	89,9	83,8	68,6	46,6	
VARIO1-20 PVM 1-19 F	2x1,1	1 ~ 230	2x7,4		110	108	100,7	82,4	55,6	
VARIO1-20 PVM 1-23 F	2x1,1	1 ~ 230	2x8,3		134,5	132,2	123,1	100,7	67,7	
VARIO1-20 PVM 1-27 F	2x1,5	1 ~ 230	2x9,9		159	156,4	145,6	119	79,7	

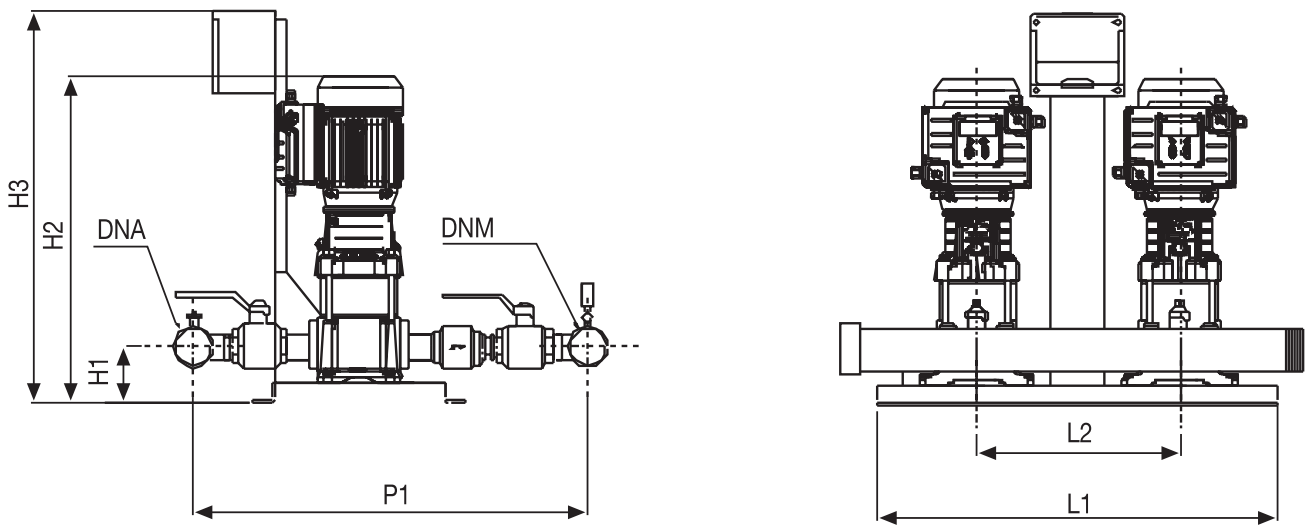

### OVERALL DIMENSIONS AND WEIGHTS

MODEL	Dimensions mm.								WEIGHT Kg
	L1	L2	H1	H2	H3	P1	DNA	DNM	
VARIO1-20 PVM 1-5 F	600	370	105	580	700	620	2"	2"	60
VARIO1-20 PVM 1-8 F	600	370	105	594	700	620	2"	2"	62
VARIO1-20 PVM 1-11 F	600	370	105	648	700	620	2"	2"	67
VARIO1-20 PVM 1-15 F	600	370	105	766	700	620	2"	2"	73
VARIO1-20 PVM 1-19 F	600	370	105	838	700	620	2"	2"	80
VARIO1-20 PVM 1-23 F	600	370	105	910	700	620	2"	2"	90
VARIO1-20 PVM 1-27 F	600	370	105	1030	700	620	2"	2"	94



# VARIO 1-20 PVM

PRESSURE BOOSTER SET WITH TWO VARIABLE SPEED PUMPS

## HYDRAULIC PERFORMANCE

---

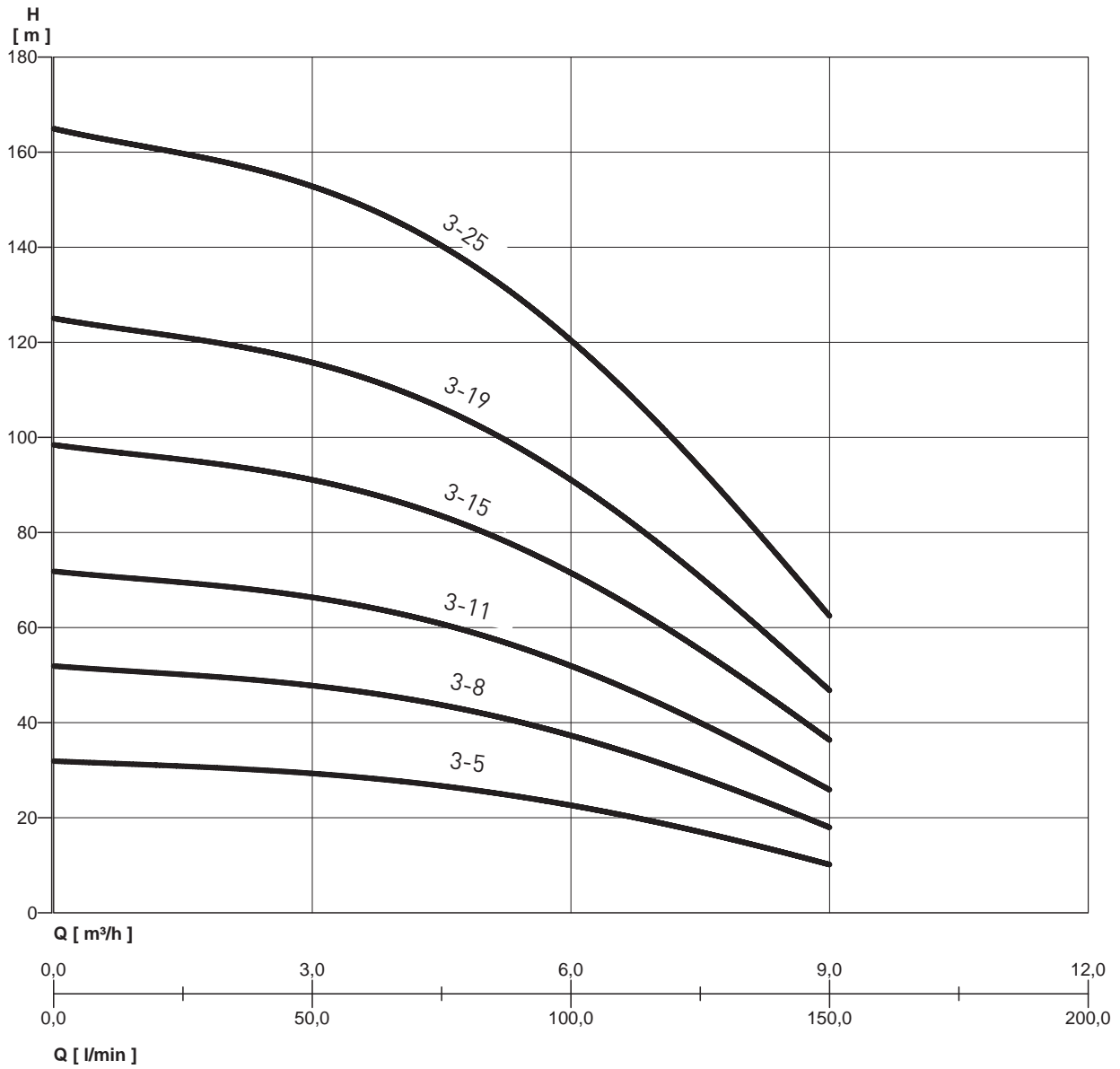

# VARIO 1-20 PVM

## PRESSURE BOOSTER SET WITH TWO VARIABLE SPEED PUMPS

### PERFORMANCE TABLE

MODEL	P2	VOLT. (V)	In (A)	0	m.c.w.									
	kW				l/min	0	20	40	60	80	100	120	140	150
					m <sup>3</sup> /h	0	1,2	2,4	3,6	4,8	6	7,2	8,4	9
VARIO1-20 PVM 3-5 F	2x0,37	1 ~ 230	2x3			31,9	31,1	30	28,3	26,2	22,6	18	13,3	10
VARIO1-20 PVM 3-8 F	2x0,75	1 ~ 230	2x4,8			51,9	50,5	48,9	46,2	42,9	37,3	30,1	22,7	17,8
VARIO1-20 PVM 3-11 F	2x1,1	1 ~ 230	2x6,6			71,8	70	67,9	64,1	59,6	52,1	42,1	32,1	25,7
VARIO1-20 PVM 3-15 F	2x1,1	1 ~ 230	2x9			98,4	96	93,2	88	81,9	71,7	58,2	44,7	36,1
VARIO1-20 PVM 3-19 F	2x1,5	1 ~ 230	2x11			125	121,9	118,4	111,9	104,2	91,3	74,3	57,2	46,5
VARIO1-20 PVM 3-25 F	2x2,2	1 ~ 230	2x15			164,9	160,8	156,3	147,8	137,6	120,8	98,4	76	62,1

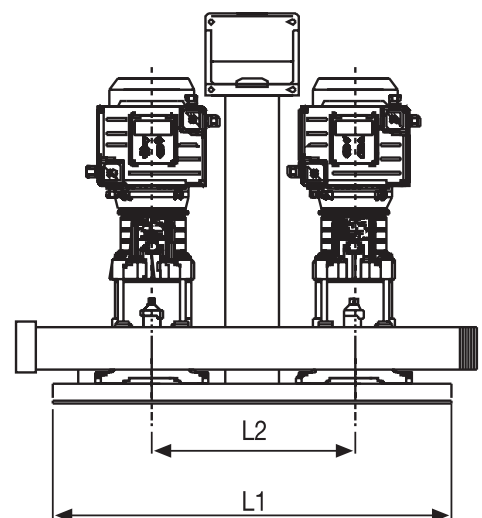
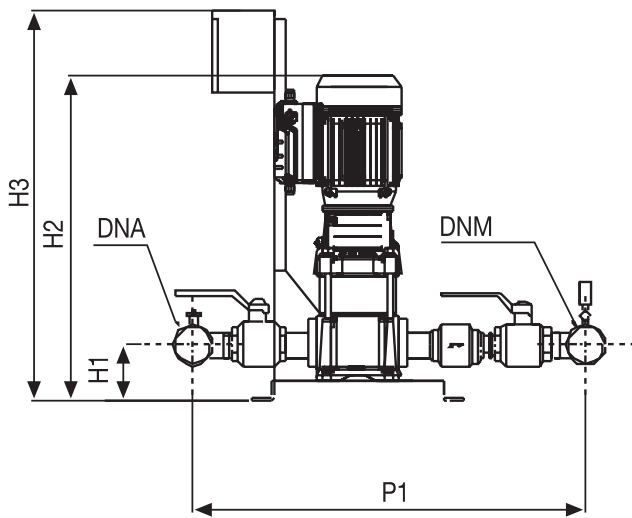

### OVERALL DIMENSIONS AND WEIGHTS

MODEL	Dimensions mm.								WEIGHT Kg
	L1	L2	H1	H2	H3	P1	DNA	DNM	
VARIO1-20 PVM 3-5 F	600	370	105	540	700	620	2"	2"	62
VARIO1-20 PVM 3-8 F	600	370	105	640	700	620	2"	2"	65
VARIO1-20 PVM 3-11 F	600	370	105	694	700	620	2"	2"	73
VARIO1-20 PVM 3-15 F	600	370	105	766	700	620	2"	2"	75
VARIO1-20 PVM 3-19 F	600	370	105	886	700	620	2"	2"	80
VARIO1-20 PVM 3-25 F	600	370	105	994	700	620	2"	2"	90

# VARIO 1-20 PVM

PRESSURE BOOSTER SET WITH TWO VARIABLE SPEED PUMPS

HYDRAULIC PERFORMANCE

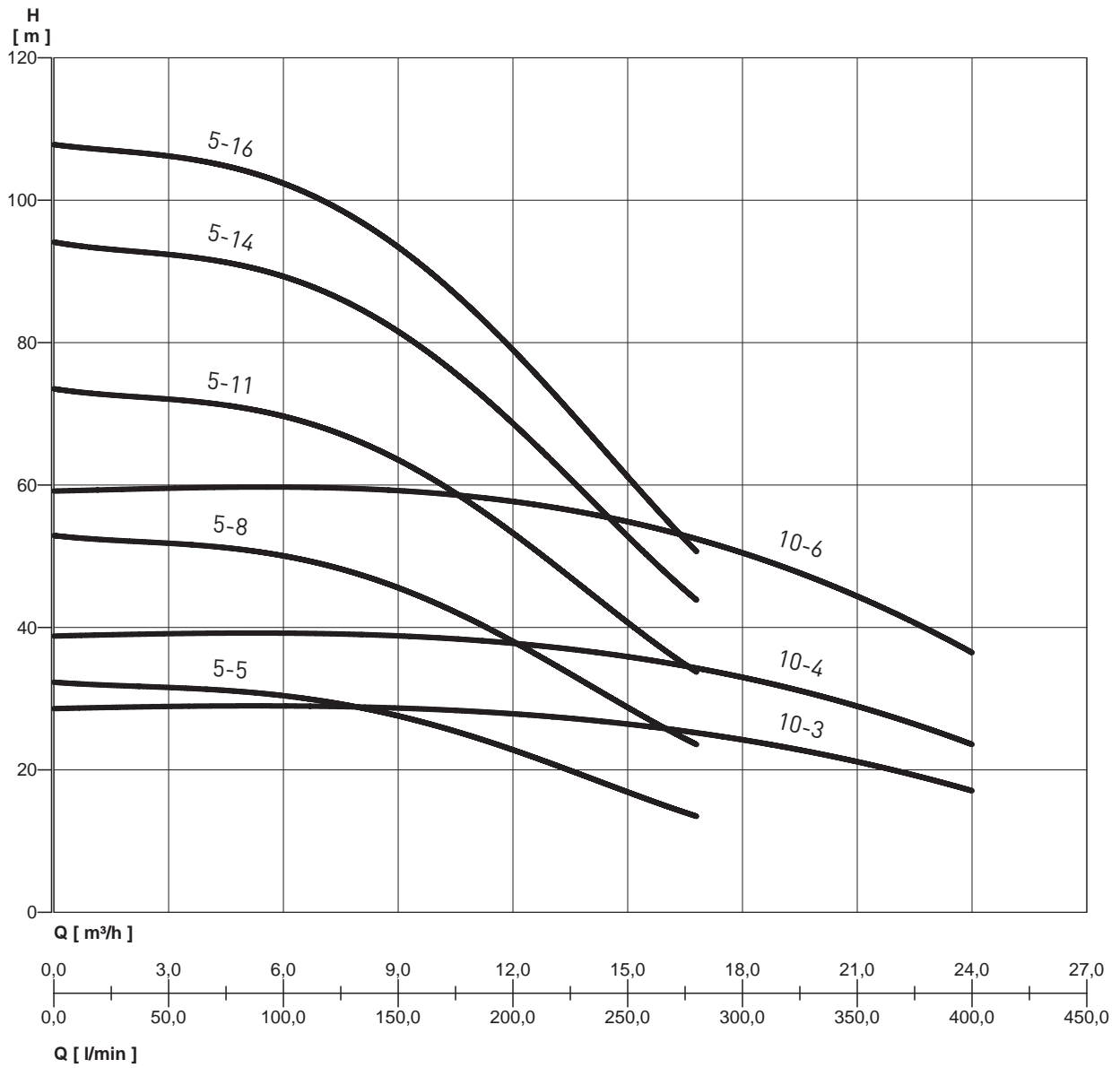

# VARIO 1-20 PVM

## PRESSURE BOOSTER SET WITH TWO VARIABLE SPEED PUMPS

### PERFORMANCE TABLE

MODEL	P2	VOLT. (V)	In (A)	0	l/min	0	80	120	160	200	240	280
	kW				m <sup>3</sup> /h	0	4,8	7,2	9,6	12	14,4	16,8
VARIO1-20 PVM 5-5 F	2x0,75	1 ~ 230	2x5,4	m.c.w.	32,3	31,1	29,4	26,8	22,9	18	13,5	
VARIO1-20 PVM 5-8 F	2x1,1	1 ~ 230	2x8,7		52,9	51,1	48,5	44,3	38,2	30,5	23,6	
VARIO1-20 PVM 5-11 F	2x2,2	1 ~ 230	2x12		73,5	71,1	67,5	61,8	53,5	43	33,8	
VARIO1-20 PVM 5-14 F	2x2,2	1 ~ 230	2x15,2		94,1	91,1	86,6	79,4	68,9	55,8	43,9	
VARIO1-20 PVM 5-16 F	2x2,2	1 ~ 230	2x17,4		107,8	104,5	99,3	91	79,1	64,7	50,7	

MODEL	P2	VOLT. (V)	In (A)	0	l/min	0	50	100	150	200	250	300	350	400
	kW				m <sup>3</sup> /h	0	3	6	9	12	15	18	21	24
VARIO1-20 PVM 10-3 F	2x1,1	1 ~ 230	2x2,4	m.c.w.	28,6	28,9	29	28,7	27,8	26,4	24,4	21	17,1	
VARIO1-20 PVM 10-4 F	2x1,5	1 ~ 230	2x3,2		38,8	39,1	39,2	38,9	37,7	35,8	33,2	28,8	23,6	
VARIO1-20 PVM 10-6 F	2x2,2	1 ~ 230	2x4,8		59,2	59,4	59,8	59,4	57,5	54,7	50,8	44,2	36,5	

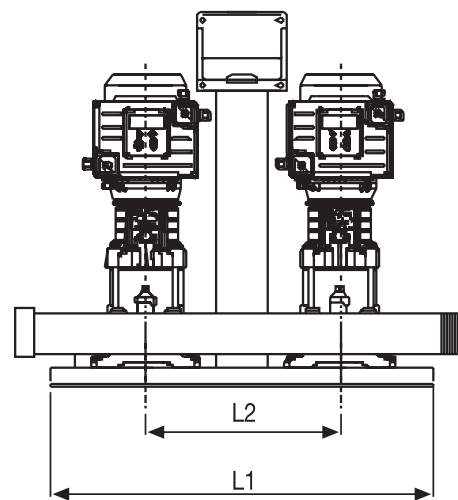
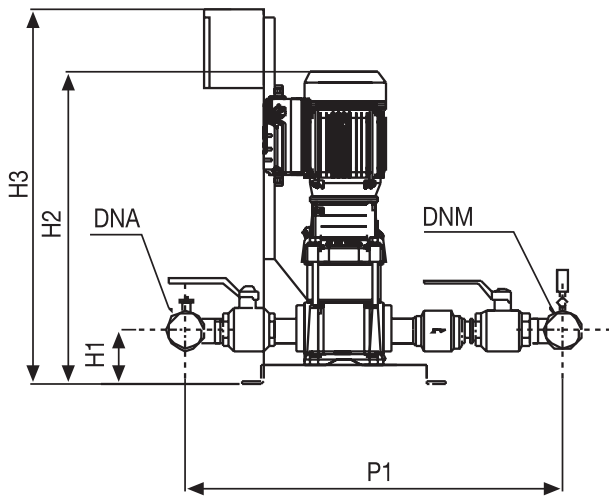

### OVERALL DIMENSIONS AND WEIGHTS

MODEL	Dimensions mm.								WEIGHT Kg
	L1	L2	H1	H2	H3	P1	DNA	DNM	
VARIO1-20 PVM 5-5 F	600	370	105	631	810	660	2"	2"	76
VARIO1-20 PVM 5-8 F	600	370	105	712	810	660	2"	2"	80
VARIO1-20 PVM 5-11 F	600	370	105	841	810	660	2"	2"	92
VARIO1-20 PVM 5-14 F	600	370	105	922	810	660	2"	2"	98
VARIO1-20 PVM 5-16 F	600	370	105	976	810	660	2"	2"	100
VARIO1-20 PVM 10-3 F	620	370	100	612	820	700	2" 1/2	2" 1/2	100
VARIO1-20 PVM 10-4 F	620	370	100	714	820	700	2" 1/2	2" 1/2	110
VARIO1-20 PVM 10-6 F	620	370	100	714	820	700	2" 1/2	2" 1/2	120

## VARIO 3-20

### THREE-PHASE PRESSURE BOOSTER SET WITH TWO VARIABLE SPEED PUMPS

Easy to install, Low power consumption, Versatile operation

The new series of variable speed pressurization booster set VARIO3-20 represents a reliable solution which is easy to use, for residential and industrial applications. The systems involves the installation of two pumps in parallel featuring electronic control. VARIO3 is an electronic device capable of changing the frequency of an pump. Integrated directly on the motor, it allows to adjust its speed so as to supply the same pressure at all times, even when the water demand changes.

When the system pressure drops below the set threshold, the module starts the first pump of the unit to restore to set-point pressure; the speed of rotation of the pump varies according to the water demand so, a greater demand will correspond to a higher speed, until the

maximum speed set has been reached, after which, if the system requires greater performance, the module will activate the second pump to keep the pressure stable. As the water demand decreases, the speed of the last pump started is reduced, until it turns off. The module will keep the first pump on until the minimum set speed has been reached, after which, if there are no further pressure drops, the pump will be stopped. VARIO3-20 features five operating modes to meet the operating needs.



#### TECHNICAL FEATURES

- Inverter supply voltage: 3x380-500 Vac
- Inverter output voltage: 3x380-500 Vac
- Maximum output power: up to 2x11 kW
- Input frequency: 50/60 Hz
- Output maximum rated power: up to 20 Amp
- Degree of protection: IP55
- Max. ambient temperature: + 50°C
- Input filter complying with EMC directive
- Pressure transducer: 0-5 Volt 0-10 bar
- Connectivity: Serial interface RS 485
- Optional contacts: 3 (external set-point, alarm, system inhibition)

#### BASE

- in galvanized metal complete with rubber isolated pads

#### SUCTION MANIFOLD

- in stainless steel AISI 304 with 2 ball valves

#### DELIVERY MANIFOLD

- In stainless steel AISI 304 with:
- n. 2 ball valves
- n. 2 check valves
- n. 1 pressure gauge
- n. 2 pressure sensors

USAGE DATA	MULTINOX VE+			PVM						
	4	6	8	1	3	5	10	15	20	32
Maximum capacity (m <sup>3</sup> /h)	10,8	16,8	25,2	4,8	9	17	26	47	58	80
Maximum head (m.c.a.)	140	110	140	16	16	160	160	165	145	120
Maximum operating pressure	12 bar	16 bar	16 bar	16 bar						
Power supply VOLT						3-400 V				
Ambient temperature						50° C				
Degree of protection of pump						IP55				
Degree of protection of electrical panel						IP54				

# VARIO 3-20

## THREE-PHASE PRESSURE BOOSTER SET WITH TWO VARIABLE SPEED PUMPS

### CONTROL PANEL

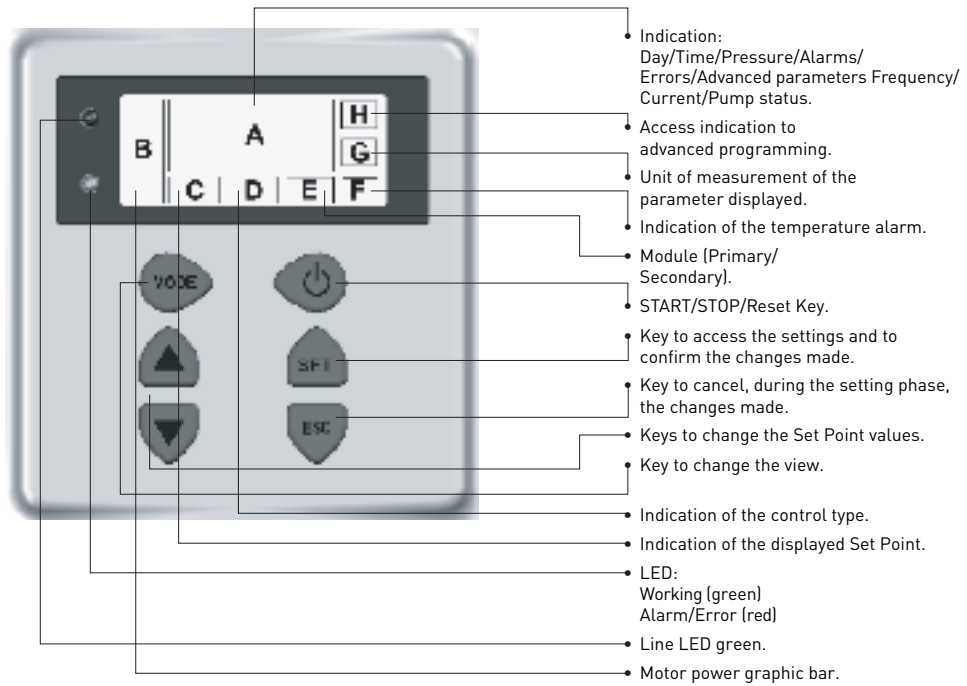

- Backlight display (switches off automatically after a reset time and can be turned on again by pressing any key)

# VARIO 3-20 MULTINOX VE+

THREE-PHASE PRESSURE BOOSTER SET WITH TWO VARIABLE SPEED PUMPS

## HYDRAULIC PERFORMANCE

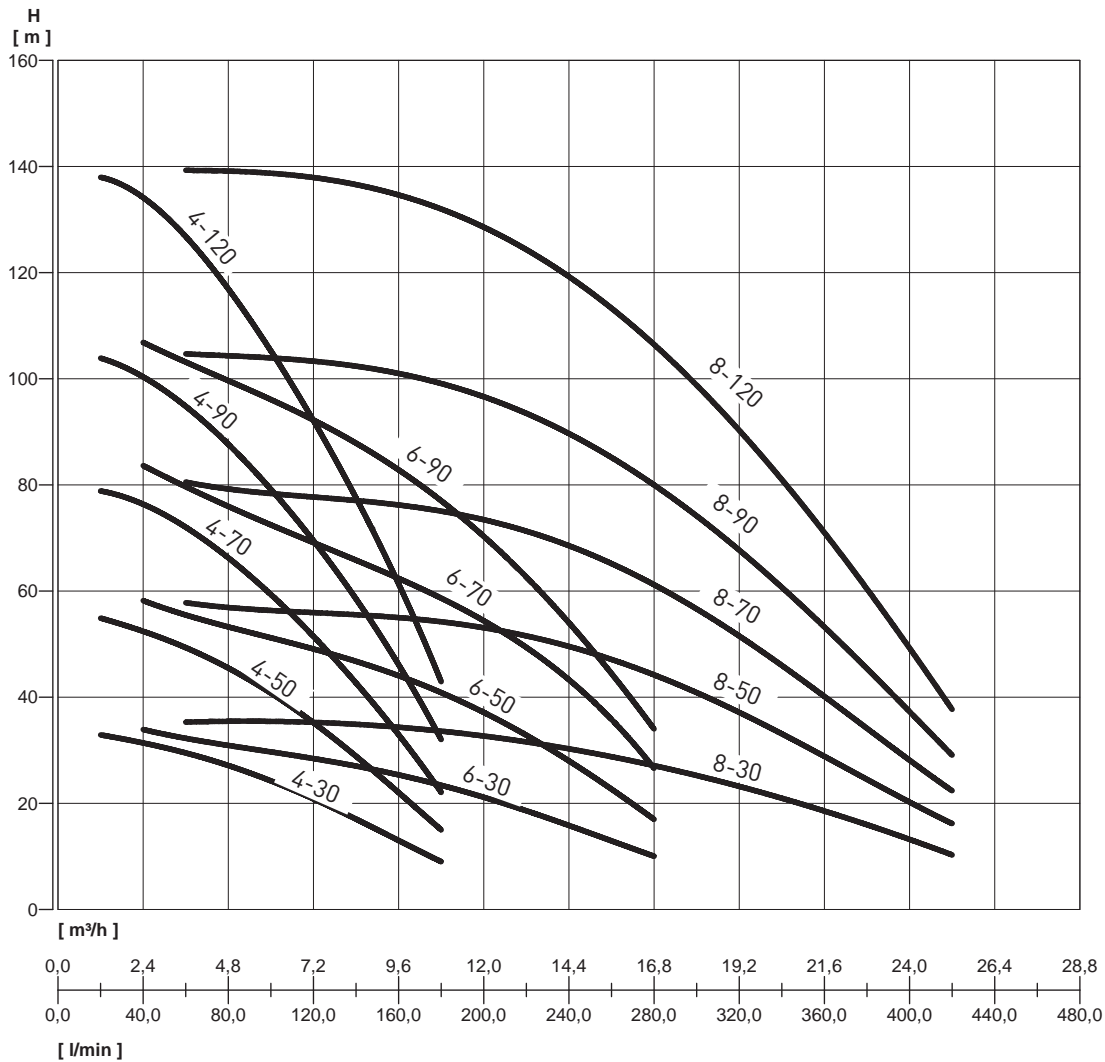

## PERFORMANCE TABLE

MODEL	P2 kW	VOLT. (V)	In (A)	0	m.c.w.																
					l/min	20	40	60	80	100	120	140	160	180	200	240	280	300	360	420	
					m³/h	1,2	2,4	3,6	4,8	6	7,2	8,4	9,6	10,8	12	14,4	16,8	18	21,6	25,2	
VARIO3-20 MULTINOX VE+ 4-30	2x0,5	3 ~ 400	2x2,54			33	31	30	27	24	21	17	13	9							
VARIO3-20 MULTINOX VE+ 4-50	2x0,84	3 ~ 400	2x3,90			55	52	50	45	41	35	29	22	15							
VARIO3-20 MULTINOX VE+ 4-70	2x1,17	3 ~ 400	2x5,46			79	76	72	67	59	51	43	33	22							
VARIO3-20 MULTINOX VE+ 4-90	2x1,5	3 ~ 400	2x7,22			104	100	95	88	79	69	59	46	32							
VARIO3-20 MULTINOX VE+ 4-120	2x2	3 ~ 400	2x9,42			138	134	127	117	105	92	78	61	43							
VARIO3-20 MULTINOX VE+ 6-30	2x0,67	3 ~ 400	2x3,58				34	32	31	30	28	27	26	23	21	16	10				
VARIO3-20 MULTINOX VE+ 6-50	2x1,1	3 ~ 400	2x5,26				58	56	53	51	49	47	44	41	37	28	17				
VARIO3-20 MULTINOX VE+ 6-70	2x1,5	3 ~ 400	2x8,21				83	80	77	76	61	68	64	59	55	42	27				
VARIO3-20 MULTINOX VE+ 6-90	2x2	3 ~ 400	2x9,13				107	103	99	97	92	88	83	76	71	54	34				
VARIO3-20 MULTINOX VE+ 8-30	2x1	3 ~ 400	2x2,60					35	35	35	35	35	34	33	32	30	27	25	18	10	
VARIO3-20 MULTINOX VE+ 8-50	2x1,5	3 ~ 400	2x4,33					57	57	56	56	56	54	53	52	50	45	40	28	16	
VARIO3-20 MULTINOX VE+ 8-70	2x1,9	3 ~ 400	2x6,13					80	79	78	78	77	75	74	73	70	60	56	40	22	
VARIO3-20 MULTINOX VE+ 8-90	2x3	3 ~ 400	2x9,7					104	104	104	103	103	101	98	94	90	82	73	52	29	
VARIO3-20 MULTINOX VE+ 8-120	2x4	3 ~ 400	2x12,3					139	139	139	138	138	135	131	126	120	109	98	70	38	

# VARIO 3-20 MULTINOX VE+

THREE-PHASE PRESSURE BOOSTER SET WITH TWO VARIABLE SPEED PUMPS

## OVERALL DIMENSIONS AND WEIGHTS

FIG. 1

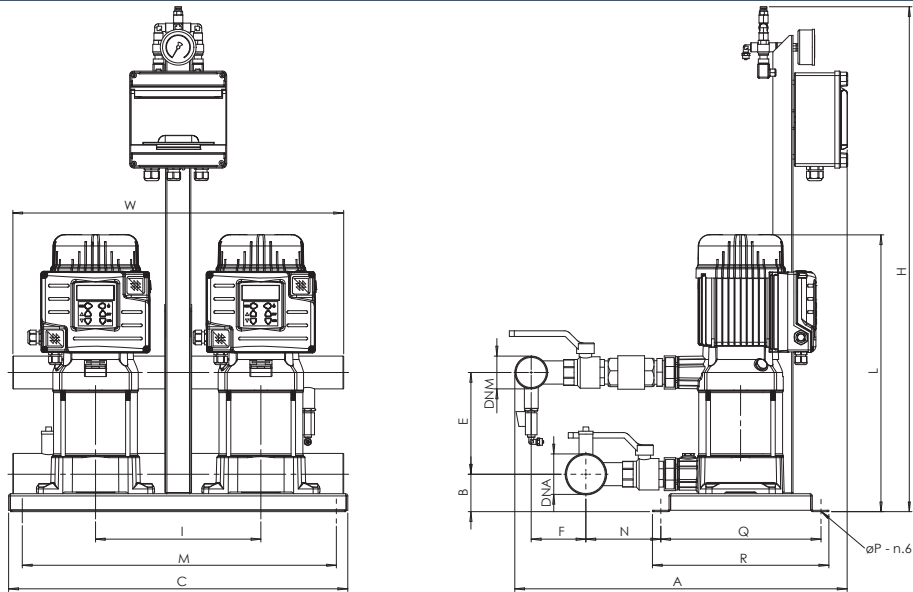
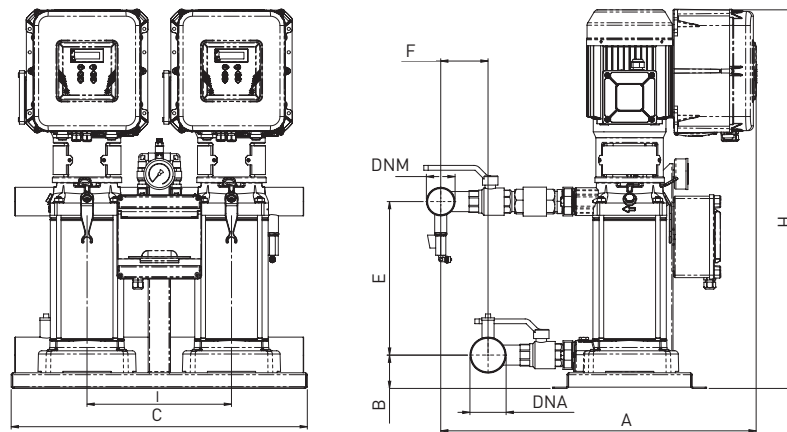

FIG. 2



## OVERALL DIMENSIONS AND WEIGHTS

MODEL	Fig.	Dimensions mm.															WEIGHT Kg	
		A	B	C	E	F	H	I	L	M	N	P	Q	R	W	DNA		DNM
VARIO3-20 MULTINOX VE+ 4-30	1	615	68	608,5	130	96	910	300	449	578,5	145	10,5	290	320	600	2-1/2"	2"	69
VARIO3-20 MULTINOX VE+ 4-50	1	615	68	608,5	184	96	910	300	503	578,5	145	10,5	290	320	600	2-1/2"	2"	77
VARIO3-20 MULTINOX VE+ 4-70	1	615	68	608,5	238	96	910	300	557	578,5	145	10,5	290	320	600	2-1/2"	2"	85
VARIO3-20 MULTINOX VE+ 4-90	1	615	68	608,5	292	96	910	300	611	578,5	145	10,5	290	320	600	2-1/2"	2"	87
VARIO3-20 MULTINOX VE+ 4-120	1	615	68	608,5	373	96	910	300	693	578,5	145	10,5	290	320	600	2-1/2"	2"	91
VARIO3-20 MULTINOX VE+ 6-30	1	615	68	608,5	130	96	910	300	449	578,5	145	10,5	290	320	600	2-1/2"	2"	69
VARIO3-20 MULTINOX VE+ 6-50	1	615	68	608,5	184	96	910	300	503	578,5	145	10,5	290	320	600	2-1/2"	2"	77
VARIO3-20 MULTINOX VE+ 6-70	1	615	68	608,5	238	96	910	300	557	578,5	145	10,5	290	320	600	2-1/2"	2"	85
VARIO3-20 MULTINOX VE+ 6-90	1	615	68	608,5	292	96	910	300	611	578,5	145	10,5	290	320	600	2-1/2"	2"	87
VARIO3-20 MULTINOX VE+ 8-30	1	615	68	608,5	130	96	910	300	449	578,5	145	10,5	290	320	600	2-1/2"	2"	69
VARIO3-20 MULTINOX VE+ 8-50	1	615	68	608,5	184	96	910	300	503	578,5	145	10,5	290	320	600	2-1/2"	2"	77
VARIO3-20 MULTINOX VE+ 8-70	1	615	68	608,5	238	96	910	300	557	578,5	145	10,5	290	320	600	2-1/2"	2"	85
VARIO3-20 MULTINOX VE+ 8-90	2	780	68	608,5	292	96	765	300	765	578,5	145	10,5	290	320	600	2-1/2"	2"	110
VARIO3-20 MULTINOX VE+ 8-120	2	780	68	608,5	373	96	890	300	890	578,5	145	10,5	290	320	600	2-1/2"	2"	116



# VARIO 3-20 PVM

THREE-PHASE PRESSURE BOOSTER SET WITH TWO VARIABLE SPEED PUMPS

## HYDRAULIC PERFORMANCE

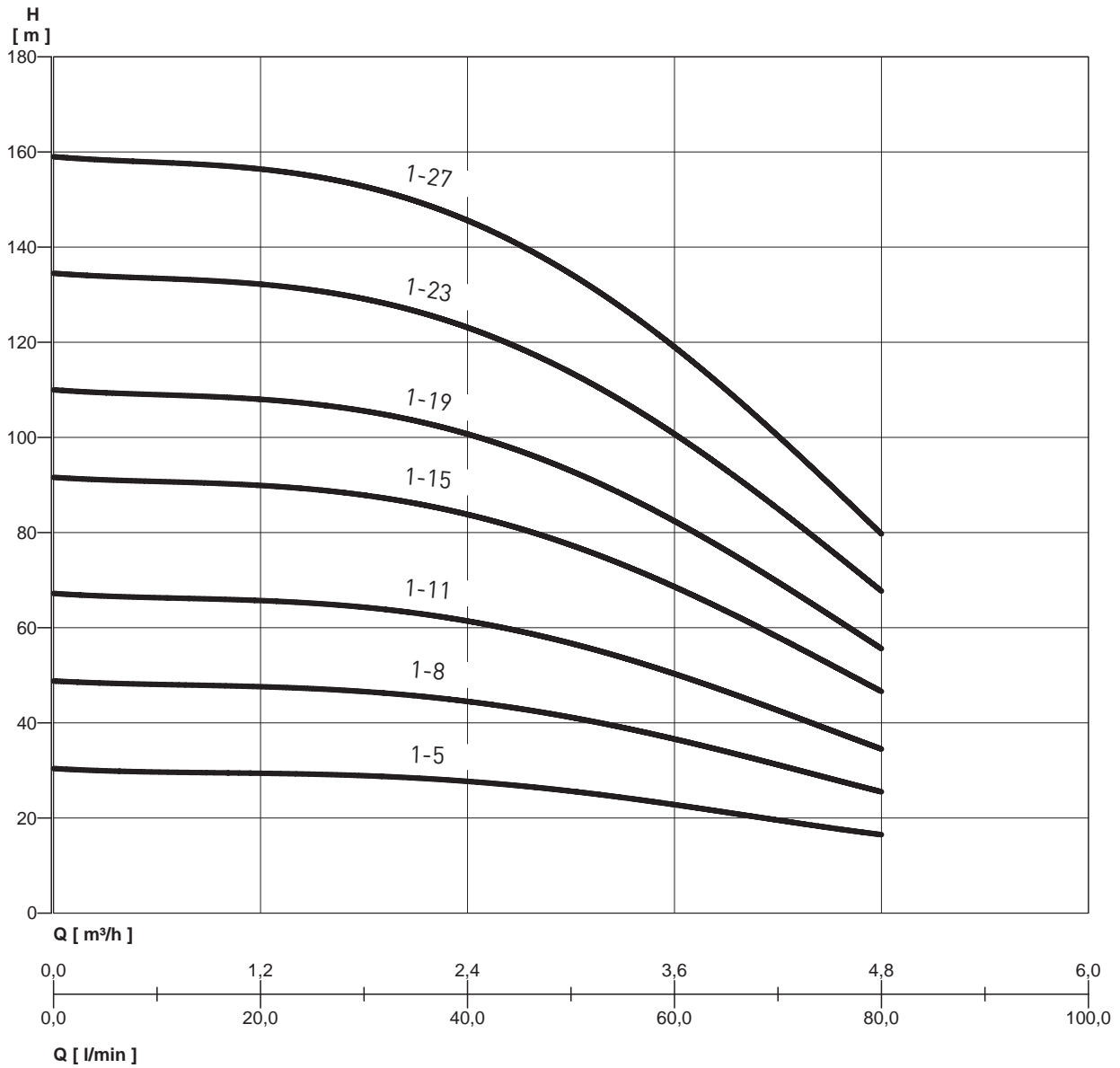

## PERFORMANCE TABLE

MODEL	P2	VOLT. (V)	In (A)	Q	l/min				
	kW				0	20	40	60	80
					0	1,2	2,4	3,6	4,8
VARIO3-20 PVM1-5 F	2x0,37	3 ~ 400	2x1,5	m.c.w.	30,4	29,4	27,7	22,8	16,5
VARIO3-20 PVM1-8 F	2x0,55	3 ~ 400	2x2,3		48,8	47,6	44,5	36,6	25,5
VARIO3-20 PVM1-11 F	2x0,55	3 ~ 400	2x3,2		67,2	65,7	61,4	50,3	34,5
VARIO3-20 PVM1-15 F	2x0,75	3 ~ 400	2x4,4		91,6	89,9	83,8	68,6	46,6
VARIO3-20 PVM1-19 F	2x1,1	3 ~ 400	2x5,5		110	108	100,7	82,4	55,6
VARIO3-20 PVM1-23 F	2x1,1	3 ~ 400	2x6,7		134,5	132,2	123,1	100,7	67,7
VARIO3-20 PVM1-27 F	2x1,5	3 ~ 400	2x7,8		159	156,4	145,6	119	79,7

# VARIO 3-20 PVM

THREE-PHASE PRESSURE BOOSTER SET WITH TWO VARIABLE SPEED PUMPS

## OVERALL DIMENSIONS AND WEIGHTS

FIG. 1

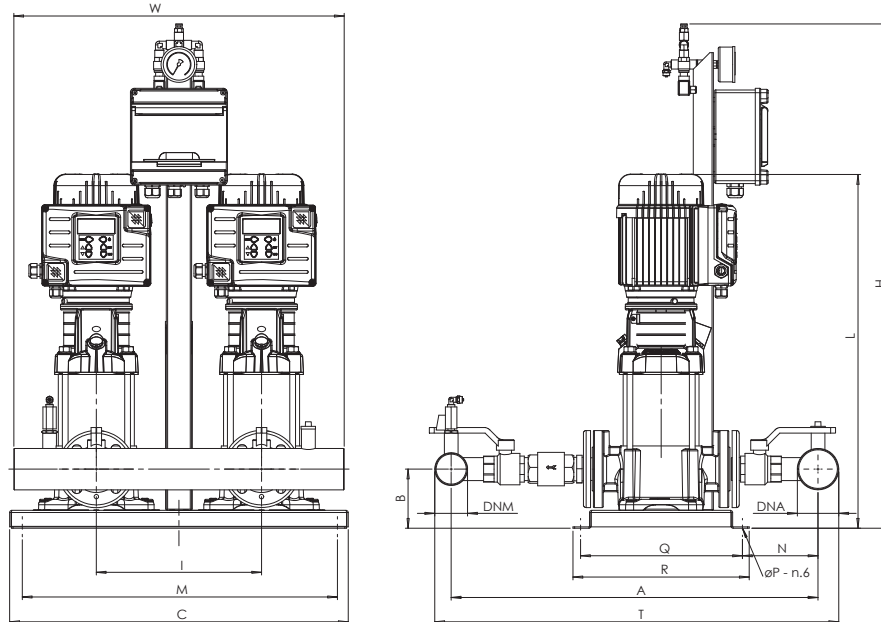
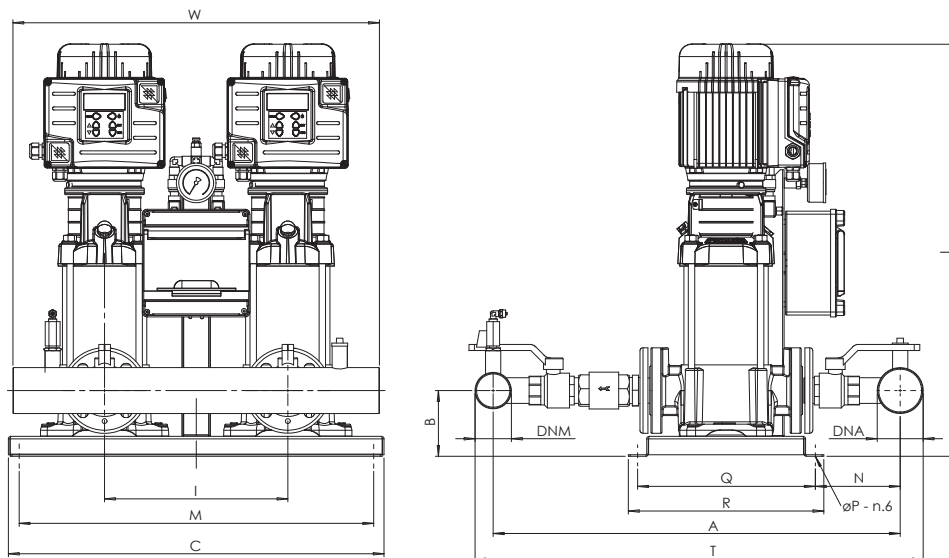

FIG. 2



## OVERALL DIMENSIONS AND WEIGHTS

MODEL	Fig.	Dimensions mm.															WEIGHT Kg
		A	B	C	H	I	L	M	N	P	Q	R	T	W	DNA	DNM	
VARIO3-20 PVM1-5 F	1	690	108	615	910	300	543	578,5	145	10,5	290	320	757	600	2"	2"	60
VARIO3-20 PVM1-8 F	1	690	108	615	910	300	597	578,5	145	10,5	290	320	757	600	2"	2"	62
VARIO3-20 PVM1-11 F	2	690	108	615	-	300	651	578,5	145	10,5	290	320	757	600	2"	2"	67
VARIO3-20 PVM1-15 F	2	690	108	615	-	300	769	578,5	145	10,5	290	320	757	600	2"	2"	73
VARIO3-20 PVM1-19 F	2	690	108	615	-	300	841	578,5	145	10,5	290	320	757	600	2"	2"	80
VARIO3-20 PVM1-23 F	2	690	108	615	-	300	913	578,5	145	10,5	290	320	757	600	2"	2"	90
VARIO3-20 PVM1-27 F	2	690	108	615	-	300	1033	578,5	145	10,5	290	320	757	600	2"	2"	94

# VARIO 3-20 PVM

THREE-PHASE PRESSURE BOOSTER SET WITH TWO VARIABLE SPEED PUMPS

## HYDRAULIC PERFORMANCE

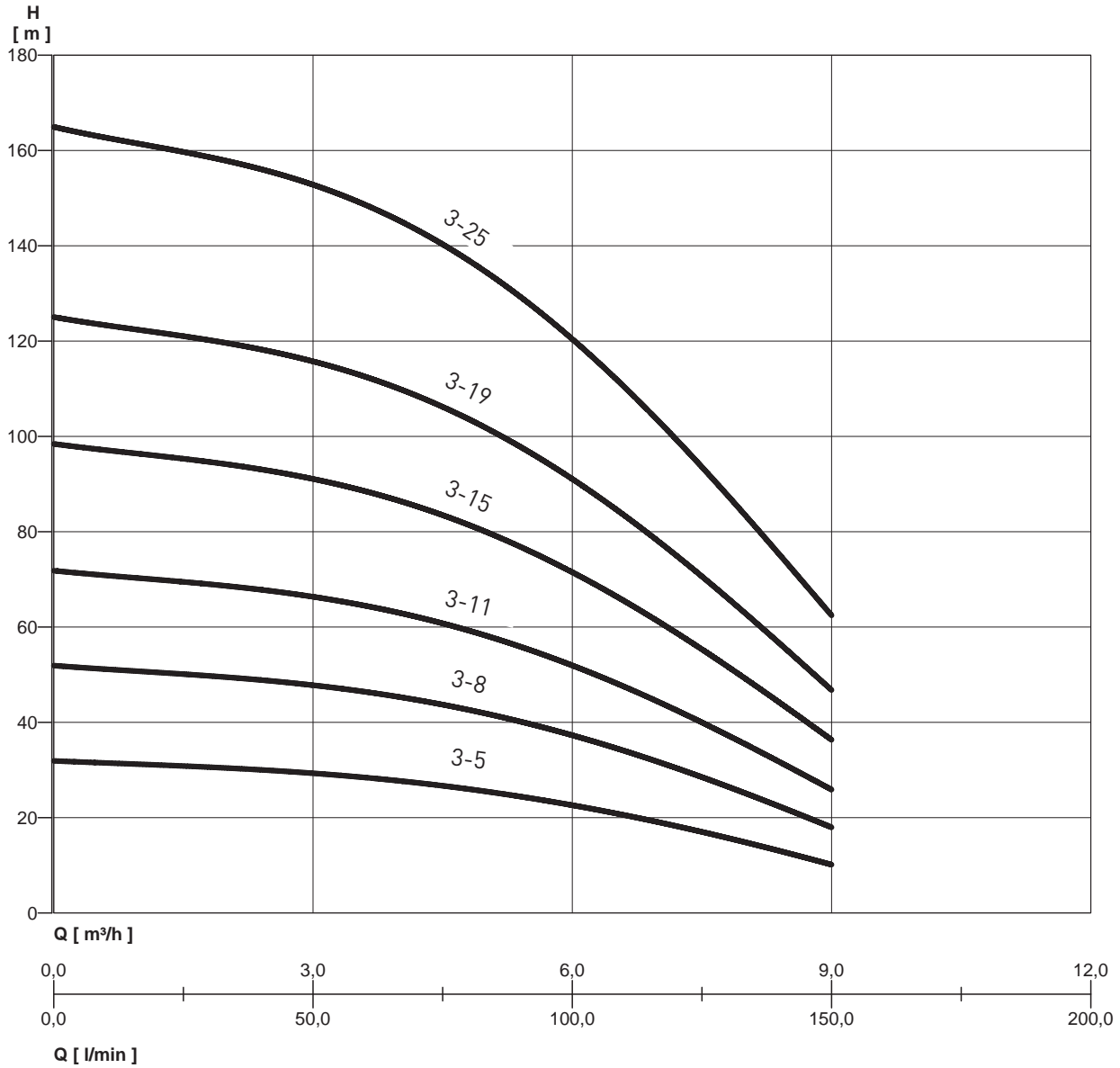

## PERFORMANCE TABLE

MODEL	P2	VOLT. (V)	In (A)	0	l/min	0	20	40	60	80	100	120	140	150
	kW				m³/h	0	1,2	2,4	3,6	4,8	6	7,2	8,4	9
VARIO3-20 PVM 3-5 F	2x0,37	3 - 400	2x0,9	m.c.w.	31,9	31,1	30	28,3	26,2	22,6	18	13,3	10	
VARIO3-20 PVM 3-8 F	2x0,75	3 - 400	2x1,45		51,9	50,5	48,9	46,2	42,9	37,3	30,1	22,7	17,8	
VARIO3-20 PVM 3-11 F	2x1,1	3 - 400	2x2		71,8	70	67,9	64,1	59,6	52,1	42,1	32,1	25,7	
VARIO3-20 PVM 3-15 F	2x1,1	3 - 400	2x2,7		98,4	96	93,2	88	81,9	71,7	58,2	44,7	36,1	
VARIO3-20 PVM 3-19 F	2x1,5	3 - 400	2x3,4		125	121,9	118,4	111,9	104,2	91,3	74,3	57,2	46,5	
VARIO3-20 PVM 3-25 F	2x2,2	3 - 400	2x4,5		164,9	160,8	156,3	147,8	137,6	120,8	98,4	76	62,1	

# VARIO 3-20 PVM

THREE-PHASE PRESSURE BOOSTER SET WITH TWO VARIABLE SPEED PUMPS

## OVERALL DIMENSIONS AND WEIGHTS

FIG. 1

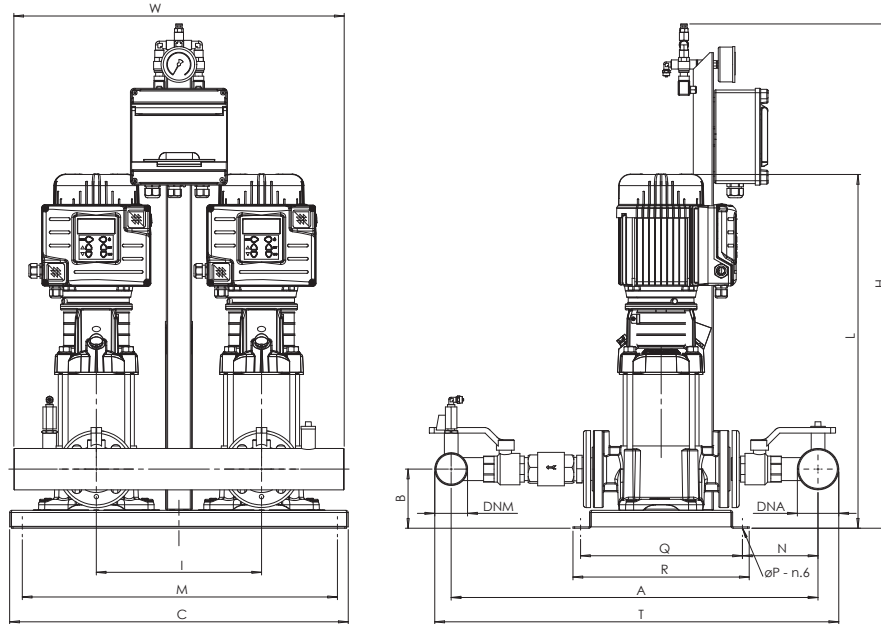
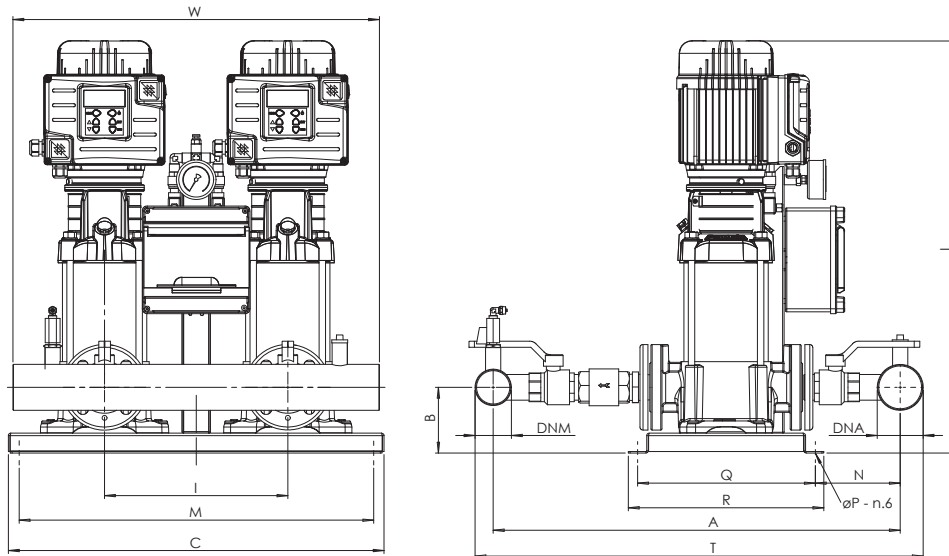

FIG. 2



## OVERALL DIMENSIONS AND WEIGHTS

MODEL	Fig.	Dimensions mm.															WEIGHT Kg
		A	B	C	H	I	L	M	N	P	Q	R	T	W	DNA	DNM	
VARIO3-20 PVM 3-5 F	1	690	108	615	910	300	543	578,5	145	10,5	290	320	757	600	2"	2"	62
VARIO3-20 PVM 3-8 F	1	690	108	615	910	300	643	578,5	145	10,5	290	320	757	600	2"	2"	65
VARIO3-20 PVM 3-11 F	2	690	108	615	-	300	697	578,5	145	10,5	290	320	757	600	2"	2"	73
VARIO3-20 PVM 3-15 F	2	690	108	615	-	300	769	578,5	145	10,5	290	320	757	600	2"	2"	75
VARIO3-20 PVM 3-19 F	2	690	108	615	-	300	889	578,5	145	10,5	290	320	757	600	2"	2"	80
VARIO3-20 PVM 3-25 F	2	690	108	615	-	300	997	578,5	145	10,5	290	320	757	600	2"	2"	90

# VARIO 3-20 PVM

THREE-PHASE PRESSURE BOOSTER SET WITH TWO VARIABLE SPEED PUMPS

## HYDRAULIC PERFORMANCE

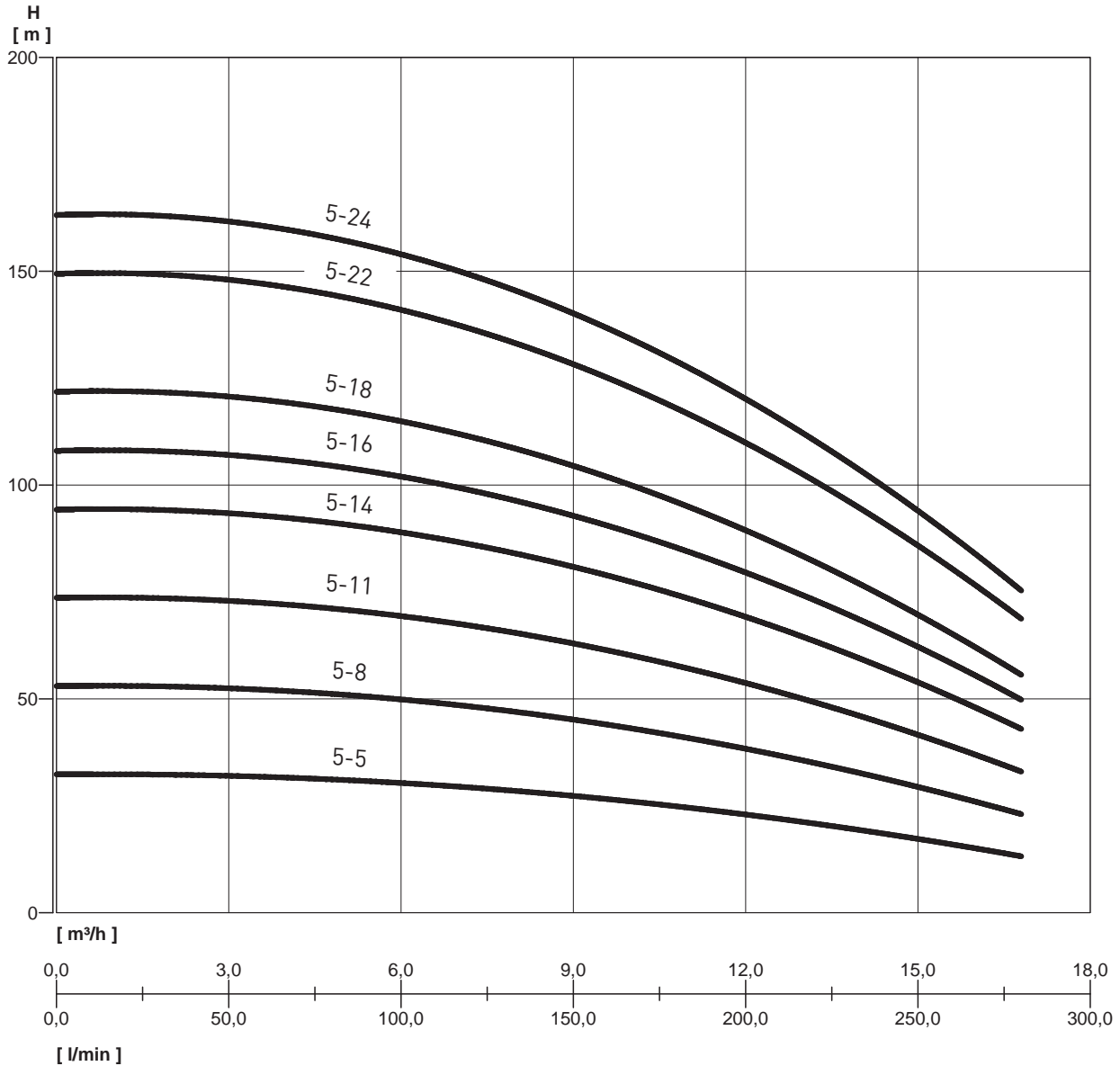

## PERFORMANCE TABLE

MODEL	P2	VOLT. (V)	In (A)	Q	m.c.w.						
	kW				l/min	0	80	120	160	200	240
					0	4,8	7,2	9,6	12	14,4	16,8
VARIO3-20 PVM 5-5 F	2x0,75	3 ~ 400	2x1,7	m.c.w.	32,3	31,1	29,4	26,8	22,9	18	13,5
VARIO3-20 PVM 5-8 F	2x1,1	3 ~ 400	2x2,7		52,9	51,1	48,5	44,3	38,2	30,5	23,6
VARIO3-20 PVM 5-11 F	2x2,2	3 ~ 400	2x3,7		73,5	71,1	67,5	61,8	53,5	43	33,8
VARIO3-20 PVM 5-14 F	2x2,2	3 ~ 400	2x4,8		94,1	91,1	86,6	79,4	68,9	55,8	43,9
VARIO3-20 PVM 5-16 F	2x2,2	3 ~ 400	2x5,4		107,8	104,5	99,3	91	79,1	64,7	50,7
VARIO3-20 PVM 5-18 F	2x3	3 ~ 400	2x6,1		121,5	117,8	112	102,7	89,3	71,1	57,4
VARIO3-20 PVM 5-22 F	2x4	3 ~ 400	2x7,5		149	144,5	137,4	126,1	109,7	87,6	70,9
VARIO3-20 PVM 5-24 F	2x4	3 ~ 400	2x8,2		162,7	157,8	150,1	137,8	119,9	95,9	77,7

# VARIO 3-20 PVM

THREE-PHASE PRESSURE BOOSTER SET WITH TWO VARIABLE SPEED PUMPS

## OVERALL DIMENSIONS AND WEIGHTS

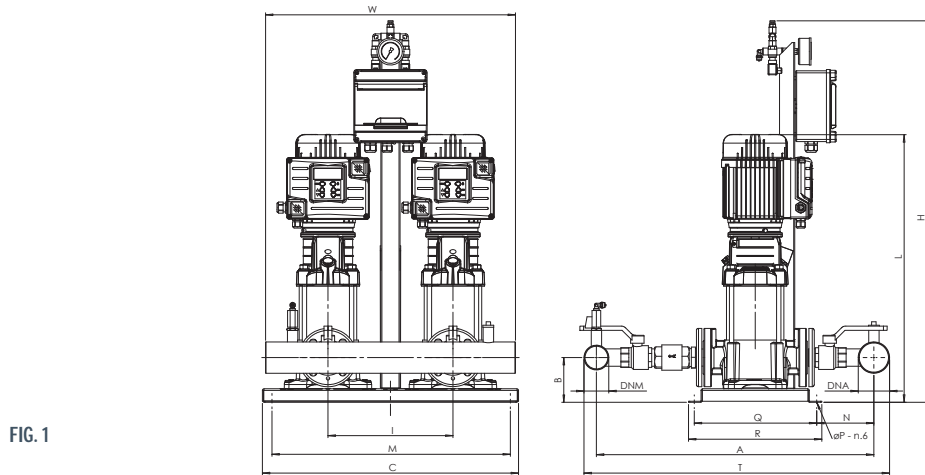

FIG. 1

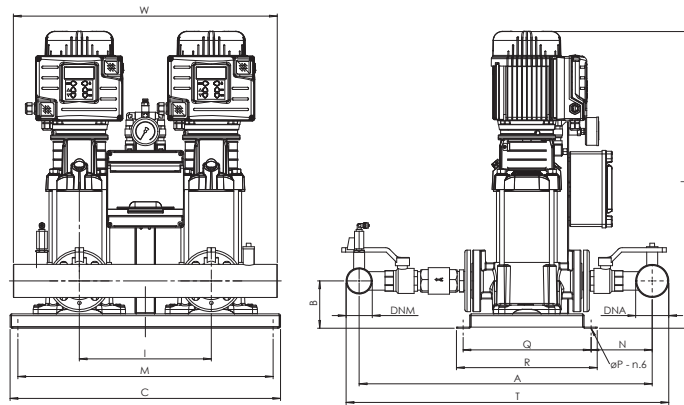

FIG. 2

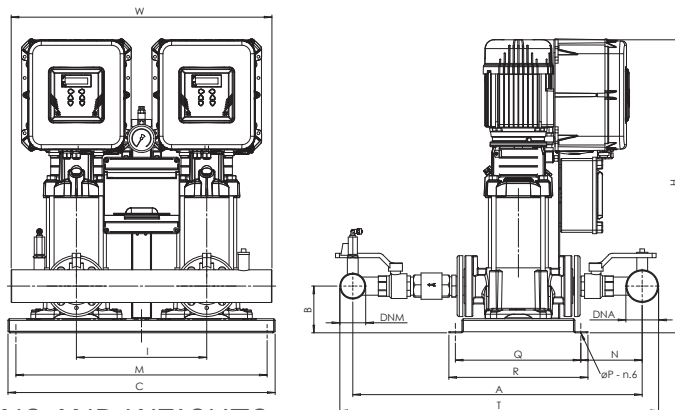

FIG. 3

## OVERALL DIMENSIONS AND WEIGHTS

MODEL	Fig.	Dimensions mm.															WEIGHT Kg
		A	B	C	H	I	L	M	N	P	Q	R	T	W	DNA	DNM	
VARIO3-20 PVM 5-5 F	1	690	108	615	910	300	634	578,5	145	10,5	290	320	757	600	2"	2"	76
VARIO3-20 PVM 5-8 F	2	690	108	615	-	300	715	578,5	145	10,5	290	320	757	600	2"	2"	80
VARIO3-20 PVM 5-11 F	2	690	108	615	-	300	844	578,5	145	10,5	290	320	757	600	2"	2"	92
VARIO3-20 PVM 5-14 F	2	690	108	615	-	300	925	578,5	145	10,5	290	320	757	600	2"	2"	98
VARIO3-20 PVM 5-16 F	2	690	108	615	-	300	979	578,5	145	10,5	290	320	757	600	2"	2"	100
VARIO3-20 PVM 5-18 F	3	690	108	615	1091	300	-	578,5	145	10,5	290	320	757	600	2"	2"	142
VARIO3-20 PVM 5-22 F	3	690	108	615	1206	300	-	578,5	145	10,5	290	320	757	600	2"	2"	153
VARIO3-20 PVM 5-24 F	3	690	108	615	1260	300	-	578,5	145	10,5	290	320	757	600	2"	2"	155

# VARIO 3-20 PVM

THREE-PHASE PRESSURE BOOSTER SET WITH TWO VARIABLE SPEED PUMPS

## HYDRAULIC PERFORMANCE

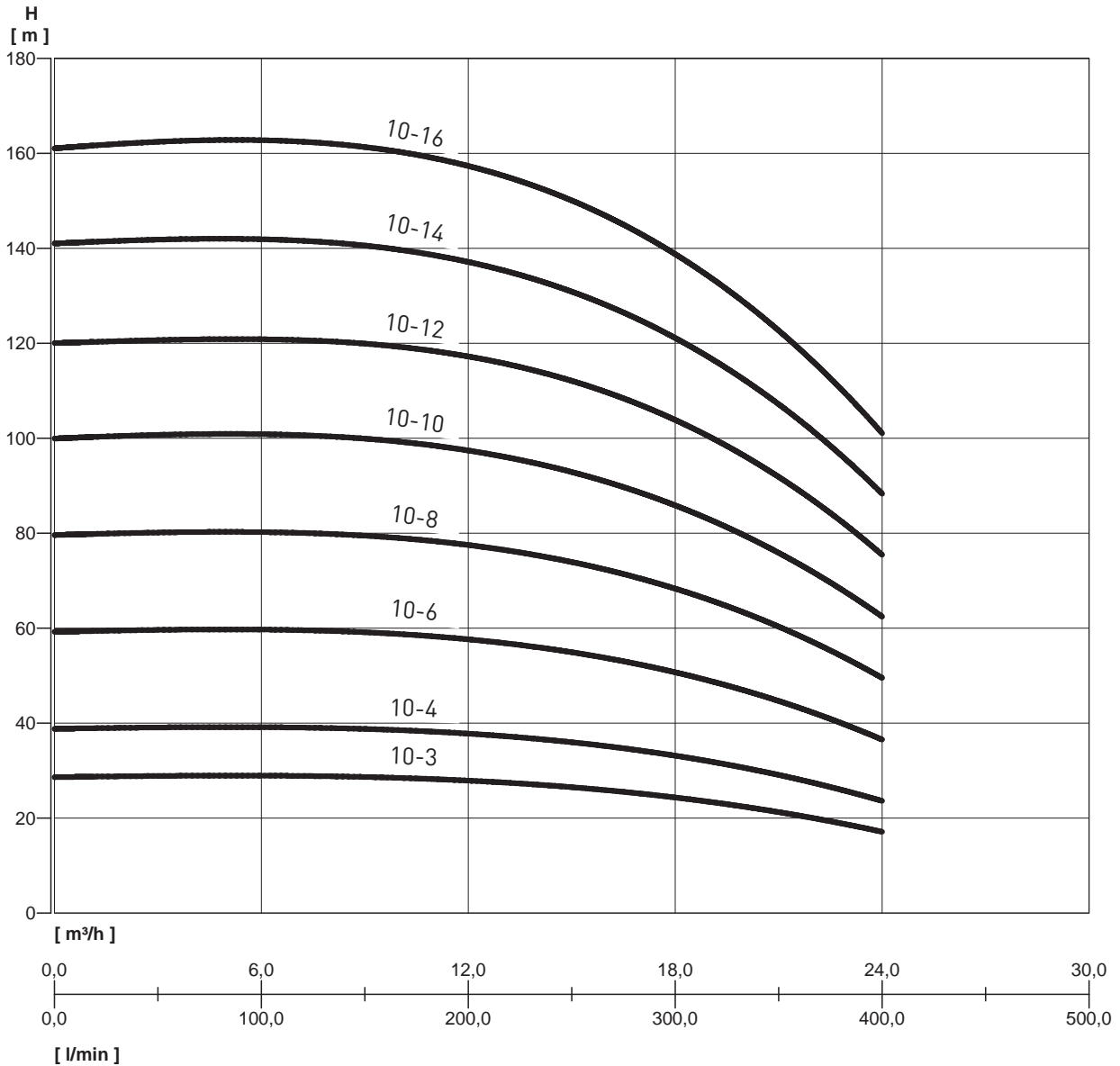

## PERFORMANCE TABLE

MODEL	P2	VOLT. (V)	In (A)	0	l/min	0	100	200	300	400
	kW					0	6	12	18	24
					m³/h					
VARIO3-20 PVM 10-3 F	2x1,1	3 ~ 400	2x2,4	m.c.w.		28,6	29	27,8	24,4	17,1
VARIO3-20 PVM 10-4 F	2x1,5	3 ~ 400	2x3,2			38,8	39,2	37,7	33,2	23,6
VARIO3-20 PVM 10-6 F	2x2,2	3 ~ 400	2x4,8			59,2	59,8	57,5	50,8	36,5
VARIO3-20 PVM 10-8 F	2x3	3 ~ 400	2x6,4			79,6	80,3	77,4	68,4	49,5
VARIO3-20 PVM 10-10 F	2x4	3 ~ 400	2x8			99,9	101	97,2	86	62,4
VARIO3-20 PVM 10-12 F	2x4	3 ~ 400	2x9,6			120	121	117	104	75,4
VARIO3-20 PVM 10-14 F	2x5,5	3 ~ 400	2x11			141	142	137	121,2	88,3
VARIO3-20 PVM 10-16 F	2x5,5	3 ~ 400	2x13			161	163	157	139	101

# VARIO 3-20 PVM

## THREE-PHASE PRESSURE BOOSTER SET WITH TWO VARIABLE SPEED PUMPS

### OVERALL DIMENSIONS AND WEIGHTS

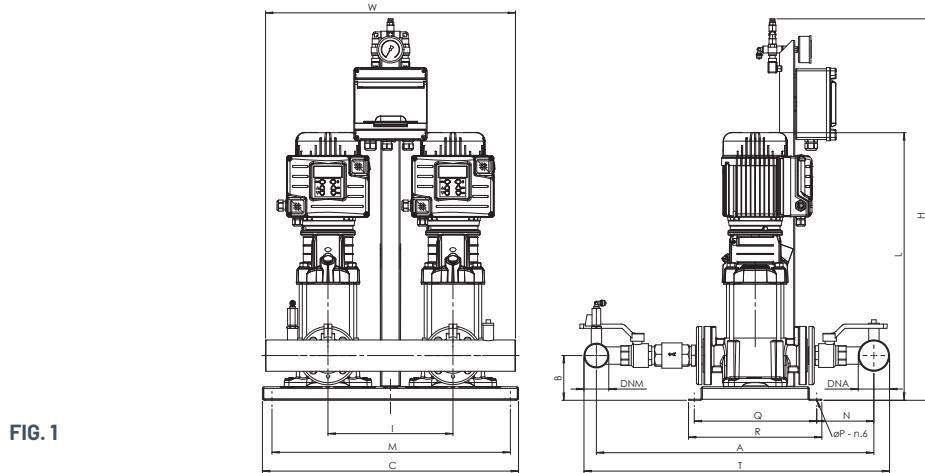

FIG. 1

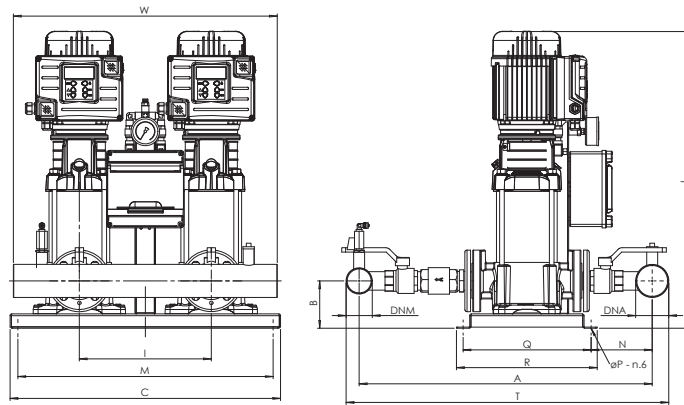

FIG. 2

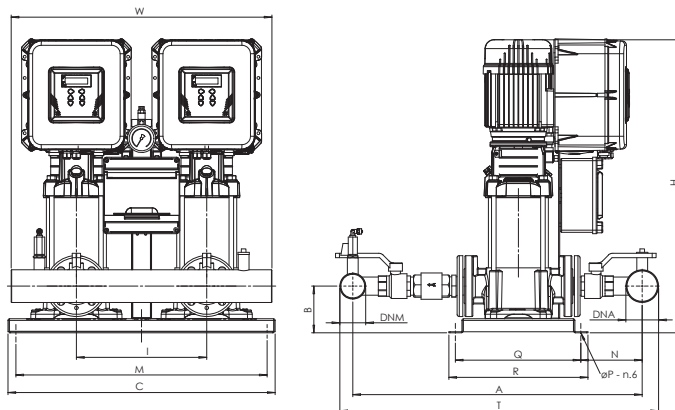

FIG. 3

### OVERALL DIMENSIONS AND WEIGHTS

MODEL	Fig.	Dimensions mm.														WEIGHT Kg	
		A	B	C	H	I	L	M	N	P	Q	R	T	W	DNA		DNM
VARIO3-20 PVM 10-3 F	1	720	113	620	910	370	645	590	158	10,5	290	320	795	670	2-1/2"	2-1/2"	85
VARIO3-20 PVM 10-4 F	2	720	113	620	-	370	723	590	158	10,5	290	320	795	670	2-1/2"	2-1/2"	105
VARIO3-20 PVM 10-6 F	2	720	113	620	-	370	783	590	158	10,5	290	320	795	670	2-1/2"	2-1/2"	115
VARIO3-20 PVM 10-8 F	3	720	113	620	902	370	-	590	158	10,5	290	320	795	670	2-1/2"	2-1/2"	135
VARIO3-20 PVM 10-10 F	3	720	113	620	969	370	-	590	158	10,5	290	320	795	670	2-1/2"	2-1/2"	140
VARIO3-20 PVM 10-12 F	3	720	113	620	1029	370	-	590	158	10,5	290	320	795	670	2-1/2"	2-1/2"	145
VARIO3-20 PVM 10-14 F	3	720	113	620	1158	370	-	590	158	10,5	290	320	795	670	2-1/2"	2-1/2"	150
VARIO3-20 PVM 10-16 F	3	720	113	620	1218	370	-	590	158	10,5	290	320	795	670	2-1/2"	2-1/2"	155



# VARIO 3-20 PVM

THREE-PHASE PRESSURE BOOSTER SET WITH TWO VARIABLE SPEED PUMPS

## HYDRAULIC PERFORMANCE

---

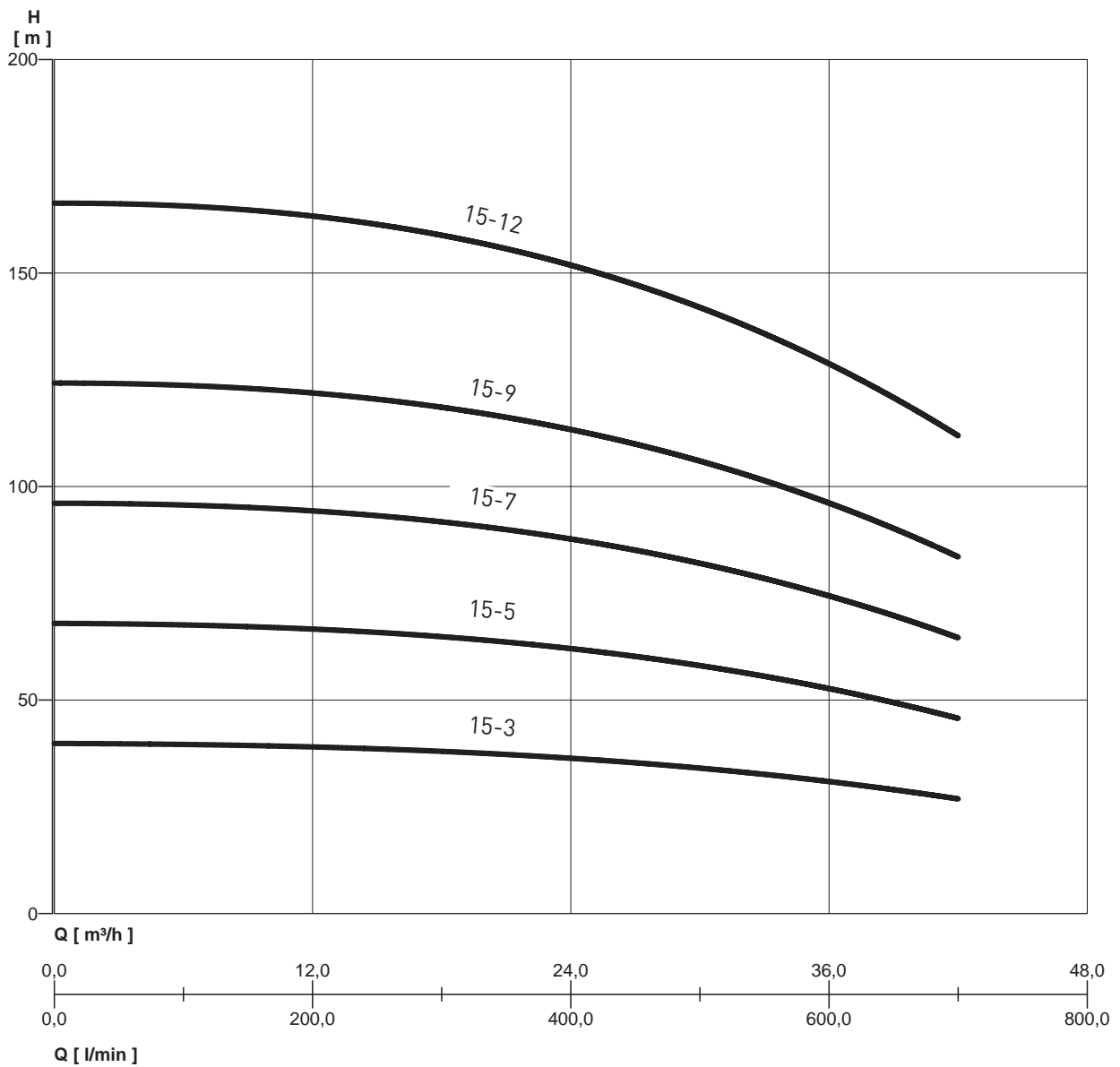

# VARIO 3-20 PVM

THREE-PHASE PRESSURE BOOSTER SET WITH TWO VARIABLE SPEED PUMPS

## PERFORMANCE TABLE

MODEL	P2	VOLT. (V)	In (A)	0	l/min	0	100	200	300	400	500	600	700
	kW					0	6	12	18	24	30	36	42
VARIO3-20 PVM 15-3 F	2x3	3 ~ 400	2x5,1	m.c.w.	39,8	39,6	39,2	37,8	36,3	34,1	31	26,8	
VARIO3-20 PVM 15-5 F	2x4	3 ~ 400	2x8,5		68	67,4	66,9	64,7	62	58,1	52,7	45,7	
VARIO3-20 PVM 15-7 F	2x5,5	3 ~ 400	2x12		96,2	95,3	94,7	91,6	87,7	82	74,4	64,6	
VARIO3-20 PVM 15-9 F	2x7,5	3 ~ 400	2x15		124,4	123,2	122,4	118,4	113,4	106	96	83,6	
VARIO3-20 PVM 15-12 F	2x11	3 ~ 400	2x20		166,6	165	163,9	158,8	151,9	141,9	128,6	112	

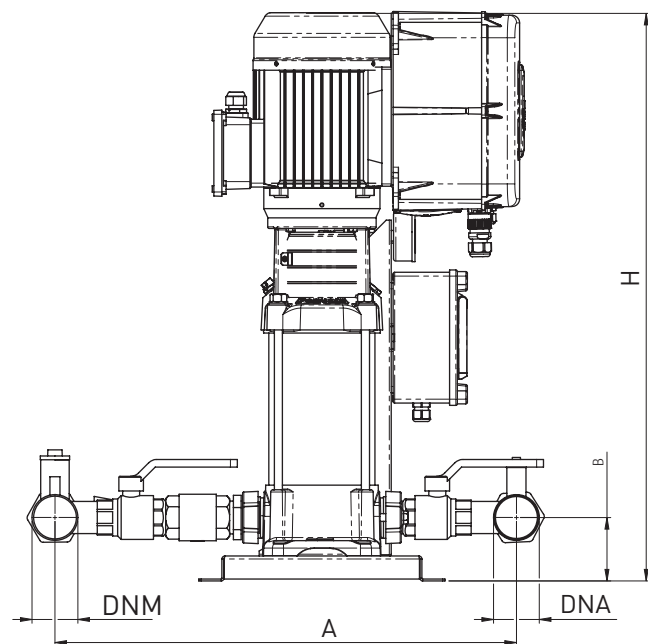
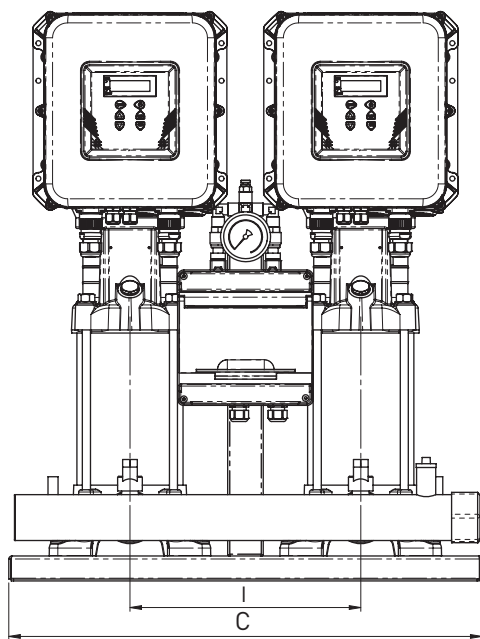

## OVERALL DIMENSIONS AND WEIGHTS

MODEL	Dimensions mm.							WEIGHT Kg
	A	B	C	H	I	DNA	DNM	
VARIO3-20 PVM 15-3 F	850	125	710	816	360	3"	3"	140
VARIO3-20 PVM 15-5 F	850	125	710	913	360	3"	3"	160
VARIO3-20 PVM 15-7 F	850	125	710	1072	360	3"	3"	210
VARIO3-20 PVM 15-9 F	850	125	710	1182	360	3"	3"	226
VARIO3-20 PVM 15-12 F	850	125	710	1507	360	3"	3"	250

# VARIO 3-20 PVM

THREE-PHASE PRESSURE BOOSTER SET WITH TWO VARIABLE SPEED PUMPS

## HYDRAULIC PERFORMANCE

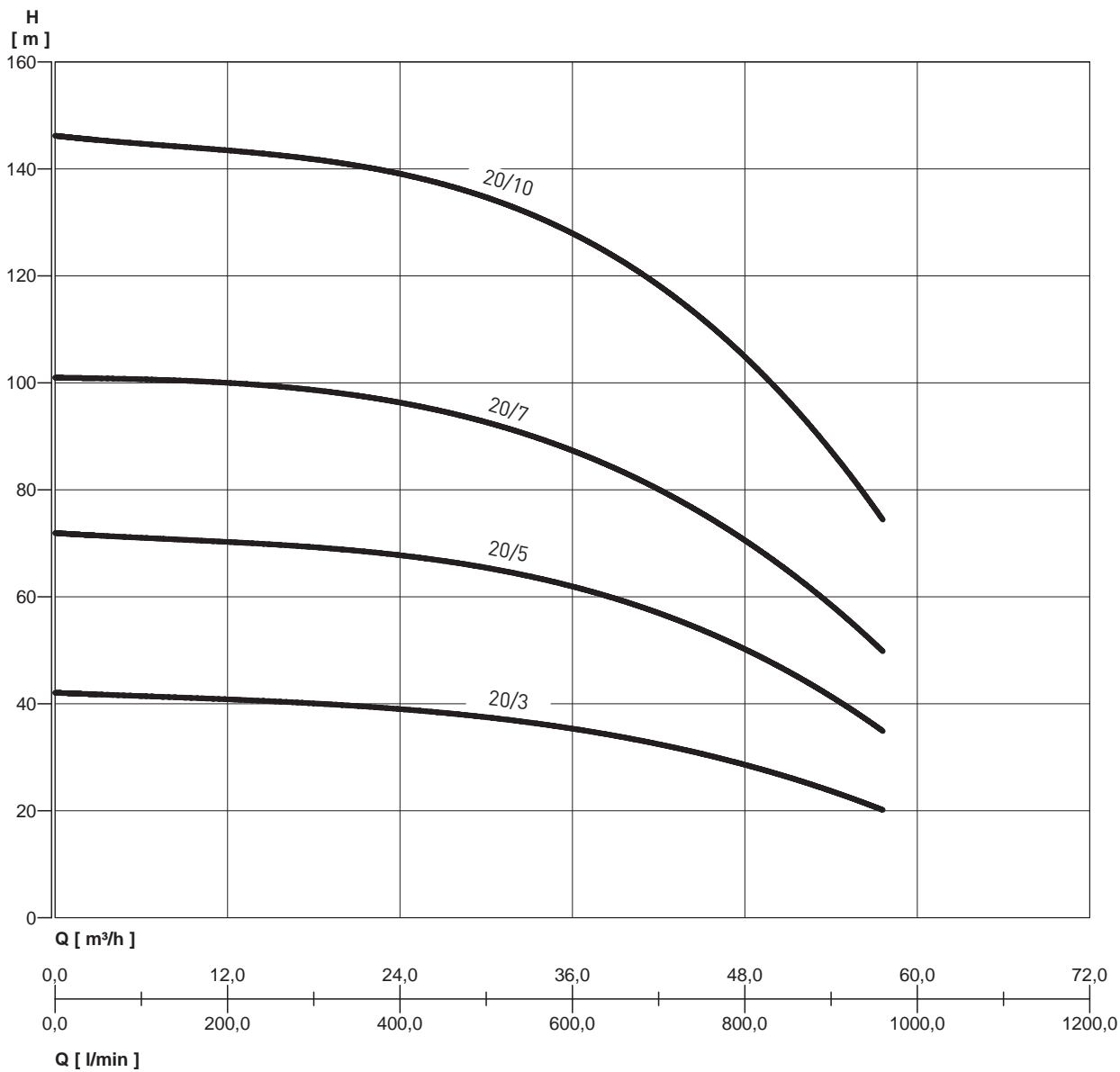

# VARIO 3-20 PVM

## THREE-PHASE PRESSURE BOOSTER SET WITH TWO VARIABLE SPEED PUMPS

### PERFORMANCE TABLE

MODEL	P2	VOLT. (V)	In (A)	Q	l/min	0	200	400	600	800	960
	kW					0	12	24	36	48	57,6
VARIO3-20 PVM 20-3 F	2x4	3 ~ 400	2x8,5	0	m.c.w.	42	41	39	35	29	20
VARIO3-20 PVM 20-5 F	2x5,5	3 ~ 400	2x11,9			72	70	68	62	50	35
VARIO3-20 PVM 20-7 F	2x7,5	3 ~ 400	2x15,3			101	100	96	88	70	50
VARIO3-20 PVM 20-10 F	2x11	3 ~ 400	2x20,4			146	144	139	127	106	74

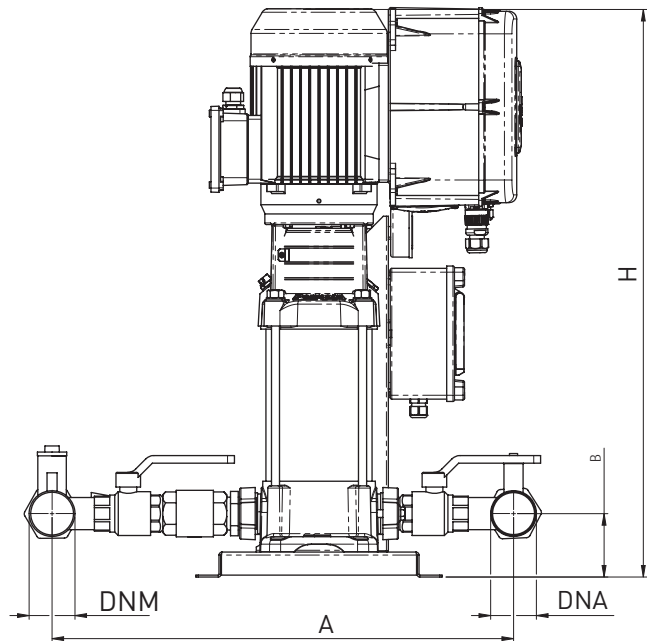
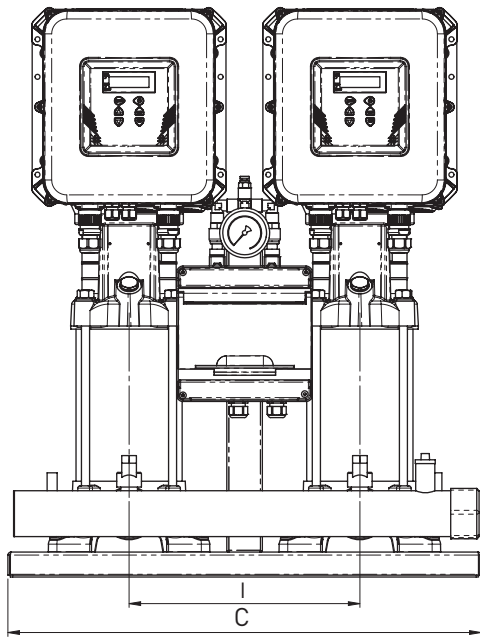

### PERFORMANCE TABLE

MODEL	Dimensions mm.							WEIGHT Kg
	A	B	C	H	I	DNA	DNM	
VARIO3-20 PVM 20-3 F	850	125	710	690	360	3"	3"	140
VARIO3-20 PVM 20-5 F	850	125	710	845	360	3"	3"	160
VARIO3-20 PVM 20-7 F	850	125	710	992	360	3"	3"	180
VARIO3-20 PVM 20-10 F	850	125	710	1122	360	3"	3"	210

# VARIO 3-20 PVM

THREE-PHASE PRESSURE BOOSTER SET WITH TWO VARIABLE SPEED PUMPS

## HYDRAULIC PERFORMANCE

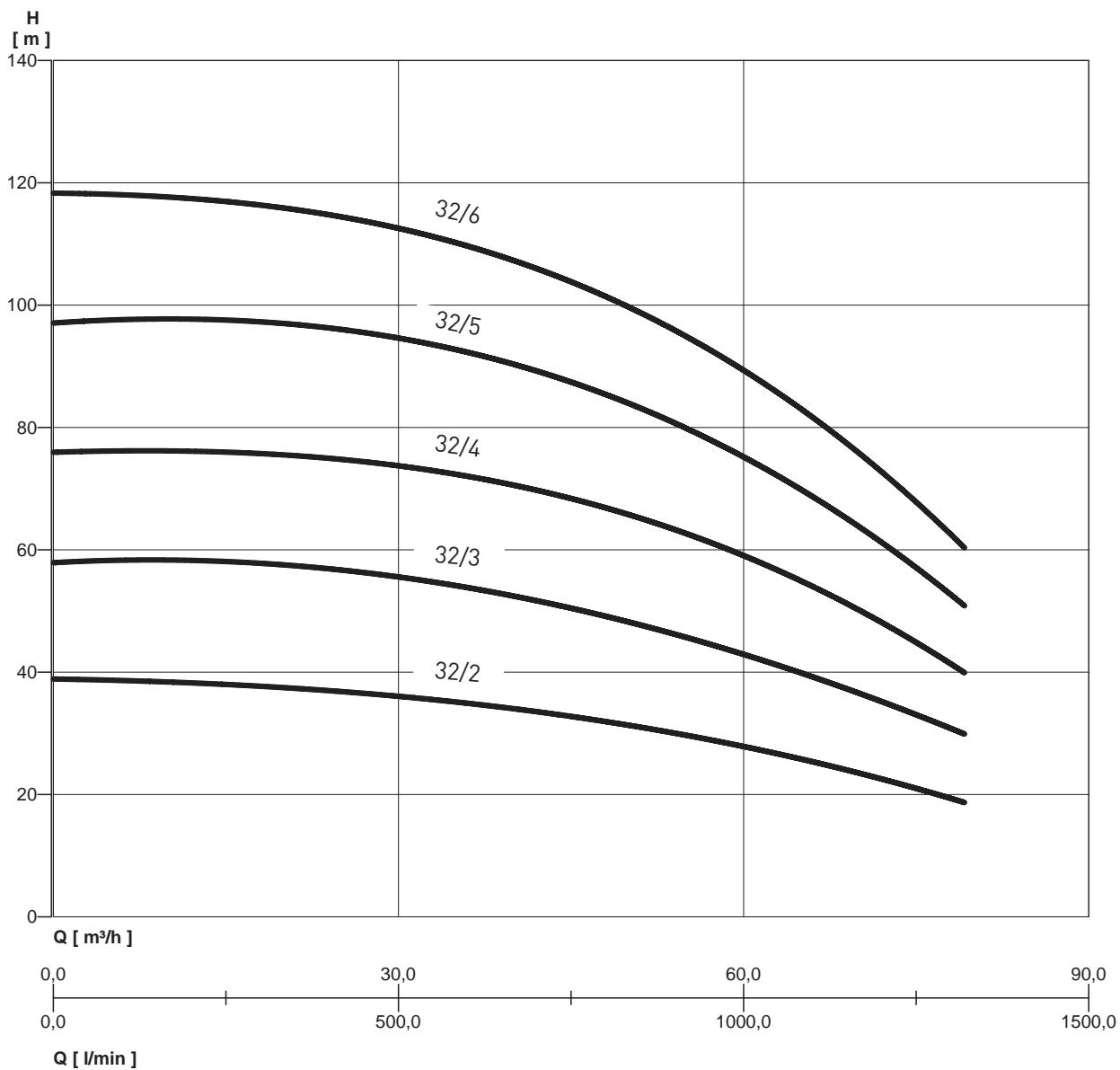

# VARIO 3-20 PVM

## THREE-PHASE PRESSURE BOOSTER SET WITH TWO VARIABLE SPEED PUMPS

### PERFORMANCE TABLE

MODEL	P2	VOLT. (V)	In (A)	Q	l/min	0	12	24	36	48	60	72	79,2
	kW				m <sup>3</sup> /h	0	200	400	600	800	1000	1200	1320
VARIO3-20 PVM 32-2 F	2x4	3 ~ 400	2x7,1	m.c.w.	39	38	37	35	32	28	22	19	
VARIO3-20 PVM 32-3 F	2x5,5	3 ~ 400	2x10,7		58	58	57	54	49	43	35	30	
VARIO3-20 PVM 32-4 F	2x7,5	3 ~ 400	2x14,3		76	76	75	72	67	59	48	40	
VARIO3-20 PVM 32-5 F	2x11	3 ~ 400	2x17,8		97	98	96	92	86	75	61	51	
VARIO3-20 PVM 32-6 F	2x11	3 ~ 400	2x21,4		118	118	115	109	101	90	73	60	

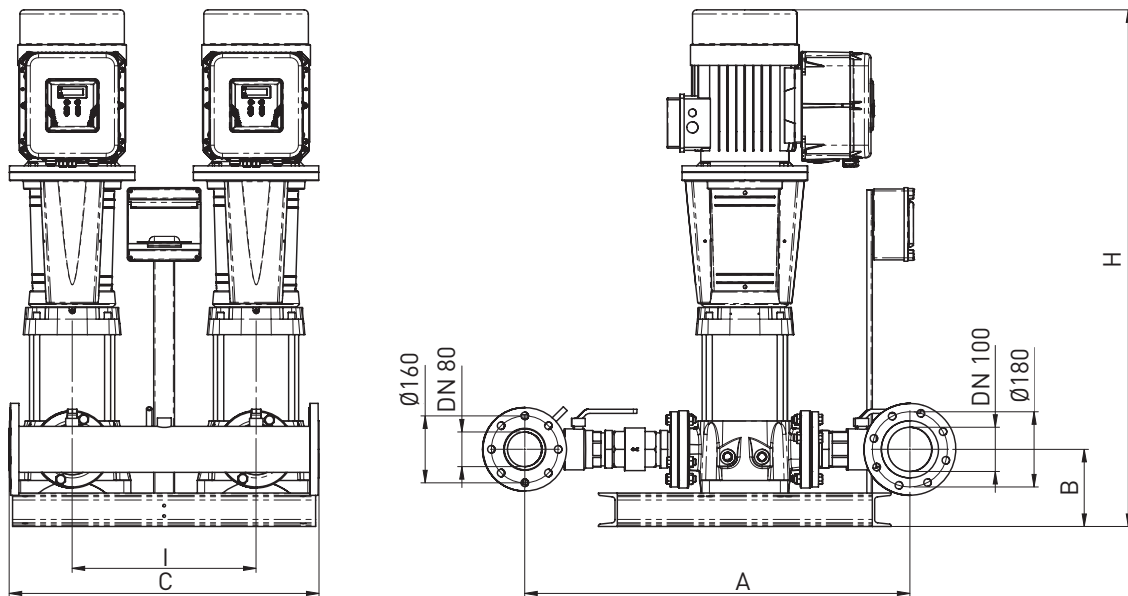

### OVERALL DIMENSIONS AND WEIGHTS

MODEL	Dimensions mm.							WEIGHT Kg
	A	B	C	H	I	DNA	DNM	
VARIO3-20 PVM 32-2 F	950	185	750	982	440	4"	3"	300
VARIO3-20 PVM 32-3 F	950	185	750	1089	440	4"	3"	320
VARIO3-20 PVM 32-4 F	950	185	750	1179	440	4"	3"	360
VARIO3-20 PVM 32-5 F	950	185	750	1472	440	4"	3"	380
VARIO3-20 PVM 32-6 F	950	185	750	1542	440	4"	3"	420

## VARIO 3-30

### THREE-PHASE PRESSURE BOOSTER SET WITH THREE VARIABLE SPEED PUMPS

Easy to install, Low power consumption, Versatile operation

The new series of variable speed pressurization booster set VARIO 3-30 represents a reliable solution which is easy to use, for residential and industrial applications. The system involves the installation of three pumps in parallel featuring electronic control. VARIO3 is an electronic device capable of changing the frequency of a pump. Integrated directly on the motor, it allows to adjust its speed so as to supply the same pressure at all times, even when the water demand changes.

When the system pressure drops below the set threshold, the module starts the first pump of the unit to restore to set-point pressure; the speed of rotation of the pump varies according to the water demand so, a greater demand will correspond to a higher speed, until the

maximum speed set has been reached, after which, if the system requires greater performance, the module will activate the second and then the third pump to keep the pressure stable. As the water demand decreases, the speed of the last pump started is reduced, until it turns off. The module will keep the first pump on until the minimum set speed has been reached, after which, if there are no further requests for water, the pump will be stopped. VARIO3-30 features five operating modes to meet the operating needs.



#### TECHNICAL FEATURES

- Inverter supply voltage: 3x380-500 Vac
- Inverter output voltage: 3x380-500 Vac
- Maximum output power: up to 3x11 kW
- Input frequency: 50/60 Hz
- Output maximum rated power: up to 20 Amp
- Degree of protection: IP55
- Max. ambient temperature: + 50°C
- Input filter complying with EMC
- directive
- Pressure transducer: 0-5 Volt 0-10 bar
- Connettività: Interfaccia seriale RS 485
- Connectivity: Serial interface RS 485
- Optional contacts: 3 (external set-point, alarm, system inhibition)

#### BASEMENT

- in galvanized metal complete with rubber isolated pads

#### SUCTION MANIFOLD

- in stainless steel AISI 304 with 3 ball valves

#### DELIVERY MANIFOLD

- In stainless steel AISI 304 with:
- n. 3 ball valves
- n. 3 check valves
- n. 1 pressure gauge
- n. 2 pressure sensors

USAGE DATA	MULTINOX-VE+			PVM				
	4	6	8	5	10	15	20	32
Maximum capacity (m <sup>3</sup> /h)	16,2	25,2	37,8	25,5	39	70,5	87	120
Maximum head (m.c.a.)	140	110	140	160	160	165	145	120
Maximum operating pressure	12 bar	16 bar	16 bar	16 bar				
Power supply VOLT.:	3-400 V							
Ambient temperature	50° C							
Degree of protection of pump	IP55							
Degree of protection of electrical panel	IP54							

# VARIO 3-30 MULTINOX VE+

THREE-PHASE PRESSURE BOOSTER SET WITH THREE VARIABLE SPEED PUMPS

## HYDRAULIC PERFORMANCE

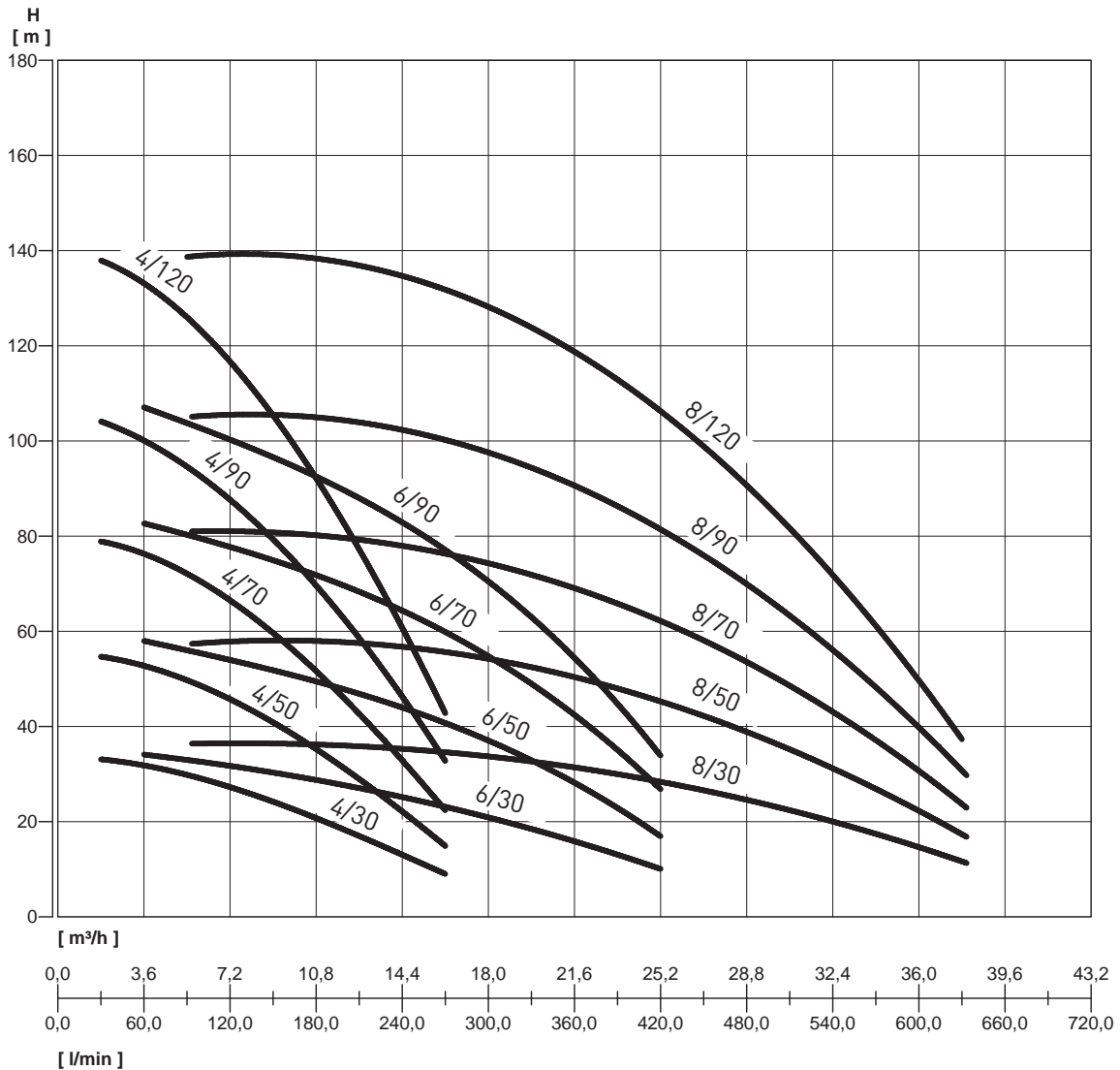

## PERFORMANCE TABLE

MODEL	P2	VOLT. (V)	In (A)	0	m.c.w.																
	kW				l/min	30	60	90	120	150	180	210	240	270	300	360	420	450	540	630	
					m³/h	1,8	3,6	5,4	7,2	9	10,8	12,6	14,4	16,2	18	21,6	25,2	27	32,4	37,8	
VARIO3-30 MULTINOX VE+ 4-30	3x0,5	3 - 400	3x2,54		33	32	30	27	24	21	17	13	9								
VARIO3-30 MULTINOX VE+ 4-50	3x0,84	3 - 400	3x3,9		55	52	50	46	41	35	29	22	15								
VARIO3-30 MULTINOX VE+ 4-70	3x1,17	3 - 400	3x5,46		79	76	72	67	60	51	42	34	22								
VARIO3-30 MULTINOX VE+ 4-90	3x1,5	3 - 400	3x7,22		104	100	95	88	79	69	58	48	32								
VARIO3-30 MULTINOX VE+ 4-120	3x2	3 - 400	3x9,42		138	133	126	117	105	92	78	60	43								
VARIO3-30 MULTINOX VE+ 6-30	3x0,67	3 - 400	3x3,58			34	33	32	30	29	27	25	23	21	16	10					
VARIO3-30 MULTINOX VE+ 6-50	3x1,1	3 - 400	3x5,26			58	56	54	52	49	47	44	41	37	28	17					
VARIO3-30 MULTINOX VE+ 6-70	3x1,5	3 - 400	3x8,21			83	80	77	76	71	69	64	60	55	42	27					
VARIO3-30 MULTINOX VE+ 6-90	3x2	3 - 400	3x9,13			107	104	100	97	92	88	83	77	71	54	34					
VARIO3-30 MULTINOX VE+ 8-30	3x1	3 - 400	3x2,6				35	35	35	35	34	34	33	32	30	27	25	18	10		
VARIO3-30 MULTINOX VE+ 8-50	3x1,5	3 - 400	3x4,33				57	56	56	56	56	55	54	53	50	44	40	28	16		
VARIO3-30 MULTINOX VE+ 8-70	3x1,9	3 - 400	3x6,13				80	80	79	78	77	76	75	73	69	60	56	40	22		
VARIO3-30 MULTINOX VE+ 8-90	3x3	3 - 400	3x9,7				104	104	104	103	103	101	98	94	90	82	73	52	29		
VARIO3-30 MULTINOX VE+ 8-120	3x4	3 - 400	3x12,3				139	139	139	138	138	135	131	126	120	109	98	70	38		



# VARIO 3-30 MULTINOX VE+

THREE-PHASE PRESSURE BOOSTER SET WITH THREE VARIABLE SPEED PUMPS

## OVERALL DIMENSIONS AND WEIGHTS

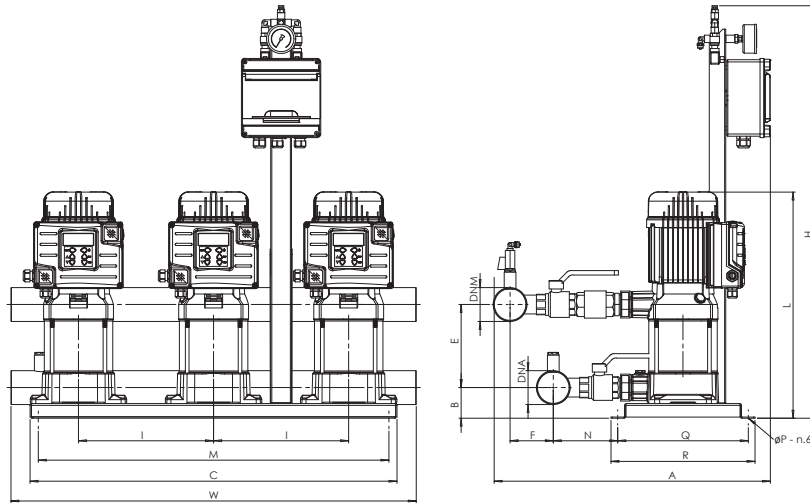

FIG. 1

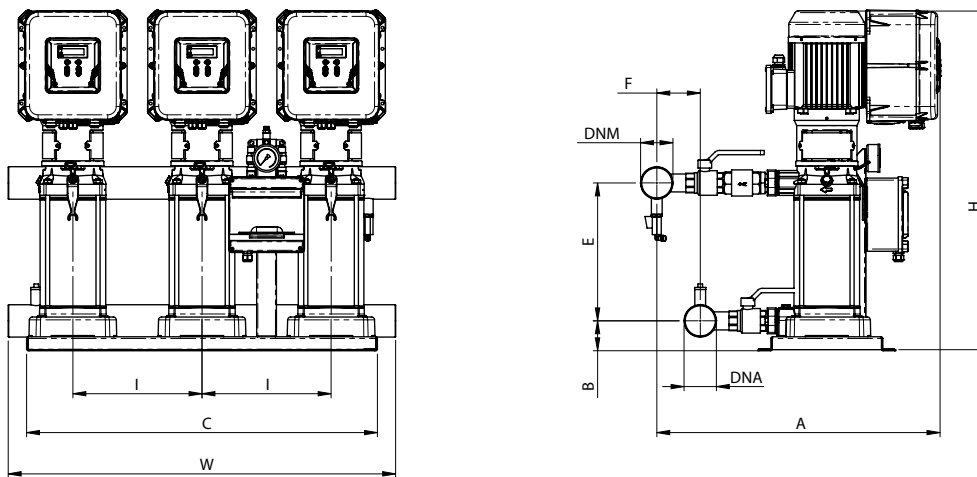

FIG. 2

## OVERALL DIMENSIONS AND WEIGHTS

MODEL	Fig.	Dimensions mm.															WEIGHT Kg
		A	B	C	E	F	H	I	L	M	N	P	Q	R	W	DNA	
VARIO3-30 MULTINOX VE+ 4-30	1	615	68	815	130	96	910	300	449	778,5	145	10,5	290	320	900	2-1/2"2-1/2"	116
VARIO3-30 MULTINOX VE+ 4-50	1	615	68	815	184	96	910	300	503	778,5	145	10,5	290	320	900	2-1/2"2-1/2"	129
VARIO3-30 MULTINOX VE+ 4-70	1	615	68	815	238	96	910	300	557	778,5	145	10,5	290	320	900	2-1/2"2-1/2"	141
VARIO3-30 MULTINOX VE+ 4-90	1	615	68	815	292	96	910	300	611	778,5	145	10,5	290	320	900	2-1/2"2-1/2"	144
VARIO3-30 MULTINOX VE+ 4-120	1	615	68	815	373	96	910	300	693	778,5	145	10,5	290	320	900	2-1/2"2-1/2"	150
VARIO3-30 MULTINOX VE+ 6-30	1	615	68	815	130	96	910	300	449	778,5	145	10,5	290	320	900	2-1/2"2-1/2"	117
VARIO3-30 MULTINOX VE+ 6-50	1	615	68	815	184	96	910	300	503	778,5	145	10,5	290	320	900	2-1/2"2-1/2"	129
VARIO3-30 MULTINOX VE+ 6-70	1	615	68	815	238	96	910	300	557	778,5	145	10,5	290	320	900	2-1/2"2-1/2"	141
VARIO3-30 MULTINOX VE+ 6-90	1	615	68	815	292	96	910	300	611	778,5	145	10,5	290	320	900	2-1/2"2-1/2"	144
VARIO3-30 MULTINOX VE+ 8-30	1	615	68	815	130	96	910	300	449	778,5	145	10,5	290	320	900	2-1/2"2-1/2"	117
VARIO3-30 MULTINOX VE+ 8-50	1	615	68	815	184	96	910	300	503	778,5	145	10,5	290	320	900	2-1/2"2-1/2"	129
VARIO3-30 MULTINOX VE+ 8-70	1	615	68	815	238	96	910	300	557	778,5	145	10,5	290	320	900	2-1/2"2-1/2"	141
VARIO3-30 MULTINOX VE+ 8-90	2	780	68	815	292	96	765	300	765	778,5	145	10,5	290	320	900	2-1/2"2-1/2"	178
VARIO3-30 MULTINOX VE+ 8-120	2	780	68	815	373	96	890	300	890	778,5	145	10,5	290	320	900	2-1/2"2-1/2"	185

# VARIO 3-30 PVM

THREE-PHASE PRESSURE BOOSTER SET WITH THREE VARIABLE SPEED PUMPS

## HYDRAULIC PERFORMANCE

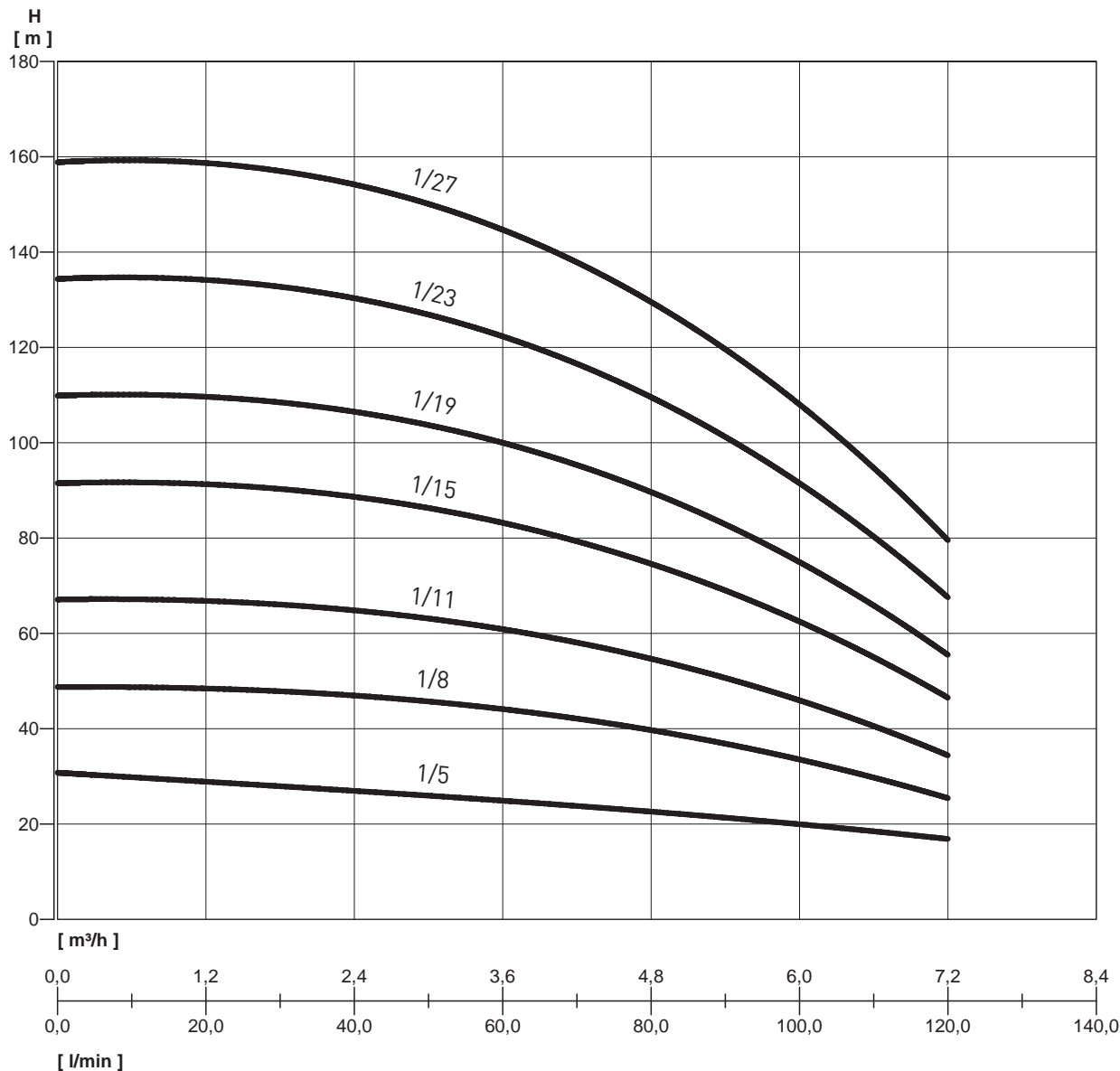

## PERFORMANCE TABLE

MODEL	P2	VOLT. (V)	In (A)	Q	l/min	0	30	60	90	120
	kW				m³/h	0	1,8	3,6	5,4	7,2
VARIO3-30 PVM1-5 F	3x0,37	3 ~ 400	3x1,5	m.c.w.	30,4	29,4	22,7	22,8	16,5	
VARIO3-30 PVM1-8 F	3x0,55	3 ~ 400	3x2,3		48,8	47,6	44,5	36,6	25,5	
VARIO3-30 PVM1-11 F	3x0,55	3 ~ 400	3x3,2		67,2	65,7	61,4	50,3	34,5	
VARIO3-30 PVM1-15 F	3x0,75	3 ~ 400	3x4,4		91,6	89,9	83,8	68,6	46,6	
VARIO3-30 PVM1-19 F	3x1,1	3 ~ 400	3x5,5		110	108	100,7	82,4	55,6	
VARIO3-30 PVM1-23 F	3x1,1	3 ~ 400	3x6,7		134,5	132,2	123,1	100,7	67,7	
VARIO3-30 PVM1-27 F	3x1,5	3 ~ 400	3x7,8		159	156,4	145,6	119	79,7	

# VARIO 3-30 PVM

THREE-PHASE PRESSURE BOOSTER SET WITH THREE VARIABLE SPEED PUMPS

## OVERALL DIMENSIONS AND WEIGHTS

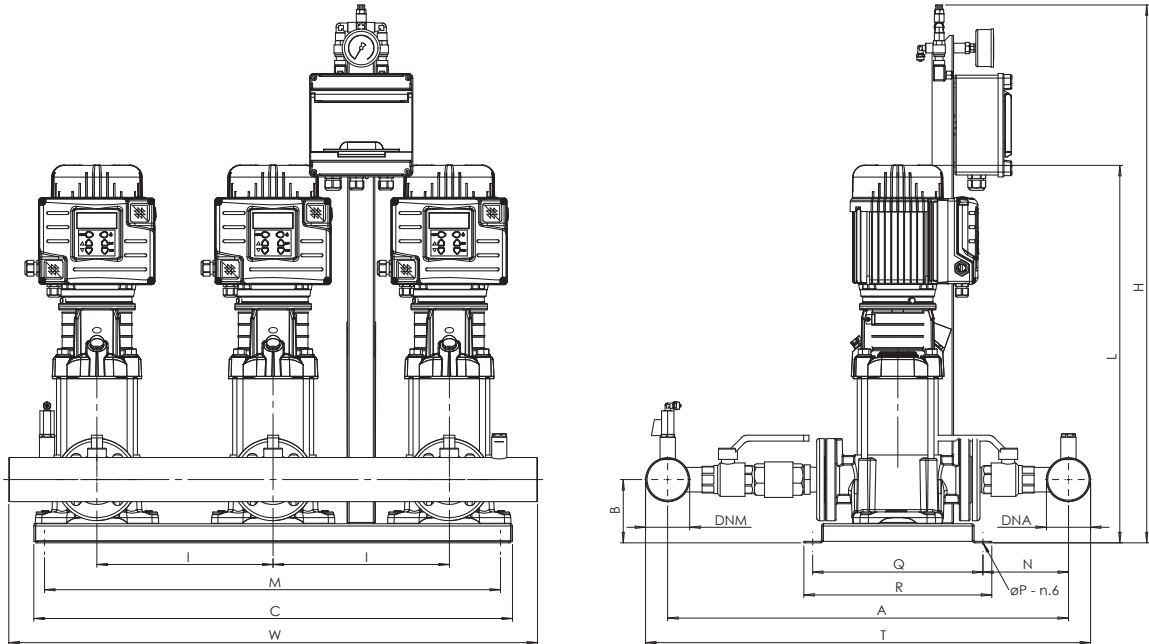

FIG. 1

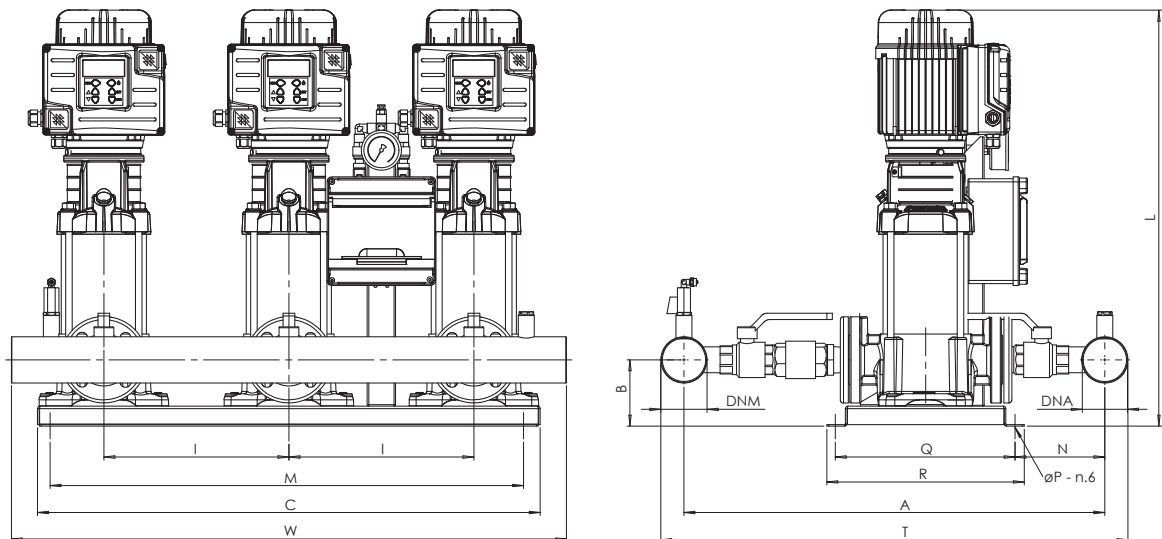

FIG. 2

## OVERALL DIMENSIONS AND WEIGHTS

MODEL	Fig.	Dimensions mm.														WEIGHT Kg	
		A	B	C	H	I	L	M	N	P	Q	R	T	W	DNA		DNM
VARIO3-30 PVM1-5 F	1	690	108	815	910	300	543	778,5	145	10,5	290	320	765	900	2-1/2"	2-1/2"	90
VARIO3-30 PVM1-8 F	1	690	108	815	910	300	597	778,5	145	10,5	290	320	765	900	2-1/2"	2-1/2"	93
VARIO3-30 PVM1-11 F	2	690	108	815	651	300	651	778,5	145	10,5	290	320	765	900	2-1/2"	2-1/2"	101
VARIO3-30 PVM1-15 F	2	690	108	815	769	300	769	778,5	145	10,5	290	320	765	900	2-1/2"	2-1/2"	110
VARIO3-30 PVM1-19 F	2	690	108	815	841	300	841	778,5	145	10,5	290	320	765	900	2-1/2"	2-1/2"	120
VARIO3-30 PVM1-23 F	2	690	108	815	913	300	913	778,5	145	10,5	290	320	765	900	2-1/2"	2-1/2"	135
VARIO3-30 PVM1-27 F	2	690	108	815	1033	300	1033	778,5	145	10,5	290	320	765	900	2-1/2"	2-1/2"	141

# VARIO 3-30 PVM

THREE-PHASE PRESSURE BOOSTER SET WITH THREE VARIABLE SPEED PUMPS

## HYDRAULIC PERFORMANCE

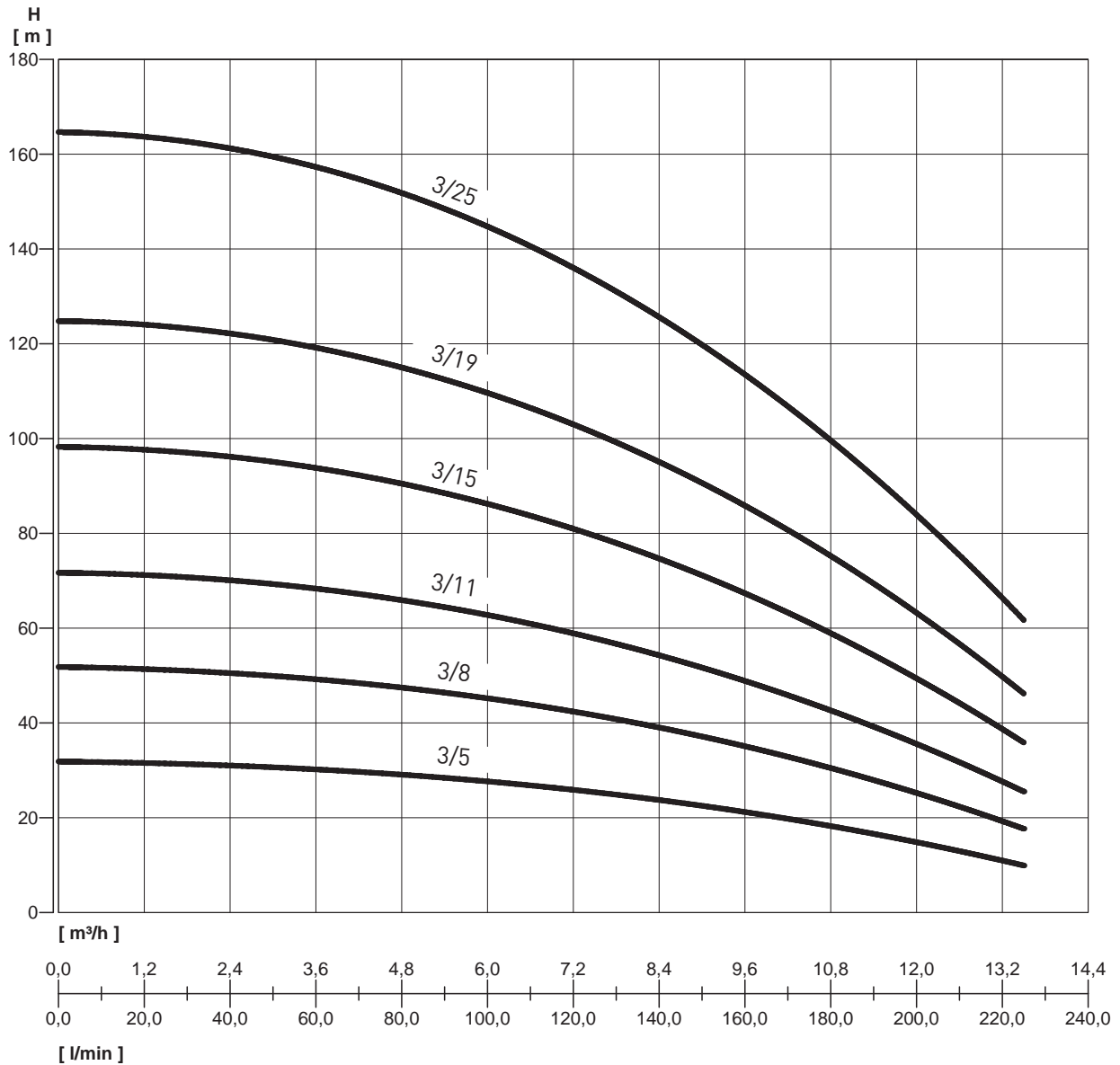

## PERFORMANCE TABLE

MODEL	P2	VOLT. (V)	In (A)	0	l/min	0	60	120	180	225
	kW				m³/h	0	3,6	7,2	10,8	13,5
VARIO3-30 PVM 3-5 F	3x0,37	3 - 400	3x0,9	m.c.w.		31,9	30	26,2	18	10
VARIO3-30 PVM 3-8 F	3x0,75	3 - 400	3x1,45			51,9	48,9	42,9	30,1	17,8
VARIO3-30 PVM 3-11 F	3x0,75	3 - 400	3x2			71,8	67,9	59,6	42,1	25,7
VARIO3-30 PVM 3-15 F	3x1,1	3 - 400	3x2,7			98,4	93,2	81,9	58,2	36,1
VARIO3-30 PVM 3-19 F	3x1,5	3 - 400	3x3,4			125	118,4	104,2	74,3	46,5
VARIO3-30 PVM 3-25 F	3x2,2	3 - 400	3x4,5			164,9	156,3	137,6	98,4	62,1

# VARIO 3-30 PVM

THREE-PHASE PRESSURE BOOSTER SET WITH THREE VARIABLE SPEED PUMPS

## OVERALL DIMENSIONS AND WEIGHTS

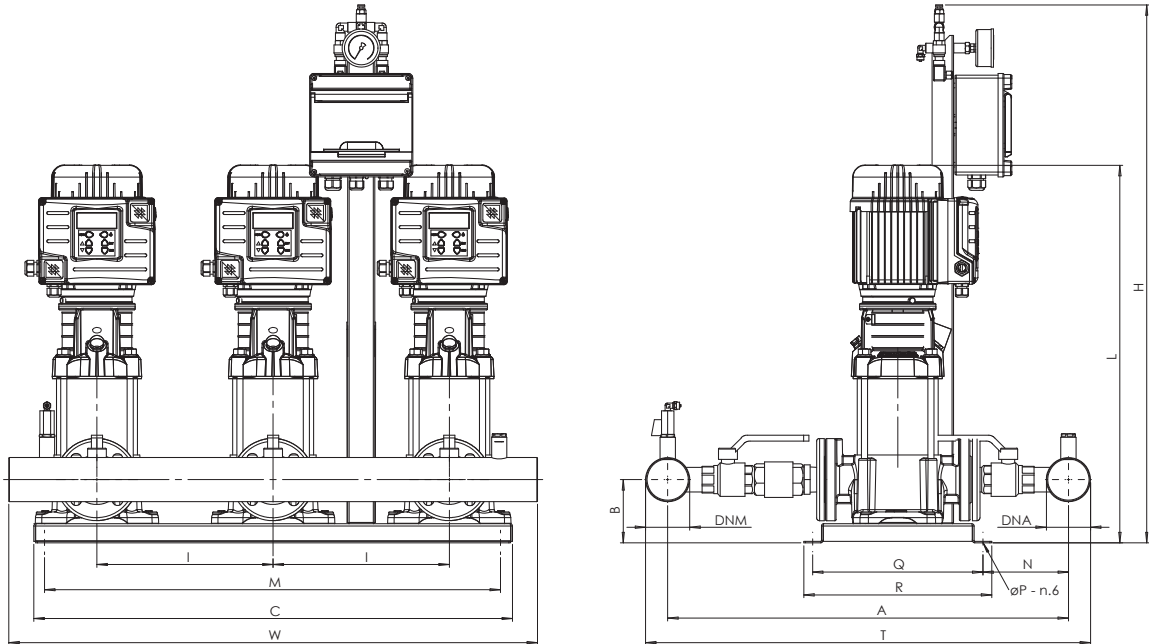

FIG. 1

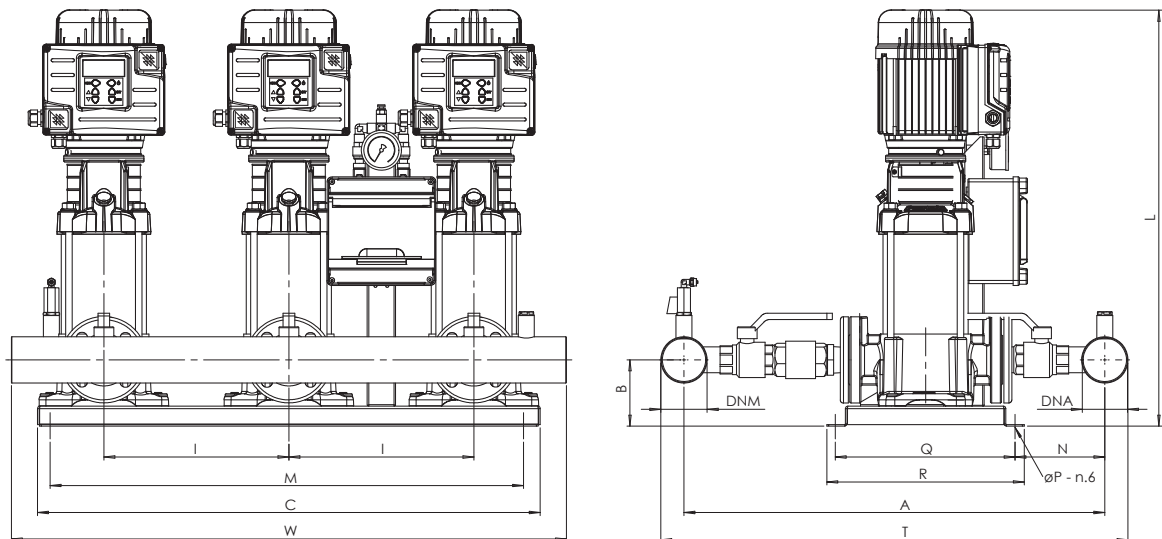

FIG. 2

## OVERALL DIMENSIONS AND WEIGHTS

MODEL	Fig.	Dimensions mm.														WEIGHT Kg	
		A	B	C	H	I	L	M	N	P	Q	R	T	W	DNA		DNM
VARIO3-30 PVM 3-5 F	1	690	108	815	910	300	543	778,5	145	10,5	290	320	765	900	2-1/2"	2-1/2"	93
VARIO3-30 PVM 3-8 F	1	690	108	815	910	300	643	778,5	145	10,5	290	320	765	900	2-1/2"	2-1/2"	98
VARIO3-30 PVM 3-11 F	2	690	108	815	697	300	697	778,5	145	10,5	290	320	765	900	2-1/2"	2-1/2"	110
VARIO3-30 PVM 3-15 F	2	690	108	815	769	300	769	778,5	145	10,5	290	320	765	900	2-1/2"	2-1/2"	113
VARIO3-30 PVM 3-19 F	2	690	108	815	889	300	889	778,5	145	10,5	290	320	765	900	2-1/2"	2-1/2"	120
VARIO3-30 PVM 3-25 F	2	690	108	815	997	300	997	778,5	145	10,5	290	320	765	900	2-1/2"	2-1/2"	135

# VARIO 3-30 PVM

THREE-PHASE PRESSURE BOOSTER SET WITH THREE VARIABLE SPEED PUMPS

## HYDRAULIC PERFORMANCE

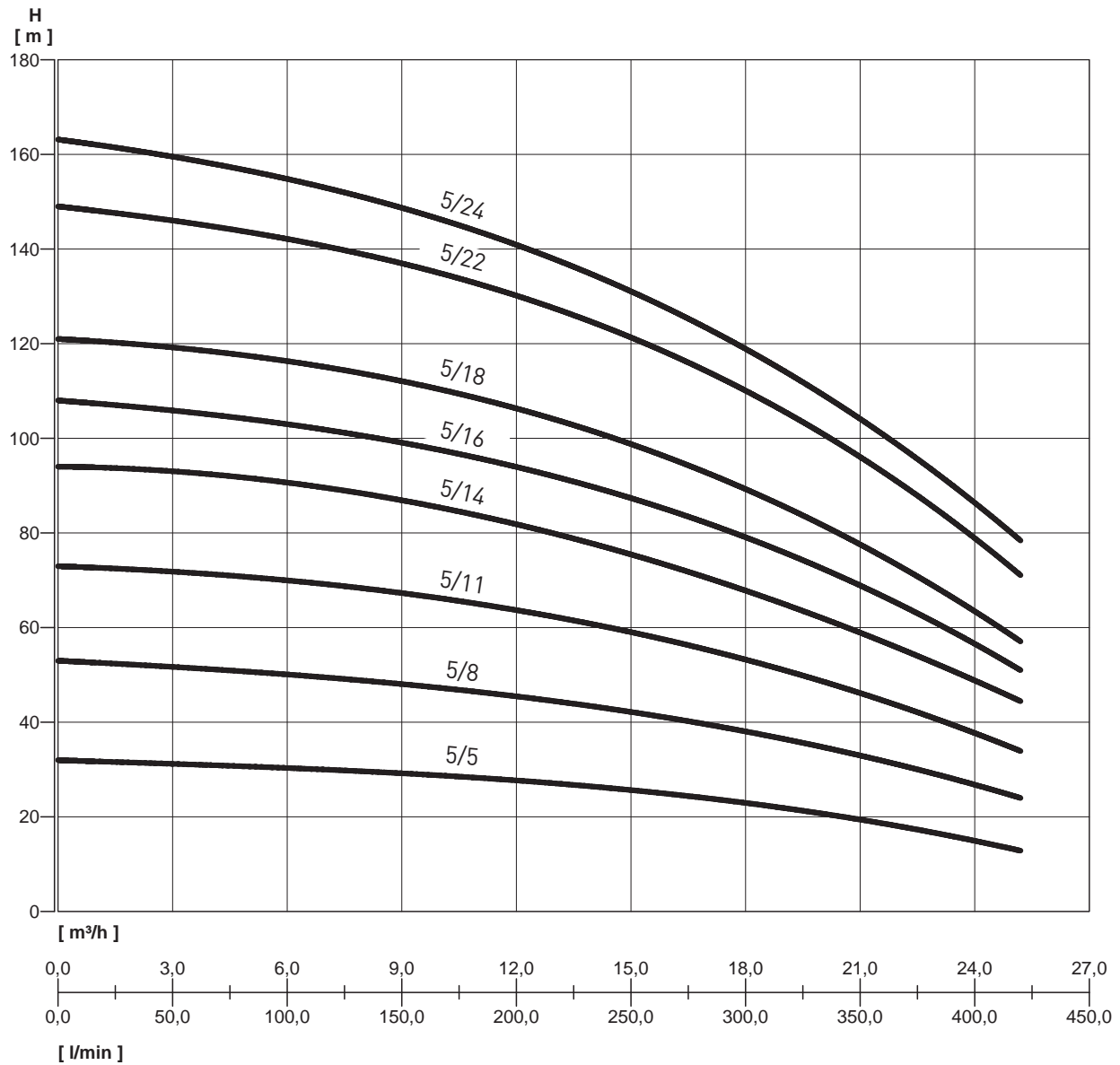

## PERFORMANCE TABLE

MODEL	P2	VOLT. (V)	In (A)	Q	l/min	0	120	180	240	300	360	420
	kW					0	7,2	10,8	14,4	18	21,6	25,2
VARIO3-30 PVM 5-5 F	3x0,75	3 - 400	3x1,7	m.c.w.	32	31	30	30	29	28	13,5	
VARIO3-30 PVM 5-8 F	3x1,1	3 - 400	3x2,7		52	51	50	48	47	45	23,6	
VARIO3-30 PVM 5-11 F	3x2,2	3 - 400	3x3,7		74	72	70	69	68	65	33,8	
VARIO3-30 PVM 5-14 F	3x2,2	3 - 400	3x4,8		93	91	90	89	87	84	43,9	
VARIO3-30 PVM 5-16 F	3x2,2	3 - 400	3x5,4		107	105	101	102	98	95	50,7	
VARIO3-30 PVM 5-18 F	3x3	3 - 400	3x6,1		122	117,8	112	102,7	89,3	71,1	57,4	
VARIO3-30 PVM 5-22 F	3x4	3 - 400	3x7,5		149	144,5	137,4	126,1	110	87,6	70,9	
VARIO3-30 PVM 5-24 F	3x4	3 - 400	3x8,2		163	157,8	150,1	137,8	120	95,9	77,7	

# VARIO 3-30 PVM

THREE-PHASE PRESSURE BOOSTER SET WITH THREE VARIABLE SPEED PUMPS

## OVERALL DIMENSIONS AND WEIGHTS

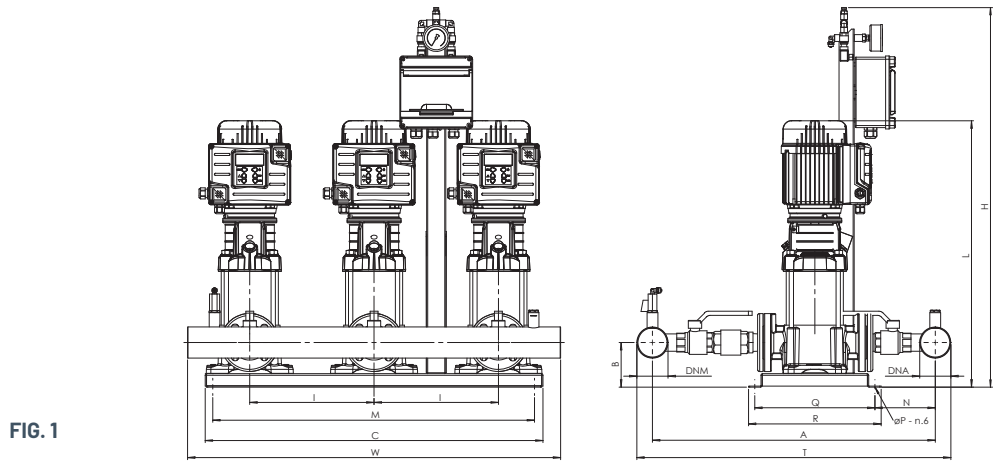

FIG. 1

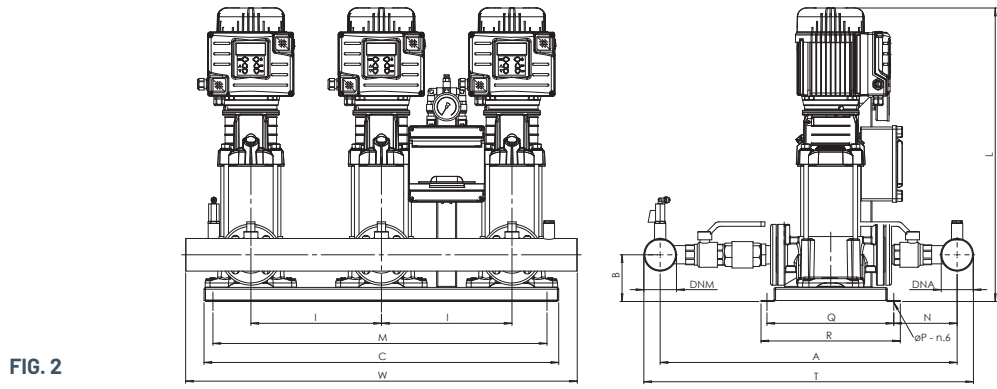

FIG. 2

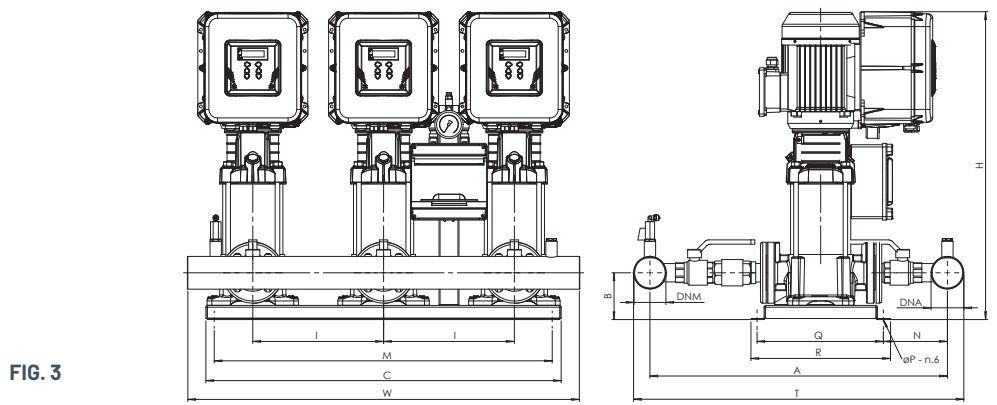

FIG. 3

## OVERALL DIMENSIONS AND WEIGHTS

MODEL	Fig.	Dimensions mm.															WEIGHT Kg
		A	B	C	H	I	L	M	N	P	Q	R	T	W	DNA	DNM	
VARIO3-30 PVM 5-5 F	1	690	108	815	910	300	634	778,5	145	10,5	290	320	765	900	2-1/2"	2-1/2"	114
VARIO3-30 PVM 5-8 F	2	690	108	815	715	300	715	778,5	145	10,5	290	320	765	900	2-1/2"	2-1/2"	120
VARIO3-30 PVM 5-11 F	2	690	108	815	844	300	844	778,5	145	10,5	290	320	765	900	2-1/2"	2-1/2"	138
VARIO3-30 PVM 5-14 F	2	690	108	815	925	300	925	778,5	145	10,5	290	320	765	900	2-1/2"	2-1/2"	147
VARIO3-30 PVM 5-16 F	2	690	108	815	979	300	979	778,5	145	10,5	290	320	765	900	2-1/2"	2-1/2"	150
VARIO3-30 PVM 5-18 F	3	690	108	815	1091	300	-	778,5	145	10,5	290	320	765	900	2-1/2"	2-1/2"	224
VARIO3-30 PVM 5-22 F	3	690	108	815	1206	300	-	778,5	145	10,5	290	320	765	900	2-1/2"	2-1/2"	229
VARIO3-30 PVM 5-24 F	3	690	108	815	1260	300	-	778,5	145	10,5	290	320	765	900	2-1/2"	2-1/2"	248

# VARIO 3-30 PVM

THREE-PHASE PRESSURE BOOSTER SET WITH THREE VARIABLE SPEED PUMPS

## HYDRAULIC PERFORMANCE

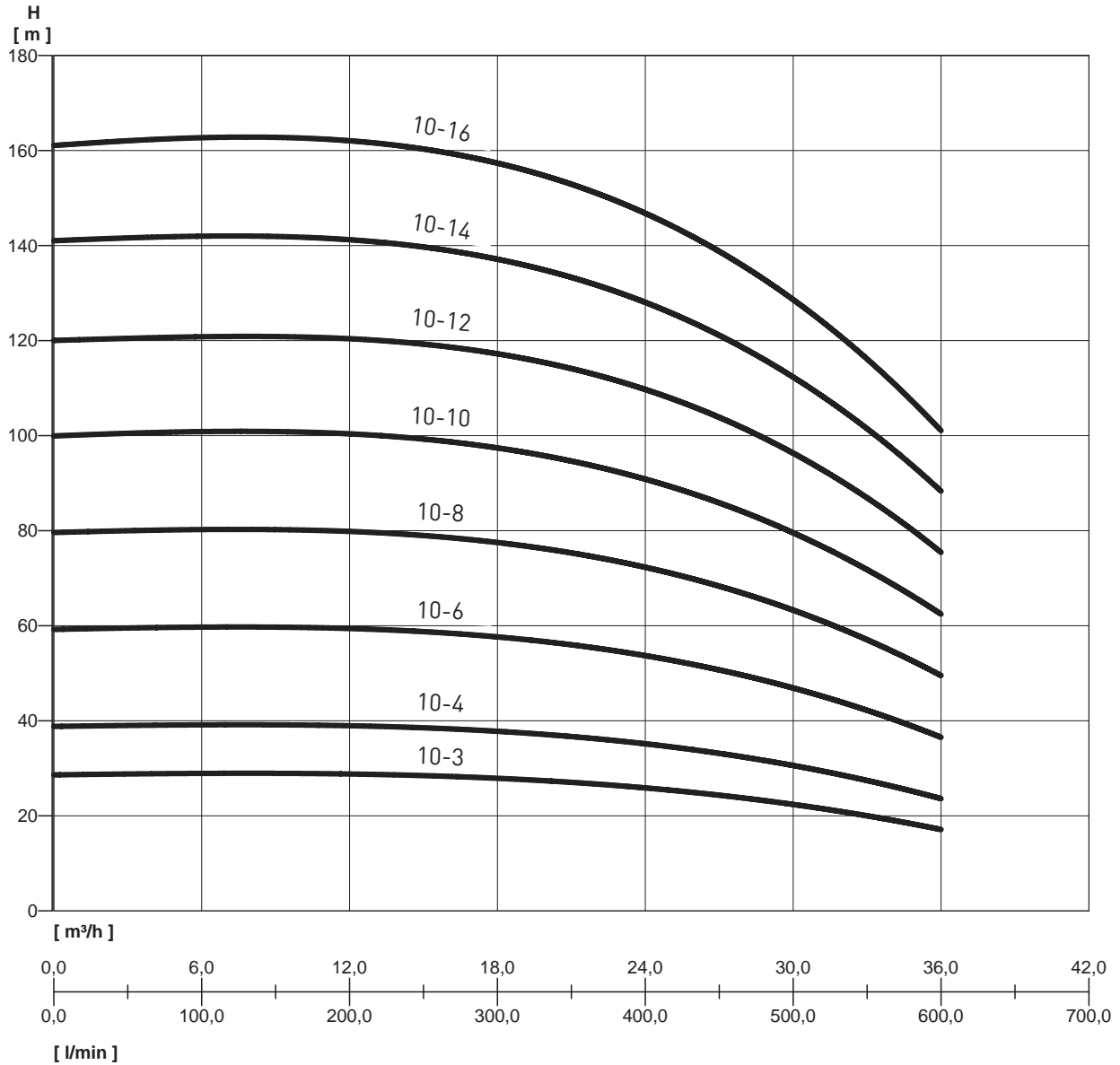

## PERFORMANCE TABLE

MODEL	P2	VOLT. (V)	In (A)	0	l/min	0	150	300	450	600
	kW				m³/h	0	9	18	27	36
VARIO3-30 PVM 10-3 F	3x1,5	3 ~ 400	3x2,4	m.c.w.	28,6	29	27,8	24,4	17,1	
VARIO3-30 PVM 10-4 F	3x2	3 ~ 400	3x3,2		38,8	39,2	37,7	33,2	23,6	
VARIO3-30 PVM 10-6 F	2x2,2	3 ~ 400	3x4,8		59,2	59,8	57,5	50,8	36,5	
VARIO3-30 PVM 10-8 F	3x3	3 ~ 400	3x6,4		79,6	80,3	77,4	68,4	49,5	
VARIO3-30 PVM 10-10 F	3x4	3 ~ 400	3x8		99,9	101	97,2	86	62,4	
VARIO3-30 PVM 10-12 F	3x4	3 ~ 400	3x9,6		120	121	117	104	75,4	
VARIO3-30 PVM 10-14 F	3x5,5	3 ~ 400	3x11,2		141	142	137	121,2	88,3	
VARIO3-30 PVM 10-16 F	3x5,5	3 ~ 400	3x12,8		161	163	157	139	101	



# VARIO 3-30 PVM

THREE-PHASE PRESSURE BOOSTER SET WITH THREE VARIABLE SPEED PUMPS

## OVERALL DIMENSIONS AND WEIGHTS

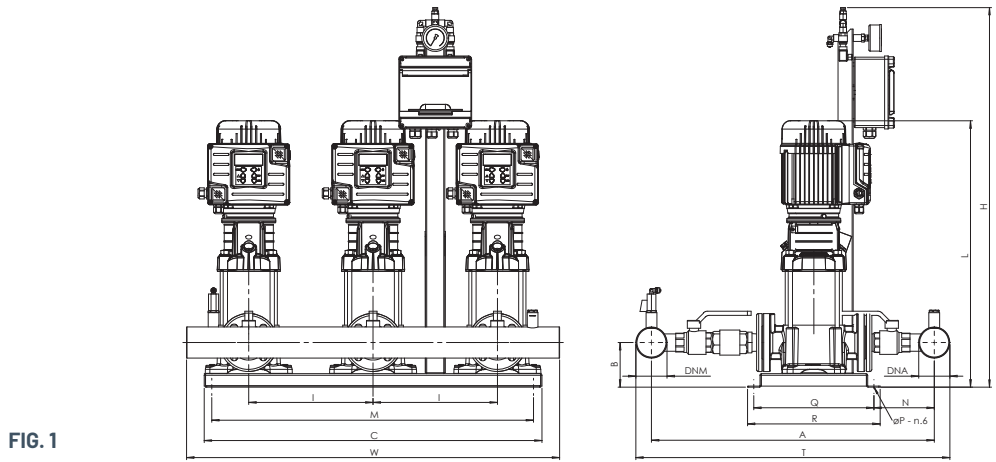

FIG. 1

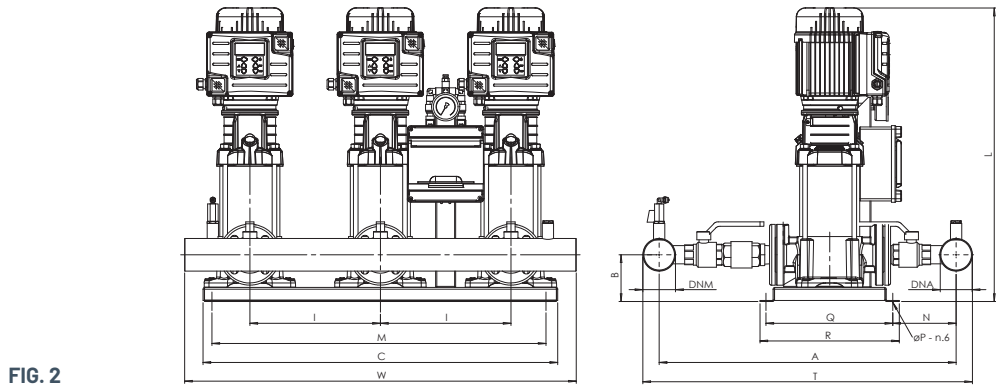

FIG. 2

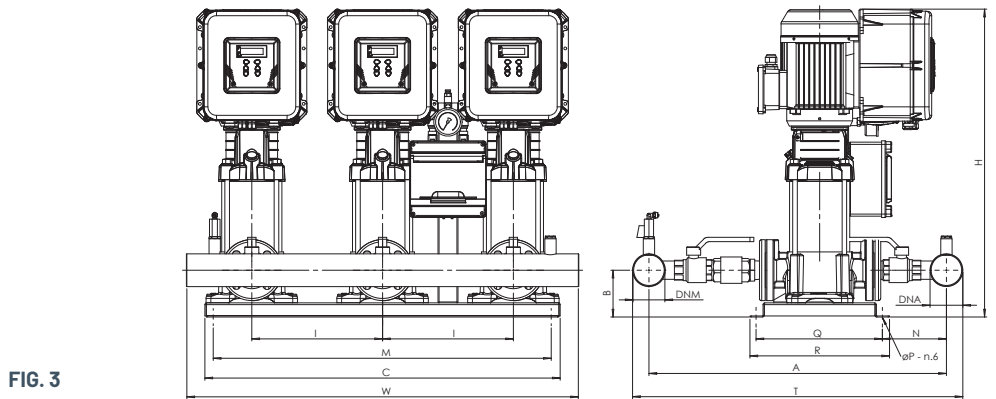

FIG. 3

## OVERALL DIMENSIONS AND WEIGHTS

MODEL	Fig.	Dimensions mm.													WEIGHT Kg	
		A	B	C	H	I	L	M	N	P	Q	R	T	W		DNA
VARIO3-30 PVM10-3 F	1	720	113	1000	910	370	645	963,5	158	10,5	290	320	795	1040	2-1/2"2-1/2"	128
VARIO3-30 PVM10-4 F	2	720	113	1000	723	370	723	963,5	158	10,5	290	320	795	1040	2-1/2"2-1/2"	158
VARIO3-30 PVM10-6 F	2	720	113	1000	783	370	783	963,5	158	10,5	290	320	795	1040	2-1/2"2-1/2"	173
VARIO3-30 PVM10-8 F	3	720	113	1000	902	370	-	963,5	158	10,5	290	320	795	1040	2-1/2"2-1/2"	147
VARIO3-30 PVM10-10 F	3	720	113	1000	969	370	-	963,5	158	10,5	290	320	795	1040	2-1/2"2-1/2"	150
VARIO3-30 PVM10-12 F	3	720	113	1000	1029	370	-	963,5	158	10,5	290	320	795	1040	2-1/2"2-1/2"	224
VARIO3-30 PVM10-14 F	3	720	113	1000	1158	370	-	963,5	158	10,5	290	320	795	1040	2-1/2"2-1/2"	229
VARIO3-30 PVM10-16 F	3	720	113	1000	1218	370	-	963,5	158	10,5	290	320	795	1040	2-1/2"2-1/2"	248

# VARIO 3-30 PVM

THREE-PHASE PRESSURE BOOSTER SET WITH THREE VARIABLE SPEED PUMPS

## HYDRAULIC PERFORMANCE

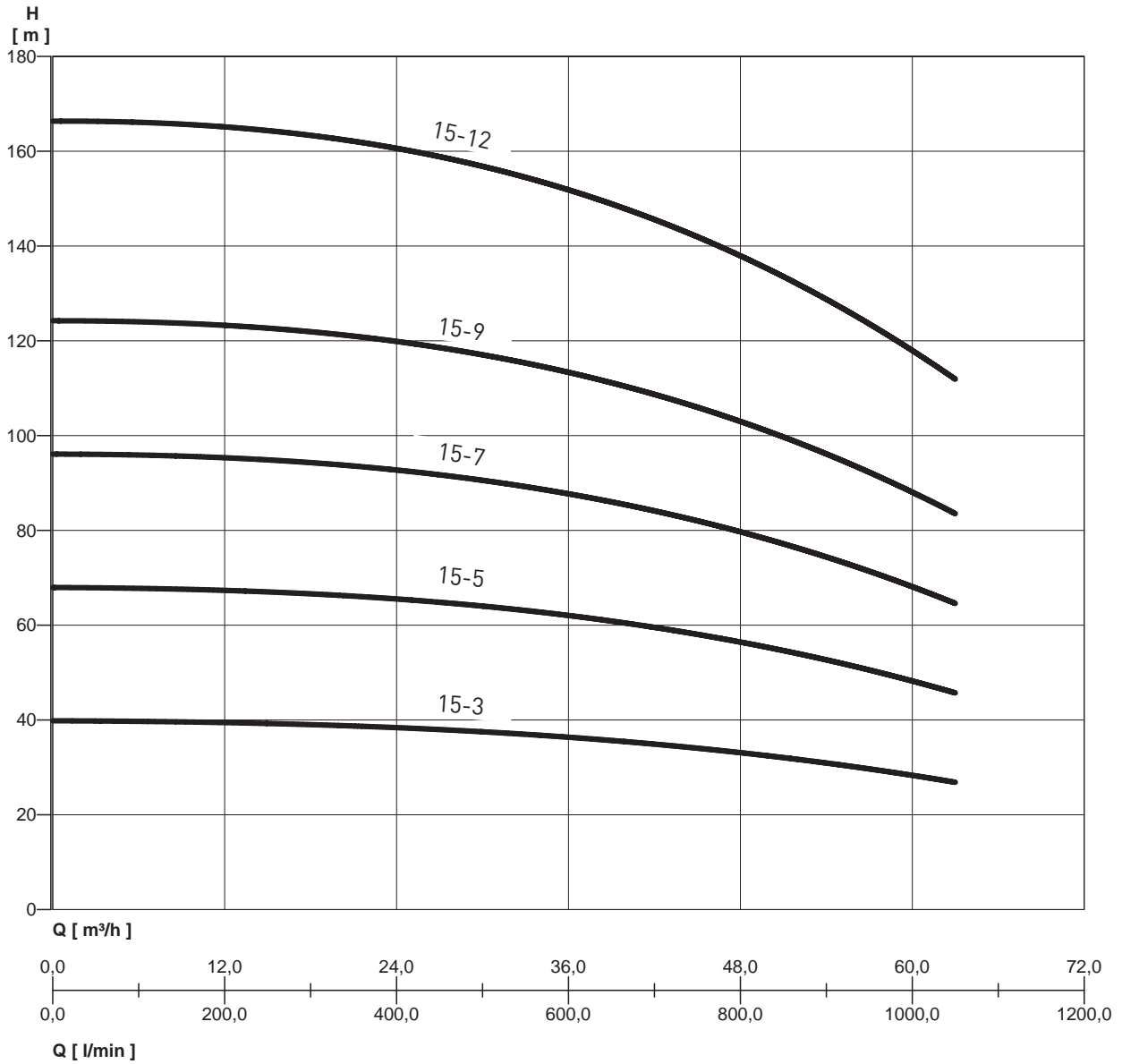

# VARIO 3-30 PVM

THREE-PHASE PRESSURE BOOSTER SET WITH THREE VARIABLE SPEED PUMPS

## PERFORMANCE TABLE

MODEL	P2	VOLT. (V)	In (A)	0	l/min	0	150	300	450	600	750	900	1050
	kW					0	9	18	27	36	45	54	63
VARIO3-30 PVM 15-3 F	3x3	3 ~ 400	3x5,1	m.c.w.	39,8	39,6	39,2	37,8	36,3	34,1	31	26,8	
VARIO3-30 PVM 15-5 F	3x4	3 ~ 400	3x8,5		68	67,4	66,9	64,7	62	58,1	52,7	45,7	
VARIO3-30 PVM 15-7 F	3x5,5	3 ~ 400	3x11,9		96,2	95,3	94,7	91,6	87,7	82	74,4	64,6	
VARIO3-30 PVM 15-9 F	3x7,5	3 ~ 400	3x15,3		124,4	123,2	122,4	118,4	113,4	106	96	83,6	
VARIO3-30 PVM 15-12 F	3x11	3 ~ 400	3x20,4		166,6	165	163,9	158,8	151,9	141,9	128,6	112	

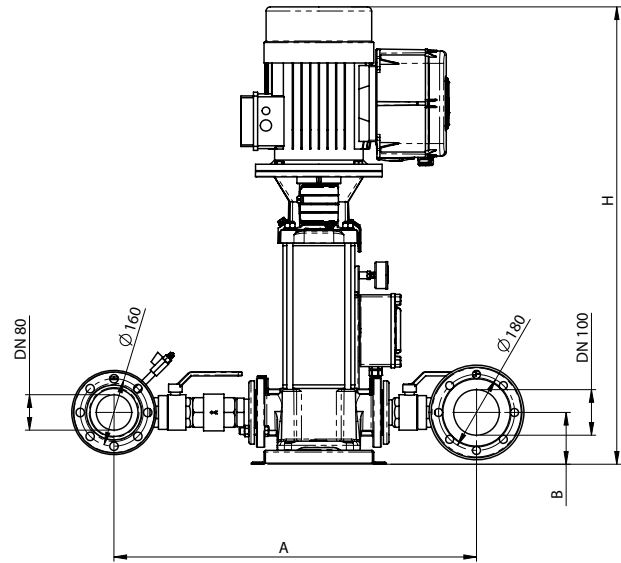
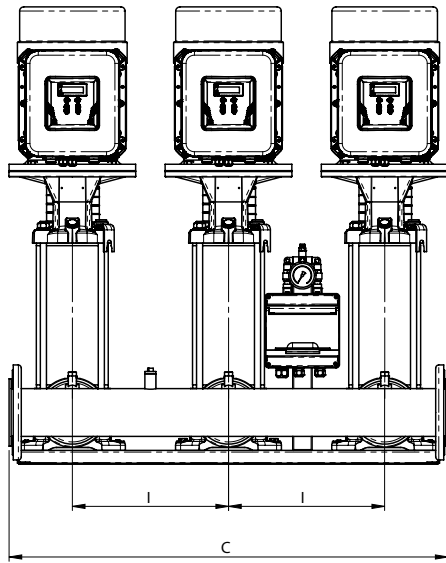

## OVERALL DIMENSIONS AND WEIGHTS

MODEL	Dimensions mm.							WEIGHT Kg
	A	B	C	H	I	DNA	DNM	
VARIO3-30 PVM 15-3 F	860	125	1040	786	370	3"	3"	207
VARIO3-30 PVM 15-5 F	860	125	1040	883	370	3"	3"	252
VARIO3-30 PVM 15-7 F	860	125	1040	1042	370	3"	3"	354
VARIO3-30 PVM 15-9 F	860	125	1040	1152	370	3"	3"	381
VARIO3-30 PVM 15-12 F	860	125	1040	1417	370	3"	3"	500

# VARIO 3-30 PVM

THREE-PHASE PRESSURE BOOSTER SET WITH THREE VARIABLE SPEED PUMPS

## HYDRAULIC PERFORMANCE

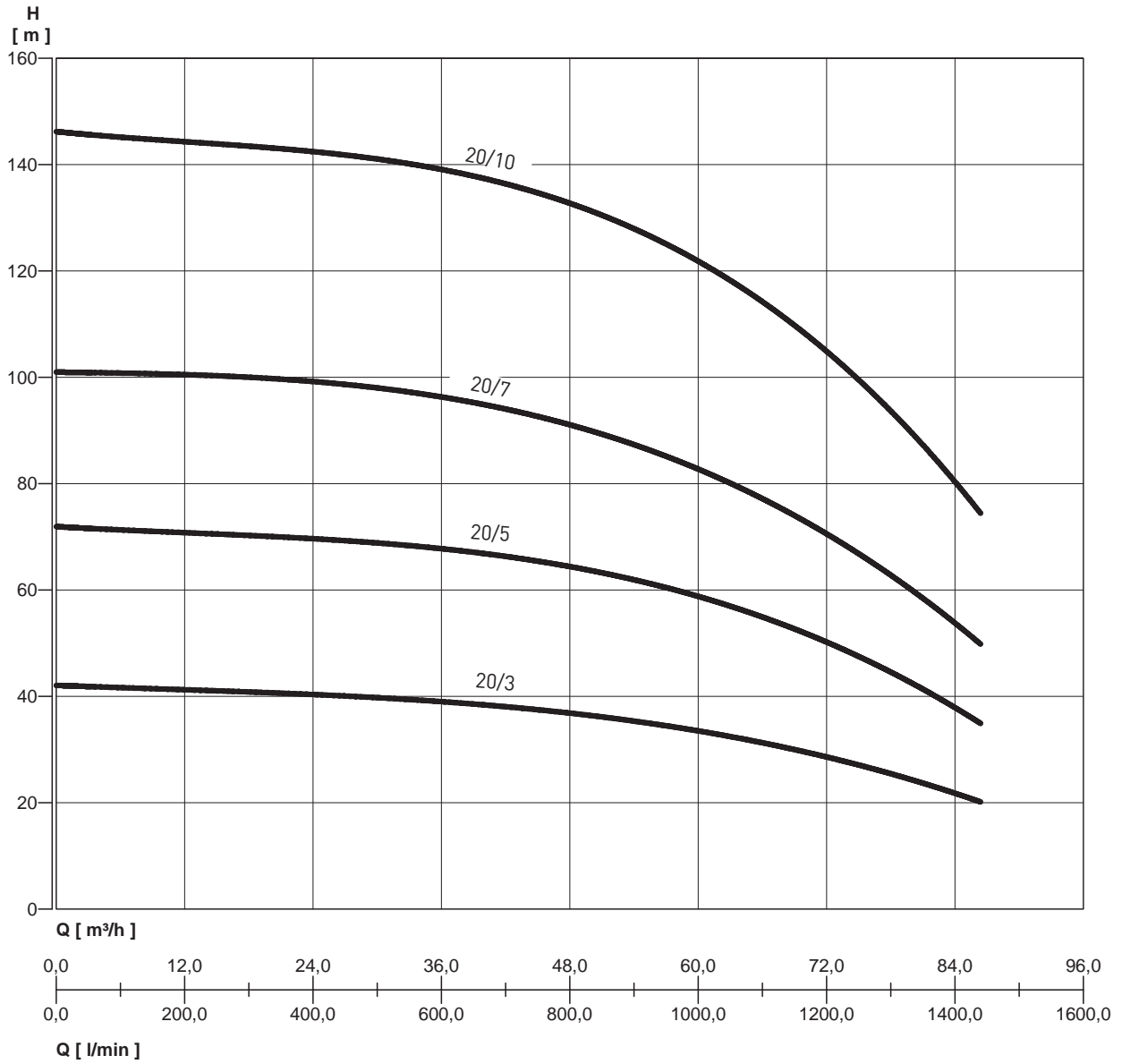

# VARIO 3-30 PVM

THREE-PHASE PRESSURE BOOSTER SET WITH THREE VARIABLE SPEED PUMPS

## PERFORMANCE TABLE

MODEL	P2	VOLT. (V)	In (A)	Q	l/min	0	300	600	900	1200	1440
	kW					0	18	36	54	72	86,4
VARIO3-30 PVM 20-3 F	3x4	3 ~ 400	3x8,5	m.c.w.	42	41	39	35	29	20	
VARIO3-30 PVM 20-5 F	3x5,5	3 ~ 400	3x11,9		72	70	68	62	50	35	
VARIO3-30 PVM 20-7 F	3x7,5	3 ~ 400	3x15,3		101	100	96	88	70	50	
VARIO3-30 PVM 20-10 F	3x11	3 ~ 400	3x20,4		146	144	139	127	106	74	

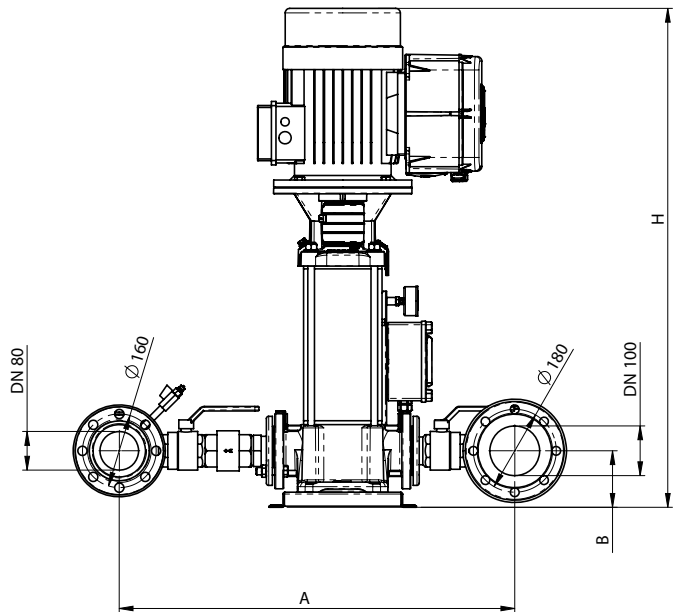
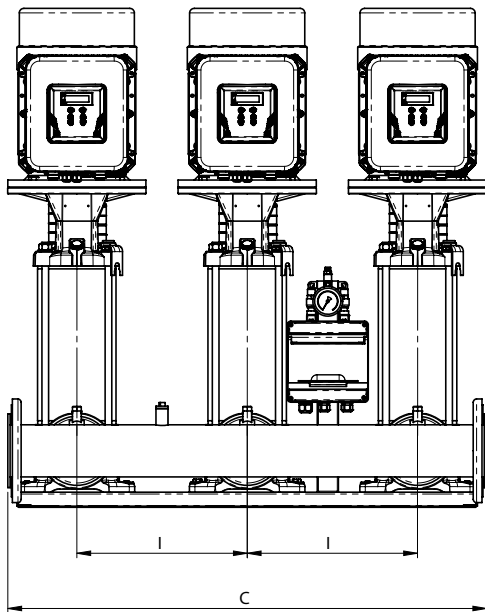

## OVERALL DIMENSIONS AND WEIGHTS

MODEL	Dimensions mm.							WEIGHT Kg
	A	B	C	H	I	DNA	DNM	
VARIO3-30 PVM 20-3 F	860	125	1040	793	370	3"	3"	243
VARIO3-30 PVM 20-5 F	860	125	1040	952	370	3"	3"	345
VARIO3-30 PVM 20-7 F	860	125	1040	1062	370	3"	3"	372
VARIO3-30 PVM 20-10 F	860	125	1040	1387	370	3"	3"	492

# VARIO 3-30 PVM

THREE-PHASE PRESSURE BOOSTER SET WITH THREE VARIABLE SPEED PUMPS

## HYDRAULIC PERFORMANCE

---

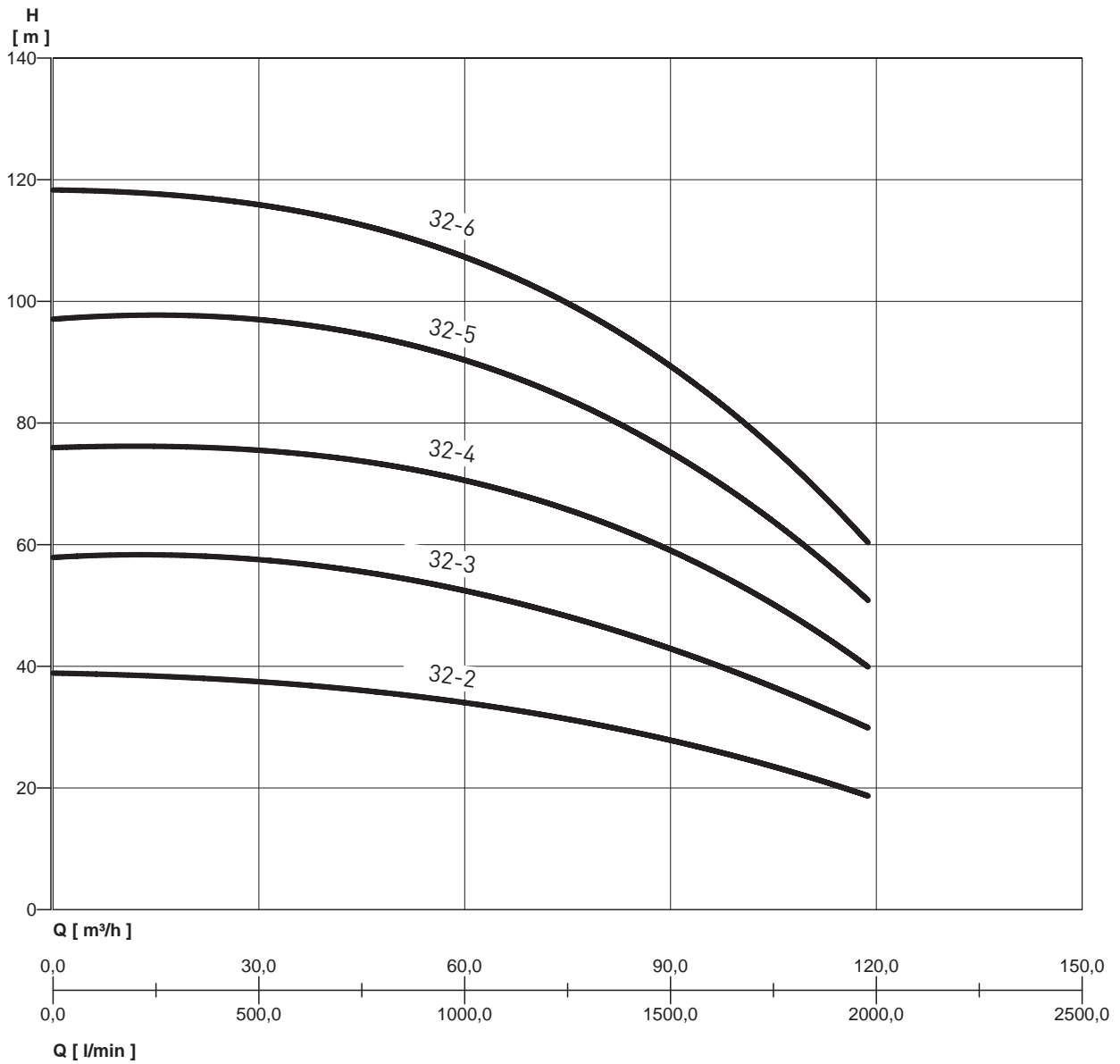

# VARIO 3-30 PVM

THREE-PHASE PRESSURE BOOSTER SET WITH THREE VARIABLE SPEED PUMPS

## PERFORMANCE TABLE

MODEL	P2	VOLT. (V)	In (A)	Q	m.c.w.								
	kW				l/min	0	300	600	900	1200	1500	1800	1980
					m <sup>3</sup> /h	0	18	36	54	72	90	108	118,8
VARIO3-30 PVM 32-2 F	3x4	3 ~ 400	3x7,1			39	38	37	35	32	28	22	19
VARIO3-30 PVM 32-3 F	3x5,5	3 ~ 400	3x10,7			58	58	57	54	49	43	35	30
VARIO3-30 PVM 32-4 F	3x7,5	3 ~ 400	3x14,3			76	76	75	72	67	59	48	40
VARIO3-30 PVM 32-5 F	3x11	3 ~ 400	3x17,8			97	98	96	92	86	75	61	51
VARIO3-30 PVM 32-6 F	3x11	3 ~ 400	3x21,4			118	118	115	109	101	90	73	60

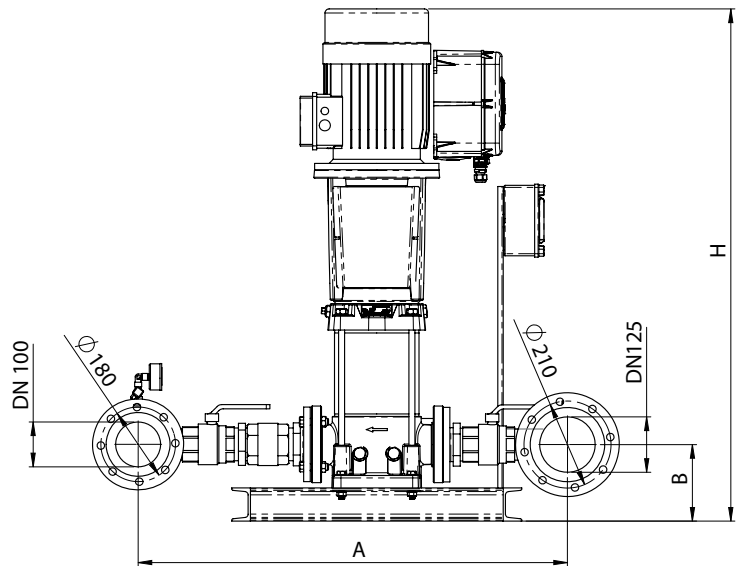
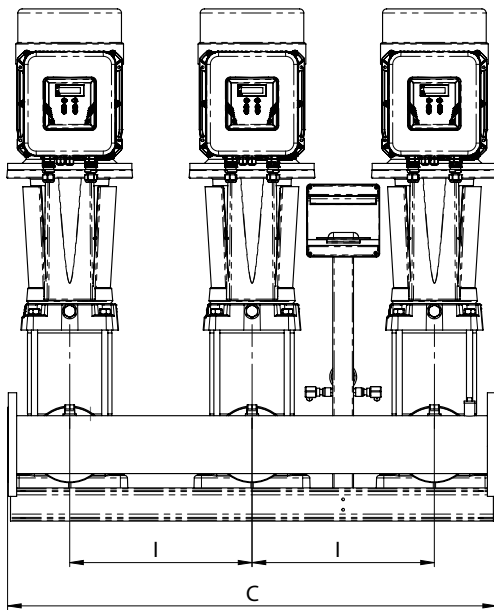

## OVERALL DIMENSIONS AND WEIGHTS

MODEL	Dimensions mm.							WEIGHT Kg
	A	B	C	H	I	DNA	DNM	
VARIO3-30 PVM 32-2 F	1040	185	1180	982	440	4"	3"	418
VARIO3-30 PVM 32-3 F	1040	185	1180	1089	440	4"	3"	485
VARIO3-30 PVM 32-4 F	1040	185	1180	1179	440	4"	3"	515
VARIO3-30 PVM 32-5 F	1040	185	1180	1472	440	4"	3"	644
VARIO3-30 PVM 32-6 F	1040	185	1180	1542	440	4"	3"	656

# PRESSURE BOOSTER SETS

## HOW TO CHOOSE A PRESSURE BOOSTER SET

The essential things you need to know to choose a pressure booster set are: the water flow required at the time of maximum use, the total head of the pressure gauge.

The flow rate required can be observed in the average statistical value diagram below (Fig. n.1).

The calculation of the total head of the pressure gauge (corresponding to the minimum operating pressure of the unit) provides for three different cases: supply from storage facilities situated at the same level of the unit (A), supply from an aqueduct situated above the unit (B),

supply from a well situated below the unit (C).

Case (A): add the maximum height of the collection point to the pressure value required in that point plus any pressure drops. (see example Fig. n. 2)

Case (B): proceed as with case A, then deduct the value of the pressure of the aqueduct or the pressure developed during the descent from the storage tank. (see example Fig. n. 3)

Case (C): proceed as with case A, then add the value in metres between the water level and the unit. (See Fig. n. 4). The data obtained, compared with the tables with the features of the

various autoclaveboosters shown in the catalogue will allow to choose the most suitable unit. Bear in mind that these tables consider a minimum pressure at the highest valve of 1.5 ATM.

They provide general information as it is not possible to consider the various particular conditions of use.

Fig. 1

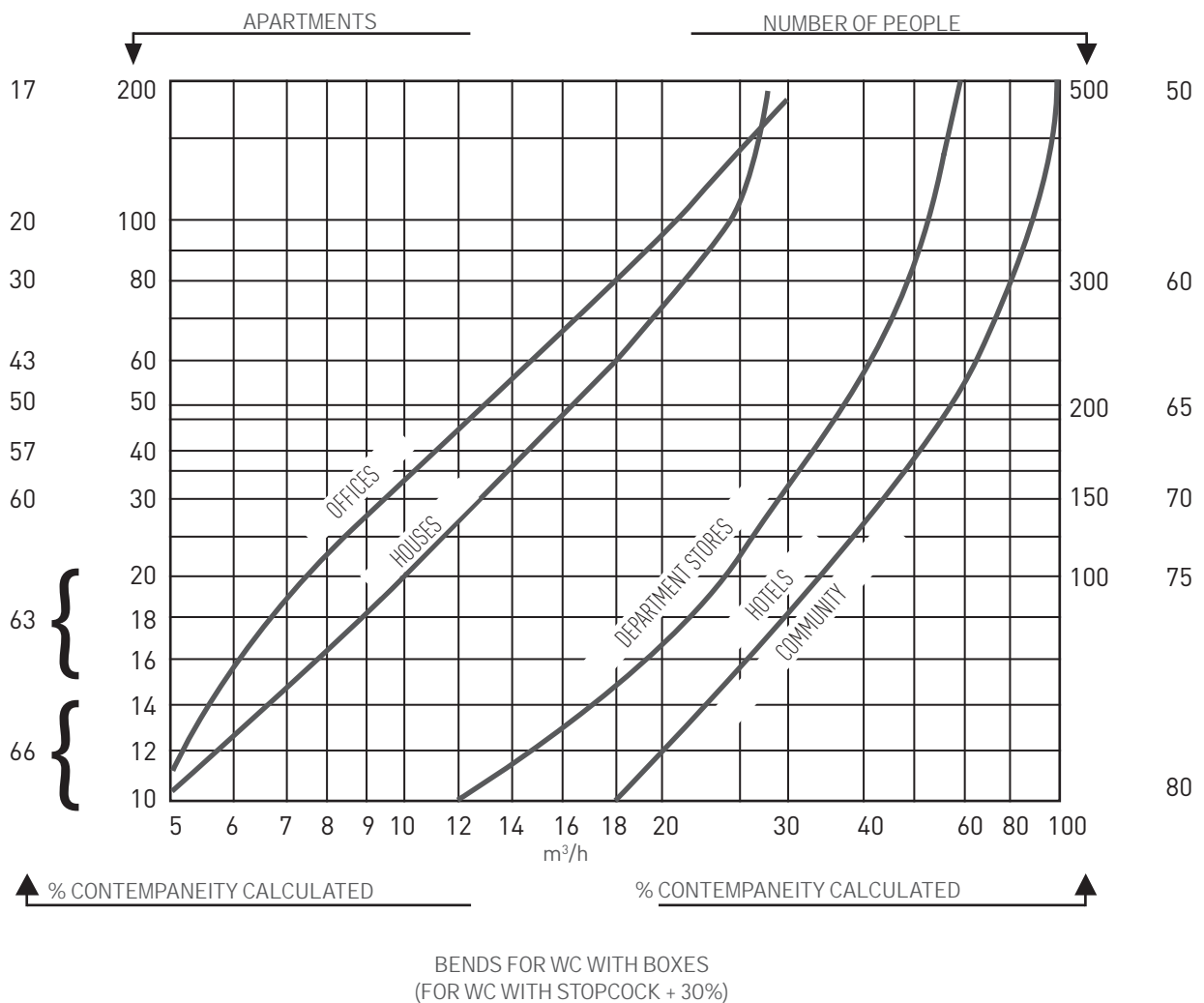



# PRESSURE BOOSTER SETS

## HOW TO CHOOSE A PRESSURE BOOSTER SET

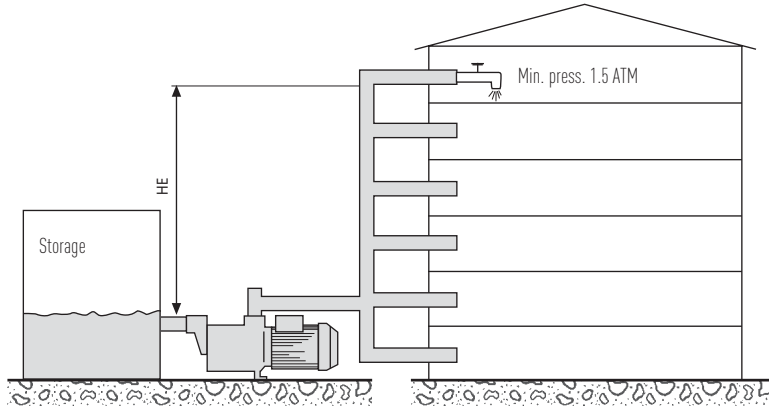

HE = Height of building 18 m.

Fig. 2

CASE A

H building	18 +	
Minimum pressure	15 +	
Pressure drops	2 =	<u>          </u>
		35 Metres

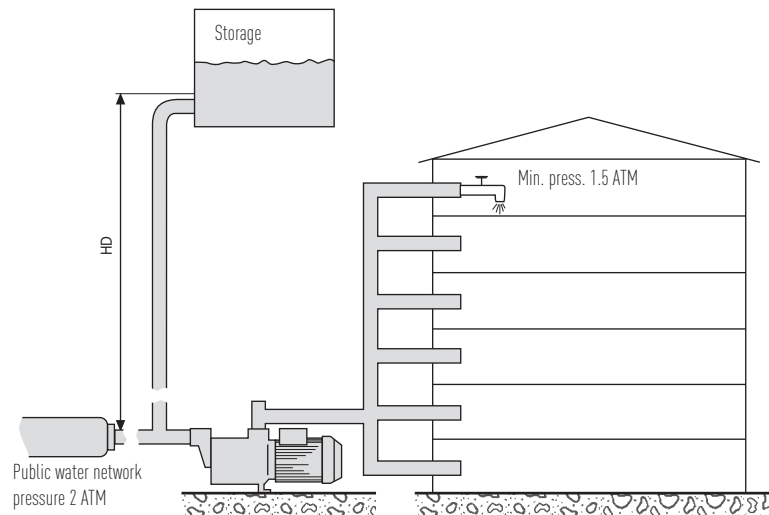

HD = Height of storage 20 m.

Fig. 3

CASE B

Required head	35 -	
Aqueduct pressure		<u>20 =</u>
		15 Metres
Metres	35 -	
II tank	20 =	<u>          </u>
		15 Metres

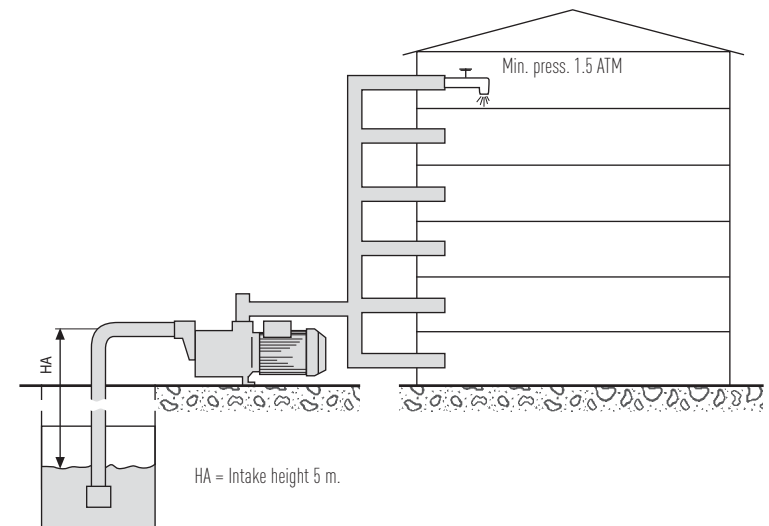

HA = Intake height 5 m.

Fig. 4

CASE C

Required head	35 +	
Intake height		<u>5 =</u>
		40 Metres

# PRESSURE BOOSTER SETS

## HOW TO CHOOSE A PRESSURE BOOSTER SET

### PRESSURE DROP AND WATER SPEED TABLE

CAPACITY			GALVANIZED PIPING - NEW											
			NOMINAL DIAMETERS IN INCHES AND MILLIMETRES											
m <sup>3</sup> /h	l/min.	l/sec.	1/2" 15.75	3/4" 21.25	1" 27.00	1 1/4" 35.75	1 1/2" 41.25	2" 52.50	2 1/2" 68.00	3" 80.25	3 1/2" 92.50	4" 105.00	5" 130.00	6" 155.50
0.6	10	0.16	0.855 9.910	0.470 2.407	0.292 0.784									
0.9	15	0.25	1.282 20.11	0.705 4.862	0.438 1.570	0.249 0.416								
1.2	20	0.33	1.710 33.53	0.940 8.035	0.584 2.588	0.331 0.677	0.249 0.346							
1.5	25	0.42	2.138 49.93	1.174 11.91	0.730 3.834	0.415 1.004	0.312 0.510							
1.8	30	0.50	2.565 69.34	1.409 16.50	0.876 5.277	0.498 1.379	0.374 0.700	0.231 0.223						
2.1	35	0.58	2.993 91.54	1.644 21.75	1.022 6.949	0.581 1.811	0.436 0.914	0.269 0.291						
2.4	40	0.67		1.879 27.66	1.168 8.820	0.664 2.290	0.499 1.1160	0.308 0.368						
3.0	50	0.83		2.349 41.40	1.460 13.14	0.830 3.403	0.623 1.719	0.385 0.544	0.229 0.159					
3.6	60	1.00		2.819 57.74	1.751 18.28	0.996 4.718	0.748 2.375	0.462 0.751	0.275 0.218					
4.2	70	1.12		3.288 76.49	2.043 24.18	1.162 6.231	0.873 3.132	0.539 0.988	0.321 0.287	0.231 0.131				
4.8	80	1.33			2.335 30.87	1.328 7.940	0.997 3.988	0.616 1.254	0.376 0.363	0.263 0.164				
5.4	90	1.50			2.627 38.30	1.494 9.828	1.122 4.927	0.693 1.551	0.413 0.449	0.296 0.203				
6.0	100	1.67			2.919 46.49	1.660 11.90	1.247 5.972	0.770 1.875	0.459 0.542	0.329 0.244	0.248 0.124			
7.5	125	2.08			3.649 70.41	2.075 17.93	1.558 8.967	0.962 2.802	0.574 0.809	0.412 0.365	0.310 0.185	0.241 0.101		
9.0	150	2.50				2.490 25.11	1.870 12.53	1.154 3.903	0.688 1.124	0.494 0.506	0.372 0.256	0.289 0.140		
10.5	175	2.92				2.904 33.32	2.182 16.66	1.347 5.179	0.803 1.488	0.576 0.670	0.434 0.338	0.337 0.184		
12	200	3.33				3.319 42.75	2.493 21.36	1.539 6.624	0.918 1.901	0.659 0.855	0.496 0.431	0.385 0.234	0.251 0.084	
15	250	4.17				4.149 64.86	3.117 32.32	1.924 10.03	1.147 2.860	0.823 1.282	0.620 0.646	0.481 0.350	0.314 0.126	
18	300	5.00					3.740 45.52	2.309 14.04	1.377 4.009	0.988 1.792	0.744 0.903	0.577 0.488	0.377 0.175	0.263 0.074
24	400	6.67					4.987 78.17	3.078 24.04	1.836 6.828	1.317 3.053	0.992 1.530	0.770 0.829	0.502 0.294	0.351 0.124
30	500	8.33						3.848 36.71	2.295 10.40	1.647 4.622	1.240 2.315	0.962 1.254	0.628 0.445	0.439 0.187
36	600	10.0						4.618 51.84	2.753 14.62	1.976 6.505	1.488 3.261	1.155 1.757	0.753 0.623	0.526 0.260
42	700	11.7							3.212 19.52	2.306 8.693	1.736 4.356	1.347 2.345	0.879 0.831	0.614 0.347
48	800	13.3							3.671 25.20	2.635 11.18	1.984 5.582	1.540 3.009	1.005 1.066	0.702 0.445
54	900	15.0							4.130 31.51	2.964 13.97	2.232 6.983	1.732 3.762	1.130 1.328	0.790 0.555

Large numbers: Pressure drops in m per 100m of piping  
Small numbers: Water speed in m. / second

N.B.: - To assess the pressure drops in piping made of different materials, the value relating to the galvanized pipe must be multiplied by the following coefficients:

- 0.6 for PVC pipes
- 0.7 for aluminium pipes
- 0.8 for rolled steel pipes
- 1.3 for fiber cement pipes

# PRESSURE BOOSTER SETS

## HOW TO CHOOSE A PRESSURE BOOSTER SET

CAPACITY			GALVANIZED PIPING - NEW											
			NOMINAL DIAMETERS IN INCHES AND MILLIMETRES											
m <sup>3</sup> /h	lt./min.	lt./sec.	1/2"	3/4"	1"	1 1/4"	1 1/2"	2"	2 1/2"	3"	3 1/2"	4"	5"	6"
60	1000	16.7	15.75	21.25	27.00	35.75	41.25	52.50	68.00	80.25	92.50	105.00	130.00	155.50
									4.589 38.43	3.294 17.06	2.480 8.521	1.925 4.595	1.256 1.616	0.877 0.674
75	1250	20.8								4.117 26.10	3.100 13.00	2.406 7.010	1.570 2.458	1.097 1.027
90	1500	25.0								4.941 36.97	3.720 18.42	2.887 9.892	2.197 3.458	1.316 1.444
105	1750	29.2									4.340 24.76	3.368 13.30	2.511 4.665	1.535 1.934
120	2000	33.3									4.960 31.94	3.850 17.16	3.139 5.995	1.754 2.496
150	2500	41.7										4.812 26.26	3.767 9.216	2.193 3.807
180	3000	50.0											5.023 13.05	2.632 5.417
240	4000	66.7											22.72	3.509 8.926
300	5000	83.3												4.386 14.42

N.B.: - To assess the pressure drops in piping made of different materials, the value relating to the galvanized pipe must be multiplied by the following coefficients:

0.6 for PVC pipes

0.7 for aluminium pipes

0.8 for rolled steel pipes

1.3 for fiber cement pipes

# SECTION 5

## ACCESSORIES



**VSD**  
ELECTRONIC FREQUENCY CONVERTER

PAG. 307



**PRESSURE TANKS**

PAG. 318



**FLUSSCONTROL**  
ELECTRONIC PRESSURE REGULATOR FOR  
SINGLE-PHASE PUMPS

PAG. 311



**ACCESSORIES**  
ACCESSORIES AND FILTERS

PAG. 320



**CONTROL PANELS**

PAG. 312

## VSD ELECTRONIC FREQUENCY CONVERTER

**VSD (Variable Speed Drive)** is a static frequency converter that controls the speed of an electric pump to maintain constant pressure even when water demand changes. This regulation is possible through a pressure sensor and a flow sensor connected to the inverter. The advantages obtained from the installation of VSD are:

- Energy savings
- Constant output pressure with an increase of comfort for the final user
- Silent operation

### VERSIONS

- **VSD Easy** controls a single-phase or three-phase pump, it is easy to install and set, it is only necessary to select the pressure set-point. The supply VOLT. of the device is single-phase 230V.
- **VSD** controls a three-phase pump and it is able to communicate with another hydraulic device thanks to the installation of a communication cable. The supply VOLT. can be single phase 230V or three-phase 400V depending on the model.

### OPERATING FEATURES

- Inverter to manage a pump
- Frequency of use Hz: 50/60
- Protection index: IP55
- Maximum water temperature °C: 40
- Maximum ambient temperature °C: 50
- ART System (Automatic Reset Test): after the device has been turned off after the intervention of the protection system against dry running, the ART system will attempt to restore the water supply, by means of scheduled restarts.
- Automatic reset system after the accidental interruption of the power supply. The device maintains the configuration present before it stopped.
- Inner pressure transducer
- Inner current sensor
- Inner flow sensor
- Control panel with LCD display
- Operation control register: possibility to track the hours of operation, the number of start-ups and the connection to the power network.
- Alarm register: the number and all the types of alarm generated in the device.

### SAFETY AND PROTECTION SYSTEMS

- Control and safety system against dry-running
- Control and safety system against over-current
- Control and safety system against short-circuit between output phases
- Control and safety system against overvoltage or undervoltage



### FEATURES ONLY RELATED TO THE VSD M/T AND T/T MODELS

- They can be mounted together with another identical device using a MASTER-SLAVE operating system. The device configured as MASTER is the controller. The operation is alternating or parallel.
- Free contact to monitor the alarms displayed, generated by irregularities or system problems.
- Additional contact for the detection of the minimum water level in the intake tank; its use is optional and independent of the protection system against dry running.

# VSD

## ELECTRONIC FREQUENCY CONVERTER

### TECHNICAL SPECIFICATIONS

MODEL	Supply VOLT. (V)	Pump supply (V)	Maximum current of pump (A)	Interface for use in parallel	Adjustable pressure (bar)	Maximum operating pressure (bar)	Maximum capacity (m <sup>3</sup> /h)
VSD EASY 9 M/M	1-230	1-230	9	NO	1-8	16	10
VSD EASY 6 M/T	1-230	3-230	6	NO	1-8	16	10
VSD EASY 10 M/T	1-230	3-230	10	NO	1-8	16	10
VSD 6 M/T	1-230	3-230	6	YES	0,5-12	16	10
VSD 10 M/T	1-230	3-230	10	YES	0,5-12	16	10
VSD 9 T/T	3-400	3-400	9	YES	0,5-12	16	15
VSD 14 T/T	3-400	3-400	14	YES	0,5-12	16	25

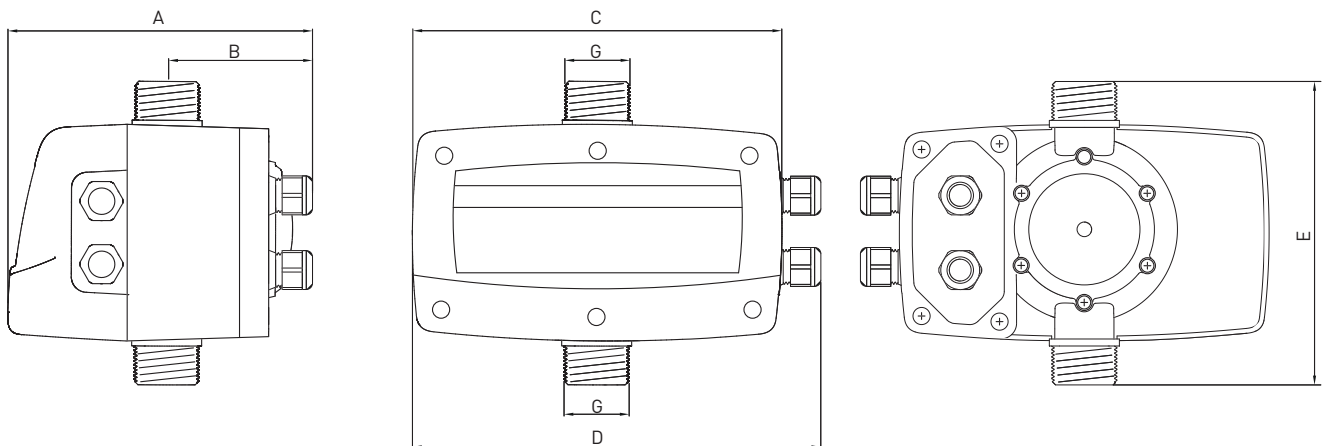

### OVERALL DIMENSIONS AND WEIGHTS

MODEL	Dimensions (mm)						WEIGHT (Kg)
	A	B	C	D	E	G	
VSD EASY 9 M/M	196	93	237	262	196	1" 1/4	2,5
VSD EASY 6 M/T	196	93	237	262	196	1" 1/4	2,5
VSD EASY 10 M/T	196	93	237	262	196	1" 1/4	2,5
VSD 6 M/T	196	93	237	262	196	1" 1/4	2,7
VSD 10 M/T	196	93	237	262	196	1" 1/4	2,7

# VSD

## ELECTRONIC FREQUENCY CONVERTER

### OVERALL DIMENSIONS AND WEIGHTS

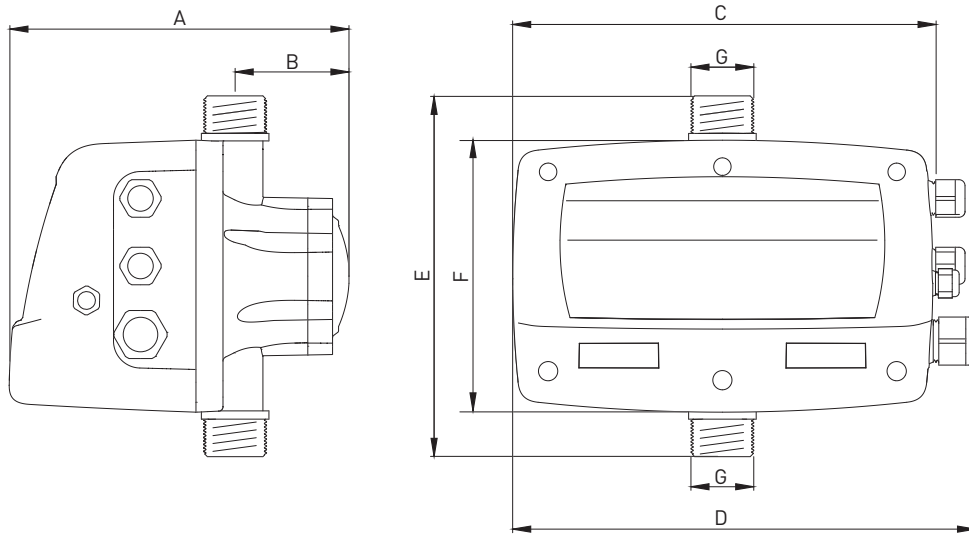

MODEL	Dimensions (mm)							WEIGHTS (Kg)
	A	B	C	D	E	F	G	
VSD 9 T/T	226	76	280	~310	240	181	1" 1/4	4.3

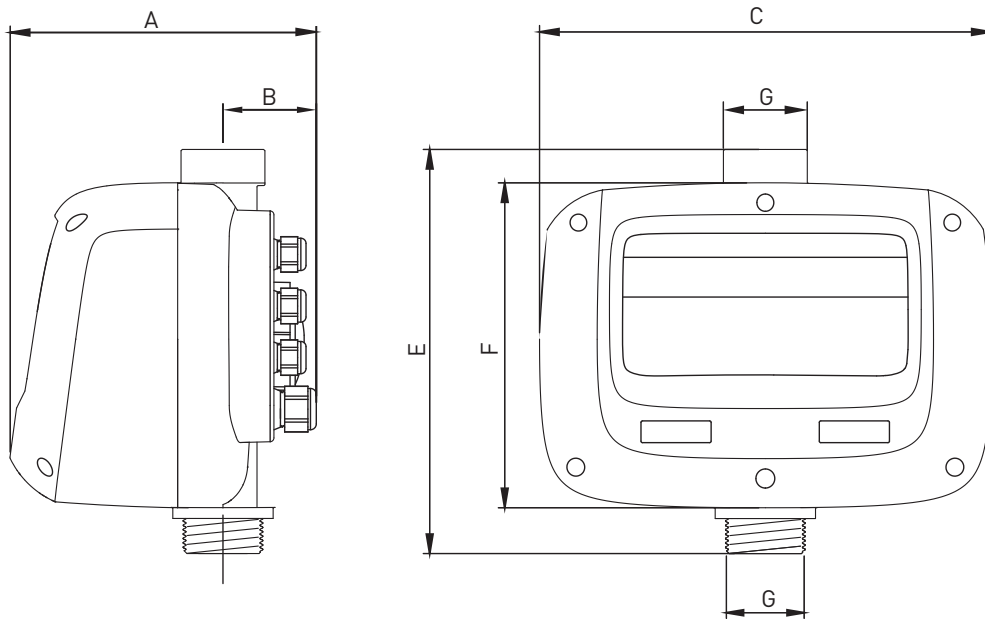

MODEL	Dimensions (mm)						WEIGHTS (Kg)
	A	B	C	E	F	G	
VSD 14 T/T	238	72	350	313	252	2"	6.1

# VSD

## ELECTRONIC FREQUENCY CONVERTER

### INSTALLATION

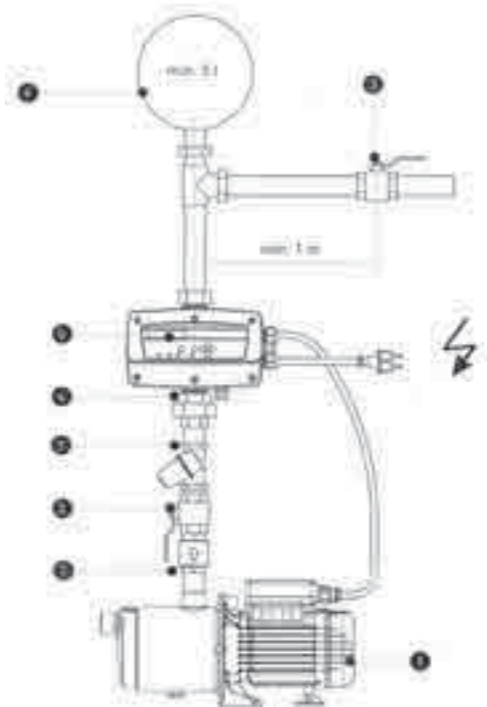

**REMARKS:**

A) The accessories 3, 4 and 7 are recommended but not essential.  
 B) In the case of pressure tank 6, it is advisable to use it in installations where water hammers should be avoided.

- 1 - Pump
- 2 - Non-return valve
- 3 - Ball valve
- 4 - Rapid elbow joint
- 5 - VSD
- 6 - Pressure tank
- 7 - Filter

### COMPATIBLE PUMPS

MODELS	VSD EASY 9 M/M	VSD EASY 6 M/T	VSD EASY 10 M/T	VSD 6 M/T	VSD 10 M/T	VSD 9 T/T	VSD 14 T/T
PRATIKA	•						
DOMINATOR 4	•						
DOMINATOR 5	•	•		•		•	
SCM4 PLUS	•	•		•		•	•
MULTINOX VE+	•	•	•	•	•	•	
DHR	•	•	•	•	•	•	•
JET / JETINOX	•	•		•			
MULTI EVO	•	•	•	•	•	•	
PVM/PVMI/PVMX	•	•	•	•	•	•	•

Choose the correct pump depending on the current and power. In the event of an extension of the power cable for the motor output, connect it to some network filters to be positioned near the VSD to make sure that the electromagnetic emission standards are met.



## FLUSSCONTROL

### ELECTRONIC PRESSURE REGULATOR FOR SINGLE-PHASE PUMPS

This device starts and stops the pump when the valve is opened and closed. In the event of no intake flow, the electronic system will block the pump protecting it from dry running.

Once the causes that led the pump to be blocked have been overcome, simply press the red Restart (reset) button to restore normal operation. In the event of a temporary power failure, the unit will reset automatically once powered again.

#### ADVANTAGES

- Reduces the effects of water hammer.
- Replaces the traditional system of the expansion module
- Requires no maintenance
- Protection in case of a lack of water
- Very easy to install
- Keeps the pressure constant during distribution



#### APPLICATIONS

- To start and stop single-phase surface or submersed pumps.
- Keeps the pressure constant during distribution
- Starts and stops the pump in function of the opening and closing the valve.

#### TECHNICAL SPECIFICATIONS

Description	Flusscontrol	Flusscontrol basic
Electrical supply	230 V single-phase	230 V single-phase
Maximum current	16 (8) A	16 (6) A
Maximum nominal power of the pump	1.5 kW (2 HP)	1.1 kW
Frequency	50-60 Hz	50-60 Hz
Degree of protection	IP 65	IP 65
Pressure drops with 6 m <sup>3</sup> /h capacity	0.95 bar	1.1 bar
Maximum pressure	10 bar	8 bar
Maximum temperature of the liquid	65° C	60° C
Maximum ambient temperature	40° C	40° C
WEIGHTS	1.07 Kg	0.8 Kg

## QES PLUS

### SINGLE PHASE ELECTRICAL PANEL TO CONTROL A SUBMERSED PUMP WITH DIRECT START

#### MAIN COMPONENTS

- Plastic casing IP 55
- Switch with circuit breaker
- Motorprotector with reset button
- Starting capacitor
- Terminal board
- Cable gland

#### OPERATION

- Manual via main switch
- Automatic via external remote control (pressure switch, float, etc...)

#### OPTIONAL ACCESSORIES

- Floats or Pressure switches (see table)

#### TECHNICAL SPECIFICATIONS

- Degree of protection: IP 55
- Power supply voltage: 230V/ 1F 50 Hz
- External dimensions: 115 - 185 - 65 mm
- Weight: Kg 0.6

#### LIMITS

- Ambient temperature: -5 / +40 °C
- Relative humidity: 50% at 40°C with no condensation.
- Reference standards: EN 60335-1 - EN 60439-1



MODEL	VOLT. (V)	Absorbed power (P1)		Field of application A	µF	COMPATIBLE PUMPS
		min kW	max kW			
QES PLUS 10/37 M	230 1F	0.37	0.55	4	16	
QES PLUS 10/55 M	230 1F	0.55	0.75	6	20	
QES PLUS 10/75 M	230 1F	0.75	1	7	30	SCM 4" PLUS
QES PLUS 10/75 M	230 1F	0.75	1	7	35	SCM 4 HF
QES PLUS 10/110 M	230 1F	1.1	1.5	9	40	4" MOTORS
QES PLUS 10/150 M	230 1F	1.5	2	12	50	

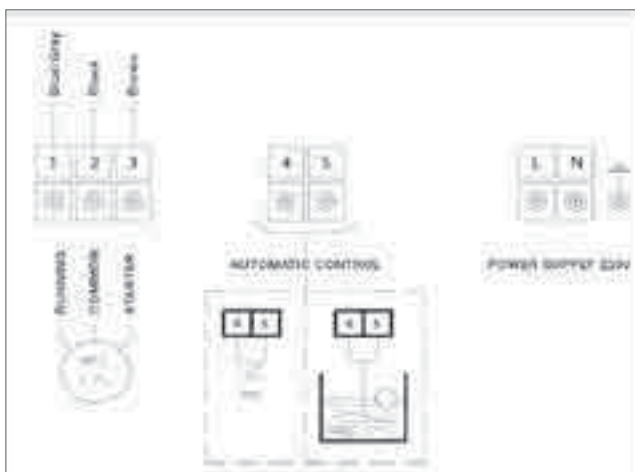

## EASYCONTROLLER

### EASYCONTROLLER M10/M20 SINGLE PHASE AND EASYCONTROLLER D10/D20 THREE PHASE STARTERS FOR THE CONTROL OF 1 OR 2 SURFACE PUMPS OR DRAINAGE PUMPS

EASYCONTROLLER control panels are indicated for residential and industrial applications and they control single and three phase electric pumps installed as:

1 or 2 surface pumps or boosters for pressurizing

1 or 2 drainage pumps or boosters for sewage

MODEL	MAIN COMPONENTS	USAGE LIMITATIONS AND TECHNICAL FEATURES
<p>EASYCONTROLLER M10 / M20</p> 	<ul style="list-style-type: none"> <li>• Plastic casing IP6X</li> <li>• Electronic board for control and protection</li> <li>• External control to select pressure switch or float switch use</li> <li>• Fuses holder for 1 or 2 pumps</li> <li>• Cable gland</li> <li>• Manual through MAN or AUT button</li> <li>• LED indicating line</li> <li>• Led electric fault (overload)</li> <li>• Led hydraulic fault</li> <li>• LED indicating pump in operation</li> </ul>	<ul style="list-style-type: none"> <li>• Ambient temperature: -5 / +50 °C</li> <li>• Relative humidity: 50% at 40°C with no condensation</li> <li>• Reference standards: EN 60730, EN 61439, EN61000</li> <li>• Degree of protection: IP6x</li> <li>• Power supply voltage: 220V/240V 1F 50 Hz</li> </ul>
<p>EASYCONTROLLER D10 / D20</p> 	<ul style="list-style-type: none"> <li>• Metal box IP54</li> <li>• Main switch</li> <li>• Fuse-holder with fuses for the auxiliary circuit</li> <li>• Contactor with motor protective relay</li> <li>• Transformer for the auxiliary circuit</li> <li>• Terminal board for the level control devices</li> <li>• Cable gland</li> <li>• Manual through MAN or AUT button</li> <li>• Led indicating line</li> <li>• Led electric fault (overload)</li> <li>• Led hydraulic fault</li> <li>• Led indicating pump in operation</li> </ul>	<ul style="list-style-type: none"> <li>• Ambient temperature: -5 / +50 °C</li> <li>• Relative humidity: 50% at 40°C with no condensation</li> <li>• Reference standards: EN 60730, EN 61439, EN61000</li> <li>• Degree of protection: IP54</li> <li>• Power supply voltage: 400V 3F 50 Hz</li> </ul>
<p><b>EASYCONTROLLER M10/D10</b></p>	<p>Control box for 1 pump equipped with electronic board for signal and control</p>	<p>Manual operation via MAN or AUT button</p>
<p><b>EASYCONTROLLER M20/D20</b></p>	<p>Control box for 2 pumps equipped with electronic board for signal and control and cycling operation</p>	<p>Automatic operation through external device</p>

# EASYCONTROLLER

EASYCONTROLLER M10/D10 SINGLE PHASE FOR THE CONTROL OF 1 SURFACE OR DRAINAGE PUMP

## PERFORMANCES DIMENSIONS AND WEIGHTS

CODE	MODEL	VOLT (V)	P2		APPLICATION FIELD A		DIMENSIONS L x W x H mm	WEIGHT kg	ACCESSORIES
			kW	Hp	min	max			
UZQ14010	EASYCONTROLLER M10-240	1x230 1F	2,4	3,2	1	13	170 x 100 x 200	1,2	
UZQ14080	EASYCONTROLLER D10-110	3x230 3F	0,5	0,7	1,6	2,5	250 x 150 x 335	6,9	
		3x400 3F	1,1	1,5			250 x 150 x 335		
UZQ14090	EASYCONTROLLER D10-150	3x230 3F	1	1,3	2,5	4	250 x 150 x 335	6,9	UZA00200 optical and acoustic alarm CE040030 Fixing fins
		3x400 3F	1,5	2			250 x 150 x 335		
UZQ14100	EASYCONTROLLER D10-220	3x230 3F	1,5	2	4	6,3	250 x 150 x 335	6,9	
		3x400 3F	2,2	2,9			250 x 150 x 335		
UZQ14110	EASYCONTROLLER D10/110-400	3x230 3F	2,4	3,2	6,3	10	250 x 150 x 335	6,9	
		3x400 3F	4	5,5			250 x 150 x 335		
UZQ14210	EASYCONTROLLER D10/750	3x230 3F	4	5,5	10	16	250 x 150 x 335	6,9	
		3x400 3F	7,5	11			250 x 150 x 335		

## CONNECTIONS

### M10

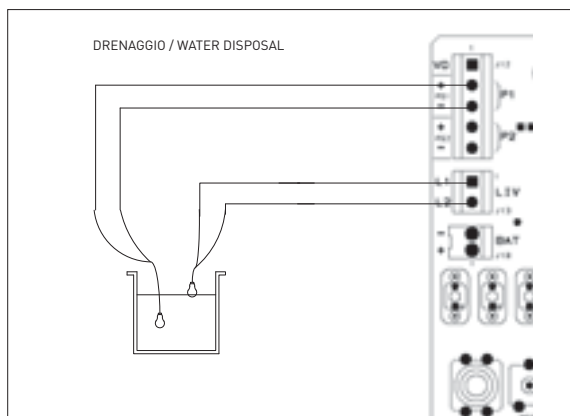
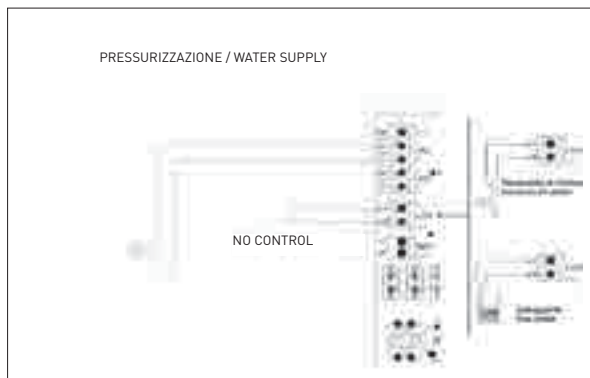
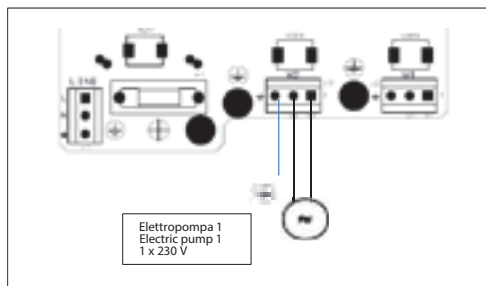

### D10

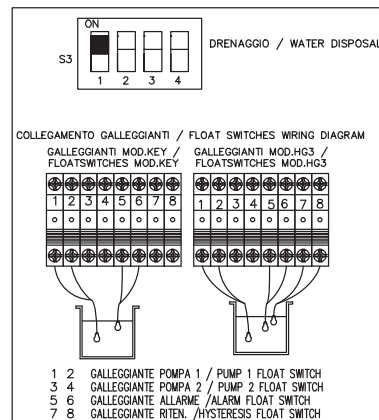
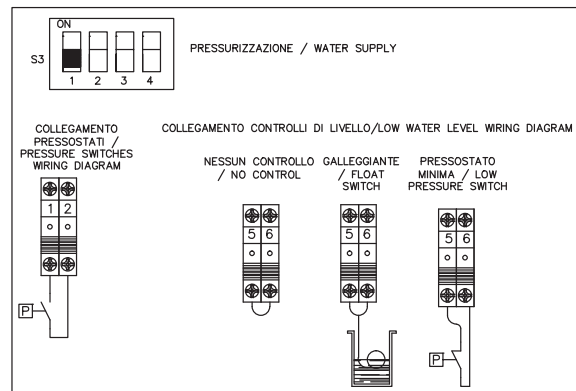
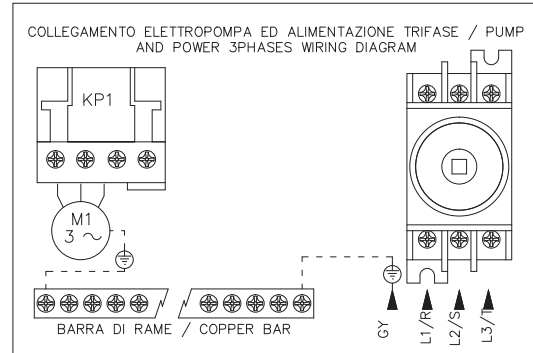

# EASYCONTROLLER

EASYCONTROLLER M10/D10 SINGLE PHASE FOR THE CONTROL OF 1 SURFACE OR DRAINAGE PUMP

## PERFORMANCES DIMENSIONS AND WEIGHTS

CODE	MODEL	VOLT (V)	P2		APPLICATION FIELD A		DIMENSIONS L x W x H mm	WEIGHT kg	ACCESSORIES
			kW	Hp	min	max			
UZQ14020	EASYCONTROLLER M20-240	1x230 1F	2x2,4	2x3,2	1	13	170 x 100 x 200	1,2	
UZQ14150	EASYCONTROLLER D20-110	3x230 3F	2x0,5	2x0,7	1,6	2,5	250 x 150 x 335	6,9	
		3x400 3F	2x1,1	2x1,5			250 x 150 x 335		
UZQ14140	EASYCONTROLLER D20-150	3x230 3F	2x1	2x1,3	2,5	4	250 x 150 x 335	6,9	UZA00200 optical and acoustic alarm CE040030 Fixing fins Float switches (see specific table)
		3x400 3F	2x1,5	2x2			250 x 150 x 335		
UZQ14130	EASYCONTROLLER D20-220	3x230 3F	2x1,5	2x2	4	6,3	250 x 150 x 335	6,9	
		3x400 3F	2x2,2	2x2,9			250 x 150 x 335		
UZQ14120	EASYCONTROLLER D20-400	3x230 3F	2x2,4	2x3,2	6,3	10	250 x 150 x 335	6,9	
		3x400 3F	2x4	2x5,5			250 x 150 x 335		
UZQ14220	EASYCONTROLLER D20-750	3x230 3F	2x4	2x5,5	10	16	320 x 230 x 450	9,7	
		3x400 3F	2x7,5	2x11			320 x 230 x 450		

## CONNECTIONS

### M20

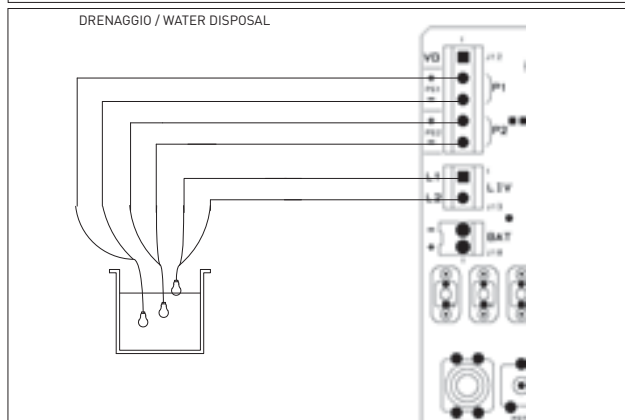
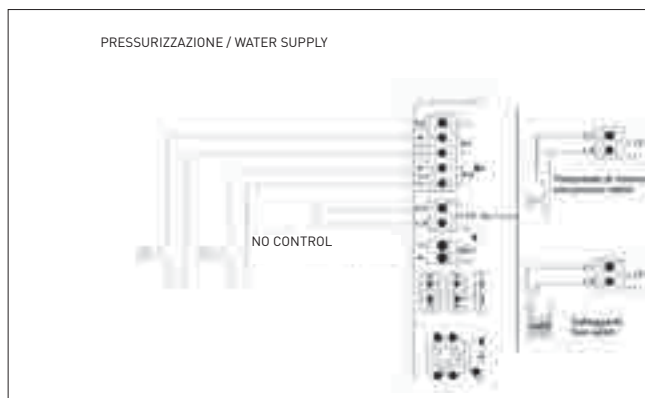
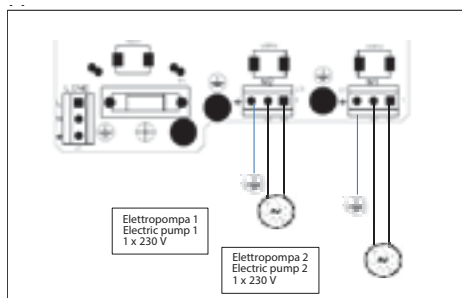

### D20

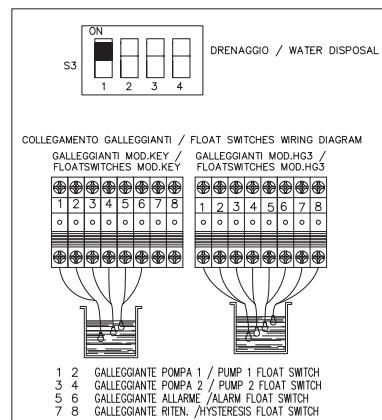
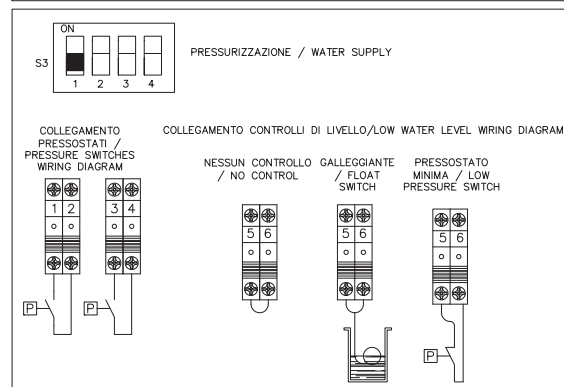
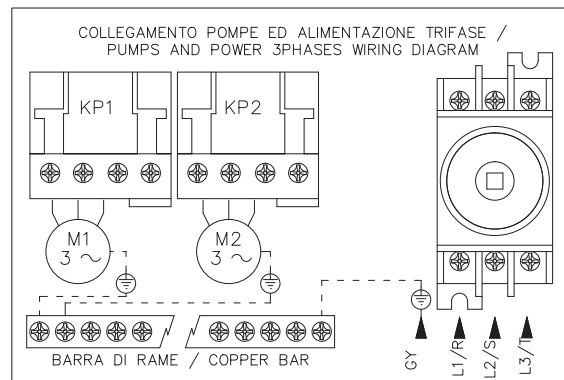

# ADRY

## THREE-PHASE ELECTRICAL PANELS TO CONTROL ONE OR TWO DRAINAGE AND SEWAGE PUMPS WITH STAR-DELTA START-UP

### MAIN COMPONENTS

- Metal box IP54
- Main switch
- Fuse-holder with fuses for pump
- Fuse-holder with fuses for the auxiliary circuit
- Contactor with thermal relay
- Transformer for the auxiliary circuit
- Terminal board for the level control devices
- Cable gland
- Electronic board indicating Volt/Amp
- LED for thermal lock
- LED indicating pump in operation
- LED indicating line

### TECHNICAL SPECIFICATIONS

- Degree of protection: IP54
- Power supply voltage: 400V 3F 50 Hz
- External dimensions: 500 - 750 - 250 mm

### OPERATION

- Manual via MAN or AUT switch
- Automatic via float switch

### LIMITS

- Ambient temperature: -5 / +40 °C
- Relative humidity: 50% at 40°C with no condensation.
- Reference standards: EN 60730 - EN 60439

### ADRY 20

- Electronic warning and control device with start-up sequence inverter
- Electrical panel controlling two pumps
- Weight: Kg 15 - 85

### ADRY 10

- Electronic board for command and control
- Electrical panel controlling an pump
- Weight: Kg 12 - 60

### OPTIONAL ACCESSORIES

- UZA00200 Optical and acoustic alarm
- CE040020 tabs for wall mounting
- Floats (see table)

MODEL	VOLT. (V)	Absorbed power (P1)		Field of application A		COMPATIBLE PUMPS
		kW	Hp	min	max	
Q.E. ADRY10/900	400 3F	9	12	12.9	19	PUMPS for drain
Q.E. ADRY10/1100	400 3F	11	15	17.2	24.1	
Q.E. ADRY10/1500	400 3F	15	20	22.4	32.8	
Q.E. ADRY10/2200	400 3F	22	30	29.3	44.8	
Q.E. ADRY10/2500	400 3F	25	33.5	37.9	55.2	
Q.E. ADRY20/900	400 3F	2x9	2x12	12.9	19	
Q.E. ADRY20/1100	400 3F	2x11	2x15	17.2	24.1	
Q.E. ADRY20/1500	400 3F	2x15	2x20	22.4	32.8	
Q.E. ADRY20/2200	400 3F	2x22	2x30	29.3	44.8	
Q.E. ADRY20/2500	400 3F	2x25	2x33.5	37.9	55.2	

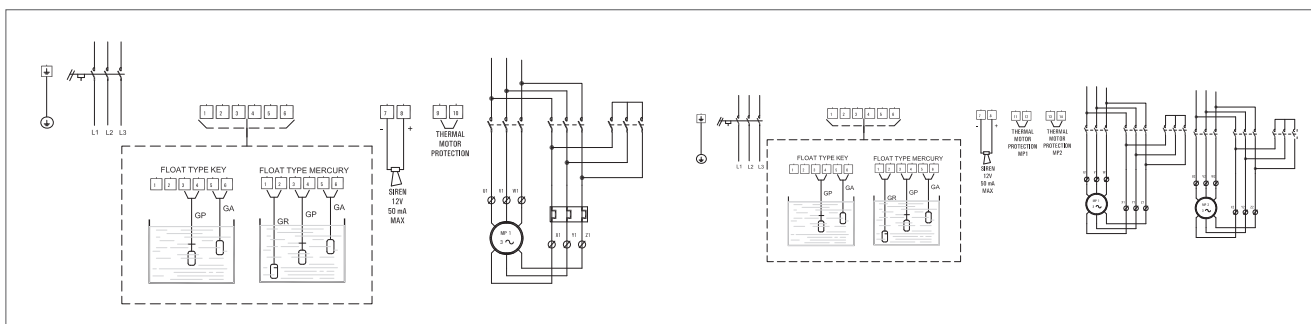

# ACCESSORIES FOR ELECTRICAL PANELS

## LEVEL ADJUSTMENT WITH COUNTERWEIGHTS

Key type level regulator for emptying and filling operations equipped with a 3 m or 10 m cable, suitable for use with clean water or featuring small amounts of suspended solids.



MODEL	ELECTRICAL PANEL
MICROSTART 3-3 Emptying/Filling	QES PLUS - AT
MICROSTART 10-2 Filling	All panels that use external control
MICROSTART 5-2 Filling	All panels that use external control
MICROSTART 10-2 (PVC) Filling	All panels that use external control
MICROSTART 10-3 Emptying/Filling	QES PLUS - AT

## PRESSURE SWITCHES



MODEL	ELECTRICAL PANEL
PN 5 ITL (6 Atm. Max)	QES PLUS -AT
PN 12 ITL (12 Atm. Max)	QES PLUS -AT
PN 6 TEL (6 Atm. Max)	QES PLUS -AT
PN 12 TEL (12 Atm. Max)	QES PLUS -AT

## PRESSURE TANKS

### STAINLESS STEEL

Sta-Rite pressure tanks are made of stainless steel AISI 304 in 7 models with the aim to meet all the requirements of civil and industrial systems and ensure the suitability of the product for use with food. Especially suitable for humid rooms CE certified.

#### HORIZONTAL

Interchangeable bromobutyl membrane with a capacity of 24 litres per membrane, with a bracket to mount the pump and a support foot. Pre-load 1.5 bar.

#### VERTICAL

Interchangeable bromobutyl membrane with a capacity of 8-20-24 litres. The latter also in the solution without membrane and with air supply. Pre-load 1.5 bar.

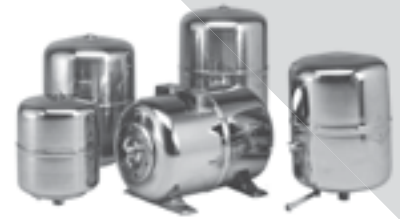

## TECHNICAL SPECIFICATIONS

MODEL	Description	Type membrane	Feet bracket	Maximum operating pressure (bar)	Capacity lt
VES INOX N 8	pressure tanks 8 lt stainless steel vertical	Bromobutyl	-	8	8
VES INOX N 20	pressure tanks 20 lt stainless steel vertical	Bromobutyl	-	8	20
VES INOX N 24	pressure tanks 24 lt stainless steel vertical	Bromobutyl	-	8	24
VES INOX N 24 H	pressure tanks 24 lt stainless steel horizontal	Bromobutyl	yes	8	24
VAA 24	pressure tanks stainless steel 24 lt for air supply	-	-	8	24
-	air supply kit with hose	-	-	-	-



## OVERALL DIMENSIONS AND WEIGHTS

MODEL	Dimensions mm.				WEIGHTS (Kg)
	A	Ø B	C	D	
N 8	280	226	-	1"	2.4
N 20	390	272	-	1"	3.3
N 24	430	272	-	1"	5
N 24 H	430	272	330	1"	4.2
VAA 24	430	272	443	1"	4.2

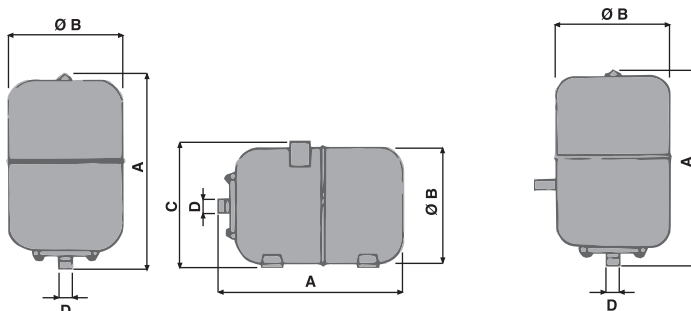



# PRESSURE TANKS

## PAINTED STEEL

### TECHNICAL SPECIFICATIONS

MODEL	Description	Type membrane	Feet bracket	Maximum operating pressure (bar)	Capacity lt
VES 2	pressure tank 2 litres	Rubber for food use	-	6	2
VES 24 V	pressure tank 24 litres vertical	Rubber for food use	-	6	24
VES 24 H	pressure tank 24 litres horizontal	Rubber for food use	yes	6	24
VEC 60 V	pressure tank 60 litres vertical	Butyl rubber	yes	10	60
VEC 100 V	pressure tank 100 litres vertical	Butyl rubber	yes	10	100
VEC 200 V	pressure tank 200 litres vertical	Butyl rubber	yes	10	200
VEC 300 V	pressure tank 300 litres vertical	Butyl rubber	yes	10	300
VEC 500 V	pressure tank 500 litres vertical	Butyl rubber	yes	10	500

Pressure tanks for water lifting systems, in painted steel, from 2 to 500 litres, with interchangeable membrane.

Painted carbon steel flange.

CE certified. Preload: 1.5 bar in models from 2 to 24 lt - 2.0 bar in models from 60 to 500 lt CE Certified.





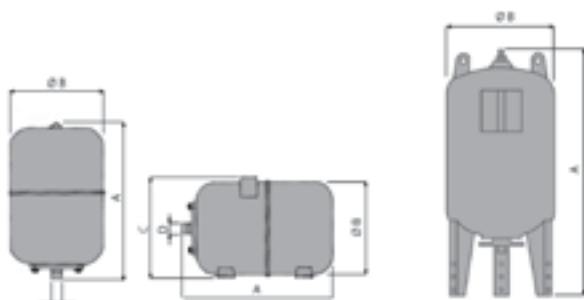

### OVERALL DIMENSIONS AND WEIGHTS

MODEL	Dimensions mm.				WEIGHTS (Kg)
	A	Ø B	C	D	
VES 2	175	155	-	1" M	0.950
VES 24 V	415	295	-	1" M	4.1
VES 24 H	415	-	310	1" M	4.8
VEC 60 V	845	382	-	1" M	17.5
VEC 100 V	950	450	-	1" M	19
VEC 200 V	1225	550	-	1" 1/2 M	37
VEC 300 V	1405	630	-	1" 1/2 M	54
VEC 500 V	1550	780	-	1" 1/2 M	104









# ACCESSORIES AND FILTERS

## ACCESSORIES

	MODEL	ELECTRICAL PANEL
	PM 5 ITAL PM 12 ITAL PTI LP3 ITAL PT 6 TEL PT 12 TEL	PRESSURE SWITCH - 6 ATM MAX - ITALTECNICA PRESSURE SWITCH - 12 ATM MAX - ITALTECNICA PRESSURE SWITCH - REVERSE LP3 - 1/4" F ITALTECNICA PRESSURE SWITCH - 6 ATM MAX - TELEMECANIQUE PRESSURE SWITCH - 12 ATM MAX - TELEMECANIQUE
	MAR 6 MAP 6 MAR 10 MAP 10	PRESSURE GAUGE, RADIAL CONNECTION 6 ATM PRESSURE GAUGE, REAR RADIAL CONNECTION 6 ATM PRESSURE GAUGE, RADIAL CONNECTION 10 ATM PRESSURE GAUGE, REAR RADIAL CONNECTION 10 ATM
	TF 500 TF 600 TF 700 TF 800 GA 12 1/4	HOSE 1" x mm 500 M-F HOSE 1" x mm 600 M-F HOSE 1" x mm 700 M-F HOSE 1" x mm 800 M-F HOSE 1" 1/4 x mm 400 M-F
	R 3 V R 5 V	BRASS FITTING A 3 WAYS 1" BRASS FITTING A 5 WAYS 1"
	MBB MG S 2 MGS 24 MB 60 MB 100 MB 200 MB 300 MB 500	BROMOBUTYL MEMBRANE FOR STAINLESS STEEL PRESSURE TANKS RUBBER MEMBRANE FOR 2 LITRE PRESSURE TANK RUBBER MEMBRANE FOR 24 LITRE PRESSURE TANK BUTYL MEMBRANE FOR 60 LITRE PRESSURE TANK BUTYL MEMBRANE FOR 100 LITRE PRESSURE TANK BUTYL MEMBRANE FOR 200 LITRE PRESSURE TANK BUTYL MEMBRANE FOR 300 LITRE PRESSURE TANK BUTYL MEMBRANE FOR 500 LITRE PRESSURE TANK
	KA4 KA7 NIPPLEX 1" M-M	INTAKE KIT, 4 m 1" WITH BOTTOM VALVE INTAKE KIT, 7 m 1" WITH BOTTOM VALVE MALE FITTING 1" FOR INTAKE KIT
	B1	BASE KIT MOULDED STAINLESS STEEL WITH SCREWS FOR MCX 80-120 AND JETINOX 45-60-70 MAX 80-120

# ACCESSORIES AND FILTERS

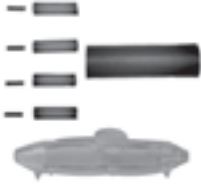
## ACCESSORIES

	MODEL	ELECTRICAL PANEL
	VF 1" VFF 1" VFF 1" 1/4 VF F1" 1/2 VF 2" VAR 1" VAR 1" 1/4 VAR 1" 1/2 VAR 2" RVFF 2"	PLASTIC BOTTOM VALVE 1" BRASS BOTTOM VALVE 1" WITH STAINLESS STEEL FILTER BRASS BOTTOM VALVE 1" 1/4 WITH STAINLESS STEEL FILTER BRASS BOTTOM VALVE 1" 1/2 WITH STAINLESS STEEL FILTER BRASS BOTTOM VALVE 2" WITH STAINLESS STEEL FILTER BRASS NON-RETURN VALVE 1" BRASS NON-RETURN VALVE 1" 1/4 BRASS NON-RETURN VALVE 1" 1/2 BRASS NON-RETURN VALVE 2" BALL VALVE WITH INTEGRAL PASSAGE 2" F
	VRP 1" 1/4 VRP 1" 1/2 VRP 2"	BALL CHECK VALVE STAINLESS STEEL 1" 1/4 F BALL CHECK VALVE STAINLESS STEEL 1" 1/2 F BALL CHECK VALVE STAINLESS STEEL 2" F
	MICROSTART 3-3 MICROSTART 10-3 MICROSTART 5-2 MICROSTART 10-2 MICROSTART S10-2 MICROSTART CP 15-3 CP	FLOAT 3 M. 3 WIRES, FOR EMPTYING/FILLING FLOAT 10 M. 3 WIRES, FOR EMPTYING/FILLING FLOAT 5 M. 2 WIRES, FOR EMPTYING H05 - RNF PVC FLOAT 10 M. 2 WIRES, FOR FILLING FLOAT 10 M. 2 WIRES, WITH PLUG AND SOCKET IN PVC FLOATING CABLE H07-RNF COUNTERWEIGHTS FOR FLOAT
	CABLE 4X1 CABLE 4X1.5 CABLE 4X2.5 CABLE 4X4 CABLE 4X6 CABLE 4X10	NEOPRENE CABLE H07 RNF 4 WIRES, 1 SQ.MM NEOPRENE CABLE H07 RNF 4 WIRES, 1.5 SQ.MM NEOPRENE CABLE H07 RNF 4 WIRES, 2.5 SQ.MM NEOPRENE CABLE H07 RNF 4 WIRES, 4 SQ.MM NEOPRENE CABLE H07 RNF 4 WIRES, 6 SQ.MM NEOPRENE CABLE H07 RNF 4 WIRES, 10 SQ.MM
	JOINT KIT 2.5 JOINT KIT 6 JOINT KIT 10 JOINT 2.5 JOINT 6 JOINT 10	JOINT KIT, HEAT SHRINK, FOR CABLES UP TO 4 X 2.5 JOINT KIT, HEAT SHRINK, FOR CABLES UP TO 4 X 6 JOINT KIT, CASTING RESIN JOINTS FOR CABLES UP TO 4X10 HEAT SHRINK JOINT 1 - 2.5 sq.mm HEAT SHRINK JOINT 4 - 6 sq.mm CASTING RESIN JOINT UP TO 4 X 10 sq.mm
	RCF 30 RCF 40 CRF 50	ELBOW HOSE CONNECTION 1" 1/4 FEMALE ø 30 mm ELBOW HOSE CONNECTION 1" 1/2 FEMALE ø 40 mm ELBOW HOSE CONNECTION 2" FEMALE ø 50 mm

-

FLANGE KIT GH DHR 9

# ACCESSORIES AND FILTERS

## CONTAINER FOR CARTRIDGES

	DESCRIPTION	Min. quantity
	CF 5" 1" CONNECTION	1
	CF 10" 1" CONNECTION	1
	CF 10" 1" 1/4 CONNECTION	1

## FILTER CARTRIDGES

	DESCRIPTION	Nom. filtration µm	Min. quantity
	CARTRIDGE 5" FA (WRAPPED WIRE)	20	20
	CARTRIDGE 7" FA (WRAPPED WIRE) FOR FILTER CONN. 1"	20	20
	CARTRIDGE 7" NY (NYLON MESH) FOR FILTER CONN. 1"	60	20
	CARTRIDGE 10" FA (WRAPPED WIRE) FOR FILTER CONN. 1"	20	20
	CARTRIDGE 10" FA (WRAPPED WIRE) FOR FILTER CONN. 1" 1/4	20	20
	CARTRIDGE 10" NY (NYLON MESH) FOR FILTER CONN. 1"	60	20
	CARTRIDGE 10" NY (NYLON MESH) FOR FILTER CONN. 1" 1/4	60	20
	CARTRIDGE 10" CA (NYLON MESH) + ACTIVE CARBON DIAM. 1	60	20
	CARTRIDGE 10" PL (CRYSTAL POLYPHOSPHATES) DIAM. 11	-	1

# ALPHABETIC INDEX

## A

ACCESSORIES	CABLES AND FITTINGS	180
ACCESSORIES	ACCESSORIES AND FILTERS	320
AUTOJET	PUMPS WITH ELECTRONIC CONTROL AND PROTECTION DEVICE	187

## C

CB	TWO-STAGE HORIZONTAL CENTRIFUGAL PUMPS	98
CM	SINGLE STAGE HORIZONTAL CENTRIFUGAL PUMPS	96
CONTROL PANELS	CONTROL PANELS	312
CPS20	PRESSURE BOOSTER SET WITH TWO VARIABLE SPEED PUMPS	239
CPS10/DHI	PUMP DHI COMPLETE WITH INVERTER	27
CPS10/DHR	PUMP DHR COMPLETE WITH INVERTER	26
CPS10/JET	PUMP JET COMPLETE WITH INVERTER	25
CPS10/MULTINOX-VE+	PUMP MULTINOX-VE+ COMPLETE WITH INVERTER	28
CPS3-10/MULTINOX-VE+	PUMP MULTINOX-VE+ COMPLETE WITH INVERTER	38
CPS10/PVM	PUMP PVM COMPLETE WITH INVERTER	30
CPS3-10/PVM	PUMP PVM COMPLETE WITH INVERTER	40

## D

DHI	AISI 316 HORIZONTAL MULTISTAGE CENTRIFUGAL PUMPS	87
DHR	HORIZONTAL MULTISTAGE CENTRIFUGAL PUMPS	80
DOMINATOR 5	MONOBLOC MULTISTAGE 5" SUBMERSED PUMPS MADE OF STAINLESS STEEL AISI 304	163
DOMINATOR 4 PLUS	MONOBLOC MULTISTAGE 4" SUBMERSED PUMPS	160
DOMINATOR 5 RW	MULTISTAGE SUBMERSIBLE PUMP	166

## E

EASYBOOST	RESIDENTIAL - PRESSURE BOOSTER SET WITH PRESSURE SWITCH CONTROL	207
EASY20/MULTI EVO	PRESSURE BOOSTER SET WITH TWO PUMPS - PRESSURE SWITCH CONTROL	199

## F

FLUSSCONTROL	ELECTRONIC PRESSURE REGULATOR FOR SINGLE-PHASE PUMPS	311
FP/MULTI EVO-A	PUMPS WITH ELECTRONIC CONTROL AND PROTECTION DEVICE	199

## J

JET	CAST IRON SELF-PRIMING CENTRIFUGAL PUMPS	57
JETINOX	STAINLESS STEEL SELF-PRIMING CENTRIFUGAL PUMPS	61

# ALPHABETIC INDEX

## M

MINIVORT P	CAST IRON SUBMERSIBLE PUMPS FOR WASTEWATER 2-4 POLES	206
MINIVORT PP	CAST IRON SUBMERSIBLE PUMPS FOR WASTEWATER	208
MOTORI 4"	ELECTRIC MOTORS FOR 4" SUBMERSED PUMPS	178
MULTI EVO	MULTISTAGE CENTRIFUGAL PUMPS	72
MULTI EVO-A	SELF-PRIMING MULTISTAGE CENTRIFUGAL PUMPS	64
MULTI EVO-E	MULTISTAGE CENTRIFUGAL PUMPS WITH INVERTER	10
MULTI EVO-E P	MULTISTAGE CENTRIFUGAL PUMPS WITH INVERTER	18
MULTI EVO-SP	MULTISTAGE CENTRIFUGAL PUMPS - SPECIAL	90
MULTINOX-VE +	VERTICAL MULTISTAGE CENTRIFUGAL PUMPS	103

## N

NRM	MONOBLOC NORMALISED CENTRIFUGAL PUMPS - 2 AND 4 POLES	144
-----	---	-----

## P

PGA-DELTA OIL	PUMPS FOR DIESEL TRANSFER	161
PRATIKA	MULTISTAGE SUBMERSIBLE PUMP	158
PRESSOMAT	INDUSTRIAL - PRESSURE BOOSTER SET WITH PRESSURE SWITCH CONTROL	223
PVM	VERTICAL MULTISTAGE CENTRIFUGAL PUMPS	111
PVMI	VERTICAL MULTISTAGE CENTRIFUGAL PUMPS	111
PVMX	VERTICAL MULTISTAGE CENTRIFUGAL PUMPS	111

## S

SCM 4 PLUS	4" MULTISTAGE CENTRIFUGAL SUBMERSED PUMPS	170
SSCX	SINGLE STAGE CENTRIFUGAL PUMPS MADE OF STAINLESS STEEL AISI 304	100
SWIMMEY	SELF-PRIMING PUMPS FOR POOLS WITH PRE-FILTER	94

## T

TANKS	EXPANSION TANKS	318
-------	-----------------	-----

## V

VARIO 1-20	PRESSURE BOOSTER SET WITH TWO VARIABLE SPEED PUMPS	257
VARIO 3-20	THREE-PHASE PRESSURE BOOSTER SET WITH TWO VARIABLE SPEED PUMPS	267
VARIO 3-30	THREE-PHASE PRESSURE BOOSTER SET WITH THREE VARIABLE SPEED PUMPS	285
VARIO 1-20/MULTI EVO-E	PRESSURE BOOSTERS WITH TWO VARIABLE SPEED PUMPS	243
VARIO 1-20/MULTI EVO-E P	PRESSURE BOOSTERS WITH TWO VARIABLE SPEED PUMPS	251
VERSAILLES	SUBMERSIBLE PUMPS FOR FOUNTAINS AND WATER GAMES	179
VSD	ELECTRONIC FREQUENCY CONVERTER	307

## W

WATERPRESS	PRESSURE BOOSTER SET WITH HORIZONTAL PRESSURE TANK	193
WP/MULTI EVO-A	PRESSURE BOOSTER SET WITH HORIZONTAL PRESSURE TANK	189





[Pentair Water Italy](#) | [Via Masaccio](#) | [13 56010 LUGNANO \(PI\)](#) | [ITALY](#) | [starite.it](#)

Pentair Sta-Rite is a trademark, or registered trademark of Pentair or its subsidiaries in the United States and/or other countries.  
Because we are continuously improving our products and services,  
Pentair reserves the right to change specifications without prior notice.  
Pentair is an equal opportunity employer.

XXXXXXXXX ED. IT - Rev.0 - 01/18 © 2013 Pentair, Inc. All Rights Reserved.