

SUPER ®

SUPER ® X6DAL-XG

USER'S MANUAL

Revision 1.0a

The information in this User's Manual has been carefully reviewed and is believed to be accurate. SUPER MICRO COMPUTER assumes no responsibility for any inaccuracies that may be contained in this document, makes no commitment to update or to keep current the information in this manual, or to notify any person or organization of the updates. Please Note: For the most up-to-date version of this manual, please see our web site at www.supermicro.com.

SUPER MICRO COMPUTER reserves the right to make changes to the product described in this manual at any time and without notice. This product, including software, if any, and documentation may not, in whole or in part, be copied, photocopied, reproduced, translated or reduced to any medium or machine without prior written consent.

IN NO EVENT WILL SUPER MICRO COMPUTER BE LIABLE FOR DIRECT, INDIRECT, SPECIAL, INCIDENTAL, OR CONSEQUENTIAL DAMAGES ARISING FROM THE USE OR INABILITY TO USE THIS PRODUCT OR DOCUMENTATION, EVEN IF ADVISED OF THE POSSIBILITY OF SUCH DAMAGES. IN PARTICULAR, SUPER MICRO COMPUTER SHALL NOT HAVE LIABILITY FOR ANY HARDWARE, SOFTWARE, OR DATA STORED OR USED WITH THE PRODUCT, INCLUDING THE COSTS OF REPAIRING, REPLACING, INTEGRATING, INSTALLING OR RECOVERING SUCH HARDWARE, SOFTWARE, OR DATA.

Any disputes arising between manufacturer and customer shall be governed by the laws of Santa Clara County in the State of California, USA. The State of California, County of Santa Clara shall be the exclusive venue for the resolution of any such disputes. Supermicro's total liability for all claims will not exceed the price paid for the hardware product.

*California Best Management Practices Regulations for Perchlorate Materials: This Perchlorate warning applies only to products containing CR (Manganese Dioxide) Lithium coin cells. "Perchlorate Material-special handling may apply. See WWW.dtsc.ca.gov/hazardouswaste/perchlorate."

WARNING: Handling of lead solder materials used in this product may expose you to lead, a chemical known to the State of California to cause birth defects and other reproductive harm.

***FCC Statement:** This equipment has been tested and found to comply with the limits for a Class B digital device pursuant to Part 15 of the FCC Rules. These limits are designed to provide reasonable protection against harmful interference in a residential installation. This equipment generates, uses, and can radiate radio frequency energy and, if not installed and used in accordance with the manufacturer's instruction manual, may cause interference with radio communications. However, there is no guarantee that interference will not occur in a particular installation. If this equipment does cause harmful interference to radio or television reception, which can be determined by turning the equipment off and on, you are encouraged to try to correct the interference by one or more of the following measures:

- Reorient or relocate the receiving antenna.
- Increase the separation between the equipment and the receiver.
- Connect the equipment into an outlet on a circuit different from that to which the receiver is connected.
- Consult the dealer or an experienced radio/television technician for help.

Revision Number: Rev. 1.0a
Release Date: July 30, 2007

Unless you request and receive written permission from SUPER MICRO COMPUTER, you may not copy any part of this document.

Information in this document is subject to change without notice. Other products and companies referred to herein are trademarks or registered trademarks of their respective companies or mark holders.

Copyright © 2007 by SUPER MICRO COMPUTER INC.
All rights reserved.

Printed in the United States of America

Preface

About This Manual

This manual is written for system integrators, PC technicians and knowledgeable PC users. It provides information for the installation and use of the **SUPER** X6DAL-XG motherboard. The **SUPER** X6DAL-XG supports single or dual Intel® Xeon Nocona™ processors at a 800 MHz front side bus. Based upon Intel's NetBurst microarchitecture with EM64T support, the Nocona processor supports IA-32 and IA-64 software and includes features found in the Xeon™ processor such as Hyper Pipelined Technology, which includes a multi-stage pipeline, allowing the processor to operate at much higher core frequencies. Packaged in a 604-pin Flip Chip Micro Pin Grid Array(FC-mPGA4) platform in a Zero Insertion Force(ZIF) socket (mPGA 604), the Nocona Processor (800 MHz) supports Hyper-Threading Technology and is ideal for high performance workstation and server environments with up to two processors on one system bus. Please refer to the motherboard specifications pages on our web site (<http://www.supermicro.com/products/motherboard/>) for updates on supported processors. This product is intended to be professionally installed.

Manual Organization

Chapter 1 begins with a checklist of what should be included in your mainboard box, describes the features, specifications and performance of the motherboard and provides detailed information about the chipset.

Chapter 2 begins with instructions on handling static-sensitive devices. Read this chapter when you want to install the processor and DIMM memory modules and when mounting the mainboard in the chassis. Also refer to this chapter to connect the floppy and hard disk drives, SCSI drives, the IDE interfaces, the serial ports, the keyboard and mouse, the power supply and various control panel buttons and indicators.

If you encounter any problems, see **Chapter 3**, which describes troubleshooting procedures for the video, the memory and the setup configuration stored in CMOS. For quick reference, a general FAQ [Frequently Asked Questions] section is provided.

Chapter 4 includes an introduction to BIOS and provides detailed information on running the CMOS Setup utility.

Appendix A lists BIOS Error Beep Codes and DS LED POST Codes.

Appendix B provides BIOS POST codes.

Appendix C provides software installation instructions.

Table of Contents

Preface

About This Manual	iii
Manual Organization	iii

Chapter 1: Introduction

1-1 Overview	1-1
Checklist	1-1
Contacting Supermicro	1-2
SUPER X6DAL-XG Image	1-3
SUPER X6DAL-XG Layout	1-4
SUPER X6DAL-XG Quick Reference	1-5
Motherboard Features	1-6
Intel Tumwater Chipset: System Block Diagram	1-8
1-2 Chipset Overview	1-9
1-3 Special Features	1-9
BIOS Recovery	1-9
Recovery from AC Power Loss	1-9
1-4 PC Health Monitoring	1-10
1-5 ACPI Features	1-12
1-6 Power Supply	1-13
1-7 Super I/O	1-14

Chapter 2: Installation

2-1 Static-Sensitive Devices	2-1
Precautions	2-1
Unpacking	2-1
2-2 PGA Processor and Heatsink Installation	2-2
2-3 Installing DIMMs	2-5
2-4 I/O Ports/Control Panel Connectors	2-6
2-5 Connecting Cables	2-8
ATX Power Connector	2-8
Processor Power Connector	2-8
NMI Button	2-9
Power LED	2-9
HDD LED	2-10
NIC1 LED	2-10
Overheat/Fan Fail LED	2-11

Power Fail LED	2-11
Reset Button	2-12
Power Button	2-12
Chassis Intrusion	2-13
Universal Serial Bus (USB0/1)	2-13
ATX PS/2 Keyboard and Mouse Ports	2-14
Fan Headers	2-14
Serial Ports	2-15
Wake-On-Ring	2-15
Wake-On-LAN	2-16
GLAN (Ethernet Port)	2-16
Power Fault	2-17
Power LED/Speaker Header (JD1)	2-17
SMB Power Connector	2-18
CD-In Header	2-18
AC'97 Audio	2-19
2-6 Jumper Settings	2-20
Explanation of Jumpers	2-20
Alarm Reset	2-21
Power Force On Enable/Disable	2-21
CMOS Clear	2-22
Watch Dog Enable/Disable	2-22
AudioEnable/Disable	2-23
2-7 Onboard Indicators	2-24
GLAN LEDs	2-24
SATA LED Header	2-24
Onboard LED Indicators	2-25
System Alert LED Indicators	2-25
2-8 Parallel Port, Floppy/Hard Disk Drive and SCSI Connections	2-26
Parallel Port Connector	2-26
Floppy Connector	2-27
IDE Connectors	2-28

Chapter 3: Troubleshooting

3-1 Troubleshooting Procedures	3-1
Before Power On	3-1
No Power	3-1
No Video	3-1
Memory Errors	3-2

Losing the System's Setup Configuration 3-2

3-2 Technical Support Procedures 3-2

3-3 Frequently Asked Questions 3-3

3-4 Returning Merchandise for Service 3-5

Chapter 4: AMIBIOS

4-1 Introduction 4-1

4-2 Main Setup 4-2

4-3 Advanced Settings 4-3

4-4 Boot Settings 4-19

4-5 Security Setup 4-22

4-6 Exit 4-23

Appendices:

Appendix A: BIOS Error Beep/POST Codes A-1

Appendix B: BIOS POST Checkpoint Codes B-1

Appendix C: Software Installation C-1

Chapter 1

Introduction

1-1 Overview

Checklist

Congratulations on purchasing your computer motherboard from an acknowledged leader in the industry. Supermicro boards are designed with the utmost attention to detail to provide you with the highest standards in quality and performance. Check that the following items have all been included with your motherboard. If anything listed here is damaged or missing, contact your retailer. All included with Retail Box.

One (1) Supermicro Mainboard

One (1) ribbon cable for IDE devices (CBL-036)

One (1) floppy ribbon cable (CBL-022)

One (1) SATA cable (CBL-044)

One (1) CPU mounting plate (SKT-159)

Two (2) CPU retention brackets (SKT-158: pre-installed)

One (1) I/O backpanel shield (CSE-PT2)

One (1) Supermicro CD containing drivers and utilities (CDR_INTC)

One (1) User's/BIOS Manual

Contacting Supermicro

Headquarters

Address: SuperMicro Computer, Inc.
980 Rock Ave.
San Jose, CA 95131 U.S.A.

Tel: +1 (408) 503-8000

Fax: +1 (408) 503-8008

Email: marketing@supermicro.com (General Information)
support@supermicro.com (Technical Support)

Web Site: www.supermicro.com

Europe

Address: SuperMicro Computer B.V.
Het Sterrenbeeld 28, 5215 ML
's-Hertogenbosch, The Netherlands

Tel: +31 (0) 73-6400390

Fax: +31 (0) 73-6416525

Email: sales@supermicro.nl (General Information)
support@supermicro.nl (Technical Support)
rma@supermicro.nl (Customer Support)

Asia-Pacific

Address: SuperMicro, Taiwan
4F, No. 232-1 Liancheng Road
Chung-Ho 235, Taipei Hsien, Taiwan, R.O.C.

Tel: +886-(2) 8226-3990

Fax: +886-(2) 8226-3991

Web Site: www.supermicro.com.tw

Technical Support:

Email: support@supermicro.com.tw

Tel: 886-2-8228-1366, ext.132 or 139

Figure 1-1. SUPER X6DAL-XG Image

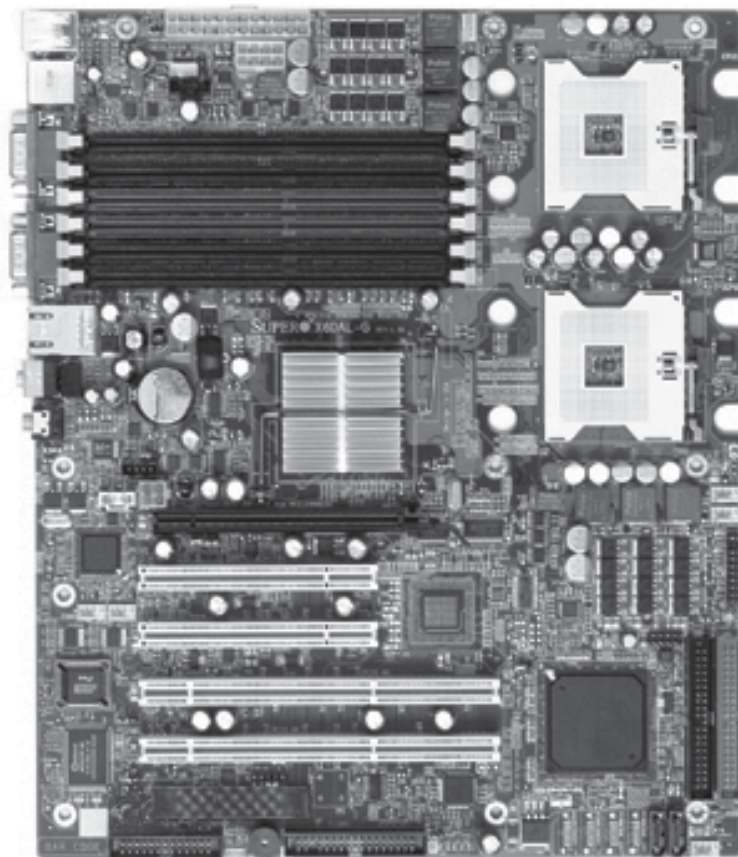

X6DAL-XG Quick Reference

<u>Jumper</u>	<u>Description</u>	<u>Default Setting</u>
CN1	Alarm Reset	Open (Disabled)
J13	SMB Data to PCI Enable	Closed (Enabled)
J15	SMB Clock to PCI Enable	Closed (Enabled)
J26	Audio Enable	Closed (Enabled)
JBT1	Clear CMOS	See Chapter 2
JPF	Force Power On Enable	Open (Disabled)
JPL1	LAN1 Enable	Pins 1-2 (Enabled)
JWD	Watch Dog Enable	Pins 2-3 (NMI)

<u>Connector</u>	<u>Description</u>
ATX PWR	Primary 24-pin ATX PWR Connector
PWR2/PWR 3	12V 8-pin CPU PWR/12V 4-pin PWR Connectors
COM1(J4)/COM2 (J5)	COM1/COM2 Serial Port Connectors
DS7, DS8	POST Code LED (*See Appendix A)
FAN #1-#6	CPU/Chassis Fans Headers
DIMM#1A-#3B	Memory (DIMM) Slots# (1A,1B, 2A,2B, 3A,3B)
LAN 1	G-bit Ethernet Port
IDE1, IDE2	IDE1/2 Hard Disk Drive Connectors
J2	Keyboard/Mouse
J6	Down: Line_in, Up: Line_out
J7	Power Fault Header
J24	Floppy Disk Drive Connector
J27	Power System Management
J41	Aux. In
J50	CD in
J61	Microphone
JF1	Front Panel Control (See Chapter 2)
JF2	Speaker, PWR LED, Keylock (See Chapter 2)
JL1	Chassis Intrusion Header
JSLED	SATA LED Header
H-SATA 0/1 (JS0/JS1)	Hance Rapids-Serial ATA Ports 0/1
Parallel	Parallel (printer) Port
WOL(JWOL)	Wake-on-LAN
WOR (JWOR)	Wake-on-Ring Header
USB 0/1	Back Panel Universal Serial Bus Ports
USB 2/3 (J42)	Front Panel Universal Serial Bus Ports

Motherboard Features

CPU

- Single or dual Intel® 604-pin Nocona™ processors (*w/EM64T support) at an 800 MHz front side (system) bus speed.

Memory

- Six 184-pin DIMM sockets supporting 12 GB/24GB Registered ECC DDR 333/266 (PC2700/PC2100) SDRAM

Notes: 1. Memory size is set via BIOS. 2. Interleaved memory; requires memory modules to be installed in pairs. See Section 2-3 for details.

Chipset

- Intel E7525 (Tumwater) chipset

Expansion Slots

- One PCI-E (x16@4GB/sec)
- Two 64-bit 66MHz PCI-X
- Two 32-bit 33MHz PCI slots

BIOS

- 8 Mb AMI® Flash ROM
- APM 1.2, DMI 2.1, PCI 2.2, ACPI 2.0, Plug and Play (PnP), SMBIOS 2.3

PC Health Monitoring

- Onboard voltage monitors for CPU cores, chipset voltage, 3.3V, +5V, +12V, 3.3V standby, and DIMM voltage.
- Fan status monitor with fan speed control via BIOS
- CPU/chassis temperature monitors
- Environmental temperature monitor and control via Supero Doctor III
- CPU fan auto-off in sleep mode
- CPU slow-down on temperature overheat
- CPU thermal trip support for processor protection, +5V standby alert LED
- Power-up mode control for recovery from AC power loss
- Auto-switching voltage regulator for CPU core
- System overheat LED and control
- Chassis intrusion detection
- System resource alert via Super Doctor III

ACPI Features

- Microsoft OnNow
- Slow blinking LED for suspend state indicator
- Main switch override mechanism

Onboard I/O

- 1 Intel 82541PI Gigabit Ethernet controller
- 2 EIDE Ultra DMA/100 bus master interfaces
- 1 floppy port interface (up to 2.88 MB)
- 1 EPP/ECP Parallel Port
- PS/2 mouse and PS/2 keyboard ports
- Up to four USB 2.0 (Universal Serial Bus) (2 ports-back panel, 2 ports-front panel)
- 2 Intel 6300ESB Serial ATA Ports
- Super I/O
- AC '97 CODEC Audio devices supported
- 2 serial ports

Other

- Internal/external modem ring-on
- Wake-on-Ring (WOR)
- Wake-on-LAN (WOL)
- Console redirection

CD/Diskette Utilities

- BIOS flash upgrade utility and device drivers

Dimensions

- ATX 12" x 10" (304.8 x 254 mm)

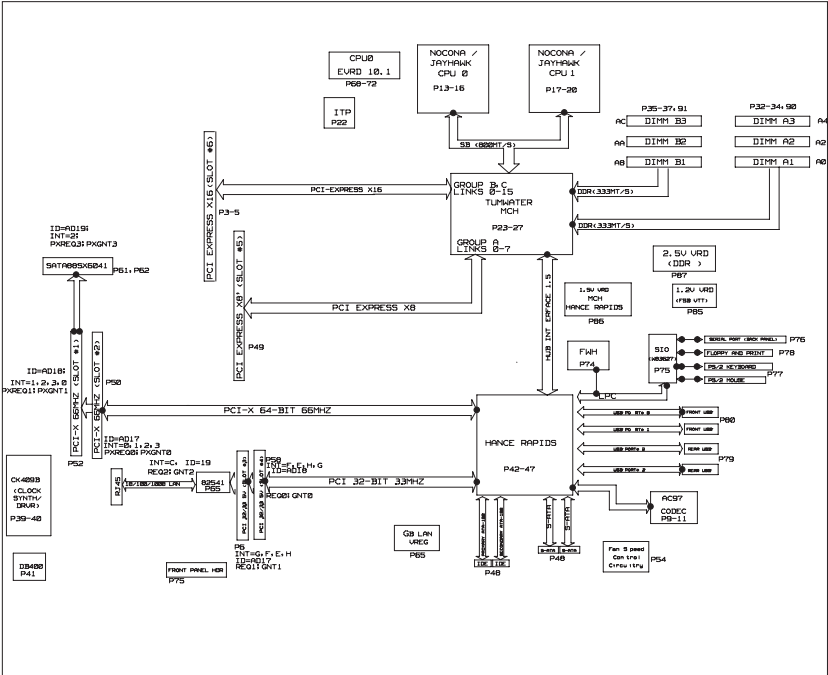

Figure 1-3. Block Diagram of the E7525 Tumwater Chipset

Note: This is a general block diagram. Please see the previous Motherboard Features pages for details on the motherboard.

1-2 Chipset Overview

Built upon the functionality and the capability of the E7525 Tumwater chipset, the X6DAL-XG motherboard provides the performance and feature set required for dual processor-based servers, with configuration options optimized for communications, presentation, storage, computation or database applications. The Intel E7525 Tumwater chipset consists of the following components: the E7525 Tumwater Memory Controller Hub (MCH), the 6300ESB I/O Controller Hub (Hance Rapids ICH), the Intel PCI-X Hub and the PCI-X Hub (PXH).

The E7525 Tumwater MCH supports single or dual Nocona processors with Front Side Bus speeds of up to 800 MHz(*Note). Its memory controller provides direct connection to two channels of registered DDR333 or DDR266 with a marched system bus address and data bandwidths of up to 2.67 GB/s (DDR 333) per channel. The E7525 Tumwater also supports the new PCI Express high speed serial I/O interface for superior I/O bandwidth. These interfaces support connection of the MCH to a variety of other bridges that are compliant with the PCI Express Interface Specification, Rev. 1.0a, such as 82801ER GLAN Adaptor, the Dobson I/O processor, H/W RAID controllers and TCP/IP Off-load engines. The MCH interfaces with the Hance Rapids ICH I/O Controller Hub via HI 1.5 Hub Interface. The PXH provides connection between a PCI Express interface and two independent PCI bus interfaces that can be configured for standard PCI 2.3 protocol, as well as the enhanced high-frequency PCI-X protocol. The PXH can be configured to support for 32- or 64-bit PCI devices running at 33 MHz, 66 MHz, 100 MHz, or 133 MHz.

6300ESB ICH System Features

In addition to providing the I/O subsystem with access to the rest of the system, the 6300ESB ICH I/O Controller Hub integrates many I/O functions.

The 6300ESB ICH I/O Controller Hub integrates: 2-channel Ultra ATA/100 Bus Master IDE Controller, two Serial ATA (SATA) Host Controllers, SMBus 2.0 Controller, LPC/Flash BIOS Interface, PCI-X (66MHz)/PCI-Express (x16 at 4GB/s) Interface, PCI 2.2 Interface and System Management Controller.

(*Notes: The CPU FSB speed is set at 800 MHz by the Manufacturer.
Please do not change the CPU FSB setting.)

1-3 Special Features

BIOS Recovery

The BIOS Recovery function allows you to recover your BIOS image file if the BIOS flashing procedure fails (see Section 3-3).

Recovery from AC Power Loss

BIOS provides a setting for you to determine how the system will respond when AC power is lost and then restored to the system. You can choose for the system to remain powered off (in which case you must hit the power switch to turn it back on) or for it to automatically return to a power-on state. See the Power Lost Control setting in the Advanced BIOS Setup section (Peripheral Device Configuration) to change this setting. The default setting is Always On.

1-4 PC Health Monitoring

This section describes the PC health monitoring features of the SUPER X6DAL-XG. All have an onboard System Hardware Monitor chip that supports PC health monitoring.

Onboard Voltage Monitors for the CPU Cores, Chipset Voltage, +3.3V, +5V, +12V, -12v, +3.3V Standby, +2.5V (for DRAM), +1.5V Standby, +1.2V

An onboard voltage monitor will scan these voltages continuously. Once a voltage becomes unstable, a warning is given or an error message is sent to the screen (only when SuperDoctorIII is installed). Users can adjust the voltage thresholds in SuperDoctorIII.

Fan Status Monitor with Firmware/Software On/Off Control

The PC health monitor can check the RPM of the cooling fans. The onboard 4-pin CPU and chassis fans are controlled by the power management functions.

Environmental Temperature Control via Supero DoctorIII

The thermal control sensor monitors the CPU temperature in real time and will increase the speed of the thermal control fan whenever the CPU temperature exceeds a user-defined threshold. The overheat circuitry runs independently from the CPU. It can continue to monitor for overheat conditions even when the CPU is in sleep mode. Once it detects that the CPU temperature is too high, it will automatically increase the speed of the thermal control fan to prevent any overheat damage to the CPU. The onboard chassis thermal circuitry can monitor the overall system temperature and alert users when the chassis temperature is too high.

TM2/CPU VRM Overheat

When the CPU reaches 70°C and above (Overheat), the CPU will slow down and CPU Voltage will decrease to reduce CPU power consumption and VRM heat dissipation.

When CPU temperature reaches 78°C and above (*Default), the system will go into the throttling state. The Overheat LED and Alarm Buzzer will be turned on. The CPU performance will drop 50%. When this happens, you can go to the Health Monitor Setting in the BIOS to reset CPU Overheat Temperature.

CPU Overheat LED and Control

This feature is available when the user enables the CPU overheat warning function in the BIOS. This allows the user to define an overheat temperature. When this temperature is exceeded, the warning LED is triggered and the fans will speed up.

Auto-Switching Voltage Regulator for the CPU Core

The auto-switching voltage regulator for the CPU core can support up to 120W current and auto-sense voltage IDs ranging from .8375V to 1.6V. This will allow the regulator to run cooler and thus make the system more stable.

1-5 ACPI Features

ACPI stands for Advanced Configuration and Power Interface. The ACPI specification defines a flexible and abstract hardware interface that provides a standard way to integrate power management features throughout a PC system, including its hardware, operating system and application software. This enables the system to automatically turn on and off peripherals such as CD-ROMs, network cards, hard disk drives and printers. This also includes consumer devices connected to the PC such as VCRs, TVs, telephones and stereos.

In addition to enabling operating system-directed power management, ACPI provides a generic system event mechanism for Plug and Play and an operating system-independent interface for configuration control. ACPI leverages the Plug and Play BIOS data structures while providing a processor architecture-independent implementation that is compatible with Windows 2000, Windows NT 5.0, WindowsXP and Server 2003.

Microsoft OnNow

The OnNow design initiative is a comprehensive, system-wide approach to system and device power control. OnNow is a term for a PC that is always on but appears to be off and responds immediately to user or other requests.

Slow Blinking LED for Suspend-State Indicator

When the CPU goes into a suspend state, the chassis power LED will start blinking to indicate that the CPU is in suspend mode. When the user presses any key, the CPU will wake-up and the LED will automatically stop blinking and remain on.

Main Switch Override Mechanism

When an ATX power supply is used, the power button can function as a system suspend button to make the system enter a SoftOff state. The monitor will be suspended and the hard drive will spin down. Pressing the power button again will cause the whole system to wake-up. During the SoftOff state, the ATX power supply provides power to keep the required

circuitry in the system alive. In case the system malfunctions and you want to turn off the power, just press and hold the power button for 4 seconds. This option can be set in the Power section of the BIOS Setup routine.

External Modem Ring-On (WOR)

Wake-up events can be triggered by a device such as the external modem ringing when the system is in the SoftOff state. Note that external modem ring-on can only be used with an ATX 2.01 (or above) compliant power supply.

1-6 Power Supply

As with all computer products, a stable power source is necessary for proper and reliable operation. It is even more important for processors that have high CPU clock rates.

The SUPER X6DAL-XG accommodates ATX power supplies. Although most power supplies generally meet the specifications required by the CPU, some are inadequate. You should use one that will supply at least 400W of power. In addition, a +12V, 8-pin CPU power supply and a +12V, 4-pin Aux. power supply are also required for high-load configurations. Also your power supply must supply 1.5A for the Ethernet ports.

NOTE: In addition to the 24-pin main power, a 12V 8-pin power connector (PW2) is required to support Intel Xeon CPUs, and a 12V 4-pin power connector (Aux. PWR) is also required for system power consumption. Failure to provide this extra power will result in instability of the CPU after only a few minutes of operation. See Section 2-5 for details on connecting the power supply.

It is strongly recommended that you use a high quality power supply that meets ATX power supply Specification 2.02 or above. It must also be SSI compliant (info at <http://www.ssiforum.org/>). Additionally, in areas where noisy power transmission is present, you may choose to install a line filter to shield the computer from noise. It is recommended that you also install a power surge protector to help avoid problems caused by power surges.

1-7 Super I/O

The disk drive adapter functions of the Super I/O chip include a floppy disk drive controller that is compatible with industry standard 82077/765, a data separator, write pre-compensation circuitry, decode logic, data rate selection, a clock generator, drive interface control logic and interrupt and DMA logic. The wide range of functions integrated onto the Super I/O greatly reduces the number of components required for interfacing with floppy disk drives. The Super I/O supports 360 K, 720 K, 1.2 M, 1.44 M or 2.88 M disk drives and data transfer rates of 250 Kb/s, 500 Kb/s or 1 Mb/s. It also provides two high-speed, 16550 compatible serial communication ports (UARTs), one of which supports serial infrared communication. Each UART includes a 16-byte send/receive FIFO, a programmable baud rate generator, complete modem control capability and a processor interrupt system. Both UARTs provide legacy speed with baud rate of up to 115.2 Kbps as well as an advanced speed with baud rates of 250 K, 500 K, or 1 Mb/s, which support higher speed modems.

The Super I/O supports one PC-compatible printer port (SPP), Bi-directional Printer Port (BPP) , Enhanced Parallel Port (EPP) or Extended Capabilities Port (ECP).

The Super I/O provides functions that comply with ACPI (Advanced Configuration and Power Interface), which includes support of legacy and ACPI power management through an SMI or SCI function pin. It also features auto power management to reduce power consumption.

The IRQs, DMAs and I/O space resources of the Super I/O can flexibly adjust to meet ISA PnP requirements, which support ACPI and APM (Advanced Power Management).

Chapter 2 Installation

2-1 Static-Sensitive Devices

Electric-Static-Discharge (ESD) can damage electronic components. To prevent damage to your system board, it is important to handle it very carefully. The following measures are generally sufficient to protect your equipment from ESD.

Precautions

- Use a grounded wrist strap designed to prevent static discharge.
- Touch a grounded metal object before removing the board from the anti-static bag.
- Handle the board by its edges only; do not touch its components, peripheral chips, memory modules or gold contacts.
- When handling chips or modules, avoid touching their pins.
- Put the motherboard and peripherals back into their antistatic bags when not in use.
- For grounding purposes, make sure your computer chassis provides excellent conductivity between the power supply, the case, the mounting fasteners and the motherboard.
- Use only the correct type of onboard CMOS battery as specified by the manufacturer. Do not install the onboard battery upside down to avoid possible explosion.

Unpacking

The motherboard is shipped in antistatic packaging to avoid static damage. When unpacking the board, make sure the person handling it is static protected.

2-2 PGA Processor and Heatsink Installation



When handling the processor package, avoid placing direct pressure on the label area of the fan. Also, do not place the motherboard on a conductive surface, which can damage the BIOS battery and prevent the system from booting up.

IMPORTANT: Always connect the power cord last and always remove it before adding, removing or changing any hardware components. Make sure that you install the processor into the CPU socket **before** you install the CPU heatsink. Note that for the X6DAL-XG you need to install the Xeon mounting plate under the board.

Installing the CPU Mounting Plate

Note: CPU Retention Brackets are pre-installed.

Install the CPU mounting plate below the retention bracket on the reverse side of the motherboard. See diagram on right.

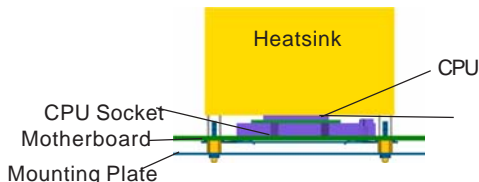
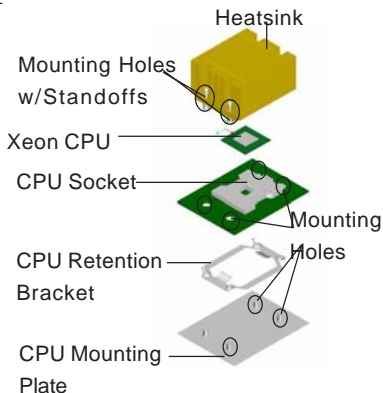

CPU Installation

1. Lift the lever on the CPU socket: lift the lever completely as shown on the picture on the right; otherwise, you will damage the CPU socket when power is applied. (Install CPU1 first.)



Socket lever

2. Insert the CPU in the socket, making sure that pin 1 of the CPU aligns with pin 1 of the socket (both corners are marked with a triangle). When using only one CPU, install it into CPU socket #1 (Socket #2 is automatically disabled if only one CPU is used).



Pin1

3. Press the lever down until you hear the *click* so you can be sure that the CPU is securely installed in the CPU socket.



Socket lever in the locking Position

Heatsink Installation

1. Do not apply any thermal grease to the heatsink or the CPU die; the required amount of thermal grease has already been applied.

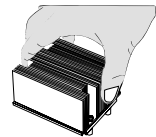

CEK Heatsink

2. Place the heatsink on top of the CPU so that the four mounting holes are aligned with those on the retention mechanism.



Screw#1 Screw#2

3. Screw in two diagonal screws (ie the #1 and the #2 screws) until just snug (-do not fully tighten the screws to avoid possible damage to the CPU.)

Screw#1

4. Finish the installation by fully tightening all four screws.

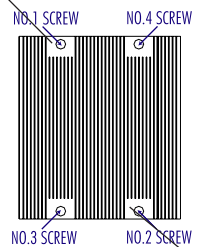

NO.3 SCREW

Screw#2

Note: heatsinks are heavy - please handle them with care.

To Uninstall the Heatsink

Caution! We do not recommend that the CPU or the heatsink be removed. However, if you do need to uninstall the heatsink, please follow the instructions below to prevent damage to the CPU or the CPU socket.

1. Unscrew and remove the heatsink screws from the motherboard in the sequence as show in the second picture on the right.

2. Hold the heatsink as show in the picture on the right and gently wriggle the heatsink to loosen it from the CPU. (Do not use excessive force when wriggling the heatsink!!)

3. Once the CPU is loosened from the heatsink, remove the heatsink from the CPU socket.

4. Clean the surface of the CPU and the heatsink to get rid of the old thermal grease. Reapply the proper amount of thermal grease on the surface before you re-install the CPU and the heatsink.

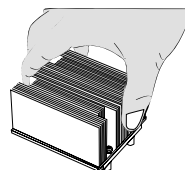
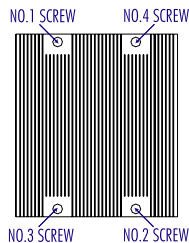
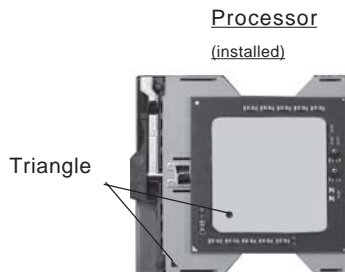
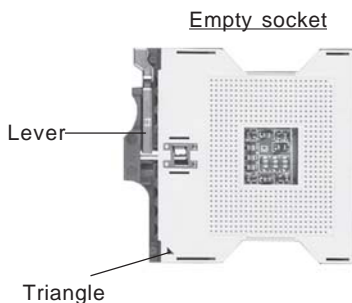

Figure 2-1. PGA604 Socket: Empty and with Processor Installed



Warning! Make sure you lift the lever completely when installing the CPU. If the lever is only partly raised, damage to the socket or CPU may result.



Mounting the Motherboard in the Chassis

All motherboards have standard mounting holes to fit different types of chassis. Make sure the location of all the mounting holes for both the motherboard and the chassis match. Although a chassis may have both plastic and metal mounting fasteners, metal ones are highly recommended because they ground the motherboard to the chassis. Make sure the metal standoffs click in or are screwed in tightly. Then use a screwdriver to secure the motherboard onto the motherboard tray.

2-3 Installing DIMMs

Note: Check the Supermicro web site for recommended memory modules.

CAUTION

Exercise extreme care when installing or removing DIMM modules to prevent any possible damage. Also note that the memory is interleaved to improve performance (see step 1).

DIMM Installation (See Figure 2-2)

1. Insert the desired number of DIMMs into the memory slots, starting with DIMM #1A. The memory scheme is interleaved so you must install two modules at a time, beginning with DIMM #1A, then DIMM #1B, and so on.
2. Insert each DIMM module vertically into its slot. Pay attention to the notch along the bottom of the module to prevent inserting the DIMM module incorrectly.
3. Gently press down on the DIMM module until it snaps into place in the slot. Repeat for all modules (see step 1 above).

Memory Support

The X6DAL-XG supports up to 12GB/24GB of registered ECC DDR333/266 (PC2700/PC2100) memory. The motherboard was designed to support 4GB (PC2100) modules in each slot, but only the 2GB modules have been tested. When using registered ECC DDR333 (PC2700) memory, installing four pieces of double-banked memory or six pieces of single-banked memory is supported.

Figure 2-2. Installing and Removing DIMMs

To Install:

Insert module vertically and press down until it snaps into place. Pay attention to the alignment notch at the bottom.

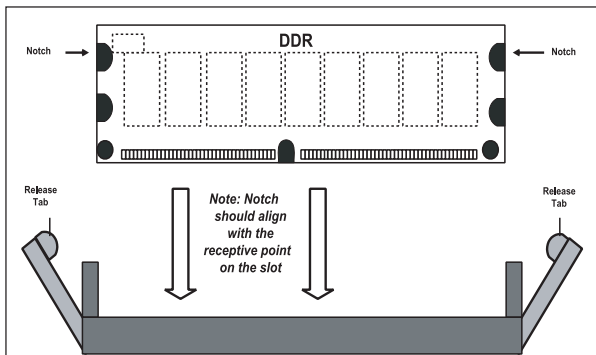

To Remove:

Use your thumbs to gently push near the edge of both ends of the module. This should release it from the slot.

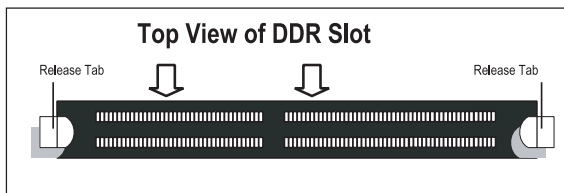

2-4 I/O Ports/Control Panel Connectors

The I/O ports are color coded in conformance with the PC 99 specification. See Figure 2-3 below for the locations of the various I/O ports.

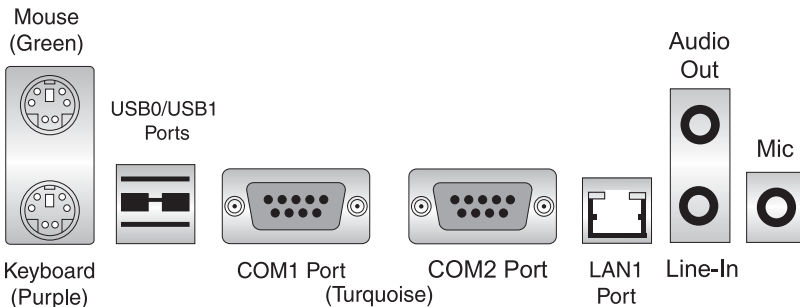
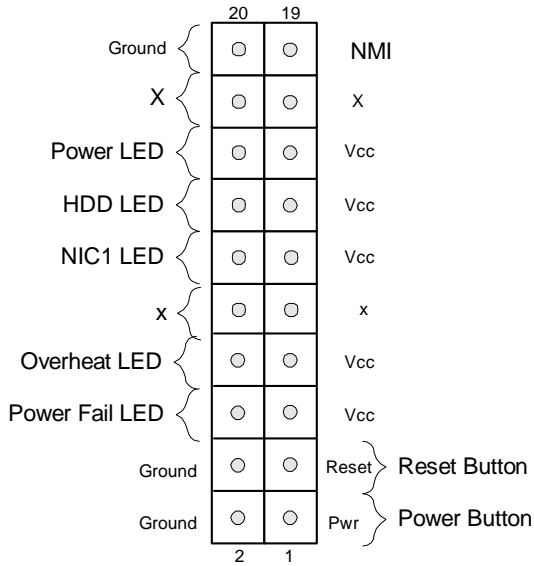

Figure 2-3. I/O Port Locations and Definitions

Front Control Panel

JF1 contains header pins for various buttons and indicators that are normally located on a control panel at the front of the chassis. These connectors are designed specifically for use with Supermicro server chassis. See Figure 2-4 for the descriptions of the various control panel buttons and LED indicators. Refer to the following section for descriptions and pin definitions.

Figure 2-4. JF1 Header Pins



2-5 Connecting Cables

ATX Power Connector

There are a 24-pin main power supply connector(PW1) and a 4-pin 12V PWR connector (PW3) on the board. (Both connections are required.) These power connectors meet the SSI EPS 12V specification. See the table on the right for pin definitions. For CPU PWR (PW2), please refer to the item listed below.

ATX Power Supply 24-pin Connector
Pin Definitions (PW1)

Pin Number	Definition	Pin Number	Definition
13	+3.3V	1	+3.3V
14	-12V	2	+3.3V
15	COM	3	COM
16	PS_ON#	4	+5V
17	COM	5	COM
18	COM	6	+5V
19	COM	7	COM
20	Res(NC)	8	PWR_OK
21	+5V	9	5VSB
22	+5V	10	+12V
23	+5V	11	+12V
24	COM	12	+3.3V

+12V 4-pin
Connector
(PW3)

Required Connection	Pins #	Definition
	1 & 2	Ground
	3 & 4	+12 V

Processor Power Connector

In addition to the power connectors indicated above, the 12v 8-pin Processor connector at PW2 must also be connected to your power supply. See the table on the right for pin definitions.

CPU 8-Pin PWR
Connector (PW2)

Required Connection	Pins	Definition
	1 thru 4	Ground
	5 thru 8	+12v

PWR3 (4-Pin) ATX PWR (24-Pin) CPU PWR(8-Pin)

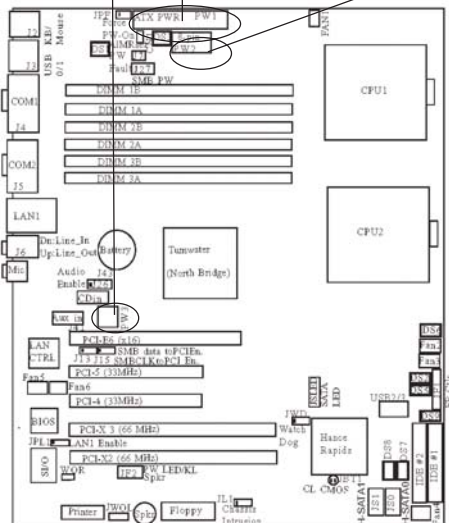

NMI Button

The non-maskable interrupt button header is located on pins 19 and 20 of JF1. Refer to the table on the right for pin definitions.

NMI Button Pin Definitions (JF1)

Pin Number	Definition
19	Control
20	Ground

Power LED

The Power LED connection is located on pins 15 and 16 of JF1. Refer to the table on the right for pin definitions.

PWR_LED Pin Definitions (JF1)

Pin Number	Definition
15	Vcc
16	Control

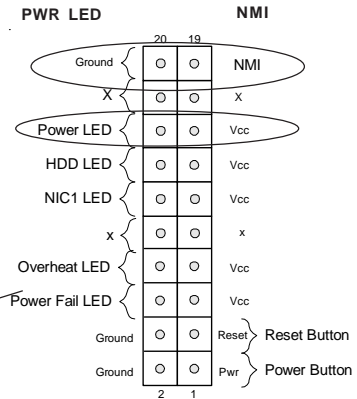
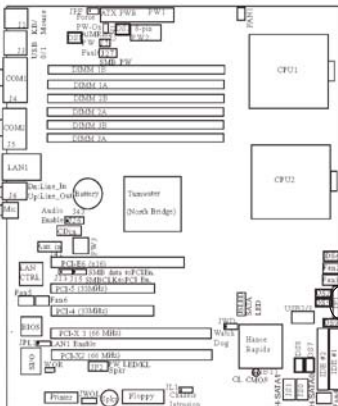

HDD LED

The HDD LED connection is located on pins 13 and 14 of JF1. Attach the hard drive LED cable here to display disk activity (for any hard drives on the system, including SCSI, Serial ATA and IDE). See the table on the right for pin definitions.

HDD LED Pin Definitions (JF1)

Pin Number	Definition
13	Vcc
14	HD Active

NIC1 LED Indicators

The NIC (Network Interface Controller) LED connections for the GLAN port1 is located on pins 11 and 12 of JF1. Attach the NIC LED cable to display network activity. Refer to the tables on the right for pin definitions.

NIC1 LED Pin Definitions (JF1)

Pin Number	Definition
11	Vcc
12	GND

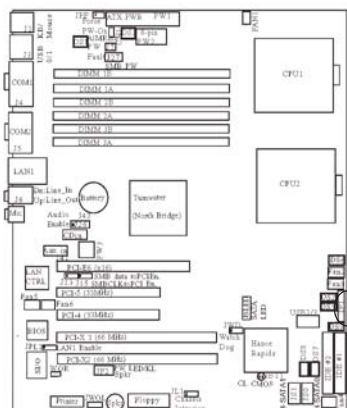

HDD LED

NIC1 LED

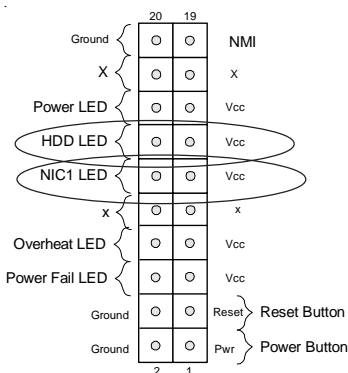

Overheat/Fan Fail LED

Connect an LED to the OH/Fan Fail connection on pins 7 and 8 of JF1 to provide advanced warning of chassis overheating. Refer to the table on the right for pin definitions.

Overheat/Fan Fail LED Pin Definitions (JF1)

Pin Number	Definition
7	Vcc
8	GND

Overheat/Fan Fail LED

State	Message
Solid	Overheat
Blink	Fan Fail

Power Fail LED

The Power Fail LED connection is located on pins 5 and 6 of JF1. Refer to the table on the right for pin definitions.

Power Fail LED Pin Definitions (JF1)

Pin Number	Definition
5	Vcc
6	GND

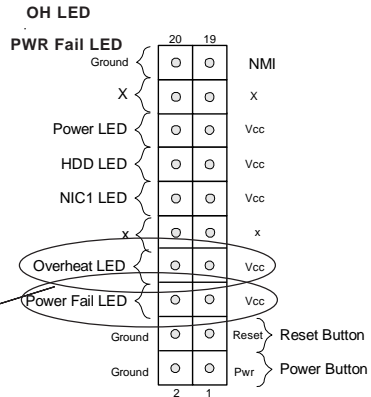
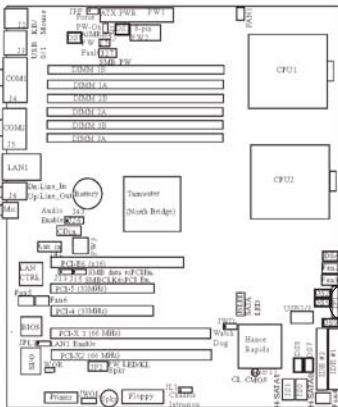

Reset Button

The Reset Button connection is located on pins 3 and 4 of JF1. Attach it to the hardware reset switch on the computer case. Refer to the table on the right for pin definitions.

Reset Pin Definitions (JF1)

Pin Number	Definition
3	Reset
4	Ground

Power Button

The Power Button connection is located on pins 1 and 2 of JF1. Momentarily contacting both pins will power on/off the system. To turn off the power when set to suspend mode, press the button for at least 4 seconds. Refer to the table on the right for pin definitions.

Power Button Connector Pin Definitions (JF1)

Pin Number	Definition
1	PW_ON
2	Ground

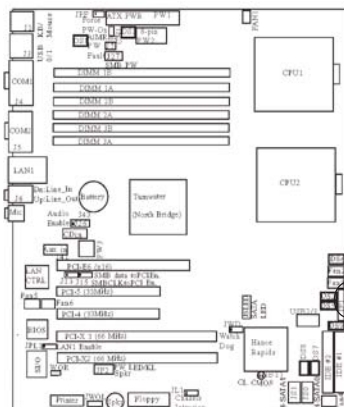

Reset PWR

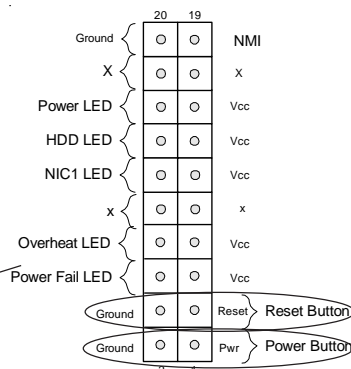

Chassis Intrusion

A Chassis Intrusion header is located at JL1. Attach the appropriate cable to inform you of a chassis intrusion.

Chassis Intrusion Pin Definitions

Pin Number	Definition
1	Intrusion Input
2	Ground

Universal Serial Bus (USB)

There are two Universal Serial Bus ports(USB 0/1) located on the I/O panel and additional two USB ports(USB 2/3) next to the IDE2 on the motherboard. These two FP USB ports can be used to provide front side chassis access (cables not included). See the tables on the right for pin definitions.

USB Pin Definition

USB 0/1 (Back Panel USB)

Pin#	Definition
1	+5V
2	PO-
3	PO+
4	Ground

USB 2/3 (Front Panel USB)

Pin Number	Definition	Pin Number	Definition
1	+5V	2	+5V
3	PO-	4	PO-
5	PO+	6	PO+
7	Ground	8	Ground
		10	Ground

USB 0/1

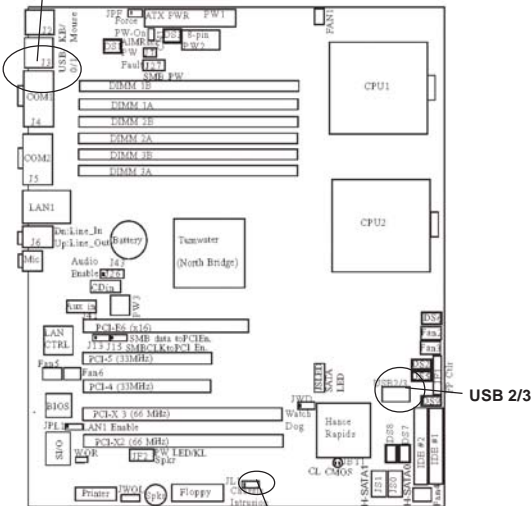

Chassis Intrusion

ATX PS/2 Keyboard and PS/2 Mouse Ports

The ATX PS/2 keyboard and the PS/2 mouse are located at J2. See the table on the right for pin definitions. (The mouse port is above the keyboard port. See the table on the right for pin definitions.)

PS/2 Keyboard and Mouse Port Pin Definitions (J2)

Pin Number	Definition
1	Data
2	NC
3	Ground
4	VCC
5	Clock
6	NC

Fan Headers

There are six fan headers (Fan 1 to Fan 6) on the X6DAL-XG). See the table on the right for pin definitions. (*Note: These fan headers are 4-pin fans. Pins#1-#3 of the fan headers are backward compatible with the traditional 3-pin fans.) (*The onboard fan speed is controlled by Thermal Management via BIOS--Hardware Monitor in the Advanced Setting. Note: Default: Disabled, When using Thermal Management setting, please use all 3-pin fans or all 4-pin fans on the motherboard. Please do not use 3-pin fans and 4-pin fans on the same board.)

4-pin Fan Header Pin Definitions (CPU and Chassis Fans)

Pin#	Definition
1	Ground (black)
2	+12V (red)
3	Tachometer
4	PWM_Control

Caution: These fan headers use DC power.

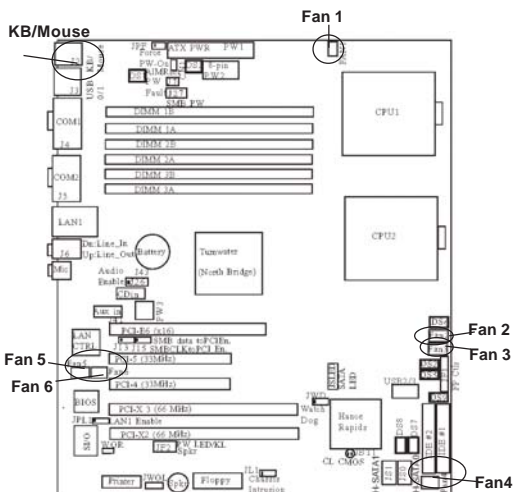

Serial Ports

The COM1 (J4) and COM2 (J5) serial ports are located on the I/O backplane (see Figure 2-3). See the table on the right for pin definitions.

**Serial Port Pin Definitions
(COM1, COM2)**

Pin Number	Definition	Pin Number	Definition
1	DCD	6	CTS
2	DSR	7	DTR
3	Serial In	8	RI
4	RTS	9	Ground
5	Serial Out	10	NC

Wake-On-Ring (JWOR)

The Wake-On-Ring header is designated WOR. This function allows your computer to receive and "be awakened" by an incoming call to the modem when in suspend state. See the table on the right for pin definitions. You must have a Wake-On-Ring card and cable to use this feature.

**Wake-on-Ring
Pin Definitions
(WOR)**

Pin Number	Definition
1	Ground
2	Wake-up

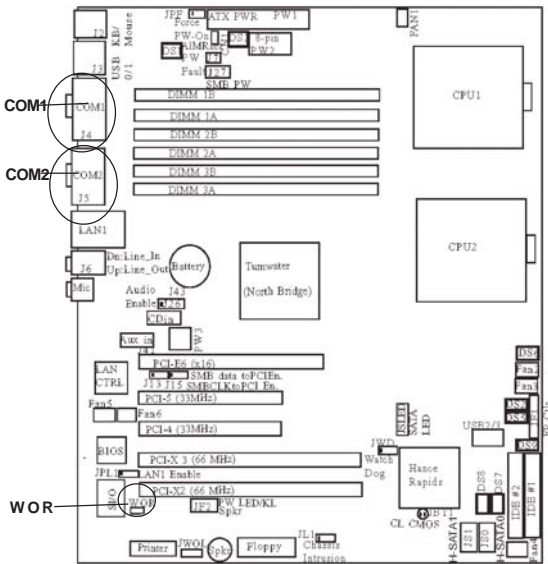

Wake-On-LAN

The Wake-On-LAN header(JWOL) is designated WOL on the motherboard. See the table on the right for pin definitions. You must enable the LAN Wake-Up setting in BIOS to use this function. (You must also have a LAN card with a Wake-On-LAN connector and cable to use this feature.)

Wake-On-LAN Pin Definitions (JWOL)

Pin Number	Definition
1	+5V Standby
2	Ground
3	Wake-up

GLAN (Giga-bit Ethernet Port)



A G-bit Ethernet port is located beside the COM2 port on the IO backplane. This port accepts RJ45 type cables.

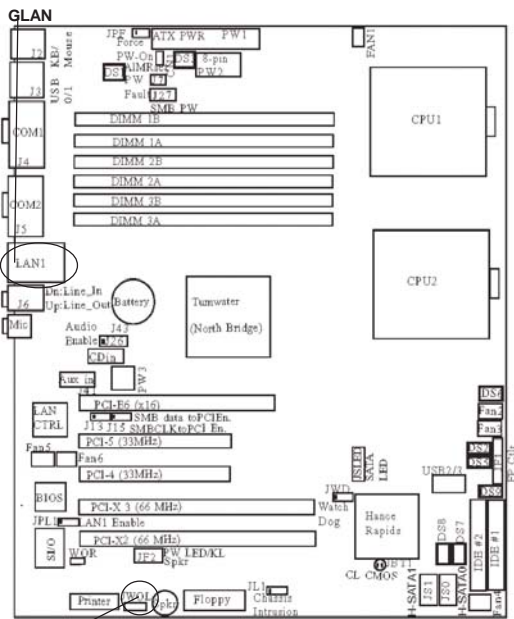

WOL

Power Fault

Connect a cable from your power supply to the Power Fault header (J7) to provide warning of power supply failure. This warning signal is passed through the PWR_LED pin to indicate of a power failure on the chassis. See the table on the right for pin definitions.

**Power Fault
Pin Definitions**

Pin Number	Definition
1	P/S 1 Fail Signal
2	P/S 2 Fail Signal
3	P/S 3 Fail Signal
4	Reset (from MB)

Note: This feature is only available when using redundant Supermicro power supplies.

Speaker/Power LED/ Keylock

On the JF2 header, pins 1/3/5/7 are for the Speaker, and Pins 2/4/6 are for the Power LED and pins 8/9 are for Keylock. See the table on the right for speaker pin definitions. **Note:** The speaker connector pins are for use with an external speaker. If you wish to use the onboard speaker, you should close pins 5-7 with a jumper.

**Speaker Connector Pin
Definitions (JF2)**

Pin Number	Function	Definition	
1	+	Red wire, Speaker data	
3			No connection
5			Key
7			Speaker data

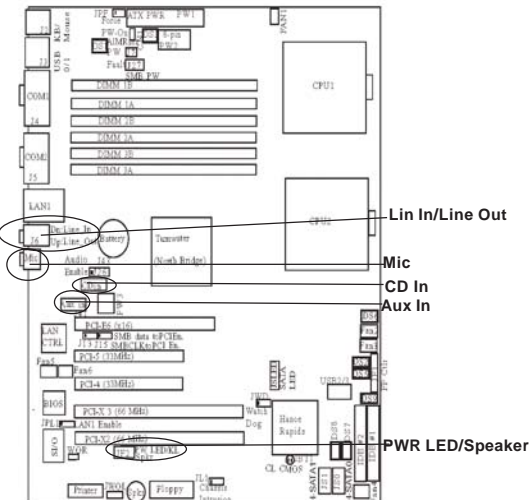

SMB Power (I²C) Connector

I²C Connector (J27), located between the Alarm Reset Header and the PWR Fault Header, monitors the status of PWR Supply, Fan and system temperature.

SMB PWR Pin Definitions (J27)

Pin #	Definition
1	Clock
2	SMB Data
3	N/A
4	N/A
5	N/A

CD-In Header

There is a 4-pin CD header on the motherboard. This allows you to use the onboard sound for audio CD playback. Connect the audio cable from your CD drive to the header. See the tables at right for pin definitions.

Audio CD Header Pin Definitions (CD1)

Pin Number	Definition
1	Left Stereo Signal
2	Ground
3	Ground
4	Right Stereo Signal

Audio CD Header Pin Definitions (CD2)

Pin Number	Definition
1	Right Stereo Signal
2	Ground
3	Left Stereo Signal
4	Ground

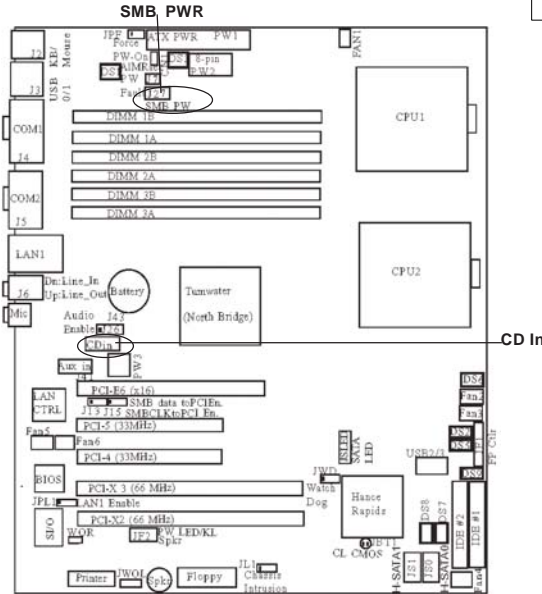

AC 97/AUX In/CD In

AC'97 provides high quality onboard audio. The X6DAL-XG features 6-channel sound for front L&R, rear L&R, center and subwoofer speakers. This feature is activated with the Advanced software (on the CD-ROM included with your motherboard). Sound is then output through the Line In, Line Out and MIC jacks (see at right). Activate AC 97 with the "AC 97 Audio" setting in the Advanced Chipset Features section of BIOS. In addition, there are also Aux In and CD In Connectors on the motherboard.



Blue: Line In (surround L/R)

Green: Line Out (Front L/R)



Pink: MIC In (Center/
subwoofer)

2-6 Jumper Settings

Explanation of Jumpers

To modify the operation of the motherboard, jumpers can be used to choose between optional settings. Jumpers create shorts between two pins to change the function of the connector. Pin 1 is identified with a square solder pad on the printed circuit board. See the motherboard layout pages for jumper locations.

Note: On two pin jumpers, "Closed" means the jumper is on and "Open" means the jumper is off the pins.

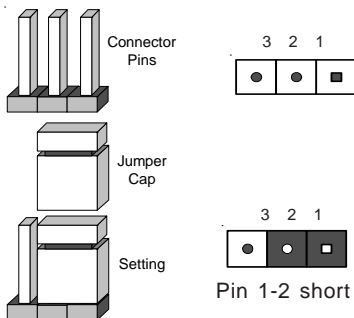

LAN Enable/Disable

JPL1 enables or disable the Giga-bit LAN port on the motherboard. See the table on the right for jumper settings. The default setting is enabled.

**GLAN
Enable/Disable
Jumper Settings
(JPL1)**

Jumper Position	Definition
Pins 1-2	Enabled
Pins 2-3	Disabled

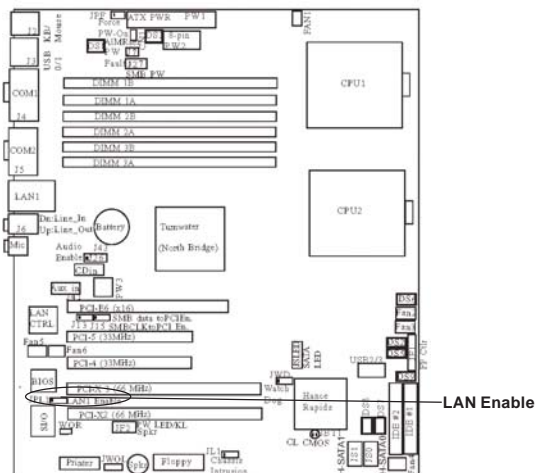

Alarm Reset

The system will notify you in the event of a power supply failure. This feature assumes that Supermicro redundant power supply units are installed in the chassis. If you only have a single power supply installed, you should disable this (the default setting) with (CN1) to prevent false alarms. See the table on the right for jumper settings.

Alarm Reset Jumper Settings

Jumper Position	Definition
Open	Enabled
Closed	Disabled

Force-Power-On Enable/Disable

Jumper JPF, allows you to enable or disable the function of Force-Power-On. If enabled, the power will always stay on automatically. If this function disabled, the user needs to press the power button to power on the system.

Force Power On (JPF)

Jumper Position	Definition
Off	Normal
On	Force On

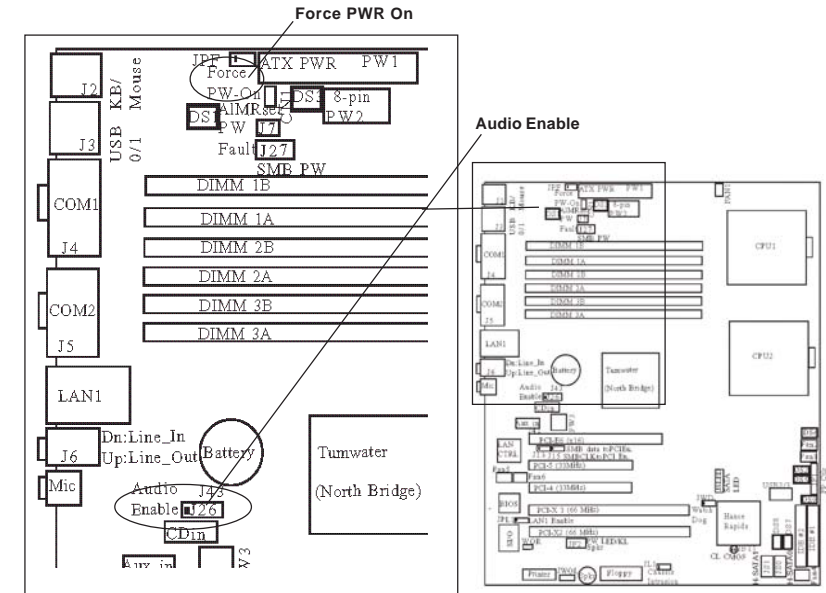

CMOS Clear

JBT1 is used to clear CMOS. Instead of pins, this "jumper" consists of contact pads to prevent the accidental clearing of CMOS. To clear CMOS, use a metal object such as a small screwdriver to touch both pads at the same time to short the connection. Always remove the AC power cord from the system before clearing CMOS. **Note:** For an ATX power supply, you must completely shut down the system, remove the AC power cord and then short JBT1 to clear CMOS.

Watch Dog Enable/Disable

JWD enables the Watch Dog function. Watch Dog is a system monitor that can reboot the system when a software application is "hung up". Pins 1-2 will cause WD to reset the system if an application is "hung up". Pins 2-3 will generate a non-maskable interrupt signal for the application that is "hung up". See the table on the right for jumper settings. Watch Dog can also be enabled via BIOS. (*Note, when enabled, the user needs to write his own application software in order to disable the Watch Dog Timer.)

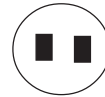

**Watch Dog
Jumper Settings (JWD)**

Jumper Position	Definition
Pins 1-2	WD to Reset
Pins 2-3	WD to NMI
Open	Disabled

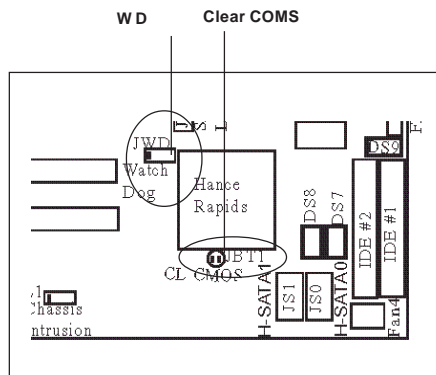
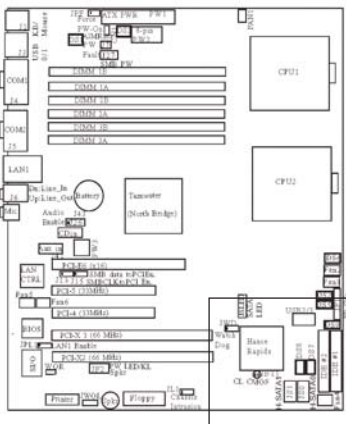

Audio Enable/Disable

J26 enables or disables the Audio Connector on the motherboard. See the table on the right for jumper settings. The default setting is enabled.

**Audio
Enable/Disable
Jumper Settings
(J26)**

Jumper Position	Definition
Pins 1-2	Enabled
Pins 2-3	Disabled

2-7 Onboard Indicators

GLAN LEDs

The Gigabit Ethernet LAN port (located beside the COM Port2) has two LEDs. The yellow LED indicates activity while the other LED may be green, orange or off to indicate the speed of the connection. See the table at right for the functions associated with the second LED.

G-bit LAN Right LED Indicator

LED Color	Definition
Off	No Connection
Green	100 MHz
Orange	1 GHz

SATA LED Header

A Serial ATA LED header is located at JSLED. Connect JSLED for indication of SATA drive activity. See the table on the right for pin definitions.

SATA LED Pin Definitions (JSLED)

Pin#	Definition
1-5	No Connection
6	Intel 6300ESB SATA Activity LED
7	Intel 6300ESB SATA Activity LED
8-9	No Connection

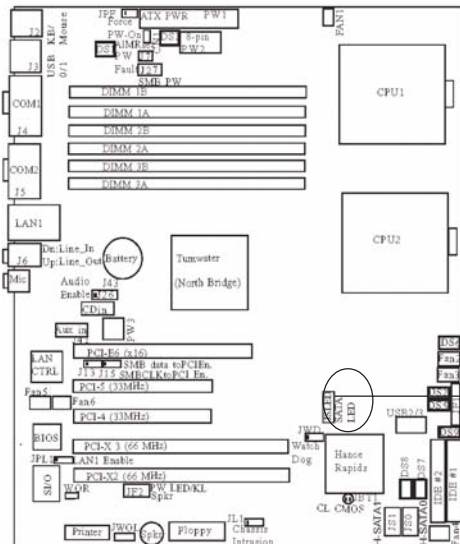

JSLED Header: pin 10 is a key.

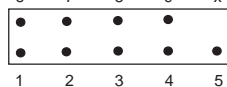

SATA LED

Onboard LED Indicators (DS1-DS8)

In addition to the LAN LED and SATA Header, there are other LED indicators (DS1-DS3, DS5-DS8) on the X6DAL-XG. See the table on the right for pin definitions. (*Note: Please refer to Appendix A for DS7 and DS8 LED POST Codes.)

On board LED Pin Definitions

DS#	Definition
DS1	CPU PWR good or CPU +12V PWR Cable must be connected.
DS2	CPU2 VRM Overheat
DS3	CPU1 VRM Overheat
DS5	PWR LED
DS6	CPU Overheat
DS7-8	POST LED

System Alert LED Indicators (DS9)

In addition to the LED indicators listed above, there is a System Alert LED indicator (DS9) on the X6DAL-XG. See the table on the right for pin definitions.

System Alert LED (DS9) Pin Definitions

DS9	Definition
Green	System: On & OK
Yellow	System: Off, PWR Cable Connected
Red	PWR or CPU Failure

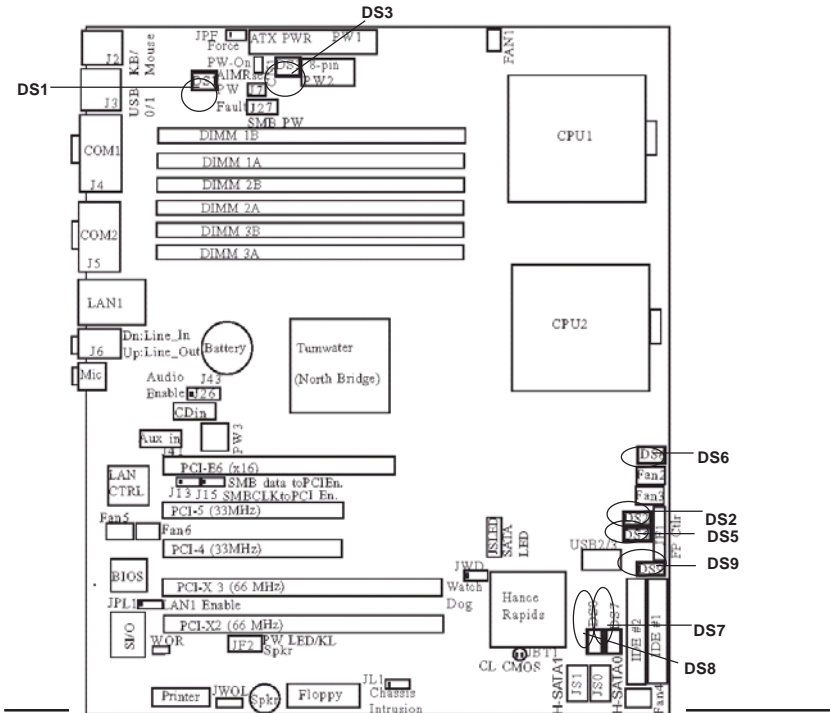

2-8 Parallel Port, Floppy/Hard Disk Drive and SCSI Connections

Note the following when connecting the floppy and hard disk drive cables:

- The floppy disk drive cable has seven twisted wires.
- A red mark on a wire typically designates the location of pin 1.
- A single floppy disk drive ribbon cable has 34 wires and two connectors to provide for two floppy disk drives. The connector with twisted wires always connects to drive A, and the connector that does not have twisted wires always connects to drive B.

Parallel (Printer) Port Connector

There is a parallel (printer) port located on the motherboard. See the table on the right for pin definitions. (*Note: This is a header. You will need to have a Parallel Port cable: CBL_081 to use this connector.)

Parallel (Printer) Port Pin Definitions

Pin Number	Function	Pin Number	Function
1	Strobe	2	Auto Feed-
3	Data Bit 0	4	Error-
5	Data Bit 1	6	Init-
7	Data Bit 2	8	SLCT IN-
9	Data Bit 3	10	GND
11	Data Bit 4	12	GND
13	Data Bit 5	14	GND
15	Data Bit 6	16	GND
17	Data Bit 7	18	GND
19	ACK	20	GND
21	BUSY	22	GND
23	PE	24	GND
25	SLCT	26	NC

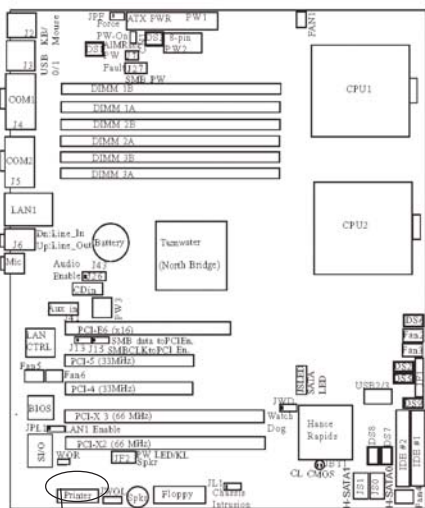

Printer

IDE Connectors

The IDE Connectors are located at J44 (IDE1) and J38 (IDE 2), You do not need to configure jumpers for these connectors. See the table on the right for pin definitions.

IDE Connector Pin Definitions
(J44, J38)

Pin Number	Function	Pin Number	Function
1	Reset IDE	2	GND
3	Host Data 7	4	Host Data 8
5	Host Data 6	6	Host Data 9
7	Host Data 5	8	Host Data 10
9	Host Data 4	10	Host Data 11
11	Host Data 3	12	Host Data 12
13	Host Data 2	14	Host Data 13
15	Host Data 1	16	Host Data 14
17	Host Data 0	18	Host Data 15
19	GND	20	Key
21	DRQ3	22	GND
23	I/O Write-	24	GND
25	I/O Read-	26	GND
27	IOCHRDY	28	BALE
29	DACK3-	30	GND
31	IRQ14	32	IOCS16-
33	Addr 1	34	GND
35	Addr 0	36	Addr 2
37	Chip Select 0	38	Chip Select 1-
39	Activity	40	GND

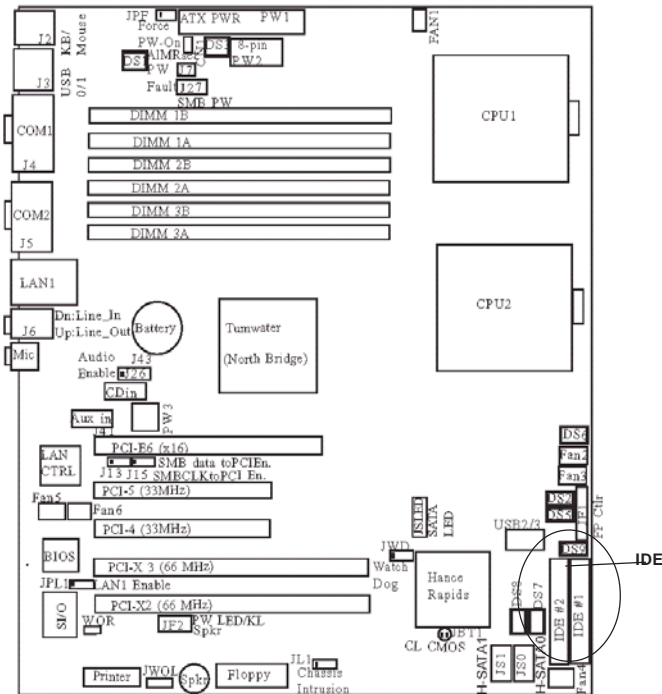

Chapter 3

Troubleshooting

3-1 Troubleshooting Procedures

Use the following procedures to troubleshoot your system. If you have followed all of the procedures below and still need assistance, refer to the 'Technical Support Procedures' and/or 'Returning Merchandise for Service' section(s) in this chapter.

Note: Always disconnect the power cord before adding, changing or installing any hardware components.

Before Power On

1. Make sure that there are no short circuits between the motherboard and chassis.
2. Disconnect all ribbon/wire cables from the motherboard, including those for the keyboard and mouse.
3. Remove all add-on cards.
4. Install one CPU in socket#1 (making sure it is fully seated) and connect the chassis speaker and the power LED to the motherboard. (Check all jumper settings as well.)
5. Use only the correct type of onboard CMOS battery as recommended by the Manufacturer. Do not install the onboard battery upside down to avoid possible explosion.

No Power

1. Make sure that there are no short circuits between the motherboard and the chassis.
2. Make sure that all jumpers are set to their default positions.
3. Check if the 115V/230V switch on the power supply is properly set.
4. Turn the power switch on and off to test the system.
5. The battery on your motherboard may be old. Check to verify that it still supplies ~3VDC. If it does not, replace it with a new one.

No Video

1. If the power is on but you have no video, remove all the add-on cards and cables.
2. Use the speaker to determine if any beep codes exist. Refer to the Appendix for details on beep codes.

NOTE

If you are a system integrator, VAR or OEM, a POST diagnostics card is recommended. For I/O port 80h codes, refer to App. B.

Memory Errors

1. Make sure the DIMM modules are properly and fully installed.
2. Determine if different speeds of DIMMs have been installed and verify that the BIOS setup is configured for the fastest speed of RAM used. It is recommended to use the same RAM speed for all DIMMs in the system.
3. Make sure you are using the correct type of Registered, ECC DDR333/266 (PC2700/PC2100) SDRAM (*recommended by the manufacturer.)
4. Check for bad DIMM modules or slots by swapping a single module between two slots and noting the results.
5. Make sure all memory modules are fully seated in their slots. As an interleaved memory scheme is used, you must install two modules at a time, beginning with DIMM #1A, then DIMM #1B, and so on (see Section 2-3).
6. Check the position of the 115V/230V switch on the power supply.

Losing the System's Setup Configuration

1. Ensure that you are using a high quality power supply. A poor quality power supply may cause the system to lose the CMOS setup information. Refer to Section 1-6 for details on recommended power supplies.
2. The battery on your motherboard may be old. Check to verify that it still supplies ~3VDC. If it does not, replace it with a new one.
3. If the above steps do not fix the Setup Configuration problem, contact your vendor for repairs.

3-2 Technical Support Procedures

Before contacting Technical Support, please take the following steps. Also, note that as a motherboard manufacturer, Super Micro does not sell directly to end-users, so it is best to first check with your distributor or reseller for troubleshooting services. They should know of any possible problem(s) with the specific system configuration that was sold to you.

1. Please go through the 'Troubleshooting Procedures' and 'Frequently Asked Question' (FAQ) sections in this chapter or see the FAQs on our web site (<http://www.supermicro.com/support/faqs/>) before contacting Technical Support.
2. BIOS upgrades can be downloaded from our web site at (<http://www.supermicro.com/support/bios/>).

Note: Not all BIOS can be flashed depending on the modifications to the boot block code.

3. *If you still cannot resolve the problem, include the following information when contacting Super Micro for technical support:*

- Motherboard model and PCB revision number
- BIOS release date/version (this can be seen on the initial display when your system first boots up)
- System configuration

An example of a Technical Support form is on our web site at (<http://www.supermicro.com/support/contact.cfm>).

4. Distributors: For immediate assistance, please have your account number ready when placing a call to our technical support department. We can be reached by e-mail at support@supermicro.com, by phone at: (408) 503-8000, option 2, or by fax at (408)503-8019.

3-3 Frequently Asked Questions

Question: What are the various types of memory that my motherboard can support?

Answer: The X6DAL-XG has six 184-pin DIMM slots that support registered ECC DDR333/266 (PC2700/2100) SDRAM modules. It is strongly recommended that you do not mix memory modules of different speeds and sizes.

Question: How do I update my BIOS?

Answer: It is recommended that you **do not** upgrade your BIOS if you are experiencing no problems with your system. Updated BIOS files are located on our web site at <http://www.supermicro.com>. Please check our BIOS warning message and the information on how to update your BIOS on our web site. Also, check the current BIOS revision and make sure it is newer than your BIOS before downloading.

Question: What's on the CD that came with my motherboard?

Answer: The supplied compact disc has quite a few drivers and programs that will greatly enhance your system. We recommend that you review the CD and install the applications you need. Applications on the CD include chipset drivers for Windows and security and audio drivers. Note: The CD is a bootable disc and can be used to create driver diskettes.

3-4 Returning Merchandise for Service

A receipt or copy of your invoice marked with the date of purchase is required before any warranty service will be rendered. You can obtain service by calling your vendor for a Returned Merchandise Authorization (RMA) number. When returning to the manufacturer, the RMA number should be prominently displayed on the outside of the shipping carton, and mailed prepaid or hand-carried. Shipping and handling charges will be applied for all orders that must be mailed when service is complete.

This warranty only covers normal consumer use and does not cover damages incurred in shipping or from failure due to the alternation, misuse, abuse or improper maintenance of products.

During the warranty period, contact your distributor first for any product problems.

Chapter 4

AMIBIOS

4-1 Introduction

This chapter describes the AMIBIOS for the X6DAL-XG. The AMI ROM BIOS is stored in a Flash EEPROM and can be easily upgraded using a floppy disk-based program. This chapter describes the basic navigation of the AMI BIOS Setup Utility setup screens.

Starting the BIOS Setup Utility

To enter the AMI BIOS Setup Utility screens, hit the <Delete> key while the system is booting-up.

(*Note: In most cases, the <Delete> key is used to invoke the AMI BIOS setup screen. There are a few cases when other keys are used, such as <F1>, <F2>, and so on.)

Each main BIOS menu option is described in this user's guide. The Main BIOS setup menu screen has two main frames. The left frame displays all the options that can be configured. "Grayed-out" options cannot be configured. Options in blue can be configured by the user. The right frame displays the key legend. Above the key legend is an area reserved for a text message. When an option is selected in the left frame, it is highlighted in white. Often a text message will accompany it.

(*Note: The AMI BIOS has default text messages built in. Supermicro retains the option to include, omit, or change any of these text messages.)

The AMI BIOS setup/utility uses a key-based navigation system called hot keys. Most of the AMI BIOS setup utility hot keys can be used at any time during the setup navigation process. These keys include <F1>, <F10>, <Enter>, <ESC>, <Arrow> keys, and so on.

(*Note: Options printed in **Bold** are default settings.)

4-2 Main Setup

When you first enter the AMI BIOS Setup Utility, you will enter the Main setup screen. You can always return to the Main setup screen by selecting the **Main** tab on the top of the screen. The Main BIOS Setup screen is shown below.

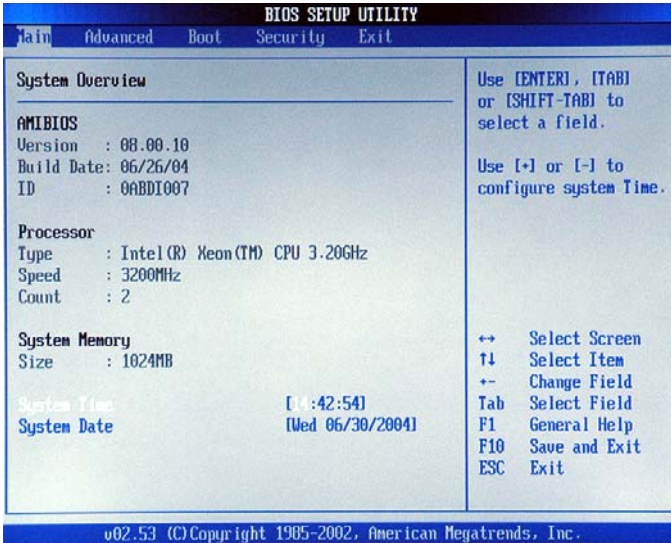

When you select the Main Setup, the following items will be automatically displayed:

System Overview: The following BIOS information will be displayed:

AMI BIOS
Version
Built Date
ID

Processors

When you select this option, the AMI BIOS will automatically display the status of processors as shown in the screen below:

Type
Speed
Count

System Memory

This option allows the AMI BIOS to display the status of memory installed in the system.

Size

This option allows the AMI BIOS to display the size of memory installed in the system.

System Time/System Date

Use this option to change the system time and date. Highlight *System Time* or *System Date* using the <Arrow> keys. Enter new values through the keyboard. Press the <Tab> key or the <Arrow> keys to move between fields. The date must be entered in DAY/MM/DD/YY format. The time is entered in HH:MM:SS format.

(***Note:** The time is in 24-hour format. For example, 5:30 A.M. appears as 05:30:00, and 5:30P.M. as 17:30:00.)

4-3 Advanced Settings

The Advanced Settings screen and sub menus are listed below:

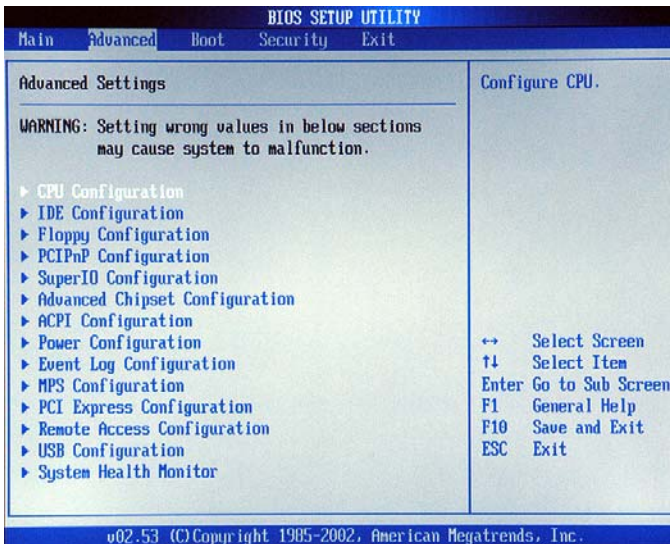

Warning

When you first enter the Advanced Setup screen, the Setup Warning will be displayed. Please follow the instruction and set the correct value for each item to prevent the system from malfunctioning.

►CPU Configuration Sub Menu

Configure Advanced CPU Settings

This option allows the user to configure Advanced CPU settings for the processor(s) installed in the system.

Ratio CMOS Setting

This option allows the user to set the ratio between the CPU Core Clock and the FSB Frequency. (*Note: if an invalid ratio is entered, AMIBIOS will restore the setting to the previous state.)

VID CMOS Setting

This option sets the VID setting for the processor(s).

Max CPUID Value Limit

This feature allows the user to set the maximum CPU ID value. Enable this function to boot legacy OS that cannot support processors with extended CPUID functions. The options are Enabled, and **Disabled**.

Hyper-Threading

This setting allows you to **Enable** or Disable the function of hyper-threading. Enabling hyper-threading results in increased CPU performance.

► IDE Configuration Sub Menu

The screen for the Primary IDE Master is shown below:

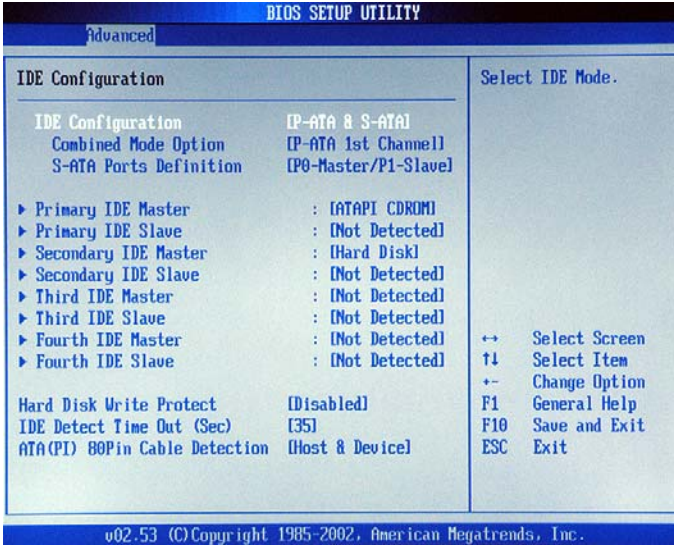

When you select this Sub Menu, the AMI BIOS automatically displays the status of the following items:

Onboard PCI IDE Operate Mode

This feature allows the user to set the Onboard PCI IDE Operation Mode. The options are: Native Mode and **Legacy Mode**. (*Please refer to Addendum D for information on Legacy Mode and Native Mode.)

IDE Configuration

This feature allows the user to set the IDE mode. The options are: Disabled, P-ATA (Parallel ATA) Only, S-ATA (Serial ATA) Only, and **P-ATA & S-ATA**. (*Please refer to Addendum D for Parallel ATA and Serial ATA information.)

P-ATA & S-ATA

Combined Mode Operation

This feature allows the user to select the IDE Combined Mode. The options are: Disabled, P-ATA (Parallel ATA) 1ST Channel and **S-ATA (Serial ATA 1st Channel)**.

S-ATA Ports Definition

This feature allows the user to configure Serial ATA Ports. The options are: **P0-Master/P1-Slave**, P0-Slave/P1-Master.

P-ATA Only

S-ATA Running Enhanced Mode

Select Yes if you want the function of Serial ATA Enhanced Mode to be enabled at all times. Options are **Yes** and No.

P-ATA Channel Selection

This feature allows the user to select which channel to set the Parallel ATA Mode. The options are: Primary, Secondary or **Both**.

S-ATA Ports Definition

This feature allows the user to configure Serial ATA Ports. The options are: **P0-3rd/P1-4th**, P0-4th/P1-3rd.

Configuring S-ATA as RAID

Select Yes to configure Serial ATA as RAID. The options are Yes, and **No**.

S-ATA Only

S-ATA Ports Definition

This feature allows the user to configure Serial ATA Ports. The options are: **P0-1st/P1-2nd**, P0-2nd/P1-1st.

Primary IDE Master/Slave, Secondary IDE Master/Slave, Third IDE Master/Slave, Fourth IDE Master/Slave Sub Menu

From the Advanced Setup screen, press <Enter> to access this sub menu for the primary, secondary, third and fourth IDE master and slave drives. Use this screen to select options for the Primary and Secondary IDE drives. Use the up and down <Arrow> keys to select an item. Use the <Plus> and <Minus> keys to change the value of the selected option.

Type

This feature allows the user to select the type of device connected to the system. The options are Not Installed, **Auto**, CDROM and ARMD.

LBA/Large Mode

LBA (Logical Block Addressing) is a method of addressing data on a disk drive. In the LBA mode, the maximum drive capacity is 137 GB. For drive capacities over 137 GB, your system must be equipped with 48-bit LBA mode addressing. If not, contact your manufacturer or install an ATA/133 IDE controller card that supports 48-bit LBA mode. The options are Disabled or **Auto**.

Block (Multi-Sector Transfer)

Block mode boosts IDE drive performance by increasing the amount of data transferred. Only 512 bytes of data can be transferred per interrupt if block mode is not used. Block mode allows transfers of up to 64 KB per interrupt. Select "Disabled" to allow the data to be transferred from and to the device one sector at a time. Select "Auto" to allow the data transfer from and to the device occur multiple sectors at a time if the device supports it. The options are **Auto** and Disabled.

PIO Mode

IDE PIO (Programmable I/O) mode programs timing cycles between the IDE drive and the programmable IDE controller. As the PIO mode increases, the cycle time decreases. The options are **Auto**, 0, 1, 2, 3, and 4" Select Auto to allow the AMI BIOS to auto detect the PIO mode. Use this value if the IDE disk drive support cannot be determined. Select 0 to allow the AMI BIOS to use PIO mode 0. It has a data transfer rate of 3.3 MBs. Select 1 to allow the AMI BIOS to use PIO mode 1. It has a data transfer rate of 5.2 MBs. Select 2 to allow the AMI BIOS to use PIO mode 2. It has a data transfer rate of 8.3 MBs. Select 3 to allow the AMI BIOS to use PIO mode 3. It has a data transfer rate of 11.1 MBs. Select 4 to allow the AMI BIOS to use PIO mode 4. It has a data transfer rate of 16.6 MBs. This setting generally works with all hard disk drives manufactured after 1999. For other disk drives, such as IDE CD-ROM drives, check the specifications of the drive.

DMA Mode

Select Auto to allow the BIOS to auto detect the DMA mode. Use this value if the IDE disk drive support cannot be determined. Select SWDMA0

to allow the BIOS to use Single Word DMA mode 0. It has a data transfer rate of 2.1 MBs. Select SWDMA1 to allow the BIOS to use Single Word DMA mode 1. It has a data transfer rate of 4.2 MBs. Select SWDMA2 to allow the BIOS to use Single Word DMA mode 2. It has a data transfer rate of 8.3 MBs. Select MWDMA0 to allow the BIOS to use Multi Word DMA mode 0. It has a data transfer rate of 4.2 MBs. Select MWDMA1 to allow the BIOS to use Multi Word DMA mode 1. It has a data transfer rate of 13.3 MBs. Select MWDMA2 to allow the BIOS to use Multi-Word DMA mode 2. It has a data transfer rate of 16.6 MBs. Select UDMA0 to allow the BIOS to use Ultra DMA mode 0. It has a data transfer rate of 16.6 MBs. It has the same transfer rate as PIO mode 4 and Multi Word DMA mode 2. Select UDMA1 to allow the BIOS to use Ultra DMA mode 1. It has a data transfer rate of 25 MBs. Select UDMA2 to allow the BIOS to use Ultra DMA mode 2. It has a data transfer rate of 33.3 MBs. Select UDMA3 to allow the BIOS to use Ultra DMA mode 3. It has a data transfer rate of 66.6 MBs. Select UDMA4 to allow the BIOS to use Ultra DMA mode 4 . It has a data transfer rate of 100 MBs. The options are **Auto**, SWDMA_n, MWDMA_n, and UDMA_n.

S.M.A.R.T. For Hard disk drives

Self-Monitoring Analysis and Reporting Technology (SMART) can help predict impending drive failures. Select "Auto" to allow the BIOS to auto detect hard disk drive support. Select "Disabled" to prevent the AMI BIOS from using the S.M.A.R.T. Select "Enabled" to allow the AMI BIOS to use the S.M.A.R.T. to support hard drive disk. The options are Disabled, Enabled, and **Auto**.

32Bit Data Transfer

Select "Enabled" to activate the function of 32-Bit data transfer. Select "Disabled" to deactivate the function. The options are Enabled and **Disabled**.

Hard Disk Write Protect

Select Enabled to enable the function of Hard Disk Write Protect to prevent data from being written to HDD. The options are Enabled or **Disabled**.

IDE Detect Time Out

This feature allows the user to set the time-out value for detecting ATA, ATA PI devices installed in the system. The options are 0 (sec), 5, Mode 1.0, 15, 20, 25, 30, and **35**.

ATA(PI) 80Pin Cable Detection

This feature allows the AMI BIOS to auto-detect 80Pin ATA(PI) Cable. The options are: **Host & Device**, Host and Device.

►Floppy Configuration

This option allows the user to configure the settings for the Floppy Drives installed in the system.

Floppy A

Move the cursor to these fields via up and down <arrow> keys to select the floppy type. The options are Disabled, 360 KB 5 1/4", 1.2 MB 5 1/4", 720 KB 3 1/2", 1.44 MB 3 1/2", and 2.88 MB 3 1/2". Default setting for Floppy A drive is **1.44 MB 3 1/2"**.

OnBoard Floppy Controller

Select "Enabled" to enable the Onboard Floppy Controller. The options are "Disabled", and "**Enabled.**"

► PCI/PnP Configuration

This feature allows the user to set PCI/PnP configurations for the following items:

Plug & Play OS

Select Yes to allow the OS to configure Plug & Play devices. (*This is not required for system boot if you system has an OS that supports Plug & Play.) Select No to allow the AMIBIOS to configure all devices in the system.

PCI Latency Timer

This option sets the latency of all PCI devices on the PCI bus. Select "32" to set the PCI latency to 32 PCI clock cycles. Select "64" to set the PCI latency to 64 PCI clock cycles. Select "96" to set the PCI latency to 96 PCI clock cycles. Select "128" to set the PCI latency to 128 PCI clock cycles. Select "160" to set the PCI latency to 160 PCI clock cycles. Select "192" to set the PCI latency to 192 PCI clock cycles. Select "224" to set the PCI latency to 224 PCI clock cycles. Select "248" to set the PCI latency to 248 PCI clock cycles.

Allocate IRQ to PCI VGA

Set this value to allow or restrict the system from giving the VGA adapter card an interrupt address. The options are **Yes** and **No**.

Palette Snooping

Select Enabled to inform the PCI devices that an ISA graphics device is installed in the system in order for the graphics card to function properly. The options are Enabled or **Disabled**.

PCI IDE BusMaster

Set this value to allow or prevent the use of PCI IDE busmastering. Select "Enabled" to allow the AMI BIOS to use PCI busmaster for reading and writing to IDE drives. The options are **"Disabled"** and "Enabled".

Offboard PCI/ISA IDE Card

This option allows the user to assign a PCI slot number to an Off-board PCI/ISA IDE card in order for it to function properly. The options are: **Auto**, PCI Slot1, PCI Slot2, PCI Slot3, PCI Slot4, PCI Slot5, and PCI Slot6.

IRQ3/IRQ4/IRQ5/IRQ7/IRQ9/IRQ10/IRQ11/IRQ14

This feature specifies the availability of an IRQ to be used by a PCI, PnP device. Select Reserved for the IRQ to be used by a Legacy ISA device. The options are: **Available**, Reserved.

DMA Channel 0/DMA Channel 1/DMA Channel 3/DMA Channel 5/DMA Channel 6/DMA Channel 7

Select **Available** to indicate that a specific DMA channel is available to be used by a PCI/PnP device. Select Reserved, if the DMA channel specified is reserved for a Legacy ISA device.

Reserved Memory Size

This feature specifies the size of memory block to be reserved for Legacy ISA devices. The options are: **Disabled**, 16K, 32K, 64K.

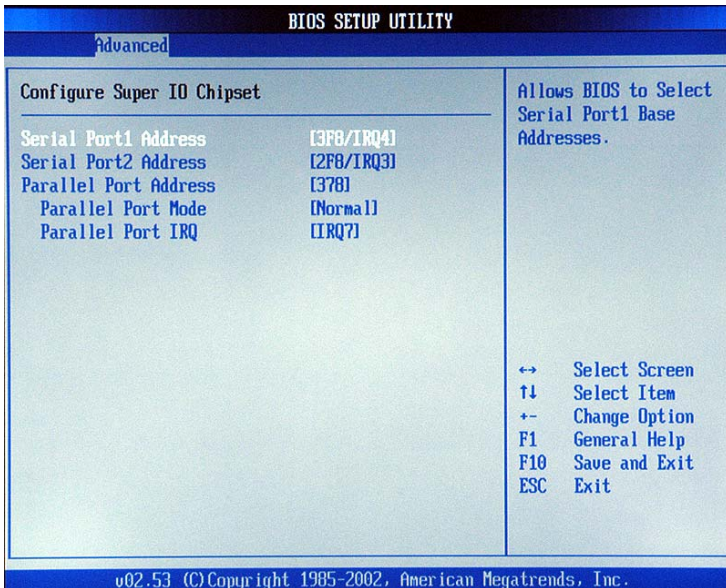
► Super IO Configuration Sub Menu

Serial Port1 Address

This option specifies the base I/O port address and Interrupt Request address of serial port 1. Select "Disabled" to prevent the serial port from accessing any system resources. When this option is set to *Disabled*, the serial port physically becomes unavailable. Select "3F8/IRQ4" to allow the serial port to use 3F8 as its I/O port address and IRQ 4 for the interrupt address. The options are Disabled, **3F8/IRQ4**, 3E8/IRQ4, 2E8/IRQ3.

Serial Port2 Address

This option specifies the base I/O port address and Interrupt Request address of serial port 2. Select "Disabled" to prevent the serial port from accessing any system resources. When this option is set to "Disabled", the serial port physically becomes unavailable. Select "2F8/IRQ3" to allow the serial port to use 2F8 as its I/O port address and IRQ 3 for the interrupt address. The options are Disabled, **2F8/IRQ3**, 3E8/IRQ4, 2E8/IRQ3.

Parallel Port Address

This option specifies the I/O address used by the parallel port. Select Disabled to prevent the parallel port from accessing any system resources. When the value of this option is set to Disabled, the printer port becomes unavailable. Select **378** to allow the parallel port to use 378 as its I/O port address. The majority of parallel ports on computer systems use IRQ7 and I/O Port 378H as the standard setting. Select 278 to allow the parallel port to use 278 as its I/O port address. Select 3BC to allow the parallel port to use 3BC as its I/O port address.

Parallel Port Mode

Specify the parallel port mode. The options are **Normal**, Bi-directional, EPP and ECP.

Parallel Port IRQ

Select the IRQ (interrupt request) for the parallel port. The options are IRQ5 and **IRQ7**.

►Advanced Chipset Settings

This item allows the user to configure the Advanced Chipset settings for the system.

►NorthBridge Configuration

This feature allows the user to configure the settings for Intel Lindenhurst NorthBridge chipset.

Memory Remap Feature

Select Enabled to allow remapping of overlapped PCI memory above the total physical memory. The options are **Enabled** and Disabled.

Memory Mirroring and Sparing

Select Enabled to enable Memory RAS (-Mirroring and Sparing) to allow the system to create a mirror copy of data written to the memory for data security. The options are **Disabled** and Enabled.

►SouthBridge Configuration

This feature allows the user to configure the settings for Intel ICH SouthBridge chipset.

CPU B.I.S.T. Enable

Select Enabled to enable the function of CPU Built In Self Test. The options are Enabled and **Disabled**.

ICH Delayed Transaction

Select Enabled to enable the function of ICH Delayed Transaction to provide back-compatibility for slower components . The options are **Enabled** and Disabled.

ICH DCB Enable

Select Enabled to enable ICH DMA Collection Buffer. The options are **Enabled** and Disabled.

Onboard AC' 97 Audio

Select Auto to enable the function of Onboard AC'97 automatically. The options are **Auto**, Enabled and Disabled.

►ACPI Configuration

This item allows the user to enable or disable ACPI support for the operating system.

General ACPI Configuration

Use this feature to configure additional ACPI options. Select "Yes" if the operating system supports ACPI. Select No if the operating system does not support ACPI. The options are No and **Yes**.

Suspend Mode

This feature allows the user to select the ACPI state when the system is on the Suspend Mode. Select S1 if you want the system to standby. Select S3 to enable the function of Suspend to RAM, which will shorten bootup time after poweroff. The options are **S1(POS)** and S1&S3 (STR).

Advanced ACPI Configuration

Use this feature to configure additional ACPI options. Select "Yes" if the operating system supports ACPI. Select No if the operating system does not support ACPI. The options are No and **Yes**.

ACPI 2.0 Features

Select Yes to allow RSDP pointers to point to the 64-bit Fixed System Description Tables. Select No to deactivate this function. The options are Yes and **No**.

ACPI APIC Support

Select Enabled to allow the ACPI APIC Table Pointer to be included in the RSDP pointer list. The options are **Enable**, and Disabled.

AMI OEMB Table

Select Enabled to allow the OEMB Table Pointer to be included in the R(x)SDT pointer lists. The options are **Enabled**, and Disabled.

Headless Mode

Select Enabled to activate the Headless Operation Mode through ACPI, which will allow the system to boot up and function properly without keyboard and monitor display. The options are Enabled, and **Disabled**.

► Power Configuration

This feature allows the user to configure PnP settings.

Power Button Mode

This setting allows you to decide if the power button will go into the On/Off mode or the Suspend mode if it is pressed. The options are **On/Off** and **Suspend**.

Restore on AC Power Loss

This setting allows you to choose how the system will react when power returns after an unexpected loss of power. The options are **Power Off**, **Power On** and **Last State**.

Watch Dog Timer

This setting is used to enable or disabled the Watch Dog Timer function. It must be used in conjunction with the WD jumper (see Chapter 2 for details). The options are **Enabled** and **Disabled**.

► Event Log Configuration

Highlight this item and press <Enter> to view the contents of the event log.

View Event Log

This feature allows the user to view all unread events.

Mark All Events as Read

Highlight this item and press <Enter> to mark the DMI events as read.

Clear Event Logs

This setting will clear all event logs when set to "OK". The options are "OK" and "**Cancel**".

ECC Event Logging

This setting allows you to enable or disable ECC Event logging. The options are **Enabled** or **Disabled**.

Hub Interface Event Logging

This setting allows you to enable or disable Hub Interface Event logging. The options are **Enabled** or **Disabled**.

System Bus Event Logging

This setting allows you to enable or disable System Bus Event logging. The options are **Enabled** or **Disabled**.

Memory Buffer Event Logging

This setting allows you to enable or disable Memory Buffer Event logging. The options are Enabled or **Disabled**.

PCI Error Logging

This setting allows you to enable or disable PCI Error logging. The options are Enabled or **Disabled**.

PCI Express Error Logging

This setting allows you to enable or disable PCI Express Error logging. The options are Enabled or **Disabled**.

►MPS Configuration

This section allows the user to configure the multi-processor table.

MPS Revision

This feature allows the user to select MPS Revision. The options are 1.1 or 1.4.

►PCI Express Configuration

This section allows the user to configure PCI Express slots.

Active State Power Management

Select Enabled to activate the function of power management for signal transactions between PCI Express L0 and L1 Link. The options are Enabled and **Disabled**.

I/O Expander Mode

This feature allows the user to set the IO Expand Mode for Hot Plug support. The options are **PCA9555**, Two PCA9554, One PCA9554 (Low), One PCA9554 (High), Two PCA9554A, One PCA9554A (Low), and One PCA9554 (High).

PCI Express Port2 (Slot 1)

This feature allows the user to configure the PCI Express slot. The options are Auto, **Enabled**, and Disabled.

PCI Express Port4 (Slot 6)

This feature allows the user to configure the PCI Express slot. The options are Auto, **Enabled**, and Disabled.

PCI Express Compliance Mode

Select Enabled to enable MCH to activate PCI Express Compliance Mode. The options are **Disabled** and Enabled.

Spread Spectrum

Select Enabled to enable Spread Spectrum. The options are **Disabled** and Enabled.

► Remote Access Configuration

You can use this screen to select options for the Remote Access Configuration. Use the up and down <Arrow> keys to select an item. Use the <Plus> and <Minus> keys to change the value of the selected option.

Remote Access

This feature allows the user to disable the function of Remote Access. If Disabled is not select, then you can select a Remote Access type. The options are Enabled or **Disabled**.

► USB Configuration

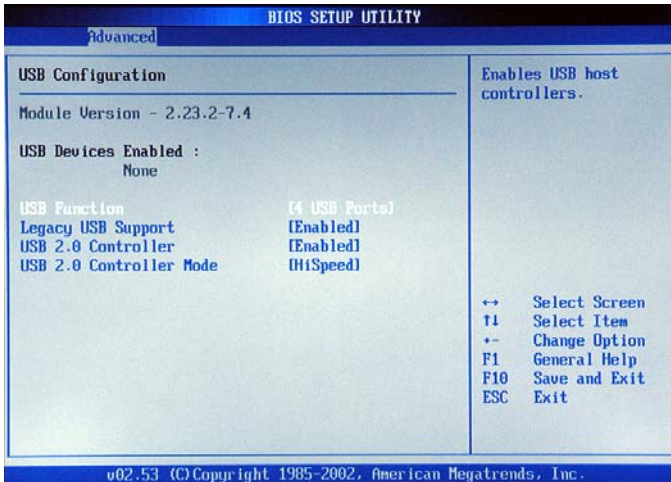

USB Function

This feature allows you to enable 2 USB Ports or 4 USB Ports. The options are Disabled, 2 USB Ports, and **4 USB Ports**.

Legacy USB Support

Select "Enabled" to enable the support for USB Legacy. Disable legacy support if there are no USB devices installed in the system. The options are Disabled, **Enabled** and Auto.

USB 2.0 Controller

This setting allows you to enable or disable USB 2.0 Controller. The options are Disabled or **Enabled**.

USB 2.0 Controller Mode

This setting allows you to configure USB 2.0 Controller Mode. The options are **Hi-Speed (480 Mbps)** or Full Speed-12Mbps.

► System Health Monitor

This feature allows the AMI BIOS to automatically display the status of the following items:

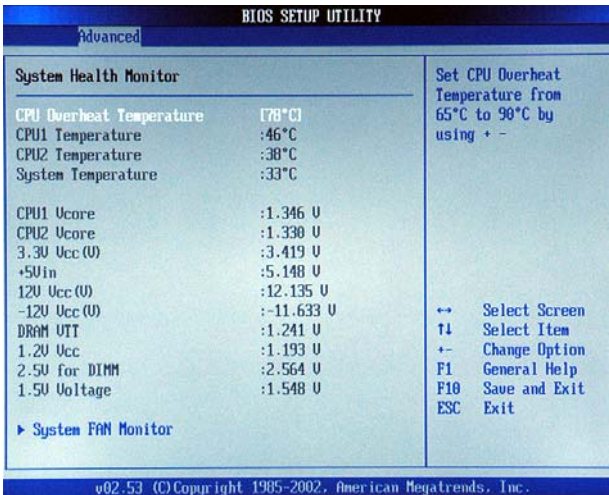

System Health Function

Select "Enabled" to enable the function of Hardware Health Monitoring Device. The options are "Enabled" and "Disabled."

CPU Temperature

The feature allows the user to set the CPU temperature threshold. The options range from 65°C to 90°C. The default setting is **78°C**. (*Note below.)

If System Health Function is enabled, the BIOS will automatically display the status of the following items:

CPU1 Temperature, CPU2 Temperature, System Temperature

Note: In the Windows OS environment, the Supero Doctor III settings take precedence over the BIOS settings. When first installed, the SD III adopts the temperature threshold settings previously set in the BIOS. Any subsequent changes to these thresholds must be made within Supero Doctor, since the SDIII settings override the BIOS settings. For the Windows OS to adopt the BIOS temperature threshold settings, please change the SDIII settings to be the same as those set in the BIOS.

The AMI BIOS will automatically display the following information:

CPU1 VCORE/CPU2 VCORE (*for 2U systems),3.3V Vcc(V), +5 Vin, 12V Vcc(V), -12V Vcc (V), DRAM VTT, 1.2V Vcc, 2.5V for DIMM, 1.5V Standby Power

System Fan Control:

If Enabled, the AMI BIOS will automatically monitor and display the speeds of Fan1 Speed to Fan6

4-4 Boot Settings

This item allows the user to configure the boot settings for the system.

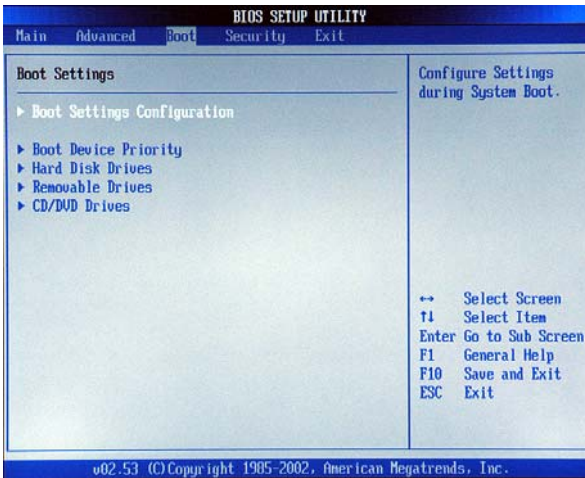
**Quick Boot**

Select Enabled to allow the AMI BIOS to skip certain tests during POST in order to shorten the time needed for the system to bootup. The options are **Enabled**, and Disabled.

Quiet Boot

Set this value to allow the boot up screen options to be modified between POST messages or OEM logo. The default setting is **Enabled**. Select Disabled to allow the computer system to display the POST messages. Select Enabled to allow the computer system to display the OEM logo.

Add-On ROM Display Mode

Set this option to display add-on ROM (read-only memory) messages. The default setting is **Force BIOS**. Select "Force BIOS" to allow the computer system to force a third party BIOS to display during system boot. Select "Keep Current" to allow the computer system to display the BIOS information during system boot. The options are Force BIOS and Keep Current.

Boot up Num-Lock

Set this value to allow the Number Lock setting to be modified during boot up. The default setting is **On**. The options are On and Off.

PS/2 Mouse Support

Set this value to allow the PS/2 mouse support to be modified. The options are **Auto**, Enabled and Disabled.

Wait for 'F1' If Error

Select Enable to activate the function of Wait for F1 if Error. The options are **Enabled** and Disabled.

Hit 'DEL' Message Display

Select Enabled to display Setup Message when the user hits the DEL key. The options are **Enabled** and Disabled.

Interrupt 19 Capture

Select Enabled to allow ROMs to trap Interrupt 19. The options are Enabled and **Disabled**.

► **Boot Device Priority**

This feature allows the user to specify the sequence of priority for the Boot Device.

The settings are "1st Floppy Drive", "CD ROM", "HDD", and "Disabled." The default settings are:

- 1st boot device – 1st Floppy Drive
- 2nd boot device – CD ROM
- 3rd boot device – HDD
- 4th boot device – IBA GE Slot 02180

► **Hard Disk Drives**

This feature allows the user to specify the Boot sequence from available Hard Drives.

1st Drive/2nd Drive

Specify the boot sequence for 1st Hard Drive. The options are HDD and Disabled.

► **Removable Drives**

This feature allows the user to specify the Boot sequence from available Removable Drives.

1st Drive

Specify the boot sequence for 1st Removable Drive. The options are **1st Floppy Drive** and Disabled.

► **CD/DVD Drives**

This feature allows the user to specify the boot sequence from available CDROM Drives.

1st Drive

Specify the boot sequence for 1st Hard Drive. The options are **CD ROM** and Disabled.

4-5 Security Settings

the AMI BIOS provides a Supervisor and a User password. If you use both passwords, the Supervisor password must be set first.

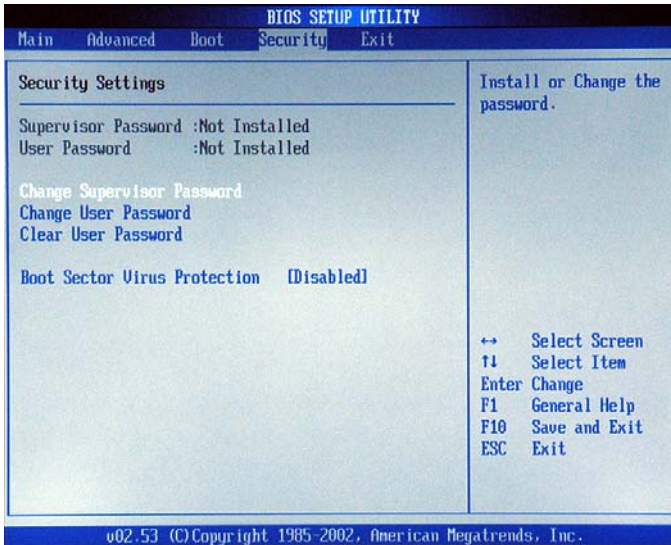

Change Supervisor Password

Select this option and press <Enter> to access the sub menu, and then, type in the password.

Change User Password

Select this option and press <Enter> to access the sub menu, and then, type in the password.

Clear User Password

Select this option and press <Enter> to access the sub menu. You can use the sub menu to clear the user password.

Boot Sector Virus Protection

This option is near the bottom of the Security Setup screen. Select "Disabled" to deactivate the Boot Sector Virus Protection. Select "Enabled" to enable boot sector protection. When "Enabled", the AMI BIOS displays a warning when any program (or virus) issues a Disk Format command or attempts to write to the boot sector of the hard disk drive. The options are "Enabled" and "**Disabled**".

4-6 Exit Options

Select the Exit tab from the AMI BIOS Setup Utility screen to enter the Exit the BIOS Setup screen.

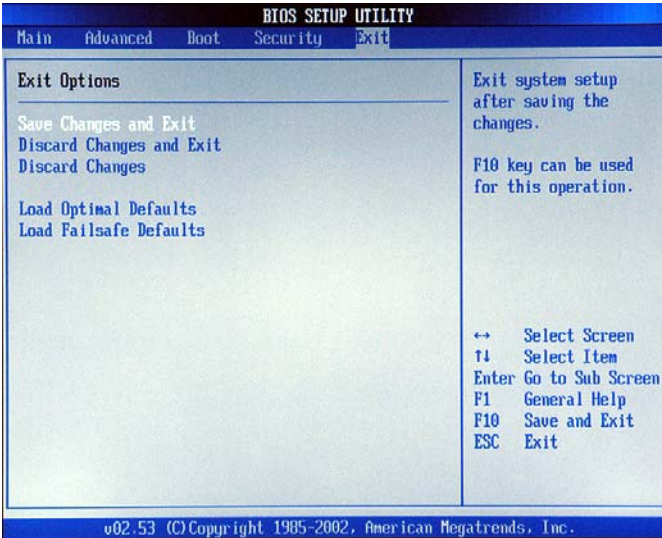

Saving Changes and Exit

When you have completed the system configuration changes, select this option to leave the BIOS Setup and reboot the computer, so the new system configuration parameters can take effect. Select Save Changes and Exit from the Exit menu and press <Enter>.

Discard Changes and Exit

Select this option to quit the BIOS Setup without making any permanent changes to the system configuration and reboot the computer. Select Discard Changes and Exit from the Exit menu and press <Enter>.

Discard Changes

Select this option and press <Enter> to discard all the changes and return to the AMI BIOS Utility Program.

Load Optimal Defaults

To set this feature, select Load Optimal Defaults from the Exit menu and press <Enter>. Then, Select "OK" to allow the BIOS to automatically load Optimal Defaults to the BIOS Settings. The Optimal settings are designed for maximum system performance, but may not work best for all computer applications.

Load Fail-Safe Defaults

To set this feature, select Load Fail-Safe Defaults from the Exit menu and press <Enter>. The Fail-Safe settings are designed for maximum system stability, but not maximum performance.

Appendix A

BIOS Error Beep/POST Codes

During the POST (Power-On Self-Test) routines, which are performed each time the system is powered on, errors may occur.

Non-fatal errors are those which, in most cases, allow the system to continue the boot-up process. The error messages normally appear on the screen.

Fatal errors are those which will not allow the system to continue the boot-up procedure. If a fatal error occurs, you should consult with your system manufacturer for possible repairs.

These fatal errors are usually communicated through a series of audible beeps. The numbers on the fatal error list, on the following page, correspond to the number of beeps for the corresponding error. All errors listed, with the exception of Beep Code 8, are fatal errors.

POST codes may be read on the debug LEDs located beside the LAN port on the motherboard backplane. See the description of the Debug LEDs (LED1 and LED2) in Section 2-6.

A-1 AMIBIOS Error Beep Codes

Beep Code	Error Message	Description
1 beep	Refresh	Circuits have been reset. (Ready to power up.)
5 short, 1 long	Memory error	No memory detected in system
8 beeps	Display memory read/write error	Video adapter missing or with faulty memory

A-2 DS7/DS8 LED Post Codes

LED Indicators		Description/Message
DS7	DS8	
On	On	PWR On
On	Off	SPD Read OK
Off	On	Memory Size-OK
Off	Off	Starting Bus Initialization

Appendix B

BIOS POST Checkpoint Codes

When AMIBIOS performs the Power On Self Test, it writes checkpoint codes to I/O port 0080h. If the computer cannot complete the boot process, diagnostic equipment can be attached to the computer to read I/O port 0080h.

B-1 Uncompressed Initialization Codes

The uncompressed initialization checkpoint codes are listed in order of execution:

Checkpoint	Code Description
D0h	The NMI is disabled. Power on delay is starting. Next, the initialization code checksum will be verified.
D1h	Initializing the DMA controller, performing the keyboard controller BAT test, starting memory refresh, and entering 4 GB flat mode next.
D3h	Starting memory sizing next.
D4h	Returning to real mode. Executing any OEM patches and setting the Stack next.
D5h	Passing control to the uncompressed code in shadow RAM at E000:0000h. The initialization code is copied to segment 0 and control will be transferred to segment 0.
D6h	Control is in segment 0. Next, checking if <Ctrl> <Home> was pressed and verifying the system BIOS checksum. If either <Ctrl> <Home> was pressed or the system BIOS checksum is bad, next will go to checkpoint code E0h. Otherwise, going to checkpoint code D7h.

B-2 Bootblock Recovery Codes

The bootblock recovery checkpoint codes are listed in order of execution:

Checkpoint	Code	Description
E0h		The onboard floppy controller if available is initialized. Next, beginning the base 512 KB memory test.
E1h		Initializing the interrupt vector table next.
E2h		Initializing the DMA and Interrupt controllers next.
E6h		Enabling the floppy drive controller and Timer IRQs. Enabling internal cache memory.
Edh		Initializing the floppy drive.
Eeh		Looking for a floppy diskette in drive A:. Reading the first sector of the diskette.
Efh		A read error occurred while reading the floppy drive in drive A:.
F0h		Next, searching for the AMIBOOT.ROM file in the root directory.
F1h		The AMIBOOT.ROM file is not in the root directory.
F2h		Next, reading and analyzing the floppy diskette FAT to find the clusters occupied by the AMIBOOT.ROM file.
F3h		Next, reading the AMIBOOT.ROM file, cluster by cluster.
F4h		The AMIBOOT.ROM file is not the correct size.
F5h		Next, disabling internal cache memory.
FBh		Next, detecting the type of flash ROM.
FCh		Next, erasing the flash ROM.
FDh		Next, programming the flash ROM.
FFh		Flash ROM programming was successful. Next, restarting the system BIOS.

B-3 Uncompressed Initialization Codes

The following runtime checkpoint codes are listed in order of execution.

These codes are uncompressed in F0000h shadow RAM.

Checkpoint	Code	Description
03h		The NMI is disabled. Next, checking for a soft reset or a power on condition.
05h		The BIOS stack has been built. Next, disabling cache memory.
06h		Uncompressing the POST code next.
07h		Next, initializing the CPU and the CPU data area.
08h		The CMOS checksum calculation is done next.
0Ah		The CMOS checksum calculation is done. Initializing the CMOS status register for date and time next.
0Bh		The CMOS status register is initialized. Next, performing any required

	initialization before the keyboard BAT command is issued.
0Ch	The keyboard controller input buffer is free. Next, issuing the BAT command to the keyboard controller.
0Eh	The keyboard controller BAT command result has been verified. Next, performing any necessary initialization after the keyboard controller BAT command test.
0Fh	The initialization after the keyboard controller BAT command test is done. The keyboard command byte is written next.
10h	The keyboard controller command byte is written. Next, issuing the Pin 23 and 24 blocking and unblocking command.
11h	Next, checking if <End or <Ins> keys were pressed during power on. Initializing CMOS RAM if the <i>Initialize CMOS RAM in every boot</i> AMIBIOS POST option was set in AMIBCP or the <End> key was pressed.
12h	Next, disabling DMA controllers 1 and 2 and interrupt controllers 1 and 2.
13h	The video display has been disabled. Port B has been initialized. Next, initializing the chipset.
14h	The 8254 timer test will begin next.
19h	The 8254 timer test is over. Starting the memory refresh test next.
1Ah	The memory refresh line is toggling. Checking the 15 second on/off time next.
2Bh	Passing control to the video ROM to perform any required configuration before the video ROM test.
2Ch	All necessary processing before passing control to the video ROM is done. Looking for the video ROM next and passing control to it.
2Dh	The video ROM has returned control to BIOS POST. Performing any required processing after the video ROM had control.
23h	Reading the 8042 input port and disabling the MEGAKEY Green PC feature next. Making the BIOS code segment writable and performing any necessary configuration before initializing the interrupt vectors.
24h	The configuration required before interrupt vector initialization has completed. Interrupt vector initialization is about to begin.

Checkpoint	Code	Description
25h		Interrupt vector initialization is done. Clearing the password if the POST DIAG switch is on.
27h		Any initialization before setting video mode will be done next.
28h		Initialization before setting the video mode is complete. Configuring the monochrome mode and color mode settings next.
2Ah		Bus initialization system, static, output devices will be done next, if present. See the last page for additional information.
2Eh		Completed post-video ROM test processing. If the EGA/VGA controller is not found, performing the display memory read/write test next.
2Fh		The EGA/VGA controller was not found. The display memory read/write test is about to begin.
30h		The display memory read/write test passed. Look for retrace checking next.
31h		The display memory read/write test or retrace checking failed. Performing the alternate display memory read/write test next.
32h		The alternate display memory read/write test passed. Looking for alternate display retrace checking next.
34h		Video display checking is over. Setting the display mode next.
37h		The display mode is set. Displaying the power on message next.
38h		Initializing the bus input, IPL, general devices next, if present. See the last page of this chapter for additional information.
39h		Displaying bus initialization error messages. See the last page of this chapter for additional information.
3Ah		The new cursor position has been read and saved. Displaying the <i>Hit </i> message next.
3Bh		The <i>Hit </i> message is displayed. The protected mode memory test is about to start.
40h		Preparing the descriptor tables next.
42h		The descriptor tables are prepared. Entering protected mode for the memory test next.
43h		Entered protected mode. Enabling interrupts for diagnostics mode next.
44h		Interrupts enabled if the diagnostics switch is on. Initializing data to check memory wraparound at 0:0 next.
45h		Data initialized. Checking for memory wraparound at 0:0 and finding the total system memory size next.
46h		The memory wraparound test is done. Memory size calculation has been done. Writing patterns to test memory next.
47h		The memory pattern has been written to extended memory. Writing patterns to the base 640 KB memory next.

Checkpoint	Code	Description
48h		Patterns written in base memory. Determining the amount of memory below 1 MB next.
49h		The amount of memory below 1 MB has been found and verified. Determining the amount of memory above 1 MB memory next.
4Bh		The amount of memory above 1 MB has been found and verified. Checking for a soft reset and clearing the memory below 1 MB for the soft reset next. If this is a power on situation, going to checkpoint 4Eh next.
4Ch		The memory below 1 MB has been cleared via a soft reset. Clearing the memory above 1 MB next.
4Dh		The memory above 1 MB has been cleared via a soft reset. Saving the memory size next. Going to checkpoint 52h next.
4Eh		The memory test started, but not as the result of a soft reset. Displaying the first 64 KB memory size next.
4Fh		The memory size display has started. The display is updated during the memory test. Performing the sequential and random memory test next.
50h		The memory below 1 MB has been tested and initialized. Adjusting the displayed memory size for relocation and shadowing next.
51h		The memory size display was adjusted for relocation and shadowing. Testing the memory above 1 MB next.
52h		The memory above 1 MB has been tested and initialized. Saving the memory size information next.
53h		The memory size information and the CPU registers are saved. Entering real mode next.
54h		Shutdown was successful. The CPU is in real mode. Disabling the Gate A20 line, parity, and the NMI next.
57h		The A20 address line, parity, and the NMI are disabled. Adjusting the memory size depending on relocation and shadowing next.
58h		The memory size was adjusted for relocation and shadowing. Clearing the <i>Hit </i> message next.
59h		The <i>Hit </i> message is cleared. The <i><WAIT...></i> message is displayed. Starting the DMA and interrupt controller test next.

Checkpoint	Code	Description
60h		The DMA page register test passed. Performing the DMA Controller 1 base register test next.
62h		The DMA controller 1 base register test passed. Performing the DMA controller 2 base register test next.
65h		The DMA controller 2 base register test passed. Programming DMA controllers 1 and 2 next.
66h		Completed programming DMA controllers 1 and 2. Initializing the 8259 interrupt controller next.
67h		Completed 8259 interrupt controller initialization.
7Fh		Extended NMI source enabling is in progress.
80h		The keyboard test has started. Clearing the output buffer and checking for stuck keys. Issuing the keyboard reset command next.
81h		A keyboard reset error or stuck key was found. Issuing the keyboard controller interface test command next.
82h		The keyboard controller interface test completed. Writing the command byte and initializing the circular buffer next.
83h		The command byte was written and global data initialization has completed. Checking for a locked key next.
84h		Locked key checking is over. Checking for a memory size mismatch with CMOS RAM data next.
85h		The memory size check is done. Displaying a soft error and checking for a password or bypassing WINBIOS Setup next.
86h		The password was checked. Performing any required programming before WINBIOS Setup next.
87h		The programming before WINBIOS Setup has completed. Uncompressing the WINBIOS Setup code and executing the AMIBIOS Setup or WINBIOS Setup utility next.
88h		Returned from WINBIOS Setup and cleared the screen. Performing any necessary programming after WINBIOS Setup next.
89h		The programming after WINBIOS Setup has completed. Displaying the power on screen message next.
8Bh		The first screen message has been displayed. The <WAIT...> message is displayed. Performing the PS/2 mouse check and extended BIOS data area allocation check next.
8Ch		Programming the WINBIOS Setup options next.
8Dh		The WINBIOS Setup options are programmed. Resetting the hard disk controller next.
8Fh		The hard disk controller has been reset. Configuring the floppy drive controller next.
91h		The floppy drive controller has been configured. Configuring the hard disk drive controller next.

Checkpoint	Code	Description
95h		Initializing the bus option ROMs from C800 next. See the last page of this chapter for additional information.
96h		Initializing before passing control to the adaptor ROM at C800.
97h		Initialization before the C800 adaptor ROM gains control has completed. The adaptor ROM check is next.
98h		The adaptor ROM had control and has now returned control to BIOS POST. Performing any required processing after the option ROM returned control.
99h		Any initialization required after the option ROM test has completed. Configuring the timer data area and printer base address next.
9Ah		Set the timer and printer base addresses. Setting the RS-232 base address next.
9Bh		Returned after setting the RS-232 base address. Performing any required initialization before the Coprocessor test next.
9Ch		Required initialization before the Coprocessor test is over. Initializing the Coprocessor next.
9Dh		Coprocessor initialized. Performing any required initialization after the Coprocessor test next.
9Eh		Initialization after the Coprocessor test is complete. Checking the extended keyboard, keyboard ID, and Num Lock key next. Issuing the keyboard ID command next.
A2h		Displaying any soft errors next.
A3h		The soft error display has completed. Setting the keyboard typematic rate next.
A4h		The keyboard typematic rate is set. Programming the memory wait states next.
A5h		Memory wait state programming is over. Clearing the screen and enabling parity and the NMI next.
A7h		NMI and parity enabled. Performing any initialization required before passing control to the adaptor ROM at E000 next.
A8h		Initialization before passing control to the adaptor ROM at E000h completed. Passing control to the adaptor ROM at E000h next.
A9h		Returned from adaptor ROM at E000h control. Performing any initialization required after the E000 option ROM had control next.
Aah		Initialization after E000 option ROM control has completed. Displaying the system configuration next.
Abh		Uncompressing the DMI data and executing DMI POST initialization next.
B0h		The system configuration is displayed.
B1h		Copying any code to specific areas.
00h		Code copying to specific areas is done. Passing control to INT 19h boot loader next.

Notes

Appendix C

Software Installation

After all the hardware has been installed, you must first configure the Adaptec Embedded Serial ATA RAID Driver before you install the Windows operating system. The necessary drivers are all included on the Supermicro bootable CDs that came packaged with your motherboard. (For the information on Adaptec's SATA HostRAID Utility based on Marvell's chip, please refer to CD that came with your motherboard.)

C-1 Introduction to the Adaptec Embedded Serial ATA RAID Controller Driver

Serial ATA (SATA)

Serial ATA(SATA) is a physical storage interface. It uses a single cable with a minimum of four wires to create a point-to-point connection between devices. It is a serial link which supports SATA Transfer rates from 150MBps. Because the serial cables used in SATA are thinner than the traditional cables used in Parallel ATA(PATA), SATA systems have better airflow and can be installed in smaller chassis than Parallel ATA. In addition, the cables used in PATA can only extend to 40cm long, while Serial ATA cables can extend up to one meter. Overall, Serial ATA provides better functionality than Parallel ATA.

Introduction to the Intel 6300ESB (Hance Rapids) I/O Controller Hub

Located in the South Bridge of the Intel E7525 Tumwater Chipset, the 6300ESB (Hance Rapids) I/O Controller Hub provides the I/O subsystem with access to the rest of the system. It supports 2-channel Ultra ATA/100 Bus Master IDE controller (PATA) and two Serial ATA (SATA) Host Controllers, which support up to two Serial ATA ports and up to two RAID drives. The 6300ESB (Hance Rapids) I/O Controller Hub supports the following Parallel ATA (PATA) and Serial (SATA) device configurations:

To configure SATA RAID for Operating Systems that support RAID functions(--Windows, Red Hat & SuSe, Linux)

1. Select "Advanced Setting" from the AMI BIOS menu.
2. Select the IDE Configuration menu.
3. Change the IDE Configuration to "P-ATA Only."
4. Under the item-"Configure S-ATA as RAID", select "Yes".
5. Tap the <Esc> key and scroll down to "Exit". Select "Save and Exit" from the "Exit" menu. Press the <Enter> key to save the changes and exit the BIOS.
6. Once you've exited the BIOS Utility, the system will re-boot.
7. During the system startup, press the <Ctrl> and the <A> keys simultaneously to run the Adaptec RAID Configuration Utility when prompted by the following message:

Press <Ctrl><A> for Adaptec RAID Configuration Utility.

The Adaptec Embedded Serial ATA with HostRAID Controller Driver

Adaptec's Embedded Serial ATA RAID with HostRAID controller adds RAID functionality to the Serial ATA I/O controller by supporting RAID 0 (Striping) or RAID 1 (Mirroring) to enhance the industry's pioneer PCI-to-e host controller products. RAID striping (RAID 0) can greatly improve hard disk I/O performance because of its capability in striping data across multiple drives. RAID mirroring (RAID 1) allows the data to be simultaneously written to two drives, so critical data is always available even if a single hard disk fails. Due to the built-in functionality, the X6DAL-XG is specially designed to keep pace with the increasing performance demands of computer systems by improving disk I/O throughput and providing data accessibility regardless of a single disk failure. By incorporating the Adaptec Embedded Serial ATA into the motherboard design, Supermicro's X6DAL-XG offers the user with the benefits of SATARAID without the high costs associated with hardware RAID applications.

(*Note: For Adaptec's RAID Driver Installation Instructions, please refer to the Adaptec RAID Controller User's Guide: "Emb_SA_RAID_UG.pdf" in the CD that came with this motherboard. You can also download a copy of Adaptec's User's Guide from our web site at www.supermicro.com.)

Using the Adaptec RAID Configuration Utility (ARC)

The Adaptec RAID Configuration Utility is an embedded BIOS Utility, including:

*Array Configuration Utility: Use this utility when you want to create, configure and manage arrays.

* Disk Utilities: Use this option to format or verify disks.

To run the Adaptec RAID Configuration Utility, you will need to enable the RAID function in the system BIOS (refer to Chapter 4 for System BIOS Configurations), and then, press the <Ctrl> and <A> keys simultaneously when prompted to do so during the system startup. (Refer to the previous page for detailed instructions.)

(***Note:** To select an option, use the arrow keys to highlight the item and then press the <Enter> key to select it. To return to the previous menu, press the <ESC> key.)

A. Using the Array Configuration Utility (ACU)

The Array Configuration Utility (ACU) enables you to create, manage, and delete arrays from the controller's BIOS, add and delete spare drives, and initialize drives. During the system startup, press <Ctrl> and <A> key

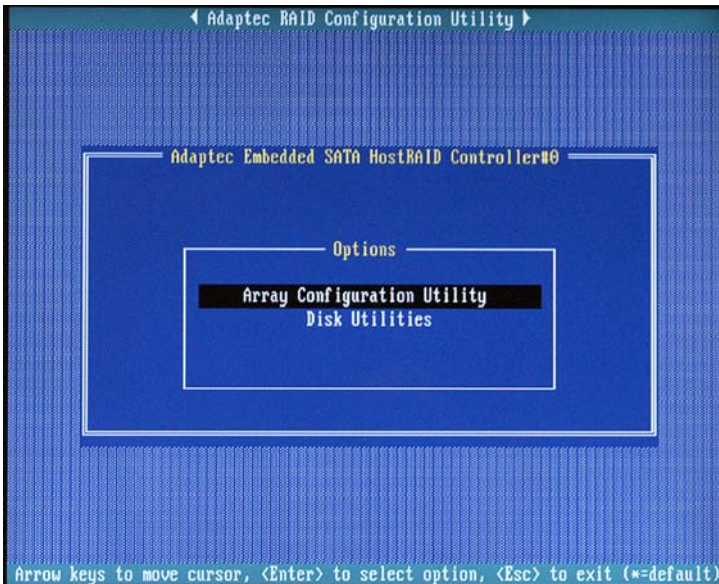

Managing Arrays

Select this option to view array properties, and delete arrays. The following sections describe the operations Of "Managing Arrays".

To select this option, use the arrow keys and the <enter> key to select "Managing Arrays" from the main menu (as shown above).

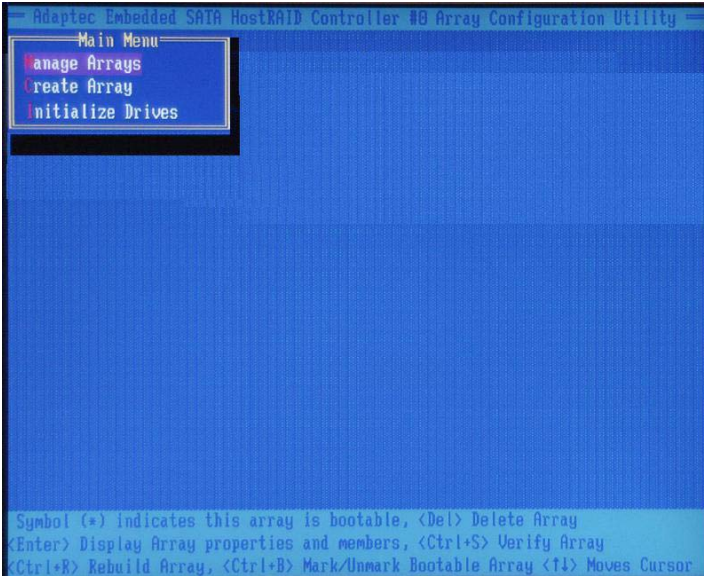

Viewing Array Properties

To view the properties of an existing array:

1. At the BIOS prompt, press **Ctrl+A**.
2. From the ARC menu, select **Array Configuration Utility (ACU)**.
3. From the ACU menu, select **Manage Arrays** (as shown on the previous screen.)
4. From the List of Arrays dialog box, select the array you want to view and press **Enter**.

The Array Properties dialog box appears, showing detailed information on the array. The physical disks associated with the array are displayed here.

5. Press **Esc** to return to the previous menu.

Deleting Arrays

**Warning: Back up the data on an array before you delete it to prevent the loss of data. Deleted arrays cannot be restored.*

To delete an existing array:

1. Turn on your computer and press **Ctrl+A** when prompted to access the ARC utility.
2. From the ARC main menu, select **Array Configuration Utility (ACU)**.
3. From the ACU menu, select **Manage Arrays**.
4. Select the array you wish to delete and press **Delete**.
5. In the Array Properties dialog box, select **Delete** and press **Enter**. The following prompt is displayed:

**Warning!! Deleting the array will render array unusable. Do you want to delete the array?(Yes/No):*

RAID 1 only—the following prompt is also displayed:

Deleting the partition will result in data loss! Do you also want to delete the partition? (Yes/No):

6. Press **Yes** to delete the array or partition or **No** to return to the previous menu.
7. Press **Esc** to return to the previous menu.

Creating Arrays

Before creating arrays, make sure the disks for the array are connected and installed in your system. Note that disks with no usable space, or disks that are un-initialized are shown in gray and cannot be used. See *Initializing Disk Drives*.

To create an array:

- 1 Turn on your computer and press **Ctrl+A** when prompted to access the ARC utility.
- 2 From the ARC menu, select **Array Configuration Utility Main Menu (ACU)** (as shown on the first screen on page C-5).
- 3 From the ACU menu, select **Create Array**.
- 4 Select the disks for the new array and press Insert (as the screen shown below).

(*Note: To deselect any disk, highlight the disk and press **Delete**.)

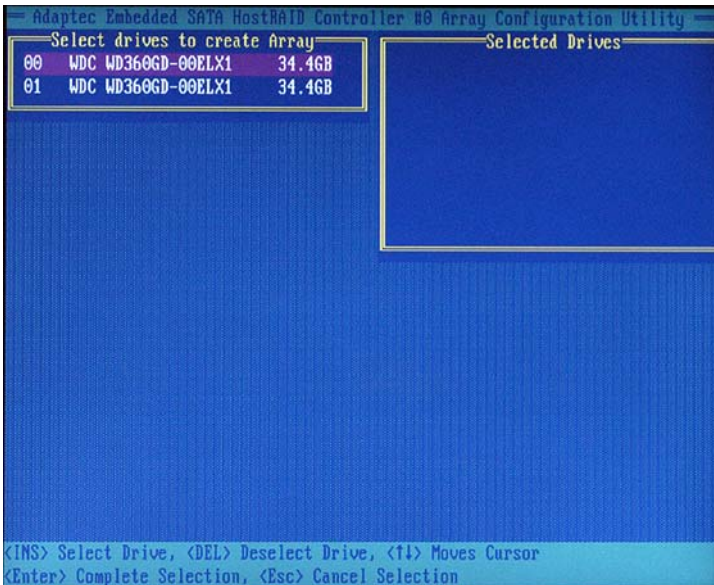

5 Press **Enter** when both disks for the new array are selected. The Array Properties menu displays (as the screen shown below).

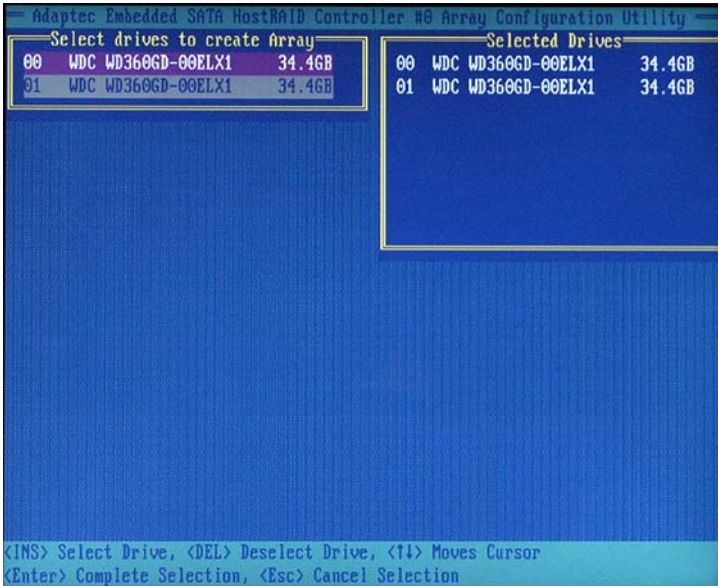

Assigning Array Properties

Once you've create a new array, you are ready to assign the properties to the array.

***Caution:** Once the array is created and its properties are assigned, you cannot change the array properties using the ACU. You will need to use the Adaptec Storage Manager - Browser Edition. (Refer to Adaptec's User's Guide in the enclosed CD.)

To assign properties to the new array:

1. In the Array Properties menu (as shown in the screen below), select an array type and press **Enter**.

Note: only the available array types: RAID 0, and RAID1, are displayed on the screen. (*RAID 0 or RAID 1 requires two drives.)

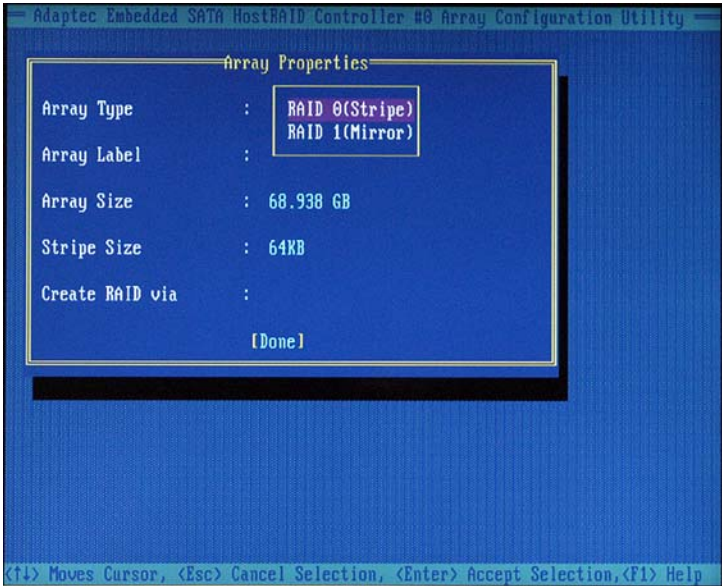

2. Under the item "**Arrays Label**", type in an label and press **Enter**. (***Note:** The label shall not be more than 15 characters.)
3. For RAID 0, select the desired stripe size. (***Note:** Available stripe sizes are 16, 32, and 64 KB-default. It is recommended that you *do not* change the default setting.)
4. The item: "**Create RAID via**" allows you to select between the different creating methods for RAID 0 and RAID 1.

The following table gives examples of when each is appropriate.

Raid Level	Create Via	When Appropriate
RAID 0	No Init	Creating a RAID 0 on new drives
RAID 0	Migrate (*Note)	Creating a RAID 0 from one new drive and one drive with data you wish to preserve
RAID 1	Build1	Any time you wish to create a RAID 1, but especially if you have data on one drive that you wish to preserve
RAID 1	Clear	Creating a RAID 1 on new drives, or when you want to ensure that the array contains no data after creation.
RAID 1	Quick	Fastest way to create a RAID 1. Appropriate when using new drives
RAID 1	Init	

(***Note:** If you select Migrate for RAID 0, or Build for RAID 1, you will be asked to select the source drive. The contents of the source drive will be preserved. However, the data on the new drive will be lost.)

5. When you are finished, press **Done** (as the screen shown below).

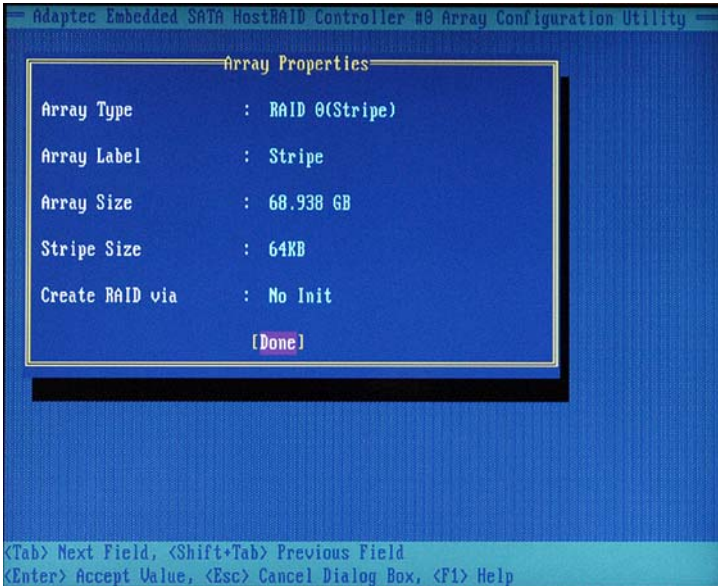

Notes:

1. Before adding a new drive to an array, back up any data contained on the new drive. Otherwise, all data will be lost.
2. If you stop the Build or Clear process on a RAID 1 from ACU, you can restart it by pressing Ctrl+R.
3. A RAID 1 created using the Quick Init option may return some data mismatches if you later run a consistency check. This is normal and is not a cause for concern.
4. The ACU allows you to use drives of different sizes in a RAID . However, during a build operation, only the smaller drive can be selected as the source or first drive.
5. When migrating from single volume to RAID 0, migrating from a larger drive to a smaller drive is allowed. However, the destination drive must be at least half the capacity of the source drive.
6. Adaptec does not recommend that you migrate or build an array on Windows dynamic disks (volumes), as it will result in data loss.

Warning: Do not interrupt the creation of a RAID 0 using the Migrate option. If you do, you will not be able to restart, or to recover the data that was on the source drive.

Adding a Bootable Array

To make an array bootable:

1. From the Main menu, select **Manage Arrays**.
2. From the List of Arrays, select the array you want to make bootable, and press **Ctrl+B**.
3. Enter Y to create a bootable array when the following message is displayed: "This will make all other existing bootable array non-bootable. Do you want to make this array bootable? (Yes/No):" Then, a bootable array will be created. An asterisk will appear next to the bootable array (as shown in the picture below):

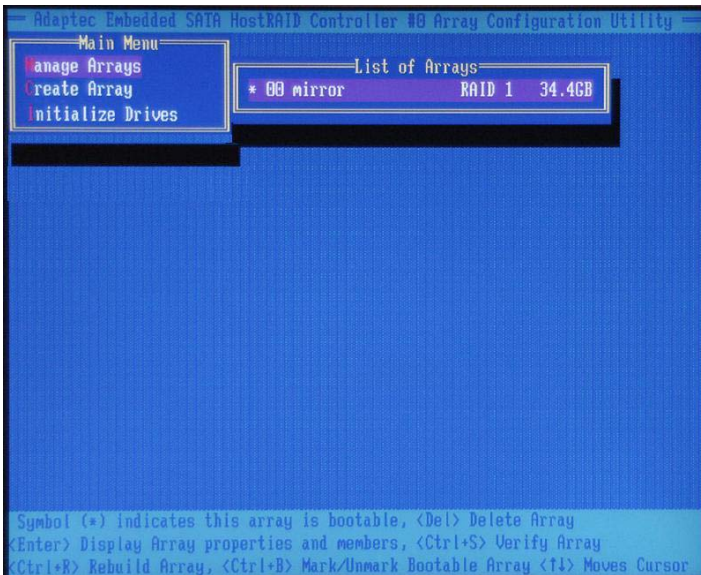

Deleting a Bootable Array

To delete a bootable array:

1. From the Main menu, select **Manage Arrays**.
2. From the List of Arrays, select the bootable array (*) you want to delete, and press **Ctrl+B**. (* a bootable array is the array marked with an asterisk (as shown in the picture above).)
3. Enter Y to delete a bootable array when the following message is displayed: "The array is already marked bootable. Do you want to make this array as not bootable? (Yes/No):" Then, the bootable array will be deleted and the asterisk will disappear.

(*Note: do not use the delete key to delete the bootable array.)

Initializing Disk Drives

If an installed disk does not appear in the disk selection list for creating a new array, or if it appears grayed out, you may have to initialize it before you can use it as part of an array. Drives attached to the controller must be initialized before they can be used in an array.

Caution: Initializing a disk overwrites the partition table on the disk and makes any data on the disk inaccessible. If the drive is used in an array, you may not be able to use the array again.

Do not initialize a disk that is part of a boot array. To determine which disks are associated with a particular array, please refer to [Viewing Array Properties](#).

To initialize drives:

1. Turn on your computer and press **Ctrl+A** when prompted to access the ARC utility.
2. From the ARC menu, select **Array Configuration Utility (ACU)** (as shown in the screen below).

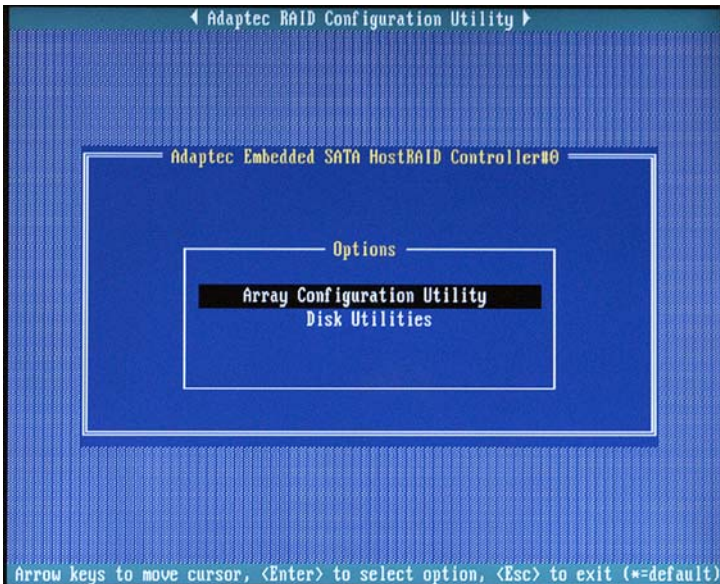

3. Select **Initialize Drives** (as shown in the screen below).

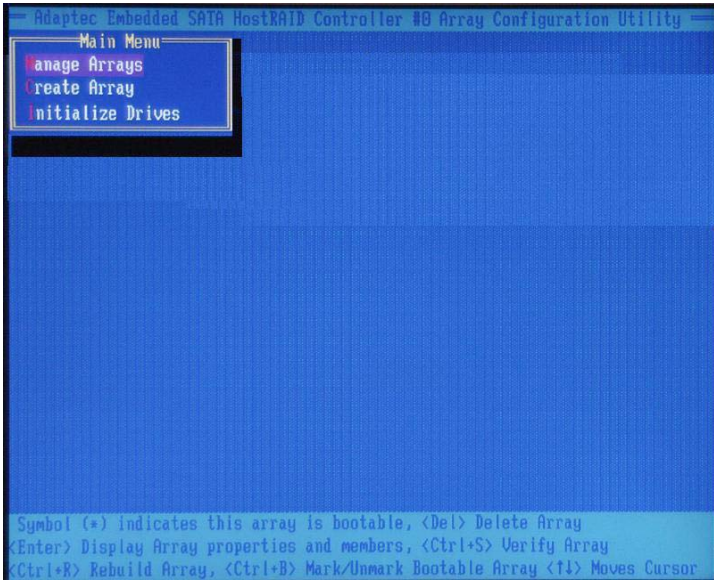

4. Use the up and down arrow keys to highlight the disk you wish to initialize and press **Insert** (as shown in the screen below).

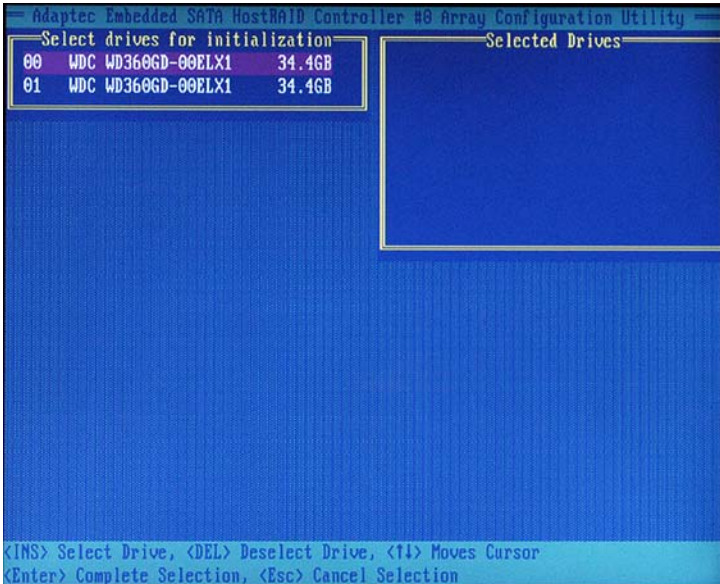

- Repeat [Step 4](#) so that both drives to be initialized are selected (as shown in the screen below).

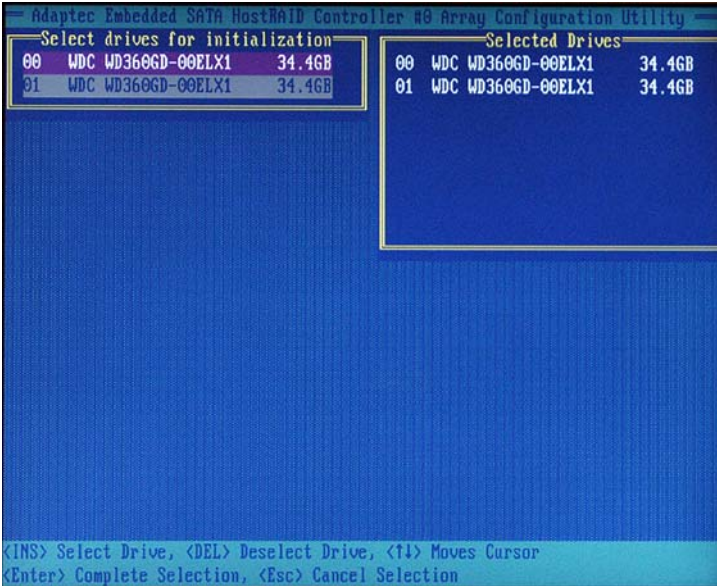

- Press **Enter**.
- Read the warning message as shown in the screen.

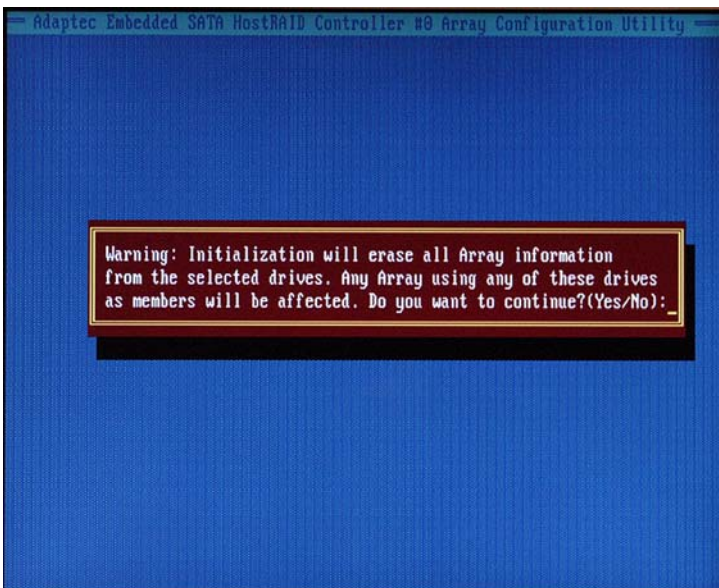

- Make sure that you have selected the correct disk drives to initialize. If correct, type **Y** to continue.

Rebuilding Arrays

***Note 1:** Rebuilding applies to Fault Tolerant array (RAID 1) only.

If an array Build process (or initialization) is interrupted or critical with one member missing, you must perform a Rebuild to get the array to Optimal status. For a critical array Rebuild operation, the optimal drive is the source drive.

***Note 2:** If no spare array exists and a hard disk drive fails, you need to create a spare before you can rebuild an array.

To Rebuild an array:

1 From the Main Menu, select **Manage Arrays** (as shown in the screen below). From the List of Arrays, select the array you want to Rebuild.

2 Press **Ctrl+R** to Rebuild.

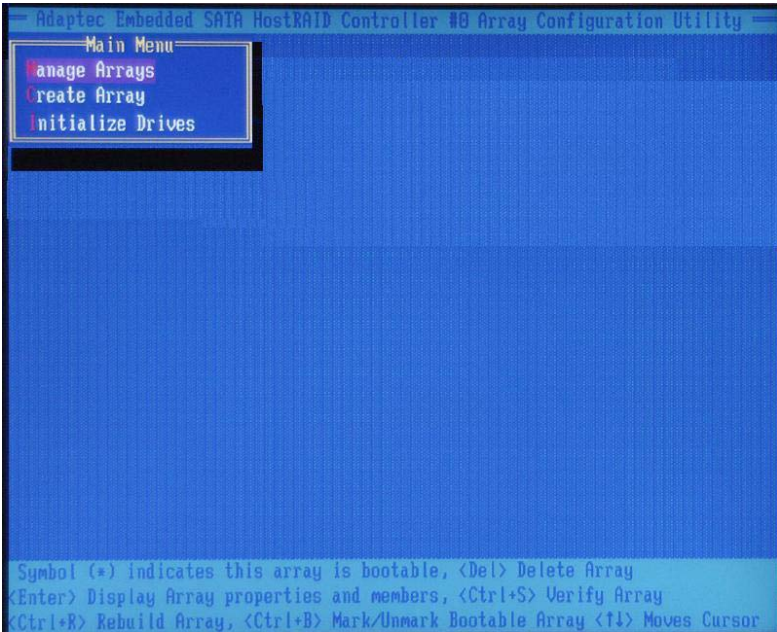

Using the Disk Utilities

The Disk Utilities enable you to format or verify the media of your Serial ATA hard disks.

To access the disk utilities:

1. Turn on your computer and press **Ctrl+A** when prompted to access the ARC utility (as shown in the screen below.)

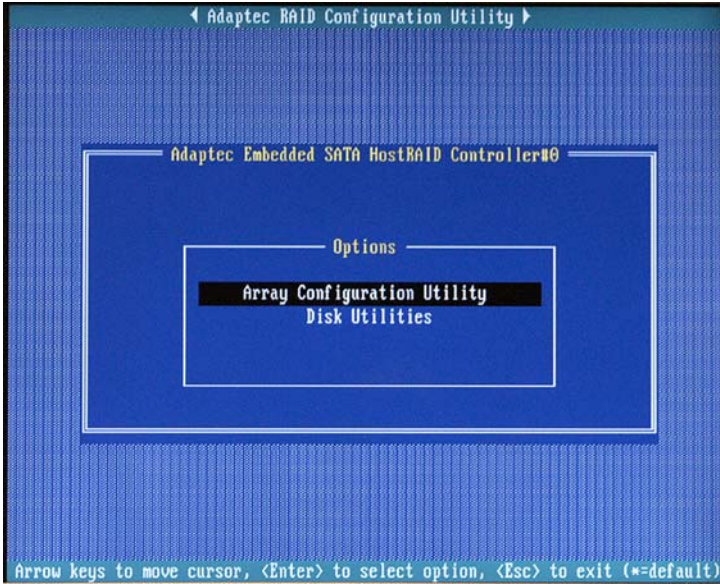

2. From the ARC menu, select **Disk Utilities** as shown in the screen below.

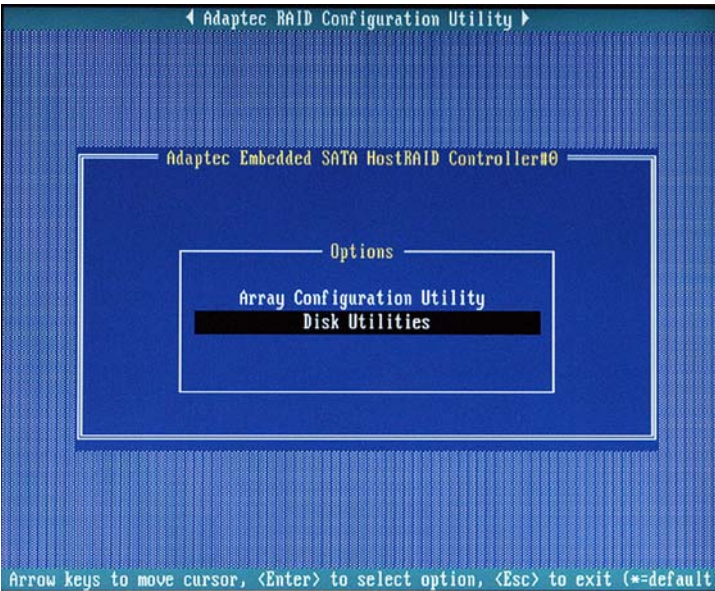

3 Select the desired disk and press **Enter** (as shown in the screen below.)

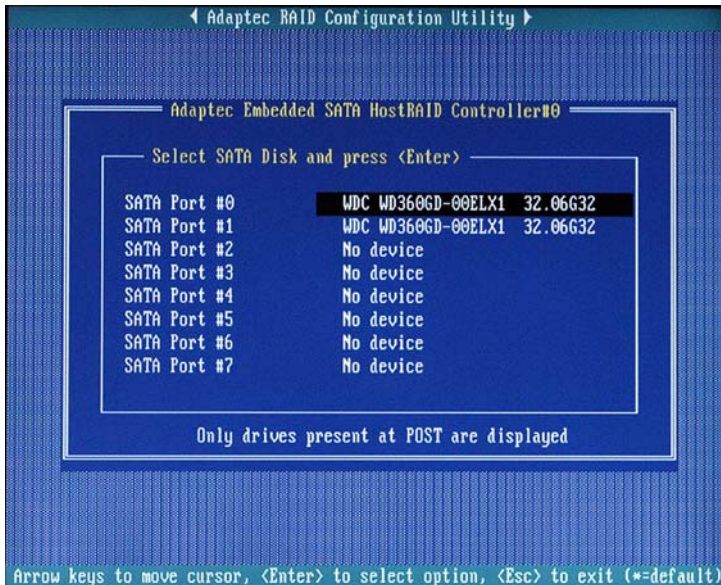

You can choose from the following options:

1. Format Disk—Simulates a low-level format of the hard drive by writing zeros to the entire disk. Serial ATA drives are low-level formatted at the factory and do not need to be low-level formatted again.

(***Caution:** Formatting destroys all data on the drive. Be sure to back up your data before performing this operation.)

2. Verify Disk Media—Scans the media of a disk drive for defects.

To Exit Adaptec RAID Configuration Utility

1. Once you have completed RAID array configurations, press **ESC** to exit. The following screen will appear.

2. Press **Yes** to exit the Utility.

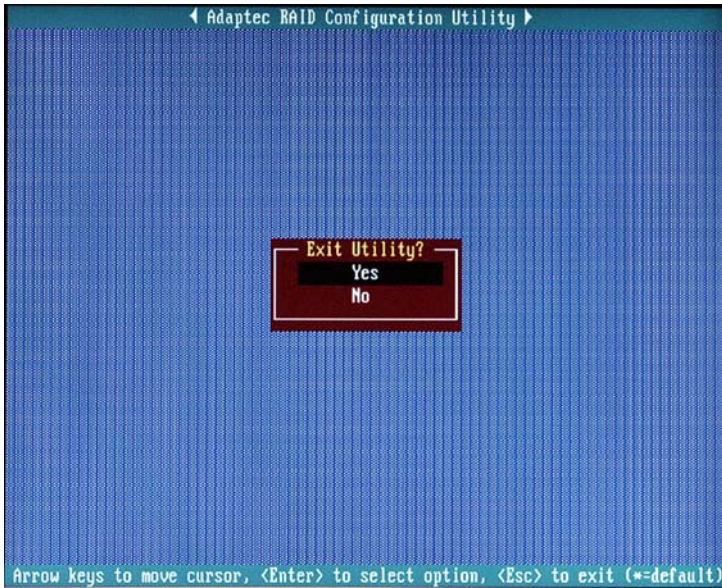

(***For more information regarding Adaptec RAID Utility, please refer to Adaptec's User's Guide in the CD included in your shipping package. You can also download a copy of Adaptec User's Guide from our web site at: www.supermicro.com.)**

C-2 Installing Intel's Hance Rapids Driver by Adaptec and Installing the Windows OS

- a. Insert Supermicro's bootable CD that came with the package into the CD Drive during the system reboot, and the screen: "Super Micro Driver Diskette Maker" will appear.
- b. From the list displayed on the screen, choose the item: "Intel Hance Rapids Driver by 3rd Party (Adaptec)" and press <ENTER>.
- c. From the next screen displayed, choose the OS driver you want to install and press <Enter>.
- d. Insert a formatted diskette into drive A: and press <Enter> as prompted.
- e. Exit the program after the process is completed. Then, reboot the system.
- f. Insert Microsoft's Windows OS Setup CD in the CD Driver, and the system will start to boot up from CD.
- g. Press the <F6> key when the message-"Press F6 if you need to install a third party SCSI or RAID driver" displays.
- h. When the Windows OS Setup screen appears, press "S" to specify additional device(s).
- i. Insert the driver diskette-"Adaptec Embedded Serial ATA Raid Controller Driver" into Drive A: and press the <Enter> key.
- j. Choose the Adaptec Embedded Host Serial ATA Raid Controller from the list indicated in the Windows OS Setup Screen, and press the <Enter> key.
- k. Press the <Enter> key to continue the installation process. (If you need to specify any additional devices to be installed, do it at this time.) Once all devices are specified, press the <Enter> key to continue with the installation.
- l. From the Windows OS Setup screen, press the <Enter> key. The OS Setup will automatically load all device files, and, then, continue the Windows OS installation.
- m. After the Windows OS Installation is completed, the system will automatically reboot.

C-3 Installing Other Software Programs and Drivers

A. Installing Drivers other than Adaptec Embedded Serial ATA RAID Controller Driver

After you've installed the Windows Operating System, a screen as shown below will appear. You are ready to install software programs and drivers that have not yet been installed. To install these software programs and drivers, click the icons to the right of these items.

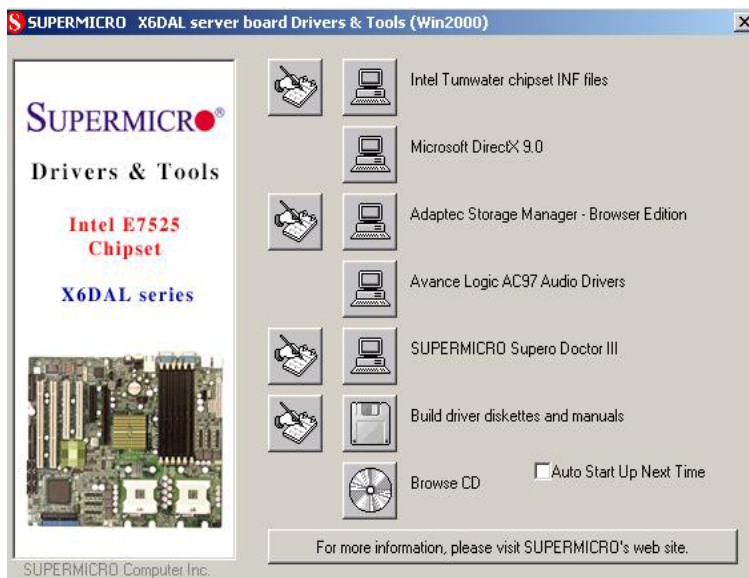

Driver/Tool Installation Display Screen

(*Note: Click the icons showing a hand writing on the paper to view the readme files for each item. Click the computer icons to the right of these items to install each item (from top to the bottom) one at a time. **After installing each item, you must re-boot the system before moving on to the next item on the list.** The bottom icon with a CD on it allows you to view the entire contents of the CD.)

(*Please refer to the Adaptec User's Guide for the installation of Adaptec's Serial ATA RAID Controller Driver. Adaptec's User's Guide is included in the CD. You can also download a copy of the user's guide from our web site.)

Supero Doctor III

The Supero Doctor III program is a Web-base management tool that supports remote management capability. It includes Remote and Local Management tools. The local management is called SD III Client. The Supero Doctor III program included on the CDROM that came with your motherboard allows you to monitor the environment and operations of your system. Supero Doctor III displays crucial system information such as CPU temperature, system voltages and fan status. See the Figure below for a display of the Supero Doctor III interface.

Note 1: The default User Name and Password are ADMIN.

Note 2: In the Windows OS environment, the Supero Doctor III settings take precedence over the BIOS settings. When first installed, the SD III adopts the temperature threshold settings previously set in the BIOS. Any subsequent changes to these thresholds must be made within Supero Doctor, since the SDIII settings override the BIOS settings. For the Windows OS to adopt the BIOS temperature threshold settings, please change the SDIII settings to be the same as those set in the BIOS.

Supero Doctor III Interface Display Screen-I (Health Information)



Supero Doctor III Interface Display Screen-II (Remote Control)

Graceful power control

Supero Doctor III allows a user to inform the OS to reboot or shut down within a specified time (the default is 30 seconds). Before the system reboots or shuts down, it's allowed to cancel the action.

Requirements

Keep Supero SD3Service Daemon running at all times on this system.
Provide TCP/IP connectivity.

Power control

(*Note: SD III Software Revision 1.0 can be downloaded from our Web site at: ftp://ftp.supermicro.com/utility/Supero_Doctor_III/. You can also download SDIII User's Guide at: <http://www.supermicro.com/PRODUCT/Manuals/SDIII/UserGuide.pdf>. For Linux, we will still recommend Supero Doctor II.)

Notes