

SUPERMICR[®]

SC823 Air Shroud

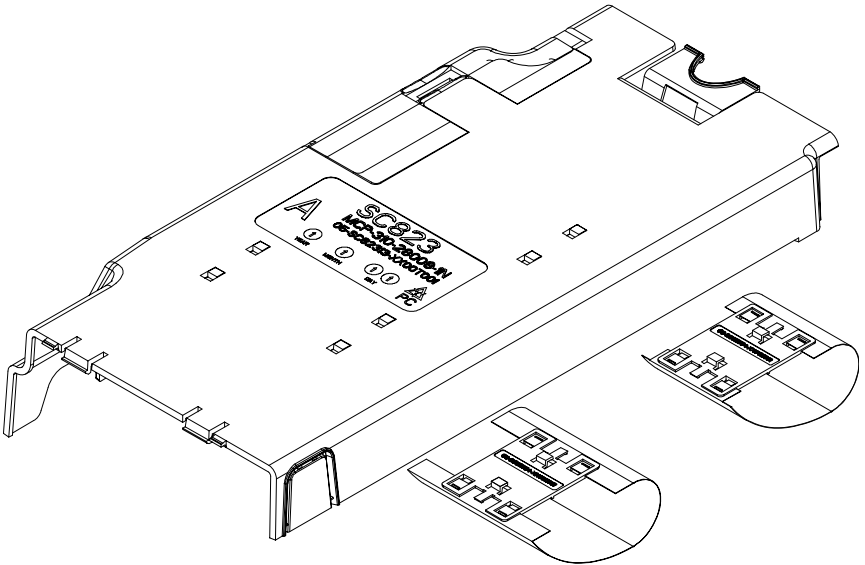

User's Guide

Revision 1.0

The information in this User's Guide has been carefully reviewed and is believed to be accurate. The vendor assumes no responsibility for any inaccuracies that may be contained in this document, makes no commitment to update or to keep current the information in this manual, or to notify any person or organization of the updates. **Please Note: For the most up-to-date version of this manual, please see our web site at www.supermicro.com.**

Super Micro Computer, Inc. ("Supermicro") reserves the right to make changes to the product described in this manual at any time and without notice. This product, including software, if any, and documentation may not, in whole or in part, be copied, photocopied, reproduced, translated or reduced to any medium or machine without prior written consent.

IN NO EVENT WILL SUPERMICRO BE LIABLE FOR DIRECT, INDIRECT, SPECIAL, INCIDENTAL, SPECULATIVE OR CONSEQUENTIAL DAMAGES ARISING FROM THE USE OR INABILITY TO USE THIS PRODUCT OR DOCUMENTATION, EVEN IF ADVISED OF THE POSSIBILITY OF SUCH DAMAGES. IN PARTICULAR, SUPERMICRO SHALL NOT HAVE LIABILITY FOR ANY HARDWARE, SOFTWARE, OR DATA STORED OR USED WITH THE PRODUCT, INCLUDING THE COSTS OF REPAIRING, REPLACING, INTEGRATING, INSTALLING OR RECOVERING SUCH HARDWARE, SOFTWARE, OR DATA.

Any disputes arising between manufacturer and customer shall be governed by the laws of Santa Clara County in the State of California, USA. The State of California, County of Santa Clara shall be the exclusive venue for the resolution of any such disputes. Super Micro's total liability for all claims will not exceed the price paid for the hardware product.

FCC Statement: This equipment has been tested and found to comply with the limits for a Class A digital device pursuant to Part 15 of the FCC Rules. These limits are designed to provide reasonable protection against harmful interference when the equipment is operated in a commercial environment. This equipment generates, uses, and can radiate radio frequency energy and, if not installed and used in accordance with the manufacturer's instruction manual, may cause harmful interference with radio communications. Operation of this equipment in a residential area is likely to cause harmful interference, in which case you will be required to correct the interference at your own expense.

California Best Management Practices Regulations for Perchlorate Materials: This Perchlorate warning applies only to products containing CR (Manganese Dioxide) Lithium coin cells. Perchlorate Material-special handling may apply. See www.dtsc.ca.gov/hazardouswaste/perchlorate for further details.



WARNING: HANDLING OF LEAD SOLDER MATERIALS USED IN THIS PRODUCT MAY EXPOSE YOU TO LEAD, A CHEMICAL KNOWN TO THE STATE OF CALIFORNIA TO CAUSE BIRTH DEFECTS AND OTHER REPRODUCTIVE HARM.

Manual Revision 1.0

Release Date: April 27, 2009

Unless you request and receive written permission from Super Micro Computer, Inc., you may not copy any part of this document.

Information in this document is subject to change without notice. Other products and companies referred to herein are trademarks or registered trademarks of their respective companies or mark holders.

Copyright © 2009 by Super Micro Computer, Inc.
All rights reserved.

Printed in the United States of America

Preface

About this Manual

This manual is written for professional system integrators, Information Technology professionals, service personnel and technicians. It provides information for the installation and use of Supermicro's SC823 air shroud. Installation and maintenance should be performed by experienced professionals only.

Manual Organization

Chapter 1: Introduction

The first chapter provides a checklist of the main components included with the SC823 air shroud and describes its main features.

Chapter 2: System Safety

You should familiarize yourself with this chapter for a general overview of safety precautions that should be followed when installing and servicing the SC823 air shroud.

Chapter 3: Configuration and Installation

Refer here for details on installing the SC823 air shroud on a computer system mainboard.

Notes

Table of Contents

Chapter 1 Introduction	1-1
1-1 Overview.....	1-1
1-2 Product Checklist of Typical Components.....	1-1
1-3 Features.....	1-2
1-4 Returning Merchandise for Service.....	1-2
1-5 Contacting Supermicro.....	1-3
Chapter 2 System Safety	2-1
2-1 Electrical Safety Precautions.....	2-1
2-2 General Safety Precautions.....	2-2
2-3 Electrostatic Discharge Precautions	2-2
2-4 Operating Precautions.....	2-2
Chapter 3 Configuration and Installation	3-1
3-1 Overview.....	3-1
3-2 SC823 Air Shroud Components	3-1
Component Part B	3-2
3-3 Removing Breakable Sections for Cabling	3-4
3-4 Configuring the SC823 Air Shroud.....	3-5
Configuring for Configuration-1	3-6
Configuring for Configuration-2.....	3-7
Configuring for Configuration-3.....	3-8
Configuring for Configuration-4.....	3-9
3-5 Installing the SC823 Air Shroud.....	3-10

Notes

Chapter 1

Introduction

1-1 Overview

The SC823 air shroud is a configurable air shroud for system mainboards to enable maximum efficient air flow through the system. It can be configured to fit different sized Intel® Xeon™ DP 5500/5400/5100/5000 series system mainboards of the same general shape and size. The SC823 air shroud is optimized for use with Supermicro SC823 series chassis designs and for Supermicro X8Dxx/X7Dxx series mainboards. See [Chapter 3](#) for configuration details.

1-2 Product Checklist of Typical Components

The SC823 air shroud comes packaged with components and parts as shown in [Table 1-1](#):

Table 1-1. SC823 Air Shroud Parts and Components

Part Number	Description	Quantity
MCP-310-28002-0N	SC823 Intel DP plastic air shroud, supports up to 12 memory DIMM slots	
MCP-310-28008-1N	SC823 X7/X8 air shroud component part A	1
MCP-310-28009-1N	SC823 X7/X8 air shroud component part B	1
MCP-310-28006-1N	X7/X8 air shroud universal component part D, tear-drop Mylar module, 2.2" (55mm) wide	1
MCP-310-28007-1N	X7/X8 air shroud universal component part E, tear-drop Mylar module, 3" (77mm) wide	1



NOTE: The default configuration is for parts A and B connected and with component parts D and E in the accessory box separate.



NOTE: Each individual part for the SC823 air shroud is labeled with its component part letter for easy identification.

1-3 Features

The SC823 air shroud includes the following features:

- Main air shroud component
- Three detachable components for creating multiple configurations
- Breakable section for power cable management
- Clear plastic material construction for ease of viewing

1-4 Returning Merchandise for Service

A receipt or copy of your invoice marked with the date of purchase is required before any warranty service will be rendered. You can obtain service by calling your vendor for a Returned Merchandise Authorization (RMA) number. When returning to the manufacturer, the RMA number should be prominently displayed on the outside of the shipping carton, and mailed prepaid or hand-carried. Shipping and handling charges will be applied for all orders that must be mailed when service is complete.

For faster service, RMA authorizations may be requested online at:

<http://www.supermicro.com/support/rma/>

Whenever possible, repack the chassis in the original Supermicro carton, using the original packaging material. If these are no longer available, be sure to pack the chassis securely, using packaging material to surround the chassis so that it does not shift within the carton and become damaged during shipping.

This warranty only covers normal consumer use and does not cover damages incurred in shipping or from failure due to the alteration, misuse, abuse or improper maintenance of products.

During the warranty period, contact your distributor first for any product problems.

1-5 Contacting Supermicro

Headquarters

Address: Super Micro Computer, Inc.
980 Rock Ave.
San Jose, CA 95131 U.S.A.

Tel: +1 (408) 503-8000

Fax: +1 (408) 503-8008

Email: marketing@supermicro.com (General Information)
support@supermicro.com (Technical Support)

Web Site: www.supermicro.com

Europe

Address: Super Micro Computer B.V.
Het Sterrenbeeld 28, 5215 ML
's-Hertogenbosch, The Netherlands

Tel: +31 (0) 73-6400390

Fax: +31 (0) 73-6416525

Email: sales@supermicro.nl (General Information)
support@supermicro.nl (Technical Support)
rma@supermicro.nl (Customer Support)

Asia-Pacific

Address: Super Micro Computer, Inc.
4F, No. 232-1, Liancheng Rd.
Chung-Ho 235, Taipei County
Taiwan, R.O.C.

Tel: +886-(2) 8226-3990

Fax: +886-(2) 8226-3991

Web Site: www.supermicro.com.tw

Technical Support:

Email: support@supermicro.com.tw

Tel: +886-2-8228-1366, ext. 132 or 139

Notes

Chapter 2

System Safety

Please read and follow all safety precautions below before using your Supermicro product.

2-1 Electrical Safety Precautions

Basic electrical safety precautions should be followed to protect yourself from harm and the server from damage:

- Be aware of how to power on/off the enclosure power supplies and the individual blades as well as the room's emergency power-off switch, disconnection switch or electrical outlet. If an electrical accident occurs, you can then quickly remove power from the system.
- Do not work alone when working with high voltage components.
- Power should always be disconnected from the blade module when removing or installing such system components as the mainboard, memory modules and processors.
- When working around exposed electrical circuits, another person who is familiar with the power-off controls should be nearby to switch off the power if necessary.
- Use only one hand when working with powered-on electrical equipment. This is to avoid making a complete circuit, which will cause electrical shock. Use extreme caution when using metal tools, which can easily damage any electrical components or circuit boards they come into contact with.
- Do not use mats designed to decrease electrostatic discharge as protection from electrical shock. Instead, use rubber mats that have been specifically designed as electrical insulators.
- The power supply power cords must include a grounding plug and must be plugged into grounded electrical outlets. Power input requires 110-240 VAC, depending upon your power supply module.
- Mainboard Battery: This battery must be replaced only with the same or an equivalent type recommended by the manufacturer (CR2032 Lithium 3V battery). Dispose of used batteries according to the manufacturer's instructions.



WARNING: There is a danger of explosion if the onboard battery is installed upside down, which will reverse its polarities.

- Mainboard replaceable soldered-in fuses: Self-resetting PTC (Positive Temperature Coefficient) fuses on the mainboard must be replaced by trained service technicians only. The new fuse must be the same or equivalent as the one replaced. Contact technical support for details and support.

2-2 General Safety Precautions

Follow these rules to ensure general safety:

- Keep the area around the server clean and free of clutter.
- Place the blade module cover and any system components that have been removed away from the system or on a table so that they won't accidentally be stepped on.
- While working on the system, do not wear loose clothing such as neckties and unbuttoned shirt sleeves, which can come into contact with electrical circuits or be pulled into a cooling fan.
- Remove any jewelry or metal objects from your body, which are excellent metal conductors that can create short circuits and harm you if they come into contact with printed circuit boards or areas where power is present.
- After accessing the inside of the system, replace the blade module's cover before installing it back into the blade enclosure.

2-3 Electrostatic Discharge Precautions

Electrostatic discharge (ESD) is generated by two objects with different electrical charges coming into contact with each other. An electrical discharge is created to neutralize this difference, which can damage electronic components and printed circuit boards.

The following measures are generally sufficient to neutralize this difference **before** contact is made to protect your equipment from ESD:

- Use a grounded wrist strap designed to prevent static discharge.
- Keep all components and printed circuit boards (PCBs) in their antistatic bags until ready for use.
- Touch a grounded metal object before removing the board from the antistatic bag.
- Do not let components or PCBs come into contact with your clothing, which may retain a charge even if you are wearing a wrist strap.
- Handle a board by its edges only; do not touch its components, peripheral chips, memory modules or contacts.
- When handling chips or modules, avoid touching their pins.
- Put the mainboard and peripherals back into their antistatic bags when not in use.
- For grounding purposes, make sure the blade enclosure provides excellent conductivity between the power supplies, the blade modules and the mainboard.

2-4 Operating Precautions

Care must be taken to assure that the cover of the blade unit is in place when the blade is operating to assure proper cooling. Out of warranty damage to the blade can occur if this practice is not strictly followed.

Any drive carrier without a hard drive installed must remain fully installed in the drive bay when the blade module is operating to ensure proper airflow.

Chapter 3

Configuration and Installation

3-1 Overview

This chapter covers the configuration and installation of the SC823 air shroud into a server or into a chassis. The main section (component part A) can be connected to other sections (component parts B, D and E) to make up to four configurations (Configuration-1 through Configuration-4).

3-2 SC823 Air Shroud Components

Figure 3-1. SC823 Air Shroud Components

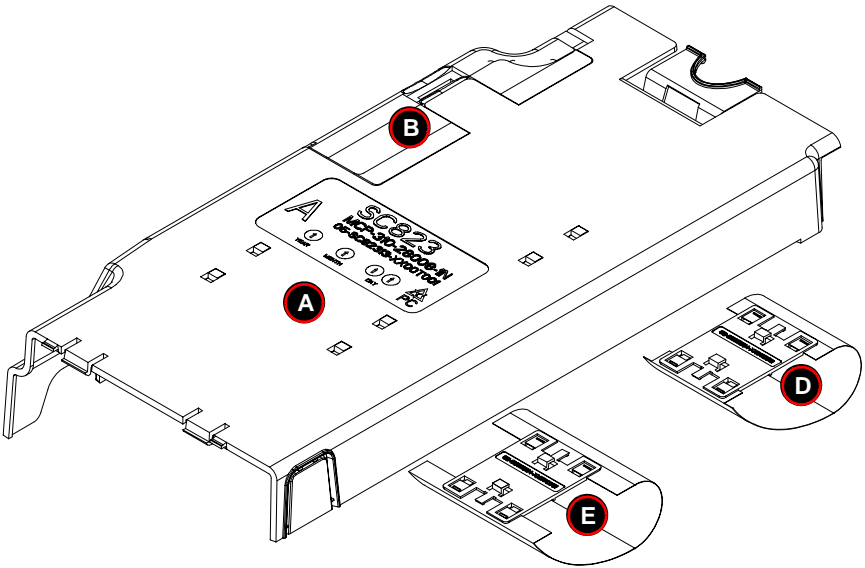

Table 3-1. SC823 Air Shroud Components

Item	Description
A	SC823 X7/X8 air shroud component part A
B	SC823 X7/X8 air shroud component part B
D	X7/X8 air shroud universal component part D, tear-drop Mylar module 2.2" (55mm) wide
E	X7/X8 air shroud universal component part E, tear-drop Mylar module 3" (77mm) wide

The SC823 air shroud comes with four detachable components (Figure 3-1 and Table 3-1). See below for details on these various components.

These components can be used to create four configurations for use in Intel Xeon DP 5500/5400/5100/5000 series systems. The SC823 air shroud is optimized for use with Supermicro X8Dxx and X7Dxx series mainboards. See Section 3-4 for further details on configurations.

Component Part B

Figure 3-2. Moving Component Part B

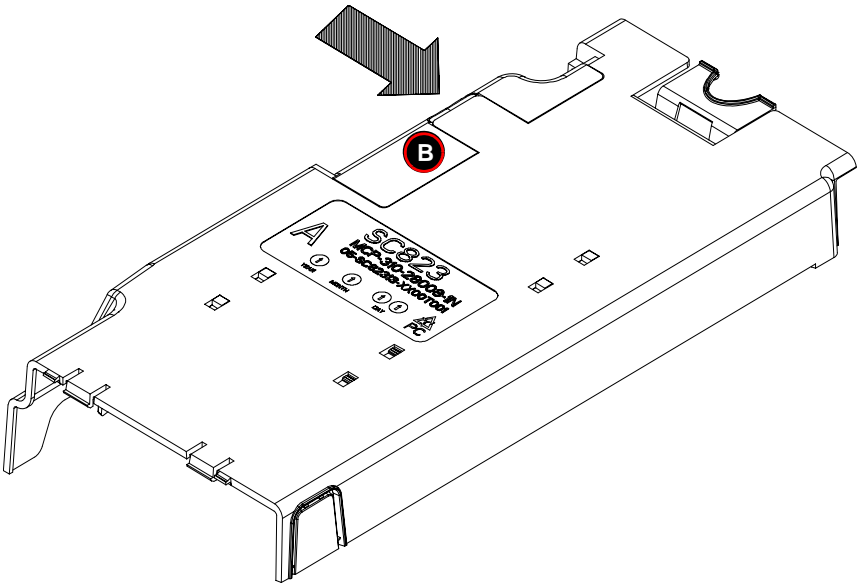

The SC823 air shroud's component part B can be moved in and out to resize the air shroud's size to fit the mainboard (Figure 3-2).

Component Part D and E

Figure 3-3. Component Part D and E

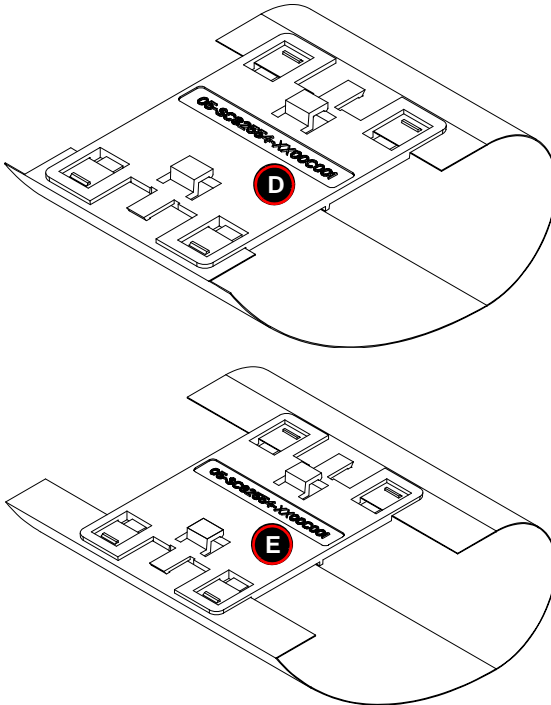

The SC823 air shroud's component part D (2.2" (55mm) wide tear-drop Mylar module), and component part E (3" (77mm) wide tear-drop Mylar module) (see [Figure 3-3](#)) can be mounted on the underside of component part A by inserting their locking tabs into the component part A alignment slots provided. You may install both parts provided, or only one.

3-3 Removing Breakable Sections for Cabling

Figure 3-4. Removing the Breakable Section

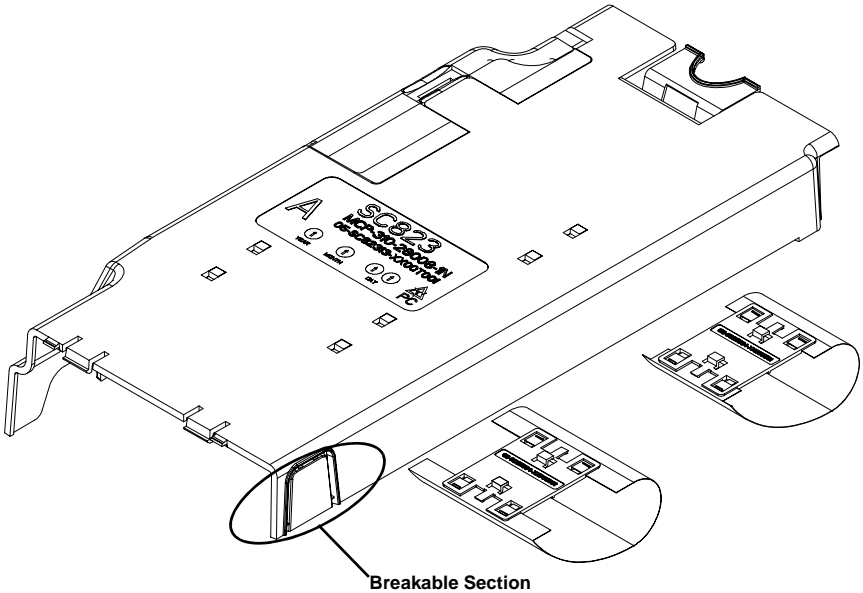

Component part A for the SC823 air shroud has a breakable section that can be permanently removed to allow cabling access if required for your system. See [Figure 3-4](#) for details.

To remove, simply cut or break the section off from component part A with a pair of scissors and discard it.

3-4 Configuring the SC823 Air Shroud

The SC823 air shroud is customizable into four configurations for 2U Supermicro SC823 series chassis systems (see [Table 3-2](#)).

Table 3-2. SC823 Air Shroud Configurations

Configuration	Description
Configuration-1	Component parts A and B for Intel Xeon DP 5500 series systems with 12" x 13" form factor mainboards, 6 PCI slots and 12 memory DIMM slots (optimized for use with Supermicro X8Dxx series mainboards).
Configuration-2	Component parts A and B for Intel Xeon DP 5500 series systems with 12" x 13" form factor mainboards, 7 PCI slots and 12 memory DIMM slots (optimized for use with Supermicro X8Dxx series mainboards).
Configuration-3	Component parts A, B, D and E for Intel Xeon DP 5400/5100/5000 series systems with 12" x 13" form factor mainboards, 6 PCI slots and 8/4 memory DIMM slots (optimized for use with Supermicro X7Dxx series mainboards).
Configuration-4	Component parts A, B, D and E for Intel Xeon DP 5400/5100/5000 series systems with 12" x 13" form factor mainboards, 7 PCI slots and 8/4 memory DIMM slots (optimized for use with Supermicro X7Dxx series mainboards).

See the sections below for instruction on configuring the SC823 air shroud to these various configurations.



NOTE: The default configuration is for parts A and B connected and with component parts D and E in the accessory box separate.

For purposes of this section's instructions assume that all parts are unconnected and assembly to one of the air shroud's configurations is required for use.

Configuring for Configuration-1

Figure 3-5. Configuration-1

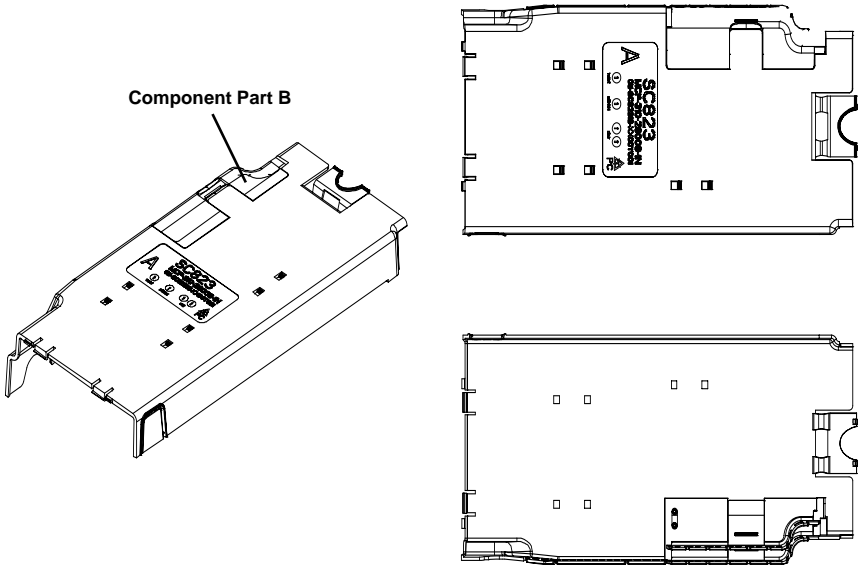

To configure the SC823 air shroud for an Intel Xeon DP 5500 series systems with 6 PCI add-on card slots, up to 12 memory DIMM slots and a 12" x 13" form factor, use Configuration-1. This configuration attaches component part B flush with the edge of component part A (see [Figure 3-5](#)).

This configuration is optimized for use with Supermicro X8Dxx series mainboards.



NOTE: Component part D and E are detached from this configuration.

Configuring for Configuration-2

Figure 3-6. Configuration-2

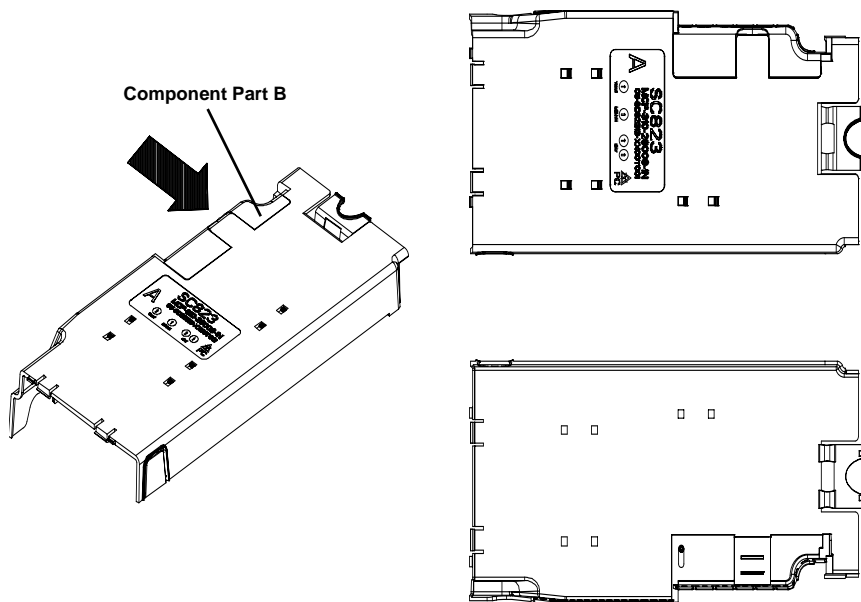

To configure the SC823 air shroud for an Intel Xeon DP 5500 series systems with 7 PCI add-on card slots, up to 12 memory DIMM slots and a 12" x 13" form factor, use Configuration-2. This configuration attaches component part B one slot deeper than the edge of component part A (see [Figure 3-6](#)).

This configuration is optimized for use with Supermicro X8Dxx series mainboards.



NOTE: Component part D and E are detached from this configuration.

Configuring for Configuration-3

Figure 3-7. Configuration-3

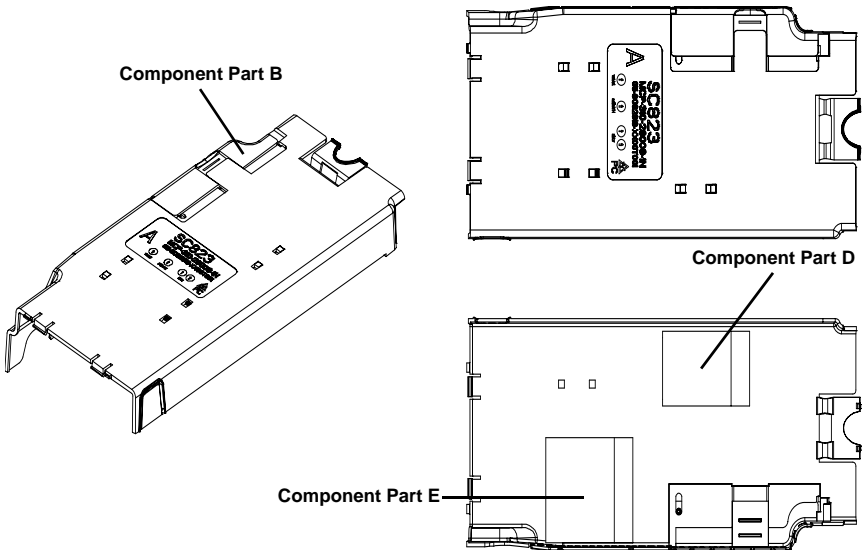

To configure the SC823 air shroud for an Intel Xeon DP 5400/5100/5000 series systems with a 12" x 13", up to 8 memory DIMM slots form factor, use Configuration-3. This configuration attaches component part B one slot deeper than the edge of component part A, and mounts component parts D and E to the underside of component part A (see [Figure 3-7](#)).

This configuration is optimized for use with Supermicro X7Dxx series mainboards.

Configuring for Configuration-4

Figure 3-8. Configuration-4

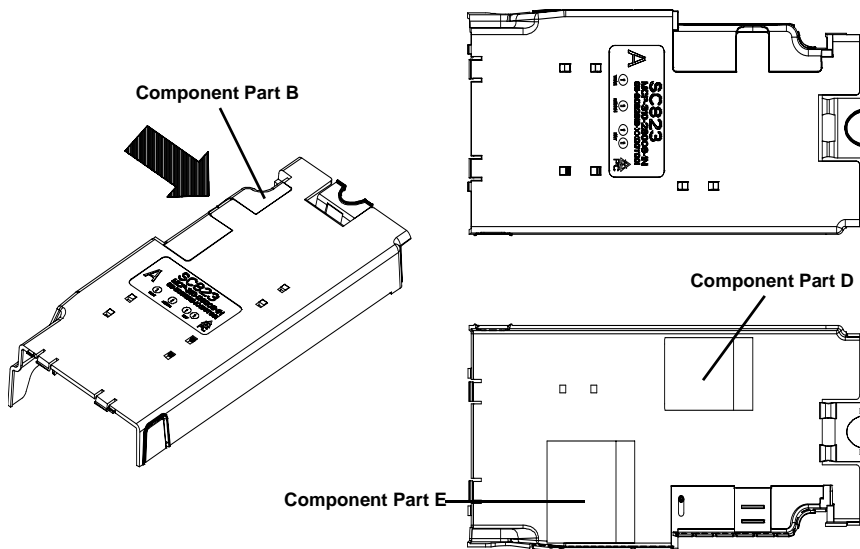

To configure the SC823 air shroud for an Intel Xeon DP 5400/5100/5000 series systems with 7 PCI add-on card slots, up to 8 memory DIMM slots and a 12" x 13" form factor, use Configuration-4. This configuration attaches component part B one slot deeper than the edge of component part A, and mounts component D and E to the underside of component part A (see [Figure 3-8](#)).

This configuration is optimized for use with Supermicro X7Dxx series mainboards.

3-5 Installing the SC823 Air Shroud

To install the SC823 air shroud follow the procedure below. This procedure is the same for all configurations of the SC823 air shroud in 2U systems.

Installing the SC823 Air Shroud in SC823 Chassis Systems

1. Configure the air shroud to fit in your system. See [Section 3-4](#) for details on configuring the air shroud.
2. Secure the forward edge of the SC823 to the forward part of the chassis interior so that the SC823 mounting tabs are locked in with the mounting slots of the chassis (see [Figure 3-9](#)).

Figure 3-9. Inserting Air Shroud onto a System Mainboard

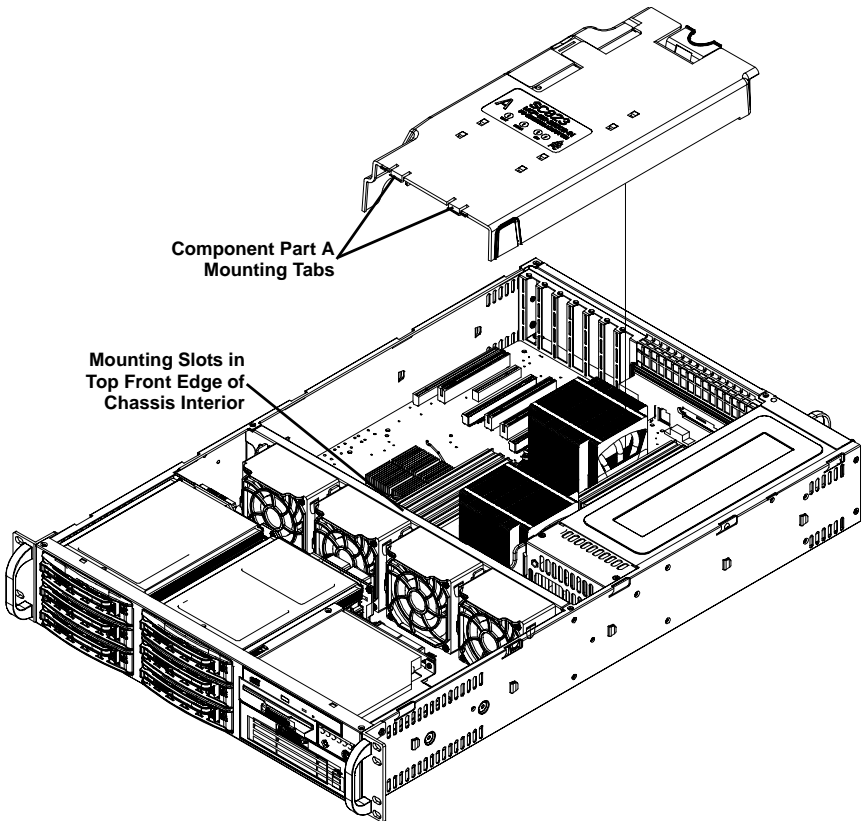

3. Make sure the SC823 air shroud is mounted directly on the mainboard of its system so that the air shroud covers the system mainboard over the CPU's and memory slots (see [Figure 3-10](#)).

Figure 3-10. Air Shroud Mounted in System

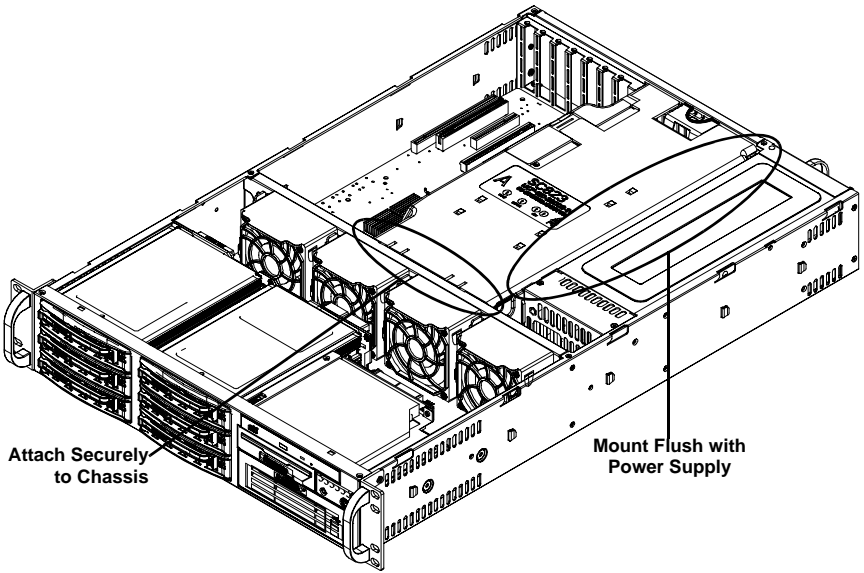

Attach Securely
to Chassis

Mount Flush with
Power Supply



NOTE: The air shroud should be mounted flush with the power supply housing if installing properly and that some cable is supposed to go under the air shroud.

4. Secure the top cover back on your system.

Notes

Disclaimer

The products sold by Supermicro are not intended for and will not be used in life support systems, medical equipment, nuclear facilities or systems, aircraft, aircraft devices, aircraft/emergency communication devices or other critical systems whose failure to perform be reasonably expected to result in significant injury or loss of life or catastrophic property damage. Accordingly, Supermicro disclaims any and all liability, and should buyer use or sell such products for use in such ultra-hazardous applications, it does so entirely at its own risk. Furthermore, buyer agrees to fully indemnify, defend and hold Supermicro harmless for and against any and all claims, demands, actions, litigation, and proceedings of any kind arising out of or related to such ultra-hazardous use or sale.

Notes