

audison

**Full DA
HD**

2017

GENERAL CATALOGUE

istinto innovativo



PHILOSOPHY



AWARDS

OVER 30 YEARS
OF PRODUCING
THE FINEST MOBILE
ELECTRONICS
IN THE WORLD

Sound reproduction has forever been a fascinating world where emotion and technology cohabit. Like any other form of art, the best result is achieved when these two values, at their peak, finally embrace.

With this combination in mind, every project we develop is born with this natural instinct.

Since the introduction of the HR 100, the application of advanced technology and emotion in every stage of a project has allowed us to create products which have marked the history of car hi-fi.

Unwaveringly dedicated to the research of perfection in sound reproduction, the recognition that world experts of the industry have shown towards the Audison brand makes us extremely proud of this choice.

Thank you!



audison

ISTINTO INNOVATIVO

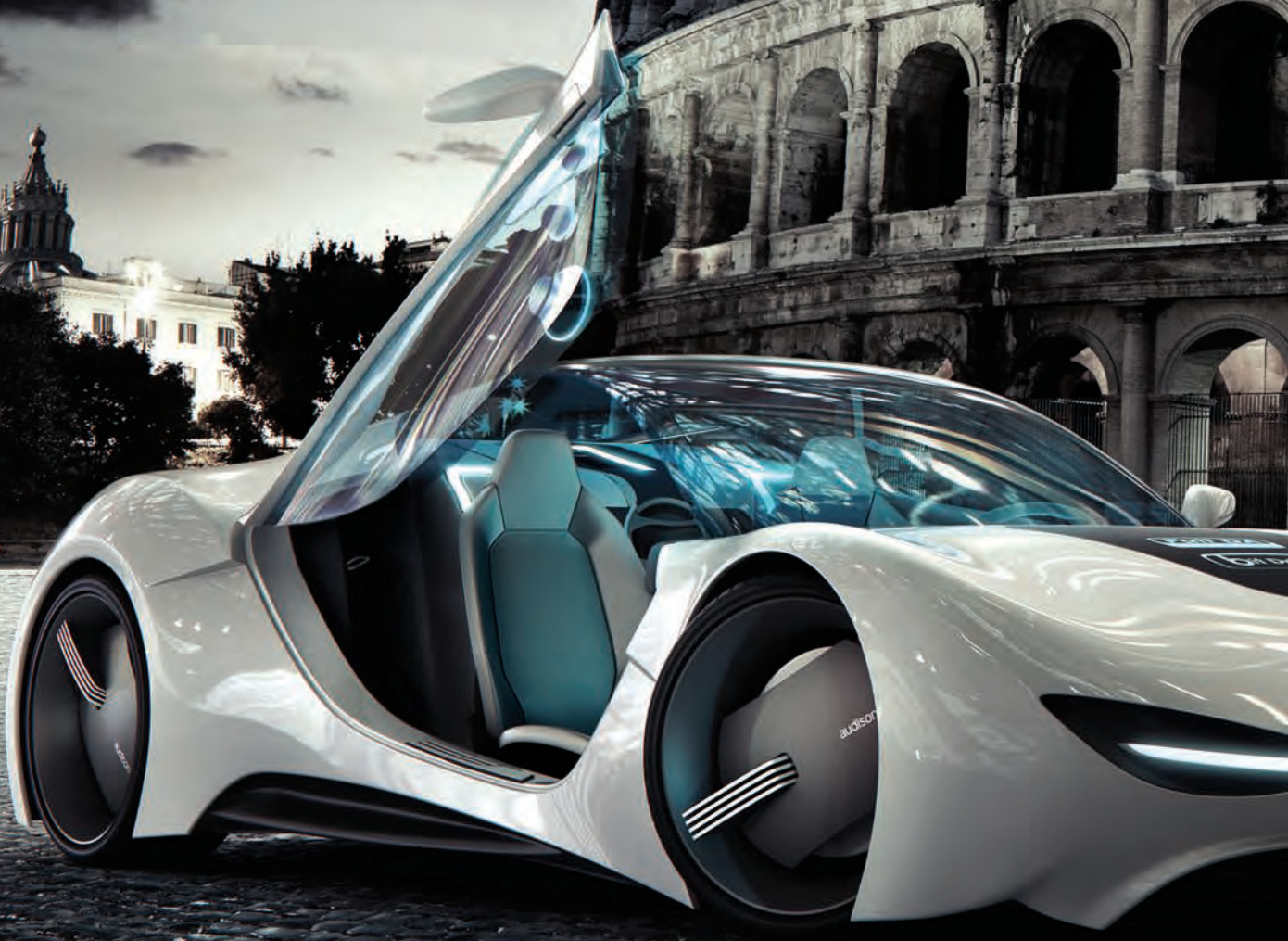

bit Drive
your sound

Full DA

**Full DA
HD**

www.audison.eu



audison

audison

BIT DRIVE

Audison is proud to announce a revolutionary digital audio technology for automobiles: bit Drive. With the introduction of bit processors, and the Prima amplifiers, Audison has been recognized by industry leaders, specialists and moreover by enthusiasts as the "reference" in the application of digital audio technologies to achieve unheard-of sound reproduction. The Audison spirit never ceases to be innovative and continues with our unique creation: the bit Tune. The Audison bit Tune is a revolutionary tool ensuring automatic calibration for Audison bit processors, quickly providing maximum audio performance. The bit Tune also includes an important set of tools useful in the everyday routine of the mobile electronics specialist, enabling the user to enhance creativity through instrumental experimentation.

Audison is proud to introduce the bit Drive technology incorporated in all of its products featuring sound digital processing functions (DSP); with these products today, thanks to the bit Tune, you can implement the audio system you have always dreamt of: "Your Sound".

www.bitdrive.it





Emidio Vagnoni, Technical Director and Audison co-founder, observes:



"Over the past 10 years our research team has focused its efforts in the field of digital audio. Our solid experience, consolidated over many years in analog topology, also highlighted the limitations of this technology to reproduce sound in a challenging environment such as the car. The study of digital technology is not limited to, as often happens, replicating traditional analog technology more efficiently, but primarily focuses on the new

possibilities it could offer to improve the sound reproduction and ergonomic integration of car audio systems. Highly innovative product solutions were introduced, such as Audison bit processors featuring DSP, AD Link and AC Link for the transmission and management of digital signals in each channel of amplification. This "wind of change" led to the emergence of the Audison bit Drive, immediately setting new sound reproduction standards in the mobile environment".

audison

THE NEXT AUDIO EXPERIENCE

Audison is renowned for offering innovative solutions, ensuring the uniqueness of each new project. Today Audison asserts its passion and technology supremacy, unveiling a new frontier in audio reproduction.

Audison Full DA technology opens the door to a new era of mobile audio reproduction. This breakthrough provides pure digital signal transfer from the source, through the processor into the amplifiers; the digital to analog conversion occurring just once, at the first stage of the amplifier. Thanks to Audison, it is now possible to enjoy an audio system free from the limitations and signal alterations of a traditional analog system.

Audison's Full DA HD technology goes beyond the standard CD resolution of 16bit/44.1kHz, transmitting a digital audio signal filled with detail and emotion. We invite you to experience your music up to 24bit/96kHz resolution; the sound of the studio master audio files!

A no compromise attitude towards acoustic reproduction; a traditional Audison philosophy.



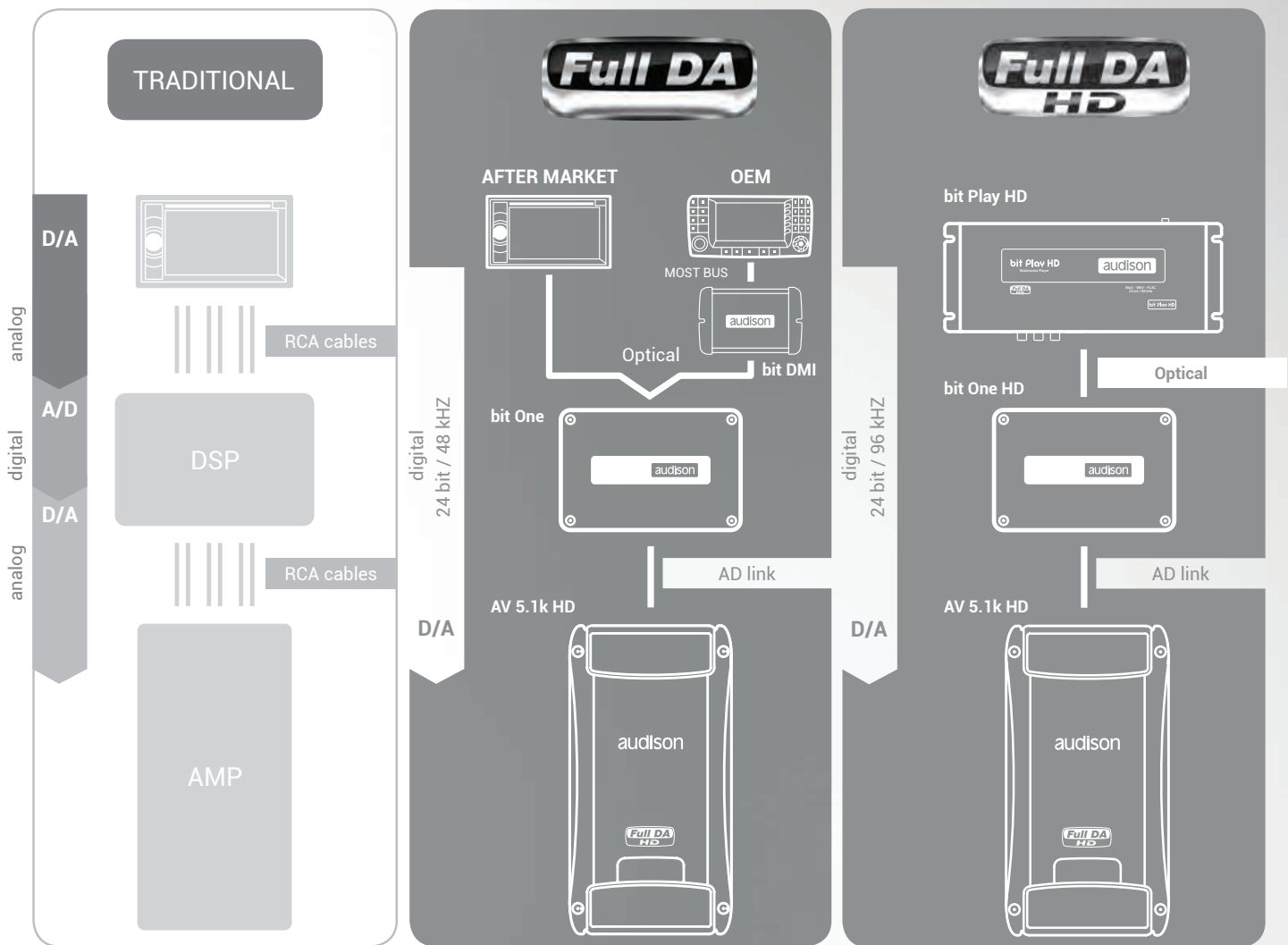

COMPARED WITH A TRADITIONAL SYSTEM, THE ADVANTAGES OF THE **FULL DA** ARE REMARKABLE:



1) A traditional system performs three conversions of the audio signal: the first one at the head unit, often through low quality D/A converters, followed by further A/D and D/A conversions at the DSP. The Audison Full DA technology performs just one single conversion of the signal from digital into analog through high quality converters inside the amplifier.

2) Full DA provides the flexibility to listen to High Definition music such as DVD-A discs or other HD music files (HD Liquid Music). Full DA delivers stunning 24 bit resolution, thus surpassing the 16 bit

sound quality barrier of the CD format used in traditional systems.

3) The Audison Full DA system requires minimal and simplified connections compared to a traditional system. An electric coaxial or optical TOSLINK digital cable runs from the source unit to the DSP. From there, a single AD Link LAN cable (CAT5S), capable of transmitting up to 8 channels of digital audio, runs from the processor to the amplifiers. Radiated noise and signal degradation common in traditional signal cables are greatly reduced.

CONNECT, CUSTOMIZE, CONTROL



How many times have we met the limits of OEM Integration, expandability or the overall sound quality of our audio system upgrades? Audison bit is the solution: multi-function digital processors capable of interfacing with any analog and/or digital source, turning ordinary audio into a highly performing integrated system.

A revolutionary technology making the acoustic domain of your car... truly yours.





bit

audison

AUDIO PROCESSOR

bit One HD



TOTAL CONNECTIVITY

The bit One HD is equipped with two optical digital inputs (TOSLINK) to connect the Audison bit DMI and bit Play HD to the processor simultaneously. The 12 analog along with 2 auxiliary inputs make it compatible with any OEM system and the 13 output channels, both analog (RCA) and digital (double AD LINK connectors to be used in a Full DA HD chain), provide the ability to create very complex full-active systems.



DELAYS COMPENSATION AND INPUT DE-EQUALIZATION

The bit One HD is equipped with a guided configuration routine which automatically synchronizes the input audio channels, which are often time-delayed from the OEM source or amplifier, prior to the signals summing. A De-equalization of the OEM system frequency response is then performed, featuring linear-phase FIR filters, to obtain an unparalleled reconstruction of the original signal without altering the phase response.

1 bit

The bit One HD features a powerful **Sharc** series DSP ADSP-21489 Analog Device which **thanks to the 32 bit floating-point arithmetic, optimized to process high resolution audio, is capable of elaborating 2.7 GFLOPS at 450 MHz**. Such a powerful hardware configuration allows for the use of digital FIR networks with zero phase shift to reach new milestones for in-car listening experience, achieving studio master quality in your car. Bit One HD allows a total integration **with any OEM system**, offering full support to the management of the car priority signals such as parking sensor alerts, GPS

messages and vocal commands. The **RVA (Remote Volume Aux)** function provides the ability to select an auxiliary source such as the Audison bit Play HD and adjust its volume via the OEM Head Unit. The **CONTROLS** external service terminals can be used to select the PC-Software presets as well as the OPTICAL 1, OPTICAL 2 and AUX inputs. The bit One HD enables the development of an **Audison Full DA HD** chain where the digital audio signal is not subject to any down-sampling, preserving all the information of the **Hi-Res digital file reproduced**.

DRC MP (included) - DIGITAL REMOTE CONTROL MULTIMEDIA PLAY



Listen to your favorite music without getting lost inside countless different controls. The DRC MP, is the digital interface between the bit One HD processor and you. Volume control, Balance and Fader, source selector and memory settings are all at your fingertips; simplifying the intricacy of the available functions. The matte black finish and the possibility of choosing among forty-two different colors for the keyboard make it easier for the DRC MP to integrate with the car dashboard. The display with white characters features a built-in sensor, for brightness automatic adjustment according to the light conditions inside the car.



NEW SOFTWARE

The Audison R&D developed a new management Windows-based (XP, Vista, 7, 8, 10) software to make the system configuration and calibration processes as user-friendly as possible, according to specific criteria required by the Car Audio industry. The guided crossover set-up procedure, according to the functions assigned to the outputs, assists the user in setting up the crossovers and equalization enabling the tuning of any system in just a few "clicks".

AUDIO PROCESSOR

Despite its compact size, the bit One is equipped with a fast, 266 MHz / 32 bit floating point DSP microprocessor, working in real time on all the functions of the most complete systems. Managed and configured by a simple and intuitive computer software, it allows the user to make adjustments to improve the signal through each phase of its path; from input to output. Eight input

channels for four different signal typologies (amplified, pre-amplified, coaxial electric and TOSLINK optical digital) and six different sources managed through a remote control, making the bit One a unique interface suitable for any need.

Eight analog and/or digital output channels ensure vast expandability for any audio system configuration.

bit One



DRC (included) - DIGITAL REMOTE CONTROL

To remotely control the main system functions, sitting comfortably in your car without your PC, the bit One can be connected to the DRC through the AC Link output. (DRC MP optional).



bit One PC SOFTWARE

The most effective, versatile and functional process to configure any system. The Windows-based software features an interface providing direct access to the endless adjustments and tuning opportunities that the bit One offers.



DSP

The bit One features a 32 bit floating point "Sharc" series DSP by Analog Devices, with a 266 MHz clock speed and Wolfson Microelectronics A/D - D/A converters working in PCM at 48 kHz with 24 bit resolution.

1 bit

bit Ten D is a digital processor featuring an analog and digital input provided with a 32 bit, 147 MHz clock speed DSP as well as 24 bit A/D and D/A converters; controlled by a software developed for signal treatment according to the vehicle acoustic peculiarities. It is conceived and built to process both input/output digital and analog

signals to the amplifier (featuring AD Link connection) and create top performance systems with any source typology. bit Ten D features an optical digital input, minimizing interference and degradations of the signal found in traditional analog interconnects, also bypassing the A/D conversion phases of analog signals.

bit Ten D



DRC (included) - DIGITAL REMOTE CONTROL

To remotely control the main system functions, sitting comfortably in your car without your PC, the bit Ten D can be connected to the DRC through the AC Link output. (DRC MP optional).



bit Ten D SOFTWARE

For full control of system parameters, the bit Ten D software is available for installation on PCs.



SYSTEM CALIBRATION

Once the system to be built is decided, any of the settings can be changed. In the initial phase, PRE-IN sensitivity levels can be calibrated with extreme operational accuracy.

audison

AUDIO PROCESSOR

bit Ten is a digital processor provided with a 32 bit, 147 MHz clock speed DSP as well as 24 bit A/D and D/A converters; controlled by a software developed for signal treatment according to the vehicle acoustic peculiarities. It is conceived and built to process analog signals and create top performance systems with analog sources.

bit Ten



DRC (optional) - DIGITAL REMOTE CONTROL

To remotely control the main system functions, sitting comfortably in your car without your PC, the bit Ten can be connected to the DRC through the AC Link output. (DRC MP alternative optional).



bit Ten SOFTWARE

For full control of system parameters, the bit Ten software is available for installation on PCs.



SYSTEM CALIBRATION

Once the system to be built is decided, any of the settings can be changed. In the initial phase, PRE-IN sensitivity levels can be calibrated with extreme operational accuracy.

bit

DIGITAL MOST INTERFACE

bit DMI is a digital interface for MOST systems, providing the ability to connect the **Audison bit processors and amplifiers**, equipped with digital input, to OEM multimedia systems in vehicles featuring MOST technology based on optical fibre. Thanks to the digital connection, **the signal can be transmitted without loss of quality**, keeping the audio controls built in the OEM head unit - such as volume, balance and tone controls - as well as the hands-free kit, navigation system and parking sensors alerts unaltered. In the bit DMI Product section of the Audison website you can find the "Vehicle Compatibility" information to check compatibility of the OEM head unit with the bit DMI interface.

bit DMI



audison

AUDIO PROCESSOR

		bit One HD	bit One
Audio Inputs	Analog inputs (high levels / pre in)	12 high lev. / 6 pre in	8 high lev. / 6 pre in
	Analog low-level stereo auxiliary input	1	2
	Optical digital input	2	1
	Electric coaxial digital input	-	1
	High-level momentary audio interrupt input with system turn on capability (with Phone Mute IN) for use with mobile phone or navigation systems	-	1
Audio Outputs	Independent analog PRE channels featuring adjustable level	13	8
	AD Link output (8 / 13 only for bit One HD independent digital audio channels through a single CAT5 STP LAN cable for use with AD Link compatible amplifiers)	√	√
Input/Output Controls	USB /B (2.0 / micro USB 2.0 only for bit One HD) connector for PC connection	√	√
	AC Link control bus connectors for DRC / DRC MP	√	√
	AC Link control bus for compatible amplifiers	√	√
	Input for external Mute	-	√
	Remote In/Key mem	√	√
	Remote out with fixed delay or adjustable by PC	adj.	fixed
	Mute In for audio interrupt by external control	-	√
	Mute In and Phone Mute controls adjustable by PC to switch the audio inputs to auxiliary inputs with turn on capability	-	√
System Configuration	Full range stereo signal derived through automatic summing high level input channels	√	√
	Guided procedure that, thanks to a wide range of set names, provides the ability to assign each speaker channel to the bit processor connections and automatically coordinate their functioning	√	√
In/Out Volume	Reference tone/signal for sensitivity adjustment	CD-DVD	CD-DVD
	Main input sensitivity adjustment	automatic with PC	automatic with PC
	Independent level control for each output channel for system fine tuning	-40 ÷ 0 dB	-40 ÷ 0 dB
Equalizer	Dynamic equalizer: self-adjusting gain between low and high listening levels	√	√
	Automatic de-equalization (with supplied Test CD or DVD)	with 'time delay compensation'	√
	Head-unit check for equalized signal	-	-
	Equalizers for auxiliary inputs	5 pole parametric FFT eq. using FIR filters	31 band (1/3 oct; +/-12dB)
	Independent graphic equalizers for each output channel	11 pole parametric eq. using IIR filters	31 band (1/3 oct; +/-12dB)
	5 parametric poles main equalization, FIR type, to "shape" the sound of the entire system according to the user's personal music preferences	√	-
Crossover Filter	Filter typology: Hi-pass, Lo-pass, Full Range, Band-pass	√	√
	Cut-off frequency steps	70 (10 Hz to 20 kHz) + direct numeric frequency input	70 (10 Hz to 20 kHz)
	Cut-off slope	6 to 48 dB/Oct.	6 to 48 dB/Oct.
	Bandpass filter with asymmetrical slope setting	√	-
	Alignments	√	√
	Mute: Selectable for each output (On/Off)	√	√
Phase: Selectable for each output (0°/180°)	Linkwitz -Butterworth -Bessel	Linkwitz -Butterworth	
Time Alignment	Guided procedure for the speaker distance data entry with an automated calculation of time delays for each channel for accurate time alignment set-up	√	√
	Fine tuning delay	0 ÷ 22 ms	0 ÷ 22 ms
DRC / DRC MP	Digital Remote Control (DRC/DRC MP) supplied with product	√ (DRC MP)	√ (DRC)
	Master Volume control, Subwoofer Volume control, Balance control, Fader control; Input selection, memory selection	√	√
	Dynamic Equalizer On/Off	√	√
	Access to digital features of Audison TH amps if connected	-	√
Memory	Available presets separately managed and recalled by the DRC/DRC MP Remote Control	8 (DRC MP)	4
bit software	Microsoft Windows-based (XP, Vista, 7, 8, 10) software with "Standard" and "Expert" operating modes; minimum screen resolution: 1024 x 600 px	√	√

bit Ten D	bit Ten
4 high lev. / 4 pre in	4 high lev. / 4 pre in
1	1
1	-
-	-
1	1
5	5
✓	-
✓	✓
✓	✓
✓	✓
✓	✓
✓	✓
adj.	adj.
✓	✓
✓	✓
✓	✓
✓	✓
CD	CD
manual	manual
-40 ÷ 0 dB	-40 ÷ 0 dB
-	-
✓	✓
✓	✓
-	-
31 band (1/3 oct; +/-12dB)	31 band (1/3 oct; +/-12dB)
-	-
✓	✓
68 (10 Hz to 20 kHz)	68 (10 Hz to 20 kHz)
6 to 24 dB/Oct.	6 to 24 dB/Oct.
✓	✓
✓	✓
✓	✓
Linkwitz -Butterworth	Linkwitz -Butterworth
✓	✓
0 ÷ 15 ms	0 ÷ 15 ms
✓ (DRC)	Optional (DRC/DRC MP)
✓	✓
-	-
✓	-
2	2
✓	✓



ES3

It prevents the processor from shutting down when turning on cars featuring the start & stop system. When starting the engine, the vehicle battery voltage might decrease below 8 Volts value. If a signal processor (bit One, bit Ten) is installed in your system, especially with cars featuring the start & stop system, low supply voltage values may cause the processor to shut down. In order to avoid waiting for the processor to complete its turn-on cycle again, you can install the ES3 by connecting it in series to the processor power supply cables.



SFC

SFC is a digital audio signal adaptor (S\PDIF) to place between two devices with digital input/output. The main purpose of this adaptor is to solve issues related to digital interfacing like in the case of the Digital head-unit having a higher sampling frequency (96/192 kHz) than the receiver that can not handle frequencies higher than 48 kHz (like bit One).

For bit One, bit Ten D



SPM 4

Stereo passive mixer (unpowered) featuring 4 input channels and 2 output channels, designed for active OEM multi-way systems where each speaker is powered by one specific amplified channel. SPM4 mixes audio through 4 audio transformers specifically developed to achieve very low distortion and highly linear acoustic response. It provides the ability to mix the midrange/woofer and tweeter channels coming from the amplifier and supply one single mid-high channel.

For all models



ECK DRC

DRC Cable Extension kit for installations on especially long vehicles. Total length of the supplied cable with the extension is equal to 6,5 m / 225,90".

For all models



TOSLINK Optical Cable

Optical digital audio signal cable, designed for car audio applications, allowing for the transfer of the optical signal without signal loss. An especially thicker sheath protects the optical fiber to prevent the cable from damages if it is pressed against sharp edges.

The metal connector protects the optical fiber for its full length, ensuring a stable transmission of the signal also in the event of strong vibrations.

- OP 1.5 • TOSLINK Optical Cable 1,5m / 59,05"
- OP 4.5 • TOSLINK Optical Cable 4,5m / 177,16"
- STA • F/F Socket TOSLINK adapter
- STR - M to F RIGHT ANGLE TOSLINK ADAPTER

For bit One, bit Ten D



RCA MULTIPOLE CONNECTOR

RCA connector for fast and effortless links. It expedites connections between the head-unit PRE OUTs (2 V min.) and the bit Ten Hi-Level inputs.

For bit Ten D, bit Ten

HI-RESOLUTION IN-CAR MEDIA PLAYER



bit Play HD



*Tablet not included.

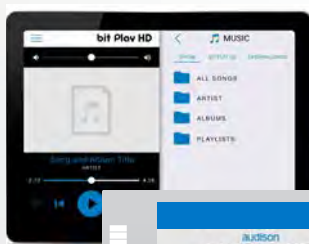
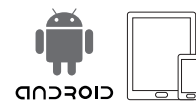

APPLE/ANDROID APP
Audison App to manage the media library and control the bit Play HD through Smartphones and Tablets. Available on the App store and Play store.

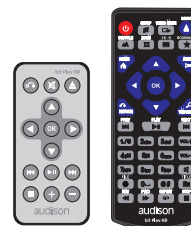

REMOTE CONTROL
ARC (Advanced Remote Control). It controls all the player functions within a compact design. USR (User Remote Control). Ultra-compact design to simplify management of audio playlists.

bit Play HD and bit Play HD SSD are high resolution media players specifically developed for car audio systems. By connecting the **bit Play HD optical output** to an Audison processor or amplifier with digital input, a **Full DA system** is created, able to reach a new standard of quality going well beyond CDs inasmuch as being capable of playing encoded **FLAC audio files up to 24 bit/96 kHz**.

To help users who do not wish to have external hard-drives, the **bit Play HD SSD** features an **internal 240GB SSD 2.5" unit** which is **insensitive to the vibration** and shaking that occur while driving thanks to solid state technology and a specially designed damped mechanical housing. In addition, the SSD is much faster than a traditional hard disk and provides

maximum access speed to multimedia content. If you have a video input, you can connect the bit Play HD and bit Play HD SSD to the head unit or to an external monitor via the **HDMI output** or composite video and view the **native interface of the media server** in order to directly control the multimedia file navigation functions via remote and access every setting of the device. Audison R&D department developed **an app for Apple and Android** devices providing the ability to connect the **smartphone to your bit Play HD and bit Play HD SSD via Wi-Fi network** and use it as a remote control manager of the multimedia library without the need to connect the player to an external monitor.

TECHNICAL SPECIFICATIONS			bit Play HD	bit Play HD SSD
GENERAL FEATURES	USER INTERFACE	Dual mode: 1) Advanced control on Video out via Remote control 2) Basic control via iOS/Android App	✓	✓
	SMARTPHONE CONTROL	Dedicated Audison App for Android and iOS smartphone, to allow: 1) Wi-Fi Streaming of smartphone multimedia contents to bit Play HD output (Android only). Alternatively standard DLNA Apps (iOS/Android). 2) Play the bit PlayHD storage multimedia contents. 3) File management of bit Play HD storage contents, with copy, delete and move functions	✓	✓
	MEDIA STORAGE	1) 240GB SSD 2.5" (Internal, optional, up to 2TB support) 2) External USB HDD/Pendrive/DVD drive (up to 2TB support)	- ✓	✓ ✓
	FILE SYSTEM - MEDIA STORAGE	FAT32 & NTFS (Windows), EXT3 (GNU/Linux), HSF+ (Mac OSx)	✓	✓
	Wi-Fi	802.11n - Internal Hotspot with external USB Wi-Fi Dongle (supplied)	✓	✓
MULTIMEDIA FORMAT	AUDIO FORMATS	Hi-Res Uncompressed: WAV, FLAC (Up to 96kHz/24bit) Compressed: OGG, AAC, MPEG Audio (MP1, MP2, MP3, MPA)	✓ ✓	✓ ✓
	VIDEO FORMATS	WMV, DivX, Xvid, MPEG, H264	✓	✓
	IMAGE FORMATS	JPG, BMP, PNG, GIF	✓	✓
SIGNAL CONNECTION	DIGITAL VIDEO OUTPUT	1 x HDMI v1.3	✓	✓
	ANALOG VIDEO OUTPUT	1 x Composite video (NTSC/PAL)	✓	✓
	TOSLINK OPTICAL OUTPUT	1 x S/P-DIF - PCM 96 kHz/24 bit	✓	✓
	ANALOG PRE OUT	2 x RCA, Left / Right	✓	✓
DATA CONNECTION	USB HARD DRIVE / PEN DRIVE	2 x USB/A (1.1/2.0) - USB extension supplied	✓	✓
	LAN	1 x 10/100M Ethernet / RJ45 port for future upgrade (Car NAS; 3G/LTE router; etc.)	✓	✓
	SATA	1 x internal mini SATA 2.0 port for 2.5" SSD Drive (Available version with SSD 240GB built-in)"	✓	✓
	FIRMWARE MEDIA UPGRADE	USB Pen Drive 1.1/2.0 (not supplied)	✓	✓
CONTROL CONNECTION	FIRMWARE MANAGER UPGRADE	1 x USB Type B (1.1/2.0) to PC	✓	✓
	Audison AC Link	1 x RJ12 - To Audison AC Link provided devices	✓	✓
INFRARED REMOTE CONTROLS (supplied)	Audison DRC	1 x RJ12 (optional)	✓	✓
	URC	User Remote Control - Ultra-Compact 14 keys for audio control	✓	✓
	ARC	Advanced Remote Control - Compact 40 keys for audio/video control	✓	✓



DRC MP (Optional)

When an Audison bit Play HD is connected, by enabling the "Navi Command" function of the DRC MP, it is possible to browse through the player main menu with the Joystick, in the same way as with the remote control.



INTERNAL MEMORY

bit Play HD SSD features a **240GB SSD 2.5" SATA 3.0** solid state drive, vibrationally damped.

BEYOND THE ABSOLUTE

In its purest essence, the synergy between technique and emotion constitutes the keystone of the Thesis project.

For pure reproduction, every element has been conceived and manufactured according to quality parameters, ensuring sheer excellence.

Since the beginning, the Thesis product range has been conceived, designed and developed according to these principles. The Thesis project is characterized by a no compromise attitude: in the world of hi-fi car audio, the Thesis name is referenced as a product with the highest technological content, capable of arousing the emotions of even the most demanding audiophile.

Thesis products; you are immersed into a fully involving experience.





THESIS

audison

HV VENTI "THE AMPLIFIER"

THESIS

HV venti

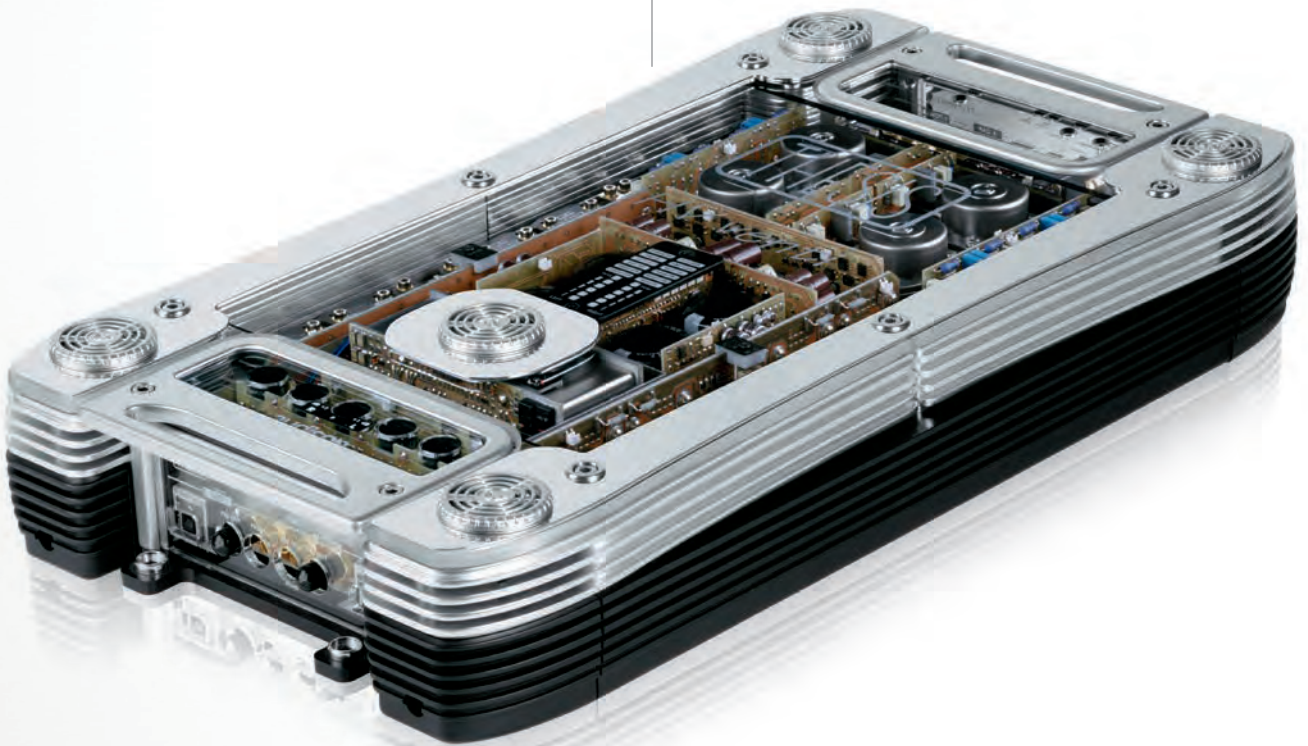

A stereo amplifier built according to absolutely Hi-End parameters.

The amplifier stages feature fully balanced input stage, Dual Mono construction, JFET differential stages, Mosfet-BJT hybrid configuration final stage, Servo DC and low feedback. All of these technologies ensure state-of-the-art performance. Dual Power function: Hi-Current and Hi-Power. Six power supplies providing current. A microprocessor monitors and stabilizes heat

sink and driver circuit temperatures. A Status Display shows the amplifier operating conditions. Innovative mechanical engineering was employed to optimize thermal dissipation.

These are only some of the unique features which characterize "the Amplifier".

The HV venti combines a Hi-Tech work of art with maximum listening pleasure, its owners proudly enthralled with choosing such a unique device.

TECHNICAL SPECIFICATIONS			Hi-Current	Hi-Power
Channel mode			2 - 1	
Output Power (RMS) @13.8 VDC	@ 4 Ω	W x Ch	200 x 2	400 x 2
		W x Ch	800 x 1	1600 x 1
	@ 2 Ω	W x Ch	400 x 2	800 x 2
		W x Ch	1300 x 1	-
@ 1 Ω	W x Ch	650 x 2	-	
Filters	Bypass		Amp / Out (Pre)	
	Hi-pass	Hz @ dB/Oct	45 - 55 - 65 - 80 @ 12 dB/Oct	
	Lo-pass	Hz @ dB/Oct	45 - 55 - 65 - 80 @ 12 dB/Oct (Stereo) / 24 dB/Oct (Mono)	
THD	1 kHz @ 4 Ω	%	< 0.05	
S/N Ratio	A weighted @ 1 V	dB	100	
Damping factor	1 kHz @ 4 Ω		80	
Size	W x D x H	mm	280 x 510 x 85	
		inch	11.02 x 20.08 x 3.35	

THE HIGHEST EXPRESSION OF SOUND



The roads travelled to reach "the Sound" have created a conceptual crossroad, where, until now, **state-of-the-art digital technology and traditional techniques** have gone their separate ways. They both have benefits of a different nature, yet are capable of merging together to achieve much higher Sound quality levels.

The Thesis amplifiers are born with the know-how and the experience achieved with the HV venti, improved by the innovation of digital technology. The result is a perfect combination between the highest level of analog technology and the advanced functions of the digital technology in one unique product.





THESIS

audison

TECHNOLOGY



ACNET

The Audison Control Network is a software used to configure the system through a computer connected to the amplifier via USB. ACNet monitors and sets all the amplifier's functions.



STATUS DISPLAY

The ASC (Amplifier Status Controller) is a visual element, providing local control, monitoring of the amplifier's status, as well as memory storage functions.



DIGITAL INPUTS AND OUTPUTS

Innovation is at the heart of the state-of-the-art digital decoding section. The S/PDIF optical input allows direct connection to digital sources with the ability to re-launch the digital signal to other Thesis amplifiers through the AD Link (Audison Digital Link) system. Each amplifier features 192 kHz/24 bit PCM D/A conversion through a very high quality converter.



DRC MP (optional) - DIGITAL REMOTE CONTROL MULTIMEDIA PLAY

Providing source selection between analog and optical inputs, it also controls the essential functions to be used frequently.

Inherited from the HV venti and making the most of TH's extreme versatility, the complete crossover circuit of the TH amplifier is removable; a high-end sound quality solution.

REMOVABLE CROSSOVER

A revolutionary function allowing the user to select the amplifiers output power configuration and the operating class.

DUAL POWER

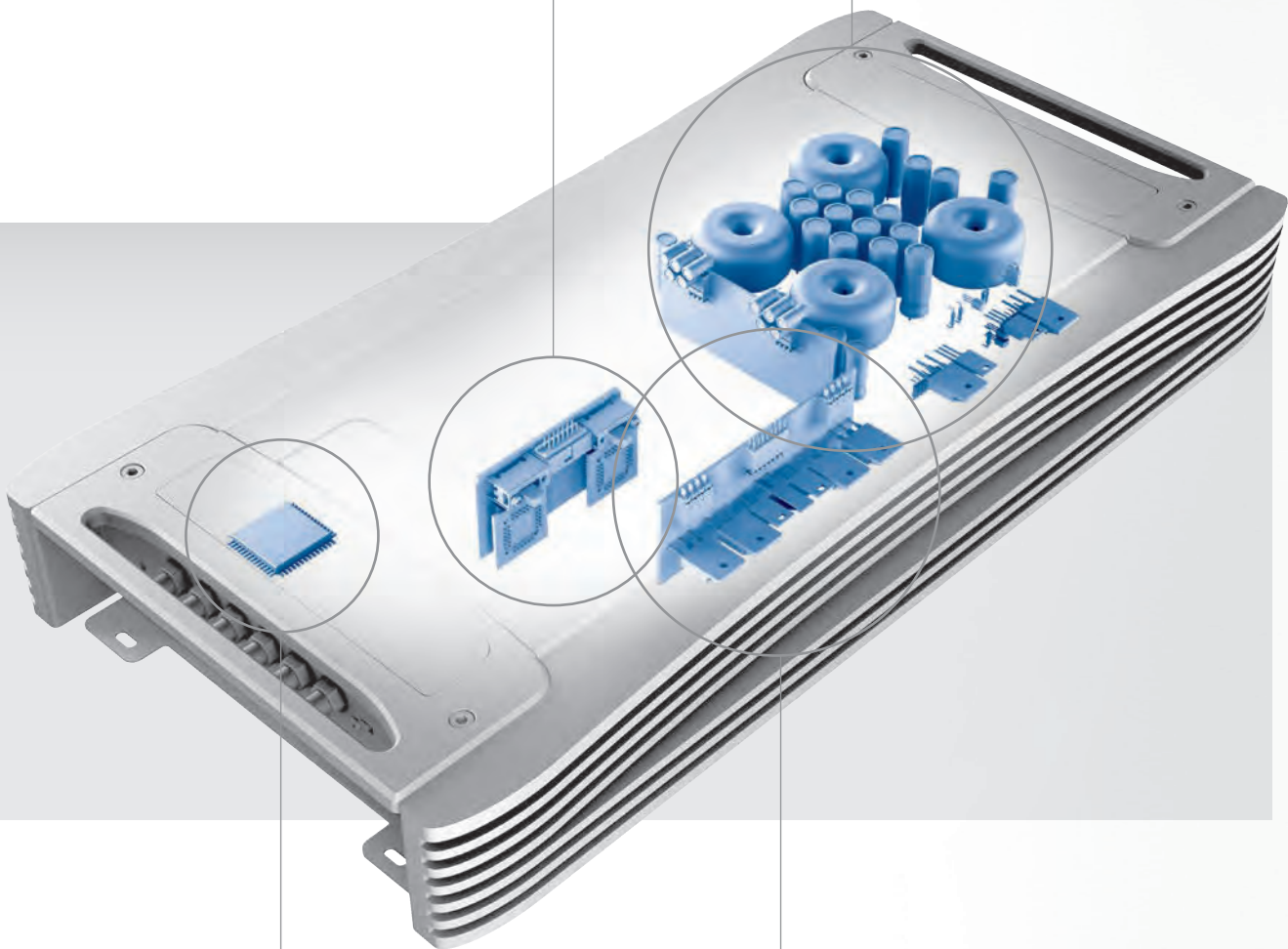

AMPLIFIER STATUS CONTROLLER

The ASC controls all the amplifier's functions, with each operation displayed on the LCD panel and/or DRC, ensuring constant monitoring.

BIAS CONTROL

Provides selection of four possible presets: Energy Saving, Hi-Current, Hi-AB Class and full A Class operation.

AMPLIFIERS



TH uno



TH due



TH uno: a single channel (mono) amplifier used to achieve maximum performance under any load. Specifically designed to drive systems and subwoofers with self-assured mastery.

TH due is a bridgeable, stereo amplifier. A logical choice and natural partner for systems where versatility, power and quality are the main parameters. The ultimate amplifier.

TH quattro is a four-channel amplifier fully adjustable and entirely manageable by the internal microprocessor, for limitless system configuration.

TECHNICAL SPECIFICATIONS			TH uno	TH due	TH quattro
Channel mode			1	2 - 1	4 - 3 - 2 (A/B)
Output Power (RMS) @ 14.4 VDC Dual Power - Hi-Current	@ 4 Ω	W x Ch	850 x 1	300 x 2	160 x 4
		W x Ch	-	1000 x 1	150 x 2 + 540 x 1
		W x Ch	-	-	500 x 2
	@ 2 Ω	W x Ch	1500 x 1	500 x 2	260 x 4
		W x Ch	-	1500 x 1	250 x 2 + 650 x 1
		W x Ch	-	-	700 x 2
@ 1 Ω	W x Ch	2300 x 1	750 x 2	340 x 4	
Dual Power - A Class	@ 4 Ω	W x Ch	200 x 1	80 x 2	55 x 4
Amp Chain Mode	@ 2 Ω	W x 2 Amp	4500 x 1	-	-
Filters - Modules	TH-MXR/Not mounted		1 / Bypass		2 / Bypass
TH-MXR Specifications			Hi-pass/Lo-pass/Band-pass @12/24 dB/Oct. (32 steps 18 ÷ 7.5k Hz)		
Inputs			Analog, Digital, Optical, AD Link		
THD	1 kHz @ 4 Ω	%	0.01	0.02	0.03
S/N Ratio	A weighted @ 1 V	dBA	106	106	104
Damping factor	1 kHz @ 4 Ω		500	100	80
Size	W x D x H	mm	259 x 510 x 67	259 x 510 x 67	259 x 510 x 67
		inch	10.12 x 20.07 x 2.63	10.12 x 20.07 x 2.63	10.12 x 20.07 x 2.63

	RMS Output Power	4 Ω, ≤ 1% THD+N, 14.4 V	W x Ch	700 x 1	300 x 2	150 x 4
	S/N Ratio	Ref. 1 W Output	dBA	75	80	80

THE AUTHENTIC VOICE



Originating directly from the experience of the outstanding Thesis line, the Voce components take the in-car listening experience to a new level of excellence. Innovative and advanced design, reference performance; the synthesis of a solid know-how employed in car audio reproduction.

At the service of sound, a new Voice for music.





voce

audison

TECHNOLOGY

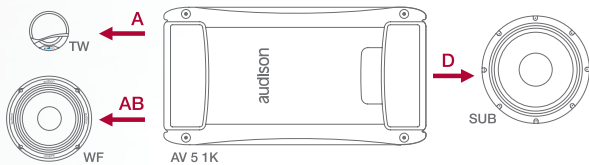

A + AB + D CLASS TECHNOLOGY:

Continuing with ground breaking Audison technology, the AV 5.1k uses three different typologies: A, AB and D Class in one chassis. A Class for linearity and detail; AB Class for accuracy and high power; D Class for enhanced power efficiency.

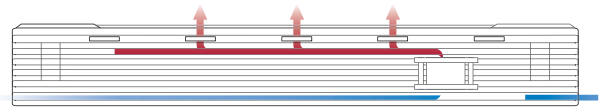

FORCED AIR FLOW

Forced air flow improves cooling, taking cool air from the outside and directing it where it is most needed. The air is directed along the top of the amplifier chassis and hot air is vented out from side openings.



AV BIT IN HD

Digital interface for all AV amplifiers. It offers one AD Link and AC Link input as well as one AD Link and AC Link output for a perfect digital connection with digital processors (bit One HD, bit One and bit Ten D) to drive a multi-amplified system. Simply remove the standard analog module and replace it with the AV bit IN HD module; the AV amplifier is now an integral element of a Full DA HD system.



VCRA - REMOTE SUB VOLUME CONTROL (optional)

When you drive the subwoofer in mono, for all AV models, you can use VCRA Analog Remote Volume Control by connecting it to the special SUB VOL socket.

Regulated power supply with double PWM (Pulse With Modulation) control. The output power does not change with variations in power supply voltage; the amplifier performance remains unchanged even with the ignition off.

POWER SUPPLY SECTION

AMP is a microprocessor that constantly analyses voltage, current, output load and temperature activating protection circuits.

AMPLIFIER MANAGEMENT PROCESSOR

MODULAR CONSTRUCTION

The amplifier is a modular design, ensuring the power supply motherboard does not interfere with the delicate audio signal, providing noise-free amplification. The removable input/crossover section provides easy insertion of the AV bit IN digital module.

DOUBLE TRANSFORMERS

The power supply stage features dual multiple-winding transformers to increase the efficiency and power delivery in any difficult load condition.

SMART AIR FLOW

A fan is the heart of this circuit; its two speed system is thermostatically controlled by the AMP; the higher the heat dissipation requirement, the higher the fans speed will be. SAF ensures maximum thermal management, with quiet operation.

AMPLIFIERS

AV 5.1k HD



AV uno



AV due



AV quattro



AV 5.1k



AV uno is a mono amplifier designed to drive the subwoofer but also suitable for high power Dual Mono systems. It allows to combine the plus points, in terms of audio quality and robustness, of the AB Class traditional amplifiers with the efficiency of the D Class modern amplifiers.

AV due is a powerful stereo amplifier. Designed to work also in mono and tri-mode, it ensures very high output current with powers up to 900 W (RMS).

AV quattro is a four channel amplifier which can work in four, three, two channel mode, delivering 800 W bursting power total. It is conceived to handle complex configurations as front/rear and multi-channel systems.

AV 5.1k is the Audison specialist amplifier for front + rear + subwoofer or multi-amplified front + subwoofer systems. A Class quality, AB Class energy and D Class power; together providing the most complete amplifier choice.

AV 5.1k HD provides the ability to connect directly to the digital outputs of a digital processor via the Audison AD Link available on the Audison processors (bit One HD, bit One, bit Ten D). The high resolution (96kHz/24 bit) digital audio signal coming from the head unit, via the processor, can be obtained up to just the Digital/Analog converter of the amplifier's audio chain, ensuring maximum reduction of any signal deterioration in a Full DA HD chain.

TECHNICAL SPECIFICATIONS			AV uno	AV due	AV quattro	AV 5.1k - AV 5.1k HD
Channel mode			1	2 - 1	4 - 3 - 2 (A/B)	5 (A/B/C)
Output Power (RMS) @14.4 VDC	@ 4 Ω	W x Ch	700 x 1	260 x 2	120 x 4 / 400 x 2	75x2/A + 140x2/B + 600x1/C
	@ 4 Ω	W x Ch (mono)	-	900 x 1	120 x 2 + 400 x 1	-
	@ 4/2 Ω	W x Ch	-	-	120 x 2 + 200 x 2	75x2/A + 140x2/B + 1000x1/C
	@ 2/4 Ω	W x Ch	-	-	200 x 2 + 400 x 1	75x2/A + 250x2/B + 600x1/C
	@ 2 Ω	W x Ch	1300 x 1	450 x 2	200 x 4	-
	@ 1 Ω	W x Ch	1700 x 1	-	-	-
All channels full range			OK	OK	OK	OK - AD Link digital inputs only for HD version
Filters	Hi-pass	Hz @ dB/Oct	-	50 ÷ 5k (2 range) @ 12	A/B: 50 ÷ 5k (2 range) @ 12	A: 50 ÷ 5k (2 range) @ 12 - Not available in HD version B: 50 ÷ 1k @ 12 - Not available in HD version
	Lo-pass	Hz @ dB/Oct	50 ÷ 150 @ 24	50 ÷ 5k (2 range) @ 12	A/B: 50 ÷ 5k (2 range) @ 12	B: 250 ÷ 5k @ 12 - Not available in HD version
			-	50 ÷ 500 (mono) @ 24	B: 50 ÷ 500 (mono) @ 24	C: 50 ÷ 150 @ 24 - Not available in HD version
	Subsonic	Hz @ dB/Oct	Off ÷ 50 @ 24	-	-	-
	PRE Out	Hz @ dB/Oct	Hi-pass: 50 ÷ 150 @ 12	Full range	Full range	Full range - AD Link digital outputs only for HD version
	Remote Sub Vol. - VCRA	(-50 ÷ 6) dB	OK	Lo-pass mono	B ch Lo-pass mono	C ch
THD	1 kHz/100 Hz @ 4 Ω	%	0.04 /-	0.04 /-	0.04 /-	A/B: 0.05 / C: 0.3
S/N Ratio	A weighted @ 1 V	dB	95	100	100	A/B: 100 / C: 87
Damping factor	1 kHz/100 Hz @ 4 Ω		160 /-	120 /-	100 /-	A/B: 100 / C: 80
VCRA - Remote Sub Volume Control (optional)			OK	OK	OK	OK - AC Link to connect a DRC only for HD version
Size	W x D x H	mm	220 x 470 x 58	220 x 470 x 58	220 x 470 x 58	220 x 470 x 58
		inch	8,66 x 18,50 x 2,28	8,66 x 18,50 x 2,28	8,66 x 18,50 x 2,28	8,66 x 18,50 x 2,28

	RMS Output Power	4 Ω, 1% THD, 14.4 VDC	W x Ch	700 x 1	260 x 2	120 x 4	75 x 2 + 140 x 2 + 600 x 1
	S/N Ratio	Ref. 1 W Output	dB	80	80	80	A/B: 80 - C: 78

TECHNOLOGY

The exclusive profile and selected materials provide full linearity as well as reliable performance.

TRIPLE WAVE SURROUND

The profile of the basket's spokes, along with the "open-air" design, ensures drastic reduction of back-wave reflections.

AERODYNAMIC BASKET

CCAW VOICE COIL

Extremely lightweight and compact, the Copper Clad Aluminium Wire voice coil provides very high efficiency and optimal thermal dissipation.

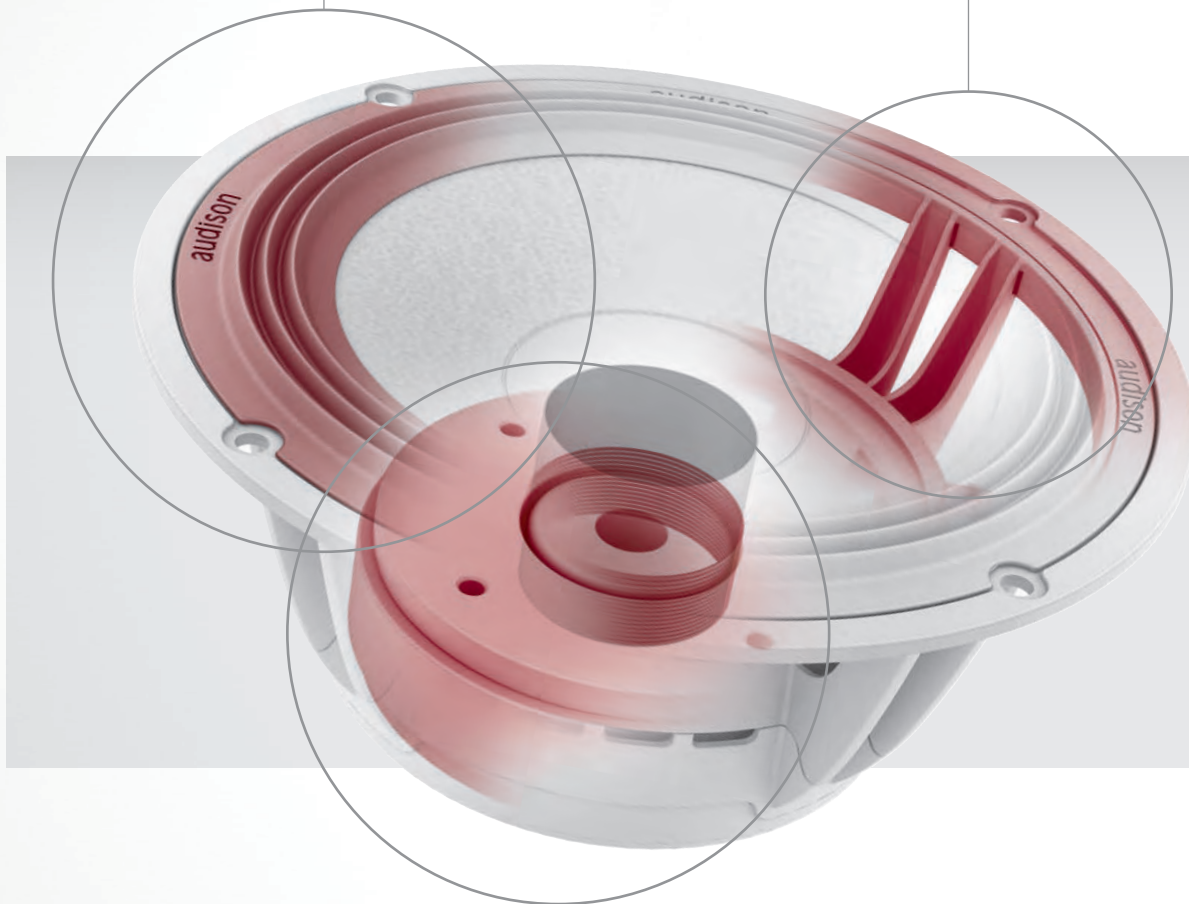

A combination of silk and cotton with proprietary damping treatment, provides low mass and resonance-free response up to ultrasonic frequencies.

TETOLON DOME

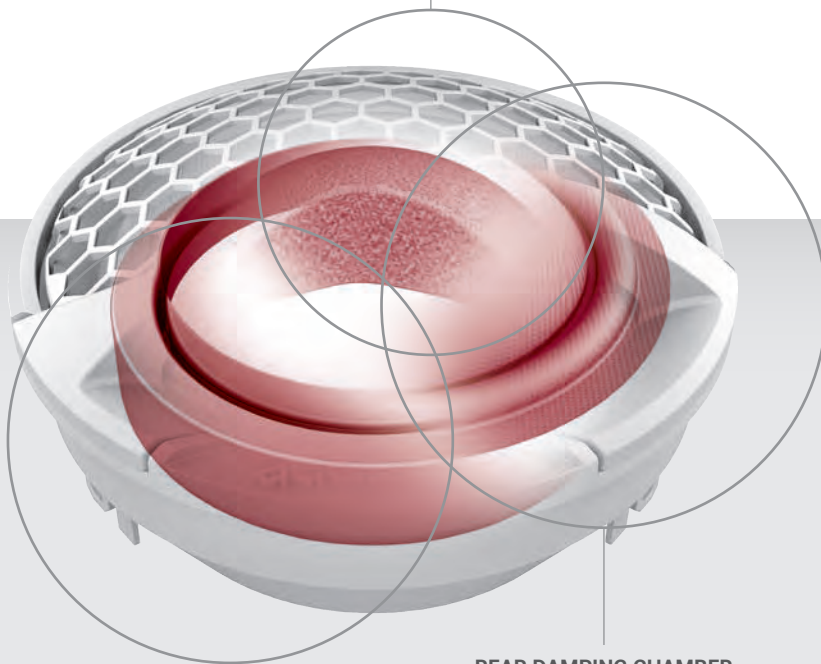

REAR DAMPING CHAMBER

The annular geometry of the rear damping chamber, together with the proprietary damping material, extends the frequency response to lower limits and reduces harmonic distortion.

CCAW VOICE COIL

The Copper Clad Aluminium Wire voice coil wound on double layer is extremely lightweight and compact, resulting in a very high efficiency and crisp, dynamic sound.



AV X6.5

Orientable High Frequency Tuning: controlled dispersion for the best performance in the listening point.



AV 6.5

Cotton fiber pressed paper cone with Light Damping treatment; a new material developed to provide a natural and linear sound performance.

SPEAKERS

AV 1.1



AV 3.0



AV X5



AV X6.5



AV 6.5



AV 10



AV 12



Three different types of mounting for woofer and coax grille.



The Audison Voce line offers a complete and versatile range of components.

The **AV 1.1** tweeter features a very light Tetolon membrane, 28 mm Copper Clad Aluminium Wire voice coil, Neodymium REN magnet and annular rear damping chamber.

The **AV 5.0**, **AV 6.5** woofers and the **AV 10**, **AV 12** subwoofers feature an aluminium basket with a great aerodynamic structure, a cotton fiber pressed paper cone with Light Damping treatment, a triple wave surround in butyl rubber and extremely lightweight Copper Clad Aluminium Wire voice coils.

The core of the **AV 3.0** midrange is a powerful Neodymium REN magnetic group: efficiency and linearity make it an irreplaceable component to achieve a fine yet dynamic mid range, while its compact size allows for versatile and high performance installations.

The **AV X5** and **AV X6.5** coax speakers represent the evolution of the woofers belonging to the same line, thanks to the introduction of an excellent 25 mm Tetolon dome tweeter, along with a refined dedicated crossover. The **Orientable High Frequency Tuning technology** also provides the ability to optimize dispersion in high range to achieve the best performance in the listening point.

TECHNICAL SPECIFICATIONS		AV 1.1	AV 3.0	AV X5	AV X6.5	AV 6.5	AV 10	AV 12
Size	mm	28	70	130 / 25 (wf/tw)	165 / 25 (wf/tw)	165	250	300
	inch	1.1	3	5 / 1 (wf/tw)	6.5 / 1 (wf/tw)	6.5	10	12
Power handling	peak W	180	100	150	200	200	800	1000
	continuous W	Hi-pass filtered 2.0 kHz @ 12 dB/Oct	Hi-pass filtered 250 Hz @ 12 dB/Oct	75	100	100	400	500
Impedance	Ω	4	4	4	4	4	4	4
Freq. response	Hz	1.2k ÷ 22k	200 ÷ 14k	60 ÷ 22k	50 ÷ 22k	50 ÷ 7k	30 ÷ 1k	25 ÷ 1k
Sensitivity	dB/Spl	92	93	90	91	91	91	91
Magnet		Neodymium REN	Neodymium REN	High density flux ferrite	High density flux ferrite	High density flux ferrite	High density flux ferrite	High density flux ferrite
Dome/cone		Tetolon Fiber	Cotton Fiber pressed paper with Light Damping treatment	Cotton Fiber pressed paper with Light Damping treatment	Cotton Fiber pressed paper with Light Damping treatment	Cotton Fiber pressed paper with Light Damping treatment	Cotton Fiber pressed paper with Light Damping treatment	Cotton Fiber pressed paper with Light Damping treatment
Grille		Included	Included	Optional	Optional	Optional	Optional	Optional
X-mech	mm	-	-	-	-	-	23	23
	inch	-	-	-	-	-	0.9	0.9

SPEAKERS



TECHNICAL SPECIFICATIONS		AV K5			AV K6		
		Tweeter	Crossover	Woofers	Tweeter	Crossover	Woofers
Size	mm	28	88,3 x 123 x 36	130	28	88,3 x 123 x 36	165
	inch	1.1	3.47 x 4.84 x 1.41	5	1.1	3.47 x 4.84 x 1.41	6.5
Power handling	peak	200			250		
	continuous	100			125		
Impedance	Ω	4			4		
Freq. response	Hz	60 ÷ 22k			50 ÷ 22k		
Sensitivity	dB/Spl	90			91		
Grille		Included			Included		

The **AV CX 2W MB** crossover is especially thought for the AV K5 and AV K6 two-way complete systems, shaping their acoustic response to achieve a consistent, harmonious sound in any vehicle, also offering the acoustic controls necessary to achieve the best balance according to one's own taste.

The **AV CX 2W MH** crossover is dedicated to the mid-high speakers of a three-way multi-amplified system, providing the ability to use multiple woofer sections, for maximum flexibility and absolute performance.

TECHNICAL SPECIFICATIONS		AV CX 2W MB	AV CX 2W MH
		Crossover	Crossover
Specific Components		AV 6.5 / AV 5.0 + AV 1.1	AV 3.0 + AV 1.1
Size	mm	88,3 x 123 x 36	88,3 x 123 x 36
	inch	3.47 x 4.84 x 1.41	3.47 x 4.84 x 1.41
Power handling	peak	250	300
	continuous	125	150
Crossover	type	LO/Hi-Pass	LO/Hi-Pass
	cut off	2.5kHz 12/12 dB/Oct	4.0kHz 12/18 dB/Oct
Component Adjustment		Tw, -2, 0, +2 dB	Tw, -2, 0, +2 dB

AV CX 2W MB

AV CX 2W MH



AUDISON PRIMA



With the Prima range, Audison wants to meet the interest of the enthusiasts who like to appreciate all the nuances of the musical message with components that are perfectly integrated in the car OEM system.

This was made possible by new solutions like the built-in processor in the amplifiers, the concentric tweeter in the coaxial speakers, the compact subwoofers and a significant reduction in the size of all the components, preserving the most precious requirement of OEM Integration: space.



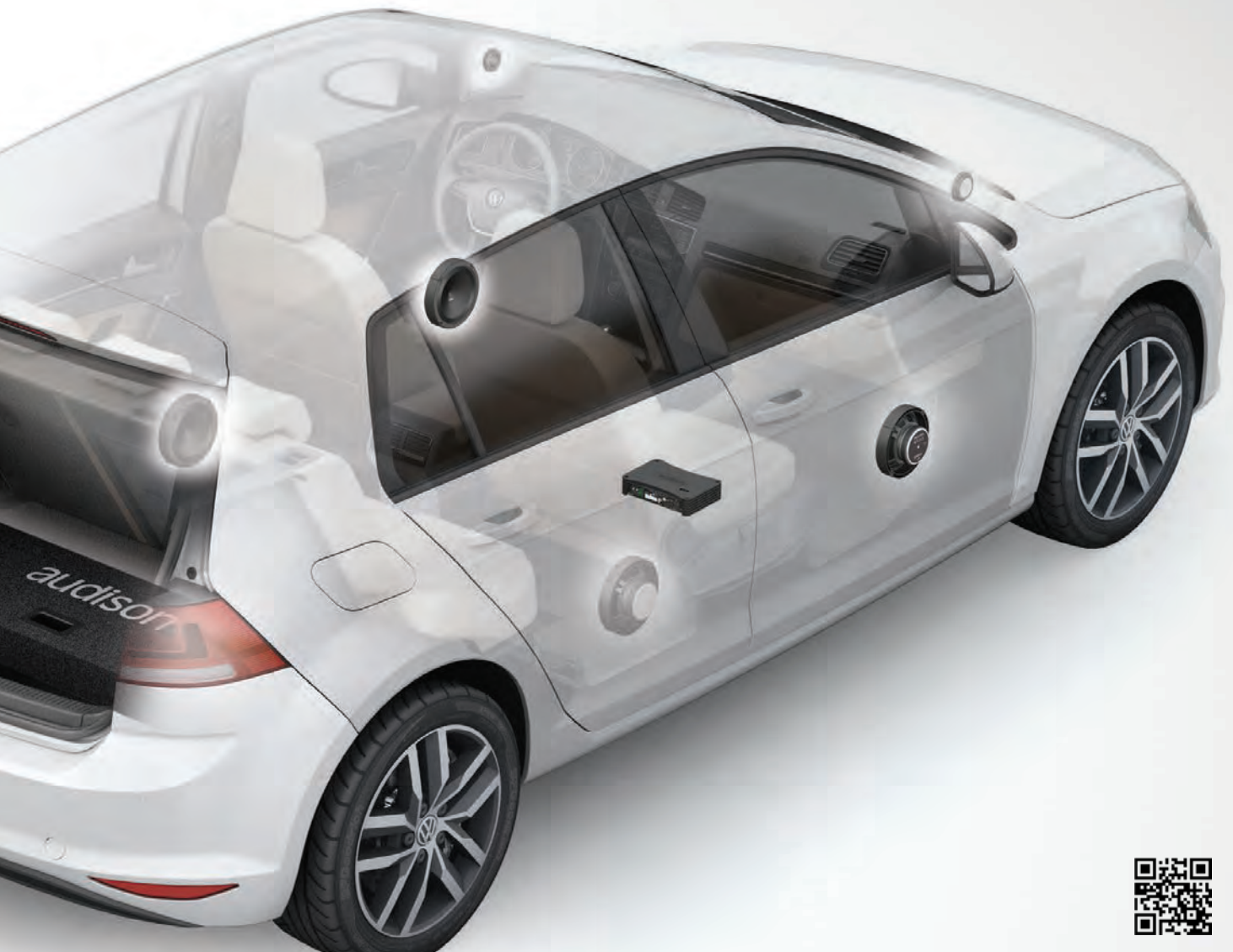

prima

audison

TECHNOLOGY

The Audison Prima amplifiers are characterized by extremely compact dimensions and elegant look. For the first time, Audison has made an amplifier equipped with a 9 channel built-in processor. This feature opens a new era: the incredible power of our DSP is now put at the service of OEM integration. The R&D team succeeded in the difficult task of condensing 520 W of traditional Audison power and quality into the palm of your hand. The reduction in dimension was achieved with the use of a special power supply, never employed in Car Audio, along with the most advanced electronic components available in the market.



INPUT / OUTPUT

All the bit models feature six analog input channels, four Front/Rear and two more selectable channels, all equipped with sensitivity adjustment manageable via software. The two auxiliary channels provide the ability to connect two more channels into the front channel mix, or can be used to create a stereo analog AUX input, selectable via the DRC.

The bit amplifiers also feature an optical digital input selectable via the DRC / DRC MP (Optional), making them fully compatible with the Audison Full DA technology.



DSP

The 9 channel built-in processor of the AP bit provides the ability to set new performance standards for OEM Integration, ensuring full compatibility with the bit Drive technology. Through the management software, the powerful 32 bit DSP provides all the functions which made the Audison bit One and bit Ten renowned worldwide.

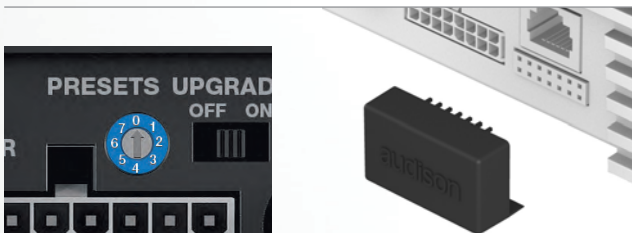

DRIVE PRESET

7 Drive preset for 7 different system configurations selectable through a switch in the front panel without PC software.

AUTOMATIC SPEAKER PRESENCE (optional)

ASP (Automatic Speaker Presence) provides the ability to simulate the OEM speakers' presence during the short time frame the head unit performs the check after being turned on.



AP bit SOFTWARE

The built-in DSP functions are similar to those found on bit Ten D, but there is something new and important on the equalizer output. Unlike a 31-band graphic equalizer, the AP bit equalizer features 10 parametric "poles" to draw the target curve via the PC software. This solution preserves a noticeable amount of resources for the DSP, with the plus of providing better acoustic response, thanks to the drastic reduction of phase variations found in graphic equalizers.

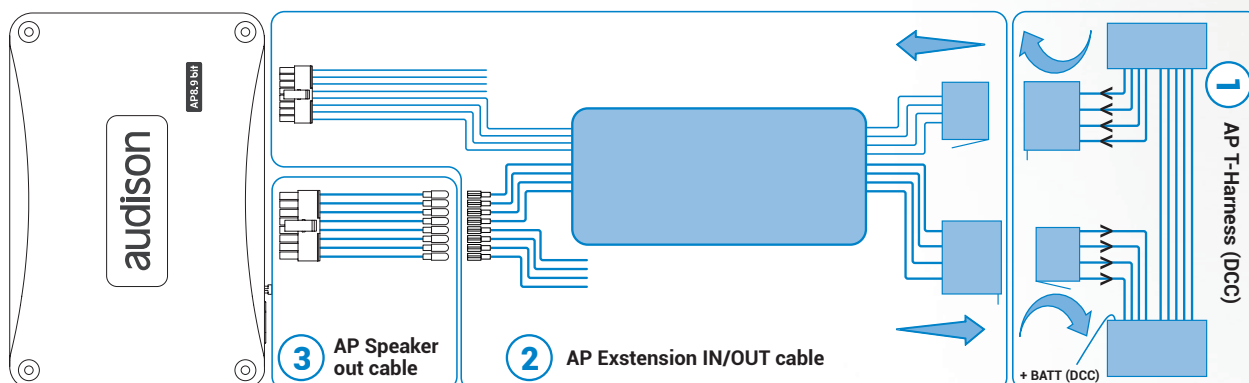

PRIMA AP PLUG&PLAY CABLES (optional)

The Prima AP Plug&Play cables for the AP bit amplifiers ensure maximum ease of installation for the Audison Prima system according to the "OEM Integrator" philosophy. For this purpose, cables with Plug&Play connections and foolproof have been built using the same materials employed to build the OEM wiring. The solutions which Audison offers are: AP T-Harness "DCC", AP Extension Cables and AP Speakers Output Cables.



Go to Audison P&P Product Information

AP T-HARNESS "DCC"

T-Harness "DCC" is the Plug&Play solution to integrate Audison Prima with the factory car audio system*.

The battery positive is taken from the head unit without the need of reaching the engine compartment thanks to the DCC** solution.

*In those vehicles featuring ignition key connection wire (ACC wire), see compatibility list on Audison Web site.

**The DCC solution, (Direct Cockpit Current) can be used combined with the AP bit amplifiers' feature which controls the amplifier absorption peaks, protecting the car power supply system.

AP EXTENSION CABLES

The Extension cable with Plug&Play connections allows total freedom in positioning the AP bit amplifiers. Two extension typologies are available: input only, to only send the audio signal coming from the head unit to the AP bit amplifiers, or input/output, to transmit also the AP bit amplifiers' output signal to the factory audio system. To do so, the AP Extension Cables IN/OUT needs to be installed together with the AP Speakers Output Cables (see following paragraph).

AP SPEAKERS OUTPUT CABLES

The AP Speakers Output cables are available in 3 versions: for AP8.9 bit, for AP5.9 bit and for AP4.9 bit. These cables are dedicated to the connection of the AP bit amplifiers with the input/output Extension cable. The Plug&Play connectors with circle terminals are numbered ("CH1 +", CH1 -, etc...) for a foolproof connection. There is no need to solder any cable.

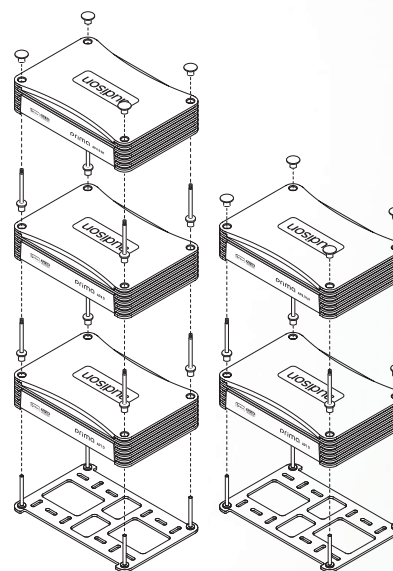

AUDISON PRIMA TOWER KIT AUTOMATIC SPEAKER PRESENCE

With the APTK 3 (Audison Prima Tower Kit 3) stacking system it is possible to stack up to 3 AP amps to save space without any problem of overheating (screws are supplied).



DRC MP (Optional)

Thanks to the new Joystick, "Rubber Touch" finished for best control of the movements along the four direction axes, the "DRC Settings" menu can be adjusted and navigation is also possible through the "Navi Command" function when the system features an Audison bit Play HD with video output connected to a monitor.

AMPLIFIERS

AP8.9 bit

AP8.9 bit eight channel amplifier featuring a nine channel built-in DSP was designed by the Audison R&D Department to achieve maximum sound quality in OEM Integration applications. The non-amplifiable ninth channel can be used to drive a subwoofer via the mono AP1 D amplifier.

AP5.9 bit

AP5.9 bit five channel amplifier featuring a nine channel built-in DSP is ideal to upgrade OEM systems with the fifth amplified mono channel for the sub. An AP4 D amplifier can also be linked to have four more amplified channels exceeding 1000 W power in a small space thanks to the Audison Prima Tower Kit.

AP8.9 bit



AP5.9 bit



AP4.9 bit



AP4 D



AP1 D



AP4.9 bit

AP4.9 bit four channel amplifier featuring a nine channel built-in DSP was designed for OEM Integration applications where a lot of power is required. An AP1 D mono amplifier can also be linked to drive a subwoofer along with an AP4 D, to obtain four additional amplified channels exceeding 1500 W power in a small space thanks to the Audison Prima Tower Kit.

AP4 D

The AP4 D amplifier has four amplified channels and can be linked to AP4.9 bit and AP5.9 bit amplifiers.

AP1 D

The AP1 D mono amplifier was designed to drive a subwoofer with 540 W stable at 2 Ω. It can be connected to all the AP bit amplifiers.

TECHNICAL SPECIFICATIONS			AP8.9 bit	AP5.9 bit	AP4.9 bit	AP4 D	AP1 D
Channel mode			8 - 4	5	4 - 2	4 - 2	1
Output Power (RMS) @ 12.0 ÷ 14.4 VDC	@ 4 Ω	W x Ch	35 x 8	20 x 2 + 50 x 2 + 150 x 1	70 x 4	70 x 4	310 x 1
		W x Ch (bridge)	130 x 4	-	260 x 2	260 x 2	-
	@ 2 Ω	W x Ch	65 x 8	40 x 2 + 90 x 2 + 270 x 1	130 x 4	130 x 4	540 x 1
DSP	Crossover	Full/Hi Pass/Low pass/Full/Hi Pass/Low Pass/Band Pass	✓	✓	✓	-	-
	Crossover type and slope	Linkwitz @ 12/24 dB Butterworth @ 6/12/18/24 dB	✓	✓	✓	-	-
	Crossover frequency	68 steps @ 20 ÷ 20k Hz	✓	✓	✓	-	-
	Phase inversion	0°/ 180°	✓	✓	✓	-	-
	Analog Input Equalizer	Automatic De-Equalization	✓	✓	✓	-	-
	Output Equalizer	N.9 Parametric Equalizers: ±12 dB;10 pole; 20 ÷ 20k Hz	✓	✓	✓	-	-
	Time Alignment Distance	0 ÷ 510 cm / 0 ÷ 200.8 in.	✓	✓	✓	-	-
	Time Alignment Delay	0 ÷ 15 ms	✓	✓	✓	-	-
	Time Alignment Step	0,08 ms; 2,8 cm / 1.1 in.	✓	✓	✓	-	-
	Time Alignment Fine set	0,02 ms; 0,7 cm / 0.27 in.	✓	✓	✓	-	-
	Drive Preset	Rotary switch for 7 installation Presets	✓	✓	✓	-	-
	Acoustic Preset	2 DSP Memories, DRC selectable	✓	✓	✓	-	-
THD	1 kHz/100 Hz @ 4 Ω	%	0.05	0.08 (Ch 1-4) / 0.1 (Ch 5)	0.08	0.08	0.02 / 0.03
S/N Ratio	A weighted @ 2 V (AP bit amps) / 1.5 V (AP D amps)	dBA	95	95	95	95	100
Damping factor	@ 1 kHz, 2 VRMS, 4 Ω		>70	>70	>70	>70	150
DRC controls			✓	✓	✓	-	-
Size	W x D x H	mm	191 x 34 x 131	191 x 34 x 131	191 x 34 x 131	191 x 34 x 131	191 x 34 x 131
		inch	7.51 x 1.33 x 4.76	7.51 x 1.33 x 4.76	7.51 x 1.33 x 4.76	7.51 x 1.33 x 4.76	7.51 x 1.33 x 4.76

	RMS Output Power	4Ω, 1%THD, 14.4 VDC	W x Ch	35 x 8	20 x 2 + 50 x 2 + 150 x 1	70 x 4	70 x 4	310 x 1
	S/N Ratio	Ref. 1 W Output	dBA	85	80	80	80	79

TECHNOLOGY

Concentric tweeter integrated inside the woofer with one single point of sound emission for consistent in-phase response, with consequent reconstruction of the acoustic scene through a system of separate woofer + tweeter. Tweeter featuring acoustic lens specifically designed to ensure an extremely linear frequency response, also off-axis, typical of in-door installations.

CONCENTRIC COAXIAL TWEETER

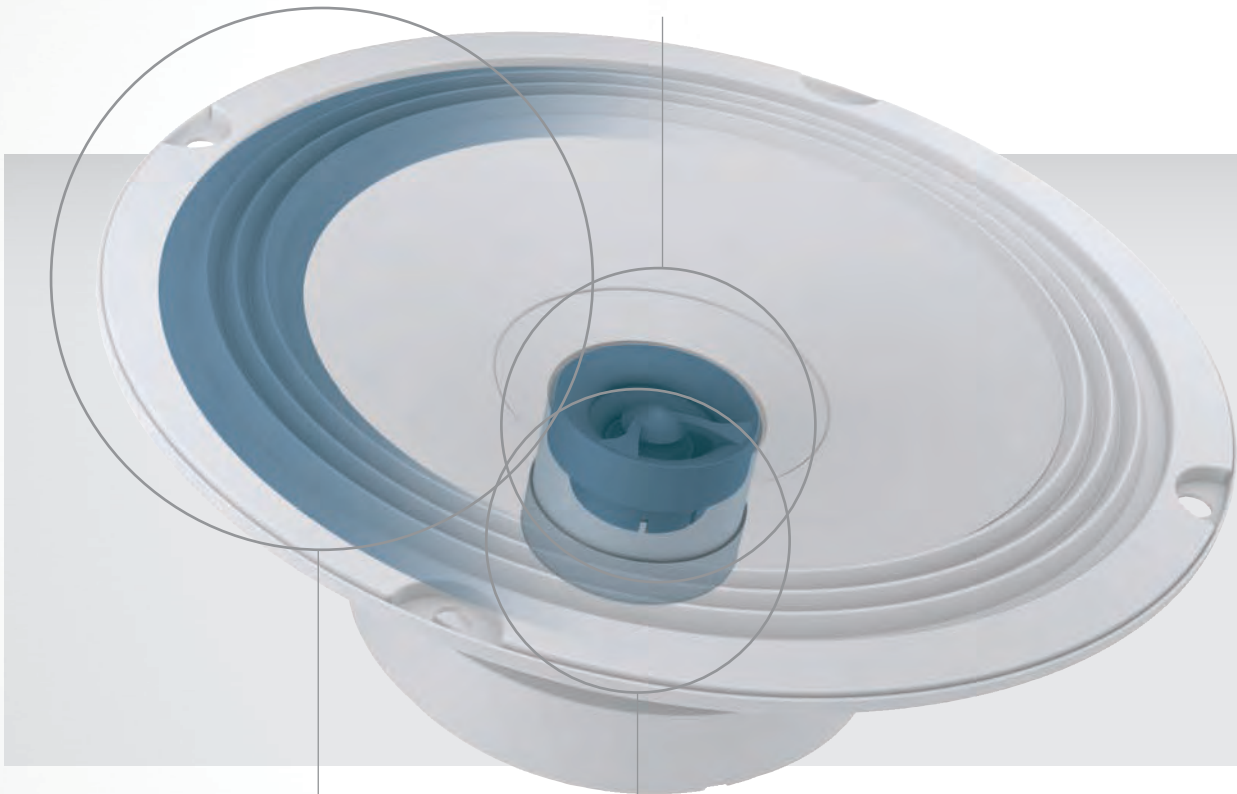

32 mm COPPER VOICE COIL

For high power handling and outstanding low frequency control.

TRIPLE WAVE SURROUND

The exclusive profile and selected materials provide full linearity as well as reliable performance.



HORN LOADED TWEETER

40 mm horn loaded dome tweeter contributing to maximize efficiency by increasing it up to 96 dB SPL, acoustic lens specifically designed and applied to the tweeter to enhance dispersion in high frequency range and a PEI supertweeter to refine emission, otherwise affected by off-axis positioning compared to the listening point.

Acoustic lens designed to compensate for the frequency response within the 10kHz - 13kHz range, to fine-tune the product emission in critical OEM placements, where the product performance is affected by the factory grille.

ACOUSTIC LENS

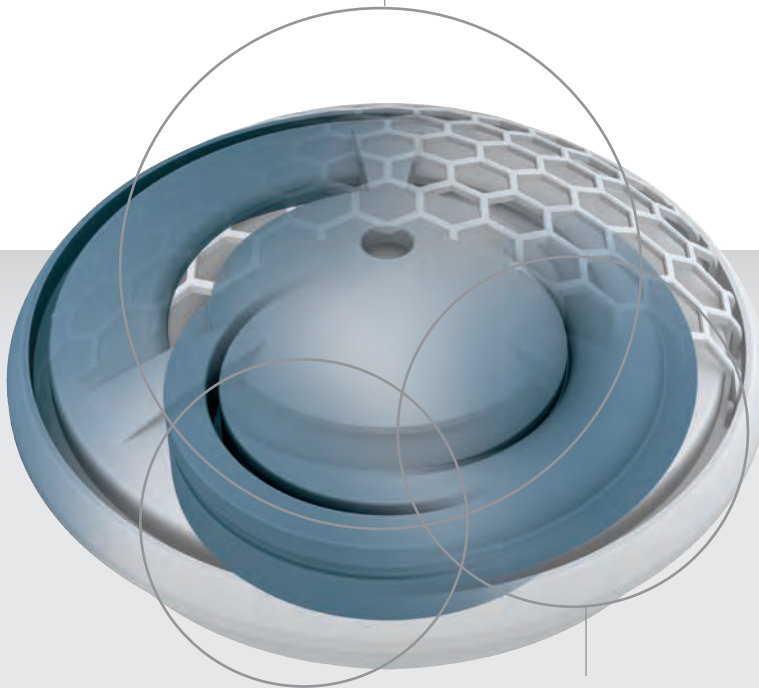

TETOLON® DOME

26 mm diameter emission diaphragm combined with a wide roll surround for maximum efficiency and a reduced resonance frequency.

CCA W VOICE COIL

CCA W (Copper Clad Aluminium Wire) ultra-light ferro-fluid-cooled voice coil, wound on Kapton former, for a better heat dissipation.

APCX TW CROSSOVER

Extremely small sized dedicated passive crossover, supplied with the product and optimized for OEM Integration, featuring an attenuation switch (0 dB, +2 dB) to tune the in-car response according to the different installation conditions.



SPEAKERS



The Audison Prima speaker line offers complete solutions for OEM Integration.

The **AP 1** tweeter features a 26 mm diameter emission diaphragm, an acoustic lens designed to compensate for the frequency response within the 10kHz - 13kHz range, a Neodymium REN magnet and extremely small sized dedicated passive crossover.

The **AP 4** midbass offers very extended frequency response, both in high and low frequencies, combined with high efficiency and features a 25 mm pure copper voice coil to ensure more balance in mid-high frequency ranges.

The **AP 5** and **AP 6.5** feature a 32 mm pure copper voice coil, for high power handling and outstanding low frequency control. To maximize efficiency all the woofers

do not employ any filter: the dome profile has been optimized with Klippel R&D Scan Vibrometer to obtain a calibrated mechanical low-pass cut-off frequency. The surround features the exclusive shallow "Triple Wave" profile, for maximum excursion linearity.

AP 6.5 Ω2 woofer has been developed with 2Ω nominal impedance with the purpose of exploiting all the power made available by the AP8.9 bit amplifier capable of 65W into a 2Ω load.

To ease the installation in OEM placements all the woofers are equipped with high current fast-on terminals with double contacts on positive and negative poles for high flexibility and quick connection. All the Prima line speakers have been developed with the KLIPPEL suite.

TECHNICAL SPECIFICATIONS		AP 1	AP 4	AP 5	AP 6.5	AP 6.5 Ω2	AP 8
Size	mm	26	100	130	165	165	200
	inch	1	4	5	6,5	6,5	8
Power handling	peak	150 Hi-Pass filtered @ 3.5 kHz - 12 dB Oct.	120	150	210	210	300
	continuous	-	40	50	70	70	100
Impedance	Ω	4	4	4	4	2	4
Freq. response	Hz	2k ÷ 20k	80 ÷ 7,5k	70 ÷ 5k	60 ÷ 5k	50 ÷ 5k	35 ÷ 3k
Sensitivity	dB/SPL	93	91	93	93,5	93,5	93,5
Magnet		Neodymium REN	High density flux ferrite	High density flux ferrite	High density flux ferrite	High density flux ferrite	High density flux ferrite
Dome/cone		Tetolon	Water repellent pressed paper	Water repellent pressed paper	Water repellent pressed paper	Water repellent pressed paper	Water repellent pressed paper
Grille		Included	Optional	Optional	Optional	Optional	Included



SPEAKERS

APX 4



APX 5



APX 6.5



APX 570



APX 690



Grille included

APX 4, APX 5, APX 6.5 and **APX 570** feature a concentric coaxial tweeter: with one single point of sound emission achieving a consistent in-phase response is made possible, with consequent reconstruction of the acoustic scene comparable to a system of separate woofer + tweeter. The tweeter is provided with an acoustic lens specifically designed to ensure an extremely linear frequency response, also off-axis, typical of in-door installations. APX 4, APX 5, APX 6.5, APX 570 are equipped with a 32 mm pure copper voice coil, for high power handling and outstanding low frequency control and all the cones feature a TPU (Thermoplastic Polyurethane) surround with the exclusive shallow "Triple Wave" profile, for maximum excursion linearity.

APX 690 is provided with an exclusive 40 mm horn loaded dome tweeter, that contributes to maximize efficiency up to 96dB SPL, and an acoustic lens specifically designed and applied to the tweeter to increase dispersion in high frequency range. To strengthen the emission of very high frequency ranges otherwise affected by off-axis positioning compared to the listening point, APX 690 features a PEI (Polyethylene Injected) supertweeter. To ease the installation in OEM placements, all the components are equipped with high current fast-on terminals for high flexibility and quick connection. All the Prima line components have been developed with KLIPPEL suite.

TECHNICAL SPECIFICATIONS			APX 4	APX 5	APX 6.5	APX 570	APX 690
Size	Woofer	mm / inch	100 / 4	130 / 5	165 / 6.5	- / 5x7	- / 6x9
	Tweeter	mm / inch	24 / 0.9	24 / 0.9	24 / 0.9	24 / 0.9	40 / 1.58
	Super Tweeter	mm / inch	-	-	-	-	15 / 0.6
Power handling	peak		120	150	210	210	300
	continuous		40	50	70	70	100
Impedance	Ω		4	4	4	4	4
Freq. response	Hz		80 ÷ 23k	70 ÷ 23k	60 ÷ 23k	60 ÷ 23k	40 ÷ 23k
Sensitivity	dB/SPL		91	93	94	93	96
Magnet			Neodymium REN	High density flux ferrite	High density flux ferrite	High density flux ferrite	High density flux ferrite
Dome/cone			PEI/Water repellent pressed paper	PEI/Water repellent pressed paper	PEI/Water repellent pressed paper	PEI/Water repellent pressed paper	PEI/Water repellent pressed paper
Grille			Optional	Optional	Optional	Optional	Included



TECHNICAL SPECIFICATIONS		APK 130		
		Tweeter	Crossover	Woofers
Size	mm	26	46,5 x 37,5 x 20,1	130
	inch	1	1.83 x 1.47 x 0.8	5
Power handling	peak	225		
	continuous	75		
Impedance	Ω	4		
Freq. response	Hz	70 ÷ 20k		
Sensitivity	dB/Spl	93 dB		
Grille		Included		



TECHNICAL SPECIFICATIONS		APK 165		
		Tweeter	Crossover	Woofers
Size	mm	26	46,5 x 37,5 x 20,1	165
	inch	1	1.83 x 1.47 x 0.8	6,5
Power handling	peak	300		
	continuous	100		
Impedance	Ω	4		
Freq. response	Hz	60 ÷ 20k		
Sensitivity	dB/Spl	93,5 dB		
Grille		Included		



TECHNICAL SPECIFICATIONS		APK 165 $\Omega 2$		
		Tweeter	Crossover	Woofers
Size	mm	26	46,5 x 37,5 x 20,1	165
	inch	1	1.83 x 1.47 x 0.8	6,5
Power handling	peak	300		
	continuous	100		
Impedance	Ω	2		
Freq. response	Hz	50 ÷ 20k		
Sensitivity	dB/Spl	93,5 dB		
Grille		Included		





All the systems mount the **AP 1** tweeter with the **APCX TW** crossover featuring a two-position level selector providing the ability to adapt its response to its two main applications: +2 dB if installed behind the OEM grille, 0 dB for an A-pillar installation without additional grilles between the tweeter and the listener.

The three-way **APK 163** system deserves special attention; the Audison designers developed a separate crossover dedicated to each speaker, simplifying OEM speaker replacement, negating the routing of additional cables through the door, which could void the car warranty.

TECHNICAL SPECIFICATIONS		APK 163					
		Tweeter	Tweeter Crossover	Midbass	Midbass Crossover	Woofers	Woofers Crossover
Size	mm	26	46,5 x 37,5 x 20,1	100	72 x 45,5 x 23	165	72 x 45,5 x 23
	inch	1	1.83 x 1.47 x 0.8	4	2.83 x 1.8 x 0.9	6,5	2.83 x 1.8 x 0.9
Power handling	peak	375					
	continuous	125					
Impedance	Ω	4					
Freq. response	Hz	50 ÷ 20k					
Sensitivity	dB/Spl	93,5 dB					
Grille		Included					



SUBWOOFERS TECHNOLOGY

OPTIMIZED GEOMETRY

The design of cone, dust-cap and basket guarantee large excursion of the mobile group while keeping the mounting depth to a minimum.

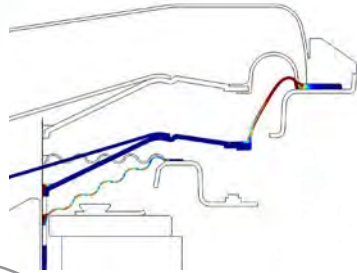

For maximum installation flexibility.

ULTRA LOW PROFILE

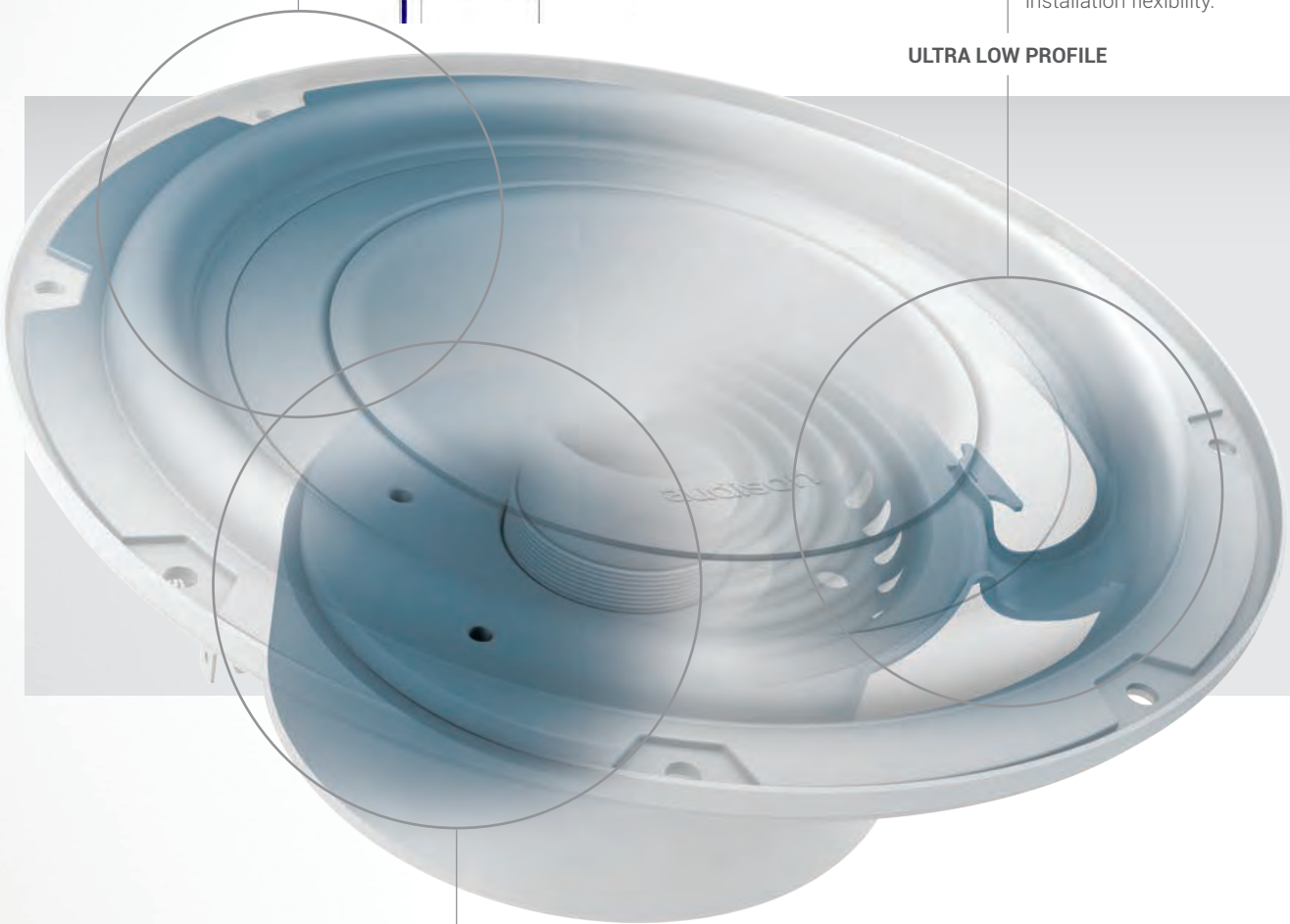

MASSIVE MOTOR

Optimized with FEM (Finite Element Modeling) for perfect control under high power, high excursion conditions.

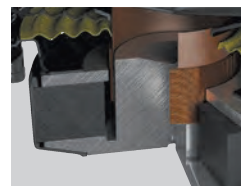

NO POLE VENT

Air vents on the basket underneath the spider, eliminating the need for vents on the bottom-plate, allowing mounting close to rear wall of enclosure.



PUSH CONTACTS

Both dual voice-coil versions feature push connectors for ease of wiring and configurations.



ADAPTABILITY TO ANY INSTALLATION

Every detail was designed to facilitate the enclosure integration within the car, with Hi-Tech features and cosmetic finishes.

Up-Firing

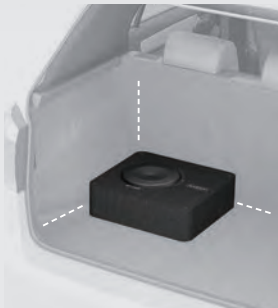

Down-Firing

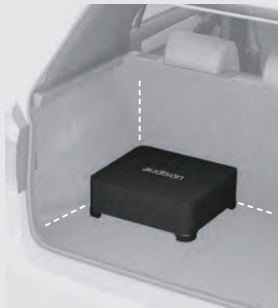

Side-Firing

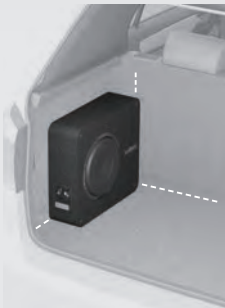

SSD - 2 SIDES 2 SOUNDS

This feature provides the ability to choose between two physical mounting methods creating two distinct aesthetics and sounds for the Audison Prima loaded enclosures. 2 Sounds is so named thanks to the choice of Up-Firing and Down-Firing mounting options. 2 Sides satisfies the cosmetic taste of every enthusiast.



SUB SMART PLUG

The enclosures SSP terminal block features both traditional push contacts and a Plug-&-Play connector allowing the impedance to be configured as required providing a quick release if the enclosure needs to be removed and protecting against short-circuits.

APBX 8R - REFLEX LOADING

Tuning designed to concentrate output in the lowest frequency range. The aim is to exploit the natural boost in output found in most cars below 60 Hz known as "cabin gain".



SUBWOOFERS

APS 8 R



APS 8 D



APS 10 D



Grille and gasket included

The R&D staff condensed all the possible combinations within the AP amplifiers in three component subwoofer models, removing all barriers to creativity with custom installations. Prima subwoofer components have been developed with a primary goal: to deliver high output in tight spaces. Output is a matter of excursion; the more air the cone moves, the more output. However reduced mounting depth traditionally has meant low excursion. Prima subwoofers employ a special cone-dust-cap-basket geometry which guarantees large excursion of the mobile group, while keeping the mounting depth to a minimum. The surround and spider have been carefully

designed to prevent the "rocking-mode" phenomenon. The **APS 10 D** and **APS 8 D** models are designed to deliver maximum performance in a sealed enclosure with ultra-compact volumes; from as small as 10 and 7.5 litres, with optimal values of 12 and 8.5 litres respectively. Both dual voice-coil versions feature push connectors for ease of wiring and configurations. With the aim of providing high acoustical output even when used with lower power, the **APS 8 R** was designed for use in an 8.5-litre reflex enclosure, with tuning between 30 and 40Hz. The APS 8 R has been specifically developed to be combined with either the AP8.9 bit or AP4.9 bit.

TECHNICAL SPECIFICATIONS		APS 8 R	APS 8 D	APS 10 D
Size	mm	200	200	250
	inch	8	8	10
Power handling	peak	500	500	800
	continuous	250	250	400
Impedance	Ω	4	4 + 4	4 + 4
Magnet		High density flux ferrite	High density flux ferrite	High density flux ferrite
Cone		Water repellent pressed paper	Water repellent pressed paper	Water repellent pressed paper
X-mech	mm	±16,5	±16,5	±18
	inch	0.65	0.65	0.71
Grille		Included	Included	Included



SUBWOOFER BOXES

APBX 8 R



APBX 8 DS



APBX 10 DS



The **APBX 8 R** loaded enclosure was developed with reflex loading, with tuning designed to concentrate output in the lowest frequency range. The aim was to exploit the natural boost in output found in most cars below 60 Hz known as "cabin gain". The 8-inch single 4 Ω voice-coil subwoofer has a powerful motor that maximizes efficiency in combination with the AP8.9 bit amplifier. The low-resonance frequency of the subwoofer, matched to the reflex enclosure keeps excursion low within the entire audio spectrum, allowing use with a pair of AP4.9 bit bridged channels, capable of delivering 260 W rms.

The **APBX 8 DS** loaded enclosure provides the highest performance/size ratio. For this purpose an 8.5-litre sealed enclosure with a 4+4 Ω dual voice-coil

configuration was adopted to exploit the full power of an AP5.9 bit (paralleling voice coils for a 2-ohm load) or with two pairs of AP8.9 bit bridged channels (one bridged pair of channels to each voice coil).

The speaker's high excursion capability allows the use of the proprietary BASS BOOST of AP bit amplifiers to make use of all the available power for rich and dynamic bass. The **APBX 10 DS**, a 10" subwoofer loaded in a 12-litre sealed enclosure, is the line's "flagship".

It is dedicated to the highest performing Prima systems, using the AP1 D amplifier for the sub section.

The speaker's mechanical excursion of more than 18 mm provides for incredible authority, while the refined Thiele&Small parameters set-up provides the ideal balance for all music genres.

TECHNICAL SPECIFICATIONS		APBX 8 R	APBX 8 DS	APBX 10 DS
Box Type		Reflex box	Sealed box	Sealed box
Size	mm	473 x 334 x 109	377 x 334 x 109	472 x 334 x 120
	inch	18.62 x 13.15 x 4.29	14.84 x 13.15 x 4.29	18.58 x 13.15 x 4.72
Power handling	peak	500	500	800
	continuous	250	250	400
Impedance	Ω	4	4 + 4	4 + 4
Magnet		High density flux ferrite	High density flux ferrite	High density flux ferrite
Cone		Water repellent pressed paper	Water repellent pressed paper	Water repellent pressed paper



A series of dedicated Plug-&-Play harnesses are provided to easily combine APBX enclosures with the AP amplifiers.

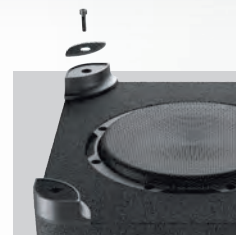

Leveling feet with Velcro included

SOUND PACKS TECHNOLOGY



DRIVE PRESET

The 7 DSP presets ensure utmost listening pleasure for a wide range of music enthusiasts, thanks to the combination of equalization, fine time alignment and level adjustments programmed by the Audison R&D team through extensive in-car measurements and listening sessions.

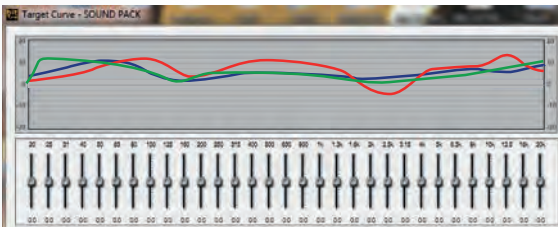

ACOUSTIC
RHYTHM
LIVE

PRESET n°	LISTENING POSITION	YOUR SOUND
1	Left seat	Acoustic
2	Left seat	Live
3	Left seat	Rhythm
4	Right seat	Acoustic
5	Right seat	Live
6	Right seat	Rhythm
7	Overall	Acoustic



BIT DRIVE PORTAL

Audison R&D is always driven by Istinto Innovativo: to fully take advantage of the AP bit features of storing setup files, they created a dedicated section on the Audison bit Drive Portal where a collection of alternative setup files are available for download, increasing the end users level of customization to achieve "Your Sound".

www.audisonbitdrive.eu



DCC - DIRECT COCKPIT CURRENT

To respond to the need of connecting the amplifier to the cockpit directly without reaching the battery, the Audison R&D team equipped the Prima amplifiers with an innovative management circuit which monitors the power supply current consumption in real-time. If a high amount of current is required for a consistent length of time, which may heat up the cables, the circuit immediately limits only the power peaks, letting the amplifier continue to play. This solution provides higher safety and reliability in OEM upgrade applications.



Prima Sound Packs are "Plug-and-Sound", providing 7 specific DSP "Drive presets" to satisfy car audio enthusiasts matching their music tastes for different listening positions (Left seat, Right seat, Overall).

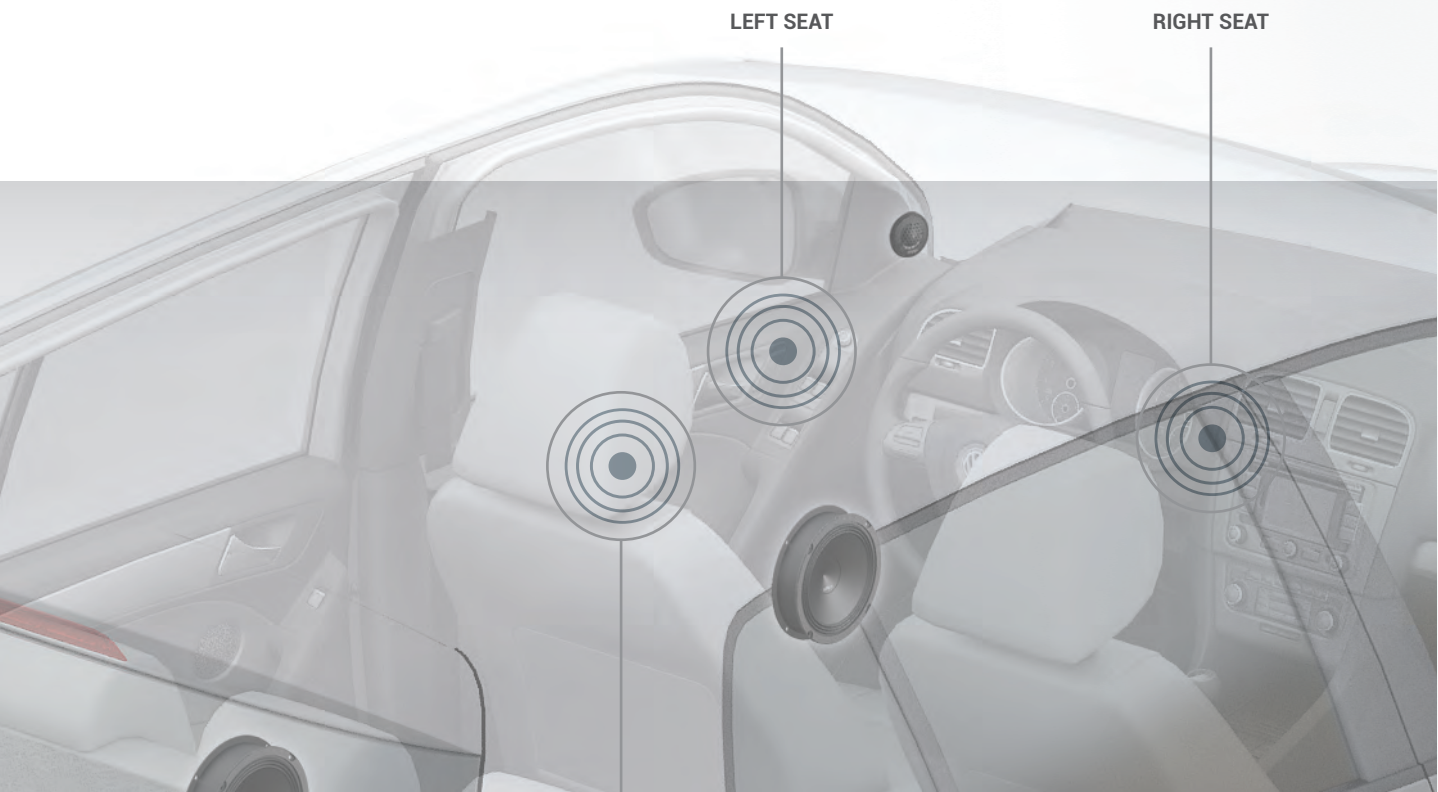

LEFT SEAT

RIGHT SEAT

OVERALL



DIGITAL REMOTE CONTROL MEDIA PLAY (optional)

Thanks to the new Joystick, "Rubber Touch" finished for best control of the movements along the four direction axes, the "DRC Settings" menu can be adjusted and navigation is also possible through the "Navi Command" function when the system features an Audison bit Play HD with video output connected to a monitor.



FULL DA INTEGRATED

Thanks to AP8.9 bit optical digital input selectable via the DRC MP, Sound Packs are fully expandable with the Audison Full DA technology, providing pure digital signal transfer with bit Play HD and bit DMI.

APSP GOLF 7

Prima Sound Pack for VW GOLF 7



TECHNICAL SPECIFICATIONS		Front
Component		AP 6.5 Ω 2 G7*
Size	mm (inch)	Woofer 165 (6.5)
Power handling	peak	300
	continuous	100
Impedance	Ω	2
Freq. response	Hz	50 ÷ 20k
Crossover type		2-Way active

* With OEM tweeters

FRONT SPEAKERS: AP 6.5 Ω 2 G7

2 way system featuring the AP 6.5 Ω 2 G7 to fully exploit the 65 W power per channel at 2 Ω of the AP8.9 bit G7 amplifier. The system is packaged with composite OEM speaker baffles, harnesses and seals to retrofit the woofers into factory locations.





A "Sound Pack" developed specifically for the VW Golf 7: the system's pulsing heart is the Audison AP8.9 bit G7 amplifier with built-in factory tuned DSP, combined with a dedicated Prima speaker system and accessories for real OEM integration!

AP 8.9 bit OUTPUT CHANNEL MAP			
CHANNEL	MODE	SPEAKER	POWER
1-2	Stereo	AP 6.5 Ω2 G7 Front Woofers	2 x 65W RMS @ 2 Ω
3-4	Stereo	OEM Rear Speakers	2 x 35W RMS @ 4Ω
5-6	Stereo	OEM Front Tweeters	2 x 35W RMS @ 4Ω
7-8	Bridge	APBX G7 - Subwoofer	1 x 130W RMS @ 4 Ω

AP8.9 bit G7

The Audison AP8.9 bit is the foundation on which the Sound Pack is built upon. The 8 channels in this flexible "all-in-one" amplifier have been configured to power the complete speaker system including the APBX G7 subwoofer.



TECHNICAL SPECIFICATIONS		
Size	mm	250
	inch	10
Power handling	peak	900
	continuous	300
Impedance	Ω	4

SUBWOOFER APBX G7*

The Plug & Sound sealed reflex subwoofer system integrates perfectly into the car's trunk. The subwoofer itself has been engineered to mate perfectly with the available enclosure volume, exploiting all the power the AP8.9 bit delivers.

**(Optional : Not included in APSP G7 - To be ordered separately.)*



DCC WIRING KIT

Using DCC Technology, the Prima Sound Pack APSP GOLF 7 is packaged with a specific harness which derives the power supply for the AP8.9 bit G7 from directly behind the OEM head-unit. The AP8.9 bit input/output connections to the OEM head-unit and OEM speaker wiring are simplified with a single customized wiring kit, easy to route in the vehicle interior.



APSP GOLF 6

Prima Sound Pack for VW GOLF 6



TECHNICAL SPECIFICATIONS		Front
Component		APK G6 2-way System
Size	mm (inch)	Woofer 165 (6.5)
		Tweeter 26 (1)
Power handling	peak	300
	continuous	100
Impedance	Ω	4
Freq. response	Hz	60 ÷ 20k
Crossover type		APCX TW G6

APK G6 FRONT SPEAKERS

APK G6 is a 2 way system featuring the AP 6.5 G6 woofer, AP 1 tweeter and a specific tweeter crossover. The system is packaged with composite OEM speaker baffles, harnesses and seals to retrofit the woofer and tweeter into factory locations.





A "Sound Pack" developed specifically for the VW Golf 6: the system's pulsing heart is the Audison AP8.9 bit G6 amplifier with built-in DSP factory tuned, combined with a dedicated Prima speaker system and accessories for real OEM integration!

AP 8.9 bit OUTPUT CHANNEL MAP			
CHANNEL	MODE	SPEAKER	POWER
1-2-3-4	Bridge	APK G6 - Front	2 x 130W RMS @ 4Ω
5-6	Stereo	OEM Rear Speakers	2 x 35W RMS @ 4Ω
7-8	Bridge	APBX G6 - Subwoofer	1 x 130W RMS @ 4Ω

AP 8.9 BIT AMPLIFIER

The Audison AP8.9 bit is the foundation on which the Sound Pack is built upon. The 8 channels in this flexible "all-in-one" amplifier have been configured to power the complete speaker system including the APBX G6 subwoofer.



TECHNICAL SPECIFICATIONS		
Size	mm	250
	inch	10
Power handling	peak	900
	continuous	300
Impedance	Ω	4



APBX G6 SUBWOOFER G6*

The Plug & Sound sealed passive subwoofer system integrates perfectly into the car's interior. The subwoofer itself has been engineered to mate perfectly with the available enclosure volume, exploiting all the power the AP8.9 bit delivers thanks to its dual voice coil configuration.

**(Optional : Not included in APSP G6 - To be ordered separately.)*



DCC WIRING KIT

Using DCC Technology, the Prima Sound Pack APSP GOLF 6 is packaged with a specific harness which derives the power supply for the AP8.9 bit G6 from directly behind the OEM head-unit. The AP8.9 bit input/output connections to the OEM head-unit and OEM speaker wiring are simplified with a single customized wiring kit, easy to route in the vehicle interior.



elettromedia

Elettromedia, an Italian company, is a leader within the world-wide car Hi-Fi market.

Born in 1987 in Potenza Picena by a group of friends who shared the same passion for in-car high fidelity, throughout the past years Elettromedia has been walking the path of excellence: its products are distributed in more than 50 countries; the company has received many awards and acknowledgements from the most authoritative leaders within the car audio industry; it also boasts reviews of more than 3000 pages published in 30 different languages (visit: www.elettromedia.com/media-centre/press-review/).

The Elettromedia brands are Audison, Hertz, Connection and AZaudiocomp. Through a co-branding strategy, the company offers all of the components required for a complete, top-level car audio system.

audison

ISTINTO INNOVATIVO

audison

ISTINTO
INNOVATIVO

www.audison.eu

