

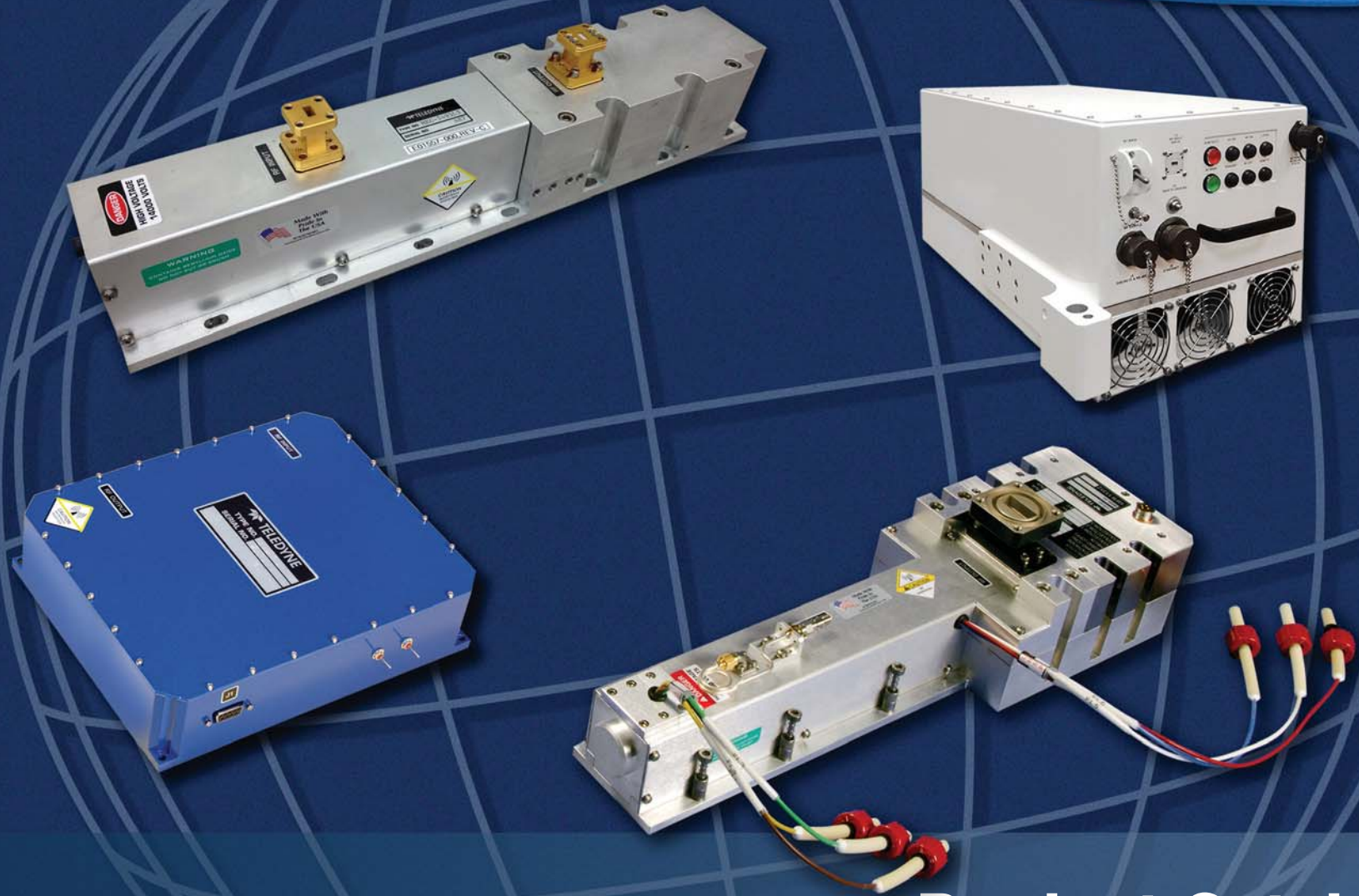

Teledyne Microwave Solutions TWT PRODUCTS



Product Catalog

Significant Events in TMS TWT Products History



1959
MEC (Microwave Electronics Corporation) formed by Dr. Stanley Kaisel to design and manufacture low power broadband metal ceramic Traveling Wave Tubes; occupied 10,000 sq. ft. facility in Palo Alto, CA



1964 Acquired Sylvania High Power TWT product line

1965 MEC acquired by Teledyne and becomes Teledyne MEC

1966 First high power broadband TWT

1967 Bulk Acoustic Delay Device

1976 First multi-octave Traveling Wave Tube

1984 Opened 75,000 sq ft manufacturing facility in Rancho Cordova, CA

1994 Developed Tri-Band communication TWT

2004 Opened 85,000 sq. ft. addition to Rancho Cordova, CA facility

2008 Shipped 3,000th Tri-Band TWT

2009 50th anniversary of TWT innovations

2009 First U.S. Military Airborne High Power Amplifier Delivered

2012 Joined six other Teledyne microwave companies to form Teledyne Microwave Solutions, combining experience and leadership to provide products from components to integrated assemblies and technologies from GaAs and TWT to GaN and beyond.

2012 MEC 3080RMI Program delivered 1000th TWT to Raytheon

2013 First 500W Satellite Communications High Power Amplifier delivered

2013 First UHF Solid State High Power Amplifier delivered

2013 Total number of TWTs shipped exceeded 78,000



Teledyne Microwave Solutions (TMS)

delivers advanced microwave technologies for demanding aerospace, military, commercial, and industrial applications. From catalog parts and single function components to integrated assemblies, sub-systems, and custom solutions, TMS solves the most complex microwave challenges.

TMS has been an industry pacesetter in the design, development, and manufacture of sophisticated microwave products for over 50 years. Forged from the consolidation of seven leading microwave companies, TMS has the expansive R&D and manufacturing capabilities needed to research, design, develop, and manufacture products from RF through 220 GHz.



The collaboration and combined R&D power of Teledyne TWT Products (MEC), Teledyne Microwave, Teledyne Labtech, Teledyne Paradise Datacom, Teledyne KW Microwave, Teledyne Cougar, and Teledyne Defence Ltd. have enabled TMS to create a host of new products across a wide range of disciplines, including remote body scanners, radar and threat detection systems, and ultra compact satellite communication amplifiers.

Our veteran staff of engineers, machinists, chemists, technicians, and assemblers are continually developing new products to meet the industry's most sophisticated and exacting standards. With nine manufacturing sites and the ability to provide local customer support across six continents, we collaborate closely with our customers to produce the custom configuration or off-the-shelf solution that meets their needs, and deliver it with speed and precision.

With global reach and the industry's most comprehensive portfolio of microwave technologies, Teledyne Microwave Solutions is truly **Everything Microwave, Everywhereyoulook™**.

Teledyne TWT Products,

a business unit of Teledyne Microwave Solutions, is a world leader in the design, development and manufacture of broadband high power helix Traveling Wave Tubes (TWTs), TWT Amplifiers (TWTAs), and Solid State High Power Amplifiers (SSPAs) from 10MHz to 44GHz, for top performance in the stringent fixed and mobile environments used in today's ECM, radar and communications markets.

Our state of the art products are found on nearly all major EW, Radar, and Communication platforms of the United States and its allies throughout the world.

TMS recognizes and strives to meet the needs of our customers with quality, value, and service at competitive prices. We look forward to meeting your needs with these same standards of excellence.

Teledyne Microwave Solutions Manufactures Broadband, High Power Helix Traveling Wave Tubes for . . .

Communications

Highly efficient TWTs for Tri-Band, C, X, Ku, C/Ku, X/Ku, DBS, Ka and Ka/Q Band for use in Earth, Mobile and Fly-Away Terminals.



EW and Radar

Shadow Gridded Helix TWTs for Broadband EW and Radar Applications from L through Ku Bands at Peak Power Levels to 12 kW and Average Power Levels to >700 W.

Instrumentation/General Purpose

CW and Pulse TWTs for General Laboratory Amplifier Use Spanning the 1 to 44 GHz Frequency Range with Average Output Power to 750 W.



The Continuing Role of TWTs

Although developments in GaN and LDMOS technologies have boosted the power output of solid state amplifiers, TWTs are still the benchmark in performance and efficiency for many applications. For example, for multi-octave high power generation, TMS TWTs are smaller, lighter, and more efficient than equivalent SSPA assemblies.

SSHPAs - TRMs - HPAs

In addition to industry-leading TWT expertise, the TMS group leverages its collective capabilities to design and build Solid State High Power Amplifiers (SSHPAs) and High Power Amplifiers (HPAs) for defense, commercial, and communications applications. And when Solid State is mandated for a function previously filled by a TWT, TMS has the experience to design and manufacture TWT Replacement Modules (TRMs) for a smooth transition.

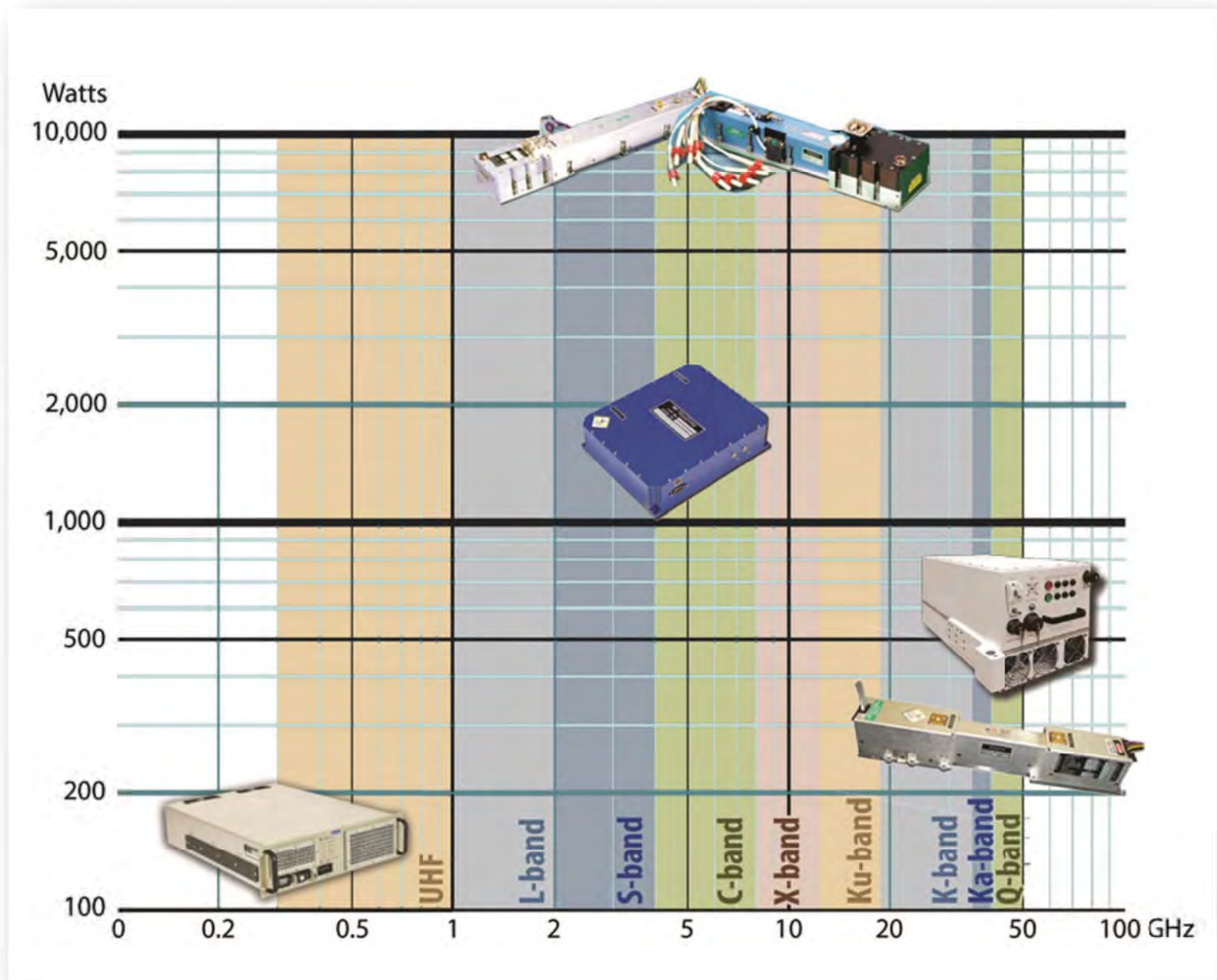

Solid State High Power Amplifiers

TMS provides in-house **Solid State High Power Amplifier (SSHPA)** design capability and total solutions to meet the most demanding requirements in today's and next generation ECM, radar and communications transmitter markets. For customer-driven designs, whether new, complementing or replacing a mature TWTA system with a SSHPA, our product development and manufacturing experience allows us to select the best suited solid state device technology to satisfy the power, reliability and mechanical specifications for airborne, shipboard and transport vehicle environment hardware. Our standard line of SSHPAs provides a comprehensive selection of frequency ranges, from UHF to Ku-Band, CW or pulsed power from 100W to kW in compact, hermetically sealed packages for operation over -40°C to +80°C in conjunction with air and liquid cooling techniques.

Teledyne's historical position and experience in the TWT market provides the SSHPA R&D team with a unique perspective and understanding of requirements for TWT Replacement Modules (TRMs), which has resulted in proprietary solutions to RF high power combining and heat management problems. Full circuit, EM field, thermal and structural modeling capabilities provide efficient and optimized custom solid-state amplifier designs utilizing the LDMOS, GaN and GaAs devices best suited for frequency band, power and mode of operation. The advent of highly rugged LDMOS power devices and ever higher power GaN HEMT MMICs, for frequencies up to S-Band and Ka-Band respectively, can make the SSHPA a cost and performance competitive solution, with higher reliability than its TWT counterpart. Our internal manufacturing, environmental test and quality engineering resources assure a short product design cycle and a time-efficient field deployment schedule.

TMS SSHPAs: Power vs. Frequency

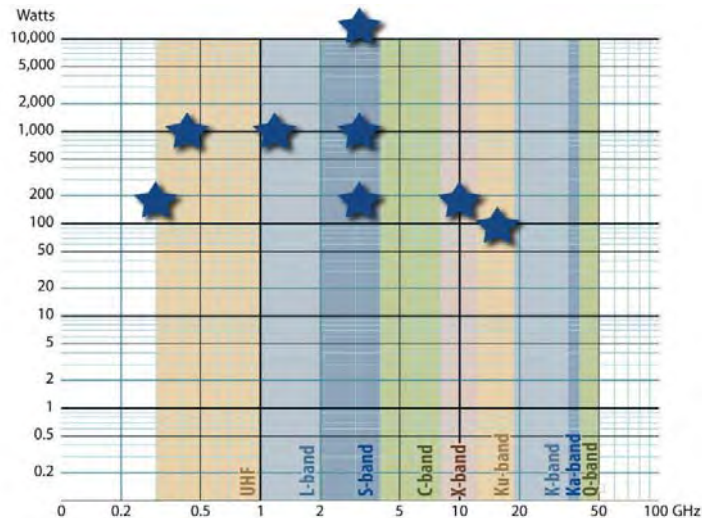

TMS's **250W to 1kW X-Band Solid State Power Amplifier** offers superior RF performance for commercial & military markets. With options available for 1GHz Bandwidth anywhere in the 8-11GHz band, the amplifier provides 250W, 500W and 1000W peak output power.

Solid State High Power Amplifiers

Solid State High Power Amplifier Typical Feature Set

- Specific frequency bands & multi-octave coverage
- Proprietary RF power combining
- CW or Pulsed operation mode
- Gain frequency response optimized
- Output VSWR optimized for frequency range
- Inherent low harmonic levels or internal low pass filter
- Power stage open & short
- Circuit protection
- Output forward & reflected power monitoring
- Control & communication port

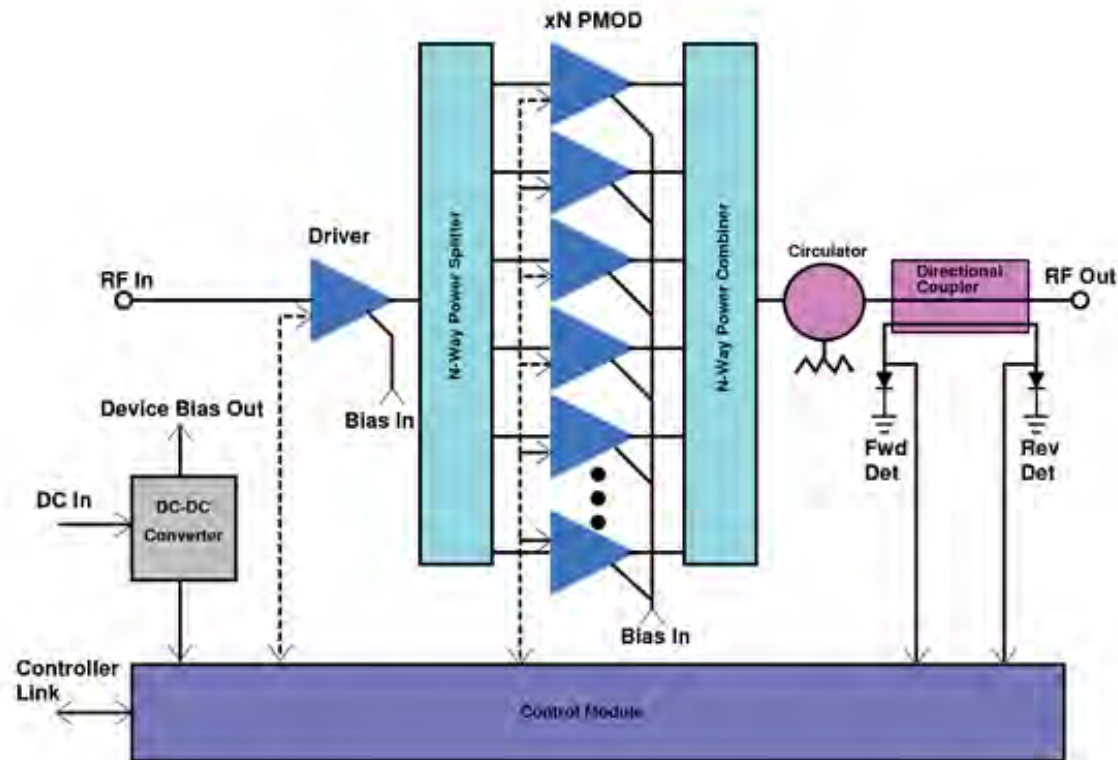

Satcom High Power Amplifier Features

- Satellite uplink
- Compact Environmentally Sealed Housing
- Integrated Linearizer
- RF Sample port
- Alarms
- RS-232/422/485, Ethernet

Options

- BUC
- Harmonic Filter

Common Specifications

- 27.0-30.0 GHz
- 30.0-31.0 GHz
- 502W Peak Power
- 175W Linear Power @ flange w/-25dBc Intermodulation performance
- 73dB Small Signal Gain
- 100-240Vac
- -40C to +55C Operating temperature

A High Power Amplifier (HPA) typically consists of a single power amplification block (TWT), which incorporates a High Voltage Power Supply (HVPS) section ranging from 5 to 20 KV to provide power to the TWT. The HPA also includes secondary protection and control circuitry interfaced through an external Monitor & Control (M&C) connection. This external M&C connection is available in several interfaces, including RS-232, RS-422, RS-485 and Ethernet.

Each HPA is equipped with a custom Graphic User Interface (GUI) optimized for customer comfort, HPA setup, and system compatibility. Depending on the particular application, additional filtering and/or protection, linearization circuitry, a Block Up Converter (BUC), and a pre-amplification block are incorporated into the HPA.



502-Watt Peak Ka-Band HPA

- High Linear Power
- 502W Peak Power
- Robust Design
- Integral L-Band BUC (option)
- Built around Teledyne's Microwave MEC-5530 TWT

High Power Amplifiers (HPAs)

TMS Satcom HPAs: Power vs. Frequency

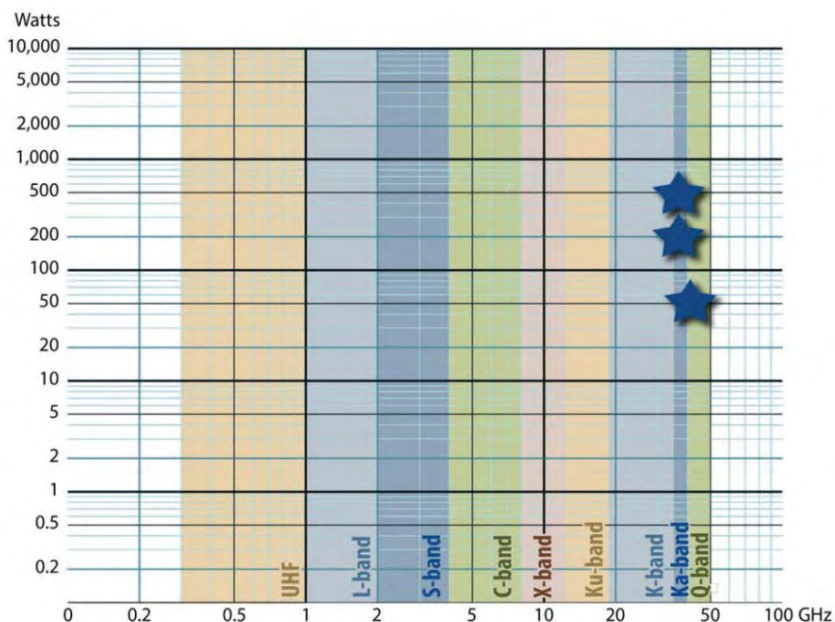

A Voltage Variable Attenuator (VVA) is used along with the pre-amplification section to adjust HPA gain dynamically across temperature to maintain tight gain flatness requirements. The VVA's primary function is to select the desired RF output levels, under system control, based on the system mission.

The BUC section (available for specific applications) allows base-band signals to drive the HPA at great physical cable length to minimize losses when the HPA is driven at higher frequencies. Typically, the BUC module requires an external 10 MHz system synchronization source to up-convert input RF modulations to the desired output frequencies without compromising signal integrity.

Most HPAs are constructed within a self-contained housing to protect internal components from any outdoor environment, and to allow operation up to 10,000 feet above sea level (much higher for airborne applications). Internal thermal management systems maintain the desired internal temperature for the TWT and the HVPS, spanning -40°C to $+55^{\circ}\text{C}$.



Traveling wave tubes remain the best source for efficient generation of microwave power over broad frequency bandwidths. When compared to solid state technology, today's metal-ceramic traveling wave tube amplifiers combine low acquisition price with affordable maintenance and support. TWTA systems are smaller, lighter, and much more efficient than their SSA counterparts. TWT amplifiers do behave somewhat differently than SSAs. Following is a discussion of some of the more important TWT performance features and design attributes.

Power and Bandwidth

TWT power output is determined by the efficiency with which energy in the electron beam is converted to microwave energy (sometimes called "interaction efficiency" or "beam efficiency").

$$P_{out} = I_{beam} V_{beam} \eta_{interaction}$$

Current emitted from a thermionic cathode obeys a 3/2 power law with respect to applied voltage

$$I_{beam} = K V_{beam}^{3/2}$$

where the constant K is called perveance. Perveance is an important design parameter since it is totally determined by electron gun dimensions. Using this expression, power output often is given by

$$P_{out} = K V_{beam}^{5/2} \eta_{interaction}$$

CW (continuous wave) TWTs generally use electron guns which operate in the 0.2 to 1.0×10^{-6} perveance range while pulse TWTs push the limits imposed by practical electron gun design and magnetic focusing materials which is not much greater than 2.0×10^{-6} . Interaction efficiency is determined by beam size, the uniformity of beam electron trajectories (often called beam laminary), and helix circuit parameters such as helix and backwall

diameter, helix pitch, dielectric support material and shape, helix loss, etc. It varies with frequency because the interaction of helix parameters in a given circuit change as frequency is varied. For example, backwall diameter predominantly affects low band edge performance while the shape of the dielectric rods predominantly affect the high band edge. Practical helix designs have band center interaction efficiencies which range from 10% to 25% and band edge to center efficiency variations of 50% or more. Practical bandwidths range from hundreds of MHz to double octave ($F_{hi} = 4 F_{lo}$). Teledyne specifies "rated output power" which typically is several tenths of a dB or more below saturation.

Efficiency

As the beam gives up energy to the amplified signal, it slows down. By tapering or stepping helix pitch to maintain synchronism between the RF wave and the slowing beam, interaction efficiency often can be enhanced. Determining a satisfactory pitch configuration that works well over the entire frequency band and which preserves other important performance parameters requires computer simulation of the non-linear beam-helix interaction and involves numerous compromises which often trade one desirable effect for another.

A second means of enhancing TWT efficiency is to depress the beam collector voltage(s) below ground so that unused energy can be recovered from the spent electron beam. The power consumed by a TWT with n stages of collector depression is calculated as follows where collector voltages are referenced to cathode:

$$P_{prime} = V_{filament} I_{filament} + V_{beam} I_{helix} + \sum_n V_{collector} I_{collector}$$

$$\eta_{overall} = P_{out} / P_{prime}$$

Since both output power and prime power vary with signal frequency, RF input drive, etc., it is best to state the maximum allowable prime power consumption rather than efficiency when specifying a TWT. Waste heat dissipation is given by

$$P_{diss} = P_{prime} - P_{out}$$

The electro optics of a multi-stage depressed collector are quite complicated and depend not only on the geometry and relative voltages of the collector segments but also upon the degree of RF modulation, the magnetic field used to focus the beam, the yield of secondary electrons at the collecting surfaces, etc. The higher the interaction efficiency, the greater the difficulty in collecting the spent beam since strong RF modulation causes the electron velocity distribution to spread. In wide band TWTs, the low band edge harmonic interaction causes a similar effect. Pulse TWTs with high interaction efficiency often cannot practically utilize more than a single stage collector while CW TWTs with lower interaction efficiency successfully utilize two or three stages. In a TWT having a well designed multi-stage depressed collector, the waste heat dissipated by the TWT is nearly constant as RF input drive is varied.

Gain

The dynamic range of a TWT is the region between the point at which the RF output signal just breaks through the noise threshold to the point at which the output power saturates. The linear or small signal region is most often defined as ending when increasing RF drive causes gain to drop 1 dB from its small signal level (1 dB compression point). Saturation generally occurs at an input drive level 6 to 8 dB above the 1 dB compression point and with 2 to 3 dB higher output power.

AM / AM conversion is a measure of the change in RF output power that results from a change in the RF input drive, i.e. the slope of the transfer curve. In the linear region, AM / AM conversion is 1.0 dB / dB. At saturation, AM / AM conversion is 0 dB / dB. TWTs with high interaction efficiency often exhibit gain

expansion near the high band edge (AM / AM > 1.0). This is caused by the inability of the helix velocity tapers to equally match beam slow-down at all frequencies within the band. It generally is undesirable to operate the TWT too far into overdrive as severe beam defocusing can occur in this region. Gain variations over the frequency band result from the frequency dependence of helix velocity and impedance. Additionally, gain varies with the electrical length of the circuit, which, in turn, varies with frequency. A two octave TWT can exhibit as much as 25 dB gain variation. This typically can be reduced to ± 2.0 dB with the use of an external gain equalizer.

Gain ripple results from signal reflections either internal or external to the tube. Since a TWT is electrically "long" (a typical TWT has a phase length of about 10,000 degrees), a relatively small change in frequency (typically 100 to 300 Mhz) shifts phase 360° . Most TWTs exhibit an approximate ± 0.2 dB gain ripple at this frequency.

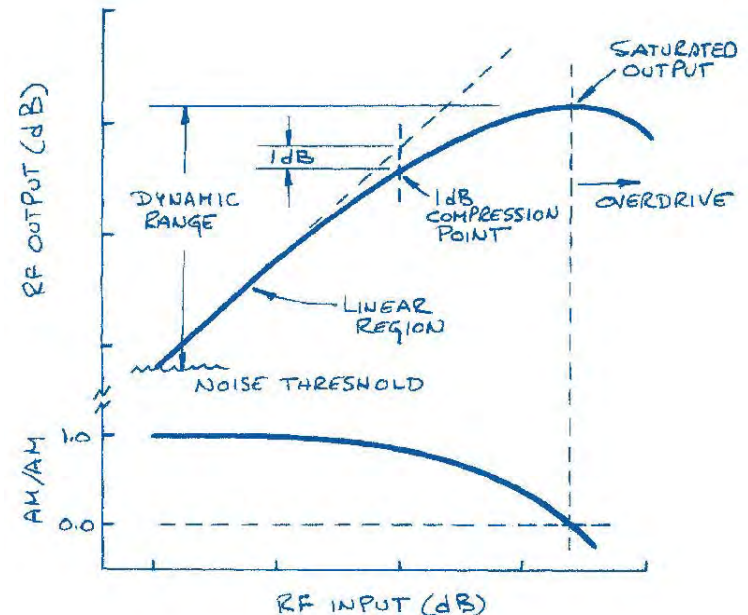

Phase

Any factor which affects the velocity of the electron beam produces phase changes in the RF output signal. As the RF drive level is increased into the non-linear region, the phase length of the tube increases as beam velocity is slowed by transfer of energy to the RF wave. This effect, called AM / PM conversion, is relatively insensitive to RF drive in the linear region. As the TWT is driven toward saturation, the rate of phase change increases. The peak value of AM / PM generally occurs at or several dB below saturation and is frequency dependent (typically increasing with increasing frequency for a given helix design).

If the factor that changes beam velocity varies with time, the result is phase modulation of the RF output signal. The primary factor affecting the velocity of the beam is the cathode voltage. Other voltages or external affects (such as voltages induced by placement of a blower motor too close to the tube) have secondary affects.

Typical phase pushing values for TWTs are:

- 100° / 1% change in Cathode Voltage
- 10° / 1% change in Grid "on" Voltage
- 0.0005° / 1% change in Collector Voltage

These numbers are approximate. The actual values of phase pushing for any specific TWT are determined by gun perveance, gain, efficiency, etc. Any periodic voltage modulation produces signal side bands, separated from the main signal by the modulation frequency. The depression below carrier of these spurious signals (δ in dB) for sinusoidal ripple can roughly be approximated by the following expression:

$L = \text{TWT pin-to-pin length (in)}$	$F = \text{RF Signal Frequency (GHz)}$
$v = \text{peak-to-peak Cathode ripple (Volts)}$	$V = \text{Cathode Voltage (Volts)}$

$$\delta = 10 \text{Log} \left[\frac{1.13 \times 10^3 \times L^2 \times F^2 \times v^2}{V^3} \right]$$

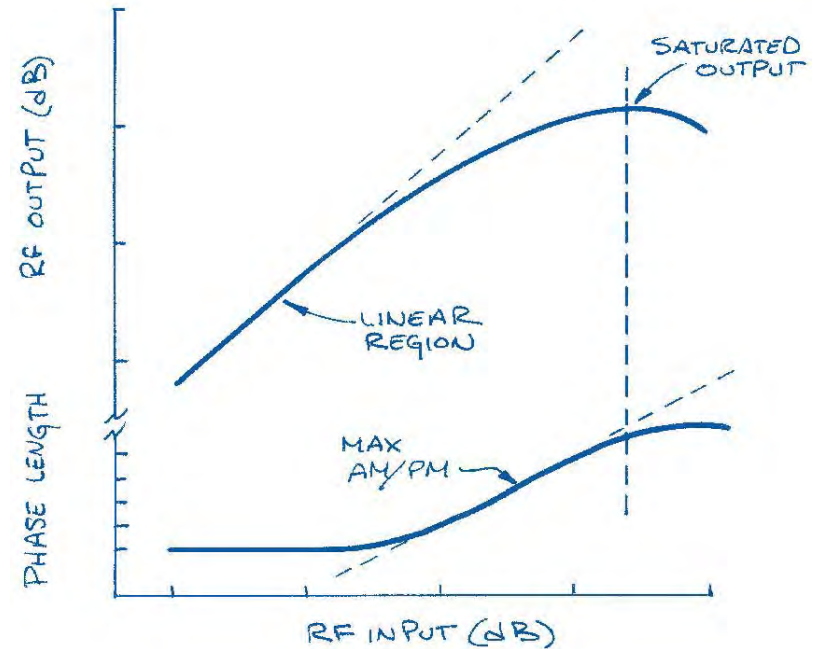

A ± 0.5 volt sinusoidal ripple on a 10 kV TWT with 10" input-to-output length produces -49.5 dBc sidebands at 10 GHz. Peak-to-peak phase ripple ($\Delta\phi$ in degrees) is directly related to small signal gain ripple (dG -- peak-to-peak in dB) by the following expression:

$$\Delta\phi \cong 57.3(10^{dG/20} - 1)$$

A small signal gain ripple of ± 0.2 dB produces phase ripple of $\pm 1.35^\circ$. Time delay is the total time it takes for a signal to pass through the tube (typically 3 to 5 nsec) and is the derivative of phase delay. Thus, the same mechanisms that cause phase non-linearity are responsible for time delay distortion. The maximum rate of change of time delay ($\Delta\gamma$ in nsec / MHz) due to gain and phase ripple is calculated by:

$$\Delta\gamma \cong \frac{\pi \times (10^{dG/20}) - 1}{dF^2} \times 10^{18}$$

where dF is the frequency periodicity of the small signal gain ripple (in Hz). A 200 Mhz gain ripple with ± 0.2 dB amplitude causes 3.7 psec / MHz time delay distortion.

Power Combining

With the tube-to-tube performance consistency that is achieved with modern TWT manufacturing technology, power combining is a practical and relatively inexpensive means of achieving high power levels. Typical tracking of a TWT to a phase standard over an octave or greater frequency band when the absolute phase difference between the tubes is zeroed with an input phase shifter is $\pm 20^\circ$ (40° maximum imbalance between any two randomly selected tubes). When combined in a standard 4-port hybrid junction, such as a waveguide Magic Tee, the resultant combined power in Watts of two tubes with output powers P_1 and P_2 due to phase (ϕ) and amplitude imbalance at the input ports is:

$$P_{combined} = (P_1 + P_2) \times \left\{ \frac{1 + 2X \cos \phi + X^2}{2 + 2X^2} \right\}$$

$$X = \left[\frac{P_2}{P_1} \right]^{1/2} \text{ for } P_2 \leq P_1$$

Ignoring combining losses (which are on the order of tenths of dB), two 300W TWTs with equal power output and 40° maximum phase imbalance combine to produce 530W (0.54 dB phase imbalance loss). If it were desired to combine a 400W TWT with a 200W TWT with the same maximum phase imbalance, the result would be 517W (0.65 dB phase and amplitude imbalance loss). Because of the relative insensitivity to amplitude imbalance, odd numbers of TWTs combine reasonably well. Power combining neither reduces the amplifier's tolerance to output mismatch nor its modulation fidelity. With the use of 180° hybrids, harmonic content can be reduced by at least 10 dB relative to the tube's stand-alone performance since in this case, harmonic is directed to the "lost-power" rather than to the "combined-power" port of the hybrid. Likewise, since TWT noise output is non-coherent and thus splits evenly between the two output ports of the hybrid, noise is reduced 3 dB per combination.

Harmonics

Due to the wide bandwidth and high gain of the TWT, harmonics of the fundamental RF drive signal will appear in the output spectrum as the tube is driven into the non-linear region. Single octave TWTs typically have 3 dB or more low band edge harmonic separation while dual octave TWTs may exhibit harmonics equal to or greater than the fundamental. Higher harmonics also will be present, but to a lesser degree. Broadband TWTs may react to harmonics in the RF drive which, if sufficiently strong, can either enhance or degrade output power depending upon the relative phase angle between the harmonic and fundamental input signals.

Noise

Noise in the output spectrum of a TWT results from the fact that electron emission from the cathode is a random process. Furthermore, the velocities of electrons emitted by the hot cathode have a Maxwellian distribution. TWT noise figure (in dB) is given by the following expression:

$$NF = 114 + NPO - 10 \text{ Log}(BW) - G_{ss}$$

-114 dBm/Mhz is the reference thermal noise caused by a room temperature termination at the TWT input. BW is the bandwidth relative to 1 Mhz over which the noise power output (NPO in dBm) is measured. G_{ss} is the small signal gain in dB averaged over the bandwidth BW. Typical noise figures for medium power TWTs are 25 to 35 dB.

Noise can be reduced by gating off the beam when signal transmission is not required either with a grid or focus electrode (FE). A grid cuts off noise to the thermal level. A focus electrode typically cuts gain to zero dB which generally results in noise output 25 to 35 dB above thermal. Most Teledyne CW TWTs are offered in both gridded and focus electrode gated versions. With modern design and fabrication techniques, the reliability of shadow grid versions is equal to or greater than their FE counterparts.

Spurious outputs not correlated to the fundamental signal frequency are minimized by oscillation suppression techniques such as special helix attenuation patterns and pitch changes. Operation of the TWT into highly mismatched loads may increase spurious output since these suppression techniques are sometimes less effective in the presence of strong reflected signals.

Intermodulation Distortion

When the RF input signal contains two or more discrete carrier frequencies, a mixing process occurs which results in intermodulation products displaced from the carriers at multiples of the difference frequencies. The power levels of these intermodulation products are dependent upon the relative power levels of the carriers and the linearity of the TWT. The two-tone third order intermodulation products (at $2F_1 - F_2$ and $2F_2 - F_1$) are the most important because they are closest to the signal frequencies and largest in amplitude. At saturation, the separation of IM products from the fundamental is typically 10 dB. The amplitude of these products decrease 2 dB for every dB the power is backed down from saturation.

$$P_{IM3} \cong 2 \times \text{Back-off} + 10 \text{ dB}$$

The third order intercept point OIP3 is a figure of merit and is equal to the output power of each of the two tones when the third order IM separation is 0 dBc. Obviously, the TWT saturates before this point is reached but it can be calculated by projecting the single carrier and IM3 linear gain slopes to their intersection. The separation in dB of the intermod from carrier (at power P_o) is more accurately given by:

$$P_{IM3} = 2 (OIP3 - P_o)$$

An effect related to IM distortion is spectral regrowth. The name comes from the observation that band limited signals, after passing through a non-linear amplifier, often have components outside of the original band that the signal occupied at the input. This phenomenon is often encountered with a digitally modulated carrier. For example, with Quadrature Phase-Shift Keying (QPSK)

modulation, the amplitude of the signal is theoretically constant. However, in the frequency domain, the signal occupies a relatively wide bandwidth. When a QPSK signal is filtered to limit its bandwidth, the sidebands furthest from the carrier are removed. The result is that in the time domain, the signal is no longer constant in amplitude, and AM / AM and AM / PM processes within the amplifier generate new sidebands. Typically, these "regrowth skirts" are separated 8 dB further from carrier than the two-tone IM3 products that would result with the same average carrier power, i.e., -18 dBc IM3 (4 dB back-off) roughly corresponds to -26 dBc spectral regrowth. Use of a predistortion linearizer with the TWT can allow comparable operation to within 2 dB of saturation.

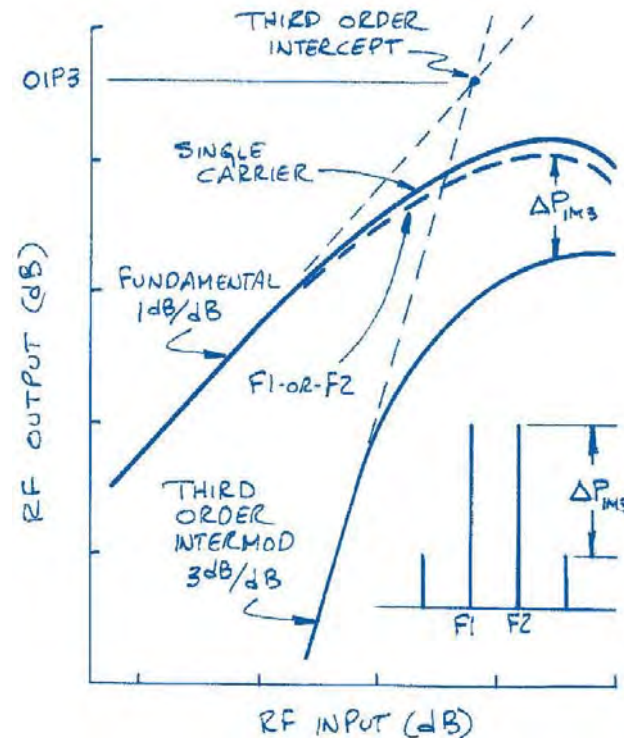

TWTs traditionally have been used for FM applications where they're operated to saturation and are typically so specified. SSAs, on the other hand, traditionally have been specified at their one dB compression point. As a result, the two cannot be compared at a given output back-off level. When specifying a power requirement it is best to specify the absolute output power required for a given level of IM3 distortion, spectral regrowth, or the OIP3. At this point, a SSA will operate closer to saturation but will not have the approximate 3 dB reserve "burn-through" capability of a TWT.

TWT Reliability

If a large number of TWTs were simultaneously put into service, their survival rate history would be characterized by three distinct periods:

- Infant Mortality
- Random Failures
- Wear-out

Infant mortality failures due to workmanship defects are effectively screened-out by "burn-in" before delivery. Random failures during the long middle period are characterized by the time constant MTBF (Mean Time Before Failure) which is a measure of the time to which about 37% (e-1) of the tubes will have survived. Cathode exhaustion triggers the point at which tubes wear-out and failure rates increase substantially. MTBF and life clearly are two different measures of a tubes history. Ideally, MTBF exceeds life by a substantial amount. In some cases, cathode life may be so long or the environment may be so severe that random failures account for the majority of tube removals. The best currently available measure of TWT MTBF is MIL-HDBK-217F Notice 2¹ which provides the following estimates:

Air Conditioned Fixed Site

$$MTBF = \frac{10^6}{5.5 \times (1.00001)^P \times (1.1)^F}$$

Fixed Site with Unconditioned Air

$$MTBF = \frac{10^6}{16.5 \times (1.00001)^P \times (1.1)^F}$$

Ground Mobile

$$MTBF = \frac{10^6}{77.0 \times (1.00001)^P \times (1.1)^F}$$

Where P is the rated power in Watts (peak if pulsed) and F is the operating Frequency in GHz (the geometric mean of the end points is used if the operating frequency ranges over a band).

As an example, the 250W 0.8 to 2.0 GHz M5670NO is predicted by this model to have MTBFs of 158,494 hrs for Air Conditioned sites, 52,831 hrs for unconditioned sites, and 11,321 hrs for ground mobile operation. This model is very simplistic and does not address failure drivers such as thermal and voltage stress gradients within the TWT, system VSWR, heater on – off cycling, power supply energy discharge during fault conditions, etc. Despite these concerns, experience with modern TWTs used on switching power supplies indicates that the MIL-HDBK typically under predicts MTBF by a factor of 2².

A Safety and Set-up instruction booklet is provided with each Teledyne TWT. It contains good advice on set-up procedures to prevent infant mortality problems. The high voltage power supply should be designed to limit energy dissipation to substantially less than 10J with at least several ohms of series resistance in the TWT cathode connection. The tube also should be provided with adequate cooling so that temperatures are maintained within the recommended ranges under all operating conditions. Unlike SSAs, however, TWTs can operate for short periods at chill plate temperatures above their recommended level. TWTs are equipped with thermal interlocks to prevent permanent damage. Any TWT in this catalog can be special ordered for prolonged operation at temperatures reasonably beyond the recommended limits.

TWT Life

Modern TWTs are designed with low temperature cathodes capable of at least 20,000 hours of continuous operation. Many Teledyne TWTs have accumulated three to five times this life. A key to achieving long cathode life is to maintain heater voltage within its recommended range. If the tube is to spend a substantial portion of its' life in standby, cathode life can be extended by reducing heater voltage 10% during standby. The majority of Teledyne TWTs employ shadow grids to turn the electron beam on and off. For most applications the life and reliability of shadow grid versions is equal to or greater than their ungridded counterparts. However, for those situations where the TWT is expected to be turned on and off infrequently and to operate uninterrupted for thousands of hours, ungridded versions will offer maximum life.

Current process and fabrication technologies have eliminated the need to periodically "refresh" tube vacuum during prolonged storage. If there is concern about turning-on a tube after storage, an extended heater warm-up of from 8 to 24 hours prior to the application of cathode voltage should be adequate. The primary enemies of TWTs are foreign material in HV and RF connectors and corrosion-causing moisture. Keeping stored tubes clean and dry is the best means of insuring high vacuum integrity and long life.

The current generation of TWTs is amassing an excellent reliability record. This is being illustrated by experience in Space where the failure rate of TWTs on Intelsat satellites has been 15% lower than for SSAs.

¹ Military Handbook, Reliability Prediction of Electronic Equipment, MIL-HDBK-217F Notice 2, 28 February, 1995

² A. S. Gilmour, Jr., Principles of Traveling Wave Tubes, Artech House, Inc., See especially p. 523

dBm to Watts Conversion Table

dBm	Watts	dBm	Watts	dBm	Watts	dBm	Watts	dBm	Watts	dBm	Watts	dBm	Watts
30.0	1.00	38.6	7.24	47.2	52.50	52.9	195.00	57.2	525.00	61.5	1410.00	65.8	3800.00
30.2	1.05	38.8	7.59	47.4	55.00	53.0	200.00	57.3	537.00	61.6	1450.00	65.9	3890.00
30.4	1.10	39.0	7.94	47.6	57.50	53.1	204.00	57.4	550.00	61.7	1480.00	66.0	3980.00
30.6	1.15	39.2	8.32	47.8	60.30	53.2	209.00	57.5	562.00	61.8	1510.00	66.1	4070.00
30.8	1.20	39.4	8.71	48.0	63.10	53.3	214.00	57.6	575.00	61.9	1550.00	66.2	4170.00
31.0	1.26	39.6	9.12	48.2	66.10	53.4	219.00	57.7	589.00	62.0	1580.00	66.3	4270.00
31.2	1.32	39.8	9.55	48.4	69.20	53.5	224.00	57.8	603.00	62.1	1620.00	66.4	4370.00
31.4	1.38	40.0	10.00	48.6	72.40	53.6	229.00	57.9	617.00	62.2	1660.00	66.5	4470.00
31.6	1.45	40.2	10.50	48.8	75.90	53.7	234.00	58.0	631.00	62.3	1700.00	66.6	4570.00
31.8	1.51	40.4	11.00	49.0	79.40	53.8	240.00	58.1	646.00	62.4	1740.00	66.7	4680.00
32.0	1.58	40.6	11.50	49.2	83.20	53.9	245.00	58.2	661.00	62.5	1780.00	66.8	4790.00
32.2	1.66	40.8	12.00	49.4	87.10	54.0	251.00	58.3	676.00	62.6	1820.00	66.9	4900.00
32.4	1.74	41.0	12.60	49.6	91.20	54.1	257.00	58.4	692.00	62.7	1860.00	67.0	5010.00
32.6	1.82	41.2	13.20	49.8	95.50	54.2	263.00	58.5	708.00	62.8	1910.00	67.1	5130.00
32.8	1.91	41.4	13.80	50.0	100.00	54.3	269.00	58.6	724.00	62.9	1950.00	67.2	5250.00
33.0	2.00	41.6	14.50	50.1	102.00	54.4	275.00	58.7	741.00	63.0	2000.00	67.3	5370.00
33.2	2.09	41.8	15.10	50.2	105.00	54.5	282.00	58.8	759.00	63.1	2040.00	67.4	5500.00
33.4	2.19	42.0	15.80	50.3	107.00	54.6	288.00	58.9	776.00	63.2	2090.00	67.5	5620.00
33.6	2.29	42.2	16.60	50.4	110.00	54.7	295.00	59.0	794.00	63.3	2140.00	67.6	5750.00
33.8	2.40	42.4	17.40	50.5	112.00	54.8	302.00	59.1	813.00	63.4	2190.00	67.7	5890.00
34.0	2.51	42.6	18.20	50.6	115.00	54.9	309.00	59.2	832.00	63.5	2240.00	67.8	6030.00
34.2	2.63	42.8	19.10	50.7	117.00	55.0	316.00	59.3	851.00	63.6	2290.00	67.9	6170.00
34.4	2.75	43.0	20.00	50.8	120.00	55.1	324.00	59.4	871.00	63.7	2340.00	68.0	6310.00
34.6	2.88	43.2	20.90	50.9	123.00	55.2	331.00	59.5	891.00	63.8	2400.00	68.1	6460.00
34.8	3.02	43.4	21.90	51.0	126.00	55.3	339.00	59.6	912.00	63.9	2450.00	68.2	6610.00
35.0	3.16	43.6	22.90	51.1	129.00	55.4	347.00	59.7	933.00	64.0	2510.00	68.3	6760.00
35.2	3.31	43.8	24.00	51.2	132.00	55.5	355.00	59.8	955.00	64.1	2570.00	68.4	6920.00
35.4	3.47	44.0	25.10	51.3	135.00	55.6	363.00	59.9	977.00	64.2	2630.00	68.5	7080.00
35.6	3.63	44.2	26.30	51.4	138.00	55.7	372.00	60.0	1000.00	64.3	2690.00	68.6	7240.00
35.8	3.80	44.4	27.50	51.5	141.00	55.8	380.00	60.1	1020.00	64.4	2750.00	68.7	7410.00
36.0	3.98	44.6	28.80	51.6	145.00	55.9	389.00	60.2	1050.00	64.5	2820.00	68.8	7590.00
36.2	4.17	44.8	30.20	51.7	148.00	56.0	398.00	60.3	1070.00	64.6	2880.00	68.9	7760.00
36.4	4.37	45.0	31.60	51.8	151.00	56.1	407.00	60.4	1100.00	64.7	2960.00	69.0	7940.00
36.6	4.57	45.2	33.10	51.9	155.00	56.2	417.00	60.5	1120.00	64.8	3020.00	69.1	8130.00
36.8	4.79	45.4	34.70	52.0	158.00	56.3	427.00	60.6	1150.00	64.9	3090.00	69.2	8320.00
37.0	5.01	45.6	36.30	52.1	162.00	56.4	437.00	60.7	1170.00	65.0	3160.00	69.3	8510.00
37.2	5.25	45.8	38.00	52.2	166.00	56.5	447.00	60.8	1200.00	65.1	3240.00	69.4	8710.00
37.4	5.50	46.0	39.80	52.3	170.00	56.6	457.00	60.9	1230.00	65.2	3310.00	69.5	8910.00
37.6	5.75	46.2	41.70	52.4	174.00	56.7	468.00	61.0	1260.00	65.3	3390.00	69.6	9120.00
37.8	6.03	46.4	43.70	52.5	178.00	56.8	479.00	61.1	1290.00	65.4	3470.00	69.7	9330.00
38.0	6.31	46.6	45.70	52.6	182.00	56.9	490.00	61.2	1320.00	65.5	3550.00	69.8	9650.00
38.2	6.61	46.8	47.90	52.7	186.00	57.0	501.00	61.3	1350.00	65.6	3630.00	69.9	9770.00
38.4	6.92	47.0	51.10	52.8	191.00	57.1	513.00	61.4	1380.00	65.7	3720.00	70.0	10000.00

RECTANGULAR WAVEGUIDE SPECIFICATIONS

EIA WG Designation	Recommended Operating Range for TE _{1,0} Mode		Cut-Off for TE _{1,0} Mode		Range In $\frac{2\lambda}{\lambda}$	Range In $\frac{\lambda}{\lambda}$	Recommended Power Rating (At One Atmosphere)		Theoretical Attenuation lowest to highest frequency (dB/100 ft.)	DIMENSIONS (Inches)				Wall Thickness Nominal
	Frequency (GHz-Sec)	Wavelength (cm)	Frequency (GHz-Sec)	Wavelength (cm)			cw(KW)	peak(KW)		Inside	Tol. ±	Outside	Tol. ±	
WR137	5.85-8.20	5.12-3.66	4.285	6.996	1.47-1.05	1.48-1.17	10.0 8.0	1980	1.987-1.562 2.955-2.348	1.372 x .622	0.004	1.500 x .750	.004	.064
WR102	7.00-11.00	4.28-2.72	5.786	5.182	1.65-1.05	1.78-1.18	5.0 4.0	1020	3.516-2.217 5.285-3.333	1.020 x .510	0.005	1.148 x .638	.005	.064
WR112	7.05-10.00	4.25-2.99	5.260	5.700	1.49-1.05	1.51-1.17	6.0 4.8	1280	2.776-2.154 4.173-3.238	1.122 x .497	0.004	1.250 x .625	.004	.064
WR90 R/H	8.20-12.40	3.66-2.42	6.560	4.572	1.60-1.06	1.68-1.18	2	340	10.47-9.254	.900 x .200	0.003	1.000 x .300	.003	.050
WR90	8.20-12.40	3.66-2.42	6.560	4.572	1.60-1.06	1.68-1.18	3.0 2.4	760	4.238-2.995 6.506-4.502	.900 x .400	0.003	1.000 x .500	.003	.050
WR75 R/H	10.00-15.00	2.99-2.00	7.847	3.820	1.57-1.05	1.64-1.17	1.8	280	7.806-5.950	.750 x .200	0.003	.850 x .300	.003	.050
WR75	10.00-15.00	2.99-2.00	7.847	3.820	1.57-1.05	1.64-1.17	2.8 2.2	620	5.121-3.577 7.698-5.377	.750 x .375	0.003	.850 x .475	.003	.050
WR62	12.40-18.00	2.42-1.66	9.490	3.160	1.53-1.05	1.55-1.18	1.8 1.4	460	6.451-4.743 9.700-7.131	.622 x .311	0.002	.702 x .391	.003	.040
WR28	26.50-40.00	1.13-.75	21.10	1.422	1.59-1.05	1.65-1.17	0.5 0.4	100	23.02-15.77 34.46-23.59	.280 x .140	0.001	.360 x .220	.002	.040

DOUBLE RIDGE WAVEGUIDE SPECIFICATIONS

Waveguide Size	MIL-W-23351 Dash No.	Material	Recommended Frequency Range TE _{1,0} Mode (GHz)	(3) Cut-Off Frequency for TE _{1,0} Mode (GHz)	(1) $F = \sqrt{3}Fc_{1,0}$ Theoretical Attenuation Decibels/Foot	(2) Recommended Power Rating (at One Atmosphere)		DIMENSIONS (Inches)							
						cw (KW)	peak (KW)	A	B	C	D	E	F	R1	R2
WRD 475D24	4-033 4-034 4-035 4-036	Aluminum Alloy Brass Copper Silver Alloy	4.75 - 11.0	3.961	0.0487 0.0481 0.0324 0.0347	8.0	85	1.090	0.506	1.190	0.606	0.272	0.215	0.043	0.030
WRD 580D28		Aluminum Alloy Brass Copper Silver Alloy	5.80 - 16.00	4.892	0.100 0.098 0.067 0.070	5.2	32	0.780	0.370	0.880	0.470	0.200	0.120	0.043	0.015
WRD 650D28		Aluminum Alloy Brass Copper Silver Alloy	6.50 - 18.00	5.348	0.106 0.105 0.070 0.076	4.0	25	0.721	0.321	0.821	0.421	0.173	0.101	0.022	0.020
WRD 750D24	4-037 4-038 4-039 4-040	Aluminum Alloy Brass Copper Silver Alloy	7.50 - 18.00	6.239	0.0964 0.0951 0.0641 0.0686	4.8	35	0.691	0.321	0.791	0.421	0.173	0.136	0.027	0.020
WRD 180C24	4-045 4-046 4-047 4-048	Aluminum Alloy Brass Copper Silver Alloy	18.00 - 40.00	14.995	0.358 0.353 0.238 0.255	0.8	5	0.288	0.134	0.368	0.214	0.072	0.057	0.011	0.015
WRD 584		Aluminum	5.80 - 18.40	4.467	0.188	4	30	0.720	0.310	0.925	0.510	0.180	0.064	0.043	0.015

Courtesy of Continental Microwave & Tool Company, Inc. and Microwave Development Co. (MDC)

Continuous Wave TWTs

Page No.	Model	Frequency (GHz)	Power (W)	Duty (%) Max.	Typical Gain (dB) Min/Max @ Rated P _{out}	Efficiency (%) Typical	Modulation (Control Electrode)	Output Connection	Weight (lbs/kg) (NTE)
18	M5670NO	0.8 - 2.0	250*	100	24/36	17*	N/A	N	10/4.5
	MEC 5670	0.8 - 2.0	250*	100	24/36	17*	GRID	N	10/4.5
20	MTD 5119	0.8 - 2.8	250*	100	32/47	20*	N/A	N	10/4.5
	MEC 5119	0.8 - 2.8	250*	100	32/47	20*	GRID	N	10/4.5
22	MEC 5203	1.0 - 2.5	500	100	24/35	22*	GRID	SC	15/6.8
24	MTE 5107	2.0 - 4.0	250	100	44/53	22	N/A	N	8/3.6
26	MEC 5500E	2.0 - 6.5	400*	100	34/38	35*	GRID	SC	8.3/3.8
28	MEC 5208	2.0 - 8.0	250*	100	37/62	19*	GRID	SC	8.0/3.6
30	MEC 5196	2.0 - 8.0	450*	100	26/46	26*	GRID	SC	9/4.1
32	MTG 5082H	2.5 - 8.0	275	100	40/64	23	GRID	SC	8/3.6
34	MEC 5296	2.5 - 7.5	535	100	31/43	28	GRID	SC	9/4.1
36	MEC 5498	2.5 - 7.5	535	100	26/43	28	GRID	WRD 250	9.5/4.32
38	MEC 5497	2.5 - 7.5	630*	100	31/43	37	GRID	SC	9/4.1
40	M5889NO	4.0 - 8.0	250	100	46/59	21	N/A	N	9/4.1
	MEC 5889	4.0 - 8.0	250	100	46/59	21	GRID	N	9/4.1
42	MTG 5130	5.0 - 11.0	500*	100	40/57	21	FE	WRD 475	8/3.6
44	MEC 5413	6.0 - 18.0	200	100	35/46	20	GRID	WRD 650	9/4.1
	MEC 5414	6.0 - 18.0	200	100	35/46	20	FE	WRD 650	9/4.1
46	MEC 5423	6.0 - 18.0	250	100	35/46	23	GRID	WRD 650	9/4.1
	MEC 5424	6.0 - 18.0	250	100	35/46	23	FE	WRD 650	9/4.1
48	MEC 5415	6.0 - 18.0	300	100	35/46	26	GRID	WRD 650	9/4.1
	MEC 5416	6.0 - 18.0	300	100	35/46	26	FE	WRD 650	9/4.1
50	MEC 5508	6.0 - 18.0	200*	100	26/28	28	FE	WRD 650	3/1.36
52	MEC 5409	6.5 - 18.0	200	100	35/48	20	GRID	WRD 650	9/4.1
	MEC 5410	6.5 - 18.0	200	100	35/48	20	FE	WRD 650	9/4.1
54	MEC 5421	6.5 - 18.0	250	100	35/45	24	GRID	WRD 650	9/4.1
	MEC 5422	6.5 - 18.0	250	100	35/45	24	FE	WRD 650	9/4.1
56	MEC 5411	6.5 - 18.0	300	100	35/45	25	GRID	WRD 650	9/4.1
	MEC 5412	6.5 - 18.0	300	100	35/45	25	FE	WRD 650	9/4.1
58	MEC 5405	7.5 - 18.0	200	100	35/55	22	GRID	WRD 750	9/4.1
	MEC 5406	7.5 - 18.0	200	100	35/55	22	FE	WRD 750	9/4.1
60	MEC 5419	7.5 - 18.0	250	100	35/55	25	GRID	WRD 750	9/4.1
	MEC 5420	7.5 - 18.0	250	100	35/55	25	FE	WRD 750	9/4.1
62	MEC 5407	7.5 - 18.0	300	100	35/55	29	GRID	WRD 750	9/4.1
	MEC 5408	7.5 - 18.0	300	100	35/55	29	FE	WRD 750	9/4.1
64	MEC 5487	8.0 - 18.0	325	100	44/47	32	GRID	WRD 750	9/4.1
66	MEC 5519	11.0 - 18.0	500*	100	53/55	28	FE	WRD 750	9/4.1
68	MEC 5493	18.0 - 26.5	50	100	26/28	20*	FE	WRD 180	7/3.2
	MEC 5493E	18.0 - 26.5	50	100	26/28	20*	FE	WR 42	7/3.2
70	MEC 5496	26.5 - 40.0	40	100	35/50	20*	FE	WRD 180	7.5/3.4

* Over majority of frequency range - Performance may be reduced at band edges.

M5670NO/MEC 5670

Continuous Wave TWT

0.8 GHz – 2.0 GHz

- 200 W Minimum Power
- 0.8 to 2.0 GHz
- -40° to 85° C
- 1500 W Typ. Prime Power
- 24-36 dB Typical Gain
- 23.9" L x 3" W x 2.95" H (62 x 7.65 x 7.5 cm)
- Phase Match Available



RF Performance

Freq (GHz)	Typ. Sat. Power Output (W)	Min. Spec. Power Output (W)	Typ. Gain @ Spec. Power (dB)
0.8	230	200*	24
0.9	285	250	27
1.0	330	250**	31
1.2	320	250	34
1.4	300	250	36
1.6	300	250	35
1.8	295	250	33
2.0	280	250	29

Typical power output is shown to illustrate capability.
Typical gain shown is without equalizer.

Typical Operating Conditions

Element	Voltage	Current	Power Supply Requirements		
			Voltage Min.	Voltage Max.	Current Max.
Heater	-6.3 Vdc	3.4 A	-5.2 Vdc	-6.6 Vdc	4.5 A
Helix					
with RF	Ground	30 mA	Ground	Ground	80 mA
without RF	Ground	4 mA	Ground	Ground	80 mA
Anode	140 Vdc	0.4 mA	0	500 Vdc	4 mA
Grid On	110 Vdc	0.5 mA	100 Vdc	250 Vdc	10 mA
Grid Off	-200 Vdc	0.1 mA	-200 Vdc	-500 Vdc	1 mA
Cathode (E _k)	-3.75 kV	450 mA	-3 kV	-4 kV	550 mA
Collector w/RF	3.2 kV	420 mA	87% x E _k ±2%		550 mA

Cathode and Anode voltages are measured with respect to ground.
Heater, Collector, and Grid voltages are measured with respect to Cathode.
Anode voltage not required with Grid modulated version.

Performance

	Typical	Spec
Input VSWR.....	1.7:1	2.5:1
Output VSWR.....	1.6:1	2.5:1
Max. Duty	—	CW
Grid Capacitance.....	50 pF	65 pF
Min. Harmonic Separation.....	-4/-7 dBc	-2*/-3** dBc
Noise Power Density (dBm/MHz)	-40	-30
Prime Power.....	1500 W	1700 W

This model number is subject to the jurisdiction of the U.S. Department of Commerce.

NOTES:

1. THERMOSTAT OPTIONS: N/C OR N/O

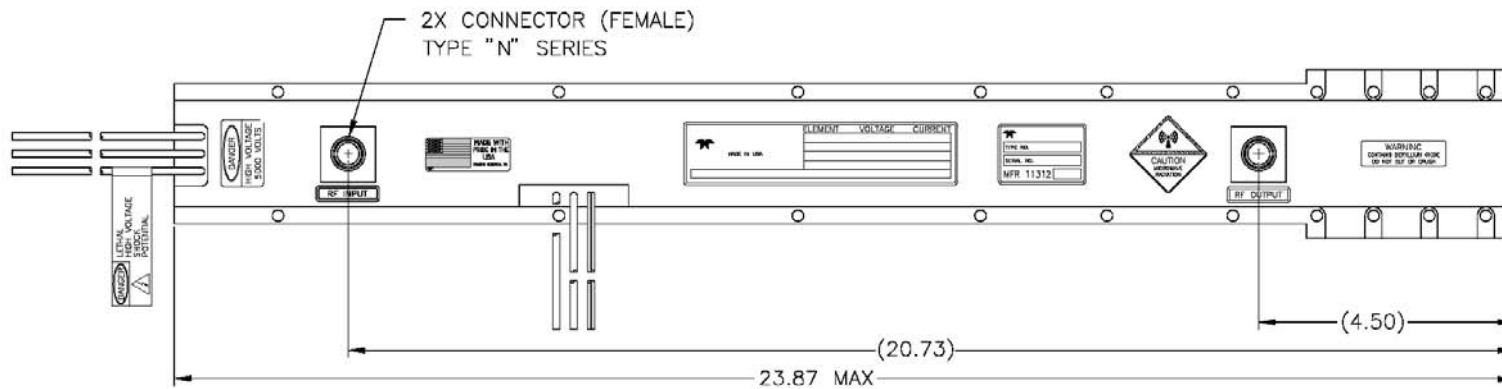
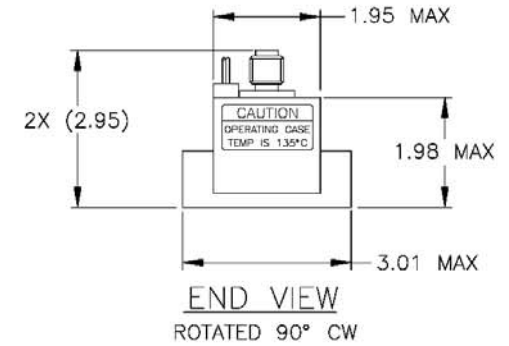

SUBJECT TO CHANGE W/O NOTICE ISO 9001:2008 Registered

TELEDYNE MICROWAVE SOLUTIONS
TWT Products
11361 Sunrise Park Drive, Rancho Cordova, CA 95742 (916) 638-3344
TITLE
MEC 5670/M5670NO

This model number is subject to the jurisdiction of the U.S. Department of Commerce.

MTD 5119/MEC 5119

Continuous Wave TWT

0.8 GHz – 2.8 GHz

- 200 W Minimum Power
- 0.8 to 2.8 GHz
- -40° to 85° C
- 1560 W Typ. Prime Power
- 32-47 dB Typical Gain
- 27" L x 3" W x 2.95" H
(68.4 x 7.65 x 7.5 cm)
- Phase Match Available



RF Performance

Freq (GHz)	Typ. Sat. Power Output (W)	Min. Spec. Power Output (W)	Typ. Gain @ Spec. Power (dB)
0.8	210	200	33
0.9	355	250	35
1.0	390	250	43
1.2	355	250	46
1.4	315	250	47
1.6	325	250	47
1.8	325	250	47
2.0	315	250	45
2.2	315	250	42
2.4	325	250	39
2.6	335	250	35
2.8	335	250	32

*Typical power output is shown to illustrate capability.
Typical gain shown is without equalizer.
±4 dB gain equalizer available.*

Typical Operating Conditions			Power Supply Requirements		
Element	Voltage	Current	Voltage Min.	Voltage Max.	Current Max.
Heater	-6.3 Vdc	3.4 A	-5.2 Vdc	-6.5 Vdc	4.5 A
Helix					
with RF	Ground	40 mA	Ground	Ground	80 mA
without RF	Ground	4 mA	Ground	Ground	80 mA
Anode	250 Vdc	1.5 mA	0	500 Vdc	4 mA
Grid On	120 Vdc	0.5 mA	100 Vdc	250 Vdc	10 mA
Grid Off	-250 Vdc	0.1 mA	-200 Vdc	-500 Vdc	1 mA
Cathode (E _k)	-3.75 kV	480 mA	-3 kV	-4 kV	550 mA
Collector w/RF	3.2 kV	440 mA	87% x E _k ±2%		550 mA

*Cathode and Anode voltages are measured with respect to ground.
Heater, Collector, and Grid voltages are measured with respect to Cathode.
Anode voltage not required with Grid modulated version.*

Performance	Typical	Spec
Input VSWR.....	1.6:1	2.5:1
Output VSWR.....	1.6:1	2.5:1
Max. Duty	—	CW
Grid Capacitance.....	50 pF	65 pF
Min. Harmonic Separation.....	-3.5/-8 dBc	-2/-3 dBc
Noise Power Density (dBm/MHz)	-25	-20
Prime Power.....	1560 W	1700 W

Specifications are subject to change without notice.



NOTES:

1. THERMOSTAT OPTIONS: N/C OR N/O

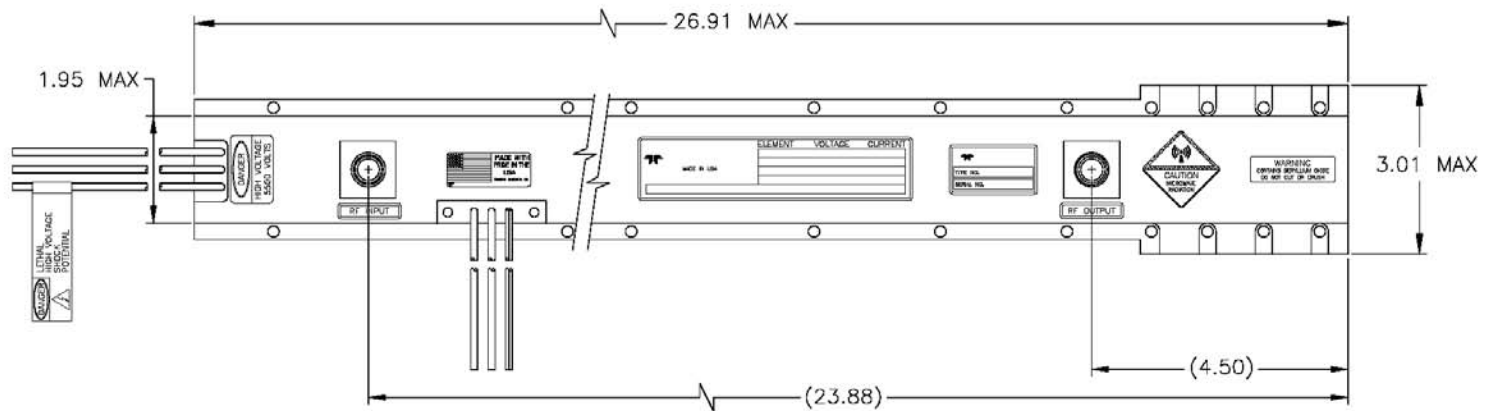
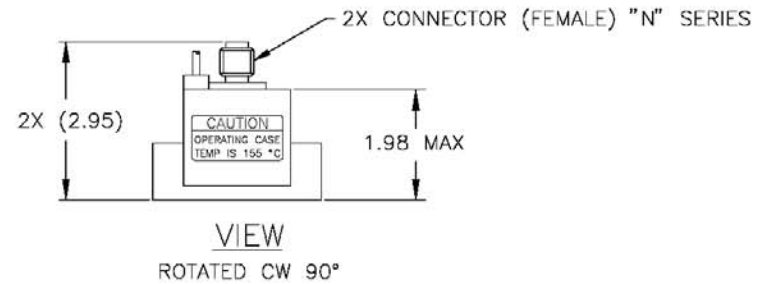

TELEDYNE MICROWAVE SOLUTIONS
TWT Products

11361 Sunrise Park Dr., Rancho Cordova, CA 95742 (916) 638-3344

TITLE

MEC 5119/MTD 5119

SUBJECT TO CHANGE W/O NOTICE

ISO 9001:2008 Registered

MEC 5203

Continuous Wave TWT

1 GHz – 2.5 GHz

- 500 W Minimum Power
- 1.0 to 2.5 GHz
- -40° to 85° C
- 2000 W Typ. Prime Power
- 24-35 dB Typical Gain
- 24.4" L x 4" W x 4.5" H
(62 x 10.2 x 11.4 cm)

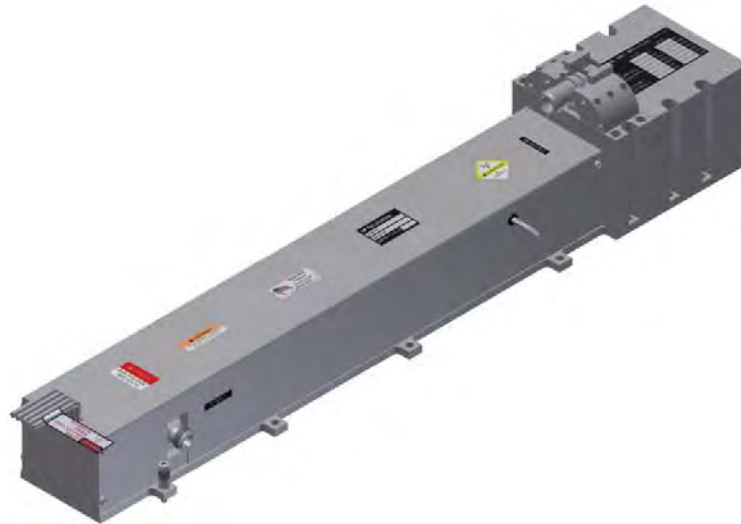

RF Performance

Freq (GHz)	Typ. Sat. Power Output (W)	Min. Spec. Power Output (W)	Typ. Gain @ Spec. Power (dB)
1.0	515	500	24
1.2	600	500	30
1.4	625	500	32
1.6	670	500	34
1.8	650	500	35
2.0	550	500	33
2.2	540	500	31
2.4	535	500	29
2.5	525	500	28

*Typical power output is shown to illustrate capability.
Typical gain shown is without equalizer.
±4 dB gain equalizer available.*

Element	Typical Operating Conditions		Power Supply Requirements		
	Voltage	Current	Voltage Min.	Voltage Max.	Current Max.
Heater	-6.3 Vdc	3.5 A	-5.2 Vdc	-6.6 Vdc	4.5 A
Helix					
with RF	Ground	75 mA	Ground	Ground	100 mA
without RF	Ground	5 mA	Ground	Ground	100 mA
Grid On	150 Vdc	1 mA	100 Vdc	250Vdc	10 mA
Grid Off	-200 Vdc	0.1 mA	-200 Vdc	-500 Vdc	1 mA
Cathode (E _k)	-4.80 kV	578 mA	-4.5 kV	-5.2 kV	650 mA
Collector w/RF					
Coll. #1	3.71 kV	312 mA	79% x E _k ±2%		450 mA
Coll. #2	1.65 kV	191 mA	35% x E _k ±2%		650 mA

*Cathode voltage is measured with respect to ground.
Heater, Collector, and Grid voltages are measured with respect to Cathode.*

Performance	Typical	Spec
Input VSWR.....	2:1	2.5:1
Output VSWR.....	2:1	2.5:1
Max. Duty	—	CW
Grid Capacitance.....	45 pF	60 pF
Min. Harmonic Separation.....	-2 dBc	-1 dBc
Noise Power Density (dBm/MHz)	-35	-30
Prime Power.....	2000 W	3000 W

This model number is subject to the jurisdiction of the U.S. Department of Commerce.

NOTES:

1. THERMOSTAT OPTIONS: N/C OR N/O

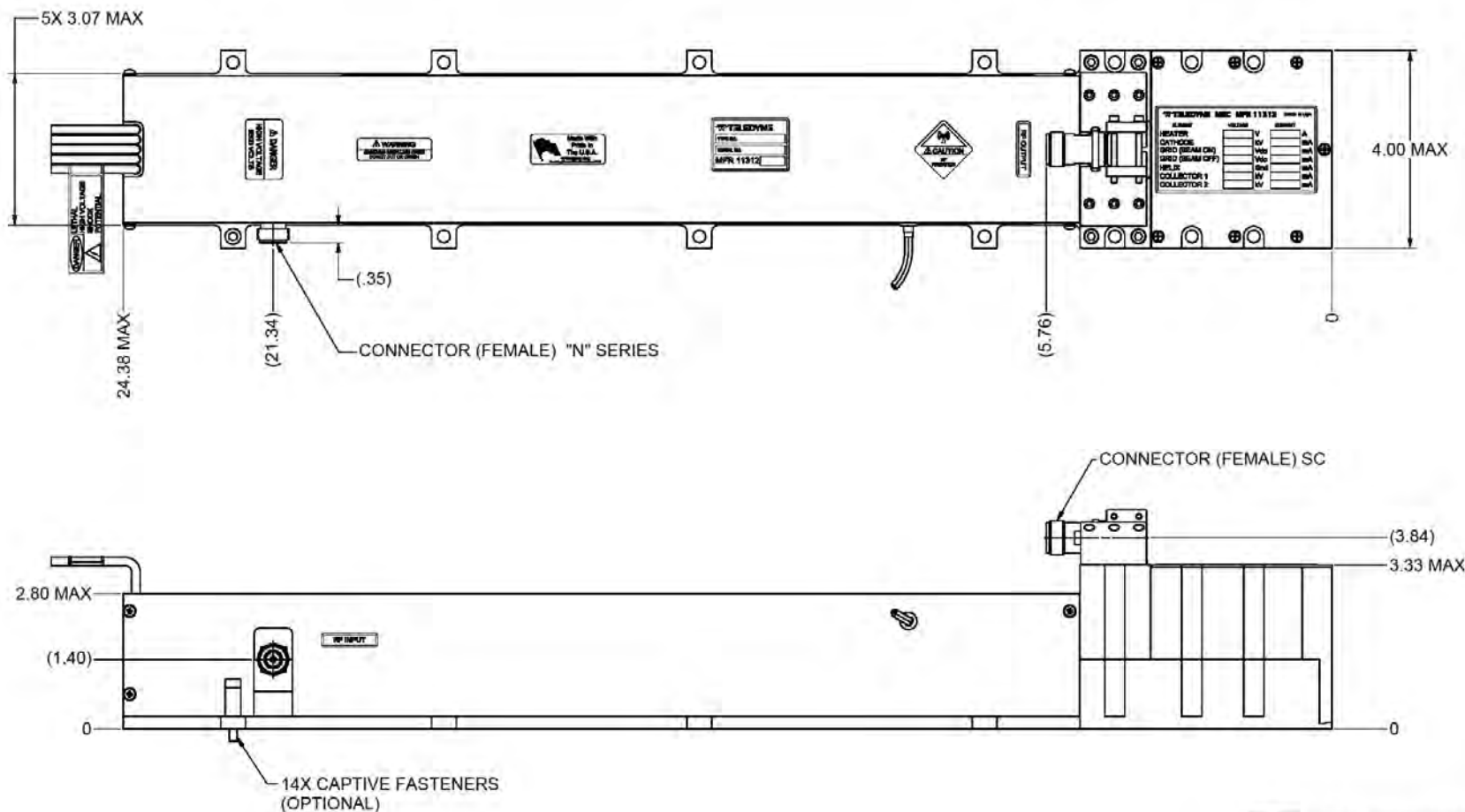

SUBJECT TO CHANGE W/O NOTICE

ISO 9001:2008 Registered

TELEDYNE MICROWAVE SOLUTIONS TWT PRODUCTS	
11361 Sunrise Park Dr., Rancho Cordova, CA 95748-0001	
TITLE	MEC 5203

This model number is subject to the jurisdiction of the U.S. Department of Commerce.

MTE 5107

Continuous Wave TWT

2.0 GHz – 4.0 GHz

- 250 W Minimum Power
- 2.0 to 4.0 GHz
- -40° to 85° C
- 1300 W Typ. Prime Power
- 44-53 dB Typical Gain
- 21" L x 2.5" W x 2" H (53.3 x 6.4 x 5.2 cm)
- Phase Match Available



RF Performance

Freq (GHz)	Typ. Sat. Power Output (W)	Min. Spec. Power Output (W)	Typ. Gain @ Spec. Power (dB)
2.00	250	250*	44
2.25	295	250	48
2.50	320	250	51
2.75	330	250	52
3.00	345	250	53
3.25	360	250	53
3.50	360	250	52
3.75	355	250	51
4.00	345	250	49

*Typical power output is shown to illustrate capability.
Typical gain shown is without equalizer.*

Typical Operating Conditions			Power Supply Requirements		
Element	Voltage	Current	Voltage Min.	Voltage Max.	Current Max.
Heater	-6.3 Vdc	2.1 A	-6 Vdc	-6.6 Vdc	3 A
Helix					
with RF	Ground	33 mA	Ground	Ground	45 mA
without RF	Ground	3 mA	Ground	Ground	45 mA
Anode	210 Vdc	0.7 mA	0	500 Vdc	4 mA
Cathode (E_k)	-4.4 kV	410 mA	-4.1 kV	-4.6 kV	450 mA
Collector w/RF	3.08 kV	375 mA		70% x $E_k \pm 2\%$	450 mA

*Cathode and Anode voltages are measured with respect to ground.
Heater and Collector voltages are measured with respect to Cathode.*

Performance	Typical	Spec
Input VSWR.....	1.9:1	2.5:1
Output VSWR.....	1.7:1	2.5:1
Max. Duty	—	CW
Min. Harmonic Separation.....	-5 dBc	-4 dBc*
Noise Power Density (dBm/MHz)	-30	-10
Prime Power.....	1300 W	1500 W

This model number is subject to the jurisdiction of the U.S. Department of Commerce.

NOTES:

1. THERMOSTAT OPTIONS: N/C OR N/O

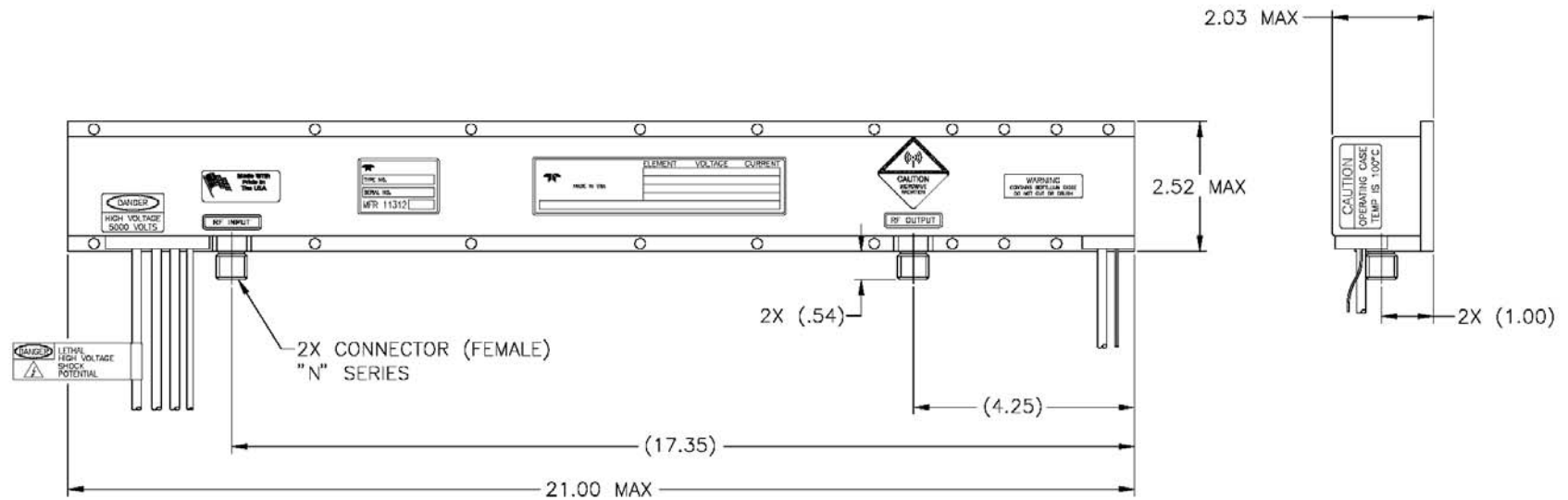

SUBJECT TO CHANGE W/O NOTICE

ISO 9001:2008 Registered

TELEDYNE MICROWAVE SOLUTIONS TWT Products <small>11361 Sunrise Park Drive, Rancho Cordova, CA 95742 (916) 638-3344</small>
TITLE
MTE 5107

This model number is subject to the jurisdiction of the U.S. Department of Commerce.

MEC 5500E

Continuous Wave TWT

2 GHz – 6.5 GHz

- 400 W Minimum Power (325 W @ 6.5 GHz)
- 2.0 to 6.5 GHz
- -20° to 85° C
- 1200 W Typ. Prime Power
- 34 to 39 dB Typical Gain
- 17.51" L x 3.60" W x 3.45" H (44.5 x 9.14 x 8.76 cm)
- Phase Match Available

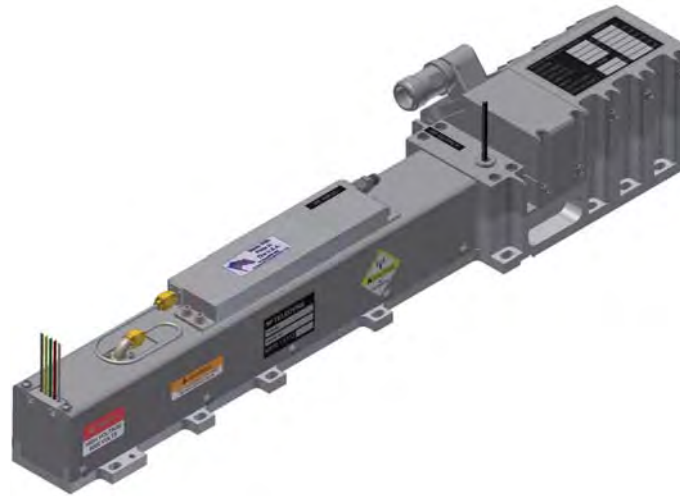

RF Performance

Freq (GHz)	Typ. Sat. Power Output (W)	Min. Spec. Power Output (W)	Typ. Gain @ Spec. Power (dB)
2.0	450	400	34
2.5	500	400	38
3.0	575	400	37
3.5	575	400	37
4.0	575	400	38
4.5	560	400	37
5.0	500	400	36
5.5	500	400	37
6.0	450	400	37
6.5	375	325	37

Typical power output is shown to illustrate capability.
Typical gain shown is with equalizer.

Typical Operating Conditions

Element	Typical Operating Conditions		Power Supply Requirements		
	Voltage	Current	Voltage Min.	Voltage Max.	Current Max.
Heater	-6.3 Vdc	2.1 A	-6.1 Vdc	-6.6 Vdc	2.5 A
Helix					
with RF	Ground	36 mA	Ground	Ground	50 mA
without RF	Ground	4 mA	Ground	Ground	50 mA
Grid On	180 Vdc	0.5 mA	100 Vdc	250 Vdc	10 mA
Grid Off	-250 Vdc	0.1 mA	-200 Vdc	-500 Vdc	1.0 mA
Cathode (E _k)	-4.9 kV	375 mA	-4.6 kV	-5.4 kV	450 mA
Collector w/RF					
Coll. #1	3.38 kV	229 mA	69% x E _k ±2%		400 mA
Coll. #2	1.91 kV	110 mA	39% x E _k ±2%		450 mA

Cathode voltage is measured with respect to ground.

Heater, Collector, and Control Grid voltages are measured with respect to Cathode.

Performance

	Typical	Spec
Input VSWR:.....	2.2:1	2.5:1
Output VSWR.....	2.0:1	2.5:1
Max. Duty	-	CW
Grid Capacitance.....	50 pF	65 pF
Min. Harmonic Separation	-5.0 dBc	-2 dBc
@ 3.5GHz @ 400W		
Noise Power Density (dBm/MHz)	-30	-20
Prime Power.....	1200 W	1500 W

Specifications are subject to change without notice.

NOTES:

- 1. THERMOSTAT OPTIONS: N/C OR N/O
- ◊ EQUALIZER OPTIONAL BASED UPON CUSTOMER REQUIREMENT.

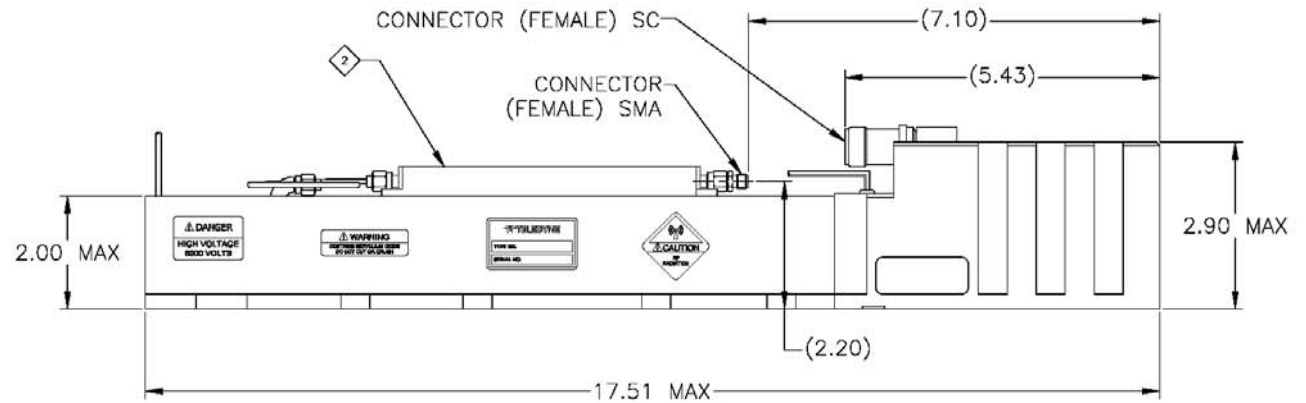
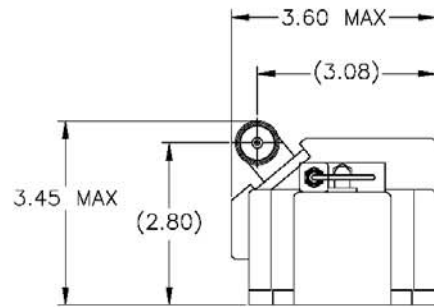
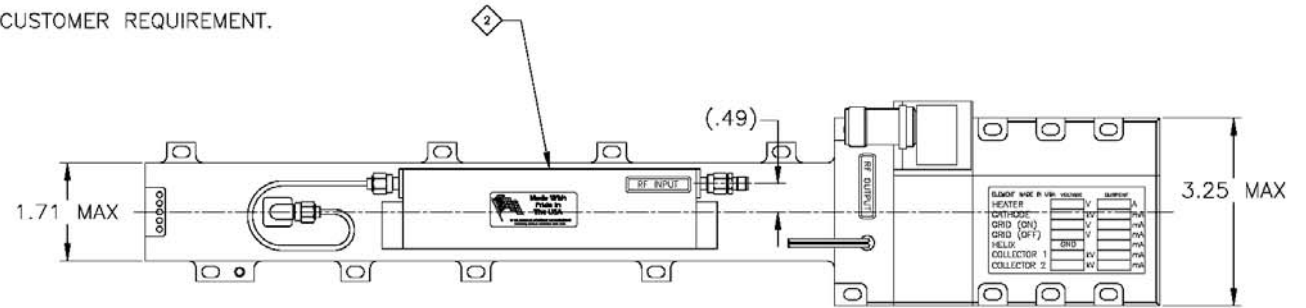

TELEDYNE MICROWAVE SOLUTIONS
TWT Products
11361 Sunrise Park Drive, Rancho Cordova, CA 95742 (916) 638-3344

TITLE

MEC 5500E

SUBJECT TO CHANGE W/O NOTICE ISO 9001:2008 Registered

MEC 5208

Continuous Wave TWT

2 GHz – 8 GHz

- 175 W Minimum Power
- 2.0 to 8.0 GHz
- -40° to 85° C
- 1398 W Typ. Prime Power
- 37-62 dB Typical Gain
- 20.6" L x 3.25" W x 3.46" H (52.3 x 82.55 x 8.8 cm)
- Phase Match Available

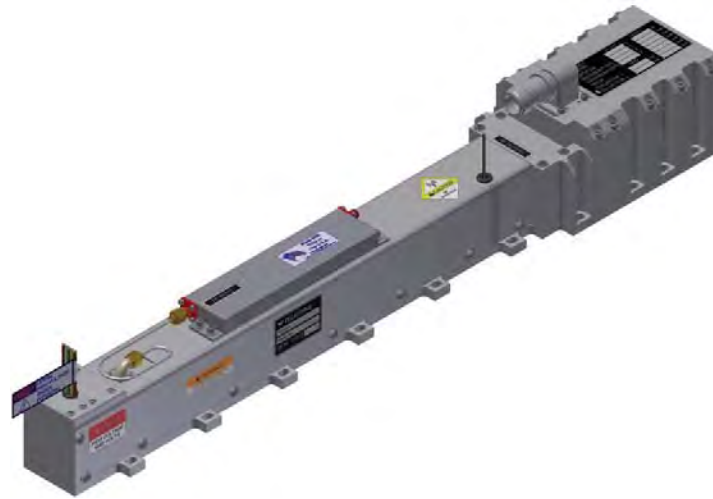

Typical Operating Conditions

Element	Typical Operating Conditions		Power Supply Requirements		
	Voltage	Current	Voltage Min.	Voltage Max.	Current Max.
Heater	-6.3 Vdc	1.85 A	-6.0 Vdc	-6.5 Vdc	2.5 A
Helix					
with RF	Ground	40 mA	Ground	Ground	55 mA
without RF	Ground	5 mA	Ground	Ground	55 mA
Grid On	125 Vdc	0.2 mA	90 Vdc	190 Vdc	5 mA
Grid Off	-200 Vdc	0.05 mA	-200 Vdc	-500 Vdc	0.5 mA
Cathode (E_k)	-5.6 kV	405 mA	-5.2 kV	-5.8 kV	500 mA
Collector w/RF					
Coll. #1	3.58 kV	180 mA	64% x $E_k \pm 2\%$		425 mA
Coll. #2	2.8 kV	185 mA	50% x $E_k \pm 2\%$		500 mA

Cathode voltage is measured with respect to ground.
Heater, Collector, and Grid voltages are measured with respect to Cathode.

RF Performance

Freq (GHz)	Typ. Sat. Power Output (W)	Min. Spec. Power Output (W)	Typ. Gain @ Spec. Power (dB)
2.0	200	175	38
2.1	250	200	40
2.2	300	250	41
2.3	425	250	44
2.4	500	250	45
2.5	500	250*	48
3.0	600	250	55
3.5	630	250	58
4.0	600	250	61
4.5	560	250	62
5.0	550	250	61
5.5	525	250	59
6.0	450	250	56
6.5	450	250	53
7.0	400	250	48
7.5	350	250	43
7.7	280	250	40
7.8	265	250	39
8.0	260	250	37

Typical power output is shown to illustrate capability.
Typical gain shown is without equalizer.

Performance	Typical	Spec
Input VSWR.....	2:1	2.5:1
Output VSWR.....	1.75:1	2.0:1
Max. Duty	—	CW
Grid Capacitance.....	32 pF	50 pF
Min. Harmonic Separation.....	-4.5 dBc	-3 dBc*
Noise Power Density (dBm/MHz)	-30	-25
Prime Power.....	1398 W	1800 W

Specifications are subject to change without notice.

NOTES:

- 1. THERMOSTAT OPTIONS: N/C OR N/O
- ② EQUALIZER OPTIONAL BASED UPON CUSTOMER REQUIREMENT.

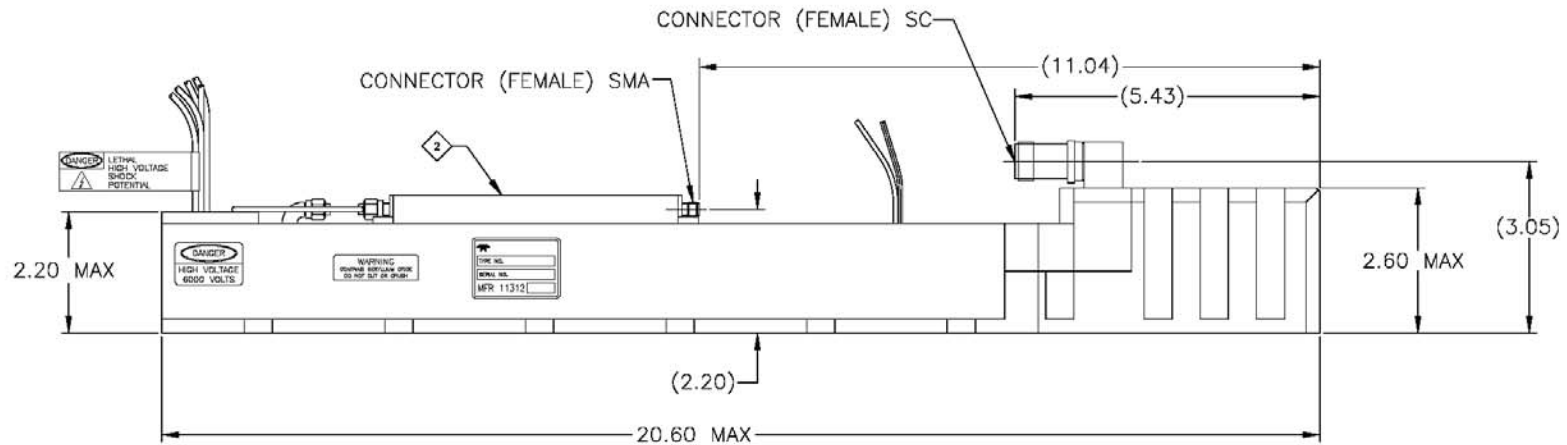
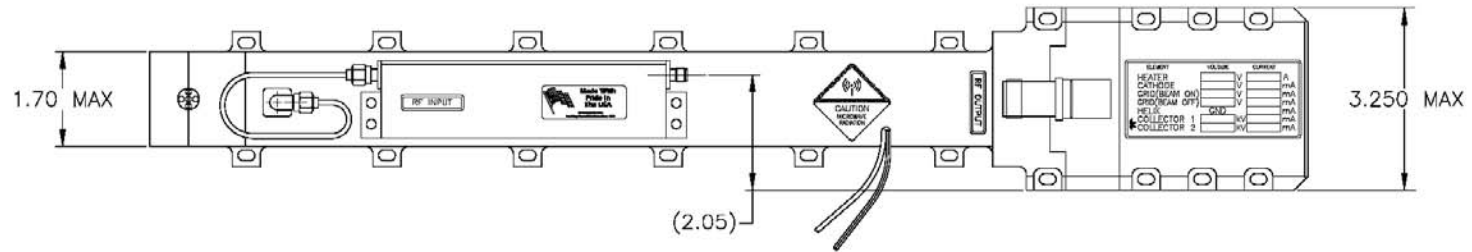

TELEDYNE MICROWAVE SOLUTIONS
TWT Products
11361 Sunrise Park Dr., Rancho Cordova, CA 95742 (916) 638-3344

TITLE

MEC 5208

SUBJECT TO CHANGE W/O NOTICE ISO 9001:2008 Registered

MEC 5196

Continuous Wave TWT

2.0 GHz – 8.0 GHz

- 150 W Minimum Power
- 2.0 to 8.0 GHz
- -40° to 85° C
- 1825 W Typ. Prime Power
- 26-46 dB Typical Gain
- 20.15" L x 4" W x 2.65" H
(5.1 x 10.2 x 6.7 cm)
- Phase Match Available

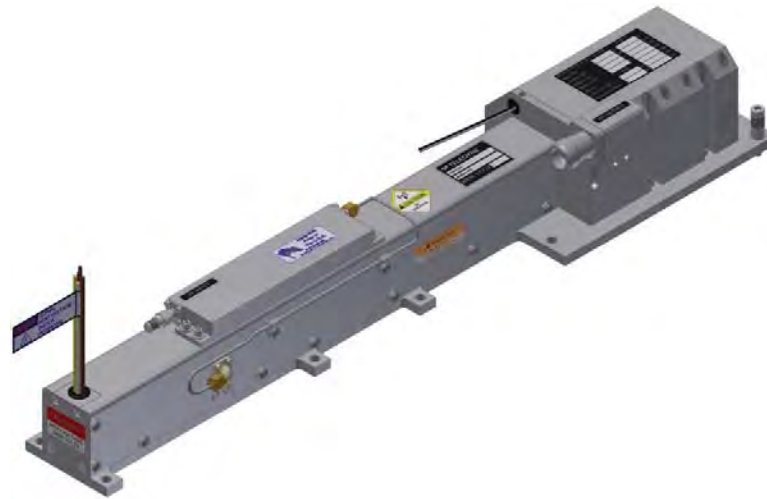

RF Performance

Freq (GHz)	Typ. Sat. Power Output (W)	Min. Spec. Power Output (W)	Typ. Gain @ Spec. Power (dB)
2.0	175	150	26
2.5	500	450	32
3.0	650	450	40
3.5	700	450	44
4.0	700	450	46
4.5	725	450	46
5.0	675	450	46
5.5	630	450	45
6.0	600	450	45
6.5	550	450	43
7.0	525	450	39
7.5	500	450	34
8.0	475	450	28

*Typical power output is shown to illustrate capability.
Typical gain shown is without equalizer.*

Typical Operating Conditions

Element	Voltage	Current	Power Supply Requirements		
			Voltage Min.	Voltage Max.	Current Max.
Heater	-6.3 Vdc	2.1 A	-6 Vdc	-6.6 Vdc	2.5 A
Helix					
with RF	Ground	30 mA	Ground	Ground	50 mA
without RF	Ground	5 mA	Ground	Ground	50 mA
Grid On	165 Vdc	0.2 mA	100 Vdc	250 Vdc	5 mA
Grid Off	-200 Vdc	0.05 mA	-200 Vdc	-500 Vdc	0.5 mA
Cathode (E_k)	-6.2 kV	495 mA	-5.8 kV	-6.5 kV	550 mA
Collector w/RF					
Coll. #1	3.95 kV	350 mA	64% x $E_k \pm 2\%$		450 mA
Coll. #2	2.1 kV	115 mA	34% x $E_k \pm 2\%$		550 mA

*Cathode voltage is measured with respect to ground.
Heater, Collector, and Grid voltages are measured with respect to Cathode.*

Performance	Typical	Spec
Input VSWR.....	2:1	2.5:1
Output VSWR.....	1.75:1	2.5:1
Max. Duty	—	CW
Grid Capacitance.....	32 pF	50 pF
Min. Harmonic Separation.....	-3.5 dBc	-3 dBc
Noise Power Density (dBm/MHz)	-35	-25
Prime Power.....	1825 W	1850 W

NOTES:

1. THERMOSTAT OPTIONS: N/C OR N/O
- ◊ EQUALIZER OPTIONAL BASED UPON CUSTOMER REQUIREMENT.

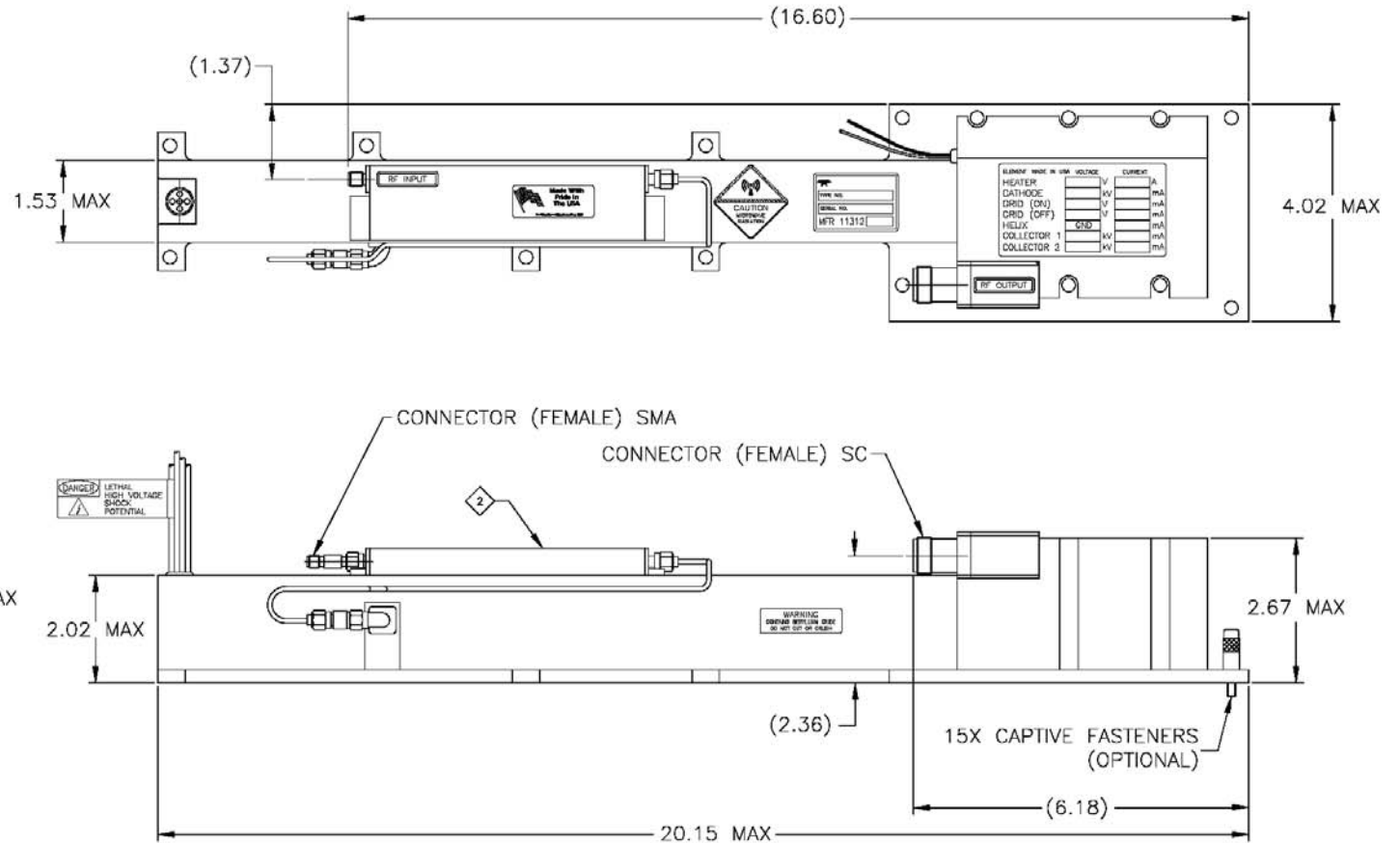

TELEDYNE MICROWAVE SOLUTIONS TWT Products <small>11361 Sunrise Park Dr., Rancho Cordova, CA (916) 838-3344</small>	
TITLE	MEC 5196

SUBJECT TO CHANGE W/O NOTICE ISO 9001:2008 Registered

MTG 5082H

Continuous Wave TWT

2.5 GHz – 8.0 GHz

- 215 W Minimum Power
- 2.5 to 8.0 GHz
- -40° to 85° C
- 943 W Typ. Prime Power
- 40-64 dB Typical Gain
- 19.9" L x 2.52" W x 3.2" H (50.5 x 6.4 x 8.1 cm)
- Phase Match Available

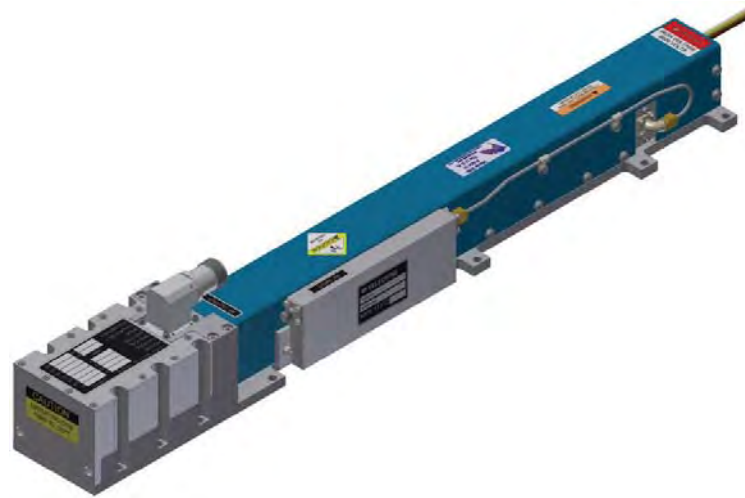

RF Performance

Freq (GHz)	Typ. Sat. Power Output (W)	Min. Spec. Power Output (W)	Typ. Gain @ Spec. Power (dB)
2.5	230	220	42
3.0	280	275	55
4.0	280	275	62
5.0	280	275	64
6.0	280	275	55
7.0	250	234	48
8.0	250	215	40

Typical power output is shown to illustrate capability.
Typical gain shown is without equalizer.

Typical Operating Conditions

Element	Voltage	Current	Power Supply Requirements		
			Voltage Min.	Voltage Max.	Current Max.
Heater	-6.3 Vdc	1.9 A	-6 Vdc	-6.6 Vdc	2.5 A
Helix					
with RF	Ground	37 mA	Ground	Ground	45 mA
without RF	Ground	5 mA	Ground	Ground	45 mA
Grid On	114 Vdc	0.25 mA	75 Vdc	130 Vdc	10 mA
Grid Off	-200 Vdc	0.01 mA	-200 Vdc	-500 Vdc	0.1 mA
Cathode (E_k)	-5 kV	320 mA	-4.75 kV	-5.2 kV	400 mA
Collector w/RF					
Coll. #1	3.25 kV	138 mA	65% x $E_k \pm 2\%$		200 mA
Coll. #2	2.05 kV	145 mA	41% x $E_k \pm 2\%$		400 mA

Cathode voltage is measured with respect to ground.
Heater, Collector, and Grid voltages are measured with respect to Cathode.

Performance

	Typical	Spec
Input VSWR.....	2:1	2.5:1
Output VSWR.....	2:1	2.5:1
Max. Duty	—	CW
Grid Capacitance.....	47 pF	50 pF
Min. Harmonic Separation.....	-2.5 dBc	-2 dBc
Noise Power Density (dBm/MHz)	-12	-9
Prime Power.....	943 W	1085 W

This model number is subject to the jurisdiction of the U.S. Department of Commerce.

NOTES:

1. THERMOSTAT OPTIONS: N/C OR N/O
- ◇ EQUALIZER OPTIONAL BASED UPON CUSTOMER REQUIREMENT.

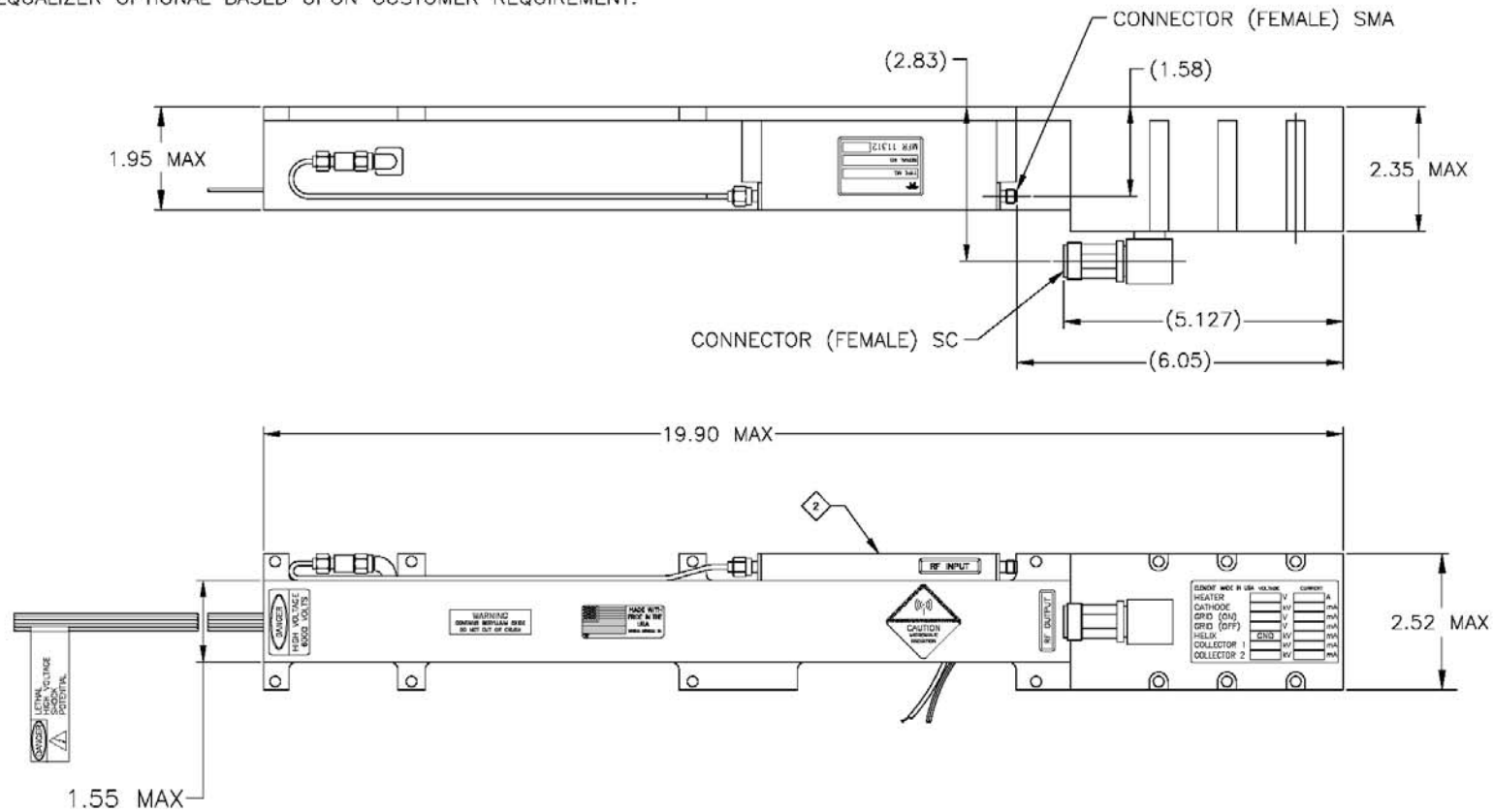

TELEDYNE MICROWAVE SOLUTIONS
TWT Products

11361 Sunrise Park Dr., Rancho Cordova, CA 95742 (916) 638-3344

TITLE

MTC 5082H

SUBJECT TO CHANGE W/O NOTICE

ISO 9001:2008 Registered

This model number is subject to the jurisdiction of the U.S. Department of Commerce.

MEC 5296

Continuous Wave TWT

2.5 GHz – 7.5 GHz

- 535 W Minimum Power
- 2.5 to 7.5 GHz
- -40° to 85° C
- 1995 W Typ. Prime Power
- 31-43 dB Typical Gain
- 20.15" L x 4" W x 2.8" H (5.12 x 10.2 x 7.1 cm)
- Phase Match Available

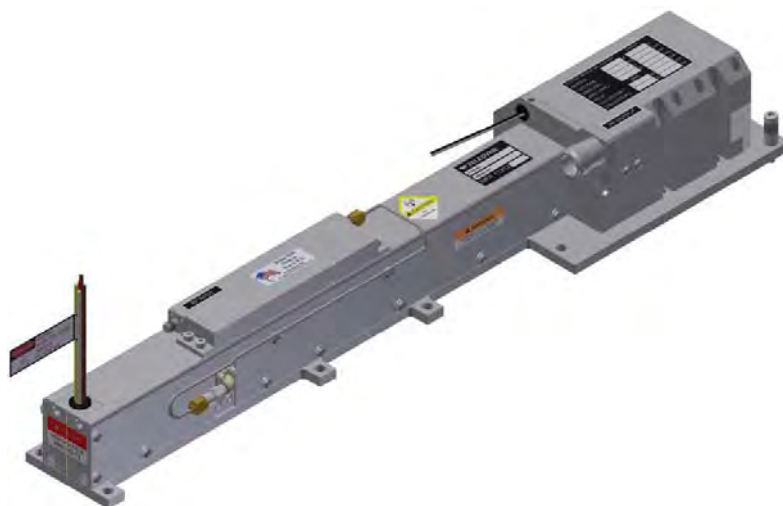

Typical Operating Conditions

Element	Voltage	Current	Power Supply Requirements		
			Voltage Min.	Voltage Max.	Current Max.
Heater	-6.3 Vdc	2.1 A	-6 Vdc	-6.5 Vdc	2.5 A
Helix					
with RF	Ground	35 mA	Ground	Ground	50 mA
without RF	Ground	5 mA	Ground	Ground	50 mA
Grid On	165 Vdc	0.2 mA	100 Vdc	250 Vdc	5 mA
Grid Off	-200 Vdc	0.05 mA	-200 Vdc	-500 Vdc	0.5 mA
Cathode (E_k)	-6.15 kV	500 mA	-5.8 kV	-6.5 kV	550 mA
Collector w/RF					
Coll. #1	4.31 kV	300 mA	70% x $E_k \pm 2\%$		450 mA
Coll. #2	2.89 kV	165 mA	47% x $E_k \pm 2\%$		550 mA

Cathode voltage is measured with respect to ground.
Heater, Collector, and Grid voltages are measured with respect to Cathode.

RF Performance

Freq (GHz)	Typ. Sat. Power Output (W)	Min. Spec. Power Output (W)	Typ. Gain @ Spec. Power (dB)
2.5	600	535	32
3.0	775	535	38
3.5	825	535	40
4.0	775	535	42
4.5	750	535	43
5.0	750	535	43
5.5	700	535	42
6.0	675	535	40
6.5	675	535	38
7.0	635	535	34
7.5	550	535	31

Typical power output is shown to illustrate capability.
Typical gain shown is without equalizer.

Performance	Typical	Spec
Input VSWR.....	2:1	2.5:1
Output VSWR.....	1.75:1	2.5:1
Max. Duty	—	CW
Grid Capacitance.....	32 pF	50 pF
Min. Harmonic Separation.....	-5 dBc	-3 dBc
Noise Power Density (dBm/MHz)	-40	-25
Prime Power.....	1995 W	2500 W

NOTES:

- 1. THERMOSTAT OPTIONS: N/C OR N/O
- ◊ EQUALIZER OPTIONAL BASED UPON CUSTOMER REQUIREMENT.

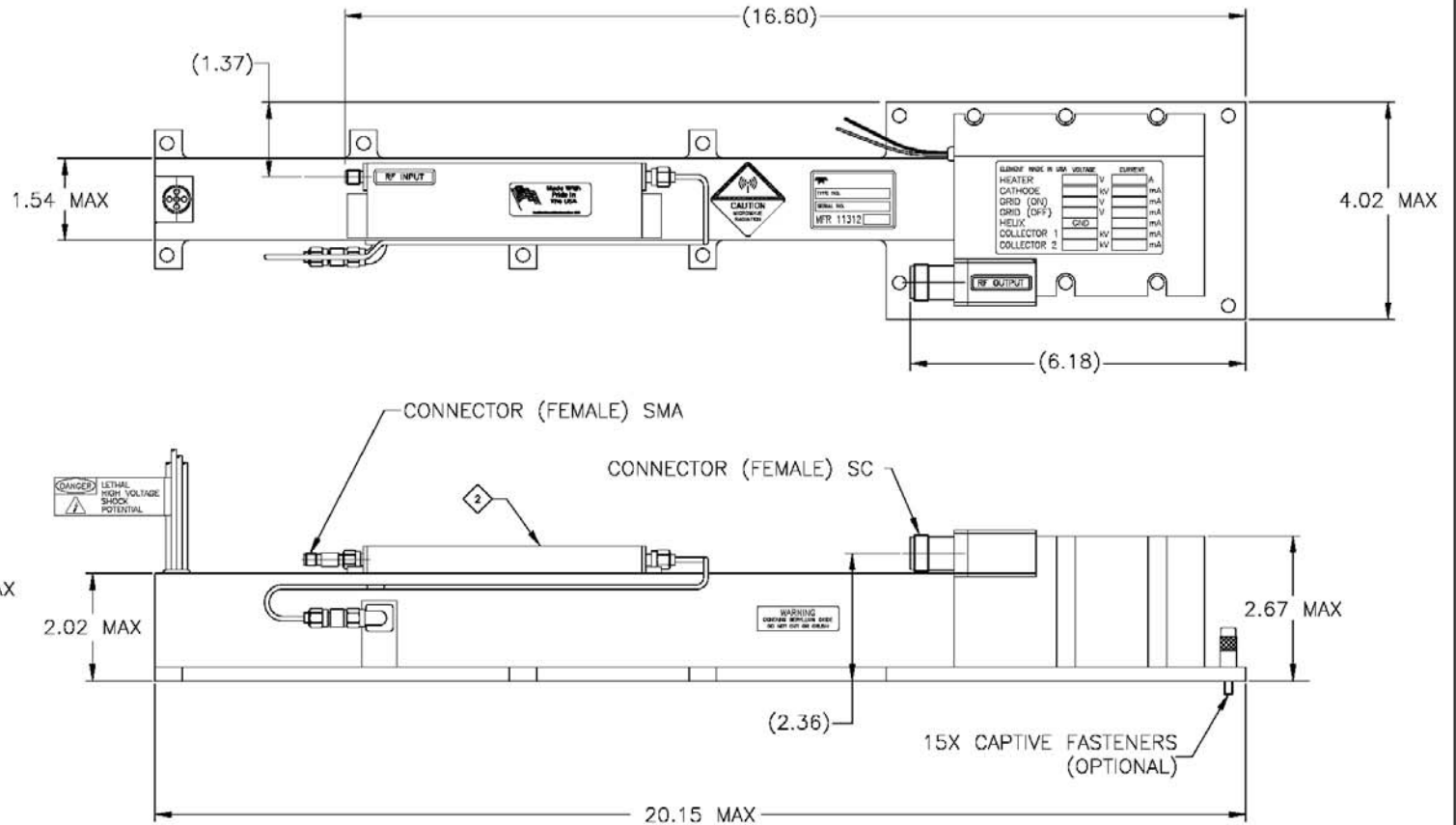

TELEDYNE MICROWAVE SOLUTIONS
TWT Products

11361 Sunrise Park Dr., Rancho Cordova, CA 95742 (916) 638-3344

TITLE

MEC 5296

SUBJECT TO CHANGE W/O NOTICE ISO 9001:2008 Registered

MEC 5498

Continuous Wave TWT

2.5 GHz – 7.5 GHz

- 535 W Minimum Power
- 2.5 to 7.5 GHz
- -40° to 85° C
- 1995 W Typ. Prime Power
- 26-43 dB Typical Gain
- 17.5" L x 3.25" W x 4.55" H (44.5 x 8.25 x 11.6 cm)
- Phase Match Available

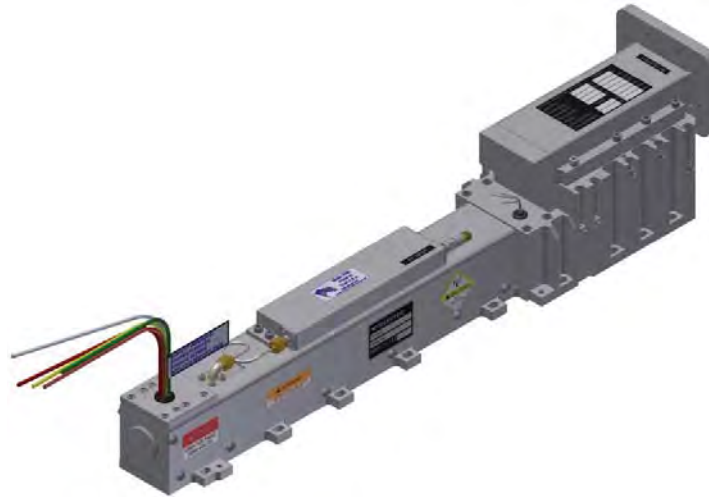

RF Performance

Freq (GHz)	Typ. Sat. Power Output (W)	Min. Spec. Power Output (W)	Typ. Gain @ Spec. Power (dB)
2.5	550	535	26
3.0	775	535	38
3.5	825	535	40
4.0	775	535	42
4.5	750	535	43
5.0	750	535	43
5.5	700	535	42
6.0	675	535	40
6.5	675	535	38
7.0	635	535	34
7.5	550	535	31

Typical power output is shown to illustrate capability.
Typical gain shown is without equalizer.

Typical Operating Conditions

Element	Voltage	Current	Power Supply Requirements		
			Voltage Min.	Voltage Max.	Current Max.
Heater	-6.3 Vdc	2.1 A	-6 Vdc	-6.5 Vdc	2.5 A
Helix					
with RF	Ground	35 mA	Ground	Ground	50 mA
without RF	Ground	5 mA	Ground	Ground	50 mA
Grid On	165 Vdc	0.2 mA	100 Vdc	250 Vdc	5 mA
Grid Off	-200 Vdc	0.05 mA	-200 Vdc	-500 Vdc	0.5 mA
Cathode (E_k)	-6.15 kV	500 mA	-5.8 kV	-6.5 kV	550 mA
Collector w/RF					
Coll. #1	4.31 kV	300 mA	70% x $E_k \pm 2\%$		450 mA
Coll. #2	2.89 kV	165 mA	47% x $E_k \pm 2\%$		550 mA

Cathode voltage is measured with respect to ground.
Heater, Collector, and Grid voltages are measured with respect to Cathode.

Performance

	Typical	Spec
Input VSWR.....	2:1	2.5:1
Output VSWR.....	2.2:1	2.5:1
Max. Duty	—	CW
Grid Capacitance.....	40 pF	60 pF
Min. Harmonic Separation.....	-5 dBc	-3 dBc
Noise Power Density (dBm/MHz)	-40	-25
Prime Power.....	1995 W	2500 W

This model number is subject to the jurisdiction of the U.S. Department of Commerce.

NOTES:

- 1. THERMOSTAT OPTIONS: N/C OR N/O
- ② EQUALIZER OPTIONAL BASED UPON CUSTOMER REQUIREMENT.

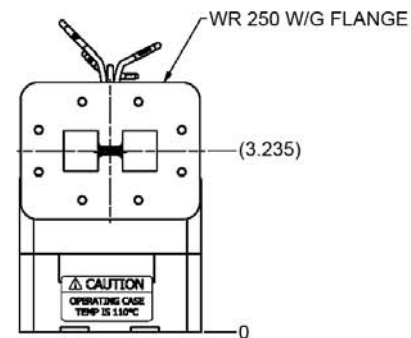
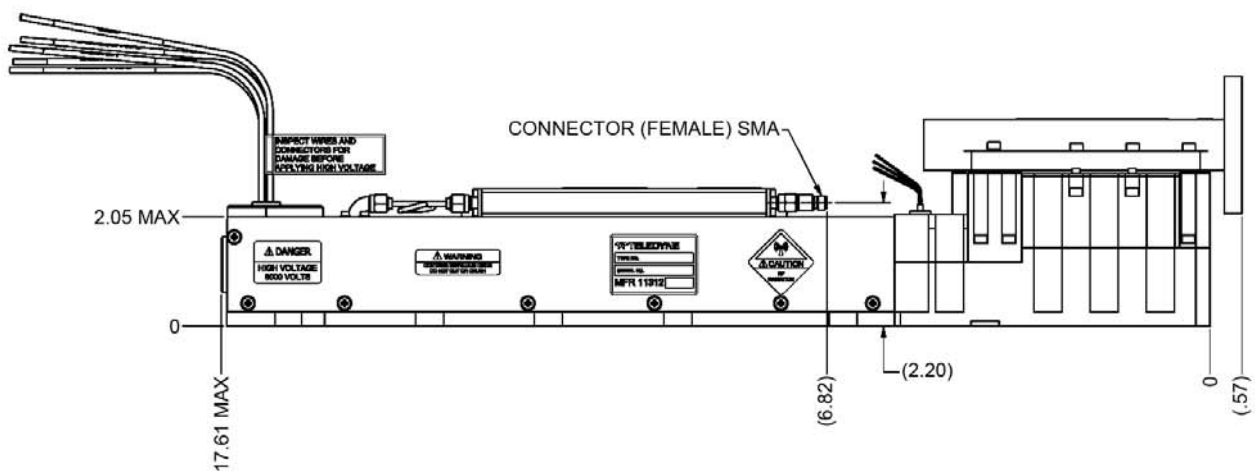
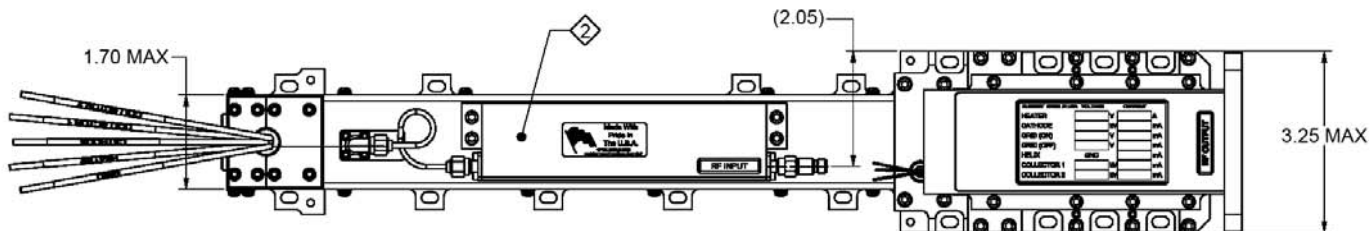

SUBJECT TO CHANGE W/O NOTICE

ISO 9001:2008 Registered

TELEDYNE MICROWAVE SOLUTIONS
TWT PRODUCTS
11361 Sunrise Park Dr., Rancho Cordova, CA, (916) 638-3344

TITLE

MEC 5498

This model number is subject to the jurisdiction of the U.S. Department of Commerce.

MEC 5497

Continuous Wave TWT

2.5 GHz – 7.5 GHz

- 400 W Minimum Power
- 2.5 to 7.5 GHz
- -40° to 85° C
- 1575 W Typ. Prime Power
- 30-43 dB Typical Gain
- 17.5" L x 3.25" W x 4.1" H (44.5 x 8.25 x 10.4 cm)
- Phase Match Available

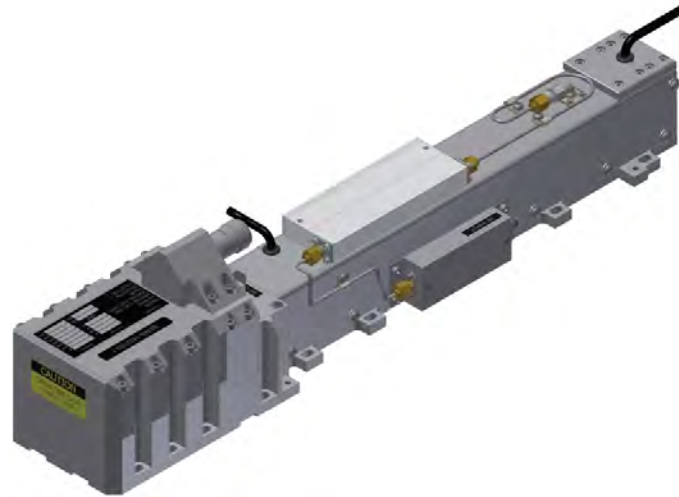

Typical Operating Conditions

Element	Voltage	Current	Power Supply Requirements		
			Voltage Min.	Voltage Max.	Current Max.
Heater	-6.3 Vdc	1.93 A	-6.0 Vdc	-6.6 Vdc	2.5 A
Helix					
with RF	Ground	35 mA	Ground	Ground	55 mA
without RF	Ground	5 mA	Ground	Ground	55 mA
Grid On	138 Vdc	0.2 mA	100 Vdc	250 Vdc	10 mA
Grid Off	-250 Vdc	0.05 mA	-250 Vdc	-350 Vdc	1 mA
Cathode (E_k)	-5.60 kV	430 mA	-5.4 kV	-5.7 kV	475 mA
Coll. #1	3.584 kV	360 mA (w/RF) 42 mA (w/o RF)	64% x $E_k \pm 2\%$		425 mA
Coll. #2	2.184 kV	35 mA (w/RF) 383 mA (w/o RF)	39% x $E_k \pm 2\%$		475 mA

Cathode voltage is measured with respect to ground.
Heater, Collector, and Grid voltages are measured with respect to Cathode.

RF Performance

Freq (GHz)	Typ. Sat. Power Output (W)	Min. Spec. Power Output (W)	Typ. Gain @ Spec. Power (dB)
2.5	575	500	31
3.0	700	630	40
3.5	700	630	41
4.0	680	630	43
4.5	725	630	43
5.0	700	630	42
5.5	650	575	40
6.0	600	550	37
6.5	600	550	37
7.0	500	450	32
7.5	450	400	30

Typical power output is shown to illustrate capability.
Typical gain shown is without equalizer.

Performance	Typical	Spec
Input VSWR.....	2:1	2.5:1
Output VSWR.....	2:1	2.5:1
Max. Duty	—	CW
Min. Harmonic Separation.....	-5 dBc	-3 dBc
Noise Power Density (dBm/MHz)	-30	-20
Prime Power	1575 W	1650 W

NOTES:

1. THERMOSTAT OPTIONS: N/C OR N/O
- ◊ EQUALIZER OPTIONAL BASED UPON CUSTOMER REQUIREMENT.

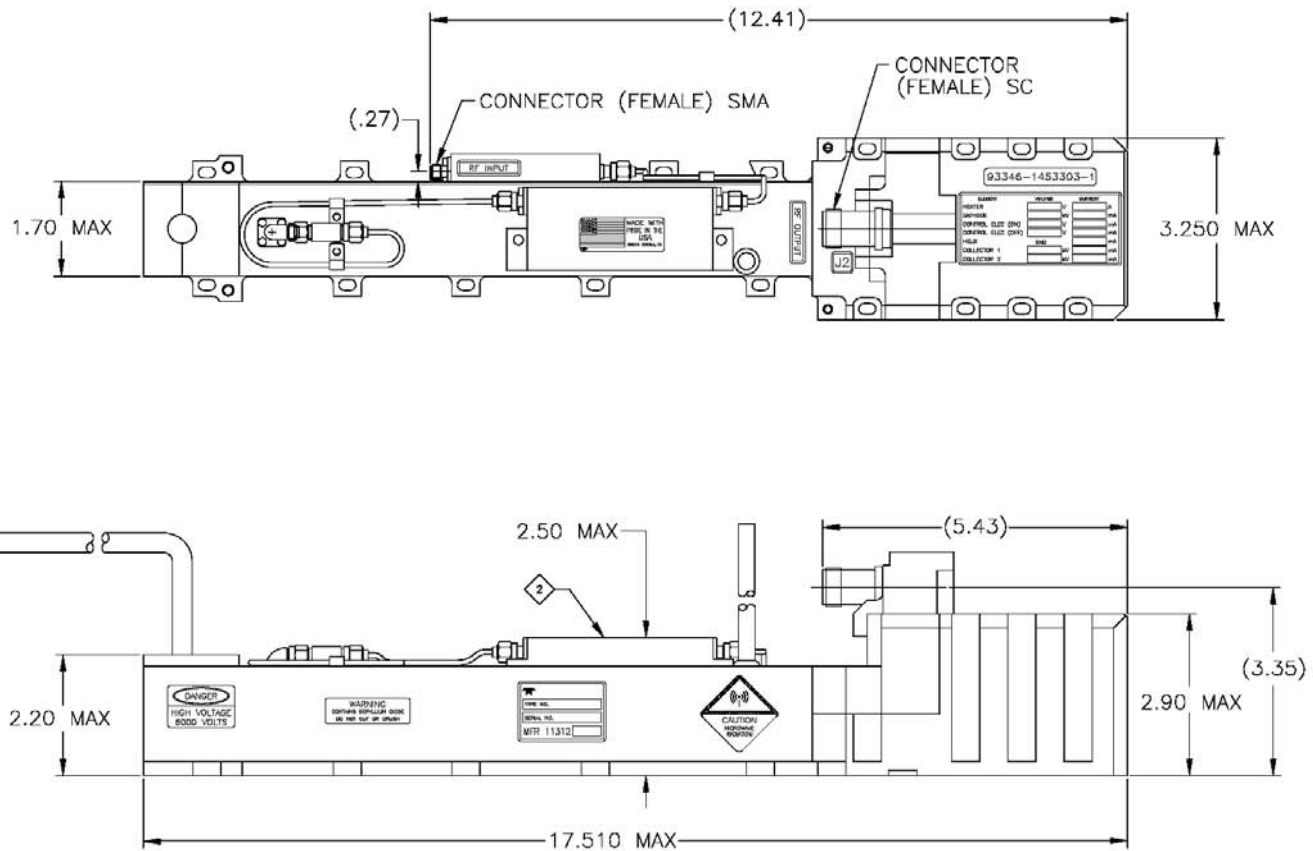

SUBJECT TO CHANGE W/O NOTICE ISO 9001:2008 Registered

TELEDYNE MICROWAVE SOLUTIONS TWT Products 11361 Sunrise Park Drive, Rancho Cordova, CA 95742 • (916) 638-3344
TITLE
MEC 5497

M5889NO/MEC 5889

Continuous Wave TWT

4.0 GHz – 8.0 GHz

- 250 W Minimum Power
- 4.0 to 8.0 GHz
- -40° to 85° C
- 1300 W Typ. Prime Power
- 46-59 dB Typical Gain
- 20.6" L x 2.52" W x 2.8" H (52.2 x 6.4 x 7.1 cm)
- Phase Match Available

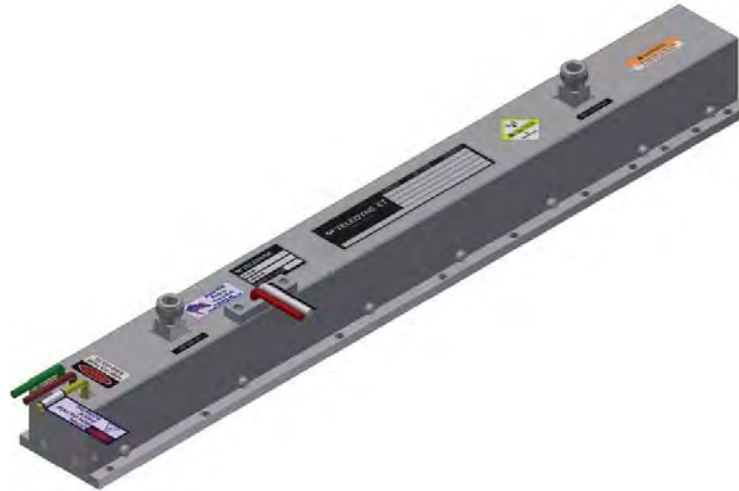

RF Performance

Freq (GHz)	Typ. Sat. Power Output (W)	Min. Spec. Power Output (W)	Typ. Gain @ Spec. Power (dB)
4.0	260	250	48
4.5	320	250	54
5.0	370	250	57
5.5	395	250	59
6.0	395	250	59
6.5	385	250	57
7.0	370	250	54
7.5	360	250	50
8.0	285	250	46

Typical power output is shown to illustrate capability.
Typical gain shown is without equalizer.

Typical Operating Conditions

Element	Typical Operating Conditions		Power Supply Requirements		
	Voltage	Current	Voltage Min.	Voltage Max.	Current Max.
Heater	-6.3 Vdc	2.3 A	-6 Vdc	-6.6 Vdc	3.5 A
Helix					
with RF	Ground	6 mA	Ground	Ground	12 mA
without RF	Ground	2 mA	Ground	Ground	12 mA
Anode	240 Vdc	1 mA	0	450 Vdc	4 mA
Grid On	140 Vdc	0.5 mA	125 Vdc	250 Vdc	10 mA
Grid Off	-200 Vdc	0.5 mA	-200 Vdc	-500 Vdc	1 mA
Cathode (E _k)	-8 kV	260 mA	-7.7 kV	-8.2 kV	300 mA
Collector w/RF	4.4 kV	275 mA		55% x E _k ±2%	300 mA

Cathode and Anode voltages are measured with respect to ground.
Heater, Collector, and Grid voltages are measured with respect to Cathode.
Anode voltage not required with Grid modulated version.

Performance

	Typical	Spec
Input VSWR.....	1.6:1	2.5:1
Output VSWR.....	2:1	2.5:1
Max. Duty	—	CW
Grid Capacitance.....	50 pF	65 pF
Min. Harmonic Separation.....	-8 dBc	-4 dBc
Noise Power Density (dBm/MHz)	-20	-10
Prime Power.....	1300 W	1400 W

This model number is subject to the jurisdiction of the U.S. Department of Commerce.

NOTES:

1. THERMOSTAT OPTIONS: N/C OR N/O

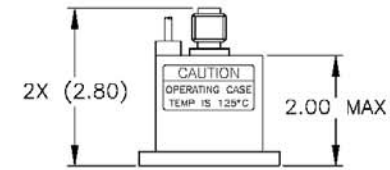

END VIEW
ROTATED 90° CW

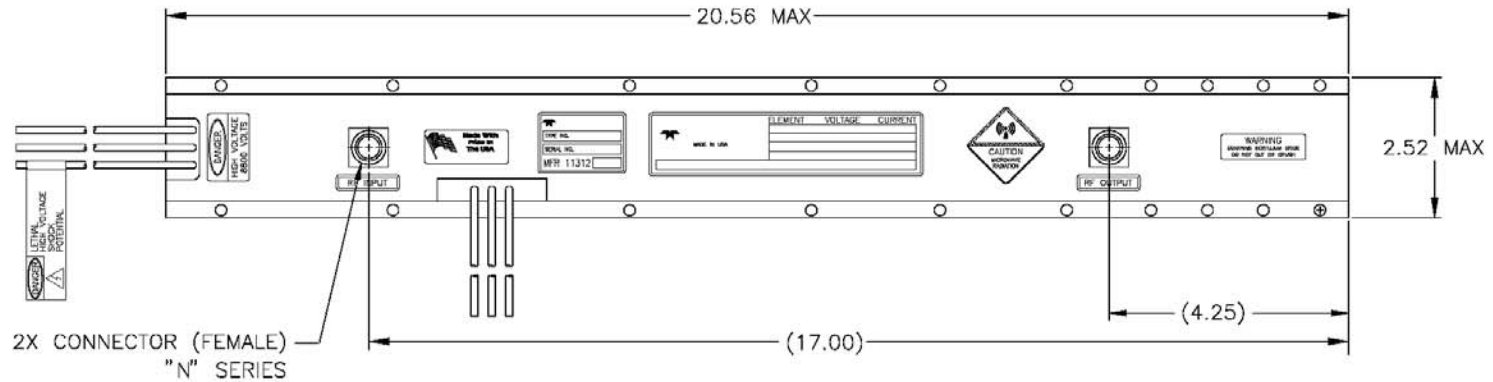

TELEDYNE MICROWAVE SOLUTIONS
TWT Products
11361 Sunrise Park Dr., Rancho Cordova, CA 95742-3344

TITLE
MEC 5889/M5889NO

SUBJECT TO CHANGE W/O NOTICE ISO 9001:2008 Registered

This model number is subject to the jurisdiction of the U.S. Department of Commerce.

MTG 5130

Continuous Wave TWT

5 GHz – 11 GHz

- 300 W Minimum Power
- 5 to 11 GHz
- -40° to 85° C
- 1655 W Typ. Prime Power
- 38-57 dB Typical Gain
- 19.5” L x 4.14” W x 3.82” H
(49.6 x 10.5 x 9.7 cm)

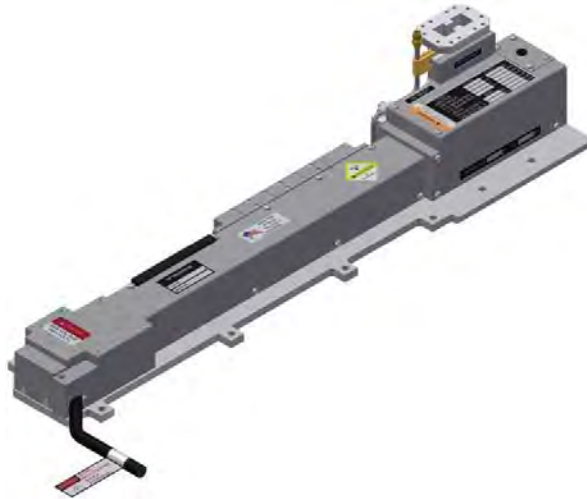

RF Performance

Freq (GHz)	Typ. Sat. Power Output (W)	Min. Spec. Power Output (W)	Typ. Gain @ Spec. Power (dB)
5.0	400	300	56
5.5	450	300	56
6.0	415	400	53
6.5	500	450	56
7.0	589	500	57
7.5	589	500	56
8.0	646	500	55
8.5	646	500	54
9.0	617	500	51
9.5	537	500	47
10.0	550	500	45
10.5	550	400	43
11.0	450	400	38

*Typical power output is shown to illustrate capability.
Typical gain shown is without equalizer.*

Typical Operating Conditions

Element	Voltage	Current	Power Supply Requirements		
			Voltage Min.	Voltage Max.	Current Max.
Heater	-6.3 Vdc	1.7 A	-6.1 Vdc	-6.5 Vdc	2.7 A
Helix					
with RF	Ground	25 mA	Ground	Ground	30 mA
without RF	Ground	6 mA	Ground	Ground	30 mA
FE On	-3 Vdc	0	0	-50 Vdc	0.1 mA
FE Off	-1200 Vdc	0	-1200 Vdc	-1500 Vdc	1 mA
Cathode (E_k)	-9.05 kV	430 mA	-8.5 kV	-9.6 kV	475 mA
Collector w/RF					
Coll. #1	4.7 kV	105 mA	52% x $E_k \pm 2\%$		250 mA
Coll. #2	3.08 kV	300 mA	34% x $E_k \pm 2\%$		450 mA

Cathode voltage is measured with respect to ground.

Heater, Collector, and Focus Electrode (FE) voltages are measured with respect to Cathode.

Performance

	Typical	Spec
Input VSWR.....	2:1	2.5:1
Output VSWR.....	1.8:1	2.5:1
Max. Duty	—	CW
FE Capacitance.....	40 pF	50 pF
Min. Harmonic Separation.....	-6 dBc	-4 dBc
Noise Power Density (dBm/MHz)	-20	-18
Prime Power.....	1655 W	2000 W

Specifications are subject to change without notice.

NOTES:

- 1. THERMOSTAT OPTIONS: N/C OR N/O
- 2. EQUALIZER OPTIONAL BASED UPON CUSTOMER REQUIREMENT.

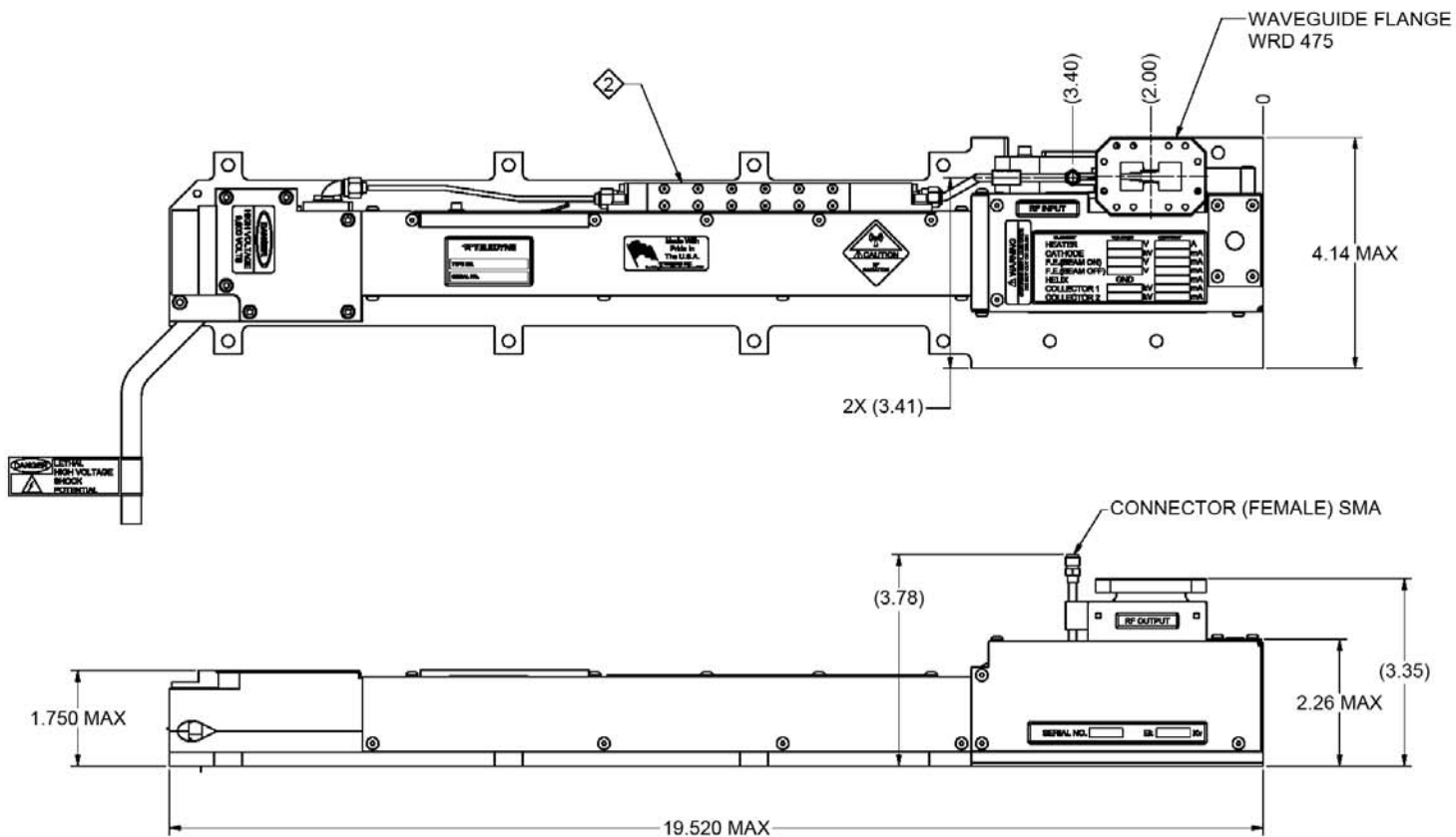

SUBJECT TO CHANGE W/O NOTICE ISO 9001:2008 Registered

TELEDYNE MICROWAVE SOLUTIONS
TWT PRODUCTS

11361 Sunrise Park Dr., Rancho Cordova, CA, 95742

TITLE

MTG 5130

MEC 5413/MEC 5414

Continuous Wave TWT

6.0 GHz – 18.0 GHz

- 200 W Minimum Power
- 6.0 to 18.0 GHz
- -40° to 85° C
- 1132 W Typ. Prime Power
- 35-46 dB Typical Gain
- 19.8" L x 3.47" W x 3.4" H (50.3 x 8.8 x 8.64 cm)
- ±20° Phase Match

5413 – Grid
 5414 – Focus Electrode (FE)

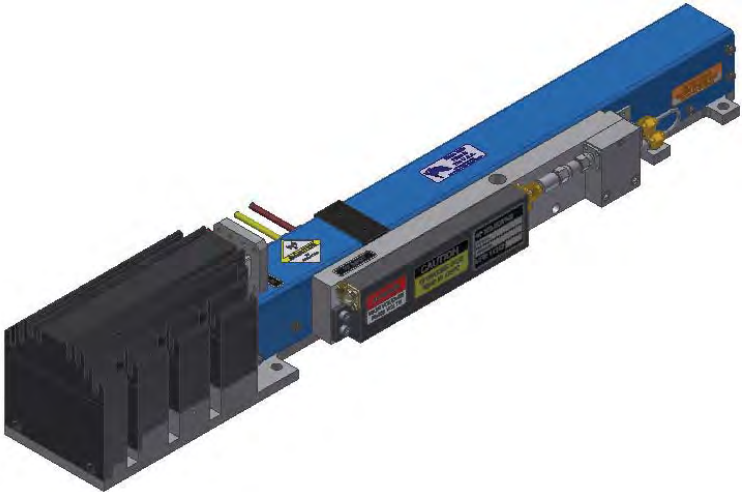

Typical Operating Conditions			Power Supply Requirements		
Element	Voltage	Current	Voltage Min.	Voltage Max.	Current Max.
Heater	-6.3 Vdc	1.6 A	-6.0 Vdc	-6.6 Vdc	2 A
Helix					
with RF	Ground	7 mA	Ground	Ground	15 mA
without RF	Ground	1 mA	Ground	Ground	15 mA
FE On	-50 Vdc	0.1 mA	0	-75 Vdc	1 mA
FE Off	-1300 Vdc	0.1 mA	-1500 Vdc	-1700 Vdc	1 mA
Grid On	180 Vdc	1 mA	125 Vdc	250 Vdc	10 mA
Grid Off	-200 Vdc	0.1 mA	-200 Vdc	-500 Vdc	1 mA
Cathode (E _k)	-10.3 kV	270 mA	-10 kV	-10.5 kV	300 mA
Collector w/RF					
Coll. #1	5.36 kV	45 mA	52% x E _k ±2%		100 mA
Coll. #2	3.71 kV	218 mA	36% x E _k ±2%		300 mA

Cathode voltage is measured with respect to ground.
 Heater, Collector, and Grid or Focus Electrode (FE) voltages are measured with respect to Cathode.

RF Performance

Freq (GHz)	Typ. Sat. Power Output (W)	Min. Spec. Power Output (W)	Typ. Gain @ Spec. Power (dB)
6.0	225	200	35
7.0	245	200	38
8.0	245	200	41
9.0	245	200	43
10.0	225	200	45
11.0	250	200	46
12.0	250	200	46
13.0	250	200	46
14.0	250	200	45
15.0	245	200	43
16.0	240	200	41
17.0	230	200	38
18.0	220	200	35

Typical power output is shown to illustrate capability.
 Typical gain shown is without equalizer.

Performance	Typical	Spec
Input VSWR.....	2:1	2.5:1
Output VSWR.....	2:1	2.25:1
Max. Duty	—	CW
FE Capacitance.....	50 pF	65 pF
Grid Capacitance.....	37 pF	50 pF
Min. Harmonic Separation.....	-5.5 dBc	-5 dBc
Noise Power Density (dBm/MHz)	-15	-10
Prime Power.....	1132 W	1400 W

Specifications are subject to change without notice.

NOTES:

1. THERMOSTAT OPTIONS: N/C OR N/O

② EQUALIZER OPTIONAL BASED UPON CUSTOMER REQUIREMENT.

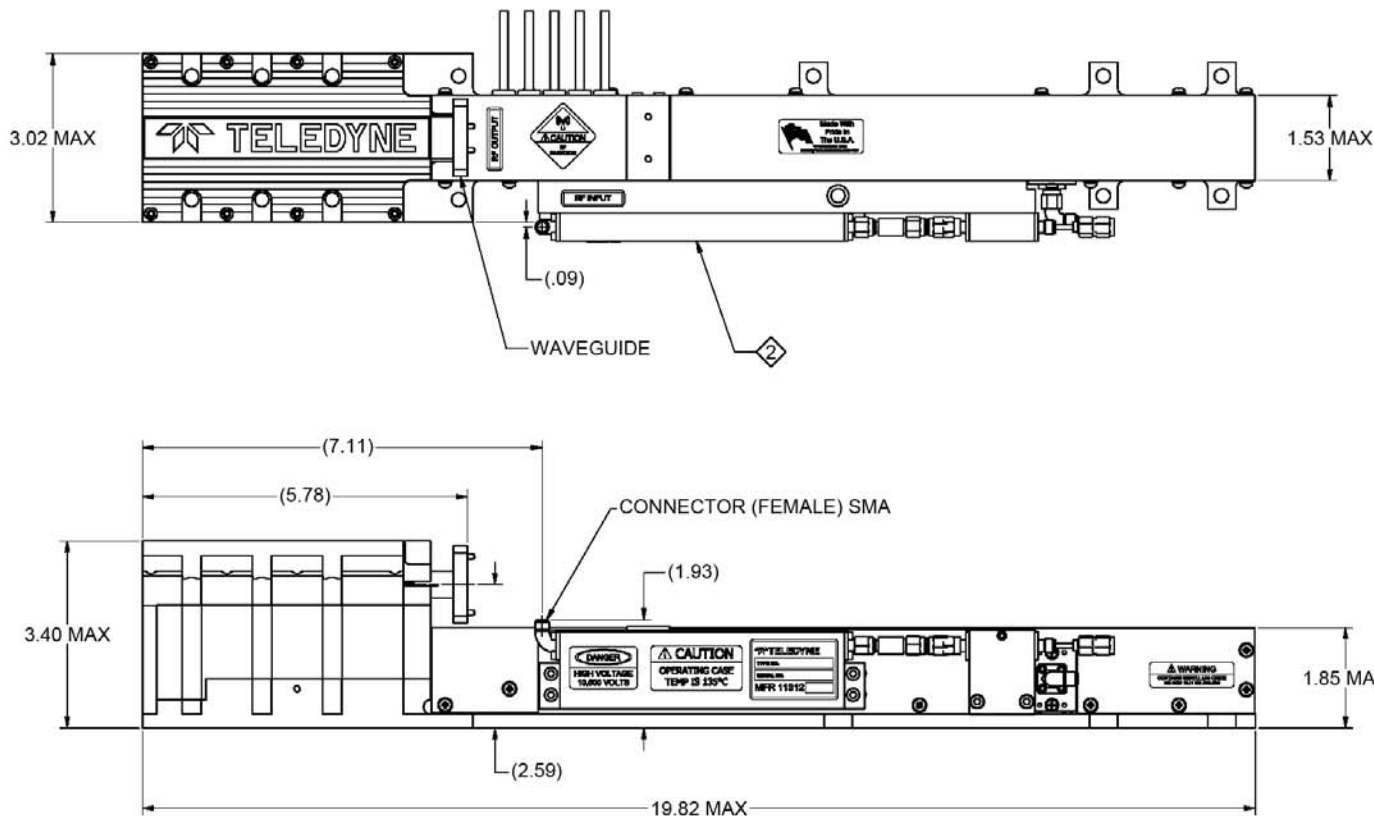

SUBJECT TO CHANGE W/O NOTICE

ISO 9001:2008 Registered

TELEDYNE MICROWAVE SOLUTIONS TWT PRODUCTS <small>11361 Sunrise Park Dr., Rancho Cordova, CA, (916) 638-3344</small>	
TITLE	MEC 5405, MEC 5406, MEC 5407, MEC 5408, MEC 5409, MEC 5410, MEC 5411, MEC 5412, MEC 5413, MEC 5414, MEC 5415, MEC 5416, MEC 5419, MEC 5420, MEC 5421, MEC 5422, MEC 5423, MEC 5424

MEC 5423/MEC 5424

Continuous Wave TWT

6.0 GHz – 18.0 GHz

- 250 W Minimum Power
- 6.0 to 18.0 GHz
- -40° to 85° C
- 1191 W Typ. Prime Power
- 35-46 dB Typical Gain
- 19.8" L x 3.47" W x 3.4" H (50.3 x 8.8 x 8.64 cm)
- ±20° Phase Match

5423 – Grid
 5424 – Focus Electrode (FE)

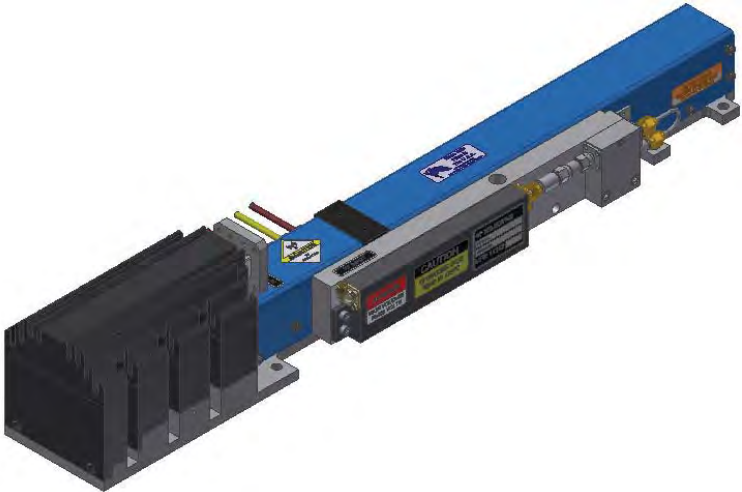

Typical Operating Conditions			Power Supply Requirements		
Element	Voltage	Current	Voltage Min.	Voltage Max.	Current Max.
Heater	-6.3 Vdc	1.6 A	-6.0 Vdc	-6.6 Vdc	2 A
Helix					
with RF	Ground	9 mA	Ground	Ground	15 mA
without RF	Ground	1 mA	Ground	Ground	15 mA
FE On	-50 Vdc	0.1 mA	0	-75 Vdc	1 mA
FE Off	-1300 Vdc	0.1 mA	-1500 Vdc	-1700 Vdc	1 mA
Grid On	180 Vdc	1 mA	125 Vdc	250 Vdc	10 mA
Grid Off	-200 Vdc	0.1 mA	-200 Vdc	-500 Vdc	1 mA
Cathode (E _k)	-10.3 kV	280 mA	-10 kV	-10.5 kV	300 mA
Collector w/RF					
Coll. #1	5.36 kV	50 mA	52% x E _k ±2%		100 mA
Coll. #2	3.71 kV	221 mA	36% x E _k ±2%		300 mA

Cathode voltage is measured with respect to ground.
 Heater, Collector, and Grid or Focus Electrode (FE) voltages are measured with respect to Cathode.

RF Performance

Freq (GHz)	Typ. Sat. Power Output (W)	Min. Spec. Power Output (W)	Typ. Gain @ Spec. Power (dB)
6.0	275	250	35
7.0	290	250	38
8.0	290	250	41
9.0	290	250	43
10.0	275	250	45
11.0	300	250	46
12.0	300	250	46
13.0	300	250	46
14.0	300	250	45
15.0	300	250	43
16.0	290	250	41
17.0	275	250	38
18.0	275	250	35

Typical power output is shown to illustrate capability.
 Typical gain shown is without equalizer.

Performance	Typical	Spec
Input VSWR.....	2:1	2.5:1
Output VSWR.....	2:1	2.25:1
Max. Duty	—	CW
FE Capacitance.....	50 pF	65 pF
Grid Capacitance.....	37 pF	50 pF
Min. Harmonic Separation.....	-5.5 dBc	-5 dBc
Noise Power Density (dBm/MHz)	-15	-10
Prime Power.....	1191 W	1400 W

Specifications are subject to change without notice.

NOTES:

1. THERMOSTAT OPTIONS: N/C OR N/O

② EQUALIZER OPTIONAL BASED UPON CUSTOMER REQUIREMENT.

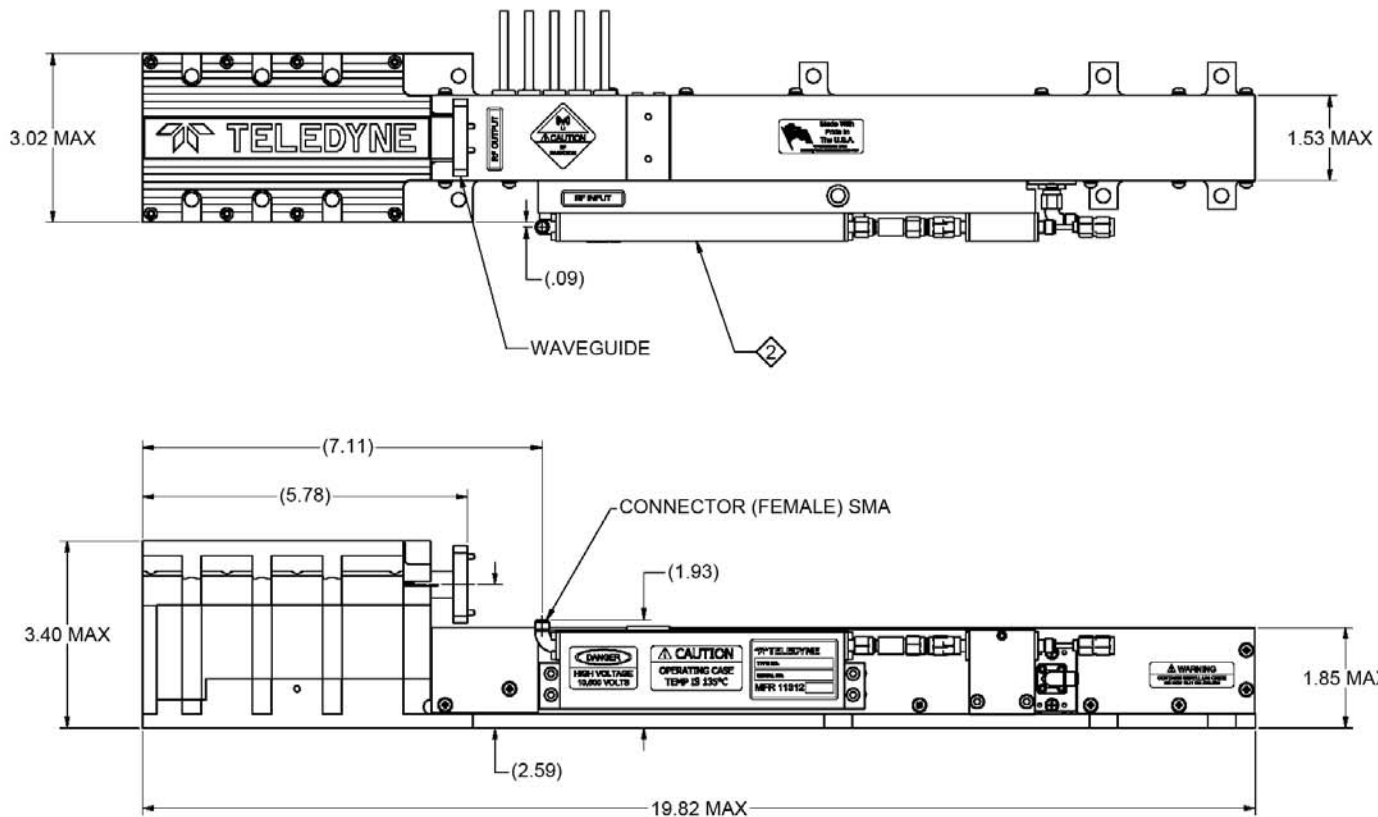

SUBJECT TO CHANGE W/O NOTICE

ISO 9001:2008 Registered

TELEDYNE MICROWAVE SOLUTIONS
TWT PRODUCTS

11361 Sunrise Park Dr., Rancho Cordova, CA, (916) 638-3344

TITLE
MEC 5405, MEC 5406, MEC 5407,
MEC 5408, MEC 5409, MEC 5410,
MEC 5411, MEC 5412, MEC 5413,
MEC 5414, MEC 5415, MEC 5416,
MEC 5419, MEC 5420, MEC 5421,
MEC 5422, MEC 5423, MEC 5424

MEC 5415/MEC 5416

Continuous Wave TWT

6.0 GHz – 18.0 GHz

- 300 W Minimum Power
- 6.0 to 18.0 GHz
- -40° to 85° C
- 1251 W Typ. Prime Power
- 35-46 dB Typical Gain
- 19.8" L x 3.47" W x 3.4" H (50.3 x 8.8 x 8.64 cm)
- ±20° Phase Match

5415 – Grid
 5416 – Focus Electrode (FE)

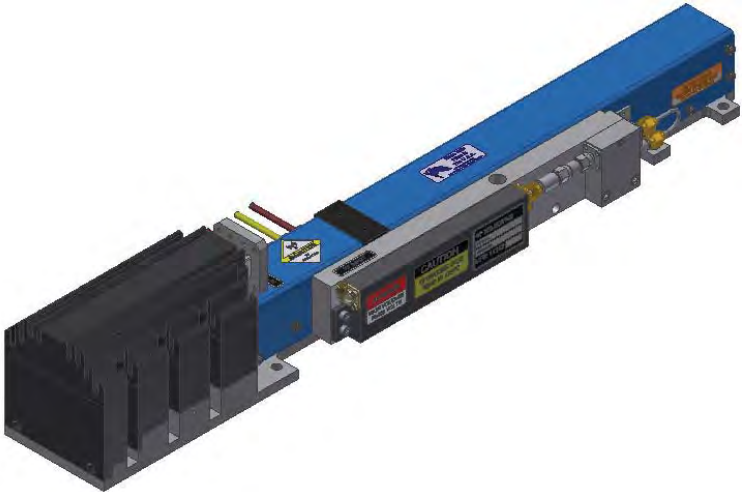

Typical Operating Conditions			Power Supply Requirements		
Element	Voltage	Current	Voltage Min.	Voltage Max.	Current Max.
Heater	-6.3 Vdc	1.6 A	-6.0 Vdc	-6.6 Vdc	2 A
Helix					
with RF	Ground	10 mA	Ground	Ground	15 mA
without RF	Ground	2 mA	Ground	Ground	15 mA
FE On	-25 Vdc	0.1 mA	0	-75 Vdc	1 mA
FE Off	-1300 Vdc	0.1 mA	-1500 Vdc	-1700 Vdc	1 mA
Grid On	200 Vdc	1 mA	125 Vdc	250 Vdc	10 mA
Grid Off	-200 Vdc	0.1 mA	-200 Vdc	-500 Vdc	1 mA
Cathode (E _k)	-10.3 kV	290 mA	-10 kV	-10.5 kV	300 mA
Collector w/RF					
Coll. #1	5.36 kV	60 mA	52% x E _k ±2%		100 mA
Coll. #2	3.71 kV	220 mA	36% x E _k ±2%		300 mA

Cathode voltage is measured with respect to ground.
 Heater, Collector, and Grid or Focus Electrode (FE) voltages are measured with respect to Cathode.

RF Performance

Freq (GHz)	Typ. Sat. Power Output (W)	Min. Spec. Power Output (W)	Typ. Gain @ Spec. Power (dB)
6.0	325	300	35
7.0	330	300	38
8.0	340	300	41
9.0	350	300	43
10.0	325	300	45
11.0	350	300	46
12.0	350	300	46
13.0	350	300	46
14.0	350	300	45
15.0	340	300	43
16.0	330	300	41
17.0	325	300	38
18.0	325	300	35

Typical power output is shown to illustrate capability.
 Typical gain shown is without equalizer.

Performance	Typical	Spec
Input VSWR.....	2:1	2.5:1
Output VSWR.....	2:1	2.25:1
Max. Duty	—	CW
FE Capacitance.....	50 pF	65 pF
Grid Capacitance.....	37 pF	50 pF
Min. Harmonic Separation.....	-5.5 dBc	-5 dBc
Noise Power Density (dBm/MHz)	-15	-10
Prime Power.....	1251 W	1400 W

Specifications are subject to change without notice.

NOTES:

1. THERMOSTAT OPTIONS: N/C OR N/O

② EQUALIZER OPTIONAL BASED UPON CUSTOMER REQUIREMENT.

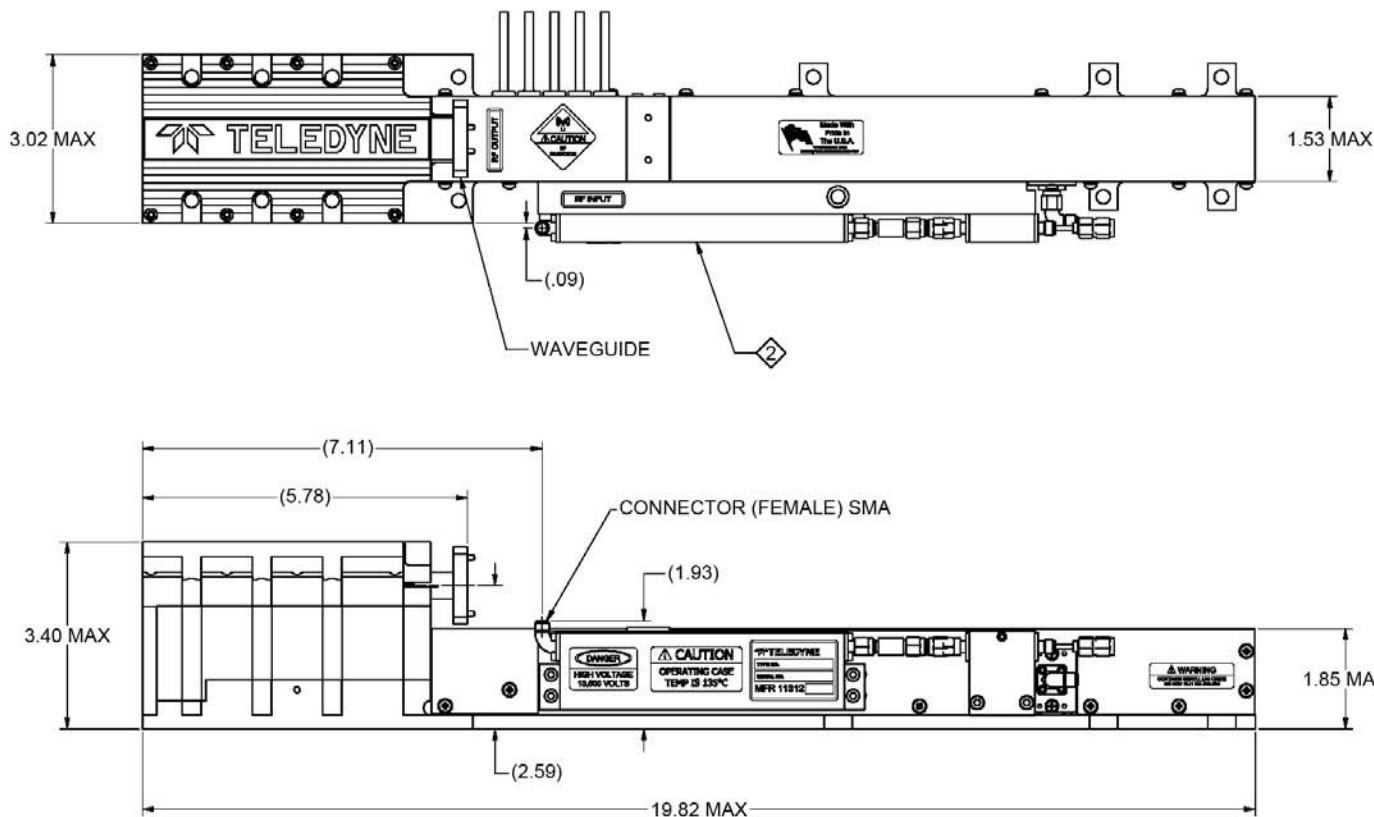

SUBJECT TO CHANGE W/O NOTICE

ISO 9001:2008 Registered

TELEDYNE MICROWAVE SOLUTIONS TWT PRODUCTS <small>11361 Sunrise Park Dr., Rancho Cordova, CA, (916) 638-3344</small>	
TITLE	MEC 5405, MEC 5406, MEC 5407, MEC 5408, MEC 5409, MEC 5410, MEC 5411, MEC 5412, MEC 5413, MEC 5414, MEC 5415, MEC 5416, MEC 5419, MEC 5420, MEC 5421, MEC 5422, MEC 5423, MEC 5424

MEC 5508

Continuous Wave TWT 6.0 GHz – 18.0 GHz

- 200 W Minimum Power
- 6.0 to 18.0 GHz
- -40° to 85° C
- 840 W Typ. Prime Power
- 21 dB Typical Saturated Gain
- 10.95" L x 3.35" W x 2.16" H
(27.81 x 8.51 x 5.49 cm)

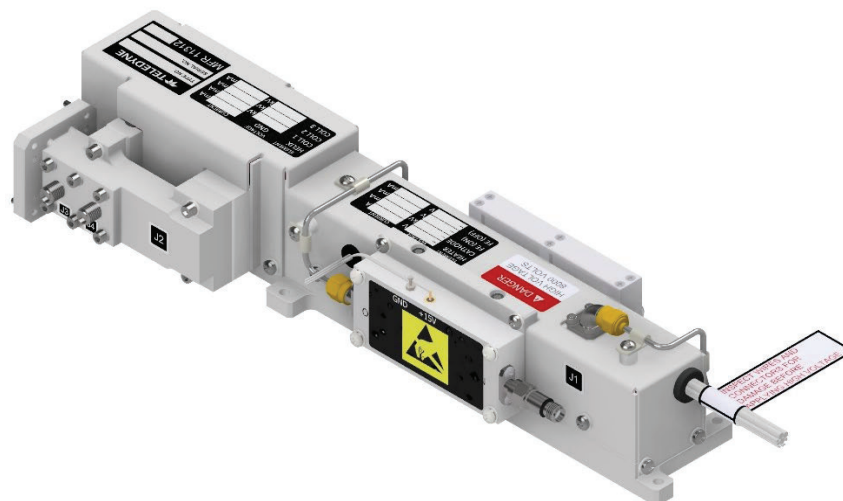

Typical Operating Conditions			Power Supply Requirements		
Element	Voltage	Current	Voltage Min.	Voltage Max.	Current Max.
Heater	-6.1 Vdc	0.54 A	-6.0 Vdc	-6.6 Vdc	1.0 A
Helix					
with RF	Ground	12 mA _{pk}	Ground	Ground	18 mA
without RF	Ground	3 mA _{pk}	Ground	Ground	18 mA
FE Drive	-25 V	0.1 mA	-10 Vdc	-60 V	1.0 mA
FE Bias	-1600 Vdc	0.1 mA	-1500 Vdc	-1700 Vdc	1.0 mA
Cathode (E _k)	7.4 kV	265 mA	7.2 kV	7.6 kV	215 mA
Collector w/RF					
Coll. #1	4.6 kV	80 mA	62.7% x E _k ±2%		100 mA
Coll. #2	3.2 kV	120 mA	42.7% x E _k ±2%		200 mA
Coll. #3	1.1 kV	53 mA	14.7% x E _k ±2%		250 mA

Cathode voltage is measured with respect to ground.
Heater, Collector, and Grid voltages are measured with respect to Cathode.

RF Performance

Freq (GHz)	Typ. Sat. Power Output (W)	Min. Spec. Power Output (W)	Typ. Gain @ Spec. Power (dB)
6.0	220	200	21
7.0	250	200	21
9.0	255	200	21
11.0	260	200	21
12.0	270	200	21
13.0	250	200	21
14.0	250	200	21
15.0	260	200	21
16.0	255	200	21
17.0	230	200	21
18.0	220	200	21

Typical power output is shown to illustrate capability.
Typical gain shown is with equalizer.

Performance	Typical	Spec
Input VSWR.....	2:1	2.5:1
Output VSWR.....	1.75:1	2.25:1
Max. Duty	—	CW
FE Capacitance	24 pF	35 pF
Min. Harmonic Separation (at 6.0 GHz).....	-3.0 dBc	-3 dBc
Noise Power Density (dBm/MHz)	-35	-26
Prime Power.....	840 W	1000 W

For operation into a load system with a VSWR greater than 2.0:1, contact TMS.

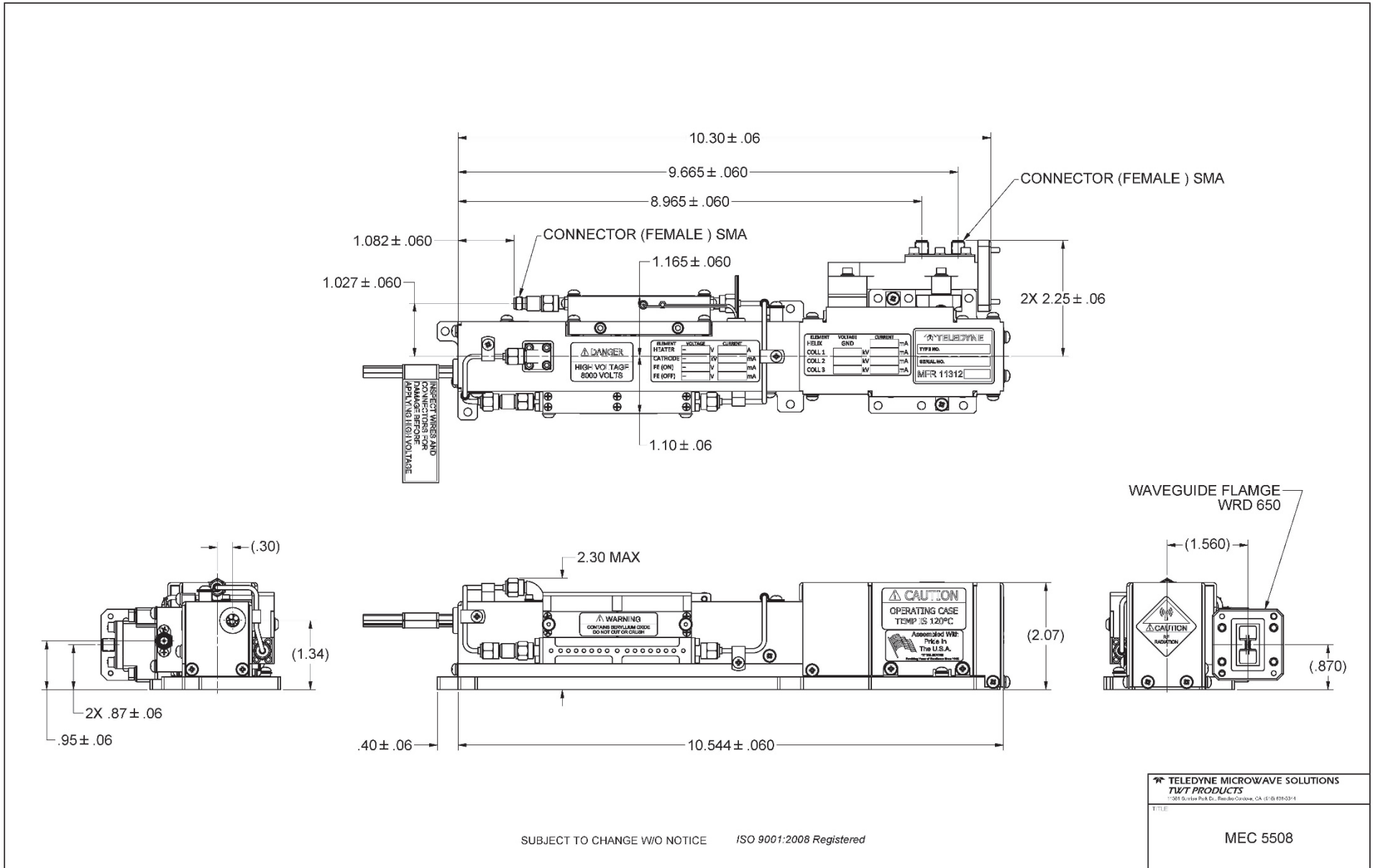

MEC 5409/MEC 5410

Continuous Wave TWT

6.5 GHz – 18.0 GHz

- 200 W Minimum Power
- 6.5 to 18.0 GHz
- -40° to 85° C
- 1095 W Typ. Prime Power
- 35-48 dB Typical Gain
- 19.8" L x 3.47" W x 3.4" H (50.3 x 8.8 x 8.64 cm)
- ±20° Phase Match

5409 – Grid
 5410 – Focus Electrode (FE)

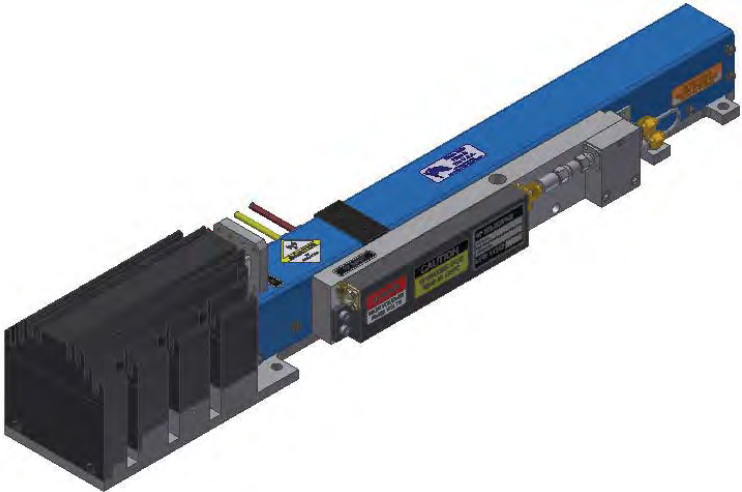

Typical Operating Conditions			Power Supply Requirements		
Element	Voltage	Current	Voltage Min.	Voltage Max.	Current Max.
Heater	-6.3 Vdc	1.6 A	-6.0 Vdc	-6.6 Vdc	2 A
Helix					
with RF	Ground	7 mA	Ground	Ground	15 mA
without RF	Ground	1 mA	Ground	Ground	15 mA
FE On	-50 Vdc	0.1 mA	0	-75 Vdc	1 mA
FE Off	-1300 Vdc	0.1 mA	-1500 Vdc	-1700 Vdc	1 mA
Grid On	180 Vdc	1 mA	125 Vdc	250 Vdc	10 mA
Grid Off	-200 Vdc	0.1 mA	-200 Vdc	-500 Vdc	1 mA
Cathode (E _k)	-10.3 kV	260 mA	-10 kV	-10.5 kV	280 mA
Collector w/RF					
Coll. #1	5.36 kV	45 mA	52% x E _k ±2%		100 mA
Coll. #2	3.71 kV	208 mA	36% x E _k ±2%		280 mA

Cathode voltage is measured with respect to ground.
 Heater, Collector, and Grid or Focus Electrode (FE) voltages are measured with respect to Cathode.

RF Performance

Freq (GHz)	Typ. Sat. Power Output (W)	Min. Spec. Power Output (W)	Typ. Gain @ Spec. Power (dB)
6.5	215	200	35
7.0	240	200	40
8.0	250	200	41
9.0	275	200	43
10.0	225	200	45
11.0	275	200	45
12.0	275	200	46
13.0	275	200	46
14.0	275	200	45
15.0	250	200	43
16.0	240	200	41
17.0	230	200	48
18.0	220	200	35

Typical power output is shown to illustrate capability.
 Typical gain shown is without equalizer.

Performance	Typical	Spec
Input VSWR.....	2:1	2.5:1
Output VSWR.....	2:1	2.25:1
Max. Duty	—	CW
FE Capacitance.....	50 pF	65 pF
Grid Capacitance.....	37 pF	50 pF
Min. Harmonic Separation.....	-6 dBc	-5 dBc
Noise Power Density (dBm/MHz)	-15	-10
Prime Power.....	1095 W	1400 W

Specifications are subject to change without notice.

NOTES:

1. THERMOSTAT OPTIONS: N/C OR N/O

2. EQUALIZER OPTIONAL BASED UPON CUSTOMER REQUIREMENT.

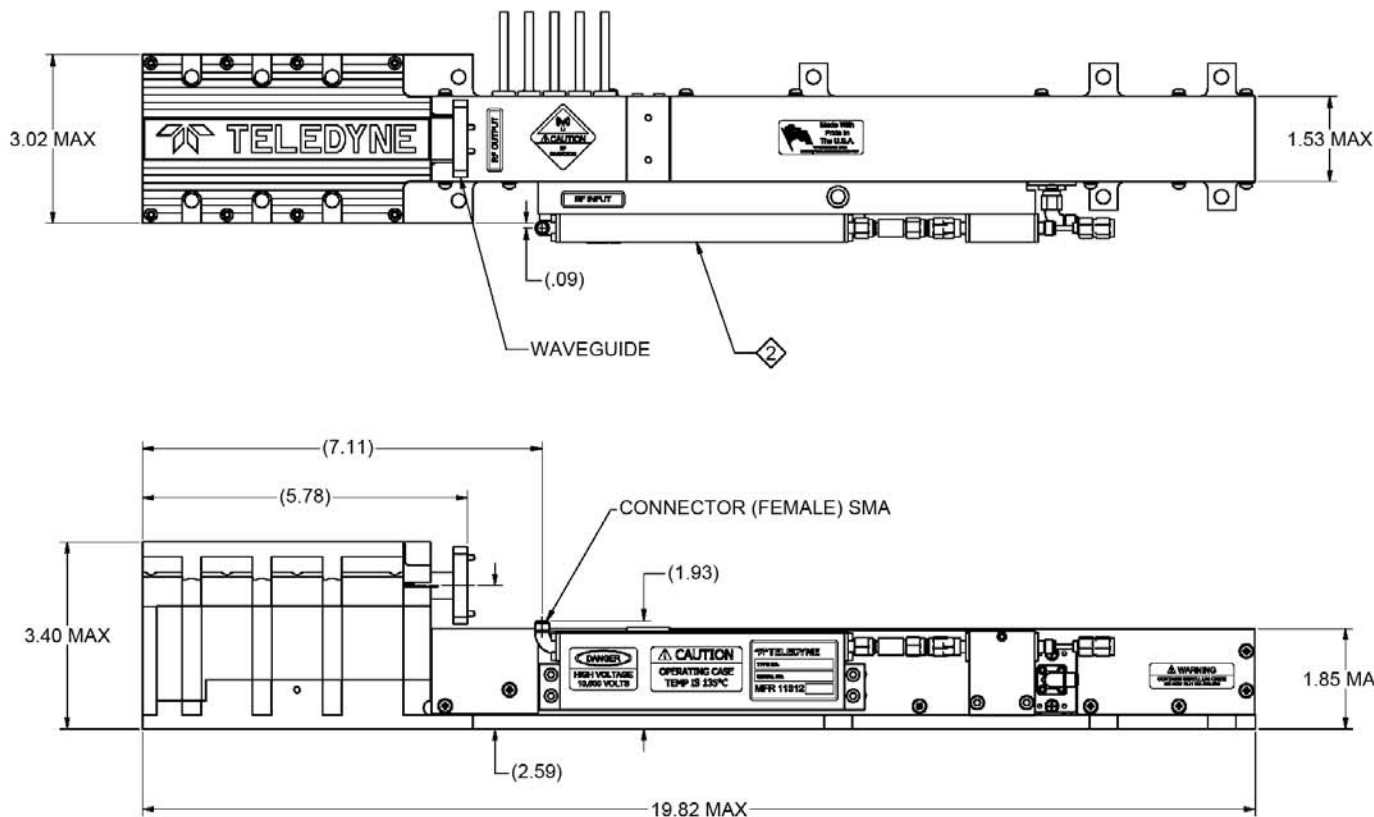

SUBJECT TO CHANGE W/O NOTICE

ISO 9001:2008 Registered

TELEDYNE MICROWAVE SOLUTIONS
TWT PRODUCTS

11361 Sunrise Park Dr., Rancho Cordova, CA, (916) 638-3344

TITLE
MEC 5405, MEC 5406, MEC 5407,
MEC 5408, MEC 5409, MEC 5410,
MEC 5411, MEC 5412, MEC 5413,
MEC 5414, MEC 5415, MEC 5416,
MEC 5419, MEC 5420, MEC 5421,
MEC 5422, MEC 5423, MEC 5424

MEC 5421/MEC 5422

Continuous Wave TWT

6.5 GHz – 18.0 GHz

- 250 W Minimum Power
- 6.5 to 18.0 GHz
- -40° to 85° C
- 1147 W Typ. Prime Power
- 35-45 dB Typical Gain
- 19.8" L x 3.47" W x 3.4" H (50.3 x 8.8 x 8.64 cm)
- ±20° Phase Match

5421 – Grid
5422 – Focus Electrode (FE)

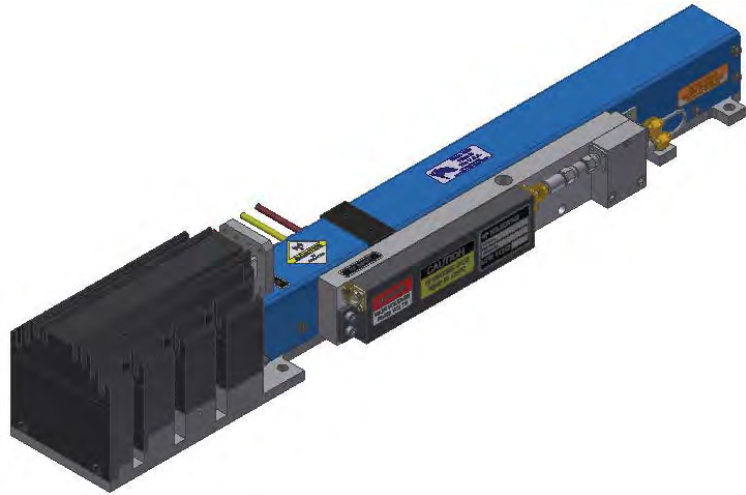

Typical Operating Conditions			Power Supply Requirements		
Element	Voltage	Current	Voltage Min.	Voltage Max.	Current Max.
Heater	-6.3 Vdc	1.6 A	-6.0 Vdc	-6.6 Vdc	2 A
Helix					
with RF	Ground	8 mA	Ground	Ground	15 mA
without RF	Ground	2 mA	Ground	Ground	15 mA
FE On	-25 Vdc	0.1 mA	0	-75 Vdc	1 mA
FE Off	-1300 Vdc	0.1 mA	-1500 Vdc	-1700 Vdc	1 mA
Grid On	200 Vdc	1 mA	125 Vdc	250 Vdc	10 mA
Grid Off	-200 Vdc	0.1 mA	-200 Vdc	-500 Vdc	1 mA
Cathode (E _k)	-10.3 kV	270 mA	-10 kV	-10.5 kV	300 mA
Collector w/RF					
Coll. #1	5.36 kV	50 mA	52% x E _k ±2%		100 mA
Coll. #2	3.71 kV	212 mA	36% x E _k ±2%		300 mA

Cathode voltage is measured with respect to ground.
Heater, Collector, and Grid or Focus Electrode (FE) voltages are measured with respect to Cathode.

RF Performance

Freq (GHz)	Typ. Sat. Power Output (W)	Min. Spec. Power Output (W)	Typ. Gain @ Spec. Power (dB)
6.5	275	250	35
7.0	275	250	38
8.0	290	250	41
9.0	280	250	43
10.0	275	250	45
11.0	280	250	45
12.0	300	250	45
13.0	300	250	45
14.0	300	250	45
15.0	300	250	43
16.0	285	250	41
17.0	275	250	38
18.0	275	250	35

Typical power output is shown to illustrate capability.
Typical gain shown is without equalizer.

Performance	Typical	Spec
Input VSWR.....	2:1	2.5:1
Output VSWR.....	2:1	2.25:1
Max. Duty	—	CW
FE Capacitance.....	50 pF	65 pF
Grid Capacitance.....	37 pF	50 pF
Min. Harmonic Separation.....	-7 dBc	-5 dBc
Noise Power Density (dBm/MHz)	-15	-10
Prime Power.....	1147 W	1400 W

Specifications are subject to change without notice.

NOTES:

1. THERMOSTAT OPTIONS: N/C OR N/O

2. EQUALIZER OPTIONAL BASED UPON CUSTOMER REQUIREMENT.

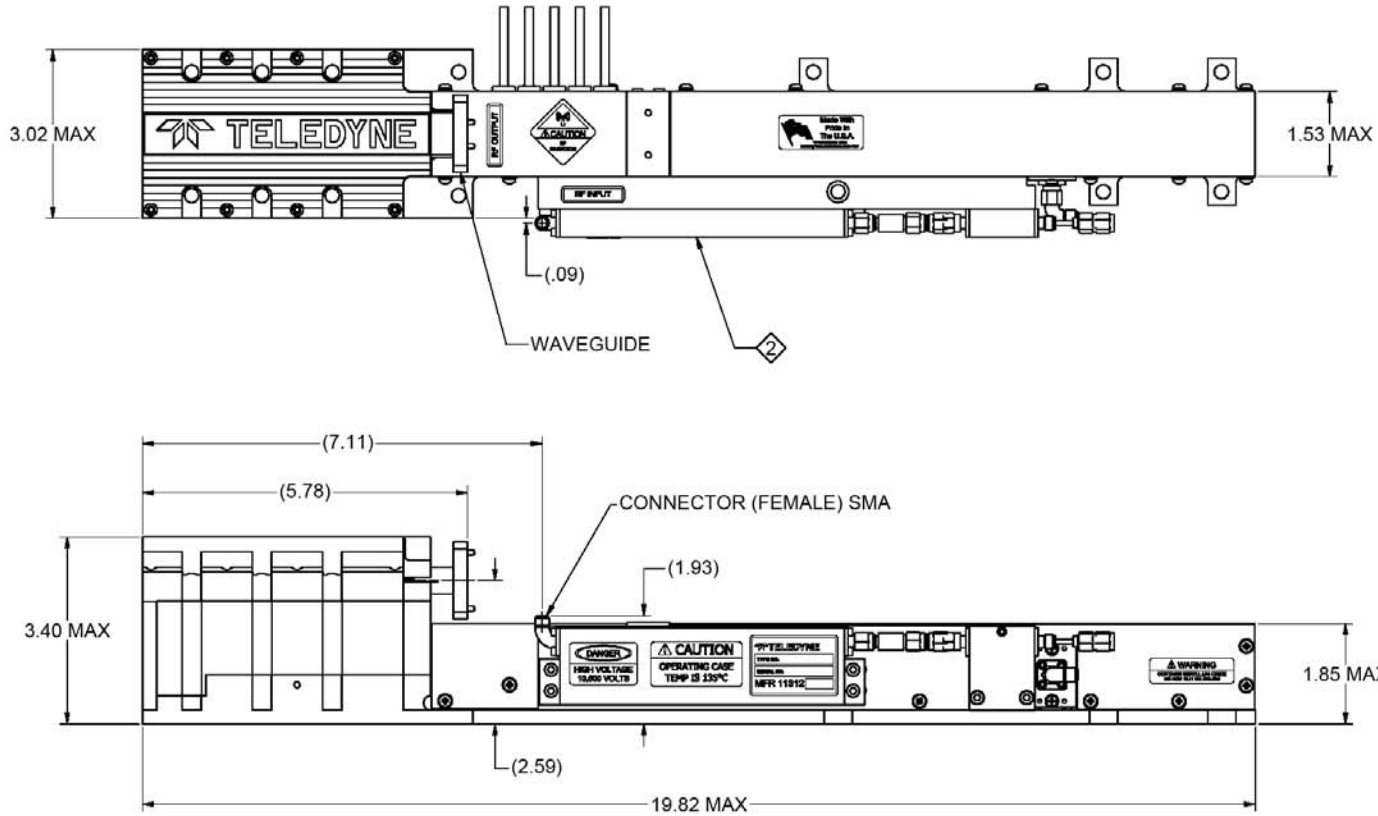

SUBJECT TO CHANGE W/O NOTICE

ISO 9001:2008 Registered

TELEDYNE MICROWAVE SOLUTIONS
TWT PRODUCTS

11361 Sunrise Park Dr., Rancho Cordova, CA, (916) 638-3344
TITLE
MEC 5405, MEC 5406, MEC 5407,
MEC 5408, MEC 5409, MEC 5410,
MEC 5411, MEC 5412, MEC 5413,
MEC 5414, MEC 5415, MEC 5416,
MEC 5419, MEC 5420, MEC 5421,
MEC 5422, MEC 5423, MEC 5424

MEC 5411/MEC 5412

Continuous Wave TWT

6.5 GHz – 18.0 GHz

- 300 W Minimum Power
- 6.5 to 18.0 GHz
- -40° to 85° C
- 1221 W Typ. Prime Power
- 35-45 dB Typical Gain
- 19.8" L x 3.47" W x 3.4" H (50.3 x 8.8 x 8.64 cm)
- ±20° Phase Match

5411 – Grid
5412 – Focus Electrode (FE)

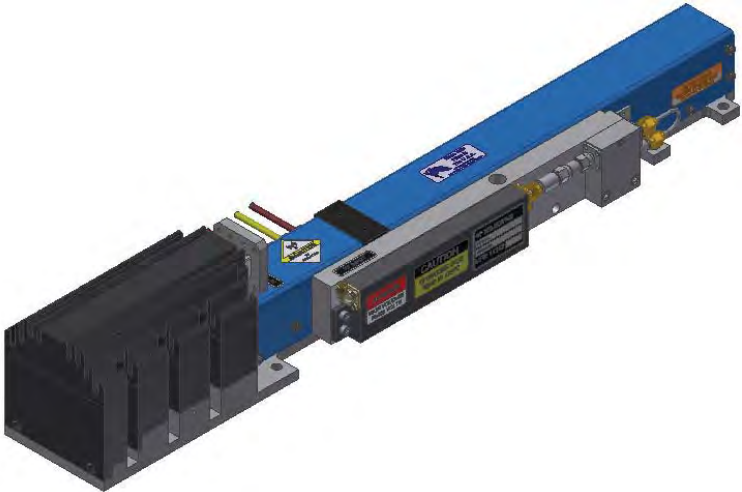

Typical Operating Conditions			Power Supply Requirements		
Element	Voltage	Current	Voltage Min.	Voltage Max.	Current Max.
Heater	-6.3 Vdc	1.6 A	-6.0 Vdc	-6.6 Vdc	2 A
Helix					
with RF	Ground	8 mA	Ground	Ground	15 mA
without RF	Ground	2 mA	Ground	Ground	15 mA
FE On	-25 Vdc	0.1 mA	0	-75 Vdc	1 mA
FE Off	-1300 Vdc	0.1 mA	-1500 Vdc	-1700 Vdc	1 mA
Grid On	200 Vdc	1 mA	125 Vdc	250 Vdc	10 mA
Grid Off	-200 Vdc	0.1 mA	-200 Vdc	-500 Vdc	1 mA
Cathode (E _k)	-10.3 kV	290 mA	-10 kV	-10.5 kV	300 mA
Collector w/RF					
Coll. #1	5.36 kV	50 mA	52% x E _k ±2%		100 mA
Coll. #2	3.71 kV	232 mA	36% x E _k ±2%		300 mA

Cathode voltage is measured with respect to ground.
Heater, Collector, and Grid or Focus Electrode (FE) voltages are measured with respect to Cathode.

RF Performance

Freq (GHz)	Typ. Sat. Power Output (W)	Min. Spec. Power Output (W)	Typ. Gain @ Spec. Power (dB)
6.5	310	300	35
7.0	325	300	38
8.0	350	300	41
9.0	350	300	43
10.0	325	300	45
11.0	350	300	45
12.0	375	300	45
13.0	375	300	45
14.0	375	300	45
15.0	365	300	43
16.0	350	300	41
17.0	340	300	38
18.0	325	300	35

Typical power output is shown to illustrate capability.
Typical gain shown is without equalizer.

Performance	Typical	Spec
Input VSWR.....	2:1	2.5:1
Output VSWR.....	2:1	2.25:1
Max. Duty	—	CW
FE Capacitance.....	50 pF	65 pF
Grid Capacitance.....	37 pF	50 pF
Min. Harmonic Separation.....	-7 dBc	-5 dBc
Noise Power Density (dBm/MHz)	-15	-10
Prime Power.....	1221 W	1400 W

Specifications are subject to change without notice.

NOTES:

1. THERMOSTAT OPTIONS: N/C OR N/O

2. EQUALIZER OPTIONAL BASED UPON CUSTOMER REQUIREMENT.

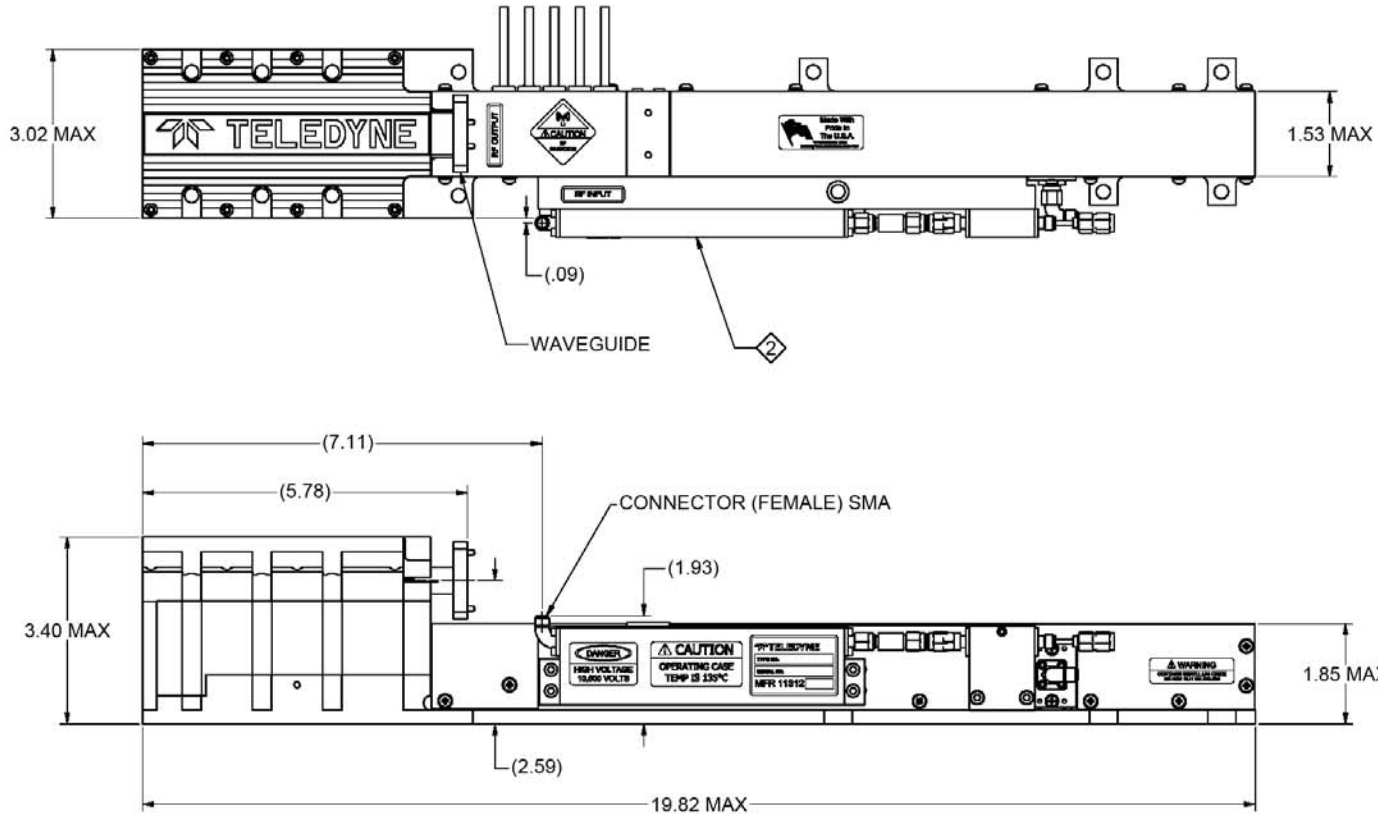

SUBJECT TO CHANGE W/O NOTICE

ISO 9001:2008 Registered

TELEDYNE MICROWAVE SOLUTIONS
TWT PRODUCTS

11361 Sunrise Park Dr., Rancho Cordova, CA, (916) 638-3344
TITLE
MEC 5405, MEC 5406, MEC 5407,
MEC 5408, MEC 5409, MEC 5410,
MEC 5411, MEC 5412, MEC 5413,
MEC 5414, MEC 5415, MEC 5416,
MEC 5419, MEC 5420, MEC 5421,
MEC 5422, MEC 5423, MEC 5424

MEC 5405/MEC 5406

Continuous Wave TWT

7.5 GHz – 18.0 GHz

- 200 W Minimum Power
- 7.5 to 18.0 GHz
- -40° to 85° C
- 1047 W Typ. Prime Power
- 35-55 dB Typical Gain
- 19.8" L x 3.47" W x 3.4" H (50.3 x 8.8 x 8.64 cm)
- ±20° Phase Match

5405 – Grid
5406 – Focus Electrode (FE)

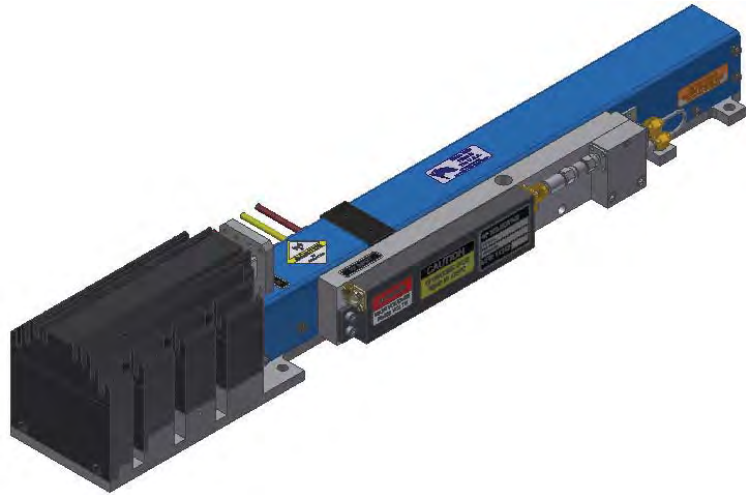

Typical Operating Conditions			Power Supply Requirements		
Element	Voltage	Current	Voltage Min.	Voltage Max.	Current Max.
Heater	-6.3 Vdc	1.6 A	-6.0 Vdc	-6.6 Vdc	2 A
Helix					
with RF	Ground	7 mA	Ground	Ground	12 mA
without RF	Ground	0.5 mA	Ground	Ground	12 mA
FE On	-65 Vdc	0.1 mA	0	-75 Vdc	1 mA
FE Off	-1300 Vdc	0.1 mA	-1500 Vdc	-1700 Vdc	1 mA
Grid On	160 Vdc	1 mA	125 Vdc	250 Vdc	10 mA
Grid Off	-200 Vdc	0.1 mA	-200 Vdc	-500 Vdc	1 mA
Cathode (E _k)	-10.2 kV	250 mA	-10 kV	-10.5 kV	280 mA
Collector w/RF					
Coll. #1	5.36 kV	45 mA	52% x E _k ±2%		100 mA
Coll. #2	3.67 kV	198 mA	36% x E _k ±2%		280 mA

Cathode voltage is measured with respect to ground.
Heater, Collector, and Grid or Focus Electrode (FE) voltages are measured with respect to Cathode.

RF Performance

Freq (GHz)	Typ. Sat. Power Output (W)	Min. Spec. Power Output (W)	Typ. Gain @ Spec. Power (dB)
7.5	250	200	35
8.0	250	200	45
9.0	270	200	50
10.0	250	200	55
11.0	270	200	55
12.0	270	200	55
13.0	270	200	55
14.0	270	200	55
15.0	260	200	55
16.0	250	200	55
17.0	240	200	50
18.0	230	200	35

Typical power output is shown to illustrate capability.
Typical gain shown is without equalizer.

Performance	Typical	Spec
Input VSWR.....	2:1	2.5:1
Output VSWR.....	2:1	2.25:1
Max. Duty	—	CW
FE Capacitance.....	50 pF	65 pF
Grid Capacitance.....	37 pF	50 pF
Min. Harmonic Separation.....	-8 dBc	-5 dBc
Noise Power Density (dBm/MHz)	-15	-10
Prime Power.....	1047 W	1250 W

Specifications are subject to change without notice.

NOTES:

1. THERMOSTAT OPTIONS: N/C OR N/O

2. EQUALIZER OPTIONAL BASED UPON CUSTOMER REQUIREMENT.

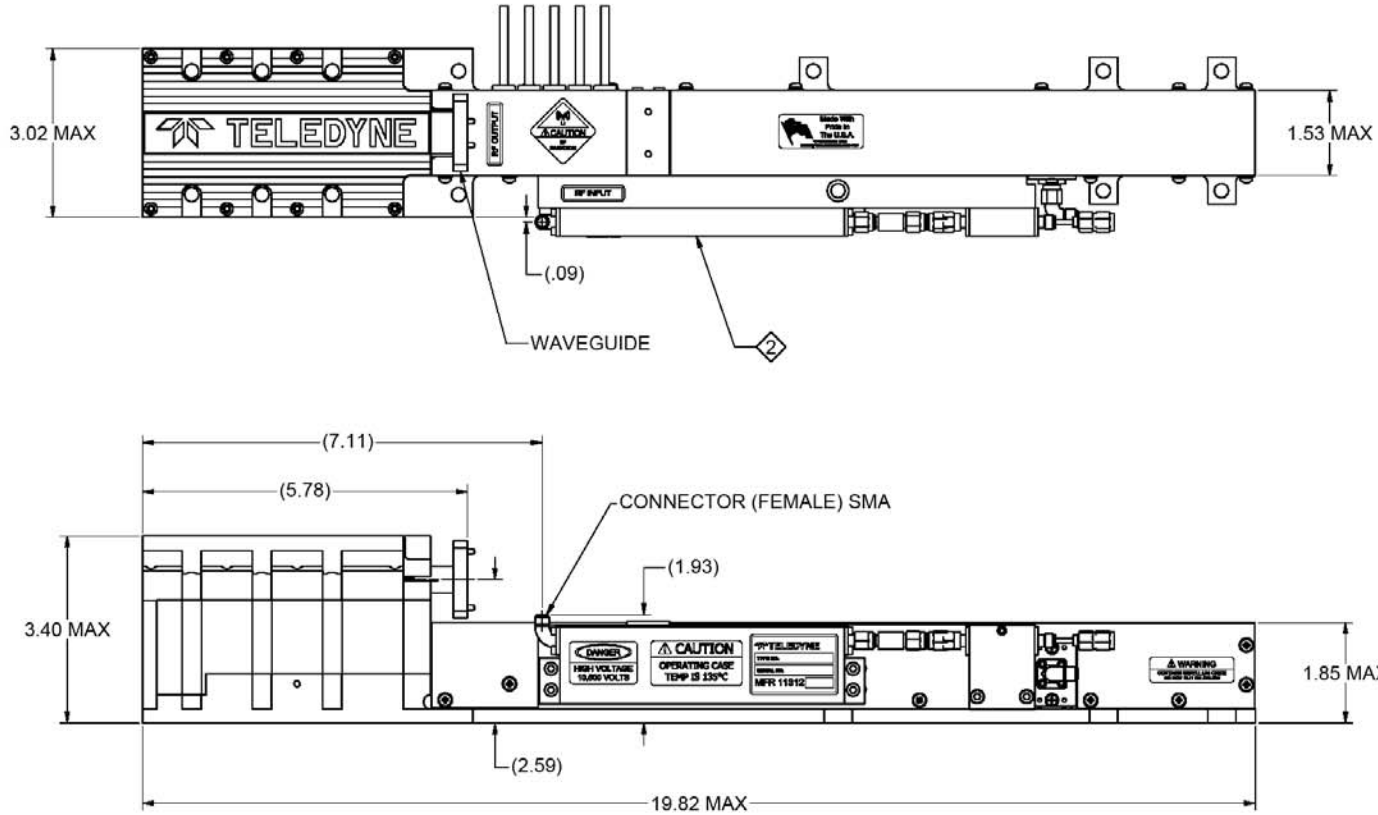

SUBJECT TO CHANGE W/O NOTICE

ISO 9001:2008 Registered

TELEDYNE MICROWAVE SOLUTIONS TWT PRODUCTS <small>11361 Sunrise Park Dr., Rancho Cordova, CA, (916) 638-3344</small>	
TITLE	MEC 5405, MEC 5406, MEC 5407, MEC 5408, MEC 5409, MEC 5410, MEC 5411, MEC 5412, MEC 5413, MEC 5414, MEC 5415, MEC 5416, MEC 5419, MEC 5420, MEC 5421, MEC 5422, MEC 5423, MEC 5424

MEC 5419/MEC 5420

Continuous Wave TWT

7.5 GHz – 18.0 GHz

- 250 W Minimum Power
- 7.5 to 18.0 GHz
- -40° to 85° C
- 1083 W Typ. Prime Power
- 35-55 dB Typical Gain
- 19.8" L x 3.47" W x 3.4" H (50.3 x 8.8 x 8.64 cm)
- ±20° Phase Match

5419 – Grid
5420 – Focus Electrode (FE)

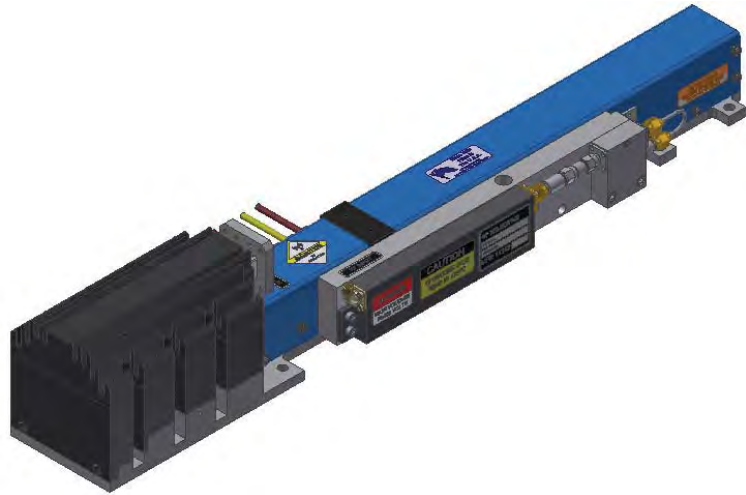

Typical Operating Conditions			Power Supply Requirements		
Element	Voltage	Current	Voltage Min.	Voltage Max.	Current Max.
Heater	-6.3 Vdc	1.6 A	-6.0 Vdc	-6.6 Vdc	2 A
Helix					
with RF	Ground	7 mA	Ground	Ground	12 mA
without RF	Ground	1 mA	Ground	Ground	12 mA
FE On	-45 Vdc	0.1 mA	0	-75 Vdc	1 mA
FE Off	-1300 Vdc	0.1 mA	-1500 Vdc	-1700 Vdc	1 mA
Grid On	190 Vdc	1 mA	125 Vdc	250 Vdc	10 mA
Grid Off	-200 Vdc	0.1 mA	-200 Vdc	-500 Vdc	1 mA
Cathode (E _k)	-10.2 kV	260 mA	-10 kV	-10.5 kV	280 mA
Collector w/RF					
Coll. #1	5.36 kV	45 mA	52% x E _k ±2%		100 mA
Coll. #2	3.67 kV	208 mA	36% x E _k ±2%		280 mA

Cathode voltage is measured with respect to ground.
Heater, Collector, and Grid or Focus Electrode (FE) voltages are measured with respect to Cathode.

RF Performance

Freq (GHz)	Typ. Sat. Power Output (W)	Min. Spec. Power Output (W)	Typ. Gain @ Spec. Power (dB)
7.5	275	250	35
8.0	275	250	45
9.0	300	250	50
10.0	275	250	55
11.0	300	250	55
12.0	300	250	55
13.0	300	250	55
14.0	300	250	55
15.0	300	250	50
16.0	290	250	55
17.0	280	250	50
18.0	270	250	35

Typical power output is shown to illustrate capability.
Typical gain shown is without equalizer.

Performance	Typical	Spec
Input VSWR.....	2:1	2.5:1
Output VSWR.....	2:1	2.25:1
Max. Duty	—	CW
FE Capacitance.....	50 pF	65 pF
Grid Capacitance.....	37 pF	50 pF
Min. Harmonic Separation.....	-8 dBc	-5 dBc
Noise Power Density (dBm/MHz)	-15	-10
Prime Power.....	1083 W	1250 W

Specifications are subject to change without notice.

NOTES:

1. THERMOSTAT OPTIONS: N/C OR N/O

② EQUALIZER OPTIONAL BASED UPON CUSTOMER REQUIREMENT.

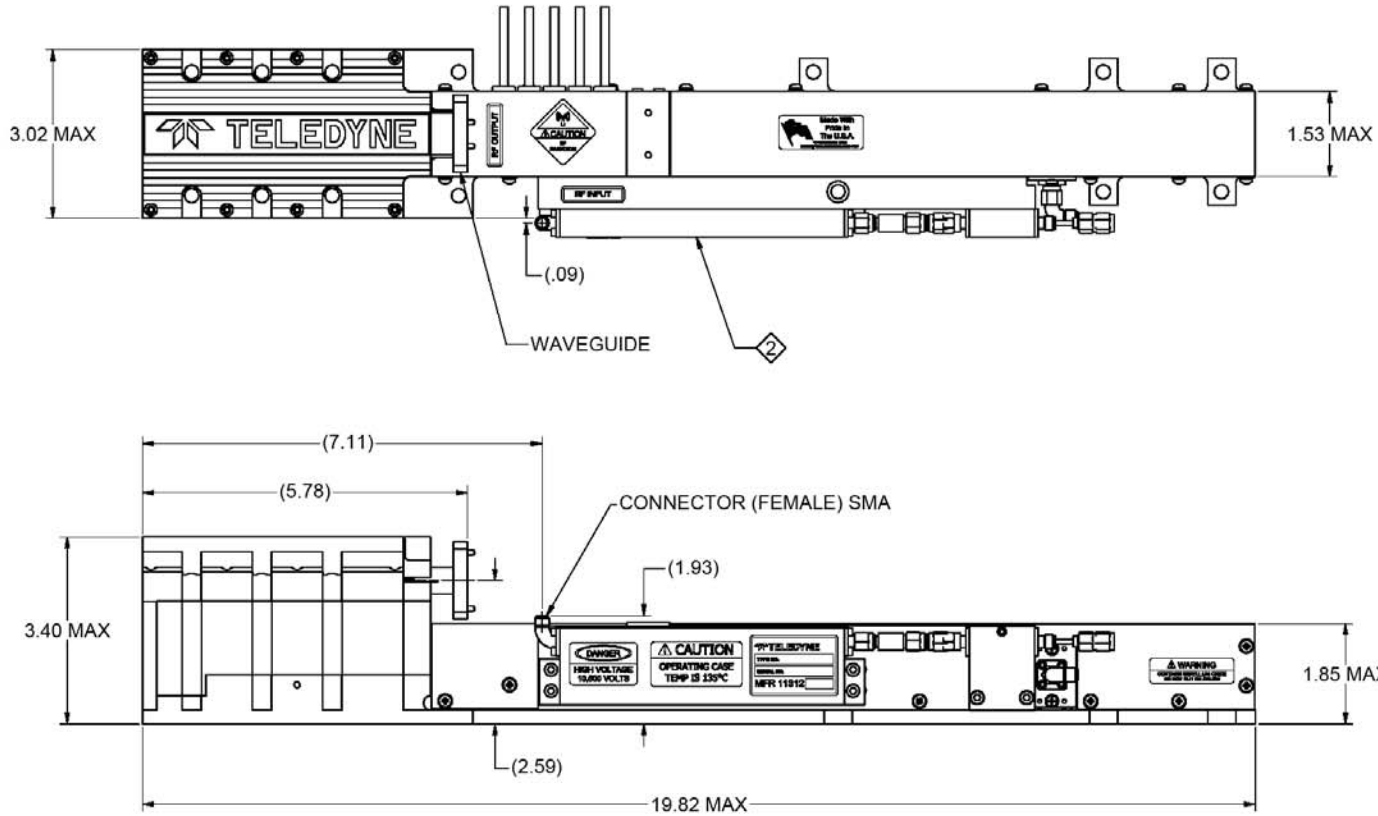

SUBJECT TO CHANGE W/O NOTICE

ISO 9001:2008 Registered

TELEDYNE MICROWAVE SOLUTIONS
TWT PRODUCTS

11361 Sunrise Park Dr., Rancho Cordova, CA, (916) 638-3344
TITLE
MEC 5405, MEC 5406, MEC 5407,
MEC 5408, MEC 5409, MEC 5410,
MEC 5411, MEC 5412, MEC 5413,
MEC 5414, MEC 5415, MEC 5416,
MEC 5419, MEC 5420, MEC 5421,
MEC 5422, MEC 5423, MEC 5424

MEC 5407/MEC 5408

Continuous Wave TWT

7.5 GHz – 18.0 GHz

- 300 W Minimum Power
- 7.5 to 18.0 GHz
- -40° to 85° C
- 1120 W Typ. Prime Power
- 35-55 dB Typical Gain
- 19.8" L x 3.47" W x 3.4" H (50.3 x 8.8 x 8.64 cm)
- ±20° Phase Match

5407 – Grid
 5408 – Focus Electrode (FE)

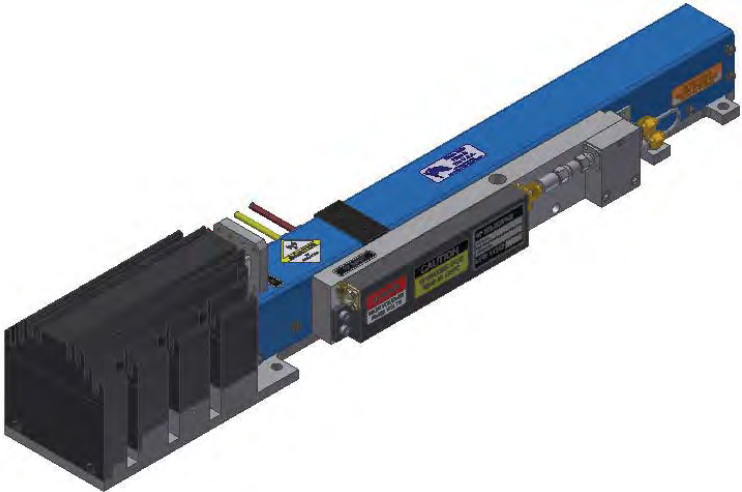

Typical Operating Conditions			Power Supply Requirements		
Element	Voltage	Current	Voltage Min.	Voltage Max.	Current Max.
Heater	-6.3 Vdc	1.6 A	-6.0 Vdc	-6.6 Vdc	2 A
Helix					
with RF	Ground	7 mA	Ground	Ground	12 mA
without RF	Ground	1 mA	Ground	Ground	12 mA
FE On	-45 Vdc	0.1 mA	0	-75 Vdc	1 mA
FE Off	-1300 Vdc	0.1 mA	-1500 Vdc	-1700 Vdc	1 mA
Grid On	190 Vdc	1 mA	125 Vdc	250 Vdc	10 mA
Grid Off	-200 Vdc	0.1 mA	-200 Vdc	-500 Vdc	1 mA
Cathode (E _k)	-10.2 kV	270 mA	-10 kV	-10.5 kV	300 mA
Collector w/RF					
Coll. #1	5.36 kV	45 mA	52% x E _k ±2%		100 mA
Coll. #2	3.67 kV	218 mA	36% x E _k ±2%		300 mA

Cathode voltage is measured with respect to ground.
 Heater, Collector, and Grid or Focus Electrode (FE) voltages are measured with respect to Cathode.

RF Performance

Freq (GHz)	Typ. Sat. Power Output (W)	Min. Spec. Power Output (W)	Typ. Gain @ Spec. Power (dB)
7.5	320	300	35
8.0	325	300	45
9.0	350	300	50
10.0	325	300	55
11.0	340	300	55
12.0	350	300	55
13.0	350	300	55
14.0	350	300	55
15.0	350	300	50
16.0	340	300	55
17.0	330	300	50
18.0	320	300	35

Typical power output is shown to illustrate capability.
 Typical gain shown is without equalizer.

Performance	Typical	Spec
Input VSWR.....	2:1	2.5:1
Output VSWR.....	2:1	2.25:1
Max. Duty	—	CW
FE Capacitance.....	50 pF	65 pF
Grid Capacitance.....	37 pF	50 pF
Min. Harmonic Separation.....	-7 dBc	-5 dBc
Noise Power Density (dBm/MHz)	-12	-10
Prime Power.....	1120 W	1400 W

Specifications are subject to change without notice.

NOTES:

1. THERMOSTAT OPTIONS: N/C OR N/O

② EQUALIZER OPTIONAL BASED UPON CUSTOMER REQUIREMENT.

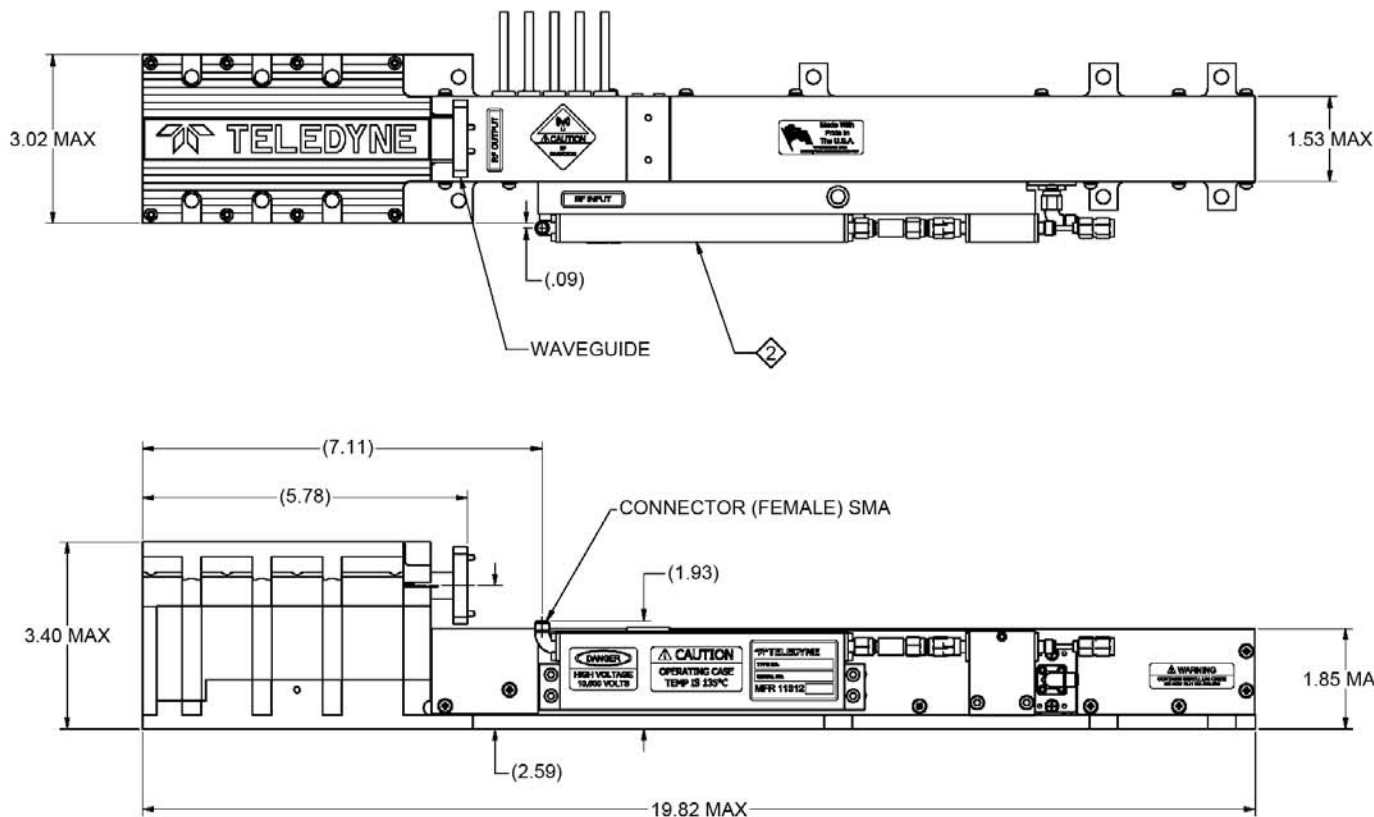

SUBJECT TO CHANGE W/O NOTICE

ISO 9001:2008 Registered

TELEDYNE MICROWAVE SOLUTIONS TWT PRODUCTS <small>11361 Sunrise Park Dr., Rancho Cordova, CA, (916) 638-3344</small>	
TITLE	MEC 5405, MEC 5406, MEC 5407, MEC 5408, MEC 5409, MEC 5410, MEC 5411, MEC 5412, MEC 5413, MEC 5414, MEC 5415, MEC 5416, MEC 5419, MEC 5420, MEC 5421, MEC 5422, MEC 5423, MEC 5424

MEC 5487

Continuous Wave TWT

8 GHz – 18 GHz

- 400 W Typical Minimum Power
- 8 to 18 GHz
- -40° to 85° C
- 1300 W Typical Prime Power
- 44 to 47 dB Typical Gain @ Specified Power Output
- 19.8" L x 3.00" W x 3.34" H (50.3 x 7.62 x 8.5 cm)
- Phase Match Available

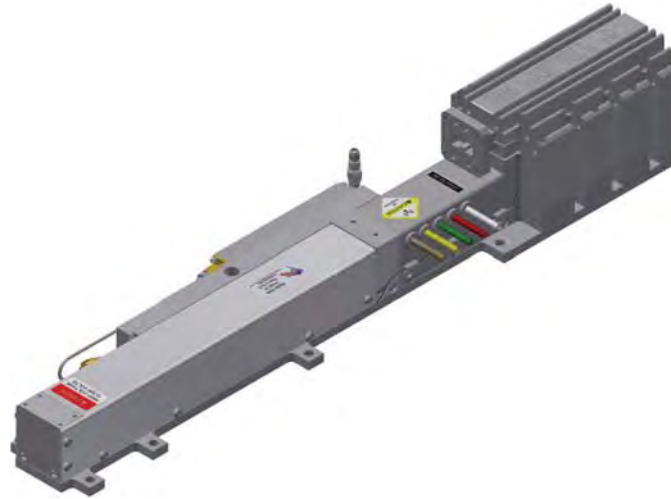

RF Performance

Freq (GHz)	Typ. Sat. Power Output (W)	Min. Spec. Power Output (W)	Typ. Gain @ Spec. Power (dB)
8.0	410	325	45
9.0	415	325	44
10.0	400	325	46
11.0	400	325	47
12.0	425	325	46
13.0	425	325	45
14.0	425	325	45
15.0	410	325	45
16.0	425	325	45
17.0	425	325	46
18.0	425	325	47

Typical power output is shown to illustrate capability.
Typical gain shown is with equalizer.

Typical Operating Conditions			Power Supply Requirements		
Element	Voltage	Current	Voltage Min.	Voltage Max.	Current Max.
Heater	-6.3 Vdc	1.4 A	-6.0 Vdc	-6.6 Vdc	2 A
Helix					
with RF	Ground	7.0 mA	Ground	Ground	12 mA
without RF	Ground	0.7 mA	Ground	Ground	12 mA
Grid On	-14 Vdc	0.1 mA	125 Vdc	250 Vdc	10 mA
Grid Off	-250 Vdc	0.0 mA	-200 Vdc	-500 Vdc	1.0 mA
Cathode (E _k)	-10.45 kV	301 mA	-10.0 kV	-10.5 kV	325 mA
Collector w/RF					
Coll. #1	5.43 kV	80 mA	52% x E _k ±2%		100 mA
Coll. #2	3.76 kV	213.9 mA	36% x E _k ±2%		320 mA

Performance	Typical	Spec
Input VSWR:.....	2.25:1	2.5:1
Output VSWR:.....	1.8:1	2.25:1
Max. Duty	-	CW
Grid Capacitance.....	50 pF	65 pF
Noise Power Density (dBm/MHz)	-19	-10
Prime Power	1300 W	1400W

Cathode voltage is measured with respect to ground.
Heater, Collector, and Grid voltages are measured with respect to Cathode.

This model number is subject to the jurisdiction of the U.S. Department of Commerce.



Specifications are subject to change without notice.

Teledyne TWT Products • 11361 Sunrise Park Drive • Rancho Cordova, CA 95742 • 916.638.3344 • www.teledynemicrowave.com

NOTES:

- 1. THERMOSTAT OPTIONS: N/C OR N/O
- 2. EQUALIZER OPTIONAL BASED UPON CUSTOMER REQUIREMENT.

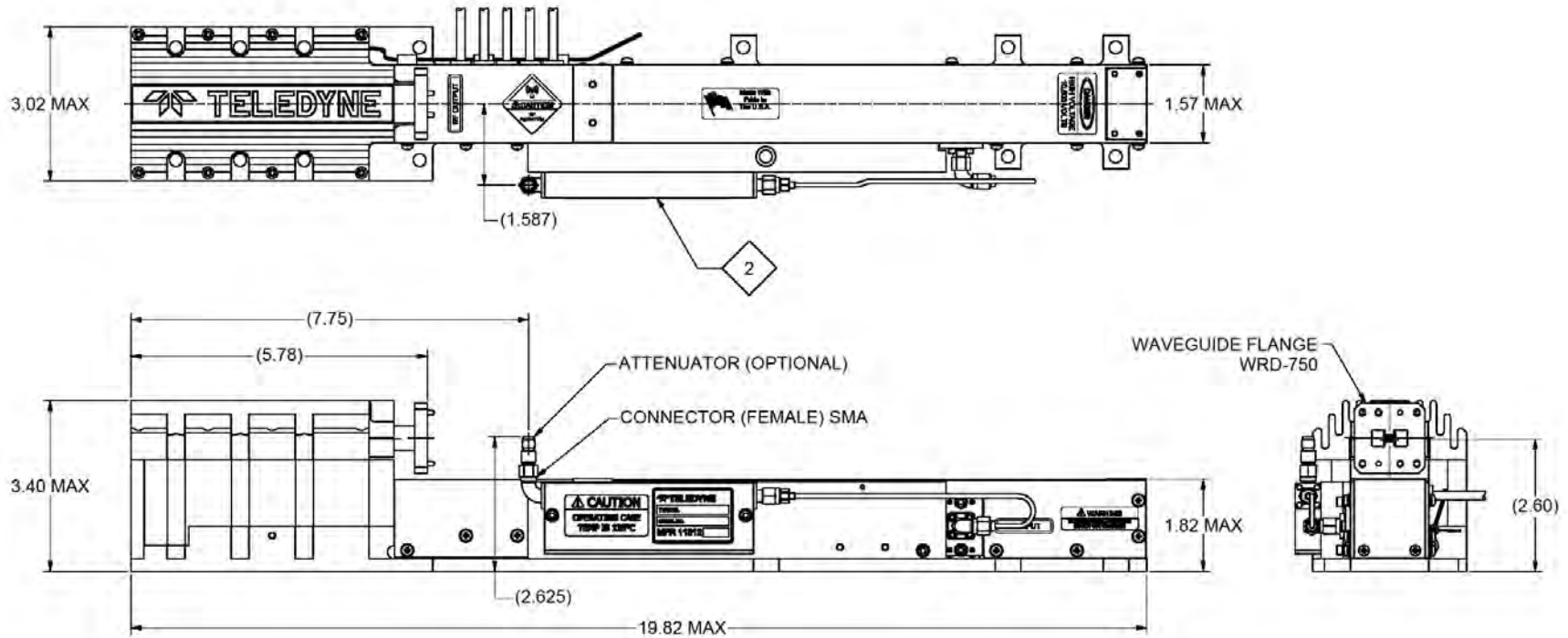

SUBJECT TO CHANGE W/O NOTICE ISO 9001:2008 Registered

<p>TELEDYNE MICROWAVE SOLUTIONS TWT PRODUCTS 11361 Sunrise Park Dr., Rancho Cordova, CA 95742-6044</p>
<p>MEC 5487</p>

This model number is subject to the jurisdiction of the U.S. Department of Commerce.

MEC 5519

Continuous Wave TWT

11 GHz – 18 GHz

- 500 W Minimum Power
- 11.0 to 18.0 GHz
- -40° to 85° C
- 2000 W Typ. Prime Power
- 54 dB Typical Gain
- 19.8" L x 3.9" W x 3.33" H
(50.3 x 9.9 x 8.45 cm)

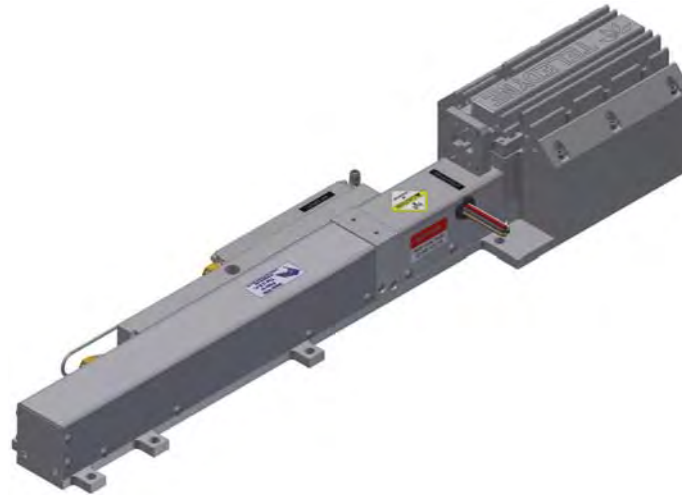

RF Performance

Freq (GHz)	Typ. Sat. Power Output (W)	Min. Spec. Power Output (W)	Typ. Gain @ Spec. Power (dB)
11.0	550	500	55
12.0	560	500	54
13.0	560	500	54
14.0	560	500	54
15.0	560	500	54
16.0	570	500	55
17.0	575	500	55
17.5	575	500	55
18.0	520	450	53

Typical power output is shown to illustrate capability.
Typical gain shown is with equalizer.

Typical Operating Conditions

Element	Voltage	Current	Power Supply Requirements		
			Voltage Min.	Voltage Max.	Current Max.
Heater	-6.0 Vdc	1.67 A	-5.8 Vdc	-6.6 Vdc	2.0 A
Helix					
with RF	Ground	2 mA	Ground	Ground	10 mA
without RF	Ground	7 mA	Ground	Ground	10 mA
FE On*	-6.0Vdc	0 mA	@ Heater	@Heater	3 mA
Cathode (Ek)	-12.35 kV	420 mA	-12 kV	-13.5 kV	425 mA
Collector w/RF					
Coll. #1	6.06 kV	176 mA	49% x Ek ±2%		250 mA
Coll. #2	3.34 kV	237 mA	27% x Ek ±2%		420 mA

* FE tied to heater internally for bias

Cathode voltage is measured with respect to ground.

Heater, Collector, and Focus Electrode (FE) voltages are measured with respect to Cathode.

Performance

	Typical	Spec
Input VSWR:	1.93:1	2.25:1
Output VSWR:	1.75:1	1.80:1
Max. Duty:	—	CW
FE Capacitance:	50 pF	65 pF
Min. Harmonic Separation:	-15 dBc	-10 dBc
Noise Power Density (dBm/MHz):	-12	-10
Prime Power	2000 W	2200 W

NOTES:

1. THERMOSTAT OPTIONS: N/C OR N/O

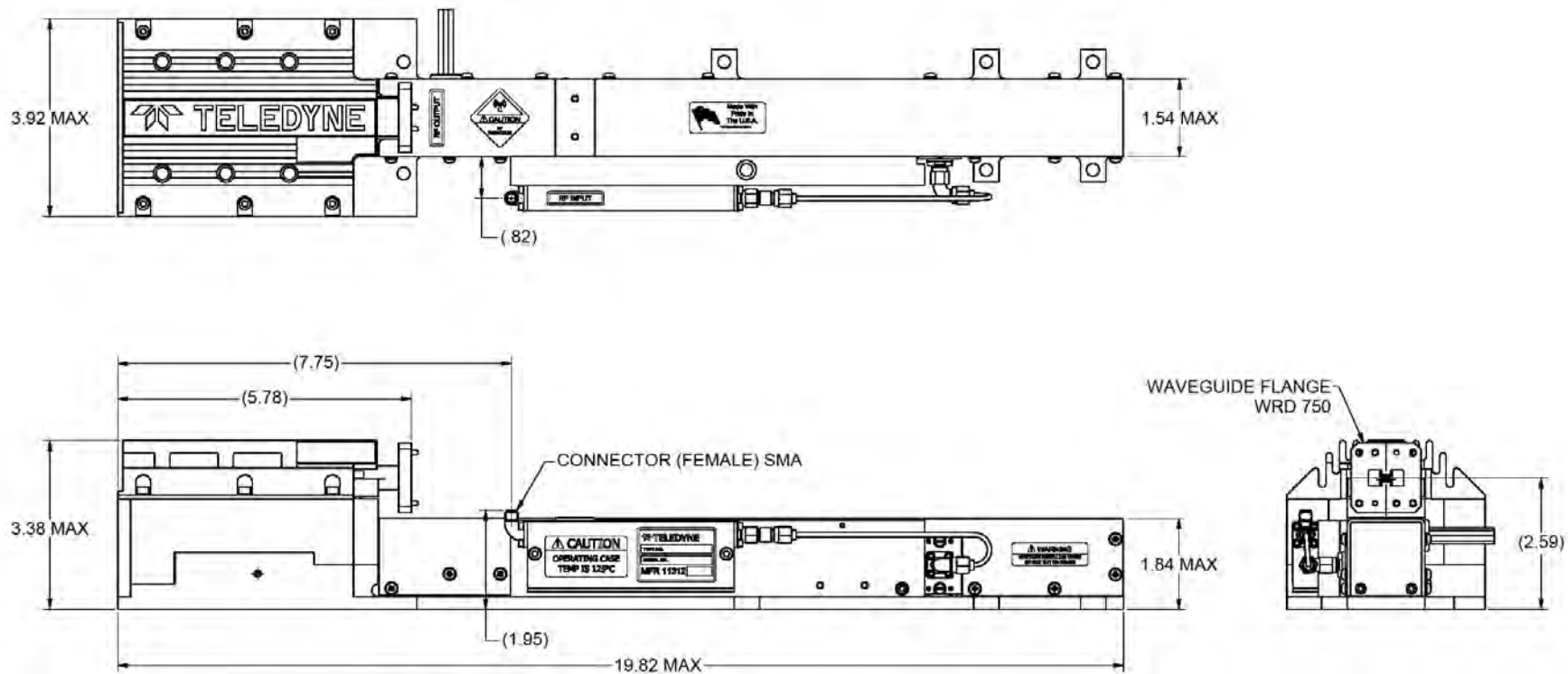

SUBJECT TO CHANGE W/O NOTICE ISO 9001:2008 Registered

<p>TELEDYNE MICROWAVE SOLUTIONS TWT PRODUCTS 12001 Sunrise Park Dr., Rancho Cordova, CA 95748-2044</p>
TITLE
MEC 5519

MEC 5493/MEC 5493E

Continuous Wave TWT

18.0 GHz – 26.5 GHz

- 50 W Minimum Power
- 18.0 to 26.5 GHz
- -40° to 85° C
- 450 W Typ. Prime Power
- 26-28 dB Typical Gain
- 16.1" L x 2.76" W x 3.4" H
(62 x 7 x 8.6 cm)



RF Performance

Freq (GHz)	Typ. Sat. Power Output (W)	Min. Spec. Power Output (W)	Typ. Gain @ Spec. Power (dB)
18.0	75	50	35
19.0	80	50	38
20.0	80	50	39
21.0	100	50	41
22.0	100	50	41
23.0	100	50	41
24.0	100	50	40
25.0	100	50	40
26.0	90	50	40
26.5	90	50	39

Typical power output is shown to illustrate capability.
Typical gain shown is without equalizer.

Typical Operating Conditions

Element	Typical Operating Conditions		Power Supply Requirements		
	Voltage	Current	Voltage Min.	Voltage Max.	Current Max.
Heater	-6.3 Vdc	0.7 A	-5.8 Vdc	-6.4 Vdc	1.5 A
Helix					
with RF	Ground	1.4 mA	Ground	Ground	4 mA
without RF	Ground	0.5 mA	Ground	Ground	4 mA
FE On	-19 Vdc	0.1 mA	0	-40 Vdc	1 mA
FE Off	-850 Vdc	0.1 mA	-800 Vdc	-1200 Vdc	0.2 mA
Cathode (E_k)	-10.55 kV	113 mA	-10.3 kV	-10.8 kV	140 mA
Collector w/RF					
Coll. #1	5.28 kV	40.8 mA	50% x $E_k \pm 2\%$		75 mA
Coll. #2	2.64 kV	70.8 mA	25% x $E_k \pm 2\%$		140 mA

Cathode voltage is measured with respect to ground.

Heater, Collector, and Focus Electrode (FE) voltages are measured with respect to Cathode.

Available with integrated SSM.

Performance

	Typical	Spec
Input VSWR.....	2.0:1	2.5:1
Output VSWR.....	2.0:1	2.5:1
Max. Duty	—	CW
FE Capacitance.....	50 pF	60 pF
Min. Harmonic Separation.....	-8 dBc	-6 dBc
Noise Power Density (dBm/MHz)	-25	-20
Prime Power.....	450 W	500 W

This model number is subject to the jurisdiction of the U.S. Department of Commerce.

NOTES:

1. THERMOSTAT OPTIONS: N/C OR N/O

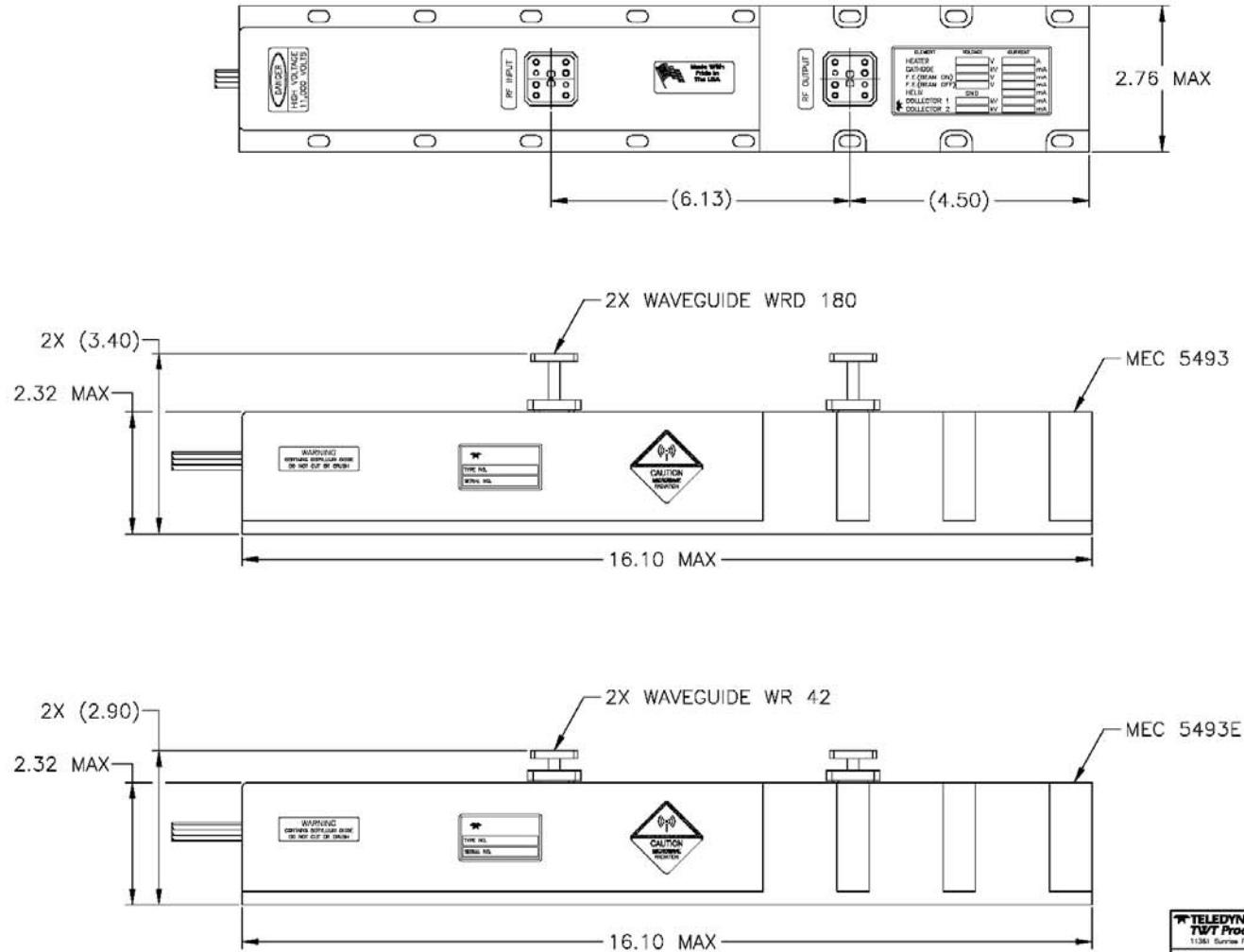

SUBJECT TO CHANGE W/O NOTICE ISO 9001:2008 Registered

TELEDYNE MICROWAVE SOLUTIONS TWT Products <small>11361 Sunrise Park Dr., Rancho Cordova, CA 95742 916.638.3344</small>
TITLE
MEC 5493/MEC 5493E

This model number is subject to the jurisdiction of the U.S. Department of Commerce.

MEC 5496

Continuous Wave TWT

26.5 GHz – 40 GHz

- 40 W Minimum Power
- 26.5 to 40 GHz
- -40° to 85° C
- 400 W Typ. Prime Power
- 35-50 dB Typical Gain
- 16.45" L x 2.76" W x 2.35" H
(41.8 x 7 x 6 cm)



RF Performance

Freq (GHz)	Typ. Sat. Power Output (W)	Min. Spec. Power Output (W)	Typ. Gain @ Spec. Power (dB)
26.5	40	40	45
27.0	40	40	46
28.0	40	40	47
29.0	50	40	48
30.0	50	40	50
31.0	50	40	50
32.0	50	40	50
33.0	60	40	50
34.0	70	40	50
35.0	65	40	50
36.0	60	40	50
37.0	55	40	42
38.0	45	40	38
39.0	40	40	36
40.0	40	40	35

Typical power output is shown to illustrate capability.
Typical gain shown is without equalizer.

Typical Operating Conditions

Element	Typical Operating Conditions		Power Supply Requirements		
	Voltage	Current	Voltage Min.	Voltage Max.	Current Max.
Heater	-6.3 Vdc	0.7 A	-5.8 Vdc	-6.4 Vdc	1.5 A
Helix					
with RF	Ground	2 mA	Ground	Ground	4 mA
without RF	Ground	0.5 mA	Ground	Ground	4 mA
FE On	-6.3 Vdc	0.1 mA	0	-40 Vdc	1 mA
FE Off	-1200 Vdc	0.1 mA	-1200 Vdc	-1500 Vdc	0.2 mA
Cathode (E_k)	-13.5 kV	100 mA	-12.8 kV	-13.8 kV	110 mA
Collector w/RF					
Coll. #1	6.75 kV	10 mA	50% x $E_k \pm 2\%$		50 mA
Coll. #2	3.38 kV	80 mA	25% x $E_k \pm 2\%$		110 mA

Cathode voltage is measured with respect to ground.

Heater, Collector, and Focus Electrode (FE) voltages are measured with respect to Cathode.

Performance

	Typical	Spec
Input VSWR.....	2:1	2.5:1
Output VSWR.....	2:1	2:1
Max. Duty	—	CW
FE Capacitance.....	50 pF	60 pF
Min. Harmonic Separation.....	-8 dBc	-6 dBc
Noise Power Density (dBm/MHz)	-25	-20
Prime Power.....	400 W	500 W

This model number is subject to the jurisdiction of the U.S. Department of Commerce.

NOTES:

1. THERMOSTAT OPTIONS: N/C OR N/O

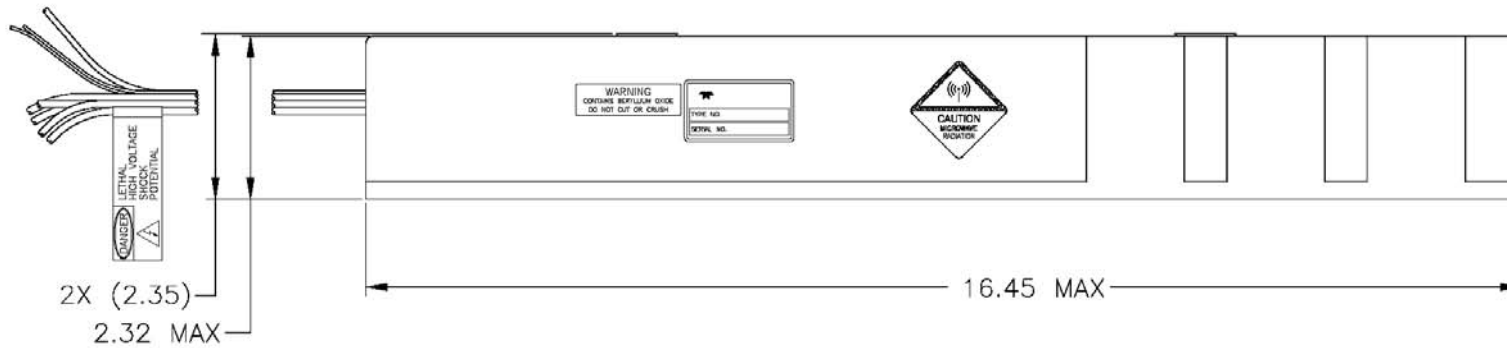
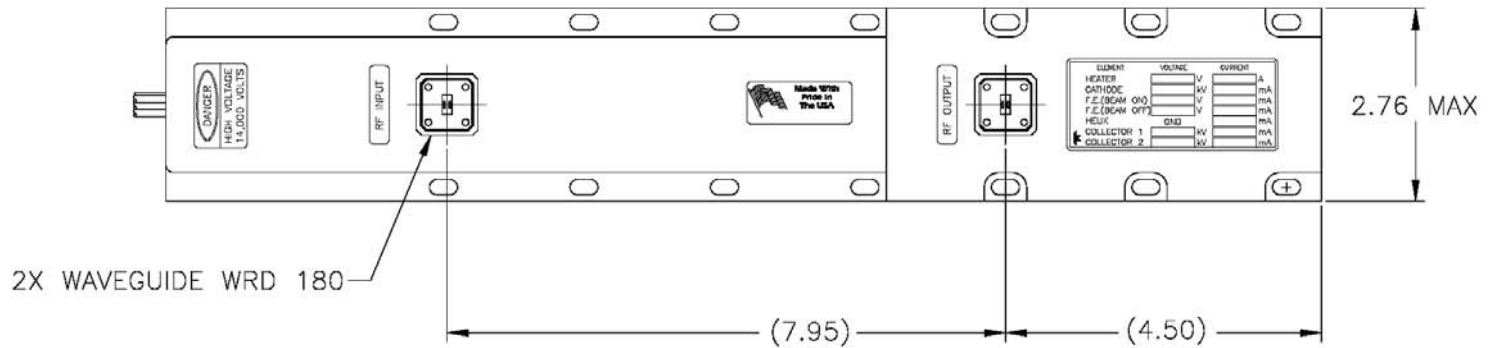

TELEDYNE MICROWAVE SOLUTIONS
TWT Products

11361 Sunrise Park Drive, Rancho Cordova, CA 95742 (916) 638-3344

TITLE

MEC 5496

SUBJECT TO CHANGE W/O NOTICE

ISO 9001:2008 Registered

This model number is subject to the jurisdiction of the U.S. Department of Commerce.

**This page
intentionally
left blank**

Pulse TWTs

Page No.	Model	Frequency (GHz)	Peak Power (W)	Duty (%) Max.	Typical Gain (dB) Min/Max @ Rated P _{out}	Efficiency (%) Typical	Modulation (Control Electrode)	Output Connection	Weight (lbs/kg) (NTE)
74	MEC 3102	2.0 - 4.0	4,500	6	35	29	GRID	SC	15.0/6.8
76	MTG 3041L2	2.0 - 8.0	2,000	6	38/58	24	GRID	SC	8.0/3.6
78	MEC 3132	2.0 - 8.0	1000	6	40/48	17*	GRID	TNC	8.0/3.6
80	MTG 3041K	2.5 - 8.0	2,000*	6	43/68	21*	GRID	SC	8.0/3.6
82	MEC 3082B	2.7 - 4.0	10,000	4	41/47	33*	GRID	SC	15.0/6.8
84	MEC 3090X	2.8 - 3.6	13000	2	38/41	27	GRID	N	30.0/13.6
86	MEC 3103	4.0 - 8.0	4,500	6	32/34	34	GRID	WRD 350	15.0/6.8
88	MEC 3096	5.0 - 11.0	1,780	5	37/38	34	GRID	WRD 475	9.0/4.1
90	MEC 3094A	5.35 - 5.65	8,000	4	46	33	GRID	SC	8.0/3.6
92	MEC 3119	6.0 - 8.0	7000	4	41/43	33	GRID	WRD 350	15.0/6.8
94	MTI 3444L	6.5 - 18.0	1,580*	6	43/46	14*	GRID	WRD 650/750	7.0/3.2
96	MEC 3848	8.0 - 11.0	8,000*	5	48/51	40	GRID	WR 90	10.0/4.5
98	MEC 3106	8.0 - 12.0	1000*	20	26/38	45	GRID	TNC	2.0/0.9
100	MEC 3848N	8.0 - 12.0	5,000	8	48/50	32	GRID	WR 90	10.0/4.5
102	MTI 3044C	8.0 - 12.4	1200	4	57/64	12*	GRID	TNC	6.0/2.7
104	MTI 3044J	8.0 - 18.0	1,000	4	42/62	12*	GRID	TNC	6.0/2.7
106	MTI 3048Q	8.2 - 12.4	3,000*	8	43/50	24*	GRID	WR 90	6.0/2.7
108	MTI 3048D	8.7 - 10.5	4,000*	10	45/47	32*	GRID	WR 90	6.0/2.7
110	MTI 3948B	8.8 - 10.5	8,000*	5	48/51	35*	GRID	WR 90	7.5/3.4
112	MTI 3948	8.8 - 10.5	8,700*	2	50/51	30*	GRID	WR 90	7.5/3.4
114	MTI 3948U	9.0 - 10.0	7,945	5	47/48	35	GRID	WR 90	9.5/4.3
116	MEC 3104	12.0 - 18.0	3,470	6	32/39	25	GRID	WR 62	9.0/4.1
118	MTI 3056C	15.0 - 17.0	4,000*	2	50/56	16*	GRID	WR 62	6.5/3.0
120	MEC 3116X	15.0 - 18.0	1250	4.5	43/45	20*	GRID	WR-62	7.0/3.2
122	MEC 3117X	15.2 - 18.2	400*	35	34/35	32	GRID	WR-51	2.0/0.9
124	MEC 3333 (FWU)	15.5 - 16.5	850	33	46/48	34	GRID	WR-51	3.5/1.5
126	MEC 3086	15.5 - 17.9	700	35	45/48	32	GRID	WR 62	9.5/4.3

* Over majority of frequency range - Performance may be reduced at band edges.

MEC 3102

Pulse TWT

2 GHz – 4 GHz

- 6% Maximum Duty
- 4.5 kW Minimum Power
- 2.0 to 4.0 GHz
- -40° to 85° C
- 1220 W Typ. Prime Power @6%
- 35 dB Typical Gain
- 25.7" L x 4" W x 4.07" H
(65.3 x 10.2 x 10.34 cm)
- Phase Match Available



RF Performance

Freq (GHz)	Typ. Sat. Power Output (W)	Min. Spec. Power Output (W)	Typ. Gain @ Spec. Power (dB)
2.0	5500	4500	35
2.25	5500	4500	35
2.5	6000	4500	35
2.75	6500	4500	35
3.0	6500	4500	35
3.25	6500	4500	35
3.5	6000	4500	35
3.75	5500	4500	35
4.0	5500	4500	35

Typical power output is shown to illustrate capability.
Typical gain shown is with equalizer.

Typical Operating Conditions

Element	Voltage	Current	Power Supply Requirements		
			Voltage Min.	Voltage Max.	Current Max.
Heater	-6.5 Vdc	4.3 A	-6.4 Vdc	-6.8 Vdc	5.00 A
Helix					
with RF	Ground	600 mA	Ground	Ground	800 mApk @ 6%
without RF	Ground	70 mA	Ground	Ground	800 mApk @ 6%
Grid On	157 Vpk	3.3 mA	100 Vpk	300 Vpk	30 mApk
Grid Off	-325 Vdc	0.010 mA	-300 Vdc	-500 Vdc	1 mA
Cathode (Ek)	-10.9 kV	2.3 Apk	-10.2 kV	-11.2 kV	2.5 Apk
Collector w/RF					
Coll. #1	8.7 kV	530 mApk	80% x Ek ±2%		0.7 Apk
Coll. #2	7.7 kV	780 mApk	71% x Ek ±2%		1.2 Apk
Coll. #3	4.21 kV	425 mApk	39% x Ek ±2%		2.5 Apk

Cathode voltage is measured with respect to ground.

Heater, Collector, and Grid voltages are measured with respect to Cathode.

Performance

	Typical	Spec
Input VSWR.....	2.0:1	2.5:1
Output VSWR.....	1.7:1	2.0:1
Max. Duty	—	6%
Max. Pulsewidth	—	100 μs
Grid Capacitance.....	59 pF	65 pF
Min. Harmonic Separation.....	-3.8 dBc	-3 dBc
Noise Power Density (dBm/MHz)	-30	5
Prime Power.....	1220 W	1800 W

NOTES:

1. THERMOSTAT OPTIONS: N/C OR N/O

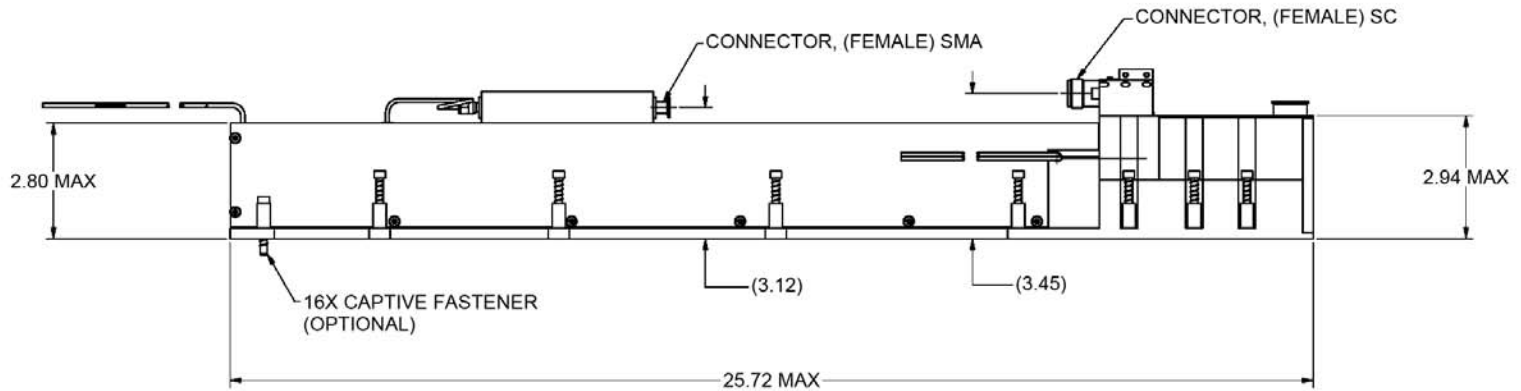
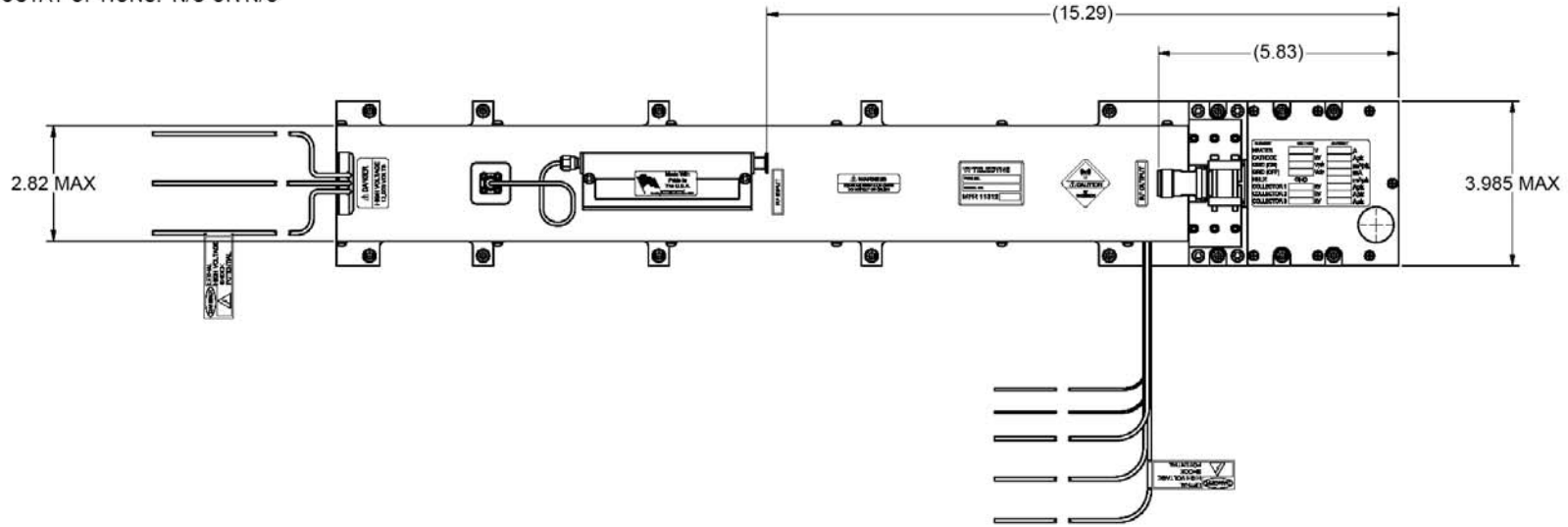

SUBJECT TO CHANGE W/O NOTICE ISO 9001:2008 Registered

TELEDYNE MICROWAVE SOLUTIONS
TWT PRODUCTS
11361 Sunrise Park Dr., Rancho Cordova, CA 95742

TITLE

MEC 3102

MTG 3041L2

Pulse TWT

2.0 GHz – 8.0 GHz

- 6% Maximum Duty
- 2 kW Minimum Power
- 2.0 to 8.0 GHz
- -40° to 85° C
- 725 W Typ. Prime Power @6%
- 38-58 dB Typical Gain
- 21.25" L x 2.55" W x 3.25" H
(54 x 6.5 x 8.3 cm)



RF Performance

Freq (GHz)	Typ. Sat. Power Output (W)	Min. Spec. Power Output (W)	Typ. Gain @ Spec. Power (dB)
2.0	2040	2000*	38
2.2	2040	2000	38
2.3	2300	2000**	39
2.5	2400	2000	40
2.6	2500	2000***	44
3.0	2500	2000	50
4.0	2500	2000	57
5.0	2500	2000	58
6.0	2500	2000	55
7.0	2350	2000	50
7.5	2300	2000	48
8.0	2040	2000	44

Typical power output is shown to illustrate capability.
Typical gain shown is with equalizer and limiter (for harmonic injection).

Typical Operating Conditions

Element	Typical Operating Conditions		Power Supply Requirements		
	Voltage	Current	Voltage Min.	Voltage Max.	Current Max.
Heater	-6.3 Vdc	2.2 A	-6.1 Vdc	-6.5 Vdc	3.0 A
Helix					
with RF	Ground	650 mApk	Ground	Ground	700 mApk @ 6%
without RF	Ground	150 mApk	Ground	Ground	700 mApk @ 6%
Grid On	217 Vpk	1.8 mApk	100 Vpk	250 Vpk	20 mApk
Grid Off	-250 Vdc	0.01 mA	-250 Vdc	-500 Vdc	0.1 mA
Cathode (Ek)	-8.5 kV	1.65 Apk	-8.2 kV	-8.8 kV	1.8 Apk
Collector w/RF	6.38 kV	1 Apk		75% x Ek ±2%	1.8 Apk

Cathode voltage is measured with respect to ground.
Heater, Collector, and Grid voltages are measured with respect to Cathode.

Performance	Typical	Spec
Input VSWR.....	3.5:1	3.5:1
Output VSWR.....	1.8:1	2.5:1
Max. Duty	—	6%
Max. Pulsewidth	—	100 μs
Grid Capacitance.....	47 pF	50 pF
Min. Harmonic Separation (dB).....	3.5/0/-2.5	4.5*/1.5**/-1***
Noise Power Density (dBm/MHz)	-12	-10
Prime Power.....	725 W	800 W

Specifications are subject to change without notice.

NOTES:

1. THERMOSTAT OPTIONS: N/C OR N/O

② EQUALIZER OPTIONAL BASED UPON CUSTOMER REQUIREMENT.

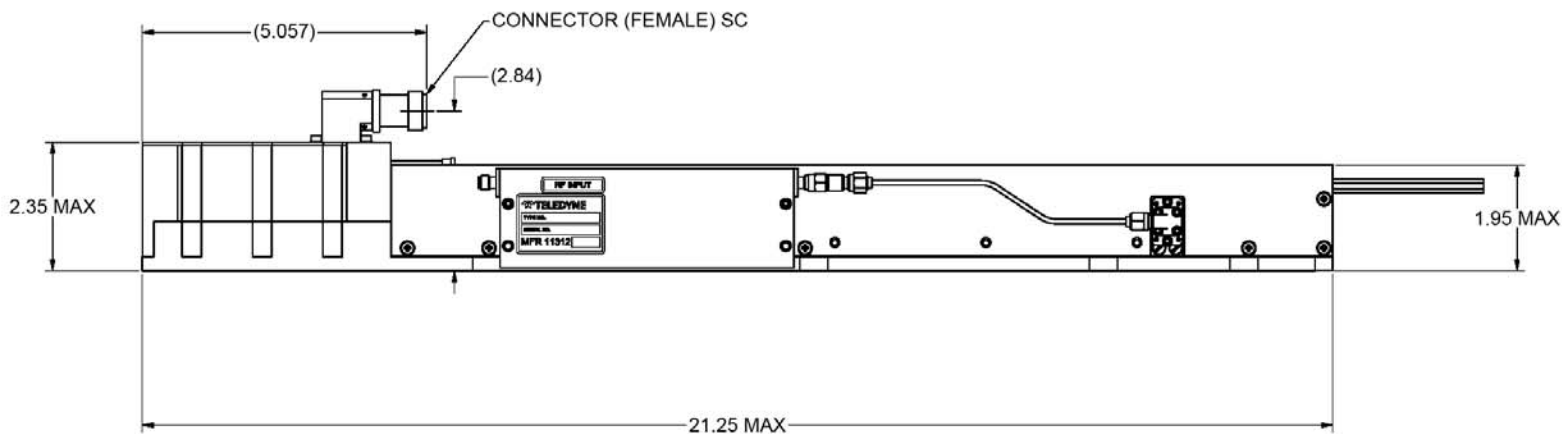
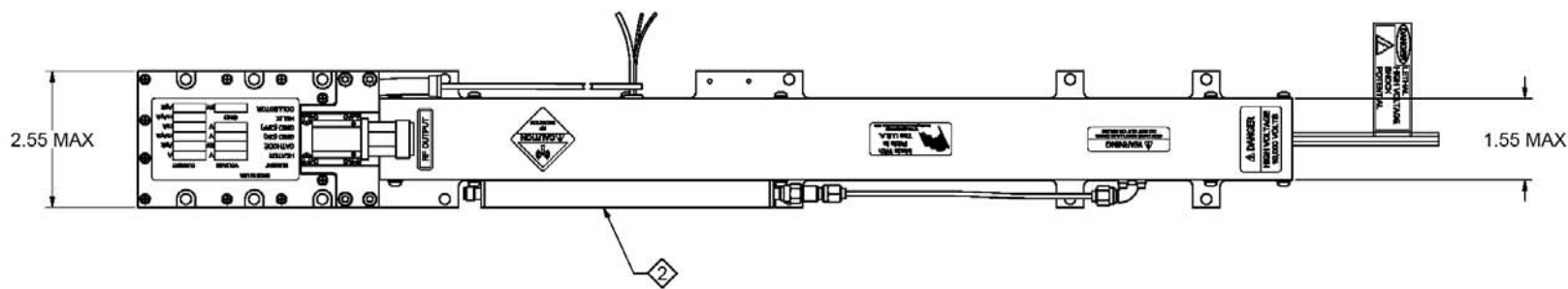

SUBJECT TO CHANGE W/O NOTICE ISO 9001:2008 Registered

<p>TELEDYNE MICROWAVE SOLUTIONS TWT PRODUCTS 11361 Sunrise Park Dr., Rancho Cordova, CA 95742 (916) 638-3344</p>
TITLE
MTG 3041L2/MTG 3041K

MEC 3132

Pulse TWT

2.0 GHz – 8.0 GHz

- 1kW Minimum Power
- 2.0 to 8.0 GHz
- -40° to 85° C
- 6% Maximum Duty
- 40-48 dB Typical Gain for Sat.
- 21.0" L x 2.45" W x 3.0" H
(53.3 x 6.2 x 7.62 cm)



RF Performance

Freq (GHz)	Typ. Sat. Power Output (W)	Min. Spec. Power Output (W)	Typ. Gain @ Saturated Power (dB)
2.0	1100	1000	40
3.0	1500	1000	46
4.0	1700	1000	47
5.0	1900	1000	48
6.0	1800	1000	47
7.0	1800	1000	47
8.0	1800	1000	47

Typical power output is shown to illustrate capability.
Typical gain shown is with equalizer.

Typical Operating Conditions			Typical Power Supply Requirements		
Element	Voltage	Current	Voltage Min.	Voltage Max.	Current Max.
Heater	-6.3 Vdc	1.7 A	-6.0 Vdc	-6.6 Vdc	2.5A
Helix					
with RF	Ground	400 mApk	Ground	Ground	500 mApk
without RF	Ground	150 mApk	Ground	Ground	500 mApk
Grid On	185 Vpk	1 mApk	130 Vpk	230 Vpk	20 mApk
Grid Off	-200 Vdc	0.1 mA	-200 Vdc	-300 Vdc	0.5 mA
Cathode (E _k)	-8.6kV	1.35 Apk	-8.0 kV	-9.2 kV	1.7 Apk
Collector w/RF	6.02kV	0.95 Apk		70% x E _k ±2%	1.7 Apk

Cathode voltage is measured with respect to ground.
Heater, Collector, and Grid voltages are measured with respect to Cathode.

Performance	Typical	Spec
Input VSWR.....	2.0:1	3.0:1
Output VSWR.....	2.0:1	3.0:1
Max. Duty	—	6%
Max. Pulsewidth	—	100 μs
Noise Power Density (2 to 8 GHz) (dBm/MHz)	-10	0
Prime Power	612 W	750 W

NOTES:

- 1. THERMOSTAT OPTIONS: N/C OR N/O.
- 2. EQUALIZER OPTIONAL PER CUSTOMER REQUIREMENT.

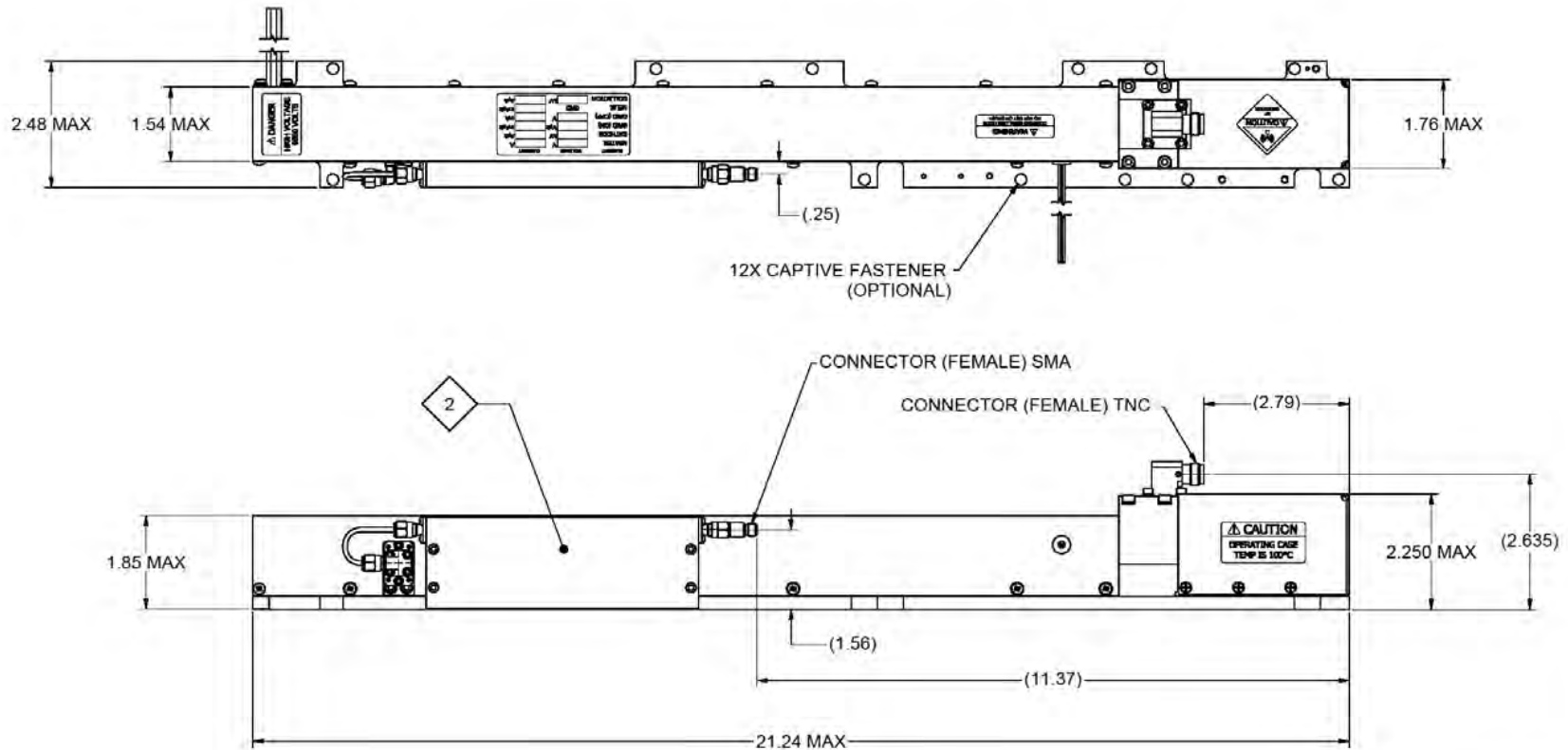

SUBJECT TO CHANGE W/O NOTICE ISO 9001:2008 Registered

TELEDYNE MICROWAVE SOLUTIONS
TWT PRODUCTS
11361 Sunrise Park Dr., Rancho Cordova, CA 95764-3044

Title:

MEC 3132

MTG 3041K

Pulse TWT

2.5 GHz – 8.0 GHz

- 6% Maximum Duty
- 1900 W Minimum Power
- 2.5 to 8.0 GHz
- -40° to 85° C
- 650 W Typ. Prime Power @6%
- 43-68 dB Typical Gain
- 21.25" L x 2.55" W x 3.25" H
(54 x 6.5 x 8.3 cm)



RF Performance

Freq (GHz)	Typ. Sat. Power Output (W)	Min. Spec. Power Output (W)	Typ. Gain @ Spec. Power (dB)
2.5	2000	1900	50
2.7	2040	2000	52
3.0	2150	2000	54
4.0	2450	2000	60
5.0	2450	2000	68
6.0	2450	2000	59
7.0	2450	2000	51
8.0	2400	2000	43

Typical power output is shown to illustrate capability.
Typical gain shown is without equalizer.

Typical Operating Conditions

Element	Voltage	Current	Power Supply Requirements		
			Voltage Min.	Voltage Max.	Current Max.
Heater	-6.3 Vdc	2.2 A	-6.1 Vdc	-6.5 Vdc	3.0 A
Helix					
with RF	Ground	400 mApk	Ground	Ground	600 mApk @ 6%
without RF	Ground	150 mApk	Ground	Ground	600 mApk @ 6%
Grid On	217 Vpk	1.8 mApk	100 Vpk	250 Vpk	50 mApk
Grid Off	-250 Vdc	0.01 mA	-250 Vdc	-500 Vdc	0.1 mA
Cathode (Ek)	-8.6 kV	1.4 Apk	-8.2 kV	-8.8 kV	2.0 Apk
Collector w/RF	6.45 kV	1.0 Apk		75% x Ek ±2%	2.0 Apk

Cathode voltage is measured with respect to ground.

Heater, Collector, and Grid voltages are measured with respect to Cathode.

Performance

	Typical	Spec
Input VSWR.....	2:1	2.5:1
Output VSWR.....	1.8:1	2.5:1
Max. Duty	—	6%
Max. Pulsewidth	—	100 μs
Grid Capacitance.....	47 pF	50 pF
Min. Harmonic Separation.....	-1.7 dBc	-1.5 dBc
Noise Power Density (dBm/MHz)	-12	-10
Prime Power.....	650 W	750 W

NOTES:

1. THERMOSTAT OPTIONS: N/C OR N/O

② EQUALIZER OPTIONAL BASED UPON CUSTOMER REQUIREMENT.

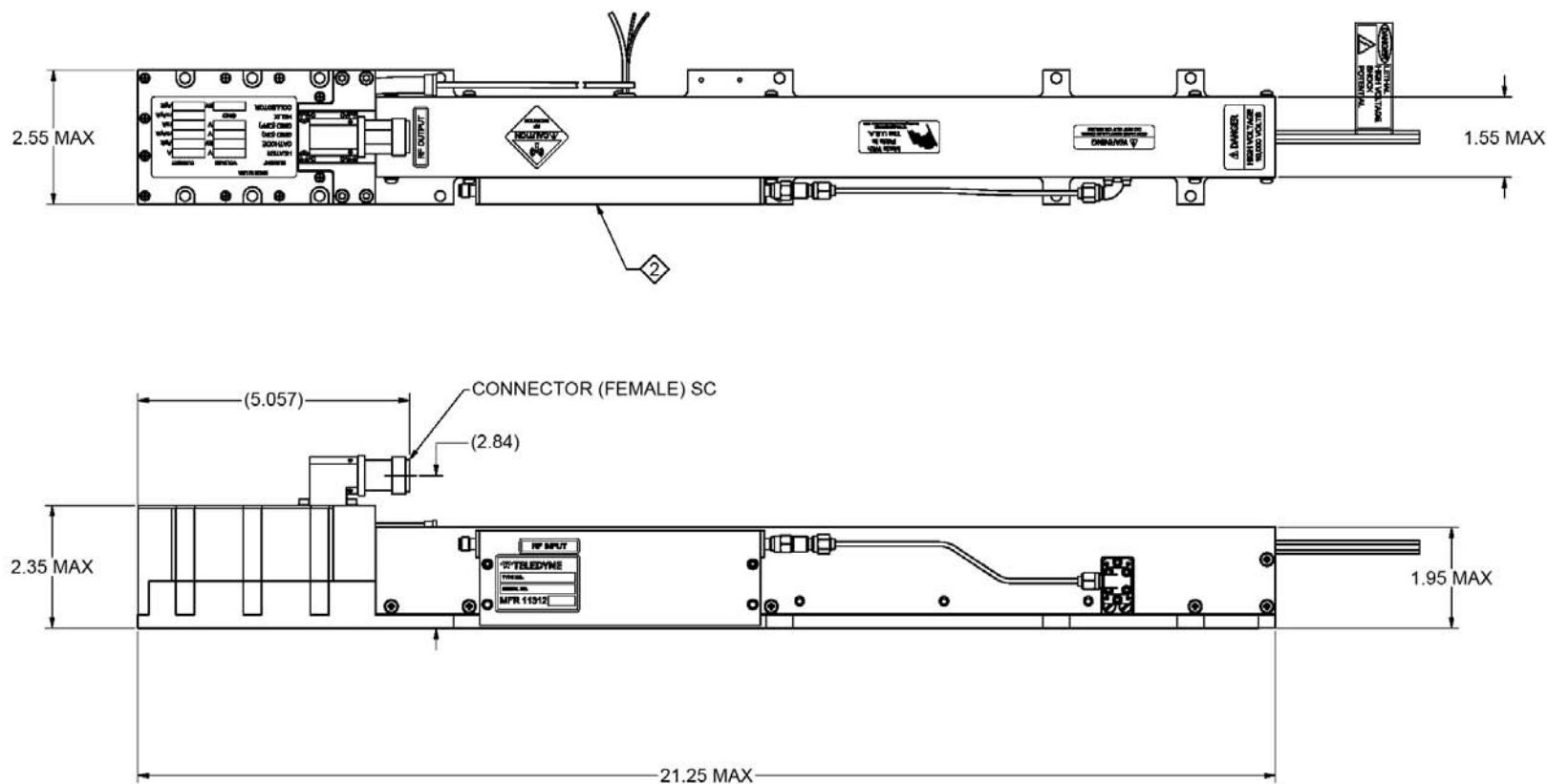

SUBJECT TO CHANGE W/O NOTICE ISO 9001:2008 Registered

<p>TELEDYNE MICROWAVE SOLUTIONS TWT PRODUCTS 11361 Sunrise Park Dr., Rancho Cordova, CA 95742 (916) 638-3344</p>
TITLE
MTG 3041L2/MTG 3041K

MEC 3082B

Pulse TWT

2.7 GHz – 4.0 GHz

- 4% Typical Maximum Duty
- 10 kW Minimum Power
- 2.7 to 4.0 GHz
- -40° to 85° C
- 1400 W Typ. Prime Power @4%
- 42-47 dB Typical Gain
- 23.5" L x 4" W x 4.2" H
(59.7 x 10.2 x 10.7 cm)
- ±20° Typical Phase Match



RF Performance

Freq (GHz)	Typ. Sat. Power Output (W)	Min. Spec. Power Output (W)	Typ. Gain @ Spec. Power (dB)
2.7	10,000	10,000	42
2.9	10,500	10,000	45
3.25	12,500	10,000	47
3.4	12,500	10,000	46
3.7	13,325	10,000	45
3.85	13,500	10,000	45
4.0	13,800	10,000	43

Typical power output is shown to illustrate capability.
Typical gain shown is without equalizer.

Typical Operating Conditions			Power Supply Requirements		
Element	Voltage	Current	Voltage Min.	Voltage Max.	Current Max.
Heater	-6.6 Vdc	4.5 A	-6.4 Vdc	-6.8 Vdc	5 A
Helix					
with RF	Ground	0.63 Apk	Ground	Ground	0.8 Apk @ 4%
without RF	Ground	0.12 Apk	Ground	Ground	0.8 Apk @ 4%
Grid On	175 Vpk	2.0 mApk	100 Vpk	250 Vpk	30 mApk
Grid Off	-400 Vdc	0 mA	-400 Vdc	-500 Vdc	1.0 mA
Cathode (Ek)	-14.49 kV	2.94 Apk	-12.5 kV	-15 kV	3.5 Apk
Collector					
Coll. #1	12.75 kV	1.080 Apk (w/RF) 0.172 Apk (w/o RF)	88% x Ek ±2%		2 Apk
Coll. #2	8.58 kV	0.746 Apk (w/RF) 0.093 Apk (w/o RF)	66% x Ek ±2%		3.5 Apk
Coll. #3	4.69 kV	0.378 Apk (w/RF) 2.630 Apk (w/o RF)	41% x Ek ±2%		3.5 Apk

Cathode voltage is measured with respect to ground.
Heater, Collector, and Grid voltages are measured with respect to Cathode.

Performance	Typical	Spec
Input VSWR.....	1.55:1	2:1
Output VSWR.....	1.6:1	2:1
Max. Duty	—	4%
Max. Pulsewidth	—	150 μs
Grid Capacitance.....	45 pF	50 pF
Second Harmonic.....	-8.7 dBc	-6 dBc
Noise Power Density (dBm/MHz)	-26	-20
Prime Power.....	1400 W	1500 W max.

NOTES:

1. THERMOSTAT OPTIONS: (N.C./N.O.)

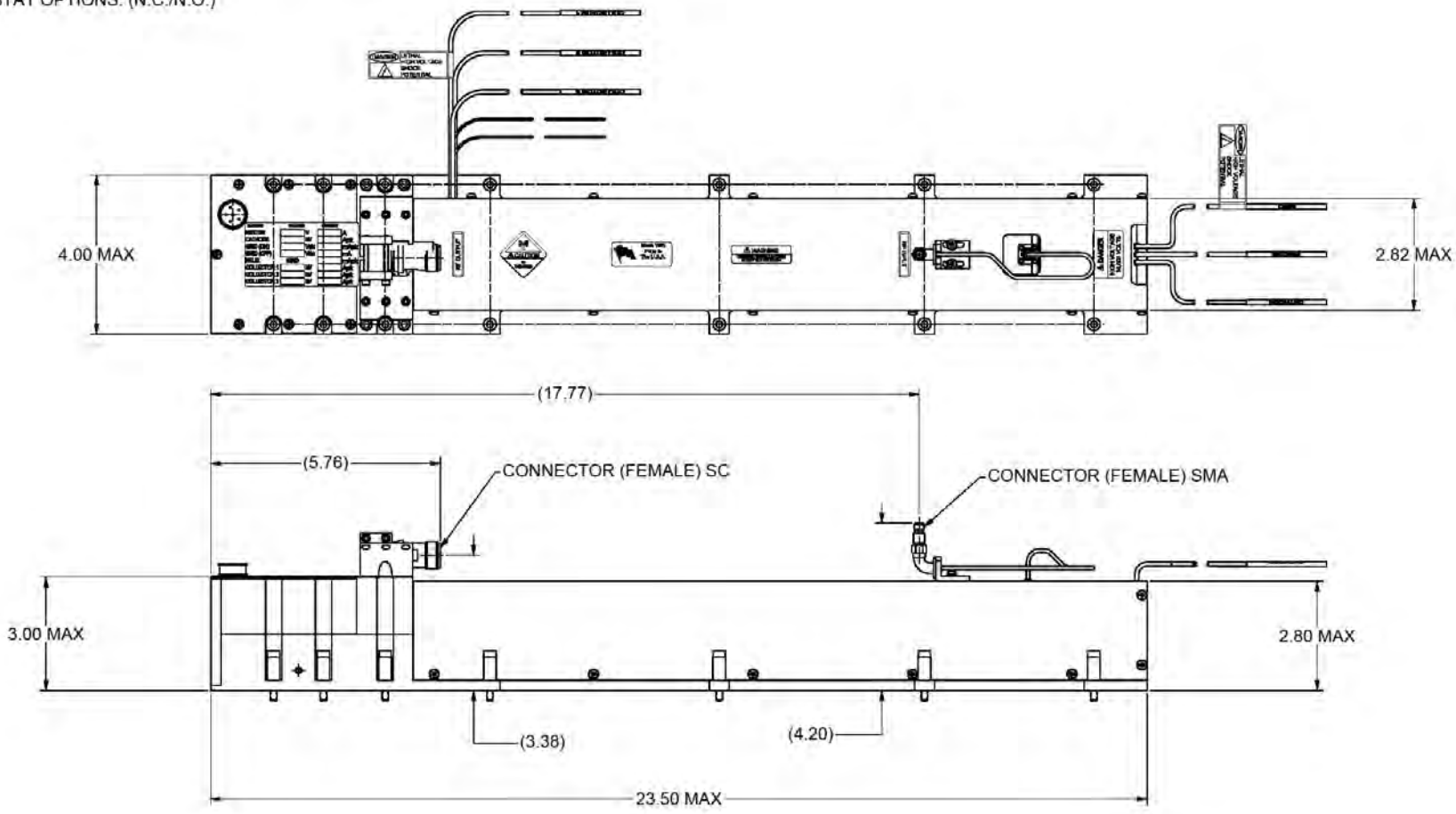

SUBJECT TO CHANGE W/O NOTICE ISO 9001:2008 Registered

TELEDYNE MICROWAVE SOLUTIONS TWT PRODUCTS <small>4140 Central Express Way • Santa Ana, CA 92705-5000</small>
TITLE
MEC 3082B

MEC 3090X

Pulse TWT

2.8 GHz – 3.6 GHz

- 2% Maximum Duty
- 14+ kW_{pk} Typical Minimum Power
- 2.8 to 3.6 GHz
- Liquid Cooled Design
- On board Vac-Ion Pump
- 1300 W Typ. Prime Power
- 100 μS PW Max
- 40 dB Typical Sat. Gain
- 27.5" L x 4.75" W x 3.72" H (70 x 12 x 9.45 cm)



RF Performance

Freq (GHz)	Typ. Sat. Power Output (W)	Min. Spec. Power Output (W)	Typ. Gain @ Sat. Power (dB)
2.8	13500	13000	38
2.9	14500	13000	39
3.0	16000	13000	40
3.1	17500	13000	41
3.2	19500	13000	41
3.3	21000	13000	41
3.4	21000	13000	41
3.5	21000	13000	41
3.6	19500	13000	41

Typical power output is shown to illustrate capability.
Typical gain shown is with equalizer.

Typical Operating Conditions			Power Supply Requirements		
Element	Voltage	Current	Voltage Min.	Voltage Max.	Current Max.
Heater	-6.3 Vdc	5.55 A	-6.1 Vdc	-6.5 Vdc	6 A
Helix					
with RF	Ground	1.39 Apk	Ground	Ground	1.5 Apk
without RF	Ground	300 mApk	Ground	Ground	1.5 Apk
Grid On	216 Vpk	1.0 mApk	175 Vpk	350 Vpk	50 mApk
Grid Off	-300 Vdc	0.1 mA	-300 Vdc	-500 Vdc	0.5 mA
Cathode (E _k)	-16.75 kV	4.63 Apk	-16.0 kV	-17.0 kV	5.0 Apk
Collector w/RF	14.75 kV	3.24 Apk	88% x E _k ±2%		4.8 Apk
Vac-Ion Pump	3.3 kV	0 to 5 uA	3.3 kV		5.0 uA

Cathode voltage is measured with respect to ground.
Heater, Collector, and Control Grid voltages are measured with respect to Cathode.

Performance	Typical	Spec
Input VSWR.....	1.5:1	2.0:1
Output VSWR.....	1.7:1	2.5:1
Max. Duty	2%	2%
Max. Pulsewidth	100 μs	100 μs
Grid Capacitance.....	55 pF	65 pF max.
Prime Power.....	1300W	1400 W

NOTES:

1. THERMOSTAT OPTIONS: N/C OR N/O

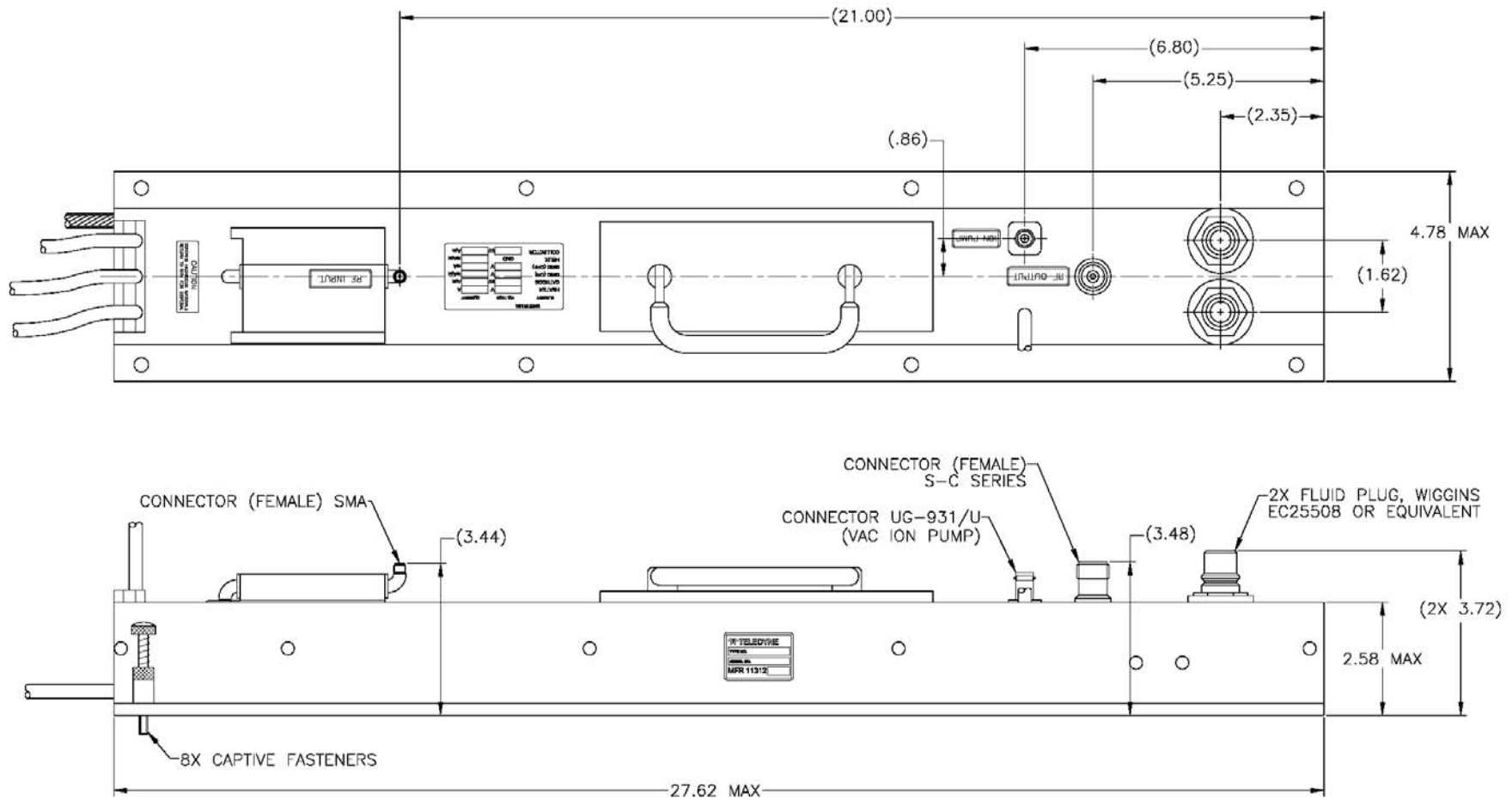

SUBJECT TO CHANGE W/O NOTICE ISO 9001:2008 Registered

TELEDYNE MICROWAVE SOLUTIONS TWT Products 11361 Sunrise Park Dr., Rancho Cordova, CA 95744 (916) 638-3344
TITLE
MEC 3090X

MEC 3103

Pulse TWT

4 GHz – 8 GHz

- 6% Maximum Duty
- 4500 W Minimum Power
- 4.0 to 8.0 GHz
- -40° to 85° C
- 1185 W Typ. Prime Power @6%
- 32-34 dB Typical Gain
- 22.27" L x 5.54" W x 4.34" H
(56 x 14 x 11 cm)
- Phase Match Available

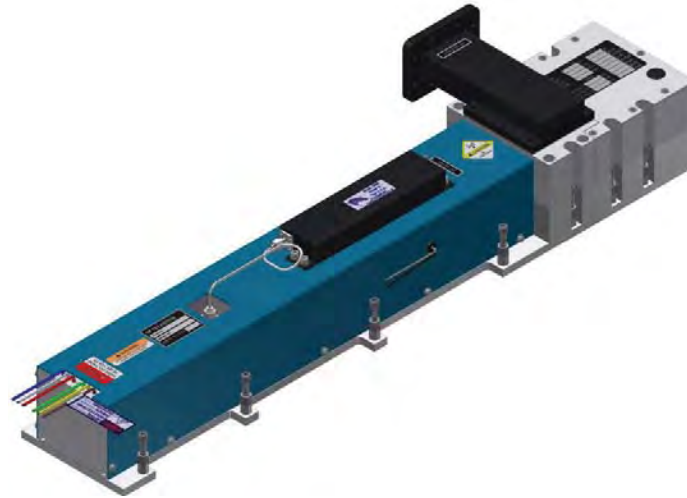

RF Performance

Freq (GHz)	Typ. Sat. Power Output (W)	Min. Spec. Power Output (W)	Typ. Gain @ Spec. Power (dB)
4.0	4790	4500	32
4.5	4570	4500	33
5.0	4570	4500	33
5.5	6170	4500	34
6.0	6310	4500	34
6.5	5890	4500	34
7.0	5890	4500	33
7.5	5750	4500	33
8.0	4790	4500	32

Typical power output is shown to illustrate capability.
Typical gain shown is with equalizer.

Typical Operating Conditions

Element	Typical Operating Conditions		Power Supply Requirements		
	Voltage	Current	Voltage Min.	Voltage Max.	Current Max.
Heater	-6.3 Vdc	2.25 A	-6.1 Vdc	-6.5 Vdc	3.0 A
Helix					
with RF	Ground	600 mApk	Ground	Ground	800 mApk @ 6%
without RF	Ground	80 mApk	Ground	Ground	800 mApk @ 6%
Grid On	216 Vpk	3 mA	100 Vpk	300 Vpk	30 mApk
Grid Off	-300 Vdc	0.1 mA	-300 Vdc	-500 Vdc	1.0 mA
Cathode (Ek)	-12.6 kV	1.9 Apk	-12 kV	-14 kV	3.0 Apk
Collector w/RF					
Coll. #1	9.70 kV	485 mApk	77% x Ek ±2%		700 mApk
Coll. #2	7.30 kV	555 mApk	58% x Ek ±2%		1200 mApk
Coll. #3	5.65 kV	700 mApk	45% x Ek ±2%		2700 mApk

Cathode voltage is measured with respect to ground.

Heater, Collector, and Grid voltages are measured with respect to Cathode

Performance

	Typical	Spec
Input VSWR.....	1.8:1	2.5:1
Output VSWR.....	1.9:1	2.0:1
Max. Duty	—	6%
Max. Pulsewidth	—	100 μs
Grid Capacitance.....	64 pF	70 pF
Min. Harmonic Separation.....	-5.1 dBc	-0.5 dBc
Noise Power Density (dBm/MHz)	-29	-5
Prime Power.....	1185 W	1800 W

Specifications are subject to change without notice.

NOTES:

1. THERMOSTAT OPTIONS: N/C OR N/O

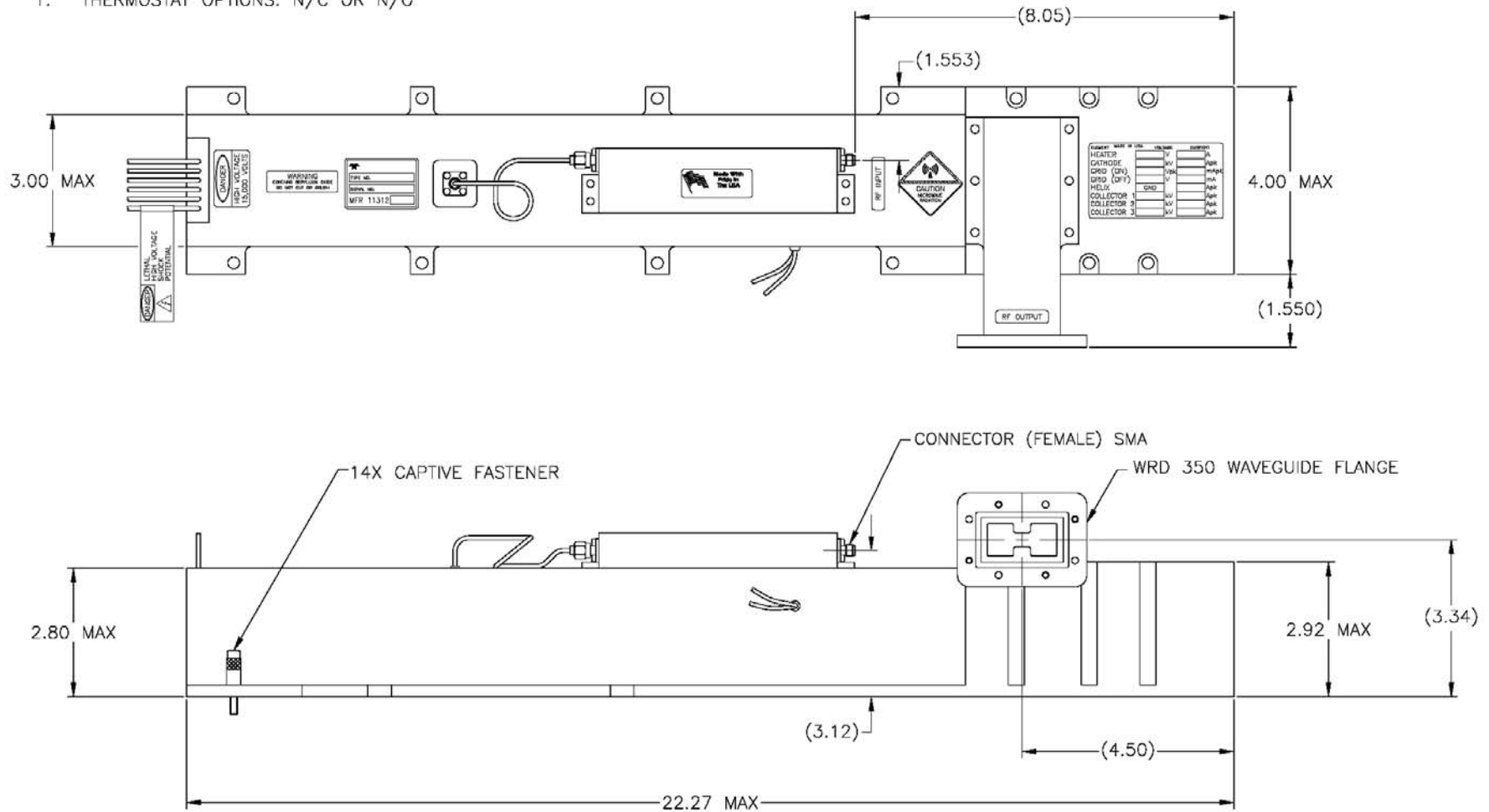

SUBJECT TO CHANGE W/O NOTICE ISO 9001:2008 Registered

TELEDYNE MICROWAVE SOLUTIONS
TWT Products
 11361 Sunrise Park Drive, Rancho Cordova, CA 95742 (916) 638-3344
 TITLE
MEC 3103

MEC 3096

Pulse TWT

5.0 GHz – 11.0 GHz

- 5% Maximum Duty
- 1780 W Minimum Power
- 5.0 to 11.0 GHz
- -40° to 85° C
- 570 W Typ. Prime Power @5%
- 37-38 dB Typical Gain
- 19" L x 2.48" W x 3.65" H (48.3 x 6.3 x 9.27 cm)
- Phase Match Available

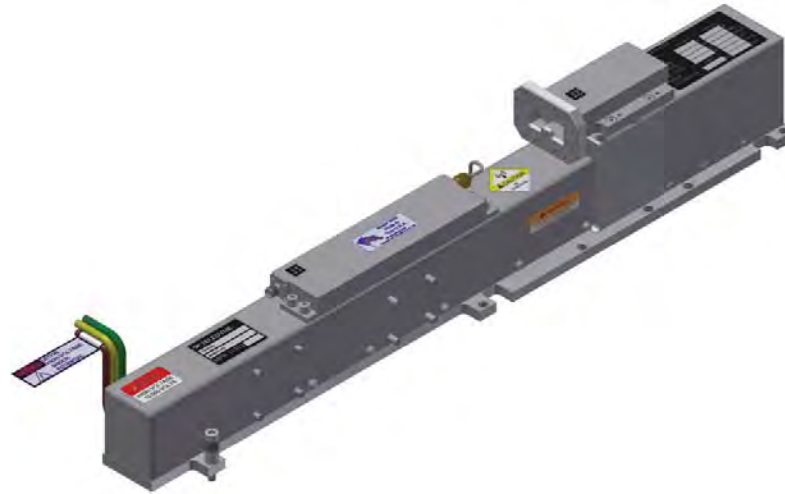

RF Performance

Freq (GHz)	Typ. Sat. Power Output (W)	Min. Spec. Power Output (W)	Typ. Gain @ Spec. Power (dB)
5.0	2400	1780	38
6.0	2750	1780	38
7.0	2290	1780	38
8.0	2510	1780	38
9.0	2750	1780	38
10.0	2750	1780	38
11.0	2090	1780	37

Typical power output is shown to illustrate capability.
Typical gain shown is with equalizer.

Typical Operating Conditions			Power Supply Requirements		
Element	Voltage	Current	Voltage Min.	Voltage Max.	Current Max.
Heater	-6.3 Vdc	2.0 A	-5.985 Vdc	-6.615 Vdc	2.8 A
Helix					
with RF	Ground	270 mApk	Ground	Ground	500 mApk @ 5%
without RF	Ground	100 mApk	Ground	Ground	500 mApk @ 5%
Grid On	225 Vpk	0 mApk	100 Vpk	250 Vpk	10 mApk
Grid Off	-200 Vdc	0 mA	-200 Vdc	-200 Vdc	1.0 mA
Cathode (Ek)	-10.2 kV	1300 mApk	-10.2 kV	-11 kV	1300 mApk
Collector					
w/RF	8.16kV	1030 mApk	80% x Ek ±2%		800-1200 mApk
w/o RF	8.16 kV	1200 mApk	80% x Ek ±2%		1300 mApk

Cathode voltage is measured with respect to ground.
Heater, Collector, and Grid voltages are measured with respect to Cathode.

Performance	Typical	Spec
Input VSWR.....	1.8:1	2.0:1
Output VSWR.....	1.8:1	2.0:1
Max. Duty	5%	5%
Max. Pulsewidth	—	100 μs
Grid Capacitance.....	48 pF	50 pF max.
Min. Harmonic Separation.....	-5.5 dBc	-3 dBc max.
Noise Power Density (dBm/MHz)	-19.5	0
Prime Power.....	570 W	1000 W

NOTES:

1. THERMOSTAT OPTIONS: N/C OR N/O

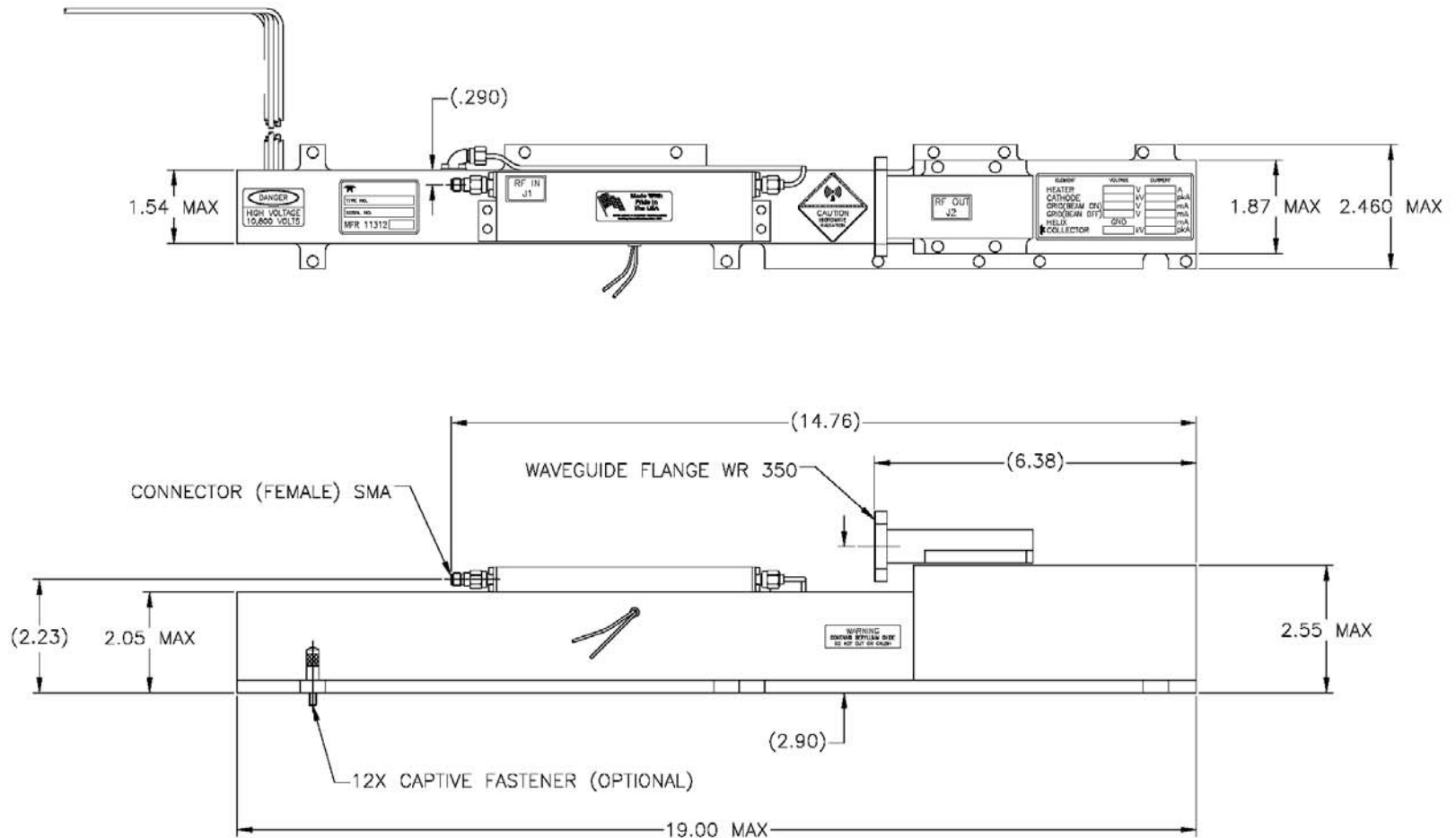

SUBJECT TO CHANGE W/O NOTICE ISO 9001:2008 Registered

TELEDYNE MICROWAVE SOLUTIONS TWT Products 11361 Sunrise Park Dr., Rancho Cordova, CA 95742 (916) 638-3344
TITLE
MEC 3096

MEC 3094A

Pulse TWT

5.35 GHz – 5.65 GHz

- 4% Maximum Duty
- 8 kW Minimum Power
- 5.35 to 5.65 GHz
- 1000 W Typ. Prime Power @4%
- 46 dB Typical Gain
- 21.25" L x 2.55" W x 3.25" H
(54 x 6.48 x 8.26 cm)
- Phase Match Available



RF Performance

Freq (GHz)	Typ. Sat. Power Output (W)	Min. Spec. Power Output (W)	Typ. Gain @ Spec. Power (dB)
5.35	8510	8000	46
5.40	8130	8000	46
5.45	7800	8000	46
5.50	8200	8000	46
5.55	8300	8000	46
5.60	8200	8000	46
5.65	8100	8000	46

Typical power output is shown to illustrate capability.
Typical gain shown is without equalizer.

Typical Operating Conditions

Element	Typical Operating Conditions		Power Supply Requirements		
	Voltage	Current	Voltage Min.	Voltage Max.	Current Max.
Heater	-6.3 Vdc	2.25 Apk	-6.0 Vdc	-6.6 Vdc	3.0 A
Helix					
with RF	Ground	300 mApk	Ground	Ground	500 mApk @ 4%
without RF	Ground	80 mApk	Ground	Ground	500 mApk @ 4%
Grid On	180 Vpk	1.8 mApk	100 Vpk	250 Vpk	30 mApk
Grid Off	-300 Vdc	0 mA	-300 Vdc	-300 Vdc	1 mApk
Cathode (Ek)	-14.0 kV	2.3 Apk	-13.5 kV	-14.5 kV	2.8 Apk
Collector					
w/RF	10.3 kV	2.0 Apk	73.5% x Ek ±2%		2.8 Apk
w/o RF	10.3 kV	2.2 Apk	73.5% x Ek ±2%		2.8 Apk

Cathode voltage is measured with respect to ground.

Heater, Collector, and Grid voltages are measured with respect to Cathode.

Performance

Performance	Typical	Spec
Input VSWR.....	1.3:1	2:1
Output VSWR.....	1.5:1	2:1
Max. Duty	—	4%
Max. Pulsewidth	—	100 μs
Grid Capacitance.....	40 pF	60 pF
Noise Power Density (dBm/MHz)	-35	-10
Prime Power.....	1000 W	1100 W

This model number is subject to the jurisdiction of the U.S. Department of Commerce.

NOTES:

1. THERMOSTAT OPTIONS: N/C OR N/O

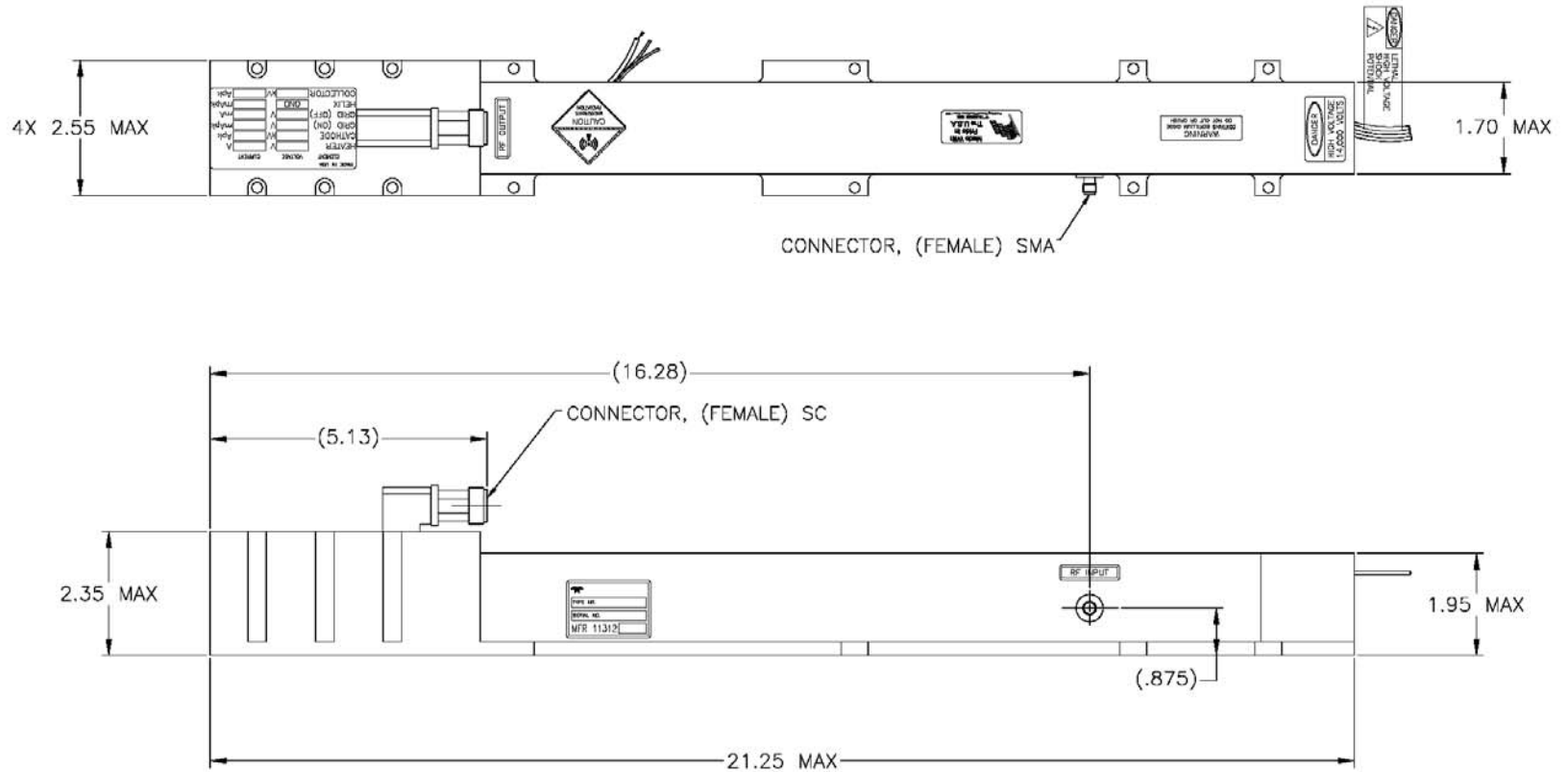

SUBJECT TO CHANGE W/O NOTICE ISO 9001:2008 Registered

TELEDYNE MICROWAVE SOLUTIONS TWT Products <small>11361 Sunrise Park Dr., Rancho Cordova, CA 95742 916-638-3344</small>
TITLE
MEC 3094A

This model number is subject to the jurisdiction of the U.S. Department of Commerce.

MEC 3119

Pulse TWT

6.0 GHz – 8.0GHz

- 4% Maximum Duty
- 7000 W_{pk} Minimum Power
- 6 to 8 GHz
- -40° to 85° C
- 900 W_{pk} Typ Prime Power @ 4%
- 160 μS PW Max
- 42 dB Typical Sat. Gain
- 22.27" L x 5.54" W x 4.34" H
(56 x 14 x 11 cm)

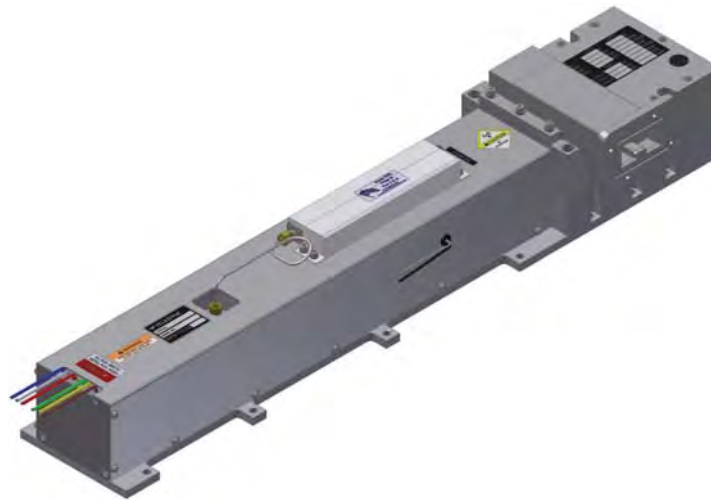

RF Performance

Freq (GHz)	Typ. Sat. Power Output (W)	Min. Spec. Power Output (W)	Typ. Gain @ Sat. Power (dB)
6.0	8500	7000	42
6.5	8800	7000	42
7.0	8900	7000	43
7.5	8500	7000	42
8.0	7500	7000	41

Typical power output is shown to illustrate capability.
Typical gain shown is without equalizer.

Typical Operating Conditions

Element	Voltage	Current	Power Supply Requirements		
			Voltage Min.	Voltage Max.	Current Max.
Heater	-6.3 Vdc	2.23 A	-6.1 Vdc	-6.5 Vdc	3.0 A
Helix					
with RF	Ground	542 mApk	Ground	Ground	800 mApk
without RF	Ground	45 mApk	Ground	Ground	800 mApk
Grid On	150 Vpk	2.0 mApk	100 Vpk	220 Vpk	30 mApk
Grid Off	-250 Vdc	0.0 mA	-300 Vdc	-500 Vdc	1 mA
Cathode (Ek)	-13.8 kV	2468 mApk	-13.0 kV	-14.5 kV	3000 mApk
Collector w/RF					
Coll. #1	10.63 kV	512 mApk	77% x Ek ±2%		700 mApk
Coll. #2	8.00 kV	760 mApk	58% x Ek ±2%		1200 mApk
Coll. #3	6.21 kV	654 mApk	45% x Ek ±2%		2700 mApk

Cathode voltage is measured with respect to ground.

Heater, Collector, and Control Grid voltages are measured with respect to Cathode.

Performance

	Typical	Spec
Input VSWR:.....	1.3:1	1.6:1
Output VSWR:.....	1.6:1	2.0:1
Max. Duty	4%	4%
Max. Pulsewidth	160 μs	160 μs
Grid Capacitance.....	55 pF	65 pF max.
Noise Power Density (dBm/MHz)	-22	-20
Prime Power @ 4%	950 W	1800 W

MTI 3444L

Pulse TWT

6.5 GHz – 18.0 GHz

- 6% Maximum Duty
- 1260 W Minimum Power
- 6.5 to 18.0 GHz
- -40° to 85° C
- 818 W Typ. Prime Power @6%
- 43-46 dB Typical Gain
- 17.3" L x 2.72" W x 3.3" H
(44 x 6.9 x 8.38 cm)

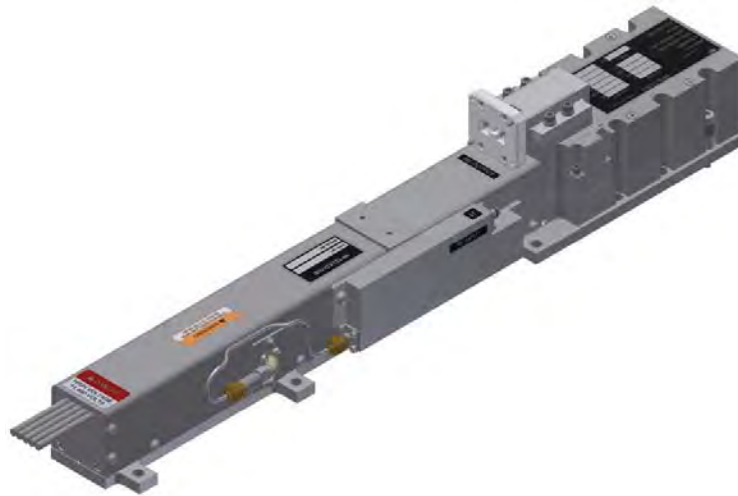

Typical Operating Conditions

Element	Voltage	Current	Power Supply Requirements		
			Voltage Min.	Voltage Max.	Current Max.
Heater	-6.3 Vdc	1.9 A	-6.1 Vdc	-6.5 Vdc	2.5 A
Helix					
with RF	Ground	450 mApk	Ground	Ground	500 mApk @ 6%
without RF	Ground	110 mApk	Ground	Ground	500 mApk @ 6%
Grid On	160 Vpk	4 mApk	100 Vpk	250 Vpk	20 mApk
Grid Off	-200 Vdc	0.1 mA	-200 Vdc	-500 Vdc	0.5 mA
Cathode (Ek)	-11.2 kV	1.65 Apk	-10.5 kV	-11.5 kV	1.9 Apk
Collector w/RF	7 kV	1.2 Apk		63% x Ek ±2%	1.9 Apk

Cathode voltage is measured with respect to ground.

Heater, Collector, and Grid voltages are measured with respect to Cathode.

RF Performance

Freq (GHz)	Typ. Sat. Power Output (W)	Min. Spec. Power Output (W)	Typ. Gain @ Spec. Power (dB)
6.5	1320	1260	43
7.0	1580	1510	44
8.0	2140	1580	45
9.0	2340	1580	46
10.0	1660	1580	46
11.0	2140	1580	46
12.0	2450	1580	46
13.0	2510	1580	46
14.0	2450	1580	46
15.0	2400	1580	46
16.0	2240	1580	46
17.0	2000	1580	46
18.0	1700	1580	45

Typical power output is shown to illustrate capability.

Typical gain shown is with equalizer.

Performance	Typical	Spec
Input VSWR.....	2.2:1	2.5:1
Output VSWR.....	2.3:1	2.5:1
Max. Duty	—	6%
Max. Pulsewidth	—	100 μs
Grid Capacitance.....	38 pF	50 pF
Min. Harmonic Separation.....	-3 dBc	-2 dBc
Noise Power Density (dBm/MHz)	2	3
Prime Power.....	818 W	950 W

Specifications are subject to change without notice.

NOTES:

1. THERMOSTAT OPTIONS: N/C OR N/O

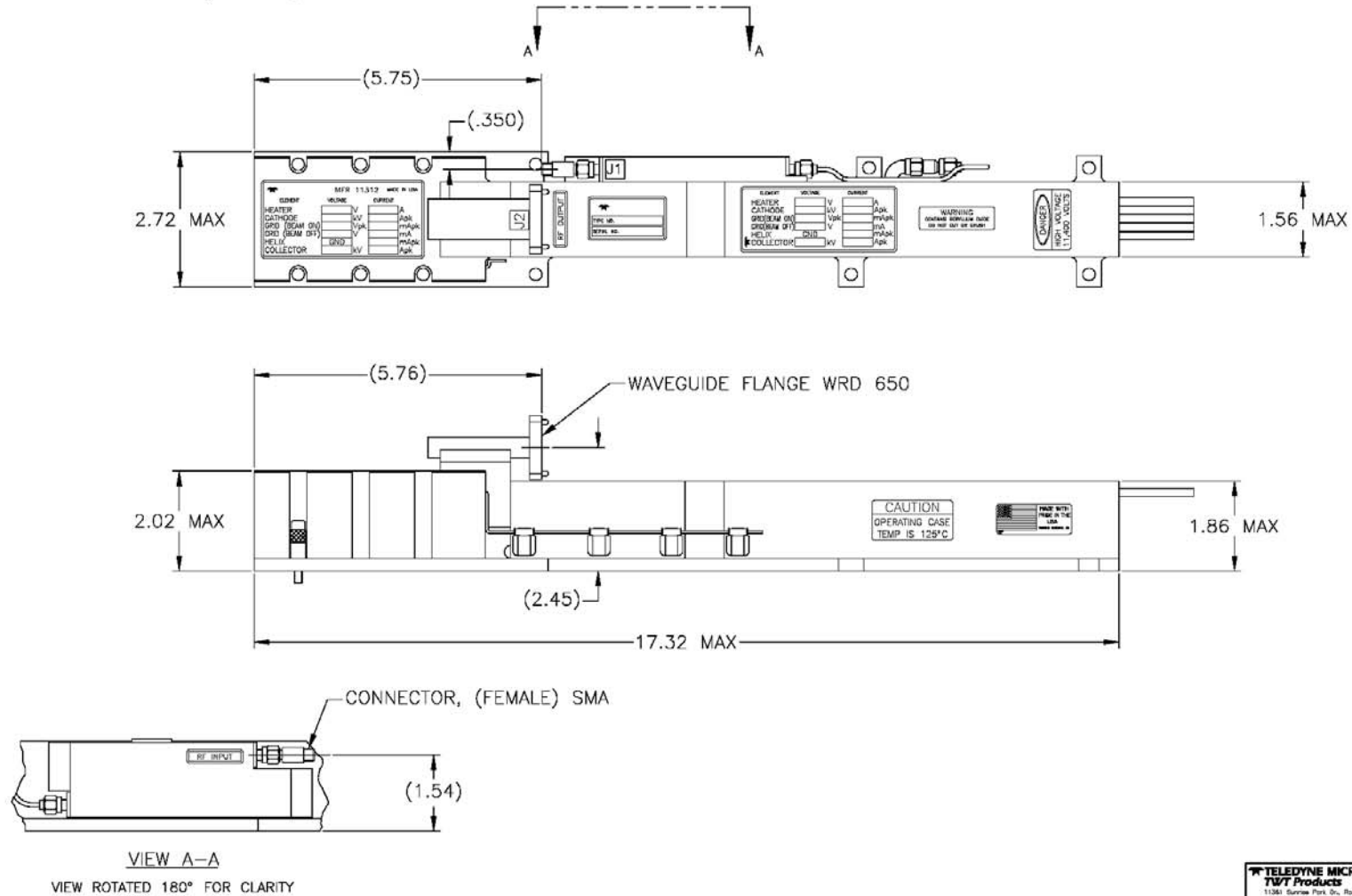

SUBJECT TO CHANGE W/O NOTICE

ISO 9001:2008 Registered

TELEDYNE MICROWAVE SOLUTIONS
TWT Products

11361 Sunrise Park Dr., Rancho Cordova, CA 95670-3344

TITLE

MTI 3444L

MEC 3848

Pulse TWT

8.0 GHz – 11.0 GHz

- 5% Maximum Duty
- 6500 W Minimum Power
- 8.0 to 11.0 GHz
- -40° to 85° C
- 947 W Typ. Prime Power @ 5%
- 48-51 dB Typical Gain
- 15.8" L x 4" W x 4.44" H
(40.1 x 10.2 x 11.3 cm)
- ±15° Phase Match

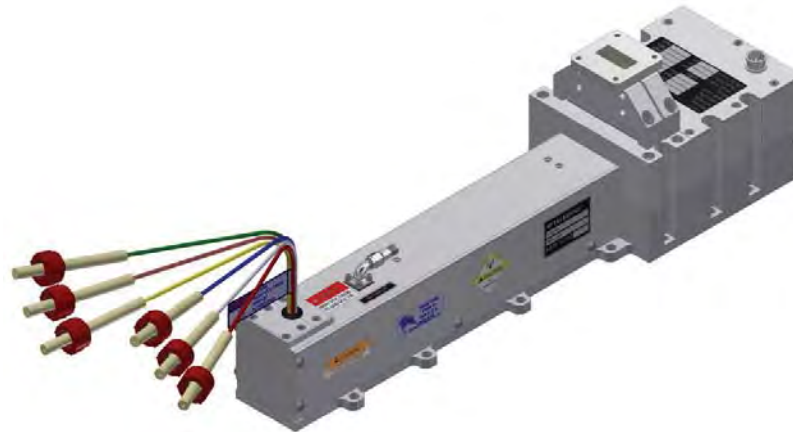

RF Performance

Freq (GHz)	Typ. Sat. Power Output (W)	Min. Spec. Power Output (W)	Typ. Gain @ Spec. Power (dB)
8.0	8000	7500	48
8.5	8300	8000	48
9.0	8300	8000	49
9.2	8300	8000	50
9.4	8300	8000	50
9.6	8300	8000	50
9.8	8300	8000	50
10.0	8300	8000	51
10.5	8000	7500	50
11.0	7000	6500	49

Typical power output is shown to illustrate capability.
Typical gain shown is without equalizer.

Typical Operating Conditions

Element	Typical Operating Conditions		Power Supply Requirements		
	Voltage	Current	Voltage Min.	Voltage Max.	Current Max.
Heater	-6.3 Vdc	2.1 A	-6.1 Vdc	-6.5 Vdc	2.50 A
Helix					
with RF	Ground	400 mApk	Ground	Ground	500 mApk @ 5%
without RF	Ground	75 mApk	Ground	Ground	500 mApk @ 5%
Grid On	150 Vpk	0	100 Vpk	300 Vpk	30 mApk
Grid Off	-300 Vdc	0	-300 Vdc	-500 Vdc	0.5 mA
Cathode (Ek)	-13.3 kV	2.3 Apk	-13 kV	-15 kV	2.8 Apk
Collector w/RF					
Coll. #1	9.0 kV	0.84 Apk	69% x Ek ±2%		1.1 Apk
Coll. #2	6.4 kV	0.48 Apk	48% x Ek ±2%		0.8 Apk
Coll. #3	4.7 kV	0.58 Apk	35% x Ek ±2%		2.5 Apk

Cathode voltage is measured with respect to ground.

Heater, Collector, and Grid voltages are measured with respect to Cathode.

Performance

	Typical	Spec
Input VSWR.....	1.5:1	2:1
Output VSWR.....	1.5:1	2:1
Max. Duty	—	5%
Max. Pulsewidth	—	100 μs
Grid Capacitance.....	40 pF	60 pF
Min. Harmonic Separation.....	-14 dBc	-10 dBc
Noise Power Density (dBm/MHz)	-14	-10
Prime Power.....	947 W	1200 W

Specifications are subject to change without notice.

NOTES:

1. THERMOSTAT OPTIONS: N/C OR N/O

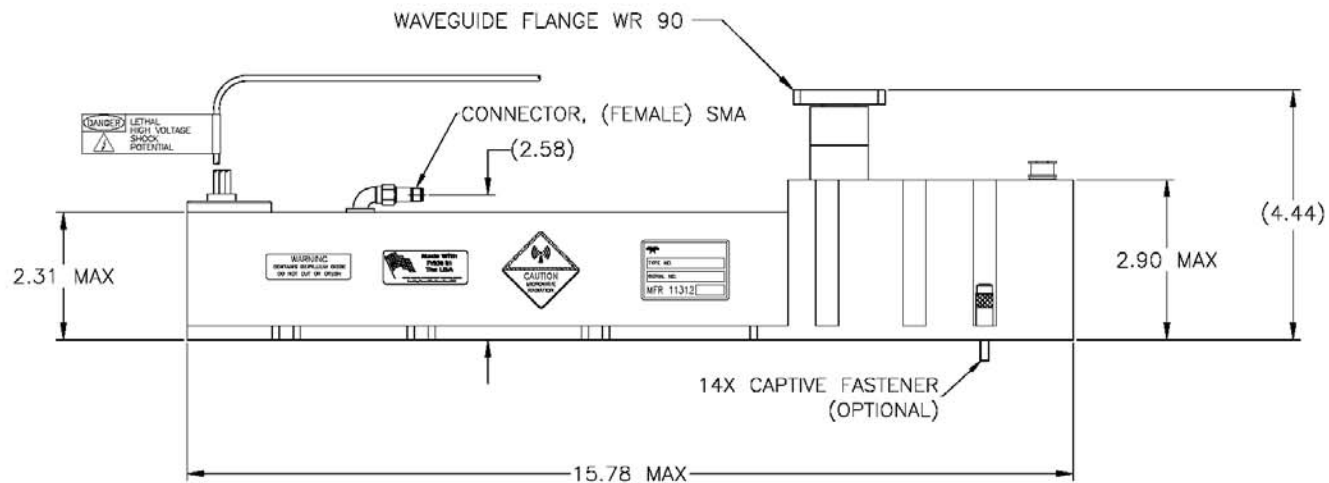
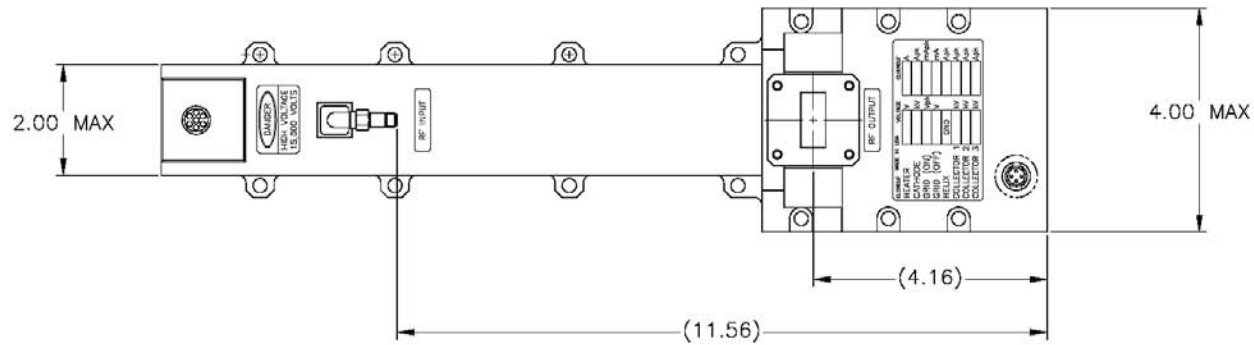

SUBJECT TO CHANGE W/O NOTICE

ISO 9001:2008 Registered

TELEDYNE MICROWAVE SOLUTIONS
TWT Products

11361 Sunrise Park Dr., Rancho Cordova, CA 95742-3344

TITLE

MEC 3848

MEC 3106

Pulse TWT

8.0 GHz – 12.0 GHz

- 10% Typical Maximum Duty
- 900 W Minimum Power
- 8.0 to 12.0 GHz
- -40° to 85° C
- 438 W Typ. Prime Power @10%
- 26-38 dB Typical Gain
- 9.9" L x 1.6" W x 1.57" H
(25.1 x 4.1 x 4 cm)

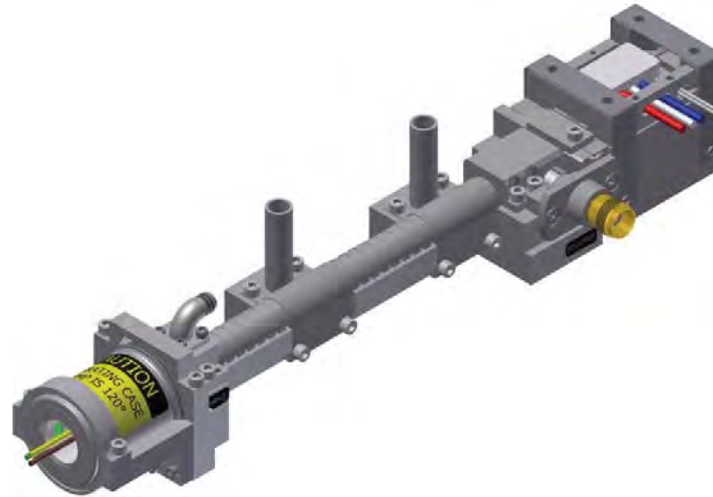

RF Performance

Freq (GHz)	Typ. Sat. Power Output (W)	Min. Spec. Power Output (W)	Typ. Gain @ Spec. Power (dB)
8.0	1000	900	38
8.5	1000	900	34
9.0	1100	1000	33
9.5	1250	1000	31
10.0	1300	1000	31
10.5	1300	1000	29
11.0	1300	1000	27
11.5	1200	1000	27
12.0	1000	900	26

Typical power output is shown to illustrate capability.
Typical gain shown is without equalizer.

Typical Operating Conditions

Element	Typical Operating Conditions			Power Supply Requirements		
	Voltage	Current		Voltage Min.	Voltage Max.	Current Max.
Heater	-6.3 Vdc	1.75 A		-6.1 Vdc	-6.5 Vdc	2.0 A
Helix						
with RF	Ground	300 mApk		Ground	Ground	325 mApk @ 10%
without RF	Ground	60 mApk		Ground	Ground	325 mApk @ 10%
Grid On	100 Vpk	1.0 mApk		90 Vpk	200 Vpk	30 mApk
Grid Off	-200 Vdc	0 mA		-200 Vdc	-500 Vdc	1.0 mA
Cathode (Ek)	-6.6 kV	940 mApk		-6.5 kV	-7.0 kV	1.0 Apk
Collector w/RF						
Coll. #1	4.90 kV	318 mApk		71% x Ek ±2%		500 mApk
Coll. #2	3.04 kV	242 mApk		46% x Ek ±2%		1.0 Apk
Coll. #3	1.91 kV	76 mApk		29% x Ek ±2%		1.0 Apk

Cathode voltage is measured with respect to ground.
Heater, Collector, and Grid voltages are measured with respect to Cathode.

Performance

	Typical	Spec
Input VSWR.....	1.6:1	2.0:1
Output VSWR.....	1.83:1	2.0:1
Max. Duty	10%	10%
Max. Pulsewidth	50 μs	50 μs
Grid Capacitance.....	53 pF	60 pF
Min. Harmonic Separation.....	-12 dBc	-10 dBc
Noise Power Density (dBm/MHz)	-27	-20
Prime Power.....	438 W	500 W

NOTES:

1. THERMOSTAT OPTIONS: N/C OR N/O.

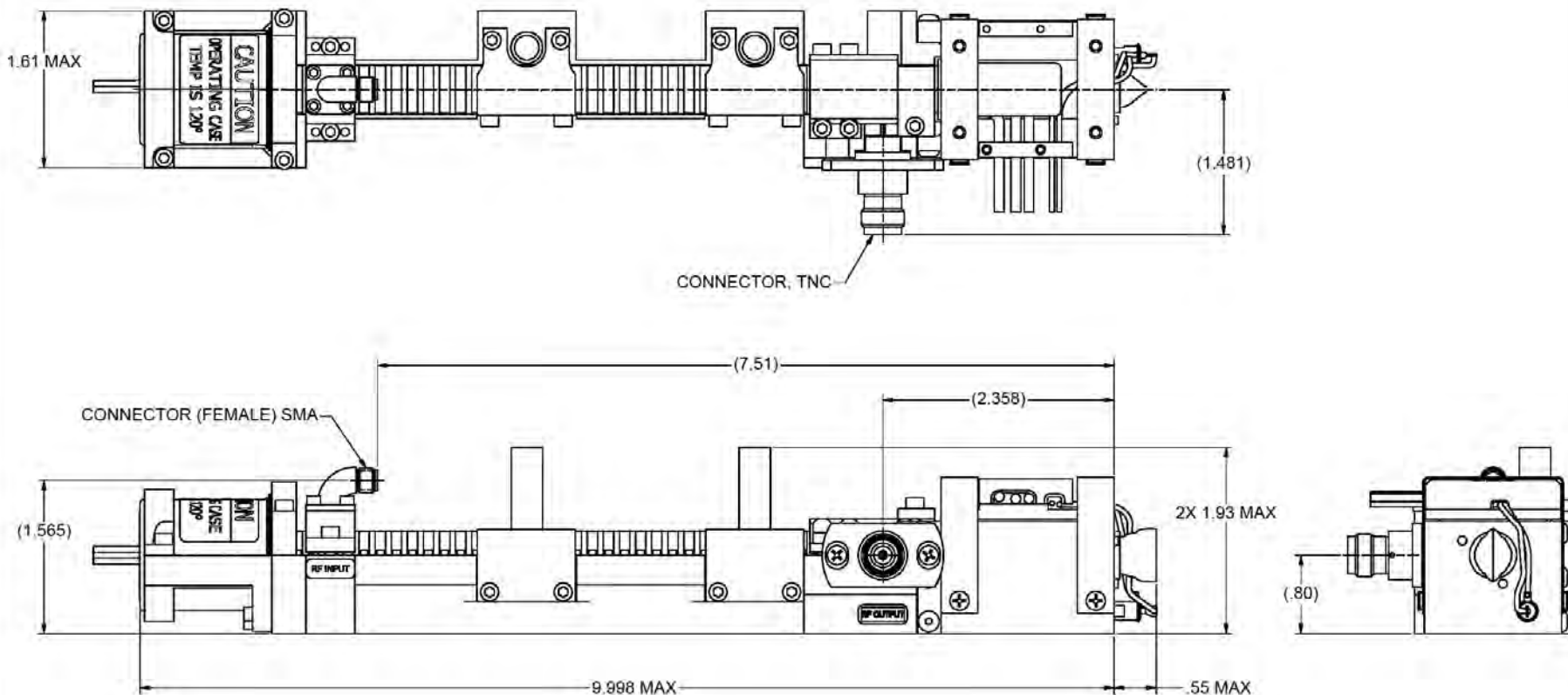

SUBJECT TO CHANGE W/O NOTICE

ISO 9001:2008 Registered

<p>TELEDYNE MICROWAVE SOLUTIONS TWT PRODUCTS 11361 Sunrise Park Dr., Rancho Cordova, CA 95744</p>
<p>MEC 3106</p>

MEC 3848N

Pulse TWT

8 GHz – 12 GHz

- 10% Maximum Duty
- 5 kW Minimum Power
- 8.0 to 12.0 GHz
- -40° to 85° C
- 1250 W Typ. Prime Power @8%
- 41-50 dB Typical Gain
- 15.8" L x 2.8" W x 4.5" H
(40.1 x 7.1 x 11.4 cm)
- ±15° Phase Match

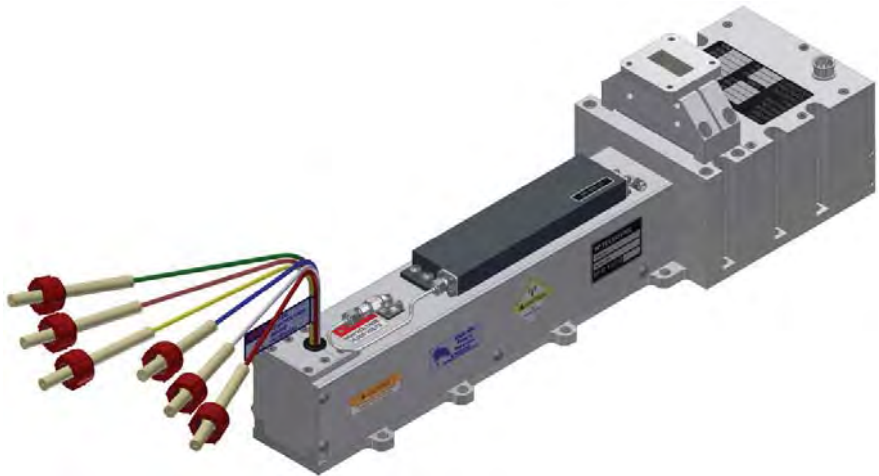

RF Performance

Freq (GHz)	Typ. Sat. Power Output (W)	Min. Spec. Power Output (W)	Typ. Gain @ Spec. Power (dB)
8.0	6610	5000	48
8.5	7080	5000	48
9.0	7080	5000	49
9.5	6610	5000	50
10.0	6610	5000	50
10.5	7240	5000	49
11.0	6760	5000	48
11.5	6610	5000	44
12.0	5620	5000	41

Typical power output is shown to illustrate capability.
Typical gain shown is without equalizer.

Typical Operating Conditions

Element	Typical Operating Conditions		Power Supply Requirements		
	Voltage	Current	Voltage Min.	Voltage Max.	Current Max.
Heater	-6.3 Vdc	2.1 A	-6.1 Vdc	-6.5 Vdc	2.50 A
Helix					
with RF	Ground	250 mApk	Ground	Ground	300 mApk @ 8%
without RF	Ground	75 mApk	Ground	Ground	300 mApk @ 8%
Grid On	150 Vpk	0.0 mApk	100 Vpk	300Vpk	30 mApk
Grid Off	-350 Vdc	0.0 mA	-300 Vdc	-500 Vdc	0.5 mA
Cathode (Ek)	-13.0 kV	1.8 Apk	-13 kV	-15 kV	2.5 Apk
Collector w/RF					
Coll. #1	8.97 kV	650 mApk	69% x Ek ±2%		1.1 mApk
Coll. #2	6.24 kV	430 mApk	48% x Ek ±2%		0.8 mApk
Coll. #3	4.55 kV	470 mApk	35% x Ek ±2%		2.5 mApk

Cathode voltage is measured with respect to ground.
Heater, Collector, and Grid voltages are measured with respect to Cathode.

Performance	Typical	Spec
Input VSWR.....	1.82:1	2.0:1
Output VSWR.....	1.65:1	2.0:1
Max. Duty	8%	10%
Max. Pulsewidth	50 μs	100 μs
Grid Capacitance.....	50 pF	50 pF max.
Min. Harmonic Separation.....	-13.0 dBc	-10 dBc
Noise Power Density (dBm/MHz)	-20	-10
Prime Power.....	1250 W	1700 W

NOTES:

1. THERMOSTAT OPTIONS: N/C OR N/O

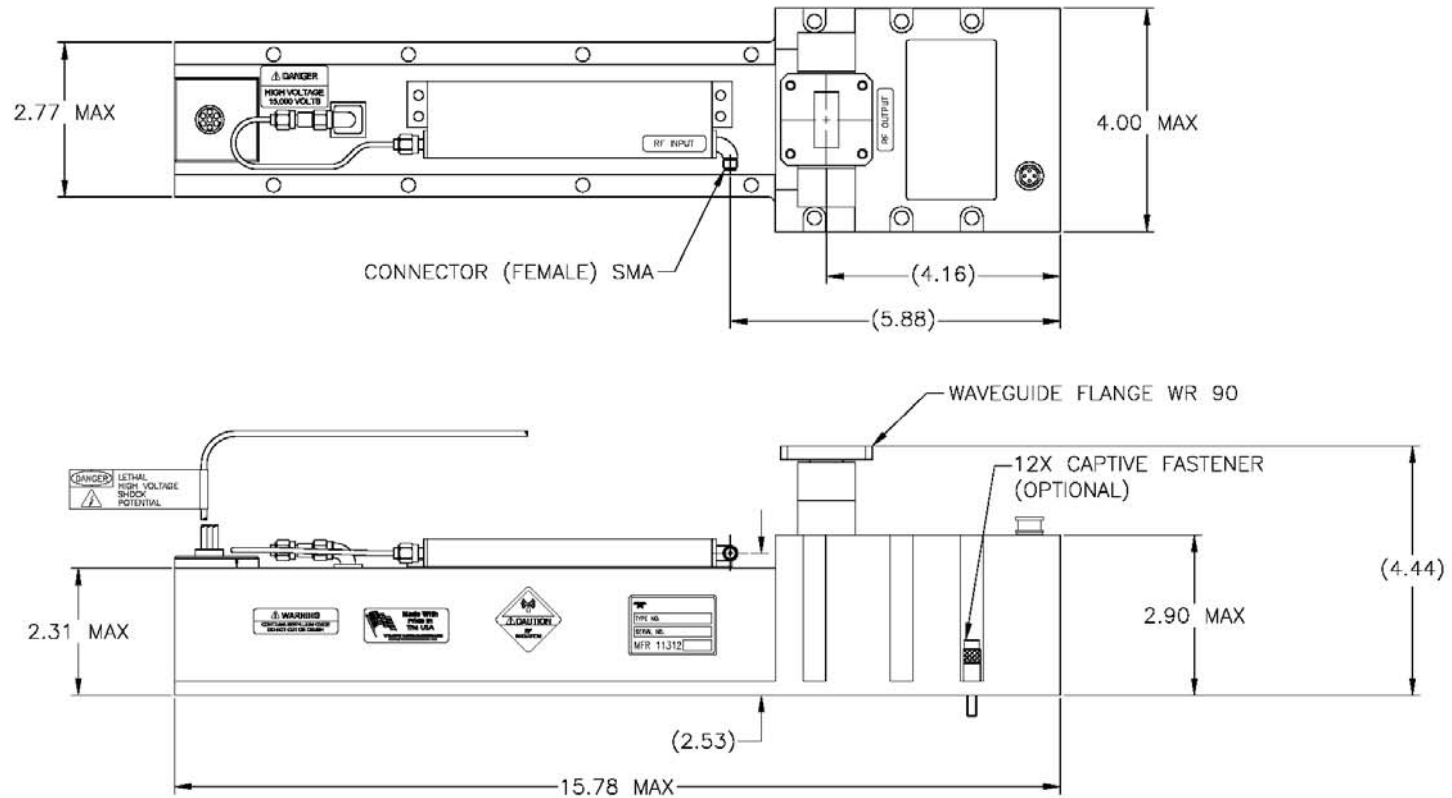

SUBJECT TO CHANGE W/O NOTICE ISO 9001:2008 Registered

TELEDYNE MICROWAVE SOLUTIONS TWT Products 11361 Sunrise Park Drive, Rancho Cordova, CA 95742 (916) 638-3344 TITLE:
MEC 3848N

MTI 3044C

Pulse TWT

8.0 GHz – 12.4 GHz

- 4% Maximum Duty
- 1.2 kW Minimum Power
- 8.0 to 12.4 GHz
- -40° to 85° C
- 583 W Typ. Prime Power @4%
- 57 - 62 dB Typical Gain
- 14.35" L x 3" W x 1.7" H
(36.45 x 7.77 x 4.3 cm)



RF Performance

Freq (GHz)	Typ. Sat. Power Output (W)	Min. Spec. Power Output (W)	Typ. Gain @ Spec. Power (dB)
8.0	1500	1200	57
9.0	1600	1200	60
10.0	2000	1200	63
11.0	2000	1200	64
12.0	2300	1200	64
12.4	2300	1200	64

Typical power output is shown to illustrate capability.
Typical gain shown is without equalizer.

Typical Operating Conditions

Element	Typical Operating Conditions		Power Supply Requirements		
	Voltage	Current	Voltage Min.	Voltage Max.	Current Max.
Heater	-6.3 Vdc	1.9 A	-6.0 Vdc	-6.6 Vdc	2.2 A
Helix					
with RF	Ground	310 mApk	Ground	Ground	600 mApk @ 4%
without RF	Ground	75 mApk	Ground	Ground	600 mApk @ 4%
Grid On	134 Vpk	1 mApk	100 Vpk	220 Vpk	20 mApk
Grid Off	-150 Vdc	0.2 mA	-150 Vdc	-200 Vdc	1 mA
Cathode (Ek)	-11.4 kV	1.58 Apk	-10.5 kV	-11.5 kV	1.8 Apk
Collector w/RF	8.2 kV	1.27 Apk		72% x Ek ±2%	1.8 Apk

Cathode voltage is measured with respect to ground.

Heater, Collector, and Grid voltages are measured with respect to Cathode.

Performance

	Typical	Spec
Input VSWR	1.6:1	2.5:1
Output VSWR	1.5:1	2.5:1
Max. Duty	—	4%
Max. Pulswidth	—	20 μs
Grid Capacitance	46 pF	50 pF
Min. Harmonic Separation	-4.3 dBc	-3 dBc
Noise Power Density (dBm/MHz)	-12	-8
Prime Power	583 W	750 W

NOTES:

1. THERMOSTAT OPTIONS: N/C OR N/O

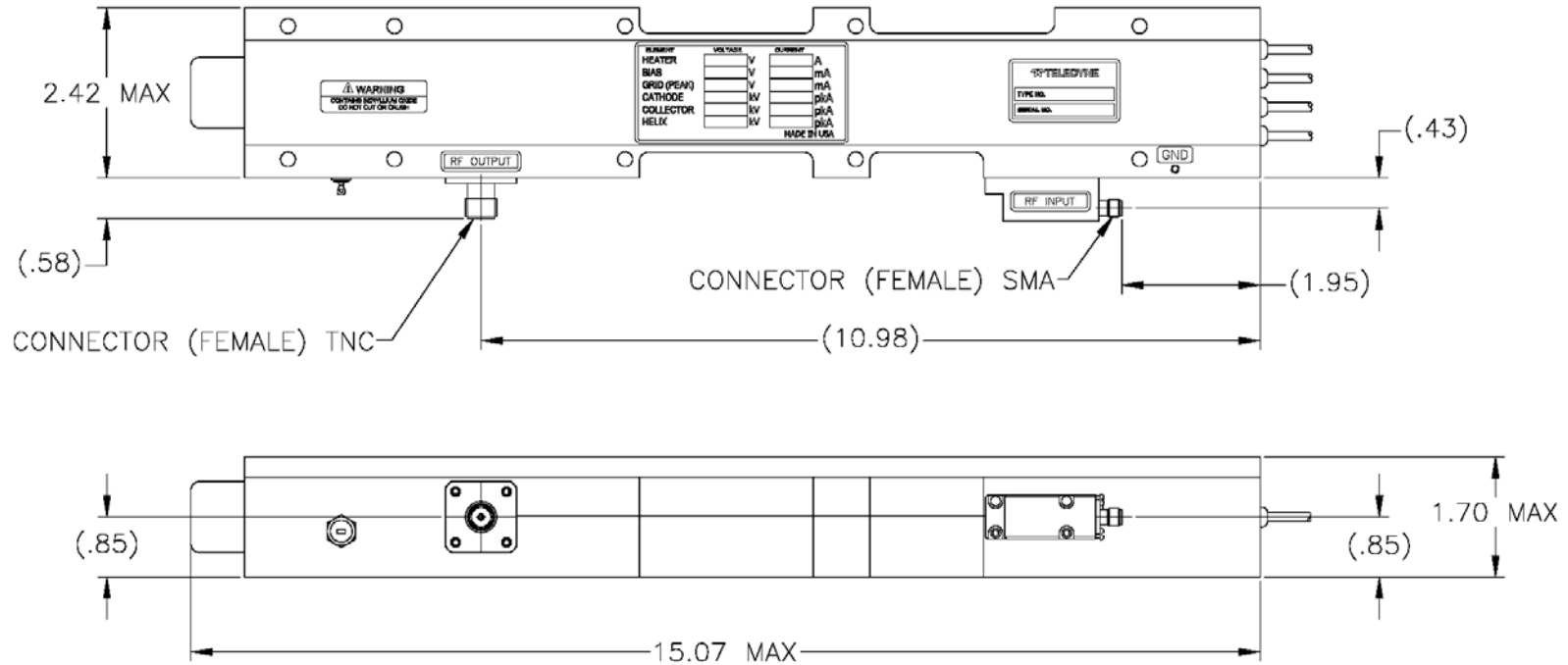

SUBJECT TO CHANGE W/O NOTICE ISO 9001:2008 Registered

TELEDYNE MICROWAVE SOLUTIONS TWT Products 11361 Sunrise Park Dr., Rancho Cordova, CA (916) 838-3344
TITLE
MTI 3044C

MTI 3044J

Pulse TWT 8.0 GHz – 18.0 GHz

- 4% Maximum Duty
- 1 kW Minimum Power
- 8.0 to 18.0 GHz
- -40° to 85° C
- 566 W Typ. Prime Power @4%
- 42-62 dB Typical Gain
- 14.35" L x 3" W x 1.7" H
(36.45 x 7.77 x 4.3 cm)

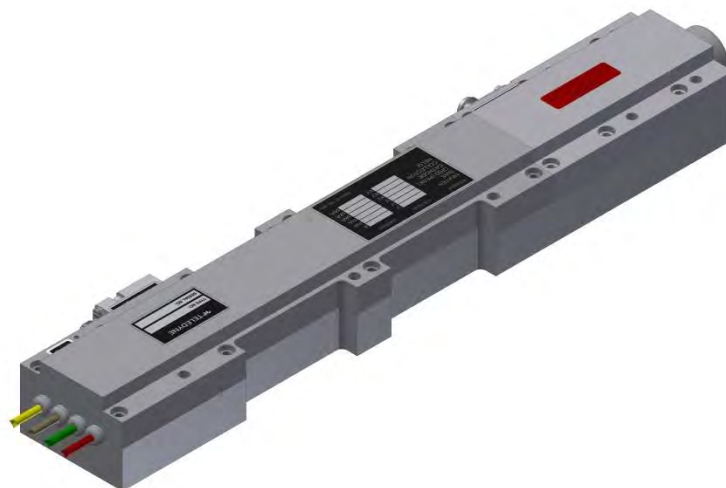

Typical Operating Conditions

Element	Typical Operating Conditions		Power Supply Requirements		
	Voltage	Current	Voltage Min.	Voltage Max.	Current Max.
Heater	-6.3 Vdc	1.9 A	-6.1 Vdc	-6.5 Vdc	2.5 A
Helix					
with RF	Ground	325 mApk	Ground	Ground	500 mApk @ 4%
without RF	Ground	75 mApk	Ground	Ground	500 mApk @ 4%
Grid On	123 Vpk	1 mApk	100 Vpk	200 Vpk	30 mApk
Grid Off	-200 Vdc	0.2 mA	-200 Vdc	-500 Vdc	1 mA
Cathode (Ek)	-11.2 kV	1.6 Apk	-10.5 kV	-11.5 kV	1.8 Apk
Collector w/RF	8 kV	1.275 Apk		72% x Ek ±2%	1.8 Apk

Cathode voltage is measured with respect to ground.

Heater, Collector, and Grid voltages are measured with respect to Cathode.

RF Performance

Freq (GHz)	Typ. Sat. Power Output (W)	Min. Spec. Power Output (W)	Typ. Gain @ Spec. Power (dB)
8.0	1170	1000	54
9.0	1475	1000	60
10.0	1580	1000	60
11.0	1780	1000	62
12.0	2140	1000	62
13.0	2250	1000	61
14.0	2090	1000	59
15.0	2000	1000	58
16.0	2000	1000	55
17.0	1900	1000	48
18.0	1250	1000	42

Typical power output is shown to illustrate capability.
Typical gain shown is without equalizer.

Performance	Typical	Spec
Input VSWR	2.1:1	2.5:1
Output VSWR	1.9:1	2.5:1
Max. Duty	—	4%
Max. Pulswidth	—	20 μs
Grid Capacitance	46 pF	50 pF
Min. Harmonic Separation	-4.3 dBc	-3 dBc
Noise Power Density (dBm/MHz)	-12	-8
Prime Power	566 W	750 W

Specifications are subject to change without notice.

NOTES:

1. THERMOSTAT OPTIONS: N/C OR N/O

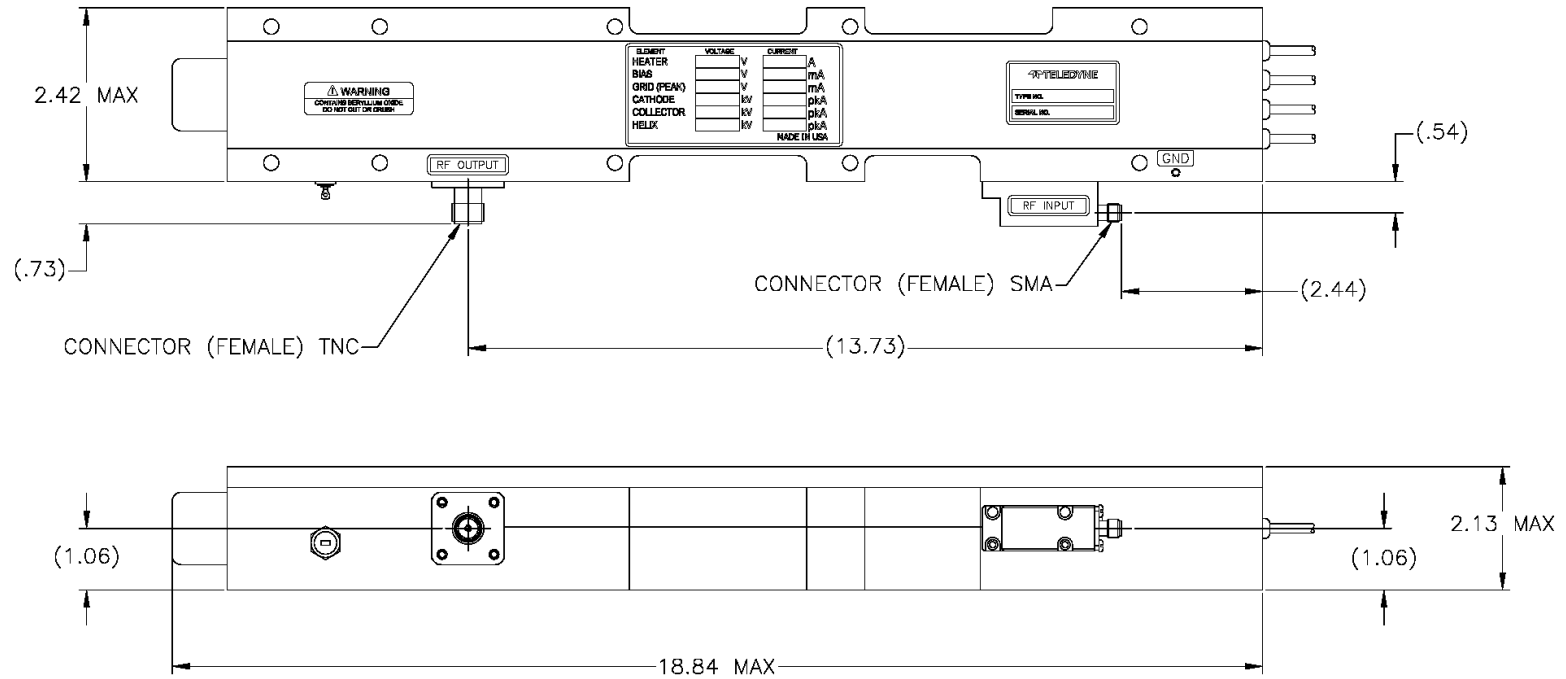

SUBJECT TO CHANGE W/O NOTICE ISO 9001:2008 Registered

TELEDYNE MICROWAVE SOLUTIONS
TWT Products

11361 Sunrise Park Dr., Rancho Cordova, CA (916) 638-3344

TITLE
MTI 3044J

MTI 3048Q

Pulse TWT

8.2 GHz – 12.4 GHz

- 8% Maximum Duty
- 2500 W Minimum Power
- 8.2 to 12.4 GHz
- -40° to 85° C
- 1020 W Typ. Prime Power @8%
- 43-50 dB Typical Gain
- 15.0" L x 2.75" W x 2.8" H
(38.1 x 7.0 x 7.1 cm)

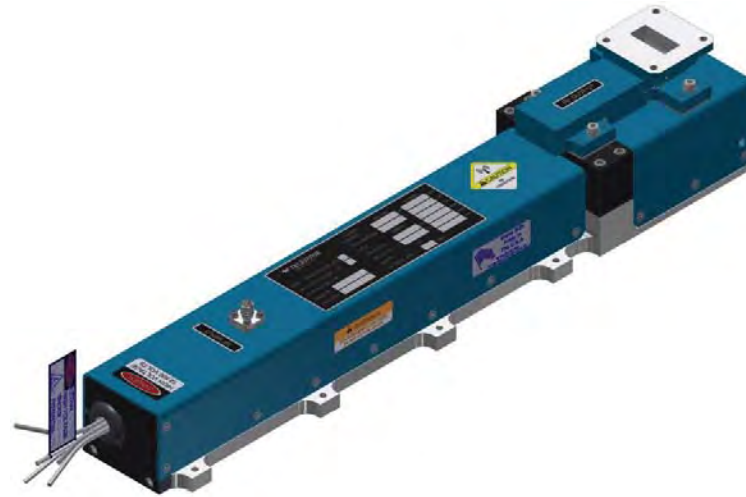

RF Performance

Freq (GHz)	Typ. Sat. Power Output (W)	Min. Spec. Power Output (W)	Typ. Gain @ Spec. Power (dB)
8.2	2600	2500*	45
8.5	3500	3000	47
9.0	4000	3000	50
10.0	4300	3000	50
11.0	4180	3000	48
12.4	3020	3000	43

Typical power output is shown to illustrate capability.
Typical gain shown is without equalizer.

Typical Operating Conditions

Element	Voltage	Current	Power Supply Requirements		
			Voltage Min.	Voltage Max.	Current Max.
Heater	-6.3 Vdc	1.7 A	-6.1 Vdc	-6.5 Vdc	2.5 A
Helix					
with RF	Ground	300 mApk	Ground	Ground	550 mApk @ 8%
without RF	Ground	70 mApk	Ground	Ground	450 mApk @ 8%
Grid On	200 Vpk	2.5 mApk	110 Vpk	300 Vpk	150 mApk
Grid Off	-200 Vdc	0	-150 Vdc	-230 Vdc	0.5 mA
Cathode (Ek)	-12 kV	1.6 Apk	-11 kV	-13 kV	2 Apk
Collector w/RF					
Coll. #1	7.8 kV	0.9 Apk	65% x Ek ±5%		1.2 Apk
Coll. #2	5 kV	0.4 Apk	42% x Ek ±2%		2 Apk

Cathode voltage is measured with respect to ground.
Heater, Collector, and Grid voltages are measured with respect to Cathode.

Performance

	Typical	Spec
Input VSWR.....	2.3:1	2.5:1
Output VSWR.....	2.0:1	2.5:1
Max. Duty	—	8%
Max. Pulsewidth	—	100 μs
Grid Capacitance.....	49 pF	55 pF
Min. Harmonic Separation.....	-10 dBc	-8 dBc*
Noise Power Density (dBm/MHz)	-15	-10
Prime Power.....	1020 W	1300 W

* Minimum harmonic separation applies to the minimum specified power output at the indicated frequency.

NOTES:

1. THERMOSTAT OPTIONS: N/C OR N/O

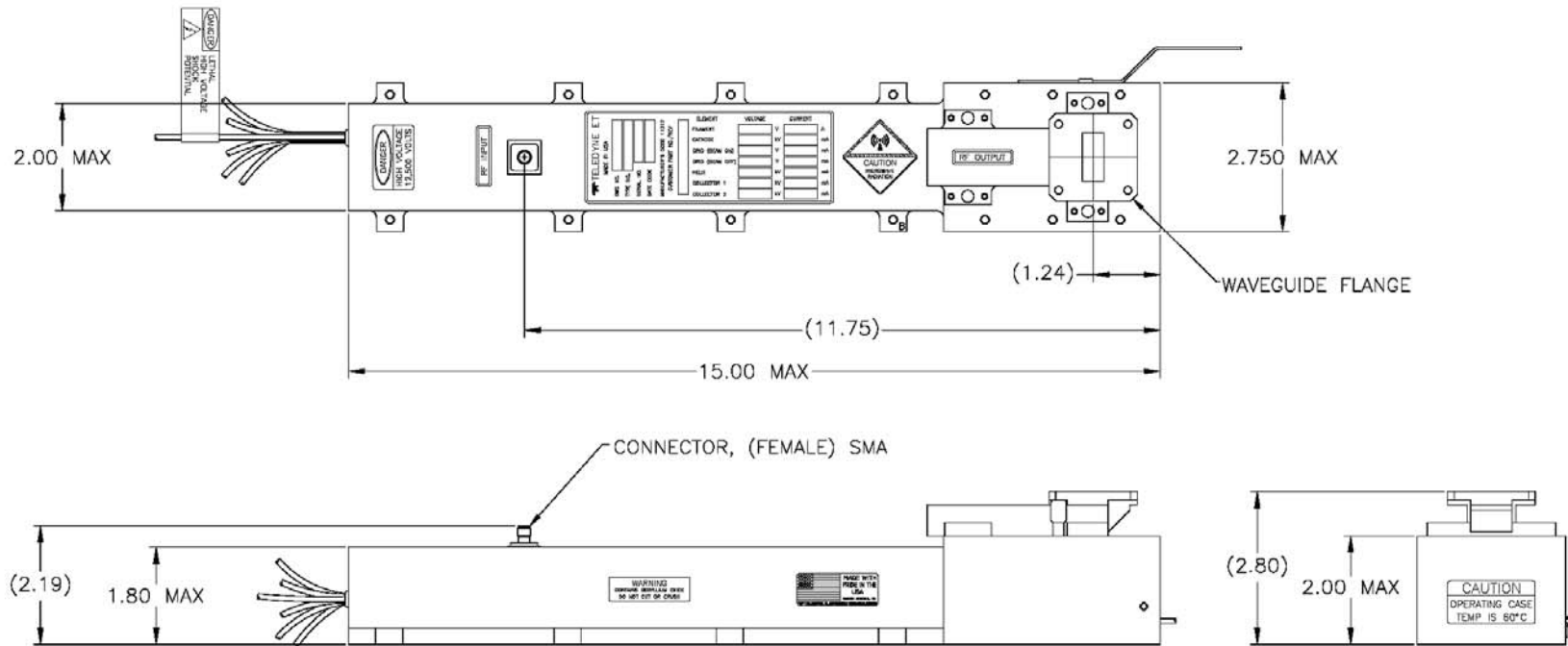

SUBJECT TO CHANGE W/O NOTICE ISO 9001:2008 Registered

TELEDYNE MICROWAVE SOLUTIONS TWT Products <small>11361 Sunrise Park Dr., Rancho Cordova, CA 95742 916.638.3344</small>
TITLE
MTI 3048Q

MTI 3048D

Pulse TWT

8.7 GHz – 10.5 GHz

- 10% Maximum Duty
- 3 kW Minimum Power
- 8.7 to 10.5 GHz
- -40° to 85° C
- 1270 W Typ. Prime Power @10%
- 45-47 dB Typical Gain
- 15.0" L x 2.75" W x 2.8" H
(38.1 x 7.0 x 7.1 cm)

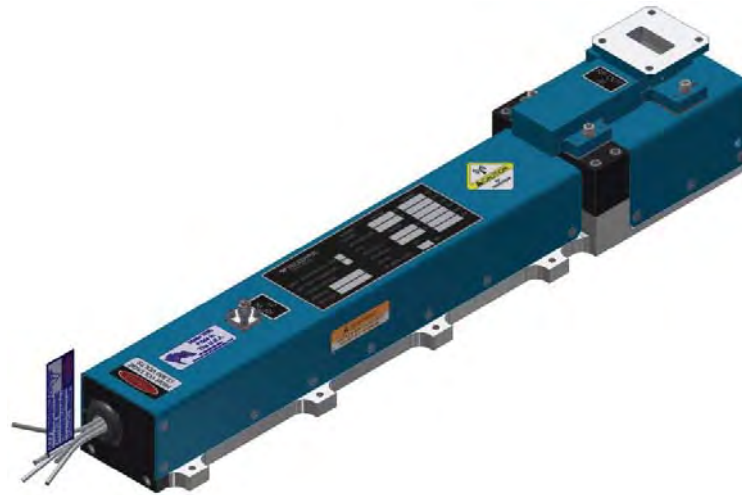

Typical Operating Conditions

Element	Typical Operating Conditions		Power Supply Requirements		
	Voltage	Current	Voltage Min.	Voltage Max.	Current Max.
Heater	-6.3 Vdc	1.7 A	-6.1 Vdc	-6.5 Vdc	2.5 A
Helix					
with RF	Ground	300 mApk	Ground	Ground	230 mApk @ 10%**
without RF	Ground	70 mApk	Ground	Ground	75 mApk @ 10%
Grid On	200 Vpk	2 mApk	110 Vpk	300 Vpk	150 mApk
Grid Off	-200 Vdc	0	-150 Vdc	-230 Vdc	0.5 mA
Cathode (Ek)	-11.9 kV	1.6 Apk	-11 kV	-13 kV	2 Apk
Collector w/RF					
Coll. #1	7.8 kV	0.9 Apk	65% x Ek ±5%		1.2 Apk
Coll. #2	5 kV	0.4 Apk	42% x Ek ±2%		2 Apk

Cathode voltage is measured with respect to ground.
Heater, Collector, and Grid voltages are measured with respect to Cathode.

** May not exceed 23 mA avg. at any duty.

RF Performance

Freq (GHz)	Typ. Sat. Power Output (W)	Min. Spec. Power Output (W)	Typ. Gain @ Spec. Power (dB)
8.7	3700	3500	46
8.8	3800	3500	46
8.9	3900	3600	46
9.0	4000	3600*	46
9.2	4000	3800	46
9.4	4100	4000	46
9.6	4100	4000	47
9.8	4200	4000	47
10.0	4200	4000	47
10.1	4100	3800	47
10.2	4000	3700	47
10.3	3800	3600	46
10.4	3600	3200	46
10.5	3400	3000	45

Typical power output is shown to illustrate capability.
Typical gain shown is without equalizer.

Performance	Typical	Spec
Input VSWR.....	1.8:1	2.0:1
Output VSWR.....	1.8:1	2.0:1
Max. Duty.....	—	10%
Max. Pulsewidth.....	—	100 μs
Grid Capacitance.....	49 pF	55 pF
Min. Harmonic Separation.....	-16 dBc	-10 dBc*
Noise Power Density (dBm/MHz).....	-15	-10
Prime Power.....	1270 W	1400 W

* Minimum harmonic separation applies to the minimum specified power output at the indicated frequency.

NOTES:

1. THERMOSTAT OPTIONS: N/C OR N/O.

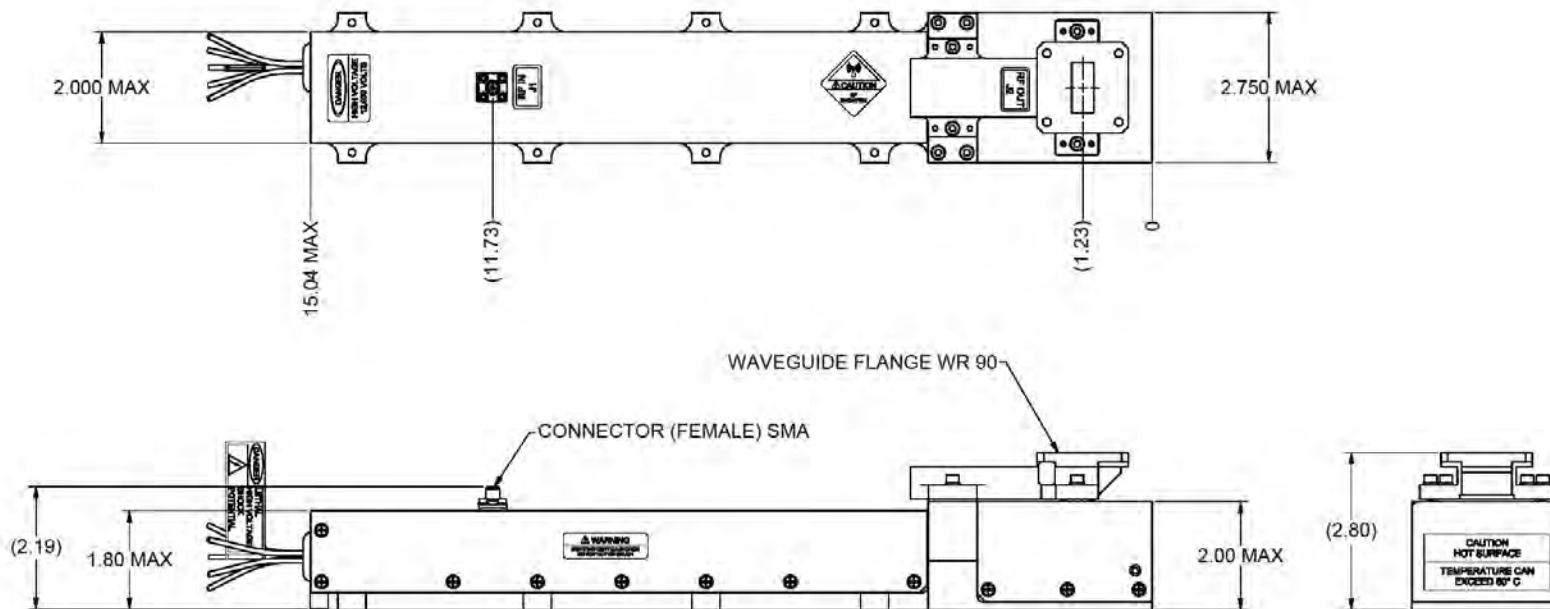

SUBJECT TO CHANGE W/O NOTICE

ISO 9001:2008 Registered

TELEDYNE MICROWAVE SOLUTIONS
TWT PRODUCTS

11361 Sunrise Park Dr., Rancho Cordova, CA 95742-2844

TITLE:

MTI 3048D

MTI 3948B

Pulse TWT

8.8 GHz – 10.5 GHz

- 5% Maximum Duty
- 7400 W Minimum Power
- 8.8 to 10.5 GHz
- -54° to 85° C
- 1179 W Typ. Prime Power @5%
- 48-51 dB Typical Gain
- 15.45" L x 2.77" W x 3.25" H
(39.2 x 7 x 8.27 cm)
- ±15° Phase Match

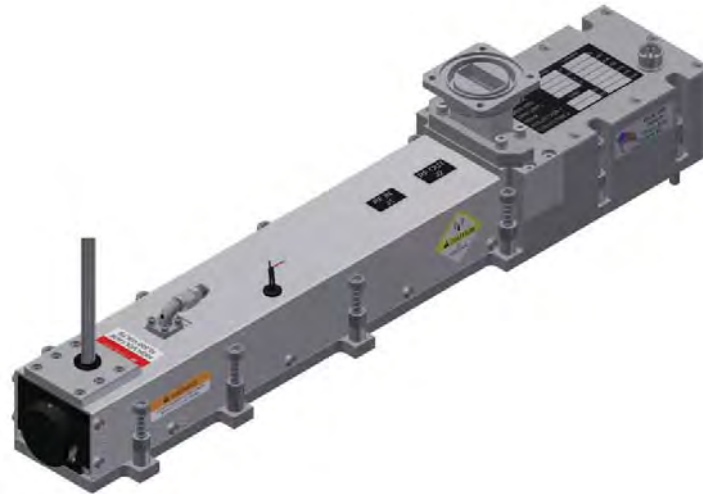

RF Performance

Freq (GHz)	Typ. Sat. Power Output (W)	Min. Spec. Power Output (W)	Typ. Gain @ Spec. Power (dB)
8.8	7400	6800	48
8.9	7800	7400	49
9.0	8300	8000	50
9.2	8350	8000	50
9.4	8400	8000	50
9.6	8500	8000	50
9.8	8600	8000	51
10.0	8700	8000	51
10.1	8700	8000	51
10.2	8700	8000	51
10.3	8300	7800	50
10.4	8200	7500	50
10.5	8200	7500	49

Typical power output is shown to illustrate capability.
Typical gain shown is without equalizer.

Typical Operating Conditions

Element	Typical Operating Conditions		Power Supply Requirements		
	Voltage	Current	Voltage Min.	Voltage Max.	Current Max.
Heater	-6.3 Vdc	2.2 A	-6.1 Vdc	-6.5 Vdc	2.5 A
Helix					
with RF	Ground	400 mApk	Ground	Ground	500 mApk @ 5%
without RF	Ground	75 mApk	Ground	Ground	460 mApk @ 5%
Grid On	250 Vpk	0	100 Vpk	300 Vpk	30 mApk
Grid Off	-300 Vdc	0	-300 Vdc	-500 Vdc	0.5 mA
Cathode (Ek)	-14.2 kV	2.3 Apk	-14 kV	-15 kV	2.5 Apk
Collector w/RF					
Coll. #1	11.7 kV	0.4 Apk	80% x Ek ±2%		1 Apk
Coll. #2	8.5 kV	1.5 Apk	58% x Ek ±2%		2.5 Apk

Cathode voltage is measured with respect to ground.
Heater, Collector, and Grid voltages are measured with respect to Cathode.

Performance

	Typical	Spec
Input VSWR.....	1.5:1	2.0:1
Output VSWR.....	1.5:1	1.8:1
Max. Duty	—	5%
Max. Pulsewidth	—	50 μs
Min. Harmonic Separation.....	-12 dBc	-10 dBc
Noise Power Density (dBm/MHz)	-14	-10
Prime Power.....	1179 W	1300 W

Specifications are subject to change without notice.

NOTES:

1. THERMOSTAT OPTIONS: N/C OR N/O

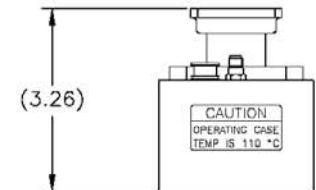
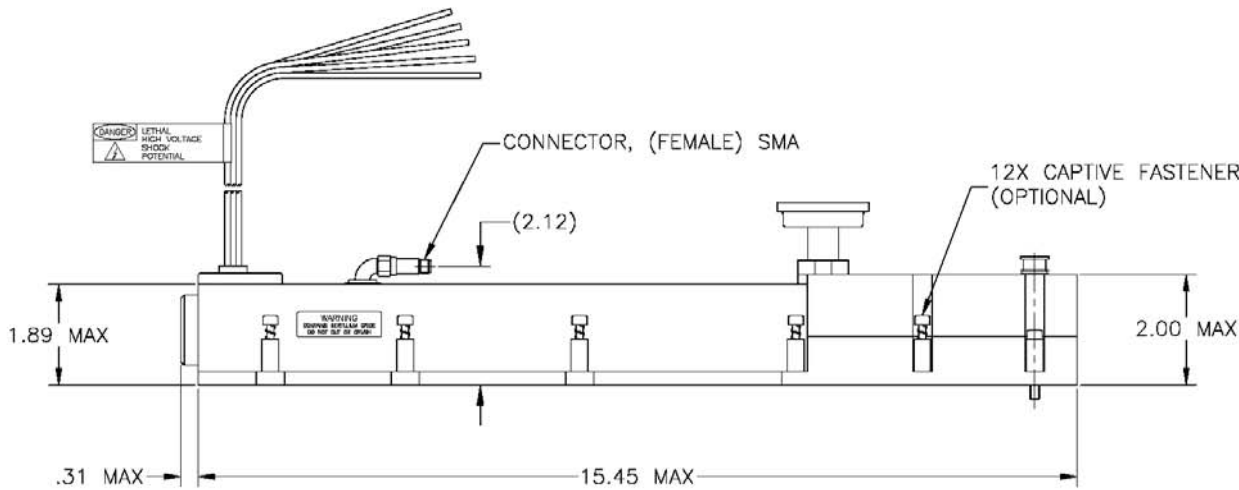
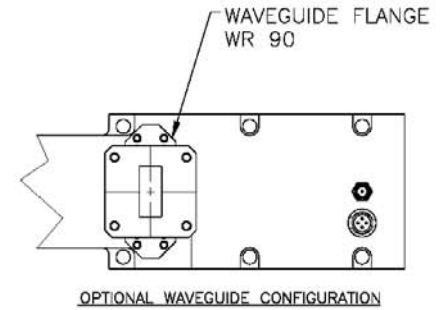
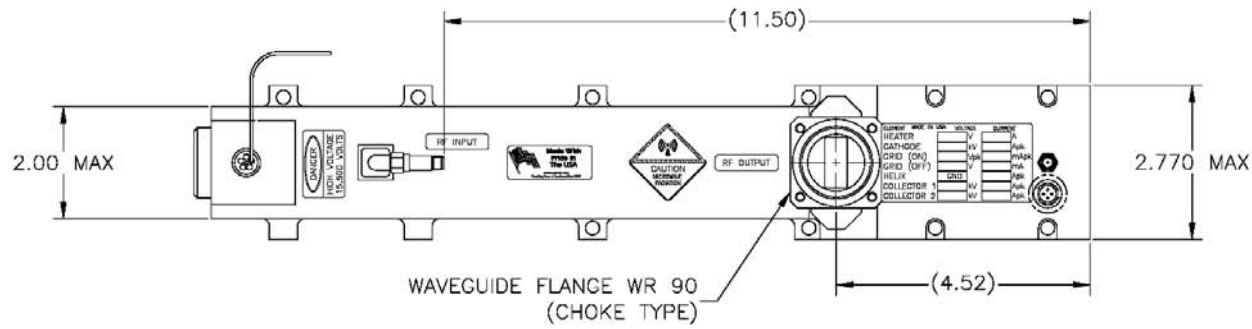

SUBJECT TO CHANGE W/O NOTICE ISO 9001:2008 Registered

<p>TELEDYNE MICROWAVE SOLUTIONS TWT Products 11361 Sunrise Park Drive, Rancho Cordova, CA 95742 (916) 638-3344</p>
TITLE
MTI 3948B

MTI 3948

Pulse TWT

8.8 GHz – 10.5 GHz

- 2% Maximum Duty
- 8200 W Minimum Power
- 8.8 to 10.5 GHz
- -40° to 85° C
- 621 W Typ. Prime Power @2%
- 50-51 dB Typical Gain
- 15.4" L x 2.75" W x 3.25" H (39.2 x 7 x 8.3 cm)
- ±15° Phase Match

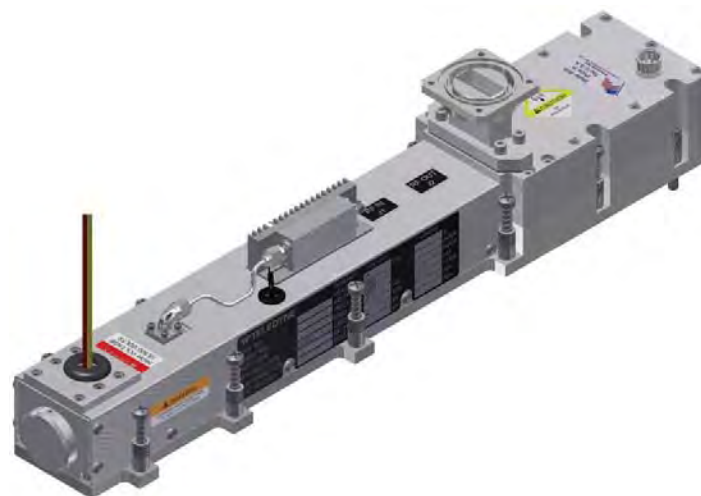

RF Performance

Freq (GHz)	Typ. Sat. Power Output (W)	Min. Spec. Power Output (W)	Typ. Gain @ Spec. Power (dB)
8.8	8510	8200	50
8.9	8700	8600	50
9.0	8700	8700	51
9.2	8800	8700	51
9.4	8900	8700	51
9.6	8900	8700	51
9.8	8900	8700	51
10.0	8900	8700	51
10.1	8900	8700	51
10.2	8800	8700	51
10.3	8800	8700	51
10.4	8800	8700	51
10.5	8700	8500	50

Typical power output is shown to illustrate capability.
 Typical gain shown is without equalizer.
 Higher gain is available with SSA.

Typical Operating Conditions

Element	Voltage	Current	Power Supply Requirements		
			Voltage Min.	Voltage Max.	Current Max.
Heater	-6.3 Vdc	2.2 A	-6.1 Vdc	-6.5 Vdc	2.5 A
Helix					
with RF	Ground	470 mApk	Ground	Ground	800 mApk @ 2%
without RF	Ground	75 mApk	Ground	Ground	800 mApk @ 2%
Grid On	250 Vpk	0	50 Vpk	250 Vpk	30 mApk
Grid Off	-300 Vdc	0	-300 Vdc	-500 Vdc	0.5 mA
Cathode (Ek)	-14.2 kV	2.5 Apk	-14 kV	-15 kV	2.5 Apk
Collector w/RF					
Coll. #1	11 kV	2.13 Apk	75% x Ek ±2%		2.5 Apk

Cathode voltage is measured with respect to ground.
 Heater, Collector, and Grid voltages are measured with respect to Cathode.

Performance	Typical	Spec
Input VSWR.....	1.5:1	2.0:1
Output VSWR.....	1.5:1	1.8:1
Max. Duty	—	2%
Max. Pulsewidth	—	50 μs
Grid Capacitance.....	40 pF	60 pF
Min. Harmonic Separation.....	-12 dBc	-10 dBc
Noise Power Density (dBm/MHz)	-14	-10
Prime Power.....	621 W	750 W

Specifications are subject to change without notice.

NOTES:

1. THERMOSTAT OPTIONS: N/C OR N/O

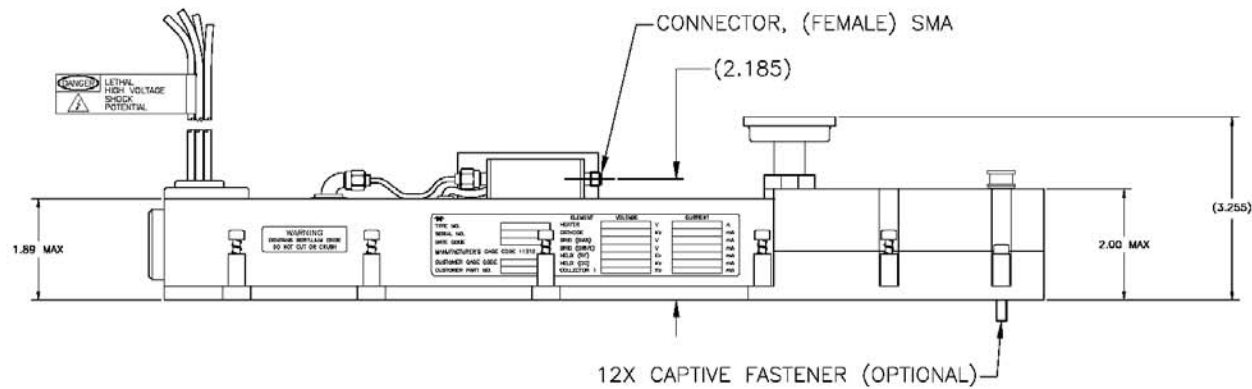
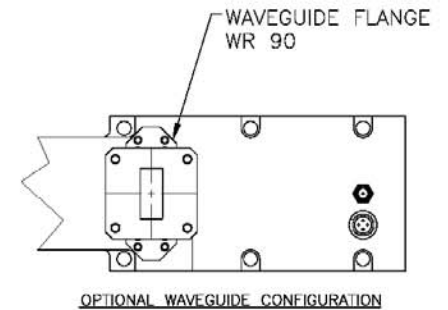
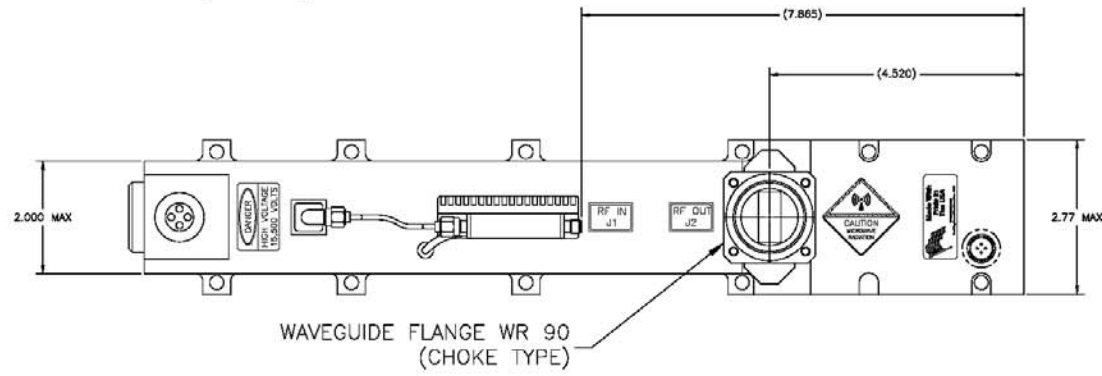

SUBJECT TO CHANGE W/O NOTICE ISO 9001:2008 Registered

TELEDYNE MICROWAVE SOLUTIONS TWT Products <small>11361 Sunrise Park Dr., Rancho Cordova, CA 95742 (916) 638-3344</small>
TITLE
MTI 3948

MTI 3948U

Pulse TWT

9 GHz – 10 GHz

- 5% Maximum Duty
- 7945 W Minimum Power
- 9.0 to 10.0 GHz
- -40° to 85° C
- 1150 W Typ. Prime Power @5%
- 47-48 dB Typical Gain
- 15.45" L x 4" W x 3.78" H
(39.2 x 10.15 x 9.6 cm)
- ±15° Phase Match

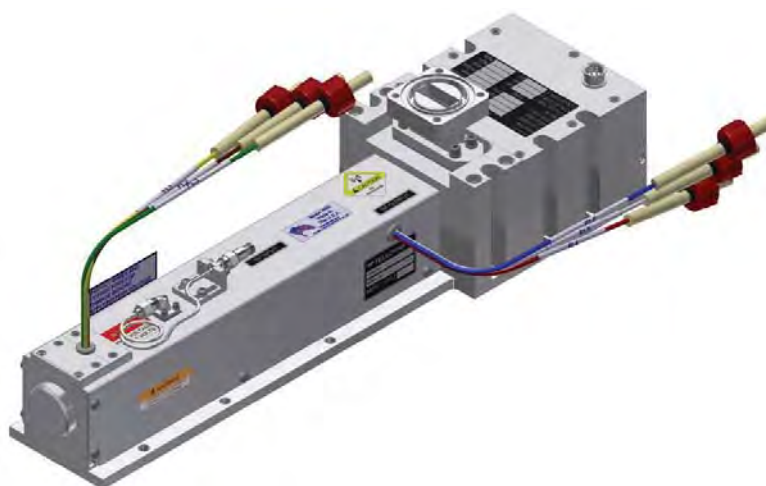

Typical Operating Conditions

Element	Typical Operating Conditions		Power Supply Requirements		
	Voltage	Current	Voltage Min.	Voltage Max.	Current Max.
Heater	-6.3 Vdc	2.2 A	-6.1 Vdc	-6.5 Vdc	2.8 A
Helix					
with RF	Ground	400 mApk	Ground	Ground	460 mApk @ 5%
without RF	Ground	80 mApk	Ground	Ground	460 mApk @ 5%
Grid On	185 Vpk	1.0 mApk	100 Vpk	300 Vpk	30 mApk
Grid Off	-325 Vdc	0.02 mA	-300 Vdc	-500 Vdc	0.5 mA
Cathode (E _k)	-14.2 kV	2.25 Apk	-13 kV	-15 kV	2.5 Apk
Collector w/RF					
Coll. #1	10.5 kV	825 mApk	74% x E _k ±2%		1.1 Apk
Coll. #2	7.67 kV	740 mApk	54% x E _k ±2%		1.0 Apk
Coll. #3	5.4 kV	285 mApk	38% x E _k ±2%		2.4 Apk

Cathode voltage is measured with respect to ground.

Heater, Collector, and Grid voltages are measured with respect to Cathode.

RF Performance

Freq (GHz)	Typ. Sat. Power Output (W)	Min. Spec. Power Output (W)	Typ. Gain @ Spec. Power (dB)
9.0	8000	7945	47
9.1	8000	7945	47
9.2	8000	7945	47
9.3	8000	7945	47
9.4	8000	7945	48
9.5	8000	7945	47
9.6	8000	7945	47
9.7	8000	7945	47
9.8	8000	7945	47
9.9	8000	7945	47
10.0	8000	7945	47

Typical power output is shown to illustrate capability.

Typical gain shown is without equalizer.

Performance	Typical	Spec
Input VSWR.....	1.6:1	2.0:1
Output VSWR.....	1.4:1	2.0:1
Max. Duty	5%	5%
Max. Pulswidth	50 μs	100 μs
Grid Capacitance.....	49 pF	60 pF
Min. Harmonic Separation.....	-12 dBc	-10 dBc
Noise Power Density (dBm/MHz)	>-14	-10
Prime Power.....	1150 W	1500 W

Specifications are subject to change without notice.

NOTES:

- 1. THERMOSTAT OPTIONS: N/C OR N/O
- ◊ SOLID STATE AMPLIFIER OPTIONAL BASED UPON CUSTOMER REQUIREMENT.

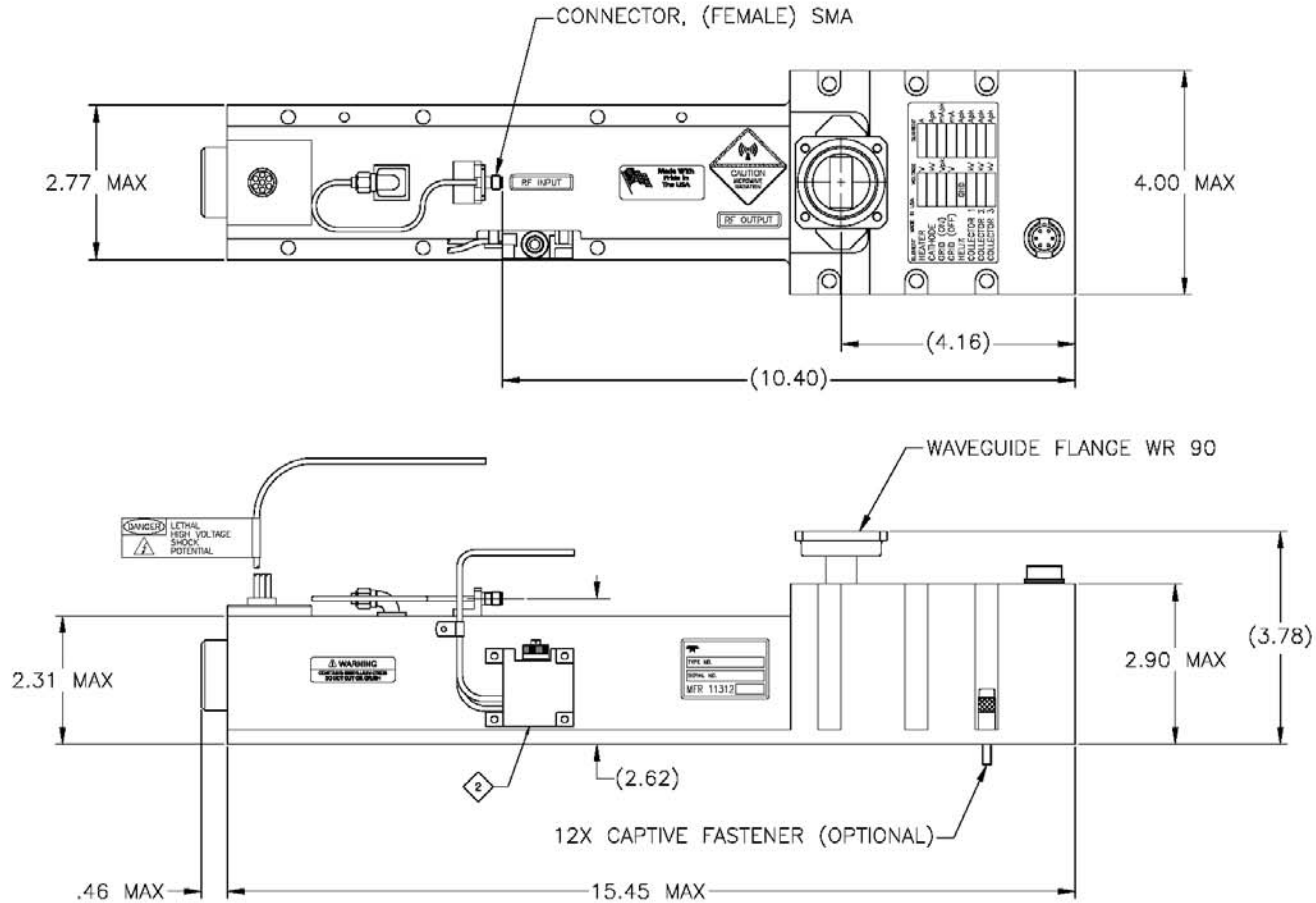

SUBJECT TO CHANGE W/O NOTICE ISO 9001:2008 Registered

TELEDYNE MICROWAVE SOLUTIONS TWT Products <small>11261 Sunrise Park Dr., Rancho Cordova, CA 95742 916-638-3344</small>
TITLE
MTI 3948U

MEC 3104

Pulse TWT

12 GHz – 18 GHz

- 6% Maximum Duty
- 3470 W Minimum Power
- 12.0 to 18.0 GHz
- -40° to 85° C
- 1000 W Typ. Prime Power @6%
- 35-39 dB Typical Gain
- 14.7" L x 4" W x 4.17" H
(37.2 x 10.2 x 10.6 cm)
- Phase Match Available

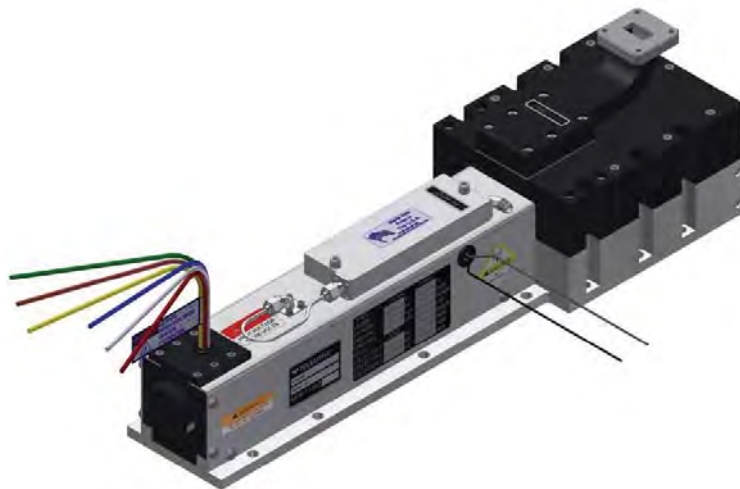

RF Performance

Freq (GHz)	Typ. Sat. Power Output (W)	Min. Spec. Power Output (W)	Typ. Gain @ Spec. Power (dB)
12.0	3800	3470	35
13.0	4100	3470	35
14.0	4300	3470	37
15.0	4500	3470	39
16.0	4400	3470	37
17.0	4500	3470	35
18.0	3900	3470	35

Typical power output is shown to illustrate capability.
Typical gain shown is with equalizer.

Typical Operating Conditions

Element	Voltage	Current	Power Supply Requirements		
			Voltage Min.	Voltage Max.	Current Max.
Heater	-6.3 Vdc	2.2 A	-6.1 Vdc	-6.5 Vdc	2.75 A
Helix					
with RF	Ground	375 mApk	Ground	Ground	700 mApk @ 6%
without RF	Ground	139 mApk	Ground	Ground	700 mApk @ 6%
Grid On	176 Vpk	2 mApk	100 Vpk	300 Vpk	30 mApk
Grid Off	-300 Vdc	0.5 mA	-200 Vdc	-500 Vdc	1.0 mA
Cathode (Ek)	-14.0 kV	1.92 A	-13.4 kV	-15.4 kV	2.0 Apk
Collector					
Coll. #1	10.4 kV	259 mApk (w/RF) 110 mApk (w/o RF)	74% x Ek ±2%		410 mApk
Coll. #2	8.3 kV	520 mApk (w/RF) 54 mApk (w/o RF)	59% x Ek ±2%		700 mApk
Coll. #3	6.17 kV	849 mApk (w/RF) 1620 mApk (w/o RF)	44% x Ek ±2%		1800 mApk

Cathode voltage is measured with respect to ground.
Heater, Collector, and Grid voltages are measured with respect to Cathode.

Performance

	Typical	Spec
Input VSWR.....	2.0:1	2.5:1
Output VSWR.....	1.6:1	2.0:1
Max. Duty	—	6%
Max. Pulsewidth	—	50 μs
Grid Capacitance.....	58 pF	60 pF
Noise Power Density (dBm/MHz)	-10	5
Prime Power.....	1000 W	1800 W

NOTES:

1. THERMOSTAT OPTIONS: N/C OR N/O

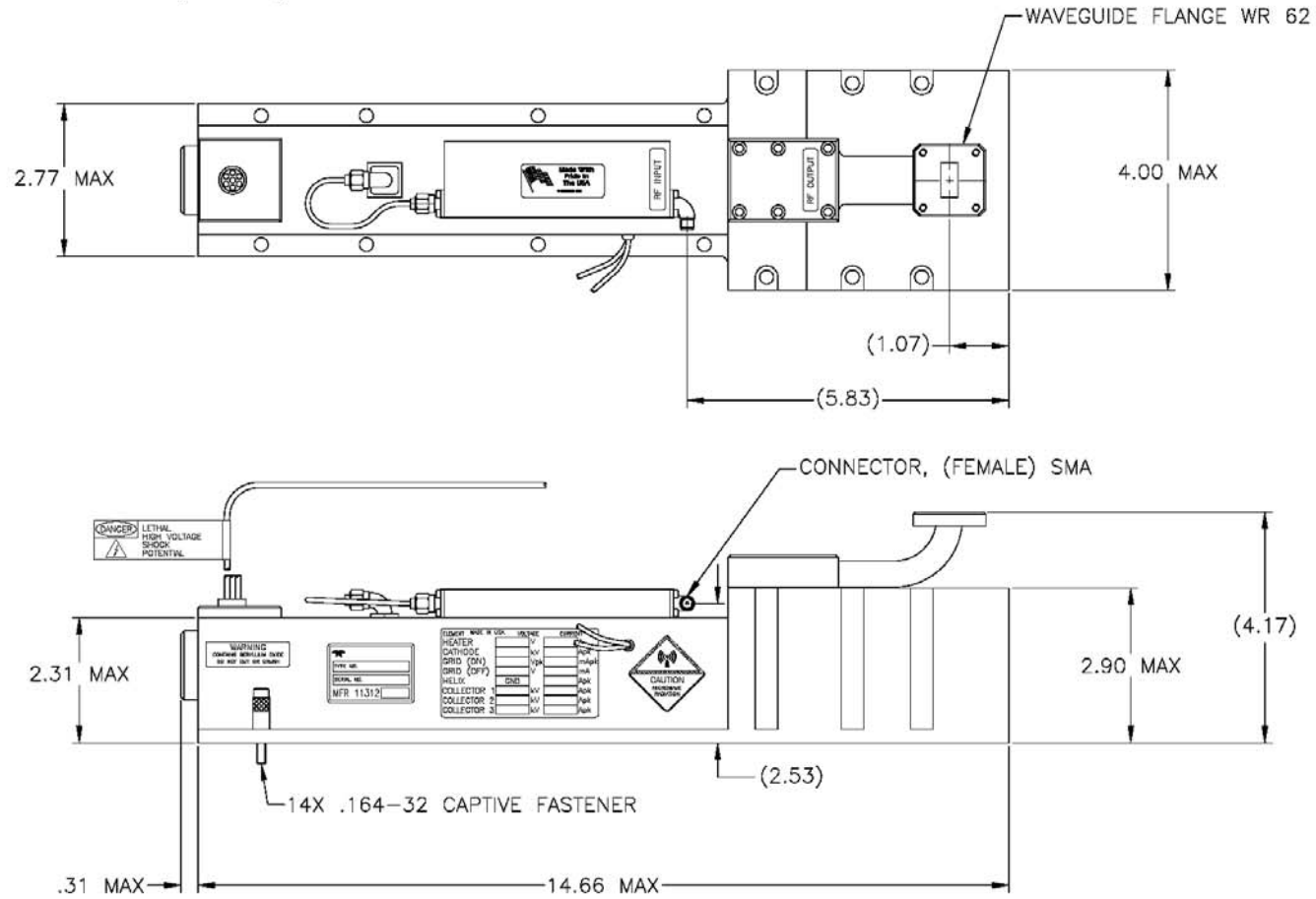

SUBJECT TO CHANGE W/O NOTICE ISO 9001:2008 Registered

TELEDYNE MICROWAVE SOLUTIONS TWT Products <small>11361 Sunrise Park Dr., Rancho Cordova, CA 95742 (916) 638-3344</small>
TITLE
MEC 3104

- 2% Maximum Duty
- 3800 W Minimum Power
- 15.0 to 17.0 GHz
- -40° to 85° C
- 492 W Typ. Prime Power @2%
- 50-56 dB Typical Gain
- 16.78" L x 3.03" W x 3.0" H
(42.6 x 7.7 x 7.62 cm)

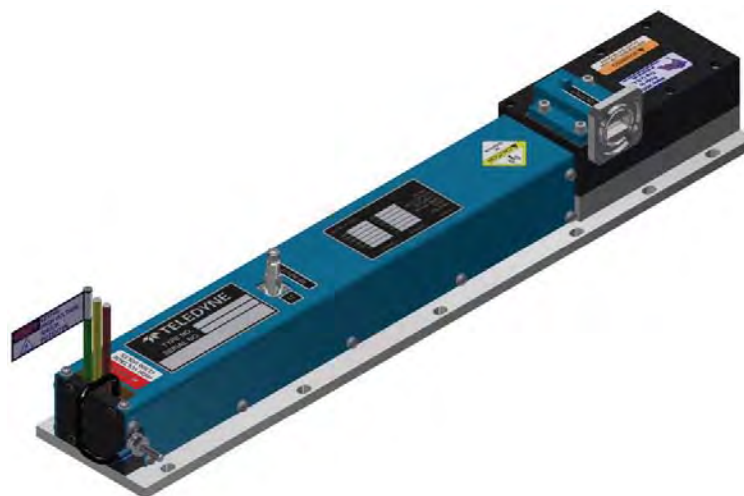

RF Performance

Freq (GHz)	Typ. Sat. Power Output (W)	Min. Spec. Power Output (W)	Typ. Gain @ Spec. Power (dB)
15.00	3800	3800*	50
15.25	3850	3800	52
15.50	3900	3800	50
15.75	4075	4000	51
16.00	4175	4000	50
16.25	4200	4000	53
16.50	4250	4000	54
16.75	4300	4000	55
17.00	4400	4000	56

Typical power output is shown to illustrate capability.
Typical gain shown is without equalizer.

Typical Operating Conditions

Element	Typical Operating Conditions			Power Supply Requirements		
	Voltage	Current		Voltage Min.	Voltage Max.	Current Max.
Heater	-6.3 Vdc	2 A		-6.0 Vdc	-6.6 Vdc	3.0 A
Helix						
with RF	Ground	400 mApk		Ground	Ground	500 mApk @ 2%
without RF	Ground	150 mApk		Ground	Ground	500 mApk @ 2%
Grid On	235 Vpk	2 mApk		130 Vpk	300 Vpk	30 mApk
Grid Off	-250 Vdc	0.005 mA		-250 Vdc	-500 Vdc	0.1 mA
Cathode (Ek)	-13.5 kV	1.65 Apk		-13 kV	-13.75 kV	3.0 Apk
Collector w/RF	Ground	1.1 Apk		Ground	Ground	1.6 Apk

Cathode voltage is measured with respect to ground.

Heater, Collector, and Grid voltages are measured with respect to Cathode.

Performance

	Typical	Spec
Input VSWR.....	1.8:1	2:1
Output VSWR.....	1.8:1	2:1
Max. Duty	—	2%
Max. Pulsewidth	—	100 μs
Grid Capacitance.....	35 pF	50 pF
Min. Harmonic Separation.....	-20 dBc	-15 dBc*
Noise Power Density (dBm/MHz)	-13	-10
Prime Power.....	492 W	500 W

* Minimum harmonic separation applies to the minimum specified power output at the indicated frequency.

NOTES:

1. THERMOSTAT OPTIONS: N/C OR N/O

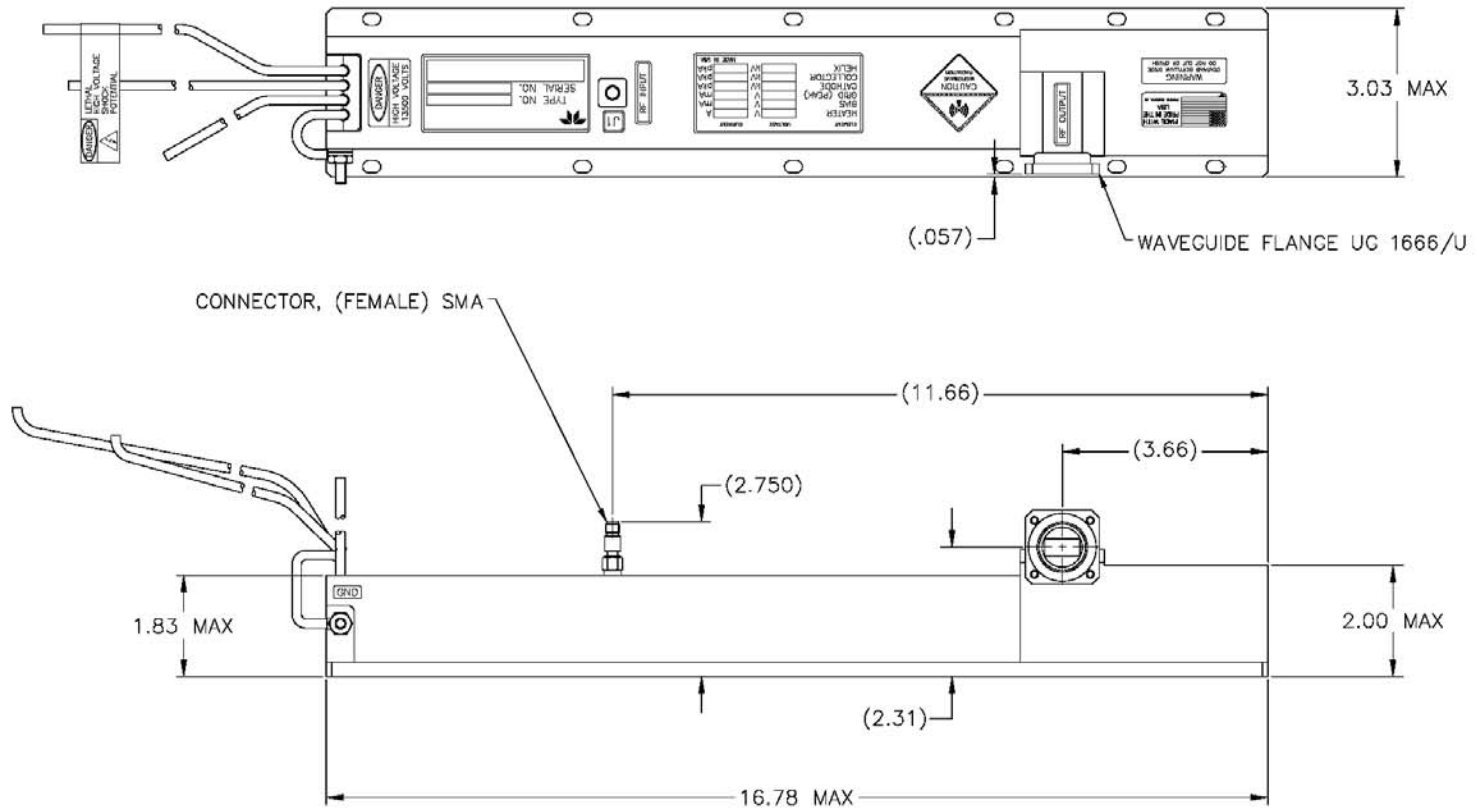

SUBJECT TO CHANGE W/O NOTICE ISO 9001:2008 Registered

TELEDYNE MICROWAVE SOLUTIONS TWT Products <small>11361 Sunrise Park Dr., Rancho Cordova, CA 95742 916-638-3344</small>
TITLE
MTI 3056C

MEC 3116X

Pulse TWT

15.0 GHz – 18.0 GHz

- 4.5% Maximum Duty
- 2500 W_{pk} Typical Minimum Power
- 15 to 18 GHz
- -40° to 85° C
- 415 W Typ. Prime Power
- 50 μS PW Max
- 44 dB Typical Sat. Gain
- 15.85" L x 1.98" W x 2.95" H (40.3 x 5.0 x 7.5 cm)

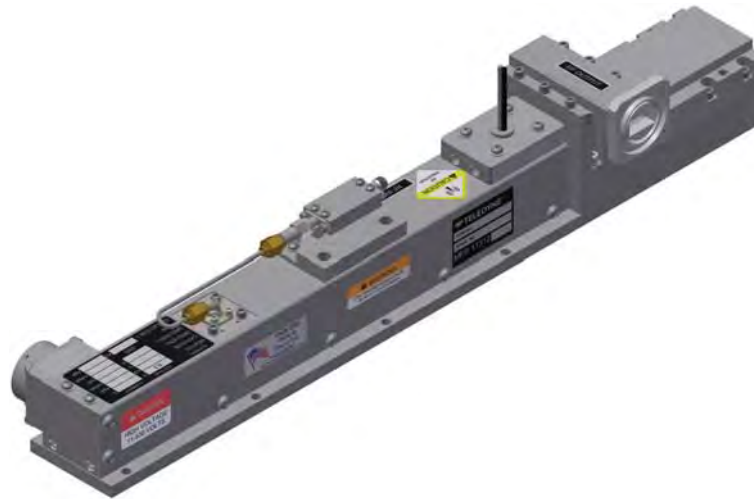

RF Performance

Freq (GHz)	Typ. Sat. Power Output (W)	Min. Spec. Power Output (W)	Typ. Gain @ Sat. Power (dB)
15.0	2200	1250	43
15.5	2300	1250	44
16.0	2450	1250	43
16.5	2500	1250	43
17.0	2500	1250	43
17.5	2400	1250	44
18.0	2400	1250	43

Typical power output is shown to illustrate capability.
Typical gain shown is with equalizer.

Typical Operating Conditions			Power Supply Requirements		
Element	Voltage	Current	Voltage Min.	Voltage Max.	Current Max.
Heater	-6.3 Vdc	2.0 A	-6.1 Vdc	-6.5 Vdc	2.5 A
Helix					
with RF	Ground	270 mA _{pk}	Ground	Ground	450 mA _{pk}
without RF	Ground	45 mA _{pk}	Ground	Ground	450 mA _{pk}
Grid On	150 V _{pk}	2.0 mA _{pk}	125 V _{pk}	250 V _{pk}	250 mA _{pk}
Grid Off	-200 Vdc	0.0 mA	-125 Vdc	-250 Vdc	1 mA
Cathode (E _k)	-10.7 kV	1.5 A _{pk}	-10.3 kV	-11.5 kV	1.8 A _{pk}
Collector w/RF					
Coll. #1	6.21 kV	1.25 A _{pk}	58% x E _k ±2%		1.55 A _{pk}

Cathode voltage is measured with respect to ground.
Heater, Collector, and Control Grid voltages are measured with respect to Cathode.

Performance	Typical	Spec
Input VSWR:.....	1.5:1	2.0:1
Output VSWR:.....	1.7:1	2.5:1
Max. Duty:.....	4.5%	4.5%
Max. Pulsewidth	50 μs	50 μs
Grid Capacitance.....	55 pF	65 pF max.
Noise Power Density (dBm/MHz)	-3	-0
Prime Power415 W	.525 W

NOTES:

1. THERMOSTAT OPTIONS: N/C OR N/O

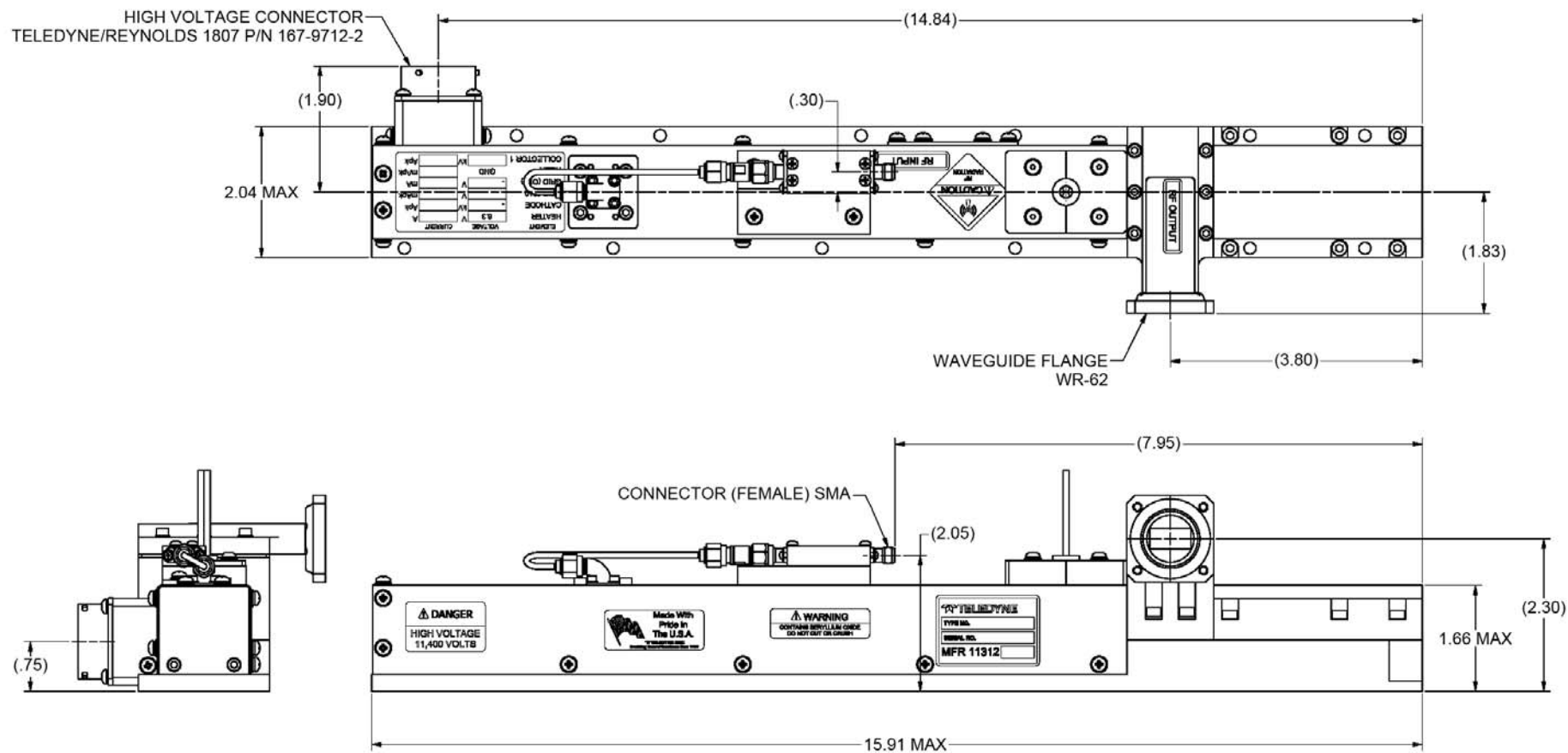

SUBJECT TO CHANGE W/O NOTICE ISO 9001:2008 Registered

TELEDYNE MICROWAVE SOLUTIONS
TWT PRODUCTS
11361 Sunrise Park Dr., Rancho Cordova, CA 95742 (916) 638-3344

TITLE

MEC 3116

MEC 3117X

Pulse TWT

15.2 GHz – 18.2 GHz

- 35% Maximum Duty
- 350/400 W_{pk} Minimum Power
- 15.2 to 18.2 GHz
- Output Power Flatness 1.0 dB
- -55° to 85° C
- 385 W_{pk} Typ. Prime Power @35%
- 300 μS PW Max
- 34 dB Typical Rated Gain
- 9.21" L x 1.16" W x 1.73" H (23.4 x 2.95 x 4.4 cm)
- Weight 2 lbs. Max



RF Performance

Freq (GHz)	Typ. Sat. Power Output (W)	Min. Spec. Power Output (W)	Typ. Gain @ Spec. Power (dB)
15.2	410	350	34
15.5	410	350	34
16.0	410	400	34
16.5	430	400	34
17.0	440	400	34
17.5	450	400	34
18.0	450	350	35
18.2	440	350	35

Typical power output is shown to illustrate capability.
Typical gain shown is with equalizer.

Typical Operating Conditions

Element	Typical Operating Conditions		Power Supply Requirements		
	Voltage	Current	Voltage Min.	Voltage Max.	Current Max.
Heater	-6.3 Vdc	0.85 A	-5.9 Vdc	-6.6 Vdc	1.50 A
Helix					
with RF	Ground	15 mApk	Ground	Ground	23 mApk @ 35%
without RF	Ground	6 mApk	Ground	Ground	23 mApk @ 35%
Grid On	150 Vpk	0.0 mApk	100 Vpk	220 Vpk	6 mApk
Grid Off	-250 Vdc	0.0 mA	-200 Vdc	-300 Vdc	1 mA
Cathode (E _k)	-7.3 kV	304 mApk	-7.3 kV	-7.9 kV	350 mApk
Collector w/RF					
Coll. #1	5.91 kV	52 mApk	81% x E _k ±2%		100 mApk
Coll. #2	3.41 kV	147 mApk	46.7% x E _k ±2%		175 mApk
Coll. #3	1.90 kV	90 mApk	26% x E _k ±2%		350 mApk

Cathode voltage is measured with respect to ground.

Heater, Collector, and Control Grid voltages are measured with respect to Cathode

Performance

	Typical	Spec
Input VSWR:.....	1.3:1	1.6:1
Output VSWR.....	1.6:1	2.0:1
Max. Duty	35%	35%
Max. Pulsewidth	300 μs	300 μs
Grid Capacitance.....	50 pF	50 pF max.
Noise Power Density (dBm/MHz)	-20	-10
Prime Power.....	1250 W	1700 W

NOTES:

1. THERMOSTAT OPTIONS: N/C OR N/O

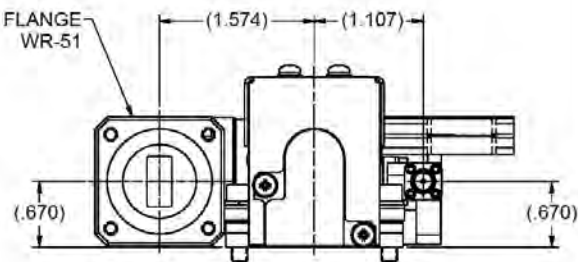
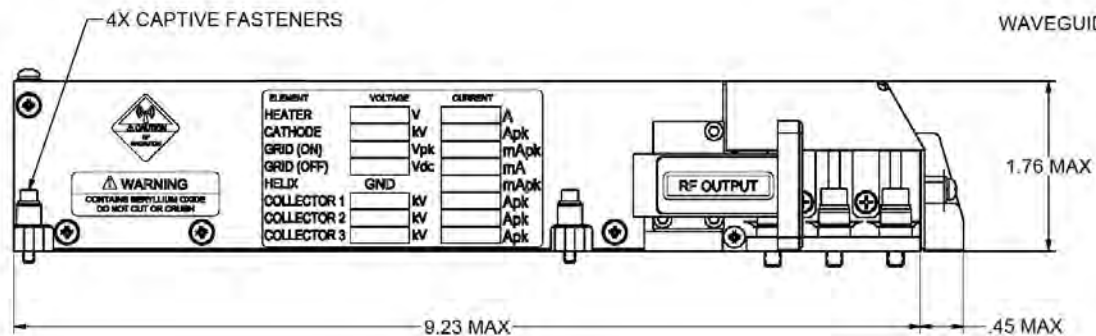
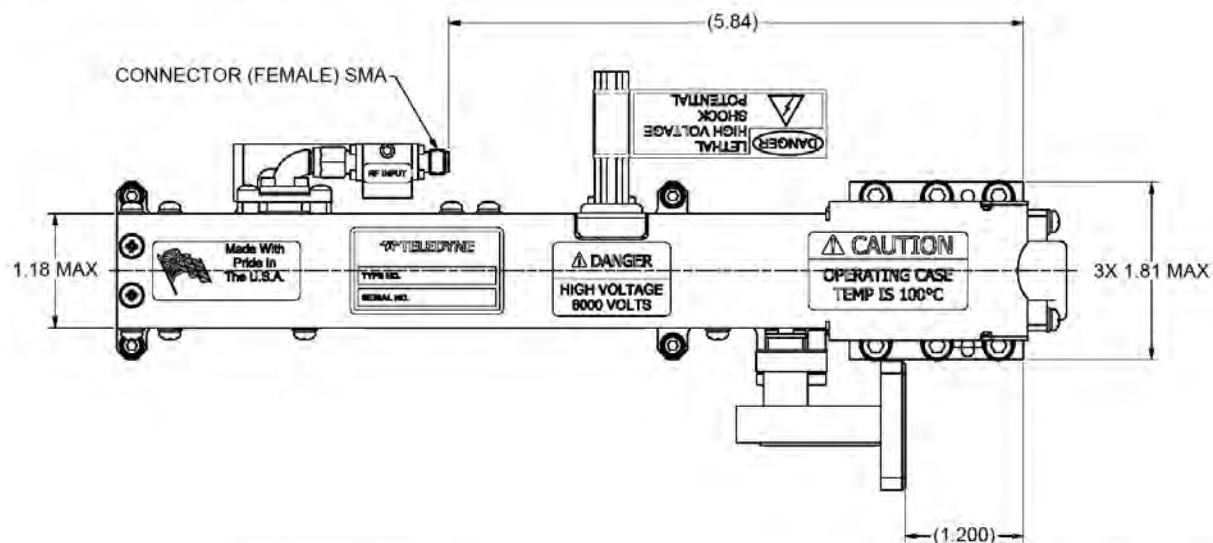

SUBJECT TO CHANGE W/O NOTICE ISO 9001:2008 Registered

<p>TELEDYNE MICROWAVE SOLUTIONS TWT PRODUCTS 1281 Sunrise Park Dr., Rancho Cordova, CA 95748-2844</p>
TITLE
MEC 3117X

MEC 3333

Fast Warm-Up TWT 15.5 GHz – 16.5 GHz

- 33% Maximum Duty
- 850 W_{pk} Minimum Power
- 15.5 to 16.5 GHz
- Output Power Flatness 0.5 dB
- 820 W Typ. Prime Power @33%
- -40 dBm/MHz Typ. Noise Power Density
- 46 dB Typical Rated Gain
- 9.84" L x 3.41" W x 2.75" H (23.9 x 8.66 x 7 cm)
- Weight 3.3 lbs. Max.
- -40° to 85° C

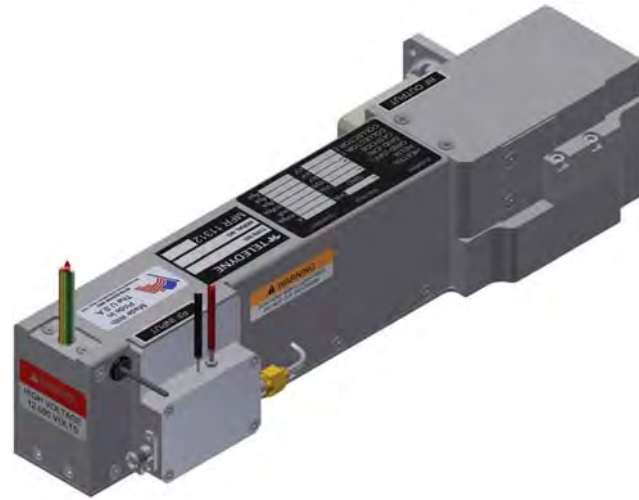

RF Performance with Solid State Amplifier

Freq (GHz)	Typ. Sat. Power Output (W)	Min. Spec. Power Output (W)	Typ. Gain @ Spec. Power (dB)
15.5	880	850	46
15.6	890	850	46
15.7	900	850	46
15.8	920	850	47
15.9	950	850	47
16.0	975	850	46
16.1	980	850	47
16.2	940	850	48
16.3	925	850	46
16.4	900	850	46
16.5	880	850	46

Typical power output is shown to illustrate capability.
Typical gain shown is without equalizer and using an SSA.

Typical Operating Conditions

Element	Typical Operating Conditions		Power Supply Requirements		
	Voltage	Current	Voltage Min.	Voltage Max.	Current Max.
Heater (Normal)	-5.2 Vdc	1.67 A	-4.8 Vdc	-5.2 Vdc	2.0 A
Heater (FWU)	-10.5 Vdc	6.0 A	-10.0 Vdc	-12.0 Vdc	7.0 A
Helix					
with RF	Ground	13 mApk	Ground	Ground	25 mApk @ 33%
without RF	Ground	7 mApk	Ground	Ground	15 mApk @ 33%
Grid On	200 Vpk	4.0 mApk	120 Vpk	220 Vpk	20 mApk
Grid Off	-250 Vdc	0.0 mA	-250 Vdc	-350 Vdc	1 mA
Cathode (E _k)	-12.05 kV	414 mApk	11.5 kV	-12.5 kV	485 mApk
Collector w/RF					
Coll. #1	7.11 kV	83 mApk	59% x E _k ±2%		120 mApk
Coll. #2	4.94 kV	318 mApk	41% x E _k ±2%		440 mApk

Cathode voltage is measured with respect to ground.
Heater, Collector, and Control Grid voltages are measured with respect to Cathode.

Performance	Typical	Spec
Input VSWR:.....	1.4:1	2.0:1
Output VSWR:.....	1.5:1	2.0:1
Max. Duty	33%	33%
Max. Pulsewidth	50 μs	20 μs
Grid Capacitance.....	25 pF	50 pF max.
Noise Power Density (dBm/MHz)	-40	-30
Prime Power	820 W	860 W

Specifications are subject to change without notice.

NOTES:

1. THERMOSTAT OPTIONS: N/C OR N/O

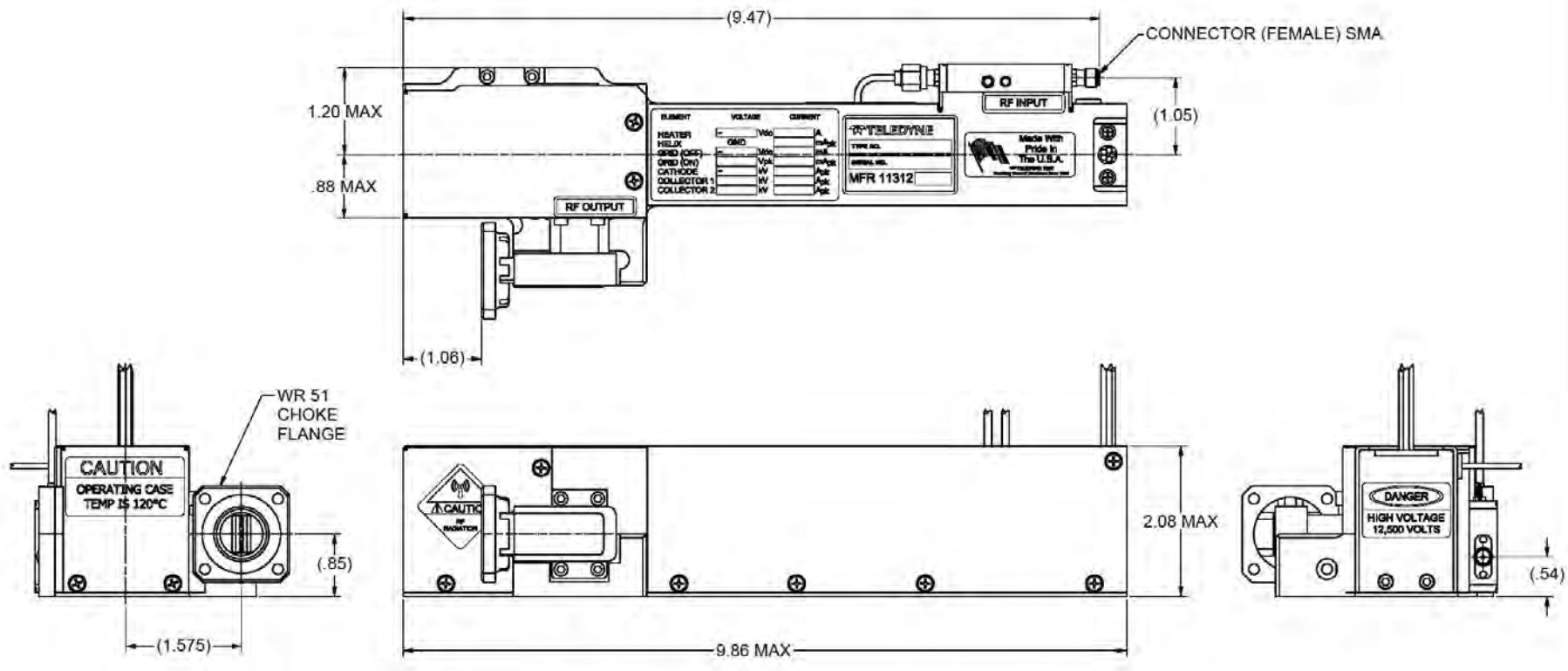

SUBJECT TO CHANGE W/O NOTICE

ISO 9001:2008 Registered

TELEDYNE MICROWAVE SOLUTIONS
TWT PRODUCTS

MEC 3333

MEC 3086

Pulse TWT

15.50 GHz – 17.90 GHz

- 40% Duty Cycle
- 700 W Minimum Power
- 15.50 to 17.90 GHz
- -40° to 85° C
- 45-48 dB Typical Gain
- 19.8" L x 3.9" W x 3.4" H
(50.3 x 9.9 x 8.6 cm)
- ±20° Phase Match

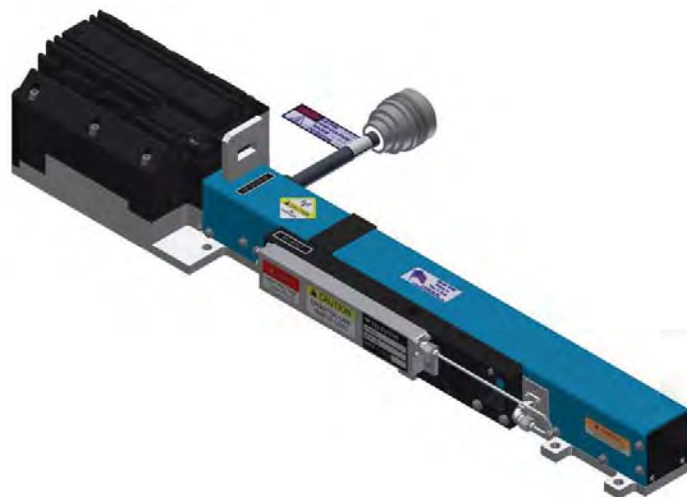

RF Performance

Freq (GHz)	Typ. Sat. Power Output (W)	Min. Spec. Power Output (W)	Typ. Gain @ Spec. Power (dB)
15.50	710	700	45
16.10	725	700	47
16.70	725	700	48
17.30	725	700	47
17.90	710	700	47

Typical power output is shown to illustrate capability.
Typical gain shown is with equalizer.

Typical Operating Conditions			Power Supply Requirements		
Element	Voltage	Current	Voltage Min.	Voltage Max.	Current Max.
Heater	-6.3 Vdc	1.70 A	-5.8 Vdc	-6.6 Vdc	2.5 A
Helix					
with RF	Ground	7.0 mApk	Ground	Ground	20 mApk
without RF	Ground	3.3 mApk	Ground	Ground	20 mApk
Grid Drive	195 Vpk	0 mApk	150 Vpk	275 Vpk	20 mApk
Grid Bias Off	-350 Vdc	0 mA	-300 Vdc	-500 Vdc	1.0 mA
Cathode (E _k)	-12.2 kV	416 mApk	-12 kV	-13 kV	480 mApk
Collector					
Coll. #1	7.2 kV	85.0 mApk (w/RF) 6.0 mApk(w/o RF)	59% x E _k ±2%		200 mApk
Coll. #2	5.0 kV	324 mApk (w/RF) 406 mApk(w/o RF)	41% x E _k ±2%		480 mApk

Cathode voltage is measured with respect to ground.

Heater, Collector, and Grid voltages are measured with respect to Cathode.

Performance	Typical	Spec
Input VSWR.....	1.90:1	2.0:1
Output VSWR.....	1.47:1	2.0:1
Duty Cycle	40%	40%
Noise Power Density (dBm/MHz)	>-105	-105
Spurious	>-50 dBc	-50 dBc
Prime Power	938 W	1200 W

NOTES:

1. THERMOSTAT OPTIONS: N/C OR N/O

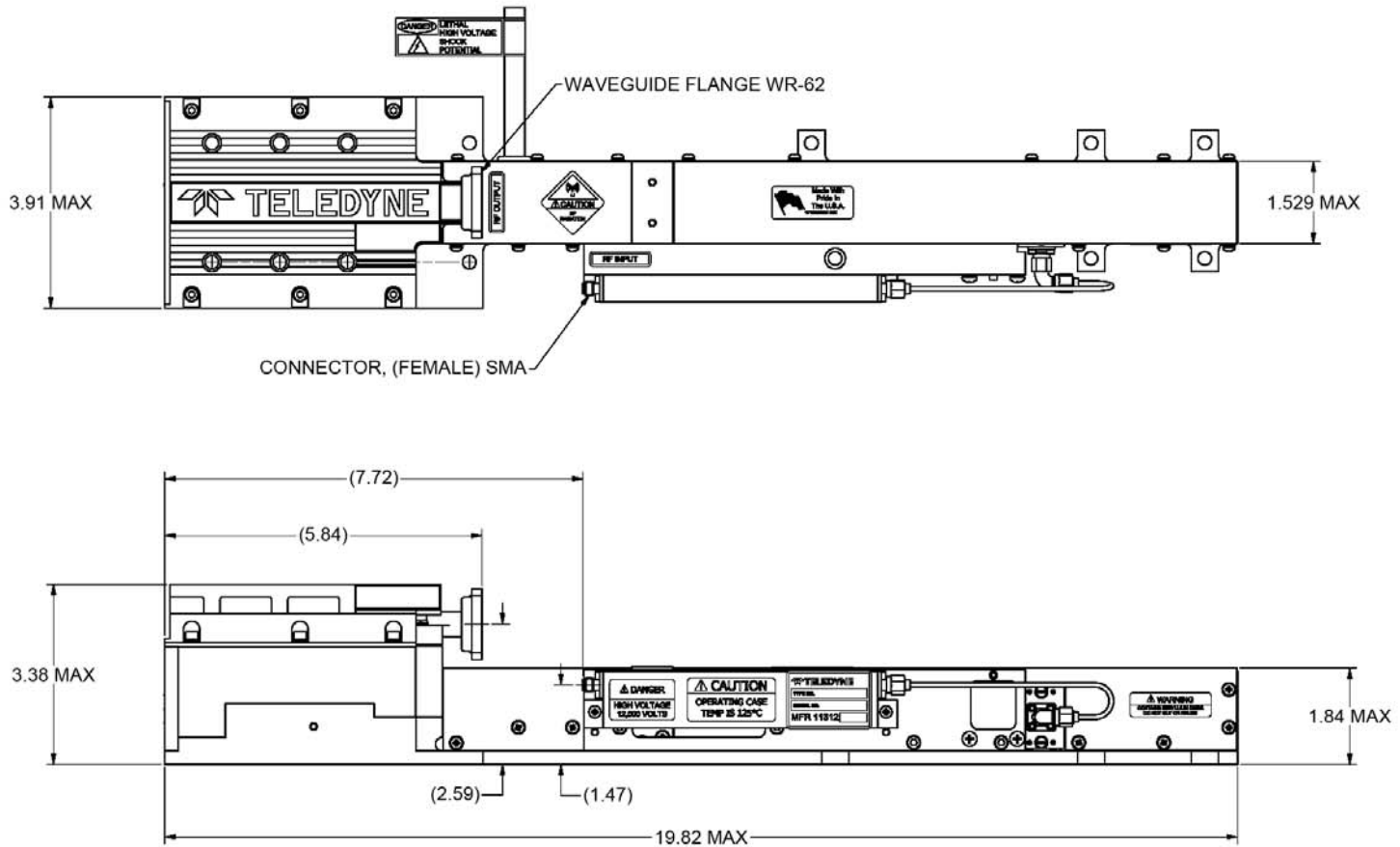

SUBJECT TO CHANGE W/O NOTICE

ISO 9001:2008 Registered

TELEDYNE MICROWAVE SOLUTIONS
TWT PRODUCTS
11361 Sunrise Park Dr., Rancho Cordova, CA, 95742-3344

TITLE

MEC 3086

**This page
intentionally
left blank**

Communication TWTs

Page No.	Model	Frequency Band	Power (W)	Duty (%) Max.	Typical Gain (dB) Min/Max @ Rated P _{out}	Efficiency (%) Typical	Modulation (Control Electrode)	Output Connection	Weight (lbs/kg) (NTE)
130	MEC 5417	5.85 - 6.45	282**	100	39/41	19	GRID	WRD 580	8.5/3.9
132	MEC 5337	C/Ku	350/400	100	38/52	27	GRID	WRD 580	8.5/3.9
134	MTG 5336B	C/Ku	325/325	100	38/52	27	FE	WRD 580	8.5/3.9
136	MTG 5336AX	C/Ku	400/400	100	38/52	30	FE	WRD 580	8.5/3.9
138	MTG 5333	C/X/Ku	325/400/325	100	37/46/48	27	GRID	WRD 580	8.5/3.9
	MTG 5336	C/X/Ku	325/400/325	100	37/46/48	27	FE	WRD 580	8.5/3.9
140	MEC 5599	C/X/Ku	112/158/91	100	41/41/40	28	FE	WRD 580	4.5/2.0
142	MTG 5338X	C/X/Ku	350/600/350	100	37/46/48	35*	FE	WRD 580	8.5/3.9
144	MEC 5450X	7.9-8.4	600	100	46	35	FE	CMR 112	8.5/3.9
146	MEC 5499/A	13.75 - 14.5	200	100	53/55	32**	FE	WR 75	8.5/3.9
148	MEC 5517	13.75 - 14.5	295	100	48/50	34	FE	WR 75	4.5/2.0
150	MEC 5516	X and Ku	125	100	51/53	24	FE	WRDG 650	5.5/2.5
152	MEC 5441	Ku/DBS	350/300	100	43/51	29*	GRID	WR 62	7.5/3.4
	MEC 5442	Ku/DBS	350/300	100	43/51	29*	FE	WR 62	7.5/3.4
154	MEC 5452	13.75 - 14.5	500	100	60	40	FE	WR 75	8.5/3.9
	MEC 5455	13.75 - 14.5	500	100	60	40	GRID	WR 75	8.5/3.9
156	MEC 5466	17.3 - 18.4	450/500	100	45/47	32*	FE	WR 62	9.0/4.1
158	MEC 5530L	27.0 - 30.0	250	100	37/40	25	FE	WR 28	7.0/3.2
160	MEC 5495	27.0 - 31.0	120	100	34	17**	FE	WR 28	7.0/3.2
162	MEC 5530H	30.0 - 31.0	250	100	36/37	25	FE	WR 28	7.0/3.2
164	MEC 5523	43.5 - 45.5	125	100	30/33	23	FE	WR 22	7.0/3.2

* Over majority of frequency range - Performance may be reduced at band edges.

** With <-26 dBc QPSK spectral regrowth @ mid-band.

Note: RF input components may be integrated with the TWT at TELEDYNE to improve system gain and phase variation performance.

MEC 5417

Communication TWT

5.85 GHz – 6.45 GHz

- 282 W Minimum Power
- 5.85 to 6.45 GHz
- -40° to 85° C
- 1459 W Typ. Prime Power
- 39-41 dB Typical Gain
- 19.8" L x 3" W x 3.4" H (50.34 x 7.67 x 8.64 cm)
- Phase Match Available

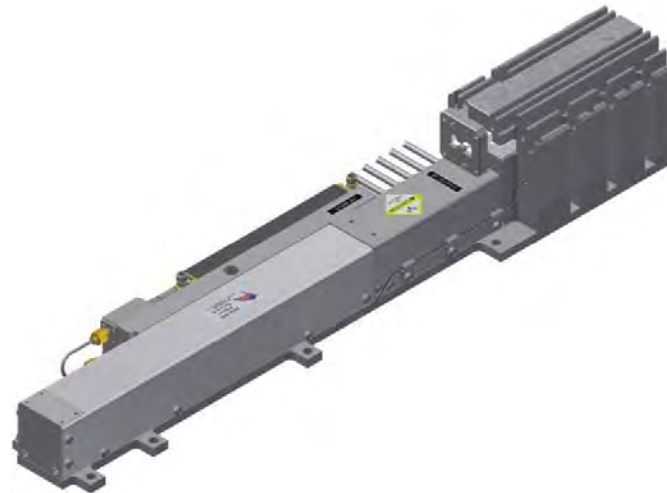

Typical Operating Conditions			Power Supply Requirements		
Element	Voltage	Current	Voltage Min.	Voltage Max.	Current Max.
Heater	-6 Vdc	1.6 A	-5.0 Vdc	-6.5 Vdc	3 A
Helix					
with RF	Ground	5 mA	Ground	Ground	10 mA
without RF	Ground	1 mA	Ground	Ground	10 mA
Grid On	200 Vdc	0.5 mA	100 Vdc	250 Vdc	5 mA
Grid Off	-250 Vdc	0.1 mA	-250 Vdc	-500 Vdc	1 mA
Cathode (E_k)	-10.7 kV	300 mA	-10 kV	-11 kV	325 mA
Collector w/RF					
Coll. #1	5.99 kV	75 mA	56% x $E_k \pm 2\%$		150 mA
Coll. #2	4.28 kV	220 mA	40% x $E_k \pm 2\%$		325 mA

Cathode voltage is measured with respect to ground.
 Heater, Collector, and Grid voltages are measured with respect to Cathode.
 Currents measured at linear power output.
 Collector voltage optimized for linear performance. Helix current will exceed max if TWT driven to saturation.

RF Performance

Freq (GHz)	Typ. Sat. Power Output (W)	Min. Linear Power Output (W)***	Typ. Gain @ Spec. Power (dB)
5.85	445	282*	41
6.15	445	282**	41
6.45	445	282	39

Typical power output is shown to illustrate capability.
 Typical gain shown is with equalizer.

Performance

Performance	Typical	Spec
Input VSWR.....	2.4:1	2.5:1
Output VSWR.....	2.4:1	2.5:1
Third Order Intercept.....	61 dBm	—
Grid Capacitance.....	37 pF	65 pF
Min. Harmonic Separation.....	-15 dBc	-10 dBc*
Noise Power Density (dBm/MHz).....	-12	-10
Prime Power.....	1459 W**	1500 W**

* Minimum harmonic separation applies to the minimum specified power output at the indicated frequency.

** Prime power applies to the minimum linear power output at the indicated frequency.

*** Spectral regrowth (QPSK modulation) measured at one symbol rate shall be no greater than -26 dBc.

NOTES:

1. THERMOSTAT OPTIONS: N/C OR N/O

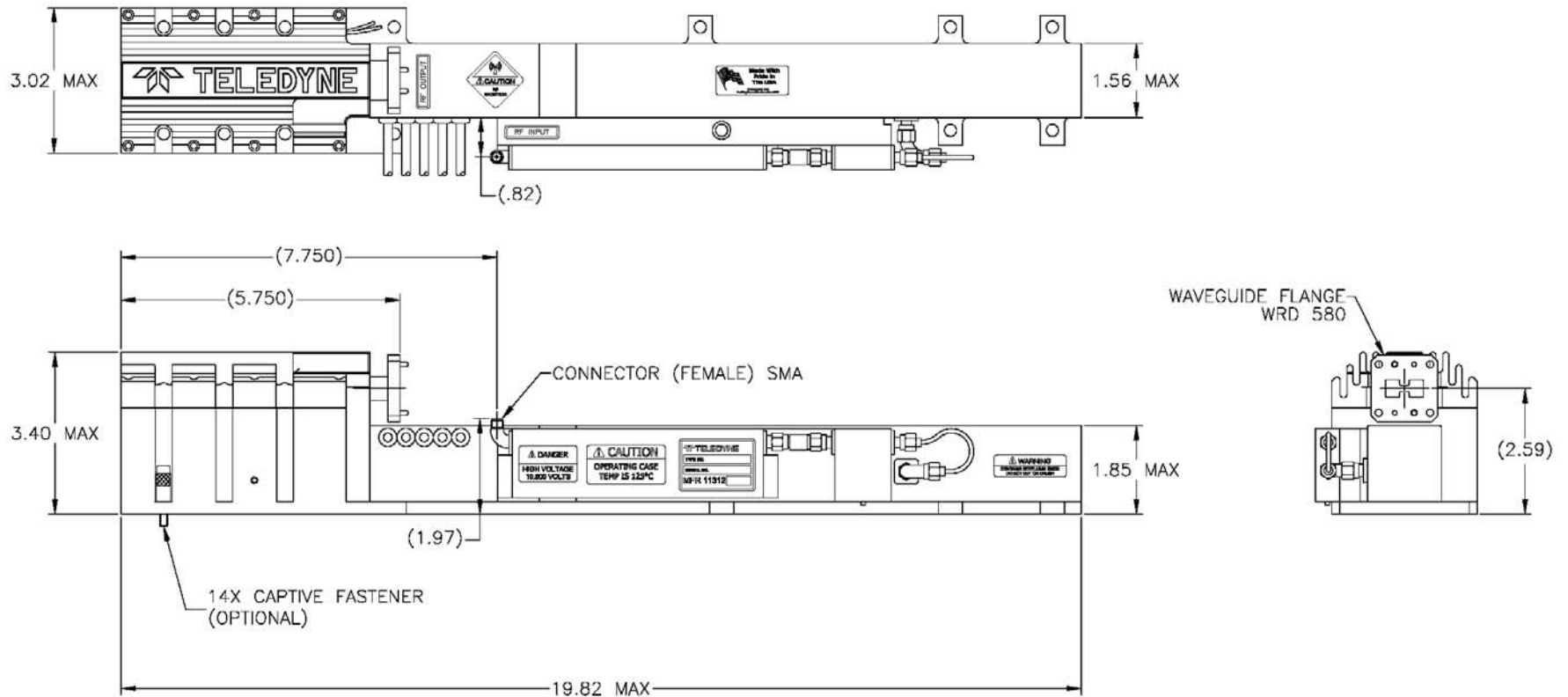

SUBJECT TO CHANGE W/O NOTICE ISO 9001:2008 Registered

TELEDYNE MICROWAVE SOLUTIONS TWT Products 11361 Sunrise Park Drive, Rancho Cordova, CA 95742 (916) 638-3344 TITLE MEC 5417
--

NOTES:

1. THERMOSTAT OPTIONS: N/C OR N/O

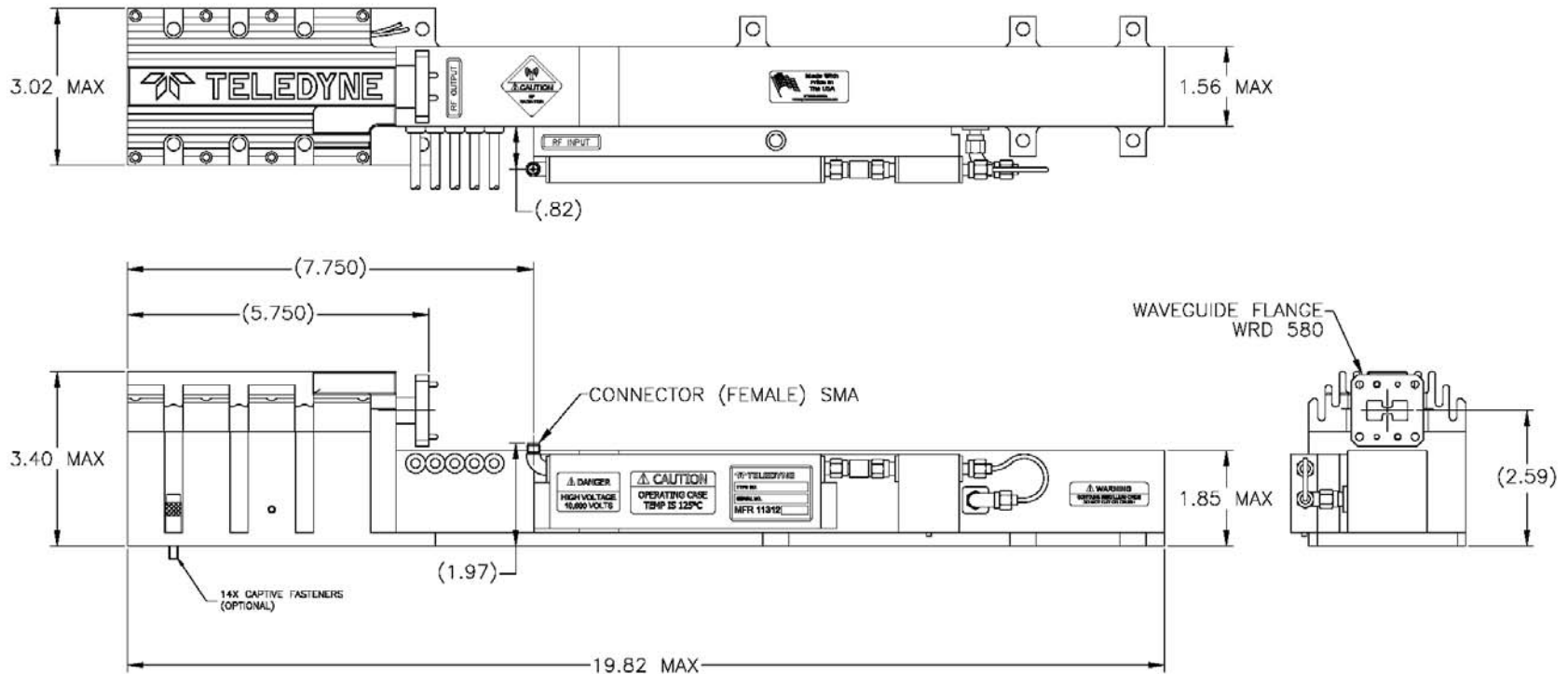

SUBJECT TO CHANGE W/O NOTICE ISO 9001:2008 Registered

TELEDYNE MICROWAVE SOLUTIONS TWT Products <small>11361 Sunrise Park Drive, Rancho Cordova, CA (916) 636-3344</small>
TITLE
MEC 5337

MTG 5336B

Communication TWT

Dual Band

- 325 W Minimum Power
- Dual Band
- -40° to 85° C
- 1412 W Typ. Prime Power
- 38/52 dB Typical Gain
- 19.8" L x 3" W x 3.4" H
(50.34 x 7.67 x 8.64 cm)
- Phase Match Available

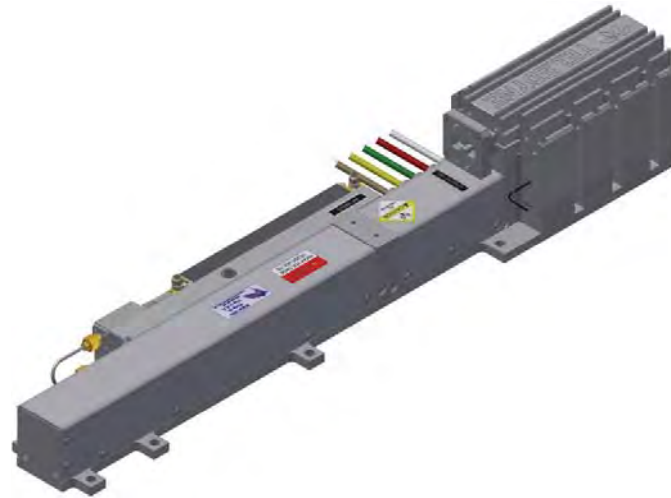

RF Performance

Freq (GHz)	Typ. Sat. Power Output (W)	Min. Spec. Power Output (W)	Typ. Gain @ Spec. Power (dB)
5.850	375	325*	38
6.000	375	325	38
6.425	375	325	38
6.650	375	325	38
13.750	420	325	52
14.000	420	325**	52
14.250	420	325	52
14.500	420	325	52

Typical power output is shown to illustrate capability.

Typical gain shown is with equalizer.

** Minimum harmonic separation applies to the minimum specified power output at the indicated frequency.

Typical Operating Conditions

Element	Typical Operating Conditions		Power Supply Requirements		
	Voltage	Current	Voltage Min.	Voltage Max.	Current Max.
Heater	-6 Vdc	1.62 A	-5.6 Vdc	-6.6 Vdc	2.5 A
Helix					
with RF	Ground	5 mA	Ground	Ground	10 mA
without RF	Ground	0.6 mA	Ground	Ground	10 mA
FE On	-40 Vdc	0.1 mA	0	-75 Vdc	1 mA
FE Off	-1300 Vdc	0.1 mA	-1300 Vdc	-1500 Vdc	1 mA
Cathode (E _k)	-10.75 kV	290 mA	-10 kV	-10.8 kV	300 mA
Collector w/RF					
Coll. #1	6.02 kV	80 mA	56% x E _k ±2%		150 mA
Coll. #2	4.3 kV	202 mA	40% x E _k ±2%		300 mA

Cathode voltage is measured with respect to ground.

Heater, Collector, and Focus Electrode (FE) voltages are measured with respect to Cathode.

Spectral Regrowth

Freq (GHz)	Min. Linear Power (W)	Modulation	Level @1 Symbol Rate
5.85	225	QPSK	-26 dBc
6.425	225	QPSK	-26 dBc
13.75	125	QPSK	-26 dBc
14.5	125	QPSK	-26 dBc

Performance

	Typical	Spec
Input VSWR.....	2.3:1	2.5:1
Output VSWR.....	2.0:1	2.3:1
Max. Duty	—	CW
Grid Capacitance.....	50 pF	65 pF
Min. Harmonic Separation.....	-5/-20 dBc	-3*/-15** dBc
Noise Power Density (dBm/MHz).....	-12	-10
Prime Power.....	1412 W	1450 W

Specifications are subject to change without notice.

NOTES:

1. THERMOSTAT OPTIONS: N/C OR N/O

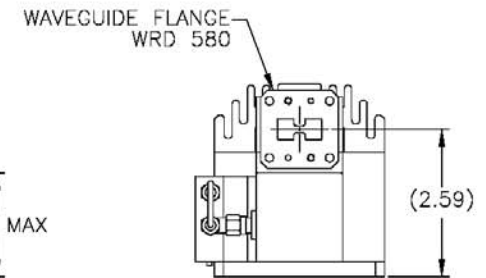
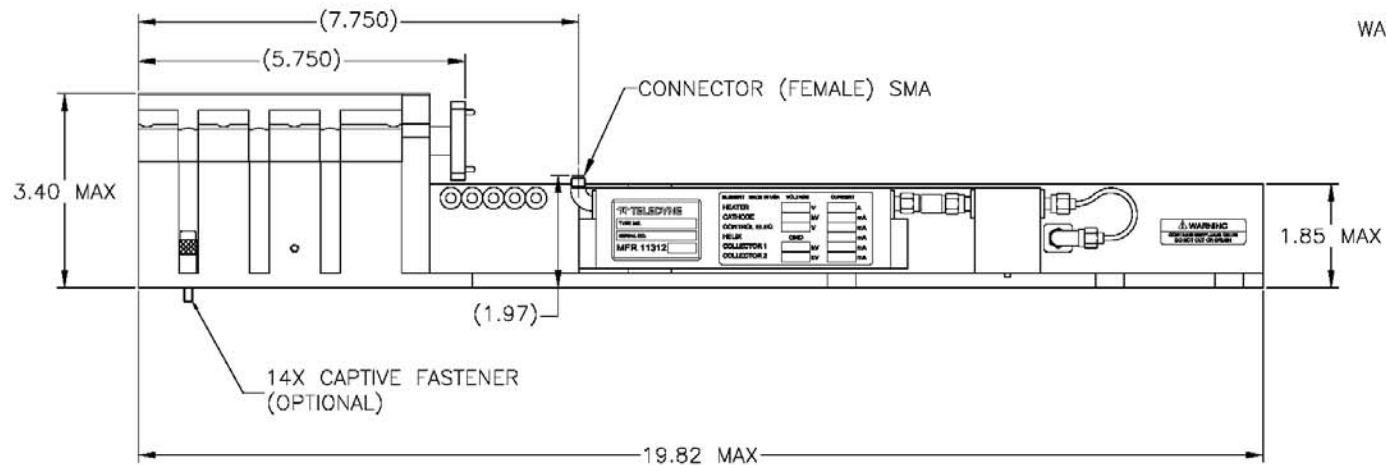
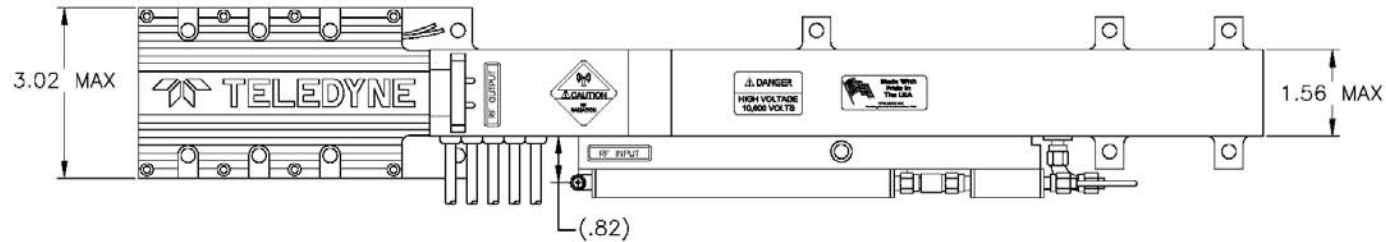

SUBJECT TO CHANGE W/O NOTICE ISO 9001:2008 Registered

<p>TELEDYNE MICROWAVE SOLUTIONS TWT Products 11361 Sunrise Park Dr., Rancho Cordova, CA 95742 • 916.638.3344</p>
TITLE
MTC 5336B

MTG 5336AX

Communication TWT

Dual Band

- 400 W Minimum Power
- Dual Band
- -40° to 85° C
- 1465 W Typ. Prime Power
- 38/52 dB Typical Gain
- 19.8" L x 3" W x 3.4" H
(50.3 x 7.7 x 8.6 cm)
- Phase Match Available

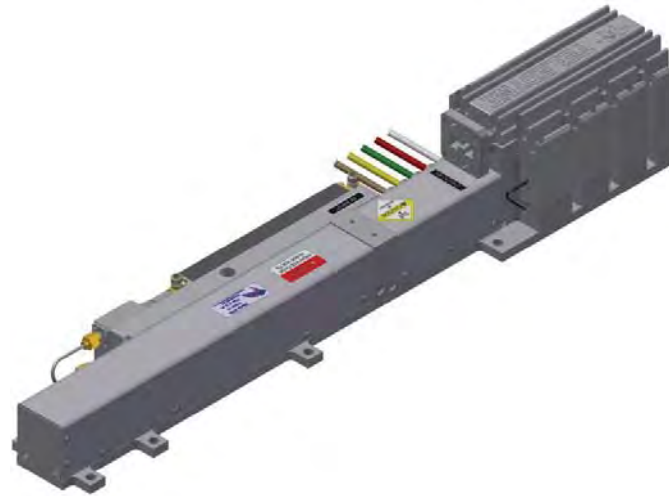

RF Performance

Freq (GHz)	Typ. Sat. Power Output (W)	Min. Spec. Power Output (W)	Typ. Gain @ Spec. Power (dB)
5.850	425	400*	38
6.250	425	400	38
6.650	425	400	38
13.750	420	400**	52
14.250	420	400	52
14.500	420	400	52

Typical power output is shown to illustrate capability.

Typical gain shown is with equalizer.

*** Minimum harmonic separation applies to the minimum specified power output at the indicated frequency.*

Typical Operating Conditions

Element	Voltage	Current	Power Supply Requirements		
			Voltage Min.	Voltage Max.	Current Max.
Heater	-6 Vdc	1.3 A	-5.6 Vdc	-6.6 Vdc	2 A
Helix					
with RF	Ground	6 mA	Ground	Ground	10 mA
without RF	Ground	1 mA	Ground	Ground	10 mA
FE On	-6 Vdc	0.1 mA	0	-10 Vdc	1 mA
FE Off	-1600 Vdc	0.1 mA	-1600 Vdc	-1800 Vdc	1 mA
Cathode (E_k)	-10.8 kV	300 mA	-9.6 kV	-11.4 kV	340 mA
Collector w/RF					
Coll. #1	6.05 kV	70 mA	56% x $E_k \pm 2\%$		125 mA
Coll. #2	4.32 kV	224 mA	40% x $E_k \pm 2\%$		330 mA

Cathode voltage is measured with respect to ground.

Heater, Collector, and Focus Electrode (FE) voltages are measured with respect to Cathode.

Performance

	Typical	Spec
Input VSWR.....	2.0:1	2.25:1
Output VSWR.....	2.2:1	2.3:1
Max. Duty	—	CW
FE Capacitance.....	50 pF	.65 pF
Min. Harmonic Separation (dBc)	-5/-20	-3*/-15**
Noise Power Density (dBm/MHz)	-14	-12
Prime Power.....	1465 W	1550 W

Specifications are subject to change without notice.

NOTES:

1. THERMOSTAT OPTIONS: N/C OR N/O

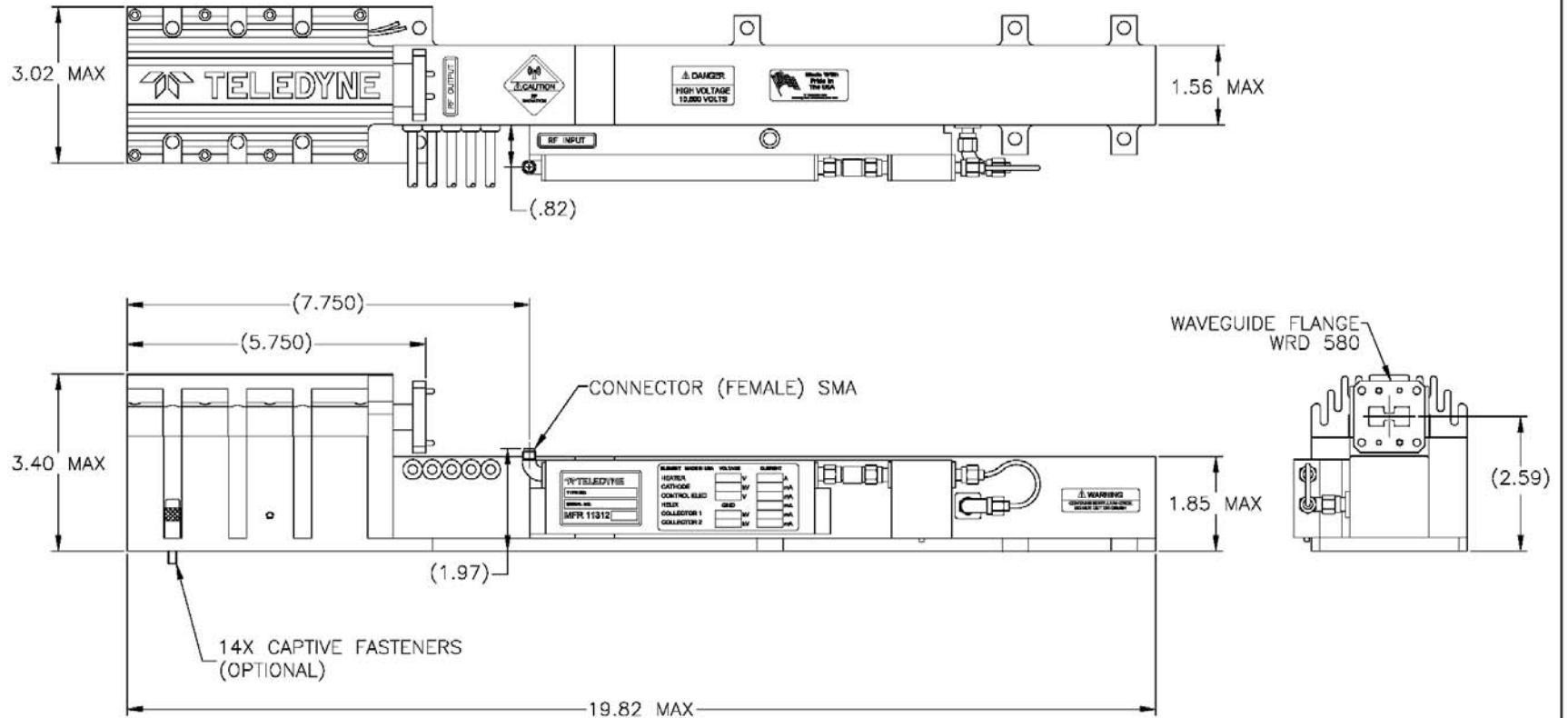

SUBJECT TO CHANGE W/O NOTICE ISO 9001:2008 Registered

<p>TELEDYNE MICROWAVE SOLUTIONS TWT Products 11361 Sunrise Park Dr., Rancho Cordova, CA 95744-3344</p>
TITLE
MTG 5336AX

NOTES:

1. THERMOSTAT OPTIONS: N/C OR N/O

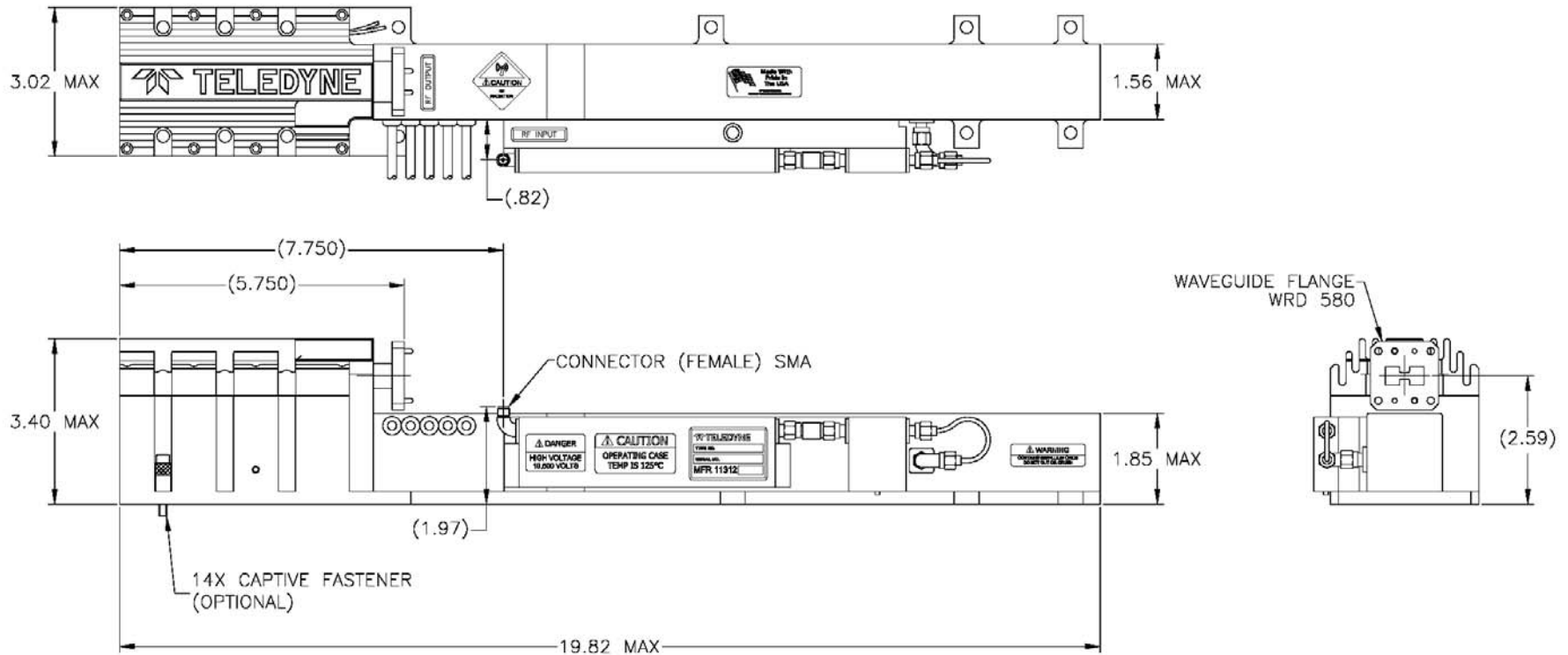

SUBJECT TO CHANGE W/O NOTICE ISO 9001:2008 Registered

<p>TELEDYNE MICROWAVE SOLUTIONS TWT Products 11361 Sunrise Park Drive, Rancho Cordova, CA 95742 • (916) 638-3344</p>
TITLE
MTG 5333/MTG 5336

MEC 5599

Communication TWT

Tri-Band

- 91 W Minimum Power
- Tri-Band
- -40° to 85° C
- 640 W Typ. Prime Power
- 41/41/40 dB Typical Gain
- 12" L x 2.1" W x 2.8" H (30.6 x 5.33 x 7.1 cm)
- Phase Match Available

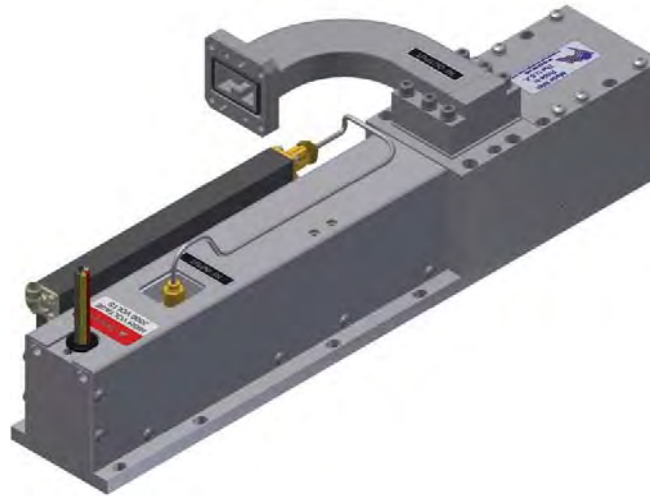

Typical Operating Conditions

Element	Voltage	Current	Power Supply Requirements		
			Voltage Min.	Voltage Max.	Current Max.
Heater	-6.0 Vdc	1.3 A	-5.9 Vdc	-6.7 Vdc	1.5 A
Helix with RF	Ground	15 mA	Ground	Ground	22 mA
without RF	Ground	5 mA	Ground	Ground	22 mA
FE On	-6 Vdc	0.1 mA	0	-10 Vdc	1 mA
FE Off	-1400 Vdc	0.5 mA	-1400 Vdc	-1600 Vdc	1 mA
Cathode (E _k)	-5.0 kV	220 mA	-4.6 kV	-5.5 kV	220 mA
Collector w/RF					
Coll. #1	4.0 kV	65 mA	80% x E _k ±2%		100 mA
Coll. #2	2.0 kV	140 mA	40% x E _k ±2%		220 mA

Cathode voltage is measured with respect to ground.

Heater, Collector, and Focus Electrode (FE) voltages are measured with respect to Cathode.

*/**/*** Minimum harmonic separation applies to the minimum specified power output at the indicated frequency.

This model number is subject to the jurisdiction of the U.S. Department of Commerce.

RF Performance

Freq (GHz)	Typ. Sat. Power Output (W)	Min. Spec. Power Output (W)	Typ. Gain @ Spec. Power (dB)
5.850	130	112*	41
6.000	140	112	41
6.425	160	112	41

7.900	199	158**	41
8.200	190	158	41
8.400	181	158	41

14.000	95	91***	40
14.250	95	91	40
14.500	100	91	40

Typical power output is shown to illustrate capability.

Typical gain shown is with equalizer.

Requires independent (E_k) in each band.

Spectral Regrowth

Freq (GHz)	Min. Linear Power (W)	Modulation	Level @1 Symbol Rate
5.85	42	QPSK	-26 dBc
6.425	50	QPSK	-26 dBc

7.9	43	QPSK	-30 dBc
8.4	32	QPSK	-30 dBc

13.75	45	QPSK	-26 dBc
14.5	44	QPSK	-26 dBc

Performance

	Typical	Spec
Input VSWR.....	2.95:1	3.0:1
Output VSWR.....	2.1:1	2.3:1
Max. Duty	—	CW
FE Capacitance.....	46 pF	65 pF
Min. Harmonic Separation (dBc) ...	-5/-10/-20	-3*/-8**/-12***
Noise Power Density (dBm/MHz)	-19	-17
Prime Power	640 W	660 W

Specifications are subject to change without notice.

Teledyne TWT Products • 11361 Sunrise Park Drive • Rancho Cordova, CA 95742 • 916.638.3344 • www.teledynemicrowave.com

NOTES:

1. THERMOSTAT OPTIONS: N/C OR N/O

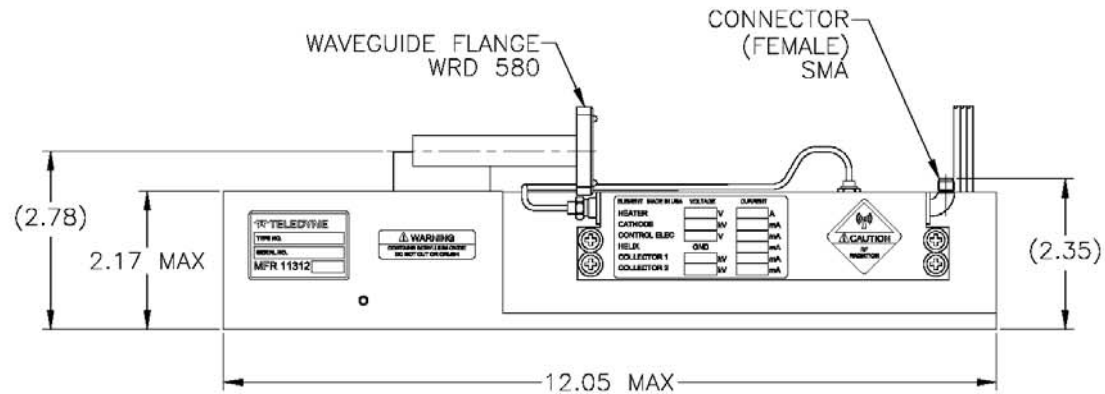
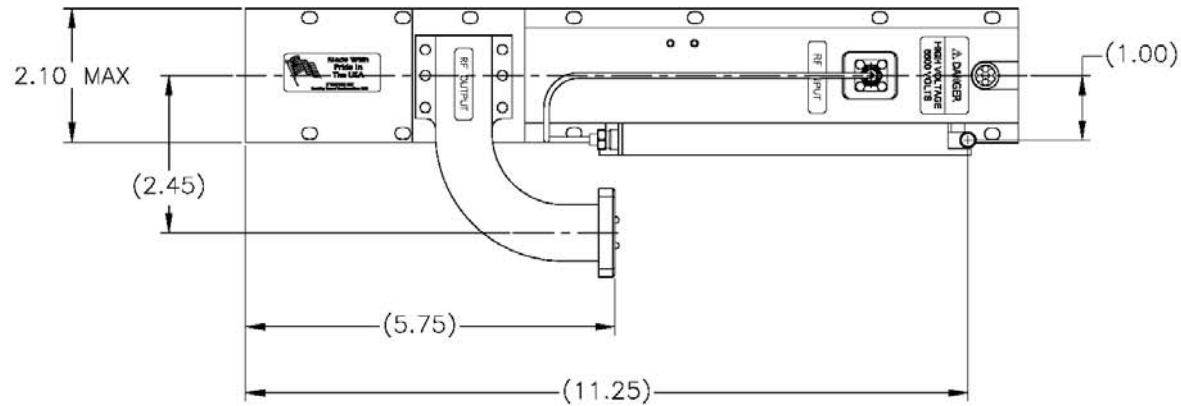

SUBJECT TO CHANGE W/O NOTICE ISO 9001:2008 Registered

TELEDYNE MICROWAVE SOLUTIONS
TWT Products
11361 Sunrise Park Drive, Rancho Cordova, CA 95742 (916) 638-3344

TITLE
MEC 5599

This model number is subject to the jurisdiction of the U.S. Department of Commerce.

MTG 5338X

Communication TWT

Tri-Band

- 350 W Minimum Power
- Tri-Band
- -40° to 85° C
- 1700 W Typ. Prime Power
- 37/46/48 dB Typical Gain
- 19.8" L x 3.9" W x 3.4" H
(50.34 x 9.9 x 8.64 cm)
- Phase Match Available

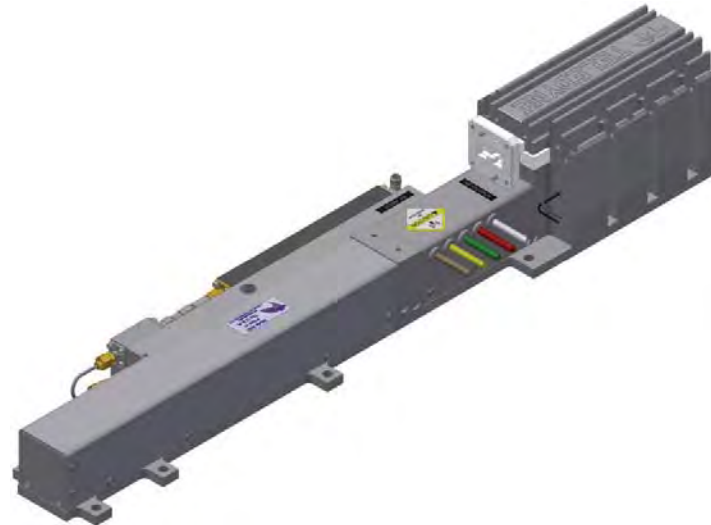

RF Performance

Freq (GHz)	Typ. Sat. Power Output (W)	Min. Spec. Power Output (W)	Typ. Gain @ Spec. Power (dB)
5.850	400	350*	37
6.000	400	350	37
6.425	400	350	37
/ / / / /			
7.900	640	600**	46
8.200	635	600	46
8.400	630	600	46
/ / / / /			
14.000	400	350***	48
14.250	400	350	48
14.500	400	350	48

Typical power output is shown to illustrate capability.
Typical gain shown is with equalizer.
Requires independent (E_k) in each band.

Typical Operating Conditions			Power Supply Requirements		
Element	Voltage	Current	Voltage Min.	Voltage Max.	Current Max.
Heater	-5.8 Vdc	1.62 A	-5.8 Vdc	-6.8 Vdc	2 A
Helix with RF	Ground	4 mA	Ground	Ground	10 mA
without RF	Ground	1 mA	Ground	Ground	10 mA
FE On	-6 Vdc	0.1 mA	0	-10 Vdc	1 mA
FE Off	-1300 Vdc	0.1 mA	-1300 Vdc	-1500 Vdc	1 mA
Cathode (E_k)	-10.95 kV	340 mA	-10.1 kV	-11.1 kV	340 mA
Collector w/RF					
Coll. #1	6.68 kV	80 mA	61% x $E_k \pm 2\%$		125 mA
Coll. #2	4.38 kV	256 mA	40% x $E_k \pm 2\%$		340 mA

Cathode voltage is measured with respect to ground.
Heater, Collector, and Focus Electrode (FE) voltages are measured with respect to Cathode.

*/**/*** Minimum harmonic separation applies to the minimum specified power output at the indicated frequency.

Spectral Regrowth

Freq (GHz)	Min. Linear Power (W)	Modulation	Level @1 Symbol Rate
5.85	280	QPSK	-26 dBc
6.425	280	QPSK	-26 dBc
/ / / / /			
7.9	380	QPSK	-30 dBc
8.4	380	QPSK	-30 dBc
/ / / / /			
13.75	125	QPSK	-26 dBc
14.5	125	QPSK	-26 dBc

Performance	Typical	Spec
Input VSWR.....	2.3:1	2.5:1
Output VSWR.....	1.8:1	2.0:1
Max. Duty	—	CW
FE Capacitance.....	50 pF	65 pF
Min. Harmonic Separation (dBc)	-5/-8/-20	-3*/-5**/-15***
Noise Power Density (dBm/MHz)	-14	-12
Prime Power.....	1700 W	1750 W

Specifications are subject to change without notice.

NOTES:

1. THERMOSTAT OPTIONS: N/C OR N/O

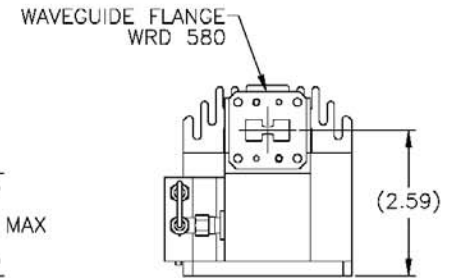
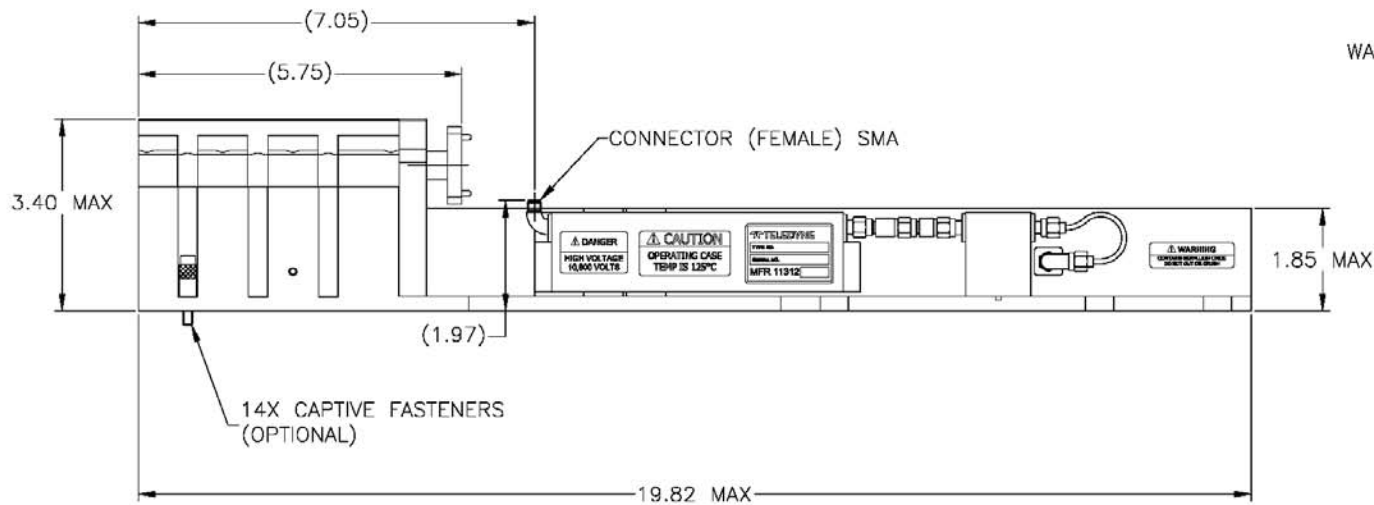
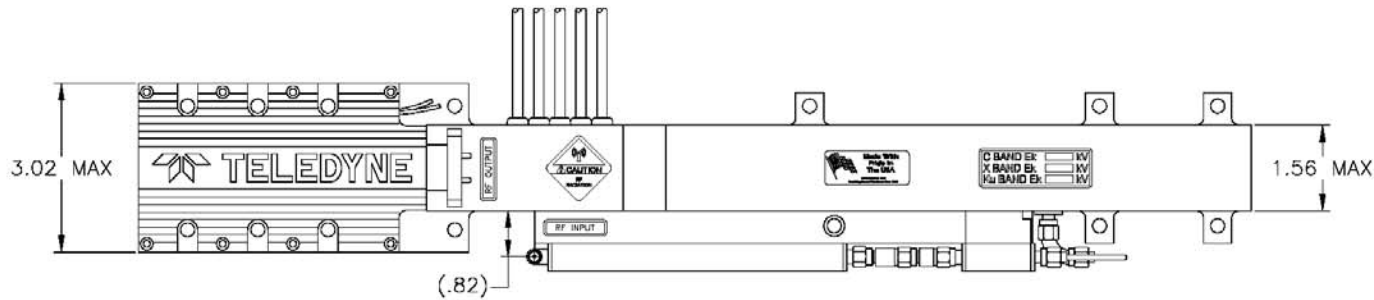

SUBJECT TO CHANGE W/O NOTICE ISO 9001:2008 Registered

TELEDYNE MICROWAVE SOLUTIONS TWT Products <small>11361 Sunrise Park Dr., Rancho Cordova, CA 95742 916-638-3344</small>
TITLE
MTC 5338X

MEC 5450X

Communication TWT

7.9 GHz – 8.4 GHz

- 600 W Minimum Power
- 7.9 to 8.4 GHz
- -40° to 85° C
- 1700 W Typ. Prime Power
- 46 dB Typical Gain
- 19.8" L x 3" W x 3.4" H
(50.34 x 7.67 x 8.64 cm)
- Phase Match Available

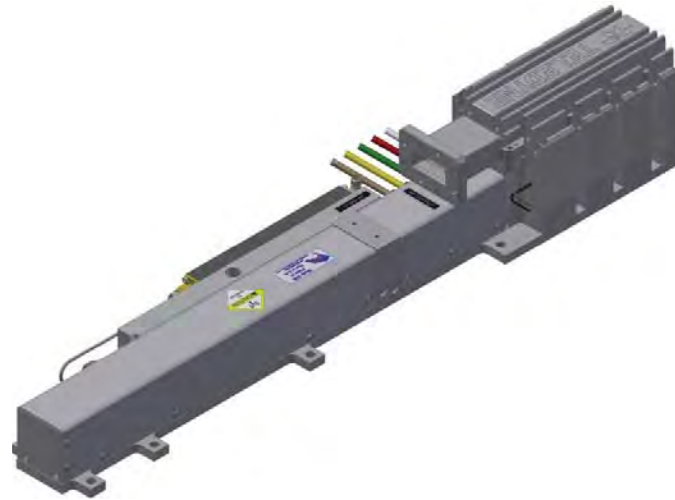

RF Performance

Freq (GHz)	Typ. Sat. Power Output (W)	Min. Spec. Power Output (W)	Typ. Gain @ Spec. Power (dB)
7.900	630	600	46
8.200	630	600	46
8.400	630	600	46

Typical power output is shown to illustrate capability.
Typical gain shown is with equalizer.

Spectral Regrowth

Freq (GHz)	Min. Linear Power (W)	Modulation	Level @1 Symbol Rate
7.9	380	OQPSK	-30 dBc
8.4	380	OQPSK	-30 dBc

Typical Operating Conditions

Element	Voltage	Current	Power Supply Requirements		
			Voltage Min.	Voltage Max.	Current Max.
Heater	-5.8 Vdc	1.62 A	-6.0 Vdc	-6.6 Vdc	2 A
Helix					
with RF	Ground	2 mA	Ground	Ground	10 mA
without RF	Ground	1 mA	Ground	Ground	10 mA
FE On	-6 Vdc	0.1 mA	0	-10 Vdc	1 mA
FE Off	-1300 Vdc	0.1 mA	-1600 Vdc	-1500 Vdc	0.2 mA
Cathode (E_k)	-10.95 kV	340 mA	-10.5 kV	-11.1 kV	340 mA
Collector w/RF					
Coll. #1	6.68 kV	80 mA	61% x $E_k \pm 2\%$		125 mA
Coll. #2	4.38 kV	258 mA	40% x $E_k \pm 2\%$		340 mA

Cathode voltage is measured with respect to ground.

Heater, Collector, and Focus Electrode (FE) voltages are measured with respect to Cathode

Performance

	Typical	Spec
Input VSWR.....	1.6:1	2.0:1
Output VSWR.....	1.8:1	2.0:1
Max. Duty	—	CW
FE Capacitance.....	50 pF	65 pF
Min. Harmonic Separation.....	-20 dBc	-15 dBc
Noise Power Density (dBm/MHz)	-16	-14
Prime Power.....	1700 W	1750 W

NOTES:

1. THERMOSTAT OPTIONS: N/C OR N/O

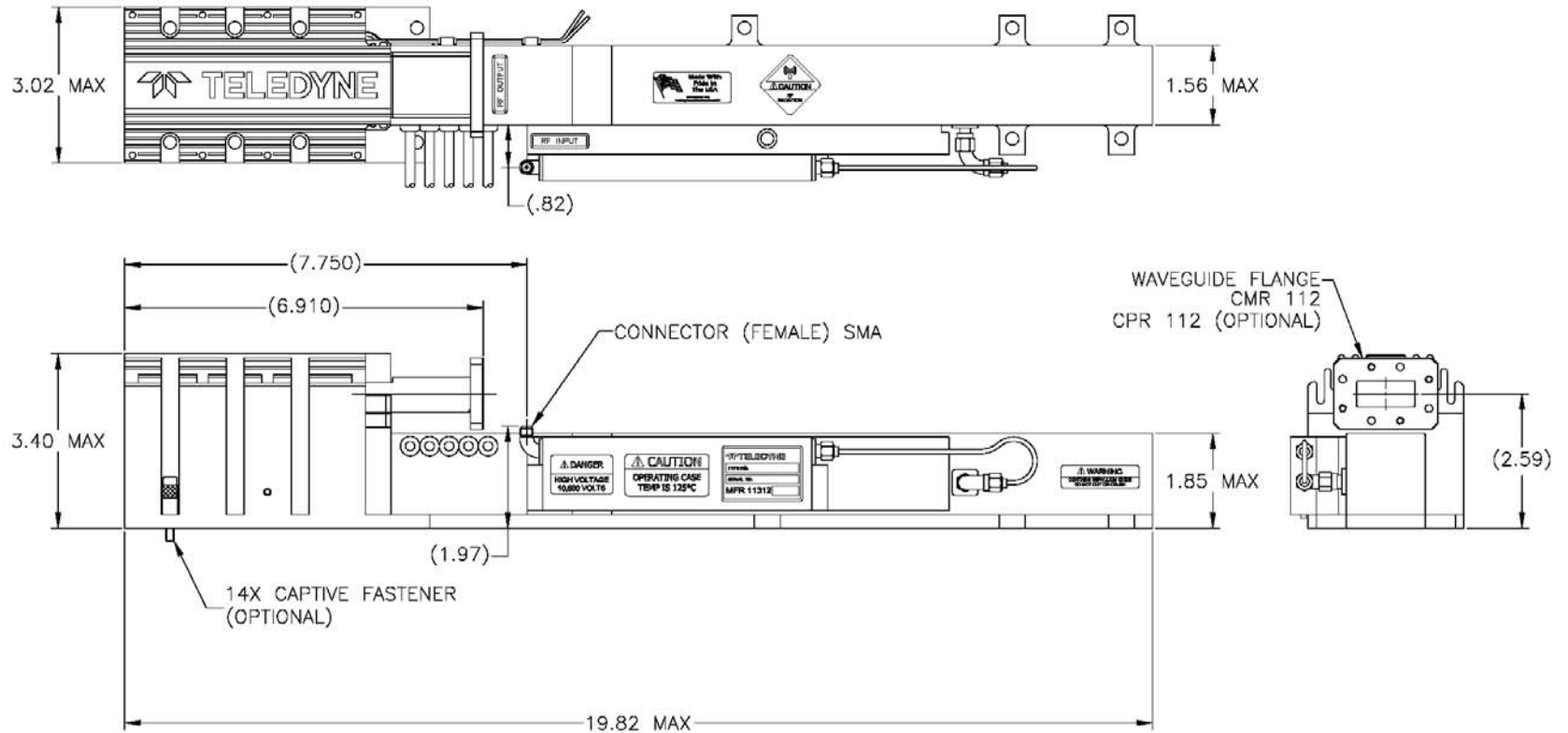

SUBJECT TO CHANGE W/O NOTICE ISO 9001:2008 Registered

TELEDYNE MICROWAVE SOLUTIONS
TWT Products
11361 Sunrise Park Dr., Rancho Cordova, CA 95744 (916) 638-3344

TITLE

MEC 5450X

MEC 5499/MEC 5499A Communication TWT 13.75 GHz – 14.5 GHz

- 200 W Minimum Power
- 13.75 to 14.5 GHz
- -30° to 75° C
- 615 W Typ. Prime Power
- 53-55 dB Typical Gain
- 12.05" L x 2.1" W x 2.45" H
(30.6 x 5.33 x 6.22 cm)
- Phase Match Available

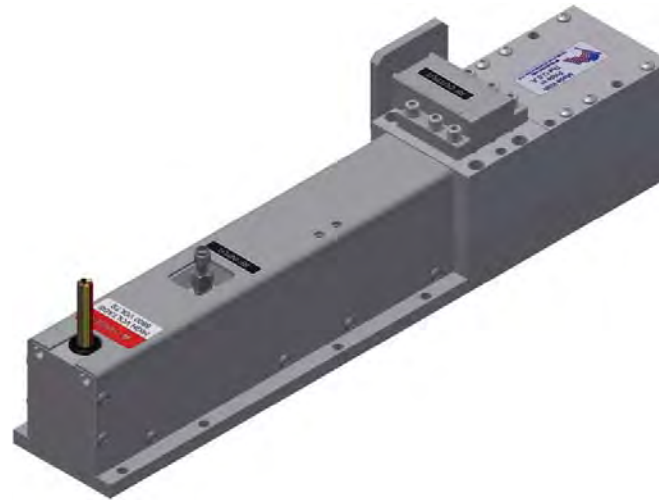

RF Performance

Freq (GHz)	Typ. Sat. Power Output (W)	Min. Spec. Power Output (W)	Typ. Gain @ Spec. Power (dB)
13.75	210	200	55
14.0	210	200	55
14.1	210	200	54
14.2	210	200	54
14.3	210	200	53
14.4	210	200	53
14.5	210	200	53

Typical power output is shown to illustrate capability.
Typical gain shown is with equalizer.

Spectral Regrowth

Freq (GHz)	Min. Linear Power (W)	Modulation	Level @1 Symbol Rate
13.75	90	QPSK	-26 dBc
14.5	90	QPSK	-26 dBc

Typical Operating Conditions			Power Supply Requirements		
Element	Voltage	Current	Voltage Min.	Voltage Max.	Current Max.
Heater	-6.3 Vdc	1.3 A	-6.0 Vdc	-6.6 Vdc	1.5 A
Helix					
with RF	Ground	6 mA	Ground	Ground	12 mA
without RF	Ground	2 mA	Ground	Ground	12 mA
Cathode (E_k)	-6.4 kV	235 mA	-5.2 kV	-6.5 kV	300 mA
Collector 1					
w/RF	3.1 kV	150 mA	48% x $E_k \pm 2\%$		165 mA
w/o RF	3.1 kV	34 mA	48% x $E_k \pm 2\%$		165 mA
Collector 2					
w/RF	1.47 kV	80 mA	23% x $E_k \pm 2\%$		290 mA
w/o RF	1.47 kV	195 mA	23% x $E_k \pm 2\%$		290 mA

Cathode voltage is measured with respect to ground.
Heater, Collector, and Focus Electrode (FE) voltages are measured with respect to Cathode.

This model number is subject to the jurisdiction of the U.S. Department of Commerce.

Performance	Typical	Spec
Input VSWR.....	1.3:1	1.6:1
Output VSWR.....	1.4:1	1.6:1
Max. Duty	—	CW
Noise Power Density (dBm/MHz)	-30	-26
Prime Power	615 W	649 W

Specifications are subject to change without notice.

Teledyne TWT Products • 11361 Sunrise Park Drive • Rancho Cordova, CA 95742 • 916.638.3344 • www.teledynemicrowave.com

NOTES:

1. THERMOSTAT OPTIONS: N/C OR N/O

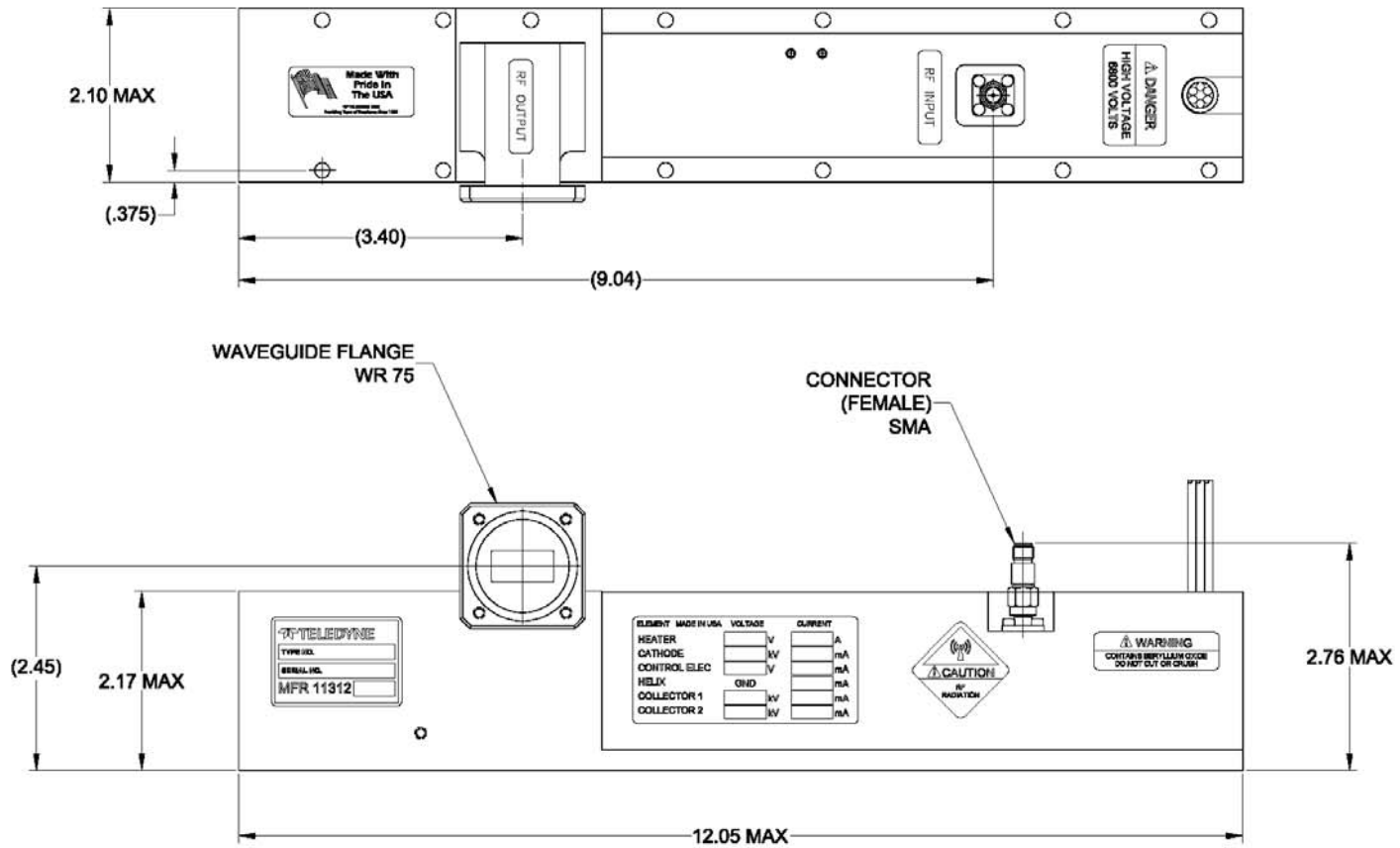

SUBJECT TO CHANGE W/O NOTICE ISO 9001:2008 Registered

TELEDYNE MICROWAVE SOLUTIONS TWT Products <small>11361 Sunrise Park Drive, Rancho Cordova, CA 95742 (916) 638-3344</small>	
TITLE	
MEC 5499/MEC 5499A	

This model number is subject to the jurisdiction of the U.S. Department of Commerce.

MEC 5517

Communication TWT

13.75 to 14.5 GHz

- 530 W_{pk} Saturated Power
- 295 W CW Minimum Power
- 265 W Linear Power Minimum (Linearized)
- 13.75 to 14.5 GHz
- -40° to 85° C
- 860 W Typical Prime Power
- 50 dB Typical Gain @ CW
- 13.4" L x 2.78" W x 2.86" H (34 x 7.0 x 7.26 cm)
- Weight 4.5 lbs.

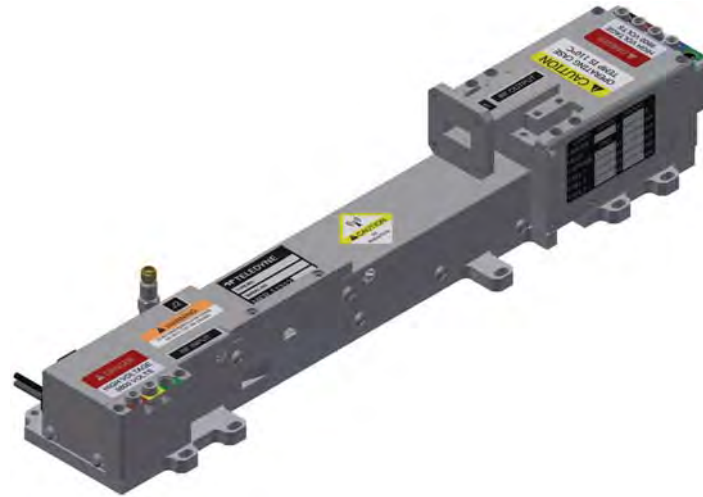

RF Performance

Freq (GHz)	Typical CW Power Output (W)	Min. Spec. CW Power Output (W)	Typ. Gain @ Spec. Power (dB)
13.75	338	295	50
13.90	325	295	50
14.00	325	295	50
14.25	305	295	49
14.5	315	295	48

Typical power output is shown to illustrate capability.
Typical gain shown is without equalizer.

Typical Operating Conditions

Element	Typical Operating Conditions		Power Supply Requirements		
	Voltage	Current	Voltage Min.	Voltage Max.	Current Max.
Heater	-6.3 Vdc	1.36 A	-5.8 Vdc	-6.6 Vdc	1.5 A
Helix					
with RF	Ground	6.0 mA	Ground	Ground	10 mA
without RF	Ground	2.0 mA	Ground	Ground	10 mA
FE On*	-6.3 Vdc	0.1 mA	@ Heater	@ Heater	3 mA
Cathode (E _k)	-9.4 kV	303 mA	-9.0kV	-10.5 kV	315 mA
Collector w/RF					
Coll. #1	4.03 kV	37.0 mA	42.9% x E _k ±2%		90 mA
Coll. #2	3.45 kV	142.0 mA	36.7% x E _k ±2%		185 mA
Coll. #3	1.34 kV	118.0 mA	14.3% x E _k ±2%		320 mA

*FE tied to heater internally for bias

Cathode voltage is measured with respect to ground.

Heater, Collector, and Focus Electrode (FE) voltages are measured with respect to Cathode.

Performance

	Typical	Spec
Input VSWR:.....	1.6:1	2.0:1
Output VSWR:.....	1.7:1	2.0:1
Max. Duty	-	CW
FE Capacitance	50 pF	65 pF
Noise Power Density (dBm/MHz)	-25	-21
Prime Power @ Linear	860 W	930 W

NOTES:

1. THERMOSTAT OPTIONS: N/C OR N/O

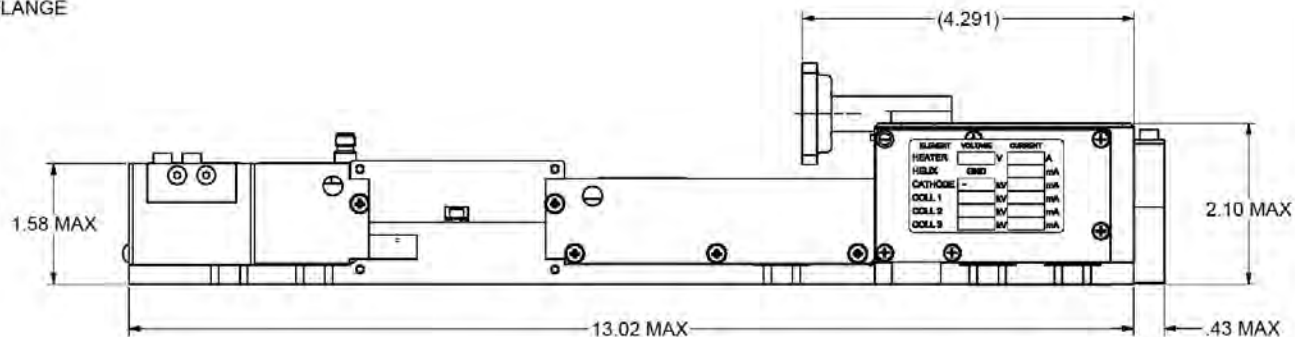
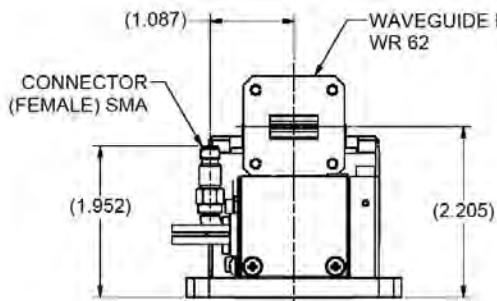
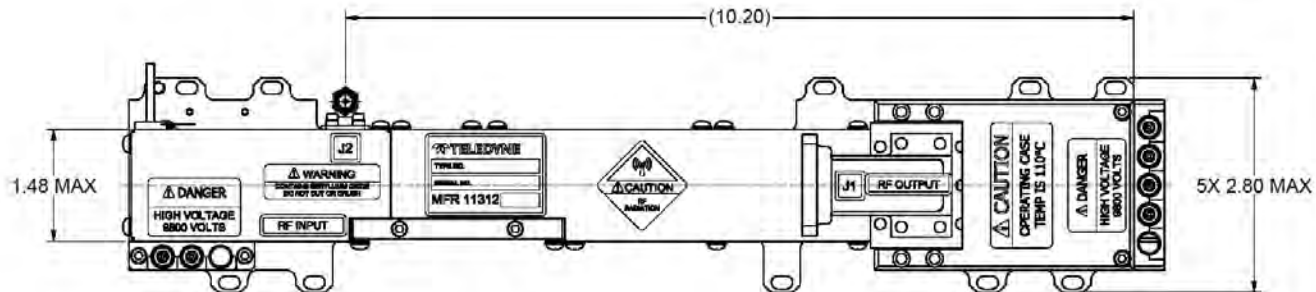

SUBJECT TO CHANGE W/O NOTICE

ISO 9001:2008 Registered

TELEDYNE MICROWAVE SOLUTIONS
TWT PRODUCTS
1201 Sunrise Park Dr., Rancho Cordova, CA 95748-2044

TITLE

MEC 5517

MEC 5516

Communication TWT

Dual Band

- 400 W Peak Minimum Power
- 125 W CW Minimum Power
- 100W Linear Minimum Power Non-Linearized
- X and Ku Bands for Satcom
- -40° to 85° C
- 800 W Typ. Prime Power @52.0 dBm
- 51 dB Typical Gain
- 15.0" L x 2.6" W x 2.25" H (38.1 x 6.6 x 5.7 cm)

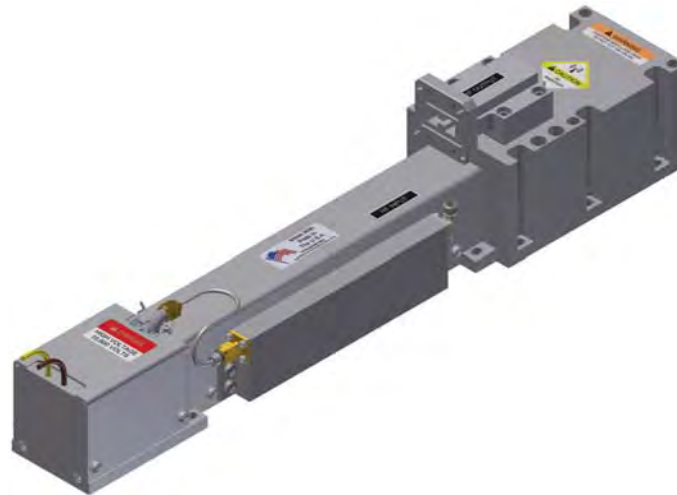

RF Performance

Freq (GHz)	Typ. CW Power Output (W)	Min. Spec. Power Output (W)	Typ. Gain @ Spec. Power (dB)
7.9	170	125	51
8.0	175	125	51
8.15	185	125	51
8.4	180	125	51

13.750	200	125	53
14.000	180	125	53
14.250	180	125	53
14.500	175	125	53

Typical power output is shown to illustrate capability.
Typical gain shown is with equalizer.

Spectral Regrowth

Freq (GHz)	Min. Linear Power (W)	Modulation	Level @1 Symbol Rate
7.9	100	QPSK	-30 dBc
8.4	100	QPSK	-30 dBc

13.75	100	QPSK	-30 dBc
14.5	100	QPSK	-30 dBc

Performance	Typical	Spec
Input VSWR.....	1.75:1	2.5:1
Output VSWR.....	1.95:1	2.0:1
Max. Duty	—	CW
FE Capacitance.....	50 pF	65 pF
Min. Harmonic Separation at 125W	-20 dBc	-15dBc
Noise Power Density (dBm/MHz).....	-23	-19
Prime Power @ 52.0dBm.....	760 W	800 W

Typical Operating Conditions

Element	Typical Operating Conditions		Power Supply Requirements		
	Voltage	Current	Voltage Min.	Voltage Max.	Current Max.
Heater	-6 Vdc	1.26 A	-5.8 Vdc	-6.3 Vdc	2 A
Helix					
with RF	Ground	3.8 mA	Ground	Ground	10 mA
without RF	Ground	1.0 mA	Ground	Ground	10 mA
FE On*	-6 Vdc	0.1 mA	@ Heater	@ Heater	1 mA
Cathode (E _k)	-10.65 kV	302 mA	-8kV	-12 kV	315 mA
Collector w/RF					
Coll. #1	4.69 kV	68.6 mA	44% x E _k ±2%		75 mA
Coll. #2	1.70 kV	229.6 mA	16% x E _k ±2%		305 mA

* FE tied to heater internally for bias

Cathode voltage is measured with respect to ground.

Heater, Collector, and Focus Electrode (FE) voltages are measured with respect to Cathode.

NOTES:

1. THERMOSTAT OPTIONS: N/C OR N/O

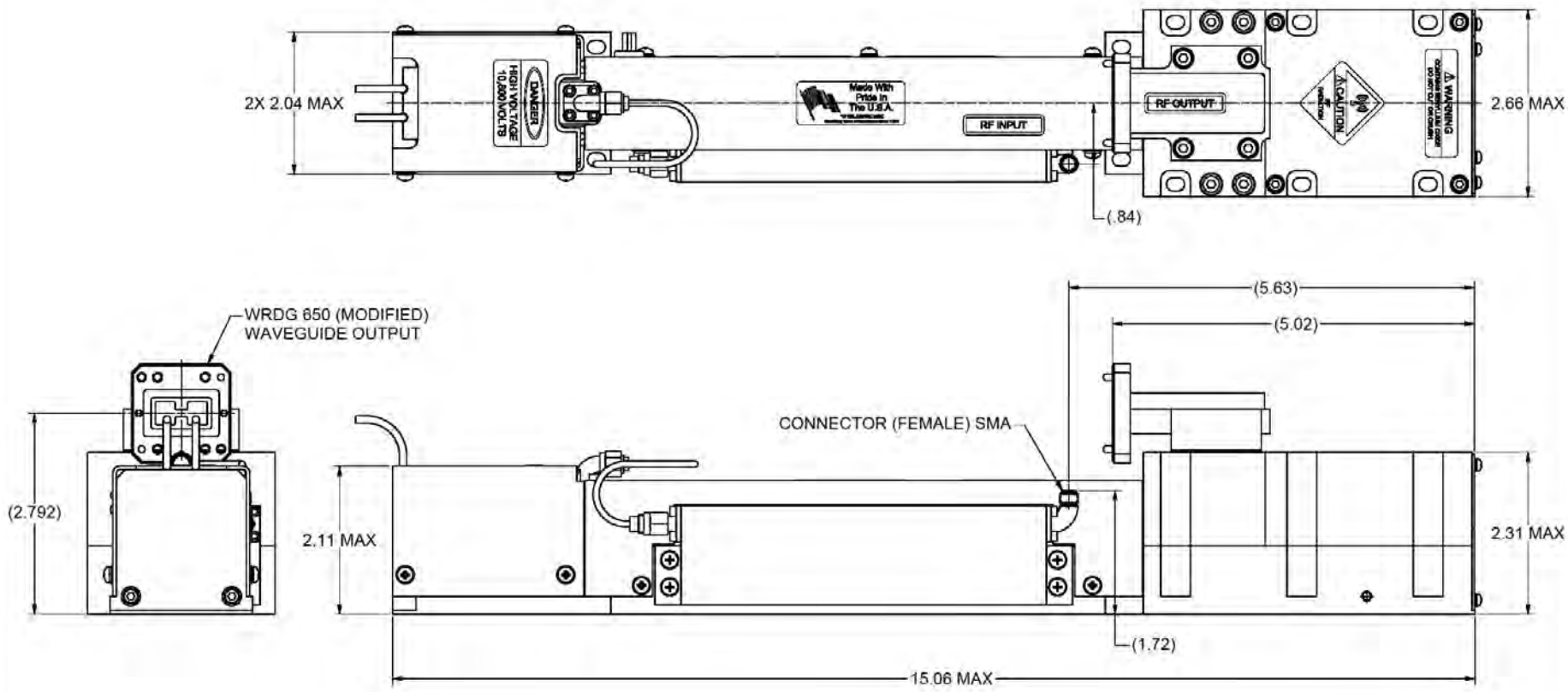

SUBJECT TO CHANGE W/O NOTICE ISO 9001:2008 Registered

<p>TELEDYNE MICROWAVE SOLUTIONS TWT PRODUCTS 11361 Sunrise Park Dr., Rancho Cordova, CA 95768-0004</p>
<p>TITLE</p> <p>MEC 5516</p>

MEC 5441/MEC 5442

Communication TWT

Ku/DBS Band

- 300 W Minimum Power
- Ku/DBS Band
- -40° to 85° C
- 1299 W Typ. Prime Power
- 43-51 dB Typical Gain
- 19.8" L x 3" W x 3.4" H (50.34 x 7.67 x 8.64 cm)
- Phase Match Available

5441 – Grid
5442 – Focus Electrode (FE)

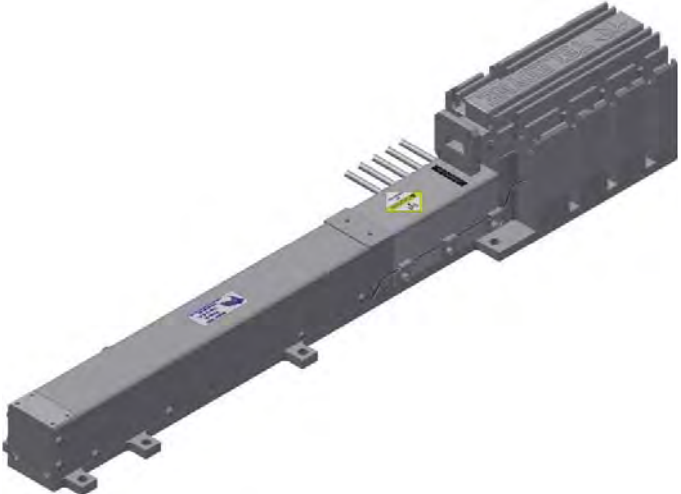

Typical Operating Conditions			Power Supply Requirements		
Element	Voltage	Current	Voltage Min.	Voltage Max.	Current Max.
Heater (MEC 5441)	-6.1 Vdc	1.6 A	-5.8 Vdc	-6.6 Vdc	2.5 A
Heater (MEC 5442)	-6.1 Vdc	1.6 A	-5.6 Vdc	-6.6 Vdc	2.0 A
Helix					
with RF	Ground	2.3 mA	Ground	Ground	10 mA
without RF	Ground	1.0 mA	Ground	Ground	10 mA
FE On	-25 Vdc	0.3 mA	0	-75 Vdc	1 mA
FE Off	-1300 Vdc	0.02 mA	-1300 Vdc	-1500 Vdc	1 mA
Grid On	174 Vdc	0.5 mA	125 Vdc	250 Vdc	5 mA
Grid Off	-250 Vdc	0.5 mA	-250 Vdc	-500 Vdc	1 mA
Cathode (E _k)	-10.2 kV	295 mA	-10 kV	-10.8 kV	300 mA
Coll. #1 w/RF	5.71 kV	38 mA	56% x E _k ±2%		100 mA
Coll. #2 w/RF	4.08 kV	255 mA	40% x E _k ±2%		300 mA

Cathode voltage is measured with respect to ground.
Heater, Collector, and Grid or Focus Electrode (FE) voltages are measured with respect to Cathode.

This model number is subject to the jurisdiction of the U.S. Department of Commerce.

RF Performance

Freq (GHz)	Typ. Sat. Power Output (W)	Min. Spec. Power Output (W)	Typ. Gain @ Spec. Power (dB)
14.0	400	350*	51
14.1	400	350	51
14.2	400	350	51
14.3	400	350	51
14.4	400	350	50
14.5	400	350	50
17.3	400	300	46
17.4	400	300	46
17.5	400	300	46
17.6	400	300	46
17.7	400	300	46
17.8	400	300	46
17.9	390	300	45
18.0	380	300	45
18.1	360	300	44
18.2	355	300	43
18.3	340	300	43
18.4	330	300	43

Typical power output is shown to illustrate capability.
Typical gain shown is without equalizer.
* Minimum harmonic separation applies to the minimum specified power output at the indicated frequency.

Performance	Typical	Spec
Input VSWR.....	1.7:1	2.5:1
Output VSWR.....	2:1	2.5:1
Max. Duty	—	CW
FE Capacitance.....	50 pF	65 pF
Grid Capacitance.....	37 pF	50 pF
Min. Harmonic Separation.....	-30 dBc	-15* dBc
Noise Power Density (dBm/MHz)	-13.9	-5
Prime Power.....	1299 W	1400 W

Specifications are subject to change without notice.



NOTES:

1. THERMOSTAT OPTIONS: N/C OR N/O

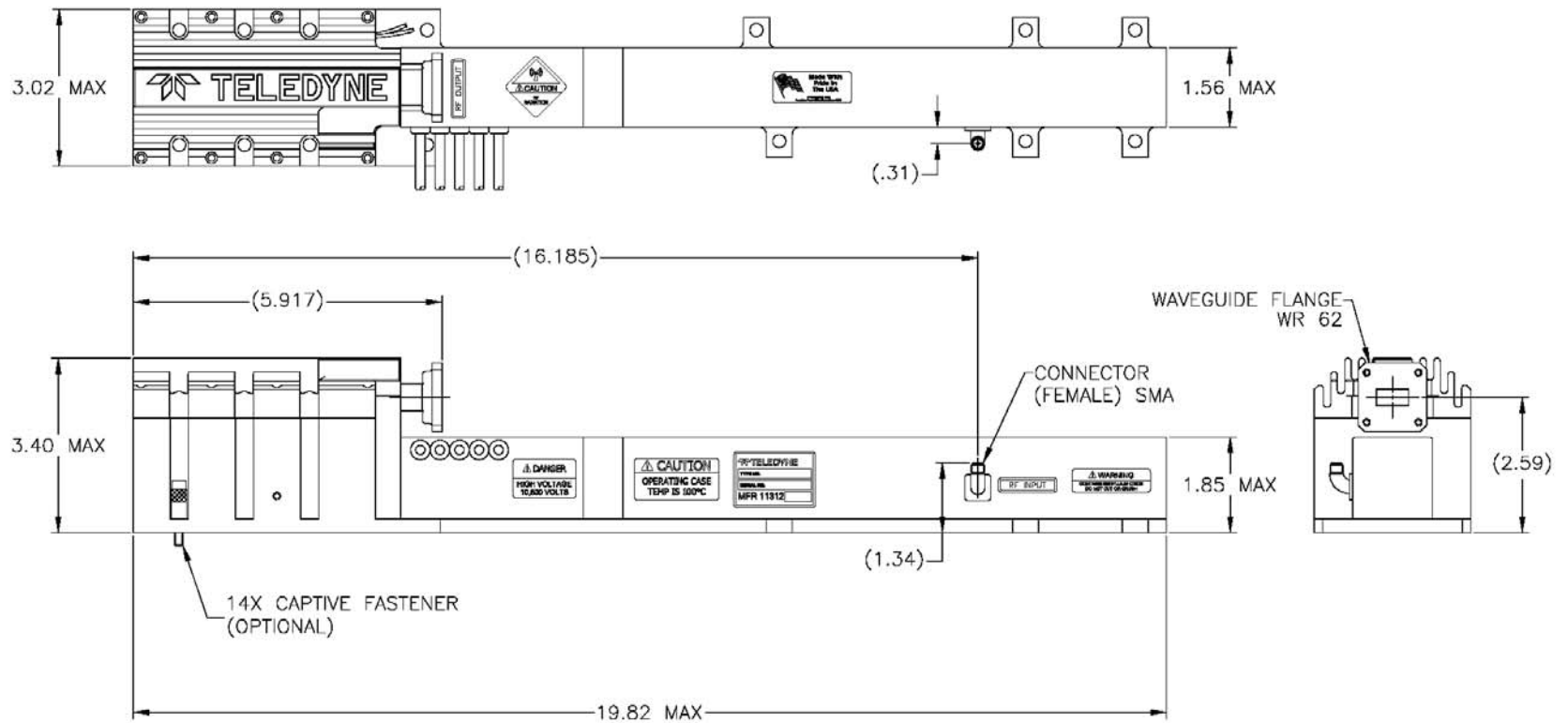

SUBJECT TO CHANGE W/O NOTICE ISO 9001:2008 Registered

TELEDYNE MICROWAVE SOLUTIONS
TWT Products
11361 Sunrise Park Dr., Rancho Cordova, CA 95742 (916) 638-3344
TITLE
MEC 5441/MEC 5442

This model number is subject to the jurisdiction of the U.S. Department of Commerce.

MEC 5452/5455 Communication TWT 13.75 GHz – 14.5 GHz

- 500 W Minimum Power
- 13.75 to 14.5 GHz
- -40° to 85° C
- 1320 W Typ. Prime Power
- 60 dB Typical Gain
- 19.8" L x 3" W x 3.4" H
(50.3 x 7.9 x 8.6 cm)
- Phase Match Available

5452 – Focus Electrode (FE)
5455 – Grid

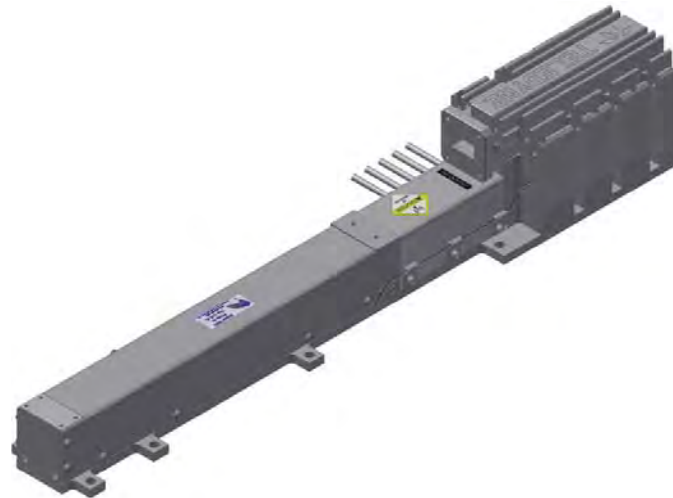

Typical Operating Conditions			Power Supply Requirements		
Element	Voltage	Current	Voltage Min.	Voltage Max.	Current Max.
Heater	-6.3 Vdc	1.6 A	-5.8 Vdc	-6.6 Vdc	2.5 A
Helix					
with RF	Ground	5 mA	Ground	Ground	10 mA
without RF	Ground	0.5 mA	Ground	Ground	10 mA
FE On	-35 Vdc	0.3 mA	0	-75 Vdc	1 mA
FE Off	-1300 Vdc	0.05 mA	-1200 Vdc	-1500 Vdc	1 mA
Grid On	160 Vdc	0.1 mA	125 Vdc	250 Vdc	10 mA
Grid Off	-250 Vdc	0.02 mA	-250 Vdc	-500 Vdc	1 mA
Cathode (E_k)	-10.3 kV	320 mA	-10 kV	-10.8 kV	320 mA
Collector w/RF					
Coll. #1	5.5 kV	88 mA	54% x $E_k \pm 2\%$		100 mA
Coll. #2	3.4 kV	226 mA	33% x $E_k \pm 2\%$		320 mA

Cathode voltage is measured with respect to ground.
Heater, Collector, and Grid or Focus Electrode (FE) voltages are measured with respect to Cathode.

RF Performance

Freq (GHz)	Typ. Sat. Power Output (W)	Min. Spec. Power Output (W)	Typ. Gain @ Spec. Power (dB)
13.75	510	500	60
14.0	510	500	60
14.1	510	500	60
14.2	520	500	60
14.3	520	500	60
14.4	520	500	60
14.5	510	500	60

Typical power output is shown to illustrate capability.
Typical gain shown is without equalizer.

Performance	Typical	Spec
Input VSWR.....	1.38:1	1.5:1
Output VSWR.....	1.45:1	1.7:1
Max. Duty	—	CW
FE Capacitance.....	50 pF	65 pF
Grid Capacitance.....	37 pF	50 pF
Min. Harmonic Separation.....	-30 dBc	-15 dBc
Noise Power Density (dBm/MHz)	-7	-5
Prime Power.....	1320 W	1450 W

This model number is subject to the jurisdiction of the U.S. Department of Commerce.

NOTES:

1. THERMOSTAT OPTIONS: N/C OR N/O

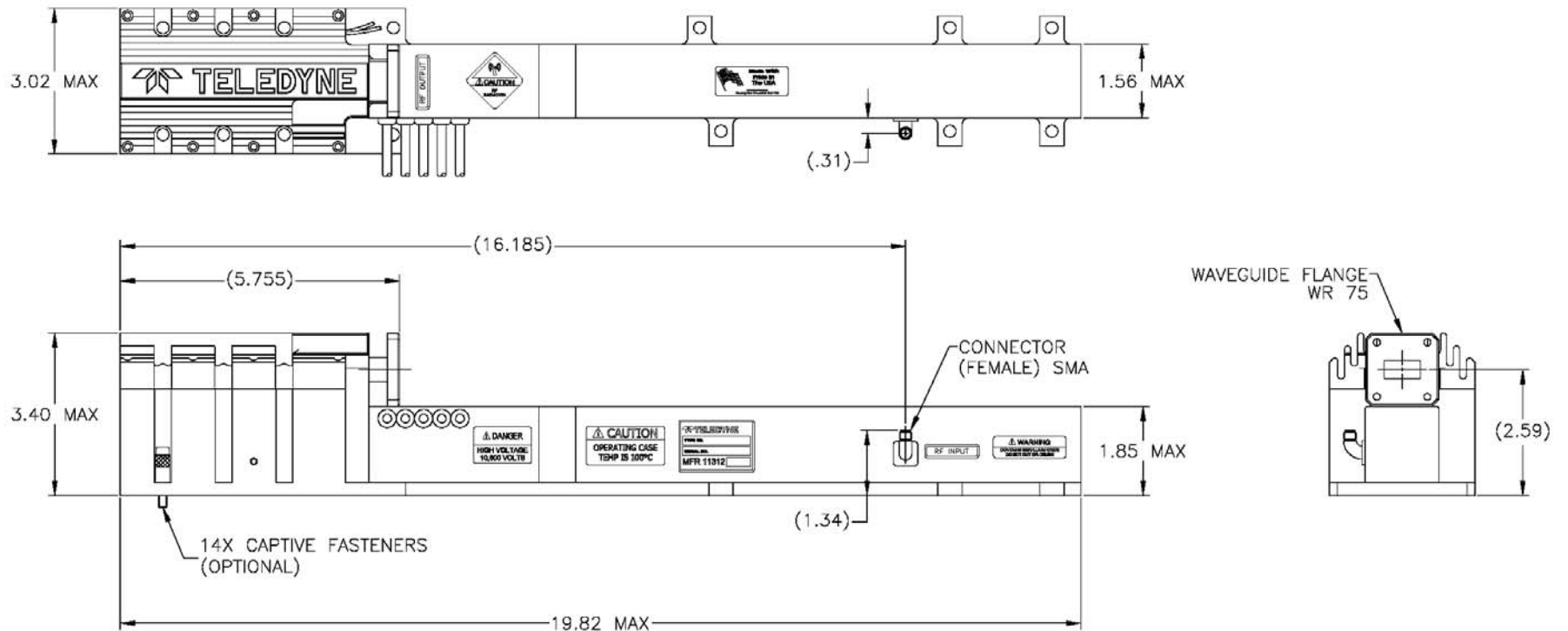

SUBJECT TO CHANGE W/O NOTICE ISO 9001:2008 Registered

TELEDYNE MICROWAVE SOLUTIONS TWT Products <small>11361 Sunrise Park Dr., Rancho Cordova, CA 95742 (916) 638-3344</small>
TITLE
MEC 5452/MEC 5455

This model number is subject to the jurisdiction of the U.S. Department of Commerce.

MEC 5466

Communication TWT

17.3 GHz – 18.4 GHz

- 450 W Minimum Power
- 17.3 to 18.4 GHz
- -40° to 85° C
- 1555 W Typ. Prime Power
- 45-47 dB Typical Gain
- 19.8" L x 3.9" W x 3.4" H (50.3 x 10 x 8.6 cm)
- Phase Match Available

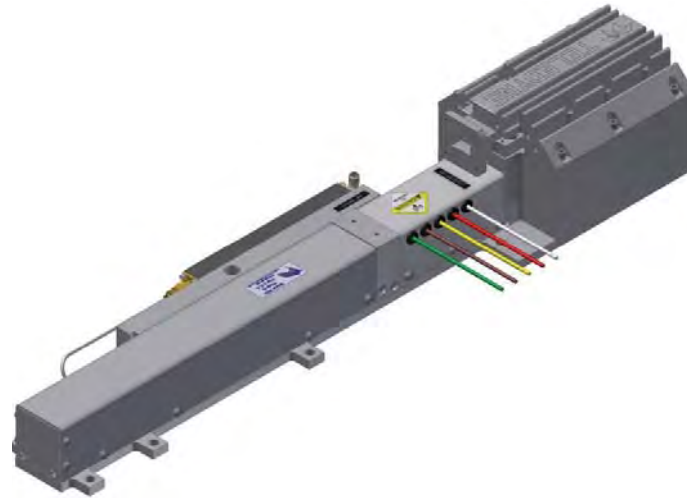

RF Performance

Freq (GHz)	Typ. Sat. Power Output (W)	Min. Spec. Power Output (W)	Typ. Gain @ Spec. Power (dB)
17.3	550	500	47
17.4	550	500	47
17.5	550	500	47
17.6	550	500	47
17.7	540	500	47
17.8	530	500	47
17.9	525	500	47
18.0	500	450	46
18.1	490	450	46
18.2	480	450	46
18.3	460	450	45
18.4	450	450	45

Typical power output is shown to illustrate capability.
Typical gain shown is without equalizer.

Typical Operating Conditions

Element	Typical Operating Conditions		Power Supply Requirements		
	Voltage	Current	Voltage Min.	Voltage Max.	Current Max.
Heater	-6.1 Vdc	1.7 A	-5.8 Vdc	-6.6 Vdc	2 A
Helix					
with RF	Ground	5 mA	Ground	Ground	10 mA
without RF	Ground	1 mA	Ground	Ground	10 mA
FE On	-10 Vdc	0.1 mA	0	-50 Vdc	1 mA
FE Off	-1600 Vdc	0.1 mA	-1600 Vdc	-2000 Vdc	1 mA
Cathode (E_k)	-11.8 kV	385 mA	-11.5 kV	-12.5 kV	400 mA
Collector w/RF					
Coll. #1	5.81 kV	110 mA	49% x $E_k \pm 2\%$		250 mA
Coll. #2	3.20 kV	270 mA	27% x $E_k \pm 2\%$		375 mA

Cathode voltage is measured with respect to ground.

Heater, Collector, and Focus Electrode (FE) voltages are measured with respect to Cathode.

Performance

	Typical	Spec
Input VSWR.....	1.75:1	2.25:1
Output VSWR.....	1.92:1	2.3:1
Max. Duty	—	CW
FE Capacitance.....	50 pF	65 pF
Min. Harmonic Separation.....	-30 dBc	-15 dBc
Noise Power Density (dBm/MHz)	-20	-15
Prime Power.....	1555 W	1600 W

Specifications are subject to change without notice.

NOTES:

- 1. THERMOSTAT OPTIONS: N/C OR N/O
- 2. EQUALIZER OPTIONAL, BASED UPON CUSTOMER REQUIREMENT.

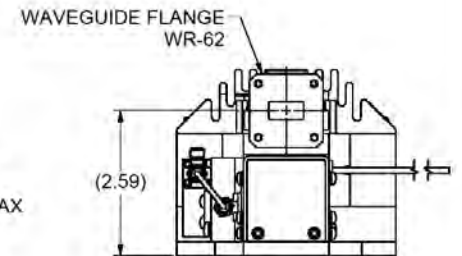
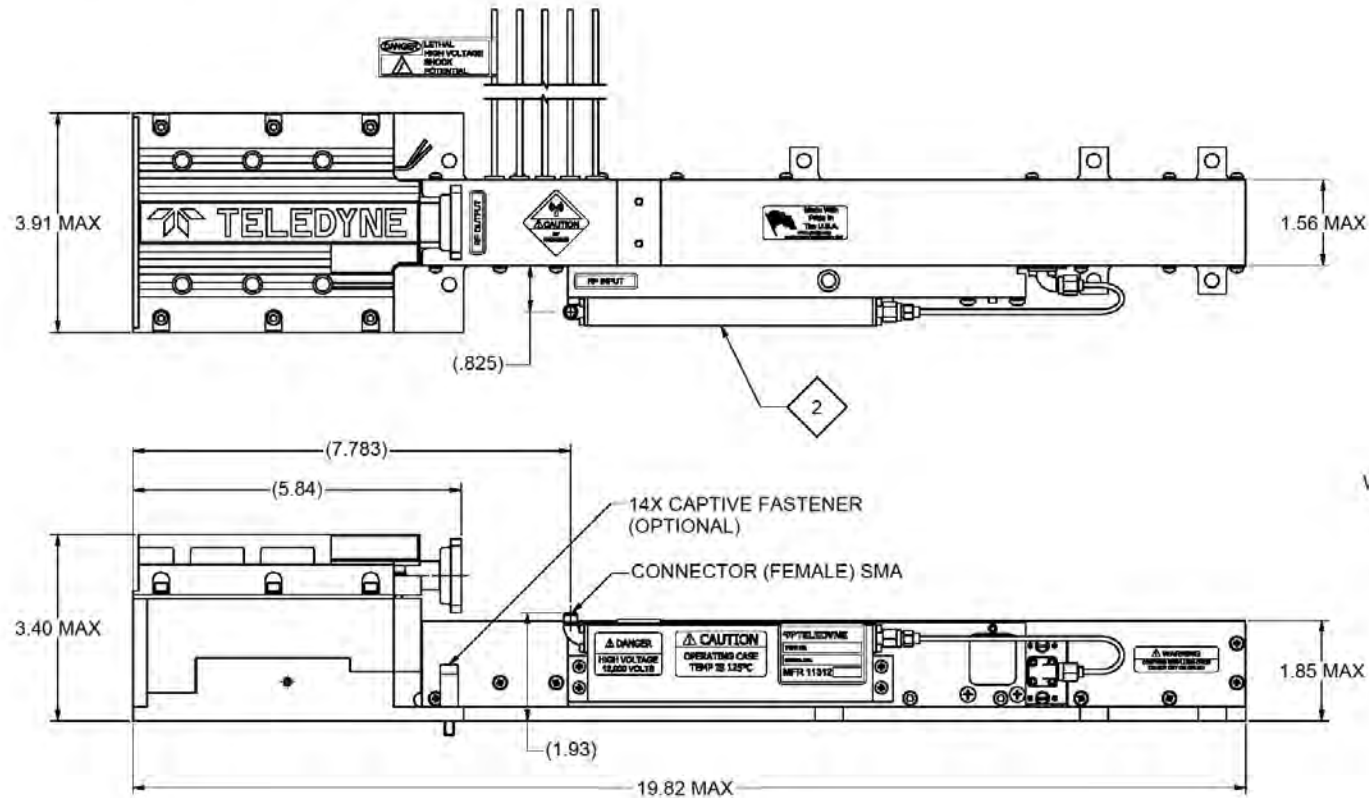

SUBJECT TO CHANGE W/O NOTICE ISO 9001:2008 Registered

<p>TELEDYNE MICROWAVE SOLUTIONS TWT PRODUCTS 1201 Sunrise Park Dr., Rancho Cordova, CA 95742-2044</p>
TITLE
MEC 5466

MEC 5530L

Dual Band Communication TWT

27 GHz – 30 GHz

- 502 W Peak Minimum Power
- 250 W CW Minimum Power
- 175 W Linear Minimum Power (Linearized)
- 27.0 GHz to 30.0 GHz
- -40° to 85° C
- 990 W Typ. Prime Power @ 53.5dBm
- 38 dB Typical Gain
- 14.1" L x 2.76" W x 3.15" H (36 x 7.0 x 8.0 cm)



Typical Operating Conditions			Power Supply Requirements		
Element	Voltage	Current	Voltage Min.	Voltage Max.	Current Max.
Heater	-6.3 Vdc	0.78A	-5.8 Vdc	-6.6 Vdc	1.5 A
Helix					
with RF	Ground	1.7 mA	Ground	Ground	4 mA
without RF	Ground	0.7 mA	Ground	Ground	4 mA
FE On	-18 Vdc	0.1 mA	0 Vdc	-40 Vdc	1 mA
FE Off	-1300 Vdc	0.1 mA	-1300 Vdc	-1400 Vdc	0.2 mA
Cathode (E _k)	-17.8 kV	185 mA	-17.2 kV	-18.2 kV	200 mA
Collector w/RF					
Coll. #1	8.53 kV	60.4 mA	49% x E _k ±2%		90 mA
Coll. #2	3.65 kV	116.3 mA	21% x E _k ±2%		185 mA

Cathode voltage is measured with respect to ground.
 Heater, Collector, and Focus Electrode (FE) voltages are measured with respect to Cathode.

RF Performance

Freq (GHz)	Typ. CW. Power Output (W)	Min. Spec. Power Output (W)	Typ. Gain @ Spec. Power (dB)
27.0	250	250	38
27.5	250	250	37
28.0	250	250	39
28.5	250	250	40
29.0	250	250	38
29.5	250	250	37
30.0	250	250	39

Typical power output is shown to illustrate capability.
 Typical gain shown is without equalizer.

Spectral Regrowth

Freq (GHz)	Min. Linear Power (W)	Modulation	Level @1 Symbol Rate
27.0	175	QPSK	-30 dBc
27.5	175	QPSK	-30 dBc
28.0	175	QPSK	-30 dBc
28.5	175	QPSK	-30 dBc
29.0	175	QPSK	-30 dBc
29.5	175	QPSK	-30 dBc
30.0	175	QPSK	-30 dBc

Performance	Typical	Spec
Input VSWR.....	1.45:1	2.0:1
Output VSWR.....	1.50:1	2.0:1
Max. Duty	—	CW
FE Capacitance	50 pF	.65 pF
Noise Power Density (dBm/MHz)	-23	-20
Prime Power @ 53.5dBm	990 W	1100 W

This model number is subject to the jurisdiction of the U.S. Department of Commerce.

NOTES:

1. THERMOSTAT OPTIONS: N/C OR N/O

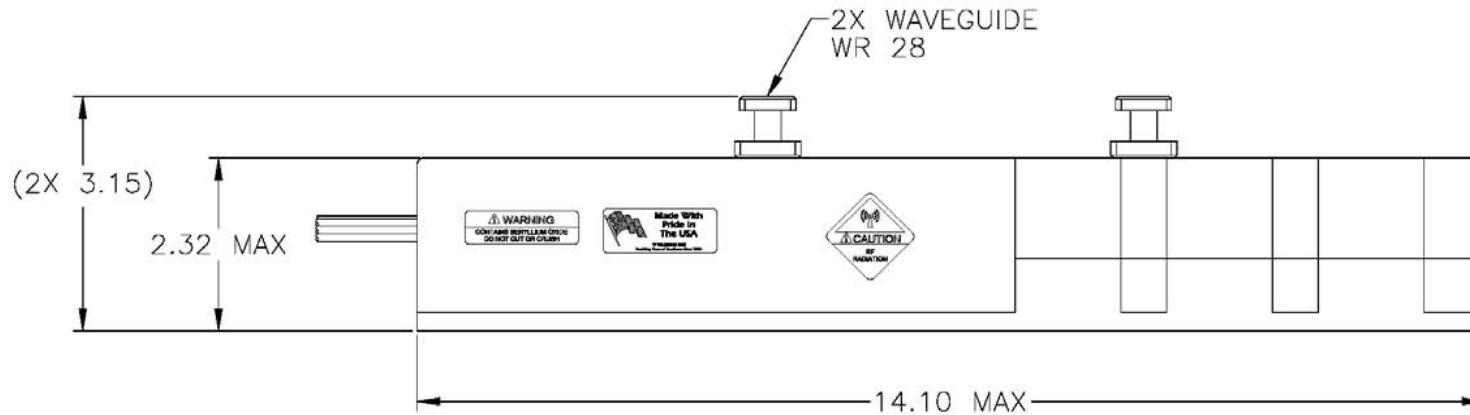
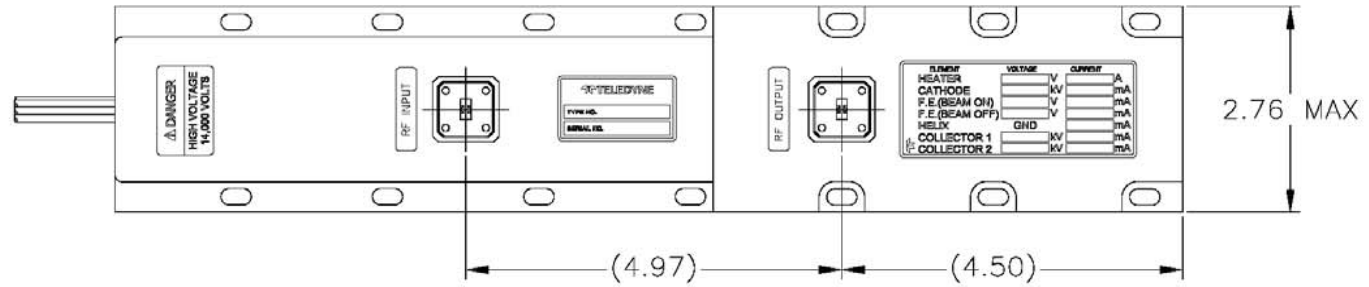

TELEDYNE MICROWAVE SOLUTIONS
TWT Products

11361 Sunrise Park Dr., Rancho Cordova, CA (916) 638-3344

TITLE

MEC 5530L/MEC 5530H

SUBJECT TO CHANGE W/O NOTICE

ISO 9001:2008 Registered

This model number is subject to the jurisdiction of the U.S. Department of Commerce.

MEC 5495

Communication TWT

27 GHz – 31 GHz

- 120 W Maximum Power Output
- 27.0 to 31.0 GHz
- -40° to 85° C
- 600 W Typ. Prime Power (@120 W)
- 34 dB Typical Gain
- 14" L x 2.76" W x 3.15" H (40.9 x 7 x 8 cm)
- ±20° Phase Match

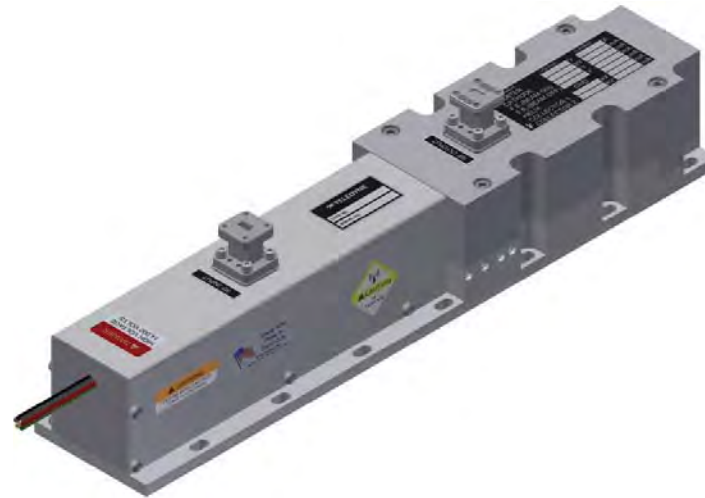

RF Performance

Freq (GHz)	Typ. Sat. Power Output (W)	Min. Spec. Power Output (W)	Typ. Gain @ Spec. Power (dB)
27.0	250	120	34
28.0	250	120	34
29.0	250	120	34
30.0	250	120	34
31.0	250	120	34

Typical power output is shown to illustrate capability.
Typical gain shown is without equalizer.

Typical Operating Conditions

Element	Typical Operating Conditions		Power Supply Requirements		
	Voltage	Current	Voltage Min.	Voltage Max.	Current Max.
Heater	-6.3 Vdc	0.7 A	-5.8 Vdc	-6.6 Vdc	1.5 A
Helix					
with RF	Ground	1.5 mA	Ground	Ground	4 mA
without RF	Ground	0.5 mA	Ground	Ground	4 mA
FE On	-6.3 Vdc	0.1 mA	0	-40 Vdc	1 mA
FE Off	-1200 Vdc	0.1 mA	-1200 Vdc	-1400 Vdc	0.2 mA
Cathode (E _k)	-14.25 kV	190 mA	-13.5 kV	-14.5 kV	200 mA
Collector w/RF					
Coll. #1	4.42 kV	10 mA	31% x E _k ±2%		75 mA
Coll. #2	2.28 kV	180 mA	16% x E _k ±2%		200 mA

Cathode voltage is measured with respect to ground.

Heater, Collector, and Focus Electrode (FE) voltages are measured with respect to Cathode.

This model number is subject to the jurisdiction of the U.S. Department of Commerce.

Performance

	Typical	Spec
Input VSWR.....	1.25:1	2:1
Output VSWR.....	1.5:1	1.75:1
Max. Duty.....	—	CW
FE Capacitance.....	50 pF	60 pF
Min. Harmonic Separation.....	-30 dBc	-15 dBc
Noise Power Density (dBm/MHz).....	-35	-30
Prime Power (@120 W).....	600 W	700 W

NOTES:

1. THERMOSTAT OPTIONS: N/C OR N/O

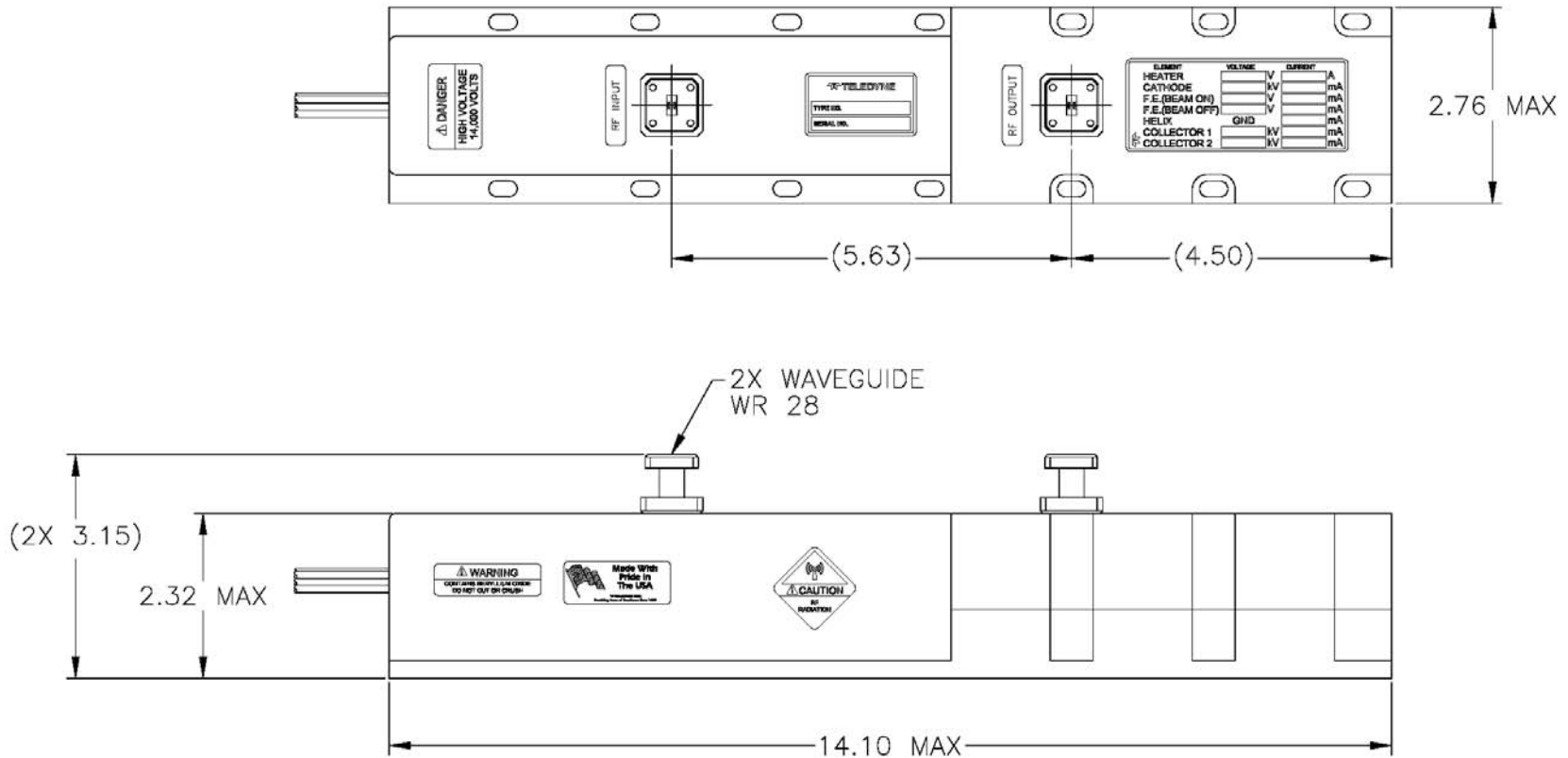

SUBJECT TO CHANGE W/O NOTICE ISO 9001:2008 Registered

TELEDYNE MICROWAVE SOLUTIONS
TWT Products
11361 Sunrise Park Dr., Rancho Cordova, CA 95742 (916) 638-3344

TITLE

MEC 5495

This model number is subject to the jurisdiction of the U.S. Department of Commerce.

MEC 5530H

Dual Band Communication TWT

30 GHz – 31 GHz

- 502 W Peak Minimum Power
- 250 W CW Minimum Power
- 175 W Linear Minimum Power (Linearized)
- 30 GHz to 31 GHz
- -40° to 85° C
- 970 W Typ. Prime Power @ 53.5dBm
- 40 dB Typical Gain
- 14.1" L x 2.76" W x 3.15" H (36 x 7.0 x 8.0 cm)



Typical Operating Conditions			Power Supply Requirements		
Element	Voltage	Current	Voltage Min.	Voltage Max.	Current Max.
Heater	-6.3 Vdc	0.78A	-5.8 Vdc	-6.6 Vdc	1.5 A
Helix					
with RF	Ground	1.3 mA	Ground	Ground	4 mA
without RF	Ground	0.6 mA	Ground	Ground	4 mA
FE On	-18 Vdc	0.1 mA	0 Vdc	-40 Vdc	1 mA
FE Off	-1300 Vdc	0.1 mA	-1300 Vdc	-1400 Vdc	0.2 mA
Cathode (E _k)	-17.4 kV	178 mA	-17.2 kV	-18.2 kV	200 mA
Collector w/RF					
Coll. #1	8.53 kV	60.4 mA	49% x E _k ±2%		90 mA
Coll. #2	3.65 kV	116.3 mA	21% x E _k ±2%		185 mA

Cathode voltage is measured with respect to ground.
 Heater, Collector, and Focus Electrode (FE) voltages are measured with respect to Cathode.

RF Performance

Freq (GHz)	Typ. CW. Power Output (W)	Min. Spec. Power Output (W)	Typ. Gain @ Spec. Power (dB)
30.0	250	250	40
30.5	250	250	39
31.0	250	250	40

Typical power output is shown to illustrate capability.
 Typical gain shown is without equalizer.

Spectral Regrowth

Freq (GHz)	Min. Linear Power (W)	Modulation	Level @1 Symbol Rate
30.0	175	QPSK	-30 dBc
30.5	175	QPSK	-30 dBc
31.0	175	QPSK	-30 dBc

Performance	Typical	Spec
Input VSWR.....	1.30:1	2.0:1
Output VSWR.....	1.30:1	2.0:1
Max. Duty	—	CW
FE Capacitance.....	50 pF	65 pF
Noise Power Density (dBm/MHz)	-23	-20
Prime Power @ 53.5dBm	970 W	1100 W

This model number is subject to the jurisdiction of the U.S. Department of Commerce.

NOTES:

1. THERMOSTAT OPTIONS: N/C OR N/O

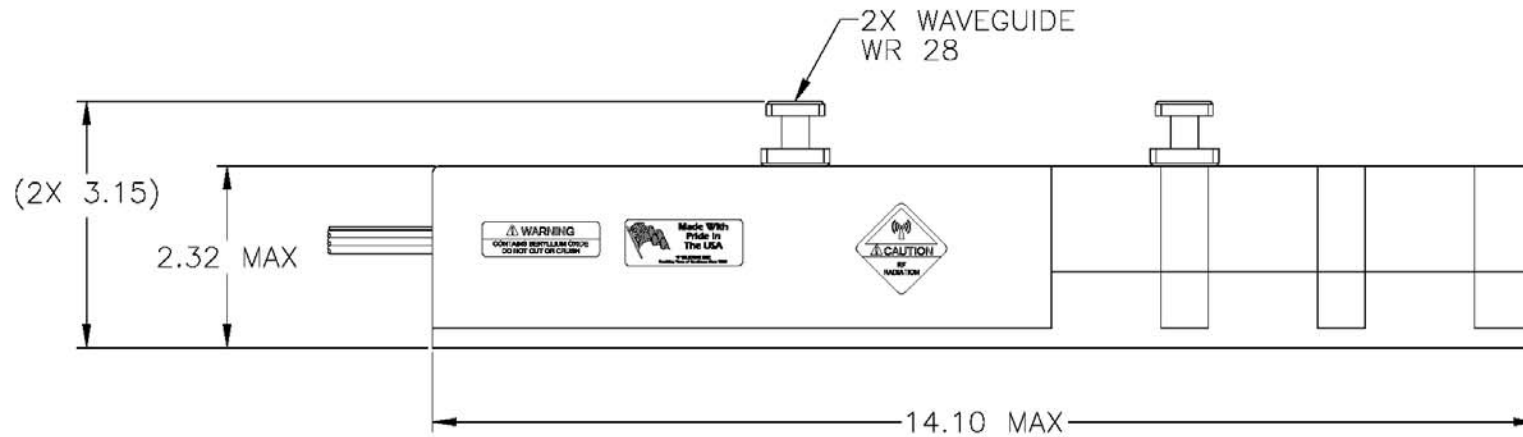
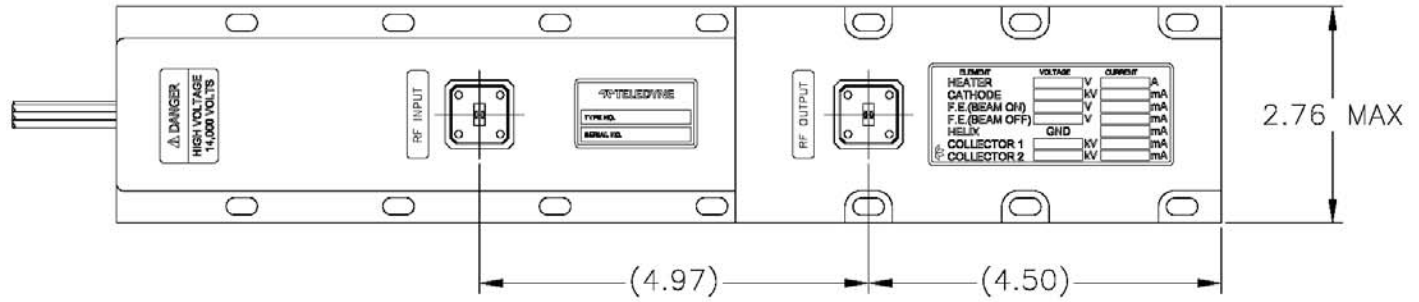

TELEDYNE MICROWAVE SOLUTIONS
TWT Products
 11361 Sunrise Park Dr., Rancho Cordova, CA 95742 (916) 638-3344
 TITLE
 MEC 5530L/MEC 5530H

SUBJECT TO CHANGE W/O NOTICE ISO 9001:2008 Registered

This model number is subject to the jurisdiction of the U.S. Department of Commerce.

MEC 5523

Communication TWT

43.5 GHz – 45.5 GHz

- 125 W Minimum Power
- 43.5 to 45.5 GHz
- -40° to 85° C
- 575 W Typical Prime Power
- 30 to 32 dB Typical Gain @ Saturation
- 14.1" L x 2.76" W x 3.15" H (35.8 x 7.0 x 8.0 cm)

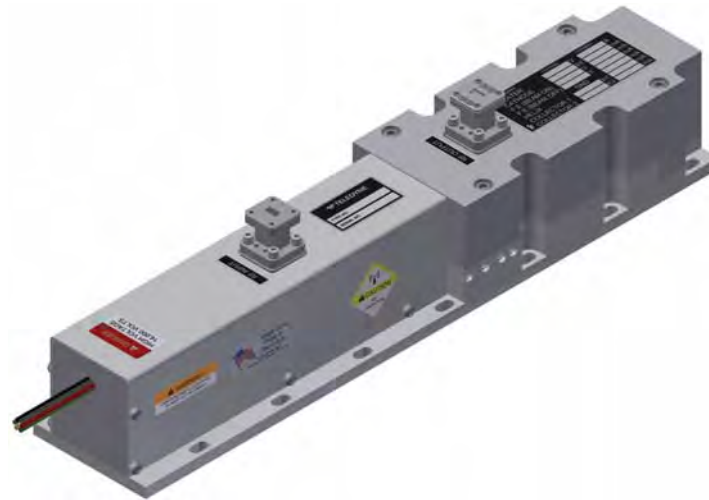

RF Performance

Freq (GHz)	Typ. Sat. Power Output (W)	Min. Spec. Power Output (W)	Typ. Gain @ Spec. Power (dB)
43.50	140	125	33
43.75	135	125	32
44.00	145	125	32
44.25	145	125	32
44.50	145	125	32
44.75	145	125	32
45.00	135	125	31
45.25	135	125	31
45.50	132	125	30

Typical power output is shown to illustrate capability.
Typical gain shown is without equalizer.

Typical Operating Conditions			Power Supply Requirements		
Element	Voltage	Current	Voltage Min.	Voltage Max.	Current Max.
Heater	-6.3 Vdc	0.75 A	-5.8 Vdc	-6.6 Vdc	1.5 A
Helix					
with RF	Ground	1.4 mA	Ground	Ground	4 mA
without RF	Ground	0.7 mA	Ground	Ground	4 mA
FE On	-14 Vdc	0.1 mA	0 Vdc	-40 Vdc	1 mA
FE Off	-1300 Vdc	0.0 mA	-1300 Vdc	-1400 Vdc	0.2 mA
Cathode (Ek)	-15.1 kV	152 mA	-15.1 kV	-16.1 kV	185 mA
Collector w/RF					
Coll. #1	4.98 kV	47.8 mA	33% x Ek ±2%		90 mA
Coll. #2	3.02 kV	102.8 mA	20% x Ek ±2%		185 mA

Cathode voltage is measured with respect to ground.
Heater, Collector, and Focus Electrode (FE) voltages are measured with respect to Cathode

Performance	Typical	Spec
Input VSWR:.....	1.9:1	2.0:1
Output VSWR:.....	1.7:1	2.0:1
Max. Duty.....	-	CW
FE Capacitance.....	50 pF	60 pF
Noise Power Density (dBm/MHz).....	-26	-20
Prime Power.....	575 W	650W

NOTES:

1. THERMOSTAT OPTIONS: N/C OR N/O

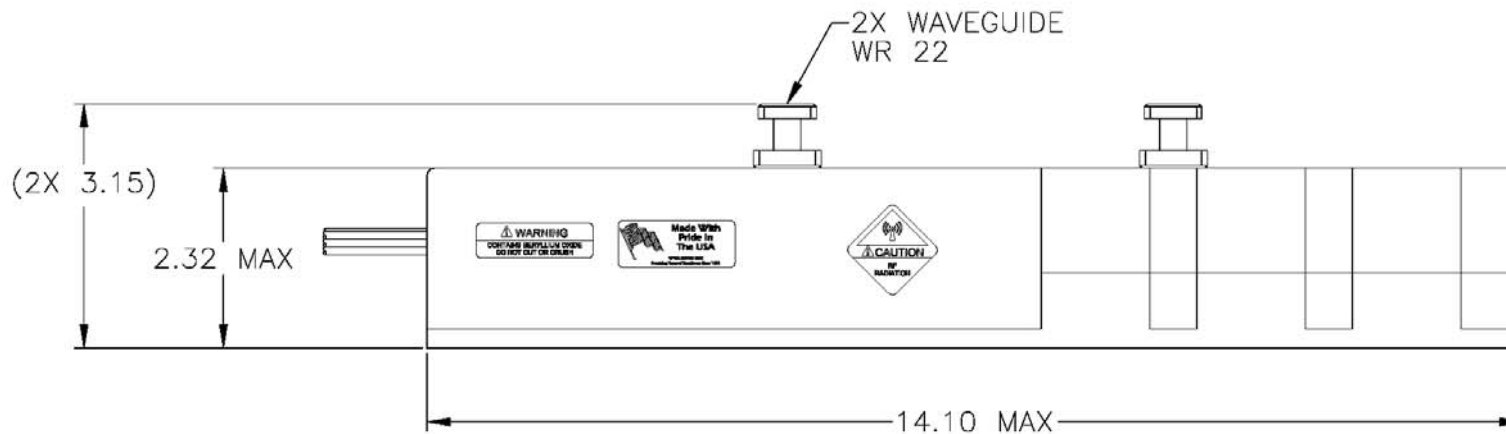
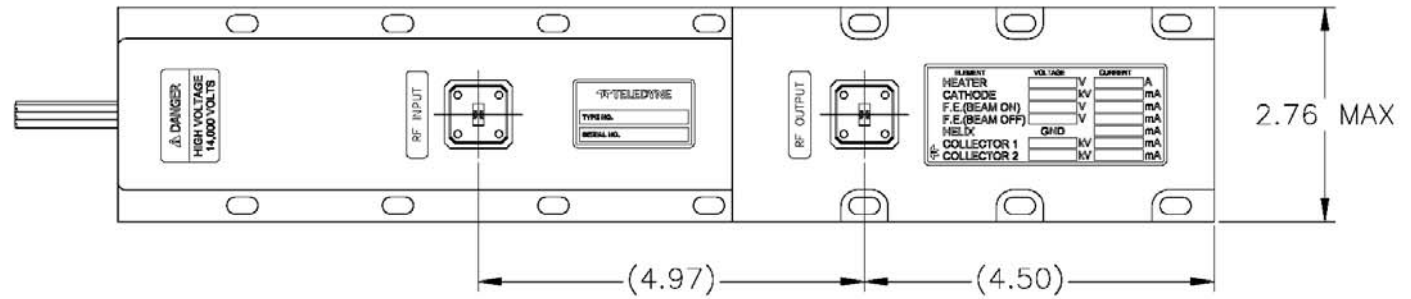

TELEDYNE MICROWAVE SOLUTIONS
TWT Products

11361 Sunrise Park Drive, Rancho Cordova, CA 95742 (916) 638-3344

TITLE

MEC 5523

SUBJECT TO CHANGE W/O NOTICE

ISO 9001:2008 Registered

**This page
intentionally
left blank**

Solid State Power Amplifiers

Page No.	Model	Frequency Band	Power (W)	Duty (%) Max.	Typical Gain (dB) Min/Max @ Rated P _{out}	Efficiency (%) Typical	DC Voltage Input	Output Connection	Weight (lbs/kg) (NTE)
168	MEC 7011U	225-400 MHz	200	CW	50	20	48	N	10
170	MEC 7003S	2.7-3.5 GHz	200	20	25	30	32	SMA	3
172	MSX 100AB	9-10 GHz	1000	20	60	23	18-36	TNC	10

MEC 7011U

200W CW SSPA

225 MHz – 400 MHz

- CW
- 100 W Minimum Power
- 225-400 MHz
- Gain Flatness +/-1.6 dB
- 600 W Typ. Prime Power
- -40 dBm/MHz Typ. Noise Power Density
- 53 dB Typical Rated Gain
- 12.5" L x 6" W x 1.5" H (317 x 150 x 3.75 cm)
- Weight 5 lbs. Max.
- -40° to 85° C
- Rack Mount Configurable

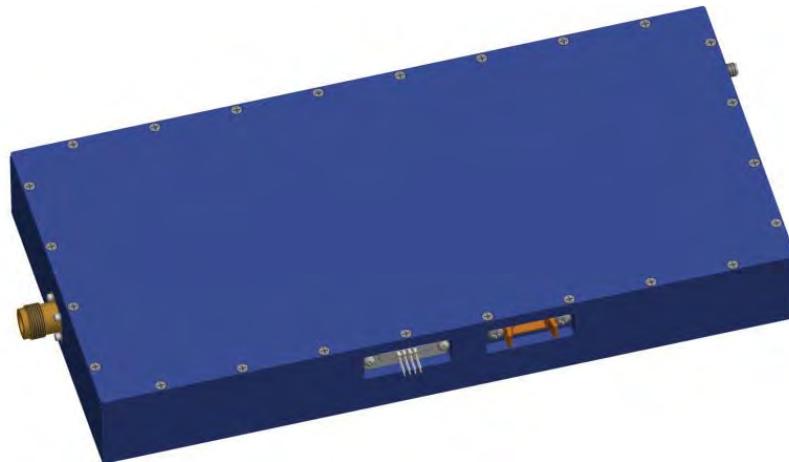

RF Performance

Freq (GHz)	Typ. Sat. Power Output (W)	Min. Spec. Power Output (W)	Typ. Gain @ Spec. Power (dB)
225	120	100	53
243	125	100	53
270	135	100	53
291	230	160	53
300	230	160	53
318	230	160	53
325	150	100	53
350	150	100	53
400	125	100	53

Typical power output is shown to illustrate capability.

Power Supply Requirements

Voltage Min.	Voltage Max.	Current Max.
48Vdc	50Vdc	12.0 A

Connectors

DC	Monitor	RFin	RF out
Screw Terminal	9 pin Dsub	SMA	Type N

Monitoring Options

Pout, Iavg, Gain, Temperature

Performance

	Typical	Spec
Input VSWR:.....	1.4:1	2.0:1
Max. Duty	CW	CW
Max. Pulsewidth	N/A	N/A
Noise Power Density (dBm/MHz)	-40	-30
Prime Power	500 W	600 W

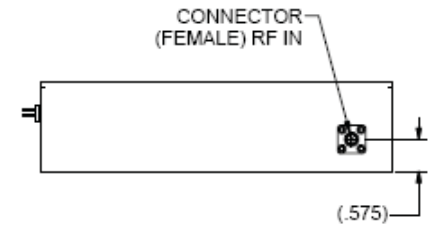
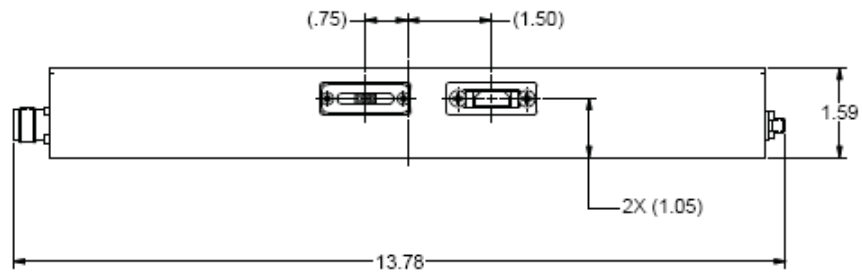
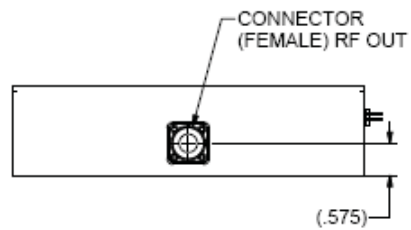
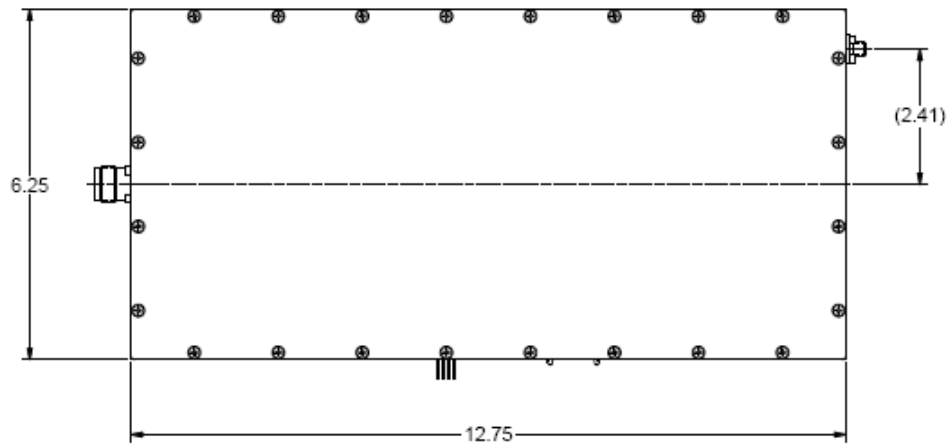

SUBJECT TO CHANGE W/O NOTICE ISO 9001:2008 Registered

TELEDYNE MICROWAVE SOLUTIONS TWT PRODUCTS <small>1181 Sunrise Park Dr., Pacific Grove, CA 95026-0208</small>
TITLE:
MEC 7011U

MEC 7003S

200 W Pulse SSPA

2.7 GHz – 3.5 GHz

- 20% Maximum Duty
- 200 W_{pk} Minimum Power
- 2.7 to 3.5 GHz
- Output Power Flatness 0.5 dB
- 80 W Typ. Prime Power @10%
- -40 dBm/MHz Typ. Noise Power Density
- 25 dB Typical Rated Gain
- 9" L x 3.25" W x 1.5" H (22 x 8 x 6 cm)
- Weight 3 lbs. Max.
- -40° to 85° C
- Rack Mount Available



RF Performance

Freq (GHz)	Typ. Sat. Power Output (W)	Min. Spec. Power Output (W)	Typ. Gain @ Spec. Power (dB)
2.7	230	200	25
2.8	230	200	25
2.9	230	200	25
3.0	230	200	25
3.1	220	200	25
3.2	220	200	25
3.3	210	200	25
3.4	210	200	25
3.5	210	200	25

Typical power output is shown to illustrate capability.

Power Supply Requirements

Voltage Min.	Voltage Max.	Current Max.
31Vdc	33Vdc	3.0 A

Connectors

DC	Monitor	RFin	RF out
Screw Terminal	9 pin Dsub	SMA	SMA

Monitoring Options

P_{out}, I_{avg}, Duty Cycle, Gain, Temperature

Performance

	Typical	Spec
Input VSWR:.....	1.4:1	2.0:1
Max. Duty	20%	20%
Max. Pulsewidth	300 μs	100 μs
Noise Power Density (dBm/MHz)	-40	-30
Prime Power	80 W	100W

This model number is subject to the jurisdiction of the U.S. Department of Commerce.

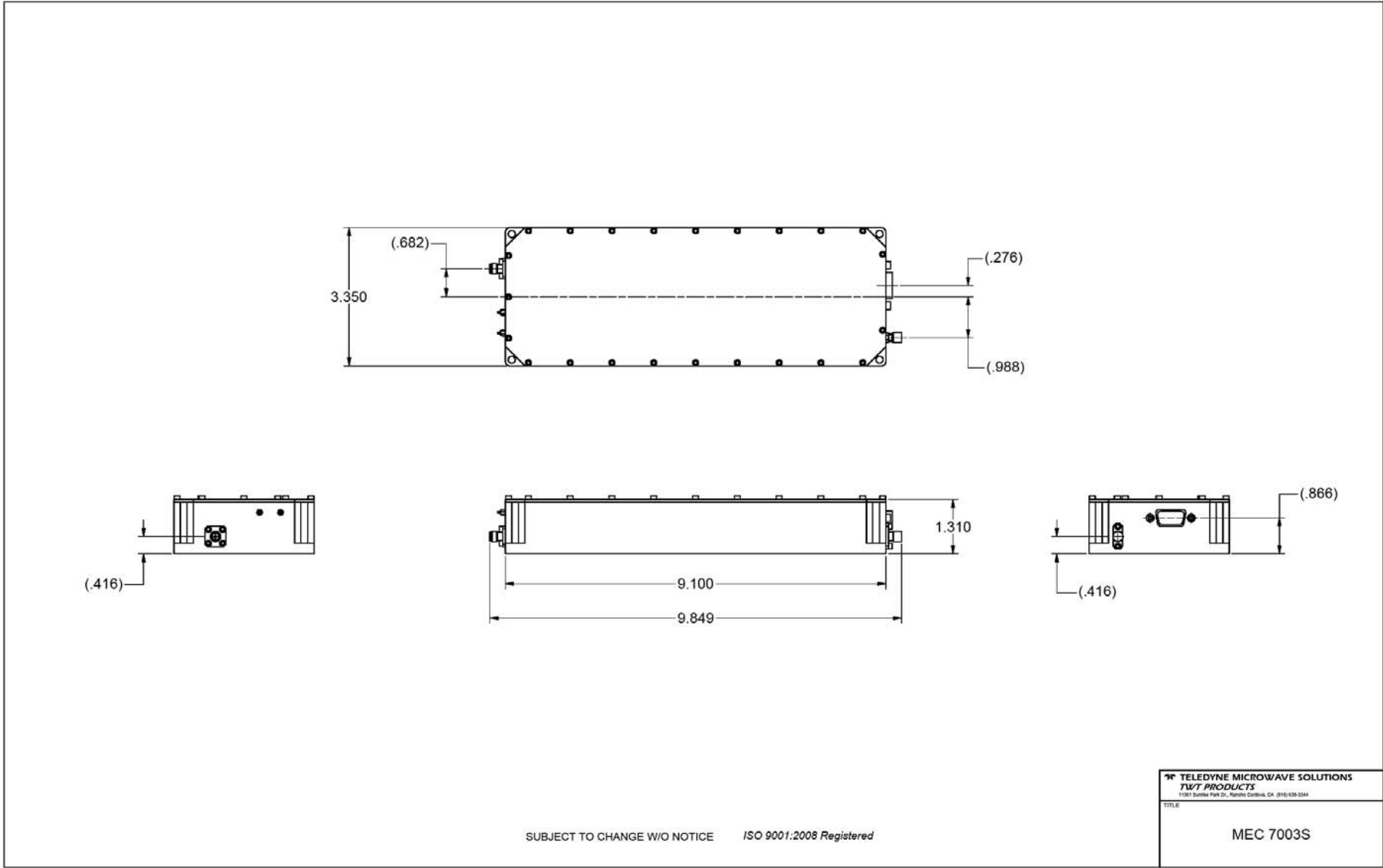

This model number is subject to the jurisdiction of the U.S. Department of Commerce.

MSX 100AB

1 kW Pulse SSPA

9.0 GHz – 10.0 GHz

- 20% Maximum Duty
- 1000 W_{pk} Minimum Power
- 9.0 to 10.0 GHz
- Output Power Flatness 0.5 dB
- 500 W Typ. Prime Power @10%
- -40 dBm/MHz Typ. Noise Power Density
- 60 dB Typical Rated Gain
- 13" L x 8.5" W x 2.5" H (32 x 21 x 6 cm)
- Weight 10 lbs. Max.
- -40° to 85° C
- Rack Mount Available



Power Supply Requirements

Voltage Min.	Voltage Max.	Current Max.
18 Vdc	36 Vdc	16 A

Connectors

DC	Monitor	RFin	RF out
Screw Terminal	9 pin Dsub	SMA	WR90/TNC

Monitoring Options

P_{out}, I_{avg}, Duty Cycle, Gain, Temperature

This model number is subject to the jurisdiction of the U.S. Department of Commerce.

RF Performance

Freq (GHz)	Typ. Sat. Power Output (W)	Min. Spec. Power Output (W)	Typ. Gain @ Spec. Power (dB)
9.0	1000	1000	60
9.1	1050	1000	60
9.2	1050	1000	60
9.3	1100	1000	60
9.4	1150	1000	60
9.5	1150	1000	60
9.6	1150	1000	60
9.7	1100	1000	60
9.8	1050	1000	60
9.9	1050	1000	60
10.0	1000	1000	60

Typical power output is shown to illustrate capability.

Performance	Typical	Spec
Input VSWR:.....	1.4:1	2.0:1
Max. Duty	20%	20%
Max. Pulsewidth	300 μs	100 μs
Noise Power Density (dBm/MHz)	-40	-30
Prime Power	500 W	550 W

Specifications are subject to change without notice.

Teledyne SSPA Products • 11361 Sunrise Park Drive • Rancho Cordova, CA 95742 • 916.638.3344 • www.teledynemicrowave.com

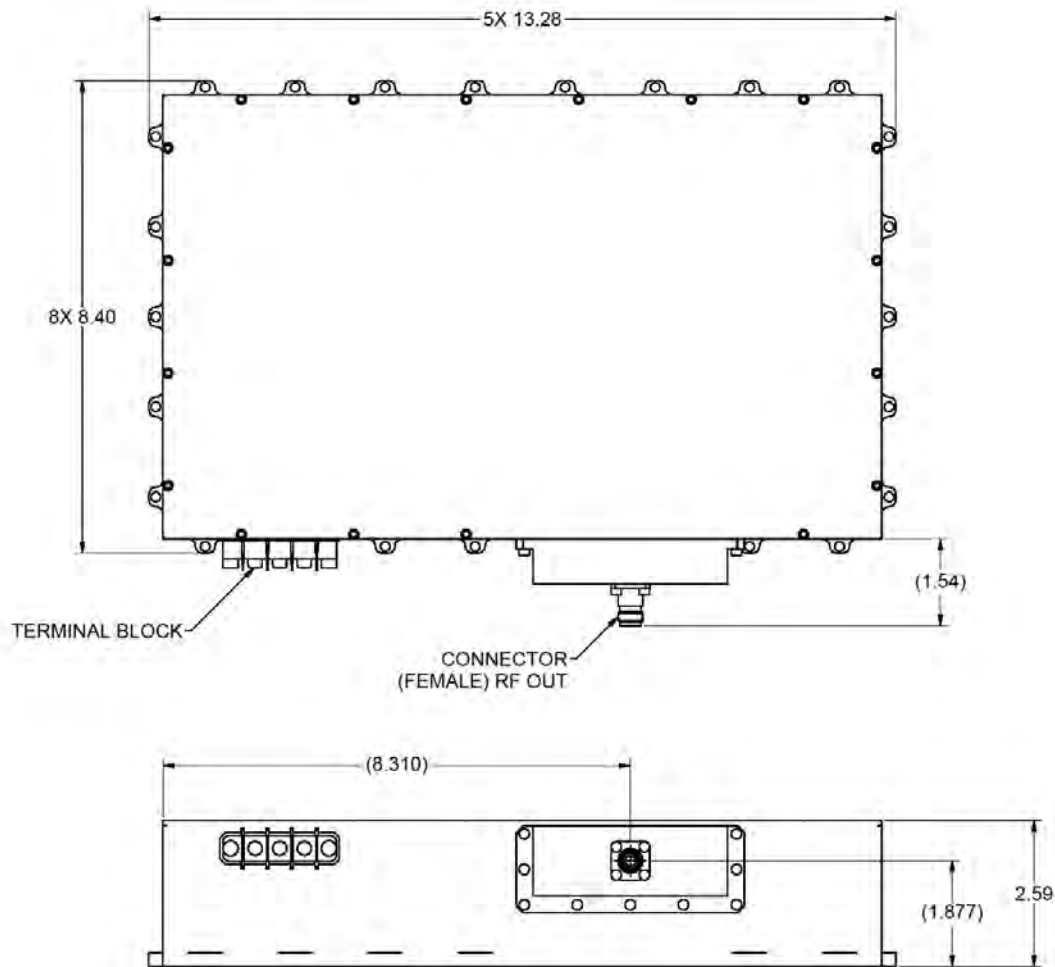

TERMINAL BLOCK

CONNECTOR
(FEMALE) RF OUT

SUBJECT TO CHANGE W/O NOTICE

ISO 9001:2008 Registered

TELEDYNE MICROWAVE SOLUTIONS
TMT PRODUCTS
1201 Green Park Dr., Milpitas, CA 95035-5041

T757

MSX 100AB

This model number is subject to the jurisdiction of the U.S. Department of Commerce.

**This page
intentionally
left blank**

Teledyne TWT Products, a business unit of Teledyne Microwave Solutions, is a world leader in the design, development and manufacture of broadband high power helix Traveling Wave Tubes (TWTs), TWT Amplifiers (TWAs), and Solid State High Power Amplifiers (SSPAs) from 10MHz to 44GHz, for top performance in the stringent fixed and mobile environments used in today's ECM, radar and communications markets.

Our state of the art products are found on nearly all major EW, Radar, and Communication platforms of the United States and its allies throughout the world.

TMS recognizes and strives to meet the needs of our customers with quality, value, and service at competitive prices. We look forward to meeting your needs with these same standards of excellence.



Teledyne TWT Products Mission Statement

We recognize the importance of our employee commitment and participation to continually improve our products and services. Above all, we will endeavor to provide our customers with the highest quality products and services, delivered when promised, and to their specifications.



TELEDYNE MICROWAVE SOLUTIONS
TWT PRODUCTS

www.teledynemicrowave.com

Prices subject to change without notice.