

TOSHIBA

TOSHIBA INTERNATIONAL CORPORATION

ADJUSTABLE SPEED DRIVES

G9[®]



**LOW
VOLTAGE**

ADVANCED FEATURES FOR MAXIMUM DRIVE PERFORMANCE

Plain-English LED/LCD Interface Startup Wizard allows for quick, user-friendly programming and easy modification of the expanded parameter set. The keypad is able to store parameter sets, which allows the user to set up multiple drives using these saved parameters. In addition, a built-in fault-logging chip records faults in the keypad memory. These records contain time and date stamps as well as detailed information about operating conditions at the time of the fault.

My Function, Toshiba's Proprietary Programming Feature, allows the user to utilize logic-type programming without the expense of a micro PLC. The user is able to read all analog and digital inputs and outputs as well as to monitor and compare data. When programmed in a user-defined logic sequence, the use of this data will allow for a higher level of process control not normally seen in an adjustable speed drive. These functions, along with timers, counters, and comparators, allow the G9® to help meet the user's performance expectations.

Eight Digital Inputs & Three Digital Outputs are an integral part of the G9's versatility. Each digital input/output is individually programmable with more than 60 possible functions. When used in conjunction with My Function programming, the capabilities of these terminals are virtually limitless. Additionally, the G9 is setting a new industry standard by providing an isolated analog input (4 to 20 mA) on its standard terminal strip.

A Built-In Proportional/Integral/Derivative (PID) Control Algorithm provides regulation of critical processes. High and low speed limits, deviation limits, online switching, and a built-in sleep function are included to enhance the flexibility and reliability of PID process control.

Toshiba's Proprietary Windows®-Based ASD Pro Software is available at no additional cost. This easy-to-use software is designed to provide a full range of programming and monitoring tools for the G9. ASD Pro Software offers trending and logging features that allow the user to save and transfer parameters and to export data and graphs to an electronic file. Parameter groups and trending data can be easily converted into spreadsheets or graphs for field and validation reports.

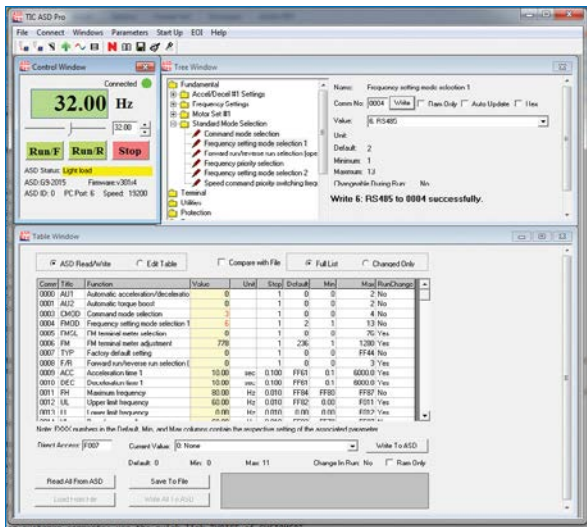

ASD Pro Main Control Screen

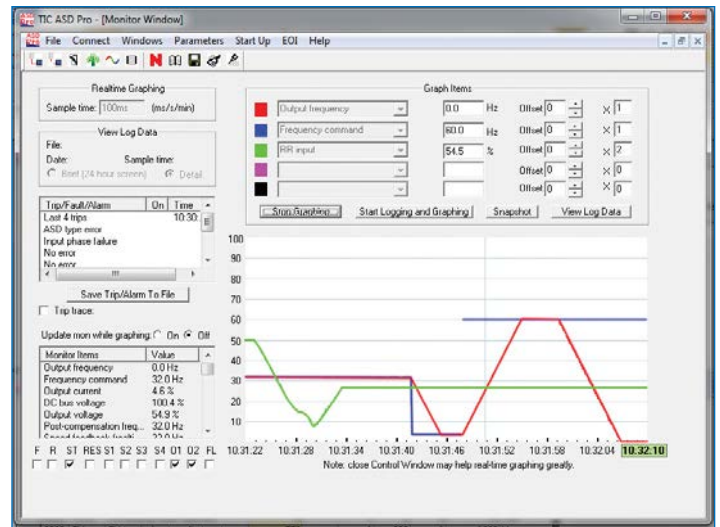

ASD Pro Real-Time Monitoring Screen

A LOOK INSIDE THE G9 ASD



- | | |
|---|---|
| <ul style="list-style-type: none"> 1. High Visibility LED Display 2. Rotary Encoder 3. Discrete Input & Output Status 4. Single Retaining Screw for Easy Terminal Board Removal | <ul style="list-style-type: none"> 5. Selectable Voltage or Current Analog Output 6. Isolated Voltage or Current Input 7. Half/Full Duplex RS485 |
|---|---|
-
- Stackable Option Cards Available
 - Parameter Storage Available in Removable EOI
 - Built-In Real-Time Clock
 - Backlit Character Display for Monitoring & Programming
 - Eight Programmable Discrete Inputs
 - 24 VDC Input for External Control Power
 - NEMA 1 Conduit Box
 - One Form-C & Two Form-A Programmable Relays
 - One Isolated Voltage or Current Input

COMMUNICATION OPTIONS

The G9 drive offers an array of easily installed option boards. These boards allow the user to communicate with a wide variety of systems. Options include:

- DeviceNet®
- Ethernet/IP
- Modbus® Plus
- Modbus® TCP/IP
- Profibus DP
- Profinet® IO



ADDITIONAL OPTIONS

The G9 can be customized with additional options to best suit a user's specific needs. Options include:

- Extended Terminal Cards
- Encoder Feedback Cards
- 120 VAC Discrete Inputs
- AC Line & Load Reactors
- DV/DT Long-Lead Filters
- Harmonic Filters
- Remote-Mountable Keypads

OTHER SPECIAL FEATURES

The G9 includes several standard top-of-the-line features. Options include:

- Dynamic Braking Transistor
- UL Type-1/NEMA 1 Enclosure
- 100 or 200 KAIC Rating
- UL® Listed & Labeled
- NEC Motor Overload Retention (No External Motor Overloads Required)

DIMENSIONS

230 V	HP	FLA	Model	Drawing	Height (in.)	Width (in.)	Depth (in.)
	0.75	3.5	VT130G9U2010	Figure 1	11.2	5.2	6.1
	1	4.2	VT130G9U2015				
	2	6.9	VT130G9U2025				
	3	10	VT130G9U2035				
	5	15.2	VT130G9U2055				
	7.5	23.8	VT130G9U2080				
	10	28.6	VT130G9U2110				
	15	46.8	VT130G9U2160	Figure 2	19.3	9.1	7.6
	20	57.2	VT130G9U2220				
	25	76	VT130G9U2270				
	30	90	VT130G9U2330				
	40	104	VT130G9U2400				
	50	152	VT130G9U2500				
	60	176	VT130G9U2600				
75	221	VT130G9U2750	Figure 3	51.7	14.6	17.6	
100	285	VT130G9U210K					

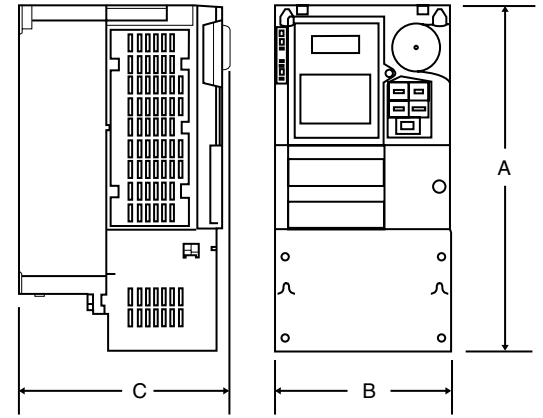

Figure 1

460 V	HP	FLA	Model	Drawing	Height (in.)	Width (in.)	Depth (in.)
	1	2.7	VT130G9U4015	Figure 1	11.2	5.2	6.1
	2	3.6	VT130G9U4025				
	3	5	VT130G9U4035				
	5	9.1	VT130G9U4055				
	7.5	12.4	VT130G9U4080				
	10	15.3	VT130G9U4110				
	15	24	VT130G9U4160				
	20	28.6	VT130G9U4220	Figure 2	19.3	9.1	7.6
	25	35.7	VT130G9U4270				
	30	42	VT130G9U4330				
	40	57.2	VT130G9U4400				
	50	68.5	VT130G9U4500				
	60	81.5	VT130G9U4600				
	75	100.8	VT130G9U4750				
	100	138.7	VT130G9U410K	Figure 3	51.7	14.6	17.6
	125	179	VT130G9U412K				
	150	215	VT130G9U415K				
	200	259	VT130G9U420K				
	250	314	VT130G9U425K				
300	387	VT130G9U430K					
350	427	VT130G9U435K					

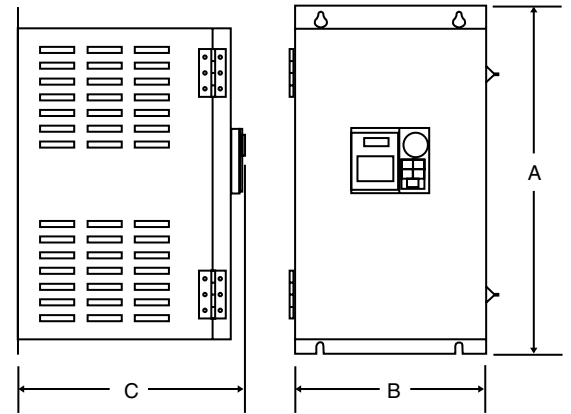

Figure 2

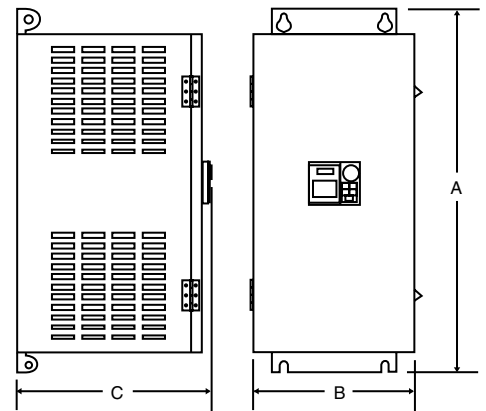

Figure 3

A POWERFUL DRIVE SOLUTION

The G9 low voltage adjustable speed drive is a severe duty drive offered by Toshiba. Designed with the end-user in mind, this drive combines a rugged proven power platform with the an advanced micro-processor to provide users with a smarter, stronger and more reliable drive with flexible application control.



G9 EXTREME DURABILITY FOR GENERAL PURPOSE

Powerful performance separates the G9 from the competition. This drive offers one of the toughest overload ratings in the industry. On ratings up to 100 HP at 460 V and 50 HP at 230 V, the G9 provides a continuous overload rating of 115% of its full-load amp and 150% for up to two minutes. Above these frames, the drive is rated for 110% of its full-load amp rating for continuous operation and 150% for up to one minute.

Superior control allows the user ultimate flexibility. The G9 can operate using open or closed-loop vector control volts/hertz patterns. Toshiba's advanced vector-control algorithm offers speed regulation of 0.1% sensorless and 0.02% with motor encoder feedback. While operating in the feedback vector control mode, the G9 can generate 100% torque at zerospeed to hold the shaft stationary while the motor is stopped. The G9 drive also offers advanced torque control operation with high torque accuracy and the ability to switch on-the-fly between speed and torque modes.

INDUSTRIES SERVED

- Oil & Gas
- Mining & Minerals
- Metal
- Quarry
- Timber

APPLICATIONS

- Chippers
- CNC Machines
- Grinders
- Crushers
- Cupping Presses
- Looms
- Mixers
- Punch Presses
- Rolling Mills



MODEL RANGE	1 to 100 HP	1 to 350 HP
Voltage Rating	200 to 240 V	380 to 480 V
POWER REQUIREMENTS		
Input Voltage Tolerance	Voltage: $\pm 10\%$; Frequency: $\pm 2\%$	
Output Frequency	0 to 299 Hz	
CONTROL SPECIFICATIONS		
Control Method	Sinusoidal Pulse Width Modulation (PWM); Flux-Field Current Vector Control; Set Point Control (PID)	
Voltage Regulation	Main Circuit Voltage Feedback Control: Automatic, Fixed & Off	
V/Hz Control	Constant Torque, Voltage Decrease Curve, Automatic Torque Boost, Sensorless Vector Control, 5-Point V/Hz Custom Curve, PM Drive & PG Feedback Vector Control	
PWM Carrier Frequency	Adjustable 0.5 to 15 kHz (For Drive Specific Information Consult Factory)	
Frequency Setting	Rotary Encoder Integrated into EOI, 0 to 10 VDC, ± 10 VDC, 4 to 20 mA, Binary Input & Motorized Potentiometer Input	
Frequency Precision	Analog Input: 0.2% of Maximum Output Frequency; Discrete/Communications Input: 0.01% of Maximum Output Frequency	
Speed Regulation	Open Loop: Up to 0.1%, 60:1 Speed Range; Closed Loop: Up to 0.01%, 1000:1 Speed Range	
Main Protective Functions	Current Limit, Overcurrent, Overvoltage, Inverter Overheat, Load-Side Short Circuit, Ground Fault, ASD Overload,	
Retry	Communications Error, Auto-Tuning Error, Emergency Stop, Undervoltage, Overtorque, Open-Output Phase, Motor Overload, Low Operating Current, Stall Protection, Pre-Alarm, Dynamic Braking Resistor & External Trip	
Restart	User-Set Number of Retries for Automatic System Restart After Trip; Able to Smoothly Catch Freewheeling Motor (Bidirectional)	
Overload Current Rating	115% Continuous, 150% for Two Minutes; 110% Continuous, 150% for One Minute (≥ 60 HP/230 V; 100 HP/480 V)	
CONTROL INTERFACE		
Digital Input	Eight Discrete Input Terminals Programmable to 67 Functions (May Be Increased Using Optional Hardware)	
Digital Output	Three Discrete Output Terminals Programmable to 84 Functions; Two Form-A Contacts & One Form-C Contact	
Analog Input	Three Programmable: One 0 to 20 mA or 0 to 10 VDC Isolated Input, One 0 to 10 VDC Input & One ± 10 VDC Input	
Analog Output	Two Programmable: One 4 to 20 mA or 0 to 10 VDC & One 4 to 20 mA Output	
Communication Ports	Two-Wire/Four-Wire RS485	
ELECTRONIC OPERATOR INTERFACE (EOI)		
Display	Graphical Full-English LCD Back-Lit Display & Four-Digit Seven-Segment LED Display for Programming, Monitoring & Diagnostics	
LED Indicators	Run (Red)/Stop (Green), Hand (Green) & DC Bus Charge Indicator (Red)	
Keys	Local/Remote, ESC, Run, Mode, & Stop/Reset	
Monitoring	Frequency Command Screen; Multiple Parameters Displayed: Output Current, DC Voltage, Output Voltage, Run Time, PID Feedback, Motor Load, Motor Overload, ASD Load, Output Power, Input Power, RR Input, VI/II Input, RX Input, RX2 Input & AM/FM Output	
CONSTRUCTION		
Enclosure	NEMA 1; Free-Standing/Wall Mount; Front-Access Only	
Power Cables	Top/Bottom Access for Input/Motor Cables	
Cooling	Forced-Air Cooled; Heat Exchanger	
Standards & Compliances	UL Listed in US & Canada, NEMA® & American Recovery & Reinvestment Act Compliant	
AMBIENT CONDITIONS		
Ambient Temperature	-10 to 40°C (14 to 104°F)	
Altitude	3300 ft. Above Sea Level	
Humidity	95% Maximum (Non-Condensing)	
Installation	Indoor; No Direct Sunlight; Protect from Corrosive Gases	



Typical Connection Diagram

Figure 20. The G9 ASD Typical Connection Diagram.

Note: When connecting multiple wires to any of ASD terminals, do not connect a solid wire and a stranded wire to the same terminal.

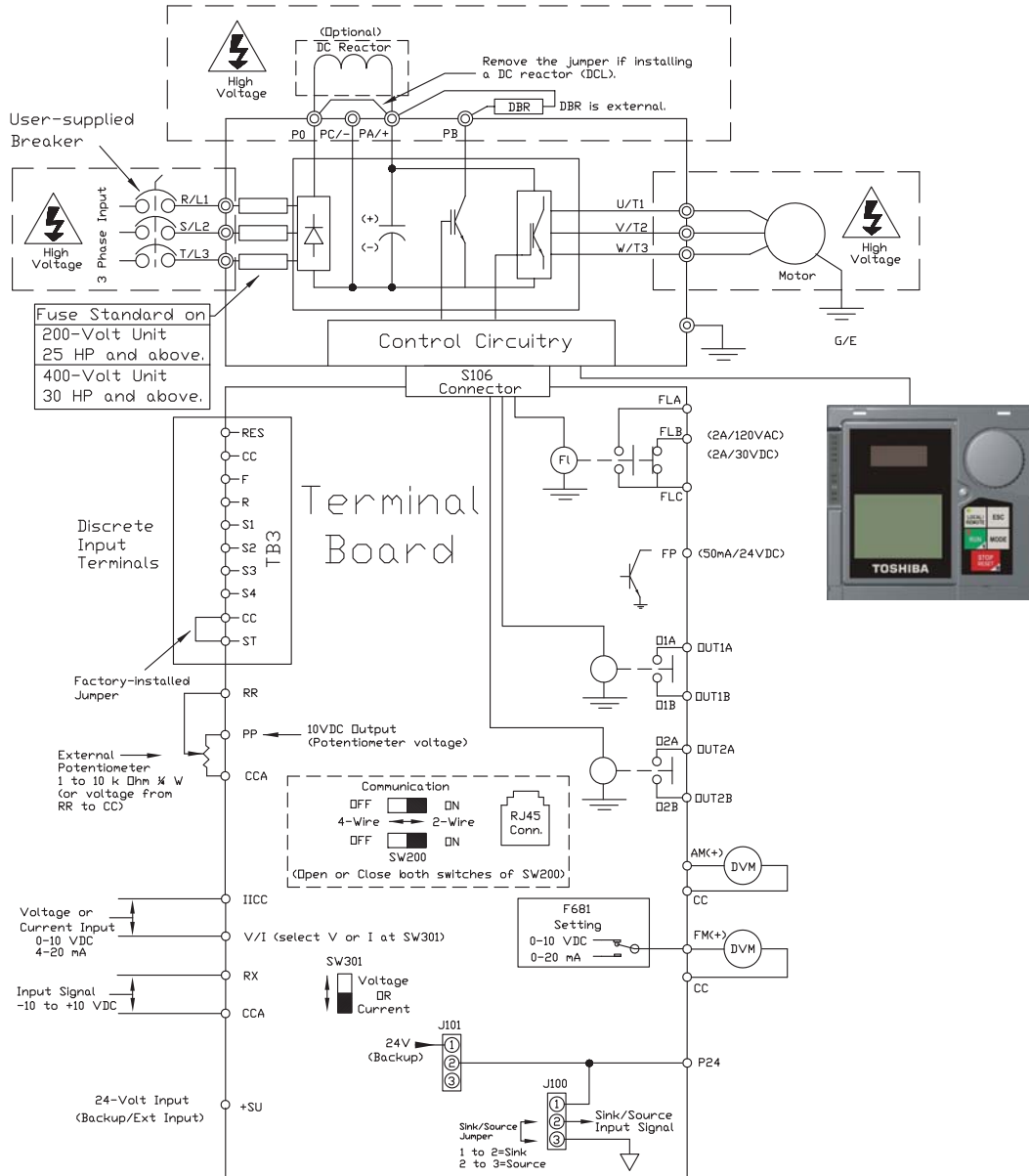

Note: The AM, FM, and the +SU analog terminals are referenced to CC.

Note: The PP, RR, RX, and the P24 analog terminals are referenced to CCA.

Note: The isolated V/I analog terminal references IICC.

DEVICE LEGEND:

- 1. CIRCUIT DISCONNECT HANDLE
- 2. G9 OPERATOR KEYPAD
- 3. FILTERED INLET FAN
- 4. FILTERED OUTLET VENT
- 5. FILTERED OUTLET FAN

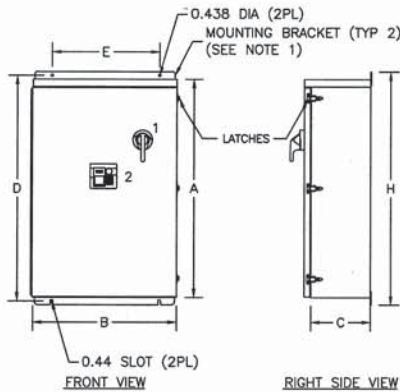

FIGURE 1

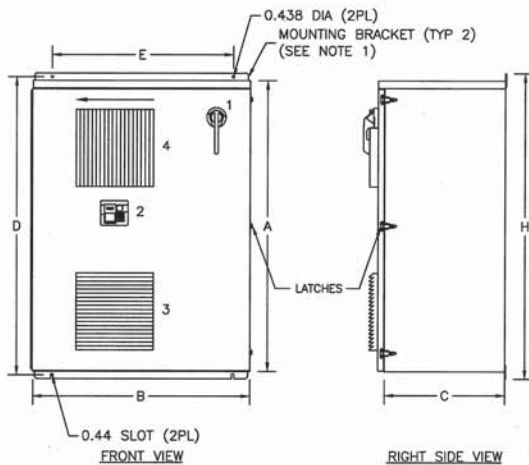

FIGURE 2

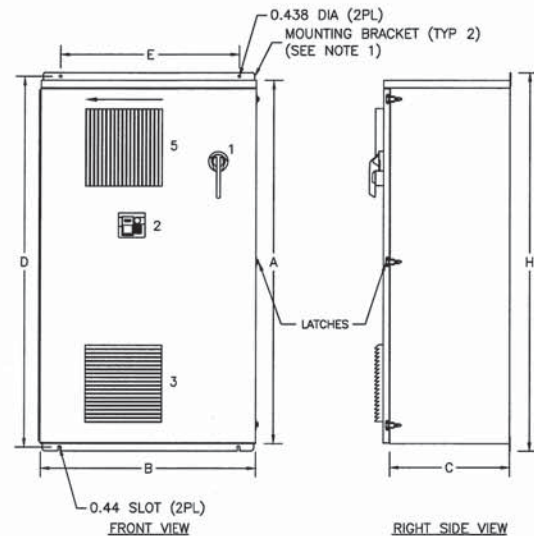
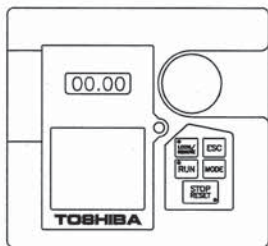

FIGURE 3



G9 KEYPAD DETAIL

NOTE 1: NOT TO BE USED FOR LIFTING PURPOSES.
 NOTE 2: PAINT TO BE ANSI 61 GRAY.
 NOTE 3: ENCLOSURE SIZE MAY CHANGE WITH ACL OPTION.

DESCRIPTION OF ENCLOSURE	G9 HP RATING		FIGURE	ENCLOSURE SIZE			MOUNTING DIMENSIONS		
	230V	460V		A	B	C	D	E	H
36x24x10	.75-5	1-7.5	1	36.00	24.00	10.00	37.25	18.00	38.50
48x24x12	7.5	10	1	48.00	24.00	12.00	49.25	18.00	50.50
48x36x20	N/A	15	1	48.00	36.00	20.00	49.25	30.00	50.50
48x36x20	10-25	20-50	2	48.00	36.00	20.00	49.25	30.00	50.50
60x36x20	30-40	60-75	3	60.00	36.00	20.00	61.25	30.00	62.50

REV	DATE	DESCRIPTION	BY	CHK	APPR
4					
3					
2	09/15/16	ECO#93490	CW	JE	RKR
1	01/05/11	REMOVED CLEARANCE NOTATION	RKR		
0	11/09/07	FIRST ISSUE	RKR	RKR	GBF

TOSHIBA
 TOSHIBA INTERNATIONAL CORPORATION
 MADE IN HOUSTON, TEXAS U.S.A.
 THIS MATERIAL IS THE EXCLUSIVE PROPERTY OF TOSHIBA INTERNATIONAL CORPORATION AND SHALL NOT BE REPRODUCED, USED, OR DISCLOSED TO OTHERS UNLESS PRIOR WRITTEN AUTHORIZATION IS OBTAINED.

TITLE: ENCLOSURE OUTLINE (1)	
CUSTOMER:	PROJECT NUMBER:

REVISION: 2	SCALE: 1.0=20.0
DRAWING NUMBER: 1808KP19	

DEVICE LEGEND:

1. CIRCUIT DISCONNECT HANDLE
2. G9 OPERATOR KEYPAD
3. FILTERED INLET FAN
4. FILTERED OUTLET FAN

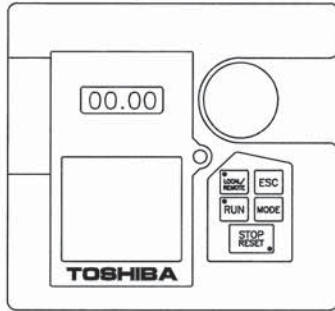

G9 KEYPAD DETAIL

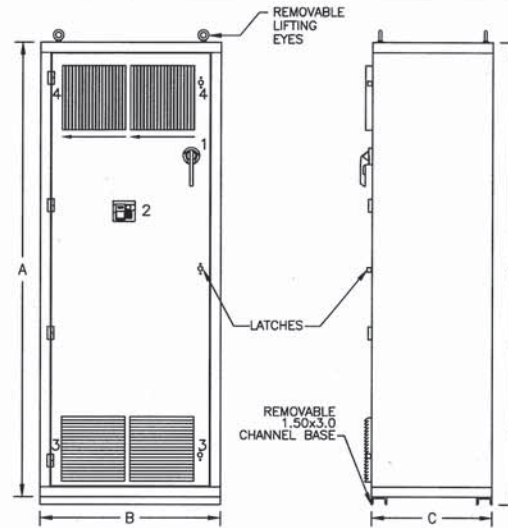

FRONT VIEW

RIGHT SIDE VIEW

FIGURE 1

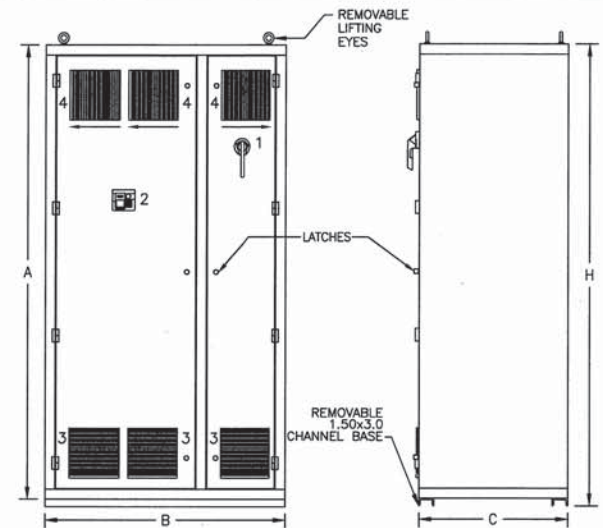

FRONT VIEW

RIGHT SIDE VIEW

FIGURE 2

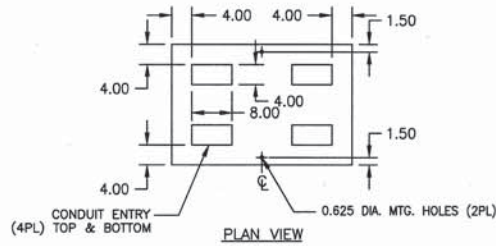

PLAN VIEW

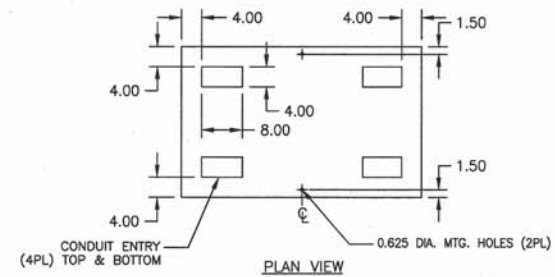

PLAN VIEW

DESCRIPTION OF ENCLOSURE	G9 HP RATING 230V	460V	FIGURE	ENCLOSURE SIZE			MOUNTING DIMENSIONS		
				A	B	C	D	E	H
90x36x24	50-75	100-150	1	90.00	36.00	24.00	N/A	N/A	91.50
90x48x30	100	200-350	2	90.00	48.00	30.00	N/A	N/A	91.50

NOTE 1: PAINT TO BE ANSI 61 GRAY.
NOTE 2: ENCLOSURE SIZE MAY CHANGE WITH ACL OPTION.

REV	DATE	DESCRIPTION	BY	CHK	APPR
4					
3					
2	09/15/16	ECO#93490	CW	JE	RKR
1	01/05/11	REMOVED CLEARANCE NOTATION	RKR		
0	11/09/07	FIRST ISSUE	RKR	RKR	GBF

TOSHIBA
TOSHIBA INTERNATIONAL CORPORATION
MADE IN HOUSTON, TEXAS U.S.A.
THIS MATERIAL IS THE EXCLUSIVE PROPERTY OF TOSHIBA INTERNATIONAL CORPORATION AND SHALL NOT BE REPRODUCED, USED, OR DISCLOSED TO OTHERS UNLESS PRIOR WRITTEN AUTHORIZATION IS OBTAINED.

TITLE: ENCLOSURE OUTLINE (2)	
CUSTOMER:	PROJECT NUMBER:

REVISION: 2	SCALE: 1.0=24.0
DRAWING NUMBER: 1808KP20	