

U.S. Marines In Iraq, 2003: ANTHOLOGY AND ANNOTATED BIBLIOGRAPHY



*U.S. Marines in
the Global War
on Terrorism*

Cover: Marines of Company I, 3d Battalion, 7th Marines, provide cover fire for an advance on the Fedayeen Saddam headquarters in Baghdad. The Fedayeen Saddam operated as a paramilitary unit of the irregular forces and reported directly to President Saddam Hussein.

(Associated Press Photo/Laura Raunch)

U.S. MARINES IN IRAQ, 2003: ANTHOLOGY AND ANNOTATED BIBLIOGRAPHY

*U.S. Marines in the
Global War on Terrorism*



Compiled by
Major Christopher M. Kennedy, Wanda J. Renfrow,
Evelyn A. Englander, Nathan S. Lowrey

History Division
United States Marine Corps
Washington, D.C.
2006

Other publications in the Series
U.S. Marines in the Global War on Terrorism

U.S. Marines in Iraq, 2003: Basra, Baghdad and Beyond

PCN 190 0024 6400

Foreword

This volume presents a collection of 47 articles describing different aspects of U.S. Marine Corps participation in Operation Iraqi Freedom during 2003. As with the previously published anthologies on the Spanish American, Vietnam, and Persian Gulf Wars, our intent is to provide a general overview that will serve as an interim resource for educating Marines and informing the public about the conflict, until the History Division completes an intended series of monographs dealing with major Marine Corps operations in that campaign. As the operational environment continues to mature, the authors' varied accounts will also serve as an introduction to changing tactics and strategies encountered or developed by Marines conducting stability and support operations in Iraq. Subsequent volumes will cover other campaigns being conducted elsewhere during the Global War on Terrorism.

I would like to thank the editors of *U.S. Naval Institute Proceedings*, *Inside the Pentagon*, *Marine Corps Gazette*, *The New York Times Magazine*, *Marine Corps News*, *Field Artillery Journal*, *The Dallas Morning News*, *Navy Medicine*, *21st Century Defense*, and *The Crisis* for their cooperation in permitting the reproduction of the aforementioned articles. Their support made this anthology possible and further enhanced the record of Marine Corps participation in Operation Iraqi Freedom.

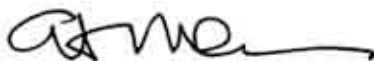

C.D. MELSON

Acting Director of Marine Corps History

Preface

The nature of any military anthology is necessarily influenced by the type of operations being conducted, the time available for historical accounts to accumulate, and the perspectives of the contributing authors. In this volume, we draw from a variety of resources (briefings, award recommendations, press interviews, media reports, and journal articles) to characterize a series of increasingly complex civil and military operations that occurred between March and September 2003. These accounts were generated shortly after the fact by embedded journalists, staff officers, and commanders, who reveal a wide range of experiences that extend from combat on the frontlines to planning in theater command centers.

In choosing the representative articles, we reviewed more than 200 potential nominations (which are listed in an annotated bibliography). Those selected are grouped according to the Marines' conventional air ground task force organization, and arranged to flow from broad overviews to more focused discussions. Part I reflects the perspectives of the commanding generals and staff officers from U.S. Central Command and I Marine Expeditionary Force. Parts II, III, and IV present the experiences of Marines serving in the ground combat, aviation combat, and combat service support elements. Integrally linked as part of the team effort to oust Saddam Hussein, the accounts describe infantry, armor, artillery, air control, air support, engineer, logistics, medical, and dispersing operations extending from support bases in Kuwait to northern Iraq. Parts V, VI, and VII deal with less conventional stability and support operations, and the sometimes-tense relationship between the military and embedded reporters. The volume concludes with five appendices presenting additional information on the commanders and their units, military terms and abbreviations, a chronology of significant events, and the annotated bibliography.

Collation of the anthology was a collaborative affair, involving the contributions of numerous individuals at the Marine Corps History Division. Wanda J. Renfrow, editorial assistant, and Evelyn A. Englander, librarian, were indispensable and spent a considerable amount of time collecting, cataloguing and transcribing the articles derived from both print and internet sources. Interns Erin McAdams of American University and Janet Nahrstedt of George Washington University provided the bulk of the bibliographic annotations. Nathan S. Lowrey, historian, assumed the role of project officer in September 2005, and selected many of the accompanying photographs. The Editing and Design Section, W. Stephen Hill in particular, labored diligently to transform the collection of clippings, photocopies, and artwork into its present format. Additional guidance was provided by Jon T. Hoffman, former Deputy Director of Marine Corps History and Museums Division, Charles D. Melson, Chief Historian, and Charles R. Smith, head of the Historical Branch.

Major Christopher M. Kennedy would also like to acknowledge the assistance of Colonel Nicholas E. Reynolds, head of the Field History Branch, for helping him with the review of selected material and for providing him with editorial oversight.

Table of Contents

Foreword iii

Preface v

Part I **Commanders' Perspective**

“I Marine Expeditionary Force Summary of Action”
Lieutenant General Wallace C. Gregson 1

“Briefing on Military Operations in Iraq”
General Tommy R. Franks, U.S. Army 15

“I Marine Expeditionary Force Commander Live Briefing from Iraq”
Lieutenant General James T. Conway 25

“Briefing on I Marine Expeditionary Force in Iraq”
Lieutenant General James T. Conway 35

“‘We’ve Always Done Windows’”
Lieutenant General James T. Conway 45

Part II **Ground Combat**

“Marine General: Iraq War Pause ‘Could Not Have Come At Worse Time’”
Elaine M. Grossman 51

“Blue Diamond Intelligence: Division-Level Intelligence Operations During Operation IRAQI FREEDOM”
Lieutenant Colonel Michael S. Groen 55

“1st Marine Division and Operation IRAQI FREEDOM”
Lieutenant Colonel Clarke R. Lethin 61

“Logistics Support to the 1st Marine Division During Operation IRAQI FREEDOM”
Lieutenant Colonel John J. Broadmeadow 65

“Aviation Integration in Operation IRAQI FREEDOM I: A Division Air Officer’s Perspective” <i>Lieutenant Colonel Patrick A. Gramuglia and Major Richard L. Phillips</i>	69
“The Battle of An Nasiriyah” <i>Company Commanders, 1st Battalion, 2d Marines</i>	77
““Good Kills”” <i>Peter Maas</i>	83
“Charlie Company Leads BLT into Northern Iraq” <i>First Lieutenant Christopher Mercer</i>	91
“Experience and Adaptability Ensure Success for 24th MEU (SOC) in Iraq” <i>Corporal Jeff Sisto</i>	97
“Cannon Cockers at War: The 11th Marines in Operation Iraqi Freedom” <i>Lieutenant Colonel Michael R. Melillo</i>	101
“Marine Artillery in the Battle of An Nasiriyah” <i>Major Walker M. Field</i>	107
“Alone and Unafraid”” <i>Jim Landers</i>	113
“Combat Engineer Battalion in Operation IRAQI FREEDOM” <i>Commanders and Staffs, 1st and 2d Combat Engineer Battalion</i>	121
“Combining 1st and 2d Combat Engineer Battalions: Should We Do It Again?” <i>Lieutenant Colonel Michael A. Micucci</i>	127
Part III	
Air Combat	
“A Different Air War: Marine Air Control in Operation Iraqi Freedom” <i>Lieutenant Colonel Michael J. Kibler</i>	133
“4th MAW JFACC Liaison in OIF” <i>Colonels Thomas C. Byron and William Kane</i>	141
“Airborne Recon Supported Marines’ Advance in Iraq” <i>Lieutenant Colonel Lawrence R. Roberts and Major John P. Farnam</i>	145

“Harrier Carriers Perform in Iraqi Freedom”
Lieutenant Commanders Cindy Rodriguez, USN, and Major Michael Manzer, Jr., Shawn Lobree, and Jon Dachos, USN149

“Close Air Support in the U.S. Marine Corps: A FAC’s Perspective”
Major Donald S. Hawkins155

Part IV
Combat Service Support

“MLC: Sustaining Tempo on the 21st Century Battlefield”
Brigadier General Michael R. Lehnert and Colonel John E. Wissler159

“Brute Force Combat Service Support: 1st Force Service Support Group
in Operation IRAQI FREEDOM”
Commanders and Staff, 1st Force Service Support Group165

“Marine Engineer Group: A Force for the Future”
Kirk Ross173

“8th Engineer Support Battalion’s Support of Operation IRAQI FREEDOM”
Lieutenant Colonel Niel E. Nelson and Major Joseph Klocek177

“No Farp Too Far!”
Commander and Staff, Marine Wing Support Group 37185

“Disbursing Goes to War”
Lieutenant Colonel James A. Hogberg189

“Caring for the Fallen: Mortuary Affairs in Operation Iraq Freedom”
Lieutenant Colonel John M. Cassady, Major Jefferson L. Kaster, and Chief Warrant Officer-4 Cheryl G. Ites193

“MCLB Corpsmen Return from Iraq”
Corporal Joshua Barhardt201

“Marine Corps CH-46’s Vital to CASEVAC Mission in Iraq”
Sergeant Matthew P. Shelato205

“Operation Iraqi Freedom: A Surgeon’s Perspective”
Captain Stephen F. McCartney, U.S. Navy Reserve209

U.S. Shock-Trauma Platoons Put Emergency Room in Iraq: Units Treat Marines, Civilians, Prisoners <i>James W. Crawley</i>	213
--	-----

“Fleet Hospital Three Makes Navy Medical History in Sands of Southern Iraq <i>Chief Journalist Al Bloom, USN, and Rod Duren</i>	217
--	-----

Part V
Stability and Security Operations

“Tikrit, South to Babylon” <i>Brigadier General John F. Kelly</i>	221
--	-----

“Part II: Tikrit, South to Babylon” <i>Brigadier General John F. Kelly</i>	227
---	-----

“Part III: Tikrit, South to Babylon” <i>Brigadier General John F. Kelly</i>	233
--	-----

“What Do You Do For An Encore?” <i>Colonel Christopher C. Conlin</i>	239
---	-----

“Raid in Iraq’s ‘Indian Country’” <i>Pamela Hess</i>	247
---	-----

Part VI
Media Operations: Telling the Story

“Public Affairs Guidance on Embedding Media” <i>Office of the Assistant Secretary of Defense (Public Affairs)</i>	253
--	-----

“Conducting Expeditionary Public Affairs” <i>Captain Joseph M. Plenzler</i>	261
--	-----

“The Military-Media Relationship: From Bull Run to Baghdad” <i>Major Douglas M. Powell</i>	267
---	-----

“CLOWNS to the left of me...” <i>Captain Daniel J. McSweeney</i>	273
---	-----

“Live from Baghdad” <i>Byron Pitts</i>	277
---	-----

Part VII
Déjà Vu

“Farther and Faster”
Lieutenant General James T. Conway285

Appendix A
Command List291

Appendix B
Unit List295

Appendix C
Selected Glossary of Terms and Abbreviations303

Appendix D
Chronology of Events307

Appendix E
Selected Bibliography311



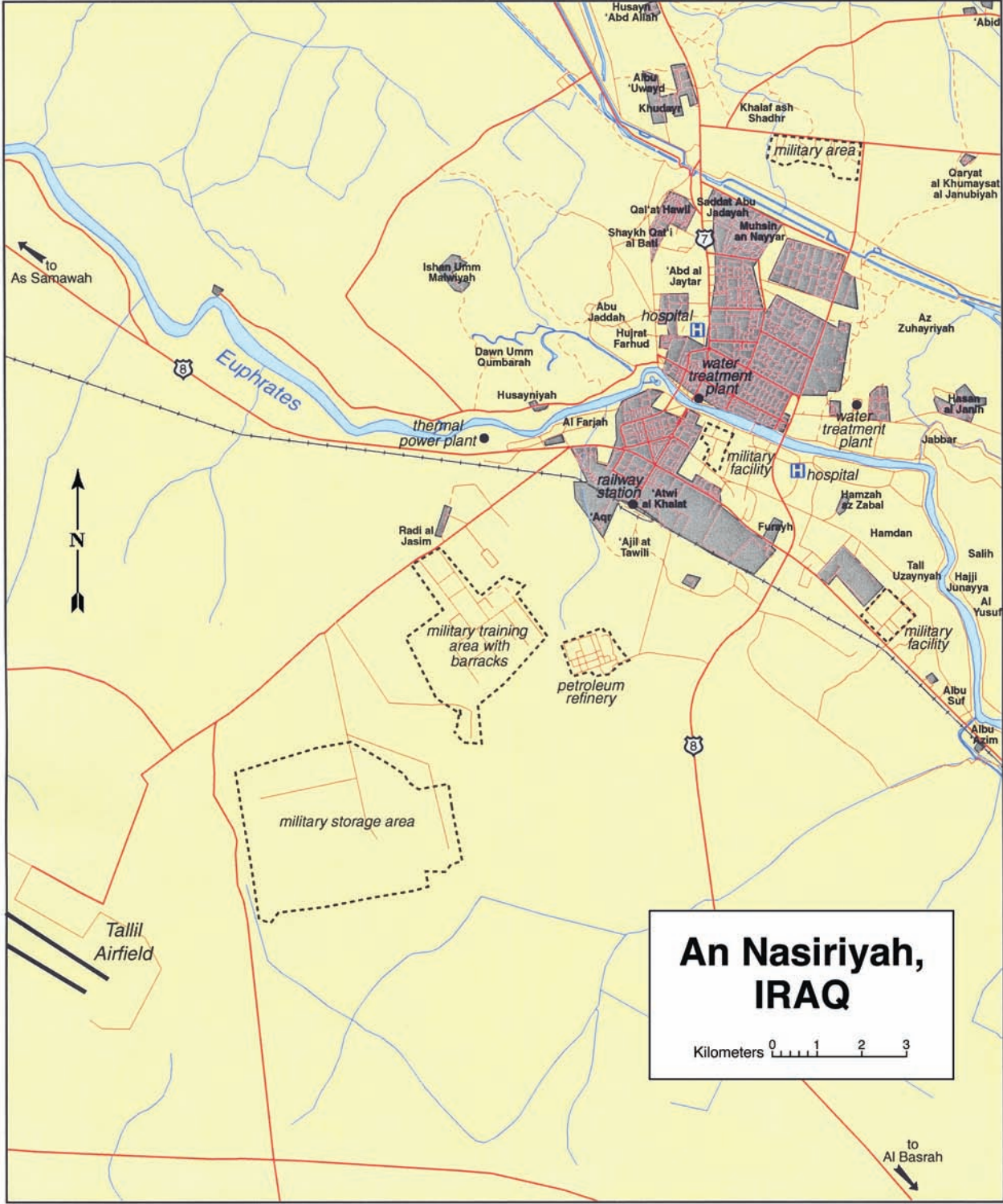

DI Cartography Center/MPG 763294AI (C00600) 4-03

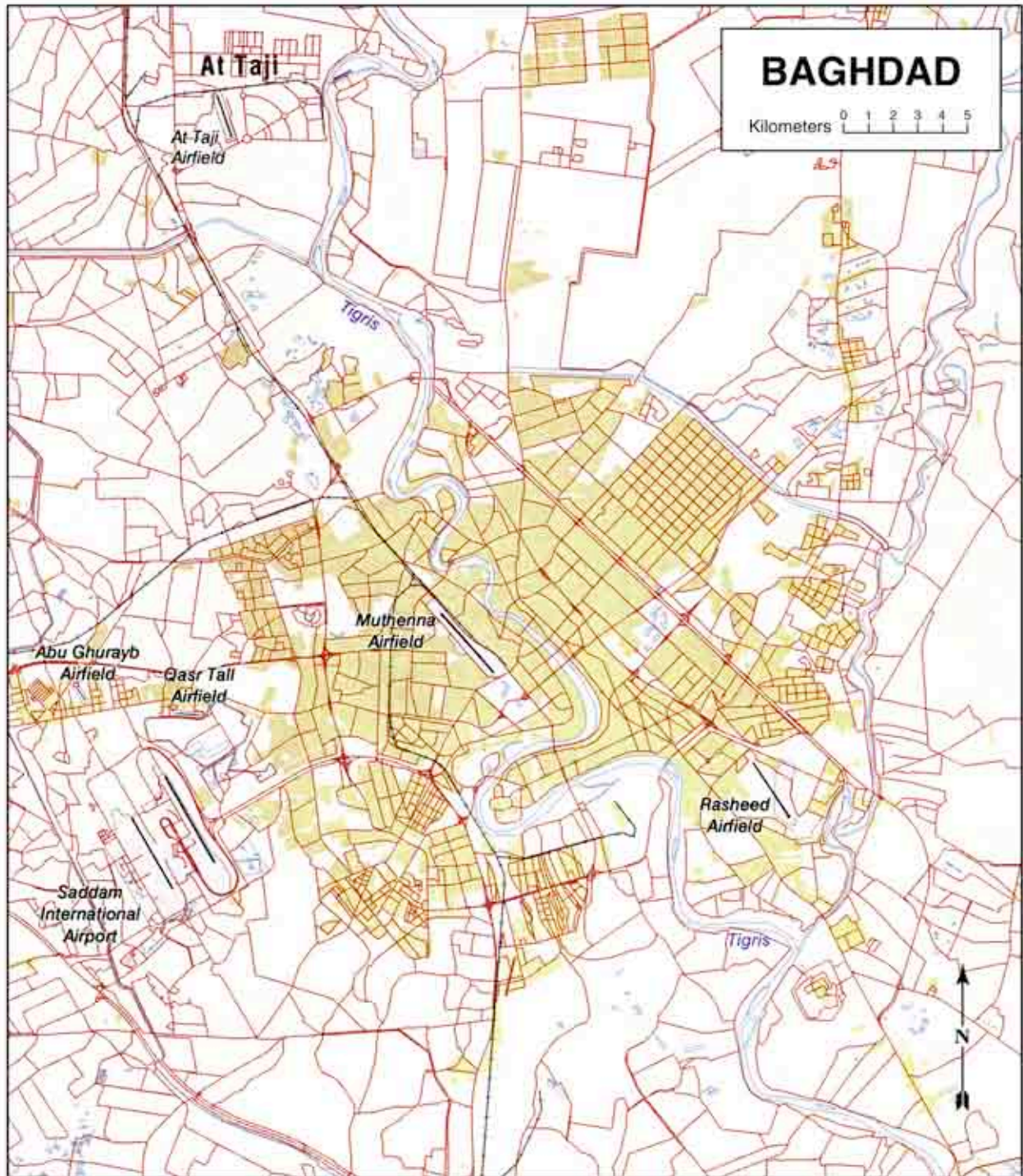

Part I
Commanders' Perspective

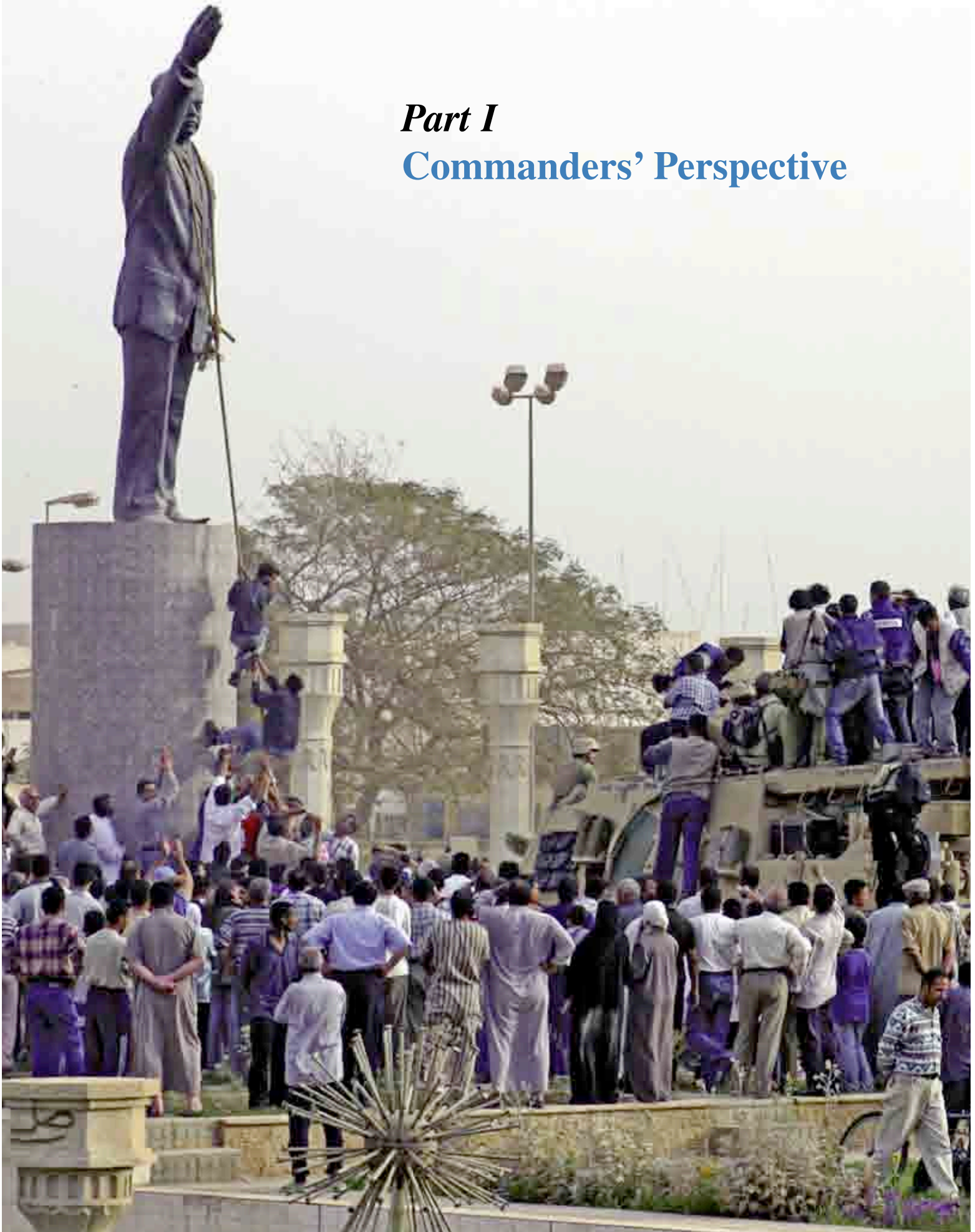

I Marine Expeditionary Force Summary of Action

by Lieutenant General Wallace C. Gregson

Commander, Marine Forces Pacific, 7 August 2003.

I Marine Expeditionary Force (MEF) (Rein) was composed of the I Marine Expeditionary Force Headquarters Group, 1st Marine Division (-) (Rein), 3d Marine Aircraft Wing (-) (Rein), 1st Force Service Support Group (-) (Rein), the I MEF Engineer Group, Task Force Tarawa (2d Marine Expeditionary Brigade), 15th Marine Expeditionary Unit (Special Operations Capable), 24th Marine Expeditionary Unit (Special Operations Capable), and the 1st Armoured Division of the United Kingdom. This task organized Marine Air Ground Task Force (MAGTF) began deployment for combat operations in October 2002 and is most deserving of being awarded the Presidential Unit Citation for actions from 21 March to 24 April 2003. Operation Iraqi Freedom resulted in a number of firsts for the United States Marine Corps. Contained below is a summary of action from each major subordinate command and major subordinate element to support the award of the Presidential Unit Citation (PUC).

I Marine Expeditionary Force Headquarters Group (I MHG)

Operation Iraqi Freedom was the first operational use of the MEF since Operation Desert Shield/Desert Storm twelve years earlier. I MHG provided the basic life support for the MEF command element, the largest force reconnaissance company in the history of the Corps, a significantly reinforced intelligence battalion, two full communications battalions, and two complete ANGLICO's. I MHG developed and secured five separate MEF command post locations from which basic command and control of assigned forces was executed. Throughout the operation, I MEF command element, supported by I MHG, operated continuously with no less than three command and control nodes: I MEF, I MEF (Forward), and I MEF Camp Pendleton. Leveraging information technology to the fullest and using reach back capabilities to the fullest extent, I MEF was able to web-base the majority of its' war fighting applications thereby giving all subordinate, adjacent, and higher units near real-time information on battlefield activities.

1st Marine Division

During the successful execution of Operation Iraqi Freedom, the 1st Marine Division conducted the longest sequence of coordinated overland attacks in Marine Corps history. From crossing the line of departure (LOD) on the border between Kuwait and Iraq, to the culmination of hostilities well north of Baghdad, the division covered 808 kilometers in 17 days of sustained combat.

Preparation

On short notice, and prior to the commencement of hostilities, the division was required to develop a deception plan to cover its movement to designated attack positions. This plan and its subsequent, complex night movement enabled the division to tactically move 20,000 Marines and sailors from their life support areas (LSAs) in Kuwait to their intermediate attack positions/position areas (Aps/Pas) immediately south of the Iraq/Kuwait border. The division successfully completed this movement in less than 24 hours, without loss of life and without being detected by the enemy. Once in its Aps/Pas, the division set conditions to cross the LOD on four hours notice.

Initial Attack

On 19 March, intelligence sources indicated that enemy action was threatening to destroy the strategic Rumaylah oilfield previously identified in plans as Division Objective 3. In light of this information, Regimental Combat Team-5 (RCT-5) crossed the LOD nine and a half hours early and secured the mission-critical gas and oil separation plants (GOSPs). Despite the fact that two Iraqi Regular Army Brigades, supported by artillery, were defending the GOSPs, the regiment was able to secure the objective in 16 hours of hard fighting while limiting damage and suffering only one killed in action (KIA) and one wounded in action (WIA).

On the morning of 21 March, the remainder of division units crossed the LOD and commenced their attack to secure Division Objective 2, which included the Az Zubayr Pumping Station (considered the key oil infra-

structure node in southern Iraq). Despite a determined defense by the Iraqi 51st Mechanized Division, RCT-7 secured the objective 24 hours after crossing the LOD. By the morning of 22 March, the 1st Marine Division destroyed the 51st Mechanized Division, secured its first four objectives and transferred approximately 300 enemy prisoners of war (EPW) to British forces.

In the next 48 hours, the division captured the area south of the Saddam River and transferred control of that area to the British during an efficiently executed 12-hour relief in place (RIP). This action succeeded in fixing in place three Iraqi divisions and opened the way for the advance on Baghdad via the critical crossroads city of Al Kut. During this time, the division captured Iraqi Lieutenant General Amir Hamudi Al-Sadi, the regime's Presidential Advisor for Scientific and Technical Affairs. LtGen Al-Sadi was number 32 on the U.S. list of most wanted Iraqi regime officials and was wanted for his knowledge of Iraq's weapons of mass destruction (WMD) program, particularly his key part in the development of Iraq's nuclear weapons program. During this phase the division suffered 14 casualties: 1 KIA and 13 WIA.

Across the Euphrates

On 23 March, the division began crossing the Euphrates River in the vicinity of An Nasiriyah using bridges to the east and west of the city. Within 12 hours, the division passed 8,000 vehicles through this vital choke point and was then poised for operational maneuver on Baghdad.

The division used a two-pronged attack from An Nasiriyah to the Tigris River crossings. RCT-1 advanced through the gauntlet of An Nasiriyah and north up Highway 7. This RCT battered through regular and irregular forces in Al Gharraf, Ash Shatrah, and Al Hayy to the vicinity of Al Kut, where it succeeded in fixing the Baghdad Division of the Iraqi Republican Guard, preventing it from threatening the division's crossing of the Tigris River and, subsequently, the division's flank and rear. The remaining two RCT's (RCT-5 and RCT-7) advanced north up Highway 1, successfully attacking through the vicinity of Ad Diwaniyah, where they captured an enormous 40-bunker ammunition supply point (ASP) of the Saddam Fedayeen and Al Quds militias. Also, the division seized an operational highway airstrip at Hantush in central Iraq. This movement posed a significant threat to southern Baghdad that could not be operationally ignored by the Iraqi high command.

In order to relieve the stress on its logistics throughput capabilities, and to provide the needed support for the planned crossing of the Tigris River and the impending assault on Baghdad, the division opened a highway airstrip to C-130 traffic within eight hours. This assault airstrip accepted and processed over 400 tons of supplies, including 180 tons of fuel and 300 pallets of [Meals ready to eat], in support of the planned assault.

Across the Tigris

On 2 April, the division attacked across the Tigris River near An Numaniyah, seizing a key bridge and successfully conducted the second major river crossing in one week. The division's attack effectively cut off the Baghdad Division of the Republican Guard from the capitol and denied its escape route to reinforce defensive positions within Baghdad. The remainder of the Baghdad Division was destroyed in a simultaneous attack by RCT-1 and RCT-7 near Al Kut. Within 12 hours the division had massed its combat power to the north of the Tigris and continued its attack on Baghdad, while also seizing a terrorist camp near Salmon Pak, and the Iraqi Nuclear Energy Commission Research Facility.

Into Baghdad

Keeping the enemy off balance and retaining its tactical momentum, the division conducted an assault bridging operation while under fire to cross the Diyala River and enter Baghdad, a city of six million people, on April 7. This was the first assault bridge crossing conducted in the face of the enemy since World War II. The division secured the eastern half of Baghdad in six days with a total of 76 casualties, four KIA and 72 WIA. The division's fire discipline and judicious use of supporting arms in this densely populated area avoided a potentially catastrophic toll among the civilian population and minimized collateral damage.

During the fight for Baghdad, the division seized key facilities, including the Rasheed Military Complex, the Atomic Energy Commission, the Baghdad University, Tariq Aziz's residence, the Ministry of Defense Complex, the Fedayeen Headquarters, and the Directorate for General Security (DGS) Headquarters. Additionally, one RCT supported the employment of TF-20 in the successful capture of Abal Abbas, one of the key terrorist leaders associated with the 1985 Achille Lauro cruise ship attack. During the attack on the Al

Azamiya Palace area, the division received a verbal MEF fragmentary order (FragO) to contain a mosque suspected of holding Saddam Hussein. Division Marines displayed noteworthy valor in this mission, incurring one KIA and 22 WIA.

Upon achieving its objectives in eastern Baghdad, the division initiated actions to create conditions for good order by leveraging the existing support infrastructure, i.e., public safety, food supply, health services, transportation, and utilities. Additionally, the division supported three Task Force 20 raids searching for high-ranking Iraqi Regime officials and exploited documents and information from captured Iraqis via its embedded human exploitation teams (HETs).

North to Tikrit

On 10 April, at CFLCC and MEF direction, the division formed an LAR-based task force, TF Tripoli, which, within 24 hours, attacked Tikrit, Saddam Hussein's birthplace and a significant regime bastion. TF Tripoli secured Tikrit within two days. Along the way, it opened a secure route for follow-on use by the U.S. Army's 4th Infantry Division, seized ammunition storage facilities that included Roland surface-to-air missiles, SA-3 SAMs, and Abibil surface-to-surface missiles. Acting on intelligence information, TF Tripoli entered Samara and rescued seven U.S. POWs without incurring casualties.

Leveraging goodwill among the tribal leaders in northern Iraq that was generated by Division Civil Military Operations personnel, TF Tripoli exploited the opportunity to secure the key northern city of Bayji without firing a shot. Within days the division was able to pacify the Tikrit region and turn over significant operating responsibilities to the local inhabitants.

Stabilization Operations

In Baghdad, the division established a Civil-Military Operations Center (CMOC) to work with key civil leaders and nongovernmental organizations (NGOs) to restore services to Baghdad. This center quickly became a hub of stabilization and reconstruction activity, sending a positive message to the citizens of Baghdad concerning the U.S. presence. The division and civil affairs (CA) personnel continued working with the International Committee of the Red Cross to make area hospitals operational again and initiated joint Marine-Iraqi Police patrols to restore order and confidence. The division transitioned from combat operations to civil-military operations in Baghdad with no disruption—a significant event for any military force.

The division's initiation and conduct of security and civil-military affairs in a city of six million inhabitants and, subsequently, to holy cities and areas of influence, are preceded in U.S. military history only by the United States' occupation forces facilitating rebuilding programs in post-World War II Europe and Japan. These accomplishments were all firsts for a Marine division and are emblematic of the unprecedented valor, determination, and resolve among the individual Marines, soldiers, and sailors of 1st Marine Division.

3d Marine Aircraft Wing

3d Marine Aircraft Wing (3d MAW) set new standards of achievement during its execution of both the deployment and combat phases of Operation Iraqi Freedom. Executing a massive deployment of troops and equipment in record time, 3d MAW then carried out an unparalleled campaign against Iraqi forces that resulted in the destruction of at least eight Iraqi divisions and an air campaign that significantly removed the enemy's will to fight.

Deployment

Deployment Order 164 initiated 3d MAW participation. 3d MAW positioned a force of 135 Marines in Kuwait during November of 2002 to establish initial basing sites and orchestrate the flow of personnel and equipment. From this initial presence, 3d MAW provided key support of the offload of two complete maritime propositioned shipping (MPS) squadrons (a total of 11 ships) with MAW and MEF equipment. This was followed by four fast sealift ships loaded with the aircraft of several helicopter squadrons. The offload of these ships was conducted on a 24 hour a day, seven day a week basis and was completed in 45 days without a single injury to any Marine or sailor. The result was the assembly of more equipment in one location than had been accomplished in Marine Corps history. Additionally, 3d MAW offloaded three ammunition ships that ultimately provided 29.1 million pounds of aviation ordnance for the pending operation and contributed to the establishment of the largest cache of aviation ordnance ever. Aircraft and personnel from the east and west coasts

arrived aboard 17 amphibious ships (plus two T-AVB aviation logistics ships) and by the air ferrying of other aircraft to the theater of operations. At its peak, 3d MAW grew to 15,451 personnel. Augmentation was provided from the 1st, 2d and 4th MAWs and a host of additional sources to meet the requirements of combat. This made the 3d MAW the largest Marine air wing deployed since Vietnam.

Basing

Establishing itself at two primary Air Bases in Kuwait (Al Jaber Air Base and Ali Al Salem Air Base), wing elements built compounds and improved operational areas. 3d MAW set up 440 tents at Al Jaber and 400 tents and mess facilities at both sites. Seabees constructed concrete ramps where constructed at Al Jaber to accommodate the huge influx of aircraft and addition ground preparation was made to lay AM-2 matting for additional ramp space. Additional detachments were also established at Prince Sultan Air Base, Saudi Arabia and at Sheik Isa Air Base, Bahrain. Ultimately, 3d MAW deployed 435 aircraft, making it the largest overseas deployment of Marine aviation assets since the height of the Vietnam War.

Shaping the Battlefield

During deployed operations leading up to Operation Iraqi Freedom, 3d MAW flew sorties between 15 February 2003 and 20 March 2003 into Iraq in support of Operation Southern Watch. Additional unmanned aerial vehicle (UAV) missions were also flown into Iraq during this period. These missions provided key imagery intelligence of the enemy situation and allowed commanders at the highest level to shape the initial planning for the conduct of a ground offensive against Iraq.

Direct Support

Preparations for combat included a focus on best methods to support ground forces. 3d MAW units established unique direct support relationships at the regimental combat team (RCT) level and above allowed ground units to be supported with the full range of MAW assets, including direct air support centers (DASC), air support elements (ASE), imagery liaison cells from VMU squadrons, dedicated casualty evacuation (CASEvac), and command and control aircraft.

Forward Basing

3d MAW forces began combat and combat support actions immediately at the start of hostilities by moving over 4,000 Marines and sailors and over 900 vehicles from the Marine Air Control Group and Marine Wing Support Group with ground forces as they crossed the berm into Iraq in order to establish a chain of forward arming and refueling points (FARPs) and forward operating bases (FOBs) that would allow MAW rotary and fixed wing assets to support ground combat elements at all times. This action resulted in the creation of 15 FARP and FOB sites that provided ordinance and fuel for hundreds of aircraft sorties during the campaign and covered over 500 miles as the ground forces advanced; an accomplishment unparalleled in Marine Corps history. Although designed to provide fuel and ammunition only to MAW aircraft, these forward sites provided fuel for tanks, light armored vehicles and a variety of rolling stock from Marine ground combat elements at critical times in order to allow the ground attack to continue its aggressive forward momentum. These elements of 3d MAW were frequently at the forward most combat areas and sustained both killed in action (KIA) and wounded in action (WIA) casualties.

Strike Air

Marine fixed wing assets of MAG-11 provided over 4,000 sorties in close air support (CAS) and air interdiction missions, dropping over 3.8 million pounds of ordnance. Quickly adapting to the fluid nature of the battlefield, the fixed wing elements developed tactical innovations that allowed them to maximize the use of imagery intelligence in order to quickly attack mobile targets while this intelligence information was still current. The use of airborne 'wolf packs,' using F/A-18D forward air controllers (FACs) to search for targets and channel aircraft to engage enemy armored assets, led to the successful attack of units such as the Baghdad Division and the Al Nida Division. These two Republican Guard Divisions were stuck with such intensity that contemporary battle hit assessments rated them at less than 25 percent strength with remaining military equipment abandoned prior to ground attack by elements of 1st Marine Division. AV-8 aircraft were deployed with equal lethality and with the ability to provide all weather CAS. Despite the challenges of an austere operating environment, elements of MAG-13 staged aircraft far forward into Iraq as part of the air campaign, dropping

939 precision guided munitions (PGM) and 814 non-guided bombs. They also provided imagery intelligence with the Litening II system that became valued not only at the tactical level, but also as a national level collection asset during the POW raid at the hospital compound in An Nasiriyah. Aircraft maintenance elements worked around the clock to maintain readiness throughout the force and to continue to provide constant aircraft support to ground units. Ultimately, the fixed wing assets of 3d MAW achieved these impressive results while suffering no combat aircraft losses or casualties.

Assault Support

Rotary wing assets from MAG-29, MAG-39 and MAG-16 were instrumental in providing effective support of the ground campaign. Close coordination with ground elements was again the hallmark of the success of these units. Helicopter crews consistently landed or staged at ground force areas to conduct face-to-face liaison in order deliver the full impact of the Marine air-ground task force (MAGTF) on the enemy. Assault support lift assets had conducted intense preparations to conduct the largest heliborne assault lift in history by moving Royal Marines of 42 Commando to the Al Faw Peninsula. Initial attack missions successfully destroyed numerous key Iraqi border outposts, while specialized lift missions inserted and extracted Marine force reconnaissance teams to support the advance of combined forces. Assault support aircraft played a key role in CASEvac during intense fighting in An Nasiriyah. Helicopter crews repeatedly came under fire and advanced into 'hot' landing zones (LZs) without regard to their own safety to quickly extract Marine casualties. Throughout the operation, these crews also routinely conducted CASEvac missions to retrieve enemy prisoners of war (EPW) and Iraqi civilians who had been wounded in the fighting. Marine assault support aircraft provided hundreds of sorties to provide forward ground combat elements with food, water and ammunition, as well as transportation of personnel. Elements of MAG-16 flew in support of the successful special operations POW snatch mission in An Nasiriyah and also for numerous ongoing reconnaissance inserts and extracts.

Rotary Wing CAS

Marine UH-1 gunships and AH-1 attack helicopters exemplified the aggressive spirit of 3d MAW in providing close in attack of enemy positions immediately forward of friendly forces. These aircrews constantly exposed themselves to enemy fire performing road reconnaissance, CAS and command and control missions. Attack helicopters destroyed numerous enemy armored vehicles, tanks, and enemy firing positions. They were particularly adept at engaging targets in the close spaces of urban areas, where they frequently used TOW missiles and 20mm guns to target enemy sniper positions while minimizing damage to adjacent areas. Road reconnaissance missions were executed with the distinct intention of drawing enemy fire and thereby determining enemy positions before ground forces were exposed to fire. 3d MAW HMLA squadrons received enemy fire on an ongoing basis; 22 AH-1 aircraft and 2 UH-1 aircraft sustained damage from enemy action, some sustaining hits again on additional missions.

Combat Resupply

3d MAW pooled the assets of both active and reserve KC-130 squadrons to form a KC-130 force of 24 aircraft that was key to the sustainment of forward operating forces. These aircraft flew over 1,011 sorties and transported thousands of pounds of fuel and supplies to unimproved forward operating bases under dangerous flight conditions, frequently receiving anti-aircraft fire. KC-130 aircraft were instrumental in moving key supplies forward when other ground convoy methods had become bottlenecked. This included the movement of MRE's forward to 1st Division at a point when Division rations had been cut from 3 MRE's per day/per man to 1 MRE per day/per man. They also moved 155mm artillery shells forward to fill a critical shortage in 11th Marines prior to the final push toward Baghdad. These actions were in addition to the ongoing lift of personnel and equipment to sustain the attack. Finally, they provided transport to seven U.S. POWs retrieved north of Baghdad.

Destruction of the Enemy

Employing 9,800 sorties of fixed and rotary wing aircraft to adeptly execute its mission, 3d MAW ruthlessly attacked enemy forces while minimizing the unnecessary loss of civilian lives and property. Constantly keeping the enemy 'between a rock and a hard place' by forcing them to choose between destruction by moving, or destruction by remaining stationary, 3d MAW decimated the Iraqi 11th, 14th, 18th, and 51st Infantry

Divisions, the 6th and 10th Armored Divisions, the Baghdad Republican Guard Infantry Division, and the Al Nida Republican Guard Armored Division. These formations were rendered combat ineffective through such focused and intense application of aerial firepower that most offered no resistance above the small-unit level once contact was made by Marine ground forces. The actions of 3d MAW were clearly instrumental in diminishing the enemy's 'will to fight' and significantly shortened the ground campaign. The close coordination of the 3d MAW fight demonstrated the full combat power of the MAGTF team. The actions of the 3d MAW are of the highest order and rank with the greatest achievements of the U.S. Marine Corps.

1st Force Service Support Group

During Operation Iraqi Freedom, 1st FSSG Battalions played a critical role supporting all I MEF personnel. 6th Engineer Support Battalion (ESB)—Upon activation and consolidation and follow-on relocation to Kuwait, 6th ESB was assigned the bulk liquids mission, consisting of both fuel and water. Assigned the deployment of the hose reel system, this battalion constructed 60 miles of fuel hose, along with a 1.2 million gallon fuel farm in order to push bulk quantities of fuel deep into Iraq. The system installed was six times larger than any other previously built system and was constructed in one-half the time allotted. The system installation continued during the worst sand storm in 20 years, enabling the timely providing of fuel to wing and division units engaged in the Battle for An Nasiriyah. Subsequently, the system was enlarged with another 30 miles of hose and an additional 600,000 gallons of fuel storage in order to become a theater level asset. In total, 7.9 million gallons of fuel were pumped through the hose reel system. Five additional fuel sites were established and provided a total storage capacity of 4.8 million gallons of fuel.

8th Engineer Support Battalion—8th ESB was assigned the assault bridge mission in direct support of the 1st Marine Division and Task Force Tarawa. The battalion completed nine assault bridge crossings and five of the crossings were opposed by direct enemy combat action. In 14 hours and during darkness on 29-30 March 2003, the battalion built a single lane across the Tigris River west of An Numaniyah, under enemy fire. Once established, the bridge enabled the Division to continue the attack towards Baghdad. Over a 36-hour period during 6-7 April 2003, the battalion built three bridges at separate sites and under enemy fire, across the Narh Diyala River east of Baghdad. The bridges directly facilitated the crossing of three regiments into Baghdad. The battalion then maintained the bridges to support logistics traffic in support of the attack and after the city was secured, the bridges allowed for the normalization of civilian traffic into and out of the city.

7th Engineer Support Battalion—7th ESB was assigned the mobility, counter-mobility, survivability, and general engineering support mission in the I MEF zone. At the start of combat operations, the battalion cut breach lanes through the Kuwait-Iraq border enabling 1st Marine Division and Task Force Tarawa's rapid attacks into Iraq. As the 1st Marine Division and Task Force Tarawa moved north into Iraq, the battalion improved dozens of kilometers of Route 1, the main supply route for I MEF's push forward to Baghdad. Additionally, as I MEF moved further forward into Iraq, the battalion constructed, maintained, and improved Support Areas Coyote, Viper, Anderson, Basilone, Chesty, and Edson. During combat operations, the battalion's engineers were operating simultaneously over 450 miles, enabling the movement of huge quantities of material. After the fall of the Iraqi regime, the battalion transitioned to the collection, movement, and destruction of captured ammunition and safely disposed of thousands and thousands of tons of captured enemy material, significantly reducing the threat such materials posed to the Iraqi people and coalition military forces. 7th ESB also provided potable water for I MEF forces. By the third day of the war, the first water site was established and produced 200,000 gallons of fresh water daily. Eight additional separate reverse osmosis water purification unit (ROWPU) sites were established from southern Iraq to Baghdad, producing over 3 million gallons of fresh water at those sites.

Combat Service Support Battalion 10—CSSB-10 provided direct support to all 1st Marine Division units in the I MEF zone. The battalion's primary method of support was through the establishment of repair and replenishment points (RRPs). During the combat phase of the operation, the battalion established 14 separate RRP's, covering hundreds of miles in span of control and rapid movement, mostly at night and often under enemy fire. The battalion also operated convoys in order to support those units unable to receive supplies at the designated RRP's. During the combat phase of the operation the battalion conducted over 400 such convoys,

covering nearly 120,000 miles, in order to sustain the forward momentum of the 1st Marine Division in its attack towards Baghdad. The battalion distributed nearly 3,000 pallets of MREs, nearly 1,000,000 gallons of water, over 2,000,000 gallons of fuel, and over 2,000 tons of ammunition. The battalion also processed 1,453 EPWs and handled 124 containers (the equivalent of 148,800 bags) of mail destined for I MEF Marines and sailors.

Combat Service Support Battalion 12—CSSB-12 provided general support to units in the I MEF zone. While in Kuwait, the battalion established the largest deployed ammunition supply point (ASP) in Marine Corps history. The battalion established and operated five separate MEF support areas, traveling nearly 700 miles. During the 28 days of most intense operations, the battalion transported and distributed 3,452 pallets of MREs, received, stored and distributed 1,848,310 gallons of fuel, produced, stored, and distributed 752,988 gallons of water, and received 5,342 tons of ammunition. In particular, one emergency ammunition package involved the direct delivery re-supply of over 1000 artillery high explosive projectiles, powders and fuses from Support Area Chesty forward 110 miles to 11th Marine Regiment firing positions 17 miles east of Baghdad. The battalion accomplished this critical re-supply support mission within six hours of the battalion's receipt of the mission tasking. The battalion also conducted third and fourth echelon maintenance on I MEF equipment, completing repairs on 4,262 principle end items of combat equipment. The battalion's medical treatment facility saw 493 patients during the most intense days of combat '345 US military, 81 EPWs, 64 foreign nationals, and 3 civilian reporters. Many of the procedures performed were major surgical (life saving) procedures.

Fleet Hospital 3—This fleet hospital, personnel and equipment, was forward deployed to SA Viper in Iraq and became fully operational within five days of emplacement. This fleet hospital was the most medically and surgically advanced facility ever forward deployed in a combat zone. The hospital was able to provide 21 distinct surgical and medical specialties in a 116-bed fully transportable hospital setting. During combat operations, the hospital admitted 437 war casualties and performed 546 major surgical procedures.

Combat Service Support Battalion 18—CSSB-18 provided general support to units in the I MEF zone. Within hours of the inception of combat operations in Iraq, the battalion crossed into Iraq and rapidly established the first U.S. Marine Corps support area inside Iraq. During combat operations, the battalion transported and distributed 5,270 pallets (253,000 cases) of MREs, coordinated the movement of nearly 7,000,000 gallons of fuel, and unloaded and issued nearly 15,000 short tons of ammunition.

1st Transportation Support Group—The group's mission was to provide general support distribution to I MEF forces. The group was organized into convoy control companies, heavy, light, and bulk liquids companies, landing support companies, and a headquarters company. The group was comprised of active duty elements from 1st Transportation Support Battalion, Marine Corps Reserve elements from 6th Motor Transport Battalion, and an activated Army Reserve unit, the 319th POL Company. The group's convoys routinely numbered more than 60 vehicles per convoy and the convoys were often engaged by enemy forces attempting (unsuccessfully) to delay or disrupt the flow of needed material to the operating forces. The group operated from Kuwait to Baghdad, traveling over 1.3 million road miles to successfully deliver thousands of tons of supplies and over 7,000,000 gallons of fuel to I MEF operating forces.

I Marine Expeditionary Force Engineer Group

U.S. Marines and Navy Seabees have had a special relationship since the Battle for Guadalcanal in 1942. In combat 63 years later, the closeness of this unique relationship continued to hold true in Kuwait and Iraq in the form of the MEF Engineer Group (MEG). The MEG was established by the I MEF CG, General Anthony C. Zinni, at Camp Pendleton in 1995. It was based upon the original Marine Corps engineer regiments within each Marine division during World War II. Each of these was comprised of both Marine engineers and Seabees.

For Operation Iraqi Freedom, under the command of Admiral Charles Kubic, the MEG consisted of three distinct task forces: TF Mike (mobility) which had the mission of moving forward directly behind the MAGTF's GCE to provide Mabey-Johnson Bridging (non-standard replacements for USMC AVLB, MGB, and Ribbon Bridge); TF Charlie (construction) which would follow in trace of TF Mike providing support through construction and maintenance of MSRs; and TF Echo (endurance) which would follow in trace of the others providing sustainment support. All three task forces were heavily Seabee in personnel, with a solid represen-

tation of Army units. The MEG headquarters consisted of a large degree of Seabees and Marines with some Army staffing. All told, the MEG had approximately 4,000 Seabees, soldiers, and Marines serving in it. Toward the end of the war, the MEG technically became a "CMEG" ("C" for combined) when a Republic of Korea engineer battalion was assigned to TF Echo.

Major accomplishments of the MEG are significant and focused on the names of the task forces: mobility, construction, and endurance (sustainment). The main mobility support provided to the MEF was British-built Mabey-Johnson Bridging (very similar to the famous Bailey of World War II). The MEG had 1,120 meters of this and carefully planned to fully transport and employ it at key crossing sites on the Euphrates, Tigris, and Diyala Rivers of Iraq. Innovative use of moles, culverts, sheet pile, and other construction methods were incorporated so that this vital bridging could be used even in a worse case scenario. This was planned against the potential for the enemy confronting I MEF with up to 1,800 meters of blown bridge gaps. Not only was the MEG able to fully transport itself (some 2,200 major pieces of civil engineer support equipment or CESE) over some 400 miles of advance from the Kuwaiti border to Baghdad, but it created new roads and maintained most of the MSRs for this entire distance. This equipment consisted of extensive earthmoving, line haul, construction, weight and material handling capabilities. And the MEG was able to do this in record time from the attack of 19 March through the handover of the Marine Corps' portion of Baghdad to the Army on 20 April 2003.

The eyes and ears of the MEG were provided by specially developed SERTs (Seabee engineer reconnaissance teams). These squad-sized units were extremely mobile and well protected crews with a wide range of civil engineer estimate capabilities. Their early and advance assessment of countermobility situations allowed Seabee expeditionary logistics to be highly utilized across the entire battlespace in close support of the MAGTF.

The Seabee motto of "Can Do" best exemplifies the fact that the MEG did all of this by convoying its own troops, vehicles, construction materials, camps and bridges, while all the time staying focused and attuned to the needs of the Marines it supported. This devotion to 1st Marine Division (as it was on Guadalcanal) can in no better way be exemplified than during the Battle for Baghdad. At the height of this struggle in the eastern sector of the city, when Marines found themselves desperately short of MRE's and ammo, Seabees used their considerable line haul to improvise lift and physically distribute these badly needed commodities to their Marine buddies.

The MEG has earned an honored position as a major subordinate command within I MEF. Seabees have proven again in combat that they can be counted upon to go into battle alongside their Marine "band of brothers." This solid teamwork, positive interaction, accomplishments, and speed of execution throughout the past month of combat have made a unique statement in U.S. & world military history. I MEF in under 4 weeks covered the same distance it took Britain to cover in 4 years in World War II. Engineers made an important difference here within a winning, task organized, MAGTF configuration. Speed, agility, shock, and combat leadership proved decisive. The MEG concept is now combat proven as an important MEF "arrow in the quiver" of Marine infantry.

Task Force Tarawa (2d Marine Expeditionary Brigade)

Task Force Tarawa (TF Tarawa) with its headquarters as the 2d Marine Expeditionary Brigade (2d MEB) stood up on 6 Jan 2003 and departed North Carolina aboard amphibious shipping on 16 January arriving in Kuwait on 15 February 2003. TF Tarawa engaged in planning and training with I MEF, then on order moved to its attack position in Assembly Area Hawkins for the attack into Iraq.

TF Tarawa occupied a critical position on left flank of I MEF adjacent to V Corps' 3d Infantry Division (3d ID), assigned to attack in zone and conduct a relief in place (RIP) with 3d ID forces, thus enabling 3d ID to continue their attack to the west and north towards Baghdad. Subsequently, TF Tarawa was to facilitate the movement of 1st Marine Division forces west and north along Highways 1 and 7 by seizing and securing key choke points in zone and enabling the free flow of traffic along those routes.

On 21 March, TF Tarawa attacked into Iraq through four breach lanes in the Kuwaiti and Iraqi berms. One of the lanes created by TF Tarawa was ASR Aspen, which would be utilized throughout the war as a key supply route. Moving cross-country to free up roads for heavy wheeled traffic, TF Tarawa occupied defensive posi-

tions east of Jalibah to protect the right flank of 3d ID, allowing them to focus on seizing a bridge over the Euphrates River, west of An Nasiriyah. Due to the swift advance of coalition forces, TF Tarawa altered its timeline and conducted RIP with 3d ID on evening of 22 March, and prepared to secure Highway 1 crossing of the Euphrates River, a critical juncture on what turned out to be the major supply route for coalition forces through much of the war. The early RIP enabled the 3d ID to maintain momentum and cross the Euphrates ahead of schedule.

On 22 March, TF Tarawa attacked to seize and secure the eastern bridges across the Euphrates within the city of An Nasiriyah, in order to allow 1st Marine Division forces to utilize Highway 7 as an avenue of approach into northern Iraq. This initiated the Battle for An Nasiriyah, which unfolded over an eight-day period, during which TF Tarawa seized and secured the bridges and liberated the city.

On morning of 23 March, TF Tarawa attacked towards the bridges with Regimental Combat Team 2 (RCT-2) and 1st Battalion, 2d Marines, in the lead. 1st Battalion, 2d Marines, encountered resistance from enemy forces in civilian clothes armed with heavy machineguns, small arms and mortars on the outskirts of An Nasiriyah. Attacking forward 1st Battalion, 2d Marines, encountered vehicles and personnel from an Army convoy of the 507th Maintenance Company of the 5-52 Air Defense Artillery Battalion. Securing the site around the Army vehicles 1st Battalion recovered 14 soldiers of which four were wounded. After arranging CASEvac for the wounded TF Tarawa discovered that these soldiers represented only part of a convoy that had mistakenly driven into An Nasiriyah the night previously and had been ambushed by enemy forces. Quickly the 1st Battalion continued the attack into An Nasiriyah to attempt to rescue any remaining Army personnel and to secure the assigned bridges. Encountering stiff resistance from enemy forces occupying urban terrain, RCT-2 and TF Tarawa utilized supporting fires from air and artillery to advance and seize the southernmost of the two eastern bridges, in the process destroying eight enemy tanks and inflicting over 100 enemy dead. At this point RCT-2 moved 2d Battalion, 8th Marines, forward to secure the bridge seized by 1st Battalion and continued the assault with 1st Battalion, 2d Marines, towards the northernmost bridge. 1st Battalion, 2d Marines, seized the northern bridge utilizing tanks, assault amphibian vehicles (AAVs), and infantry along with supporting arms against significant resistance. Enemy forces conducted counterattacks rushing from buildings to close with 1st Battalion vehicles to lob grenades and fire rocket propelled grenades (RPGs). Several AAVs and a tank recovery vehicle were destroyed in this manner. RCT-2 maintained its hold on the bridges despite continued attacks.

On 24 March the fighting around the bridges continued as TF Tarawa cleared the enemy from the route through An Nasiriyah. Significant indirect fire was directed at TF Tarawa throughout the day and 1st Battalion, 10th Marines, conducted 14 separate counter-battery fire missions, which covered a 360-degree arc in and around the city.

On 25 March, TF Tarawa had secured the route across the bridges through the city and RCT-1 conducted a passage of lines along the route to continue the attack north along Highway 7. Additionally, RCT-7 and RCT-5 of the 1st Marine Division passed through TF Tarawa at the bridge over the Euphrates on Highway 1 in order to continue their advance north. TF Tarawa also began to expand its control of the city by attacking with 2d Battalion, 8th Marines, to seize an enemy strongpoint at the Tykar Hospital in eastern An Nasiriyah. Upon seizing the hospital, TF Tarawa discovered 3,000 NBC suits, large caches of weapons and ammunition, and evidence relating to the capture of members of the 507th Maintenance Company. Evidence obtained at the hospital confirmed that it was being used as an enemy strongpoint/command post in defiance of Geneva Convention restrictions. At the same time as 2d Battalion, 8th Marines, attacked in the east 3d Battalion, 2d Marines, attacked in the west of the city to clear enemy opposition. Moving quickly 3d Battalion, 2d Marines, captured two busloads of enemy reinforcements approaching the city. Throughout the day TF Tarawa took over 500 enemy prisoners of war.

On 26 March, TF Tarawa continued operations to clear An Nasiriyah. Fighting house to house and utilizing supporting arms TF Tarawa expanded the area under its control within the city. Meanwhile enemy forces intent on counterattacking to regain the bridge sites gathered at a train station to the south of the city. The estimated strength was over 1,000 enemy fighters. ODA forces verified the enemy rally point at the station and TF Tarawa engaged with artillery to destroy and disperse the enemy. Later intelligence estimated 200 enemy dead

in this engagement. Despite the effectiveness of the artillery fire, enemy forces conducted counterattacks against the TF throughout the night. Due to poor weather conditions air support was unavailable and TF Tarawa responded with organic assets against these attacks directed toward every sector. Throughout the night ground CASEvacs were organized from the TF headquarters to evacuate friendly and enemy wounded.

On 27 and 28 March, TF Tarawa forces began to expand their control over An Nasiriyah, pushing forces east and west of the crossing sites and clearing out pockets of enemy resistance. An additional 100 EPW/detainees were captured. Using the intelligence from our ODA/OGA teams, TF Tarawa identified specific military targets that were being used by the paramilitary forces. Again using coalition air and PGM's, targets were struck with minimal or no damage to civilian structures. These surgical air strikes on military targets in the area further diminished the enemy's combat power and will to fight. Using members of Seal Team 6 attached to TF Tarawa and based on intelligence gathered from our ODA teams, the city of Suk Ash Shuykah southeast of An Nasiriyah was identified as marshalling place for enemy forces. Redirecting ISR assets, and using Seal Team 6, TF Tarawa again directed precision air strikes against military targets in the city, resulting in numerous secondary explosions and unconfirmed reports of numerous enemy casualties, including some Ba'ath party leadership members.

As TF Tarawa continued its push to secure the city of An Nasiriyah, the ODA/OGA teams in support gained information from a local family that PFC Jessica Lynch, 507th Maintenance Co, was in the Saddam Hospital in eastern An Nasiriyah and had been severely injured in the initial ambush of the convoy. With the information deemed solid TF Tarawa began planning with TF 20 to conduct an operation to rescue PFC Lynch. Working together, TF 20 and TF Tarawa created a plan utilizing TF 20 forces to assault the hospital while TF Tarawa forces provided LZ control, counter sniper support, and supporting air and ground fire along with deception attacks by ground forces. In addition TF Tarawa provided a reaction force to extract TF 20 should significant opposition be encountered. To control the operation TF 20 co-located their command post within TF Tarawa's current operations center. The mission was executed on 1 April as planned and succeeded in recovering PFC Lynch alive along with the bodies of several missing members of the 507th. This was the first successful rescue of an American POW since World War II.

On 3 April, the big move to seize Baghdad began. TF Tarawa was immediately redirected to provide security along the major supply routes of Highway 1 and Highway 7 while maintaining forces to bring stability to An Nasiriyah. Augmented with forces from 15th MEU (SOC) and later 24th MEU (SOC), the area covered equaled that of the state of South Carolina. TF Tarawa's new zone covered a large area that included some cities and towns bypassed by previous coalition forces. In the western sector, in cities such as Ad Diwaydiah, enemy forces continued to operate and posed a threat to traffic on Highway 1. Making utmost use of its ODA assets, TF Tarawa identified enemy military targets in the city and struck them with precision munitions while cordoning off the city to reduce the threat. Al Hamsha, a city south of Ad Diwaydiah, was also targeted by TF Tarawa based on information gathered from ODA forces. The air strikes resulted in the death of the leading Ba'ath party official. The next day, the citizens who supported the U.S. attack against the Saddam regime took over the city. Along Highway 7, Marines from 24th MEU began clearing out several cities along the route that included Ash Shutra, An Nasr, Ar Rifa and Al Hayy. During a reconnaissance in force mission to Ash Shutra 24 MEU (SOC) captured several Fedayeen soldiers and found the body of a Marine from 1st Marine Division who had been reported as missing in that area a week earlier. In the city of Suk Ash Shuykah, southwest of An Nasiriyah where earlier TF Tarawa had engaged enemy forces with precision air strikes, Marines from 15th MEU supported a direct action mission from Seal Team 6 with aviation assets and a quick reaction force. The mission was successful in destroying numerous air defense pieces, and destroying several large cache sites. Throughout the area, TF Tarawa forces maintained secure supply lines. During the period from 3 April to 22 April, only three convoys reported being sniped at, and not one single convoy was ambushed, allowing important supplies to get through to support the attack on Baghdad.

With the main effort being the attack on Baghdad by both the V Corps and 1st Marine Division, the CFLCC commander became concerned with the threat represented by enemy forces still existing in the eastern portion of the country. The 10th Armored Division (10th AD) was known to be located in the vicinity of Al

Amarah and had not been struck since the first days of the war. With all other major combat forces engaged in Baghdad the mission to eliminate the 10th AD fell to TF Tarawa. With no additional forces available, and having to retain its current missions and extensive battlespace, TF Tarawa restructured its forces to accomplish the new mission. Consideration of the space involved and span of control required forced TF Tarawa to split its control capabilities for an extended period in order to accomplish all the missions assigned. On 8 April, as the forces assembled, TF Tarawa conducted coordinated coalition air strikes on the remaining elements of the 10th AD. Assessing these strikes and determining that the 10th AD was no longer a viable force, TF Tarawa elements moved quickly to seize key areas in the vicinity of the city. Gaining information that one of the air strikes had killed the commander of the 10th AD, and that Iraqis who supported the Coalition's war against the Saddam regime were rising up, TF Tarawa entered Al Amarah. This eliminated any possible threat to the eastern flank of the main attack on Baghdad.

With the success of the Al Amarah operation TF Tarawa was able to conduct a RIP with British forces on 12 April and return west. As TF Tarawa forces, were relocating to Qalat Sikar following the Al Amarah operation, orders came down to attack and seize Al Kut to open up the Highway 7/Highway 6 route of supply.

Al Kut was reported to have from 500 to 2000 enemy forces that included Fedayeen, militant Islamic terrorist groups, and remnants of Republican Guard forces. Working with ODA forces in direct support, and making extensive use of force reconnaissance assets, initial assessments were made concerning the city. Reports came back that Al Kut no longer had significant enemy forces present and that local resistance had control of the city. Consequently, TF Tarawa quickly moved on the city with the forces in hand and entered the city on the 12th of April. Assessing that no major threat remained in the area, coordination was quickly made and on 13 April the first convoy from 1st FSSG went through the city without incident.

After 13 April, TF Tarawa forces maintained security from An Nasiriyah along Highway 1 and Highway 7. Civil affairs operations began in the major cities of An Nasiriyah, An Numaniyah, and Al Kut along with several other minor cities in the region. An Nasiriyah was declared a permissive environment for NGO support on 16 April, with civil-military operations centers (CMOCs) established at An Nasiriyah and Al Kut. TF Tarawa continued to conduct security operations in zone, which included Highway 6 from Al Kut to An Numaniyah.

During combat operations TF Tarawa was involved in some of the heaviest fighting in the war during the Battle of An Nasiriyah, taking 19 KIA and 57 WIA. These lives were not lost in vain. Through the sacrifices of TF Tarawa Marines the towns of An Nasiriyah, Al Amarah, and Al Kut were captured and secured. The maintaining of the main supply routes to support the V Corps and 1st Marine Division attacks on An Naraj, Karbala, Baghdad and Tikrit was critical to their success. An estimated 2,000 plus enemy were killed in action from direct combat and air directed missions, an enormous amount of enemy tanks, artillery and air defense equipment was destroyed, as well as 700 EPWs taken. An enemy officer captured in An Nasiriyah stated that they were sure that if they put up a strong fight the U.S. soldiers would retreat. When, after repeated attacks, the Marines fought on, many of his soldiers lost their will to fight.

Although An Nasiriyah was the scene of some of the most difficult fighting throughout the war it was the first city to be declared by the U.N. as secured allowing the introduction of IO and NGOs. The U.N. declaration of the securing of An Nasiriyah is a testament to the abilities of TF Tarawa to excel in their performance of duty throughout the spectrum of warfare from all-out hostilities to civil affairs operations.

15th Marine Expeditionary Unit (Special Operations Capable)

On 16 February, 15th Marine Expeditionary Unit (Special Operations Capable) (15th MEU(SOC)) reported TACON to 3 UK Commando Brigade (3 Cdo Bde) of the British Royal Marines, commanded by Brigadier John Dutton. The Brigade Commander and selected subordinates and staffers from 3 Cdo Bde flew to the USS Tarawa to conduct working groups for Operation Telic. Operation Telic was the codename for coalition operations to seize the Al Faw Peninsula, its key oil infrastructure and the 15th MEU's subsequent attack to secure Umm Qasr port for humanitarian relief.

The 15th MEU(SOC), the supporting effort for the attack, attached Battery S to 29 Commando for long range prep fires for the main effort's attack; once released from that role, the battery returned to direct support of BLT 2/1. Battery D, 7 Royal Horse Artillery, and 17/16 Battery, 3 Royal Horse Artillery fired in direct sup-

port of the 15th MEU's supporting attack on Umm Qasr. The BLT coordinated continuously to ensure maximum response for fires and counter-fires from UK batteries.

Prior to crossing the line of departure, 15th MEU received TACON of Sensitive Site Exploitation Team 2(SST 2). SST 2 was a joint unit of soldiers, sailors and airmen. They integrated with the 15th MEU S-3's E-NBCD Section. During the campaign, SST 2 and the MEU exploited 17 sensitive sites. Among the items recovered were evidence of war crimes against U.S. POWs, U.S. remains and U.S. personal effects from POWs and casualties.

The Intelligence Section of the 15th MEU(SOC) command element integrated its human exploitation team and Radio Battalion detachment with those of the British forces. Combined U.S./U.K. teams uncovered information and provided actionable intelligence to missions in progress in Umm Qasr, facilitating the rapid opening of the port so that Humanitarian Assistance could flow into Iraq even as hostilities continued.

CTF 56, an EOD task force, also fell under control of the 15th MEU in Umm Qasr. Once the port was declared secured, 15th MEU(SOC) coordinated their efforts to rid the port of waterborne mines and UXO, enabling humanitarian shipping to arrive unimpeded into Iraq.

After just two days of fierce fighting the majority of Iraqi conventional forces in the Umm Qasr area were defeated, with the port facilities remaining intact to expedite follow-on humanitarian assistance efforts in the theatre. 15th MEU's BLT 2/1 defeated the 45th Brigade of 11th ID, two platoons of 82mm mortars, four D-30 batteries and a mechanized company in the first two days of fighting. The MEU took over 600 Iraqi POWs. Sporadic fighting against Saddam Fedayeen and other paramilitaries continued for three more days in the urban areas of Umm Qasr and Khor az Zubayhr against forces of up to company size.

While the MEU fought in Umm Qasr, a task-organized formation secured crossing points over the waterways connecting the mainland to the Al Faw Peninsula. This force of BLT recon and CAAT vehicles screened the flank of the Royal Marines on the peninsula, reducing bunkers overlooking the waterways and capturing Iraqi Army regulars.

Upon consolidating Khor az Zubayhr, a MEU convoy moved to link up with Task Force Tarawa, and transferred 200 EPWs from An Nasiriyah to HA Freddy—a trip of 320 km.

15th MEU(SOC) provided a security force to run a 200 vehicle convoy through An Nasiriyah to Qalat Sikar in support of 1st Marine Division. While enroute, the LAR company escorting the convoy encountered heavy resistance and defeated deliberate ambushes along Highway 7. The convoy was delivered to Qalat Sikar with minimal losses to personnel and equipment.

The 15th MEU (SOC) then chopped to TF Tarawa. Reinforced with a NSWTU, ODA, OGA, 4th CAG, and a PSYOP det, the MEU relieved RCT-2 in place in An Nasiriyah. The MEU secured previously unoccupied areas of the city and quickly turned to assisting in the restoring city services, including health services, water distribution, police and city government.

MEU forces coordinated a Seal direct action mission in Suk Ash Shuyukh to destroy an anti-air weapons cache. Force reconnaissance, a MEU QRF, and MEU aviation supported the raid, which destroyed the cache and associated facilities.

The 15th MEU contributed a supporting effort to a joint mission by TF 20 and TF Tarawa to recover U.S. Army POW PFC Jessica Lynch and the remains of other American soldiers previously listed as missing in action. During that action, the MEU's maritime special purpose force (MSPF), supported by BLT tanks and LAR, conducted a feint across the Euphrates River in order to allow TF 20 to enter the Saddam General Hospital of Nasiriyah unhindered and accomplish their mission.

After the movement North of TF Tarawa the 15th MEU inherited over 2,400 square kilometers of terrain. MEU forces helped ensure the safety of convoys moving north in support of the MEF main effort. Not a single vehicle was lost transiting An Nasiriyah after 15th MEU(SOC) took over. The MEU eventually effected and maintained stability in the 13,400 square kilometers of Dhi Gar Province.

During stability operations, the MEU took tactical control of Seabees from TF Echo, additional PsyOp augments and coordinated the efforts of HA forces from the MEF and theater. MEU forces restored key infrastructure such as hospitals, courthouses, police stations, power, and water facilities and provided humanitarian

assistance to orphanages and pediatric clinics.

Reachback Operations

Throughout Operation Iraqi Freedom the command element of I MEF (Rein), supported by I MHG; and the headquarters elements of I MEF MSCs maintained and utilized an unprecedented level of reachback operations and capabilities, reducing the human and equipment footprints in theater and leveraging national, joint, and service assets and capabilities to the maximum extent possible, a complex process involving all staff sections and requiring constant interface between all command and control nodes.

I MEF G-2 integrated new, cutting edge intelligence, surveillance and reconnaissance (ISR) technologies and resources never before leveraged in MEF-level operations, including P-3 aerial imagery platform (AIP); Hunter Unmanned Aerial Vehicle (UAV); Predator UAV; tactical exploitation system; JSTARS; U-2; United Kingdom tactical signals intelligence (Sigint); and critical source (National Security Agency). Working in concert, the G-2 sections devised and implemented an integrated Coalition ISR concept of operations (Conops) for employment of UK-proprietary signals and imagery intelligence resources; and accomplished an unprecedented degree of ISR push-down to regimental level, significantly enhancing the sensor-to-shooter process.

Working in concert from all disparate and widely separated nodes throughout Operation Iraqi Freedom, I MEF G-1, G-3, G-4, and G-5 sections worked tirelessly to ensure a constant flow of personnel, equipment, and all classes of supply when and as needed; ensuring accurate reporting at all levels; and ensuring accurate and timely casualty reporting, evacuation, and assistance. I MEF's deployment operations team (DOT) provided direct coordination with deploying units, coordinating time phased force deployment data (TPFDD) for 39,517 Marines and sailors and 14,328 short tons of cargo and providing the massive amount of critical transportation data required by higher commands.

I MEF G-6 developed and maintained an unprecedented level of continuous and redundant communications between all command and control nodes, including reliance on video tele-conferences (VTC) for vital and continuous communication between deployed force and I MEF Camp Pendleton. Noteworthy actions included preparation, submission, approval, and fielding of numerous universal need statements (UNS) for critical communications equipment acquisition. Efforts resulted in acquisition of mission-essential equipment including: PRC-150 and 148 radios for reconnaissance units; ruggedized computers for FSSG CSS elements; intel analysis workstations for I MEF G-2 and Intelligence Battalion; tactical data network router upgrades; OS-302 SatCom antennas to allow for long-range voice and data communications for units on the move; and TQ:G-804A generators to increase power generation capabilities throughout the MEF.

Deployed forces at all levels benefited from extensive reachback capabilities established by I MEF and MSC's. I MEF comptroller provided a specific example of the success of these efforts. Throughout Operation Iraqi Freedom the I MEF comptroller section accomplished the complex and critical functions of financial management solely through reachback to I MEF Camp Pendleton, maintaining only a small cell forward. During the period mid-November 2002 through mid-July 2003 I MEF comptroller section executed and maintained accountability for approximately \$750 million, 725 percent of a normal 12-month funding level.



Briefing on Military Operations in Iraq

by General Tommy R. Franks, USA, with Brigadier General Vincent K. Brooks, USA

<<http://www.centcom.mil/CENTCOMNews/Transcripts/20030322.htm>>. 22 March 2003.

Gen. Franks: Well, good afternoon. Let me begin by saying that my heart and the prayers of this coalition go out to the families of those who have already made the ultimate sacrifice. Because of the courage and the dedication of these heroes, the mission of Operation Iraqi Freedom will be achieved.

As President Bush said, as a last resort, we must be willing to use military force. We are willing, and we're using military force.

I'm pleased to be joined today by Air Marshall Bryan Burrige, Great Britain; Brigadier Maurie McNarn of Australia; Rear Admiral Per Tidemand from Denmark; Lieutenant Colonel Jan Blom from the Netherlands—four coalition partners represented here with us. And as many of you would know, we have at our home in Tampa, Florida, the home of Central Command, 52 nations represented. What many of you may not know is that many of these nations are also represented in the command posts of our component commands, located in a number of countries in the region.

You know, Secretary of Defense Don Rumsfeld, my boss, yesterday outlined the military objectives of Operation Iraqi Freedom. Let me review them with you.

First, end the regime of Saddam Hussein.

Second, to identify, isolate and eliminate Iraq's weapons of mass destruction.

Third, to search for, to capture and to drive out terrorists from that country.

Fourth, to collect such intelligence as we can related to terrorist networks.

Fifth, to collect such intelligence as we can related to the global network of illicit weapons of mass destruction.

Sixth, to end sanctions and to immediately deliver humanitarian support to the displaced and to many needy Iraqi citizens.

Seventh, to secure Iraq's oil fields and resources, which belong to the Iraqi people.

And last, to help the Iraqi people create conditions for a transition to a representative self-government.

Today, I thought I would describe the campaign you're seeing and provide you an operational update.

Let me begin by saying this will be a campaign unlike any other in history, a campaign characterized by shock, by surprise, by flexibility, by the employment of precise munitions on a scale never before seen, and by the application of overwhelming force.

Let me talk for a minute about our capabilities. The coalition now engaged in and supporting Operation Iraqi Freedom includes Army and Marine forces from the land component; air forces from several nations; naval forces, to include the Coast Guard, and Special Operations forces.

Our plan introduces these forces across the breadth and depth of Iraq, in some cases simultaneously and in some cases sequentially. In some cases, our Special Operations forces support conventional ground forces. Examples of this include operations behind enemy lines to attack enemy positions and formations or perhaps to secure bridges and crossing sites over rivers or perhaps to secure key installations, like the gas-oil platforms, and, of course, in some cases, to adjust air power, as we saw in Afghanistan.

Now, in some cases, our air forces support ground elements or support special operations forces by providing (inaudible) and intelligence information, perhaps offensive electronic warfare capabilities. At other times, coalition airmen deliver decisive precision shock, such as you witnessed beginning last night.

At certain points, special operations forces and ground units support air forces by pushing enemy formations into positions to be destroyed by air power. And in yet other cases, our naval elements support air, support ground operations or support Special Operations forces by providing aircraft, cruise missiles or by conducting maritime operations or mine-clearing operations.

And so the plan we see uses combinations of these capabilities that I've just described. It uses them at times and in places of our choosing in order to accomplish the objectives I mentioned just a moment ago.

That plan gives commanders at all levels and it gives me latitude to build the mosaic I just described in a way that provides flexibility so that we can attack the enemy on our terms, and we are doing so.

And now a bit on what you have seen over the last, now less than 72 hours. The initiation of combat operations—we refer to that as D-Day. The introduction of special operation forces—we refer to that as S-Day. The introduction of ground forces, G-Day. And the introduction of shock air forces, A-Day.

Additionally, a number of emerging targets have been struck along the way and will continue to be struck as they emerge. So the sequence you have seen up to this point has been S-G-A. That sequence was based on our intelligence reads, how we see the enemy, and on our sense of the capabilities of our own forces.

In a few minutes, Brigadier General Vince Brooks, one of our operations officers, will provide a number of visuals which reflect operations up to this point. In the days ahead, you will see evidence of the truth of Secretary Rumsfeld's statement yesterday when he said Saddam Hussein was given a choice by the international community to give up his weapons of mass destruction or lose power. He chose unwisely and now he will lose both.

Let me introduce General Vince Brooks to give you a little bit of an idea of what operations over the last three days have looked like. Vince?

Gen. Brooks:

Thank you, sir, very much. And, ladies and gentlemen, good afternoon. I want to take a few minutes to brief you now on some of the operations that have occurred by the coalition over the last several of days. The operation of course began on the 19th of March, and since that time, coalition forces have already achieved a number of several key mission objectives.

Our first effort is aggressive and direct attacks to disrupt the regime's key command, control, communications, integrated air defense and ballistic missiles using various targeting and methods that will achieve the desired effects. This video shows an attack against an Ababil-100 in southern Iraq, and resulted in its destruction.

Our second focus is on special operations. Coalition special operations forces entered Iraq at night, after destroying Iraqi military outposts, as this short video shows. You will see two clips. The first is an outpost along the border, and the second is a building that supported observers on the border.

The special operation forces then began looking for Saddam Hussein's and the regime's weapons of mass destruction and their ballistic missiles that threaten their neighbors. Additionally, coalition special operations forces saved three key oil terminals that are used for export through the Gulf, and these terminals are key to the future of Iraq. By preventing certain destruction, the coalition has preserved the future of Iraq. This is the area where the three terminals were in southern Iraq, and in the Arabian Gulf. On these platforms we found a variety of things. We found weapons, ammunition, and explosives. These explosives are not meant for defenders.

Our coalition maritime forces have destroyed Iraqi naval forces, as the following video shows. This is a patrol boat being attacked from the air, and in a moment you'll see the secondary explosion completing its destruction.

They are also very active in ensuring that the waterways remain open and unmined so that Iraq is not cut off from the aid that is prepared to flow in.

What you see in the next image is a tugboat that appears to be carrying oil drums. In fact, it is a mining vessel that transport mines. Interdictions like this one done by our coalition maritime forces and others over the last few days prevented, for sure, the release of 139 floating mines into the Khor Abdullah, which is an inlet that joins the Iraqi inland waterways with the Arabian Gulf.

Ground maneuver forces attacked to seize the key Rumaila oil fields, simultaneously began an unprecedented combined arms penetration deep into Iraq. The attack continues as we speak, and has already moved the distance of the longest maneuver in the 1991 Gulf War in one quarter of the time. The oil fields were spared destruction that was intended by the regime because of the effectiveness of these attacks.

In the next image you will see wells that were set afire on the 19th in the afternoon, before the coalition attack began. By the next day, the land component had already entered Iraq and had prevented any further

destruction. And this is video from the entering forces. And the good news is only nine of the roughly 500 oil wells that are in the Rumalah oil fields—only nine were sabotaged by the regime. The flame on the bottom shows where that location is. All the rest of them are okay.

I should add that the power of information has been key throughout this operation, and it is truly having the effect of saving lives—of the Iraqi people and military units who are choosing not to fight and die for a doomed regime. The leaders from several regular army divisions surrendered to coalition forces, and their units abandoned their equipment and returned to their homes, just as the coalition had instructed.

We know that there are other forces on the battlefield that we haven't even arrived at yet, and as this next image shows, there are Iraqi units that are preparing to surrender even now as we speak. These are lines of roughly 700 Iraqi soldiers that we imaged in the desert away from their equipment, awaiting our arrival.

The coalition is committed to disarming Iraq. But the coalition is equally committed to bringing humanitarian assistance to the Iraqi people. Our humanitarian work in Iraq is only beginning. The U.S. military, coalition partners and other civilian organizations from around the world have positioned millions of meals, medicines and other supplies for the Iraqi people. This image shows some of the stocks of humanitarian daily rations that we are already preparing to push forward as they are required.

Our coalition forces will continue to coordinate closely with a broad array of organizations, and ensure that as much aid as possible can be provided to the Iraqi people when it is required and where it is required.

Sir?

Gen. Franks:

Thanks, Vince. So, as we speak, our forces are operating inside Iraq. We have operations ongoing in the north, in the west, in the south, and in and around Baghdad. Our troops are performing as we would expect—magnificently. And, indeed, the outcome is not in doubt. There may well be tough days ahead. But the forces on the field will achieve the objectives that have been set out by the governments of this coalition. And with that we would be pleased to take your questions. Please.

Q: Sir, George Stephanopoulos, ABC News. I wonder if you could comment on the status of the surrender negotiations with the senior Iraqi military or civilian leadership. Are they continuing? Are you personally involved? And is the U.S. willing to accept a coalition of Iraqi commanders to assume control as part of the deal?

Gen. Franks: George, I wouldn't comment on what the U.S. government is prepared to accept. I'd leave that for my boss to talk about.

I will say that we have ongoing dialogues—as I think was mentioned in the Pentagon press brief yesterday—with a number of senior Iraqi officials. And so those discussions, both with people in uniform and not in uniform, will continue in the hours and the days ahead.

Q: Are you involved?

Gen. Franks: Please?

Q: General, Tom Fenton (ph), CBS News. The campaign so far has gone with breath-taking speed. Has it surprised you, or is it going more or less as you expected?

Gen. Franks: I think any time forces are joined in a war it's a blessing when very few people lose their lives; it's a blessing when it's possible for us to move in the direction of our objectives. I believe that the time for us to celebrate will be when the mission is accomplished. We believe that we are on our timeline, as we say. And I am satisfied with what I see up to this point, sir. Please?

Q: General Franks, Tom Mintier with CNN. We have seen bombing both during the day and the night. This afternoon it appeared that there wasn't much resistance from aircraft positions in Baghdad in and around the city. Could you describe to us what kind of opposition you are facing on the ground as the bombing campaign goes on?

Gen. Franks: In two parts, in the air and on the ground. Our forces on the ground, to include our special operations forces, have encountered enemy formations on a number of occasions in a number of places, and the fight has been joined in several places inside Iraq.

With respect to the air defenses in and around Baghdad, we—I think it was pretty evident last night that there was a lot of air defense going up in the air. We are pleased at this point that we have not had any of our coali-

tion aircraft damaged by any of that air defense. It is obvious that the regime continues to move air defense assets around as best it can for the purpose of survivability. We will continue to do our work with these magnificent airmen, and over time we will take down all the air defense capability that exists today. Sir?

Q: General, Jeff Meade (ph), Sky News. Can I ask you to talk to the blitz on Baghdad. How does it help you to be regarded as liberators by the Iraqi people when they are being terrified by that display of ordnance? And also bearing in mind that some of the targets may have suspect military value, because if they are obvious regime buildings they would have long ago been evacuated.

Gen. Franks: I think there are those who would say many of the buildings could be evacuated. I think there are many others who would say many of the buildings would not be evacuated. I don't use exactly the terminology that you used. I think rather what we are about is approaching the problem of this regime from a number of directions simultaneously. That's as I described the business of special operations forces, ground forces and air power.

The times and the locations where we put each of these ingredients will vary actually by day. That is the nature of this plan. It is built on flexibility beyond any that I have seen in the course of my service. And so it's very difficult to comment about the specific achievement of any one of those arms. We thought that the work that was done at the beginning of A-Day, last evening, was exceptionally well done. The targeting was precise. The munitions used in fact were all precision munitions. And there were no targets selected that were not precisely appropriate to what the plan calls for.

Sir?

Q: Having done—ITB (ph) News of London. General Franks, what can you tell us about the success in attacking so-called regime targets? What can you tell us what you know of the status, whereabouts or health of Saddam Hussein? And what do you say to those people who say that the people who are most likely to be shocked and awestruck by the shock are the Iraqi civilians you claim to be liberating?

Gen. Franks: I think on the third point I wouldn't offer anything beyond what I said a minute ago.

With respect to what is going on with the regime right now, I think that there is a certain confusion that is going on within the regime. I believe command and control is not exactly as advertised on Baghdad television. I believe that we should all be very confident that the effort was designed to be so precise that it avoids in every way possible exposure of non-combatants to that.

And with respect to the first part of your question, I think—actually, I don't talk about strategic targets and so forth. What I talk about is emerging targets. Emerging targets can be leadership targets. They can be military formations. They can be some communications, mobile communications capability that the regime has. And on several occasions up to this point in fact we have attacked the emerging targets—several within the last 24 hours.

And so in order for me to pick one and isolate it, it just actually doesn't serve our purpose or our plan. And so it is part of that mosaic that I described. We see it every day, and we'll continue to see it as these targets emerge.

Let me come over here, please. Sir?

Q: General, David Lee Miller (sp) with Fox News. Have you been able to locate any weapons of mass destruction? Or are you hearing anything about weapons of mass destruction from some of the people you are now taking into custody, POWs and detainees?

Gen. Franks: Weapons of mass destruction represent one of the key objectives that we have here—to locate them, to control them. We receive information every day from a number of sources with respect to weapons of mass destruction. Some of it may turn out to be good information; some of it is a bit speculative. One would expect that weapons of mass destruction would perhaps be found in certain parts of the country, and that is work that lies in front of us rather than work we have already accomplished—is probably the best way I can answer your question. Please?

Q: Good day, general, Kelly O'Donnell from NBC. Can you update us on the status of Basra? And to what extent are Turkish forces in the north complicating your plan? **Gen. Franks:** Basra is the second largest population center in Iraq. And although we have seen the regime position weapons in and around (various?) facilities, civilian facilities inside Basra, we have not seen large numbers of formations. So our intent is not to move through and create military confrontations in that city. Rather we expect that we will work with Basra and the

citizens in Basra, the same way I believe has been widely reported in Umm Qasr. What we have seen up to this point is that the Iraqis are welcoming the forces when they come in. And, so, once again this is about liberation and not about occupation, and so our desire will be to work with the civilian populations in Basra. And, I'm sorry, what was your other question?

Q

Turkish forces—Turkish forces that are reported to be encroaching into Iraq. What is the degree of complication?

Gen. Franks: I've seen much about that. And actually I believe that the Turkish formations that we see in northern Iraq are very light formations. We see them move in and out of Turkey. There is continuing discussion I know at the political level to decide exactly how much of that is acceptable and so forth. And I guess I would say that that's sort of above my pay grade. Obviously, we have consultations. We have contact. I have one of my general officers in Turkey working with the Turks and have had him there for some time. So we are able to maintain coordination, and I believe the necessary cooperation with the Turkish government up to this point.

Q: General, Paul Adams (ph) from the BBC. Your targeting of regime targets in Baghdad seems to be that you are targeting some parts of the regime, some parts most closely identified with Saddam Hussein himself, some ministries, and leaving other untouched. Is this part of sowing confusion in the regime, perhaps setting one part of it against another?

Gen. Franks: It actually is simply a part of the mosaic that I talked about a minute ago. It is an issue of taking what we know and what we form into target sets, specific locations, and using appropriate weapon systems against those targets at points and at times of our choosing. And it is a complex process. It is very, very carefully done. It is very carefully planned, and at least up to this point I believe has been magnificently executed. Please?

Q: (Off mike)—with Newsweek magazine. You talked a little bit about the agility of the modern military. Could you possibly walk us back to Wednesday when you got the information about the target of opportunity and explain in some detail if you would, sir, how did you react? What did you have to do to scramble to get that to happen, and how did it affect the actual start of the war?

Gen. Franks: Why would you ask if we had to scramble? (Laughter.) Actually, as I said, a plan that's agile, a plan that is flexible, provides what we call branches to be able to undertake a number of actions at the same time. I talked a little bit about S-Day and G-Day and A-Day, and I also said that throughout the course of this planning and this operation there will always be a need to engage emerging targets. Now, sometimes emerging targets will be engaged by ground forces and sometimes engaging targets will be engaged by air forces, and so forth.

Now actually what I will say about that emerging target, which is much reported on and much talked about, is from my view that was about as close a coordination as I have ever seen work a time-sensitive or an emerging target, and as you know I've worked a great many of them in Afghanistan. That target was worked on an amazing time line, and in fact did not cause the adjustment of a single aspect of what we have been about since this thing started. Please?

Q: General Franks—(inaudible)—Marcus from BBC World Service. One of the most striking things in your—

Gen. Franks: I see a lot of you BBC guys.

Q: We're like you—we've got lots of different arms, lots of different services.

One of the most striking things in your briefing was your comment several regular Iraqi army divisions have surrendered or their leaders have surrendered—

Gen. Franks: Right.

Q: —the troops have abandoned their weapons, the soldiers have gone home. You showed us a picture of troops in the desert—it wasn't a great picture as far as I was concerned—I couldn't see much about it. This is a very important propaganda issue—if Iraqi forces hear through a whole variety of means that the units are just simply melting away.

Gen. Franks: Right.

Q: That would be information that would be very useful for you to have imparted by the world's media. What further information, what further evidence can you give us that leads us to accept that probably tens of thousands

or many thousand Iraqi troops are simply melting away or going home?

Gen. Franks: Whoa, whoa. (Laughter.) I don't recall having said thousands or tens of thousands. I think—I think when I walked out to come over here we had seen enemy prisoners of war in the range of a thousand to two thousand, which we actually have in custody right now. We have with certain knowledge the fact that thousands more have laid down their weapons and have gone home.

And we have with certain knowledge that that little picture that Vince Brooks showed up here a minute ago is in fact about 700 Iraqis lined up in a way that they were instructed by way of leaflets and radio broadcasts to line up if they chose not to be engaged.

Sir, please?

Q: First of all, thank you for being with us finally. Do you have any personal message for the families of the casualties? And for the second question, do you think Iraqi President Saddam Hussein would become a black shadow like Osama bin Laden is right now?

Gen. Franks: I think that the president of the United States was very clear when he talked about regime change and when he talked about this regime's weapons of mass destruction. I've said on a number of occasions that when our nations—when the international community commits as we have to go to war to unseat this regime, that this is not about a single personality. This is about the control over a country for decades in a way that has been threatening to peace-loving peoples of the world. And so that's probably the best I can give you on the second—on your second question. And I'm sorry, I didn't understand the first one.

Q: First is about a personal statement for the families of the casualties.

Gen. Franks: Oh, for the families of the casualties? Absolutely. As I said in my—in my opening remarks, my heart goes out to the loved ones and to the families of those who have fallen. I think all of us who have served in prior wars at different times in different places have a certain feeling about the loss of a comrade. These are wonderful—these are wonderful young people. And my personal thoughts and prayers and the thoughts and prayers of a great many nations go out to their families.

Please, ma'am.

Q: Yes—(inaudible)—Hong Kong. There's been so many rumors about Saddam Hussein's whereabouts. Do you have any idea where Saddam is at right now? And how confident are you in capturing him? Thank you.

Gen. Franks: Actually, I have no idea where he is right now. I suppose—I suppose we'll know more in the days ahead, and that's the best answer I can give you.

Sir, please.

Q: Paul Hunter with Canadian Broadcasting. Given all the talk leading up to this of chemical weapons, how surprised are you that no chemical weapons have been fired at your troops? And what does that tell you about whether or not they exist? And how concerned are you that they still might be coming?

Gen. Franks: I think it's—well, of course we're concerned. And we'll remain concerned. I think that there are two ways to look at an enemy, and one way is to try to anticipate what he might think or what he might do. That's not the way that I think we choose to do it. What we try to do is determine his military capacity and then prepare our forces and and prepare ourselves to meet the weapon of mass destruction use if he should choose to do so.

You know, I think the President said the other day that there will be people, and there have been—there have been people, who have believed that through the use of terrorism, potentially through the use of weapons of mass destruction, that we can—that we, this coalition, can be driven away from our goals. Simply not gonna happen. Someone asked me not too long ago, "What happens if this regime uses weapons of mass destruction?" And my response was, we win. And that's because we have—we have a commitment to this operation, and our people have a commitment. And so, I would give you the same answer.

We would be hopeful that those with their triggers on these weapons understand what Secretary Don Rumsfeld said in his comments yesterday—don't use it. Don't use it, sir.

Q: This is Li Jingxian (ph) from Shanghai TV, China. General Franks, it was reported that more than 200 Iraqi civilians have been killed or injured ever since the war began. Do you have any comment on that? And what kind of measurements has the coalition taken or is going to take in order to minimize the civilian casualties dur-

ing the military action? Thank you very much.

Gen. Franks: All right. With respect to a question of, you know, how do you feel about that, I think that the nature of war—which is why my own president said it’s a last resort, it’s final option—is that noncombatants are injured and killed in a war. That’s why the members of this coalition go literally to extraordinary lengths in order to be able to be precise in our targeting. We’ve done that and will continue to do that, because there is no assurance that this operation, Operation Iraqi Freedom, ends in a matter of hours, or that it ends in a matter of days. I think what we do is we remain guided by principles. And the principles involve the accomplishment of our mission on the shortest timeline possible, protecting innocent lives, both our own and the lives of innocent civilians. Sir, that’s the best I can give you. Sir.

(Off mike.) There’s an impression here in the region that you’re having more trouble than you’re willing to admit, that you’re meeting stiffer resistance than you’re willing to admit. One case being brought to mind is Umm Qasr. If you can talk about that.

And yesterday, following the air strikes, the Iraqi information minister said that your forces are going to be decapitated and routed. If you can comment on that. Thank you.

Gen. Franks: Sure. I think there might be an expected response to that question, which actually you won’t get from me. I don’t think it’s appropriate for senior military people to wave their arms in response to the sort of hype that was described, and so I won’t do that.

I’ll simply say that we have been and will remain deadly serious about our business, and all in this room should remain convinced that what we say from this podium—myself or my staff—or what we say from the various press centers associated with this coalition, will be absolute truth as we know it. Please, sir.

Q: (Off mike)—ABC News. Sir, does the Iraqi military still have the ability to strike Israel with ballistic missiles?

Gen. Franks: One doesn’t know whether the regime has the ability to strike any neighboring country with missiles. We do know that more than two dozen Scud launchers remain unaccounted for since the days of the Gulf War. (Brief audio break)—provide the best defensive capability that we can. And we know that we want to posture our force dispositions in a way that makes attacks on neighboring countries just as hard as we can make it.

Now, as you know, there have been, at least to my knowledge, six surface-to-surface missile attacks into Kuwait over the last couple of days. And if my memory serves, four of those were destroyed by Patriot units—in fact, one was destroyed by a Kuwaiti Patriot unit; one was permitted to fly harmlessly into the northern Arabian Gulf, and another into an unpopulated desert area.

And so, is that—does that provide fact-certain that we can provide the 100th percentile of defense? Absolutely not. There is no certainty. I will say, sir, that I like our posture the way we see it right now. Ma’am.

Q: (Off mike)—from the Associated Press. You mentioned at the start of the briefing the efforts to route the terrorist networks from Iraq. Can you give us some details of what you’re doing specifically in that regard? Ansar al-Islam up in the Kurdish areas, can you give us some details on that effort?

Gen. Franks: I can’t really provide you a lot of detail. I can tell you that from time to time, in Iraq, we will come across what we believe to be terrorist-associated activity or people, and when we do so, we will strike them, and then we will exploit the site subsequent to the strike. I can tell you that in fact we did strike last evening a terrorist complex, the one that you just made reference to. And I won’t describe exactly what action we’ll be taking in the next few days with regard to that particular site. Okay?

Sir, please, back here.

Q: (Off mike.) We are getting close from the fourth day of war, and until now, we can’t see any sign of weapons of mass destruction, we can’t see anyone using of weapons of mass destruction by Iraq. Was it a big lie or just a cover to justify your invasion of Iraq and to remove its regime, which still cannot use any kind of these weapons to defend itself against your attacks? Thank you.

Gen. Franks: A bit less than 72 hours of this operation so far, and as I said earlier, potential for days and for weeks ahead. There is no doubt that the regime of Saddam Hussein possesses weapons of mass destruction. And at—and as this operation continues, those weapons will be identified, found, along with the people who have produced them and who guard them. And of course there is no doubt about that. It will come in the future. Sir, please.

Q: (Off mike) A point of clarification: Do you know the locations of weapons of mass destruction or is this effectively an army of inspectors?

Gen. Franks: I'm sorry, I didn't—I didn't hear you.

Q: Do you know the locations of the WMD you're talking about, have you some indications, or is this effectively an army of inspectors?

Gen. Franks: Well, no, I think what this is is a coalition force that is designed to take down this regime and to control the weapons of mass destruction, which for certain, sure exist within Iraq. And the approaches and the amount of time that it will take to identify those weapons and control them remains to be seen, very candidly. Please.

Q: General Franks, Jeff Shaeffer, Associated Press Television. I understand you can comment specifically on that whereabouts of Saddam Hussein, you might not know that, but do you believe that he's still alive? Do you believe he was wounded in the strike the other day? And do you believe, if he is alive, is he still running the country?

Gen. Franks:

Actually, I don't know. I don't know if he's alive or not. But interestingly, the way we're undertaking this military operation, it would not be changed, irrespective of location or the life of this one man. And that's why we talk about the regime. It would not surprise any of us that, whether Saddam Hussein is alive or dead, that our forces have engaged, as I mentioned earlier, in combat operations against the forces of this regime, both in and around Baghdad, which we all saw on television last night and in a number of other cases in this country.

And so it is not about that one personality. In fact, it is about this regime. And so that's what we're going to focus on.

Sir, please.

Q: (Off mike)—from the Daily Telegraph in London. Do you think it was an error that the Stars and Stripes were raised in Iraqi territory yesterday? And what kind of military government beckons for post-war Iraq?

Gen. Franks: Actually—actually, I don't—I don't know. I think that is—that depends on the eye of the beholder. I think that in zeal, people will want to represent that they have—that they have achieved a certain milestone. And if you're from our country, then one of the first things that can pop into the young man's mind is to raise his national colors.

I suppose I found it to be much more instructive that immediately following that, and recognizing that his job had to do with liberation and not occupation, that he quickly brought down his colors.

Please.

Q: This is News Channel from Shanghai TV, China. Mr. Franks. Could you please tell me why this news conference was delayed—

Gen Franks: Sure.

Q:—because, you know, this is quite unusual. Everybody expect that there's going to be a news conference at the first night of the air strike, so lots of rumors were confirmed by not Central Command but the Pentagon.

Gen. Franks: A very good question, and having to do with why the timing of this press conference and why not yesterday or the day before or whatever. Actually, the—many of the media embedded with coalition forces would tell you that we're a bit sensitive about the possibility of leaking information that risks the lives of our people who are engaged in this work. I could give you an example.

Were we to have a press conference here, or in fact a press conference in Washington, that described what might happen on S-Day or answered questions, the nature of which you've asked me here today, all very good questions, then the risk of providing just that one piece of information that winds up risking the mission or winds up risking the lives of the people who have been—who have been put to this task, it seems to me, just isn't worth it. And so the decision has been that we would move through the first few days of this before our command here made any comment. We'll try our best to provide fact-based information on a daily basis to the press center here. I feel very good about that. But I will also tell you that I feel very good about the work that's been done up to this point.

Last question, please. Sir.

Q: General, Chas Henry from WTOP Radio. Operationally, what's the greatest surprise you've encountered to this date, a circumstance with the outcome that you least expected?

Gen. Franks: Actually—actually, my greatest surprise was when I—when I got up this morning and I looked at my computer and I realized that my wife had sent me a “happy anniversary” note this morning that I had—and I had forgotten to send her one.

(Laughter.)

Actually, there have been no surprises in the way that you—in the way that you asked the question. One is surprised, I think, when one has not had a year to think through the possibilities. Much has been said and written about this business of one plan good enough and another not, and so forth. And the fact of the matter is that for a period of about a year, a great deal of intense planning and a great deal of what-iffing by all of us has gone into this so that we prepare ourselves and prepare our subordinates in a way that we minimize the number of surprises. There will be surprises, but we have not yet—we have not yet seen them.

Thanks a lot. Best to you.



I Marine Expeditionary Force Commander Live Briefing from Iraq

by Lieutenant General James T. Conway

<<http://www.defenselink.mil/transcripts/2003/tr20030530-0229.html>>. 30 May 2003.

(Participating in the briefing was Deputy Assistant Secretary of Defense for Public Affairs [Media Operations] Bryan G. Whitman)

Whitman:—from Baghdad. General Conway commands the I Marine Expeditionary Force, which is a 65,000-person division-size element, which is the largest warfighting unit that the Marine Corps assembled—has assembled since Operation Desert Storm. It brought together Marines from both the Pacific and Atlantic forces, and as all of you had followed, had tremendous success during combat operations. And many of those Marines are still in the country as the stabilization efforts continue.

And with that, General, I believe you have a few things you'd like to say before we start taking questions.

Conway: I do. Thank you for the introduction.

Good morning, ladies and gentlemen, and thank you for the opportunity to answer questions about my Marines and sailors. Just seven to 10 weeks ago, the I Marine Expeditionary Force [MEF], consisting of about 85,000 U.S. and British troops, was accomplishing feats in combat never envisioned for a force whose origins were from the sea. Marine Air was smashing Iraqi armor well in advance of attacking troops, flying columns of armor were slashing through and around the area defenses, and our support troops were making 22-hour trips one way to supply the materiel of war.

The war now is essentially over. Those courageous Marine aviators are now flying Iraqi children injured in automobile accidents to treatment centers. The armor has been parked, and our ground troops are engaged in building police forces and repairing schoolhouses. Our support troops are clearing unexploded ordnance, providing Iraqi farmers with diesel fuel and rebuilding bridges destroyed during the fighting.

Our Marines were extremely innovative and adaptive during the campaign, and they've carried those characteristics into the aftermath. Our current mission is to provide a safe and secure environment in order to eventually be able to turn Iraq back over to the Iraqis.



As Marines, we go about that tasking in a no-nonsense manner. What we tell the Iraqis is that we're here to do a job. Don't get in our way, and nobody will get hurt; indeed, you will like the results. Interfere with our efforts or threaten our forces in any way, and there will be consequences.

Thus far, we are pleased to say that the people of southern Iraq have generally welcomed our presence in the cities and in the countryside. In fact, since the MEF left Baghdad some five weeks ago, there's been no significant incidents that have resulted in a Marine or sailor being seriously wounded or killed. Today, with the help of non-governmental organizations, Army civil affairs teams, and multiple nations that will soon join the coalition, we go about creating—recreating a quality of life.

We recently took pride in our ability to rapidly topple the regime of a vicious dictator. Today we take pride in our ability to offer a bright and prosperous future to the children of Iraq.

Ladies and gentlemen, I'd be happy to take questions.

Whitman: General, I'm not sure—we're not getting real good audio. If there's any way to move the microphone a little closer to you, that would be good.

And we'll start here with Charlie Aldinger. Please go ahead and give your name and your news organization so the general knows who he's talking to.

Q: (Off mike.)—how many Marines are still in Iraq now? And General Hagee said last week that plans were to have all of the Marines out of Iraq by the end of August. He said that any final decision would be made by General Franks. I wonder how that schedule looks now. Is it possible, given the problems you're having there and the attacks, that you'll have all your Marines out by the end of August?

Conway: Charlie, to answer your first question, we still have about forty—maybe 41,000 Marines in Iraq and in Kuwait. We've always had a significant chunk of the Expeditionary Force in Kuwait, because now I can say that our aviation was based there for the war, as well as a rear command post, as well as some of our logistics folks that were forcing material forward from the piers and the airports.

In terms of the second question, we don't know the answer to that yet. We're examining right now the results of these last series of attacks. I will tell you, as I mentioned in my comments earlier, that things have been fairly quiet in the South. But in conjunction with our adjacent and higher headquarters, we're taking a look, even as we speak, at what our force structure needs to be in the weeks, and perhaps months, to come.

We do feel that when we leave, we will not be able to leave a void. So we very much may be dependent upon the arrival of additional coalition forces to relieve in place with us and allow the Marines to go home.

Q: General, this is Thelma LeBrecht with AP Broadcast.

And could I also make a request again; if there's any way you can get that mike wherever you're speaking into closer to you.

And if I could just follow up a little bit on Charlie's question. What happens if the coalition forces, as we're now hearing, there are not enough international troops now stepping up to the plate? How do you foresee the U.S. military being able to contend with—is it going to be a longer stay, do you think?

Conway: Pamela (sic), we're here to do a job, and we don't leave until the job is done. Now, there are pressures, of course, that I think it's fair to say the administration, the Department of Defense will experience in terms of getting our Marines out of the theater due to additional deployments that those Marines face. We have kept up our deployment routine for the entire time that we've been here. And at this point, I have Marines who are in country now seven and eight months, so we do have some concern that they not be kept here any longer than must be the case, so that they can get home, enjoy their families and once again be prepared to go someplace else in the not-too-distant future.

Q: General, this is Bob Bums from Associated Press. Your comment about how it's been relatively quiet in the south; I'm wondering if you can elaborate on why you think it is that the Marines have encountered less violence. And are you doing something different than your Army folks are doing further to your north?

Conway: Bob, I think there's a number of things that contribute. One, of course, we're organized a lit-

tle bit differently from the Army. We have a lot more infantry Marines in our regiments and in our division that are able to get boots on the ground, so to speak, and create perhaps a more diffused presence. I think that's one difference, perhaps, between us and the Army.

But I think we're also fortunate in that the south of Iraq has a much larger Shi'a population. And of course, as you know, they were very much downtrodden during the Saddam years. There are not as many Ba'athists, I think, remaining in the south as perhaps there are in the north, a lesser number of Sunnis, who were sympathetic to the regime.

So I think a number of factors pertain. I have been told by some of the local Iraqis that just being a Marine makes a difference; that the reputation somewhat speaks for itself and people don't want to be in our sector because they know if they get hit, they'll get hit pretty hard.

Q: General, this is Pam Hess with United Press International. I have two questions for you, if you have the time. The first is about the logistics. We saw, you know, a pretty amazing military campaign where you all moved very fast and over a very long way. And one of the things they said was that this was a real triumph of logistics. But I've talked to a bunch of returning Marines who recall going at least a week eating one MRE [Meals Ready to Eat] a day and having their water rationed. That doesn't really add up to a triumph of logistics to me. Could you explain what happened there and if that is an acceptable level of support, and how you might be looking to change that?

Conway: Yeah. Pam, let me say at the outset that I am so proud of my logisticians that I can probably not convey it in words. The Marine Corps is not designed or organized to go 600 miles deep into enemy territory. Our logistics are simply not built that way. We have tremendous reliance on our shipboard logistics. We essentially say that we come from the sea. That said, that was not the CINCs [Commanders in Chief] or the CFLCC's [Coalition Forces Land Component Command] plan in this case, and so we were asked to execute something that was in excess of what we were built to do. With Army augmentation, however, and with, I think, some wise planning that tied our logistics to airfields along the avenues of approach, we made it work.

Now, if you ask me if every Marine went into the attack with a full tank of gas in his tank and three MREs in his pack and all the water that we might like to have, the answer is absolutely not, because we certainly stretched the rubber band. But that said, I think there was a level of comfort in the Marines in the combat units that as they crossed the line of departure in the morning, they could look over their shoulder and see a supply convoy arriving that would have those things for them by the end of the day.

So logistics never truly halted the attack, but based upon those supply lines that we faced, even doing the best job we could with emergency resupply via air and so forth, we were never rich in supplies. That was a conscious risk that we were willing to accept, and one in this case, I think, proved itself to be worth the risk. We felt that through speed, we could save lives. And we weren't willing to sacrifice that speed for the sake of full tanks and full packs.

Q: Hey, General, it's Mark Mazzetti with U.S. News. I hope you're doing well. Question: Talking to your staff toward the end of the war, they said that since the area you control is predominantly Shi'a, that they were concerned that—of actions that Iran might take to sort of move over the border and try to establish sort of a base of influence in Iraq. Have you seen that at all since the war ended, or any actions by Iranian elements to move over the border and do that?

Conway: Hey, Mark, good seeing you again. But I'm sorry; now you all are breaking up. I got about 30 percent of your question. Could you please repeat it?

Q: Sure. I'll go a little more slowly, too. Talking to your guys during—toward the end of the war, they were saying that since the area you control is predominantly Shi'a, they were concerned about actions Iran might take to move over the border and establish a little bit of a, you know, sphere of influence in eastern Iraq. And I'm wondering whether you've seen any of that since the end of the war or any actions by Iranian elements to do that?

Conway: Yeah, Mark. Got it that time. We have seen some of that. We have—in fact, there are SCIRI personnel who—and that acronym I'll provide to you—but they are folks, they are Iraqis, who have spent time

in Iran who are now coming home who are a political presence. And I think their beliefs are basically fundamentalist beliefs. The military arm of SCIRI is the Badr Corps. It has a military connotation, but I will tell you that we have not seen any threat yet arising from them. That said, they are here in some numbers, we're keeping a close track on their activities and we will watch them with great interest in the days and weeks to come. At this point, they're playing by all the rules. And we have no reason to be convinced that they're doing things untoward that would cause us to react towards them in any way. SCIRI, by the way, stands for Supreme Council for Islamic Revolution in Iraq.

Q: It's John McWethy with ABC News, General. You described stretching the rubber band; that there were times when your forces never had full packs, but the risk was worth the reward of speed and saving lives.

There are generals in uniform back here who are telling us privately that to stretch the rubber band was a high risk, and that had been a bit more resistance, it could have turned very bad for U.S. Marines in particular, on that march to Baghdad.

Can you describe the measure, the level of risk that you did in fact take?

Conway: Yeah, that's a very perceptive question, John. And I think I can. As you all will recall, there was a halt, an operational halt, that allowed us to build supplies. We were well up Highway 1 at that point, still south of the Tigris River, at that point really making a feint on the underbelly of Baghdad. And we held forces in place for two or three days, allowing that rubber band to maybe become a little less taut, and to get some supplies built up to the point where we were comfortable that we weren't experience extreme risk.

While that was happening—and you have to understand, I guess, some about how this MEF fights. But we have a tremendous air arm that was able to put about 300,320 sorties a day on our enemies out in advance of our ground troops. So while we were stationary, we were, in fact, attacking with our air, taking maximum advantage of intelligence, surveillance and reconnaissance capabilities to determine what the enemy was that we faced.

And quite frankly, again, we weren't fully topped off with the supplies that we might like, but every indication that we had was that the enemy had been significantly pounded by our air, and our intelligence resources were telling us that he was not there in large numbers. So those two things combined told me, and I suspect my superiors, that it was a risk that was manageable and a risk that we could take, again, in order to generate the speed that we did.

Q: General, thanks for being with us. This is Hunter Keeter from Defense Daily. I wanted to ask you about the movement from the sea to marry the troops up with their equipment. Could you just detail a little bit about that process from the Maritime preposition stocks that you met your troops with? And then talk a little bit about, if you would, what your assessment is of the future of that capability; where you would like to see it go, if you had to do this all over again with a little bit better capability.

Conway: Hunter, we have always felt in the Marine Corps that the MPS concept, Maritime Prepositioning Ship concept, is a real success story.

It proved to be so during the last Gulf War, to the extent, I think, the United States Army saw the value in it and it created a very similar capability, at least here in Southwest Asia.

This time through, it performed magnificently. We brought 11 ships in from two separate MPS squadrons, and the estimate was somewhere between 20 and 25 days for the off-load. We did it in 16. And we're extremely proud of our Marines and the process that allowed that to happen, because it gave us two full brigade sets of equipment on deck. And that did not include the Amphibious Task Forces, East and West, sailing with additional Marines, armor, helicopters, fixed-wing aircraft and those types of things. So, this Marine Expeditionary Force truly arrived from the sea.

Now, an important component of that is the support that we get from the United States Air Force in that they fly over large numbers of Marines, both with Air Force air and contract air, to link us up with that equipment and then move it into tactical assembly areas. But suffice it to say that we brought in about 60,000 Marines in about 45 days, once the Department of Defense and the administration decided

that it was time to prop the force and make it ready.

Where we go from here is, I think, an interesting question. I will tell you that our planners at Headquarters Marine Corps are looking at even more efficient ways to organize the ships, and I think the commandant has made the decision that that will happen. What is basically involved is like types of ships in like squadrons. But I've got to tell you, this is a pretty tremendous capability right now, and I think any tweaking that we do will be pretty much on the margins, because now in two successive conflicts, it has truly proven its value.

Q: Good morning, General. Otto Kreisher with Copley News Service. The corps had about one-third of the ground combat forces during the war, and yet, you took half or slightly over half of the combat casualties. There's a question of whether that's you know, Marine aggressiveness, or whether it was the fact that you got the hard—the tough end of the stick; you had to fight your way through most of the cities while the Army was doing the sweep to Baghdad mostly through the desert. What would you say about, you know, your ratio of casualties you took?

Conway: Otto, you broke up a little bit, but I think I have the essence of your question, so I'll answer what I think you said. If I'm off the mark, please ask it again.

From the outset, the Marine Expeditionary Force was a supporting attack. We had to cross one, two, three—arguably, four rivers. We had an avenue of approach that Marine and Army planners both agreed was essentially a brigade-size avenue of approach, and we were putting, essentially, a reinforced division over it.

I asked my people in the end how many Iraqi divisions did we engage, and it's arguably somewhere between eight and 11. We always knew that An Nasiriyah was going to be a critical point on the battlefield; that our supply lines, up Highway 7 and across Highway 1, both cross the Euphrates River at An Nasiriyah. And we simply had to take that place and hold it in order for the 1st Marine Division to be able to sweep north, as it finally did.

It involved some close combat. And we saw that, I think, repeatedly as we attacked north; that we knocked out great formations of Iraqi armor, but the forces that we had come up against us were pretty much in the villages and towns along the single avenues of approach that we had that led into Baghdad. It was close-quarter fighting, in some cases hand-to-hand fighting. And I just think that a combination of things, that nature of close-in combat and the number of forces that we had to face on secondary avenues of approach to get to Baghdad, have led us to those number of casualties.

And let me tell you, we felt every one of them. I think based upon some of the equipment that we now have in the force, we're fortunate that they were not worse. We tried to ensure that every Marine had what we call a SAPI [small arms protective inserts] plate, an armor plate that goes on the front of the flak vest. It covers the vital parts of the upper torso. And we compute that we had somewhere between 25 and 30 strikes 762 or larger on the SAPI plates and they worked. And we think that they truly save lives.

Now, that's the question I think you asked. If it was different, please restate it.

Q: General, Dale Eisman with the Virginian Pilot in Norfolk. You had a number of friendly fire incidents, and I'm thinking in particular of one near Nasiriyah; I think you had something like 30 Marines wounded. Can you tell us what you've learned about what might have been behind those incidents? Was there a common thread running through them? And what steps you might be able to take in the future to further reduce friendly fire?

Conway: Dale, you just hit on what is probably my biggest disappointment of the war, and that is the amount of blue on blue, what we call blue on blue, fratricide in a lot of instances, that occurred.

I spoke to every formation before we crossed the line of departure, I spoke separately to the officers and I emphasized a number of things, but among them were the fact that our weapons are so accurate, are so deadly, that anymore, that when it goes off the rail or it goes out the tube, it's probably going to kill something. And so you've got to make certain that what you're shooting at is indeed the enemy.

We did have a large number of wounded at An Nasiriyah, based upon a friendly fire incident.

Fortunately, no killed came out of that, that particular engagement. There is another one that's under investigation where we think that there may have been an airstrike roll in on our forces. And there are a number more, frankly, lesser in number, that still present—

(Audio brake due to loss of feed from Iraq).

(Pause.)

Whitman: (Referring to teleconference video feed.) It looks like he's frozen there, doesn't it?

Q: Yes.

Whitman: Let's see if we get him back in a second.

(Incidental chatter not transcribed.)

Whitman: If we have lost the signal, it requires to reboot, and rebooting is about a four-, five-minute process. So let's see if we've really been knocked off the air or not. We'll know here in a second.

(Pause.)

Whitman: (To staff.) Are we going to have to reboot?

Staff: No, sir. I think we're just going to be able to reconnect, redial.

Whitman: All right, well let's just stand fast a second, then.

(Pause while connection is restored. Incidental chatter not transcribed.)

Whitman: General Conway, can you hear me?

Conway: Yes, I can. Can you hear me?

Whitman: Yes, we can hear you fine now. We lost you for a moment. You were talking—where we lost you, you were talking about friendly fire incidents, and you had talked about a possible aviation one. And then you said that there were a number of others that were being looked into or something, and that's where we lost you.

Conway: Okay. I went on to say that we had some devices that we used in this war. One was called Blue Force Tracker. It gave us position locations and identification on major units. It helped some, I think, with location and identification friendly forces.

But what we truly need is something that can identify a friendly vehicle—it either squawks or beeps or emits some sort of power source that tells a shooter—an airplane or a tank or whatever—that they're looking at a friendly piece of equipment. And I think that the—we've been trying to develop that now ever since the Gulf War, without success, I might add. And the man that invents that, I think, will be very rich, indeed. Because it continues to be something that we see happen in the U.S. military, and it's really something that we've got to stop.

Q: General, this is Lisa Burgess with Stars and Stripes. It's a little bit difficult back here to get a sense of how the Iraqi people are reacting to the American force. Reading the newspaper in the last couple of days, it would seem that there's a growing resentment against what's being perceived as an occupation force. Can you give a sense of what you're seeing there, and whether there's been a change in the past week or so?

Conway: Lisa, I can speak for the southern region. And I can tell you that I still see that the reception that our Marines and sailors are receiving here is overwhelmingly positive. I fly over the landscape a lot, and we don't pass a village without little children, and oftentimes, adults waving at our helicopters. They wave at our helicopters more than the people in southern California wave at our helicopters, and that's because, I think, they're happy we're here.

We've been told by some sources that people want to see us go away, and of course sooner is better. A number more are saying, you know, we're afraid when you leave that our freedoms will leave with you because there are bad people still there who would like to see other things happen aside from democratic principles and the ability to elect their leaders.

I met just this morning with about—I don't know, 60, maybe 70 sheikhs, influential people who are tribal leaders throughout all of southern and central Iraq. And let me tell you, they are delighted that we're here. They're delighted with the progress that we're making, again, especially in the south. They want to complement our efforts as much as they possibly can. I think that they will probably—they will

be willing and happy to say goodbye to us, but that day is not yet. And I think that, again, the reception that our Marines receive day in and day out is just tremendously positive.

Q: General Conway, Barbara Starr from CNN. Even given the fact that you have a more—what you describe as a more stable situation in the south, nonetheless, as a senior commander in Iraq, what are your thoughts specifically about what the U.S. military can do to get a handle on what appears to be a continuing series of random and sporadic attacks against U.S. forces in Iraq? What can be done to stop it, since it is so widespread and so sporadic?

Conway: Barbara, good seeing you again.

You've got some great people out here working on that very problem. I will tell you first of all how we handle it in the south. I mean, yesterday morning, we had a battalion-size attack on what we were told was a training area up in the very northern part of one of our provinces. So I think that any commander would much rather ferret out a threat based on solid intelligence and act on it quickly to eliminate it. You go preemptive and don't allow them a chance to finish training, in this case, perhaps disperse to various locations and then do the sniping and the ambushing and that type of thing that we've seen potentially in the north.

I think what we're seeing are a limited numbers of attacks that are, I think, in some cases being mischaracterized as how the whole nation is seeing our presence. I really don't think that there's anarchy in Iraq, to include northern Iraq. But there are specific individuals that are very aware of the fact that even a small-scale attack makes large-scale news; are taking advantage of that fact to create, I think, levels of overreaction in some cases, and will continue to do so because they don't want us to be here.

But I think from a U.S. military perspective, we have to keep doing the things that we're doing—build the police forces, gain confidence in them; provide point security on key infrastructure, because these guys also know if they start tearing down infrastructure, it also will reflect badly on us. And there are places where it's simply not guarded; you can't guard it everywhere. And then we have to be prepared to act quickly and severely where we see that armed people are resisting the future that we're trying to create for this country.

Whitman: Someone else?

Q: No.

Whitman: Okay. Go ahead, Pam.

Q: This is Pam Hess from UPI again. Just to tie up a couple of loose ends, could you tell us how many wounded or dead you might have had from friendly fire attacks? And could you give us an estimate of the number of SCIRI and Badr Corps personnel that are in your region that you know of?

Conway: Pam, on your first question, I can't give you an exact figure because those things are still under investigation. And the first thing the investigation has to determine is whether or not it was friendly fire. So, I can't give you a feel for that at this point. But I will tell you that one is one too many.

On the second issue, the numbers vary widely. We tend to think that in the southern area, there's probably less than 1,000 of the Badr Corps types. But again, that's not certain.

We're told that X number will come in, perhaps, from Iran, but then will attempt to recruit X number more who may be sympathetic to their beliefs. And again, a Badr Corps individual isn't necessarily a bad guy. He doesn't become that until he does something again that goes against the rules that the Coalition Provisional Authority has posed, and then we would have to take action.

Q: General, it's Mark Mazzetti again. The goal of the military campaign in Iraq was not just regime change, but also to get rid of the weapons of mass destruction in Iraq. And I'm wondering—first of all, are you surprised that seven weeks on, no weapons caches have been found? And what is your sense of the status of the WMD programs, having been on the ground in Iraq for so long? And, you know, what may have happened to the weapons?

Conway: Mark, you may recall as we moved north, there were a couple of times there where everybody was sleeping with their boots on and with their gas masks pretty close. So, one of the real surprises I think we all experienced was that we did not get struck with weapons of mass destruction as we crossed

the Euphrates or even as we crossed the Tigris and went up against Republican Guard divisions.

In terms of what we're doing about it now, we continue to contribute our part in the south against SSEs—sensitive sites, if you will—that may yield weapons of mass destruction. We've put teams on virtually every one that intelligence or local Iraqis or any other means has pointed out to us as perhaps might be containing weapons of mass destruction, or residuals of those kinds of things or whatever.

So we continue to join in the search to try to ferret it out.

I can't answer your question in terms of what may have happened to it. I don't think that we've given up on the search yet. And I think if you're tracking the high-value target captures, like all of us are, the interrogations that followed, I think that the day might well come when we ask the right question of the right person and we open a panacea of weapons storage and that type of thing.

So seven weeks is probably not enough time to look at a country the size of California and come to the conclusion that they simply do not exist here, especially if you consider that the regime had ample experience attempting to hide those things as much as they were visited by the inspectors.

Q: General, Otto Kreisher again. You mentioned earlier that you had a battalion-size operation against what you thought was a training area, but you didn't say what you found there. What did you encounter on that raid?

Conway: Yes, sir. What our intelligence told us was that there were some Ba'ath Party members who were conducting training, with a good bit of shooting, with intent to potentially use that force in some negative way on down range. The battalion swept in a first light. They rolled up on five different objectives. They found a number of automatic weapons, a number of rocket-propelled grenades, which in tandem were probably the favorite weapons of the Fedayeen, certainly. They took 13 detainees, at least one of whom, a couple of the detainees pointed out to us fairly quickly, was a fairly high-level Ba'ath Party member; and, unfortunately, had to shoot two people who chose to resist their movement.

So we consider that a fairly successful sweep. It's a pattern that we will continue to follow. My division commander prefers a cordon in the early hours before first light and a first-light attack. First, we find some of these people don't get up too early around here, and that's a good thing; but secondly, we're able to be more discerning with our targets and we don't wind up shooting innocent people, ostensibly women and children, because of trying to do so during the hours of darkness.

Q: It's John McWethy from ABC again, General. Back to the weapons of mass destruction. You had, we were led to believe, fairly credible intelligence indicating that some of the units that you would be encountering had live weapons of mass destruction, probably CW shells, that had been moved forward to deal with your units. At this point, understanding that the exploitation of the sites is still under way and that there are a lot of unanswered questions, do you feel that the intel was just wrong? Do you feel that the enemy may not have ever had any of these things in forward units?

It seems inconceivable that if they had them in the forward units that you have not found something in a forward unit, and not buried away in some storage area. Help us out here.

Conway: John, as Mark could probably tell you, the fact that we were, again, not hit with weapons of mass destruction—I think we had four triggers that we were prepared to defend ourselves against—different times when we thought that the regime might try to employ the weapons of mass destruction against us. And we truly thought that they were distributed—not to everybody, not to the regular army divisions that we saw in the south. But my personal belief was that they probably did reside in the Republican Guard units, and we encountered, arguably, three, maybe four, Republican Guard divisions on the way to Baghdad. But my personal belief was that the Republican Guard corps commander probably had release authority, and that we might well see them when we started to encounter his force or enter his area.

It was a surprise to me then, it remains a surprise to me now, that we have not uncovered weapons, as you say, in some of the forward dispersal sites. Again, believe me, it's not for lack of trying. We've been to virtually every ammunition supply point between the Kuwaiti border and Baghdad, but they're simply not there. Now, what that means in terms of intelligence failure, I think, is too strong a word to

use at this point. What the regime was intending to do in terms of its use of the weapons, we thought we understood or we certainly had our best guess, our most dangerous, our most likely courses of action that the intelligence folks were giving us. We were simply wrong. But whether or not we're wrong at the national level, I think, still very much remains to be seen.

Whitman: General Conway, if I could thank you for taking the time out of your busy schedule to spend some time with us here today and to give us some insight into your operations and what you've been doing over there. Thank you very much.

Conway: Thank you, folks, for the great job you do. Have a nice day.





Briefing on the First Marine Expeditionary Force in Iraq

by Lieutenant General James T. Conway

<http://www.defenselink.mil/transcripts/2003/tr20030909-0658.html>. 9 September 2003.

(Participating in the briefing was Deputy Assistant Secretary of Defense for Public Affairs [Media Operations] Bryan G. Whitman)

Whitman: Well, thank you again for joining us this afternoon. Today it's my real pleasure to welcome back into this room, because we've seen him by scottie briefing from Iraq, Lieutenant General James T. Conway, who is the commanding general, I Marine Expeditionary Force, which is headquartered at Camp Pendleton.

During combat operations in Iraq, though, General Conway commanded 89,000 Marines. They attacked from Kuwait all the way north to Tikrit, and took—by my count—on and defeated eight Iraqi divisions. I MEF has recently—more recently been responsible for security and stability operations in and around An Najaf, and is in the process of completing their turnover to the Multinational Division that has come in to that sector, led by Poland.

He has some time today to talk to you about their mission and their operations and a little bit about some of the lessons that they learned. He has some opening remarks, a little bit of a presentation, and then would be happy to take your questions for about the next 30 minutes.

General?

Conway: Afternoon, ladies and gentlemen. Let me apologize, first of all, for my uniform. My aide and I packed our “Alphas” when we left San Diego the last time, but we think they probably joined Jimmy Hoffa somewhere. We can't find them right now. And so I'm in the best uniform I could bring forward.

I returned from Iraq yesterday in the wake of a transfer of authority ceremony, conducted at the ruins of Babylon on the 3rd of September. There, after five months of stabilization and security operations, my command, the I Marine Expeditionary Force, turned over responsibilities for four of the five governants in South Central Iraq to the Polish-led Multinational Division. Although the MND appears quite capable, we maintained U.S. control of the governant of Najaf in order to provide a sense of security following the cleric Hakim's bombing assassination at the Imam Ali Mosque on 29 August. We plan a final turnover of that governant in the next few days, and a closeout of U.S. Marine

operational presence in Iraq not later than about the first week of October.

I'm almost as proud of my Marines, sailors and soldiers for their performance and conduct during the stabilization phase as I was during the attack up through Iraq into Baghdad and beyond. In the attack, they demonstrated aggressiveness, raw courage, and the ability to deal with any scenario. During stabilization ops, they dealt firmly with the local population, but that was tempered with compassion, professionalism and the ability to deal with any scenario.

There were attacks against Marines and others who moved through our zones—over 330 of them in five months. Many Iraqis were killed and many more captured or detained because our methods were always to respond to force with even greater force, and Marines normally hit what they shoot at. However, for every attack, there were an equal number of Iraqi warnings that helped us avoid attacks and, therefore, casualties. Indeed, over the course of five months, though we had many Marines wounded, we have not lost a single Marine to hostile fire.

Yet Marines normally don't do nation-building. The last time was in Vietnam, almost 35 years ago. We have no consolidated doctrine for it. However, sometimes a negative can result in a positive. Absent doctrine, we developed a set of guidelines or principles that our leaders and troops were to follow. Chief among them was to treat Iraqis as they would like to be treated themselves, were the situation reversed. We sought out Iraqi leadership at the local level and asked them to help focus our efforts at reconstruction.

And among other areas of emphasis, we pay particular attention to the children. The children of Iraq represent the future of the country, and we made every effort to rebuild the schools, clean up the playgrounds and hand out soccer balls. We held a belief that it's hard for a man to be angry with those who are doing good things for his children.

We found in the people of southern Iraq an industrious, intelligent society, very knowledgeable in the state of current affairs and very interested in what was to be the future of their country. I used to think Americans were the most impatient people on Earth. I now believe that distinction belongs to the Iraqis.

We should encourage that characteristic, however, especially as it relates to their security. We must continue to mature the Iraqi police, resource the Iraqi militia and oversee the revitalization of the new Iraqi army, so that the next time there is a transfer of authority in an historic place, like the amphitheater at Babylon, it will be between a multinational division and the people of Iraq.

Thank you. Your questions, please.

Q: Could you give us, if possible, as firm a timetable as you can on the turnover of authority to the Polish-led division? And can you say—did the decision to put that off reflect a negative assessment of the capabilities of that division?

Conway: General Tyszkiewicz, the two-star Polish division commander, joined us probably 20 or 25 days at Babylon before the turnover actually took place. That turnover, again, was on 3 September. That was the final turnover of our five governates. Leading up to that time, we had turned over provinces on an individual basis to various brigades that he owned, just a few days before the 3rd, but the 3rd actually was the ceremony, and again, we turned over four of the five governates officially that day.

Q: Najaf—

Conway: Yes. Najaf, now, we held. And the reason we held it was not in any way related to what we assessed to be the capability of a multinational division. Essentially, it was in the wake of two bombings in Najaf, the latter very much more the more severe, and a feeling that the Marine presence would simply serve to lend a greater degree of stabilization and security to the people.

We had the two Latin American battalions who would assume responsibility for it with us there at the time. We continue to work, turn over with those folks. They appear to be good troops, are anxious for their mission. And I think that we will turn it over it again in two or three more days.

Q: Physically?

Conway: Yes. We hope—I would hope by the end of the week. That is based on a conversation I had just before I left with Lieutenant General Sanchez.

Yes, sir ?

Q: General, if I heard you correctly, I think you—did you say that not a single Marine has been lost to hostile fire since—

Conway: Since about the 21st of April, when we headed south into our—actually, at that point, seven governorates, in south and south-central Iraq.

Now, let me clarify. We have had one Marine who was killed responding to a firefight. He was a member of a light armored unit. The vehicle went off the road, and he, unfortunately, was crushed and killed—a vehicle accident many miles from the actual scene of the shooting.

Q: My question is if you can explain that—the sharp contrast of that to the situation elsewhere; the Army, in particular, having lost so many people?

Conway: Well, I think for starters, we're fortunate that we're in the south-central sector of Iraq. That is a predominantly Shi'a population. We went in with an attitude that the war was over; that we were there for security and stabilization operations. We wanted to make friends and we wanted the people to understand, of course, that we would not tolerate anyone shooting at our troops. And as I have said, we've had to respond to a lot of that. But I'd like to think that the combination of the population where we were—good methods well-applied have kept down the numbers of casualties that we have had.

Q: General, there's been a lot of talk about whether there are more—whether there's a need for more U.S. troops, whether there's a need for more troops period. Your assessment in the south-central area and how the force is arranged there?

Conway: Bret, I would say first of all, I don't think we need more troops. We think that the numbers of troops that we have are sufficient. We have had essentially one battalion applied to each governorate, and that has been plenty, based upon our methodologies. And let me explain that for just a moment, if I can.

We have tried, and have been very successful, I would argue, to train new Iraqi police in Western policing methods, and they represent our first line of defense. Behind that, we have incorporated into the MEF some very capable Army MP companies who take up residence inside the cities. They reinforce the police and they take care of that next level of problems, if and when they arise. We have used Marines after a time principally as quick response forces, QRFs, who respond when something starts to get out of control, and you need a very capable force to accomplish that. So in that regard, we've been able to make max use of the troops that were available. And we think that we don't need any more.

Q: That's (defining?) the mission to execute infrastructure protections?

Conway: Yes. We have a lot of pipelines, power lines and that type of thing, of course, that roll through our area. We have enlisted the support of some of the Iraqi tribes to assist us in security there. The FPS system, the protection system that's been developed to use Iraqis, is having some good results. We think they'll get better as they get more mature. We fly helicopters along the pipelines. We have mobile patrols that run the pipelines and those types of things. And I think it's fair to say that in the past five weeks or so now we have not had sabotage or stealing—sometimes stealing results in a sabotage to the pipeline because there are explosions and there are fires and those manner of things. But, knock on wood, in recent weeks we have not seen either of those in any kind of numbers.

Q: Just to follow up, what did you find was the best way of enlisting the tribes in this? I mean, to pay them per day trouble-free or what?

Conway: Well, a personal relationship works. And we've tried to manifest those things in time.

If you appeal to the logic that the thieves and others, the saboteurs, are committing crimes against the people of Iraq and that the result that you're seeing is a large black market and your people are paying unfair prices, they understand the logic of that. So there has been some minor payment of seized funds, but not—not on an exorbitant scale.

Q: General, the Army's 4th Infantry Division commander told us a couple months ago that the Marines had come to him with concerns about the Javelin missile in combat and that they were working to address those. Have you heard, you know, what the results of that were, and—

Conway: No, I have not. I read some of the same things that you're talking about in regards to Javelin. And we had some concerns before we crossed the line of departure about some of our tank-killing methods. Some of it

was reliability in some of the blocks, some of it was training on TOW 2s. You know, the missiles are so expensive any more that you don't get a lot of opportunities to fire in training. But we didn't have problems with the Javelin. And when I went back to just informally canvas in the wake of having read that report, I didn't get a lot of negative comment on the Javelin. So I'll be anxious to see what the Army's study presents, when all is said and done.

Q: General, since the bombing in Najaf there have been militias that have been appearing on the streets. I understand that there's been an ultimatum given to one—at least one of the militias to have to clear out, basically. Can you explain what—that situation is all about, and also, what is the risk of militias moving in to basically take control of security, you know, if there—if there aren't U.S. forces there? And they're creating a situation where you may have militias later competing with the police or fighting among themselves for turf.

Conway: Let me give you the bottom line first, if I can. What you described is exactly right. It applies to all militias. And that is, that there will be no armed militias on the streets of Najaf. That has been worked through our assistant division commander and the mayor of the city. And those people are no longer present today.

Now, the effort came to pass as a well-intended, short-term, almost experiment, if you will, on the part of the CPA to see if we couldn't get rapid security into the shrine area in the wake of the bombings as we trained up—provided additional training for a 400-man police force in the Najaf city police. It was to be for a two- or three-day period. We let it run that far and then we terminated it because of some of the very things that you describe. It was getting to be a little bit problematic. People were ranging outside of the assigned area, conducting vehicle checkpoints. They weren't always identifiable to us. And so some of the things you very, I think, adroitly picked up in your question were the things that we thought were problematic with regard to recognizing militia. That was something that we had said we wouldn't do. And in retrospect, it's something that we think is still the right call for the country.

Q: And has the—I think it's called the Mehdi Army. Have they cleared out of the streets at this point?

Conway: What we have done—because the problem is real—is said to the various clerics, “If you want to increase the size of your protection detail, you can do that.”

To the extent that—in the case you're describing—Sadr wants to have a somewhat larger detail, and that would be some of his Mehdi Army people, we would probably let that happen. But only in his exact location would we allow those people to serve as a protective detail.

Okay. I'm just working my way back here, folks. Please?

Q: General, there has been some talk of Marines being used in more peacekeeping operations. Can you say if any I MEF units would go back to Iraq to perhaps relieve Army troops there?

Conway: Probably too early to say. I will tell you that when we put the preponderance of our force out of Iraq, the guidance that we were given was to recock. Now, to me that meant get back into what had been our deployment routine; in the case of I MEF, for most units, about six months deployed, about 18 months home. I have since seen the projected requirements in the out years. And what is being said, I think, essentially by the people who are doing the planning is it will be a brigade or a division, service not given. And I think that at this point we probably shouldn't say it will or will not be Marines. I think the JCS will have to evaluate that, and I think we'll have to be prepared to field that requirement if, in fact, it's headed our way.

You're right in that Marines don't normally do this type of thing, but I think we all recognize that the Army is being fairly well stretched now with all the other requirements that it has, so it would not be an inordinate request, I would not think.

Yes, Sir?

Q: General, can you give us an idea of the composition of the quick-reaction forces that have been developed over the course of the post-combat operations: you know, what kind of structure they are, is it helicopters, is it LAVs? Can you give any idea of the structure?

Conway: It's some of all; it depends upon the situation. The—my reaction force—I don't hold a reserve, but I do have a squadron of Cobras that can be employed in virtually any situation; troops that can be heli-lifted based on the medium helicopters that we have left back.

At the division level, General Mattis' reserve is a light armored reconnaissance battalion, quick on the

ground with a good bit of firepower. At the battalion level, and that's where we have seen them deployed in virtually every instance, it's a platoon or a company-based upon a scenario, could be as much as two companies, or the entire battalion, if the battalion commander thinks it necessary. We have not seen that at all. We have seen, in one instance, the deployment of a two-company QRF, with a number of demonstrators in the city of Najaf some weeks back now.

Q: Do you find that the MAGTF [Marine Air Ground Task Force] structure allows for more flexibility than other coalition forces in the region?

Conway: I can't speak to that. I can say that it gives us great flexibility. We have ground transportation for those folks. Again, the other methods I mentioned to you, the LAR, the helicopters, are all very quick response, especially based on our ability to put detachments in—in what we say “the dirt” at various locations around south-central Iraq.

Okay. Yes, ma'am?

Q: You said in your earlier comments that the Marines Corps does not have a nation-building consolidated doctrine. Is that something that the Marine Corps is looking to address (word inaudible)—permanently, versus doing it ad hoc—on an ad hoc basis?

Conway: We think we've got to do that. We—what we used were essentially two documents. One is a small wars manual that goes back to Marine Corps intervention in Nicaragua in the '20s and '30s. You'd be interested on how many of the lessons are still applicable, really. And that document has maintained its application over the decades. The other is a concept that was developed by one of our former commandants, General Krulak, that talked about the three-block war. And in that, he said in the first block, Marines will be feeding hungry people; in the second block, you're keeping warring tribes apart for whatever combination of reasons; and in the third block, you're in full-scale combat; all of those things on the same day in the same locale. And that captures what we've seen there from time to time, quite frankly. It's pretty close.

Now, we feel like that we will have to, in the wake of this experience, provide some much more detail how-to to those young commanders that follow, and that will be, in great part, the responsibility of my MEF to be the advocate for that.

Q: Any civil affairs roles that you foresee expanding—(inaudible)?

Conway: Well, I think—I mentioned earlier numbers of troops. I think that we need to make sure we send in the right kinds of troops. And among those would be greater numbers of MPs, a greater representation by Civil Affairs, Psychological Operations, Information Operations types of folks. I just think that this, what we call Phase 4-type environment is a much better place to use those types of forces, perhaps, and your grunt, you know, that will do as he's told and do a great job at it but doesn't have the necessary background or training to be that expert.

Yeah.

Q: General, two questions. One, the rotation of the troops out. What unit is still up in Najaf, and will they be coming out to Kuwait, or be—will they be going home? And then a forward-looking thing. The Marine Corps now has fought two wars in the last 12 years where you basically are a mechanized force. And you're—you know, the Marines prides itself on being light infantry. Do you need to reorganize at all, you know, creating some kind of permanent mech force, or can you—the way you've done it in the last two times is ad hocing it. So, is that really the way to go?

Conway: First of all, 1st Battalion, 7th Marines is the battalion that's located at An Najaf. The commanding officer up there is Lieutenant Colonel Chris Woodbridge. They will pull out of there as directed by CGTF 7, but they will move back through Kuwait to base camps that we had established there before we crossed the line of departure. And then it takes anywhere from a week to two weeks to line up aircraft tail numbers to get them home. So that would be the sequence of their withdrawal.

Now, we don't just have a battalion there, I think it's important to say. In this MAGTF structure that someone pointed out earlier, we have a support detachment, and slice of Marines from our 1st FSSG that are in Najaf with them. There's a headquarters element, if you will, that still oversees their efforts. The—and the wing has a Marine air group, comprising CH-53s, C-130s, CH-46s and Cobras, that provide them, again, that variation on

support. So it's not just a thousand Marines or so that are in the battalion; it takes a larger chunk than that to keep those folks there and doing the job.

Q: They'll all be coming out?

Conway: They will be coming out, that's correct.

Q: (Off mike)?

Conway: Well, when I left we had a couple of pretty good flights out. But I would suspect there's still probably 8,000 Marines in Iraq and Kuwait at this point.

To answer your second question, my advice to my commandant has been that we look at, certainly, this most recent experience as an anomaly, and not that we look at re-organizing the Marine Corps to give it that heavier capability: more HETs—heavy equipment transporters—more tankers, those types of things that would support a heavy mechanized force. You call it ad hoc; I call it task organization. I think it means the same thing. But we are probably the best in the world at doing that. It just—it tends to confuse most other people. But we feel we can throw together a force very quickly with those elements of a Marine air-ground task force that are necessary, very well supported by Navy shipping, to get us where we have to go.

And so I would advocate that that balance that we've got is something that makes us ready to go anywhere on short notice and do what the nation asked. So I would not advocate that, in effect, we become a second army, if you will, with their task organization and some of the same equipment that they use.

Q: Well, we don't have the long—the heavy transporters. A lot of them you've had—in most cases, you've had to borrow or rent the long-haul trucks, things like that. And you've made it work, you know, two times now.

Conway: And we think we can make it work a third time if we have to. So we'll not reorganize in the face of that.

Yes, sir? Here.

Q: General, in your estimation, what more still remains? What do you think still needs to be done before Iraqis will be fully capable of taking over security in the areas of the country where you are working?

Conway: Yeah, that's a great question. I think one of the things that we need to focus on heavily is getting the infrastructure up and keeping it up. And in turn, that will have a very positive effect on security.

Right now the factories of Iraq are not working, and they're not working because there's no dependable electricity to give them anything akin to a 24-hour steady energy base. If we can do that, I think it'll take a population of Iraqis, young Iraqis, off the streets, that I think some of the former regime leadership are using for the ambushing and the mortar attacks and those types of things. Right now the young 22-year-old Iraqi has very little means to make a living and earn an income. If we can get them into the factories, get them into the militia, get them into the new Iraqi army and so forth, I think we'll be helping ourselves in the process. So that's the first thing. That, I think, really has to happen pretty quickly.

Beyond that, again, the formulation of these various groups that will put an Iraqi face on it, I think, will give us additional intelligence that will allow us to respond to that diminishing number of people that are there that would disrupt the process and do our people harm.

So it all is related. I think it's an integrated effort that needs to occur. And when we get the country back on its feet from an economic perspective, I think it will, again, help greatly with the security.

Q: Do you have any sort of notion as to how long you think this might take?

Conway: It will take a while. I don't—I can't put it in terms of months or years. I had an Army Corps of Engineer colonel tell me that even once we get the electrical grid back in place, it's not going to be very dependable. And the reason for that is that it's had 30 years of neglect; that there are parts in these power stations from 15 different countries, so when you go in with a problem, you never know quite what you're going to face. There's no constancy to the parts requirement, for instance.

So how long? I can't say. But as I mentioned, the Iraqis are very impatient people. They're holding us to the "man on the Moon" standard. In their mind, it should have happened yesterday. And so we probably can't do it too soon.

I missed you here. Go ahead.

Q: From my understanding, Central Command now has the findings of the friendly fire incident back on March

21st, I think, in An-Najaf, where I think it's between six to 12 Marines might have been killed by an A-10. Do you have any detail on that report at all, or what may have happened in that incident?

Conway: It was March 23rd. And I have seen a draft of the investigation. It's my understanding that it has been sent back for some rework. I'm not purposely being vague, I just don't know. But I think that CENTCOM has sent it back to the Air Force, and it will be CENTCOM's responsibility to publish it, of course, as soon as it's approved by the commander in chief—or by the commander of Central Command.

Q: There's no other details you can—

Conway: Not at this point. I think we should wait for the investigation to come out.

Q: Thank you, General. Over here. The Blue Force Tracking was supposed to be a step ahead in avoiding fratricide this time. Did you all have Blue Force Tracking equipment in your system? And do we need—is that the answer, I mean—

Conway: No. No, it's not. We had over 400 sets, some given to us by the Army, some that we procured ourselves. But Blue Force Tracker, ladies and gentlemen, creates situational awareness on the battlefield. When my counterpart, General Wallace, in V Corps looked at his screens, it showed the same as my screens in terms of where units were.

Fratricide is caused by our inability for the Air Force A-10 pilot to look at a vehicle and have an immediate recognition, friend or foe. The same is true with tanks. If a tanker, on a dusty, dark night, lines up his main gun and he can't query a target, then we aren't where we need to be with regard to the avoidance of fratricide.

Blue Force Tracker helps tell you where units are in general design; it does not solve the problem of blue on blue, or fratricide.

Q: General, there have been a number of news reports speculating about a possible civil war developing between the Shi'a in the south, and that maybe some moderate factions and some extremist factions would be butting heads. Just on your experience, what's your assessment of that possibility?

Conway: I don't see that in the south. There are a lot of accusations, a lot of uncertainties associated with that, I believe, that are flying about in terms of who's doing the bombing and who would stand to gain most from it; who would like to see destabilization, be it in a religious context or in a governmental context or whatever. But I don't see factionalism being brought about as a result of that. So—I have read some things like that. I just don't think that the Shi'as—the wise Shi'as, who see a future Iraq with a heavy Shi'a imprint on it, allowing that to happen.

Q: Is the overall perception in that community a welcoming one or a skeptical one about U.S. presence?

Conway: Oh. I wish I could take every one of you here on a trip from Najaf to Karbala back to Hillah in military vehicles. Little kids run a quarter-mile on a hot pavement with bare feet to wave. And the adults do the same thing. You drive by, I mean, it's like you're constantly on parade. And I won't say you tire of it, because it's a very gratifying feeling. But it's there in spades. They welcome us. They're still welcoming us because, any number have said, "We fear, when you go, that the people who wanted to see you go will come in and we won't have our democracy."

So it's just a tremendous experience. I'm delighted every one of my young Marines has been able to be close up and a part of it and see it. And it's a good-news story that, in my mind, is not really reaching the American people, and I think that's unfortunate.

Q: General ?

Conway: Yes, Sir?

Q: On phase four operations, it's proven difficult for us here to sort out who was meant to be doing what and which and whom. Could you tell us what tasking did I MEF get for phase four; and were you quietly doing planning for it? Tell us what you expected or what you did and then what happened.

Conway: We were told about halfway to Baghdad what our sector would be, first of all. And it turned out to be the nine governates in the southern half of the country, two of which belong to the British. And after 15 June when the British went national, those two governates were exclusively theirs.

Our mission, to paraphrase, was to create a safe and secure environment in order to turn Iraq back over to the Iraqis. And that's been our drive and motivation ever since, is to, again, incorporate as many Iraqis into the

reconstruction efforts, have them tell us what it was that they wanted to see built back first—be it schools, hospitals, sewage, all those types of things, and as soon as we could, to get Iraqis making decisions. And I do. I think we're having some great success there.

If you use what happened in Najaf, as regrettable as the bombing was with the loss of life, the response on the part of the City Council, the mayor, the Najaf Police Department with regard to controlling the scene, getting emergency help in right away, calling the FBI, arresting some who they think are perpetrators very quickly on the heels of that, followed by the control that they exercised during the procession that resulted in the burial of Hakim, we were very much on the sidelines watching that take place, but very happy that we had seen the community grow to the degree that they could do that without real difficulty.

Q: And the—just to be sure, the biggest unexpected in your experience of phase four turned out to be what? (Pause.)

Conway: Hm. I guess it has to do with the infrastructure and just how brutal we found it to be. We call it sort of the basic needs, the hierarchy of needs that the population has. You know, I would say food, water, power and fuel are the things that a community has to have before it's going to grow and prosper and do other things. And it's just been very difficult to get that back up on plane and keep it there with any level of consistency.

So I—you know, when you fly over the country, where you see all these power lines headed all the different directions—it's a nation with the second-largest resources in the world in terms of raw fuels, so it was a little bit incredulous to me after a time that we continue to struggle with that and just try to bring it up on line.

Q: General, what about the absence of WMD? You said previously that—when we talked to you some weeks ago, that you were surprised that none were found. What's the latest on that, and what's your overall assessment?

Conway: We continue to receive leads from time to time, from well-intended Iraqis that saw this happen or saw that happen in the dark of night. We put teams to go and investigate and research, to see if there's actually something there. I will tell you, to date, that we have not had any of those leads turn into anything tangible.

If you have patterned it, the high-value targets that have been rolled up have almost entirely come from the northern part of the country. So we don't have immediate access to the interrogations.

But I still am optimistic that we will find the existence of a program. I don't think—and in fact, I can tell you, from our operational experience, that weapons were not at the operational level, as much as we thought we would find to be the case. But I—

Q: (Off mike.)

Conway: We have not found any. We had reports, but they did not bear fruit.

But I still think that somewhere out there barrels are buried in the desert. We recently found MiGs buried that we didn't know about. So if you contrast that with the difficulty of burying 55-gallon drums, I think it's certainly within the art of the possible. So I still remain optimistic that we will find out, in the long term, based upon the people we are rolling up, the interrogations and so forth, that elements of a program existed.

Q: Sir, General Amos mentioned that a large portion of Cobras had received damage in combat. Can you say if there are any efforts right now to reevaluate doctrine of helicopter combat?

Conway: You know, I will tell you that during the fighting, we continually reevaluated the doctrine on the use of Cobras. The first night we crossed the line of departure, I said to General Amos, you know: I don't want to be imminently successful on the ground only to turn to you and find out that we had six Cobras shot down. So initially, I want you to be conservative with your tactics as it relates to your shooters, until such time as we determine the density of the area of defense threat, and then we'll go from there.

Was good but not great in terms of that level of anti-air that the Iraqi army demonstrated. So, our pilots became more and more bold as we went up towards Baghdad.

After a time, the Iraqis patterned us, and they realized that we would have aircraft on the flanks of the troops, running up and then turning off the nose of the lead elements. And we found, up around Azezia (sp), that they had actually dug rifle pits well off to the flank but parallel to our line of movement, which gave them some great shots against our helicopters.

So then, we had to change that pattern to come back over the heads of troops, one aircraft shooting, another

er one, an (over-watch). And when we got into Baghdad per se, we consciously did not over fly the city unless we had troops in extremis and we had to get in and get the support that they needed.

So, it was a cat-and-mouse game of sorts. We had a number of aircraft damaged. We had six that were downed by enemy fire, but fortunately, all six landed inside friendly lines. We lost two pilots, unfortunately, who crashed into a tower when they were providing air support one night to troops up in the vicinity of the Tigris.

But I would say that outside of that continual evaluation of your methods and tactics, that the Cobra was a tremendous airframe for what we needed to do. We're going to make continued improvements, putting four blades on it to make it faster and even more deadly. And I think it's going to be a very viable aircraft for us for a number of years to come.

Whitman: One more, I think.

Conway: Okay?

Q: General, this is another helicopter question, but it relates to the Apache Longbow. Last week, General Hagee said that when V Corps gave I MEF a layout of the tactics, and that the TTP for the Apache Longbow usage, that the Marines found out that they couldn't support those Apache Longbows if they got in trouble. Can you expand on what kind of, you know, conundrum you ran into when the Apache Longbow TTPs were delivered to I MEF, and what kind of problems you had supporting those helicopters?

Conway: Well, the essence of it is that for the Longbow, I think, to be successful, and I would—General Wallace would say this, I feel fairly certain—that you need close air support that is also helping to prep the area where they're operating. And it was simply a matter of boundaries and passing our fixed wing air, had they asked for it, over into the Army area of operations with the right-forward air controllers working our air. That was the essence, I suspect, of General Hagee's comments. I have not had that conversation with him. But if you asked me what would be the difficulty in providing that close air support, that would be it.

The Air Force, for the most part, provides it for the Army. The Navy augments that with their forces at sea. We gave them some of our air in a couple of situations in extremis. We were not asked to support it the night that they had their Longbows damaged. But that would have been, I think, the issue he'd had to work through in order to make that happen.

Thank you very much, ladies and gentlemen. I appreciate it.

Q: Thank you, General.



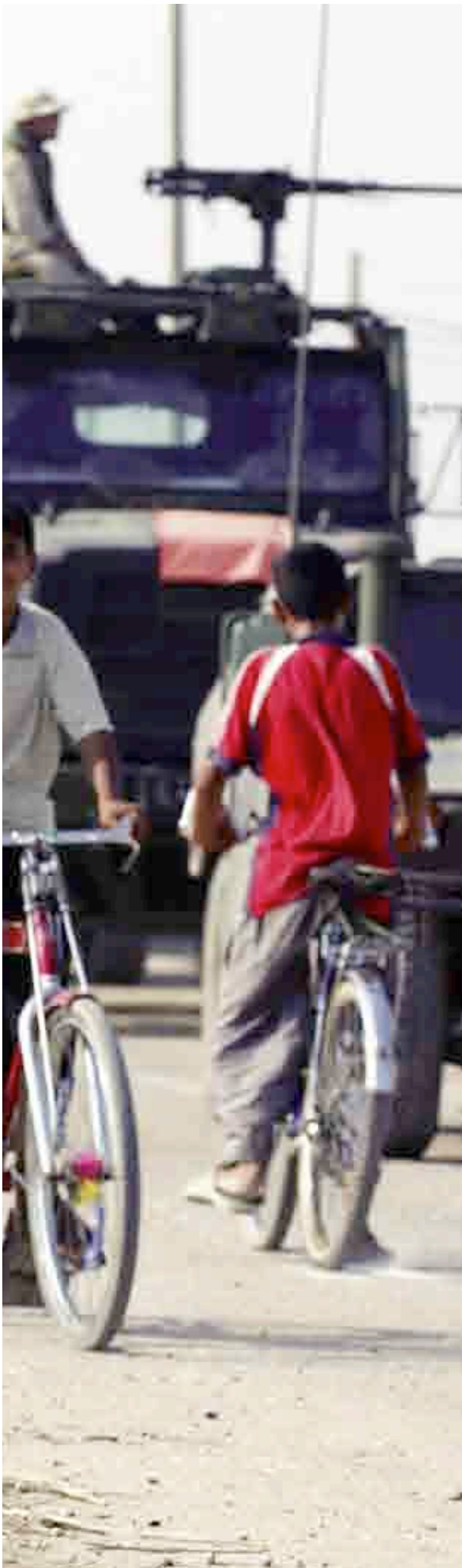

‘We’ve Always Done Windows’

interview with Lieutenant General James T. Conway

U.S. Naval Institute Proceedings, November 2003.

Lieutenant General James T. Conway, Commanding General of I Marine Expeditionary Force and senior Marine in Operation Iraqi Freedom . . . spoke with the Naval Institute’s Senior Editor Gordon Keiser on 7 August.

Proceedings: What was your perception of the alleged meddling in Operation Iraqi Freedom (OIF) by the Office of the Secretary of Defense—especially in the planning process?

Conway: I think there’s probably only one man who can answer that question and his name is General Tommy Franks, then—Commander of the U.S. Central Command (CentCom).

If it was happening, it was transparent at my level, with one exception—and I would not call it meddling. It was simply a technique of deployment. We spent probably about six weeks, over three different conferences, preparing the time-phased force deployment data. When it came time to deploy, it actually was done by requests for forces. And each of those was scrutinized, not necessarily by Secretary of Defense Donald Rumsfeld, but by his office. They were lumped and approved in “groupments” of forces for deployment. Not the way we would typically do things; perhaps not the way we would advocate doing them in the future.

That said, we deployed 60,000 Marines in about 45 days, using all manner of strategic lift: Air Force aircraft, Navy ships, and black-bottom shipping. I can’t complain about it too loudly because, at least for the Marine Corps, it worked.

Proceedings: Can you tell us about the intelligence support you got—intelligence preparation of the battlefield, both human and technical?

Conway: It was good. We had all the intelligence that a full Marine expeditionary force (MEF) could expect to have, because we had sources from I MEF and II MEF. Marine Force CentCom Commander Lieutenant General Earl Hailston committed what he could. Of course, we had the intelligence resources of higher headquarters to draw on and all the national imagery we could use. As always, you get more information than you do pure intelligence, and there was the distillation process we had to go through.

Proceedings: Were you able to distribute it effectively?

Conway: We were, especially before the war. I think speed of the advance caused some complications from our subordinate units’ perspective on what they were able to get after we were under way. They weren’t always able to set up their means to reach back.

We weren't always able to get them a product before they shut down and moved again.

We didn't get a lot of intelligence about the Iraqis per se. For example, we were told they had civilian clothes in their packs and were just waiting to capitulate. When we attacked, they were going to get into civilian clothes and surrender or go home. Well, what they did was get into civilian clothes and fight us, which made things harder. So even with intelligence, you had interpretations that might not have been on the mark. But I would not complain about it overall.

Proceedings: Some observers, including retired general officers on TV, continue to worry that the ongoing U.S. campaign in Iraq will detract from the worldwide war on terrorism. What is your view?

Conway: I really think [OIF] is central to it. Not that we believe there were numerous ties between Iraq and terrorists, although there were some in the country. A certain momentum among the terrorists was gained after 9/11 that caused us to act in Afghanistan, that caused the President to look at that hole in New York City and say "Never more." I think he looked around and said, "Okay, who's the guy most likely to cause this type of event again—based on attitude, weapons availability, intent, which we could never fully gauge—and we went after him. And I think the momentum of terrorism has been slowed.

Proceedings: Would you describe how U.S. and allied command relations developed for I MEF?

Conway: When we crossed the line of departure (LOD) from Kuwait on 20 March, we had roughly 81,500 people assigned to I MEF. Our top figure was just short of 90,000, about twice the size of a normal MEF.

Proceedings: All services?

Conway: All U.S. services and 20,000 Brits. We started out with the belief we would have an understrength Royal Marine commando brigade assigned to assist us in the south. When the 1st U.K. Armored Division was unable to go ashore in the north, they rotated south and were assigned to us. So, we joined a whole British division, consisting of three brigades: the commando brigade; an air assault brigade; and a U.K. armored brigade, consisting of four battle groups. These were very capable troops, with great equipment. All in all, the relationship was magnificent.

Proceedings: You reported to whom?

Conway: I reported to Lieutenant General David McKiernan, Coalition Forces Land Component Commander. General Franks decided to go with a functional alignment, which meant all the ground forces would fight under General McKiernan. Under him were two corps: 5th Corps and I MEF, in a corps-like configuration. It worked and was jointness in its finest sense. I had a solid relationship with General McKiernan. The staffs had the inevitable friction over pop-up issues, but level heads always prevailed.

We thought the commando brigade was a bit light to accomplish our taskings. So we assigned the 15th Marine Expeditionary Unit, with its tank platoon and company of light armored vehicles, to that brigade for operations on the Al Faw Peninsula. We left that arrangement intact for about 100 hours after we crossed the LOD, until the brigade had accomplished its mission; then we pulled it back. This task-organized unit was very proud of its role and rightly so. It was the first time since World War II that we put a U.S. force of that size under any foreign commander. The 15th MEU commanding officer worked for the British brigadier until he was chopped back to I MEF for subsequent assignment to Task Force (TF) Tarawa.

Some other things were a little unusual. Task Force Tarawa—essentially, 2nd Marine Expeditionary Brigade from the East Coast—was a Marine air-ground task force (MAGTF), though we took their aircraft. We likewise assigned the 15th MEU (and later the 24th MEU) to TF Tarawa, leaving them with their headquarters and combat service support elements. We stripped away their aviation elements and assigned them to 3rd Marine Aircraft Wing, just for efficiency's sake.

Proceedings: This was done for ease of air scheduling?

Conway: Yes. Doctrinally you're not supposed to have a MAGTF working for a MAGTF, working for yet another MAGTF—but we did it. It worked quite well. So maybe our doctrine needs to be reviewed.

Proceedings: How about your command relations with Army Special Forces (SF) and Navy SEALs?

Conway: They were good in the early going, when we could do deliberate planning. For instance, the SEAL's takedown of the oil manifold (distribution facility) on the Al Faw Peninsula and the two gas-oil platforms at sea worked very well. They were under the tactical control (TACON) of I MEF for that operation, once they

were ashore. The Army also did some good things for us around Nasiriya. In time, the problem we had was their ability to respond quickly. They had about a 96-hour string on them—their ability to take a mission, resource it, post it to higher headquarters, and get back to us with a green light.

Proceedings: You mean their Special Forces headquarters?

Conway: Yes. Even though they were under our TACON, their higher headquarters stayed engaged, to a degree that such a relationship wouldn't necessarily prescribe. They first said it would take about five days to complete that preparation cycle. I said, "Hey, that's entirely too long. When we see a gap in enemy defenses, the first thing we want to do is kick out the reconnaissance. I can't wait five days to do that." A little later they said they could do it in 96 hours. I said, "Okay, thank you very much. Marine force reconnaissance can do it in 12 to 24 hours, and I think those guys are going to get a lot of work." So it was difficult after we crossed the LOD, with the speed of maneuver that we had, to employ them much beyond those initial missions.

Proceedings: Did you use your force reconnaissance units much?

Conway: We had nine platoons and used them a good bit. I suppose if you talked to those guys, they would say they were underused. We were cautious up front because many of the special operations forces used in the previous Gulf War had been rolled up, killed, or captured. We didn't want that to happen to our force teams. We wanted to make sure we could go in and get them, or they had a chance to escape and evade back to friendly lines.

Initially, we employed a couple of force recon platoons for tactical recovery of aircraft and pilots. A lot of aircraft went down—not any shot down, but aircraft that had to land because of holes in their fuselages or blades. In virtually every case, they landed inside friendly lines. Had the mission been as difficult or risky as we had anticipated, the force teams could have been extremely busy. As it turned out, that was not so.

Proceedings: Since the end of the combat phase, how do you account for the difference in Army and Marine casualties—different tactics or different operational areas?

Conway: I think some of both. Some people will say it's because we're in the south and we've got the Shia population, which is peaceful at this point. What they might need to be reminded of is that, before the war, they were called the volatile-Shia—all one word, with a hyphen. Well, they're not volatile; they're peaceful and working with us. Together it's a great partnership. We're applying our own approach. Perhaps one of the best things about what we're doing is that we don't have a lot of doctrine on nation building. We're issuing commander's intent. We're describing the desired end states and applying what resources we can to them. In the early going, seven battalion commanders were doing things seven different ways. But in every instance it worked—and it still is.

We've got the ability to put a lot of boots on the ground—as much ability in a single Marine regiment for troops, squad-sized patrols, as an Army infantry division. We can permeate an area completely, and that's what the 1st Marine Division and TF Tarawa did in the early going on the eastern side of Baghdad. We said our long-range fight—the MEF fights the rear battle, the close battle, and the long-range battle—would focus on the children. Let's get the schools cleaned out and the weapons removed from them. Let's rebuild them and regenerate what used to be a highly literate society. We've handed out a lot of soccer balls to the kids. The patrols dispensed candy. Our approach was: if you're doing something for the kids, how can the parents go out and throw rocks at you?

At the same time, we've got a no-nonsense policy that deals sternly with people who try to do us harm. We've worked an inside-out policy that says we go into the cities and quell any concerns with security and stabilization. We established working relationships with the Iraqi police and U.S. Army military police.

Baghdad is tough. It's a big city, without the distinctive borders you have in the southern cities. You don't have rural areas you can rotate troops into and that type of thing. You've got high-rise buildings, where the enemy can fire on the Army troops. Even so, our approach—recognizing the war was essentially over; that all the Iraqis in our zone that needed killing had been killed; and that it was time to go to soft covers, sling-arms, and mix with the people to show them we're there to help—has indeed made a difference.

Proceedings: How do you see the Marine Corps' commitment in Iraq in the long term?

Conway: I think there will be a U.S. commitment for at least another year or two. I don't think it's going to

be all that long, because the Iraqis are very impatient people. I used to think that Americans were impatient—we don't hold a candle to the Iraqis. They want it all now, to include us turning over their government, policing, and all that type of thing to them now. If there is a continuation of U.S. military force, as far as I know the request for forces simply will read a division or a brigade. It could be a Marine brigade that winds up going over there again in a rotation policy. We've always "done windows," I guess, and we'll do whatever the President, Secretary of Defense, or the combatant commander directs.

Proceedings: What is your opinion of OIF media coverage in general, and the embedded reporter concept?

Conway: I would give "OK" grades to both—especially the embed concept. I think that's a home run and the wave of the future. We've got to understand what it means to us, because it's a different dynamic. I would offer it as much more akin to the way the Navy and the Marine Corps have always done business, and more foreign probably to the Army and Air Force. But I think those services would say it succeeded very well.

We have to realize, though, that what those folks report essentially is what goes on 500 yards around wherever they are on the battlefield. It does not give the overarching perspective that is necessary. We could get only one channel after we crossed the LOD; however, from what I saw, other folks provided that function. So, all in all, it gave our American public the human-interest stories they enjoyed reading and wanted to see.

I would contrast that coverage to what we're seeing in the stabilization phase, which is not nearly as positive. I don't know why that is. We've got some folks who don't want to hear good news stories. In fact, we had one reporter tell us, "Hey, good news is no news these days. Go ahead and open your schools and do whatever. I won't be there." Every day you hear about soldiers being killed and the negative aspects of what's taking place. I really think it's starting to have strategic importance, and I hope there would be a better balance in what we're seeing.

Proceedings: How do you account for the Corps' apparently good record of public relations in OIF?

Conway:

When a media rep comes to talk to me, or he comes into our camp, we say, "Go talk to the corporal; go talk to the sergeant. He'll tell you all you need to know. And we'll fill in the blanks, all right?" I've yet to see it fail. I met with a newspaper reporter the other day and he said he was absolutely amazed that commanders would have that level of confidence in their troops. He had access to everybody up and down the chain of command.

Invariably the young troops describe it like it is; they provide colorful language and tell their story. At our morning meeting each day, we had a "quote of the day" that some Marine—normally lance corporal through gunnery sergeant—had said the day before. Any officer would be hard pressed to say it better. That relative level of comfort is something that hits home runs—and the troops invariably cast us in a proper light.

Proceedings: A great deal has been reported about severe strains on the services' reserves and National Guard. How have Marine Corps Reserve forces stacked up in I MEF?

Conway:

They did great. It was tough to tell the difference between an active battalion and a reserve battalion as soon as their faces got dirty and their gear got dusty. We were delighted with them. There was some difficulty in the initial call-ups and those types of things, but it was chicken feed compared to the overall performance. A battalion on the East Coast and a battalion on the West Coast were called up to assist in force-protection duties before the conflict. Those guys had been on active duty almost a year. When the time came, they didn't want to go home; they wanted to go to Iraq. That level of motivation represents what we saw in all other facets of the reserve establishment as well. I'm told the unhappiest people in the reserves are folks who did not get the call to go.

I received figures the other day verifying that about 48% of the Corps' reserve establishment was called up in one capacity or another. Is there a strain over time? Probably. But I think our program is the model for all services.

Proceedings:

Are recruiting and retention in the face of continuing major commitments your biggest challenges today?

Conway: You know, the troops are doing wonderfully. We had a couple of battalions take "head fakes"—they thought they were going home earlier and that got changed. If you go to those units now and ask them, they'll

tell you, “Hey, I’ll go home when my battalion commander tells me I can go home. We’re here; we’re making a difference.” They even have a sense of ownership about those cities where they are located.

The one thing we face, an age-old problem for the Corps, is simply having enough money to buy everything we need. Although I did discover—and it was a nice lesson to learn—we are probably state-of-the-art in most of our communications equipment and training.

Proceedings: How has the profession—and the Corps’ professionals—changed since you graduated from Southeast Missouri State and were commissioned?

Conway: We’ve got a lot more married Marines than before, which has its impact when you deploy and in how you take care of the families back home. But there are some great programs in place that have adjusted to that new dynamic and we’re good to go.

The Corps’ ability to deploy any unit and expect it to do great things is far better than it was before. We had an executive conference two months ago, when Commandant of the Marine Corps General Michael Hagee met with his three-star generals. I said I knew that senior body is responsible for making adjustments that will prosper the Marine Corps in the long term. But I also said we are closer to institutional excellence than we have been in my 32 years in the Corps, and we should be very careful of things we would change. At this point, our go-to-war capabilities are the envy of the other services.

Part II
Ground Combat

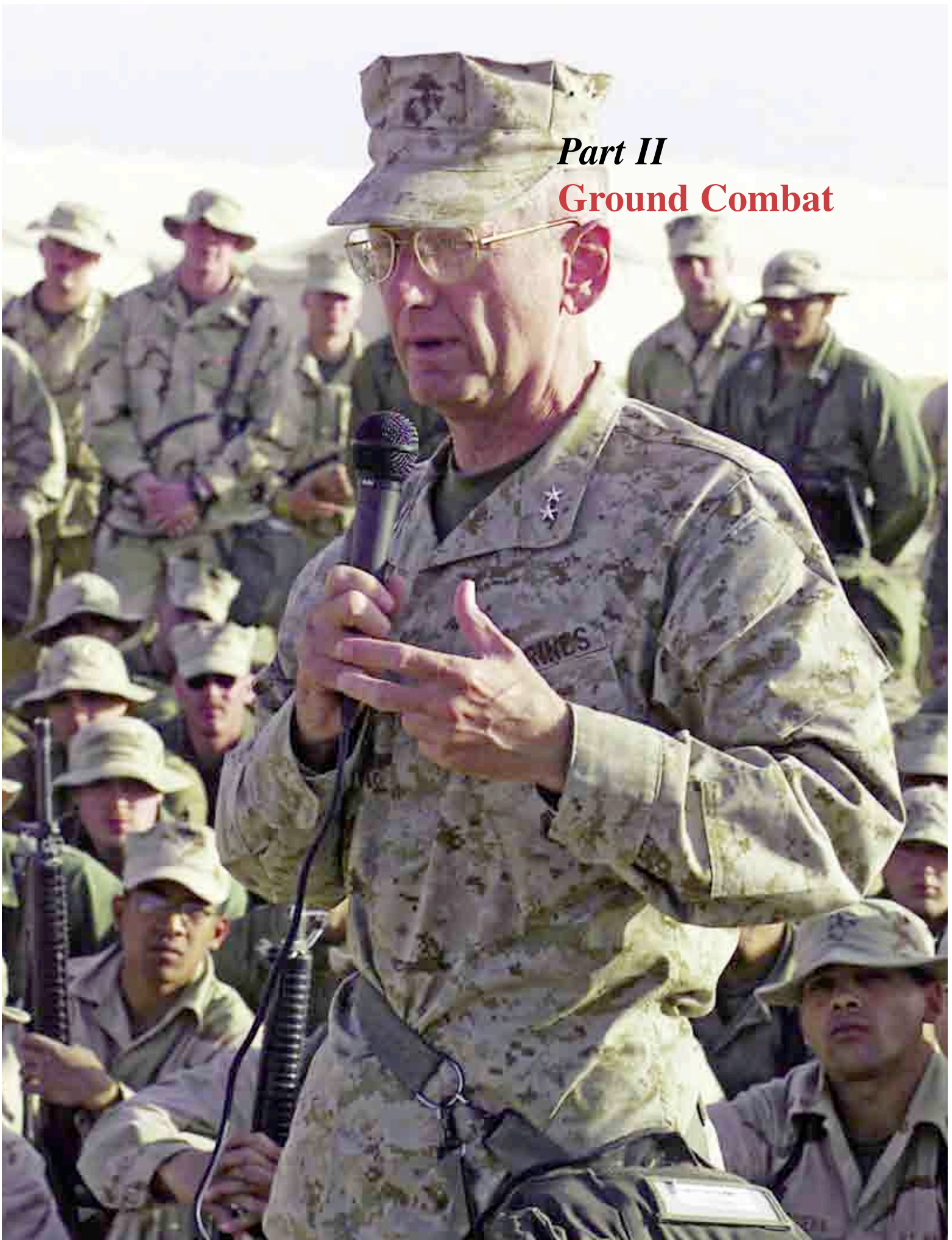

Marine General: Iraq War Pause ‘Could Not Have Come At Worse Time’

by Elaine M. Grossman

Inside The Pentagon, 2 October 2003.

Copyright 2005 *Inside The Pentagon*. Reprinted with Permission

The five-day “pause” U.S. troops took before capturing Baghdad last spring “could not have come at a worse time” for Marine Corps forces poised outside the Iraqi capital, according to Maj. Gen. James Mattis, commander of the 1st Marine Division. The Marines were told to put the reins on the Baghdad offensive just as Mattis’ troops became highly vulnerable to Iraqi counterattack, he told *Inside the Pentagon* in a Sept. 25 interview.

Top wartime commanders have insisted there was no real pause in combat during the war because fierce ground battles and heavy air attacks continued throughout late March (ITP, May 8, p1). But it was clear at the time that the impending attack on Baghdad was put on hold beginning March 26 and continuing through the end of the month, *Inside Defense.com* first reported March 25. “We’re going to take the next couple days—the next several if necessary—to concentrate on the enemy where he’s at,” a top coalition commander said at a daily battlefield update briefing held March 26 at the Camp Doha, Kuwait, ground combat headquarters. With a sand-storm imposing “zero visibility” around Baghdad, “we’ve got to finish up taking care of all these bastards down here,” said the commander, referring to irregular militias that threatened lagging U.S. supply lines in southern Iraq. A March attack on one convoy resulted in 11 U.S. casualties and the capture of seven troops, including Army Pfc. Jessica Lynch. U.S. forces moved into Baghdad in early April and quickly captured the city, facing only light resistance.

“I didn’t want the pause. Nothing was holding us up,” Mattis told ITP. “The toughest order I had to give [in] the whole campaign was to call back the assault units when the pause happened.” Mattis said most of his division was moving up Route 1 towards Baghdad, while one Marine unit was heading to Al Kut to pin down the Baghdad Division, when the pause was imposed. He said the order was handed down from above, but he did not know exactly where the idea of a pause originated. Marine Corps Lt. Gen. James Conway, commander of 1st Marine Expeditionary Force, and Army Maj. Gen. Buford Blount, the 3rd Infantry Division commander, shared the desire to press on to Baghdad instead of pause, Mattis said.

“There was some thought about putting up operating bases outside of Baghdad and making raids into it,” Mattis told ITP. “But clearly Baghdad was falling if we went in.” The general said his forces were at a critical junction about 100 kilometers southeast of Baghdad where it would have been unclear to Iraqi commanders whether the Marines would proceed directly into southeast Baghdad, or come around from the northeast. Hooking around from the northeast would allow the Marines to exploit a gap between two batteries of Iraqi artillery fire.

“What I don’t want to do is reveal what I’m going to do because the enemy’s artillery from Al Kut can only reach this far,” said Mattis, pointing to a map he had scrawled on scrap paper. “And the enemy’s artillery out of the Al Nida Division can only reach this far. And that seam is a way for me to get across.” Mattis’ 1st Division was about to cross a critical bridge over the Tigris River “when I finally get told about the pause,” he said. “So now what I can’t do is leave that road open because they’ll figure it out that they’ve got this thing uncovered and I’ve got a way across the Tigris,” he said. “So I have to order these guys who have lost Marines, killed and wounded now, to come back,” Mattis continued. “And Marines don’t like doing that.”

He bought time by sending a light armored reconnaissance unit directly northwest towards Baghdad. Mattis said it was akin to telegraphing the Iraqis, “Hey, Diddle Diddle, here come the dumb Marines right up the middle.” In fact, he wanted to avoid that obvious approach because it was the most heavily defended.

Meanwhile, Mattis readied the 5th Marine Regiment for the main attack from the northeast. But just one day before the pause was lifted, then-Iraqi President Saddam Hussein's military "figured out we're using this roadbed, Highway 1," Mattis reports. "They come up and start putting in tanks and artillery and troops, dumping them off in school buses."

At the same time, there was serious concern about the Iraqi military using chemical weapons to defend Baghdad. "Here's the prevailing wind in Iraq" moving south towards troops, Mattis said. "And there I have the division, two-thirds of the division strung out along this. So, no, I don't want to pause." This was one of two locations where the Marines used Mark-77 firebombs—something the Marines loosely term "napalm"—to clear foliage during the war, he said. "But here the enemy was figuring it out. So the last thing we wanted to do was pause," Mattis said. "It's at the worst possible time frame."

Once given the go-ahead to move on Baghdad, the Marines easily overran the newly deployed Iraqi forces, he said. "And now I pack up 5th Marines and I say, 'Go.' And they cross Saddam Canal and the Tigris River in hours," said Mattis. The Iraqi commanders had failed to capitalize on the American troops' vulnerability outside Baghdad during the pause. "The generals were dumber than you-know-what," Mattis said. "They were real dumb." Mattis attributed the Iraqi failure to anticipate the Marine attack to "incompetence." But he said the Iraqi forces ultimately did blow up the only two bridges for 40 kilometers across the Diyala River to try and blunt the Marine attack. "That's why we were held up outside of Baghdad," said Mattis, adding that was "after the pause." "You don't blow bridges in a country full of rivers unless you have to," Mattis said.

"And then by the time they realized this [was the attack route], it was all over. We killed everybody there and [suddenly] we're across and we're on our way." Mattis said his forces "could have grabbed" the bridges earlier but he opted not to. "Looking back now, maybe I should have, I don't know. But the bottom line is we had a lot of urban fighting going on there and I had to get that area cleared out before I ran the bridge companies out there."

Mattis said he anticipated before the war that Iraqi irregular forces—the Fedayeen Saddam militia—would threaten the long U.S. supply lines en route to Baghdad. But he said the Marines were ready for such a contingency. A Corps motto, "Every Marine a Rifleman," meant "I was not concerned about my supply lines," Mattis said. "The combat service support troops had been warned you are going to have to fight your way through to get supplies to us. Every Marine is trained as a rifleman, unlike some services. And this was not a concern to us."

Army leaders have recently said that, given the lessons from the Iraq war, they will provide additional marksmanship training to support forces. In addition to consolidating supply lines, the coalition ground commander used the pause in attack on Baghdad to ensure that Iraqi Republican Guard forces defending the capital were sufficiently weakened through ground and air attacks, senior officials say.

Mattis believes some U.S. leaders overestimated the strength of the Iraqi forces, though. "What would you do if you hated Saddam, you hadn't been paid in three months, you didn't get fed daily, and the war's over because the Americans just showed up? You're going to go home," he said.

Mattis said he thinks some commanders and intelligence analysts became overly concerned with counting Iraqi units, interpreting "icons" on a map as evidence of military force rather than trying to read the situation on the ground. "I think that what happened [is] we had all of these icons, and because those things are countable, and satellites count things, and people like counting things—they like certainty—we got out of [thinking] what's most [important in] war. It's what's in a Marine's or soldier's heart, that's what war is. We knew their hearts weren't going to be in it." He said "these icons remained" throughout the war, even though it meant little to him when intelligence reports "counted troops [with] 85 percent strength, [in] this division in this sector," Mattis said. "We bombed them but we didn't get good BDA [battle damage assessment]. You can't ever get good BDA. How do you know if you really hit the tank or you hit the decoy tank?"

Eventually, he said, some command center officers acknowledged they were uncertain what to make of units on the map that seemed to evaporate on the battlefield. "Well, the reason is all the troops just walked home," Mattis said. "They left the tanks there." He said there were "still people around there because civilians came around to rip off everything they could and go. So [some assumed] it must still be active." He added:

“We never expected this army, I guess, to evaporate could and go. So [some assumed] it must be active.” He added: “We never expected this army, I guess, to evaporate the way it did. Some people didn’t expect it to, let me put it that way.” In the end, Mattis said, he attempted to make the most of the pause before attacking Baghdad. “Wars never go the way you want them to,” he said, “Once we were freed up to get going again [and] we were on our way, I took advantage of the pause. I got more guns and ammo and fuel up there, so no sweat.”



Blue Diamond Intelligence: Division-Level Intelligence Operations During Operation IRAQI FREEDOM

by Lieutenant Colonel Michael S. Groen

Marine Corps Gazette, February 2004.

The author provides readers a glimpse of intelligence support, both good and bad, during operations in Iraq.

Division-level intelligence operations during Operation IRAQI FREEDOM (OIF) were a story of “mission success” and reflected the progress made in Marine Corps intelligence capabilities over the last decade. During the campaign, the 1st Marine Division (1st MarDiv) was able to rapidly and successfully attack across difficult terrain over 800 kilometers into Iraq. The 1st MarDiv (reinforced with elements of 2d and 4th MarDiv and individual augments from a number of sources) defeated elements of several Iraqi divisions and destroyed hundreds more paramilitary fighters and foreign jihadists. When combat operations began to wind down the intelligence effort was able to smoothly transition to the support of stabilization operations in Baghdad and seven southern governates in Iraq.

The division G-2 (intelligence) relied heavily on direct support or attached collection platforms combined with local analysis to produce intelligence responsive to each tactical commander’s unique needs. Although never *operationally* surprised, the division still had to deal with repeated *tactical* surprises. A glaring shortfall in organic tactical intelligence collection capability within the ground combat element (GCE) was partially overcome by superb support from associated human intelligence (HumInt), 3d Marine Aircraft Wing (3d MAW) assets, and several other supporting organizations. The intelligence effort still struggled with a digital divide between technological “haves” and “have-nots,” but it also revealed promising technological solutions to this issue. OIF clearly demonstrated one of the ironies of the intelligence business—that those tactical commanders who require the highest resolution of the battlefield are those least able to influence a very complex and highly centralized intelligence architecture.

What Worked Well

Unmanned aerial vehicles (UAVs) in direct support (DS) of the division. I Marine Expeditionary Force (I MEF) chose early to assign the Marine UAV squadrons (VMUs) (both VMU-1 and VMU-2) in DS of the GCE for most of the fight. This relationship grew into a strong partnership between the VMUs and the division/regimental intelligence sections. The proactive support of the 3d MAW in enabling this partnership was essential. The VMUs worked aggressively to provide forward support to the division under difficult conditions. The VMUs provided remote receive teams that provided live video feeds to the division and regimental combat team (RCT) intelligence sections. Mission control was conducted over tactical radio nets or in networked chat rooms (enabled by the recent fielding of an improved data communications backbone down to the regimental level—the secure mobile antijam reliable tactical terminal). Because of the close relationships established, the supported intelligence section was able to directly drive the Pioneer to a point of tactical relevance for the commander. On several occasions the decentralized control of this asset enabled true “sensor to shooter” performance. Intelligence and fires personnel sat side-by-side detecting targets, clearing their prosecution, providing adjustments for artillery fires, and conducting damage assessments, all within minutes. This responsiveness was unrivaled by any other imagery collection platform. During security and stabilization operations the VMUs continued to provide critical support to raids on regime holdouts, security patrols over oil pipelines, surveillance of mass gravesites, and monitoring of political demonstrations. The mandate for a UAV flying in direct support of, and directly responsive to, division and regimental intelligence requirements was made resoundingly clear.

HumInt exploitation teams (HETs). During most of OIF the division had seven HETs in a direct support-

ing relationship, and a HumInt officer assigned to the division G-2. Twice as many HETs would have been almost enough. The HETs proved their worth time and again, and their presence with the forward battalions enabled the tempo of operations to continue as it did. As with the VMUs, assigning a number of HETs to a direct relationship with the supported commanders provided a goldmine of intelligence during both combat and stabilization operations enabling immediate exploitation of time-sensitive intelligence. Many HumInt successes may have been achievable by building a stronger core linguist capability in the Operating Forces, perhaps with some modicum of HumInt training. This would have partially compensated for the limited number of HETs available, and would have freed the traditional HETs to do more indepth operations as required. The lack of opportunity to train and establish habitual relationships with HumInt assets is a longrunning shortfall, and one that caused some small bit of friction during combat operations. Infantry battalion commanders and HET leaders had to come to know and trust each other only days before combat operations began.

Organic topographic production capability. The division's tiny organic topographic production capability proved invaluable. The I MEF topographic capability provided terrific support to high-volume production requirements when the division and MEF were collocated and time frames allowed iterative product development. Once deployed, however, organic topographic capability was the only reliable way to get responsive, timely topographic products into the hands of intelligence consumers forward on the battlefield. The ability for intelligence officers to look over the shoulder of the topographic Marines and quickly build products tailored to the exact need at hand was crucial and meant the commander's information requirements were met in hours rather than days. Expanding this capability to regimental command elements would have a high pay-off.

Trojan Spirit connectivity at the regimental level. The success of decentralized combat operations applied at the regimental level as well as the division level. Having reliable connectivity to fused intelligence products, daily intelligence reports, national signals intelligence reporting, and access to the raw collection data from theater platforms was critical to success. The Trojan Spirit II systems located with the division G-2 and each regimental S-2 (intelligence) enabled the decentralization of the intelligence mission. The 24-hour secure, high-quality Trojan phone network was an unplanned but much used fringe benefit of the system. One limitation of note, the Trojan "lite" configuration was unsupportable for RCT or division operations as it required the supported unit to provide lift, power, air-conditioning, shelter, and workspace. All of these are in short supply in a lean fighting headquarters as found in a regiment, or even in a mobile division in the attack.

Instant text messaging for intelligence indicators and warnings (I&W). The Marine Corps continues to achieve incremental success in pushing the digital divide down the chain of command. Disseminating time perishable intelligence to all of the digital haves and have-nots across the division remained a tremendous challenge during OIF. In partnership with the G-6 (communications), intelligence Marines used a combination of digital data, very high-frequency, high-frequency, tactical satellite radio, satellite telephone networks, and couriers to reach the widely spaced elements of the division. One capability fielded only days before crossing the line of departure was a blue force tracker (now if we could only develop the corresponding red force tracker!), a combat identification system that included an instant text messaging capability down to battalion level. This capability proved critical for passing warning intelligence to a small forward unit when a threatening Republican Guard armored movement occurred during a raging sandstorm that had disabled the unit's primary means of communications. Fielding a satellite-based intelligence text messaging capability down to battalion (or lower) level would be a tremendous boon to our ability to disseminate time-sensitive intelligence regardless of terrestrial digital access.

U.S. Navy P-3 surveillance aircraft in DS of the division. Building on the experiences of Task Force 58 in Afghanistan, the division continued to work closely with the Navy's P-3 community to use an imagery-equipped variant, the P-3 Antisurface Warfare Improvement Program for surveillance and I&W. Like the Pioneer, this platform was made tactically effective by the DS relationship used during planning and combat phases. A team of division riders rode along on every tactical mission, talking directly to Marines on the ground over ultra high-frequency radio. The platform was used to give ground commanders a look at their

objectives prior to combat operations (either in person or on video-tape). During combat operations the riders were able to relay requests for information to the sensor operator to receive answers in minutes.

Dragon Eye UAV. The Marine Corps Warfighting Laboratory proactively supported the division by providing a number of prototype Dragon Eye UAVs. Select individual battalions operated these systems in a hugely successful effort. A number of minor technical problems will be fixed in the eagerly anticipated production system. Much more important to the Dragon Eye's success was the command and control hierarchy and collections management process used for their tasking. There wasn't any. The maneuver commander used the system to answer his own questions, on his own schedule, in his own priority order. The maneuver commanders did not have to navigate a cumbersome collections bureaucracy, did not have to schedule operations around an air tasking order, and did not have to coordinate with a supporting unit. When Blue Diamond approached the Diyala River on the outskirts of Baghdad, for example, the lead battalion commander simply turned to his S-2 and asked if the bridges were still intact. The Dragon Eye was dispatched to quickly overfly the bridges and ascertain their status. This responsiveness would have been unthinkable if the S-2 had been required to influence the external collections architecture. The success of Dragon Eye validated the concept of a tiered tactical intelligence gathering capability organic to maneuver units.

Joint surveillance target attack radar system (JSTARS) common ground station (CGS). The division G-2 was fortunate to have an attached JSTARS CGS from the Army's 513th Military Intelligence Brigade. The ability for the division intelligence Marines and Army CGS operators to work side by side allowed us to use the system in unconventional ways with tremendous tactically relevant results. For example, when the division was considering the use of the unfinished Highway 1 corridor, the attached JSTARS team conducted a pattern analysis of speed and direction of civilian traffic that validated the route's viability as an attack corridor. Even when subjective assessments of this route from other sources cast serious doubt on its viability, the division was able to make an informed decision and take a calculated risk versus a reckless gamble. As a result, 15,000 men stormed up an unexpected avenue of approach all the way to the Tigris River. The ability of the G-2 to look over the shoulder of the operator and guide product development in a realtime manner made the difference between a tactically relevant capability and a less effective centralized capability located hundreds of miles away from the point of decision.

Marine Corps Intelligence Activity (MCIA) and reachback support. The division used intelligence and infrastructure databases from a number of sources. These databases provided the tools for decentralized intelligence analysis responsive to specific tactical missions. Continuing its sterling reputation that had been built in Afghanistan, the MCIA did superb service by the division, providing timely and accurate terrain products, route studies, and inundation analyses. The entire national intelligence effort proved very strong when it came to fixed facilities with established target numbers, or conventional forces with well-defined organization and standard equipment. The solid basis of understanding developed during the planning stages allowed the division to react with confidence when the enemy on the ground did not match the enemy in the plan. After combat operations began, the rapid pace of operations naturally outstripped the ability of supporting intelligence activities to provide timely and actionable intelligence. With planning cycles for many operations measured in hours, decentralization of analysis was critical. Like politics, all intelligence is local. There are significant implications for intelligence reachback concepts, as the division reached back for *information* but generated *intelligence* on the spot. Personalizing the battlespace for maneuver commanders mandated a continued decentralized analysis capability.

FalconView terrain visualization computers. Supported by the Marine Corps Systems Command (MarCorSysCom) program manager for intelligence, the division was able to field high-speed laptops with enough memory and storage capacity to store the maps and controlled imagery base imagery for all of Iraq, and run the FalconView three-dimensional (3D) terrain visualization software. This single action by MarCorSysCom to support the division (one of many such actions) had a significant tactical impact. With this 3D battlespace visualization capability down to battalion level, even company commanders could conduct detailed mission planning and rehearse video fly-throughs of their objective areas. Integrating and expanding a type of 3D terrain visualization software into a program of record available to all Marine units would be

operationally beneficial and would decrease the support burden posed by multiple systems and vendors.

What Did Not Work So Well

Inability to influence national and theater imagery collections. The division's ability to influence the theater and national intelligence collection activity was limited. A shortage of theater collection platforms was aggravated by the use of these collectors for deep missions at the expense of support to maneuver units. The division had no organic access to the imagery requirements system and relied on external advocacy in a complex collections bureaucracy. Raw imagery support requires a tremendous amount of bandwidth that was not available during OIF, thereby increasing reliance on a centralized exploitation capability. Increasing the ability of tactical commanders to access national and theater imagery collections and exploited products remains a challenge.

Lack of a tiered, tactical intelligence collection capability. The nature of the battlefield, the extreme distances covered, and the rapid operational tempo all made it nearly impossible for any centralized intelligence source to provide timely and actionable intelligence to units in the attack. OIF revealed a gap in our tactical intelligence collection capability and pointed out the need for a tiered, decentralized, organic collections capability at the division, regiment, and battalion levels. The light armored reconnaissance and tank battalions were the most productive tactical intelligence collection capabilities the division had as they continued to move out and draw fire. On a high-tempo battlefield, the highly centralized theater intelligence architecture proved too slow and cumbersome to be tactically relevant. OIF clearly demonstrated a requirement for the Marine Corps to procure a scalable family of tactical intelligence collection technologies, both ground and air. The strength of the intelligence network should be in the distributed nodes, and creating a toolkit of intelligence collection capabilities at each node is crucial to energizing the entire system.

Challenges with the advanced tactical airborne reconnaissance system (ATARS) capability. The crews and exploiters did a fantastic job with the ATARS, but the promise of this relatively new capability in support of the GCE was never fully realized due to a number of issues with platform availability, data connectivity, and exploitation constraints. Technical limitations complicated rapid receipt, exploitation, and dissemination of intelligence products based on ATARS imagery. Building a decentralized requirements management and exploitation capability that adequately conveys the GCE's imagery requirements through the process remains a challenge.

Ensuring access to the intelligence architecture without information inundation. The Marine Corps ethos of thriving on decentralized execution of a commander's intent demands an intelligence organization that has the ability to personalize the battlefield for farflung commanders. During OIF all echelons received and passed on an overwhelming number of information reports and had access to thousands of others. At no level of the organization did we do a very good job of filtering out the chaff to provide only the fused products and timely and relevant raw information required by decentralized tactical users. One of the true ironies of the intelligence profession is that the lower the level of the commander, the higher the resolution of the intelligence products he requires. Yet, the lowest echelon S-2 is least capable of accessing the intelligence architecture. Solving this information management challenge would be a watershed event as it would further open the doors for responsive intelligence support to many of the Marine Corps' emerging doctrinal concepts, most of which are premised on long-range, decentralized operations.

Summary

Our current intelligence systems across the board are effective against fixed facilities and organized enemy forces waging a well-ordered conventional fight. It is likely that very few of our future enemies will present such a surface for us to bring our force to bear upon. Paramilitary fighters, ill-defined enemy motivations, chaotic urban environments, and a strong civil-military component to operations will likely aggravate some of the shortfalls noted above in future conflicts.

In spite of these challenges, the 1st MarDiv's intelligence operations were a success thanks to the dedicated efforts of a large number of supporting organizations and Marine intelligence professionals at all levels. The results achieved are a tribute to those professionals who have made revolutionary improvements in our intelligence capabilities over the last decade. Continuing evolutionary improvements are possible, and

solutions to most of the issues presented (technical and nontechnical) are already underway. Increasing access to the intelligence architecture for our lowest echelon consumers is the logical next step, and equipping battalion S-2s with the tools needed to support the decentralized tactical fight is one of the most important challenges that remains for Marine intelligence professionals.





1st Marine Division and Operation IRAQI FREEDOM

by Lieutenant Colonel Clarke R. Lethin

Marine Corps Gazette, February 2004.

'No better friend, no worse enemy': planning, speed, and intent within the 1st Marine Division.

On the evening of 20 March 2003, months, days, and hours of planning and preparation for combat against enemy forces in Iraq were put to the test. The combat phase of Operation IRAQI FREEDOM lasted approximately 28 days and ended in the seizure of eastern Baghdad, Tikrit, the destruction of regular Iraqi divisions, Republican Guard divisions, and countless fedayeen and foreign thugs within the 1st Marine Division's (1st MarDiv's) zone. The operations by I Marine Expeditionary Force (I MEF) have been well-documented by the media, soon to be released after-action reports, and unit command chronologies. The focus of this article will be on three critical concepts developed and used by the division.

Even though we were hugely successful against the enemy, that success was paid for in the lives and injuries of brave Marines and sailors who served or supported the division's operations; this should not be forgotten.

There are volumes of lessons learned from the conduct of operations for the division and how we chose to fight. There is no way to cover them all in this article, so I will discuss three areas: how we planned (in preparation for and during combat operations), how we used speed as a metric, and the value of commander's intent. Although these issues seem fundamental, it is brilliance in the basics that is the foundation of all great teams.

Planning

In the summer of 2002 there were sufficient indications that the United States would commit forces to remove the Iraqi regime. I MEF was the Marine Corps' operational command for Marine forces under operational control to Coalition Forces Land Component Command (CFLCC). The division was the primary ground combat element for I MEF throughout planning and execution of operations in Iraq. The Marine Corps Planning Process (MCPP) works. If you don't know it now, learn it. If you think you know it, keep learning because you haven't mastered it until you've been in combat, and even then you keep learning. From the I MEF led operational planning teams (OPTs), to division OPTs, to the regiments and separate battalions, planning was continuous until we crossed the line of departure (LD). The plan was continually refined, scrapped, rewritten, published, changed—in other

words, we planned early and planned often. The commencement of combat operations did not negate the value and requirement to continue to plan. We were planning current and future operations during combat. The shared situational awareness gained from prior planning was invaluable.

What is important is that we must all understand the doctrine and process of MCPP. MCPP places everyone on the same playing field, providing a common point of departure and set of procedures. The process can be modified and adapted as circumstances and time allow. The other tool required during planning is the ability to conduct rapid planning, much like the rapid response planning process (R²P²). MCPP and R²P² are complementary and were extremely valuable during combat operations when speed was essential to getting the next fragmentary order (FragO) to subordinate units. The division's "opening gambit" plan was a thorough plan that changed hours before crossing the LD due to a fluid friendly situation and the assessment of enemy intelligence. Remember, the guy across the LD has a mind of his own. During the division's attack north to Baghdad, our OPT published no fewer than 30 FragsOs that included changing main efforts, reorganizing the assault units, changing directions, and conducting operations on urbanized terrain. These FragsOs were issued with as near a seamless transition between planners and operators as you could find on that chaotic battlefield.

How was this done? Experienced planners, trained and tested at Camp Pendleton, Twentynine Palms, and Kuwait, all understood many months prior to crossing the LD that any day could be their last before combat, and we had to make the most of every day. The division assumed back in August 2002 that every week was our last week at peace.

Speed

The second area to discuss is speed as a metric. Most of us think of speed in operations as how fast we can get from point A to point B. That's only one measure. For the division, speed was a culture. Speed means more than just physical speed; it's a way of thinking—the mental gymnastics we have to do to solve a problem quickly and efficiently. Our team had the physical capacity for speed. One of our guiding tenets was that every Marine had to be mobile and have a seat. An operational design that relied on shattering the enemy's will to fight by cutting him off from his logistics and command and control required division units to move everyone and everything at the same time. When enemy intelligence indicated the Iraqis were destroying oil infrastructure in the Rumaylah oilfields, Regimental Combat Team 5 was able to attack from a standing start within 5 hours of notification—a dawn attack modified into a night attack.

With physical speed we also needed the means to communicate and to deliver devastating fires on the enemy. Our speed of communications was obtained by using the newly fielded SMART-T (secure mobile anti-jam reliable tactical terminal), high-frequency radios, AN/PSC-5, Iridium phones, blue force tracker, messengers, carrier pigeons—you name it, we used it. Speed of fires was delivered by the full integration of artillery units in our maneuver forces and a dogged determination by the artillery to get forward to support the assault units. Additionally, the speed of aviation fires was delivered day and night under some of the harshest conditions by our brother aviators. An example of this is the night 3d Light Armored Reconnaissance Battalion (3d LAR) pushed over 100 miles up Route 1 and triggered an enemy ambush. When "sling shot" (code word for overwhelming enemy attack) was heard over the airwaves, 3d Marine Aircraft Wing responded immediately, reprioritized and built a close air support stack over 3d LAR, and ensured the complete destruction of the enemy unit. Our ability to think and move rapidly, from the youngest private first class assaulting that last 100 yards to our senior commanders and planners, was extraordinary.

My observations center on how the division's main and forward combat operations centers (COCs) functioned. From setup to breakdown of the COC, every Marine knew that rapid transfer of control was critical to maintaining momentum of the division. Within the COC, information flow and the simple axiom was applied:

- What do I know?
- Who needs to know?
- Have I told them?

Speed and accuracy of passing information in a chaotic atmosphere such as a COC is challenging. It was fully understood that to have speed of thought and action there could be no egos and that teamwork, not individuals, would make for rapid action.

The social energy to continue to connect the dots, keep people motivated, and make rapid and concise decisions is not easily taught and can only be earned, never demanded.

Commander's Intent

We will swiftly secure key oil nodes allowing the least possible opportunity for their destruction. We will shatter enemy forces south of the Euphrates, west of the Shatt al Basrah and east of An Nasiriyah, opening the MSR [main supply route] and gaining positions north of the river to facilitate operations in the vicinity of Al Kut via Routes 1, 7 or 6 as the situation dictates. In order to achieve tactical surprise, we will first blind enemy reconnaissance, then close on the border. We will be prepared to accept enemy capitulation, but destroy the 51st Mech Division and its adjacent/supporting units if they fight. To the greatest extent possible, we will limit enemy or friendly damage to the oil infrastructure.

We must negate enemy artillery through shaping, preparatory, or responsive counter fires. I expect maximum use of air fires; assault support will be used if rapid linkup is achievable. Speed is the measure: speed coupled with harmony of information flow; rapidity in decision making; orders promulgation; counter fire; response to changing conditions; re-supply; CAS-EVAC [casualty evacuation]; identification of multiple routes; obstacle reduction; maneuver; relief in place; and hand off of EPWs [enemy prisoners of war]. We will avoid all possible FPOL [forward passage of lines] and any other mingling of forces, and whenever possible create conditions of chaos for our enemies. Aggressive tempo and initiative are vital. Once we have seized the nodes, we will rapidly hand over the zone and EPWs to 1st UK Div and reposition north of Jalibah. Crossing the Euphrates and moving against Al Kut, 1st MarDiv supports 3ID's [3d Infantry Division's] attack along our western flank, denying the enemy opportunity to mass against CFLCC's main effort.

The last point is commander's intent. How many times have we seen commander's intent developed by the staff, lethargically reviewed by the commander, and then delivered in a briefing without the least bit of emotion? The division fought by commander's intent—a statement of intent that reflected the commander's personality, intuition, sense of purpose, and then delivered to every Marine and sailor in the division. Prior to crossing the LD there were a thousand issues the commander needed to address. One issue that was never compromised was the commander taking the time to speak with every unit and deliver his intent.

Initially our aim point was in the vicinity of Al Kut, over 200 miles from the Kuwait border. That aim point changed approximately 200 miles from Baghdad with the intent to split the enemy's defenses and drive rapidly to the outskirts of Baghdad. What made this possible was the unequivocal understanding by the division staff and commanders of what the commander wanted. Every sentence and word in the commander's intent carried weight. What was highlighted included, “. . . secure key oil nodes . . . destroy the 51st Mech Division . . . maximum use of air fires . . . speed is the measure . . . aggressive tempo.” The initial intent carried the division through the opening gambit, past An Nasiriyah, and up Routes 1 and 7 toward Baghdad. Subsequent commander's intent was given to the OPT to be included in FragOs or personally delivered to the subordinate commanders. Equally important to the commander giving the intent was the division staff fully understanding the intent. This can only be accomplished by the social energy and the force of will by commanders and staff to get it right and carry the message, because success depends on it. Our mutual experiences from boot camp, Officer Candidates School, career-level school, training exercises, and shared hardships in combat give all of us the capacity to understand each other like no other profession. When out of communications with the commander, the subordinate commanders knew what to do. The commander's intent is the glue that holds us together and ensures we can achieve objectives beyond expectations.

In the past 2 years our Marine Corps has been actively involved in the operations in Afghanistan, the Horn of Africa, and Iraq. Having been involved in Afghanistan and Iraq, I see the strengths of our operations as our ability to plan, our willingness to move swiftly where others wouldn't, and the quality of our leaders to give us clear and concise guidance. Our successes have come from shared experiences and a determination to get it right with the lowest possible butcher's bill. It's not easy. It takes education, experience, sacrifice, but when it is time to stand and deliver a victory at the least cost, the Corps can be counted on.



Logistics Support to 1st Marine Division During Operation IRAQI FREEDOM

by Lieutenant Colonel John J. Broadmeadow

Marine Corps Gazette, August 2003.

The good, the bad, and the ugly of logistics support during Operation IRAQI FREEDOM.

Operation IRAQI FREEDOM (OIF) provided an opportunity for I Marine Expeditionary Force (I MEF) and the 1st Marine Division (1st MarDiv) to again demonstrate the strength and flexibility of the Marine air-ground team in many areas, including logistics. The unprecedented distances over which the 1st MarDiv fought, and the speed with which it traveled, placed a considerable burden on logistics and fostered several innovative changes to doctrinal concepts of support. From early planning efforts, the division scheme of maneuver was based on the concept that speed equals success. Supporting a rapid speed of advance became the metric that guided all of the division G-4s' (logistics officers') preparations for combat.

Creating a light but fully supportive logistics infrastructure was key to enabling speed. The effort started internally with a restructuring of the division's G-4 section. Prior to the war the logistics operations center (LOC) was manned with more than 120 Marines and sailors, occupied several tents, and required several trucks to move. Additionally, it was physically and functionally separated from the combat operations center (COC). During predeployment preparations—with the goal of reducing staff size in the division main and forward command posts (CPs) and fully integrating with the COC—the LOC was reduced to 26 Marines primarily focused on current logistics operations and movement control but also conversant in all logistics specialties. Finally, the LOC was moved into a tent with immediate access to the COC, and the G-4 watch officer sat immediately behind the G-3's senior watch officer. As a result, logistics was fully integrated with current operations. The LOC was able to maintain complete situational awareness of division operations and provide timely advice for key decisions.

The remaining logistics functional areas set up shop in the division support area (DSA) collocated with the headquarters in Camp Commando, Kuwait. By locating the bulk of the G-4 in the DSA and using reachback techniques, movement and life support requirements were greatly decreased, and the logistics functions of supply, ammunition, maintenance management, food service, mobility, and embarkation provided a stable interface with the division LOC, MEF G-4, force service support group (FSSG) main, and the Marine Logistics Command (MLC). This interface proved its worth as the forward and main CPs continually leapfrogged, focusing on the division's attack while the DSA provided continuity of effort for long-term, critical logistics actions.

With foresight and innovativeness, 1st FSSG developed an agile, capable, and wholly unique combat service support (CSS) structure to interface with the division and I MEF. This structure did more than support our high-tempo operations. It made the regimental combat team (RCT) S-4s the linchpins of logistics for the division, providing the interface between their subordinate battalions and the CSS companies (CSSCs) in direct support of each RCT. Resupplied by general support CSS Battalion 10 (CSSB-10), CSSCs worked hand in glove with the RCT S-4 for sustainment and traveled directly in trace of the RCT's logistics trains. Additionally, CSSB-10 provided support directly to 11th Marines and separate battalions not integrated into an RCT. CSS Group 11 (CSSG-11) directed the efforts of the CSSCs and CSSB-10 and provided a critical link between division and the FSSGs and MLC sources of supply. Within this framework, division had the first fully embedded CSS capability in recent history.

Aside from organizational changes, the division's logisticians also enabled speed with several planning and equipment innovations. Enhancing the generic "days of supply" planning factors from doctrinal planning publications, G-4 plans developed metrics to measure a unit's tactical objectives against potential logistics culmi-

nating points and determine the optimal locations for resupply points. The culminating point analysis graphically depicted where the division would require an operational pause to refuel and helped determine material and functional solutions to push off the pause. This analysis, combined with strength and flexibility afforded by the close ties with CSSG-11, paid dividends when actual fuel consumption was significantly higher than planned. Locations for rapid replenishment points were adjusted on the fly to support the division's continuing attack. Working in close coordination with I MEF and Marine Corps Systems Command, the division obtained flexcells for M1A1 tanks, fast fuel storage devices for assault amphibious vehicles (AAVs), and inexpensive "gypsy racks" that could attach to HMMWVs to augment fuel capabilities and extend the time and distance that the division could fight before refueling.

The desire to maintain the light footprint needed for speed led to a fanatical approach toward conservation and reduction. The living standard for the division was set at the 0311 lance corporal level for all hands. Across the division, comfort items were omitted to make lift available. Omitting one item in particular—cots—meant that all Marines would sleep on the deck, but also that the equivalent of eight medium-lift tactical vehicles would be freed up to meet the more pressing need. Fuel test kits were procured from the Defense Reutilization and Marketing Office, and Marines in every battalion were trained in their use so that captured fuel sources could be tested and exploited, reducing the requirement to line haul fuel. A strict equipment list was published, and any gear not on it stayed in seabags locked away in the DSA. Many other initiatives, from a prohibition on excessive idling of vehicles to a requirement to consume 100 percent of issued meals, ready-to-eat drove home the point that we were on a logistics light diet necessary to sustain the speed and momentum of our attack.

Innovative methods of preparing supplies for rapid shipment were also developed. The division ammunition officer working with the MEF, FSSG, and subordinate units created standard ammunition packages that had preestablished stocks and were prebuilt in the ammunition storage points waiting to be called forward. When 11th Marines needed more ammunition in support of long-range fires, they ordered a "longball" package, and the FSSG sent forward the rounds, powders, and fuses needed to support a deep fight.

The division worked in concert with the MEF and FSSG to create and manage a movement control system that effectively coordinated thousands of vehicles delivering supplies, personnel, and equipment throughout a large and diverse battlespace. The division unit movement control center (UMCC) operating in the division main gathered and prioritized all movement requirements in and out of the division's zone. Working in complete synchronization with the UMCC forward, the DSA represented the division's requirements at the MEF's force transportation board to apply scarce resources against our most critical requirements.

Starting early in the planning efforts and continuing throughout the war, close ties were developed between the division G-4 and Marine Wing Support Group 37. Planners from both organizations worked to integrate forward arming and refueling point (FARP) packages into the tactical columns of the RCTs, positioning FARPs well forward and extending the reach of the assault support assets that provided invaluable support during combat operations. When the 3d Marine Aircraft Wing started flying fuel into the Hantush Highway Strip with KC-130s, it directly and meaningfully contributed to the division's ability to continue its attack up Highway 27 and Highway 6 on the way to Baghdad.

While the division enjoyed many historical logistics successes, not all aspects worked as planned or even worked well. The supply support system was inadequate most times and a total failure at its worst. OIF has shown that there is no such thing as a unified Marine Corps supply system. As units from throughout the Marine Corps came together, it was immediately apparent that no standard method of requesting or conducting resupply exists. In computer systems alone there are multiple, incompatible systems; I MEF uses supported activities supply system and Asset tracking logistics and supply system (ATLASS I); II MEF uses ATLASS II; Blount Island Command uses a commercial supply system for maritime prepositioning force equipment. The field warehouse system used by MLC at the start of the operation had to be scrapped because of its inability to perform. It was only through the dedication and hard work of many Marines at the MLC that parts could be sorted and sent on to division units. The supply system architecture planned for use during OIF was a "workaround" combination of systems and methods. The workaround never permitted visibility at the battalion or division level of a requisition from inception to receipt. Problems were directly attributable to the incom-

patibility of these systems, lack of training in their use, lack of a standard method of passing supply requisitions from MEF units through an MLC, and lack of a dedicated logistics communications architecture.

In general, the supply officers were not familiar with the system. Although they were familiar with using ATLASS to induct requisitions, they did not understand how their requisitions were being handled by the supporting CSSBs through the MLC. Also, an absence of any type of local area network connectivity at the battalion level meant that battalion supply officers had no automated means to pass requisitions and get the feedback data necessary for management reports. The amount of offline requests on “yellow canaries” far outnumbered those that were sent by automated processes.

Compounding the problem further, none of these systems provide any interface with an intransit visibility system at either the operational or tactical level. Although many convoys were put on the road, their contents and location remained a mystery to division supply officers eagerly awaiting their supplies. As a result, many lost faith in the processes established, started using workarounds, and gave up on any type of established supply management. This is an area ripe for improvements and hopefully will be the subject of many professional discussions in future *Gazette* articles.

Despite these problems, the teamwork and cooperation engendered between all elements of I MEF and the MLC, along with the innovative tenacity of our Marines, made logistics support for 1st MarDiv a success. The division traveled and fought over unprecedented distances. Some AAVs logged more than 1,000 miles, and almost all light armored vehicles logged even more. Its speed of advance left tenuous, undefended lines of communications in its wake. Yet, throughout the entire course of the campaign, the division was always able to press forward and continue its attack.





Aviation Integration in Operation IRAQI FREEDOM I: A Division Air Officer's Perspective

by Lieutenant Colonel Patrick A. Gramugulia and Major Richard L. Phillips

Marine Corps Gazette, May 2004.

The flexibility and responsiveness of Marine aviation was a major contributor to 1st Marine Division's success in OIF. An analysis of the employment of aviation assets in support of the division provides many lessons learned.

1st Marine Division's (1st MarDiv's) accomplishments during Operation IRAQI FREEDOM (OIF) were exceptional. The division's success in its march to Baghdad can be attributed in large part to innovative employment of, and extensive integration with, Marine aviation. As MajGen James N. Mattis, the division commander, stated, "This is the most air-centric division in the history of warfare." This approach was an overwhelming success, and there are numerous lessons to be learned regarding the employment of aviation and its integrated support of ground maneuver forces.

While we should take pride in the Marine Corps' unique capability to integrate air and ground forces, we must continue to strive for improvement. As we analyze our performance in OIF we must capitalize on and continue our successful innovations—and learn from our mistakes. In this article we will discuss issues involving command, control, communications, staffing, equipment, and tactics. We will highlight successes and suggest ways in which we can improve.

Command

Commander's intent. One of the main contributors to 1st MarDiv's overall success was the universal knowledge and understanding of the commander's intent. MajGen Mattis personally conveyed his intent to all subordinate units and down to all ranks. He ensured that his vision, scheme of maneuver, and end state were clearly and completely understood by all Marines within the 1st MarDiv and those supporting it—including supporting elements of the aviation combat element.

As a manifestation of this understanding of intent, the 1st MarDiv conducted numerous rehearsals of concept drills and fires walk-through briefs. All major aviation players and all aircrew participating in the first day of the operation attended this thorough walk-through of the first day's scheme of maneuver

and fire support plan. While this is not unusual, it displayed and strengthened the intrinsic link between the ground combat element (GCE) and the aviators who supported it. All aviators involved in day one's events had an intuitive understanding of the scheme of maneuver and intent. This enabled them to continue the division's deep fight when communications became difficult and the scheme of maneuver changed. As the Marine Corps moves toward joint concepts, operations, and acquisitions we must never forget the unique benefits provided by our organic aviation and the power of the Marine Corps' philosophy, organization, and training in this regard.

Division combat operations center (COC). The large battlespace of OIF provided a perfect venue for the employment of aviation. We had a tremendous number of aviation assets available for support, but our ability to command and control (C²) these assets needs to evolve.

The air portion of a division COC usually consists of an air officer (AO) who is part of the fire support coordination center. This individual is responsible for the planning, coordination, and tracking of aviation employment across the division's battlespace. In our case the large number of organic and joint air assets (including numerous intelligence, surveillance, and reconnaissance platforms), along with recent improvement in joint connectivity, resulted in the division COC receiving continuous and often overwhelming targeting and reconnaissance information. The division air department was not staffed to handle this volume of information and coordination responsibility.

The AO would receive about 20 yellow notes with target tracks about every 5 to 10 minutes. These tracks were deep in the battlespace and needed to be engaged or reconnoitered by aviation assets. The AO would collect, evaluate, deconflict, and prioritize these requirements and then pass them to the direct air support center (DASC) for assignment to aviation assets. At times the AO would be simultaneously involved in close operations that delayed the handling of the deep tracks. Because there were not sufficient personnel to handle these tracks, the associated air tasking was often redundantly executed or not executed at all.

On many occasions aircraft would see targets in the deep area of the battlespace, but they would be unable to engage them due to a lack of (1) information on the surrounding situation on the ground, (2) personnel to provide a "cleared hot," or (3) a communications path to work these deep area targets. The AO would attempt to facilitate the prosecution of these targets from the COC using Type III controls, but he lacked sufficient information about the target area.

The situation described above is clearly inefficient, and it carries the potential for dangerous target engagement errors. A solution would be the establishment of a deep battle air cell within the division COC. This cell would consist of the target information officer and a deep AO with a radio and a deep air coordination frequency. This cell would be located near—and linked with—the intelligence cell and the DASC. It would be able to take all deep battle inputs—both internal and external to the division—and evaluate them within the context of the scheme of maneuver, restricted target list, and friendly positions and control the aviation assets tasked with deep battle missions. This would reduce accidental, redundant tasking of air assets. This would also enhance continuity with the intelligence picture as these deep air cell personnel would track pilot reports and battle damage assessments (BDAs). Most importantly, this cell would have enough information on friendly positions and target area awareness to permit control of Type III close air support (CAS) missions from their position. This would enhance our ability to bring the fight to the enemy and to engage enemy units prior to their contact with friendly ground units.

Control

Aviation assets in direct support. The Marine Corps does not usually employ aviation assets in a direct support (DS) role. This employment method, however, became absolutely critical during the 1st MarDiv's movement to, and operations in, Baghdad. Long distances and severe weather conditions resulted in delays of up to 3 days for assault support request missions to be flown. This caused a backlog within the wing and division and did not support operations on a fluid battlefield.

As a result, DS assets were assigned. The wing sent sections of CH-46Es and UH-1Ns to the division for assault support, C², and reconnaissance. These assets became a true force multiplier. Often the same

assets supported reconnaissance, C², CAS, and assault support missions in the same day. Though DS is not the preferred or doctrinal (or most efficient) method of aviation employment, its use in OIF demonstrated the incredible flexibility of the Marine air-ground task force (MAGTF) to adapt to changing battlefield conditions.

Two aspects were essential to the successful use of DS assets. First, the regimental logistics trains had forward arming and refueling points (FARPs) embedded. These Marine wing support squadron assets provided flexible expeditionary bases that were able to keep up with the rapid scheme of maneuver and support forward deployed aviation assets that were operating on a fluid battlefield up to 500 miles from their home base.

Second, the maturity of the aviators who operated DS assets was critical. Requests for air support could be overwhelming, creating the potential for a pilot in command to make a decision to execute a mission whose risks outweighed the potential benefits. During combat the theme of air requests from operational ground units is “more,” but fortunately, the aircrews who supported 1st MarDiv exhibited professionalism and maturity in balancing necessity and risk.

Some maneuver units also had DS casualty evacuation (CasEvac) assets attached to them. The theoretical concept of employment was that these aircraft would pick up casualties in forward areas and bring them back to a safe landing zone where theater-level assets would transport them to an appropriate facility. In reality, we relied almost exclusively on our Marine CasEvac assets for the majority of our CasEvac requirements. The relationship that developed between the DS aircrew and the supported Marines became very close. On numerous occasions, their proximity and existing bond provided a response time and dedication to mission accomplishment that was unmatched and saved lives. As Marine aviation continues its transformation in aircraft platforms, we should not forget the criticality of the CasEvac capability and mission.

Fire support coordination measures (FSCMs). Theater aviation control measures were similar to the Kuwait integrated CAS (KICAS) concept of operations. This approach subdivided the battlespace into square grids—or kill boxes—aligned with lines of latitude and longitude. Each box was further broken down into nine “keypads.” This KICAS method enabled seamless employment of any aviation asset anywhere on the battlefield. Our current doctrinal control measures do not provide this flexibility. We were, however, able to use some doctrinal ground control measures within this existing framework.

The flexibility of the KICAS control measures matches the speed and tempo with which the Marine Corps now operates. We should continue to employ these measures, and we must train with them! Many forward air controllers (FACs) learned this KICAS system in the weeks immediately preceding combat operations, which was not the optimum training method. These measures, if they are to be used in the future, should be employed at schools and exercises such as Combined Arms Exercises and the weapons and tactics instructor course.

Air tasking order (ATO). We found the ATO to be unusable due to the rapid pace and large distances covered during our operations. The 96-hour planning cycle of the ATO was unresponsive to the ever-changing scheme of maneuver and rapid battle rhythm; the ATO was obsolete by the time it was to be executed. As a result, the wing simply placed the majority of assets on alert or assigned them to CAS stacks, and air was requested in realtime when it was needed. FACs and AOs were not able to anticipate their requirements for air 3 days ahead or to submit target requests to a targeting board. The ATO cycle, which works best in a fixed target/“air war” environment, needs to be adjusted to better support a fast-paced, moving target style of ground warfare.

We encountered problems when FACs did not have the special instructions (SPINS). Often we were unable to get the SPINS to our FACs due to our communications architecture and the actual size of the document. Though communications systems are partly responsible for this failure, we also did not train sufficiently in using SPINS as this would have highlighted the need for effective methods to transmit SPINS to FACs in forward units. One reason for this training deficiency was that our training flights conducted prior to Iraq were not conducted using an ATO, as only flights in support of Operation SOUTHERN WATCH were allowed on the ATO. In future conflicts we need to put training flights on an ATO to train both ground

and air personnel. We also need to continue to develop communications paths with sufficient bandwidth to allow transmission of vital information to the tactical units that need it.

BDA tracking was also a challenge during our operations. There were numerous instances in which a condition for initiating a certain ground mission was the engagement of specific targets by aviation assets. There was no defined mechanism to confirm that a target was on the ATO, so we were unable to find out if a mission was run against a certain target, much less the BDA from that mission. We did develop an interim solution: the planners put target designators in the remarks column of the ATO, but this method was prone to error. We need to pursue a simple method of getting this pertinent mission data to tactical-level troops to avoid delaying combat actions.

Communications

Division air communications: a tactical air control party net. Battalion and regimental AOs have communications nets that connect an AO at the command post to his FACs in the field. No such communications path exists for the division air department. On numerous occasions key information could not be passed due to lack of formal communications paths between the division and regimental or battalion air departments, especially during movements. A communications path—either voice or digital—would have proved beneficial during this operation.

DASC. The DASC is the GCE's direct, and oftentimes only, link to its aviation assets. The senior air director's (SAD's) primary function is to control aircraft in direct support of the GCE scheme of maneuver. This single function demands all of the attention of the SAD under any circumstances, and it is even more challenging during an intense combat operation. A key part of the DASC's job is to maintain awareness of the current situation, scheme of maneuver, and commander's intent. The situational awareness (SA) within the DASC is often highest because of its direct contact with aircraft that have line of sight communications with many units. This results, however, in a constant flow of people and requests for information flowing into the DASC. This task of maintaining SA can directly compete with the SAD's primary duty of controlling airplanes.

The DASC and, more importantly, the SAD need to be free to concentrate on their primary duties. To facilitate this we designated a runner between the division COC and the DASC. This individual's responsibility was to push information to the decision makers in the COC, which aided in their prosecution of the current fight. This Marine also stayed abreast of the constantly changing situation and updated the DASC situation boards, enabling the SAD to focus on his primary job.

One element of the DASC that proved invaluable was the air support operations center (ASOC) liaison officer. The ASOC is the U.S. Army/U.S. Air Force version of the DASC, and this liaison was our direct link for deconfliction issues that arose in the tight battlespace just south of Baghdad. We were able to prosecute targets that affected us but were not in our battlespace by coordinating with the ASOC liaison. Our DASC runner coordinated closely with the ASOC liaison, allowing us to procure numerous air sorties that were not needed by our adjacent Army units (including A-10 and B-52 sorties vital to the division's attack). This liaison officer also gave us a link to numerous intelligence assets that had overlapping coverage of our area. This link provided warnings of enemy activity on our flanks, enabling us to act preemptively.

DASC (Airborne) (DASC(A)). The DASC(A) is still the most vital link between the ground units and their aviation support. On numerous occasions it was the only link through which forward units could get information or fire support. We relied heavily on forward deployed aviation assets located at FARPs, and often the only way to launch these assets was through the DASC(A). The SA of the entire division went up when the DASC(A) was airborne. The current module used to perform this function is the UYC-3, which is a technologically outdated system. The next generation of the DASC(A) should have more radios, satellite communications, video capability, and a theater battle management core system and advanced field artillery tactical data system capability.

Chat. We used secret Internet protocol router network chat rooms extensively throughout the operation. At times this was our only communications path to certain units, especially those located on ships. Chat is a great method of secure immediate communications with units across the entire battlespace. We

need to continue to develop this capability by deploying it with as many units as possible. Chat rooms should be assigned doctrinal names and users so they can be listed in the automated communications electronic operating instructions.

Blue force tracker (BFT). This system holds great potential for communications. Although the system is currently not secure, it would be of great benefit if it were available in the DASC, tactical air command center, FARPs, and squadron ready rooms to display current unit positions. The system's greatest strengths are beyond line of sight capability and high reliability. Immediate request and assets launch instructions could be sent using its text messaging capability.

Communications training. We often received text messages prior to getting voice reports from units located far from our COC. On many occasions these messages included calls for fires or some other type of time-sensitive request. When we received these text messages (usually via BFT) we would immediately try to contact the unit through a voice communications path. As we continue to transform our communications capability and the speed with which we execute operations, we need to train to make decisions and act based on information that we receive from all sources, even those that come to us in the form of an e-mail or text message.

Multichannel secure communications between ground units and aircraft needs to be improved. Throughout our operation most communications between ground units and aircraft occurred over a clear (nonsecure) single-channel frequency. All players involved have the correct equipment to use secure frequency-hopping communications—we just have to train to this standard.

One issue that requires attention is the limitations created by the small, fixed set of net identification (ID) loaded in the radios of forward deployed ground units and aircraft. On numerous occasions aircraft arrived on station with their radios loaded with the net IDs of the units that they originally were supposed to support, but the situation had changed and they were now supporting another unit. In these cases, secure multichannel communications was not possible because neither user could change the information in their radios.

FAC Staffing and Equipment

FACs. The division received more than 16 augment FACs to support its aviation-centric battle plan. The intent was to provide every maneuver unit with the ability to plan and employ aviation, and although not all of these FACs received a tremendous amount of work, they provided their commanders significant additional flexibility. Normally, a commander must decide where to assign his FACs, and they must often be moved between units in the middle of operations. Because this operation was not linear, it was difficult to predict when and where a unit was going to need aviation support. Having this aviation knowledge and control capability with every unit was a true force multiplier.

An unintended but important benefit resulted from the high experience level of these augment FACs, as most were majors or lieutenant colonels with previous FAC tour experience, and many had combat experience. This experience level provided unit commanders with additional MAGTF expertise throughout the operation. This extra experience also proved beneficial during the civil-military portion of the operation where many of these individuals were used as liaison officers with the village government and in staff billets to replace personnel lost due to combat or individual rotation.

Equipment. In order for the division to carry out its aviation-centric plan, it required new target location and designation equipment. The division's original laser pointers and designators were cumbersome, unreliable, and incompatible with many aviation assets. Equipment was not standardized across the division leading to slight differences in procedures.

Prior to deploying, the 1st MarDiv set out to update equipment for various capabilities, including laser rangefinding and infrared (IR) pointing. Urgent universal need statements were submitted through division G-7 in an effort to provide a new "FAC suite" prior to crossing the line of departure. IR pointers and ground laser target designators arrived just prior to combat operations and proved tremendously beneficial, especially during the numerous bouts of bad weather in which FACs had to talk aircraft onto targets.

We must continue to improve our FAC suite. We should seek an improved IR pointer and a lighter and

more reliable designator with a range comparable to the weapons for which it designates.

Tactics

Strike coordinator and reconnaissance (SCAR) managers. SCAR managers were responsible for a significant part of aviation's contribution to the division's operations. SCAR is a newer doctrinal term that includes more than just the direction of deep strikes—it can involve an airborne platform that fights the ground commander's scheme of maneuver and target priorities within his battlespace prior to the arrival of ground units. This allows a commander to engage the enemy from afar, and it can facilitate a more seamless transition to the close battle.

At times large portions of the division's battlespace (that was not yet covered by ground units) were engaged heavily by SCAR managers who used their knowledge of the ground scheme of maneuver. These assets firmly validated the SCAR doctrinal concept, and it became a mainstay of the ground commander's fire support planning. We could improve the integration of the SCAR managers by connecting them directly to the COC through a deep air support radio net (discussed earlier). This would allow SCAR managers to pass intelligence, BDA, and updates on battlefield conditions and keep them abreast of changing target priorities, friendly positions, and commander's intent.

Convoy operations. OIF was heavily dependent upon extended convoy operations, but our current tactics, techniques, and procedures (TTP) and equipment are not optimized for these operations. In the initial phases of OIF we had convoys of hundreds of vehicles that stretched for miles without sufficient FACs or radios. There were instances in which more than 100 vehicles did not have a FAC, an ultrahigh-frequency (UHF) radio, or an available means of suppression. Our current FSCMs are not effective during high-speed movements due to their linear orientation and static nature. The kill box concept from the KICAS framework outlined earlier has the flexibility for convoy operations, but the division did not have sufficient familiarity with KICAS measures to use them effectively for convoy operations.

Task organization, equipment distribution, and TTP for aviation support of convoy operations need improvement. Sufficient UHF radios and personnel trained in aviation control need to be distributed throughout convoys. The route, intentions, and locations of key personnel (FACs) need to be briefed to all players in convoys. Most importantly, we need to train with all key players using convoys of realistic sizes if we are to become proficient in major combat operations conducted over extended distances.

Air counterfire managers. Counterbattery fire was the most frequent mission we coordinated in the division COC. We often received scores of missions per hour. This stressed our architecture and created confusion and backlogs. The Iraqis employed "shoot and scoot" tactics in which they fired one mortar round from the back of a truck and drove away. By the time we were able to engage with counterbattery fire, the target had displaced. (They also employed a similar tactic in Baghdad. They fired from a position near a school or mosque with the hope that we would retaliate after they had displaced, causing collateral damage.) In general, though it only took minutes for us to retaliate with counterbattery fire, it was often too late.

Because most of these counterbattery targets were clustered all within a grid square, we used an air counterfire manager. After the first two radar hits we put a FAC(A) over the target area. The FAC(A) would look for subsequent firing within the area and coordinate an appropriate supporting arm to engage the target. This tactic provided two advantages: it enabled us to keep eyes on a target, even when it was driving away, and it gave us human eyes on the target to prevent collateral damage. This air counterfire manager was a useful and effective tactic. We should evaluate and refine it.

Conclusion

Our successes in OIF validated many of the Marine Corps' bedrock concepts and principles: our expeditionary nature, our leadership focus, our flexible task organization, and our ability to quickly adapt to meet new challenges. We should be proud of the accomplishments of our Marines. We must, however, honestly critique our operations and engage in earnest discussion to facilitate improvement and evolution. As the old saying goes, "if you aren't getting better, you're getting worse."

In this article we have suggested a number of areas in which small changes could create big improve-

ments in operational effectiveness, and we highlighted innovations and adaptations made by the 1st MarDiv and their supporting aviation units. It is our hope that these will stimulate discussion, analysis, and ultimately lead to positive changes.



The Battle of An Nasiriyah

by the Company Commanders, 1st Battalion, 2d Marines

Marine Corps Gazette, September 2003.

This article was written by the company commanders of 1/2 to document the efforts of the Marines who fought at An Nasiriyah. Eighteen Marines paid the ultimate price and 14 others were wounded in 3 hours of intense urban combat.

The battle for the bridges of An Nasiriyah was one of the most important engagements of Operation IRAQI FREEDOM and also one of the most misunderstood. Even now, newspaper and magazine reports describe the battle as an ambush. Nothing could be further from the truth. While an Army convoy was attacked after mistakenly driving through An Nasiriyah that morning, the action that followed was a deliberate attack against an enemy stronghold. The only miscalculation was in how tenaciously the enemy was expected to resist. However, the men from 1st Battalion, 2d Marines (1/2) who attacked north to seize the bridges were prepared for a fight. At the small unit level there were no expectations about capitulation or surrender. As always, the individual infantryman couldn't afford to make such reckless assumptions. What followed that day was a pitched battle in the streets of the city. On one side was a paramilitary force that had already bloodied an American unit and learned that Americans hadn't the stomach for a real fight. On the other side was a group of Marines who were determined to win despite the enemy, despite the cost.

The battle was fought in and around An Nasiriyah, a large city in southern Iraq that guarded key supply routes to the north. The battalion began its movement to contact north at 0400 (all times are local) on 23 March with tanks and a combined antiarmor team (CAAT) forming the vanguard of the column. The battalion was fatigued from driving almost nonstop from the Iraqi border 2 days before. Most Marines had not eaten or slept as the sun slowly replaced the gray dawn. In their approach north the battalion's lead element suddenly encountered machinegun fire and nearby explosions from bracketing mortars as Iraqi paramilitary forces south of the city attempted to halt the battalion's advance.

Although the enemy force had suffered some attrition from desertion, it was essentially three brigades defending in depth along a 12-kilometer stretch, south to north, centered on An Nasiriyah. The Iraqi fighters consisted of the notorious Saddam Fedayeen, Al Quds, and Republican Guard Special Forces, as well as Iraqi regular army soldiers. An assault amphibious vehicle (AAV) company reinforced the battalion, thus every rifle company was mechanized. A reserve tank company also augmented the force and was utilized in the team mech and team tank task organization. The battalion was essentially road bound due to the consistently unreliable off-road terrain in the region.

The first enemy fires were indicative of what was to come. Most of the enemy fighters were wearing civilian attire. They were employing mortars and machineguns from the roofs of mud huts in close proximity to civilians. The rules of engagement were well-understood and had been rehearsed time and again by situational training exercises, but the training and thoughtful preparation did not present a solution that a Marine could feel good about. The necessity to destroy an active enemy target could potentially exact a toll on the lingering civilian population.

Throughout the early morning, 1/2 sliced through enemy resistance along Route 7. Close air support and indirect fires were integral in providing an opportunity for added momentum to the battalion's push north. Initially, the enemy forces were not determined to defend their terrain and quickly folded under pressure from the combination of maneuver, direct fire, and supporting arms. As the battalion pressed the attack, a beleaguered Army convoy from the 507th Maintenance Company was found strewn along the road. Elements of 1/2 rescued the remnants of the convoy from enemy fire and evacuated the wounded soldiers. Eventually it was learned that the Army convoy made a wrong turn and instead of continuing up the relative safety of Route 1, drove up the enemy held Route 7.

They drove deep into enemy territory—through An Nasiriyah before realizing their mistake. As the Army convoy turned around and moved south, the enemy became emboldened and began firing at the convoy, killing and capturing most of the soldiers. The enemy's success against the Army convoy bolstered their confidence for their defense of An Nasiriyah throughout the remainder of the day.

Sporadic fighting continued as 1/2 advanced to the railway bridge just a couple of kilometers south of the Euphrates River. It was just before arriving there that the tank company needed to break contact in order to replenish its dwindling fuel. With tanks refueling well to the rear, Bravo Company took the lead across the railway bridge. Soon after climbing the south side of the bridge, Bravo Company spotted several T-55 tanks and requested battalion antimechanized assets to move forward and engage the tanks. With the M1A1 tanks still refueling, the CAAT moved forward and engaged the enemy tanks, destroying at least five. An additional T-55 was killed by the Javelin team with Bravo Company and was possibly the first tank kill by a Javelin in combat.

Throughout the movement and engagement of enemy tanks, Marine aviators provided killing fires in support of the 1/2 advance. Marine pilots lived up to the high standards set by their predecessors, providing close air support to the infantry units in contact without regard for their own personal safety. Over and over the Marine fliers attacked enemy tanks, machinegun and mortar positions, and troop concentrations. Their fires were lethal and in concert with the ground scheme of maneuver. Repeatedly the pilots checked off with the 1/2 forward air controllers after running out of fuel or ordnance, or sustaining battle damage, only to quickly return and continue their impressive support.

Having destroyed the enemy tank company near the railway bridge, the battalion commander ordered the attack to continue to the north. Upon return of their tank platoon, Bravo Company, organized as Team Mech, led the attack toward the Euphrates River Bridge in the southeast corner of An Nasiriyah. The other companies followed in column carefully steering around the burning remains of a U.S. Army vehicle and smoldering Iraqi T-55 hulks before accelerating toward the city. As the companies wound through gentle turns along lush, palm-lined streets leading to the bridge, rocket-propelled grenades (RPGs) were fired at the column, and machinegun fires could be seen and heard from the far side of the Euphrates River.

The Marines of 1/2 experienced soaring levels of confidence until this point. Most of the enemy fires experienced thus far were sporadic and ineffective. The surgical destruction of the enemy forces was not unlike any other combined arms drill executed over and over at Combined Arms Exercise 9-02 the previous summer. Crossing the Euphrates River into the city presented a more imminent threat to the battalion. The Marines suddenly did not feel so impervious inside the thin aluminum skin of the AAVs that were not equipped with the enhanced applique armor kits that were available to most mechanized infantry battalions in the 1st Marine Division.

The plan was a "be prepared to" mission. The battalion was supposed to defend south of the city and then possibly attack north to seize the bridges, providing a supply route through the eastern side of An Nasiriyah. As the battalion was attacking north earlier in the morning, the battalion commander was ordered to seize the bridges in order to allow other I Marine Expeditionary Force (I MEF) forces to use Route 7 as an alternate route toward Baghdad. The seizure of the bridges became a higher priority than the defensive mission, and the attack continued past the planned battle positions into the city of An Nasiriyah.

Bravo Company was tasked with entering the city first, turning to the right, and bypassing the built-up area by using the vast open area to the east. The planned route would avoid the road through the city already known as "Ambush Alley." Bravo would only turn back to the west to drive toward the northern bridge and establish a support by fire position on the southern side of the bridge below the Saddam Canal. Alpha Company's mission was to follow Bravo Company and seize the Euphrates River Bridge. Charlie Company was tasked with following in trace of Bravo Company's advance and seizing the northern bridge over the Saddam Canal. Shortly after crossing the Euphrates River Bridge and heading to the east, Bravo Company came under intense fire from small arms, machineguns, and RPGs. Their progress was brought to a sudden halt as the apparently firm ground turned out to be a thick muddy bog disguised by a thin crust of hardened dirt. Vehicle after vehicle quickly became stuck in the deceiving terrain forcing Bravo Company to stop in order to recover vehicles

and search for a new route. The vehicles of the forward command post that were following in trace of Bravo Company's advance also halted due to the impassable terrain. At this point Bravo Company continued north with essentially one infantry platoon while the rest of the company stayed behind to provide security for the vehicles that were stuck in the mud bog. The pilots from Marine Light/Attack Helicopter Squadron 269 continuously provided coverage to the immobile force, and their heroic actions thwarted the enemy attacks for over 4 hours.

Moving behind Bravo Company and the forward command post across the Euphrates River Bridge, Alpha Company was executing "sagger" drills, a technique used to dodge RPGs. Not yet across the bridge, Alpha Company had already come under fire from the far side and from enemy fighters south of the bridge. Having rehearsed the attack several times, the battle positions were quickly established just prior to 1300. There was a lull in the action for a few minutes as Alpha Company Marines dismounted their AAVs and took up positions in the southern area of the city. It was extremely hard to pick out targets because there wasn't a uniformed soldier to be found. At first it just appeared to be noncombatants moving around in front of the Alpha Company Marines, but continued observation revealed other activities.

The soldiers were wearing civilian attire and moving toward weapons caches inside buildings. There were others who were moving combatants around the city and resupplying the fighters by using civilian vehicles, especially orange and white taxis and white pickup trucks. Many of the vehicles had white flags attached to them even while they were actively participating in an attack against the battalion of Marines.

While the fires directed toward the Alpha Company Marines began to increase to a deafening level, Charlie Company began passing through Alpha's position. Charlie Company pushed north through the 4 kilometers of Ambush Alley, coming under intense machinegun, small arms, and RPG fire throughout the gauntlet. Sensing that something wasn't right about the disposition of the battalion's forces, the Charlie Company commander decided to quickly seize the northern bridge to ensure the overall success of the battalion. Meanwhile, Bravo Company was split into two forces. Half of the company were engaged in a street-to-street fight, the rest were recovering wheeled and tracked vehicles from the mud, leaving the northern bridge unchallenged. Charlie Company's understanding of commander's intent and aggressiveness in an uncertain situation made the biggest difference in the battalion's victory that day, but the success came with a price.

During the final stretch through Ambush Alley, an RPG struck the flank of a Charlie Company AAV. The blow engulfed the vehicle in flames and wounded four of the Marines inside. Damaged and on fire, the AAV crew managed to drive the vehicle out of the city several hundred meters to the northern side of the Saddam Canal. Upon arriving at the far side of the Saddam Canal Bridge, Charlie Company immediately established a defensive perimeter and began engaging enemy forces with heavy machineguns and company mortars. A medical evacuation (MedEvac) was requested for the four injured Marines, but the volume of fire eliminated the possibility of using helicopters. Demonstrating bold initiative, Charlie Company Marines loaded the casualties into an AAV that promptly headed south through the hornets' nest. Under fire the entire way, the lone AAV screamed through the city and over the Euphrates River Bridge until it reached the friendly lines of 2/8 where the casualties were treated and evacuated.

The battalion Marines could feel the pressure building from a coordinated and determined enemy attack. Enemy paramilitary forces were attacking along multiple axes converging on the Marines in the city. The enemy fighters were bounding from house to house, drawing closer to the company battle positions, and increasing their volume of fires. Suddenly, the headquarters section from Team Tank crested the Euphrates River Bridge and entered Alpha Company's position. A brief conversation took place between the two company commanders, and the four tanks were quickly brought to bear against the mounting enemy attack. Throughout the position, tank crewmen and young infantry leaders coordinated the tank fires that resulted in several well-placed tank main gun rounds and extremely effective coaxial machinegun bursts. The effect was a change in the momentum in favor of the Marines. The enemy volume of fires was dramatically reduced, and the Marines became more effective in destroying enemy targets.

Things looking a little better for now, the Alpha Company Marines looked back toward the street to see a Charlie Company AAV limp into their position. It was already badly damaged, dragging its ramp, and stopped

dead in the middle of the street in Alpha's most hotly contested piece of terrain. Within moments of its arrival, the sickening white plume from an RPG was seen plunging into the flank of the vehicle, shaking it mercilessly, but leaving it intact. Seconds later another RPG dove into the open troop hatch, detonating the large ammunition stores and resulting in a devastating explosion that collapsed the weakened structure. The smoldering wreckage remained in the street yielding only three survivors. For the next 90 minutes the fight continued in the Alpha Company position as the Marines successfully defended the enemy counterattack and worked to recover a survivor buried beneath the heavy wreckage of the destroyed vehicle. Meanwhile, the tank company commander and his executive officer decided to push to the north with their two tanks to reinforce Charlie Company. With the arrival of two more AAVs into the Alpha Company perimeter came the news that Charlie Company was taking heavy casualties in their fight to the north. Five AAVs had been organized to move Charlie's dead and wounded south across the Saddam Canal Bridge. Only three vehicles made it to the Alpha Company position, and the location of the other two remained a mystery for the time being.

At approximately 1430 each of the three rifle companies was decisively engaged in nonmutually supporting positions throughout An Nasiriyah. Urban obstacles negated lateral communications between the maneuver elements. Each commander was intermittently frustrated in his attempts to coordinate with the battalion command post. Casualties were beginning to mount, and the anticipated relief by 2/8 Marines was waylaid by enemy resistance to the south.

The company defense continued north of the Saddam Canal, and Charlie Company was in a fight unlike any other. It had now been 2 hours since the decision was made to push north to seize the bridge. The original defensive perimeter was now beset with mounting casualties, continual strafing fire, and bracketing artillery. Now separated into squad-sized defensive positions, the company was valiantly fighting against an enemy force that was effectively using indirect fires and maneuvering behind protective terrain. The company fire support team, AAV platoon, and 60mm mortar section were the only means to accurately range the counterattacking enemy, and they were all sustaining heavy casualties during the battle. Adding to the dilemma was the havoc that was caused by friendly fire from an A-10 Thunderbolt aircraft that had mistaken Charlie Company for an Iraqi mechanized force. The remainder of the Marines maneuvered under continuous pressure to move the wounded to casualty collection points while rigorously defending the strategic terrain.

At 1530 a CH-46E from Marine Medium Helicopter Squadron 162 began to circle the Alpha Company position searching for the smoke marking the landing zone. The pilot quickly dropped into the middle of the street, heroically exposing his aircraft to enemy fire to save the life of a fellow Marine. Upon loading the casualty, the aircraft lifted, miraculously escaping intact from the red-hot zone. With 2/8 delayed in their fight to the south, the Alpha Company commander made the decision to move north through Ambush Alley in an attempt to relieve the pressure on Charlie Company to the north. The fires were relentless along the route and the Alpha Company Marines witnessed first hand more of the destruction endured by Charlie Company. The two missing AAVs were found along the main supply route just south of the Saddam Canal Bridge. One was disabled on the east side of the road, and the other was torn open in the center of the road, churning out a thick plume of gray-black smoke.

Bravo Company and battalion forward had linked up in the center of An Nasiriyah along Ambush Alley. They gained a clear line of sight to the north and witnessed the disabled Charlie Company AAVs south of the Saddam Canal Bridge. The Bravo Company commander could see Alpha Company taking an increasingly heavy volume of fire as their vehicles screamed by in the movement to Charlie Company's position. The Bravo Company artillery forward observer immediately directed suppressive artillery fires upon the western side of Ambush Alley. These fires allowed Bravo Company and the battalion forward command post to move to the downed vehicles and recover an additional casualty.

As Alpha Company quickly crossed the bridge and entered Charlie Company's position, another pair of abandoned AAVs could be seen. A raging fire consumed one vehicle, and the other, just off the west side of the road, appeared seriously damaged. The fight was already over. Charlie Company, reinforced by the tank company headquarters section, had driven the enemy from the bridge and secured the second battalion objective through 3 hours of relentless combat. Upon Alpha Company's arrival, the Marines consolidated their combat

power and began the heart-rending MedEvac process. Shortly after 1700 CH-46E helicopters evacuated more than 30 casualties from the day's fight, and Bravo Company and the forward command post crossed the Saddam Canal Bridge into the defensive perimeter. The company commanders quickly discussed the situation with the battalion commander and were directed to push the remaining kilometer to the "T" intersection, 2 kilometers north of the Saddam Canal, to establish a defensive position for the night.

On 24 March, 2d Light Armored Reconnaissance Battalion passed through An Nasiriyah along the route that was forced open the day prior. Their use of Route 7 spearheaded the I MEF attack north to Baghdad and gave satisfaction to the Marines who had fought so hard for that purpose. Over the next week the battalion and the rest of Regimental Combat Team 2 (RCT-2) continued to capture or destroy remaining regime forces, beginning the steady transition to security operations and humanitarian assistance. The victory was hard fought and won by all of the members of the RCT. Such critical actions as the aggressive urban fighting by 3/2 and 2/8, the massed artillery strike that destroyed a gathering Fedayeen force of over 2,000 fighters, the selfless and courageous flying by pilots and aircrew of 2d and 3d Marine Aircraft Wings, and the critical flow of combat service support throughout were critical in the overall victory. It became obvious that most of the enemy resistance in the city had broken. The steady flow of civilian traffic increased, and crowds of thousands of people moved through the city trying to return to their lives. Although much hard work remained, it was clear to the Iraqi people that their freedom was close at hand.





‘Good Kills’

by Peter Maas

The New York Times Magazine, 20 April 2003.

Copyright 2003 *The New York Times Magazine*. Reprinted with Permission

As the war in Iraq is debated and turned into history, the emphasis will be on the role of technology—precision bombing, cruise missiles, decapitation strikes. That was what was new. But there was another side to the war, and it was the one that most of the fighting men and women in Iraq experienced, even if it wasn’t what Americans watching at home saw: raw military might, humans killing humans. The Third Battalion, Fourth Marines was one of the rawest expressions of that might. Based in Twentynine Palms, Calif., it specializes in desert warfare, and its forces number about 1,500 troops, equipped during the war in Iraq with about 30 Abrams tanks and 60 armored assault vehicles, backed up with whatever artillery and aircraft were required for its missions, like 155-millimeter howitzers and Cobra gunships and fighter jets. The battalion made the ground shake, quite literally, as it rumbled north from Kuwait through Iraq, beginning its march by seizing the Basra airport, continuing on past Nasiriyah, into the desert and through a sandstorm that turned the sky red and became, at its worst moments, a hurricane of sand that rocked armored vehicles like plastic toys nudged by a child’s finger. On the way to Baghdad, the battalion also fought fierce but limited battles in Afaq and Diwaniya, about 120 miles south of Baghdad, and in Al Kut, about 100 miles from the Iraqi capital.

On April 6, three days before the fall of Baghdad, the battalion arrived at the Diyala bridge, a major gateway into the south-eastern sector of the city. The bridge crosses the Diyala River, which flows into the Tigris. Once across its 150-yard span, the Third Battalion would be only nine miles from the center of Baghdad. The bridge was heavily defended on the north side by both Republican Guard and irregular forces, and the battle to seize and cross it took two days. It was, in retrospect, a signal event in the war, a vivid example of the kind of brutal, up-close fighting that didn’t get shown on cable TV.

The Third Battalion had a consistent strategy as it moved toward Baghdad: kill every fighter who refused to surrender. It was extremely effective. It allowed the battalion to move quickly. It minimized American casualties. But it was a strategy that came with a price, and that price was paid in blood on the far side of the Diyala bridge.

The unit’s commander, Lt. Col. Bryan McCoy, had a calm bearing that never seemed to waver as he and his troops made their way through Iraq. His mood stayed the same, whether he

was in battle or drinking his morning coffee or smoking a cigar; neither the tone nor the pace of his voice strayed from its steady-as-she-goes manner. Perhaps his calm came from experience. His father was an Army officer in Vietnam, serving two combat tours there. McCoy was born into the military and has lived in it for his entire life. This wasn't the first time he fought against Iraqi soldiers; he was a company commander during the Persian Gulf war in 1991.

When I spoke to him on the southern side of the Diyala bridge soon after the battalion arrived there on the morning of April 6, he was in a serene mood. "Things are going well," he said. "Really well."

When Colonel McCoy told you that things were going well, it meant his marines were killing Iraqi fighters. That's what was happening as we exchanged pleasantries at the bridge. His armored Humvee was parked 30 yards from the bridge. If one of the Republican Guard soldiers on the other side of the bridge had wanted to shout an insult across the river, he would have been heard—were it not for the fact that Colonel McCoy's battalion was at that moment lobbing so many bullets and mortars and artillery shells across the waterway that a shout could never have been heard, and in any event the Iraqis had no time for insults before dying. The only sound was the roar of death.

"Lordy," McCoy said. "Heck of a day. Good kills."

McCoy's immediate objective was to kill or drive away enough of the forces on the north side of the river to let him move his men and equipment across. He had no doubt that he would succeed. He was sitting in the front seat of his Humvee, with an encrypted radio phone to his left ear. He had the sort of done-it-again pride in his voice that you hear from a business executive who is kicking back at the clubhouse as he tells you he beat par again. Two Abrams tanks lumbered past us—vehicles that weigh 67 tons apiece do not move softly—and the earth shook, though not as much as it was shaking on the other side of the river, where American mortars were exploding, 150 yards away. The dark plumes of smoke that created a twilight effect at noon, the broken glass and crumpled metal on the road, the flak-jacketed marines crouching and firing their weapons—it was a day for connoisseurs of close combat, like the colonel.

"We're moving those tanks back a bit to take care of them over there," he explained, nodding to his right, where hit-and-run Iraqi fighters were shooting rocket-propelled grenades at his men, without success. Colonel McCoy's assessment was Marine blunt: "We're killing 'em."

He turned his attention to the radio phone, updating his regiment commander. His voice remained calm.

"Dark Side Six, Ripper Six," he said, using his call sign and his commander's. "We're killing them like it's going out of style. They keep reinforcing, these Republican Guards, and we're killing them as they show up. We're running out of ammo."

McCoy, whose marines refer to him as, simply, "the colonel," was not succumbing, in his plain talk of slaughter, to the military equivalent of exuberance, irrational or otherwise. For him, as for other officers who won the prize of front-line commands, this war was not about hearts and minds or even liberation. Those are amorphous concepts, not rock-hard missions. For Colonel McCoy and the other officers who inflicted heavy casualties on Iraqis and suffered few of their own, this war was about one thing: killing anyone who wished to take up a weapon in defense of Saddam Hussein's regime, even if they were running away. Colonel McCoy refers to it as establishing "violent supremacy."

"We're here until Saddam and his henchmen are dead," he told me at one point during his march on Baghdad. "It's over for us when the last guy who wants to fight for Saddam has flies crawling across his eyeballs. Then we go home. It's smashmouth tactics. Sherman said that war is cruelty. There's no sense in trying to refine it. The crueler it is, the sooner it's over."

When I suggested to Colonel McCoy one morning that Iraqi civilians might not appreciate the manner in which his marines tended to say hello to the locals with the barrels of their guns raised, he did not make any excuses.

"They don't have to like us," he said. "Liking has nothing to do with it. You'll never make them like you. I can't make them like me. All we can do is make them respect us and then make sure that they know we're here on their behalf. Making them like us—Yanks always want to be liked, but it doesn't always work out that way."

Though the fighting was lopsided, the marines did not get to the Diyala bridge unscathed. On April 3, three days before the battle for the bridge, the Third Battalion entered the town of Al Kut. It was an incursion intended to convey the point that, as Colonel McCoy described it, there were new “alpha males” in the country.

The attack began at dawn with an artillery barrage that had excited marines next to my vehicle. They yelled “Bam! Bam!” as each shell was fired into the air. Tanks led the way into town, and as I stayed a kilometer behind at a medic station, the sounds of battle commenced, mortars and machine-gun fire that were accompanied, as ever, by the visuals of war—smoke plumes that were an arsonist’s dream.

A half-hour into the battle, a Humvee raced out of the city and stopped at the medic station. A marine, whose body was rag-doll floppy, was pulled out and put on a stretcher. A marine doctor and medics surrounded him. His clothes were stripped off and needles and monitors placed on and into his body, and the dialogue of battlefield medicine began among the team, all of whom had slung their M-16’s over their backs as they tried to save their comrade’s life.

“Left lower abdomen.”

“He’s in urgent surgical.”

“Wriggle your toes for me.”

“Ow, ow.”

“He needs medevac, now.”

“Iodine.”

“My arms are numb.”

“Keep talking, Evnin.”

His name was Mark Evnin. He was a corporal, a sniper who was in one of the lead vehicles going into Al Kut. Iraqi fighters were waiting in ambush and had fired the first shots; one of them got him.

“Keep talking to us. Where are you from?”

“Remon,” he mumbled.

“Where? Where are you from?”

“Verrrmon.”

Evnin was not doing well. The battalion chaplain, Bob Grove, leaned over him, and because the chaplain knew Evnin was Jewish, he pulled out of his pocket a sheet with instructions for “emergency Jewish ministrations.” Grove read the Sh’ma, which begins, “Hear, O Israel, the Lord our God.” Then he began reading the 23rd Psalm, at which point Evnin said, “Chaplain, I’m not going to die.”

A Chinook landed 50 yards away. Evnin’s stretcher was lifted from the asphalt and rushed to the chopper. Shortly after he was airborne, he went into shock and died.

Colonel McCoy was just a few feet from where Corporal Evnin was mortally wounded. “I saw him go down,” he said afterward. “That fight lasted about nine seconds. We had about 15 human-wave guys attack the tanks. They were mowed down. They drew first blood. They got one of us, but we got all of them.”

Corporal Evnin was the battalion’s first K.I.A., but he was certainly not the only marine to die in Iraq. The men of the Third Battalion paid close attention to news of marine battle deaths. The day before they arrived at the Diyala bridge, a Marine tank was blown up by an explosives-laden truck that drove alongside it and was detonated by its driver. It was the realization of one of the marines’ worst fears: suicide bombers.

McCoy remained focused; he told me that his mission, to kill Iraqi fighters, had not changed. “I’m not allowed to have the luxury of emotions to guide my decisions,” he said. “It’ll cloud my decisions, and I’ll make a bad one if I submit to that. I have to look at everything very clinically.” He reacted to the suicide bombing tactically: a new danger had emerged, and his troops would have to be on increased alert to the threat posed by civilian vehicles.

But the deaths of their comrades deeply affected the grunts, and when the battalion got to Diyala bridge, every man was primed to kill.

“There’s an unspoken change in attitude,” McCoy told me a few days before we reached the bridge. “Their blood is up.”

The battle for the Diyala bridge lasted for two days. One of the bridge's main pylons had been badly damaged, and armored vehicles could not move over it. So after the first day of fighting on April 6, the battalion dug itself into the southern side for the night, giving itself time to plan an infantry assault over the span the next morning.

In the morning, the battalion released another round of heavy artillery barrages to soften up the opposition on the northern side of the river. In the fighting, two more marines were killed when an artillery shell hit their armored vehicle on the southern side of the bridge. Eventually, the battalion killed most of the Republican Guard fighters, or at least pushed them back from their dug-in positions on the northern side, and McCoy decided that it was time to try a crossing.

The men of the Third Battalion moved across the Diyala bridge "dismounted," that is, on foot. It was a tableau from Vietnam, or even World War II; grunts running and firing their weapons in front of them. This was, as McCoy described it, "blue-collar warfare."

When the marines crossed to the northern side, they found themselves in a semi-urban neighborhood of one-story shops and two-story houses, a few dozen palm trees and lots of dust. A narrow highway led away from the bridge, toward Baghdad. Immediately, they were met with incoming fire—occasional bullets and the odd rocket-propelled grenade, fired mostly from a palm grove on the eastern side of the road to Baghdad. Colonel McCoy set up his command position—basically, himself and his radioman—adjacent to a house by the bridge. Marines fanned out into the palm grove, while others moved north up the road, going house to house. Advance units set up sniper positions and machine-gun positions a few hundred yards farther up the road; beyond them, American mortars and bombs, fired by units near and behind Colonel McCoy's position, were loudly raining down.

One of Colonel McCoy's sergeants ran up to him and told him that Iraqi reinforcements had just arrived.

"A technical vehicle dropped off some [expletives] over there," he said, pointing up the road.

"Did you get it?" Colonel McCoy asked.

"Yeah."

"The [expletives]?"

"Some of them. Some ran away."

"Boys are doing good," the colonel said moments later. "Brute force is going to prevail today."

He listened to his radio.

"Suicide bombers headed for the bridge?" he said. "We'll drill them."

Then, one by one, about a half-dozen vehicles came up the road, separately, and the marines got ready to drill them.

Battle is confusion. If a military unit is well trained and well led, the confusion can be minimized, but it can never be eliminated. Split-second decisions—whether to fire or not fire, whether to go left or right, whether to seek cover behind a house or in a ditch, whether the enemy is 200 yards ahead or 400 yards ahead—these kinds of decisions are often made on the basis of fragmentary and contradictory information by men who are sleep-deprived or operating on adrenaline; by men who fear for their lives or for the lives of civilians around them or both; by men who rely on instincts they hope will keep them alive and not lead them into actions they will regret to their graves. When soldiers make their split-second decisions, they do not know the outcome.

The situation was further complicated on the north side of the Diyala bridge, because what was left of the Iraqi resistance had resorted to guerrilla tactics. The Iraqis still firing on the marines were not wearing uniforms. They would fire a few shots from a window, drop their weapons, run away as though they were civilians, then go to another location where they had hidden other weapons and fire those.

Amid the chaos of battle McCoy was, as usual, placid yet focused. Black smoke blew overhead and through the streets; hundreds of marines crept forward on their bellies or in low runs, darting, as fast as they could with their combat gear, from palm tree to palm tree or from house to house. On all sides, there was the sound of gunfire, an orchestra of sounds—the pop-pop of assault weapons, the boom-boom of heavy machine guns, the thump of mortars. Harmony was taking a day off. There would be a sudden burst of a few shots, then a crescendo in which, it seemed, every marine in the vicinity was firing his weapon at an enemy who was, for

the most part, unseen; and then it would stop, briefly.

The bulk of the fire emanated from McCoy's forces, not the Iraqis. Some marines branched farther out to the east, beyond the palm grove. Others moved forward, straight down the road, trying to "go firm" on a front line there, to establish a defensive perimeter into which Iraqi fighters could not penetrate.

The plan was for marine snipers along the road to fire warning shots several hundred yards up the road at any approaching vehicles. As the half-dozen vehicles approached, some shots were fired at the ground in front of the cars; others were fired, with great precision, at their tires or their engine blocks. Marine snipers can snipe. The warning shots were intended either to simply disable a vehicle—wrecking the engine or the tires—or to send the message that the cars should stop or turn around, or that passengers should get out and head away from the marines.

But some of the vehicles weren't fully disabled by the snipers, and they continued to move forward. When that happened, the marines riddled the vehicles with bullets until they ground to a halt. There would be no car bombs taking out members of the Third Battalion.

The vehicles, it only later became clear, were full of Iraqi civilians. These Iraqis were apparently trying to escape the American bombs that were landing behind them, farther down the road, and to escape Baghdad itself; the road they were on is a key route out of the city. The civilians probably couldn't see the marines, who were wearing camouflage fatigues and had taken up ground and rooftop positions that were intended to be difficult for approaching fighters to spot. What the civilians probably saw in front of them was an open road; no American military vehicles had yet been able to cross the disabled bridge. In the chaos, the civilians were driving toward a battalion of marines who had just lost two of their own in battle that morning and had been told that suicide bombers were heading their way.

One by one, civilians were killed. Several hundred yards from the forward marine positions, a blue minivan was fired on; three people were killed. An old man, walking with a cane on the side of the road, was shot and killed. It is unclear what he was doing there; perhaps he was confused and scared and just trying to get away from the city. Several other vehicles were fired on; over a stretch of about 600 yards nearly a half dozen vehicles were stopped by gunfire. When the firing stopped, there were nearly a dozen corpses, all but two of which had no apparent military clothing or weapons.

Two journalists who were ahead of me, farther up the road, said that a company commander told his men to hold their fire until the snipers had taken a few shots, to try to disable the vehicles without killing the passengers. "Let the snipers deal with civilian vehicles," the commander had said. But as soon as the nearest sniper fired his first warning shots, other marines apparently opened fire with M-16's or machine guns.

Two more journalists were with another group of marines along the road that was also involved in the shooting. Both journalists said that a squad leader, after the shooting stopped, shouted: "My men showed no mercy. Outstanding."

The battle lasted until the afternoon, and the battalion camped for the night on the north side of the bridge. The next morning, April 8, I walked down the road. I counted at least six vehicles that had been shot at. Most of them contained corpses or had corpses near them. The blue van, a Kia, had more than 20 bullet holes in its windshield. Two bodies were slumped over in the front seats; they were men in street clothes and had no weapons that I could see. In the back seat, a woman in a black chador had fallen to the floor; she was dead, too. There was no visible cargo in the van—no suitcases, no bombs.

Two of the van's passengers had survived the shooting; one of them, Eman Alshamneri, had been shot in the toe. She had passed out and spent the night in the vehicle. When she woke in the morning she was taken by marines for treatment by their medical team.

Alshamneri told me that her home in Baghdad had been bombed and that she was trying to flee the city with her sister, who was the dead woman I had seen in the back seat of the van. Alshamneri said she had not heard a warning shot—which doesn't mean that one wasn't fired. In fact, it would have been difficult, particularly for civilians unaccustomed to the sounds of war, to know a warning shot when they heard it, or to know where it came from, or how to react appropriately.

Alshamneri, who spoke to me through a Marine interpreter, was sitting next to another woman, who gave

her name as Bakis Obeid and said she had been in one of the other passenger vehicles that was hit. She said her son and husband had been killed.

There were other survivors. A few yards down the road from the Kia van, three men were digging a grave. One gravedigger gave his name as Sabah Hassan and said he was a chef at the Al Rashid hotel, which is in the center of Baghdad and, in more peaceful times, was where foreign journalists stayed. Hassan said he was fleeing the city and was in a sedan with three other men on the road when they came under fire, apparently from the marines. A passenger in his car was killed. I asked him what he felt.

“What can I say?” he replied. “I am afraid to say anything. I don’t know what comes in the future. Please.” He plunged his shovel back into the earth and continued his funeral chores.

Not far from the gravediggers, I came across the body of the old man with the cane. He had a massive wound in the back of his head. He died on his back, looking at the sky, and his body was covered with flies. His cane, made of aluminum, lay by his right hand.

Just a few yards away, a Toyota pickup truck was by the side of the road, with more than 30 bullet holes in its windshield. The driver, who was wearing a green military tunic, was dead, his head thrown back, slightly to the left. Nearby, the body of another man lay on the ground, on his stomach; attached to the back of his belt was a holster for a pistol. An AK-47 assault rifle was in the sand nearby. These were the only fighters, or apparent fighters, that I saw on the road or in adjacent buildings.

As I took notes, several marines came by and peeked inside the blue van.

“I wish I had been here,” one of them said. In other words, he wished he had participated in the combat.

“The marines just opened up,” another said. “Better safe than sorry.”

A journalist came up and said the civilians should not have been shot. There was a silence, and after the journalist walked away, a third marine, Lance Cpl. Santiago Ventura, began talking, angrily.

“How can you tell who’s who?” said Corporal Ventura. He spoke sharply, as though trying to contain his fury. “You get a soldier in a car with an AK-47 and civilians in the next car. How can you tell? You can’t tell.”

He paused. Then he continued, still upset at the suggestion that the killings were not correct.

“One of these vans took out our tank. Car bomb. When we tell them they have to stop, they have to stop,” he said, referring to civilians. “We’ve got to be concerned about our safety. We dropped pamphlets over these people weeks and weeks ago and told them to leave the city. You can’t blame marines for what happened. It’s bull. What are you doing getting in a taxi in the middle of a war zone?”

“Half of them look like civilians,” he continued. He was referring to irregular forces. “I mean, I have sympathy, and this breaks my heart, but you can’t tell who’s who. We’ve done more than enough to help these people. I don’t think I have ever read about a war in which innocent people didn’t die. Innocent people die. There’s nothing we can do.”

Two days later, the Third Battalion arrived at the Palestine Hotel in the center of Baghdad, the first marines to reach the heart of the city. They had made it from the Kuwaiti border in 22 days. As the marines were taking up defensive positions around the hotel, I noticed a sniper I had become acquainted with during the past weeks. (Because he has children who do not know precisely what he does in the Marines, he had asked me not to name him.) He was squatting on the ground in Firdos Square, in front of the hotel, scanning nearby buildings through the scope on his rifle, looking for enemy snipers. About 150 yards away, at the other end of the square, one of the battalion’s armored vehicles was in the process of wrapping a metal chain around the statue of Saddam Hussein, preparing to pull it down.

Although this was a moment of triumph, I was still thinking about the civilians killed at Diyala bridge, and I said to the sniper that I had heard that he was one of the men who had fired shots there. He nodded his head, and I didn’t need to ask anything more, because he began to talk about it. It was clear the bridge was weighing on his mind, too. He said that during the battle, he fired a shot at the engine block of a vehicle and that it kept moving forward. For him, this had been evidence that the person behind the wheel was determined to push ahead, and to do harm.

I said that a civilian driver might not know what to do when a bullet hits his vehicle, and might press ahead out of fear or confusion.

“It’s easy to be a Monday-morning quarterback on Monday morning,” he replied. “But we did everything we could to avoid civilian casualties.”

When I visited the kill box down the road from Diyala bridge the morning after the battle, I noticed that the destroyed cars were several hundred yards from the marine positions that fired on them. The marines could have waited a bit longer before firing, and if they had, perhaps the cars would have stopped, or perhaps the marines would have figured out that cars contained confused civilians. The sniper knew this. He knew that something tragic had happened at the bridge. And so, as we spoke in Baghdad, he stopped defending the marines’ actions and started talking about their intent. He and his fellow marines, he said, had not come to Iraq to drill bullets into women and old men who were just trying to find a safe place.

Collateral damage is far easier to bear for those who are responsible for it from afar—from the cockpit of a B-1 bomber, from the command center of a Navy destroyer, from the rear positions of artillery crews. These warriors do not see the faces of the mothers and fathers they have killed. They do not see the blood and hear the screams and live with those memories for the rest of their lives. The grunts suffer this. The Third Battalion accomplished its mission of bringing military calamity upon the regime of Saddam Hussein; the statue of Saddam fell just a few minutes after the sniper and I spoke. But the sniper, and many other marines of the Third Battalion, could not feel as joyous as the officers in the rear, the generals in Qatar and the politicians in Washington.

The civilians who were killed—a precise number is not and probably never will be available for the toll at Diyala bridge, or in the rest of Iraq—paid the ultimate price. But a price was paid, too, by the men who were responsible for killing them. For these men, this was not a clean war of smart bombs and surgical strikes. It was war as it has always been, war at close range, war as Sherman described it, bloody and cruel.



Charlie Company Leads BLT into Northern Iraq

by First Lieutenant Christopher Mercer, Forward Observer, Charlie Company, BLT 1/8

<http://www.usmc.mil/26thmeu/Releases/Charlie%20Comp%20in%20Iraq.htm>>. 12 June 2003.

The Marines and Sailors of Battalion Landing Team 1/8 were summoned to action in early April to go ashore and secure the Al-Mosul Airport in order to provide a means of strategic airlift for the joint arena of northern Iraq. The airport was located in the fourth largest city in Iraq and home to an Iraqi Republican Guard Unit. As they have prepared for so many months to operate in any clime or place, the men of Charlie Company expeditiously answered their call to duty receiving a mere 24 hours notice before they began deploying from their ship in the Mediterranean Sea. Capt John J. Miles, commanding officer of Charlie Company, seemingly put it best when briefing his Marines before flying into northern Iraq, "You've sung about it while running, now you're going to do it. 'C-130 rollin' down the strip, Charlie Company's gonna take a little trip."

In the early morning hours of April 12th the Marines did exactly that as they boarded C-130's and settled down for lengthy plane ride into Irbil, Iraq. On deck, they were first greeted by elements of Joint Special Operation's Task Force North (JSOTF) and immediately began staging in preparation for insertion into Mosul. Throughout that first day several planeloads brought in the BLT staff, Charlie Company, and some supporting elements. After nightfall, Charlie Company was lined up on the flight line in helo-stick order, as they are accustomed to doing as the BLT's primary helicopter-borne raid company.

Helicopter lift from Irbil into the Mosul airfield was provided by a section of the Air Force's Special Operations Support Squadron flying their specialized version of the CH-53 helicopter. Outfitted with .50 caliber machineguns, they flew in and began shuttling Marines from Irbil to Mosul. The Marines knew they were flying into hostile territory as tracers from small arms fire streaked up through the night sky from the city below. Once on the ground in Mosul, the company was directed to a concrete, open-ended aircraft hangar at the south end of the airfield to settle in for the night while the staff was establishing a command post in the terminal and making appropriate liaison with the Army's Special Forces unit operating out of the same building.

By sunrise on the 13th, the flights inbound from Irbil ceased. A portion of Charlie Company was still in Irbil along with all the supplies that the Marines couldn't carry on their backs into Mosul. With the likelihood of the remainder of the company moving by air being doubtful, Charlie Company's executive officer, 1st Lt Scott M. McGuckin, sought to make liaison to insert the remainder of Charlie Company into Mosul anyway possible. Luckily, he stumbled into some Special Forces soldiers leaving Irbil heading west to Mosul. He informed the BLT and a combination of the available civilian and military vehicles was organized into a convoy. Taking charge of a platoon from of the 10th Mountain Division, the remaining Marines of Charlie Company, and setting the SF soldiers in the lead vehicle, 1stLt McGuckin executed a tactical forty-mile convoy to Mosul and arrived intact later that afternoon.

The Marines already in Mosul had their work cut out for them. First platoon of Charlie Company took over security of the Main Gate of the airport from the Kurdish PDK forces that were guarding much of the airfield perimeter. First platoon also was placed in charge of the terminal building to provide security for the MEU's command element. Second platoon set up security to the south, and portions of third platoon and weapons platoon were sent to the North Gate of the airfield. When the Marines arrived at the North Gate they found the post being abandoned by the PDK who loaded onto trucks and left.

As the sun went down the Marines hurried to set in to the best positions they could manage in lowlight conditions. A section of Weapons Company's heavy guns arrived at the gate at sunset to provide support. Throughout the night the Marines sat quietly, waiting, until just before 0500 local time when they heard words spoken in Arabic being broadcast through a speaker in the distance. They later learned this was one of several "calls to prayer" to be issued throughout the day from the community's mosque. Within minutes a shot rang out close by, then more shooting from multiple sources along the platoon's position. The tracer rounds from those AK-47's were directed at the positions that the Marines had established only hours ago just before sun-

down. Cpl Khattab of third platoon was the first to return fire. Other Marines then immediately joined him as they spotted muzzle flashes coming from the tall grass that separated them from the perimeter wall. After a couple of minutes the enemy fire stopped as abruptly as it had begun. In the silence that followed, team leaders began assessing the condition of their Marines and passing reports to higher while the distant sound of prayers being sung from the wailing tower could be heard.

After sunrise the next morning the Marines began continuing actions by improving their positions and their defensive posture. As one of the squad leaders from third platoon, Sgt Philippe, began crossing the main street leading out of the North Gate shots rang out again. "I heard the 'crack' of rounds passing close by and I grabbed the first piece of cover I could find," he said. No one could identify the source of the shooting only the general direction. After a pause and no further shooting, Sgt Philippe set out again to cross the street and was fired upon a second time. This time the source was identified and the Marines returned fire. A clear and search team was formed and dispatched to the building, but there was nothing there.

Later in the morning, a platoon from Bravo Company relieved the Marines at the North Gate and the Main Gate while Charlie Company loaded up in vehicles. Convoys ferried the Charlie Company Marines out to each of the five bridges connecting northeast Mosul to southwest Mosul. For several hours the Marines manned these bridges straddling the Tigris River, stopping vehicles to note the numbers and types of weapons among the populace. This also served as a message to the people of Mosul that the Marines had arrived. The majority of the people expressed their appreciation and welcomed the Marines to their country.

At dusk, Charlie Company returned to the airfield and resumed their duties performing security at the terminal and the southern perimeter. The third day in country, after manning the bridges, Charlie Company was tasked with relieving Bravo Company's Marines on the North Gate and establishing a company defensive position in that sector while providing gate security. This gate was to serve as the primary military access point to the airfield. The company quickly went to work setting in machine gun positions, delegating sectors of fire to each weapon system the company employs, and clearing through all of the buildings in that portion of the airfield. Many of the buildings were former classrooms and administrative offices for a Republican Guard unit stationed there. How long the buildings had been vacant was unclear. Many military items such as old helmets and personal uniform items could be found throughout. During the clearing of buildings Marines discovered large wooden shipping crates labeled "Machine Parts" but filled with NBC decontamination kits and gas masks. In other places large sacks labeled "Grain" or "Detergent" were opened and found to contain combat boots or other uniform items.

Some of the rooms that appeared to be training classrooms had murals depicting the silhouettes of American aircraft painted on their walls. There were land navigation classrooms and rooms adapted for large-scale sand table exercises. The Marines took that sand and put it into sandbags for their defensive positions as it was just a little less to dig up. They fortified the buildings along their perimeter, and over the course of the next few days they filled over 5,000 sandbags. They dug trench systems, strung barbed wire over ground-floor entrances to blockade them from enemy infiltration and ran as much concertina wire around their perimeter that they could acquire. Unfortunately, due to the tall grass and number of buildings in close proximity to the perimeter walls there were gaps that could only be covered by fire and limited observation in the event of an attack.

Immediately the Marines began conducting urban combat patrols throughout the streets to the immediate front of the North Gate's location. These foot mobile patrols were conducted day and night to show a presence of force to the local community and never extended much further than two to three kilometers away from the gate. At nearly every street corner there were men gathered on the street with bonfires and roadblocks in an effort, they said, to prohibit robbers and looters from damaging their community. Many of the men carried AK-47 assault rifles and it became commonplace to hear gunshots fired within hundreds of meters of the patrols as they made their way through the neighborhoods along their routes.

One patrol from 1st Platoon that went out discovered an SA-7 shoulder-fired surface-to-air missile lying abandoned in the grass near the side of the main road leading from the gate. An EOD (explosive ordnance disposal) team was dispatched to meet the patrol and neutralize the weapon. Further investigation of the area and

questioning of the local people by HET (human exploitation team) discovered that a nearby group of buildings was, in fact, an abandoned Baath Party Compound. This area was searched and piles of burned documents were found scattered about, including some actual photos showing Saddam Hussein or his sons with local leaders (whose faces had been cut out of the pictures).

On another patrol later in the week, one Marine observed a discarded AK-47 magazine near the gate to an apparently abandoned complex of buildings. The patrol leader decided to send a fire team behind the walls of the compound to perform a quick cursory search of the area. Immediately the fire team leader reported finding ammunition in large quantities. Uncovered there was a room with crates of mortar rounds littering the floor, and in one section of the courtyard there were dozens of 12.7mm heavy machine gun rounds strewn about. Many of the rounds had been separated from their shell casings and the gunpowder removed, but it was unclear why. Once again an EOD team was dispatched to deal with the unexploded ordnance.

Many of the patrols were greeted by young children who gave the Marines flowers and spoke to them in what little English they had learned in school saying phrases like, "How are you?" or "Good, good. USA." They would smile and give a "thumb's up" sign while following the patrols for as long as they could till older men on the streets would tell the kids to not bother the Marines. Many of the people were dressed in a western style of clothing, but the Marines noted that the younger men who wore traditional clothing seemed to act the unfriendliest to their presence patrolling the streets. Throughout the day, towers with large speakers atop them would broadcast Arabic to the people calling them to prayers at any of the community mosques. The broadcasts were often sung and they lasted for five to ten minutes at a time.

On Easter Sunday, the Marines were especially vigilant. Due to the religious significance of the day, an attack was expected. All during the previous week men would observe the Marine's activities with binoculars from the rooftops of houses across from the perimeter. Men would ride up to the gate in taxi cabs and count the number of Marines manning the post and noting the Marine's reactions before riding away. But Easter morning passed without incident and the Marines returned to conducting patrols and hardening their defensive positions. It was reported that elements of the army's 101st Airborne and 4th Infantry Division would begin arriving that day and to expect them to enter the airfield through the North Gate. But by the end of the day, no soldiers had arrived.

Marine discover a tunnel system inside the company perimeter after a firefight. Enemy muzzle flashes were seen coming from this position during the engagement. Throughout the night the Marines kept watch and at around 4:40 a.m. local time the next morning Charlie Company, along with the Light Armored Reconnaissance Platoon and the 81mm Mortar Platoon was attacked. "I saw the shadow of a figure climbing over the wall. When I looked through my night vision scope I saw the silhouette of a weapon in the hand of the figure and I opened fire," said LCpl Adair of 2nd Platoon. Immediately the enemy began firing on LCpl Adair's position from two other sources. Then from the rooftops of the buildings along the perimeter wall the enemy engaged Charlie Company's defensive positions in an attempt to suppress them. There were enemy tracers also coming up from the high-grass along the perimeter. The enemy directed their fires at the sandbagged positions and the Marines responded with overwhelming firepower. The enemy stopped shooting after a few minutes and the Marines ceased fire and began collecting ammunition and casualty reports. During the lull, Sgt Leclair of third platoon reported, "Sir, I see something in the grass that wasn't there before . . . now I see movement," with which he fired three rounds into the high grass where the movement was. Immediately the enemy returned fire from the high grass and the fight began again. The enemy fires increased as other aggressors climbed on rooftops in the town and began firing in the direction of the North Gate. The glowing paths of tracers were nighttime's evidence of the rounds that were punching into the sides of the buildings Marines were returning fire from. From a distance tracers could be seen arching over the rooftops of the Marine's positions as the enemy continued attacking from the perimeter. The Marines directed their fires at the sources of enemy fires sighting in on muzzle flashes and gaining fire superiority. Eventually the enemy withdrew and the Marines ceased their fires.

Charlie Company resumed their ammunition and casualty reporting and learned they had taken no casualties during the firefight. At dawn, patrols of the perimeter were initiated. The Marines cleared and searched the

residential houses along the perimeter from which they were being shot at. The houses were empty of people and the rooftops yielded little more than the strong smell of gunpowder and AK-47 shell casings. Within the high-grass there were dug-in fighting positions and the openings to a tunnel system not visible before due to the thick vegetation. The perimeter fence-line had been breached in more than one place. There was a manhole cover leading to a pipeline that opened up in the street running parallel to the Marine's perimeter immediately outside the airfield. The Marines got right to work booby-trapping these breach points while they requested additional supplies to fortify their position and to guard against further penetration. The intensity of the morning's attack was evident in the bullet holes dotting the sandbagged positions and the pockmarked concrete walls surrounding the windows from which the Marines returned fire.

It must have seemed to the enemy imbedded in the local populace that the Marines had called for reinforcements as elements of the army finally began arriving. Throughout the day of April 21st, convoys of vehicles numbering more than twenty and thirty strong began arriving. Bradley Fighting Vehicles, armored HMMWV's, and M1A1 Abrams tanks shook the ground as they rolled through the North Gate and began staging in the airfield. Charlie Company continued to defend the North Gate and accept the army as they arrived throughout the following night.

As the army amassed their forces on the airfield Charlie Company was told to prepare to be relieved by them. The Marines continued to harden and improve their positions anyway throughout the day of the 22nd and ended up remaining in position for an additional night. Just before dusk, snipers attached to the company watched as a teenager walked along the east of the perimeter with an AK-47 rifle in his hands examining it. The sniper's line of fire was obstructed and while he was working to clear it his spotter observed the teenager raise the rifle to his shoulder and fire a round in the direction of the Marines. As the sniper sighted back in on him, the shooter disappeared from view for a few seconds. He re-emerged running into the street with no weapon and began playing soccer with several children there. 2ndLt R.L. Miller, the platoon commander who was responsible for that sector of the company's position, decided to send a squad of his Marines out to snatch the shooter and detain him for interrogation. As the squad left the company's lines in pursuit of the enemy, the shooter went into a nearby house. The Marines entered the residence and returned with the shooter and the shooter's father. While searching the detainees, it was discovered that the shooter still had a cartridge belt underneath his clothing and was carrying a large sum of cash. At the North Gate there were Marines from the MEU's human intelligence unit waiting to take these detainees away for interrogation. It was learned that the shooter was seventeen years old but the weapon he used to shoot at the Marines was never retrieved. Several hours later the detainees were returned to the gate and released.

Just before dawn on the 23rd, Charlie's defensive lines were tested yet again. This time the focus of the attack came from the northeastern flank. A force of about a fire-team sized element opened fire on the Marines who returned fire in kind. Just as in previous firefights, the enemy ceased attacking and the Marines ceased fire. With thermal imaging devices the Marines scanned the perimeter for any sign of enemy movement. Within minutes the enemy picked up and attempted to flee. The Marines opened fire. This initiated another firefight lasting for several minutes until eventually the enemy withdrew from the perimeter. The Marines ceased fire and once again the sandbags of their positions had evidence of enemy fire. Fortunately, Charlie Company took no casualties and once again succeeded in repelling the assault with overwhelming firepower.

As the sun rose, the Marines sent out a search team only to find empty shell casings from the enemy and nothing more. A company from the army's 101st Airborne came forward to relieve Charlie Company of their responsibilities on the gate. Turnover of the defensive position was completed when a mechanized company from the army's 4th Infantry Division reinforced the gate and augmented the 101st. Charlie Company was moved back to its original location at the southern end of the airfield to stage awaiting transportation back to the ship.

While the BLT began back-loading Marines out of the country, Charlie Company settled down to wait their turn. The nightly fireworks display of small arms tracer rounds lighting up the sky as aircraft flew in to the airfield was so common that it became expected. During the days the Marines were in Mosul several black funnel clouds were visible as ammunition supply points within a few miles of the airfield continued to burn and

detonate unexpended ordinance. The sounds of distant explosions and the smoke filled skies were something everyone had grown accustomed to and hardly took notice of.

On Saturday, the 26th, the first flights of Charlie Company left Iraq. The first half of the company boarded C-130's and began the long flight back. By the next day the entire company completed its extraction from northern Iraq and returned to the USS Iwo Jima where the ship's crew greeted them with much enthusiasm and a warm welcome. After turning in their unexpended ammunition, cleaning their weapons, and grabbing a quick bite of chow, the Marines got their first shower and haircut in more than two weeks. Then they began the arduous task of cleaning all the personal gear covered in the fine dust and dirt of northwestern Iraq. But, it was good to be "home."

For many in Charlie Company this was their first time in actual combat. Due to the leadership and initiative at the lowest levels the Marines were successful. They were tested several times and they held their ground. Many of them reflect on the short time they were in Iraq and say they wish they could have stayed longer. But, in the simplest of terms, they were given a mission and they accomplished it. Now they are standing by, prepared and waiting for the next mission.



Experience and Adaptability Ensure Success for 24th MEU (SOC) in Iraq

by Corporal Jeff Sisto

<<http://www.globalsecurity.org/...03/05/mil-030512-usmc01.htm>>. 12 May 2003.

USS NASSAU (LHA-4), Underway (May 8, 2003)—As the USS Nassau (LHA-4) Amphibious Ready Group steamed out of the Arabian Gulf, members of the 24th Marine Expeditionary Unit (Special Operations Capable) looked forward to returning home after eight months away. Throughout the deployment, the MEU experienced a variety of foreign terrain and diverse cultures, challenging training exercises and real world missions—all of which helped prepare them for their ultimate test—Operation Iraqi Freedom.

OIF proved the MEU's effectiveness on many levels. As a relatively small, amphibious unit, the MEU first demonstrated, and then broke the boundaries of its doctrinal capabilities by conducting combat operations over 250 miles inside the Iraqi border. Ultimately, the MEU operated as far north as Al Kut—a city 60 miles south of Baghdad.

Experience played a large part in the 24th MEU (SOC)'s effectiveness in the war. Working with the USS Nassau ARG for a year and a half perfected their ability to ensure safe and efficient offload procedures—a skill that defines an effective ARG and keeps a MEU in business. In addition, the MEU had experience in anti-terrorism, peace support operations, and months of desert warfare training in the Middle East. With a resume like that, it was no surprise that they would successfully participate in the war in Iraq.

The Order

While on ship, the 24th MEU received the order to go into Iraq well after preparations had been made to return home. However, within 96 hours of receiving the order to go in, MEU Service Support Group 24 worked with the USS Nassau ARG to facilitate a successful offload of all MEU personnel, cargo, vehicles, and supplies.

Operationally, the MEU assumed their role in Operation Iraqi Freedom would be to support Task Force Tarawa and fill in the gaps left by the 1st Marine Expeditionary Force and the Army's 3rd Infantry Division during their push for Baghdad. Yet, operations officers remained flexible, planning for a number of different contingencies.

"I MEF and the 3rd ID pushed so far, so fast, that it left communication and supply lines vulnerable to remaining pockets of resistance," said Capt. Mark Paolicelli, 24th MEU (SOC) Assistant Operations and Fire Support Officer. "We knew we would be used to help secure those vulnerabilities, but we also knew we had to be adaptable from there on out."

A successful offload and convoy brought the MEU to Logistics Support Area Viper in Iraq. After a brief consolidation at Camp Viper, the MEU's Battalion Landing Team, 2nd Battalion, 2nd Marines, pushed forward to Qalat Sukar Airfield, while I MEF continued their advance north. The threat of convoy ambushes along the way was constant and the Marines expected to be engaged by Iraqi paramilitaries, who had already inflicted numerous casualties to I MEF Marines in the town of An Nasiriyah.

"By securing the rear supply lines and lingering pockets of resistance, it allowed I MEF to focus on the more conventional fighting with the Iraqi Army," said Maj. Darrel Benfield, Operations officer, BLT 2/2. "This also meant that we would have to face the unpredictable fighting style that unconventional forces use."

Upon arriving at Camp Viper, the MSSG led a 93-vehicle convoy with the remaining MSSG and Command Element personnel to Qalat Sukar Airfield to establish a command post. The Qalat Sukar Airfield soon became Camp Fenway—the command post of the 24th MEU (SOC). From there, the MEU conducted a series of missions that ensured safe supply routes, destroyed Iraqi paramilitaries, and ensured successful peace support operations.

With An Ace

One of the most challenging aspects of the MEU's participation in OIF is the fact that they operated without the support of their Aviation Combat Element. Once the MEU received word to go into Iraq, Marine Medium Helicopter Squadron 263 was split up and chopped out to different Marine Aircraft Groups operating inside Iraq to conduct challenging missions of their own.

The AV-8 Harriers were sent to the all-Harrier MAG-13, flying Offensive Air Support (both Close Air Support and Ariel Interdiction) mostly between Baghdad and Tikrit.

Parts of the ACE's Marine Air Control Group Detachment were chopped to MACG-38, where they provided Air Support services to Task Force Tarawa and 1st Marine Division from Al Kut to the Yankee Forward Arming and Refueling Point outside of Baghdad.

Rotary-wing aircraft joined MAG-29, operating from Riverfront Forward Operating Base and the USS Nassau providing Assault Support, Offensive Air Support, and Visual Reconnaissance to both 1st Marine Division and TFT units as well as the UK Division in Basrah. CH-46 Helicopters flew mostly Casualty Evacuations and Assault Support, as well as transporting Enemy Prisoners of War. CH-53 helicopters also conducted Assault Support by carrying water, chow, and ammunition to various units. They were also used to insert an Explosive Ordnance Disposal team to assist in the recovery of the body of an F/A-18 pilot who had been shot down. The UH-1N helicopter performed the utility role, conducting everything from command visits to Cas-Evacs, to route and visual reconnaissance.

Throughout their missions, each type of aircraft received fire—mostly from small arms. None were lost.

“Our only known battle damage was one AH-1 that was hit in the fuselage and in the tail rotor drive shaft,” said Maj. Jim Jenkins, Operations Officer, HMM-263. “Marines from a west coast unit took the same part off another aircraft that was more shot up and our aircraft flew again the same day it was hit. It was a great example of the teamwork and mission focus that all the Marines had out there.”

“The Harriers received radar indications of threat systems on nearly every sortie, but never had visual indications of a launch,” Jenkins added.

Missions

One of the first missions that the MEU conducted was the recovery of the body of a Marine from Marine Wing Support Squadron 371 in the town of As Ashatrah. BLT's Fox Company led a successful recovery mission that brought the body of the Marine back home. There were also several raids conducted in the towns of Qalat Sukar, where a former Ba'ath Party headquarters building stood, Al Hay, and Al Rifa.

The biggest conventional threat to the MEU was the position of the Iraqi 10th Armored Division, located 50 miles to the east of Camp Fenway at an airfield in Al Amarah. An attack was soon planned to invade and secure the airfield held by the Iraqis. Riding in the back of Assault Amphibian Vehicles, Echo Co. and other members of the BLT pushed east into the airfield in Al Amarah, only to find the enemy had abandoned it, leaving their tanks and ammunition behind.

Several blocking positions were also set up by the BLT, which helped in detaining over 60 deserters of the Iraqi Army, hundreds of small arms weapons, and thousands of rounds of ammunition.

The last offensive mission that the 24th MEU (SOC) participated in was the raid on the city of Al Kut. While I MEF headed the push through the city, the MEU set up blocking positions in the most probable routes of retreat. Several detainees and weapons were found this way.

Peace support operations then became the main focus for the MEU. Members of Golf Co. soon began conducting foot and vehicle patrols through the city of Qalat Sukar. This helped in getting additional information about Ba'ath party officials and opened the lines of communication with the citizens. The MEU was able to recover valuable information about the needs of the city. Electricity, food, water, and trash were the main concerns, as well as establishing a local police force.

Throughout the patrols, the Marines still took every precaution to protect themselves from sniper fire and suicide bombers. It took a delicate balance of being cautious and abiding by the Rules of Engagement.

“We never saw a uniformed Iraqi soldier,” said Benfield. “Many of the soldiers we came across were deserters in civilian clothing. Our Marines exercised a lot of restraint while operating in a lot of uncertain-

ty. They did a great job of interpreting the ROE.”

None of these missions would have been possible without the continued support of the MSSG. Throughout OIF, the MSSG would end up totaling more than 30,000 miles on the road during convoy security missions and supply runs. The MSSG also produced 142,935 gallons of potable water for the MEU and surrounding units with their two Reverse Osmosis Water Purification Units or (ROWPU). Approximately 10,000 Marines and Sailors stayed hydrated through their efforts.

“There were four hygiene specialists to operate two different ROWPU sites. They did everything I expected them to do because of their prior training,” said Capt. Erik Post, Engineer Officer, MSSG 24. “They operated these ROWPUs for 26 days and produced more water than they ever did before. They did an outstanding job.”

Additionally, the MSSG performed Humanitarian Assistance missions—cleaning up a school, building a soccer field, leveling birms, fixing ambulances, and training local police forces—all in the vicinity of Qalat Sukar and Al Rifa.

“I think the overall sentiment of the Marines was that they were not ready to go home until they contributed to the war effort,” said Capt. Denise Garcia, Operations Officer, MSSG 24. “They just wanted a mission and wanted to know where they could help, above and beyond what is normally asked of them.”

Ultimately, the MEU was one of the first units to leave Iraq. After turning over their Area of Operation to the 15th MEU and elements of Task Force Tarawa, the MEU began the retrograde back to Kuwait and then onto the ships. At last, they began the journey home.

“We engaged the enemy on several occasions and, thankfully, we’ve had no casualties,” said Col. Richard Mills, Commanding Officer, 24th MEU (SOC), “Our Aviation Combat Element flew numerous combat missions in support of the I Marine Expeditionary Force and did a superb job. I’m proud of what all my Marines have accomplished here.”



Cannon Cockers at War: The 11th Marines in Operation Iraqi Freedom

by Lieutenant Colonel Michael R. Melillo

Field Artillery Journal, September-October 2003.

During the 1st Marine Division's epic attack from northern Kuwait to Basrah, Al Kut, Baghdad and Tikrit, the 11th Marine Regiment moved farther and faster than any Marine artillery regiment in history. Despite the arduous conditions, rapid advance and difficult terrain, the 11th Marines engaged the enemy in every battle of the campaign. No other regiment can make that claim. The 11th Marines processed more than 1,900 radar missions and fired 19,883 rounds with tremendous accuracy and devastating effects in support of the 1st Marine Division. This is the story of the 11th Marines in Operation Iraqi Freedom (OIF).

The 11th Marine Regiment began deploying in support of Operation Enduring Freedom (OEF) and OIF on 17 January 2003 when elements of the 1st Battalion, 11th Marines (1/11) set sail from San Diego, California, as part of the seven-ship flotilla comprising Amphibious Task Force West (ATF-West).

Training for War. Although 17 January marked the beginning of the regiment's deployment, the 11th Marines began preparing for the deployment and eventual combat operations months before. All training focused on the potential deployment: moving rapidly, delivering accurately massed fires and defeating the Iraqi Army's potent artillery threat.

Initial training exercises at Camp Pendleton, California, (July 2002) and the Marine Corps Air Ground Combat Center (MCAGCC) at Twentynine Palms, California, (September 2002) focused on moving through restricted terrain, deploying using maritime prepositioning force (MPF) assets, meeting the five requirements of accurate predicted fire and streamlining command and control (C²) of the regiment. This initial training culminated with a live-fire division tactical exercise without troops (TEWT) at MCGACC.

Upon returning from Twentynine Palms, the regiment participated in a I Marine Expeditionary Force (I MEF) exercise that served as a rehearsal for operations in Iraq. This enabled the regiment to integrate many of the command, control, communications and computer (C⁴) systems that were not employed during the division TEWT in September and exercise (C²) in a scenario it was likely to face in the near future.

In each of these exercises, the regiment learned new lessons. The interaction between the staffs within the regiment served to build a cohesive team and developed a greater understanding of the enemy and the terrain on which the regiment would fight.

FA-Air Wing Quick-Fire Counterfire Tactics, Techniques and Procedures (TTP). In the fall, as the regiment began more detailed planning for initial operations against the Iraqi III Corps in southeastern Iraq, the 11th Marines developed TTP to strike at the enemy's tactical center of gravity: his artillery. Based on the 11th Marines' assessment, the threat was, specifically, the Iraqi Army's multiple rocket launchers (MRLs) and its long-range artillery (GHN-45 and G-5 howitzers).

To counteract this threat, the regiment developed, tested and established a reactive counterfire procedure that integrated the division's artillery with the Marine air wing's fixed-wing aircraft using a "quick-fire" link between the 11th Marines combat operations center (COC) and the direct air support center (DASC).

The regiment communicated digitally—via the advanced FA tactical data system (AFATDS)—with the 1st Marine Division fire support coordination center (FSCC) and used a DASC hotline to accelerate the tasking of "on-station" aircraft to the target, which had been located by a radar. This process reduced the time it took to pass the request between sensor and shooter and to destroy the enemy artillery through a combination of artillery and fixed-wing fires.

Through command post exercises (CPXs) at the I MEF and MCAGCC Simulation Center and a subsequent

live-fire exercise at Camp Pendleton, the 11th Marines validated the quick-fire TTP and trained to aggressively employ Q-46A and Q-37 radars to locate the enemy artillery and destroy it with artillery and fixed-wing fires. Throughout the campaign in Iraq, these procedures were employed with great success.

11th Marines Task Organization.

The 11th Marines deployed to Kuwait during January and February in support of OEF. Deployed by both air and sea, the regiment had a combination MPF and organic equipment. (See the 11th Marines task organization in Figure 1.)

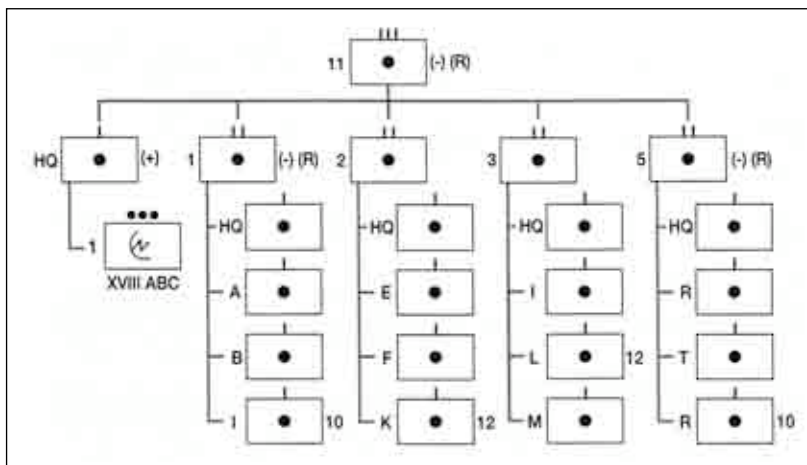

Figure 1. 11th Marines Task Organization. The 1st Battalion, 11th Marines (1/11) and 5/11 were reinforcing (R).

In Kuwait, the regiment had a counter-battery radar (CBR) detachment from the 10th Marines attached—four Q-46A radars, a target processing center (TPC) and 23 Marines—as well as two batteries (I/3/10 and R/5/10). (The two batteries from the 12th Marines were in their six-month rotation with the 11th Marines as part of the routine unit deployment program.) Additionally, the 1st FA Detachment (1st FAD) from the Army’s XVIII Airborne Corps in Fort Bragg, North Carolina, was attached, bringing two Q-37 radars, a TPC and 24 soldiers.

During February as the entire regiment slowly reassembled in Kuwait, the regiment maximized its time planning and rehearsing through a combination of CPXs and live-fire training. The regiment calibrated propellant lots on the MPF shipping and conducted a live-fire rehearsal of anticipated initial combat tasks.

By early March, the 11th Marines had integrated its attached units. On 5 March, the regiment occupied position areas in northern Kuwait to provide counter-battery support to the engineers conducting berm-clearing operations along the Kuwaiti-Iraqi border. On 19 March, the 1st Marine Division was ordered to move to attack positions in northern Kuwait.

Going into this operation, the 11th Marines Commanding Officer’s guidance to his staff and subordinate commanders was simple: “We must *kill* the enemy at every opportunity—no *pinpricks*.” His intent was equally succinct and left no doubt as to the 11th Marines’ purpose: “Protect the Marines and sailors of the 1st Marine Division from the effects of enemy indirect fire systems.”

These straightforward words resonated throughout the 11th Marines and were put into action during the 1st Marine Division’s attack from northern Kuwait to Al Kut, Baghdad and then Tikrit.

Early on 19 March, the 11th Marine Regiment occupied its tactical dispersal areas south of the Kuwaiti-Iraqi border and made final preparations for the attack into southern Iraq. Task organized with its four organic cannon battalions, the additional CBR detachment from the 10th Marines and the 1st FAD, the regiment was reinforced by two British Army artillery units: the 7th Royal Horse Artillery (RHA) Regiment (18 L118 105-mm towed howitzers) and the 3d RHA (-) (16 AS-90 155-mm self-propelled howitzers).

Integrating these combined forces required detailed coordination to establish unique C² arrangements and assign tactical missions to exploit the British artillery’s capabilities and complement the division’s scheme of maneuver.

With 106 howitzers, six Q-46A radars, two Q-37 radars and more than 3,000 Marines, sailors and soldiers from two allied nations, the 11th Marines was prepared to support the 1st Marine Division’s “Opening Gambit.” This was the division’s simultaneous two-pronged attack to seize the Ar Rumaylah Oilfields with Regimental Combat Team 5 (RCT-5) in the west and destroy the Iraqi 51st Mechanized Division with RCT-7 in the east, the latter the division’s main effort.

Opening Gambit. Early on 20 March, the 11th Marines occupied their initial position areas just south of the international border. While the remainder of the division occupied its attack positions, the regiment continued to provide counterbattery coverage across the division zone.

At 1132Z, the 11th Marines fired the first rounds of OIF in counterfire to Iraqi cross-border mortar fires. The regiment's response to the mortar fire—a two battalion fire-for-effect (FFE)—set the tone for the war.

H-Hour was planned for 0300Z on 21 March. At 1500 on 20 March, the division issued a fragmentary order (FRAGO) altering the timing of the attack. RCT-5 was to start its attack to seize the key gas-oil separation plants in the Ar Rumaylah Oilfields at 1730Z, nine and one-half hours earlier than planned. In response to this order, 1/11 and 2/11 displaced forward immediately to their planned firing positions.

At 1700Z, the 11th Marines initiated the 1st Division attack against the enemy with a 30-minute counterbattery program against the 51st Mechanized Division and III Corps Artillery defending the Ar Rumaylah Oilfields.

Because the weather conditions on 20 and 21 March reduced the number of close air support (CAS) sorties flown, the 11th Marines had to fill the gap in fire support. Firing at targets previously planned for aviation attacks, the regiment fired with deadly accuracy nearly non-stop throughout the night, destroying several high-payoff targets (HPTs). The HPTs included two Iraqi artillery D-30 battalions, a Type 59-1 battery, a regimental command post, armored vehicles, tanks and an entrenched infantry battalion.

The division FSCC played a key role in the unfolding fight, directing artillery on previously planned air targets and coordinating with the division collections officer for unmanned aerial vehicle (UAV) coverage. The UAVs located the enemy artillery and armor formations, and the 11th massed multiple artillery battalions on the formations.

When RCT-7 crossed the line of departure (LD) at 0300Z on 21 March, the 11th Marines weighted the main effort with three battalions. Leapfrogging battalions to keep pace with RCT-7's tank and mechanized task forces, the regiment delivered unrelenting artillery fires with devastating effects, stripping the enemy defenders of their will to resist.

Within 24 hours, the 1st Marine Division had secured the critical oil infrastructure and rendered the 51st Mechanized Division ineffective—the 11th Marines had silenced the Iraqi artillery.

By nightfall on 22 March, the opening gambit was complete. No friendly forces suffered casualties due to indirect fire, the relief in place by the 1st Armor Division (United Kingdom) was complete, the 7th and 3d RHA Regiments reverted to the tactical control of the 1st Armor Division, and the 11th Marines were displacing west in preparation for the next attack.

Attack Across the Euphrates. On 23 March, the 1st Marine Division attacked across the Euphrates River on a movement-to-contact toward Ad Diwaniyah. By 24 March, sandstorms blinded the force and fuel was in short supply. Fedayeen forces engaged the halted division column all along Highway 1 east of Ad Diwaniyah.

Because visibility was near zero, the conditions prevented aviation from supporting the division. The 11th Marines were the only fire support available to protect the division's forward elements from mortar and surface attack.

For six days and nights, despite fatigue, severely worsening weather, countless enemy mortar attacks and constant probing by Fedayeen "death squads," the 11th Marines provided reactive counterbattery and suppressive fires all along the division's main supply route, Highway 1.

Attack Along Highway 7. Simultaneously, for the division's supporting attack up Highway 7, the regiment weighted 1/11 with a TPC and an additional radar to support RCT-1's attack in the east. This decision had an impact on the counterfire fight to the east as one Q-46A radar that routinely supported RCT-1 was down with mechanical problems; the additional radar had to serve as the sole counterfire "eyes."

Once the 11th Marines were within range of Al Kut, the regiment took the division fight to the Baghdad Republican Guard Division, destroying multiple artillery batteries, fortified positions and a regimental headquarters.

While the Division amassed adequate logistics to continue its attack to Baghdad, the 11th Marines coordinated with RCT-5, the division's lead regiment, to integrate 11th Marines units into its column for the attack north. Because of the narrow attack corridor and the length of the column, integrating the artillery with the mechanized

infantry and armor was the only way to ensure the artillery could range RCT-5's forward battalion.

This required the already fatigued regiment to move more aggressively and maintain the speed and flexibility of the mechanized infantry and tanks. The regimental headquarters integrated its forward and main COCs into the subordinate battalions' convoys and employed battalion clusters to maximize the limited terrain that was suitable for howitzers and trucks.

Due largely to this innovation on-the-fly, the 11th Marines consistently maintained at least two battalions within range to support the division's main effort in its attack across the Tigris River while fighting the Baghdad and Al Nida Republican Guard Divisions.

On 31 March, the division continued its attack toward Baghdad, seizing the Hantush Airstrip on Highway 1 to sustain subsequent attacks across the Tigris River toward Baghdad. The next day RCT-5 secured a vital crossing site over the Saddam Canal and, by 2 April, had seized the bridge across the Tigris River at An Numaniyah, a few kilometers east of Sabat.

Throughout this historic advance, the 11th Marines were directly behind the lead maneuver battalion with never less than two artillery battalions and six radars providing close support and counterbattery fires.

11th Marines Crosses the Tigris River. On 3 April, the division attacked to destroy the Baghdad Republican Guard Division at Al Kut. RCT-7 attacked from the west along Highway 6 north of the Tigris (supported by 3/11 and reinforced by 5/11), and RCT-1 fixed the enemy division from the south along Highway 7 (supported by 1/11).

When the battle was won, the main effort shifted back to RCT-5 as it sustained the division's advance toward Baghdad along Highway 6. Interspersed with RCT-5 were 2/11 in direct support (DS), 5/11 reinforcing 2/11, 3/11 in general support (GS) to the 1st Marine Division and the 11th Marines' forward and main COCs.

By 4 April, the 11th Marines had reassembled for the first time since 21 March. (1/11 had been DS to RCT-1 for its attack up Highway 7 to Al Kut and completed an arduous 200-kilometer road march to rejoin the regiment). Located less than four kilometers behind the 3d Battalion, 5th Marines (3/5) along Highway 6 and just east of the Diyala River, the entire regiment assembled in a four-kilometer area. The regiment was so close to 3/5 that it had to fire reduced charges to provide close support to the infantry battalion during its battle with the Egyptian, Iraqi and Syrian "Jihadists" who stopped its advance.

To break through the enemy blocking force, RCT-5 broke contact with the dug-in enemy forces to allow a six-minute regimental mass mission using dual-purpose improved conventional munitions (DPICM). This four-battalion fire mission disintegrated the battalion-sized enemy formation, reopened Highway 6 and allowed RCT-5 to regain the momentum. The mass mission also cleared the remaining enemy forces in zone, thus opening the route for the rest of the 1st Marine Division to advance to the eastern approaches to Baghdad on 5 April.

Artillery Adaptability in Baghdad. As the Division established its cordon around the city, the 11th Marines continued to provide counterbattery fires against the Iraqi artillery, firing from within the open areas in the city (stadiums, racetracks, roadways and military complexes). To minimize collateral damage to noncombatants and civilian infrastructure, many of the radar-acquired targets were passed exclusively to aviation to engage with precision munitions using the quick-fire TTP the regiment established before the operation.

In another innovation, the COC used high-resolution imagery to check for the potential of collateral damage before initiating counterfire missions.

Artillery targets became fewer, and by 11 April, the 11th Marines headquarters and two battalions, 1/11 and 3/11, were in the city conducting security and stability operations and establishing the 1st Marine Division civil-military operations center (CMOC).

Also on 11 April, 5/11 was ordered to support Task Force Tripoli's attack to Tikrit, 170 kilometers north of Baghdad. To support the operation, two Q-46A radars and a TPC were attached to 5/11 to provide target acquisition. In the ensuing seven-day operation, the battalion fired 36 counterbattery missions against enemy mortars and artillery and confirmed the destruction of two D-30 batteries defending the city.

Upon entering Baghdad, the 11th Marines gained two additional tasks not typically assigned to an artillery regiment: establish the 1st Marine Division CMOC and establish its own zone in which to conduct security and stability operations. The 11th Marines approached these new tasks with the same gusto and professionalism it had when preparing to cross the LD 22 days earlier.

Security and Stability Ops. The regimental headquarters immediately established two command posts: one in the 11th Marines' zone to command and control security and stabilization operations in the 11th Marines sector and a second at the Palestine Hotel in downtown Baghdad where the CMOC would operate.

In the 11th Marines zone, the regiment's task was to restore order and help ease suffering. Within 24 hours, the zone was greatly improved and 1/11 and 3/11 were in the community conducting patrols, removing weapons caches, detaining looters and showing the Iraqi people that Americans were not conquerors, but liberators. Throughout it all, the 11th Marines still maintained a firing capability to support in and around the city.

The 11th Marines Commanding Officer was assigned as the Civil-Military Operations Coordinator for the 1st Marine Division, and he set the tone for accomplishing the daunting challenges in Baghdad. He had daily meetings with the RCT commanders, 3d Civil Affairs Group liaison detachment, civic leaders, nongovernmental organizations (NGOs) (such as the International Red Cross and Red Crescent, CARE, Doctors Without Borders, etc.), and former Iraqi government officials. He organized the CMOC into functional departments to focus the humanitarian efforts in east Baghdad, the 1st Marine Division's area of responsibility.

The priorities of work were security, electrical power, water and medical support. Each day the CMOC accomplished more, achieving small victories to improve the situation in Baghdad.

Working with RCTs 1 and 7, the 11th Marines began providing security at key locations within the city (hospitals, government ministries, power plants, the banking district, and food and medical storage warehouses). This prevented looting of critical supplies and provided a secure environment for Iraqi citizens to return to work and help in the recovery effort. Policemen who returned were incorporated into a "ride along" program with Marines with positive results.

Water. Daily fuel convoys delivered fuel to fill the generator tanks that pump fresh water from northern watersheds to help provide clean water to the 6.5 million residents of Baghdad.

In Saddam City, where a large Shi'ite population resides, the water infrastructure had to be reinforced with water storage bladders to prevent a humanitarian catastrophe. The 11th Marines' logistics train delivered in excess of 55,000 gallons of fresh water made by Combat Service Support Group 11 (CSSG-11).

Key Infrastructure. The CMOC coordinated convoy escort for key infrastructure personnel and support agencies (electrical engineers, medical personnel and NGO/private volunteer organizations) to assess electrical power plants, water treatment facilities, telephone switching centers and hospitals.

Explosive Ordnance Clean Up. 11th Marines coordinated the division's explosive ordnance retrieval and disposal. It established an ordnance storage site at the Rasheed Military Complex and a disposal site that destroyed several hundred tons of ordnance recovered in the division's zone.

The conditions in Baghdad began to improve.

Taking Tikrit. The 11th Marines steadily coordinated its own "three-block war" for 11 days with one battalion fighting with Task Force Tripoli at Tikrit, one supporting RCT-5 north of the city and two battalions conducting security in zone. The regiment's remaining resources were fully engaged in the humanitarian efforts throughout east Baghdad.

On 21 April, the 2d Armored Cavalry Regiment (ACR) relieved the 1st Marine Division in Baghdad with the ACR's civil affairs (CA) assuming the duties as CMOC in east Baghdad. The next day, 3-7 Infantry conducted a relief-in-place with the 11th Marines, and by 23 April, the 11th Marines were in the division assembly area at Ad Diwanayah, awaiting guidance on MPF reconstitution and redeployment.

During OIF, the 11th Marines provided complete fire support to the 1st Marine Division. The results of the 32-day campaign bear witness to the devastatingly accurate fires and decisive impact the regiment had on the enemy—and the equally positive impact the regiment had on the people of Baghdad while conducting civil-military operations.

The effectiveness of the 11th Marines as the division's counterfire shield was significant with few casualties due to enemy indirect fires—a testament to the regiment's pre-war foresight, professionalism and battle leadership.

During Operation Iraqi Freedom, the Marines, soldiers, and sailors of the 11th Marines wrote a new chapter in the long and proud history of Marine Corps Artillery support.



Marine Artillery in the Battle of An Nasiriyah

by Major Walker M. Field

Field Artillery Journal, November-December 2003.

According to intelligence reports, An Nasiriyah, a city in south central Iraq, would present little military resistance to the Coalition Forces' rapid advance toward Baghdad. Instead, Regimental Combat Team-2 (RCT-2) encountered an extremely violent confrontation with an enemy force occupying complex urban terrain. What followed was a fiercely fought eight-day urban battle against a large concentration of paramilitary forces and remnants of the Iraqi 11th Infantry Division, both of whom were determined to exact a heavy toll of Coalition casualties and retain control of the city.

From the initial fire mission on the morning of 23 March to the final mission fired in support of Task Force 20's rescue of Private First Class (PFC) Jessica Lynch, the Marine Artillery of 1st Battalion (Reinforced), 10th Marines (1/10) provided RCT-2's only all-weather, long-range, continuous fire support. The battalion fired more than 2, 100 rounds in this short period, enabling RCT-2 to seize and secure the eastern bridges of the city, thus opening a vital line of communications (LOCs) through which elements of the I Marine Expeditionary Force (I MEF) could continue the fight north to Baghdad.

This article provides a brief overview of the task organization, sequence of events and artillery specific-lessons identified by 1/10 from a battle that can be characterized as a military operation in urban terrain (MOUT). **Overview.** 1/10 deployed from Camp Lejeune, North Carolina, to Kuwait in January 2003 in support of Operation Enduring Freedom (OEF). The battalion then deployed to Iraq in March in support of Operation Iraqi Freedom (OIF). 1/10 was attached to RCT-2, 2d Marine Infantry Regiment.

RCT-2 was a reinforced motorized and mechanized infantry regiment consisting of two motorized medium tactical vehicle replacement (MTVR) infantry battalions, 2d Battalion, 8th Marines (2/8) and 3d Battalion, 2d Marines (3/2); one reinforced mechanized amphibious assault vehicle (AAV) infantry battalion, 1st Battalion, 2d Marines (1/2); a light armored reconnaissance (LAR) company; and a recon company. RCT-2's higher headquarters was the 2d Marine Expeditionary Brigade (2d MEB), designated Task Force Tarawa (TF Tarawa) upon arrival in Kuwait.

1/10 received the official deployment order on 31 December 2002 to deploy in support of OEF. The order directed the battalion's four batteries (Headquarters, A, B and C), a counterbattery radar detachment (CBR) with two Q-46A radars and a target processing center (TPC), and a heavy engineer squad from the 10th Marine Artillery Regiment deploy with 1/10. Via amphibious ships, the battalion sailed for the Persian Gulf and arrived at Kuwait Naval Base on 15 February. The battalion immediately moved inland to Camp Shoup within Tactical Assembly Area (TAA) Coyote (I MEF's logistical support area, or LSA) and established its base of operations. From 20 February until 19 March, 1/10 focused on combat training and equipment maintenance.

The battalion deployed from Camp Shoup on the morning of 20 March for an assembly area along the northwestern border of Kuwait and Iraq, its final destination before starting offensive combat operations. The 1st Marine Division was on TF Tarawa's right flank while the 3d Infantry Division (Mechanized) (3d ID) was on the left.

On 21 March, 12 hours behind the lead elements of the 3d ID, RCT-2 crossed the border obstacle belt into Iraq. Following a route parallel but slightly east of the 3d ID's route, RCT-2 moved north toward the Al Luhays Oil Facility located southeast of Jalibah Airfield.

1/10 assumed a "desert wedge" formation consisting of three battery columns abreast, each with an element of headquarters battery in trace. It moved behind 1/2 and in front of 3/2. TF Tarawa's mission was to occupy initial defensive positions to enable the 3d ID to clear through Jalibah Airfield.

The next morning, 1/10 continued north and occupied firing positions just north of Jalibah Airfield. That afternoon, the CBR detachment repeatedly detected counterfire targets originating from the same location. Gaining RCT-2 approval, the battalion engaged the target. As a result of 1/10's first fire mission in OIF, CBR

received no further detections from that vicinity, and 42 Iraqi Regular Army soldiers surrendered to a nearby LAR unit.

That evening, after TF Tarawa consolidated at Jalibah, it was directed to conduct a relief in place of 3d ID forces in the vicinity of Tallil Airfield and the Highway 1 bridge across the Euphrates River west of Nasiriyah. TF Tarawa also issued orders to RCT-2 to move forces northwest toward Nasiriyah and be prepared to continue the attack to seize and secure the eastern bridges across the Euphrates River and the Saddam Canal within the city of An Nasiriyah.

Battle for An Nasiriyah: 23 March–2 April. On the morning of 23 March, 1/10 moved in trace of RCT-2's lead element (1/2) when it began receiving indirect and direct fire from covered positions to the east and west of Highway 7, the main road leading into southern Nasiriyah. 1/10 quickly emplaced in restricted terrain and began processing fire missions. Simultaneously, 1/10 provided medical aid to soldiers from the 507th Maintenance Company who had been ambushed in the city and were moving south along Highway 7.

The battle continued throughout the day as 1/10's batteries bounded forward, firing a number of fire-for-effect (FFE) and adjust fire missions in support of infantry companies in contact. The battalion also continued to engage radar-generated targets, totaling five missions and firing 108 dual-purpose improved conventional munition (DPICM) rounds. While actively processing fire missions, Bravo Battery's main body received incoming mortar fire, forcing the battery to conduct an emergency displacement.

During the afternoon of 23 March, the battalion was reinforced with fires from India Battery, 3/10 (attached to 1/11). 1/11 was southeast of the city awaiting orders to either pass through RCT-2 in Nasiriyah or bypass the city to the west.

Dawn on 24 March found RCT-2 heavily engaged throughout Nasiriyah in urban combat operations. 1/10 displaced farther north within the outskirts of the city to achieve a greater range fan north of the Saddam Canal. Proficient azimuth of fire management was critical, as RCT-2's mechanized battalion (1/2) remained north of the city while the two motorized battalions (3/2 and 2/8) operated principally south of the city.

1/10 had to carefully position itself to balance its fire support. The battalion had to be close enough to the city to provide fires well north in support of 1/2, which was about 14 to 30 kilometers from 1/10, but not too close to preclude its supporting the two motorized battalions operating in the southern portion of the city, about five kilometers north of 1/10.

As the fighting intensified, scores of the enemy and indigenous displaced personnel poured out of the city to the south. As a result, the battalion processed a number of enemy prisoners of war (EPWs) and redirected numerous displaced persons.

Although the two motorized battalions were less than five kilometers to the north, an industrial corridor where paramilitary forces could freely maneuver was within the noncontiguous battlespace. Thus, 1/10 was exposed to civilian and enemy foot and vehicle traffic on all sides.

Each of the batteries was responsible for security in all directions. Although well-equipped and trained to perform this mission, it was difficult to man 360-degree security while also processing fire missions 24 hours a day. As the battle raged on, the battalion implemented the firebase concept to economize the security effort and better contend with displaced personnel and EPWs.

On the afternoon of 24 March (35 hours after the attack began), the battalion received its first artillery ammunition resupply of 120 high-explosive (HE) and 100 DPICM rounds per battery. 1/10 had had a significant shortage of HE and had been forced to fire rocket-assisted projectiles (RAP) in the rocket-off mode with Charge Three green bag in lieu of HE.

Just as the ammunition resupply arrived, the remainder of 1/11 arrived to provide forward passage of line (FPOL) and reinforcing fires. The decision had been made to pass RCT-1 through the city north toward Al Kut on Highway 7. The FPOL took a number of hours, and 1/11 supported the passage with reinforcing fires until it was ordered to move north of the city. Although 1/11 provided reinforcing fires to RCT-2 and fires for the FPOL of RCT-1, 1/11 remained in direct support (DS) of RCT-1 and never officially assumed the role of reinforcing (R) to 1/10.

Deploying with 1/11 was Battery G from the 6th Parachute Brigade (UK), an M118 (105-mm) battery with

an Arthur radar. This brought the total number of Coalition howitzers trained on Nasiriyah to 42. 1/10 remained the controlling fire direction center (FDC) for all artillery fires in Nasiriyah.

Through the night of the 24th of March, RCT-1 attacked north along Highway 7 to continue the fight toward Al Kut with 1/11 following in support. Battery G remained with 1/10 until first light on 25 March before returning to its unit to prepare for action in Basrah. Battery G and 1/11 expended more than 200 rounds during the night in support of RCT-2's and RCT-1's FPOL.

The fight for Nasiriyah continued with ferocity on the 25th as numerous fire missions were processed during the morning. In a raging windstorm, an enemy T-55 tank dug in to the east of Highway 7 attempted to ambush a 2/8 combined anti-armor team (CAAT) patrol. The wind and dust prevented 2/8 from engaging the enemy tank by anti-tank missile (TOW) or air support, so the patrol initiated a FFE mission to destroy the dug-in tank. Battery C rose to the challenge and destroyed the tank using DPICM.

In the most demanding combat conditions, the artillery once again proved to be the *only* all-weather continuous fire support asset for TF Tarawa.

As if the enemy had been reinvigorated by the sandstorm and heavy overnight rains, on 26 March the urban battle increased in intensity and lethality and proved to be the most prolific day of artillery firing in the battle for An Nasiriyah. Around noon on the 26th, the battalion fired suppressive HE rounds with concrete-piercing fuzes into a hospital that was serving as a paramilitary strongpoint. This fire enabled 2/8 seize the building.

Throughout the battle, aerial reconnaissance reported a number of mortar and artillery pieces in a garrison gun park.

The Iraqi regular forces gave the impression they were capitulating, having staged their equipment in accordance with terms of surrender. By 26 March it was clear the Iraqi paramilitary forces and regular army elements were firing the "surrendered" weapon systems and then quickly vacating the positions and hiding until they wanted to fire another mission.

With unmanned aerial vehicles (UAVs) now on station, TF Tarawa provided accurate, real-time targeting of many of the staged weapon systems. Receiving fire missions from the UAVs and aerial forward observers (FOs) via the RCT-2 fire support coordination center (FSCC), 1/10 prosecuted more than 15 fire missions on the afternoon of the 26th, destroying two Type 59-1 batteries and three D-30 batteries.

As RCT-2 fought in the streets and within neighborhoods of Nasiriyah, CBR continued to detect enemy indirect fire originating from the vicinity of a railroad station in the southern portion of the city. Both US Army Special Forces and human intelligence (HUMINT) sources verified the target as a paramilitary assembly area containing an estimated 1,000 irregular forces. Adding this information to the many radar-detected targets originating from the same location seemed to confirm the validity of the target. The final corroboration came in the form of a report by an element of the 2d Radio Battalion (RADBN) indicating not only that the assembly area existed, but also that the enemy numbered up to 2,000 and was preparing to launch a counterattack. The fire mission, a battalion-10 rounds of DPICM, yielded an estimated 200 enemy dead and broke up the coordinated enemy counterattack. Referring to this mission, the commanding general of TF Tarawa credited the artillery with being instrumental in breaking the back of the enemy defending Nasiriyah.

The morning of 27 March found 1/10 consolidating defensively into a battalion firebase. The firing position was an oval-shaped position one kilometer in diameter with 42 crew-served weapons and five Avenger anti-air defense vehicles protecting it. The battalion christened the defensive firing position Firebase Pokorney in honor of First Lieutenant Fred E. Pokorney, Jr., a forward observer from 1/10 killed in action on 23 March while calling in artillery fires on the enemy just north of the Saddam Canal.

Throughout the morning, the battalion processed sporadic fire missions and conducted security and reconnaissance patrols around the firebase. Having reached a crescendo on 26 March, the number of missions and enemy forces being engaged was reduced significantly for the remainder of the month.

On 28 March, RCT-2 directed 1/10 to form a task force to reinforce and secure the Highway 1 bridge over the Euphrates River.

The mission was important as Highway 1 was the main supply route for I MEF forces advancing north to Baghdad. Commanded by the battalion executive officer, TF Rex (for the King of Battle) numbered more than

300 personnel with Bravo Battery forming the core of the task force as its provisional infantry.

During the last three days of March, the battalion fired three counterfire missions and five adjust fire battalion mass missions in support of 2/8's and 3/2's clearing of pockets of resistance throughout the city. Of the counterfire missions, one resulted in the destruction of a Type 59-1 battery actively firing on 2/8.

On 1 April, Army Special Forces conducted a raid to recover PFC Jessica Lynch, a member of the US Army's 507th Maintenance Company convoy ambushed on 23 March. Battery C fired deception fires in support of the mission, destroying a suspected enemy command post and arms cache as a diversion for the Special Forces. This mission was the last fired by 1/10 in the Battle for Nasiriyah.

During the next three weeks, RCT-2 expanded its battlespace north along Highways 1 and 7. Moving from city to city in search of pockets of resistance and protecting 1st Marine Division's LOC (the MEF's main effort), the battalion traveled more than 700 kilometers.

The combat highlight of this period occurred when RCT-2 was ordered to force the capitulation of the 10th Armored Division in southeast Iraq near Al Amarah. As 1/10 deployed in front of the mechanized battalion but in trace of a LAR company, RCT-2 conducted a movement-to-contact east of Qalat Sakar toward Al Amarah, a maneuver that caused the 10th Division to capitulate.

Returning to An Nasiriyah as RCT-2 began setting the conditions for Phase IV of OIF, 1/10 organized and operated as provisional infantry from 23 April until 12 May. 1/10 established traffic control points, secured a petroleum distribution facility and provided point security of the Highway 1 bridge.

1/10 then began to retrograde by infiltration back to Kuwait for redeployment by amphibious ships, with the last elements departing An Nasiriyah on 12 May.

Lessons Learned. 1/10 identified a number of lessons learned during OIF and has submitted an official compilation in Marine Corps lessons learned (MCLLS) format. The following are a few of the lessons specific to an artillery-supported MOUT battle and applicable to all towed artillery units.

Towed Artillery Keeping Up with Mechanized Infantry. Considering the speed and mobility of the modern main battle tank and armored personnel carriers, some doubted towed artillery's ability to keep pace with mechanized maneuver elements. In the June 2003 *Marine Corps Gazette*, Lieutenant Colonel Clark wrote, "In today's fast paced, fluid maneuver environment, a towed [artillery] system is simply unrealistic."¹ This was clearly refuted during RCT-2's movement over most of central and eastern Iraq; towed artillery proved more than capable of providing accurate, timely fire support in movement-to-contacts that often exceeded 100 kilometers.

Although the M1A1 tank and AAV have greater rates of march over unimproved surfaces than a towed artillery piece, they had to allow their resupply vehicles to keep pace with them. The logistics vehicles necessary to sustain mechanized forces are wheeled, like that of a howitzer prime mover. Although there are logistic variants of the tank and AAV, they can't serve as a stand-alone combat service support (CSS) element for their respective units over a sustained period of time.

Tanks and AAVs need dedicated CSS elements to provide replenishment, replacement, refitting and refueling of the bulk supplies associated with mechanized forces. Planning considerations and movement rates are tempered to accommodate sustaining the force logistically.

Also, the debilitating effects of moving wheeled systems great distances in a very hot climate, even over roads with improved surfaces, caused RCT-2's rate of march rarely to exceed 25 kilometers per hour.

1/10's experience in OIF illustrated that, in spite of the inherent raw speed of mechanized vehicles, towed artillery is more than capable of keeping up with mechanized forces.

Artillery Ammunition Apportionment in an Urban Fight. RCT-2's battle in An Nasiriyah was, for the most part, an MOUT fight. Before departing Camp Shoup on 20 March, the initial issue of artillery ammunition was based on a combat planning factor of a composite enemy threat (armor and infantry) and included a much greater mix of "long shooters" than HE munitions—RAP and base bleed DPICM (BBDPICM).

Would a different mix of ammunition have been requested if an urban fight were anticipated? Yes, but based on what planning factor? The primary source for ammunition planning, *Marine Corps Order (MCO) 8010.1E Class V(W) Planning Factors for Fleet Marine Force Combat Operations*, depicts ammunition allo-

cations based on enemy composition (armor- or infantry-specific or a composite of each) rather than terrain, such as the urban environment of An Nasiriyah.

Figure 1 depicts the artillery ammunition 1/10 was issued before going into An Nasiriyah—the battalion’s “go to war ammo.” This allocation equaled one combat load (CL) and one day of ammunition (DOA) at the assault rate, based on a conventional composite threat.

Figure 2 shows the percentages of ammo that 1/10 actually expended during OIF, 99 percent of which was fired during the battle in An Nasiriyah from 23 to 29 March. 1/10 fired primarily HE in urban operations.

The ammunition allocation percentages derived from the battle of An Nasiriyah could serve as a basis to initiate a planning template for future artillery MOUT engagements.

Resurrection of the Firebase. It was apparent in An Nasiriyah that the non-contiguous nature of the battlefield, namely the battalion’s exposure on all sides, would necessitate economizing the local security effort of each battery. Based on a prevailing enemy threat consisting of paramilitary forces with limited indirect fire capability and no air assets, the battalion consolidated into a firebase.

A firebase is defined as an area in hostile territory that requires a 360-degree defense and supports combat patrols or larger operations with combat support and CSS assets.² Due to the ground threat, wide dispersion of the batteries was traded for berming and hardening. Fighting positions with overhead cover for crew-served weapons were prepared, exterior and interior berms created and the interior LOCs maximized by wiring-in every element.

During the Battle for An Nasiriyah, the Marines of 1/10 (Reinforced) distinguished themselves by providing continuous fire support to RCT-2 forces.

Through driving sandstorms and torrential rains, artillery repeatedly affirmed itself as an all-weather, long-range fire support capability. Artillery fire effectively destroyed the enemy’s major indirect fire assets and his ability to influence the battle.

In only eight days of fighting, the battalion processed 112 fire missions while expending more than 2,100 rounds. Counterbattery radar was invaluable to maneuver commanders as “Red Rain” (radar missions) accounted for 30 percent of all fire missions. 1/10 was credited with having broken the enemy’s back in the Battle for An Nasiriyah—maneuver endorsement of the effectiveness of Marine artillery in an urban environment.

¹ Lieutenant Colonel J.E. Clark, “What is the Future of Field Artillery in the Expeditionary Warfare Environment?” *Marine Corps Gazette*, 86, No. 6 (June 2003), 14.

² *Field Manual 101-5 Operational Terms and Graphics* Marine Corps Reference Publication No. MCRP 5-2A (Washington, DC, Headquarters, Department of the United States Marine Corps, 30 September 1997).





‘Alone and Unafraid’

by Jim Landers

The Dallas Morning News, 18 May 2003.

The Marines’ 2d Tank Battalion used speed and armor to make quick work of Saddam Hussein’s regime

AL AZIZIY AH, Iraq—The Iraqis fired rocket-propelled grenades from behind a taxi parked along a distant canal. One grenade zipped across the nose of an armored amphibious vehicle and exploded in the dirt.

That angered Maj. Andrew Bianca, executive officer of the Marines’ 2nd Tank Battalion. Sheathed in aluminum plate, the tracked amphibious vehicles known as amtracks can withstand rifle fire, but not rocket grenades. And Maj. Bianca’s support team was in amtracks. He ordered his tank crew to fire a round at the Iraqis.

The 120 mm cannon barrel dropped slightly, then erupted with smoke and flame. The noise ripped the air so violently that Marines standing in an amtrack behind the tank were knocked off balance.

A cloud of dirt appeared behind the taxi. The shell had gone through the taxi’s open windows. But shrapnel from the round finished the Iraqis, and a finger of black smoke and flame soon rose from the taxi.

The tank column resumed its march to Baghdad.

For Marines and Army soldiers fighting throughout southern Iraq, this was their war: armored columns blasting through urban ambushes.

Air Force and Navy bombers made it impossible for the Iraqis to fight effectively with tanks and artillery. So when the Iraqis chose to fight, they hid in buildings and alleyways with automatic rifles and rocket-propelled grenades.

The 2nd Tank Battalion started several fights with these urban opponents. Speed mattered more than body counts or seized ground. Using tanks to punch through enemy ambushes put the Marines closer to Baghdad and Saddam Hussein’s regime.

Lt. Col. Mike Oehl, the battalion’s commanding officer, put it to his officers this way: “Speed is the essence of this endeavor.” He was talking about a planned raid, but the remark held true for the battalion’s mission in the war.

“It’s hard to know what our part was in the overall war, but I’d like to think we made it a shorter war because we got here so quickly,” Col. Oehl said when his unit reached Baghdad.

No single unit won the war with Iraq. The 2nd Tank Battalion out of Camp Lejeune, N.C., brought 44 tanks, 249 other vehicles and 975 Marines to a fight spread across almost 300,000 U.S.,

British and Australian men and women. The 2nd Tank Battalion suffered five killed and dozens wounded; other units saw more fighting and suffered more casualties.

Yet several analysts agreed that the battalion exemplified the strategy and tactics that toppled Mr. Hussein in just three weeks of warfare.

“Armor played an incredibly important role,” said Marine Lt. Col. Dale Davis, director of international programs at the Virginia Military Institute. “The real objective was not the destruction of the Iraqi military but the unseating of the regime, and these flying columns, at the end, were key to causing the regime to collapse.”

New life for the tank

Just a few years ago, the Marine Corps was so anxious to fund a new generation of aviation and amphibious equipment, it was willing to give up its tanks. Both Army and Marine Corps strategists argued that attack helicopters and helicopter-borne infantry forces were the machines needed for fast attacks.

The war gave armor advocates new life. The Army’s one major attack with Apache helicopters went awry when the Iraqis, alerted that the helicopters were coming, shot up most of the force using rocket-propelled grenades and small-arms fire.

“We’re going to keep the tank, and it will be highly useful,” said Kenneth Estes, author of *Marines Under Armor* and a retired lieutenant colonel. “Commandants and others who would like it to go away because of its monstrous budget, I’m sorry. If you are ever going to fight someone who is a serious opponent, you are going to have to have the tank again.”

The 2nd Battalion’s tanks traveled inland more than 500 miles from the shores of Kuwait to the streets of Tikrit, Mr. Hussein’s hometown—farther than any battalion in Marine Corps history, said Lt. Gen. Earl B. Hailston, commander of Marine Forces at Central Command. They fought in Baghdad, Al Aziziyah and four other towns and villages in the 26 days it took for one of the battalion’s companies to reach Tikrit.

Their main weapon was the M1A1 Abrams tank.

The Abrams has a 120 mm cannon and three machine guns. It was designed in the 1970s to give the Army tanks that were superior to anything in the Soviet arsenal.

The Russians developed the T-72 and T-84 tanks with a 125 mm cannon, and the T-72 became the main battle tank of Iraq’s Republican Guards. But the Abrams fires a high-velocity round that the Marines say is superior to the Soviet-designed 125 mm cannon. Some Abrams rounds are made with depleted uranium that is so dense it burns through layers of tank armor before exploding inside an enemy armored vehicle.

Firepower makes tanks the battleships of land warfare. Unlike the warships of old, the Abrams does not need several range-finding shots to find its target. The tank’s “ballistic solution” computer is so precise, the first shot usually finds its mark, tank gunners say. The same targeting excellence holds for the tank’s .50-caliber “co-ax” machine gun mounted beside the cannon.

About halfway along the barrel rests a thick pad called a “bore evacuator” that allows air to rush inside to fill the vacuum created when a shell is fired. Tankers paint names for their tanks on the bore evacuators.

Col. Oehl’s crew named its tank “Deadly Mariah” and animated the name with an angry cloud blowing swords from its mouth. Maj. Bianca’s tank crew reached back to Greek mythology for the name “Two Furies”—anger and vengeance, minus the third fury, jealousy, which seemed out of place in Iraq.

An Abrams tank makes little room for its four-man crew. The driver is beneath the cannon barrel, by himself toward the front of the tank. He lies on a tilted bench and peers outside through thick prisms.

The gunner sits in the well of the turret, using thermal sights that enable him to find targets emanating heat at night or during severe storms. To his left is the tank loader, who pulls shells from a rear compartment and feeds them into the cannon. He has a turret hatch above his head equipped with a machine gun.

The tank commander sits behind and above the gunner. During the Iraq war, a Marine tank commander usually fought with his head and shoulders exposed above the turret hatch, where he could see the battlefield and fire a .50-caliber machine gun.

The tank weighs 68 tons and is powered by a 1,500-horsepower jet turbine engine. From the perspective of an opposing foxhole, it is a dreadful machine. It shakes the earth. It can travel at speeds as high as 55 mph. The shock from its cannon blast is incapacitating to anyone standing (or cowering) before it.

'Bully of the battlefield'

"The bully of the battlefield," marveled Lance Cpl. Billy Peixotto, a tank driver with the battalion from McKinney.

The Army's 3rd Infantry Division fought with more tanks than the Marines, and led the way into Baghdad with armored assaults that showed Mr. Hussein and his sons no longer controlled the capital.

But while the Army has other armored and mechanized divisions, the Pentagon turned to the Marines to fight the eastern prong of the war as a second land army.

"They've been able to sell themselves better than the Army as the embodiment of the 'revolution in military affairs' that [Defense Secretary Donald] Rumsfeld wants," said Col. Davis. "They train and fight as a combined arms force, with maneuver and flexibility tactics."

The 2nd battalion spent most of the war at the tip of the Marines' spear. It came within three miles of Baghdad on April 4, after three days that destroyed what was left of the Al Nida Division of the Republican Guards. They cleared the way to Baghdad for the 1st Marine Division and killed a large number of Arab Muslim volunteers who heeded Osama bin Laden's call to come to Iraq to kill Americans.

In the 1991 Gulf War, the Marines played a secondary role in the land forces that reclaimed Kuwait, said Patrick Garrett, an analyst with the Alexandria, Va., online firm Globalsecurity.org.

"In the Gulf War, they were used largely as a deception—to make the Iraqis believe there'd be an amphibious landing," he said. "It was not as front and center as the Marines would have liked. In Operation Iraqi Freedom, they got rid of that shadow."

Mr. Garrett credits 12 years of intense training by the Marines in combining infantry, artillery, tanks and aircraft for overcoming doubts about their fighting ability.

The 2nd Battalion used such tactics from the onset of the war. As part of the 5th Marine Regiment, the battalion sprinted into Iraq during the night of March 20, eight hours ahead of schedule and well ahead of the rest of the U.S. forces poised to attack from Kuwait.

The regiment was ordered to strike first because of alarming (though faulty) intelligence about Iraqis firing their oil fields and placing 90 of their best tank near the border.

The battalion raced through the night in a swinging left hook from western Kuwait to the gates of Basra. Three companies of Abrams tanks charged into Iraq, along with four armored amphibious vehicles serving as tracked command posts. Platoons of Scouts and anti-tank missile teams in Humvees followed, along with the Fox Infantry Company in their amtracks.

That left 75 percent of the battalion's vehicles behind: the fuel trucks, the ambulances, and the trucks and Humvees carrying food, water, tents, ammunition and many of the other necessities of military life.

The Marine tanks outraced their communications lines, their supplies and even their air cover. Col. Oehl was reduced to sending e-mails by satellite phone to let regimental headquarters know where he was.

Col. Oehl put fuel bladders on each side of the tanks to stretch their range and lessen their dependence on supply lines. When the tanks started running low on fuel, they dropped the large black bladders under the tank treads and squeezed the precious fluid into their tanks as though it were toothpaste.

The column destroyed about 30 Iraqi vehicles that night, including 10 tanks, and broke all hope of reinforcements reaching the Iraqi defenders of the 51st Mechanized Division.

Col. Oehl's demand for speed was so relentless that the battalion left behind two disabled tanks and their crews. The crews were told to catch up as best they could and did not rejoin the battalion until it reached Baghdad.

Before the assault, the battalion's nickname was "Masters of the Iron Horse." At the gates of Basra, Master Gunnery Sgt. Frank Cordero suggested a new slogan: "Alone and unafraid."

Lighter, quicker

The Marines take pride in their reputation for having lighter and quicker supply lines than the Army. The 2nd Battalion exemplified this as well, though it came with a price.

The sand and dust storm on March 26 obliterated all that was even vaguely familiar about the Marines' war machines. An orange glow backlit the walls of dirt whipping across the barren Iraqi landscape. Before long,

even the light disappeared as the storm swallowed all trace of the afternoon sun.

The Marines hunkered down for fitful naps. A thunderstorm broke around 9:30 p.m., and the rain fell as mud.

Col. Oehl left regimental headquarters in the black storm to head back to the battalion in a Humvee. His eyes were glued to his Magellan GPS satellite compass. He was yelling directions above the noise of the storm so his driver, unable to see a thing, could precisely retrace the 16 miles.

The meeting at 5th Regiment headquarters ended with commanders uncertain how to get back to their units, let alone when they might resume the race to Baghdad.

It was the low point of the war. Victory was just a couple of weeks away, and the miles between the Marines and Baghdad would soon fly by like laps at a NASCAR race. On this night, though, weather and exhaustion brought the Marines to a standstill.

“In retrospect, the sandstorm was very fortuitous for the U.S. forces,” said Col. Davis. “Had the sandstorm not occurred, we would have still had to take that pause. . . . People who said there was no supply problem were talking bull. We were very extended.”

The emphasis on speed put tremendous demands on the tank battalion’s supply lines. The Marines carrying fuel, food, ammo and water went several days without any sleep as they chased the tanks in their long, balky convoys.

Before the war’s end, the tank crews were limited to two meals a day, and some days it was just one. Once, Marines guarding the battalion’s command vehicles were down to just 30 rounds of M-16 ammo apiece.

Fuel was the most crucial supply throughout the war. The tank uses the same jet turbine engine used in the Army’s Apache helicopters. The tank consumes eight gallons of fuel just to start its engine.

The race to Baghdad left no time to spare, even for topping off the fuel tanks.

“We were still refueling while we were leaving,” Col. Oehl said just before the sandstorm. “We’re pushing the envelope. We really are. The only thing that’s going to give us that rest is if something happens up north [to Mr. Hussein]. We really need to stop here at some point and get our senses and see what tanks have issues.”

Capt. Dave Bardorf of Middletown, R.I., was the officer responsible for moving supplies to the tanks. He was awake for four days in a row before the sandstorm brought the battalion to a halt and gave him a chance to sleep.

“You make yourself uncomfortable to stay awake,” he said. “You tighten the strap on your Kevlar [helmet].”

In the darkness, behind night-vision goggles that illuminated a two-dimensional green-and-black landscape, Capt. Bardorf found himself hallucinating.

“I was staring through the night-vision goggles and telling the driver, ‘Stay straight. Watch that hill. There’s a ditch on the right.’ And the driver was yelling, ‘Captain, Captain!’ I told him, ‘Yeah, just stay straight.’ He shook my shoulder and told me we’d been stopped for five minutes.”

The dust, lightning and mud gave Capt. Bardorf a chance to sleep. He woke up the next day “feeling like a million bucks.”

Maj. Pat Cox, the commanding officer of a Marine reserve company attached to 2nd Tanks as Delta Company, had a grimmer perspective. Lance Cpl. Eric Orłowski, 26, of Buffalo, N.Y., died when another Marine accidentally tripped the trigger of a .50-caliber machine gun on March 24. The major believed that fatigue—to both men and machines—played a role in Cpl. Orłowski’s death.

“We’re trying to make this a second land army, and it ain’t working out too well,” he said.

The battalion was consciously trading fatigue for speed.

“The Marines believe speed is a casualty saver,” said Mr. Estes. “It may look chaotic, and worse, but you upset the enemy plan by showing up faster than anyone anticipated. It allows you to take advantage of the chaos that exists on his side.”

Aggressive commanders

Central Command’s Gen. Tommy Franks wanted aggressive commanders who would move their units with speed and mobility.

One of the 1st Marine Division's regimental commanders was replaced during the war. The Marines offered no official explanation, but the talk among officers in the field was that the commander and his operations officer had not been aggressive enough.

Before the war began, 1st Marine Division commander Maj. Gen. James Mattis held a press conference to explain his expectations.

"We can move very, very quickly," he said. "These boys were brought up in southern California [at Camp Pendleton]. They're fast on the freeway."

The Marines integrate their own air forces into their battle plans, including combat aircraft such as F-18 fighter-bombers, Harrier jets and Cobra attack helicopters.

All of these units train together. The Marines feel so strongly about integrating ground and air forces that their pilots spend a year with infantry and tank units as forward observers calling in air strikes.

Capt. Mike Shayne, a Cobra pilot who fought in Afghanistan, was a forward observer and tank cannon loader with the 2nd Battalion. A fellow Marine looked at Capt. Shayne's size 11 1/2 feet one day and nicknamed him "Krusty" (after the clown on *The Simpsons*). Krusty was painted on the side of the "Polish Knights" tank in the 2nd Battalion's Alpha Company.

Capt. Shayne watched glumly one afternoon as Cobra helicopters destroyed an Iraqi position while the tanks sat silent.

"I'm not having any fun right now, because I can't jump in the fight," he said.

Capt. Shayne and his tank crew soon had more fight than he'd seen in a Cobra when the 2nd Battalion led the Marines to Baghdad.

Col. Oehl had planned a reconnaissance raid to the bridges across the Saddam Canal and the Tigris River to see if they could support the 68-ton Abrams tanks.

Cobra helicopters, tanks, reconnaissance vehicles, infantry and engineers in amtracks, scout and anti-tank missile Humvees, and even mortar crews were to be in the column. The assault group was expected to move at an average speed of 30 mph, using all four lanes of an unfinished, divided highway.

But division headquarters canceled the raid. The 5th Regiment was advancing up a path that forced the Iraqis to concentrate their defenses on southern Baghdad. The Saddam Canal and the bridge over the Tigris at Al Numaniyah were well east of the regiment's position. A raid to those bridges would tell the Iraqis that the Marines' offensive was designed to hit Baghdad from the east.

Since the battalion and the rest of the 5th Regiment were ready to attack, Gen. Mattis instead ordered the regiment to head for Baghdad. Tanks would blast through the Iraqi defenses, followed by mechanized infantry units that would finish the job.

The attack seemed likely to result in a major battle with the Al Nida Republican Guard Division. Former Marine Col. Oliver North, a commentator covering the war for Fox Television, asked Col. Oehl if he could come along. Col. Oehl turned him down.

Iraqis overwhelmed

The attack began after midnight on April 2. The regiment's light-armored reconnaissance vehicles and infantry hit the Saddam Canal and overwhelmed the Iraqi defenders.

Engineers checked the bridge and declared it sound enough to handle the tanks. Now the heavier armored vehicles of the 2nd Battalion moved into the lead.

By the time the tanks reached Al Numaniyah, it was daylight. And the Iraqis had prepared a defense.

The Marine tank crews had no trouble dispatching about a dozen Iraqi T-54, T-55 and T-62 tanks. The Marines' Abrams also easily took out several BMPs—armored infantry vehicles with 73 mm anti-tank cannon.

But Iraqis in civilian clothes—a mix of Al Nida infantrymen and military volunteers with the Fedayeen Saddam—hid in the alleys and back streets of the city firing rocket-propelled grenades and automatic weapons. The Marines' tanks responded with more than 160 rounds of cannon fire. It was the heaviest fighting the battalion had seen, and there were several close calls.

Capt. Bardorf was standing in the passenger door of his Humvee when an Iraqi rifleman shot off the side view mirror. The captain spun around with his M-16.

“He raised his head back up in the bunker to see if he’d hit me, and that was his mistake,” Capt. Bardorf said.

The bridge across the Tigris at Al Numaniyah is a high concrete span that looked suspect to Marine engineers who’d studied it from aerial photos. The tank commanders had been told to cross one at a time to prevent a collapse from the weight of the tanks.

While waiting to cross, one of the tanks was hit in the rear engine compartment by an Iraqi firing a rocket-propelled grenade. The grenade disabled the tank, and uncovered the Abrams’ Achilles heel.

Such a grenade aimed at the rear of an M1A1 can damage the engine and stop the tank. It was a lesson the Iraqis learned well enough to use again when the 2nd Battalion reached Baghdad.

The battle of Al Numaniyah continued for two more days as the 5th Regiment’s infantry companies took over from the tanks. The battalion suffered no casualties in its share of the fight, however, and it was 60 miles closer to Baghdad.

White flags, cheering

The battalion fought again the next day, on April 3. The plan was to attack Al Nida troops defending the Basra-to-Baghdad highway at Zubaydiyah and Al Aziziyah and halt a little farther up the highway.

Col. Oehl led one part of the battalion, and Maj. Bianca, the battalion’s second in command, followed with the rest of the column around 11 a.m.

The column was startled by a convoy of Iraqis waving white flags and headscarves out the windows of their cars and darting in and out of the tank column.

The Iraqis were cheering the advance of the Americans.

At Al Aziziyah, however, the column once again ran into a maelstrom of grenades and small arms fire. Iraqi snipers were starting to aim at the Marine tank commanders and amtrack crews who stood up through the turrets of their vehicles.

Capt. Jon Lauder of Hastings, Minn., had placed sandbags around his turret hatch after the fight at Al Numaniyah. He dug a bullet out of one of the bags after the fight at Al Aziziyah.

“I’m a big believer in sandbags tonight,” he said.

Capt. Todd Sudmeyer, commander of the Battalion’s Alpha Company, led the way through Al Aziziyah. At the point where 5th Regiment commander Col. Joe Dumford wanted the tanks to stop, Capt. Sudmeyer kept going—looking, he said, for a suitable bivouac spot.

When Col. Dumford heard the tanks were six miles past the point where he wanted to halt, he growled over the battalion radio. “I’m going to have to put a bit in the Iron Horse,” he said.

The tanks continued up the highway until they reached an Iraqi military camp. Surprised Iraqi troops opened fire, only to have their barracks blasted by the tanks.

Capt. Lauder jumped from his vehicle and ran to the rooftop of the Iraqi headquarters. He tore down the Iraqi flag flying from a pole.

“That’s going home right next to the Japanese Zero my grandfather got,” he said.

The battalion came through the fighting with only one injury requiring medical evacuation. First Lt. Matt Zummo, commanding officer of the battalion’s Scout Platoon, took shrapnel in his arm and torso when a rocket-propelled grenade hit his Humvee.

“Lt. Zummo was reluctant to leave, but he’d had a lucky day. The grenade hit the Humvee’s antenna, which deflected it into a box at the back of the vehicle housing a laser range finder, which absorbed most of the blast.

“We never had much use for that range finder before, but now I think it’s an awesome piece of equipment,” said Sgt. Andrew Michael of Coral Springs, Fla.

Baghdad was now just 30 miles away.

An Iraqi lieutenant taken prisoner said the Marines had surprised the Al Nida division. His unit had lost radio contact with Baghdad early in the war. Aircraft had pulverized their positions on the highway. The Iraqi lieutenant said he thought the Marines were still far away when they stormed into his ranks along the highway.

Slow start

Friday, April 14, began lazily for the 2nd battalion. There was plenty of time in the morning for a meal.

Navy Chaplain Lt. Anthony Bezy persuaded Sgt. Brodie Matherne to give him a haircut in the middle of the highway. Col. North flew in with the crews of a pair of Marine CH-46 helicopters and posed for pictures with many of the Marines.

By day's end, Sgt. Matherne had a bandage around a wound caused when a bullet grazed his head.

Three Marines were dead after an Iraqi ambush at At Tuwayhah, and a fourth was dying.

Cpl. Bernard Gooden, 22, of Mount Vernon, N.Y., died when a rocket-propelled grenade exploded into his tank turret hatch. First Lt. Brian McPhillips, 25, of Pembroke, Mass., died in his first day as commanding officer of the Scout Platoon. He was shot in the back of the head while firing the .50-caliber machine gun in his Humvee.

Sgt. Duane Rios, 35, of Hammond, Ind., was shot in the head while standing through the turret of his infantry amtrack.

First Sgt. Edward Smith, 38, of Chicago, was mortally wounded when the battalion hit the remnants of the Al Nida's headquarters at an intersection near Hatif Haiyawi.

The battalion was surrounded by smoke and fire, exploding ammunition, smashed Iraqi armor and broken glass. Three rockets blasted craters near the weary Marines as they attempted to sleep.

The infantrymen on watch that night fired on speeding trucks, cars and a bus that seemed intent on crashing into their positions. Nine Iraqi civilians died.

But the road to Baghdad was open. Infantry units coming in behind the tank battalion reported more than 100 dead Arab Muslim volunteers who fought under the banner of Islamic Jihad. Huge ammo dumps were captured. The Al Nida Division of the Republican Guards was deemed "combat ineffective."

An Iraqi major general who was the chief of staff of the Special Republican Guards—the elite among Mr. Hussein's forces—was dead, killed by machine gun fire from one of the battalion's tanks.

"In that engagement, they put a hurtin' on us. But we put a hurtin' back on them," said Staff Sgt. Efrain Torres of Miami, the commander of the battalion's anti-tank missile TOW platoon.

Mr. Estes said the 2nd Battalion's aggressive assault was crucial to bring the Marines to Baghdad and ending the war.

"They did well. No doubt about it," he said. "You got there far too fast for the Iraqis, and you had far too much firepower for them."

"There is no doubt that the Iraqis were unhinged by the rapid movement."





Combat Engineer Battalion in Operation IRAQI FREEDOM

by the Staff and Commanders of 1st and 2d Combat Engineer Battalions

Marine Corps Gazette, December 2003.

Tasked organized combat engineer battalions supported combat operations in Iraq.

The events of 11 September 2001 required the United States to reevaluate its own national security strategy and establish a new policy of striking first before being struck. Of major concern was Iraq, labeled by President George W. Bush as one of the axes of evil. Its possible connections to al-Qaeda, weapons of mass destruction, and atrocities committed by the Saddam Hussein regime brought Iraq to the forefront of our concern. 1st Marine Division (1st MarDiv), Camp Pendleton also began focusing on Iraq. The division practiced its war plans through tactical exercises without troops and division command post (CP) exercises between Camp Pendleton and Twentynine Palms over and over again.

The Camp Lejeune Marines from II Marine Expeditionary Force (II MEF) became force providers to the 1st MarDiv and provided 2d Combat Engineer Battalion (2d CEB), 2d Amphibious Assault Battalion, 2d Light Armored Reconnaissance Battalion (2d LAR), 2d Tank Battalion, and two artillery batteries from 10th Marines.

Contingency planning among the Marine Corps' three CEBs—1st CEB of Camp Pendleton, 2d CEB of Camp Lejeune, and 4th CEB of Baltimore, MD—began in the summer of 2002. They held planning sessions among the commanders and staffs to determine how best to fight the CEBs.

There were two primary courses of action (COAs): (1) combine the three battalions into one, or (2) attach each CEB to a regimental combat team (RCT).

Under COA 1, the CEBs would remain in general support of the 1st MarDiv with three engineer support companies (ESCs) while attaching their lettered companies to the RCTs. Under COA 2, each CEB would operate autonomously and be attached to each RCT—1st CEB to RCT-7, 2d CEB to RCT-5, and 4th CEB to RCT-1.

After careful consideration, COA 1 was unanimously chosen. The primary reason was the commanding general's (CG's) requirement for unity of command of the CEBs and wanting one

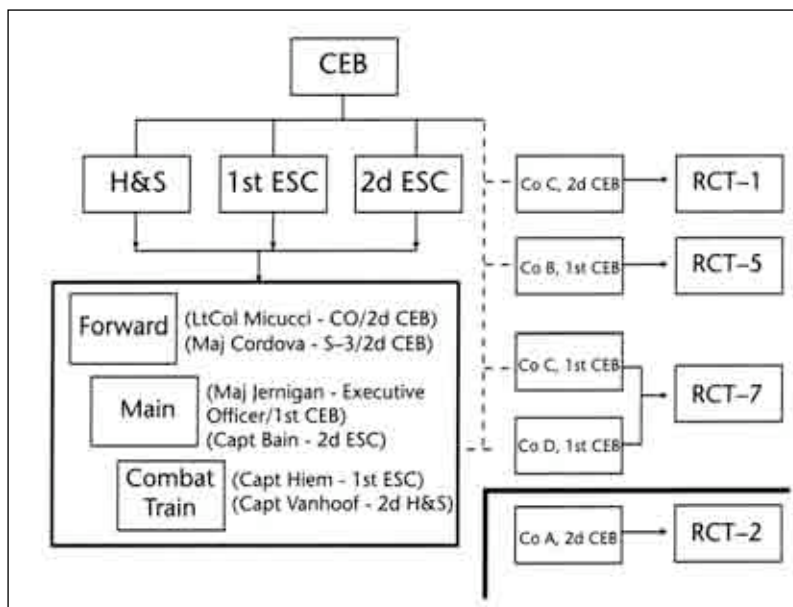

Figure 1.

point of contact for engineers. As a result, the commanding officer (CO) of 1st CEB was chosen to lead a robust G-3 (operations) division engineer section and became the primary adviser to the CG's staff for engineer related matters, while the CO of 2d CEB would lead the combined CEB and carry out the engineer missions.

4th CEB headquarters did not become a part of the combined CEB, and instead became the nucleus of the MEF engineer group. Their lettered companies, although requested to be a part of the combined CEB, were unable to activate due to a cap on Reserve mobilization.

In early January the Chairman of the Joint Chiefs of Staff issued the deployment warning order. Both 1st and 2d CEBs readied equipment and personnel for their respective ports of embarkation. When the deployment order was released, 4th CEB was not included, and only 1st and 2d CEBs provided combat engineer support to 1st MarDiv, which was swelling to unprecedented size with its new attachments.

By mid-February, both CEBs were in Kuwait. Their equipment from black bottom shipping and maritime prepositioning ships was following. Most all of it would arrive by early March. The combat engineer lettered companies were attached to the RCTs—Company C, 2d CEB to RCT-1; Company B, 1st CEB to RCT-5; and both Companies C and D, 1st CEB to RCT-7. 2d CEB also attached Company A to RCT-2 as part of Task Force Tarawa. CEB (minus) retained one combined headquarters and service (H&S) company, two separate ESCs, and a security force company. (See Figures 1 and 2.)

The combining of the two battalions doubled the staff traditionally found in a CEB, and as a result, the additional officers and staff noncommissioned officers (SNCOs) augmented the division engineer section. With a division forward and main CP running 24-hour operations, the normal table of organization of two officers and three SNCOs would not suffice. Instead, the division engineer section included one lieutenant colonel, two majors, three captains, two master sergeants, one staff sergeant, and one corporal.

In early March CEB (minus) divided into a forward command element, main CP, and combat train. The forward and main allowed the battalion to echelon forward and support varied and potentially independent missions while still maintaining command and control. Each could reinforce

Unit	Personnel	Purpose
CEB (Forward, Main, Combat Train)	455	CEB Main, Forward, Combat Train
RCT-1 (Co C, 2d CEB)	130	Co C, 2d CEB
RCT-5 (Co B, 1st CEB)	150	Co B, 1st CEB
RCT-7 (Co C, Co D, 1st CEB)	228	Co C and Co D, 1st CEB
2d LAR Bn	11	Engr Reconnaissance
1st Reconnaissance Bn	9	Engr Reconnaissance
Combat Service Support Companies 111, 115, 117	57	Water Detachment
8th ESB	33	Bridge Builders
Kuwait Det	15	Admin and Logistics Support

Figure 2.

one or more RCTs with additional breaching or mobility capabilities, assist in military operations on urbanized terrain, cut expedient combat roads and trails, or provide survivability or other combat support. The CEB combat train reinforced the forward and main but also took on separate missions of its own.

The reinforced lettered companies attached directly to the RCTs with their platoons attached to the maneuver battalions. They provided an immediate combat engineer capability and facilitated a substantial amount of engineer capability forward. Each RCT also had a robust ESC detachment of six to eight M9 armored combat earthmovers, two or more bulldozers, three or more dump trucks, armored HMMWVs, a maintenance contact vehicle, and the operators and mechanics required to provide ample support. The cell for RCT-7 was led by a major and included a captain as an assistant, a SNCO as an engineer chief, and two radio operators/drivers.

Combat operations kicked off on 19 March, and the combined CEB immediately proved a valuable asset to the 1st MarDiv. The attached combat engineer lettered companies quickly marked the regimental lanes through the breaches from Kuwait into Iraq, supported RCT-7 in their attack on the Iraqi 51st Mechanized Infantry Division at Basrah, and were used as infantry with RCT-1 and RCT-5 in securing the southern gas oil separation plants. Throughout the war the engineers provided mobility to each of the RCTs and the tank battalions, route and engineer reconnaissance to reconnaissance and LAR battalions, and bridge builders for 8th Engineer Support Battalion (8th ESB).

CEB (minus) remained in direct support of the division and, once north of An Nasiriyah, began making improvements along a major logistics route of Highway 1. The mission required a combination of CEB, force service support group, and SeaBee assets. CEB (minus), along with its attachment of ESC, 7th ESB, and four Army D9 armored bulldozers, improved more than 40 kilometers of highway by backfilling/constructing bypass routes for 14 open box culverts that were limiting the division's movement.

By 25 March RCTs-1, -5, and -7 moved well north along Highway 1 with their combat engineers. This was the day of the infamous sandstorm that brought all movement and operations to a grinding halt. In the evening RCT-7 began moving again and the following morning arrived in its position to the southeast of Ad Diwaniyah. The engineers from each battalion were quickly put to work searching for and destroying weapons caches that the Saddam Fedayeen were utilizing to ambush the convoys moving north along the line of communications.

Company C, 2d CEB drove north with RCT-1. The engineer platoons assisted with a deliberate defense in anticipation of a 4- to 6-day pause in operations. They assessed and repaired portions of the Qulat Sikar Airfield, to include repair of a taxiway used to land KC-130s. This engineering effort was accomplished in concert with both Company C, 7th ESB and Marine Wing Support Squadron 272 (MWSS-272).

1st Battalion, 5th Marines (1/5) with 1st Platoon, Company B, 1st CEB attacked to seize Hantush Airfield on 27 March. 2d Platoon was conducting defensive operations with 3/5, as 3d Platoon supported 2/5's feint to the north along Highway 1 in support of the seizure of Hantush. During this period intense fighting took its toll. CEB lost a platoon sergeant from Company B, 1st CEB. It was also about this time that 18 Marines from Company A, 2d CEB, attached to Task Force Tarawa, were injured in combat operations at An Nasiriyah.

By early April units were nearing the Tigris River. The RCTs with their combat engineers destroyed the enemy in the vicinity of An Numaniyah and Al Kut. Combat engineers cleared a minefield on the main supply route entering Al Kut and fought alongside the infantry attacking in zone to seize the bridge crossing sites at the Saddam Canal and the Tigris River. They classified existing bridges to determine load-bearing capability and suitability for heavier vehicles, and also performed engineer reconnaissance to determine the suitability of the river for ribbon bridge operations.

CEB (minus) forward and combat train followed in trace of RCT-7 and assumed control from 1/7 over the An Numaniyah Airfield. They cleared the runway and taxiway of earthen berms and old vehicle hulks left by the Iraqis to deny our use. CEB held the airfield until conducting a relief in place with MWSS-271. CEB (minus) forward and combat train then moved across the Tigris River and north to clear another airfield at Saribaldi. CEB (minus) cleared the airfield of ammunition, earthen berms, debris, antiaircraft artillery pieces, and unexploded ordnance (UXO). Upon completion of this airfield, CEB forward and combat train moved to

Salmon Pak East Airfield, again to clear the runway of earthen berms and debris, and to check for mines and UXO. While at the airfield the commander and key staff met with the local tribal leaders in the immediate area to inform them of upcoming airfield clearing operations.

Meanwhile, CEB (minus) main conducted sensitive site exploitation (SSE) of an ammunition storage facility at Highway 17 and Highway 1 near Ad Diwaniyah. They later moved on to another SSE site, this time north of the Tigris River crossing in the town of Al Aziziyah. Under special orders, their SSE team dug up freshly poured concrete slabs that were suspected of hiding chemical weapons from coalition forces. While maintaining security of the site the SSE team also examined two other sites in the town and investigated an Iraqi general's house. While in Al Aziziyah residents pointed out multiple weapons caches throughout the town. The SSE team also found several caches independently. The SSE team collected countless ammunition and weapons stores and destroyed everything that could be used immediately against coalition forces, including a T-55 tank.

As forces moved closer to Baghdad, Company C, 1st CEB used demolitions to destroy part of the span of the bridge allowing construction of the medium girder bridge. 1st Tank Battalion crossed the river approximately 15 kilometers to the north utilizing an armored vehicle-launched bridge (AVLB) to span the destroyed section of their bridge. Company C, 2d CEB assisted 8th ESB and the Army's 65th Engineers in a river crossing operation on a canal on the east side of Baghdad.

They also helped construct a ribbon bridge across the canal and set up an AVLB span over a partially destroyed civilian bridge.

Further to the north, the Platoon Commander, 4th Platoon, Company C, 2d CEB and one of his squad leaders swam across the canal and performed a ford site reconnaissance to determine the suitability for amphibious assault vehicles to cross. After crossing the Diyala River, RCT-7 continued their push into Baghdad, dividing the area of responsibility into sectors for each battalion. The units located and either destroyed or removed hundreds of weapons, equipment, and ammunition caches.

On 8 April the CEB (minus) forward sent an SSE team to the Iraqi Atomic Energy Commission facility—also known as the Tuwaitha Atomic Energy Facility. This impressive facility, comprising 94 buildings ranging from libraries to laboratories and over 16 square kilometers of grounds, was critical to determining the status of the Iraqi weapons of mass destruction research program. The SSE team of more than 90 Marines and sailors secured the facility from looters and preserved valuable evidence of interest to the U.S. Government and the International Atomic Energy Agency. Looters continually jumped the fence and crossed earthen berms but were repelled with appropriate force.

As Company B entered Baghdad they assisted in securing an urban area northeast of Saddam City and conducted countermobility operations along Route 5 in Baghdad with revetments and survivability positions, as well as manned foot-mobile and vehicle checkpoints.

On 11 April, conducting its final push into Baghdad, CEB (minus) relocated near the Rasheed Airfield. They were tasked with consolidating all arms and ammunition caches in the eastern half of Baghdad while at the same time conducting SSE at the Iraqi atomic agency. Augmented by companies from 7th and 8th ESBs, they seized and destroyed large ammunition caches, created mobile teams to examine ordnance, searched for boobytraps, and determined if the ordnance could be safely transported to the ammunition holding site. All of the combat engineers with the RCTs conducted similar missions.

During mid-April, Task Force Tripoli stood up and conducted offensive combat operations at Iraq's last stronghold—the town of Tikrit. Company D, 1st CEB augmented the task force and established a blocking obstacle south of the city. They also provided heavy equipment support to 2d LAR for blocking operations, assisted in rapid runway repair with MWSS-372, and disposed of large weapons caches.

On 20 April CEB (minus) moved south to an Iraqi military facility in Ad Diwaniyah after conducting a relief in place with units from the 3d Infantry Division. It was during this time that the combined CEB transformed back to two separate battalions, 1st and 2d CEBs. Each began to focus on their redeployment to the United States.

Conclusion

Operation IRAQI FREEDOM proved once more that there are never enough combat engineers on the battlefield and why both 1st and 2d CEBs were required. The combining of two CEBs was the first of its kind. They were spread throughout the division and attached to more than 12 different battalions. This robust and highly capable organization of more than 1,100 Marines and sailors, whether conducting bridge or route reconnaissance, clearing mines or airfields, guarding sensitive sites, or fighting as infantry, accomplished every mission assigned to them and provided the 1st MarDiv with a combat engineer capability unseen in any previous war.





Combining 1st and 2d Combat Engineer Battalions: Should We Do It Again?

by Lieutenant Colonel Michael A. Micucci

Marine Corps Gazette, December 2003.

While combining CEBs during OIF provided a capable combat engineer resource, questions remain concerning the best way to employ combat engineers in the future.

Operation IRAQ FREEDOM (OIF) presented many challenges that gave rise to new opportunities for the Marines Corps. Among these was the forming of a combined combat engineer battalion (CEB) from the resources of the two active duty CEBs—1st CEB from Camp Pendleton and 2d CEB from Camp Lejeune. The combined CEB proved successful during OIF, effectively accomplishing all assigned missions while providing the 1st Marine Division (1st MarDiv) with a robust, highly capable combat engineer resource. While overall success was enjoyed by the battalion, it is worth examining several issues encountered during this experience in order to ascertain if this was, in fact, the best way to employ the combat engineers. This article will provide such an examination and will offer some lessons learned for consideration if such combination is to be planned for in the future.

Other battalions combined for OIF, such as the amphibious assault battalions, but none combined and integrated to the extent as the CEBs that merged two staffs so that there was only one commanding officer (CO), executive officer, S-1 (personnel), and so forth. Even our name changed to “Combat Engineer Battalion” with no number designator of 1st or 2d CEB.

The combined CEB was distributed in support of more than 12 separate battalions. It was comprised of more than 1,100 Marines and sailors completing missions ranging from bridge and route reconnaissance, improving the mobility along Highway 1, breaching and clearing mines, sensitive site security, clearing airfields, fighting as infantry, building bridges, collecting and destroying weapons caches, and conducting civil-military operations and humanitarian assistance.

1st, 2d, and 4th CEBs met in December 2002 to finalize how the battalions would organize for combat. The 1st MarDiv commanding general’s sole mandate was that he wanted one point of contact for the engineers; specifically, the CO, 1st CEB would assume the role as the division engineer officer. This requirement essentially allowed the CEBs two courses of action

(COAs). First, attach each CEB to a regimental combat team (RCT), or secondly, combine the battalions under the CO, 2d CEB, and attach the letter companies to the RCTs. Collectively, we selected the second COA. Under this arrangement the letter companies were augmented with a robust heavy equipment/motor transport detachment, and the CEB personnel remaining—consisting of two headquarters and service (H&S) companies, two engineer support companies, and a combat engineer platoon—were consolidated and placed in general support of the 1st MarDiv. This slice of combat engineers would carry out separate missions, but more importantly, was available to reinforce the RCTs as required.

For each RCT we also decided to establish a regimental engineer cell led by a major who would coordinate the efforts of the combat engineer companies (two to three per regiment) and the support detachment. He would also become the primary advisor to the regimental commander for all engineer matters.

All CEB commanders agreed this was a solid plan, and everything was on track until January when the Marine Corps was unable to activate 4th CEB. This situation reduced the number of combat engineer companies by 50 percent. Fortunately, ground operations succeeded and occurred at the speed required by the force commander, but the engineers were definitely undermanned from the start. Without 4th CEB's combat engineer companies we were only able to field four companies for the 1st MarDiv. (Company C, 2d CEB, supported RCT-1; Company B, 1st CEB, supported RCT-5; and both Companies C and D, 1st CEB, supported RCT-7. 2d CEB also attached Company A to RCT-2 as part of Task Force Tarawa.) We also decided to scratch the regimental engineer cell except for RCT-7, who was designated as the division's initial main effort.

Combining two battalions provided a substantial combat engineer capability, but it also created some unforeseen consequences that should be addressed in the future before a decision is made to combine battalions. Specifically, there are four major issues: time, leadership, increased size of the H&S company, and the engineer capability with the RCTs. I will describe how the combined CEB dealt with each of these along with how we attempted to alleviate some of the challenges we had to face.

Time and the Impact of Unit Cohesion

We had 5 weeks until we crossed the line of departure. This was not a significant amount of time considering the majority of our effort was spent receiving equipment from strategic shipping and trying to integrate the new group into a cohesive unit. This effort occurs in every major deployment but not to the degree experienced by battalions deploying from opposite coasts. The inevitable consequence was reduced time available for the necessary detailed planning, immediate actions refinement, and conducting "what if" drills. Although we did accomplish these things within the 5 weeks prior to combat operations, our ability to do it to the depth desired was severely restricted because we also experienced significant growing pains trying to determine who we were as a combined unit and who was the best qualified for particular requirements.

OIF was a I Marine Expeditionary Force fight with 2d MarDiv serving as a force provider (with the exception of 2d Marine Expeditionary Brigade and Task Force Tarawa). Although 2d CEB had been involved in most of the planning and coordinated with 1st CEB in deciding how to outfit the combined battalion with personnel and equipment, we continued to work off of the 2d MarDiv training schedule until December 2002. Our focus did not totally shift to OIF until Combined Arms Exercise 3/4 was canceled, and we knew with some degree of certainty that we were deploying to Southwest Asia.

Clearly, in the future, sufficient time must be allotted for the merged battalions to become a cohesive unit. If there is not enough time, then don't combine the battalions. Ultimately, we made the combination work and did so with success. However, I believe there were other battalions, who had trained together for the past year, that were better synchronized.

There Will Be Leadership Changes and Challenges

When merging battalions it seems reasonable to assume that the combination of leadership will be a 50/50 split, but this was not the case for CEB. 2d CEB came in with some very senior staff. For example, we had three master sergeants, senior first lieutenants in most sections, and four major selectees. As a result 2d CEB took many of the senior billets within the combined battalion. Assigned as the commander I felt

very comfortable with this outcome. After all, I had trained and deployed with my Marines for the past year during battalion-and division-level exercises at Fort AP Hill, VA and Camp Lejune, and I knew their capabilities. More importantly, I knew how they would react under stress and in the absence of orders. I could not say the same about my sister battalion, since I knew few of their officers or staff noncommissioned officers (SNCOs) before meeting them either a few months prior or while in theater.

Merging of sections, such as the communications platoon, proved very challenging. Senior Marines were placed in senior billets and junior Marines who had done much of the planning became assistants. This became very frustrating and upsetting for some of them. Merging battalions will create a new command, and the mixture of the staff will never seem fair to all. Additionally, some junior leaders found difficulty in relinquishing their loyalties to their former superiors knowing that when the war was over they would serve for them again. Although most were professional and accepted the combined arrangement, there were some who eagerly sought out their previous bosses when the outcome of decisions was not to their liking. This was frustrating and had unsatisfactory impacts to say the least.

Both commanders of 1st and 2d CEBs were selected by a board to command their battalions and lead Marines. All of a sudden when it comes time to deploy, one is relegated to being a staff officer as the division engineer while the other is going to lead both battalions. If not for the division engineer cell, one commander may have been forced to work for the other. Only a very gracious and unselfish commander will relinquish his command to someone else, especially during time of war. Even so, the arrangement is bound to produce friction at some level.

Also very unique, the merging of the battalions accounted for two sergeants major. My hat goes off to both of them because they made the arrangement work. I do not know many sergeants major who are willing to share command, but these two gentlemen did so professionally and selflessly. The battalion was better served with both of them because we had two sets of eyes from the senior enlisted leadership. This arrangement was successful but could have been a catastrophe. During ground offensive operations my sergeant major went with me in the CEB forward, and 1st CEB's sergeant major went with the battalion XO in the CEB main.

Have a Plan for a Headquarters That Is Double the Normal Size

Although combining two CEBs established unity of command, we did not realize the impact of doubling the H&S company. The unintended consequence was too many chiefs—too many leaders who were underutilized. As the two battalions merged, only one person could be in charge of each of the many sections within the H&S company. We had three supply lieutenants, but only one would be in charge. We had three communications officers, but only one would be the battalion communications officer. The others became “Alphas” or “Zulus” or convoy serial commanders. During time of war Marines will do whatever is asked of them, but each wants to contribute to the success of the organization. With so many extra SNCOs and officers this was not always possible, at least not in the manner expected. It requires a great deal of maturity to deal with change on this level and to remain focused on “mission first.”

To partially alleviate the problem we established a security company led by one of the H&S company commanders. The company's primary mission was to provide security for the CEB. This worked well. This company also had an additional combat engineer platoon to reinforce the RCTs if required and to hold sensitive sites—that became a primary CEB mission. We also split the battalion into a forward, main, and combat train ensuring capable leadership within each element and reducing our maneuver footprint vice moving all elements together.

CEB's two engineer support companies, who had their own staffs and distinct styles, were more than capable of carrying out assigned missions. They did so but were often accompanied with additional oversight from an enlarged H&S company.

The additional staff officers allowed us to increase the size of the division engineer cell. This was a positive development because the traditional division engineer cell consists of two officers and three SNCOs, which may not be sufficient for completing all of the required tasks during combat operations. Combining the battalions permitted four additional officers to work in the division engineer cell, which

accommodated 24-hour operations for both the division engineer forward and main.

Ensure Combat Engineer Capability at the RCTs Is Sufficient

Of all of the issues, the most important is providing sufficient combat engineer capability to the RCTs. Placing engineer assets where they can best influence the battle, exploit the main effort, and provide the required mobility, countermobility, and survivability to the ground combat forces will facilitate success.

For OIF we placed 75 percent of our capability forward with the RCTs and equipped them with additional heavy equipment and motor transport assets. CEB's combined H&S company, two engineer support companies, and one combat engineer platoon were held in general support of the division and conducted independent missions throughout the division's zone. Having this capability prevented the division from pulling engineer assets from the RCTs. One of the most critical missions CEB performed while in this role was the clearance of three airfields at An Numaniyah, Saribaldi, and Salman Pak East. Intelligence showed obstacles and possible mines on each. CEB had the equipment, manpower, and know-how to clear the airfields. We also held four sensitive sights consisting of possible weapons of mass destruction and large weapons caches, improved 40 kilometers of Highway 1, and conducted civil-military operations and humanitarian assistance.

The Iraqi terrain made cross-country movement impossible, and all units were fixed to the roads where massive traffic jams occurred. CEB was often bogged down within these. Forcing our way forward into the RCT zones proved difficult because the RCTs did not want additional forces in their zones. They were concerned about safety and fratricide. Their arguments were valid, but CEB was a division element and a tremendous capability. Our primary mission was to reinforce the RCTs with additional engineer personnel and assets, and this could not occur if we didn't move forward. Because of the Iraqi terrain and highway congestion, reinforcements were slow to effect, and moving additional equipment forward often took days. Retrieving the equipment was just as difficult. This is why we attached more than three-quarters of our assets to the RCTs. The other alternative, attaching a CEB to each RCT, would have only added about 10 percent additional combat engineer capability to each. There would have been no problem getting into their zones, but there also would have been no general engineer support capability to carry out separate missions or reinforce a particular RCT if required.

Conclusion

Was combining the CEBs the best thing? For OIF it was, considering our desire to have a combat engineer capability in general support of the division and at the same time sufficiently outfitting the RCTs with combat engineers. The general support force proved valuable on numerous occasions either reinforcing the RCTs or carrying out independent missions.

But combining battalions was not trouble-free, and the success of the merger lies with the Marines and sailors of both 1st and 2d CEBs who, as expected, overcame all adversities and adapted to the combined battalion arrangement despite some of the unforeseen challenges. Even though all missions were successfully accomplished, I would be cautious in thinking that the merging of battalions should be the norm.

There are some major issues to address as far ahead of time as possible. First, before combining battalions ensure there is enough time to create a team that will operate and fight as a cohesive unit. If not, then don't combine the battalions. Also, understand there will be leadership changes and challenges. Some can be worked out ahead of time, but many will have to be taken care of in theater. Be ready to face them, and have a plan to employ an H&S company double the normal size. This is something we should have looked at more closely during our planning. I would recommend writing out the table of organization down to the last Marine before deploying so that everyone knows their roles. We partially did this but not to the detail required. Last, and most importantly, ensure that the RCTs are properly outfitted with sufficient combat engineer capability to win. We did this by attaching more than 75 percent of our overall combat engineer resources to them. I feel this engineer force facilitated success, although the addition of 4th CEB would have been a definite asset.

OIF presented an opportunity unseen before in the Marine Corps and that was the combining of the combat engineers. It is important we take the lessons learned to make decisions about how we will fight in

the future. Carefully addressing the issues of time, leadership, an oversized H&S company, and the resources available to the RCTs during the planning stages, or at least being prepared to address them in theater, will assist in determining if combining battalions is the best course of action.

Part III

Aviation Combat



A Different Air War: Marine Air Control in Operation Iraqi Freedom

by Lieutenant Colonel Michael J. Kibler

Historical Branch, History and Museums Division

From the opening attacks of Operation Iraqi Freedom, it was clear the air war was going to be very different than the 1990-1991 Gulf War. Unlike the 1990 deployment, where many U.S. Marines and civilians alike could not find Kuwait on a map, many of the 3d Marine Aircraft Wing (3dMAW) Marines, commanded by Major General James F. Amos in Miramar, California, had either been operating in the U.S. Central Command area of responsibility or studying and refining the plan for the invasion of Iraq for months.¹ Unlike the conflict 12 years prior where television sets around the world saw sortie after sortie take off to attack targets in Iraq and Kuwait, this time the news focus would be on the infantry. Marine Aviation would find itself following the more doctrinal role of supporting the Marine on the ground. In many aspects, Marine aviation was better prepared for operations in Iraq, however it faced different challenges that did not arise in the 1990-1991 Gulf War.

The 3d Marine Aircraft Wing consists of four aircraft groups whose subordinate squadrons operate fixed- or rotary-wing aircraft; Marine Aircraft Group 11 commanded by Colonel Randolph D. Alles; Marine Aircraft Group 13 commanded by Colonel Mark R. Savarese; Marine Aircraft Group 16 commanded by Colonel Stuart L. Knoll; and Marine Aircraft Group 39 commanded by Colonel Richard W. Spencer. The wing has two additional non-aircraft groups; Marine Air Control Group 38 commanded by Colonel Ronnell R. McFarland, which provides air command and control assets and personnel; and Marine Wing Support Group 37 commanded by Colonel Michael C. Anderson, whose subordinate squadrons provide aviation ground support. During the conflict, 3d MAW was augmented by other units, detachments, or personnel from the other two active wings, the reserve wing, and various commands throughout the Marine Corps and from the U.S. Army. At its peak, 3d MAW had 15,451 personnel in theater. Initially, the wing established itself at two primary bases in Kuwait, Al Jaber and Al Salem air Bases.²

Planning Phase

It was common knowledge throughout 3d MAW that they would have to deploy to the Middle East for a potential conflict. As with any potential hot spot, when events heat up the military reviews the operational plan associated with that area. Marines involved in planning were working the details as early as the summer of 2002.³ Unlike the surprise attack on Kuwait by Iraq in 1990, which caught most of the world and the U.S. military by surprise, this conflict was planned, reviewed, and modified over and over. Most in the military knew or believed they knew, that they would be called on to enforce the United Nations resolutions against Iraq especially during 2002, therefore they wanted to be as ready as possible this time. One of the problems that developed for aviation planners was that various units that were designated to deploy if called on were also participating in the unit deployment plan (UDP).

So as time progressed with no deployment order, planners had to keep track of which units were rotating in or out and adjust the time-phased force and deployment data (TPFDD) accordingly.⁴ Of course during this time units were also looking at what “holes” in the table of organization needed to be filled prior to deploying. The manpower planners up and down the chain were ready to identify and “cut” orders, but again with no deployment order in hand, they had to wait and adjust the lists as time went by.⁵ In addition, during the past 12 years, Marine fixed-wing aircrews and aircraft were rotated in and out of the theater as part of Operation Southern Watch (OSW), enforcing the southern no-fly zone. These pilots gained invaluable experience supporting OSW, not only knowledge of the enemy but also of the procedures and control methods used by U.S. Central Command.

To reduce the number of unaccompanied tours and improve unit continuity, the Commandant of the

Marine Corps established unit deployment plan to provide for the deployment of units to the Western Pacific for periods of approximately six months. The initial program was a six-phased evolution that sequenced infantry battalions and aircraft squadrons/detachments into Westpac deployments, thus eliminating the 12-month permanent change of station assignments for personnel assigned to these units. The program began in October 1977 and has gone through six phases. In August 1985, tank companies began phasing into the program but following Gulf War, were discontinued. In Fiscal Years 1987 and 1988, assault amphibian vehicle companies and direct support artillery batteries were phased in and later, light armored reconnaissance companies were also included in the program. The Marine Corps' objective is to adhere as closely as possible to a six-month period of deployment away from a unit's home base. In the case of Hawaii-based infantry battalions, which employ a three-battalion rotation base, a seven-month period of deployment is executed to support the unit cohesion program and efficient staffing of first term Marines.

The joint operation planning and execution system database also called TPFDD portion of an operation plan contains time-phased force data, non-unit-related cargo and personnel data, and movement data for the operation plan, including: in-place units; units to be deployed to support the operation plan with a priority indicating the desired sequence for their arrival at the port of debarkation; routing of forces to be deployed; movement data associated with deploying forces; estimates of non-unit-related cargo and personnel movements to be conducted concurrently with the deployment of forces; and estimate of transportation requirements that must be fulfilled by common-user lift resources as well as those requirements that can be fulfilled by assigned or attached transportation resources.

Operation Southern Watch followed in the wake of the Gulf War when the United Nations imposed restrictions on the government of Iraq in response to Iraqi efforts to suppress the Kurds in northern Iraq and Marsh Arabs in the south. Iraqi brigade-sized ground and air forces, using combined arms tactics, carried out search and destroy operations on these refugees and their villages. In addition, Iraqi government began large-scale engineering efforts to divert waters away from the marshlands in these regions to facilitate their genocidal operations. To allow monitoring, an Iraqi no-fly zone south of the 32d parallel was established. Named Operation Southern Watch, the coalition effort to enforce the no-fly zone, as well as banning any surface-to-air weapons presenting a threat to aircraft conducting the monitoring mission, was begun August 1992.

JFACC and Marine Aviation

The Goldwaters-Nichols Defense Department Reorganization Act of 1986 together with the omnibus agreement began to codify who task, Marine Corps air assets, the Marine air ground task force (MAGTF) commander or the joint force commander (JFC). Also it allowed the joint force commander to establish and designate a joint forces air component commander (JFACC), who would be responsible for supporting the joint force with air assets from the entire theater. In essence, the omnibus agreement allowed the MAGTF commander to retain his tactical air to support ground operations while making sorties available for tasking by the JFACC in support of the JFC's overall objective. This relationship was later incorporated into Joint Pub 0-2 Unified Action Armed Forces. The first practical operational use of this new command relationship was during the 1990-1991 Gulf War. Many Marines looked at the JFACC concept with suspicion and as the possible loss of Marine tactical air. Although there were growing pains during the 1990-1991 Gulf War, the Marine Corps did not "lose" its tactical air as some had predicted. Many years, exercises, and operations later, Major General James F. Amos, Commanding General 3d MAW, would work the aviation tasking issues with U.S. Central Command's combined forces air component commander, Lieutenant General Michael T. 'Buzz' Mosley, U.S. Air Force. In August 2002, Major General Amos noted that, Lieutenant General Mosley said he was going to let "Marine aviation fight over the MAGTF." Major General Amos went on to say "we got to fight the Marine aviation part of the MAGTF, in a major regional contingency, for the very first time in the history of Marine aviation the way we always said we wanted to be able to do it."⁶ In fact the relationship between the CFACC and the MAGTF proved to be more beneficial to the Marines. Although Marine sorties were provided to the combined force through the air component commander during the course of the war, Lieutenant General James T. Conway, Commanding General, Marine Expeditionary Force, had days when there were multiple U.S. Air Force B-52, B-1, or B-2's carrying 30, 40 or 60 joint direct attack muni-

tions (JDAMs) in support of the MAGTF. There were also days when more than one hundred U.S. Air Force A-10 Thunderbolt attack aircraft flew in the Marine sector supporting the Marines on the ground.⁷

The Goldwater-Nicholas Department of Defense Reorganization Act of 1986, sponsored by Senator Barry Goldwater and Representative Bill Nichols, initiated a major defense reorganization, the most significant since the National Security Act of 1947. Operational authority was centralized through the Chairman of the Joint Chiefs as opposed to the Service chiefs. The chairman was designated as the principal military advisor to the President, National Security Council, and Secretary of Defense. The act established the position of vice chairman and streamlined the operational chain-of-command from the President to the Secretary of Defense to the unified commanders. "The Secretaries of the Military Departments shall assign all forces under their jurisdiction to unified and specified combatant commands to perform missions assigned to those commands."

There are many possible reasons why the relationship between the MAGTF and the CFACC worked so well during this conflict and may be debated and written about for years to come. The reasons could be due to any of the following factors or a combination thereof:

- Liaison officers the MEF had at the CAOC. The MEF staffed the liaison billets at U.S. Central Command Air Forces' (CENTAF) combined air operations center (CAOC) at Prince Sultan Air Base in Saudi Arabia, which provided the MEF with a presence and a voice within the CAOC as well as feedback to the MEF.

These liaison officers were critical as they articulated the U.S. Marine Corps position to the air component commander and his staff.

- Proximity of aircraft to Marine units. Since the Marines were closer to most of the airbases and aircraft carriers and were in contact with enemy forces more often, aircraft could be diverted to support the Marine ground forces without additional support assets.

- Marine air control doctrine and agencies. There was a fundamental difference in doctrine between the U.S. Air Force and the U.S. Marine Corps when it dealt with controlling aircraft within a kill box. The difference arose from whether aircraft can drop ordnance in a closed kill box. The U.S. Marine Corps doctrine during OIF was that ordnance could be dropped in a closed kill box if there was someone (strike coordination and reconnaissance, forward air controller, forward air controller (airborne) or flight lead) with eyes on target and they had situational awareness of where friendly forces were. There were times when the E-3 Sentry airborne warning and control system (AWACS) was in control of kill boxes within the MEF's sector.

The E-3 would not allow aircraft to drop ordnance in a closed kill box. Later during the war, attack aircraft that were turned away from a closed kill box by the U.S. Air Force controlling agencies would work with Marine controlled closed kill boxes and be able to expend their ordnance.⁸

Unlike the 1990-1991 Gulf War, U.S. forces used an additional control measure, the battlefield coordination line (BCL), which was between the fire support coordination line (FSCL) and the forward line of troops (FLOT). The U.S. Marine Corps position was that kill boxes short of the FSCL could be open whereas the U.S. Air Force would consider them closed. In these open kill boxes short of the FSCL, aircraft could drop ordnance as long as there was a controlling agency such as the DASC, DASC(A), FAC(A), TAC(A), which knew there are no troops located within the kill box and cleared the attack aircraft "hot." However, if aircraft moved into V Corps area, they would have to call a U.S. Air Force controlling agency and get a portion of the kill box open in order to attack a target.

A kill box is a square area within a larger grid to provide for an easy way to deconflict air interdiction (AI) type missions, ones in which coordination with controlling agencies is not required. Aircraft could be assigned to a kill box for a specified time and would not have to worry that other aircraft would engage targets within the kill box. A closed kill box was one that has friendly troops. This "closed" concept was created to ensure aircraft conducting AI missions would not attack friendly forces.

- Emphasis on ground operations instead of strategic or interdiction air operations. During the Gulf War, aviation was the focus of effort instead of aviation in support of the ground forces. Most aircraft were sched-

uled for strategic bombing or air interdiction type targets. These type of targets are nominated through the formal targeting process and required numerous airframes due to the number of targets nominated. Since the ground forces were not actively involved in combat operations, the JFACC could and did task U.S. Marine Corps aircraft to fly in support of joint force requirements. This is in stark contrast to Operation Iraqi Freedom where the emphasis almost from day one was to support the ground forces.

- Years of joint exercises and training. The 1990-1991 Gulf War was too soon after the 1986 Reorganization Act to be put into practical use. The DOD designated system for distributing the air tasking order (ATO) was the contingency theater air planning system (CTAPS). However it was a U.S. Air Force system in its infancy and was not fully utilized by the U.S. Marine Corps or U.S. Navy. Paper copies of the ATO still had to be flown or driven to units. During the 12 years after the war, the Services joint doctrine and equipment in all joint exercises or operations. s units operated further under the new doctrine, the more proficient they became and more acceptive of the new way of doing business.

- Personality of the commanders involved. Lieutenant General, U.S. Air Force, and Major General Amos had a positive working relationship that in turn may have influenced Lieutenant General Mosley to allow the U.S. Marine Corps to use its air as a supporting arm for its ground forces as Marine Corps doctrine states. The bottom line is that it worked and to quote Major General Amos “[he] and the Marine Corps will be forever grateful to Lieutenant General Mosley for making it happen the way it did.”¹⁰

Opening Moves

The old adage that operations go only to plan until the operation begins was true of air operations for I MEF. As indicators began to alert the coalition forces of possible attacks/sabotage to southern Iraqi oil fields and refineries, Marines with other coalition forces were ordered to seize the oil fields in order to prevent the Iraqi’s from destroying them as they had done to the oil fields in Kuwait 12 years earlier. Major General Amos was forced to become reactive instead of use of air power against the enemy. His desire early on was to hit the enemy hard, especially those units that could hinder the division’s movement, in order to destroy them or cause them to see the futility of resistance and lay down their arms.¹¹ According to Colonel Jeffrey A. White, a battle captain in 3d MAW’s tactical air command center (TACC): “the Marine Corps was operating on the enemy’s timeline since we were reacting to movement of his forces rather than on our timeline.” It would take until about D+4 before Marine aviation was able to get back on their timeline and become proactive.¹²

Once the southern oil fields were secure, 3d MAW was able to execute the battle plan they developed; attacking enemy, tanks, and the 11th and 6th Iraqi Divisions that could hinder Major General James N. Mattis’ 1st Marine Division as it moved north.⁸ During the fast paced drive north by the ground forces, it soon became clear to the wing that the speed of advance would tax many aspects of their command and control (C²) and logistics.

Herculean Logistics

It is hard to imagine the amount of material and manpower that was moved into theater in such a relatively short period by the Marines of I MEF. They off loaded 11 maritime prepositioning ships (MPS) 24 hours a day for 45 straight days. Following behind the MPS off load, four fast sealift ships pulled in with aviation related equipment ranging from helicopters to Marine wing support squadron (MWSS) specific equipment. Again these sealift ships had personnel unloading them around-the-clock. To round out the seaborne logistical effort, three ammunition ships arrived carrying 4.5 million pounds of aviation ordnance, which also was unloaded. To the credit of all involved, not one Marine was injured or killed during this monumental effort.¹³

The Marine Corps’ maritime prepositioning force [MPF] mission is to support the rapid deployment of Marine forces by providing mobile, long-term storage of equipment and supplies near areas of potential trouble. When conflict arises—such as Operation Desert Storm or Restore Hope in Somalia—these ships can respond immediately to provide rapid deployment forces with critical sustaining support. The MPF concept calls for Marines and sailors to fly into a secured airfield to link up with the MPF ships. More than 17,000 Marines and sailors can be flown in on fewer than 250 aircraft sorties. If the equipment on the ships had to

be flown in with the Marines and sailors, it would take more than 3,000 sorties. The 16 Maritime Prepositioning Ships are part of Military Sealift Command's Prepositioning Program. They preposition U.S. Marine Corps vehicles, equipment, and ammunition throughout the world. The MPS ships are assigned to three Maritime Prepositioning Ship squadrons located in the Mediterranean, the Indian Ocean the Western Pacific. The MPS ships in each squadron have sufficient equipment, supplies, and ammunition to support a Marine expeditionary brigade of about 17,000 personnel for 30 days.

In order to provide the ground forces with timely air support during the drive to Baghdad, the wing had planned to establish forward arming and refueling points (FARPs) and forward operating bases (FOBs). These FARPs and FOBs would greatly reduce the distance required to be flown, allowing both fix- and rotary-wing aircraft to respond more timely to requests from ground forces. However, the timetable for establishing these facilities was radically adjusted once the drive north began. One of the FOBs in northern Iraq (at Al Amarah) was scheduled, according to the Oplan to be setup on the 78th day of the war, but due to the lightning speed at which the ground forces moved, it was established 17 days into the war.¹⁴ Major General Amos was surprised at how quickly the MWSSs were able to move with the ground maneuver elements in order to set up the FARPs and clear the runways so the wing could operate closer, and thereby respond more rapidly to the requests from the ground forces.¹⁵

C2 Flexibility

"Stove-piped and rigid" is one way the Marine Air Command and Control System (MACCS) has been described over the years. Whether this connotation was well deserved or given out of ignorance, the MACCS would adapt itself in order to meet the needs of the wing. The Marines of the Marine Air Control Group 38 (MACG-38), commanded by Colonel Ronnell R. McFarland, augmented by Marines of MACGs' -28 and -48, would demonstrate just how flexible air command and control could be.

Early in the preparations for Operation Iraqi Freedom, Major General Amos would change the way his tactical air command center (TACC) would operate. As the TACC is unable to be fully utilized during peacetime since there are few wing/MEF level" exercises for them to train with the full breadth of command and integration, not to mention having the full wing staff participating, the TACC seldom gets the required training of all personnel who would be assigned to the TACC. Major General Amos knew he wanted a more senior as well as "seasoned" Marine in charge of the current operations section of the TACC. (The senior watch officer (SWO), who is usually a lieutenant colonel, heads the current operations section.) Major General Amos established a more senior billet to the senior watch officer in what was to be known as "battle captain." The battle captain was to be a colonel who had a previous successful command. There were to be a total of four battle captains in the TACC; this would allow for each twelve-hour-crew watch and a day off, which in reality was a day of working in future operations which built the ATO that they would work the next day. P/N7 One of the side benefits of battle captains being a colonel, was that it placed the commanding general's representative on equal footing with various group commanders and thus ended rank becoming an issue when a group commander was involved in a dispute. The battle captain concept, although not doctrinal, served the needs of 3d MAF and Major General Amos well during OIF and shows the adaptability within the Marine air command and control. Major General Amos looked back on this concept and stated that this was one of his greatest satisfactions in turning them loose to run the current operation thereby giving him and his assistant wing commander, Brigadier General Terry G. Robling, the latitude to look at future plans coordinate with the MEF and division commanders, as well as sit back and watch the current battle and next day's ATO unfold.

¹⁶

The ATO is used to task and disseminate to components, subordinate units, and command and control agencies the targets and specific missions of projected sorties, capabilities, and forces. It normally provides both general instructions and specific instructions, including call signs, targets, and controlling agencies. It also includes special instructions that provide amplifying notes, important details, and changes.

The tactical air operation center (TAOC) and its smaller subordinate, the, early warning control (EW/C) detachment are normally concerned with air defense and providing navigational assistance to friendly aircraft within their assigned air sector. When the TAOC and EW/C detachment controlled aircraft within "kill

boxes,” this marked a small but important change. Usually the direct air support center (DASC) is the most likely candidate for this type of operation. However, the DASC and the smaller air support elements (ASEs) were busy coordinating assault support and close air support (CAS) for the ground combat element. In addition to coordinating requests for assault support close air support, they had to ensure that each component in this air support system was kept abreast of the whole scheme of maneuver. This was no easy task since there were ASEs with each of the three regimental combat teams (RCTs), the artillery regiment, and the British division. Also there was the DASC (main) with the division headquarters main, and the DASC (forward) with the division headquarters forward. Since the air support Marines were busy coordinating the air for the ground forces, the TAOC and EW/C assumed mission of coordinating air attacks within the kill boxes. As noted earlier, the Marines would routinely allow the delivery of air ordnance inside a closed kill box as long as it was coordinated. Using the TAOC and EW/C, air defense agencies, to coordinate air support missions is another example of the flexibility of Marine air command and control.

The speed of advance by the ground forces and subsequently the aviation assets tasked the ability of the wing to communicate throughout the theater. One way the wing was able to bridge the communication gap was to have the DASC airborne, (DASC(A)), aloft on a 24-hour basis. The DASC(A) was flown out of Sheikh Isa air base, Bahrain, as the Marine KC-130s were based there. At times the DASC(A) was the only reliable way Marines could request air or the wing could communicate with its rotary-wing assets.¹⁷ The wing was also able to setup some tactical satellite (TACSAT) radios at some FARPs in order for the TACC to relay new missions to aircraft refueling or rearming. Without these TACSAT radios it would have been nearly impossible to re-task aviation assets for follow-on missions, hence defeating the whole principle of the FARP.¹⁸

Targeting

For the Marines of 3d MAW involved in targeting, there was a new challenge and new ally during this war. As with most battles the utmost care is taken to ensure that no civilian casualties occur. During this conflict, 3d MAW was following that course as well as trying only to target the “regime” or forces loyal to the regime. Major General Amos was clear in his guidance that he wanted as little damage as possible to the Iraqi people and their country’s infrastructure. He was determined to make it clear that this conflict not with the civilian populace, but with their leaders and those who supported them.¹⁹ This precise targeting always makes it just a little harder on the Marines involved with intelligence and targeteering.

For AV-8B Harrier II pilots, locating and identifying targets became a little easier with the use of the Litening II targeting and navigation pod. The pod provided the pilot with both forward looking infra-red (FLIR) and charged coupled device (CCD) camera. The pod also had the ability to laser designate a target, either for itself or for another delivery system. The FLIR and CCD camera give the Harrier II pilots the ability to identify a target at greater distances and at higher level of confidence than other Marine Corps airframes. An additional benefit of the Litening pod was the video that was taken during the flight. This video allowed targets to be identified and located by aircrews and intelligence personnel after the flight.

Conclusion

Although this conflict entailed many new challenges for Marine aviation to the 1990-1991 Gulf War, in the end it allowed Marine aviation to be used more in line with Marine Corps doctrine?using aviation as a combat arm to support the ground forces. Flying more than 9,800 sorties of fixed-and rotary-wing aircraft, the wing adeptly execute its mission; Major General Amos’ Marines mercilessly attacked the Iraqi forces while trying to minimize the loss of civilian lives and property. From the opening day to the end of major conflict, 3d MAW drop more than 3.8 million pounds of ordnance, decimating numerous Iraqi units, the 11th, 14th, 18th, and 51st Infantry Divisions; the 6th and 10th Armored Divisions; the Baghdad Republican Guard Division, and the Al Nida Republican Guard Division. These units were rendered combat ineffective through the focused and intense application of aerial firepower that most offered no resistance above the small-unit level once contact was made with Marine ground forces. The actions of 3d MAW were clearly instrumental in diminishing the enemy’s will to fight significantly shortened the ground campaign.²⁰

¹ Col Jonathan G. Miclot, 3d MAW G-3 intvw 20Mar03

- ² 3d MAW ComdC Jan-Jun03.
- ³ Col Michael L. Sawyers, 3d MAW G-5 intvw 3Mar03.
- ⁴ Col Chad W. Hocking, 3d MAW G-1 intvw 9Mar03, hereafter Hocking intvw.
- ⁵ Ibid.
- ⁶ MajGen James F. Amos, 3d MAW CG intvw 16May03, hereafter Amos intvw 16May03.
- ⁷ Ibid.
- ⁸ Col Jeffery A. White intvw 23Mar03, hereafter White intvw
- ⁹ Ibid.
- ¹⁰ Amos intvw 16May03.
- ¹¹ MajGen Amos, 3d MAW CG intvw 17Mar03, hereafter Amos intvw 17Mar03.
- ¹² White intvw.
- ¹³ MajGen Amos address to 3d MAW staff 19Mar03.
- ¹⁴ BGen Terry G. Robling, 3d MAW AWC intvw 28Mar03
- ¹⁵ Amos intvw 16May03.
- ¹⁶ Ibid.
- ¹⁷ Ibid.
- ¹⁸ MACG-38 ComdC Jan-Jun03.
- ¹⁹ Amos intvw 17Mar03.
- ²⁰ 3d MAW ComdC Jan-Jun03.





4th MAW JFACC Liaison in OIF

by Colonels Thomas C. Byron and William Kane

Marine Corps Gazette, May 2005.

4th MAW personnel played a key role in OIF air operations.

An integral part of the Marine Corps' successful aviation effort in Operation IRAQ FREEDOM (OIF) was the little-known Marine liaison element to the Coalition Force Air Component Commander (CFACC). Based with the CFACC at Prince Sultan Airbase (PSAB), Kingdom of Saudi Arabia, the majority of this team came from the Reserve Component, specifically the 4th Marine Aircraft Wing (4th MAW) Joint Force Air Component Command (JFACC) liaison cell. This article will discuss the history, development, training, and deployment of the 4th MAW's JFACC liaison cell.

History

The current Marine air-ground task force (MAGTF) concept was formalized by the Commandant of the Marine Corps in 1983 and the current joint force command concept in 1986. However, it was not until 1991 during Operation DESERT STORM (ODS) that these two concepts met and were required to function together as an effective warfighting team. By MAGTF design, the Marines brought a potent mix of fixed-and rotary-wing aviation assets to the fight. The Marines expected autonomy to task these assets as they saw fit to support the MAGTF commander, his battle plan, and his scheme of maneuver. However, the commander, JFACC wanted to incorporate Marine fixed-wing assets into the centralized air battle planning, a function tasked to his command. The compromise reached was not particularly satisfactory to either commander. The Marine Corps gave up control of assets they expected to use, and the JFACC commander did not receive all of the assets he would have liked. This has been well-documented in numerous books and articles. (*The Generals' War* by Michael R. Gordon and LtGen Bernard E. Trainor or, USMC (Ret) (Little, Brown, and Co., NY, 1995); *Every Man a Tiger* by Tom Clancy and Gen Chuck Horner, USAF (Ret), (Penguin Putnam, NY, 1999); and "Marine Air in the Mainstream" by Rebecca Grant, *Air Force Magazine*, June 2004.)

A lesson learned during ODS was that there exists a significant need within the Corps for experienced and senior aviators who are intimately familiar with the ways of the JFACC commander, his staff, and his joint air operations center (AOC). The implementation of this lesson learned by both the Active and Reserve Components has proven invaluable to the Marine Corps' warfighting efforts. By having Marine officers embedded in the JFACC staff for both joint exercises and real-world operations, the

Marine Corps is better able to support both the MAGTF and CFACC missions. This applies to coalition (CFACC, combined AOC (CAOC)) and U.S./Korea combined (CFACC, hardened theater air control center) commands, exercises, and operations as well.

Development

The Reserve Component recognized that the JFACC function could be performed using Reserve personnel and that it could be highly relevant to the total force concept. Not only could a Reserve JFACC liaison team provide experienced post-command aviators, it could afford to make appropriate training and exercise support its primary mission. In addition, the continuity of personnel would allow for the development of relationships with the numbered Air Forces that would most likely man, equip, and operate an AOC for training or real-world operations.

Early in the JFACC liaison development, cells with varied levels of formality were formed in the Reserve Component at the Marine aircraft groups, Marine expeditionary force (MEF) augmentation command elements, and 4th MAW headquarters. Ultimately, the 4th MAW commanding general directed the wing staff to organize, train, and man the JFACC liaison team within his G-3 (operations).

This team consists primarily of senior officers and is led by a Reserve colonel. To highlight the experience level in the staff, the group mobilized in support of 3d MAW for OIF included six postcommand individuals (two Hornet squadrons, a CH-46 squadron, a Cobra detachment, a Marine air control squadron, and an air/naval gunfire liaison company (ANGLICO)). This is consistent with normal personnel experience within the team. JFACC-trained individuals throughout 4th MAW are also tracked to allow efficient augmentation of active duty MAWs should the JFACC liaison team be called for support in large numbers for exercises or real-world operations. This was the case for OIF.

Training and Deployment

The appropriate base-level schoolhouse training is the Joint Air Tasking Order Processing Course/Initial Qualification Training (previously known as Joint Air and Space Command and Control Course). This course generally runs 28 training days and provides the basics of joint operations, the JFACC's role in those operations, air tasking order (ATO) production, "standard" AOC operations and, depending on an individual's training track, AOC functional area instruction. Training is centered around the UNIX (uniplexed information and computing system)-based theater battle management core system that is used to plan, publish, distribute, and monitor the execution of the ATO. From the JFACC liaison team's perspective, emphasis is placed on combat plans and combat operations for this training. The 28-day course length is an issue with Reserve personnel, but the team has been successful in getting its personnel to this fundamental course.

To develop classroom training into a practical, working knowledge of joint operations and specifically CFACC/CAOC operations, the team has regularly participated in BLUE FLAGS, RED FLAGS, and other exercises that man a fully operational AOC. This is usually in support of one of the active MAWs.

As hostilities in Iraq became more likely, the 4th MAW JFACC team honed its skills by participating in Exercise INTERNAL LOOK. This was in support of 3d MAW and was a trial run to exercise I003V plans and possibilities. Since the 9th Air Force (9th AF) (U.S. Central Command Air Force or CentAF) area of responsibility (AOR) includes Iraq and they are tasked to execute the CFACC fight in that AOR, the CAOC portion of the exercise was conducted primarily in their home CAOC at Shaw Air Force Base, Sumter, SC. A small portion of the liaison for the exercise was conducted from their warfighting CAOC at PSAB. At the time, the PSAB CAOC was entrenched in Operation SOUTHERN WATCH (OSW) and Operation ENDURING FREEDOM (OEF). The 4th MAW JFACC liaison team paralleled this by sending the vast majority of the team to Shaw to fully integrate with the 9th AF CAOC team.

It is important to note that the 4th MAW team at Shaw performed not only in the table of organization Marine/Marine liaison officer (MarLO) (green) billets but also filled joint (purple) billets in strategy, plans, and operations. Of further interest, the CFACC tasked Reserve Marine aviators to head both shifts of the close air support cell and the interdiction cell on the combat operations floor. In other words, Reserve Marine officers were tasked with the execution of the CFACC's offensive air war from the close fight all the way out through battlefield shaping with kill-box interdiction. This carried over into OIF CAOC manning as well.

Exercise INTERNAL LOOK allowed the team to develop familiarity with CentAF's tactics, techniques, procedures and, perhaps most importantly, allowed working relationships and professional trust to be developed.

Shortly after INTERNAL LOOK, the 4th MAW JFACC liaison team was mobilized and deployed to PSAB. Not only did the team fill billets in support of both OSW and OEF, they assumed leadership roles in the planning and training efforts that enhanced warfighting capability and efficiency of the CAOC. The CFACC recognized this as a critical effort since I003V sortie flow was expected to be orders of magnitude greater than what it previously had been for OSW and OEF.

When OIF kicked off, the 4th MAW JFACC liaison team represented about three-quarters of the MarLO team (both green and purple billets) at PSAB. The remainder of the team were primarily Marine Aviation Weapons and Tactics Squadron 1 officers who filled the combat plans and combat operations billets that required the most current type/series/model and weapons systems knowledge.

Having Marine aviators staff the purple CAOC billets, coupled with the phenomenal ability of the direct air support center to dynamically process and utilize air, led to a very flexible and efficient use of coalition sorties. The various bomber and attack duty officers soon learned to come to the Marines on the operations floor with excess, rerolled, or unscheduled sorties because, as one stated, "The Marines will use anything."

As a result of the liaison effort, reports indicate that the CFACC and MEF/MAW command structures, unlike with ODS, appear very pleased with the air integration, coordination, and cooperation between commands. Building on the success of the JFACC liaison function at OIF, 4th MAW aviators have manned the senior MarLO billet in the CAOC (now at Al Udeid Airbase) for all follow-on OIF and OEF versions. Stateside, the team continues to support the active MAWs in exercises such as ULCHI FOCUS LENS and JOINT RED FLAG. In addition, 4th MAW continues to develop and build the JFACC capabilities within the Reserve Component.

In summary, the 4th MAW JFACC liaison team has proven its relevance and value to the Active Component by supporting MEF/MAW needs and continuing to contribute to the OIF and OEF fight. This team, built primarily with senior postcommand officers, brings a broad range of depth and experience to any fight. Though senior, this level of manning is critical to maximizing value to both the CFACC and MEF/MAW commanders' efforts. Training and continuity requirements make this critical capability inherently well-suited to the Reserve Component, and 4th MAW intends to continue to develop and man the JFACC liaison cell with the most experienced and trained personnel available.



Airborne Recon Supported Marines' Advances in Iraq

by Lieutenant Colonel Lawrence R. Roberts and Major John P. Farnam

U.S. Naval Institute Proceeding, June 2004.

Close coordination among Marine air controllers, strike and reconnaissance aircrews, and their joint and coalition partners enabled decisive realization of Marine Air Group 11's objectives in Operation Iraqi Freedom—which included knocking out Iraqi artillery batteries capable of firing at long ranges.

For decades, Marines jealously have guarded Marine fixed-wing aviation for the near-exclusive use of the Marine air-ground task force commander. Operation Iraqi Freedom (OIF) was no exception. As the war progressed from planning to execution, the maneuver commander had an impressive and at times overwhelming amount of coalition air supporting his scheme of maneuver. It was the coordination and employment of this “unbriefed” coalition air by Marine airborne forward air controllers (FAC[A]s) that helped speed the advance of the 1st Marine Division (1stMarDiv) toward its objective.

1stMarDiv's movement to Baghdad during OIF leveraged the abundance of coalition fixed-wing aircraft by capitalizing on the capabilities of the F/A-18D and its two-man crew. Improving on the lessons of Operation Desert Storm, a flexible and high-initiative air plan was used throughout the I Marine Expeditionary Force (I MEF) battle space. Experienced Marine F/A-18D aircrews, each composed of a pilot and a weapons and sensors officer armed with in-depth knowledge of the ground scheme of maneuver, controlled land- and sea-based joint and coalition tactical aircraft (TacAir) to establish and maintain the condition required by 1stMarDiv to achieve its objective. (The average flight experience of the pilot and weapons and sensors officer of a FAC(A)-qualified crew in Marine Fighter Attack Squadron [All-Weather] 533 was 1,560 hours.) F/A-18D FAC(A) and strike coordination and reconnaissance aircrews (SCARs), representing the most seasoned and capable aircrew of Marine Air Group 11 (MAG-11), were a crucial element in ensuring the Marine command-and-control system supported rapid and decisive maneuver.

The drawdown of the U.S. armed services since Desert Storm made it more important for TacAir to support ground maneuver efficiently. Planning for OIF centered on this fact and limited the maneuver force to a two-division force supported by 50% fewer TacAir squadrons than in Desert Storm. A highly maneuver-dependent ground force, lack of a significant air shaping campaign (which establishes battlefield objectives, such as reducing air defenses to an acceptable level or destroying or damaging enemy forces to a certain percentage of effectiveness), and enemy disposition and structure demanded a high-initiative air plan. Built around flexible employment of joint and coalition air and extensive use of armed helicopters, the air plan needed to ensure sufficient aircraft in the battle space at any given time to fulfill close air support (CAS), air control, and reconnaissance in support of maneuver units.

The 3d Marine Aircraft Wing (3d MAW) fixed-wing planner initially focused on maximizing fixed-wing sorties from the five MAG-11 squadrons based at Al Jaber, Kuwait, and the five Harrier squadrons based ashore and on board ship. While this is an important part of determining the sortie capability of fixed-wing aircraft operating from land and sea bases, it is only one aspect. Planners did not consider the effectiveness of the sortie or the desired effects of the airframe. In addition, planners did not account for the large number of coalition sorties that would be available to the maneuver commander along with the 3d MAW fixed-wing sorties.

The flaw in this planning is the assumption that all fixed-wing sorties are equivalent. For example, in addition to its own weapons, an F/A-18D operating as a FAC(A) or SCAR has the potential to control many other sections of coalition aircraft performing close air support. Therefore, as OIF progressed, it became apparent that keeping air controllers airborne longer affected directly the ability of 3d MAW to manage coalition sorties in support of 1stMarDiv.

Preconflict Aviation and Ground Coordination

The threat of most concern to the division commander was Iraq's indirect fire capability. Relying heavily on former Soviet Union doctrine, the Iraqi military possessed a large number of artillery systems capable of firing chemical and conventional ordnance at ranges much greater than those of Marine artillery batteries. To offset this enemy advantage, Major General James N. Mattis charged 3d MAW and MAG-11 with finding and destroying enemy artillery units that could range friendly forces, while simultaneously screening the eastern flank of the division as it moved northwest toward Baghdad. To facilitate this mis-

sion and to provide high-initiative aviation fires, MAG-11 established relationships between Marine regimental combat teams and Marine F/A-18D squadrons. This put each of the three F/A-18D squadrons in direct support of a regiment during the first 36 hours of the conflict.

These relationship led to two of the most basic but crucial requirements for aviation support of a highly maneuverable and aggressive ground force: understanding the unit's scheme of maneuver and developing personal relationships among key leaders of the air and ground units. To ensure this, the F/A-18D aircrews met frequently with their respective combat team air officers, and less frequently with other key personnel (regimental commanders, intelligence and operations officers, and battalion commanders). These relationships naturally led to sharing of expertise between aviators and ground officers. In addition, regimental intelligence officers worked with squadron intelligence personnel and imagery interpreters to template enemy positions according to Iraqi doctrine using current advanced targeting and reconnaissance system (ATARS) imagery. This practice identified large numbers of Iraqi defenses along the regiment's route of advance that previously were overlooked by MAG-11 photo interpreters.

Another benefit of this relationship culminated in the weeks leading to the commencement of OIF as MAG-11 supported Operation Southern Watch. Armed with the ground commander's concerns, objectives, and scheme of maneuver, F/A-18D squadrons heavily imaged each of the combat teams' areas of responsibility with ATARS and became visually familiar with regimental and division objectives. Aircrews identified and code-named geographic references that could be used by the regiment and squadron to facilitate rapid engagement of enemy forces. This relationship, established weeks in advance of OIF, proved vital during the chaos of the first day of the conflict.

MAG-11 Employment Plan

A number of conditions had to be met for Marine aviation to dominate the battle space in front of the division and set the conditions for a rapid ground offensive. First, squadrons had to understand thoroughly the ground scheme of maneuver. Then, MAG-11 squadrons had to adopt a 24-hour sortie flow. Finally, relationship between squadrons and supported regiment had to be strong enough that voice recognition and clear understanding of each other's requirements capabilities, and goals were the norm. These three themes led to the formation of a trusted-agent relationship between (FAC(A) aircrews and 1stMarDiv officers.

Twenty-four hour sortie flow allowed squadrons—most important, FAC(A)/SCAR aircrews—to build situational awareness on the battlefield that was passed from crew to crew as they relieved each other. A 24-hour flow distributed the individual squadrons' and Marine Air Group's daily sortie count over a longer period, requiring fewer aircraft (six instead of eight) to be in a flying status per squadron to meet air tasking order (ATO) requirements. This also gave individual squadrons the ability to provide spare aircraft for their ATO events, yielding higher completion rates.

An example of the effectiveness of this kind of relationship occurred on 20 March 2003, the day OIF commenced, as elements of 1stMarDiv were poised to cross the line of departure. Division intelligence sources reported 70-90- T-72 tanks moving toward Marine positions in Kuwait from Basra. Eager to confirm this information, the 1stMarDiv air officer and Regimental Combat Team 7 air officers used route code names and common geographic references developed during the planning process to focus the F/A-18D FAC(A)s' search of key avenues of approach for the reported armor. In return, FAC(A) used these same names and references to confirm or deny enemy activity along 1stMarDiv's routes of advance, to communicate rapidly where enemy activity was detected, and then promptly receive clearance to engage them with both aviation and indirect fire assets.

Recon Pull

Reconnaissance pull (recon pull) calls for reconnaissance forces to identify enemy weaknesses to be exploited by the main effort. To implement it—which calls for decentralized, integrated execution—the commander must ensure all subordinates understand his intent.

Once air superiority and supremacy are established, fixed-wing TacAir is a major contributor to recon pull. Fixed-wing TacAir is scheduled into the battle space forward of ground forces to confirm or deny enemy locations, and then to engage enemy units and capabilities before they become a threat to the ground forces. When required, fixed-wing assets can be pulled back or diverted by the airborne tactical air coordinator (TAC[A]), tactical air operations center (TAOC), or direct air support center (DASC) to meet close air support requirements that exceed the capability of attack helicopters. In effect, fixed-wing aircraft required for immediate close air support are "pulled" from the battle space rather than from a close air support stack. This concept maximizes the inherent capabilities of fixed- and rotary-wing assets, allowing attack helicopters to engage the enemy

within close proximity of friendly forces and satisfying most CAS requirements, while fixed-wing aircraft are engaging the enemy deeper in the battle space.

Marine TacAir's greatest contribution to recon pull in the joint/combined environment is the maximization of F/A-18D FAC(A)/SCAR aircrews and their battle management expertise. Joint and coalition aircraft often originate from locations that prohibit their crews from conducting the type of detailed integration described above. The combined effect is TacAir populating the battle space, each aircraft and crew acting as a sensor, to either engage or report on the plethora of mobile targets arrayed along 1stMarDiv's avenue of advance. Flowing aircraft forward, in particular FAC(A)/SCAR aircraft, instead of holding them in CAS stacks allows aircrew time to detect and engage enemy forces under complex and restrictive rules of engagement and collateral damage requirements. This tactic facilitated 1stMarDiv's bypass-and-isolate strategy and allowed aviation to reduce isolated enemy forces.

Perhaps the most beneficial outcome of a continuous presence by FAC(A)/SCAR aircraft was realized after the first week of OIF. F/A-18D FAC(A)/SCAR aircrew became natural extensions of the 3d MAW's tactical air operations officer and 1stMarDiv's direct air support center in providing control and coordination for coalition air in I MEF's area of operations. Once Iraqi air defenses were dismantled completely, large numbers of coalition TacAir and strategic bombers were available to support the MEF's area of operations and often were sent by the tactical air operations officer to Marine FAC(A)/SCAR aircrew for employment. However, coalition TacAir possessed little or no knowledge of friendly positions or ground commanders' intent, and were very hesitant to employ ordnance within the MEF's area of operations. When Iraqi formations were found in I MEF's area of operations by FAC(A)/SCAR aircrew, or by sensors, such as unmanned aerial vehicles and the joint surveillance targeting and reconnaissance system (JSTARS), FAC(A)/SCAR aircrew coordinated and controlled joint and coalition TacAir in destroying Iraqi forces.

The framework of the preconflict training enabled F/A-18D aircrew operating as FAC(A)/SCAR to employ rapidly and effectively large volumes of coalition air to support 1stMarDiv's scheme of maneuver. In effect, the Marine FAC(A)/SCAR aircrews became the hunters, finding and prioritizing targets; coalition air were the killers, employing ordnance under the control of Marine FAC(A)/SCAR aircrews. The resulting air presence afforded by multiple FAC(A)/SCAR aircrews allowed coalition TacAir to be leveraged, most often with first-pass success. During the 25 OIF FAC(A)/SCAR missions we flew, we controlled the delivery of 72 sorties of coalition TacAir in support of 1stMarDiv.

Examples of recon pull can be seen in aviation units' fixing and destruction of the sixth and tenth Iraqi divisions south of Al Amara, as well as the Baghdad and Al Nida Republican Guard divisions in Al Kut and east of Baghdad, respectively. In all cases, Marine FAC(A)/SCAR aircrews in F/A-18Ds controlled a multitude of Marine and coalition aircraft, ensuring their weapons most effectively engaged enemy targets.

Continuous presence—and therefore enhanced aircrew situational awareness—affords many benefits. During OIF there were no blue-on-blue engagements by aircraft under the control of Marine FAC(A)s. In one case, U.S. Army M-1 Abrams tanks inadvertently crossed a bridge over the Tigris River into the Marine sector in Baghdad. Ground terminal controllers in both sectors requested the Marine F/A-18D FAC(A) engage what they believed to be an enemy force. Before complying with this request, the FAC(A) applied his understanding of U.S. and Iraqi military tactics as well as his grasp of the ground situation developed by previous missions and decided to verify the position of U.S. forces through Marine, Air Force, and Army command-and-control agencies. His efforts identified the “enemy forces” as U.S. Army. In another instance, JSTARS cued a Marine FAC(A) to the location of a possible enemy armored column. The Marine FAC(A) was able to identify the possible enemy column as friendly because he recognized a difference in the tactical formation of the vehicles in comparison to Iraqi columns he previously had encountered. On hearing aircraft overhead, the column turned on their infrared identification aids and confirmed the FAC(A)'s suspicions.

During the planning for Operation Iraqi Freedom, General Mattis made his intent for aviation clear when he said 1stMarDiv would be the most air-centric division in the history of the Marine Corps. His success, to a large extent, depended on rotary- and fixed-wing aviation finding and fixing Iraqi units to speed 1stMarDiv's advance. The 3d MAW, in particular MAG-11, developed an aviation employment plan that met the division's needs. Recon pull and pull CAS were effective techniques and, more important, enabled 3d MAW to use the core capabilities of F/A-18D aircrew to leverage a large volume of coalition air to support 1stMarDiv's scheme of maneuver. F/A-18D FAC(A)/SCAR aircrews provided the critical element to enhance Marine command and control's ability to assimilate rapidly joint and coalition TacAir into the MEF. This method of employment allowed 3d MAW to attack, destroy, and influence the Iraqi military throughout the depth of the battle space. Recon pull enhanced the rapid advance of 1stMarDiv that led to the collapse of the Iraqi military.



Harrier Carriers Perform in Iraqi Freedom

by Lieutenant Commander Cindy Rodriguez, USN, Major Michael Manzer Jr., and Commanders Shawn Lobree and Jon Dachos, USN

U.S. Naval Proceedings, February 2004.

War is a catalyst for innovation. During Operation Iraqi Freedom, large-deck amphibious ships adapted to a new mission for which they had never trained—acting in an aircraft carrier role by conducting expeditionary strike warfare. These “Harrier carriers” increased the Navy’s warfighting options. Their mission modification capitalized on the ships’ multifaceted capabilities and recognized that naval expertise on board large-deck amphibious platforms, combined with Marine air assets, is a powerful force multiplier.

The Harrier carrier concept proved quite successful during Iraqi Freedom despite numerous operational challenges. Because this mission was never part of the interdeployment training cycle, amphibious airspace, ordnance sustainment, intelligence, and meteorologic and oceanographic issues all had to be addressed. How the Navy overcame these operational realities can point the way for future Harrier carrier operations.

Genesis of the Concept

The Harrier carrier concept was conceived in December 1990, as U.S. forces were preparing for the first war in Iraq. Twenty AV-8 Harriers embarked on the *Nassau* (LHA-4) and six on the *Tarawa* (LHA-1) deployed to the Persian Gulf for Operation Desert Shield. Lieutenant General Walter Boomer, Commander, U.S. Marine Forces Central Command, agreed to offload the *Tarawa*’s Harriers in Saudi Arabia, but opposed offloading the *Nassau*’s, arguing they would have better maintenance support and flexibility if left on board. The general understood the Harrier carrier at sea would be a force multiplier for the Marine air-ground task force.¹

Some were reluctant to rely on this unorthodox concept, and more traditional, proven strike assets—the carrier air wings’ A-6s and F/A-18s—were chosen to provide close air support. As a result, the *Nassau*’s Harriers did not participate until an amphibious raid was planned for Faylakah Island. On 20 February 1991, the *Nassau* finally launched her Harriers, and Marine Attack Squadron 331 flew 240 combat missions and dropped more than 900 bombs in support of battle area interdiction and close air support. During the final week of Desert Storm, the *Nassau* became the first LHA used as a Harrier carrier, with up to 60 sorties per day.²



Twelve years later, with war in Iraq again on the horizon, Amphibious Task Forces (ATF) East and West were stood up for deployment to the northern Arabian Gulf. Two amphibious assault ships were designated as Harrier carriers and equipped with 24 Harriers—the *Bataan* (LHD-5) and the *Bonhomme Richard* (LHD-6). In March 2003, the two task forces, which included seven amphibious big decks, unified under Rear Admiral W. Clyde Marsh, Commander, Task Force 51, in the Arabian Gulf.

This time the Harrier carrier met with more enthusiasm, and technological improvements made the LHD more versatile. On 19 March 2003, after receiving President George W. Bush's execute order, the *Bataan* launched her first AV-8 mission in support of Iraqi Freedom.

Operational Realities

The *Bataan* had to overcome several key challenges while operating as a Harrier carrier. Coupled with the chaos of a short-notice surge deployment, her crew had never trained for this mission. The only historical information came from a 1991 Center for Naval Analyses report on the *Nassau's* short stint as a Harrier carrier during Desert Storm. The report provided bomb stats and advocated increasing the number of Harriers on the flight deck from 20 to 24, but little else was applicable. In particular, there were few standard operating procedures for handling amphibious air space, ordnance sustainment, and intelligence and meteorological and oceanographic needs.

- *Overcoming Amphibious Air Space Constraints.* During war, maritime air space often is at a premium, and flight safety is paramount when ships are operating in a confined space such as the Arabian Gulf. When all the East Coast large decks were on station in their assigned operating areas near Kuwait, the air boss and air traffic controllers discovered they had to expand the amphibious carrier's air space when she is operating in close proximity to other amphibious ships flying Harriers. ATF East's three large decks (the *Bataan*, *Kearsarge* [LHD-3], and *Saipan* [LHA-2]) were operating within ten nautical miles of each other during the transit. Both the *Bataan* and *Kearsarge* carried a complement of Harriers, often resulting in overlapping traffic patterns. To alleviate this problem, all ATF East Harriers were consolidated on board the *Bataan*. When more than one amphib must conduct joint Harrier flight operations, a physical separation of at least 20 nautical miles must be established for air space deconfliction. In addition, a coordination frequency between all helicopter direction centers and air operations coordination centers is necessary to maintain safety of flight.

- *Sustaining Ordnance Resupply.* The *Bataan's* personnel understood the criticality of ensuring sufficient ordnance to sustain the Harrier carrier mission. Based on expected continuous heavy bombing, the ship's goal was to maintain a week's worth of aviation ordnance on board. By late February 2003, there were two fast combat support ships and one ammunition ship in theater, but they were tied to carrier battle groups and their ordnance was earmarked for air wing use.

Logistical staff officers explored several alternatives for resupply, including using stockpiled ammunition from ashore sources and resupply using Military Sealift Command break-bulk ships. Although connected replenishment from an ammunition ship was an option, the cramped deck space configuration at the single station available on an LHD is not conducive to rapid ammunition delivery. Another option tried was delivery using a dock landing ship (LSD) shuttle and air-cushion landing craft (LCACs), and this became the preferred means of resupply.

Acting as shuttle ship, the *Pearl Harbor* (LSD-52) received several ordnance replenishments from both the *Cape John* (T-AK 5022) and the *Cape Gibson* (T-AK 5051). The *Bataan* used an embarked MH-60 helo to support the vertical replenishment from the T-AK to the *Pearl Harbor*.

The ordnance typically then was moved from the shuttle ship's flight deck to her well deck, and loaded on an LCAC from there. LCACs carried up to 50 pallets of aviation ordnance, and tarps were used to keep the ordnance dry. Bringing two aviation ordnancemen and two fork trucks with them to expedite loading, the LCACs then shuttled the ordnance to the *Bataan*. Because delivery through the well deck did not affect flight operations, ordnance supplied by LCACs gave the Harrier carrier the greatest operational flexibility.

- *Solving Intelligence Issues.* Because they were designed to facilitate amphibious ready groups, LHA/LHD joint intelligence centers (JICs) are not concerned with strike operations. However, in choosing the *Bataan* to embark the AV-8s, the Navy serendipitously chose the JIC best suited to support a Harrier carrier.

Prior to reporting to the *Bataan*, the ship's intelligence officer had completed a tour at the Naval Strike and Warfare Center where she was head of its Strike Cell Division. She already was advocating strike warfare on board amphibians and had obtained a Tactical Operational Scene 400 unit specifically for the JIC. She also had portable flight planning software installed on computers in the JIC and trained the majority of her intelligence specialists (ISs) on its use. Quite coincidentally, the *Bataan's* JIC already had a plan in place to stand up an expeditionary strike intelligence cell (ESIC) approved by the commanding officer. This plan, Tactical Operational Scene, and portable flight planning software were critical to quickly establishing an ESIC capable of meeting the needs of Marine AV-8s. Most important, the *Bataan* was able to rapidly establish an ESIC because of the federation of intelligence among the JICs of ATF East.

The federation among the JICs proved vital to successful Navy/Marine intelligence support of the war. To mitigate information overload and duplication of effort, collection and reporting taskings were shared among all seven of Task Force 51's JICs. This solidified the team concept, reduced Fifth Fleet overhead, and eased the burden of daily intelligence requirements for undermanned JICs (such as those on board the *Bataan* and *Saipan*, which were not yet plussed up to 24 ISs). Imagery requirements also were federated to distribute the exploitation workload. Briefs, complete with notes, were pushed to the *Bataan's* JIC throughout the day. In addition, any significant threat information was passed via e-mail and chat. These processes ensured timely and pertinent information was briefed during the commanding officer's daily operations/intelligence brief. They significantly lessened the *Bataan* JIC's workload and ensured it could monitor threats to the ship instead of committing hours to research and building PowerPoint briefs.

To establish a strike cell, 6 of 15 intelligence specialists were carved out of the JIC and integrated with 6 Marines, their captain, and the ship's intelligence officer to man the ESIC. Cooperation was key since no one had worked together before, and hardly anyone had conducted real-world targeting. Because of time constraints, it was not possible to send personnel to schools prior to deployment. Personnel received on-the-job training on writing mission reports, debriefing pilots, and reading ground order of battle from imagery and Lightning Pod video. There was a steep learning curve, but effectiveness improved over time. One of the advantages the JIC had was that the majority of its ISs had completed a combat deployment just eight months earlier during Operation Enduring Freedom. They were seasoned veterans, which made them more flexible in dealing with both new mission requirements and the extra workload brought on by the ESIC and war. The Imagery Processing Intelligence Center became the heart of the ESIC. Its analysts became adept at providing imagery, selecting targets, and mensurating them via the Joint Service Imagery Processing System–Navy. They also analyzed AV-8 Lightning Pod video and provided bomb hit assessment, which was critical to battlefield commanders.

- *Minimizing the Effects of Wind and Visibility Problems.* Accurate forecasting was vital to getting aircraft safely on and off the night deck, and technology and experienced weather forecasters on board the *Bataan* greatly mitigated the effects of weather flight operations. The most critical meteorological parameter for the *Bataan* during Iraqi Freedom was visibility: 103 combat missions on five days were canceled because of reduced visibility. On these occasions, the *Bataan* was engulfed in dust storms so dense it was impossible to see beyond a few feet. While operating in the northern Arabian Gulf, weather forecasters discerned two patterns: frontal passage from February through April produced 11 dust storms; and southwesterly winds and remnants of afternoon thunderstorms over central Saudi Arabia advecting dust over the northern Gulf. Dust storms were accurately forecasted and briefed, resulting in zero weather-related mishaps and no aircraft being stranded at divert fields.

Another parameter for launching AV-8s was wind. To launch, combat-loaded Harriers require up to 30 knots of relative wind down the deck. Accurate microscale wind forecasts were critical to timely launches and enabled the officer of the deck to set up launch and recovery patterns in advance, to anticipate and account for changing wind conditions and thereby optimize the finite sea room assigned. Distractions in the assigned operations area, including heavy vessel traffic, anchorage areas, shoal water, and oil platforms, made it vital for the ship to get the required winds to launch the aircraft on the straightaway. In April, thermal heating of land had more of an effect on winds, as sea breeze and land breeze circulations developed. When the sea breeze condi-

tions set up, the winds on the western side of the operational area were different from the eastern side. This forced a change in course and/or speed, reducing the already small 12 nautical mile leg even further.

Striking Power of the Harrier Carrier

The Harrier carrier concept is intriguing, but is it an option for providing more fire power for the Navy? The numbers speak for themselves. The *Bataan's* Harrier squadrons dropped more than 122 tons of ordnance, most of which was laser guided. More than 470 targets were eliminated, helping to defeat three Republican Guard divisions. Together, the *Bataan* and the *Bonhomme Richard's* squadrons expended more than 250 tons of ordnance, damaging, destroying, or removing from the fight some 1,200 targets.

Another advantage of the LHD is her inherent flexibility and adaptability to meet evolving missions. Before launching Harriers into battle, the *Bataan* carried major combat elements of Regimental Combat Team II from the East Coast to the fight, including 1,900 Marines, 175 vehicles, 270 tons of cargo and equipment, and hundreds of pallets of ground ammunition. She proved an LHD can deliver a Marine expeditionary unit, then rapidly reconfigure into a Harrier carrier for added strike capability. Both missions were done successfully in a wartime environment without loss of life, aircraft, or equipment.

Recommendations

- *Harrier Carrier Relevance to the Expeditionary Strike Group.* Combat proven in two major conflicts, the Harrier carrier is vital and relevant to the expeditionary strike group (ESG). Although the Navy and Marine Corps likely will continue to have a mission to maintain a traditional Marine expeditionary unit (special operations capable) capability, the Harrier carrier concept should become a mission-essential training task and a required operational capability for all ESGs.

Amphibious ready groups have been required to practice certain contingency operational capabilities during predeployment training (such as emergency landing of a Harrier on an amphibious transport dock or dock landing ship; amphibious assault ship refueling alongside; LCAC safe haven in amphibs, etc.). In addition, each ESG amphibious assault ship should practice loading out and operating as a Harrier carrier so she can be an option for forward-deployed expeditionary forces, should the need arise. A pack-up kit to support a Harrier carrier also should be developed for deployed ESGs.

- *Future Weapon Development.* To ensure the Harrier carrier capability is executable while new technologies are being developed, it should become a practiced mission for both the Amphibious Assault Ship (Replacement) and the Joint Strike Fighter. By making it an objective requirement, inserted into the operational requirements document for both platforms, the concept will not fade away and both programs will include it as is a serious possibility for future conflicts and plan accordingly.

- *Future JIC Support.* Because of the many missions a JIC must support, an expeditionary strike intelligence cell is not a viable permanent element. It is more a capability among other competing capabilities that JICs must be able to perform whenever the need arises. Unfortunately, it is also a perishable capability that must be constantly trained and honed. Doctrine and operating procedures for JICs must be developed and implemented. West Coast JICs already have done this, and the East Coast must follow suit. Because platforms and forces from both coasts may one day operate together again, doctrine and procedures should be standardized.

Iraqi Freedom was a sneak preview of a mission that is fast becoming a requirement for JICs—supporting strike operations. JIC must continue to train and equip their personnel with the latest strike technology. Early training and integration with their Marine air counterparts is paramount for further success. If they follow these recommendations, JICs will be ready to establish and support another strike cell on short notice in defense of U.S. interests.

Final Thoughts

Transformation recognizes the need for a meaner, leaner military to respond to emerging threats. Using large-deck amphibious carriers as strike platforms undoubtedly adds flexibility to a Navy hard-pressed to face a larger number of volatile threats in the post-Cold War era. Harrier carrier also can reduce the load borne by today's heavily tasked aircraft carriers. To capitalize on this capability and ensure its flawless execution, doctrine should recognize and incorporate the Harrier carrier concept. Training should be modified to reflect this

new capability, and it should become standard procedure for future operations. This will ensure amphibious carriers are prepared to carry out this vital new mission the next time it is needed.

¹ Marvin Pokrant, *Desert Shield at Sea* (Westport, CT: Greenwood Press, 1999), pp 207-8.

² William F. Morgan, "USS *Nassau* (LHA 4) and VMA 331 Strike Operations during Operation Desert Storm," CRM 91-140 (Alexandria, VA: Center for Naval Analyses, June 1992), p 1. Document is now declassified.



Close Air Support in the U.S. Marine Corps: A FAC's Perspective

by Major Donald S. Hawkins

Marine Corps Gazette, September 2003.

The close air support (CAS) battle at An Nasiriyah started at approximately 0500Z on 23 March when Company A, 8th Tanks, as the lead element for 1st Battalion, 2d Marines, 2d Marine Expeditionary Brigade (Task Force Tarawa), executed an opposed rescue of Army personnel in a convoy ambushed south of the city. Marine air continued to provide heroic and uninterrupted CAS to the battalion for over 36 hours during our succeeding assault through 'Ambush Alley,' the capture of the two bridges, and the consolidation north of the city.

In the middle of the engagement the Iraqi T-55 tank exposed itself to the Cobra working with the ground forward air controller (FAC). Smoothly shifting targets from the dismounts firing on the ground elements, the Cobra engaged the tank with a Hellfire missile. Shortly after the missile left the rail it went "stupid" and missed the target. Still unaware of the Cobra's presence the enemy tank continued its advance toward the Marines on the ground. Immediately the FAC directed the Cobra to designate the target and instructed the Hornet orbiting overhead to drop a laser-guided bomb. The Cobra pulled hard right, stabilized, and painted the tank for the Hornet pilot who immediately called inbound with the spot. Just as the Hornet rolled "wings level" out of the west an urgent call from the command track came over the radio, "ABORT! ABORT! ABORT!" The FAC relayed the order, and the Hornet pulled off the target without dropping. Now aware of the threat, the T-55 pulled back into the tree line near the industrial complex where the Cobra pilot lost visual contact.

When asked why the decision was made to abort the aircraft the FAC was informed that there were counterbattery fires (that the FAC knew about through the fire support team (FiST) leader) being shot approximately 6 kilometers east and 12 kilometers north of the tank's location. Because there was confusion over where the gun target line was located the fire support coordinator (FSC) called for the abort. With the threat of an enemy tank still on the battlefield trying to kill Marines on the ground, the FAC immediately instructed the Cobra to coordinate the drop of the Harrier's ordnance along the tree line in an attempt to kill the tank and address the fires coming from that area.

As I am sure you realize, this scenario, unfortunately, is not a page from a poorly written war novel. It is a factual accounting of the events I experienced as the FAC attached to 1st Battalion, 2d Marines, Alpha Company, 8th Tanks. We were attempting to kill an enemy tank that was trying to kill us on 23 March south of An Nasiriyah, Iraq during a rescue of ambushed Army personnel.

At this point, to those of you who are shaking your heads in disbelief, let me point something out. The officers in the command track did nothing wrong. In fact, they did exactly what they were trained to do. They had even practiced their trade at a Combined Arms Exercise (CAX) less than 6 months prior to the war. Prior to departing the assembly area it was made clear that we would conduct fire support coordination exactly as it is conducted at CAX. The fire support coordination techniques that they used were in strict compliance with the current policies and procedures with which we train.

For those of you who wonder why I raise this as an issue, realize that while the concepts of "silence is consent"¹ and "the FiST controls the indirect fires and CAS" may still be contained in our formal doctrine, they have been effectively "washed" out of our training. In practice, indirect fires and CAS must be verbally approved by the FSC prior to execution.

It is also quite right to point out that the Marine Corps does not presently subscribe to the "big sky, little bullet" theory. However, does the actual threat of shooting down one of our own aircraft really require us to obtain the FSC's overt approval for every engagement?

So, for the sake of discussion let me pose these questions and offer up some personal observations: (1)

What about the threat to the lives of the Marines on the ground? That was an enemy tank (not a tire stack), and its mission was to kill us. Where does protecting the lives of the Marines on the ground weigh in on the risk analysis? (2) Unlike a stack of tires, enemy tanks and dismounted infantry do not expose themselves and then cooperate by sitting still in one place for 30 minutes while everyone pulls out their high-speed plotting boards to put together a “quick fire plan.” (Quick fire plan plotting boards don’t work well in military operations on urbanized terrain or when operating from a tank or in an assault amphibious vehicle (AAV) or when being shot at in general.) (3) Unlike a stack of tires, enemy tanks and dismounted infantry do not expose themselves and then cooperate by sitting still while the FAC puts together a pristine nine-line brief and reads it to the air officer over the tactical air control party (TACP) local net for approval before he reads it to the pilot over the tactical air direction net. (4) I never used a nine-line brief in Iraq. In each engagement we used the “team building approach” whereby all of the “players” (FAC, rotary-wing pilot, fixed-wing pilot) quickly worked together to build each other’s situational awareness, develop a plan, and execute the plan as soon as possible. (5) Suppression of enemy air defenses (SEAD) sounds good in the manuals, but let’s face facts. Just doing the basics in a combat environment can be challenging enough for artillery. Furthermore, if the artillery can suppress the target, why not just fire for effect and kill it. (6) The AH-1, UH-1, and the A-10 are invaluable tools for the ground FAC to use to increase situational awareness, coordinate CAS, and engage close-in targets. (What I would have given for an OV-10 overhead!) (7) The formalization of the FiST with a designated leader is one of the best things to have happened since 1990. Now the question is, who is in the best position to coordinate the placement of integrated fires—the FiST, with eyes on the target, or the FSC buttoned up in an AAV without eyes on the target?

Fellow Marines of the CAS jury, I submit that procedurally how we as a Marine Corps execute CAS at the infantry or tank battalion level needs a serious examination. I submit to you that we now have two recent, albeit short, wars under our belts, and both suggest that it is time for a change.

Now this is the part of the dissertation whereby, after identifying the issues, I am supposed to offer up some profound guidance as to what the solution(s) should be. Well, why not? This is my account, and I am already in deep so here goes.

Here are my suggestions. (1) We need to embrace silence is consent and let the FAC and the forward observer (FO) fight the close air and indirect fires battle at the company level in accordance with the directions provided by the FiST leader or the company commander. In all honesty, how many times have we seen the FSC effectively control fires in a timely manner in the air conditioned combined arms staff trainer at Camp Lejeune? What logic says that the FSC magically becomes more efficient in the fog of combat? I submit to you that the company commander, the FiST leader, the FO, and the FAC know how to kill the enemy in their sights better than someone buttoned up kilometers away from lead trace. Even if you have communications with the FSC (not guaranteed in combat), the less chatter on the radio the better. (2) Let’s remember that the mission is to “locate, close with, and kill the enemy by fire and maneuver” not locate, close with, and plead for approval to kill the enemy. This becomes much more important when the enemy is actively pursuing its mission, which is to locate, close with, and *kill* Marines. (3) Retire the nine-line brief. Establish procedures for using the team building approach to conducting CAS. Emphasis should be placed on knowing and understanding the various weapons systems and their capabilities to support target acquisition and designation.² (4) Cease pouring money into the target location designation handoff system (TLDHS) program. That system is based on the obsolete nine-line brief, initial points, control points, etc. I used the TLDHS system to control Harriers in a demonstration at Quantico prior to departing to join my unit in Kuwait. I was not impressed. Put the money into building a system that simply identifies and transmits the FAC location and identifies and transmits the target’s 10-digit grid coordinates to the aircraft without all the flimsy wires and multiple components. Package the unit in something as small and portable as a pair of binoculars.

The rationale for wasting any further time and money on the current TLDHS system can’t be because it is “better than anything we already have in the fleet,” because it is not. A trained Marine FAC with a radio and a map is better than the TLDHS hodgepodge of electrical components and software represented in the *Marine Corps Concepts and Programs 2003* publication. (5) Increase training in the use of global positioning system

guided munitions in the close-in fight. Refer to item (4). (6) Retire the concept of SEAD—front door, back door, red, blue, dislocated, collocated, etc.—just let the artillery go out there and engage and kill targets. They have enough going on with shooting, moving, communicating, and responding to radar guided counterbattery fires (which they thankfully do very well by the way). Let the FAC and the FO decide how to work the air around, over, or under the artillery if necessary. (7) While I am at it, let's just give up on thinking that the high-frequency (HF) radio will reliably talk to the direct air support center (DASC) located miles away on the ground. The unsecured HF does not reliably work at CAX. Why should we fool ourselves and think that HF will reliably work in combat? Let's adopt a doctrine whereby the DASC (or a reliable repeater) is always airborne where very high-frequency and ultra high-frequency (UHF) communications work. Better yet, let's just adopt secure satellite communications for this purpose. We have endured this Achilles' heel long enough. It is time that current technology comes to this function.³

By now I am certain that it's obvious I don't write for a living, nor am I a graduate of any of our advanced warfighting institutions. I am simply a FAC who went to TACP school in 1990 and has seen us conduct CAS in a much more effective manner. Thirteen years later I find out the hard way that the practical application of our doctrine has evolved in a direction that is not the most efficient way of doing business when the tire stacks start shooting back.

Fortunately, it is still abundantly clear that we remain the premier Service when it comes to CAS directly integrated with our indirect fires and ground maneuver. From the aviation perspective, the heroics of the AH-1, UH-1, H-46, AV-8, F-18, and A-10 pilots I controlled on 23 March and subsequent days prove that argument. The purpose of writing this article is to promote a serious review of our systems, policies, doctrine, and procedures as it relates to CAS in the Marine Corps so that we keep our edge.

¹ Silence is consent was once a practiced coordinating technique in which the FSC and the supporting staff (air officer and artillery liaison officer) monitored the radio circuits and *only* came on the net if necessary to avoid fires into known friendly positions or to provide assistance to the FiST. All fires called for by the FO and the FAC were considered approved unless the FSC or one of the supporting staff interceded.

² There were no control or initial points designated in Iraq suitable for use in a nine-line brief that were ever made available to this FAC.

³ In the battle at An Nasiriyah, the FACs were reduced to calling for CAS using the UHF "guard" frequency because HF once again was not working when we needed it.

Part IV

Combat Service Support





MLC: Sustaining Tempo on the 21st Century Battlefield

by Brigadier General Michael R. Lehnert and Colonel John E. Wissler

Marine Corps Gazette, August 2003.

The Marine Logistics Command came of age during Operation IRAQI FREEDOM putting velocity and endurance into the logistics support operations for I MEF.

The Marine Logistics Command (MLC) concept was born in the sands of Saudi Arabia during Operations DESERT SHIELD and DESERT STORM when 1st and 2d Force Service Support Groups (FSSGs) provided general support and direct support (DS) logistics support to I Marine Expeditionary Force (I MEF). As the Marine Corps began innovative thinking regarding operational logistics, it became apparent we needed an organization that could function at the operational level of war and provide both the interface with theater logistics organizations and a tactical linkage to Marine Corps forces in theater. Thus, the MLC manages the resources necessary to sustain the operational tempo of the modern campaign and extend Marine Forces' operational reach to distances more in keeping with the tenets of expeditionary maneuver warfare and advanced seabasing. Coming of age in the sands of Kuwait and Iraq, the MLC allows the warfighter to focus on the near battle.

In December 2002, elements of 2d FSSG assumed the operational logistics mission of the MLC and deployed to the U.S. Central Command area of operations—operational control to Marine Forces Central Command (MarCent)—in support of Operations ENDURING FREEDOM and IRAQI FREEDOM (OIF). 2d FSSG task organized a lean, functionally aligned 4,500-Marine and sailor organization that became the MLC. Maintaining its function of wholesale support, asset control was centralized and highly directive in order to fulfill specific sustainment requirements. After mission analysis reflected that 8th Engineer Support Battalion and 2d Medical Battalion were more likely to be used in a tactical role, they were chopped to I MEF to enhance their functional depth. Functions that could be accomplished by reachback, like disbursing and personnel administration, were not deployed.

MLC had one customer (I MEF) and one boss (MarCent). As the operational logistics organization, the MLC supported all Marine forces in Kuwait and Iraq and became the flexible link between strategic and tactical logistics. The role of the operational logistician is fluid and demands continuous operational assessment and thorough mission analysis. It means expanding the limits of the possible by employing initiative, creativity, and adaptability in

the design and execution of logistics activities.

The MLC executed the following specified tasks in support of Marine forces in theater:

- Provided landing force support party for multiple maritime prepositioning ship squadron (MPSRon) offload.
- Provided operational logistics support.
- Coordinated combat service support (CSS)/common item support (CIS) and common user land transportation assets with the theater logistics command.
- Planned and executed regeneration, reconstitution, and redeployment operations to include port operations supporting follow-on shipping.

Initially, MLC focused on setting conditions for battlefield success through early arrival and executing reception, staging, onward movement, and integration (RSO&I) so that the DS CSS organization (1st FSSG) could occupy their tactical positions and support other elements of I MEF.

Simultaneously, MLC established Logistics Support Area (LSA) Fox, carving a 50-square-mile, 5,000-man camp complete with hardstand, warehouses, improved roads, seven self-contained subordinate camps, and the largest field ammunition supply point in the history of the Marine Corps from a patch of desert defined by a single, untrafficable dirt track.

Upon arrival in theater, MLC focused on RSO&I while Marines from both MLC and I MEF completed the MPSRon offload of 2 squadrons, 13 black bottom ships, and 18 amphibious vessels, shortening doctrinal timelines by almost 4 days. This once more confirmed that the maritime prepositioning force concept is flexible and provides rapid expeditionary combat capability to the geographic combatant commander.

Early planning inaccurately assumed the Army would provide for CSS/CIS requirements. Often, Army and Marine combat units arrived before their organic logistics support, and although not planned, the lack of Army line haul and other logistics units required the Theater Support Command (TSC) to become the alternate, vice primary, means of line haul and theater-level transportation support. MLC became the primary source for Marine Corps battlefield distribution and CIS. Theater common user land transportation assets were available only after MLC assets were completely committed. This process left the MLC no reserve for emergent requirements or distribution targets of opportunity. Bridging the requirements gap, MLC contracted over 300 cargo and fuel tanker trucks including drivers from 14 different countries. Heavy-lift requirements were sourced from the TSC; however, without coalition forces land component command priority of effort, Marine forces received only a small allocation of Army heavy lift during combat operations.

The extended battlespace and limited theater line haul support demanded MLC contract host-nation support to provide services and support functions unavailable via Service or joint channels. Expeditionary contracting provided operational flexibility, freeing contractable occupational specialties to serve in other capacities. For example, every MLC cook became a rifleman as we contracted all meals, freeing most cooks to serve as ride-along security for contracted drivers crossing into Iraq.

During decisive combat operations, the MLC ground lines of communications extended over 400 miles. MLC provided DS logistics support to I MEF units in Kuwait and pushed logistics forward to 1st FSSG using every transportation means available including Marine Corps tactical trucks, Army line haul, contracted Third Country National (TCN) driven vehicles, C-130 (Marine Corps, British (UK), and U.S. Air Force) air delivery, and rotary-wing aircraft (Marine Corps, Army, and UK). Most supplies were distributed on the “push” system; however, critical supplies and emergent “pull” requirements were invariably flown due to extensive distances and compressed time frames involved.

Fuel resupply became critical to maintaining battlefield tempo. Both I MEF and MLC used every Marine Corps tactical refueler in theater. MLC alone leased an additional 39 8,400-gallon commercial refuelers to meet the voracious fuel appetite of a mechanized force on the move. Average daily fuel usage in the MEF was 450,000 gallons. Supplying this monumental requirement was accomplished through a well-developed fuel plan and around-the-clock line haul of fuel from both 1st FSSG and MLC refuelers. As part of the plan, 1st FSSG established a hose reel system moving fuel over 130 miles into southern Iraq. This hose reel system supplied the northernmost fixed fuel site for both the MEF and the U.S. Army early in the war. In all, MLC delivered over

4 million gallons of fuel in Kuwait and Iraq, and more than 2.6 million gallons to LSAs in Iraq.

Battlefield distribution of sustainment demanded full use of every air and ground delivery platform available. Often 100 percent of MLC vehicle assets were in use on any given day with an average convoy size of 60 vehicles. Large convoys and the need to execute around-the-clock operations placed drivers at a premium. Despite deploying with every available organic driver, the driver to vehicle ratio was far below the 1.2 to 1 required for sustained 24-hour operations. Headquarters Marine Corps globally sourced over 200 additional drivers to meet this need, and the use of reservists who were professional truck drivers, incidental drivers, and TCNs filled the critical driver shortfall.

Air transportation, both fixed-and rotary-wing, was used to move critical repair parts and supplies. The value of Marine aviation and its expeditionary capability to add velocity to logistics can't be overstated.

With the constant movement of large convoys through lightly secured areas, force protection was a challenge. Most logistics nodes could only be reached by passing through nonpermissive areas inhabited by bypassed enemy units of up to company size. Organic, hard skill CSS military occupational specialties and 2d Military Police Battalion Marines provided convoy security to include force protection for Army assets assigned to MLC missions. Without both, MLC would have had significant problems defeating the threat and completing the battlefield distribution mission.

Communications over non doctrinal distances were challenging. FSSGs are not organically equipped to provide command and control over the long distances experienced on the OIF battlefield. The best means of communicating with—and locating—logistics forces was the blue force tracker (BFT), but MLC possessed only three systems. In addition to the BFT, Iridium modem trackers provided an alternate means for convoy tracking when more than three convoys were deployed. Iridium cell phones provided the most immediate means of long-distance communications, yet they experienced only a 75 percent to 80 percent success rate due to climatic conditions and other impediments. Tactical satellite with ViaSat software proved exceptionally valuable, but required about 10 minutes in a stationary position before communications could be established.

Salvage operations became vital to the continued flow of sustainment in both the near and long term. With several hundred combat destroyed principal end items (PEIs), movement to collection points became critical to supporting the regeneration of major end items for all Marine units. Recovery operations became a true task force operation with security, lift, and explosive ordnance demolition support all required for safe recovery. Immediate recovery was essential as abandoned vehicles were stripped and burned in less than 20 minutes. Employment of trail maintenance in every MLC convoy prevented the loss of vehicles to this most immediate destruction.

Rolling stock was at a premium as many I MEF battlefield distribution assets were often detained at the delivery point, reducing the available pool of assets for tactical delivery. As I MEF units pushed to Baghdad, an MLC convoy commander could expect to be on the road for 2 to 5 days before returning to LSA Viper, the hub of MLC battlefield distribution in Iraq.

MLC used integrated logistics capability (ILC) maintenance concepts throughout OIF and task organized core capabilities among the various MLC nodes to maximize timely response and full-spectrum repair capability. Task Force Pegasus, (2d Transportation Support Battalion (Minus) (Reinforced)) (2d TSB) is perhaps one of the great success stories of ILC maintenance. Vehicles inducted into maintenance received bumper-to-bumper attention, but perhaps more important, returning convoys were serviced by line mechanics while drivers slept in preparation for the next convoy. Mechanics swarmed on vehicles, performing preventive and corrective maintenance, registering continued MLC readiness rates over 90 percent throughout the war. The close relationship developed with line mechanics attached to 2d TSB, combined with the expertise developed through a single, centralized maintenance capability, resulted in superior readiness.

Further testimony to ILC's success was resident in MLC's maintenance battalion repairing over twice the number of PEIs with approximately one-half of the personnel during OIF compared to average peacetime statistics. Additionally, maintenance battalion owned secondary reparables and maintained an unheard of 86 percent fill rate through aggressive use of their deployed general support maintenance company. The ILC concept for maintenance works well in garrison and works even better in the field, and the refinements in CSS migration

initiated before OIF proved invaluable in combat operations.

During OIF, MEF sustainment was critical, and the volume of support provided was staggering. MLC supply filled nearly 65 percent of over 108,000 demands, issuing over 143 million pounds of ground and aviation ammunition and over 9.7 million meals, ready-to-eat. 2d Supply Battalion ran a combined map facility with British coalition forces and issued over 330,000 maps. Perhaps most vital to the entire effort, contingency contracting executed over 600 contracts for services and material totaling over \$115 million. Contingency contracting was a huge success, and this capability was often the difference between failure and victory when organic resources could not bridge existing requirements.

In-transit visibility of repair parts, both inter- and intra-theater, was not acceptable during OIF. Visibility of material was only feasible when stopped at a distribution node. The MLC could not track in-transit repair parts, and it was particularly tough to identify lost or frustrated items. We desperately need a decent logistics command and control architecture and the bandwidth to support it.

So What Is Needed?

Good situational awareness of the logistics status of forward deployed units is critical. For the MLC, because of the length of supply lines, the problem was not what was required at the moment but what would be required 4 to 6 days in the future. Combining experience and a clear understanding of the scheme of maneuver is critical. The current and future requirement is for predictive operational logistics to anticipate the warfighter's needs. The MLC must drive this future focus because the near battle is well-handled by fellow Marine Corps logisticians in the DS FSSG.

We need one logistics information technology system for the entire Marine Corps and an end to Balkanization of different systems on different coasts and legacy systems that can't talk to one another. We need a commitment to test systems in the field first instead of developing optimized garrison systems and suboptimized battlefield systems.

We need one supply chain manager for distribution who controls the traffic management office functions currently firewalled in the Supporting Establishment. Processes for support of forces must be the same in garrison and on the battlefield.

We need to create one system for all classes of supply. The argument that any particular class of supply is fundamentally different reflects protectionism not progress. Medical supply support planning and doctrine requires a major overhaul. It must be integrated into the rest of the supply system and not managed as a stand-alone facet of sustainment.

We need the same command and control capability as any other element of the Marine air-ground task force, to include position tracking and long-haul communications.

Equipment

We need an institutional decision on how much line haul the Marine Corps should own. The logistics vehicle system must be replaced. It has been a great system, but it has reached the end of its service life. The medium tactical vehicle replacement, as good as it is, *cannot* sustain a MEF. Centralizing distribution assets provided most efficient use of resources, and the multifunctional transportation support company proved invaluable in battlefield distribution across all means—air, land, and sea.

Organization

If the Marine Corps is going to continue to fight inland, we need to organize for the fight. Total force line haul capability that can flow into the theater with ease and be reinforced by the activation of Reserves is vital to maintaining line haul distances in the ranges employed during OIF. We cannot institutionally rely on host-nation assets to meet our warfighting requirements, if for no other reason than they will not always be available.

The contribution of expeditionary contracting was well out of proportion to the number of personnel involved. Increasing the structure must be considered.

Reachback works. The need for consolidated administration and disbursing in the Operating Forces must be evaluated. Use of "civilian Marines" to perform this function in the Supporting Establishment should be considered.

Conclusion

The Marine Corps' ability to extend its logistics culminating point up to eight times the doctrinal distances is a success story for all Marine forces in OIF. The operational reach of the Corps is better than ever. Moreover, we can sustain the force over those distances, provided we are able to anticipate operational requirements. The key to future successes will be investing in the intellectual development of Marines, and accompanying organizations and equipment to create logistics organizations that can maintain velocity on the modern battlefield.





Brute Force Combat Service Support: 1st Force Service Support Group in Operation IRAQI FREEDOM

by the Commanders and Staff of 1st FSSG

Marine Corps Gazette, August 2003.

“Recently, GEN [Tommy] Franks (Combatant Commander, Central Command) visited with the staff of the I Marine Expeditionary Force (I MEF). After the standard brief and discussions, GEN Franks asked the MEF staff what the biggest success for the MEF was during OIF [Operation IRAQI FREEDOM]. Much praise was given to the successful use of combined arms, close air support, and those warfighting functions that one would assume are the ingredients for success on the battlefield. When it was LtGen [James T.] Conway’s (Commanding General (CG), I MEF) turn to provide his insight, he said one word . . . ‘LOGISTICS!’”

*—BGen Edward G. Usher,
CG, 1st FSSG*

The logistics that the I MEF CG identified is the delivery of combat service support (CSS) over some of the longest lines of communication (LOCs) and main supply routes (MSRs) ever traveled by Marine units. Upon the seizure of Tikrit, those LOCs and MSRs stretched nearly 600 miles. I MEF moved farther north than any other major subordinate command (MSC) in the Coalition Force Land Component Command (CFLCC). Without the right-sized, organized, and equipped CSS force, this would have been difficult. For the 1st Force Service Support Group (1st FSSG), it was all part of the plan.

Planning

Early in the planning for OIF, 1st FSSG recognized that its functional battalion structure was not suited for the mission of moving inland over long distances and supporting ground and air combat forces in Iraq. A more task organized type structure was needed. In particular, the need to provide direct support CSS to the 1st Marine Division (1st MarDiv), Task Force (TF) Tarawa (aka 2d Marine Expeditionary Brigade), and 3d Marine Aircraft Wing (3d MAW) was a necessity. Additionally, a general support CSS capability was required to support the MEF, as a whole, with the ability to echelon sustainment forward as the forces rapidly moved farther north. This was a break from the somewhat traditional practice of creating large and somewhat immovable supply dumps. Further planning brought to light the need for additional engineer,

motor transport, and military police (MP) capabilities. This all required a great deal of integration, both in planning and deployment.

The final result was 1st FSSG composed of elements of 4th FSSG and 2d FSSG, as well as echelon above corps (EAC) Army capability from the CFLCC. (See Figure 1.) From 4th FSSG in particular, 6th Engineer Support Battalion (6th ESB) and 6th Motor Transport (MT) Battalion in their entirety, as well as significant portions of Headquarters & Service (H&S) Battalion, 4th Landing Support Battalion (4th LSB), 4th Supply Battalion, and 4th Medical Battalion were attached to 1st FSSG. 2d FSSG provided most of 8th ESB and 2d Medical Battalion. U.S. Army units provided to 1st FSSG included the 716th MP Battalion, 319th Truck Company (petroleum distribution), the 727th Medium Truck Company (pallet load system), the 459th Multirole Bridge Company, and a variety of nuclear, biological, and chemical units. With the attachment of Fleet Hospital Three in the days just prior to the start of the war, 1st FSSG's total strength was over 14,000 Marines, sailors, and soldiers, truly emulating what the 1st FSSG Chief of Staff (Col Darrell M. Moore) liked to call the "largest FSSG ever assembled in wartime." In particular, the deployment of 6th ESB marked the first time in its history that the entire battalion had assembled for one operation.

In this organization, CSS Group 11 (CSSG-11), with three CSS companies (CSSCs) built around the transportation support companies of 1st Transportation Support Battalion (1st TSB), provided mobile direct support CSS to each regimental combat team (RCT) in the 1st MarDiv, as well as providing a general support CSS capability via CSS Battalion 10 (CSSB-10). CSSB-22, built around Marine Expeditionary Unit Service Support Group 22 (MSSG-22), provided similar mobile CSS to TF Tarawa. CSSB-13, whose headquarters was composed totally of the headquarters of 4th LSB, provided direct support to the 3d MAW. Their CSSCs provided direct support to both the rotary-wing (RW) and fixed-wing (FW) assets based in Kuwait, and general support

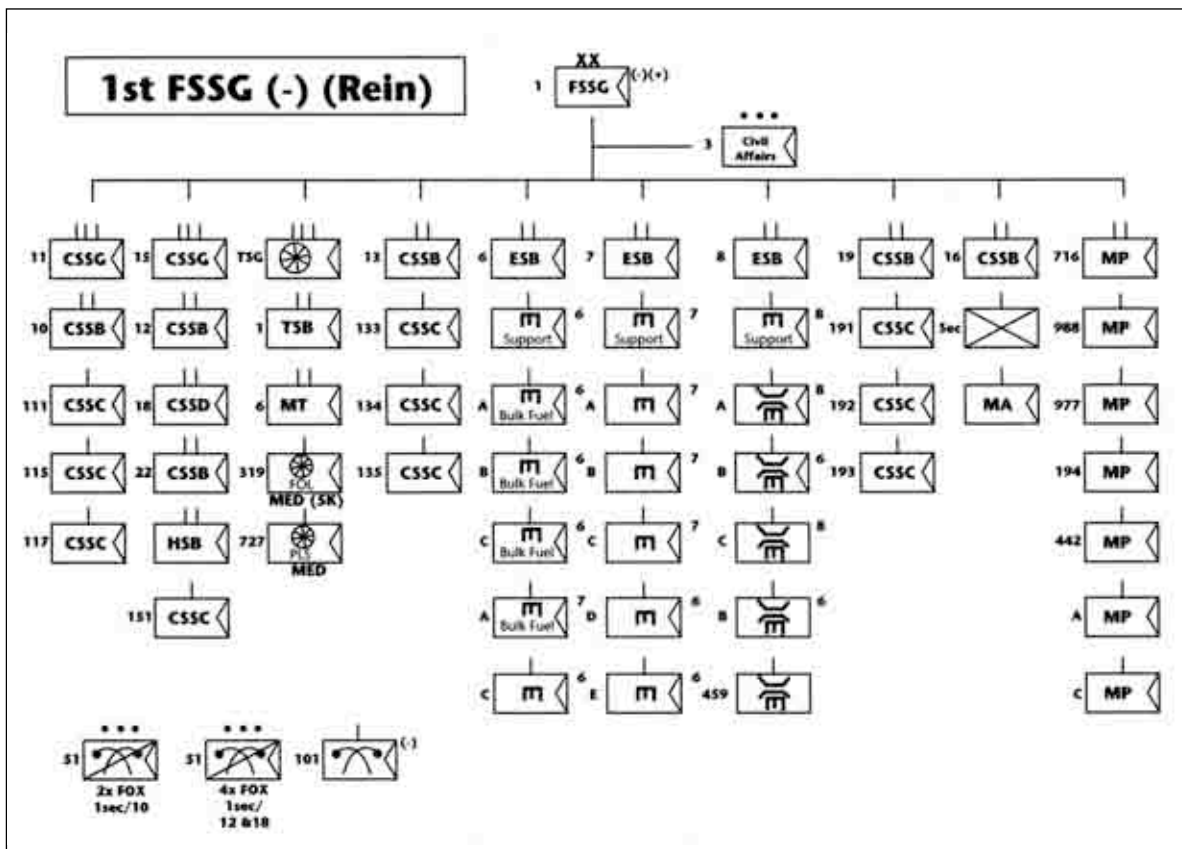

Figure 1. Expeditionary FSSG for OIF.

to both RW and FW assets operating from forward operating bases (FOBs) in Iraq. CSSG-15, whose staff was largely comprised of the staff of 1st Supply Battalion, provided the capability to echelon CSS forward to CSS areas (CSSAs) established in the vicinity of 3d MAW FOBs. The organizations conducting these CSSA operations were CSSB-12 (centered on 1st Maintenance Battalion) and CSSB-18 (centered on H&S Battalion). Health Services Battalion (HSB), composed of 1st Medical Battalion with the addition of two surgical companies each from 2d and 4th Medical Battalions, provided critical level two (surgical) medical capability by means of the surgical companies and forward resuscitative surgical systems (FRSSs) and shock trauma platoons (STPs) strategically placed across the battlefield. Transportation Support Group (TSG), with the headquarters of 1st TSB, provided general support transportation to I MEF via 6th Motor Transport Battalion and the EAC Army transportation assets mentioned previously, as well as the landing support capability found in the TSB. The three ESBs were “functionalized” along specific engineer missions based upon the critical engineer requirements of I MEF. 6th ESB conducted all bulk liquids missions (both fuel and water). 7th ESB was assigned the mobility, countermobility, and survivability mission. 8th ESB, possessing the only active duty bridge company in the Marine Corps, was assigned initially in direct support of TF Tarawa, then 1st MarDiv, to conduct the bridging mission. This functionalization also required cross attachment of engineer companies, bridge companies, and bulk fuel companies from all three ESBs. The 716th MP Battalion, consisting of four organic MP companies and MP Companies Alpha and Bravo of H&S Battalion, 4th FSSG, provided convoy security, maneuver and movement support operations along MSR, and enemy prisoner of war (EPW) operations. With the use of H&S Battalion as an operational unit, a headquarters capability was still required to provide support to the FSSG staff. CSSB-16 was formed just prior to the commencement of hostilities. Along with the standard H&S functions, CSSB-16 also possessed a security company that provided area security at established CSSAs and a mortuary affairs company that provided rapid and respectful personnel recovery and processing operations of remains. The lack of an FSSG reserve was filled by CSSB-19, using the existing personnel and equipment from MSSG-11 to conduct convoy security missions and support to EPW operations.

In addition to the internal planning and reorganization mentioned above, close coordination was required with the Marine Logistics Command (MLC) formed by 2d FSSG. Serving as the component logistics support element for U.S. Marine Forces Central Command (USMarCent), the MLC coordinated theater-level Marine logistics operations; coordinated and monitored the reception, staging, onward movement, and integration of Marine forces at the joint movement control center; coordinated port operations; and served as US MarCent representative for coordination with all Marine Corps service logistics providers. Teamwork with the MLC was the vital link to all external logistics support for I MEF.

As the main effort, CSSG-11 orchestrated the movement of CSS in direct support of 1st MarDiv via pre-planned repair and replenishment points (RRPs). CSSG-15, by virtue of CSSB-12 and CSSB-18, established CSSAs at Tactical Assembly Area (TAA) Coyote in Kuwait (CSSA Coyote), Jalibah Airfield (Logistics Support Area (LSA) Viper), in the vicinity of Ad Diwaniyah (Support Area (SA) Anderson), Qalat Sikar Airfield (SA Basilone), and An Numaniyah Airfield (SA Chesty) in order to echelon general support CSS capability forward in the areas of supply, maintenance, services, and medical services. At the end of hostilities, SAs were also established in the vicinity of Ad Diwaniyah (SA Edson) and Al Kut (SA Geiger) to continue support to I MEF forces. CSSG-15 also provided direct support to the I MEF command element and headquarters group through CSSC-151. Major engineer planning centered around the potential for five separate river crossings, using the improved ribbon bridge, of between 100 and 300 meters, and the construction of the longest fuel “pipeline” ever built in combat, stretching 60 miles from the initial breach point on the Iraq-Kuwait border to Jalibah Airfield. The last bit of planning just prior to execution involved determining shortfalls and requirements for transportation support over and above the assets attached to TSG. As a result, I MEF contracted for host-nation support in the form of commercial trucks to be used throughout the conflict.

Execution

After receiving and integrating nearly all of the required components of 1st FSSG, and equipping units with both maritime prepositioning force assets and organic assets delivered via strategic airlift and military sealift, 1st FSSG assembled, trained, and prepared itself to cross the line of departure in support of I MEF. CSSA

Coyote was set up and operational nearly 1 month before combat forces crossed into Iraq, with CSSB-12 maintaining 6 days of all classes of supply and a field ammunition supply point that continued operations well after combat had ended. HSB also established a surgical company at Coyote, providing the first in a series of level two medical capabilities well-positioned throughout the war. In an effort to have equipment and supplies properly staged for rapid movement into Iraq, CSSB-18, 6th ESB, 8th ESB, and TSG moved to the vicinity of the Iraq-Kuwait border in the northwest of Kuwait in order to quickly establish LSA Viper and construct the 60-mile tactical fuel system (TFS). Upon the order for 1st MarDiv and TF Tarawa to move to their attack positions, CSSG-11 and CSSB-22 moved into position to move with their respective supported units into Iraq.

On 20 March, with breaching support from 7th ESB, RCT-5 crossed into Iraq to conduct the initial seizure of the Ar Rumaylah oil fields, and CSSC-115 became the first unit in 1st FSSG to enter Iraq. TF Tarawa soon followed with CSSB-22, 8th ESB, and CSSB-18 moving forward to conduct a relief in place elements of the 3d Infantry Division in the vicinity of Jalibah. By the morning of 21 March, elements of CSSB-18 began establishing LSA Viper at Jalibah Airfield, and 6th ESB began construction of the TFS.

In establishing the direct support relationship between CSSG-11 and the 1st MarDiv, 1st FSSG played a major role in the rapid movement of combat forces. Each CSSC was able to carry 1 to 2 days of supply of Classes I (rations/water), III (B) (fuel), and V (W) (ground ammunition) in support of each RCT. Additionally, CSSB-10 provided the flexibility to surge support to the CSSCs and establish RRP. The establishment of RRP was critical to the FSSG's support plan. The 23 RRP established by CSSB-10 allowed the division to resupply themselves quickly and were responsible for preparing sites for the quick establishment of 1st FSSG SAs. SAs were set in areas already secured and prepared by CSSG-11/CSSB-10 as RRP. A major measure of 1st FSSG's success was support of the 1st MarDiv via rapid establishment of RRP.

6th ESB's work on the TFS consisted of using the hose reel system in concert with assemblies of the amphibious assault fuel system (AAFS) to move fuel nearly 60 miles to a complete AAFS fuel farm at LSA Viper. Of particular note was the use of the hose reel system that was originally designed to pump fuel no farther than the 5-mile segments of which it was composed. Training at Camp Pendleton never extended farther than 15 miles of hose, so in essence, the first time the TFS was put to test at the required distance was when it was employed. The system was constructed in 5 days, nearly 3 days ahead of schedule, and in total pumped over 9 million gallons of fuel from the Army's terminal fuel farm in Kuwait to AAFS fuel farm at LSA Viper. The system was eventually extended past LSA Viper to the theater support area in the vicinity of Tallil Airbase, essentially becoming the means of conducting fuel resupply for the entire theater.

As LSA Viper continued to build to its required 4 days of supply and become the forward command post for 1st FSSG, it quickly became the first forward base of operations for 1st FSSG, and the first line of resupply for I MEF as it continued to maneuver north. Nearly immediately upon CSSB-18's arrival, support was required to all forces in the area and in particular to TF Tarawa during intensive combat operations in the vicinity of An Nasiriyah. Capitalizing on the basing of TSG assets and 3d MAW RW assets and C-130 aircraft, CSSB-18 was able to sustain combat operations from their position to as far north as the An Numaniyah area, just south of the Tigris River and west of Al Kut. As the war continued, Viper transitioned to the entry point for all sustainment into Iraq. Convoys from the MLC bringing Classes I, V (W), and IX (repair parts and secondary reparable) made their initial deliveries to Viper, and assault support missions flying in and out of the Jalibah Airfield and TSG convoys carried supplies forward.

Along with being the entry point into Iraq for sustainment, LSA Viper also provided significant medical support, specifically in the form of Expeditionary Medical Facility 3 (EMF-3). EMF-3, the 116-bed "slice" of the 500-bed Fleet Hospital 3, became the first fleet hospital unit to move inland from a port or beach to conduct operations. The ability to provide level three medical care this far forward on the battlefield clearly benefited the lifesaving capability of the medical services of 1st FSSG. The hospital treated U.S. servicemen from all units in Iraq as well as EPWs and Iraqi civilians. In all, EMF-3 treated nearly 600 patients in the 2 months it was operational.

In addition to the EMF, HSB effectively echeloned level two medical care forward by virtue of surgical companies positioned at each SA and the FRSS/STP teams at smaller SAs and RRP. A new concept, the FRSS

was a small (two surgeons, eight personnel total), mobile (two vehicles), limited surgical capability designed to provide emergent lifesaving surgery and stabilization prior to evacuation to the appropriate level of care. Teamed with an STP this capability quickly became a force multiplier, adding a ward and battalion aid station. These single operating room units also moved across the battlefield with the mobile CSS units, shortening the “golden hour” of care for combat casualties. Of note was the work of FRSS-2 and FRSS-4, at LSA Viper as an initial surgical capability prior to the establishment of Surgical Company Charlie, during TF Tarawa’s attack on the 11th Infantry Division in the vicinity of An Nasiriyah. Although the loss of life here was greater than any other battle during the war, without this quick initial capability being established, the totals would have been much greater.

As the fight continued, the actions of both CSSG-11 and CSSB-22 ensured that ground forces received required sustainment. With an emphasis on transportation and distribution, both units kept up with their supported forces during the fastest moving portions of the war. The 1st MarDiv’s sprint to the Tigris River and their sustained combat operations as they defeated in succession the Baghdad and Al Nida Republican Guard Divisions and then closed in on the outskirts of Baghdad required “brute force push logistics.” This was accomplished by the integrated, rapid distribution of fuel, water, rations, and ammunition to the nearest SA or RRP to the fight, moved by assets from CSSG-11, CSSB-22, TSG, and in some cases the MLC, at distances farther than anyone had imagined prior to the beginning of the war. At the height of action, more than 250,000 gallons of fuel were moved on a daily basis from as far south as SA Coyote to as far north as SA Chesty at the An Numaniyah Airfield, stretching more than 300 miles over improved and unimproved highways. Due to the I MEF battlespace and the unconventional threat along the LOCs and MSRs, 1st FSSG was restricted almost solely to one LOC, Highway 1, stretching from just west of An Nasiriyah to just east of Ad Diwaniyah, the majority of which was unimproved surface still under construction by the Iraqis when the war began. The tireless efforts of 7th ESB ensured that this critical artery was as well-maintained as both the weather and the traffic allowed. The journey was more than a day one way, taxing distribution assets availability at all levels of support.

Much of the rapid movement across Iraq can be attributed to the fact that prior to the attack to seize the An Numaniyah Airfield, no significant bridges were destroyed. This did not mean, however, that 8th ESB was not significantly employed emplacing standard bridges. Numerous medium girder bridges were constructed on the small gaps and culverts along both Highway 1 and Highway 7 (heading north from An Nasiriyah to Al Kut). The first assault float bridge was constructed on 1 April across the Saddam Canal moving toward An Numaniyah. Subsequent bridges were constructed across the Tigris (three total) and the Diyala Rivers along the approaches to Baghdad.

On 2 April, 1st MarDiv crossed the Tigris River, dealing a substantial blow to enemy forces and hastening the push to Baghdad. As this occurred, 1st FSSG continued its echelonment of CSS with the establishment of SA Chesty at the An Numaniyah Airfield. In much the same way that CSSB-18 sustained the force initially from LSA Viper, CSSB-12 reestablished itself some 300 miles from its original position in Kuwait. This farthest forward of support areas for the MEF enabled that brute force push to be shortened substantially. At this point of the war, with much of the maneuver stabilizing close to Baghdad, the 1st MarDiv’s artillery assets were taxed harder than at any point during the war. Artillery rounds (155mm) were literally taken off of the trucks of the supporting CSSCs and immediately loaded into M198s for fire support as ground forces closed in on Baghdad. Due to this immediate need, CSSB-12 became as much of a direct support CSS organization as did CSSG-11 to the 1st MarDiv.

Once it appeared that Baghdad had fallen, I MEF was given one final combat mission, the seizure of the city of Tikrit, home of Iraqi President Saddam Hussein. To maneuver some 130 miles from both Baghdad and the closest RRP, 1st MarDiv built TF Tripoli around the majority of their three light armored, reconnaissance battalions. CSSG-11, in turn, built CSSC Tripoli with a heavy reliance on fuel and distribution assets. Once again, the maneuverability of a mobile CSSC paid dividends in allowing combat forces to move without the need for an operational pause. In total, I MEF had traveled in excess of 600 miles from the initial breaches in Kuwait to Tikrit.

In the days following the end of hostilities and movement of I MEF forces to positions in southwest Iraq in order to perform stability and security operations, 1st FSSG also consolidated forces to continue to provide support. SA Chesty was transitioned to SA Geiger in the vicinity of Al Kut as 3d MAW moved its FOB from An Numaniyah. SA Edson, on the campus of the Al Qadisiyah University in Ad Diwaniyah, served as the new central location of CSS functions as well as the new location for the 1st FSSG (Forward) command post. 7th ESB took on the mission of collecting captured enemy material putting a heavy reliance on explosive ordnance disposal and combat engineer functions. Upon retrograde of forces no longer required for continued operations and their subsequent redeployment to the continental United States, 1st FSSG moved back to its original positions in TAA Coyote, with CSSG-11 and reinforcement from 7th ESB and HSB remaining in Iraq.

Challenges

No operation can be conducted without challenges and areas identified for improvement. While there were many successes, work remains to ensure that future expeditionary operations are better supported by CSS organizations.

Supply support was a major challenge throughout the war. The brute force logistics mentioned in this article primarily worked for Classes I, III (B), and V (W). Demand-based pull logistics, specifically Classes VIII (A) (medical) and IX, was clearly inadequate. A 30-plus-year-old mainframe-based supply system, significant communications shortfalls, lack of in-transit visibility, and the tyranny of distance caused unit supply officers to lose faith in the supply system. Many either continually resubmitted requisitions for the same parts and items, which in turn clogged the distribution system, or bypassed the supply system altogether and reverted to e-mails and spreadsheets, most times with insufficient information to effect timely and responsive action. The lack of in-transit visibility and a low priority for demand-based requisitions in the ground transportation order further exacerbated the problem. This all illustrates the critical need for a tactical logistics command and control (C²) system that is institutionalized with requests formatted in much the same way fires or air support is handled.

Lack of C² across the FSSG can also be attributed to the paucity of communications assets and capabilities. Even with the employment of the communications companies of both 1st and 4th FSSGs, communications was severely lacking. For years the FSSG has been left out of the “information revolution” of the rest of the Marine air-ground task force (MAGTF). Specifically missing is the lack of “long-haul” communications. This capability was not envisioned in the past for CSS operations but was definitely needed for OIF, and will be for future operations as well. The result was twofold. First, placement of 1st FSSG units and support areas required them to be tied into communications architecture of other MSCs. Due to the rapid advances of the 1st MarDiv, communications with CSSG-11 was often nonexistent. Unfortunately, it was also not unusual for CSSG-15 to not have any communications with subordinate units for days at a time, particularly during the early phases of SA establishment. Additionally, 1st FSSG had to temporarily loan such assets as the AN/TRC-170 and AN/TSC-93 in order to pass both data and voice communications within Iraq from fixed site to fixed site. Assets like the AN/TSC-154 secure mobile antijam reliable tactical terminal, that are present at the infantry battalion in the Marine division, are neither in the FSSG inventory nor planned for fielding. With the potential for future MAGTF operations stretching over distances not planned for in the past for CSS organizations, this capability is mandatory in the FSSG.

Successes

The successes in OIF of 1st FSSG are directly attributable to the hard work in planning that was conducted throughout all levels of the organization.

The task organized concept of CSS companies, battalions, and groups clearly contributed to moving as deep into Iraq as I MEF did. Much is misunderstood as to the organization of the FSSG, mainly because it is organized into functional battalions in peacetime, but reorganized into task organized units for exercises and combat. This causes the FSSG, more times than not, to be a team supporter rather than a team player. Creating multifunctional organizations and habitual relationships with specific units in the MEF established a greater understanding of what the FSSG can do for the MAGTF. Due to this success and greater understanding across I MEF, this new structural framework of 1st FSSG will be carried back to Camp Pendleton and used in garrison upon redeployment.

The success of the FRSS, and its teaming with the STP, greatly enhanced battlefield casualty care for the entire MEF. This lighter, flexible, and more mobile medical capability enabled critical emergency surgical care to be positioned farther forward than ever envisioned in combat. As well as the ability to be positioned forward to shorten the time and distance from casualty to care, this capability also served as the initial medical treatment facility at an SA until the assigned surgical company could displace and establish operations. While not a replacement for the surgical company, the FRSS enabled lifesaving surgeries to be conducted in order to stabilize patients before being transitioned to higher care levels. A review of all patients received by a 1st FSSG FRSS revealed that only one patient received did not survive. OIF clearly validated this concept of medical support for the future. This combat multiplier, and its success, will quickly become the medical capability of choice for expeditionary operations.

Even with the challenges that C² presented, one system—the blue force tracker (BFT)—paid multiple dividends. A satellite-based, vehicle-mounted system, BFT provides real-time location of units throughout the battlefield while on the move. Due to the lack of mobile communications assets, BFT became the primary means to determine locations of units, specifically convoys, and their eventual linkup with supported units. Its ability to be used in conjunction with C² personal computers (C²PCs) enabled unit locations to be displayed on any networked PC. With the additional text messaging capability, BFT enabled convoys to send information back to higher headquarters. Without BFT, 1st FSSG would have been hard-pressed to direct convoys on the move and determine their exact location.

Although somewhat unorthodox in nature and a bit cumbersome in design and preparation, the functionalization of the three ESBs reaped tremendous benefits. Granted, this was a plan totally driven by the peculiarities of the engineer missions required in OIF; the assignment of specific engineer missions to whole battalions created an economy of effort and a massing of forces for these critical functions. Attempting to assign the missions of bulk liquids, standard and assault float bridging, and mobility/countermobility/survivability to all three battalions would have been difficult to control and clearly would not have been as responsive to the overall engineer mission.

Conclusion

Throughout the global war on terrorism and Operation ENDURING FREEDOM, the Marine Corps, whether internally or externally, has been pushed to conduct operations not otherwise normally planned for. In Afghanistan it was clearly the move from ship to objective of over 300 miles that extolled the virtues of both our air and land combat mobility systems. In Iraq it was the maneuver from the Kuwait-Iraq border to Tikrit, under fire, spanning over 600 miles. Sustaining the force over this great expanse could not have been accomplished without the careful orchestration and integration of CSS. 1st FSSG took great care in planning and worked closely with the MSCs of I MEF to ensure timely and effective support. The execution, though not perfect, yet again demonstrated the will to succeed of each and every Marine, sailor, and soldier assigned to 1st FSSG during OIF.





Marine Engineer Group—A Force for the Future

by Kirk Ross

U.S. Naval Institute Proceedings, July 2003.

Around 1300 on 23 March, it was clear and warm outside, but air conditioning made it cool inside the tent. I sat in Navy Rear Admiral Charles Kubic's small, spare office—a map of southern Iraq, small table and laptop computers, three chairs, and dark industrial carpeting on the floor. Outside, in front of the large tent that housed the headquarters of the I Marine Expeditionary Force (MEF) Engineer Group—the MEG—was the main working area, noisy with the buzz of Navy and Marine Corps staff personnel hovering over computers and monitoring communications. They were following the course of coalition forces operating around the Iraqi cities of An Nasiriyah and Umm Qasr.

Foremost in the minds of these men and women was the progress of those elements of the MEG—Task Force Mike and Task Force Charlie—that since the opening gambit had been advancing close in the wake of the assault forces, positioned to provide support critical to the battle plan. Their progress certainly was on the mind of Admiral Kubic when he entered his office and greeted me.

Since crossing the line of departure, coalition forces had experienced what Colonel Michael Howard, the MEG operations officer, characterized as “catastrophic success.” The speed of execution of the battle plan has been something between breathtaking and awesome,” said the admiral, adding that much of the work he thought engineers would have to perform early in the campaign—construction of assault bridges in support of advancing forces—had not been necessary. So far, bridges over the Euphrates and myriad other canals and small rivers had been left to the coalition undamaged. At about that time, word came that the Euphrates bridge east of An Nasiriyah had fallen intact to the Marines. “Culverts near the bridges had been mined,” said the admiral, but the Iraqis failed to set them off. He pointed to An Nasiriyah on the map and explained that Marines were fighting for control of the two Euphrates River bridges west of the city. If the Iraqis destroyed the bridges, the MEG's Task Force Mike was in position to quickly throw an assault bridge across the river. Meanwhile, Task Force Charlie worked on an enemy prisoner of war (EPW) compound just inside Iraq.¹ Task Force Echo had not yet crossed the line of departure.

Colonel Howard said the MEG was an evolutionary rather than revolutionary arrangement. According to him, the idea was generated in 1995 by General Anthony C. Zinni, then Commanding General of I MEF. But the roots of the organizational structure go back to the engineer regiments that were organic to the Marine divisions of World

War II.² Each of those regiments had an engineer battalion to meet the tactical engineering requirements of divisional assault forces: a pioneer battalion to handle supplies flowing across landing beaches and perform general engineering missions, and a naval mobile construction battalion that came ashore during general unloading to reinforce and expand the Marine engineers' construction and repair work.³

Organization of the MEG for Operation Iraqi Freedom closely reflects historical antecedents. Similar to the Marine engineer regiments of World War II, the MEG has three light regimental task forces with shared and unique capabilities: Task Force Mike (for mobility), Task Force Charlie (for construction), and Task Force Echo (for endurance). The task forces are organized around large Seabee detachments, such as those deployed to the Balkans, and kept light so they do not bog down on the roads. Admiral Kubic put Navy captains in charge of each one because he wanted more senior leadership at the front.

Among the MEG's primary missions are main supply route repair, and construction of EPW compounds, expeditionary airfields, and encampments. The primary difference between the task forces is the type of nonstandard bridging each is capable of deploying. According to Colonel Howard, the first MEG unit to respond to a call for bridging is Task Force Mike, which is capable of quickly deploying an armored vehicle-launched bridge in support of advancing ground forces. As the ground combat element advances, so does Task Force Mike, which picks up its bridges and takes them along—but not before Task Force Charlie arrives to construct a medium girder bridge over the same obstacle.⁴ When Task Force Charlie moves forward, Task Force Echo (equipped with the excellent Mabey-Johnson bridge) will construct a permanent bridge at the site. Colonel Howard says the three regimental task forces combined can provide bridging across the range of engineer support needed by the MEF.

Like their predecessors, the MEG's task forces have been tailored to meet specific mission requirements. For Iraqi Freedom, the MEG integrated Navy and Marine engineer assets of the First Naval Construction Division (Reinforced), Marine Augment Detachment 88835, and the 4th Marine Combat Engineer Battalion.⁵ Planners envisioned that task organization of theater engineer support forces would enable the MEF to better manage its assets, thus enhancing its mobility and lethality. But this doctrinal growth has not come without growing pains.

Throughout the Seabee community at Camp Commando there were complaints from officers and petty officers alike over the MEG's organization plan, which divided Seabee battalions and distributed their component elements to the task forces. Objections centered on ownership of equipment under several tables of allowance, dissolution of unit integrity, and the Seabees' changing role.

One Seabee officer, scheduled to relieve a unit already engaged, tried unsuccessfully to gain authorization to keep his unit's vehicles and equipment (including radios, computers, and weapons), all of which had been fine-tuned by his men to suit their individual peculiarities and those of the equipment. No matter where he went, his practical arguments fell on deaf ears. (One of his men noted that combat was not the place to be searching an unfamiliar hard drive for the right file.) Who owned the equipment, the Seabee battalion or the task force?

The MEG assigned elements of Seabee battalions to task forces in a confusing fashion. Parts of one battalion were mixed with parts of other battalions and assigned to the same task force. To the Seabees, there was not enough of a difference from one battalion to the next to justify dividing assets. I was told Seabee battalions had to parcel out staff personnel to several components and then augment their staffs from within to compensate for headquarters personnel lost to the smaller, separated elements of the battalion. According to Lieutenant Commander Mark Edelson, much of the MEG's strength—perhaps 20-25%—was used to provide security. Some thought these redistributions of personnel in an organization of only 3,200 were not justified by what appeared to be marginal gains.

The pride Seabees take in their traditional duties as builders is evident and may explain why assuming new roles in a tactical force is unpopular. Training is another reason. For example, Seabees remarked bitterly about the condition of Camp Commando's shower and mess facilities, and were equally critical of decisions that left to civilian firms the tasks of delivering the camp's water and fuel. "We're Seabees. We build. That's what we do best," many said, obviously longing for the days when that was their primary job. Finally, a number of them were not convinced they had enough combat and weapons training to cope with the various tactical scenarios.

Admiral Kubic weighed the criticism and opted to press ahead, noting the historical reality—"Seabees have always been task organized." He assumed command of the First Naval Construction Division in August 2002. Soon after being assigned to command the MEG as a collateral duty, he took on the task of forging the MEG into an organiza-

tion that could function as an integral part of “Sea Power 21.” As he sees it, “the MEG gives ‘Sea Strike’ its foothold ashore and bridges the gap between Marines and the seagoing Navy.” On the 21st-century battlefield, the Navy’s combat engineer forces will have to be light, highly mobile, modular task forces capable of using the latest command, control, and communications equipment to quickly concentrate units where they are needed most. Although task organizing caused friction and highlighted shortcomings that must be corrected, the resulting successes indicate clearly that reorganization was necessary.

The MEG’s promise for future wars was exemplified in an innovative action on 21 March, when the MEG launched an operation on the Hawr al Hammar (Hammar Marsh) Bridge a few miles north of the Rumaila oil fields to prevent the Iraqis from using it to attack the flanks of advancing coalition forces. Planners aimed at preventing enemy use of the bridge while allowing friendly forces to repair it easily in case it was needed. Moreover, they had to bear in mind the crucial political imperative of sparing Iraq’s infrastructure.

Intelligence was gathered from satellite imagery, low-level reconnaissance flights flown by Marine aircraft, and from data collected by Seabee engineer reconnaissance teams (SERTs). These teams are organic to naval mobile construction battalions and composed of approximately ten Seabees (two engineer officers and eight enlisted personnel with primary engineering specialties). Their mission is to provide tactical reconnaissance in advance of major engineering elements to permit them to react rapidly to changing battlefield conditions. Admiral Kubic developed the SERT concept while deployed to Bosnia in 1995.

Data compiled by the MEG were evaluated and a key discovery was made. One of the images, captured by aircraft during low-level reconnaissance of the bridge, revealed that its center spans had been reinforced since the 1991 Gulf War. Using its “reach-back” capability, the MEG transferred the raw target data and details of the mission to the Pacific Division of Naval Facilities Engineering Command for detailed analysis. A highly skilled team of experts there evaluated the data and provided the correct solutions for striking the end of the bridge closest to friendly forces. The precise bombing caused only the damage necessary to cut the span in a small place. Thus, coalition forces could repair the bridge easily at the end farthest from the enemy, and the structure could be rebuilt quickly in the postwar period.

The Marine Engineer Group’s preparations for Iraqi Freedom began in September 2002, when Task Force Mike Seabees began to build hardstands, helicopter pads, munitions storage areas, and encampments at the Ali Al Salem Air Base in preparation for the arrival of the 3rd Marine Aircraft Wing. Engineers were key to all phases of the operation. At the same time, Admiral Kubic hopes to show that the MEG can provide an internal reconstruction capability to assist in initial postwar construction and clear the way for humanitarian aid efforts. In that regard, Task Force Echo is organized to support long-term military operations and provide for transfer of its duties to local civil works authorities. I was briefed on preparations already under way for the Iraqi port city of Umm Qasr, where relief supplies would soon start flowing to Iraqi civilians.

The MEG’s multifaceted organization can support efforts ranging from peace-keeping missions to sustained combat operations in the most hostile terrain. Although further refinement is essential, its major contribution to Iraqi Freedom demonstrated that Seabees and Marine engineers are geared up for the difficult tasks facing the United States in the years ahead.

¹I recall being more than a little surprised at the small number of EPWs—fewer than 1,000 at that time, I believe. With the coalition’s advance so dramatic, I imagined they would have taken many more. The camp covered 42 acres and could accommodate 14,400 enemy prisoners.

²Maj. Ed Maguire, USMC, “Complexion of Engineer Support,” Marine Corps Command and Staff College paper (1989), executive summary. “Until the latter part of World War II, the Seabees provided the majority of construction support to Marine Aviation. In support of Marine Aviation, the Marine Corps established a third type of engineer battalion called the aviation engineer battalion.”

³In World War II, Marine engineer regiments were subordinate to Marine divisions. The Marine Engineer Group, however, has “equal billing” with I MEF’s division, aircraft wing, and combat service support group.

⁴According to Colonel Howard, the medium girder bridge can be built more quickly than the Mabey–Johnson; but after approximately 10,000 crossings, its aluminum begins to fracture. Thus, it cannot be considered permanent.

⁵Planned integration of the Georgia Army National Guard’s 265th Engineer Group had not been effected by late March.





8th Engineer Support Battalion's Support of Operation IRAQI FREEDOM

by Lieutenant Colonel Niel E. Nelson and Major Joseph J. Klocek

Marine Corps Gazette, December 2003.

“Whatever it takes.”

Early in the spring of 2002, while I Marine Expeditionary Force (I MEF) was diligently planning and wargaming its role in what was to be called Operation IRAQI FREEDOM (OIF), 8th Engineer Support Battalion (8th ESB) was engaged in engineering projects around the globe with its construction, bulk fuel, bridge, and engineer support companies in Florida, Texas, Virginia, Barbados, Bulgaria, and Panama. The secrecy with which OIF was being organized and planned prevented many of the units who would be involved the ability to get a jumpstart on preparation. In July 2002 the command element of 8th ESB was invited to participate in the I MEF command post exercise (MEFEx) held at Camp Pendleton. During the preplanning for MEFEx, 1st Force Service Support Group (1st FSSG), in a unique and thoughtful move, decided it could best support the engineer missions by functionalizing the ESB into three distinct areas—bulk liquids, led by 6th ESB; construction support, led by 7th ESB; and bridging, to be led by 8th ESB. To accomplish this never before tried task, 8th ESB had to reorganize its entire battalion and create tactics, techniques, and procedures (TTP) in order to fulfill the command and control (C²) aspect of a single bridge battalion in support of a Marine division. Time was short, tactical bridging was scattered around the globe and, adding to the dilemma, the Marine Corps in the aftermath of DESERT STORM cadred the bridge companies of 7th and 9th ESBs, leaving them only a small bridge training set but without the table of organization structure of a bridge company to maintain proficiencies. Only 8th ESB was left with an active bridge company. The following is how this battalion lived up to its motto, “whatever it takes,” to successfully meet the challenge.

Building a Bridge Battalion

Preparations commenced with the battalion forming a core planning group made up of the operations officer, bridge company commander, and enlisted bridge experts from the battalion and the Camp Lejeune area. The Marine

Corps Planning Process model was the heart of the initial planning and tactics rework. The planning centered on distilling *Field Manual 90-13, River Crossing*, that was written by the U.S. Army for engineer brigade-level C² of river crossings into a usable Marine Corps engineer battalion-level document. Long hours and many drafts later, the initial battalion standing operating procedure (SOP) was written. The battalion directed its bridge company to try out and test the SOP by performing a series of river crossings in the surrounding North Carolina counties that closely resembled crossing requirements we could expect in Iraq. The support from the local communities was outstanding. The TTP were laid out and the bridge company convoyed, maneuvered, emplaced its control points, and placed a ribbon bridge. Numerous times over the following months tests were conducted, including diverting an artillery battery from 10th Marines in retrograde from Fort Bragg, NC to Camp Lejeune over an improved ribbon bridge (IRB) across the Cape Fear River. The testing enabled the bridging company to hone its techniques and modify the operation as required, turning the river crossing SOP into an effective document for division-level operations. The battalion hosted the engineer brigade staff of the Army's 3d Infantry Division (3d ID) in early December 2002 to participate in the first ever joint river crossing exercise culminating in a 325-meter IRB spanning from Engineer Point into French Creek aboard Camp Lejeune. This effort employed armor, artillery, amtracks, trucks, military police, and infantry units adding friction and realism to the efforts. The organizational and personal relationships built here proved invaluable later during the transfer of the Army's multirole bridge companies (MRBCs) to 8th ESB during the conduct of the war.

The battalion staff continued to work on bridge equipment improvements, maintenance, employment, and transportation configurations. Most of the fleet of bridge erection boats (BEBs) were in poor shape from a combination of age, lack of parts, minimal maintenance, and continual use in brackish water. The 8th ESB's single active bridge company did not have a history of enough usage to ensure that the Defense Supply Agency maintained an adequate stock of required repair parts. To compound the repair problems, the realignment and subsequent experimentation with the integrated logistics concepts (ILC) showed severe limitations in that ability to repair the BEB fleet. As the war loomed the battalion requested an infusion of funding and outside support from Marine Corps Systems Command (MarCorSysCom). This support came from the U.S. Coast Guard rebuild facility in Baltimore, MD. BEBs from Camp Lejeune and Marine Corps Logistics Base Albany were taken in and rebuilt to meet the needs of the deployment. Marines from 7th and 8th ESBs were sent to both Marine Corps logistics bases to inventory and repalletize medium girder bridge (MGB) components into usable combat loads. IRB stock was identified throughout the Marine Corps, and the process of consolidation began. During this time period 7th ESB, under the direction of 1st FSSG and I MEF, sent their bridging equipment to Kuwait for prepositioning. The challenge became clear as we gathered equipment and deduced requirements through refinements in the planning process. Bridge and heavy equipment transport was woefully insufficient to load the bridge companies. MarCorSysCom again supported our needs with a commercial off-the-shelf (COTS) purchase of BEB trailers. This effort increased our crossing capability by allowing an MK48-18 truck to haul an IRB bay while pulling a BEB on a trailer.

Forming the Battalion

Discovering the whereabouts of the equipment and Marines to support the 8th ESB's vision of an assault bridge battalion was another challenge to overcome. 2d FSSG, as 8th ESB's parent command, was designated as the Marine Logistics Command (MLC). As such, the MLC acquired portions of the battalion's capability for self-sustainment. With the battalion unable to regain control of its assets that migrated to other battalions under the ILC, the battalion lobbied 1st FSSG, I MEF for support and received augmentation from 1st Transportation Support Battalion (1st TSB), 1st Supply Battalion, 6th ESB, 7th ESB, 6th Motor Transport Battalion, 1st and 2d Combat Engineer Battalions (CEBs), and Headquarters and Service (H&S) Battalion, 1st FSSG. This loss of core competencies from within the battalion is analogous to an infantry battalion consolidating its mortars and crews at the regiment or

division level and then getting back a pickup team of mortar men who did not have the culture and training of the infantry battalion. The Marines and sailors who were placed under the command of 8th ESB were highly motivated but required extensive training in order to be independent bridge builders under wartime conditions. (See Figure 1.)

Rehearsals

Training to river crossing standards in the middle of the

Kuwaiti desert was a challenge overcome by the ingenuity of the young Marines. Engineer support company was given the task of building both a dry gap pit and a pond large enough to test the BEBs, and they accomplished both in short order. The training regimen undertaken prior to crossing the line of departure (LD) was intense both day and night in order to build a cohesive and bridge savvy battalion. Repetitive C² exercises, large-scale convoy operations, and bridge building became the daily task for each bridge company. This effort proved immensely helpful during the war as each company, C² element, and individual Marine or sailor became proficient in the procedures and immediate action required of them in both movement and bridge emplacement. Small unit leadership in executing mission type orders, complete understanding of command intent, and adherence to supporting the division with the “whatever it takes” initiative was exhibited by the battalion’s officers, staff noncommissioned officers (SNCOs), and NCOs.

Fighting for Needs

The requirement to cross the Euphrates, Tigris, and Al Garraffh Rivers in a nearly simultaneous time frame was a daunting task. The most pressing difficulty was the loss of each set of bridging assets as they were emplaced. Preliminary plans suggested the possibility of reloading the empty bridge carriers with spare bridge components and continuing the movement. This sounded like the best course of action, but it became increasingly difficult to achieve. Competition for the very scarce MK48-18 and qualified drivers who could launch and retrieve the ribbon bridge between all three ESBs and the combat service support battalions was fierce. One solution was the purchase of COTS boat trailers modified slightly to accommodate the BEB. The purchase of 26 trailers was to relieve the MK48-18 from carrying the BEB by only carrying IRB, with the BEB in tow. Unfortunately, only half of the trailers were delivered prior to crossing the LD. Marines took risks by loading two pallets of MGB on each MK48-18 vice one. The load configuration required the operator to slide an MGB pallet as far forward as possible with the second MGB pallet load being positioned sideways on the rear of the trailer. This presented an awkward traveling load, but the drivers quickly mastered the problem.

Combat Operations

The battalion was under the administrative control of 2d FSSG (Rear) located in Camp Lejeune but under the operational control (OpCon) of 1st FSSG, who in turn placed the battalion in direct support (DS) of the 1st Marine Division (1st MarDiv). This C² relationship was understood by all participants. Joint planning and frequent exercises took place between 8th ESB and 1st MarDiv. However, as with many tactical operations, change is constant. Adding friction to the battalion’s already overextended communications mechanisms and C², the battalion was transferred OpCon to Task Force Tarawa (TFT) with a different staging and starting point just under 72 hours prior to crossing the LD. This required a revision to the battalion’s plan for movement, staging, and follow-on 1st MarDiv oper-

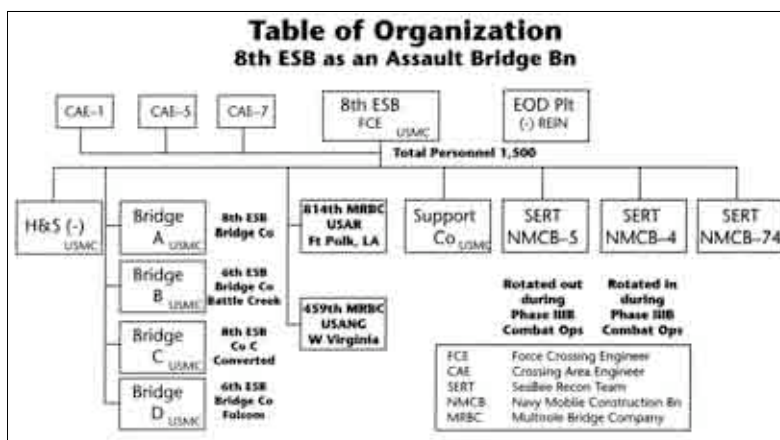

Figure 1.

ations as TFT attacked north from Breach Point West to An Nasiriyah. To support this movement the battalion placed Bridge Company A and Bridge Company B under the Crossing Area Engineer 5 (CAE-5) C² cell. The force crossing engineer (FCE) C² cell was collocated with the TFT command element. After crossing the LD into Iraq the battalion echeloned its forces toward An Nasiriyah where it was planned to establish two bridgeheads in the vicinity of both the eastern and western bridges across the Euphrates River. As the battle was waged it was determined the bridging effort was not required as the eastern and western bridges were taken intact by 3d ID and TFT.

The battalion, in the midst of three forces (TFT, 1st MarDiv, and 3d ID) maneuvering along a very narrow frontage, was detached from TFT and placed OpCon to 1st MarDiv while on the move. Additionally, during this change of C², the battalion accepted two MRBCs from the U.S. Army's 3d ID while simultaneously linking up with 1st MarDiv. Adding to the overall confusion associated with these ongoing efforts, the enemy began to increase its resistance in and around the An Nasiriyah eastern bridges.

Assuming OpCon of two MRBCs in the vicinity of the western Euphrates bridge, while supporting 1st MarDiv in the attack up both Routes 1 and 7, was successful because of the small unit leadership displayed by the CAEs. The support plan was simple: support Regimental Combat Team 1 (RCT-1) up highway 7 to Al Kut with CAE-5 with two bridge companies, and support the division main effort up Highway 1 with CAE-1 and CAE-7 with two bridge companies. At this point, and adding to the friction, both U.S. Army MRBCs reported their fuel supplies nearly exhausted. The 1st FSSG engineer cell coordinated a successful 3d Marine Aircraft Wing resupply mission that required the use of twenty 500-gallon bladders to a point just south of the western bridge sites. The Marines' fuel supply was adequate because prior to crossing the LD the battalion's fuel storage capability was doubled when all companies were outfitted with locally produced and commercially acquired gypsy racks purchased by the 1st MarDiv during the prewar preparation stage. These COTS items proved their worth time and again as the units rarely ran out of fuel.

The CAE C² cells became pivotal points, enabling the battalion to continue its movement and combat support. Both CAE commanders understood the battalion's intent and the 1st MarDiv requirement for dual-axis support up Highways 1 and 7. Abbreviated operational commands were given over secure Iridium phones, and the CAEs, with their bridge companies in trace, maneuvered up both routes in support of their assigned RCTs. CAE-5, following RCT-1 up Route 7, ran a gauntlet of small arms and rifle propelled grenades (RPGs) indiscriminately shooting from An Nasiriyah to the junction of Routes 7 and 15. The Army's 459th MRBC, encountering its first enemy contact and unfamiliar with the execution of immediate action drills, required direct supervision from the Marines of CAE-5 in order to conserve ammunition and continue its forward movement. To ensure the unit was ready for their next contact, CAE-5 Marines provided immediate action drill training and stressed the need for small unit leaders to take charge and effectively employ their organic weapons to neutralize the threat.

The FCE and CAE-1 traveled up Route 1 in trace of the 1st MarDiv main assault force. The route required the construction of four MGBs to span box culverts in order to permit follow-on logistics traffic. This effort took place during what turned out to be the worst sandstorm of the war. Following the emplacement of the MGBs and in coordination with Combat Engineer Battalion (1st and 2d CEBs), 8th ESB filled in 13 additional culverts using D7G bulldozers. During these efforts the battalion was ordered to return one of the MRBCs to the U.S. Army. This, unfortunately, was a very difficult task as all four forward bridge companies were employed or on the move in support of the 1st MarDiv. CAE-5 and the 459th MRBC were well up Highway 7 in general support (GS) of RCT-1; CAE-1 with the 814th MRBC and Bridge Company B, 8th ESB were emplacing MGB along Route 1; and CAE-7 and Bridge Company A, 8th ESB were en route up Highway 1 behind RCT-7. Once the sandstorm subsided the 814th MRBC, less its MGB, was ordered off the road to wait for an opening that would allow them to return to the 3d ID. Coordination with 3d ID was nonexistent, and the loca-

tion of the 814th MRBC was passed up through the I MEF to the combined forces land component commander (CFLCC) to be pushed down to the engineer brigade of 3d ID. Recovery of the 814th's MGB did not take place until 3 weeks later.

Flexibility on the Move

With the ability to mobile load only two of the four Marine Corps bridge companies and the need to have six employed within the 1st MarDiv plan, a flexible and innovative echelon plan was required. The force movement control center from 1st FSSG was inundated with movement demands and could only fulfill movement requests assigned the highest priority. This took approximately 96 hours from the time of demand. This time delay was not the most responsive with 1st MarDiv moving 50 to 65 miles a day. Therefore, once the bridge companies began the employment of floating bridges at the Saddam Canal and Tigris River, requirements for movement of additional bridge components could not be fulfilled in a timely manner. The battalion's engineer support company created two convoys from empty trucks and traveled back to Kuwait to move additional bridging forward, again living up to the battalion's motto, "whatever it takes."

To compound the difficulties the convoys, with their own internal security, had to travel through multiple zones belonging to the 1st MarDiv, FSSG, 3d ID, British forces, and I MEF controlled space without adequate communications. Iridium phones were the only source of reliable communications but required constant alternating current charging and were susceptible to the elements.

While resupplying the expended bridge components, 1st MarDiv continued their attack toward An Numaniyah and across the Saddam Canal where a single-lane bridge, rated at a maximum of 20 tons, was located. A bypass route was identified as a requirement to ensure the line of communications remained open. CAE-1, in concert with lead elements of RCT-5, conducted a reconnaissance of the bridge immediately after the RCT-5 secured the far bank. Bridge Company A, 8th ESB was tasked to emplace the bypass bridge, completing the task by the following morning. Simultaneous to the emplacement of the Saddam Canal bridge, CAE-5 and its attached bridge company arrived via Route 17 after detaching from RCT-1 and collocated with the division forward command post to support the division's movement toward An Numaniyah. As 1st MarDiv approached An Numaniyah, the battalion was directed to emplace a supporting bridge across the Tigris River north of the An Numaniyah bridge. Emplacement of this 155-meter IRB was initiated by Bridge Company A and completed by Bridge Company B. This bridge supported elements of RCT-5's movement north and provided the only alternate crossing site in the case of failure or loss of the An Numaniyah bridge.

Following the emplacement of this bridge, personnel and motor transport assets from Bridge Company A were transferred to Bridge Company C to make this company self-mobile. Once across the Tigris the 1st MarDiv maneuvered up Route 6 toward Baghdad. The battalion's FCE with CAE-5, Bridge Company C, and the 459th MRBC moved to a position approximately 5 kilometers south of the Route 6 bridge over the Diyala River leading into Baghdad. The FCE was tasked with locating bridge crossing sites to the north of the city. The FCE directed the efforts of both CAE-1 and CAE-5 with reconnaissance elements of RCT-1 and RCT-5 to locate the crossing points. Crossing the river was not the issue, finding appropriate approach routes was. After 24 hours of looking, no appropriate sites could be located, and the division directed the battalion to cross in the southern approaches. The battalion located five possible crossing sites, emplaced bridging over three, and directed the use of armored vehicle launched bridging over a fourth. The southern bridge along Route 6 had been partially destroyed by the enemy early in the week. The crossing operation required the removal of the remaining partially destroyed concrete support pier to allow the emplacement of MGB. Assets and personnel were moved where they could best be employed. Marines from Bridge Company C took control of the 459th MRBC's MGB and emplaced the bridge. After reviewing the military and civilian traffic flow that would be passing through this point, it was decided to emplace a ribbon bridge just north of the Route 6 bridge site and designate it for military use only. This effort required an enormous engineer effort to shape the extreme inclines of entrance and exit banks. Rubbling of structures

next to the sites was required to stabilize the banks. Simultaneous to these actions, CAE-1, with additional reorganized elements of Bridge Company A and portions of the 459th MRBC, were sent north to emplace the third ribbon bridge. These efforts required route improvement to and from the crossing sites that was interrupted on a number of occasions by small arms fire. Within a 24-hour period the battalion had emplaced three bridges totaling over 200 meters, built entrance and exit points, and set up traffic control points that provided 1st MarDiv with full access to continue its attack into Baghdad.

Postcombat Assignments

With the operational success of 1st MarDiv came additional assignments from CFLCC to attack and secure Tikrit. This change of direction required extending the supply lines while simultaneously supporting the division's main effort of securing the suburbs of Baghdad. The battalion and 1st FSSG determined that additional bridging missions could be on call with capability staged for employment within 12 to 24 hours of its request. The battalion moved its base of operations south from Baghdad to An Numaniyah and Logistics Support Area (LSA) Chesty. At this point the battalion established on call bridging with Bridge Company C. They placed the daily crossing maintenance for the emplaced bridging across the Nahr Diyala under the supervision of CAE-1 with the 459th MRBC in support and detached a bridging C² element to accompany the attack to Tikrit. Bridge Companies B and C were downloaded and their MK48-18s were formed into convoy operation teams. The battalion's main body arrived at An Numaniyah and established battalion maintenance, food, and administration services. CAE-7 converted to managing convoy operations. The battalion formed, loaded, and led convoys each day from LSA Chesty to Refueling and Rearming Point 26 at the division forward support area east of Baghdad. During this time period the battalion was relieved of its DS mission to 1st MarDiv and directed to begin planning captured enemy munitions support missions. The battalion's explosive ordnance disposal (EOD) detachment, which had been in GS to I MEF, collocated with the battalion and began sweeps and unexploded ordnance (UXO) removal in the local area. The battalion organized Bridge Company C with support from Engineer Support Company, EOD, and H&S Company into an engineer task force in support of 1st CEB's effort inside Baghdad to clear the UXO. This task lasted for 5 days until the battalion received orders to move to Al Kut in GS of TFT and I MEF in the Wasit Province of Iraq. The battalion convoyed to Al Kut and established itself on the eastern end of the runway: Once established, the battalion's utilities section detached from the MLC and located with the battalion. This section provided showers, laundry, and air-conditioning support to units in the Al Kut area.

At this time the battalion turned over its long haul logistics support missions to 1st TSB and reformed its bridge companies into captured enemy material retrieval and destruction units. Each platoon was dispatched with two to four EOD technicians to render safe or destroy captured enemy munitions. This was a monumental effort that will not be fully appreciated until well into the future. Every home, vehicle, culvert, school, and public area contained munitions and weapons caches that required disposal. This effort lasted for a month, and the battalion destroyed or rendered unusable vast amounts of trucks, tanks, antiaircraft guns, rifles, pistols, RPGs, and all calibers of ammunition.

During this time period, TFT requested the battalion's support for humanitarian efforts in and around Al Kut and other cities in the Wasit Province. Engineer platoons were dispatched to repair playgrounds and fill in fighting and artillery holes, as well as remove war materials. Company C provided demolition expertise and engineer support to the SeaBees in their repair of the main runway at the Al Kut airbase. Other portions of the battalion supported various units within TFT with hygiene support. As a gesture of support and friendship, the battalion undertook the cleanup and partial restoration of a British war cemetery dating back to World War I. This task required a week's worth of effort just to clear trash, remove overgrowth, and piece together over 50 headstones. The end result was celebrated in a combined ceremony between the British military forces present and Marines. The British standard was raised over the cemetery once again.

Summary

With the end of hostilities the battalion retrograded to Kuwait, disbanded, and transferred back to the 2d FSSG. Throughout their previous year and in combat, 8th ESB undertook its tasking to reform and employ as a bridge battalion with great pride. Through the resourcefulness and determination of its personnel, their employment in combat was a great success. The battalion overcame the effects of peacetime personnel and equipment losses; aggressively pursued, obtained, and employed over 600 large vehicles with 1,500 personnel; successfully emplaced 10 bridges; supported the destruction of captured enemy material; converted portions of the battalion to logistics support; and maneuvered over 250 miles into Iraq without the death of a Marine, soldier, or sailor. The small unit leader initiative, motivation, and esprit were commonplace. The battalion's motto of "whatever it takes" was epitomized by these courageous men and women in their unwavering support of the 1st MarDiv and TFT in combat operations.



No Farp Too Far!

by the Commander and Staff, MWSG-37

Marine Corps Gazette, December 2003.

Aviation ground support provided by MWSG-37 to Marine aviation units during Operation IRAQI FREEDOM was a critical part of the overall success of I MEF combat operations.

The guiding philosophy of Marine Corps warfighting is maneuver warfare. Maneuver warfare emphasizes rapid, focused effort; tactical and operational flexibility; and decentralized adaptation upon the enemy and the enemy's cohesion. 3d Marine Aircraft Wing (3d MAW) offered the I Marine Expeditionary Force (I MEF) a potent maneuver element across the spectrum of war during Operation IRAQI FREEDOM (OIF). Marine Wing Support Group 37 (MWSG-37) provided critical aviation ground support (AGS) functions to 3d MAW in order to enhance its abilities as a I MEF maneuver element. The inherent mission of the MWSG was and is more closely aligned with combat support in an operational environment than combat service support. Combat support as defined by Joint Publication 1-02 (JP 1-02), *Department of Defense Dictionary of Military and Associated Terms*, is “. . . operational assistance [emphasis added] provided to combat elements.” Whereas combat service support as defined by JP 1-02 “. . . encompasses those activities at all levels of war that produce *sustainment* [emphasis added] to all operating forces on the battlefield.” The MWSG was not, and is not, a “mini force service support group” (FSSG) within the MAW. Instead, OIF demonstrated that the MWSG was a ground maneuver element of the MAW that provided essential AGS functions to enhance the MAW's mobility and survivability, much as a combat engineer battalion supports a Marine division. MWSG-37 supported 3d MAW by bounding or “leapfrogging” forward arming and refueling points (FARPs) every 40 to 50 kilometers, which allowed for both the rapid movement of the FARPs and the continuous rotary-wing aircraft support to I MEF forces. Thus, the MWSG acted conceptually as a Marine wing expeditionary group.

MWSG-37 arrived at Ahmed Al Jaber and Ali Al Salem airbases in mid-November 2002 charged with the task of establishing support infrastructure sufficient to support over 15,000 Marines and nearly 400 tactical aircraft. These sites would prove to be the home base of the entire 3d MAW as it prepared for the impending war. To accomplish this task, three west coast Marine wing support squadrons (MWSS-371, -372, -373) and two east coast MWSSs (MWSS-271, -272), totaling over 3,400 personnel, were deployed and in place by February. MWSS-374 remained behind at Marine Corps Air-Ground Combat Center Twentynine Palms to support the training of any follow-on forces as well as to be ready to support operations on the Korean peninsula, if necessary. Four of the MWSSs (MWSS-271, -371, -372, -373) would maneuver into Iraq providing FARP and forward operating base (FOB) support, while the fifth MWSS (MWSS-272) would continue critical support to the airbases in Kuwait. Additionally, Company C, 1st Battalion, 24th Marines, 4th MAW, Marine Wing Headquarters Squadron 4 Military Police (MP) Detachment, and detachments from 3d Low Altitude Air Defense were attached to MWSG-37 to enhance our limited organic force protection capabilities that were severely diminished because of the MP battalion consolidation at II MEF. The consolidation reassigned MWSS-271's and MWSS-272's MP platoons to the 2d FSSG, removing any organic internal airbase force protection capability. (See Table 1.)

At Ahmed Al Jaber Airbase the U.S. Navy SeaBees, with assistance from MWSG-37, constructed an 880,000 square foot concrete aircraft/parking ramp in just over 4 weeks. This around-the-clock construction resulted in a parking ramp large enough for all of the F/A-18s and AV-8Bs assigned to 3d MAW. The Marines from 3d MAW installed almost 1.7 million square feet of Aluminum Matting 2 at both airbases and several camps in Kuwait to support aviation operations. Furthermore, over 900 hardback sleeping tents and scores of other maintenance and support tents were constructed to support 3d MAW operations in Kuwait.

MWSG-37 quickly responded when the requirement for a KC-130 expeditionary airfield (EAF) close to I MEF's center of logistics operations was identified. MWSS-272 designed and constructed this EAF in the Kuwaiti desert within 2 weeks of receiving the requirement. Affectionately named Marine Corps Air Station (MCAS) Joe Foss in honor of the recently deceased World War II Marine aviator and Medal of Honor recipient, the KC-130 EAF was an improved dirt

runway that provided a hot refueling capability and parking ramps for KC-130s and rotary-wing aircraft. Maintenance and upkeep of the EAF was a constant effort as the dirt strip deteriorated with every KC-130 landing, but the Marines of MWSS-272 kept the EAF open throughout combat operations. Due to its strategic placement and proximity to key logistics elements, MCAS Joe Foss was constantly utilized by KC-130s and proved invaluable throughout the war.

West Coast MWSSs		
MWSS-371	MCAS Yuma	Sand Sharks
MWSS-372	MCAS Camp Pendleton	Diamondbacks
MWSS-373	MCAS Miramar	Aces
East Coast MWSSs		
MWSS-271	MCAS Cherry Point	Workhorses
MWSS-272	MCAS New River	Untouchables
Reserves That Supported MWSG-37		
Charlie Company, 1st Battalion, 24th Marines		
MP Det, Marine Wing Headquarters Squadron 4, 4th MAW		

Table 1.

While the necessary improvements to the infrastructure of the existing Kuwaiti airbases occurred, the staff of MWSG-37 worked diligently on an aggressive FARP and FOB plan that would support not only the maneuver of 3d MAW but also 1st Marine Division (1st MarDiv), Task Force Tarawa, and 1st British Armored Division. Working closely with representatives from Marine Aircraft Groups 29 and 39, a plan was developed to leapfrog FARP teams past one another so that continuous FARP support could be provided while simultaneously keeping pace with 1st MarDiv and Task Force Tarawa. (See Table 2.)

With the necessary infrastructure in place and the commencement of combat operations, MWSG-37 set up two rotary-wing FARPs close to the Iraqi-Kuwaiti border to support the breaching of Iraqi defenses and subsequent crossing of the Iraqi obstacle belts. MWSS-372 had a “be prepared to” mission to support the breaching of obstacles in Regimental Combat Team 7’s sector and subsequently established a coalition FARP at Safwan with British helicopter units. The rapid success of the border crossing set the pace for the war as coalition forces quickly gained hold of all of southern Iraq with MWSG-37 emplacing FARPs approximately every 40 to 50 kilometers and leaping FARP and rapid runway repair (RRR) teams to the next location based on the tactical situation. Utilizing everything from repaired Iraqi airfields to wide stretches of highway, as well as flat empty fields and concrete slabs previously used as building foundations, the Marines of MWSG-37 established 21 FARPs and 8 KC-130 tactical landing zones (TLZs) throughout Iraq.

Due to shipping delays of organic equipment before the start of combat operations, MWSG-37 was forced to outfit the five assigned MWSSs with the equipment usually associated with the table of equipment for four MWSSs. By the time hostilities commenced MWSG-37 was able to task organize eight FARP teams and three RRR teams to accomplish our assigned missions, stretching our personnel and equipment to the absolute limits. At one point during the war MWSG-37 was supporting eight different FARP and FOB sites simultaneously across Iraq and Kuwait, while also providing line haul to resupply our organic units. Additionally, MWSG-37 FARPs provided 130,000 gallons of fuel to 1st MarDiv and Task Force Tarawa to support their continued combat operations into An Nasiriyah and Baghdad.

While 1st MarDiv and Task Force Tarawa continued their fight around An Nasiriyah and toward Baghdad, MWSG-37 was tasked to insert a FARP team at Qalat Sikar. This task required MWSS-371’s FARP and RRR convoy, with help from the 15th Marine Expeditionary Unit’s light armored reconnaissance company, to fight its way past the town of Ash Shatrah on Highway 7 in order to reach its assigned destination. This unfortunately resulted in the only MWSG-37 Marine death during OIF. Sgt Padilla-Ramirez gave his life so that a crucial FARP in support of RCT-1 could be established at Qalat Sikar. MWSS-371’s FARP mission to provide the necessary fuel, ordnance, chow, and water via a logistics air bridge at Qalat Sikar was further elevated when all resupply convoys up Highway 7 were halted for over a week due to the heavy resistance by Iraqi paramilitary forces. MWSS-371 met this challenge head on and had the FARP operational within 2 hours of arriving, and a KC-130 TLZ in less than 8 hours. Fuel, repair parts, ammunition, and other key supplies to fight the war were flown into Qalat Sikar until Highway 7 was made safe for convoy operations.

As the coalition forces marched onward to and beyond Baghdad, the FARPs continued to be the key stepping stones in supporting the aviation combat element that in turn supported the most important element of all—the infantry Marines

on the frontlines. With the relevance of the FARPs proving their importance to 1st MarDiv, 1st Combat Engineer Battalion assisted MWSS-271 at An Numaniyah airfield by removing numerous obstacles off the runway prior to MWSS-271's RRR team arriving. This allowed the arrival of KC-130s with critical logistics hours earlier. As 1st MarDiv approached Baghdad they became critically low in artillery ammunition and meals, ready-to-eat. MWSS-372 promptly repaired an existing airfield 20 miles outside of Baghdad within 6 hours of arrival so that KC-130s could provide the logistics air bridge to the frontline forces. Although not their doctrinal mission, MWSS-372 additionally provided the line haul for those same critical supplies to the RCTs on the outskirts of Baghdad.

After 1st MarDiv had seized northern Baghdad, they were assigned a follow-on mission to seize Saddam's hometown of Tikrit. The MWSG-37 jump command element met with 1st MarDiv planners in Baghdad and within 2 hours developed a FARP plan to support the movement of Task Force Tripoli from Baghdad to Tikrit. Within 24 hours FARP and RRR convoys were assembled and subsequently moving with Task Force Tripoli while refueling and rearming the rotary-wing aircraft from Marine Aircraft Group 29, who was charged with providing the essential close air and assault support.

During the war MWSG-37 accepted the additional task of tactically recovering downed helicopters, and by the conclusion of the war, MWSG-37 had recovered 21 helicopters with limited organic security assets. These recovery missions often used an impromptu task organized force of personnel and vehicles from varying MWSSs to quickly rush to a crash site to recover the helicopter before it was stripped or further destroyed by enemy forces.

Throughout OIF the FARPs were implemented and controlled by the MWSG-37 jump command post (CP) based on the tactical situation and intelligence information that was gathered from direct communications with 1st MarDiv, Task Force Tarawa, and Task Force Tripoli. Utilizing both voice and data communications assets from the collocated Marine Air Control Group 38 (MACG-38) jump CP, MWSG-37 jump was able to keep the 3d MAW tactical air control center aware of the ever-changing ground situation, essentially acting as 3d MAW's forward "eyes and ears" on the ground. The

<u>CODE NAME</u>	<u>LOCATION</u>	<u>FARP/FOB</u>
Ali Al Salem	Kuwait	Airbase
Al Jaber	Kuwait	Airbase
Sheikh Isa	Bahrain	Airbase
MCAS Joe Foss	Kuwait	FOB/EAF
Turner Field	Kuwait	FARP
Astrodome	Kuwait	FARP
Busch Stadium	Safwan	FARP
Arlington	Ar Rumaylah	FARP
Riverfront	Jalibah	FOB/TLZ
Camden Yards	An Nasiriyah	FARP
Fenway	Qalat Sikar	FARP/TLZ
PacBell	Hwy 1	FARP
Wrigley	Hwy 1	FARP/TLZ
QualCom	Shaykh Hantush	FARP/TLZ
Three Rivers	An Numaniyah	FOB/TLZ
Ebbets Field	Sarabadi	FARP
Yankee	Salaman Pak East	FOB/TLZ
T.A. Wolf	N. of Baghdad	FARP
	Hwy 1 (Hasty)	FARP
	Samarah	FARP
	Tikrit South	FARP/TLZ
	Al Kut	FOB/TLZ
	Ad Diwaniyah	FARP
	Tallil	FOB
	Al Hillah	FARP

Table 2.

MWSG-37 command element traveled over 530 miles into Iraq, finally coming to a halt in Tikrit. The MWSG-37 headquarters, along with the MACG-38 headquarters, fought farther into Iraq than any other 3d MAW group headquarters. During OIF MWSG-37 set up and supported 21 FARPs, 6 FOBs, and 8 KC-130 TLZs stretching from Kuwait to northern Iraq over a distance of 530 miles, delivering in excess of 11 million gallons of JP-8 (jet petroleum) to 3d MAW aircraft. By the end of major combat operations 3d MAW aircraft had delivered over 6 million pounds of ordnance via 7,800 combat sorties in support of I MEF forces.

OIF enabled MWSG-37 to provide an excellent demonstration of how the MWSG should be properly employed in combat as well as trained in peacetime. MWSG-37's performance during OIF prompted the 1st MarDiv plans officer, LtCol Paul Kennedy, to comment during a



Disbursing Goes to War

by Lieutenant Colonel James A. Hogberg

<<http://www/mca-marines.org/gazette/2004/04hogberg.html>>. January 2004.

Disbursing services during wartime range from contracting to ensuring that Marines receive their pay in the combat zone.

As a Service operation that rarely deploys beyond a Marine expeditionary unit, disbursing services were used extensively and in depth throughout Operations ENDURING FREEDOM/IRAQI FREEDOM in support of the Marine expeditionary force (MEF). Sixty-six Marines were assigned to disbursing billets within I MEF, and another 25 billets were assigned to 2d Marine Expeditionary Brigade and Marine Logistics Command disbursing operations. Additionally, 60 disbursing Marines were assigned to other duties such as company commanders, watch officers, force protection, assistant machinegunners, mortuary affairs, and first sergeants. Disbursing agents not only displaced far into Iraq with combat service support units, they also were placed in direct support of the ground combat element (GCE) at the battalion level. The latter suggests that disbursing operations might also be described as a reaffirmation that every Marine is first, and foremost, a rifleman. More than a few disbursing agents earned combat action ribbons while deployed.

Combat Service Support Battalion 12 (CSSB-12), with a general support mission to the MEF, served as the hub for disbursing operations. With a table of organization of 36 billets (including the disbursing officer), CSSB-12 disbursing operations not only provided routine pay support, it was the central bank for the 5 other disbursing detachments located within the MEF. Activities included providing functional oversight for all disbursing operations, the collection and processing of all payrolls, liaison with U.S. Army Finance Command and the Marine Logistics Command, distribution of cash, establishment of captured currency collection points, maintaining reachback support with Camp Pendleton, and facilitating commercial contracting operations within Iraq/Kuwait.

While the 1st Force Service Support Group (1st FSSG) disbursing officer deployed with \$2.5 million in order to begin startup operations, sustained cash resupply in theater came from the Army Finance Command. The 336th Army Finance Battalion maintained the theater-level central funding vault at Arif-jan, Kuwait. They provided currency and coin in all denominations. Throughout the deployment the central funding vault was used to receipt for more than \$20 million in currency necessary to support Marine Corps deployed pay operations.

During the planning stage, disbursing operations were oriented toward (1) making cash available to Marines (split pay, casual pay, check cashing), (2) commercial vending and contracting support, and (3) currency/deposit support for the field exchanges and postal detachments. Interestingly, as combat operations commenced and the need for these services expectedly lessened, the need for other, less practiced disbursing support areas increased. Combat forces seized large amounts of Iraqi and U.S. currency from government vaults and buildings requiring the establishment of disbursing captured currency collection points. Civil affairs units used disbursing agents extensively to make small purchases on the local economy, often as a token of goodwill as much as they were to buy needed goods and services. I MEF also initiated guidance for solatium payments, or payments that offer a small token of money as an expression of sympathy or remorse for an indigenous victim. Additionally, disbursing agents were used to help pay civil servants and Free Iraqi Forces soldiers.

The most unexpected use of disbursing agents, however, was their direct support assignment with the 1st Marine Division (1st MarDiv) at the battalion level. The 1st MarDiv Commanding General, MajGen James N. Mattis, had made limited use of paying agents while in Afghanistan and wanted to replicate that success on a larger scale in Iraq. As a result, disbursing agents were sent to division units on or around G+5 (fifth day of the ground war). Their purpose was twofold. First was to buy goods and services the Marines might need, such as translators, day laborers, short-term property rentals, and construction materials. Second was to promote goodwill among the Iraqi people; even small purchases went a long way in demonstrating to the Iraqis that we were

not there as conquerors. The intent was to establish disbursing agent, field ordering agent, and translator teams that could communicate with the local citizenry. These disbursing agents lived and moved forward with their respective units (tanks, infantry battalions, etc.). As they reached Baghdad some were consolidated in the Palestine Hotel where they were used to make more substantial purchases from the larger downtown economy. Most worked with the civil affairs groups as they made their rounds among the communities. Some of these Marines were put in harm's way and earned combat action ribbons. In one instance, Cpl Morales, a disbursing agent, was involved in a downtown Baghdad shootout while the civil affairs team to which he was assigned sought to confiscate weapons and apprehend illegal arms merchants. As the MEF moved into stabilization operations, these disbursing agents were each assigned to a regional governorate established at each of the major cities within the I MEF area of responsibility (AOR). Assigned to a governorate, the disbursing agents worked with translators and field ordering agents to make necessary purchases on the local economy. Disbursing agents also assisted in the payments of civil servants and other government employees. The funding sources varied from appropriated funds to seized currency to approved reconstruction funds. Each funding source had to be accounted for separately.

It is important to note that the majority of disbursing agents were noncommissioned officers (NCOs). Normally, paying agent responsibilities are reserved for officers or staff NCOs; however, because of the sheer volume of support necessary to service a MEF, NCOs were required to assume greater responsibilities. These disbursing pay agents made over 260,000 individual cash payments totaling nearly \$27 million to Marines and other servicemembers. It was not unusual for a corporal to sign out several hundred thousand dollars and then, as a member of a mobile support team, drive from unit to unit making payments to Marines. In some instances these Marines would be cash couriers for deliveries between disbursing detachments and tasked with carrying over \$500,000.

Pay support was provided to all servicemembers (Marines, sailors, soldiers), as the Marine disbursing agents, at times, represented the only pay support present within the I MEF AOR. This deployment also represented the most extensive support provided to other Services by Marine Corps disbursing in decades. With over 22,000 Marines signed up for the Marine Corps split pay program, other Marines and other servicemembers were offered casual payments (\$100 per month) as well as check cashing services. The support provided by disbursing agents was not only extensive but also encompassing. Marine disbursers deployed well forward with over 90 percent of the overall number of disbursing agents placed in Iraq. Again, pay services were heavily utilized as Marines were provided access to the tactical field exchanges where they could purchase hygiene items, sundry food items, and miscellaneous field gear.

Another success story worth expanding on is the relationship between the civil affairs teams and their designated field ordering officer, translators, and disbursing agents. Together this team provided the commander with an important tool in winning the hearts and minds of the Iraqi people. Small purchases from local vendors went a long way in bridging cultural gaps and establishing working relationships; the sooner local Iraqis could be convinced that our intent was positive, the sooner the reduction in distrust and tension.

Support for I MEF contracting exceeded \$600 million in payments. More than 6 months before the deployment, coordination was made with the National Bank of Kuwait for the purpose of establishing a local depository account. Approval for establishing this account was required by the U.S. Embassy in Kuwait. With an account established at the National Bank of Kuwait, payments could be made by local check and currency. This capability proved to be the lifeline for the MEF, necessary to procure major sources of goods and services that were required but unavailable through normal supply channels. Items purchased included vehicle rentals, food service, bottled water, and construction materials. Again, this was a transparent service to the end user yet managed by the disbursing officer (directing account activity through his designated disbursing agent in Kuwait City), as coordination was required with reachback services at Camp Pendleton for funds transfers from the Federal Reserve Bank to the overseas account.

The disbursing Marines assigned to 1st FSSG contributed in different ways. With many trained as vehicle drivers, to include the 7-ton medium tactical vehicle replacements (MTVRs), they were frequently required to support unit movements and the transportation of things. During the first days of the war, disbursing Marines

drove ammunition convoys north into Iraq directly supporting the division movement. Other duties included augmenting the battalion-level force protection teams, manning crew-served weapons, and combat operation center watch standers.

The overall concept of support for disbursing was based on simplicity—focus on pay support, make access to cash by Marines unencumbered, and provide a transparent service. Obtaining money was as easy as showing an identification (ID) card and signing your name. Mobile pay support was in coordination with the warfighter express service teams and, along with the exchange, postal, and legal services, traveled from unit to unit. These mobile support teams even went into downtown Baghdad where Marines from Task Force Tarawa were in desperate need of exchange services. Some Marines had had their uniforms and other gear destroyed in battle and appreciated the mobile exchange and disbursing services where they could purchase hygiene and uniform items. Some Marines used their dog tags (attached to their boots) as identification for payment as they had even lost their ID cards.

Disbursing management of captured currency was another unique, operationally oriented mission. Marine units seized almost 3 billion Iraqi dinars and 10 million U.S. dollars. Most of the money came from government buildings, Ba'athist safe houses, or disrupted bank robberies. The volume of Iraqi dinars was enough to literally swim in as it at times filled a 20-foot container more than waist high. The seized currency was earmarked as funds for the Office of Reconstruction and Humanitarian Assistance (later to be called the Office of the Coalition Provisional Authority). As such, commanders were authorized to spend some of the monies on various civil projects or to aid the Iraqi people. In one instance captured Iraqi dinars helped to pay for repairs to a university after rioters looted it. Disbursing agents managed the payment schedule set in place by contracting officials. The bill for the university repairs totaled approximately \$170,000 (U.S.); however, it was paid in equivalent Iraqi dinar notes. Because the devalued Iraqi dinar was used for payment, it took an MTVR truck for disbursing pay agents to deliver the currency, and special containers were used to keep the notes from spilling over the sides.

Disbursing operations also supported the tactical field exchanges and post offices. Disbursing officers receipted for over \$9 million in exchange receipts. The exchange sales were deposited with the disbursing office each night and then consolidated for a weekly electronic funds transfer payment to preestablished stateside bank accounts. The monies were then able to be recycled through this “I MEF economy” via check cashing and split payments, thereby helping to limit the need for cash resupply into Iraq. Disbursing also supported the exchange and postal units with currency support. More than \$50,000 in quarters and over \$200,000 in \$1 bills would be required to support these operations throughout the deployment.

Disbursing operations were conducted primarily in a field environment (desert, urban, temperate). Unlike Operation DESERT STORM where disbursing operations were mostly static, disbursing moved well forward and into Iraq. Perhaps the most extensive disbursing field operations since Vietnam, disbursing agents lived and operated alongside other CSS units, some even with the GCE. Marines were paid out of general purpose tents as well as from the back of 7-ton trucks. The demand for disbursing services was unprecedented and received only a nominal number of complaints and an overwhelming number of compliments. It may have been an unanticipated surprise, something that was possibly overlooked or perhaps frowned upon as less than necessary in the planning processes yet turned out to be of great benefit to commanders and a necessity while deployed for individual Marines.

Value to the Marine Air-Ground Task Force

Marine disbursing was a business force multiplier to the MEF. It facilitated and made transparent to the average Marine the procurement of large-scale goods and services necessary to conduct the I MEF campaign. Marines and other servicemembers enjoyed an unencumbered pay service that did not carry a large logistical footprint. Because the Marine Corps split pay program allowed monies to accumulate, commanders were not tied to twice a month paydays and therefore, when engaged in combat operations, could forego payments for a later time when Marines had the opportunities to spend money. The commanders and individual Marines were able to tell disbursing when they wanted to be paid. This paid big dividends and added to the overall Service mission—unencumbered support.

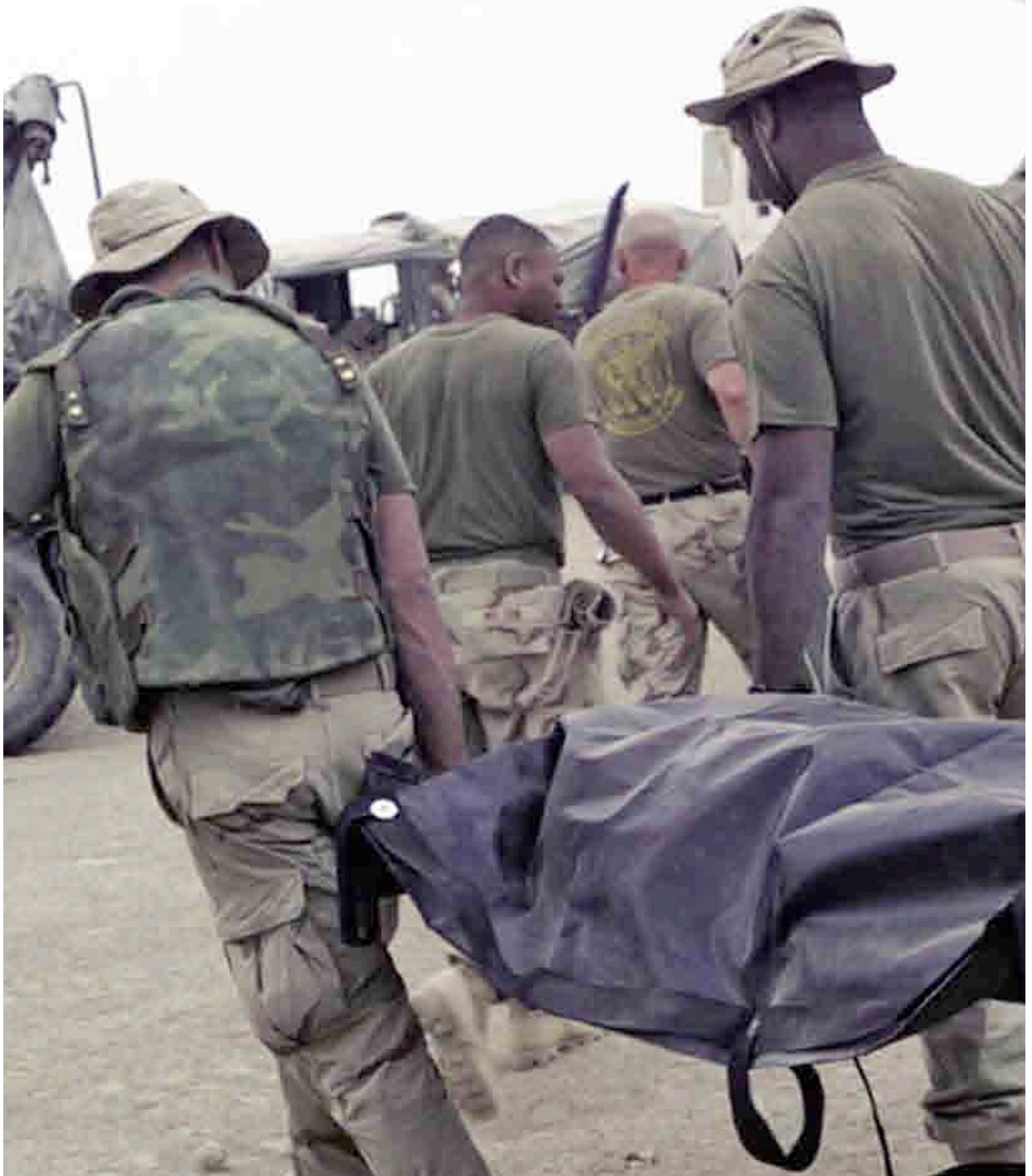



Caring for the Fallen: Mortuary Affairs in Operation Iraqi Freedom

by Lieutenant Colonel John M. Cassady, Major Jefferson L. Kaster, and Chief Warrant Officer 4 Cheryl G. Ites

U.S. Naval Institute Proceedings, April 2004.

The recovery of battlefield casualties requires respectful, competent, well-trained and well-equipped Marines to complete. Anything less places the Marine Corps at risk and breaks faith with those who have sacrificed the most.

Just off the town square in Bastogne, Belgium, is a small commercial museum. It is a worn-out place, barely eking out a living for its owners. The upper floors contain artifacts of the local farming industry, and the cellar is dedicated to the historic battle for Bastogne during December 1944. Most of the cellar exhibits are of no real significance. However, immediately on the right through the curtained entrance is an arresting display.

There are photographs of a fallen German paratrooper, killed in the battle for Bastogne. His resting place for some 40 years was under an overhang of roots, where he crawled or was left by comrades. The vegetation served as a natural crypt, preserving the soldier's remains in remarkable integrity. Discovered in the mid-1980s by relic hunters, the soldier's bones were returned to Germany, but his personal items, equipment, and photograph apparently were felt to have commercial value. Among the artifacts on display are the belt buckle with a .30-caliber bullet hole, the uniform, with dried blood and skin still clinging to it, and the helmet, with snatches of sandy-colored hair intertwined in its webbing.

Forlorn and ghoulish, this display desecrates the memory of fallen warriors everywhere. It does not matter that this man was an enemy: military ethos demands that the remains of all nations' fallen soldiers are respectfully and properly handled.

Among U.S. Marines, it is expected that those who pay the ultimate price in combat will be reverently, respectfully, and rapidly returned to their loved ones. This expectation, backed by more than 200 years of tradition, allows the living to carry on, knowing their comrade is cared for. It gives maneuver commanders the ability to execute their concept of operations unfettered. Friendly or enemy, the dead are an impediment to the actions of the living out of proportion to their number.

To be true to our values, the Marine Corps maintains a small, trained cadre to accomplish battlefield recovery of fallen Marines. This unit is comprised of reservists, and it operated with distinction during Operation Iraqi Freedom (OIF). Nearly 300 Marines from Marine Forces Reserve were activated, mobilized, and deployed to Iraq to do what no Marine wants to do—care for those who have fallen. Lessons from this mission, if considered and implemented, will ensure that the Marine Corps' mortuary affairs (MA) capability is ready for the next conflict.

Iraqi Freedom Mission

Combat produces fatalities. The recovery of remains and personal effects and the identification and evacuation of remains to a cemetery or mortuary facility are the responsibility of mortuary affairs.¹ This is a difficult job, made even more difficult when remains are disassociated, mingled, contaminated, or otherwise rendered unidentifiable by any number of circumstances created by the violence of modern weapon systems. A single pilot in an aviation crash, for example, might present multiple remains portions, each of which must be treated separately to ensure all persons involved are accounted for—e.g., a bystander who might have been hit and killed by the crashing aircraft.

For Iraqi Freedom, Headquarters, Marine Corps, used a casualty model that suggested casualties would be in the thousands.² Marine Corps mortuary affairs personnel, by definition and doctrine focused primarily on graves registration, found themselves tasked with combat recovery of remains under the concurrent return program, which required much more capability in terms of personnel numbers, skills, and equipment than existed at the outset of OIF. The need to position MA personnel forward on the battlefield, where they could be responsive to emerging requirements, and the size of the battle space resulted in a plan to employ five MA platoons (approximately 250 Marines) plus an MA headquarters. The concept of operations assumed one MA platoon would be employed with each regimental combat team.

The combat service support provider for I Marine Expeditionary Force (I MEF) was 1st Force Service Support Group (1st FSSG). Its mortuary affairs mission was to “establish MA collection points (MACP) which will receive, process, and expeditiously evacuate I MEF remains to the theater mortuary evacuation point. Be prepared to assist in the search, recovery, and tentative identification of I MEF remains and decontaminated remains as they are moved to the MACPs.”³

MA operations flow from search and recovery to processing to evacuation. There are two types of search-and-recovery operations. In the first type, the unit experiencing the death of a Marine is responsible for initial efforts to recover the remains. The unit then “packages” the remains, placing them in a sleeping bag cover or a remains pouch, and moves them to a collection point. The unit also must record the fallen Marine's identification (unit, name, and social security number), as well as the date, time, and location of death. For cross-reference purposes, the unit should provide the same information for the Marine making the identification.

The deceased Marine's major subordinate command (MSC) also is responsible for releasing the personnel casualty report. The MSC should ensure that the mortuary affairs unit and Commander, Marine Forces Reserve, are info addresses on the report.

During OIF, unit-level accountability for remains and personal effects was not properly maintained. The MA team drafted and disseminated a point paper to the commands listing proper procedures. In the future, all Marines need to be taught how to mark remains for identification, as well as to establish a chain of custody for both the remains and the personal effects.

In the second type of operation, the MA team conducts a deliberate search-and-recovery mission after collecting as much information and intelligence about the tactical situation as time allows.

In both types of search-and-recovery operations time is of the essence for a number of reasons:

- It helps the commander know his casualty rate and accountability. Personnel accountability is of utmost importance to the Marine Corps for tactical as well as public relations reasons.
- It helps eliminate confusion about a Marine's status: killed in action, missing in action, prisoner of war, etc.

Mortuary Affairs Responsibilities & Programs

The Marine Corps has three primary mortuary affairs responsibilities:

- “The Marine Corps maintains a mortuary affairs force structure capability to provide support during operations to Marine Corps units. Personnel are fully trained to provide mortuary. The Army provides back-up and [general support] to Marine units.”²

- “To facilitate the transition to and from war, the Marine Corps maintains and designates a single office as [point of contact] to respond to mortuary affairs issues.”

- “The Marine Corps provides the [Army Office of the Deputy Chief of Staff for Logistics] with a report of requirements, on-hand stockage levels, and shortages of mortuary affairs supplies and equipment stocked to support joint operation plans and [military operations other than war] on an annual basis. . . . coordinated with the Navy Mortuary Affairs Office.”

By doctrine, there are three mortuary affairs programs:³

- *Current death* “is in effect during peacetime and during hostilities of short duration when few casualties are expected. Remains are moved from a unit’s area of operation to a collection point, then to a mortuary either within or outside the continental United States, and finally to the person authorized to direct disposition of remains.”

- *Concurrent return* “is in effect during wartime. Under this program, remains move from the unit area of operation to a collection point, then to a theater mortuary evacuation point, next to a mortuary located in the continental United States, and finally to the person authorized to direct disposition of remains.”

- *Graves registration* “is used only as a last resort and only upon order of the geographic combatant commander. This program is only enacted when an overwhelming number of remains prevent normal mortuary affairs operations from occurring or when contaminated remains cannot be decontaminated.”

How the Marines Corps’ mortuary affairs assets and capabilities are trained, organized, and equipped is not mandated by doctrine. Accomplishing the three doctrinal responsibilities across the three programs requires a critical analysis of past efforts and a plan for the future.

¹Joint Publication 4-06, *Joint Tactics, Techniques, and Procedures for Mortuary Affairs in Joint Operations*; Chairman, Joint Chiefs of Staff, August 1996, pp. 1-4, 1-5. Emphasis omitted. See also FM 10-64, *Mortuary Affairs Operations*, and FM 286, *Identification of Deceased Personnel*. Both are available online.

²“Back-up” is not doctrinally defined, but however it is defined, this statement is not true. The Army provides general support, nothing more.

³See Marine Corps Warfighting Publication 4-11.8, *Services in an Expeditionary Environment*, Marine Corps Combat Development Command, September 2001, pp. 4-1, 4-2, and JP 4-06, p. 1-2, 1-3.

- It helps ensure remains are protected from the effects of weather and animals. Delay in recovery may render a body unviewable, which is an inestimable loss to the family.⁴

- It prevents hostile personnel from desecrating U.S. remains, for example, parading them around or selling them as ghoulish souvenirs, or using them as political capital in later negotiations, à la Vietnam.

- It helps sustain the morale and health of the Marines continuing the fight. They know if they fall they will not be abandoned, and they do not have to maneuver around the dead, friendly or otherwise, to prosecute the fight. In addition, as a force protection issue, rapid recovery of remains helps prevent the spread of diseases.

This “rapid response” paradigm is a uniquely Marine Corps view that is neither shared nor taught by U.S. Army MA doctrine. Rapid response requires MA platoons to be forward positioned in support of the maneuver elements, and their personnel to be fluent in the art and language of tactical operations, as well as in the profession of mortuary affairs. This operational awareness signif-

icantly improves the chance of recovering remains rapidly.

Marine MA units recover in both permissive and hostile environments to meet the expectations and operational needs of unit commanders. In contrast, current U.S. Army doctrine assumes recovery of remains by MA personnel will occur after hostile risk is reduced to acceptable levels.⁵ According to Army doctrine, initial recovery is the responsibility of the unit commander. Army MA personnel are not used until the area is secure. The Army does not risk the living to recover remains.⁶ This philosophy is completely untenable in the Marine Corps.

After the search-and-recovery operation is complete, the MA Marines process the remains. During processing, a medical officer, usually a battalion surgeon or higher, officially certifies death and the MA team establishes a believed-to-be identity and accounts for all personal effects found with the remains. Then the remains are evacuated by air to the appropriate military mortuary for positive identification and disposition to the family.

The MA teams deployed to Iraq found they lacked a substantial skill set, which threatened the MA mission. These missing core competencies included combat search and recovery; hazardous material- and nuclear, biological, and chemical-contaminated remains handling; heavy rescue; recovery operations; transportation planning;⁷ and explosive ordnance handling. MA teams also needed to provide their own security, which required availability of and proficiency in crew-served weapons.

Explosive ordnance handling is a critical skill because MA personnel frequently encounter ordnance such as fragmentation grenades, smoke grenades, and live ammunition. In one instance, an intact M-16 magazine of ball ammunition was recovered from a casualty's chest cavity.

Heavy rescue is the retrieval of remains from a catastrophically damaged structure that requires major excavating (sometimes by machine), tunneling, shoring up of the structure, and in the case of a catastrophically damaged vehicle, "jaws of life" type equipment to get to the remains. When a Marine was killed when an ammunition supply point exploded, MA personnel had to conduct heavy rescue and then process the remains, all the while surrounded by smoldering live ordnance, including artillery high explosive, white phosphorous, and primers.

It would be erroneous to conclude that Marine Corps MA operates in a Marine-only environment. Personnel in Iraq processed the remains of U.S. soldiers and sailors, foreign personnel, and civilians, including journalists.⁸ As a result, MA Marines frequently must coordinate with other services, coalition forces, diplomatic and political agencies (including U.S. and foreign Departments of State), nongovernmental organizations such as U.N. agencies, the International Committee of the Red Cross, and others. Thus, future training for MA senior noncommissioned officers and officers needs to include professional liaison skills.

MA personnel also need to coordinate the processing of remains with numerous service agencies—intelligence agencies,⁹ unit postal officers,¹⁰ civil affairs, the Criminal Investigative Division/Naval Criminal Investigative Service (CID/NCIS), Military Police, the staff judge advocate, the Armed Forces Medical Examiner (AFME), and the Disaster Mortuary Response Team (DMART), to name a few. For example, 38 MA Marines assisted in processing a U.S. Army Pavehawk crash site, which required coordination with the Army, AFME, and DMART. Over five days, these Marines laid out the recovery grid and dug and sifted a ten-square-meter area of desert to a depth of six inches. This effort recovered many remains not visible to the initial (untrained) recovery team.

The loss of a Marine CH-46 with four U.S. and eight British Royal Marines required coordination by DMART, U.S. and British MA Marines, U.S. Army MA, British liaison officers, British Headquarters, Marine air wing units, a security team, the combined forces land component commander, I MEF, AFME, and medical personnel. This crash site took eight days to close.

MA operations are unpredictable. Frequently, MA personnel are the first to discover evidence of war crimes, and occasionally find wounds that might indicate torture or murder. They also often

are involved in the excavation of mass graves, the presence of which could indicate a Law of Land Warfare violation. As part of the maneuver element, MA personnel need to understand certain components of Operational Law. Occasionally, they process the remains of suicide victims. These functions and operations require liaison with CID, NCIS, and the staff judge advocate. MA Marines need to be trained to work with these agencies to ensure proper legal authorities are notified and pertinent evidence is not inadvertently destroyed.

During OIF, Marine MA officers coordinated the transport of civilian and enemy remains from the USS *Comfort* (T-AH-20) to an interment site in Iraq or to the families when possible. These efforts involved not only the captain of the *Comfort* and MA officers, but also the civil affairs unit, Red Cross, and I MEF personnel. Burials had to be documented and a report prepared for I MEF for the combined forces land component commander. In addition, procedures for burial of enemy and civilian remains had to be approved by higher headquarters to ensure compliance with different religious demands. These procedures were received and a one-page reference sheet was prepared for each collection point.

MA personnel also were tasked with supporting criminal cases involving loss of life. In these situations, coordination was made with AFME, CID, NCIS, and other related agencies to ensure evidence was safeguarded and remains returned quickly to the families. The discovery of several mass

Training & Staffing

According to Marine Corps Warfighting Publication (MCWP) 4-11.8, “the Army is the executive agent of mortuary affairs for all Services. However, each Service plays a major role in the handling of its deceased.”¹

Prior to Operation Iraqi Freedom, the only mortuary affairs (MA) capability in the Marine Corps was a single Mortuary Affairs Platoon, located with Military Police Company C (which is part of Headquarters Company, Headquarters and Services Battalion, 4th Force Service Support Group [FSSG] in Dayton, Ohio. To increase the capability available to deploy to the Middle East, the staffs of 4th FSSG and Marine Forces Reserve developed a program to use MA Marines from the Dayton platoon to train reserve Marines. Lieutenant Colonel John M. Cassidy was activated in October 2002 to lead this effort. Beginning on 15 January 2003, the MA unit cross-trained approximately 300 Marines—from Rations Company, 4th Supply Battalion, Anacostia, D.C., and Battery A, 1/14, Aurora, Colorado, and Headquarters and Service Battalion, Marietta, Georgia—in mortuary affairs.

Currently, Marine Corps MA personnel are trained at the U.S. Army Mortuary Affairs Center, Fort Lee, Virginia. There is only one military occupational specialty for Marine Corps MA personnel: 9051, Graves Registration Specialist, and it is a skill designator only, for all grades from lance corporal through master gunnery sergeant.²

According to MCWP 4-11.8, MA Marines “conduct tactical search and recovery operations in hostile, benign, and/or contaminated environment; recover personal effects and record personal information; conduct temporary interment/disinterment; and conduct temporary burials, if necessary, of human remains. The platoon must also be prepared to establish and operate casualty collection points, supervise theater evacuation point operations, and coordinate the transfer of remains and personal effects of deceased service members.”³ The MOS manual requires a larger skill set.

¹Marine Corps Warfighting Publication 4-11, Services in an Expeditionary Environment, Marine Corps Combat Development Command, September 2001, p. 4-2.

²USMC MOS Manual, pp. 3-397 and 3-398.

³MCWP 4-11.8, pp. 4-2, 4-3.

gravesites led MA Marines to partner with Iraqi civil authorities and civilian communities. A mass gravesite in southern Iraq required coordination with the Kuwaiti government, I MEF, and the combined forces land component commander to ensure proper excavation and repatriation of remains to Kuwait. The MA officer was tasked with liaison duties and coordinating the efforts of different commands to ensure compliance with international laws and procedures.

Future of Marine Corps Mortuary Affairs

The clarion call for MA in the Marine Corps as a result of OIF is that MA must be a primary focus. The training, equipping, and organizational structure of the entire capability must be updated:

- Foremost, mortuary affairs needs to be restructured as a primary military occupational speciality (MOS), and relevant, practical doctrine, techniques, tactics, and procedures need to be drafted and implemented. Specifically, two new MOSs need to be created, and the MA establishment renovated to reflect a permanent professional capability within Marine Forces Reserve, including permanent professional schools. In addition, two MA platoons should be created within the present Reserve structure and relocated from Dayton, Ohio, for easier access to training and education facilities—ideally, close to or located with NBC units, somewhere along the eastern seaboard.

- The MA capability must be part of operational and tactical planning from the earliest stages. It will require that MA Marines be included in drafting the ops plan and that the MA capability is in theater, on the ground, and forward deployed with the maneuver elements as early as possible.

- Marine Forces Reserve MA Marines need meaningful annual training—working with the Central Identification Lab, Hawaii; Chemical Biological Incident Response Force; Federal Emergency Management Agency; DMART, and other military and civilian homeland defense or domestic crisis response agencies.¹¹

- MA issues should be integrated into traditional training exercises. Marines of all grades should be introduced to MA and understand their roles in the recovery process. This can be done at basic training and at professional military education schools, including noncommissioned officer courses and Command and Staff.

- MA units need to be properly equipped for the mission. Among the most pressing needs are better tables of equipment and allowances. Specifically, MA units need communication and motor transport assets, refrigerators, and enough MA-specific tools/supplies to equip 150 Marines.

Failure to correct the problems identified during Iraqi Freedom will cripple our ability to properly recover, process, and return our fallen Marines to their families. The recovery of battlefield casualties is a long and involved process that requires respectful, competent, well-trained and well-equipped Marines to complete. Anything less places the Marine Corps at risk and breaks faith with those Marines who sacrifice the most.

¹Marine Corps Warfighting Publication (MCWP) 4-11.8, *Services in an Expeditionary Environment*, Marine Corps Combat Development Command, September, 2001, p. 4-1. Hereinafter MCWP 4-11.8.

²What was not predicted was the number of civilian, coalition, and enemy combatant deaths. Had the actual number approached the prediction (even one mass casualty event) Army and Marine MA capabilities would have been overwhelmed.

³Tentative identification, otherwise known as “believed-to-be” identification is made by a casualty’s unit members based on personal knowledge or by recovery personnel based on identification cards and other identifying material. Positive identification is made by the armed forces medical examiner based on dental and/or DNA tests once the remains have evacuated to either Landstuhl, Germany, or Dover, Delaware. For the Marine Corps, there were no reported discrepancies between tentative and positive identifications. At this writing there are no unknown Marine casualties from OIF.

⁴In today’s era of embedded reporters and cellular telephones, rapid recovery is critical as it relates to the casualty call for the family.

⁵The initial Army model for OIF was to deploy teams from Germany to recover remains after combat operations ceased. This changed once ground combat operations were under way, and Army MA assets were moved into theater. Such delay could have resulted in the MA assets on the ground being overwhelmed, particularly in cases of mass casualties or chemical, biological, or radiological contaminated remains.

⁶Thomas Bourlier, director, Mortuary Affairs Center and School, Ft. Lee, Virginia, interview with authors.

⁷MA units did not have organic transportation assets, as these assets arrived in theater late because of transportation shortages. 1st FSSG supplied vehicles to MA units, meeting minimal requirements. MA Marines need to know how to request air and ground transportation assets from higher headquarters and coordinate their efficient use, to include proper convoy techniques.

⁸1st FSSG MA Marines processed remains of U.S. Marines, soldiers, sailors, and personnel from England, Jordan, Argentina, Canada, Kuwait, and Iraq. The remains were those of soldiers and civilians, including journalist.

⁹MA needs to coordinate with these agencies before identification media are stripped from the enemy remains.

¹⁰Hopefully, the casualty call has been made to the next of kin before mail is returned as undeliverable.

¹¹From a recruiting standpoint, including these skills makes an otherwise unattractive MOS palatable to those who have the mettle, desire, and capability to do this kind of work. These skill sets are very marketable in the civilian sector, particularly in professions related to homeland defense (fire, police, emergency medical technician, etc.)





MCLB Corpsmen Return from Iraq

by Corporal Joshua Barhardt

<http://www.leatherneck.com/forums.showthread.php?t=8329>>.10 July 2003.

MARINE CORPS LOGISTICS BASE BARSTOW, Calif. (July 10, 2003)—Eleven corpsmen from MCLB Barstow were deployed in support of Operation Iraqi Freedom.

Some of those who were attached to forward Marine units have started returning home. Their experiences over there are just some of the many shared by U.S. service members during the war.

“I was deployed with 3rd Battalion, 4th Marines, Lima Company,” said Hospital Corpsman 3rd Class Jay-R Enguillado, a corpsman attached to MCLB Barstow’s Branch Medical Clinic. “We went into Iraq at night time and went all the way to Baghdad.

Enguillado said they didn’t really encounter major resistance.

“We only had two major battles on our way to Baghdad,” said Enguillado. “We stayed where Saddam’s statue was torn down.”

Enguillado said the Iraqi people destroyed the statue.

“When we got there the statue was gone,” said Enguillado. “The people took the head off and it disappeared.”

Even though they saw some fighting, Enguillado said he only treated minor wounds on Marines.

“I only had to treat a couple shrapnel wounds,” said Enguillado. “I treated mostly civilians who stepped on land mines or got shot by their own people.”

“The worst thing I saw was a 5-year-old kid with his face all burnt up,” said Enguillado. “I wrapped it up for him and sent him on his way because that’s all I could do for him.”

Enguillado said the civilians knew he was medical personnel.

“I guess they figured out our rank or something, but the civilians would always know I was a corpsman and

come to me for help,” said Enguillado.

Enguillado said he had enough Meals Ready to Eat to last him a lifetime.

“I don’t ever want to eat M&M’s or Skittles again,” said Enguillado.

Hospital Corpsman 3rd Class Phil Alexanian was deployed with 3rd Battalion, 4th Marines, India Company. He said he was there to watch the Saddam statue come down.

Alexanian said combat wasn’t fierce, but it still will stay with him.

“I saw enough,” said Alexanian. “I saw all I wanted to see.”

“The worst thing I saw was actually the first thing I saw,” said Alexanian.

He said he went into an area after it was attacked by an AH-1W Cobra helicopter and came across an 8-year old boy who was missing the bottom half of his face.

Alexanian said the boy was probably injured during the attack. If the boy was injured during the attack, it’s an example that it was nearly impossible to eliminate collateral damage even though the U.S. military went to great lengths to limit civilian deaths and injuries and to minimize damage to nonmilitary facilities.

“When I came home, my wife and mother had it on video tape because one of the embedded reporters was there and it got put on the news,” said Alexanian.

He said that he heard the boy survived because the boy was airlifted to a hospital for medical treatment.

Alexanian was among many American combat medics who treated scores of Iraqi civilians and service members throughout that country.

On April 8 it was reported that there were nearly 300 wounded Iraqi soldiers and civilians being treated in coalition hospitals, and many more were being treated medics on the battlefield.

Alexanian said the Iraqi people were really happy to see them.

“All the Iraqi’s were full-on happy we were there when we came into Baghdad,” said Alexanian. “They kept saying, ““Good Bush.””

When the armed forces took over Baghdad, Alexanian said the looting was pretty serious.

“It made the L.A. riots look like a joke,” said Alexanian.

Chief Petty Officer Dave Bockelman was attached 1st Battalion 7th Marines Headquarters and Service Company. He helped set up battalion aid stations and get them ready for triage and other aspects of medical care for when the United States moved into Iraq.

He said there is definitely things he will remember.

“Well I definitely remember getting shot at with RPGs,” said Bockelman. “That’s something you don’t forget.

“A lot of the trauma was with Iraqi soldiers and civilians,” said Bockelman. That was because the Republican Guard were setting up their civilians in areas they knew we were going to hit.”

Bockelman said when they got to Baghdad, they were in charge of some presidential palaces.

“I got to go into Saddam’s closet and look at his stuff,” said Bockelman.

The following corpsmen were sent to Iraq from MCLB Barstow’s Branch Medical Clinic: Enguillado, Alexanian, Bockelman, Hospital Corpsman 3rd Class Dominic Topete, Hospital Corpsman 2nd Class Terry Morocco, Hospital Corpsman 2nd Class Jimmy Oglesby, Hospitalman Micah Davis, Hospital Corpsman 1st Class Advinto Alejo, Hospital Corpsman 3rd Class Jay Angle, Hospital Corpsman 1st Class Allen Maluto, and Hospital Corpsman 1st

Class Dave Pope.





Marine Corps CH-46's Vital to CASEVAC Missions in Iraq

by Sergeant Matthew P. Shelato

<globalsecurity.org/military/library/news/2003/07/mil-030729-mcn05a.htm>. 30 June 2003.

ALI AL SALEM, Kuwait (July 30, 2003)—During peacetime in their home country, sick and injured service members can typically rely on emergency medical services and an ambulance to transport them quickly to a nearby hospital.

When those servicemembers are sent to the front lines on foreign soil, however, conventional means of transporting injured personnel are “up in the air.”

During the fighting to depose former Iraqi president Saddam Hussein and his regime, wounded warriors on both sides of the campaign have learned to trust the corpsmen and Marines flying aboard the CH-46E helicopters of the First Marine Expeditionary Force's Casualty Evacuation Teams with their lives.

To date, I MEF casevac teams have had a 99.007 percent survival success rate in the treatment of U.S. service members, enemy prisoners of war and Iraqi civilians cared for by aircrew casevac corpsmen, according to Navy Lt. Erik P. Voogd, flight surgeon of Marine Medium Helicopter Squadron 165.

In this conflict, the enemy has had the “hometown advantage” and the most intense ground fighting has been done house-to-house in urban areas. Regardless, the death rate for servicemembers during Operation Iraqi Freedom is only one-eighth what it was during the Vietnam War and the Gulf War combined, Voogd explained.

“I'd like to say medicine is better today,” Voogd said of the degree of success the Casevac flights have had in saving lives. “But the one thing making a difference here is how quickly we get in there and remove those (injured) Marines from danger. That couldn't be done without combat pilots and aircrew who can get to a hostile landing zone and get the patients out.”

According to Voogd, a Parkersburg, Iowa, native, the most critical period of time for anyone who is seriously injured is the “golden hour,” or the interval between the occurrence of the injury and the administration of first aid. The faster a patient with a gunshot wound or shrapnel injury can get to an established medical facility, the better the victim's chances of surviving. During the operation, one of the best methods of getting out of harm's way has been aboard the “Phrogs” of the casevac team, said Voogd.

“These guys flew in horrible conditions, facing everything from Iraqi aggressors to bad weather, to get as close to an injured Marine as possible,” Voogd said of the ability of the CH-46 pilots

and aircrews. “During the heavier fighting, they would fly low and slow to make their way through dust storms and low visibility just to pick up a patient.”

Each member of the aircrew, including the medical corpsmen, has been trained for combat situations, including operating in a “hot” landing zone, near active combat operations. The “Devil Docs” are also qualified to operate the two .50-caliber machine guns aboard the aircraft, which are meant for defending the crew and helicopter when in danger.

Other helicopters, such as the CH-53E and Army UH-60, were used opportunistically for Casevac missions, while the CH-46 belonging to the Marine Medium Helicopter Squadrons here were the primary aircraft tasked with casualty evacuation. Other types of missions flown by the Phrog squadrons include assault support and command and control flights.

“There’s definitely a difference between a casevac and a medevac flight,” Voogd said.

Voogd said the medical evacuation system, or “Medevac” flight, were created as a means to carry wounded or ill personnel from an established battalion aid station or an basic medical facility to a higher echelon medical clinic. The primary helicopter used for Medevac missions has been the Army UH-60A Blackhawk, with CH-53D and CH-46E and aircraft also participating in medevac operations.

Casevac missions flown by Phrog squadrons have medical corpsmen on hand who are trained to treat trauma patients. The hospital corpsmen who fly aboard casevac missions have completed combat aircrew training and can assist the aircrew and pilots during flight operations. A casevac aircraft is capable of landing near an active combat zone, loading patients rapidly and defending the aircraft from enemy fire upon withdrawal.

“We can assist the pilots when landing, make sure the (landing zone) is clear, then jump out of the aircraft and take care of the wounded.” said Petty Officer 2nd Class Jeff S. Coslett, search and rescue medical technician for HMM-268.

Coslett, a member of the I MEF casevac team, has experience as a civilian paramedic in his native city of San Diego.

“It’s a different experience when someone is shooting at you,” Coslett said, comparing his service in Iraq and San Diego. “Working in a combat zone is a reality check—it’s so loud on the aircraft, we couldn’t tell when (the enemy) was shooting at us and the patient can’t usually tell me what’s wrong with him,” said Coslett.

Even in the “fog of war” created in a combat zone, Coslett said the medical corpsmen attached to the infantry units were giving the injured warriors the best treatment available.

“The corpsmen on the ground were the ‘Johnny on the spot’ guys,” Coslett said. “The work they did for the injured was outstanding—a patient would always be packaged up and ready for evacuation by the time we were there to pick (the patient) up.”

Once the wounded were flying aboard the helicopter, traveling at speeds reaching 145 knots, the work of the casevac team’s corpsmen had just begun. Several of the patients were in need of constant medical attention, which was made difficult by the environment aboard the aircraft.

“If you could picture an emergency room or an ambulance back in the states, it would almost be a controlled environment,” Coslett said. “Here (on a CH-46E) it’s difficult to even take a pulse because of the noise and vibration. We constantly have to make decisions from our experiences and training.

The casevac team also saved the lives of several Iraqi civilians and soldiers who needed medical attention. Coslett said his team carried more injured Iraqis than coalition forces, but the language barrier was only one difficulty overcome by the Corpsmen providing medical care for the enemy.

“A Marine knows I’m there to help him, but an (Iraqi soldier) might not understand,” said Coslett. “He’s probably asking himself, ‘Who is this, and what is he doing to me?’”

The casevac teams often risk their lives to be able to help others. During the conflict, the corpsmen and aircrew would remain as close as possible to the infantry units they were supporting, enabling them to get to a patient as fast as possible.

When on standby, the casevac team’s nights were often spent near or aboard the aircraft, usually sleeping on the same stretchers used to carry the wounded. Coslett recalls long nights spent near the front lines, eating Meals Ready to Eat while listening to “talking” artillery and receiving enemy mortar attacks. “Iraq artillery

would land nearby, almost too close sometimes,” Coslett said.

“Our artillery would respond with their own barrage and the enemy would usually get one more chance to return fire. By then our guys had zeroed in on their position, and we’d hear ‘BOOM BOOM BOOM!’ and (the Iraqis) would stop shooting back.

The skill of the medical corpsmen and aircrews of the I MEF casevac teams are evident in the amount of success they’ve had in saving lives during Operation Iraqi Freedom.

“I don’t see how anything I’ll ever do in the future for the Navy will ever compare to what I’ve done out here,” Coslett said.



Operation Iraqi Freedom: A Surgeon's Perspective

Captain Stephen F. McCartney, MC, USNR

Navy Medicine, March-April 2004.

During a sophomore medical school lecture I clearly recall being told that the only person who ever benefits from war is the surgeon. It sounded rather bold, masculine, and right up my alley since I had already decided to be a surgeon as early as junior college. I suppose that is why I have always remembered that comment for almost 30 years. Or maybe it was because the guy who said it was a real geek. I could never quite reconcile where he came about that bit of treasured knowledge that only a macho surgeon should know. I'm still not sure about those particulars but I recently found myself as one of those surgeons mentioned.

Far from being a medical student, I was a 54-year-old vascular surgeon in the Navy practicing in San Diego. Since 11 September 2001, I had the experience of serving on USS *Enterprise* (CVN-65) as she launched the first strikes into Afghanistan and most recently being deployed to Kuwait and Iraq for 5 months.

In January 2003 nearly 200 personnel from Naval Medical Center San Diego reported to the First Marine Expeditionary Force at Camp Pendleton for the purpose of providing surgical support to the large operational combat force. Three general surgeons, one vascular surgeon, as well as two orthopedic surgeons, podiatrists, oral surgeons, and a gynecological specialist made up the corps surgical team. Nine non-surgical physicians as well as six dental officers, two psychologists, a psychiatrist, and a chaplain completed the team. Twenty-four nurses and more than a 100 corps staff and 32 Marines joined us as support. We left Camp Pendleton in early February and flew from March Air Force Base to Kuwait.

After several hours, we arrived in northern Kuwait at the logistical support area base called LSA Coyote near the Iraqi border. Fortunately, we had tents to stave off what was surprisingly cold weather, especially at night when we slept fully dressed. We had been issued 9mm Beretta side arms with ammunition, as well as flak jackets, Kevlar helmets, a variety of undergarments, mosquito netting, sleeping bags, and canteens.

By no means were we completely unprepared. We had been assigned to this "platform" long before and had trained for such desert operations. Two other surgical companies joined us and we became the Alpha, Bravo, and Charlie surgical companies, each given a specific surgical mission for the upcoming war. I was assigned as chief of the medical staff of Alpha Company, and we promptly unloaded 212,000 pounds of our gear from large metal shipping containers off flatbed trucks. In less than 24 hours we stood up what is known as a level 2 combat surgical hospital. This was my first sense that the essence of teamwork was going to be defined over and over again in this mission.

We received our first surgical case within hours of turning on the first 200kw generator. On one of our six operating room tables, we saw two of the biggest peritonsillar abscesses we had ever drained. Within days, an errant M16 round shattered a leg, which required surgery. Within hours, we also diagnosed a case of acute appendicitis, and operated on the Marine. We fully engaged in providing surgical care to over 25,000 Marines and coalition forces in the only Navy hospital in Kuwait, seeing more than 900 patients and performing 24 surgeries even before the beginning of the war.

All the while, we conducted 24 mass casualty drills. The shrill whistle signaling incoming casualties was a common occurrence. We drilled for the smooth flow of severely wounded from the landing zone a half-mile away all the way through the postoperative ward. These exercises emphasized all scenarios from dealing with retained ordnance, threatening POWs, chemical assault, compartment syndromes, and pulmonary emboli. Our camaraderie and confidence grew exponentially at Alpha Surgical Company. We would need every bit of it as 20 March arrived with a roar.

Operation Iraqi Freedom Begins

With no TV, usable phones, and internet and mail being non functional for the most part, we only knew what our intelligence briefs had confirmed. War was imminent. Convoys had been driving by Camp Okinawa (the 2-acre plot where Alpha Company was stood up) for 3 days without a break. Marine generals were dropping by for "tours" of our hospital more frequently. I believe it was for that last minute "warm fuzzy" of knowing we were ready for their soon to be bleeding Marines. I made sure we had enough type O blood on hand, our walking blood bank was ready to make up for any shortfalls, and our anesthesia machines were stocked with enough Forane for unlimited use.

The night before the war started, we experienced the first of 36 scud missile attacks. These attacks sent us diving for cover into 8-foot-deep bunkers. So much to remember. Gas masks on, gas masks off when the “all clear” signal is given. Don’t run in the pitch dark or you will find yourself impaled on an angulated tent stake aiming at your lower abdomen. Know the password of the day, or the sentry will shoot. Alpha Company fostered no misconceptions now, as Silkworm missiles impacted a few miles away. Our commanding general enlightened me that it took 123 seconds for a scud missile launched in Basra to impact at Alpha Company. My desire to appear “in the know” was slightly less than my desire not to terrify the company, so I never shared that bit of information until days later.

The next morning the first CH-46 helicopter arrived with several wounded onboard. One was an Iraqi officer with a large open defect behind his knee from an M16 round. He was white as a sheet and tachycardic, but I saw a clear save here if we could get some blood into him. Multiple IV attempts by the best of us failed. As we exposed the saphenous vein for cannulation, he arrested and died from prolonged hemorrhagic shock.

The same ambulance carried a Marine officer. He was dead, shot through the abdomen, with the round exiting his lower back. I had to enter the ambulance to record the injuries. I had seen plenty of dead, having trained in a trauma center. But this was a “good guy,” not some gang banger from an inner city neighborhood. It didn’t quite fit. I noticed the quiet as he and I shared the inside of the ambulance. I would feel this disconnect many times in the next few weeks.

C-130s joined the helicopters to bring in the wounded. It was controlled chaos. Calm determination described our hospital company. All were committed; all were somewhat numbed. No one complained; they just worked. They all had the same blank look on their faces. They all remembered the young officer. There was no more rationalizing, no more denials. This was war, and no one faltered.

We received a group of Marines and a Navy corpsman. All had leg injuries from landmines. The corpsman triggered a mine while running to the aid of one of his injured Marines. Their muscular legs were horrifically deformed and shredded. Under the tent lights, the shrapnel glistened and reflected from inside their wounds. The Marines were quietly answering questions, polite and dignified. Even their injuries and pain didn’t keep them from saying “Yes ma’am, no ma’am” or Yes sir, no sir.”

The general surgeon met with the orthopedist for an ad hoc discussion about immediate amputation versus limb salvage in some of these cases. I had started this policy a few weeks earlier to ensure all amputations were deemed the best option with the agreement of at least two surgeons. Two Marines and the Navy corpsman left the resuscitation area for the OR. Their legs would have to be amputated.

Four hours earlier in southern Iraq, a rocket-propelled grenade (RPG) interrupted a smoke break in the cab of a 7-ton truck, hitting the three Marines inside. Two arrived with shrapnel in their eyes and necks but not serious enough to warrant immediate surgery. Their master sergeant had open head wounds, skull fractures, and was not arousable. He was intubated. He went to surgery, bleeding profusely from the head and face. The OR team arrested the bleeding and, while still intubated, staff took him to a Blackhawk helicopter. He would see an Army neurosurgeon within 2 hours and undergo more surgery. Later, we heard he had survived.

A helicopter dropped off several Marines ambushed while taking an Iraqi surrender. Nine of their fellow “devil dogs” were dead.

An RPG killed a 26-year-old corpsman from our hospital. Many of the Alpha Company staff knew him from San Diego. He had two children and a wife. Alpha Company began to hurt, but the numbness quickly disappeared. It had to. There was more work to be done.

A friendly fire injury brought in more Marines. One escaped three burning vehicles, only to be badly injured by 30mm fire from our own A-10 Warthogs. His treatment included an exploratory lap, a colostomy, and debridement of buttock and flank wounds prior to being medevaced.

An Army soldier arrived after being shot through the left thigh; he had no pulses. I joked with him about checking for proper HMO authorization. He laughed loudly. His artery was grafted and regained its pulse. One hour after surgery, he was evacuated.

As we left for the OR, stretcher bearers lifted a Marine behind me for his journey to surgery. He looked down from the stretcher at the large puddle of blood underneath and apologized to the nurse for leaving a mess behind. He said his mother taught him always to clean up after himself. Looking at his face, it was clear it could not have been all that long ago. He appeared barely 18. I asked myself “Where do these young men come from? What makes them able to do this?”

How does the Marine Corps find them amongst all others?" At this point I took my one and only trip to the "time out" box. I needed to take some deep breaths out in the cool night to regain composure before surgery. While this young man was losing his leg a Saddam Fedeyeen arrived. A very serious Marine stood over him with an M16.

Treatment for this enemy patient turned out to be uncomplicated. A Marine sharpshooter had previously placed a shot through his left eye which exited a large defect on the side of his head. I had a quick consultation with our Catholic Dominican chaplain and the patient was made comfortable. He arrived in "martyr's heaven" early in the morning while most of us were curled up on or under racks (cots), anywhere we could find them.

The incoming patients continued for 5 to 6 days. As the war moved north, and Bravo and Charlie surgical companies arrived in Iraq, our activity lessened.

From the "front" we received many walking wounded and some of those operated upon by our sister companies. The number of patients arriving with horrific injuries decreased, as did the unannounced arrival of dead soldiers and Marines. Emergency surgeries stopped almost as quickly as they started a week earlier.

Nevertheless, terrible weapons accidents, as well as some heartbreaking suicides still occurred. Tired young men crashed their trucks. No one wore seat belts as there was a morbid fear of being trapped after an RPG attack and not being able exit the vehicles. Weapons at the ready are hard to use when confined by a seat belt.

Some personnel were just careless. In quiet rage, I noted their mangled bodies and considered how they made it through the war, only to die in an accident. Seeing the carnage still occurring after combat operations were over was very difficult for Alpha Company.

By late April, we thought free passes or "get out of jail free" cards should have been distributed. But it was not to be. Painful, albeit irregular, events plagued us. The Combat Stress Team and chaplains worked 24 hours a day, 7 days a week dealing with Alpha Company's many heroes. Even though the superlative performance of so many young people was remarkable, it was preposterous to think that anyone could get through this experience without serious emotional and spiritual wounds. Some had never seen a dead body, certainly not someone their own age. Many of us with children had to sort out what we had experienced and how these events might affect them. Over the years, the replays will become uninvited and unwelcome guests. And we will all have to deal with them.

Early on, we dealt with our our feelings privately. Then small groups formed up to discuss things, in most cases indirectly. No one wanted to awaken the sleeping monster yet, just whisper a bit and get some relief and sleep. One day, it seemed, we all had the same epiphany. We discussed things, and, since then, we haven't again spoken about the most painful events. There just wasn't anything else to say. Even now, I cannot describe the feelings, so it's best not to speak about it anymore. Perhaps later the words will come. I feel everyone's journey will be different.

The Iraqi People

In May I accompanied the commanding general, of "123 seconds" fame and assisted with medical affairs throughout Iraq and Kuwait. I was impressed by the infrastructure already in place. As opposed to Afghanistan, Iraq has much of what it needs. It just doesn't work. I saw the opulence of Saddam's palaces next to the harsh environs of his people. Children and teenagers jumped up and down on the streets happily when we drove by in convoy. Many adults looked at us blankly or with open hostility. Most of the Iraqis I interacted with are pleasant. The father of a severely injured 12-year-old boy we cared for taught me much about the people and how they feel. This date farmer, who actually held an MBA, now loves the three Navy doctors who cared so much for his son, even though he was very angry and hostile in the first days. I couldn't blame him.

Perhaps nation building starts with the healing of people, one by one, heart by heart. I never wandered about alone when I was in their cities. I was always armed with a pistol and sometimes an M16. True, meaningful social interaction is sharply stunted when you dress like this. But it was essential in the towns near Baghdad. Interestingly, about the time you think they all want you dead, a few people will walk up, as they did to me and say, "Thank you America. . . thank you George Bush." I feel whoever gives them water, fuel, and electricity will always have their gratitude. They are very intelligent people, proud but dreamless, damaged by Saddam and other elements for so long. They love their children as we do ours. There are no great differences between moms and dads no matter where you live. The real future of Iraq, I believe, lies within the hearts of those kids jumping and dancing in the street. I hope they get a government that allows them the freedom to dream. I hope also that someday they will never forget the hundreds of young Marines, Sailors, and Soldiers who sacrificed their future and died in Iraq so these children could have those dreams fulfilled.





U.S. Shock-Trauma Platoons Put Emergency Room in Iraq: Units Treat Marines, Civilians, Prisoners

by James W. Crawley

http://www.signonsandiego.com/news/iraq/marines/20030417-9999_1n17medics.html. 17 April 2003.

BAGHDAD, Iraq—The man, his face wrapped with duct tape, his torso marked by dozens of purplish-black bruises, was dumped at a Marine Corps checkpoint in northwest Baghdad.

His attackers said he had opened fire on a crowd of civilians, who then caught and beat him.

Navy corpsmen pulled the tape from the moaning Iraqi and began examining his injuries.

“It looks like he met Mr. Ax Handle,” said Lt. Cmdr. William Cupo, a Navy emergency-room doctor from Camp Lejeune, N.C.

Cupo is in charge of Shock Trauma Platoon 4, which has been treating Marines from Camp Pendleton and Iraqi prisoners and civilians since the war began last month. The 20 medical personnel are from military hospitals in North Carolina and Florida.

Many of the wounded Marines have been cared for by small units of doctors and medical workers assigned to several such platoons—portable emergency rooms designed to stabilize patients before they are airlifted to field hospitals farther in the rear.

During a recent two-day period, Cupo’s group treated more than a dozen Marines and Iraqis who had suffered injuries such as internal bleeding, third-degree burns, broken bones, cuts, dehydration, and gunshot and shrapnel wounds.

“If they get to our door, we take care of them,” Cupo said.

The doctors wear flak jackets and sidearms. Marines guard captured Iraqis as medical personnel perform their work.

“It’s a challenge for the staff (to treat prisoners),”

Cupo said. "Six or seven hours ago, he wanted to kill us."

Cupo strode around the platoon's treatment tent with his hands grasping the armholes of his protective vest, supervising corpsmen as they administered morphine and started intravenous fluids.

Grabbing a laptop-size ultrasound machine, Cupo moved a transducer over the beaten man's abdomen. Resting the monitor on his left hip, the doctor ran the sensor back and forth, looking for any internal bleeding.

Cupo and his colleague, Dr. Troy Borema, also a Navy lieutenant commander, suspected the man, whose name was never learned by the Marines, had internal bleeding, possibly from a damaged liver or spleen.

It wasn't known why he fired into the crowd. Some suggested the man was a Baath Party member, or perhaps a militiaman or Republican Guard member.

But because the unit doesn't have a surgeon and a fully equipped operating room, it was decided to airlift the prisoner to a Navy field hospital south of Baghdad.

The trauma platoon has been handling injured Marines, said Chief Petty Officer Torsak Vimoktyon, a senior Navy corpsman.

"We've been fortunate that we haven't had a lot of wounded," he said

Platoons like this one are a middle link in a sophisticated system to treat the sick, injured or wounded. Traveling in a small convoy of Humvees, the units can be moved close to the action.

Along with battalions aid stations and resuscitation units, called Forward Resuscitating Surgical Suites, the platoons are steppingstones for the wounded on their way to Navy surgical companies—small field hospitals dozens of miles farther back—and large hospital complexes in Kuwait and offshore, aboard the Navy hospital ship Comfort.

On the battlefield, corpsmen moving with the Marines are usually the first medical personnel to treat the wounded. Those requiring more care are taken to a battalion aid station. Some go to a shock-trauma platoon, like No. 4

Then, after evaluation and stabilization, helicopters fly them to better-equipped medical units.

If the wound is very serious, the patient can be evacuated from the field directly to a resuscitation surgical suite.

Trauma platoons use two inflatable tents that fold up into the back of specially built Humvees. Because the tents are designed to withstand chemical attack, stretchers are moved into the tent through an airlock, and medical personnel must enter through a double-door hatch with sprayers to decontaminate people.

Within a few minutes of a trauma platoon's arrival at a location, blowers inflate the tents, and the unit can be treating patients within an hour of being set up.

While every battalion has two doctors with just a year or two of experience, shock-trauma platoons such as Cupo's have two board-certified physicians, usually with extensive emergency-room experience.

The shock-trauma platoon is made up of active-duty doctors and corpsmen. Just before the war, they were assigned to this platoon and met only days before flying to Kuwait, Vimoktyon said.

There were some growing pains at first, like learning how to work together to erect the inflatable tents, the Navy chief said. But now the relationship between officers and

enlisted men is relaxed.

“We’ve worked well together,” Vimokyton said.

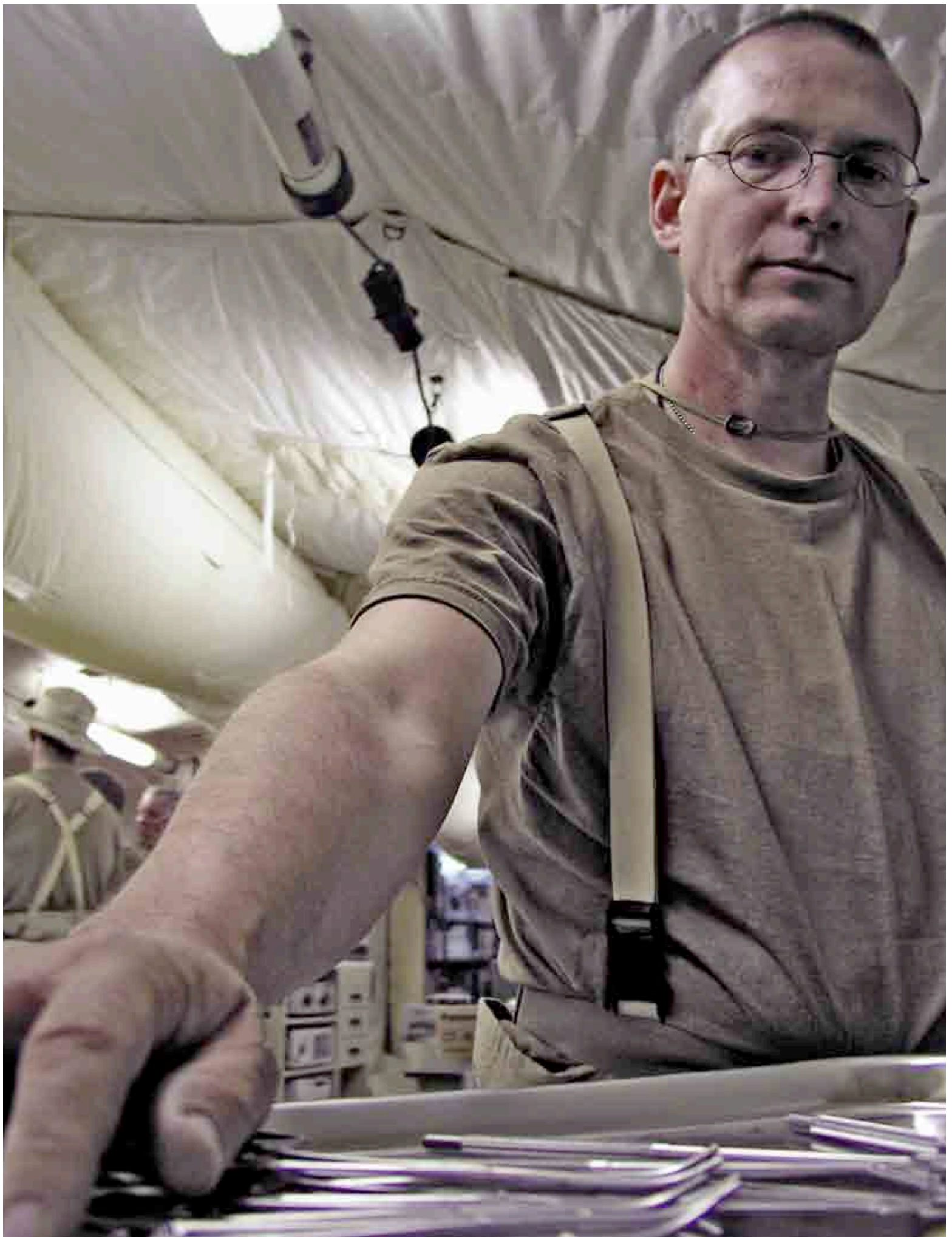

Fleet Hospital Three Makes Navy Medical History in Sands of Southern Iraq

Chief Journalist Al Bloom, USN, and Rod Duren

Navy Medicine, July-August 2003.

The responsibility of providing casualty care during Operation Iraqi Freedom has taken on a new look. While care is still delivered in the traditional manner by battlefield corpsmen and field surgery units, the men and women of Fleet Hospital Three (FH-3)—beginning 1 April—added to the lifesaving capabilities of Navy medicine by constructing the Navy’s first Expeditionary Medical Facility (EMF) in a war zone.

“I am truly impressed with the way the Fleet Hospital has come together here,” said the Commanding General of the First Force Service Support Group (1st FSSG) BGEN E.G. Usher shortly after FH-3 started seeing patients.

“The teamwork displayed to get this great facility up and running and operationally capable, while almost simultaneously starting to see patients, has been amazing.”

“The result a significant increase in our ability to save lives,” said CAPT Peter F. O’Connor, Fleet Hospital Three commanding officer.

FH-3 was a 9-acre, 116-bed Echelon III facility manned by more than 300 medical service support personnel and Construction Battalion personnel.

“Echelon One is the treatment provided in the field by our physicians and corpsmen who travel and risk their lives on the front lines,” explained HMCM (FMF/SW) Don L. Nelson. “Without their efforts, our work would be all but impossible.”

Even after receiving treatment from a field corpsman, a service member can receive care from an Echelon II facility known as a Force Service Support Group Surgical Company, but these companies, while mobile and capable of providing vital surgical capabilities, are not nearly as robust as a fleet hospital.

“When we arrived at Camp Viper, the folks attached to Charlie Surgical Company, (Force Service Support Group, First Marine Expeditionary Force) were busy receiving patients,” said FH-3 Executive Officer, CAPT John S. Gibson, who lead the advance party move from Camp Luzon, Kuwait, into southern Iraq to start construction of the fleet hospital. That trip was through a sand storm that turned a 5-hour trip into a half-day, blinding excursion. “We all knew Charlie Company was getting ready to move forward to keep pace with our forces.”

Getting to work meant the Seabees would begin surveying and grading the desert site. Upon completion, the remainder of the FH-3 staff would begin erecting tents and placing and installing equipment ranging from surgery and x-ray suites to crews’ living quarters and galley.

Treating “all” patients

As FH-3 completed its medical/surgical assignment during the latter days of May, the staff had seen more than 600 patients and performed more than 315 surgeries. FH-3 had provided compassionate care to all, including lifesaving support for Operation Iraqi Freedom, and tangible battlefield benefits.

“We arrived here knowing full well that we’d be needed,” said CAPT O’Connor. “We also knew that we’d be treating all comers. We were to take care of everyone in need of our care . . . it’s what we do.”

“We treated all patients regardless of their nationality” said HM2 Connie Martini, “To tell you the truth, there have been times when [Iraqi patients] were obviously untrusting and a little combative,” said the ICU corpsman.

“One patient in particular came in and clearly didn’t trust us,” added HM2 Martini. “He had a pretty bad attitude and even went as far as pulling out his IVs. But by the time he left, he saw firsthand that we were really here to help. He wrote down a note that we had translated. ‘Saddam bad: America good.’ That note meant a lot,” she said.

“Right now we’re one of only two Echelon III hospitals in the entire country of Iraq,” said CAPT Gibson describing the robust capabilities available at FH-3. “The majority of hospitals here are located in Baghdad, and considering how hard they’ve been hit by looting and the war, it’ll take some time until they’re back on their feet and capable of receiving patients like they were.”

“That said,” added CAPT Gibson, “the southern part of Iraq didn’t have much in terms of hospitals prior to the war. The Iraqi people need our assistance. We’re the best they’ve got right now.”

Considering what FH-3 brings to the table it may indeed be the best hospital currently in Iraq. After constructing the \$12 million facility in the desert, FH-3 personnel brought their mix of expertise to bear.

“We’ve got a strong mix,” said HMCM (FMF/SW) Nelson. “The vast majority of our folks, whether in casualty receiving, x-ray or surgery, nursing and in our (laboratory), were hand picked.”

“We’re capable in providing several different disciplines in surgery,” said FH-3 Director of Surgical Services, CAPT Charles Reese. “We have specialists in neurosurgery, ophthalmology, orthopedics, a vascular surgeon, and I’m an ENT (ear, nose and throat) specialist. Plus, we also have some outstanding general surgeons.”

Specialty shortage

Unfortunately, one other specialty area available at FH-3 has been busier than anyone desired. “We’ve got a pediatrician who has seen more than his fair share of patients,” said FH-3 Director of Medical Services, CAPT Bob Hoyt. “Many children arrived with families, and to see them going through that sort situation and trying to make the best of it was moving. The way our staff responded, it was easy to see that they weren’t just folks in a modern facility. They were doing their best to ensure there was a healing process,” said the NH Pensacola internal medicine specialist.

“We had one child with a shrapnel wound to the foot that virtually everyone fell in love with,” said FH-3 pediatrician, LT Carlos Williams, “We’ve got a lot of parents out here. That parental love crosses all lines. The love of a child allows us to recognize our common ground,” Dr. Williams pointed out.

“This hospital is our only hope,” said Dr. Hassan Ali, an Iraqi physician who accompanied a 12-year-old boy from Baghdad to the fleet hospital. The youngster suffered wounds to both legs and chest when a piece of ordnance exploded while he was playing with it. “Our hospitals are all unable to see patients,” he said. “The doctors have all fled in fear that looters will hurt them in order to take drugs and medical supplies.

“It’s harder because you want to be able to do something to soothe the children,” explained operating room technician, HM2 Bradley Gann. “They’re disoriented, in a place often by themselves, and we have a hard time communicating.

“Even when they arrive with family, the parents are often apprehensive,” added the corpsman. “We had one little girl with a bullet wound and the father was here. But he had a hard time trusting us. We were able to communicate through an interpreter that his daughter’s well-being was the most important thing to us. It really hit home, because I have a son who is about her age.”

“I hold the care of the sick and injured to be a privilege and a sacred trust . . .” reads the Hospital Corpsman Oath. Maybe it’s not really that difficult to reconcile the treatment of battlefield casualties regardless of nationality after all.

Training, training . . . and training

“Our folks went through more than a week of hands-on training at FHOTC (Fleet Hospital Operations and Training Center) in Camp Pendleton, CA,” said HMCM (FMF/SW) Nelson. “Then we successfully completed a 3-day Operational Readiness Exercise (ORE). We had to be sure we were capable of putting the hospital together once we arrived in country. We are our own construction work force.”

Adding the two training evolutions together, FH-3 personnel garnered more than 70,000 man-hours of training. After years of planning, training, and pre-positioning, there was still one more integral role to be played to ensure the successful build of FH-3.

“The construction of any fleet hospital would be impossible without Construction Battalions,” said CAPT O’Connor. “From the preparation of our initial camp in Kuwait and their driving our equipment through a blinding sand storm in the advance party to the non-stop, 24-hour days they put in once we arrived in Iraq, our Seabees from CBU 412 and CBU 402 have done a magnificent job.” “Bottom line, this has been a shining example of the definition of teamwork, added CAPT O’Connor. “I’ve said it before to our families. This is the best fleet hospital in the Navy and I’m proud to be a part of it.”

Twenty-eight days after receiving orders; 24 days after flying to Kuwait; 7 days after traveling through a blinding sand storm; 5 days after beginning construction in the desolate environment of the Iraqi desert; and 2 days after treating their first patient, Fleet Hospital Three took a moment to extend their pride in teamwork homeward. In a brief ceremony they reflected on their accomplishment and raised a flag that had flown over Naval Hospital Pensacola to signify the strong bond between everyone in Navy medicine, whether at home or in the field.

Then . . . they went back to work.

Upon opening for business 1 April, “the surgeons were operating 24/7 during that first week. It was non-stop,” said CAPT Pam Roark, head of nursing.

“The nurses were working 12-hour shifts yet it’s been the most rewarding experience in my nursing career,” said the 22-year Navy Nurse Corps officer.

After the first weeks of war, FH-3 was “surprised” and nearly overwhelmed with civilian patients and enemy prisoners of war, including women and children, some of whom had purportedly been used as human shields.

LCDR Suzanne Timmer, a pulmonary critical care physician, saw no faces of an enemy, but said the sole purpose of her being with FH-3 was “to take care of people just as I do at home.”

“FH-3 must have done a miraculous job. No U.S. or Coalition Forces’ injuries were fatal.

Some of the wounded soldiers that came into FH-3 had significant combat injuries, said CAPT Roark with an awe-inspiring hint to her voice, “but their only concern was about getting back to their units. . . not talking about going home.”

Language and children

There were several experiences FH-3 staff had involving children and families and an initial misunderstanding based on language.

“We had placed a child on a ventilator to transport to a Kuwaiti children’s hospital,” said Dr. Timmer. “We’d gotten the child into an ambulance, the father was following, and the equipment died.”

The doctors placed the child into a different ambulance, with a working ventilator, and sped off quickly for Kuwait.

“The look in his eyes told me what he was thinking,” said LCDR Timmer, “that his daughter had died . . . and I didn’t have the skills of speaking the language to explain it initially.”

CAPT Roark had a different experience with an Iraqi man who had been helping the U.S. troops with information. He was later shot in the arm by soldiers when he failed to heed warnings because he hadn’t heard them, she said. The medical team had to amputate his arm above the elbow.

“I told him I felt very badly that he had lost his arm,” said CAPT Roark. “He said his family had not known freedom for more than 35 years, and that he would gladly give his other arm for freedom.”

“Ground zero for nation building”

LT Dallas Braham, a Navy nurse and reservist, who was recalled to active duty in February, has spent the past 11 weeks as part of Navy medicine’s historical FH-3.

He hadn’t given much thought to the “historical” aspects of being the first EMF in a combat zone or the “austere living and working conditions we were in and level of care we provided,” he said recently as the command prepared to complete its duties in southern Iraq as a combat field hospital.

“Until then, we simply had a task to perform and we have done it extraordinarily well,” said the ICU nurse. “We have shown that several aspects of Navy medicine can meld together to be the immediate support for the ‘pointy end of the spear.’

“We are not warriors,” he continued, “but through our care, we have provided tactical support and have been, as one of my close friends said: ‘ground zero for nation building.’”

FH-3, through the trust it has built among the citizenry, has saved many lives outside the hospital and “some patients’ lives and outlooks within the hospital have even begun to be rebuilt,” said LT Braham. “Our success here will change the course of Navy medicine in the field,” said the 40-year-old Navy nurse.

In describing one of the more moving experiences while being a part of FH-3, LT Braham, the father of three young children, said the most difficult aspect of the deployment has been “caring for the wounded children. It was tough on me.”

“I spent several hours one night caring for a young girl who had received a gunshot wound to the head, reportedly from celebratory gunfire near the city of Basra soon after the liberation of that area began,” the critical care nurse continued.

“Through an interpreter, I spent much of that time conversing with her father as I hovered over his daughter. We spoke of our families and how protective we were of our daughters,” said LT Braham who had missed the birth of his third child while deployed.

“Through him, I think I got my greatest affirmation of our purpose to care for their wounds and for our forces to liberate these good people from the tyrant that has ruled over them.”

Part V

Stability and Support Operations



Tikrit, South to Babylon

by Brigadier General John F. Kelly

Marine Corps Gazette, February 2004.

Major combat operations ended in Iraq during April 2003. Marine and coalition forces, however, were just entering into Phase IV of the operation. This phase—security and stabilization operations—has received little attention. Following is the first of a three-part series providing details about 1st Marine Division’s Phase IV operations.

I would imagine that by now the readership has been fully exposed to the specifics of the 1st Marine Division’s (1st MarDiv’s) attack across Mesopotamia to Baghdad, Tikrit, Bayji, and beyond. As I have only just returned from the theater, I am behind in my professional reading and do not know what I have missed in terms of the operations treatment in the literature. By now I would suppose that all are somewhat aware of a plan that focused on speed—indeed, in generating so much speed that the resulting tempo would itself, in reality, be a weapon. It was also a plan that depended on mental and physical agility, multiple thrusts, bypassing resistance, reinforcing success wherever it was achieved, and creating chaos—then thriving on that chaos. Every commander was expected to be at the point of decision, not to micromanage events but to feel the battle and be in a position to exploit even the smallest successes that are always fleeting. Additionally, it looked to set conditions so ambiguous that enemy commanders, from small units in bunkers strung along the border to Saddam himself, would not understand what was taking place. That their every reaction, like the French in 1940, might in fact be the right one at the time they made the decision, but would also be irrelevant as our pace of operations had made it so. Logistically the division’s “log dogs,” heroes all to include our embedded Combat Service Support Group 11 (CSSG-11), *pushed* materiel and themselves to the limit—and did not wait to be asked. They were also innovative, and we deployed with fuel test kits in every unit to live off the land and use Saddam’s stocks if need be, and we did occasionally, just to say we could. We never ran out of food although there were a few minor, local “crises” at the end, but ammunition and fuel win. The entire division understood that getting there fast was far more important than arriving with full stomachs.

We were ordered into the attack early and unexpectedly on 20 March 2003. The division, over 22,000 strong and with 8,000 vehicles, met the timeline. Two very powerful regimental combat teams (RCTs) attacked directly into the Ramaylah oilfields, while a third moved toward the critical road and bridge network just



south of An Nasiriyah astride the Euphrates River. The Marine expeditionary force's (MEF's) second division, 1st United Kingdom (1st UK), was attacking on the right focused on Basra. The basic plan had an amazing amount of flexibility built in, and just as importantly, commanders and staff throughout the division had so socialized every eventuality that an audible was all it took to redirect an action or execute the unexpected. With an apparent focus on Iraq's most productive oilfield and facilities, one can only wonder if Saddam really did think it was all about oil. Worst case from his perspective might have been that if the invasion continued it would follow the failed British 1915 example making its way along the Tigris River-Highway 6 corridor from Basra to Baghdad. His defensive dispositions certainly suggested this was his expectation, and the MEF avoided them. What could not have been readily apparent to him or his generals was that while the three RCTs and 1st UK were taking the oilfields and associated infrastructure intact, Task Force (TF) Tarawa was already closing on An Nasiriyah and the Euphrates crossings. They also could not have known that the soldiers of the 3d Infantry Division (3d ID), "The Rock of the Marne," were out of Kuwait attacking northwest through the flat and uninhabited desert toward the capital.

Readers might be aware that after the "opening gambit" we executed a rapid relief in place with 1st UK in the oilfields, reoriented west, and by 23-24 March, after rearming and refitting in stride along Highway 1, were pushing furiously across the Euphrates. Both RCT-5 and RCT-7 would cross the Euphrates west of An Nasiriyah, while RCT-1 crossed through the eastern edge of the urban area moving directly north on Highway 7. From this point on, the attack, with the exception of an unexpected and unneeded pause, would not slow until 9 April when all three RCTs isolated Baghdad east and north of the city. Neither of the two divisions (1st MarDiv and 3d ID) were ever in favor of taking ground by a series of armored raids, then withdrawing. I cannot speak for the 3d ID, but we very definitely had our own ideas and very strong feelings in this regard and had no intention of ever again surrendering ground taken.

In reality the division's effort in the conventional stage of Operation IRAQI FREEDOM (OIF) continued even after Baghdad's fall. With nothing more than a verbal from the I MEF, in well under a day TF Tripoli was organized and on 13 April attacked to Tikrit. Combining all three light armored reconnaissance battalions for the first time ever; an artillery battalion in 5th Battalion, 11th Marines (5/11); a detachment of SEALs; and CSS and Marine wing support squadrons elements, Tripoli stole out of the capital under the cover of darkness attacking over 100 miles north to seize Saddam's hometown. A few days later the attack, this time conducted very gently, pushed an additional 45 kilometers to take the surrender and enjoy the hospitality of the city of Bayji delivered up by the enthusiastic inhabitants of the region. At this point the MEF battlespace extended some 900 kilometers from its start point in Kuwait and, in fact, Tripoli was closer to the Mediterranean or Black Sea than the Persian Gulf.

The division's main effort along Highway 1 has received the lion's share of discussion. I thought, however, for a view of how the plan was designed and executed, RCT-1's efforts (Highway 7) might provide another perspective. The battlespace was more swamp than desert and was a maze of thousands of irrigation ditches—all significant impediments to vehicular movement. The division moved in multiple thrusts with RCT-1 separated from the main body by 65 miles. Once the RCT had successfully negotiated a stressful passage of lines through TF Tarawa, forcing a crossing of the Euphrates River at An Nasiriyah, it followed a line directly north on Route 7 toward Al Kut. The Baghdad Division of the Republican Guard (RG) defended the city, but we had no intention of fighting in Al Kut. We were also not concerned about another division, the 10th Armored, 65 miles to the east of RCT-1 at Al 'Amarah.

With little regard for its flanks, RCT-1 cut loose entirely from its support base south of the Euphrates. Moving north, with speed as its primary metric, it pushed into one of the most densely populated regions of Iraq fighting through numerous urban-based ambushes. The RCT was not tasked to reduce or eliminate resistance in detail but, rather, to threaten Al Kut and fix enemy forces in the city. It could take this risk for two reasons, one of which was the innovative use of the 1st Reconnaissance Battalion as a maneuver battalion, and also to screen the RCT's eastern flank as required. Among many missions, to include taking its turn in maneuvering against urban ambushes along Highway 7, the battalion stood ready to detect any thrust from the east and call in hell as delivered by the 3d Marine Aircraft Wing (3d MAW), and this was the second reason.

Although in the MEF—and not division zone—we could only hope the 10th Armored would be lured out of its prepared positions. An armored force attacking along the very canalized axis into the division’s flank would have triggered the preplanned swarming of 3d MAW. The result would surely have been a “highway of death” all the way back to the enemy’s original defenses. The lesson again is that there is nothing you cannot accomplish, no risk too great, if you have Marine air on station not only in a close support role, but working the zone “deep” as well for the Marine air-ground task force commander. As it was, these units—both the 10th Armored and Baghdad Divisions—received virtually nonstop attention by the MAW and other coalition assets and, as it turned out, were either dead, happy to remain stationary, and a long way from their vehicles—or they would desert.

By D+6 Saddam certainly had surmised that 1st UK’s attack on Basra was to capture that city, and the expected attack up Highway 6 was not to materialize. He must have known powerful mechanized forces moving on Baghdad along three of the four avenues of approach from the south threatened him, all sidestepping his Highway 6 defenses. Without knowing which units, he certainly must have been aware that the coalition was speeding toward him on Highways 8 (V Corps), 1, and 7 (I MEF). He could not have guessed, however, that the Marines would soon turn almost 90 degrees east along Highway 27 toward An Numaniyah and grab, almost in a coup de main, the Tigris crossings upstream of Al Kut. This maneuver would “shoot the gap” identified early on by the division between the powerful artillery assets of the Baghdad Division in Al Kut and the Al Nida RG Division north on the approaches to Baghdad. Most of these systems were generally of greater range capability than our own—and also chemical capable—always a major concern during the conflict. This move also set the division up to threaten Baghdad from the east and north and, just as importantly, isolate it from possible reinforcement by RG divisions positioned near Tikrit, Mosul, and Kirkuk.

All of this I am confident has been addressed in articles and perhaps even books by now. What I am sure has not been documented, however, is the phase of OIF that evolved from 10 to 20 April when the division repositioned from its Phase III to Phase IV positions in the south. This was the phase in which we formally transitioned from conventional military operations to security and stabilization operations (SASO). In reality this phase began long before the repositioning with the establishment of a division civil-military operations center (CMOC) in Baghdad, organized by the 11th Marine Regiment (artillery). The CMOC was up and functioning even before hostilities ended as it was clear that some form of civil control was required amidst the chaos of looting, retribution, and crime. Even in faraway Tikrit the emphasis had quickly shifted from combat operations to the reestablishment of police, civil services, and production and distribution of potable water. I also do not think that there is a full appreciation for the environment in which we fought after assuming the zone, through the departure of the last battalion in early October. It was tough, stressful, and dangerous work in humidity and heat that climbed steadily until it peaked in August at 130-plus degrees! In addition to repairing infrastructure and winning over an initially hostile population, it involved day and night urban patrolling, nightly ambushes in rural areas, and forever seeking to kill or neutralize an enemy that by June 2003 was increasingly organized and determined. All of these actions, however, were executed while steadfastly avoiding injury to innocent civilians and minimizing damage to their property.

The division now faced the even greater challenges of providing security, stability, and humanitarian assistance to a country and a people devastated by decades of brutal repression and neglect. This may have seemed from some reporting like a pickup program cobbled together without much consideration, but the reality was that nearly a year prior the MEF opened discussions and worked solutions assuming the worst and disregarding the hope that some predicted for the situation once Saddam’s regime was dead. As hope is never a course of action, we implemented our program first in Baghdad, then in a large swath of southern Iraq across an area the size of Missouri with nearly half the population of the country. As many of the division’s units began the long trek home after turning the hard-won Phase III battlespace over to the Army’s 3d and 4th IDs, those left behind opened an entirely new chapter of OIF.

SASO in Baghdad

The doctrinal definition for the business that lay ahead—SASO—made the mission sound unambiguous and concise. Neat doctrinal terms did not capture the realities on the ground, however, and “Blue Diamond” (divi-

sion's call sign) embarked on an effort that although planned for in general terms, few outside the MEF, in my view, foresaw the eventual length, size, scope, and complexity of the commitment. With the removal of the regime leadership an enormous power vacuum was created, a vacuum that the Coalition Provisional Authority was simply not ready to fill. Due to the ethnic, religious, tribal, and cultural fissures that are the reality of Iraqi society, it was quite likely that the unstable security situation would degenerate into bloody civil war. Even before combat operations ended, a multitude of factions were jockeying for their piece of the post-Saddam pie. There was no time to pause and catch a breath as looting, factional violence, and tribal vendettas had already begun. Mindful of its motto, "no better friend, no worse enemy," operations to restore a sense of normalcy to the lives of ordinary Iraqis and to help set the conditions for restoring public order and services commenced. Yet, the attention paid to these new tasks did not detract the force from continuing combat actions. There were still a great many former regime loyalists, foreign terrorists, and jihadists active. For those who sought a return to repression or worked to bring violence to the streets of Iraq, the men and women of Blue Diamond responded in no uncertain terms; however, the vast majority of the population would enjoy our protection and a freedom they are still unsure how to deal with.

What became immediately obvious was that we could never sustain half of a city that contained 6 million people. To coordinate the resumption of critical services the CMOC operated out of the centrally located Palestine Hotel. Initial CMOC meetings were specifically designed to take place with participation by the city's secular and religious leaders, all recruited as full partners in the effort to repair and rebuild. With this partnership, progress was made in restoring the civil bureaucracy and the establishment of a reasonably safe environment. Both of these factors would be critical if we hoped to lure nongovernmental organizations (NGOs) to the city. In this regard we advertised an extended hand of cooperation and protection and that we looked forward to working with every NGO willing to help. Additionally, liaison was established early with the 3d ID to ensure the harmonization of civil-military operations on both sides of the Tigris River.

Coincident with the CMOC actions in early April, the RCTs shifted positions as the division received tasks to assume new missions. An internal relief in place was executed to free RCT-5 to move 50 miles north of Baghdad to Samarra and provide support for TF Tripoli's operations in Tikrit. Throughout this period all units hunted members of the former regime, and many by this time began to turn themselves in or risk identification, or worse, from local citizens. The vast majority of Iraqis welcomed us as liberators, but a wary eye and lightning quick life-and-death decisions were required of every member of the force regardless of rank, age, or occupational specialty. There was no front, no rear, no secured area, only reliance on a buddy to cover your "six," and the professional maturity to know when and how to act. This was Gen Charles C. Krulak's "three block war," and the Marines understood it and performed as if they were born to it.

With no help from without, the CMOC established functional areas for police, fire, electricity, water, and medical care. It appointed an interim police chief and opened a police academy. Electrical engineers were gathered up and set to work reestablishing the power grid, an effort central to restoring the most basic of human services. A wide range of philanthropic agencies like CARE (Cooperation for Assistance and Relief Everywhere, Inc.), Red Crescent, and the World Food Program arrived and joined the effort. Psychological operations messages were produced and disseminated via broadcast and leaflet to assist in informing and protecting the innocent of eastern Baghdad. We encouraged civilian media coverage of all CMOC-NGO meetings and activities as it provided objective reporting regarding our level of determination and progress on the restoration of order. Radio broadcasts, in particular, assisted local leaders and security forces by appealing to the citizens of Baghdad that, for their own safety, they remain in their homes between the calls to evening and morning prayers. The CMOC's activities accelerated in the face of these and many more challenges—and successes. By the combined efforts of the CMOC, NGOs, local citizens, and American military units on both sides of the Tigris, the reestablishment of the city's services and repair of its infrastructure was given organization, efficiency, and hope.

By 15 April, the MEF/division was well into preparations for the turnover of eastern Baghdad to the 3d ID. The staffs and subordinate commanders worked out the details of turning the slowly recovering eastern half of the city over, even as Blue Diamond forces had commenced their move south. The relief was initiated on 18

April. First out was RCT-7, and after handing over its sectors of the city, it headed south to staging areas near Al Iskandariyah. Elements of RCT-5, to include 2/5 and 3/5, began their move from the vicinity of Samarra where it had supported TF Tripoli's actions for over a week. TF Tripoli came out last from Tikrit-Bayji, another 100 miles north of Samarra. On 21 April Blue Diamond completed its move to an interim assembly area and planted its colors in the vicinity of Ad Diwaniyah in an abandoned tank repair facility.



Down..Down
Baath regime police..

هل فرض جيش الشرطة النظام السابق... يعبر عنه الديمقراطية الأمريكية؟
Is it U.S.A Democracy to impose the police
of the old regime

نريد الأمن والسلا...
We seek peace and security, but not at the
account of our Dignity.

Part II: Tikrit, South to Babylon

by Brigadier General John F. Kelly

Marine Corps Gazette, March 2004.

This is Part II of a three-part series concerning Phase IV—security and stabilization operations—during Operation IRAQI FREEDOM.

The division's zone of occupation amounted to the entire southern half of the country (excluding 1st United Kingdom's zone in the southeast corner around Basra), with over 40 percent of Iraq's population. Borders with Iran, Saudi Arabia, Kuwait, and the southern suburbs of Baghdad bound it. A complicating factor in our repositioning to the south was the unexpected movement of thousands of Shia faithful participating in the Arba'een pilgrimage. Out of respect and necessity we delayed movement into some Phase IV positions until the pilgrimage was completed. The fact that thousands of Shia were, for the first time in decades, participating freely in one of their most revered traditions was a historic event. We took full advantage of this opportunity as well and, where we could, handed out fresh water and provided medical support to a disbelieving mass of worshippers. This is perhaps the first example of our opening initiatives to establish positive relations with a still very suspicious and even hostile population. In any event, by 24 April 2003 the division successfully staged those units preparing to return to Camp Pendelton and deployed the battalions slated to remain in their Phase IV zones taking responsibility for the following provinces: Al Muthanna (2d Battalion, 5th Marines (2/5)), Karbala (3/7), Babil (1/4), Al Qadisiyah (3/5), and An Najaf (1/7). Additionally, the provinces of Wasit and Dhi Qar were added when 2/25, 3/23, and 4th Light Armored Reconnaissance Battalion were attached from Task Force (TF) Tarawa—already in the process of retrograding to Kuwait and home. These battalions were in place in An Nasiriyah, Al Kut, and on the Iranian border, respectively.

The battlespace assumed by the division was unique. Labeled "south-central" by a still all but absent Coalition Provisional Authority (CPA), the population was overwhelmingly Shia. Recent combat operations, 12 years of United Nations sanctions, and willful neglect on the part of the regime all resulted in the south's infrastructure being in a condition of collapse. This created a major series of challenges for the newly designated military governors—read battalion commanders—in control of the seven provinces. Generally speaking there was no reliable water purification system, no intact power grid, and not even basic sanitation, sewage treatment, or trash collection. It was among the world's highest malaria threat areas. Years of filth piled high along roadsides made an outbreak of serious disease a major concern, with both coalition forces and local inhabitants at risk. Local police never protected or served the community but are a cog in the regime's machine of repression. They were overwhelmingly corrupt and on the take at every level. The real power at the local level—below the Ba'ath Party's interest—rested with tribal sheikhs, many themselves corrupt, often in league with the regime, and generally only interested in maintaining hold on power and petty perquisites. In addition to tribal affiliations the Shia community was made up of many different religious factions. Allegiance to one cleric or another defined the southern Shia almost as much as clan loyalties. Religious spats between rival clerical groups were often violent and were to have a significant impact on stability.

The battalions thrown into this complex, dangerous, and unhealthy environment responded with valiant efforts. They were, from commanders to squad leaders on patrol, in essence benevolent dictators with the wisdom of a Solomon required to cut through the maze of competing agendas and emotions that dominate Iraqi society. They were well-suited to the task as they were outfitted with the high ethical and moral foundations common to American military professionals, and set to work armed with their initiative, their imaginations, and the power of their wills to restore basic services and security throughout scattered cities, towns, and villages. They were no doubt hobbled in their efforts by the poor material condition of the infrastructure and the lack of competent technicians to operate it. They were also initially handicapped financially as the CPA, and the dollars for recovery they would eventually provide, were themselves in the organization phase and not yet able to

take up the task. The commanders leaned into the mission undeterred, however, and not only unshackled the people but set their provinces on a true course for eventual recovery.

The immediate task at hand was to evaluate each province and design a coordinated strategy tailored to the needs of each. This strategy included an assessment of infrastructure, threats to good order, and identification of local authorities who could help bring order out of the chaos. Provinces were different and each had its own challenges. To help focus the efforts in each province and provide a more effective battalion to division connection, understudy officers were assigned by Blue Diamond and immersed themselves in local issues with the aim of becoming objective experts. They were soon invaluable in keeping commanders and staffs informed of intelligence trends, local gossip, clerical proclamations (fatwahs), and events on the street. They met frequently among themselves trading information and experiences, and ensured that everyone concerned benefited from lessons learned across the zone.

The approach was to decentralize with local commanders piloting the endeavor as those closest to the “rocks and shoals” in each region. The overall goal was to quickly bring the maximum benefit to the greatest number of people, avoiding at almost any cost the accidental death or injury of an innocent civilian, farm animal, or damage to crops. By starting their work in the largest population centers then moving outward into the countryside, the program enjoyed almost immediate success; although even this logical approach encountered problems due in large measure to the ages old tension between city dwellers and rural communities. It seemed that every action taken to benefit one village, group, or tribe would serve to alienate another. The battalions walked a tightrope until they understood to link initiatives and demonstrate advantages for all. As they grew more skilled in Iraqi diplomacy, workable compromises emerged and improvements benefited every group. Electrical power, for instance, in the city also translated into pumps irrigating crops in rural areas. Functioning sanitation for urban dwellers meant raw human waste was no longer trucked out into the country and dumped indiscriminately on fields, alongside roads, or into rural water sources. As time passed, this effort built trust with the local citizens across the republic.

Each province, city, and even village had its own unique personality, but two—Karbala and Najaf—were particularly difficult to manage. These two holiest cities in the Shia tradition have rather direct ties to Iran—the only entirely Shia nation in Islam. The sensitivities of the religious community based in these holy cities were of tremendous concern and unbelievably complicated. Predictions were dire. The “experts” and “Arabists” advised that as unbelievers, largely Christian and (worst of all) Americans, these cities would be tinderboxes of discontent and resistance. Karbala, with a population of nearly 550,000, was home to the shrine of Imam Abi Abdillah Al-Husain, the martyred grandson of Mohammed and a founder of the Shia sect of Islam. Najaf, slightly larger than Karbala, was the site of the tomb of Hussein, son-in-law of the prophet. Both cities are filled with highly sensitive religious sites, mosques, and revered tombs. As the spiritual centers of Shiite Islam they also contain the offices of many of the sect’s most important and influential ayatollahs—all with some relationship to Iran. As it turned out, however, these were success stories as were the other five provinces—just more complicated.

All of us learned early that Islam is very much a part of every aspect of Iraqi life—including civil government—unlike anything we experience as Americans. There is little separation between church and civil authority as we understand it or would ever allow. It is completely intertwined, seemingly inseparable and, as we learned, not necessarily what the population desires. As with every city, however, the approach taken was one that assumed we already had the “hearts and minds” of the people, even if they did not necessarily know it yet. We worked to conquer whatever reservations and animosities some might have toward us with respect for their culture, opinions, and religion. By treating every member of the society with fairness and dignity we were confident we would, over time, gain the trust and cooperation of even the most unconvinced. Our sense was that if the power of American openness, decency, and ideals could not win, no amount of military power could. This was, however, tougher than we thought. It was, and remained, a dangerous place as former regime loyalists, radical religious fanatics, and violent criminals were present in relative force. Additionally, the local population held us in great suspicion, and even animosity, as they blamed America for what they perceived to be our lack of action after Operation DESERT STORM. They are convinced that the United States broke its promis-

es of support if they would only rise up and attempt the overthrow of Saddam. They made the attempt and for their trouble reportedly suffered many hundreds of thousands dead and tortured when his butchers were finished. This fact, they will tell you, is borne out by the many mass gravesites throughout the region.

Considering these factors, and many more, the force was warned to be ever on their guard as scattered throughout the population were a small number of violent men seeking to discredit our civil-military initiatives, draw us into responses that would cause us to inadvertently injure and kill the greatest number of innocent civilians possible and, finally, send as many of us home in body bags as they could. Blue Diamond was also introduced to a new watchword—"do no harm"—and instructed to add this to their philosophy of dealing with the Iraqi population, the overwhelming numbers of whom were simply trying to survive.

Police, Power, and Government

Assessments in every province identified that the three most pressing needs were for police, electric power and fuel deliveries, and local governmental structures. The restoration of police services was a challenge made more difficult by the suspicion with which the population held every member of every department in the country. Winning the public's trust and confidence here would be a daunting task. Formerly, the police were underpaid with full expectation that these officers would make up for their low income by extortion and bribery. In spite of the urgent requirement to put police on the streets right away, it was more important to send a signal to the officers themselves that their role had changed. Improper conduct by police officers and officials would not be tolerated in the new force. In almost every case, the battalion commanders fired the entire force and then rehired those they were personally convinced were salvageable. Some commanders invited trusted local officials and private citizens to participate in this process. Commanders established their own police academies with programs of instruction that included ethics training, basic police techniques, weapons use, and community relations. "You can't shake down the locals anymore," was lesson one. Joint patrols operated on the streets in this opening stage, building trust and confidence in departments that historically had not deserved either.

After initial training programs came longer term initiatives including expanded training opportunities, internal affairs functions, management, expanded ethics sessions, and instruction in law. In As Samawah, for instance, a 10-day course was established by 2/5 that graduated over 700 officers. In many of the provinces, commanders requested and received the services of Reserve Marines who were police officers in their civilian lives. Marine and Army military policemen were instrumental throughout, adding their talents and expertise to the daily functioning of the departments. This once hated institution evolved into relevant law enforcement and service departments under the careful instruction and supervision of noncommissioned officers and junior officers—backed by Marine quick reaction forces. By July 2003 these initiatives had matured to the point that joint patrols were all but eliminated. The streets were placed almost entirely into the hands of Iraqi policemen with departments working in close concert with the battalions for more complex or dangerous operations. This by no means meant the police were unsupervised, as they were monitored continuously by our commanders and their attached Army military police and backed by Marine reaction forces, but it did mean that the process of putting an Iraqi face on security was well underway.

Energy Starved in Iraq

Electrical power and fuel, or more accurately sufficient and reliable quantities, were the bane of our existence during the entire security and stabilization operations period. This was a major issue and the test of our effectiveness as all sources of energy, including diesel, benzene (gas), and propane, were essential. Elements of energy included the facility infrastructure, sources of fuel, and distribution system. Each element was burdened with corruption, inefficiency, and shortages. The infrastructure was decrepit with little maintenance conducted since the uprisings and repression after the Gulf War. For the battalions that inherited this system, and were supposed to restore it to working order, it was unbelievable that a country so rich in these products had little available for local use. Commanders assaulted all three problems at once, seeking out engineers and workers too afraid to come to work and ensuring their protection. Most distribution pipelines, for example, were out of service. Those in service had much of their fuel stolen by thieves who for years made a living tapping into the lines and selling their pickings on the black market outside Iraq. This was the case with natural gas lines as well. There was also a rise in sabotage as the former regime criminals worked to undermine and discredit us.

Until pipelines were repaired and protected, precious fuel had to be trucked long distances from the refineries around Basra. This was not a very practical solution as power facilities required more than 100,000 gallons of fuel daily, and there were many to feed.

A similar situation existed with the electrical infrastructure. One of the major problems was looters who made a living of tearing down high-tension lines and stripping them for the copper. As with pipelines, saboteurs were also active. In Karbala 3/7 organized the repair of a series of downed 200-foot-high pylons and worked out an equitable means to ration electricity between industrial and residential users. An Nasiriyah and 2/25 faced a unique power dilemma as a huge circuit involving a number of interconnected grids required repair. With time, money, perseverance, and installation of a huge transformer, the electric grid between Baghdad-Hillah-Nasiriyah was completed and power restored as far south as Basra and the Kuwaiti border.

The answer was security, but it was impossible to patrol many thousands of miles of pipeline and power systems. Over the road movement was also unreliable as convoys were subject to frequent hijackings and, even at that, could only be a stopgap considering the amount of fuel required. There was no single answer to the problem. In Najaf 1/7 organized TF Rio to provide security to the lines within its zone. Another was to involve the I Marine Expeditionary Force's aviation element with all pilots directed to fly the lines and report. This was a secondary mission on every flight, and we tied reaction forces to these reports. The arrival of the aircraft alone, however, was often enough to deter the activity and set the thieves scurrying into the desert. The problem certainly never went away, but we were well along in getting out in front of it when we redeployed home at mission's end.

Reinventing Local Government

The difficulty of running half a country can be summed up by a lack of a dependable public service bureaucracy. With over 10 million inhabitants, and all of the associated functions of providing utilities, schools, sanitation, medical care and nutrition, this level of organization was critical—and nonexistent. Recovery would not be as easy as simply rehiring the Iraqis who had previously held these posts. The regime's method for civil service had been irrationally centralized and inefficient. Loyalty to the party was, of course, infinitely more important than competence as this was a key component in how the regime penetrated to the lowest level of Iraqi life, entered the home, and exercised control. The system was almost entirely corrupt and nepotistic in the worse way, without concern or interest in the well-being of constituents. Town councils or city managers had no concept of how to do anything that required a decision. As in the past it was safer to execute instructions issued directly from Baghdad. The absence of the regime's corrupt henchmen, however, left the now vetted local leadership without even basic instructions. Again, battalion commanders, assisted in this case by the government support teams organized out of necessity that someday will be taken over by CPA, stepped into the role.

The tactics were the same throughout the Marines' area of responsibility. Commanders at all levels met with local government officials, technocrats, and sheikhs, and vetted them in terms of how connected to the former regime they may have been. Pledges of commitment to granting political power to the people in a newly organized civil structure came quickly. In Al Hillah, for example, 1/4 held initial meetings and convinced officials and government workers to create a city council to provide a check and balance on the new government's actions. Meetings were also held with religious and tribal leaders to identify independent delegates for the council. The goal was to establish a council that was not dominated by a single constituency and included not only the majority Shia, but women as well.

Similarly in Karbala, the city council, led by a serving official, was engaged by representatives of 3/7 to start the process of restoring city services and critical infrastructure. Trouble developed, however, when hundreds of citizens demonstrated over the retention of the incumbent, a man they accused as a high-ranking and corrupt Ba'ath Party goon. The commander met with the demonstrators and reached a solution. In mid-May, elections for a new interim city council were held, with all positions temporary and performance-based until the establishment of a more permanent structure once the CPA decided on future political structures. The end result, once approved by the commander, was, for the first time in any Iraqi's memory, a council with real leadership ability and the interests of the community at heart. From this initiative a more pragmatic and responsi-

ble group of public servants emerged and were almost immediately making real and measurable progress.

In As Samawah 2/5 took advantage of a unique set of circumstances that made the environment more conducive to honest government. Under the firm direction of the commander, the city's government made a miraculous turnaround in its ethical service orientation to the populace. With the effort led by the battalion's legal officer, the first structure rebuilt was the local criminal and civil court system. The effort gained credibility by partnership with the 12 most prominent tribal leaders. In May the new judiciary was stood up with four honest and popularly screened judges sworn in. City payroll procedures were next with checks and balances in place to minimize extortion, corruption, and skimming by senior officials. The city council, once a tool of the regime, was reelected in a way that would make Americans proud. A viable, responsive, and all-inclusive council went to work for the first time in anyone's memory. As a check to the power of the sheikhs, technocrats were included, as were a total of nine political and religious parties.

An Najaf—ever the thorn—serves as a final example. Citizen groups appealed to 1/7 and expressed a complete lack of confidence in any of the sitting judges, all of whom were charged as corrupt and closely associated with the terrible repression the regime focused on this city in the past. The commander investigated and, when convinced, removed all but a very few who could convince him of their honesty. At the same time the mayor, also identified as corrupt and murderous, stood as an impediment to honest government. The mayor's removal became the first real test case of the Iraqi judicial system in south central—a system reformed by Americans who were not experts but understood what a legal justice system was supposed to be from at least high school civics classes, if from nowhere else. The mayor, Abu Haydar Abdul Mun'im, was a former army colonel set in office by American forces a month before. The process of removing him began almost immediately after 1/7's assumption of the zone. The mayor was wildly unpopular before the appointment, and his popularity declined even more as he conducted himself in a way reminiscent of the previous regime hacks. Less than 3 months after his appointment, an Iraqi investigative judge, supported and shown the way by the battalion staff, ordered his arrest on corruption and murder charges. Once the warrant was issued, Marines strode into the mayor's compound, surrounded by his Praetorian Guard of special police and bodyguards, and took him into custody. Delivered to the newly reformed national court system in Baghdad, he was scheduled to be the first high-profile prosecution. Immediately after his arrest the city's governing council chose an interim mayor, approved by the commander, who was eager to institute reforms.

In virtually every province, city, and village it was the same. Corrupt governing councils and courts, the former regime's local means of control and repression, were replaced by the most honorable men and women that commanders could locate and convince to serve. These emerging leaders assumed the roles of popular representatives, something denied Iraqis for longer than some of the new appointees had been alive. Remember, there had not been a single honest and fair election in Iraq since long before even Saddam. The citizens also looked to the commanders, and the civil affairs soldiers attached from our Army to every battalion headquarters, for the lessons on how to govern democratically. Just as importantly, the Iraqis gazed at us in American and British uniforms for their first glimpse of what selfless dedication and ethical public service were all about.

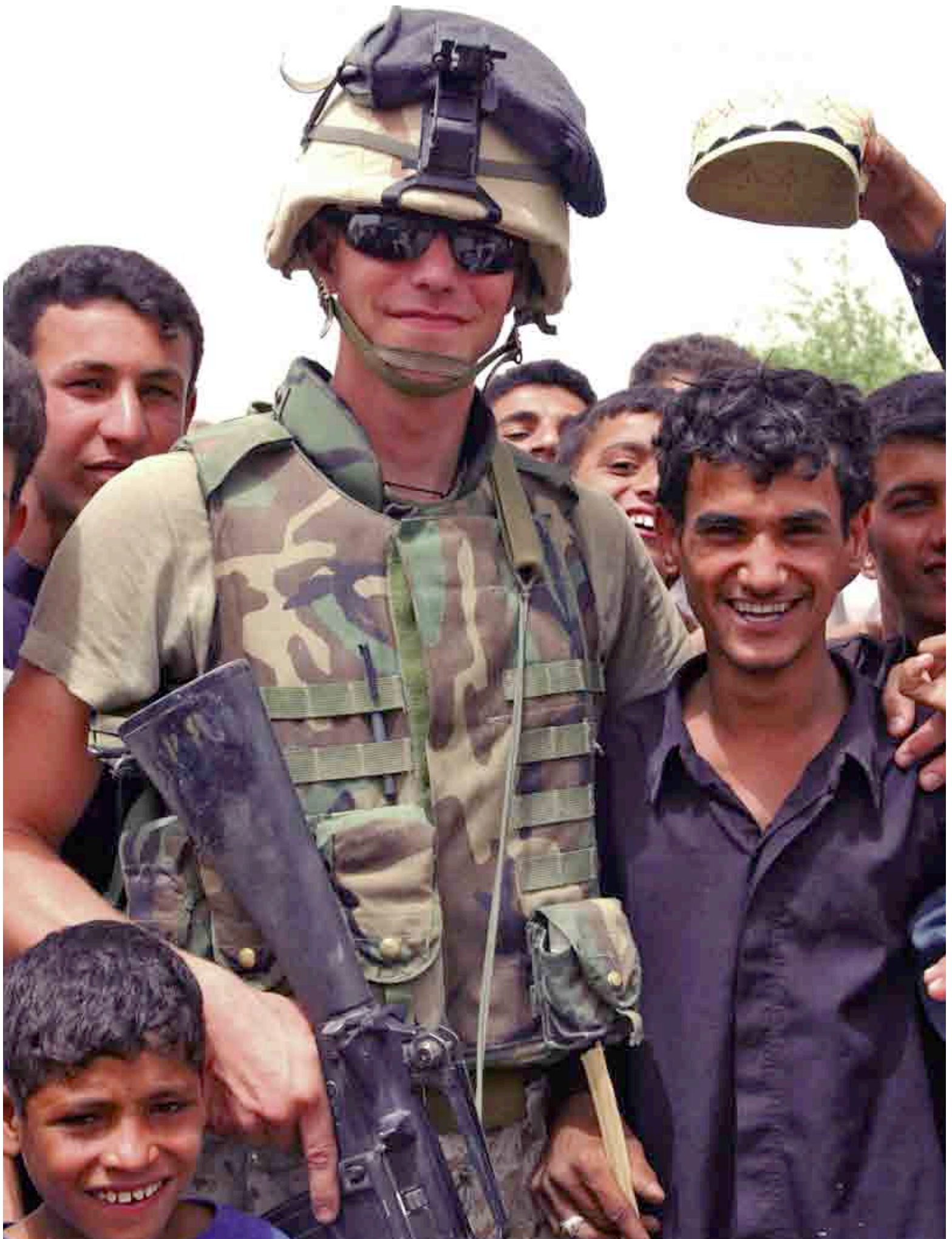

Part III: Tikrit, South to Babylon

by Brigadier General John F. Kelly

Marine Corps Gazette, April 2004.

This is the third of a three-part series on security and stabilization operations (SASO) during Operation IRAQI FREEDOM.

A key responsibility inherited after the collapse of the regime was the territorial sovereignty of Iraq. Air and ground patrols were periodically dispatched to the border with Saudi Arabia where we found crossing points well controlled by their officials. The Iranian border was a more significant issue. Unlike the border with Saudi Arabia that was hundreds of miles from Iraqi centers of population with almost no trade, religious, or family links, the Iranian border north of Al Kut had all of these and more. Many argued that Iran had a vested interest in a weak and destabilized Iraq. Others made the point that Tehran would attempt to exert anti-American pressure on the Shia in Iraq through the clerics, particularly those in Karbala and Najaf. The most immediate issue on the border, however, was the violent, abusive, and reportedly criminal behavior of the Iranian border guards. These guards had taken to extorting and abusing the hordes of religious pilgrims now free to travel into Iraq exercising religious freedom as a result of Saddam's removal. For the first time since Saddam established his murderous regime, the holy cities of Najaf and Karbala were open to all Shia. Pilgrims poured in from Iran, primarily in family units, to worship at religious sites and even bury long dead loved ones in the earth adjacent to the sacred mosques. Additionally, refugees desired entry, as did Iranians seeking to visit family—a privilege denied them since before the Iran-Iraq War. Screening every individual who desired entry in an effort to “keep the terrorists out” proved impossible without a system of passports, visas, and or databases with which to work. The good will generated by allowing the free movement of Shia made closing the border ill-advised, and we resisted suggestions to do so.

The border region was remote, sparsely populated, and very difficult terrain. Again, to put an Iraqi face out front, the reestablishment of an Iraqi border guard force in the area by 3d Battalion, 23d Marines (3/23) was a major step forward. Like the police and government officials, these officers were first vetted, then trained, and finally supervised. As there were insufficient Marine assets initially to maintain a permanent presence on the border, we covered the requirement with regular aerial reconnaissance flights and intermittent short-term missions by 4th Light Armored Reconnaissance Battalion (4th LAR). By July sufficient forces were made available due to the increasingly cooperative environment in Al Kut to the south, allowing 3/23 to permanently assign an infantry company to the border. The task fell to Company I, 3/23, with Marines and corpsmen from Arkansas, Utah, and Pennsylvania. Setting up living spaces in one of the many abandoned Iraqi concrete forts that line the border, the company—true to form—began to work the few villages in the region, mark the numerous minefields left unrecorded from the Iran-Iraq War, and generally provide a presence and “stiffener” for the Iraqi border officials with whom they worked and supervised daily.

Cross border activity increased exponentially during the summer. Only documented individuals were allowed passage with no vehicles allowed either way. The operation remained generally organized and benign with the presence force from 3/23 overseeing the Iraqi operation of the crossing, patrolling the few roads running parallel to the border, and monitoring the many smuggler routes through the hills and along the washes of the rough desert terrain. There were sporadic occasions of abuse by the Iranian guards when in early August a dangerous incident of violence occurred as Iranian soldiers began assaulting travelers waiting in the buffer zone. A number were injured by beatings with truncheons. Without reason the Iranians began to deliver a large volume of AK-47 fire in the direction of the crowd, just above their heads, and into Iraq. A squad of Marines maintained at the crossing deployed just outside the buffer standing ready to protect the unarmed civilians, but with this action the cowardly Iranian guards fled back to Iran and safety. The squad leader on the scene, truly a “strategic corporal,” closed the crossing until the situation cooled and later opened the border for traffic. The company continued working the border in true *beau geste* fashion and circumstances until relieved by the Ukrainian brigade in September.

The Northern Babil Province Heats Up

Although the entire zone was dangerous—with criminals and unrepentant Saddam loyalists active throughout—our efforts with the local population assisted us in all but eliminating violence by midsummer. I should add that having the people on your side means more than anything in this environment, but it also helps when it is widely known that no one had yet beat the Marines in the “10-second firefight.” There was, however, a far northern slice of our zone where we had not yet spent much effort that grew increasingly active with hit and run violence. During May, as the Army continued its buildup at the end of the conventional stage of the conflict, Forward Logistics Base Dogwood was established at a former military base in northern Babil Province astride the Euphrates River 12 miles southwest of Baghdad. This area of Iraq was a faultline between the predominately Shia south and Sunni north. Nearly all roads to Baghdad from the south passed through this zone. The main supply route—Highway 1 from Kuwait—and alternate supply routes (ASRs)—Highways 8 from Al Hillah and 9 from the west and Karbala—all converged here. Most notably, however, was ASR “Sue,” a narrow two-lane road that meandered through the lowland villages and agricultural fields for 22 miles. ASR Sue was a connector route and an important logistical lifeline for soldiers in Baghdad. It was used by up to 90 convoys a day.

By early June Blue Diamond-Main, now collocated with I Marine Expeditionary Force (IMEF) in the ancient ruins complex of Babylon near Al Hillah, received frequent reports of convoy ambushes along ASR Sue, although the number of actual attacks was difficult to determine. There was no system in place to verify reports as they came through any of a number of command channels, seldom timely, often turning incomplete and inaccurate initial reports, including double reporting, into “fact.” For instance, in the first 2 weeks of June there were 51 reported attacks along this route, although the standard by which an attack was measured ranged from a single driver thinking he had been shot at to the tragic wounding or death of a soldier and vehicles destroyed by combined automatic weapons and rocket propelled grenade (RPG) fire. Thankfully there were few of these. Reports at the time indicated there had been, on average, three attacks per day by small arms—two per day involving RPGs. During this period another weapon made an occasional appearance—the improvised explosive device (IED)—a weapon that is today the weapon of choice for the guerillas. In any event, regardless of the confusion, we owned the terrain and, in response to the local commander’s immediate concerns. Blue Diamond organized and deployed Task Force (TF) Scorpion named for the base unit’s call sign.

TF Scorpion’s mission and task organization evolved over time as the tactical situation changed and the enemy reacted to our increasingly successful initiatives. Initially the threat was against defenseless logistics convoys that some described as “manatees.” Convoy personnel on interview typically revealed they had not been briefed that the nature of the threat changed significantly once they put Kuwait in their rearview mirrors. Even convoys coming out of Dogwood or down from Baghdad were not always taking the precautions prudent while operating in such a threat. This made the vehicles easy targets for a host of Iraqi predators. In the beginning the ambush action was no more than one or two assailants standing next to the road in plain sight during the day, emptying an AK-47 magazine at the approaching vehicles, and walking away. Occasionally an RPG might be fired. The convoy’s immediate action was to drive through the “kill zone.” It was difficult to determine if fire was ever returned or if there was any effort on the part of convoy personnel to maneuver against the renegades. This is not a criticism, but we had to understand the facts to design a campaign.

On 13 June, TF Scorpion, organized around the 4th LAR, moved into its battlespace carved out of 1/4’s zone and thereafter referred to as the “Northern Babil.” It was reinforced with a number of smaller units and capabilities. The first order of business was the obvious requirement to secure ASR Sue from the paid Iraqi thugs who preyed upon the convoys unmolested. This was accomplished in short order by saturating the immediate vicinity of the roadway with aggressive Marine patrols. Instead of manatees the terrorists encountered hunters. Every would-be ambusher soon knew the capability of the light armored vehicle (LAV). Like the Cobras, the “light horsemen” of the LAR community were respected—and feared—their reputations earned and well-deserved. The second task was to work with senior Army leaders in Dogwood and Baghdad to encourage them to improve the awareness, and encourage defensive reaction by convoy personnel when departing secure logistics bases.

TF Scorpion’s initial “do something right away” action was to intersperse LAVs in among the convoy’s vehicles in the hopes that ambushers might engage. The terrorists were ruthless but not particularly suicidal, and this

tactic failed to lure many into our kill zone. Another technique in this “cat and mouse” game was to run small “Trojan horse” convoys through the area. The “bait” vehicles themselves had been hardened with a continuous wall of meals, ready-to-eat boxes filled with sand lining the outer edges of the vehicle beds to give the appearance of a defenseless logistic vehicle. The vehicles were not defenseless, however, because in addition to the driver and assistant driver in the cab—who were riflemen as well as logistics professionals—there were Marines hidden within the wall of boxes “chomping at the bit” to return fire and deploy. Terrorists fighters must have been amazed as convoys of HMMWVs or medium tactical vehicle replacements now were just as likely to stop on contact, return fire, and deploy riflemen, as rush past to safety. After only a few days of operations the enemy adjusted tactics. They were no longer willing to stand next to the road and shoot at American vehicles regardless of how slow they traveled and helpless they appeared. The ambushers adjusted by moving farther and farther back from the road in order to survive, resulting in their fire growing increasingly ineffective. By mid-June the number of attacks had fallen off to a fraction of what they had been. By early July there were no direct fire attacks at all.

As effective as the combat tactics were, working the convoy routes in hopes of killing a few not so dedicated trigger-pullers was treating the “symptom” and not the “disease” of suspicion and hostility toward the coalition in this contested region. There were those outside the MEF who encouraged us to go more “kinetic” and consider the use of AC-130s, close air support, and artillery against suspected hostile sites. We took a different approach. We needed to do here what had worked so well for us throughout the rest of the zone—to win the trust of the locals whom we were here to help and who were here to stay. The Scorpion team implemented a parallel program of civil affairs activities in the population centers with explosive ordnance disposal (EOD) serving as a particularly effective tool in helping penetrate the civilian communities, many of which lived in terror of anticoalition forces. The use of U.S. fire support assets had been heavy here, as units fought through the area in April on the way to Baghdad. There was a massive amount of unmarked unexploded ordnance (UXO) spread across the fields and villages. A tremendously effective psychological operations and information campaign, developed by the Army soldiers attached to the division from the 432d Civil Affairs Battalion (from Green Bay, WI), first warned local citizens of the dangers of UXO and provided posters and handbills to help identify the objects. The second aspect of the campaign was to encourage the Iraqi citizens to contact the newly arrived Marines for removal of dangerous materials from their fields, homes, schools, and neighborhoods. The EOD Marines began a nonstop campaign that ultimately, over a period of many weeks, resulted in the removal of 250,000 pounds of UXO, but at the cost of several dead and wounded. This common interest also began a process of extending TF Scorpion’s influence and trust into the population. The real intelligence sources would be found among the people—a reality, again, we had learned previously. Soon the people were overtly and covertly stepping forward with tips and warnings to the Marines and soldiers with whom they had developed a fragile relationship of trust.

By early July the enemy once again changed tactics. They gave up on the ineffective—and highly dangerous to themselves—direct fire ambush, altering their tactics to the almost exclusive use of IEDs. These were most often mortar or artillery shell “daisy chained” together and command detonated. Soon the TF found its stride here as well, and although IED attacks rose to a high average of July, they began to fall in number almost immediately to near zero by the end of the month. In dealing with the evolving threat it was clear the LAR-centric TF had the mobile patrols covered but was in need of “grunts” to do the dirty work off-road and in the towns. The need for infantrymen to hunt down and kill this elusive enemy working in the shadows along the roadsides at night or cordon target sites for search or ambush was obvious; however, just as obvious was the need to get “boots on the ground” in amongst the citizenry of the Northern Babil and in those places where we were warned by friends, and threatened by our few enemies, not to tread. We went there first.

In late June two rifle companies—Company I, 3/7, traveling up from Karbala, and Company E, 2/5, As Samawah—were attached. In the first case the company commander selected a position adjacent to Al Mahmudiyah and directly astride a very active IED “mixing bowl.” The company had not yet even unrolled their sleeping mats when they were out prowling the night on initial patrols. In exactly the same way, Company G selected a similarly dangerous position near the city of Al Yusufiyah, one that would give it access to both the population and active IED zones. Many of these tough young men were in ambush sites and first night seeking early contact and were not disappointed. The impact of the infantry’s arrival, along with the combined efforts of the TF of nearly 1,000

personnel from 3 Services, clearly presented the enemy with more dilemmas than he could handle. The anticoalition forces were forced to alter their tactics a third time. We now saw the introduction of sporadic mortar attacks from hastily laid ground or vehicleborne tubes. These attacks were obviously conducted by men who were not only unskilled with the weapons but also very interested in not directly confronting the infantry who were everywhere and nowhere at the same time. Great tactical headwork by junior leaders was quick to figure the enemy's procedures, predict his routines, and set ambushes and sniper teams in those places that presented a mortar threat—and they ceased. We once again resisted the suggestion to reply to these attacks with heavy firepower, a response that we felt would likely wound or kill innocent Iraqis. Even if innocents were not hit—and more importantly from a hearts and minds perspective—we felt it would severely erode our message that innocent Iraqi lives were as precious to us as were our own. We calculated that the use of bombs and artillery against a fleeing enemy long gone before the first ordnance struck made no tactical sense, was in fact counterproductive, and would send the message that we held the lives of Iraqis in low regard. Some argued it would show Iraqis who was boss, or our resolve and power. We elected to rely on a high degree of field craft and the tactical expertise and confidence of our company grade infantry leaders.

The final stage of operations for TF Scorpion, before their relief by elements of the 82d Airborne Division, was a spoiling attack against a large number of unrepentant former regime supporters just prior to their own offensive. Our counteractions were made possible by the wealth of actionable intelligence the small units were gleaned from the many sheikhs, clerics, police, and private citizens throughout the zone but particularly in Babil. Long before being alerted by Commander, Joint Task Force 7 in Baghdad of the pending offensive, the G-2 (intelligence) sections at MEF and Blue Diamond, in collaboration, detected an unmistakable increase in indications and warnings focused on a 4-day period corresponding to the 14 July anniversary of the founding of the Ba'ath Party in Iraq. The intelligence unquestionably pointed toward an aggressive campaign of IED and other terrorist-type attacks. Our response was a simultaneous counteroffensive against a number of these suspected individuals designed and executed to disrupt the expected attack. Building up a large number of detailed target folders we held off striking individuals until 12 July in order to maximize the disruption of this plan and minimize the period of time they had available to recover. So successful was this initiative that the division continued this tactic in an effort to round up senior regime officials, fedayeen, and terrorists until we departed the zone. By continuing the attack and taking the fight to the enemy, we greatly reduced hostile influence against us in Northern Babil. Each raid led to the next and were most often conducted by the infantry companies or attached force reconnaissance assets from the Reserves. These raids, or “cordons and knocks” as we first termed them, were typically executed at night and were backed by invaluable Cobra and Huey support from the 3d Marine Aircraft Wing. These actions were highly successful in capturing large arms and ordnance caches, IED production facilities and their technicians, Ba'ath Party stalwarts responsible for hiring local trigger-pullers, and even occasional cells working against our soldiers to the north in Baghdad.

The Division Heads Home

By early summer, forces from as many as 24 nations began to descend on Babylon to begin the process of turning southern Iraq over to the Polish-led multinational division (MND). Among the first to arrive was an advance party from the Italian Defense Ministry arriving in the Dhi Qar Province to prepare the way for the arrival of the Garibaldi brigade and the relief of 2/25. The Garibaldi brigade's main body arrived on 26 June and included Carabinieri as well as Romanian soldiers. On 9 July the relief progressed with the Italians establishing command and control nodes at Qalat Sukkar and Ash Shattrah, scenes of heavy fighting in March along Highway 7 south of Al Kut. The Dhi Qar Province was turned over on 20 July.

Six more reliefs were accomplished in rapid succession. The pattern was similar for each of them. Planners and liaison officers were exchanged followed by advance parties arriving shortly thereafter. Finally, the main body of replacement troops would arrive. I do not think it is an understatement to say that the multinational soldiers were shocked at the unexpected level of danger that was the reality in the zones they were assuming. Most were also visibly impressed—even intimidated—by the air of quiet confidence and obvious indifference to hazard demonstrated by the members of Blue Diamond as they commenced their “left seat-right seat” patrols. It was the 130-degree heat they were already enduring, the threat of instant violence all around them taken for granted by

those they were replacing, and the Spartan conditions these Marines considered “living large,” that made the allies understand they were replacing expeditionary warriors of the first order.

End of Operations

The MEF commander handed the formal responsibility for the zone to the MND commander in a Babylon ceremony conducted on 3 September 2003, although 1/7 was delayed by the unwillingness on the part of the Spanish brigade to assume responsibility for Najaf until a number of U.S. Central Command issues were sorted out delaying the transfer until early October. We Marines, with our attached Army professionals, had certainly conducted operations differently in the south than SASO had been executed in the north. What had worked for us may not have worked in Baghdad, Kirkuk, or Mosul, but the results for us were startling.

Some have said we have no doctrine for what we did in Phase IV, but I disagree. I know it is not technically doctrine, but I suggest our *Small Wars Manual* for a starter, not to mention our documented successes learned for us in Vietnam by some very brave men. There is also a wealth of knowledge available for those who read in the lessons of our southern colonies during the Revolution, Napoleon’s peninsula campaign, Forrest’s Tennessee-Mississippi-Alabama campaign, Lawrence’s Arab revolt, Tito’s Yugoslavia, the French in Indochina and Algeria, and the British in Malaysia and Northern Ireland. Luckily we had men who were very familiar with these campaigns and many, many more. In reality, however, we do have a doctrine and a warfighting philosophy that opens the mind to problem-solving and avoids the set piece. The debate about maneuver warfare is thankfully over. I would be lying to you, and kidding myself, if I said everyone was an avid practitioner, and I do not know if the schools have it right even now. I do know it very much depends on the person, his or her traits, and life’s experiences. What we do have, I can assure you, are sufficient leaders at every level who run through the loop very fast—and act without hesitation. These are individuals who will employ a 2,000 pound joint direct attack munition or pass out water to anticoalition protesters, situation depending. I think for much of this we can thank Cols John Boyd, USAF(Ret) and Mike Wyly, USMC(Ret), and certainly my friend, William Lind, from Ohio, all men I have known and worked with in the past.

Basic to everything we did was a sense that we were freeing a people and not conquering a nation. We had flown from March Air Force Reserve Base in southern California or floated from the 32d Street pier in San Diego with the attitude that the Iraqi people were victims of a terrible disaster and that we were going to help. This was as important a message as the search for weapons of mass destruction ever was to those of us who deployed. We had already gained the “hearts and minds” of the Iraqis during combat operations, of that we were sure. The wild demonstrations of Iraqi joy delivered that message clearly. We also knew that these hearts and minds were ours to lose and that possession was a fragile thing. We treated the people with dignity and respect, and it was returned. We also won every firefight in Phase IV and, from 28 April 2003 until our departure in October, lost no Marines from hostile fire. During this time when those foolish enough decided to contest our presence, we responded with civic action programs, medical treatment, and lastly, a very deliberate and discriminating application of deadly force. Our first instinct had been to do no harm to the innocent, and we left a trail of good will behind. We had made friends one Iraqi at a time. Our belief is that they, over time, appreciated the sacrifices made on their behalf. As one Iraqi told someone, his change of heart came one day on departing his mosque in Al Kut after Friday prayers. For weeks his cleric had ranted about the Americans and how we had only come to steal their oil—that we were a godless people who brought pornography, drugs, and alcohol to their society, and would do nothing good for Iraq. The man then would exit the mosque into the furnace that is the afternoon heat during Iraq’s summer and see Marines patrolling at the risk of their lives, Army military policemen apprehending violent criminals, and SeaBees rehabilitating schools and hospitals, repairing bridges, and all of the other examples of our actions on the ground. Over time the clerics had no choice but to adjust their rhetoric as seeing was believing.

We are now redeploying our forces and people are asking if we will do the same thing in 2004 as we did in 2003. The answer, of course, is every situation is different. We are already working our way through the history books and reports of units now in the zone we will assume. Whatever is ultimately decided, I believe we will still seek to first and foremost do no harm to those who mean us none.



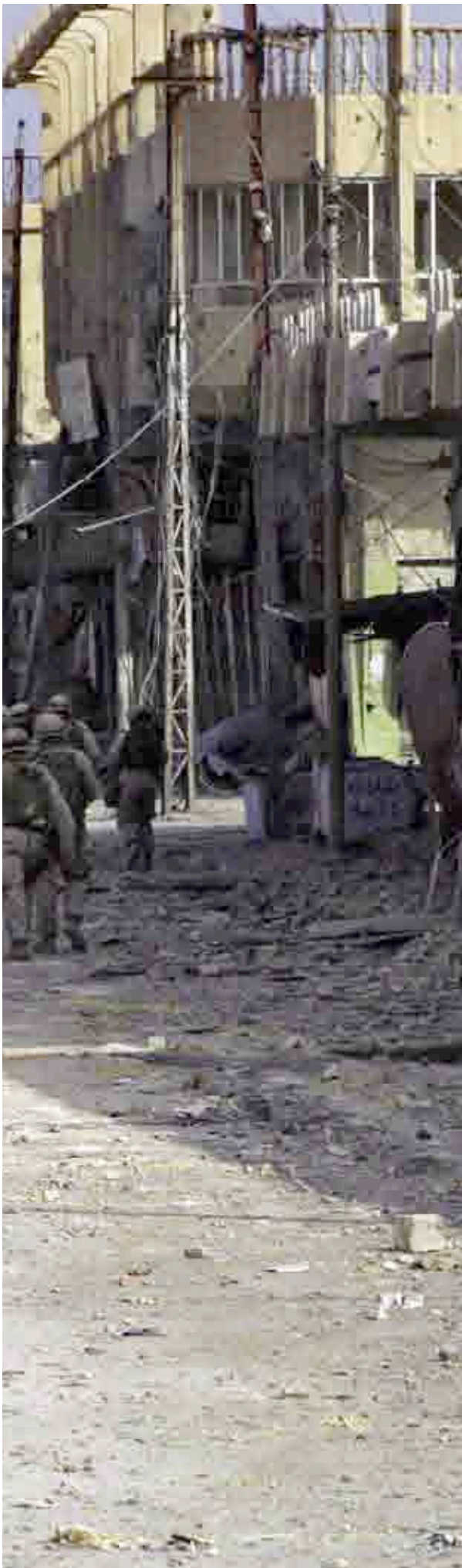

What Do You Do for an Encore?

by Colonel Christopher C. Conlin

Marine Corps Gazette, September 2004.

'[S]mall wars are operations undertaken under executive authority, wherein military force is combined with diplomatic pressure in the internal or external affairs of another state whose government is unstable, inadequate, or unsatisfactory for the preservation of life and of such interests as are determined by the foreign policy of our nation. . . Small Wars represent the normal and frequent operations of the Marine Corps.'

—Small Wars Manual 1940

Evening was falling on 9 April 2003. "First Team," 1st Battalion, 7th Marines (1/7) was consolidating in our just won section of downtown Baghdad. We had inherited over 28 square kilometers of dense urban terrain that included the "Manhattan" equivalent of the city, home to the remaining Embassies and national figures like Terik Aziz. It had been a heady victory making this final push. In the space of a few hours we had been welcomed by a disorienting mix of cheering crowds, a frenzied press, and a full-blown ambush on the grounds of the Baghdad University. Surreal!

But now we were hit by a far more perplexing challenge. Having thoroughly defeated the "evil empire" of Saddam, we had effectively stripped away all vestiges of his Orwellian dictatorship, leaving only . . . us. What to do for an encore? We were now the single center of authority. In a blinding flash, we had become the local government, the utilities, the banks, the information bureau, the health care provider, the police, the court system, even the dogcatchers. We were it. Just over 1,000 Marines, soldiers, and sailors comprising our battalion task force became responsible for an area and population the size of Manhattan Island.

Transition Mission

The following article will outline how 1/7 addressed the daunting issue of what are often called "transition operations" in Baghdad. Of course, no one operates in isolation, and this article should hopefully address the great support we received from our higher and adjacent commands. But it will also identify some thoughts on how we can better affect these operations when presented with similar circumstances. Additionally, this will be the first of a series of articles that also address the challenge of what are being called "stability operations" as we further refined our tactics in the southern city of Najaf. These articles will provide a little history, a bit of perspective, some strong opinions, and some suggestions on what to do if you find yourself similarly challenged.

The most significant aspect of the transition I saw in Baghdad was the immediacy of our succession to the sole responsible authority in the city. Within minutes of our seizure of the capital one of my lieutenants was presented with the rapidly expiring body of an Iraqi who had been pried from a vehicle accident seconds before. He was not a war casualty but a simple victim of a “routine” incident. The fact that the locals brought him to us as he was in his final death spasms was their unequivocal realization that the normal procedure—going to the hospital or calling the police—was gone. This episode was duplicated throughout our zone with geometrically increasing frequency. Frantic locals ran up to tell us phones were out and that the water was off. Doctors reported hospitals being looted. Locals were desperate to know where they should dump the trash, could they use cell phones, or was it okay to drive to their father’s house in Mosul. They wanted us to arrest a strange man with a gun lurking in their neighborhood. We were approached by alleged sheiks who demanded to see “his Excellency the General” about their tribe’s loyalty to Mr. Bush. On and on the requests came—all being diligently received and somehow answered by our young squad leaders and platoon leaders.

We, too, were in transition. Having overwhelmed organized resistance, we were hot on the trail of Saddam’s more shadowy secret police organization (SSO) and fedayeen. As if a great light had been turned on, the locals were quickly letting us know the identities of these terror troops, and we found them fairly easy hunting. Stripped of their official protection—and well-known as a result of their horrific bullying—our aggressive small unit leaders were able to hit them in their homes and offices in ever quickening succession. We created hunter-killer teams on the fly, sending our very talented human exploitation teams (HETs), psychological operations (PsyOps), and civil affairs group (CAG) teams down to the platoon level in some cases to rapidly turn around actionable intelligence from one target to the next. Companies worked huge urban sectors, usually rotating platoons to achieve a 24/7 battle rhythm. The effect was dramatic. And as the locals saw our progress they joined even more enthusiastically into the feeding frenzy.

At the same time the city was changing under our feet. Prior to our attack we had reports of scattered looting of government buildings and the disappearance of the local police and “Gestapo”-type secret police. Immediately following the attack we saw some looting, but it was limited to the homes of the ousted (and absent) government officials, mostly being done by rejoicing neighbors. But this quickly changed to a wholesale “grab and go” of whatever was of value. And the grabbers were multiplying and getting more and more aggressive, using weapons where needed to burgle what they could not simply walk away with. Literally, it was a chapter out of H.G. Wells as the Morlocks were feasting on the proverbial Eloi.

On top of this was the total lack of operating city infrastructure. The electricity, water, sewage, fuel stations, police, fire department, public hospitals, and all those things that make a city function were off, closed, or absent. Some blamed Saddam; others said the United States had bombed the critical nodes during our attack. Regardless, every facet of this modern city was hard down, and no one knew where the magic “big red switch” was to turn it back on. Instead, it appeared that it was all fatally interlinked like a circle of dominoes. Each critical service was dependent on another couple to get back on line, and none could be easily kick started. From time to time we ran into individuals who claimed to have the answers, but the sad truth was that the utilities infrastructure had been in a death spiral before we came and gave its last gasp as we arrived.

Governing 101

My battle journal notes dated 10 April 2003 lists a plethora of deduced tasks to include “power on,” “more interpreters,” “water/sewage on,” “trash pick up,” “locate police/police authority,” “open schools,” “destroy SSO/fedayeen,” ad infinitum with the final comment, “Who is government? What is government? Where is government?” The answers turned up in our shaving mirrors.

So like good Marines we confidently waded in and figured it out as we went along. The staff met early the morning after liberation and conducted a mission analysis. Effectively our mission was to run a city with a battalion. Of course, several other battalions, regiments, and the division were conducting the same analysis. As a true testament to the trust our leaders had in us, all of the battalions were allowed to create their solutions with only the most general mission tasking and guidance from above. But every option for support was offered and taken. The dilemma was that our rapid push to Baghdad left us barely able to support ourselves with basic necessities, let alone a city of 5 million. But the last thing we could afford to do was to suck off

the already overtaxed local infrastructure as parasites.

We were very fortunate to have a particularly talented crew working on our solution set. I had a brilliant operations officer, a well-seasoned and savvy executive officer, very creative staff officers, and a group of exceptionally experienced company commanders who averaged over 18 months in command, in addition to a battalion of incredibly creative Marines, soldiers and sailors. This talented pool dissected the mission into digestible pieces and created, on the spot, a very effective “battlefield organization” and tactics, techniques, and procedures (TTP) for controlling our area of responsibility (AOR).

Their first product was a list of 21 critical priority information requirements (PIRs) that we placed into the hands of every small unit leader or individual with the potential for direct contact with the local population or environment. These PIRs were our metrics for determining crisis areas in the city where we could direct critical assets. They included the condition of key utilities, location and condition of hospitals, identification of local leaders (non-Ba’ath Party), traffic flow, commercial activities, religious affiliations, ethnicity of neighborhoods and their opinion of us, opening of political party offices, status of local schools, and criminal activities. In addition, we also tracked a healthy list of threat-related information requirements as we continued to dismantle the Ba’ath /SSO/fedayeen insurgents as well as other potential sensitive sites. These collection requirements were reported out every night during staff meetings and analyzed in depth by our S-2 (intelligence). Together they provided us a very raw but telling look at our AOR and allowed us to allocate resources, track trends, and focus on what we determined were centers of gravity. We also rapidly discovered that in this environment, literally every Marine, sailor, and soldier was a collector, as they were in the environment and able to fill in the blanks on our report to great effect.

Our next product was to rebuild the staff to reflect our changing mission. With our attacks focused on smaller targets, we no longer needed the robust fire support control staff we did in our fight through Iraq. That left a group of very talented Marines to reassign as our battalion-level civil-military operations center (CMOC). In short order our air officer became the head of our CMOC with all our forward air controllers/forward observers and their communicators as his staff. Now instead of processing fires they became city managers processing our reports and going out as contact teams to trouble areas to find solutions. This was a powerful tool. It also allowed our CAG teams, who were our duty experts on civil affairs, to focus their efforts on the most critical issues without becoming tied down in the more mundane concerns our CMOC handled. Our higher and adjacent headquarters organized in the same fashion providing great continuity between the various CMOC’s.

We also substantially reorganized and retasked our intelligence staff. Gone were the large enemy formations we had been tracking. Now the enemy consisted of disorganized, fleeting former regime members that our small units were doing very well tracking using the locals and HETs on site. But our requirements for analysis of the city’s population needs, organizations, and affiliations were daunting. That changed dramatically the methodology and organization of our intelligence staff. With a battalion of collectors, and reams of raw information coming in, they organized into a joint intelligence center that combined the talents of our CMOC, PsyOps detachment, CAG, and HETs into an analytical body that could relate the information for trends and targets. This quickly refined intelligence became the lifeblood for our operations as we “fought” the city’s problems in order to win it back for the population and encourage our popular support.

Within the battalion we reorganized our combat formations to complement the city. Each rifle company was assigned a zone to provide security and “govern” like a borough. They then assigned platoons smaller zones to operate from in combined action program-type linkages with the locals. We set up “firm bases” within large facilities like the Baghdad University for each company to use as a logistics/beddown site. The firm bases allowed commanders to run continuous operations in their zones with at least a reinforced platoon providing presence, while still being able to rest and refit the remainder of the company. This was important because our preferred tactic was foot mobile patrolling that we called “saturation patrolling.” Firm bases allowed us to always have an alert unit on patrol or conducting operations, while resting small units were kept away from the public eye. In order to increase our coverage we turned weapons company into a provisional rifle company, although we used the combined antiarmor teams as a quick reaction force (QRF) throughout

the AOR. Our headquarters and services company provided security for one of our firm bases and also rotated in and out of QRF duty.

Tactically, our operations consisted of random saturation patrols to collect information and keep our sector secure. These foot mobile patrols were very approachable by the locals, and we facilitated this contact by pushing interpreters down to the platoon level. This allowed us to get tips from the locals on threats, as well as to gain situational awareness on our collection requirements. If we got actionable information on a threat, the company would often simply handle it internally, informing the battalion combat operational center as they were going in so we could position the QRF to support if things went awry. This resulted in an extremely high tempo of operations that yielded great success against the disorganized and overwhelmed former regime combatants. We paid a price sometimes from dry holes, but by allowing the attacks to be executed at the lowest level possible, these misses had little effect on our overall operations. At the same time our aggressive actions gave a very positive sign to the locals that we were serious about tearing down all of the remnants of Saddam's regime, further engendering their support.

Our rules of engagement (ROE) also changed rapidly. Prior to our entry into Baghdad we had discussed at length the necessity to rapidly adjust to the changes of entering a dense urban environment where our actions could easily turn the population against us. The 1st Marine Division's now famous credo, "no better friend, no worse enemy" lent itself to this transition. We started to discuss more and more the requirements for positive identification (ID) of all targets and limiting weapons effects to decrease collateral damage. Our higher headquarters was also tailoring back the ROE and TTP to meet emerging realities. Military vehicles turned lights back on at night to match civilian traffic. Vehicle checkpoints used long, serpentine entry points to reduce "runners." Shoot first engagements were replaced by more forgiving peacetime ROE with graduated levels of force. These changes were critical to winning the population and avoiding our own fratricide in a densely populated environment.

Another facet of modifying our ROE was changing from a "no rules" combat mentality in how we drove, acted, and talked in front of the local community. If we were the government then we needed to set the example vice join in the anarchy. Where possible, our Marines obeyed traffic rules. They avoided social taboos like relieving themselves in public, using foul language, or leering and pointing weapons at innocents. Uniforms were policed up from combat standards to a more professional look. Sunglasses were removed to reveal eyes, considered an important "mirror to the soul" for the Iraqis. Washing became an influence operation as we tried to "humanize" our warriors in the eyes of our new public. Where tactically possible, we shed body armor to look less threatening and less threatened. There were hundreds of these small details that we incorporated, but their sum total was powerful. It added normality to the community and created a level of respect that bullying would not.

Our last major reorganization involved all of the commanders. Having inherited the yoke of local government, we now needed to match that responsibility with some good old-fashioned politicking. It meant all of us going out and meeting the locals, sitting in on their neighborhood meetings, and becoming a physical presence in their lives as a sign of stability and control. Effectively, the population had been subjected to 35 years of "big brother" type omnipotent tyranny from Saddam. Perhaps they were free, but their comfort zone was to have a strong leader to look to for direction. Add to this the utter confusion of little or no utilities, many suddenly irrelevant jobs, no media after having it force fed, no phones, and the complete absence of the usual repressive bureaucracy. This resulted in a tremendous feeling of isolation and instability for the population. Many simply stayed home fearing the great unknown—who was us in most cases. So we started spending our days traveling around like incumbents in an election year, meeting our "constituents," and building up our popular support. It took some getting used to, but the effect was dramatic. Senior officers shaking hands in the street? Accepting criticism? Pitching in to help neighborhoods? Destroying the invincible Saddam regime? Amazing to the locals, but very welcome.

This Could Be Working

The TTP listed above helped to get us on the road to recovery and to provide a way ahead in a confused and chaotic environment. But it was impressive to see the reorganization of the city under this influence.

Again, we were not unique. The other battalions, as well as our regimental headquarters and the division, were all making similar adjustments as the city/country came under more control. Within a week of liberation the markets were open again in our sector, many were going back to work, there was a new police force reorganizing, hospitals were reopening, and most impressively, neighborhoods were organizing their first attempts at representative government councils. These nascent steps toward democracy generated tremendous excitement in the population despite their concerns over their lack of critical services.

But, at the same time, we were starting to see the enormity of the challenge offered by the political transformation of a diverse city like Baghdad. Like most of the world's great cities, Baghdad is made up of a wide compilation of cultures and ethnic groups. I think we understood that we would find divisions like Sunni and Shiá neighborhoods, but we were surprised to find large boroughs of Palestinians, Syrians, Armenians, and Christians, as well as smaller communities of even more variety. The locals told us that Saddam purposely created these segregated pockets of division in order to keep the various communities in check. Whether this Machiavellian construct was deliberate was academic as we now were faced with the seeds of ethnic tension in a no longer totalitarian setting. The issue was to manage these groups fairly without showing any overt favoritism, but effectively use their stabilizing influence to promote security and popular support. We found ourselves operating more in the political realm as we balanced competing groups seeking influence in the post regime power vacuum. These early experiences would become invaluable lessons in our later stability operation missions.

From Embedded to Dreaded

A final component of the transition period was the sea change in our relationship with the media. During the combat phase we experienced unprecedented media access via the embedded reporters. The First Team had a television crew from Cable News Network and two newspaper reporters (*The Washington Post* and *Chicago Tribune*). Our relationship with them followed the same pattern as most units in Operation IRAQI FREEDOM (OIF), going from a wary start as we sized each other up to all out mutual acceptance as we shared the battle across Iraq. By Baghdad there were few secrets as we had each proved trustworthy under extreme circumstances.

But that relationship came to an abrupt end as we transitioned out of combat operations. Media home offices were eager to point their valuable news crews at more focused and "newsworthy" events than the seemingly mundane affairs of security operations. So our "embeds" were quickly extracted and joined large press pools downtown in the Palestine Hotel. As the embeds withdrew, we encountered geometrically increasing numbers of free roaming "freelancers" out to find the story of the day. They had come to Baghdad on the coattails of the advancing forces, having been shut out of most of the combat units during the fighting. These freelancers had a completely different view of the war and our occupation of Baghdad, and a wide range of agendas that matched their parent media and national diversity. They also were fond of flaunting their perceived freedom of access across the still unstable city without the battlefield sense of the embeds and with credentials that were as minimal as the letters "TV" taped on their sport utility vehicles and calling cards for an IDs. Handling these droves of swarming reporters became a major consideration that was as much a security issue as a public relations and information operation. Although some were vetted and certified by our higher headquarters, the sheer numbers of reporters and no opportunity to control their ingress into the city left this a constant problem.

In retrospect, I believe that this was an opportunity lost for both the media and our military. Prematurely severing the embed linkage removed the opportunity to report on the reawakening of the country and the metamorphosis of an exclusively combat force into a reconstruction force. While this may not have first appeared to be a newsworthy subject, I would argue that it has become a major story of late. In later operations the division was very successful in dealing with freelancers by attaching public affairs office noncommissioned officer (U.S. Army/U.S. Marine Corps combat correspondents) to battalion task forces and by using our PsyOps to monitor the messaging we were delivering in the local and international media.

Handoff and Rehack

On 20 April 2003, Easter morning, we handed off our sector of Baghdad to several units from the U.S.

Army. We accomplished the relief in place (RIP) in about 3 days, emphasizing “right side/left side” type interactions down to the platoon level. This process had relieving small unit leaders accompanying our live patrols, raids, and security operations as observers, followed by our small unit leaders accompanying their first operations in their new zone. We also conducted more formal turnovers of our local intelligence on our sector to the respective staffs, as well as the physical turnover of obstacles, firm bases, and static support. The most unique portion of this RIP was our focus on passing along our assessment of the political and social architecture of our city, as well as detailed surveys of the local infrastructure. Key to this was the sharing of the names and introductions to the key local leaders and contacts we had developed. These interpersonal contacts were invaluable pathways to the support of the local community and the maintenance of critical balance between competing groups.

We withdrew to an assembly area well south of Baghdad and awaited our next mission. That mission would start 4 days later as we occupied and conducted security/stabilization operations in the 1.2 million person Governate of Najaf in south-central Iraq. Our experiences in Baghdad would prove critical in our next mission, and we spent the intervening days reviewing our lessons learned and incorporating them into our new operating plans and standing operating procedures. The Najaf mission will be the next article in this series.

Lessons Learned

- Transition operations are key to long-term success but should not be exclusively a military show. Marines can do it militarily, even politically for a very short time, but what is needed is the rapid replacement of a civil power vacuum with civil solutions. This is no time for amateurs and promises. Bring in the pros from Dover right behind the attack for a lasting peace.

- Invest in critical transition forces. For example, our PsyOps teams needed the capability to immediately saturate the local media with our message but could not do it because all they had were loudspeakers and leaflets. They need portable radio/television transmitters in transition/stability operations. You can lead a population but only if you can effectively get your message and personality out to citizens. In urban settings even the poorest have some access to electronic media, and its use provides immediate influence over the population. Other critical military skills sets were HETs, translators (especially U.S. citizens who are expatriots of the host country), civil affairs, engineers, lawyers, and military police.

- We need to better plan for actions and effects during the combat phase that will produce the best complement of subsequent transition and stability operations. I think this was attempted in varying degrees by higher and adjacent commands, but there did not seem to be a unity of purpose throughout the theater in defining a cohesive political end state fully supported in all phases of the operation. As a result, I believe that post-conflict operations were complicated by how we waged the combat phase.

- Be ready for instantaneous transition. Don’t stop being a warrior, but be ready to dual hat as a mayor/city manager/borough chief. Press flesh, kiss the babies, and kill the enemy.

- Read more than field manuals. Understand the local culture, political history, and the basics to managing a successful government. The *Small Wars Manual* is certainly a great start, but Machiavelli’s *Prince*, *The Articles of Confederation*, *The Constitution*, *The Federalist Papers*, international political journals/texts, area histories, and cultural studies like *The Arab Mind* (Raphael Patai) and the Koran are just as critical as Sun Tsu and Clausewitz in transition operations.

- Be creative. You have many untapped secret weapons in your units. Create special skills lists prior to combat that identify your Marines with past experience as electricians, oil workers, heavy machinery operators, firefighters, police, political campaigns workers, media creators, etc. Look at opportunities to build unique nonmilitary skills during peacetime operations that will be key enablers later. Few of these investments are wasted.

- Experience is a critical asset in the unique environment of transition operations, just as it is in combat. Foreign deployments with maximum international contact, bilateral training, and any opportunity for interagency and multinational interactions are invaluable. And when those opportunities are not there, the next best thing is to read about someone else’s experiences to gain their lessons for free.

In summary, if we accept Clausewitz's dictum that "war is politics by other means" then we must also accept that war and military actions are simply phases and enablers for the entire political solution to international crises. That being the case, we must be able to "work the seams" by ensuring that military operations are embedded in political strategies in order to complement and facilitate national objectives. Transition operations represent the operational merger between high-intensity combat operations and nonmilitary solutions to a political crisis. Our epiphany was discovering just how far down that linkage goes and just how politically astute our "strategic corporals" must be. In a perfect world there exists a detailed political/military plan for any crisis that would address these transition periods with the early insertion of critical civil stabilizing assets. The reality is that most conflicts are come as you are occasions where the price of early success will be ad hoc transition operations flowing into long-term stability operations using predominantly military forces. And, as the lead quote in this article states, these are "normal and frequent operations" for our Marine Corps, so we need to be very good at them. What do you do for an encore? Play well enough that you never need to come back.





Raid in Iraq's “Indian Country”

by Pamela Hess

United Press International, 6 August 2003.

Copyright 2003 United Press International. Reprinted with Permission.

CAMP SCORPION, Iraq, Aug. 5 (UPI)—Northern Babil province is what the Marines call, in their typically politically incorrect way, “Indian country.” When there are ambushes on Army supply convoys, when roadside explosions claim the limbs and lives of American servicemen driving in Humvees, when humanitarian aid workers’ cars are shot at, this is usually where it happens.

The army has lost about 50 soldiers to enemy fire since the war ended. Task Force Scorpion is here to do something about it. What was once a clash of armies has come to this: painstaking detective work, and then a hunt for the “bad guys,” one at a time.

The 4th Light Armored Reconnaissance Battalion heads Scorpion. They have moved from hot spot to hot spot throughout Iraq and have now brought their peculiar blend of high spirits and blood thirst to north Babil. Their morale is disproportionate to the squalid conditions in which they live.

Mad Max would turn his nose up at Camp Scorpion. There is nothing but garbage and dirt and sand as far as the eye can see. Marines live and sleep in the open air of a gravel parking lot, except for the few one-story concrete buildings that are air conditioned on the rare occasions the generators can be coaxed to work. They have no chow hall (they drive to an army supply outpost a few miles away to eat twice a day) and until portable toilets arrived recently, bathroom facilities were a plywood bench with four holes in it, side by side. Powerful winds sweep the grounds, kicking up massive dust clouds that coat everything in dull brown powder several times a day.

“This is the best we’ve had it!” laughs Master Gunnery Sgt. Paul D. Clark, from Austin, Texas, the battalion’s operations chief.

Clark is not kidding. It’s better than the underground bunker, where their faces and hands inexplicably swelled like sausages. It is better than the sheep farm, where they were covered head to toe with unknown insect bites. It is better than the castle on the Iran-Iraq border where it was never less than 115 degrees and the rooms were filled with flies and mosquitoes.

Once they cleaned out months of accumulated human and animal feces—origins unclear—with shovels and wheelbarrows, Camp Scorpion became Club Med in comparison.

“See that brown line?” Clark asks, enjoying the telling, pointing to a faint horizontal mark circumnavigating the room about a foot off the floor. That was the top of the pile, he says.

The rough concrete walls are covered in Arabic graffiti. There is a framed picture of a young Saddam Hussein that one sergeant intends to “liberate” when he leaves. Camouflage ponchos cover the doors, and the harsh sun is blocked with torn cardboard boxes in the window frames. It looks like every war movie set ever built, but 100 times worse.

The 4th LAR is the only Marine reserve battalion commanding active duty forces in Iraq, says commander Lt. Col. Anthony Pappas. Like most of the men in the 1,000-man task force, Pappas is a civilian most of the year. He works at the Drug Enforcement Administration in southern California.

The 4th LAR moved to north Babil in June from the castle on the Iran-Iraq border at the Army’s request.

The Army had set up its main resupply depot at a desolate place known as Dogwood. It is a relatively straight shot north to the bulk of Army forces at the Baghdad International Airport. It has good roads, but they require passing through a highway intersection known as the “Mixing Bowl.”

“The army out of the blue picked Dogwood. It is the most ambush-friendly place in Iraq,” Pappas says. “Every terrorist-wannabe is coming here to kill Americans.”

While the Army loses soldiers to guerilla attacks on an almost daily basis, the Marines have not lost one. They have suffered heavy casualties, however.

“We’ve had a lot of wounded,” says Maj. Joe Cabell, who in his civilian life plans military exercises in Hawaii. “My detachment of 50 has had five injuries. Three are back on duty and two had to be medevaced. Still, that’s 10 percent.” Although the area is close to Baghdad and it was Army convoys being attacked, Babil is technically within the 1st Marine Division’s area of operation. It falls to them to get it under control.

“It was a joke when we came here,” Pappas says of the security situation.

Like Fallujah and Baghdad to the north, north Babil is dangerous.

“It’s our problem child,” acknowledges Lt. Col. David Furness, operations officer for the 1st Marine Division based in Babylon.

In the haste to get to Baghdad during the war, no forces stayed behind to tame the area. Most of the Marines’ progress to the capital city was conducted as a leapfrog operation: One unit would fight forward, then stay in place for three or four days while another pushed ahead. The Marines left back would resupply, rest, clean their weapons and then fan out into the villages to hand out candy and food, assess their humanitarian needs, and forcibly bring order where it was needed.

North Babil never received such attention.

“They roared through the area because they were wanting to hit Baghdad,” says Maj. Dave Bellon, a lively San Diego personal injury attorney and the task force’s operations director.

The problem, say Pappas and Bellon, was standard Army land-warfare doctrine. When a supply convoy is attacked, it is supposed to speed up and get out of the danger zone. Once the vehicles are through the ambush area, the force can swing around and go after the enemy if it has the firepower to do so.

That response only makes sense, however, if the convoy were attacked by an enemy that knows how to ambush, Bellon says. A well-trained enemy would shoot the first and last vehicles in line, halting the procession in place, and then destroying it in its own good time.

The 4th LAR soon figured something out.

“They didn’t know what they’re doing!” Bellon says. “They fire at the middle truck and then run away. If Marines were doing the ambushes, they’d all be dead.”

But it was enough to do serious damage to the Army: The lumbering supply convoys were sitting ducks, as the Marines tell it. The drivers sometimes wore flip-flops and headphones instead of Kevlar and body armor, and they frequently stopped at roadside stands for sodas, Bellon says.

“This place was going off like a firecracker,” he says.

What the Marines did was simple: They escorted the convoys and fired back. In the two weeks before the 4th LAR arrived, there were 51 ambushes on convoys. For the first eight days after the Marines arrived and began work, there was none.

“We thought we had it pretty well snapped,” Bellon says, “Marines were stopping and fighting, and they (the shooters) were getting killed.”

The shooters, who the military says were generally out-of-work locals paid by remnants of Saddam’s Baathists to

take potshots at Americans, were no match for Task Force Scorpion. Gunmen who survived contact with the Marines went back to their villages and told of their enemy's mystical powers—the force-field that protected the snub nosed, 14-ton Light Armored Vehicles, and the “magic eyes”—infrared sensors—that let them see at night.

“Suddenly it became a bad summer job to have,” Bellon says.

With the enemy now engaged on the roads, Task Force Scorpion turned its attention to a “hearts-and-minds” campaign for the two main towns, Yusifiyah and Mumadiyah. The 4th LAR has begun what will be \$350,000 worth of projects that will be completed next month.

Of critical importance is electricity. Hundreds of miles of canals crisscross the area, providing the only irrigation; it almost never rains. It takes three full days of electric power to pump water through the canal system from start to finish. The best the Marines have been able to muster is about 3 hours on and 3 hours off.

After a month of working in the villages—handing out candy and toothbrushes to children, refurbishing schools and running 3,000 meters (nearly 2 miles) of electrical wire to hook into the Baghdad power grid—they began to see a change. The people, if not waving from the streets, are at least beginning to point out the “bad guys” to them in private. Sometimes a sheikh appears at the camp gate with a note, other times the information comes when a Marine is walking a patrol.

“For 35 years, anyone with an innate leadership either was on board with the Baath party or killed. This is an entire generation of people who watch and wait,” Bellon says. “We also told them not to let their sons take the money, because we’ll kill them (if they shoot at us).”

But one day in June, someone fired a rocket-propelled grenade into a military ambulance and then moved in for the kill with guns. The daylight attack—the first one Task Force Scorpion had seen—claimed one soldier and critically wounded two, including the injured man being transported.

“The day we lost that soldier was like a gut shot. There was a lot of anger,” Bellon says. “That was the first indication we were involved in a chess match. They were evolving, and we were evolving.”

Forced to fire from farther and farther away from the road to avoid certain death, the shooters soon switched to “improvised explosive devices”—often a 120mm artillery shell with a fuse, or a car battery packed with C-4 explosives. As days wore on, the devices got more sophisticated, evolving from command detonation—with the attacker on the scene to set off the bomb—to trip wires and timing devices. Sometimes a motorcycle will pull up next to a convoy and toss a landmine underneath.

Despite the escalation, a Marine intelligence officer sees an improvement.

“They are afraid to engage us up close,” he says. “We’re winning.”

But defensive operations can no longer handle the threat. The 4th LAR is now on the offensive, collecting intelligence and swooping down on their enemies' homes in the minutes before dawn. They have conducted more than 20 raids on the houses of people suspected of organizing the attacks.

“We’re right in their face. It’s great!” says Pappas, gleeful in the hours before the night’s raid.

As godforsaken as Camp Scorpion seems, a few miles west on the banks of the Tigris is a shady green paradise that would not look unfamiliar to wealthy Floridians—blue sky, palm trees, jasmine and a fast-moving waterway behind well-kept, large, modern homes.

“This is beach-front property for Baghdad,” Bellon says.

The Marines are convinced these are the homes of the moneymen—the brains and resources behind the attacks.

This weekend, the 4th LAR saw something new: an Improvised Explosive Device—or IED—made from a soda can sitting on a pile of rocks a few feet high on the side of the road. The added height allowed the bomb to bypass the armored undersides of the target vehicle and to spray its shrapnel at a level calculated to do maximum damage to the person. On Friday, a Humvee drove into the trip wire, about a kilometer—just over half a mile—from the task force command center. The can exploded, firing rocks and gravel at the driver and tearing apart his arm. It may have to be amputated.

This was especially dispiriting news at command headquarters. On July 22, they had captured a man they believed to be behind the 18 IED attacks on the roads near the Mixing Bowl. They were pretty sure they had their man, as there had been no attacks for 10 days—until the soda-can bomber.

Friday night’s raid, however, had a different quarry.

The raid went after one man, a well-heeled resident of the Baath neighborhood with a house on the river, a Mercedes and a satellite dish.

“This is the suburb of Baghdad where all these knuckleheads live,” Pappas says.

The raid involved two UH-1 helicopters with forward-looking infrared sensors in case there are “squirters”—people who escape and hide in the surrounding vegetation.

Also participating were almost 50 Marines, four Light Armored Vehicles, two Humvees and a team of engineers that will use metal detectors to look for buried weapons or explosives on the property. Cabell, the military-exercise planner who lives in Hawaii, planned the raid.

“We’ve had this guy’s name for four weeks,” he says.

Task Force Scorpion asked that the target’s name not be released.

They have information that this man planned and financed a late June ambush against a military police convoy that was heading to repair a water-treatment facility. The attack seriously wounded one Marine and hurt two more. An LAV unit got the distress call and raced to the fight. It flipped in a gully. One Marine was crushed and seven more were wounded.

“That was a big day for us,” Bellon says. “We’ve been waiting for this guy.”

After a series of briefings and small unit rehearsals, the raid party left Camp Scorpion at 3 a.m. local time. The LAV units were to arrive at the house about 45 minutes before dawn and knock on the door. An Arab linguist would direct those inside to open the door and ask for permission to search.

“We search anyway,” Cabell says with a sly smile. “But it’s good to ask.”

But there’s a snag—the raid party arrived 15 minutes late. The helicopters had been waiting in the air, burning fuel.

Finally in place, the raid party knocked on the door and asked for permission to enter. No response. They kicked in the door.

“We’ve got a squighter!” a voice crackled over the radio.

They found seven sleeping men on a roof deck. The eighth man heard the raid and launched himself—wearing nothing but underwear, according to the Marines—from the deck to the backyard, and slid down the steep, muddy slope to the Tigris.

The Marines gave chase but couldn’t find him. His ride down the bank had camouflaged him in mud. They were 2 meters away from his hunched form and had no idea where he was.

Overhead, the Huey turned on its infrared sensor and quickly located the man in the mud. With a laser pointer, Bellon designated the target’s body. At that moment, he lurched into the river and disappeared into the reeds that stand 6 feet tall.

Three Marines tore off their body armor and boots and dived in after him. At the same moment, the Hueys had to pull off. They were out of fuel.

The search continued on the river. Without the Hueys, though, they had no way of distinguishing their well-hidden target in all the vegetation. The sun was fully up now, diminishing the edge that thermal sensors would give them when the helicopters returned.

In the backyard of an adjacent house, seven handcuffed men knelt in a circle, facing out, on a patch of grass surrounded by bedraggled rose bushes and Marines whose M-16s pointed at the ground or hung off their backs. Nearly a dozen pajama-clad children and four women watched through curtains from inside the house.

Two boys brought water to the captives. A Marine grabbed one of the captives who was watching the search party and forced him to look down.

The Hueys returned and flew low over the reeds, using the powerful downwash of the rotors to flatten the thick brush on the banks. They saw the escapee pop up once before he disappeared again. The helicopters pulled off for more fuel.

“When the helos had to refuel we lost him on IR,” Cabell says, shaking his head, angry. “I had to blow one of 40 raids. I’m almost perfect every time. I miscalculated by 15 minutes.”

The prisoners told the Marines the man they were looking for was not there. He had left the house the day before, they said. Moments later, Saudi-born Staff Sgt. Rashed Qawasmi emerged from the house with the man’s wallet, driver’s license and car keys. He also carried a letter that discussed the jihad against the Americans at length.

“Left yesterday? Without his keys and wallet?” Cabell asks. “These people must think we’re retarded.”

He gave the order and one by one the men’s heads were hooded with empty sand bags. Although they could breathe—the plastic fabric is porous—it is a frightening experience for them and their watching families. The Marines use the hoods to control their prisoners without having to use force, and to keep them from knowing where they are going.

“It keeps ‘em from looking around,” Cabell says grimly.

The children came to the door and then into the yard, crying and beating their legs and arms in fear and anger. The women pleaded in Arabic, pointing to the crying children. It was an awful scene.

“I told her to keep the damn kids inside, they don’t need to see this,” Cabell said sharply to Qawasmi.

This is the hardest part for the Marines, who are well aware these women and children think their loved ones are going to be executed—because that is what Saddam used to do when he brought out the hoods. But most of these men will be home within hours or days, they say.

“The kids just kill you,” a sergeant says. “They break your heart.”

One of the hooded seven was about 17. As he was led away, he began to sob and beg to see his mother one last time. Qawasmi pulled him aside. Still, in the hood, the boy began to whisper: Three of the men came here for a meeting last night with the Iraqi who disappeared into the brush. They are planning an attack on the Americans. The man who fled is the man the Marines want.

The boy was allowed to see his mother, and then was put in an LAV with the others. He was warned not to speak to them.

All the prisoners would return to Camp Scorpion’s detention facility where they would sit for 8 hours before anyone interrogates them. They would get food and water, but the wait is critical for wearing them down, an intelligence officer says. U.S. military rules say they can only be kept for 72 hours at Camp Scorpion. At that point, they will either be freed or sent to a prisoner of war camp in southern Iraq, said an intelligence officer.

A young sergeant told Cabell he found fresh tracks in the mud, leading away from the river. The man somehow got from the water, around the Marines looking for him, and past the point guard on the road.

“He’s probably in someone’s house by now,” the sergeant says.

Cabell reluctantly called off the raid, most of which United Press International was present for. His man got away. But they have a huge haul—they’ve never pulled in seven potential plotters before, and they are sure they disrupted a future attack. And they also have their target’s Mercedes.

“We’ll give a receipt to his wife and tell her he can come pick up the car tomorrow,” Cabell laughs. “You wouldn’t believe how often that works. These guys will just come to the gate.”

Despite the escape and fruitless search, Pappas says the mission is a success.

“He’s running around in his underwear, covered in mud and smelling like the river and he knows we’re looking for him,” Pappas says. “That’s not small.”

The psychological blow to the men who are targeting the Americans will be major, Pappas says. They know their neighbors are giving up their names and their addresses. They no longer act with impunity.

Besides, Pappas has something else in mind for the man who got away.

“We’re telling the seven guys we got that he didn’t escape. We let him go,” he laughs. “The search was for show. We’re telling them he is working for us.”

After the 6-hour mission, which has caused them to miss breakfast, lunch will likely be a small can of tuna and an orange, the 50 exhausted Marines return to Camp Scorpion.

Six sweating engineers and a Navy medic tumble out of the back of the cramped LAV and unload their gear under the scorching sun. Their home is a taped off square of gravel parking lot, wedged between LAVs and Humvees and port-a-potties. They have eight nylon cots among them. They do not have a tent. A dust storm is kicking up, coughing hot, dry sand all over them.

They have another mission in 18 hours: to capture three men who have put a bounty on Qawasmi’s head.

“The latest intel says its about \$2,000,” Qawasmi laughs. “That’s cheap, huh?”

The Saturday night raid yields two of the three men. The most important one got away, a senior military official told UPI.

Part VI

Media Operations: Telling the Story

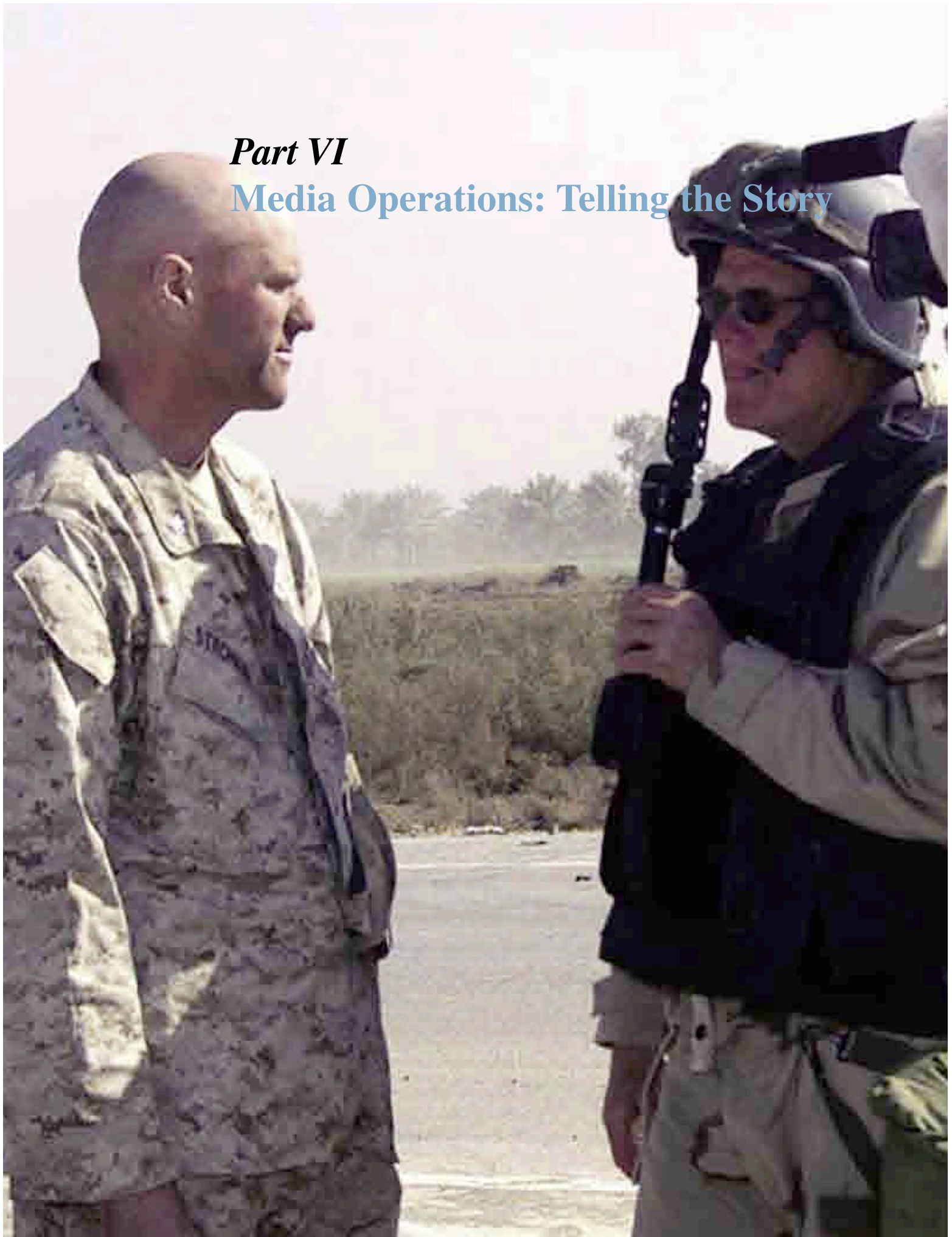



Public Affairs Guidance on Embedding Media

Office of the Assistant Secretary of Defense (Public Affairs)

www.defenselink.mil/news/Feb2003/d20030228pag.pdf.10
February 2003.

Subject: Public Affairs Guidance on Embedding Media During Possible Future Operations/Deployments in the U.S. Central Commands (CENTCOM) Area of Responsibility (AOR)

References: Ref. A. SECDEF MSG, DTG 172200Z Jan 03, Subj: Public Affairs Guidance (PAG) for Movement of Forces into the CENTCOM AOR for Possible Future Operations.

1. Purpose: This message provides guidance, policies and procedures on embedding news media during possible future operations/deployments in the CENTCOM AOR. It can be adapted for use in other unified command AORS as necessary.

2. Policy.

2.A. The Department of Defense (DOD) policy on media coverage of future military operations is that media will have long-term, minimally restrictive access to U.S. Air, ground and naval forces through embedding. Media coverage of any future operation will, to a large extent, shape public perception of the national security environment now and in the years ahead. This holds true for the U.S. public; the public in allied countries whose opinion can affect the durability of our coalition; and publics in countries where we conduct operations, whose perceptions of us can affect the cost and duration of our involvement. Our ultimate strategic success in bringing peace and security to this region will come in our long-term commitment to supporting our democratic ideals. We need to tell the factual story—good or bad—before others seed the media with disinformation and distortions, as they most certainly will continue to do. Our people in the field need to tell our story—only commanders can ensure the media get to the story alongside the troops. We must organize for and facilitate access of national and international media to our forces, including those forces engaged in ground operations, with the goal of doing so right from the start. To accomplish this, we will embed media with our units. These embedded media will live, work and travel as part of the units with which they are embedded to facilitate maximum, in-depth coverage of U.S. forces in combat and related operations. Commanders and public affairs officers must work together to balance the need for media access with the need for operational security.

2.B. Media will be embedded with unit personnel at air and

ground forces bases and afloat to ensure a full understanding of all operations. Media will be given access to operational combat missions, including mission preparation and debriefing, whenever possible.

2.C. A media embed is defined as a media representative remaining with a unit on an extended basis—perhaps a period of weeks or even months. Commanders will provide billeting, rations and medical attention, if needed, to the embedded media commensurate with that provided to members of the unit, as well as access to military transportation and assistance with communications filing/transmitting media products, if required.

2.C.1. Embedded media are not authorized use of their own vehicles while traveling in an embedded status.

2.C.2. To the extent possible, space on military transportation will be made available for media equipment necessary to cover a particular operation. The media is responsible for loading and carrying their own equipment at all times. Use of priority inter-theater airlift for embedded media to cover stories, as well as to file stories, is highly encouraged. Seats aboard vehicles, aircraft and naval ships will be made available to allow maximum coverage of U.S. troops in the field.

2.C. 3. Units should plan lift and logistical support to assist in moving media products to and from the battlefield so as to tell our story in a timely manner. In the event of commercial communications difficulties, media are authorized to file stories via expeditious military signal/communications capabilities.

2.C.4. No communications equipment for use by media in the conduct of their duties will be specifically prohibited. However, unit commanders may impose temporary restrictions on electronic transmissions for operational security reasons. Media will seek approval to use electronic devices in a combat/hostile environment, unless otherwise directed by the unit commander or his/her designated representative. The use of communications equipment will be discussed in full when the media arrive at their assigned unit.

3. Procedures

3.A. The office of the Assistant Secretary of Defense for Public Affairs (OASD (PA)) is the central agency for managing and vetting media embeds to include allocating embed slots to media organizations. Embed authority may be delegated to subordinate elements after the commencement of hostilities and at the discretion of OASD (PA). Embed opportunities will be assigned to media organizations, not to individual reporters. The decision as to which media representative will fill assigned embed slots will be made by the designated POC for each news organization.

3.A. IAW Ref. A, commanders of units in receipt of a deployment order may embed regional/local media during preparations for deployment, deployment and arrival in theater upon receipt of theater clearance from CENTCOM and approval of the component command. Commanders will inform these media, prior to the deploying embed, that OASD (PA) is the approval authority for all combat embeds and that their particular embed may end after the unit's arrival in theater. The media organization may apply to OASD (PA) for continued embedding, but there is not guarantee and the media organization will have to make arrangements for and pay for the journalists' return trip.

3.B. Without making commitments to media organizations, deploying units will identify local media for potential embeds and nominate them through PA channels to OASD (PA). . . . Information required to be forwarded includes media organization, type of media and contact information including bureau chief/managing editor/news director's name; office, home and cell phone numbers; pager numbers and email addresses. Submissions for embeds with specific units should include an unit's recommendation as to whether the request should be honored.

3.C. Unit commanders should also express, through their chain of command and PA channels to OASD (PA), their desire and capability to support additional media embeds beyond those assigned.

3.D. Freelance media will be authorized to embed if they are selected by a news organization as their embed representative.

3.E. Units will be authorized direct coordination with media after assignment and approval by OASD (PA).

3.E.1. Units are responsible for ensuring that all embedded media and their news organizations have signed the "Release, indemnification, and hold harmless agreement and agreement not to sue," found at <http://www.defenselink.mil/news/feb2003/d20030210EMBED.PDF>. Units must maintain a copy of this agreement for all media embedded with their unit.

3.F. Embedded media operate as part of their assigned unit. An escort may be assigned at the discretion of the unit commander. The absence of a PA escort is not a reason to preclude media access to operations.

3.G. Commanders will ensure the media are provided with every opportunity to observe actual combat operations. The personal safety of correspondents is not a reason to exclude them from combat areas.

3.H. If, in the opinion of the unit commander, a media representative is unable to withstand the rigorous conditions required to operate with the forward deployed forces, the commander or his/her representative may limit the representatives participation with operational forces to ensure unit safety and inform OASD (PA) through PA channels as soon as possible. Gender will not be an excluding factor under any circumstance.

3.I. If for any reason a media representative cannot participate in an operation, they will be transported to the next higher headquarters for the duration of the operation.

3.J. Commanders will obtain theater clearance from CENTCOM/PA for media embarking on military conveyance for purposes of embedding.

3.K. Units hosting embedded media will issue invitational travel orders, and nuclear, biological and chemical (NBC) gear. See Para. 5. For details on which items are issued and which items the media are responsible to provide for themselves.

3.L. Media are responsible for obtaining their own passports and visas.

3.M. Media will agree to abide by the CENTCOM/OASD (PA) ground rules stated in Para. 4 of this message in exchange for command/unit-provided support and access to service members, information and other previously-stated privileges. Any violation of the ground rules could result in termination of that media's embed opportunity.

3.N. Disputes/Difficulties. Issues, questions, difficulties or disputes associated with ground rules or other aspects of embedding media that cannot be resolved at the unit level, or through the chain of command, will be forwarded through PA channels for resolution. Commanders who wish to terminate an embed for cause must notify CENTCOM/PA prior to termination. If a dispute cannot be resolved at a lower level, OASD (PA) will be the final resolution authority. In all cases, this should be done as expeditiously as possible to preserve the news value of the situation.

3.O. Media will pay their own billeting expenses if billeted in a commercial facility.

3.P. Media will deploy with the necessary equipment to collect and transmit their stories.

3.Q. The standard for release of information should be to ask "why not release" vice "why release." Decisions should be made ASAP, preferably in minutes, not hours.

3.R. There is no general review process for media products. See Para 6.A. For further detail concerning security at the source.

3.S. Media will only be granted access to detainees or EPWS within the provisions of the Geneva Conventions of 1949. See para. 4.G.17. For the ground rule.

3.T. Having embedded media does not preclude contact with other media. Embedded media, as a result of time invested with the unit and ground rules agreement, may have a different level of access.

3.U. CENTCOM/PA will account for embedded media during the time the media is embedded in theater. CENTCOM/PA will report changes in embed status to OASD (PA) as they occur.

3.V. If a media representative is killed or injured in the course of military operations, the unit will immediately notify OASD (PA), through PA channels. OASD (PA) will contact the respective media organization (s), which will make next of kin notification in accordance with the individual's wishes.

3.W. Media may terminate their embed opportunity at any time. Unit commanders will provide, as the tactical situation permits and based on the availability of transportation, movement back to the nearest location with commercial transportation.

3.W.1. Departing media will be debriefed on operational security considerations as applicable to ongoing and future operations which they may now have information concerning.

4. Ground Rules. For the safety and security of U.S. Forces and embedded media, media will adhere to established ground rules. Ground rules will be agreed to in advance and signed by media prior to embedding. Violation of the ground rules may result in the immediate termination of the embed and removal from the

AOR. These ground rules recognize the right of the media to cover military operations and are in no way intended to prevent release of derogatory, embarrassing, negative or uncomplimentary information. Any modification to the standard ground rules will be forwarded through the PA channels to CENTCOM/PA for approval. Standard ground rules are:

4.A. All interviews with service members will be on the record. Security at the source is the policy. Interviews with pilots and aircrew members are authorized upon completion of missions; however, release of information must conform to these media ground rules.

4.B. Print or broadcast stories will be datelined according to local ground rules. Local ground rules will be coordinated through command channels with CENTCOM.

4.C. Media embedded with U.S. forces are not permitted to carry personal firearms.

4.D. Light discipline restrictions will be followed. Visible light sources, including flash or television lights, flash cameras will not be used when operating with forces at night unless specifically approved in advance by the on-scene commander.

4.E. Embargoes may be imposed to protect operational security. Embargoes will only be used for operational security and will be lifted as soon as the operational security issue has passed.

4.F. The following categories of information are releasable.

4.F.1. Approximate friendly force strength figures.

4.F.2. Approximate friendly casualty figures by service. Embedded media may, within OPSEC limits, confirm unit casualties they have witnessed.

4.F.3. Confirmed figures of enemy personnel detained or captured.

4.F.4. Size of friendly force participating in an action or operation can be disclosed using approximate terms. Specific force or unit identification may be released when it no longer warrants security protection.

4.F.5. Information and location of military targets and objectives previously under attack.

4.F.6. Generic description of origin of air operations, such as "land-based."

4.F.7. Date, time or location of previous conventional military missions and actions, as well as mission results are releasable only if described in general terms.

4.F.8. Types of ordnance expended in general terms.

4.F.9. Number of aerial combat or reconnaissance missions or sorties flown in CENTCOM's area of operation.

4.F.10. Type of forces involved (e.g., air defense, infantry, armor, marines).

4.F.11. Allied participation by type of operation (Ships, aircraft, ground units, etc.) After approval of the allied unit commander.

4.F.12. Operation code names.

4.F.13. Names and hometowns of U.S. military units.

4.F.14. Service members' names and home towns with the individuals' consent.

4.G. The following categories of information are not releasable since their publication or broadcast could jeopardize operations and endanger lives.

4.G.1. Specific Number of troops in units below corps/MEF level.

4.G.2. Specific number of aircraft in units at or below the air expeditionary wing level.

4.G.3. Specific numbers regarding other equipment of critical supplies (e.g. artillery, tanks, landing craft, radars, trucks, water, etc.).

4.G.4. Specific numbers of ships in units below the carrier battle group level.

4.G.5. Names of military installations or specific geographic locations of military units in the CENTCOM area of responsibility, unless specifically released by the department of defense or authorized by the CENTCOM commander. News and imagery products that identify or include identifiable features of these locations are not authorized for release.

4.G.6. Information regarding future operations.

4.G.7. Information regarding force protection measures at military installations or encampments (except those which are visible or readily apparent).

- 4.G.8. Photography showing level of security at military installations or encampments.
- 4.G.9. Rules of Engagement.
- 4.G.10. Information on intelligence collection activities compromising tactics, techniques or procedures.
- 4.G.11. Extra precautions in reporting will be required at the commencement of hostilities to maximize operational surprise. Live broadcasts from airfields, on the ground or afloat, by embedded media are prohibited until the safe return of the initial strike package or until authorized by the unit commander.
- 4.G.12. During an operation, specific information on friendly force troop movements, tactical deployments, and dispositions that would jeopardize operational security or lives. Information on on-going engagements will not be released unless authorized for release by on-scene commander.
- 4.G.13. Information on special operations units, unique operations methodology or tactics, for example, air operations, angles of attack, and speeds; naval tactical or evasive maneuvers, etc. General terms such as “low” or “fast” may be used.
- 4.G.14. Information on effectiveness of enemy electronic warfare.
- 4.G.15. Information identifying postponed or canceled operations.
- 4.G.16. Information on missing or downed aircraft or missing vessels while search and rescue and recovery operations are being planned or underway.
- 4.G.17. Information on effectiveness of enemy camouflage, cover, deception, targeting, direct and indirect fire, intelligence collection, or security measures.
- 4.G.18. No photographs or other visual media showing an enemy prisoner of war or detainee’s recognizable face, nametag or other identifying feature or item may be taken.
- 4.G.19. Still or video imagery of custody operations or interviews with person under custody.
- 4.H. The following procedures and policies apply to coverage of wounded, injured, and ill personnel.
- 4.H.1. Media representatives will be reminded of the sensitivity of using names of individual casualties or photographs they may have taken which clearly identify casualties until after notification of the NOK and release by OASD (PA).
- 4.H.2. Battlefield casualties may be covered by embedded media as long as the service member’s identity is protected from disclosure for 72 hours or upon verification of NOK notification, whichever is first.
- 4.H.3. Media visits to medical facilities will be in accordance with applicable regulations, standard operating procedures, operations orders and instructions by attending physicians. If approved, service or medical facility personnel must escort media at all times.
- 4.H.4. Patient welfare, patient privacy, and next of kin/family considerations are the governing concerns about news media coverage of wounded, injured, and ill personnel in medical treatment facilities or other casualty collection and treatment locations.
- 4.H.5. Media visits are authorized to medical care facilities, but must be approved by the medical facility commander and attending physician and must not interfere with medical treatment. Requests to visit medical care facilities outside the continental United States will be coordinated by the unified command PA.
- 4.H.6. Reporters may visit those areas designated by the facility commander, but will not be allowed in operating rooms during operating procedures.
- 4.H.7. Permission to interview or photograph a patient will be granted only with the consent of the attending physician or facility commander and with the patient’s informed consent, witnessed by the escort.
- 4.H.8. “Informed consent” means the patient understands his or her picture and comments are being collected for news media purposes and they may appear nationwide in news media reports.
- 4.H.9. The attending physician or escort should advise the service member if NOK have been notified.
5. Immunizations and personal protective gear.
- 5.A. Media organizations should ensure that media are properly immunized before embedding with units. The Centers for Disease Control (CDC)—Recommended immunizations for deployment to the Middle East include Hepatitis A; Hepatitis B; Rabies; Tetanus-Diphtheria; and Typhoid. The CDC recommends meningococcal immunizations for visitors to MECCA. If traveling to certain areas in the CENTCOM AOR, the CDC recommends taking prescription antimalarial drugs. Anthrax and smallpox vaccines will be provided to the media at

no expense to the government (the media outlet will bear the expense). For more health information for travelers to the Middle East, go to the CDC web site at <http://www.cdc.gov/travel/mideast.htm>.

5.B. Because the use of personal protective gear, such as helmets or flak vests, is both a personal and professional choice, media will be responsible for procuring/using such equipment. Personal protective gear, as well as clothing, will be subdued in color and appearance.

5.C. Embedded media are authorized and required to be provided with, on a temporary loan basis, nuclear, biological, chemical (NBC) protective equipment by the unit with which they are embedded. Unit personnel will provide basic instruction in the proper wear, use, and maintenance of the equipment. Upon termination of the embed, initiated by either party, the NBC equipment shall be returned to the embedding unit. If sufficient NBC protective equipment is not available for embedded media, commanders may purchase additional equipment, with funds normally available for that purpose, and load it to embedded media in accordance with this paragraph.

6. Security

6.A. Media products will not be subject to security review or censorship except as indicated in Para. 6.A.1. Security at the source will be the rule. U.S. military personnel shall protect classified information from unauthorized or inadvertent disclosure. Media provided access to sensitive information, information which is not classified but which may be of operational value to an adversary or when combined with other unclassified information may reveal classified information, will be informed in advance by the unit commander or his/her designated representative of the restrictions on the use or disclosure of such information. When in doubt, media will consult with the unit commander or his/her designated representative.

6.A.1. The nature of the embedding process may involve observation of sensitive information, including troop movements, battle preparations, materiel capabilities and vulnerabilities and other information as listed in Para. 4.G. When a commander or his/her designated representative has reason to believe that a media member will have access to this type of sensitive information, prior to allowing such access, he/she will take prudent precautions to ensure the security of that information. The primary safeguard will be to brief media in advance about what information is sensitive and what the parameters are for covering this type of information. If media are inadvertently exposed to sensitive information they should be briefed after exposure on what information they should avoid covering. In instances where a unit commander or the designated representative determines that coverage of a story will involve exposure to sensitive information beyond the scope of what may be protected by prebriefing or debriefing, but coverage of which is in the best interests of the DOD, the commander may offer access if the reporter agrees to a security review of their coverage. Agreement to security review in exchange for this type of access must be strictly voluntary and if the reporter does not agree, then access may not be granted. If a security review is agreed to, it will not involve any editorial changes; it will be conducted solely to ensure that no sensitive or classified information is included in the product. If such information is found, the media will be asked to remove that information from the product and/or embargo the product until such information is no longer classified or sensitive. Reviews are to be done as soon as practical so as not to interrupt combat operations nor delay reporting. If there are disputes resulting from the security review process they may be appealed through the chain of command, or through PA channels to OASD/PA. This paragraph does not authorize commanders to allow media access to classified information.

6.A.2. Media products will not be confiscated or otherwise impounded. If it is believed that classified information has been compromised and the media representative refuses to remove that information notify the CPIC and/or OASD/PA as soon as possible so the issue may be addressed with the media organization's management.

7. Miscellaneous/Coordinating Instructions:

7.A. OASD (PA) is the initial embed authority. Embedding procedures and assignment authority may be transferred to CENTCOM PA at a later date. This authority may be further delegated at CENTCOM's discretion.

7.B. This guidance authorizes blanket approval for non-local and local media travel aboard DOD airlift for all embedded media on a no-cost, space available basis. No additional costs shall be incurred by the government

to provide assistance IAW DODI 5410.15, Para 3.4.

7.C. Use of lipstick and helmet-mounted cameras on combat sorties is approved and encouraged to the greatest extent possible. . . .



Conducting Expeditionary Public Affairs

by Captain Joseph M. Plenzler

Marine Corps Gazette, February 2004.

“Left unsung, the noblest deed will die”
—MajGen James N. Mattis

The 1st Marine Division (1st MarDiv) attacked across the line of departure from Kuwait into Iraq on 20 March 2003 to topple the regime of Saddam Hussein. The division, together with the U.S. Army’s 3d Infantry Division, accomplished this mission by destroying resisting Iraqi forces and capturing the capital city of Baghdad. More than 80 national and international media, embedded within the division’s tactical units, witnessed the campaign and saturated the world’s airwaves and newspapers with reports of the division’s exploits and experiences in combat. The division’s success in the media was predicated on five essential elements:

(1) The initiative and aggressiveness of junior Marines and officers who embraced the media, shared their courage with the world, and proved to the Iraqi people that there is no better friend, no worse enemy than a U.S. Marine.

(2) Building realistic expectations of the media in our ranks and ensuring every Marine and sailor had a clear understanding of the commanding general’s (CG’s) mission and intent.

(3) Early engaging and maintaining contact with the international and national media upon arrival in theater.

(4) Embracing the media through a humanistic reception, staging, onward movement, and integration (RSO&I).

(5) Capitalizing on key critical events by exploiting tactical successes in the media.

Public affairs officers (PAOs) and commands with embedded journalists can best influence the course of the “information war” at the tactical level by setting the conditions for individual and unit success in the media prior to combat and by providing “reinforcing fires” on key communications objectives and tactical victories during the fight.

Preparation for Combat—Building Expectations

There are no finer Marine Corps spokesmen than our junior enlisted Marines. The division’s PA team decided early in the planning phase that the division’s story would be primarily told “where the rubber meets the road.” Early in August 2002, the CG charged his PA section with supervising the development of a predeployment brief to be given to the 20,000 Marines and sailors of the division. The predeployment brief was designed to “image” each Marine and sailor from southern California through deployment and subsequent combat operations on foreign shores with the specified intent of crystallizing the CG’s intent and key mission expectations into the minds of the audience.

The brief provided a powerful vehicle for the PA section to reach out to the commanders, Marines, and sailors of the division; forewarn of the large numbers of media to accompany units in combat; and disarm skepticism about the media’s presence. The media would be riding along with the Marines into battle—living, sweating and, in some cases, bleeding alongside them. To encourage the junior Marines to tell their story to the media, the PAO correlated engaging the media to the “free beer” that patriotic civilians buy Marines on liberty in their hometowns and increased stature in the eyes of attractive members of the opposite sex due to the representation of Marines in the entertainment media. The brief highlighted the photographing of the flag raising atop Mount Surabachi by Associated Press photographer Joe Rosenthal as a positive example of cooperation between the two different camps. The CG encouraged the division telling all hands that the media is an entirely winnable constituency and, that “left unsung, the noblest deed will die.”

Movement to Contact

From the onset, the division PA section recognized the criticality of gaining and maintaining contact with

the media in Kuwait City. The 400 reporters in country, frustrated by the slow pace of media opportunities at the Coalition Forces Land Component Command (CFLCC) press information center, languished in hotel lobbies as irate editors in New York and London screamed for copy. The PA section recognized this hunger for media opportunities and, pockets bulging with journalist' business cards, embarked on a media blitzkrieg hosting more than 400 reporters in 40 days.

The PA Marines put together media opportunities on "bubble gum and bailing wire" often hitchhiking with the media due to the scarcity of available military and commercial vehicles. In one instance they led 36 journalists in a 16-media-vehicle convoy to visit 1st Tank Battalion out at Udari Range #9 in the middle of a tooz—an Arabian sandstorm—navigating by global positioning system and map alone with visibility at less than 50 feet through 40 to 60 mile per hour winds. The tanks couldn't see their targets on the range. The story of the tank company training in harsh weather conditions carried the headlines, taught the reporters about the tenacity of our young Marines, and also provided a good lesson of what to expect should they decide to embed with the division for combat operations.

To further develop the relationship between the division and the media, the PA team organized professional military education (PME) sessions for the reporters at the CFLCC weekly meetings. Topics covered nuclear, biological, and chemical (NBC) defense familiarization; a gear packing seminar; tips on field living; and division-specific media ground rules. The objective of the PME sessions was to convey to the media that the 1st MarDiv cares whether embedded media live or die.

Concurrently, the PA team began exploring the feasibility of many television (TV) reporters' requests to use hard-wired, satellite transmission capable, 4-wheel-drive, diesel, desert colored vehicles, and night vision qualified drivers to support their broadcasts while embedded with the division. The team determined that allowing the media to use their own vehicles would benefit the division by ameliorating some of the logistics burden on receiving units (a TV crew generally requires ten 10-cube equivalents of space and lift) and allow the media to broadcast "live on the fly" in combat. (The setup time for transmission without the hard-wired vehicle is 2 hours.) Division PA requested to I Marine Expeditionary Force (I MEF) to appeal the Assistant Secretary of Defense prohibition on media vehicles in embedded units. Most TV media opted to assign vehicles to their embedded correspondents in the hope that the verdict would be positive and fielded the vehicles on short-term embeds with division units. On all early tests they performed spectacularly. Unfortunately, the division's appeal to allow the vehicles was rejected. This subsequently limited some embedded TV media's ability to file their stories.

RSO&I

On 10 March the PA section met at the Hilton Hotel in Kuwait City with 80 reporters assigned to embed within the division's tactical units. Marines issued NBC suits, masks, and nerve agent antidote kits. Doctors turned correspondents into pincushions with anthrax and smallpox vaccinations. Senior Marine leaders gave briefings on ground rules and the organization and mission of I MEF. The division PA team worked furiously to address the needs of individual media, answer hundreds of questions, and ensure that the media were prepared to embed. During one briefing a reporter skeptically asked, "Really, how close are you going to allow me to get to the frontlines?" The division PAO replied:

I can put you in the back of an LVTP-7 amphibious assault vehicle with 18 angry grunts, drive you within 300 meters of the objective, and send you in the assault as the Marines storm the enemy's trench lines and drive bayonets into their hearts.

The room went silent. The audience could have heard a pin drop. "Is he serious?" asked one skittish reporter. The division would later deliver, in scores.

Prior to embedding, the PA team spent many hours determining the best spread load of correspondents across the battalions to ensure a balance of print, radio, and TV journalists throughout the division's battlespace. Every news agency would get their own "exclusive" and be separated from their competitors. The PA team honored every previous habitual relationship between commanders and reporters without exception—going so far as to promise reporters with prior experience with the division that they would be "picked up at Starbucks in Kuwait City" if their official request to embed was not approved. The PA team aggressively lob-

bied for the additional media, and the requests were eventually approved.

The PA team made every effort to maximize the social bonding potential of the Marines and media by assigning reporters to units based on the hometown of the commander (or home station in the case of Reserve units). PAO considered media embedded within the regimental combat teams (RCTs) and separate battalions almost to be in a “direct support” relationship and retained a small group of “general support” reporters from the *Los Angeles Times*, *The New York Times*, National Public Radio, and *El Correo* at the division main to exploit key successes in the media by transporting them to key locations on the battlefield. The PA team purposely chose the reporters residing at the main on three key factors: circulation, depth of reporting, and acknowledgement of international contribution to the coalition (in the case of *El Correo*—the largest circulating newspaper in Spain).

All too often, words such as “handle,” “escort,” and “manage” are used to describe interactions with the media. This vocabulary insinuates that PAOs can control or manipulate the media, and Marines caught using such foul language in the division had their collective mouths washed out with proverbial soap. The CG suggested to the unit commanders, Marines, and sailors that the media is an entirely winnable constituency, and a new lexicon was established to set the tone. Marines assigned to assist the media were called buddies. Media were not escorted; they were “adopted” and made members of the division team. This subtle difference framed the division’s desired approach to interactions between Marines and the media and, coupled with the Marines’ traditional comradeship, resulted in quick assimilation of journalists into the ranks. Journalistic professionalism and the desire to remain “objective” could not stop human nature, and the media quickly bonded with the Marines amid austerity, danger, and hardship.

Reinforcing Fires

PA is a combat multiplier. Properly conducted, media operations can provide “reinforcing fires” that support operational and strategic objectives by exploiting fleeting opportunities that emerge on the battlefield. The following are some examples.

Moustaches. As the division prepared for combat in Kuwait, the G-2 (intelligence) section learned that Iraqi paramilitary forces possessed U.S. military uniforms and could wear them to infiltrate friendly units and to commit atrocities against the Shia population in an attempt to turn local public opinion against the U.S. forces. It is common knowledge that Iraqi males prize their moustaches and loathe shaving them off. To illustrate the significance of the seriousness of the issue, a common insult in the region is, “A curse upon your moustache!” In an effort to neutralize the infiltration threat, the CG invited all Marines and sailors in the division to participate in the “First Annual Moustache Growing Contest” that was promptly reported by the media and presumably collected in the open press by Iraqi intelligence. The desired effect was for the Iraqi infiltration squads to feel reassured in keeping their moustaches. Immediately prior to crossing the line of departure, all division Marines were promptly told to shave their moustaches and challenge any moustache-bearing individual in U.S. uniforms.

Securing the south Rumaylah oilfields and liberation of Safwan. The division attacked and defeated the Iraqi 51st Mechanized Infantry Division to secure the south Rumaylah oilfields and liberate the town of Safwan in a lightning strike during the night from 20 to 21 March. This attack was launched a day early due to intelligence reports and unmanned aerial vehicle reconnaissance indicating that Saddam Hussein’s forces were preparing to destroy critical oil infrastructure in the hopes of creating an environmental disaster and deny the use of the oilfields to the new Iraq. Following the advance of assault forces, the division PA team scrambled the headquarters battalion embedded media and hurried them to the oilfields and border town.

SSgt John Jamison took John Kifner, a *New York Times* correspondent, and photographer Ozier Mohammed aboard a UH-1N helicopter to inspect one of the gas and oil separation and pumping stations secured by RCT- 5. The simple fact that the sky was not ablaze with burning oil smoke and the Persian Gulf was not slick with crude was a clear and early victory for the coalition forces. This fact was not lost on the press.

The PAO and deputy G-3 (operations), LtCol Clarke Lethin, drove Mercedes Gallego of *El Correo*, John Burnett of National Public Radio, and Tony Perry of the *Los Angeles Times* to the small border town of Safwan. On scene the embedded reporters and a host of unilateral media from the Associated Press and *Newsweek*, to

name a few, watched as jubilant Iraqis looted the Ba'ath Party headquarters and U.S. Marines tore down murals of Saddam Hussein. The interactions of the Marines with the Iraqis reinforced, early on in the campaign, the President's message that coalition forces were liberators, not conquerors. Cecil B. Demille could not have created a better scene for the media on the first day of the war than the reality of Safwan in front of them.

The fedayeen and "Chicken Little" reporting. The division battled fedayeen militants using unconventional terrorist tactics from the Euphrates to the Tigris and beyond. Highly motivated and poorly trained, they routinely fired on Marines from ambulances, behind women and children, in apartments, and inside hospitals, schools, and mosques. The inflated news of fedayeen attacks became prominent in the press at a time when the Marines were killing the zealots by the scores. This hyperbole of fedayeen capability sent visions of Vietnam dancing in journalists' heads. The PA team acted quickly to highlight the destruction of fedayeen and Ba'ath Party loyalists in villages and small towns by transporting headquarters battalion's embedded media to RCT-1 to observe combat operations along Highway 7. As the division resumed its attack toward Baghdad, the press quickly realized the Marines had the Iraqis on the run. The CG conducted a well-timed press conference near the banks of the Diayala River to highlight the fedayeen's cowardice and flagrant violations of the Geneva Convention, Law of Land Warfare, and any code of chivalry. "They are as worthless an example of men we have ever fought," MajGen Mattis said, "and it is a pleasure to kill them." His words resounded in the media within hours. The combined effort assisted in taking the wind out of fedayeen sails on the battlefield of public opinion.

The suicide school. At 1530Z, 10 April 2003, a 30-year-old Iraqi male walked up to a checkpoint manned by 3d Battalion, 5th Marines, pulled a pin on a handgrenade, and blew himself in half, injuring four Marines and one sailor. Fifteen minutes after the incident, the division PAO went live on the air with Cable News Network (CNN's) Christiana Amanpour to discuss the incident. The reporter asked pointed questions about "new suicide tactics and the state of security measures," yet the PAO used the opportunity to highlight that the:

. . . division planned on encountering every dirty trick. That's what you get when you fight a regime that has systematically raped, tortured, and imprisoned its populace for the past 22 years.

The interview quickly departed the issue of security and allowed the PAO to take the "bully pulpit" and highlight the regime's complete disregard for the Law of War and Geneva Convention. It reinforced the CG's earlier remarks about the lack of manhood and cowardly acts of the paramilitary fighters

The next day the division staff judge advocate, Maj Joe Lore, called to notify the PA team of an emerging, immediately exploitable event. Earlier in the day RCT-7 captured an elementary school in a highly populated area in central Baghdad that the fedayeen were using as a training facility for suicide bombers and storage for their deadly cargo. The RCT's explosive ordnance disposal team diffused several timed explosive boobytraps left behind in briefcases and boxes. Had the devices detonated, the resulting explosion would have leveled the neighborhood.

Within minutes the PA team scoured the hotel and rounded up CNN, CBS (Columbia Broadcasting Station), and NBC (National Broadcasting Corporation) camera teams and drove them to the site. Inside of what appeared to be a health science classroom, 60 handsomely fabricated black leather vests were laid on the floor in plastic bags. Each vest was filled with explosives and ball bearings and wired with blasting caps. Timed, command activated, and mercury switch detonators that were designed to fire when the assailant raised his arms over his head in a surrendering pose sat in boxes nearby. Nearly 250 other, less sophisticated suicide devices filled other rooms. The vests and detonators were of Palestinian design, and the markings on the boxes read, "Made exclusively for the Saddam Fedayeen."

The press reported that the discovery of the materials conclusively linked the regime to international terrorism.

The Palestine Hotel. Returning to the Palestine Hotel, the PA team exploited the day's success in the media. Concurrently, the division established a civil-military operations center (CMOC), led by LtCol Pete Zarcone, the division's civil-military liaison officer, in the briefing room previously used by Tariq Azziz. The CMOC immediately set about trying to "jump start" the city back to life. The first priority was the reestablish-

ment of civil order, and to do that, the Marines needed the local police and traffic cops to come back to work. But how do you find the police, and how do you get them back to work? With all of the mass communications stations knocked off air by coalition bombing and the lack of electricity in the city, only one means existed to reach the people of Baghdad—radio.

The PA team immediately located nearby Iraqis and, with the help of a translator, determined that Baghdadis preferred their own radio stations but had been listening to the British Broadcasting Corporation's Arabic World Service. Coordinating with the CMOC, the PA team and a Free Iraqi Forces' interpreter went on the air to deliver an appeal to get the local police supervisors, electrical power grid technicians, water engineers, and other critical infrastructure personnel to come to the hotel to start coordinating with military officials to bring the city back to life. Over 300 Baghdadis showed up at the front entry control point the next morning.

Throughout the week the PA team made the daily rounds of a circuit judge throughout the hotel, visiting news agency after agency to highlight the division's successes in the reestablishment of an interim police force, the delivery of 15,000 gallons of fuel to critical water treatment and pumping stations, the reestablishment of power to limited parts of the city, and many others. The PA team set up radio interviews for local Imams to call on the Iraqi people to stop the looting and cooperate with the coalition forces. In nearly every instance, correspondents would devour the information and broadcast it to the world minutes later.

Conclusion—A Qualified Success

Embedding media into the division's tactical units was a qualified success. It significantly countered any Iraqi propaganda attempts by having the media reporting the division's combat operations to the world. Embedding helped mitigate negative news due to the bonds formed between the media and their assigned units. Reporting was positively influenced by the unavoidable human tendency for Marines and reporters to bond while living together for extended periods of time amid austerity, danger and hardship. Embedding brought the sacrifices, trials, and victories of 18-year-old Marines and sailors to the American and international public on an hourly basis. And, ultimately, embedding closed some of the gap that exists between the military and media. Marines and members of the press built significant bonds and grew to respect each other's professions and common goals.

One must remember that, in this campaign, the coalition forces were both good and lucky. I caveat the success of the embed process with the words of George Orwell:

In general, one is only right when either wish or fear coincides with reality—we are all capable of believing things which we know to be untrue, and then, when we are finally proved wrong, impudently twisting the facts so as to show that we were right. Intellectually, it is possible to carry on this process for an indefinite time: the only check on it is that sooner or later a false belief bumps against the solid reality, usually on a battlefield.

We were fortunate to have achieved victory with minimal casualties—friendly, enemy, and civilian. Shock, speed, and surprise shattered the enemy's will to fight. How would American public opinion have changed if the media reported that coalition forces suffered mass casualties in a chemical attack? How would support for the war on the homefront have changed if Baghdad had been a long, bloody slog and was broadcast live into the living rooms of America on a nightly basis? Although the division experienced success with the embed construct in this conflict, a new risk-benefit analysis must be conducted prior to embedding media in anticipation of and during future conflicts. The division only hopes that the Iraqi people will wisely spend this gift of newly found liberation and freedom paid for by the blood of the young men and women of the United States of America and United Kingdom.





The Military-Media Relationship: From Bull Run to Baghdad

by Major Douglas M. Powell

21st Century Defense: U.S. Joint Operations, 2003

“The first essential in military operations is that no information of value should be given to the enemy. The first essential in newspaper work and broadcasting is wide-open publicity. It is your job and mine to try and reconcile these sometime-diverse considerations.”

—Gen Dwight D. Eisenhower, 1944

Since the Civil War, the US military and media have struggled to find common ground regarding freedom of information and the nature of the relationship between the military and media. The relationship has flexed, bent and broke at various points of our nation’s history. In a democracy, the military and the media have a natural tension between them. In response to this tension, access provided the media in wartime has varied. Nevertheless, the mission of the military is fundamentally the same as the media: to uphold and defend democracy, the constitution, and personal freedoms. It’s unfortunate that the military and media’s means of accomplishing our respective missions is sometimes at odds. At its root, the tension between the military and media is healthy, and will probably always exist at some level. The government and military exist to serve the interests of the American people. There is no argument from either side that access to public records and openness in government are essential in a democracy, and freedom of information is essential in times of crisis and change.

In a time when our country faces threats inside our borders and against US citizens and interests overseas from terrorists who engage in asymmetrical warfare, both the military and the media face the difficult task of deciding how information is gathered, distributed and used. Often times, the interests of the media and military are competing. The media in general recognize the need for confidentiality and secrecy in certain military endeavors, and government endeavors for that matter, and the importance of privacy protection in an ever-increasing electronic information era. Transformations in the nature of warfare, technology improvements, and the structure and speed of the mass media have wrought major changes in the military-media relationship.

Bull Run to Baghdad

The level of cooperation and understanding between the military and the media has changed significantly from one war to another. During the Civil War the government imposed restrictions on the press for operational security reasons and because of

the speed at which the telegraph allowed news reporters to reach the presses. Reporters were able to send reports of the battle of Bull Run to New York City in 24 hours by using the telegraph. During World War I Congress passed the Sedition Act of 1918, part of the Espionage Act, which prohibited anyone from printing, writing, or publishing anything that could be construed as counter to the war effort. During World War II the media reported on the war with a self-censorship methodology. Although these guidelines relied upon voluntary censorship by journalists, military commanders in the field proved far more restrictive. Six months after the Korean War started, full military censorship was imposed, and correspondents were placed under the complete jurisdiction of the Army. Reporters could be punished by court-martial for any violation of a long list of instructions. The media's coverage of the War in Vietnam was drastically different and caused a significant rift between the military and the media. The media roamed freely and censorship was practically non-existent because the military had no means to enforce it. The invasion of Grenada in October 1983 involved severe media censorship and control, but was a significant point in the military-media relationship because it resulted afterwards in much effort at military-media cooperation. As a result of Grenada the Chairman of the Joint Chiefs of Staff convened a panel of experts to re-evaluate the military-media relationship. The panel's report contained eight major recommendations, the most significant of which was the creation of a 'pool system' of reporting, which ultimately became the Department of Defense National Media Pool (DNMP). Another significant recommendation was that military commanders conduct public affairs (media relations) planning concurrently with operational planning. All of these brought with them significant impact on the operational commander and his planning staff. The first use of the DNMP occurred in 1989 during Operation Just Cause, the US invasion of Panama. During this operation the 'pool' system received mixed reviews. Although media were deployed from Washington DC to Panama to cover the operation, the media's access to troops and the battlefield was very limited and after-action reports later indicated that public affairs planning was not done concurrently with operational planning.

Birth of Public Affairs Doctrine

From Department of Defense Directives to individual service instructions and directives, today's military makes public affairs planning an integral part of operational planning. However, that was not always the case. Over the course of several decades the Pentagon and the services have struggled with the 'how' and 'why' of incorporating public affairs planning into operational planning.

Not until the 1991 Gulf War, the dawning of the "CNN War," and the Pentagon's development of the "Principles for News Media Coverage of DoD Operations," did commanders fully realize the importance of preparing for combat coverage. On the flip side, journalists and editors and the mass media industry have faced an internal struggle with their own military reporting. During the 1991 Gulf War many journalists were ill-prepared to describe or assess American performance on the battlefield. Military control over the media during the Gulf War was very restrictive once again. Essentially, the military implemented the 'Press Pool' system. Some of the pools went into the field for a few hours at a time, some for days. Public affairs officers accompanied the press pools, selected and pre-briefed the troops to be interviewed, checked TV shots, reviewed photos and written reports, removed information deemed sensitive, changed wording of stories in some cases, and sometimes ordered further review of stories and pictures. Once again, the media were unsatisfied with the level of control and limited access on the battlefield.

After the Gulf War, in April 1992, a significant conference with far-reaching implications was held between military and media leaders in Chicago. This successful conference resulted in the mutually agreed upon 'Nine Principles for News Coverage of the US Military in Combat,' and have since been incorporated into the Pentagon's, and subsequently all the service's, doctrine for media relations. The military's doctrine can be found in Joint Publication 3-61, titled 'Public Affairs Support of Joint Operations.'

The agreement reached in Chicago in April 1992 set the stage for media coverage of future operations. In essence, the agreement stated that during conflict, the military services would follow the new principles to improve combat news coverage. While the 'Nine Principles for News Coverage' highlighted concepts and procedures that had been in other DoD documents for years, the publication of Joint Publication 3-61 in 1997 went a step further and emphasized to commanders at all levels the importance of their personal involvement in plan-

ning for news coverage of combat operations. Furthermore, it solidified three concepts: that open and independent reporting was the standard for combat coverage for the future, that pools were to be an exception rather than the rule, and that voluntary compliance with security guidelines was a condition of access to US military forces.

Post Desert Storm

The media's coverage of the US' and United Nations' intervention in Somalia influenced military operations primarily because the press had unprecedented access on the battlefield. The media's freedom to move virtually unrestricted on the Mogadishu battlefield gave reporters unprecedented access to cover hostilities.

The US led invasion of Haiti in September 1994 saw military-media cooperation significantly improved from the 1991 Gulf War. Detailed media planning was integrated into operational plans with special emphasis from Lieutenant General H. Hugh Shelton, Commander Joint Task Force for the operation. Lieutenant General Shelton later wrote, "In this operation, the media were assigned to units spearheading the planned invasion. This way, reporters, and thus, the American people, would see how their Armed Forces performed in action. While operations in Haiti may not be the new paradigm for the media-military relationship it certainly improved it."

War reporting in Afghanistan as part of Operation Enduring Freedom was difficult for reporters because the military campaign, meant to topple the Taliban government and destroy the Al Qaeda terrorist network, relied heavily on special operations units and air power. The media's access to military units throughout the majority of operations in Afghanistan was limited. However, the Marine Corps embedded 46 journalists with Task Force 58, which resulted in more than 350 stories being filed about Marines at Camp Rhino and Kandahar. Although the official DoD press pool system was never activated during the Afghanistan campaign, the Corps' proactive engagement with the media opened the door for future DoD endorsement of embedding during later operations, such as Operation Anaconda. The Pentagon's decision to limit media coverage of operations in Afghanistan had some negative effects. For example, a raid by the Army's 10th Mountain Division on the remote village of Danditemur, a purported Taliban holdout, allowed the Taliban to put out damaging propaganda against the US after the raid. When US reporters, who were not allowed to accompany forces during the actual raid, visited the village a day after, residents claimed soldiers had run down and killed a small child and then beat an 80-year-old man to death with their gun butts. This account dominated some reports about the episode.

In November of 2002, with the expectation that the US would be at war with Iraq within a few months, the Marine Corps initiated a 'media boot-camp' training course at Quantico, Virginia the brilliance of the concept was quickly realized by others in the Pentagon, and the effort soon grew into a Pentagon-sponsored, joint program. The media boot-camp was meant to improve the military-media relationship and was not intended to be a certification program guaranteeing journalists an embed position with military units during any future conflict or a prerequisite for access to military units. The focus of the one-week courses was to educate journalists in regards to things that would help them better understand military culture, provide journalists with skills that would help them survive and cope in a combat or hostile environment, and expose them to the physical requirements of field training. Two hundred and thirty two journalists attended four separate media boot camps, representing the largest and smallest of media organizations, from Reuters and New York Times to smaller newspapers such as the Virginia Pilot. Some of the media included foreign journalists representing Agency France Press, Russian ITAR-TASS, and Abu Dhabi television network.

Embedding Program

In December 2002 the Pentagon announced that if there was fighting in Iraq, reporters would accompany the troops. The media looked upon the Pentagon's announcement with a weary eye based upon past experience. Nevertheless, the Pentagon was embarking on a public-relations experiment of unprecedented size and scope. In March 2003, as part of a coalition force of approximately 250,000, the US military launched Operation Iraqi Freedom. Accompanying the military force were approximately 600 'embedded' journalists. The last time journalists accompanied a large American invading force in this fashion was on the beaches of Normandy in World War II, and then the number of journalists was significantly less.

The Pentagon's intent for the embedding program was to maximize coverage of coalition operations,

which was a significant departure from operations in Afghanistan and other operations in recent history. Reporters lived with, ate, slept and worked alongside coalition forces from beginning to end of the operation. With the exception of Special Operation Forces, the embeds were permanent. Journalists could not leave the unit and did not have the choice to move to a different unit. However, journalists did have the option of leaving a unit and returning to a safe area if desired. Once embedded, journalists operated as part of the unit and commanders provided media with every opportunity to observe actual combat operations, and the reporter's safety was not a reason to limit a reporter's movement or access. Nevertheless, there were a few bumps along the way.

Many in the mass media felt the reporting that resulted from the embed system was like "looking at the Grand Canyon through a thousand straws" or an 'ant's view of an ant hill.' Despite the mass media's investment of tens of thousands of dollars and hundreds of journalists, the collective story about the war was often blurry. Prior to the war's start, editors at the major newspapers and networks were very excited at the embed program because the expectation was that journalists would be able to see and report actual combat as it happened while other journalists receive the larger operational or strategic story of the war from US Central Command or the Pentagon. However, journalists attending the Central Command briefings in Qatar and the Pentagon briefings in Washington were frustrated by what many perceived as vague briefings. In addition, communications technology caused much frustration among the media because of the information gap created by the real-time war reporting that was being provided by the embedded journalists. With their satellite telephones and other high-tech communications gear, they often were providing colleagues at Central Command headquarters in Doha, Qatar with battlefield information before the military's public affairs team knew anything about it.

Prior to the start of Operation Iraqi Freedom, Secretary of Defense Donald Rumsfeld and Chairman of Joint Chiefs of Staff, Air Force General Richard B. Myers, released a joint message to all US combatant commanders explaining the importance of facilitating media coverage of the war, which would play a large part in shaping public perception of the war effort, both at home and abroad. They knew that the speed of the media and scope of impact has greatly accelerated and increased since the 1991 Gulf War. They knew that the speed and breadth of news coverage on the battlefield could not be contained, nor controlled, but must be embraced in order for military commanders to have any significant influence in shaping the 'information' war. Commanders were asked to engage not only journalists from the US, but foreign media as well. Commanders were told to make plans for declassification of information and release of video and images at the lowest possible levels in order to allow journalists to rapidly get the story back to their news organizations.

Faced with the churn of 24/7 news and the prospect that former Iraqi President Saddam Hussein would mount an effective media campaign of his own, Pentagon officials concluded that reporters embedded with units would be more credible than military briefers.

The Pentagon's embedding strategy was very much an effort to fight a public relations battle at home and abroad during the course of a war. Also, it is a natural progression towards improving the military-media relationship in light of the lessons learned in all the conflicts since Vietnam.

Embed Ground Rules

If it's true and it's news, journalists will report it. In reporting the news journalists do not always consider whether or not the story will hinder or help the war effort. However, the Pentagon and White House are undoubtedly concerned about the effect news reporting has towards the war effort. In light of this, the Pentagon required all media embeds to comply with a set of ground rules, which were established for the safety and security of coalition forces and embedded media.

These embed ground rules were not meant to prevent the release of derogatory, embarrassing, negative or uncomplimentary information. Similar to the DoD's self-censorship rules during the Civil War and WW II, the journalists had the freedom to transmit or file text, images or video without prior review by military censors for the most part. There were times that the media had to agree to content review in order to gain access to sensitive briefings, but as a matter of course, however, there was no censor review. Embedded media were exposed to battle plans, troop movements, battle preparations, material capabilities, vulnerabilities, as well as some ele-

ments of enemy order of battle. As much as journalists and military commanders both understand the importance of maintaining operational security, operational security is often difficult to explicitly define. Commanders in the field had the responsibility of ensuring media were thoroughly briefed as to what information was sensitive and the parameters for reporting such information. As a member of the unit, journalists were aware that release of certain operational information could potentially be detrimental and harmful. For their own safety and the safety of the unit, self-censorship worked well and the ground rules were adhered to. However, there were a few instances where journalists reported information deemed by the Pentagon to be potentially harmful to operational security. The most publicized incidents along those lines involved non-embedded reporters, such as Fox's Geraldo Rivera, who drew a map on camera indicating troop positions, or Christian Science Monitor freelancer Phil Smucker, who was accused of revealing troop locations in a TV interview.

If one of the Pentagon's top priorities is to keep reporters from reporting sensitive information, the embed program is most certainly the answer. There is no faster way to sensitize a news organization to the dangers of reporting too much information than assign one of their reporters and camerapersons to a combat unit, according to Jamie McIntyre, senior CNN reporter at the Pentagon.

Reporters or Cheerleaders

Some journalists and editors worried that the embed program engendered one-sided coverage. However, as much as some people felt the embedded journalist were nothing more than 'cheerleaders,' embedded reporters didn't always follow the Pentagon's party line, particularly when things went wrong. Early in the conflict, embedded journalists offered a dramatic look at the attacks on supply lines, for example. The Christian Science Monitor's Ann Scott Tyson, embedded with the Army's 3rd Infantry Division, reported that the Army nearly ran out of food and ammunition, due to poor planning. The most memorable situation where a field dispatch discredited the official line at the Pentagon was a Washington Post story that told of members of the Army's 3rd Infantry Division who 'slaughtered' an Iraqi family approaching their checkpoint in a civilian vehicle without firing enough warning shots. "You just [expletive] killed a family because you didn't fire a warning shot soon enough," the Post's William Branigin wrote, quoting an Army Captain. Branigin's report was exceptional enough that the Pentagon used it as an example of how the embeds were telling the whole story, good and bad.

Future Looks Bright

There is absolutely no question that the Pentagon's embedding program has made a positive impact on the military-media relationship. Without question, there are now more than 600 very seasoned combat reporters around the world who have a solid understanding of how the military conducts warfare and perhaps a greater respect for service members. Also, thousands of US troops now have a greater understanding of the professionalism and dedication of journalists and a healthy respect for the role the media now plays and will always play in future military operations. In the near future, the professionalism and bravery of our nation's service men and woman will be detailed in the history books that will soon begin rolling off the presses, thanks in no small part to the comprehensive 'rough draft' written by more than 600 journalists who risked their lives to witness the truth and write it.

There will no doubt be much discussion and analysis in the near future regarding what worked and what didn't about the media's coverage of Operation Iraqi Freedom as well as the military's control of journalist and the amount of access granted. However, both the media and the military must keep in mind that regardless of how successful the embedding program worked during Operation Iraqi Freedom, there is no certainty, nor should there be, that the Pentagon will use the same concept of dealing with the media during future conflicts. However, a very strong precedent has been set and even Bryan Whitman, assistant press secretary for the Pentagon and architect of the embedding program, said, "I think this is how we're going to cover wars in the future."



CLOWNS to the left of me...

by Captain Dan McSweeney

U.S. Naval Institute Proceedings, November 2003.

A Marine Corps public affairs officer and his media embeds ride the "clown cart" to help tell the story of the war in Iraq.

Charlie scrawled "clown cart" in magic marker on the back of a wooden Saddam sign and tied it to the grille of our seven-ton truck. That's how we got the label. On the surface, he was just adding levity to a stressful journey across the highways and dusty side roads of central Iraq during the third week of the war. Over the next few days, however, I began to understand the significance of the sign.

In addition to Charlie, who writes for *The New York Times*, there were journalists from CNN, BBC, NPR, *Newsweek*, Associated Press, Abu Dhabi TV, Getty Images, and *Stern* magazine in our group. They were embedded with the 24th Marine Expeditionary Unit (MEU) and I, as the unit's public affairs officer, was their escort. During the two weeks they spent in country with us, I came to some realizations about military-media relations and had some memorable, if trying, experiences with these men.

The 24th MEU had been deployed for seven months and was on board ships of the *Nassau* (LHA-4) Amphibious Ready Group, preparing to head home, when the ground war in Iraq began. A week later, the Marines heard they were going in. Spirits were high as the unit readied to go ashore, and my focus became gathering and preparing the embeds assigned to us by the Pentagon.

They all had been reporting on the war from Kuwait and were anxious to go north. Though the group was a virtual dream team, I could sense there would be some challenges ahead.

At the Coalition Press Information Center, I described the MEU to them, discussing our capabilities, size, assets, and missions and answering all manner of questions on what they could expect. A few days later, we flew north and joined the 24th MEU at a base camp between Nasiriyah and Al Kut. After settling in, the reporters and I traveled with the MEU commander to the outskirts of Al Amarah, just west of the Iranian border, for a mission.

Our artillery battery had set up a gun position in muddy field and was waiting for fire missions to be called by the mechanized company that had rolled into the city, looking for the 10th Iraqi Division. We soon discovered that there was little resistance, mostly thumbs up from the locals, so we spent the night at a nearby military airfield secured by "Easy" Company, and the journalists all set up videophones to file their reports.

The clown cart sign appeared the next morning, salvaged from the airfield headquarters building. Although I initially did not like the label, it stuck. To my surprise, the 14 reporter and 6 Marines in our group developed a sort of shared identity once that sign was placed on the truck.

To their credit, these reporters did not take themselves too seriously. They, like the Marines they were covering, were all about mission accomplishment. It probably was ingenious for them to embrace the clown cart concept, as it caught most of my unit off guard. Many of our Marines cringed at the thought of having to deal with fussy, self-important journalists, but the clown cart sign elicited begrudging smiles—and the reporters got good access.

There was a lot of experience on that truck—top-notch reporters who had been there, done that. They had an insatiable desire to question and to move and to push, and they had no qualms about living the way we did. They slept next to us and jumped into their survivability holes when the alarm was sounded. (The miniature gear tents several of them brought, mistaking them for full-sized shelters, did elicit laughs from our Marines, though.)

According to protocol, the reporters were the equivalent of majors and, therefore, outranked me. I tried my best not to yell at them, but they regularly infuriated me. They brought way too much gear. They had to be told over and over to close the doors of their work tent at night to maintain light discipline. They apparently were incapable of picking up after themselves. The list goes on. In spite of all of this, I liked them.

We rode our crowded, clanging truck through the ruins of ancient Mesopotamia, listening to classic rock and Miles Davis, in logistics convoys led by force reconnaissance Marines, military police, and antitank vehicles. I got them where they needed to go; they got what they needed to get; and as combat operations subsided, they left us.

It was a symbiotic relationship fraught with fundamental and irreconcilable differences. We butted heads at least once a day, and at one point I heard myself yelling “Good riddance!” at a reporter who was telling me about his upcoming departure. (We later made plans to have a beer in Washington after the war.)

Stuck in the Middle with Them

These reporters and the Marines in my unit met in a continuously redefined middle. Neither they nor we had any choice in the matter. They approached the situation from a certain culture: individualistic, informal, committed to disseminating information. We came to the experience from a different place. Our primary concern was the group, and preserving the security of information was fundamental to our operations. Still, each cohort made significant efforts to compromise. Each came to the field and literally found common ground on which to walk, sleep, and work during the embedment. The effort led to a mutual, if guarded, sense of trust.

This was classic military-media tension. The only two innovations were quantity (almost 800 embedded reporters and more than 2,000 unilateral registered at Coalition Press Information Centers) and reporting speed (potentially instant global coverage).

Come to think of it, this was revolutionary.

The time we drove to the Al Amarah stadium is a perfect illustration of the grey areas we inhabited during our time together. I had planned to let the TV guys do a live shot from the site, in front of an Al Samoud missile that had been discovered beneath the bleachers there. As the reporters conducted interviews and photographed the missile on its bullet-ridden mobile launcher, hundreds of locals gathered around and began to press into the clown cart, fascinated by the cameras and microphone.

My Marines provided security around the truck. Though we understood that this was a neutral-to-friendly crowd, we quickly realized that all the ingredients for riot, ambush, or abduction were present. Surrounded by several hundred Iraqis, I was caught between wanting to maximize exposure of the missile and the need to get out of there before anything came undone. In the end, the BBC crew was the last to break down, complaining that we were being too cautious, although some of the other reporters exclaimed that we already had stayed too long.

We split the difference between access and security and, thankfully, no one got hurt. Part of me feels I should have moved us out earlier. And yet, it was a relatively safe setting in the context of wartime reporting. The 24th MEU had helped liberate the city, and most of the locals were waving to us.

Our experiences in and around Al Kut were just as insightful for me. The 24th MEU’s role in the assault on that city was to establish a blocking position south of the city limits—but the reporters wanted more. They wanted to see what was happening in the center of town.

“Why can’t we just drive in and take a look around?” one of them asked. It took some effort, but I accepted that this was not a completely ludicrous question.

“Because your embedment is with the 24th MEU and the 24th MEU has no Marines going into the city right now,” I replied.

“We’ll there’s no story here,” another said.

“Well, I can’t tell the commanding officer of this unit to change the operations order for this mission and send a detachment of Marines into the center of Al Kut because our reporters want to cover what is happening there.”

Probably, I did not say it as smoothly as that. Their attitude surprised—almost galled—me. They were hard-headed, stubborn. I was frustrated. But the more I thought about it, the more I realized that getting them into town was a relevant objective. Luckily, my commanding officer understood that too and looked into getting us closer.

I eventually got permission to push the clown cart north on a scheduled logistics run. We got a glimpse of the city while in the convoy and continued to the I Marine Expeditionary Force (MEF), the senior command for all Marines in Iraq. There, I thought we might be able to link with some psychological operations (psyops) or civil affairs guys and head back to the center of Al Kut for a closer look.

By chance, while we were at the I MEF base camp, the seven prisoners of war rescued outside Samarra were flown in for transport to Germany. Our unexpected arrival led to a disagreement among the reporters and public affairs officers about how the rescue should be reported. I MEF had its own embedded reporters, who felt their agreement with the command to receive special access to its activities would be violated if all my reporters were allowed to cover the event. That made sense to me, since the I MEF embeds had spent weeks developing a relationship with the command and had shown commitment to it.

Regardless, many of my embeds mounted a well-coordinated effort to be granted access. After several minutes of raised

voices and negotiations, the deal was made to have my TV and photo guys cover the arrival along with I MEF embeds, both of whom were writers. This allowed for the widest possible coverage while preserving the I MEF embeds' expectations. It was a fair deal brokered by the I MEF public affairs officer, who was put in a difficult situation by our unannounced arrival.

Those prisoners of war became one of the biggest stories of the war, and the manner in which their rescue was reported illustrates one of the fundamental tensions in the embed program. While the reporters embedded with I MEF had a right to expect special access, the importance of disseminating visuals of rescued Americans was clear. So this hybrid coverage occurred, and I realized that, like every other important construct in life, media activity must turn on a dime, as one of my reporters pointed out. You need to be flexible. You need to constantly push and adapt.

It was a two-way street: They constantly pushed me stories and I reminded them they would be sitting in a hotel in Kuwait were it not for their embedment with us.

One last anecdote. Our unit's translator, Khuder al-Emiri, was a native of Qalaat Sukaar. Our first mission in that town was to raid the local Ba'ath Party and secret police headquarters buildings. We arrived early one morning, and on securing and searching the buildings, found weapons ranging from rifles to mortar rounds, which we began loading on our trucks.

All the while, Khuder was in the psyops vehicle, broadcasting prerecorded warnings in Arabic for the locals to stay away and not interfere with the mission. Their curiosity piqued, some approached the vehicle, and Khuder stepped outside the Humvee. Everything changed then. The locals recognized him, and they broke into singing, laughter, even crying, which quickly spread to hundreds of others in an impromptu homecoming celebration.

I had never seen anything like it. The scene approached ecstatic pandemonium when the crowd produced two young men whom Khuder did not recognize. They were his sons, and he had not seen them or any of the other locals in 12 years. The event was captured in video, still image, and sound for a global audience.

This occurred at a point when, at least in certain media outlets, our success in the war effort was in question. Khuder's story ran widely for several days, and I would like to think it convinced many people of the Iraqis' support for regime change.

For me, the larger lesson was that a significant portion of the media business comes down to chance. I did not know Khuder was from that village; no one knew how the locals would react when they saw him. Again, the importance of flexibility and trust between the military and the media was made clear.

The Morning After

Overall, the media embed experience was as satisfying as it was frustrating for our unit. We all were doing our part to tell the story of the war. Through these reporters, we were demonstrating U.S. resolve to do well and to do good.

There were some drawbacks. As in most things military and media, the main challenge was logistical. My commanding officer earmarked one of the 24th MEU's trucks for the reporters. If not for his support, they would have come away with only half of the stories they covered. Granted, the media effort was an important aspect of Operation Iraqi Freedom, but that truck could have provided additional support to our companies in the field.

Our reporters enjoyed intimate access to our small units and leaders—the main goal of the embed program—but they also got to observe and report on many events tangential to the 24th MEU's operations.

I realize now that these reporters, like the Marines they covered, represent American society at large. For better and for worse, they are us. The good news is that, by and large, they meant well. Our embeds were concerned about what was going on with the unit and what was happening around us, and they wanted the best for everyone involved. Their ethics and practices were above reproach.

Together, we rode the clown cart because, like clowns, we lived and worked in a kind of controlled chaos. And, like clowns, we could not remain still. As information workers, we searched for stories, action, connections.

I would be surprised if our reporters did not consider the embedment program a success. Being stuck in the middle with these reporters showed most of us that while there are worlds of difference between the military and the media, both groups share many traits. They are probably more willing to admit it than we are, though.

As it became clear that the 24th MEU would be leaving Iraq, the reporters discussed their next moves with me. Most of them transferred to Task Force Tarawa, which was beginning heavy civil-military operations in Al Kut. Some went home. On the day of their departure, we reminisced about our experiences. The separation was more than cordial. I saw them off at the airfield then returned to the MEU's base camp. It seemed empty somehow. I gathered my gear, saw the clown cart sign, and hesitated only briefly before putting it in my rucksack.





Live from Baghdad

by Byron Pitts

The Crisis, May-June 2003.

Copyright 2003 *The Crisis*. Reprinted with Permission

A reporter recounts his experience covering the war in Iraq embedded with the U.S. Marine Corps

During my time in Iraq, every night felt like the 4th of July in small-town America: the sound of fire works in the distance, the flash of light from an explosion and, on occasion, the ground shaking when a blast came too close. But in Iraq it was not the celebration of liberty, it was the crackle of gunfire, the rumble of precision bombs striking their targets and the frightening sound of death slamming to Earth like lightning.

By comparison to the epic wars of the past, World War I, World War II, Korea and Vietnam, Gulf War 2, as the troops call it, or “Operation Iraqi Freedom,” as the Bush Administration refers to it, the war in Iraq was, for the most part, “War Lite.” By war’s grotesque standard, the losses were light (at press time, 145 U.S. military casualties) and the fighting brief. It is a standard, of course, that doesn’t mean much if you’re one of the many who lost a parent, sibling, child or friend.

I covered the war for CBS News as an embedded journalist with the First Marine Expeditionary Force. Being “embedded” meant eating, sleeping and traveling with the military, close enough to cover the war firsthand. I was assigned to an air wing, HMLA 169: The Vipers from Camp Pendleton, Calif. They were 363 of the finest men and women I’ve ever met. The Vipers fly Cobra Attack helicopters and Huey helicopters in support of Regimental Combat Team 7 (RCT 7), 6,400 Marines who scratched and pushed their way from the Kuwait/Iraq border 300-plus miles to downtown Baghdad. It’s a six-hour drive that took RCT 7 16 days and cost five lives.

Many of the enlisted Marines and certainly most of the officers had trained for this moment for most of their lives. And in many ways so had I. Legendary newsman Edward R. Murrow helped put CBS News on the map with his coverage of World War II. CBS newsmen like Ed Bradley, Dan Rather and Morley Safer built their reputations in Vietnam. In fact, Rather has a saying, “Fish gotta swim, birds gotta fly and reporters gotta go.” I have great respect for what it means to be a “CBS News Correspondent,” so I have always known if a war started I would want to cover it.

There were no official requirements to be an “embed.”

Each news organization submitted names of reporters, producers, photographers and technicians to the Pentagon. At CBS News we were all volunteers. I am certain that is how it worked at the majority of media outlets.

Most news organizations, including CBS, sent employees to a week-long risk management course taught either in the United States or London. Survival training is a growing industry, typically run by former British Royal Marines. Journalists are taught the do's and don'ts of covering a war: how to react to explosions, gunfire, chemical and biological weapons; where to hide; how to run; first aid. Basically it's a How-to-Stay-Alive-and-Cover-the-War class.

In addition to these courses, the Pentagon offered a week-long training course for journalists. I attended their first session months before the war. The training started at the Pentagon, included an overnight stay on an aircraft carrier and ended at the Basic School on the Marine base in Quantico, Va. At 6-foot-1 and 220 pounds, the first lesson I took from this physical training course was to get in better shape. So when I got back home, I hit the gym and the pavement. Five-mile walks with a 30-pound backpack three times a week. I was mistaken for a homeless guy more than once. And, of course, I read all I could on Iraq, Saddam Hussein and the rules of war. I had been to Iraq on assignment in 1998, so that experience would also help.

I arrived in Kuwait City Jan. 11, part of the first wave from CBS to arrive in the region. If you ever need to set up a multimillion dollar business in a day's time, look up two guys named Larry Doyle—he and I spent a harrowing month together in Afghanistan—and Bruce Rheins. They are legendary producers at CBS News. The two hit the ground running, and within 24-hours the CBS News Kuwait Bureau was online and in operation.

We were there when two American businessmen were ambushed in their car not far from the U.S. military base in Kuwait City. One was killed, and the very next day a local newspaper carried a front-page picture of the dead American slumped over the dashboard. Such an image would never appear in a modern-day U.S. newspaper. Many Americans, especially military people, were outraged. I kept a copy in my hotel room taped to my mirror. It was my daily reminder that despite the fine hotel and the hospitality of most Kuwaiti people, I was in the region to do a job. And at times it could be a dangerous job.

For the next several weeks, I filed stories on the slow troop build up to war and the steady stream of American civilians (oil industry workers and their families) leaving Kuwait as the war drew closer.

Finally in late March, I was embedded with my Marine unit. Each journalist received a gas mask, chemical suit and three atropine auto-injectors. The injectors would be our last line of defense in case of a nerve agent attack. To stem the symptoms of a nerve gas attack (drooling, severe headache, difficulty breathing or twitching) we would have to jab ourselves in the leg. The alternative to doing so was certain death. It was the one part of being an embed that scared me the most. Thank God it never came to that. The military also offered each journalist vaccinations for anthrax and smallpox, but I declined both. After a brief crash course on how to use the gear, it was off to my squad. I felt like the new kid on the first day of school.

My team included two other colleagues: CBS cameraman Mark Laganga and Charles (Chuck) Ranney, a freelance engineer. Mark and I had covered Afghanistan, but this was Chuck's first adventure in a combat zone. By the end, Chuck was a proven veteran.

The members of HMLA 169 were all professional and welcoming. Even during the most stressful moments, the Marines I worked with were always focused.

For the first week we had an escort almost every place we went; briefings, chow hall, around the air base. Eventually we were allowed to move around on our own. Both sides quickly realized that in order for us to get the access we needed and report accurately, we had to trust each other. Or as Ronald Reagan once said about the Soviet Union, "trust but verify."

When the war started, I was required to report that I was at a "secret U.S. airbase somewhere in

the region.” That’s how we were instructed by the military to refer to the base. It actually seemed pretty ridiculous to me and most of the Marines we were with, because if every pizza delivery boy in Kuwait knew where we were, then certainly the Iraqis did, too. But those were the rules we agreed to, so we always followed them.

As the days passed, there was no official notice sent around saying, “The war will start at high noon on ‘X’ date.” All of us, both journalists and rank-and-file Marines, found out at the same time when an air raid siren went off Thursday, March 20. It meant the base was under attack, most likely from some sort of Iraqi missiles.

We all feared the bombs might be carrying chemical weapons. That was probably the single most frightening moment for me and my colleagues and, I am sure, for a number of the young Marines. Without warning we were under attack.

Hours earlier, the U.S. had bombed a bunker in Iraq where they thought Saddam Hussein and his two sons were hiding. We were witnessing the Iraqis’ response. Those sirens sent thousands of Marines, sailors and airmen and a few journalists running to cement shelters. There had been drills in days past, but this was the real deal. We had to run about 200 yards to get to our shelter. But before we ran, everyone put on a gas mask. Over and over we had been told that we’d have nine seconds to put it on. In case of a real chemical attack, a person could be dead in 10 seconds.

Once in the shelter, everyone put on their chemical suits: jacket, pants, boots and gloves. Between the gear and the panic, it was hard to breathe. There we sat for nearly an hour. Between the siren blasts, you could hear everyone breathing. Eventually a U.S. built patriot missile destroyed at least one Iraqi rocket. The others missed their target. We were safe. Everyone returned to work. We would repeat that drill about 15 more times in the next 24 hours.

What made that first siren alert most stressful for me was the presence of one journalist in particular: my wife. Lyne Pitts is the executive producer of the CBS *Early Show*. She and one of her anchors, Julie Chen, had come out to the air base for one of their broadcasts. Those first few minutes in the shelter, I sat next to my wife, wondering what our five children would do if we both died? Fortunately that’s one question we never had to answer. Lyne is a tough journalist and a wonderful wife, so she survived the day and ended up staying in the region for about two weeks. That day we hugged and kissed and wished each other well. The experience reminded us both there were real risks involved. But besides loving each other, we respect and trust each other.

And so now the war was really on. The Vipers were flying combat missions. We went along on a number of them. Flying sometimes 50 to 100 feet off the ground in Huey helicopters. We saw the aftermath of battle. The Cobras traveled ahead armed with rockets and bombs. Along with artillery, tanks and troops on the ground, the Cobras destroyed buildings, Iraqi tanks and vehicles. From the air we could not see many dead soldiers, but there were plenty of destroyed vehicles on the ground that no man inside could have survived.

But we didn’t have to wait long to see bodies. Once we joined RCT 7, the ground combat unit, there were plenty of bodies to see. Most were Iraqi soldiers, but there were some civilians. For the next three weeks, the Marines pushed north and we went along for the ride.

Days usually started at 5 a.m. and went until about 9 p.m. We ate what the Marines ate, a selection of MREs, or Meals Ready to Eat. (Marines would trade cigarettes and clean socks to get meal No.8—the hamburger. They’d rather go hungry than eat the pork chops.) For three weeks I didn’t bathe (except for the occasional wet wipe), brush my teeth or comb my hair. It was both awful and liberating. In a war zone, fresh breath doesn’t mean too much. The Marines were, however, concerned about hygiene. U.S. commanders knew the Iraqi military couldn’t defeat them, but disease could stop troops dead in their tracks. So we washed our hands before we ate and carried a shovel and toilet paper when we went to the bathroom in the desert. There are no restrooms—and no shame—on the battlefield.

We’d file a story almost every day: our slice of the war. The embeds provided the slices, and it

was up to New York to serve the pies. From the sandstorm that stopped the troops, to the small battles on the road to Baghdad, those were the stories we told each day. Small is a relative term. Whenever bullets were flying overhead, it seemed for a moment like the world was coming to an end. I heard someone refer to “small arms fire” (AK-47s, etc.) as if the Iraqis were tossing Tic-Tacs at American forces. Small arms still caused big holes.

A Huey pilot told me once, “It’s my job to make sure the Marines on the ground come home, not me.” What an odd thing to say, I thought. That was days before the war started. Weeks later, I better understood what the pilot meant. HMLA 169 lost three men in one crash. It was an apparent accident. Their colleagues cursed and cried, but then went back to work because they had to and because honor required it.

No one suffered more than the families of those men and perhaps their commanding officer. Lt. Col. James Braden is a stocky man, with a stern handshake and gentle eyes. He cried during our interview about the three who died. He talked as if he was discussing his own children. I fear their loss will haunt him the rest of his life. I never saw him smile again. But I also never saw him or the others lose their focus.

Much has been written about the “kids” who go into the U.S. military because they lack options. Let the record show, the young men and women I met represent the very best of America. Many could teach any Ivy League school more about sacrifice, skill, discipline and honor than any of those fine institutions could teach them. The Marines I met did not cut corners. They did not seek the easy solution. They were given an objective and accomplished it, often in short order and always without complaining. Many entered the service just as their father or uncle or other relatives had, others for the adventure and indeed some because it was their best opportunity to better themselves.

The members of HMLA 169 are a bit older than the men and women in most of the ground units. Because the squadron included pilots and highly trained mechanics, the average age is probably about 27. Most are married with children. Besides being skilled, one had to be mature to survive in this squad. There are a few teenagers, but just as many 40-somethings. In many of the frontline combat units, the average age was about 20. Many were just out of high school, but there were no kids. The Marines seemed to do a good job of weeding out the children before the boat ride over.

That’s one myth. Now here’s another. The number of African Americans in the military is high, but the numbers of Blacks on the front lines in Iraq were not as significant as one might think. There were a number of combat units I encountered and did not see a single African American male. The overwhelming majority of frontline combat troops in Iraq were White or Hispanic. That was my personal observation supported by the latest statistics from the Department of Defense. Blacks make up 21 percent of the enlisted force, but account for only 15 percent of “combat arms,” which includes infantry, armor and artillery troops (a rate slightly higher than the overall population of Blacks in the United States—13 percent).

There are many high-ranking African Americans, including Brig. Gen. Vincent Brooks, who was based at Central Command in Doha, Qatar, and served as the military’s spokesman for the war. But the largest single percentage of African Americans in the military (36 percent) serve in support and administrative roles, not on the front lines. This very issue was often the topic of discussion between me and other African American journalists (there were probably about a dozen Black journalists out of the 600 or so embeds) embedded with the troops. Our conversations usually started this way: “So how’re you holding up and where are all the brothers?”

Be clear, African American men and women were on the front lines in Iraq, and a number were killed (at least 23 at press time, putting the Black U.S. casualty rate at about 16 percent thus far—higher than their representation in “combat arms” forces and the general population). But I only saw pockets of Black faces, not the sea of brown some in America have come to believe.

By contrast, consider this statistic from Vietnam: By the end of the war, African Americans had suffered 12.5 percent of the total deaths in Vietnam (58,000 Americans killed). And yet in 1969

African Americans made up only 11 percent of the U.S. population.

One African American woman I met during the war was Capt. Vernice Armour from Memphis. A graduate of Middle Tennessee State University, she was actually promoted from lieutenant to captain in Kuwait. Armour, 29, is the first African American female combat pilot in the history of the United States Marine Corps.

Armour loves to fly. She was a police officer in Arizona and Tennessee before joining the United States Marine Corps. She is a woman accustomed to both adventure and danger. She hoped the Marines would provide both.

“This is not my father’s military,” she told me. According to Armour, her father was in the service during Vietnam. He pleaded with her not to join the Marine Corps.

“My dad is still bitter about the discrimination he and other Blacks faced in Vietnam,” she says. “My experience has had its ups and downs, but overall it’s been very positive. The Corps makes an effort to be colorblind.”

I had similar conversations with a number of African American servicemen and women, and most told of a similar experience. Race is still an issue, most agreed, but the U.S. military, in their estimation, was far ahead of corporate America and the rest of the country.

Armour talked more about her faith than fighting, more about Jesus than Saddam. She took no joy in the prospect of taking another human being’s life, but she would do her job. I walked Armour out to her helicopter for her very first combat mission: We were both nervous. “Please pray for me,” she asked with a smile. It was the first of many missions she flew successfully.

Like many of the troops I met during the war, she wore a cross around her neck. “There are no atheists in a foxhole,” it has been said. I didn’t meet many in Iraq. Most of the young men and women I met believed in God, and came from working-class families with little more than a high school education.

I actually did meet one young soldier who had just graduated from Princeton. “I’m a liberal Democrat from Northeast, so what am I doing here?” he chuckled as he stood next to a tank in downtown Baghdad.

This generation of American warriors are said to be better educated and a bit older than the men and women who served in Vietnam. Unlike Vietnam, this is an all-volunteer fighting force. But like the many before them, they served their country honorably.

During the war, reporters chronicled almost every detail. Here’s one I did not report. It is the story we watched every evening when Mark, Chuck and I let Marines use our satellite phone to call home. Most reporters did it. It seemed the least we could do for the front row seat and armed escort to history.

There we’d sit in the back of a delivery truck (our makeshift satellite truck), sunset framed by the corners of the rear door of the truck. It looked like a movie screen with Marines in silhouette calling home.

From the mundane to the romantic to the sad, each told a story of war. There was the Marine who woke his wife up in the middle of the night. We could hear her crying, she was so thrilled to hear his voice. They hadn’t spoken in months. Then there was the Marine who called his wife, but she’d changed the number and moved to a new address. Not good. No one asked any questions.

And none of us who were there will ever forget the 19-year-old Marine who got his first letter (it took about three to six weeks for mail to arrive) from home in early March, only to discover his grandmother had died. The woman who raised him and sent him off to war was gone. She was the one person he doted on most as he talked to us and to his friends. We all sat in silence as this young man trembled and cried on the phone, his M-16 slung on his shoulder.

War isn’t simply about winning or losing, it is also about sacrifice. Not every American servicemember in Iraq fired their weapon, but they all made some sacrifice for their country.

And in war, mistakes are made. Innocent people die. We went along on one mission when a

Marine company got it right. Lima Company from Twentynine Palms, Calif., had just taken control of the Iraqi Oil Ministry. It was one of the last symbols of Saddam's regime still standing in Baghdad. When 80 or so Marines stormed the building, it was empty except for a few looters. The Marines went in the back door. Outside the front door Iraqi civilians were tearing down a life-size statue of Saddam Hussein. The scene was almost comical. The Marines rolled in looking for a fight and a party broke out. But the party did not last long. Minutes after Saddam's likeness was belly down in street, we all heard the snap of an AK-47 firing in our direction. For the next two hours, that sound grew louder and closer. A snapping sound punctuated every few moments by an exploding RPG (rocket propelled grenade).

During this surprise attack, the Marines were taking fire from three sides. It took a while to determine the source. A young corporal told his commanding officer he had "eyeballed" at least one gunman and he wanted permission to take the shot. Capt. George Schreffler from Harrisburg, Pa., listened, almost politely. It was an odd scene, gunfire crackling just above our heads, and Schreffler sitting with his ankles crossed, patiently listening to his breathless young Marine.

Schreffler asked one question: "Have you positively identified the weapon?" The corporal gave great detail but could not answer the question. So Schreffler ordered him to stand down and said, "Do not take the shot." The corporal was disappointed, to say the least. And truth be told, so was I. We were getting peppered with gunfire, RPGs and falling plaster (as bullets hit the building, pieces of plaster and cement rained down on us), so the desire to shoot something was very high.

Minutes later we all saw the target the young corporal was talking about. Three heads bobbed along behind a wall from the same direction as the shots. Eventually the three heads came into view from behind the wall: a husband, wife and their young daughter. The captain had made the perfect call. The civilians survived, two of the snipers were killed and there were no American casualties. The attack lasted two hours. It felt like two days.

But in war, perfection, like peace, is hard to find. It seems in war, old men start them and young men and women die fighting to end them.

I also met a number of Iraqi civilians during the war. Most welcomed U.S. forces. I often wondered how sincere those welcomes were, however, since the visitors all had guns. But nonetheless, most seemed genuine. During my visit in 1998, people spoke privately about how much they hated Saddam Hussein. So I suspect seeing U.S. troops roll into Baghdad sparked a range of emotions, both relief and sadness.

I am certain the typical Iraqi citizen wants the United States out sooner rather than later. We walked in on one Iraqi family (mom, dad and five children) looting one of Saddam's offices. The father took out a stack of Iraqi money with Saddam's picture, then proceeded to spit and stomp on each bill. "I hate Saddam. I love America," he said. Then he shook my hand, kissed my cheek and finished taking all that he and his family could carry.

For me the war ended in Baghdad April 20 with a helicopter ride out of the city. Shortly before we left, word came that another Marine had just been shot to death at one of the checkpoints. A civilian walked up to him and shot him in the shoulder. The bullet bounced off the Marine's collarbone and went through his heart. Two nights earlier we listened to that every Marine tell his girl back home, "Honey, I'm okay. The worst is over. I'll be home soon."

Now that I am home, I have begun to ponder the questions I ask myself after every "big" story: What have I learned? What do I hope for? Usually I only hope for a little time off to spend with my family and friends to laugh and relax. But this time feels different. This time I still want to see my family and friends, but I also hope to find the courage to cry, a long and cleansing cry. I'm not a crier, so this will be a different journey. And these will be tears not simply of sadness, but tears to relieve a full heart. I'll cry the way parents cry when they watch their children achieve things they once thought impossible. Regardless of how one feels about war and why the United States went after Saddam Hussein, the young men and women who fought in Iraq deserve our gratitude and our respect.

There is one thing I learned in Iraq. In war you never sleep, you only nap. On the battlefield, sleep is reserved for the dead. For those who died in this war, I pray their families will find peace and that each of their lost loved ones now enjoys a sweet sleep, a long good night free from pain and where angels sing.

Part VII **Déjà Vu**

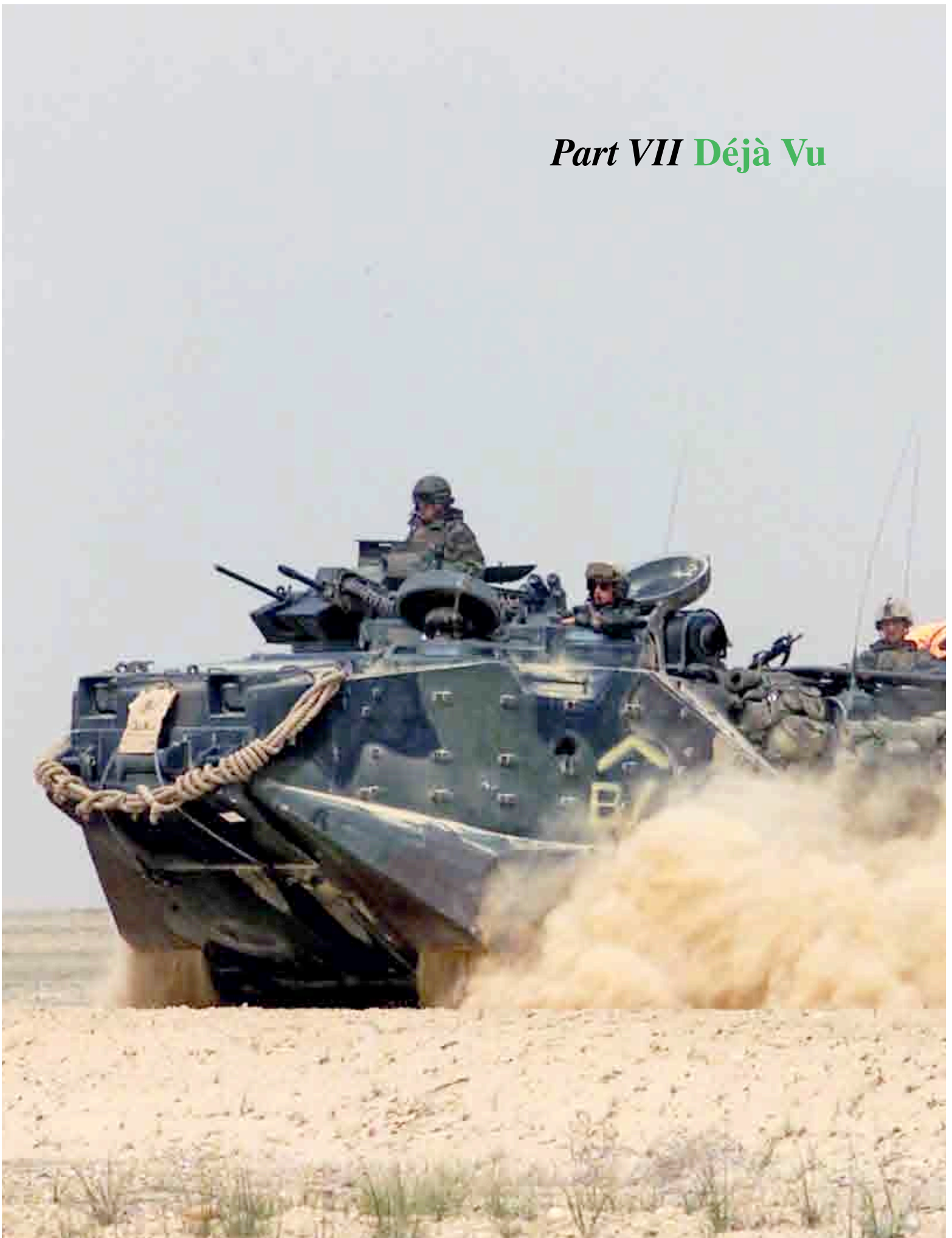



‘Farther and Faster’

by Lieutenant General James T. Conway

U.S. Naval Institute Proceeding, January 2005.

According to the commander of the I Marine Expeditionary Force (MEF) for 22 months of planning for and fighting in Operation Iraqi Freedom (OIF), the war’s two segments thus far have proved very different. In 2003, OIF I was comparatively less difficult, with Marines fighting mostly against Shia in the south. . . . In OIF II against Sunni tribes in the west, “our vision to win hearts and minds was met squarely with a 300% increase in the number of attacks in our sector,” he says, which translated into casualties . . . in “the turbulent city of Fallujah.”

Operation Iraqi Freedom unfolded in four distinct phases: a deployment phase, a shaping phase, a decisive operations phase, and a reconstruction phase. During January and February 2003, the Marine Corps flexed its expeditionary muscle, with 60,000 Marines and sailors and their heavy equipment deployed to Kuwait in 45 days. Operation Iraqi Freedom, just as Operation Desert Storm more than a decade before, was a logistical victory. No other nation on earth even could have attempted such a monumental transfer of men and materiel, to a moonscape on exactly the opposite side of the globe, in preparation for an attack.

Our organization for combat remained dynamic throughout phases I and II. The I Marine Expeditionary Force was assigned to the Third Army, where we joined with the V Corps as the ground force. This would be the main attack force in a fast-moving sweep across mainly desert terrain southwest of Baghdad. We would be the supporting attack, crossing rivers and other poorer avenues of approach. Our role was to look like the main attack: pick a fight with anybody who would engage us, and yet keep battlefield geometry so we were abreast or even slightly in advance of V Corps. Both forces were to focus like a laser on Baghdad. When Turkey closed its borders to Coalition forces, the entire British First Armored Division was assigned to the MEF. Marvelous troops and leaders, with first-rate equipment, they swelled our ranks to just short of 90,000 Marines, soldiers, and sailors. I told the colorful British formations that there was a time in our country when the phrase, “The British are coming,” was used to scare children. In this instance, however, U.S. Marines in Kuwait were glad to hear it.

The all-volunteer force has provided an amazing quality of Marine and sailor. Bigger, stronger, and faster than their namesake of decades past, they also are more informed, and therefore more opinionated and inquisitive. My commanders and I constantly spoke to the troops in their training bases in Kuwait to provide

information and squelch rumors. Their number-one question was: "Is the country behind us?" They had read or heard about large antiwar demonstrations in the United States and elsewhere and wanted assurances. We told each formation not to worry about it; just do their jobs. American citizens were mature enough in their beliefs that even if they didn't support the war, they would still support the troops.

In what had become a predictable pattern, a U.S. air campaign was planned to precede the ground attack. What had been 40 days was reduced to 16 days, and that was cut in half to an 8-day period of "shock and awe" by the air planners. Increasing reports of explosives being moved into the southern oil fields, however, made it apparent that air attack could be the signal for Iraqi forces to demolish the oil platforms in a calculated act of senseless destruction. Since rapid and intact seizure of the southern oilfield production was a MEF mission, we were early advocates of launching the ground attack before an air campaign. For a time, the best we could do was launch them simultaneously. But there is an old adage, well remembered, that "the enemy gets a vote." Without warning or provocation, on 20 March, Saddam started destruction of the fields. Our attack was moved forward initially 24 hours, then 8 hours more. It's okay to delay an attack, as long as you rest the troops. Moving an attack forward is very much another matter. That said, I could not have been more pleased with the response of my commanders, air and ground, as we thundered across the international border of full 32 hours ahead of plan.

Our intelligence offered different analyses of enemy strength and intentions, and where he would use his chemical weapons. We faced three Iraqi Corps in our sector—two Regular Army and one Republican Guard, consisting of nine total divisions. We were led to believe major portions of some of those divisions would capitulate, the division most likely to collapse being the 11th Infantry division around An Nazariah. We found the opposite to be true. Some intel experts thought Saddam would unleash his chemical weapons as soon as we crossed the Kuwaiti border; others thought it would happen when we crossed the Euphrates River. My own view was, they would hit us with chemicals as we approached the Republican Guard divisions anchored on the Tigris River southeast of Baghdad. Taking no chances, we crossed the line of departure in our bulky chemical suits and stayed in them for two and a half weeks.

The MEF had been honed by our predecessors to be the most efficient killing machine on the battlefield. With integrated ground, air, and logistics elements under a single commander, the force generated a level of speed and momentum that only the enemy could appreciate fully. The MEF had available more than 340 combat aircraft that could generate almost 700 sorties each day against any target we chose. During the Gulf War it took ten bombs to destroy each target. During Operation Iraqi Freedom, a single aircraft could destroy ten targets. It has been said that the Iraqis melted away, but that does not give proper credit to the Iraqi Army. When they amassed, they were blown away by the effects of our deep air attack. A captured Iraqi tank brigade commander told of making an 80-mile forced march to position his tanks east of Baghdad. So he could rest his troops on the first night, he moved his tanks into palm groves. At 0200, during the worst sandstorm in 20 years, under complete cover of darkness and deep in the palm groves, Marine air began the systematic destruction of his tanks. When 30 had been destroyed by pinpoint bombing, his troops then melted away. He told us, "I wanted to order them back but knew that if I did, it meant certain death."

We employed a revitalized concept for reporting the war with multiple media embedded in our formations. The program was without its faults, but on the whole it was a huge success. Members of the media lived the lifestyle of "the grunt" in the cold, the wet, and the biting sandstorms. They saw raw emotions as Marine aggressiveness overcame fog and friction, and, as the exhilaration of battle was tempered by the realities of casualty evacuation. They marveled repeatedly at the professionalism of the 19-year-old lance corporals as they handled all of the above. The stories they filed were 95% positive, and there were more than a few tearful farewells as they left us. Not since the days of Ernie Pyle and World War II had such bonding occurred between the media and the war fighter.

In every war, some things make you smile, and other things make you cry. One such incident occurred as armor columns attacked up Highway 6 southeast of Baghdad. It was difficult to maintain, but we still showed readiness rates of 93% and 94% on tanks and tracks, respectively. As I stood watching the troops move up the highway, I understood why. I saw one amphibious assault vehicle steam past me at 40 miles per hour, towing

another. Atop the second vehicle were three Marine mechanics, with feet and hands into the engine compartment, working on the engine. I said to the division commander standing next to me, "General [Major General James N.] Mattis, that is a safety violation. God bless 'em!"

Later in the attack on Baghdad, the 1st Battalion, 8th Marines got into a serious fight in and around the Imam Ali mosque in the north-central portion of the city. They killed roughly 250 Republican Guards, Baathists, and Sadaam Fedayeen as they took their objectives. First casualty reports coming in on our side were one gunnery sergeant killed and 41 troops wounded. The next day that figure zoomed to 1 killed and 73 wounded. As we asked how that happened, we learned of the lance corporal who came to the battalion aid station weak and with a bloody arm. The corpsman asked him how many times he had changed the bandage, and the Marine told him he had lost count. The doc, as he should, got on the Marine's case. The trooper said, "Doc, I'm not the only guy out there like this." Indeed, he was not. As the company commanders and first sergeants examined their men, they came across the additional casualties. Asked why they didn't turn themselves in to the aid station for treatment and possible, evacuation, they answered, "Sir, I am the only automatic rifleman left in my squad," or "Sir, I thought there might be another big fight today," or just "Sir, I didn't want to leave my buddies." With troops like those, the outcome of Operation Iraqi Freedom was never in doubt.

After securing Baghdad, we then dispatched a light armor column north to take out any remaining resistance around Saddam's birthplace, in the vicinity of Tikrit. The MEF had attacked farther and faster than any unit in U.S. history. Feeling pretty spirited, I announced to my Army boss, Lieutenant General Dave McKiernan, that Marines are assault troops, we don't do nation-building, and we were ready for backload. He said to me, get your butt down south and get started with reconstruction until I can get you relieved. In fact, we spent five and a half months in the southern provinces of Iraq in phase IV operations. We found our 1920s-vintage "small wars manual," written by Marines on duty in Nicaragua and Haiti, to be very applicable to the situations we faced in cities like Najaf, Karbala, and Samawah. One passage captured the essence of our activities: It said, "Conceived in uncertainty, reconstruction operations are often conducted with precarious responsibility, and doubtful authority, under indeterminate orders, lacking specific instructions." Our battalion commanders and their company commanders thrived under those conditions and rapidly became effective little potentates until we turned over our sector, and could break them of it, in September 2003.

The MEF had been back at its bases in Southern California for roughly five months when we were unexpectedly ordered back to Iraq for Operation Iraqi Freedom II. We were tasked to replace the 82nd Airborne with a 25,000-Marine air-ground task force in the Al Anbar province during March 2004. On arrival, our numbers grew to 30,000 with the inclusion of a very capable Army brigade combat team. Our responsibilities included the turbulent city of Fallujah and major portions of the Iraq-Syria border. Our new area was about the size of Wyoming and included most of the Sunni Triangle, where Saddam had drawn many of his best officers for the Republican Guard and other elite units.

Returning to western Iraq was very different from our experiences in the south. The tribes were Sunni, not Shia, they were already quite hostile toward Coalition forces, and our ability to employ our proven techniques was much abated. In the Shia provinces, we had been attacked frequently but had not lost a single Marine to enemy fire. After two weeks in the Al Anbar province, by the time of the transfer of authority with the 82nd, we had lost five killed in action. Our vision to win hearts and minds was met squarely with a 300% increase in the number of attacks in our sector.

Initially, we found Iraqi security forces in the region very undependable. Iraqi society is driven by loyalty to the tribal sheiks and religious imams, and this cultural norm frequently made it impossible to rely on the police or national guard units as effective paramilitary forces. Further, they were intimidated by the insurgents and were watching to see which side was going to win. As we built the forces to be more secular, however, and provided them with the weapons and equipment they needed to succeed, they became much more reliable. Indeed, in the fighting in Samarra, Najaf, and the northern Babil province, Army and Marine commanders have given the Iraqi security forces, especially the regular army, a solid grade of "B" for their performances there.

The Coalition forces learned many lessons about information operations (IO) in southwest Asia, and we frankly need to get better in our approach at every level. We tended to treat all media the same, assuming a level

of journalistic integrity and responsible reporting. The Arab media, however, were different. We found right away in Fallujah that Al Jazeera and Al Arabia were bound by no such principles of integrity and routinely provided a shrill and outrageous perspective to an Arab public all too willing to believe such distortions. Eventually, we treated them as enemy combat camera and controlled their access to our actions. Our most consistent and effective IO message to the Iraqis was, "You may not want us here, and we don't particularly want to be here, but we aren't leaving until there is a level of stability and security in Iraq. So help us achieve that end."

An amazing figure accompanied our casualty rates in Iraq. As a result of superb planning and execution at all levels, for every 11 Marines or sailors hit, one would be killed but seven would be returned to duty almost immediately. Never before in combat had such recovery figures been the norm. Our protective gear, the helmets, and SAPI (small arms protection insert) plates worked. Our corpsmen in the line companies were magnificent, as were the medevac pilots and the docs at Alpha and Bravo surgical companies. They were truly the "angels of the battlefield," and when we see each other again, none will ever buy his own drink as long as I am at the bar.

During this deployment, our Commandant won a major victory in Washington, D.C. Secretary of Defense Donald Rumsfeld had questioned our seven-month rotation policy and initially felt that all services should adhere to the Army's 12 months "boots-on-the-ground" approach. We argued that our overall operational tempo was equal to or greater than any other service. For instance, all the MEF's major headquarters were in Kuwait or Iraq for 17 of the 22 months I was the MEF commander. We argued that six- or seven-month rotations were the norm for the Marine Corps—though not as frequently as we are experiencing now—and that we risked breaking the force if we posed an even more serious burden on our young men and women, especially those with families. The Secretary said to the Commandant "Okay, I've got it." In the Pentagon, you are never sure you have completely won a fight; but we felt much better when Secretary Rumsfeld began asking the Army Chief of Staff to explain why the Army was not doing seven-month rotations.

Operation Iraqi Freedom II continues, and Marines from I MEF will continue to be in Iraq until April or May 2005. That said, our view since 28 June and the declaration of national sovereignty is that Iraqi security forces must win against the insurgency in Iraq. We can only set the conditions for success by the host nation. Even then, we must act to ensure an Iraqi lead.

The contrast between the two OIF operations is stark. To begin, they were two very different scenarios: OIF was a classic offensive operation. We never lost the initiative as we put the enemy on his heels from the outset and kept him there until we had secured all objectives. OIF II has evolved into a classic insurgency. Out of necessity to maintain logistical hubs, we operated from fixed sites. But that allowed the enemy to match our freedom to maneuver. Ours was more a defensive role, with emphasis on heavy offensive patrolling and significant civil affairs work. There was a constant effort to hold the initiative, both militarily and psychologically, because as one military dictum says, the commander who maintains the initiative wins.

During OIF II, for reasons still not clear, the media were bent on providing a comparatively more negative slant. Our observations were supported by the reporter who, when asked to come out from Baghdad to cover the opening of a women's hospital, declined, telling our public affairs officer he "wasn't really looking for a good news story." Katie O'Beirne is a political commentator, but she may have offered some insight when she remarked, "You've got to remember, most journalist spent their high school years being stuffed into lockers by the kind of males who are running our military. Now they're determined to get even." My perception since being home is that any bad news coming out of Iraq is not properly balanced with the great things troops from all the nations are doing.

One thing that remained constant during both operations was the magnificent performance of the troops. Whether they were infantrymen running toward enemy fire, mechanics working in 130^o heat, Cobra pilots dueling with heavy-caliber machine guns in support of ground troops, or corpsmen dashing forward to treat a wounded Marine, our young troops were unbelievable in their resolve, discipline, and courage under fire. The older generation worried about this new generation "Y." We saw them as the joy-stick generation and were concerned they might not measure up when the time came. In the hands of these young warriors, our

Corps—indeed, our nation—has absolutely nothing to worry about.

What about the way ahead in Iraq? I believe there will be elections in January, and I suspect very shortly afterward you will start to see a reduction in U.S. forces, not because U.S. planners will seek it, but because the Iraqis will demand it. I used to think that Americans were impatient, but we don't hold a candle to the Iraqis. We are seen as infidels and nonbelievers, and further, most Iraqis now consider us occupiers. They will expect us to provide regional security for a long time because we have destroyed their army. But they will be willing to accept internal security risks in exchange for a reduced Coalition presence.

I think our strategic planners have it right. When the Iraqis establish a free and democratic state, it probably will not be Jeffersonian, but it will put a stake in the very heart of the region producing terrorists. We will not just be killing terrorist. Rather, we will be doing something about the very cause of terrorism. In a region that has made little progress over the centuries, Iraq has the potential to be a prosperous and powerful regional player. Every day we are in Iraq brings us another step closer to Iraqi victory. Iraqi infantry and counterterrorism forces are being stood up at a rate that will field 27 secular battalions, trained and equipped, by March. These battalions are loyal to the central government and have the support of average Iraqi citizens. When they focus their full attention on the insurgents and foreign fighters, they will have little problem gaining actionable intelligence from their countrymen. Will there continue to be bombings and attacks? I fully expect so, because the terrorists recognize the threat to their very existence. I anticipate Iraqis will one day soon make short work of the principal threats to their government.

For the United States and its allies, Iraq and Afghanistan are important battlegrounds in the war on terrorism—not the whole war. Many of the young Arabs we kill are would-be suicide bombers. These are the same fanatical misfits who would otherwise be seeking their way into Los Angeles or Boston. We are engaged in a defense against these people far from our borders and our families. That's okay with our troops; they understand it, and they very much prefer to take care of business in Iraq. Coalition forces will, covertly or overtly, battle terrorists in many other locations across the globe, but history might well show Iraq was our most important fight.

Finally, I ask three things of anyone reading these remarks.

- Don't wait for the historians to put the world we live in today in their context. Think of the nation at war instead of enjoying an interrupted peace and it will shape your outlook.

- Don't lose patience, or more important, your resolve to see the job done. Our enemy knows popular support is the center of gravity for any U.S. government engaged in conflict and he works to disassemble that support every day. You are the ultimate target of the beheadings and bombings. So stay the course.

- Continue to support the troops. Their exterior is hardened and battle-ready. But their psyches are more fragile and susceptible to the convictions of their countrymen. Without your support their will will weaken, their confidence wane, and their morale suffer. With the enthusiastic support of the American people, however, our forces are the most formidable, most responsive, and most disciplined troops on the face of the earth. I can only hope they make you, as they have made me, very proud.

Appendix A

Command List

U.S. Marine Forces, Central Command March–November 2003*

Commanding General: LtGen Earl B. Hailston
Chief of Staff: Col Peter T. Miller
G-1: Col Richard B. Harris
G-2: Col William E. Rizzio
G-3: Col Timothy C. Wells
G-4: Col Philip N. Yff
G-5: Col Timothy L. Hunter
G-6: Col Kevin B. Jordan
SJA: LtCol Robert E. Pinder
Comptroller: Col Robert J. Herkenham

Combined/Joint Task Force-Consequence Management
Commanding General: BGen Cornell A. Wilson

Marine Logistics Command
Commanding General: BGen Michael R. Lehnert

Special Purpose MAGTF
Commanding General: BGen Ronald S. Coleman

I Marine Expeditionary Force (Reinforced)

Commanding General: LtGen James T. Conway
Deputy: MajGen Keith J. Stalder
Chief of Staff: Col John C. Coleman
G-1: Col William J. Hartig
G-2: Col Alan R. Baldwin
Col James R. Howcroft
G-3: Col Larry K. Brown
G-4: Col Matthew W. Blackledge
G-5: Col Christopher J. Gunther
Col Anthony L. Jackson
G-6: Col George J. Allen (to 15 June)
Col Marshall I. Considine (after 30 June)
SJA: Col William D. Durrett
Surgeon: Captain Joel A. Lees, USN
Chaplain: Captain John S. Gwudz, USN
I MEF Headquarters Group: Col John T. Cunnings
15th Marine Expeditionary Unit (SOC)
Commanding Officer: Col Thomas D. Waldhauser

24th Marine Expeditionary Unit (SOC)
Commanding Officer: Col Richard P. Mills (to 6 June)
Col Ronald J. Johnson (after 6 June)

11th Marine Expeditionary Unit, Command Element (-)
Commanding Officer: Col Anthony M. Haslam

Marine Ground Combat Element

1st Marine Division (Reinforced)
Commanding General: MajGen James N. Mattis
Assistant Division Commander: BGen John F. Kelly
Chief of Staff: Col Bennett W. Saylor
Col Joseph F. Dunford

1st Marine Regiment (-)(Reinforced) (Regimental Combat Team 1)
Commanding Officer: Col Joseph D. Dowdy (to 4 April)
Col John A. Toolan

5th Marine Regiment (-) (Reinforced) (Regimental Combat Team 5)
Commanding Officer: Col Joseph F. Dunford
(to 23 May)

7th Marine Regiment (-) (Reinforced) (Regimental Combat Team 7)
Commanding Officer: Col Steven A. Hummer

11th Marine Regiment (-)(Reinforced)
Commanding Officer: Col Michael P. Marletto

2d Marine Expeditionary Brigade (Task Force Tarawa)
Commanding General: BGen Richard F. Natonski
Chief of Staff: Col James W. Smoot

2d Marine Regiment (-) (Reinforced) (Regimental Combat Team 2)
Commanding Officer: Col Ronald L. Bailey

Marine Aviation Combat Element

3d Marine Aircraft Wing
Commanding General: MajGen James F. Amos
Assistant Wing Commander: BGen Terry G. Robling
Chief of Staff: Col Gerald A. Yingling, Jr.

Marine Aircraft Group 11 (-) (Reinforced)
Commanding Officer: Col Randolph D. Alles

Marine Aircraft Group 13 (-) (Reinforced)
Commanding Officer: Col Mark R. Saverese

Marine Aircraft Group 16 (-) (Reinforced)
Commanding Officer: Col Stuart L. Knoll

Marine Aircraft Group 29 (-) (Reinforced)
Commanding Officer: Col Robert E. Milstead, Jr.

Marine Wing Support Group 37 (-) (Reinforced)
Commanding Officer: Col Michael C. Anderson

Marine Air Control Group 38 (-) (Reinforced)
Commanding Officer: Col Ronnell R. McFarland

Marine Aircraft Group 39 (-)(Reinforced)
Commanding Officer: Col Richard W. Spender
Col Kenneth P. Gardiner

Marine Combat Service Support Element

1st Force Service Support Group
Commanding General: BGen Edward G. Usher III
BGen Richard S. Kramlich

Deputy Commander: Col John L. Sweeney, Jr.
Chief of Staff: Col Darrell L. Moore

Combat Service Support Group 16 (Headquarters Elements)
Commanding Officer: LtCol Michael J. Taylor

Combat Service Support Group 11 (Brigade Service Support Group G 1)
Commanding Officer: Col John J. Pomfret
Col Charles L. Hudson

Combat Service Support Battalion 13 (4th Landing Support Battalion)
Commanding Officer: LtCol Michael D. Malone

Combat Service Support Group 14 (4th Supply Battalion)
Commanding Officer: Col John T. Larson

Combat Service Support Group 15 (1st Supply Battalion)
Commanding Officer: Col Bruce E. Bissett

Transportation Support Group
Commanding Officer: Col David G. Reist

I Marine Expeditionary Force Engineer Group
Commanding Officer: RAdm (UH) Charles R. Kubic, USN

United Kingdom Forces

1st Armoured Division (UK) (-)(Reinforced)
Commanding General: MajGen Robin V. Brims
Chief of Staff: Col Patrick Marriott

7th Armored Brigade (British Army)
Commanding Officer: Brig Graham Binns

16th Air Assault Brigade (British Army)
Commanding Officer: Brig Jacko Page

3 Commando Brigade, Royal Marines (-)
Commanding Officer: Brig Jim Dutton

*Includes billets in units which served in theater for part but not all of the period covered. Basic sources are MarAdmin 507/03, various versions, Oct-Dec03, with "Modifications to the I MEF Presidential Unit Citation Unit Listing," and unit command chronologies.

Appendix B: Unit List

U.S. Marines In Operation Iraqi Freedom March-November 2003*

U.S. Marine Forces, Central Command [USMarCent]

Command Element
Combined Joint Task Force-Consequence Management [CJTF-CM]
Marine Corps Logistics Command [MarLogCom]
Special Purpose Marine Air-Ground Task Force [SPMAGTF]

I Marine Expeditionary Force (Reinforced) [I MEF]

Command Element

15th Marine Expeditionary Unit (Special Operations Capable) [15th MEU (SOC)]

Battalion Landing Team 2d Battalion, 1st Marines [BLT 2/1]
Marine Medium Helicopter Squadron 161 (Reinforced) [HMM-161]
Marine Expeditionary Unit Service Support Group 15 [MSSG-15]

24th Marine Expeditionary Unit (Special Operations Capable) [24th MEU (SOC)]

Battalion Landing Team 2d Battalion, 2d Marines [BLT 2/2]
Marine Medium Helicopter Squadron 263 (Reinforced) [HMM-263]
Marine Expeditionary Unit Service Support Group 24 [MSSG-24]

Task Force Yankee [TF Yankee]

11th Marine Expeditionary Unit, Command Element (-) [11th MEU, CmdEle]
2d Battalion, 6th Marines (-) (Reinforced) [2d Bn, 6th Mar]
Sensitive Site Team Number 3, U.S. Army [SenSiteTm #3, USA]
75th Exploitation Task Force, U.S. Army [75th ExpTF, USA]
Company C, 478th Engineer Battalion, U.S. Army [Co C, 478th EngrBn, USA]

I Marine Expeditionary Force Headquarters Group [I MEF HqGru]

6th Communications Battalion (-) [6th CommBn]
9th Communications Battalion (-) [9th CommBn]
1st Radio Battalion (-) (Reinforced) [1st RadBn]
1st Intelligence Battalion (-) (Reinforced) [1st IntelBn]
1st Force Reconnaissance Company (-) (Reinforced) [1st ForReconCo]
I Marine Expeditionary Force Liaison Element [I MEF LsnEle]
3d Air Naval Gunfire Liaison Company [3d ANGLICO]

4th Air Naval Gunfire Liaison Company [4th ANGLICO]
3d Civil Affairs Group [3d CAG]
4th Civil Affairs Group [4th CAG]

Marine Ground Combat Element

1st Marine Division (Reinforced) [1st MarDiv]

Headquarters Battalion [HqBn]

1st Marines (-) (Reinforced)/Regimental Combat Team 1 [1st Mar/RCT-1]

Headquarters Company [HqCo]
3d Battalion, 1st Marines [3d Bn, 1st Mar]
1st Battalion, 4th Marines [1st Bn, 1st Mar]
2d Battalion, 23d Marines [2d Bn, 23d Mar]
2d Light Armored Reconnaissance Battalion (-) [2d LARBn]

5th Marines (-) (Reinforced)/Regimental Combat Team 5 [5th Mar/RCT-5]

Headquarters Company [HqCo]
1st Battalion, 5th Marines [1st Bn, 5th Mar]
2d Battalion, 5th Marines [2d Bn, 5th Mar]
3d Battalion, 5th Marines [3d Bn, 5th Mar]
2d Tank Battalion (-) (Reinforced) [2d TkBn]
1st Light Armored Reconnaissance Battalion (-) [1st LARBn]
Company C, 4th Combat Engineer Battalion [Co C, 4th CbtEngrBn]

7th Marines (-) (Reinforced)/Regimental Combat Team 7 [7th Mar/RCT-7]

Headquarters Company [HqCo]
1st Battalion, 7th Marines [1st Bn, 7th Mar]
3d Battalion, 7th Marines [3d Bn, 7th Mar]
3d Battalion, 4th Marines [3d Bn, 4th Mar]
1st Tank Battalion (-) (Reinforced) [1st TkBn]
3d Light Armored Reconnaissance Battalion, (-) (Reinforced) [3d LARBn]

11th Marines (-) (Reinforced) [11th Mar]

Headquarters Battery (-) [HqBtry]
Detachment, Headquarters Battery, 10th Marines [Det, HqBtry, 10th Mar]
1st Battalion, 11th Marines (-) [1st Bn, 11th Mar]
2d Battalion, 11th Marines (-) [2d Bn, 11th Mar]
3d Battalion, 11th Marines (-) [3d Bn, 11th Mar]
5th Battalion, 11th Marines (-) [5th Bn, 11th Mar]
1st Combat Engineer Battalion (-) (Reinforced) [1st CbtEngrBn]
2d Combat Engineer Battalion (-) (Reinforced) [2d CbtEngrBn]
1st Reconnaissance Battalion (-) (Reinforced) [1st ReconBn]
2d Assault Amphibian Battalion (-) (Reinforced) [2d AABn]
3d Assault Amphibian Battalion (-) (Reinforced) [3d AABn]

4th Assault Amphibian Battalion [4th AABn]
2d Radio Battalion [2d RadBn]
Military Police Company, 4th Marine Division [MPCo, 4th MarDiv]
Communications Company, 4th Marine Division [CommCo, 4th MarDiv]
Battery I, 3d Battalion, 10th Marines [Btry I, 3d Bn, 10th Mar]
Battery R, 5th Battalion, 10th Marines [Btry R, 5th Bn, 10th Mar]

2d Marine Expeditionary Brigade (Task Force Tarawa) [2d MEB TF Tarawa]

Command Element
Detachment, II Marine Expeditionary Force Headquarters Group [Det, II MEF HqGru]
II Marine Expeditionary Force Liaison Element [II MEF LsnEle]
2d Battalion, 6th Marines (Originally with Task Force Yankee) [2d Bn, 6th Mar]
Company C, 4th Reconnaissance Battalion [Co C, 4th ReconBn]
2d Force Reconnaissance Company [2d ForReconCo]
2d Intelligence Battalion (-) [2d IntelBn]

2d Marines (-) (Reinforced)/Regimental Combat Team 2 [2d Mar/RCT-2]

Headquarters Company [HqCo]
1st Battalion, 2d Marines [1st Bn, 2d Mar]
3d Battalion, 2d Marines [3d Bn, 2d Mar]
2d Battalion, 8th Marines [2d Bn, 8th Mar]
1st Battalion, 10th Marines [1st Bn, 10th Mar]
Battery F, 2d Battalion, 10th Marines [Btry F, 2d Bn, 10th Mar]
Company A, 2d Combat Engineer Battalion [Co A, 2d CbtEngrBn]
Company A, 8th Tank Battalion [Co A, 8th TkBn]
Company C, 2d Light Armored Reconnaissance Battalion [Co C, 2d LARBn]
Company A, 2d Assault Amphibious Battalion [Co A, 2d AABn]
Company A, 2d Reconnaissance Battalion (Reinforced) [Co A, 2d ReconBn]

Marine Aviation Combat Element

3d Marine Aircraft Wing [3d MAW]

Marine Wing Headquarters Squadron 3 [MWHS-3]
Detachment, Marine Wing Headquarters Squadron 2 [Det, MWHS-2]

Marine Aircraft Group 11 (-) (Reinforced) [MAG-11]

Marine Aviation Logistics Squadron 11 (-) (Reinforced) [MALS-11]
Marine Aviation Logistics Squadron 14 (-) [MALS-14]
Detachment, Marine Aviation Logistics Squadron 31 [Det, MALS-31]
Marine Aerial Refueler Transport Squadron 352 (-) (Reinforced) [VMGR-352]
Detachment, Marine Aerial Refueler Transport Squadron 234 [Det, VMGR-234]
Detachment, Marine Aerial Refueler Transport Squadron 452 [Det, VMGR-452]
Marine Fighter Attack Squadron 232 [VMFA-232]
Marine Fighter Attack Squadron 251 [VMFA-251]
Marine All Weather Fighter Attack Squadron 121 [VMFA(AW)-121]

Marine All Weather Fighter Attack Squadron 225 [VMFA(AW)-225]
Marine All Weather Fighter Attack Squadron 533 [VMFA(AW)-533]
Marine Tactical Electronic Warfare Squadron 1 [VMAQ:-1]
Marine Tactical Electronic Warfare Squadron 2 [VMAQ:-2]

Marine Aircraft Group 13 (-) (Reinforced) [MAG-13]

Marine Aviation Logistics Squadron 13 (-) [MALS-13]
Marine Attack Squadron 211 (-) [VMA-211]
Marine Attack Squadron 214 [VMA-214]
Marine Attack Squadron 223 (-) [VMA-223]
Marine Attack Squadron 311 [VMA-311]
Marine Attack Squadron 542 [VMA-542]

Marine Aircraft Group 16 (-) (Reinforced) [MAG-16]

Marine Aviation Logistics Squadron 16 (-) [MALS-16]
Detachment, Marine Aviation Logistics Squadron 26 [Det, MALS-26]
Marine Medium Helicopter Squadron 163 [HMM-163]
Marine Heavy Helicopter Squadron 462 [HMH-462]
Marine Heavy Helicopter Squadron 465 [HMH-465]

Marine Aircraft Group 29 (-) (Reinforced) [MAG-29]

Marine Aviation Logistics Squadron 29 (-) [MALS-29]
Marine Medium Helicopter Squadron 162 [HMM-162]
Marine Medium Helicopter Squadron 365 (-) [HMM-365]
Marine Heavy Helicopter Squadron 464 [HMH-464]
Marine Light Attack Helicopter Squadron 269 [HMLA-269]

Marine Wing Support Group 37 (-) (Reinforced) [MWSG-37]

Marine Wing Support Squadron 271 [MWSS-271]
Marine Wing Support Squadron 272 [MWSS-272]
Marine Wing Support Squadron 371 [MWSS-371]
Marine Wing Support Squadron 372 [MWSS-372]
Marine Wing Support Squadron 373 [MWSS-373]
Company C, 1st Battalion, 24th Marines [Co C, 1st Bn, 24th Mar]
Detachment, Military Police, 4th Marine Air Wing [Det, MP, 4th MAW]

Marine Air Control Group 38 (-) (Reinforced) [MACG-38]

Air Traffic Control Detachment B, Marine Tactical Air Control Squadron 2 [ATCDet B, MTACS-2]
Marine Air Control Squadron 1 (Reinforced) [MACS-1]
Detachment, Marine Air Control Squadron 2 [Det, MACS-2]
Marine Wing Communications Squadron 28 (-) [MWCS-28]
Marine Wing Communications Squadron 38 (Reinforced) [MWCS-38]
Detachment, Marine Tactical Air Control Squadron 28 [Det, MTACS-28]

Marine Tactical Air Control Squadron 38 (Reinforced) [MTACS-38]
Detachment, Marine Tactical Air Control Squadron 48 [Det, MTACS-48]
Marine Air Support Squadron 1 [MASS-1]
Marine Air Support Squadron 3 (Reinforced) [MASS-3]
Battery B, 2d Low Altitude Air Defense Battalion [Btry B, 2d LAADBn]
3d Low Altitude Air Defense Battalion [3d LAADBn]
Detachments, Marine Air Support Squadron 6 [CA, MA Dets, MASS-6]
Marine Unmanned Aerial Vehicle Squadron 1 [VMU-1]
Marine Unmanned Aerial Vehicle Squadron 2 [VMU-2]

Marine Aircraft Group 39 (-) (Reinforced) [MAG-39]

Marine Aviation Logistics Squadron 39 (-) [MALS-39]
Marine Light Attack Helicopter Squadron 169 [HMLA-169]
Marine Light Attack Helicopter Squadron 267 [HMLA-267]
Marine Medium Helicopter Squadron 268 [HMM-268]
Marine Medium Helicopter Squadron 364 [HMM-364]
Marine Light Attack Helicopter Squadron 369 [HMLA-369]
Atlantic Ordnance, Command Expeditionary Force [LantOrd, CmdExpedFor]
Detachment, Headquarters and Headquarters Squadron, Marine Corps Air Station,
Miramar [Det, HHS, MCAS Miramar]

Marine Combat Service Support Element

1st Force Service Support Group [1st FSSG]**

Detachment, Headquarters and Service Battalion [Det, H&SBn]

Combat Service Support Group 11 (Brigade Service Support Group 1) [CSSG 11]

Headquarters [Hq]
Combat Service Support Battalion 10 (Combat Service Support Group 1) [CSSB 10]
Combat Service Support Company 111 [CSSC 111]
Combat Service Support Company 115 [CSSC 115]
Combat Service Support Company 117 [CSSC 117]

Combat Service Support Group 13 (4th Landing Support Battalion) [CSSG 13]

Headquarters, 4th Landing Support Battalion [Hq, 4th LdgSptBn]
Combat Service Support Company 133 [CSSC 133]
Combat Service Support Company 134 [CSSC 134]
Combat Service Support Company 135 [CSSC 135]

Combat Service Support Group 14 (4th Supply Battalion) [CSSG 14]
4th Supply Battalion (-) [4th SupBn]

Combat Service Support Group 15 (1st Supply Battalion) [CSSG 15]
1st Supply Battalion (-) [1st SupBn]
Combat Service Support Battalion 12 (1st Maintenance Battalion) [CSSB 12]

Combat Service Support Battalion 18 (Headquarters and Service Battalion, 1st Force Service Support Group) [CSSB 18]
Combat Service Support Battalion 22 [CSSB 22]
Combat Service Support Company 151 [CSSC 151]

Transportation Support Group [TransSuptGru]
1st Transportation Support Battalion (-) [1st TSptBn]
6th Motor Transport Battalion [6th MTBn]

7th Engineer Support Battalion (-) (Reinforced) [7th EngrSptBn]
6th Engineer Support Battalion (-) (Reinforced) [6th EngrSptBn]
8th Engineer Support Battalion (-) (Reinforced) [8th EngrSptBn]
Communications Company, 4th Force Service Support Group [CommCo, 4th FSSG]
Mortuary Affairs Company, 4th Force Service Support Group [MortAffairsCo, 4th FSSG]
Company A, Military Police, 4th Force Service Support Group [Co A, MP, 4th FSSG]
Company B, Military Police, 4th Force Service Support Group [Co B, MP, 4th FSSG]
Company C, Military Police, 4th Force Service Support Group [Co C, MP, 4th FSSG]
Combat Service Support Battalion 16 (Combat Service Support Detachment 16) [CSSB 16]
Combat Service Support Battalion 19 (Marine Expeditionary Unit Service Support Group-11) [CSSB 19]
1st Dental Battalion (-) [1st DentBn]
Fleet Hospital Three, U.S. Navy [FH 3, USN]
Fleet Hospital Fifteen, U.S. Navy [FH 15, USN]
Preventive Medicine Unit, Navy Environmental Health Center [PM-MMART-5]
Preventive Medicine Unit, Navy Environmental Health Center [PM-MMART-2]
Health Services Battalion (1st Medical Battalion) [Health ServBn/1st MedBn]
Company A [Co A]
Company B [Co B]
Company C [Co C]
Company E [Co E]
Company F [Co F]

I Marine Expeditionary Force Engineer Group [I MEFEngrGru]
Command Element:
30th Naval Construction Regiment [30th NCR]
Naval Mobile Construction Battalion 5 [NMCB 5]
Naval Mobile Construction Battalion 7 [NMCB 7]
Naval Mobile Construction Battalion 74 [NMCB 74]
Naval Mobile Construction Battalion 133 [NMCB 133]
Naval Mobile Construction Battalion 4 [NMCB 4]
Naval Construction Force Support Unit 2 (-) [NCFSU 2]
Air Detachment, Underwater Construction Team 2 [AirDet, UCT 2]

22d Naval Construction Regiment [22d NCR]

Air Detachment, Naval Mobile Construction Battalion 15 [AirDet, NMCB 15]
Air Detachment, Naval Mobile Construction Battalion 21 [AirDet, NMCB 21]
Air Detachment, Naval Mobile Construction Battalion 25 [AirDet, NMCB 25]
Detachment, Construction Battalion Maintenance Unit 303 [Det, CBMU 303]

United Kingdom (UK) Forces

1st Armoured Division (UK) (-) (Reinforced) [1st ArmdDiv (UK)]
7th Armoured Brigade (UK) [7th ArmdBde (UK)]
1st Battalion, The Black Watch [1st Bn, BlackWatch]
1st Battalion, The Royal Regiment of Fusiliers [1st Bn, RoyalFusiliers]
The Royal Scots Dragoon Guards [RoyalScotsDragoons]
2d Royal Tank Regiment [2d Royal TkRegt]
3d Regiment, Royal Horse Artillery [3d Regt, RoyalHorseArty]
32 Engineer Regiment [32 EngrRegt]
16th Air Assault Brigade (UK) [16th AirAsltBde (UK)]
1st Battalion, The Parachute Regiment [1st Bn, ParaRegt]
3d Battalion, The Parachute Regiment [3d Bn, ParaRegt]
1st Battalion, The Royal Irish Regiment [1st Bn, RoyalIrishRgt]
7th Regiment, Royal Horse Artillery (Parachute) [7th Regt, RoyalHorseArty (Para)]
3 Commando Brigade, Royal Marines (-) [3 CdoBde, RM]
40 Commando Group [40 Cdo, RM]
42 Commando Group [42 Cdo, RM]
29 Commando Regiment, Royal Artillery [29 Cdo, RoyalArty]

U.S. Army Reinforcing Units

Detachment, 9th Psychological Operations Battalion [Det, 9th PsyOpsBn]
354th Public Affairs Detachment [354th PADet]
Detachment, Headquarters and Headquarters Company, 468th Chemical Battalion
[Det, HHCo, 468th ChemBn]
U.S. Army Space Support Team [USASpaceSptTm]
86th Signal Battalion [86th SigBn]
208th Signal Company [208th SigCo]
Company C, 40th Signal Battalion [Co C, 40th SigBn]
3d Battalion, 27th Field Artillery [3d Bn, 27th FldArty]
1st Field Artillery Detachment [1st FldArtyDet]
498th Medical Company [498th MedCo]
Headquarters and Headquarters Battery, 108th Air Defense Artillery Brigade [HHBtry,
108th AirDefArtyBde]
2d Battalion, 43rd Air Defense Artillery [2d Bn, 43d AirDefArty]
3d Battalion, 124th Infantry [3d Bn, 124th Inf]
555th Maintenance Company [555th MaintCo]
Detachment, Headquarters and Headquarters Company, 378th Support Battalion
[Det, HHCo, 378th SptBn]
777th Maintenance Company [777th MaintCo]
727th Transportation Company [727th TransCo]
319th Transportation Company [319th TransCo]
319th Transportation Detachment [319th TransDet]
299th Engineer Company [299th EngrCo]
459th Engineer Company [459th EngrCo]
Detachment, Headquarters and Headquarters Co., 716th Military Police Battalion
[Det, HHCo, 716th MPBn]
Headquarters and Headquarters Company, 265th Engineer Group [HHCo, 265th EngrGru]

130th Engineer Battalion [130th EngrBn]
478th Engineer Battalion [478th EngrBn]
Headquarters and Headquarters Company, 358th Civil Affairs Brigade
[HHCo, 358th CABde]
304th Civil Affairs Brigade [304th CABde]
402d Civil Affairs Brigade [402d CABde]
432d Civil Affairs Battalion [432d CABn]
367th Mobile Public Affairs Detachment [367th MOPADet]
305th Tactical Psychological Operations Company [305th TacPsyOpsCo]
307th Tactical Psychological Operations Company [307th TacPsyOpsCo]
312th Tactical Psychological Operations Company [312th TacPsyOpsCo]
1092d Engineer Battalion [1092d EngrBn]

Marine Follow-on Forces

3d Battalion, 23d Marines [3d Bn, 23d Mar]
4th Combat Engineer Battalion (-) [4th CbtEngrBn]
4th Light Armored Reconnaissance Battalion (-) [4th LARBn]
2d Battalion 25th Marines [2d Bn, 25th Mar]
Truck Company, 4th Marine Division [TkCo, 4th MarDiv]

Marine Forces with Fifth and Sixth Fleets

26th Marine Expeditionary Unit (Special Operations Capable) [26th MEU (SOC)]
Battalion Landing Team 1st Battalion, 8th Marines [BLT 1/8]
Marine Medium Helicopter Squadron 264 [HMM-264]
Marine Expeditionary Unit Service Support Group 26 [MSSG 26]
Marine Fighter Attack Squadron 115 (USS *Harry S. Truman* CVN 75) [VMFA-115]
Marine Fighter Attack Squadron 312 (USS *Enterprise* CVN 65) [VMFA-312]
Marine Fighter Attack Squadron 323 (USS *Constellation* CV 64) [VMFA-323]

*Unit list based on I Marine Expeditionary Force Presidential Unit Citation Award Recommendation, 7Aug03; MarAdmin 507/03, various versions, Oct-Dec03; "Modifications to the I MEF Presidential Unit Citation Unit Listing," with additions and/or corrections provided by Ms. Annette Amerman, Historian, Reference Branch; and Col Nicholas E. Reynolds' troop list of Oct04. Unit abbreviations are provided in brackets.

**1st Force Service Support Group reorganized shortly before deployment; previous unit designations are shown in parentheses after the unit's designation in Operation Iraqi Freedom. The Force Service Support Group's headquarters elements were reorganized into Combat Service Support Group 16 [CSSG 16] in April 2003.

Appendix C

Selected Glossary of Terms and Abbreviations

AA–Assault Amphibian
AAA–Antiaircraft Artillery
AAOE–Arrival and Assembly Operations Echelon
AAV–Amphibious Assault Vehicle
ACE–Aviation Combat Element
ADC–Assistant Division Commander
ADOCs–Automated Deep Operations Coordination System
APOD–Air Port of Debarkation
APOE–Air Port of Embarkation
ASLT–Air Support Liaison Team
ASOC–Air Support Operations Center
ASP–Ammunition Supply Point
ATARS–Advanced Tactical Air Reconnaissance System
ATO–Air Tasking Order
BCL–Battlefield Coordination Line
BCT–Brigade Combat Team
BDA–Battle Damage Assessment
BFT–Blue Force Tracker
BSSG–Brigade Service Support Group
C2PC–Command and Control Personal Computer
CBR–Counter Battery Radar
CE–Command Element
CEB–Combat Engineering Battalion
CENTCOM–U.S. Central Command
CFACC–Combined Forces Air Component Commander
CFLCC–Combined Forces Land Component Commander
CG–Commanding General
CGS–Common Ground Station
CIP–Combat Identification Panel
Class II–Batteries
Class VIII–Medical Supplies
Class IX–Repair Parts
CMOC–Civil-Military Operations Center
CPAO–Consolidated Public Affairs Office
CP–Command Post
CPX–Command Post Exercise
CRAF–Civil Reserve Air Fleet
CSS–Combat Service Support
CSSB–Combat Service Support Battalion
CSSC–Combat Service Support Company
CONPLAN–Contingency Plan
CONUS–Continental United States

COP–Common Operational Picture
DA–Dispersal Area
DAC–Division Administration Center
DASC–Direct Air Support Center
DIA–Defense Intelligence Agency
DOC–Deployment Operations Center
DS–Direct Support
DSA–Division Support Area
EMCON–Emissions Control
EOD–Explosive Ordnance Disposal
EPW–Enemy Prisoner of War
FAC–Forward Air Controller
FAD–Field Artillery Detachment
FARP–Forward Arming and Refueling Point
FOB–Forward Operating Base
FOE–Follow on Echelon
FPOL–Forward Passage of Lines
FRAGO–Fragmented Order
FRSS–Forward Resuscitative Surgery System
FSCC–Fire Support Coordination Center
FSS–Fast Sealift Ships
FSSG–Force Service Support Group
GBS–Global Broadcasting System
GCE–Ground Combat Element
GOSP–Gas-Oil Separation Plant
HDR–Humanitarian Daily Ration
HET–Human Exploitation Team
HF–High Frequency
HHA–Hand Held Assay
HUMINT–Human Intelligence
IC–National Intelligence Community
IMINT–Image Intelligence
IMO–Information Management Officer
IO–Information Officer
IPSA–Intermediate Pumping Stations
JDAM–Joint Direct Attack Munition
JMEM–Joint Munitions Effectiveness Manual
JSTARS–Joint Surveillance and Target Attack Radar System
KAF–Kuwaiti Armed Forces
KI–Killbox Interdiction
KLF–Kuwaiti Land Forces
KMOD–Kuwaiti Ministry of Defense
LAR–Light Armored Reconnaissance
LASER–Light Amplification through Stimulated Emission of Radiation
LAV–Light Armored Vehicle
LD–Line of Departure
LOC–Line of Communication
LSA–Life Support Area and Logistical Support Area
LTO–Logistics Tasking Order

LZ–Landing Zone
MACCS–Marine Air Command and Control Squadron
MAG–Marine Air Group
MAGTF–Marine Air-Ground Task Force
MANPAD–Man-Portable Air Defense
MARCORSYSCOM–Marine Corps Systems Command
MAW–Marine Aircraft Wing
MCIA–Marine Corps Intelligence Activity
MCRE–Marine Corps Readiness Evaluation
MCWL–Marine Corps Warfighting Laboratory
MDACT–Mobile Data Automated Communication Terminal
MEB–Marine Expeditionary Brigade
MEF–Marine Expeditionary Force
MEFEX–Marine Expeditionary Force Exercise
MEG–MEF (Marine Expeditionary Force) Engineer Group
MEWSS–Mobile Electronic Warfare Support System
MLC–Marine Logistics Command
MOD–Ministry of Defense (Kuwait)
MOI–Ministry of the Interior (Kuwait)
MOPP–Mission Oriented Protective Posture
MOS–Military Occupational Specialty
MOUT–Military Operations on Urban Terrain
MP–Military Policy
MPF–Maritime Prepositional Force
MPSRON–Maritime Prepositioning Ship Squadron
MRLS–Multiply Rocket Launcher System
MSC–Major Subordinate Command
MSTP–MAGTF Staff Training Program
MWSG–Marine Wing Support Squadron
MWSS–Marine Wing Support Squadron
NBC–Nuclear,Biological, and Chemical
NBCRS–Nuclear, Biological, and Chemical Reconnaissance System
OCD–Obstacle Clearing Detachment
OMC-K Office of Military Cooperation-Kuwait
OPCON–Operation Control
OPLAN–Operations Plan
OPP–Offload Preparation Party
OPT–Operational Planning Team
ORCON–Originator Controlled
OSW–Operation Southern Watch
PA–Public Affairs
PALT–Public Affairs Liaison Team
PIR–Priority Intelligence Requirement
PLI–Position Location Information
POL–Passage of Lines
POW–Prisoner of War
PRR–Personal Role Radio
QRF–Quick Reaction Force
RA–Regular Army

RCT–Regimental Combat Team
RFF–Requested for Forces
RG–Republican Guard
RGFC–Republican Guard Forces Command
RIP–Relief in Place
ROZ–Restrictive Operation Zone
RRP–Refueling and Replenishment Point
RSO&I–Reception, Staging, Onward Movement and Integration
RUC–Reporting Unit Code
SAPOE–Sea and Aerial Ports of Embarkation
SAM–Surface-to-Air-Missile
SASO–Security and Stabilization Operations
SIGINT–Signal Intelligence
SIPRNET–Secret Internet Protocol Routed Network
SLTLP–Survey, Liaison, and Reconnaissance Party
SMART-T–Secure Mobile Antijam Reliable Tactical Terminal
SOP–Standing Operating Procedure
SRG–Special Republican Guard
SPINS–Special Instructions
SPOD–Sea Port of Debarkation
SPOE–Sea Port of Embarkation
SSE–Sensitive Site Exploitation
SSM–Surface-to-Surface Missile
TAA–Tactical Assembly Areas
TACON–Tactical Control
T/E–Table of Equipment
TEWT–Tactical Exercise Without Troops
TIO–Target Information Officer
TIP–Thermal Identification Officer
T/O Table of Organization
TPC–Target Processing Center
TPFDD–Time-Phased Force Deployment Data

Appendix D

Chronology of Events

2001

- 11 September Al Qaeda terrorists attack the World Trade Center and the Pentagon.
- 25 November Marines of Task Force 58 land in Afghanistan as part of operations to deprive Al Qaeda of its base in that country.

2002

- January Marine Forces, Pacific, orders I Marine Expeditionary Force (I MEF) to focus on preparing for contingencies in the CentCom theater; MEF planners begin more than a year of work on plans to invade Iraq.
- 2 August MajGen James N. Mattis becomes Commanding General, 1st Marine Division, and puts the division on a virtual war footing.
- 11 October The Pentagon orders I MEF to deploy its headquarters staff to Kuwait for service with Coalition Forces Combined Land Component (CFLCC) under U.S. Army LtGen David D. McKiernan.
- 15 November I MEF headquarters deploys to Kuwait; newly appointed I MEF commander LtGen James T. Conway deploys with his headquarters.
- 16 November 3d Marine Aircraft Wing forward command post, under MajGen James F. Amos, arrives in Kuwait.
- 18 November 1st Marine Division forward command post arrives in Kuwait.
- 24 November CFLCC exercise to test command and control links with I MEF and other commands, "Lucky Warrior 03-1," begins.
- 9 December CentCom exercise "Internal Look," based on the current version of the plan for the invasion of Iraq, begins.

2003

- January Intense preparations to integrate 1st Armoured Division (UK) into I MEF occur; this division assumes responsibility for securing southeast Iraq.

2 January	Pentagon issues Deployment Order 177A, soon to be followed by 177B, which orders the wholesale deployment of MEF forces to theater.
6 January	Rehearsal of concept (ROC) drill occurs at 3d MAW in Miramar, California; many ROC drills at various levels follow in the coming weeks.
13 January	Gen Michael W. Hagee becomes the 33d Commandant of the Marine Corps.
15 January	Amphibious Task Force (ATF) East departs Morehead City, North Carolina, for Kuwait with 2d Marine Expeditionary Brigade (2dMEB).
17 January	Amphibious Task Force (ATF) West departs San Diego, California, for Kuwait carrying elements of I MEF.
8 February	With MEF, participation, CFLCC exercise "Lucky Warrior 03-2," labeled "a dress rehearsal" for war, begins.
16 February	2d MEB begins to go ashore in Kuwait to reinforce with ATF I MEF; its aviation elements transfer to 3d MAW control and the ground elements are redesignated Task Force Tarawa.
24 February	ATF West begins offloading its West Coast Marine units in Kuwait; most other Marines follow by air.
9 March	First leaflets dropped on Baghdad urging noninterference with coalition operations and soliciting support from Iraqi people.
17 March	President Bush issues an ultimatum to Saddam Hussein to leave Iraq within 48 hours.
18 March	Operation Southern Watch aircraft conduct air strikes against Iraqi early warning radars and command-and-control capabilities; Marine forces are ordered to staging areas.
Night of 19-20 March	U.S. Air Force aircraft and Navy vessels conduct unplanned attack against Saddam Hussein and other Iraqi leadership targets in what becomes popularly known as the "decapitation strike," which does not succeed but does initiate hostilities
20 March	Iraq retaliates by firing surface-to-surface missiles against coalition troops in Kuwait; ground combat operations begin at night; MEF is supporting attack to Army's V Corps; Regimental Combat Team 5 is leading Marine unit.
21 March	Marines capture the Rumaylah oil fields, a key CentCom objective; Marines and British forces secure the port of Umm

	Qasr before moving on the city of Basrah, the most important British objective.
23 March	Task Force Tarawa begins to secure the city of An Nasiriyah and its key bridges over the Euphrates River and the Saddam Canal; heavy fighting ensues; friendly fire incident occurs at bridge over canal; II MEF commander MGen Henry P. Osman deploys to northern Iraq to establish the Military Coordination and Liaison Command (MCLC) under operational control of CentCom in order to maintain political stability.
Night of 24–25 March	“Mother of all sandstorms” begins, slowing operations’ tempo for approximately two days.
24–27 March	1st Marine Division continues to advance up Routes 1 and 7 towards Baghdad.
27 March	“Operational pause” begins to consolidate supply lines and address threats by irregular Iraqi formations on the ground; 3d MAW air offensive continues unimpeded, rendering many Iraqi units combat ineffective.
1 April	1st Marine Division resumes progress towards Baghdad; Force Service Support Group performs Herculean feats of resupply with cooperation of wing and Marine Logistics Command.
3 April	U.S. Army troops move on Saddam International Airport, key terrain outside Baghdad.
5 April	U.S. Army conducts first “Thunder Run,” armored raid, into Baghdad.
6 April	Most of Basrah, Iraq’s “second city,” is in British hands.
7 April	RCT 7 crosses the Diyalah River and moves on outskirts of Baghdad from the east; U.S. Army conducts second “Thunder Run” into capital.
9 April	Marines of 3d Battalion, 4th Marines, part of RCT 7, assist Iraqi civilians in toppling a large statue of Saddam Hussein in Firdos Square in Marine AO, eastern Baghdad.
10 April	RCT 5 engaged in heavy fighting at Al Azimilyah Palace and Abu Hanifah mosque in Baghdad; looting begins as fighting tapers off; Marines begin post-combat operations.
11–12 April	After the collapse of Iraqi authority in northern cities of Mosul and Kirkuk, Kurdish forces fill the resulting power vacuum, followed by U.S. forces over succeeding days, including Marines from 26th MEU (SOC).

13-14 April	Task Force Tripoli, out of 1st Marine Division, takes control of Tikrit, Saddam Hussein's hometown.
20 April	The relief in place with U.S. Army in eastern Baghdad is complete; I MEF redeploys its forces to the southern third of Iraq; mission is now security, humanitarian assistance, and reconstruction; focus of effort is seven infantry battalions from 1st Marine Division in seven governates (or districts).
22 April	24th MEU (SOC), which had supported TF Tarawa, begins redeploying to its ships; other Marine units soon follow suit as part of drawn-down to reduced manning levels that are maintained throughout the summer.
1 May	Under a banner reading "Mission Accomplished," President George W. Bush announces that major combat operations are over; 26th MEU (SOC) departs Mosul and returns to its ships in the Mediterranean.
12 May	Ambassador L. Paul Bremer takes over as civil administrator in Iraq, replacing Jay M. Garner; Bremer's Coalition Provisional Authority soon replaces Garner's Office of Reconstruction and Humanitarian Assistance.
22 July	Saddam Hussein's sons Uday and Qusay are killed in firefight with U.S. Army in Mosul.
19 August	A truck bomb explodes at the U.N. headquarters in Baghdad, killing 20 people, including the U.N. High Commissioner for Human Rights.
3 September	In Babylon, I MEF conducts a transfer of authority to a Polish-led international coalition force; most remaining Marines return to CONUS.
10 November	Marines of Special Purpose MAGTF celebrate the Marine Corps birthday in CONUS after completing the work of repatriating all Marine Corps equipment from theater.

Appendix E

Selected Bibliography

Entries in **boldface** type are reprinted in this anthology.

Allen, Mike, and Thomas E. Ricks. "Hill Braces for Iraq Request: Lawmakers Want Details from Bush." *The Washington Post*, 7Sep03.

The authors outline Congressional criticisms of anticipated high budget estimates from the WhiteHouse for the occupation and rebuilding of Iraq. Lawmakers are cited in support of more international economic control of Iraqi reconstruction.

Allison, Maj Fred, H. "Midnight in Baghdad." *U.S. Naval Institute Proceedings*, Feb02, pp. 32-35.

The author describes the role of Marine Corps F/A-18 aircraft operating from Navy carriers in a strike on Baghdad during February 2001. The strike was in reaction to increased Iraqi anti-coalition activity in the southern no-fly zone. This cooperation between the Marine Corps VMFA-312, F/A-18 squadron and the Navy aircraft carrier USS *Harry S. Truman* helped strengthen coalition forces and supplied Marines with important combat experience.

Amos, MajGen James F. "3d Marine Aircraft Wing Memorial Remarks." Commanding General's Message to All Hands, 2Dec03.

The commanding general of the 3d Marine Aircraft Wing honors the memory of 15 Marines who lost their lives during Operation Iraqi Freedom at a memorial service on 2 December 2003.

Anderson, Jon Lee. "The Collapse." *The New Yorker*, 21&28 Apr03, pp.70-75.

The author vividly describes the chaotic conditions in downtown Baghdad as a result of attacks on the city, injuries sustained by civilians and journalists, looting by civilians, and occupation of city palaces by U.S. Marines.

Atkeson, MajGen Edward B., USA (Ret). "Iraq Through the Prism of American Experience." *Army*, Dec03, pp. 17-26.

The author draws comparisons between American occupation of Iraq and previous military experiences in the Spanish-American War, Haiti, North Korea, and the Civil War among others. He emphasizes lessons to be learned from these experiences in current decision-making, particularly concerning the scale of American commitment in rebuilding and occupying Iraq.

Bacon, Maj Peter K. "Whatever It Takes: Redlegs and Riflemen." *Army*, Dec03, pp. 10-16.

The author discusses many of the challenges faced by artillery battalions in the postwar environment in Iraq.

Bahrani, Yasmine. "After Shock." *The Washington Post Magazine*, 5Oct03.

A woman visits family in her birthplace of Baghdad after 20 years in exile in the United States. She describes the physical and emotional effects of warfare in the region on her family members and other Baghdadis.

Baker, Peter. "A 'Turkey Shoot,' but With Marines As the Targets." *The Washington Post*, 28Mar03.

U.S. Marines face unconventional tactics and sustain significant damage and casualties from Fedayeen and Republican Guards while traveling through the strategic city of Nasiriyah, Iraq. Marines are hesitant to return fire from Iraqi soldiers dressed as and hiding behind civilians as the struggle to maintain key supply routes through the city.

Baker, Peter. "Marine Predicts Brief Bombing, Then Land Assault." *The Washington Post*, 17Mar03.

LtGen James T. Conway rallies Marines and British soldiers who are scheduled for a ground invasion of Iraq preceded by two to three days of air attack aimed at reducing Iraqi resistance along the southern border.

Barnett, Thomas P.M., and Henry H. Gaffney. "Global Transaction Strategy Operation Iraqi Freedom Could be First Step Toward a Larger Goal True Globalization." *Military Officer*, May03, pp. 68-77.

The authors, both defense strategists, suggest a plan for globalization involving the export of security measures from the United States. They identify the U.S. as central to the stability and globalization of the world economy, and cite several measures to ensure this goal, including U.S. military protection in economically non-integrating countries, heightened management of population growth in economically-developing countries, control of energy trade between Asian and Middle Eastern countries, and increased American and European investment in the struggling Asian economy. In this way, the authors claim that the U.S. can counter its role as the world's largest consumer and provides the security and stability necessary to promote economic globalization.

Barhardt, Cpl Joshua. "MCLB Corpsmen Return from Iraq."
<<http://leatherneck.com/forums/showthread.php?t=8329>>. 10Jul03.

Three corpsmen from Marine Corps Logistics Base Barstow Branch Medical Clinic share their experiences after they returned from Iraq.

Berry, 1stSgt Paul A. "From the Warlords." *Marine Corps Gazette*, Feb04, pp. 34-37.

An email exchange between the author and the first sergeant of 2d Battalion, 2d Marines, and his former battalion commander following operations in Iraq. First Sergeant Berry's response includes a list of successful measures taken by his battalion that aided them in combat in Iraq.

Biggs, Patricia. "Back from Ambush Alley." *The Arizona Republic*, 11Jul03.

The author describes fierce and deadly attacks by Iraqi men, women, and children on U.S. Marines as they secure routes through the city of Nasiriyah, Iraq. Several Marines share their experiences and descriptions of injuries received while facing ambush from locals.

Birch, Douglas. "As Ambushes Continue In Iraq, Some Soldiers Rethink Strategy." *The Baltimore Sun*, 12Jul03.

The author reports growing concerns among Marines that the United States should reduce occupation of Iraq in efforts to attract less aggression from hostile Iraqis. These sentiments come as a response to several guerilla-style attacks in hostile areas from Iraqi groups demanding a reduction of American patrols.

Blackledge, Col Matthew W. "Professionals Talk Logistics." *Marine Corps Gazette*, Aug03, pp. 40-43.

Col Blackledge discusses many of the challenges, successes, and other concerns of I Marine Expeditionary Force logistics. Among logistical challenges he lists fuel, ammunition, and medical supply methods and communication coordination. Blackledge praises the planning and flexibility of I MEF in action, and the innovation and teamwork shown by Marines toward improving performance at every opportunity. He also suggests restructuring of the Reserves and incorporation of international coalition support to improve logistical efficiency and thus the future success of the Marine Corps.

Bloom, Chief Journalist, AI, USN, and Rod Duren. "Fleet Hospital Three Makes Navy Medical History in Sands of Southern Iraq," *Navy Medicine*, Jul-Aug03, pp. 8-12.

Fleet Hospital Three, located in southern Iraq, constructed the Navy's first Expeditionary Medical Facility in a war zone. The facility added greatly to the lifesaving capabilities of the hospital.

Boot, Max. "A Century of Small Wars Shows They Can Be Won." *The New York Times*, 6Jul03.

The author discusses the *Small Wars Manual* written by Marine Corps officers in the 1930s. The manual, focusing on American involvement in the Philippines, Haiti, the Dominican Republic, and Nicaragua, outlines the steps to be taken during a small war to ensure success, including fighting rebels, humanitarian efforts for civilians, and training and recruiting local military forces. The author applies these steps to current efforts in Iraq.

Boot, Max. "The Lessons of a Quagmire." *The New York Times*, 16Nov03.

The author compares effective measures used during the Vietnam War and suggests them for use against Iraqi insurgents. He disapproves of conventional strategy and proposes the recruitment of local Iraqis in cooperation with American and coalition forces to identify and combat rebels.

Boot, Max. "Reconstructing Iraq." *Weekly Standard*, 15Sep03.

The author discusses the roles of the 101st Airborne Division and Marines in reconstructing Iraq. He cites humanitarian measures taken by soldiers to serve as, in MajGen James Mattis' words, "no better friend, no worse enemy" to the Iraqi people.

Borer, Douglass A. "Inverse Engagement: Lesson From U.S.-Iraq Relations, 1982-1990." *Parameters*, Summer03, pp. 51-63.

The author discusses the history of the United States' policy of economic interdependence and engagement and the effectiveness of influencing Iraqi behavior through trade sanctions.

Bowman, Steve. "Iraq: U.S. Military Operations." Congressional Research Service Report, <<http://fpc.state.gov/documents/organization/25375.pdf>>. 2Oct03.

Bowman submits a summary to Congress of U.S. military operations in Iraq, concerning plans and objectives for entering the war, combat operations, resistance faced, involvement of coalition forces, and estimated operational costs.

Brill, Arthur P., Jr., "Marines Corps Studies Lesson Learned In Iraq to Plan for Future Conflicts." *Sea Power*, Jun03, pp. 9-10.

LtGen Edward Hanlon, Jr., Commander, Marine Corps Combat Development Command, is interviewed regarding his task of assessing the successes of Marine forces in Iraq. He discusses the effectiveness of tactics, equipment, and training that influenced the performance of U.S. Marines. These assessments will be included in a "lessons-learned" report Hanlon is preparing for the U.S. Marine Forces Central Command, and will be used to ensure the development of effective methods in future military engagements.

Broadmeadow, LtCol John J. "Logistics Support to 1st Marine Division During Operation IRAQI FREEDOM." *Marine Corps Gazette*, Aug03, pp. 44-45.

The author discusses the advances and improvements made in the Marine Logistics Command during Operation Iraqi Freedom. He cites specific practices implemented by the MLC to increase speed of supply lines to aid I Marine Expeditionary Force.

Byron, Col "Stretch" Thomas, and William "Citizen" Kane. "4th MAW JFACC Liaison in OIF." *Marine Corps Gazette*, May05, pp. 39-40.

The authors discuss the history, development, training, and deployment of the 4th MAW's JFACC liaison cell.

Commander and Staff, 1st FSSG. "Brute Force Combat Service Support: 1st Force Service Support Group in Operation IRAQI FREEDOM." *Marine Corps Gazette*, Aug03, pp. 34-39.

The authors discuss the challenges and successes experienced by 1st Force Service Support Group in adapting to unfamiliar situations to deliver necessary combat service support.

Commander and Staff, MWSG-37. "No Farp Too Far!" *Marine Corps Gazette*, Dec03, pp. 24-27.

The authors describe the activities performed by Marine Wing Support Group 37 in support of 3d Marine Aircraft Wing and I Marine Expeditionary Force in Operation Iraqi Freedom.

Commander, Marine Corps Forces Pacific. I Marine Expeditionary Force Summary of Action, 7Aug03.

A summary of I Marine Expeditionary Force operations Iraq, 21 March-24 April 2003, to support the award of a Presidential Unit Citation.

Company Commanders, 1st Battalion, 2d Marines. "The Battle of An Nasiriyah." *Marine Corps Gazette*, Sep03, pp.40-46.

The commanders of 1st Battalion, 2d Marines, discuss the harrowing battle U.S. forces faced against Iraqi resistance in capturing key bridges in the city of An Nasiriyah.

Cassady, LtCol John M., Maj Jefferson L. Kaster, and CWO4 Cheryl G. Ites. "Caring for the Fallen: Mortuary Affairs in Operation Iraqi Freedom." *U.S. Naval Institute Proceedings*, Apr04, pp. 36-40.

Marine Corps Mortuary Affairs unit carried out duties in Operation Iraqi Freedom of recovering and accounting for combat casualties. The unit now faces reassessment of their training in order to provide a higher level of professionalism and efficiency in the future.

Catto, BGen William D. "Expeditionary Acquisition: Not Business as Usual." *Marine Corps Gazette*, Jun03, pp. 27-29.

The author discusses the successes of and lessons to be learned from expeditionary supply acquisition in Operation Iraqi Freedom. He also suggests improvements to increase effectiveness of processing universal needs statements.

Cerre, Mike. "Going in; Riding into Iraq With the 1st Marines." <http://abcnews.go.com/sections/nightline/world/carre_notebook_030321.html>. 21Mar03

An embedded reporter with the 2d Tank Battalion describes the initial hours of their advance into Iraq.

Chandrasekaran, Rajov, and Kevin Sullivan. "Hussein's Two Sons Killed in Firefight With U.S. Troop." *The Washington Post*, 23Jul03.

The authors describe the information tip-off and raid of a Baghdad mansion that resulted in the deaths of Saddam Hussein's sons Qusay, heir apparent and leader of the Special Republican Guard, and Uday, publisher and commander of the Fedayeen militia.

Chandrasekaran, Rajov, and Thomas E. Ricks. "In Postwar Iraq, the Battle Widens: Recent Attack on U.S. Forces Raise Concerns of a Guerrilla Conflict." *The Washington Post*, 7Jul03.

Concerns mount among legislators and military experts over growing aggression from guerilla groups in Iraq. Insurgent groups aim to provoke U.S. soldiers into overreactions that would erode support and increase resistance. Troop morale is also called into question as it affects reactions in tactical situations.

Chenelly, Sgt Joseph R. "Rescues. Medevacs and Fightfights—Marine Get it on in Iraqi." *Leatherneck*, Jun03, pp. 22-27.

Sgt Joseph R. Chenelly provides several personal accounts from Marines in Iraq, including the rescue of seven American prisoners of war in Samarra, the recovery of Army PFC Jessica Lynch, and several Marines injured in combat eager to rejoin their units.

Cobbold, Richard. "War in Iraq, Thoughts From Afar." *RUSI Journal*, Apr03, pp. 4-5.

The author summarizes the progress of the war in Iraq by identifying intended strategy, listing successes, and describing opposition and casualties suffered by both sides. Cobbold ends by describing the fighting and reconstruction that lies ahead as the most critical period of the conflict, emphasizing that a quick end may not be feasible.

Cohen, Eliot A. "If We Cut and Run." *The Washington Post*, 19Nov03.

Cohen warns against premature withdrawal of American troops from Iraq. He writes that a "cut-and-run" policy, although it may save American lives, would only encourage insurgency and would result in an ultimate failure in the war against global terrorism.

Colleton, CWO4 Charles F. "A New Page in Combat Marksmanship." *Marine Corps Gazette*, Jan04, pp. 46-47.

Colleton discusses the usefulness of riflescopes to Marine marksmen in increasing accuracy, identifying targets, and making better combat decisions.

Collins, Col John M., USA (Ret). "You Can't Assume Nothin'." *U.S. Naval Institute Proceedings*, May03, pp. 50-51.

The author identifies and proves or disproves the accuracy of 12 assumptions concerning war with Iraq made by U.S. officials before the start of fighting.

Cone, BGen Robert W., USA, and MajGen Gordon C. Nash. "DOD Briefing on Operation Iraqi Freedom Lessons Learned Process." ><http://www.defenselink.mil/transcripts/2003/tr20030603-0243.html>>. 3Jun03.

Transcript of a video-teleconference briefing on Operation Iraqi Freedom lessons learned process between Marine Corps MajGen Gordon C. Nash, commander of the U.S. Joint Forces Command Joint Warfighting Center, and Army BGen Robert W. Cone, director of the Operation Iraqi Freedom Joint Lessons Learned Collection Team.

Coner, Sherri. "Marine Had Close Calls On Patrol to Baghdad." *Daily Journal*, Johnson County, Indiana, 10Jul03.

Marine Cpl Aaron Bousley recalls the fierce ambushes and resistance his Recon unit encountered while on a mission to capture an airfield in Baghdad.

Conlin, Col Christopher C. "What Do You Do For An Encore?" *Marine Corps Gazette*, Sep03, p. 74.

Colonel Conlin outlines the tasks undergone by "First Team" (1st Battalion, 7th Marines) after taking over Baghdad and toppling Saddam Hussein's regime. The battalion task force worked on "Transition Operations" to provide basic utilities and government in the post-war region.

Connell, Rich, and Robert J., Lopez. "A Deadly Day for Charlie Company." *Los Angeles Times*, 26Aug03.

Members of Company C, 1st Battalion, 2d Marines, recall an ill-fated mission to capture a bridge in Nasiriyah, Iraq. The company was sent without reinforcements through a dangerous stretch of

highway known as “Ambush Alley,” where they encountered heavy fire from Iraqi army soldiers, Fedayeen Saddam militiamen, Baath Part loyalists, and friendly fire from an Air Force A-10 Thunderbolt. Eighteen men were killed that day and 15 were injured from the company alone.

Connolly, Kate. “We Want to be Feared Not Loved, Say U.S. Marines.”
<[http://dailytelegraph.co.uk/news/2003/06/05/wirq05.xml\\$\\$Sheet=/news](http://dailytelegraph.co.uk/news/2003/06/05/wirq05.xml$$Sheet=/news)>. 6Jun03.

The U.S. military works to create a new credible television news program in the city of Kut. TV Kut has been created in efforts to end years of government propaganda, and to support free press. However, the U.S. military retains strict controls over the stories to be broadcast.

Conway, LtGen James T. “I Marine Expeditionary Force Commander Live Briefing from Iraq.” *DOD Daily News Transcript*, 30May03.

LtGen Conway gives a teleconference from Iraq on the First Marine Expeditionary Forces involvement in Operation Iraqi Freedom and stabilization activities in post-war Baghdad.

Conway, LtGen James T. “We’ve Always Done Windows.” *U.S. Naval Institute Proceedings*, Nov03, pp. 32-34.

In an interview with Naval Institute Senior Editor Gordon Keiser, LtGen James T. Conway, commanding general of I Marine Expeditionary Force, discusses many aspects of the Marine Corps’ involvement in Iraq, ranging from intelligence distribution, involvement of coalition and U.S. Special Forces, casualties, media relations, and troop morale.

Conway, LtGen James T. “Briefing on I Marine Expeditionary Force in Iraq.” *DOD Daily News Transcript*, 9Sep03.

LtGen James T. Conway of I Marine Expeditionary Force gives a briefing at the Pentagon and answers questions from the press concerning I MEF’s performance in Iraq and the transfer of authority to the Polish-led Multinational Division.

Conway, LtGen James T. “Farther and Faster.” *U.S. Naval Institute Proceedings*, Jan05, pp. 48-52.

According to LtGen Conway, during the 22 months of planning for and fighting in Operation Iraqi Freedom (OIF), the war’s two segments have proved very different. In 2003, OIF I was less difficult, with Marines fighting mostly against Shia in the south. In OIF II against Sunni tribes in the west, as Marines sought to win hearts and minds, attacks increased which translated into casualties.

Cooper, Christopher. “The Marines Raise a Caution Flag Over Use of Embedded Journalists.” *Wall Street Journal*, 16Dec03.

Marines of the 1st Marine Division express concerns over the use of embedded journalists in reporting warfare. They note occasional negative reporting, but express overall support for the embedded journalist program as helpful in relating the events of the war to readers at home.

Copp, LtCol Adam J., and Maj Christian Veeris. "Back to the Basics." *Marine Corps Gazette*, Jul03, pp. 29-31.

The authors discuss the roles of 1st Force Reconnaissance Company in Operation Iraqi Freedom.

Cramer, Capt Eugene A., and LtCol Alan L. Thomas. "Marine Corps Airfield Damage Repair." *Marine Corps Gazette*, Dec03, pp. 18-20.

The engineers of the Marine Wing Support Squadron perform many engineering duties. More importantly, they repair damage to airfield surfaces necessary for air-based supply modes.

Crawley, James W. "U.S. Shock-Trauma Platoons Put Emergency Room in Iraq: Units Treat Marines, Civilians, Prisoners." *Union-Tribune*, 17Apr03.

Shock Trauma Platoon 4 sets up makeshift emergency rooms in Iraq to treat Marines, civilians and prisoners. The author describes the stages of treatment: corpsman, aid station, surgical company and fleet hospital.

Dawisha, Adeed I., and Karen Dawisha. "How to Build a Democratic Iraq." *Foreign Affairs*, May-Jun03, pp. 37-50.

The authors map out a blueprint for the institution of democracy in Iraq. They address issues ranging from the structure of government branches, leadership, and preparation of the populace.

De Atkine, Norvell B. "It's An Information War." *U.S. Naval Institute Proceedings*, Jan04, pp. 64-65.

The author identifies the capture of Saddam Hussein as a psychological victory, but puts it into perspective with threats from other insurgent groups in the continuing war, and cites failures of U.S. policy in Iraq, including loss of the information war.

Disbro, 1stLt Jonathan S. "Expedient Ordnance/Munitions Destruction." *Marine Corps Gazette*, Feb04, pp. 37-40.

The author outlines several effective methods for use in explosive ordnance disposal.

Dodge, Toby. "U.S. Intervention and Possible Iraqi Futures." *Survival*. Autumn03, pp. 103-122.

Dodge discusses the United States' role in liberating Iraq. He outlines Iraqi political and cultural history in relation to cooperation with American forces. He also warns of the long-term nature of U.S. involvement in the region, that cutting corners to expedite occupation will result in an overall failure to institute change in the region.

Dorsey, Jack. "Bataan Sails Toward Iraq; Strike Force Will Follow." *The Virginian-Pilot*, 20Jan04.

The amphibious assault ship Bataan is deployed from Norfolk, Virginia, to deliver supplies and troops to the Middle East for the fourth time in as many years.

Dowd, Alan W. "Thirteen Years: The Causes and Consequences of the War in Iraq." *Parameters*, Autumn03,

pp. 46-60.

The author outlines the history of American foreign relations, particularly concerning Iraq, and stresses the importance of “Three R’s: rebuilding, reviewing, and reforming” in the nation.

Dunfee, CWO3 David R. “Ambush Alley Revisited.” *Marine Corps Gazette*, Mar04, pp. 44-46.

CWO3 David R. Dunfree, of the 1st Battalion, 2d Marines, discusses inaccuracies of an account of the March 2003 battle in An Nasiriyah’s Ambush Alley as it is portrayed in the book “The March Up.”

Dunn, VAdm Robert, USN (Ret). “Navy Cannot Rest On Its Laurels.” *U.S. Naval Institute Proceedings*, May03, pp. 53-54.

Task force history undergoes the task of collecting information on the role of the Navy in Operation Iraqi Freedom, an important task in assessing lessons learned and managing peacetime forces and equipment.

Duren, Rod. “Ground Zero for Nation Building.” <http://news.navy.mil/search/display.asp?story_id=7576>. May03.

On 1 April 2003, Fleet Hospital Three became the first Navy medical command to establish an Expeditionary Medical Facility in a war zone. FH-3 provided better tactical support and life-saving capabilities.

Eby, CWO3 Jeffrey L. “Rifle Combat Optic.” *Marine Corps Gazette*, Jan04, pp. 50-51.

The author discusses the usefulness of rifle combat optics in enhancing Marines’ effectiveness in combat and reducing non-combatant engagements. He suggests a departure from traditional marksman training when faced with non-traditional opposition.

Eby, CWO3 Jeffrey L. “A Marine Gunner’s View.” *Marine Corps Gazette*, Oct03, pp. 30-32.

CWO3 Jeffrey L. Eby discusses his own experiences and observations as a gunner in Operation Iraqi Freedom.

Etzioni, Amitai. “Stop Obsessing Over Saddam.” *USA Today*, 12Aug03.

Iraqi’s struggle to govern their country facing foreign occupation. The author stresses that political issues in the country must not be personalized or personified as removing one person will not necessarily bring about change on its own.

Field, LtCol Christopher A., “A Liaison Officer’s Observation and Insights.” *Marine Corps Gazette*, Feb04, pp. 32-34.

LtCol Field, a liaison officer with the Australian Defence Force, offers suggestions to enhance the capabilities of U.S. and coalition forces in Iraq.

Field, Maj Walker M. “Marine Artillery in the Battle of An Nasiriyah,” *Field Artillery Journal*, Nov-Dec03, pp. 26-30.

The author provides an overview of the 1st Battalion, 10th Marines, in An Nasiriyah as a military operation in urban terrain. The article discusses specific events and lessons learned.

Filkins, Dexter. "Chaos and Calm are 2 Realities for U.S. After the War: The Reconstruction" *The New York Times*, 24Aug03.

Regions of Iraq stand divided between those in the south such as Diwaniya where Iraqis cooperate with and display appreciation toward American Marines, and cities in the north such as Tikrit, Ramadi, and Fallujah in which former Ba'athist loyalists continue to fight U.S. troops.

Ford, Col W.G. "Embedded Media in OIF" *Leatherneck*, Jun03, p. 40.

Embedded journalists proved themselves competent and ultimately essential in their coverage of Iraq alongside U.S. Marines. They reported accurately and effectively and prevented disinformation to connect Americans at home with the soldiers abroad.

Franks, Gen Tommy R. "Briefing on Military Operations in Iraq."
<<http://www.centcom.mil/CENTCOMNews/Transcripts/20030322.htm>>. 22Mar03.

Gen Franks in this press conference discusses the objectives and current status of military operations in Iraq.

Freeman, Maj Lloyd D. "Winning Future Battles: Why the Infantry Must Change." *Marine Corps Gazette*, Apr03, pp. 54-58.

The author raises questions about the success of small unit combat in conjunction with massive air support, and whether conditions in Afghanistan can be used to predict the nature of future warfare. He is particularly concerned over whether this new warfare will require restructuring of many aspects of Marine Corps infantry training.

Friedman, Norman. "Both Gulf Wars Offer Lessons." *U.S. Naval Institute Proceedings*, May03, pp. 60-62.

Friedman compares and contrasts both gulf wars to prove that past lessons are still present today. He explains that while U.S. objectives in 1991 and 2003 are similar, different tactics are required to meet them.

Friedman, Thomas L. "Bad Planning." *The New York Times*, 25Jun03.

Friedman sites several examples in which he claims that the United States and the Pentagon were poorly prepared for postwar Iraq.

Friedman, Thomas L. "Starting From Scratch." *The New York Times*, 27Aug03.

Friedman claims that for success in Iraq, the United States must reinvent the country under the control of Iraqis to create a sense of responsibility and ownership of the government.

Friedman, Thomas L. "Presidents Remade by War." *The New York Times*, 7Dec03.

The author discusses changes in President Bush as a result of the war with Iraq, citing a shift in purpose of the war from finding weapons of mass destruction to installing democracy in the Middle East. He compares this shift to those made by Abraham Lincoln in the Civil War and Woodrow Wilson in World War I.

Friedman, Thomas L. "It's No Vietnam." *The New York Times*, 3Oct03.

Friedman cites the source of insurgency in Iraq to be former Saddam loyalists who fear loss of power under a new more democratic society.

Garden, Timothy. "Iraq: The Military Campaign." *International Affairs* 79, 4, Jul03. pp. 701-717.

The author records the sequence of events in Iraq as they pertain to military operations. He attempts to draw conclusions based on the fact that Operation Iraqi Freedom was comparatively short to other operations, and that the full impact of the war had not yet manifested.

Gordon, Michael R. "The Capture of Hussein: The Insurgency; for U.S. Foes, a Major Blow: Fighters Now Lack a Symbol." *The New York Times*, 15Dec03.

Gordon explains how the capture of Saddam Hussein was an important turning point in the war with Iraq. He points out that the Iraqi insurgents no longer have a unifying symbol to rally behind and the capture has given U.S. forces an important military and political boost in the eyes of America and the rest of the world.

Gordon, Michael R. "Marines Plan to Use Velvet Glove More Than Iron Fist in Iraqi." *The New York Times*, 12Dec03.

LtGen James T. Conway discusses the more precise methods adopted by U.S. Marines in Iraq for facing insurgency. These tactics include lessening use of artillery, engaging more of the Iraqi populace in policing efforts, and learning to accommodate to Iraqi culture.

Gourley, Scott R. "The Arsenal of the Ground War." *Army*, May03, pp. 37-44.

The author provides photos and explanations of a sample of ground and attached air equipment that played major roles in combat during Operation Iraqi Freedom. He also provides photos and explanations of the relatively inferior equipment employed by the opposing forces.

Graham, Bradley. "Pentagon Considers Creating Postwar Peacekeeping Forces." *The Washington Post*, 24Nov03.

Graham reports on the idea posed by the Pentagon that would create military forces specifically designed for peacekeeping and recovery operations. The Army believes that combat troops can act as peacekeepers, but the advantages of having a specially trained division are profound.

Gramuglia, LtCol Patrick A. and Maj Richard L. Phillips. "Aviation Integration in Operation Iraqi Freedom I: A Division Air Officer's Perspective." *Marine Corps Gazette*, May04, pp. 28-32.

The authors discuss Marine aviation's flexibility and responsiveness as a major contributor to 1st Marine Division's success in OIF.

Gregson, LtGen Wallace C. "Asia, Now: Winning the War of Ideas." *U.S. Naval Institute Proceedings*. Feb04, p. 36.

LtGen Gregson differentiates between terrorism of the past and terrorism of the present. This shift poses real threats to the United States and its allies. He gives two responses to resist the new forms of terrorism—improve ability to counter conventional threats and to carry these methods over to the roots of terrorism and their forces and resources.

Groen, LtCol Michael S. "Blue Diamond Intelligence: Division-Level Intelligence Operations During Operation IRAQI FREEDOM," *Marine Corps Gazette*, Feb04, pp. 22-25.

The author focuses on supportive intelligence during operations in Iraq. He details tactics that worked both well and not so well. Overall, the author concludes that Marine intelligence was a success due to the efforts of multiple organizations and Marine intelligence professionals.

Grossman, Elaine M. "Marine General: Iraq War Pause 'Could Not Have Come at Worse Time.'" <http://www.d-n-i.net/fcs/grossman_itp_mattis.htm>. 2Oct03.

Grossman describes the five-day pause outside of Baghdad before U.S. forces went in to capture the city. She focuses on the views and remarks of Marine Major General James Mattis, who was opposed to the pause.

Gugliotta, Guy. "Iraq Museum is Slowly Recovering Artifacts." *The Washington Post*, 15Sep03.

Marine Col Matthew Bogdanos, investigating the theft of artifacts from Iraq's National Museum, reports on a few particular artifacts and tries to give estimates as to the numerous pieces still missing. The museum houses artifacts from Mesopotamia—the area in which the first human civilizations are known to have existed.

Hart, Capt David E., and LtCol Vernon C. Prevatt. "No More Brownouts: Dust Abatement in Support of Tactical Helicopter Operations." *Marine Corps Gazette*, Dec03, pp. 29-30.

The author explains and tracks solutions to the problem of brownouts in Operation Iraqi Freedom. The brownout conditions reduce pilot visibility to zero, potentially resulting in the loss of aircraft and life.

Hawkins, Maj Donald S. "Close Air Support in the U.S. Marine Corps: A FAC's Perspective." *Marine Corps Gazette*, Sep03, pp. 48-52.

The author discusses the glitches in the application of close air support in combat missions. He reviews the systems, policies, doctrine, and procedures related to Marine Corps CAS.

Henderson, Kristen. "Maneuvers." *The Washington Post*, 5Oct03.

A Marine chaplain's wife recounts the deployments and homecomings she has been through. She sheds light on what the families of soldiers go through when they are away, and the unpredictability of their homecoming.

Hess, Pamela. "Raid in Iraq's Indian Country." *United Press International*, 6Aug03.

Hess discusses the experiences of Task Force Scorpion from its squalid living conditions to hunting down the enemy one by one in northern Babil, Iraq.

Hessman, James D. "Homeland Defense Strategists Have Much To Learn From Afghan, Iraq Operations." *Sea Power*, Jun03, pp. 21-22.

Hessman explains how the qualities of speed, agility, and flexibility contributed to the U.S./coalition forces success in Iraq. The Department of Homeland Security should take these strategies used by the Department of Defense and apply them when dealing with terrorist incidents at home.

Hodierne, Robert. "Moving Those Beans and Bullets: Asset Visibility Keeps Supplies Moving to Troop in Iraq." *Armed Forces Journal*, May03, p. 16.

During the first Gulf War, there were tie-ups in supply lines that led to thousands of unused supplies at war's end. This time around, better technology and integrated information systems, including a Joint Logistics Warfighting Initiative, are in place to make sure supplies are identified and sent to where they need to go on a more accurate basis.

Hogberg, LtCol James A. "Disbursing Goes to War." *Marine Corps Gazette*. <<http://www.mca-marines.org/gazette/2004/04hogberg.html>>. Jan04.

The author outlines the activities performed by disbursing services in Operations Enduring Freedom and Iraqi Freedom. Disbursing agents were able to provide Marines in the field with pay and supplies, and many even took part in fighting and earned combat action ribbons.

Holt, CWO2 C.L., Capt D.S. Morrison, and Capt P.J. Nash. "Selected Services in Postwar Iraq During Phase IV Operations." *Marine Corps Gazette*, Mar04, pp. 46-47.

The authors provide enlightenment on areas not often given a lot of thought in combat operations such as civil affairs, mortuary affairs, and post exchange.

Jaffe, Greg, and Christopher Cooper. "U.S. Intelligence in Iraq Comes Under Fire From Army, Marines." *Wall Street Journal*, 8Dec03.

The author assesses the current status of intelligence in the military and its shortcomings in the war with Iraq.

Johnson, Scott, and Thomas Evan. "Still Fighting Saddam." *Newsweek*, 21Jul03, p. 22.

The authors assess the current status of intelligence in the military and its shortcomings in the war with Iraq guerrillas, revealed to be Saddam's tactic of resistance. The author explains that although the president has been deposed, there is still considerable fighting going on in Iraq, and this affects both the military and political sides of the War.

Judah, Tim. "In Iraqi Kurdistan." *Survival*, Winter02-03, pp. 39-51.

The author assesses the status of the Kurdish population of Iraq. Judah details a history of this group, and establishes their relationship with the United States. He focuses on the question of whether the Kurds will fight with coalition forces to reach their objectives, or if they will continue to lay quiet.

Kahn, Operation Specialist 2d Class Wendy. "Medical Warriors: Navy Reserve Surgeons Care for Combat Wounded," <http://www.news.navy.mil/search/display.asp?story_id=7360>. May03.

The author describes the mission of three orthopedic surgeons and how they contributed to Operations Iraqi and Enduring Freedom.

Keene, R.R. "Appointment in Samarra." *Leatherneck*, Jun03, pp. 16-20.

Keene follows the incidents that led up to the disposition of Saddam Hussein, and relates Saddam's life to a man trying to cheat death—it is only a matter of time before Saddam meets his fate.

Keene, R.R., ed. "In Every Clime and Place." *Leatherneck*, Jul03, pp. 22-23.

Although Marines have a different mission in Iraq now that Baghdad has been taken, they still have a job to do to secure and protect civilians.

Keene, R.R., comp. "It's War! Five Days on the Road to Baghdad." *Leatherneck*, May03, pp. 20-25.

Keene follows Marine units through the first five days of Operation Iraqi Freedom. He provides information and knowledge of what is happening from the perspective of an embedded journalist, reporting from one battlefield to the next.

Kelly, BGen John F. "Tikrit, South to Babylon." *Marine Corps Gazette*, Feb04, pp. 16-19.

The first in a series of articles by BGen John F. Kelly on Phase IV, security and stabilization, operations of the 1st Marine Division. He assesses the movements of the division leading up to the security operations.

Kelly, BGen John F. "Part II: Tikrit, South to Babylon." *Marine Corps Gazette*, Mar04, pp. 42-46.

The second in the series of articles following the movements of the 1st Marine Division and their eventual switch from combat operations to security and stability operations.

Kelly, BGen John F. "Part III: Tikrit, South to Babylon." *Marine Corps Gazette* Apr04, pp. 43-47.

The third and last installment in the series of articles on security and stabilization operations of the 1st Marine Division in Operation Iraqi Freedom.

Kibler, LtCol Michael J. "A Different Air War: Marine Air Control in Operation Iraqi Freedom." *History Division*. 2004.

Report summarizes the activity of the 3d Marine Aircraft Wing in Operation Iraqi Freedom, and includes lists of supporting active and reserve units.

Kifner, John. "May25-31: Iraq: More Evidence of a Troubled Situation." *The New York Times*, 1Jun03.

The author describes the troubles in the aftermath of the war. There are still many obstacles to be overcome in Iraq, especially concerning peacekeeping missions and the Iraqi civilians.

Klocek, Maj Joseph J., and LtCol Niel E. Nelson. "8th Engineer Support Battalion's Support of Operation IRAQ I FREEDOM." *Marine Corps Gazette*, Dec03, pp. 38-44.

Klocek documents the reforming of 8th Engineer Support Battalion, engaged in engineering projects, into a bridge battalion. The ESB overcame many obstacles to achieve its goals in support of Operation Iraqi Freedom.

Koopman, John. "McCoy's Marines: Darkside Toward Baghdad Chapter 1." *San Francisco Chronicle*, 10Nov03.

In a series of chapters, John Koopman, embedded with the 3d Battalion, 4th Marines, follows LtCol Bryan P. McCoy and his unit through the hours and days of Operation Iraqi Freedom. Koopman provides historical perspective and interesting facts about the unit and the Marines in general. This chapter covers units wait for battle in Kuwait.

Koopman, John "McCoy's Marines: Darkside Toward Baghdad, Chapter 2." *San Francisco Chronicle*, 11Nov03.

In this second chapter, Koopman recounts the first hours of war with the unit.

Koopman, John. "McCoy's Marines: Darkside Toward Baghdad, Chapter 3." *San Francisco Chronicle*, 12Nov03.

Marines cope with sandstorms, seesaw temperatures, and long periods of waiting and training in this third chapter of McCoy's Marines.

Koopman, John. "McCoy's Marines: Darkside Toward Baghdad, Chapter 4." *San Francisco Chronicle*, 13Nov03.

Koopman recounts the first major combat engagement the Marines of 3d Battalion, 4th Marines, experience in Operation Iraqi Freedom.

Koopman, John. "McCoy's Marines: Darkside Toward Baghdad, Chapter 5." *San Francisco Chronicle*, 14Nov03.

The Marines reach the outskirts of Baghdad and take one of the eastern bridges that led into the city in this fifth installment.

Koopman, John. "McCoy's Marines: Darkside Toward Baghdad, Chapter 6." *San Francisco Chronicle*, 15Nov03.

McCoy's Marines finally enter Baghdad. Koopman gives an account of the dismantling of Saddam Hussein's statue. He then goes on to describe the homecoming of the Marine unit to Twentynine Palms, California.

Kreisher, Otto. "Marines to Come Home Soon But Might Have to Go Back." *San Diego Union-Tribune*, 10Sep03.

LtGen James Conway says that Marine forces will soon be out of Iraq. They have relinquished most of the provinces that were occupied, but remain in the holy city of Najaf to promote stability and security.

Kurtz, Howard. "Embedded Reporter's Role in Army Units Action Questioned by Military." *The Washington Post*, 25Jun03.

Embedded reporter Judith Miller is said to have taken aggressive actions leading to the capture of Saddam Hussein's two sons. She is said to have exercised influence over Ahmed Chalabi, the Iraqi National Congress leader. The newspaper denies that she did anything out of her sphere as a reporter with the Army Mobile Exploitation Team Alpha. The military says that she did play a considerable role and are critical of her actions.

Lacy, Col Warren S. "Operation Iraqi Freedom War in Iraq is Seen As a Fight for Strategic Security in the New Age." *Military Officer*, May03, p. 8.

Lacy, editor of the *Military Officer* magazine, expresses the challenges of publishing a monthly magazine and how to cover breaking news and changing situations. The author suggests a bigger approach and focusing on the big picture and not so much on fine details. The United States role in strategic security is one of these larger issues in modern military operations.

Landers, Jim. "Alone and Unafraid." *The Dallas Morning News*, 18May03.

Landers, embedded with the 2d Tank Battalion, describes the swiftness and deftness of the unit in its fight into Baghdad. The Marines agree that it was the quickness and overwhelming fire-power of the U.S. military that prevented the Iraqis from waging tank and aerial war, and forced them to hide in buildings and use guns and rocket-propelled grenades to counter the U.S. forces.

Layton, Capt Peter, RAAF. "The New Arab Way of War." *U.S. Naval Institute Proceedings*, Mar03, pp. 62-65.

The author describes the 'new Arab way of war' as a combination of education in bomb making and holy-war doctrine. This new way of war is asymmetrical and does not have a front or rear, or even a land base. This new war power seems to lie in people and groups rather than in countries and states.

Lehnert, BGen Michael R. and Col John E., Wissler. "MLC: Sustaining Tempo on the 21st Century Battlefield." *Marine Corps Gazette*, Aug03, pp. 30-33.

The Marine logistics command commenced itself as a necessary component in support of I Marine Expeditionary Force in Operation Iraqi Freedom. The MLC supported all Marine forces in Kuwait and Iraq, and linked tactical and strategic logistics.

Lethin, LtCol Clarke R. "1st Marine Division and Operation IRAQI FREEDOM." *Marine Corps Gazette*, Feb04, pp. 2-20.

Lethin discusses the issues of planning, speed, and commander intent used by the 1st Marine

Division in Operation Iraqi Freedom. The author says that it is these areas that led to the success of the operation.

Love, Col Robert E. "Operation IRAQI FREEDOM-Marine Corps Logistics at Its Best?" *Marine Corps Gazette*, Jan04, pp. 48-50.

Love explores the role of Marine Corps logistics in OIF. He criticizes 'modern' logistics support as being outdated and that there is room for improvement of this system.

Ma, Jason. "Marines Assess Force Structure, Civil Affairs, Police Functions." *Inside the Navy*, 22Dec03, p. 3.

LtGen Jan Huly offers commentary on the strength of the Marine Corps. As Marines prepare to deploy for peacekeeping missions in Iraq, troop rotations and unit activation become critical issues needing to be addressed.

Maass, Peter. "Good Kills." *The New York Times Magazine*, 20Apr03.

Peter Maass gives an account of the battle for Diyala bridge during Operation Iraqi Freedom. Col McCoy of 3d Battalion, 4th Marines, talks about war casualties and how they are tragic but unavoidable. As the unit's commander, McCoy knows it is his job to break through enemy lines to reach military objectives, and that the cost will be in blood. Maass goes on to talk about Iraqi civilian losses and what the unit thinks of killing.

Maass, Peter. "Professor Nagl's War." *The New York Times Magazine*, 11Jan04.

A graduate of West Point who specializes in counterinsurgency, Maj John Nagl, gets hands-on experience in Iraq where he is third in command of Task Force 1/34, part of the 1st Infantry Division. In Iraq, Nagl experiences attacks by insurgents on American forces and those domestic forces cooperating with the Americans. Nagl finds it one thing to study counterinsurgency and another to experience it and help with operations against insurgents.

McCaffrey, Gen Barry R., USA (Ret). "We Need More Troops." *Wall Street Journal*, 29Jul03.

Gen McCaffrey stresses the importance of having adequate military personnel. The success of U.S. combat forces has made the United States more secure, but in the process troops have been stretched too thin. To finish the War on Terror and operations in Iraq, more combat forces need to be on active duty.

McCartney, Capt Stephen F., MC, USNR. "Operation Iraqi Freedom: A Surgeon's Perspective." *Navy Medicine*, Mar-Apr04, pp. 6-9.

The author recalls his experiences with Alpha Surgical Company, 1st Medical Battalion in Operation Iraqi Freedom. He relates how hectic battle is, and the fact that both Americans and Iraqis were treated for wounds.

McEntree, Marni. "Marines Adjust With Time." *European and Pacific Stars and Stripes*, 6Jun03.

As major combat operations come to a close, Marines adjust themselves to peacekeeping and rebuilding of the war zone in Babylon, Iraq.

MacFarquhar, Neil. "Occupation: Marines Turn Over a South-Central Area of Iraq to a Polish-Led International Force." *The New York Times*, 4Sep03.

The United States hands over command of an area in south-central Iraq to Polish forces. Poland became the third nation to become an official occupying power. The transfer signifies the change of power from occupying forces to the new Iraqi government.

MacFarquhar, Neil. "In Najaf, Justice Can Be Blind but Not Female." *The New York Times*, 31Jul03.

LtCol Christopher C. Conlin postpones a decision to swear in Najaf, Iraq's first female judge. An Islamic group protests that it is against Islamic law for a woman to take the position.

MacFarquhar, Neil, "Iraq Shiites Protest in Formerly Calm Najaf." *The New York Times*, 20Jul03.

Demonstrators of the Shiite majority rally around Moktada al-Sadr, a cleric and supporter of theocracy, to oppose the American presence in their city.

McSweeney, Capt Dan. "CLOWNS to the Left of Me." *U.S. Naval Institute Proceedings*, Nov03, pp. 46-48.

Capt McSweeney describes military-media relations during the war in Iraq. This is a short personal account of embedded reporters and the military each trying to do their job and not step on each other's toes.

Maples, MajGen Michael D., USA. "Fires in Operation Iraqi Freedom." *Field Artillery Journal*, May-Jun03, p. 1.

MajGen Maples discusses field artillery in the context of Operation Iraqi Freedom. He discusses the fielding and employment of new systems such as integration of new technology and strategy. History in the making is stressed as an important tactic to see what works and what does not.

"Marines Work to Restore Ancient Hammurabi." *The New York Times*, 27Jul03.

U.S. Marines repair damage to museums in the ancient city of Babylon, Iraq. The museums were vandalized and robbed following the fall of Saddam Hussein's regime, contained significant archaeological artifacts from the 4,300- year old city.

Mater, Journalist Seamen Erica, USNS. "Comfort Faces Different War." http://www.news.navy.mil/search/display.asp?story_id=7213. 2May03.

The author compares the contributions of the Comfort and her crew made during Operation Desert Shield/Desert Storm with those made during Operations Enduring Freedom and Iraqi Freedom.

Matthews, William. "The High Cost of Peace: Postwar Iraq Will Drain Federal Coffers, Army Ranks." *Armed Forces Journal*, May03, pp. 11-12.

William Matthews assesses post-war Iraq. He discusses the differing opinions and estimates made

by officials on topics such as the cost of peacekeeping forces and the cost to America in the long run.

Mattis, MajGen James N. "The Professional Edge." *Marine Corps Gazette*, Feb04, pp. 19-20.

MajGen Mattis discusses the importance of reading and studying the experience of leadership and the nature of war throughout history. These experiences of those that have fought, conquered, discovered and theorized should be applied to modern day warfare and tactics. By doing this, modern-day warriors can be better prepared to make judgments and decisions in critical situations.

Mattis, MajGen James N. "1st Marine Division (Rein): Commanding General's Message to All Hands," Mar03.

MajGen Mattis addresses the Marine warriors on Operation Iraqi Freedom. It is a motivational document with a prescription for war etiquette.

Mazzetti, Mark. "Fighting Words: A Marine Commander Readies his Troops for Combat." <<http://www.usnews.com/usnews/new/iraq/articles.marines030317.html>>. 17Mar03.

LtGen James Conway, commanding officer of I Marine Expeditionary Force, gives a motivational speech to assembled Marines concerning the impending war with Iraq.

Melillo, LtCol Michael R. "Cannon Cockers at War: The 11th Marines in Operation Iraqi Freedom." *Field Artillery Journal*, Sep-Oct 03, pp. 28-32.

This article recounts the 11th Marines' importance role in Operation Iraqi Freedom. Topics covered are training, task organization, various battle engagements, artillery adaptability, and security. The 11th Marines was the only regiment to engage the enemy in every battle campaign during Iraqi Freedom.

Mercer, 1stLt Christopher. "Charlie Company Leads BLT into Northern Iraq." 26th Marine Expeditionary Unit Public Affairs Office. <<http://www.freerepublic.com/Focus/F-News/928060/posts>>. Jun03.

The author describes Charlie Company's first mission into northern Iraq to secure the Al'Mosul airport, and their defense of the airport as more troops arrived.

Micucci, LtCol Michael A. "Combining 1st and 2d Combat Engineer Battalions: Should We Do It Again?" *Marine Corps Gazette*, Dec03, pp. 21-24.

LtCol Micucci explores the pros and cons of combining Combat Engineer Battalions during Operation Iraqi Freedom and if this strategy would work in other cases as well.

Moore, Capt Dan, USN. "Penetrate-Isolate-Subvert-Reorient-Reharmonize." *U.S. Naval Institute Proceedings*, May03, pp. 51-52.

Moore defines the strategy PISRR: penetrate-isolate-subvert-reorient-reharmonize and its' role in defeating the Iraqi regime.

Mortenson, Darrin. "Marines Prepare for Guerrilla War." *North County Times*, 5Dec03.

Marines of the I Marine Expeditionary Force train in preparation of replacing Army soldiers in Iraq. Mortenson notes that most of the Marines in training sessions are not used to combat because of their respective positions in logistics and administration, but in Iraq everyone is a foot soldier.

Mortenson, Darrin. " 'Good Intel' Key to Marines' Iraq Mission." *North County Times*, 17Feb04.

Marine officers read and study about the culture and society of Iraq, as preparation for U.S. occupancy. This form of intelligence is different from tactical intelligence, but just as important and necessary.

Mroue, Bassem. "Southern Iraqi Cities Mostly Peaceful Since End of War." *Southeast Missourian*, 15Jul03.

Marine officers read and study about the culture and society of Iraq, as preparation for U.S. occupancy. This form of intelligence is different from tactical intelligence, but just as important and necessary.

Mundy III, LtCol Carl E. "Spare the Rod, Save the Nation." *The New York Times*, 30Dec03.

MajGen James Mattis took a "do no harm" approach as military operations came to a close in Iraq. Soldiers tried to win over the people and be aware of Iraqi sensitivity because this tactic worked better than being tough.

Myrick, Amy. "Marine Sergeant Wins Honors In Iraq." *East Bay Newspapers*, 5Jun03.

Amy Myrick follows the career of Marine Corps Sgt Calise, from his enlistment to the various missions. These missions have earned Sgt Calise meritorious honors.

Nakash, Yitzhak. "The Shi'ites and the Future of Iraq." *Foreign Affairs*, Jul-Aug03, pp. 17-26.

Yitzhak Nakash offers a history of the Shi'ite and Sunni Muslims in relation to Operation Iraqi Freedom. The history of these people reveals insights into the decisions that the groups would most likely make in terms of government, ruler-ship, and the future of Iraq.

O'Brien, Dennis. "Former Navy Secretary Blasts Bush on Iraq." *The Virginian-Pilot*, 30Aug03.

James Webb, former Secretary of the Navy under George Bush senior, gives his opinion on what the current Bush administration should do regarding the occupation of Iraq. He believes that the United Nations should be involved as quickly as possible, and emphasizes a quick exit by the U.S.

Office of the Assistant Secretary of Defense (Public Affairs). Public Affairs Guidance (PAG) on Embedding Media During Possible Future Operations/Deployments in the U.S. Central Command (CENTCOM) Area of Responsibility (AOR).

<<http://defenselink.mil/news/Feb2003/d20030228pag.pdf>>. 10Feb03.

Document providing guidance, policies, and procedures on embedding news media during possible future operations or deployments in the U.S. Central Commands Area of Responsibility.

Oppel, Richard A., Jr. "U.S. Troops Delay Exit From Najaf." *The New York Times*, 1Sep03.

American troops in Najaf, Iraq hold of replacement by the Polish troops due to a bombing at the

holiest Shiite temple in the area. This sort of violence had not been seen before in Najaf, and Americans insist on staying to help out.

Osman, LtGen H.P. "Recent Successes Have Been A Team Effort." *Jacksonville Daily News*, 5Aug03.

LtGen Henry Osman credits recent successes in the Middle East and the Horn of Africa to the team of people who make up II Marine Expeditionary Force. He not only gives credit to the Marines and Sailors who make up the Force, both in the theater and abroad, but also to the civilian employees at home base and the families of the Marines.

Packer, George. "Letter From Baghdad: War After the War, What Washington Doesn't See in Iraq." *The New Yorker*, 24Nov03, pp. 59-85.

George Packer reviews the violence, crime, and politics during the aftermath of Operation Iraqi Freedom. He proves a point that although the Baathist regime is gone, Iraq is still a long way from the objectives of freedom and democracy that President Bush laid out.

Phillips, Michael M. "For Some Marines, The Next Battlefield Is An Emotional One—Hoping to Fend Off Trauma, They Share War Horrors; 'Life Flowed Right Out'" *Wall Street Journal*, (Eastern edition), 11Apr03.

After arriving in Iraq, Marines of Lt Isaac Moore's 2d Platoon experienced combat for the first time. Individual soldiers reveal their encounter with the hard realities of war, and the emotional trauma that results from battle.

Phillips, Michael M. "Job for a Marine: Taking First Breath After a Gas Attack—In Kuwait Drills, Someone Must Test the 'All Clear'; Sending in the Chickens." *Wall Street Journal*, (Eastern edition), 20Feb03.

The author describes Marine training for chemical and biological attack. The 7th Marines in Kuwait demonstrate 'selective unmasking,' where one unlucky Marine takes his gas mask off to see if it is safe to breath.

Phillips, Michael M. "Marines Do It All in Iraq City, But Now They're Going Home." *Wall Street Journal*, 22Aug03.

Basic security operations run by the Americans are handed off to the Bulgarians. However, Col Panayot Panayotov is unsure that his force will be able to do all that the Marines were doing before such as painting schools and training the local police force.

Pitts, Byron. "Live From Baghdad." *The Crisis*, May-Jun03, pp. 31-35.

Reporter Byron Pitts from CBS News recounts his experience as an embedded reporter during Operation Iraqi Freedom. Byron was with HMLA-169, which provided aerial support for Regimental Combat Team 7.

Plenzler, Capt Joseph M. "Conducting Expeditionary Public Affairs." *Marine Corps Gazette*, Feb04, pp. 26-29.

The internal workings of the Public Affairs team in the 1st Marine Division are detailed. The successful embedding of reporters into the unit was based on the cooperation between the soldiers and the reporters.

Pollack, Kenneth M. "Securing the Gulf." *Foreign Affairs*, Jul-Aug03, pp. 2-16.

Since the United State's victory in Iraq the problems have become more challenging as opposed to easier to deal with. The problem of Persian Gulf security is the main focus of military missions in the Middle East. There are three issues that the United State's must deal with to achieve the end of a more stable Persian Gulf. These issues are the reconstruction of Iraq, Iran's nuclear weapons program, and unrest in the countries comprising the Gulf Cooperation Council.

Powell, Maj Douglas M. "The Military-Media Relationship: From Bull Run to Baghdad." *21st Century Defense: U.S. Joint Operations*, pp. 84-89

The author discusses the history of the embedded journalist program, and the importance of embedded reporters in Operation Iraqi Freedom in relating the war to those at home.

Prine, Carl. "Reflections on a Firefight." *Pittsburgh Tribune-Review*, 11May03.

Embedded reporter Carl Prine gives a moving account of what it is like to be caught in a firefight.

Pugh, Willie B. "Braving My Little Sister's Call to War." *The Crisis*, May-Jun03, p. 54.

LCpl Devan S. Pugh's experience in Kuwait as seen through the eyes of her brother, Willie B. Pugh, is discussed. He recounts her history and dedication to the Marine Corps in the midst of battle.

Quigley, 1stLt Brendan F. "Combined Arms: Losing the Effects?" *Marine Corps Gazette*, Feb04, pp. 30-32.

The author posits that current combined arms training tactics are unrealistic, ineffective, and inefficient. He suggests more realism and imagination in the training.

Rabassi, 1stLt Christopher E. "What Happened to Class IX in Iraq?" *Marine Corps Gazette*, Sep 03, pp. 54-56.

Lt Rabassi concludes that Class IX, consumable parts and secondary reparable, did not support sustained combat operations in Operation Iraqi Freedom. He therefore outlines three areas critical to the management of Class IX items: information management, transportation, and distribution control.

Reed, LCdr Meg, USN. "MEF Engineer Group Seabees Helping to Rebuild Iraq." *Navy Newsstand*, 30May03.

The I Marine Expeditionary Force Engineer Group Seabees still have a major role to play in the Middle East even though Marines and soldiers are packing up to go home. The Seabees are responsible for the rebuilding projects in Iraq.

Reid, Chip. "Recalling Life as an Embedded Reporter: Digging Ditches to Sleep in, Dodging Gunfire – A long Way From D.C." <<http://www.msnbc.msn.com/id/4400708>>.15Mar04.

Chip Reid recalls his life as an embedded reporter with the 3d Battalion, 5th Marine Regiment. He describes ground warfare, the uncertainty in war, and the difficulty he had maintaining an objective viewpoint.

Richardson, Herb, ed. "We—the Marines." *Leatherneck*, Jun03, pp. 44-47.

A series of short articles on different topics concerning Marines. Some topics covered the Marine Band, Marine memorial services, and various individual's personal achievements.

Richey, Warren. "War Reporter in Limbo." *The Christian Science Monitor*, 12Jun03.

Warren Richey flies to Kuwait and spends 17 days waiting to be embedded with the U.S. military to cover the war on Iraq. Finally embedded, Richey expresses what it was like to be in a group of soldiers anticipating battle.

Ricks, Thomas E. "Marines to Offer New Tactics In Iraq: Reduced Use of Force Planned After Takeover from Army." *The Washington Post*, 7Jan04.

Based on an internal Marine document and interviews, the Marine Corps has come up with alternative tactics for use in Iraq. The U.S. Army, which will be replaced by some Marine Corps units, feels that the document is critical of the job they did in Iraq. However, the Marine Corps and Army officials do not see it that way, and are focused on achieving the same goals as the Army—peace and stability in the Sunni Triangle.

Roberts, LtCol Lawrence R., and Maj John P. Farnam. "Airborne Recon Supported Marines' Advances in Iraq." *U.S. Naval Institute Proceedings*, Jun04, pp. 40-43.

Close coordination among Marine air controllers, strike and reconnaissance aircrews, and their joint and coalition partners enabled decisive realization of Marine Air Group 11's objectives in Operation Iraqi Freedom—which included knocking out Iraqi artillery batteries capable of firing at long ranges.

Rodriguez, LCdr Cindy, USN, Maj Michael Manzer, Jr., Cdr Shawn Lobree, USN, and Cdr Jon Dachos, USN. "Harrier Carriers Perform in Iraqi Freedom." *U.S. Naval Institute Proceedings*, Feb04, pp. 32-35.

New "Harrier carrier" ships are being used to multiply the force power of naval expertise and Marine air power to achieve more effective operations. The details of the Harrier carriers' advantages are investigated.

Rolfson, Bruce. "Air Power Unleashed: Lessons from Iraq." *Armed Forces Journal*, Jun03, pp. 30-33.

Rolfson discusses air power in Operation Iraqi Freedom. He compares it with Operation Desert Storm to show the differences. He describes aircraft and weapons in detail that played a particularly large role in the effectiveness and speed of missions.

Roos, John G. "What Has U.S. Learned?" *Armed Forces Journal*, May03, pp. 24-30.

John Roos covers some of the important lessons learned during Operation Iraqi Freedom. He discusses the war in terms of the media and politics, enemy encounters, tactics, and older concerns such as friendly fire. Ross also stresses the importance of capitalizing on these lessons to enhance effectiveness of war and strategy.

Ross, Kirk. "Marine Engineer Group: A Force for the Future." *U.S. Naval Institute Proceedings*, Jul03, pp. 84-86.

The Marine Engineer Group is described as an evolutionary group, capable of supporting varying efforts and missions. The MEG's primary missions involve construction, repair, supply, and support. MEG has three task forces, Mike (for mobility), Charlie (for construction), and Echo (for endurance), each of which has capabilities that are unique and shared.

Rude, Maj David J., USA, and LtCol Daniel E., Williams, USA. "The 'Warfighter Mindset' and the War in Iraq." *Army*, Jul03, pp. 35-40.

AH-64D Longbow Apache helicopters were for the first time employed in combat missions during Operation Iraqi Freedom. The Apache's attributes, comparisons to other roles the helicopter has filled, and the future of the aircraft is covered in detail.

Rumsfeld, Donald H. "Help Iraq to Help Itself." *Wall Street Journal*, (Eastern edition), 29Sep03.

The media reports on the war in Iraq do not reveal the whole picture of what is actually occurring. The media focuses on the security situation in Iraq, but there is much more than this going on. Rumsfeld attempts to set the record straight by listing and defining the good things that are happening such as reopening of bridges, schools, and businesses, and the formation of the Iraqi Governing Council.

Ryan, RAdm Paul, J., USN. "Mine Countermeasures a Success." *U.S. Naval Institute Proceedings*, May03, pp. 52-53.

Mine warfare and countermeasures operations in Iraq have contributed greatly to the overall effectiveness of Operation Iraqi Freedom. The missions and accomplishments of this type of warfare are detailed.

Sambrook, Richard. "Military and the Media." *RUSI Journal*, Aug03, pp. 40-45.

The relationship between the military and the media is a tedious one, especially during war coverage. Operation Iraqi Freedom is an example of the divergent goals of the two groups. Sambrook says the military want to win and the media want the truth. Sambrook gives an account of military-media relations in recent history.

Schmidt, Col John W. "The Principles of War and Iraqi Freedom." *U.S. Naval Institute Proceedings*, Jun03, pp. 70-71.

Schmidt offers a new perspective on Operation Iraqi Freedom. He puts the operation in the context of the principles of war and concludes that the war did follow the principles, and was thus successful.

Schreiber, LtCol Paul, Cdr Brian Kelley, USCG, LtCol Gary Holland, USAF, and Cdr Stephen Davis, USN. "Iraq After Saddam." *U.S. Naval Institute Proceedings*, Apr03, pp. 32-35.

Schreiber analyzes the post war conditions in Iraq and evaluates what still needs to be done to make the country stable. He focuses on security issues as a multi-faceted issue concerning both civilian and military spheres.

Seamon, LtCol Richard. "Military Not Complaining About Coverage." *U.S. Naval Institute Proceedings*, May03, p. 56.

Embedded journalists are reporting their individual experiences and opinions as well as the truth of the war as it progresses. Although there are problems with this type of coverage, the military does not seem to condemn the news, but to condone it.

Sedge, Michael H. "Not-so-Friendly Fire: War in Iraq Shows Fratricide Remains an Enduring Problem." *Armed Forces Journal*, May03, p. 18.

Despite technology and detailed systems that are in place, fratricide, or friendly fire, still remains a problem to be overcome by U.S. military forces. Specific examples are given from Operation Iraqi Freedom, showing that there are still breakdowns in the system.

Shachtman, Noah. "Tough Talking for Marines in Iraq." <http://www.wired.com/news/technology/10,1282,59106,00.html>. 7Jun03.

The array of equipment Marines have to use to communicate with each other during combat missions is overwhelming. Radios, speakers, laptops, and other equipment overload the limited space convoys have. Solutions are in the making, but until then Marines have to cope.

Shadid, Anthony. "Marines Put Militias on Deadline in Najaf." *The Washington Post*, 10Sep03.

Iraqi militiamen deployed in Najaf, Iraq, to help improve the security situation and avert violence. However, U.S. military officials told that the religious factions removed the armed followers because of a decision to only let the police force carry weapons.

Shelato, Sgt M.P. "Marine Corps CH-46's Vital to CasEvac Mission in Iraq." <http://www.usmc.mil/marinelink/mcn2000.nsf>. 30Jul03.

This account differentiates between CasEvac and MedEvac flights, describes the composition of the crew and their procedures, and emphasizes the dangers inherent to flying in bad weather during combat conditions.

Simpson, Ross W. "Battle for Baghdad." *Leatherneck*, Oct03, pp. 14-18.

Simpson describes the Battle for Baghdad from the viewpoint of the 1st Battalion, 5th Marines. Although it took 21 days to liberate Baghdad, the fighting is far from over.

Simpson, Ross W. "Marine Close Air Support: Never More Important." *Leatherneck*, May03, pp. 16-18.

Marines of the 1st Marine Division rely on the 3d Marine Aircraft Wing for support. Marines support their own units before any others. Simpson interviews members of the 3d MAW to gain perspective on their mission in the Persian Gulf.

Simpson, Ross W. "Training the Media for War," *Leatherneck*, Jun03, pp. 38-41.

Prior to the deployment of embedded journalist to the hot areas of the Persian Gulf, the journalists

underwent training exercises to prepare them for the harsh conditions of battle. The author describes the “prep school” these journalists attended, courtesy of the Department of Defense.

Simpson, Ross W., “Going to War.” *Leatherneck*, Jul03, pp. 30-35.

Embedded reporter Ross Simpson describes what it was like going to war with the 1st Battalion, 5th Marines. The author focuses on day-to-day activities, training, and preparation for Operation Iraqi Freedom.

Sinnreich, Richard Hart. “Iraqi Freedom Confirms Some Familiar Lessons.” *Army*, Jun03, p. 7-8.

The author concludes that although Operation Iraqi Freedom presents new challenges in warfare, the familiar lessons of past wars are confirmed in this war. Despite such aspects as combined arms operations, training and self-discipline of the troops, swift operations and adaptability, and the role of air and sea power, the war must still be won on the ground.

Sisto, Cpl Jeff. “Experience and Adaptability Ensure Success for 24th MEU (SOC) in Iraq.” <<http://www.Marines.mil/marinelink/mcn2000.nsf/lookupstoryref/200351228360>>. May03.

The author discusses the skills and training that allowed for the successes of the 24th Marine Expeditionary Unit in the challenging missions they faced in Operation Iraqi Freedom.

Smith, MajGen Ray L., and F. J. West. Implications from Operation IRAQI FREEDOM for the Marine Corps, *Marine Corps Gazette*, Nov03, pp. 40-46.

The authors investigate the implications of Iraqi Freedom as they pertain to the Marine Corps. West and Smith focus on how the Operation was a military victory. Speed, logistics, deterrence, planning, and maneuver warfare are some of the aspects the authors use to prove U.S. military power.

Sousa, 1stLt Anthony G. “FiST Up! Task Organizing Fire Support Teams for Maximum Flexibility in Mechanized Operations.” *Marine Corps Gazette*, Jan 04, pp. 42-43.

The author emphasizes the importance of fire support teams (FiST) and the placement of these teams in a company. FiST give battlefield commanders supporting fires, but their place in task organization can make a significant difference in the effectiveness of the FiST.

Staff and Commanders, 1st and 2d Combat Engineer Battalions. “Combat Engineer Battalion in Operation IRAQI FREEDOM.” *Marine Corps Gazette*, Dec03, pp. 18-21.

Operation Iraqi Freedom proved once again that there are never enough combat engineers on the battlefield and why both 1st and 2d Combat Engineer Battalions were needed.

Steel, Dennis. “Baghdad: Aftermath and Prelude.” *Army*, Jul03, pp. 26-34.

Steele documents the transfer from combat operations to security and reconstructive operations in Iraq after the fall of Baghdad.

Steinkopff, Eric. "2d MEB Commander Describes the Differences with Deployment in Iraq." *Jacksonville Daily News*, 29Jun03.

The 2d Marine Expeditionary Brigade commander, Brigadier General Richard Natonski, describes the challenges and uncertainties of combat.

Sweet, Sgt Mike, USA. "New Council, Mayor Mark New Iraqi Government." *Marine Corps News*, 15Jul03.

A new government council will help to establish democracy in the holy city of Najaf. Although Marines still patrol the area, Najaf is stated to be a safe and secure environment.

Sweet, Sgt Mike, USA. "Marines Open Last Legacy School before Shipping Home." *Marine Corps News*, 18Aug03.

The 1st Battalion, 7th Marines, opens the Al Gary Secondary School for Girls after renovation. The Marines strive to leave behind a legacy of freedom, not of war.

Tomkins, Richard. "War Diary: Tales From the Front." *United Press International*, 22Apr03.

Tomkins records his observations and reflections on being embedded with Company B, 1st Battalion, 5th Marines, and the push into Baghdad.

Tomkins, Richard. "War Reflection: With the Marines in Iraq." *Washington Times*, 21Apr03.

Tomkins again recounts the time spent embedded with Company B, 1st Battalion, 5th Marines. As a reporter, he remembers the individuals of the company and how they were like family to him.

Torriero, E.A. "GIs Doubt Foreign Troops' Readiness." *Chicago Tribune*, 7Sep03.

Torriero reports on the readiness of foreign troops deployed to replace Marine and Army units in the Persian Gulf. The integrated units must overcome complications such as language barriers and training and readiness differences in order to work with each other.

Tripp, Charles. "After Saddam." *Survival*, Winter02-03, pp. 23-37.

The author provides a speculative view on Iraq after the overthrow of Saddam Hussein. He discusses the hypothetical overthrow of the dictator, reconstruction, and the staying power of the United States in the region as well as the reactions of the surrounding countries.

Truscott IV, Lucian K. "A Million Miles from the Green Zone to the Front Lines." *The New York Times*, 7Dec03.

Truscott tells of the hardships Company B, 101st Airborne Division, must endure while trying to make Mosul, Iraq, a livable place. Although its missions were nonmilitary, there was no one else to do them and the company does them well.

Tyler, Patrick E. "There's a New Enemy in Iraq: The Nasty Surprise." *The New York Times*, 1Jun03.

After the fall of Saddam, it was expected that troops would withdraw and democracy would prevail in Iraq. Tyler makes the point that expectations are not working out on either side. Misunderstandings could provoke aggression by Iraqis and more unorganized combat.

Tyler, Patrick E., and Amy Waldman. "After the War: Combat; G.I. Is Killed in Grenade Attack on Convoy; Another Blast Starts Fire on Oil Pipeline." *The New York Times*, 23Jun03.

The author recounts the violence and small-scale assaults on American troops. Once such assault led to the death of an American soldier, the 14th in a series of attacks in the past month.

Warner, Margaret. "A Marine's View." *Jim Lehrer Transcript*, 26Sep03.

Margaret Warner interviews MajGen James Mattis. As commander of the 1st Marine Division, Mattis recounts his experience in combat, including the Battle for Baghdad, and running the occupation in Iraq.

West, F.J. "Bing." "Maneuver Warfare: It Worked in Iraq." *U.S. Naval Institute Proceedings*, Feb04, pp. 36-38.

West says that maneuver warfare techniques, not network-centric warfare concepts, were what won the war in Iraq.

West, F.J. "Bing" "Quagmire?" *Wall Street Journal*, (Eastern edition), 23Jul03.

The author compares what the media presents to the public with what the military and government see as the truth. He especially refers to the casualties of the war—in this conflict, America as a nation has lost relatively few men, but each loss is an individual tragedy.

White House. "President Bush Addresses the Nation." <<http://www.whitehouse.gov/news/releases/2003/03/20030319-17.html>>. 19Mar03.

President George W. Bush addresses the nation regarding Operation Iraqi Freedom. He gives the causes for going to war, the objectives, and coalition support that America has for the operation.

Wilson, George C., "Bottom Up." *Government Executive Magazine*, 26Apr03.

It is the author's conclusion, after being embedded with Marines in Iraq, that the top commanding officers do not understand what the embedded reporters job is in the war. He says that the reporters are there to win the propaganda war in Iraq, but that the officers are not conducive to this mandate.

Wong, Edward. "Iraq's 'Faceless Enemy': Rebels Without a Cause or a Web Site." *The New York Times*, 7Dec03.

Edward Wong investigates the "faceless enemy" who attack American forces in Iraq. He compares them with guerrilla fighters of past wars, but concludes that they are indeed a new kind of enemy.

Woolley, Wayne. "Reservists' Last Convoy a Joyful One." *The Star-Ledger*, 14Jul03.

The author follows the 6th Motor Transport Battalion as it heads home from Iraq. The Marines are happy they are going home; confident they have completed their mission; did what they were sent to Iraq to do, and come home with everyone they started out with.

Wright G., Andrew. "Navy, Marine Engineers Battle to Win Iraqi Hearts and Minds." *Construction*, 14Apr03.

Back Cover: The device reproduced on the back cover is the oldest military insignia in continuous use in the United States. It first appeared, as shown here, on Marine Corps buttons adopted in 1804. With the stars changed to five points, the device has continued on Marine Corps buttons to the present day.



While other coalition forces are still securing Baghdad, Rear Admiral Chuck Kubic and his unit are concentrating on winning the battle for support by Iraqi residents of Umm Qasr

Wright, Evan. "The Killer Elite: The True Story of Bullets, Bombs and a Marine Platoon at War in Iraq." *Rolling Stone*, 26Jun03.

Writer-photographer Evan Wright risked his life to get this story—a rollicking, profane, brutal look at the Marines of Company B, 1st Reconnaissance Battalion, who led the charge into Iraq. In the course of myriad firefights, mortar attacks and ambushes on their way to Baghdad, Wright won the trust of his subjects, but he remained clear-eyed, depicting the soldier's cold-bloodedness as well as their humanity. For the three part series, Wright received the 2004 National Magazine Award for Excellence in reporting.

Wright, Evan. "The Killer Elite, Part Two: From Hell to Baghdad." *Rolling Stone*, 10Jul03.

Wright, Evan. "The Killer Elite, Part Three: The Battle for Baghdad." *Rolling Stone*, 24Jul03.

"Young Shiites Make Power Play, But Their Ambitions Cause Friction."
<http://www.charleston.et/stories/072703/ter_27younshi.shtml>. Jul03.

A group of young Shiite Muslim clerics, the al-Sadr, organize a religious army in the city of Najaf, to protest American occupation of the country.