

*THE ORBAN
STEREO
TELEVISION
SYSTEM*

NEW!
Second-Generation
Stereo Generator
MODEL 8185A
see insert



orban

ORBAN: THE SYSTEM APPROACH TO QUALITY STEREO TV

ORDER GUIDE

1 OPTIMOD-TV Audio Processor

- 8182A** **OPTIMOD-TV Audio Processor**
Integrated signal-processing system for stereo and mono television audio.
- 8182A/ST** **Studio Chassis Accessory**
Level control before the STL—without adding additional audio processing. Moves AGC circuits from transmitter to studio.

2 OPTIMOD TV Stereo Generator

- 8182A/SG** **TV Stereo Generator**
Ultra-stable BTSC-standard Stereo Generator. Companion to 8182A OPTIMOD-TV Audio Processor.

3 Subcarriers

- 8182A/SAP** **Second Audio Program Generator**
A high-performance Audio Processor and BTSC-standard Subcarrier Generator. Works with 8182A/SG or directly into aural exciter. Usable with 8182A/ST Studio Chassis Accessory (see above).
- ACC-21** **Monitor Card for 8182A/SAP**
For full-time monitoring of SAP system up to, but not including, the modulator.
- 8182A/PRO** **Professional Channel Generator**
Speech Processor/Data Conditioner and BTSC-standard Subcarrier Generator. Two cards that plug into the 8182A/SG Stereo Generator.

Additional Stereo TV related equipment

- 275A** **Automatic Stereo Synthesizer—**
see separate brochure
Generates pseudo-stereo from mono source material. Recognizes mono/stereo and switches automatically—smoothly cross-fades between bypass and synthesized stereo. Improved Orban patented stereo synthesis effectively centers dialog. Reverse-Polarity Detection corrects out-of-phase problems automatically. Noise Reduction reduces hiss and hum on mono material by up to 10dB.
- 275A/RC** **Remote Control Panel for 275A**

COMMON SYSTEM CONFIGURATIONS

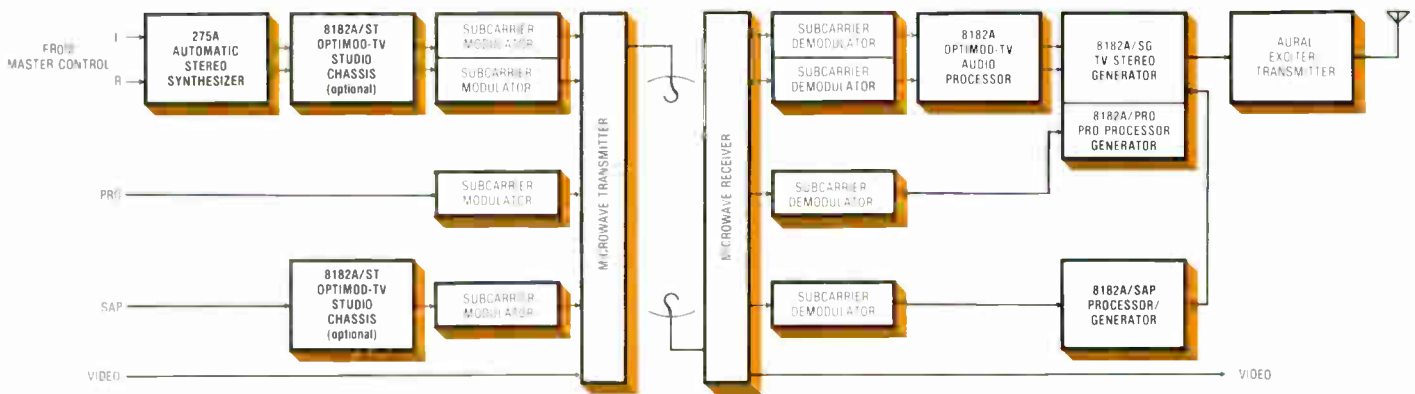

Stereo TV System with discrete subcarrier microwave STL

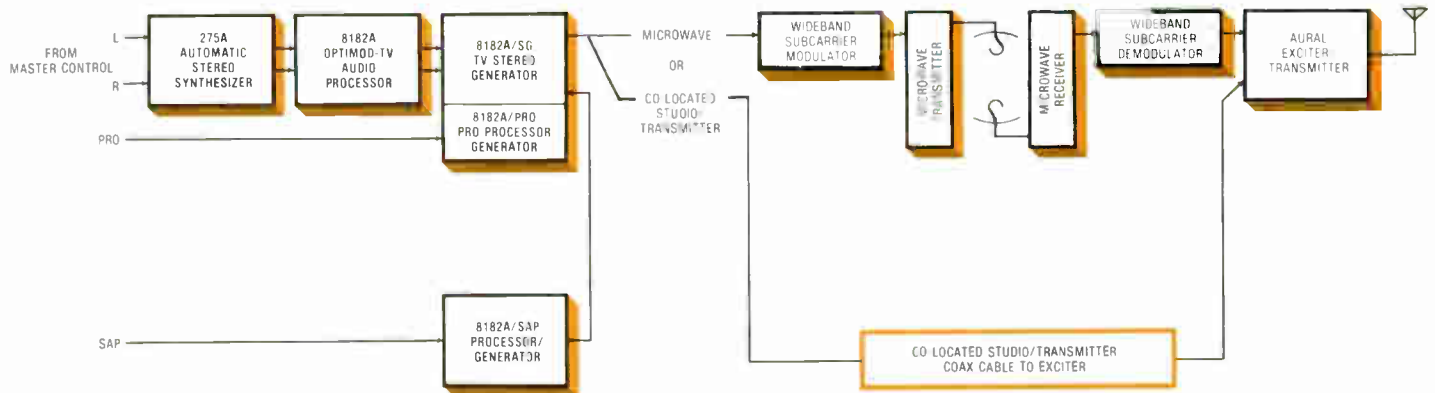

**Stereo TV System with composite subcarrier microwave STL
or
co-located studio/transmitter**

1 OPTIMOD-TV AUDIO PROCESSOR

OPTIMOD-TV At A Glance



Model 8182A: Integrated signal-processing system for stereo and mono television audio

- Rides gain over a range of up to 25dB (user adjustable)
- Provides consistent subjective loudness from source to source
- Precisely controls peak modulation levels for mono or stereo
- Designed expressly for TV audio—mono or stereo
- Usable with 8182A/ST Studio Chassis Accessory for split studio-transmitter operation to provide gain control before the STL
- Replaces conventional compressors, AGCs, limiters, and clippers

Audio Processing For Quality And Consistency

Effective TV audio processing is a challenge: It must provide consistent loudness. It must control dynamic range to provide comfortably listenable sound on sets with small speakers while still sounding open and natural on today's newer stereo audio and video components. It must control peak modulation levels for mono or MTS stereo transmission. And it must do all of this while introducing no audible processing artifacts.

Orban has been the leader in audio processing for broadcasters since the mid-1970s. And OPTIMOD-TV has set the standard for TV audio processing, with its natural sound and its ability to handle typical television audio feeds—from master tape to live voice to 16mm optical film—smoothly and gracefully, without introducing processing artifacts.

This brochure provides a technical description of OPTIMOD-TV. However, it can't adequately describe its most important feature: **natural sound.**

Consumers have become more and more accustomed to good sound, and OPTIMOD-TV helps you provide quality audio to augment the quality video that you work so hard to achieve.

OPTIMOD-TV At Work

OPTIMOD-TV provides four level control functions: (1) gain riding, (2) adjustable reduction of dynamic range, (3) taming of excessively loud commercials, and (4) very effective peak control to prevent overmodulation.

Gain riding—by OPTIMOD instead of your Master Control operator—controls levels over a 25dB range, compensating for varying input levels from source to source—while maintaining consistent sound quality on the air.

Dynamic range in the home viewing/listening environment is limited on the low side by background noise—traffic outside, noisy kids, dishwasher going in the kitchen. On the high side, dynamic range is often limited by the need to avoid disturbing family and neighbors, and by the power limitations of the tiny loudspeakers and underpowered amplifiers all too common in many TV sets.

The degree of dynamic range control offered by OPTIMOD-TV is totally user-adjustable to achieve an optimum level of viewer satisfaction.

Level control that's imperceptible: Gain riding and dynamic range control in OPTIMOD-TV are performed by a dual-band AGC. Exceptional smoothness is assured by advanced "smart" program-controlled time constants. Level-dependent gating prevents noise rush-up during pauses. The dual-band AGC prevents intermodulation of the midrange by bass material, and can also control frequency imbalances between bass and midrange.

Subjective Loudness Control tames excessively loud commercials: The concept of loudness is different from the concept of level. Loudness is *subjective* sound intensity—what the listener *perceives in the mind*, while level is a simple electrical measurement. Average level (as shown on a VU meter) or peak level (as shown on a PPM) does not correlate well with perceived loudness.

CBS Technology Center, after 20 years of research, developed a technique for measuring perceived loudness by means of a complex algorithm. Orban utilizes this algorithm in the Automatic Loudness Controller to end the problem of excessively loud commercials and other program material. When excessively loud audio is detected, the Automatic Loudness Controller subtly reduces level to retain

consistent loudness. Users of OPTIMOD-TV report a substantial reduction or elimination of viewer complaints regarding loud commercials.

Peak control without the “peak limiter” sound: To prevent overmodulation, peaks must be controlled while taking into account the effects of the steep standard broadcast preemphasis curve and the variable preemphasis characteristic of the dbx[®] noise reduction used in the BTSC Stereo TV system. But if the processing, while controlling peaks, affects the average level, its action will be audible and irritating—the ear is sensitive to changes in average level.

So Orban designed the Hilbert-Transform Clipper and FCS (Frequency-Contoured Sidechain) Overshoot Compensator—sophisticated and patented circuits that do not affect average level in any way and do not introduce audible distortion.

The Result

The *viewer* enjoys an amazingly natural and pleasant sound that is easy to listen to in the home—from the portable TV with its tiny speaker to the component video tuner that feeds audio through the hi-fi system. Your station’s sound has superb balance between voice and music, and a consistency that makes it easy to listen to for long periods of time.

The *broadcast engineer* achieves a sound free from the processing artifacts that often plague other signal processing approaches, with a signal properly band-limited and peak-controlled for conventional mono broadcast, MTS Stereo, or satellite uplink.

STUDIO CHASSIS ACCESSORY At A Glance



Model 8182A/ST: Level control before the STL—without adding additional audio processing

- Extensive metering assures easy setup and maintenance
- Usable with the 8182A OPTIMOD-TV Audio Processor and 8182A/SAP Separate Audio Program Generator

The STL Problem

Control of audio level feeding a microwave audio subcarrier generator has always been vital. Usually, the subcarrier is the weakest link in the audio chain, with limited headroom and barely adequate signal-to-noise ratio. Phone lines often suffer from the same problems.

If audio level is reduced to prevent overload, low level signals will get closer to the noise. At the transmitter, the AGC will increase audio level and the noise with it.

OPTIMOD-TV Audio Processing was designed to offer “complete” audio control—additional processing would simply degrade your sound.

The OPTIMOD Solution

The 8182A/ST lets you relocate the AGC and Automatic Loudness Controller circuit cards from the main OPTIMOD chassis (at the transmitter) to the the Studio Chassis Accessory (installed in the studio just before the microwave subcarrier generator or phone lines).

Improves STL performance:

Level control prior to the subcarrier allows you to maximize use of the available dynamic range, and prevents overload.

Self-contained/easy to install:

The Studio Chassis Accessory includes its own power supply, balanced output line drivers, and all the comprehensive audio metering found on OPTIMOD-TV.

Control the station “sound” at the studio: Relocating these cards also relocates the controls that most affect the sound of the station: RELEASE TIME, GATE THRESHOLD, BASS COUPLING, RELEASE SHAPE, CLIPPING.

2 OPTIMOD TV STEREO GENERATOR

OPTIMOD TV Stereo Generator At A Glance



Model 8182A/SG TV Stereo Generator: Ultra-stable BTSC-standard Stereo Generator—companion to OPTIMOD-TV Audio Processor

- Excellent performance: Exceeds all BTSC specifications
- Exceptionally stable over time and wide temperature variations
- Built-in monitor circuit (including dbx® decoder) to verify system performance independently of exciter, transmitter, and monitor
- Genuine dbx-manufactured noise reduction encoder and decoder cards to assure tightest conformance with standards
- Extensive metering for easy setup and maintenance; special stereo test modes allow alignment of separation and pilot phase using only an oscilloscope
- Comprehensive remote control and remote indicator facilities
- Auxiliary input for separate 8182A/SAP Second Audio Program Generator
- Prewired card positions for optional 8182A/PRO Professional Channel Generator

The Stereo Generator With Experience

In the years since the introduction of Orban's original OPTIMOD-FM (in 1975), FM stereo has grown up and we've grown with it. There are more Orban FM stereo audio processors and stereo generators in service than all other makes combined. We've brought this extensive experience to the design of our BTSC TV Stereo Generator.

The stereo encoder in the 8182A/SG is based upon the proven design of the Model 8100A OPTIMOD-FM Stereo Generator, literally thousands of which are in service.

Harmonized to 8182A OPTIMOD-TV Audio Processor:

The 8182A/SG has been specifically designed to mate with the 8182A OPTIMOD-TV Audio Processor to create a fully-harmonized system that achieves the highest standards of accuracy and audio quality.

The 8182A/SG includes filtering that is "interleaved" with the OPTIMOD-TV audio processing, resulting in a system whose performance is significantly better than if the stereo generator was merely cascaded after the audio processor.

Easy To Install

Monitoring and measurement: Monitoring outputs and metering permit closed-circuit verification of the operation of all circuitry except the stereo encoder (independently of the RF link and modulation monitor). Users report this feature to be very useful.

Special stereo encoder test modes allow alignment of separation and pilot phase using only an oscilloscope, and permit easy measurement of the separation performance of the entire plant.

The monitoring circuitry includes a dbx N/R decoder card, deemphasis, and dematrixing circuitry (L + R/L - R to L/R).

Remote control/status: The three operating modes of the 8182A/SG (STEREO, MONO LEFT, MONO RIGHT) can be selected by remote control. The MONO LEFT and MONO RIGHT functions are useful in case of failure of one channel of the STL or audio processing. In addition, the Professional Channel can be turned ON/OFF.

A SYNC LOCK status output is also provided.

The System

The 8182A OPTIMOD-TV Audio Processor and 8182A/SG OPTIMOD TV Stereo Generator—each embody Orban's years of experience in the successful design of audio processing and baseband generating equipment. Together they provide the ideal means of generating BTSC signals of the highest objective and subjective quality.

Use Of The Stereo Generator Without OPTIMOD-TV Audio Processing

While the 8182A/SG has been optimized to be closely married to the 8182A OPTIMOD-TV Audio Processor, it is possible to use it with other processing, or alone (as a test instrument, for example). Some additional external circuitry is necessary to provide the input with preemphasized sum-and-difference signals.

Orban Customer Service can provide an Application Note for those who may wish to use the Stereo Generator with other than the 8182A OPTIMOD-TV Audio Processor.

Excellent Performance: Where It Counts

Filtering: One of the largest hurdles to be overcome in the development of the 8182A/SG TV Stereo Generator was the design of the matched sum-and-difference low-pass filters, responsible for pilot protection and elimination of aliasing-related non-linear crosstalk.

The Orban audio processor and stereo generator successfully achieve the required protection through a system approach to filter design: The twelve poles of 15kHz lowpass filtering that already exist in the audio processor are complemented by 17 poles of 15.734Hz notch/lowpass filtering housed in the stereo generator. This *filter system* results in *very* flat passband response to 15,000Hz, and stopband response that is well below -80dB at the pilot frequency, and *at all frequencies above*.

Non-linear crosstalk is an enormously important yet commonly overlooked factor in the BTSC system. The main cause is the lower sideband of the stereo sub-channel leaking into the main channel due to inadequate lowpass filtering of the audio prior to the stereo encoder.

This effect can be greatly exaggerated at low audio levels by the action of the dbx compression which increases the stereo sub-channel gain, and the crosstalk, proportionately. Non-linear crosstalk is heard as non-harmonically related beat tone distortion which is very offensive to the ear. It sounds similar to aliasing in digital audio which, research has shown, is highly audible even in small amounts.

In the Orban Stereo TV System, non-linear crosstalk is effectively eliminated by filtering that stays below -80dB in the very important area above 15.734Hz.

Separation—what's really required? There are several factors in the design of the BTSC system that affect separation performance. Foremost is the matching between the dbx N/R *encoder* in the generator, and the *decoder* in the receiver or test demodulator/monitor. When one is attempting to measure system separation beyond 30dB, miniscule variations between even the best *professional* encoders and decoders can affect separation measurements by 5dB or more.

Another factor is filter design—there's a tradeoff between high separation measurements and effective control of non-linear crosstalk. Even using state-of-the-art componentry and advanced design techniques, high-performance filters will have a slight phase difference between channels at high frequencies. Maximum separation requires perfect tracking of phase and frequency response between the two filters.

Extensive technical studies, taken into account when the BTSC standards were developed, indicate that an increase in separation beyond 17dB in the midrange frequencies results in *no audible improvement in stereo imaging*. At low and high frequencies, separation requirements for subjectively perfect imaging are even less. The BTSC requirements for professional encoders (30dB midband separation, smoothly declining to 20dB at 14kHz) therefore wisely and conservatively leave most of the error budget in the receiver, where cost constraints are most likely to force performance compromises. If BTSC specs are met at the transmitter, the receiver only needs to have 20dB separation to achieve the necessary 17dB for the entire system.

Design priorities were easy to set: Instead of trying to exceed BTSC separation specs as far as possible (an exercise that makes for pretty spec sheets but achieves no audible benefit), we opted to use aggressive lowpass filtering which resulted in our exceeding BTSC specs by fewer dB, but which dramatically reduced the *audible* distortion caused by aliasing. At Orban, we believe that "specsmanship" does not serve the customer—maximizing *real, audible* performance is the essence of good engineering.

Long-term stability: Orban's filter and stereo generator circuitry has been subjected to intensive computer "sensitivity analysis" to determine the tolerances and temperature coefficients required of individual components. Accordingly, we are confident that the system will remain stable over temperature variations and time, and that each unit will be readily field repairable by simple card-swapping techniques.

An audible improvement: The care taken in filter design pays off with aliasing protection that effectively eliminates the problem with *all* program material, along with separation that typically exceeds the BTSC specifications by 10dB or more—an unbeatable combination.

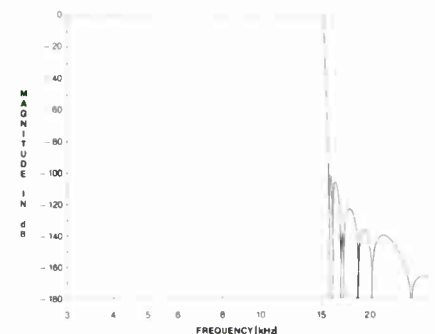

**OVERALL 8182A & 8182A/SG
FREQUENCY RESPONSE**

3 SAP AND PRO SUBCARRIERS

SAP Generator At A Glance



Model 8182A/SAP Second Audio Program Generator: A high-performance Audio Processor and BTSC-standard Subcarrier Generator

- Can be used with the Orban 8182A/SG TV Stereo Generator, or stand-alone
- Incorporates OPTIMOD-TV Audio Processing of a quality equal to the mainchannel 8182A OPTIMOD-TV Audio Processing—includes Automatic Loudness Controller *standard*
- Subcarrier generator features extremely low distortion and excellent transient response to cleanly achieve maximum average subcarrier modulation, resulting in best system noise performance
- Exceptionally stable over time and wide temperature variations
- Genuine dbx® N/R encoder card to assure tightest conformance with standards
- Extensive metering for easy setup and troubleshooting
- Comprehensive remote control and remote indicator facilities
- 8182A/ST Studio Chassis Accessory permits split studio-transmitter operation to provide AGC before the STL

First-Class Sound For Your Second Audio Program

Orban's 8182A/SAP Second Audio Program Generator was designed from the ground up for SAP—it's not a rehash of an FM SCA generator! Accordingly, we've built-in the audio quality appropriate to the first-class broadcast service that SAP was intended to be.

OPTIMOD-TV Audio Processing:

The audio processing in the 8182A/SAP is essentially a single channel of OPTIMOD-TV processing—but with 10kHz bandlimiting. This processing provides full multiband AGC to prevent bass energy from modulating the midrange, and a CBS Automatic Loudness Controller—because loud commercials are annoying *regardless* of which language they're in!

Peak limiting: The SAP generator embodies a fresh approach to peak limiting that embeds extremely sophisticated distortion-cancelling clipping and overshoot control within the dbx compressor. The payoff is high average modulation capability without any need to over-compress and squash the signal. This makes best use of the marginal signal-to-noise ratio available from the basic SAP subcarrier while

simultaneously protecting the integrity of the baseband spectrum.

Subcarrier Generator: Our newly-developed subcarrier generator uses an ultra-linear VCO and phase-locked-loop AFC that locks to the horizontal sync reference. Particular care was paid to assuring accurate square wave response at both low and high frequencies. This guarantees that the tightly-controlled peaks produced by the audio processor will be faithfully reproduced by the modulator, maximizing average modulation and signal-to-noise ratio.

Amenities: They're all there—everything from comprehensive metering to remote control of SAP ON/OFF and Loudness Controller ON/OFF. There's automatic subcarrier muting if sync reference is lost—and auto-restart when it's restored, plus provision for a remote gain reduction meter and remote indication of sync lock.

The Bottom Line

Quality. We were amazed at how good SAP can sound with Orban's advanced processing, in spite of the BTSC 10kHz bandwidth limitation. It's dramatically better than FM SCA!



ACCESS DOOR REMOVED SHOWING SETUP CO

Take your choice—whether you want to broadcast a second language to accompany the original video, or entirely separate programming, Orban's system approach to SAP gives you sound quality that approaches the full fidelity of the main channel.

Model ACC-21 Optional Monitor Card

For N/R decoded output. The Model ACC-21 Optional Monitor Card supplies a built-in calibrated monitor system, containing a dbx N/R decoder and appropriate deemphasis. It is used to monitor performance of the entire SAP system up to, but not including, the modulator. The monitor output is available on the rear panel barrier strip.

The 8182A/SG Stereo Generator is supplied standard with a card identical to the ACC-21, where it is used to monitor stereo performance. If convenient, that Monitor Card may be moved from the SG to the SAP when needed for diagnostic or monitor purposes. Otherwise, a separate ACC-21 card may be bought to be installed permanently in the SAP Generator.

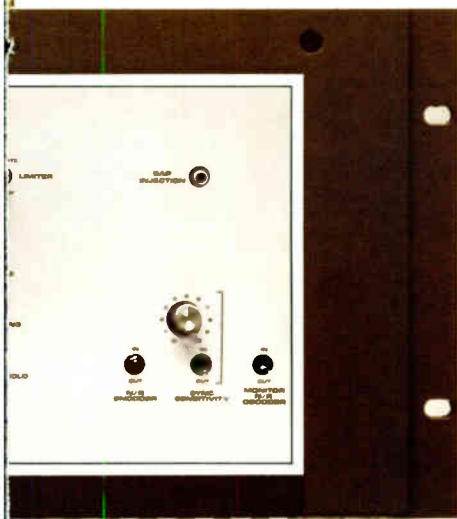

Pro Channel Generator At A Glance

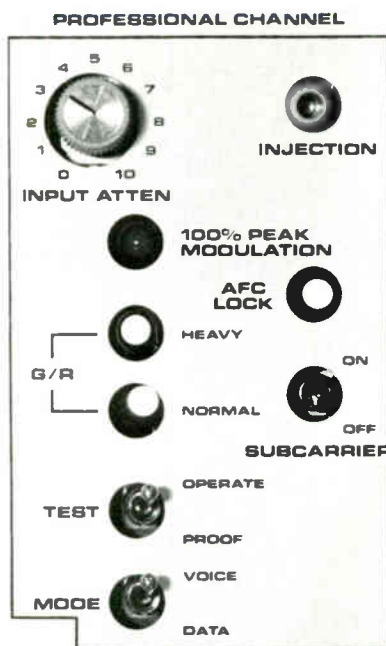

Model 8182A/PRO Professional Channel Generator: A Speech Processor/Data Conditioner and BTSC-standard Subcarrier Generator

- Consists of two cards that plug into the Orban 8182A/SG TV Stereo Generator
- Switchable for speech or data
- Speech processing to maximize intelligibility
- Data conditioning for 1200 baud FSK data
- High-stability subcarrier generator
- Remote control of subcarrier on/off
- LEDs for easy setup: Indicate 100% modulation and compressor gain reduction NORMAL and HEAVY

A Pro Channel System With A Dual Personality

The Orban 8182A/PRO Professional Channel Generator offers all the features required of a Pro Channel Generator: your choice of processing for speech or flat response for data, and a high-stability subcarrier generator—all at no cost in valuable rack space, and at a very reasonable price.

Effective speech processing: At best, the audio quality of Pro Channel is comparable to a long-distance voice-grade phone line, due to Pro Channel's location at 6.5f_H, and its limited deviation, injection, and frequency response.

For Pro Channel to be effective for voice communications, the audio must be carefully processed to maximize received intelligibility—punching the voice as loudly and crisply as possible. To achieve this, Orban's Pro Channel audio processing employs aggressive 3.4kHz lowpass filtering, modest frequency contouring, compression, limiting, and the patented Orban Clipper/Overshoot Correction System.

The result is maximum *talk power* under difficult reception conditions.

Data conditioning: Data has a different set of requirements: error-free data transmission at high rates.

In the data mode, the Orban Pro Channel generator offers flat frequency and phase response to 3kHz. A phase-corrected sharp-cutoff 7th-order Cauer filter prevents intersymbol interference (a data transmission term referring to data pulses smearing together), while protecting the rest of the baseband from interference. Under reasonable reception conditions, Pro Channel should be able to carry 1200 baud FSK.

Remote Control: The subcarrier may be switched ON/OFF from the subpanel of the Stereo Generator, or by remote control.

1 OPTIMOD-TV AUDIO PROCESSOR

The Technical Details

1 Input conditioning filter: An allpass phase scrambler makes peaks more symmetrical to reduce clipping distortion and allow better control of loudness. A 30Hz 18dB/octave highpass filter prevents subsonic information from disturbing the operation of the audio processor or the exciter's AFC.

2 Dual-band AGC: The dual-band design divides the audio into two bands with a 200Hz crossover that feeds a BASS compressor and a MASTER compressor.

The BASS COUPLING control determines if the two compressors operate independently (INDEPENDENT) making audio quality more consistent by correcting frequency imbalances between bass and midrange, or if the BASS band will track the MASTER band (WIDEBAND) preserving frequency balances. Settings in-between allow you to tune the processing to your exact requirements.

Even in WIDEBAND, the bass control loop is activated. Heavy bass will affect only the bass band gain, rather than forcing gain reduction of the entire signal, as in a single-band system. This, along with program-controlled attack and release time-constants, eliminates audible "pumping" and gain modulation.

The RELEASE TIME control determines how fast the gain of the master compressor recovers when the program material falls below the compression threshold, and is adjustable over a wide range. It affects the *density* of the sound and the short-term dynamic range. When the control is set towards "slow," the AGC acts as a gentle gain riding device, offering an open sound with no audible compression.

The GATING function prevents noise rush-up, offers additional control over the sound of OPTIMOD-TV, and makes the 25dB gain reduction range fully useful. The GATING control adjusts the level below which the AGC "freezes" gain. A high gating level preserves long-term dynamic range by preventing quiet passages in wide dynamic range audio from being increased unnaturally.

3 Automatic Loudness Controller: Ordinarily, gain reduction in the OPTIMOD-TV is determined by the AGC's control circuitry. However, when loudness exceeds a threshold, the Automatic Loudness Controller acts to further reduce the gain as necessary. This is the most advanced technique known for controlling the perceived loudness of broadcast audio.

4 L and R 15,743Hz notch filters (for BTSC Stereo TV): These filters are located in the 8182A/SG Stereo Generator chassis, but are inserted in the audio path of the 8182A OPTIMOD-TV Audio Processor to prevent horizontal sync leakage in the incoming audio from affecting the action of the high-frequency and peak limiters.

5 Lowpass filter, preemphasis, and high-frequency limiter: The lowpass filter prevents intermodulation between in-band and out-of-band frequency components in the clipper, and prevents out-of-band components from affecting the operation of the high-frequency limiter. This filter is followed by the preemphasis network.

The high-frequency limiter is controlled by high frequencies *only*, eliminating any possibility of modulation of high frequency content by low frequency material.



ACCESS DOOR REMOVED SHOWING SETUP CONTROLS

6 Hilbert-Transform Clipper:

The patented Hilbert-Transform Clipper provides effective peak control without introducing audible distortion, and it contains filters to assure that the clipping does not introduce out-of-band frequency components. It allows substantially more clipping than in conventional systems, significantly improving audible high frequency response by minimizing the amount of high frequency limiting necessary to avoid audible distortion.

The Hilbert-Transform Clipper takes advantage of psychoacoustical factors and the deemphasis included in all receivers: Its action introduces no harmonic distortion when it processes frequencies below 4kHz. Simultaneously, IM distortion below 2.2kHz is sharply cancelled by an adaptation of the patented Orban feedforward distortion-cancelling filter.

The result is very low perceived distortion on both voice and music. Harmonic distortion, not IM, most severely degrades voice—no harmonic distortion is produced in the voice frequency range, keeping voice clean. Sibilance distortion is

eliminated by the distortion-cancelling filter. Above 4kHz where music has substantial energy (particularly after preemphasis), IM distortion is minimized, optimizing music reproduction as well.

Because band-limited voice (from 16mm optical film, for example) is so prevalent in TV audio and because band-limited voice is easily degraded by the harmonic distortion introduced by more conventional clippers, the Hilbert-Transform Clipper is extremely effective in achieving cleaner sound on the air.

7 Frequency-Contoured Side-chain (FCS) Overshoot Corrector:

The output of the Hilbert-Transform Clipper contains overshoots due to the addition of the distortion-cancelling signal and overshoots in its integral 15kHz lowpass filter. These overshoots are eliminated in the FCS Overshoot Corrector without adding out-of-band frequency components—the circuit acts essentially as a band-limited safety clipper.

Because this circuit acts instantaneously and employs no gain reduction or dynamic filtering, it causes neither pumping nor dulling of program material.

8 Output: The output stage interfaces to the outside world through non-overshooting RFI filters that are effective from 500kHz to 1GHz.

A variety of output options are available: preemphasized or deemphasized, and L/R or L + R/L - R. For BTSC, the preemphasized signal is matrixed to L + R/L - R, then fed to the 8182A/SG TV Stereo Generator via a multi-pin cable supplied.

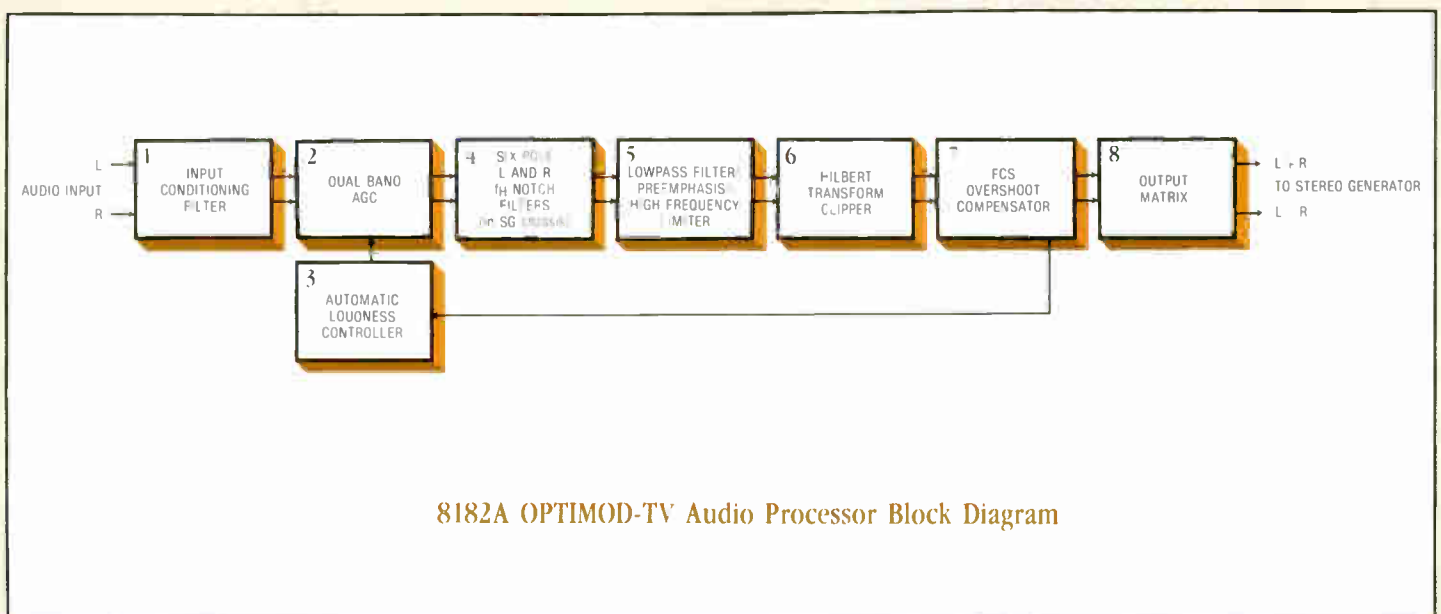

8182A OPTIMOD-TV Audio Processor Block Diagram

5 Stereo encoder: The stereo encoder accepts the processed sum and difference signals and produces the stereo baseband signal. The generator is characterized by high stability with time and temperature, very low distortion, and minimal spurious outputs.

The baseband is generated by the "matrix" technique, using high-stability servo loops to control pilot phase, pilot level, and separation. Using a highly-linear analog multiplier, the L-R signal is multiplied by a $2f_H$ sinewave to form the double-sided suppressed-carrier subchannel. The subchannel, baseband, and $1f_H$ pilot tone are then summed to form the composite baseband.

This design modulates only the L-R component, and passes the L+R component through to the output without degradation due to switching. Since the L+R component almost always dominates, this results in maximum audio quality.

6 Variable Exciter Protection Clipper: A defeatable baseband clipper with continuously adjustable threshold. This removes the most radical overshoots introduced by the extremely steep filters required by BTSC recommended practice. If uncontrolled, these overshoots may overload and/or destabilize some exciters. (Without the clipper, we have observed short-duration overshoots as large as 300% modulation.)

Experience with stereo FM has demonstrated that the baseband clipping of the Variable Exciter Protection Clipper is a most innocuous way of controlling overshoots. It is adjustable from 100% to more than 300% (effectively out-of-circuit), and is typically set at 125-150%. Note that this clipping differs greatly from "composite clipping" used to increase loudness (and distortion!) in FM.

7 Monitor circuit: The monitor circuit consists of a pair of matched 75 μ s deemphasis networks, a dbx N/R decoder card, a decoder sum compensator, and a precision matrix.

8 Output amplifier: The output amplifier is strappable as a voltage (approximately 0 Ω) or 75 Ω source. As a voltage source, it can drive up to two 75 Ω loads in parallel and up to 0.047 μ F of capacitance (2200ft of RG-59/U) without degradation. It is isolated from chassis ground, greatly reducing the likelihood of ground loop problems.

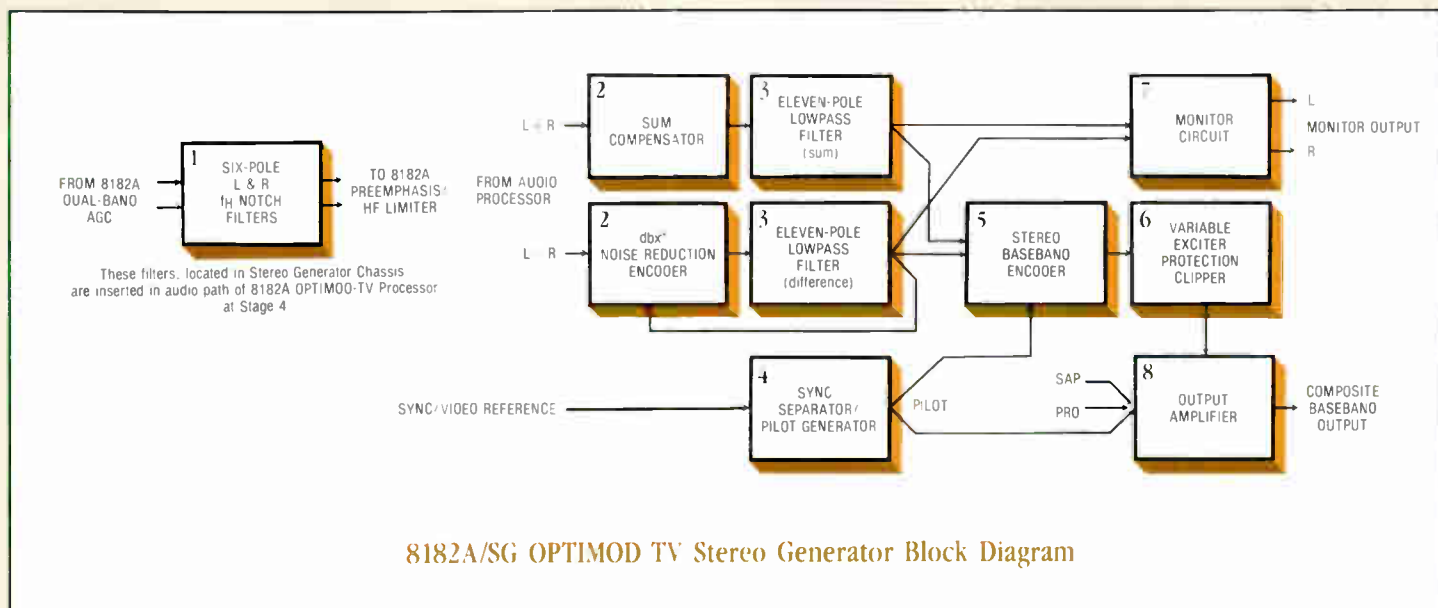

SPECIFICATIONS

Orban Stereo TV System 8182A and 8182A/SG

Performance meets or exceeds all specifications for the BTSC System, as defined by FCC OST-60 and EIA's BTSC System: Television Multichannel Sound Recommended Practices. Stereo measurements made with dbx N/R IN unless otherwise noted; mono measurements made with 75us deemphasis.

Total system frequency response (mono, left, or right): ± 0.75 dB, 35-15,000Hz; ± 0.5 dB typical.

Total system noise (mono, left, or right): -75dB referenced to 100% modulation, 50-15,000Hz; -81dB typical.

Total system distortion (50% modulation, mono, left, or right): 0.25% THD, 50-15,000Hz; 0.1% THD, 50-10,000Hz typical.

Equivalent stereo separation (N/R OUT, all filters IN): 40dB, 50-8,000Hz, smoothly declining to 35dB @15kHz.

BTSC system separation (10% 75us equivalent-input modulation, N/R IN): Guaranteed >30dB, 50-15,000Hz; typical units exceed this specification by 5 to 10dB, 50-8,000Hz.

Audio Processor Performance

Frequency response (PROOF mode): Strapped for preemphasized output, follows standard 75us (or 50us) preemphasis curve ± 0.75 dB, 50-15,000Hz. Strapped for flat output, ± 0.75 dB, 50-15,000Hz.

Noise: -75dB referenced to 100% modulation, 50-15,000Hz; -81dB typical.

Total system distortion (PROOF mode, deemphasized, 100% modulation): <0.25% THD, 50-15,000Hz; 0.02% typical. <0.1% SMPTE Intermodulation Distortion.

System separation: >50dB, 50-15,000Hz; 60dB typical.

Installation

AUDIO INPUT

Configuration: Left and right.

Impedance: >10K ohm load impedance, electronically balanced by means of true instrumentation amplifier. Requires balanced source ≤ 600 ohms. Common mode rejection >60dB @60Hz.

Sensitivity: -30dBm to +10dBm to produce 10dB "Master Band" gain reduction @1kHz.

AUDIO OUTPUT

Configuration: Left and right or sum and difference, selectable with internal jumpers; pre-emphasized or flat, selectable with internal jumpers.

Impedance: 370 ohm source impedance, independent of OUTPUT ATTEN setting, balanced. Recommended load impedance 600 ohms $\pm 20\%$.

Peak Output Level: Adjustable from - ∞ dBm to >+20dBm with 15-turn OUTPUT ATTEN controls. Output clipping level +26dBm/600 ohms.

Connector: Barrier strip (#5 screw), EMI suppressed.

INTERCONNECT TO 8182A/SG

Signals: Left and right compressor output to 8182A/SG six-pole filter input; SG left and right six-pole filter output to 8182A HF limiter input; 8182A sum and difference preemphasized output to SG input.

Connector: 14 pin connector to mate with shielded jumper cable supplied with 8182A/SG.

REMOTE CONTROL

Function: Selects Loudness Controller ON/OFF.

Voltage: 6 to 24V AC or DC, momentary or continuous, optically isolated.

Connector: Barrier strip (#5 screw).

REMOTE GAIN REDUCTION

METER OUTPUT

Configuration: Negative DC voltage proportional to total master gain reduction. Scale approximately -0.33V/dB, source impedance 8.8K ohms.

Connector: Barrier strip (#5 screw).

POWER

115/230VAC (switch selectable), $\pm 15\%$, 50-60Hz; 31VA. IEC mains connector with detachable 3-wire "U-Ground" power cord supplied. Leakage to chassis <0.5mA. AC is EMI suppressed.

Ground: Circuit ground is independent of chassis ground; both appear on terminal strip on rear panel for strapping as required.

DIMENSIONS

19" (48.3cm) W, 7" (17.8 cm) H, 12.5" (31.2cm) D, 4 rack units.

ENVIRONMENTAL

Operating temperature range 0-50°C (32-122°F). Humidity 0-95% RH, non-condensing.

Circuitry

INPUT CONDITIONING

Highpass filter: Third-order Chebychev with 30Hz cutoff and 0.5dB passband ripple;

-0.5dB @30Hz, -10.5dB @20Hz, -31.5dB @10Hz.

Phase scrambler: Allpass network makes peaks more symmetrical to best utilize the symmetrical peak overload characteristics of the FM medium.

CROSSOVER (US Patent No. 4,249,042)

Control: 6dB/octave, 200Hz.

Program: 12dB/octave, 200Hz, in unique "distributed crossover" configuration.

"MASTER BAND" COMPRESSOR

Attack time: Approximately 1ms.

Release time: Program controlled; varies according to program dynamics and amount of gain reduction. Process can be scaled fast or slow with continuously variable RELEASE TIME control. Employs delayed release for distortion reduction.

Threshold of compression: Controlled by left and right input attenuators.

Operation: Gains of left and right channels track to avoid stereo perspective shift.

Total harmonic distortion (at VCA output, OPERATE mode, RELEASE TIME control centered):

<0.1%, 200-15,000Hz, +10 to -15dB gain reduction.

Available gain reduction: 25dB.

"BASS BAND" COMPRESSOR

Attack time: Program controlled.

Release time: Program controlled. Employs delayed release for distortion reduction.

Operation: Gains of left and right channels track to avoid stereo perspective shift.

Total harmonic distortion (at VCA output, OPERATE mode): <0.1%, 50-200Hz, +10 to -20dB gain reduction.

Available gain reduction: 30dB.

Bass coupling (US Patent No. 4,249,042): Enables gains of "Bass Band" to track gain of "Master Band" to any degree, from identical tracking to fully independent operation. Adjustable with BASS COUPLING control.

HIGH FREQUENCY LIMITER

Attack time: Approximately 5ms.

Release time: Approximately 20ms. Employs delayed release for distortion reduction.

Threshold of IIF limiting: User-adjustable over 3dB range to meet user requirements.

Operation: Left and right channels operate independently to prevent high frequencies in one channel from causing audible timbre modulation in opposite channel.

HILBERT-TRANSFORM CLIPPER

(US Patent No. 4,495,643)

Bandwidth: 15-4kHz.

Distortion characteristics: <2.5% THD produced by individual frequencies 30-4,000Hz when driving Hilbert-Transform Clipper to 6dB beyond threshold of limiting. Further distortion cancellation assures that, for any input including program material, distortion components in the frequency range 0 to 2,200Hz are cancelled better than 30dB below overshoot compensator threshold. With drive frequencies above 4,000Hz, characteristics revert to those of a "hard" clipper.

Amount of clipping: User-adjustable over 6dB range.

FREQUENCY-CONTOURED SIDE-CHAIN (FCS) OVERSHOOT COMPENSATOR

(US Patent No. 4,460,871)

Operation: The FCS circuit is best thought of as a "bandlimited safety clipper." It operates like a hard clipper, but without producing out-of-band frequency components. It is followed by a safety clipper, aligned so that it is almost *never* active, fully preserving the bandlimiting provided by the FCS circuit.

Peak modulation control: Within $\pm 2\%$ on typical program material; $\pm 3.5\%$ worst-case.

Sinewave modulation ability: 93% modulation (0.6dB below maximum overshoot level) at all frequencies.

"PROOF" TEST MODE

Compressor: Defeats "Master" and "Bass" gain reduction control; switches "gate" ON to force unit into 10dB gain reduction (0dB on GR meter).

Limiter: Defeats HF limiter, Hilbert-Transform Clipper, FCS Overshoot Compensator, and safety clipper.

Studio Chassis Installation

AUDIO INPUT

Configuration: Left and right.

Impedance: >10K load impedance, electronically balanced by means of true instrumentation amplifier. Requires balanced source ≤ 600 ohms. Common mode rejection >60dB @60Hz.

Sensitivity: -30dB to +10dB to produce 10dB "Master Band" gain reduction @1kHz.

Connector: Barrier strip (#5 screw), EMI suppressed.

AUDIO OUTPUT

Configuration: Left and right.

Impedance: 600 ohm resistive source impedance, balanced to ground.

Level (600 ohm load): Adjustable from - ∞ dBm to >+3dBm, measured on a VU meter with typical program; corresponds to typical maximum peak level of +18dBm. Designed to correctly interface with +4dBm and +8dBm systems.

Connection: Barrier strip (#5 screw), EMI suppressed.

REMOTE GAIN REDUCTION

METER OUTPUT

Configuration: Negative DC voltage proportional to total master gain reduction. Scale approximately -0.33V/dB, source impedance 8.8K ohms.

Connector: Barrier strip (#5 screw).

POWER

115/230VAC (internally selectable), $\pm 15\%$, 50-60Hz; 15VA. IEC mains connector with detachable 3-wire "U-Ground" power cord supplied. Leakage to chassis <0.5mA. AC is EMI suppressed.

Ground: Circuit ground is independent of chassis ground; both appear on terminal strip on rear panel for strapping as required.

DIMENSIONS

19" (48.3cm) W, 3.5" (8.9cm) H, 11.5" (29.2cm) D, 2 rack units.

ENVIRONMENTAL

Operating temperature range 0-55°C (32-122°F). Humidity 0-95% RH, non-condensing.

TV Stereo Generator Installation

LOCATION

Immediately below 8182A OPTIMOD-TV.

AUDIO INPUT

Configuration: Sum and difference, preemphasized, via 8182A chassis interconnect connector.

SYNC REFERENCE INPUT

Impedance: 20K ohms, balanced. Switchable 75 ohm termination.

Level: Composite video or sync, 0.6 to 1.6Vp-p; 1V nominal.

Connector: Two BNC connectors, looped-thru, shell insulated from chassis.

SAP SUBCARRIER INPUT

Impedance: >10K ohms, unbalanced; shell capacitively coupled to chassis through approximately 500pF for EMI suppression.

Level: 1.5V peak to produce ± 15 kHz carrier deviation (100% modulation of SAP subcarrier).

Connector: BNC.

COMPOSITE OUTPUT

Impedance: Voltage source (0 ohms) or 75 ohm source impedance (selectable with internal jumpers), single-ended, impedance independent of OUTPUT LEVEL setting.

Level: Adjustable from 0 to >2.2V peak (4.4V p-p) with 18-turn TOTAL BASEBAND OUTPUT LEVEL control.

Load: When jumpered for voltage source, will drive two 75 ohm loads in parallel. Maximum permissible load capacitance 0.047 μ F.

Connector: BNC, floating over chassis ground to permit interface to other equipment without need for wideband transformer to suppress ground loops. EMI suppressed.

MONITOR OUTPUT

Configuration: Left and right, N/R decoded (or 75us deemphasized, depending on setting of internal MONITOR N/R IN/OUT switch).

Impedance: 600 ohm source impedance, single ended.

Level: Fixed: 5V peak corresponds to 100% modulation.

Connector: Barrier strip (#5 screw), EMI suppressed.

REMOTE CONTROL

Function: Selects MONO LEFT/MONO RIGHT/STEREO, Pro Channel ON/OFF.

Voltage: 6 to 24V AC or DC, momentary or continuous, optically isolated. 22VDC supplied to facilitate use with contact closure.

Connector: Barrier strip (#5 screw).

SYNC LOCK INDICATOR

Configuration: Relay-controlled contact closure to indicate successful lock to sync or composite video. Limit applied voltage to 50V, total load to 10VA non-reactive, current to 0.5A.

Connector: Barrier strip (#5 screw).

POWER

115/230VAC (switch selectable), $\pm 15\%$, 50-60Hz; 35VA. IEC mains connector with detachable 3-wire "U-Ground" power cord supplied. Leakage to chassis 0.5mA. AC is EMI suppressed.

Ground: Circuit ground is independent of chassis ground; both appear on terminal strip on rear panel for strapping as required.

DIMENSIONS

19" (48.3cm) W, 7" (17.8cm) H, 12.5" (31.2cm) D, 4 rack units.

ENVIRONMENTAL

Operating temperature range 0-50°C (32-122°F). Humidity 0-95% RH, non-condensing.

Circuitry

LEFT AND RIGHT LOWPASS FILTERS

Type: Six-pole filters with two high-Q notches.

Rejection: > -50dB @15.734Hz.

SUM AND DIFFERENCE

LOWPASS FILTERS

Type: Eleven-pole elliptical filter.

Passband response: Typically +0.05, -0.1dB to 15,000Hz.

Stopband rejection: > 60dB @15.734Hz and above.

STEREO BASEBAND GENERATOR

Noise: < -83dB referenced to ± 50 kHz deviation.

Distortion (deemphasized, 100% modulation): < 0.1% THD, 50-15,000Hz. < 0.05% SMPTE Intermodulation Distortion.

Equivalent stereo separation: > 50dB, 50-15,000Hz; 60dB typical.

Crosstalk—linear: < -60dB, main channel to subchannel or subchannel to main channel, referenced to ± 50 kHz deviation.

Crosstalk—non-linear: < -80dB, main channel to subchannel or subchannel to main channel, referenced to ± 50 kHz deviation.

31.468Hz subcarrier suppression:

< -50dB, referenced to ± 50 kHz deviation.

Other spurious outputs: Exceeds requirements of FCC Sec. 73.682(c)(4) by 10dB or better.

SAP Generator

Performance

Frequency response (PROOF mode, N/R in): ± 0.75 dB, 50-10,000Hz. Measured with reference SAP demodulator and professional N/R decoder.

Noise: -75dB referenced to 100% modulation, 50-10,000Hz; -81dB typical.

Total system distortion—N/R in (PROOF mode, 100% modulation): < 0.4% THD, 50-10,000Hz. < 0.4% SMPTE Intermodulation Distortion. Measured with reference SAP demodulator and professional N/R decoder.

Total system distortion—N/R out (PROOF mode, 100% modulation): < 0.2% THD, 50-10,000Hz. Measured with 75us preemphasis and deemphasis.

Installation

LOCATION

Up to 100ft (31m) RG-58A/U from exciter or 8182A/SG.

AUDIO INPUT

Impedance: 10K ohm load impedance, electronically balanced by means of true instrumentation amplifier. Requires balanced source ≤ 600 ohms. Common mode rejection > 60dB @60Hz.

Sensitivity: -30dB to +10dBm to produce 10dB "Master Band" gain reduction @1kHz.

Connector: Barrier strip (#5 screw), EMI suppressed.

SYNC REFERENCE INPUT

Impedance: 20K ohms, balanced. Switchable 75 ohm termination.

Level: Composite video or sync, 0.6 to 1.6V p-p; 1V nominal.

Connector: Two BNC connectors, looped-thru, shell insulated from chassis.

SAP OUTPUT

Impedance: Voltage source (0 ohms) or 75 ohm source impedance (selectable with internal jumpers), single-ended, impedance independent of OUTPUT LEVEL setting.

Level: Adjustable from 0 to >2.2V peak (4.4V p-p) with 18-turn OUTPUT LEVEL control.

Load: When jumpered for voltage source, will drive two 75 ohm loads in parallel. Maximum permissible load capacitance 0.047 μ F.

Connector: BNC, floating over chassis ground to permit interface to other equipment without need for wideband transformer to suppress ground loops. EMI suppressed.

MONITOR OUTPUT (When optional ACC-22 Monitor Card is installed)

Configuration: N/R decoded (or 75us deemphasized), depending on setting of internal MONITOR N/R IN/OUT switch).

Impedance: 600 ohm source impedance, single ended.

Level: Fixed: 5V peak corresponds to 100% modulation.

Connector: Barrier strip (#5 screw), EMI suppressed.

REMOTE CONTROL

Function: Selects SAP ON/OFF, Loudness Controller ON/OFF.

Voltage: 6 to 24V AC or DC, momentary or continuous, optically isolated. 22VDC supplied to facilitate use with contact closure.

Connector: Barrier strip (#5 screw).

SYNC LOCK INDICATOR

Configuration: Relay-controlled contact closure to indicate successful lock to sync or composite video. Limit applied voltage to 50V, total load to 10VA non-reactive, current to 0.5A.

Connection: Barrier strip (#5 screw).

POWER

115/230VAC (switch selectable), $\pm 15\%$, 50-60Hz; 31VA. IEC mains connector with detachable 3-wire "U-Ground" power cord supplied. Leakage to chassis < 0.5mA. AC is EMI suppressed.

Ground: Circuit ground is independent of chassis ground; both appear on terminal strip on rear panel for strapping as required.

DIMENSIONS

19" (48.3cm) W, 7" (17.8cm) H, 12.5" (31.2cm) D, 4 rack units.

ENVIRONMENTAL

Operating temperature range 0-50°C (32-122°F).

Humidity 0-95% RH, non-condensing.

Circuitry

INPUT CONDITIONING, CROSSOVER, "MASTER BAND" COMPRESSOR, "BASS BAND" COMPRESSOR,

HIGH-FREQUENCY LIMITER

Same as 8182A OPTIMOD-TV.

DISTORTION-CANCELLED CLIPPER

(US Patent No. 4,208,548)

Operation: Provides peak limiting function.

Nominal bandwidth: 10kHz.

Distortion cancellation: Clipping distortion below overshoot compensator threshold cancelled better than 30dB, 0 to 2,200Hz; +40dB typical.

FREQUENCY-CONTOURED SIDE-CHAIN

(FCS) OVERSHOOT COMPENSATOR

(US Patent No. 4,460,871) Same as 8182A OPTIMOD-TV.

LOWPASS FILTER

Type: 10kHz ninth-order elliptical filter. Follows N/R encoder.

Passband response: Typically +0.05, -0.1dB to 10,000Hz.

Stopband rejection: Affords >80dB protection to stereo subchannel.

SAP GENERATOR

Residual FM noise: -70dB referenced to 100% modulation (with 75us deemphasis).

Pro Generator

Performance

SPEECH MODE

Frequency response: Follows standard 150us preemphasis curve ± 0.5 dB, 50-3,000Hz. Strappable 6dB/octave bass-cut filter provides greatest intelligibility and modulation efficiency.

Noise (150us deemphasis): < -60dB referenced to 100% modulation.

Total system distortion (PROOF MODE, 150us deemphasis): < 0.5% THD, 50-3,000Hz.

DATA MODE

Frequency response: ± 0.1 dB, 5-3,200Hz.

Group delay: Constant $\pm 2\%$ or better, 5-3,200Hz.

Total system distortion (no deemphasis): < 0.5% THD, 50-3,000Hz.

Installation

LOCATION

8182A/PRO is contained on two cards that mount into slots in the 8182A/SG TV Stereo Generator.

INPUT

Impedance: >10K ohm load impedance, electronically balanced by means of true instrumentation amplifier. Requires balanced source ≤ 600 ohms. Common mode rejection 54dB @60Hz.

Sensitivity: -30dBm to +10dBm to produce 10dB gain reduction @1kHz (SPEECH mode), or 100% modulation (DATA mode).

Connector: Barrier strip (#5 screw), EMI suppressed.

Circuitry

SPEECH PROCESSING

Phase scrambler: Allpass network makes asymmetrical voice waveforms more symmetrical.

Compressor: Fast-attack variable gain circuit; compression ratio nearly infinite. Uses delayed release-time to minimize distortion on low frequency signals. Two LEDs on the subpanel indicate NORMAL and HEAVY gain reduction.

Peak clipper and overshoot compensator: Peak clipper limits the signal to 100% modulation. Uses patented Orban Overshoot Compensator to avoid overmodulation after the subsequent 3.4kHz lowpass filter. (US Patent No. 4,103,243).

PHASE-CORRECTED LOWPASS FILTER

Type: Seventh-order elliptical filter, with sixth-order phase-correction. Cutoff frequency of 3.4kHz complies with BTSC system specification.

Stopband rejection: >55dB above 4.5kHz.

PRO GENERATOR

Residual FM noise: -60dB referenced to 100% modulation (with 150us deemphasis); -50dB (no deemphasis).



Orban Associates Inc. 645 Bryant Street, San Francisco, CA 94107
(800) 227-4498 or (415) 957-1067 Telex: 17-1480

The Orban 275A Automatic Stereo Synthesizer

An unrivaled problem-solver for Stereo TV Transmission



Features

- **Two methods of automatic mono recognition**
“Single-Channel” detects absence of audio on one channel, “Mono/Stereo” recognizes mono in both channels.
- **Two stereo synthesis modes**
NARROW mode effectively centers dialog, WIDE mode is more dramatic for music and effects.
- **Smooth cross-fading between true and synthesized stereo**
No pops, clicks, or discontinuities.
- **Full mono compatibility**
Sum of synthesized outputs is identical to mono input.
- **Patented Orban phase-shift derived comb-filter stereo synthesis technique**
Provides synthesized stereo without addition of unnatural resonances or “flanging” colorations.
- **Automatic detection and correction of polarity-reversed (“out-of-phase”) stereo inputs**
- **Noise reduction for mono material**
Typically 10dB reduction of hiss and hum; single-ended.
- **Optically-isolated external automation control interface**
- **Optional remote control unit duplicates main unit functions**
- **Fully balanced stereo inputs and outputs**
Can be used with +4dBm or +8dBm lines.

A Stereo Synthesizer That’s Right for Stereo TV

The scarcity of true stereo program material has caused many television broadcasters to look for a device that could effectively and automatically reprocess mono material into synthesized stereo. Orban has responded to this need by developing an automatic stereo synthesizer specifically designed for in-line stereo synthesis of mono TV audio.

The **Model 275A Automatic Stereo Synthesizer** improves upon the popular, manually-operated Model 245F Stereo Synthesizer with these added features:

- Automatic mono/stereo recognition and switching with smooth cross-fade.
- A choice of *two* methods of automatic mono recognition and *two* stereo synthesis modes.
- Important stereo television “utility” features like polarity error correction and noise reduction.
- Exceptionally versatile remote control.

Manual, Automatic, or Remote Control

The 275A Stereo Synthesizer is designed to be placed permanently in the program line. Unless one of its synthesis or utility functions is selected, the 275A will pass audio transparently.

Manual controls on the front panel select whether stereo is to be synthesized from left or right channel mono, whether the “wide” (best-suited for music and effects) or “narrow” (best-suited for voice) synthesis mode is used, and whether noise reduction should be applied to the mono signal prior to stereo synthesis.

Front-panel pushbuttons also allow the operator to activate the automatic recognition and synthesis circuitry, bypass the synthesizer, lock out external automation, or route true-stereo audio through the reversed-polarity detector and corrector.

LED indicators show the functions selected, as well as the operating status of the noise reduction and polarity correction utilities.

All of these controls and indicators are duplicated on the optional, rack-mountable 275A/RC Remote Control Panel.

In addition, the 275A Stereo Synthesizer can be controlled from the station’s automation system, tally, or vertical interval decoder through optically-isolated logic inputs available at a rear-panel connector.

Automatic Recognition of Mono/Stereo

It is very difficult to design a circuit which accurately distinguishes between mono and true stereo program material. What defines true mono? If the program material on the left and right channels is identical but differs slightly in level or phase due to recorder or plant errors and tolerances, is that true mono? And should a synthesizer switch-in during those segments of a stereo program when there is no stereo music or sound effects—only center-channel dialog or effects which are electronically identical to true mono?

Although electronic recognition is required, it is clear that no electronic circuit using present-day technology can perform this task perfectly—positive identification of center-channel material still requires the human ability to perceive meaning and high-level context. Nevertheless, at the request of broadcasters Orban is providing such automatic recognition, painstakingly refined and fine-tuned to make fewer errors than other center-channel recognition devices. Because some errors are still inevitable with center-channel recognition, the 275A also provides a more reliable alternative: single-channel recognition.

Single-Channel Recognition:

With this approach, the station routes all mono material through the program lines on *one channel only*. If the 275A detects a mute channel, it will automatically synthesize stereo from the other, active channel. If



both channels are active, the signal is considered stereo and the synthesizer is bypassed. Single-channel recognition assures reliable detection without recognition errors.

Mono/Stereo Recognition:

In this technique, no special routing of program material is required. Audio present on both channels is analyzed by the 275A's recognition circuitry. Even if the program material is primarily hard-center dialog with low-level stereo music or audience noise background, the 275A will recognize it as stereo and bypass the synthesizer. If the material is electrically mono, it is routed to the synthesizer. Minor phase and level differences caused by plant tolerances are ignored. Audio present on only one channel always activates the synthesizer, as in the single-channel technique.

Regardless of which method of recognition you choose, the 275A Stereo Synthesizer cross-fades between synthesized and true stereo material smoothly and unobtrusively.

Stereo Synthesis

The patented Orban stereo synthesis technique creates a compelling pseudo-stereo effect from a mono signal by dividing the audio spectrum into several frequency bands, then directing these bands alternately to the left and right channels. It does this by passing a mono signal through a chain of phase shifters to generate an artificial L-R signal, which is then added to the mono to obtain the synthesized left channel and subtracted from the mono to obtain the synthesized right channel. The net effect is a "complementary comb filter" (see figure 1). The sum of the two synthesized channels always remains equal to the original mono, ensuring mono compatibility.

Because the audio spectrum is divided logarithmically, the undesirable harmonic reinforcement and cancellation which can result

from arithmetic band-splitting is avoided. The number of bands (and therefore their individual bandwidths) determines how "dramatic" the stereo effect is. With the 275A Automatic Stereo Synthesizer, two types of remote-selectable stereo synthesis effects are available: a small number of wider bands results in a dramatic sense of stereo space on music and effects (similar to our 245F), while a larger number of narrower bands centers dialogue more accurately. A recessed SEPARATION control adjusts the amount of inter-channel difference (L-R), which determines the relative width of the stereo image.

To maximize loudness while making efficient use of the modestly-priced amplifiers in most consumer TV sets, energy below approximately 200Hz remains mono. The ear can not detect stereo separation in this region.

Noise Reduction

Older mono material often suffers from hiss and other forms of noise. The 275A can apply single-ended noise reduction to mono audio prior to stereo synthesis processing. This noise reduction combines program-controlled high-frequency filtering with broadband expansion. 10dB of noise reduction is typically achieved — without unnaturally reducing ambience and dialog intelligibility when program levels are low.

Because the noise reduction system is single-ended, no encoding (or later decoding) of the program material is necessary. This makes the process ideally suited to noisy optical soundtracks and satellite feeds. Operation is exceptionally smooth and subtle, and "pumping" and "breathing" are entirely absent.

Noise reduction is not available for true stereo material, since the quality of most stereo material is high and the feature would not justify the additional cost.

Polarity Correction

In stereo material, it is essential that the two channels be in phase with each other. If they are not, the mono sum signal will be seriously degraded as the two channels cancel each other. And that means that the viewer with a mono set (a majority of your audience) will hear disastrously inferior audio, and in some cases no sound at all!

To ensure the mono compatibility of your stereo broadcasts, the 275A can act as a "watchdog" over your program line polarity, correcting errors when detected. The detection technique is very reliable and highly resistant to "falsing" — even when subjected to substantial high-frequency phase errors (due to misaligned heads or other mechanical problems) or when monitoring soundtracks containing out-of-phase "surround" energy.

An LED on the front (and remote control) panel lights when a polarity reversal is being corrected. The detection/correction circuit can be activated or defeated at any time.

The OPTIMOD Tradition

The 275A Automatic Stereo Synthesizer has been designed to be an integral part of Orban's OPTIMOD® Television Stereo System, along with the:

- 8182A Audio Processor
- 8185A/SG Stereo Generator
- 8182A/SAP Second Audio Program Generator
- 8182A/PRO Professional Channel Generator

The stability, reliability, and superb performance that distinguish Orban products make them the equipment of choice for the innovative stereo television broadcaster.

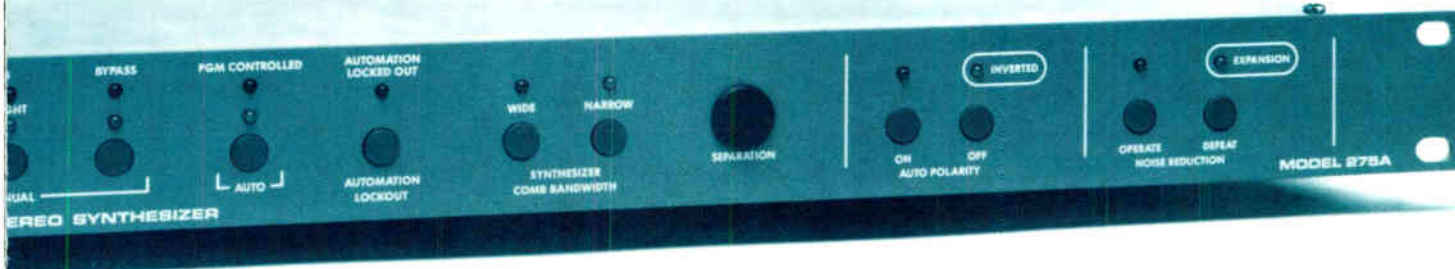

Remote Control of the 275A

Remote Control Panel: An optional 19" rack-mount remote control panel provides duplication of all front-panel indicators and functions except for the SEPARATION control.

Control By Automation: The 275A has a rear-panel connector which provides optically-isolated logic inputs for automated control of noise reduction, automatic polarity correction, and synthesis functions. These inputs can accept pulsed (latching) or continuous control signals.

Pulsed signals duplicate the functions of the front-panel buttons. For example, an automated switching system could trigger the desired synthesis mode for each event, setting the 275A's mode with a short contact closure or logic pulse. The 275A would remain in that mode until given another command from the automation or front-panel controls.

Continuous control signals would be used where the desired synthesizer mode is encoded continuously, as in the vertical interval. Continuous control signals override the 275A's current mode and force it to switch to the mode specified by the control signal. When the signal ceases, the 275A returns to the mode that was active before the control signal appeared. (If a front-panel button is pressed while a continuous signal is present, the mode will not change until the signal ends—only then will the 275A return to the newly-selected mode.)

The advantage of using continuous control signals is that the 275A cannot get "hung up" in the wrong mode because the automation failed to notice that one event had ended, and that a new event requiring different 275A processing was on-line. The end of each event is automatically indicated by the end of its control signal. If the "default" mode is AUTO (as it most often will be), then there is no possibility of a catastrophic error, such as loss of audio.

The 275A provides several graceful exits from automation failure. If two or more automation control lines are active simultaneously, the unit will immediately return to AUTO recognition mode. In addition, an AUTOMATION LOCKOUT button (duplicated on the optional Remote Control Panel) allows the operator to lock out all automation signals, and to control the 275A manually until proper automation system operation is restored.

SYNTHESIZER FREQUENCY RESPONSE IN NARROW MODE

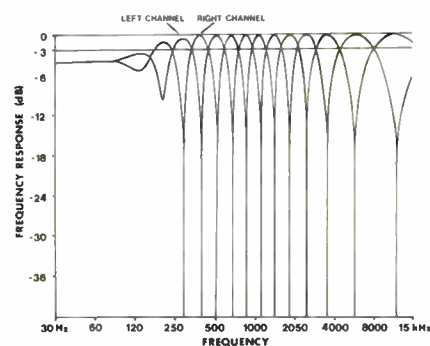

FIGURE 1

Specifications

Frequency Response

(ref mono sum):

- ± 1/2dB, 30-15,000 Hz (Bypass mode)
- ± 1dB, 30-15,000 Hz (Synthesize mode)

Total Harmonic Distortion

(+ 18dBm/600 ohms):

- < 0.02%, 30-15,000 Hz (Bypass mode)
- < 0.3%, 30-15,000 Hz (Synthesize mode)

Noise At Output

(30-15,000 Hz):

- < -80dBm (Bypass mode)
- < -67dBm (Synthesize mode)

Input

Impedance: >10K ohms, balanced bridging.
Absolute overload occurs at +26dBm.

Output

Impedance: <100 ohms, balanced to ground.
Clipping occurs at +26dBm into 600 ohms.

Connectors

Audio: Cinch-type 140-Y barrier strip (#5 screw).

User Control Interface:

Type DB-25S jack (accepts DB-25P plug).

275A/RC Remote Control:

Type DC-37S jack (accepts DC-37P plug, supplied).

Power Requirements

115-230V AC 50/60Hz, 9VA.
Supplied with "U-ground" grounding-type plug to USA standards.

Mounting

Requires 1 unit (1 3/4", 4.5cm) of vertical space in an EIA 19" (48.3cm) rack.
Depth is 9 5/8" (24.5 cm).
Optional 275A/RC remote control unit requires the same space, except depth is 2 1/4" (5.7cm), including supplied connector.

Shipping Weight

12 lbs. (5.4 kg)

orban

Orban Associates Inc., 645 Bryant Street, San Francisco, California 94107
(415) 957-1067 Telex: 17-1480



Orban Stereo Television Stations On The Air

In Order By Network, State and City
As of October 15, 1987

<u>CALL</u>	<u>CH</u>	<u>AFFIL</u>	<u>CITY, STATE</u>	<u>ADI</u>	<u>GROUP</u>
NBC Network					
WVIM	13	NBC	Birmingham, AL	43	Times Mirror
WSFA	12	NBC	Montgomery, AL	108	Cosmos
KARK	4	NBC	Little Rock, AR	53	
KPNX	12	NBC	Phoenix, AZ	22	Gannett
KVOA	4	NBC	Tucson, AZ	81	H & C Communications
KCPM	24	NBC	Chico, CA	141	
KCRA	3	NBC	Sacramento, CA	20	
KSBW	8	NBC	Salinas, CA	111	Gillett
KCST	39	NBC	San Diego, CA	25	
KRON	4	NBC	San Francisco, CA	5	Chronicle
KCNC	4	NBC	Denver, CO	19	General Electric
WVIT	30	NBC	Hartford, CT	23	Viacom Broadcasting
WJKS	17	NBC	Jacksonville, FL	57	Media General
WSVN	7	NBC	Miami, FL	14	
WXIA	11	NBC	Atlanta, GA	12	Gannett
WAGT	26	NBC	Augusta, GA	99	Schurz
WMGT	41	NBC	Macon, GA	131	
KWQC	6	NBC	Davenport, IA	74	
WHO	13	NBC	Des Moines, IA	66	Palmer
KIFI	8	NBC	Idaho Falls, ID	159	
WFIE	14	NBC	Evansville, IN	90	Cosmos
WKJG	33	NBC	Fort Wayne, IN	97	
WTHR	13	NBC	Indianapolis, IN	24	Dispatch Printing
WAVE	3	NBC	Louisville, KY	49	Cosmos
WPSD	6	NBC	Paducah, KY	77	
KALB	5	NBC	Alexandria, LA	161	Lanford Stations
WDSU	6	NBC	New Orleans, LA	33	Cosmos
WBZ	4	NBC	Boston, MA	6	Westinghouse
WWLP	22	NBC	Springfield, MA	106	Adams
WMDT	47	NBC	Salisbury, MD	164	
WDIV	4	NBC	Detroit, MI	7	Post-Newsweek
WILX	10	NBC	Lansing, MI	102	Adams
WDAF	4	NBC	Kansas City, MO	29	Taft
WPCQ	36	NBC	Charlotte, NC	32	Odyssey Television
WPTF	28	NBC	Raleigh, NC	35	
WECT	6	NBC	Wilmington, NC	152	News-Press & Gazette
WXII	12	NBC	Winston-Salem, NC	51	Pulitzer
KTHI	11	NBC	Fargo, ND	104	Morgan Murphy
KNOP	2	NBC	North Platte, NE	211	
KOB	4	NBC	Albuquerque, NM	65	Hubbard Broadcasting
WGRZ	2	NBC	Buffalo, NY	36	Smith Broadcasting
WLWT	5	NBC	Cincinnati, OH	28	Multimedia
WLIO	35	NBC	Lima, OH	195	Blade Communications
WFMJ	21	NBC	Youngstown, OH	87	
WHIZ	18	NBC	Zanesville, OH	202	
KTVY	4	NBC	Oklahoma City, OK	37	Knight-Ridder
KJRH	2	NBC	Tulsa, OK	52	Scripps Howard
KGW	8	NBC	Portland, OR	26	King
WGAL	8	NBC	Lancaster, PA	45	Pulitzer
KYW	3	NBC	Philadelphia, PA	4	Westinghouse
WPXI	11	NBC	Pittsburgh, PA	13	Cox
WJAR	10	NBC	Providence, RI	42	Wesray
WCIV	4	NBC	Charleston, SC	109	Allbritton Communications
WIS	10	NBC	Columbia, SC	88	Cosmos
WYFF	4	NBC	Greenville, SC	38	Pulitzer
KDLT	5	NBC	Sioux Falls, SD	98	Heritage Media Inc.
WSMV	4	NBC	Nashville, TN	31	Gillett

Orban Associates Inc. 645 Bryant Street San Francisco, CA 94107

(415) 957-1067 Telex: 17-1480 FAX: (415) 957-1070

World Radio History

<u>CALL</u>	<u>CH</u>	<u>AFFIL</u>	<u>CITY, STATE</u>	<u>ADI</u>	<u>GROUP</u>
KRBC	9	NBC	Abilene, TX	157	
KAMR	4	NBC	Amarillo, TX	117	
KTVV	36	NBC	Austin, TX	72	LIN
KRIS	6	NBC	Corpus Christi, TX	119	
KCBD	11	NBC	Lubbock, TX	150	Caprock Telecasting
KXXV	25	NBC	Waco, TX	95	
WCYB	5	NBC	Bristol, VA	82	
WVIR	29	NBC	Charlottesville, VA	196	
WAVY	10	NBC	Portsmouth, VA	46	LIN
WBBT	12	NBC	Richmond, VA	60	Jefferson-Pilot
KHQ	6	NBC	Spokane, WA	78	
WMTV	15	NBC	Madison, WI	107	Wesray
WTMJ	4	NBC	Milwaukee, WI	30	The Journal Company
WSAZ	3	NBC	Huntington, WV	47	Lee

CBS Network

KTVA	11	CBS	Anchorage, AK		Northern TV
WBMG	42	CBS	Birmingham, AL	43	Park
WKRK	5	CBS	Mobile, AL	55	
WAKA	8	CBS	Selma, AL	211	Bahakel
KPOM	24	CBS	Fort Smith, AR	147	
KTHV	11	CBS	Little Rock, AR	53	
KTSP	10	CBS	Phoenix, AZ	22	Taft
KXTV	10	CBS	Sacramento, CA	20	Belo
KPIX	5	CBS	San Francisco, CA	5	Westinghouse
KMGH	7	CBS	Denver, CO	19	McGraw-Hill
WINK	11	CBS	Fort Myers, FL	101	
WJXT	4	CBS	Jacksonville, FL	57	Post-Newsweek
WTVT	13	CBS	Tampa, FL	17	Gaylord
WAGA	5	CBS	Atlanta, GA	12	Storer
WMAZ	13	CBS	Macon, GA	131	Multimedia
KOAM	7	CBS	Pittsburg, KS	118	
WIBW	13	CBS	Topeka, KS	144	Stauffer
KWCH	12	CBS	Wichita, KS	58	Kansas Broadcasting
KLFY	10	CBS	Lafayette, LA	112	Woods Communications
WNEV	7	CBS	Boston, MA	6	
WBOC	16	CBS	Salisbury, MD	164	Draper Communication
WCBI	4	CBS	Columbus, MS	135	
WBTW	3	CBS	Charlotte, NC	32	Jefferson-Pilot
WOWT	6	CBS	Omaha, NE	69	Chronicle
KGGM	13	CBS	Albuquerque, NM	65	
WIVB	4	CBS	Buffalo, NY	36	
WBNS	10	CBS	Columbus, OH	34	
WPOL	11	CBS	Toledo, OH	64	Cosmos
KWTV	9	CBS	Oklahoma City, OK	37	
WHP	21	CBS	Harrisburg, PA	45	
KDKA	2	CBS	Pittsburgh, PA	13	Westinghouse
WCSC	5	CBS	Charleston, SC	109	
WREG	3	CBS	Memphis, TN	39	New York Times Co.
KFDA	10	CBS	Amarillo, TX	117	R.H. Drewry Group
KHOU	11	CBS	Houston, TX	10	Belo
KWTX	10	CBS	Waco, TX	95	KWTX Broadcasting
KSL	5	CBS	Salt Lake City, UT	41	Bonneville
WISC	3	CBS	Madison, WI	107	Morgan Murphy

ABC Network

WBRC	6	ABC	Birmingham, AL	43	Taft
WAAY	31	ABC	Huntsville, AL	89	Smith Broadcasting
KTVK	3	ABC	Phoenix, AZ	22	
KOVR	13	ABC	Sacramento, CA	20	
WFTV	9	ABC	Orlando, FL	27	Cox
WSIL	3	ABC	Harrisburg, IL	77	Mel Wheeler Inc.
KTKA	49	ABC	Topeka, KS	144	
KAKE	10	ABC	Wichita, KS	58	Chronicle
KTBS	3	ABC	Shreveport, LA	62	
KARD	14	ABC	West Monroe, LA	115	Woods Communications
WJZ	13	ABC	Baltimore, MD	21	Westinghouse
WXYZ	7	ABC	Detroit, MI	7	Scrapps-Howard

<u>CALL</u>	<u>CH</u>	<u>AFFIL</u>	<u>CITY, STATE</u>	<u>ADI</u>	<u>GROUP</u>
KDEB	27	ABC	Springfield, MO	83	Woods Communications
WSOC	9	ABC	Charlotte, NC	32	Cox
WRAL	5	ABC	Raleigh, NC	35	Capitol
KETV	7	ABC	Omaha, NE	69	Pulitzer
KOAT	7	ABC	Albuquerque, NM	65	Pulitzer
KTNV	13	ABC	Las Vegas, NV	94	The Journal Company
WKBW	7	ABC	Buffalo, NY	36	
WAKR	23	ABC	Akron, OH	11	Group One
WKRC	12	ABC	Cincinnati, OH	28	Taft
KOCO	5	ABC	Oklahoma City, OK	37	Gannett
WAXA	40	ABC	Anderson, SC	38	
WCBD	2	ABC	Charleston, SC	109	Media General
WKPT	19	ABC	Kingsport, TN	82	Home News Publishing
WATE	6	ABC	Knoxville, TN	61	Nationwide
KVII	7	ABC	Amarillo, TX	117	Marsh Media
WFAA	8	ABC	Dallas, TX	8	Belo
KVIA	7	ABC	El Paso, TX	105	Marsh Media
KSAT	12	ABC	San Antonio, TX	44	H & C Communications
KTVX	4	ABC	Salt Lake City, UT	41	United Television Inc.
WXEX	8	ABC	Richmond, VA	60	Nationwide

PBS

KAET	8	PBS	Phoenix, AZ	22	
KEET	13	PBS	Eureka, CA	187	
WPBT	2	PBS	Miami, FL	14	
WFSU	11	PBS	Tallahassee, FL	129	
WEDU	3	PBS	Tampa, FL	17	
WXEL	42	PBS	West Palm Beach, FL	54	
WGTV	8	PBS	Atlanta, GA	12	
KDIN	11	PBS	Des Moines, IA	66	
WYES	12	PBS	New Orleans, LA	33	
WMPT	22	PBS	Annapolis, MD	21	
WMPB	67	PBS	Baltimore, MD	21	
WCPB	28	PBS	Salisbury, MD	164	
KOZJ	26	PBS	Joplin, MO	118	
WTVI	42	PBS	Charlotte, NC	32	
WNET	13	PBS	New York, NY	1	
WXXI	21	PBS	Rochester, NY	70	
WNEO	45	PBS	Alliance, OH	11	
WBGU	27	PBS	Bowling Green, OH	64	
WOIO	19	PBS	Cleveland, OH	11	
WGTE	30	PBS	Toledo, OH	64	
WHYY	12	PBS	Philadelphia, PA	4	
KERA	13	PBS	Dallas, TX	8	
KUHT	8	PBS	Houston, TX	10	
KUED	7	PBS	Salt Lake City, UT	41	
WMVS	10	PBS	Milwaukee, WI	30	

Independent

WNAL	44	IND	Gadsden, AL	43	
WDBB	17	IND	Tuscaloosa, AL	186	
KJTM	38	IND	Pine Bluff, AR	53	TVX Broadcast Group
KPOL	40	IND	Tucson, AZ	81	
KMSG	59	IND	Fresno, CA	63	
KHJ	9	IND	Los Angeles, CA	2	RKO General
KTXL	40	IND	Sacramento, CA	20	
KOFY	20	IND	San Francisco, CA	5	Jim Gabbert
WHCT	18	IND	Hartford, CT	23	
WDCA	20	IND	Washington, DC	9	TVX Broadcast Group
WFTG	5	IND	Washington, D.C., DC	9	Fox Television
WTGI	61	IND	Wilmington, DE	4	
WIYE	55	IND	Leesburg, FL	27	
WLTN	23	SIN	Miami, FL	14	Hallmark & First Capital
WCIX	6	IND	Miami, FL	14	TVX Broadcast Group
WFLX	29	IND	West Palm Beach, FL	54	Malrite
WTBS	17	IND	Atlanta, GA	12	Turner
WATL	36	IND	Atlanta, GA	12	Wesray

<u>CALL</u>	<u>CH</u>	<u>AFFIL</u>	<u>CITY, STATE</u>	<u>ADI</u>	<u>GROUP</u>
WJCL	22	IND	Savannah, GA	110	Lewis Broadcasting
WPWR	50	IND	Aurora, IL	3	Home Shopping Network
WXIN	59	IND	Indianapolis, IN	24	Wesray
WDKY	56	IND	Danville, KY	73	Backe
WNOL	38	IND	New Orleans, LA	33	TVX Broadcast Group
KMSS	33	IND	Shreveport, LA	62	
WCVX	58	IND	Hyannis, MA	42	
KTMA	23	IND	Minneapolis, MN	15	
KDNL	30	IND	St. Louis, MO	18	Cox
WXXV	25	IND	Gulfport, MS	179	
WHLT	22	IND	Hattiesburg, MS	162	
WKFT	40	IND	Fayetteville, NC	35	
WLFL	22	IND	Raleigh, NC	35	TVX Broadcast Group
KPTM	42	IND	Omaha, NE	69	
KGSW	14	IND	Albuquerque, NM	65	
WUHF	31	IND	Rochester, NY	70	Malrite
WXIX	19	IND	Cincinnati, OH	28	Malrite
WUAB	43	IND	Lorian, OH	11	Gaylord
WUPW	36	IND	Toledo, OH	64	
WKBN	27	IND	Youngstown, OH	87	
KSWO	7	IND	Lawton, OK	126	
WFMZ	69	IND	Allentown, PA	4	
WGBS	57	IND	Philadelphia, PA	4	Grant Broadcasting
WOLF	38	IND	Scranton, PA	59	Scranton TV Partners
WTAT	24	IND	Charleston, SC	109	
WETO	39	IND	Greenville, TN	82	
KTHT	67	IND	Alvin, TX	157	Home Shopping Network
KDFI	27	IND	Dallas, TX	8	
K05HU	5	IND	Houston, TX	10	
K05IL	5	IND	Houston, TX	10	
KRRT	35	IND	Kerrville, TX	44	
KJTV	34	IND	Lubbock, TX	150	Home Shopping Network
KJTL	18	IND	Wichita Falls, TX	126	
WJPR	21	IND	Lynchburg, VA	71	
WVFT	27	IND	Roanoke, VA	71	Family Group
KTZZ	22	IND	Seattle, WA	16	Alden Television
WVTV	18	IND	Milwaukee, WI	30	Gaylord
<u>Canada</u>					
CKVU	10	IND	Vancouver, BC		
CFCN	4	CTV	Calgary, AB		
CKND	9	IND	Winnipeg, MB		
CKY	7	CTV	Winnipeg, MB		Moffat Communication Ltd.
CJAP	3	4S	Argentia, NF		Newfoundland Broadcasting
CFRS	4	4S	Jonquiere, PQ		
CFJP	35	4S	Montreal, PQ		
CFCF	12	CTV	Montreal, PQ		
CFAP	2	4S	Quebec City, PQ		
CFCM	4		Quebec City, PQ		Pathonic Network
CFKS	30	4S	Sherbrooke, PQ		Television St. Francois
CHLT	7	TVA	Sherbrooke, PQ		Pathonic Network
CHEM	8	TVA	Trois-Rivieres, PQ		Pathonic Network
CKTM	13	CBC	Trois-Rivieres, PQ		Cogeco Inc.
CFKM	16	4S	Trois-Rivieres, PQ		Cogeco Inc.
<u>Other</u>					
	9		Rio de Janeiro, Braz		TV Manchette
	33	IND	Sao Paulo, Brazil		TV Manchete
			Lima, Peru		Emperessa Radiodifusora

TOTAL: 239

In respect for the confidential business plans of our clients, we are not disclosing the names of the many stations who have taken delivery of an Orban stereo generator or who have one on order, but are not yet broadcasting in stereo.

ADI's are for 1987.

Announcing Orban's Second-Generation OPTIMOD TV Stereo Generator Model 8185A



All the features of the original 8182A/SG plus these new features:

- Digital baseband encoder.
- Works with any audio processor.
- Easier to install and operate.
- Built-in Bessel null calibration tone.
- Improved built-in peak-indicating meter for input, circuit, and output levels.
- Better protection from aliasing.
- Group delay equalization of low-pass filters to minimize overshoots.
- Improved subchannel noise reduction encoder.

Orban's first-generation OPTIMOD® TV Stereo Generator has proven to be an excellent BTSC-standard stereo generator with superb audio quality and exceptional stability over time and wide temperature variations. About 60% of all North American television stations currently broadcasting in stereo are equipped with the Model 8182A/SG Stereo Generator.

The new Model 8185A second-generation Stereo Generator improves on the 8182A/SG's performance, and adds several features designed to make installation, operation, and maintenance more convenient. The 8185A will work with *any* audio processor, not just with the Orban 8182A as was the case with the 8182A/SG.

Enhanced Performance

The earlier 8182A/SG far exceeds BTSC requirements, delivers unimpeachable subjective audio quality, and uses extremely high-performance low-pass filters to achieve excellent high-frequency response and the industry's best aliasing rejection. The new 8185A Stereo Generator adds a digital baseband encoder, group delay equalization, and upgraded noise reduction circuitry for better overall performance and better measured specifications.

Digital Baseband Encoder

The 8185A Stereo Generator uses digital and switching techniques to generate the stereo subchannel. The 8185A's **Hadamard Transform Baseband Encoder™** applies the L-R audio to several parallel switches, which are controlled by pulse trains synchronized to 2H. The result is an extremely accurate and stable approximation of multiplying the L-R signal by a 2H sine wave.

The baseband spectrum produced by the new encoder speaks for itself (see Fig. 1).

Use of the Hadamard Transform Baseband Encoder **simplifies the 8185A's set-up controls**. The only baseband encoder set-up control is the SEPARATION control, which adjusts the ratio between the L+R and stereo subchannel signals and lets you compensate for less-than-perfect frequency response in the exciter or other parts of the plant.

Better Protection from Aliasing

Aliasing is heard as non-harmonically related beat tone distortion that is very offensive to the ear. It is mainly caused by the lower sideband of the stereo sub-channel leaking into the main channel due to inadequate audio filtering prior to the baseband encoder. Because it is not unusual for the dbx® compression to increase the stereo subchannel gain 20–30dB at some frequencies, it can greatly exaggerate the effects of aliasing at low audio levels.

The steep low-pass filters in Orban Stereo Generators provide pilot protection which exceeds BTSC specifications, and they eliminate audible aliasing by typically exceeding the specification in the EIA's *Recommended Practices* by more than 10dB at significant frequencies. However, the disadvantage of steep filters is that they can cause overshoot and ringing if their delay is not constant with frequency. The new 8185A Stereo Generator employs a complex **group delay equalizer** to greatly decrease overshoot — no baseband clipping is needed.

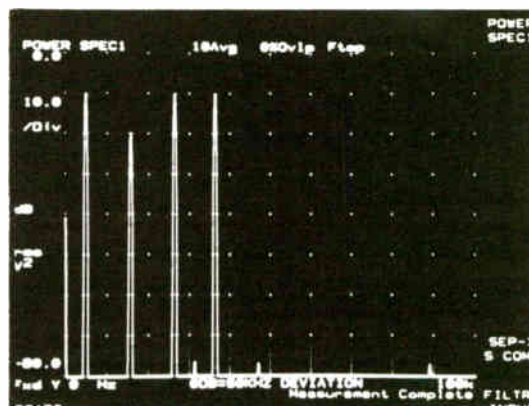

Fig. 1: Baseband Spectrum (5kHz L-only modulation, equivalent mode, ±55kHz deviation)

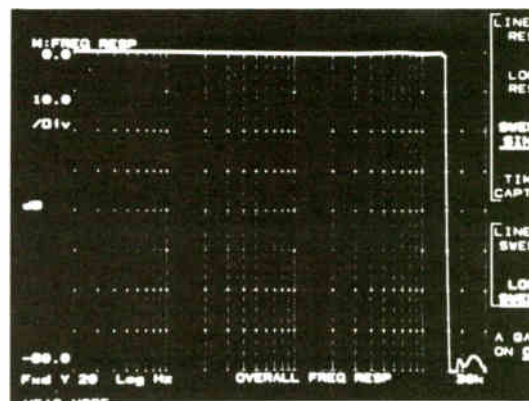

Fig. 2: Level vs. Frequency (Demonstrating stopband filtering effectiveness)

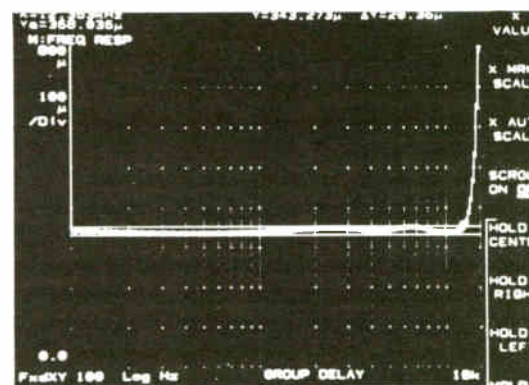

Fig. 3: Group Delay vs. Frequency



Fig. 4: Separation Performance
(Measured with dual-channel FFT, using program material)

Excellent Separation

Like its predecessor, the 8185A Stereo Generator exceeds all BTSC specifications, including those for swept sine-wave separation.

A major factor affecting swept sine-wave separation measurements is the matching between the noise reduction *encoder* in the stereo generator and the *decoder* in the receiver. When measuring system separation beyond 35dB, minuscule variations between encoders and decoders can skew results by 5dB or more. Orban has been working closely with dbx to optimize system separation. The improved dbx encoder and monitor decoder in the 8185A reflect this effort.

Nevertheless, swept sine-wave separation measurements cannot predict dynamic separation in BTSC stereo, because they do not correlate well to separation performance with real-world program material. Swept sine-wave measurements are simultaneously completely *insensitive* to dynamic separation artifacts that are produced by non-complementary noise reduction encoder and decoder nonlinearities, and *overly sensitive* to small linear errors which “average out” in the broadband energy of program material. Thus, swept sine-wave measurements could lead one to expect to hear linear interchannel crosstalk that one does not, while not revealing non-linear crosstalk distortion that one *does* hear.

For these reasons, Orban assesses separation with a dual-channel FFT analyzer, using both program material and pink noise for excitation. The role of swept sine-wave measurements is limited to verifying that BTSC specifications are met. Relying on swept sine-wave measurements alone as a indicator of the overall quality of a stereo generator ignores these limitations; it also ignores potential degradations in audio quality due to the multiplex nature of the BTSC system, such as aliasing distortion.

It is well-established that there is no audible improvement in stereo imaging when *real-world dynamic separation* is improved beyond 17dB. Since all Orban stereo generators greatly exceed 30dB dynamic separation at all frequencies contributing to the stereo effect, almost all of the error budget is left for the receiver.

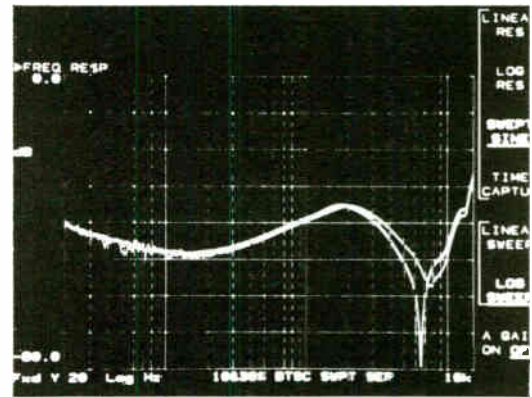

Fig. 5: BTSC Swept Sine-Wave Separation Performance
(10% and 30% 75µs equivalent input level)

Easier to Install

The 8185A Stereo Generator has been designed for easy installation and operation. New, easy-to-follow set-up instructions are included in the Operating Manual, as are detailed troubleshooting and performance verification instructions, circuit descriptions, schematics, and assembly drawings. Operating instructions are presented in quick-reference chart form, backed up with a thorough discussion of control functions and interactions.

Built-in Bessel null calibration tone, built-in metering of inputs, outputs, and circuitry, and a built-in decoder and monitor further simplify installation and maintenance.

Adjustment of modulation level is as simple as activating the 8185A's **built-in Bessel null calibration tone**, then adjusting the TOTAL BASEBAND OUTPUT LEVEL control until the carrier nulls (as observed on an RF spectrum analyzer connected to the aural exciter or transmitter).

Accurate Bessel null calibration is essential to ensure accurate noise reduction tracking. The 8185A derives the calibration tone from station sync (which is often locked to an atomic clock standard) to avoid any potential inaccuracies that might result from using a separate crystal oscillator.

All metering in the new 8185A is true peak-reading. **Improved metering methods and additional metering points** simplify set-up and performance verification of the 8185A. Metering of left and right audio inputs facilitates establishment of audio modulation levels.

The 8185A Stereo Generator's **built-in monitor** enables closed-circuit, back-to-back checking of all circuitry except the baseband encoder (which can be easily checked with an oscilloscope). The monitor can, therefore, give immediate indication of problems in the sum-and-difference low-pass filters, the sum compensator, or the noise reduction encoder. If the 8185A's monitor output is fine, but demodulated RF indicates a problem, the trouble is in the exciter, RF amplifiers, diplexer, or other RF components.

Flexibility

Compatible with Any Audio Processor

To get the brightest sound with the lowest distortion, the OPTIMOD Television Stereo System "interleaves" filters in the Stereo Generator with the circuitry of the 8182A OPTIMOD-TV Audio Processor. This arrangement prevents stray energy at and above 15,734Hz from affecting the Audio Processor's high-frequency limiter or intermodulating with the signal in the Audio Processor's peak limiting and clipping circuitry (important because 75 μ s pre-emphasis amplifies such leakage by more than 17dB). Integrating the units in this way results in significantly better performance than could be achieved by simply placing the Stereo Generator after the Audio Processor.

Since some engineers prefer other audio processing, the new 8185A has been provided with +10dBm active-balanced left and right inputs to facilitate use with non-Orban audio processing. (The 8185A can accept flat or pre-emphasized input). While the 8185A performs at least as well as any other stereo generator with non-Orban processing, processors from other manufacturers obviously cannot benefit from the integration of circuitry possible with mated Orban units.

Remote Control

The 8185A can be switched between STEREO, MONO LEFT, and MONO RIGHT by the station's remote control system through terminals on the 8185A's rear panel. This provides the ability to switch to mono when one channel of the audio chain or STL fails. Connections are also provided for remote activation/deactivation of the 8185A/PRO Professional Channel Generator, and for remote monitoring of SYNC LOCK status.

SAP and PRO Channel Generators

The Model 8182A/SAP Second Audio Program Generator and Model 8185A/PRO Professional Channel Generator are designed to conveniently interface with the 8185A.

The circuit cards for the 8185A/PRO plug into the 8185A's card rack; 8185A/PRO controls are then available on the 8185A's set-up control panel.

Although the SAP Generator is a separate unit with its own audio processor, the 8185A has a SAP input for mixing the SAP subcarrier into the baseband at the 8185A — this can be especially useful if the exciter doesn't have a spare subcarrier input. If the 8185A's SAP input is used, all metering required to easily achieve correct SAP injection level is available in the Orban units.

Orban Experience and Technical Support

Orban has been the leader in broadcast audio since the mid-seventies, with many thousands of our OPTIMOD units in operation all around the world. We like to think that we hold this position because we put exacting, thoughtful engineering into an easily serviceable package and back it up with responsive technical support for the life of the product. That, and the fact that Orban products *sound* good — something specifications alone cannot adequately convey.

Orban products are among the most reliable in the industry. When a problem does occur, we're standing by to help. We try to incorporate our experience with common problems into the troubleshooting sections of our manuals. If that information doesn't help, call us. With each OPTIMOD comes the experience and expert assistance of our Customer Service group. They've seen most things that can go wrong with your audio system, and can often solve your problem in a short time over the telephone.

Estimated first delivery: July, 1987
Price: \$6295

OPTIMOD is a registered trademark of Orban Associates Inc.
Hadamard Transform Baseband Encoder is a trademark of
Orban Associates Inc.
dbx is a registered trademark of dbx, Inc



Orban Associates Inc.

645 Bryant Street, San Francisco, CA 94107 USA
Telephone (415) 957-1067 or (800) 227-4498 Telex 17-1480

World Radio History



The Second-Generation Orban BTSC Stereo Generator

by Robert Orban
Chief Engineer, Orban Associates Inc.

The first-generation Orban 8182A/SG Stereo Generator was designed in the latter half of 1984 in response to broadcasters' desires for a fairly-priced, competent stereo generator that met all BTSC specifications. The unit has been well-received. Even though it was designed to interface only with the Orban OPTIMOD-TV® Model 8182A Audio Processor, the 8185A/SG is used in about 60% of all North American television stations currently broadcasting in stereo.

Our new Model 8185A Stereo Generator builds on our experience and upon the suggestions of users of the 8182A/SG over the last two and half years. We've added interfacing for non-Orban processing, simplified installation with features like a built-in calibration tone, and improved overall performance with digital baseband encoding, group delay equalization, and upgraded noise reduction circuitry.

Transmitter Interface

The original 8182A required an external audio oscillator as a source of 10.396kHz tone used for matching level to the aural exciter with the Bessel null method. The 8182A's calibrated VU meter was used to set the level of the tone. While factory tests convinced us that this method could provide repeatability well within the 1% window specified in the EIA's *Recommended Practices*, we nevertheless recognized that there was room for improvement.

The new 8185A has a built-in Bessel null calibration tone. To avoid the potential inaccuracy and the expense of a separate on-board 10.396kHz crystal oscillator, we instead divide the station's sync reference by 2 to produce a 7.867kHz tone. To achieve exactly the same match to the exciter as would be achieved by performing a Bessel null with a 10.396kHz tone at ± 25 kHz, the 7.867kHz tone level is servo-controlled to an internal level equivalent to ± 18.918 kHz carrier deviation (amplitude stability is better than $\pm 0.1\%$). The tone is filtered

by the 8185A's internal 11-pole low-pass filter to produce a sine wave with less than 0.03% THD.

Matching the new stereo generator to the exciter is very simple: the built-in calibration tone is activated, and then the TOTAL BASEBAND OUTPUT LEVEL control is advanced from "0" until the carrier nulls (as observed on an RF spectrum analyzer or communications receiver fed by the aural exciter or transmitter). Accuracy of the calibration tone is ensured by the very high accuracy of the station's sync frequency, and by the stability of the amplitude servo. This in turn results in most accurate possible noise reduction tracking and best separation.

External Audio Processor Interface

The new 8185A has +10dBm active-balanced left and right inputs for processing other than that provided by Orban's OPTIMOD-TV Audio Processor. (Sum-and-difference inputs were not provided because separation can be severely degraded by relatively small imbalances between sum and difference gains external to the stereo generator.) Both pre-emphasized and flat sources are accommodated. These new inputs are located ahead of the 6-pole left and right input filters in the 8185A.

We've also retained the special multipin connector for interfacing with our OPTIMOD-TV Audio Processor. This special interface allows us to place the stereo generator's left and right filters *before* the audio processor's high-frequency limiters and clippers. Because any H sync leakage on the audio input is amplified slightly more than 17dB by the 75 μ s pre-emphasis in the processor, relatively small amounts of sync leakage can degrade audio processor performance by causing premature operation of the high-frequency limiter and/or IM distortion in the clippers. Placing the stereo generator's filters so they protect these elements therefore ensures the cleanest, brightest audio possible within the limitations of the source material.

Hadamard Transform Baseband Encoder™

Our first-generation stereo baseband encoder used a stable analog multiplier to generate the L-R subchannel. While we believe that no *audible* improvement over this design is possible, we have nevertheless designed a new baseband encoder for the 8185A that uses digital and switching techniques to achieve even higher *measured* performance than our original encoder.

The multiplication process that produces the stereo subchannel occurs when the L-R audio is applied to several parallel switches, each controlled by pulse trains synchronized to horizontal sync. By correctly choosing the proportion of the composite baseband output contributed by each switch, the desired operation (multiplication of the L-R by a 2H sine wave) can be approximated to extremely high accuracy. All significant residual inaccuracies are in the form of harmonics well beyond 100kHz, which are easily removed with a constant group-delay low-pass filter.

The required proportion of the output contributed by each parallel switch can be calculated by means of the "Hadamard Transform" which is (in a sense) the digital equivalent of the more familiar Fourier Transform used to approximate waveforms by sums of sine and cosine waves and their harmonics.

Use of the Hadamard Transform Baseband Encoder simplifies the 8185A's set-up controls. Pilot level is controlled with great accuracy by servos, so no pilot level control is needed. And since the pilot is derived by the same process that produces the stereo subchannel (and is passed through the same low-pass filter), the need for pilot phase adjustments is also eliminated.

The ratio between the L+R signal and the stereo subchannel can be adjusted with a SEPARATION control, included to enable the user to compensate for less-than-perfect frequency response in the exciter or in other parts of the plant.

Figure 1 shows a typical baseband spectrum from the new encoder with 5kHz left-only excitation at ± 55 kHz deviation (including pilot tone) with noise reduction switched off. All spurious is better than -75 dB below ± 50 kHz, with particularly outstanding protection for the SAP region of the spectrum.

The Hadamard Transform Baseband Encoder has only three internal trims, which are set at the factory to compensate for tolerance build-up among stable, passive parts (and never need to be adjusted again).

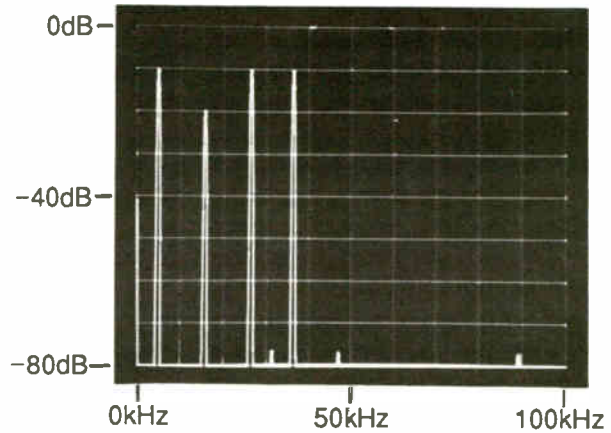

Fig. 1: Baseband Spectrum
(5kHz L-only modulation, equivalent mode
 ± 55 kHz deviation)

Carrier balance and output DC offset are stabilized with servos, so no trims are required for these functions. Output DC offset is typically less than 2mV; the 2H subcarrier is typically suppressed better than 75dB below ± 50 kHz deviation.

Group Delay Equalization

Very selective low-pass filters are used in Orban stereo generators to protect the pilot tone and to prevent audible aliasing distortion. These types of filters have group delay that is quite non-constant with frequency — unless group delay equalization is employed. In the new 8185A, we have added two pairs of group delay equalizers: one pair for the input (left and right) low-pass filters, and the other pair for the sum-and-difference filters. This equalization makes the stereo generator look like a delay line (358 microseconds $\pm 3\%$) from 50Hz to 12.5kHz, and prevents the stereo generator from affecting the peak levels of any energy in this frequency range.

Although it is impractical to equalize group delay between 12.5kHz and 15kHz, this frequency range contains such a small percentage of the total energy that peak levels are still scarcely affected (especially when the stereo generator is used with the Orban 8182A OPTIMOD-TV Audio Processor, which presents the generator with very little energy above 15kHz). Thus baseband clipping, with its potential for side-effects due to its nonlinearity, is unnecessary to achieve acceptable peak control.

The 8185A's ability to sharply reject any frequency components beyond 15kHz while retaining favorable group delay performance is particularly important because the stereo subchannel is highly compressed by the noise reduction encoder. At lower

program levels in particular, the subchannel modulation can greatly exceed the main channel modulation. If the lower sideband of the stereo subchannel leaks into the main channel because of inadequate low-pass filtering, it is not unusual for this leakage to be exaggerated 20–30dB by the action of the noise reduction compressor. Thus low-pass filter stopband requirements for TV stereo are *far* more stringent than for FM stereo for a given amount of alias rejection. Group delay equalization permits us to create low-pass filters that substantially exceed the requirements of paragraphs 2.4.1.1 and 2.4.1.2 of the EIA's *Multichannel Television Sound – BTSC System Recommended Practices* with regard to stopband rejection, yet produce substantially *less* overshoot than much less selective low-pass filters without delay equalizers.

There is considerable debate within digital audio circles as to whether the non-constant group delay of the sharp low-pass filters used in digital audio causes sonic degradation. The excellent group delay performance of the new Orban stereo generator should reassure the “golden eared” types who might otherwise be concerned about potential subjective quality degradations associated with low-pass filters that are not delay-corrected.

Separation

Much hot air has been expelled over the topic of swept sine-wave separation. Some have gone so far as to try to rank the overall quality of different BTSC stereo generators primarily on the basis of their swept sine-wave separation performance. This not only ignores the degradations that can occur due to the multiplex nature of the BTSC system (such as aliasing distortion), but also ignores the limitations of swept sine-wave measurements. Lack of understanding of these limitations can result in irrelevant or incorrect conclusions.

The measurements' major limitation is that they are strictly relevant only to *linear* systems. If the system is non-linear, results obtained from sine waves cannot be extrapolated to real-world program material: superposition does not hold.

BTSC is most emphatically *not* a linear system because both the noise reduction encoder and decoder are non-linear (although, ideally, complementary so that their non-linearities cancel at the receiver's output). Non-complementary encoder and decoder non-linearities can produce dynamic separation artifacts to which swept sine-wave tests are completely insensitive. Such non-linearities are primarily overshoot clipping subsequent to the encoder (non-complementary by definition), and mistracking between

the time constants of the RMS detectors in the encoder and decoder. Listening tests reveal that loss of separation in the BTSC system using real-world program material is dominated by these two mechanisms.

Swept sine waves are simultaneously *insensitive* to these errors and *overly sensitive* to others. With program material, the RMS detectors in the noise reduction encoder and decoder see broadband energy, such that small linear errors within filters and other parts of the noise reduction encoder “average out”. These same small linear errors are exaggerated by swept sine-wave measurements.

[The situation is very similar to that of magnetic tape compandor systems. The consumer press is finally realizing that a compandor exaggerates any lack of flatness in the frequency response of the tape recorder when swept sine-wave measurements are made. Yet this “lack of flatness” is not *heard* (or, in fact, produced) when the same system reproduces program material, and cannot be seen when the system is measured with pink noise and a third-octave or FFT analyzer. This is because the level detectors in the compandor are now seeing broadband energy instead of energy at only one frequency.]

Thus we encounter a situation where swept sine-wave measurements may lead us to expect to hear considerable *linear* interchannel crosstalk (which we do not hear), while simultaneously not revealing the substantial *non-linear* crosstalk that we *do* hear! The conclusion is inescapable: *swept sine-wave separation cannot and does not predict dynamic separation in BTSC stereo.*

For this reason, Orban assesses separation using program material and pink noise as sources, and a dual-channel FFT analyzer for measurement. Figure 2 shows an FFT dynamic separation measurement of the new Orban stereo generator using program material. (Basically, this measurement represents the average at the stereo decoder's output of the ratio of the desired channel to undesired channel as a function of frequency when only one channel is driven with program material.) It can be seen that dynamic separation is comfortably in excess of 40dB throughout the entire frequency range that contributes to the stereo effect.

We recently completed a study on optimization of BTSC separation, and made a fascinating discovery: optimizing the circuitry of the noise reduction encoder for best dynamic separation with program material or pink noise results in poorer swept sine-wave separation than can be obtained when the circuitry is optimized for best swept sine-wave separation! Conversely, when the circuitry is optimized for best

swept sine-wave separation, dynamic separation decreases.

Faced with a choice between swept sine-wave specsmanship and optimized dynamic separation performance with program material, we went for real-world performance, since that is what benefits our customers. We are limiting the role of swept sine-wave measurements to verifying that OET-60 specifications are comfortably met.

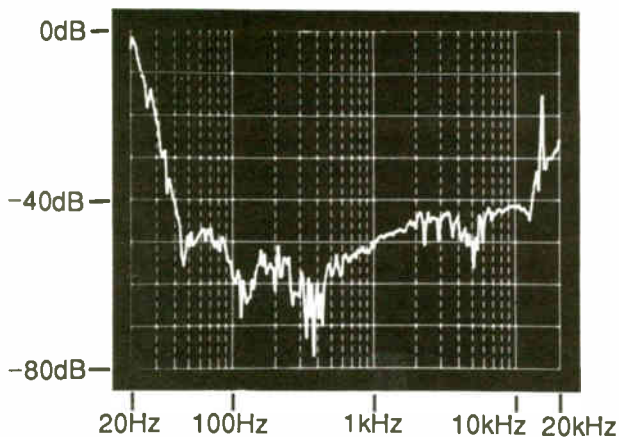

Fig. 2: Separation Performance
(Measured with dual-channel FFT
using program material)

It is well-established that there is no audible improvement in stereo imaging when dynamic separation is improved beyond 17dB — even through headphones (and speakers require even less). Since all Orban stereo generators greatly exceed 30dB dynamic separation at all frequencies contributing to the stereo effect, almost all of the error budget is left for the receiver.

If, for example, receiver separation is 25dB, then 35dB separation at the transmitter will decrease system separation to 22.6dB worst-case (i.e., when all errors are maximally additive). Increasing separation at the transmitter to 45dB will only improve this by 1.56dB at best, and not affect the already subjectively perfect separation.

Monitor Provides De-emphasized, De-matrixed, De-coded Audio

Like its predecessor, our new stereo generator has a built-in monitor circuit with a high-precision ($\pm 0.1\%$) de-emphasis and de-matrix circuit (for performing “equivalent 75 μ s” decoding), as well as a professional dbx[®] noise reduction decoder (for “BTSC mode” tests). This monitor permits closed-circuit back-to-back checking of all circuitry in the stereo generator except for the stereo baseband encoder (which can be easily checked with a scope). Thus, the monitor circuit can immediately indicate if there is a problem with the sum-and-difference low-pass filters, the sum compensator, or the noise reduction encoder. If the stereo generator’s monitor output is good, but demodulated RF is not, the trouble is in the exciter, RF amplifiers, diplexer, or other RF components.

To unambiguously verify the accuracy of each monitor card, we test each one with an RE Instruments Type 540 BTSC Test Generator. This instrument digitally synthesizes test signals which match the “ideal” dbx noise reduction characteristics, and has typical separation of 60dB in BTSC mode. It is thus about 15–20dB better than the circuitry that it is measuring, ensuring meaningful test results. At the Orban factory, this instrument is part of an automated test set-up that performs complete separation and frequency response tests of every monitor card at 100%, 33%, 10%, and 3.3% equivalent 75 μ s input modulation.

Conclusion

Some three years after its introduction, BTSC stereo seems to have achieved sufficient acceptance by the marketplace to ensure its long-term success. Our new 8185A OPTIMOD Television Stereo Generator incorporates the industry’s experience with stereo to date. It retains the very high subjective quality of our earlier stereo generator, while enhancing performance and convenience with a built-in calibration tone for matching exciter level, optimized noise reduction encoding and monitoring, an extremely stable digital baseband encoder for even better accuracy and easier set-up, group delay equalization for better protection from overshoot, and simple interfacing for non-Orban processing.

OPTIMOD and Hadamard Transform Baseband Encoder are trademarks of Orban Associates Inc.
dbx is a registered trademark of dbx, Inc.

800053-000-01

Orban Associates Inc. 645 Bryant Street San Francisco, CA 94107-1693
Main: (415) 957-1063 Sales: (415) 957-1067 Telex: 17-1480 FAX: (415) 957-1070

World Radio History



Revision 08, Effective 1 April 1987
 Supersedes Revision 07, 1 April 1986
 Changes: 8182A/SG superseded by 8185A;
 8185A/PRO added

**ORDERING GUIDE &
 SUGGESTED LIST PRICES**

**OPTIMOD-TV
 BROADCAST PRODUCTS**

<u>Model</u>	<u>Description</u>	<u>USA List Price</u>
<u>OPTIMOD-TV</u>		
8182A	OPTIMOD-TV AUDIO PROCESSING SYSTEM Audio processing for television broadcast. Includes dual-band stereo AGC, CBS Automatic Loudness Controller, high-frequency limiter, Hilbert-Transform Clipper. 115/230V, 50-60Hz. 75us pre-emphasis is standard; order OPT-018 for 50us (no charge).	\$4,995.00
8185A	TV STEREO GENERATOR -- <u>NEW</u> -- First deliveries July 1987 BTSC-standard TV Stereo Generator. Left and right inputs for use with your choice of audio processing, or mates directly with 8182A or converted 8180A OPTIMOD-TV Audio Processor. Includes group-delay corrected low-pass filters, dbx noise reduction encoder, Hadamard Transform Stereo Baseband Generator, Bessel null set-up tone, monitoring circuit with dbx noise reduction decoder, connection for separate SAP Generator, slots for optional 8185A/PRO Channel Generator plug-in cards. 115/230V, 50-60Hz.	\$6,295.00
8182A/SG	TV STEREO GENERATOR -- While supplies last	\$4,995.00
8182A/SAP	SECOND AUDIO PROGRAM (SAP) GENERATOR BTSC-standard SAP Generator. Operates stand-alone or with the 8185A or 8182A/SG TV Stereo Generator. Incorporates full OPTIMOD-TV Audio Processing, CBS Automatic Loudness Controller, SAP subcarrier generator, slot for optional ACC-021 dbx Monitor Card. 115/230V, 50-60Hz.	\$4,995.00
8185A/PRO	PRO CHANNEL GENERATOR (for 8185A)	\$995.00
8182A/PRO	PRO CHANNEL GENERATOR (for 8182A/SG) BTSC-standard Pro Channel Generator. Plug-in card set for the 8185A or 8182A/SG TV Stereo Generator. Provides switching for audio or data, audio speech processing, data filtering, subcarrier generator, 100% modulation indicator. Includes two cards and new sub-panel.	\$995.00
<u>TV ACCESSORY CHASSIS</u>		
8182A/ST	Studio Chassis Separates 8182A OPTIMOD-TV Audio Processing into two chassis to locate AGC and Automatic Loudness Controller at studio. Controls average levels prior to STL microwave or telephone/post lines to optimize signal-to-noise ratio. 115V/230V, 50-60Hz.	\$895.00

See reverse side for **RELATED AUDIO PRODUCTS, TV ACCESSORIES, and CONVERSIONS**

Prices are FOB ORBAN ASSOCIATES INC., SAN FRANCISCO, and are subject to change without notice. Orban Broadcast Products are sold through authorized Orban Broadcast Dealers worldwide. For names of Dealers near you, or for more information, call or Telex Orban.

<u>Model</u>	<u>Description</u>	<u>USA List Price</u>
<u>RELATED AUDIO PRODUCTS</u>		
275A	Automatic Stereo Synthesizer	\$1,895.00

Converts mono audio to pseudo-stereo. Automatic mono/stereo and single-channel recognition with smooth cross-fade; reverse polarity correction; noise reduction; full automation control access. 275A/RC Remote Control Panel: \$295.00.

TV ACCESSORIES

ACC-021	dbx Monitor Card for 8182A/SAP Generator	\$595.00
---------	---	-----------------

Used where full-time audio decoding of the SAP channel is desired. For occasional tests, the dbx Monitor Card may be borrowed from the Stereo Generator.

RET-037	Connector Kit for 8180A to interface with 8185A or 8182A/SG	\$65.00
---------	--	----------------

Field Retrofit Kit to add connector to previous 8180A to permit direct interconnection of the 8185A or 8182A/SG TV Stereo Generator. (RET-025, below, is preferred to this kit.)

FACTORY CONVERSIONS (8180A OPTIMOD-TV)

The 8180A OPTIMOD-TV was Orban's first generation audio processor for television. It is readily convertible to incorporate the features and functions of the 8182A OPTIMOD-TV.

RET-025	8180A to 8182A OPTIMOD-TV Conversion	\$995.00
---------	---	-----------------

Adds Hilbert-Transform Clipper, Automatic Loudness Controller, stereo matrix circuitry, and interface connector. Requires return of unit to factory for modification and alignment--allow approximately three weeks after receipt. Loaner OPTIMOD-TV provided for rental change of \$100.00 plus shipping, as available.

RET-026	8180A/ST to 8182A/ST Studio Chassis Conversion	\$295.00
---------	---	-----------------

Requires return of unit to factory for modification and alignment--allow approximately three weeks after receipt. Loaner Studio Chassis provided for rental change of \$50.00 plus shipping, as available.