

APRIL 17, 1980

# Special Commemorative Issue



NINE DOLLARS A MCGRAW-HILL PUBLICATION

# Electronics

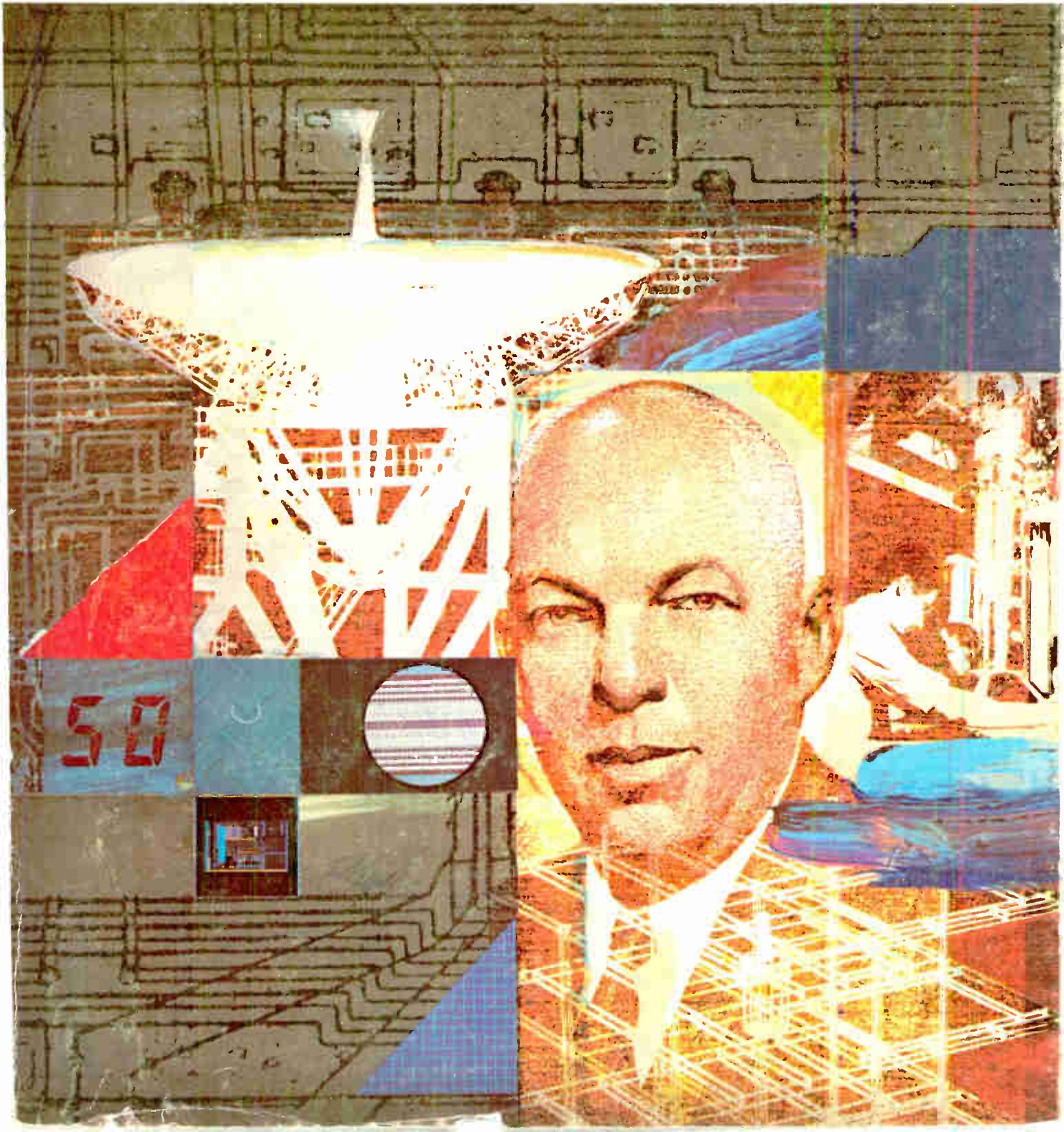



**A RECORD OF A HALF-CENTURY OF ACHIEVEMENT/ 16**  
**THOSE WHO MADE IT HAPPEN: A GALLERY OF GREAT INNOVATORS/418**  
**THE FOUNDATIONS OF DESIGN: TWELVE CLASSIC CIRCUITS/436**  
**LOOKING AHEAD: TWENTY YEARS OF CHALLENGE AND OPPORTUNITY/444**





# What if you made Hewlett-Packard?

## You could expect continuity...

### ...through a succession of innovative products that reflect the latest technologies.

Our annual investment in research and development equals or exceeds our net earnings. This investment enables us to deliver products with advanced performance on a continuing basis.

### ...in terms of products that work together.

Because our products are interrelated, they are designed to work together. And with the continuous exchange of ideas throughout HP, advances in one product area often contribute to improved capabilities in other HP products and systems.

### ...in terms of designed-in reliability across all product lines.

HP's engineering practices focus on "designed-in" reliability coupled with uniform standards that make quality assurance more a manufacturing process than a question of inspection.

### ...in after-sales support services for all product lines.

We supply our customers with full product documentation, customer training, application and software assistance where required, and dependable maintenance services—throughout the world.

**In short, HP is a responsible source for reliable products, systems, and services to meet your measurement and computation needs, worldwide.**

## For example...

**In computation.** HP makes computers that include microcomputers for industrial and technical applications, data base management systems for business applications, and powerful mainframe computers for scientists and engineers. Their advanced data processing capabilities make them easy to use for distributed processing applications. HP computers were first designed as logical extensions of our measurement activity, to interpret measurement data. This end-user orientation provides much of the development of HP's computers and hardware.

**In electronic measurement.** HP provides general purpose electronic measurement systems for a wide range of applications and data acquisition needs. These systems include signal sources, voltmeters, electronic counters, power meters, oscilloscopes, recorders, and plotters. HP also makes special instruments and systems for RF and microwave measurement, logic and process control, circuit analysis, digital signal analysis, and telecommunication. HP instruments have long been known for advanced design, accuracy, and reliability.

**In computed measurement.** HP provides an alliance between measurement and computation which enables measuring elements to interact for accurate solutions to complex measurement problems. In many cases, computed measurement opens up new results that previously were either unobtainable or unaffordable. Computed measurement is available in three formats: smart (microprocessor controlled) instruments; flexible HP-IB systems, which can be easily connected for various applications; and packaged HP-IB systems forming specific and repeatable measurement systems.



# ard your first choice?

Manufactures a range of real-time systems for operations, on-line systems for business, powerful desktop and engineering data computers and microcomputers. Developed for electronic products to reduce and improve efficiency. Development thrust for handheld calculators.

HP manufactures a wide range of instruments and test equipment. These include voltmeters, current sources, signal analyzers, and spectrum analyzers. HP's signal processing systems are well known for accuracy, speed, and dependability.

HP has engineered a wide range of measurement and computing systems. These include faster, more accurate measurement systems, computer-aided design systems, and user-friendly systems. These systems can be used in a wide variety of applications; they are dedicated to performance tasks.

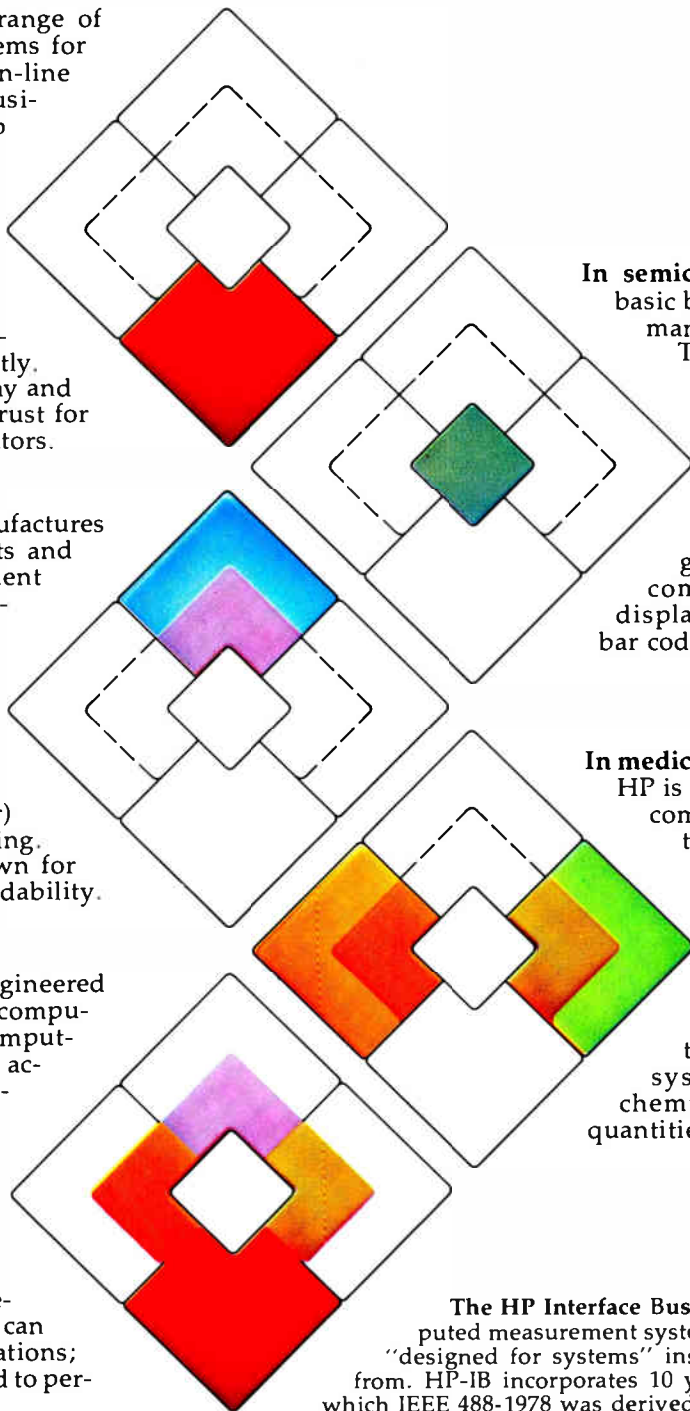

**In semiconductor circuit components.** These basic building blocks vitally affect the performance, cost, and reliability of our products. That's why we develop and manufacture many of them exclusively for our computers and instruments. We also develop and manufacture a wide range of components for sale commercially, worldwide. HP's microwave and RF components include diodes, transistors, and integrated circuits; our optoelectronic components include LED lamps and displays, optocouplers, emitter/detectors, bar code wands, and fiber optic links.

**In medical measurement and chemical analysis.** HP is a leading supplier of measurement and computation equipment to medical facilities throughout the world for diagnosis and patient monitoring, including electrocardiographs, neonatal monitors, blood-gas monitors, and pulmonary function analyzers. HP instruments for chemical analysis, such as liquid and gas chromatographs, mass spectrometers, and laboratory automation systems, make possible the positive chemical identification of substances in quantities as small as a picogram.

The HP Interface Bus (HP-IB) is the key to building computed measurement systems, with more than 120 compatible, "designed for systems" instruments and computers to choose from. HP-IB incorporates 10 years of interfacing experience from which IEEE 488-1978 was derived.





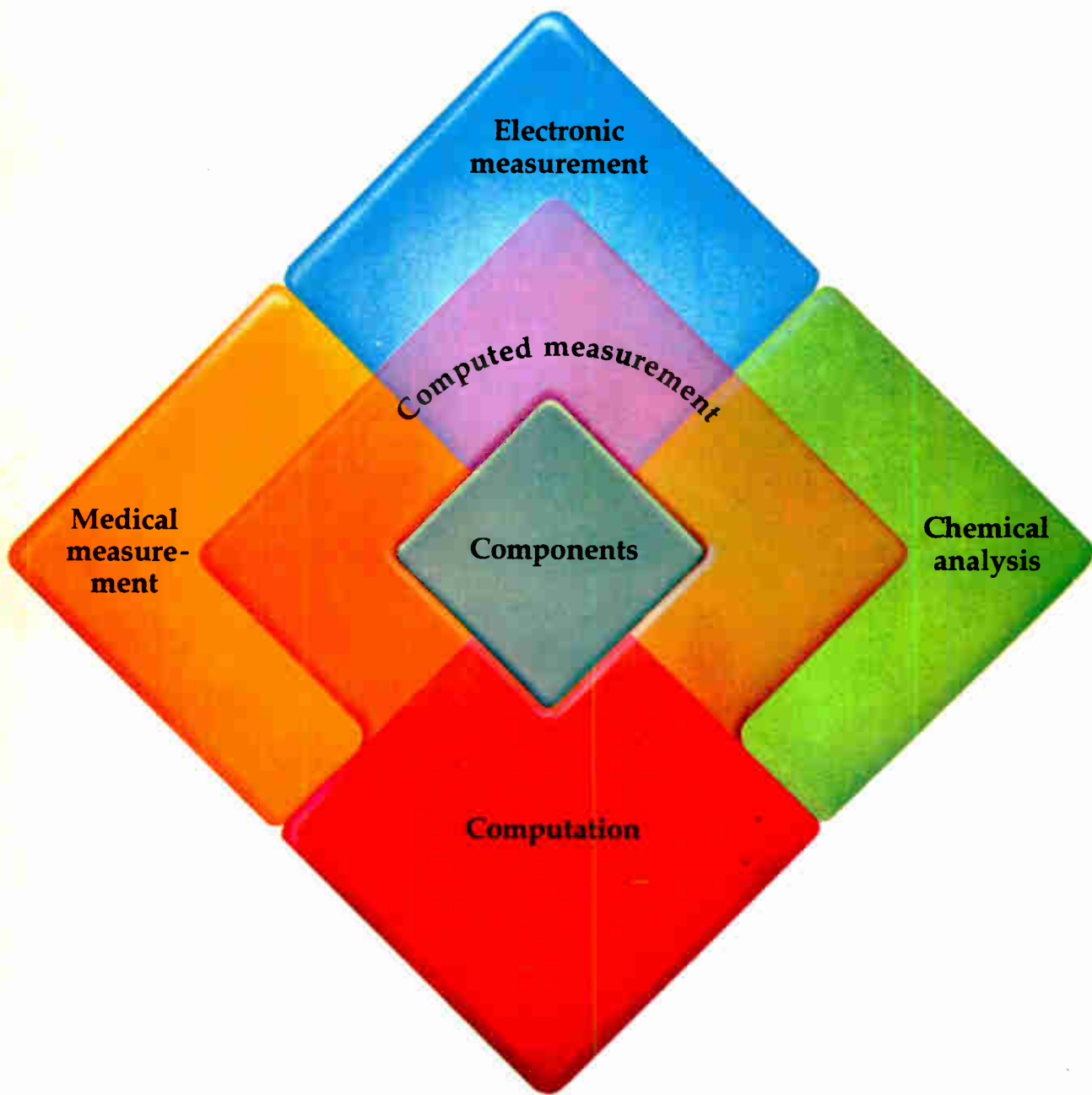

**There are many reasons why Hewlett-Packard should be your first choice.**

See pages 21 through 34 for  
specific product information.





# Power Splitters in a flash!

## ONE WEEK DELIVERY

Select from hundreds of models  
2 kHz to 4.2 GHz



Series may include several models to cover frequency range. To select appropriate model, see MicroWaves Product Directory Pages 16-369 or EEM pages 2770-2973, or consult factory.

Series	Output Ports	Phase Degrees	Freq Range	Connector	Model Item Price (Qty.)
PSC-2	2	0	2 kHz-1000 MHz	8 pin	\$ 9.95 (1-4)
MSC-2	2	0	10 kHz-500 MHz	8 pin	\$16.95 (1-4)
ZSC-2	2	0	2 kHz-650 MHz	BNC/TNC	\$27.95 (1-2)
ZMSC-2	2	0	2 kHz-650 MHz	SMA	\$37.95 (1-2)
ZFSC-2	2	0	2 kHz-1500 MHz	BNC, TNC, N, SMA	\$31.95 (1-2)
ZAPD	2	0	0.5 GHz-4.2 GHz	BNC, TNC, SMA, N	\$39.95 (1-2)
PSCQ-2	2	90	12 MHz-180 MHz	8 pin	\$12.95 (1-4)
ZSCQ-2	2	90	25 MHz-180 MHz	BNC, TNC	\$39.95 (1-2)
ZMSCQ-2	2	90	25 MHz-180 MHz	SMA	\$49.95 (1-2)
PSCJ-2	2	180	10 kHz-200 MHz	8 pin	\$19.95 (1-4)
ZSCJ-2	2	180	10 kHz-200 MHz	BNC, TNC	37.95 (1-2)
ZMSCJ-2	2	180	10 kHz-200 MHz	SMA	\$47.95 (1-2)
ZFSCJ-2	2	180	1 MHz-500 MHz	BNC, TNC, SMA, N	\$39.95 (1-2)
PSC-3	3	0	10 kHz-500 MHz	8 pin	\$19.95 (1-4)
ZSC-3	3	0	10 kHz-200 MHz	BNC, TNC	\$37.95 (1-2)
ZMSC-3	3	0	10 kHz-200 MHz	SMA	\$47.95 (1-2)
ZFSC-3	3	0	1 MHz-750 MHz	BNC, TNC, SMA, N	\$39.95 (1-2)
PSC-4	4	0	10 kHz-1000 MHz	8 pin	\$23.95 (1-4)
ZSC-4	4	0	2 kHz-250 MHz	BNC, TNC	\$43.95 (1-2)
ZMSC-4	4	0	2 kHz-250 MHz	SMA	\$53.95 (1-2)
ZFSC-4	4	0	1 MHz-1000 MHz	SMA, BNC, TNC, N	\$74.95 (1-4)
PSC-6	6	0	1 MHz-175 MHz	16 pin	\$68.95 (1-5)
ZFSC-6	6	0	1 MHz-175 MHz	BNC, TNC, SMA	\$89.95 (1-4)
PSC-8	8	0	101 MHz-500 MHz	16 pin	\$68.95 (1-5)
ZFSC-8	8	0	101 MHz-700 MHz	BNC, TNC, SMA	\$89.95 (1-4)
ZFSC-16	16	0	100 kHz-125 MHz	BNC, TNC, SMA	\$174.95 (1-4)
ZFSC-24	24	0	200 kHz-100 MHz	BNC, TNC, SMA	\$264.95 (1-4)

Photograph by Harold M. Lamb

2 to 24 way models  
pin or connector versions  
... from \$9.95

2-way to 24-way, 0°, 90°, 180°, pin or connector models... Mini-Circuits offers a wide variety of Power Splitters/Combiners to choose from... with immediate delivery. But there are always "special" needs for "special applications"... higher isolation, SMA and Type N connectors intermixed, male connectors or wider bandwidths. Contact us. We can supply them at your request... with rapid turnaround time.

World's largest manufacturer of Double-Balanced Mixers  
**Mini-Circuits**  
MINI-CIRCUITS LABORATORY

2625 E. 14th St Brooklyn, New York 11235 (212) 769-0200  
Domestic and International Telex 125460  
International Telex 620156

Y44/Orig

For other Mini-Circuit Lab Products see ads on pgs. 50,327 and 537

2 Circle 2 on reader service card

Electronics / April 17, 1980

- 4 Publisher's letter
- 12 Introduction
- 16 *Electronics: the living record of a technology*

---

## **FIFTY YEARS OF ACHIEVEMENT: A HISTORY**

*Tinkerers and isolated experimenters started a new technology, nurtured by bold entrepreneurs and stimulated by society's needs.*

- 36 Chapter 1. Fifty years ago
- 58 Chapter 2. How technology got there
- 94 Chapter 3. The radio years
- 150 Chapter 4. At war
- 214 Chapter 5. The solid-state era
- 274 Chapter 6. In the wake of the transistor
- 322 Chapter 7. Computers & space
- 372 Chapter 8. The digital age
- 418 Great innovators
- 436 Classic circuits

---

## **LOOKING AHEAD TO THE YEAR 2000**

*Twenty years from now, profound changes will have been wrought in the technology, the engineering profession, and the structure of the industry.*

- 444 Overview
- 446 Systems
- 530 Technology
- 564 Engineers
- 598 Industries
- 637 Index
- 646 Credits



# Electronics

EDITOR-IN-CHIEF: Samuel Weber

## MANAGING EDITORS

*Technical:* Raymond P. Capece,  
Alfred Rosenblatt  
*News:* Gerald M. Walker  
*International:* Arthur Erikson

ASSISTANT MANAGING EDITORS: Howard Wolff,  
Margaret Eastman

SENIOR EDITOR: Ray Connolly

ART DIRECTOR: Fred Sklenar

ASSOCIATE EDITOR: Benjamin A. Mason

## DEPARTMENT EDITORS

*Aerospace/Military:* Ray Connolly  
*Circuit Design:* Vincent Biancomano  
*Communications & Microwave:*  
Harvey J. Hindin  
*Components:* Roger Allan  
*Computers & Peripherals:* Anthony Durniak  
*Industrial/Consumer:* Gil Bassak  
*Test, Measurement & Control:*  
Richard W. Comerford  
*New Products:* Ana Bishop  
*Packaging & Production:* Jerry Lyman  
*Solid State:* John G. Posi

CHIEF COPY EDITOR: Margaret Eastman

COPY EDITORS: Mike Robinson,  
Charlotte Wiggers, Jeremy Young

ART: Charles D. Ciatto, *Associate Director*  
Paula Piazza, *Assistant Director*

EDITORIAL SECRETARIES: Maryann Tusa,  
Penny Reitman, Gail Walker

EDITORIAL ASSISTANT: Marilyn B. Steinberg

## REGIONAL EDITORS

*New York:* Pamela Hamilton (212) 997-2306  
*Boston:* James B. Brinton,  
Linda Lowe (617) 262-1160  
*Chicago:* Larry Marion (312) 751-3805  
*Dallas:* Wesley R. Iversen (214) 742-1747  
*Los Angeles:* Larry Waller (213) 487-1160  
*Palo Alto:* Bruce Le Boss, *Manager*  
Martin Marshall, *Computers & Instruments*  
(415) 968-2712  
*Washington:* Ray Connolly (202) 624-7592  
*Frankfurt:* John Gosch 72-5566  
*London:* Kevin Smith 493-1451  
*Paris:* Arthur Erikson,  
Kenneth Dreyfack 720-20-70  
*Tokyo:* Charles Cohen 581-9816

CONTRIBUTING EDITOR: Michael J. Riezenman

## EDITORIAL CONSULTANTS:

Yvonne R. Freund, *Picture Editor*  
Richard Haitch, *Copy*

## McGRAW-HILL WORLD NEWS

*Editor:* Michael Johnson  
*Brussels:* James Smith  
*Milan:* Jeff Ryser  
*Moscow:* Peter Hann  
*Stockholm:* Robert Skole  
*Tokyo:* Robert Neff

PUBLISHER: Paul W. Reiss

GENERAL MANAGER, DIRECT MARKETING  
OPERATIONS: Horace T. Howland

CIRCULATION MANAGER: Herbert A. Hunter

RESEARCH MANAGER: Margery D. Sholes

MARKETING ADMINISTRATION MANAGER:  
Frances M. Vallone

BOOKS & SPECIAL PROJECTS MANAGER:  
Janet Eylar

## Publisher's letter

Almost from the beginning, over a year ago, this anniversary issue became known as Project 50 among the editors of *Electronics*. It started with a series of meetings at which it was decided to include both a history and a detailed look at the future. Then at a full staff meeting last May the project was truly launched.

Everyone realized it would be a lot of work, but no one foresaw quite how time-consuming it would be.

Project 50 involved not only the entire *Electronics* staff, domestic and foreign, but also several free-lancers brought in to handle specific tasks such as digging up old photographs, checking facts, editing, preparing the index, and creating the cover. But on the whole, the regular staff did the sweating and writing while at the same time continuing to put out the regular issues of the magazine every two weeks.

Not surprisingly, the editors had a love-hate relationship with Project 50. On the love side, everyone became interested in the content. Those preparing the history discovered or rediscovered fascinating information from the past. Those peering into the future got caught up in the fascination of forecasting the next two decades. Our field bureaus interviewed scores of industry observers and planners for their views, who also enjoyed the opportunity of looking ahead.

The hate side of the relationship was well to the fore, too. At times the project seemed endless, and as with all long-term endeavors, deadlines were missed left and right. Editors who prided themselves on being

fast writers found the Project 50 sections long and demanding. More than a few began referring to the effort as their life's work. And relatives and friends learned to endure the sudden cancellation of social plans.

A project of this nature always inspires a number of jokes and wisecracks. One of the best came from an outsider.

"The earlier you get behind on a project, the more time you have to catch up," he remarked. That maxim should endure.

The logistics of handling the manuscripts, the illustrations, and the typesetting were staggering as well. Also, all processing of the extra material had to be interwoven with the regular biweekly publication schedule, and the printing had to be interspersed with the printing of the regular issues.

Now that Project 50 has finally become the Special Commemorative Issue, we are tempted to speak of it in Hollywood terms: "Cast of thousands! Years in the making! The greatest spectacle of our times!" Hyperbole, certainly, though we are pleased with the result. As with a piece of electronic hardware developed over a long period, there is a certain thrill to learning that the finished product works. Tired we may be, but we are also proud.



April 17, 1980 Volume 53, Number 9 108,203 copies of this issue printed

*Electronics* (ISSN 0013-5070). Published every other Thursday with an additional issue this April by McGraw-Hill, Inc. Founder James H. McGraw 1860-1948. Publication office 1221 Avenue of the Americas, New York, N.Y. 10020. Second class postage paid at New York, N.Y. and additional mailing offices. Executive, editorial, circulation and advertising addresses: *Electronics*, McGraw-Hill Building, 1221 Avenue of the Americas, New York, N.Y. 10020. Telephone (212) 512-2000; Teletype 12-7960 TWX 710-581-4879. Cable address: MCGRAW HILL L N E W Y O R K. Subscriptions limited to professional persons with active responsibility in electronics technology. No subscriptions accepted without complete identification of subscriber name, title or job function, company or organization, and product manufactured or services performed. Based on information supplied, the publisher reserves the right to reject non-qualified requests. Subscription rates: in the United States and possessions \$18 one year, \$31 two years, \$46 three years, company addressed and company libraries \$23 one year, \$41 two years, \$58 three years; APO/FPO addressed \$35 one year only; Canada and Mexico \$19 one year, \$32 two years, \$47 three years; Europe \$50 one year, \$85 two years, \$115 three years; Japan, Israel and Brazil \$70 one year, \$115 two years, \$165 three years; Australia and New Zealand \$95 one year, \$170 two years, \$240 three years, including air freight, all other countries \$50 one year, \$85 two years, \$125 three years. Limited quota of subscriptions available at higher-than-basic rate for persons allied to field served. Check with publisher for these rates. Single copies: \$4.00; special Anniversary issue: \$9.00 each. Please allow four to eight weeks for shipment. Officers of McGraw-Hill Publications Company: Paul F. McPherson, President; Executive Vice Presidents James E. Boddorf, Gene W. Simpson; Group Vice President Daniel A. McMillan, Senior Vice President-Editorial; Ralph R. Schultz; Vice Presidents: Kemp Anderson, Business

Systems Development; Stephen C. Croft, Manufacturing; Robert B. Doll, Circulation; James E. Hackett, Controller; William H. Hammond, Communications; Eric B. Hart, Planning and Development; John W. Patten, Sales; Edward E. Schirmer, International. Officers of the Corporation: Harold W. McGraw, Jr., President, Chief Executive Officer, and Chairman of the Board; Robert N. Landes, Senior Vice President and Secretary; Ralph J. Webb, Treasurer. Title registered in U.S. Patent Office, Copyright © 1980 by McGraw-Hill, Inc. All rights reserved. The contents of this publication may not be reproduced in whole or in part without the consent of copyright owner. Where necessary, permission is granted by the copyright owner for libraries and others registered with the Copyright Clearance Center (CCC), P.O. Box 8891, Boston, MA 02114, to photocopy any article herein for the base fee of \$0.50 per copy of the article plus \$0.25 per page. Payment should be sent directly to the CCC. Copying done for other than personal or internal reference use without the express permission of McGraw-Hill is prohibited. Requests for special permission or bulk orders should be addressed to the publisher ISSN 0013-5070/80\$0.50+.25. Subscribers: The publisher, upon written request to our New York office from any subscriber, agrees to refund that part of the subscription price applying to copies not yet mailed. Please send change-of-address notices or complaints to Fulfillment Manager; subscription orders to Circulation Manager, *Electronics*, at address below. Change-of-address notices should provide old as well as new address, including zip codes. Attach address label from recent issue. Allow one month for change to become effective. Subscriber Service call (609) 448-8110, 9 a.m. to 4 p.m. EST. Postmaster: Please send form 3579 to Fulfillment Manager, *Electronics*, P.O. Box 430, Hightstown, N.J. 08520.

# The Source.

Every industry comes to rely on certain sources for the products and services it needs. Over the years, Signetics has demonstrated the reliability

and concern for your needs that make us your best source for integrated circuits. For that same commitment to reliable service, we congratulate *Electronics* magazine on its fiftieth anniversary as a dependable source of timely information.



## signetics

a subsidiary of U.S. Philips Corporation



# Your Best Source

**For advanced LSI solutions  
to military/avionics needs,  
design in Signetics.**

We've been supporting major military/avionics programs for more than 19 years. With advanced IC technologies, and reliable products.

Today our separate Military Products Division draws from the multiple technologies of six other Signetics divisions. That's why *LSI breakthroughs* at Signetics routinely become *Mil-Spec solutions*.

Take our 8X300  $\mu$ P, for example. As the world's fastest bipolar  $\mu$ P, it's changing the way avionics systems are designed. Because its high speed and control-oriented architecture help reduce parts count.

When your design calls for bipolar memory, remember that Signetics leads with more than 40 devices processed to MIL-STD 883B. Here, you'll find parts that boast the highest density and lowest power available. You also get an unmatched choice of product solutions with our "top 12" list of JAN/QPL PROMs.

And our bipolar memory leadership doesn't stop there. It extends to field-programmable logic where we've merged our advanced PROM technology with Schottky logic. To stretch your design freedom.

This LSI family now offers three MIL-STD 883B solutions: FPLA (logic array), FPGA (gate array) and FPRP (ROM patch).

Soon our FPLS (logic sequencer) will join the Mil-Spec line. It has everything you need to implement a synchronous state machine. Including on-chip register and internal feedback loop.



# for Military ICs.

With programmable logic from Signetics, it's much easier to go from logic design straight to hardware. With fewer parts, and at significant cost savings.

If your system calls for Mil-Spec linears, count on us for a wide range of functions. We offer  $\mu$ P-compatible DACs and low-noise op amps, plus switching regulators, comparators, timers, drivers and special function

parts. Within this broad mix, you'll find 6 JAN-qualified linears. Advanced LSI solutions for the military/avionics OEM.

That's what the Signetics military commitment is all about. Find out how you can put our advanced IC technologies to work. Send for your copy of our *Military Product Reference Guide*. Or contact your nearest Signetics sales office or distributor.

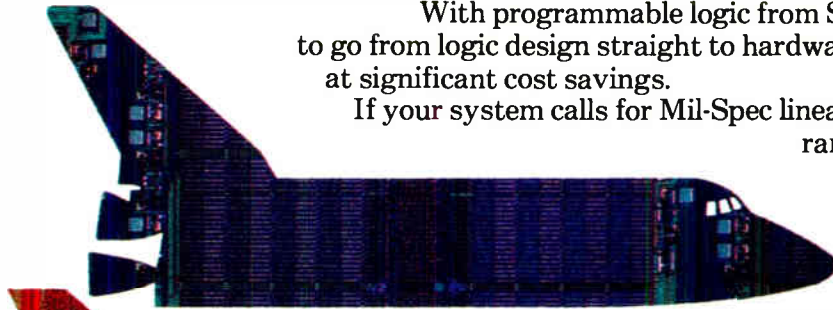

*Space Shuttle*



*F-16 Tactical Fighter*



*Cruise Missile*

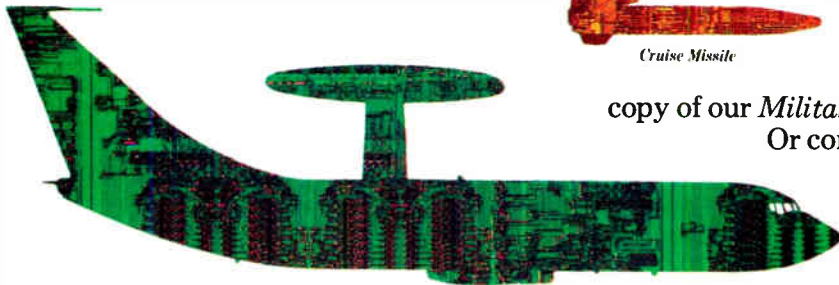

*AWACS*

*Signetics takes great pride in the advanced LSI solutions it has provided for the above military/avionics programs.*

## signetics

a subsidiary of U.S. Philips Corporation

Signetics Corporation  
811 East Arques Avenue  
P.O. Box 409  
Sunnyvale, California 94086  
Telephone 408/739-7700



# Your Best Source

## We'll translate your next computer terminal design into the right ICs.

We make it our business to know your business. We have to. Because we know your future depends on it.

It's no secret that things change fast in your business. Or that success or failure depends on how well you use semiconductor technology in your next computer terminal design.

That's where we come in.

Our people speak your language. They know how to save you time. And money. By helping you select the right ICs for your design. Every time.

Signetics wants to help keep you ahead in the terminal design game. Because if you're not ahead, you're not even a player.

That's why we give you more than just the right product.

We also give you the Signetics Commitment. We don't publish specs on it. And it's not scribed on our ICs. But we do market this extra, personal commitment. And it's free.

Our professionals in IC technology and market support are backed by Signetics' six integrated divisions. That means we can combine our total resources in both MOS and bipolar technologies to give you the edge in computer terminal OEM design.

For example, our MOS Microprocessor Division's 2652 is the fastest multi-protocol communications controller in the world at



# Your Best Source

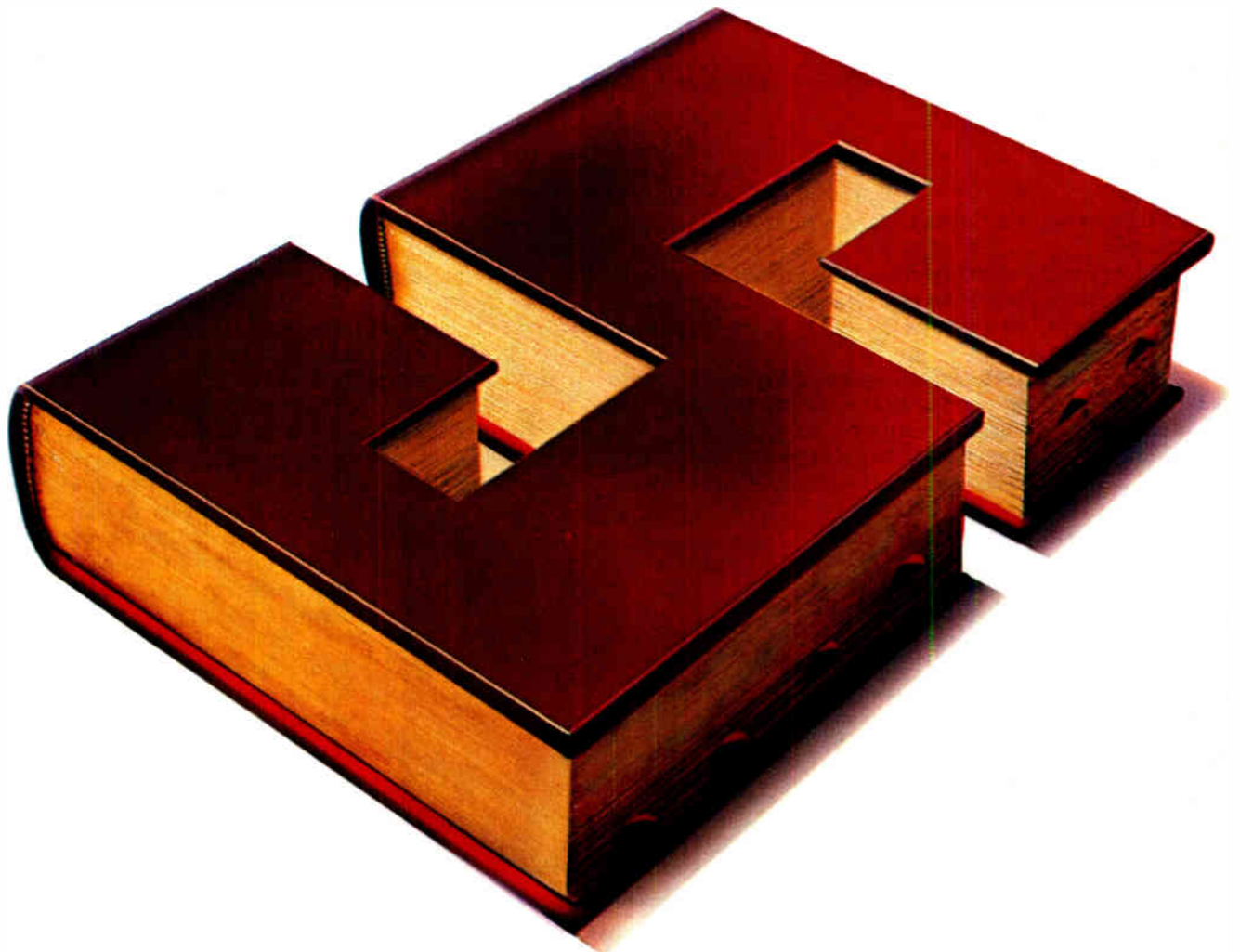

**Signetics (sig-net'iks). n.** *Eight integrated divisions controlling hundreds of products and multiple technologies.* Signetics may be the only SOURCE you will ever need for all your IC requirements. Eight divisions cover the entire product range: From consumer to industrial to Hi-Rel military ICs, Signetics has it all. And each division supports your needs with its own product development, manufacturing and marketing department.



# for Computer ICs.

2Mbits/second. It's right at home with most high-level protocols.

Every computer terminal OEM looks for unique logic functions. With the smallest amount of random logic practical. And Signetics wants to make it easy for the designer.

Working together, our Logic and Bipolar Memory Divisions have responded to the terminal OEM's demands for speed and flexibility.

We've gone beyond LSI to give the terminal OEM the 8A2000 I<sup>2</sup>L Gate Array. It's got 2000 gates. And you can customize the 8A2000 to your proprietary needs without losing LSI benefits.

In fact, all you stand to lose is the need to use 50 to 75 random logic packages by going with the 8A2000 in your design.

With our family of field programmable logic, including the FPLA, FPGA, and ROM patch, we make it easy for you to out-design the competition.

And more design freedom is yours with our new Field Pro-

grammable Logic Sequencer. Use it to convert your complete state diagram to hardware—easily.

Responding to your needs, our Logic Division created the bipolar 8X300  $\mu$ P. Its blazing speed of 4 million operations/second and control-oriented architecture make it ideal for adding state-of-the-art peripherals to your terminal system.

While our field professionals help computer terminal OEMs translate difficult design choices into the right ICs, other Signetics professionals are applying the most advanced technologies into devices to meet the OEM's future demands.

Talk to a Signetics professional. We've bridged the communications gap between terminal OEM and IC manufacturer.

To learn how our leading-edge technologies are making innovation simpler for terminal OEM designers, write us today.

We've got a brochure that tells you how you can put our advanced ICs to work for you. On your own terms.

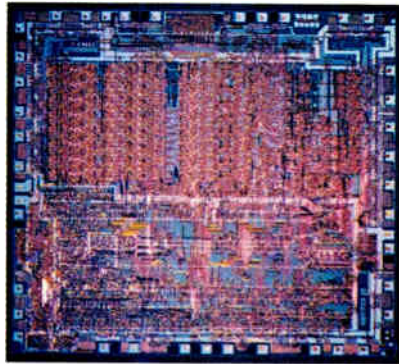

2652 multi-protocol communications controller

## signetics

a subsidiary of U.S. Philips Corporation

Signetics Corporation  
811 East Arques Avenue  
P.O. Box 409  
Sunnyvale, California 94086  
Telephone 408/739-7700

# By Definition.

**analog** (an'a-log). n. *A rapidly expanding industry leader which set the standard for phase lock loop and timer ICs.* Our analog strength lies in other breakthrough products as well—like the fastest (the NE5539) and quietest (5532/33) op amps, and the powerful NE/SE5560 SMPS control circuit. And no one offers more DAC options than we do. No matter how specialized your application, Signetics' Analog Division has it! And we back it all with the latest I<sup>2</sup>L, Bipolar and MOS technologies.

**automotive/telecom** (au" to-mo' tiv-tel' e-kom"). n. *Providing high reliability at large volumes of industry-standard and custom products.* Our super-efficient product flows always insure low defect levels. Couple this with our commitment to meeting the special environmental and data retention requirements of these market segments, and you'll find Signetics means the answer to your automotive/telecom IC needs.

**bipolar LSI** (bi-po' lar). n. *The division which developed the fastest bipolar microprocessor.* You can be sure of Signetics' innovative excellence when you look at the 8X300. At 4 million operations/second, it can't be beat. And with other outstanding devices like I<sup>2</sup>L and ISL gate arrays, plus a growing line of companion parts for the 8X300, this division will continue to be a leading supplier of LSI and VLSI.

**bipolar memory** (bi-po' lar mem'o-re). n. *The uncontested technical leader with the first 16K PROM.* Our continuing bipolar development evolved the first 50ns FPLA, high-speed FPGA and low-power 8K PROM as well. Not to mention the FPLS, the most sophisticated programmable logic device available. There just isn't a broader bipolar memory line on the market. When you want to find state-of-the-art bipolar memory, look up Signetics.

**logic** (loj' ik). n. *Superb breadth of line and matchless quality control.* That's what this division means for you. Our TTL and vast range of Schottky and low-powered Schottky—backed by our SUPR IIB burn-in option—are enough to claim a leading position in logic supply. Add to this our broad choice of 10K ECL devices—soon to be followed by the lightning-quick 100K series—and you'll agree that Signetics is the last word in logic.

**military** (mil' i-tar" e). n. *Syn.: total reliability.* Whether used in avionics or missile control electronics, Signetics ICs perform to specs. Our arsenal today includes over 100 Mil-Spec linear circuits alone. You can also choose from the broadest range of militarized bipolar memories and over 240 QPL logic circuits—including the largest number of Class S TTL circuits. It's tough to meet military requirements. But we've been doing it for almost 20 years.

**MOS memory** (mem'o-re). n. *One of the top three ROM suppliers in the world.* The state-of-the art speed and density of our MOS memory products—like our 64K N-channel ROM in industry-standard pinout—are what gives this division its reputation for excellence. It was also among the leaders with 8K, 16K and 32K fully static N-channel ROMs. You needn't look further than Signetics for high performance and responsive delivery in MOS ROM.

**MOS microprocessor** (mi" kro-pros' es-er). n. *Most innovative in data communications ICs.* *Syn.: commitment to advanced microcomputer components.* For example: Our UART and USART controllers (2641/5161) keep your datacom options open while our 2652 expands the possibilities of multi-protocol communications control with unexcelled operating speed. And our 2653 data integrity controller distinguishes control characters from data, all on one chip. Watch for more LSI system solutions which can simplify your designs for communications or control.

Leadership defines Signetics. We're your best source. Our eight integrated divisions prove it. To find out about how you can put our advanced IC technologies to work, use the coupon below—or call us today.

## signetics

a subsidiary of U.S. Philips Corporation

Signetics Corporation  
811 East Arques Avenue  
P.O. Box 409  
Sunnyvale, California 94086  
Telephone 408/739-7700

To: Signetics Publication Services, 811 East Arques Avenue,  
P. O. Box 409, Sunnyvale, CA 94086

I'm interested in ICs from the following division(s):

- |   |   |
|---|---|
| <input type="checkbox"/> Analog             | <input type="checkbox"/> Bipolar LSI        |
| <input type="checkbox"/> Automotive/Telecom | <input type="checkbox"/> Bipolar Memory     |
| <input type="checkbox"/> Logic              | <input type="checkbox"/> Military           |
| <input type="checkbox"/> MOS Memory         | <input type="checkbox"/> MOS Microprocessor |

Name \_\_\_\_\_ Title \_\_\_\_\_

Company \_\_\_\_\_ Division \_\_\_\_\_

Address \_\_\_\_\_ MS \_\_\_\_\_

City \_\_\_\_\_ State \_\_\_\_\_ Zip \_\_\_\_\_

---



# 50 YEARS YEAR

**I**n April of 1930, O. H. Caldwell, the first editor of *Electronics*, outlined the new magazine's function in his editorial for its first issue.

"For this vital, pulsing electronic art a clearinghouse is needed—an engineering journal that will gather together these widespread activities; chronicle scientific and industrial advances abroad and here, and provide practical usable information which can be put to work," he wrote. "Such a journal must have scientific vision to look above and beyond the present; it must be courageous and devoted in its stand for progress and for expanding applications. . . ."

"The art of the electron tubes goes forward to great and greater achievements. To the engineers and executives in all the ramified branches of electronics, the editors and publishers pledge a service worthy of this field of unparalleled opportunity."

Caldwell's words are old-fashioned and somewhat stilted. But they set a course for *Electronics* from which the magazine has never veered.

The issue you are about to read and, we hope, enjoy and cherish was conceived as a celebration of the first 50 years of *Electronics*' existence. But it has become more

than that—it also celebrates a technological revolution that has transformed modern life. It is a testimonial to the enterprise and the imagination and the daring that have given rise to great companies and institutions and a mighty industry. And above all, it is a tribute to thousands of creative people, those engineers, scientists, and inventors, whose vision and energy have fueled the ever-accelerating progress of electronics over the past half century and promise to continue to do so into the foreseeable future.

A 50th anniversary is both an occasion to look backwards and an opportunity to look forward, and that's precisely what we've done. The task was simple on the surface—after all, we had an excellent archive in the form of the magazine itself—but it turned out to be massive and time-consuming. Planning started over a year ago, and the project ultimately involved all of the 40 or so editorial staff members in New York and around the world, supplemented by consultants to help in the research and editing required.

The history of electronics occupies about two thirds of this special issue. For a very few of our editors, it was a refreshing bout with nostalgia, reviving memories of the





exciting events that have pushed electronics into the pivotal position that it occupies in today's world. For most of our younger editors, it was a revelation, as they discovered that the manifestations of today's technology—television, computers, solid state—which they had seen as creations of their own time, had their roots in the dreams of men who labored long before they were born. And as you read on, I suspect that you, too, will share these mixed reactions of surprise and pleasurable recall.

The history has eight chapters. The first is a snapshot of the technological and sociological milieu of 1930—the setting in which *Electronics* was born—and the next explores the developments that led up to that point. The remaining six proceed roughly by decades, each dominated by some technological or sociological watershed. For example, Chapter 3 describes the Depression-ridden thirties; Chapter 4, the war years. The advent of solid-state technology in 1948 is of such monumental importance that Chapter 5 is devoted wholly to it and to the subsequent growth of the semiconductor industry. Chapter 6 then backtracks to the years immediately following the transistor's arrival, Chapter 7 covers the space age, and the digital era, heralded by the arrival of the micro-

processor and family, is described in Chapter 8.

Recognizing that history is made by people and is not just a dry record of events and dates, we've included a gallery of "Great Innovators," profiles of men who have made significant contributions to electronics. A remarkable vitality pervades the interviews they gave our editors. As another historic aside, we have assembled a collection of "Classic Circuits," those that in the view of our editors were turning points in the development of electronic systems. We've even chronicled the chroniclers of these people and events in "A living record of a technology," a history of the magazine itself.

The remainder of the special issue is given over to a forecast of the future—an especially risky business in the case of electronics. Such predictions tend to be a linear projection of the past, but our historical section reveals that technological discoveries tend to elevate the terms of the algorithm of history to higher and often exponential powers. Still, we elected to take the risk and chose the year 2000 as an approachable horizon. Then, with the help of knowledgeable people who are reputable trend-spotters and planners in their own right, as well as much reading and heated discussion among ourselves, we

produced a four-part prognosis for the future.

The first part focuses on the electronic systems and applications of the next two decades and their impact on the home, the workplace, and our lives. The second part examines the changing semiconductor technology underlying these systems, its ever-higher component densities and faster speeds and the trend toward more and more use of digital techniques. How these changes will affect our readers professionally in the next 20 years is examined in the third part. Finally, in the fourth part, we discuss how the electronics industries could be structured by the year 2000.

This volume is the product of the efforts of many people, from editors, who responded magnificently to this mammoth assignment, to the supporting staff of copy editors, editorial assistants and secretaries, who cheerfully accepted the burdens imposed by this issue above and beyond their normally heavy workload. Special recognition is due to Assistant Managing Editor Margaret Eastman without whose unflagging energy the results would have been far less than they turned out to be; Art Director Fred Sklenar and his staff for their highly creative response to the demands of designing this

special issue; consultant Richard Haitch, who integrated the huge mass of inputs from our editors into a smoothly flowing historical narrative; and photo editor Yvonne Freund, who relentlessly tracked down and acquired the many interesting and often rare illustrations that grace the pages of the history.

Our gratitude is also extended to the many companies, universities, and other institutions who generously opened their archives and made historic material available to us. Special thanks are also due to Paul Reiss, publisher of *Electronics*, and Dan McMillan, group vice president, for their enthusiastic support of the project, and to Kemp Anderson, my predecessor, who helped establish the standards that guided our efforts.

And finally, we wish to thank you, the readers of *Electronics*, for the support and interest that have sustained us for 50 years. The achievements chronicled here are your achievements. We pledge to continue to serve you in the spirit of the charter established by O. H. Caldwell and his editors 50 years ago. This special issue is our gift to you.

**Samuel Weber**  
Editor-in-Chief



**Anniversary portrait.** At home in the McGraw-Hill headquarters building are the New York management and editorial staff of *Electronics*.

# The advanced design line of RF power amplifiers... ENI.

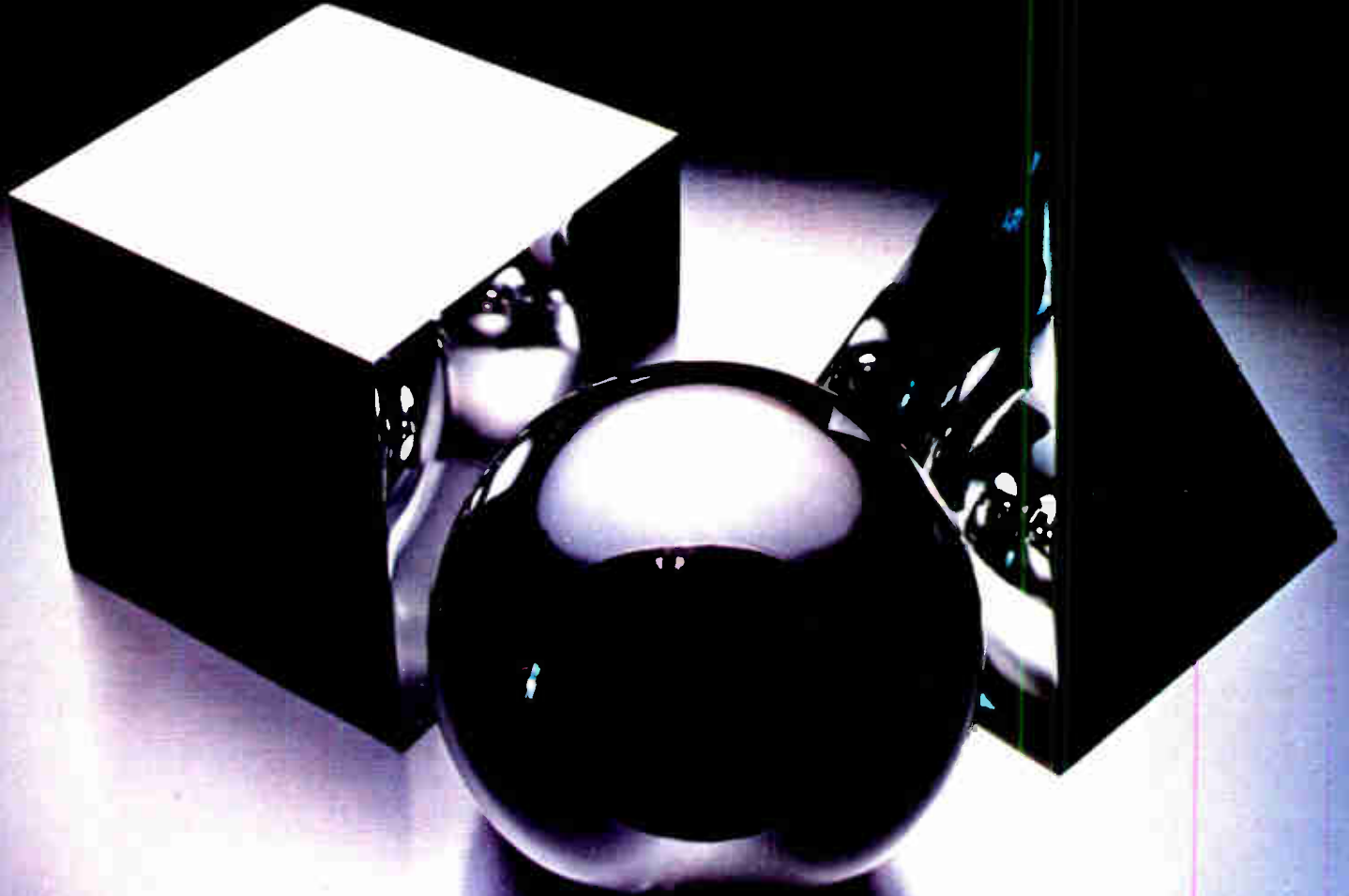

You can't claim to be "the world's leader in power amplifiers" unless you are. And being the world's leader means giving customers the ultimate in RF power flexibility with a clearly advanced design. That's the reputation we've earned with our product line because there's simply nothing finer in all the world.

And our instrumentation can meet all of your applications, for RF signal generator amplification, RFI/EMI testing, signal distribution, RF or data transmission, NMR/ENDCR ultrasonics and more.

ENI's selection of solid state Class A power amplifiers is unsurpassed, combining a frequency spectrum of



10 kHz to 1 GHz with power outputs that range from 300 milliwatts to over 4,000 watts. Rugged, compact, and versatile, these units can be driven by virtually any signal source. They're completely broadband and untuned, amplifying inputs of AM, FM, TV, SSB, and pulse modulations with minimum distortion. Their unconditional stability and failsafe

design make them impervious to severe mismatch conditions, and capable of delivering rated power to any load impedance from an open to a short circuit.

Clearly, when it comes to meeting your power amplification needs, you'll get the utmost in flexibility from the advanced design of RF power amplifiers... ENI.

For our latest full-line catalog, please contact us at ENI, 3000 Winton Road South, Rochester, NY 14623. Call 716/473-6900 or telex 97-8253 ENI ROC.

## ENI





# Electronics

## The living record of a technology

---

There it was, a brand-new magazine  
with a new word for a name: *Electronics* . . .

---

. . . what could that mean? The editors made no secret of it, for right underneath the title ran a legend, "Electron tubes—their radio, audio, visio and industrial applications."

Listed in tiny type down the left side of that first cover were 28 applications, some as specific as "musical instruments" and some as general as "measurements." Yes, "radio" was there, along with "television" and "telephony," but then so were "photo-electric cells." The manifold applications of computing power were absent, but who in April, 1930, was thinking about them?

Over the years, the legend has grown up that the founders minted the word, and indeed "electronics" did not appear in dictionaries until many years after the launching of the magazine. However, the word did exist—someone ran across it in a contemporary British publication and plucked it from obscurity to serve as the name. Safe to say, then, that *Electronics* was the making of "electronics."

One of the two associate editors in the magazine's infant years was Keith Henney, who looks back fondly on that period from his retirement home in Snowville, N. H. "Although I was hired to be one of the editors

and although I got out the first issue, I was not in on the invention of the paper and had no part in persuading the company to initiate it," he recalls. "*Electronics* was invented by Orestes H. Caldwell and Maurice Clements, then editor and manager, respectively, of Radio Retailing." Manager meant publisher; in those days there was only one publisher at McGraw-Hill, and that was founder James H. McGraw.

"OHC was a superb editor," Henney recalls. "He was very valuable in that he saw broadly . . . *Electronics* under Caldwell was always way ahead of the procession."

At \$3 for 12 monthly issues, the magazine attracted 4,366 paid subscribers during its first year. A glance at early issues makes one thing clear immediately: it was very different from today. The difference lay not just in the subject matter (concentrating heavily on radio, of course), but even more in the type of coverage given to the subject matter. *Electronics* for many years was much like the learned journal of a scientific society. Oh, there were news and new product sections and ample use of photographs showing actual applications, but at the heart of each issue were articles like "An analysis

of efficient modulation,” and “The sun’s effect on radio,” to pick a couple from the 1934 bound volume of issues.

“I wanted a highly technical magazine,” Henney recalls. “I wanted to put into writing the things I would talk about at conventions, at Hazeltine, at Bell Labs . . . I wanted the kind of magazine that these fellows would respect, read, and write for.”

The community of engineers was considerably smaller then, so the tiny editorial staff could cover the field. “The things that interested me would interest the guys I talked to,” says Henney. “Of course, there weren’t nearly as many of them then. I figure about 25 good friends like Harold Wheeler [see the Great Innovators section] and Major Armstrong [developer of the superheterodyne radio receiver and of fm transmission] and that’s all I needed.”

In retrospect, the tight community of interests may have been the principal factor in keeping the magazine going. It never lost more than a few thousand dollars a year, and it turned slightly profitable well before the end of the Depression, but it was a bare-bones operation. Henney recalls that for a year or so he was the only person putting out the editorial matter—without even a secretary.

He was the linchpin of the magazine, but clearly that could not last forever. The September 1934 issue carries him as managing editor and adds a new name: Donald G. Fink. “I wanted a man who could take my job away from me,” Henney says. “He was a lifesaver—had just what we needed: solid technical background, good administrative ability, good news sense, could write.” Fink eventually got his boss’s job and, to anticipate a bit, went on to a distinguished career in research and at the Institute of Electrical and Electronics Engineers.

The September 1934 issue also

carried a lead editorial, “The new day of visual transmission,” which included facsimile, as well as television. Forty-five years later, it is difficult to establish a link between that editorial and Fink’s arrival. But certainly it is safe to say that the new editorial employee pioneered the coverage of television.

“Caldwell told me he thought I ought to select a specialty that had a potential for growth,” Fink says. “I selected TV.” He plunged in, visiting RCA Laboratories, Hazeltine Corp., and the few other labs researching TV. He even set up his own lab, at the very top of the old McGraw-Hill Building on West 42nd Street in Manhattan, and there he “produced the first TV set described in print,” in a six-part series beginning in the July 1936 issue.

The receiver had a 9-inch, round, green-phosphor cathode-ray tube, with certain key parts coming from RCA Laboratories. A couple of years later, Fink’s lab produced a smaller version, described in the magazine as a home receiver. He also began work on a landmark textbook, “Principles of Television,” published in 1940 by McGraw-Hill.

By the late 1930s, *Electronics* had begun to grow. Henney dates the growth from the rise in subscription rates from \$3 to \$5, about the same time he took over as editor, with the September 1935 issue.

The corporation executive vice president, Howard Erlich, was looking for ways to make the magazine profitable, and he proposed to hike the subscription rate. “He thought that half of our circulation at that time [about 6,500 subscribers] would represent the hard core of all the [electronics] purchasing and buying power in the country,” Henney recalls.

“I made a deal with him. If he would give me \$1 of the extra \$2, I would plow it back into the editorial content. We got an art director, used

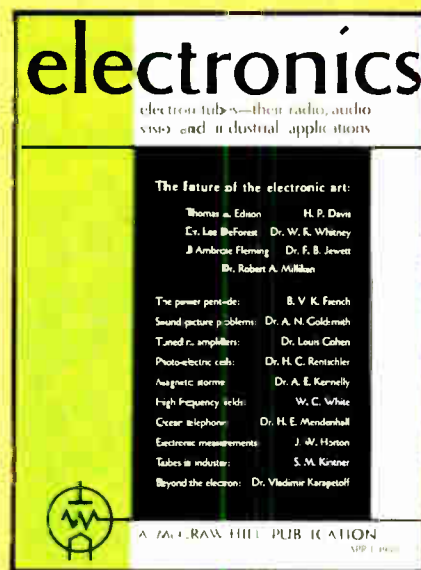

April 1930

**“Other than the Proceedings of the IRE, it was the only magazine that attempted to deal with complex electronic matters.”**

---

**“OHC was a superb editor,” Henney recalls.  
“He was very valuable in that he saw broadly . . . *Electronics*  
under Caldwell was always way ahead of the procession.”**

---



**Keith Henney**

better paper, dressed the thing up and expanded the content. We put on a circulation campaign. Instead of losing readers, the circulation began to grow, and with a bigger audience, it was easier to sell advertising,” he says.

Moreover, the magazine was achieving renown for its coverage of technical matters, certainly a factor in the circulation growth. “It always had a pretty solid reputation,” Don Fink maintains. “Other than the Proceedings of the IRE [the Institute of Radio Engineers], it was the only magazine that attempted to deal with complex electronic matters . . . Armstrong said all along *Electronics* was the only magazine that always got it right on his development of wideband fm.”

All too soon the war years loomed, changing the face of the world, of electronics, and of *Electronics*. The January 1943 issue gives an idea of the changes. Along with articles like “Electron microscope in chemistry” (by Vladimir K. Zworykin—see the Great Innovators section), there were such features as “Checking resistance welding controls” with CRTs and “Wartime developments in carrier current communication.” Also appearing were articles like “Plant procedure for expediting war production.”

Henney was putting out the magazine with four editors and an art director. Two more editors were on the masthead, but they were listed “on leave,” doing war duty.

One of the two was Fink, who was head of the loran division of the Radiation Laboratory of the Massachusetts Institute of Technology. He went on to become an expert consultant on loran for the Secretary of War, then returned to the magazine.

“When I first got back from the war, of course, I had access to just about everything that had happened at the Radiation Lab,” he says. “It was all rapidly declassified and there were a great many great radars that were ready to be described in *Electronics*.” The result was an extraordinary series of articles, written by Fink. Of these, Henney recalls: “We got some extra paper, started a series called a war report, and Don began to reveal wartime stuff. I believe the first article was the radar equation. It was a wonderful series.”

By now Henney had been shepherding the magazine through its inevitable monthly crises for 16 years, and he was ready for some-

thing new. On Nov. 1, 1946, Fink became editor, and his former boss assumed a kind of supervisory editorship, as well as launching a new magazine called *Nucleonics* (which lived into the 1960s) and playing a key role in the Technical Writing division of the McGraw-Hill Book Co. He was no stranger to books, since he had begun writing them in the 1920s. Eventually his list totaled eight, including two on photography that had led to Photo-Technique, a sister magazine that the *Electronics* staff put out for a couple of years just before World War II.

Fink remembers his editorship as a period of expansion, sparked by the growth in the industries the magazine was covering. “Right after the war, electronics was booming in a way that no one could stop,” he says. “Consumer electronics was booming; TV was new. Also, there was all that technology—microwaves, superhigh frequencies, magnetrons, solid state (diodes, not transistors)—that was developed during the war and now was available for consumer and industrial use.”

In the latter part of Fink’s tenure, the magazine took the first steps down what was to prove a sometimes painful road of evolution. “In 1951–52, we felt great pressure from top management to become a magazine more like *Business Week*,” he says. It had gone on from its birth in the depression to scale the heights of general-purpose business coverage. Similar news about the industries covered by the technical magazines would benefit their readers, corporate management reasoned.

Inclined as he was towards tech-

---

**“I wanted to put into writing the things I would talk about at conventions,  
at Hazeltine, at Bell Labs. . . . I wanted the kind of magazine  
that these fellows would respect, read, and write for.”**

---



---

**“Caldwell told me he thought I ought to select a specialty that had a potential for growth,” Fink says. “I selected TV” and “produced the first TV set described in print.”**

---

nological development, Fink joined Philco Corp. in mid-1952 as a director of consumer electronics research, eventually becoming vice president of research. On Jan. 1, 1963, he became the first executive director and general manager of the newly formed Institute of Electrical and Electronics Engineers, remaining there until his retirement. Somehow he also managed to find time to write 14 books, and even now he is working on new editions of “Standard Handbook for Electrical Engineers” and “Electronics Engineers’ Handbook,” both McGraw-Hill publications.

His successor was W. W. McDonald, who started on the corporation’s electrical magazines in the 1920s and joined *Electronics* in 1942. Looking back from retirement in Florida, he says his early years on the magazine were devoted to expanding the technical coverage to areas other than radio and communications, where Henney and Fink concentrated. “That I needed a ballpark of my own was a lucky accident,” he says, for the magazine needed to expand its coverage as much as he needed his own bailiwick.

As editor, McDonald presided over special issues dealing with subjects like electronics in Europe and microcircuitry. Eventually, of course, coverage of these areas was to become a staple in the magazine’s editorial diet.

He also presided over a series of changes in editorial format, as *Electronics* struggled to provide news of the business along with technology news. It all began in December 1956, with what a then ad salesman and later publisher, Dan McMillan, calls

“the only trimonthly magazine in the world.” Around the first of the month, readers received the engineering edition; around the 10th and 20th they received the business edition. The trimonthly lasted for just over a year, then became a weekly with alternating engineering and business editions, finally becoming a weekly magazine with both kinds of coverage in early 1959.

Resolution of the struggle came in 1964, when Lewis H. Young took over as editor. The magazine was set to go biweekly, since the readers (and the editors) found a weekly *Electronics* too much to digest. Then the Business Week bureau manager in Detroit, Young came on board after extensive discussions with the new publisher, C. C. “Jim” Randolph, and so he knew what changes he wanted.

“We wanted to take the magazine back to what it was: a technical magazine aimed at engineers,” he says. “At the same time, we broadened this coverage to include some of the nontechnical elements that impinge on engineering.” Of course, a key nontechnical element is business considerations and so the magazine continued to provide that coverage. What was new was the integration of business and technology, notably in the news stories, but also in the technical articles.

The new format bowed with the March 23 issue, timed to coincide with the IEEE International Convention in New York (now the Electro show). “We wanted it out for the show; we could explain it in person to the readers and advertisers,” Young says. No need to describe the format: it continues to this day. Also



**Donald G. Fink**

unchanged is partitioning technical coverage by specialties and assigning individual editors to follow them.

Sometime during Young’s tenure at *Electronics*, the title of the job was changed to editor-in-chief. He left the magazine with the Jan. 8, 1968, issue to become managing editor and then editor-in-chief of Business Week, later adding to that the title of vice president of the McGraw-Hill Publications Co., which is the magazine operation of the corporation. He left a legacy that is more than a format, for his charges sparked the coverage of the electronics industries as creators and exploiters of technology. Such a view is, of course, rooted in events, for the solid-state revolution was just beginning to be felt.

Young’s successor was Donald

---

**Henney recalls: “We got some extra paper, started a series called a war report, and Don began to reveal wartime stuff. I believe the first article was the radar equation. It was a wonderful series.”**

---

---

**"We wanted to take the magazine back to what it was: a technical magazine aimed at engineers." . . . What was new was the integration of business and technology, notably in the news stories, but also in the technical articles.**

---



**Lewis H. Young**

Christiansen, the associate managing editor of the technical section and now the editor of the IEEE Spectrum. In recent years, in fact, *Electronics* has served as a spawning ground for editors of a number of other publications.

About the time Christiansen left, a new triumvirate formed to lead the magazine through the 1970s. It consisted of Kemp Anderson as editor-in-chief, Samuel Weber as executive editor, and Dan McMillan as publisher. Their first issue together was June 8, 1970.

The new team could boast of a wide range of experience. Anderson had been a member of the publication company's World News operation and was head of the *Electronics* news operation under Lew Young. Weber had been a practicing electri-

cal engineer for 10 years before first joining the magazine in 1958, eventually becoming the head technical editor. Also, both men had held executive-level jobs in the publications company. McMillan had spent 1961-69 in executive jobs in the electronics manufacturing field at TRW Inc.

Anderson looks back at his stewardship as a period of consolidation. For example, the bureau system of locating reporters in regions that are centers of electronics technological advance was expanded and refined, with particular attention being paid to international coverage. "We continued to pay more attention to international news, and it became more significant as overseas caught up with the U. S.," he says.

Also important was the honing of the concept of the special report. The magazine had for many years pursued an occasional topic in depth, but the 1970s saw a commitment to a continuing process of in-depth coverage. For Sam Weber, an important event was the Oct. 25, 1973, issue devoted to "The Great Takeover." "At that time, we perceived that the pervasiveness of electronics was growing and affecting everyday life beyond belief," he says.

The issue was a success and spawned the annual Technology Update issue. Meanwhile the idea of the special report came into full bloom. "In a long special report, you can emphasize a subject by pulling all the material together," says Anderson. "Also, you can start touching more bases than before: information that was not in earlier stories you now have room for. It is a way of keeping people up to date in a fast developing field and relating that to

other developments." Some of the special reports turned out to be prize winners, a notable example being "The Gathering Wave of Japanese Technology" in the June 9, 1977, issue. It garnered one of the prestigious annual Neal Awards for outstanding journalism from the American Business Press association. In the 25 years of those awards, the magazine has won three of them and received three certificates of merit, most of these awards within the last five years.

With *Electronics* poised to enter the 1980s, some important changes took place at the helm. Anderson moved on to become vice president for business systems development for the publications company, and Sam Weber succeeded him as editor-in-chief effective with the Sept. 13, 1979, issue. McMillan had already been promoted to group vice president, which gives him overall responsibility for several McGraw-Hill magazines in addition to *Electronics*. His successor is Paul W. Reiss, who moved up from the position of advertising sales manager.

The magazine is entering its 51st year with an editorial staff of more than 40 men and women, a circulation of about 96,000 including 24,000 overseas, and an international reputation for providing significant news and technical articles. The new team looks forward to a long, productive life.

"Electronics is probably the most significant technology to be applied to problem solving for the next 100 years," Weber says. "The increasing recognition of its importance as a mainstay of technological society makes *Electronics'* role more important than ever." □

---

**"At that time, we perceived that the pervasiveness of electronics was growing and affecting everyday life beyond belief."**

---





# MEASUREMENT COMPUTATION **NEWS**

product advances from Hewlett-Packard

APRIL 1980



Computers

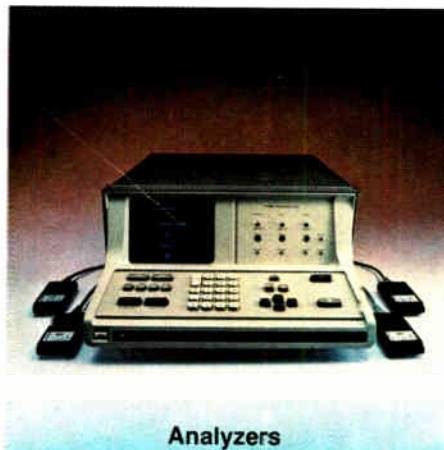

Analyzers



Oscilloscopes

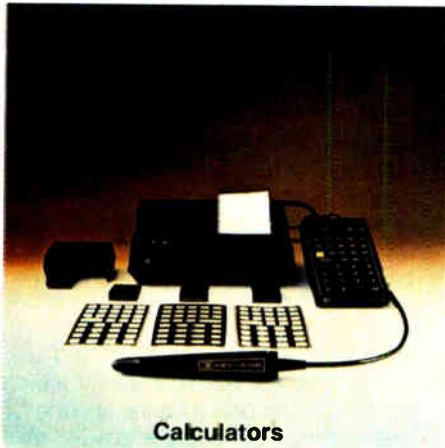

Calculators



Signal Generators

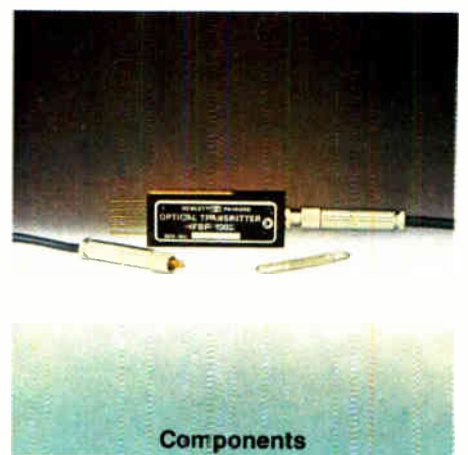

Components



Counters



Voltmeters



Test and Measurement Controllers

Hewlett-Packard—a responsible source for reliable products, systems and services to meet your measurement and computation needs—worldwide.



# A new, low-cost HP 1000 computer dramatically improves I/O performance and throughput

HP-IB



The HP 1000 L-Series is a new, low-cost addition to the Hewlett-Packard family of real-time computers. The L-Series puts two advanced processors to work in one computer to create a "Distributed Intelligence" architecture with exceptional I/O speed and flexibility.

The two processors teamed within the L-Series are the result of HP's proprietary CMOS/SOS (Silicon-on-Sapphire) Large Scale Integration manufacturing process, which offers the benefits of very high circuit densities, high speed and low power consumption. One of these custom SOS circuits serves as the L-Series central processor. The other SOS processor is used on every interface board, where it autonomously handles the computer's I/O traffic.

## Distributed Intelligence

Because the CPU is relieved of the need to control I/O operations, the "in-board" central processor can concentrate on its main role of computation. The "outboard" processors on each interface board each have full access to memory along with the CPU. The resulting multi-streamed I/O capability allows multiple high or low-speed data transfers without intervention by the CPU. Each I/O processor can monitor and control direct data transfers to memory. Direct Memory Access (DMA) bandwidth is an extremely fast 2.7M bytes per second.

This I/O concept reduces interrupt response times, reduces CPU overhead and simplifies the design of interfaces. As a result, an HP 1000 L-Series—available

in board, box and system configurations—can perform instrumentation and other I/O-intensive applications faster than computers costing up to five times as much. A wide selection of I/O boards, including an HP-IB interface to many HP instruments and peripherals, is available.

## Software

Software for the new L-Series is based upon RTE-L, a compatible member of HP's family of Real-Time Executive operating systems. RTE-L is a real-time multiprogramming system designed to take full advantage of the new L-Series I/O structure to improve overall CPU and I/O throughput. RTE-L offers a wide range of configurations, from a small, memory-based, execute only system to a full disc-based system with on-line program development. RTE-L can supervise execution of multiple, priority-ordered functions in its real-time foreground area while less time-critical operations can share its swappable background processing area. RTE-L supports program development in FORTRAN IV, BASIC and Assembler, plus execution of PASCAL programs. Program development for the L-Series also can be performed on a larger HP 1000 system under RTE-IV.

## Configurations for OEM's

The simplest possible configuration consists of the board containing the CPU and its support circuitry, and a 64K memory board. This version is called the 2103LK. OEM's can add a power supply, a 5- or 10-slot card cage and any desired interface boards. \$2,250.

Another configuration, a rack-mountable computer, the 2103L, comes complete with processor, memory board, power supply, and 8 I/O slots. \$4,450.

The L-Series is also available as a complete system. This Model 10 includes the processor, memory board with battery backup, HP-IB and serial interfaces, a card cage, cabinet, power supply, HP 2621 CRT terminal, a 1.2M byte flexible disc drive and a 12M byte Winchester disc.

Check **B** on the HP Reply Card for more information.

## Do your own system design in weeks, instead of months



Designing your instrumentation system or expanding an existing one? A new HP-IB brochure is now available which describes HP's complete selection of "Designed For Systems" instruments and computers.

This 16-page brochure, *Do Your Own System Design in Weeks, Instead of Months* explains how HP's 10 years of experience building HP-IB instruments and computers for automatic test systems can save you time and energy in your own design.

How can HP-IB products from Hewlett-Packard accomplish this? They can because HP-IB means much more than simply HP's implementation of the IEEE-488. HP-IB represents an integration of features developed and refined over 10 years of experience. These "Designed For Systems" features include:

- a wide selection of measurement system components
- a quick, easy, internationally standardized interfacing scheme
- a large base of documentation and software support
- a variety of customer training courses
- on-site service

The remainder of the brochure is a very complete and comprehensive overview of the more than 119 "Designed For Systems" Hewlett-Packard instruments and computers. Special information on HP-IB product documentation, software, training, and service support is also provided.

*For your complimentary copy of this HP-IB brochure, check C on the HP Reply Card.*



**Not just IEEE-488, but the hardware, documentation and support that delivers the shortest path to a measurement system.**

## Introducing PASCAL/1000: a new high-level language for HP 1000 computers



A conversational language logically organized in program "blocks," Pascal is easy to learn and easy to follow.

Pascal/1000, Hewlett-Packard's new block-structured programming language for HP 1000 computers, helps improve program design, simplify program maintenance, and reduce overall software costs. Pascal/1000 fully implements the "standard" language defined by Niklaus Wirth, but we've also added several important extensions to enhance Pascal in the HP 1000 programming environment. Furthermore, Pascal/1000 is compatible with other HP 1000 software subsystems—IMAGE/1000, DATA CAP/1000, GRAPHICS/1000, and DS/1000.

### Technical Applications

Pascal's powerful data structuring and statement control constructs make the language well suited for technical applications. Its general-purpose structure fits non-technical usage as well, and its record-handling capabilities are comparable to those found in COBOL. The addition of Pascal gives programmers greater flexibility in choosing the language most appropriate and efficient for a given project. Moreover, Pascal's readability is invaluable when the program must be maintained later by some-

one other than the author.

### Program Development

For Pascal program development, an HP 1000 system with at least 384K bytes of memory and RTE-IVB operating system is required. The Pascal/1000 compiler translates Pascal source code to assembly language source code, which is then automatically assembled to produce object code. Extensive error-checking is performed during compilation and (optionally) during execution, thus increasing program reliability. In keeping with HP's philosophy of compatible instruction sets, Pascal/1000 object code will execute on any HP 1000 computer.

Right-to-copy licenses, software support, and user training are available. HP order number 92832A includes three Pascal/1000 programming manuals and the Pascal/1000 compiler, library, error message file and cross reference generator on a choice of mini-cartridges, 800 bpi magnetic tape, or 1600 bpi magnetic tape.

*For additional details, check D on the HP Reply Card.*

# New 9030 system simplifies equipment control and electromechanical testing

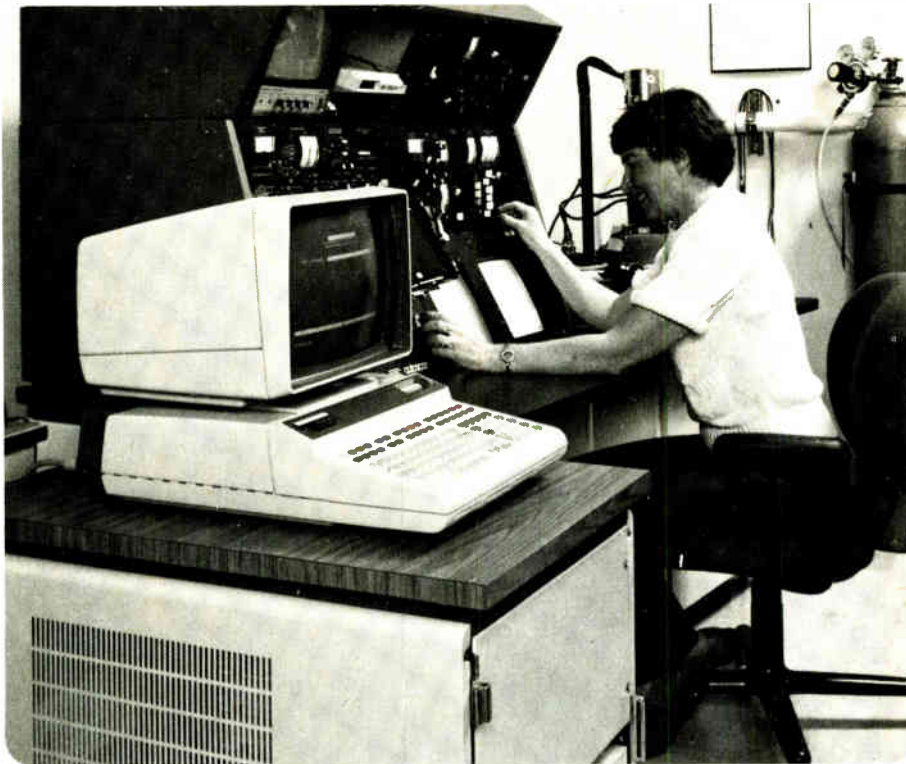

This combination of a desktop computer and a versatile measurement and control processor makes the 9030 a powerful tool for controlling automatic equipment, and for product testing of electromechanical devices.

Hewlett-Packard's newest addition to its family of test, measurement and control systems takes the concept of intelligent instrument control one step further by combining a powerful desktop computer with a versatile measurement and control processor. This fully integrated package, designated the HP 9030, offers computer-independent task execution of analog and digital inputs and outputs, HP-supplied System Integration Software, programming simplicity and an HP-IB interface—all in an easy-to-use, roll-around cabinet.

The 9030 consists of an HP System 35, System 45 or 9825S Desktop Computer atop a special instrumentation cabinet containing an extended performance version of the HP 2240A Measurement and Control Processor.

Whether your task is instrumentation interaction, control operations, system debugging, lab development or product design simulation, the 9030 is flexible enough to meet most demanding requirements. This flexibility comes from assigning the computational tasks to the

9030's Desktop Computer while the burden of the control tasks is off-loaded to the separate control subsystem located in the console.

## Added Flexibility

The heart of the control subsystem is the HP 2240A Measurement and Control Processor. A state-of-the-art SOS (silicon-on-sapphire) microprocessor gives the 2240A its own intelligence to perform tasks independent of the desktop computer. An HP-IB interface cable connects the control subsystem to the desktop computer. A major advantage of this type of connection is that it allows the desktop computer to control a wide selection of other HP-IB instruments and peripherals.

In addition to independently performing normal input/output operations, the 2240A can also:

- continuously gather large amounts of high-speed data with a single, programmed REQUEST,
- gather historical data leading up to and following a critical event,



- provide a built-in decision making capability based on digital input status,
- perform equipment shut-down upon an alarm condition,
- allow REPEAT/NEXT logic to be nested for subsystem programming convenience and efficiency,
- interrupt the desktop computer upon completion of tasks or upon detection of an error to a measurement.

## Minimized Development

With the 9030 you can reduce development time by interacting with the control subsystem through an HP desktop computer. The HP System 35 (9835A) is designed for highly-interactive, single-user applications. Its raster scan CRT, typewriter-like ASCII keyboard, versatile program debugging tools and HP Enhanced BASIC language help you get your system up and running quickly. It also offers:

- 12 digit floating point precision,
- APL-like matrix commands,
- flexible, string variable manipulations,
- high level I/O drivers,
- 50K bytes of user-available r/w memory (expandable to 246K).

If you choose HP's System 45 (9845T) as your desktop computer you get all the features of the System 35, plus full graphic capability (optional) and 187K bytes of r/w memory that is expandable to 449K bytes. Or choose the HP 9825S Desktop Computer. It features an LED line display, built-in thermal strip printer and tape cartridge drive, and 3 I/O ports (expandable to 14). Its high performance capabilities and Direct Memory Access allow the capture of real time data at high speeds.

To find out more about HP's new system, check **E** on the HP Reply Card.



# HP solves more problems. . .

**With a broader range of programmables and more extensive software solutions than anyone else!**

With programmable calculators, hardware is only half the story. Having software solutions that work is the other half. Hewlett-Packard's superior software support often means the difference between spending time solving your problems and spending time doing the programming necessary to solve them.

HP's growing library of over 3,500 software solutions covers a wide range of disciplines and applications. From aircraft navigation to x-ray diffraction. And HP software is available in several convenient forms:

- Hundreds of easy to use, step-by-step key-in programs for all Hewlett-Packard programmables
- Preprogrammed magnetic cards for fully programmables

- Plug-in modules
- And soon, bar-coded programs for the HP-41C.

There are also thousands of software solutions in the HP Users' Library. So when you buy a Hewlett-Packard programmable, you're buying a useful, efficient, and complete problem solver.

However, the problem it can't solve is deciding which HP programmable is right for you! Hewlett-Packard has eight different scientific and financial programmables to choose from. From the popular HP-33E to the innovative HP-41C—one of them is sure to meet your particular needs. The most extensive range of programmable calculators backed by the most extensive line of software solutions. It's an unbeatable combination.

*For prices or more information check **A** on the HP Reply Card.*

Now over 1900 programs available for IC tester

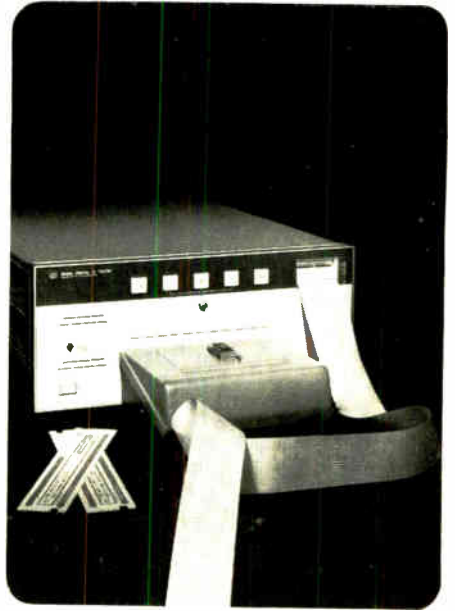

**A simple magnetic programming card makes it a lot easier to learn the truth about the quality of your incoming IC's with HP's 5045A Digital IC Tester.**

There's probably no easier way to get fast, accurate screening of your incoming ICs than with HP's 5045A. Set-up is as easy as inserting a magnetic card. You can get as much or as little data as you want. The IC programs you need are almost certain to be in our growing library of over 1900 programs covering today's most used ICs from bipolar to MOS and from gates to RAMs.

### **Find Out a Little or a Lot**

Touch a button and you get immediate pass/fail indication. Need to know more about the failure? Push another button and get a complete printout of the test with the failure point indicated.

### **Customize Your Test Programs**

Want to refine a test procedure? Need a test for a special IC? The HP 5046A Digital IC Test System lets you write your own custom test programs. It includes the HP 9825S Desktop Computer, a powerful computing instrument that you can also use for many other tasks, such as program storage or general-purpose computing. The 5045A also interfaces with a large variety of the major IC handlers.

*For further technical data, check **F** on the HP Reply Card.*

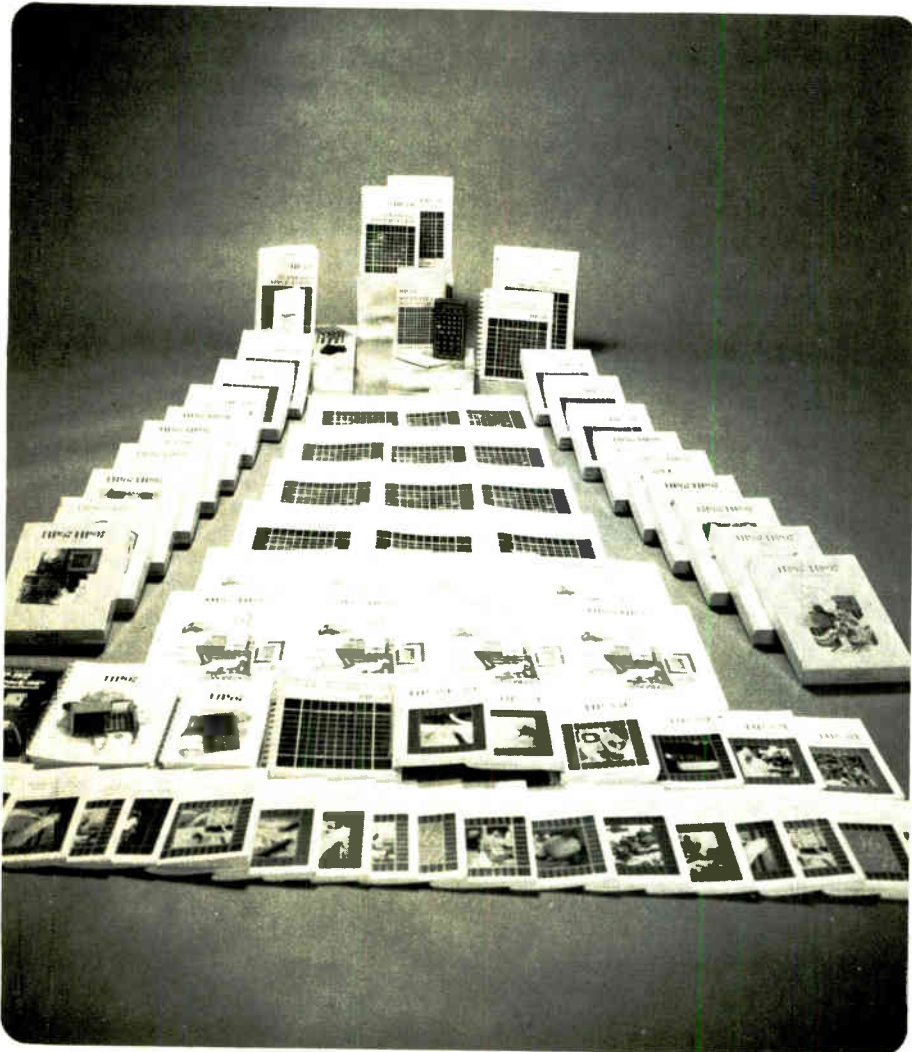

# HP's 1700 series oscilloscopes solve 3 common measurement problems

HP recently surveyed the electronics market to learn more about how oscilloscopes are being used and the problems encountered when making measurements. The three most common measurement problems reported by oscilloscope users were triggering, hard to see traces, and displaying fast pulses. HP's 1200 series oscilloscopes solve all three of these problems.

## Stable Triggering

The most often reported problem, triggering, is solved by HP with a custom ECL triggering circuit which offers exceptionally stable triggering. In all HP 1700 series oscilloscopes, this proven integrated circuit is independent of vertical position controls—traces can be repositioned without the need to reestablish trigger synchronization. Triggering is more reliable than with the more conventional tunnel diode circuits which can drift due to both temperature and aging.

## Bright Traces

The second most reported problem, hard to see traces, is solved by 1741A and 1744A variable persistence storage oscilloscopes. Variable persistence integrates repetitive signals for easy viewing. Practically any signal can be viewed as a sharp, bright trace regardless of repetition rate or speed. And with the auto-intensity feature, both oscilloscopes

make it easy to avoid trace blooming over a wide range of beam intensities and sweep speeds.

## Fast Writing Speeds

The third problem, display of extremely fast pulses, is solved by the fast writing speeds of HP's storage oscilloscopes—200 cm/ $\mu$ s in the 1741A and 1800 cm/ $\mu$ s in the 1744A. With 1800 cm/ $\mu$ s you can display a single shot, 100 MHz sinewave with an amplitude of eight divisions.

Full writing speed is available in all operating modes—variable persistence, auto-erase, and auto-store—giving you the freedom to select the operating mode that matches your measurement.

Additionally, the 1741A will wait indefinitely in the auto-store mode for a single-shot event to occur. When coupled with the auto camera option, this instrument will operate unattended to provide a permanent trace photograph of an event—even if it occurs during the night or over a weekend.

What's more these 1700 series oscilloscopes have established an excellent record for reliable performance. However, if a failure does occur, easy access to internal components makes these oscilloscopes very easy to repair.

*To learn more about the features and benefits offered by these scopes, check G on the HP Reply Card.*

Measure pulsed and CW frequencies up to 40 GHz automatically

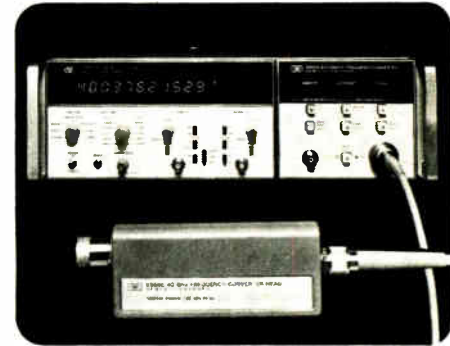

With HP's new 40 GHz Universal Microwave Counter package you'll be able to make all the frequency and time interval measurements you're likely to need in microwave applications.

Now you can measure pulsed and CW frequencies automatically and accurately all the way up to 40 GHz. Just add HP's new 5356C Frequency Head to HP's 5355A Automatic Frequency Converter and HP's 5345A Universal Counter. Then, with a single set up, using a single input, you can quickly measure these radar parameters:

- Average frequency in a pulse
- CW microwave frequency (STALO, magnetrons)
- Pulse repetition frequency
- Pulse width
- Pulse repetition interval

External gating enables you to profile frequency changes within the pulse, using sample sizes as brief as 20 ns.

FM tolerance is excellent: 60 MHz CW and 80 MHz pulsed. Input sensitivity is high: -25 dBm (1.5-12.4 GHz), -20 dBm (12.4-26.5 GHz), -15 dBm (26.5-34 GHz), -10 dBm (34-40 GHz).

The 5345A Counter and 5355A Converter together measure frequency from DC to 1.6 GHz. The new 5356C extends the range from 1.5 to 40 GHz. The HP 5356A Frequency Heads have ranges of 1.5-18 GHz and 1.5-26.5 GHz respectively.

The 5356C standard input connector is an APC 3.5; option 001 substitutes a waveguide connector which acts as a high pass filter to limit the measurement range to 26.5-40 GHz. For the systems capabilities of the HP-IB, order your 5345A Counter with option 011.

Check H on the HP Reply Card for all the details.

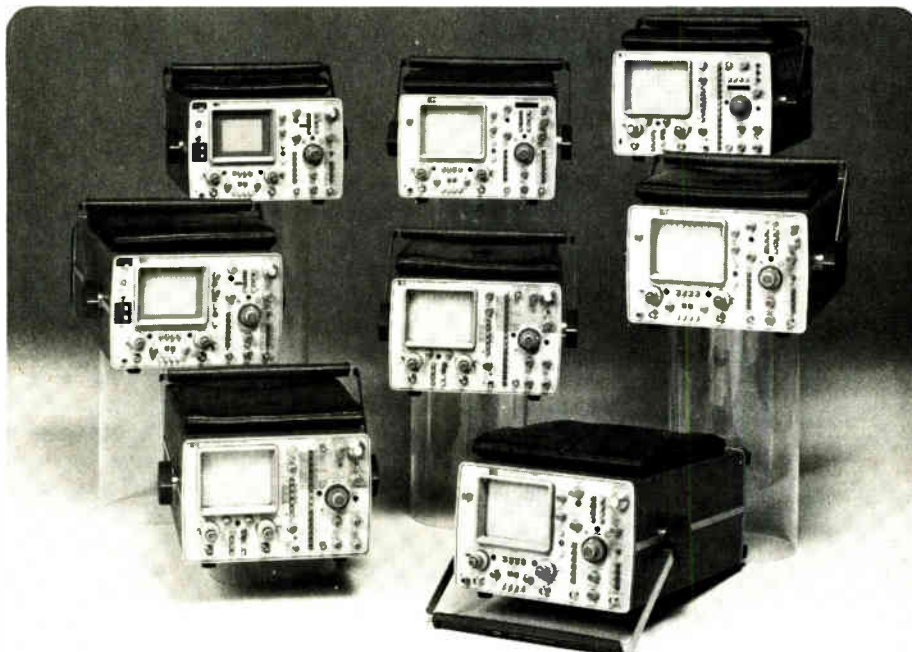

HP's 1700 oscilloscopes can provide the answer to your measurement needs with 100, 200 and 275 MHz bandwidths, with reliable triggering and operation.



# HP's 5½, 6½ digit digital voltmeter checks and calibrates itself



**Microprocessor-controlled digital voltmeter checks its dc and ohms circuits for accuracy then makes corrections.**

Using two microprocessors, one for measurement control, and the other for computation and remote programming, Hewlett-Packard's fully-guarded, integrating 3455A Digital Multi-Voltmeter is designed for bench or systems use. It measures dc from 1  $\mu$ V to 1,000 V, true rms ac from 10  $\mu$ V to 1,000 V, and either two or four wire resistance from 1 m $\Omega$  to 15 M $\Omega$ . A high-resolution mode uses 6½ digits, but for faster reading, 5½ digits are used.

Using a parallel structure control oriented microprocessor, the HP 3455A has autocalibration which provides high accuracy and a removable reference assembly that greatly simplifies calibration of dc and ohms.

Mathematical functions built into the 3455A let the user offset, take ratios, or to scale readings so that readouts are in physical units. A '% ERROR' mode converts readings into percent change compared to a predetermined reference.

DC measurements are made at 24 readings per second (22 readings per second for 50 Hz) with 1  $\mu$ V sensitivity. Greater than 60 dB normal mode noise



rejection is obtained on all dc ranges. Dc accuracy is  $\pm 0.0023\%$  at full scale.

True rms measurements are made to 13 readings per second at frequencies above 300 Hz. True rms is measured with the best accuracy of 0.1% over a 30 Hz to 1 MHz bandwidth. Signals with a crest factor as high as 7:1 full scale can be measured.

Resistance is measured in six ranges from 100  $\Omega$  to 10 M $\Omega$  full scale with best accuracy of 0.0025% at full scale.

Maximum current through the unknown is less than 1 mA. Internal circuits are protected against overvoltage.

Standard on the 3455A is an HP-IB I/O for systems operation. The front panel indicators on the 3455A display range, function, and HP-IB status during remote operation.

*Check I on the HP Reply Card for full information.*

## New high-speed scanner card expands multiprogrammer production test capability



**Use HP's 6940B Multiprogrammer with its 32 different plug-in functions for interfacing a desktop computer to the equipment you want to automatically control.**

A new HP 69336A High-Speed Scanner Card now permits HP's 6940B Multiprogrammer, to sample 20,000 channels-per-second of voltage input.

This enables the multiprogrammer to act as the vital link between an HP desktop computer or minicomputer and your test or control process.

Thousands of 6940B multiprogrammers are now in operation, saving time and money in user defined and assembled systems for production testing and control, data acquisition, and process monitoring. Multiprogrammer hardware includes mainframes and a family of 32 plug-in cards providing specialized stimulus, measurement, control and acquisition functions.

*Check J on the HP Reply Card to obtain more information on the 6940B Multiprogrammer and technical data on the 69336A High Speed Scanner Card.*



## Today's state-of-the-art in 10 kHz to 1280 MHz signal simulation

Signal generators are used as calibrated transmitters for testing receivers in design, production, and maintenance phases. With today's revolution going forward in communications systems, the demands placed on signal simulators continue to get more stringent.

Synthesized signal generators have often been preferred for test applications because of their inherent frequency accuracy, high resolution, long term stability and programmability. But their spectral purity characteristics could not usually measure up to other oscillator types such as cavities or special filtered equipment.

The 8662A represents the current state-of-the-art signal quality performance on SSB phase noise with less than  $-144$  dB/Hz at 10 kHz offset at 160 MHz. Non-harmonic spurious signals are below  $-100$  dBc. It also achieves superior performance on output level accuracy of  $\pm 1$  dB from  $+13$  to  $-120$  dBm.

As a forerunner of future signal generators it is perhaps even more significant that the front panel design makes use of its internal microprocessor to store and recall nine complete sets of front panel settings, either individually or in a specified sequence. Powerful step-sweep capability with log or linear scan further enlarges the generator capability into applications requiring sweep tests of high stability components. Also, certain frequency agility receivers can be tested because the 8662A switching time is typically less than 12 ms settling time to be within 100 Hz.

Check **K** on the HP Reply Card for full specifications.



The SSB phase noise of this 1280 MHz synthesizer rivals the best cavity-type generators

## A significant advance in waveguide/coax adapters

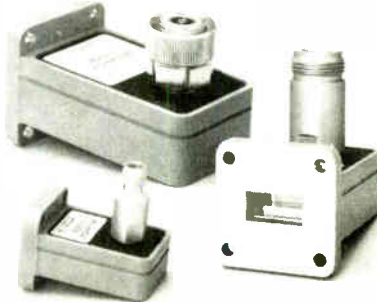

Low SWR ( $< 1.07$  vs. typical 1.25) adapters improve measurement accuracy in the 8.2 to 26.5 GHz range.

The utility waveguide/coax adapter used for years by the microwave industry has been typified by the HP 281A. At the band edges, the 281A typically exhibits an SWR of 1.2 and at band center can be as good as 1.08. For system use, such performance was usually satisfactory. But for measurement applications, better SWR is desirable to minimize errors.

The new HP 281C series adapters now meet that need with a stepped taper design concept which delivers very low SWR. Three bands are available:

- X281C, 8.2-12.4 GHz, SWR $< 1.06$ ;
- P281C, 12.4-18 GHz, SWR $< 1.06$ ;
- K281C, 18-26.5 GHz, SWR $< 1.07$ .

Typical units have SWR about half that value.

This low SWR now allows coaxial components such as power sensors or noise sources to be adapted to waveguide with almost the same performance as if they had been designed directly in waveguide. Programmable step attenuators for waveguide can be configured from the HP 8494-5-6 coaxial series and two 281C adapters.

Up to this time it has been difficult to find high directivity coaxial directional couplers from 18-26.5 GHz. Now an HP K752C waveguide coupler and a K281C adapter can provide an APC-3.5 test port with equivalent directivity of 28 dB.

If you need more details, check **L** on the HP Reply Card.

## Increased value in RF network analysis: extended frequency coverage and new application note

HP's 8754A Network Analyzer, a complete and cost effective stimulus-response test system covering 4 to 1300 MHz, is now also offered in a modified version that will measure to 2600 MHz. This version, designated 8754A Option H26, performs just like the standard unit to 1300 MHz with only nominal loosening of specs clear to 2600 MHz. For example, dynamic range, which is 80 dB to 1300 MHz, is still 72 dB at 2600 MHz. A transmission-reflection test set and precision power splitter with 2600 MHz capability are also available. The price increment between the standard system and the 2600 MHz version is about 15%!

The 8754A Network Analyzer also plays a "starring role" in a new application note that describes how to configure and operate a computer-controlled measurement and data logging system. The system described in AN 294, "Semi-Automatic RF Network Measurements," is especially valuable in applications where many measurements must be made efficiently and where collection of actual measured data is important. Included are programming instructions, sample programs, and modifications needed to make crystal filter measurements.

Check **M** for information on the 2600 MHz version of the 8754A. Check **N** for a complimentary copy of AN 294.

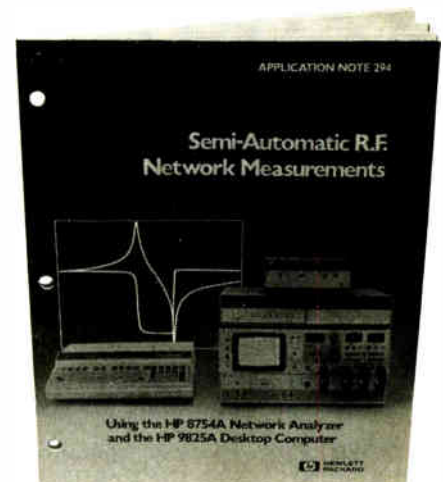

# HP logic analyzers have measurement solutions for digital dilemmas

Do you want to sort out multiplexed buses, trace real-time execution of complex branches, check out hardware problems tied to software sequences, or find that random glitch that causes your system to crash? Then look at the feature sets of any of HP logic analyzers to find the optimal tools for your digital measurements.

An increasing number of newer microprocessors are using multiplexing.

With three clocks (using from one to six edges) and a holding register, HP's 1610B Analyzer can capture related events occurring at different times, and display them as a single, 32-bit line on the analyzer's display. It allows the user to see and trigger on system activity with the address, data, and control lines correlated as one event, rather than appearing as three sequential lines.

HP's 1615A Logic Analyzer not only

collects state and timing information simultaneously, but it also offers a variety of trigger modes using both functions. Either function can immediately trigger the other, or one function can arm the second. Of course, the 1615A can also operate as a stand-alone state analyzer or only as a timing analyzer. The HP analyzers solve glitch problems by separating the glitches from other incoming information, storing them separately, and displaying them distinctly. Glitches can be used as trigger parameters, too.

## Troubleshooting with Analyzers

Troubleshooting and debugging with logic analyzers are described in Application Note 292, a 16-page booklet, "Minicomputer Analysis Techniques Using Logic Analyzers."

Hewlett-Packard has a complete line of logic analyzers to meet your digital measurement needs.

Check **O** on the HP Reply Card for literature with more specifics on HP logic analyzers. Check **P** for a free copy of Application Note # 292.



Real-time, transparent monitoring of digital systems with HP logic analyzers lets you pinpoint minor flaws before they become major crises in the design, production, or service of your digital system.

# Convenient solution for stimulating wider buses

Your requirement for digital stimulus with up to 32 bits parallel can be solved by master/slaving two HP 8170A Logic Pattern Generators.

Designed for simulating system conditions for a wide range of digital devices, the 8170A generates control signals and address, as well as data. Consequently, devices using latch-, RAM- and handshake-interfaces can be functionally tested independent of the rest of the system.

A new brochure is now available which shows how the bus width capability can be extended by synchronizing the outputs of two 8170A's. In addition to giving timing and operating information, the publication also describes the 8170A-HO2 which offers an additional clock output to improve synchronization of the slave.

For full master/slave details, and 8170A data sheet, check **Q** on the HP Reply Card.

8170A LOGIC PATTERN GENERATOR - MASTER

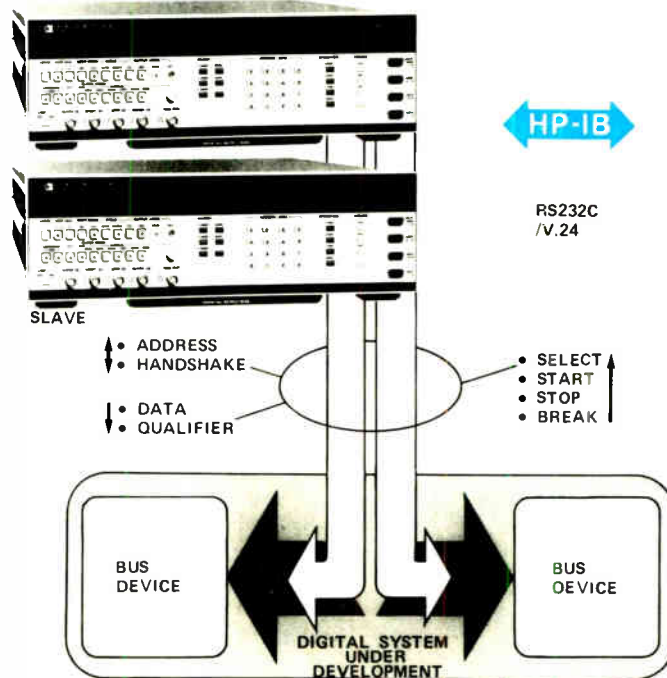

With many bus capabilities, the 8170A can stimulate practically any bus device. A single slave 8170A increases the bus width capability to 32 bits.



## Now, measure power to 26.5 GHz in coax



Power measurements to 26.5 GHz can now be made easier and more accurately. Hewlett-Packard's new 8485A Power Sensor covers a frequency range from 50 MHz to 26.5 GHz and a power range from  $-30$  dBm to  $+20$  dBm ( $1 \mu\text{W}$  to  $100\text{mW}$ ). A very low SWR specification results from using thermocouple technology (1.25 at 26.5 GHz) which reduces mismatch uncertainty.

CAL FACTOR is plotted at 34 frequencies on the attached label with data traceable to the U.S. National Bureau of Standards. This permits an adjustment on the power meter to compensate for variations of the sensors' efficiency and mismatch loss. For example, RSS uncertainty at 26.5 GHz is  $\pm 3.21\%$ . Further correc-

tion for mismatch uncertainty can be made using actual measured SWR which is furnished.

The input connector is APC-3.5 to provide rugged and repeatable performance over hundreds of connections. It mates directly with SMA.

The 8485A was designed to be used with HP's 435A and 436A power meters. The 435A Analog Power Meter features one percent instrumentation accuracy. The 436A Digital Power Meter features 0.5 percent instrumentation accuracy and optional programmability through BCD or HP-IB.

Check **R** on the HP Reply Card for data sheet.



## New test system designed for fast, accurate, automatic semiconductor and electronic component evaluation

This new Hewlett-Packard 4061A Semiconductor/Component Test System provides reliable and accurate measurements and high speed data processing. Measurement results such as an impurity profile or surface state density of a semiconductor device in any data format can be obtained. Such measurements are possible through HP's new, remotely-controlled impedance and current measuring instruments with a switching subsystem that eliminates cable changes between the instruments and the device under test.

The HP 4061A consists of a 4275A Multi-frequency LCR Meter for AC impedance measurements, a 4140A pA Meter/DC Voltage Source for current-voltage measurements, a switching sub-

system, a 9835A desktop computer and a systems library.

The Systems Library contains manuals, diagnostic programs and includes seven application pacs; semiconductor high/low frequency C-V characteristics, I-V characteristics, C-t characteristics, Zerst analysis, Impedance Frequency/Bias characteristics and an ideal C-V curve.

Current-voltage measurements are  $\pm 0.001$  pA to  $\pm 10.00$  mA and 0 to  $\pm 100$  V. Frequency range for impedance measurements are 10 kHz to 10 MHz. Eleven parameters are available: L, C, R, Z, D, Q, ESR, G,  $\theta$ , X, and B. Impedance range is 0.01 m $\Omega$  to 19.99 M $\Omega$ . DC bias is 0 to  $\pm 35$  V.



Further information can be obtained by checking **S** on the HP Reply Card.



## Oscillator transistor has guaranteed output power

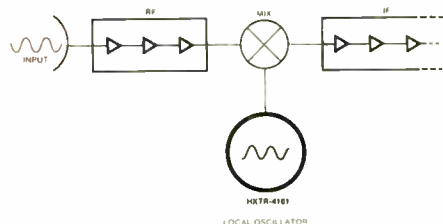

Local oscillator, alimeter and other fixed frequency applications requiring a predictable microwave frequency source can now be designed with the HP HXTR-4101, a new silicon bipolar transistor. Each transistor undergoes testing in a fixed tuned oscillator circuit to guarantee a minimum  $+19$  dBm output power at 4.3 GHz.

The device-to-device consistency which permits such oscillator testing can be employed in your system over a wide range of frequencies through the use of

characterization data available.

With typical output power of 112 mW at 4.3 GHz, 50 mW at 6 GHz, and 15 mW at 8 GHz, this device is an effective selection for applications up to 10 GHz that require a reliable source with low phase noise characteristics.

The HXTR-4101 is hermetically packaged in a 2.5 mm square HPAC-100.

Check **T** on the HP Reply Card for more information.





## New 1000 metre fiber optic transmitter extends the range of data communication links

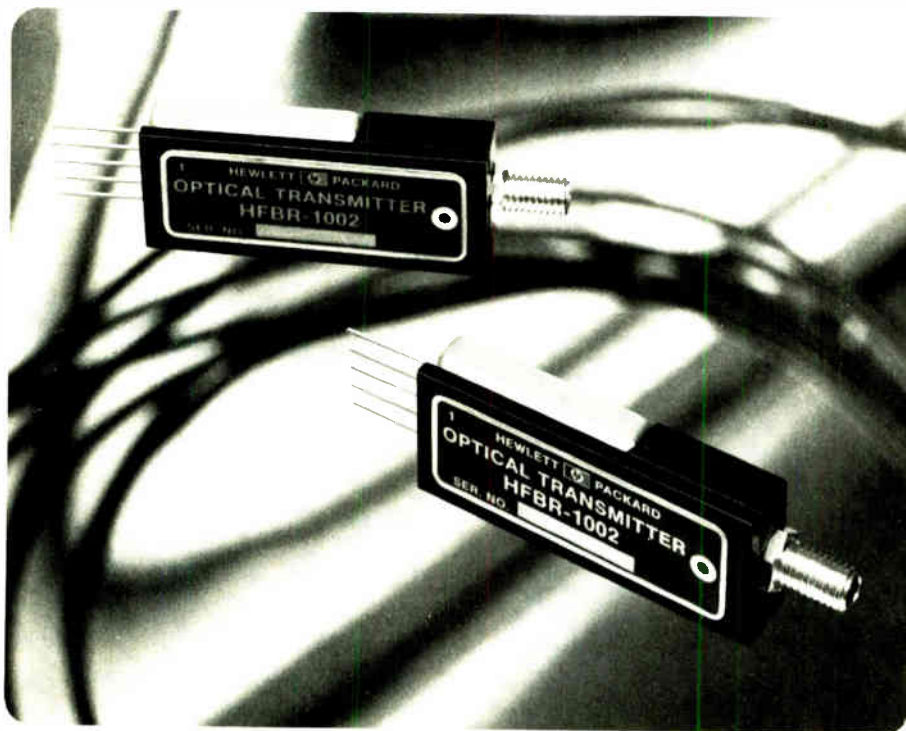

Fiber optic systems transmit digital information in the form of light pulses guided by hair-thin optical fibers instead of the traditional electrical signals using copper-based wires. As such, fiber optic systems are neither affected by nor contribute to the surrounding electromagnetic noise in the environment.

The new Hewlett-Packard HFBR-1002 Fiber Optic Digital Transmitter makes it possible to install new fiber optic links or extend the range of existing HP links to 1,000 metres. The transmitter is an integrated electrical-to-optical transducer designed for digital data transmission over single fiber optical cables. A bipolar integrated circuit and a new high-efficiency emitter convert TTL-level inputs to optical pulses at data rates from dc to 10 Mbaud.

### Burrus LED

The heart of this new transmitter is a high power, high efficiency GaAlAs infrared emitter which makes the longer transmitting distance possible. The new

emitter is a Burrus light emitting diode specifically designed by HP for fiber optic applications. The output wavelength of the emitter is 820 nm which matches the optimum spectral transmission of the silica core and clad fibers used in Hewlett-Packard systems. Reliability of the new device has been confirmed by thousands of hours of life testing under both normal and accelerated conditions.

The HFBR-1002, when used with the HFBR-2001 Fiber Optic Receiver and an HFBR-3000 Series Cable/Connector assembly, guarantees system performance at 1,000 metres with at least a 2.6 dB flux margin. The bit error rate at this distance is better than  $10^{-9}$  at the maximum specified data rate of 10 Mbaud.

### Extended Range

The new HFBR-1002 transmitter is pin-compatible with the HP HFBR-1001 100-metre transmitter and thus can be used to extend the range of existing systems to 1,000 metres. The HFBR-2001 receiver is designed to work with the HFBR-1002 transmitter at any distance from 1 to 1,000 metres without requiring adjustments. This performance is made possible by the built-in automatic level control of receiver amplifier gain over a 23 dB range.

To complement the new transmitter in system installations, HP is now also making available its fiber optic cable/connector assemblies in user-specified lengths. They are available in one metre increments from 1 to 1,000 metres.

Features of Hewlett-Packard fiber optic systems include:

- Specially designed plug-together transmitters, receivers, and cable/connector assemblies
- PC board mountable transmitter and receiver packages
- Standard LSTTL electrical interfaces
- Single +5 V power requirement
- No restriction on input data format from dc to 10 Mbaud
- Special "link monitor" built into receiver to provide warning when information flow is interrupted.

Check **U** on the HP Reply Card for complete details.

### BURRUS EMITTER STRUCTURE

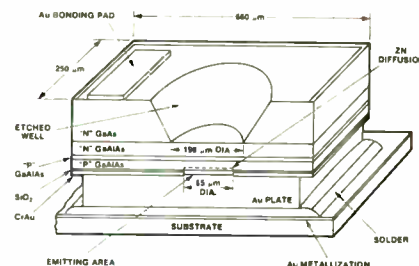

## Microwave link analyzer offers low-cost solution to digital-radio testing

Direct RF modulation radio relay systems are becoming increasingly popular. The testing of these systems does not always require the IF transmitter sections of conventional microwave link analyzers. Hence the new HP 3707A BB + Sweep Generator has been designed to drive an HP 8620C Up Converter to give a swept, frequency-modulated source with a range of 0.5 to 18 GHz. This source, in conjunction with a standard HP 3702B or 3712A IF/BB Receiver, allows the measurement of transmission distortions in a radio link. Although the principal area of application is in digital radio testing, the measurements are equally useful for analog radio systems which use direct modulation.

The 3707A provides a single, low-frequency test tone of 250 or 500 kHz

(internally selectable) which allows the measurement of linearity or group delay. The 3702B IF/BB Receiver is suitable for use on systems operating at 70 MHz IF while the 3712A, in addition to 70 MHz IF, provides a capability at 140 MHz IF. Further, an HP 3730A Down Converter, with appropriate RF plug-in, may be used to help isolate distortions in the RF parts of a link.

The new MLA system has been designed with low cost and ease of use as primary considerations and is ideally suited for routine maintenance measurements, as well as installation and production applications.

*For additional specifications, check **V** on the HP Reply Card.*



Measuring a 6 GHz branching filter with HP's new low-cost RF/IF MLA system.

## Portable monitor makes in-service measurements on 2 Mb/s PCM/TDM transmission systems

With HP's new, low-cost 3783A 30 Channel PCM Alignment Monitor and Error Detector you can make both in-service and out-of-service measurements on 2048 kb/s digital transmission systems conforming to CCITT Recommendation G.732 (European CEPT 30-channel PCM multiplex standard). The instrument detects and counts Frame Alignment Signal errors and AMI or HDB3 code violation errors.

In accordance with a new CCITT O-series Recommendation relating to PCM frame alignment monitoring and code error detection, the 3783A displays measured results as an error count over a

manually selected period and also an error rate. When used as a frame alignment monitor, the bit error rate is calculated using a statistical technique based on the assumption that the overall signal contains a Poisson distribution of errors.

The instrument also incorporates a LED display of the system alarm states contained in TS0 and TS16. An integral loudspeaker allows you to hear the presence of either errors or the PCM bit stream. In external operation, the 3783A counts low frequency TTL pulses. A rechargeable battery option is available.

*Check **W** on the HP Reply Card for details.*

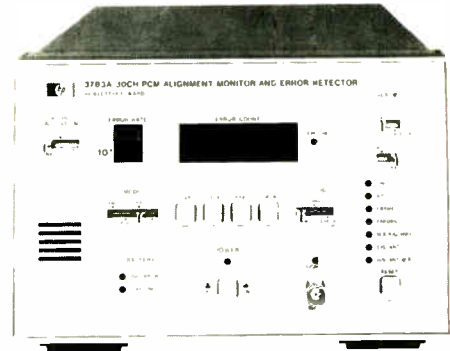

The easy-to-use 3783A 30 Ch PCM Alignment Monitor and Error Detector has a strip chart recorder output to let you make hard copies of the measurement results.

**East**-4 Choke Cherry Road, Rockville, MD 20850.  
Ph. (301) 258-2000

**South**-P.O. Box 10505, 450 Interstate North Pkwy.  
Atlanta, GA 30348, Ph. (404) 434-4000

**Midwest**-5201 Tollview Dr., Rolling Meadows, IL 60008.  
Ph. (312) 255-9800

**West**-3939 Lankershim Blvd, North Hollywood, CA  
91604, Ph. (213) 877-1282

**Europe**-Central Mailing Depot., P.O. Box 529,  
Amstelveen-1134, Netherlands.  
Ph. (020) 47 20 21

**Japan**-Yokogawa-Hewlett-Packard Ltd. Ohashi  
29-21 Takaido-Higashi 3-chome  
Suginami-ku, Tokyo 168, Ph. 03-331-6111



**HEWLETT  
PACKARD**

**hp** MEASUREMENT COMPUTATION **news**  
*product advances from Hewlett-Packard*

March/April 1980

New product information from

**HEWLETT-PACKARD**

Editor:  
**Bojana Fazarinc**

Editorial Offices:  
1507 Page Mill Road  
Palo Alto, California, 94304 U.S.A.

Check the **circle** below if you wish to receive literature only.

- |  |  |
|--|--|
| <input type="radio"/> A. HP Programmable Calculators           | <input type="radio"/> L. 281C Series Adapters                      |
| <input type="radio"/> B. HP 1000 L Series Computer             | <input type="radio"/> M. 8754A Network Analyzer                    |
| <input type="radio"/> C. HP-IB Brochure                        | <input type="radio"/> N. Application Note #294                     |
| <input type="radio"/> D. PASCAL/1000 Computer Language         | <input type="radio"/> O. 1610B/1615A Logic Analyzers               |
| <input type="radio"/> E. 9030 Test, Measurement Control System | <input type="radio"/> P. Application Note #292                     |
| <input type="radio"/> F. 5045A IC Tester                       | <input type="radio"/> Q. 8170A Logic Pattern Generator             |
| <input type="radio"/> G. 1700 Series Oscilloscopes             | <input type="radio"/> R. 8485A Power Sensor                        |
| <input type="radio"/> H. 5345/55/56A Universal Counter Package | <input type="radio"/> S. 4061A Semiconductor/Component/Test System |
| <input type="radio"/> I. 3455A Digital Multivoltmeter          | <input type="radio"/> T. HXTR-4101 Bi-polar Transistor             |
| <input type="radio"/> J. 69336A Hi-speed Scanner Card          | <input type="radio"/> U. HFBR-1002 Fiber Optic Digital Transmitter |
| <input type="radio"/> K. 8662A Synthesized Signal Generator    | <input type="radio"/> V. 3707A Sweep Generator                     |
|  | <input type="radio"/> W. PCM Alignment Monitor                     |

Please **contact** me about \_\_\_\_\_  
(List the alphabetical code(s) from above items.)

PLEASE PRINT and include zip code

Name \_\_\_\_\_

Company \_\_\_\_\_ Title \_\_\_\_\_

Address \_\_\_\_\_

City \_\_\_\_\_

State \_\_\_\_\_ Zip \_\_\_\_\_

Telephone Number \_\_\_\_\_ 52A

Check the **circle** below if you wish to receive literature only.

- |  |  |
|--|--|
| <input type="radio"/> A. HP Programmable Calculators           | <input type="radio"/> L. 281C Series Adapters                      |
| <input type="radio"/> B. HP 1000 L Series Computer             | <input type="radio"/> M. 8754A Network Analyzer                    |
| <input type="radio"/> C. HP-IB Brochure                        | <input type="radio"/> N. Application Note #294                     |
| <input type="radio"/> D. PASCAL/1000 Computer Language         | <input type="radio"/> O. 1610B/1615A Logic Analyzers               |
| <input type="radio"/> E. 9030 Test, Measurement Control System | <input type="radio"/> P. Application Note #292                     |
| <input type="radio"/> F. 5045A IC Tester                       | <input type="radio"/> Q. 8170A Logic Pattern Generator             |
| <input type="radio"/> G. 1700 Series Oscilloscopes             | <input type="radio"/> R. 8485A Power Sensor                        |
| <input type="radio"/> H. 5345/55/56A Universal Counter Package | <input type="radio"/> S. 4061A Semiconductor/Component/Test System |
| <input type="radio"/> I. 3455A Digital Multivoltmeter          | <input type="radio"/> T. HXTR-4101 Bi-polar Transistor             |
| <input type="radio"/> J. 69336A Hi-speed Scanner Card          | <input type="radio"/> U. HFBR-1002 Fiber Optic Digital Transmitter |
| <input type="radio"/> K. 8662A Synthesized Signal Generator    | <input type="radio"/> V. 3707A Sweep Generator                     |
|  | <input type="radio"/> W. PCM Alignment Monitor                     |

Please **contact** me about \_\_\_\_\_  
(List the alphabetical code(s) from above items.)

PLEASE PRINT and include zip code

Name \_\_\_\_\_

Company \_\_\_\_\_ Title \_\_\_\_\_

Address \_\_\_\_\_

City \_\_\_\_\_

State \_\_\_\_\_ Zip \_\_\_\_\_

Telephone Number \_\_\_\_\_ 52A

**PRICES**

Following are U.S.A. domestic prices only

X281C, P281C	each \$250.00	5045A	\$10,250.00
K281C	\$290.00	5046A	\$24,700.00
PASCAL/1000	\$4,000.00	5345A	\$1,900.00
HP 1000 Series L		5355A (Opt. 001)	\$900.00
2103 LK	\$2,250.00	5356A	\$1,150.00
2103 L	\$4,450.00	5356C	\$1,300.00
Model 10	\$22,500.00	69336A (Opt. 001)	\$2,100.00
1610B	\$12,500.00	8170A	\$5,430.00
1615A	\$6,800.00	8495A	\$1,000.00
1700 Series		8662A	\$4,700.00
3455A (Opt. 001)	\$2,475.00	8755A	\$13,200.00
4061A	\$1,500.00	9030	\$19,000.00
HXTR-4101 (Qty. 1-9)	\$15,600.00		
	\$39.00		

(base price)

**DIRECT RESPONSE SYSTEM**

For fast response, use the above reply cards. Please note that you can choose two types of HP response

Literature. (You will receive more information on a product.) Please contact me. (You will receive product information and a follow-up call from a Hewlett-Packard representative.)

If both reply cards on this page have been used, contact your nearest HP field office or one of the regional offices listed on the preceding page. Or, write directly to the Hewlett-Packard Company, 1820 Embarcadero Road, Palo Alto, California, 94303, U.S.A.



**HEWLETT  
PACKARD**



Place  
Postage  
Here

**HEWLETT-PACKARD**  
1820 Embarcadero Road  
Palo Alto, California 94303

Place  
Postage  
Here

**HEWLETT-PACKARD**  
1820 Embarcadero Road  
Palo Alto, California 94303

# Offshoots of our magnetic know-how.

Maghematite materials

Avilyn materials

Pure iron materials

## Black materials

(Magnetically soft)

### Soft ferrite materials

Ferrite cores for electronic and industrial applications  
Ferrite core applications include coils, transformers, power supplies, noise filters

### Hard ferrite materials

Ferrite magnets, ferrite magnets, plastic magnets

### Metal magnet materials

Rare earth cobalt magnets

### Microwave magnetic materials

Spinel ferrites, garnet ferrites, microwave ferrites

## White materials

### Dielectric materials

Electronic capacitors

### Semiconductor materials

High speed switching diodes

### Piezoceramic materials

Ultrasonic transducers, transmitters

Acoustic wave devices

Surface acoustic wave devices

### Electrical insulation materials

High voltage insulators

### Heat-proof materials

We started business as a specialist manufacturer of magnetic parts and materials back in 1935, and we've been responding to the needs of the fast-moving electronics marketplace with innovative products ever since.

Our 45 years of experience transformed our original magnetic know-how into three offshoots—black ferrite, white ceramic and magnetic tape materials. Materials which are today furthering the development of the electronics industry.

The know-how we gleaned as the first commercial producer of ferrite led to the recent development of low-loss H6H3 which has a  $1.2 \times 10^{-6}$  relative loss factor,

and of high- $\mu$  H5E which has an initial permeability of 18,000. High power H7C1 for switching power supply transformers is but another example of the applications of our ferrite know-how.

The sintering technology that's gone into ferrites is applied to our other products, ceramic components. Our completely automated high speed production lines, for example, let us make ceramic capacitors in taping form, which when combined with AVISERT, our electronic parts inserter, lowers assembly costs.

AVILYN, a highly sophisticated cobalt-enriched magnetic material, is another product of our magnetic know-how. The

ultra-high density of the particles in this formulation allowed us to respond to market demands for longer VTR recording times with no loss in quality.

Our strong commitment to R&D, our technological leadership in developing innovative parts and materials and our ability to continually meet market needs with products of ever greater sophistication is why we have made electronics history.

TDK manufactures ferrite cores, magnets, coil components, memory devices, ceramic components and magnetic recording tapes

 **TDK**  
TDK ELECTRONICS CO., LTD.  
13-1, Nihonbashi 1-chome, Chuo-ku, Tokyo 103, Japan

Circle 31 on reader service card





# FIFTY YEARS AGO

---



1930: AS THE NATION AND THE WORLD BEGAN THE LONG ECONOMIC SLIDE THAT WOULD TERMINATE IN WORLD WAR II, THE ELECTRONICS INDUSTRY—A MAJOR BENEFICIARY OF THAT BLOODY CONFLICT—WAS BUSILY DEVISING SOLUTIONS TO ITS MANY TECHNICAL AND ECONOMIC PROBLEMS. COMMERCIAL BROADCASTING WAS 10 YEARS OLD; IN HIS NEW YORK LABORATORIES, E. HOWARD ARMSTRONG WAS WORKING ON FM; AT RCA'S CAMDEN, N.J., FACILITY, VLADIMIR ZWORYKIN WAS PERFECTING TELEVISION; AND BELL LABS ANNOUNCED THE INVENTION OF NEGATIVE FEEDBACK BY HARRY BLACK AT ITS HEADQUARTERS ON WEST STREET IN NEW YORK.

## Chapter 1



**I**t was not a good year. The start of a fresh decade, yes. But fresh hopes, new dreams? Not many.

It was 1930. The nation was still in shock from the shattering of the stock market in the autumn of 1929. Disillusionment infected financial and business circles. And worse was yet to come.

“Business is fundamentally sound” was the rallying cry uttered repeatedly by business and Government leaders. But most businesses were not sound at all. A figure that came to symbolize the Depression in the United States—the apple peddler—was to appear before 1930 was out. The bubble of the Roaring Twenties had burst. Unlimited consumption of unlimited production, all spurred by easy credit, was a frothy myth.

*Electronics* magazine was launched on this stormy economic sea. Its editors were emboldened by the state of electronic technology to write in the inaugural April 1930 issue:

“Already billion-dollar industries are built upon the vacuum tube—in telephony, in radio, in talking pictures, and in power applications. Electronics revolutionized the first three—made them possible. And in the power field, it is now affording an entirely new engineering approach to electrical problems of every kind. For although the

electrical engineering of the past was built almost wholly upon the single principle of electromagnetic induction, the electrical designer of today finds . . . that in electronic apparatus he commands a medium paralleling magnetic-induction in importance and its equal in wide adaptability.”

Radio had already become firmly established as an exceptional entertainment medium. The year 1930 marked the 10th anniversary of commercial radio broadcasts from stations in Detroit, San Francisco, Newark, and Pittsburgh. Live broadcasts just the year before from the flight of Comdr. Richard E. Byrd over the South Pole had set the world agog with speculation about what future communications technology might have in store for it.

David L. Sarnoff, president of the then Radio Corp. of America, wrote in that first issue of *Electronics*: “Potentially there are 26 million theatres in this country, awaiting development. Every home can ultimately become a theatre itself.”

The electronics that Sarnoff had in mind for his “theatres”—television—had been demonstrated by Bell Telephone Laboratories in 1927. While it was being developed, manufacturers’ sales of “radio apparatus and tubes” reached \$353.6 million in 1929, exceptional



**Once they built a railroad.** Unemployed men on bread lines like this one in front of the fashionable shops on New York's Fifth Avenue were a common sight during the Depression. Radio provided just about all the entertainment millions like them could afford.

growth from the \$198.4 million of 1927, according to Moody's Industrial Analysis for 1930. This figure was dwarfed by the "electrical machinery" category, which included telephones, lamps, motors, generators, and household appliances. Moody's set sales for these products in 1929 at \$2.33 billion.

Electric power was available in about 20 million of the the 29 million homes in the U. S., and 20.2 million telephones had been installed. An increase of 900,000 phones in 1929 was the largest in any year, according to a report in August 1930 by technical committees of the American Institute of Electrical Engineers. Some 21.5% of the phones were dial, as opposed to those relying on a central operator to place the call. Telephone circuits were also being used to connect chains of radio broadcasting stations.

It was at about this time, too, that airplanes flying at night were first guided by low-frequency directional radio beacons. The Aeronautics Branch of the Department of Commerce, created by the 1926 Air Commerce Act and a forerunner of today's Federal Aviation Administration, installed the first six of these beacons along the high-density routes between New York, Washington, and Chicago. Spaced 25 miles apart along the airway corridors were supplementary 7.5-watt radio

marker beacons. Aircraft radiotelephones followed, providing pilots with updated reports of the weather they could expect en route to an airport and at the landing ground itself.

Commercial shortwave radio service had started in 1929 from the U. S. to ships at sea, and in September of that year, at the Hague, there had been the first meeting of the newly organized International Technical Consulting Committee on Radio Communication, or CCIR. Among its goals: international understanding on technical standards for minimizing frequency interference. In the U. S. itself, the recently established Federal Radio Commission was beginning to bring order to domestic broadcasting chaos.

In entertainment, "talkies" were becoming the rage since the 1929 showing of "The Jazz Singer," the first motion picture with sound. The design and construction of sound movie photographic and projection systems became a major new outlet for the efforts of electrical engineers.

A number of companies that were to become electronic giants were already in place. RCA had 2 000 employees



# There's a little tiger in every Cherry product..



**KEYBOARDS & KEYBOARD SWITCHES.** Should you specify solid state or hard contact for your keyboards? Ask Cherry. We make *both*: Solid state (capacitive) and hard contact (gold crosspoint). This means we won't try to talk you out of either one. It also means we can fill your *every* keyboard application. Perfectly. Keyboard switches, too. With a "heart of gold" that keeps your product working.

**FOR FREE CATALOG, CIRCLE NUMBER 38**

**MULTI-POSITION SWITCHES.** When you want a switch to count...count on Cherry. For thumbwheel, push-wheel and leverwheel switches in a full range of alphanumeric readouts and output codes. For our Rotocode switch that combines the shaft actuation of a rotary switch with the coded electrical output of a thumbwheel. Or, for our matrix selector switch with up to 2784 crosspoints...standard.

**FOR FREE CATALOG, CIRCLE NUMBER 39**

# .....but we're pussycats to do business with

Our products are tough, but our people aren't...and that's the beauty of dealing with Cherry.

You see, we can control the quality of our products because we fabricate most of our own parts (moldings, stampings, printed circuits, ICs, etc.). And we can keep the price down because we're loaded with automatic equipment to handle high volume.

But the real difference is in the people you work with at Cherry: from your first contact with a technically trained sales representative...through careful analysis and recommendations by engineers who are really concerned

about your problem...to our production scheduling and customer service groups who follow-up and expedite to make sure we keep our delivery promise to you.



Of course we're proud of our modern facilities and equipment...but what we're proudest of is our reputation for customer service. Try some.

For a start, get additional data and catalogs on one or more of the tough Cherry product lines shown below. Free, of course, from the pussycats at Cherry.



## CHERRY ELECTRICAL PRODUCTS CORP.

3608 Sunset Avenue, Waukegan, IL 60085 • 312/689-7700 • TWX 910-235-1572

## CHERRY SEMICONDUCTOR CORP.

99 Bald Hill Road, Cranston, RI 02920 • 401/463-6000 • TWX 710-381-1757

Our worldwide affiliates and phone numbers:

Cherry Mikroschalter GmbH, Auerbach, Germany, 09 643 181 • Cherry Electrical Products Ltd., Sandridge (Herts) England, 44 727 32231  
Cherco Brasil Industria E Comercio Ltda., Sao Paulo, Brazil, 011 246 4343 • Hirose Cherry Precision Co., Ltd., Kawasaki, Japan, 044 933 3511

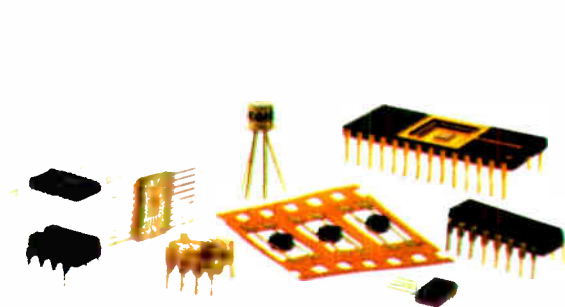

**INTEGRATED CIRCUITS.** Now, from Cherry Semiconductor Corp., your choice of standard digital or linear bipolar ICs...or the most sophisticated custom design combining both digital and linear functions (I<sup>2</sup>L) on the same chip...or anything in between! All from a group of engineers and other Cherry folks who are eager to work with you to help solve your problems.

**FOR FREE CATALOG, CIRCLE NUMBER 40**

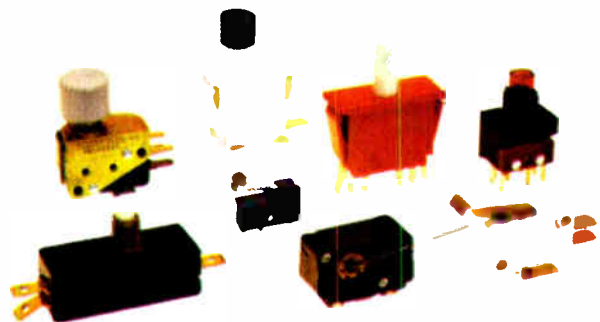

**PRECISION SWITCHES.** Whatever you make...you can make it better with a Cherry switch. Cherry snap-action switches with unique coil spring mechanism are justifiably renowned for quality and long life. Cherry gold crosspoint contact switches are the most dependable for low energy circuits. What kinds of switches? You name it, Cherry's got it. And all are the pick of the switching crop. Worldwide.

**FOR FREE CATALOG, CIRCLE NUMBER 41**

**FROKED**

**We've just  
been caught  
exceeding  
the speed  
limit.**





Our F100K family of subnanosecond logic ECL circuits is the fastest in the industry. It's been cited doing 750 ps, which is 2-3 times faster than the competition.

Not only are our components faster, but your systems get faster because we've reduced interconnect delays. Which allows for serial processing with fewer parts.

While being the most complex ECL circuit family available, it's still the easiest to use in system design.

Because it's fully voltage and temperature compensated and has higher integration levels.

Plus, the family offers some important advantages over TTL. Such as lower voltage swing, complementary outputs and a constant power supply current to reduce noise.



## Introducing a new family member— The F220 8-Bit Slice.

Our F100K family includes the F100K SSI/MSI, F200 Gate Array, and a totally new member, the microprogrammed F220 8-Bit Slice family.

With five devices, featuring 1,000-gate density and subnanosecond delays, the 8-Bit Slice family allows for excellent flexibility and building-block versatility over a wide variety of general-purpose applications.

F220 8-BIT SLICE		
Device	Function	Availability
100220	Address and Data Interface Unit (ADIU)	Now
100221	Multi-function Network (MFN)	Now
100222	Dual Access Stack (DAS)	Now
100223	Programmable Interface Unit (PIU)	2nd Q
100224	Microprogram Sequencer (MPS)	4th Q

## Where do you use the F100K family?

Anywhere speed is essential. Especially in large high-performance computers. And right down the line, from mainframes to midis, minis and special processors.

Even in communications and instrumentation equipment.

The F100K family is in production and is available now. More and more design engineers are beginning to design it in every day. In fact, 30% of the companies that build mainframes have already implemented it into their systems in order to stay at the leading edge of technology. With its

faster speed and ease of use, the F100K family has helped increase system performance while decreasing design time.

## Another superior product from the Bipolar technology leader.

The F100K family benefits from Isoplanar-S, Fairchild's evolutionary new Bipolar process for scaling down Isoplanar geometries. With it, we're giving the computer industry and related fields superior memory and logic products. And we'll continue to do so for a long time to come.

If you're not using Fairchild's F100K family, you're wasting both system and design time. And, sooner or later, you'll want to take full advantage of its performance benefits. Why not make it sooner? For more information about the fastest family in the business, call Bipolar LSI Logic at Fairchild Semiconductor Products Group, P.O. Box 880A, Mountain View, California 94042. Telephone: (415) 962-3941. TWX: 910-379-6435.

The Fairchild logo, consisting of the word "FAIRCHILD" in a bold, sans-serif font, centered between two horizontal red bars.

A Schlumberger Company

## Shaping the future of LSI technology.



**Realization.** Here at Columbia University's Statistical Bureau, a Difference Tabulator built by International Business Machines Corp. in 1929 made use of ideas put forth by Charles Babbage early in the 19th century.



worldwide by the beginning of 1930. It had been formed by the General Electric Co. in 1919 to buy control of the Marconi Co. and to manufacture radio devices and systems developed by GE, Westinghouse, AT&T, and others. Just the year before, RCA had acquired the Victor Talking Machine Co. (phonographs and phonograph records), and it owned half of the National Broadcasting Co., as well as one radio station in New York and one in Washington, D. C.

GE had 87,800 employees, but the company's interest was more electrical than electronic. The Westinghouse Electric and Manufacturing Co., also a long established electrical firm, had 49,000 employees.

International Business Machines Corp. was firmly entrenched, with 4,400 employees and a string of companies that it had acquired. The corporate entity specialized in time recorders, tabulating systems, and weighing scales. With a technological base rooted in Herman Hollerith's electromechanical, punched-card tabulating machine, IBM was looking at the upcoming decades with optimism under Thomas J. Watson. Already the company had manufactured a statistical machine for Columbia University in 1929. Using registers for data retrieval and storage, this digital calculator—or difference tabulator, as it was called—brought to life many of the ideas propounded by the mathematician and inventor Charles Babbage nearly a century earlier. It influenced the 600 series of IBM multiplying machines that were introduced in 1931 and was a forerunner of the Mark I developed by IBM and Howard Aiken at the end of the decade.

Much of the groundwork was being laid for the analog computer during this time and throughout the 1930s.

Research was ardently pursued at the Massachusetts Institute of Technology under Vannevar Bush.

Radios and tubes were being turned out by companies like the Zenith Radio Corp., the National Union Radio Corp., Crosley Radio Corp., Perryman Electric Co., and De Forest Radio Corp. All of them except Zenith, which survives today as the Zenith Corp. in Chicago, became early victims of the perpetual "shakeouts" in the electronics industry.

Enough was happening constructively in the electronics industry amid the Depression for O. H. Caldwell, first chief editor of *Electronics*, to write in its first issue: "There will be nothing that the average man sees, hears, or buys but what will be controlled, regulated or affected in some important respect by an electronic tube!"

Certainly the average man was already experiencing the effects of the radio tube. Radio sets and radio broadcasting were big business. From about 9.5 million sets in use in July 1929, according to a Department of Commerce estimate, the total had climbed to 11.5 million six months later. By July 1, 1930, there were 13.5 million radio sets in use, both battery- and ac-operated. Lee de Forest, president of the Institute of Radio Engineers, told the institute's fifth annual convention in August 1930: "Radio has largely eliminated [newspaper] extras on prize fight results, and has shown a curtailment of interest in baseball news."

The radio sets did not come cheaply. Average prices reached a peak of \$124 per set in 1927, according to figures published in the June 1930 issue of *Electronics*, declining somewhat to \$110 in 1929. To buy one, an industrial worker had to invest nearly four weeks' wages,



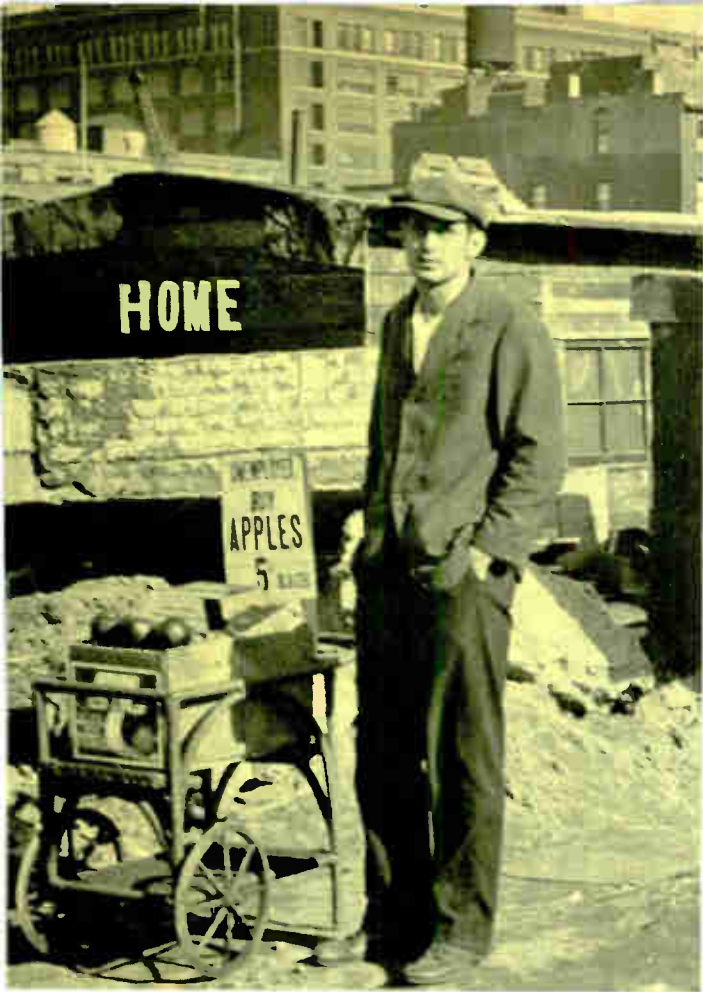

**Sight and sound.** Wrapping up the Depression in one image, the apple peddler made his first appearance during 1930. Symbolizing the era in sound, sports columnist Bill Corum (left) and announcer Don Dunphy brought the fights to life for millions of listeners.

since in 1929 the average manufacturing wage was about \$30 a week, or \$1,500 a year.

The electrical engineer was much better off. In its May 1930 issue, *Electronics* published a chart compiled by the Society for the Promotion of Engineering Education. It compared the earnings of engineering graduates employed in the "radio" and "electrical" branches. The average salary at graduation was about the same for the two—\$1,750 annually. But five years after graduation, the radio engineer was earning about \$3,500 annually, while his electrical engineer colleague averaged \$2,800, according to the chart.

"It is evident why many of the higher-class graduates are interested in linking their futures with that of radio," observed W. R. G. Baker, engineering vice president of the RCA Victor Co. of Camden, N. J., in an article accompanying the chart.

But as the Depression deepened, the future even for radio engineers became clouded. The January 1930 issue of the Proceedings of the IRE contained an announcement of an employment service for members that stated: "Beginning with the February 1930 issue, an advertising page of 'Engineers Available' will be published." The price: \$2 per insertion per month.

Further evidence of the effect of the Depression was provided by the membership figures of the IRE. From about 6,600 engineers on the rolls at the end of 1930, the organization, which had been founded in 1912, showed a dip to 6,500 members in 1931, then a sharp drop to 5,350 the following year and finally a low of 4,250 in 1934. From there, the total crept back up to 5,750 members by the end of 1940 and, with the onset of

World War II and U. S. involvement, to 7,020 in 1942.

The American Institute of Electrical Engineers, a much larger organization, had slightly more than 18,000 members in 1929 after reaching a high of 18,344 in 1927. But from there on, it was down, down. The low of 15,230 members was hit in 1935. Not until 1942 and the engineering efforts of the war years did the AIEE membership rebound to its 1927 level.

These declines were, of course, only mirror images of what was happening in the country at large. Unemployment in the U. S. had been extensive even during the seemingly good years of the 1920s. It rose as high as 5 million in that decade, was never lower than 1 million, and ranged from 1.5 million to 3 million. Most of the time anywhere from 4% to 7% of the labor force was unemployed, according to one estimate.

The Federal government reported 2.5 million workers unemployed in April 1930, the month *Electronics* was introduced. Other estimates went as high as 8 million. By 1932, it was widely reported that some 14.5 million people were out of work.

There were signs in the summer of 1929 that business activity was slowing, and after a mild renaissance in the spring of 1930, the year finished at below 80% of the so-called normal point. Nearly 80% of the total value of stocks was wiped out. Industrial profits after taxes, which had been \$8.3 billion in 1929, reached losses of \$3.4 billion in 1932. Investment in the American economy fell from \$16 billion in 1929 to \$900 million in 1932.

Before the deep gloom set in, the Radio Manufacturers Association had exuded optimism. At the group's fifth annual convention in June 1929, its president had



declared that the radio industry was "in a healthy condition." He was wrong, and his 270 members were in trouble. The radio business reflected the condition of other industries in the country: the sales peak had passed; there were simply not enough people capable of buying what was being produced.

In June 1930, *Electronics* asked admonishingly in its editorial columns: "Are we heading once more into overproduction of radio sets? Will 1930 see a repetition of the serious surplus of radio receivers which made a nightmare of 1929, and spilled over into the spring dumping of 1930?"

In 1929 a total of 4.7 million radio sets had been manufactured, of which 4.2 million were sold, according to the magazine. "In 1930," it added, "every indication in the radio field, and in general business, points to restricted demand . . . Undoubtedly, 3.5 million is the figure to put down as representing top sales for 1930."

At the 1930 convention of the Radio Manufacturers Association, membership was down by 45 companies, and further declines were in the offing.

Not everyone saw the glut of radios resulting from economic conditions. De Forest, the so-called father of radio broadcasting, had another opinion: people had stopped buying radios because they were repelled by the advertising. In his inaugural address on Jan. 8, 1930, following his election to the presidency of the IRE, de Forest said he wished to "raise my voice in most certain protest against this revolting state of affairs."

De Forest had equally strong opinions about the motion picture industry and its talking pictures. "Here, both in studio recording and in theater reproducing methods and apparatus, is witnessed a most deplorable result of engineering indigestion," he asserted. "The profession has bitten off very much more than it could properly masticate in these few years."

He described the "made voices" of talking pictures as "perhaps clearly understandable but all of one timbre—and that wholly unnatural and unpleasing, as if emanating from wooden tonsils and fibre tongues." Of the music, he said: "The present shrieking noises, at best, are only a sad burlesque of fine music, painful to endure." He mourned the "thousands of musicians actually put out of employment by this loud speaking robot."

De Forest urged the radio profession "to concentrate every human effort upon this urgent and highly baffling talk of bringing back real music to the cinema and real voice to the theater screen—or, if not, let an outrageous and long-suffering public rise in righteous wrath and curse us."

**T**here was some good news, too, in 1930: the pace of technological advance was accelerating. The negative-feedback amplifier was announced that year, although Harold S. Black actually had developed it at Bell Telephone Laboratories in 1927. Important as negative feedback is today, it "had all the initial impact of a blow with a wet noodle" in 1930, according to one of Black's laboratory assistants. It wasn't until 1932, when Harry Nyquist, also of Bell, recognized the importance of phase control in the feed-



**Waste not.** Trying to conserve in every way, this Depression man fixes his shoes at the East River near 10th Street in New York City.

**SEMICONDUCTOR.  
WE HAVE A WORD FOR IT:**

**FERRANTI.**

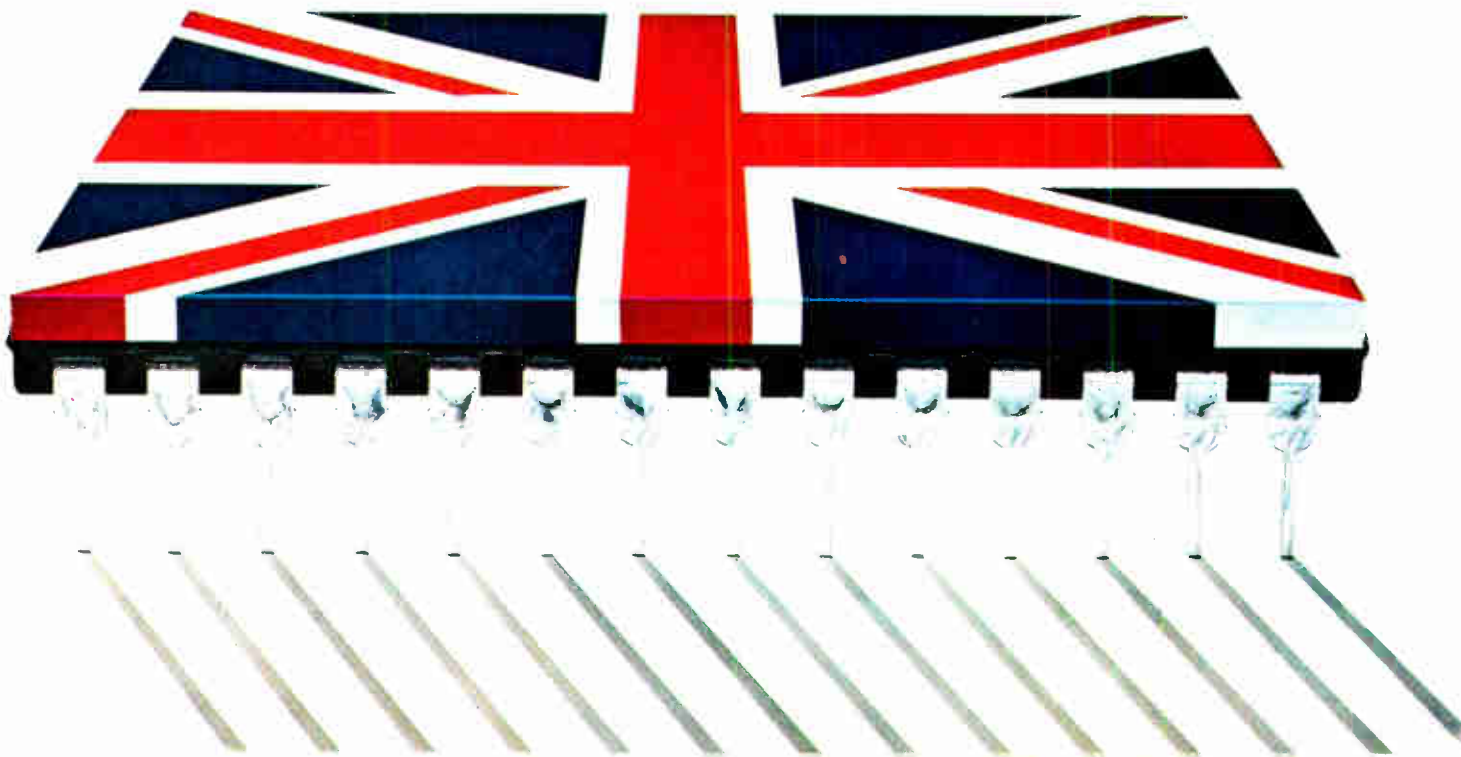



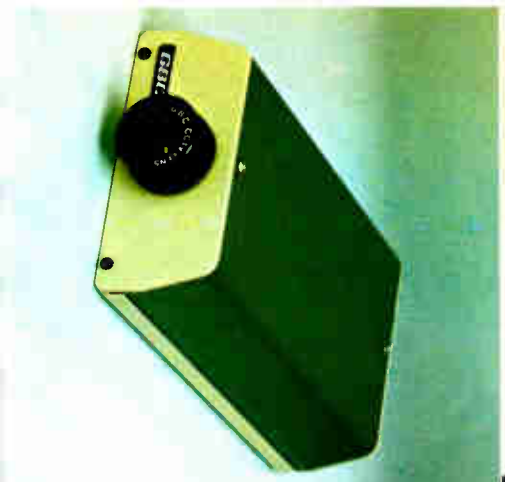
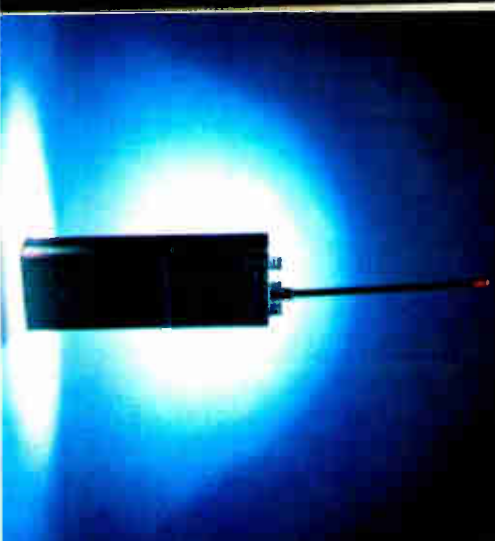



# Ferranti semiconductors are at the heart of many of the world's finest products.

You'll find Ferranti semiconductors metering gasoline in the world's first digital electronic fuel injection system used in a production car.

You'll also find them in telecommunications systems, electronic SLR cameras, video games, vending machines, medical equipment, RF communications, computer terminals, data processing equipment, aerospace and military applications plus more.

## 25 years of experience

Britain's Ferranti Limited is, in fact, one of Europe's leading producers of quality semiconductors—both discrete components and integrated circuits. We've been involved in their development and manufacture since 1954. And based on today's technology, our experience is even greater than our 25 years indicates. For at the outset we made the decision to use silicon technology rather than germanium which was then predominant.

Over the years we've developed a wide range of semiconductor components, including transistors, diodes, optoelectronic devices and integrated circuits.

**Leaders in ULAs.** It was Ferranti, for example, who introduced the concept of the ULA (uncommitted logic array) where only one mask has to be designed to produce a custom LSI circuit. Ferranti also designed, developed and manufactured Europe's first 16-bit high-speed bipolar microprocessor.

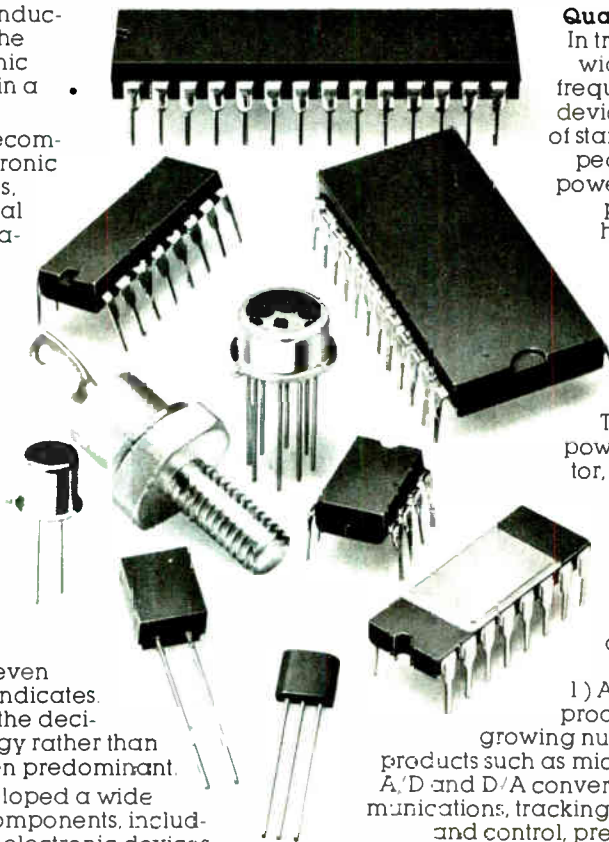

## Quality discretives in volume.

In transistors, Ferranti offers a wide range of low and high frequency small signal plastic devices covering the majority of standard U.S., U.K. and European types. We also offer RF power products, high-voltage power transistors, and the high-volume microminiature SOT-23 package for solder-reflow hybrid circuits. Ferranti optoelectronic products comprise photodiodes, photo-transistors and photovoltaic arrays. The diode range includes power rectifier, zener, varactor, Schottky and PIN diodes.

## Standard and custom IC's.

By concentrating on bipolar LSI technology using the Ferranti CDI (collector diffusion isolation) process, we're able to meet the needs of all customers. We offer:

- 1) A wide range of standard products including a rapidly-growing number of data conversion products such as microprocessor-compatible A/D and D/A converters, codecs for telecommunications, tracking converters for guidance and control, precision voltage reference sources and low-noise wideband amplifiers.
- 2) Semi-custom design with a range of 13 ULAs that offer performance from low power up to high-speed Schottky and LSI complexity to 2000 gates.
- 3) Full custom design, creating a dedicated chip where ultimate performance is required, quantities are large and economics permit higher design cost.

**No matter what you need in quality semiconductors, just say the word: Ferranti.**

# FERRANTI

better by design

Ferranti Electric Inc., 87 Modular Avenue, Commack, NY 11725 USA, Tel: 516-543-0200, TWX 510-226-149C  
Ferranti Electronics Limited, Fields New Road, Chadderton, Oldham OL98NP, England, Tel: 061-624-0515, Telex: 851-658038 Fergem G.  
Ferranti GmbH, Widenmayerstrasse 5, D-8000-Munich-22, West Germany, Tel: 89-293871, Telex: 841-523980 Ferrm D

Circle 49 on reader service card

# Get 1 watt output from your H-P generator with a Mini-Circuits amplifier!

**0.05 - 1000 MHz**  
**from \$199**

Need more than the 10 mw available from your signal/sweep generator or synthesizer for system and subsystem testing?

Just add a MiniCircuits' ZHL wideband amplifier and boost the 10 mw level to 1 watt or +30 dBm. Also, there's an additional benefit ... as much as 40 dB isolation will be added between the generator and the system under test. And VSWR is less than 2:1 over the full frequency range.

Upgrade your present generator now ... check the specs and low prices below and order your ZHL wideband amplifier today ... and we will ship within one week!

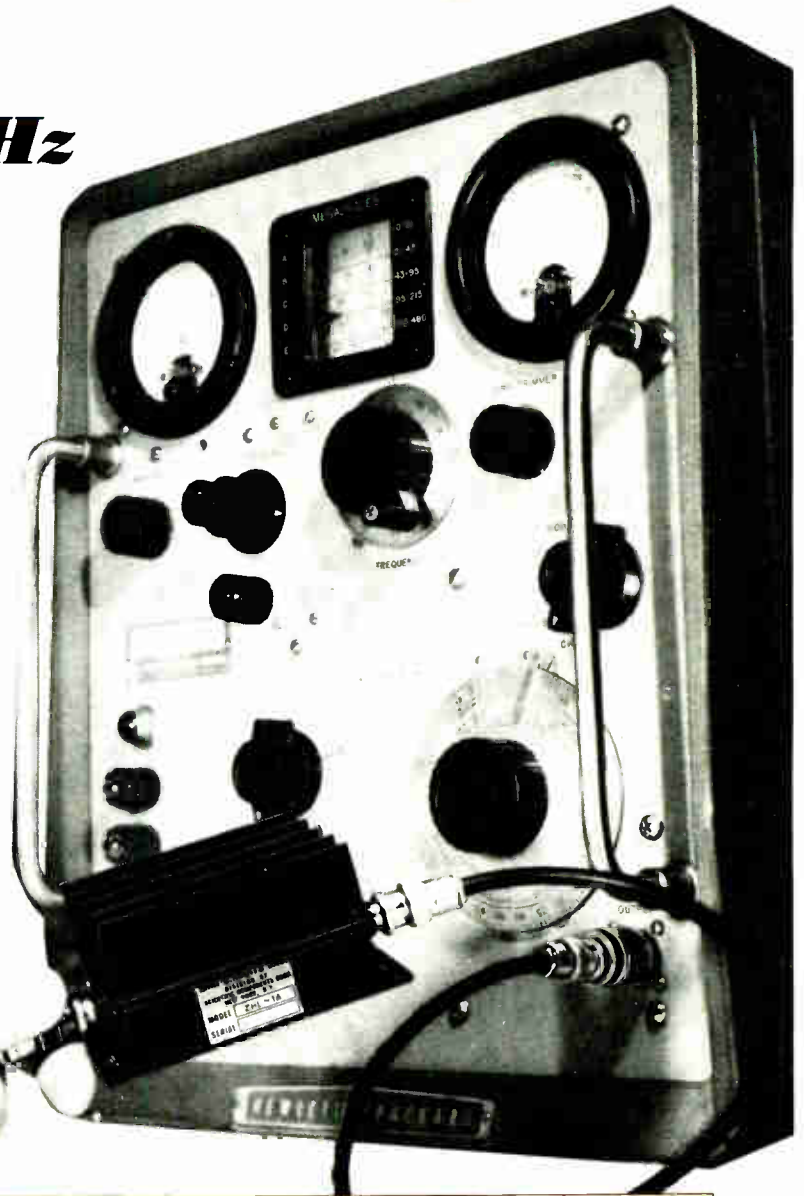

MODEL NO.	FREQ. MHz	GAIN dB	GAIN FLATNESS dB	MAXIMUM POWER OUTPUT dBm 1-dB COMPRESSION	NCISE FIGURE dB	INTERCEPT POINT 3RD ORDER dBm	DC POWER		PRICE	
							VOLTAGE	CURRENT	\$ EA.	C TY.
ZHL-1A	2-500	16 Min.	±1.0 Max.	+28 Min.	11 Typ.	+38 Typ.	+24V	0.6A	199.00	(1-9)
ZHL-2	10-1000	16 Min.	±1.0 Max.	+29 Min.	18 Typ.	+38 Typ.	+24V	0.6A	349.00	(1-9)
ZHL-2-8	0.4-150	24 Min.	±1.0 Max.	+29.5 Min.	11 Typ.	+38 Typ.	+24V	0.6A	199.00	(1-9)
ZHL-3A	10-1000	27 Min.	±1.0 Max.	+29.5 Min.	10 Typ.	+38 Typ.	+24V	0.65A	449.00	(1-9)
ZHL-32A	0.05-130	25 Min.	±1.0 Max.	+27 Min.	10 Typ.	+33 Typ.	+24V	0.6A	199.00	(1-9)

Total safe input power +20 dBm, operating temperature 0° C to +60° C, storage temperature -55° C to +100° C, 50 ohm impedance, input and output VSWR 2:1 max. For detailed specs and curves, refer to 1979/80 MicroWaves Product Data Directory, p. 364-365 or EEM p. 2970-2971.

2625 East 14th Street Brooklyn, New York 11235 (212) 769-0200  
Domestic and International Telex 125460 International Telex 620156

World's largest manufacturer of Double Balanced Mixers  
**Mini-Circuits**  
MINI-CIRCUITS LABORATORY  
A Division of Scientific Components Corp. R45/Rev.B

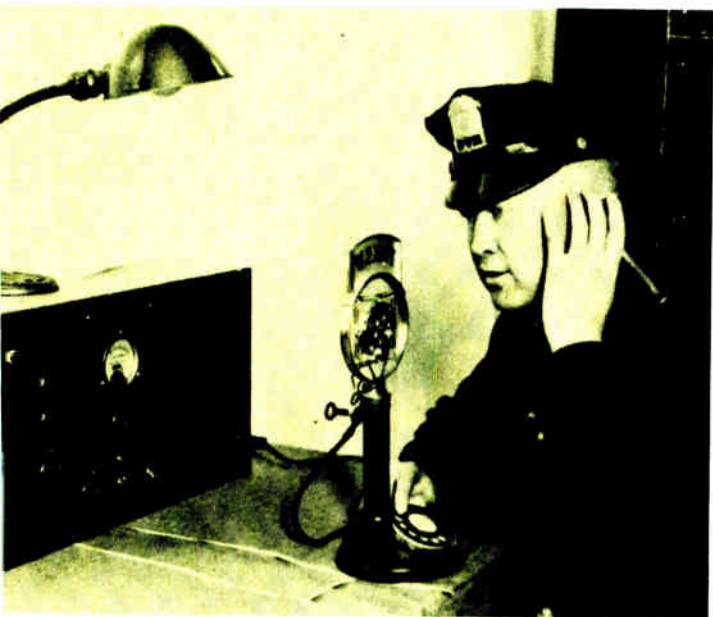

**10-4.** Not Broderick Crawford, but Patrolman H. H. Moon of the New Rochelle, N. Y., police uses radio to communicate with police cars direct from headquarters. The dial serves to connect the police system with telephone lines for local and long-distance hookups.

back loop and invented the now famous Nyquist diagram, that negative feedback began to be widely appreciated. It is now not only used to make low-distortion amplifiers with stable gains but also is the basis of all automatic control systems.

Lest young engineers today think that nothing of much importance happened before the transistor, it is worth noting that in 1930 the superheterodyne receiver was already more than 10 years old, having been invented during World War I by Maj. Edwin Howard Armstrong while he was in France. Armstrong, who had also invented positive feedback (in the form of the regenerative receiver) and superregeneration, was hard at work on the development of frequency modulation in 1930. In July of that year he filed for the first of four fm patents, all of which were to be issued to him simultaneously on Dec. 26, 1933.

Television was also under intensive development. Vladimir K. Zworykin of Westinghouse had demonstrated in 1929 a television receiver containing his kinescope picture tube and had so impressed RCA's Sarnoff that the latter invited Zworykin to join RCA to make television a commercial reality. By 1930 Zworykin was in Camden as director of RCA's Electronic Research Laboratory, and in 1931 he and his staff developed an improved version of his iconoscope camera tube, one that was much more sensitive than the device he had patented years before in 1923.

Carrier-based telephony, too, was both well established and on the verge of great technical advance. Multiplexed open-wire lines had been widely used in the 1920s, and in 1929 Lloyd Espenschied and H. A. Affel of Bell Telephone Laboratories had developed a system based on coaxial cables, which are basic to most guided-wave carrier systems in use today.

One area of communications that was only beginning

to become important in 1930 was mobile radio. Although the New York Harbor Police used spark-gap transmitters to communicate with police boats as early as 1916, technical problems had to be overcome before mobile receivers could be termed practical. Low sensitivity, high power consumption, ignition noise, and the need for frequent replacement of fragile tubes were the principal obstacles to the widespread use of radio receivers in cars and boats until 1928. That year a six-tube set was designed for the Detroit Police Department (see chapter 3). Automobile radios for the public soon followed and became quite popular in the 1930s.

Industrial electronics meant tubes and transducers in 1930. Electron tubes were doing heavy-duty work, such as controlling the amplitude and duration of output current in resistance-welding machines. Soon tubes began to replace the magnetic contactors and relays used to control motors, furnaces, and machine tools. To industry, the tube was panacea: not only was it fast and accurate, but it was also quiet, flexible, power-stingy, and safer than arc-prone mechanical contacts.

**B**y 1930 most of the basic vacuum tubes known today were around, although all were to undergo considerable refinement. There were the diode, triode, tetrode, and pentode. The heptode, the hexode, and the pentagrid converter had yet to be developed.

The basic tube of 1930 was a glass envelope with a plastic base; the steel-envelope tube was not invented at General Electric until 1935. The base and pins of the tube were plugged into sockets. Components and interconnecting hookup wires were hand-soldered between terminals on the sockets.

Even before 1930 it was recognized that better wiring methods were needed for the mass production of radios. In 1925, for example, an inventor called Charles Ducas had patented a method of forming electroplated conductor patterns in copper, gold, or silver on a nonconductive base material. These metal-plated stenciled patterns were the forerunner of the printed circuit, but they were never applied commercially.

Another competitor of point-to-point wiring—one that was used commercially—had stamped brass conductors riveted to a bakelite panel. This system was employed in a six-tube receiver prior to 1930.

Components were undergoing great changes as *Electronics* was born. Wirewound resistors were giving way to carbon-composition devices, which offered both higher resistance values and better high-frequency performance. Paper capacitors were becoming available to replace mica units. And wet electrolytic units had been introduced for power-supply filtering.

To cap the burgeoning activity in electronics, Walter A. Shewart of Bell Telephone Laboratories published in 1931 his magnum opus, "Economic Control of Quality of Manufactured Product" and in so doing essentially invented what is now known as quality control. Shewart's work led to the founding of the American Society of Quality Control.

Electronics had indeed come of age as a manufacturing industry.



**SIEMENS**

# Siemens. On

**Electronic components for every need—  
made, sold, and serviced where America needs them most.**

Siemens manufactures the widest range of components in the world, to meet every industry requirement. From tri-rectifier diodes, to tuning or power semiconductors, tantalum or ceramic capacitors, transient suppression devices, and high speed subnanosecond ECL gate arrays. For applications ranging from communications, aerospace, and data processing to automotive and consumer products.

#### **Exceptional Service**

Of particular significance is the steady growth of Siemens as a major factor on the U.S. industrial scene. Over half the Siemens components sold here are also made here. In New Jersey, Arizona, and California. With central stocking stations, automated inventory systems, 95 local distributors, offices in every state, and exceptional service—whenever and wherever it's called for.

#### **Siemens Commitment**

Siemens, a worldwide electrical manufacturing company with \$16 billion in annual sales, has committed its resources to American industry in four major areas: electronics, communications, power engineering, and health care. Almost 8,000 people are employed in five manufacturing locations and field offices serving all 50 states.

Siemens. The technology, the products, the people, the commitment.



Nationwide sales and service



Components for space research



Broad line of Siemens components

**Siemens. Constructive contributions.**

# The Scene.



**Siemens Corporation**  
Department 0453  
186 Wood Avenue South  
Iselin, New Jersey 08830  
Circle 53 on reader service card



# STANDARD EQUIPMENT WITH EVERY FAIRCHILD TEST SYSTEM.

Half the reason anybody buys a Fairchild test system is the quality of the system itself.

The other half is customer support.

We pride ourselves on providing the very best customer support program in the test system business. We offer the world's most comprehensive training to get you started. Meaningful applications to get you running. And worldwide field service to keep your downtime to an absolute minimum.

Everything we do is designed to meet a common goal: Give you maximum use of your Fairchild system at the lowest possible cost.

That's the overview.

Here are the specifics:

## **TRAINING YOUR PLACE OR OURS.**

Fairchild operates training centers in San Jose, Munich and Tokyo. Courses can also be taught in your own plant by special arrangement.

In our training centers, your personnel are given hands-on experience with the exact kind of test equipment you buy. They start with 12 to 18 man-weeks of basic training, and then choose from a broad range of courses to fit your specific needs—from testing fundamentals to advanced LSI testing techniques.

We use the very latest teaching techniques, including videotape and programmed learning courses, in addition to live lectures and demonstrations. Our average instructor has a minimum of seven years of experience. We have trained over 8,000 customer

personnel in the past seven years.

## **APPLICATIONS. NOT JUST HOW, BUT WHY.**

The key to effective applications support is making sure your Fairchild system does everything it can to meet your specific testing requirements. We maintain a worldwide team of applications engineers to help you get your

We offer a variety of service contracts that can be tailored to your needs. They give you monthly servicing and calibration of your test systems, automatic field change notices, automatic software updates, replacement of defective parts, and a commitment to be there within a matter of hours (within 50 miles of a service center, average response time is four hours).

All in all, we guarantee never to forget you after the sale. That's why every Fairchild test system you buy comes with the personal commitment of trained professionals, applications engineers and service personnel as standard equipment.

For more information, contact your nearest Fairchild Test Systems sales office. Or

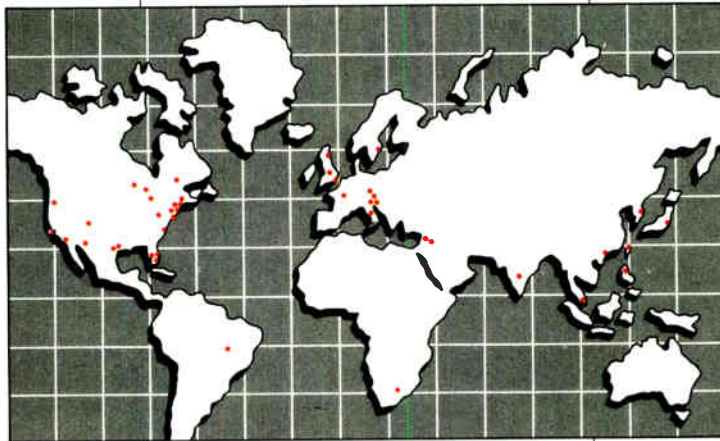

system up and running. We also have a software library containing hundreds of ready-to-run device test programs for standard ICs, almost every known microprocessor, I/O chips, bipolar RAMs, MOS RAMs and a number of support circuits. These programs would cost you tens of thousands of dollars if you had to develop them yourself from scratch.

It all adds up to an applications base that meets many of your testing needs before you begin.

## **SERVICE. ALWAYS THERE WHEN YOU NEED US.**

No matter where you are in the world, we have a field service engineer close by to keep your system uptime up. We have more than 25 major service centers throughout the U.S., Europe and the Far East.

write Test Systems Group, Fairchild Camera and Instrument Corporation, 1725 Technology Drive, San Jose, California 95110. Tel: (408) 998-0123. TWX: 910-338-0558.

**FAIRCHILD**  
**TEST SYSTEMS GROUP**

**The  
first family  
of ATE.**









## Mr. Chuck Surat of ITT is about to recreate an accidental

Nothing will happen to the cable—just as nothing happened when a tractor accidentally ran over ITT cable during a recent telephone system installation in Pennsylvania. The reason is that fiber for fiber, diameter for diameter, ITT makes the strongest optical cable on the market, with the highest degree of ruggedness in the smallest tightly bound diameter. Back at the plant, every fiber is tested to withstand 100,000 psi. It

all helps explain why no break in use has ever been reported in an ITT-designed and installed fiber optic system.

ITT fiber optic cable has another advantage: a remarkable flexibility that means easier handling even under the most adverse weather conditions. In one instance, a cable of 335 meters was installed in temperatures as low as  $-18^{\circ}\text{C}$ . Steam and rodding were needed to clear ice-clogged ducts, but the

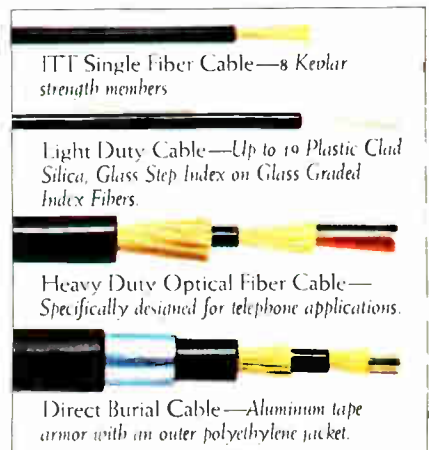



## *demonstration of our optical fiber cable's strength.*

pressures caused by subsequent re-freezing had no effect on the cable's optical properties. All pulls through ducts were made without mechanical assistance, and the entire installation, including connectors, was completed in 26 hours.

Whether you are installing a telephone fiber optic link or a complete communications system,

why not call our Marketing Department at (703) 563-0371. Mr. Surat will be happy to provide you with as many kilometers as you need of the strongest optical fiber cable made, as well as all the components to go with it.

Imagine what we can do together.



**ELECTRO-OPTICAL PRODUCTS DIVISION**

7635 Plantation Road, Roanoke, VA 24019

**ITT**

Circle 57 on reader service card



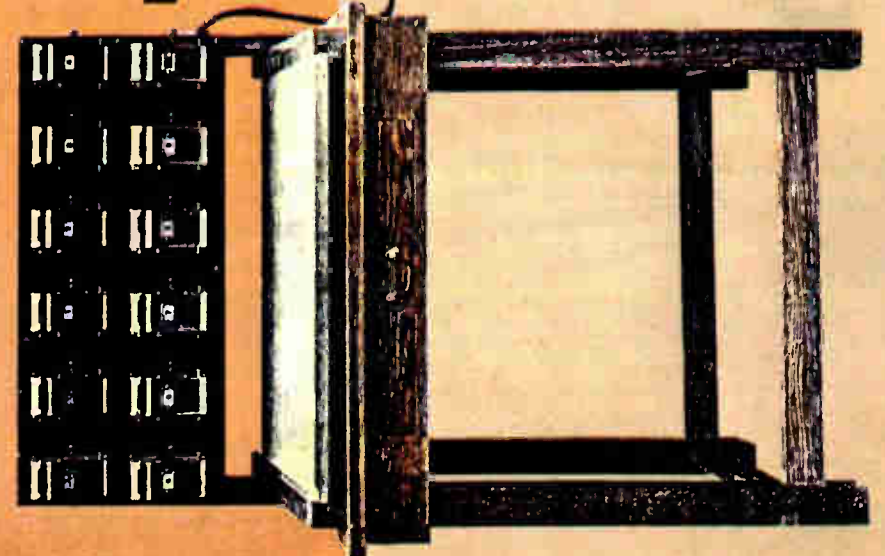
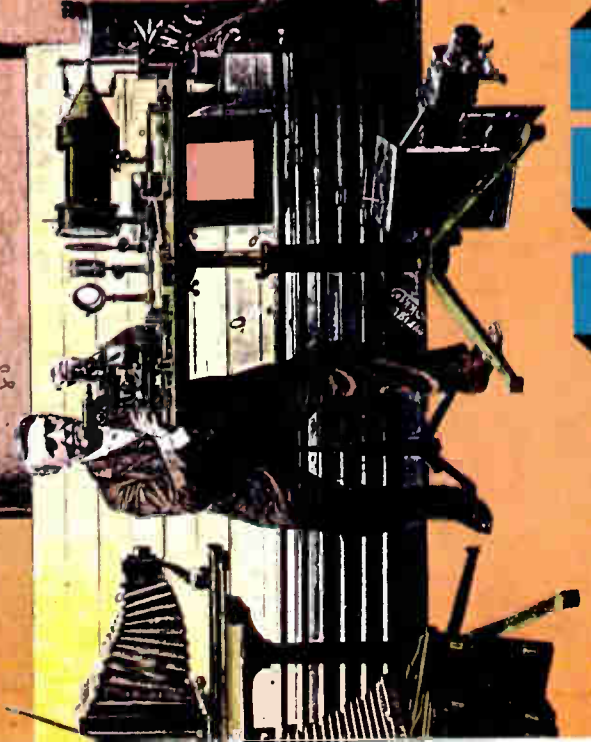
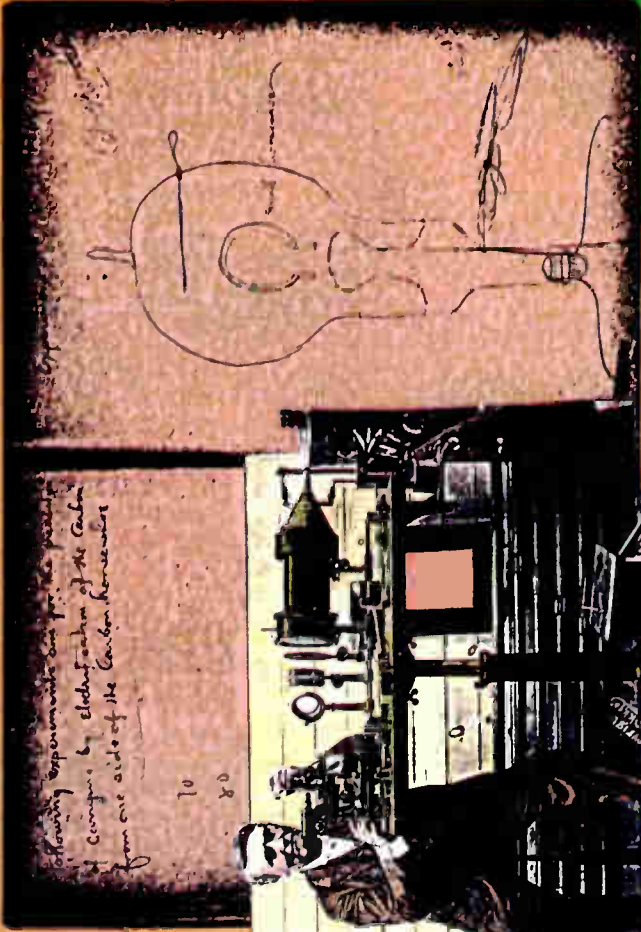

# HOW TECHNOLOGY GOT THERE

---



ALTHOUGH IT WAS 1883 WHEN THOMAS EDISON DISCOVERED THE EFFECT THAT WAS TO BECOME THE BASIS OF THE ELECTRON TUBE, THE ELECTRONICS INDUSTRIES HAVE ROOTS THAT GO MUCH DEEPER. FOR EXAMPLE, A FORERUNNER OF THE COMPUTER WAS BUILT BY BLAISE PASCAL IN 1642. NEVERTHELESS, ELECTRONIC TECHNOLOGY AS IT IS KNOWN TODAY IS ESSENTIALLY A PRODUCT OF THE 20TH CENTURY, FOR IT HINGES ON A PAIR OF RELATIVELY RECENT DEVELOPMENTS—THE DEMONSTRATION OF RADIO BY MARCONI AND POPOV INDEPENDENTLY OF EACH OTHER IN 1896 AND THE INVENTION OF THE VACUUM TRIODE BY DE FOREST IN 1906.

## Chapter 2



**S**trictly speaking, the age of electronics began in 1883 with the discovery of the Edison effect. In that year Thomas Alva Edison, in his efforts to increase the life of his early carbon-filament lamps, introduced a metal electrode into the vacuum envelope containing the glowing filament. He discovered that when a positive voltage was applied to the electrode, a current flowed across the vacuum between it and the filament. This phenomenon—the great inventor's only fundamental scientific discovery—is the basis of all electron tubes and of all electronics up to the solid-state era.

But Edison did not pursue his discovery. Some critics have taken this failure to follow up as proof that he was only a persistent tinkerer and not a first-class scientist. In Edison's defense, historians point out that he was extremely busy with many developments around this time: the pioneering Pearl Street electrical generating station had opened in 1882, and Edison was involved in 1883 with financial, managerial, and technical troubleshooting. He did publicize his findings on the Edison effect, and he described the discovery in a patent.

Nevertheless, from 1883 to 1904 neither Edison nor anyone else exploited the effect to make a useful vacuum tube for detecting or amplifying electrical signals. Perhaps there was not sufficient motivation. Although the telephone could have benefited from the invention of a suitable amplifier—as it was to eventually—it was capable at the time of profitable operation without one. Radio, on the other hand, was not. And radio was also still struggling for an identity.

In 1896 in Pontecchio, near Bologna, the Italian Guglielmo Marconi used grounded antennas to send telegraph signals through the air over a distance of about 2½ kilometers. In St. Petersburg, Russia, that same year, Aleksandr Stepanovich Popov independently sent possibly the first radio message, "Heinrich Hertz," over a distance of 300 yards. Long-distance wireless telegraphy took a few more years. Marconi established radio communication between France and England in 1899. In 1901 he made radio waves cross the Atlantic from Poldhu, Cornwall, to St. John's, Newfoundland.

Radio, of course, did not begin with Marconi and Popov—it only seems that way. Like many other advances in electricity and magnetism, it had its origins in the discoveries and inventions of Michael Faraday and in the work of the mathematical genius, James Clerk Maxwell. Among Faraday's many discoveries was his elucidation in 1831 of the principle of electromagnetic induction. In 1832, looking into the future with remarkable clarity, he wrote:

"I am inclined to compare the diffusion of magnetic forces from a magnetic pole to the vibrations upon the surface of disturbed water, or those of air in the phenomenon of sound, i.e., I am inclined to think the vibratory theory will apply to these phenomena as it does to sound, and most probably to light."

Maxwell agreed. Progress was slow, however, and it was not until 1855 that he published "On Faraday's Lines of Force" or until 1864 that he gave the world his startling "A Dynamical Theory of the Electromagnetic Field." This paper presented what we now call Maxwell's equations, explained all of the known

phenomena of electromagnetism, and predicted that radio waves could exist and would travel at the speed of light.

In 1887 Heinrich Hertz proved experimentally that Maxwell was right. Using a spark-gap transmitter and a loop antenna with a small gap in it as a receiver, he transmitted and received radio waves in his laboratory in Karlsruhe, Germany. More than that, he used a reflecting arrangement to detect standing waves and showed that the waves obeyed all the laws of geometrical optics, including those of refraction and polarization. No wonder Popov's first message was Hertz's name.

Thus although its beginnings lay early in the 19th Century, it was not until the beginning of the 20th that radio advanced far enough to make the world realize that it needed a decent amplifier.

If discovery of the Edison effect was the first step on the road to such an amplifier, the second step came in 1904 when John Ambrose Fleming invented the vacuum diode. Fleming, since 1882 a consultant to Edison Electric Light Co. in London, had met Edison personally in 1884 and learned about the Edison effect soon after its discovery. Fleming described his thermionic valve as a rectifier of high-frequency alternating currents. And that's what it was. Like cat's whisker crystal detectors and other receiving devices of the day, it rectified radio-frequency waves but it could not amplify them.

The third step on the road to amplification was taken by Lee de Forest. On Oct. 25, 1906, he applied for a patent on a three-element vacuum tube—the famous audion. This tube was similar to Fleming's valve, with one important difference: it had a control grid between the filament and the anode.

**T**oday we think of triodes as amplifiers. But de Forest's early devices had such low gains that they were little better than diodes. Something was needed to make the audion into a practical amplifier. It was six years in coming, but when it came it marked the beginning of radio and of modern electronics.

This device was Edwin Howard Armstrong's regenerative circuit. It constituted not only the sensitive receiver that everyone was looking for, but as a bonus, it was also the first nonmechanical generator of clean continuous-wave signals.

Regeneration—or positive feedback—involved coupling a portion of the plate-circuit signal back into the grid circuit to increase the amplification of a triode. With sufficient feedback, of course, the amplifier became an oscillator. First set up and operated on Sept. 22, 1912, Armstrong's regenerative circuit was quickly adopted by industry, although frequently in violation of Armstrong's patent. Transcontinental telephone service was established between New York and San Francisco early in 1915 based on regenerative repeaters, and later that same year, in a historic experiment, voice signals were successfully transmitted from Arlington, Va., to Paris. This experiment used the regenerative circuit in both its transmitter and receiver.

There was early recognition by both Irving Langmuir of General Electric and Harold Arnold of Western Elec-



**Guglielmo Marconi.** Often called the inventor of radio, Marconi was actually the first man to use grounded antennas. In 1896, he sent radio signals some 2.5 kilometers.



**Michael Faraday.** Quite likely the greatest experimenter in electromagnetism, Faraday predicted the existence of electromagnetic waves in 1832.

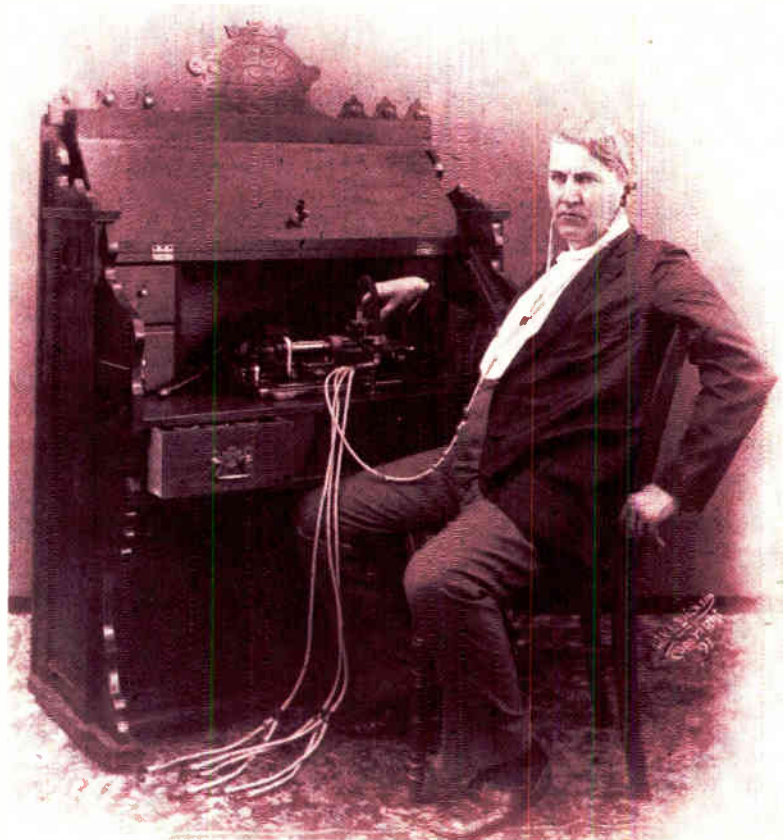

**Thomas Edison.** It was probably his preoccupation with the first commercial generating station (on Pearl Street in New York) that prevented Edison from pursuing his discovery of the Edison effect and going on to invent the electron tube.



If you're an OEM or system builder, no doubt you've been subjected to the 8-inch Winchester hustle.

Well, Century Data thinks it's time to rack up the facts and lay them on the table.

First off, the 14-inch Winchester is rebounding. Just as predicted. And Century's new Marksman disk is the perfect example.

Sure 8-inch drives will be available some day. But can you afford to wait?

Today, the need for more storage and less cost is forcing many companies to go Winchester. And we think your best shot is our Marksman drive.

Marksman is the no-risk disk with enormous expandability and optional built-in intelligence. It's also one you can get today.

Built-in intelligence means you won't get behind your competition by spending months designing, testing and debugging your own disk controller. We've already done most of the work. You're up and running in days, not months.

Built-in growth means you won't have to start over when your applications increase. Marksman comes in 10, 20, and 40 MB models, and a lot more to come soon.

For more flexibility, Century offers everything from a 2½ MB Diablo cartridge disk to the 600 MB removable-pack Trident — with lots of mixed and fixed storage in between.

So if you can't afford to get behind, call Century Data, a Xerox Company specializing in mass storage for over 11 years. Our early delivery will put you ahead. Our advanced technology will keep you there.

Century Data Systems,  
1270 North Kraemer Blvd.  
Anaheim, CA 92806  
Phone: (714) 632-7500

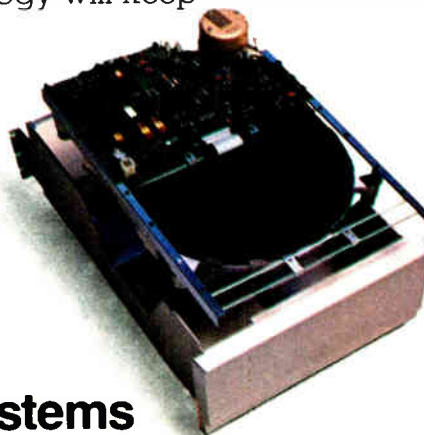

**Century Data Systems**

A Xerox Company



8



14

**WINCHESTER  
FOR COMPANIES THAT  
CAN'T AFFORD TO  
GET BEHIND.**





# THE INSTRUMENTS IS SATISFYING THE NEED FOR FOR PEOPLE ALL





# DIVISION OF GOULD INC. QUALITY INSTRUMENTATION OVER THE WORLD.



**LOGIC ANALYZERS**



**DIGITAL MULTIMETERS  
AND COUNTER TIMERS**

For more information on Gould recording, graphic display, signal analysis and measurement instruments and automatic test equipment, write Gould Inc., Instruments Division, 3631 Perkins Ave., Cleveland,

Ohio 44114. Or call toll-free  
800-331-1000. In  
Oklahoma, call collect  
918-664-8300.



**GOULD**

An Electrical/Electronics Company  
Circle 65 on reader service card





**James Clerk Maxwell.** This man invented field theory and calculated that radio waves would travel at the speed of light.



**Heinrich Hertz.** In a series of experiments in 1887 Hertz demonstrated the existence and nature of electromagnetic radiation.



**John Fleming.** He learned about the Edison effect from Edison himself in 1884 and went on to invent the vacuum diode in 1904.

tric (later the first director of research at Bell Telephone Laboratories) that improving the vacuum in the triode would make it a much better amplifier. Indeed, the tubes used in the transcontinental link in 1915 were special hard-vacuum devices made by Western Electric.

From this point onward, developments came at an ever-increasing pace. Single-sideband transmission, the superheterodyne, radio navigation, carrier systems for telephony, and the flip-flop circuit were just some of the important achievements between 1915 and 1920.

But two other modern electronic marvels—television and the computer—though far from ready, had been evolving for some time. It is perhaps a good idea to look back at their nonelectronic origins before seeing how they were affected by the vacuum tube.

**T**he need for rapid and accurate solutions to the tedious mathematics involved in setting up mathematical tables for astronomers and naval navigators may have been the greatest stimulus in the middle of the 19th Century to the development of digital calculating machines. Earlier attempts at building calculators were aimed at the man of business who had long columns of figures to add and subtract, but who had few, if any, nonlinear functions to solve. And although work on analog machines to help in the calculation of tidal functions began in the latter half of the 19th Century, little progress was made toward the analog computer until the middle of the 20th Century.

The earliest mechanized computer was no more than an adding machine that could both add and subtract; but it could neither multiply nor divide. Built by Blaise Pascal in 1642, this machine was an aid in adding columns of figures in his father's office. His calculator had number wheels with parallel, horizontal axes. The positions of these wheels could be determined and their sums read through windows in the covers. Numbers were

entered by horizontal dial wheels coupled to the number wheels by pin gearing. Most of the number wheels were geared for decimals; a carry ratchet coupled each wheel to the next higher place.

Pascal's machine is said to have been predated by one built by Wilhelm Schickhard of Tübingen, Germany, between 1623 and 1624, although this claim has never been fully substantiated.

In 1673 Gottfried Wilhelm Leibniz, the German philosopher and mathematician, completed a calculator that used a device known as the Leibniz wheel. It allowed not only automatic addition and subtraction, but also multiplication and division. Machines using a version of the Leibniz wheel were employed through World War II.

However, not until 1820, when Charles Xavier Thom- as introduced his Arithometer, was it proved that calculators performing the four basic arithmetic operations could be manufactured commercially; and this was not truly done on a large scale until the latter part of the 19th Century.

Perhaps the most significant work with early digital computers was done by the English mathematician Charles Babbage with funding from the British government. In 1823 Babbage began work on his Difference Engine, a special-purpose calculator to help the British navy draw up various nautical tables. These could be tables of multiplication, logarithms, sines, and cosines, or of physical measurements and observations.

Babbage's machine was to perform all arithmetic operations using 20-digit registers and delivering a printed output. But the mathematician never fully completed his work on this Difference Engine, and in 1833 he started work on another idea that he failed to bring to fruition: the Analytical Engine. This machine was conceived as a general-purpose computer, very close in design to the Mark I, which was built at Harvard University a century later, in the 1930s. Babbage

## Brite moments in American history.

September 14, 1716. Boston Light shines as America's first lighthouse. Originally illuminated by oil lamps, the beacon commanded a majestic view of Boston Harbor. During the Revolutionary War, British and American forces vied for control of the lighthouse. When the British evacuated Boston in 1776, rather than yield the lighthouse to the Americans, they blew up the tower, reducing it to rubble. It was reconstructed on the same site, and, more than 200 years later, Boston Light still shines bright.



Photograph Courtesy of the National Archives

# Brite-Lites® Stay Bright.

Our Brite-Lite LED lamps not only shine as bright as incandescents, they shine longer — more than 10 times longer. At 20 milliamps, they'll shine at least 10 years. Continuous or pulsed, they operate without life loss, using less than half the power of an incandescent. And they're 25 times brighter than other LEDs on the market. That's dependability in the tradition of Boston Light.

Whether installed in sophisticated computer control panels or simple telephone pushbuttons, our Brite-Lites suit your requirements. Midget-flanged, snap-ins, PC lites, and wide-angle LEDY bugs, are available in transparent or translucent red, amber, or

green; from 1.6 to 48 volts; from 10 to 30 milliamps. And our LED lamps are American-made, so you're assured of dependable, prompt delivery.

When Digital Equipment Corporation conducted a

series of tests for plug-compatible LEDs which had both the brightness and long life they required, they chose Brite-Lite LEDs with solid state reliability to replace their incandescent lamps.

For LED lamps that stay bright, isn't it time you switched to Brite-Lites.



Proven better and brighter than the rest



### Data Display Products

303 N. Oak St., Inglewood, CA 90302  
(213) 674-5940 • TWX 910-328-7208



# BEGONE CURSED ALIAS

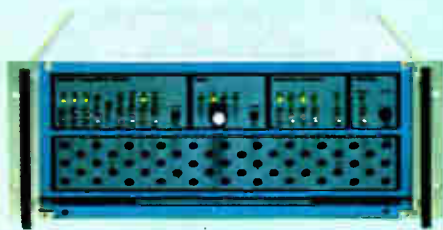

**Precision 616**  
124 programmable cut-off frequencies.

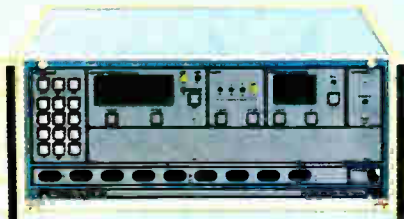

**Precision 636**  
Two models: 4092 or 6141 cut-off frequencies.



**Precision 416**  
Combined filter and amplifier. 62 cut-off frequencies.

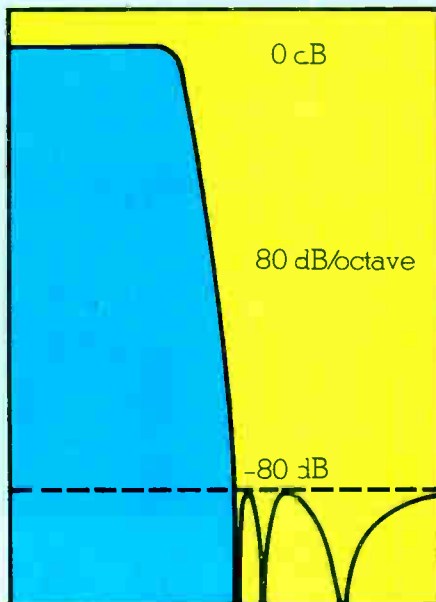

You want analog data to come clean for digital conversion.

We keep extending the Precision ways to do it with signal conditioners, amplifiers and filters.

All Precision anti-alias filters have elliptics with 80 dB/octave attenuation. All come with time delay filters superior to Bessel. All have typical phase match of  $1/2^\circ$ .

All Precision instruments are programmable. All interface with mini, micro or GPIB. All have 16 channels, except the 602.

**Call Don Chandler,**  
607-277-3550, for detailed specifications.



**Precision 602**  
Two channels. 124 cut-off frequencies.

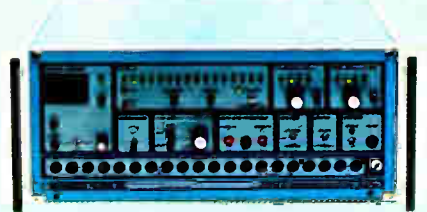

**Precision 216**  
16 channel automatic/programmable gain amplifier. 300kHz bandwidth.

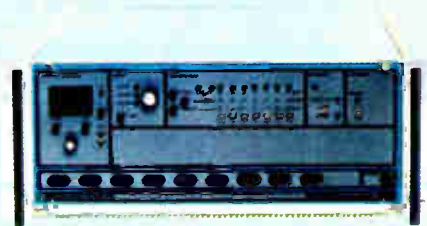

**Precision 316**  
Calibration and conditioning for charge, voltage and strain inputs.



**PRECISION FILTERS, INC.**

303 W. Lincoln, Ithaca, N.Y. 14850

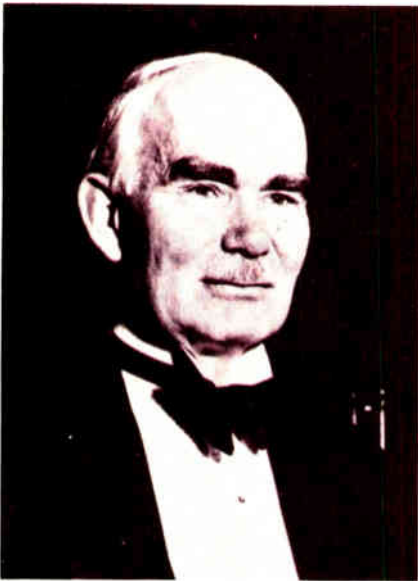

**Lee de Forest.** By putting a grid into a diode de Forest made one of the century's most important inventions—the triode.

foresaw the need for two distinct units—the store (or memory), where information and instructions were entered into the machine by punched cards, and the mill (or processing unit), where operations were to be performed by use of the stored information and instructions. Babbage had taken the idea of punched cards from Joseph Marie Jacquard, who invented an attachment to the loom in 1805 that automated the weaving of patterns. Jacquard used a series of cards with holes punched in them to represent the desired patterns. The holes allowed hooks to come up through the cards and pull warp threads down, so that when the shuttle passed through it went over certain preselected threads and under others.

Babbage's Analytical Engine was to hold 1,000 words of 50 digits each, and when random access to tables of functions was required, the machine would ring a bell to alert the operator that additional data was needed.

A machine based on Babbage's design for the Difference Engine was built by Pehr Georg Scheutz in Sweden in 1854, but it took another hundred years for a working model of the Analytical Engine to be built by International Business Machines.

Formal logic, so necessary for the workings of digital computers, could not be satisfactorily explained mathematically before George Boole. In 1848 the English logician published "The Mathematical Analysis of Logic" and in 1854 "An Investigation of the Laws of Thought," the foundation of what is now symbolic logic. With the theories expounded in these writings, it was possible to express logic in very simple algebraic systems. The equation  $x^2 = x$  for every  $x$  in the system is basic to Boolean algebra and has only 0 or 1 as an answer in numerical terms. Thus modern computers can make use



**Irving Langmuir.** Shown with Willis R. Whitney, Langmuir (holding triode) advanced electronics by explaining the space-charge phenomenon in electron tubes.

of this binary system, with their logic parts carrying out binary operations.

The year 1890 marked the beginnings of two modern computer companies: Burroughs and IBM. In that year William S. Burroughs invented the Adding and Listing Machine—a very popular office calculator—and Herman Hollerith helped solve the compilation problems of the 1890 United States Census with an early data processor. Hollerith went on to form the Tabulating Machine Co. in 1896 to make both the processing machines and the cards they used. In 1911 this company joined with one that manufactured scales and industrial time clocks to form the Computer-Tabulating-Recording Co. In 1924, under Thomas J. Watson, the latter company became the International Business Machines Corp.

Hollerith's machine had three parts: a tabulator using clocklike devices that received electrical signals from reading brushes; a sorter box with 24 bins electrically connected to the counters in the tabulator; and a hand-operated punch cards for that were  $6\frac{1}{8}$  by  $3\frac{1}{4}$  inches and had 288 locations where holes could be punched. Normally all the lids on the bins were closed, but when a hole was sensed, an electrical circuit was completed that allowed the latch holding the lid to spring open. The card was then slipped into the bin by hand. It was several



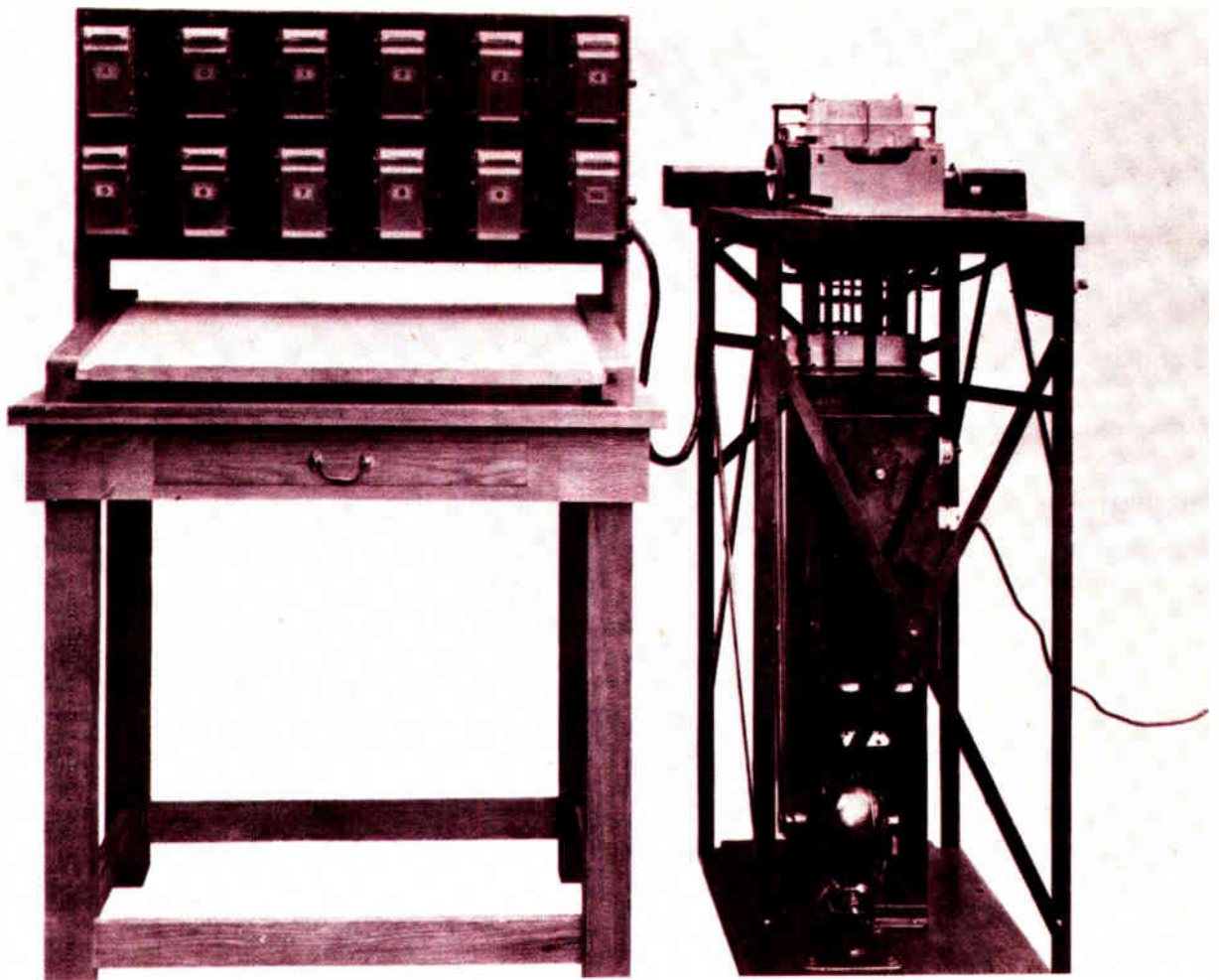

**Computer forefather.** This early Hollerith sorter and counter was one of the first products of the Tabulating Machine Co. The company, which was founded in 1896, became the Computer-Tabulating-Recording Co. as the result of a merger in 1911. It is doing nicely today as IBM.

years before Hollerith was able to automate this part of the process.

James Powers, an engineer in the census shop, was commissioned in 1907 to develop an automatic card-punching machine, and in 1911 he formed the Powers Tabulating Machine Co., a principal competitor with the Computer-Tabulating-Recording Co. for some years. In 1927 Powers' company merged with Remington-Rand, which later combined with Sperry Gyroscope in 1955.

Unlike their digital counterparts, analog calculators did not come into their own until the 1930s under Vannevar Bush at the Massachusetts Institute of Technology. Early work on analog computers had been done at the end of the 19th Century by two English brothers, James and William Thomson. James Thomson was responsible for the design of a planimeter, which used a ball and disk integrator. William Thomson (Lord Kelvin) used this integrator in a harmonic analyzer and a tide predictor. He later went on to explore the idea of a differential analyzer, although he did not build one because of technical difficulties.

Unlike digital computers—which started out as mechanical devices and then went through a brief electromechanical period during the 1930s, finally becoming electronic only in the 1940s—television was an electrical

medium from the its very beginnings.

Attempts to send images over distances with the use of electricity date to 1876, the year Alexander Graham Bell invented the telephone. At that time it was already known that the resistivity of selenium varied with the amount of light falling on it. Thus as soon as Bell made it clear that complex signals could be transmitted over a distance, inventors and would-be inventors began trying to develop means of “seeing by electricity,” as the title of one paper put it at the time.

Some of the schemes involved the use of a mosaic of selenium detectors: others called for scanning the image mechanically with one or more selenium points. Reproduction was to be by anything from the movement of a pencil to electrochemical action on a piece of chemically treated paper at the receiver.

The first television invention that had practical consequences was the “electrical telescope,” patented by Paul Nipkow in 1884. At the heart of his camera was the now famous Nipkow disk. It had 24 holes equally spaced along a spiral near the periphery of the disk. The image to be transmitted was focused on a small region at the disk's periphery, and the disk was made to spin at 600 revolutions per minute. As the disk rotated, the sequence of holes scanned the image in a straight line. A lens

## Brite moments in American history.

October 21, 1879. Thomas Edison demonstrates the first incandescent electric light. Only 14 months after he made a public prediction that he was going to invent an electric light, Thomas Edison demonstrated his carbon-filament, vacuum-bulb lamp and startled the world.

Even though this was just one of the 1,053 patents held by the self-declared "freelance commercial inventor," it soon became his most famous. Within three years of the first demonstration, under the supervision of Thomas Edison's "invention factory," the first central electric power station was completed in downtown New York City, initiating electric illumination around the world.

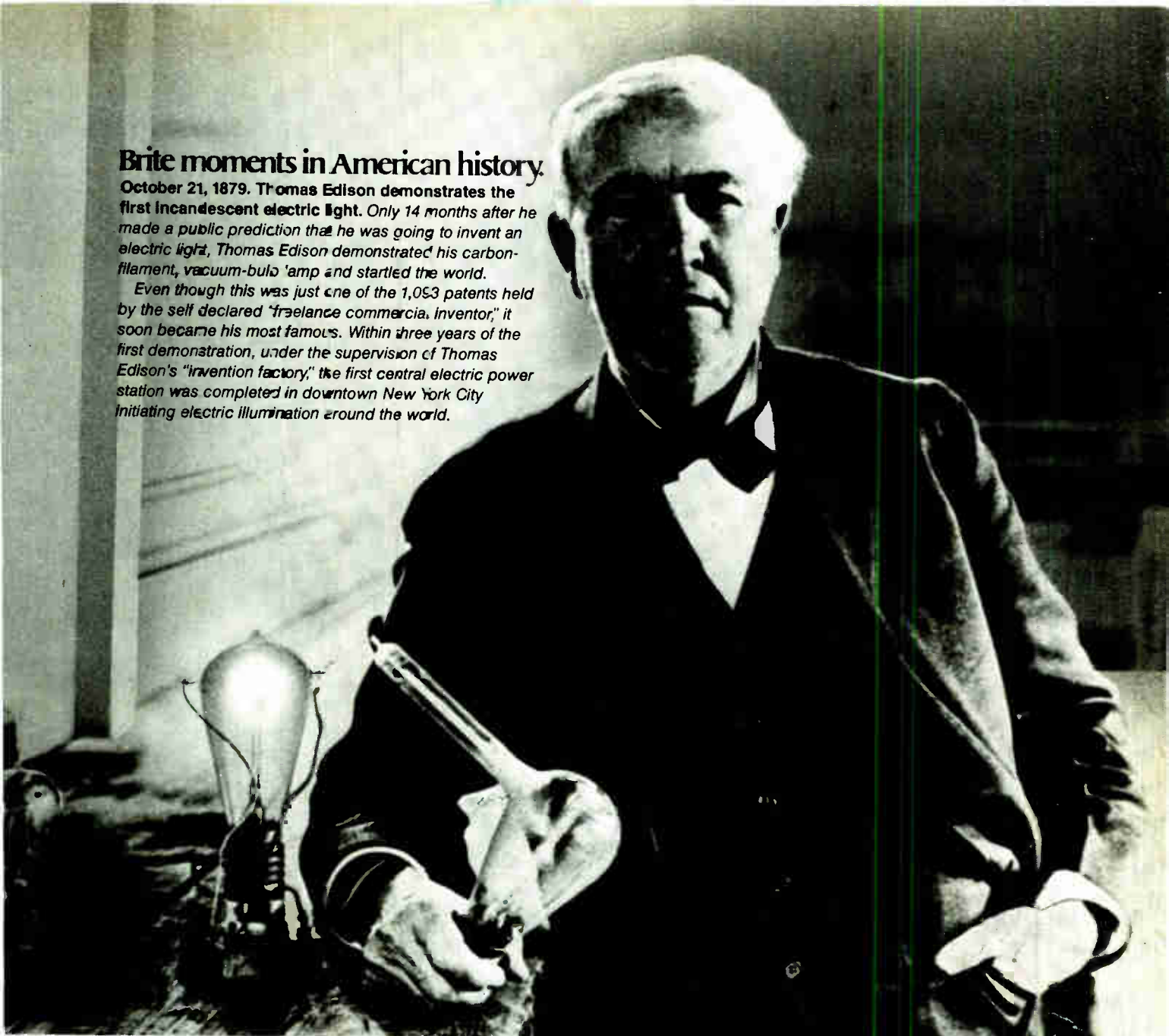

Photograph Courtesy of the National Archives

# The All-American Brite-Lite.<sup>®</sup>

They're a far cry from incandescents. Our Brite-Lite LED lamps are proven many times brighter than other LEDs giving you the same level of brightness as incandescents. At the same time, they're proven to last at least 10 times longer, while using only half the power. Brite-Lites give you solid-state reliability, not filament frailty.

Another thing on our side is we are a company that only manufactures in America. This way, you never have to wait for overseas shipments to arrive, which just

may be the second reason, after reliability, why Brite-Lites are the number one choice over any other LED lamps available.

Whether you're looking for red, green or amber, transparent or translucent, 1.6 or 48 volts, 10 or 35 milliamps, mid-gate flanged snap-ins or space-saving PC lites—or any combination of the above—you've come to the right place. For the All-American Brite-Lite.



Proven better and brighter than the rest



### Data Display Products

303 N. Oak St., Inglewood, CA 90302  
(213) 677-6166 • TWX 910-328-7205



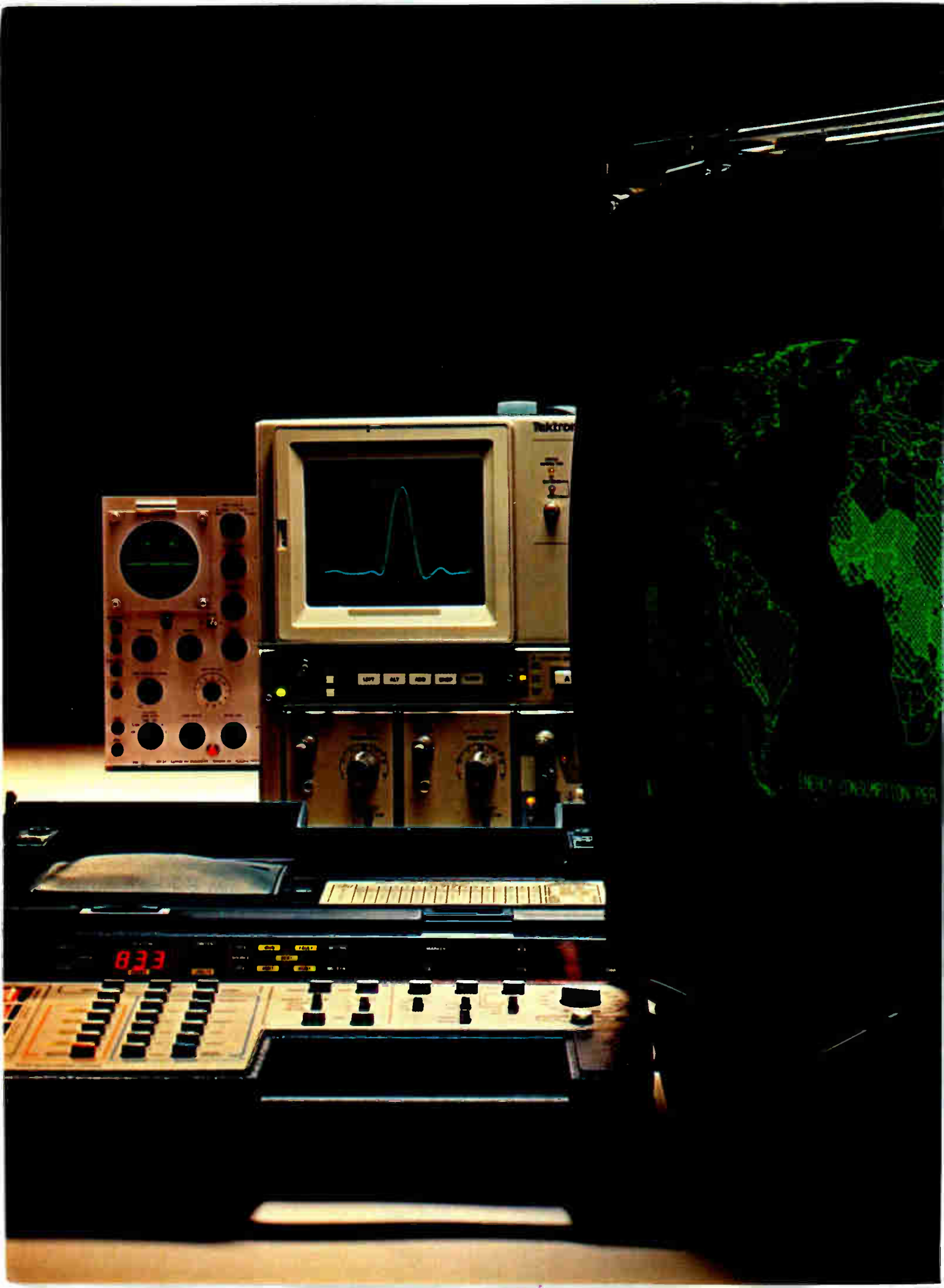

## Fifty years of foresight.

**Y**ear after year, Electronics reports new technological breakthroughs.

It hasn't mattered whether the source of innovation was a fledgling company (as we were in 1948 when Electronics announced our first revolutionary oscilloscope) or a Fortune 500 leader.

Electronics has served as an intelligent observer, analyst and reporter of our industry, performing a very important function to any company that has made an institution out of innovation. Through the pages of Electronics, volume after volume, the Tektronix commitment to customer needs has been well represented.

You can always be sure that today's state-of-the-art won't be tomorrow's. But as the issues unfold during this 50th year of Electronics you will see abundant evidence that Tektronix is continuing to support you with innovative technologies and consistently high standards in products and services.

This year we celebrate Electronics with a glimpse at the past and an eye on the promise of the future.

# Electronics, we congratulate you.

### Versatility... Plus

The Tektronix Type 511 is a portable wide band oscilloscope providing facilities formerly available only in very expensive, cumbersome instruments.

#### SWEEP CHARACTERISTICS

Continuously variable .1 second to 1 microsecond (10 cm. deflection).  
Direct reading sweep speed disc.  
Choice of triggered, recurrent or single sweeps at all speeds.  
Triggers on sine waves to 10 mc. or pulses over .05 microsecond.  
Any 20% of sweep may be expanded 5 times.  
DC coupled PP amplifier for external sweep input.

#### MISCELLANEOUS

Calibrating voltage 0-1, 0-10, 2-10 volts, 40 cycles.  
CRT: SCPIA, SCPIA or SCPI1A operating at 1 kV.  
Direct connection to all plates from side panel.  
Total weight 65 pounds, self contained.

Price \$795.00 f.o.b. Portland

Your inquiry will bring more detailed information and name of the nearest Field Engineering Representative.



712 S. E. Hawthorne Blvd.  
Portland 14, Oregon

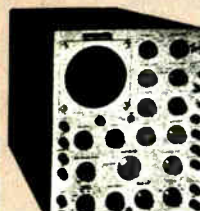

Tektronix Type 511 Oscilloscope

#### VERTICAL DEFLECTION SYSTEM

Amplifier Bandwidth 10 mc., 1 stage, 8 mc., 2 stages.  
Rise Time .04 microsec., 1 stage, .05 microsec., 2 stages.  
Maximum Sensitivity .27 V/cm. (Peak to Peak).  
Input Impedance Direct 1 meg., 40 meg., Probe 10 meg., 11 meg.

Phone, EAst 4888  
Cables, TEKTRONIX

The 1948 issues of Electronics carried this ad for our first oscilloscope, the 511. We've developed those original technologies, and pioneered new ones to create products as revolutionary today as the 511 was then.

**Tektronix**  
COMMITTED TO EXCELLENCE

For the address of your nearest Tektronix Field Office, contact:

U.S.A.  
P.O. Box 1700  
Beaverton, OR 97075  
Phone: 503/644-0161  
Telex: 910-467-8708  
Cable: TEKTRONIX

Africa, Europe  
Middle East  
European Marketing Center  
Postbox 827  
1180 AV Amstelveen  
The Netherlands  
Telex: 18312

Asia, Australia, Canada,  
Central & South America,  
Japan  
America's/Pacific  
P.O. Box 500  
Beaverton, OR 97077  
Telex: 910-467-8707  
Cable: TEKTRONIX



# 10 to 30 MHz oscilloscopes with more performance and reliability than you ever thought possible.



It's easy to see why LEADER oscilloscopes are now specified more than ever. More performance and quality for less cost... with immediate deliveries from over 100 stocking distributors. They also come with the best two-year warranty in the industry... backed by efficient factory service depots on the East and West Coasts.

## A full-range of reliable, medium bandwidth oscilloscopes.

LEADER's oscilloscope line includes 11 models, single and dual trace versions, for bench or field use. All models offer comprehensive triggering controls, TTL compatible Z-axis modulation, front panel trace alignment control and convenient, color-keyed front panel layout. Probes are furnished with every oscilloscope and options include probe pouches, carrying cases, front panel covers and rack mounting adapters.

## 30 MHz delayed sweep - \$1,530.

LBO-515B is a compact, precision oscilloscope at a moderate price. Using a PDA 4-inch CRT with parallax-free internal graticule, it features 5 mV sensitivity and delayed sweep for viewing and measuring complex waveforms. Also has 120 ns signal delay, trigger hold-off and x-y operation at full sensitivity.

## 30 MHz with signal delay - \$1,100.

LBO-520 combines a 11.7 ns rise time with 5 mV sensitivity and 120 ns signal

# The surprising leader.

delay lines. Has single shot triggering, X10 sweep magnifier and bright, sharp PDA CRT. Triggers to 50 MHz.

## 20 MHz dual and single trace - \$835., \$610.

LBO-508A and LBO-507A give you versatility at low cost. Rise time is 17.5 ns with 1 M $\Omega$  (35 pFd) input impedance. Automatic or external triggering, X5 sweep magnifier, 10 mV/cm sensitivity and add/subtract modes.

## 10 MHz with 1 mV sensitivity - \$645.

LBO-514 has both vertical and horizontal X5 magnifiers. Sensitivity is from 1 mV/cm to 10 V/cm. Sweep speeds from 0.2 s/cm to 0.1  $\mu$ s/cm. Auto or normal triggering. Z-axis modulation. (Single trace version, LBO-513, \$495.)

## 20 MHz battery/ac portable - \$950.

LBO-308S provides lab performance and high reliability in field service applications. Sensitivity is 2 mV with a complete set of triggering controls and 18 sweep ranges to 0.1  $\mu$ s/div. with X5 magnifier. Compact, lightweight with 3-inch rectangular, internal graticule CRT. (Optional 2 hour internal battery pack is recharged during ac operation, \$75.00.)

## Two-year warranty. Evaluation units.

A history of high reliability permits LEADER to provide a generous 2-year warranty... backed by factory service depots on the East and West Coasts. A free, trial use of LEADER instruments

is available to all qualified companies.

Call toll-free (800) 645-5104 to request:

- an evaluation unit
- our 40-page catalog
- the name of your nearest "Select" distributor
- additional information



Oscilloscopes, frequency counters, function generators, video and audio instruments... a LEADER instrument for almost every need.

When Quality Counts

**LEADER**  
Instruments Corporation

380 Oser Avenue  
Hauppauge, N.Y. 11787 (516) 231-6900  
Regional Offices:  
Chicago, Los Angeles, Dallas.



**Paul Nipkow.** His disk is the basis of just about all mechanically scanned television.

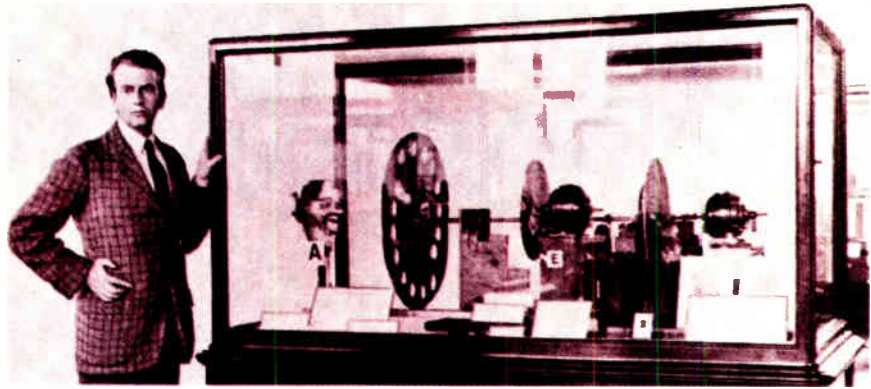

**John Logie Baird.** The first man to demonstrate (among other things) color television, stereo TV, and big-screen TV, stands beside his original 1926 apparatus.

behind the image region collected the sequential light samples and focused them on a single selenium cell. The cell would then produce a succession of currents, each proportional to the intensity of the light on a different element of the image.

At the receiving end, Nipkow proposed using a magneto-optic (Faraday-effect) light modulator to vary the intensity of the reconstructed image. To form the image, a second disk, identical to and rotating synchronously with the one at the transmitter, would be needed.

Nipkow built no hardware—which is probably just as well, because the technology of the time would not have permitted him to build his system; the light modulator alone would have required some 10 watts of control power. His disk, however, was a model for several later television systems that were built, most notably those of British inventor John Logie Baird.

Baird was apparently more interested in proving feasibility than in refining his ideas for commercial use. His feverish activity produced an incredible string of television firsts. Among them: transmission of TV pictures via telephone lines (London to Glasgow, 1927); telecast of 30-line pictures by shortwave radio across the Atlantic and to a ship at sea (the *Berengaria*, 1928); first demonstration of color TV (1928); stereo TV (1928); daylight TV (1928); regular TV service, including the transmission of synchronizing pulses (1929); simultaneous transmission of pictures and sound (1930); big-screen TV (1930); televising of a daytime public event (the Epsom Derby, 1931); televising of a motion-picture film (1931); and uhf transmission (1932).

All of this was done with variations on the Nipkow disk and the work constitutes the high-water mark of mechanically scanned television. Television as we know it today is, of course, all electronic and has a different genealogy.

The first all-electronic television system was described by Alan Archibald Campbell-Swinton in a letter to *Nature* magazine on June 18, 1908. Like Nipkow, Campbell-Swinton built no hardware but described his ideas in great detail. His system was based on the cathode-ray tube invented in 1897 by Karl Ferdinand Braun, in Strassburg. Campbell-Swinton proposed using CRTs as both the transmitter and receiver, recognizing that a key problem was “in devising an efficient trans-

mitter which, under the influence of light and shade, shall sufficiently vary the transmitted electric current so as to produce the necessary alterations in the intensity of the cathode beam of the receiver.”

One step closer to reality was Boris Rosing of the Technological Institute of St. Petersburg University in Russia, who in 1907 developed a TV system that used mechanical scanning on the transmitting end and the Braun CRT as a receiver. The Bolshevik Revolution ended his work, but it motivated one of his students, Vladimir K. Zworykin, to emigrate to the United States where, first at Westinghouse and later at the Radio Corp. of America, he helped develop television as we know it today.

Zworykin’s most critical invention was the first iconoscope camera tube, which he patented in 1923. The key to its success was the fact that its silvered-mica photocathodes stored the charges induced by the image that was focused on them until the scanning electron beam simultaneously neutralized the charges and modulated itself. Approaches that lacked this storage feature, such as Philo Farnsworth’s image dissector, were less successful.

A year after he invented the iconoscope, Zworykin invented the kinescope—a TV picture tube—thus becoming responsible for both the key transmitting and receiving elements of electronic television.

The broadcast television that followed two decades later would, of course, not have been possible without proper transmitters, receivers, modulators, demodulators, etc.—or, in other words, without proper radio. The world had been introduced to the potential of such a radio system as far back as 1906, when on Christmas Eve Prof. Reginald A. Fessenden of Harvard University made the first documented radio broadcast of speech and music. For this feat, he used a 50-kHz Alexanderson alternator, manufactured by the General Electric Co. Telegraph operators on ships crossing the North Atlantic were surprised on that historic night to hear music coming out of earphones that previously had emitted nothing but dots and dashes. Fessenden modulated the alternator’s 1-kw output simply by putting a microphone in series with the antenna of his experimental station at Brant Rock, Mass. It is likely, but not certain, that the microphone was water-cooled.

In 1915, John R. Carson of American Telephone &



# the **First** Full Spectrum of

**First**

The leading distributor of computer components, peripherals, terminals and accessories. We supply off the shelf DEC® LSI-11/2 and LSI-11/23 compatible products to end users, OEM's and systems integrators worldwide.

**First**™

...Setting the Standard in Small



LSI11/2® LSI11/23®  
COMPONENT PRODUCTS



**FIRSTLAB**™  
PDP11®  
LABORATORY SYSTEMS

**First**

TWX NUMBER 910-651-1916

**computer corporation**

corporate square/825 north cass avenue / westmont, illinois 60559 / (312) 920-1050

™ Registered trademark of First Computer Corporation

® Registered trademark of Digital Equipment Corporation, Maynard, Mass.

# Small Computer Systems



**First**

The leading systems integrator of DEC® computer systems for applications such as medical laboratories, educational institutions, process control, oil exploration and engineering research.

## Computer Systems Marketing in the 80's



**FIRSTMICRO™**

**PDP11/03® PDP11/23®  
MICROCOMPUTER  
SYSTEMS**

**FIRSTAR™**

**PDP11/23®  
ARRAY  
PROCESSOR SYSTEMS**



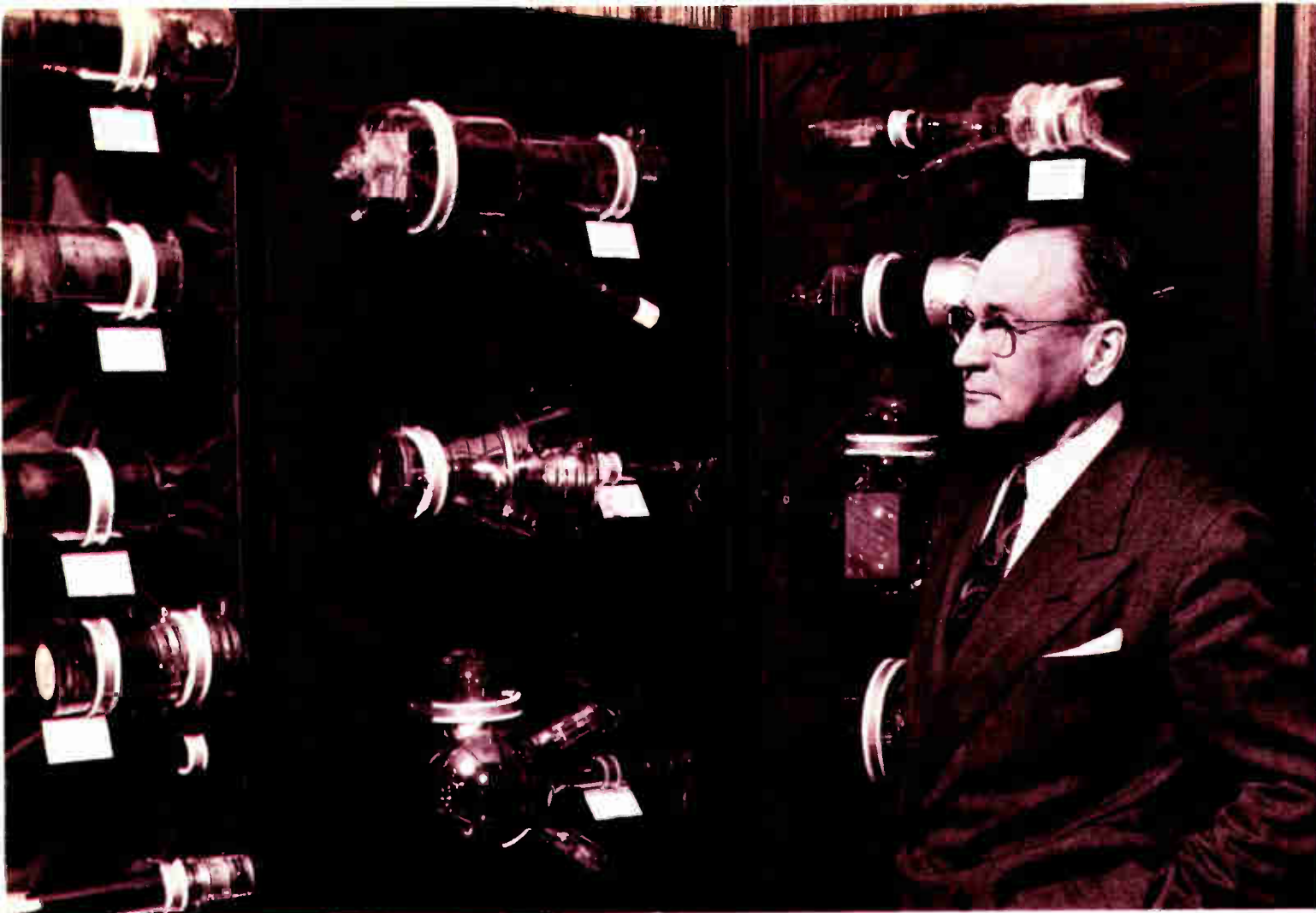

**Vladimir Kosma Zworykin.** If anyone deserves to be called the father of television that man is Zworykin, who, while working at Westinghouse, in 1923 invented the iconoscope camera tube (top right). The next year he invented the kinescope picture tube.

Telegraph invented single-sideband modulation, which saved both power and bandwidth in wire and wireless transmission. The invention resulted from a mathematical analysis of the nature of modulated carriers. Thus SSB is important not only in its own right, but as an example of the power of mathematical analysis.

Carson was also at the center of another episode involving mathematical analysis, but this showed its limitations. In 1922 he published a paper in which he proved mathematically that frequency modulation was useless for conserving bandwidth. That deduction was correct but Carson interpreted his mathematics to mean that "this type of modulation inherently distorts without any compensation advantages whatever." He concluded in a later paper (1928) that "noise, like the poor, will always be with us."

**A**long came Armstrong, who trusted his instincts more than Carson's mathematics and went on to invent fm. The flaw in Carson's mathematics was not in the elegant calculations; it was in his solving the wrong problem. Carson proved, quite correctly, that narrow-band fm was useless. Armstrong invented wide-band fm.

During World War I Armstrong, then a Signal Corps captain stationed in France, conceived and built

the first superheterodyne receiver. He filed for a U.S. patent from Paris on Dec. 30, 1918, and received the patent on June 8, 1920. The superheterodyne circuit, the basis of just about every radio, television, and radar set in the world today, probably ranks as Armstrong's greatest achievement. Reduced to its fundamentals, it uses a local oscillator that beats down rf signals to a fixed intermediate frequency, where they may be amplified. The superhet also provides excellent selectivity and low noise, although Armstrong's reason for developing it seems to have been simply to find a way of amplifying radio waves at frequencies that were too high for vacuum tubes of the day to handle.

With the advent of the superhet, radio was here to stay. Its growth was phenomenal: sales of sets went from \$60 million in 1922 to \$900 million in 1929. In the process the electronics industry got the one element that made it a genuine part of modern American life: Government regulation.

Actually there had been a Radio Act of 1912, but the courts had held that it did not give the Government the power to assign wavelengths. So in 1927 Congress passed a new Radio Act establishing a five-member Federal Radio Commission with authority over licensing, frequency allocation, and power regulation.

The Federal Communications Commission came later, but that part of the story belongs to the 1930s.





OHIO SCIENTIFIC  
Professional  
Computers  
The Challenger Line



# Ohio Scientific Microcomputers for all reasons

Ohio Scientific has been building microcomputers longer than any company currently in the personal computer and small business computer marketplace. The company features a uniquely broad line of computer systems and interchangeable accessories. Ohio Scientific computer models range from the \$279 Superboard II which is the lowest cost complete computer on the market to the world's most powerful microcomputer; the C3-B GT which features a 74 million byte, 10 millisecond access disk and a 300 nanosecond instruction cycle processor. Ohio Scientific computer products are sold and supported by a world-wide network of over 350 computer dealers. The product line featured in this brochure is Ohio Scientific's professional series computers, software and accessories. All machines in this brochure incorporate dual 8" floppy disk drives and utilize the OSI 48 line BUS architecture of modular interchangeable PC cards. This architecture allows easy servicing, modification and upgrading. All machines in this brochure have internal firmware for instant disk loading and diagnostic testing and come complete with connecting cables, operating manuals and OS-65D disk operating system with extended BASIC so they can be utilized immediately when delivered by connection to a standard RS-232 terminal.

## Business

The most popular use of Ohio Scientific professional computers is in small business accounting. The minimum configuration of each computer has dual 8" floppies, 48K bytes of RAM and an RS-232 port making each computer usable in business applications as delivered. All Ohio Scientific machines can operate as single-user, stand alone computers, but by simply adding one PC board, they can also be used as intelligent terminals in a distributed processing network. Business software includes an advanced BASIC operating system; OS-65U which features end user operating ease and security as well as highly advanced file structures and communications protocols. OS-65U is unique in that programs written in this operating language are immediately upward com-

patible from single-user floppy systems to multi-user timeshare and/or distributed processing networks with hundreds of megabytes of hard disk. Specific business applications software include a complete word processor for use on any professional series computer (WP-2), a family of conventional fully integrated accounting systems (OS-AMCAP) and a highly advanced data base manager and information management system (OS-DMS). DMS based applications modules range from simple general accounting packages to Construction Quotation, Medical and Legal billing systems in stand alone and/or integrated single-user, multi-user and network compatible configurations. The data base structure of

further provides a wide range of language capabilities including BASIC, FORTRAN, COBOL, PASCAL, APL, FORTH, ALGOL and others. Ohio Scientific's broad range of compatible accessories include a solderless interface prototyping board, a high speed analog I/O module and a PROM blaster for use in hardware labs. OSI's home security and control I/O, unique voice I/O, and new telephone interface coupled with the fast access high capacity CD-74 hard disk provide unique opportunities for advanced computer science investigations on an educational budget.

## Research and Development

The C2 and C3 series computers feature the most advanced 6500 family operating system and architecture complemented by a fast resident interactive assembler/editor, on-line debugger and optional PROM blaster capability. The C3 extends this development system capabilities to the 6800 and Z80 family by nature of its three-processor architecture. Ohio Scientific's broad range of plug compatible accessories include a unique voice recognition breadboard, a powerful Votrax® based voice output system, a general purpose telephone interface, a fast analog I/O module, very fast high storage capacity hard disks, and computer network capabilities. These leading edge technology products provide opportunities for advanced architectural investigations and development without extensive hardware modifications. To further enhance the C3's usefulness in R/D applications, the company is currently developing a 68000/Z8000 CPU expander board which is designed to plug-in to existing C3 series computer systems.

## OEM

Ohio Scientific's broad line of plug-compatible products and mass production economies provide a tremendous cost/performance benefit to both original equipment manufacturers and "systems houses". Contact your local dealer or the factory for OEM contract details on computers, accessories, complete systems and/or subassemblies.

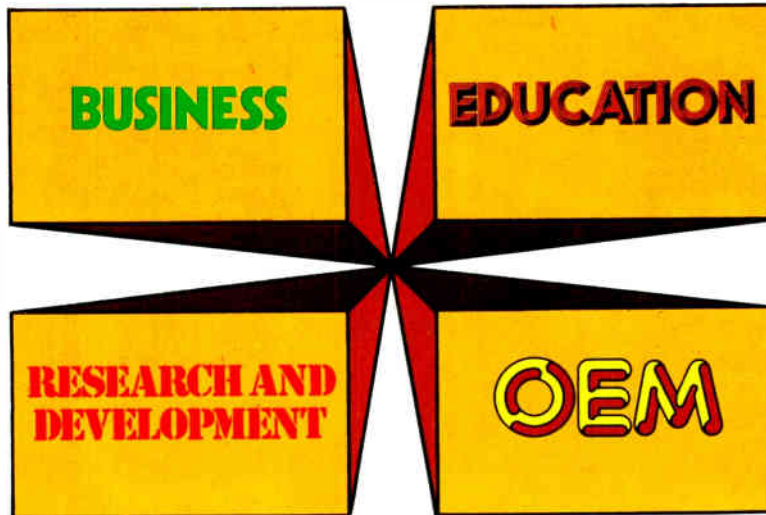

these packages allows a high degree of end user customization without programming through use of powerful general purpose report writers, mathematical packages and an on-line query facility.

## Education

Ohio Scientific personal computers are very popular in general education. The professional series offers capabilities for advanced educational use. Ohio Scientific's C1P and C4P series computers can be connected to a C2 or C3 computer to utilize its floppy disk and printer, and to allow teacher monitoring and communications under OS-65U Level 1 operating system. The Challenger III's unique three-processor architecture provides opportunities for students to compare architecture, machine code, assemblers and upper level languages for three types of processors on one machine. OS-CP/M

# C2-OEM



The C2-OEM with cover off showing the placement of floppy drives, UL recognized power supplies and 8-slot OSI 48 BUS backplane.

Ohio Scientific's new C2-OEM is designed to be the cost effective solution to business and industrial applications which can effectively utilize typical microcomputer execution speed. The C2-OEM benefits from Ohio Scientific's years of volume microcomputer production experience yielding an extremely competitively priced medium performance microcomputer.

The C2-OEM utilizes the popular 6502 microprocessor operated at 1MHz clock speed in conjunction with 48K or 450 NS Dynamic RAM memory.

This hardware configuration when used in conjunction with Ohio Scientific's ultra fast BASIC by Microsoft yields Business environment performance equal to or better than competitive microcomputer systems.

The C2-OEM is housed in a versatile table top cabinet which can also be rack mounted or incorporated in a matching desk which also accommodates a CRT terminal and printer.

The system features very simple physical construction and the use of industry standard parts for reliable operation and simple servicing. All circuitry is on two 8 x 10" OSI BUS compatible PC cards, one for the 48K memory and the other which contains the CPU, Firmware, RS-232 port and floppy controller.

The cards are plugged into an 8 slot back plane which provides tremendous expansion capability. The unit features two industry standard 8" Floppy disk drives and is powered by two standard UL recognized open frame power supplies.

The C2-OEM's low cost, simple construction, standard performance, and factory configuration make it the logical choice when a simple, rugged "no problems" computer is desired.

## Features:

Simplest, most cost-effective computer when typical microcomputer execution speed is acceptable.

- Full business configuration standard • 48K dynamic RAM
- .35 MIPS 6502 CPU • RS-232 port at 300 to 19,200 baud
- Dual 8" floppies store 600 Kbytes
- OSI BUS oriented for modular expansion
- Fast low overhead disk operating system standard
- Microsoft BASIC with random and sequential access files
- Instant load disk bootstrap and front panel emulator in ROM

## Prices

C2-OEM As specified above **\$2799**

## Options

- 01 Double-sided disks doubles capacity to 1.2 Mbytes. **800**
- 02 Internal video board and keyboard with numeric pad provide complete terminal function with upper/lower case and graphics within the computer (a low cost alternative to conventional CRT terminals). Just add a TV monitor for a complete low cost system. **299**
- 03 Conversion to static RAM uses one more slot (2-24K boards) and adds 4.5 amps additional power. **600**

- 04 Double cases—uses separate cases for computer and floppies. Identical in appearance to the C3-S1. **200**
- 05 OS-AMCAP package provides AMCAP V1.5 and OS-65U at a \$300 savings when purchased with the computer. **\$875**

## Notable Accessories

- AC-3P 12" TV monitor for use with the 02 option **129**
- CA-17 Plug-in board adds intelligent terminal capability under Level 3 NET **298**
- DSK-5A 5 foot matching desk with slide-in mounting for C2-OEM, C3-OEM or C2-NET. **300**

## Custom Desk DSK-5A

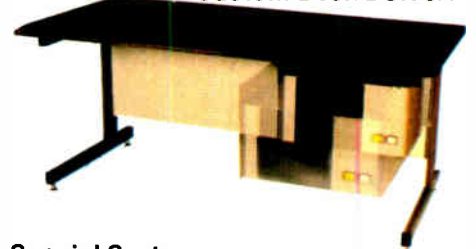

## Special System

C2-NET C2-OEM-04 with a CA-17 but without the floppy disk drives. Unit has special "down load" bootstrap ROM which loads the operating system from a network data base on power up. Just add on RS-232 terminal for the lowest cost intelligent terminal configuration. **\$1499**



# Ohio Scientific Microcomputers for all reasons

## The Premium Performance C3 Series

The Challenger III family of computers is one of the most popular small computers in existence with tens of thousands of units installed to date. The C3 series provides several unique features including

- 3 processors — the 6502A, 68B00 and Z80A
- User programmable interrupt vectors on all three processors
- OSI 48 line BUS architecture with 16 data lines and 20 address bits (1024K address space)
- Upward expandability to 74 megabyte disk drives
- Upward expandability to timeshare and distributed processing configurations
- Broadest line of plug compatible accessories in the industry
- Broadest line of systems and applications software of any small computer (three processors is unbeatable here)
- Fastest instruction execution speed commercially available in a microcomputer (with GT option)

The C3's Z80 supports Ohio Scientific's implementation of Digital Research's CP/M® operating system. This very popular operating system supports nearly a dozen upper level languages and hundreds of business, scientific and educational packages from several independent suppliers. The Challenger III's 4MHz Z80A processor, fast stepping rate floppies and large disk buffer size make it one of the fastest CP/M operating system compatible computers available.

CP/M's excellent performance is overshadowed by the C3's 6502A ultra-high performance processor which executes Ohio Scientific's OS-65D developmental operating system and OS-65U, a highly advanced business BASIC operating system with multi-user and distributed processing capabilities. The 6502A performs a memory to accumulator ADD in 1.0  $\mu$ s. and a jump extended in 1.5  $\mu$ s. with an overall average of .7 Million Instructions per Second (M.I.P.S.) making it far faster than any other widely used microprocessor (including the new 16-bit versions).

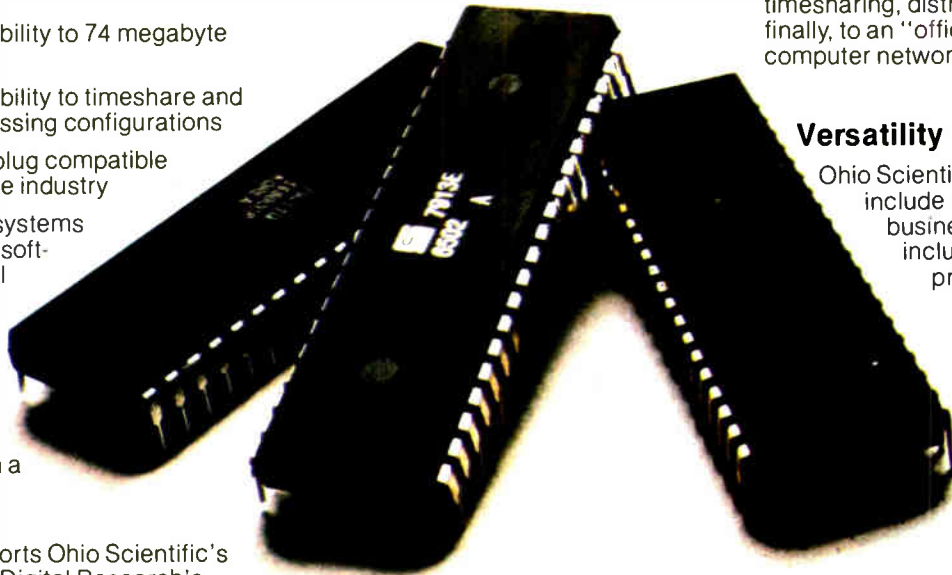

The GT option further extends Challenger III performance by utilizing the 6502C processor and high speed static RAM (150 ns. access) to achieve memory to accumulator ADD of 600 ns. and 1.2 MIPS average operation. This performance level places the C3 GT models comparable to mid-range minicomputers (\$50,000 to \$100,000 price range) in typical business and other information

intensive applications. Such computers are much faster in arithmetic operations because of their wider wordwidth but this performance advantage is not cost effective in all but the most demanding number crunching applications.

## Upward Expandability

Users can start with a relatively modest C3-OEM table-top computer and transport all of their software and most, if not all, of their hardware upward in simple plug-together expansion steps to hard disk storage, multi-programming — timesharing, distributed processing and finally, to an "office of the future" computer network.

## Versatility

Ohio Scientific's plug-in options include the full scope of business accessories including a word processing printer, modem and matching furniture. Parallel I/O, A/D D/A capability, PROM blaster, clock and prototyping options satisfy the needs of the educator and OEM.

Voice I/O, the Universal Telephone Interface, AC remote control, wireless security systems, affordable ultra-fast execution speed, network capability and huge storage capacity challenge the most creative innovators to develop the applications of tomorrow.

# The Challenger III Series



**C3-S1**

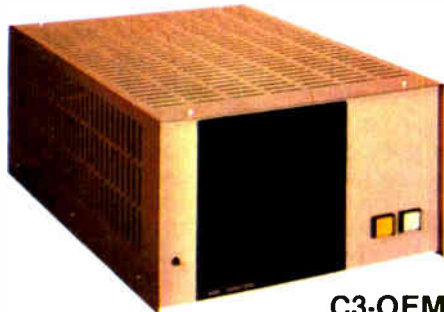

**C3-OEM**



**C3-A**

## Family Features

Premium performance 3-processor computer systems.

- Full business configuration standard
- 3-processors 6502A, 68B00, Z80A
- 6502A operation at .7 MIPS standard
- Z80A operation 4MHz, 68B00 operation 2MHz
- 48K high speed static RAM standard
- 20 address bits with memory pager addresses 768K
- User programmable interrupt vectors
- 8-bit parallel I/O port
- Instant loading floppy disk bootstrap/hard disk bootstrap/front panel emulator in ROM
- RS-232 port strappable from 300 to 19,200 baud
- Dual 8" floppies store 600K bytes
- OSI 48 line BUS oriented for modular expansion
- OS-65D fast low overhead development operating system with ultra-fast BASIC standard
- OS-65U advanced business operating system standard
- Largest accessory family in the micro-computer industry
- Largest software library in microcomputing (due to its unique 3-processor architecture)

## C3-S1, C3-OEM

These two computers are table-top versions of the C3 system with a total of eight OSI BUS slots. They are ideally suited to applications which do not require hard disk drives and/or multiple users. Both systems can be enhanced by adding the GT option and/or dual-sided drives. They support OS-CP/M by expansion to 56K and a network I/O port. (The CA-17 provides network and CP/M compatibility.) The C3-OEM is a single-case table-top unit similar to the C2-OEM except for larger power supplies and can be mounted in the DSK-5A. The C3-S1 is in two cases which can be shipped via U.P.S. (the C3-OEM must be shipped by freight). The C3-S1's floppies can be independently turned off; a useful feature for process control and security applications.

## Prices

C3-S1	As specified above with 48K	<b>\$4095</b>
C3-OEM	As specified above with 48K	<b>3995</b>
-GT Option	Increases 6502 execution speed to 1.2 MIPS average (150 ns main memory)	<b>1500</b>

## C3-A

The C3-A system is a 17-slot version of the C3 series in a stylish free-standing equipment rack. Although the standard machine has the same circuit boards and hence the same functional specifications as the C3-OEM or C3-S1, the system can be directly expanded to 8 users, hard disk operation and a network data base node configuration by simple plug-in operations. The rack also accommodates the PDS-1 system power sequencer and Alloy Engineering cartridge tape back-up units.

The C3-A features rack slide-mounted CPU and floppies as well as removable side panels and locking back door for convenient servicing and upgrading.

## Prices

C3-A	As specified above with 48K	<b>\$5995</b>
-GT Option	Increases 6502 execution speed to 1.2 MIPS average (150 ns main memory) and adds heavy duty switching power supplies.	<b>1950</b>

## C3 Family Options

-01	Double-sided drives, doubles capacity to 1.2 Mbytes	<b>\$800</b>
-06	OS-AMCAP package provides AMCAP 1.5 at a \$200 savings when purchased with the computer (65U is standard with C3's)	<b>775</b>
-07	CP/M package requires CM-10 or CA-17 for operation. Provides OS-CP/M, Z80 Assembler/Editor, Microsoft Z80 BASIC, FORTRAN and COBOL at a \$250 savings over individual prices when purchased with the computer	<b>400</b>
-08	Real time clock option.	<b>100</b>



# Ohio Scientific Microcomputers for all reasons

## Winchester Technology Disks

Floppy disks store from 250K bytes to 500K bytes per surface in a series of concentric circles called tracks which each store 2.5K to 7K bytes. To access specific information a head must be mechanically positioned over the track, then the computer must wait for the information to rotate under the head. On an 8" floppy accessing a specific piece of information this can take as long as 1.2 seconds even though the computer could have processed the information in a few microseconds. (The access time of mini-floppies is much worse.) Furthermore, in most business applications, it is impossible to store all necessary information on one floppy disk; thus requiring several diskettes and frequent disk changes.

The traditional solution to these problems is the conventional removable platter hard disk. These disks rotate ten times faster than floppies and use more elaborate head positioners to move from track to track as much as ten times faster than floppies. Hard disk storage ranges from a few megabytes to a few hundred megabytes.

There are several problems with conventional hard disks. First and foremost, the extremely high bit density on the disks makes them very sensitive to mechanical misadjustments and contamination such as vibrations, dust and temperature differences of a few degrees, etc. Attempts to use removable hard disks in any other than a big computer, air conditioned, clean room environment by other than experienced computer operators can result in expensive head crashes and the complete loss of a disk pack. The second problem with these drives is that since they require close mechanical tolerances for bit density, disk removability and interchangeability, they are very complex mechanical devices. This results in large physical size, high power requirements and, most of all, high initial cost and high maintenance cost.

## Enter the Winchester:

In the mid-70's a new disk technology was developed which eliminates most of the undesirable features of hard disks for small computer users; the Winchester hard disk. Winchesters utilize fast rotating high density disks and medium to high speed head positioners

to achieve performance comparable to the most expensive hard disks. However, to minimize mechanical complexity and difficulty of use, they use fixed or non-removable media. Because the media is factory installed, the critical head-disk tolerances can be maintained with relatively simple mechanics. The fixed nature of the drive allows the disk chamber to be sealed eliminating the possibility of contamination.

Most Winchesters simply have an on-off switch making

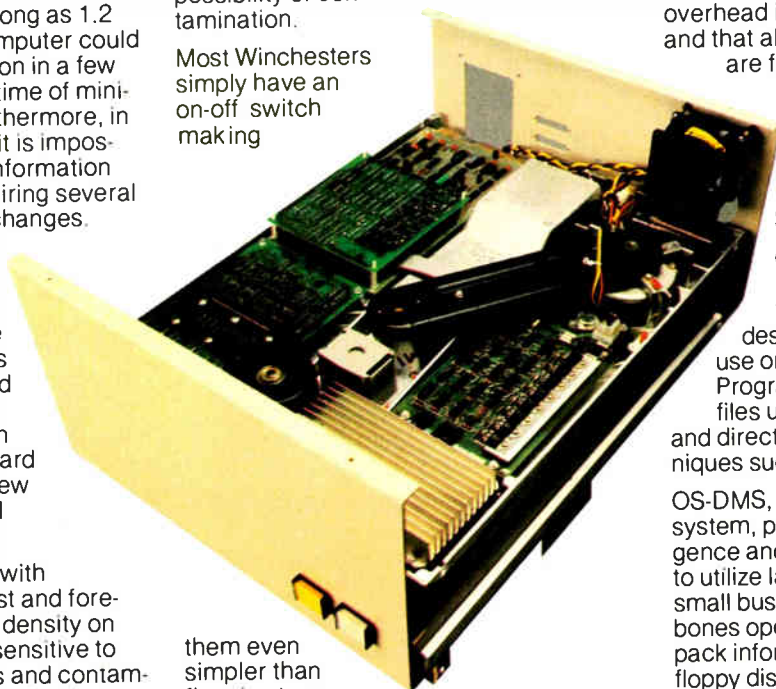

them even simpler than floppies to use from an operator viewpoint. In high storage capacity models they achieve the lowest cost per bit of any Random Access Memory technology now available.

The Winchester disk solves all the problems of floppies and conventional hard disks but creates one big new one! Back Up. Ohio Scientific has effectively solved this problem with three approaches depending on the specific application, see the box below.

## Ohio Scientific Winchesters

OSI pioneered the use of Winchesters with microcomputers in 1977. Since then, we have installed more units than anyone else and have developed the most sophisticated Winchester hardware and software products for microcomputer use.

## Hardware

Ohio Scientific offers two Winchester disks; the CD-23 and CD-74 (see next

page) although they use different disk drives, the basic architecture is the same. Both units use a dedicated but programmable hard disk controller which receives commands from the host processor and then performs disk transfers independent of the processor. Data transfers are to and from a large dual port memory buffer. The dual port architecture and stand alone disk controller mean that virtually no processor overhead is required for disk transfers and that all segments of disk transfers are fully interruptible. Thus, disk operation does not degrade terminal interrupt response time in multi-user systems, a very important feature.

## Software

OS-65U business operating systems and OS-DMS information management systems were designed from the "ground up" for use on Winchester based computers. Programs in 65U can directly access files up to 100 megabytes in length and directly support fast access techniques such as multi-key ISAM.

OS-DMS, information management system, provides a high degree of intelligence and end user versatility by its ability to utilize large disk files whereas most small business computers offer bare bones operation because of the need to pack information as tightly as possible on floppy disks.

Ohio Scientific Winchester disk based computer offer business users a dramatic improvement in total performance over floppy based micro and minicomputers at a relatively modest cost.

You now have three backup options for use with the C3-B and C3-C Winchester disk based computers:

1. Fast floppy dumper under OS-HDM for small files (5 Mbytes or less). Daily to weekly backup.
2. 3M tape backup unit from Alloy Engineering. About 11 Mbytes per tape, cost about \$3500. For medium files (Under 11 Mbytes). Weekly backup.
3. Networked C3-B's and/or C3-C's. Ultrafast backup of files up to disk capacity for Large files (over 11 Mbytes) and/or frequent backup requirements.

(Prices and specs subject to change without notice)

# Hard Disk Computers

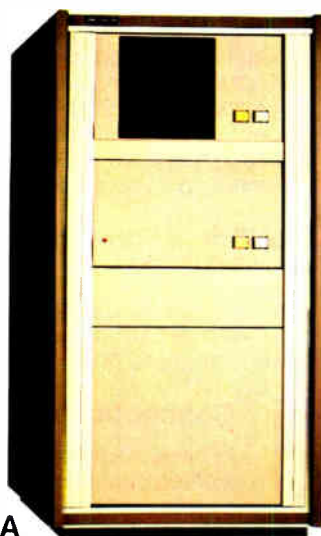

C3-A

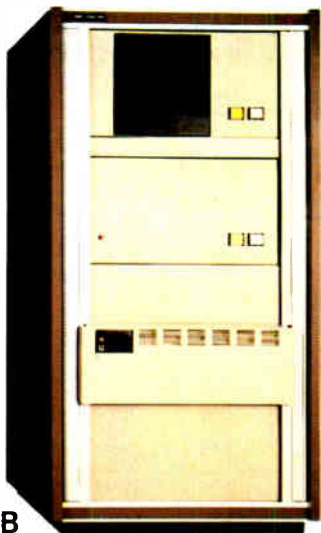

C3-B

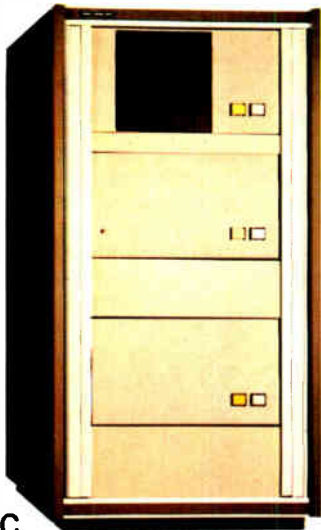

C3-C

## Family Features

All standard C3 features including:

- 3-processor CPU
- 7 MIPS 6502A
- 48K static RAM
- Dual 8" floppies
- Free standing rack for direct expansion capabilities
- 17-slot OSI 48 line BUS architecture for large system expansion
- Directly accepts up to 8 users with currently available memory boards, more with higher density boards in the future
- Directly expandable for use as Network data bases
- Slide-mounted subassemblies, removable side panels and locking rear door for easy expansions and service

## C3-A

The floppy only rack based C3 for users who anticipate expansion to hard disk, multi-user and/or networking in the future. Additional specs are on the preceding pages.

C3-A	<b>\$5995</b>
CD-74 expands C3-A to C3-B	<b>7500</b>
CD-23 expands C3-A to C3-C	<b>4500</b>
CA-16 heavy duty cooling pack (specify B or C)	<b>150</b>

## C3-B

The world's most powerful micro-computer (when GT equipped). Features the highly advanced and extensively field proven OKIDATA 3306 Winchester disk. Some 3306 drives have operated since 1977 without a single failure.

## Features

- System boots from floppies or hard disk on power up
- 74 megabytes end user workspace under OS-65U, 80 megabytes unformatted
- Ultra-high performance disk
  - 74 millisecc worst case access
  - 38 millisecc average
  - 10 millisecc access on cylinder (215K user workspace)
  - 8 megabits per second transfer rate
- Simple on/off disk operation with elaborate internal protection from improper temperature, line voltage and controller failures

- Features spindle brake and designated head landing areas for much longer operational life than the newer low-cost Winchester
- Highly advanced OS-65U operating system:
  - Multiple level pass word security
  - Multiple operating systems on disk
  - Ultra-high speed "FIND" command for high speed string searches (Associative Access)
  - Upward compatible with multi-user and network systems with full file, peripheral and communications arbitration between users
- Expandable to CP/M operation by adding 4K (CM-2 memory)
- Available factory configured for up to 8 users and network data base operation
- Comes standard with real time clock and heavy duty cooling package

C3-B	<b>\$12,995</b>
GT Option (asper C3-A) add	<b>1,950</b>

## C3-C

A medium performance Winchester disk based system which provides the ideal cost/performance ratio in typical small business applications. The C3-C uses the Shugart SA4008 29 megabyte Winchester disk.

Performance specifications, hardware configuration and software is identical to the C3-B with the following exceptions:

- 23 megabytes of end user workspace under OS-65U
- 29 megabytes unformatted capacity
- Medium performance Winchester
  - 240 millisecc worst case access
  - 87 millisecc average access
  - 10 millisecc access on cylinder (110K user workspace)
- Simple on/off disk operation

C3-C	<b>\$9,995</b>
GT Option (asper C3-A) add	<b>1,950</b>



# Ohio Scientific Microcomputers for all reasons

## Multiple User Systems

In applications where several terminals are desired, but most of which will be utilized for entry and editing (such as order entry systems), multiple user microcomputers are feasible. In environments where it is commonplace for more than one user to be processing information at a time, a single microcomputer may become annoyingly slow. A better configuration for such applications is distributed processing as discussed later.

All C3 series computers will support up to 16 timeshare users under OS-65U Level 3 providing that the computer has a real time clock, sufficient memory and the appropriate communications ports.

C3 computers utilize bank switching for multiple users. Each user must have 32K to 48K RAM and an RS-232 port. The host machine must also have 4K RAM for the multi-tasking executive. The computer timeshares individuals by interrupting a user after a set time (approximately 100 milliseconds) and bank switches to the next user in a "round robin" fashion. Bank switching architecture is not as memory efficient as techniques which use re-entrant code or swapping disks but is by far the fastest technique, requiring only a few microseconds of processor overhead per switch, a feature which is most important in multiple user systems.

Although OS-65U Level 3 will support timesharing on any C3, it is only recommended on C3-B and C3-C computers. This is because of the desirability of 17 BUS slots for multiple user memory partitions and the dramatic performance advantages of Winchester disks over floppies.

## Networking

In a distributed processing system using OSI microcomputers as intelligent terminals (local systems) most of the work

load is handled locally. Overall system performance does not degrade under heavy job loads. Each local system performs entry, editing and execution while utilizing a central data base for disk storage, printer output, and other shared resources.

For more demanding applications it is desirable to have several data bases, each with its own collection of local systems. Such an inter-connected set of data bases is called a network. Each data base and its local intelligent and dumb terminals is called a cluster.

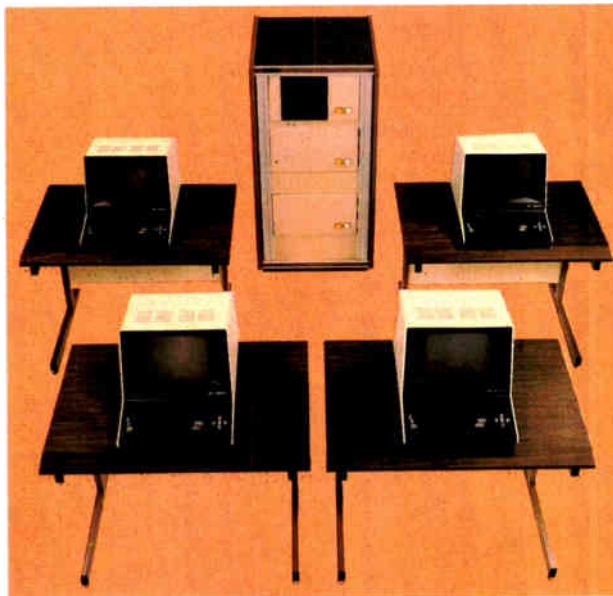

## Level 3 NET

OS-65U Level 3 NET supports this advanced networking and distributed processing capability as well as conventional single user operation and time-sharing. Level 3 NET supports local clusters of intelligent microcomputer systems as well as dumb terminals for the purpose of utilizing a central Winchester disk data base and other shared resources. The system also has full communications capability with other Level 3 data bases providing full network capability.

Level 3 resides in each network data base. A subset system resides in each intelligent terminal. Each data base supports up to 16 intelligent systems and up to 16 dumb terminals. Level 3 also supports a real time clock, printer management, and other shared peripherals.

## Data Base Requirements

Minimal requirements for a Level 3 network data base are a C3-C or C3-B computer system with 23 or 74 megabytes respectively, console terminal, 88K bytes RAM and a CA-10X 16 port I/O board for network and cluster communications.

## Intelligent Terminal Requirements

Any Ohio Scientific 8" floppy based computer with 56K RAM and one data base communications port.

## Connections

Intelligent terminals and networked data bases are connected by low-cost cabling. Each link can be up to 10,000 feet long at a transfer rate of 500K bits per second, and will cost typically 30¢ a foot (plus installation).

## Syntax

Existing OS-65U based software can be directly installed on the network with only one statement change! Level 3 has the most elegantly simple programming syntax ever offered on a computer network.

File syntax is as follows:

DEV A,B, C,D	Local Floppies	} unchanged from single user and timeshare system
DEV E	Local Hard disks	
DEV K-Z	Specific network Data Bases	

Each of up to 8 open files per user can be from 8 separate origins. Specific file and shared peripheral contentions are handled by 256 network semaphores with the syntax Wait N  
Wait N, close

The network automatically prioritizes multiple resource requests and each user can specify a timeout on resource requests. Semaphores are automatically reset on errors and program completion providing the system with a high degree of automatic recovery.

# Time Sharing/Networking

## One Step at a Time

Best of all, Ohio Scientific users can develop distributed processing systems economically one step at a time. A user can start with a single user floppy system, add a hard disk, then timesharing, then a second Winchester data base for backup and, finally, cluster intelligent terminals to achieve a full network configuration.

## Level 3 Support Group Factory Configured Systems

Prices include OS-65U Level 1 but do not include 65U Level 3 or Level 3 NET. Machines with NET prefix have the specified number of users plus NETWORK data base node capability. The NETWORK partition can be used as an extra user through its diagnostic RS-232 port.

For example, a 4-user system with networking can be used as a 5-user system without networking.

Network systems have ports for 4 intelligent terminals (cluster ports) and 1 NET port.

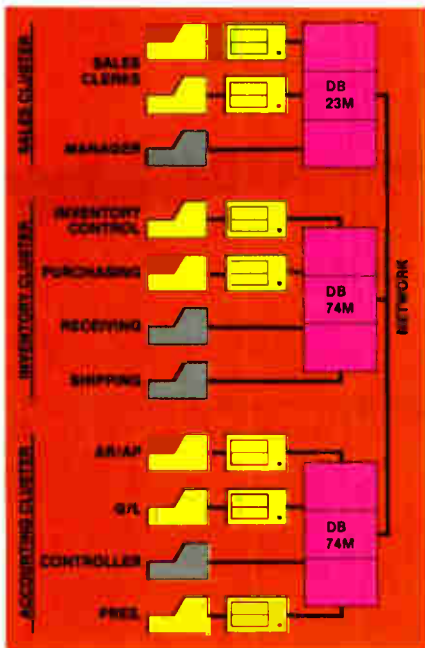

Time-share Users	C3-C .35 MIPS	C3-C .7 MIPS	C3-C .7 MIPS + NET	C3-B .35 MIPS	C3-B .7 MIPS	C3-B .7 MIPS + NET
1	NA	\$9995 C3-C	\$11,995 C3-C-N1	NA	\$12,995 C3-B	\$14,995 C3-B-N1
2	\$10,900 C3-C-12	11,400 C3-C-22	12,995 C3-C-N2	\$13,900 C3-B-12	14,400 C3-B-22	15,995 C3-B-N2
3	11,700 C3-C-13	12,400 C3-C-33	13,995 C3-C-N3	14,700 C3-B-13	15,400 C3-B-33	16,995 C3-B-N3
4	12,400 C3-C-14	13,400 C3-C-44	15,200 <sup>1</sup> C3-C-N4	15,400 C3-B-14	16,400 C3-B-44	18,200 <sup>1</sup> C3-B-N4
5	13,100 C3-C-15	NA	NA	16,100 C3-B-15	NA	NA
6	13,800 C3-C-16	NA	NA	16,800 C3-B-16	NA	NA
7	14,500 C3-C-17	NA	NA	17,500 C3-B-17	NA	NA
8	15,200 C3-C-18	NA	NA	18,200 C3-B-18	NA	NA

Note 1. Uses 16-slots, 1 open, comes with printer and word processing ports installed.



# Ohio Scientific Accessories for all reasons



## AC-7B

CRT terminal for use on all OSI single and multi-user systems. Features upper/lower case 24x80 character display, numeric keypad, dual intensity, protected fields, cursor addressing and much more. **\$995**



## AC-14

High performance word processing printer. Produces typewriter quality output at up to 55 characters per second. Features quick-change ribbon cartridges and drop-in print wheels for interchangeable fonts. Prints up to 132 columns, comes with friction-feed capability for stationary and adjustable width tractor-feed for computer forms. Complete with paper guides and silencer options. Produces proportional spaced characters when used with WP-2 word processor package. Comes complete with high speed parallel interface, cable and one print wheel. **\$2795**

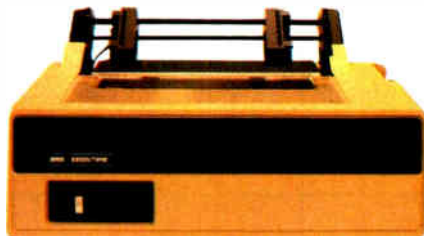

## AC-9TP

A rugged moderate performance business printer. Impact printing at 110 characters per second, prints 80 or 132 columns across the page, has adjustable width tractors and forms stacker. Comes complete with parallel interface and connecting cable. **\$1250**



## AC-5A

Deluxe business printer. This "Top of the line" shuttle printer very quietly prints an entire line at a time using dot matrix impact technology. The unit prints 160 lines per minute at a 132 character column width. Features upper and lower case, 12 programmable fonts, 11 program selectable form lengths and much more. Comes complete with adjustable width tractor-feed, high speed parallel interface and cable. **\$2950**



## AC-11P

300 baud modem for use with conventional telephone handsets. Features unique originate/answer back capability which allows two similarly equipped computers to talk to each other as well as communicating with timeshare services. Requires an RS-232 port for operation. **\$199**



## OSI Desks

**DSK-3** 3 foot wide CRT and printer stand. **\$175**

**DSK-4** 4 foot wide desk. **\$215**



**DSK-5** 5 foot wide desk. **\$250**

**DSK-5A** 5 foot desk with cutout and mounting brackets for C2-OEM, C2-NET and C3-OEM computers. **\$300**

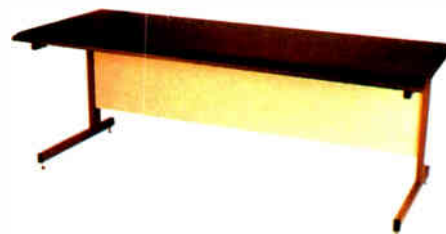

**DSK-6** 6 foot wide desk (best for CRT and printer). **\$285**

# Microcomputer Components

## OSI Power Sequencers Turn Entire Systems On/Off From One Keyswitch.

**PDS-1** Switch panel for C3-A, B, C. Sequences CPU, floppies, hard disk, CRTs, printer and other accessories. **\$350**

**PDS-3** Switch panel for DKS-5A desk. Sequences CPU, floppies, CRT, printer and other accessories. **\$200**

**CM-9**

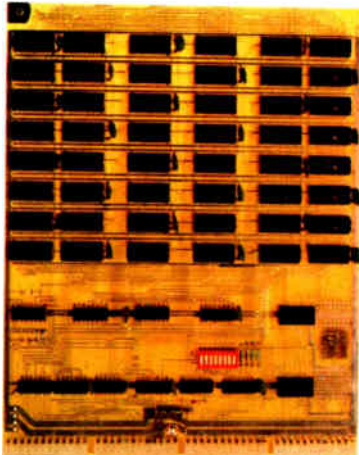

### Memories

**CM-2** 4K 2MHz static for expanding C3-B, C3-C to 56K for CP/M and/or networking. **\$129**

**CM-3A** 16K 2MHz low power static standard C3 memory. **\$399**

**CM-6** 48K 1MHz dynamic for C2-OEM and some timeshare systems. **\$549**

**CM-9** 24K 2MHz medium power statics usable in computer with booster supplies or high current switchers. **\$450**

**CM-10** 8K 2MHz static for expanding C2 and C3 computers to networking or CP/M. (C3 only) **\$198**

**CA-10-16**

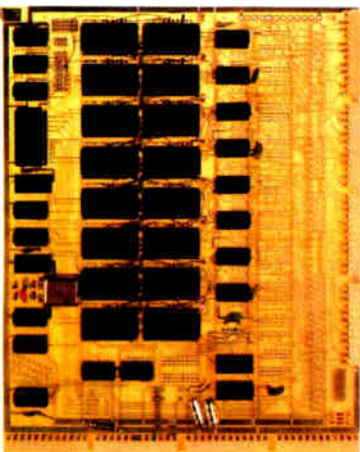

### General I/O

**CA-9** Centronics parallel printer interface with cable. **\$175**

**CA-10X** 1 to 16 RS-232 port I/O board. 300-19200 baud plus synchronous operation at 250K and 500K baud. 1 port standard. **\$125**  
Each additional port. **\$ 50**

**CA-10-N5** CA-10X port board configured for four cluster communications ports and one network communications port all at 500K baud for use in data bases. **\$349**

**CA-18A**

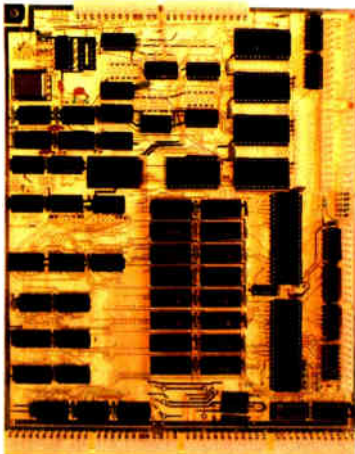

### Combinational I/O

**CA-17** 8K 2MHz RAM and 1 cluster port plus 1 auxiliary RS-232 port. (Converts any C2 or C3 to networking.) **\$298**

**CA-18** 1 Centronics parallel printer port with cable, 1 parallel word processing printer port with cable, 2 RS-232 ports and 1 cluster port. **\$398**

**CA-18A** As above with 8K 2MHz RAM and 2 additional RS-232 ports (4 total), i.e., fully populated 555. **\$598**

See the OEM and R/D section for more accessory boards.



# Ohio Scientific Accessories for all reasons

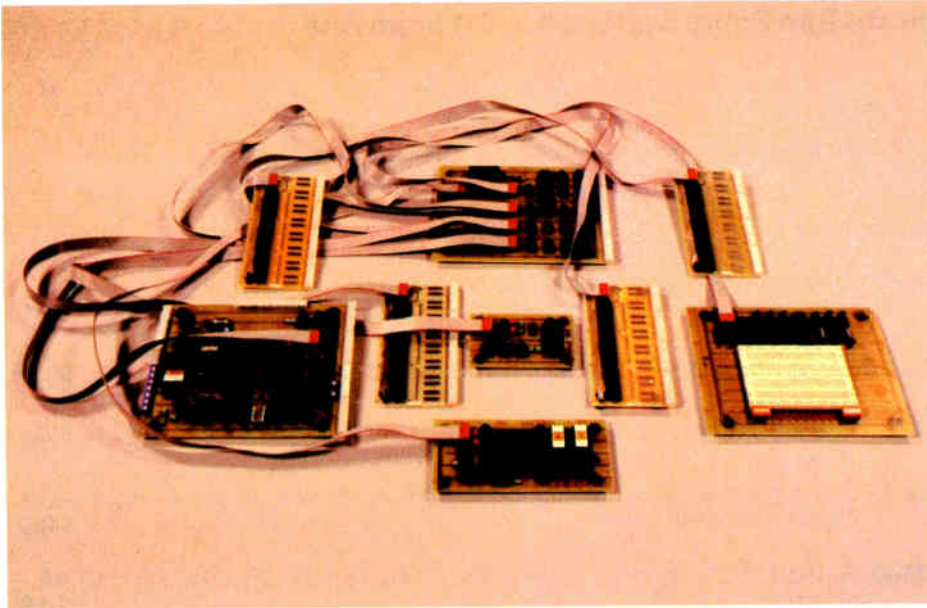

## Ohio Scientific's Revolutionary New 16 Pin I/O BUS

Modern technology has made it possible to pack far more I/O functions on a computer board than one can practically connect to. Ohio Scientific has solved this problem with a series of remote "head end cards" which feature tremendous I/O capability and connect to the computer via single inexpensive 16 pin DIP ribbon cables. Thus I/O connection can be made away from the computer's card cage.

### CA-20

8-port I/O BUS interface and calendar clock provides interfaces for 8 head end cards and a battery back up clock with hours, minutes, seconds, 1/10 second, day, and date. The automatically re-charged batteries will power the clock for months. **\$175**

### CA-20A

As above without clock **\$95**

## Head End Cards

### CA-21

48 Line Parallel I/O card features 3 PIA's and prototyping area **\$45**

### CA-22

High speed analog I/O module. Two 12-bit D/A converters, 1 12-bit/8-bit A/D converter with 16 channel input multiplexer. Factory configured for  $\pm 10V$  offset binary, user jumperable for other configurations. Max error  $\pm 2$  LSB. 28,000 12-bit conversions per second. 66,000 8-bit conversions per second, drift. -50 ppm per  $^{\circ}C$ . Note, the CA-22 can also be directly plugged into the computer without a CA-20, thus occupying one slot. **\$598**

### CA-23

PROM Blaster. Programs 2758, 2716, 2732 and 2764. 8 through 65K EPROMS. Programs and verifies from memory or other EPROM. **\$195**

### CA-24

Solderless interface prototyping board features a PIA and TTL I/O as well as provisions for direct user connection of devices such as the 6850 ACIA. Board also features 16 switches and 16 LED's. Has a large solderless breadboard for prototyping or educational lab exercises. **\$175**

### CA-25

Security and AC remote interface connects the AC-17P home security system and AC-12P wireless remote control system to C2 and C3 computers. **\$45**

16 pin BUS family boards should be powered by external means where possible, however, a few modules can be supported by the host computer's supply if necessary.

## AC-17P



A home security system, that's wireless and includes a control console, a fire detector, two window protection devices and one door unit. Additional protection devices are commercially available. **\$249**

## AC-12P



Wireless AC remote control. AC Remote Control Starter Set includes control console and modules to operate two lamps and two appliances via remote control with home control software on disk. Additional appliance and lamp modules are commercially available. **\$175**

## Process Control BASIC

A modified 9-digit BASIC under 65D with commands that support the real time clock, time of day clock (CA-20), 48 line parallel I/O (CA-21) analog I/O model (CA-22), AC remote (AC-12P) and to a limited extent the UTI (AC-15V) and security system (AC-17P). **\$250**

**Security BASIC** — Use your computer for business accounting during the day and office and plant security at night!

A modified BASIC under 65D with commands which support the real time clock, AC-remote (AC-12P), security system (AC-17P) and universal telephone interface (AC-15V). Comes complete with a library of security program demonstrations. **\$95**

# OEM and R/D Accessories

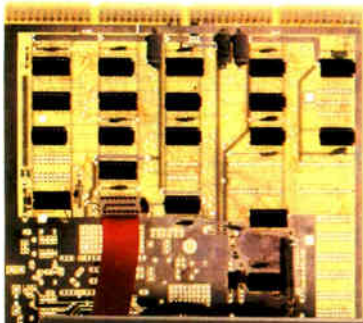

## CA-14A Votrax Voice I/O System

This Votrax Voice Synthesizer module has the capability of generating English speech phonetically. The supporting software simply feeds the phonetic spelling of English words to the module which generates medium quality spoken words. This advanced Votrax system is capable of generating all English phonemes as well as four levels of inflection on each phoneme. CA-14A also includes a voice recognition experimentation area which must be user populated. This experimentation board contains a five filter feature extractor with zero crossing detectors and envelope filters. The CA-14A in conjunction with the CA-22 high speed analog I/O module provide a complete voice recognition lab.

**\$399**

## Voice Output Software

### OS-Vocalizer I

"Generation by Rules System". Runs under OS-65D or OS-65U. Accepts conventional English spelling and outputs the phonetic spelling to the Votrax module in real time. Also, will print phonetic spellings for use by other programs.

**\$150**

### OS-Vocalizer II

Runs in one partition of a 65U Level 3 system. Accepts normal print statements from other partitions (users) and vocalizes them in real time. Uses disk look up for the 3000 most common words and generation by rules for words not on file. End user can add approximately 1500 additional words to file. Generates the most legible speech now attainable via totally synthetic means (i.e. not recorded human speech). Operates on a C3-B or C3-C with at least two partitions.

**\$975**

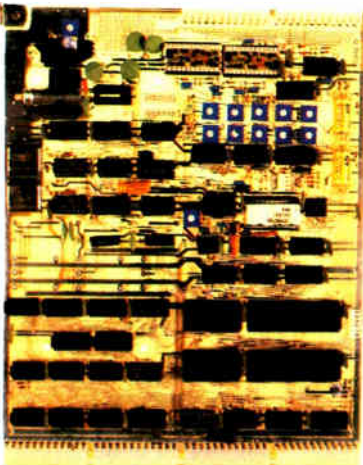

## CA-15 Universal Telephone Interface

The Universal Telephone Interface provides the host computer with general purpose telephone communications capability. The board can answer and originate calls. It can communicate with internal 300 baud modem in originate or answer back mode. It can also communicate with touch-tone and decode touch-tone. The board also has multiplexers to route spoken voice out to external devices such as recorders, voice recognition circuits, A/D converters and can accept spoken voice from several sources to dispatch to the telephone. The UTI can be used with touch-tone or rotary dial lines via its pulse code dialer. When equipped with a Votrax module or used in conjunction with a CA-14 voice I/O, it can respond with computer generated English voice output. The UTI is connected to telephone lines via a CBT. CBT's can be rented along with the telephone lines from your local telephone company or can be purchased from your local dealer and connected in parallel with your existing telephone circuitry.

**\$499**

## UTI with Votrax CA-15B

The Universal Telephone Interface as above with Votrax Voice module allows your computer to generate English speech phonetically. It also includes an audio amplifier to allow the Votrax module to be used stand alone independently of the telephone lines.

**\$799**

## CA-CBT

FCC approved telephone line isolator for use with the UTI. It allows the UTI to connect to any conventional telephone line. Note. CBT's can also be leased from your telephone company along with the telephone line.

**\$199**



**See the next page for your nearest dealer.**



# Ohio Scientific Professional Systems Specialists

## ALABAMA

Pelham, AL  
(205) 863-1287

## ALASKA

Anchorage, AK  
(907) 344-8352

## ARIZONA

Colorado City, AZ  
(602) 875-2451

Tempe, AZ  
(602) 966-6440

Tucson, AZ  
(602) 294-8700

## ARKANSAS

Fayetteville, AR  
(501) 521-8637

Little Rock, AR  
(501) 224-4508

## CALIFORNIA

Anaheim, CA  
(714) 991-3940

Anaheim, CA  
(714) 995-0224

Beverly Hills, CA  
(213) 858-0794

Brea, CA  
(714) 990-3051

Costa Mesa, CA  
(714) 540-5222

Fresno, CA  
(209) 485-3340

Fresno, CA  
(209) 299-8459

La Mesa, CA  
(714) 465-8888

Monterey Park, CA  
(213) 573-5991

Mountain View, CA  
(415) 948-9595

Newbury Park, CA  
(805) 498-6796

Oakland, CA  
(415) 523-1923

San Diego, CA  
(714) 272-8450

San Diego, CA  
(714) 292-5302

San Leandro, CA  
(415) 357-1737

Santa Monica, CA  
(213) 396-3108

Tarzana, CA  
(213) 449-2171

Tracy, CA  
(209) 836-0928

Ukiah, CA  
(707) 462-3470

## COLORADO

Boulder, CO  
(303) 444-3652

Boulder, CO  
(303) 449-3725

Denver, CO  
(303) 777-3222

Denver, CO  
(303) 426-7743

Durango, CO  
(303) 247-5905

Fort Collins, CO  
(303) 491-5692

Montrose, CO  
(303) 249-7736

Pueblo, CO  
(303) 542-8259

## CONNECTICUT

Groton, CT  
(203) 445-5186

New London, CT  
(203) 447-1079

Wilton, CT  
(203) 762-0717

## FLORIDA

Ft. Lauderdale, FL  
(305) 566-0776/566-0805

Ft. Lauderdale, FL  
(305) 772-6391

Gainesville, FL  
(904) 378-0181

Melbourne, FL  
(305) 723-7880

Miami, FL  
(305) 867-8119

Rockledge, FL  
(305) 832-1090

Sarasota, FL  
(813) 922-4257

Sarasota, FL  
(813) 921-6444

Tampa, FL  
(813) 876-8011

## GEORGIA

Athens, GA  
(404) 353-2858

Atlanta, GA  
(404) 457-8540/451-7429

Savannah, GA  
(912) 236-0498

## HAWAII

Hilo, HI  
(808) 935-2343

Honolulu, HI  
(808) 732-5246/737-2372

## ILLINOIS

Arlington Heights, IL  
(312) 870-7400

Carbondale, IL  
(618) 549-8495

Chicago, IL  
(312) 483-0847

Crest Hill, IL  
(815) 725-0749

Evanston, IL  
(312) 328-2600

Medinah, IL  
(312) 894-2583

Mundelein, IL  
(312) 724-3690

Olympia Fields, IL  
(815) 469-4775

Peoria Heights, IL  
(309) 685-1555

Prairie View, IL  
(312) 634-0076

Quincy, IL  
(217) 223-8498

Rockford, IL  
(815) 229-0200

Springfield, IL  
(217) 523-9899

## INDIANA

Columbus, IN  
(317) 376-7770

Elkhart, IN  
(219) 295-8181

Fort Wayne, IN  
(219) 468-4369

Indianapolis, IN  
(317) 359-7445

Laporte, IN  
(219) 362-5812

South Bend, IN  
(219) 277-4655

## IOWA

Lake Park, IA  
(712) 832-3616

## KANSAS

Liberal, KS  
(316) 624-1888

Wichita, KS  
(316) 688-0852

## KENTUCKY

Pikeville, KY  
(606) 437-6528

## LOUISIANA

New Iberia, LA  
(337) 367-1416/1417

New Orleans, LA  
(504) 482-4458

W. Monroe, LA  
(337) 388-2312

## MAINE

Portland, ME  
(203) 773-1051

## MARYLAND

Annapolis, MD  
(301) 263-8449

Baltimore, MD  
(301) 685-7313

College Park, MD  
(301) 277-6828

Galthersburg, MD  
(301) 840-9540

Hagerstown, MD  
(301) 739-6500

Wheaton, MD  
(301) 933-6555/933-8770

## MASSACHUSETTS

Cambridge, MA  
(617) 661-2670

West Springfield, MA  
(413) 733-6648

## MICHIGAN

Berrien Springs, MI  
(616) 429-3034

Burton, MI  
(313) 742-3701

Detroit, MI  
(313) 538-4222

Farmington Hills, MI  
(313) 477-4470

Grand Rapids, MI  
(616) 451-8348/451-8349

Midland, MI  
(517) 631-6840

Muskegon, MI  
(616) 722-3019

Richland, MI  
(616) 629-9173

Saginaw, MI  
(517) 753-9041

Troy, MI  
(313) 362-4884

## MINNESOTA

Bemidji, MN  
(218) 751-4140

Bloomington, MN  
(612) 884-6744

Duluth, MN  
(218) 727-3578

Minneapolis, MN  
(612) 588-3944

Minneapolis, MN  
(612) 559-0320

St. Paul, MN  
(612) 646-8441

Willmar, MN  
(612) 235-5971

## MISSISSIPPI

McComb, MS  
(601) 684-1688

Michigan City, MS  
(601) 224-6470

## MISSOURI

Joplin, MO  
(417) 782-1285

Lae's Summit, MO  
(816) 524-5333

Manchester, MO  
(314) 394-4545

Ozark, MO  
(417) 485-2501

St. Louis, MO  
(314) 962-0382

Warren, OH  
(800) 325-9494

## MONTANA

Helena, MT  
(406) 442-6665

## NEBRASKA

Lincoln, NB  
(402) 483-1989

Omaha, NB  
(402) 592-3590

## NEVADA

Las Vegas, NV  
(702) 382-0562

Reno, NV  
(702) 826-5055

## NEW HAMPSHIRE

Union, NH  
(603) 473-2323

## NEW JERSEY

Bayonne, NJ  
(201) 858-0115

Ft. Lee, NJ  
(201) 461-2800

Lincroft, NJ  
(201) 780-3857

Pompton Plains, NJ  
(201) 835-7080

Westfield, NJ  
(201) 232-0511

## NEW MEXICO

Albuquerque, NM  
(505) 266-8224

Albuquerque, NM  
(505) 285-8007

Albuquerque, NM  
(505) 256-9111

## NEW YORK

Bronx, NY  
(212) 231-2800

East Chester, NY  
(914) 779-5292

East Williston, NY  
(516) 746-1079

Farmingdale, NY  
(516) 694-8222

Hilton Head, SC  
(803) 785-8393

Potsdam, NY  
(315) 265-5620

Rochester, NY  
(716) 442-5861

Rochester, NY  
(716) 325-5570

Wantagh, NY  
(516) 785-4033

Williamsville, NY  
(716) 631-3011

## NORTH CAROLINA

Fayetteville, NC  
(919) 485-2661

Lumberton, NC  
(919) 739-5535

Raeford, NC  
(919) 875-2798

## OHIO

Akron, OH  
(216) 253-3389

Alliance, OH  
(216) 821-2600

Cleveland, OH  
(216) 461-7650

Columbus, OH  
(614) 866-1307

Columbus, OH  
(614) 451-6400

Columbus, OH  
(614) 436-8442

Dayton, OH  
(513) 433-8484

Euclid, OH  
(216) 289-6600

Lancaster, OH  
(614) 687-0629

Medina, OH  
(614) 725-4560

North Canton, OH  
(216) 497-0847

Northfield, OH  
(216) 467-0003

Toledo, OH  
(419) 241-1393

Warren, OH  
(800) 472-0207

Warren, OH  
(216) 392-7595

## OKLAHOMA

Oklahoma City, OK  
(405) 946-5492

Oklahoma City, OK  
(405) 947-7896

Tulsa, OK  
(918) 627-1064

## OREGON

Corvallis, OR  
(503) 754-0675

Marylhurst, OR  
(503) 635-3544

Medford, OR  
(503) 779-5612

Milwaukie, OR  
(503) 854-9574

## PENNSYLVANIA

Allentown, PA  
(215) 820-0200

Chinchilla, PA  
(717) 587-4771

Erie, PA  
(814) 454-7652

Greensburg, PA  
(412) 836-6502

Lewisburg, PA  
(717) 524-0638/523-9684

Monroeville, PA  
(412) 372-7701

New Brighton, PA  
(412) 846-3000

New Kensington, PA  
(412) 337-6080/335-9185

Philadelphia, PA  
(215) 567-2111

Reno, PA  
(814) 677-6502

State College, PA  
(814) 237-8555

West Chester, PA  
(215) 436-4750

## SOUTH CAROLINA

Greenville, SC  
(803) 244-8220

Hilton Head, SC  
(803) 785-8393

Summerville, SC  
(803) 873-8767

Sumter, SC  
(803) 773-2526

## SOUTH DAKOTA

Sioux Falls, SD  
(605) 335-6464

## TENNESSEE

Bristol, TN  
(615) 968-1599

Chattanooga, TN  
(615) 892-2411

Humboldt, TN  
(901) 784-6810

Kingsport, TN  
(615) 349-6172

Morristown, TN  
(615) 581-4909

Oak Ridge, TN  
(615) 482-9031

## TEXAS

Bryan, TX  
(713) 846-8288

Houston, TX  
(713) 680-2664

League City, TX  
(713) 3

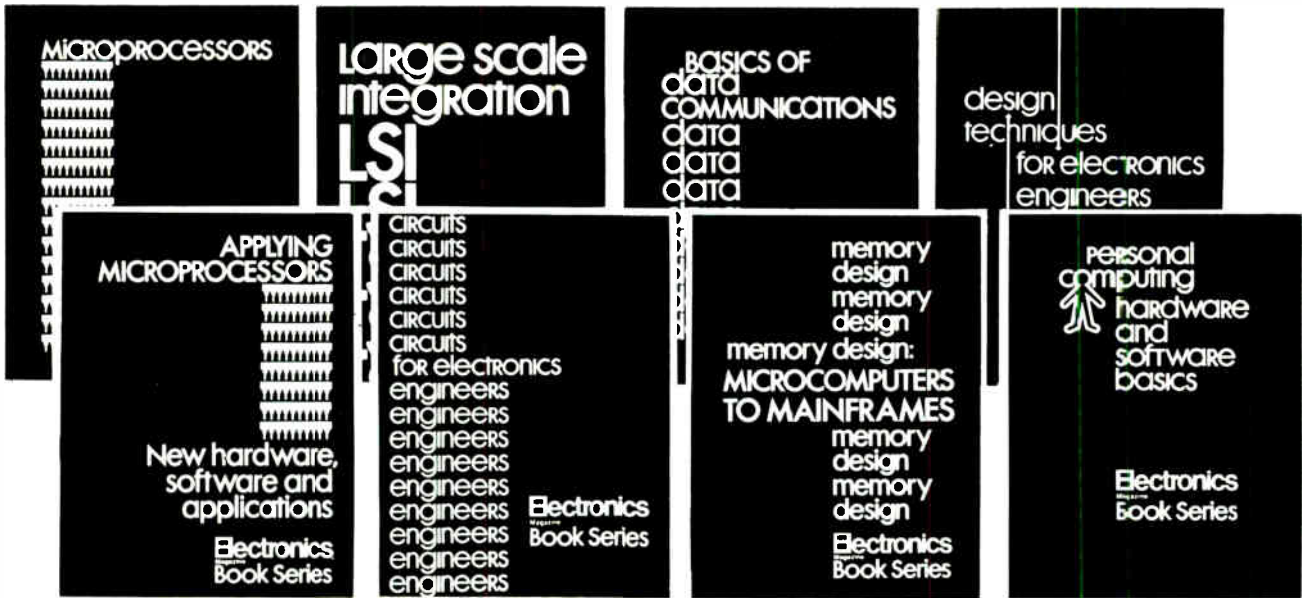

# Electronics Magazine Books

## 1. Microprocessors

What you must know about available microprocessor technology, devices, information, 4th printing. \$8.95

## 2. Applying Microprocessors

2nd and 3rd generation technology. 26 detailed applications from data networks to video games. \$9.95

## 3. Large Scale Integration

Covers the basic technology, new LSI devices, LSI testing procedures, plus system design and applications. \$9.95

## 4. Basics of Data Communications

Includes 47 articles from Data Communications magazine covering more than 11 key areas. \$12.95

## 5. Circuits for Electronics Engineers

Contains 306 circuits arranged by 51 functions from Amplifiers to Voltage Regulating Circuits. Saves design drudgery. \$15.95

## 6. Design Techniques for Electronics Engineers

Nearly 300 articles drawn from "Engineer's Notebook." A storehouse of design problem solutions. \$15.95

## 7. Memory Design: Microcomputers to Mainframes

The technology, devices, and applications that link memory components and system design. \$12.95

## 8. Personal Computing: Hardware and Software Basics

More than 50 articles from leading publications, including specifications, helpful hints, subject index. \$11.95

### Electronics Magazine Books

P.O. Box 669, Hightstown, NJ 08520  
(609) 448-1700, ext. 5494

No. of Copies	Title	Price
_____	1. Microprocessors	\$ 8.95
_____	2. Applying Microprocessors	\$ 9.95
_____	3. Large Scale Integration	\$ 9.95
_____	4. Basics of Data Communications	\$12.95
_____	5. Circuits for Electronics Engineers	\$15.95
_____	6. Design Techniques for Electronics Engineers	\$15.95
_____	7. Memory Design: Microcomputers to Mainframes	\$12.95
_____	8. Personal Computing: Hardware and Software Basics	\$11.95



If after my 10-day free-trial examination I am not fully satisfied I understand that my payment will be refunded.

Payment enclosed  Bill firm  Bill me

Charge to my credit card:

American Express  Diners Club  
 Visa  Master Charge\*

Acct. No. \_\_\_\_\_ Date Exp. \_\_\_\_\_

\*On Master Charge only, first numbers above name \_\_\_\_\_

Name \_\_\_\_\_ Title \_\_\_\_\_

Company \_\_\_\_\_

Street \_\_\_\_\_

City \_\_\_\_\_ State \_\_\_\_\_ Zip \_\_\_\_\_

Signature \_\_\_\_\_

Discounts of 40% on orders of 10 or more copies of each book.



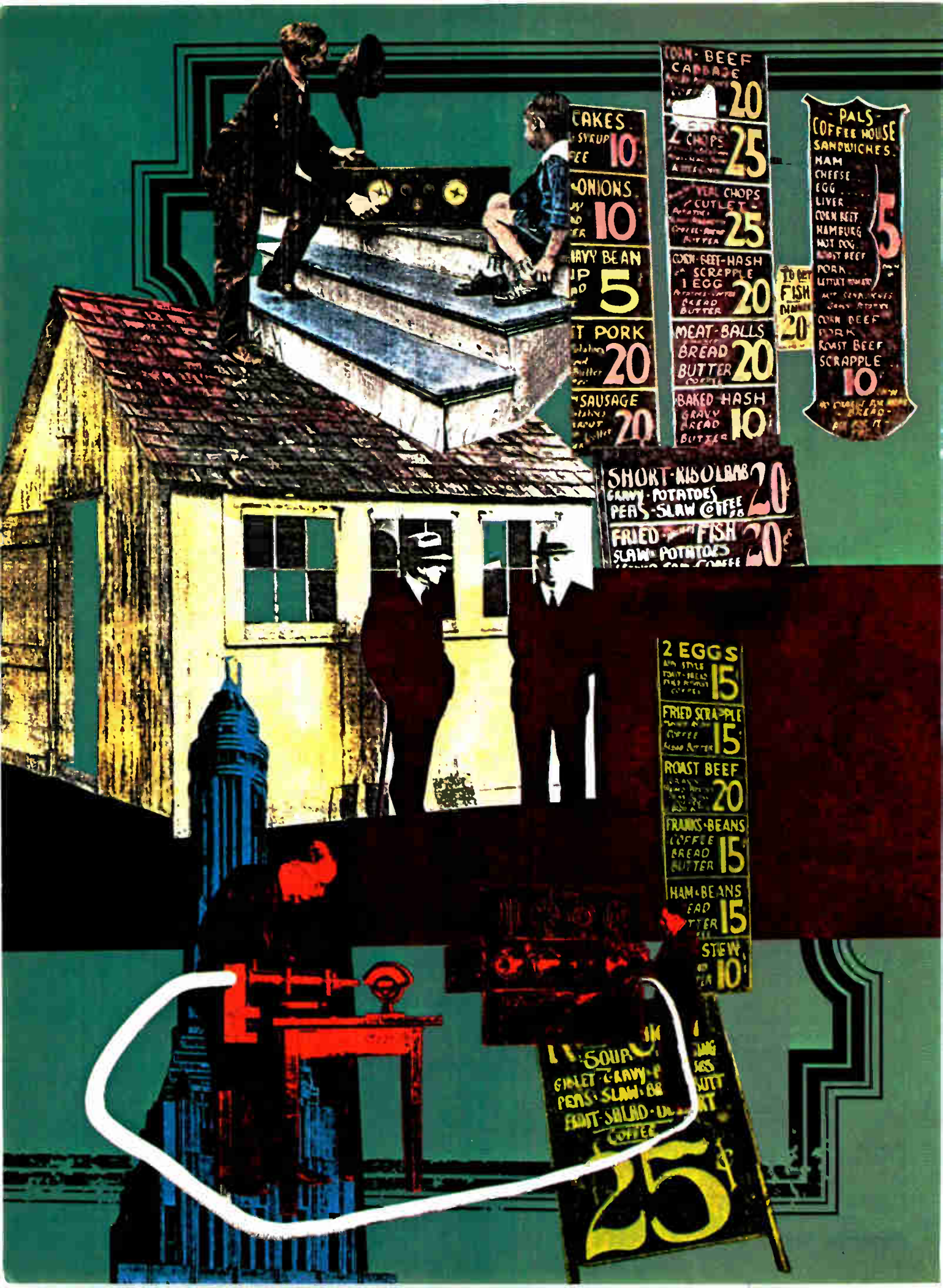

CAKES  
SYRUP FREE 10  
ONIONS  
MILK AND BUTTER 10  
NAVY BEAN  
IP AND BUTTER 5  
T PORK  
with gravy and butter 20  
SAUSAGE  
GRAVY BREAD BUTTER 20

CORN-BEEF  
CABBAGE 20  
CHOPS 25  
CHOPS  
CUTLET 25  
CORN-BEEF-HASH  
SCRAPPLE  
EGG  
BREAD BUTTER 20  
MEAT-BALLS  
BREAD BUTTER 20  
BAKED HASH  
GRAVY BREAD BUTTER 10

PALS  
COFFEE HOUSE  
SANDWICHES  
HAM  
CHEESE  
EGG  
LIVER  
CORN-BEEF  
HAMBURG  
HOT DOG  
ROAST BEEF  
PORK  
LITTLE BONES  
MILK  
CORN-BEEF  
ROAST BEEF  
SCRAPPLE 10

SHORT-RIBS OR LAMB 20  
GRAVY-POTATOES  
PEAS-SLAW COFFEE 20  
FRIED FISH  
SLAW-POTATOES 20

2 EGGS  
AND STYLE  
TOMATOES  
AND POTATOES  
COFFEE 15  
FRIED STRAPPLE  
COFFEE  
BREAD BUTTER 15  
ROAST BEEF  
GRAVY  
BREAD BUTTER 20  
FRANKS-BEANS  
COFFEE  
BREAD BUTTER 15  
HAM-BEANS  
BREAD BUTTER 15  
STEW  
ON POTATOES 10

SOUP  
GIBLET-CARVY-P  
PEAS-SLAW-OR  
FRUIT-SALAD-OR  
COFFEE  
25

# THE RADIO YEARS

---



AMIDST BRIGHT PLANS FOR ITS FUTURE, ELECTRONICS MAGAZINE WAS LAUNCHED IN APRIL 1930. THE DEPRESSION WAS BEING LAUNCHED RIGHT ALONG WITH IT, THOUGH THE FEELING AT MCGRAW-HILL INC. WAS THAT THINGS WERE BOUND TO GET BETTER SOON. ELECTRONICS AS AN INDUSTRY WAS ALREADY MAKING ITS MARK, HOWEVER. THE NATION WAS HELD IN THRALL BY RADIO BROADCASTING THROUGHOUT THE DECADE. INDEED, RADIO WAS THE ELECTRONICS INDUSTRY. TELEVISION BROADCASTING AND RADAR WERE LOOKED AT EXPERIMENTALLY. THEORETICAL FOUNDATIONS FOR ELECTRONIC DIGITAL COMPUTERS WERE LAID. THE OSCILLOSCOPE EMERGED AS A USEFUL TOOL, AND THE IDEA OF USING A SEMICONDUCTOR FOR AMPLIFICATION WAS PATENTED.

## Chapter 3



**G**uglielmo Marconi didn't see the need for it, and Lee de Forest inveighed against it, but it succeeded in spite of their pessimism. The 1930s were unmistakably the golden years of commercial radio.

Marconi would have preferred standing on the Morse Code as the cornerstone of his wireless telegraphy; he saw no mission for voice transmission. De Forest warned the Institute of Radio Engineers in January 1930 that "the greed of direct advertising will rapidly work to sap the lifeblood and destroy the greatest usefulness" of radio; he damned "this reptile of etheric advertising." The radio networks were too busy learning and succeeding to give the advice much heed.

And while radio development raced ahead, there were more cautious advances in other areas of electronics:

- Television was in gestation and finally emerged from the womb in 1939 when telecasts began from the Empire State Building in New York.
- Radar was nurtured to the point where it was ready to serve when World War II broke out.
- Oscilloscopes became useful tools of measurement.
- Vacuum-tube voltmeters were developed as sensitive instruments.
- Electromechanical analog calculators and computers

were perfected, and the foundation of the modern digital computer was laid.

■ Researchers turned up such inviting concepts as thin films, field-effect transistors, and liquid crystals, but they were filed away to be dusted off and developed in later years.

**M**any developments, most of them fortunate and at least one—the Depression—unfortunate, contributed to the flowering of commercial radio. For one thing, the technical foundation was secure. By 1930 wireless telegraphy was more than 50 years old. Carrier systems were widely used to multiplex voice signals for long-distance transmission. Single-sideband transmission had been understood as early as 1915 and had been patented in 1923 by John R. Carson of American Telephone & Telegraph. And Harold S. Black of Bell Telephone Laboratories, in 1927, had already conceived of negative feedback as a cure for the nonlinearities, gain variations, and other ills of amplifiers used as repeaters in carrier systems.

Engineers made radio an electronic success. But what helped turn it into a commercial hit, perhaps more than anything else, was the Depression. In a world made



**Special effects.** The crack of pistol shots and the squealing tires of automobiles in chase fueled the imaginations of listeners to the *Gangbusters* radio program. The scene in the studio was vastly different from the exciting pictures the mind conjured up.

dreary by unemployment and marginal living, people were ready to forget their troubles. They craved entertainment, preferably at little cost, and entertain them inexpensively commercial radio did in the 1930s, with Morton Downey, Bing Crosby, Kate Smith, Amos and Andy, Jack Benny, Fred Allen, Eddie Cantor, the Maxwell House Showboat, Gangbusters, and more, more, more. Family evenings were spent at home by the radio, and by the mid-1930s automobile motoring and radio listening were being enjoyed simultaneously by millions.

The manufacture of receivers for radio broadcasting was highly competitive. This led to millions of mass-produced sets: handsome wooden consoles at first for the parlor, as the living room was called in Middle America, and then midget radios in plastic for the kitchen, bedroom or mantelpiece. They bore names like Atwater-Kent, Philco, Majestic, and Silvertone. The midgets were growing in popularity by the turn of the decade. So many sets of all kinds were produced that *Electronics* was not three months old when the editors were scolding manufacturers:

“Every year since 1924 radio has undergone an annual overproduction. Each year manufacturers, racing for supremacy and low production costs, have swelled their

totals—and ended by unloading their excessive output at bargain prices. Will the economic blunders of 1929, 1928, 1927, etc., be committed over again in 1930?”

Apparently they were. In March 1931 the magazine reported that, as far as it had been able to determine, not a single radio manufacturer had made any profit from radio sales in 1930.

If one development paced the growth of radio more than any other, it was that of the vacuum tube. The triode had been invented by de Forest as far back as 1906, and by 1930 it was generally recognized that improvements in every aspect of transmission and reception of radio signals could be attained most easily by improving the vacuum tube. Thereafter it was a matter of harvesting the best of a fertile field of engineering concepts, so that tubes and other equipment advanced side by side.

At the right time the superheterodyne receiver emerged, for example. This circuit led to larger coils and less shielding for the entire tuning system. When it became necessary to compensate for oscillator drift, bimetal temperature-compensating capacitors moved to center stage. When static became increasingly troublesome, frequency modulation bowed in. One after another the technical challenges were met. The period of



**Real-life couple.** Marian and Jim Jordan were radio's "Fibber McGee and Molly."

**Mysterious.** The Shadow fought against the evil that lurked in the hearts of men.





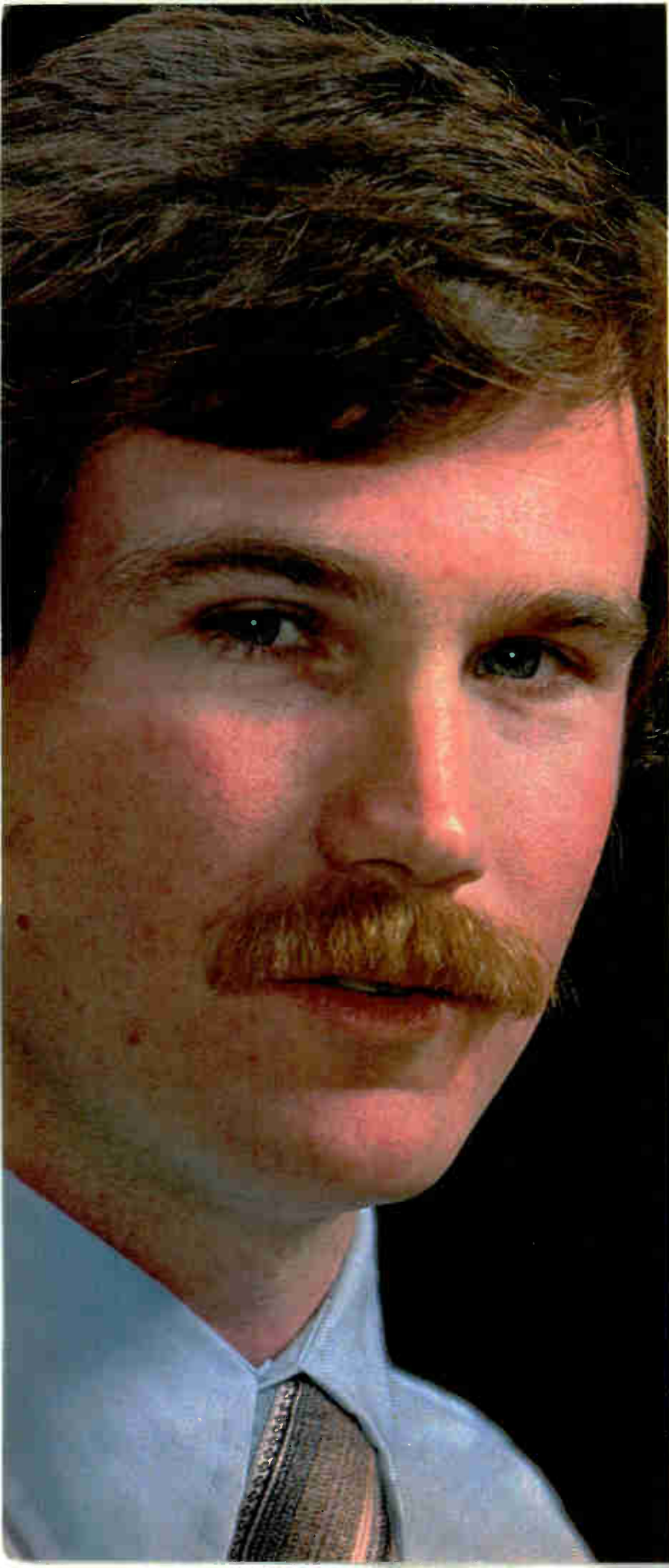

# Speaking of reliability...

## **“It’s a better investment.”**

Working with military telecommunications equipment, I’ve become well aware of the importance of reliability. And, looking ahead, you can see that the ‘science’ of reliability is certain to get increasing attention at all levels from military to commercial.

At any of these levels, the degree of reliability attained will continue to be affected by the balance of cost vs. MTBF. In working with components, I know that their MTBF is often affected by equipment design factors not related to initial quality. Parts density, cooling methods and production techniques are only a few of these. Also, through screening and thermal and electrical derating, the engineer can improve component reliability after delivery.

But in the battle of cost vs. MTBF, a vendor’s concern for designing and manufacturing to high quality standards will continue to be of primary importance. In addition, interaction between vendor and OEM in setting and maintaining quality standards is going to be even more vital. Time invested in preventing failures is always a much better investment than time spent in repairing them.

### **Mike O’Brien**

*Component Application Engineer*  
Collins Telecommunications Products Div.  
Rockwell International  
Cedar Rapids, Iowa

## **"It's a household word."**

In today's world, the main cost of ownership has in many cases shifted from acquisition to maintenance, and *reliability* has become a household word.

In the consumer area, the solid state controls in TV sets, kitchen appliances... even toys, have virtually eliminated the fix-it-yourself mode. And, with shop charges at \$30 an hour, it's often cheaper to replace than to repair.

In the instrument business, the problem is even more acute because of tighter performance specifications and generally higher parts count. So how does one achieve 10,000 hours MTBF in a commercial grade instrument that has 1,000 parts? If we assume sound design, proper component application, good workmanship and normal customer use, the MTBF becomes basically a function of component reliability. This in turn depends first on the skill of the designer and then on his component support group in selecting components and suppliers, and finally, on the component manufacturers themselves.

In general, component reliability is achieved by (1) careful, conservative design and tight manufacturing control (design and build reliability in) or (2) reliability enhancement using lower quality components (screening out early failures). Obviously, the first method is preferred and is nearly always more cost effective. Hence, we have always sought out reliability-conscious component manufacturers with a proven track record. They will be even more important in the future than they are today.

### **Bob Hammond**

*Manager, Component Management Group  
John Fluke Mfg. Co., Inc.*



## **Reliability with a competitive edge.**

DALE ELECTRONICS, INC.  
Box 609, Columbus, Nebraska 68601  
*A subsidiary of The Lionel Corporation*  
IN CANADA: Dale Electronics, Ltd.  
IN EUROPE: Dale Electronics GmbH, 8031 Puchheim, West Germany

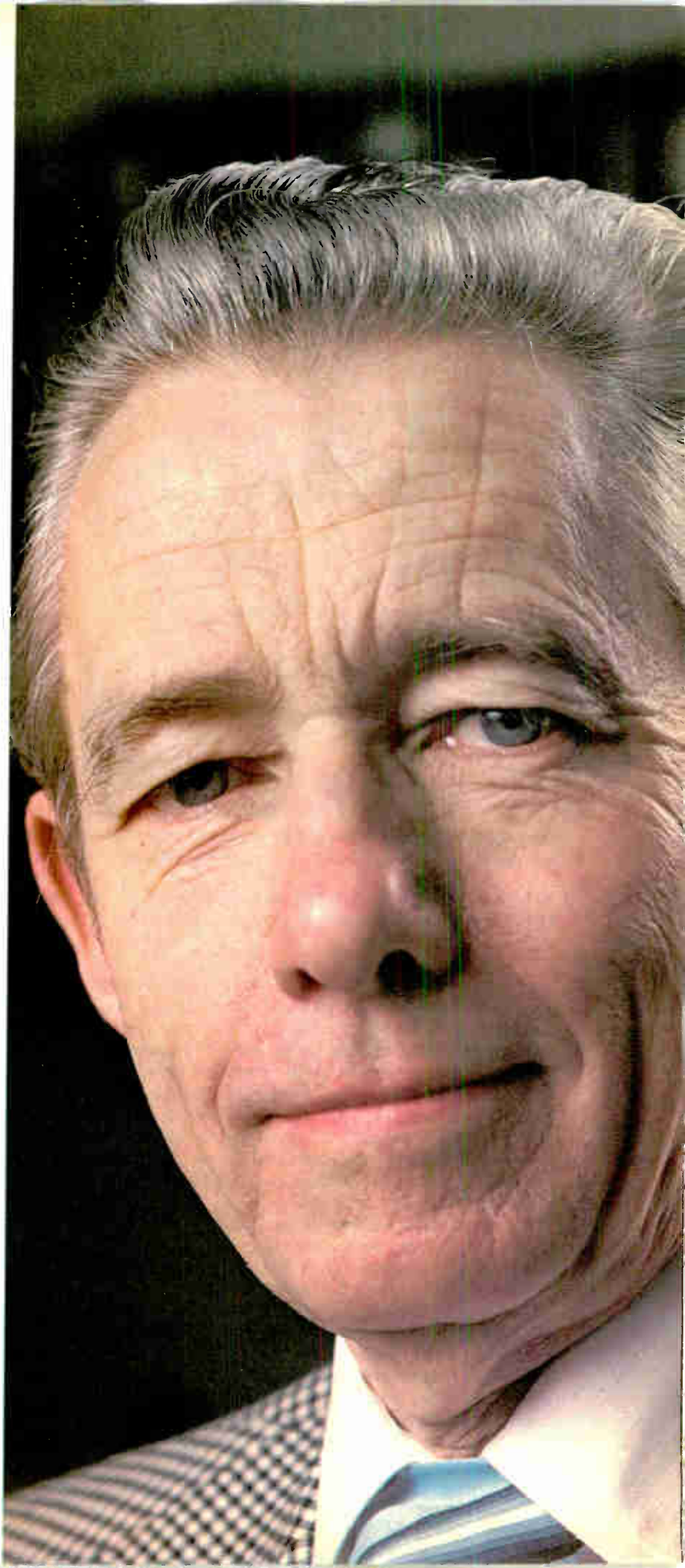





**Such music!** This family is checking the sound of a 1920s Radiola from Radio Corp. of America (now RCA) before taking delivery.

1930–35 was one of steady technical growth, while 1935–40 was a period of accelerated growth.

**C**ommercial radio broadcasting began with medium-wave transmitters. These had wavelengths of 300 to 500 meters and powers of about 3 kilowatts, but were not reliable beyond 40 kilometers.

Relay stations were set up to retransmit programs to localities outside the range of the main stations. Transmission lines carried programs from one relay center to another. At first ordinary telephone lines were used, but these were replaced by dedicated lines. As national networks grew, the use of dedicated circuits within telephone cables became common.

An important development was short-wave transmission, the use of wavelengths of 10 to 100 m. It relied on reflection from ionized layers in the upper atmosphere and could cover thousands of miles.

The fidelity of amplitude-modulated radio improved all through the 1930s, but the dramatic breakthrough came in April 1935 when Edwin H. Armstrong announced that he had developed a system of frequency-modulated radio transmission that so reduced the noise level that the range of 7-m signals was extended from 25 to 100 miles. Armstrong demonstrated side-by-side

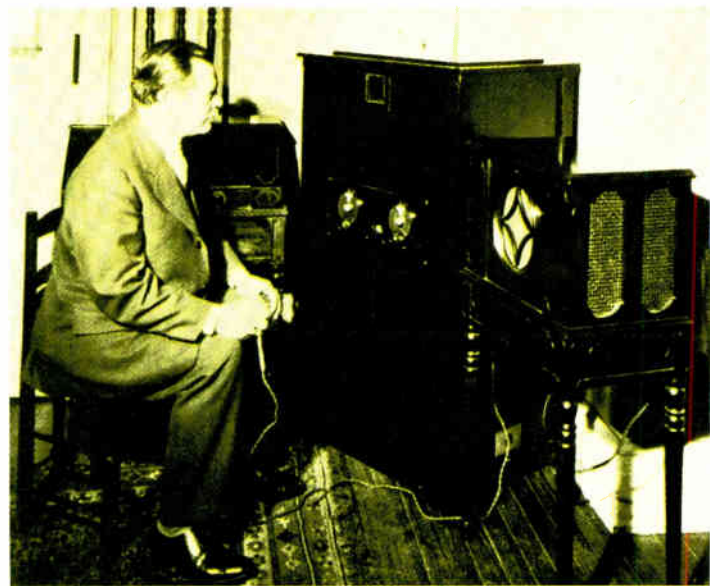

**Hardly portable.** Electronics inventor E. F. W. Alexanderson sits before a 1926-model Radiola, an impressive piece of furniture.

transmission of a-m and fm from the Empire State Building to his laboratory in Haddonfield, N. J. Noise buried the a-m signal, but was barely perceptible around the fm signal.

Armstrong's system contradicted the accepted theories of Carson, the AT&T physicist who, on the basis of an insufficiently general mathematical analysis of fm, had concluded in 1924 that "noise, like the poor, will always be with us." Fm was Armstrong's crowning glory as a radio innovator, his earlier endeavors having been the invention or development (it is often unclear which) of the oscillator (1912), the regenerative receiver (1912), the superregenerative receiver (1922), and the superheterodyne receiver (1920).

*Electronics'* editors embraced fm wholeheartedly, and this apparently caused some difficulty. In a January 1940 review of fm, they remarked that they had been "flatly accused of taking the side of the inventor in reporting demonstrations enthusiastically." They acknowledged that this was the case, and defended their position on the grounds that "the system, as demonstrated, really does perform with startling high fidelity and with startling freedom from noise."

Fidelity and noise-free reception, however, were not enough to make fm an immediate commercial success. Radio manufacturers questioned whether enthusiasm for the new medium would ruin what little prosperity they were enjoying in the late 1930s. Broadcasters argued that transmitters were at least 2,000 hertz wider than the best receivers tuned into a station and perhaps 6,000 Hz wider than the worst, and "the public apparently doesn't give a hoot."

Armstrong spent more than \$1 million to develop microphones, audio amplifiers, and other components, and his fm station went on the air in the very high-frequency spectrum in 1939. By November of that year five fm stations were operating under FCC license, and 15 stations were operating under FCC construction permits. In 1941 the first fm chain, designated

# Sprague Electric... a components manufacturer that continues to excel internationally.



Founded with a handful of employees in a New England seacoast town, Sprague Electric began manufacturing capacitors in 1926, four years before *Electronics* magazine was born. Since then, Sprague has grown to a worldwide organization with plants in the Far East, Europe, Canada, Mexico, and more than a dozen states here at home.

This, of course, is one important reason why Sprague Electric is so aware of so many specialized component requirements. It also helps explain why Sprague Electric is able to respond so promptly

to serve electronic component users in virtually any industry or area.

As the company has grown, its line of products has expanded to include all major types of capacitors, semiconductors (ICs, transistors, diodes and Zener diodes), RFI and wave filters, thick-film networks and hybrid circuits, dc-to-dc converters, pulse transformers, etc. Almost everywhere electronic components and circuitry are used today, one of the names most recognized is: Sprague Electric Company, North Adams, Mass. 01247.

45G-0108

**THE BROAD-LINE PRODUCER OF ELECTRONIC PARTS**



a subsidiary of **GK Technologies**



Your Marketing department wants a new black box design. They want it to handle 37 bytes of information. It has to be solar energized. It has to fly. It has to speak. It has to reproduce. Naturally, it'll need special cable configurations. Call Belden.

We've developed workable wire, cable and cord answers for a lot of extraordinary new products. In fact, a lot of designers have found that working with Belden in the early stages of a design project usually pays dividends in compatibility, workability and lower overall costs.

And once your product is rolling, we're ready to dig in to wire processing, assembly and installation

problems to help insure that your idea makes it to market economically.

You see, Belden's capabilities in wire, cable and cord are comprehensive. Sure, we make thousands of standards, but we can also provide just about any custom that you can imagine. And our technical knowhow ranges from innovative packaging to in-depth value analysis.

Just imagine a wire, cable or cord—and we'll come through with it. Belden Corporation, Electronic Division, P.O. Box 1327, Richmond, IN 47374; 317-966-6661. Out West, contact our Regional Sales Office in Irvine, CA at 714-833-7700.

8-7-98

# Your special designs need a special wire source



**Imagine  
what we  
can do  
for you**

**BELDEN**   
**Coming through...**

*with new ideas for moving electrical energy*

© 1979 Belden Corporation

Circle 102 on reader service card



**Sources.** Alexanderson alternators at RCA's Rocky Point, N. Y., transmitter once carried the whole load of overseas radio traffic.

the Yankee Network, was operating in New England.

A lesser-known development but one that proved significant many years later was pulse-code modulation, which was introduced by R. H. Reeves of France in 1938. By understanding the relation between information content and bandwidth, Reeves may have come up with the first true communications system based on statistics theory. In the previous year, as it happened, Claude E. Shannon, whose later work was to give PCM a theoretical basis and correct that of fm, made his initial contribution to information theory. He showed that the behavior of complex switching circuits could be analyzed by means of Boolean logic.

Although some executives feared that the manufacture of radio sets was approaching saturation in the late 1930s (in some cities more than 60% of the homes owned a radio), and although there was a continuous shakeout of manufacturers, engineering advances showed up in the new lines. The superheterodyne circuit had been introduced in 1920, and that year also saw the installation of a tone control, with which the listener could obtain more effective bass by reducing the treble response. In 1932 manufacturers introduced automatic muting circuits to cut the noise between carrier waves. That was also the year they began putting volume and tone controls on the same shaft; as the listener turned down the volume, the bass and treble increased.

Engineers wanted to improve radio fidelity, but *Electronics* noted that "sales departments decided that high-quality sound was all right for engineers, but not for the public." The growing demand for midget radios not only drove down the price of all sets—from an average of \$115 in 1928 to \$81.50 in 1930—but fidelity also slid. In January 1931, the editors of *Electronics* remarked somewhat plaintively, "There must be some way to better the fidelity of the small sets." Later that year they commented, "Quality of receivers hit an all-time low: poor workmanship, poor tone fidelity, low prices."

Some manufacturers argued that the public wanted

lower prices, not higher fidelity. *Electronics* said: "To state that listeners do not want to hear frequencies above 3,000 cycles controverts the experience of composers and musicians of several hundred years."

Still there was some interest in higher-quality sound, because in September 1935 the magazine reported new radio circuits that extended the audio range toward the low and high frequencies, reduced harmonic distortion, increased available power output, and improved speaker characteristics. It was the year the manufacturers began using cathode-ray tuning indicators in radios—so-called magic eyes.

In 1937 the big news was in mechanical tuning: telephone-dial station selection and push-button "automatic tuning" in addition to the earlier rotary dials. There was the possibility of remote tuning. "But this feature has not been pushed very actively," *Electronics* noted, "probably because of the difficulty of providing simple, inexpensive and foolproof volume control." Mechanical tuning had become possible after engineers had designed automatic frequency-controlled circuits as well as stabilized drift-free oscillators and expanding intermediate-frequency amplifier circuits.

**V**acuum tubes were sufficiently well understood from the theoretical standpoint to serve as a solid springboard for the development of radio from 1930 through 1939. The high-gain triode had been fully developed in 1927, chiefly through the efforts of Irving Langmuir, a physicist at General Electric, who had predicted that better performance would result from a high-vacuum enclosure. Tubes with ac heaters were built that same year in anticipation of the use of alternating-current power sources to carry electricity from the power plant to the home.

The development of the four-element tetrode by H. J. Round in England occurred about that time, although the idea had originated with Germany's Walter Schottky in 1919 and independently with GE's A. W. Hull in 1923. The resulting increase in tube gain improved receiver sensitivity. And the additional grid in the tetrode reduced the control-grid-to-anode capacitance, too, largely removing the need for neutralizing the tube against self-oscillation.

Then receiving and small-power rf pentodes were invented by G. Holst and Benjamin D. H. Tellegen in Holland in 1929, and the effects of random secondary emission of electrons from the plate of the tetrode were reduced. The result was a tube that had very high gain, high plate resistance, and uniform characteristics. In power tubes, the pentode could provide power at high plate dissipation without excessive distortion. The variable-mu tetrode and pentode, developed in 1930 by Stuart Ballantine and H. A. Snow at Radio Frequency Laboratories, reduced cross modulation in receivers and also decreased the number of parts needed to build automatic gain-control circuits.

As vehicular communications became popular and it became obvious that the vhf regions of the spectrum would soon be totally occupied, the country's major tube researchers—the Radio Corp. of America (RCA today),



SATELLITE  
COMMUNICATIONS

RADIOLOCATION

AMATEUR/MOBILE

SATELLITE  
COMMUNICATIONS

METEOROLOGICAL  
MOBILE

TELEMETRY

SURVEILLANCE RADAR

TACAN/DME  
COMMON CARRIER

UHF TV  
LAND MOBILE

I.L.S.  
EMERGENCY

VHF TV

AIRCRAFT

FM RADIO

VHF TV

AMATEUR (6 M.)

CB

SHIP

3 GHZ

300 MHZ

30 MHZ

3 MHZ

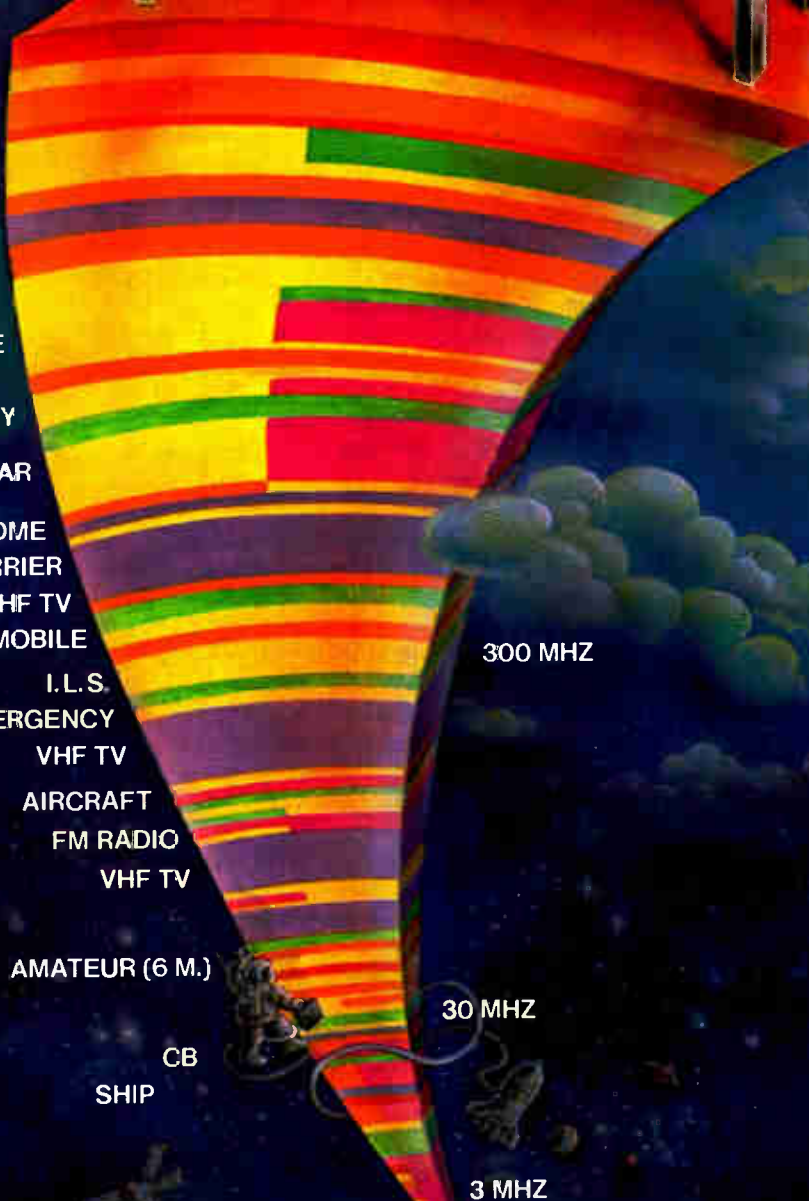

# It's lonely at the top.

Mind you, we wouldn't have it any other way.

Because we deliberately set out to be the leader in integrated circuits for communications.

And today, nobody else even comes close.

We developed the first and only 2 GHz counter. And a family of prescalers and controllers for your TV, radio and instrumentation frequency synthesizers.

We have a monolithic 1 GHz amplifier. And a complete array of complex integrated function blocks for radio communications and signal processing right down to DC.

We can supply an A-to-D converter with a propagation delay of just 2½ nanoseconds. And a range of MNOS logic that stores data for a year when you remove power, yet uses only a single supply and is fully TTL/CMOS-compatible.

Our processing was designed for quality, then applied to our

high volume lines. Process III has a projected MTBF of 400,000 hours, Process I is even better.

Most of our IC's are available screened to MIL-STD-883B, and our quality levels exceed the most stringent military, TV and automotive requirements.

Last year, millions of Plessey devices were built into TV sets and car radios; CATV, navigation and radar systems; frequency synthesizers and telecommunications systems.

This year, maybe you won't have to re-invent the wheel. Contact us for the complete information on Plessey high technology, high quality, high volume capabilities.

It could put you on top.

Plessey Semiconductors,  
Cheney Manor, Swindon,  
Wiltshire, SN2 2QW, U.K.  
Telephone 0793 36251.

1641 Kaiser Avenue,  
Santa Ana, CA 92714, U.S.A.  
Telephone (714) 540-9979.



**PLESSEY  
SEMICONDUCTORS**



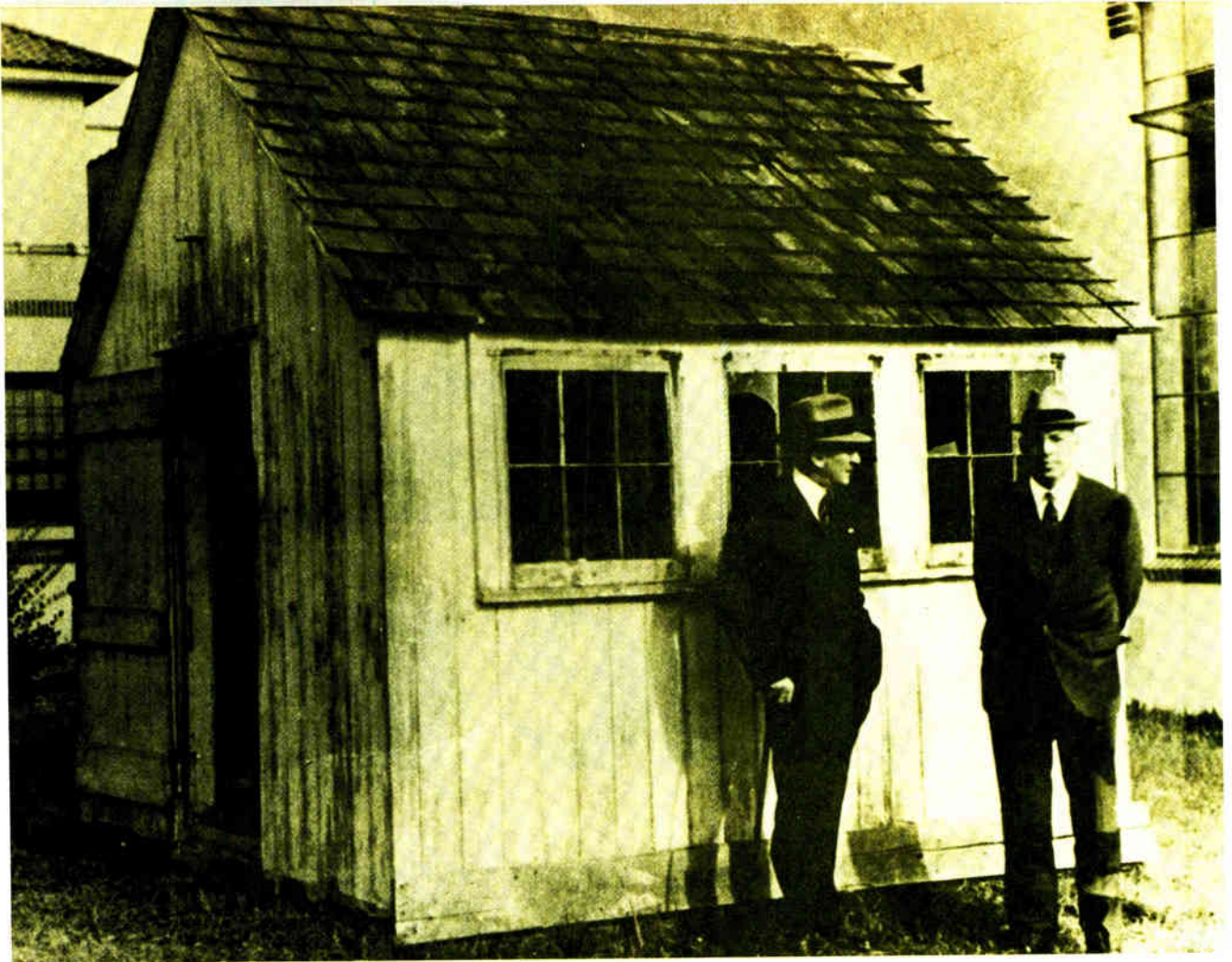

**Beginnings.** Edwin Howard Armstrong, right, met with Guglielmo Marconi on Marconi's last visit to the U. S. in 1932. Here they pose in front of the shack in which Marconi, the inventor of wireless telegraphy, built the first wireless transmitting station in the U. S. in 1900.

GE, Westinghouse, and Raytheon—pursued work on three fronts. The areas of interest were consolidation of tube function, the development of more tubes, and an attempt to increase the tubes' upper frequency limit. The multifunction heptode (1932), the hexode (1933), and the pentagrid converter (1933) resulted, along with metal-envelope tubes (1935). The tiny acorn tube (1933) permitted reliable operation into the vhf region.

A sign of the times was that in 1932 *Electronics* listed 300 different tube types (double the previous year). Around this time Sylvania came out with a line of 6.3-volt filament tubes. This tube line came to be adopted by all radio set manufacturers.

Passing almost unnoticed was the conception of the junction field-effect transistor, or J-FET, by Germany's Oskar Heil in 1935. The metal-oxide-semiconductor FET, or MOS FET, had also been envisioned in 1925 by Julius Lilienfeld (see Chapter 5). But as the technology had not reached the point where a device would be feasible, not much commercial interest was forthcoming.

Optoelectronics, on the other hand, proved highly marketable. Electric eyes proliferated in the 1930s. To the public's amazement, these phototube amplifier circuits made restaurant doors swing open ahead of waiters, and they also found many industrial uses.

Beam tetrode tubes for both transmitting and receiving were introduced in 1936, providing superior performance to a pentode without the need for a suppressor grid.

The beam construction let large plate currents be drawn at relatively low plate voltage, thereby increasing the tube's power sensitivity. The popular zero-bias class B tube made its debut in 1936 also.

With the introduction of the indirectly heated cathode (heater filament) in the power pentode, transconductances were boosted by a factor of 4; in the best tubes then available, transconductances of 6,000 siemens were achieved. Wideband amplifiers became popular, too, with the introduction of remote-cutoff tubes that could yield transconductances as high as 9,000 siemens. Finally the door-knob tube for ultrahigh frequencies was introduced in 1938 and the coplanar triode at about the same time, completing the most productive era in the history of vacuum-tube development.

**A**utomobile radio barely existed at the beginning of the decade. The January 1932 issue of *Electronics* reported that only about 100,000 car radios were sold in the U. S. in 1931, compared with a total of some 3 million sets. Among the deterrents, it said, was "the opinion often and publicly expressed that automobiles are no places for radio sets, that the driver should suffer no further attention diversion." But there were technical problems as well. They included a battery drain that reduced normal battery life from two years to one and spark-plug noise in the receiver ("One manufac-

# Lear Siegler brings you the smart terminals designed for easy OEM customizing.



## PERSONALITY PROMS AND FACTORY ASSISTANCE MAKE USER-REPROGRAMMING A SNAP.

At Lear Siegler, you don't have to decide among dozens of smart terminals, each slightly different, but none quite right for you.

We have just two smart terminals. But they can handle a range of tasks equal to four, five, or even six models from other manufacturers.

After all, we want to make your life simpler, not more complicated.

### **THE ADM-31 & ADM-42 WILL LET YOU CHANGE THEIR MINDS.**

When we designed the ADM-31 and ADM-42, we realized that no matter what capabilities we offered, somebody would always want something different. So we did the next best thing.

We gave each a truly flexible personality by putting the instruction sets inside their PROMs. So, unlike the hardware, the firmware is capable of easy OEM reprogramming.

We even have a special Application Engineering Staff to answer any questions you may have about reprogramming, interfacing or special applications.

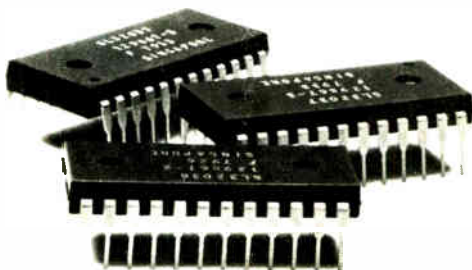

Feeling your life getting simpler yet?

### **ALL THE TERMINALS YOU'LL EVER NEED.**

Even if you decide not to reprogram their PROMs, our two terminals come with all the standard smart terminal features. And then some.

Features like full editing capabilities. Formatting. Reduced intensity for identification of protected fields. Blinking, blanking, and reverse video. High resolution monitors. Even limited line drawing capabilities.

What's more, both the ADM-31 and ADM-42 come equipped with a microprocessor and function keys making them even more reliable and easy to use.

### **THE CHOICE IS SIMPLE.**

You can choose your new smart terminal one of two ways. Start sifting through dozens of data sheets, talking to dozens of salesmen, and looking at dozens of expensive, slightly different terminals.

Or look at two smart terminals from Lear Siegler — the ADM-31 and ADM-42. Complete with user-reprogrammable personality function keys, and an eager and willing Applications Engineering Staff to help you with any reprogramming problems.

The choice seems pretty easy to us. But if you want more information, call or write to us at Lear Siegler, Inc./Data Products Division, 714 North Brookhurst Street, Anaheim, California 92803, (800) 854-3805. We'll be happy to tell you all about the ADM-31 and ADM-42. And show you how you can make your terminals behave.

Circle 107 on reader service card



**LEAR SIEGLER, INC.**  
**DATA PRODUCTS DIVISION**



# How Time Flies When You're Making Computers.

*While we're celebrating anniversaries, we couldn't let it pass unnoticed that this is Honeywell's 25th year in the data processing business. § Twenty-five years ago we had no computer customers.*

*Last year, between ourselves and our French associate, we passed \$2.5 billion in computer revenues, and now have some 20,000 customers around the world.*

*A lot of things had to happen to make that possible. 1955 The April issue of Electronics announces the formation of Datamatic Corporation. 1957*

*The first Datamatic 1000, a 25-ton vacuum tube computer, is installed.*

*1959 Our first transistorized computer, the Model 800, is announced.*

*1963 We announce Model 200, with 5 times the processing speed and Liberator program translation, as a replacement for the IBM 1401. 1966 We acquire*

*Computer Control Company, first supplier of the 16-bit industry-standard*

*minicomputer. 1970 In the industry's largest merger, we take over the computer assets of General Electric. 1974 We announce Series 60, a full range of small*

*to large systems that offers users a clear growth path. 1975 In a joint venture with Control Data, we form Magnetic Peripherals Inc. 1976 Cii Honeywell Bull,*

*Europe's foremost computer manufacturer, is formed. § We assume worldwide support responsibilities for Xerox computer users.*

*We announce a major new thrust in minicomputers with our Level 6 line. 1977*

*We announce the Distributed Systems Environment.*

*1978 We make three computer-related acquisitions:*

*Incoterm (intelligent terminals), Synertek (microprocessors), and Spectronics*

*(fiber optics systems). 1979 We announce DPS 8, large-scale distributed processing*

*systems for the 80s. § Twenty-five years in computers, and almost 100 years in controls. That's Honeywell.*

*Where computers and control come together.*

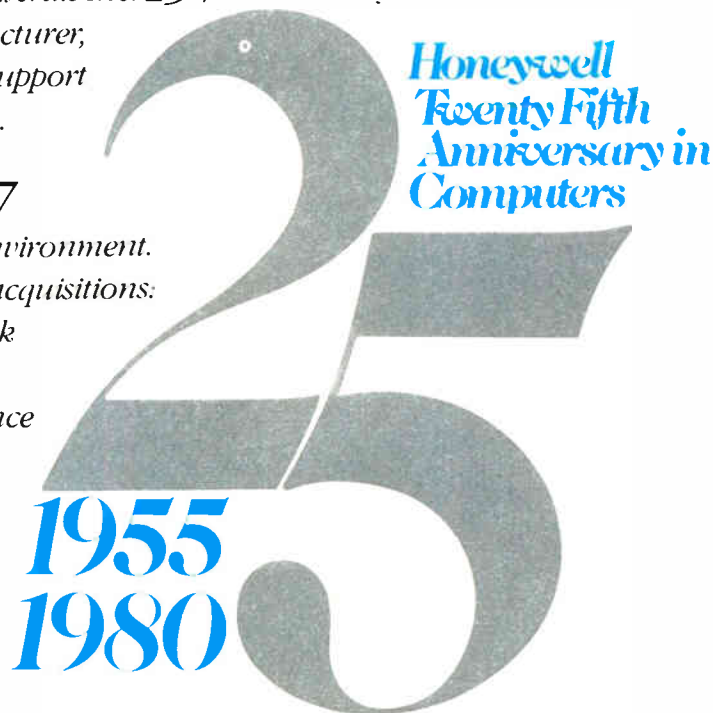

# Honeywell

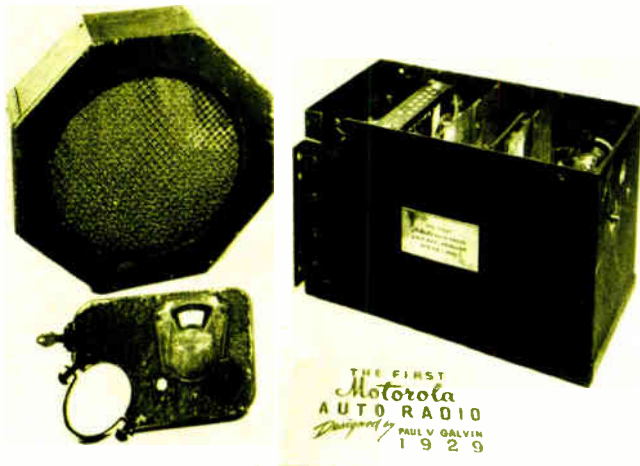

**First car radio.** Motorola (then Galvin Manufacturing) introduced it at the 1930 convention of the Radio Manufacturers' Association.

turer," *Electronics* said, "found that radio-frequency racket persisted until he had soldered the oil pressure and water lines to the frame of the car"). The sets were relatively fragile. Finally there was the price; automobile manufacturers and dealers felt that a radio should not cost more than 10% of the car's price, which in 1932 was usually around \$600.

It was obvious, however, that entertainment-minded consumers wanted automobile radios, and *Electronics* forecast that during 1932 the industry would sell 250,000 sets at an average retail price of \$45. In fact, almost 725,000 sets were sold at \$55, and in February 1934 the editors noted that the automobile radios "seen recently are much more sturdy in construction than those of a year ago."

"These sets," the magazine said, "are not only stronger physically, but easier to install, more immune from vibration troubles and in addition easier to service when something goes wrong."

By then mobile radio communication was recognized as a potentially lucrative market. A student at Purdue University, Robert Batts, had helped the Detroit Police straighten out their difficulties with one-way voice transmission to patrol cars. Batts, who once had worked in a radio parts store and had become friendly with a policeman from the Detroit force, designed the force's first acceptable receiver for a patrol car and installed it in April 1928. With six tubes (three tuned rf stages), it employed screen-grid tubes to avoid oscillation, copper-shielded compartments to reduce stray coupling, and lock-tuned capacitors to improve electrical and mechanical stability. The system was deemed a success in helping to fight crime.

Sets for the first two-way police network (transmitters and receivers at both ends) were installed in patrol cars in Bayonne, N. J., in 1933. Operating at about 33 megahertz, the sets were equipped with superregenerative receivers and tuned-circuit oscillators.

The police in Indianapolis were the first to use superheterodyne receivers. Their system, designed by Batts, was as successful as his first system in Detroit.

Meanwhile commercial advances in mobile radio brought forth the dynamotor power supply (Bosch Corp.,



**Calling Car 178.** The police in the early 1930s bought receivers and transmitters from Motorola for communication with their patrol cars.

1931) and the vibrator power supply (Mallory, 1931). RCA and GE entered the mobile radio field in 1936, and Motorola followed a year later. As a result of the success of police radio, the Federal Communications Commission in 1936 allocated 29 permanent channels for police communications in the band between 30 and 40 MHz. Interest in mobile communications then quickly spread to other areas, including industry and eventually personal radio.

**B**y now the frequency interference problems that had plagued early commercial broadcasting were becoming a memory. The present, controlled era in radio broadcasting dates from 1934, when Congress passed the New Deal legislation setting up the Federal Communications Commission. The number of commissioners was increased to seven, and control over the airwaves was tightened. The Communications Act of 1934 consolidated authority over both wire and wireless communications—point-to-point and broadcasting—in a single agency, the FCC. Empowered to revoke broadcasting licenses, the FCC moved the industry into what became known as the "cleaning up" period (1934–38).

By 1940, there were 777 a-m stations in the country, fm stations were taking root, and close to 500 million radio receivers were in use. International broadcasting was rapidly expanding in the high-frequency (3-to-30-MHz) portion of the spectrum. And commercial television was on the nation's threshold.

**T**elevision: it promised to be the largest show-biz attraction to hit the American home. David L. Sarnoff, then vice president and general manager of RCA, saw the medium in 1923 as an "adjunct" to radio that "will make it possible for those at home to see as well as hear what is going on at the broadcast station." It "will come to pass in due course," he confidently told his board of directors. The 1930s gave birth to television.

Development of the camera tube was of primary interest. It started in the 1920s (see chapter 2) and before the





# TRW Semiconductors: a chronology of leadership

**F**rom the very beginning in 1954, when we started as Pacific Semiconductors, we won recognition for major breakthroughs and leadership in the challenging new science of semiconductors.

When we became TRW Semiconductors in 1964, the tradition of leadership remained unbroken. The chronology of our achievements represents milestones in the growth of the science and industry of semiconductors.

1954 — Our first product, the improved glass-sealed AXIAL-LEADED DIODE was a highly innovative development, so much so that it is still in high production.

1958 — We invented the VARICAP®, one of our most famous products and now almost a generic term for varactor. Millions of radios and TV sets use similar products for automatic electronic tuning.

1959 — We developed the first HIGH POWER, HIGH FREQUENCY TRANSISTOR, a major semiconductor breakthrough. Now countless police, taxi, aircraft, and other radios use the products which followed this development.

1959 — We pioneered HIGH RELIABILITY SEMICONDUCTORS starting with the Minuteman program. TRW has been part of every

space and missile program since. The astronauts talked through our transistors.

1961 — We invented the TTL INTEGRATED CIRCUIT, the breakthrough that took computer construction out of the "Stone Age." Now billions of similar devices are used annually in giant computers and industrial controls.

1961 — We integrated BEO into our packages and pioneered the ISOLATED COLLECTOR STRIPLINE PACKAGE. Nearly all RF power transistors in production today utilize this innovative concept that revolutionized RF transistors.

1962 — We pioneered high voltage, TRIPLE DIFFUSED SWITCHING TRANSISTORS. Tens of thousands of power supplies employ our "3D" switching devices.

1963-1964 — TRW demonstrated the high reliability of transistors in a MOLDED PLASTIC PACKAGE. The TO-117 was the first molded package accepted by the military for HI-REL applications, and is still in wide use.

1966 — The FIRST TRANSISTOR DESIGNED SPECIFICALLY FOR CATV was developed by TRW and started the solid state revolution in that industry.

1967 — LVA® DIODES were a revolution in low voltage zener

diodes. These TRW pure avalanche devices are still unmatched in our industry.

1968 — TRW 5W, 2GHz TRANSISTORS available on the distributor's shelf started the solid state revolution in microwave communications.

1970 — CATV HYBRID AMP-LIFIERS were developed by TRW. These low cost, high performance amplifiers are in use in the majority of today's cable systems. We make more than the rest of the industry combined.

1971 — Remember the gold vs. aluminum controversy? TRW Semiconductors was the first major transistor manufacturer to successfully solve the production problems and incorporate gold into its line of MICROWAVE TRANSISTORS.

1972 — TRW patented INTERNALLY MATCHED TRANSISTORS. They made high power and broad bandwidth possible at microwave frequencies.

1972 — TRW pioneered high voltage, high speed MONOLITHIC DARLINGTON transistors. These high gain devices are in use in thousands of switching power supplies today.

1972 — TRW brought the POWER SCHOTTKY RECTIFIER from a laboratory curiosity to volume

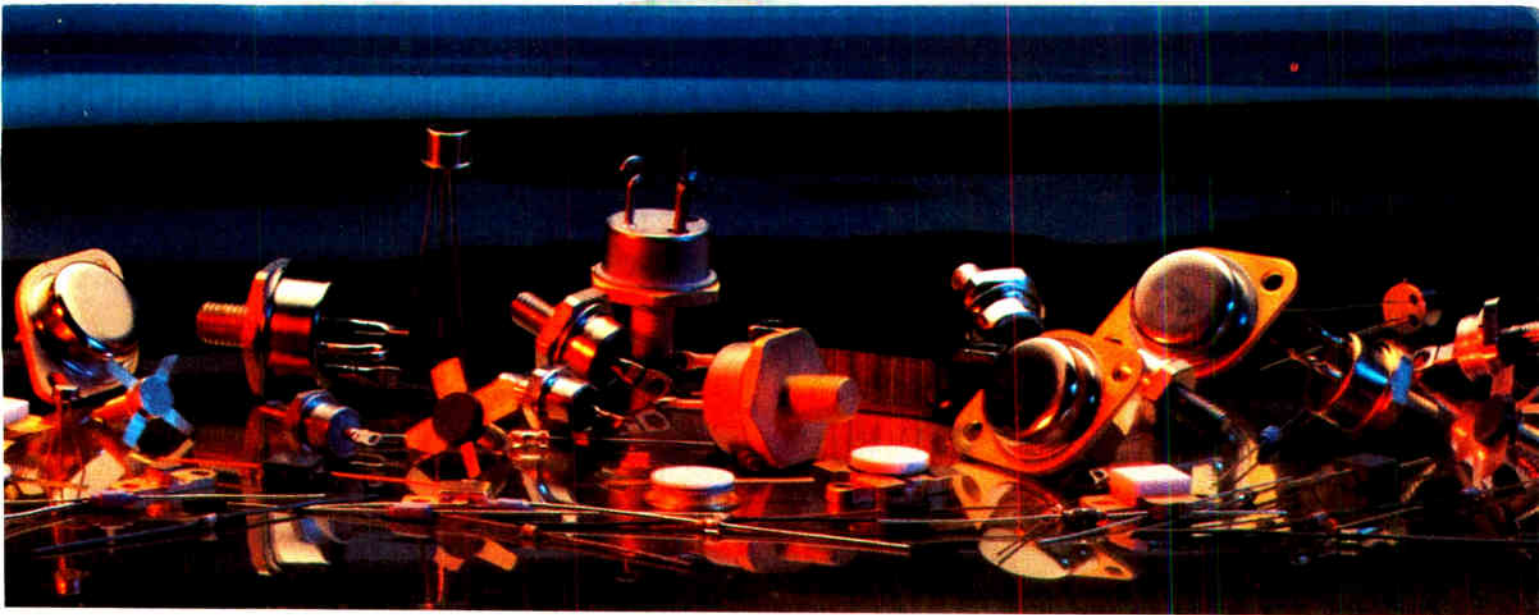

production as a highly efficient low voltage rectifier. We still manufacture more than the rest of the industry combined.

1975—TRW developed the industry's first MONOLITHIC RF L-BAND CIRCUIT, a vital milestone in advanced radar applications.

1976—Our 5W 5GHz TRANSISTORS extended the power/frequency barrier in microwave transmission.

1978—Our development of L-BAND RADAR transistors

makes us the premier supplier of these devices.

1980—Our new 53 CHANNEL CATV HYBRIDS will revolutionize TV by making 400MHz cable systems possible and bringing the viewer many more services than were available in the past.

**What does all this mean to you — today?** An unequalled breadth and depth of semiconductor products, experience and service available for your designs and your applications.

Our current product line is illustrated in three TRW Semiconductor handbook/catalogs, our **RF/Microwave Designers Handbook/Catalog**, the **TRW Power Semiconductors' Data Book**, and the **TRW RF Semiconductors Catalog, European Edition**.

They add up to over 1300 pages of product specs, diagrams, charts, tables, graphs and application notes. Contact your TRW Semiconductor Field Service Representative for one, two or all three.



## **TRW** RF SEMICONDUCTORS **TRW** POWER SEMICONDUCTORS

Each an Electronic Components Division of TRW Inc.  
14520 Aviation Boulevard, Lawndale, CA 90260

(213) 679-4561 • TWX: 910-325-6206 • Cable: TRWSEMICON • Telex 67-7148



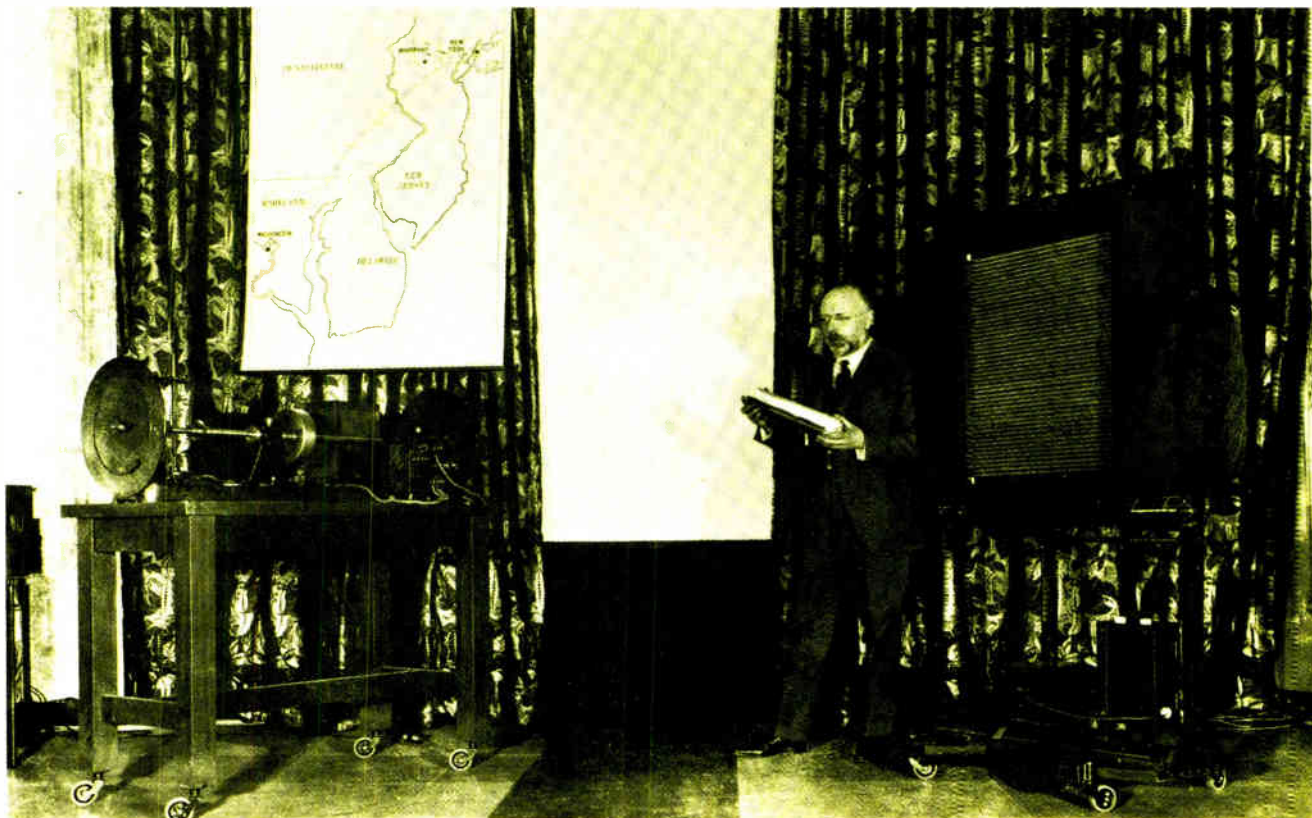

**Demo.** Bell Telephone Laboratories' Herbert Ives holds giant photoelectric cell that picked up signals at Bell's first public demonstration of TV on April 7, 1927. Screen (right) uses a meandering neon tube with electrodes placed so as to form a 2,500-element picture grid.

1930s were over two completely different systems were in competition with each other: an electromechanical approach and an all-electronic one.

The belief that an all-electronic system would be superior to the electromechanical appeared at the start of the 1930s, but it would be 7 years in Britain and more than 10 in the U. S. before the final verdict from the regulatory commissions emerged. In the interval many enterprising individuals and some pure researchers dedicated a goodly portion of their lives to finding a feasible solution. Among them were Herbert Ives of Bell Telephone Laboratories (color TV); Ernst F. W. Alexanderson of General Electric (a mirror-based scanning system for a mechanical TV approach); Germany's Manfred von Ardenne (a flying-spot cathode-ray tube for receiving images); and Allen B. Du Mont, who made significant contributions to the development of the CRT.

In August 1930, *Electronics* discussed what was needed to give television entertainment and commercial value: "We could hardly expect the home reproducer to be used for several hours a week unless one could not only recognize the face but also observe every shade of facial expression. The observer would expect to discriminate the wrinkles about the eyes and mouth when the speaker smiles, see the eyebrows change their position and observe the eyelids open and close, because it is such details which make up expression."

The writer argued that no mechanical systems could provide enough picture elements to meet these requirements, that only electrons offered sufficient control.

In June 1931 *Electronics* reported that television was a

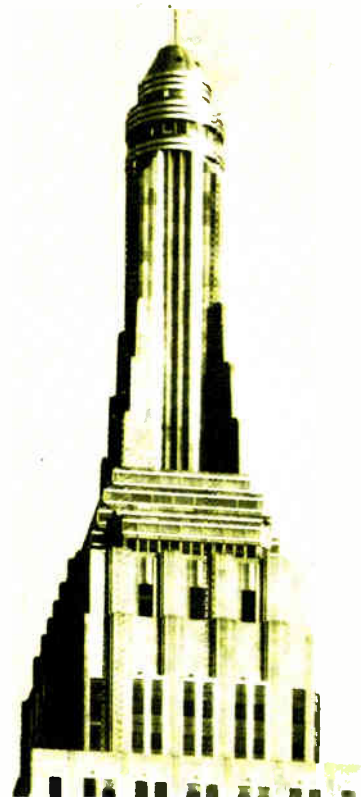

**No King Kong.** Experimental TV antenna installed by RCA in the Empire State Building broadcast its first signal on Oct. 30, 1931.

# Match with MSC custom memories

and microcomputers too. Standard off-the-shelf systems may not match up to your special needs. MSC can design and produce a memory system using the best technology, parts, and form factors available to meet your specific operating requirements. Our custom engineering capabilities also extend to microcomputers designed to an industry standard bus.

**Multiple Sourcing** MSC custom products utilize components from a wide range of industry sources, resulting in less delays in production, replacement, and delivery.

**Full Spec Components** We use only full specification components, and test string-



Monolithic  
Systems corp

gently to assure reliability and remove defective elements.

**Design Time Savings** Our custom products relieve you of unnecessary design and engineering time, allowing you to direct your resources toward other important areas.

**Cost Savings** The security of a fixed-price contract protects against cost overruns, while MSC experience assures best value component selection. For more information on MSC custom products and other Monolithic Systems Corp products and systems, please contact us at 14 Inverness Drive East, Englewood, Colorado 80112 (303) 770-7400 Telex: 45-4498.

## Extending the limits of information.

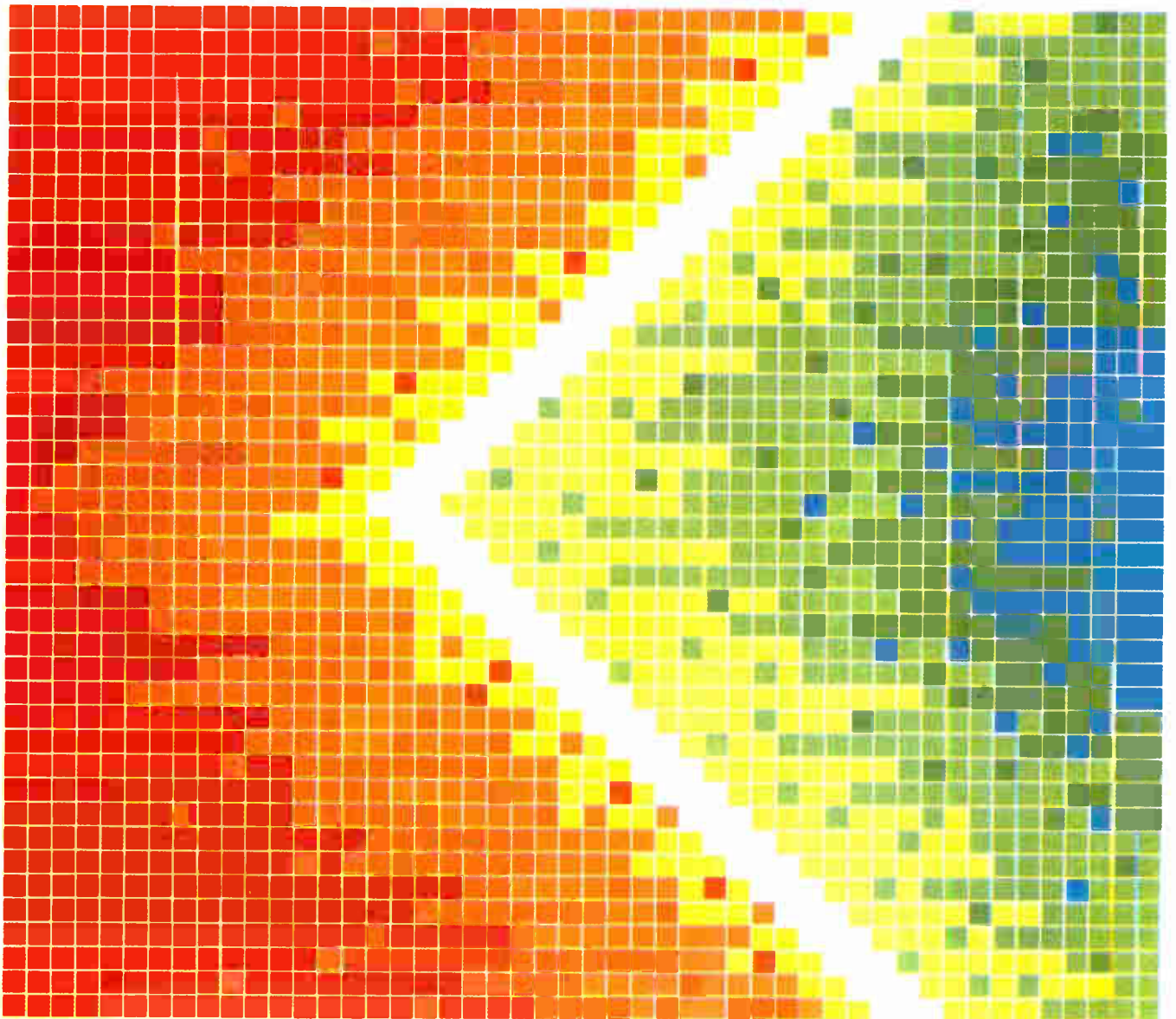

MSC Regional Sales Offices: Eastern Region 1401 B9 State Road, Princeton, NJ 08540 (609) 911-2440. Central Region 7200 East Dry Creek Road, Suite #B000, Englewood, CO 80112 (303) 770-1060. Western Region 49 South Baldwin, Suite D, Sierra Madre, CA 91024 (213) 351-8717.

Circle 113 on reader service card





## For reducing your mass termination costs...

**Molex has the answer.**

 **... Affordable Technology**

For more complete information, call or write:  
**Molex Incorporated**, 2222 Wellington Court,  
Lisle, Illinois 60532 (312) 969-4550

Molex has developed the most complete and versatile line of insulation displacement products available for .050" (1.27mm), .100" (2.54mm) and .156" (3.96mm) center applications. Whether your interconnection requirements are for signal level voltage or high current carrying power connectors; whether you have packaging density problems or a need for large spacing to prevent arcing, Molex's Jet-Flecs™ system offers you a solution.

The photo depicts the .050" (1.27mm) center product line which includes the 28 AWG cable and connectors with daisy chain, strain relief and closed-end options to meet your varied needs. Straight and right-angle headers are also available in various pin lengths and options, including the valuable lock-eject feature. The latest additions to the system include the dual in-line plug and edge connector.

But the components and cable are only half the system. The biggest advantage Molex offers you is the tooling which allows you to apply the cable or discrete wires to the connectors. Molex has a wide selection of application tooling for you to choose from; tooling that lets you terminate wires one at a time, using manpower alone, or apply up to sixteen at once with our high-speed, automatic equipment. Whatever your mass termination problems, look to Molex for the answer.

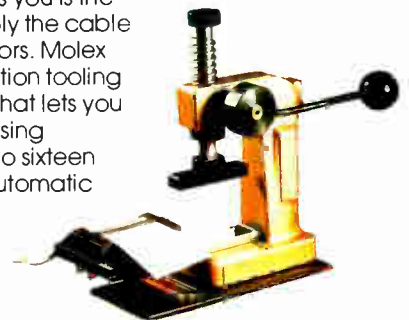

Circle 167 on reader service card

crude device for enthusiasts only, noting that in Boston one station was telecasting to owners of sets "bought in the form of parts from Kresge stores."

"In New York no less than four stations are on the air," the magazine observed. "Radio dealers, using television sets as curiosity-creators, have so far furnished the largest outlet for television receivers. Whether they can interest other 'lookers' sufficiently to spend from \$100 to \$300 for a televisor depends."

The National Broadcasting Co. completed the first television antenna on top of the Empire State Building in 1932, but at the end of the following year there were still major problems: a lack of picture detail (the number of scanning lines ranged from 45 to 343), the high cost of receivers, short transmitter range, difficulty in running stations together for network programs, and tremendous studio expense.

In May 1934, W. R. G. Baker, RCA Victor's general manager, addressed the problem of studio expense and concluded that it was at that time insoluble. He estimated that if 700,000 people bought TV sets, they would require 80 transmitters that, with a network, would cost \$58 million a year to operate, maintain, and replace. The total investment in the broadcast industry was then about \$25 million, and this had been spent over 10 years.

Programming was another problem: "A radio broadcast station is likely to have 5,000 program hours a year," Baker noted. "For a television station to show once each of the 300 feature motion pictures produced a year in the United States would take up only 300 or 350 program hours. To broadcast once each of the new plays shown on New York stages would take up only another 300 hours. Shorts and newsreels would bring the total only to 2,000 hours, and not all news events would be in reach."

*Electronics* surveyed the status of television in October 1934, comparing various systems. The six companies mentioned used different numbers of scanning lines—from 60 to more than 400. Most transmitted 24 pictures a second (the motion-picture rate). Three systems—RCA Victor, Philco, and Television Laboratories—used cathode-ray tube receivers (with green phosphor); the others used mechanical devices. It was obvious that television required standards so that development could be orderly.

It was important to decide how many scanning lines should be used, whether they should be interlaced and what field and frame rates they required. These decisions influenced video bandwidth (and, in turn, transmitter and receiver bandwidth), picture flicker, and deflection-circuit frequencies. The Radio Manufacturers Association (now the Electronic Industries Association) formed a Television Standards Committee. As early as 1931, it had recommended the allocation of vhf channels, and in 1936 and 1938 it recommended TV transmission standards. But as there was no unanimity in the industry, (Philco and DuMont disagreed with the proposals), the FCC did not set standards until 1941. The number of lines was then set at 525, transmission at 60 fields per second and interlaced 2 to 1, and video bandwidth at 4.24 MHz. In Britain, where scheduled telecasts had begun in 1936 and George VI's coronation was viewed over a wide area in 1937, a 405-line standard was



**Actor.** Felix the Cat, rotated on phonograph turntable, was a TV performer for experimental telecasts in 1930 over station W2XBS.

adopted; in France an 819-line standard emerged.

Meanwhile, throughout the 1930s in the U.S., the radio industry was reluctant to allow television to jeopardize its profitable broadcasting business, and this lack of interest was reflected in FCC inaction. The issue was further complicated by the fact that RCA, the dominant organization in TV broadcasting, was committed to its own electronic scanning approach, which was clearly many years away from commercial reality, rather than to the more immediately available mechanical scanning techniques, such as Du Mont's.

U.S. television finally showed its potential at the New York World's Fair in April 1939, when RCA began telecasting regularly from its Empire State Building transmitter. A few receivers were placed on sale at \$625 each (new cars could be bought for \$900), and visitors to the fair could watch the Republican National Convention of 1940 live from Philadelphia. Transmission was



**CRT man.** Allen B. Du Mont, shown in late 1940s photo, helped develop the cathode-ray tube for application in oscilloscopes.



# THE NEXT GREAT

**Six years ago Biotation brought you the first logic analyzer. Today we bring you the industry's broadest selection. And there's more on the way.**

Keeping abreast of the latest technological advances is half the battle these days. If you're designing with digital logic — especially microprocessors — you know how fast things are changing.

The new demands of digital logic are what Bill Moore, Biotation's first chief engineer, had in mind when he developed the logic analyzer, back in '73. He called it a "glitch fixer," designed to track and unravel the mysterious electronic glitches that plague digital logic designs.

Bill Moore was named Man of the Year by Electronics magazine for his invention.

We're proud of that. In fact, pride is a big part of everything we do. It's the secret ingredient in each logic analyzer in our broad line.

Our other "secret ingredient" is good hearing. We listen carefully to our customers. Then design our products to meet your needs. And we keep a finger on the pulse of technology. So we can understand the special demands it puts on you.

As a result, we've been first with each important logic analyzer advance. For example, when we developed "latch mode" we gave you the capabilities to latch onto glitches — random pulses — as narrow as 2 nano-seconds in current models.



# GLITCH FIXER.™

Today our K100-D includes latch mode — and much more. It's the premier logic analyzer for the most complex logic problems. It combines built-in display, keyboard input, 16 channels (up to 32 with adapter) and 100 MHz sampling rate.

Not every application requires such a powerful tool. To meet your special needs, we can deliver seven models, with 8, 9, 16, 27 or 32 channels, sampling rates to 200 MHz and memory lengths to 2048 words.

Which glitch fixer is best for your application? Call us at (408) 988-6800 to discuss your needs — or any time you need technical assistance. Our application engineers are here to help. For more information on our complete line of logic analyzers, write for our catalog.

Write Gould Inc., Biomation Division,  
4600 Old Ironsides Dr., Santa Clara, CA 95050.

And the next great glitch fixer? One thing you can be sure of. It — and the one after it — will be wearing our name.

*Got a glitch?  
Get a*  
**GLITCH  
FIXER**  
FROM GOULD

 **GOULD**

*An Electrical/Electronics Company*

Circle 117

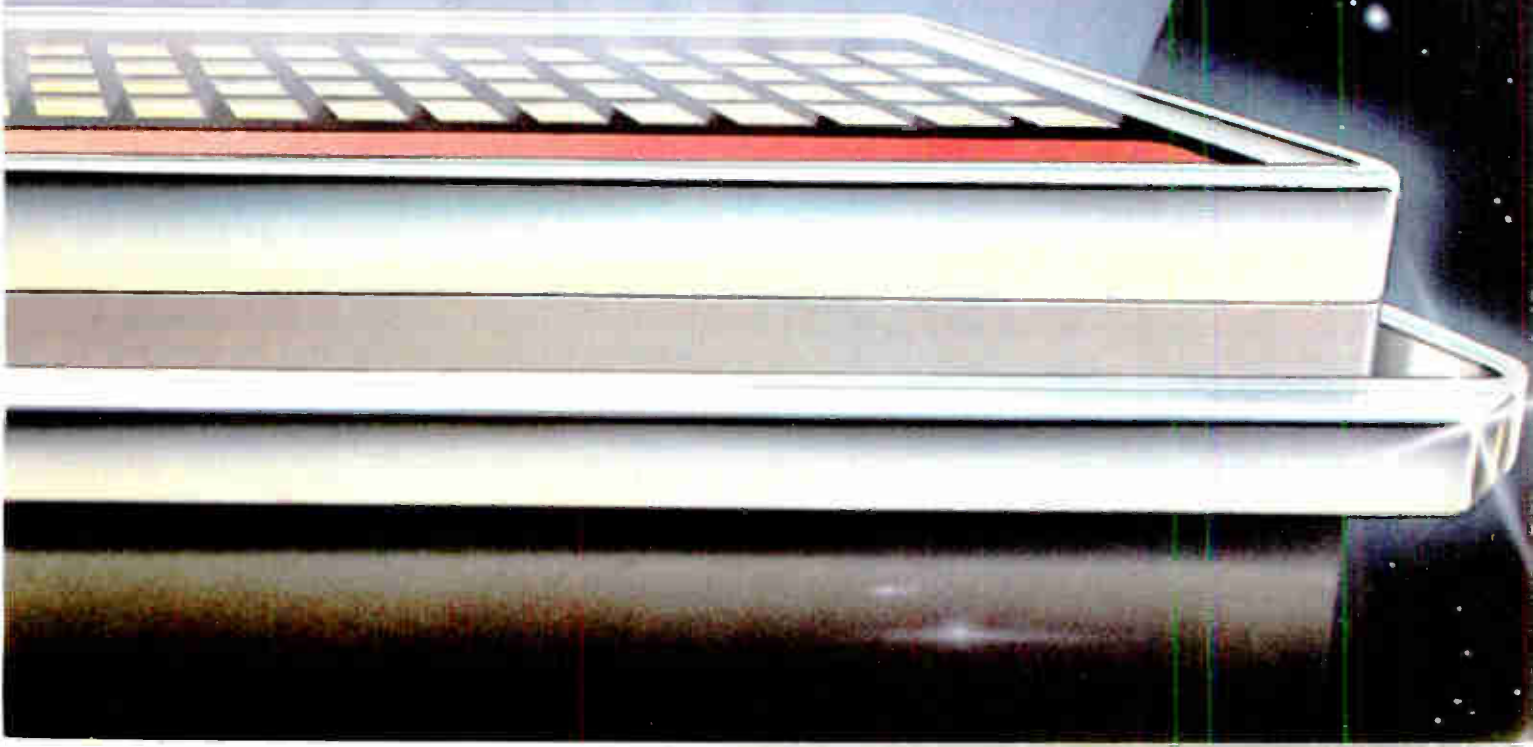



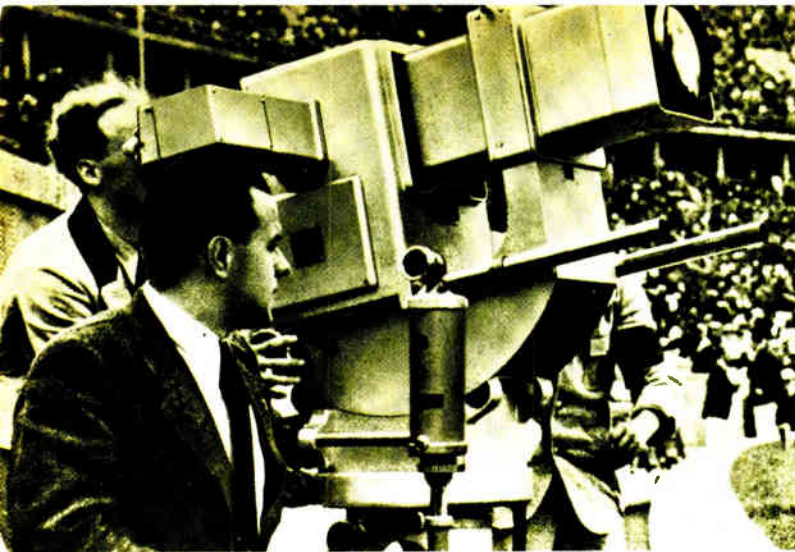

**Olympian.** Telefunken used iconoscope TV camera at 1936 Berlin Olympics. Cameraman Walter Bruch later invented PAL color TV.

via an AT&T experimental coaxial cable authorized by the FCC in 1936.

Subsequently six companies announced that they would produce TV sets for the New York market: the American Television Corp., Andrea Radio Corp., Allen B. DuMont Laboratories, General Electric, Philco Radio and Television Corp., and the RCA Manufacturing Co. Set prices ranged from \$125 for a two-channel model with a three-inch screen to \$595 for a 12-inch model that received seven channels and contained an automatic phonograph as well. These were monochrome sets, of course. Color TV emerged briefly in 1940 (see chapter 4), but World War II halted further developments.

Radio was the star and television played a supporting role in the communications drama of the 1930s, but other electronic developments waited impatiently in the wings. While some waited, they polished and improved their acts. And some new stars were born.

**B**y the early 1930s, further improvement in radio and telephone system signal-to-noise ratios was limited by amplifier distortion. Until then, amplifiers had to provide only a small amount of amplification since telephone and radio links covered only short distances. But with the growth of longer lines of communication, high amplifications were needed.

When the amplifiers were operating to deliver this power, they had to operate in the so-called nonlinear portion of their input-output characteristics. These nonlinearities were in the relationship between the instantaneous input and output voltages of vacuum-tube amplifiers. While not too much of a problem in amplifiers that are intended to handle one signal at a time, the distortion becomes intolerable when two or more channels are fed through the same amplifier, as they are in a carrier system.

What happens is that the nonlinearity actually generates new frequency components in the output signal. These are produced by the interaction of the signals in the different channels. The result is cross modulation—elements of the speech in one channel are transferred to another. The solution of the problem is the elimination of its cause. And the way to do that is to apply negative feedback.

This concept is perhaps one of the most basic in the history of electronics. As already noted, it was discovered by Black of Bell Laboratories in 1927. What negative feedback does is to feed some of the amplifier output signal back to the input in phase opposition to the input signal. Even if the original amplification is nonlinear, the resulting new amplification is practically linear. What is more, if the original amplification factor (gain) tends to drift over time, the new (lower) gain of the feedback amplifier is practically constant.

Amplifiers based on Black's feedback concept soon became the prevalent method for maintaining high-amplification, low-distortion lines. These amplifiers had, as a side benefit, a wider bandwidth than nonfeedback amplifiers. So, from about 1934, there was little problem in extending the telephone system by use of very wide bandwidths with many channels on conductors. The standard soon became basic groups of 12 speech channels in the frequency range of 60 to 180 kHz, which allowed 4-kHz channel spacing. This is the basic system used today, except for the addition of higher levels of multipliers and supergroups. Since the line costs per speech channel are drastically reduced by this approach, cheaper long-distance calls become possible.

**W**hether telephone switching should be manual or automatic is essentially an economic matter. The controversy itself dates to the beginning of telephony when both manual and electromechanical switches were used. Where the number of calls per subscriber is high, it is cheaper to use an automatic exchange. And, of course, whether the calls are long- or short-distance is a major consideration. Long-distance calls have to be routed through many switching centers; short-distance calls do not. Since in the 1930s long-distance telephony grew slowly, there was no big need for automatic networks.

Of course, all the systems had to be compatible. Automatic exchange offices had to retain some manual exchanges as it was not economic to replace them until adequate return had been obtained on their cost.

One future star was radar (an acronym for "ratio detection and ranging"). Like other communications systems, it did not emerge suddenly, full-blown, from the hand of one inventor. Many researchers contributed to its evolutionary development. Early observers did not even know what they had stumbled upon.

In September 1922, two Navy experimenters, A. Hoyt Taylor and Leo C. Young, were engaged in high-frequency radio-communication tests across the Potomac when a passing vessel intercepted the propagation path between transmitter and receiver. The interruption was noticed by Taylor and Young. They were aware of the problem of screening naval forces from penetration by other ships in darkness and fog, and though their observation was unrelated to their radio experiment, the application was obvious. They proposed that high-frequency radio transmitters and receivers be installed on destroyers to detect the passage of other ships between any two destroyers in radio contact.

It wasn't radar. It didn't even involve reflection of

# 4,000,000 PICs Prove Our Point.

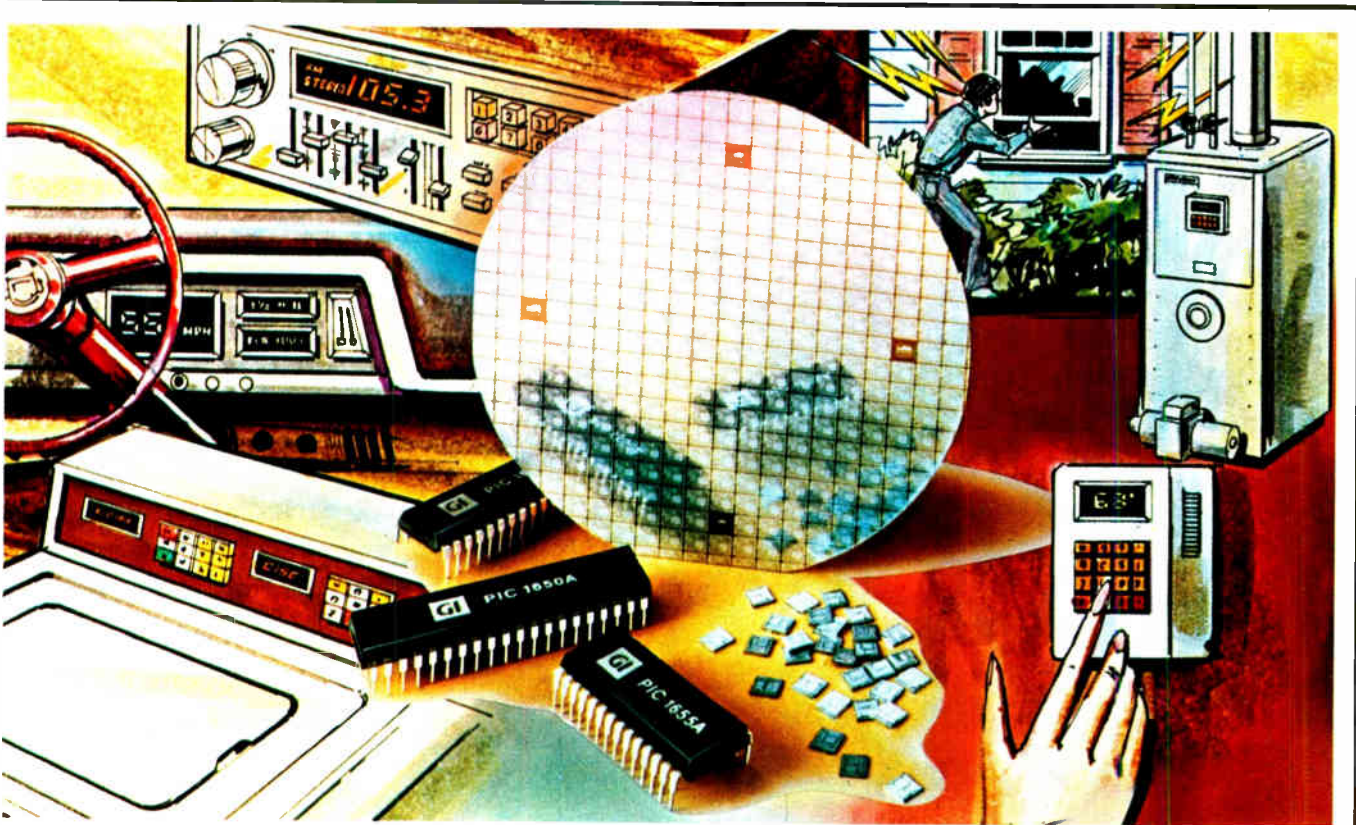

**The point is, more designers are choosing General Instrument PIC microcomputers than ever before.** And they're using them in an ever-widening range of applications; including consumer appliances, energy management systems, electronic games, security systems, keyboards, display drives, TV/radio tuning systems, and automotive dashboard instrumentation, to name but a few.

That's why General Instrument delivered more than four-million 8-bit microcomputers in 1979; more than *twice* as many as our leading competitor.

Big numbers, certainly, but more than that, our record is a direct reflection of the success and

designer acceptance of General Instrument's business philosophy: Deliver high quality products at competitive prices, backed by comprehensive customer service and support. For example, PIC can revolutionize the performance and energy efficiency of universal motors. As a closed loop controller, PIC provides soft starting and current limiting, improves efficiency under variable loads, protects against motor-jam, prevents overheating plus controls speed. What about cost? Remember the facts: General Instrument's PIC microcomputers are already proven cost effective in high volume applications.

To support our many users, we offer a complete set of hardware

and software aids, including the PICAL two-pass assembler program and PICES In-Circuit Emulation System. These help customers in their design, development, and evaluation of a particular application. In short, we deliver more microcomputers because our microcomputers deliver more to our customers. And that's the *real* bottom line.

For more information on the PIC Series, write to: Microelectronics Division, General Instrument Corporation, 600 West John Street, Hicksville, New York 11802, Attention: Literature Department, or call 516-733-3107.

**We help you compete.**

## GENERAL INSTRUMENT



# YOUR CHIPS COME IN



## MITEL'S 'CHIP + CHIP' TOUCH-TONE® RECEIVER.

At Mitel Semiconductor, we practice one-upmanship. The MT8860 DTMF Decoder and the MT8865 Band Split Filter are the lowest cost 100 per cent semiconductor solutions to a complete DTMF receiver available. Smaller than conventional receivers, this chip-set features separate filter and decoder components with applications ranging from switching systems to mobile radio.

### FEATURES

- 12 mW power dissipation.
- Single supply voltage from 4.5 to 13 volts.
- 14 dB signal to noise ratio.
- Exceptionally low talk-off rate (less than three hits on Mitel test tape).
- 30 dB dynamic range.
- 30 dB precise dial tone rejection.

Now available for immediate delivery.

LAUNCHING THE CHIPS OF TOMORROW.



# MITEL SEMICONDUCTOR

**United States:** 1735 Jefferson Davis Highway, Suite 100S, Arlington, Virginia, U.S.A. 22202. Telephone (703) 243-1600  
1223 Westchester Pike, Havertown, Pennsylvania, U.S.A. 19083. Telephone (215) 449-5556.  
2321 Morena Blvd., Suite M, San Diego, California, U.S.A. 92110. Telephone (714) 276-3421.

**Canada:** P.O. Box 13089, Kanata, Ottawa, Ontario, Canada K2K 1X3. Telephone (613) 592-2122,  
Telex: 053-4596, TWX: 610-562-8529.  
18 Airport Blvd., Bromont, Quebec, Canada J0E 1L0. Telephone (514) 534-2321, Telex: 05-267474.

**Europe:** Hamilton Road, Slough, Berkshire, England SL1 4QY. Telephone 0753-36137, 0753-36138, Telex: 847730  
Fredericiagade 16, Suite 309, 1310 Copenhagen K, Denmark. Telephone (01) 119302, Telex: 27246

**Asia:** Park-In Commercial Centre, Suite 1423, 56 Dundas Street, Mong Kok, Kowloon, Hong Kong.  
Telephone 3-318256, Telex: 54235.

Circle 120 on reader service card

Copyright 1979 Mitel Corporation  
® Registered Trademark of AT&T

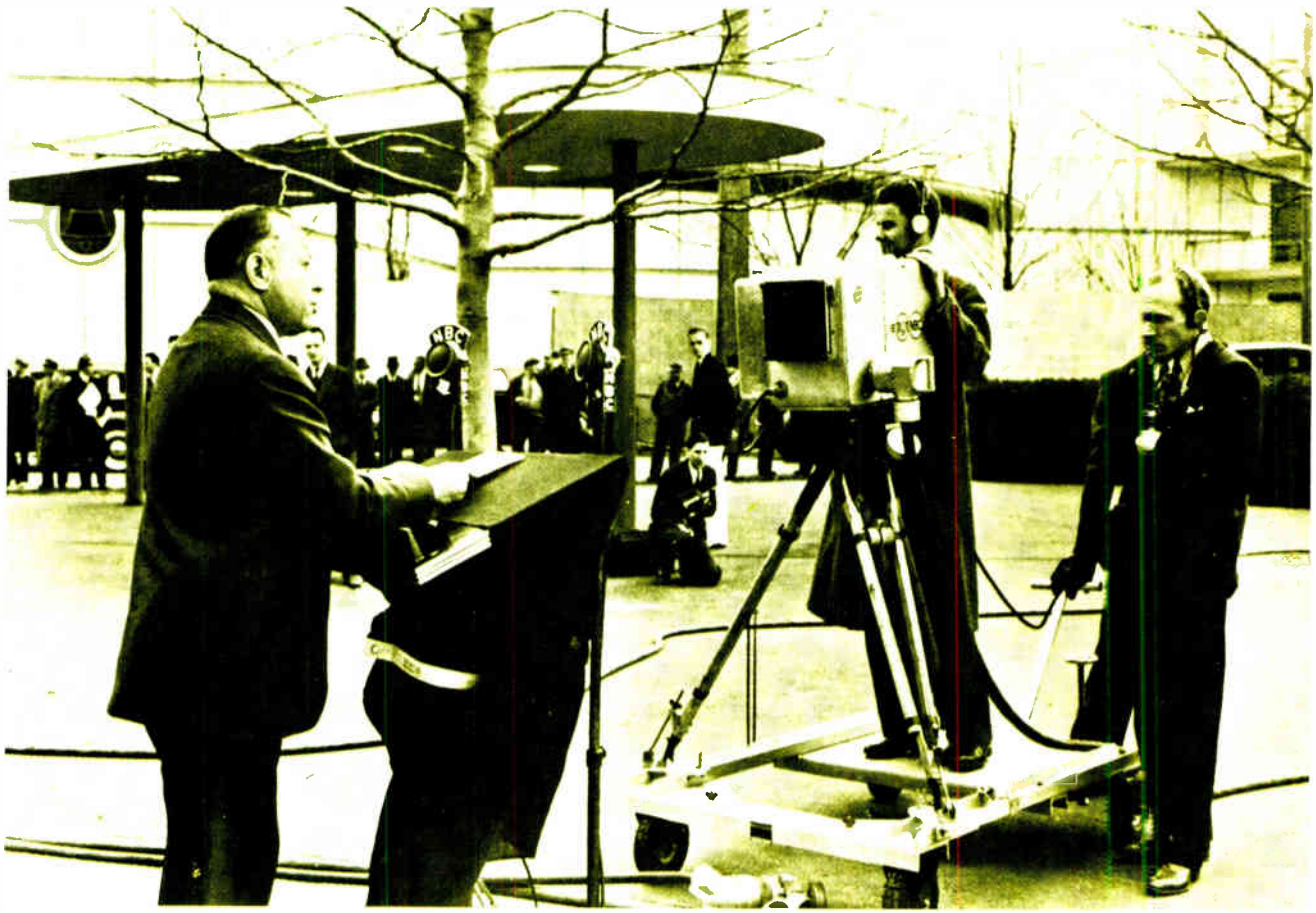

**Covering the news.** Radio Corp. of America president David Sarnoff stood in front of a television camera and dedicated RCA's pavilion at the 1939 New York World's Fair. The dedication was one of the first in the U. S. at which the fledgling TV medium covered a news event.

radio waves. But it did start Taylor and Young thinking about using radio waves to detect moving objects.

Seven years passed. In June 1930, Laurence A. Hyland, a colleague of Taylor and Young, was experimenting with high-frequency radio direction finding. He detected a severe disturbance of the propagation field by an airplane flying overhead. Hyland was a Navy man and sensitive to the threat that aircraft posed to ships in wartime. Again, the application was obvious. He proposed that high-frequency radio be used to warn against approaching aircraft.

In January 1931, the Naval Research Laboratory (then known as the Navy's Aircraft Radio Laboratory) in Washington, D. C., set up a project for the "detection of enemy vessels and aircraft by radio." It was years before even the principles of radar were fully understood and implemented. In simplified form, they might be stated as follows:

- Electromagnetic radiation at high radio frequencies is used to detect and locate remote reflecting objects.
- The radiation is sent out in pulses of a few microseconds' duration, separated by intervals many times the duration of each pulse.
- The pulses are returned from the reflecting objects, and the returns are detected and displayed by receiving equipment placed at the point of transmission.
- The distance to the objects is determined by measurement of the time it took the pulses to reach the targets

from the transmission equipment and return to it.

- The directions of the targets are determined by use of highly directive radio antennas.

While no one person did all these things, the gradual implementation of them all by contributors both in this country and abroad is generally conceded to have led to the first radar.

Radar leaned heavily on certain contemporary devices for its development. The most important, the cathode-ray tube, became generally available as a laboratory tool in the early 1930s. And, of course, radar would not have been possible without the vacuum triode.

At the U. S. Naval Research Laboratory, the radar researchers investigated the "beat" method. In this approach the transmitter and receiver were widely separated and shielded from each other. Continuous-wave transmission was used, and at the receiver the fluctuating signals, called "beats," were observed when an airplane flew through the radio propagation field. A range of 40 miles was obtained.

The wide separation of transmitter and receiver required for proper operation precluded the use of the beat method on ships. Its usefulness was therefore limited to the protection of large land areas, such as cities and military bases.

Since this was the Army's responsibility, the Navy shunted its findings to that branch in January 1932. Navy interest flagged. Then Young suggested to Taylor



**Will they  
commit the  
resources  
we  
need?**





# When it's TRW, the answer is yes.

Resources—facilities, people or capital—the TRW Electronics Group has all three and will commit them to your product program requirements. At TRW/ECG, this kind of tangible commitment is a standard company practice—not just an important-sounding phrase.

The long-lasting relationships that TRW/ECG has with its customers are based on much more than product quality, delivery or price. The relationships may have begun with these essentials, but are maintained by our

customers' knowledge that they have a dependable supplier.

To start the process that will make you one of the many organizations that have a long-range, resource-committed association with TRW, call any TRW/ECG sales office.

You'll find them listed in EEM, Gold Book, Electronics Buyers' Guide, Who's Who in Electronics, the Electronic Industry Telephone Directory and the Electronic Buyers' Handbook.

**TRW** CAPACITORS  
**TRW** CINCH CONNECTORS  
**TRW** CINCH-GRAPIK  
**TRW** ELECTRONIC FUNCTIONS  
**TRW** GLOBE MOTORS  
**TRW** INDUCTIVE PRODUCTS

**TRW** IRC NETWORKS  
**TRW** IRC RESISTORS  
**TRW** LSI PRODUCTS  
**TRW** OPTRON  
**TRW** POWER SEMICONDUCTORS  
**TRW** RF SEMICONDUCTORS

**TRW** ELECTRONIC COMPONENTS GROUP

DIVISIONS OF TRW INC.

Circle 123 on reader service card



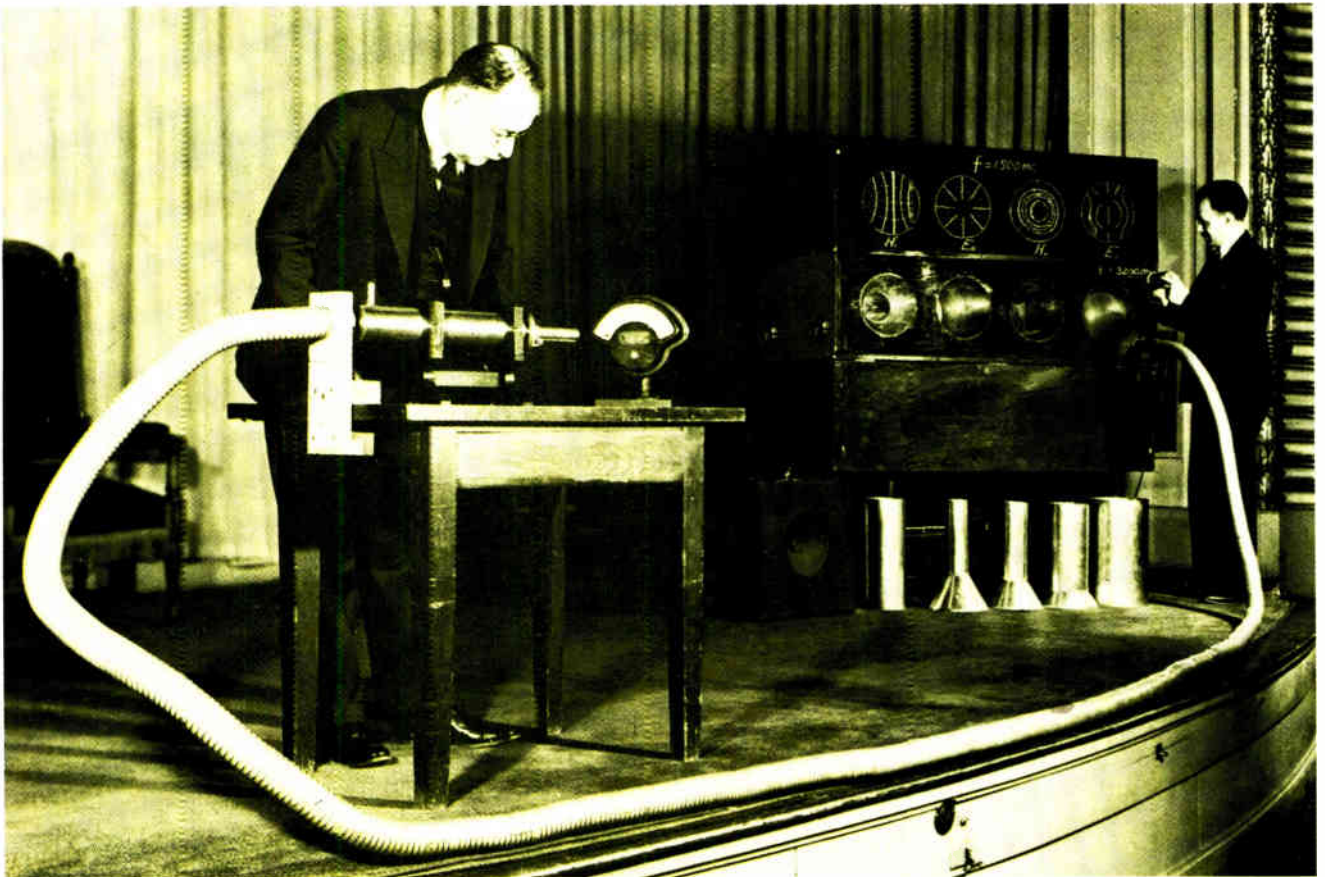

**Guide.** The work of Bell Telephone Laboratories' George Southworth represented a new way of thinking about radio waves. This photograph was taken at the first public demonstration of waveguide transmission before the Institute of Radio Engineers on Feb. 2, 1938.



**Big screen.** Telefunken TV receiver, atop loudspeaker at 1932 Berlin Radio Show, was 9 by 12 cm, had 90 lines, 25 frames per second.

that the pulse method should be tried. Work on this approach was started in 1934.

The first step was to develop an indicator to display the transmitter and receiver outputs. A suitable sweep circuit was built for a commercial cathode-ray oscilloscope. The next step: a pulse transmitter. The transmitter frequency of 60 MHz was chosen because that had been used in the beat experiments. The antenna was a

single resonant reflector. The pulse power was estimated at 100 to 200 w.

The next question was: could echo pulse energy be detected during the intervals between transmitted pulses?

A broadband, high-gain experimental communications receiver was borrowed and connected to a second antenna, similar to the transmitting antenna. When a small airplane flew across the beam at a distance of about a mile, the echo of the transmitted pulse caused the receiver output meter to fluctuate "violently," to quote one observer, between zero and saturation. It was evidence that echo signals could be detected during the intervals between transmitted pulses. Development of a practical radar receiver got under way immediately.

Radar imposed certain severe requirements on the receiver that were not encountered in conventional radio receivers of the time. Close proximity of receiver and transmitter subjected the receiver to heavy overload, and recovery to full sensitivity was essential in the incredibly short time of a few microseconds.

A second requirement was to minimize the time the receiver would oscillate, or ring, in response to the strong echo to the transmitter's high signal level. Researchers did this by redesigning the vacuum-tube amplifier circuitry and limiting the level to which the circuits could be driven by the transmitter.

A third requirement was for fast response by the receiver to amplify the short pulse echoes. This meant



# An important tip for PDP-11 users

## Play the blue-chip cards from Able.

### COMMUNICATIONS PRODUCTS

#### DMAX/16™ (16-LINE DH11 REPLACEMENT)

**INSTALLS IN:** All PDP-11's; in less than one half the space of DH11. **DATA RATES:** All 14 standard baud rates plus 19.2K baud and one user programmable data rate (16 baud rates). **PROCESSING ADVANTAGES:** Word transfers (in lieu of byte DMA) cut processing overhead by half! **OPERATING MODES:** Full or half duplex with full modem control via DM/16 option. **CAPACITY:** Up to 256 lines on a single PDP-11.

#### QUADRASYNC/B™ (4-LINE DL-11 REPLACEMENT/EIA)

**INSTALLS IN:** All PDP-11's; 4-lines per SPC slot at one unit load to Unibus. **DATA RATES:** 7 independently selectable baud rates for each of 4 channels (150-9600). **ELECTRICAL:** EIA standard RS232C (Modem control not supported). **VECTOR/ADDRESS SELECTION:** Vector and address values to be set on boundaries of 008 or 408. 16 continuous word address for Vector or Address.

#### QUADRASYNC/C™ (4-LINE DL11 REPLACEMENT/CL)

**INSTALLS IN:** All PDP-11's; 4-lines per SPC slot at one unit load to Unibus. **DATA RATES:** 7 independently selectable baud rates for each of 4 channels (150-9600). **ELECTRICAL:** 20MA current loop (Send + Receive). **VECTOR/ADDRESS SELECTION:** Vector and address values to be set on boundaries of 008 or 408. 16 continuous word address for Vector or Address.

#### QUADRASYNC/E™ (4-LINE DL11-E REPLACEMENT)

**INSTALLS IN:** All PDP-11's; 4-lines per SPC slot at one unit load to Unibus. **DATA RATES:** 7 independently selectable baud rates for each of 4 channels (150-9600). **ELECTRICAL:** EIA standard RS232C - with modem control. **VECTOR/ADDRESS SELECTION:** 16 continuous word address for Vector or Address - starting values selected on any boundary.

#### QUADRASYNC/LSI™ (4-LINE DLV11 REPLACEMENT)

**INSTALLS IN:** LSI-11 and PDP-11/03; 4-lines/card at one unit load to Unibus. **DATA RATES:** 8 independently selectable baud rates for each of 4-channels (110-9600). **ELECTRICAL:** 20MA active/passive current loop (Send + Receive) - also supports EIA standard RS232C. **VECTOR/ADDRESS SELECTION:** Like DLV-11 - 3-channels must have contiguous addresses and 1-channel may be set to any address including console address.

#### QUADRACALL™ (4-LINE DN11 REPLACEMENT)

**INSTALLS IN:** All PDP-11's; 4-lines per SPC slot at one unit load to Unibus. **PERFORMANCE:** Interfaces up to 4 Bell 801 ACU's with Unibus enabling any PDP-11 to dial any DDD network number to establish data link. **INPUT/OUTPUT:** 5-input signals from ACU are handled by EIA RS232 receivers. 6-output signals are transmitted using EIA RS232 drivers. **VECTOR/ADDRESS SELECTION:** Allows selection of device address and vector by use of pencil switches.

#### DV/16 (16-LINE DV11 REPLACEMENT)

**INSTALLS IN:** All PDP-11's; in less than one half the space of DV11. **DATA RATES:** 16-line throughput of up to 76,800 char/sec (19.2K baud full duplex for each line) total. **PROCESSING ADVANTAGE:** Word transfers (in lieu of byte DMA) permit user to operate within one half the DV11 bandwidth for data transfers. **OPERATING ADVANTAGE:** User may mix sync and async lines in combinations of 4 or 8 lines with modem control and full system software compatibility with all DV11 performance features.

### MEMORY PRODUCTS

#### SCAT/45™ (ADD-IN FASTBUS MEMORY)

**INSTALLS IN:** PDP-11/45, -11/50 and -11/55. **EXPANDS IN:** 32K word increments/board. One-half of the available Fastbus space will accept full 124K word complement. **ADDRESSES ON:** Any 4096 word boundary across entire 124K word range. User has full memory complement at 330 nsec cycle-time memory instead of 32K word limitation imposed by the computer manufacturer.

#### CACHE/45™ (CACHE BUFFER MEMORY)

**INSTALLS IN:** PDP-11/45, -11/50 and -11/55. **CAPACITY:** 2048 byte (1K word). **ENHANCEMENT FACTOR:** Run time reductions to 50% (100% speed improvement) are achievable. **CACHE PARITY:** Automatically goes off-line in event of any data error. **RANGE SELECTION:** User may optimize hit ratio by upper/lower limit switch settings. **SPECIAL FEATURE:** Cache/45 can be enabled via software or console switches.

#### CACHE/434™ (4K WORD CACHE MEMORY)

**INSTALLS IN:** PDP-11/34 and -11/34A without using any additional backplane space! **CAPACITY:** 8192 byte (4K word). **ENHANCEMENT FACTOR:** Run time reductions to 40% (70% speed improvement) are achievable. **CACHE PARITY:** Automatically goes off-line in event of any data or address error. **RANGE SELECTION:** User may optimize hit ratio by upper/lower limit switch settings. Cache action monitor indicates hit rate.

#### CACHE/440™ (4K WORD CACHE MEMORY)

**INSTALLS IN:** PDP-11/35 and -11/40 without using any additional backplane space! **CAPACITY:** 8192 byte (4K word). **ENHANCEMENT FACTOR:** Run time reductions to 40% (70% speed improvement) are achievable. **CACHE PARITY:** Automatically goes off-line in event of any data or address error. **RANGE SELECTION:** User may optimize hit ratio by upper/lower limit switch settings. Cache action monitor indicates hit rate.

#### EMULOADER™ (ODT/BOOTSTRAP/LOADER REPLACEMENT)

**INSTALLS IN:** PDP-11/05, -11/10, -11/35, -11/40, -11/45, -11/50 and -11/55. **MECHANICAL:** Dual width card replaces standard Unibus termination; requires no additional backplane space. **OPERATING ADVANTAGE:** Provides fixed console emulator (ODT) and bootstrap loaders for DL11, PC11, RF11, RK06, RK11, RP04/05/06, RP11, RS03/04, RX11, TC-11, TM11 and TU16. **SPECIAL FEATURE:** Performs memory diagnostic each time a boot operation is done from ODT.

### GENERAL PURPOSE PRODUCTS

#### QNIVERTER™ (Q-BUS TO UNIBUS CONVERTER OR UNIBUS TO Q-BUS CONVERTER)

**INSTALLS IN:** LSI-11, LSI-11/23, PDP-11/03 and PDP-11/23 via quad-width card. **APPLICATIONS:** Allows Unibus-compatible controllers and memories to be used with LSI computer systems, or LSI-based peripherals to be used with PDP-11 computer systems. **FEATURES:** Supports features of LSI-11/23 including the full 128K address capability.

#### REBUS™ (BUS REPEATER - DB11 REPLACEMENT)

**INSTALLS IN:** All PDP-11's; without using any additional backplane space. **MECHANICAL:** One dual-width card plugs into the same pair of connectors as the Unibus extension cable which is then plugged into the REBUS connectors. **COMPATIBILITY:** Allows for 18 additional bus loads and 50 foot bus extension. Requires no software changes. Bus cycle time unaffected for devices on CPU side of REBUS - increased by 2-0 nsec max. for devices on outboard side.

#### DUAL I/O™ (GENERAL INTERFACE-DR11-C REPLACEMENT)

**INSTALLS IN:** All PDP-11's; in any SPC slot via quad-width card. **APPLICATION:** Dual I/O is equivalent to two (2) DR11-C's and provides the logic for program-controlled parallel transfer of 16-bit data between two (2) external user devices and a Unibus system. **OPERATING ADVANTAGE:** Provides user the hardware/software equal to a dual DR11-C in one-half the space and one-half the bus loading of DR11-C's.

#### UNIFACE™ (UNIBUS-COMPATIBLE, GENERAL-PURPOSE I/O)

**INSTALLS IN:** All PDP-11's in any SPC slot via hex-width card. **APPLICATION(S):** Limited only by user's ingenuity: can form additional intelligent Unibus I/O channel(s), communications processor(s), efficient KMCI1 equivalent(s), or user-proprietary device(s). **OPERATING ADVANTAGE:** To PDP-11's, UNIFACE looks like a standard controller at one bus load; to devices served, UNIFACE acts as a powerful CPU.

#### BUSLINK/UNI, LSI OR U TO Q (CPU TO CPU LINK; UNIBUS TO UNIBUS; UNIBUS TO Q-BUS OR Q-BUS TO Q-BUS)

**INSTALLS IN:** All PDP-11's and/or LSI-11's via pairs of hex-width, hex/quad-width, or quad-width cards and supplied cables. **APPLICATION:** Provides full DA11-B (Unibus or Q-bus link) compatibility on single cards. BUSLINK operates at DA11-B transfer rates over distances of up to 50 feet. **OPERATING ADVANTAGE:** Requires only one card per CPU to effect link at minimal bus loading vs. full system unit per computer.

Able cards give you the best way to make your present PDP-11 run better than ever and avoid up-grading to a more expensive model. We give you time to plan ahead and to control your cash flow with the most sophisticated line on the market today. Our cards are priced competitively. They install in minutes. They provide immediate results. And they always out-perform the competition. They should. We are the only computer people in the computer-system-enhancement business. Our customers will tell you we are the best qualified to help you get the most out of your present PDP-11. Write for details. Able Computer, 1751 Lantony Avenue, Irvine, California 92714. (714) 979-7030, TWX 910-395-1729.

## Able, the computer experts

DEC, PDP, LSI, UNIBUS, and FASTBUS are registered trademarks of Digital Equipment Corporation.



**Providing  
thermoset plastics for  
the needs of industry  
demands broad variety.**

# PLENCO

**has it.**

Plenco produces diversified thermoset resins and molding materials with a wide range of properties.

Phenolic, melamine-phenolic, alkyd and polyester compounds of different formulations in each of these generic classes meet a world of varied and demanding requirements:

Heat, impact and corrosion resistance.  
Flame retardancy.

Track resistance and x-ray shielding.  
Electrical resistance. Wet-dry conditions. Close tolerances and dimensional stability.

This broad selection permits designer and manufacturer to optimize the best approach to problem and cost.

More than likely Plenco can provide a thermoset suitable for your particular application as well as

molding method—transfer, compression or screw injection. Just call us. (414) 458-2121.

**PLENCO**  
THERMOSET PLASTICS

PLASTICS ENGINEERING COMPANY  
Sheboygan, WI 53081

Circle 126 on reader service card



**Discovery.** A. Hoyt Taylor (with pipe) and Leo C. Young observed that a ship on the Potomac interrupted the signal between their high-frequency transmitter and receiver.

tailoring the tuned circuits so that the receiver characteristics would match the pulse-transmitting properties.

Finally there was a need for complete absence of regenerative feedback in the receiver in the presence of high gain. Researchers met this by using a superheterodyne receiver, limiting voltage gain on any one frequency to 1,000, and changing the intermediate frequency, as required, to accomplish an overall voltage gain on the order of  $10^7$ . Also, extreme precautions were taken in shielding, filtering, and common-point grounding.

The new Navy system was ready for full-fledged testing in April 1936. Receiver recovery to full sensitivity following the transmitted pulse seemed instantaneous, and beautifully sharp echoes from aircraft were observed almost at once. Within a few days the echoes appeared all the way to the 25-mile limit of the indicator.

The success of this experiment was followed by a greatly intensified effort at the laboratory. Of course, the primary objective was to reduce the size of the equipment so it could be used on ships. This meant higher frequencies and smaller antennas. This was done, and on July 2, 1936, a small radar was put into operation on 200 MHz. In that same month the first radar duplexer was successfully tested, also at 200 MHz. This enabled both transmitter and receiver to use the same antenna. These two quick developments made it possible to put radar on a ship for tests at sea.

The first seagoing radar tests by the United States were made in April 1937 on the World War I destroyer, the USS Leary. Their success led to the development of the model XAF, designed for Navy service at sea. Extensive shipboard tests in 1939 disclosed operational capabilities beyond all expectations. The XAF later became the prototype for the model CXAM, which was put in service on 19 ships. It was the only U. S. naval radar in service when Pearl Harbor was attacked.

**A**s is usual in such matters, because of the way science is done, interest in the radar concept developed in Europe at about the same time

(1934) as in the U. S. In Britain, for example, as in the U. S., the work was based on earlier endeavors in 1924 and 1925 that had used high-frequency radio waves to measure the height of the Heavyside layer—a region of the atmosphere that reflects radio signals.

Although in 1939 England, Germany, and the U. S. were the leaders in radar development, it was actually the French who made the first commercial application of it in 1935. What they did was both clever and useful.

Scientists of the Société Française Radioélectrique had the rescue of the shipwrecked in mind when they began studying the detection of obstacles by means of radio waves in 1934. As a result, an obstacle detector working on decimetric waves and employing pulsed magnetrons was installed on the liner *Normandie* in 1935. Its satisfactory performance led to a search radar being installed at Le Havre in 1936 to detect ships entering and leaving the harbor.

The reflection of radio waves from aircraft had been observed in England in the early 1930s and the possibility for aircraft detection was discussed in 1934. It was soon realized that radio waves would be the ideal alternative to the existing inadequate acoustic warning equipment, which merely listened for the sound of aircraft engines and had too short a range for proper warning of approach of fast aircraft. In contrast, experiments indicated that radar could give a warning when the enemy aircraft was 100 miles or more away.

Robert (later Sir Robert) A. Watson-Watt, who began as a physics teacher at University College, Dundee, was instrumental in developing radar equipment for this purpose in Britain. His Radio division of the National Physical Laboratories was the leading group involved. After successful demonstrations of his approach in early 1935, he was given funds to start production and in the summer of the same year installed the first practical radar for aircraft detection.

How to modulate his high-power transmitter with short pulses was the major practical problem for him as it was for the Americans. He solved it, and the performance of the first equipment was so good that by the end



# WHATEVER YOUR CALCOMP HAS

Whether your application is a general one like designing, mapping or schematics, or more specialized like 3-dimensional data presentation, structural analysis, contouring, piping isometrics or business charts and graphs, CalComp offers you the broadest line of plotters.

Nobody offers more ways to solve your graphics problems. Continuous roll, belt-bed and flat-bed plotters for cut sheet applications. Computer output to microfilm. On-line to your CPU. Off-line via tape-drive storage devices. And even on-line/off-line with floppy disk storage.

Add our extensive library of applications software packages to complement our operating software and you've got most of your problems solved.



1055  
Drum Plotter/1012 Desk-Top Plotter

## The best answers come from the best people.

Looking at the broadest line of computer graphics systems in the world may still present a problem to you.

Like choosing which solution is right for your particular needs, planning for growth and upgrades; and making sure your system delivers consistently excellent performance.

That's where CalComp's Sales Force can help. Because our sales

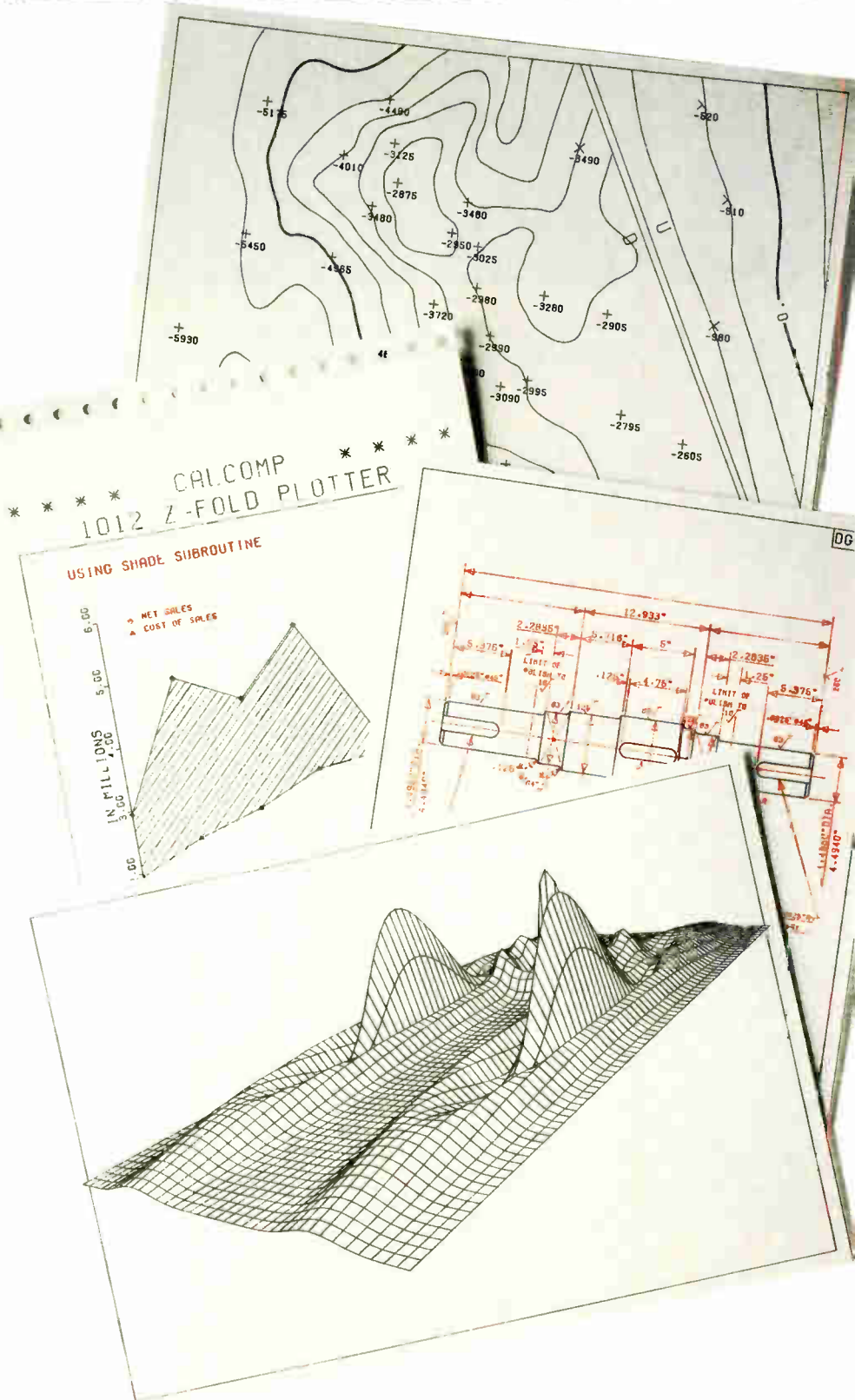

# GRAPHICS NEEDS, THE ANSWERS.

representative is really a consultant. In every sense of the word.

They are, each and every one, expert listeners, too. Eager to understand all your special needs.

That's why you can expect in-depth answers to all of your questions. About system capabilities, controllers, software, delivery and more.

You can also expect to hear a lot of discussion about our systems analysts and field service engineers. And what makes them part of a support network that's truly worldwide and second-to-none.

At CalComp, part of the right answer is the right people.

**At CalComp, hardware's a multiple choice question. Nobody offers a broader choice of answers.**

Take our compact 1012 desk-top plotter, for example. You get crisp, clean 8½" x 11" or 11" x 17" size plots



748 Flat-Bed Plotter

at an impressive 10 inches-per-second. Four-pen versatility, and the convenience of Z-fold paper.

For bigger jobs, there are six other precision drum plotters to choose from. Including the largest, our new 1065, with an extra-wide 72" drum that plots at 30ips.

Or, for the best of high-end per-

formance, there's our 960 belt-bed plotter. It delivers big 33" x 60" vertical plotting for any "E" size plot and 30 inches-per-second speed with 4g acceleration.

And nobody handles computer graphics on a grander scale than CalComp. And that's where a top-of-the-line family of flatbed plotters — the 7000 System — literally draws away from the competition. In dozens

of applications and at hundreds of sites throughout the world.

**We do some of our best work on film.**

Pen and ink plotters aren't

all we make at CalComp.

In fact, for over a dozen years, we've also been designing, building, selling and servicing exceptional COM (Computer Output Microfilm) systems.

This year we're introducing two new high-speed, high-volume COM systems, the 1581 and the 1681. The former expressly for graphics-only environments. The latter for both graphics and alphanumeric applications.

At CalComp, COM systems are an important part of the big picture.

**Nobody has more experience to draw upon.**

CalComp pioneered computer graphics way back in 1960.

That gave us a significant head-start. Now, almost twenty years later, CalComp is still the leader and prime innovator in the field. With more experience and models to choose from, up and down the line,

than any other single source.

So contact CalComp today And get the best possible answer to your specific graphics need.



1065 72" Drum Plotter

#### Sales Offices:

Tempe, AZ: (602) 894-9468. Orange, CA: (714) 639-3690, (213) 430-2104. Santa Clara, CA: (408) 249-0936. Englewood, CO: (303) 770-1950. Norcross, GA: (404) 448-4522. Rosemont, IL: (312) 696-1770. Shawnee Mission, KS: (913) 362-0707. Waltham, MA: (617) 890-0834. Rockville, MD: (301) 770-1464. Federal Accounts Manager, Rockville, MD: (301) 770-4850. Southfield, MI: (313) 569-3123. Bloomington, MN: (612) 854-3448. St. Louis, MO: (314) 968-4637. Union, NJ: (201) 686-7100. Cleveland, OH: (216) 362-7280. Dayton, OH: (513) 276-5247. Tulsa, OK: (918) 663-7392. Beaverton, OR: (503) 646-1186. Bala Cynwyd, PA: (215) 667-2895. Pittsburgh, PA: (412) 922-3430. Dallas, TX: (214) 661-2326. Houston, TX: (713) 776-3276. Bellevue, WA: (206) 747-9321.



960 Belt-Bed Plotter

## CALCOMP

California Computer Products, Inc.  
2411 West La Palma, Anaheim  
CA 92801, TEL: (714) 821-2011  
TWX: 910-591-1154.

Circle 129 on reader service card



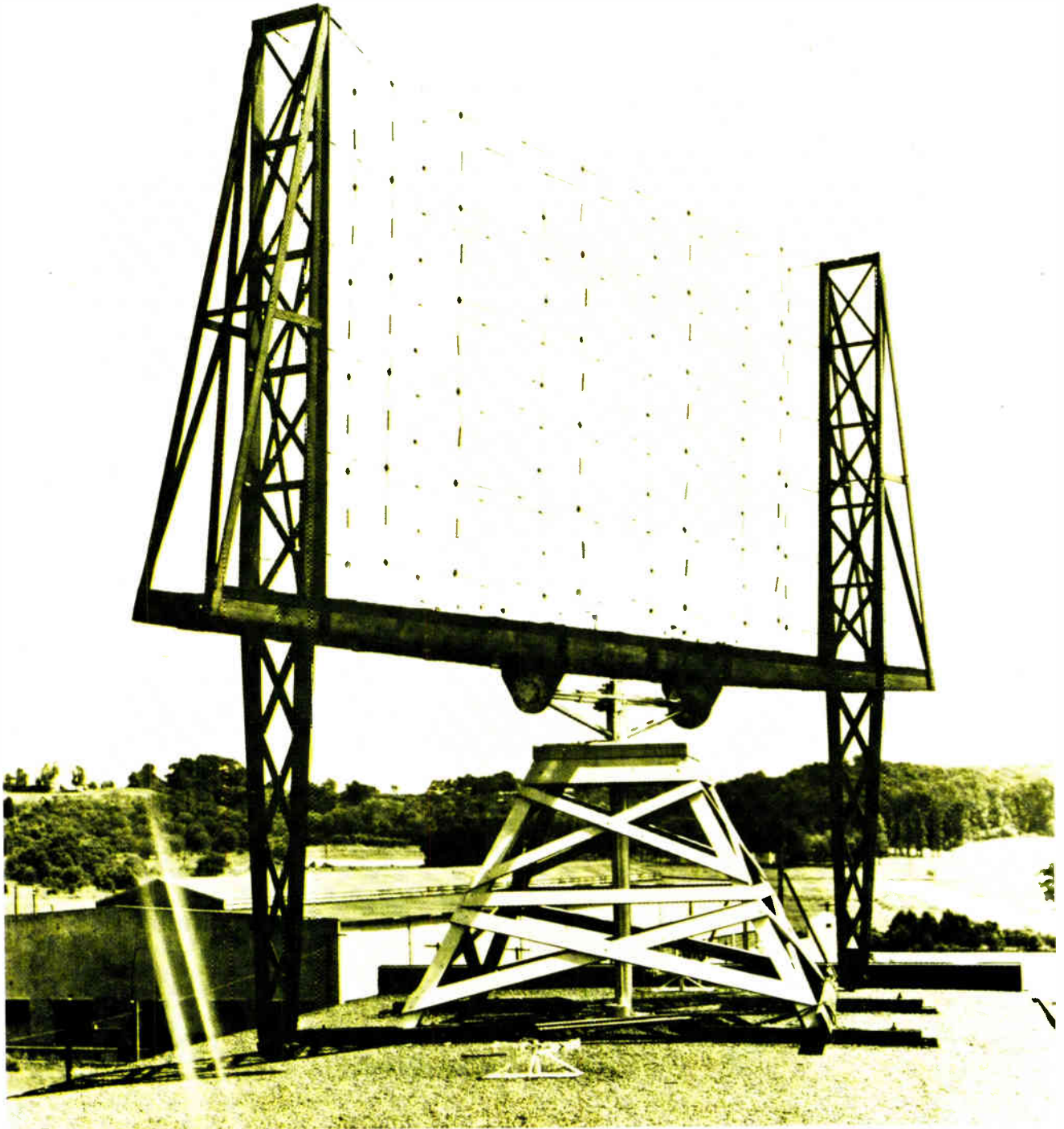

**Radar.** Antenna for first complete radar in the United States was installed atop building at Naval Research Laboratory, Anacostia, D. C., in late 1930s. It was called a "dirigible" antenna, to indicate that it could be turned in an around-the-compass search.

of 1936 the Air Ministry had built a chain of five radar stations about 25 miles apart. This would later play a crucial role in the Battle of Britain, when British fighter planes were vectored to the location of the German aircraft by the use of radar search data.

Serendipity, that happy circumstance that so often comes into play when inventors and experimenters work, did more than speed the development of radar in the United States. It was of enormous help also in advancing

electronic instrumentation in the 1930s. Early attempts to transmit pictures by radio waves in the same manner as sound led, for example, to the development of the modern oscilloscope. And it could not have come at a better time.

The oscilloscope had progressed considerably since Karl Ferdinand Braun used a cathode-ray tube to observe time-varying phenomena in 1897 at the University of Strassburg, then in Germany. Braun is generally

# We have a pollution solution!

Corcom is the world leader  
in RFI pollution control!  
Our EP series filters have  
been designed to allow  
switching power supplies  
to comply with the new  
FCC rules as well as  
being VDE, SEV and UL  
recognized. Write for  
complete technical details.



**RFI Power Line Filters**

Corcom Inc. 1600 Winchester Road Libertyville, Illinois 60048 U.S.A.  
312-680-7400 TWX 910-684-3269 ©



# polyFORTH™

shrinks your big problem  
into a small PROM.

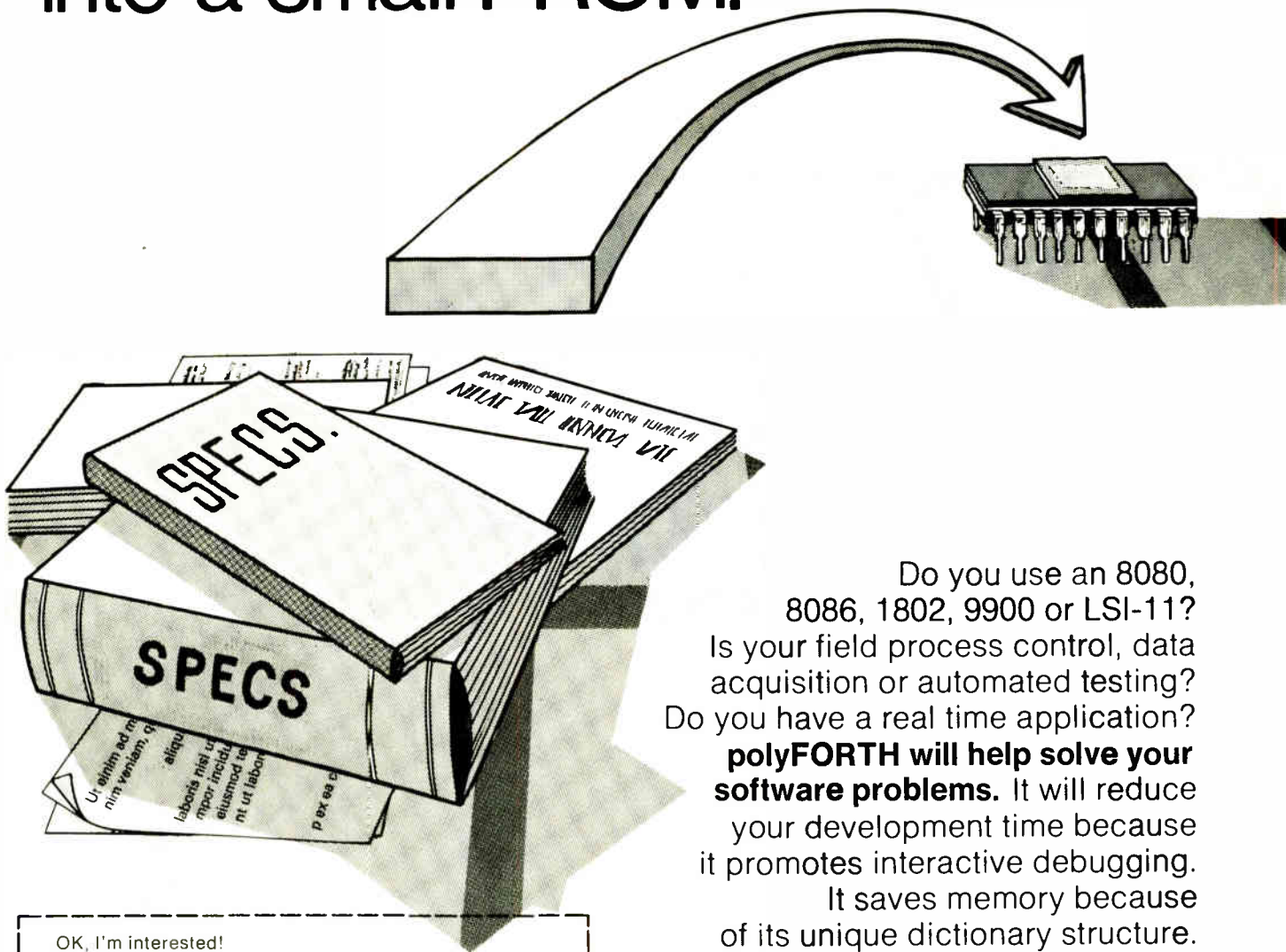

Do you use an 8080, 8086, 1802, 9900 or LSI-11? Is your field process control, data acquisition or automated testing? Do you have a real time application? **polyFORTH will help solve your software problems.** It will reduce your development time because it promotes interactive debugging.

It saves memory because of its unique dictionary structure. It allows control of run time because it is a true multilevel language.

It insures transportability because it is a virtual computer. And if your final program resides in PROM, polyFORTH's Target Compiler™ will produce exceptionally compact code. Let us tell you more. Send the coupon, attend a free seminar but first give us a call at: **213/372-8493**

OK, I'm interested!

Please rush full details on polyFORTH for

\_\_\_\_\_ microprocessors

\_\_\_\_\_ minicomputers

Contact us for immediate requirements

Tel: (     ) \_\_\_\_\_

Send dates and locations for your polyFORTH Seminars.

Name \_\_\_\_\_

Title \_\_\_\_\_

Attach coupon to company letterhead, and return to:  
FORTH INC., 2309 Pacific Coast Highway,  
Hermosa Beach, CA 90254. Or call (213) 372-8493.

Circle 132 on reader service card

**FORTH, Inc.** 

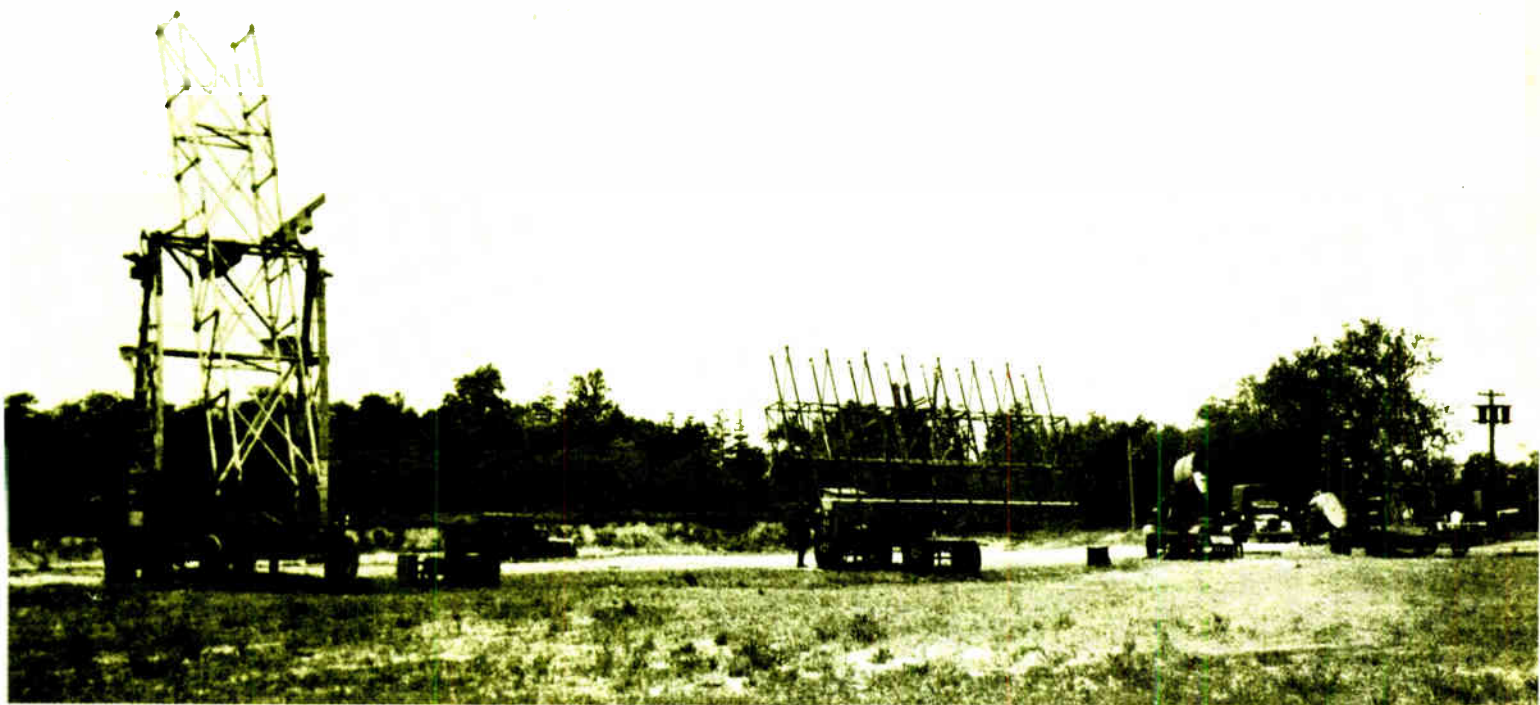

**Early radar.** The U. S. Army demonstrated an experimental long wave anti-aircraft position-finding radar, the SCR 268, in May 1937 at Fort Monmouth, N. J. Used in World War II, the radar was easily jammed by window, or chaff. The later microwave SCR 584 was more effective.

credited with having invented the device, but his CRT was of use only in the laboratory. If engineers had had to rely on such an instrument, the history of electronics would probably have advanced no further than the radio.

In the early 1930s a change was taking place in the art of electronic measurement. Engineers began to realize that to characterize the operation of equipment fully, they could not look only at the steady-state operation of a system; they had to observe its transient response as well. While there were already various oscillographs of the galvanometric type in use (Bell Telephone Laboratories had more than 100 such oscillographs in constant use in 1931), these instruments could not keep pace with the high frequencies that radio transmission involved. Enter serendipity.

**M**any experimenters were trying to improve the cathode-ray tube so it could be used to display photographs. Manfred von Ardenne of Berlin had produced what was considered a low-voltage tube, and General Radio Co. used a tube of this type to produce a cathode-ray oscilloscope in 1931. It consisted of two parts: a cathode-ray tube, housed in a cylinder to protect it from ionic bombardment, and a cabinet containing focusing controls. It provided signals visible in daylight during the 1,000-hour life of the tube, and at \$265, it was considered relatively expensive.

But it was Allen Du Mont who was largely responsible for the commercial development of the modern oscilloscope. Between 1930 and 1931, he left his position as chief engineer at the De Forest Radio Co. to open the Allen B. DuMont Laboratories, where, in addition to

consulting on television, he designed cathode-ray tubes. In August 1932 he advertised these tubes, and in November of that year he offered his first oscilloscope—or “cathode-ray oscillograph,” as he called it. A two-part unit like General Radio’s rudimentary oscilloscope, it had in its electronics cabinet both focusing controls and a power supply and sweep circuit. It sold for \$185.

In 1933, Du Mont continued to improve CRT design, particularly the low anode potential, screen materials, and beam intensity. In July of that year he introduced a single-unit oscilloscope with a sweep frequency of 10 to 5,000 Hz. This large instrument was intended for the laboratory only, however.

But in January of 1934, Du Mont introduced the model 137, and it was clearly what is termed today an oscilloscope. An engraved glass on the screen provided lines for measurement, and the front-panel knobs permitted continuous adjustment of sweep and focus. The unit operated from an ac line, sold for \$165 and had a handle on top for easy carrying.

Through the remaining 1930s Du Mont continued to improve the oscilloscope. It became a workhorse for engineering measurements, with new applications suggested for it almost monthly.

In the spring of 1935, RCA introduced its oscilloscope, the forerunner of a line of instruments for service technicians as Du Mont’s oscilloscope was for the engineer.

Vacuum-tube voltmeters were another success story. The high-input impedance of vacuum tubes had made them natural candidates for instruments since they were first developed. This characteristic suggested that they could be used to make measurements without putting any effective load on the circuit under test. But while the



# Bipolar vs. VMOS:

Germanium Bipolar Transistor

Silicon Bipolar Transistor

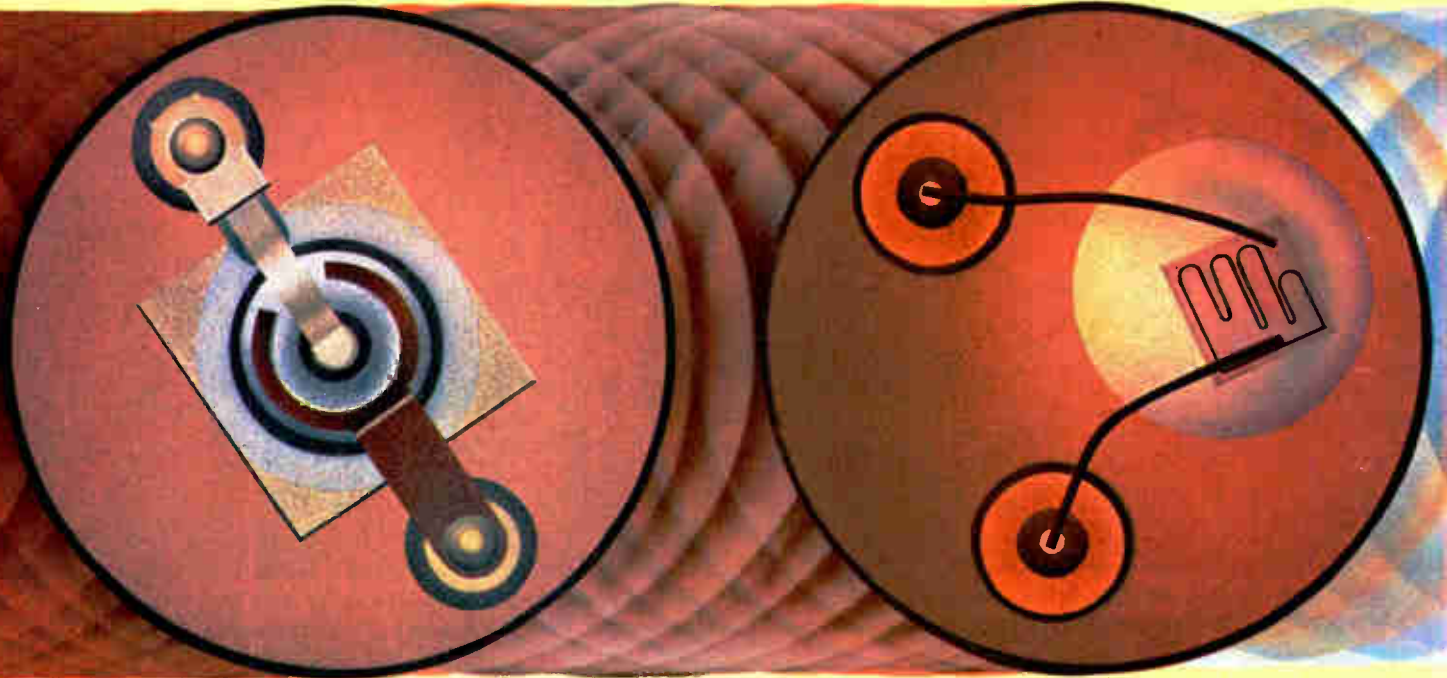

## It's survival of the fittest

The designers who are going to survive the fiercely competitive 1980's know bipolar technology is dead. That's why they're switching from bipolar transistors to vertical current flow FETs for power and for microprocessor interface in power applications. It's the switch you should make now, before it's too late.

Look at the facts. Germanium power transistors were first introduced in the early 1950's. Then, in the late 50's, silicon took over. Silicon bipolar transistor reliability and temperature performance was remarkable... for the time. But that was over 20 years ago. And a lot has changed since then.

One of the most significant changes has been the unprecedented growth of MOS technology. You saw it happen with ICs. In just a few short years, MOS replaced bipolar ICs and revolutionized the entire semiconductor industry.

Then, in 1976, Siliconix introduced the first Vertical power MOS FET and launched the VMOS power FET revolution. Three VMOS generations and four years later, VMOS equals or exceeds bipolar performance in important operating characteristics. And, as VMOS technology is still on a rapid learning curve, you can be sure there's more to come.

## What can VMOS do for you?

A lot. VMOS provides high power gain, high input impedance, linear operation and a full safe-operating-area. But even more important, VMOS offers you a new degree of reliability by eliminating the two most common causes of bipolar transistor failure: thermal runaway and secondary breakdown.

Use Siliconix VMOS instead of bipolars and you eliminate the predrivers and protective circuitry bipolar transistors require. Fewer parts mean lower costs and higher overall system reliability.

And, as they don't require the high base current drive bipolar transistors do, VMOS power FETs are ideal for interfacing to low power ICs.

# Siliconix VMOS

# The winner emerges

Siliconix VMOS Power FETs

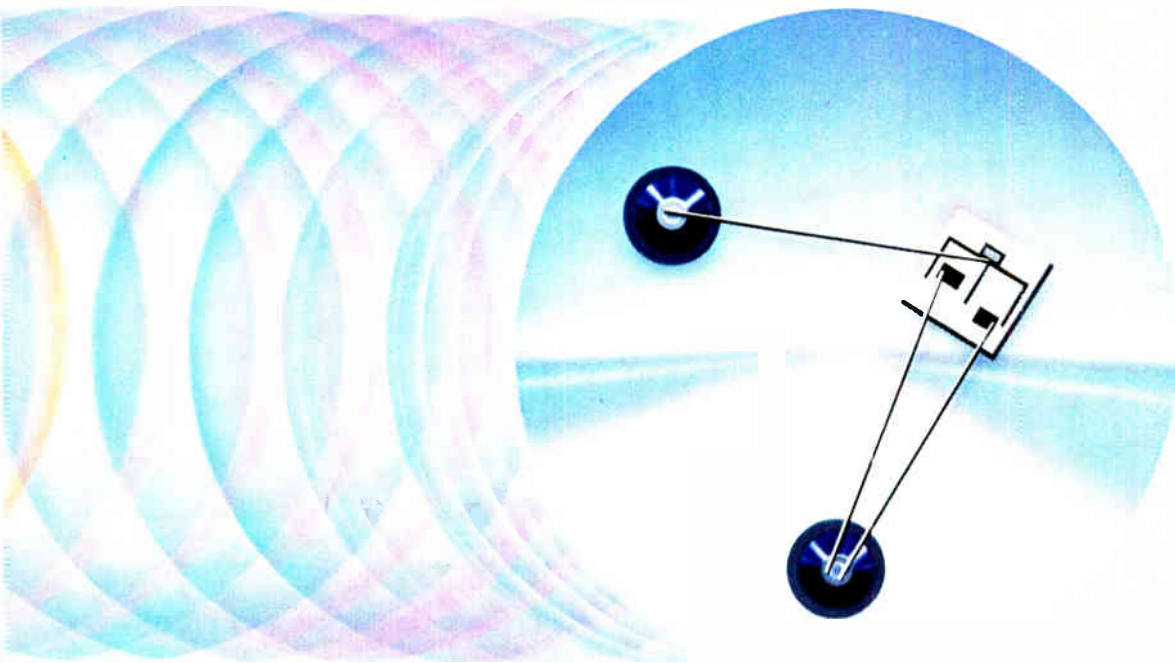

## Not just rugged, but faster too

VMOS devices switch in nanoseconds with comparable turn-on and turn-off times which you can adjust independently. This allows you to



VMOS FET magnified 2300x.

improve the efficiency of switching circuits, extend the frequency response of power control systems and even build rf power circuits. So, whether you're driving bubble memories, building power circuits or interfacing CMOS logic, you can put the advantages of VMOS to work for you.

## Price? Glad you asked

True, in the early years, VMOS cost more than bipolars. But that's all changing today. Economies of volume production have substantially reduced

the cost of VMOS. Additionally, as VMOS so dramatically reduces your component count and simplifies your designs, your big savings will be in overall system cost.

## Join the Survivors

When you look at the facts, you can see it's only a matter of time. Bipolars can't survive. But you can. With Siliconix VMOS on your side in the 80's.

For more information on Siliconix VMOS power FETs or our complete VMOS Design Catalog, just write "VMOS for the 80's" on your business card and send it to: Siliconix, P.O. Box 4777, Santa Clara, CA 95054.

**Siliconix**  
VMOS power FETs

# powers the 80's





**Scope.** The cathode-ray oscillograph, as it was called, was introduced in 1931 by General Radio Co. (now GenRad Inc.). It came with power supply (left) and sweep circuit (right) that was also sold separately. The 2-foot-long tube, from Germany, had a screen 6 inches across.

vacuum tube was being used in measurements even before 1930, J. W. Horton, chief engineer at General Radio Co., noted in the first issue of *Electronics* that the tubes lacked “that stability and consistency of performance so generally considered essential to successful measuring equipment.” When used in instruments, the vacuum tube had to be calibrated against a standard voltage reference before each measurement.

In January 1931, Ballantine, then president of the Boonton Research Corp., discussed the variable- $\mu$  tetrode that he and Snow had unveiled at the end of the previous year. He noted that the tube’s logarithmic response should be ideal for many measurements.

While improvements like these were essential to the development of reliable instrumentation, it was the discovery of a startlingly simple principle—negative feedback—that made possible stable measurements.

**B**lack at Bell Telephone Laboratories had discovered that part of an amplifier’s output could be returned to its input in such a way as to prevent unwanted gain or loss of output. But it was not until he presented a paper early in 1934 to the American Institute of Electrical Engineers and then wrote an article for Bell Telephone in June of that year that engineers became fully aware of this important principle.

By the late 1930s Ballantine had opened his own laboratory and begun to produce an instrument that was to make the phrase “hand me the Ballantine” part of engineering jargon for the next four decades. In the September 1938 issue of *Electronics*, he described this root-mean-square meter, the model 300, noting that “it is about 100 times as sensitive as the conventional electronic voltmeter, permitting readings down to 0.001 v.”

Off-the-shelf precision instruments were still relatively rare. Engineers generally built their own. The pages of the early issues of *Electronics* are filled with “how to” articles. For production testing, for example, articles told how a tube tester could be constructed with meters from Weston, Westinghouse, or GE wired into a panel that contained switching arrangements. Similar articles dealt with the design of oscillators, signal generators, and other essential equipment.

**O**ne radio-related instrument that manufacturers were quick to offer was the tube tester. It was sold to radio merchants so they could check tubes for customers. Keeping pace with the flood of new tubes that arrived during the decade kept the manufacturers of tube testers busy. Each new tube type called for an addition to the tube tester. And these testers served not only the radio era but also the era of television, which was unfolding.

Matching the relentless advances of radio were frequency standards. Those that employed tuning forks were in common use at the beginning of the 1930s and were accurate to within 1 part in  $10^7$ . But although they were highly stable, they had the disadvantage of operating at frequencies of only 1,000 Hz. Thus it was difficult to make comparisons with the higher frequencies of radio transmission.

On the basis of the work of W. Gady, who had noted the stabilizing effect of quartz crystals on the oscillations of vacuum-tube circuits, J. W. Horton and W. A. Marri-son developed the first crystal clock, which they described in a paper in the February 1928 Proceedings of the Institute of Radio Engineers. But it was not until May 1930 that the first quartz clocks were installed at

# *You'll find AUGAT products in the darndest places...*

You'd expect to find Augat products in typical computer and peripheral systems. But you might not realize the full breadth and diversity of Augat's applications and markets.

Upon close examination, you'd find "Augat" in the local hospital, or at your favorite television station...or in your neighborhood bank...even on the moon!

And that's because the name "Augat" has become synonymous in the electronics industry with words like "quality" and "dependability" and "innovation". In the brief thirty years we've been producing electronic interconnection products, Augat has become known as the industry's trailblazer.

In 1931, Ernest Augat founded Augat Brothers, a manufacturer of jewelry and jewelry findings in Attleboro, Massachusetts. At the start of World War II, much of the raw materials used to manufacture jewelry were allocated to military use, but Augat's machinery and skilled employees were admirably suited to the manufacturing of stamped component parts for the military electronics industry. Augat quickly became a subcontractor for companies engaged in the war effort.

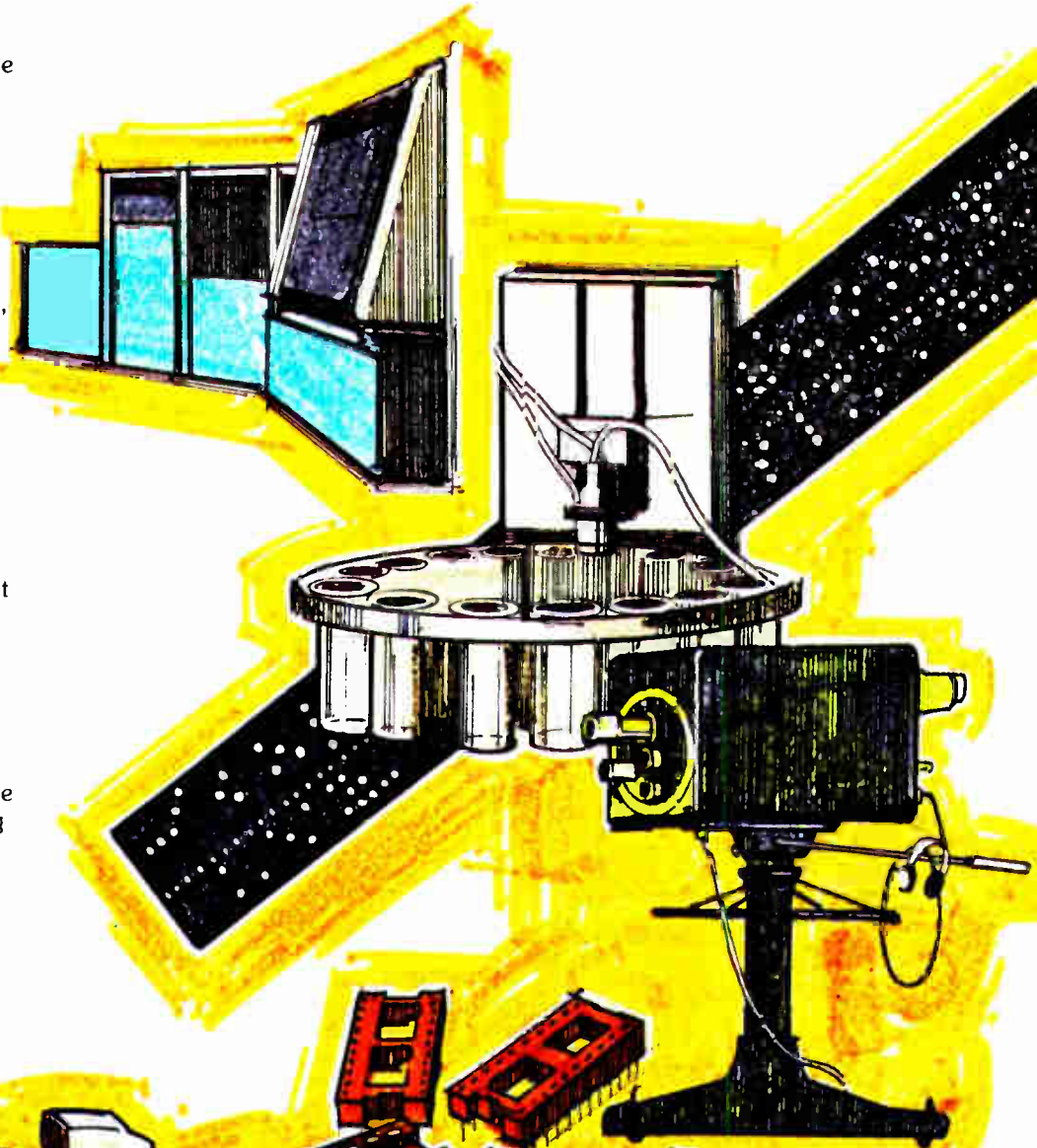

# **AUGAT**<sup>®</sup>



At the end of hostilities, Augat returned to the jewelry business, as Augat Inc. But, in 1950, at the onset of the Korean conflict, the company again began manufacturing electronic components.

Augat management soon recognized the vast potential in electronics. Previous experience in the fine jewelry business had already instilled the value of genuine craftsmanship.

By 1951, Augat had developed a product line of clamps for tubes and potentiometers, and began appointing national representatives and distributors in 1953. Component holders were added in 1955, establishing a broad base of applications and name recognition. Our first entry into the socket field was in 1958, when we developed a patented crystal socket that featured a low-profile, horizontally mounted design. In the same year, the decision was made to concentrate on the electronics portion of the business, and the jewelry business was sold.

Transistor sockets soon followed, incorporating a unique two-piece machined contact assembly. Circular integrated circuit (IC) sockets, up to 12 pins, were a logical extension of this approach.

In 1964, the industry's first dual-in line IC socket was introduced by Augat. The need to plug circuits into a socket instead of soldering them was apparent, and proved to be a strong driving force in establishing Augat as the leader in IC interconnection products.

The socket wire-wrap panel, conceived and pioneered by Augat in 1965, was a timely solution to users' problems of flexibility, design changes and density. After evaluating all cost factors including time, it even proved to be cost-effective for volume production applications. That same year, Isotronic high reliability, all metal packages were introduced for protecting hybrid and other miniature circuits through hermetic sealing.

Our new adaptor plug that allowed other components to be plugged in followed in 1966. About the same time, the interfacing plug was introduced, greatly expanding the flexibility.





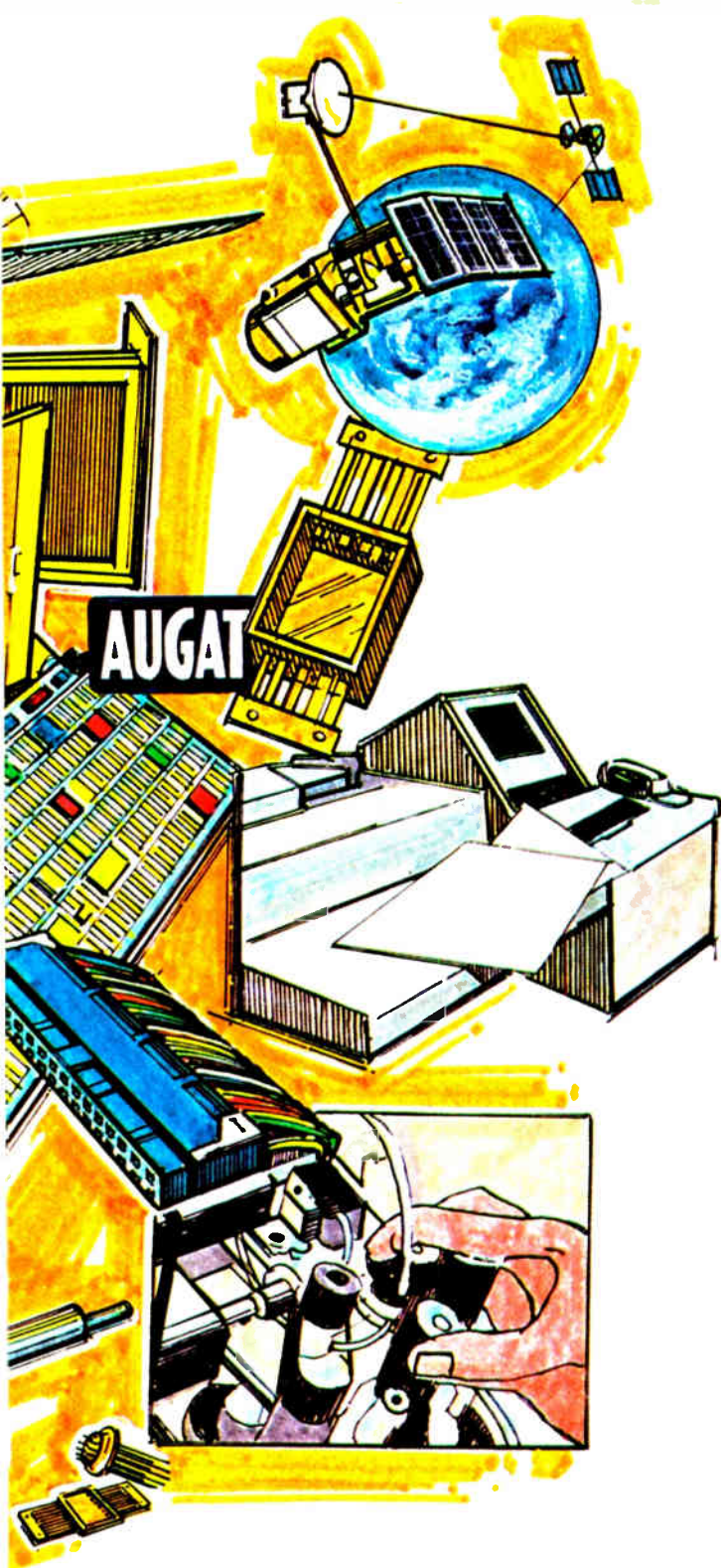

1967 saw the introduction of the high performance 500 Series Socket.

In 1970, the hi-density plug series was announced, doubling the number of input/output connections possible for each group of IC positions. And that same year, Augat introduced the innovative 700 Series Sockets, with their disposable carriers that allow for improved air-flow and total accessibility for inspection and solder rework.

Three-layer Schottky and ECL panels were introduced in 1972 for high-speed logic applications, offering the flexibility, time savings and density required for prototyping and production. The list goes on and on.

In 1976, Augat introduced a completely new type of industrial subminiature switch...the Alcoswitch TT Series, less than 60% the size of any previously available comparable product. That same year Augat began providing computer-aided design and automatic wiring services which today includes five United States locations.

When Augat introduced the zero-profile HOLTITE® socket in 1977, the industry was impressed, but hardly surprised. We had already clearly established our reputation for innovation and quality. Of course, HOLTITE® was a revolution in itself. Not only was it the first zero-profile socket, it even utilized existing printed wiring circuit boards, and eliminated soldering.

Also in 1977, we began expanding our product base to include more sophisticated data links; areas like Fiberoptics and Flat Cable Interconnection.

Fiberoptics first appears to be a departure from Augat's traditional product line, but it is in reality simply a different method of signal transmission. The major difference being that glass, instead of wire, carries the signals. So when Augat developed and introduced one of the first complete standard catalog systems in 1977, it was readily apparent to the industry that Augat's reputation for establishing standards would continue to be a strong reason for our successful growth.





And as far as flat cable interconnection is concerned, in 1979 Augat introduced what has been hailed by the industry as a totally new generation in mass-termination products; the SGF/SGH line. This revolutionary interconnection system virtually doubles the I/O portion of any panel, and provides total flexibility in any combination of signal and ground assignments. The SGF/SGH System makes flat cable interconnection more efficient and at the same time less costly by reducing the number of contact points required.

During the 1970's, Augat also increased its level of vertical integration, with the addition of high quality, high reliability capacity for plating (1972), precision component machining (1974), and plastic molding (1979). These capabilities are offered to the electronics industry through our Precision Materials Division.

Today, Augat is a major supplier of interconnection components for the cable television industry through its subsidiaries, VITEK and LRC Electronics.

Applications for Augat products include videotape recording systems, heart pacemakers, mini-computers, typesetters, flight simulation systems, microwave transmission systems, textile machinery, and our microswitches were used in the first lunar lander.

Hand-in-hand with our innovative reputation goes the reputation we have for quality.

And everyone agrees that one of the most important keys to Augat's success is its distributor network. There's at least one franchised Augat distributor in almost every major city in the world.

And that's why you'll find Augat's products in the darndest places. Like your Uncle Pete's pacemaker and on the moon.

Circle 140 on reader service card

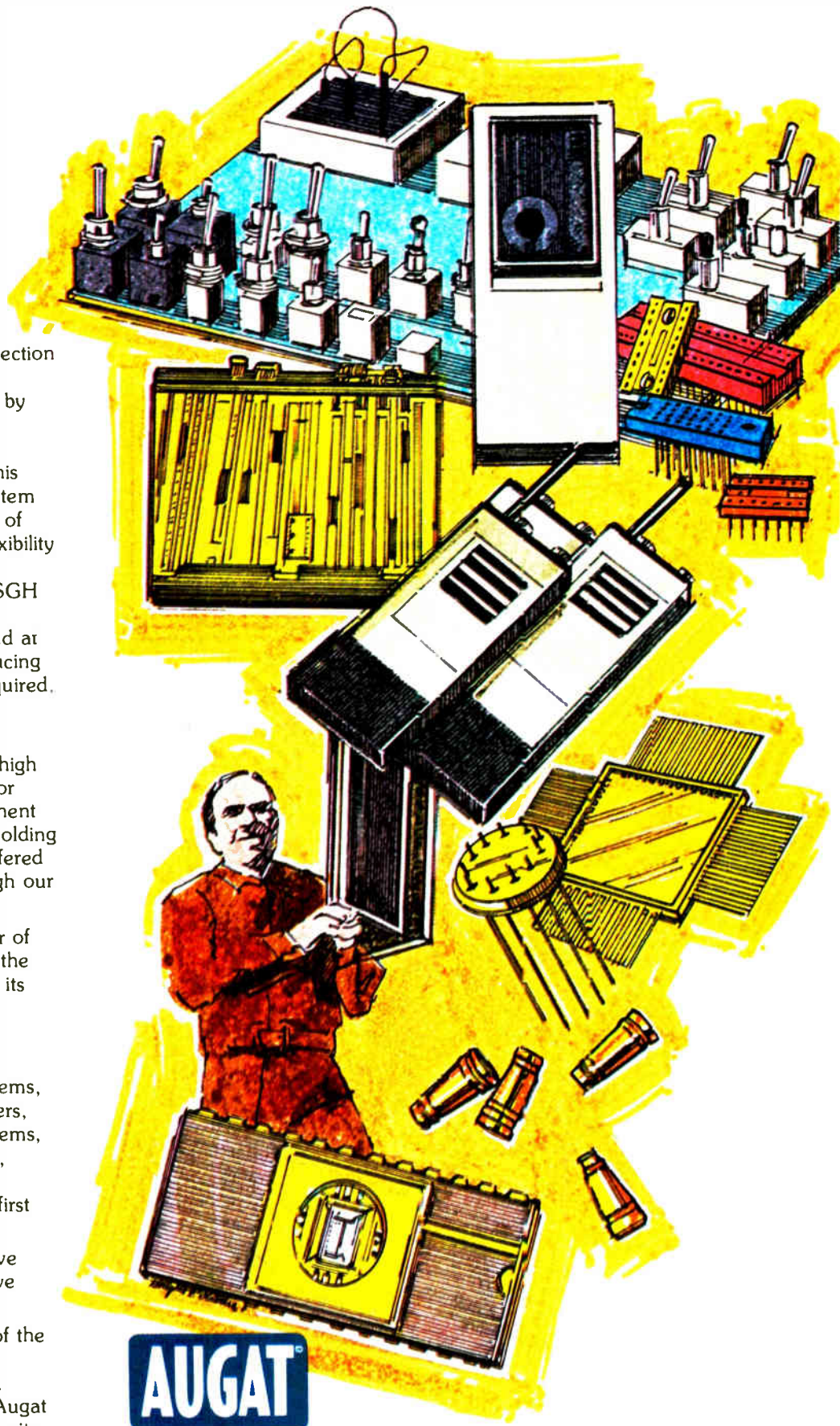

# AUGAT

**Augat Inc., Interconnection Systems Division**

40 Perry Avenue, P.O. Box 1037, Attleboro, Mass. 02703/Tel: (617) 222-2202/TWX: 710-391-0644

**Augat Inc., Interconnection Components Division**

33 Perry Avenue, P.O. Box 779, Attleboro, Mass. 02703/Tel: (617) 222-2202/TWX: 710-391-0644

Augat SA., 9 Allée de la Vanne, (Z.I. Sofitic), B.P. 440 Cedex 94263/Fresnes, France  
Tel: 668 30 90/Telex: 201 227



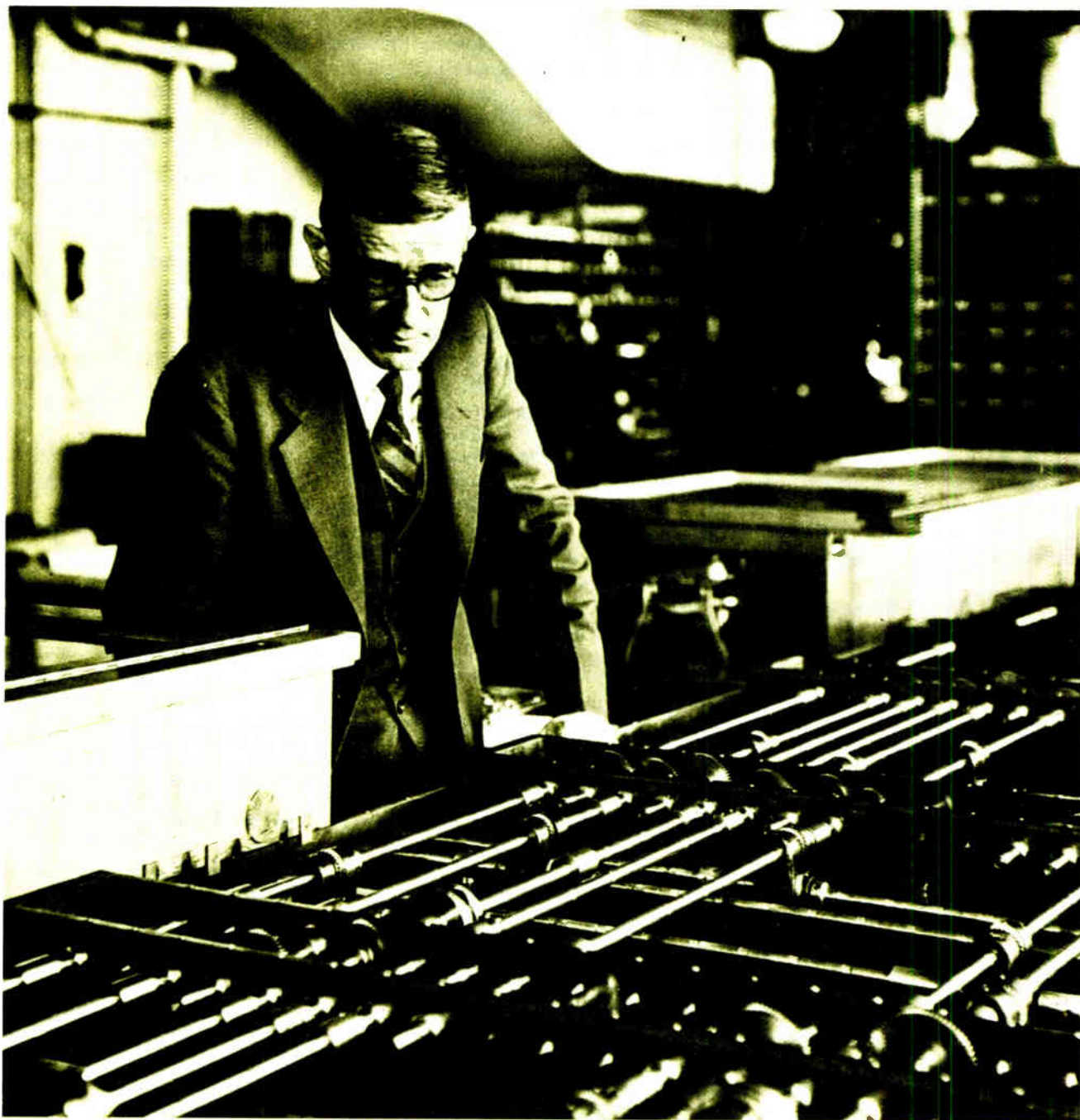

**Analyzer.** Vannevar Bush completed this differential analyzer in 1931 at the Massachusetts Institute of Technology. The analyzer was one of a series of Bush machines that were the precursors of modern analog computers. Their development stemmed from Bush's work on electric power transmission systems. He felt the need for machines that could perform analytical tasks too formidable for mathematicians alone.

the Federal Bureau of Standards in Washington, D. C. Throughout the 1930s other nations installed these clocks, and this led to an interesting discovery.

In Germany, at the National Physical Laboratory, the crystal clocks were used to time information to scientific and industrial laboratories. In 1934, after the clocks had operated for a year, the laboratory reported a discrepancy between diurnal and atomic time of 0.004 second that could only be accounted for by a change in the rotational speed of the earth.

And yet another scientific finding based on electronics led to the development of the electron microscope. The

possibility of using electron beams to provide magnification with greater resolution than that of an ordinary microscope was postulated by M. Knoll and von Ardenne in 1930. Early in 1931, workers at the Technical University of Berlin and at the German Electric Co. noted that electrons emitted by a surface could be focused by coils to form an image of that surface. E. Breuche, H. Johannson, and R. Rudenberg constructed devices that could enlarge specimens about 15 times. But the first men to truly exploit the potential of electron microscopy were Knoll and E. Ruska.

In the September 1933 issue of *Electronics*, Knoll



published a paper explaining the operation of the transmission electron microscope and noting that “the enlargement so far attained is 1:400.” The following year Ruska had improved this to 1:12,000.

In 1938, Siemens and Halske in Germany, under Ruska’s guidance, built a scanning electron microscope that enlarged specimens 30,000 times. Similar microscopes were built at the College of Technology in London, with the help of the Metropolitan-Vickers Electric Co., and at the California Institute of Technology.

**T**hroughout history, man’s progress has stimulated a desire for improved computational tools. Electromechanical analog computers and calculators continued to be perfected through the 1930s, especially through the efforts of Vannevar Bush at the Massachusetts Institute of Technology. Nevertheless it was becoming increasingly evident that the mechanical analog devices suffered inherently from inaccuracy.

The mechanical tolerances to which the parts could be machined was one limitation. With use and wear, these mechanical tolerances deteriorated, further decreasing the calculator’s accuracy. Accuracy was also inversely proportional to the speed at which the device could be operated. Finally the analog computers required human intervention to complete a calculation and were restricted by their design to solving a unique problem. Changing the problem involved changing the mechanical linkages—a cumbersome and time-consuming process.

While some researchers spent time attempting to improve the analog processor, others began exploring a new type of computing machine—one that would automatically follow a set of instructions and operate on more accurate discrete values.

The pursuit of more exacting astronomical tables for navigation prompted Columbia University to persuade Thomas J. Watson, the chief executive officer of the International Business Machines Corp., to establish the Columbia University Statistical Bureau in 1929. It was equipped with tabulating machines manufactured by IBM and then in use in the business world. In 1930, Watson was so impressed with the success of the Columbia laboratory that he authorized it to build a special tabulator called the Difference Tabulator. Finished in 1931, the machine was basically a digital calculator, based on principles first put forward by the 19th-century English mathematician Charles Babbage.

At about this time Wallace J. Eckert, a mathematician and astronomer, joined the faculty of Columbia and became active in the laboratory. Convinced that the digital calculating equipment could be even more useful to scientists, particularly astronomers, he persuaded Watson to expand the laboratory. By 1937, the expansion was complete with the founding of the Thomas J. Watson Astronomical Computing Bureau. The Columbia laboratories marked IBM’s entry into the world of computers, a move that was to blossom into a position of industry leadership.

Some of the first theoretical papers on computing were published at this time by several mathematicians working independently. Emil L. Post, a logician and

professor at the City College of New York, wrote “Finite Combinatory Processes—Formulation 1” in the *Journal of Symbolic Logic* in 1936, the same year that Alan M. Turing, an Englishman studying at Princeton University, published a paper, “On Computable Numbers, With an Application to the Entscheidungsproblem,” in the *Proceedings of the London Mathematical Society*.

While these two papers dealt with theoretical automatic machines, another by Shannon a year later began to explore how to construct electrical circuits to perform calculations. Shannon, who, as noted earlier, went on to become known as the founder of information theory, proposed in his master’s thesis at MIT in 1937 that symbolic Boolean algebraic operations be used to simplify the design of electrical switching circuits. As a corollary, he showed that these electric circuits could also perform the Boolean algebraic operations. He then proposed the design of an electric adder to operate in the base two—one of the first binary digital circuits. Concurrently but independently two groups began work on electromechanical digital computers.

George R. Stibitz, a mathematician at Bell Telephone Laboratories, built his first electrical adding circuits at home in 1937, using scrapped telephone relays. The design of a relay computer shortly became his full-time work at Bell. Assisted by a switching engineer, Samuel B. Williams, Stibitz completed in 1939 the Complex Number Calculator or Relay Interpolator, which later became known as the Bell Laboratories Model 1 relay computer. Although limited to basic addition, subtraction, multiplication, and division, the Model 1 used several concepts for the first time—notably binary-coded decimals. In September 1940, the machine was demonstrated at an American Mathematical Society meeting in Dartmouth College.

Another idea for an electromechanical calculator was formulated by Howard Aiken, a graduate physics student at Harvard University. Through one of his professors, who was also on the board of directors of Columbia University’s Astronomical Computing Bureau, the proposal was shown to Wallace Eckert and IBM. IBM was so impressed that it assigned an engineering team led by Clair D. Lake to work with Aiken on the construction of the device. When it was finished and presented to Harvard University in 1944, the Automatic Sequence Controlled Calculator was to be the first automatic general-purpose digital calculator.

**I**n every decade ideas are born and demonstrated and then laid to one side to await maturity and more opportune application. Scores of such productive ideas took root in the 1930s. Two were especially outstanding.

In April 1936, *Electronics* described how engineers at Siemens in Germany had made small condensers by sputtering a thin film of silver on a small piece of mica. They were close to today’s thin-film components.

In 1934, J. Dreyer, a researcher at Marconi Laboratories in England, discovered and patented the principle of liquid crystals. Virtually no one was interested. The effect was forgotten until the 1960s.

# SEMICONDUCTOR INNOVATIONS

In the beginning,  
when there were  
very few...

**General Electric was there.**

1951  
GERMANIUM  
POWER  
RECTIFIER

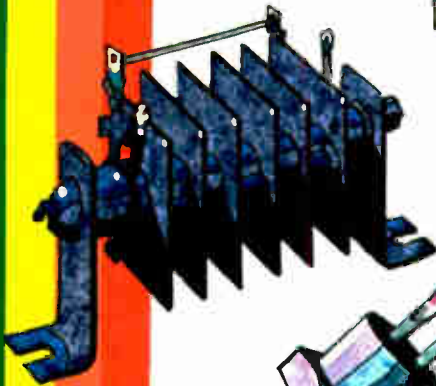

1962  
TRIAC



1957  
FIRST  
COMMERCIAL  
SCR



1967  
INFRARED  
EMITTING  
DIODE



1972  
INTRODUCTION  
OF GE-MO<sup>2</sup>  
VARISTOR



1979  
HI-LINE<sup>TM</sup>  
POWER  
MODULE







**GE-MOV<sup>®</sup> II VARISTORS** Destructive transient voltages are a critical threat to highly sophisticated electronic circuitry. General Electric introduced the solution in 1972—the GE-MOV<sup>®</sup> varistor product family. These devices clamp the transient voltage and harmlessly dissipate the energy. Delicate equipment remains intact.

In 1978, the devices were refined to yield higher energy ratings and tighter voltage clamp characteristics. Response time is under 35 nanoseconds. Voltage ranges are from 14-1200 dc and 10-1000 ac. Energy capabilities extend from .13 to 600 joules. Peak currents range from 40 to 25,000 amps. The devices are widely used to successfully protect automotive, telecommunications, major appliance and industrial control circuits.

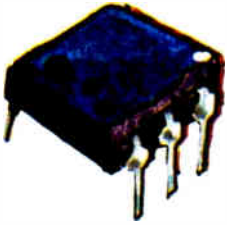

**OPTOELECTRONICS** Long life, high output infrared emitting diodes and silicon detectors form the nucleus of General Electric's extensive optoelectronics line. These devices are applied in information transfer systems and are used as building blocks for optocouplers and interrupter modules in providing electrical isolation and non-contact mechanical sensing.

Currently eighty-three types of optocouplers are available, ranging from 30 mV to 400 V output, and providing current transfer ratios up to 1000%. There are thirty types of interrupters with output capability up to 25 mA, and twenty-nine discrete emitters and detectors optimized for applications from fiber optics to remote control.



**THYRISTORS AND RECTIFIERS** Since the development of the first commercially successful SCR, General Electric has been the world leader in phase control and inverter SCRs, triacs, rectifiers and power modules...all designed to deliver high quality and reliable performance for demanding applications.

SCRs— .8 amps to 2500 amps, 25 volts to 3800 volts. Rectifiers— .5 amps to 4000 amps, 35 volts to 3800 volts. Triacs— .8 amps to 25 amps, 50 volts to 600 volts.

The HI LINE<sup>™</sup> series of power modules and power switches are the newest additions to the GE power semiconductor line.

The devices are offered in many types of packaging from low cost, plastic types to a variety of metal cans, stud mounted devices and metal ceramic Press Paks.

Applications include: sonar and radar, industrial motor controls, power supplies, induction heating systems, battery operated vehicles and welding.



**TRANSISTORS AND SWITCHING DEVICES** Signal transistors and diodes, unijunctions (standard, complementary and programmable), tunnel diodes, and the Switchpower<sup>™</sup> series of power transistors round out the General Electric discrete semiconductor line.

Signal transistors are available in both the TO-98 and TO-92 package styles.  $I_C$  (continuous) ranges from 50 mA to 800 mA, with power dissipations of 200 mW to 1 watt. Power transistors are available in three packages—the TO-202 Power Tab which dissipates up to 15 watts, the TO-220 Power Pac rated to 83 watts and TO-3 Switchpower devices rated up to 195 watts. JEDEC registered types are available to 15 amps continuous and  $V_{CEO}$  to 400 volts.

Device applications include switching power supplies, disc drives and telephone switch centers.

**General Electric makes the big difference in semiconductors.**

Circle 145 on reader service card

**GENERAL  ELECTRIC**

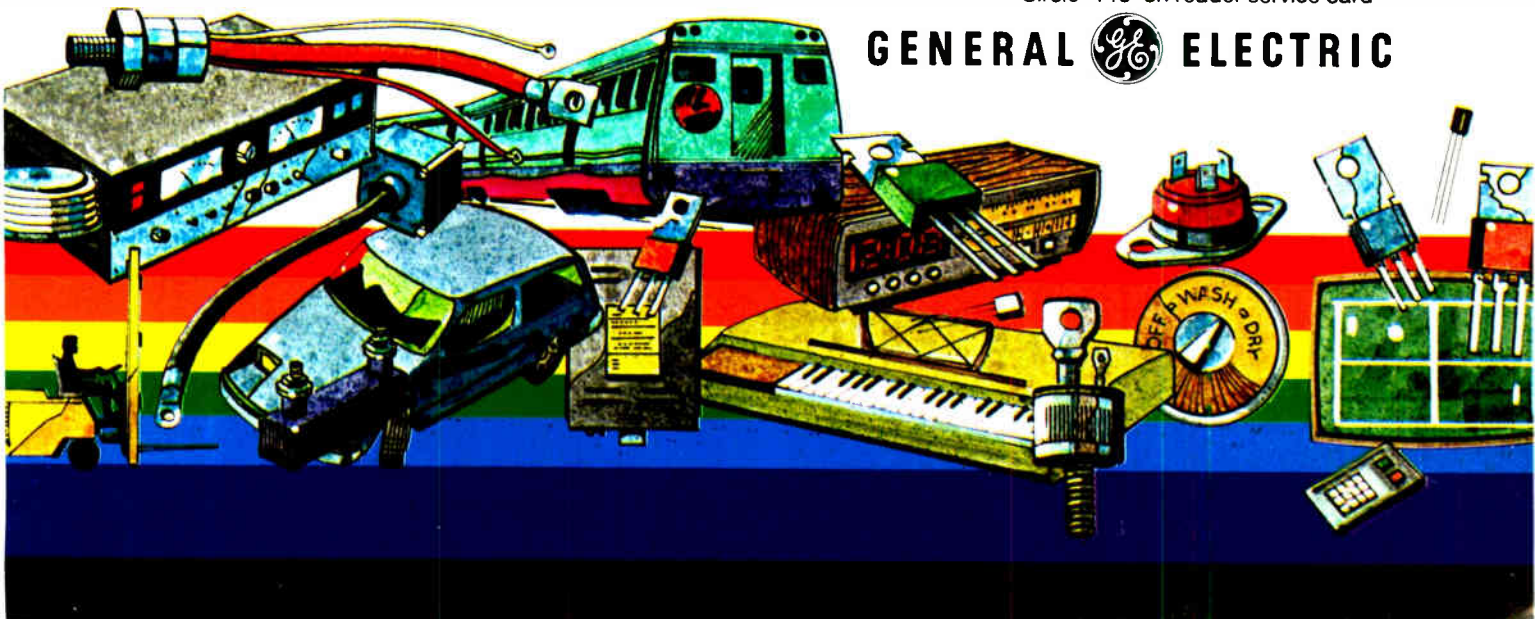





# THE COMPUTER COMPANY THAT GIVES BUSINESS THE COMPETITIVE EDGE IS ABOUT TO DO THE SAME FOR U.S. ATHLETES.

No matter how you compete, the difference between a good performance and a great one comes from knowing a little more than the other person. That's the competitive edge.

Now the computers that help people compete in the business and technical fields are out to do the same on the athletic field.

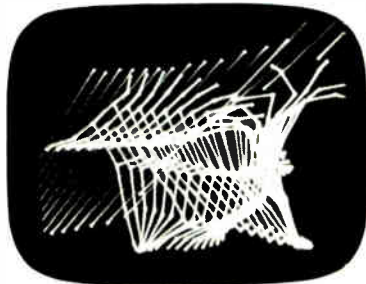

Dr. Gideon Ariel, a former Olympian, has developed a unique athletic training aid using a Data General ECLIPSE® computer system. What Dr. Ariel's device does, is employ our computer to detect the slightest flaw in an athlete's form. First, high speed movies of an athlete's performance are broken down frame-by-frame to show the body in segments, then analyzed for timing, speed and changes in center of gravity. The informa-

tion is fed into our computer, then played out on a screen allowing the complex motion of, say throwing the javelin, to be seen like no coach has seen it before.

Spotting shortcomings in an athlete's style is a new application for our Data General ECLIPSE computer that has us incredibly excited. In fact this ECLIPSE system will be used by the Sports Medicine Committee at the Olympic Training Camp in Colorado Springs.



**The Computer of the  
U.S. Olympic Sports  
Medicine Committee**

From the small CS/20 Commercial System to the large, multi-user business ECLIPSE M600, Data General computers are doing new things every day to enhance people's performance and give them a more competitive edge. For a reprint of an article on Dr. Ariel and his work, plus a brochure on our Data General business ECLIPSE computer, mail the coupon.

I want to compete better, too. Please send me the article on Dr. Ariel and your business ECLIPSE brochure.

Name \_\_\_\_\_ Title \_\_\_\_\_

Company \_\_\_\_\_ Tel. \_\_\_\_\_

Address \_\_\_\_\_

City \_\_\_\_\_ State \_\_\_\_\_ Zip \_\_\_\_\_

E417

 **Data General**  
We make computers that make sense.



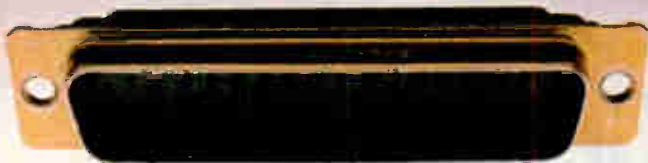

**THE OLD  
STANDBY  
THAT WON'T  
STAND STILL.**

In the beginning, there was the Cannon® Original D connector with solder pot contacts in a two-piece insulator. But as technology leapt forward, so did we. With our BURGUND, ROYAL-D and long line of designs that answered new needs and became industry standards.

Now our latest technology can be seen in our Mas/Ter™ D pin-and-socket connectors designed for mass-terminating flat cable or individual wires. Our Mas/Ter D contact design provides 25% more wire-to-contact surface area to give you increased reliability and conductivity. And for added flexibility, they are interchangeable and intermountable with our entire D Subminiature line.

If you're not content to let technology pass by, look into the Cannon D Subminiature and Mas/Ter D connector evolution. You'll find a huge selection of low-cost connectors and accessories available right now through our worldwide distributor network. For immediate information refer to our pages in EEM. For literature, the name of your local Cannon distributor or other information contact Rectangular Division Marketing Manager, ITT Cannon Electric, a Division of International Telephone and Telegraph Corporation, 666 E. Dyer Road, Santa Ana, California 92702. Telephone: (714) 557-4700. TWX: 910-595-1131. TELEX: 65-5358.

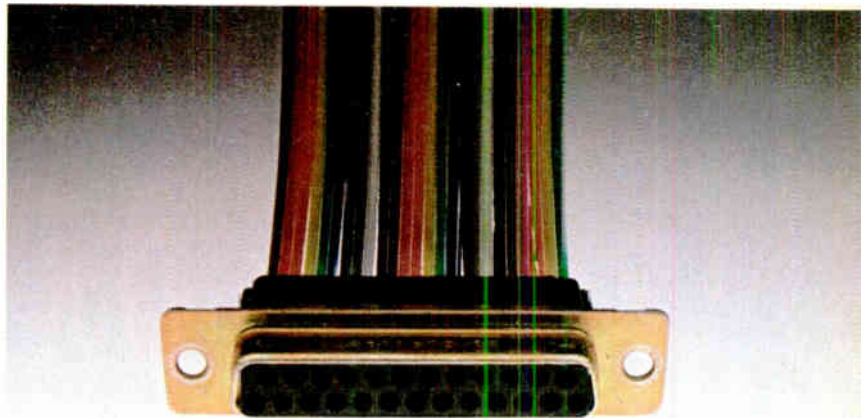
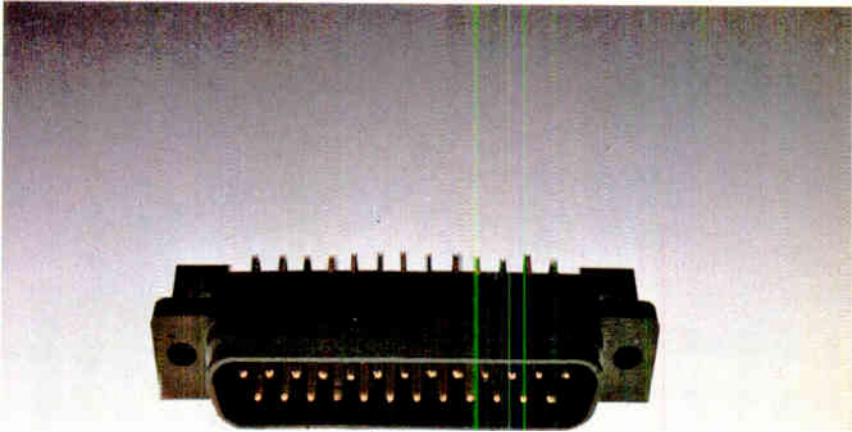
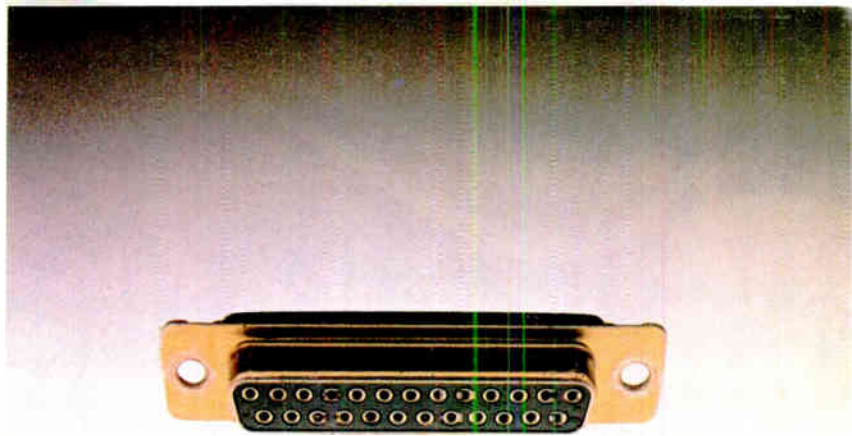

**CANNON ITT**

You can always connect with Cannon.

Circle 149 on reader service card





# AT WAR

---



HUMANITY'S GREATEST  
ACHIEVEMENTS ARE  
OFTEN INSPIRED  
BY CRISIS AND

PERIL. THUS, THE  
EXIGENCIES OF WORLD  
WAR II TRANSFORMED  
ELECTRONIC TECHNOLOGY  
FROM MERE ENTERTAINMENT  
AND NOVELTY INTO THE  
MEANS TO SURVIVAL—AND  
FOR THE ALLIES,  
ULTIMATE VICTORY.  
OUT OF THE CONFLAGRATION  
WERE BORN COMPUTERS,  
MINIATURIZATION, RADAR,  
LORAN, AND GUIDED  
MISSILES. THEN,  
TURNING FROM WAR TO  
LIFE-ENRICHING PURSUITS,  
THE TECHNOLOGY BROUGHT  
FORTH COMMERCIAL  
TELEVISION BROADCASTING  
AND STEREO AND TAPE  
RECORDING. ELECTRONICS  
WAS BEGINNING TO ASSUME  
ITS MODERN ALL-PERVADING  
CHARACTER.

## Chapter 4





**T**otalitarianism was on the march. Another World War was in the making.

Back in 1936, Germany had formed the Rome-Berlin Axis with Italy and signed the Anti-Comintern Pact with Japan. By spring of 1939, Austria and Czechoslovakia had fallen to Hitler's armies without a struggle, but with the German invasion of Poland on Sept. 1, Britain and France declared war on the Axis powers. Then for months, while German and Russian forces tore Poland asunder and the Soviet Army invaded Finland, nothing happened on the Western Front. That quietude was shattered on April 9, 1940. With roaring artillery and screaming bombs Hitler's war machine began its sweep down Europe's Northwestern coast into France, hurling the British Army into the sea at Dunkirk.

Winston S. Churchill, who took office as Britain's Prime Minister in May 1940, wrote later:

"Within six weeks we were to find ourselves alone, almost disarmed, with triumphant Germany and Italy at our throats, with the whole of Europe in Hitler's power, and Japan glowering on the other side of the globe."

The British government, having paid out more than \$4.5 billion for arms, also faced penury. In November 1940 Churchill wrote to President Franklin D. Roosevelt for help, and a month later Roosevelt responded. He publicly proposed Lend-Lease—American arms for Britain, with payment deferred—and when it became law in March 1941, the U.S. became, in Roosevelt's words,

"the great arsenal of democracy." Over the next four years it sent more than \$50 billion worth of war materials to the Allies. Roughly half went to Britain.

Before 1941 was out, the Japanese attack on Pearl Harbor had drawn the U.S. into the war. And before World War II ended, 49 nations at one time or other were fighting on the side of the Allies against 7 Axis powers. The Soviet Union, after swallowing Estonia, Latvia, and Lithuania, had joined the Allies by default when a 3-million-man German force swarmed onto Russian soil in June 1941.

**T**he war transformed the U.S., lifting it from the doldrums of the Great Depression into an era of feverish production. There was a great mobilization of industrial workers as well as soldiers. Some 3.6 million women joined 6 million men on the nation's industrial front to produce ships, trucks, guns, planes and other war supplies, and some 16 million men and women were in uniform by VJ-Day.

There was also a great effort in civil defense. Air raid wardens policed brownouts and blackouts, especially in seaboard cities, where the glow of lights could silhouette Allied shipping for enemy submarines. Something like 1.5 million civilian spotters scanned the seas for U-boats and the skies for enemy aircraft.

As part of the home front effort, civilians bought close



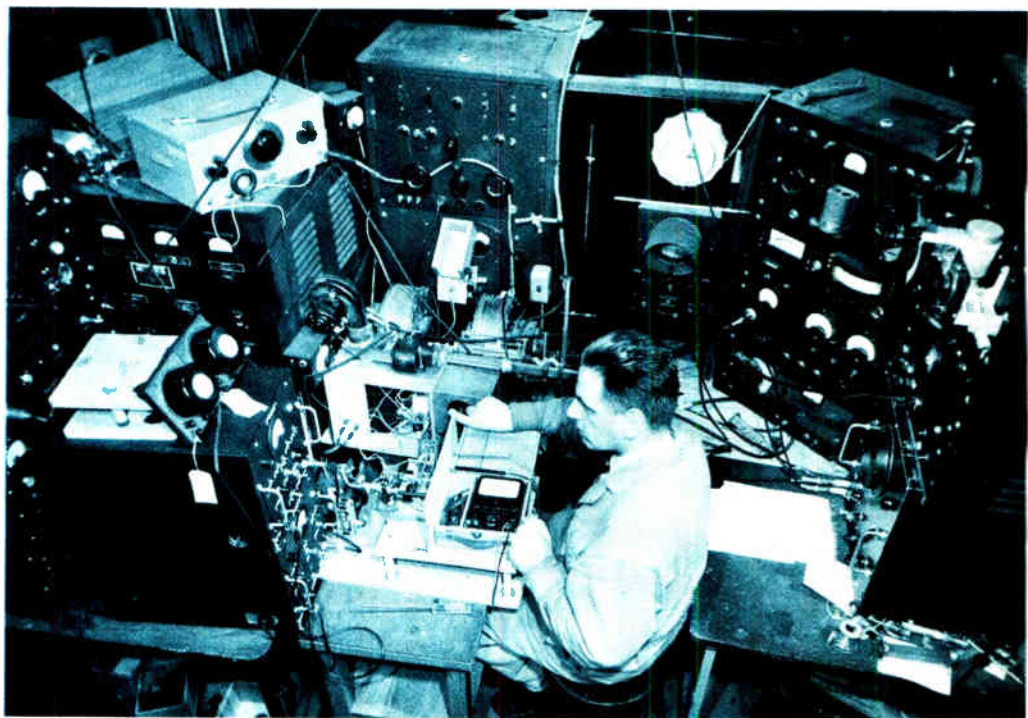

**Starting from scratch.** Technology skills had to be mobilized on a national scale to counter the Nazi threat, and new research laboratories were established. One of these was the Radiation Laboratory at MIT (above), which became the center of radar research.

**Mobilization.** America responded to total war by bringing to bear its industrial might in expanded production facilities. The use of women in factories became commonplace, as typified in this Western Electric radar assembly line in Kearny, N. J.

to \$50 billion in war bonds. With imports restricted, some commodities became scarce. Synthetic rubber came into use, and scrap metal and material of all kinds was collected—everything from empty toothpaste tubes to bacon grease for use in explosives.

Americans endured rationing of staples like meat, butter, coffee, sugar, and gasoline, paying for the items with special stamps as well as cash. They grew fresh vegetables in so-called Victory gardens in back yards, empty lots and parks. Black markets also flourished. Wage and price controls, administered by a Federal Office of Price Administration, kept inflation in check.

Then, just as victory in Europe was in sight, a stunned nation learned on April 12, 1945 of the death of President Roosevelt. On May 7, Germany surrendered unconditionally to the Allies.

On July 16, at dawn on a desert near Alamogordo, N. M., the atomic age was born. Scientists watched in awe from miles away as the world's first atomic device exploded and mushroomed upward from its fixed position atop a pole. Production of two aerial bombs was rushed, and on Aug. 6, 1945, an American B-29 crew dropped the first on Hiroshima. Three days later the second fell on Nagasaki. The next day the Japanese government asked the Allies about terms of surrender. The formal signing of unconditional surrender took place on the battleship Missouri in Tokyo Bay on Sept. 2, 1945.

The end of the war saw a rapid demobilization of the armed forces. The G. I. Bill of Rights, signed into law in June 1944, provided funds that allowed millions of veterans to return to school. It also gave them unemployment benefits, special hospitals, and loans for homes, farms, and businesses.

Internationally, the war turned the U. S. away from its isolationism. When the Senate ratified the United Nations Charter on July 28, 1945, the U. S. became the first to approve that plan for peace. It also became deeply involved in rebuilding its destroyed allies. The Marshall Plan proposed that reconstruction of the world's postwar economy be financed largely by the U. S. The Congress approved it, and President Harry S. Truman signed it into law on April 3, 1948. The nation was in a mood to forgive and forget. The fighting was over, but the cold war was just beginning.

**W**hile nation had battled nation to the death, the electronics industry entered upon a period of extraordinary creativity and growth. Under the stimulus of a multibillion-dollar flow of funds, it changed from a timid, consumer-oriented radio industry into a heroic producer of rugged, reliable military equipment, capable of withstanding the battlefield extremes of temperature, humidity, vibration, and shock.

Radar matured from infancy almost overnight and,





# Choose TI's 16-bit 9900 Family. For price. For performance. And because it's production-proven. You'll be in the best of companies.

By the hundreds, companies are staking new product designs on TI's 9900 Family. A wide diversity of products. By companies large and established. By those small and

growing. The brief recap on the opposite page lists just a few of the many innovators who have seen the future and chosen the 9900 Family. For a lot of good reasons:

## Here-and-now compatible family

Unlike others who plan or promise, the 9900 Family is a fact. Available

from your TI distributor today. Microprocessors. Peripherals. Microcomputer modules. Development tools. All compatible to protect your software investment as you move from one product design to another.

From the beginning, TI has been the 16-bit leader. The 9900 Family has grown. Matured. Become second sourced.

We'd like to say it's complete. But that will never be. TI is firmly committed to the Family's expansion according to your needs and as new technologies develop.

### Price/performance microprocessor choices

Utilizing the most advanced architecture on the market today, the microprocessors in the Family include the original NMOS TMS9900. The functional I<sup>2</sup>L equivalent, the SBP9900A, for harsh environments. The lower-cost TMS9980/9981 versions for smaller systems.

Now coming into production: TMS9940, the industry's first 16-bit single-chip microcomputer with on-chip memory and I/O.

In total, an unequalled choice that lets you more easily and quickly match price and performance to your designs.

### Low-priced peripherals

At last count, 14 peripherals support these microprocessors. The LSI "nuts and bolts" needed to complete your system. Easily. Economically.

For memory expansion to 16 megabytes there's the new TIM99610 Memory Mapper.

To fill your communication needs: TMS9902 Asynchronous Controller, TMS9903 Synchronous Controller, TMS9911 DMA Controller, and the new TMS9914 GPIB Adapter.

Also of interest: The TMS9927 CRT Controller and the new color graphics TMS9918 Video Display Processor.

### Cost-conscious microcomputer modules and minicomputers

For a headstart in systems design, look into the Family's series of 16-bit TM990 microcomputer modules for

evaluation, systems prototyping, and OEM applications.

The TM990 series includes stand-alone CPUs, memory expansion, and I/O expansion modules. And modules for program development. For learning and teaching.

TI's compatible 990 minicomputers extend the 9900 Family's level of integration to packaged host systems for distributed processing and a wide variety of other applications.

### End products:

#### Where the 9900 Family is shining.

Every day, the 9900 Family is proving itself where it counts. In the marketplace. At the core of new products, new designs.

Many major companies, whose large resources and staffs allow them to weigh carefully all considerations and options, have elected to build products around the 9900 Family. Among them are Litton Aero Products, Allen-Bradley, Tektronix, Veeder-Root, Sweda International, John Fluke, Amoco, Fisher Controls, E.I. DuPont, Sun Electric, General Electric, Otis Elevator.

Also, a large number of young, aggressive companies have selected the 9900 Family... companies who cannot afford failure. Among them are Acuity Systems, Optronics Ltd., Harowe Systems, Micor, Cubic, Praxis Ltd., Nicolet, Delta Data.

Texas Instruments, where the bottom line is as important as anywhere else, uses the 9900 Family as the heart of its pacesetter home computer. In its Loran-C receiver. In minicomputers and terminals. In satellite navigation systems. In aircraft tracking and collision avoidance support systems.

The proof is convincing. For performance, economy, versatility, support, your first choice in 16-bits is the 9900 Family. You'll be in the best of companies.

### Here-and-now Pascal

Just as many are playing catch up in 16-bit microprocessors, they're working overtime on high-level languages. Particularly Pascal. But TI has had operative Pascal for several years. Long enough to refine it for microprocessor applications.

TI's new Microprocessor Pascal offers the most extensive support available: Editor, compiler, host debugger, configurator, native-code generator, and run-time support.

Also: Compilers for Fortran and interpreters for Power Basic — all available on TI's floppy-based AMPL development system.

### Versatile development systems

In addition to a broad family of hardware, you need reliable, available — and economical — development systems. These the 9900 Family has. To boost programmer efficiency while cutting costs.

The AMPL\* prototyping lab is a complete set of software and hardware development tools for the entire 9900 Family. It provides real-time emulation and logic-state trace. It can be programmed for complex test and debugging sequences.

With this one versatile unit, you can not only develop software but also check out and verify software and hardware as you go.

Compared on a feature-by-feature, dollar-by-dollar basis, the AMPL lab is the best 16-bit microprocessor development system for your money.

### Help is available

Whenever you have a tough question or need another opinion, talk with your nearest TI systems engineer or TI distributor applications engineer. If you want to learn more about the 9900 microprocessors, TM990 modules, Microprocessor Pascal and the AMPL lab, TI training courses are being held weekly. Call your TI field sales office or your authorized TI distributor for details and locations.

For a copy of the new brochure on the 9900 Family, contact your TI distributor. Or write Texas Instruments Incorporated, P.O. Box 1443, M/S 6404, Houston, Texas 77001.

\*Trademark of Texas Instruments Incorporated

**TEXAS INSTRUMENTS  
MOVING AHEAD  
IN MICROPROCESSORS**



**TEXAS INSTRUMENTS  
INCORPORATED**



**TMS 2532**  
**32K EPROM**

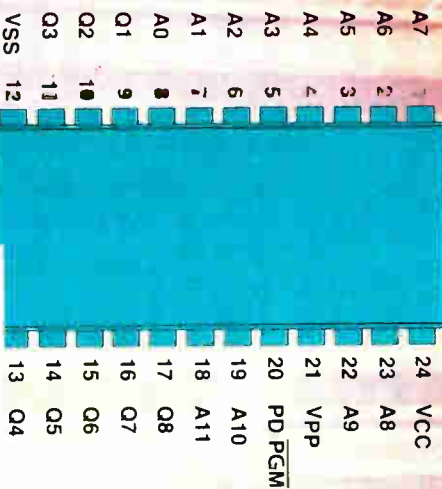

**TMS 2564**  
**64K EPROM**

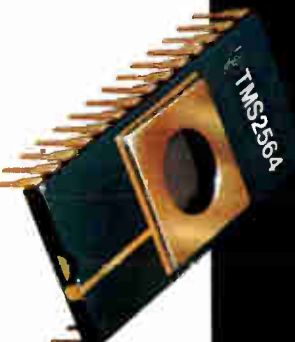
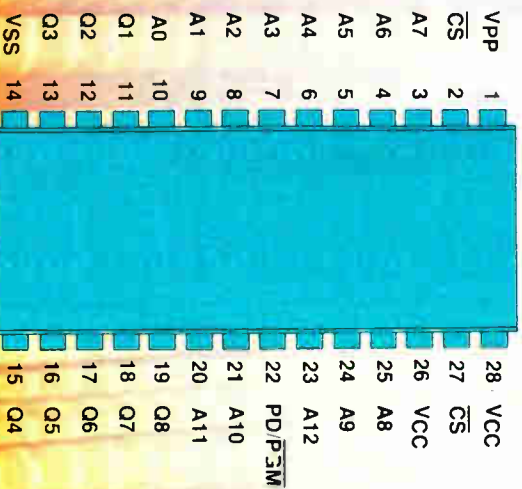

8Ks, 16Ks, 32Ks, and now...

# The first 64K EPROM. From Texas Instruments. Naturally.

Introducing the TMS2564. The industry's first 64K EPROM. The densest yet. With all the high-performance features of TI's 5-V EPROM family. Features like 8-bit word configuration, fully static operation, automatic chip-select/power down, and low-power.

## Pin compatibility

TMS2564 is offered in a 600-mil, 28-pin dual-in-line package. But, it's compatible with industry standard 24-pin 64K ROMs, as well as less dense EPROMs.

This is because pins 3 through 26 of the TMS2564 are compatible with pins 1 through 24 of the 24-pin devices. Compatibility is enhanced by reserving both pins 26 and 28 for the 5-V supply. So,

with a supply trace to pin 26, both 24 and 28-pin devices can be used, with no jumpering.

## Fully static

Like all TI EPROMs, the TMS2564 maintains the fully static tradition that makes designing easier.

No timing signals. No clocks. No strobes. No refresh. No problems. Simply, cycle time equals access time.

## Lowest power ever

Operating at an access time of 450 ns with a power dissipation of only 840 mW maximum or less than 13  $\mu$ W per bit, it's the lowest power per bit ever achieved in EPROMs.

## Easy programming

The TMS2564 is designed to facilitate rapid program changes in high density, fixed memory applications.

All that's needed for simple, in-system programming, is a single TTL level pulse.

You can program in any order. Individually. In blocks. At random. So, programming time is reduced to a minimum. And, you can use existing 5-V PROM programmers.

Erasing? Simple ultraviolet. Just like any other EPROM.

## Widest choice

By adding the new TMS2564 to our fast-growing EPROM family, we offer the designer a product breadth unmatched by any other supplier.

All TI EPROMs are available in 600-mil packages with JEDEC compatible pin-outs.

And they all share the reliable N-channel process technology.

TI's growing EPROM family. For all your present and future memory requirements.

**For more information** about the first 64K EPROM, or any other family member, call your nearest field sales office or authorized distributor. Or write to Texas Instruments, P.O. Box 1443, M/S 6955, Houston, Texas 77001.



TI'S GROWING EPROM FAMILY

Device	Description	Power Supply	Max Power (0°C)		Access Time
			Operating	Standby	
TMS2564	64K	5 V	840 mW	131 mW	450 ns
TMS25L32	32K	5 V	500 mW	131 mW	450 ns
TMS2532	32K	5 V	840 mW	131 mW	450 ns
TMS2516-35	16K	5 V	525 mW	131 mW	350 ns
TMS2516	16K	5 V	525 mW	131 mW	450 ns
TMS2508-25	8K	5 V	446 mW	131 mW	250 ns
TMS2508-30	8K	5 V	446 mW	131 mW	300 ns
TMS2716	16K	+ 12, $\pm$ 5 V	720 mW	—	450 ns
TMS27L08	8K	+ 12, $\pm$ 5 V	580 mW	—	450 ns
TMS2708	8K	+ 12, $\pm$ 5 V	800 mW*	—	450 ns
TMS2708-35	8K	+ 12, $\pm$ 5 V	800 mW*	—	350 ns

\* $T_A = 70^\circ\text{C}$

TEXAS INSTRUMENTS  
INCORPORATED



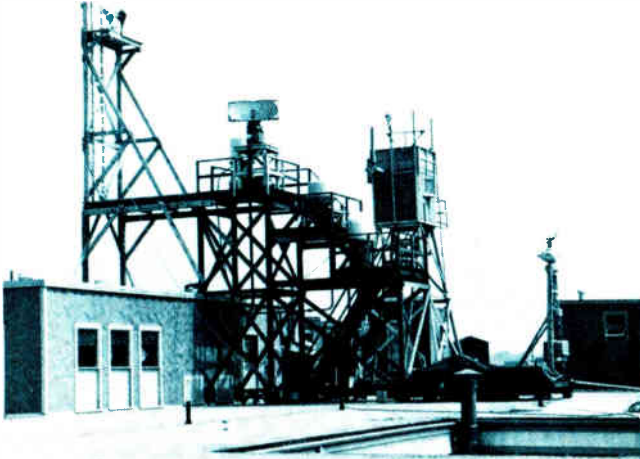

**Rooftop radar.** The MIT Radiation Laboratory was the scene of much of the experimental work that produced U. S. military radar. Shown here are experimental antennas atop the laboratory's Building 6 near Massachusetts Avenue in Cambridge.

for openers, helped the Royal Air Force win the crucial Battle of Britain. Sonar was improved, and Allied navies used it to pinpoint the position of submerged German U-boats. Miniaturization crammed circuitry into tiny spaces for airborne and backpack applications. It also gave birth to the proximity fuze, which gave Allied antiaircraft, mortar and artillery batteries an edge in hitting targets. Giant calculators, forerunners of the modern computer, were perfected and saved countless hours in figuring ballistic trajectories and the astronomical tables used in navigation. The walkie-talkie, developed back in 1933 for the Army Signal Corps, improved infantry communications.

On the home front, electronic instruments advanced to the point where they could automatically test assembly-line components and help relieve a civilian manpower shortage. In the aircraft, munitions, and metal-working industries, around-the-clock schedules put industrial electronics to the test in controllers for resistance welders and other machinery. It passed with flying colors, thanks to the ruggedized tubes developed in the 1930s.

World War II was the first war in which electronics played a decisive role, and the effect on the industry was phenomenal. A history of the War Production Board notes:

"The electronics industry expanded during the war to more than 12 times its monthly prewar net factory filling value on end equipments and from over 2 to 20 or 30 times on the major components. The expansion of labor employment was from a prewar peak of approximately 110,000 workers to a war peak of 560,000."

The radio industry was never to return to its relatively small position in manufacturing, dependent on the rise and fall of a single consumer product. Civilian production of radios was at a minimum during the war, but airmen, seamen, tank crews, and foot soldiers relied on radio sets as lifelines of communication. In 1941, the War Production Board reported, for example, that 55 radio set manufacturers had factory sales of \$240



**British pioneer.** Sir Robert A. Watson-Watt is credited with taking radar out of laboratory and making it practical. His work helped Britain achieve the system that proved itself in the Battle of Britain. Later, Watson-Watt visited the U. S. to aid American radar efforts.

million. By 1944, what was being referred to as the radio and radar industry, including parts makers, reached annual sales of \$4.5 billion—an increase of 1,875%.

Each tank of its day contained some \$5,000 worth of radio equipment, and a heavy bomber contained \$50,000 worth "of the most complex and delicate radio devices," according to William L. Batt, chairman of the War Production Board's Requirements Committee.

There were other revealing War Production Board statistics. Total vacuum tube production from 1942 through the first half of 1945 was valued at more than \$1 billion, or about 15% of the value of electronic end-user equipment. Capacitor manufacturers, who had sold about \$5 million worth a month before Pearl Harbor, were selling \$12 million a month by VJ-Day. Similarly, the 42 manufacturers of radio and radar transformers, whose output alone was valued at \$11 million in 1939, had grown to at least 95 by late 1944 and the monthly output was about \$14 million by 1945.

Standardization of all this radio and radar equipment was of course crucial to military efficiency, and much of it was handled by the engineering department of the Radio Manufacturers Association. Early in 1942 there were 2,300 designs of radio tubes in Army and Navy equipment. By the end of the war, military tube types had been reduced to 224, with a single specification for each type. Standards were also developed for many other components, including electrical indicating instruments, capacitors, coaxial cables, insulators, toggle switches, resistors, and rheostats.

**E**ven before the attack on Pearl Harbor, some electronics leaders had seen the need for a major industrial effort. In an address to the summer convention

# BECKMAN



## The number one network producer.

Making more resistor network products than anyone else makes us number one. And that makes us the company to call for all your resistor network needs. We have manufacturing facilities worldwide to serve your large production requirements. And we have the technologies, packages, and components to handle your applications.

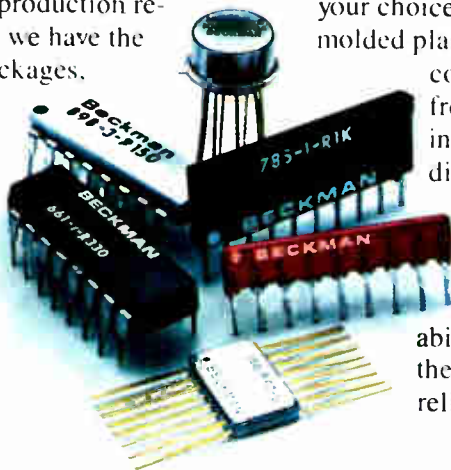

Our technical capabilities include precision, semi-precision and general purpose thick and thin films. We offer four packages: SIPs, DIPs, flat packs, and discrete transistor metal cans. Take your choice of ceramic, molded plastic, or conformal coating. Select from components including resistors, diodes, capacitors, and conductors. Besides large production and technical capability, we offer you the utmost in reliability. And our

resistor networks are designed to meet military specifications.

So for all your network needs, be they large or difficult, or both, go to the top. Go to the number one network producer—Beckman. For more information, contact your local Beckman representative or write: Network Products Operations, Beckman Instruments, Inc., 2500 N. Harbor Blvd., Fullerton, CA 92634. In Europe write: Beckman Instruments (Belgium) S.A., 14, Avenue Hamoir, 1180 Bruxelles, Belgium. Telex: 23577.

**Design Beckman in.  
Design problems out.**

## BECKMAN

Circle 159 on reader service card



# INTRODUCING THE 6800 SHORT STACK

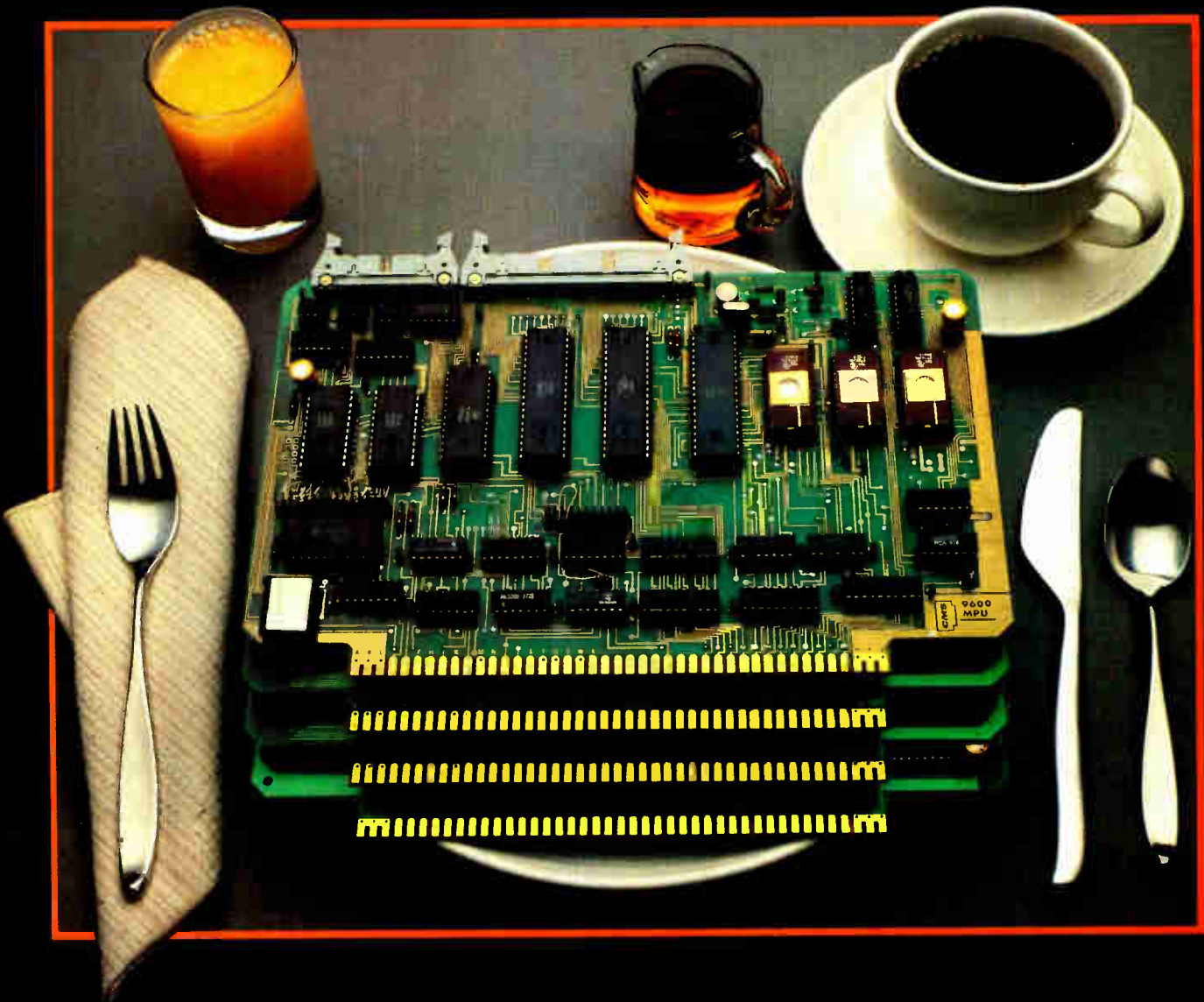

A short stack may not be the traditional way of looking at microcomputers, but at Creative Micro Systems, we use it to make a point.

## A MIGHTY TALL ORDER

We put more into our microprocessor modules so you can do more with them. A few modules can become a mighty tall order.

Take our 9600 MPU for instance — a complete microcomputer on a single board. It features the MC6802 processor, 6K of EPROM, 1.1K of RAM, 40 lines of parallel I/O channels, BREAK detect, three 16-bit programmable timers, and a power failure protect/restart circuit.

## FOR BIG APPETITES

Of course, if you should have a more extensive appetite, we have a variety

of additional items on our menu including: our 9616 32K EPROM/ RAM Module, our 9620 Parallel Interface Module, our 9622 Serial-Parallel I/O Module, our 9627 16K Static RAM Module, our 9640 Multiple Programmable Timer and our 9550 8 Port Duplex Serial I/O Module.

## SOPHISTICATED ENTREES

Our side dishes include card cage, mother boards, prototyping boards, power supplies and accessories. We even have sophisticated entrees like our 9655 Intelligent Cartridge Tape Drive Controller.

All our modules are pin and outline compatible with the industry standard Motorola EXORciser and Micromodule bus, and the Rockwell System 65.

Original Equipment Manufacturers who order Creative Micro Systems

modules have found system design is simpler, fabrication and testing is faster, and overall costs are lower and more predictable. It all adds up to saving time and money with your order.

## GET MORE WITH YOUR ORDER

Now don't expect to get orange juice and coffee with your order, but keep in mind, you do get more when you order Creative Micro Systems modules.

Hungry for more information? Write or call for our product catalog and a free copy of our newsletter.

## Creative Micro Systems,



11642-8 Knott Avenue  
Garden Grove, CA 92641  
Telephone (714) 898-9669



**Microwave key.** MIT's Radiation Laboratory revolutionized radar by using microwaves. Inspecting an early American version of the cavity magnetron are E. G. Bowen, a British scientist (left), and laboratory directors L. A. DuBridge (center) and I. I. Rabi.

banquet of the Institute of Radio Engineers on June 24, 1941, Frederick Emmons Terman of Stanford University, the group's president, said:

"Today the armed services of the nation are drawing mightily upon the intellectual inheritance handed down by radio pioneers . . . Radio and its allied arts will have much to do with the placing of force where force is needed in the event this country goes to war. Some of these applications will be to the handling of communications . . . But in addition electronic technicians are finding totally new employments . . . in navigation and in searching out the enemy, whether he come by sea, land or air. . . . The most intricate military control equipment, much of it based upon radio devices, will be commonplace in our services when and if war comes to us."

Earlier, in July 1940, the board of directors of the American Institute of Electrical Engineers had passed a resolution to the effect that the organization would help President Roosevelt carry out a program for the defense of the country. In September, the AIEE publication, *Electrical Engineering*, carried an article on the same theme by L. A. Hawkins, executive engineer in the research laboratory of the General Electric Co. in Schenectady, N. Y. Hawkins wrote:

"The Nazi juggernaut was created by engineering, and it is only by engineering that it can be destroyed. . . . The fascinating search for truth for its own sake must be temporarily abandoned and thought and effort concentrated on the problems of military preparedness. . . . Research and engineering must work together as never before to the attainment of a single end."

Others were thinking along similar lines. Vannevar Bush, president of the Carnegie Institution of Washington and an electrical engineer, had already approached President Roosevelt and his advisers and impressed upon them the need to mobilize science for war, specifically by familiarizing researchers with the needs of the military and the military with the possibilities of science.

When the Government created the National Defense



**In training.** In 1941, the use of radio-location, or radar, techniques for tracking enemy aircraft and directing anti-aircraft fire was still relatively primitive. Here British operators are shown being trained in electronics with crude equipment.

Research Committee on June 27, 1940, Bush was named its chairman. Other members included Karl Taylor Compton, a physicist and president of the Massachusetts Institute of Technology; James Bryant Conant, a chemist and president of Harvard University; Frank Baldwin Jewett, an electrical engineer and president of both the National Academy of Sciences and Bell Telephone Laboratories; and Richard Chace Tolman, a physicist and professor of physical chemistry and mathematical physics at the California Institute of Technology. The U. S. Commissioner of Patents and one representative each from the Army and the Navy also joined the panel.

The committee's job was "to correlate and support scientific research on the mechanism and devices of warfare, except those relating to problems of flight." (The latter fell within the purview of the National Advisory Committee for Aeronautics and Space Administration.)

One of the committee's first orders of business, therefore, was to bring its existence to the attention of education research centers around the country and to compile an inventory of the nation's resources, both scientific personnel and physical facilities. Conant wrote to 50 leading research centers. The objective was to match people and projects with as little disruption of education programs as possible.

In addition, some new research laboratories had to be set up. For example, with growing German submarine attacks on shipping, a big program was needed in anti-submarine warfare but no center for such activity existed. Two were quickly established by the National Defense Research Committee—one under contract with Columbia University at New London, Conn., and the other with the University of California at San Diego.

Similarly, a new center for radar research had to be



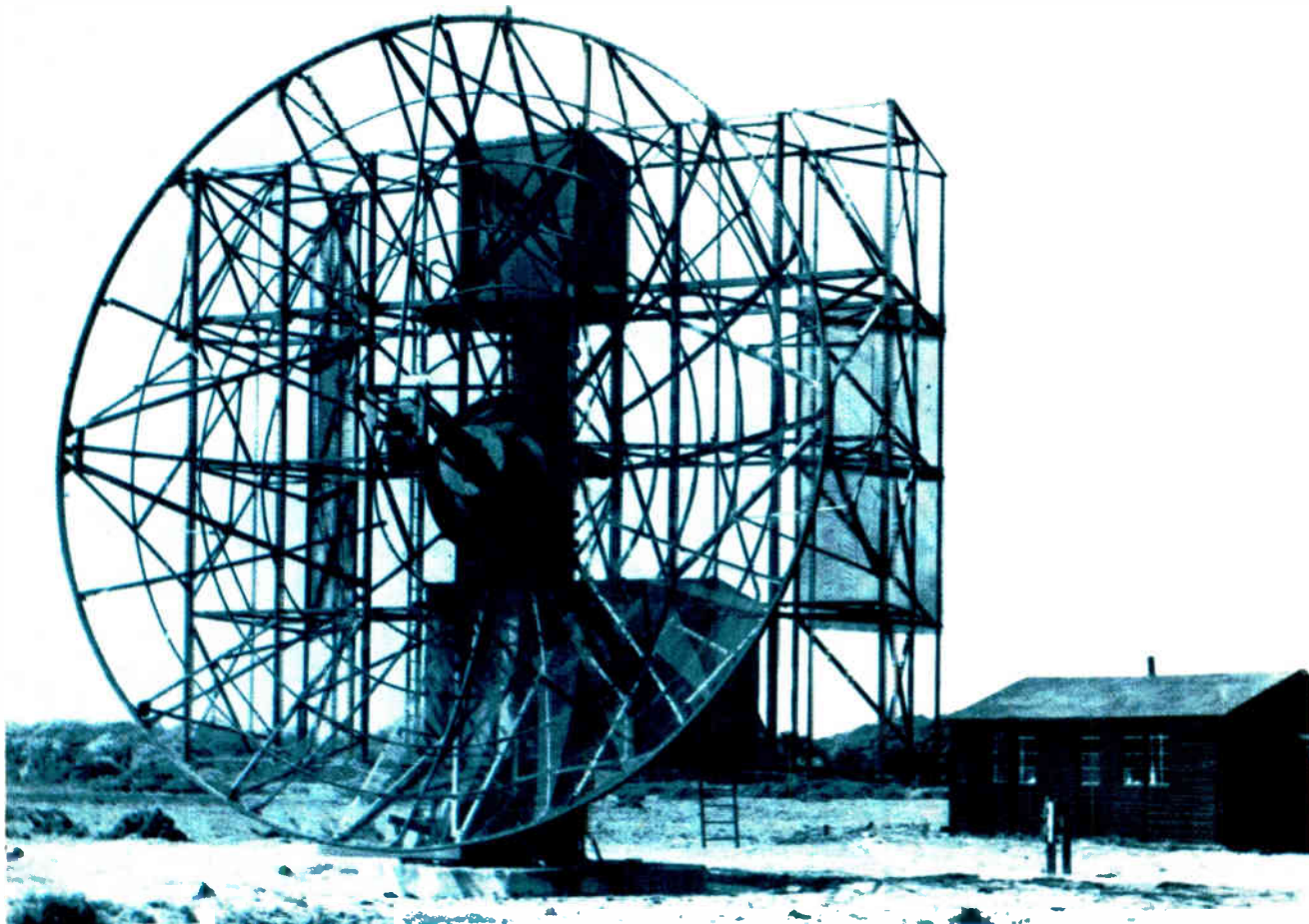

**Fighter director.** This is one of the first pictures ever released of a British radar installation. Called a type 16 Station, it was used mainly in offensive operations for observing and passing range and height data to group headquarters, permitting tactical fighter control.



**Mickey Mouse.** Its twin antennas inspired the nickname of the U. S. Army's SCR-547 anti-aircraft radar shown at the front in Italy in 1945. It was designed to measure the height of enemy planes, the data being transmitted to a remotely located gun installation.

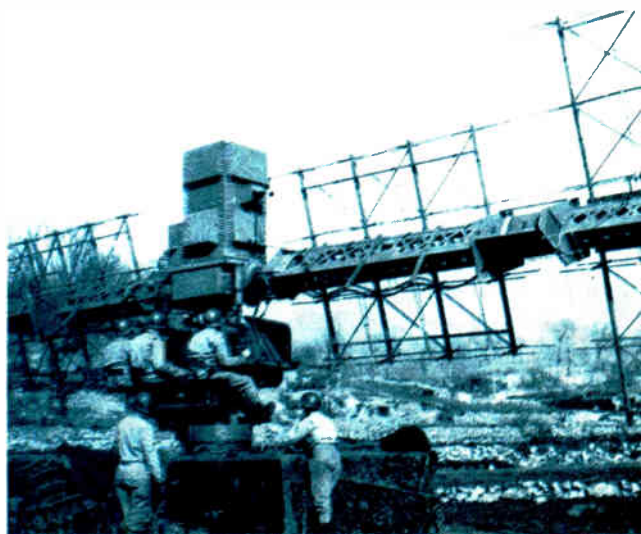

**Three-dimensional.** A five-man crew was required to operate the 9936 U. S. Signal Corps radar shown here on an Italian hillside. Three seated operators traced, respectively, the degrees from the north, the elevation, and the range of the target.

established just about from scratch. Although some work in long-wave radar had been done in the country, the field of microwave radar was unexplored. The Massachusetts Institute of Technology in Cambridge Mass., was chosen for the radar center, and this new Radiation Laboratory grew to be the largest single undertaking of the committee.

Countermeasures work—the jamming of enemy

communications and radar—also required new laboratories. The largest of these, the Radio Research Laboratory at Harvard University, was headed by Terman of Stanford.

The National Defense Research Committee operated throughout the war, finally disbanding in January 1947. Initially it had reported to the National Defense Council. Then in June 1941, to facilitate the translation of

# DESIGN BECKMAN TRIMMERS IN. DESIGN PROBLEMS OUT.

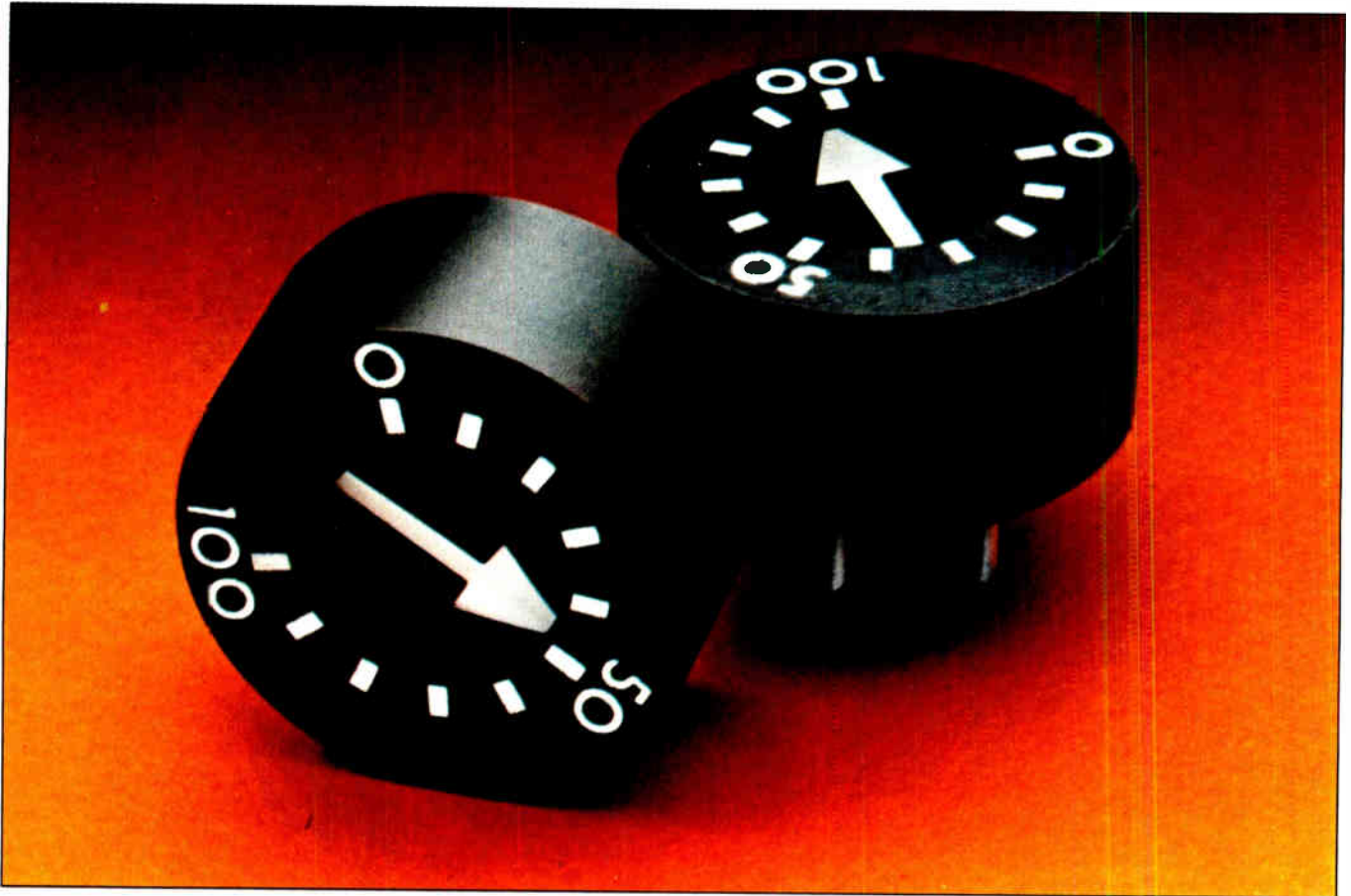

## Presenting the 93P. Our new half-inch trimmer with its built-in dial is a turn for the better.

For the first time, you can have a cermet half-inch single-turn, with dial setting capabilities. A variable resistor that's somewhere between trimmer and precision pot, designed to save labor costs with screwdriver position adjustability, and high-resistance capabilities.

Now you can write your manuals, and specify fast setting instructions. Using the 93P means reduced labor. It'll take less time to make that initial setting, less time to check the board. Calibration time is minimized. And the

93P has custom dial setting capabilities, too. Cermet technology has many advantages over wire wound. With 10% tolerance, and 100 ohms to 2 meg

ohms resistance range, it wins hands-down at high resistances. Inductive problems are eliminated. And the 93P is sealed for environmental stability.

Why a larger cermet part? The longer the element, the more the power dissipation. And it stands to reason, you can get more marking and more adjustability.

Design in a trimmer that's not a trimmer as you've known it until now. The 93P.

Call your local Beckman Helipot distributor for free evaluation samples. To get his number, or immediate technical literature, call (714) 871-4848, ext. 1776. Start designing problems out today.

# BECKMAN



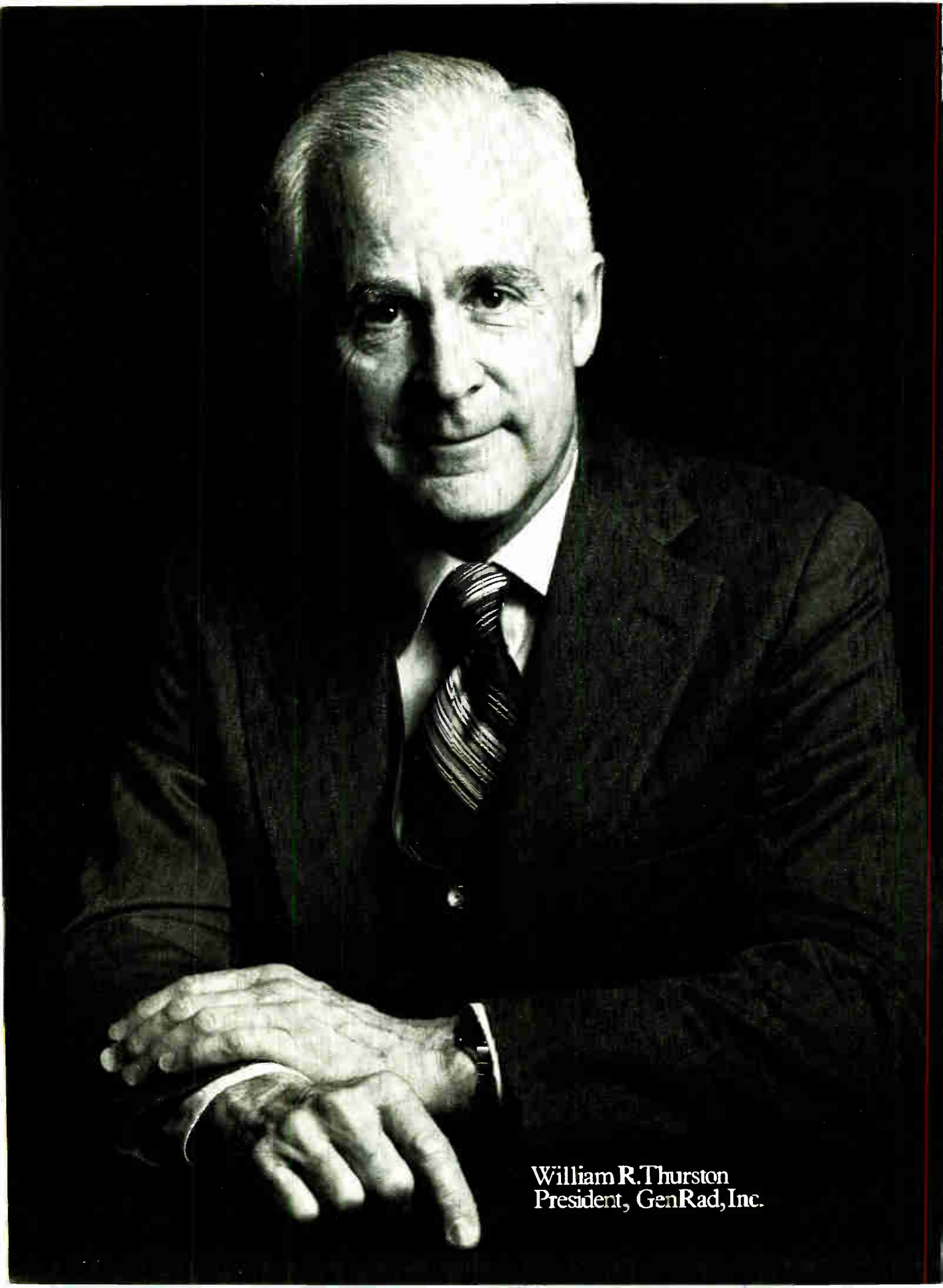

William R. Thurston  
President, GenRad, Inc.

# “By 1999, we expect your ATE network will be helping you with almost every business decision you make. Even personnel decisions.”

“The Factory of the Future is on everyone’s mind.

At GenRad, it’s on our drawing boards.

Because the way we see it, every single department in the Factory of the Future will be tied together with a vast, efficient communications network.

Perhaps it’s surprising to think of your ATE system as the very heart of this network, but if you think about it, it’s the logical conclusion.

ATE is already present all the way through the manufacturing process. The next step will be to broaden the capabilities of your test stations. To give them the ability to collect data, analyze it and transfer it to other departments. Your purchasing department, for instance, will be receiving inventory information from both incoming inspection and the manufacturing line. Your design department will receive information such as chronic design problems from your plant floor as well as from field service. And plant management will get specific work-flow, workload and productivity information, plus overall statistics, from every station in your plant.

## Meeting the opportunities, as well as the problems.

The diversification of your ATE stations seems inevitable. Because the Factory of the Future will have to be flexible enough to respond to new opportunities, as well as old problems.

Like the opportunity to gain market share by further diversifying your product line. In the future, you will be offering an even wider range of products than today, with an enormous number of options, much like the Detroit car companies.

It will be up to your ATE system, the heart of your communications network, to choreograph your entire production line.

And if you’re locked into ATE that’s not up to the task, chances are you’ll lose substantial ground to the companies that were more farsighted.

On the other hand, there will continue to be problems. Like finding the right personnel. Industry forecasts show that ten years from now, you’ll still be short of skilled people. So ATE, like all your equipment, will be aimed at making your staff far more productive.

## More sophisticated hardware alone won’t get the job done.

If the Factory of the Future evolves the way we expect it to, an entirely new generation of ATE will evolve along with it. Because in our view, the biggest payoff in the Factory of the Future will come from the automation of the production floor—not just the production office.

And this new generation of ATE will necessarily be based on software.

Software sophisticated enough to interface with your CAD systems, your CAM systems, your host computer, and all the other intelligent systems in your plant—as well as with your people.

Software that’s sophisticated enough to adapt to the inevitable changes in technology.

Software has been our platform since we designed the world’s first commercial computer-based logic board tester in 1969, and it remains our platform today. It’s why we’ve always delivered the equipment you’ve needed, when you’ve needed it.

And why we always will.”



## GenRad

Put our leadership to the test.



# SINCE 1960, WE'VE BEEN SHARPENING THE INDUSTRY'S IMAGE.

When the integrated circuit wasn't much more than a theory, we were working on ways to turn it into a profitable reality.

And since that time, we've built a tradition of excellence exemplified in systems like the Mann DSW Wafer Stepper™ and Wafertrac™.

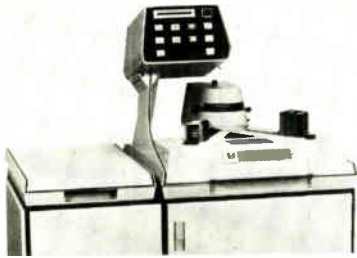

1967. First "hands off" wafer transport using patented air bearings was introduced.

Together, these remarkable systems not only bridge the gap between 1:1 projection and E-beam, they also offer the most cost-effective method of pro-



1961. GCA developed and delivered the first Photorepeater® on which the art of photolithography is based today.

ducing today's small geometry circuits. And DSW is the only direct step on the wafer system capable of imaging geometries down to 1 micrometer.

When that kind of precision is coupled with the productivity of Wafertrac, yields begin to soar over other systems.

Wafertrac provides completely automatic wafer processing from start to finish, increasing throughput and virtually eliminat-

ing the problems of manual handling.

Before DSW and Wafertrac were introduced, we also developed the industry's first pattern generator, the first Photorepeater®, and the first 10x 10mm field Photorepeater® with integral reticle alignment.

Today, we're pioneering the development of new microlithographic imaging systems that will continue to expand the capabilities of integrated circuits.

The technology in these systems will be based, in part, on our experience in building products that have consistently set industry standards and given us an image we're proud of.

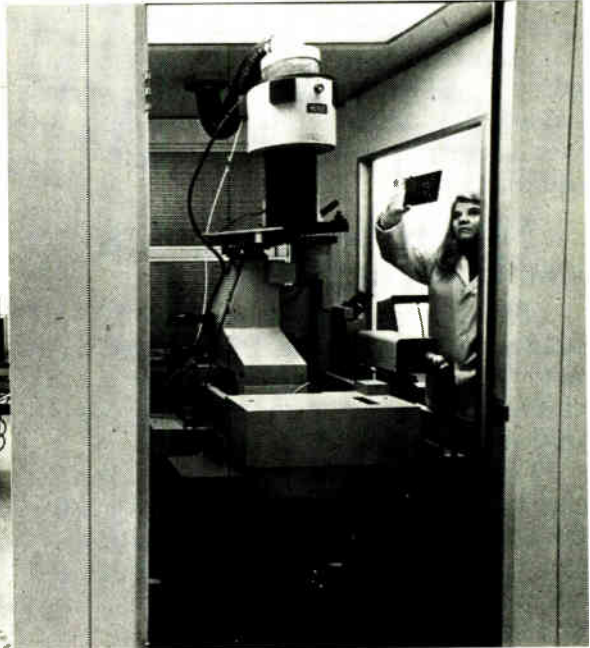

For the 1980's, GCA's DSW Wafer Stepper/Wafertrac, shown here interfaced, forms one of the most highly automated production systems for advanced device manufacture available today.

promising research projects into equipment for the armed forces, the Office of Scientific Research and Development was set up.

This new organization correlated the committee's research program of the National Defense Research Committee with those of the military and the National Advisory Committee for Aeronautics. It also maintained close liaison with British scientists. It had under it 19 divisions, about half a dozen of which involved electronics. Bush was its director too, and subsequently also became director of the Joint Committee on New Weapons and Equipment, set up by the Joint U. S. Chiefs of Staff in May 1942, to introduce new weapons to the military.

One of the divisions that came under the Office of Scientific Research and Development served as the focal point of microwave radar R&D. In addition, Division 14 devoted major efforts to designing equipment that met specifically military problems and to making more effective use of equipment already on hand.

Radars were developed for aircraft detection, jamming, ship detection, weapon-fire control, navigation, and identification systems. Many were later to become fixtures in the civilian sector.

By 1940, Britain and the United States were trading radar secrets. The British Royal Radar Establishment under Robert (later Sir Robert) Watson-Watt had come up with the magnetron, a high-frequency electron tube that generated microwave energy. It operated in radar transmitters at S band (3,000 megahertz) and ultimately in most microwave radars of all frequencies ranging to 30,000 MHz.

Designers wanted the operating frequency to be as high as possible, since the radar's resolution—its ability to discriminate a single target among multiple targets—was better at the high end of the spectrum. Unfortunately, as the frequency went up, so did the atmospheric attenuation. This limited the range.

Nevertheless, the British achievement with magnetrons was notable. The Germans were never able to approach it; their radars were mostly limited to frequencies in the hundreds of megahertz.

In the U. S., researchers at Columbia University, the Massachusetts Institute of Technology, and the Naval Research Laboratory had come up with the duplexer. This switch let the radar transmitter and receiver use the same antenna. Both behaved better electrically, and the cost of a second antenna was saved.

Other world powers had also been active in radar. France had installed a megahertz-range pulse radar for collision avoidance on the luxury liner *Normandie*. This experimental device was put out of action when the *Normandie* caught fire and sank in 1942 while interned in New York Harbor. The Soviet Union was credited with an early-warning aircraft radar at 300 MHz in 1941, and Japan with a similar radar by 1942.

Unlike the British and Americans, the Germans, with their blitzkrieg tactics, did not plan their radar development programs for a long war. By the time they realized

**Asaa.** Fire-control radar also played an important part in naval warfare during World War II. This Mark 4 radar antenna is mounted on the Mark 37 gun director of the destroyer USS *Nicholas* (DD-449). This photograph was released in January of 1944.

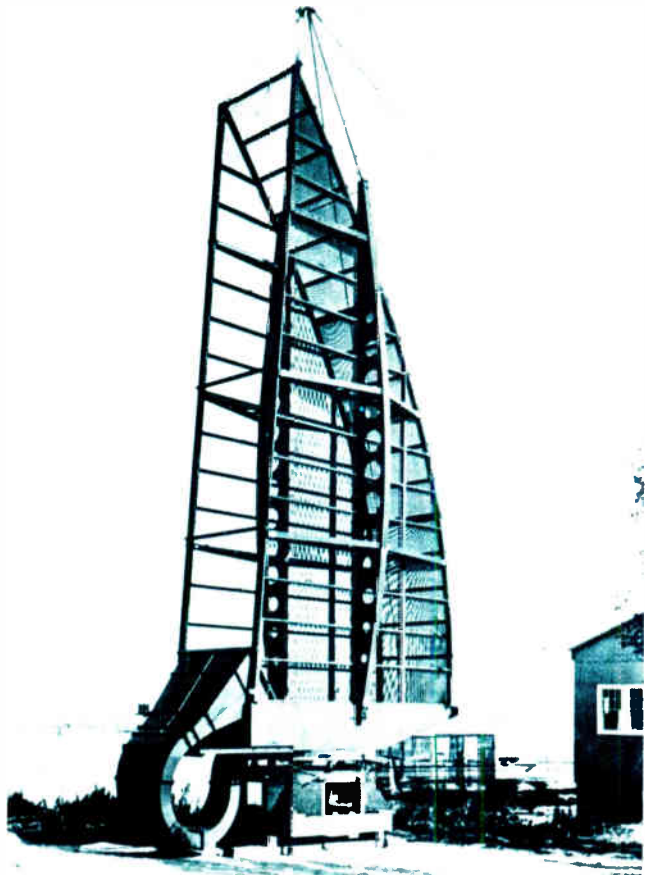
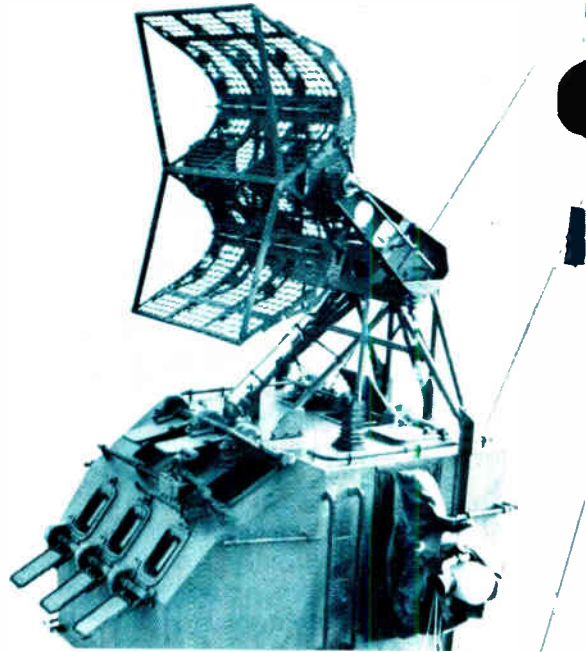

**Jammer.** This antenna was designed by Harvard University's Research Laboratory as part of "Tuba"—a huge radar used by the RAF to blind the radar of German night fighters. Its shape gives a vertical and broad horizontal beam plane and wide frequency range.



that the conflict was not going to be over on schedule, it was too late. By then Germany itself was under bombardment night and day by the Allies, and the Germans found it hard to maintain current production schedules, let alone pursue the luxury of research and development. They never got microwave radar, with its superior resolution powers, into full production. There were just prototypes of new systems.

In contrast, the British and Americans produced microwave radars in volume. This was made possible by an enormous research and development effort in the U. S., the likes of which had never been attempted.

One fifth of all physicists in the country—several hundred of them—worked on radar developments at the Radiation Laboratory of MIT. Other work was done at Columbia University's Radiation Laboratory and the Harvard Radar Laboratory. Developments were so rapid that most systems were obsolete in some way before they got into full production. This presented problems in deciding when a radar was "good enough."

According to the 1946 "History of the MIT Radiation Laboratory," 2,000 radar sets a month were eventually being produced at such industrial establishments as Raytheon, Sperry, and Westinghouse. The history estimates that more money was spent on radar and its development than was spent to put together the atomic bomb—\$2.5 billion, compared with \$2 billion.

In combat, radar played the dual role of destroyer and defender. For Britain, it was a godsend. In July 1940 the Germans had begun an all-out aerial assault on Britain. They had 2,500 bombers and fighters to send to the attack; the Royal Air Force had but 900 fighters to oppose them. By the end of October 1940, the Luftwaffe was in retreat, beaten in the Battle of Britain.

British search radar, based on the work of Watson-Watt in the late 1930s, played a major role in the victory. With the radar, controllers on the ground were able to vector the RAF fighters to the right places at the right times. In one day in September 1940, Germany lost 185 planes in an attack on London.

Two different radars were responsible for the overall

British success. One was the GCI, or ground-controlled intercept device; the other was the AI, or airborne intercept system. Both operated in the microwave range, with several versions using a 3,000-MHz magnetron. The GCI radars protected the home islands, while the AI were mounted in all the RAF fighter planes at frequencies through X band.

The 3,000-MHz radar, with a range of 50 miles or so, became the basis for many American designs from 1942 to 1945. With 300 MHz, the range was but 25 miles, and the radar had far less resolving power.

**W**hen Germany declared war on the U. S. on Dec. 11, 1941, a submarine-hunting radar, Dumbo-1, had just made its first flight on a U. S. naval patrol bomber. It was an outgrowth of the British AI. The AI also was the basic model for a U. S. fighter-plane radar.

Depending on the power available and the type of pulse that was transmitted, the useful range of the Allied radars was constantly changing. Early X-band types picked up information out to about 25 miles. On the other hand, one experimental American S-band set was operable out to 125 miles.

High-power tubes were a major source of interest for researchers at MIT's Radiation Laboratory because, besides increasing radar range, they could be used to jam enemy radars. Jammers were merely massive noise generators that, by brute force, overloaded the enemy receivers with strong signals.

For a time, lighthouse tubes—vacuum triodes that were megahertz extensions of classic radio-frequency vacuum tubes—were experimented with. One, the L-band Mark I radar, was developed at the MIT Radiation Laboratory and was the prototype for many later radars. But lighthouse tubes were mostly replaced by the more rugged and higher-powered magnetrons.

Production kept pace with radar research. Raytheon, for example, got a contract to produce several dozen S-band models, and soon the company was turning out

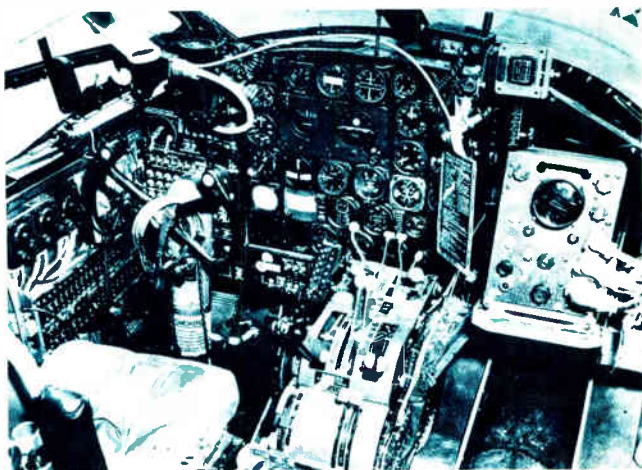

**Cannon control.** Cockpit of an Army A-26 fighter aircraft required a lot of squeezing in 1945 to be retrofitted with electronic gear. At extreme right is the Falcon M scope box, part of radar equipment used to direct fire of the 75-mm cannon, mounted below it.



**Touchdown.** This is an early Navy version of radar air traffic control. The operator directs the plane from azimuthal position scanned on scope in front of him. Meter on left indicates deviation from center of runway. Another meter, not visible, records elevation.



# First everywhere.



# BUD

**"The Housing Authority"**

BUD INDUSTRIES, INC.  
4605 East 35th Street  
Willoughby, Ohio 44094  
(216) 946-3200

BUD WEST, INC.  
3838 North 36th Avenue  
Phoenix, Arizona 85019  
(602) 269-3151

Circle 169 on reader service card



# F 303: a mass of concepts... designed

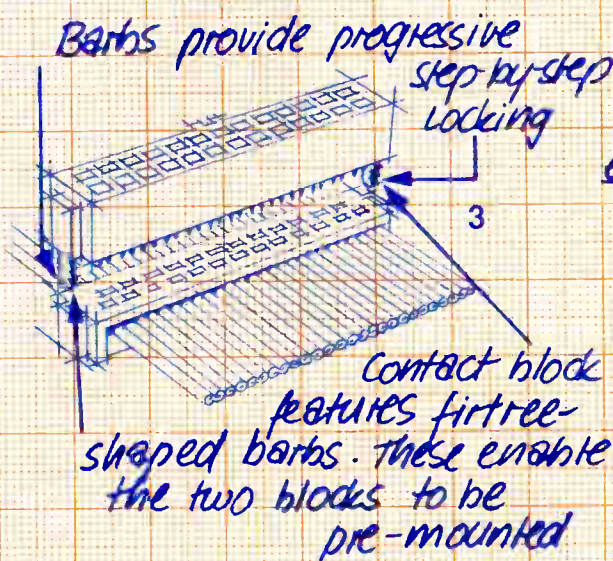
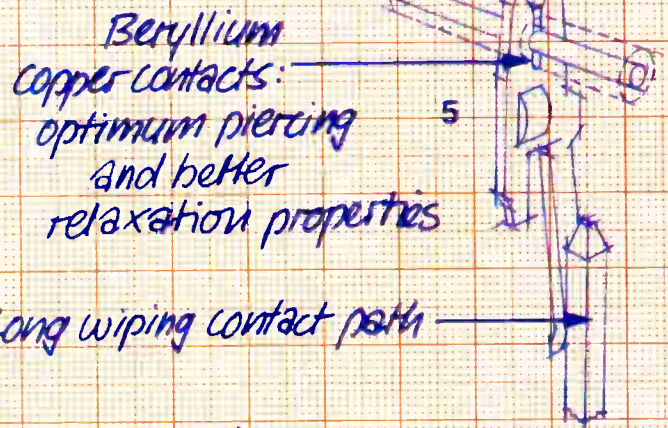
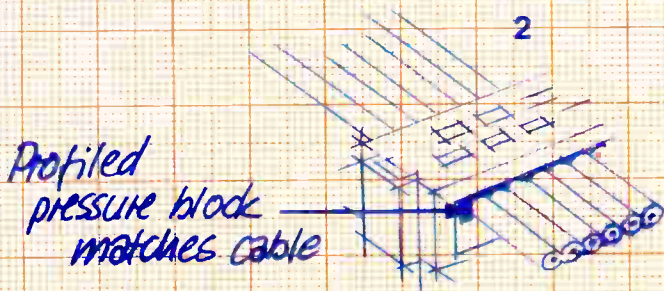
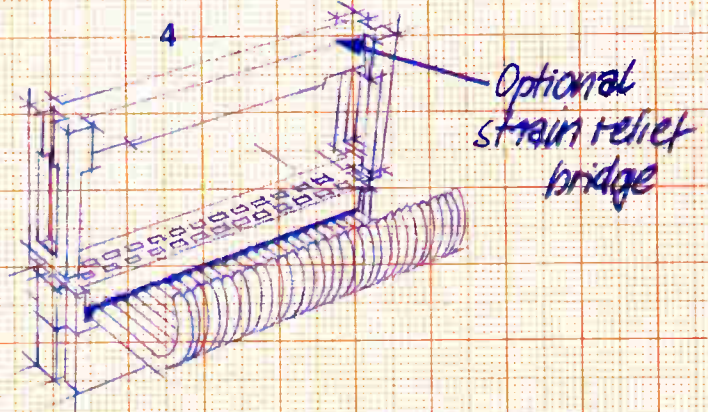
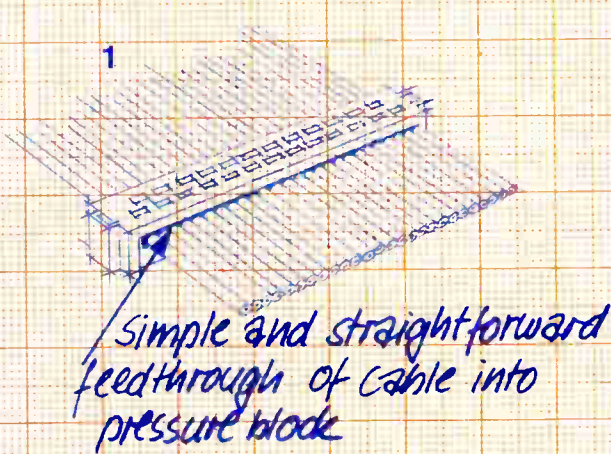

Guides facilitate accurate alignment in electrical press.  
Foot operation leaves both hands free.

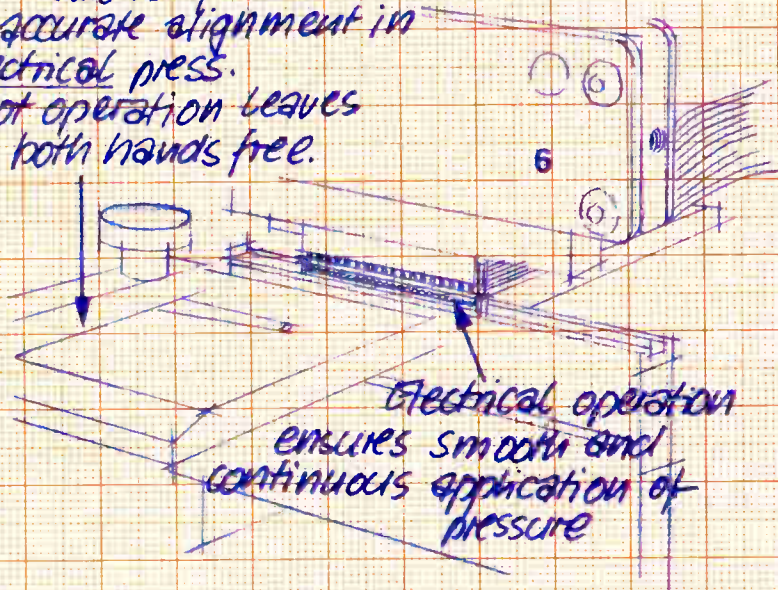

Electronic Components and Materials



# good termination and made in Europe

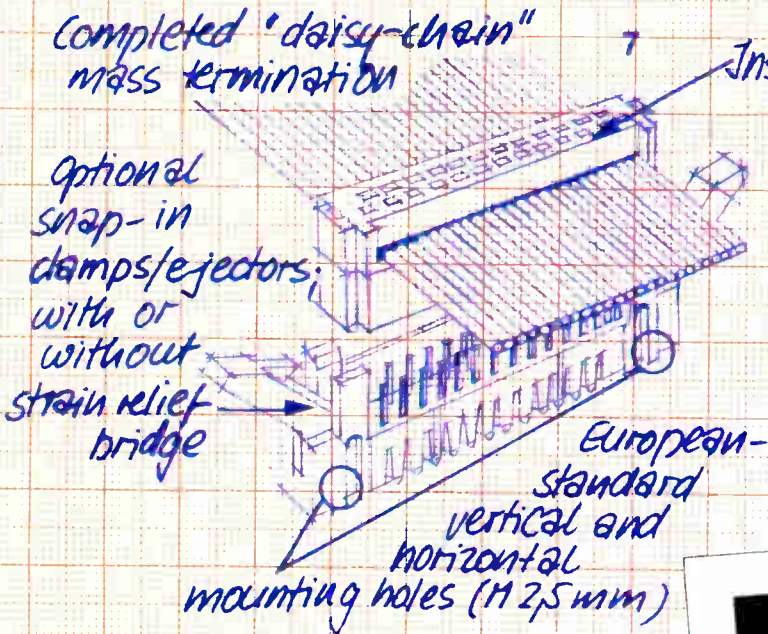

F303	Feature Check List	Yes	No
1.	Cable feedthrough	✓	
2.	Profiled pressure block	✓	
3.	Easy aligned contact block	✓	
4.	Strain relief bridge	✓	
5.	Beryllium copper contacts	✓	
6.	Electrical press	✓	
7.	European design	✓	
8.	Flexible clamp/ejector fitting	✓	

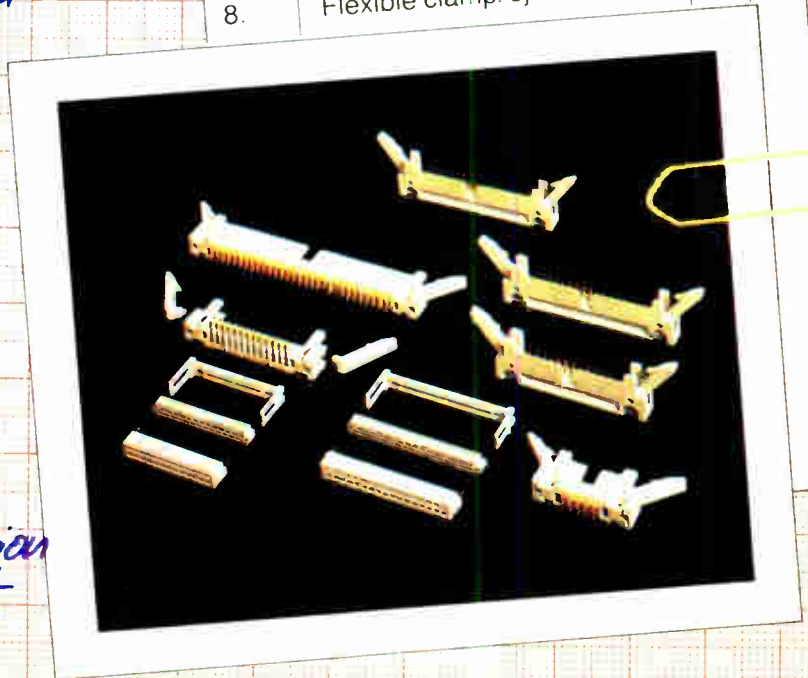
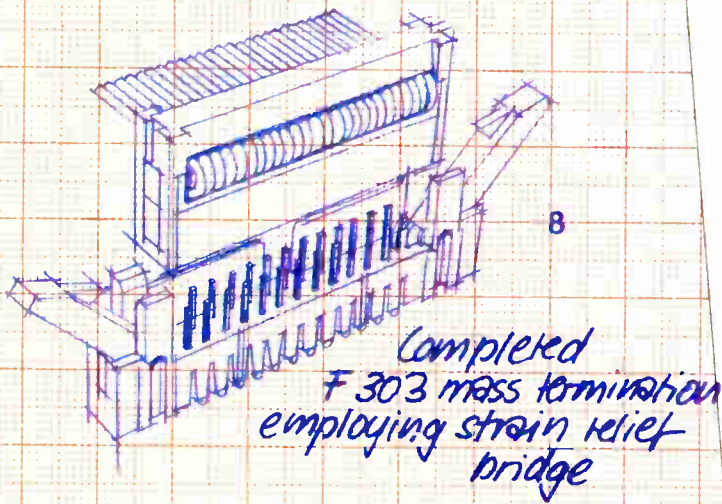

All these excellent design concepts come together in the new F 303 mass termination system. Many are unique and they add up to unmatched interconnection versatility. For example, only the F303 offers you hands-free alignment via the electrical press. And only the F303 is designed and made in Europe to European standards.

Make a list and check out our claims. But to do that you'll need the F303 brochure. It's yours if you check the reader service number below.

Philips Industries, Electronic Components and Materials Division, Eindhoven, The Netherlands.

**We'll keep you well connected**

**PHILIPS**

Circle 171 on reader service card



# SO YOU NEED AN ENVIRONMENTAL CHAMBER . . .



Full Range Temperature/Humidity Chambers meet any MIL. humidity spec. Typify complete line including exclusive air-cooled models.



Stabil-Therm® Constant Temperature Chambers use LN<sub>2</sub> or CO<sub>2</sub> for cold to -185°C., heat to +300°C. Top or front opening models.



Versa-Range® Test Chambers: -73°C. to +204°C. or -40°C. to +93°C. ranges. Also chest-type units with ambient to -85°C. or -40°C. ranges.



Thermal Cycling and Shock Test Chambers meet MIL. 202 and 883 in one unit with separate hot and cold work areas.



Versa-Whirl Baths for shock testing in liquids, have job-matched ranges. Two-bath automated transfer facility also available.

We're told that, sometimes, competitive environmental chambers are returned to the manufacturer for "adjustments."

They didn't work as required.

We're told that, sometimes, competitive environmental chambers are returned for credit.

They didn't work as promised.

We've even been told that our environmental chambers are in constant service while competitor's sit to one side unused.

They didn't work at all.

This doesn't happen *all* the time. But often enough to be noted — by us and, naturally, by those who tell us.

Customers, mostly, who have tried the others. Tried them because of low price, maybe, or exaggerated performance claims. Or simply because of an unfamiliarity with the market.

Perhaps they didn't realize that many standard features on Blue M chambers are "extras" (if they are avail-

able at all) on competitive chambers. Overtemperature protection, for example, and programming.

Perhaps they didn't know that Blue M is the *only* manufacturer that makes chambers and the controls to regulate them . . . didn't realize that this unique combination all but guarantees optimum performance.

Probably they didn't know that Blue M is the acknowledged leader in the environmental chamber field — a fact generally conceded (and understandably not mentioned) by competition.

And they probably didn't realize that Blue M chambers are individually applied by trained Blue M personnel, not reps. Chamber and job *must* match — or the chamber isn't sold.

These customers know all this now. And — if you've read this far — so do you.

## Why not buy one that works?

All that's left is for us to show you, personally, why our chambers work. We'll be glad to. Simply contact: Blue M Electric Company Corporate Headquarters: Blue Island, Illinois 60406.



hundreds of X-band devices a month. These operated at 10,000 MHz, and some used a newly developed tunable magnetron. The user could vary the operating frequencies and thereby prevent the enemy from jamming.

Among the radar-jamming techniques developed throughout the war, one of the simplest and most effective was chaff. This was made of thin strips of aluminum or tin foil, cut to the right size for a given frequency. A large air drop of chaff could jam enemy radars by producing massive energy returns. If multiple frequencies were to be countered by the chaff, different sizes of metal were used. Chaff was cheap and easy to carry and did not have to be placed with any precision.

The antennas for radars were parabolic dishes, with the diameter determined by the operating frequency. The higher the frequency, the smaller the antenna diameter could be, so researchers had good reason besides better resolution to go to the highest possible frequency for airborne radars.

**C**areful control of antenna radiation patterns was essential for high resolution. If the antenna pattern was fuzzy, so was the image of the object displayed on the radar screen. One solution to this problem was the leaky waveguide antenna.

It consisted of a long run of waveguide—a hollow metallic pipe of circular or rectangular cross section—to guide the electromagnetic radiation. According to the theory, if holes were cut in the wall of the waveguide in places chosen by mathematical analysis—much of which was done by Julian Schwinger at MIT's Radiation Laboratory—energy would “leak out” and radiate in a controlled pattern. This could function as an antenna.

These devices could be hundreds of feet long, and in general they were not convenient to make or use. But they did work. Microwave frequencies were deemed especially suitable for this kind of transmission line, because they required fairly convenient waveguide dimensions. At X band the waveguide size was only 0.4 by 0.9 inch in cross section.

As radars became better able to discriminate multiple targets through the use of better antennas and frequencies, the problem of adequate display of the returned signals grew. At first a simple cathode-ray tube—much like the one in an oscilloscope—was used. But advances were quick in coming.

The first airborne radar plan position indicator (PPI), designed at MIT's Radiation Laboratory, was installed in July 1942 in a Navy Lockheed patrol bomber. With two coordinates—range and bearing—displayed on the screen, the operator could track enemy submarines more accurately.

Radar resolution and the PPI developed to such an extent that operators could take radar “photographs.” Under ideal conditions, the shadow shapes of approaching aircraft could be seen and identified.

At this time a British visitor to the MIT Radiation Laboratory saw a PPI display of Nantucket Island. It was so like a photograph that he was quoted as saying: “This is a turning point in the war.” It was the CXBK radar—a search device at X band with a range of over 100 miles.

It had a pulsed output and tunable bandpass filters to remove noise and other spurious background signals. From this point on, the use of filters grew rapidly, and they soon were being used to reduce jamming signals.

By 1943 the Axis powers were tasting defeat regularly. And electronics had helped to turn the tide. At the Radiation Laboratory, a prototype of the MEW—a microwave early-warning radar that could look out to 150 miles or more and detect and resolve several dozen targets—was built in a few weeks after its initial design. Some facts about the MEW are still classified. It used a high-power magnetron at S band, and years later, in the 1950s, it formed the basis for the U. S. early-warning radar system installed in Canada.

Another major radar development that came to the fore in 1943 was the H2X. At first merely experimental, it turned out to be so good that it was put into production on a crash basis. A radar transmitter that allowed for precision bombing in bad weather—to within 100 yards in some cases—it was installed in the nose section of B-17 bombers and used to drop bombs over Germany.

A late version of a tunable X-band magnetron emerged from the Columbia University radar group at about this time. It was ideal for either jamming or overcoming jamming problems. Peak powers were constantly improved until tens of thousands of watts were available in some models.

Throughout the war one problem in the use of radar was the detection of incoming aircraft when the attackers hugged the ground. A phenomenon called ground clutter, or returned radar noise from the ground, sometimes masked the low-flying smaller planes. This effect was under constant study and ways were found to minimize it, which included varying the radar frequency and type of pulse. The difference in the echoes received under these varying conditions allowed for a certain amount of what is now called signal processing to reduce the effect of the clutter. Much of this work was done at MIT's Radiation Laboratory.

As the war neared an end in 1945, radar research and the design of new models slowed. Basic research contin-



**German radar.** Antenna arrays built into the nose of this German plane are part of the airborne radar equipment used by the pilot to find his target during nighttime operations. Jamming from ground installations like Tuba proved an effective countermeasure.



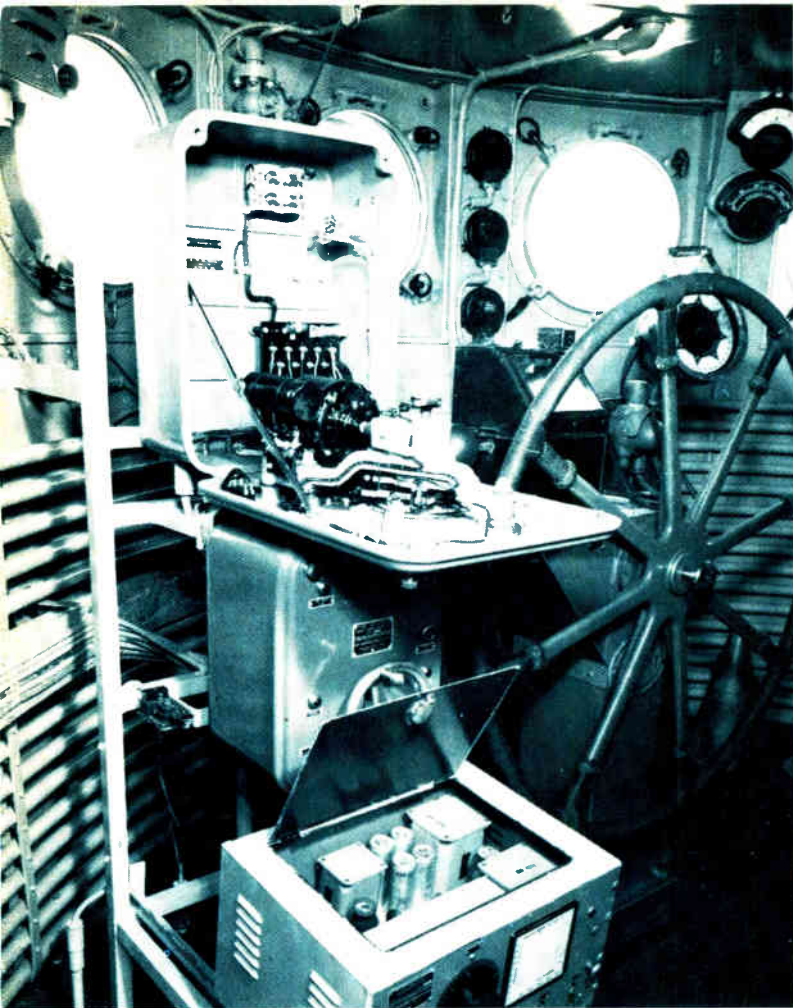

**Antisub.** In 1944, when this installation was photographed, sonar technology had enabled the Allies to greatly reduce the huge losses of shipping to German submarines. Such systems were capable of determining a submarine's depth and could track its movement.

ued in many laboratories. The Radiation Laboratory at MIT had established a Basic Research division under Julius A. Stratton, with the goal of transferring wartime research results to the civilian sector. Studies on gaseous conductors, dielectric materials, and basic physics were projected, and this work was taken over by the institute's Research Laboratory of Electronics.

A notable development that occurred too late for use in the war was chirp radar by Bell Telephone Laboratories in 1947. In chirp, or pulse-compression, radar, very long modulated pulses are transmitted and then compressed on reception. This approach solved the problem of attaining both long range and high resolution at a given frequency, while avoiding the problems of timing and of generating short pulses with high peak powers.

Other wartime developments that made their way into the commercial sector included the APS-10, an S-band airborne radar that ended up in airliners, and the K-band MK-26 radar, which had such high resolution—rivers could be clearly seen—that it became the basis for radar mapping.

Radar had indeed been the stimulus for the frantic pace of tube developments, and the magnetron's progress from a laboratory experiment to a dependable high-frequency source was a major success story. A less publicized development was the design of the transmitter-receiver tube. This was a switching tube, usually

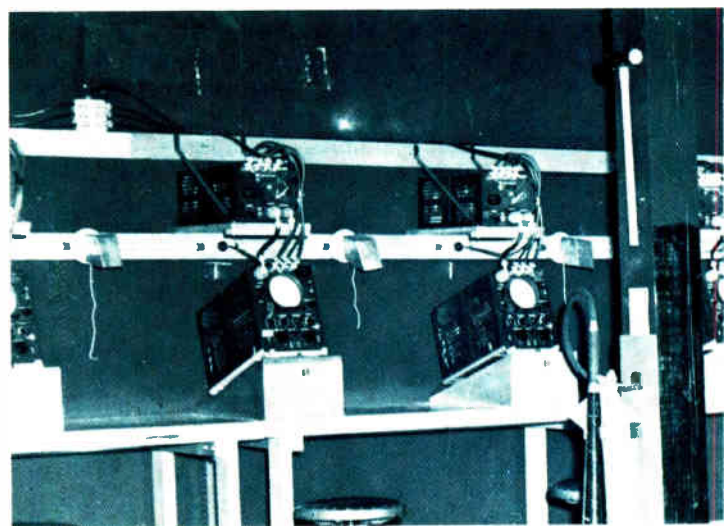

gas-filled, that protected the radar receiver input when the transmitter pulsed. It allowed radio-frequency echoes from the target to reach the receiver between pulses.

Most significant of all was radar's use of crystal rectifiers as mixers, video detectors, and dc restorers. The wartime crystal rectifiers were not the crude cat's whisker galena units of the 1920s and 1930s but sealed leaded types. Germanium crystals were most heavily used, and units at this time could withstand 50 v dc. Forward resistance was about 0.1 ohm. The diodes were applied up to frequencies of 3,000 MHz.

**W**ith the merging of British and U. S. research efforts, the two countries soon realized that their work on sonar was proceeding along almost parallel paths. One difference was that the British were working with a quartz-steel (electrostrictive) transducer to send out the system's sound waves, whereas the U. S. was developing a transducer that used magnetostriction to emit "pings." Sonar, employed to locate submerged enemy submarines, derives from the words Sound Navigation And Ranging. Like radar, it is an echo-ranging device.

To summarize its basic principles, a ship sends a sound wave into the water. Encountering an obstacle, the wave is reflected back to the ship, which—since the speed of sound through water is known—determines its distance from the object from the time it took the echo to return. To create the original sound wave, the ship generates electrical signals in a transmitter; it then sends these to a transducer, positioned on its keel as deeply in the water as possible. The transducer converts the signals into sound and transmits them through the water.

The British traced their sonar system to World War I, when a piezoelectric oscillator was used to emit the sound waves in a system called the ASDIC, named for the Allied Submarine Detection Investigation Committee, set up in 1917. At the outbreak of World War II, Britain outfitted its fleet with ASDICs that had the quartz-steel transducer. In the U. S., meanwhile, work on the magnetostriction-tube transducer was being done under contract by the Submarine Signal Co. of Newport, R. I.

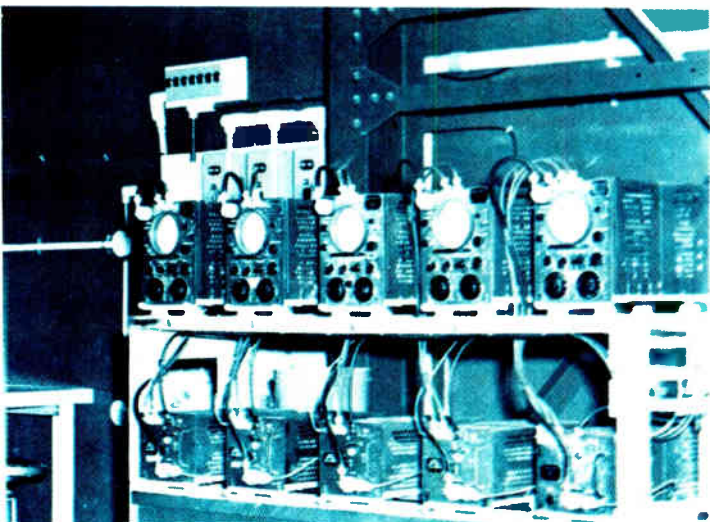

**Navigation.** Another contribution of the MIT Radiation Laboratory to the war effort was loran, a system by which vessels could determine their true position very accurately. This early installation (circa 1945) was at the Naval Air Station at Whidbey Island, Washington.

(which has since been acquired by Raytheon).

Once the U. S. entered the war, cooperation led to improvements in both systems: the Americans used a streamlined transducer dome from the British ASDIC, and the British adopted the American transducer.

From 1941 to 1943 there were heavy Allied shipping losses to submarines, but thereafter sonar-equipped escort ships were effective in protecting merchant marine convoys in the Atlantic. Sonobuoys dropped from aircraft supplemented this effort. Echoes from enemy submarines were picked up by the sonobuoys, which relayed the information to the aircraft so they could direct attacking warships to the submarines.

Other instruments appended to sonar made the system capable of detecting submerged minefields, determining a submarine's depth, and providing an indication of oncoming torpedoes.

When the Allied forces landed in Normandy in 1944, the combination of air cover and tight radar and sonar screens so protected the invasion force that no ships were lost to enemy submarines.

**N**ot as critical to the war effort as radar or sonar, loran (Long-Range Navigation) emerged from the Radiation Laboratory of MIT as somewhat of an electronic frosting on the cake. The concept called for one master station and two slave stations 200 to 500 miles away. In MIT's plan, the master transmitter would send a pulsed signal that, upon arrival at one of the slave stations, would trigger a similar pulse from that station on the same frequency. An operator could obtain a direct time-difference reading at the sender's receiver by matching the pulses from the master and slave stations, and a family of hyperbolic curves could be constructed from the time differences.

A second slave station at a third location would be similarly triggered by the master station. The signals from the first master-slave pair would be distinguished from the second pair by their different pulse-repetition rates. With a second family of hyperbolic loci, the longitude and latitude of a target could be determined.

In October 1942 the first experimental loran station

covering the Atlantic seacoast from Delaware to Nova Scotia was made operational. Its range was 300 to 800 nautical miles during the day and 1,500 nm at night. It was designed to provide a fix accurate to within 1% of a vessel's true position in the 300-to-800-nm range, called the primary area, and accurate to within 5% in secondary areas, defined as 1,000 nm or more away day or night. Using pulsed transmissions to eliminate "night effect"—sky-wave refractions and reflections of the signal that created errors in measurement at the receiver—loran covered the heart of the 160-meter amateur band, much to the chagrin of many ham operators. But under wartime conditions all amateur activity had been outlawed anyway. Nevertheless, loran retained its frequency assignment after the war, and it remains in the amateur band to this day, although it will soon be replaced on a wide scale by loran C, operating at a frequency of 100 kilohertz.

Spurred by the success of loran, researchers came up with other systems. One was the GEE system, which worked on principles similar to those of loran but over the experimental operating frequency of 20 to 85 kHz. The transmission characteristics of this band were found to be invariant to all disturbances, natural and otherwise.

Another navigational system was the British Decca, which emerged in 1946, operating on 75 to 85 kHz. Essentially it performed a phase-comparison measurement to determine position. Its accuracy was said to be 150 yards at a distance of 250 miles during the day and 800 yards at 250 miles at night, but it required three separate receivers.

Meanwhile, other short-range beacon systems, built upon both old and new principles, were developed in quantity. There were four categories.

- Fixed beacon, using both homing (1,750 kHz) and marker (75 MHz) units.
- Fixed-course beacons (200 to 400 kHz) and visual-audal rangars (108 to 118 MHz), using the radiation interference patterns of two antenna systems.
- Instrument landing systems, using a localizer (108 to 112 MHz) for azimuthal guidance and a glide-path unit (332 to 335 MHz) for guidance in the vertical plane.
- Omnidirectional rotating directive beacons, a rotating version of the fixed-course beacon types.

All of these developments helped pave the way for a revolution in navigational techniques after the war. During the war both sea and air navigators relied largely on sextant sightings of the stars and planets for long-range navigation. Closer to home, radio figured prominently in determining position. But after the war, the push was toward all-electronic navigation.

**O**ne of the great contributions of World War II research and development was that it broke ground for the electronics industries' long drive toward miniaturization. There had been efforts in this



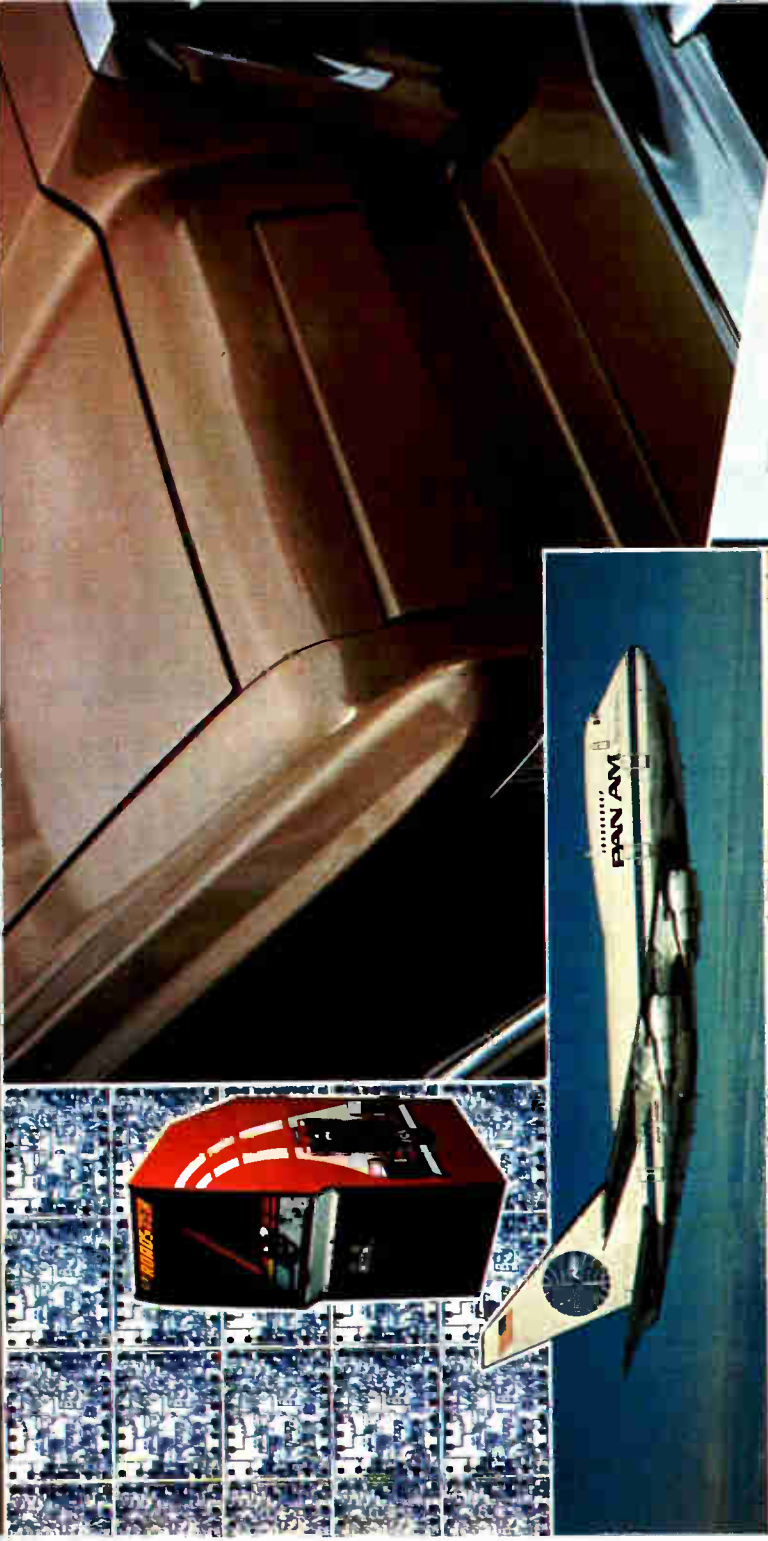



# See what a little imagination and a Monochip™ can do?

Imagine what you could do with a custom IC—make your product smaller, cut your manufacturing cost, protect your design from your competitors.

Now imagine designing that custom IC yourself to fit your special application. All it takes is your imagination—and Monochip.™

Monochip is a semi-custom IC. That means its circuit components—the first five layers—are already in place when you start designing. All you do is tell us how to connect the components to make the circuit your application requires.

Working from your layout, we'll etch the sixth layer, and in six weeks deliver prototypes for \$5,000 or less. Once you approve the prototypes, we'll make production runs of 5,000 to half a million parts.

Our Monochip Design Kits give you everything you need to develop your own custom linear, CMOS, NMOS, or bipolar IC. They cost just \$59 each.

So start designing your own IC's today. And get the benefits of custom without paying \$50,000 and waiting a year or more. With Monochip, it's simple: just add a little imagination.

Call or write today for more information. Interdesign, 1255 Reamwood Avenue, Sunnyvale, CA 94086. (408) 734-8666.

## Interdesign

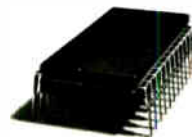

**Monochip.™**  
the semi-custom IC.

*Photographs depict representative application areas for Monochips currently in production, but do not imply usage in the specific products illustrated.*

Interdesign is a Ferranti Company.  
Circle 177 on reader service card





# CONGRATULATIONS, ELECTRONICS. FROM SOME OF YOUR BIGGEST AND SMALLEST FANS.



We're especially happy to be able to congratulate Electronics Magazine on its 50th anniversary. After all, we admire things that stay in circulation for a long time.



**ROTRON INC.**

AN **EG&G** COMPANY  
Woodstock, NY 12498

# IF YOU WERE THERE IN APRIL, 1930, TO READ THE FIRST ISSUE OF ELECTRONICS YOU ALREADY KNOW ONE OF OUR FIRSTS.

If you weren't around in April, 1930, you really missed something. Our first ad in Electronics.

But that was just the first of many electronic firsts for products of The Dexter Corporation. And since 1950, our Hysol Division:

**1950**—first formulator in the U.S. to offer liquid epoxy compounds for electronic applications.

**1953**—first commercial introduction of castable urethanes for electrical insulation.

**1955**—first formulator to

introduce an epoxy fluid-bed coating powder.

**1957**—first formulator to offer 100-percent solids epoxy conformal coatings for printed circuit boards.

**1958**—first commercial not-melt epoxy compound qualified to MIL-I-16923 for encapsulation of transformers.

**1963**—first semiconductor grade epoxy compound, for the first glop-top transistor.

**1969**—first U.S. epoxy formulator with manufacturing plants in Europe and Asia.

**1970**—first optically-clear transfer grade epoxy molding powder for opto-electronic devices.

**1975**—first successful

alkaline removable plating resists for PC boards.

**1977**—first epoxy formulator to establish semiconductor manufacturing test line.

But in electronics, you don't hold the leading edge by looking to the past.

Today, Hysol serves the electronics industry with hundreds of quality epoxy formulations—with production and performance advantages no other resource can match.

Including high-performance molding compounds and coating powders. Liquid potting compounds. Printed circuit board resists. And marking inks.

Meanwhile, we're looking ahead to our next first. And for you, it's the best first of all.

Your first call to Hysol.

 **HYSOL DIVISION**  
THE DEXTER CORPORATION

15051 East Don Julian Road,  
Industry, CA 91749.  
Telephone (213) 968-6511.







**Microminiaturization's debut.** The proximity fuze, shown here mounted on an 81-mm mortar shell, required radically new techniques for producing ruggedized miniature circuitry, such as screening and firing components on ceramic substrates.

direction with the making of hearing aids, but the wartime effort to develop the proximity fuze provided the discipline and urgency that set the stage for the present integrated-circuit era.

American work on variable time fuzes had been under way for a decade before World War II at the Navy's Bureau of Ordnance. The bureau wanted a projectile that did not have to score a direct hit but could be detonated in the vicinity of its target—as close as possible, to cause maximum damage from shrapnel. Time fuzes were available, but they had to be set by hand before the projectile was fired, and they could not compensate for evasive maneuvers by the target—enemy aircraft, say.

The proximity fuze was electronically operated. It used a miniature transceiver that radiated a highly directional rf beam at its target and was detonated by a strong return from the target. The fuze was used in artillery and mortar shells, rockets and bombs.

The major problem, of course, was building a tiny transceiver that could withstand the shock of being shot from guns. Among receiving tubes, designs allowing operation directly from a 24-volt battery had been developed for airborne use. These tubes had 26.5-v filaments and 28-v plate and screen operation. The tubes had been ruggedized to withstand vibration and to take up to 500 g of acceleration. But it was to subminiature tubes developed for hearing aids that the fuze researchers turned, and eventually a hearing aid tube, rated at 20,000 g, became the heart of the proximity fuze.

In the summer of 1940 it had become apparent that

the British were also working on a proximity fuze, because they had placed large orders in this country for vacuum tubes and photoelectric cells of the types being investigated by the U. S. Navy. The two countries pooled their research efforts.

Eventually one third of the electronics industry in the U. S. became involved. Manufacturing capacity for tubes, capacitors, and resistors was tremendously increased. The cost of the project approached \$1 billion, and over 20 million expendable fuzes were produced.

Fortunately for the Allies, the Germans had done research on proximity fuzes before the war but had failed to develop ruggedized subminiature tubes.

Two types of proximity fuzes were produced for the Allies: a wind-powered generator unit and a battery-powered unit. The wind-generator fuzes ended up in airborne rockets and bombs. The battery-powered circuitry was housed in the casing of anti-aircraft (AA) artillery shells.

No chassis was used in the construction of the AA fuzes. The tubes were mounted in close-fitting rubber cups near the center of the electronic bundle. Resistors and capacitors were then wired together in subassemblies and wrapped around the central rubber cups containing the tubes. After all the connections were made, the electronic parts were placed in a plastic nose in the shell and all air spaces filled by potting with wax. This was one of the first instances of potting of electronic equipment in the U. S.

**T**he first use of proximity fuzes at sea occurred on Jan. 5, 1943, when gunners on the U. S. cruiser *Helena* knocked down a Japanese dive bomber near Guadalcanal with their second salvo. The following month an American troop convoy was attacked at night in the same area by 12 Japanese torpedo bombers. The convoy was defended entirely by radar-controlled anti-aircraft guns using proximity fuzes. Five of the attackers were shot down, and there were no enemy torpedo hits. In the European theater, crewmen on the American destroyers *Swanson* and *Roe* used proximity-fuzed shells to knock down a German J-88 dive bomber in July 1943 in one of the earliest uses in that region.

Proximity-fuzed rounds fired in action in 1943 were said to be three times as effective as time-fuzed ammunition aided by the latest radar fire control, and from 1944 onward the use of the proximity fuze became standard. It was credited with helping to turn back the Japanese kamikaze assault on the U. S. fleet off Okinawa in 1945.

The British, meanwhile, used proximity-fuzed ammunition to help counter the German "buzz bomb" attacks on London in 1944. Anti-aircraft batteries, moved to the English coast, increased Britain's kill rate of the German missiles from 24% during the first week of the attacks to 79% by the time the attacks subsided 11 weeks later.

The proximity fuze was unquestionably a success. Calculating the trajectories of wartime projectiles raised another problem.

While business and scientific calculations had stimulated early computing developments in the United



## R-OHM DIODES odds against failure: 1 billion to 1

Astronomical odds, but it hasn't happened by chance. When it comes to workmanship standards and rigid process control, we leave nothing to fate. We use no body paint that might mask microcracks or photoelectric effects. Individual glass seals and diode chips are 100% inspected for microcracks and other abnormalities, making R-Ohm diodes unfailingly reliable, even under the most severe conditions. Because our actual accumulated Field Failure Rate is only 1.2 electrical rejects in a billion, we've never had a lot rejected by a customer. Quality like that makes AQL standards obsolete. That's why the industry's most demanding OEM's have switched to R-Ohm. For immediate delivery of incredibly reliable industry-standard diodes, contact us today.

**R.ohm**  
QUALITY · RELIABILITY

R-OHM Corporation 16931 Milliken Avenue, P.O. Box 15515, Irvine, California 92713  
Telephone: (714) 546-7750. Eastern offices: (312) 843-0404.

A CONSTANT FORCE IN A CHANGING WORLD

Circle 130 on reader service card



# FAIRCHILD

## We're helping you make better mileage standard equipment.

New cars are going a lot farther on a tank of gas. And performing a lot better, too, while producing fewer harmful emissions. Thanks to your new engine control systems that provide better engine performance. And the major role Fairchild is playing by building the semiconductor components that go into them.

The heart of today's advanced engine control system is a microcomputer and other large-scale integrated circuits. The kind we make at Fairchild.

For years, we've been supplying high-reliability semiconductor products in volume to the automotive industry. From the simplest diodes to the most complicated microprocessors. And because we understand your market's ever-growing demand for products in high volume, we've made an even greater investment in state-of-the-art equipment and facilities to meet your needs now and in the future.

We also understand how important an engine control system can be to the performance and the useful life of a car. And how important the components that go into them are.

At Fairchild, we design in reliability as we design out problems. And to make absolutely certain we've done our job to your complete satisfaction, we thoroughly test each component. So that by the time it reaches an engine control system, it will exceed your standards. That way, your systems won't break down around the corner or thousands of miles from home.

At Fairchild, we understand the automotive industry and are committed to meeting your challenges with our advanced technology. We're doing it by helping you make better mileage standard equipment. For more information, call our Automotive Marketing at (415) 962-2608. Or write Fairchild Semiconductor Products Group, P.O. Box 880A, Mountain View, CA 94042.

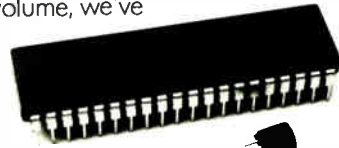





# GROWING WITH ELECTRONICS

## THE EVERETT/CHARLES COMPANIES

### BEGINNINGS . . .

Everett/Charles began in 1960 as a general partnership between Everett J. Long and Charles W. Burley to provide a variety of

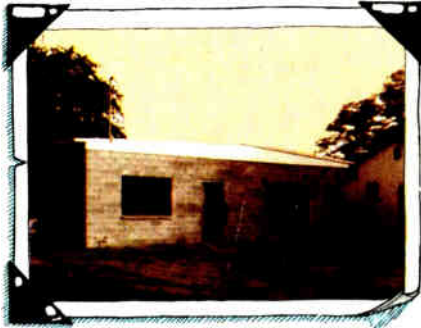

manufacturing services to electronics industries. Today Everett/Charles is comprised of closely interrelated subsidiaries which are chartered to define, develop and provide quality products and services to other manufacturers for use in the production of their own products at competitive cost and quality levels.



### CONTACT PROBES . . .

In 1967, Everett/Charles, Inc. introduced the now widely used receptacle retained "snap-out" spring contact probe to facilitate the testing requirements of higher density and more complex printed circuit boards. Contact spring probes continue to play a vital part in the reliability of our products.

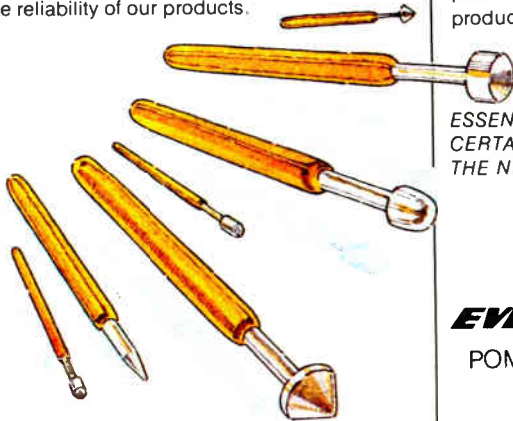

### THE PEOPLE . . .

Everett/Charles is many different people with many different kinds of skills, all working together to produce electromechanical handling, testing and assembly equipment, contact products, and electronic circuit test systems marketed worldwide to manufacturers of advanced technology products.

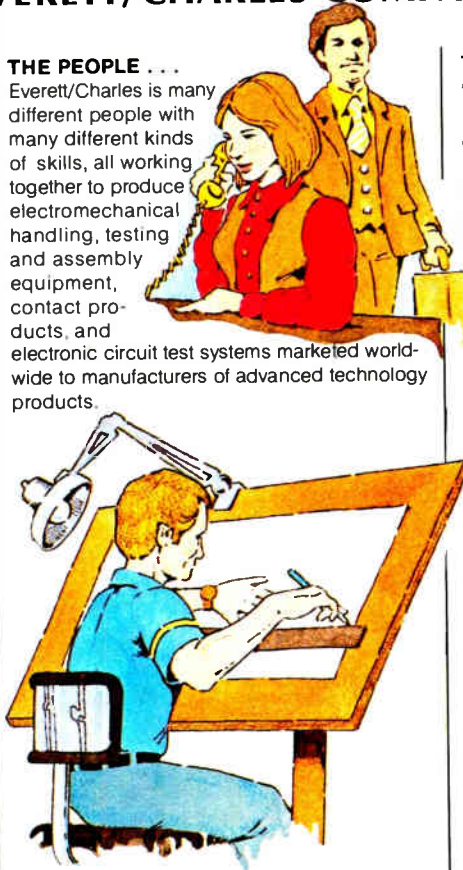

### ANSWERING CHANGING NEEDS . . .

Recently developed and introduced electronic and electromechanical products continue to provide our customers with timely and useful tools. Development and evaluation programs are continuously applied to our contact probe product lines. New designs and techniques have been employed to provide higher throughput and less expensive test fixturing systems. These have been combined with new high speed electronic test systems to assure reliable detection of faults introduced in production processes. All of these new products are directed to improvement of productivity and quality in electronic product industries.

"AWARENESS OF EMERGING TECHNOLOGY WORLDWIDE IS ESSENTIAL TO OUR EMPHASIS ON MAKING CERTAIN THAT OUR EQUIPMENT SERVES THE NEEDS OF ALL OUR CUSTOMERS."

J. R. Miller, President  
Everett/Charles, International, Inc.

### TODAY . . .

"EQUALLY AS IMPORTANT AS CONTINUING TO EARN OUR REPUTATION AS A COMPANY DEDICATED TO UNDERSTANDING THE NEEDS OF OUR CUSTOMERS, IS THE REQUISITE TO MAINTAIN THE TECHNOLOGICAL LEADERSHIP NECESSARY TO MEET THESE NEEDS."

W. G. Hill, President  
E/C Test Equipment Corporation

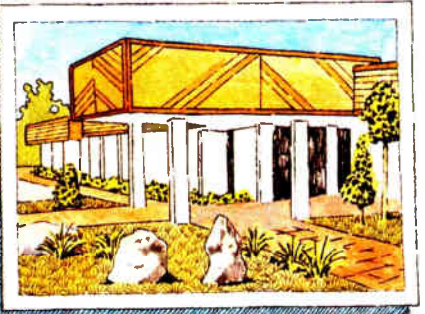

### THE FUTURE . . .

"IN THE DECADE AHEAD WE PLAN TO CONTINUE TO GROW WITHIN OUR DEFINED MARKET PLACE AND TO CONTINUE AS A MATTER OF POLICY TO PROPAGATE OUR CONCERN FOR OUR PEOPLE, FOR OUR CUSTOMERS AND FOR EXCELLENCE IN ALL WE ENDEAVOR."

E. J. Long, Chairman  
Everett/Charles, Inc.

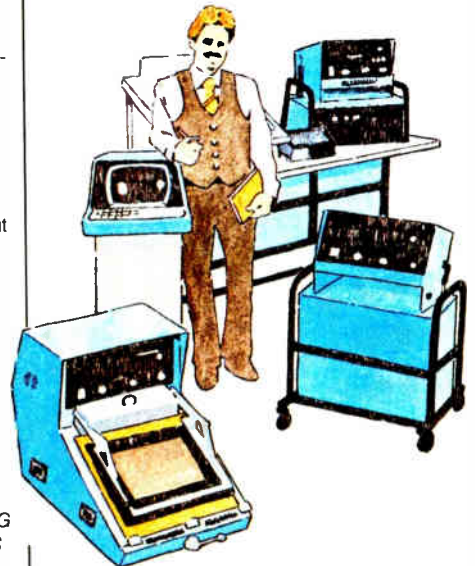

**EVERETT/CHARLES**

POMONA, CALIFORNIA U.S.A.

**EC EVERETT/CHARLES INTERNATIONAL, INC.**

**EC TEST EQUIPMENT CORPORATION**

THE EVERETT/CHARLES COMPANIES

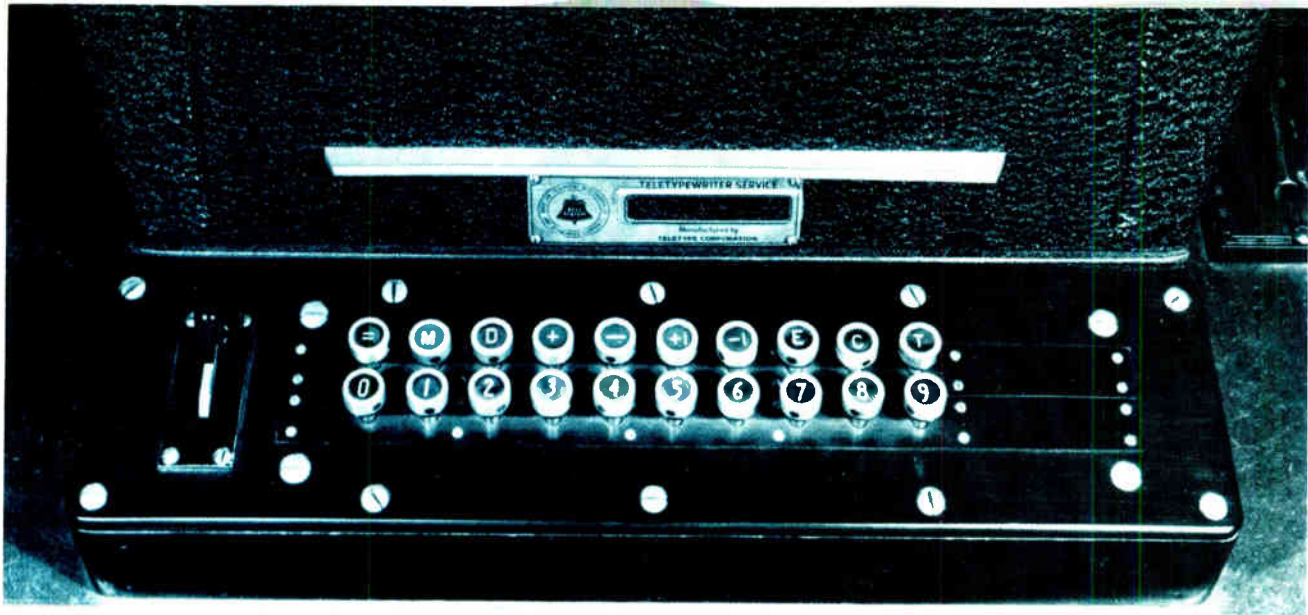

**Early computer.** This keyboard belonged to the first Bell Laboratories relay computer, which was put into operation in 1940 at the laboratories' old West Street facility in New York City. It was for this computer that binary-coded decimal notation was developed.

States, it was weapons research for World War II that proved to be the catalyst in the creation of the electronic digital computer.

Calculating the trajectory of projectiles had become more complicated as their velocity increased, and the advent of aerial warfare had added the task of performing these calculations rapidly enough to aim anti-aircraft guns at fast-moving targets. Dropping bombs from aircraft required similar rapid calculations.

To develop both the weapons and better ways to compile firing tables, which contained the various trajectory calculations, the Army's Ordnance Department had created a research division at the Aberdeen Proving Ground in Maryland in 1935. Renamed the Ballistic Research Laboratory in 1938, it was headed from the beginning by Herman H. Zornig, who chose Oswald Veblen to serve as chief scientist throughout the war.

Zornig also established a Scientific Advisory Committee to help him. It was composed of leading American scientists, including Hugh L. Dryden, an aerodynamicist and later founder of the National Aeronautics and Space Administration; Albert W. Hull, a prolific inventor of electron tubes; Theodore von Karman, another aerodynamicist; Bernard Lewis, a physical chemist; John von Neumann, the mathematician; Henry N. Russell, an astronomer; Isador I. Rabi, a Nobel Laureate in physics; and Harold C. Urey, a Nobel Laureate in chemistry.

One mathematician who joined the Ballistic Research Laboratory between 1941 and 1942, Herman H. Goldstine, noted later that the typical trajectory computation required some 750 multiplications. But to compile the average firing table, taking into account the various angles, muzzle velocities, and other conditions, one had to contend with the calculations for between 2,000 and 4,000 of these trajectories.

Goldstine estimated that a human being with a mechanical desk calculator of the day would take 10 seconds to perform a multiplication and therefore need some 2 hours to do the multiplications and a total of 12 hours to calculate a single complete trajectory. But the mechanical differential analyzer, operating at between 1.6 and 4 seconds per multiplication, took some 10 to 20 minutes per trajectory, or 750 hours—30 days—to do

the trajectory calculations for an entire table.

At MIT in 1942, Vannevar Bush and S. H. Caldwell completed a differential analyzer that replaced the machine's usual mechanical shafts with electrical connections. This allowed them to use a punched paper-tape reader to reconfigure the machine for various problems, thereby speeding its operation.

Electromechanical digital computers were under development at the time, but they were slower than the differential analyzers. Among the early digital machine developers, Ernest G. Andrews joined George Stibitz at Bell Telephone Laboratories, where two relay computers, the Model II and Model III, were finished.

The Bell Model III, the larger of the two, was completed in 1944. Using some 9,000 relays for all operations and registers, it covered about 1,000 square feet and was estimated to weigh 10 tons. The addition of numbers of up to 7 decimal digits took 300 milliseconds, their multiplication took 1 second, and their division 2.2 seconds. The machine took 40 minutes to compute a trajectory.

**T**he Automatic Sequence Controlled Calculator, Howard Aiken's machine under development by International Business Machines and Harvard University (see chapter 3) was also finished in 1944 and delivered to Harvard. Measuring 51 feet long and 8 feet high, it contained some 800,000 parts and offered 60 registers for constants, 72 storage registers for addition, a central multiplication and division unit, and the ability to compute elementary transcendental functions, such as logarithms and sine.

Later known as the Mark I, it could handle 23-decimal-digit numbers and perform additions in 0.3 second and multiplications in 3 seconds. The Harvard-IBM Mark II, the successor to Aiken's Mark I, working with 10-digit numbers and a multiplication time of 0.4 second, took about 15 minutes to do a trajectory.

The University of Pennsylvania's Moore School of Electrical Engineering at Philadelphia had been working with the Army and the Ballistics Laboratory on trajectory calculation problems since the 1930s. J. Presper



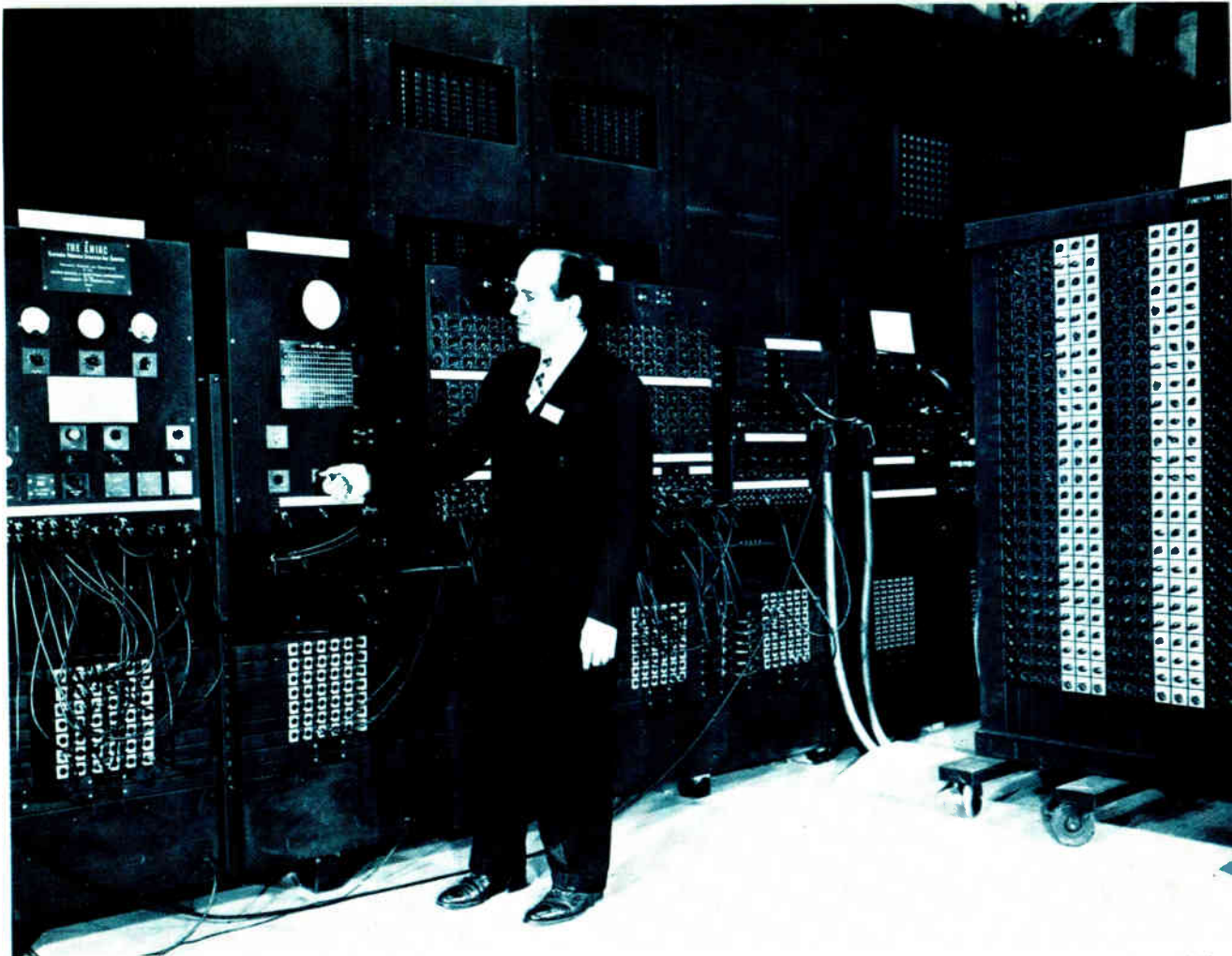

**New era.** The age of the electronic digital computer was ushered in with the dedication of Eniac at the University of Pennsylvania in 1946. J. Presper Eckert (above), with John W. Mauchly, supervised the design and construction of the system, intended to solve ballistic problems.

Eckert, a graduate student at the school when World War II began, recalls the task posed for the school. “The Moore School,” he says, “trained some 300 people to use calculators to solve the ballistic problems. Every closet you opened had a woman with a calculator.”

Also at the school was Prof. John W. Mauchly, who recalled that he “was impressed with the differential calculator but realized its limitations.” He first discovered what a burden computing could be “when I took a course in statistics.” Although the calculations took hours, he realized that statistical analysis would be a useful tool in many areas of science, particularly meteorology and weather prediction.

Mauchly had also been exposed to digital computing concepts, primarily through a visit to John V. Atanasoff at Iowa State College during the summer of 1941. Atanasoff did not become well known until years later, when he testified in a patent infringement case involving the original patent of the electronic computing concept held by Eckert and Mauchly. But Atanasoff is now recognized as having contributed to Mauchly’s electronic digital computing idea.

In 1942 Mauchly began discussing with members of the Moore School his idea for using vacuum tubes to perform calculations, and the idea came to the attention of Goldstine at the Ballistics Laboratory. After several months of discussions, the Government, on June 5, 1943, signed contract W-670-ORD-4926 with the University of Pennsylvania to develop the proposed Electronic

Numerical Integrator and Computer—known as Eniac. Mauchly supervised much of the logical design, while Eckert concentrated on the electronics engineering and Goldstine assured support for the project.

The era of the electronic digital computer was ushered in with the dedication of Eniac on Feb. 15, 1946. Although it was too late to help with the war effort, Eniac’s first practical chore was to perform some problems prepared by von Neumann for the then top-secret atomic bomb project at the Los Alamos Laboratory in New Mexico. Later moved to the Aberdeen Proving Ground, Eniac was to continue in operation until October 1955.

Accounts of the day are reminders of how awesome the new computer was: using 18,000 vacuum tubes, the U-shaped Eniac occupied a room 30 by 50 feet, weighed 30 tons, and consumed some 150 kilowatts of power. Operating with a basic clock rate of 100 kHz, it could perform additions in 0.2 ms, while multiplication took about 2.8 ms—some thousand times faster than electromechanical machines of the day.

Instead of binary notation, Eniac used decimal notation and could handle up to 10 decimal digits with decade counters functioning as the accumulators that stored the numbers in the machine. But for all its advances, Eniac had one drawback: it was controlled by a patchboard of wiring. To change a program, the operator had to disconnect wires and plug them into different locations—an operation that could easily take days. In

# PRICE BREAKTHROUGH!

ON OPEN FRAME LINEARS FROM

# Adtech Power

SINGLE OUTPUT – IC REGULATED

Industry Standard Thin Profile  
OEM Economy DC Power Supply  
5 Year Warranty

- Universal 103-130V/206-260VAC 47-63Hz Input
- Full Power Rated to 50°C
- Electrostatically Shielded Transformers for Lower Noise Experience
- Remote Sensing
- Reverse Polarity Protection
- Enclosed Insulated Shaft Potentiometer
- Metal Cased Hermetically Sealed IC Regulator
- U.L. Recognized Glass Epoxy Circuit Boards
- Over 25,000 Hour MTBF
- Series or Parallel Operation
- Meets U.L. & C.S.A. Requirements

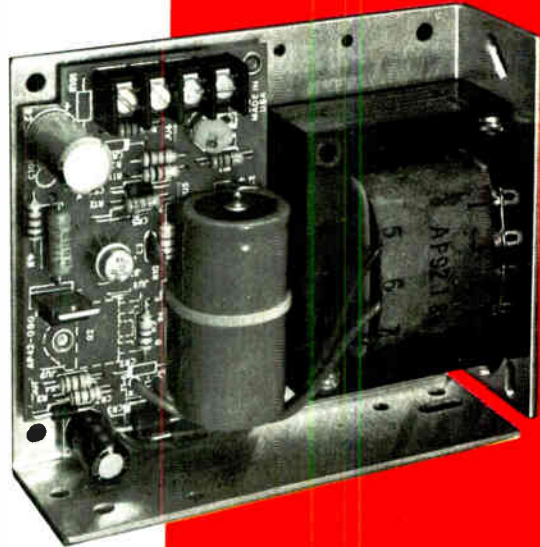

Thinner profile with interchangeability offered in four models will meet the requirements of most needs within a wide variety of applications. IC Regulation, simplified circuitry and top quality components assure long-term reliability.

Designed for low cost high volume production; permits Adtech to offer the lowest priced high quality, precision regulated power supplies equal to any major power supply manufacturer.

The new units, offered in the industry standard thin profile HB Case with three plane mounting, combination barrier strip output for screw terminals and optional solder tabs or fast-on tab connection, are directly and fully interchangeable with all competitive units, but offer many more features.

MODEL NUMBER	RATING		REGULATION		RIPPLE (PK/PK)
	VDC	AMPS	LINE	LOAD	
EAPS 5-3U	5	3.0	± 0.05%	± 0.10%	5mV
EAPS 12-1.6U	12	1.6	± 0.05%	± 0.10%	5mV
EAPS 15-1.5U	15	1.5	± 0.05%	± 0.10%	5mV
EAPS 24-1U	24	1.0	± 0.05%	± 0.10%	5mV

- 1) Production orders must be for 50 or more pieces with a firm delivery schedule.
- 2) Minimum shipment is 25 pieces, bulk packed to one address.
- 3) A one to 49 piece "Prototype" order will be accepted one time only per customer.
- 4) Optional overvoltage protection is available on factory orders over 50 pieces at a price of \$1.50/unit regardless of quantity. Add suffix "OV" to model number.
- 5) Optional solder/fast-on tabs are available on factory orders over 50 pieces at a cost of \$1.00 per unit in any quantity. Add suffix "ST" to model number.

Call our engineering sales office in your area for application engineering assistance.

- |   |   |  |   |  |
|---|---|--|---|--|
| Arizona, Phoenix<br>Phone: (602) 894-2335       | Florida, Fort Lauderdale<br>Phone: (305) 752-7520 | Michigan, Detroit<br>Phone: (313) 578-4706       | New York, Long Island<br>Phone: (516) 499-8831      | Texas, Dallas<br>Phone: (214) 387-2489               |
| Arkansas, El Dorado<br>Phone: (501) 862-2051    | Georgia, Atlanta<br>Phone: (404) 233-6679         | Minnesota, Minneapolis<br>Phone: (612) 861-3343  | New York, New York<br>Phone: (516) 487-3966         | Texas, Houston<br>Phone: (713) 988-0991              |
| California, Anaheim<br>Phone: (714) 634-9211    | Illinois, Chicago<br>Phone: (312) 437-2700        | Missouri, St. Louis<br>Phone: (314) 569-1220     | New York, Rochester<br>Phone: (716) 832-7880        | Washington, D.C.<br>Phone: (202) 363-9417            |
| California, Long Beach<br>Phone: (213) 426-7375 | Indiana, Indianapolis<br>Phone: (317) 844-2800    | New Mexico, Albuquerque<br>Phone: (505) 294-8408 | New York, Syracuse<br>Phone: (315) 637-9383         | Washington, Seattle<br>Phone: (206) 455-3480         |
| California, Los Gatos<br>Phone: (408) 354-6496  | Iowa, Cedar Rapids<br>Phone: (319) 382-9177       | New Mexico, Las Cruces<br>Phone: (505) 524-0126  | North Carolina, Hayesville<br>Phone: (704) 389-8850 | Washington, Spokane<br>Phone: (206) 455-3480         |
| California, San Diego<br>Phone: (714) 560-1009  | Kansas, Kansas City<br>Phone: (913) 381-0004      | New Jersey, Dover<br>Phone: (516) 487-3966       | Oregon, Portland<br>Phone: (206) 455-3460           | Wisconsin, Milwaukee<br>Phone: (414) 527-1500        |
| Connecticut, Meriden<br>Phone: (203) 237-9232   | Kansas, Wichita<br>Phone: (316) 884-4141          | New York, Albany<br>Phone: (518) 456-6667        | Pennsylvania, Philadelphia<br>Phone: (215) 825-9515 | Mexico, Mexico City<br>Phone: 575-58-95 or 575-62-97 |
| Florida, Clearwater<br>Phone: (813) 536-8536    | Massachusetts, Boston<br>Phone: (617) 245-0250    | New York, Buffalo<br>Phone: (716) 632-7880       | Pennsylvania, Pittsburgh<br>Phone: (412) 961-0414   | Israel, Tel Aviv<br>Phone: (03) 615469 or 622429     |

In Europe: Adtech International, Subsidiary of Adtech Power, 46 BD, Roger Salengro, 78200, Mantes La Ville, France Phone: 477-5301

## EAPS "U" SERIES SPECIFICATIONS

- Input: 103-130V/206-260VAC 47-63Hz  
 Line Regulation: ± 0.05% for ± 10% line change  
 Load Regulation: ± 0.1% for ± 50% load change  
 Ripple: Less than 5mV peak to peak  
 Transient Response: Less than 50 micro-seconds  
 Short Circuit and Overload Protection: Automatic recovery foldback current limiting  
 Reverse Polarity Protection: Standard  
 Remote Sensing: Standard with open sense lead protection  
 Output Adjustment: ± 5% minimum  
 Outputs: Screw type barrier strip output connection with optional solder or fast-on tabs  
 Operating Temperature Range: 0°C to +50°C at full power rating, derate linearly to 40% at +70°C or 20°C  
 Stability: ± 0.1% for 24 hours after warm up  
 Temperature Coefficient: ± 0.01% typical, ± 0.03% maximum  
 Vibration: Per MIL-STD-810B Method 515 procedure 1, curve AB to 50Hz  
 Shock: Per MIL-STD-810B Method 516 procedure  
 Overvoltage Protection: Optional  
 Size: 4.0" W x 4.87" H x 1.62" D x ± 0.45" transformer projection  
 Weight: 2 lbs.



ADTECH POWER, INC. 1621 S. SINCLAIR ST., ANAHEIM, CA 92805. (714) 634-9211 TELEX 68-498

Circle 187 on reader service card



AEG-TELEFUNKEN

Modules for all Branches of Electronics

# Resistors and Resistor-Networks in Thick-Film Technique

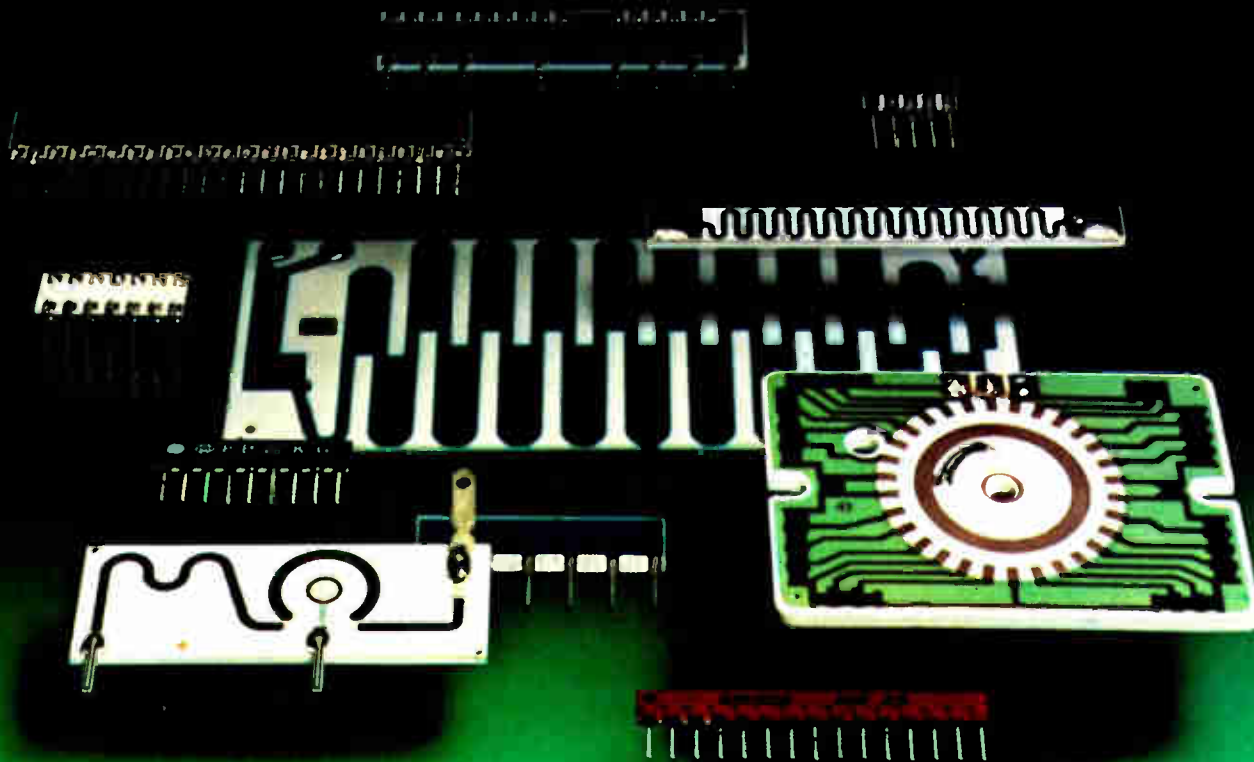

You need resistors in growing quantities with a higher accuracy at smaller dimensions.

As a producer of thick film circuits we have the right program for all applications.

#### To your specifications

Resistance values  
0,5  $\Omega$  ... 1000 M $\Omega$   
Resistance tolerance  
 $\pm 0,15\%$  ...  $\pm 20\%$

Temp. coefficient  
 $\pm 50$  ppm ... 250 ppm  
Matching of temperature coefficient  
10 ppm ... 25 ppm

Operating temperature  
- 55° C ... 125° C

Rating of individual resistors  
50 mW ... 5 W

in special cases over 50 kV  
Since the adjustment of resistance is made by computer-controlled lasers, required relative tolerances up to  $\pm 0,15\%$  are also guaranteed.

#### For standard resistor networks:

Single-in-line and dual-in-line version.  
Our data sheets inform you of all the other technical details.

Please contact our nearest representative or write directly to

AEG-TELEFUNKEN  
Serienprodukte  
Passive Bauelemente  
Obere Kanalstraße 24  
D-8500 Nürnberg 107  
Tel.: (09 11) 27 71  
Telex: 06-22551



Thick film circuits by  
AEG-TELEFUNKEN

# AEG-TELEFUNKEN

Wherever functional safety  
is a minimum requirement

## Decisively improved: the new "Mini" case for photoreceivers and transmitters



Plastic case	Red	Orange-red	Green	Yellow	IR-Emitte	Detectors
Ø 1,9	CQY 41 N	CQX 43 N	CQY 73 N	CQY 75 N	CQY 36 N CQY 37 N	BPW 16 N BPW 17 N
Ø 3	CQX 25 N CQY 85 N	CQX 42 N CQX 41 N	CQX 26 N CQY 86 N	CQX 27 N CQY 87 N	CQX 46	BPW 42

We have eliminated the disadvantages of the previously used Miniplast and 3 mm LED cases.

Our new case has advantages such as:  
Handling suitable for automatic machines. Clear identification of the polarity, good reproducibility of the optical parameters.

At the same time, we have designed the components in the new cases such that it is easy to construct LED rows! And this together with good optical insulation, which means low optical cross talk. We can supply the optoelectronic com-

ponents you need; tested, in proven quality, future oriented, and TELEFEL tested. Regardless of whether you need LEDs in various colors, different 7-segment displays, displays, infrared radiation sources or coupling elements, or, or...

If you would like to know more about our product range, ask for our newest brochures at:

AEG-TELEFUNKEN  
Semiconductor division  
Theresienstr. 2  
D-7100 Heilbronn  
Tel. (071 31) 882423  
or your nearest agent for  
AEG-TELEFUNKEN  
components







These scanning electron microscope (SEM) photos show a diversity of test and circuit patterns produced directly on wafers by different Electromask 700SLR Wafer Steppers. The photos demonstrate a resolution of 1 micron, which indicates a practical system capability for the production of reliable devices more complex than 256K bits.

## THE ELECTROMASK 700SLR™ WAFER STEPPER™ CLEARLY HOLDS THE EDGE...

For fine line resolution, layer-to-layer and machine-to-machine registration, the Electromask 700SLR Wafer Stepper is designed and built for performance. The SEM photos show how well this superb production system can handle complex circuit geometries with line resolutions to 1 micron.

How do we do it? By blending innovation with experience. First, for repeatability and registration, we use the same stable platform and computer-controlled X-Y laser staging that has been field-proven in scores of our maskmaking systems down through the years. And for high resolution, we provide die-by-die alignment through the lens as well as fully automated system operation.

The 700SLR is designed as a precision production machine for automatically step-and-repeating cir-

**AVAILABLE  
FOR  
DELIVERY IN  
1980**

cuits directly on wafers. It features fully automatic reticle loading, alignment, and masking; fully automatic wafer loading, prealignment, leveling, and unloading; and fully automatic camera focus—plus a retrofit provision for fully automatic wafer-to-reticle alignment.

But equally important, the Electromask 700SLR is the wafer imaging system that's here and available now for delivery in 1980. It's the system you can have on your production line before the year is out. Can you afford to wait and fall behind your competitors? Send for our brochure, or call and arrange for a product demonstration today.

Electromask, Inc., a subsidiary of the TRE Corporation, 6109 DeSoto Avenue, Woodland Hills, California 91367, Phone: (213) 884-5050, Telex 67-7143.



# ELECTROMASK



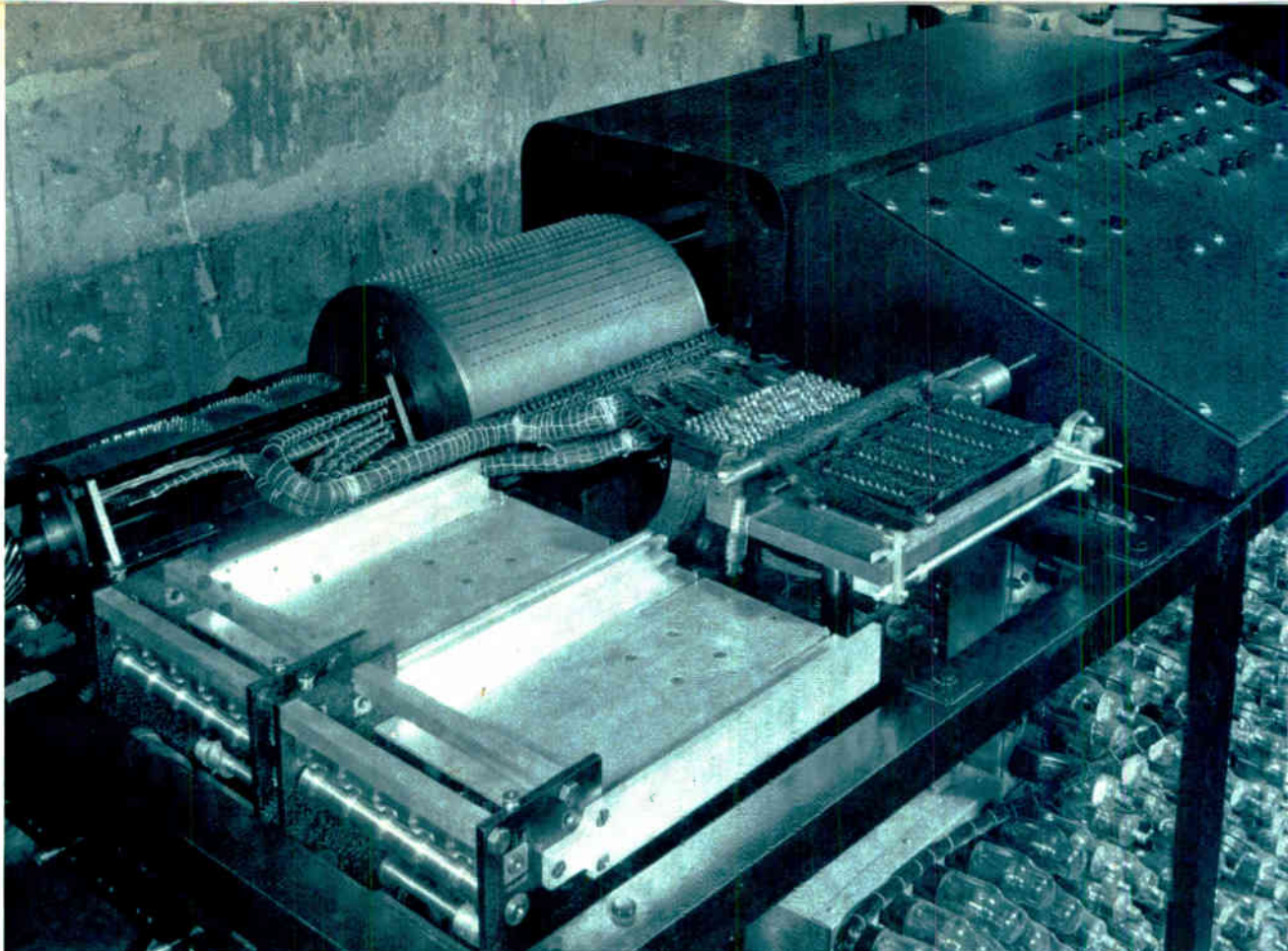

**Precursor.** This prototype digital computer, one of the earliest to use vacuum tubes as logic elements, was designed and built by John V. Atanasoff at Iowa State College for solving linear algebraic equations. He became involved in a patent dispute with Eckert and Mauchly.

Eckert's recollection, it was almost immediately evident that such a programming technique was so cumbersome that it would cancel out the computer's inherent processing speed. So plans were drawn for a computer that would store the program electronically in the same way that the machine stored data. In August 1946 the Moore School held a series of lectures on its proposal for a computer that would have a memory like this: the Electronic Discrete Variable Computer, or Edvac.

**E**ckert notes that from these earliest days of computer engineering, "memory controlled the architecture design." The only electronic memory element available as Eniac was being developed was the flip-flop tube circuit—an expensive technique that was reserved for data being processed. But the mercury delay line, a result of radar research associated with the war, was now available and designed into Edvac. The designers noted that if the signals propagated, or delayed, through the mercury were amplified and recirculated, the information could be held in the line indefinitely and could be accessed each time it came around.

The British were already involved in electronic digital techniques, having built Colossus, a 1,500-tube cryptanalysis machine at the government's Bletchley Park Establishment in 1943. The specialized Colossus is thought by some to hold the title of the first electronic digital computer.

With this beachhead in electronic computers, Britain

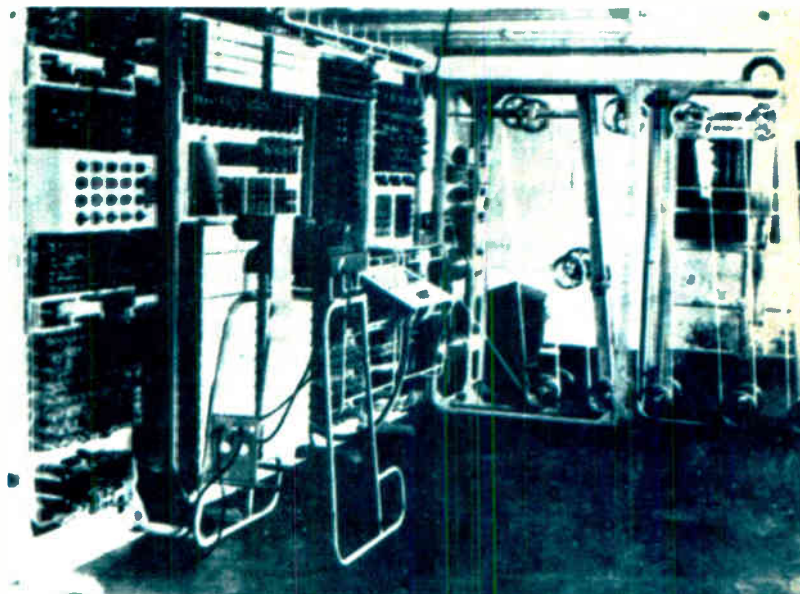

**British entry.** Claimed, by some to be the first electronic digital computer, Colossus was built by the government's Bletchley Park Establishment in 1943 for cryptanalysis applications. UK scientists went on to make significant contributions to computer technology.

moved to coordinate its developments by establishing a National Mathematical Laboratory in 1945. The laboratory worked with two groups that were to have a major influence on early computing work: one was headed by F. C. Williams, first at the Telecommunications Research Establishment and later at Manchester



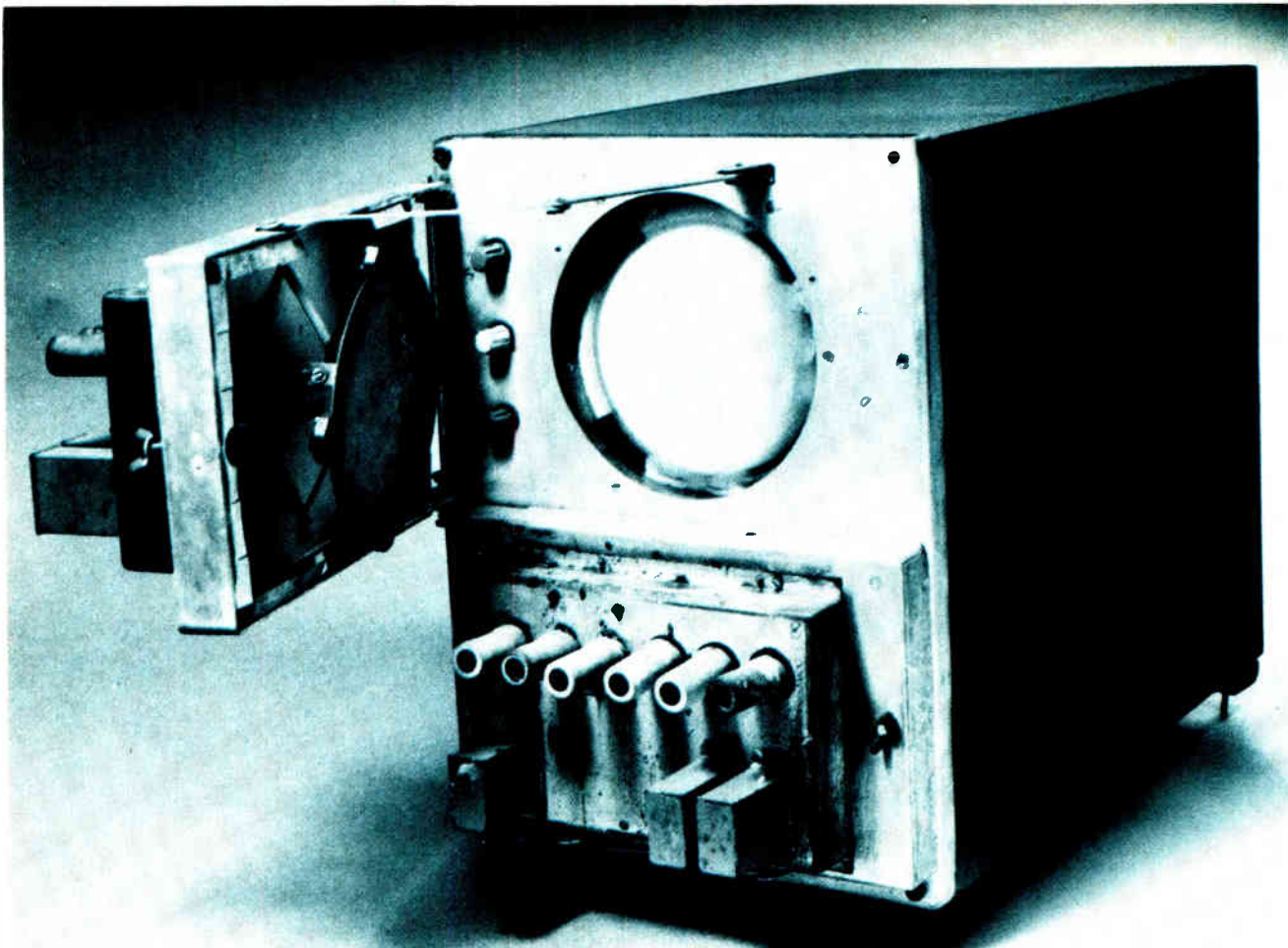

**Breakthrough.** The Williams tube, named for its inventor, F. C. Williams, was the first all-electronic memory, essentially a storage tube that utilized capacitive coupling at the tube face to sense data in the form of charges stored on the phosphor coating.

University, and the other was led by Prof. Maurice Wilkes at Cambridge University.

Williams' first significant development was the adaptation of a cathode-ray tube to store bits of data. This so-called Williams tube wrote a dash onto the phosphor coating of the CRT to represent 1 bit of data and a dot to represent 0. Placing a metal plate on the glass face of the tube created capacitive coupling, and later sweeps of the electron gun could be used to sense, or read, the presence of these dots and dashes.

A major advantage of the Williams tube was that the same electron gun could be used periodically to refresh, or regenerate, the dots and dashes. Similar storage-tube developments in the U. S.—primarily by Jay W. Forrester and Andrew Haeff at MIT and J. Rajchman at RCA—used more complex refreshing techniques with one gun for reading and writing and a second for refreshing. They proved to be less practical.

The storage-tube approach was favored because the CRT allowed random access to the stored information, instead of the serial access available in the mercury delay lines. Williams joined Manchester University in December 1946 to perfect the storage tube and at the same time begin development of what was to become the first stored-program computer.

Wilkes, the Cambridge professor, having attended the lectures on Edvac at the Moore School, returned to Britain to start development of the Electronic Delay Storage Automatic Computer, or Edsac. This was in November 1946.

At the heart of Edsac's design were 5-foot-long steel

tubes filled with mercury to function as delay lines. Although influenced by Edvac, which was being designed concurrently in the U. S., the Wilkes group finished Edsac two years earlier, in 1949.

An important event in 1946–47 was the emergence of George A. Philbrick's vacuum-tube operational dc amplifier as a commercial product. This high-gain, low-drift unit ushered in the era of the fully electronic analog computer. The initial op amp was produced by George A. Philbrick Researches Inc., which survives today as Teledyne-Philbrick, a producer of solid-state data-conversion equipment.

It was a period of feverish activity in computer research and development. Researchers at the Servomechanisms Laboratory at MIT, which had been developing analog computers to control aircraft simulators for pilot training, realized that electronic digital computing could do the simulator's real-time task faster and more accurately. So in 1947 the laboratory began developing its project Whirlwind, a program that was sponsored initially by the office of Naval Research and later by the U. S. Air Force.

Inevitably the commercial world took a growing interest in the new computers. In 1947 the two pioneers from the Moore School left to form the Eckert & Mauchly Computer Corp.—the first of what was to become an entire industry of companies dedicated to the design of electronic computers.

World War II halted the sale of radios to the civilian market. But manufacturers turned out sets for the military in record numbers. From walkie-talkie and back-

## Drawn Metal Products

One of the leaders in deep-drawn metal technologies, this Division manufactures sockets, tubes mixer valves, and quick disconnect connectors. Comprehensive production support ranges from engineering services in die design and prototyping to a fully equipped tool room.

## Malco

Malco Division specializes in interconnection systems, offering the capability to design and manufacture a wide variety of electronic connectors. Products range from stamped terminals and splices to rectangular, rack and panel, card edge, circular and coaxial connectors, as well as coaxial cable and backpanel assemblies.

## Link up with the Connector Group

One source. That's the real beauty of doing business with the Microdot Connector Group.

We're your single source for virtually every type of electronic or electro-mechanical connecting device. Switches, sockets, terminals, backpanels, card edge connectors and more. From individual components to complete sub-assemblies.

We have it all for manufacturers in the automotive, computer/peripheral, appliance, telecommunications, home entertainment and military/aerospace industries.

Call on us. We're an important chain in a progressive, responsive company.

And every link is a strong one.

Respond to:

**MICRODOT INC.**

**CONNECTOR GROUP**

Headquarters:

12 Progress Drive • Montgomeryville, PA 18936  
Phone No. (215) 699-7785 • TWX No. 510-661-£206

## Elicon

Elicon Division is your source for metal sockets assembled to plastic and metal component parts. A patented "vinyl plastisol" process assures the watertight, dustproof characteristics required for switches, lamp assemblies, wedge base sockets, and other electro-mechanical assemblies.

## Proner

The Microdot Connector Group's European Division is a leader in pre-insulated terminals, strip terminals, insulation boots and sleeves, as well as discrete rack and panel and card edge connectors. Telex—842-691525 Telephone—(1) 303-56-89

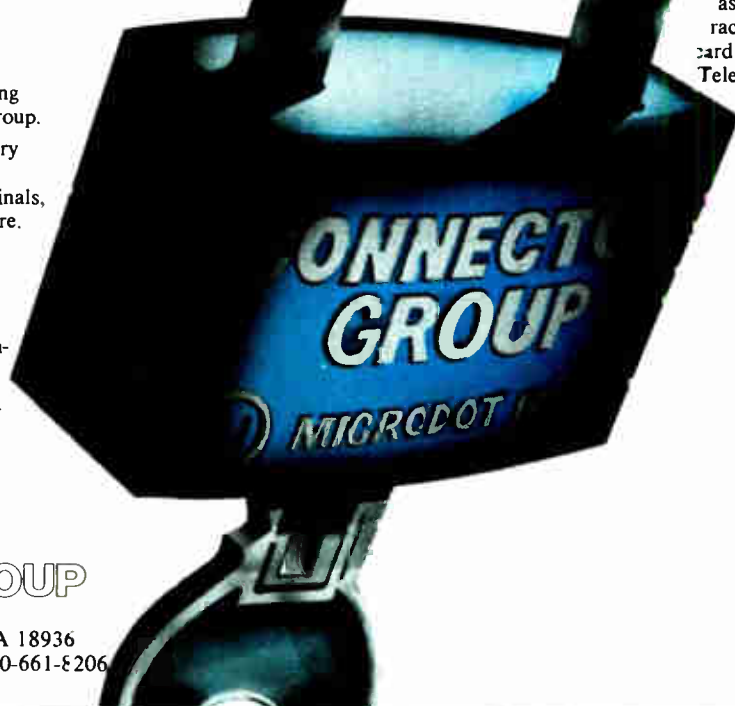



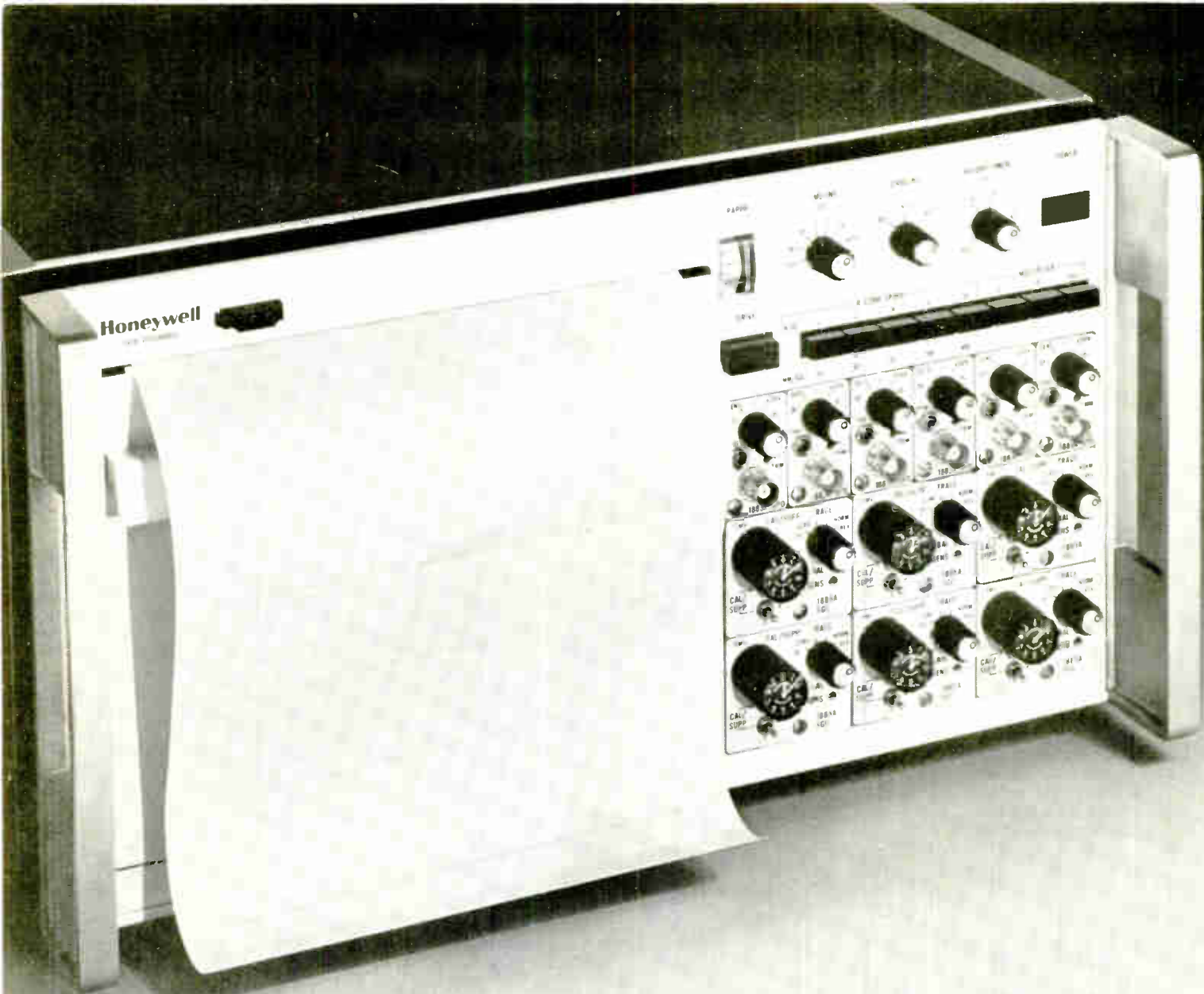

## HERE'S EVERYTHING YOU NEED FOR HIGH-PERFORMANCE RECORDING. EVERYTHING.

Pick up the Visicorder Model 1858 and you have a complete system—up to 18 channels including signal conditioning—in a package less than nine inches high. Since it's self-contained, you simply plug in the power cord, connect your signal input cables and start recording. There are no separate cases to mount; no interconnect cables to hook up; and no powders, inks, chemicals or heaters to fool with.

And if you should need more channel capacity, an auxiliary housing quickly expands your system to 32 channels, each with dc to 5 kHz response.

Whether you record in the lab or field, the Model 1858 quickly adapts to your changing requirements. Wide changes of input levels for different recording applications are easily accommodated, often with a mere

change of the sensitivity setting on the front panel. Even a complete change of type of measurements is just a matter of inserting different plug-in modules in the appropriate channels. And you have a complete family of these signal conditioning modules to choose from, for strain gages, thermocouples, flowmeters, tachometers or voltage sources.

For detailed information on how the Model 1858 might meet your recording needs, call Lloyd Moyer at (303) 771-4700. Or write for technical data sheets on the Model 1858 and our illustrated brochure that describes all of Honeywell's oscillographic recorders, magnetic tape systems and signal conditioning modules. Honeywell Test Instruments Division, Box 5227, Denver, CO 80217.

**WE'LL SHOW YOU A BETTER WAY.**

# Honeywell

pack sets in the front lines to table models and complete stations elsewhere, radio often was the fine line between victory and defeat. Variations on the state of the art sufficed for basic communications. The developmental work was secret, of course.

One effect of the war was that it delayed the natural development of frequency-modulation radio. The FCC had authorized commercial fm broadcasting on Jan. 1, 1941, assigning it to 40 channels in the 42-to-50-MHz band. That year the industry sold more than 350,000 fm receivers out of 13 million radios in all that went to consumers. Radio manufacturers and broadcasters seemed to assume that fm, because it offered better sound and noise-free reception, would simply replace amplitude-modulation broadcasting, much the way sound films had replaced silent. A November 1943 article in *Electronics*, looking ahead to postwar fm, said:

"The present system is completely commercial from a technical point of view, although it could probably be improved by granting permission to increase the power of fm transmitters so that improved signal strength would expand the proposed service areas."

The article concluded with perhaps a touch of naive optimism: "The industry had a particularly brilliant opportunity to place broadcasting on a quality high-fidelity basis, and many will make the sincere effort toward this goal."

Seven months later, in June 1944, a Zenith Radio Corp. executive, J. E. Brown, sketched a glowing picture of fm's postwar future, estimating that 28 million homes would be served by fm stations and that two thirds of these would buy an fm radio, or 18.6 million sets. He also pointed out something that must have been giving a-m station licensees anxious moments.

"The service area of a 250-w fm broadcasting station is more than four times that of a 250-w, 1,000-kHz a-m broadcasting station at night," Brown observed. He argued that the public was interested in fm's higher fidelity as a logical, natural advance in radio progress and that "unless the FCC changes broadcasting allocations, a-m can never offer the frequency response of fm."

In fact, broadcasting allocations were being reconsidered. In 1943 the FCC had asked the Institute of Radio Engineers and the electronics industry to develop plans for postwar electronic activities. The industry formed the Radio Technical Planning Board, with panels on a-m, fm, and television, while the Government formed the Interdepartment Radio Advisory Committee. In late 1944, the two groups proposed assignments covering the spectrum from 10 kHz to 30,000 MHz.

On June 27, 1945, the FCC moved the fm band from 42 to 50 MHz, which was assigned to nongovernmental fixed and mobile radiocommunications and to television channel 1. The fm band became 88 to 106 MHz, with 100 channels. The commission also cut the permissible power of fm transmitters to one tenth of the a-m level, limiting coverage of each station to a single city.

The shift affected the 46 licensed fm stations and 7 stations operating under construction permits. It meant

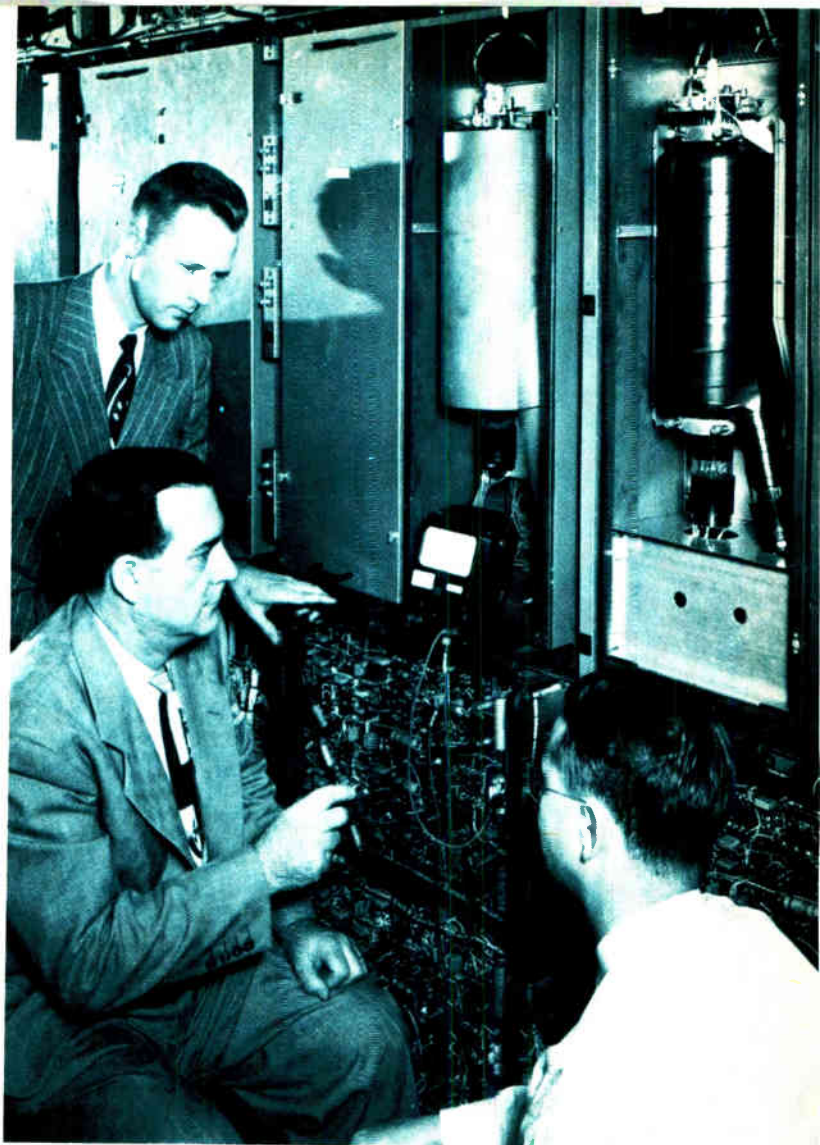

**Whirlwind.** At MIT, researchers turned to digital computing techniques to achieve real-time simulation. Project Whirlwind was set up in 1947. Shown here with Whirlwind I is memory pioneer Jay W. Forrester (left), Patrick Youtz (center), and Stephen H. Dodd.

that all 248 fm station license applications had to be withdrawn, recomputed, and resubmitted. It also made all existing fm receivers obsolete, a point that was raised at the FCC hearings and dismissed on the ground that most fm radios could also receive a-m. A \$10 converter was demonstrated to the commission that would make existing fm receivers capable of tuning to the higher frequencies.

Once the allocations had been set and the war ended, engineers began reporting technological improvements. In October 1945, for example, William Maron, a senior radio engineer with the North American Philips Co., pointed out that most existing fm receivers drifted badly until they had warmed up and even then required occasional retuning. He suggested quartz crystals in the local oscillator as the most economical way to obtain high tuning accuracy and stability.

A year later a Zenith engineer suggested that the complete home radio receiver must have standard broadcast and shortwave a-m bands, two fm bands, and automatic tuning, and he described a receiver that economically included all five.

In July 1947, *Electronics* described in detail a Crosley





**Compact.** The war years accelerated developments in radio communication gear, and here too ruggedization and reduction in size became essential, as exemplified by this Army Air Force uhf/vhf command set built by Western Electric, to be installed in fighter aircraft.



**Wartime pitch.** Sales of civilian radio sets came to a halt during the war, with the industry rallying to the cause and turning out millions of military sets, including the Handy-Talkie and the later Walkie-Talkie two-way portable radio for tactical communications.

chassis: an eight-tube double superheterodyne that covered the broadcast band; the shortwave band, including the 25- and 31-meter regions; and the fm band. The design offered high sensitivity and low noise on all bands. It was simple enough for a manufacturer to build on a high-speed assembly line and stable enough for the consumer to tune it easily.

Television hibernated, for the most part, while the war raged, though experimentation continued in low key. On June 24, 1940, a coaxial cable was used for the first time for TV transmission and reception between New York and Philadelphia, and on Aug. 27 of that year the first

experimental color telecast was made from a CBS transmitter in New York. In 1941 two stations, WNBT and WCBW in New York, became the first TV transmitters commercially licensed to go on the air. But there was nothing like normal programming today.

In March 1942 *Electronics* reported that TV was being used to help train air raid wardens in New York. Some 18,000 wardens were reported being instructed via a TV hookup three days a week. It was one of the rare times that the medium became part of the war effort.

Instead of developing commercial television tubes, electronics manufacturers improved the cathode-ray tube for war service. Radar, sonar, loran, and some of the radio direction finders used by the armed forces had CRTs for readouts. Double-layer, dark-trace, and exponential screens were produced, as well as multiple-gun and projection CRTs, and improvements were made in electrostatically and magnetically focused tubes.

With this background to build on, RCA was able to introduce the image orthicon in 1945, a new television camera tube invented by RCA researchers Albert Rose, Paul K. Weimer, and Harold B. Law. It replaced the original iconoscope, which had shortcomings in picking up pictures clearly, especially in dim light. Now television was ready to grow as an industry.

The growth started in 1946, with six commercial stations telecasting to a few thousand receiving sets in the United States. It continued at a giddy speed until, barely two decades later, more than 560 stations were telecasting to 56 million sets. Along the way, color television became the dominant medium, but not until

# ALWAYS SOMETHING NEW!!!

## The Modern, High Quality, Broad-based, Portable Test Equipment and Digital Panel Meter Line

For service dealers, MRO's field service, OEM's, educators, hobbyists and professionals.

For OEM's, MRO's and test equipment designers.

### OSCILLOSCOPES



The MS-215 Miniscope is a battery or line operated 15-megahertz, cathode-ray, dual-trace oscilloscope that weighs only three pounds and sells for \$465.45. The single-trace MS-15 is available for \$349.80; the dual-trace MS-230, a 30-megahertz unit, sells for \$598.15.

Circle 195

### DIGITAL PANEL METERS



The world's smallest, lowest priced and lowest powered DPM's. NLS' PM Series panel meters offer top quality in a wide variety of AC and DC models in 3, 3½, 4 and 4½ digits. Prices range from \$55.65 to \$170.00.

Circle 196

### DIGITAL MULTIMETERS



NLS offers eight digital multimeters in 3-, 3½- and 4-digit versions (LED's and LCD's). Prices range from \$125.40 for the LM-300, a 3-digit, LCD meter (1% accuracy) to \$250.00 for the 4-digit, LED, LM-4A with ± 0.03% accuracy.

Circle 197



The NLS' RM Series DPM's with DIN/NEMA cases are 3½- or 4½-digit meters using LCD's or LED's. They are DC reading, DC powered; DC reading, AC powered; AC reading, DC powered or AC reading, AC powered. Over 200 variations available. Prices range from \$69.55 to \$192.50.

Circle 200

### DIGITAL FREQUENCY MONITORS



The NLS' FM Frequency Monitor Series provides measurement of frequency from 45.0 to 99.9 Hz for the FM-3TB and FM-300TB, and from 045 to 450 Hz for the FM-340TB. Prices range from \$103.55 to \$115.00.

Circle 206

### DIGITAL COUNTERS



The PC-4 Event Counter (shown at left) is a low cost (\$64.20), sophisticated, electronic, high speed alternative to electromechanical counters. The RC-5TB Universal Counter, selling for \$144.00, is a unit counter which also measures frequency, frequency ratio, time interval and period.

Circle 203

NLS products are available for immediate delivery from leading local distributors.



**Non-Linear Systems, Inc.**

*Originator of the digital voltmeter.*

Box N, Del Mar, California 92014 Telephone (714) 755-1134 TWX-910-322-1132





# Fairchild's LSI know-how adds a new dimension to in-circuit testing.

## LSI test know-how.

Fairchild knows about testing LSI. Virtually every LSI device devised by man has been tested on Fairchild's Xincom, Sentry® or Sentinel™ systems. That know-how has been applied to in-circuit testing with the development of the FF303's LSI Testing Module (LTM), to bring a new dimension to LSI testing.

## LTM finds post-assembly faults.

LTM is part of a new software package designed to quickly isolate and identify faults introduced during PCB assembly. LSI test procedures first inspect an IC for orientation, adjacent shorts, opens and pins folded under. Strategic functional tests follow to verify the IC's operational integrity. An 8085 micro-processor, for example, is exercised for Address and Data Bus, HOLD, INTR, INTA, 10/M, TRAP, RESET, SIS, SOD, RD, and WR functions\* — all in about 20 milliseconds. No other in-circuit test system tests as fast and as thoroughly as the FF303.

## Software support.

You need tests that are ready to run, or easily altered, so you can use your time for testing, not programming. The special tests you may need can be quickly and easily generated by using CHIPS, our unique LSI test language compiler. That's the kind of software support you get with the FF303 — along with our commitment to maintain the industry's largest LSI testing library for in-circuit testing.

## The complete in-circuit tester.

Your PCBs do not live by LSI alone. So the FF303 is designed to test SSI, MSI, and the whole gamut of analog components. Faultfinder systems pioneered the analog in-circuit test method and the FF303 brings you the advanced component and circuit path inspection techniques you need for precise fault identification and diagnosis.

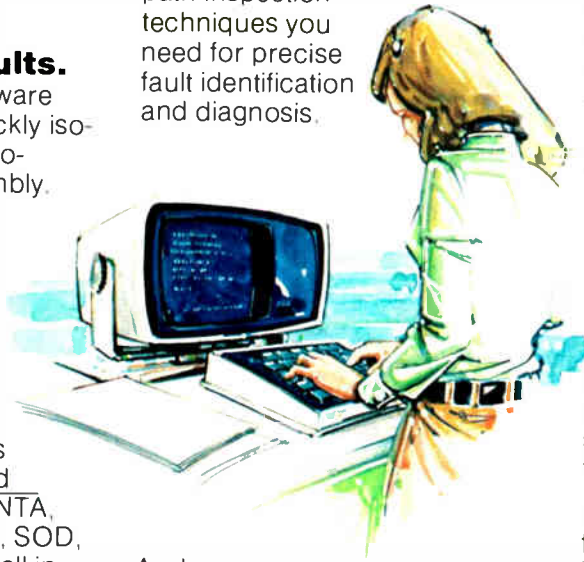

And you can choose from two different system analog and digital test point capacities with modular expansion as you need it.

With this powerful in-circuit digital/analog testing system, you can count on yields of 95% or better at final test.

## The multi-task tester.

Your FF303 will do more than test. Its computer control lets you selectively run tests, file failure data, use the FAULTS automatic program generator and call, sort and file data quickly and easily. With real-time data logging, you can generate histograms to track

PCB assembly failures by shift, day or week. And you can do more.

Add memory, for example, to handle more complex testing applications. Add a magnetic tape terminal for off-line program preparation and editing, or a line printer for hard copy output. Or add foreground/background programming options for optimum CPU capacity with concurrent program execution.

## Versatile fixturing.

Fairchild's Thinline® vacuum fixture system lets you choose from a wide variety of fixtures, fixture kits and universal personalizers. Build your own fixtures with Thinline kits or get turnkey testing with ready-to-test fixtures and programs. No other in-circuit test system manufacturer offers single-source fixturing and contract programming support.

Find out what the FF303 can do for you. Call or write Fairchild Test Systems Group, 299 Old Niskayuna Road, Latham, NY 12110. (518) 783-3600.

**FAIRCHILD**

**Test Systems Group**

**The  
First Family  
of ATE**

\*Mnemonics copyright Intel Corp., 1979.

Circle 199 on reader service card





**Lighten up.** The superior light sensitivity of the image orthicon pickup tube over the iconoscope helped television broadcasting take a significant step forward. Shown here are the inventors, RCA scientists Albert Rose, Paul K. Weimer, and Harold B. Law.

the 1960s. Actually the Federal Communications Commission had authorized commercial TV broadcasting to commence on July 1, 1941, shortly before the commission adopted the standards put forth by the National Television System Committee. RCA had demonstrated a home TV receiver in January 1941, anticipating that these standards would go into effect.

They called for a 6-MHz channel, separation of 4.5 MHz between picture and sound carriers (the sound being 0.25 MHz below the upper edge of the channel), and a line count of 525 per frame. Transmission was to be at 30 frames per second. Field tests had revealed that there were problems with sending the video portion of the signal by frequency modulation—there was distortion under multipath conditions—and accordingly the FCC had ordered a-m for the video transmission and fm for the audio.

The standards had been drafted with black-and-white television in mind. Color TV had not yet approached the point of commercial feasibility. Yet so durable were these basic specifications that they remain virtually unchanged to this day.

**E**ven as black-and-white TV was gaining a foothold, two basic approaches to achieving color TV emerged: the field-sequential method and the line-sequential. The first employed frame-by-frame transmission of signals corresponding to each of the three primary colors of light—red, blue, green. The second approach transmitted the hues simultaneously.

From the primary colors, any color in the spectrum could be synthesized.

Researchers soon realized that the field-sequential method would require rapid scanning of the scene to avoid color flicker in the received picture; this would not be compatible with black-and-white TV. But the line-sequential method appeared to be more complex, requiring more than one picture carrier and perhaps even greater bandwidth than black-and-white needed.

It was a formidable challenge, because, as Worthington Miner, manager of television for CBS in 1943, put it: "Television without color must walk with a crutch."

Miner argued that color television demanded larger bandwidth and that this, in turn, implied transfer to higher frequencies. "Television under present standards is not good enough," he said. "It can be good enough—and very quickly—if we do not wantonly dissipate, but use intelligently, the advantages of the present hiatus."

CBS went on the offensive with an electromechanical system developed by Peter C. Goldmark, who had been credited with the first broadcast transmission and reception of a color TV picture in 1940. This was shortly after RCA had demonstrated an all-electronic system for color TV at its plant in Camden, N. J.

Goldmark's system was a field-sequential one (343 lines, 120 frames per second). It used a spinning disk with red, green, and blue filters to scan the scene to be transmitted. A second filter disk, at the receiver, was made to spin in synchronism with the transmitter disk. This second disk served the function of colored phosphors in modern color TV by re-creating the color in the



## Here's the state of the art in low-cost hard-disk computers

### 11 MEGABYTES OF

#### FAST HARD-DISK STORAGE

Yes, the Cromemco Model Z-2H is in a class by itself in the computer field.

These Z-2H features tell you why:

- 11 megabytes of hard-disk storage
- 64 kilobytes of fast RAM
- Two dual-sided floppy disk drives
- Z-80A type processor
- Fast 4 MHz operation—150 nanosecond access time
- Fast hard-disk transfer rate of 5.6 megabits/second
- Low cost

And that's not all you get. Not nearly.

#### BROAD SOFTWARE SUPPORT

You also get Cromemco software support—the broadest software sup-

port in the microcomputer field. Software that Cromemco is known for. Like this:

- Structured BASIC
- FORTRAN IV
- RATFOR (RATional FORtran)
- COBOL
- Z-80 Macro Assembler
- Word Processing System
- Data Base Management

And more all the time.

#### FIELD PROVEN

The Z-2H is clearly in a class by itself. We introduced it last summer. It's field proven. It's reliable.

And it's rugged. Housed in a sturdy, all-metal cabinet.

#### EASILY EXPANDABLE

As always with Cromemco, you get expandability. The fast 64K RAM in this Model Z-2H can be expanded to 512 kilobytes. That amount of RAM combined with 11 megabytes of hard-disk storage gives you enormous

computer power—the equal or even beyond what much larger computers sometimes offer.

What's more, this computer gives you a 12-slot card cage. That's to plug in your special circuits as well as additional RAM and interface cards.

This expandability is supported by still more Cromemco value—the Z-2H's heavy-duty power supply that gives you 30A at 8V and 15A at  $\pm 18V$  to support plug-ins.

#### LOW COST — SEE IT NOW

The Z-2H is real. It's been in the field for many months. It's proven itself.

You should see the Z-2H now. Contact a Cromemco representative and arrange for a demo. Learn that Cromemco is a survey-winner for reliability.

And learn that the Z-2H is under \$10K.

In the long run it always pays to get the best.



**Cromemco**  
i n c o r p o r a t e d

280 BERNARDO AVE., MOUNTAIN VIEW, CA 94040 • (415) 964-7400  
Tomorrow's computers today



## ROI – Two actual cost/engineering studies\*

	Electronics Manufacturer	Appliance Manufacturer
Quantity of PC board designs	9	2
Quantity of boards run/year/design	47,000 (Av.)	120,000;180,000
Quantity of components/board	83 (Av.)	89;50
Total boards produced/year	420,000	300,000
Grand total component insertions	34,860,000	19,680,000
<b>Operating costs/year</b>		
Manual assembly	\$577,942.	\$254,761.
Automatic assembly	\$ 74,714.	\$ 41,526.
Net capital requirement (Investment in Universal automatic assembly equipment, less estimated equipment & tooling costs for manual assembly)	\$198,329.	\$ 92,590.
<b>Net Savings</b>	\$304,899.	\$120,645.
<b>Payback</b>	5.6 months	6.3 months
<b>Return on Investment</b>	253%	230%

\*These 1979 studies were made by Universal for two well-known producers of equipment for the consumer market. We will be glad to send you copies of the complete studies, with the names of the customers deleted. They include detailed cost analyses based on actual labor rates, assembly time studies, overhead costs, etc.

# Where else can you get this kind of return on your investment?

**Universal machines and systems have succeeded in putting circuit board assembly on a mass production basis. An amazing ROI record explains their rapidly expanding use.**

Nearly 90% of all printed circuit boards can be automatically assembled at high speed with systems that Universal has developed. And rapid pay-back can be obtained on short runs with a high mix of products as well as on long high volume applications. Our customer files include dozens of cost analyses like the two briefly summarized here. Send us your production requirements and costs. We'll be glad to work up a complete analysis to show you how much "going automatic" can save your company.

#### Universal Instruments' line includes

- Axial lead component insertion machines.
- Axial lead component sequencing machines.
- Radial lead component sequencing/inserting machines.
- DIP and DIP socket inserting machines.
- Pin insertion machines.
- Pass-Thru™ automatic board handling systems.
- Semi-automatic wire termination machines.
- Computer-based Satellite Controller\* system for single machines or entire assembly systems.

Circle 202 on reader service card



Subsidiary of **DOVER CORPORATION**

Universal Instruments Corporation ■ Box 825, Binghamton, New York 13902 ■ Tel: 607/772/7522 ■ TWX: 510/252/1990



received image. Such a system required great bandwidth (at least 12 MHz), and it could not interface with a monochrome system.

So in December 1946 CBS proposed separate channels for TV color and black-and-white systems. The FCC rejected this idea in March 1947, and the struggle for a TV color standard continued.

RCA pressed work on a system that was to develop into its so-called dot-sequential arrangement, which would be compatible with black-and-white TV. Dots of the primary colors were formed in rapid succession along each scanning line, and the colors were transmitted simultaneously with black and white by use of the monochrome scanning standards of 525 lines per frame and 60 fields (30 frames) per second. With an external adapter, the black-and-white receiver was tuned to only one component of this signal—that corresponding to the green primary image.

After some waffling by the FCC in the early 1950s, the commission settled for the RCA-compatible system.

**M**eanwhile the phonograph industry was poised for dramatic advances that were to take this instrument of entertainment a long way from its prewar days of unwieldy 78 rpm records and heavy pickups with steel needles. Since the 1930s engineers had been seeking three things: higher fidelity, longer-playing records, and more realistic sound. Electromechanical pickups had been introduced in the late 1920s, together with electronic volume and tone controls. Researchers in Britain and at Bell Telephone Laboratories almost simultaneously had demonstrated stereophonic reproduction in the early 1930s. But while engineers pushed for higher fidelity, their employers felt that the public would not pay for it.

The industry had recognized that a lightweight pickup diminished record wear and improved performance, and by coupling the stylus to a Bimorph Rochelle salt transducer element, manufacturers had placed on the market in the late 1930s a number of crystal pickups capable of tracking at one to two ounces.

In April 1941, *Electronics* reported a method of recording stereo on a conventional record: two bands, one on the outer edge of the record and one on the inner, recorded by two cutter heads, with the music reproduced by two pickups. Two years later the magazine suggested a circuit by which an engineer could divide an audio signal into high and low frequencies to give the illusion of stereo.

To answer the demand for longer playing time, engineers developed better ways to change records. A February 1942 article in *Electronics* had dismissed the long-playing tape machines and 33½ rpm records used by radio stations as too expensive for the mass home market. Mechanical record changers were able to cycle in 8 seconds, and there were three that played both sides. One by RCA used a turntable about the size of the record label and two pickups on the tone arm. Record changers by Garrard and Capehart played one side, then picked up the record, turned it over, and played the other.

In November 1945 Paul W. Klipsch described the

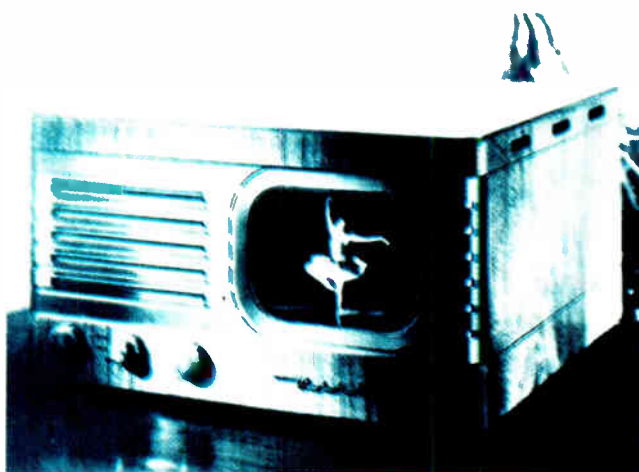

**Early model.** Regular commercial television broadcasting got under way in 1946 with six stations telecasting to a few thousand sets. This Motorola set introduced in 1947 was designed to sell for under \$200. Color did not become significant until the 1960s.

design and construction of a crossover network for feeding a low- and a high-frequency horn from a single amplifier. It used low-cost components yet gave a high-fidelity response, flat within 2 decibels from 30 to 10,000 hertz. A year later London Records announced a phonograph with a frequency response of 50 to 14,000 Hz, plus or minus 1 dB.

**A** development that ultimately improved phonograph reception radically—stereophonic sound—had hastened the growth of the infant instrument industry. From stereophonic sound, there arose a major instrument manufacturer—Hewlett-Packard.

William Hewlett and David Packard had been friends since their college days at Stanford University and had wanted to form their own electronics company. By 1938 they had converted the small garage behind the Packard home in Palo Alto, Calif., into a workshop and had constructed a resistance-tuned audio oscillator. The unit, with its enamel finish baked on in the Packards' kitchen oven, was named the model 200A because, according to Hewlett, "the number sounded big."

After the 200A had been displayed in 1938 at the West Coast meeting of the Institute of Radio Engineers, the two designers received a letter from Walt Disney Studios: could they produce a slightly different oscillator that would cover a different frequency range? Disney wanted it for his musical cartoon extravaganza "Fantasia," which was to have a new process in sound recording on film—stereophonic sound. The process called for three sound tracks, amplitude-compressed to fit on the film, plus a fourth decompression track.

With an order for eight oscillators in hand, Hewlett and Packard founded their company on Jan. 1, 1939, and built the model 200B.

During the war the instrument industry had helped out quietly. There had been, for example, a new weapon that had threatened Allied shipping: the magnetic mine. It exploded when it detected the magnetic presence of a large body of metal floating directly above. Therefore,



If Ben Experimented Today...



# He Could Rent Any One Of 18,000 Test Instruments From General Electric.



Short of a kite and a key, a broad selection of the most wanted test instruments is available—like lightning!—from a GE Rental Shop near you.

Biddle Megger Testers. Hewlett-Packard Signal Generators. Honeywell Oscillographs and Plug-in Amplifiers. Scopes from Tektronix. Recorders from Gould Brush and Esterline Angus...and many more.

So, whether you need a single scope, specialized instrumentation, a complex measurement system or application assistance, renting from GE is a breeze!

All rental instruments are maintained in tip-top shape, thoroughly checked and calibrated before each shipment. And it's on the way to you fast, normally the same day you call.

For your FREE RENTAL CATALOG, call collect (518) 372-9900, or write General Electric Company, Apparatus Service Division, Bldg. 4, Room 210, 1 River Road, Schenectady, NY 12345



ALA. BIRMINGHAM (205) 925-9449 • ARIZ. PHOENIX (602) 278-8515, TUCSON (602) 294-3139 • CAL. LOS ANGELES (213) 642-5350, SACRAMENTO (916) 383-1324, SAN FRANCISCO (415) 436-9260 • COL. DENVER (303) 320-3252 • CONN. SOUTHWINGTON (203) 621-4059 • FLA. JACKSONVILLE (904) 751-0615, MIAMI (305) 940-7723 • GA. ATLANTA (404) 457-5563 • ILL. CHICAGO (219) 933-4500, or (312) 854-2994 • IND. EVANSVILLE (812) 479-0248, FT. WAYNE (219) 484-9073, INDIANAPOLIS (317) 639-1565 • IO. DAVENPORT (319) 285-7501 • KY. LOUISVILLE (502) 452-3311 • LA. NEW ORLEANS (504) 367-6528 • MD. BALTIMORE (301) 332-4713 • MASS. BOSTON (617) 396-9600 • MICH. DETROIT (313) 285-6700, Ext. 208 or 209 • MINN. MINNEAPOLIS (612) 522-4396 • MO. KANSAS CITY (816) 231-4377, ST. LOUIS (314) 965-7115 • NEW JERSEY FAIRFIELD (201) 227-7900 • N.Y. BUFFALO (716) 876-1200, SCHENECTADY (518) 385-2195 • N.Y.C. FAIRFIELD, N.J. (201) 227-7900 • N.C. CHARLOTTE (704) 525-0311 • OH. CINCINNATI (513) 874-8512, CLEVELAND (216) 441-6111, TOLEDO (419) 691-3501 • ORE. PORTLAND (503) 221-5101 • PENN. PHILADELPHIA (609) 488-0244, or (215) 923-0383, PITTSBURGH (412) 462-7400 • S.C. GREENVILLE (803) 277-4093 • TENN. MEMPHIS (901) 525-5393 • TEX. DALLAS (214) 357-7341, HOUSTON (713) 672-3570 • UT. SALT LAKE CITY (801) 973-2253 • VA. RICHMOND (804) 232-6733 • WASH. SEATTLE (206) 575-2987 • W.V. CHARLESTON (304) 345-0920 • WISC. APPLETON (414) 739-7766, MILWAUKEE (414) 744-0110 • PUERTO RICO PONCE (809) 843-4225, or 4625.

GENERAL  ELECTRIC

Circle 240 on reader service card





**Innovator.** Peter C. Goldmark's field-sequential color TV system for CBS, which used a spinning color wheel (left), ultimately lost out to RCA's dot-sequential system. A major success was his long-playing record, which made the 78-rpm disk obsolete.

to protect ships, a method of demagnetizing them was invented. By wrapping several turns of wire around the hull of a ship and electrifying it, one could "degauss" the effect of the earth's magnetic field on the ship.

The General Electric Co. developed a special form of fluxmeter to measure the effectiveness of this degaussing. The meters were connected to coils on the bottom of a harbor, and as a test ship passed over them, the measurement was made. This same principle was applied to safeguarding harbors: by noting fluxmeter deflections and comparing them to the known movements of Allied shipping, defenders could detect the presence of an enemy submarine.

There were comparable instrumentation contributions to wartime computing. A new device that was to have great impact after the war was the four-tube decade counter. Developed by John T. Potter of the Potter Instrument Co., the simple counter used a 1-2-4-8 binary progression and could be ganged with other such units for high-order counting. It was described by Potter in the June 1944 issue of *Electronics*.

With manpower shortages at home, manufacturers came up with a wide variety of equipment to permit testing of components by fewer people of lower skills. The February 1943 issue of *Electronics* notes one such effort, a forerunner of automated assembly-line testing.

Dana Griffin and Newton Smalley of Communications Measurement Laboratories described it as the Rotobridge. The tester would automatically and sequentially check the capacitors, inductors, and resistors of a production unit against those of a known good unit. In simple go/no-go fashion, it indicated the presence of a bad element. The \$850 tester could perform both resistance and reactance tests on 120 circuits in 4 minutes.



In addition, the war was an intense training ground for engineers who, like Hewlett and Packard, formed their own companies. Among them was Howard Vollum, a graduate of Reed College in Portland, Ore., where he built his first oscilloscope. Vollum had been drafted in 1940 and sent to England, where he trained on high-resolution radar development. He returned to the Evans Signal Laboratory at Belmar, N. J., a few days before D-Day, where he worked on radars to determine enemy ground positions. While with the laboratory, Vollum encountered Hewlett, by then a fellow serviceman, who is said to have written to Packard telling him to hire Vollum after the war.

That job offer never materialized. Instead, after Vollum left the military and returned to Portland, he, Jack Murdock, and other associates founded Tektronix Inc. on Jan. 2, 1946.

The first Tektronix factory was the second floor of an electrical appliance store, which was also run by the company founders and helped to supply them with seed money. After a year and a half of steady effort, Tektronix' first product—the 511 oscilloscope—was ready for the marketplace.

The 511 incorporated many advances that had been developed for radar, including automatic triggering. Calibrated to an accuracy of  $\pm 5\%$ , the 10-MHz scope weighed 65 lb and sold for about \$700—roughly a third the cost and weight of its principal competition.

Another war veteran with a dream was Joseph Keithley. In a back-alley store in Cleveland, he began the Keithley Instrument Co. on his own.

His first product was the "Phantom Repeater," a high-impedance-input amplifier that put little drain on the circuits used in conjunction with it. While this device

# THE WORLD'S LEADING MANUFACTURER OF QUALITY AUTOMATIC INTERCONNECT ANALYZERS AND ACCESS FIXTURES!

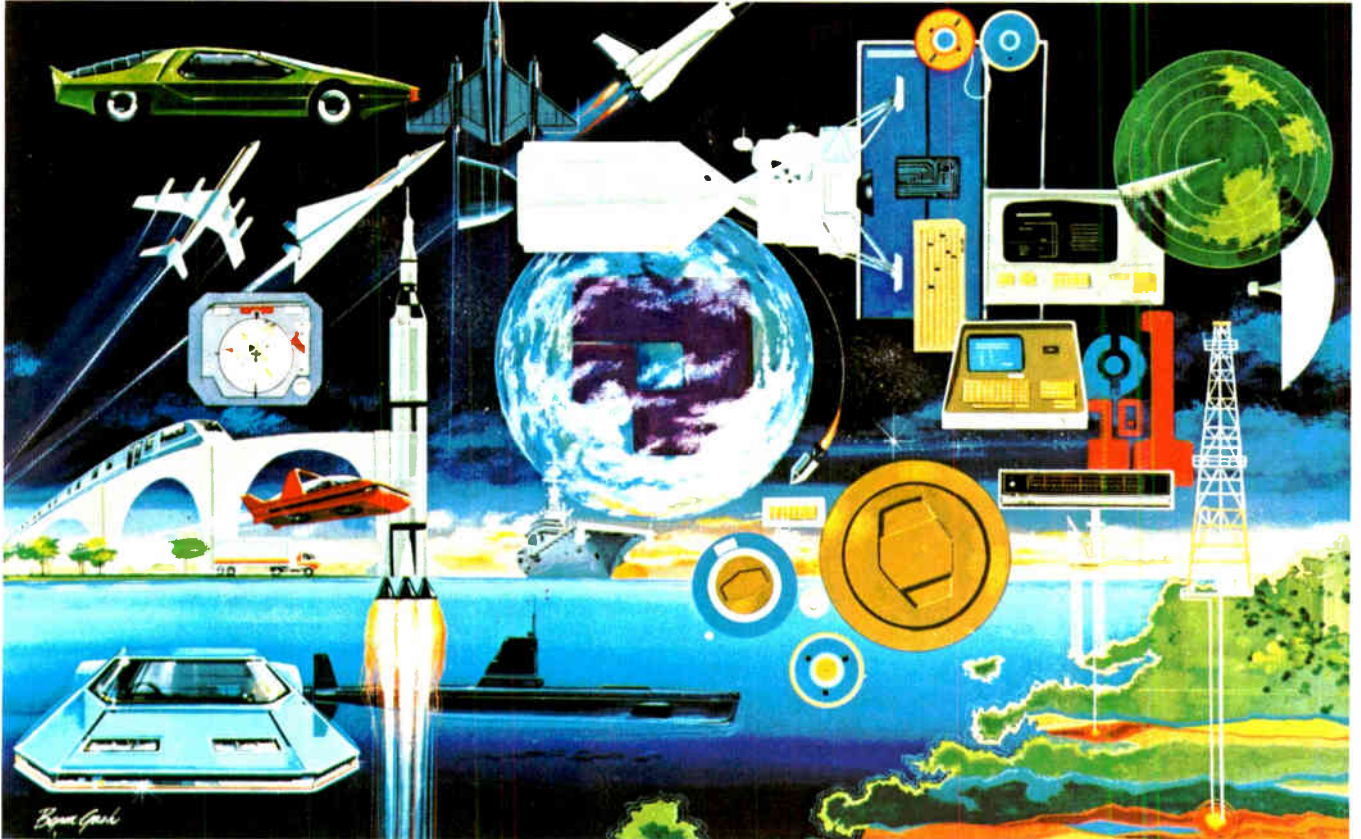

Write on your company letterhead for your free print, 22" x 18", suitable for framing.



## **PUT DIT-MCO TO THE TEST**

For over a quarter century DIT-MCO has been at the forefront of Automatic Interconnect Test Equipment/Access Fixturing development. As technologies advance there will continue to be increasing demands for more versatile, multiple function and cost-effective ATE systems. Our history of service to the aero-space, telecommunications, and dataprocessing industries speaks for itself. *We will continue that tradition with a solid commitment to meet the expanding needs for high quality ATE equipment and service.*

## **DIT-MCO INTERNATIONAL CORPORATION**

5612 Brighton Terrace Kansas City, Missouri 64130

816-444-9700 Telex 42-6149

European Technical Representative  
RADIX-HOUSE  
Central Trading Estate  
Staines, Middlesex, TW18-4-XA, England  
Telephone (0784) 51444 — Telex 935023

Japanese Representative  
TEL Inc.  
Shinjuku Nomura Building  
26-2, 1-Chome Nishishinjuku  
Shinjuku-ku, Tokyo 160, Japan  
Telephone (03) 343-4411





# NOW EDAC HELPS YOU GET MORE INTO THE BLACK.

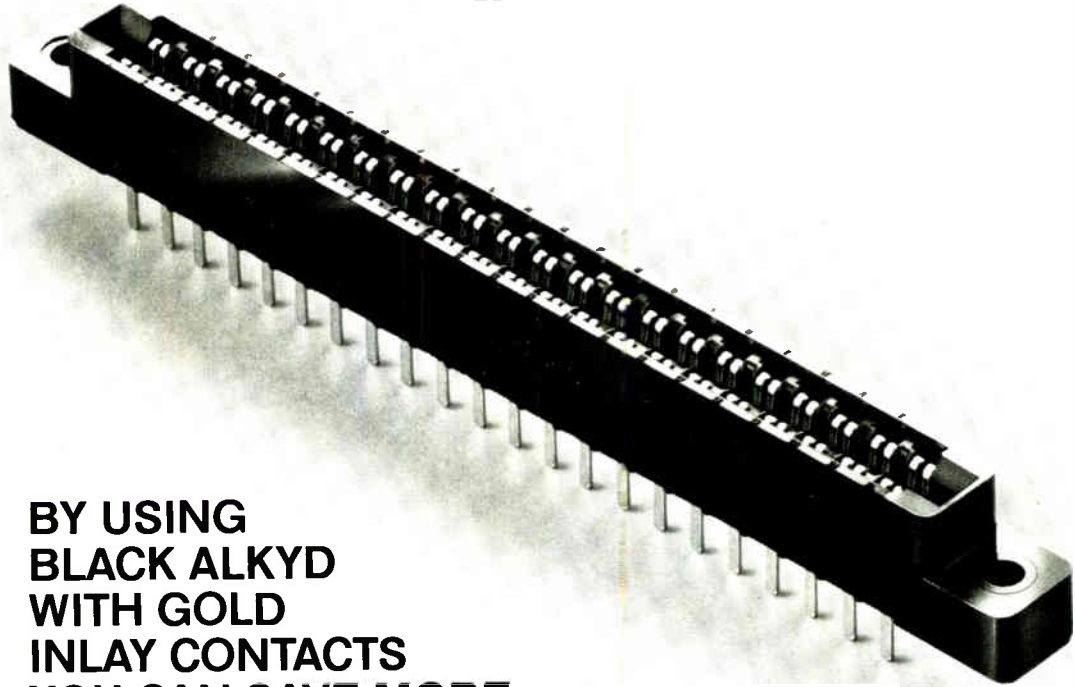

**BY USING  
BLACK ALKYD  
WITH GOLD  
INLAY CONTACTS  
YOU CAN SAVE MORE  
THAN 30% ON YOUR  
CARD-EDGE CONNECTORS.**

In this day of inflationary price increases which seem to surface with the regularity of the sun, you can once more expect the unexpected from EDAC.

Black Alkyd is now available in card-edge connectors in .156", .125" and .100" spacing. And this insulating material has outstanding molded characteristics which closely match the demanding specifications of Diallyl Phthalate.

Gold Inlay contains 30 micro-

inches of gold versus 10-20 micro-inches for gold plating.

You know that you will receive the high quality, integrity and reliability that thousands of companies have come to expect from EDAC.

For real savings on your connectors, contact EDAC today!



EDAC INC 20 Railside Road  
Don Mills, (Toronto) Ontario M3A 1A4  
Tel 416-445-2292 TWX 610-492-1398

*Available through Stocking Distributors and Representatives from Coast to Coast.*

was not the great success he had hoped for, it supplied enough capital for him to develop his first electronic electrometer, which fully launched the company.

In the realm of instrumentation theory, discoveries were recorded unostentatiously in the literature. The June 1940 issue of *Electronics* contained a cover article entitled "Panoramic Reception." Developed by Marcel Wallace, an independent consultant, the technique displayed the output of a frequency-swept superheterodyne receiver on a sweep-synchronized oscilloscope. Wallace initially saw the application of this signal-strength-to-frequency display as valuable to radio navigation, with variance in signal strength providing a measure of position. But another application of the technique is probably more familiar to engineers today.

In an August 1941 article in *Electronics*, S. F. Carlisle Jr. and A. B. Mundel of the Sonotone Corp. described the application of the principle to test circuitry, providing a logarithmic display of its response. Thus spectrum

analysis became an important new tool in engineering evaluation.

As broadcasters attempted to reach wider audiences, the dynamic characteristics of vacuum tubes—their ability to withstand higher voltages and currents when the duty cycle was low—were more closely studied. In the March 1941 issue of *Electronics*, Jacob Millman and Sidney Moskowitz of the City College of New York described a method of tracing tube characteristics on a CRT. The technique has proved so satisfactory that it is still used today for tracing the characteristics of solid-state diodes and transistors.

**W**ith the veil of wartime censorship lifted, details of some of the electronics progress that had been made began to appear. One of the biggest breakthroughs was in the development of the proximity fuze for mortar shells. To squeeze the circuitry for the radio transmitter-receiver, plus control circuitry, into a volume 3 inches in diameter by 6 inches long, a new method of interconnection was invented: thick-film hybrid technology.

The developers of the fuze—the National Bureau of Standards in cooperation with the Centralab division of Globe Union in Milwaukee—used plates of steatite as substrates. Thick-film silver conductors and carbon resistors were alternately screened and fired onto the substrates. Then small disk ceramic capacitors and subminiature tubes were attached to the substrates, in a

**Little acorn.** This resistance-tuned oscillator, the 200A, was designed and built by Bill Hewlett and David Packard in their garage. On the strength of an order for eight from Walt Disney Studios, they formed Hewlett-Packard Company in 1939.



**In the beginning.** Tektronix was one of several firms founded by veterans returning with know-how gained in the services. Tek's Howard Vollum joined Jack Murdock and others to form the company in 1946. Shown here in 1948 is the production line in Tektronix' first building.



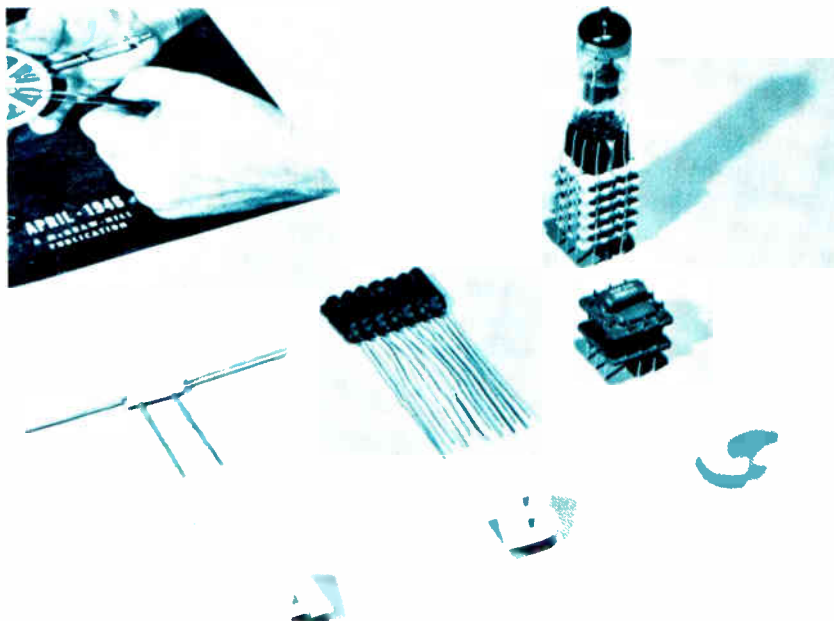

**Progenitors.** Out of proximity-fuze technology came these early attempts at modular circuit design, which ultimately led to printed circuits and hybrid devices. Shown left to right are a tubular capacitor with standard resistor inserted in tube, a phenolic panel bearing etched circuits and leadless passive components, and a stacked plate module dubbed Tinkertoy.

technique that was first described in *Electronics* in April 1946 in an article by C. Brunetti and A. S. Khouri. Centralab produced several million of these devices and went on to apply thick-film technology in the postwar years. The circuits were called printed circuits rather than hybrids, as they are known today.

In 1946 there was also the first mention in *Electronics* of germanium diodes. Writing in the February issue, E. Cornelius of Sylvania described a more refined version of the device used in wartime radar equipment.

By 1947 different forms of printed wiring were starting to appear. A news item in *Electronics* in June that year mentioned that the Franklin Airloop Co. was making radio antenna coils out of stamped wire.

**I**n England in the same year a machine-made radio being produced by John Sargrove Ltd. was using a crude form of the printed circuit. Plastic panels with preformed depressions and holes were fed automatically into electronically controlled machines, where they were successively sand-blasted and sprayed with zinc. Moving through the machine on a conveyor belt, the panels were then milled, so that zinc remaining only in the depressions formed wiring, inductances, and capacitances. Resistors were added by the spraying on of graphite. Finally tube and filter capacitor sockets and hardware were automatically installed.

Another device that was on the verge of becoming a consumer product in 1947 was the tape recorder. As early as 1932, *Electronics* had reported an Austrian tape machine. It used film on glossy printed paper that moved past a light source and a light-sensitive device—sort of a movie soundtrack without the picture. In May 1944 an engineer from the National Bureau of Standards discussed a special steel-alloy continuous tape, a machine with two recording heads, placed on opposite sides of the tape, and two erase heads. The tape was approximately 0.003 in. thick and 1/8 in. wide, and it moved past the heads at approximately 5 ft/s.

By December 1946 the magazine was able to report tape-recorder developments from Germany. The Magnetophone, used in German broadcasting, employed ferric oxide dried onto a plastic tape as a recording medium. The tape ran at 80 centimeters per second (31.2 inches) to record frequencies up to 10,000 hertz. It was 0.05 mm thick (0.002 in.) and 5 mm wide (1/8 in.).

Less than a year later, *Electronics* carried a description of a magnetic-tape recorder for movies and radio. The tape was driven by three motors: one released the tape reel, one drove the tape at a continuous speed with a capstan and idler wheel, and one took up the tape. The tape moved at 30 in./s and reportedly achieved an overall response flat within 4 decibels from 32 to 9,600 Hz.

There was another development during the war years that eventually became important to consumers. In July 1944, the editors of *Electronics* said: “The possibility of using electronic heat as a domestic cooking medium has often been considered, but the economic aspect is the real drawback to its immediate utilization in the home. The cost is prohibitive because the power tubes require an expensive high-voltage power pack.”

**B**y 1947, however, the magazine was describing industrial uses of microwave heat—for drying fabrics, curing rubber, preheating plastics—and it speculated on the possibility of cooking frozen foods. In August 1947, General Electric announced an electronic oven that could heat precooked frozen meals. A commercial unit, it heated a packet for about 75 seconds, raising the temperature to about 160°. The power required was the same as for a domestic electric range.

Perhaps the most far-reaching portent of the time, however, was in the magazine *Wireless World*. In a 1946 issue, Arthur C. Clarke, the British science-fiction writer, proposed a worldwide system of communications based on use of an earth satellite as a great amplifier in space. The satellite in his proposal appeared stationary, in what is now known as geosynchronous orbit.

# VOLUME?



This high tolerance, high density Sheldahl Flexcircuit for the solid state control system in an instant film camera is produced in a volume of over 500,000 a month.



# DENSITY?



This Sheldahl Flexcircuit for a thermal print head covers 140 sq. inches, and has a density of 74 mil lines and spaces.



# AFFORDABILITY?



Sheldahl's standard membrane Flexswitches® offer you affordability. They're designed for use in applications under the same demanding environments as the custom Flexswitch product. No tooling charges—you modify the shape and size with scissors. Add to this etched and plated copper conductors, a tough front panel and you've got proven reliability not always present in other membrane switches. Call your local distributor.



by Sheldahl

Circle 211 on reader service card

## COST EFFICIENT FLEXSWITCH® AND FLEXCIRCUITRY MAKE THE DIFFERENCE

Because Flexswitch® Brand membrane switches and Flexcircuitry afford you the opportunity of slimline and lightweight design in a product that provides you with the proven reliability not always found in other membrane switches. What's more, only Sheldahl boasts such high tolerance, high density, and high volume capability with such ensured cost efficiency. Because, Sheldahl plots accuracy beforehand on a Coordinatograph®. In manufacturing, it's the automatic difference. Roll to roll, plated through holes. With every single Flexcircuit and Flexswitch inspected before it goes out the door. Electronic and electrical testing available.

### FLEXCIRCUIT DESIGNERS KIT \$2.00

Includes applications engineering brochure, graph paper, instruction on designing your own flexcircuit into price quotation form.

### FLEXSWITCH DESIGNER KIT \$10.00

Includes design guidelines, instructions, membrane switching panel, flexcircuit corrector, and RFQ checklist.

Please send me  16 key kit(s)  5 key kit(s)  shcr to ground  shcr to ground  crosspoint  crosspoint

I enclose a check or money order for my flexcircuitry and/or membrane switch kit(s).

NAME \_\_\_\_\_ TITLE \_\_\_\_\_

COMPANY \_\_\_\_\_

ADDRESS \_\_\_\_\_

CITY \_\_\_\_\_ STATE \_\_\_\_\_ ZIP \_\_\_\_\_



# Sheldahl

Mail to:  
Sheldahl  
Electrical Products Division  
P.O. Box 17C  
Northfield, MN 55057

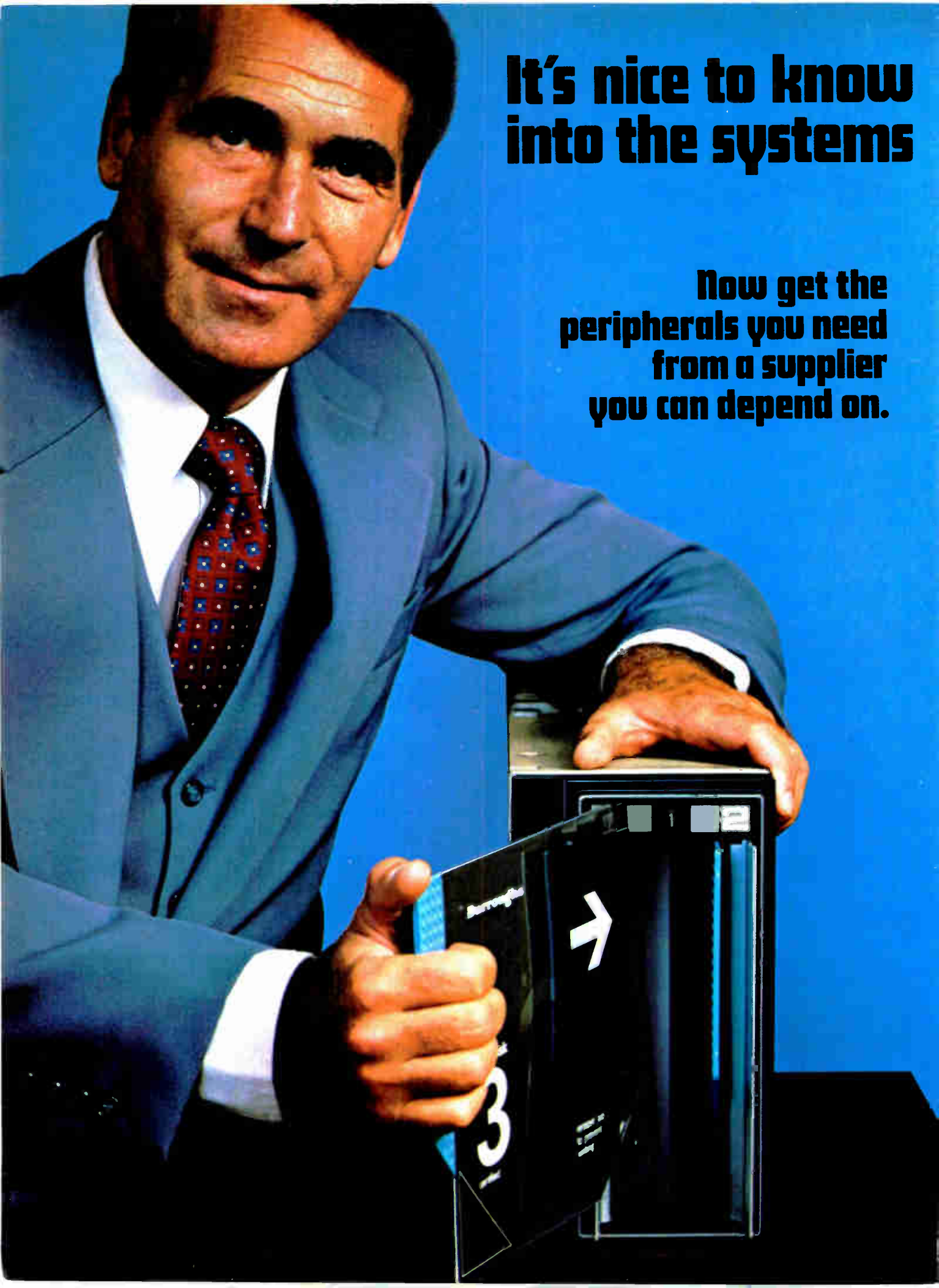

A man in a blue suit and red patterned tie is leaning over a server rack. He is holding a server drive tray that is partially inserted into a slot. The tray has a white arrow pointing right and the number '3' on it. The background is a solid blue color.

**It's nice to know  
into the systems**

**Now get the  
peripherals you need  
from a supplier  
you can depend on.**

# you've built Burroughs quality you've put your name on.

As an OEM systems decision maker, you may not be aware that Burroughs peripherals are available to the OEM. In fact, Burroughs now offers a growing line of OEM peripherals including floppy disk drives, fixed disk drives, printers, displays and many others. Rugged. Dependable. And backed by the Burroughs warranty. With worldwide production facilities to assure your supply.

For additional information, call or write **Burroughs OEM Marketing**, Burroughs Place, Detroit, MI 48232 (313) 972-8031. In Europe, High Street, Rickmansworth Hertfordshire, England. Telephone Rickmansworth (09237) 70545.



# Burroughs

Circle 224 on reader service card



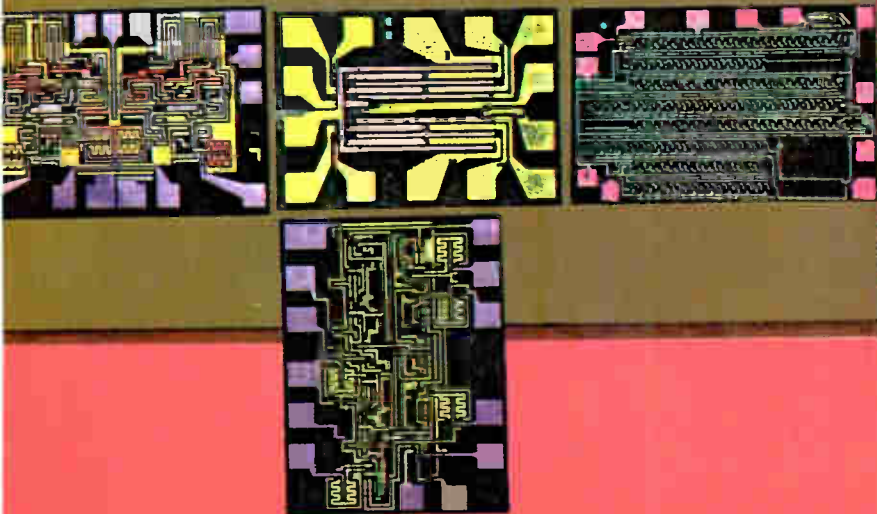
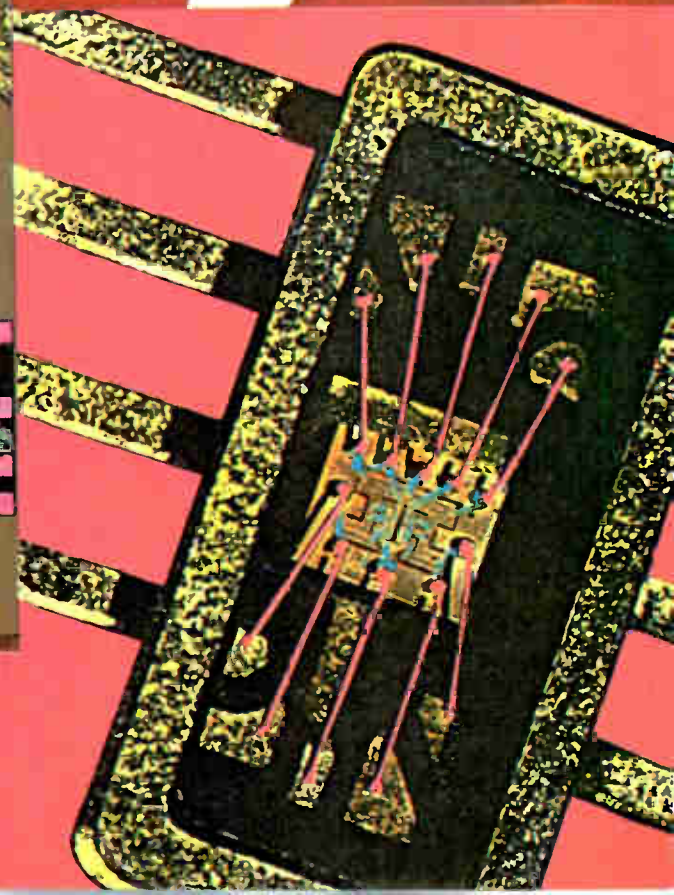
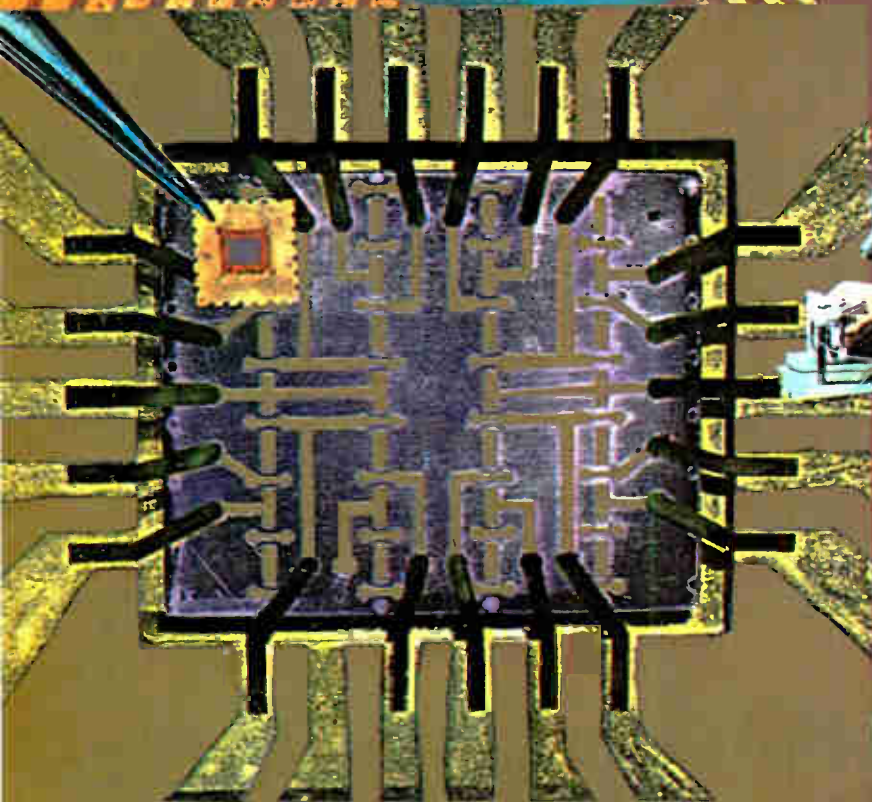
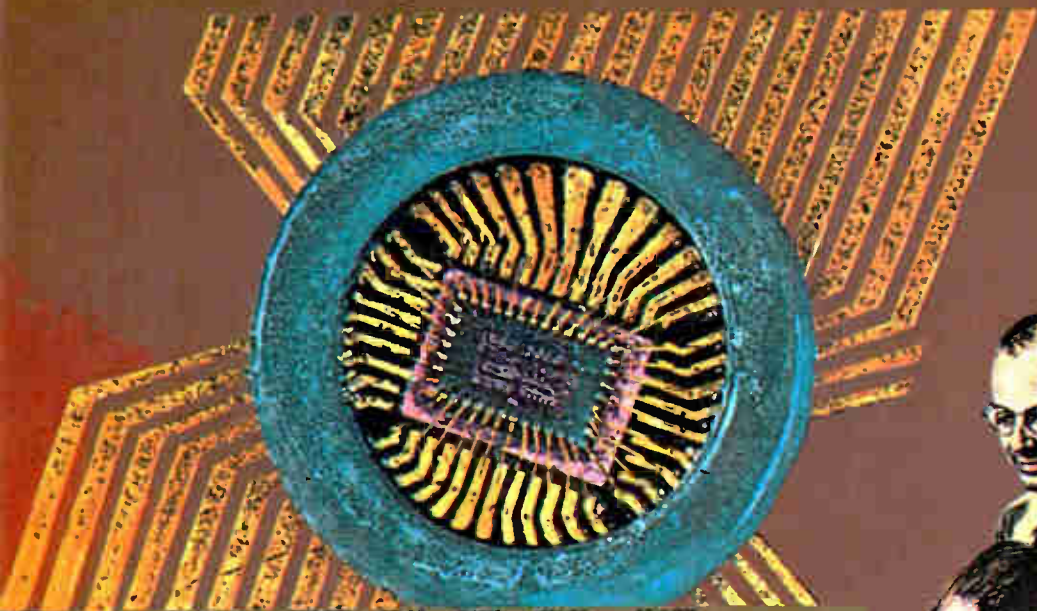

# THE SOLID-STATE ERA

---



FARADAY'S  
OBSERVATION,  
BACK IN 1833,  
OF SILVER

SULFIDE'S QUIRKINESS  
STARTED SOLID-STATE  
ELECTRONICS ON ITS  
LONG AND DIFFICULT  
PATH TO THE  
DEVELOPMENT OF  
THE TRANSISTOR  
IN 1947 AND THE  
INTEGRATED CIRCUIT  
IN THE LATE FIFTIES.  
SCHRÖDINGER'S  
QUANTUM MECHANICAL  
THEORY WAS NEEDED TO  
EXPLAIN THE BEHAVIOR  
OF SEMICONDUCTORS;  
ALCHEMY SEEMINGLY  
WAS NEEDED TO MAKE  
THEM. NONETHELESS  
SEMICONDUCTOR  
TECHNOLOGY BEGAT  
AN ADVENTUROUS  
NEW INDUSTRY THAT  
HELPED LAUNCH THE  
MISSILE AND SPACE  
PROGRAMS OF THE  
SIXTIES, ACCELERATED  
THE SPREAD OF  
COMPUTERS IN THE  
SEVENTIES, AND MADE  
MILLIONS FOR ITS  
FORTUNATE FOUNDERS.

## Chapter 5



**B**uild a better switch, and the world will beat a pathway to your door. Will it? When Bell Telephone Laboratories announced the invention of the transistor, the general press treated the development almost indifferently. The New York Times carried the news the next day, July 1, 1948, on the next to the last page of the paper. It ran, four paragraphs, as the last item in "The News of Radio" column:

"A device called a transistor, which has several applications in radio where a vacuum tube ordinarily is employed, was demonstrated for the first time yesterday at Bell Telephone Laboratories, 463 West Street, where it was invented.

"The device was demonstrated in a radio receiver, which contained none of the conventional tubes. It also was shown in a telephone system and in a television unit controlled by a receiver on a lower floor. In each case the transistor was employed as an amplifier, although it is claimed that it also can be used as an oscillator in that it will create and send radio waves.

"In the shape of a small metal cylinder about a half-inch long, the transistor contains no vacuum, grid, plate or glass envelope to keep the air away. Its action is instantaneous, there being no warm-up delay since no heat is developed as in a vacuum tube.

"The working parts of the device consist solely of two fine wires that run down to a pinhead of solid semiconductive material soldered to a metal base. The substance on the metal base amplifies the current carried to it by one wire and the other wire carries away the amplified current."

Even technical journals were slow to appreciate the inherent possibilities of the transistor. To stir enthusiasm for the device, Bell Laboratories licensed it freely and publicized it extensively in seminars and papers.

Within laboratories in the United States and Europe, however, interest in what later came to be called semiconductors had long roots. Early dealings with the electrical properties of semiconductors can be traced to the last century, when several scientists independently studied the photovoltaic and rectifying effects of certain compounds like silver or zinc sulfide and elements like selenium. Following Faraday's discovery in 1833 that the conductivity of silver sulfide increases with temperature (while metals display an opposite effect), Alexander-Edmond Becquerel of France discovered in 1839 that he could generate a voltage by illuminating the junction of an electrolyte and what was only a century later to be termed a semiconductor.

Willoughby Smith in 1873 noted a change in the conductivity of selenium under illumination, and a year later Ferdinand Braun, a professor of physics in Marburg, Germany, established the rectifying property of a "cat's whisker" contact of metal wire on galena (lead sulfide), thus creating the first metal-semiconductor junction. This cat's whisker diode detector served for a time as a somewhat temperamental detector of the radio-frequency signals generated at that time by spark-gap transmitters. Its decline began with the invention of the vacuum-tube diode by Fleming in 1904, and its virtual demise was ensured by the development in 1906 of Lee de Forest's triode; both were far more reliable.

As the need for cat's whiskers faded, so did any occasion for pursuit of a clear understanding of its operation. In fact, interest in solid-state phenomena was not to re-emerge until after World War I.

When the solid state did receive renewed attention, Bell Telephone Laboratories was among the curious. The idea of using some kind of electronic switch other than the vacuum tube to replace the telephone system's mechanical switches surfaced there in 1936, and by 1945 the Bell center was charting a deliberate course of wide-ranging research in solid-state physics aimed at developing what became the transistor.

But laboratory success did not end the struggle. It was David meeting Goliath. In 1948 the vacuum tube was a highly sophisticated commercial product. It was fragile, true; but so was the first transistor. And the transistor called for totally new production methods and system designs, and at first it was very expensive.

Still, because of the new device's small size and weight and low power consumption, the military became a customer immediately, as did hearing-aid manufacturers. What tipped the scales fully toward the transistor was the influence of computers and their need for huge quantities of small, low-power switches, as well as their ultimate digitization of much system design.

But if any one factor can be given most credit for the birth of the transistor, it is intellectual curiosity. More than any other electronic device, the transistor had its origins in scientific theory rather than in technological developments.

**T**he year was 1900, and postulation of a quantum hypothesis by Max Planck provided a basis for atomic theory and ultimately for the theory that explained the behavior of electrons in solids. It was from Planck's work that Albert Einstein was able to explain Becquerel's photoelectric effect in 1905. Though early researchers had deduced that photons caused the emission of electrons from certain materials, until Planck and Einstein there was no explanation of this puzzling question: why, if the number of electrons emitted is proportional to the intensity of light, is their energy proportional to the wavelength of the light? The quantum theory proposed a dual wave/particle nature of photons: if light actually comprises small packets whose energy is proportional to the wavelength, the experimental data could be satisfactorily explained.

Studies of the photoelectric effect were carried out in science centers throughout the world. R. W. Pohl, a young physicist in Berlin, as well as Wilhelm Röntgen, the German physicist who discovered X rays, studied that effect and the luminescent properties of solids. The problems of those times were to plague solid-state scientists right through to the birth of the transistor—namely, lack of pure substances.

By the start of the 1920s, it was generally accepted that metals were good conductors because they offered readily available electrons. In the presence of an electric field, these would be transported in a single direction to conduct electricity, and the same electrons could similarly transport kinetic energy to conduct heat. However,

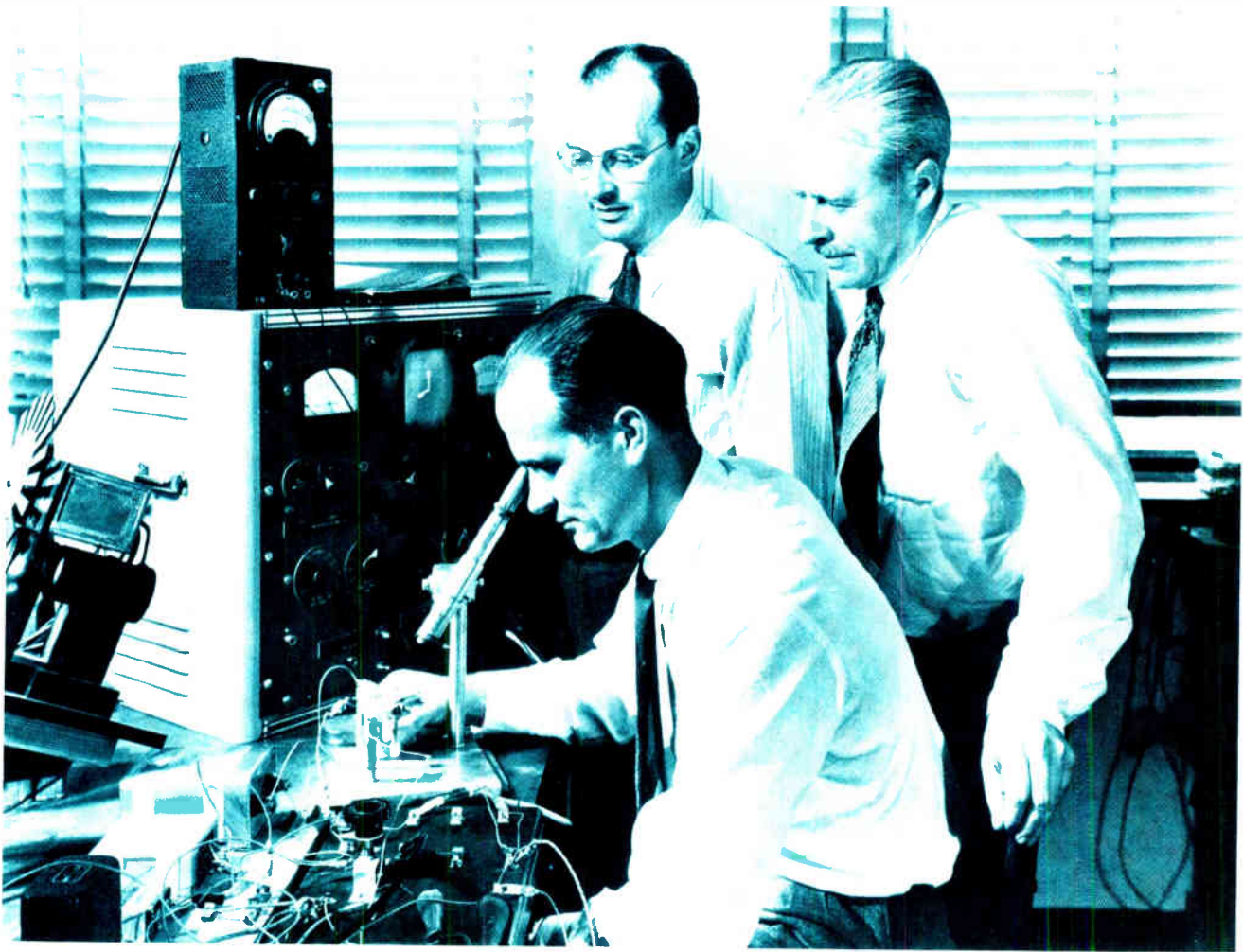

**Pioneers.** In 1947, physicists William Shockley (seated), John Bardeen (left), and Walter H. Brattain of Bell Telephone Laboratories developed the point-contact transistor—the first solid-state amplifier. The three received the Nobel Prize in physics in 1956.

a way to quantify the behavior of electrons in solids had to await Erwin Schrödinger's famous quantum-mechanical equation, which the Austrian physicist published in 1926. Within the next 10 years eager physicists were assisted by the equation, which tied together all the puzzling solid-state phenomena encountered during the preceding century.

While the theoreticians were unraveling the concepts of electrons, band theory, and valences, scientists less mathematically inclined were experimenting with various materials. In the mid-twenties, for example, newly devised solid-state rectifiers could handle far more power than the sensitive cat's whisker. These rectifiers were built of stacks of copper plates, each oxidized on one side. Despite ignorance of why they operated, manufacturers turned out the devices in substantial volumes in the 1930s, and even the problem of the stacks' high forward resistance was solved by substituting selenium for the oxide.

Then, in the late 1930s, physicists like Nevill F. Mott in England, Alexander Sergevich Davydov in the Soviet Union, and Walter Schottky in Germany set out to explain metal-semiconductor rectification. The rectification mechanism was generally agreed upon: the semiconductor material becomes depleted of current carriers at

the junction, which creates an effective barrier to equilibrium electron flow across the junction. Application of an electric field that reduces the barrier—a higher potential on the semiconductor side—permits electron flow, while reversal of that field further depletes the semiconductor of carriers, thus heightening the barrier to electron flow.

Many inventors struggled with the notion of a solid-state amplifier. The more common attempts were based on the field-effect principle, most likely because its concept was akin to the grid-control action of vacuum tubes. The first recorded attempt in the United States dates to 1925, when a former professor of physics at the University of Leipzig, Julius E. Lilienfeld, began working on a concept for a solid crystal amplifier.

In Germany, Lilienfeld had assisted Count Ferdinand von Zeppelin in designing the hydrogen-filled dirigible, and he had also experimented with X rays in the early 1920s. After arriving in the U. S., Lilienfeld managed to obtain several patents for an amplifier design based on copper sulfide. He was unable, however, to draw serious industry attention to his work. Most of those who investigated his experiments, conducted in near obscurity in Brooklyn, N. Y., doubted his devices would work at all.

Another patent to an inventor who could not explain



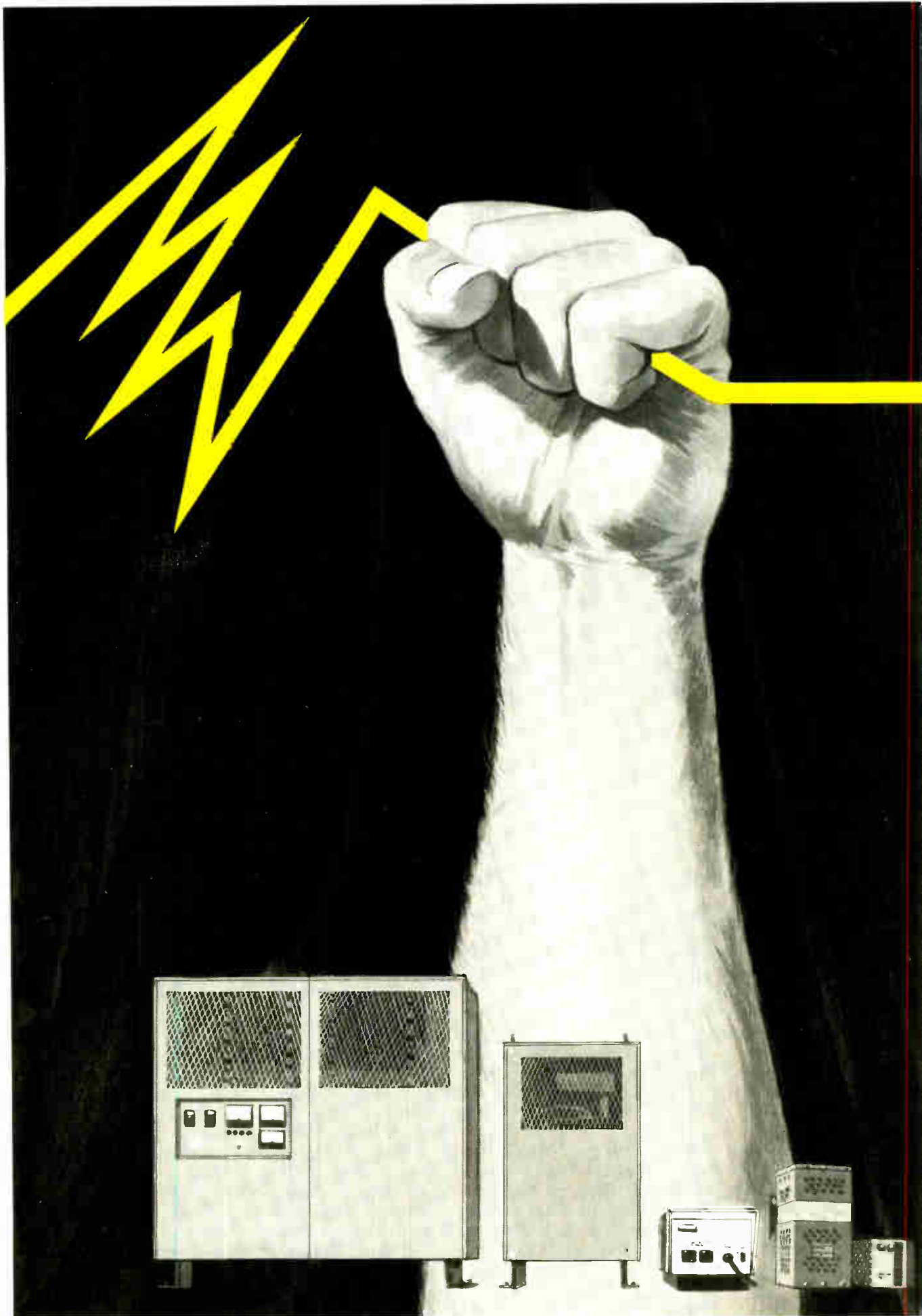

# Happy Fiftieth

**to Electronics Magazine and to Sola Electric**

**For once, we won't blow out any candles!**

## **Our hat is off to Electronics Magazine.**

It isn't often that a trade magazine demonstrates leadership by actually coining the name of the industry it serves. (Electronics registered its name in 1930, Webster picked it up in 1961).

Sola, on the other hand, is almost synonymous with voltage regulation, and adopted the name "Power Protectors" after more than 40 years of field-tested experience.

It's a healthy sign for a business publication to expand its editorial staff by ten-fold... even in 50 years.

Sola began as a loft operation with a handful of people. Today it has 750 employees plus sales representatives and distributors around the world.

Sola is pleased to have two important things in common with Electronics and its readers:

- We were launched in the early, rough-hewn days of a burgeoning technology.
- We both have an exciting prospect to contemplate.

**So, cheers to the years ahead.**



1717 Busse Road, Elk Grove Village, Illinois 60007 (312) 439-2800



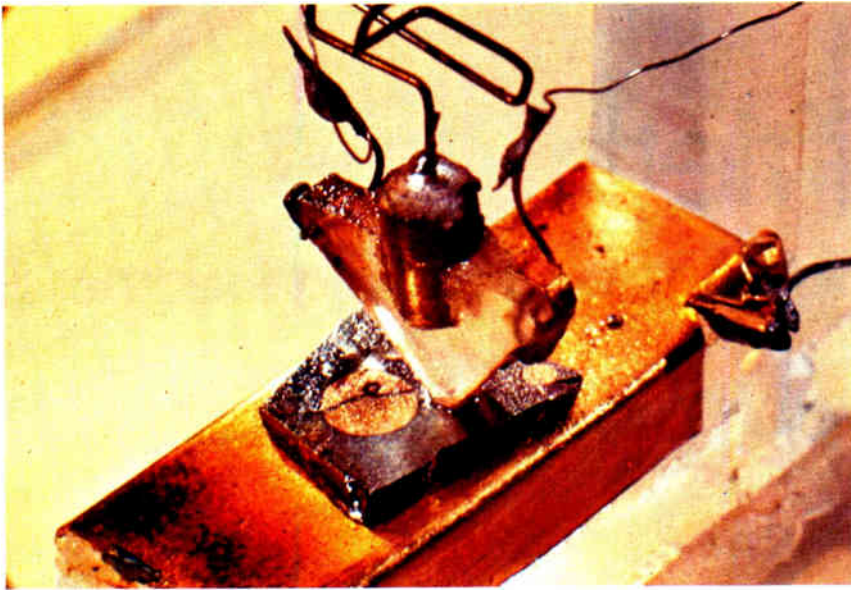

**Solid amplifier.** The first transistor placed two closely spaced contacts (the emitter and collector) on the surface of a germanium slab (the base). The V-shaped object is a plastic triangle round which gold foil was wrapped and slit at the apex with a razor; it was held on the slab by spring pressure.

the theory behind his device was issued in 1935 by Britain to Oskar Heil for a field-effect triode. Heil, a German inventor, proposed the use of a control electrode to regulate current flow through a thin semiconductor layer. The materials included copper oxide, vanadium pentoxide, tellurium, and iodine. Though it is doubtful that Heil's device ever actually worked, his design was a precursor of the insulated-gate field-effect transistor, since the control electrode was isolated from the semiconductor substrate.

Pohl meanwhile went on from his early experiments in photoelectricity to develop a working crystal amplifier in 1938. Though impractical—a slow-acting triode that relied on a wire grid to control the flow of electrons through a heated potassium bromide crystal—the device nonetheless proved to him the theoretical feasibility of solid-state amplification.

It is ironic that although the concept of a field-effect solid-state amplifier is marvelously simple, the development of a practical device was destined to come after the invention of a far more complex amplifier—the bipolar transistor. All the field-effect transistor called for was modulation of the current flowing through a chunk of semiconductor material by injection of charge carriers through a gate or grid, and the latter could even be insulated from the slab. But the key to development lay in the formation of surface states: the injected charge carriers could not affect the flow of current through the semiconductor slab because they got trapped in the material's surface. Ignorance of these surface states delayed the advent of the field-effect transistor—and the bipolar transistor as well.

**I**n retrospect, it is not surprising that the first practical solid-state amplifier was developed by Bell Telephone Laboratories, then in New York City and now headquartered in Murray Hill, N. J. It was in 1948, and is now, the largest industrial research and development organization in the world (in 1978 it employed over 19,000 people and produced 13,757 tech-

nical papers and 296 patents). At Bell, which researches every aspect of its telecommunications business, the disciplines of metallurgy, chemistry, materials science, solid-state physics, and engineering were already present; they just needed to be organized toward the goal of a solid-state amplifier.

Bell's research into solid-state physics was an offshoot of vacuum-tube research that dealt with thermionic emission and other surface properties of metals. Walter H. Brattain, one of the three men who were to play the leading roles in the invention of the transistor, was assigned to this vacuum-tube research when he joined Bell Laboratories in 1929. Brattain had received a Ph.D. from the University of Minnesota, where physicists like Schrödinger, James Franck, and Arnold Sommerfeld were guest lecturers on the new theory of quantum mechanics. Brattain's background in solid-state physics gave him a leaning toward semiconductors, and in 1931 he was reassigned at the Bell center to study the copper oxide rectifier with J. A. Becker.

Brattain and Becker were convinced that the rectifying action took place at the immediate junction of the metal and copper oxide and that current flow through the materials themselves was ohmic. These findings were confirmed by experiments in photoelectricity, in which a current flow was produced solely by illumination of the junction and not of the bulk materials. Like many other scientists of their period, the Bell researchers also struggled with the notion of how to add a third electrode—a control grid—to the rectifier to make an amplifier.

Fortunately, while Brattain was doing his practical research on rectifiers through the early 1930s, the theoretical work on semiconductors was progressing all over the world. In 1931, the British physicist Alan H. Wilson published his theoretical model of a solid semiconductor, which related earlier work on the motion of electrons in metals to insulators and semiconductors. And within the next few years there came the contributions on semiconductor theory from Mott in England, Yakob Ilyich Frenkel and Davydov in the Soviet Union, and Schottky in Germany. As these physicists lectured and published,

# ATTENTION PC DESIGNERS & DRAFTERS!



**NOW GET THE ACCURACY AND SAVINGS OF CAD\* WITHOUT ITS COSTLY CAPITAL INVESTMENT AND THRU-PUT DELAYS . . . Thanks to Bishop's Unique New PC Pin Registration, Overlay Drafting System**

*Perfect PC Artwork Registration Everytime*

\* COMPUTER AIDED DESIGN OR DRAFTING

**B**ishop's new pin registration system is a fast, error-free mechanical method of achieving and maintaining the demanding accuracy and precise registration required for PC artwork . . . without the expense and scheduling bottlenecks of CAD. Before you invest in CAD, consider the accuracy, convenience, and cost savings of Bishop's unique overlay drafting pin registration system. Here are some of its time and money saving advantages:

- Precision registration and accuracy
  - Consistent locational accuracy of  $\pm .002"$  (0,051mm) on any overlay sheet size
  - Insures absolute constant perpendicular registration
  - Prevents artwork film from buckling, stretching, or slipping due to temperature and humidity changes
- Cuts down man-hours required for registration, taping and production of PC artwork and associated documents
- Eliminates costly and time-consuming repetitive drawing and taping of common data
- Inexpensive and cost-effective . . . an easy, convenient and simple method to generate accurate PC artworks fast . . . you don't have to be a computer programmer to use it
- Speeds design changes — you only work on individual overlays affected

## WE SHOW YOU HOW!

**FREE! Bishop Technical Manual No. 1022R**

Our "How To" Technical Manual No. 1022R includes special PC artwork step-by-step instructions and illustrations . . . Send now for your FREE copy.



- Speeds and simplifies artwork checking by quickly and easily superimposing selected circuit overlays
- A complete "off-the-shelf" system including factory precision, PREPUNCHED grids and stable-based polyester ACCUFILM®
- Precision punching of sensitized materials . . . yours or ours

### The SECRET To Precision Registration . . . Bishop's Unique Pin Hole Pattern

TOP UNIVERSAL (SLOTTED) PINS

Slotted shape provides tight "hole to pin" tolerance at top and bottom of universal metal pin, insuring perpendicular registration. Also provides "room" for film expansion and contraction (without buckling). Registration radiates from stable round center pin to keep film fluctuations to a bare minimum, insuring maximum registration in the most crucial area of your artwork. — the center of the sheet.

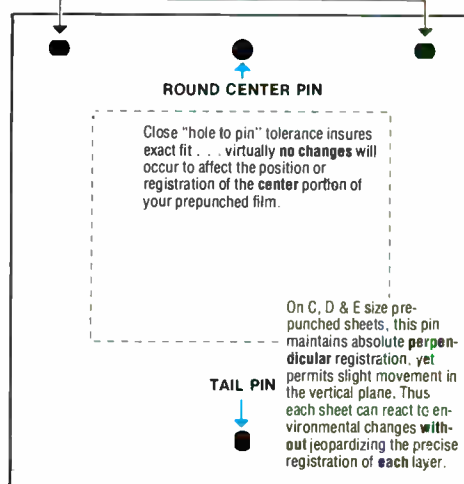

The Innovators  
**Bishop Graphics, Inc.**

5388 Sterling Center Drive • P.O. Box 5007  
Westlake Village, CA 91359 • (213) 991-2600 • Telax: 66-2400



An ounce of prevention is worth it  
at Advanced Microtechnology

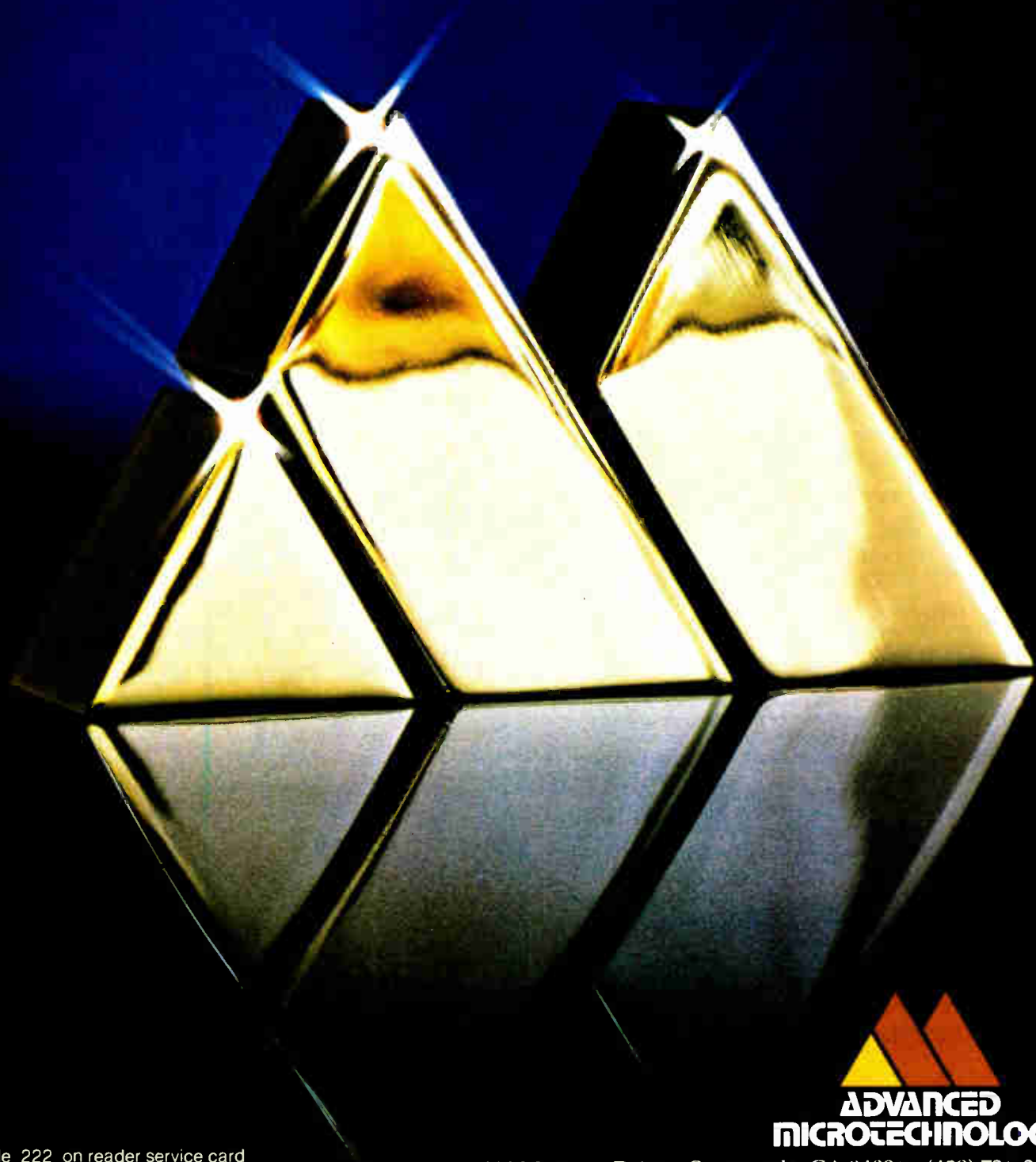

Circle 222 on reader service card

480 Mercury Drive, Sunnyvale, CA 94086 (408) 736-3860

*Providing complete test services and burn-in systems to the semiconductor industry.*



**ADVANCED  
MICROTECHNOLOGY**

information made its way quickly to the universities, where it was absorbed eagerly by young graduate students. One such student was William Shockley, the youngest of the three key developers of the transistor.

Shockley joined Bell Laboratories immediately after receiving his doctorate in physics from the Massachusetts Institute of Technology in 1936. He had studied under John Slater, a major contributor to the development of quantum mechanics and its application to the solid state. At Bell, Shockley was first told to report to C. J. Davidson in the vacuum-tube development department. Davidson, with a colleague, Lester Germer, had been the first to observe electron diffraction, for which the two received the Nobel Prize in 1937. But for Shockley, it was only a short tour of duty with the vacuum tube. After working on multiplier tubes, he was assigned to his preferred area of study, solid-state physics.

The man perhaps most responsible for planting the idea of the transistor in Shockley was Mervin Kelly, then director of research and later president of Bell Laboratories. As early as 1936, Kelly had expressed his belief to Shockley that for the growing needs of communications to be met, the phone company's mechanical switching must eventually be replaced with electronic switches of some sort. Shockley was left with an indelible impression. He was certain Kelly was not referring to a new tube technology, but something radically different.

Inevitably Brattain and Shockley crossed paths in the late 1930s. Shockley became involved in Brattain's and Becker's research on copper oxide rectifiers, and on Dec. 29, 1939, Shockley made his first notebook entry on a proposed semiconductor amplifier built of copper oxide. He had studied Schottky's theory on the space-charge region—the surface layer of the semiconductor near its junction with the metal—and had noted that this layer gets depleted of carriers in the presence of a reverse field potential. It set Shockley to thinking: why couldn't the spreading of the depletion layer under an increased electric field somehow be used as a valve to regulate current flow? He recorded in his notebook:

"It has occurred to me that an amplifier using semiconductors rather than vacuum is in principle possible. Suppose, for example, that a very fine mesh copper screen is oxidized, thus giving a metal grid embedded in oxide, and let the ohmic contacts be made to the outer surfaces. Then if the carriers of charge are for convenience regarded as positive, if the grid is made plus, a space-charge sheath with carrier deficit forms around it. This gives a region of low conductivity and accounts for high resistance in the reverse direction for the rectifying junction . . .

"We can say that the grid effectively can be used to raise the resistance in its vicinity and thereby hinder the flow of current. . . . Since the grid is being used in the reverse direction, its resistance is high and it will not consume much power, whereas relatively large currents . . . can be controlled."

Shockley's idea, however, only amused Brattain. With Becker, he had abandoned any hope a year earlier of burying a grid in the space-charge region of a copper oxide rectifier. They had based their pessimism on calculations of the microscopic dimensions involved. Still,

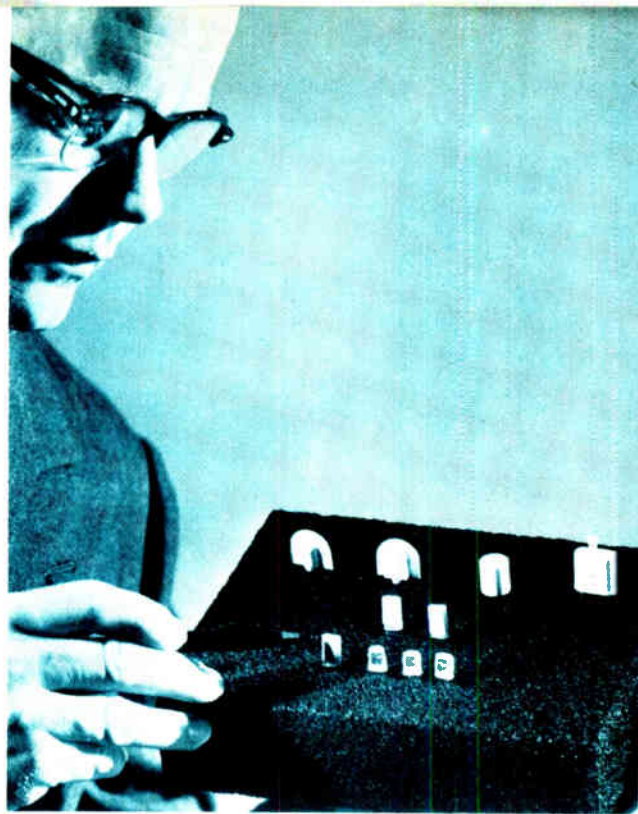

**Shaping up.** By 1952, germanium transistors had begun to take on standard shapes and pin configurations. The three rightmost transistors in the front row are point-contact devices; the rest—including the power transistors in the rear row—are junction types.

because Brattain was well aware of the importance of such a development, he began experiments with Shockley using oxidized copper wire.

The copper oxide amplifier never worked. Following his original triode idea, Shockley proposed an improved version. It called for a pair of electrodes to make contact with the top surface of a thin copper oxide slab. The control, or grid, voltage was connected to the underside of the slab. Although the structure strikingly resembled today's field-effect transistors, it, too, failed.

Brattain and Shockley continued to experiment with copper oxide. Russell S. Ohl, a chemist on the Bell research staff, was working meanwhile with silicon—a material about which little was known at the time. Ohl observed the behavior of silicon cat's whisker detectors, which Bell was looking into for improved microwave detectors, and he began working with Bell's metallurgists to improve silicon's rectifying characteristics.

Two of the metallurgists, J. H. Scaff and H. C. Theurer, had discovered that by melting silicon in a vacuum, they could obtain relatively pure ingots—though some would rectify one way, some the other, and some not at all. The material that conducted best when biased negatively they named n type; that which conducted best the other way they called p type.

Scaff and Theurer eventually discovered that what distinguished n silicon from p was the trace amount of impurity it contained. The actual level of impurity that doped the silicon p or n was exceedingly low—at that time it even defied spectroscopic detection. According to Brattain, the odor of the silicon ingots as they emerged from the oven had led Scaff to suspect the existence of phosphorus contamination.

Further, the two metallurgists found that elements on





## The milestones of printed circuitry.

If you race through the history of electronics, the high point of the past 50 years will be solid state.

If you jog through, you will realize that solid state would be largely a curiosity, except for parallel advances in printed circuitry.

Then, if you take a walking tour, you'll find Photocircuits—now expanded into four divisions of Kollmorgen Corporation—chiseled on nearly every milestone of printed circuitry.

For over 25 years, every PC-board manufacturing process in the world has been initiated or strongly influenced by our developments. A glance at the milestone inscriptions shows why:

1952: First copper-clad epoxy-glass laminate.

1953: First reliable process for making plated-through holes to join etched conductors on opposite sides of a board.

1955: Epoxy solder masks and plating resists.

1959: Printed circuit motor which improved EDP tape-drive response by several orders of magnitude.

1961: First volume production of multilayer boards.

1963: Semi-additive (CC-4 Unclad™), the only successful electroless/electroplated process.

1964: CC-4 Additive™, the first and still most successful process for making printed wiring with electrolessly deposited copper.

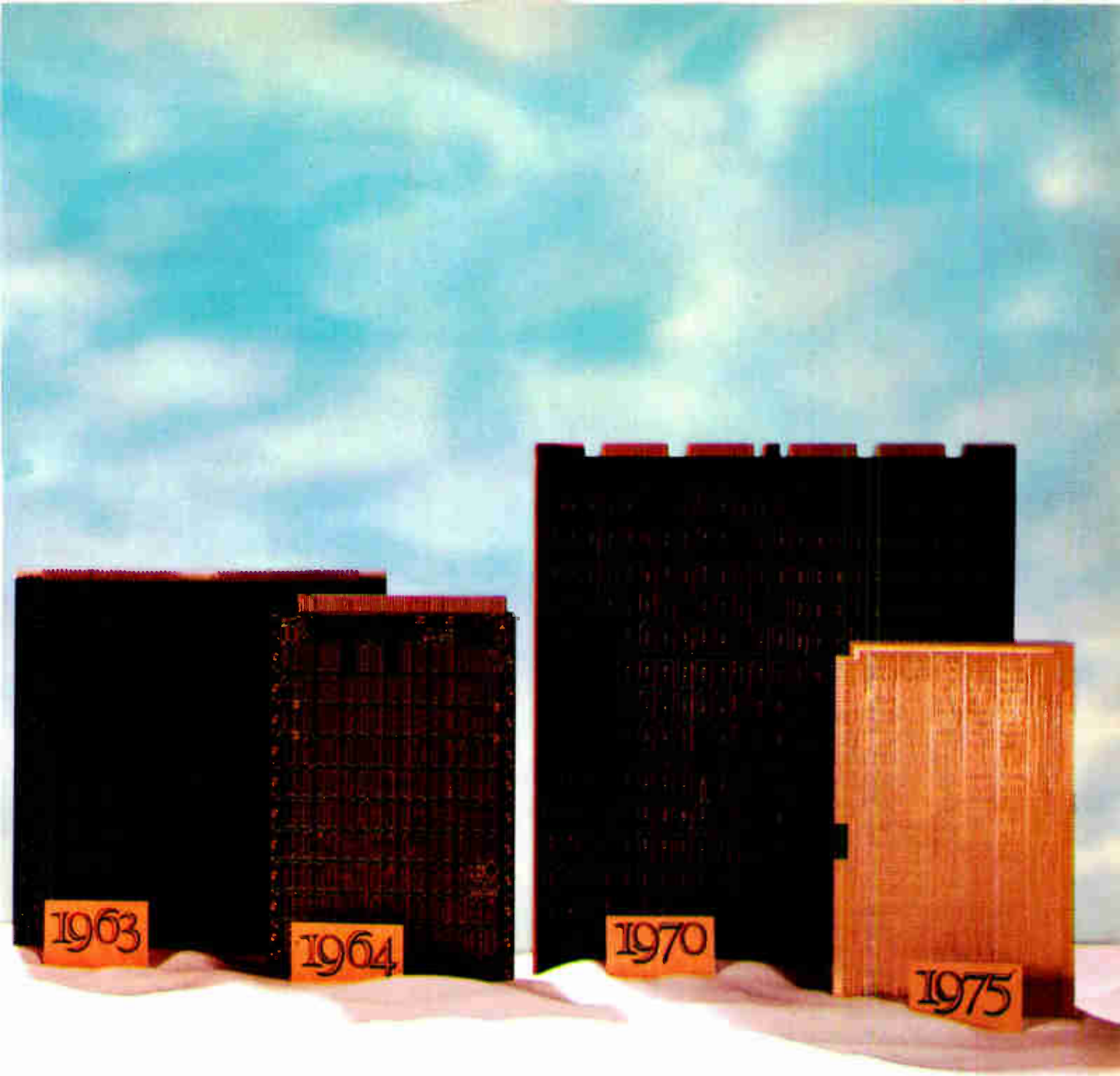

1970: Multiwire,<sup>®</sup> the computer-controlled discrete wiring machine and process which produces high density boards faster, more reliably than multilayer processes.

1975: P/F<sup>™</sup> photoformation, an additive photo-imaging process providing fine, high-density conductive patterns without use of resists.

Today, Photocircuits—with both subtractive and additive plants—is the largest independent PC board manufacturer in the world.

Our Multiwire Division and licensees manufacture in many locations.

Our printed circuit motors are manufactured on three

continents. Now offering many product lines, PMI Motors is a fast rising star in motion control.

PCK Technology makes available the complete scope of its technology to customers around the world, as it continues to play a leading role in printed circuit innovation.

As you create your own milestones, there can be no stronger ally than PCK Technology. Call us at 516-448-1201.

**PCK Technology**  
Division of Kollmorgen Corporation





**Transistorized.** To prove the viability of transistors, RCA built prototypes of all-transistor radios, a TV set with a 5-inch screen, even an amplifier for an electric ukelele. The equipment was years from commercial production, though, since transistors then cost \$15 or more.

either side of the fourth column in the periodic table of the elements—where silicon and germanium lie—could most easily produce the desired effect. Elements from the fifth column, like phosphorus and arsenic, provided an excess of electrons and thus made the material n type; those elements in the third column, including boron and indium, created an excess of holes, making the material p type. Brattain marveled at the elegant simplicity of this discovery.

In experiments, the metallurgists had grown a half-n, half-p ingot, thus creating the first pn junction. Ohl cut out a section of the ingot spanning the junction and began to experiment with it.

In early 1940 Kelly, the director of Bell's research, called Brattain and his group together to observe Ohl's experiments. Ohl was shining a light on the midsection of the silicon slab, whose ends had metal contacts and were connected to a voltmeter. As the meter deflected to a half volt, Brattain was awestruck. The reading was 10 times above any photoelectrically generated voltage he had ever seen. What's more, the light wasn't even shining on either of the metal-semiconductor junctions—it was focused somewhere in the center of the ordinary-looking black slab.

Of course, the light was illuminating a junction—the invisible pn junction in the silicon. But only after Brattain received his own piece of pn silicon to work with did he really believe what Ohl had demonstrated.

Though the stage seemed set now for the birth of the semiconductor triode, the outbreak of World War II interrupted the work of Shockley and Brattain. They were assigned to separate research groups involved in submarine-detecting radar. It was some six years before they were able to return to their work on solid-state

amplifiers. Meanwhile minimal work with silicon was carried on at the Bell center during the war years; its aim primarily was to improve detectors for radar.

As it turned out, the war had a major impact on the development of the transistor. So important was the advancement of solid-state detectors for radar to the war effort that the U. S. government sponsored a program to investigate the properties of silicon and germanium. By 1943 no fewer than 30 laboratories in universities and industry were involved in federally funded research programs, all investigating semiconductors for radar use. Outstanding among these was the one at Purdue University.

Under Karl Lark-Horovitz, the Purdue physics department began its research in 1942 almost from scratch, since its strength during the 1930s had been primarily in nuclear physics. Research focused now on germanium. In less than four years, Purdue's staff of about a dozen scientists had so completely characterized germanium that its electrical properties could be predicted from its impurity content. The ratio of the material's hole mobility to its electron mobility was determined, and diodes with reverse breakdown voltages as high as 150 v were fabricated.

Although it had made a significant contribution to the future of semiconductor electronics, Purdue University all but abandoned its solid-state studies when World War II ended. Researchers often wonder whether Purdue might otherwise have invented the transistor itself, had it continued its research.

There is little doubt that Purdue's work provided key pieces to the solid-state amplifier puzzle. After the war

1977:

CTI develops separate hybrid microcircuit Driver and Receiver for MIL-STD-1553A and MDC A3818 (Model Nos. CT2C77 and CT3078)

1978:

CTI develops first MIL-STD-1553B hybrid microcircuit Transceiver (Model No. CT3231)

1979:

CTI develops an encapsulated module Remote Terminal Unit (Model No. CT1553-1)

1980:

CTI announces the 1553 Intelligent Terminal (IT).  
Compatible with microprocessors and other terminals, CTI will custom-configure IT to your form factor requirements!

# 1553 Bus Users: This is "IT"!

Performing all functions of a MIL-STD-1553B Intelligent Terminal, CTI's new IT:

- Interfaces to a Dual Redundant MUX BUS System
- Decodes Valid Command words received over either bus.
- Subsystem Interface is compatible with latest microprocessor architectures and/or direct interface to terminal I/O Modules/Registers.
- Configured with proven Hybrid and L.S.I.

Technology used on many current programs—F-18, B-52, LAMPS, A10, P3C, F-16. CTI will manufacture "IT" with your PC card and connector configuration.

Call today for details.

**CIRCUIT  
TECHNOLOGY  
INCORPORATED**

160 Smith St., Farmingdale, N.Y. 11735  
Phone (516) 293-8636; (213) 374-7446  
TWX 512-224-6555  
England: Phone (09327) 87418



# Fiber optic connectors. Fast delivery. All you want.



Amphenol™ 906 Series single fiber connectors are available now. Available everywhere.



actual size.

Now you can get true innovation in fiber optic technology. The single fiber connector is here in the Amphenol 906 Series. And it's in stock, in quantity. Find everything you need in Amphenol 906 Series single fiber connectors. Plugs. Adapters. Receptacles. Polishing tools.

And the 906 Series gives you improved system performance and minimal insertion loss. Plus compatibility with all popular cables.

The same world-wide, off-the-shelf availability applies to Amphenol 905 Series bundle connectors and complementary products.

Ask, too, about the availability of our 801 Series multichannel connectors. With 4- and 8-channel configurations. Environmental sealing. MIL-Spec shells.

We make innovation easy to obtain. And we'll work with you to come up with even newer ideas for your special fiber optic interconnection needs.

For more information call the sales office or distributor nearest you. Or contact our Danbury, Connecticut operations. (203) 743-9272

**BUNKER  
RAMO**

## AMPHENOL NORTH AMERICA

A Division of Bunker Ramo Corporation

Amphenol North America Division Headquarters: Oak Brook, Illinois 60521

Circle 228 on reader service card

Sales Offices: Atlanta (404) 394-6298 • Boston (617) 475-7055 • Chicago (312) 986-2330 • Dallas (214) 235-8318 • Dayton (513) 294-0461  
Denver (303) 752-4114 • Greensboro (919) 292-9273 • Houston (713) 444-4096 • Indianapolis (317) 842-3245 • Kansas City (316) 737-3937  
Knoxville (615) 690-6765 • Los Angeles (213) 649-5015 • Minneapolis (612) 835-4595 • New York (516) 364-2270 • Orlando (305) 647-5504  
Philadelphia (215) 732-1427 • Phoenix (602) 265-3227 • St. Louis (314) 569-2277 • San Diego (714) 272-5451 • San Francisco (408) 732-8990  
Seattle (206) 455-2525 • Syracuse (315) 455-5786 • Washington, DC (703) 524-8700  
Canada: Montreal (514) 482-5520 • Toronto (416) 291-4401 • Vancouver (604) 278-7636 • International: Oak Brook, Illinois TELEX 206-054

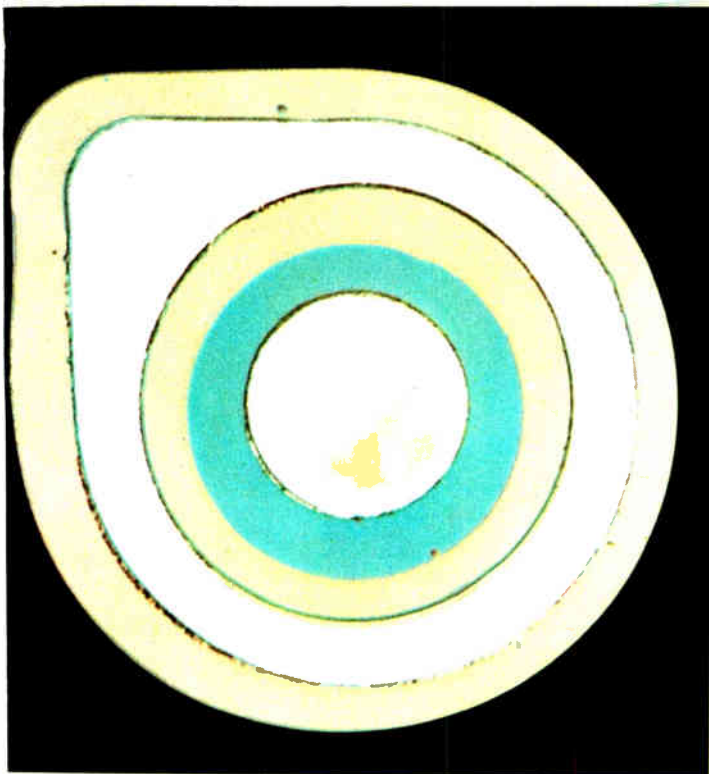

**Planar.** The transistor took on a new shape with Fairchild's planar process. So named because it was flat, the planar transistor diffused the emitter region (center) into the base region (tear shape), which itself was diffused into the collector substrate.

Bell Laboratories' research concentrated almost exclusively on germanium, whose properties now were far more clearly understood than those of silicon. But aside from this work and other studies at the International Business Machines Corp. and a handful of other companies, not many laboratories were left with a lively interest in semiconductors. The wartime research effort—except for the work on solid-state radar detectors—had turned the electronics industry predominantly back toward more applicable research in the area of vacuum tubes.

Bell knew where it was headed, however, even before the war had ended. On April 9, 1945—five months before V-J Day—a meeting on germanium crystals was held at the research center, and representatives of all Bell wartime semiconductor research laboratories were present. Three months later Bell issued its "Authorization for Work" on solid-state materials—the document that led to the establishment of the center's semiconductor group, from which the transistor emerged. The internal Bell Laboratories document, which went on for several pages, began:

"Subject: Solid State Physics—the fundamental investigation of conductors, semiconductors, dielectrics, insulators, piezoelectric and magnetic materials.

"Statement: Communication apparatus is dependent upon these materials for most of its functional properties. The research carried out under this case has as its purpose the obtaining of new knowledge that can be used in the development of completely new and improved components and apparatus elements of communication systems . . . The modern conception of the constitution of solids that has resulted indicates that there are great possibilities of producing new and useful properties by finding physical and chemical methods of controlling the

arrangement and behavior of the atoms and electrons which compose solids."

It was just a few months after this that a solid-state physics group was established at Bell Laboratories under Shockley and Stanley O. Morgan. Within the group were many subgroups, one of which—semiconductors— included Brattain and Gerald Pearson, an experimental physicist. In the fall of 1945, Brattain and Pearson were joined by John Bardeen, a physicist returning to his field after a five-year wartime assignment with the Naval Ordnance Laboratory.

Bardeen, who knew Fisk and Shockley from college days in Boston, had had no introduction to semiconductors before arriving at the Bell center. He had, however, received a doctorate in solid-state physics from Princeton and had later, like Brattain, studied quantum mechanics under John H. Van Vleck at Harvard.

Bardeen at first shared an office with Brattain and Pearson. Like the others, he was eager to immerse himself in the study of solid-state physics, having shelved his prewar interest in it while on wartime assignment. That interlude, he later maintained, actually contributed to the group's creativity and zeal.

"We were able to take advantage of the important advances made in that period in connection with the development of silicon and germanium detectors, and at the same time have a fresh look at the problems," he said in the lecture he gave upon receiving the Nobel Prize in physics in 1956.

One of the first major decisions made by the semiconductor group was to restrict research to germanium and silicon, the simplest semiconductors. The group believed that the only explanation for the continued lack of understanding of semiconductors—despite intensive worldwide research—was the diffuse experimentation on so many different complex materials. Silicon and germanium, on the other hand, were elemental, simple; moreover, their atomic structure had revealed the same strong covalent bonding as a diamond, and thus their crystals tended to be strikingly free of defects.

**I**nitial work in the semiconductor group picked up on Shockley's original field-effect concept for a triode. Based on the Mott-Schottky theory of rectification, the group reasoned, it should be possible to control the density of electrons near the surface of a semiconductor by applying an electric field between the surface and a metal electrode insulated from the surface. Nevertheless every experiment failed.

Brattain and Bardeen set out to explain these failures. The lead they had followed stemmed from Schottky's field-effect theory, which stated that the number of free electrons in a semiconductor was the same at the surface as in the interior. In fact, Brattain discovered that Schottky's theory did not hold up. He learned this by comparing the rectifying properties of different metal contacts to a semiconductor. Bardeen then proposed a hypothesis that evolved into one of his most important contributions to electronics: the theory of surface states.

Bardeen theorized that a semiconductor surface must



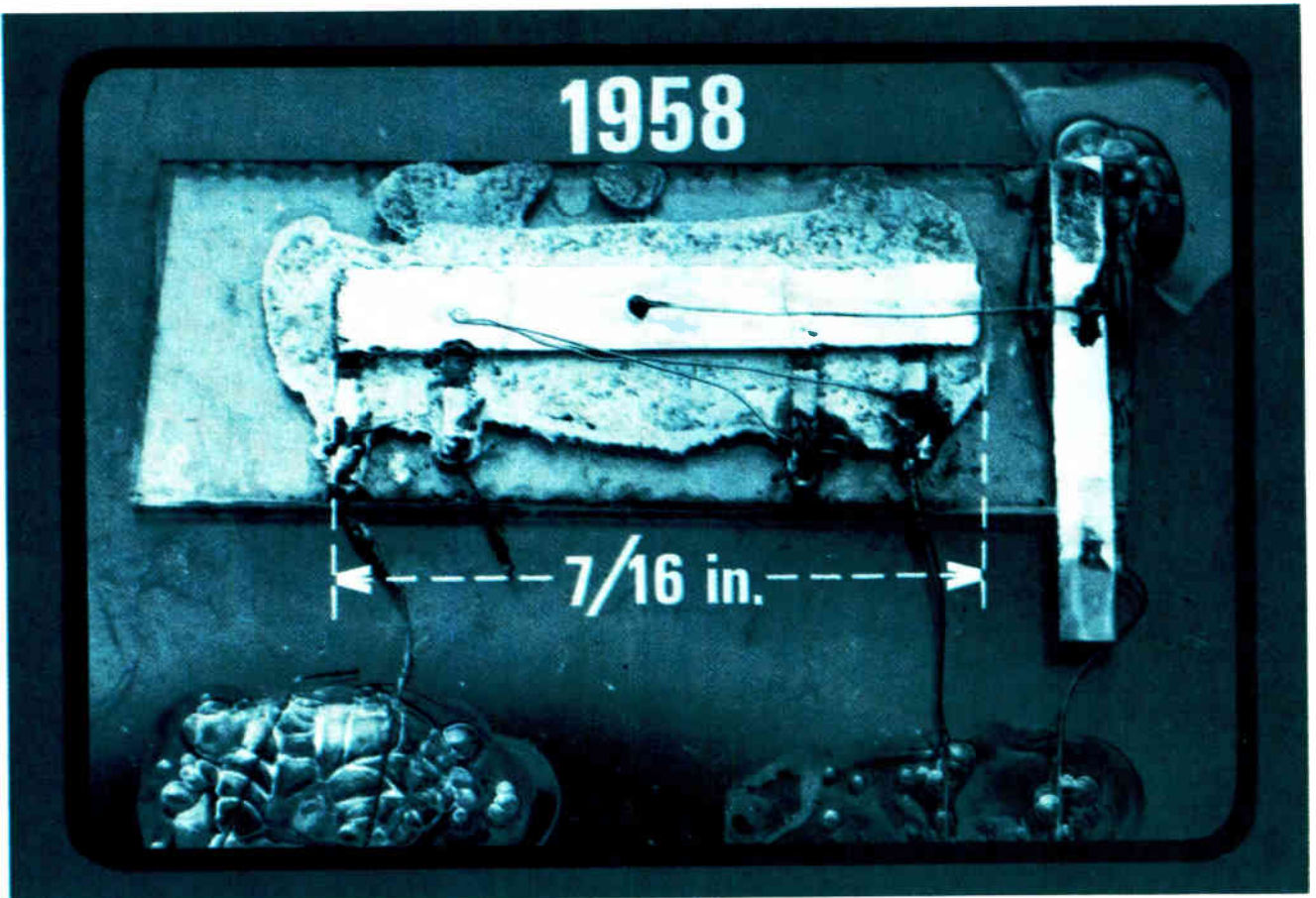

**First integrated circuit.** The first IC, developed at Texas Instruments Inc., proved an entire circuit could be built with silicon. The bars, actually sections from a wafer of mesa transistors, became breadboards in this oscillator using silicon as resistors, capacitors, and transistors.

be in equilibrium even before any electrical contact is made to it. For that to be so, any electrons trapped at the surface must be neutralized by a space charge region equal and opposite to the electrons' charge at the surface. This would explain why Schottky rectification took place with little bearing on the type of contact metal used: it was the electrostatic potential change between the interior of the semiconductor and its surface that did the rectifying.

With this new theory, Brattain and Bardeen undertook a series of experiments to gain a better understanding of surface states. One experiment, which was suggested by Shockley, was to determine if the trapping centers for electrons at the surface were limited. The test involved comparing the contact potentials of semiconductor samples that differed in resistivity. The results were positive: the points where electrons were trapped were fixed in number.

Another experiment verified the existence of the electric field caused by the space-charge region. Carriers generated by illumination of the junction were apparently swept apart by that field, since a significant change in contact potential was measured.

The time was mid-December 1947, and though the bustle of Christmas had begun, the pace of experimentation at Bell quickened. Pearson and Bardeen proved by lowering the temperature of the semiconductor that electrons trapped at the surface could be frozen and their

field effect detected. A follow-up attempt to measure the change in surface potential of germanium with temperature proved inconclusive; condensation interfered.

As a possible solution, it was suggested that entire apparatus—a semiconductor chunk with the contacts, reference electrodes, and wires used to measure contact potentials and photoelectric voltages—be immersed in an insulating liquid or an electrolyte. Varying the potential between the semiconductor surface and the reference electrode proved to change the photoelectrically generated voltage significantly. The group realized that it had found Shockley's field effect.

The week before Christmas an adaptation of that last experiment actually produced an amplifying triode. A potential applied between a drop of water surrounding a metal contact to silicon and the silicon slab itself could regulate current flowing from the semiconductor to the contact. Other liquids—electrolytes—gave even better results, but the group knew that the amplifier they were seeking could not use liquids. Attempts were made to use an evaporated gold film surrounding the point, but because of the tiny dimensions, a low-voltage arc destroyed the point contact.

Four days later, on Dec. 23, 1947, the group saw its greatest triumph. Bardeen and Brattain had decided that the thing to do was to get two contacts extremely close together on the surface of the semiconductor. By their calculations, the distance had to be no greater than 2

# sepa automation

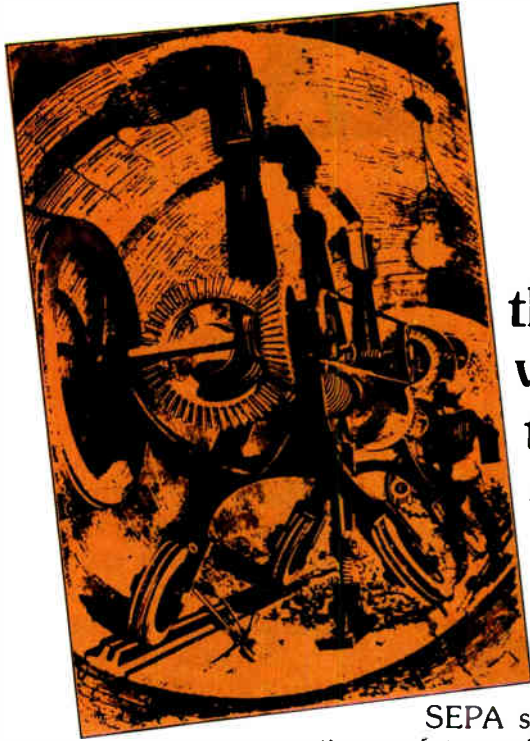

the maturity that comes  
with experience,  
the strictness that  
science demands,  
the flair that comes from ideas.

Experience, science, ideas -  
words that have become  
woven into the texture of

SEPA since it first laid the founda-  
tions of its independence in the fields of  
hardware, software and systems engineering  
over twenty years ago.

Today, SEPA designs, builds, installs and  
services systems renowned for their maxi-  
mum reliability.

The name SEPA, in fact, has come to stand  
for start-to-finish automation. And for intelli-  
gent, versatile automation as well.

This is clear in all our achievements in a wide  
range of activities: industrial automation and  
instrumentation, the automation of services  
and utilities, marine automation, weapon sys-  
tems, and the automation of power sta-  
tions. You'll find it built into the next job we  
do for you - the next time you choose the ex-  
perience, science and  
ideas that add up to  
SEPA.

**User size electronics**

**SEPA - Società di Elettronica per l'Automazione S.p.A.**

**Lungo Stura Lazio 45 - 10156 Torino (Italy) - Tel. (011) 262.3333 (5 linee r.a.) - Telex 221527 Sepa I**



# Current index.

Bussmann's newest Small Dimension Fuse Catalog is indexed by electrical properties for easy selection. And protection.

The Bussmann Small Dimension Fuse Catalog puts component and circuit protection at your fingertips. It's the most complete listing of

small dimension fuses, indicating devices and accessories in the industry.



And since everything is indexed by electrical characteristics, it's easier than ever to select the right type of protection.

This new, condensed, full-color edition gives you time current characteristic curves, too, so you know how the product will perform.

To take the guesswork out of circuit and component protection, get our current index—the new Buss Small Dimension Fuse Catalog. Just call your Bussmann representative or your local distributor today and ask for Form SFB.

**McGraw-Edison**

**Bussmann.  
The Protection  
Experts.**

Bussmann Division  
McGraw-Edison Company  
P.O. Box 14460  
St. Louis MO 63178

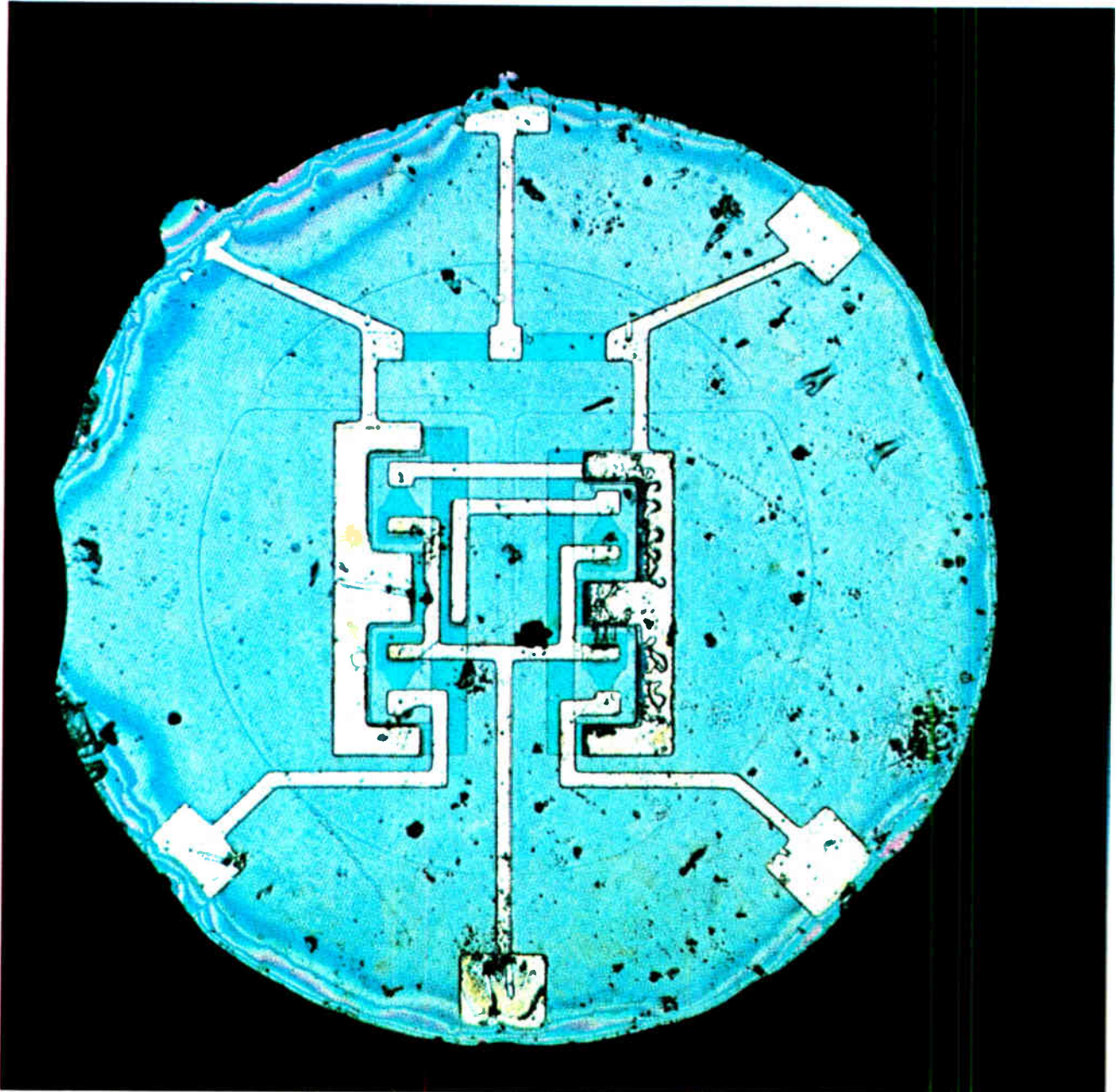

**Flip-flop.** The industry's first commercially available monolithic integrated circuit was this flip-flop from Fairchild Semiconductor, introduced in 1961. A member of the Micrologic family, the chip used resistor-transistor logic (RTL) and held four bipolar transistors and two resistors.

mils. That posed a problem, since the finest wire they had to work with was 5 mils in diameter. Brattain's ingenuity came to the rescue.

He cemented gold foil to the edge of a polystyrene triangle and sliced through the foil at the triangle's apex very carefully with a razor. The point was then set down on the semiconductor—germanium was used—and wiggled until both ends of the foil made good contact. One contact became the emitter, the other the collector, and the slab was the base.

Bardeen and Brattain had earlier discovered that a small potential on the emitter, positive with respect to the base, would inject holes into the semiconductor's surface and greatly increase its current-carrying capacity. Using that valve action, their amplifier achieved a

voltage gain of about 100 that operated clear up to the audio range.

The original circuit was even spoken over that day and used the very next day to build an oscillator, dispelling any doubts that it was truly an amplifier. The only urgent problem left was what to call the invention.

The two had in mind a term in keeping with the varistor and thermistor, but they were at a loss for a suitable word. One day the subject came up when John R. Pierce was in Brattain's office. Pierce, better known for his work in satellite communications, proposed a name that fit the device's duality with vacuum tubes. The important parameter in a tube, he reasoned, is its transconductance, or ratio of output current to input voltage; the solid-state amplifier provided gain by trans-





# LEAVES SO LITTLE TO CHANCE.

The Honeywell Model 101—it's like no other tape system you've ever used. Because no other system makes it so easy for you to get all your data—and get it right—on the first try.

## HERE'S WHY:



**Auto Test.** Initiate this automatic routine and the Model 101 tells you if it's correctly calibrated. If not, the control panel display identifies the required adjustments.



**Preamble.** This unique feature simultaneously records calibration signals on all channels. Your playback instrument can then be adjusted to match the setup of the recording system for optimum reproduction.



**Selective Track Recording.** This lets you program the tracks you wish to record. You can automatically record forward on odd-numbered tracks, for example, then in reverse on even-numbered tracks. The result is maximum use of the tape and fewer tape changes.



**Transport Sequencing.** Two or more Model 101's can be programmed to record sequentially for continuous recording with no gaps in the recorded data.

**Multipurpose Meter.** During checkout or calibration this built-in meter can measure frequency, Vdc, Vac peak, or Vac rms. During actual operation it becomes a monitor meter that gives you a real-time look at the normalized inputs or outputs.



**Built-in Calibration Equipment.** A small screwdriver is all you need to calibrate the Model 101. Since there is no external test equipment to hook up, and no test points or calibration signals to remember, calibration takes just half the usual time.

The Model 101 also offers such advanced features as an adjustment-free triplanar tape path for exceptionally gentle tape handling, microprocessor control of operation and checkout functions, wideband and intermediate-

band 3000-hour heads of solid ferrite, large reels for up to 32 hours of recording time, and up to 32 data channels in a single unit.

For more information on the Model 101, just call Darrell Peterson at (303) 771-4700. Or write for a free illustrated brochure that describes all our magnetic tape systems and other instrumentation products. Honeywell Test Instruments Division, Box 5227, Denver, CO 80217.

**WE'LL SHOW YOU A BETTER WAY.**

# Honeywell



Circle 235 on reader service card



resistance. Pierce suggested “transistor.”

It was nearly seven months more before Bell Laboratories publicly announced its transistor. The semiconductor group needed that time to understand fully what the transistor effect involved, so that they could write a paper about it and apply for a patent for it. Also, the military had to be invited in to see if it thought the transistor should be guarded as a classified invention. But a brief glimpse of the device satisfied the military that that would not be necessary, and a week later its first public demonstration was held in New York on June 30, 1948. The lukewarm reception by the public, however, made it clear that the transistor would remain a laboratory rarity until more practical versions were made and designed into equipment.

Although Shockley had not actually participated in the discovery of the point-contact transistor—the patent was issued to Bardeen and Brattain—he was the leader of the semiconductor group and certainly a key contributor to the knowledge that led to its discovery. In fact, Shockley’s face appears in all the pictures with the two coinventors, and he joined his colleagues in accepting science’s highest accolade—the Nobel Prize in physics—for research on semiconductors and the discovery of the transistor effect in 1956. But all during the experimentation that led to the first transistor, Shockley maintained his earlier belief that a simpler, perhaps better device—a field-effect transistor—was possible. His frustration was increased by his inability to obtain a patent on his ideas because of the prior work by Pohl and Lilienfeld.

Immediately following the invention of the point-contact transistor, Shockley decided to abandon his quest for a field-effect transistor temporarily and to concentrate on another idea he had for a better bipolar device. He suggested that transistor action would still take place in a structure that sandwiched an n semiconductor region between two p regions. Shockley called the structure a junction transistor, but he was unable to verify its theory of operation simply because there was no way to build it at the time.

Meanwhile the electronics industry began to buzz with interest in the transistor. Bell Laboratories had decided that the way to get better, more reliable semiconductor devices was to stimulate industry production of them, for the early point-contact transistors were hardly more dependable than cat’s whisker detectors, relying on springy wires pressed against a germanium chunk. Besides seminars and a widespread licensing program that it started, Bell waived all license fees and royalties on transistors built for use in hearing aids. This was done in honor of Alexander Graham Bell and his concern for the deaf.

But despite their promise, the first transistors were not received ecstatically by designers. Not only was their point-contact structure delicate, but the nature of their manufacture also rendered them difficult to match, inconsistent in characteristics, and quite expensive. All that characterizing a transistor meant in 1949 was figuring out its transfer resistance, usually given as a matrix of four parametric resistances. The industry had a long

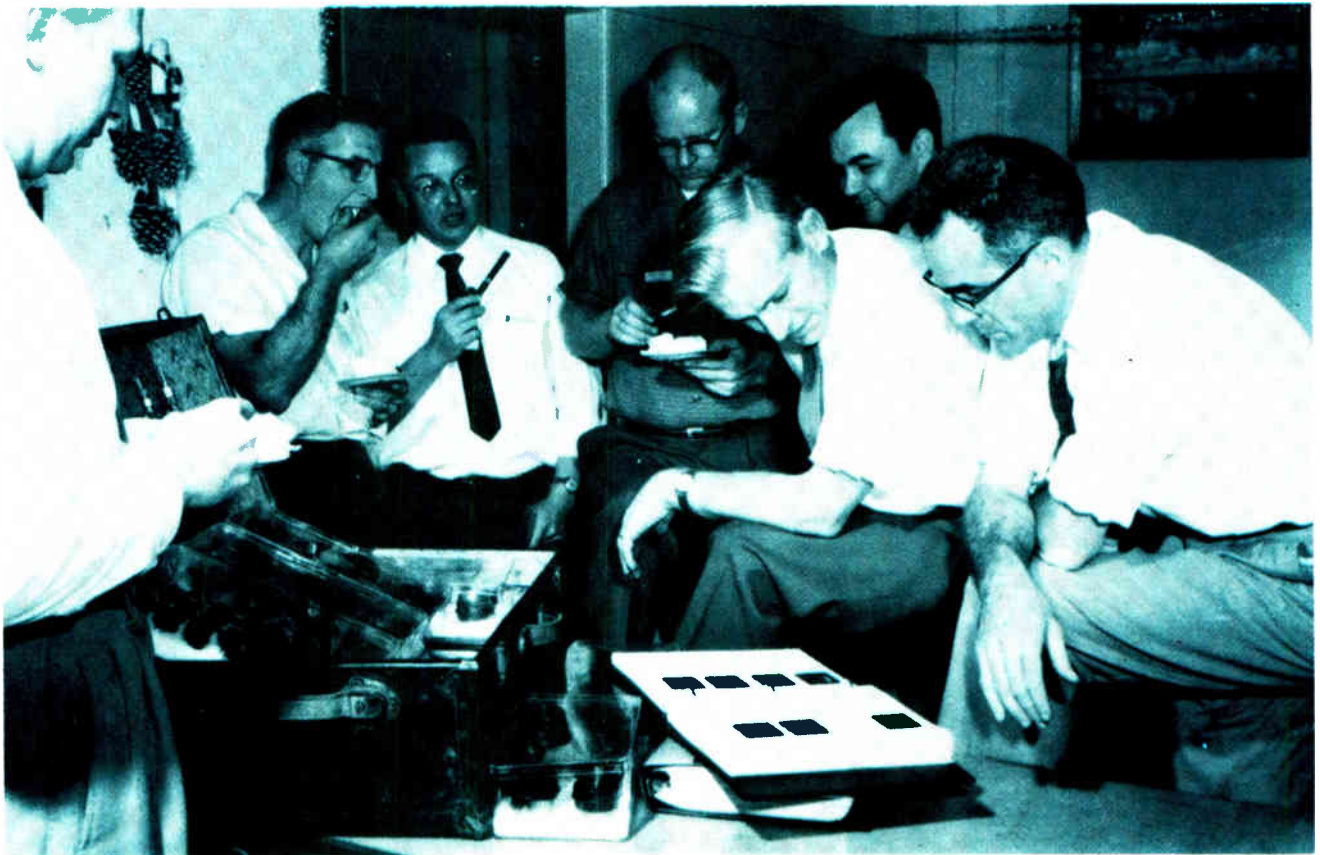

**TTL celebration.** After the development in 1961 of transistor-coupled transistor logic (TCTL)—the forerunner of TTL—members of the design team at Pacific Semiconductors Inc., a small Culver City, Calif., company, celebrated the award of the patent to James L. Buie, left.

# VICTOR... Number 1 in Impact Matrix Printing!

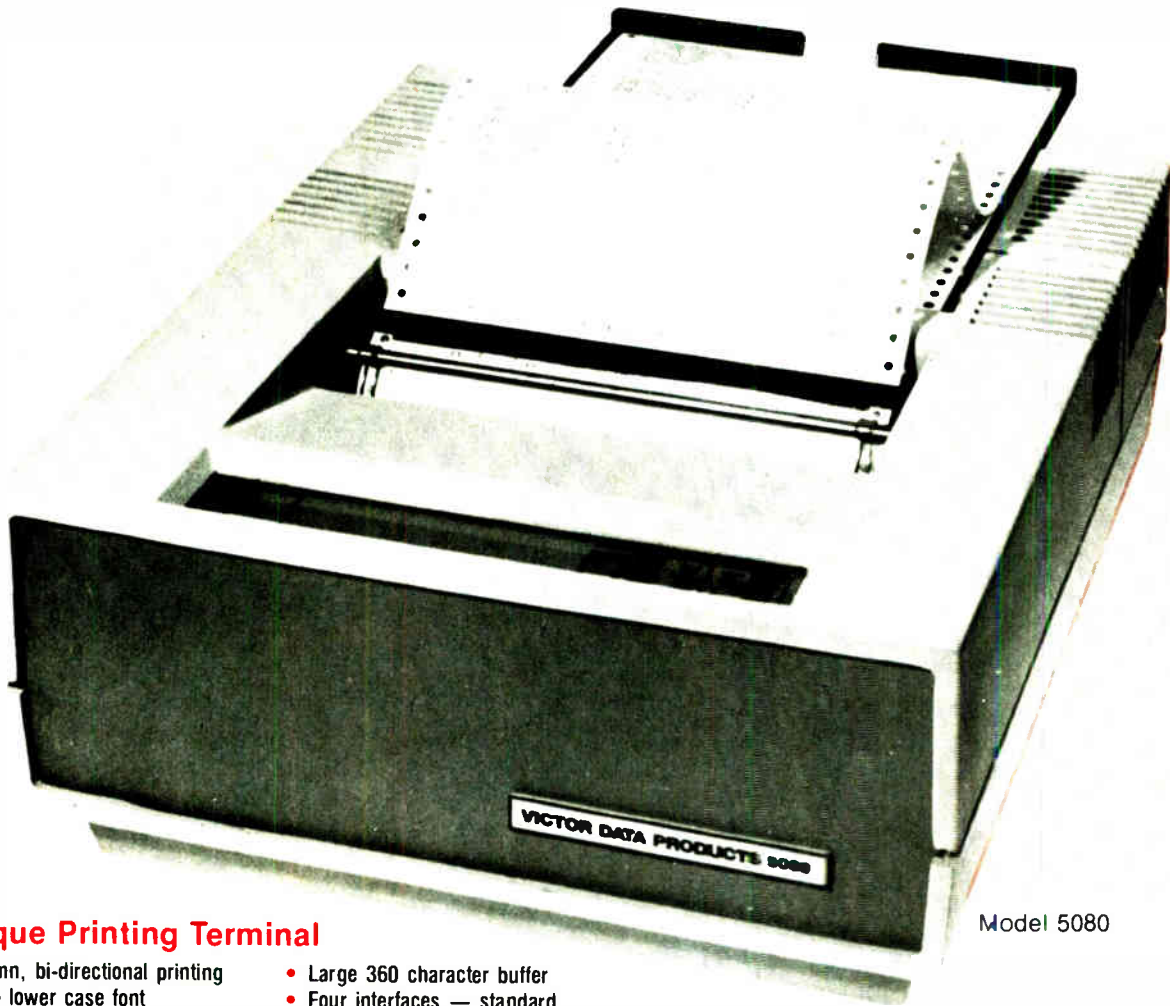

Model 5080

## A Unique Printing Terminal

- 80 column, bi-directional printing
- Upper & lower case font
- Full graphics — 480 columns per line
- Top of form & horizontal tabs
- True 100 cps throughput
- Bi-directional friction and sprocket paper feed
- Large 360 character buffer
- Four interfaces — standard parallel & RS232 & TTY & IEEE-488
- Baud rate switch selectable
- Self-test
- UL/CSA approved
- Intelligent shortest path head return

The Model 5080, shown above, is a heavy-duty printing terminal offered for sale at most competitive prices. Only \$995 in single quantity! This printer has been designed to conform to the most stringent computer specifications, including software on/off control, status feedback signals and a busy signal should you fill our extra large buffer. Don't delay, order now to insure early delivery!

Victor has delivered more than 700,000 industrial, quality matrix printers. These are terminals, mechanisms, and heads designed to solve your problems. Products that are backed by a strong application engineering staff, worldwide service and 50 years of Victor pride in product.

## VICTOR DATA PRODUCTS

Subsidiary of Walter Kidde & Company, Inc.

### KIDDE

3900 North Rockwell Street, Chicago, Illinois 60618 Telephone: 312-539-8200

GREAT BRITAIN — DATAPLUS, 0242-30030 GERMANY — BDT, (07 41) 8041 ITALY — C.A.I., 23.63.851  
 SPAIN — CETA, 254 6607 SWITZERLAND — ERNI, 01 833 33 33 CANADA — MUNRO, (416)676-1042  
 FRANCE — METROLOGIE, (1) 791 44 44 SOUTH AFRICA — EAGLE, 45-1421  
 SINGAPORE — OG, 917788 or 918592 HONG KONG — GILMAN, 3-427144

## A Complete Line of Impact Matrix Printers



Model 5010

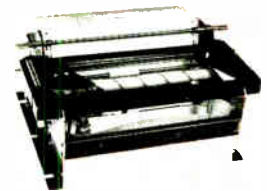

Model 80



Model 130



Model 129



# It's 50 years for "Electronics" and 25 years for Spectrol.



## Pots, Dials, Trimmers, and Switches

As "Electronics" celebrates its 50th year, Spectrol completes its 25th. Spectrol's been supplying the industry with precision potentiometers and related components since 1954. Today, the Spectrol catalog carries more than 150 pages of product illustrations and detailed specifications, covering both wirewound and non-wirewound precision and trimming potentiometers, concentric and digital turns-counting dials, and miniature rotary switches. Send for your copy of the Short Form of our new Spectrol Catalog, or, for the unabridged version, contact your local Spectrol representative.



**SPECTROL ELECTRONICS GROUP**

**UNITED STATES** Spectrol Electronics Corporation, P.O. Box 1222, City of Industry, Calif. 91748, U.S.A. • (214) 864-8280 • TWX (310) 564-1014

**UNITED KINGDOM** Spectrol Reliance Ltd., Great Wix, Swindon, Wiltshire, England • SWINDON 21381 • TELEX: 84802

**ITALY** SP Electronica SpA, Via Carlo Passadori 7, 20118 Pisa (Italy) Italy • 05 30 241 • TELEX: 330091

**GERMANY** Spectrol Electronics GmbH, Oppestrasse 7, 8000 Munich 72, West Germany • (089) 718096 • TELEX: 52/3014

Circle 238 on reader service card

way to go to standardize the specifications for these radically new devices.

The inadequacies of transistors aside, there was another reason for the reluctance of industry to adapt to solid-state electronics. Many engineers had grown up with vacuum tubes and felt a strong resentment toward the upstart transistor. It may have been billed as a replacement for the tube, but it was clearly no in-circuit replacement — its supply voltages, power capability, even its very operation as a current-gain device, required a different design philosophy that old-school engineers were reluctant to adopt.

**I**n February 1950 *Electronics* noted that “tubeless devices are already appearing on the horizon at a rapidly increasing rate, and it is already apparent that people in this business must broaden their thinking to include such devices. . . . The tendency of designers in the future will be to use tubes where only tubes can do the job, or where tubes do the job best.”

Exactly three years later the message in *Electronics* reflected a new awareness of the role of the transistor: “As we enter the age of transistors, it is important that engineers open their eyes wide to the potentialities of these new devices that are like tubes and yet are not like tubes. Circuits can be developed by thinking of transistors as substitutes for tubes. But more important circuits will come in the harnessing of characteristics that are peculiar to transistors themselves.”

Because of the premium prices at which they entered the market, transistors were slated at first for places where tubes could not fit. The military, already hotly pursuing miniaturization and virtually unconstrained by prices, bought batches of the first transistors from companies like Raytheon, General Electric, and Western Electric. But even at the market’s other extreme — consumer products, where cost is the primary concern — a demand for transistors arose. Transistorized entertainment equipment may still have been a few years off, but another consumer product picked up on the transistor from the start: hearing aids.

There, manufacturers were on a continuing campaign to reduce the size, weight, and battery requirements of the product well before transistors had come on the scene. It was a market that could absorb the premium cost of the devices, which sold in the early fifties for about \$15 each.

The first transistorized hearing aid was announced by Sonotone in February 1953. It used five transistors, but still required a pair of miniaturized tubes for the input and driver stages, since solid-state devices were still too noisy and lacking in drive capability.

While point-contact transistors were being improved, scientists at Bell were perfecting crystal-growing techniques. Gordon Teal and J. B. Little as early as the fall of 1948 had successfully produced single crystals of germanium by slowly pulling ingots from the melt. But techniques for doping the germanium accurately and uniformly eluded Teal for more than a year. Moreover, during all that time he faced opposition from other researchers at Bell, who argued that single crystals were

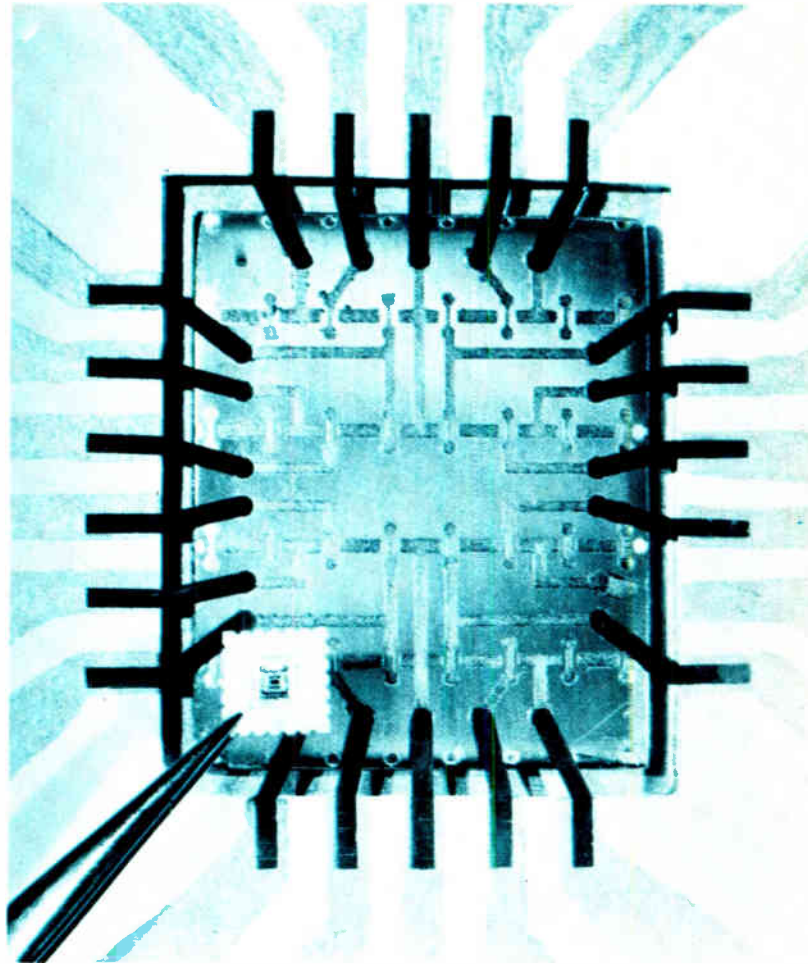

**Early MOS.** The close-up of the ceramic-packaged metal-oxide-semiconductor chip (held by tweezers) is actually a mockup, but it shows the details of the metal interconnecting 16 MOS transistors in this logic circuit from RCA. The year was 1963.

not only unaffordable for production, but also unnecessary. Teal carried on.

By 1950 he was able to adapt his crystal-pulling apparatus to accept pellets of impurity materials. This finally made possible the device that Shockley had envisioned years before: the junction transistor. By changing the impurity during the pulling of a p-type ingot to make a thin layer of n-type germanium, then reverting back to the impurity for p-type conductivity, Bell Laboratories produced a crystal that could be sliced into many pnp bars. Wires attached to each of the three regions completed the grown-junction transistor, which was far less noisy and could handle significantly more power than its point-contact predecessor.

**B**y this point, industry interest was thoroughly aroused. In March 1952 a meeting of the Institute of Radio Engineers on transistors had to be repeated to accommodate overflow crowds. That September the number of transistor licensees under Western Electric patents totaled 26 domestic and 9 foreign. Transistor technology was finally moving.

The U. S. military contributed significantly to the





advance through major contracts that boosted production volumes. In October 1952 over \$5 million in military contracts were signed with four of the major independent suppliers of semiconductor devices—Raytheon, General Electric, Sylvania, and RCA. The contracts called for weekly deliveries of over 5,000 units each of point-contact and junction transistors and germanium diodes.

By the end of 1952, point-contact transistors were oscillating at over 300 megahertz, Raytheon had announced the mass availability of junction transistors, Cornell University had introduced a course on the subject, and the devices were cropping up in equipment everywhere.

That the transistor signaled a new era of design was made clear by an RCA radio output stage. It provided 500 milliwatts to its directly coupled speaker. The circuit hooked pnp and npn transistors together in a “complementary symmetry” arrangement—for which no vacuum-tube analog existed. Demand for the new devices spurted so fast in 1952 that manufacturers began to seek ways to automate production. And major technological developments were reported outside of Bell Laboratories. General Electric developed a technique for building junction transistors by alloying indium pellets to opposite sides of a thin piece of germanium. The device was called an alloy-junction transistor, and it was later produced in volume by RCA and Raytheon.

An improvement in the alloy process came in 1953

**MOS man.** Although field-effect transistors were in production at the time, in 1963 Steven Hofstein of RCA developed a form of insulated-gate FET suitable for integrated circuits. Working with Frederic P. Heiman, Hofstein produced the circuit shown projected to his right.

when Philco developed a technique for electrolytically jet-etching the germanium thickness at the point where the indium pellets were to be alloyed. Nozzles directed a spray of indium sulphate at either side of the germanium, while the slice was held at a positive potential. An infrared sensor detected when the semiconductor had been etched to the proper degree, as low as 0.2 mil, and shut off the process. Reversing the potential on the germanium then plated indium into the depressions. Philco’s so-called surface-barrier transistor achieved the highest frequency of operation for a junction transistor—100 MHz.

A concern for transistor standards also began to emerge by 1953. Device manufacturers had to proceed cautiously in the introduction of new products for general use, because there was widespread confusion about what constituted a good transistor. Physical standards—lead spacing, package shapes, and so on—were established in early 1953. In mid-year, through the initiative of the Army Signal Corps in collaboration with the Navy, the Air Force, and representatives of leading manufacturers, standards for the operating characteristics of transistors were proposed.

All through the fifties most manufacturers of transistors were focusing their research on improving the devices and improving assembly techniques. One development came in 1953 from engineers at General Electric’s Advanced Semiconductor Laboratory in Syracuse, N. Y. While experimenting with germanium alloy tetraodes—actually double-base transistors—researchers who were trying to come up with a device that would operate at higher frequencies stumbled upon an oscillatory signal that led to the unijunction transistor. The device, which was at first called a double-base diode, exhibited a negative resistance that could be put to use in relaxation oscillator circuits.

Other device developments stemmed from fundamental semiconductor research. One was the controlled silicon rectifier, developed at GE’s rectifier engineering laboratory in 1957. It was a silicon rectifier whose forward current could be blocked under control of a gate electrode, and it had great potential as a high-power ac switch. The device, known today as the silicon controlled rectifier, or SCR, relied on a four-layer (pnpn) structure with a high impedance. It could be made to avalanche by a current injected into its internal n layer.

Another such case was the commercial development finally of the field-effect device conceived by Lilienfeld some 30 years before. In 1958 Stanislas Tetzner, a Polish scientist employed by CFTH, an affiliate of General Electric Co. in France, created the first junction field-effect transistor. Called the Tecnitron, it was a germanium alloy device without an insulated gate. It operated into the megahertz region. Crystalonics, a division of Teledyne Inc. in Cambridge, Mass., produced the first domestic commercial JFETs in 1960.

Perhaps the most classic case of pure research result-



We started with a simple  
idea design and produce electronic  
test and measurement  
equipment that provides the ultimate  
performance for the dollar. Function generators  
came first — then sweep generators, signal generators,  
pulse generators, and programmable signal sources.  
Along the way, just about everything  
in electronics has changed dramatically.  
And so have we.

Except the idea we started with.



Here's an inexpensive way to give your existing products a face lift.

Our new snap-in pushbuttons fit standard rocker switch mounting holes. And they're available now, so you can use them to enhance your panel design *without costly restamping or re-cutting of the face panel.*

These new pushbuttons are available with all the circuits, terminations and

ratings found in our standard rocker switch line. Actuators can be hot-stamped, illuminated or color-coded to meet every need.

For more information, contact your Cutler-Hammer salesman or switch distributor. Or write for our new catalog of commercial switches. Eaton Corporation, Commercial Controls Division, 4201 N. 27th St., Milwaukee, WI 53216.



## Snap our new Cutler-Hammer pushbutton into your plans. The switch is easy.

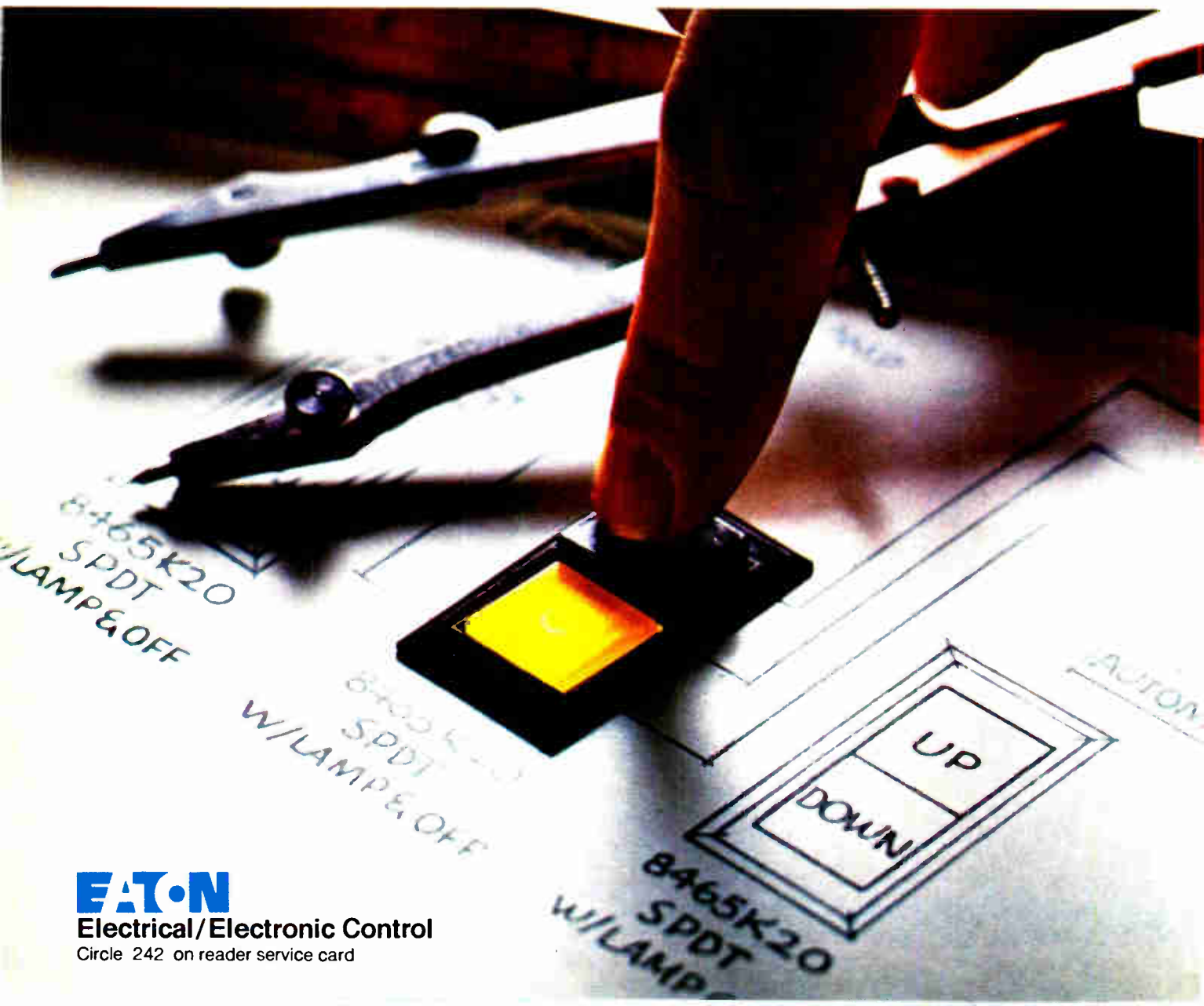

**EAT•N**

Electrical/Electronic Control

Circle 242 on reader service card

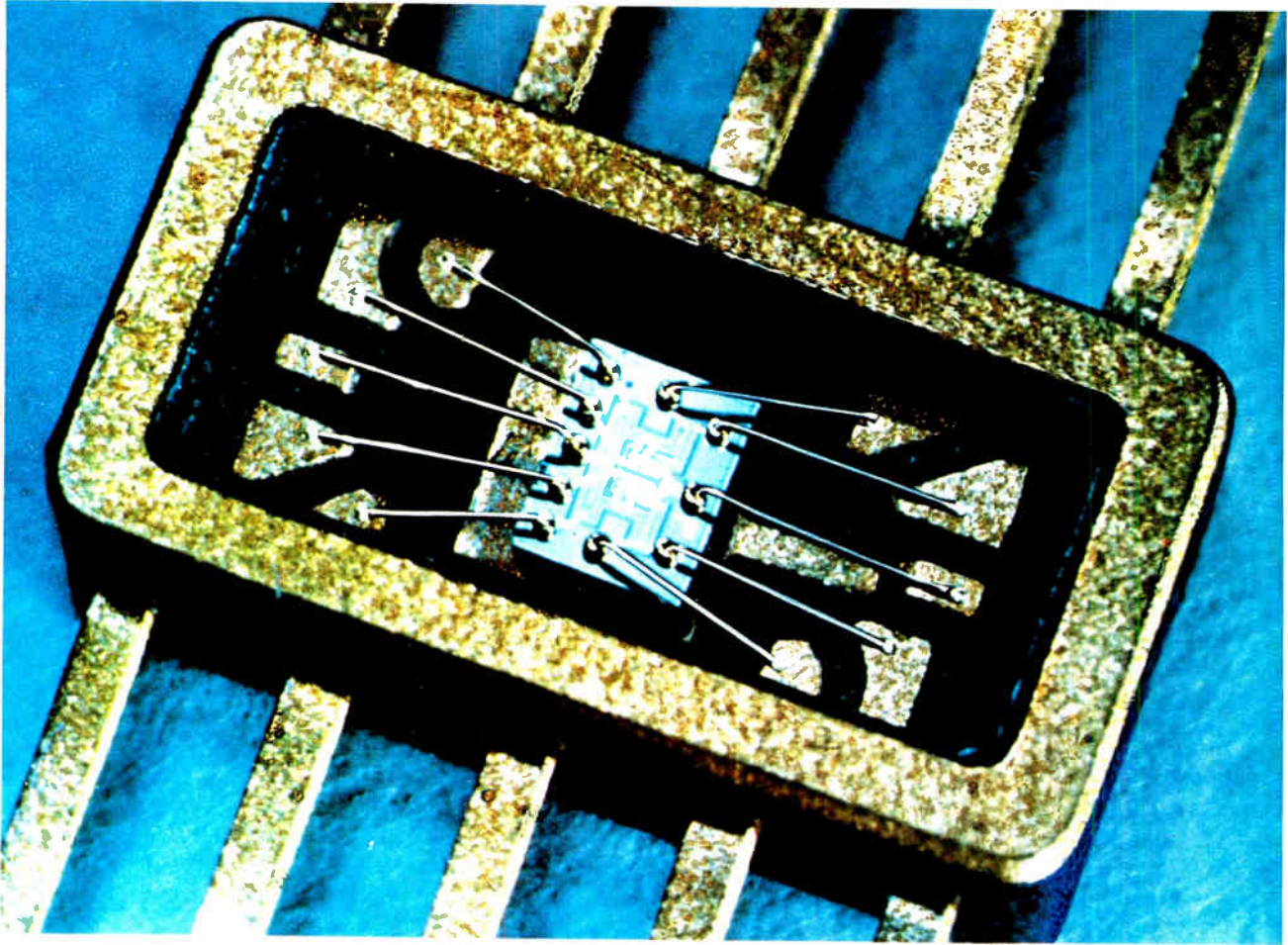

**Apollo chip.** One of the early bipolar integrated circuits, this chip—a three-input NOR gate using resistor-transistor logic (RTL)—was built by Philco-Ford for MIT Lincoln Labs. It emphasized reliability—a backup computer for an Apollo program launch was built entirely of these chips.

ing in a semiconductor device was the development of the tunnel diode. Its feasibility had been predicted in essence in 1929 by George Gamow and two others, all of whom independently suggested that because of the wave nature of matter, particles of a given potential would probably be capable of penetrating barriers of higher potential.

Then, in 1958, Leo Esaki, a Japanese scientist with the Sony Corp. in Japan, shook the semiconductor world with his development of the tunnel diode. It was so named because its operation relied on the quantum-mechanical probability of electrons tunneling through an energy barrier they could not surmount. Esaki formed an extremely abrupt junction between very highly doped p and n regions of germanium to make the depletion region of his diode very thin—on the order of a few hundred angstroms.

Application of a forward bias to such a diode increases the net tunneling current in the forward direction. Beyond a certain bias, however, fewer and fewer states for tunneling are available, and forward current decreases with increasing bias. That behavior corresponds in effect to a negative resistance, which can be put to use for high-frequency amplification, oscillation, or switching.

By mid-1959 RCA had developed experimental tunnel diodes that operated at frequencies in excess of 1 giga-

hertz, and it predicted that the devices would be used in computers for memory elements “whose operating limits were only imposed by the speed of light.” GE reported devices that switched in 100 picoseconds, and the company saw a great future for the diode. In a tribute to its importance, Esaki received a leave of absence from Sony in February 1960 to pursue research at IBM’s laboratory in Poughkeepsie, N. Y., as a resident consultant.

Then interest in the tunnel diode waned rapidly. Several reasons were cited in the early 1960s. One was that transistors had improved significantly in high-speed switching characteristics, and their prices had fallen swiftly as batch processes made tremendous volumes available. *Electronics* reported that epitaxially grown semiconductor devices had replaced tunnel diodes as the glamour product at the 1960 International Electron Devices Meeting. Ultimately its death knell was sounded by the integrated circuit, which was to become the heart of computers and computer memory—an area targeted for the Esaki diode.

Gaining in importance throughout the late fifties and early sixties were semiconductor devices whose operation extended to the uppermost frequencies—millimeter waves—and beyond to the visible-light spectrum. Most of these emerged from compound semiconductors, such as gallium arsenide and indium phosphide. As early as 1955 physicist R. Braunstein had observed infrared



# Quality is the difference between technology and technology that lasts.

Since its founding in 1957, Digital Equipment Corporation has been committed to quality as a corporate goal.

This means we design for the long run.

The result is the broadest compatible computer family in the entire industry, ranging from intelligent terminals to microcomputers to complete computer systems.

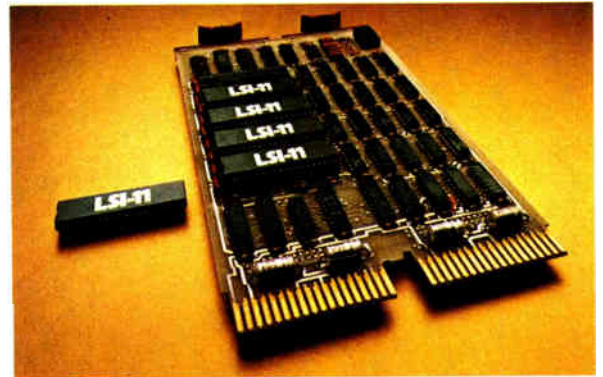

*Digital's LSI-11 microcomputers are backed by years of PDP-11 technology and software development.*



*One of the most recent applications of Digital's PDP-11 architecture: the PDT-11 intelligent terminal family.*

## **The compatible computer family.**

Digital's PDP-11 computer family represents one of the most flexible and long-lasting computer architectures ever developed. For nine years we've been

expanding the performance capability of this architecture.

Since all the PDP-11 computers are based on the same architecture, they run virtually the same software. Even across generations.

That gives you enormous flexibility as a customer. You can build on your software investment year after year, always taking advantage of the latest proven technology at constantly lower hardware costs.

Even our new 32-bit VAX-11/780 is designed to protect your software investment. It can run PDP-11 programs in compatibility mode, and offers the same Digital Command Language to make programming procedures as consistent as possible.

But lasting technology is only one part of our commitment to quality.

## **Leadership in reliability.**

Over the years, we've led the industry in designing reliability into our products. Today, service specialists are a part of every Digital design team. And during manufacture, we use the tightest quality control procedures. In fact, burn-in is a routine process for Digital's products.

## Computers that travel worldwide.

We think quality even extends to the way you market your products.

So Digital's computers are designed to go anywhere your business takes you.

They've been tested specifically for shipping and handling conditions. And many of our products include universal power supplies so they can be used in any country.

In addition, Digital's hardware and software are supported by our worldwide customer service network. Today we have more than 13,000 people working at 400 locations in 38 countries, to provide you with a wide range of high quality services. These services include remote diagnosis for larger systems from

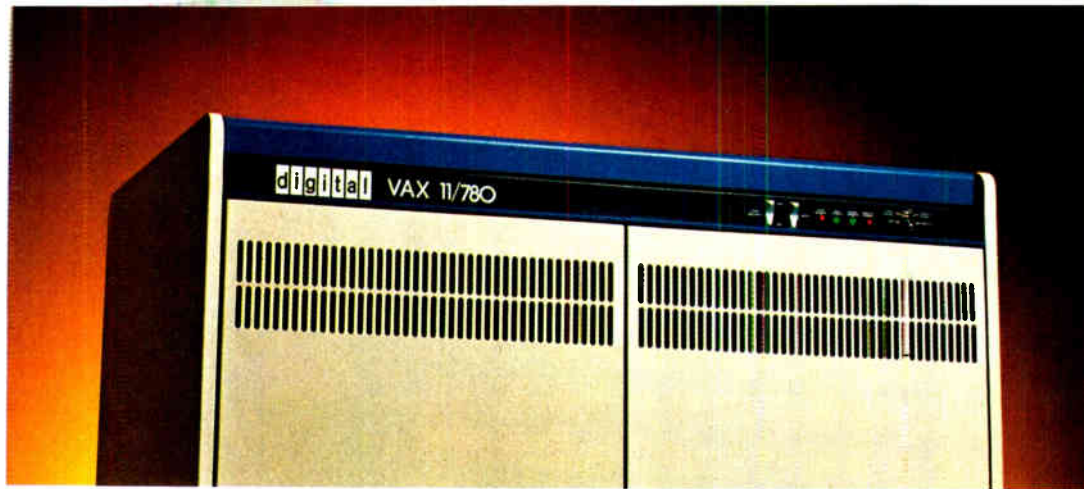

*VAX is Digital's newest architecture, designed so performance capabilities can be expanded for years to come.*

centers in the U.S. and Europe, software product services, and applications consulting.

Digital can even train you and your staff at any of 23 training centers, in 17 languages.

## Answering customer needs.

We could go on.

But the point is really simple. To design, build and support quality computers, a company has to respond to the needs of customers.

That's why we pioneered interactive computers and distributed data processing, to make computers more accessible, more affordable, and easier to use.

It's also why we've developed comprehensive software resources. Like operating systems that are optimized for specific environments. And DECnet networking software that lets you link Digital's computers into a single network.

At Digital, we've spent more than two decades striving for the highest quality computers possible.

And it's meant the difference between ordinary technology, and technology that lasts.

**Digital Equipment Corporation,**  
129 Parker Street, Maynard, Massachusetts 01742. Department PK3-2/M18. European headquarters: 12 av. des Morgines, 1213 Petit-Lancy/Geneva. In Canada: Digital Equipment of Canada, Ltd.

*Digital's wide range of service agreements reflect the corporate philosophy of responding to customer needs.*

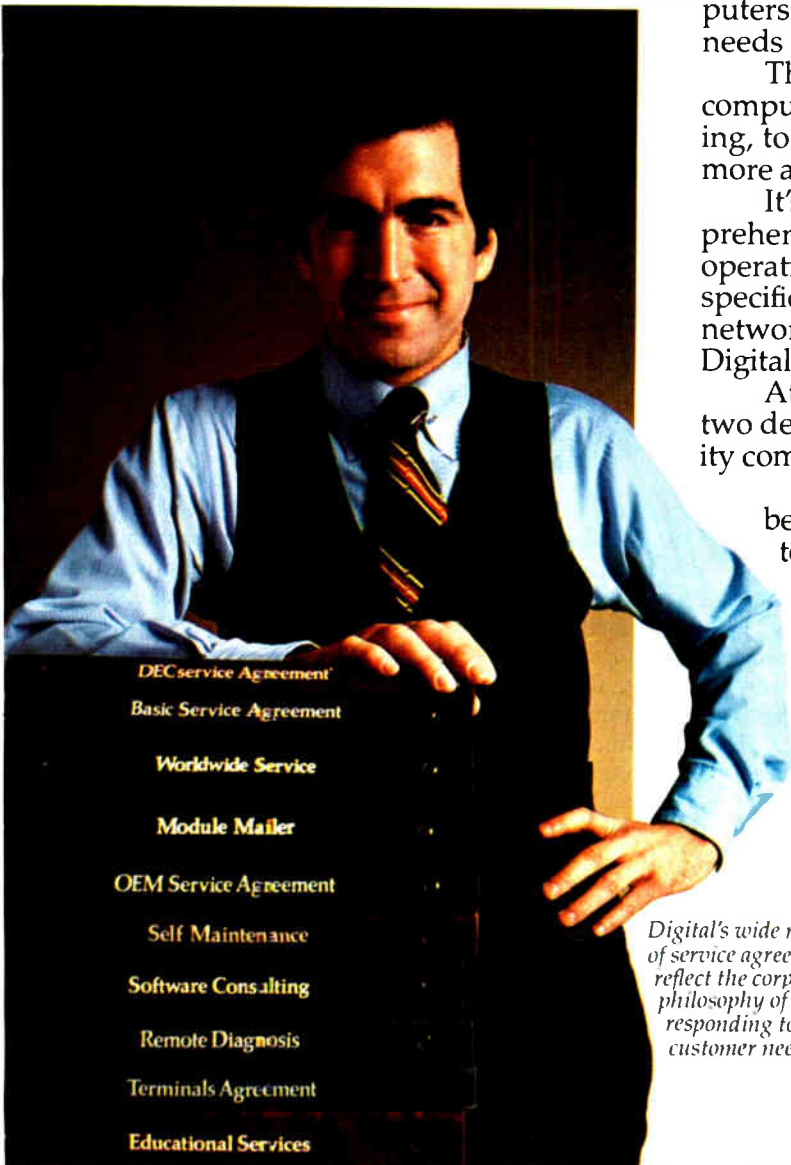

DEC Service Agreement

Basic Service Agreement

Worldwide Service

Module Mailer

OEM Service Agreement

Self Maintenance

Software Consulting

Remote Diagnosis

Terminals Agreement

Educational Services

**digital**

Circle 245 on reader service card



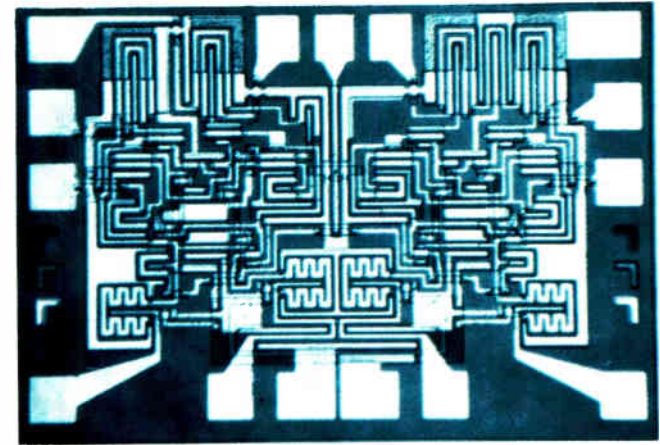
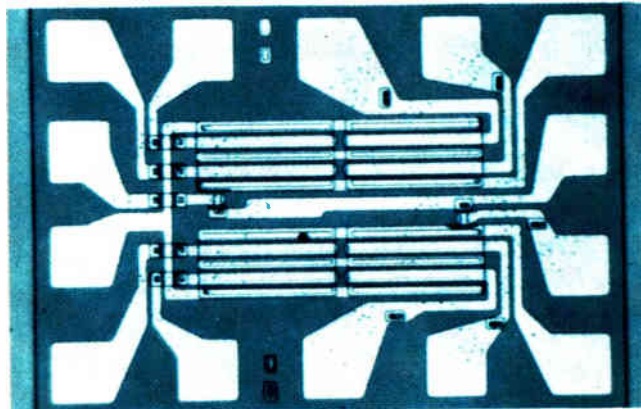
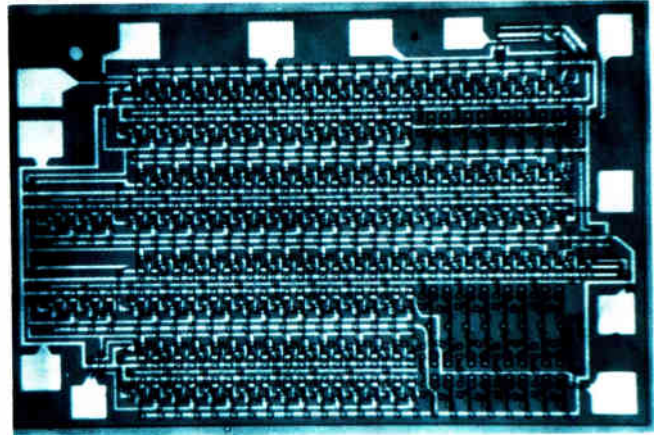
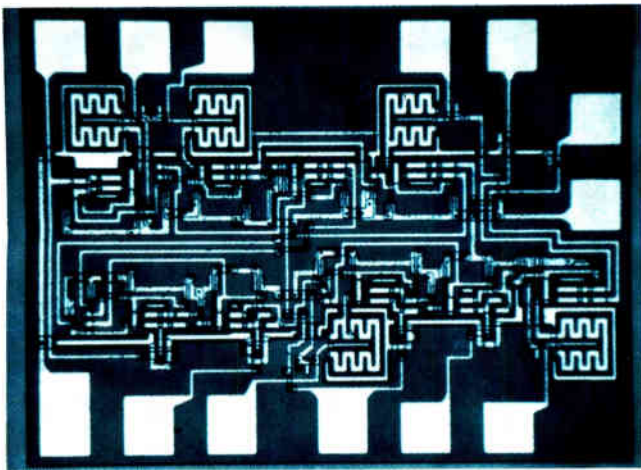

**Chip set.** Shown are four of the 29 MOS chips General Microelectronics built for the Victor Comptometer Corp. in 1964. Top left is a BCD-to-binary converter, top right a dual 20-bit shift register. Below left is a dual four-input gate, and below right a dual J-K flip-flop.

radiation produced by carrier injection in gallium antimonide, gallium arsenide, and indium phosphide semiconductors. He surmised then that the radiation was due to the direct recombination of electron-hole pairs. But it was not until 1960, when British physicists J. W. Allen and P. E. Gibbons built point-contact gallium phosphide light-emitting diodes (LEDs), that a wide spectrum of visible light was produced.

When it was discovered in 1958 that the principle of masers—microwave amplification by stimulated emission of radiation—could be applied to visible light, interest was aroused in the idea of producing laser action with semiconductor junctions. Not until 1962, however, was coherent infrared radiation observed from forward-biased gallium arsenide pn junctions at Bell Labs.

In the early sixties the microwave field also became aware of semiconductors, both for generating the signals and detecting them. This was because of developments like the Gunn diode—named after its inventor, J. B. Gunn, who in 1963 observed oscillations in compound semiconductors under an applied electric field. Another significant device was the Impatt diode—developed by two Bell scientists, R. L. Johnston and B. C. DeLoach, who coined the name for their microwave-generating impact avalanche transit time diode in 1964.

Although nearly all the early manufacturers of transistors were well-established makers of tubes—including Raytheon, Philco, General Electric, RCA, and Sylvan-

ia—that was no assurance that any company would be successful in the semiconductor business. Many newcomers, relying on perseverance and ingenuity, quickly built sales that rivaled those of the largest corporations. One company, Transitron, set up shop in an old bakery in Melrose, Mass., and by the mid-fifties grew to become the second largest manufacturer of semiconductors.

**A** classic case of a successful latecomer to the transistor business was a Dallas-based manufacturer of geophysical instrumentation apparatus: Texas Instruments Inc. After procuring its transistor manufacturing license from Bell in 1952, TI turned swiftly to production by forming a semiconductor laboratory in 1953. It was headed by Gordon Teal, who had left Bell. The TI laboratory produced point-contact transistors as well as junction transistors later that year, but it made its most significant contribution in 1954, when it announced the first transistor made of silicon.

Silicon, with its 1,420°C melting point, could build transistors that had a much wider operating temperature range than germanium—and that was of utmost importance to the military. Moreover, since the silicon grown-junction transistor could tolerate the excessive temperatures produced by large currents, it could handle more power than a germanium one. By resorting to the grown-junction technique, TI had succeeded in producing a

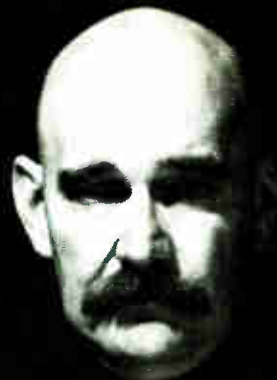

**NOW...**  
**WINCHESTER TECHNOLOGY**  
**FOR YOUR INTEL MDS**

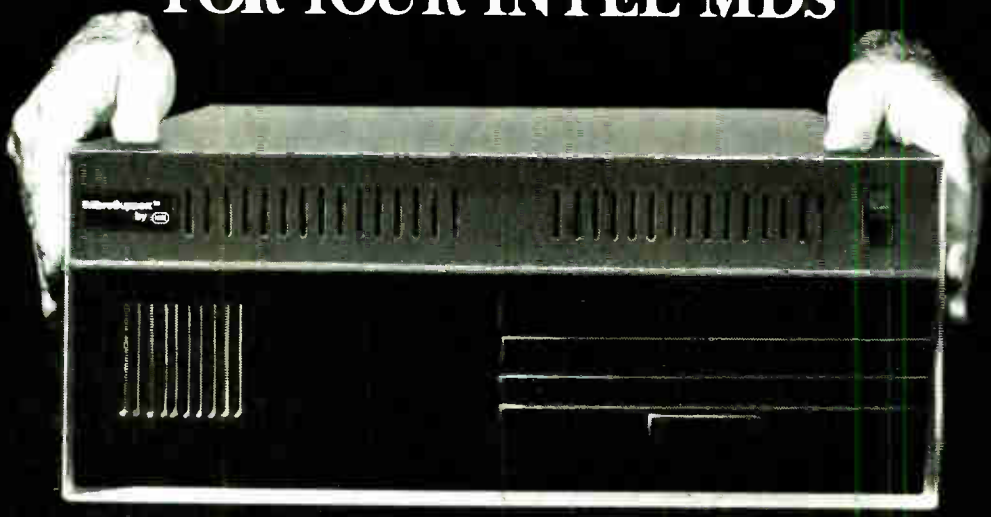

Today's more sophisticated microprocessor programs need more data storage capacity than you can get with your Intel MDS.

That's why we developed the MicroSupport™ 105 10-Megabyte Data Storage Unit.

The MicroSupport Mass Storage Unit dramatically extends the capabilities of your Intel MDS, gives you the features you've been looking for and saves you a bundle.

It combines the storage capabilities, reliability and speed of a Winchester Disk with the removability of a floppy disk.

You get 10 megabytes of hard disk storage *plus* 0.5 megabytes of floppy disk storage.

That's seven times more storage than with multiple floppies at a fraction of the cost.

The MicroSupport Winchester Disk also improves your MDS speed by responding up to 20 times faster than conventional floppies. It's even three times faster than cartridge disks.

Best of all, by using the most advanced design, the MicroSupport 105 Data Storage Unit is 50 times more reliable than a cartridge disk.

Speed . . . reliability . . . capacity . . . they're all available in a compact, economic package.

For about what you'd pay for three floppy disk systems, you can add the MicroSupport 105 10-Megabyte Data Storage Unit to extend your creativity and the usefulness of your Intel MDS.

If you want tomorrow's technology today for your Intel MDS, call or write us today.

**Advant for MicroSupport™ by E-H.**

**ADVANT**  
for  
**MicroSupport™**  
by 

Circle 247 on reader service card  
696 Trimble Road • San Jose, CA 95131 • (408) 946-9300

Send me more information on the MicroSupport Intel Add-On 10 Megabyte Data Storage Unit.

NAME \_\_\_\_\_ TITLE \_\_\_\_\_

COMPANY \_\_\_\_\_

ADDRESS \_\_\_\_\_

CITY \_\_\_\_\_ STATE \_\_\_\_\_ ZIP \_\_\_\_\_

PHONE ( \_\_\_\_\_ ) \_\_\_\_\_

MicroSupport is a Trademark of E-H International. MicroSupport products are marketed worldwide by Advant Corporation.



# HAPPY BIRTHDAY. THANKS FOR YOUR PRESENCE.

For 50 years, you've been bringing us the electronics industry's news. Sometimes good. Sometimes bad. But always useful. So we got together to say congratulations. And to thank you for being around.

The individual members of the ITT Components Group North America have served this industry for a long time now. Introducing new technologies and new solutions to answer industry needs.

To tell your readers about some of them, we've placed individual ads in this issue. So check the Advertiser's Index for page numbers. And, again, thanks for your presence.

## Electronics

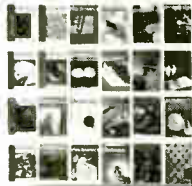

COMPONENTS GROUP **ITT**  
NORTH AMERICA

The Electronics Industry  
has been connecting  
with us since 1915.  
**CANNON ITT**

Since 1966,  
Canada's Source for all  
Component Needs.  
**COMPONENTS  
TORONTO ITT**

Providing vacuum products  
for communications  
since 1942.  
**JENNINGS ITT**

THE INDUSTRY HAS BEEN  
SWITCHING WITH US  
SINCE 1946.  
**Schadow ITT**

PROVIDING SPECIAL  
PURPOSE TUBES TO THE  
INDUSTRY SINCE 1921.  
ELECTRON  
TUBE DIVISION **ITT**

The first name in  
Capacitors and Relays  
Since 1968.  
**Components ITT**

The industry has been  
entering data with our  
keyboards since 1970.  
**Datanetics ITT**



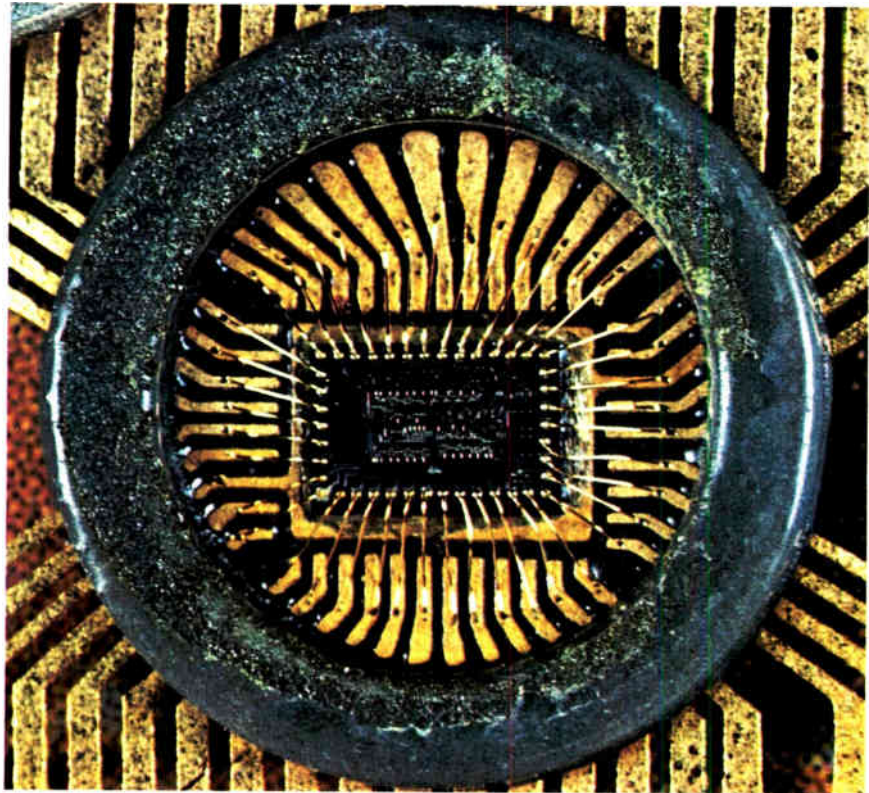

**Round flatpack.** The MOS integrated circuit's capacity for denser ICs than bipolar devices brought about this packaging scheme in 1965. The chip, a custom circuit for the military, integrated 968 components in the 44-pin package.

silicon device of good quality when many engineers in industry thought that its fabrication lay years beyond the then current techniques.

TI's hastening of the silicon transistor into production gave it a three-year jump in that market segment. And it proved that in the exciting new semiconductor industry nearly any energetic company could overpower the established manufacturers and secure a market niche in a surprisingly short time.

With production processes that were not just different from conventional manufacturing techniques but in many respects bordered on alchemy, semiconductor makers sought the brilliant young physicists and other scientists needed to advance the state of the art. This soon created a rash of job-hopping. Some scientists who had trained in large, established companies abandoned them for more exciting, even risky, opportunities. Among them was William Shockley, who left Bell Telephone Laboratories in 1954 to start his own company. His co-inventors Bardeen and Brattain stayed on with Bell Laboratories to continue basic research—Bardeen became the recipient of a second Nobel Prize for his work on superconductors.

It was mainly the reputation of its founder that enabled the Shockley Semiconductor Laboratory to attract some of the best talent in the industry to Palo Alto, Calif. Though the enterprise lacked business direction and ultimately faltered, it was the seed from which the entire Santa Clara area semiconductor industry—Silicon Valley—sprang, for Shockley excelled in picking able young men whose leadership qualities would be proved in later endeavors.

After approaching several potential backers—including Raytheon and even the Rockefellers—Shockley suc-

ceeded in setting up his company as a subsidiary of Beckman Instruments. The next step was to staff it, and Shockley did so with, among others, Eugene Kliner, Jay Last, Victor Grinich, Jean Hoerni, Sheldon Roberts, Julius Blank, Gordon E. Moore, and Robert N. Noyce. Those eight—all in their twenties, all from established electronics companies in the East, and all noted in their professions—were to abandon Shockley later to found Fairchild Semiconductor and make semiconductors their own way.

It came as no surprise to knowledgeable observers in the industry that the eight became disgruntled and left after only two years, for they were never certain under Shockley's leadership just what their business was. Although Shockley Semiconductor was a manufacturing concern, its atmosphere was more that of a laboratory at a university. Shockley was good at generating innovative ideas, they said, but unable to focus on a product line. He eventually sought to develop a new device, a four-layer avalanche diode, but by that time many at the company had made up their minds to leave. Once they did—in 1957—Shockley's company lost its lifeblood. In 1958 he changed its name to Shockley Transistor Laboratories, to emphasize manufacturing, but in 1959 the company was bought by Clevite, which itself was bought by ITT in 1965. ITT closed the Palo Alto plant in 1969.

The "traitorous eight"—as Shockley came to call them—had managed to get in touch with John Carter, then president of the Fairchild Camera and Instrument Corp. He agreed to finance them as a separate venture, but reserved an option to buy the operation in two years. With funds secure, the eight men—plus Murray Siegel, an electrical engineer who had journeyed cross-country to Shockley but joined the new outfit instead—set up



their facilities in Palo Alto. By mid-September 1957 they had their work cut out for them. Siegel took responsibility for the applications laboratory with Grinich, also an electrical engineer, who would define and specify device characteristics. Roberts had the job of growing silicon crystals. Noyce and Last were in charge of the photoetching techniques. Moore and Hoerni contributed the diffusion expertise. Kliner was the administrator, responsible for running the business side of the new company.

Fairchild's first product was one that it thought Shockley should have focused on: the diffused-base transistor, based on the mesa process. Fairchild could not have made a better choice; the transistor-building process that was to have the most far-reaching implications was based on diffusion.

Diffusion offered the immediate advantage over earlier transistor-making processes of tremendous control over the thickness of the base region: because the impurities entered the semiconductor to a depth accurately predictable from temperature, vapor pressure, and time, base thickness could be controlled some 10 times more accurately than with previous methods. Another advantage, not so immediately apparent, was that diffusion lent itself to batch processing of transistors.

The first device built by diffusion was the mesa tran-

sistor, named for the flat-topped mountain its cross section suggested. The mesa could operate at higher frequencies than earlier devices—some of the first mesas reached the gigahertz level—and it was more rugged and better able to dissipate heat because of its structure. The device first made its appearance in 1958, and by 1959 it seemed to be the last word in transistors. It was then, however, that Fairchild Semiconductor made its mark in the transistor industry with the planar process.

Though it still relied on diffusion and masking steps, the planar process made several improvements on the mesa process. The mesa transistor was in production at the time and selling well, but it was relatively fragile and still subject to surface contamination. In focusing on the latter drawback, Fairchild intended to figure out a way to passivate the transistor. Silicon dioxide, which had become the conventional mask in the diffusion process, would not serve as a passivator because certain impurities would in time diffuse through it to the junction below and cause failure. This Bell Laboratories knew well. It was Fairchild's Hoerni, a physicist with two doctorates, who discovered that doping the oxide with impurities would render it an effective passivator.

Passivation of the semiconductor surface was just one advantage of the planar process. Leaving the oxide covering the transistor strengthened the delicate junctions;

**Laser diode.** In announcing this laser diode chip (dwarfed by the grain of salt at the right), Bell Labs promised that phone conversations would be carried over a beam of light. The gallium arsenide device was developed after the solid-state maser in the late sixties.

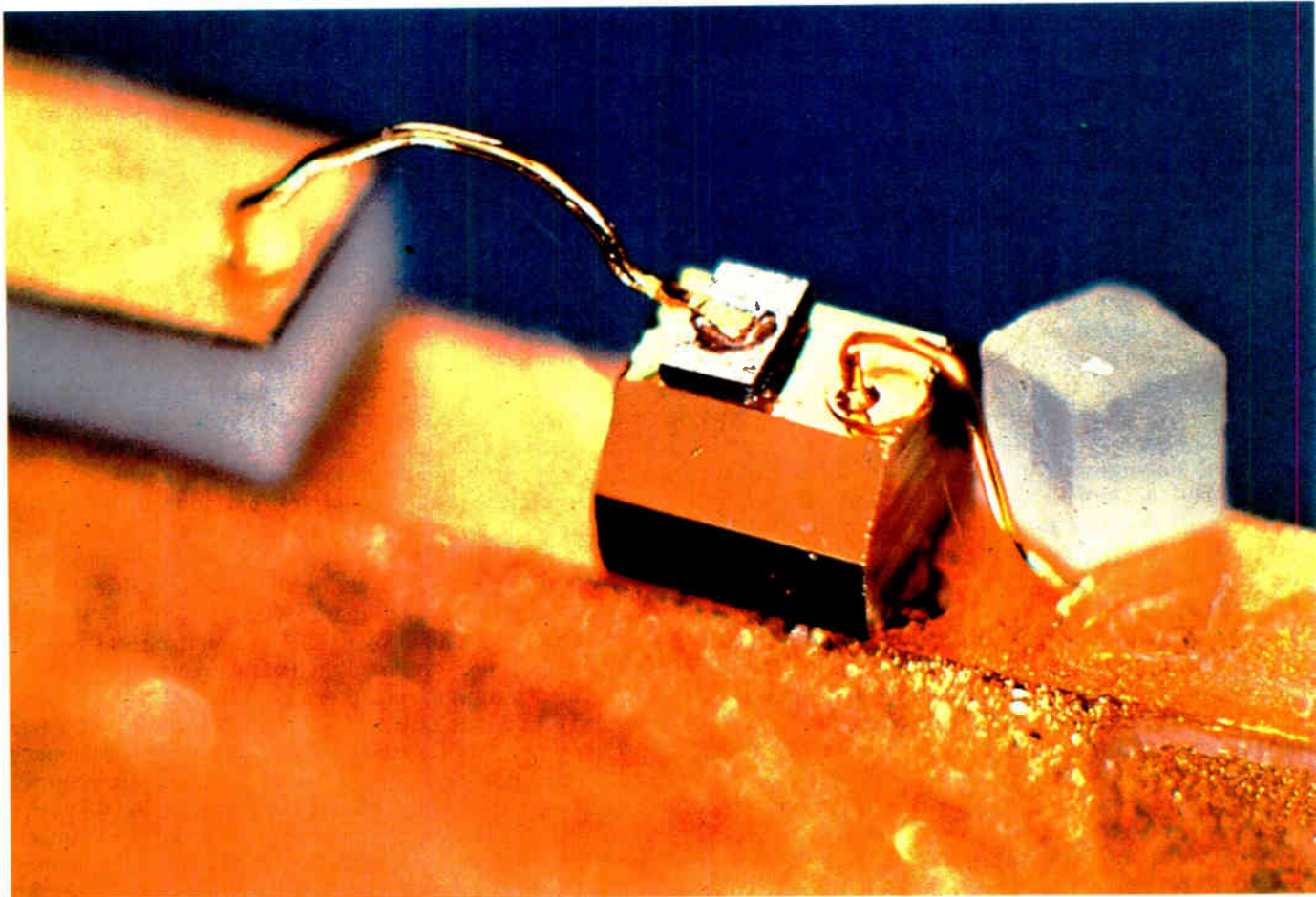

now a less brittle, more reliable device was possible. But Hoerni's process had another significant advantage: as its name implies, the planar process was flat. Rather than mounting the base layer on top of the collector substrate, Hoerni diffused it down into the collector. That not only made the structure less delicate, but also allowed interconnection to the transistor's three regions to be made by metal lines evaporated onto the oxide—rather than by painstakingly hand-attached wires.

Fairchild's new process moved to commercial production in less than a year, though it was not announced until 1960 and the secret of its workings was not revealed for several years. Hugely successful from the start, the planar process nevertheless had a drawback: the inability to produce power transistors, because of the high resistance of the collector material. But that problem was soon to be overcome.

In June 1960 Bell Telephone Laboratories announced a new, epitaxial method of fabricating transistors—the growing of a thin silicon layer on a single-crystal substrate. Since the resistivity of the layer could differ from that of the substrate, the process allowed the formation of transistors within the epitaxial layer whose characteristics were independent of the substrate material. That meant that transistors with a thin base (high frequency) and low collector resistivity (high power) could be built on a strong, thick substrate.

Though not unique to the semiconductor industry, one concept that was to become almost a cliché was the

learning curve. That an increase in production volume—and hence manufacturing experience with a product—could lower its cost was well known. Not only had components like resistors, capacitors, and vacuum tubes slid down the cost curve, but products in other industries routinely also did so. However, in no business was the curve so steep as in the semiconductor industry.

While all these advances seemed by mid-1960 to forecast an unending boom in the semiconductor business, rapidly escalating production saturated the market—not because applications were lacking, but simply because buyers were unable to use the devices as fast as they were being turned out.

The assembly of electronic equipment was a laborious, time-consuming process, slowed even further by the increasing complexity of the circuits. The sheer numbers of switching devices in digital equipment—computers in particular—had risen astronomically. Control Data Corp.'s CD 1604 computer, introduced in 1960, for example, comprised some 100,000 diodes and 25,000 transistors. The demand for the functions existed, but not the means to speed building the end equipment.

The stage was set for a new technology, one that could accommodate the increasing complexity of circuits by eliminating the interconnections of discrete parts. The integrated circuit was bound to be invented.

**S**o pressing was the need for fabricating entire circuits in a single semiconductor block that had neither Jack Kilby nor Robert Noyce conceived of the integrated circuit in 1959, someone else surely would have. The mesa and the planar transistor had both lent themselves to batch processing, in which many transistors on a single wafer are diffused and etched at once. Doubtless more than one researcher had thought it senseless to cut them apart to be packaged, only to be reconnected later into a circuit. But the means for single fabrication had escaped the thinkers of the late fifties.

One scientist with an eye on the future, however, had proposed the integrated-circuit concept first in 1952, long before any batch processing of semiconductors even existed. Geoffrey William Arnold Dummer of Britain's Royal Radar Establishment at Malvern was delivering a paper on the reliability of radar components at the annual Electronic Components Conference in Washington, D. C. His statement, remembered only after the development of the IC, was incredibly prophetic:

“With the advent of the transistor and the work in semiconductors generally, it seems now possible to envisage electronic equipment in a solid block with no connecting wires. The block may consist of layers of insulating, conducting, rectifying and amplifying materials, the electrical functions being connected directly by cutting out areas of the various layers.”

The two men independently credited with the inven-

**Cleanliness.** As semiconductor processing advanced, the clean room had to become cleaner still to prevent the occurrence of defects caused by dust. Class 100 became the byword—air with less than 100 parts per million of contaminants.

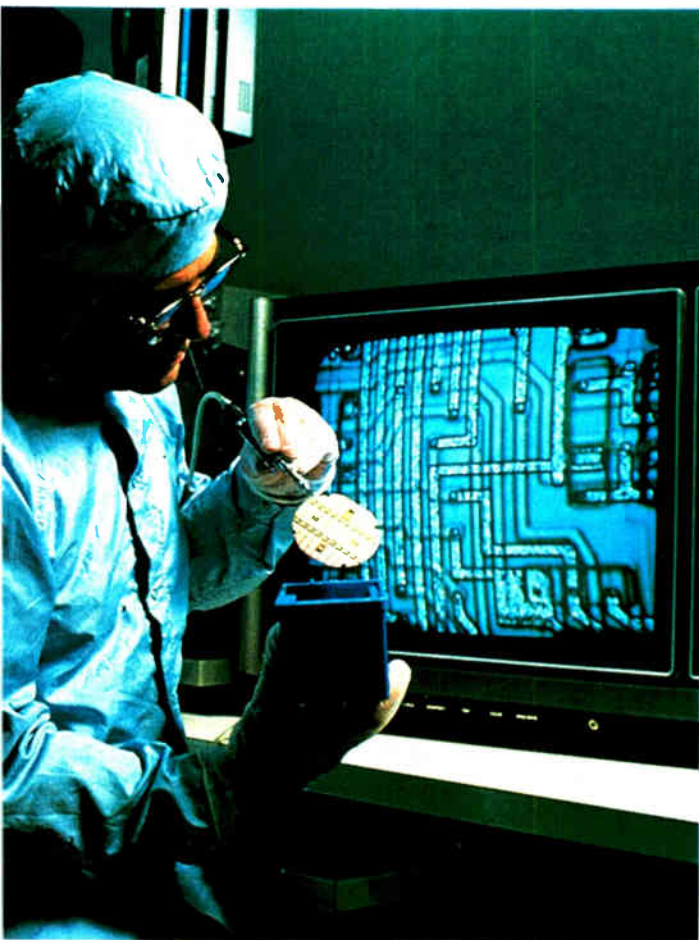



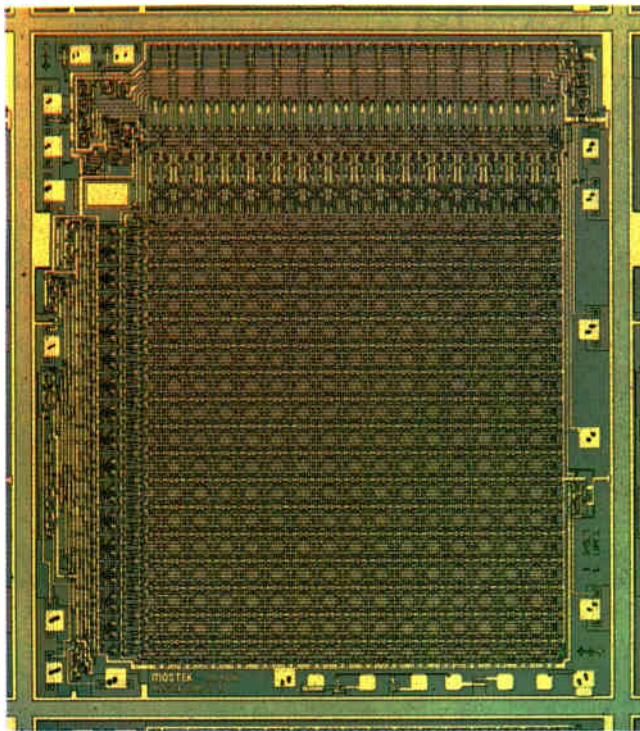

**Implanted.** One of MOS processing's greatest shots in the arm came with ion implantation, which was used first by Mostek in the production of this 1-K p-channel random-access memory, the MK4006. Doping the silicon by injecting ions allowed TTL compatibility.

tion of the integrated circuit, however, had neither heard Dummer's words nor even knew of him when their thinking began. They were simply scientists—Kirby at Texas Instruments and Noyce at Fairchild Semiconductor—who took the time to puzzle out a solution to a major problem in their industry: the skyrocketing costs of interconnecting discrete components into increasingly complex circuits.

Jack St. Clair Kilby had started his electronics career in 1947 as an engineer with Globe-Union's Centralab division, a radio parts manufacturer in Milwaukee. An extremely inventive man, Kilby was fascinated by Bell Telephone Laboratories' transistor and became hooked on transistor electronics when he attended the symposium Bell Labs gave in 1952 to its licensees, one of which was Centralab.

Kilby was put in charge of Centralab's hearing-aid development program, for which the company set up a small germanium transistor production facility. He was primarily responsible for the company's first tiny transistorized hearing aid, a project he oversaw until 1958. All during that time, however, Kilby's interest in the transistor grew more intense. He was frustrated because Centralab lacked the resources for semiconductor development, and he made up his mind to move on.

In May 1958 Kilby joined TI. His duties at first were not entirely clear, since he was to be working in the general area of microminiaturization. TI was at the time becoming involved with the Signal Corps' micromodule program, and Kilby felt that if he were to come up with a better circuit concept, he could avoid assignment to a micromodule proposal.

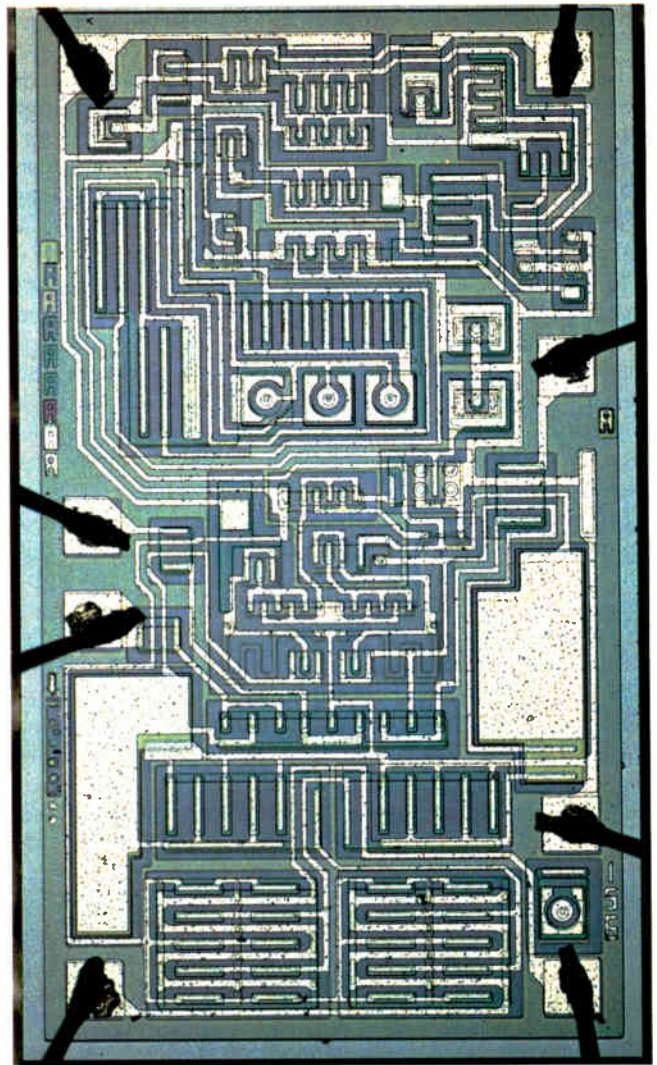

**Mixing.** By the seventies, linear circuit designs had expanded greatly, even allowing the mixing of field-effect and bipolar transistors on a chip. This operational amplifier from National Semiconductor, the LF156, was the first to use FETs for high input impedance.

It was during one of TI's mass vacations—the first few weeks in July 1958—that the seed for the integrated circuit first began to germinate within Kilby. As a new employee, he was not yet entitled to vacation; he spent those weeks alone in the plant, thinking about a way to build entire circuits with semiconductors.

He knew it was already feasible to fabricate resistors, capacitors, and transistors from semiconductor materials. Resistors could make use of the ohmic property of bulk material, and capacitors were formed by reverse-biased pn junctions. His next step was to see if such junctions could possibly be fabricated from a single piece of silicon.

Kilby's bosses showed enthusiasm for his ideas, but they were also skeptical and needed proof that the circuits would work. So he set out to build circuits out of discrete semiconductor components. The first was a flip-flop that was built entirely of interconnected semiconductor devices.

TI had just begun at this time to develop diffused

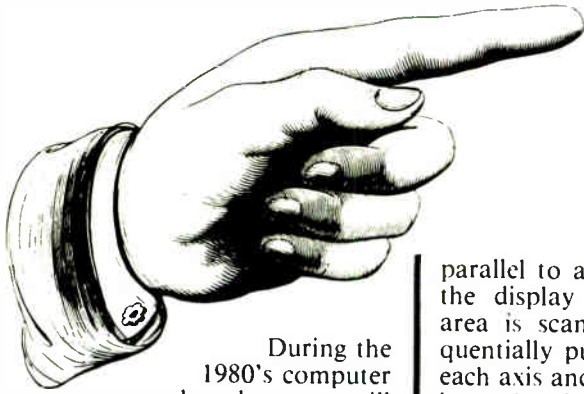

# TOUCH

During the 1980's computer based systems will continue to be introduced into virtually every area of our society, areas where potential users have little, if any, experience with computer systems. These systems should not demand that users become computer experts or learn typing skills and awkward command languages. Systems which demand these skills may invoke feelings of frustration, inadequacy, and hostility. Rather, the interaction should be at a level that respects the user's intelligence and knowledge. Carroll's **Touch** Input Systems offer a solution to this perplexing man/machine interface problem. By simply **touching** the display, the user selects a function in a confident and relaxed way . . . what is more natural than pointing?

parallel to and directly in front of the display surface. The window area is scanned repeatedly by sequentially pulsing the LED's along each axis and detecting whether any beam has been broken. **Touch** activation occurs when both an X and Y beam (**touch** point) are broken.

**Touch** Input has been successfully designed into a variety of applications including education, computer aided design, process control, interactive graphics, and personal computing systems. The medical profession has found **touch** advantageous in automating medical records, medical histories, and in radiology reporting systems. A major railroad system is specifying **Touch** Input as part of its track control system. The advantages of **touch** are now being recognized by government agencies which are specifying **touch** as a system requirement.

These application areas address a wide range of potential users: Elementary school students where reading and typing skills are limited . . . process control operators where fast and accurate interaction is critical . . . experienced users in applications (such as interactive graphics) where the interaction is complex and developing a command language is difficult . . . factory operators where the environment is hostile. Carroll's **Touch** Input Systems have accumulated millions of reliable operational hours in these application areas.

**Touch** has solved the man to machine problem because the user can interact confidently, accurately, and naturally without feeling frustrated or intimidated by a keyboard command language interface.

Carroll, the leader in **Touch** Technology, is dedicated to the belief that **Touch** is a technology of the future and is continuously working on research and development to improve the technology.

Carroll welcomes your inquiries on how **Touch** can make your products more competitive in the markets of the 80's.

Carroll's **Touch** Systems are based on scanning infrared beam technology, chosen for its simplicity and unobtrusive operation. Infrared LED emitters are mounted on the left and bottom of a printed circuit 'window frame.' Phototransistor detectors mounted opposite the emitters produce a grid of invisible infrared light beams. Each point where an X and Y beam intersect is a **Touch** Point. The frame is mounted

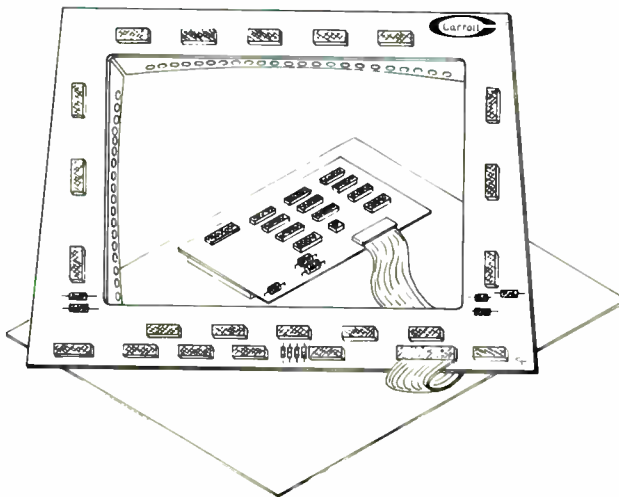

## CARROLL TOUCH INPUT SYSTEMS

For simplicity, for reliability, for versatility — no other system can **touch** it.



**Carroll**

1212 Hagan Street, Champaign, IL 61820

(217) 351-1700





# THOMSON-CSF

## 1930 : a pioneer in electronics

Airborne communications...



... for the first Paris-New York transatlantic flight (Costes & Bellonte).

Radio receivers...



... bringing the world into French homes.

## 1980 : a world leader in electronics



Air traffic control radar station in Mexico, located 3.700 meters above the sea level at CERRO POTOSI - one of the highest radar sites in the world. Connected by a line-of-sight microwave link more than 100 km long to the Monterrey ATC Center.

### Avionics - detection - systems ...

- Avionics equipment
- Surface radars
- Aviation and Marine infrastructures
- Marine and underwater activities
- Electronic systems
- Simulators

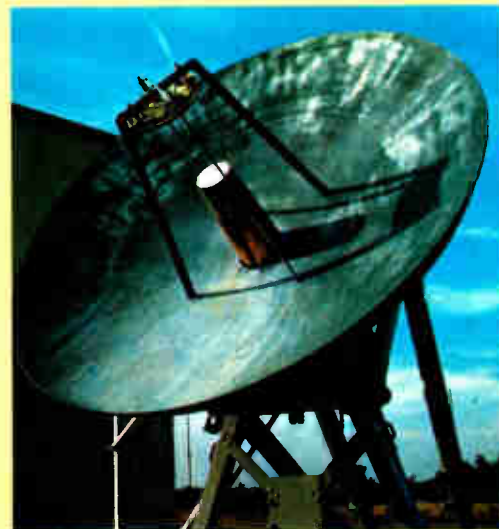

An 11-GHz, 3-meter diameter antenna, for communicating with France's first domestic satellite, TELECOM I, whose transmission capacity will be equivalent to 150 Mb/s.

### Radiocommunications

#### transmission - broadcasting ...

- Radiocommunications equipment
- Microwave links
- Space activities
- Cable transmission equipment
- Radiobroadcasting - Television

THOMSON-CSF

23, RUE DE COURCELLES / B.P. 96-08  
75362 PARIS CEDEX 08 / FRANCE / TÉL. : (1) 563 12.12



Radio transmitters...



... carrying voice of France to the world.

... and high power transmitting tubes



... making all this possible.



SEMS Interactive System, which permits fast access to real-time updated information, is a system which allows acquired data to be checked, processed, interpreted and transmitted.

**Electronic data processing ...**

- Minicomputer systems
- Military and Aerospace EDP
- Computer peripherals
- Computer services and software



P-range display console: advanced space division PABX systems - all electronic, stored-program controlled, high-performance, using completely new technologies and engineering concepts

**Telephone switching ...**

A complete range of telephone switching systems for public and private use. (Space Division and Time Division)

- Local and rural exchanges, long distance and international transit centers
- CENTREX and PABX
- Key systems - Intercom systems - Paging
- Network management devices
- Subscriber terminals





## ... and key to equipment performance and reliability: high quality components.

### □ SEMICONDUCTORS

- The most complete range of high performance discrete devices, from signal to power.
- Bipolar IC's for all applications from computing to power, from industrial to consumer goods.

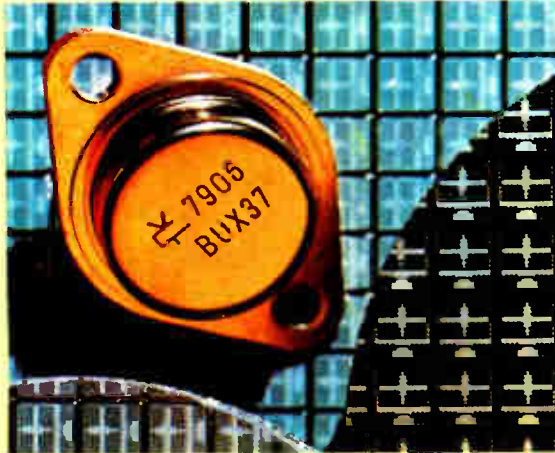

Power Darlington for auto-motive electronic ignition, switchmode power supplies, etc.

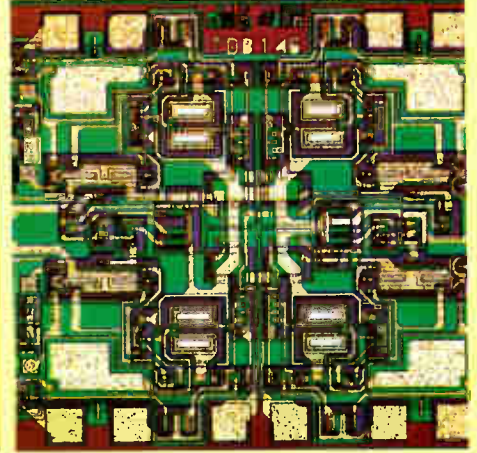

Quadruple op. amp. for active filters, telephone, ...

- THOMSON EFCIS  
MOS Integrated Circuits

A full capability in MOS technologies:  
microprocessors and memories -  
microcomputer systems - IC's for  
telecommunications - display IC's -  
custom design circuits.

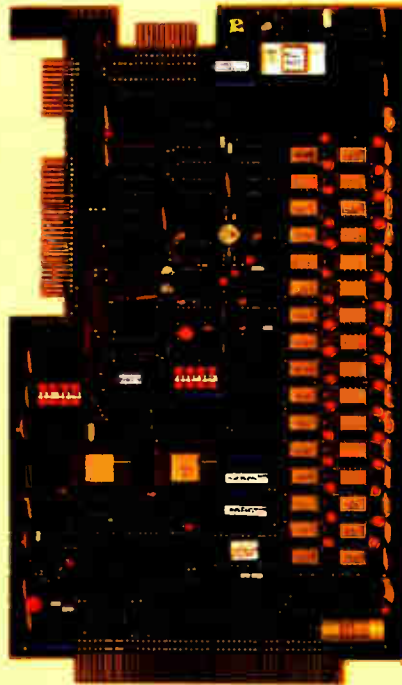

Monocarte 2 - high integration processor board.

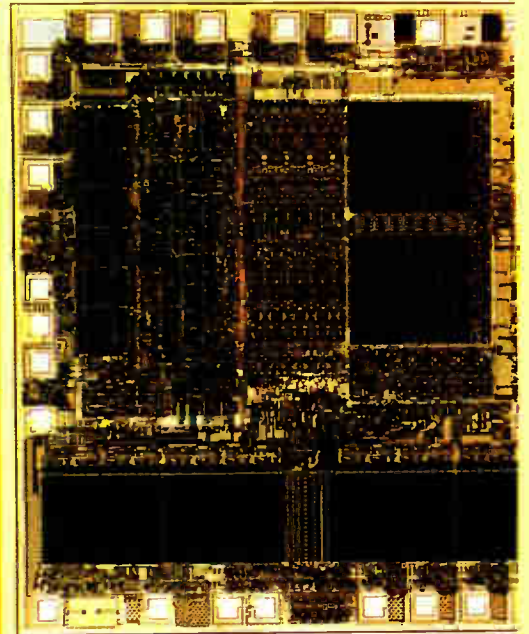

EF 6305 - 8-bit microcomputer IC for consumer applications.

### □ MICROWAVE COMPONENTS

The widest range of high-  
technology microwave  
components available on  
the market.



Microwave Integrated Circuits.



Microwave ferrite isolators and circulators.



### □ ELECTRON TUBES

The world's broadest range of professional electron tubes and allied devices for telecommunications - radio and television broadcasting - medicine - defense - air navigation - science and industry.



A world leader in power-grid tubes.



TWT's for INTELSAT V, OTS, ECS, TELECOM I and TV-broadcasting satellites.

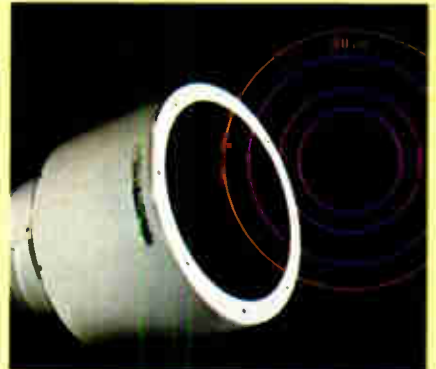

The world's best-selling X-ray image intensifier line.

### □ PIEZOELECTRIC DEVICES

High quality quartz, filters and oscillators for the most advanced professional equipment.

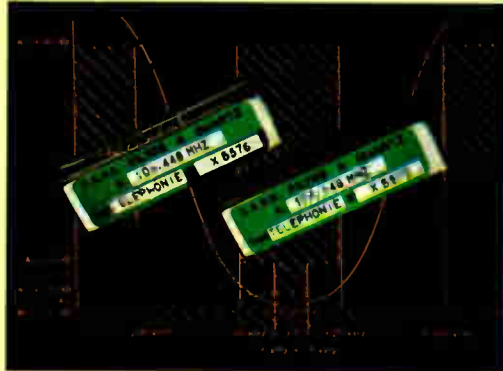

Quartz filters for telephone applications.



Time-reference quartz oscillators.

### □ PASSIVE COMPONENTS

An extensive effort in materials research, mass production and quality control facilities result in high reliability capacitors, thermistors, ferrites, etc.

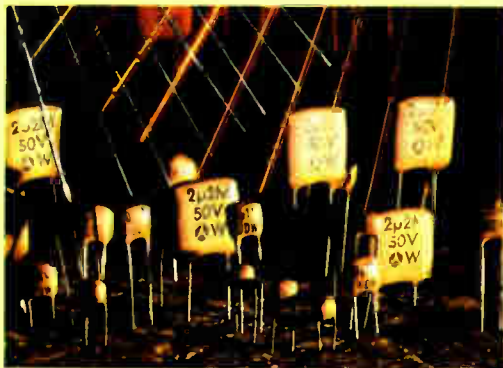

Multilayer ceramic capacitors of this family have been space qualified.



Monolithic ferrite magnetic heads.

### □ SOCAPEX CONNECTORS

More than 1,500,000 contacts... are assembled daily to produce high quality connectors for printed circuits, multiwire and coaxial cables for the telephone industry, for fiber optic communications, etc.



Fiber-optic connector.



Coaxial connectors.



# Acquire and compute data...

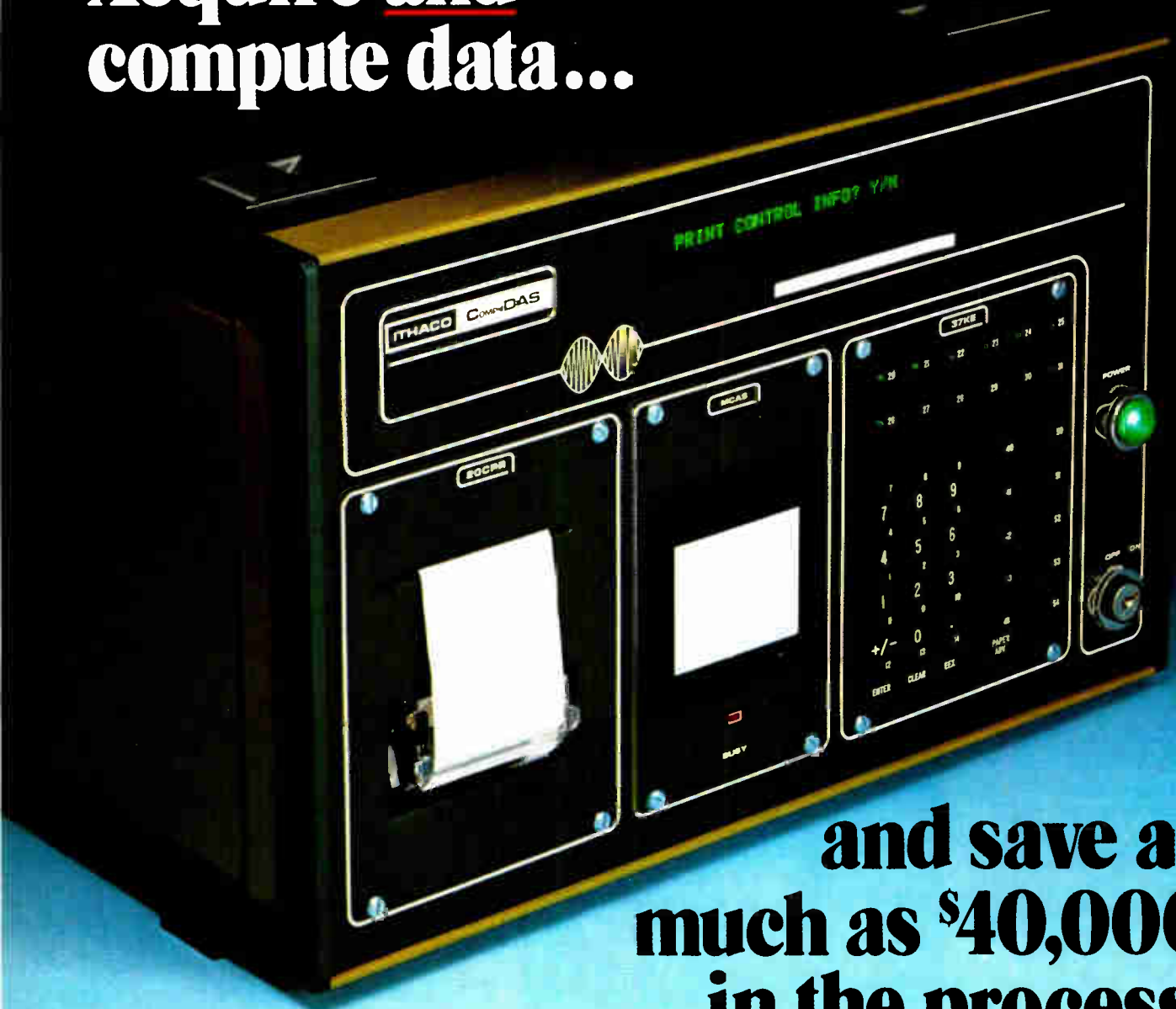

## and save as much as \$40,000 in the process.

If you're about to spend \$50,000 for a data acquisition/minicomputer system, consider this.

For as little as \$10,000, you can buy the CompuDAS™ data acquisition/microcomputer system. It measures, monitors, compares, conditions, stores, displays and performs high level computations and data reduction . . . in real time.

Another big benefit of the versatile CompuDAS: it is equally at home in the lab or on the production line through a variety of available functional and packaging options. Its rugged construction allows use in production environment for on-line monitoring, data manipulation and control: Production personnel can operate it without difficulty.

CompuDAS software is a specifically developed version of Basic called DABIL™ Data Acquisition Basic Interpretive Language. It is designed to simplify user programming (in English) while retaining minicomputer power, flexibility

Circle 258 on reader service card

and speed. CompuDAS accepts analog and digital data from up to 500 data points and allows time sharing where as many as four individual programs can be run simultaneously. Of course, ITHACO provides all the applications assistance you may require, and we offer excellent service backup.

Get real-time performance and versatility along with real world savings. For complete CompuDAS data, read our new brochure. Call toll-free 1 (800) 847-2080 or (607) 272-7640, or use the reader service number. ITHACO, INC., 735 W. Clinton Street, Ithaca, NY 14850.



801A  
**ITHACO**



**Founders.** Intel Corp., founded by Andrew S. Grove (left), Robert N. Noyce (center), and Gordon E. Moore, was one of the most successful spinoffs from Fairchild. Intel was one of 13 semiconductor startups in the Santa Clara (or Silicon) Valley in 1968.

transistors—the only one it had in production was a small-signal germanium mesa device, fabricated 25 to a wafer. Kilby actually used the wafers as his breadboard for early integrated-circuit development.

He had a wafer cut up into a  $\frac{1}{16}$ -by- $\frac{3}{8}$ -inch bar to allow him a pair of diffused regions, and he made use of these and of existing contacts to build a phase-shift oscillator by interconnecting the elements with fine gold wires. One of the diffused regions was etched as usual after hand-masking to form the mesa transistor; the other became the distributed RC network to provide the phase shift. Kilby's integrated circuit worked, and he proceeded to build a flip-flop in a similar way.

Early in October 1958, he began design of a flip-flop to be built from scratch of monolithic germanium. It was to use bulk resistors, pn junction capacitors, and mesa transistors, fabricated simultaneously with photoetching techniques that TI had acquired. The device was completed early in 1959, and the "solid circuit" was unveiled at the Institute of Radio Engineers show in March,

**8-bit microprocessor.** The 8008, the first 8-bit microprocessor, established Intel as a leader in MOS circuit design. The p-channel silicon-gate chip integrated some 2,900 devices—a major step in integration in 1971—and executed 50,000 instructions per second.

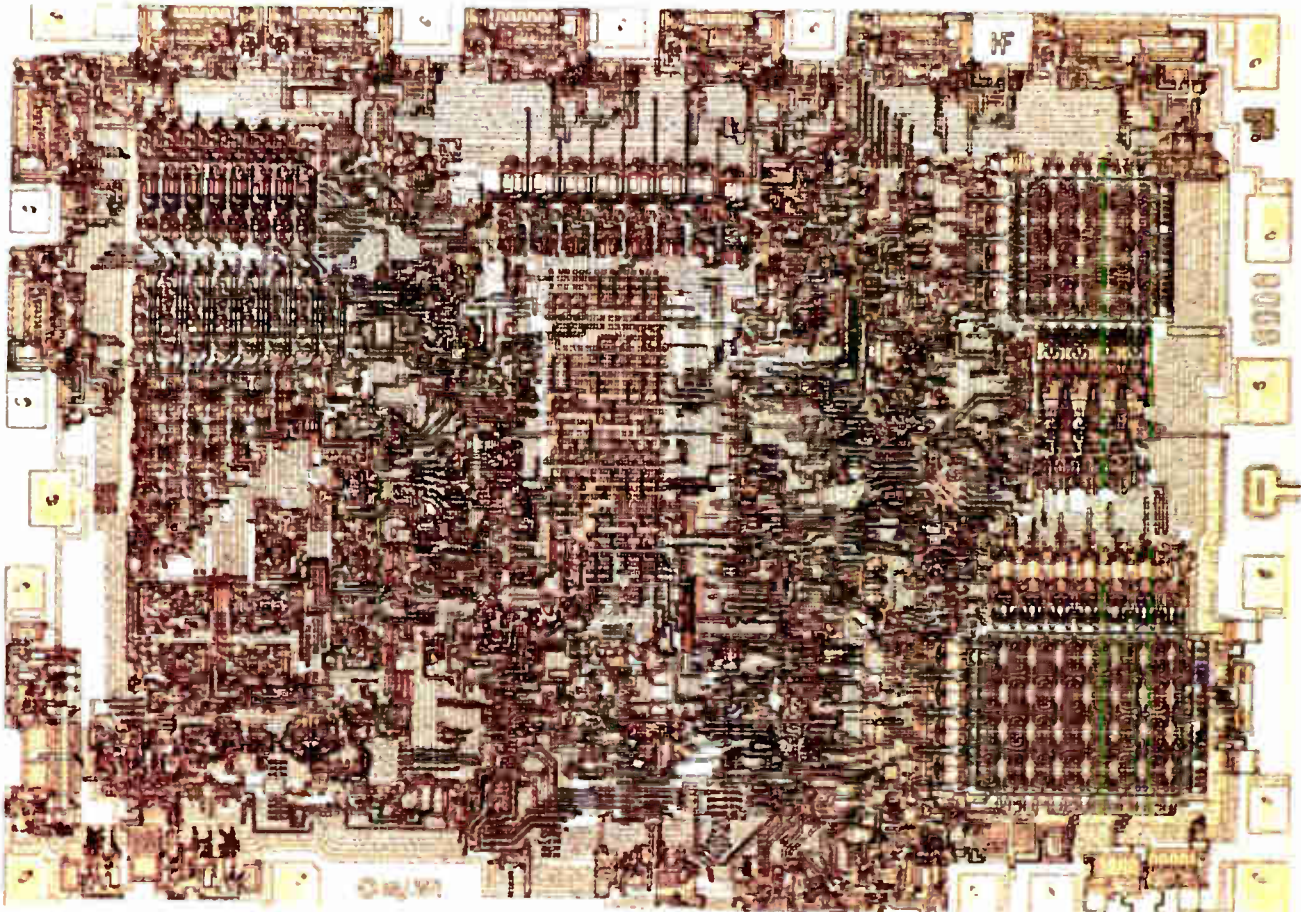



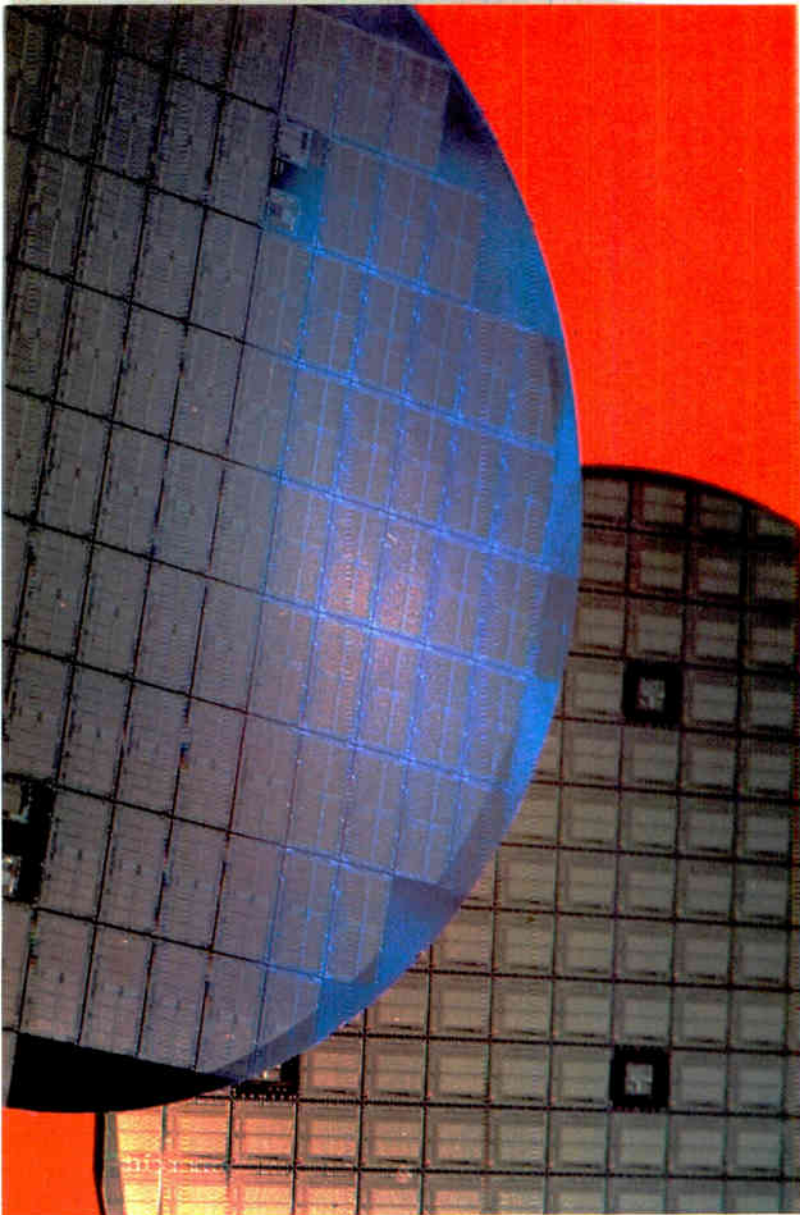

**RAM wafers.** By the mid-seventies, the name of the game was good dice per wafer—or yield. These wafers hold Texas Instruments' 4-K static RAMs, which got a boost in yield when fabrication equipment was converted from 3-inch to 4-inch wafers.

where Mark Shepherd, then a TI vice president, hailed it as “the most significant development by Texas Instruments since . . . the silicon transistor.” By then, Kilby had applied for his patent.

Oddly, though the announcement was reported widely in the press, it was greeted with inordinate skepticism. Many of the criticisms were true: the constraints of integration meant that the performance of individual components of the circuit could not be optimized; the interconnection of devices made it difficult to manufacture the circuit (its yield, figured by the product of the yields of the individual devices, would be little better than 10%); and its designs were expensive and difficult if not impossible to change.

But many of the solid circuit's shortcomings were wiped out by the process of another semiconductor company. In January 1959 Robert N. Noyce, manager of research and development at Fairchild Semiconductor in Mountain View, Calif., was exploring the possibilities of the planar transistor, which Hoerni had developed the year before. He had entered in his notebook that month ideas about incorporating diffused or deposited resistors, about isolating devices from one another by means of reverse-biased pn junctions, and about interconnecting elements through holes in the oxide by evaporating metal onto the surface.

A month or so later Noyce called a meeting at Fairchild, after having heard of TI's impending announcement of the solid circuit. That meeting marked the first time that Noyce shared with his associates his ideas about putting several components on a single chip. From that day on, the evolution of the integrated circuit took a natural course at Fairchild. The patent had been applied for, and the process men worked closely with the photoetching experts to begin interconnecting diffused resistors and transistors on slabs of silicon.

Once the groundwork had been laid by Kilby and Noyce, the manufacture of integrated circuits commenced frantically in 1959. Fairchild hired as its circuit designer Robert Norman from Sperry. Norman was familiar with resistor-transistor logic, and it was RTL that Fairchild chose to implement in its Micrologic product line of integrated circuits. By February 1960 Fairchild announced that it was life-testing “large numbers” of its Micrologic family.

Texas Instruments had adopted Noyce's technique for evaporated metal interconnections and in March 1960 announced its first IC, a custom circuit for the military. By the end of 1961, both TI and Fairchild were producing commercial integrated circuits in production quantities—Fairchild its Micrologic and TI its series 51 logic family. In October of that year, TI delivered to the Air Force a small computer, complete with a few hundred bits of semiconductor memory, and announced its series 51<sup>2</sup> family, which used junction-isolated components and evaporated-metal interconnections.

Although only a few thousand integrated circuits were

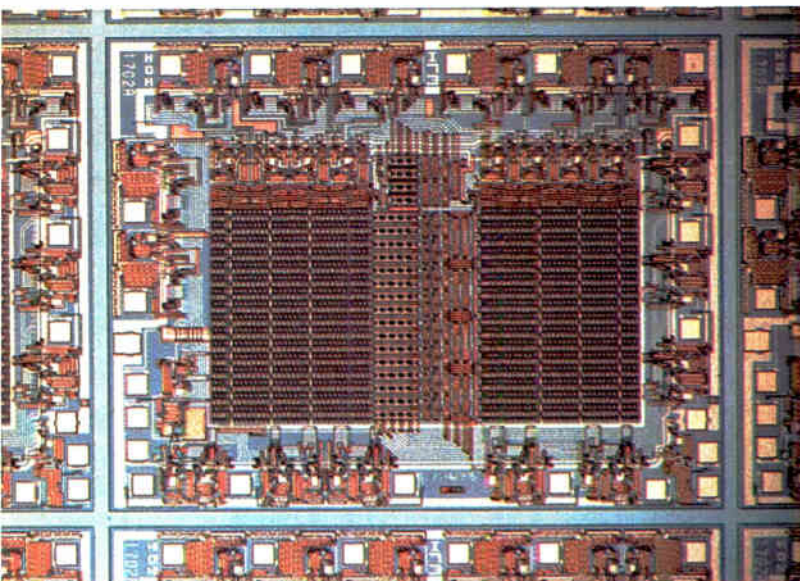

**Erasable memory.** The first erasable programmable read-only memory was developed by Intel in 1972. The 1702, a 2-K device, relied on charge stored on oxide-embedded floating gates, which could be discharged under exposure to ultraviolet light.



# TUNISIA WELCOMES OFFSHORE ELECTRONICS

At a time when the universal emphasis is on export, discover your POTENTIAL FOR PROFIT and improve your market position by being in the right place at the right time.

If you are planning to expand your business into the Mediterranean region, consider Tunisia, one of the fastest growing countries in the developing world.

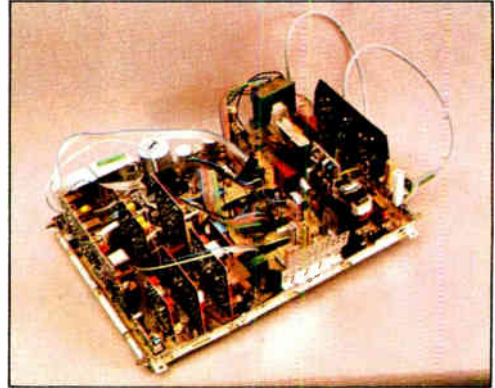
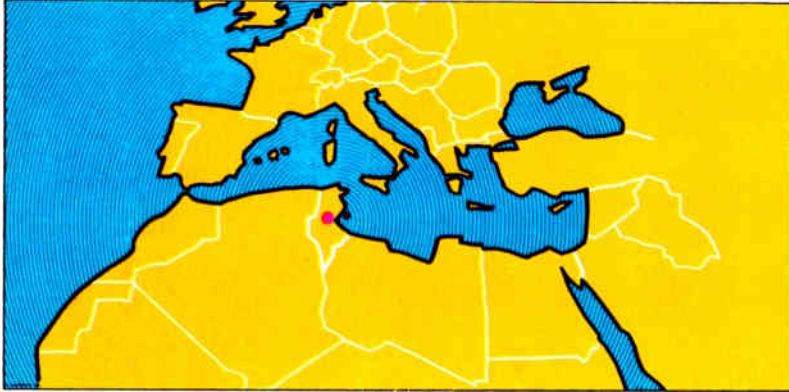

Here are some of the many reasons why it's good business to locate your business in Tunisia—

## TUNISIA OFFERS:

- Political stability and good industrial relations with strong commitment to free enterprise.
- Communities genuinely interested in new business development.
- Steady economic growth and low rate of inflation.
- Government contribution to customized training for your employees.
- Buildings and sites at cost in fully equipped industrial parks.
- An abundance of water for industrial use plus ample and reliable energy supplies.
- Excellent communications and transportation infrastructures.
- Strategic location for European, Mideast and African markets.
- Duty-free entry to Common Market.
- 20-year tax holiday including exemption from customs duty and corporate income, property and turnover taxes.
- Free repatriation of profits and capital.
- Project financing through U.S. and other offshore banks.
- Political risk insurance and financing by the Overseas Private Investment Corporation (OPIC) which, in some cases, reimburses U.S. investors for certain feasibility study costs.
- Excellent cultural, recreational and school facilities including an American school, two graduate business schools and many fine technical colleges.
- Californian climate and a quality of life that translate to excellence of effort—for people and businesses alike.
- 50 American banks and corporations, including GM, IBM, NCR, ITT, Firestone, Singer and Standard Brands, Bank of America and Citibank, have already chosen Tunisia as a base for their operations in the region.
- 250 foreign manufacturers, mostly German and French, have taken advantage of the above incentives and are operating profitably in our country.

## THE TUNISIAN AGENCY FOR THE PROMOTION OF INVESTMENTS (A.P.I.)

is a one-stop, free service, government agency dedicated to helping new and expanding businesses locate or relocate in areas best suited to their needs within Tunisia's Free Trade Zones. API will:

- supply the information you require promptly and confidentially.
- help you find Tunisian and/or foreign partners (if required).

- prepare your appointments schedule prior to your visit to Tunisia.
- review and approve your project proposal within six to eight weeks.
- facilitate the implementation of your project at each and every stage.

## IN THE U.S. Call us or write in confidence

### MAIN OFFICE:

Agence de Promotion des Investissements  
7 rue du Royaume d'Arabie Saoudite  
Tunis/Tunisia—Phone: (01) 282-155 TLX: 12166 APRIN



**Mr. Abderrahmane Krichène, Director**  
TUNISIA INVESTMENT PROMOTION AGENCY  
630 Fifth Avenue, Suite 862  
New York, NY 10020

Telephone: (212) 265-7117 Telex: 640567 TUNINVEST NYK

- Please send me more information on the advantages of locating a business in Tunisia.
- Please put me on your mailing list for a free subscription to your newsletter "Tunisia Industrial News".

Name \_\_\_\_\_  
Title \_\_\_\_\_ Mfg. Company \_\_\_\_\_  
Address \_\_\_\_\_  
City/State/Zip \_\_\_\_\_

The material is issued by Tunisia Investment Promotion Agency, 630 Fifth Ave., New York, N.Y. 10020, which is registered with the Department of Justice under the Foreign Agents Registration Act as an Agent of the Government of Tunisia. This material is filed with the Dept. of Justice where the required registration statement is available for public inspection. Registration does not indicate approval of the contents of this material by the U.S. Government.



# A Programmable Cavity Oscillator?

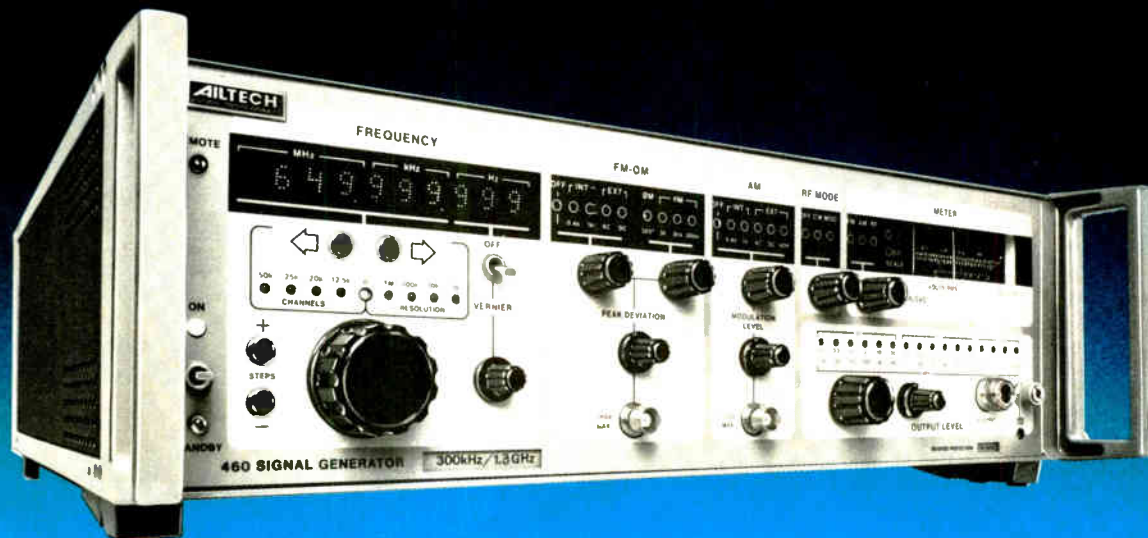

## The Measure of Excellence Continues with the AILTECH 460 Signal Generator

If you're a believer in instrument versatility, you'll want to know more about the new AILTECH 460 Signal Generator.

Using the same instrument, now you can experience the low noise performance of a cavity generator in a programmable frequency synthesizer. The AILTECH 460 takes you from initial development through your production ATE operation, and it's no longer necessary to settle for a noisy synthesizer incapable of providing selectivity and spurious measurements at the expense of giving up programmability.

Not only is the 460 a low noise source, but check the AM performance—100% at levels to +13 dBm.

If that isn't enough, it has FM,  $\phi$ M, output power from +20 to -140 dBm, from 0.3 MHz to 650 MHz and an optional 1300 MHz range at +10 dBm to -140 dBm.

Complete with Spin-Wheel Tuning, the AILTECH 460 not only operates like a Signal Generator, but also delivers Synthesizer accuracy tied to its internal 10 MHz frequency standard.

Why not see the 460 in action in the convenience of your own laboratory. Simply call or write Eaton Corporation, Electronic Instrumentation Division, 2070 Fifth Avenue, Ronkonkoma, New York 11779, (516) 588-3600 today... and don't forget to ask about our new equipment leasing plan.

Circle 262 on reader service card

**EATON** Advanced  
Electronics

**LED displays.** Light-emitting diodes, developed in the early sixties, had been assembled into digital displays by the seventies. This seven-segment unit by Hewlett-Packard used gallium arsenide phosphide LEDs to build quarter-inch characters in 1971.

delivered in 1962, that year marked the beginning of mass IC production. TI received a large military contract to design and build a family of 22 special circuits for the Minuteman missile program. At the same time Fairchild received substantial contracts from the National Aeronautics and Space Administration and from a number of commercial equipment manufacturers. To be sure, the first ICs were expensive. Though they were simple devices, containing but a couple of digital gates per package, they commanded \$100 each in small quantities and perhaps half that in large volumes.

The logic known today as standard transistor-transistor logic, or TTL, evolved from work done at several sources, but can be traced back to a small company in Culver City, Calif., which was called Pacific Semiconductors Inc.

In 1960, logic ICs were employing a number of different coupling techniques between transistor stages, but each had some drawback. The yields of diode-coupled and direct-coupled logic could drop abruptly with process variations, and resistor-capacitor coupling was slow. James L. Buie, an IC designer at Pacific Semiconductors, had devised in 1961 a better coupling technique that isolated stages with coupling transistors. The key advantage of Buie's transistor-coupled transistor logic (TCTL) was that the coupling transistors offered extremely wide tolerances—thus the logic IC would have high yields. Just after Buie filed for a patent late in 1961, TRW acquired Pacific Semiconductors, and it became TRW's semiconductor division.

Other manufacturers under military contracts had developed their own logic families. In 1963 Sylvania introduced a successful transistor-transistor-logic family it called SUHL, for Sylvania universal high-level logic. Because it was one of the first commercially available families, it grew in popularity and eventually became available from other suppliers. Second sourcing—as it came to be called when one supplier's products were duplicated in all specifications by another—was an important factor in the marketing of IC logic families. Manufacturers wanted a sure supply of parts, and that meant multiple sources.

**W**hile the bipolar IC was still under development, other experimenters were drawn to the field-effect transistor. Even before Tszner had produced a junction field-effect transistor in France in 1958, many studies were under way in the U. S. on the possibilities of such a device. Researchers were lured by at least two features: the FET's use of little power and its potentially simple design.

At RCA Laboratories, John T. Wallmark was experimenting with field-effect devices and was granted a patent early in 1957 for a field-effect transistor. Not thinking merely of discrete devices, he envisioned his FETs strung together into networks that could serve as

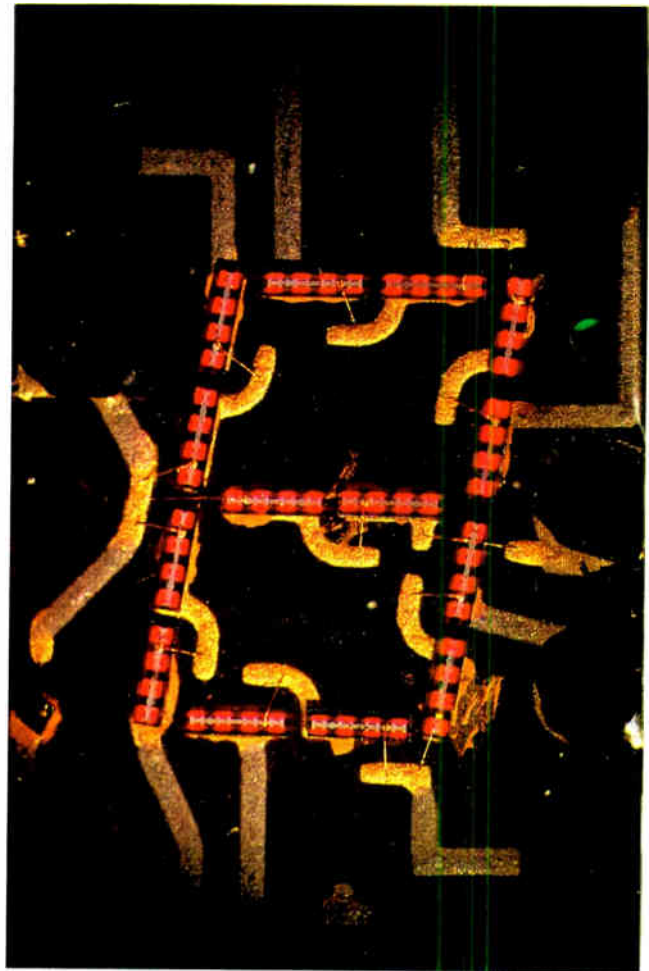

logic for computers. He called his concept integrated logic nets. But although he had a patent, Wallmark never brought his concept to fruition. Two years later Paul Weimer, another researcher at RCA, did.

Weimer built working thin-film field-effect transistors in 1959, using cadmium sulfide. At the same time M. M. Atalla, a scientist at Bell Telephone Laboratories, was investigating the possibility of building an insulated-gate FET using silicon as the semiconductor and silicon dioxide as the insulator.

Then in 1959 a young graduate engineer named Steven Hofstein joined RCA. He was assigned to the integrated electronics group of RCA's electronic research laboratory and began working with Frederic P. Heiman, another young engineer.

Their goal was to produce a silicon insulated-gate FET that would be the only part needed to create a multi-thousand transistor circuit, and they finally achieved it in 1962.

It proved a significant departure from the junction FET already in substantial commercial production at that time. The JFETs used the depletion region of a reverse-biased pn junction to control the effective cross section (and therefore the conductivity) of a semiconductor bar. Drawing from Fairchild's development of the planar process, Hofstein and Heiman replaced the reverse-biased junction control structure of JFETs with a metal gate, insulated from the silicon by a layer of silicon





# The stuff that dreams are made of.

A whole kingdom of richly endowed electron devices to make your design dreams come true.

The imaginative shall inherit the earth. And we want you to be part of our kingdom. We have a mind-boggling collection of wondrous little electron devices to ensure that all your design dreams for the future do indeed come true.

Modern electronic systems are becoming more complex and tinier by the day. Any "wonder product"—from a liquid crystal watch to a huge intercontinental telecommunications system—is only as good as the components inside. NEC wants you to be choosy when selecting such components. After all, a failed diode, transistor or capacitor can make a total system look bad. A failure is a failure. It makes sense to go with the best.

Rummage through our treasure of tiny gems. NEC has established a global reputation for producing a wide range of highly sophisticated and reliable electronic com-

ponents. We deliver hundreds of millions of them each year to discerning design and component engineers. Our tough pre-test burn-in techniques and fully automated QA methods make failure virtually an event of the past.

If you can imagine it, NEC probably manufactures it. Check out our rich range of products: tantalum capacitors, zener diodes, TO-92 and SOT-23 small signal transistors, power transistors, optoelectronic devices, Fluorescent Indicator Panels (FIPs™), SCRs and TRIACs, DIACs, linear ICs and ECL memory ICs.

Give your ideas the best our kingdom has to offer. Specify NEC. For the royal treatment, just fill out accompanying coupon and send it to us today.

## NEC

If you have designs on the future.



Let the crown prince of *The House of NEC*, Jason Stewart, show you the way to an enriched electronics future that won't cost you a king's ransom.

NEC Electron, Inc.  
Mr. Jason Stewart, Executive Vice President  
3120 Central Expressway  
Santa Clara, CA 95051

Dear Jason:

I'm interested in your royal collection of little gems. Please send along your latest product line catalog and current rep list.

NAME \_\_\_\_\_

TITLE \_\_\_\_\_

COMPANY \_\_\_\_\_

ADDRESS \_\_\_\_\_

CITY \_\_\_\_\_

STATE \_\_\_\_\_ ZIP \_\_\_\_\_

ELECT-4

Circle 265 on reader service card



**The CCD.** Although developed by Bell Telephone Labs in 1970, the charge-coupled device took nearly a decade to establish itself. Intended originally as a memory device, CCD circuits proved more practical as imagers or analog filters. This chip, slightly over a quarter inch long, is a filter for detecting Touch-tone frequency pairs.

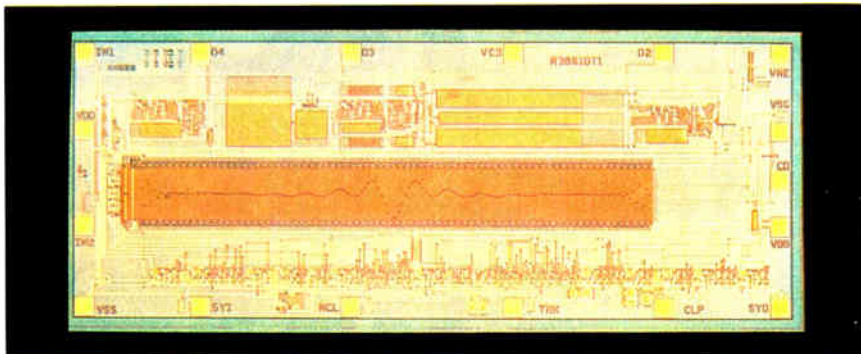

dioxide. The gate could control the current flow from one diffused region in the silicon surface (the source) to another (the drain).

Hofstein and Heiman found not only that the metal-oxide-semiconductor FET structure could restrict current flow by depleting charge but also that forward-biasing the gate with respect to the drain—something that could not be done with junction FETs—would actually enhance the charge near the semiconductor surface and thus improve the current flow. They maintained that the geometry of the new structure lent itself especially well to integrated-circuit fabrication, and they proved that late in 1962 by building a multipurpose logic block comprising 16 MOS FETs on a 2,500-square-mil chip.

By 1963 RCA had fabricated large arrays of several hundred MOS devices. The circuits were not without shortcomings, however. For one thing, they were extremely sensitive to static charge; the slightest overvoltage could break down the thin oxide and destroy an MOS device in an instant. What's more, the operating voltages of MOS devices were significantly higher than those of the bipolar logic families that emerged. MOS FETs were also very much slower than bipolar circuits.

Though the MOS FET was heralded as a significant development, it ran into commercial problems in short time. Its advantages were known from the outset: the fabrication process was far simpler than that of bipolar circuits, requiring less than half as many processing steps; it consumed far less power, and therefore a greater level of integration was possible than for bipolar devices; and it was cheaper to make. But production was plagued with oxide defects and other problems that manufacturing experience with bipolar circuits could not aid.

Few companies had the perseverance to see MOS circuits through. Fairchild Semiconductor, which was working with MOS devices in 1962, abandoned the process after difficulties and returned its focus to bipolar circuit fabrication. Even RCA, which had stayed with the MOS FET long enough to solve several of its problems, shifted its emphasis back to bipolar, the primary money-maker in the early sixties.

At about this time General Microelectronics—founded in 1963 by three former Fairchild employees, Howard S. Bobb, Robert H. Norman, and James P. Ferguson, with Arthur C. Lowell, a retired Marine Corps colonel—saw an attractive competitive spot in metal-oxide-semiconductor ICs. One of the company's major contracts was with the Victor Comptometer Corp. of Chicago, which announced plans late in 1964 to

produce a low-cost desktop calculator built with 29 MOS chips instead of the 21,000 discrete components used in conventional calculators. But throughout 1965 and 1966 General Microelectronics was plagued by production gremlins.

In mid-1965 only two companies were producing MOS ICs—General Microelectronics and General Instrument—but interest in the new process was high. Many larger companies merely took a wait-and-see stance. MOS ICs took off in 1969, when shipments rose in one year in value from \$15 million to \$35 million. By the end of 1970, the total exceeded \$100 million, surpassing nearly all predictions.

Advances in processing helped propel the industry to its heights. Electron-beam production of masks also helped revolutionize the semiconductor process. Direct writing of the mask to actual size by a microscopic electron beam sounded the death knell for huge and expensive step-and-repeat cameras, mask aligners, and ruby lithography.

Many instrument and computer manufacturers developed their own integrated-circuit expertise. Hewlett-Packard, for example, opened an IC facility in part “to guard instrument design secrets.”

More than 25 companies were producing and selling ICs by the end of 1965, with Fairchild clearly the technology leader. In August of that year it introduced the dual in-line package. The DIP, designed to cut assembly time and costs, was immediately adopted by Sylvania, Westinghouse, and Motorola—and by TI a year later.

Fairchild then began forays into linear integrated circuits. One of the company's designers, Robert Widlar, had radical ideas for linear IC design. He espoused the use of transistors whenever possible to avoid using other circuit elements—a transistor replaced a large-value resistor, for example. Widlar developed the first practical integrated operational amplifier, the  $\mu$ A709, and then went on to design the  $\mu$ A702, a high-impedance op amp; the  $\mu$ A710, the first comparator; and the  $\mu$ A741, the first compensated operational amplifier that became the standard, low-cost one.

The year 1966 saw the first commercial Gunn diodes, from International Semiconductor Inc., make inroads in solid-state microwave circuits. Avalanche diodes and microwave transistors also grew in popularity. At the same time prices of discrete semiconductors, which had finally gained acceptance in new, less expensive plastic packages, were falling rapidly, and evidence of a price war was at hand. TI was offering unijunction transistors

- The CENTUM distributed process control system heralds a new era—that of micro-processor-based control instrumentation



- I-series all-electronic control instrumentation



● 1915 Yokogawa Electric founded. ● 1950 Electronic vacuum tube type self-balancing instruments developed. ● 1957 Sales outlet established in New York. ● 1963 Yokogawa-Hewlett Packard established through joint-venture with Hewlett Packard Company of the U.S.A. ● 1967 Direct digital computer control system for processes developed. ● 1971 I-Series all-electronic control instruments developed. ● 1975 CENTUM distributed process control system developed. Singapore factory started operations. ● 1976 A tie-up with the Medical Systems Division of General Electric of the U.S.A. extended activities into the medical systems field. YODIC-1000 process control computer for large volume, high-speed control developed. ● 1977 NQR standard thermometer developed. ● 1978 The high-accuracy Uni-delta Series of differential-pressure transmitters developed. Business tie-up with Gerber Scientific Instruments Company of the U.S.A. extended activities into design automation field. ● 1979 YEWFLO vortex flowmeter developed. Work started on factory in Georgia, U.S.A., exclusively to manufacture YEWFLO. YEWPACK packaged control system completed. Service center established in Peking, China. Agreement for knock-down production of I-Series all-electronic control instrumentation in China.

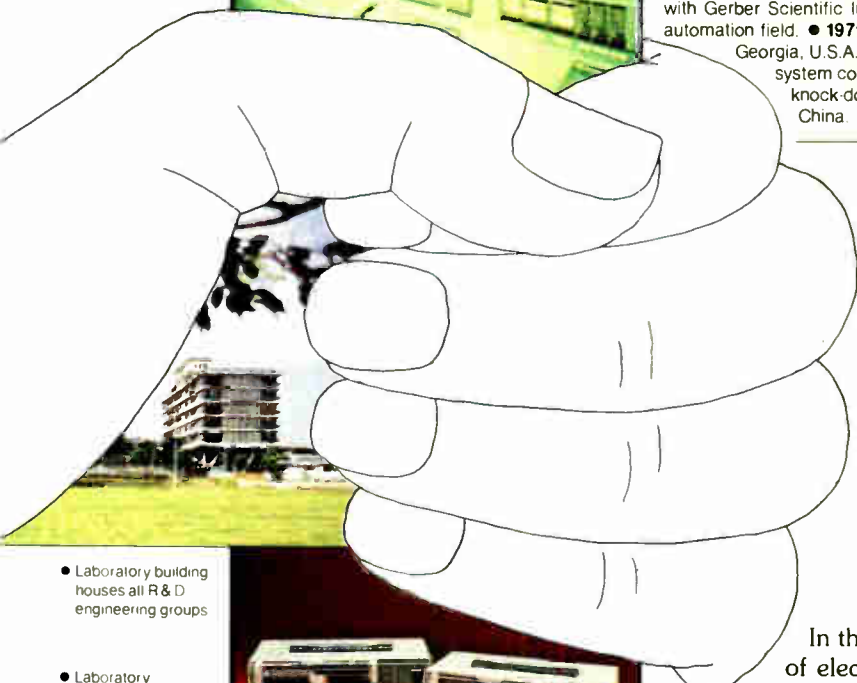

- Laboratory building houses all R & D engineering groups

- Laboratory recorders are suited for the recording of a wide variety of inputs



- Linear array electronic scanner



- YEWFLO vortex flowmeter



- Interactive design systems



# Great Capabilities



In the more than 60 years since beginning production of electrical measuring instruments, Yokogawa Electric has never ceased developing new instruments and systems to meet the needs of the changing times. For example, in 1952 Yokogawa Electric developed the ER electronic self-balancing recorder which aids today's industrial automation. This was followed by others such as the I-Series all-electronic control instrumentation and CENTUM distributed process control systems. Our patented PWM (Pulse Width Modulation) method is used in precision digital measuring instruments, a voltage standard with an accuracy of 0.001% and the NQR reference standard thermometer. Future plans include expanded research in semiconductor, thin membrane, radiation, and laser technology, as well as new applications for sensor technology. These new technologies will be used to make instruments and control equipment more "intelligent" to meet demand for more versatile and sophisticated instrumentation, and to contribute to labor saving as well as to the conservation of energy and natural resources. Yokogawa Electric is also making efforts to expand into new fields such as medical equipment and design automation.

## YOKOGAWA ELECTRIC WORKS, LTD.

9-32, Nakacho 2-chome, Musashino-shi, Tokyo 180, Japan Telex 02822-327 YEW M J

U.S.A.: YOKOGAWA CORPORATION OF AMERICA.  
 Europe: YOKOGAWA ELECTRIC (EUROPE) B.V.  
 YOKOGAWA ELECTRIC WORKS, LTD. GERMAN LIAISON OFFICE.  
 Asia: YOKOGAWA CORPORATION OF ASIA PTE. LTD.  
 YOKOGAWA ELECTRIC SINGAPORE, PTE. LTD.  
 Brazil: YOKOGAWA ELETRICA DO BRASIL IND. E COM. LTDA.  
 Middle East: YOKOGAWA ELECTRIC WORKS, LTD. IRAN LIAISON OFFICE.





## BRAIN CELLS.

Employed by smart engineers for reliable, dependable, rechargeable power.

Now available in four, basic 2V cell sizes, ranging from 2.5 to 25Ah, for dozens of battery configurations and hundreds of applications.

With outstanding float and cyclical characteristics and superior storage life.

All invented, manufactured and refined by Gates Energy.

Be wise. Contact Gates Energy Products Inc., 1050 S. Broadway, P.O. Box 5887, Denver, CO 80217. Phone (303) 744-4806.

# GATES ENERGY

Circle our number on the reader service card for additional input.

Circle 268 on reader service card

**Bubbles.** Magnetic-bubble memories rely on the storage of data by the presence or absence of a tiny domain of reverse magnetization (white dots) in a thin magnetic film. Pioneered in 1969 by Bell Labs, this simple shift register had 4-mil-diameter bubbles.

packaged in plastic for 72¢ in hundreds. RCA broke the \$1 barrier with triacs, the popular ac switches GE had developed in 1964. Soon all semiconductor makers had hopped on the plastic bandwagon.

Interest grew that year in sapphire as an insulating substrate material. Primarily it was Autonetics that demonstrated the density and low-power possibilities for silicon-on-sapphire (SOS) circuits; the company delivered the first SOS chip—a matrix of 6,144 diodes for a character generator in a display—to the Massachusetts Institute of Technology in 1966.

The read-only memory (ROM), which found its use first in lookup tables—such as one that produces the sine of an angle—or in character generators for displays, appeared first in early 1967. A 64-bit MOS memory organized into 16 4-bit words was offered by Fairchild. A year later Philco-Ford announced a 1,024-bit ROM. Big memories brought the term firmware—for software in ROM—into vogue.

At the end of the sixties, it seemed every aspect of semiconductor production was developing and changing. Manufacturers were planning to replace 1½- to 2-inch-wafer-processing equipment with new models to handle the 3-inch wafers becoming available. Light-emitting diodes, developed in the mid-sixties, were used in larger and larger numerical displays, while prices plummeted to a dollar a digit. The linear IC business began a scramble, as new devices cropped up weekly from the many manufacturers. National Semiconductor mixed bipolar and field-effect devices to build the LF156, the first high-input-impedance bi-FET op amp.

But on the business side, certain segments of the industry were undergoing a slump that would be partly responsible for kicking off the greatest period of executive reshuffling the industry has yet seen. The first signs came early in 1967, when TI's president, Mark Shepherd, moved J. Fred Bucy to vice president of the semiconductor division after a year of decline in new orders under division vice president Cecil P. Dotson.

In March of 1967, Fairchild was stung by a mass exodus of executives to National Semiconductor. Charles E. Sporck, general manager of Fairchild Semiconductor, left to become president of National and took with him four key men. The entrepreneurial prospects of the young, vital semiconductor industry had begun to capture the fancy of brilliant young executives. But it was the start of a bad period for Fairchild. With new business declining, John Carter resigned as chairman. Then Noyce, in line for the presidency, resigned. At the same time, research and development director Gordon Moore left for other endeavors.

With little time wasted, C. Lester Hogan resigned from Motorola to take over as president and chief officer of Fairchild Camera and Instrument. Six aides came with him. By that time, Noyce and Moore had already formed an association called Intel Corp.—and had raided Fairchild for two of its employees.

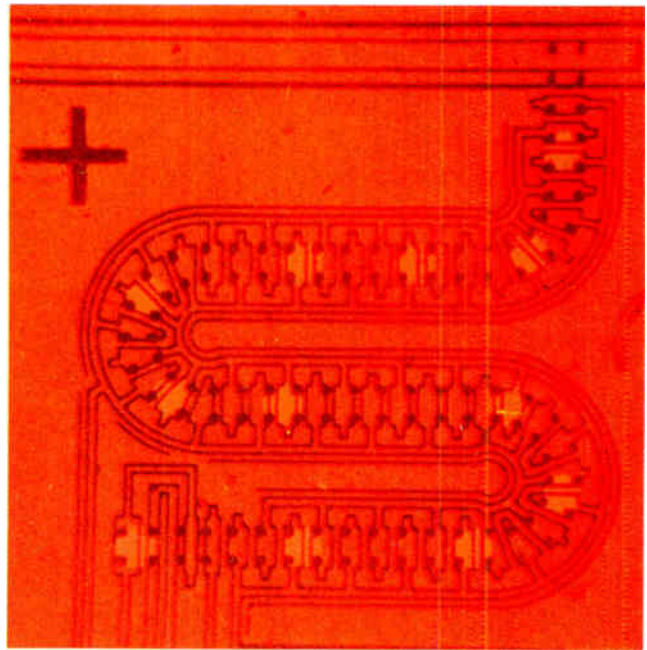

The game of musical chairs went on and on. Along with the jumps came an onslaught of semiconductor startups. Whereas three chip-making firms arose in Silicon Valley in 1966 and 1967 each, there were no fewer than 13 startups in 1968 and another 8 in 1969. Outside the valley, companies were forming as well. In 1969, ex-TI employees formed Mostek Corp. in Dallas.

The early-to-mid-1970s became an era of process competition and experimentation. Clean rooms became cleaner as circuit features got smaller. Ion implantation—the method by which impurity ions are accelerated under high potential into silicon—supplanted thermal diffusion; it had come on the scene in the mid-sixties and by the next decade would enter the production environment. It was used first for high-density memories, made easier because the ion-implantation process could introduce dopants over a greater range of concentrations and with more precise control than could the usual diffusion. Mostek Corp. was the first to use implantation in its MK4006 dynamic random-access memory (RAM).

Manufacturers of MOS devices found they could give their devices a great boost in speed by substituting n-channel for p-channel processing. The step was difficult, for the doping and control of n-MOS was far more difficult than with p-MOS. But the speed improvement was immediate: n-channel carriers (electrons) move faster than p-channel ones (holes).

Integrated injection logic (I<sup>2</sup>L) was the engineering brainchild of bipolar manufacturers. It was devised independently at IBM in Böblingen, West Germany, and at Philips in Eindhoven, the Netherlands. The process offered the potential for bipolar circuit speed with MOS circuit density, and from its introduction in 1972, news of it spread quickly among bipolar manufacturers. It was cross-licensed and adopted for use in microprocessors, custom gate-array chips, and memories. But overshadowed by MOS, it attracted a small though steady market.

There were other approaches to processing silicon. One that seemed to defy the impossible was the floating-



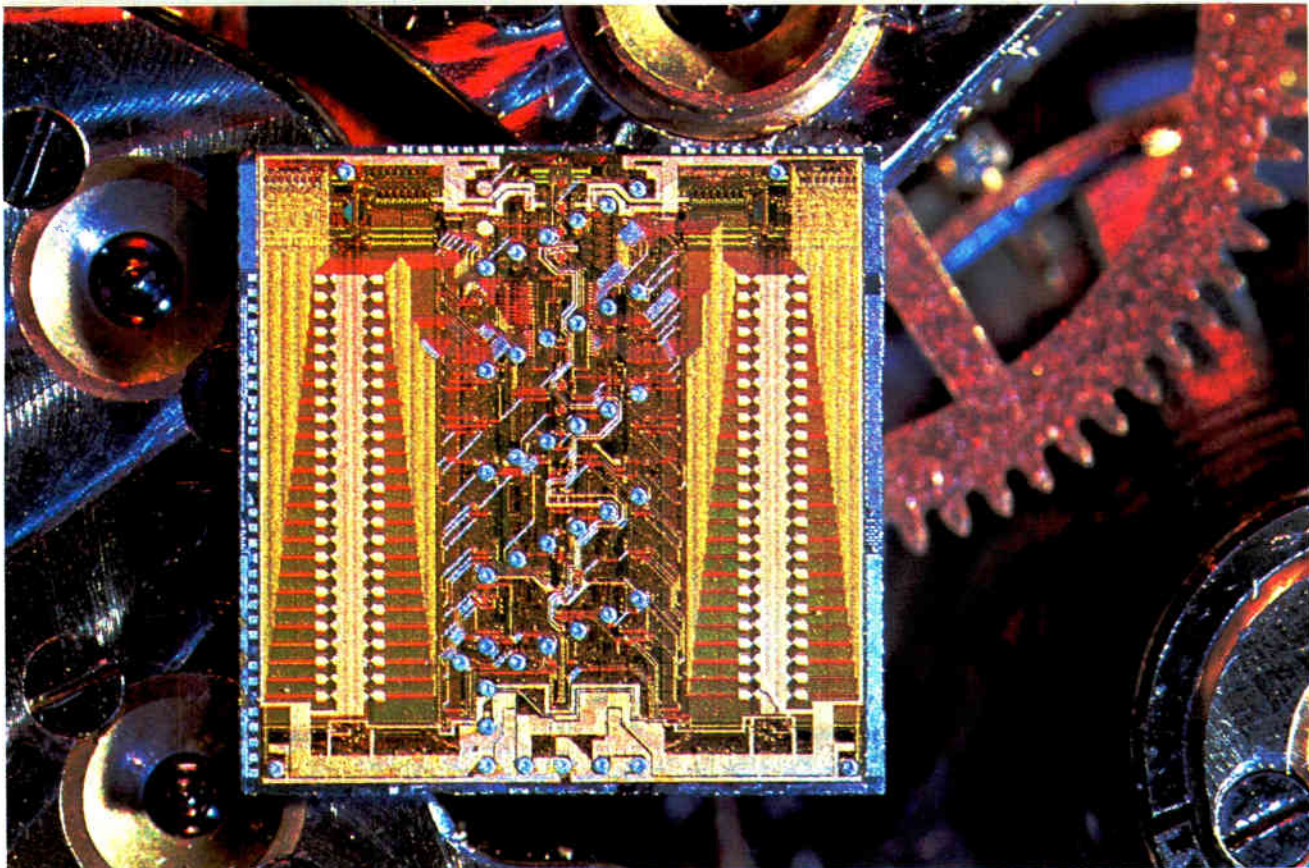

**On to VLSI.** The era of very large-scale integration was heralded in 1979 with the announcement of 64-K dynamic random-access memories. The first, by IBM Corp., used nonstandard processing and redundant circuits to ensure good yields of the complex device.

gate avalanche cell, found in erasable programmable read-only memories, or E-PROMs. Developed by engineers at Intel in 1972, the memory element had remarkable properties: relying on an oxide-embedded silicon gate, on which a charge could be placed by avalanche breakdown of the oxide, data in the E-PROM could be erased by exposing the cells to ultraviolet light, which let the charge leak off. Moreover, the cells could be read an enormous number of times and still retain charge for many years. The first device, Intel's 2,048-bit (2-K) 1702, caught on immediately for changeable microprocessor program storage. It was improved and doubled in density almost yearly.

At about the same time, a new semiconductor storage device appeared that was to undergo a stormy journey from the laboratory to production: the charge-coupled device, developed in 1970 by W. S. Boyle and G. E. Smith of Bell Laboratories. The charge-coupling principle basic to CCDs was very simple. Carriers are stored in the inversion regions (or potential wells) under depletion-biased electrodes and moved from under one electrode to under the next by appropriate pulsing of the electrodes. Although the CCD structure promised memory densities unheard of in any type of RAM—projections of CCD chip size and cost were less than a third that of three-transistor-cell RAM designs—the realities of production fixed the fate of CCDs. The devices would mainly be used as TV camera imagers and analog filters.

A surprising process was complementary MOS. From humble beginnings as a slow, low-density metal-gate process for watch chips, C-MOS underwent scaling down, oxide isolation, and silicon-gate processing that lifted its speed and density to rival that of n-MOS, yet still dissipate only microwatt-level standby power.

In a different area of research—magnetics—a significant discovery was made in 1969 that was to have great impact on semiconductor electronics. Researchers at Bell Laboratories turned up the phenomenon of magnetic bubbles—small cylindrical magnetic domains that would remain stable under the application of an externally applied static magnetic field.

The application of bubbles as memory elements seemed almost immediately apparent: the presence of a bubble could represent a logic 1, its absence, a logic 0. The theoretical densities possible—at a time when semiconductor memories were packing but a few hundred bits on a chip—were almost incredible: millions of bits per square inch. In addition, magnetic-bubble memories were nonvolatile and therefore could retain data even if the power failed.

But though the bubbles could be made to move through an array of propagating elements under a rotating external magnetic field—which meant that bubble memories could take shape as shift registers—the design of elements to generate, detect, split, and annihilate the bubbles was far from perfected. This and the establishment of practical memory organizations and architectures held up commercial exploitation of bubble memories for nearly 10 years.

By the end of the 1970s, semiconductors had grown to a \$6 billion market, and the era of very large-scale integration—hundreds of thousands of devices on chips a quarter-inch square and using lithography of micrometer line widths—was beckoning. The 64-K RAM had made its debut. It was an overwhelming prospect as the semiconductor industry faced the eighties—and a far cry from the modest “device called a transistor” announced in the *New York Times* of July 1, 1948.

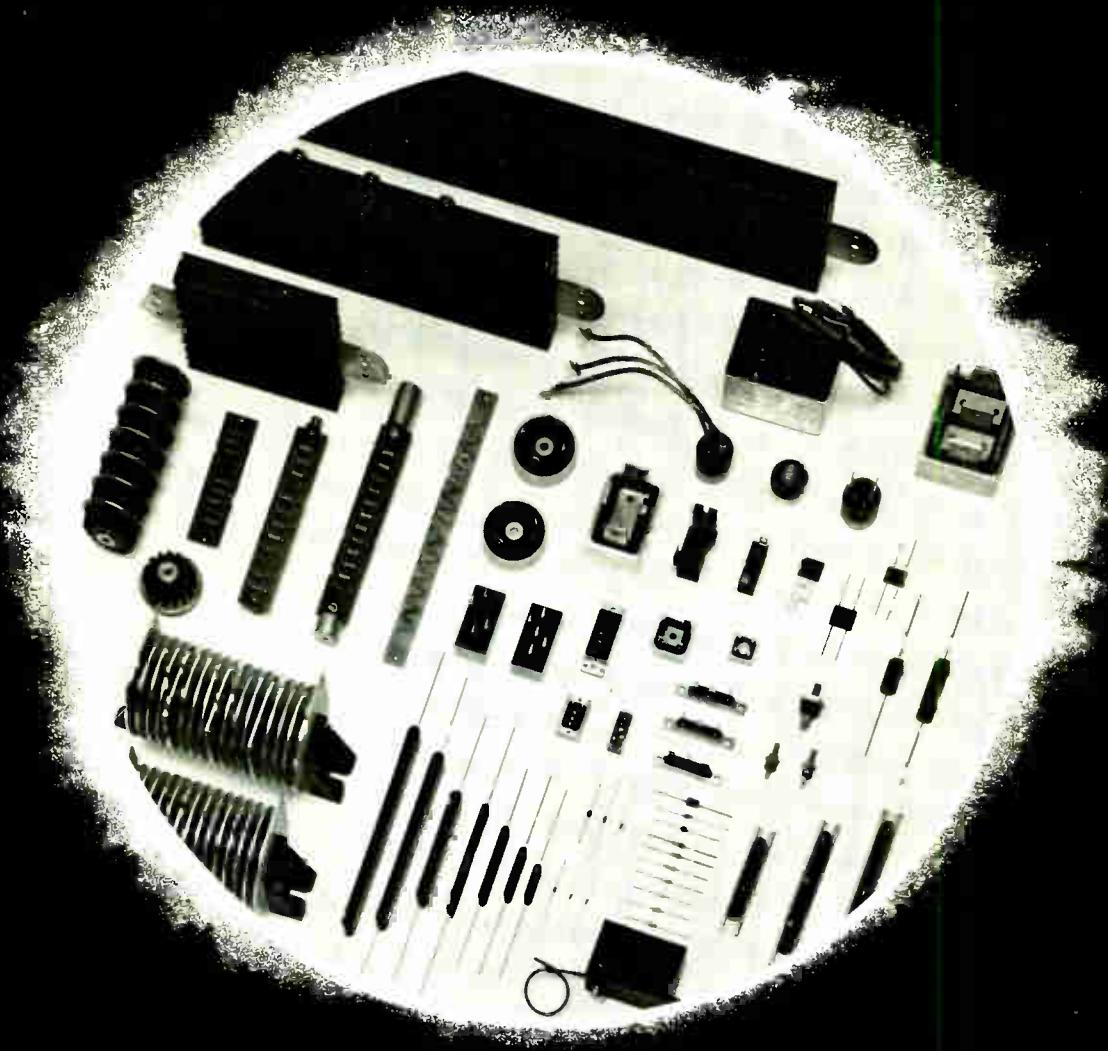

# POWER UNLIMITED

**Efficient, Reliable High Voltage - High Current Rectifiers**

*Semtech's high current-high voltage devices efficiently solve the most sophisticated rectification, clamping, damping or switching problems. Proprietary design concepts allow Semtech to offer assemblies with unlimited voltage-current handling capabilities.*

*Although Semtech offers many standard catalog high voltage power components, it fully understands that these components can seldom be treated independently. Semtech engineers are continually concerned with the special problem of high voltage applications. Our modular design concept, in depth stocks of sub-components and Application Engineering Department enable us to supply your particular needs reliably, efficiently and competitively.*

*Call the Semtech representative nearest you and ask about Semtech's unlimited power. We have immediate capacity to handle your specifications.*

820,000 volt  
fast recovery  
device.

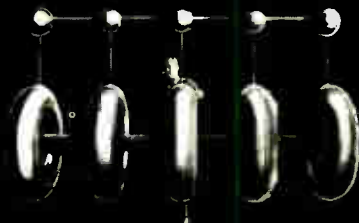

**SEMTECH**  
CORPORATION

652 Mitchell Road, Newbury Park, California 91320  
(805) 498-2111 • (213) 628-3392 • TWX: 910-336-1264

CHICAGO (312) 352-8227 • DALLAS (214) 638-8215  
DAYTON (513) 542-8711 • FLORIDA (305) 888-4402  
MARYLAND (301) 987-0070 • NEW YORK • NEW JERSEY (201) 964-9305  
SAN FRANCISCO (415) 494-0113 • SEATTLE (206) 455-4807  
CANADIAN SALES: Adronics, Ltd. (416) 493-5711  
KPC Sales, Ltd. (644) 273-3523  
SEMTECH LTD., Whitehill, Glenrothes, KY62RF Scotland  
Phone STD 0592 77394 • TELEX 72146

Circle 271 on reader service card



# How Nicolet fits into this box than

Fitting more oscilloscope into a cubic foot took one big first step—the use of modern digital methods. Plus a lot of little steps such as recognizing what's "oscilloscope," what's not, and keeping the "not" outside where it belongs. Here are some of the great things the digital method has made possible.

## Resolution and Accuracy

Scientists and engineers (thousands of them)



are delighted with the Explorers' 4000-line resolution, and accuracy literally an order of magnitude better than that of analog scopes and other digital scopes.

## Super Storage

Users appreciate the Explorer's waveform

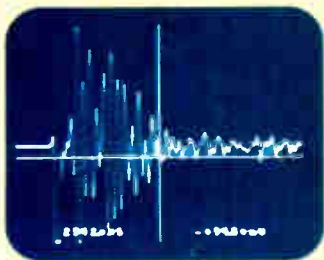

storage. At equivalent writing rates of up to 50 cm/ $\mu$ sec an Explorer can clearly remember, every time, without fade or bloom, literally hundreds of times as much about signals as the finest analog

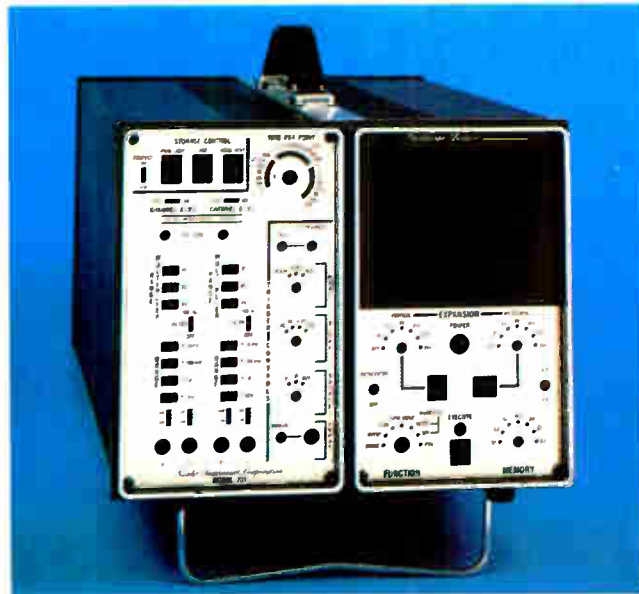

storage scopes. Best of all, Explorers store waveforms with no hassle.

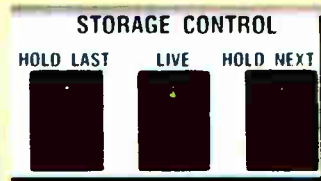

## 64X Zoom Display

Explorer users enjoy the convenient display that allows them to *zoom in* on details of interest. They also can superimpose "old" signals and

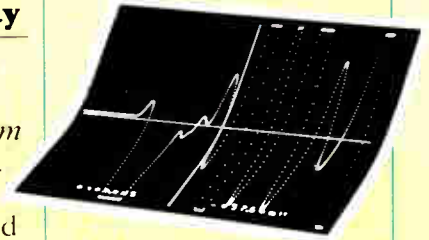

live, "fresh" signals for extremely sensitive observation of differences or changes. They can

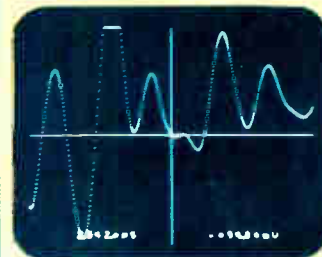
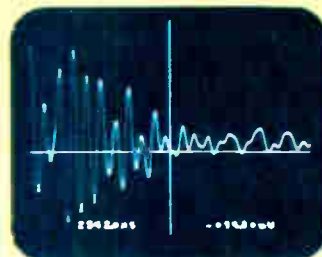
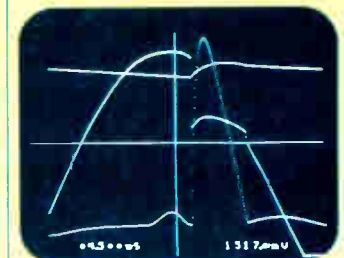
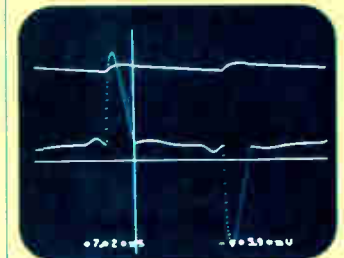
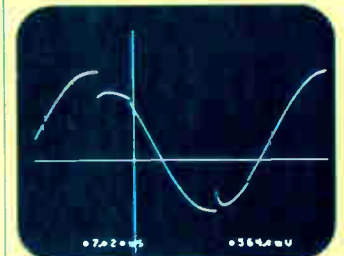

superimpose two (or four) old waveforms, or two live waveforms. And zoom in on details with up to 64X digital display scale magnification.

# more oscilloscope anyone else.

## They're Pure Oscilloscopes

The digital method results in other welcome improvements. Sweep speeds that range down to days in length to allow you to precisely measure very slow phenomena. Pre-trigger sweep start



allows you to see what precedes an event as well as what follows. XY operation provides even greater precision



than servo-driven XY recorders, but at speeds a million times greater. Speeds as high as most analog XY oscilloscopes.

All of these are oscilloscope function improvements. The



improvements include greater ease of use, for a dozen reasons. The Explorers are "pure oscilloscope." They interface between the signal source and the most intelligent and powerful computer in the world. You.

## Disk Memory Option

The optional, built-in disk memory can remember signals for years, storing as much data per disk as you could capture

on thousands of photos. Disks are inexpensive and reusable, don't need developing, and store data at the touch of a button.

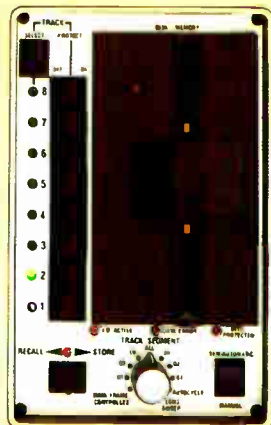

## Matching Your Needs

You can choose the Explorer model that fits your measurement needs from a family of instruments, plug-ins and IEEE-488 or RS-232 options.

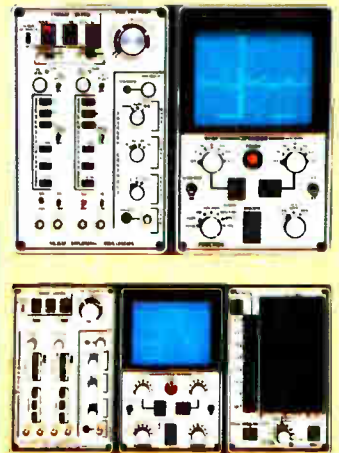

## For More Details

To get complete information quickly, to discuss your application or to arrange a demonstration, call (608) 271-3333.

**NICOLET**  
INSTRUMENT  
CORPORATION  
OSCILLOSCOPE DIVISION

5225 Verona Road  
Madison, WI 53711  
Telephone: (608) 271-3333  
TWX: 910-286-2737  
Sales and Service Offices Worldwide



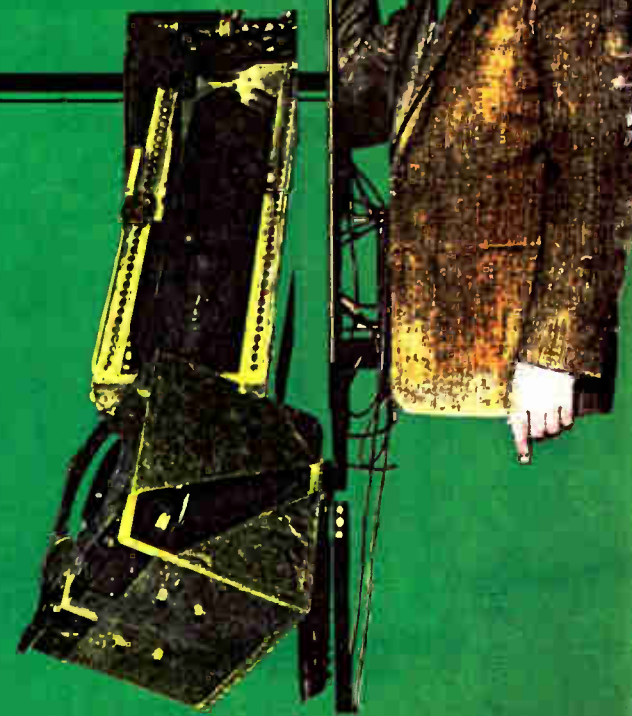
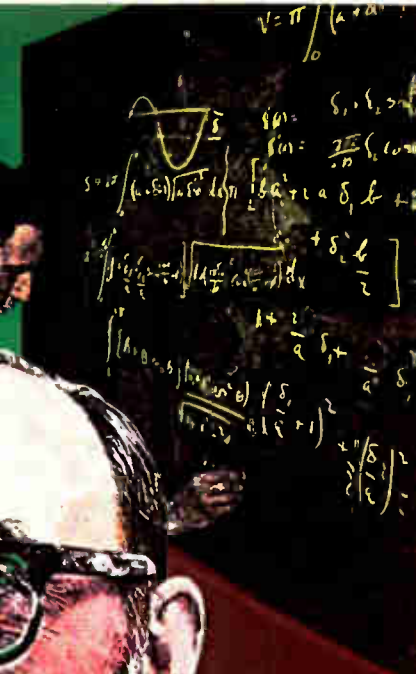

# IN THE WAKE OF THE TRANSISTOR

---



THE SAME  
INVENTIVE  
SPIRIT THAT  
FOSTERED THE  
TRANSISTOR PROPELLED  
THE ELECTRONICS  
INDUSTRIES IN A  
DOZEN DIFFERENT  
DIRECTIONS IN THE  
YEARS THAT FOLLOWED.  
DESPITE THE COLD WAR  
AND KOREA, THIS  
DIVERSIFICATION WAS  
LARGELY COMMERCIAL.  
TELEVISION BOOMED.  
LONG-PLAYING  
RECORDS APPEARED.  
BIG COMPUTERS  
BEGAN MAKING THEIR  
MARK. CLAUDE  
SHANNON FINALLY PUT  
COMMUNICATIONS ON A  
FIRM THEORETICAL  
BASIS, AND THE FIRST  
LASER WAS BUILT.  
THEN THE FLIGHT OF  
SPUTNIK I IN 1957  
PROVOKED THE U.S. INTO  
ESTABLISHING A SPACE  
PROGRAM THAT WOULD  
EVENTUALLY LAND A MAN  
ON THE MOON.

## Chapter 6



**I**t was a time of peace. It was a time of guns and butter. It was a time for starting planetary explorations that a scant decade before would have been unthinkable, except as science fiction. It was also a time when the sparks of inflation became noticeable, a portent of big economic trouble to come. The period was 1947 to 1960.

Though it was peace, it was turbulent peace. With each passing month, it became clear that though the Soviet Union and the West had been allies in the war against Hitler, they were widely split as partners in peace. Berlin was the first major point for a test of wills.

In June 1948 the Russians blocked all routes from East Germany to West Berlin, cutting off vital supplies to the western city. The Western powers responded with the Berlin Airlift. In May 1949 the Russians lifted the blockade.

But it was a short-lived respite in the East-West cold war. In August 1949 the Soviet Union tested its first atomic bomb, and a race to stockpile the new weapon was under way.

Korea was the second big test of wills. Hastily rebuilt American forces bore the brunt of defending South Korea from invading North Korean troops. The war ended in a truce in July 1953 after mainland China had entered the conflict on the side of North Korea.

At home in the U. S. there was fear that the sudden involvement in the Korean War would squeeze supplies of consumer goods. There was an enormous expansion of electronics in consumer and industrial markets at this time as demand, pent up by World War II, exploded. Some scare buying took place during the Korean conflict, but the familiar war shortages never developed. Manufacturing for the civilian sector continued, and the Korean War served to revive military markets for the electronics industry.

But with dollars flowing copiously for military supplies and consumer buying at home, prices crept upward. Cars that had cost \$990 when the U. S. entered World War II were now \$1,500 and up, and more than one conservative civilian buyer was saying: "I think I'll wait until prices come down." They never did, of course. The cost, not only of cars but also clothes, appliances, real estate, and other items, continued to rise.

The electronics industry reported record civilian sales. In March 1950 the total was put by *Electronics* at \$1.1 billion. Combined with military sales, this total exceeded \$10 billion by the end of 1959. Electronics manufacturing, according to Wallace B. Blood, business manager of *Electronics*, had undergone "a metamorphosis unique in industrial history."

No longer did electronics revolve around radio, as it had in 1930, when 90% of the \$103.5 million in factory sales was attributed to radio. Now radio equipment represented about 20% of the electronics industry's income. The advent of television, the increasing application of electronics to industrial uses, and the expanding consumer and military markets had brought about exceptional growth.

In the July 1951 issue of *Fortune*, Lawrence P. Lessing wrote in "The Electronics Era": "Electronics has in progress more revolutions of profound impact upon

industrial society than any other technology. For electronics is not simply radio and television, but it is the deep-probing instrument of science, the intricate nerve center and sensory system of modern industrial power."

Immediately after World War II there had been high demand for radio sets and radio replacement parts, because of restriction on their production for civilian use during the war. Receiving tube sales rose into the hundreds of millions in the late 1940s, reaching some 400 million by 1950. This compared with 115 million tubes sold in 1940, before the U. S. entered the conflict.

But now television was also a factor. From a trickle of sets built and sold in 1947, the TV industry zoomed in 1950 to sales of \$1.35 billion at the factory and accounted for roughly half of the electronics industry's gross in the U. S. The number of TV set makers climbed from 14 in 1947 to more than 80 in 1950. More than 7 million TV sets were built in 1950, as well as 8 million radios.

It was estimated that 3.1 million American homes had TV sets in 1950, and five years later the total was put at 32 million homes. The big name in telecasting in 1948 was Milton Berle. By 1952, Lucille Ball and Desi Arnaz in "I Love Lucy" had displaced Berle and Arthur Godfrey as the top-rated TV personalities.

Also hitting it big in those years was a 20-year-old truck driver from Memphis named Elvis Presley. He had a big hand in the boom of the record industry, which capitalized first on the 45-rpm record and then on 33 $\frac{1}{3}$ -rpm long-playing disks.

Television's first nationwide broadcasting of spot coverage of a national political convention was the Republican National Convention in July 1952. Seventy million Americans tuned in to hear the opening session called to order by the Republican national chairman, Guy Gabrielson. Later that year TV audiences watched Sen. Richard M. Nixon give his so-called Checkers speech, in which he defended himself against charges of political gift-taking when his spot on the Republican ticket as Vice Presidential nominee was threatened.

Amid all this, electronics just grew and grew. At the beginning of the 1950s, a major part of the industry was represented by about 40 tube makers that included General Electric, the Radio Corp. of America, Westinghouse Electric, Sylvania Electric, Philco, Zenith, Raytheon, and, for its own use, AT&T. Most of the big tube companies also built the tubes into finished radio and television sets and other electronic devices.

**T**he transistor was already on the scene. The tube makers, with millions invested in their plants, saw no threat in this. "After all, they argue, some 30 years' development and refinement of the vacuum tube in hundreds of specialized forms is not likely to be upended overnight," wrote science writer Lessing in his *Fortune* article.

Indeed, the new vacuum tubes of which he spoke went far beyond devices destined for home radio or TV sets. Lessing pointed to metal-cavity magnetrons taken from radars and being applied to marine and aeronautical navigation systems and also to diathermy machines. He





**Turning 'em out.** Pent-up demand following the beginning of regular commercial television broadcasting in 1946 kept a dozen TV manufacturers like Admiral Radio Corp. busy in Chicago, turning out more than a million sets annually by 1949.

noted that klystrons were being used in television transmitters. And he singled out Varian Associates, founded in San Carlos, Calif., in 1948 by the inventors of the klystron, as an up and coming star.

Electronics companies were diversifying and some nonelectronic industries were either purchasing or creating their own electronics divisions. By 1953 the Radio-Television Manufacturers Association, which had changed its name only three years before, felt its name was no longer representative of the electronics industry. Accordingly, the association became the Radio-Electronics-Television Manufacturers Association. But the electronics industry continued to grow. Just four years later, the enlarged association became the Electronic Industries Association, its name today.

With the postwar electronics boom in so many different areas, high school graduates were attracted to college electrical engineering programs. So were ex-servicemen who had received electronics training as communications and radar technicians. They were enrolling in EE courses under the GI Bill. Just how the electronics industry would absorb the new engineers began to worry some people.

One was H. B. Richmond of the General Radio Co. in Cambridge, Mass. In an article, "An Engineer in the Electronics Industry: Prospects—Preparation—Pay," appearing in the June 1948 issue of the Proceedings of the Institute of Radio Engineers, Richmond noted that 1950 should see about a fourfold increase in the supply

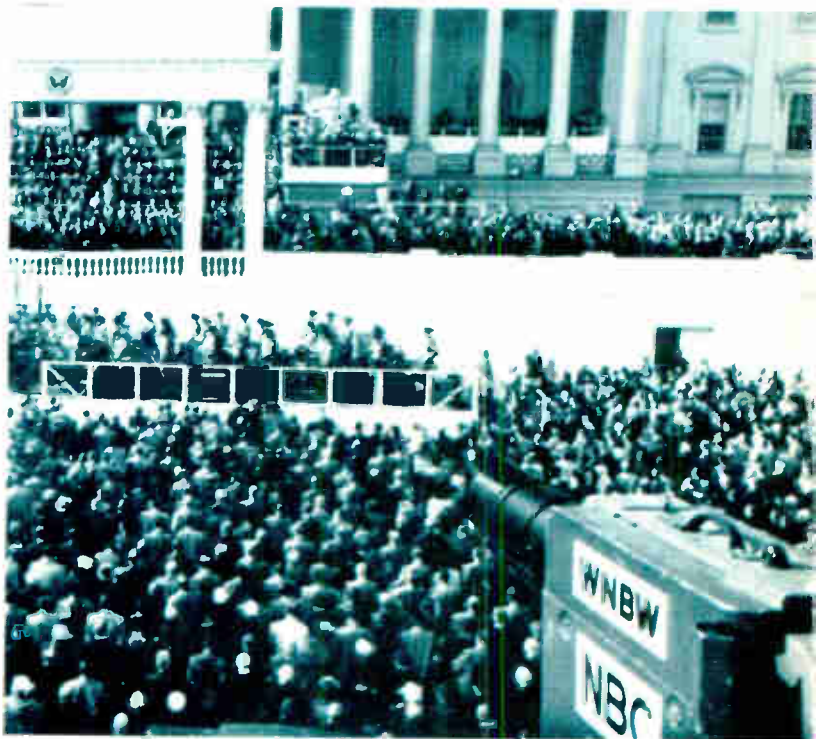

**Impact.** Television established itself as a powerful political and social force during the fifties when it was used for nationwide coverage of the Republican National Convention in July 1952 and later to broadcast the inauguration of President Eisenhower in 1953.





**In color.** Color TV began to move once the FCC adopted in 1953 the National Television Standards Committee's recommendation of the dot-sequential system. RCA's shadow-mask color tube helped black-and-white compatibility. This is a 19-inch 1954 version.

of young electrical engineers with a bachelor's degree. "Taken by itself, this is not a serious employment situation," he wrote. "The problem comes from the fact that most of these people will want to engage in radar and similar war developments, and the number is greater than the current indicated need."

Many believed such statements, which were picked up and given wide circulation by the news media. It contributed in a big way to declining enrollments in engineering schools—and to a shortage of engineers that seemed to exist for much of the 1950s.

The year 1960 saw the Institute of Radio Engineers warning of another decline in the enrollment of freshmen

in engineering colleges—for the third successive year—despite the launching by the Russians of their Sputnik satellite in 1957, signaling the start of a space race that would require many engineers and scientists.

The 1950s ended with membership in the IRE at a peak. The number of engineers belonging to the institute increased from about 27,500 members in 1950 to about 79,200 by the end of 1959. Somewhere around 1955 or 1956, the IRE passed the older American Institute of Electrical Engineers in total members. The AIEE finished the decade with about 55,000 on its rolls.

**W**ith war scarcities behind it and the Depression forgotten, the nation snapped up electronic consumer products eagerly from 1947 to 1960. These were years of development for television, record players, and tape recorders, and each step forward fueled the fires of buying.

After years of talk about what television would do, finally it was a pulsing reality. Sales accelerated so that Dorman D. Israel, executive vice president of the Emerson Radio and Phonograph Corp. in New York, warned: "The cost-cutting project pressure presently rampant on the TV designer's bench is closely patterned on a similar effort that struck radio in the early thirties. The lessons learned then should be applied with profit and benefit to TV today."

Color television advanced cautiously as researchers wrestled with problems of compatibility with black-and-white and the need for industry standards on this. But it was clear that black-and-white TV had benefited enormously from World War II. Not only was there impatient consumer demand, but manufacturers also simplified designs, improved production efficiency through war-learned techniques, and maintained quality.

In March 1950, *Electronics* noted that even though prices and labor costs had more than doubled since 1930, "a householder can buy a good television set with a 1950 dollar today for about what he paid for a good radio with a 1930 dollar in that period of 20 years ago."

Black-and-white TV progress was swift. In May 1950, broadband television tuners were beginning to be used widely. By choosing an intermediate frequency above 30 MHz, so that the image spectrum fell outside the television band, the engineer could design a low-noise front end with a broadband rf stage and select stations by tuning the local oscillator only.

Emerson Radio and Phonograph announced that it planned to introduce a modularized TV set in March 1954, and DuMont said it was working on one (Motorola was then using modules in a portable radio). Screen sizes went up and down and back up and back down again. "Public preference for larger TV screens seems to have reached saturation," *Electronics* said in April 1956. "Now tubes under 15 inches are making a comeback."

By January 1959, however, the magazine reported that 10- and 12-inch sets had not been popular, and "current industry activity points to a leveling off now taking place, with the smallest popular picture tube sizes stopping at 14 inches."

Manufacturers pressed for battery-operated portable

# Look to Varo for the widest choice of Schottky devices for power supplies.



**0.75A BRIDGE VSB51 Series:**  
10/20/30/40  $V_{RRM}$  0.65  $V_F$  @  
0.75 mA  $I_F$



**1A VSK 1 Series:** 20/30/40  $V_{RRM}$   
0.55  $V_F$  @ 1.0 A  $I_F$



**3A VSK 3 Series:** 20/30/40  $V_{RRM}$   
0.475  $V_F$  @ 3.0 A  $I_F$



**5A VSK 5 Series:** 20/30/40  $V_{RRM}$   
0.450  $V_F$  @ A  $I_F$



**15A VSK15 Series:** 20/30/40  $V_{RRM}$   
0.60  $V_F$  @ 15.0 A  $I_F$

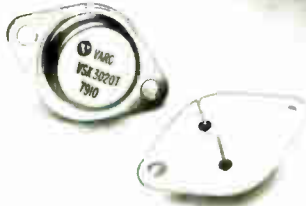

**30A VSK30T Series:** 20/30/40  $V_{RRM}$   
0.64  $V_F$  @ 15.0 A  $I_F$



**30A VSK30S Series:** 20/45  $V_{RRM}$   
0.64  $V_F$  @ 30 A  $I_F$



**40A VSK40 Series:** 20/30/40  $V_{RRM}$   
0.62  $V_F$  @ 40.0 A  $I_F$



**60A VSK51 Series:** 45  $V_{RRM}$  0.60  $V_F$   
@ 60 A  $I_F$



**60A VSK51B Series:**  
45  $V_{RRM}$  0.63  $V_F$   
@ 60 A  $I_F$

## Look to Varo for the widest choice of Schottky devices for power supplies.

Efficiency is today's basic design criteria, and energy-saving begins in the power supply. That's why Varo has developed the most comprehensive line of Schottky devices around today. From a practical, dual in-line bridge family to a tough, 60 amp braided lead rectifier, we've got your requirements covered. Devices are available now; ready to meet your prototype or production schedules.

For application info, specs or a sample device, call: (214) 271-8511. Varo Semiconductor, Inc. Box 40676 Garland, Texas 75040.



## The world's leading rectifier company

Customer Service 7D  
Varo Semiconductor, Inc.  
Box 40676; Garland, Texas 75040  
Please send me:

Specs and pricing on: \_\_\_\_\_

My application is: \_\_\_\_\_

Name \_\_\_\_\_

Company \_\_\_\_\_

Address \_\_\_\_\_

City \_\_\_\_\_

State \_\_\_\_\_ Zip \_\_\_\_\_

Phone \_\_\_\_\_



# The first burn-in "system"

We've designed and built the first burn-in equipment that's truly a "system" rather than a collection of power supplies, ovens and controls. We call it BISIC™.

The BISIC™ System is the only modular system in the industry that can be easily modified to your own changing requirements; a system that can perform both static and dynamic

burn-in selectively in the temperature chamber under program control, with nitrogen purge; and the only system with its own auxiliary heat exchanger.

With BISIC™ you can simulate eight months of operational stress into a few hours, thereby screening out the devices under test that are likely to fail.

We've taken the time to design a true "system" so we invite you to take the time to evaluate it before you make that important buying decision. We back our BISIC™ Burn-in Systems with the same know-how and support services you've come to expect from our Gross and Fine Leak Testing Equipment and CENTRISAFE® Centrifuges.



**Corporate Offices & Manufacturing Facilities**  
2040 N. Lincoln St., Burbank, CA, 91504, USA (213) 846-9200  
TLX 194811 (TTI INTL BUBK) Cable: TRIOCAL

**Field Sales Offices:**  
1400 Sterlin Road, Mountain View, CA, 94043, USA, (415) 969-9600, TWX910 379-6940  
1F-7F, Block 3, 6th floor, Lorong 1, Toa Payoh North, Singapore 12, 2540257, Telex 78623276  
Albrecht-Durer-Strasse 4, 6200 Wiesbaden, West Germany, (06121) 401856, Telex 4186449

Circle 101 on reader service card

**Request our 24-page  
Burn-in Information  
Package.**

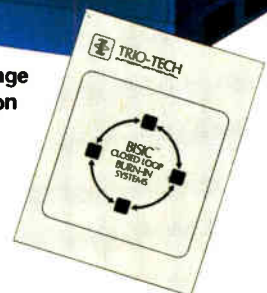

TV sets, but the problem in January 1959 seemed to be price. "The large number of specialized transistors that are called for by current designs places set costs in a range of \$350 to \$500," *Electronics* reported. Ac-operated portables were then selling for around \$150.

Nevertheless, only six months later Philco showed a completely transistorized, battery-operated portable that listed for \$250. And six months after this, Sony announced a transistorized battery-operated portable that listed for \$300 in Japan.

**A**s color television moved slowly and expensively from the laboratory to the living room, the question of frequency allocations for all television remained frustratingly unresolved. Broadcasters, receiver manufacturers and the Government tussled with the problem starting in the mid-1940s and continuing into the 1960s. There was similar agitation over color TV standards, though not as long-lasting.

In 1945 the Federal Communications Commission had allocated to television the vhf channels plus additional uhf space, 440 MHz wide, for experimental operations. But by 1948, TV was racing ahead at such break-neck speed—improvements in sets, conflicting color transmission systems, more and more receivers in homes—that the FCC "froze" all applications for television station licenses and permits pending a study of channel allocations and engineering standards for the TV set. Not until July 1952 was this freeze lifted.

An attempt was made in 1949 to set up worldwide engineering standards for television sets. In July of that year representatives from 11 countries met in Zurich and agreed on three points: the aspect ratio should be four units horizontally to three units vertically; interlacing should be adopted and the 2-to-1 odd-line method used; and vertical scanning and the power-system frequency should be independent. There was no agreement on scanning standards.

The London Conference of the International Radio Consultative Committee was host to 22 nations in July 1950. U. S., French, Dutch, and British TV versions were inspected by the conferees. Picture brightness was compared with flicker rate, and consideration was given to modulation polarity and dot-interlace schemes for resolution improvements. But in the end, the conference concluded that as yet it was too early to mandate color TV standards.

It praised the invention of the tri-color (three-gun) picture tube, however. And it asked the French to rescind their 819-line TV scanning system, which seemed to stand apart from any system then used in Europe or the U. S.

The only point agreed to by most conferees was that a system in the 525-to-625-line range would eventually be the international standard. But there never was an international standard.

After the U. S. adopted its standard of 525 lines at 30 frames per second, most of Europe, Asia, Africa, and Australia adopted theirs: 625 lines/25 frames. Britain used 405 or 625 lines. France stayed with its 819-line system, alternatively using 625 lines. South America and

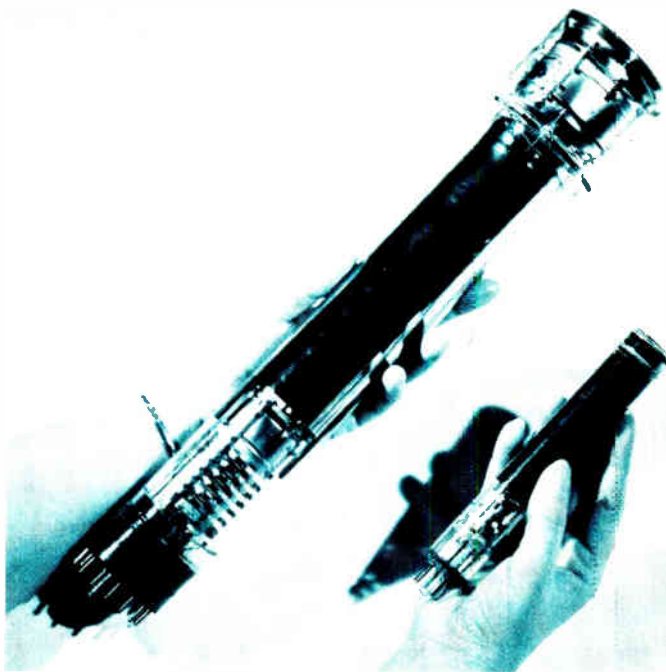

**New light.** A major advance for television broadcasting was the introduction by RCA in 1950 of the vidicon, shown here with its predecessor, the image orthicon. Its small size and simple, rugged construction made it ideal for portable camera applications.

Japan decided to adopt the U. S. standard.

Immediately after World War II, engineers were in general agreement that a channel wider than 6 MHz was necessary for satisfactory transmission of color images and that any color system adopted would therefore be incompatible with the standards of the monochrome system. Researchers turned to the ultrahigh-frequency portion of the spectrum to develop their experimental wideband color-TV systems. The field-sequential method of transmission, put forward by CBS, was considered to hold the most promise.

The television panel of the Radio Technical Planning Board, meeting to discuss color methods at its first postwar gathering in December 1946, favored a color TV standard that would provide the same resolution and freedom from flicker as the monochrome system—525 lines per frame and 180 fields per second. But this standard implied a channel width of more than 15 MHz.

The scanning standards proposed by CBS were designed to fit the transmission into two adjacent 6-MHz channels—525 lines per frame at 144 fields per second. These scanning parameters could accommodate the color transmission in a 12-MHz channel, although the maximum highlight brightness of the images produced would be reduced to about a seventh that obtained with the 180-field system.

CBS petitioned the FCC for immediate acceptance of its wideband system in the uhf portion of the spectrum. RCA suggested that color be sent on a simultaneous basis, using the monochrome scanning standards of 525 lines and 60 fields. The monochrome receiver would be tuned to one component of this signal—that corresponding to the green primary image—by means of an external adapter. A laboratory demonstration of this simultaneous system was presented, but the system was not yet ready for field tests.

In March 1947 the FCC denied the CBS petition. But in



## WHAT SPERRY UNIVAC IS DOING IN THE MINICOMPUTER BUSINESS.

---

# WE'RE GIVING OEMs THE BUSINESS.

---

Literally.

We're out to build the biggest, best OEM base in the industry. And we've decided to do it the fastest, surest way possible. By offering OEMs the best deal in the business.

---

## HOW DO WE DO IT?

---

Easy. You tell us your problem. We'll solve it. For example:

Have you ever been interested in becoming a supplier to a specific vertical market only to find you already had too much invested in software to warrant conversion to a new system with an expensive start-up price tag?

We've got a plan that provides you with a specific vertical market software package. We know where to find software that runs on our hardware with all the necessary capabilities. So we can practically eliminate start-up time and make your new system profitable with your very first sale.

---

## WE WANT TO SUPPORT YOU.

---

Opening doors to vertical markets is only the first step in our plan. After we get you started, we keep you going. We'll provide marketing support suited to your specific market. And we'll provide leads from your geographic area.

---

## YOU CAN'T LOSE.

---

Because we're out to win. And we've got

the support that can make it happen. Sperry Univac was first in the computer industry. And we're growing from the success established by Sperry Univac with over \$10 billion in installed systems worldwide.

That total support includes a heavy commitment to the kind of research and development that produced some of the first systems to run COBOL, FORTRAN, PASCAL, RPG II, TOTAL, Timesharing, Transaction Processing and a mix of communications protocols concurrently.

And we're going to keep it up. Providing a wide-range of products at the forefront of technology is as much our business as selling and delivering equipment.

We've done just about everything we can think of to make working with Sperry Univac easy. And of course, all our products are supported by 10,000 technicians servicing our hardware worldwide.

If you can think of anything else we can do for you, give us a call right now. We mean business.

For more information write to us at Sperry Univac Mini-Computer Operations, Marketing Communications, 2722 Michelson Drive, Irvine, CA 92713. Or call (714) 833-2400, Marketing Communications.

In Europe, write Headquarters, Mini-Computer Operations, London NW10 8LS, England.

In Canada, write Headquarters, Mini-Computer Operations, 55 City Centre Drive, Mississauga, Ontario, L5B 1M4.

**SPERRY**  **UNIVAC**

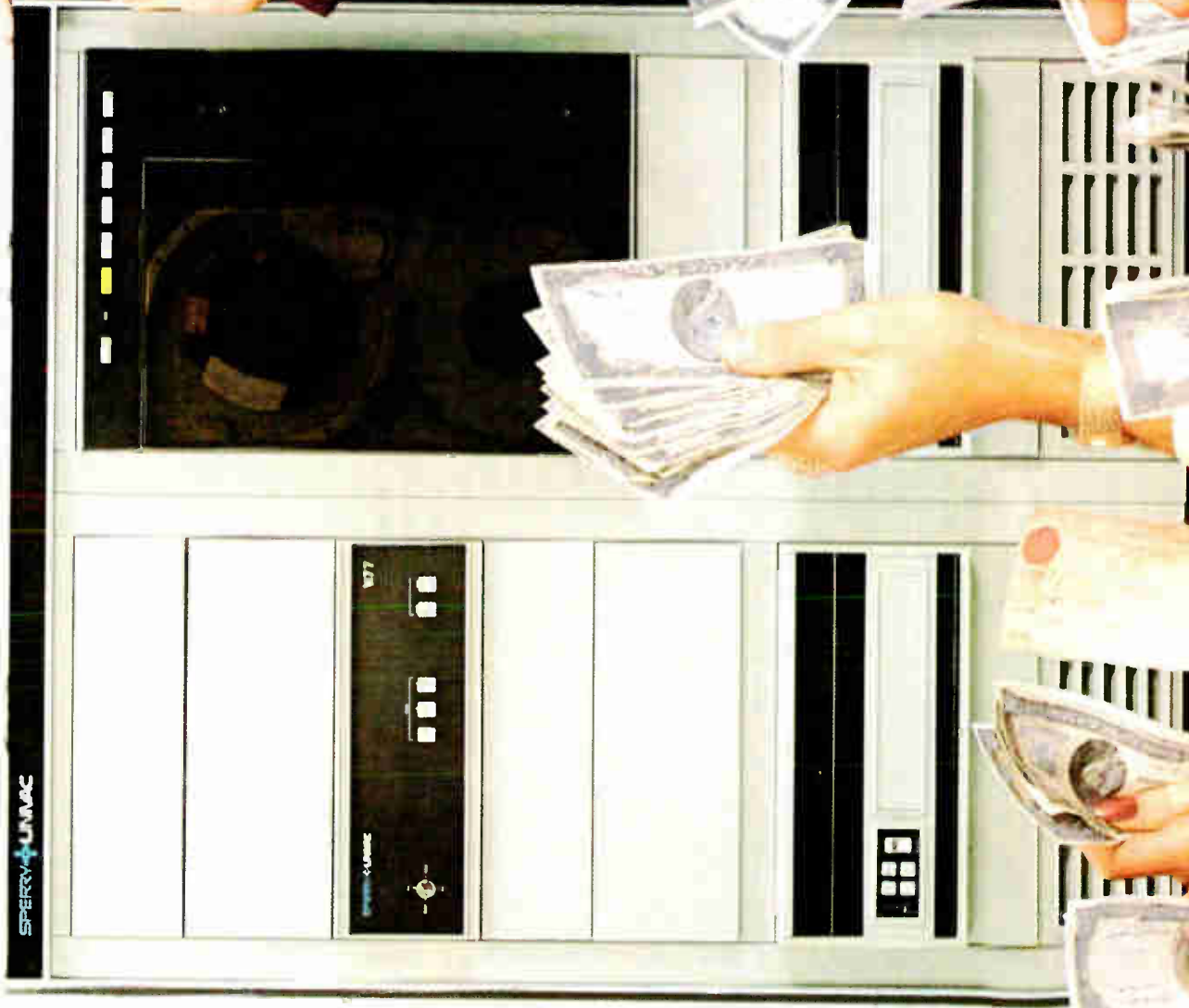



July 1949 CBS demonstrated its field-sequential system before the American Medical Association convention in Atlantic City, N. J. The demonstration, which employed scanning standards suitable for a 6-MHz channel, convinced the majority of those who observed it that the field-sequential system was capable of rendering excellent images, even with a 6-MHz limitation. The standards used were 405 lines per frame and 144 fields per second. They had been chosen to augment the vertical resolution at the expense of the horizontal resolution and to permit flicker-free operation at the minimum acceptable level of image brightness.

By October 1950 the FCC had made up its mind. It adopted the CBS field-sequential color standard of 405 lines and 48 color fields, interlaced, leading to a flicker rate of 48 Hz. Since this color standard and the existing black-and-white standard were incompatible, the commission indicated that TV sets should have a manual or automatic switch that would select the monochrome scanning standards in one position and the CBS color standards in the other. The Federal agency said it would have preferred a compatible color system if one had been ready for commercial use.

RCA carried its opposition to the FCC ruling to the Supreme Court, which in May 1951 upheld the FCC's order. On June 25, 1951, regular color telecasts to the public began in New York City with the CBS system.

It was to be more than two years—December 1953—before the FCC reversed its decision and approved a compatible color-TV system. In the interim, confusion and contention swept the television industry.

At least two compatible systems were in contention: the line-sequential and the dot-sequential.

The line-sequential display had been first demonstrated in 1949. In it, successive lines in red, green and blue were scanned. Since the display involved triple interlace, however, objectionable traveling patterns intruded on the picture.

RCA had been working on a dot-sequential system in which three sets of phosphor dots in the primary colors were interspersed in sequence along each line. The company had demonstrated a color tube in May 1950 that had 351,000 dots arranged in triangular groups. Behind the tube face was a metal mesh screen containing 117,000 holes. A color receiver using a new shadow-mask tube would probably cost 20% to 25% more than a comparable black-and-white set, RCA estimated, but the set would be compatible with existing monochrome broadcast standards.

The National Television Standards Committee recommended the dot-sequential system. The standard it proposed was an adaptation of the black-and-white arrangement, with a chrominance subcarrier located about 3.58 MHz above the frequency of the picture carrier. On the chrominance carrier would be two color-carrying signals that would be added to the monochrome system's luminance signal to provide hue and saturation of the color image. The chrominance carrier was to be modulated in phase to change hues. Saturation information, sent by a-m, was to represent the ratio of the instantaneous chrominance amplitude to the instantaneous luminance amplitude.

The scanning frequencies chosen—15,734.264 Hz horizontally and 59.94 Hz vertically—were 0.1% lower than the nominal monochrome standards and precisely defined because of the requirement that the chrominance signal be an odd multiple of half the line-scanning frequency. This action ensured that the chrominance signal would be virtually invisible on the CRT of a monochrome receiver.

The FCC adopted the recommendations of the standards committee in December 1953. In the U. S., TV color compatibility was no longer a problem.

The matter of frequency allocations was more troublesome. By 1950 there was wide recognition in the United States that there were not enough television channels available. When the FCC ended its freeze on TV station permits in July 1952, it made available 70 channels in the uhf band from 470 to 890 MHz. But uhf stations were not money-makers.

One FCC commissioner, T. A. M. Craven, proposed consolidating all TV channels in one continuous block from 174 to 324 MHz—25 channels in the upper end of the vhf spectrum. In January 1959, another commissioner, R. E. Lee, suggested that all television be made uhf. And in February the FCC chairman, J. C. Doerfer, said: "Expansion of the vhf band is the logical solution and would create the least disruption."

Expansion of the vhf band it was. Rather than bury uhf, however, the Federal Government decided to spend \$2 million to put a uhf test site atop the Empire State Building in New York City. It planned to conduct studies during fiscal years 1961 and 1962 to find out definitely whether or not uhf television would work in the New York market area.

**A**dapting the cathode-ray tube for color TV was a major problem for designers. A secondary problem lay in the circuit area, and part of this problem was in achieving compatibility with black-and-white systems. RCA is generally credited with introducing major improvements in CRTs and the Hazeltine Corp. with playing a leading role in the systems and circuits arena.

Early color CRTs had used a clumsy arrangement of three separate electron guns for scanning and a bank of mirrors for the color-mixing process. Researchers developed two basic tubes: one with three self-contained guns, the other with a single electron gun scanning at three times the rate to do the work of three guns.

The vidicon, announced by Paul Weimer, Stanley Forgue, and Robert Goodrich of RCA in May 1950, was the first camera tube to employ the principle of photoconductivity, not photoemission, as its predecessors had. Its major advantage was its size; it was smaller than an image orthicon because of its simple construction, and this made it ideal in portable applications. Because no structural limits were placed on the photoconductive material, the electronic scanning spot imposed the only limit on image detail. As many as 200,000 picture elements could be accurately scanned from a photosensitive area no larger than 0.2 square inch.

Harold Law's shadow-mask tube, developed at RCA in 1951, used three electron guns, each of which excited

one phosphor dot, either red, blue or green. The guns were so placed as to beam electrons through an apertured plate (mask) onto the phosphor screen placed parallel to it. The screen contained 900,000 holes, arranged in groups of three to correspond to the groups of red, blue, and green dots. Three signal-processing circuits were used to feed the red, green, and blue scanning signals between the grid and cathode of each gun. Color mixing relied on the human eye's ability to retain three-tone images produced by each dot group.

A version of this tube was in RCA's dot-sequential system, which was shown to the FCC in hearings on color compatibility in June 1950. Despite its drawbacks—screen brightness limited by the brightness of the image; the need for precision mask alignment; and the need for congruent scanning patterns—the tube was widely used until about 1970.

E. O. Lawrence's single-gun Paramount tube, developed at the University of California in 1951, used 1,200 horizontal strips of phosphor arranged in a repeating red-green-blue and blue-green-red pattern to overcome the mask and scanning disadvantages of the shadow-mask tube. Deflection plates running parallel to the phosphor lines were used to deflect the scanning beam selectively, so that it could be focused on any of the phosphors at instants when the video signal amplitudes were appropriate to control its luminance.

The Lawrence invention never achieved practical importance because of its need to switch from phosphor to phosphor periodically, which inherently lowered screen brightness.

There were other improvements that from a system viewpoint were just as important as tube advances. The Hazeltine Corp. introduced in 1950 a new method for processing so-called dot-sequential images. The constant luminance technique removed the dotlike appearance of observed images, reduced the tendency of finely colored areas to shimmer, and made the image less susceptible to rf interference, all while using a 4-MHz video channel.

The images provided by the constant-brightness method were reported to be of such high quality that they were indistinguishable from those attainable with a 12-MHz TV channel.

**S**ales of color TV sets were somewhat disappointing after the FCC swing to compatibility standards in 1953. There was not the rapid growth that had marked the expansion of black-and-white TV in 1947-48.

RCA began commercial production in December 1954 of receivers using its 21-inch color tube, with a retail suggested price of \$895. Hoffman Electronics planned limited production using the RCA color tube and a price range of \$895 to \$995. Other companies that announced limited production included Admiral, DuMont, Emerson, Motorola, Olympic, Magnavox, and Sentinel. Westinghouse introduced a set employing a 22-inch rectangular all-glass color tube for a table model that was not much larger than a 21-inch black-and-white set.

Industry executives estimated that retailers would sell between 50,000 and 750,000 color TV sets during 1955;



**Short take.** Another nail in the coffin of the 78-rpm phonograph system was the 45-rpm record and changer introduced by RCA in 1949. Earlier, the 33-1/3 rpm long-playing system devised by CBS Laboratories started the revolution in the recording industry.

the average of all guesses was 300,000. In fact, the industry sold about 35,000 sets.

There were not enough color tubes. RCA was producing only 2,000 a month during much of 1955. There were not enough color programs being telecast. And the sets were deemed too expensive.

In July 1956, RCA and Admiral both introduced color sets listing for less than \$500 retail, and the number of TV stations that could obtain network color programs over Bell System facilities reached 203 in 141 cities. By contrast, there had only been 130 stations in 101 cities at the end of 1954.

Growth continued cautiously. TV retailers sold fewer than 100,000 color sets in 1956. The industry did not sell a million color sets in a year until 1964.

**T**he phonograph industry, meanwhile, was in the throes of a revolution. Peter C. Goldmark, Rene Snepvangers, and William S. Bachman of Columbia Broadcasting System Laboratories announced a new long-playing record in June 1948, and the industry never was the same again. The 33 1/3-rpm LP disk could play as long as 50 minutes, compared with 8 minutes for a 78-rpm record. The grooves of the newcomer were 2.6 mil wide, against 6 mil for the 78-rpm record. The bottom radius was 0.2 mil, against 1.5, and the LP disk had an average of 260 grooves per inch of radius, compared with 100 for the 78-rpm record.

It was not the first time that 33 1/3-rpm disks had been





**On guard.** Computer-controlled operator consoles built by IBM were part of the high-performance ground radar system known as Sage, an ambitious aircraft defense system developed for the Defense Department, deployed in the U. S. and Canada, and linked by computers.

produced for the home market. They had been tried as early as 1931 as part of an attempt to offer movies with sound; the disks played as long as a single reel of film. But these attempts failed because the engineers could not cut the groove pitch fine enough to secure a substantial increase in recording time; the noise and distortion were high.

Keys to the new LP were Vinylite plastic for the pressings, a new efficient, lightweight tone arm and cartridge, and mechanical refinements in the turntable driving mechanism.

In March 1949, RCA introduced the 45-rpm record and changer. The groove width was similar to that of the LP, but the smaller record, turning more rapidly, could hold only about 5 minutes of sound. The system's advantage was the fast, simple changing mechanism built into the phonograph's center post; the player held eight records, for about 40 minutes of playing time.

Despite the clear advantages of the LP for classical music and the 45 for popular, the 78 was still outselling both as late as 1954. In that year the industry shipped 121 million 78s worth around \$24 million, 76 million 45s worth some \$21 million, and 24 million LPs valued at about \$22 million.

There had been two approaches to stereophonic disk recording: the vertical/lateral technique and the 45/45. In the former, one channel was recorded vertically and the other laterally in a single groove. In the 45/45 technique one channel was identified with a 45° motion on the inside groove wall and the other channel with a -45° motion on the outside groove wall. The quality of most of these early stereo disks was poor, however; they suffered from mechanical difficulties, including cross-coupling between the channels.

But by 1957 vertical/lateral equipment had reached

the commercial stage. And a commercial 45/45 stereo system was also announced in 1957. The Standards Committee of the Recording Industries Association of America adopted the 45/45 as technically superior to the vertical/lateral system. It was one of the rare times that the consumer electronics industry had decided on a standard before producing competing equipment.

There were improvements also in turntables, amplifiers, and speakers. Transistors first appeared in high-fidelity gear in a humless preamplifier-equalizer in early 1956. The Fisher Radio Corp. mounted three transistors on a printed-circuit board to boost a low-level input sufficiently to drive a conventional amplifier system. The transistors permitted the engineers to match the input to low-impedance magnetic cartridges without resorting to transformers.

There were also dramatic advances in tape-recording equipment. *Electronics* reported in August 1948: "Magnetic tape carrying three simultaneous channels gives a striking illusion of presence when played back through properly oriented speakers." Much of the stimulus for the stereo disk apparently came from the success of recorded stereo tape. The three channels were flat within 5 decibels from 50 to 10,000 cycles. "At the normal running speed of 1 foot a second," the magazine noted, "a full reel of quarter-inch tape plays for 20 minutes." Of course this oddball tape machine did not set the standard for the medium, which settled for only two channels at 7½ or 15 inches per second.

In June 1955, RCA announced an experimental color video tape recorder, and Ampex planned to deliver three prototype video tape recorders to CBS by August 1956 and to begin commercial production of the machines in February 1957. The prototypes sold for \$75,000 each. RCA announced a new color video tape

# The Panasonic Dream Machine.

Selecting the right microcomputer for your product is tricky business. There are so many variables. Like the technology. What's available to fit your design requirements? With how many on-chip functions? How many instructions? How fast? How much memory?

Now there's one family of microcomputers with all the right answers. The Panasonic 4-bit MN1400 series.

## Three technologies

Panasonic MN1400s are available as C-MOS, P-MOS and N-MOS to fit your specific design requirements. You can fit the right chip to your design.

	Model	Package	On-Chip Memory	
			Instruction ROM	Data RAM
N-MOS	MN1400	40 Pin DIP Plastic	1024 x 8 bits	64 x 4 bits
	MN1402	28 Pin DIP Plastic	768 x 8 bits	32 x 4 bits
	MN1403	16 Pin DIP Plastic	512 x 8 bits	16 x 4 bits
	MN1404	16 Pin DIP Plastic	512 x 8 bits	16 x 4 bits
	MN1405	40 Pin DIP Plastic	2048 x 8 bits	128 x 4 bits
	MN1406	40 Pin DIP Plastic	Extreme	64 x 4 bits
P-MOS	MN1430	40 Pin DIP Plastic	1024 x 8 bits	64 x 4 bits
	MN1432	28 Pin DIP Plastic	768 x 8 bits	2048 x 8 bits
	MN1435	40 Pin DIP Plastic	32 x 4 bits	16 x 4 bits
C-MOS	MN1400	40 Pin DIP Plastic	1024 x 8 bits	64 x 4 bits
	MN1453	16 Pin DIP Plastic	512 x 8 bits	16 x 4 bits
	MN1454	16 Pin DIP Plastic	512 x 8 bits	16 x 4 bits
	MN1455	40 Pin DIP Plastic	2048 x 8 bits	128 x 4 bits

## Varying computing power

The 12-strong MN1400 microcomputer family offers devices with varying amounts of computing power, so you can choose the chip that meets your specific requirements. And even if your memory needs change, you can substitute another model within the family and save your basic design. You pay only for the computing power you need.

## They're all on the chip

We put all these microcomputer functions on a single chip:

- ALU
- Up to 16,384 (2048 x 8) bit ROM
- Up to 512 bits (128 x 4) RAM
- Two 4-bit parallel input ports
- 4-bit parallel output port
- 8-bit output port with PLA
- With 12 discrete output lines
- 8-bit counter/timer
- Clock generator

Add to that the fast 10...s instruction speed and a powerful instruction set with up to 75 versatile instructions that let you computerize a variety of end products with ease.

And you needn't stop with design. Panasonic takes you from concept through production with software and hardware development tools: cross-assemblers, edit software and debugging and prototyping hardware, and, of course, fast turnaround in mask preparation.

So if on-chip capability has been giving you sleepless nights, take the Panasonic cure. For complete information and prices write to Panasonic Electronic Components, One Panasonic Way, Secaucus, NJ 07094; or call (201) 348-7269.

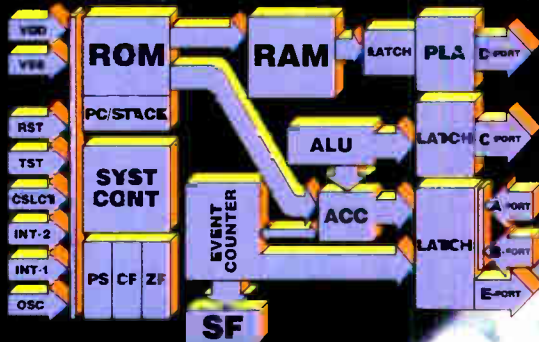

**The 4-bit  
microcomputer with  
three technologies  
and varying  
computing power**



**Panasonic®**  
just slightly ahead of our time

Circle 104 on reader service card



# FOR A CLEANER, BRIGHTER PICTURE, TRY A TUBE OF MITSUBISHI.



Mitsubishi cathode ray tubes will do wonders for your image.

Because each of our high-resolution color CRTs actually discriminates among 64 distinct colors.

Our radar CRTs give your data systems the kind of pin point clarity that assures pin point accuracy.

And our black and white CRTs differentiate between shades of grey.

We begin with our own phosphors, specially developed for their brightness. They give our screens their notably short, or long flicker-free persistence.

Our precision electron gun system insures that each beam is perfectly aligned with the shadow mask.

And, combined with our ultra-fine pitched shadow mask, the gun system produces a picture so sharp, it actually encourages reading fine print.

Another Mitsubishi innovation is our internal magnetic shield. It not only more efficiently eliminates exterior magnetic forces, but makes the unit much easier to service. Not to mention what the magnetic shield does for a purer image, in both monochrome and color.

Mitsubishi's complete CRT line includes high-resolution flying spot scanner CRTs. Fiber optic recording CRTs. High-precision display, radar and beam penetration CRTs.

For more information on a display that's worthy of your data system, call our Display Products Group at 800-421-1132 (in California call 213-537-7132) or write Melco Sales, Inc., at 3030 East Victoria Street, Compton, California 90221.

We'll gladly show you a CRT for sore eyes.

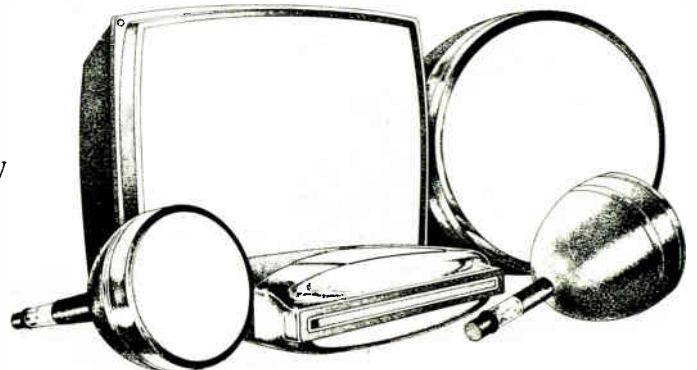

## **MITSUBISHI ELECTRIC COLOR CATHODE RAY TUBES**

*For other Mitsubishi Electric products such as general purpose motors, motor control devices, semiconductors, monitors, CRT's and other electronic apparatus, contact the above.*

recorder/player, with prototypes available in early 1958. The price was estimated at "under \$100,000."

The consumer audio tape recorder business grew from about 255,000 units in 1954 to 700,000 units in 1959.

**R**adar, which had spurred dramatic improvement of the cathode-ray tube during World War II and thereby had laid a sound foundation for television growth in the postwar years, underwent refinement from 1947 to 1960. There were improvements in components, circuitry, and the processing of received data. There were new methods for detecting moving targets.

In the military sector, the ever higher megawatt powers available in transmitters and the ever greater sensitivities of receivers led to the development of long-range radars capable of detecting ballistic missiles. At the same time the development of the pulse-doppler technique allowed for supersensitive radars for ground surveillance and personnel detection.

The civilian sector saw commercial and marine vessels increasingly employing radar aids to navigation, and highway police started to use a form of continuous-wave radar for the detection of speeding vehicles.

Military radar did not begin major development past the World War II stage until the mid-1950s. This is well illustrated by the fact that the SCR-584 long-range search radar was still used in various forms by the military forces of the North Atlantic Treaty Organization until 1955. But by then long-range bombers, missiles, and nuclear weapons were on the scene, and they made it possible for one country to wipe out another with just one surprise attack. The U. S. deemed it necessary to have a long-range radar system to give warning of such an attempt in enough time to mount both defensive and offensive action.

Older radars lacked both the range and sensitivity, and the quickness of response to do the job. What is more, they could not distinguish fast enough between a potential enemy and the hordes of civilian aircraft that now filled the skies. Fortunately the automatic operation that was required for the new job became available in the mid-1950s with the advent of high-speed digital computers. These made it possible to mechanize the gathering and analysis of radar data.

The most ambitious undertaking of this sort was the development by the Department of Defense of the semi-automatic ground environment (Sage) system. It was designed to control weapons defending the U. S. against air strikes.

High-performance ground radar sets in the Sage system were installed in the U. S. and southern Canada and pointed toward the North Pole. These gave almost complete coverage of the skies except at low altitude. This was the traditional weak point of the system, due to ground radar returns and the curvature of the earth.

These radars were linked to central computers, which, among other chores, identified civilian flights from flight plans stored in their memories and directed interceptor aircraft to unidentified planes. But all this was not enough as aircraft got faster and faster and the time available to react to an attack became shorter and short-

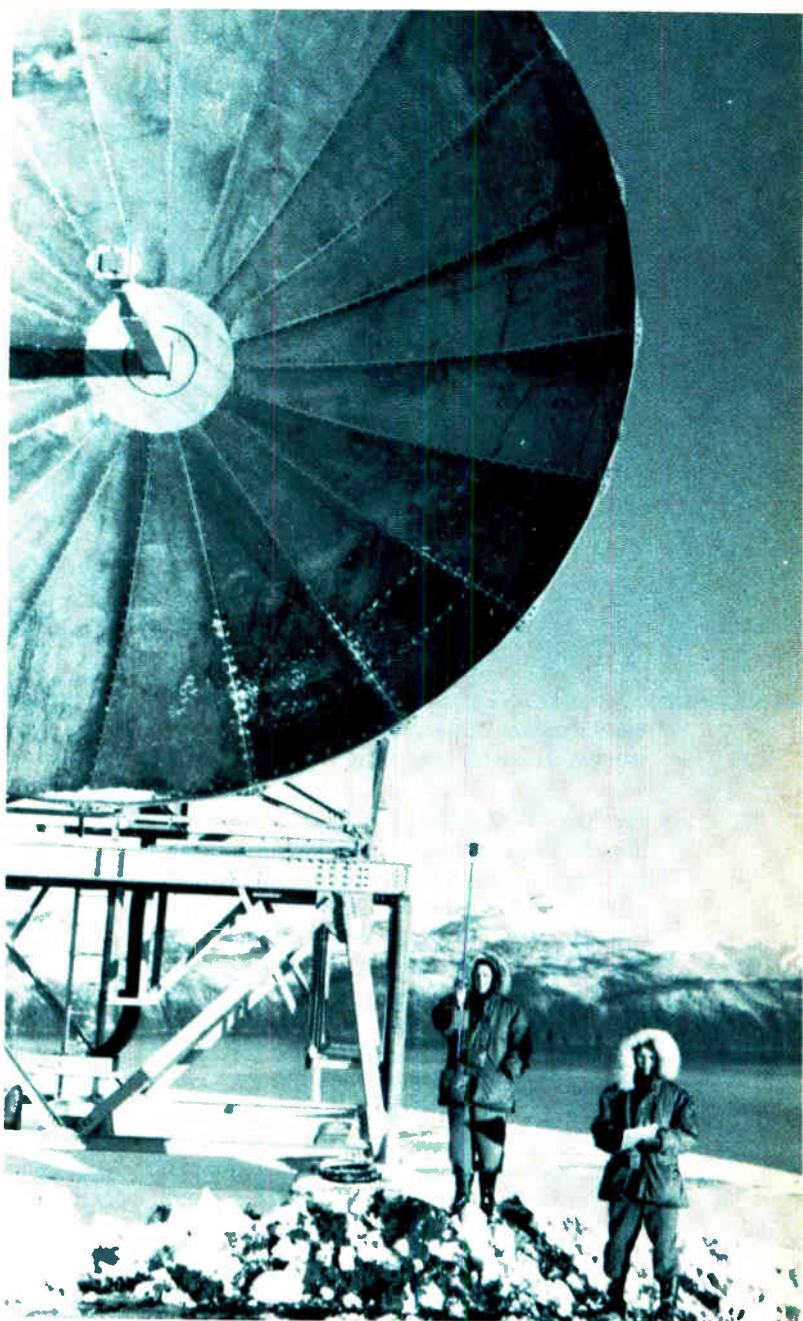

**Outpost.** As aircraft speeds got higher and higher, available reaction time to an attack required longer-range equipment. This Distant Early Warning (DEW-line) station was one of a chain of such installations set 200 miles apart in mid-Canada.

er. More and longer-range installations were put up in the 1950s in mid-Canada. This Distant Early Warning (DEW) line, which cost \$1 billion, was able to detect and locate the faster aircraft but not missiles. So the DEW line was superseded by the Ballistic Missile Early Warning System (BMEWS).

The first BMEWS station, built in Greenland in 1959, had four antenna arrays, each standing 165 feet high. The transmitters put out more than 2 million watts of peak power in two fanlike beams, one above the other. These were pointed at the North Pole and were capable of detecting a missile 3,000 miles away when it reached a



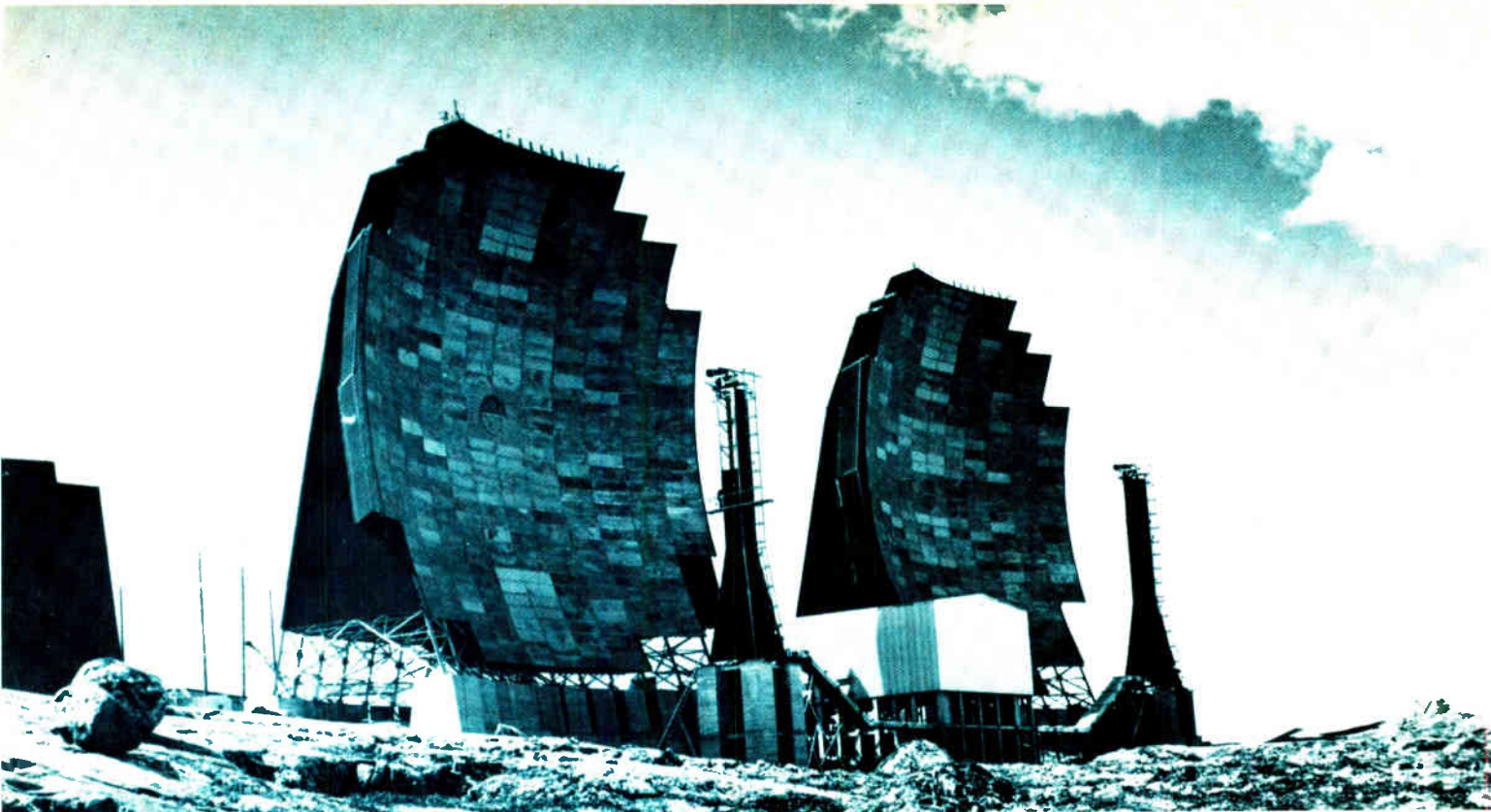

**Missile seeker.** This pair of antennas was part of the Ballistic Missile Early Warning System (BMEWS) built by Western Electric in Labrador. BMEWS could detect missiles 3,000 miles away at a height of 600 miles, giving about 20 minutes of warning.

height of 600 miles. Two sets of data—received as the missile passed through first the lower and then the upper fan beams—enabled computers to calculate the missile's course and to give about 20 minutes of warning.

While the early-warning systems were perhaps the highlight of radar development of the time, other military applications were not ignored. Small combat surveillance radars, for one, resulted from the need to detect such moving targets as a creeping soldier or a moving Jeep or tank. Such radars were built in the mid-to-late-1950s, and they incorporated a combination of both continuous-wave and pulse-wave techniques. They were dubbed PD (for pulsed doppler) radars, and several types were built. One was a small, portable set called the Silent Sentry.

The Silent Sentry was able to detect moving tanks or troops 3 miles away by converting the radar echoes it received into audible tones in an operator's earphones. As reported in *Electronics* in the issue of Aug. 14, 1959, the Silent Sentry could tell the difference between a man and a woman on the basis of how they walked. The difference in the sound also made it possible to discriminate a walking person from a running person up to a half a mile away. The location error was less than 25 yards. One version—the AN/PPS-4, produced by the Sperry Gyroscope Co. in Great Neck, N. Y.—had a usable range of up to 5,000 meters.

Another remarkable radar development of the late 1950s flowed from the military need for surveillance of areas without flying directly over them. This led to the development, by the University of Michigan and the U.S. Army Signal Corps, of a side-looking, terrain-mapping radar that provided a permanent record. With this device, the return echoes from a radar transmitter mounted in an airplane were recorded on film during the

surveillance flight. The film was then developed and processed by a computer to enhance the received image. The final result was a detailed picture of the scanned area, as if the plane had flown directly over it.

Civilian airborne radars were not neglected. The U. S. Civil Aeronautics Administration (which later became the Federal Aviation Administration) promoted the installation of ground-controlled approach (GCA) radars. Once these were in place at major airports, traffic controllers could observe airliners approaching in bad weather or at night and “talk” them down to a safe landing by means of radio.

The impact of the transistor on radar was limited in the 1950s. This was because transistors were not yet readily available for this application at reasonable cost. It is not surprising, then, that early uses of the transistor in radar were in the low-frequency, or signal-processing, circuits and not in the high-frequency, or transmission, portions of the system.

**T**he end of World War II signaled the beginning of the growth period for electronic digital computers. Unencumbered by wartime secrecy, the technology flourished, and the computer became a commercial product that soon changed the industrial world. Scientists and engineers who had worked on wartime government computing projects returned to civilian life and contributed to the growth of the industry on both sides of the Atlantic.

Although Britain and the U. S. were neck and neck in early development of the computer, the U. S. began to take a clear commercial lead during the 1950s. Analog computers advanced with the invention of the operational amplifier in the early 1950s, but it was a short-

# An Incredible History...



## Electronics, the Trimmer and Bourns.

If one word is needed to sum up Bourns corporate history, that word would have to be "growth" . . . rapid, continued, and expansive growth.

Launched shortly after World War II when Marlan Bourns introduced new concepts in transducer instrumentation with a device called the linear motion potentiometer, the company that was to bear the name of this young California physicist, was incorporated six years later . . . in 1952. And, it was in that year, too, that Bourns placed into the record the innovative concept of the lead screw actuated trimming potentiometer . . . or trimmer.

Trademarked TRIMPOT<sup>®</sup>, this new electronic device offered an answer for precision trimming of electronic circuitry and opened what is today a major segment of the electronics components industry.

With the trimming potentiometer has come growth . . . in products, in personnel, in facilities and in innovative technological capability. A capability that reaches not only trimming and precision potentiometers, but includes resistor networks, industrial panel controls, miniature transformers, aerial reconnaissance cameras, monolithic integrated circuits, medical equipment and, of course, transducer instrumentation, where it all started . . . more than 30 years ago. Write for the brochure, "A Simple Philosophy" describing Bourns incredible history. BOURNS, INC., 1200 Columbia Avenue, Riverside, CA 92507









# THE SOURCE.

**Nobody offers you more in mass termination - more connectors, more concepts, more cable, more tooling, more proven reliability - than 3M.**

What's in your head right now? Point-to-point interconnects? Designing for circuit density? Reducing interconnection costs? Improving reliability? Today there are so many interconnect options available to the engineer that selection is often as complicated as the design process itself.

3M is The Source for solutions: Scotchflex® Brand mass termination systems. 3M pioneered the development of the insulation displacement concept. We were the first to make it available to electronic designers for industry-wide application.

Scotchflex cable and connectors represent the industry standard for insulation displacement systems. Quality is one reason: 3M's wide range of precision spaced cables and computer-designed connectors give you optimum long term electrical and mechanical characteristics. (Another reason:

the industry has put more Scotchflex mass termination products to work than any other brand.)

You get benefits from the technological leader that you can't get anywhere else. For example, technical back-up from 3M sales and laboratory experts. They can help solve difficult interconnect problems with existing products, or help create special products to fit your needs.

With today's critical production parameters, availability counts. A nationwide network of Scotchflex distributors, backed up by additional inventory in regional locations makes product available to you when you need it. Most of our distributors can also supply you with custom jumper assemblies in prototype or full production quantities.

Nobody offers you more in mass termination than 3M-THE SOURCE.

A hefty promise. But we can prove it, every time you put your mind to work on making reliable interconnections.

## **THE SOURCEBOOK - FREE.**

All the product data you'll need for mass termination is in our 65-page Scotchflex catalog—a valuable design resource. It's yours free. Ask your 3M Scotchflex distributor, or write Electronic Products

Division/3M,  
Building  
223-4SE,  
3M Center,  
St. Paul, MN  
55101.



“Scotchflex” is a registered trademark of 3M Co.

## **SPECIFY THE SOURCE**

# **3M**

Circle 111 on reader service card



# Gould powers any size idea.

Gould Gelyte®  
2.6 A.H. to 30 A.H. Multiples  
of 6 volts. Cyclic and float  
applications.

Gould silver-zinc  
4 A.H. to 250 A.H.  
High energy density.  
Mil-std. Field proven.

Gould Nicad®  
.070 A.H. to 7.0 A.H.  
Polytemp™ for high temperature  
applications and long life.  
P.C. board mounting capability.

Gould Activair®  
Highest energy density  
available. Flat discharge voltage  
profile. Non-hazardous.

From tiny hearing aids to massive communication systems, pocket calculators to giant computers, cordless shavers to submarines... whatever size your idea, look to Gould to make it go.

Because nobody manufactures more battery power than Gould.

Nicad® nickel-cadmium, Gelyte® sealed lead-acid, Activair® zinc-air, silver-zinc... only Gould makes all four. And Gould offers all the flexibility you need. With a wide variety of capacities and configurations.

Gould offers powerful support, too. With design and engineering professionals ready to pitch in and help bring your idea to reality.

Add a nationwide network of stocking distributors and you've also got fast delivery.

Good ideas come in all sizes. Power up yours with the real performer. Go with Gould.

 **GOULD**

An Electrical/Electronics Company

Gould Inc., Portable Battery Division, 931 N. Vandalia Street, St. Paul, Minnesota 55114, Telephone (612) 645-8531

Circle 114 on reader service card

lived advance. Almost immediately the analog approach was overtaken by the rapid pace of digital progress.

While the concept of storing the computer's instructions and data electronically had originated in the U. S., the British were the first to implement the technique. Tom Kilburn and Frederic C. Williams ran the first program on Manchester University's Mark I computer on June 21, 1948. Using a single Williams storage tube that held 32 32-bit words for main storage, and similar tubes for the accumulator and control register, the serial Mark I performed one instruction each 1.2 milliseconds. Maurice V. Wilkes's group at Cambridge University in England ran its first program on its Edsac computer on May 6, 1949.

Meanwhile John W. Mauchly and J. Presper Eckert, the Eniac pioneers who were now established in their own company, had begun early in 1948 to design the binary automatic computer, or Binac, for the Northrop Aircraft Co. With mercury delay lines as the storage medium, the Binac was finished in 1950. The stored-program concept had been proposed earlier for the Edvac computer, which was finally finished in 1950 at the Moore School of Engineering at the University of Pennsylvania.

An electronic automatic computer called Seac was built at the National Bureau of Standards and put into operation in May 1950. In its September 1950 issue, *Electronics* called the serial synchronous machine, which sent signals at a 1-MHz rate, the fastest computer then in operation.

**A**t the Massachusetts Institute of Technology, another significant milestone was reached when Whirlwind I was completed in March 1951 after six years of development. The project had begun at MIT's Servomechanisms Laboratory in 1944 as an effort to develop an airplane stability and control analyzer for the Navy. The project engineers—especially the laboratory's assistant director, Jay W. Forrester—realized that digital computing techniques were needed for the real-time analysis of data. The result was a 5,000-tube, 11,000-diode machine that operated on 15 binary digits.

While most of the other machines in 1951 operated serially—that is, transmitted the numerous bits representing numbers through the machines one at a time—Whirlwind handled the data in parallel fashion, the way Eniac had. Forrester's group had recognized that transmitting the bits together across a set of parallel wires would speed the machine's operation and ease the synchronization requirements.

But lack of a fast memory was a stumbling block for computer designers in the early 1950s. Research concentrated on the storage properties of toroids of magnetic material strung on a matrix mesh of wire—the so-called coincident-current magnetic-core memory.

In January 1950, An Wang (now chairman of Wang Laboratories) and W. D. Woo described work on the magnetic material in the *Journal of Applied Physics*. In the same journal in January 1951, Forrester described the application of the magnetic-core technique to digital



**Silent Sentry.** That was the nickname of the AN/PPS-4 portable combat surveillance radar produced by Sperry Gyroscope Co. in the mid-1950s. With a usable range of up to 5,000 meters, it converted radar returns into audible signals using a pulsed doppler principle.



**First run.** Though the stored program idea originated in the U. S., the British tried it first in the Mark I computer at Manchester University. Shown here in 1952 are (from left) the university's T. Kilburn and manufacturer Ferranti's B. W. Pollard and K. Lorisdale.

information storage, and in 1953 the Whirlwind computer got core memory.

Magnetic-core technology, perfected during the 1950s, offered large, fast, and economical memory to computer designers, and it revolutionized their work. The computer was now ready for mature growth. Eniac, the machine credited with starting it all in 1946, was turned off for the last time on Oct. 2, 1955, at the Aberdeen Proving Grounds in Maryland.

The commercial development of the computer soon



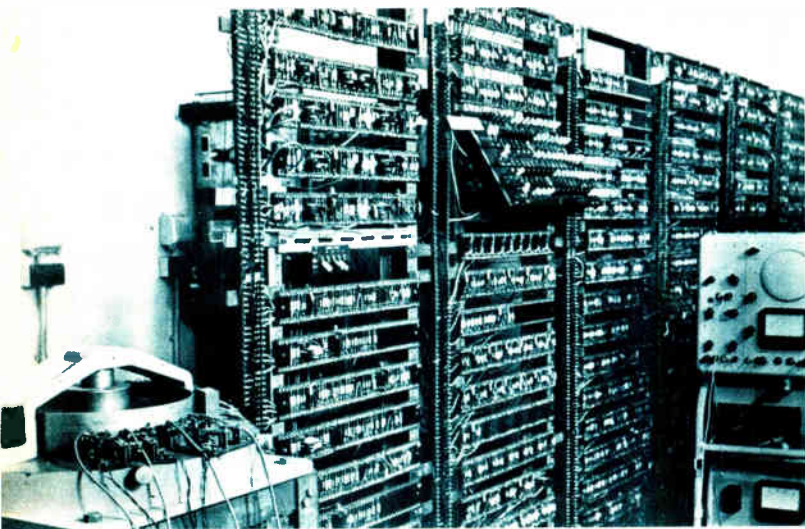

**Transistors arrive.** Another first for the British was this experimental computer assembled at Manchester University, with germanium point-contact transistors. Using a magnetic drum as main store, it was slow but probably the first stored-program transistor computer.

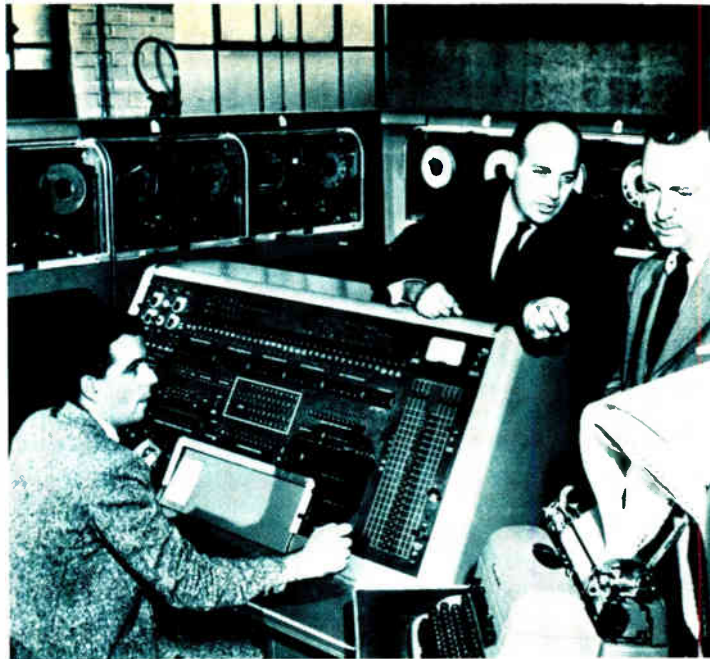

**In the news.** Eisenhower's victory in the 1952 presidential election was projected by Remington Rand's Univac I computer for CBS-TV. A young Walter Cronkite is at far right. The Univac family was responsible for many technological innovations in computers.

turned into one of the most spirited competitions in the electronics industry. A late starter, the International Business Machines Corp. prevailed. By 1959 it had clearly become the dominant computer manufacturer in the world. But the biggest supplier at the beginning of the 1950s was the Remington Rand Corp., a leading typewriter manufacturer and second only to IBM in the production of punched-card equipment. In 1950 Remington Rand acquired the first commercial computer manufacturer, the Eckert Mauchly Computer Corp.

The distinction of delivering the first commercial computer belongs to Ferranti Ltd. in England. Working with Manchester University, Ferranti delivered its first commercial Mark I in February 1951 to the Royal Society Computing Machine Laboratory at Manchester University.

Perhaps of greater marketing significance was the delivery in June 1951 by Remington Rand of its universal automatic computer, or Univac I, to the U. S. Census Bureau. The Univac I was a serial synchronous machine that operated at a 2.25-MHz rate and contained some 5,000 vacuum tubes. The computer could store 1,000 12-digit decimal numbers in its 100 mercury delay lines, while 12 additional delay lines operated as input/output registers. The instruction set comprised 45 distinct instructions, consisting of one-alphabet-character operation code and a three-decimal-digit address. Addition took 0.5 ms and multiplication 2.5 ms. Console switches and an electric typewriter were primary input/output devices, but most significant was the use of a metal-based magnetic tape—the first adaptation of that technology to data processing.

The Univac division of Remington Rand surged to public attention in the presidential election of 1952, when CBS-TV used the Univac I to predict Gen. Dwight D. Eisenhower's election shortly after the polls had closed on Election Day.

Univac was also responsible for many of the early technological innovations in computers. For example, the

transition to the more powerful magnetic-core memory was swift once it was used in 1952 in the model 1103, designed by Univac's newly acquired company, Engineering Research Associates. The 1103 was some 50 times faster than the Univac I.

Univac led the industry in moving away from the vacuum tubes towards solid-state devices in computers. The company also advanced the concept of a special executive, or operating system software, for controlling the computer in 1960 when it introduced the Univac III. The machine was described as nine times faster than Univac II, and it offered concurrent programming. And just as the Univac division had pioneered in core memory technology with its 1103, it introduced in 1960 the 1107, which was the first computer to use thin-film memory as its control store.

Among IBM's earliest efforts was the Selective Sequence Electronic Calculator, unveiled at its New York headquarters in 1948. A hybrid machine consisting of 21,400 electromechanical relays and some 12,500 vacuum tubes, it could add 3,500 19-digit numbers a second. But it wasn't until 1952 that IBM introduced its first production electronic computer—the scientifically oriented 701.

First installed in IBM's New York City headquarters, the parallel synchronous 701 employed 4,000 vacuum tubes and 12,000 germanium diodes and had a master clock frequency of 1 MHz. Working with 36-bit words, the machine could perform 16,000 additions or subtractions per second (62.5  $\mu$ s each) or 2,000 multiplications per second (50 ms each). With Williams storage tube technology licensed from Manchester University, IBM used 72 tubes that each stored 1,024 bits to build a 2,048-word memory with a 12- $\mu$ s memory cycle. Punched cards provided input and output, and also available were a 150-line-per-minute alphanumeric printer and a magnetic-tape driver that stored 100 bits per inch.

IBM followed the 701 with the 702, and by 1954 it had replaced the 701 and the 702 with the faster 704 and



# WHEN SPACE, WEIGHT AND RELIABILITY ARE ESSENTIAL...



## SPECIFY SOLITRON POWER HYBRIDS!

The F-16 fighter is an example of how Solitron technology can meet the defense needs of our nation. Sixteen power hybrids are designed into the most advanced radar system ever built for a fighter plane. We solved one requirement by designing four regulators into a single hybrid package.

At Solitron, we've developed a system for condensing power circuits into the most efficient hybrid packages to meet stringent size and weight requirements. Our power hybrids qualify to Mil-Std-883, Class B and Mil-M-38510 specs with temperature performance over a  $-55^{\circ}\text{C}$  to  $+125^{\circ}\text{C}$  range.

The high reliability hybrids we designed for the F-16 reflect the same excellence in dependability and performance by Solitron in other military programs including:

- TOW
- MAVERICK
- AWACS
- PATRIOT
- ROLAND
- COPPERHEAD
- WILD WEASEL
- POSEIDON
- SIDEWINDER
- TWS
- ANTI-ICBM MISSILES
- STANDARD MISSILE
- F-4, F-14, F-15, F-16, F-18 FIGHTERS
- LO-CAL
- HARPOON
- HAWK
- NIMROD
- PHOENIX
- B-1 BOMBER

*Solitron is the launching pad for successful military programs of the 1980's!*

**Solitron**  
DEVICES, INC.

1177 Blue Heron Blvd.  
Riviera Beach, Florida 33404  
(305) 848-4311 / TWX: (510) 952-7610

**Call toll-free 800-327-8462 today.**

Circle 115 on reader service card





## When the Doctor heard we were famous for our custom work, he wanted to order a bride for Frankie.

**Sorry Doc. It's custom MOS/LSI.**

Match-making is a little out of our line. But we *have* come up with quite a few original creations. For custom MOS/LSI circuits.

Over the past couple of years, in fact, we've designed and built well over 100 different custom LSI circuits for America's leading companies. In every field, from data communications and computer peripherals to business machines, avionics and entertainment.

A leader in creating new MOS/LSI technology, we pioneered high performance n-channel silicon gate devices with our patented COPLAMOS® technology. We also introduced another technological breakthrough that's fast becoming a buzzword in the industry. It's called CLASP® which stands for COPLAMOS Last Stage Programmable.

With CLASP we can complete all of the wafer

Circle 116 on reader service card

processing steps including metalization before defining the bit pattern for read-only-memories.

Standard Microsystems provides a total capability. We design, develop, process, assemble and test state-of-the-art MOS/LSI circuits. That means we can design from scratch, or enter the custom cycle at any point you want. And assisting us at every step is the latest computer-aided design and diagnostic equipment.

So, whenever you need custom LSI, come to Standard Microsystems for your own special creation.

**STANDARD MICROSYSTEMS CORPORATION**

35 Marcus Blvd., Hauppauge, N.Y. 11787  
(516) 273-3100 TWX-510-227-8898

We keep ahead of our competition so you can keep ahead of yours.



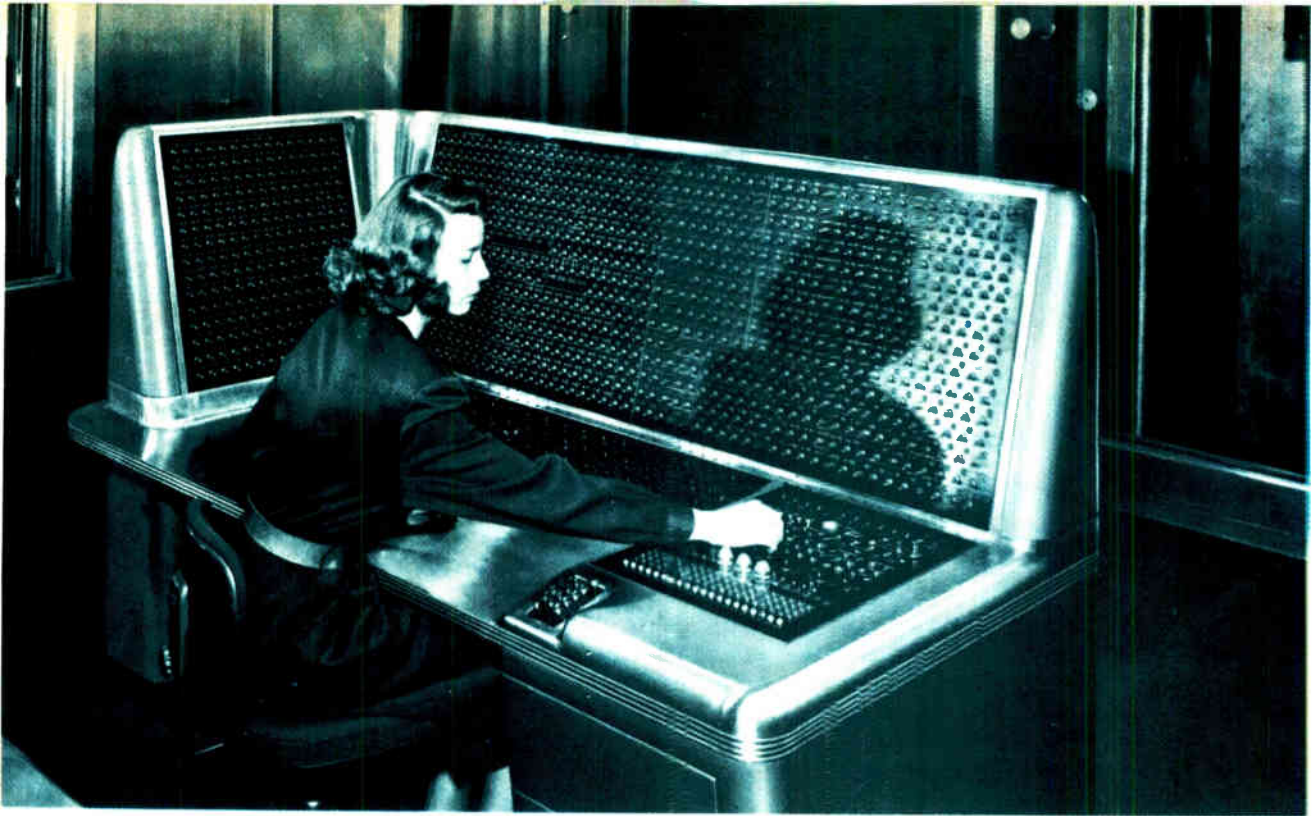

**Early biggie.** One of IBM's earliest entries into the computer field was the Selective Sequence Electronic Calculator (SSEC), a hybrid machine shown here at IBM's New York headquarters in 1948. It used 21,000 relays and about 13,000 vacuum tubes.

705. Both featured faster magnetic-core memory.

A revolutionary disk-storage unit came with the IBM 305 and 650 Ramac machines. Developed at the company's branch in San Jose, Calif., the Ramac had a stack of 50 magnetically coated metal disks that spun at 1,200 revolutions per minute. The surface of the disk could hold 100 tracks of data, each storing 10,000 characters. A single read/write head moved to the desired disk in the stack, then to the desired memory track on that disk—a procedure described at that time as analogous to that used by the single tone arm on a juke box.

IBM joined the switch to transistor logic circuits in 1958 with the introduction of its top-of-the-line 7090 computer. And one of the most successful computers IBM introduced was the transistorized model 1401. Unveiled in 1959, it became one of the most widely used computers in the world.

**B**esides IBM and Remington Rand, National Cash Register and Burroughs were among office equipment makers who went into computer making in the early 1950s. By the middle of the decade they were joined by a host of electrical machinery and electronics concerns, such as General Electric, the Radio Corp. of America, Philco, and Honeywell.

GE, which had been manufacturing the electronics for NCR's operation, began marketing its own computer in 1960. It had opened a computer department in 1955 in Phoenix, Ariz., to produce a system called Erma (Electronic Recording Method of Accounting) for the Bank of America in California. Erma, developed by the Stanford Research Institute, used 12 tape drives and two drum memories, as well as a processor that contained 8,000 tubes. The first computer that GE put on the market, the GE 210, was an outgrowth of the Erma project.

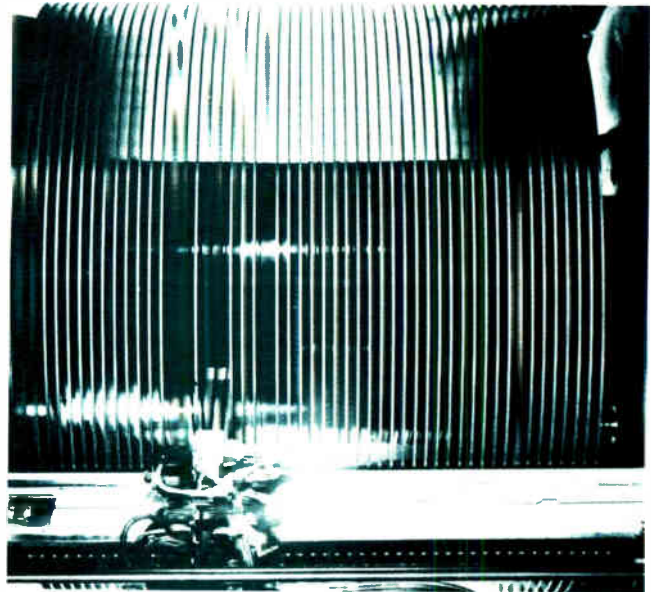

**Juke-box memory.** Considered revolutionary when introduced was this disk-storage unit designed for the IBM 305 and 650 Ramac machines. It comprised 50 magnetically coated spinning disks. Each disk had 100 data tracks, each storing 10,000 characters.

RCA started with the design of storage cathode-ray tubes. In 1952 it introduced the Bizmac, a very large-scale data-processing system based on storage tubes and magnetic-tape storage. The machine was one of the first variable-word-length computers.

RCA's commercial computer effort began in 1958 with the introduction of the model 501. Two years later the company unveiled its 301 and 601 computers, featuring a juke-box type of disk memory that was similar to the one used in IBM's earlier Ramac.

Toward the end of the 1950s several companies were



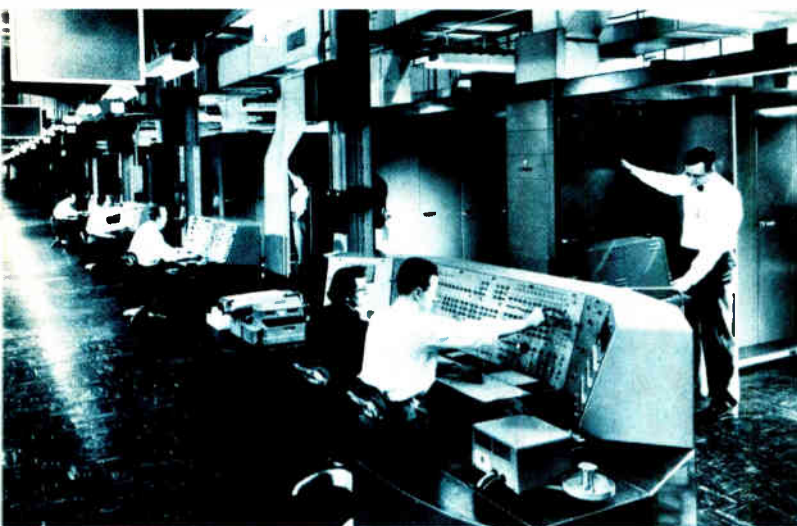

**Show Bizmac.** RCA's entry in the computer field was Bizmac, claimed by the company to be the world's largest data-processing system at the time. This installation was shown at the Army Ordnance Tank Automotive Command in Detroit in 1957.

formed solely to manufacture computers. William C. Norris was elected president of the new Control Data Corp., which incorporated on July 8, 1957. Seymour Cray, a founder of Control Data, made his designing debut in 1956 with the 1605 computer. The machine, delivered two years later, used 100,000 diodes and 25,000 transistors and was equipped with 32,768 48-bit words of magnetic-core storage. Cray designed his second machine for Control Data, the desk-sized solid-state 160, in 1959.

In Maynard, Mass., Ken Olsen, who had worked on Whirlwind at MIT, joined his brother Stan and Harland Anderson to begin the Digital Equipment Corp. on Aug. 23, 1957. They had \$70,000 in capital to manufacture basic digital logic circuit modules.

In 1959 the small Digital Equipment Corp. began to lower the price range of computers with its first Programmed Data Processor, the PDP-1. Based on the company's existing 10-MHz line of logic modules, the 18-bit machine could address as many as 32 kilowords of core memory. The average price was only \$120,000.

With computers proliferating, designers searched for better techniques both to design the machines and to write their instructions. Wilkes at Cambridge University published two pioneering works in 1951 that helped in both areas.

With two co-workers, David J. Wheeler and Stanley Gill, he wrote the first programming text, "The Preparation of Programs for an Electronic Digital Computer," and at a computer conference at Manchester University in July 1951, he presented a paper, "The Best Way to Design an Automatic Calculating Machine." The design method he proposed became the basis for the microprogramming techniques that were to become popular two decades later, in the 1970s.

Univac, with the largest number of users in the early 1950s, led in making the machines easier to program. Early programming had involved coding in so-called machine language—strings of 1s and 0s whose pattern

resembled hieroglyphics. Univac offered first, in October 1952, the more algebraic Short Code, which was interpreted by the machine line by line as it executed the program. But of more importance was the A-0 compiler developed by Grace Hopper for Univac.

This compiler took the entire program, written in easier-to-understand algebraic notation, and translated or compiled it at one time into machine language. The computer was then given the completely translated program to execute.

IBM's attempt to help users of its early 701 resulted in the Speedcoding System, released in 1953. But between 1956 and 1957 IBM put the finishing touches on a more significant programming aid—its Formula Translation method for programming computers, better known as Fortran.

Written by John Backus and by Irving Ziller for IBM's 704 computer, the software allowed the use of familiar algebraic notation. One of the most sophisticated programming languages around at the time, Fortran encouraged the use of computers. Univac also introduced its English language-like Flowmatic programming compiler that year.

One problem plaguing the computer industry at the end of the 1950s was the lack of standard programming languages. By design, every computer had its own machine language. One attempt to topple this tower of Babel was Algol, which stands for algorithmic language. It was developed jointly in 1959 by the Association for Computing Machinery and the German Association for Applied Mathematics.

In May 1959, the Pentagon also moved to establish a common programming language. A committee led by Grace Hopper, then a Navy captain, took just about a year to publish the Common Business Oriented Language, better known as Cobol.

By 1959 a number of applications were encouraging the use of computers. As the Bank of America had shown earlier, the processing requirements of the banking industry could easily justify the expense of computing equipment. Another application perfect for the computer was airline reservations.

In mid-1960 *Electronics* reported that the U.S. computer industry had installed 100 large computer systems that year, bringing the total to 600; 200 medium-scale machines for a total of 800; and 400 small-scale units for a total of 3,000.

The industry was looking forward to a dynamic future. At the Eastern Joint Computer Conference that year, a paper predicted that "miniaturization will allow vast amounts of available electronic storage, and this will drastically alter programming methods."

**T**he greatest international cooperative research effort in history began on July 1, 1957, when researchers in 66 countries undertook simultaneous scientific probings of the earth and its environment. The investigation, called the International Geophysical Year, ended Dec. 31, 1958. Its primary objective was to gather data in three general areas:

- Seismology, gravity, and earth-related subjects.

# IE System 390™

**The most Versatile  
Low Cost Solution  
Available...Today!**

# the ATE innovators

The IE System 390 family of general purpose functional testers meet all of your printed circuit board testing requirements. We offer:

- A digital subset designed to test present and future digital logic circuits which encompass the latest technologies from SSI to VLSI.
- An analog subset utilizing sophisticated software controlled switching matrixes to route a large variety of stimulus and measurement devices to any UUT pin under program control. Ability to route up to 18 device leads simultaneously.
- A flexible hybrid system which combines the analog and digital subsets. The digital and analog subsets are combined through an internal multiplexing system.
- Automatic guided probe diagnostics using CRT instructions to allow low skill level operators to troubleshoot complex digital boards under software control.

**Get all the facts. Call or write:**

Instrumentation Engineering  
769 Susquehanna Ave.  
Franklin Lakes, N.J. 07417  
Telephone (201) 891-9300

Instrumentation  
Engineering



- 1. HIGH SPEED**  
Programmable data rates to 6 MHz with up to 4K bits of data behind each pin.
- 2. MULTI-PROGRAMMING**  
Up to 4 CRT terminals per system for simultaneous program preparation.
- 3. MODULARITY**  
Field upgradable to meet expanding test requirements through modularity of hardware and software.
- 4. ADAPTED "ATLAS" TEST LANGUAGE**  
Easy to learn English-like test language that is UUT oriented. Uses terminology familiar to your test technicians.
- 5. MICROSIM™ SIMULATOR**  
Advanced four-state time domain simulator designed specifically for real-time testing of digital circuits.



**While others are talking,  
we're doing it.**

Circle 118 on reader service card



# STR® technology for high data integrity. Three major tape formats for design flexibility.



## We don't forget the OEM's needs.

The **STR-810** digital recorder is designed for data logging, data acquisition and as a system loader. Using either the 3M DC-300A or DC-300XL cartridges, packing density is 1600 bpi, for respective data capacities of 2.3M bytes and 3.4M bytes per cartridge, using four tracks. Features include microprocessor-controlled tape movement and read/write electronics. For maximum versatility, interfaces include RS-232 and IEEE-488. Or, using control and status lines available, you can interface to specific microcomputers such as LSI-11 and 8080. EPI's optional ANSI X3.56 formatter, with NRZI or phase-encoded personality cards, turns the 810 into a plug-in component for industrial instrumentation and mini/microcomputer-interfaced peripheral markets. Price: \$756 in quantities of 100. **STR-STREAM** is a high-speed, high-capacity version of the 810 designed for Winchester disc backup. Density is 6400 bpi for 17M bytes capacity per cartridge. Features include advanced head design, MFM formatting and compatibility with 8" or 14" discs.

EPI's **STR-610** is a compact, low cost digital recorder that's ideal for use with POS terminals, smart CRT terminals and as a general peripheral for mini/microcomputer-based systems. The 610's recording density is 800 bpi for a capacity of 168K bytes/track, using a two-track 3M DC-100 mini-cartridge. Formatting is ANSI Standard and interfacing is parallel, with a variety of options. Price: \$165 in quantities of 100. The **STR-LINK III** is a high-speed (9600 baud), portable program loader that uses the STR-610's drive system and shares the same specifications. It is used as a field service tool for diagnostic work or as a peripheral in a mini/microcomputer system. STR-LINK III uses a serial RS-232 interface for data communications or data terminal applications, and it can be controlled through RS-232, ASCII control codes, or manually. Price: \$1,561 in single quantity.

**STR-LINK II** is EPI's proven medium-speed (1200 baud) universal portable program loader for programmable controllers and process control systems. Using a standard cassette, it features switch-selectable transmission modes for maximum flexibility. Price: \$1,735 in single quantity.

For maximum design freedom, proven reliability and high data integrity through Speed Tolerant Recording technology, remember EPI—the company that doesn't forget the OEM's needs. For more information, contact Electronic Processors Inc., P.O. Box 569, Englewood, Colorado 80110. Phone (303) 761-8540.

EO 1

*Let EPI remember for you.*

**ELECTRONIC PROCESSORS  
INCORPORATED**

- Meteorology, oceanography, and glaciology.
- The upper atmosphere, the sun and stars, and space.

The last two areas were the most important to communications engineers. Much was learned about the effect of atmospheric absorption and reradiation of rf energy, clarifying the refraction principle that had been so useful in surface communications. A comprehensive study of atmospheric noise showed that the highest levels were over land in tropical regions, with rapid diminution above 50° latitude, whether south or north. It was also determined that because of ionospheric shielding a receiver placed in space would experience less noise from ground-based transmitters than would a receiver placed on the ground.

A high correlation was found between the sun's activity and variations in many earth phenomena, such as magnetism and auroras. And a more complete understanding was gained of the charged-particle energy-exchange process in the ionosphere. The mystery of the Faraday effect—the previously known pattern of rf signal fading—was solved: it was found to be due to the steady rotation of the polarization of signals under the influence of the earth's magnetic field.

The Explorer satellites launched during this time led to the discovery of the Van Allen radiation belts, and more was found of the origins of cosmic noise. These discoveries helped scientists speculate further on the beginnings of earth and the universe.

The dramatic news in space, though, was being made in conjunction with rocketry. The Soviet Union had electrified the world by launching Sputnik I into orbit around the earth. The announcement came on Oct. 4, 1957, while an American Vanguard rocket was on the launch pad at Cape Canaveral, Fla., going through a checkout before attempting the same orbital feat.

Not only had the Russians been first, but their Sputnik also weighed an impressive 183 lb against Vanguard's initial 4 lb. Later Vanguard satellites reached 22 lb—still far from Sputnik's weight.

Americans were still in turmoil over the Russian success when the Soviet Union less than a month later, on Nov. 3, launched the 1,100-lb Sputnik II carrying a dog as a passenger. The United States had lost the first heats of the space race by default. On paper, the U. S. had a significant advantage, with studies by Government laboratories to lean on and Robert H. Goddard's pioneering work in rocketry in the 1920s. Perhaps most

important, it had the premier German rocket team of Wernher von Braun and some 60 of Germany's V-2 rockets captured at the end of World War II.

After the shock of Sputnik, the Navy attempted on Dec. 6, 1957, to orbit a Vanguard payload, but the first stage failed after the rocket rose 3 feet from the pad. Vanguard burst into flames.

Meanwhile the White House had authorized the von Braun team at the Army Ballistic Missile Agency to launch its Explorer-Jupiter combination. American prestige was partly redeemed by the successful launching of the 31-lb Explorer I on Jan. 31, 1958, but the U. S. was clearly behind and more embarrassment lay ahead.

In the summer of 1958 it had become clear that a single agency would have to pull together the scattered space efforts if the U. S. were to match the Russian successes. Although the Pentagon was the logical choice and the Atomic Energy Commission was making a strong case based on its work with nuclear warheads, President Dwight D. Eisenhower preferred a civilian agency for diplomatic purposes.

**T**he decision, backed by Senate Majority Leader Lyndon B. Johnson, was to use the relatively obscure National Advisory Committee for Aeronautics as the nucleus of the new agency. Established during World War I as the focal point of the nation's aeronautical research, this body already had major wind tunnels, laboratories, and even a rocket-launching facility. All it needed was sufficient money and a space project.

The National Aeronautics and Space Act, signed into law July 29, 1958, gave the agency both. The new agency, the National Aeronautics and Space Administration, opened its doors Oct. 1 that year with the Navy's 150-man Vanguard team, 8,000 people of its own, \$300 million worth of facilities, a budget of \$100 million a year, and another \$100 million of unspent Defense Department funds. A week later, NASA's first administrator, Thomas Keith Glennan, a former commissioner of the Atomic Energy Commission and former president of Case Institute of Technology, gave the go-ahead for project Mercury. The goal: put a man in space. The job was assigned to a space task group headed by Robert R. Gilruth at the Langley Center near Hampton, Va.

But NASA still had to wrest the von Braun team from the Army to have a viable space program. After a good



**Design whiz.** One of the founders of Control Data Corp., Seymour Cray (left) established his reputation for innovative design with the all-solid-state 1605 computer, which made its debut in 1956. Cray followed this with the desk-sized 160 three years later.

**Programming guru.** Two pioneering works by E. V. Wilkes (right) of Cambridge University helped advance computer design and use. With two associates he wrote the first book on programming principles, later proposing a design technique that is basic to modern-day microprogramming.





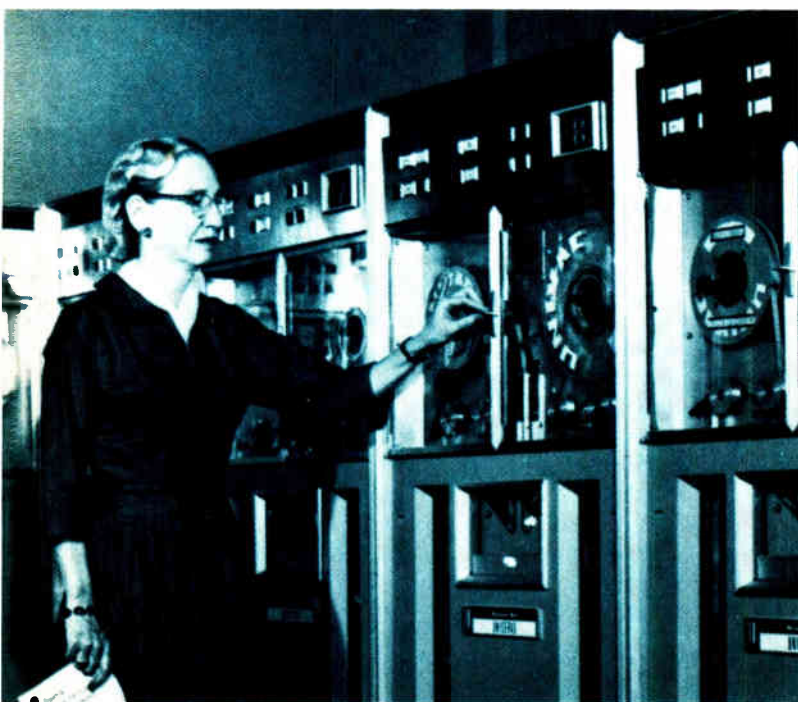

**Captain of industry.** A major development in the programming art was the A-O compiler developed for Univac by Grace Hopper. Later, as a Navy captain, she headed a committee that developed the Common Business Oriented Language—better known as Cobol.

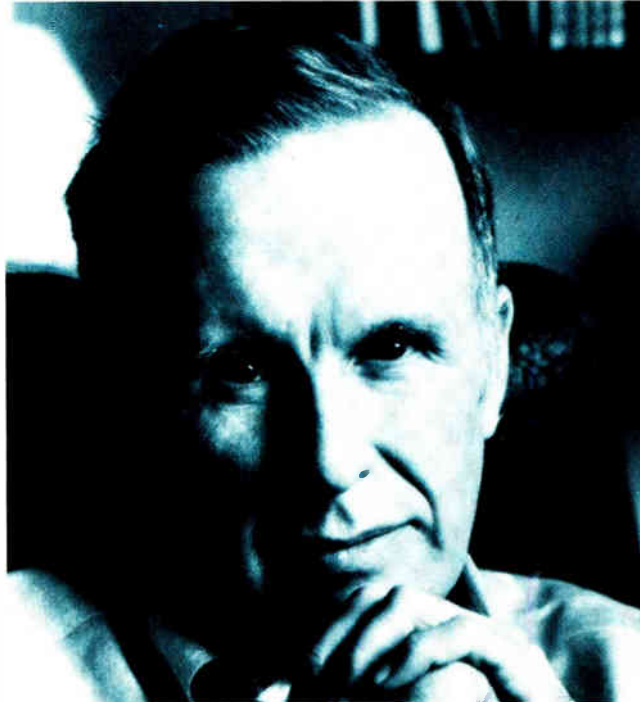

**Father of Fortran.** The Formula Translation method of programming, more familiarly known as Fortran, was written by IBM's John Backus (above) and Irving Ziller for the 704 computer. Its familiar algebraic notation encouraged the proliferation of computer use.

deal of political logrolling this was accomplished in two steps. First, the Army's Jet Propulsion Laboratory at Pasadena was transferred to NASA sponsorship in December 1958. Then the Army Ballistic Missile Agency at Huntsville, Ala. (with von Braun's Saturn booster program), was shifted to NASA control in March 1960. With this nucleus in place, NASA proceeded to build facilities of its own at the Cape Canaveral launching area and at the Goddard Center in Greenbelt, Md.

NASA's biggest problem in its first two years was to develop reliable launch vehicles. Seven of 17 launched failed in 1959, but finally in August 1959 NASA launched its first fully functioning satellite, Explorer VI, and the U. S. space effort was headed for supremacy.

**W**hile American attention was focused on the more sensational aspects of space exploration—putting a man on the moon—communications researchers weighed other values.

Earth satellites, they knew, had several important characteristics for communications. One was the availability of bandwidths far exceeding anything otherwise available. For example, transatlantic television transmission could take place only after a satellite for this purpose had been placed in orbit; it could not be done with transatlantic underwater cables. The satellite concept enabled the globe to be covered without the major disadvantage of wire hookup.

Meanwhile there were major leaps forward in communications theory. In a pioneering paper in the *Bell System Technical Journal*, a Bell Laboratories scientist, Claude E. Shannon, had introduced in 1948 a numerical

measure of the randomness, or uncertainty, with which a message arrived at its destination correctly. He called it entropy, a new use of the thermodynamic term for the level of randomness in matter.

Shannon showed that entropy measures, in a practical way, just how sophisticated a communication facility must be to transmit usable messages, whether by television, radar, or other means. What's more, he proved that this sophistication could be predetermined as a function of the accuracy of the communication system, or the level of errors that could be allowed in the system.

As Shannon himself said in an article in *Electronics* in April 1950: "The newer systems of modulation, such as fm, pulse-position modulation, and pulse-code modulation, have the interesting property that it is possible to exchange bandwidth for signal-to-noise ratio; that is, we can transmit the same information with a smaller transmitter power, provided we are willing to use a larger bandwidth. Conversely, in pulse-code modulation, it is possible to use a smaller bandwidth at the expense of an increased signal power. The discovery of these systems has prompted a re-examination of the foundations of communications theory."

Shannon's work and its later developments became known as information theory. It was put down in great detail by Shannon and a colleague, Warren Weaver, in their book "The Mathematical Theory of Communication," published by the University of Illinois Press in Urbana in 1949.

From then on, all of the system parameters of interest in any electronic communication could be related to one another. These included signal-to-noise ratio, bandwidth, modulation rate, power, and others. In the main,

# Add Electronic Vision to your automated system



## with 100% solid-state CID cameras from General Electric

With both analog and digital outputs, these lightweight, compact camera systems are readily applicable to a variety of automated operations, from machine tool production control to remote monitoring. Precise spatial geometry and driftfree scanning, with no image burn or lag, are among the built-in features of the PTN2200/2201

and TN2500 systems. Both are operable in high magnetic environments and require no operating adjustments.

Added to your existing computer- or numerically-controlled equipment, these reliable camera systems can help reduce waste, monitor continuous processes and perform alignment tasks in assembly operations.

### PTN2200/2201 System

Includes PN2110A Automation Interface. Offers analog, 8-bit digital and binary thresholded video outputs ... variable pixel scan rates to 700 kHz ... simplifies processor or computer interface



### TN2500 System

Parallel analog and 8-bit digital outputs ... selectable interlaced or sequential scan ... antiblooming imaging ... automatic gain control.



### For more information:

Optoelectronic Systems Operation  
General Electric Company  
Room 201, Building 3, Electronics Park  
Syracuse, New York 13221  
315-456-2832 or 2808

GENERAL  ELECTRIC

Circle 122 on reader service card





# DATEL-INTERSIL: A TEN-YEAR HEAD START ON THE FUTURE.

A decade ago, we began our company in response to a need . . . and have continued to meet needs in just about every new important category in data acquisition technology.

50 years ago, Electronics Magazine started down a new road armed only with a Pioneer's vision.

On the occasion of its 50th Anniversary, and Datel-Intersil's 10th, we salute Electronics for guiding the way.

Today, these two leaders continue their world-wide commitment— that of supporting the hundreds of thousands of engineers gathering and converting data.

With more than a million products in use, using Monolithic, Hybrid, and Discrete technologies, Datel-Intersil pledges to the user of the 80's and beyond, the finest technology, highest value, and strongest support in data acquisition.

Whether the application is test, measurement, industrial, analytical and laboratory, research and development, military or commercial, Datel-Intersil will offer carefully planned products with the highest utility, marketed with Datel's personal reputation for integrity.

Imagine: all this, from a mere ten-year-old.



DATEL-INTERSIL, INC. • 11 CABOT BOULEVARD, MANSFIELD, MA 02048 / TEL. (617)339-9341 / TWX 710-346-1953 / TLX 951340  
Santa Ana, (714)835-2751, (L.A.) (213)933-7256 • Sunnyvale, CA (408)733-2424 • Gaithersburg, MD (301)840-9490 • Houston, (713)781-8886 • Dallas, TX (214)241-0651  
OVERSEAS DATEL (UK) LTD.— TEL. ANDOVER (0264)51055 • DATEL SYSTEMS SARL 602-57-11 • CATELEK SYSTEMS GmbH (089)77-60-95 • DATEL KK Tokyo 753-1031

Shannon's theories provided upper bounds on just how efficient a system could be.

The successful use of the maser (which stands for microwave amplification by stimulated emission of radiation) represented a breakthrough in low-noise amplification at microwave frequencies. This amplifier, which had to operate at liquid-helium temperatures, enabled engineers to construct a receiver with no more self-generated noise than that produced by the antenna and transmission line connected to it.

The maser was a byproduct of basic research on microwave absorption by paramagnetic materials cooled to a temperature near absolute zero. Like all amplifiers, the maser depended on control and conversion of energy from one form into a more useful form.

The first clear recognition of the possibility of amplification of electromagnetic radiation by stimulated emission appears to have been made by a Russian, V. A. Fabrikant. He filed for a Soviet patent in 1951, although it was not published in Russia until 1959. In fact, Fabrikant had written about parts of this theory in 1940 and had tried but failed to produce amplification in cesium gas.

Several proposals for masers of various types appeared in American physics journals in the early 1950s. But the real breakthrough and excitement was caused by a short article by James P. Gordon, Herbert J. Zeiger, and Charles H. Townes in 1954. In this seminal paper, they announced that they had indeed made a maser operate in 1954 by using ammonia gas as the active medium. Contributing to their success were Townes's earlier experiments in microwave spectroscopy—the study of microwave absorption in materials.

In later years many other maser methods were tried, including two-level and three-level techniques. But the one with the most practical results was a three-level approach. Here the excited atoms were put through three changes in internal energy to produce the maser amplification action. This maser amplifier was devised by Nicolas Bloembergen, a physics professor at Harvard University, and was the workhorse of the field for many years. By actual measurement, the noise figure of a maser was just over 1 dB, near the ultimate of 0 dB.

A problem with the maser was its inherently limited bandwidth—a couple of hundred megahertz at best. It was difficult to make it more broadband; still worse, the maser had to be operated at liquid-helium temperatures, or about 4° above absolute zero. The expensive and inconvenient refrigerators this required were not suitable for practical communications systems.

But the maser did make a major contribution to communication technology: extension of its concept led to the development of the optical amplifier, or laser.

The maser and laser principles were similar, but the operating wavelengths differed. In 1977, the U. S. Patent and Trademark Office granted a patent covering "optically pumped laser amplifiers" to physicist R. Gordon Gould after a long legal struggle based on one of Gould's notebooks notarized Nov. 13, 1957. But the laser was developed independently in 1958 by Townes, working with Arthur L. Schawlow at Bell Telephone Laboratories. They said it might be possible to cause

vapors of the element potassium to show laser action.

Laser "action" meant that under proper stimulation, the vapor would give off an intense beam of coherent light. A laser beam, it was realized, was ideal for a communication system because of the large amount of information that could be modulated onto it without disturbing its coherent characteristics. Moreover, such a source of energy opened up previously unused regions of the electromagnetic spectrum, and the spectrum appeared destined to be in short supply, if the world's information needs grew as predicted.

The first solid-state laser action was achieved in synthetic ruby, though the ruby available at the time was originally thought to be too poor to give satisfactory results. It was a surprise, therefore, when Theodore Maiman of Hughes Aircraft's Research Laboratory achieved laser action with it in 1960. In 1961, only a few months after this success, the first working gas laser, using a mixture of helium and neon, was announced by Bell Labs. The laser age was now in full swing.

Later, cesium vapor was found to work. Within a few years successful laser action was demonstrated in literally hundreds of materials. Many applications were developed over the next decade, including the first practical demonstration of holography, which Dennis Gabor had enunciated in principle in 1949.

**R**adio communications, with a wartime of experience to draw on, expanded enormously in the civilian sector. When the World Administrative Radio Conference convened in 1947 in Atlantic City, N. J., the 78 countries represented faced increased demand for communication channels in every service. The conference undertook to open the vast region of the spectrum from 300 MHz to 10 GHz. It designated 300 MHz to 3 GHz the ultrahigh-frequency region and the balance of the spectrum the low end of the superhigh-frequency region. The space accommodated experimental TV systems, navigational radar, and common-carrier microwave relays.

In June 1949, the FCC created citizens' band radio in the U. S., with operator licenses for the asking. Unlike amateur radio operators, CB users did not need personal technical qualifications. The original frequencies allocated to CB were 460 to 470 MHz, and there were 41 stations in 20 states at the onset, divided between hobbyists, experimenters, and commercial interests.

Civilian communication of all types had so mushroomed by the end of 1959 that more than 1.7 million transmitters were being operated in the U. S. and 570,000 radio stations had been licensed by the FCC. The stations included 92,000 marine, 81,700 aviation, 81,000 land transportation services, 55,000 industrial, 31,000 public safety and almost 60,000 Class D citizens' band at 27 MHz, a category established in September 1958. Only 5,000 of all the licenses had been issued for commercial broadcast stations—some 3,500 for a-m, 825 for fm, and 672 for TV.

Civilian aviation and communications growth were inextricably intertwined. Though in wartime thousands of aircraft were allowed to roar off relatively uncon-



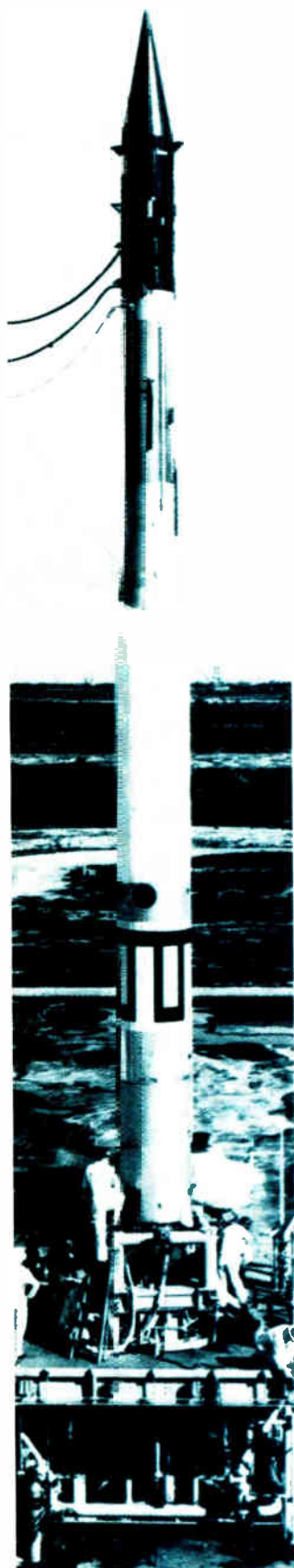

**Embarrassment.** America's shock at the Soviet launching of Sputnik in October 1957 was compounded by the failure of the Navy's Vanguard rocket on the launching pad two months later. More than a year later Explorer I recovered some U. S. prestige.

**Redeemer.** Explorer I, a model of which is at right, was placed in orbit on Jan. 31, 1958, launched by a Jupiter C rocket from Cape Canaveral. The 18-lb satellite discovered the first of the radiation belts around the earth now known as the Van Allen belts.

trolled into the "wild blue yonder," civilian planes depended on reliable electronics for safe operation.

After World War II both commercial and private flying increased rapidly, and air traffic control became a matter of concern. A national network of traffic control centers had been started by the Federal government in 1936. By 1941 there were 15 such centers run by the Civil Aeronautics Authority, a predecessor of today's Federal Aviation Administration.

A vhf omnidirectional radio (VOR) airway system and distance-measuring equipment (DME) were suggested in 1948 by the Radio Technical Commission on Aeronautics, a group of industry and Government experts in aeronautical telecommunications. These recommendations came after a study of air traffic control.

By October 1950 there were 271 VOR stations, and the first VOR airways were commissioned; they linked Kansas City; Denver; Albuquerque, N. M.; El Paso, Texas; Omaha, Neb.; and Oklahoma City in a 4,380-mile network. By 1952 the network extended to 45,000 miles, and the CAA had begun to decommission earlier low-frequency radio-range stations.

Increasing air traffic continued to demand expansion of the available radio frequencies, and in 1957 the CAA began to change to narrow-band equipment that doubled the channels for vhf communications by reducing the spectrum used from 200 kHz to 100 kHz per channel.

Congress, spurred to action by a midair collision of two airliners over the Grand Canyon in June 1956 and two midair collisions of military and civil aircraft in the spring of 1958, finally passed the Federal Aviation Act of 1958. This repealed all the previous aviation legislation and redistributed all the functions to two independent agencies: the Civil Aeronautics Board, with responsibility for economic regulation of air carriers and for accident investigations, and the FAA, with sole responsibility for managing the nation's airspace.

One immediate development was the use of automation in the ground-based phase of air traffic control. Commercial Univac computers introduced in 1956 were installed between 1959 and 1961 at the air route traffic control centers (ARTCCs) in New York, Washington, Pittsburgh, Cleveland, and Boston to prepare flight progress strips that previously had been prepared by hand and to exchange information between centers.

**F**or components, the years 1947 to 1960 were memorable. In addition to the invention of the transistor, there were other important events and trends that also helped shape present-day electronics. They included:

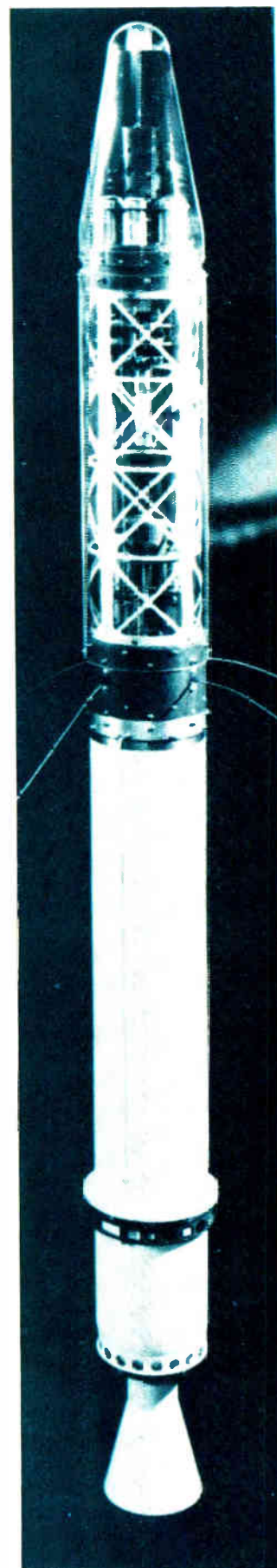

# The Leading Edge

MOS/LSI Technology at  
Solid State Scientific

## Experience puts us on the leading edge.

Solid State Scientific has more than twelve years experience producing quality MOS/LSI ICs. We have focused on high technology in device development, fabrication and testing. This focus has made us an acknowledged leader in such high technology products as DataCom, Memory and Custom MOS/LSI.

**Our leadership is maintained through reliability.** Reliability built in through the most sophisticated wafer fabrication technology available anywhere, all maintained by stringent in-process controls, inspections and tests. This means our standards of reliability are the highest in the industry.

Repeat business by the most demanding customers is a true measure of our products' success. These customers manufacture critical parts for life support, military and aerospace applications. They return to us time after time. They return for reliability at competitive prices. They return because we are on the leading edge of MOS/LSI technology.

**Want more information?** Write or call for our free product guide describing our complete line of ICs: Solid State Scientific, Inc. Montgomeryville, PA 18936; 215 855-8400. EI 4/24 Custom



## Solid State Scientific

Circle 127 on reader service card



## We do not only supply you with film you are getting dimensional stability into the bargain!

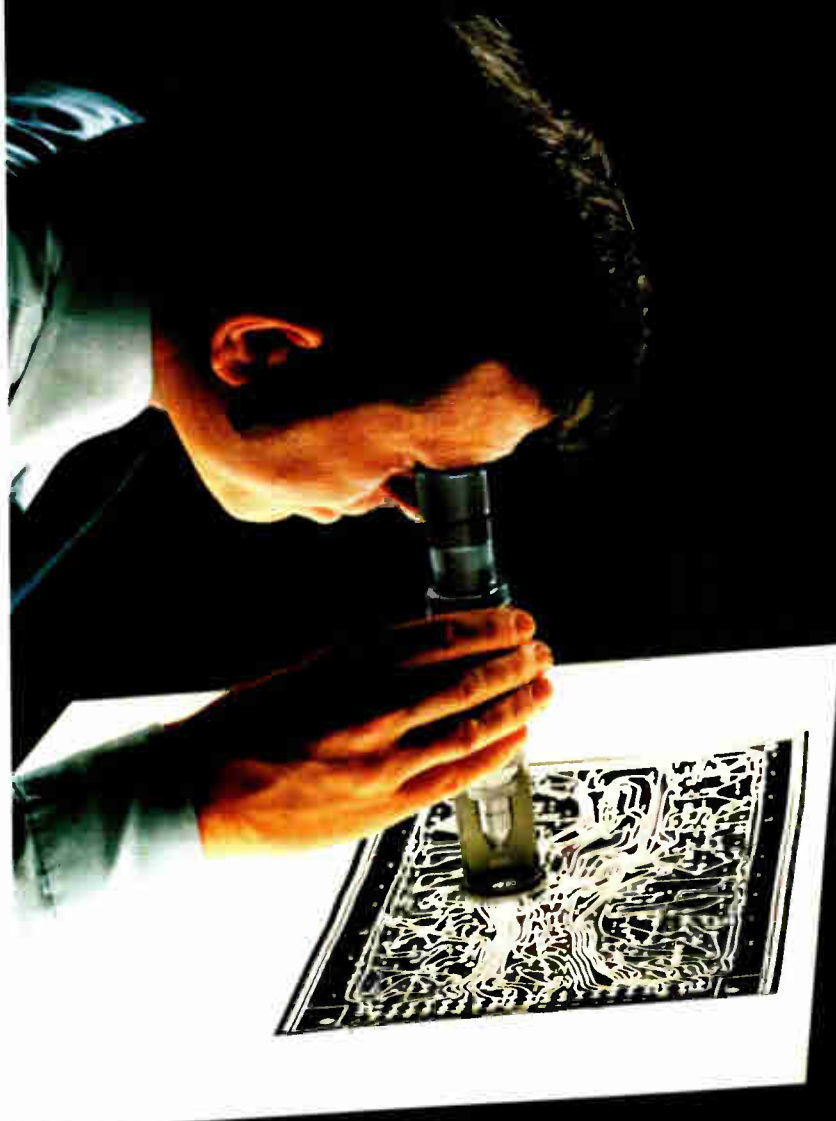

A polyester base that got a special treatment... An extremely thin low gel emulsion...

The two together give Copyline HD and HDU film this extreme dimensional stability.

Films that under all circumstances ensure outstanding quality (as well as line sharpness, contrast, capability of being written on, retouchability, etc.).

Our technician will be glad to show you the numerous possibilities. Also in automatic processing, in Copyline AP 126, Rapimat 65 or in a lith processor, dimensional stability will be ensured.

And this is important, particularly in electronics. When making printed circuits, by way of example. As average always some 10 to 12 superposed layers: extremely small and needing scrupulous care.

You start out from drawings (no problems when making them on Copyline drawing film). Then you work by means of photographic techniques, reduced, duplicated on Copyline HD or HDU film. You will highly appreciate the dimensional stability. For all these films have to fit exactly on each other, without any register differences. Copyline in electronics: the pat answer!

AGFA-GEVAERT N.V.,  
B-2510 Mortse-Belgium

### Agfa-Gevaert: your go-ahead partner!

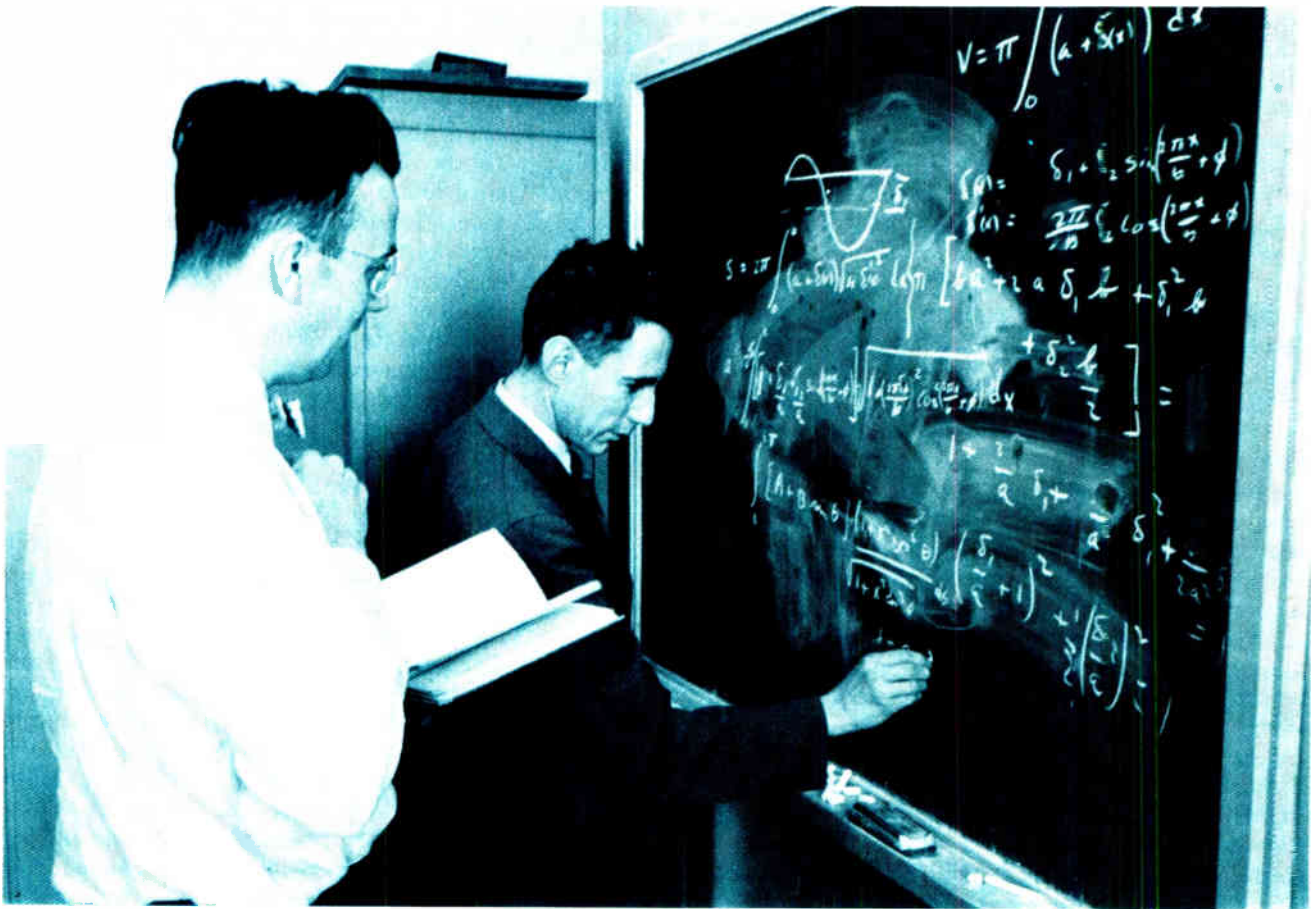

**Enter entropy.** Bell Telephone Laboratories scientist Claude E. Shannon, at the blackboard, wrote the landmark work on information theory. Using entropy as a basis of measurement, it helped define the limits and relate all the parameters of communication systems.

- Miniaturized packaging methods, micromodules, thin films and the start of the integrated circuit.
- The emergence of etched printed-circuit boards.
- High-density wiring with wirewrapping techniques.
- Automatic insertion of parts into pc boards.
- Fully automated television and radio assembly lines.
- Advances in miniaturized passive components.

In addition there were interesting developments in miniature ceramic tubes, but they came too late. They were superseded by transistor technology.

Screened and fired thick-film conductors and resistors on steatite substrates had been used in World War II in the electronic portion of the proximity fuze. After the war, the company that had introduced these devices, the Centralab division of Globe Union Inc., applied thick films commercially, calling its modules “packaged electronic circuits,” or PECs. They were quite successful, as the thick-film technique lent itself to automation.

The circuitry in a PEC in 1949 ranged from simple RC coupling and filter networks to binary counters and complete hearing-aid and telephone amplifiers. Centralab still builds PECs, but transistors and diodes in tiny plastic packages replace the subminiature tubes. Hundreds of millions of PECs have been produced.

The war years had also seen the first attempts at potting modules and circuitry to protect them from the environment. The anti-aircraft version of the proximity fuze, for example, was sealed in wax. In the late 1940s, a

few concerns embedded objects in Lucite and Plexiglass, but this technique was discarded because of the poor electrical properties of the materials. Then, in June 1950, William R. Cuming of Emerson Cuming in Boston discussed the first of the polystyrene cast resins. It had a low dissipation factor and dielectric constant, along with excellent mechanical and environmental properties, and it became a heavily used potting material.

In 1951, the National Bureau of Standards, under Navy sponsorship, initiated a three-dimensional packaging scheme called Project Tinkertoy. The process, which had a component packaging density of 10,000 parts per cubic foot, lent itself to automation.

The building block of Tinkertoy was a steatite wafer  $\frac{7}{8}$  inch square by  $\frac{1}{16}$  inch thick. Components, screened or discrete, were mounted onto screened and fired silver conductor patterns on the wafers. Each had 12 notches with conductive paint in them. About four to eight of the wafers with different components were automatically selected, stacked, and joined mechanically and electrically by machine-soldered riser wires to form a standard module with a tube socket on the top wafer. Each wafer had one to four components.

This method was used by Sanders Associates to produce Navy sonobuoys, but in 1957 a new system—the Signal Corps/RCA micromodule program—made Project Tinkertoy obsolete. RCA engineers concluded that a system based on a smaller, thinner wafer could give them



a parts density 50 times greater than Tinkertoy could. The basic block was a square ceramic wafer, 31 mils on a side and 10 mils thick, with 12 conductively coated notches. The wafers, usually with a single component, were called microelements and were stacked into micro-modules, then potted and plugged into a pc board.

These modules, using transistorized circuitry, were successfully designed for rf audio and digital circuits. The micromodular equipment, with automated assembly, cost about one and a half to two times less than conventionally assembled equipment. The micromodule involved more than 40 companies and cost over \$15 million. It was made obsolete by the integrated circuit.

Miniaturization advanced in 1959 with the development of the thin-film hybrid at Bell Telephone Laboratories. In this method, thin-film conductors, resistors and capacitors, all of tantalum, were sputtered in high vacuum onto a glass or ceramic substrate. By 1960 companies like Varo and IBM were experimenting with the technique. Varo was putting down lumped RC networks onto ceramic substrates. IBM was evaporating thin films of Nichrome, silicon dioxide, and aluminum onto a glass substrate 0.7 inch on a side. Seventeen successive masks were used to form conductors, resistors, and insulating layers. Bare transistor chips were compression-bonded on.

While the packaging of electronic circuitry was evolving from the thick films of World War II to thin films, the etched printed circuit was beginning steady growth to become the preeminent method of interconnection. There had been many false starts. In 1949, however, the Army Signal Research and Development Laboratory at Fort Monmouth, N. J., announced the development of dip-solderable etched pc boards.

In 1950, Powers Chemco started a small pc laboratory under Robert Swigget to investigate the possibilities of manufacturing pc boards with the Signal Corps process. In 1951 the Photocircuits Corp. was formed on Long Island in New York State, and the independent pc industry began.

From this time to 1960, pc technology evolved gradually, with plated through-holes appearing in 1953, glass-epoxy copper-clad laminates in 1952, solder masks in 1955, and the multilayer board concept in 1960.

**A** parallel development with the rise of printed circuitry was the automatic assembly of standard leaded parts into pc boards. In September 1954 United Shoe Manufacturing came out with a machine that could insert parts so fast that 100 boards could be completed in an hour. The unit was capable of inserting axial resistors or jumpers. In March 1955 General Mills built a 24-head automatic insertion system for IBM.

Another form of automation was introduced by R. F. Mallina of Western Electric in 1953—wirewrapping of insulated wire around square pins. This solderless, fully or semiautomatic wiring method is still in heavy use today, particularly in computers and other data-processing equipment.

And while packaging techniques, printed circuits, and automation were speeding ahead, the passive compo-

nents affected by these three developments became smaller and more stable. In the resistor field, deposited-carbon and metal-film resistors, both developed in the 1950s, gave better temperature stability.

Power resistors, too, were changing. Sprague came out in 1954 with the Blue Jacket, a 3-watt wirewound, porcelain-coated unit about 35/64 inch long and 13/64 inch in diameter. These units were about the size of a 1-W carbon-composition type with three times the power rating and less derating at higher temperatures.

In the potentiometer field, resistance elements were made from deposited metallic films and conductive plastics, along with the normal wirewound elements. The new types gave essentially infinite resolution. In the trimmer field, small rectangular units first appeared about 1954–55, followed by small, square trimmer potentiometers in 1960. Both of these types found heavy use in military equipment.

The emphasis in capacitor design through the 1950s was on new materials and techniques to give more capacitance in less space. The prime example was the use of tantalum as a dielectric in polarized and nonpolarized capacitors. The new material allowed high-temperature operation—easily up to 125°C—and a size reduction of two thirds over equivalent electrolytics. For the low-voltage applications of the transistor circuitry of this time, the new small units were ideal. PR Mallory, General Electric, and Sprague produced many of them.

In magnetic components, ferrite and powdered iron cores in varied shapes were giving high-frequency inductors and transformers the versatility and compactness of low-frequency units. Toroidal construction was finding greater use, and metalized glass inductors were giving stability and ruggedness. By 1957 new wires, cores, and insulation were shrinking magnetic components.

In the relay field, the subminiature crystal-can relay made its first appearance in about 1954. The reed relay, developed at Bell Telephone Laboratories in 1950, also began to be used extensively.

Two developments in ceramic tubes were outstanding engineering feats in the 1950s, but both were quickly made obsolete by the transistor. In 1956, under a joint contract from the military and the Atomic Energy Commission, General Electric designed a group of components capable of withstanding temperatures in the 600°C range. One component was a tiny ceramic tube (about the size of a low-level cased transistor) that had no filament. At about 600°C and over, the tube's cathode would emit electrons.

In 1956 GE used these tubes to design and fabricate digital modules that operated at 580°C. About 0.32 inch in diameter and 0.36 inch high, these small units were known as thermionic integrated micromodules, or TIMMs. The circuits proved stable at high temperatures and were extremely radiation-tolerant.

In 1959 the RCA Nuvistor emerged. It was a ruggedized miniature ceramic tube with low power drain and increased performance at high frequency, as well as excellent reliability. The small tube had a pinned base and was aimed at both military and consumer uses, unlike the GE type.

Meanwhile the success of electronic industrial control

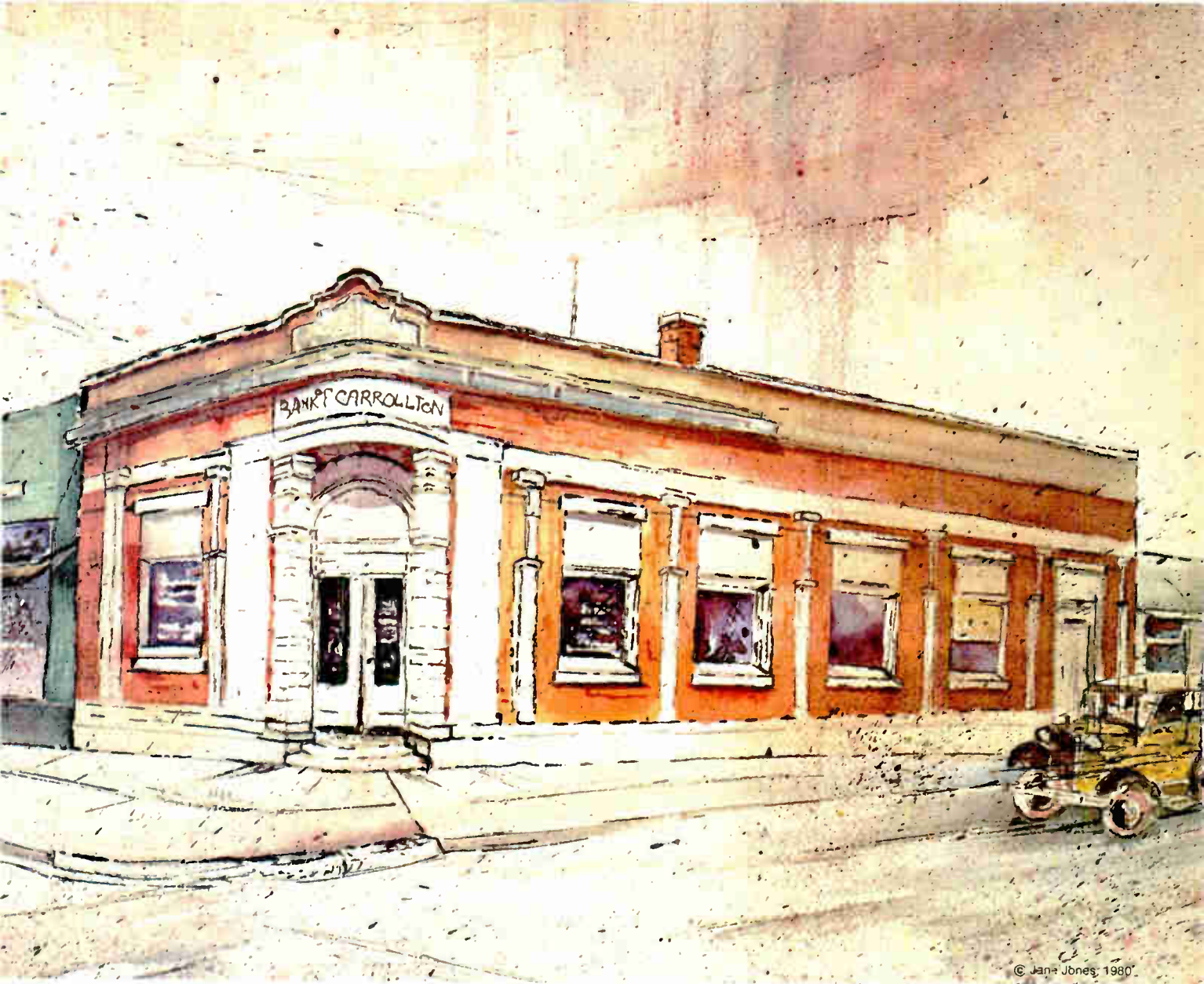

© Jane Jones, 1980

## Only a few blocks from the past, we're building the future.

This peaceful little square is a remnant of the past in Carrollton, Texas. It radiates the image of a quiet little town where nothing much could happen out of the ordinary. But only a few blocks away, some of the most exciting advances in microelectronic technology are being made.

Mostek was one of the first to grasp the potential of MOS technology ten years ago. Since then, we've combined innovative techniques and state-of-the-art engineering with a creative design environment to allow us the freedom to plan well into the future, anticipating the needs of the industry.

When the electronics industry wants to know the latest in MOS-LSI technology, they need look no further than Carrollton, Texas; the quiet town with the exciting future.

For a complimentary print of the above painting write Mostek, 1215 W. Crosby Road, Carrollton, Texas 75006.

## MOSTEK.



# Keep It In The Family.

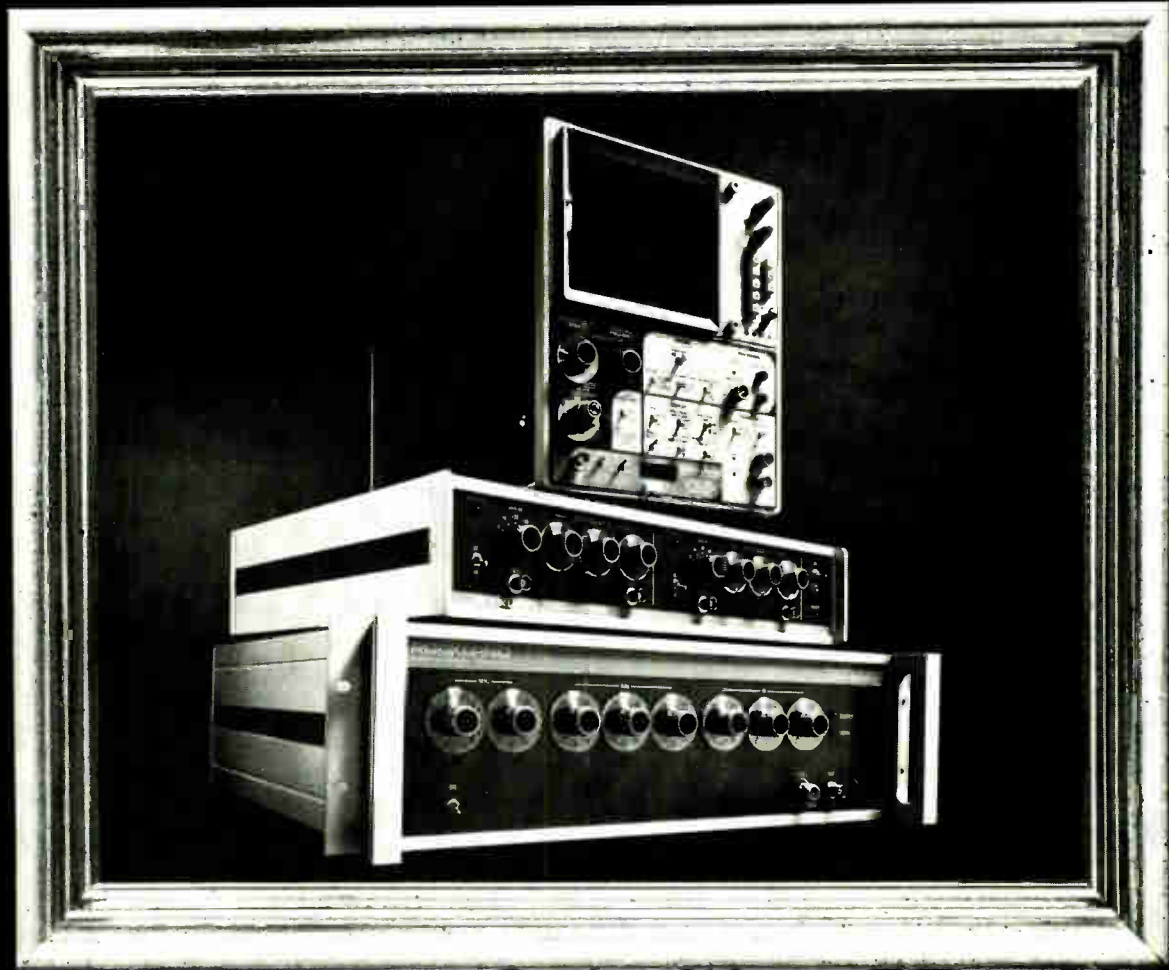

...whether you synthesize, filter or analyze.

When it comes to advanced signal technology, you can count on our family. Because whatever the application, Rockland has a line of Frequency Synthesizers, Filters, and Spectrum Analyzers that offer state-of-the-art performance at competitive prices.

#### Synthesize It

Our frequency synthesizers employ *direct synthesis*, with all the advantages it has over the phase-locked-loop technique: spectral purity; fast transient-free switching; phase continuity;

smooth sweeping; and constant resolution.

#### Filter It

Rockland filters are the industry's first choice for accuracy, stability and wide-range flexibility. They offer unmatched performance in a broad range of signal processing applications, including band-limiting, anti-aliasing, signal-to-noise enhancement and signal smoothing.

#### Analyze It

Our advanced FFT-based spectrum analyzers are well known for their unmatched performance,

operational simplicity, and impressive versatility. For most any spectrum analysis application, they will give you every imaginable piece of qualitative and quantitative data, available.

Want to know more about our fine family of advanced signal technology? Contact us or your nearest Rockland representative for complete data or a free demonstration.

**Rockland Systems Corporation.**  
Rockleigh Industrial Park  
Rockleigh, NJ 07647  
(201) 767-7900

in the war had led researchers to develop even more reliable control tubes with higher transconductances, transducers for temperature and speed, and such power-conversion devices as thyratrons and ignitrons.

By 1950 the chemical, petroleum, textile, pulp and paper, metal-working, and food industries all had experimented with new generations of electronic measurement and control hardware and even with automatic process-control systems. Those closed-loop systems took control completely out of the hands of the operator and gave rise to some workers' resistance to automation.

**T**he equipment of the early 1950s was conceptually identical to today's hardware: transducers and circuits that measured physical quantities like length, mass, time, temperature, level, and pH; automatic controllers that compared the measured to the desired value of a variable and then took action to correct it; control-element drivers like diaphragm motors, electric motors, and solenoids; and recorders and indicators.

In the mid-1950s industry asked for even more sensitive and reliable instruments and control equipment, and electronics suppliers responded. Typical of the state of the art then was the range of instruments available to the oil industry in 1954. It included such aids to exploration as radiation-sensitive scintillation counters, gravity meters employing phototube amplifiers, seismographs, infrared analyzers, oscillograph recorders, and a full line of sensitive RC-coupled multistage amplifiers with miniature 12-v vacuum tubes.

At the same time industrial electronics assumed a slightly digital flavor. In 1956 at least 15 manufacturers, including Bendix, GE, and RCA, offered punched-card- or magnetic-tape-programmed milling machines to the metal-working industry. Some machines used multi-element tubes in digital configurations, among them multipliers and binary counters.

**I**n the era opened by the invention of the transistor, instrument manufacturers were faced with demands for finer resolution, greater accuracy, and broader measurement capability.

The Government and industry were looking for new ways in which to use atomic energy, and they sought research tools to help them understand and apply the new power. In filling that demand, the instrument makers devised techniques that could be applied to frequency measurement as well. This was indeed fortunate, because increased use of the lower portion of the spectrum for radio and television broadcasting was necessitating finer measurement to prevent interference.

For atomic investigations a better way was needed to quantify the scintillations sensed by the Geiger-Muller tube. The Potter Instrument Co. found it in the 1944 invention of the counter circuit by its founder, John Potter (see Chapter 4). This had already proved its usefulness in early computers and in predetermined counters for measuring fixed amounts of discrete objects, such as resistors. In 1948, a four-decade version of the

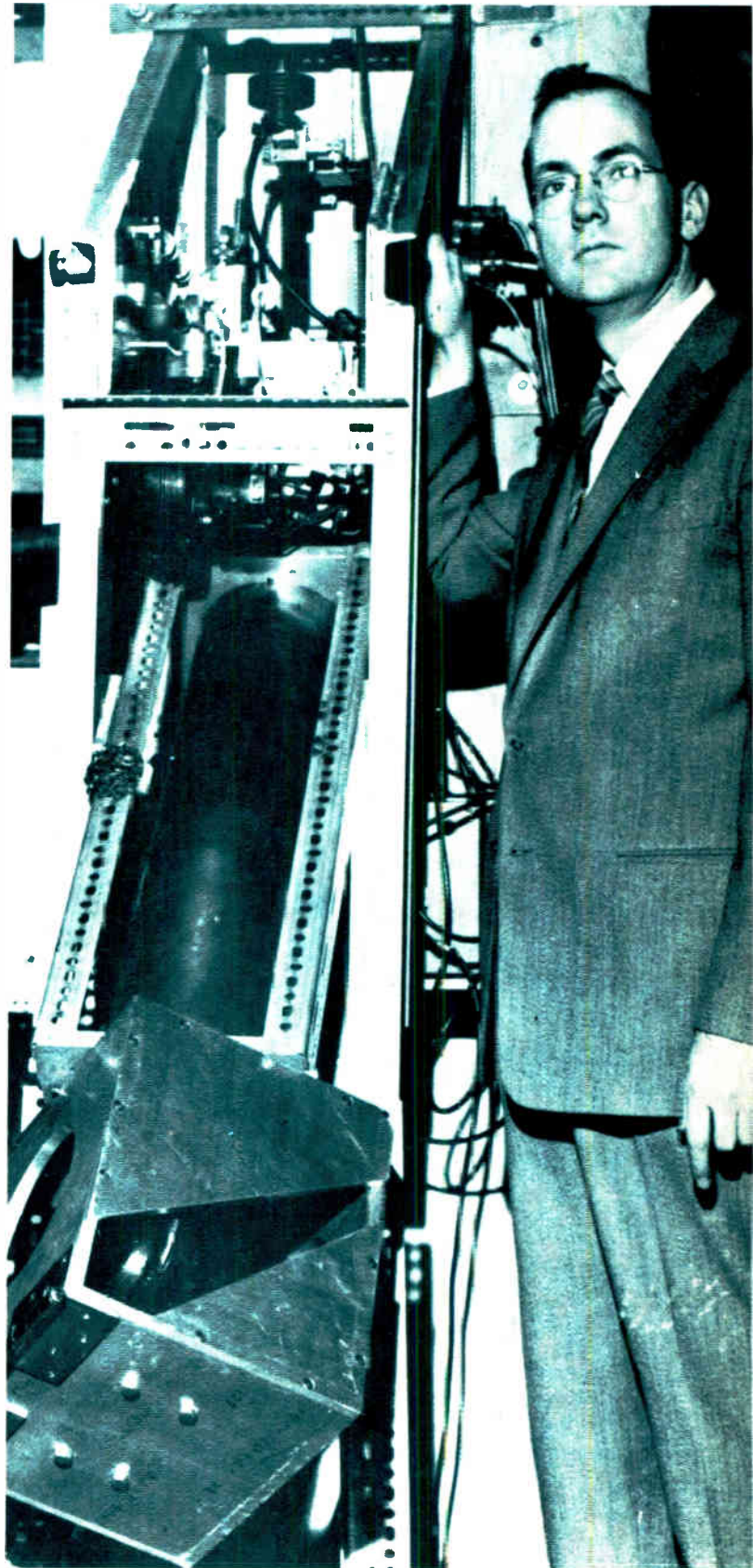

**Low noise.** An early application of quantum mechanics to electronics was the maser, first proposed by a Russian and first built by Charles H. Townes (above) and associates in 1954. It was the forerunner of the laser for which Townes later shared the Nobel prize.



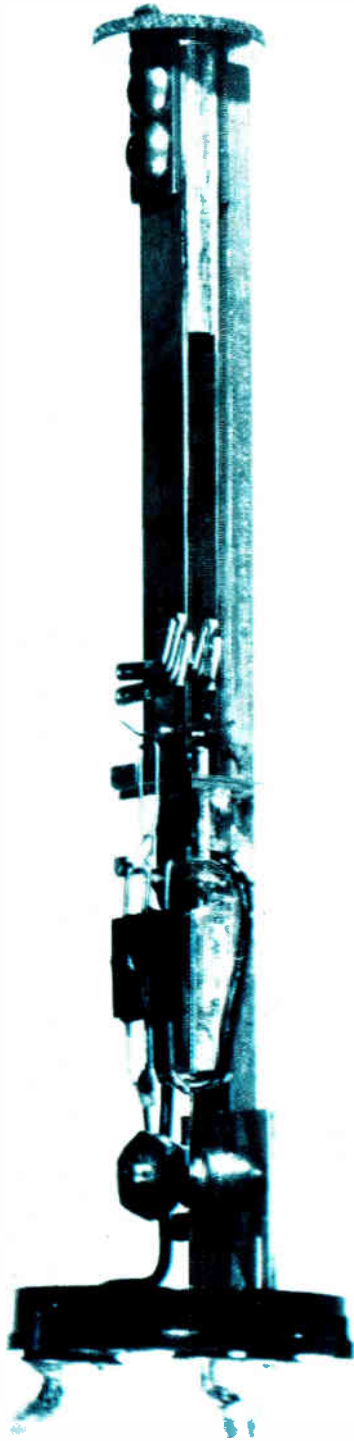

**Magnetic shrink.** The thrust toward miniaturization reached magnetic components such as crystal-can and reed relays developed at Bell Telephone Laboratories in 1950. By 1956, reed relays like those above were showing up in subscriber ringers.

instrument was used in radiation measurement.

In 1949 El-tronics found that it could simplify the reading of a count if it used a different type of circuit, the Higgenbotham, which provided an output directly in decimal notation rather than BCD. Then the Berkeley Instrument Co. realized that adding a time base to the counter would make it much easier to measure the half

life of radioactive materials. With an internal interval timer, the instrument could automatically make the measurement for a known, fixed period, and from this the half life could be derived. The same instrument, researchers realized further, could also be used for time and frequency measurements. Result: the first universal counter was built.

Hewlett-Packard, on the other hand, concentrated on the application of these techniques directly to frequency measurement and in 1952 introduced the first instrument to bear the name frequency counter. It was the model 524A, and it was able to display frequencies up to 10 MHz. On an analog meter, frequencies of this range could be read directly only to within 100 kHz at best. But using the counter display, one could read 10 MHz with a resolution of 0.01 hertz.

The demand for radiation counters attracted Haydu Brothers (later to be known as Burroughs) in Plainfield, N. J. A manufacturer of cathode-ray and other types of electron tubes, it designed the Nixie tube in 1951. These gas-filled, cold-cathode tubes had 10 cathodes shaped as numerals 0 to 9. When addressed by applying a voltage between the anode and individual cathodes, the gas surrounding the selected cathode glowed, displaying the appropriate numeral in pleasing orange.

These tubes, in turn, caught the attention of an engineer named Andrew Kay. Using them, he built a digital meter that excited the cathodes by closing the contacts of telephone relay switches. The relays were set, depending on the voltage level presented to them, by a divider network with a dc voltage across it. Kay formed a company, Non-Linear Systems, to market the digital voltmeter, called the model 419, and in 1952 the first digital voltmeter was sold.

Because of the custom circuitry that went into these early DVMS, they were fairly expensive, as well as bulky. Yet the higher resolution they provided—to 4 digits—was needed in laboratories, and thus they found a narrow market. Not until the end of the decade, when digital computing became more firmly entrenched, was Kay's concept widely employed by the instrument industry.

The speed with which the fast-developing digital computers could solve complex equations presented another problem: how to capture and display the results of these computations. The teletypewriters of the time were not fast enough, and buffer memories had not been developed. The research for a suitable display not only provided a market for new instruments, but eventually it also resulted in new displays for instruments.

The cathode-ray tube had already proved its ability as a display device in oscilloscopes, radar, and television. It was a logical choice for computers. In February 1948, Harrison W. Fuller of Harvard University's Computer Laboratory described the development of the Numeroscope. Built under contract to the U. S. Navy's Bureau of Ordnance, this device electronically generated numbers on the face of the CRT under the control of a computer. It was the granddaddy of all CRT terminals and digital read-out oscilloscopes.

The Government's willingness to pay for the most sophisticated electronics led to measurement refinements throughout the industry and a demand for precise stan-

# MICROSOFT. NOBODY DOES IT BETTER.

In 1975, Microsoft wrote the first BASIC interpreter for the 8080. Today, hundreds of thousands of microcomputers run with Microsoft software. And tomorrow—a full line of system software for the 8086 and Z8000. With microcomputer software, nobody does it better.

**BASIC Compiler** Microsoft's BASIC compiler is the ideal software tool for the development of BASIC applications programs for resale. Compiled object code for any application may be distributed to your customers on diskette or ROM. It safeguards the source program. And execution speeds with our compiled BASIC code are faster than with any other BASIC. Highly optimized, compact object code means maximum efficiency in any application. The BASIC Compiler supports all the language features of our BASIC-80 interpreter. Comes with macro assembler and loader. Runs with CP/M, ISIS-II, TRSDOS. \$395.

**BASIC Interpreters for 8080, Z80, 8086, 6800, 6809** Language features above and beyond any other BASIC have made Microsoft's BASIC the world's most popular interpreter. And now three new versions are available for the 8080, 6300, and 6809. The latest releases of BASIC-80 and BASIC-86 support the new WHILE conditional, plus CHAINing of programs with COMMON variables, dynamic string space allocation and variable length records in random files. All versions have double precision arithmetic, full PRINT USING, tracing, renumbering, edit mode, and many other features. BASIC-80 for CP/M, ISIS-II, TEKDOS: \$350. BASIC-86 standalone on SBC 86/12: \$600. BASIC-68 or FLEX: \$200. BASIC-69 for FLEX: \$250

**COBOL-80 Compiler** The best implementation of the world's most widely used programming language is COBOL-80 from Microsoft. As small business applications become not-so-small, COBOL-80 is ready with powerful use of disk files, data manipulation facilities, CHAIN, segmentation and interactive ACCEPT/DISPLAY. Plus three-dimensional arrays, full COPY facility, indexed and relative files and an optional packed decimal format that saves on mass storage by as much as 40%. Comes with macro assembler and loader. Runs on CP/M, ISIS-II, and TRSDOS. \$750.

## NEW! muSIMP/muMATH-79

At last, a sophisticated math package for microcomputers. muMATH performs mathematical operations efficiently and accurately. Use it to solve equations and simplify formulas; or perform exact arithmetic, symbolic integration and differentiation, infinite precision integer arithmetic and symbolic matrix inversion. muMATH is an invaluable tool for engineering and scientific applications involving lengthy, analytical computations. It is also an ingenious teaching method for all levels of math from arithmetic to calculus. muMATH is implemented in muSIMP, a highly structured language for complex symbolic manipulations. muSIMP/muMATH Package, CP/M versions: \$250.

**NEW! muLISP-79** LISP—the lingua franca of the artificial intelligence world—is now available in this efficient, low-cost version for microcomputers. Features include dynamic allocation of storage resources; program control structures such as an extended COND and a multiple exit LOOP; user functions defined as CALL by Value or CALL by Name; and 83 LISP functions. muLISP-79, CP/M version: \$200.

**NEW! XMACRO-86** For the development of 8086 programs, our new XMACRO-86 cross assembler has just been released. It supports the same features as our MACRO-80 assembler. Develop 8086 programs now on your current CP/M, ISIS-II, or TEKDOS system. \$300.

**NEW! Micro-SEED DBMS** If you are developing applications software in-house or bundling hardware and software for resale, a database manager could be the software tool you've been looking for. Micro-SEED is the first CODASYL compatible database management system to run with CP/M; and Microsoft's FORTRAN-80 has been implemented as the host language. When an application becomes limited by traditional floppy disk file handling, but remains overpowered by the cost and maintenance of a minicomputer, the solution is Micro-SEED. \$900.

**FORTRAN-80 Compiler** Microsoft FORTRAN-80 is the most complete microcomputer FORTRAN available. It has all of ANSI-66 FORTRAN (except COMPLEX data), plus unique enhancements for use in the microcomputer environment. An extensive library of single and double

precision scientific functions, too. Comes with macro assembler and loader. Versions for CP/M, ISIS-II, TEKDOS. \$500.

**MACRO-80 Assembler** The most powerful microcomputer assembler on the market today is Microsoft's MACRO-80. It is fast, and it supports Intel-standard macros, relocation pseudo-ops, conditionals and listing controls. MACRO-80 comes with a relocatable linking loader and runs with CP/M, ISIS-II, and TEK DOS. \$200.

**EDIT-80 Text Editor** Random access to floppy disk files makes EDIT-80 the fastest microcomputer text editor. It's the essential tool for creating and maintaining all files. EDIT-80 includes FILCOM, a file compare utility. EDIT-80, CP/M version: \$120. Prices quoted are USA domestic only. OEMs should contact Microsoft for prices.

MICROSOFT	CP/M	ISIS-II	TRSDOS	TRSDOS Mod II	TEKDOS
BASIC-80 INTERPRETER	●	●	■	■	●
BASIC COMPILER	●	●	□	●	
FORTRAN-80 COMPILER	●	●	□	■	●
COBOL-80 COMPILER	●	●		●	
muMATH/muSIMP muLISP	●		□		
MICROSEED DBMS	●				
EDIT-80 TEXT EDITOR	●		□	■	
MACRO-80 ASSEMBLER	●	●	□	■	●

● contact Microsoft      ■ contact Manufacturer  
□ contact Microsoft Consumer Products

## MICROSOFT

10800 NE 8th, Suite 819  
Bellevue, WA 98004  
206-455-8080 Telex 328945



We set the standard.



# Split Personality.



Primary side  
Barrier  
Secondary side



Recognized Component  
Underwriters Laboratories, Inc.

## Our ingenious split bobbin transformer design gives you high isolation... at low cost.

Ordinary transformers have to be shielded to get high isolation. Our transformers are different... and better. By separating the primary from the secondary windings—through our split bobbin design—we achieve high isolation at lower cost. That's what you should expect from the world leader in off-the-shelf transformers and chokes. And that's why thousands of companies swear by Signal for quality, value and complete satisfaction. Wide choice of secondary outputs available on all types.

### PRONTO DELIVERY

We ship your prototypes in 48 hours. These three distinct, hard-working personalities are always available for Pronto delivery.

### SPLIT/TRAN®

2500 V RMS HIPCT.  
Non-concentric windings and low capacitive coupling. Available with 115V or dual 115/230V primaries. Split secondary windings can be series or parallel connected.

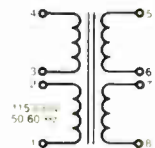

8 PIN TYPE D5T

### free

Our complete catalog with over 1,000 standard transformers and chokes, from 1 to 10,000 VA. All are available from stock, and all at low, factory-direct prices.

Write or call:  
Signal Transformer Co., Inc.  
500 Bayview Ave.,  
Inwood, NY 11696  
Tel.: (516) 239-7200  
Or (516) 239-4510

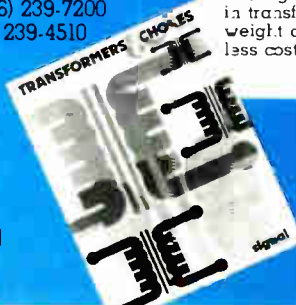

### FLATHEAD®

For optimum powering of 1" space PC boards. Delivers 6 VA in less than .085" height. (Semi-Toroidal windings.)

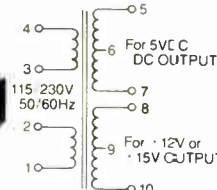

DMPC & MPL TYPES

### 2-4-1®

2500 V RMS HIPCT. The signal for a 50% cut in transformer size & weight at significantly less cost.

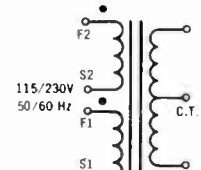

DUAL PRIMARY

**signal**  
TRANSFORMERS



**Next-to-last gasp.** A strong attempt to stave off the threat of the transistor was made by RCA in introducing the Nuvistor, a miniature ceramic tube with low power drain and high reliability. Despite many merits, it failed to halt the inexorable march of solid-state devices.

dards. One manufacturer who benefited was John Fluke.

Fluke and a roommate at MIT, Art Anderson, had formed an engineering company in 1948 to produce power supplies and instruments. The company's first instrument was the model 101 VAW, a meter that electronically measured power at frequencies from 20 Hz to 200 kHz, as well as current and voltage. Shortly thereafter, the company discovered another lucrative market, nuclear research, and began to supply it with high-voltage dc power supplies.

In 1952, Anderson-Fluke Engineering moved to Seattle, Wash., and the following year incorporated under the name John Fluke Manufacturing, Anderson having left to pursue his civil engineering interests. Testing the power supplies, which were selling in volume, was proving to be an arduous task; an entire basement of batteries was needed to provide high voltages in order to prevent current flow from the supply under test. Patience was also required to allow the batteries to stabilize between measurements.

In 1955, one of the company's first employees, Robert Hammond, came up with a highly stable and accurate 500-v power supply. With a null meter and a bridge circuit, a user could find the difference between the reference voltage and the voltage of the supply being tested. A small box thus contained everything needed to test the supplies, and the box was called a differential voltmeter.

Initially the company made five differential voltmeters for its own use, and then John Fluke decided to let his salesmen see if there was any interest outside the plant. He recalls that these first units were snapped up so quickly that it was hard to get back his sales samples. Given model number 800, but familiarly known as the Flukemeter, it was responsible for doubling the gross of the young company that fiscal year.

Another engineer who benefited from the universal need for more exact measurement was Joseph Keithley (see Chapter 4). In 1948 he had written an article for *Electronics* on the development of a low-frequency oscillator that employed the resistance-tuning technique of the HP 200. In 1951, he built his own model 200, and it, too, was a first for the industry: a dc electrometer voltmeter with an input impedance of  $10^{14}$  ohms. In the late 1950s, the model 410 picoammeter, the 610 electrometer, and the 150 microvoltmeter were introduced, the beginning of Keithley's major product lines.

But the instrument most closely associated with engineering, not only throughout the 1950s but also the decade that followed, was the oscilloscope.

In the 1950s Tektronix committed itself to the manufacture of its own CRTs. At what proved to be a critical point, Howard Vollum suggested that a helical configuration of post-acceleration plates be tried. This design increased the brightness of the display and permitted the tube to work at higher writing speeds. Scopes moved from the 10-MHz to the 100-MHz region.



# Hamilton/Avnet makes



In 1957, Tony Hamilton, then Director of Purchasing for Lear, Inc., left that position and began a manufacturer's representative company. Within a year he took on the General Electric line of tantalum capacitors for distribution. This was the beginning of Hamilton Electro Sales. A year after going public in 1961, Hamilton merged with Avnet, Inc. and their chain of electronic distribution facilities. Under the leadership of Tony Hamilton, both chains grew with stocking locations in every major U.S. and Canadian market.

In 1970, Hamilton Electro Sales and Avnet Electronics merged, forming the present Hamilton/Avnet which has grown to 40 stocking locations serving over 110,000 buying points with gross sales in excess of \$530,000,000.



Tony Hamilton, President

**PROM Programming History.** Whatever your programming needs, be they bipolar, MOS, or FPLA, Hamilton/Avnet's local PROM programming centers are at your service. Customer PROM orders will be processed imme-



The finest electronic components

diately because each location is backed by a system of the best programming equipment, in-depth inventory, and local programming specialists. The constantly upgraded equipment is able to meet the ever expanding PROM technology and can already handle 32K and 64K requirements.

**Military History.** For OEM's who demand service, dependability, and off-the-shelf delivery, Hamilton/Avnet has made a multi-

# distribution history.

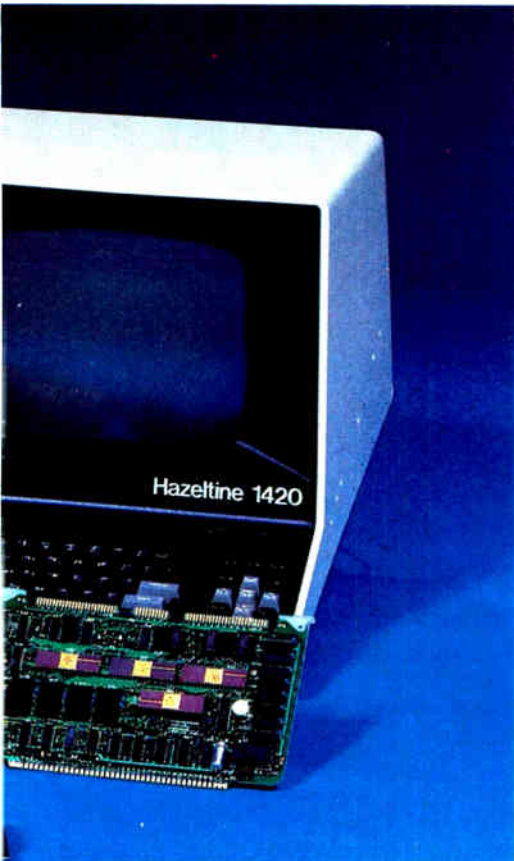

product with a complete history. All of our mil-spec products are kept in a restricted warehouse area to insure their integrity.

A customer will also find a complete selection of Mepco/Electra and Dale military and commercial resistors, both fixed and variable; Kemet and Sprague capacitors; Potter & Brumfield Relays; Cutler-Hammer switches; Globe motors and hardware.

**Computer Products History.** We have over a \$15,000,000 inventory of quality computer products such as Centronics printers, Hazeltine terminals, and Shugart floppy disk drives, plus microcomputers and their components including chips, logic devices, and EPROM's from Advanced Micro, Digital, Intel, Motorola, and National.

Computer Products Specialists at each location provide an index of knowledge and products for potential users, along with local demonstration centers where designers can evaluate equipment through hands-on demonstrations. Equipment support is provided by local literature centers where users can purchase the programming, technical and higher level programming language manuals to meet their requirements.

**Connector History.** Hamilton/Avnet has specialized in Bendix connector operations for over 25 years. Add to this our Bendix assembly and testing facilities in Los Angeles, Dallas, New York, and Boston and you begin to get the connection. Our Bendix assembly service and an inventory of over \$25,000,000 provide continuous shifts to meet any emergency Bendix connector requirement.

Each Bendix connector is backed with an in-depth program of extra quality assurance—above and beyond our standard inspection procedures.

We are also franchised on Dage, Malco/Microdot, and Winchester Electronics connector products.

40 locations nationwide stocking the finest computer products and components.

## SOUTHERN CALIFORNIA

Avnet, L.A. (213) 558-2345  
Avnet, O.C. (714) 754-6111  
Hamilton, L.A. (213) 558-2121  
Hamilton, O.C. (714) 641-4100

## SOUTHWEST

San Diego (714) 571-7510  
Phoenix (602) 275-7851

## NORTHWEST

San Francisco (408) 743-3355  
Portland (503) 635-8831  
Seattle (206) 746-8750

## ROCKY MOUNTAIN

Salt Lake City (801) 972-2800  
Denver (303) 779-9998  
Albuquerque (505) 765-1500

## NORTH CENTRAL

Chicago (312) 678-6310  
Minneapolis (612) 941-3801  
Milwaukee (414) 784-4510

## MID CENTRAL

Kansas City (913) 888-8900  
St. Louis (314) 344-1200

## GREAT LAKES

Cleveland (216) 831-3500  
Dayton (513) 433-0610  
Detroit (313) 522-4700

## SOUTH CENTRAL

Dallas (214) 661-8661  
Houston (713) 780-1771  
Austin (512) 837-8911

## NORTHEAST

Boston (617) 273-7500  
Syracuse (315) 437-2641  
Rochester (716) 442-7820

## METROPOLITAN

Long Island (516) 454-6060  
Connecticut (203) 762-0361  
No. New Jersey (201) 575-3390

## MID ATLANTIC

Baltimore (301) 796-5000  
So. New Jersey (609) 424-0100  
Raleigh (919) 829-8030

## SOUTHEAST CENTRAL

Atlanta (404) 448-0800  
Huntsville (205) 837-7210

## SOUTHEAST

St. Petersburg (813) 576-3930  
Miami (305) 971-2900

## CANADA

Toronto (416) 677-7432  
Montreal (514) 331-6443  
Ottawa (613) 226-1700

## INTERNATIONAL

Telex 66-4329  
Telephone (213) 558-2441

## JAPAN

Tokyo (03) 662-9911



Hamilton/Avnet makes the military commitment

million dollar commitment on the military components front. In being a locally franchised distributor, we have been able to secure long term agreements from key military components manufacturers such as Advanced Micro, Fairchild, Harris, Intel, Motorola, National, RCA, and Signetics. While typical lead times are 25-50 weeks, we can usually deliver your product in less than 24 hours. Hamilton/Avnet's military product specialists know customer needs and assure our traceability and documentation system backs each

**Hamilton Avnet**  
ELECTRONICS



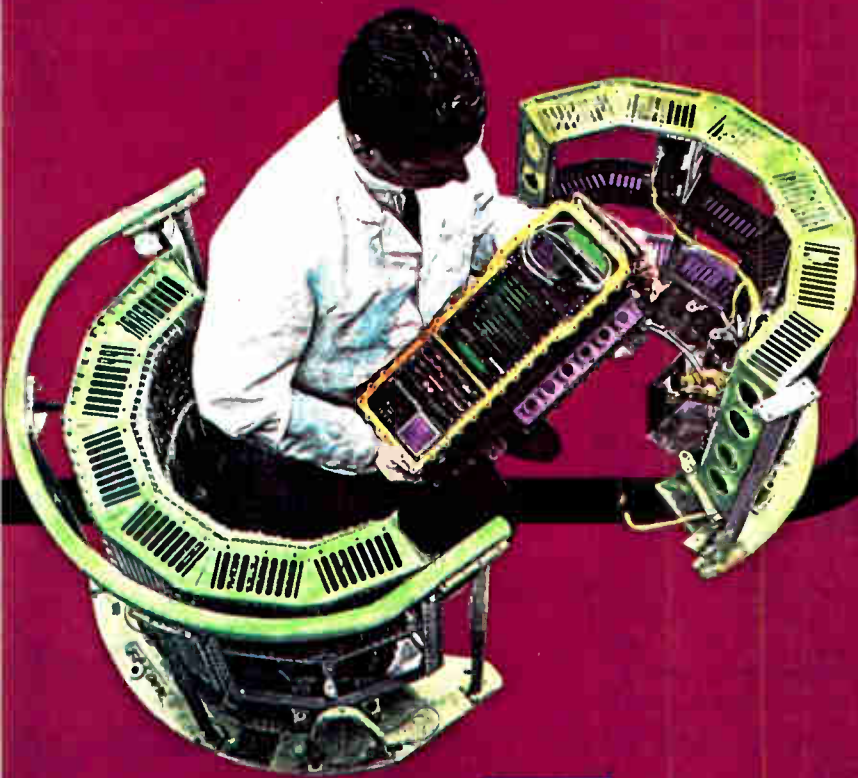

# COMPUTERS & SPACE

---



THE IDEALISM  
INSPIRED BY  
PRESIDENT  
JOHN F. KENNEDY

WAS SOON DISPELLED  
BY HIS ASSASSINATION  
AND U.S. INVOLVEMENT  
IN THE VIETNAM WAR.  
BUT BY THEN THE  
SPACE RACE WAS WELL  
UNDER WAY. LEANING  
HEAVILY ON LARGE  
DIGITAL COMPUTERS  
FOR GUIDANCE AND  
CONTROL, APOLLO  
TOOK MEN TO THE  
MOON, AND WEATHER,  
COMMUNICATIONS,  
AND NAVIGATION  
SATELLITES WENT INTO  
ORBIT. IN EVERYDAY  
LIFE COMPUTERS  
ALSO CONSOLIDATED  
THEIR POSITION AS  
SEMICONDUCTOR  
DEVICES WERE  
PERFECTED AND THE  
MONOLITHIC INTEGRATED  
CIRCUIT WAS BORN.  
BY THE END OF THE  
DECADE, ELECTRONICS  
AND SOCIETY WERE  
ON THE BRINK OF THE  
DIGITAL REVOLUTION.

## Chapter 7





Some saw it as a decade of idealism after 10 years of relative apathy. Others called it the violent sixties. To still others, it was the sensual sixties. It had freedom marches, the Peace Corps, and the dream of a political Camelot to right the wrongs of the past. There were racial conflicts, assassinations, and war in Vietnam. For some, it ushered in liberated sex, pornography, drugs, and flower children.

In his inaugural address in January 1961, President John F. Kennedy envisioned the opening of a "New Frontier," led by "a new generation of Americans." He called on Americans to "ask not what your country can do for you—ask what you can do for your country."

Within three months the bold, uplifting spirit was flagging. On April 12, 1961, the Soviet Union placed the first man in space, Yuri Gagarin. He orbited the earth once and returned to Russian soil.

On May 25, 1961, in a message to Congress "on urgent national needs," the President called for a greatly enlarged space program, including the landing of an American on the moon by 1970. Thereafter the U. S. gradually recouped its confidence, and it placed its own astronaut, John H. Glenn Jr., in orbit on Feb. 20, 1962. Glenn made three passes around the earth, and the nation was on its way to space supremacy.

Then Nov. 22, 1963: a routine Presidential visit to Dallas, Texas, with crowds cheering the Chief Executive as his motorcade passed. Suddenly a seeming fusillade of bullets poured forth. John Fitzgerald Kennedy, the youngest American to be elected President, was also the youngest to die in office.

Other important figures besides the President were assassinated in the decade. The Rev. Martin Luther King Jr., the black civil-rights leader, was slain by a rifleman in Memphis in April 1968. Sen. Robert Kennedy, the President's younger brother, was shot to death on June 5, 1968, in Los Angeles as he campaigned for the Democratic Presidential nomination.

The early sixties also marked the start of a drive by black people in the United State for equal rights. Some 250,000 blacks and whites marched in Washington in August 1963 in a show of strength. The frustration felt by blacks exploded in riots in some 60 cities between 1964 and 1967, killing 140 and injuring 4,550.

The middle sixties saw the war in Vietnam escalate sharply. American intervention had begun mildly in 1959 with the sending of military "advisers" to help the Republic of South Vietnam defeat Communist guerrilla forces supported by North Vietnam. The advisory role began to expand under Kennedy, grew to a "brush war," and, under President Lyndon B. Johnson, became a major conflict.

Through all the turmoil, the National Aeronautics and Space Administration kept its sights on landing a man on the moon. On Dec. 21, 1968, Apollo 8 became the first manned space vehicle to go into moon orbit. And on July 20, 1969, the crew of Apollo 11 radioed historic words: "The Eagle has landed." Man had set down on the moon. On that day at 10:56:20 p.m. eastern daylight time, millions of television viewers saw Neil A. Armstrong take man's first steps on the moon.

After the moon landing it soon became evident that





**Moonbound.** The U. S. astronauts certainly dressed the part (far left). Here, Apollo 11 lunar module pilot Edwin E. Aldrin (front) and spacecraft commander Neil Armstrong, the first man to walk on the moon, scoop material from a replica of the moon's surface.

**Mission control.** Backing up the spacecraft were dedicated people in the Mission Operations Control Room in NASA's Mission Control Center, Houston. The earth's image (at the front of the room) was telecast in late 1968 from the Apollo 8 176,000 miles away.

larly semiconductor materials—was important, he said. A result of these new efforts was the IC, which was to transform electronics just as the transistor had done before it.

At first, application of ICs was limited to such programs as Army battlefield missiles, the antiballistic-missile effort, some secret cryptographic gear at the National Security Agency, the ill-fated X-20 Dyna-Soar military manned space program, and the Saint, Surveyor, and Syncom spacecraft.

The breakthrough for the IC industry came in the sixties with the Minuteman missile program. The United States, unable to match the Soviet Union in rocket engine power, moved to achieve strategic parity by increasing the effectiveness of its intercontinental ballistic missiles. The decision was made to upgrade the improved Minuteman with weight-saving microcircuits.

The Minuteman improvement program demanded what was then the unprecedented production rate of 4,000 ICs a month. This requirement ultimately was instrumental in propelling Texas Instruments to world leadership in the manufacture of ICs, a position that it still holds in 1980.

If there was one outstanding technical trend toward the end of the decade, it was that integrated circuits were swarming into everything—large-scale computers and minicomputers, desktop calculators, cash registers, TV sets, radios, tape recorders, stereo components, numerical controllers, and telephone switching systems, to name only some products.

The two main professional organizations for electrical engineers—the 79-year-old American Institute of Electrical Engineers and the 51-year-old Institute of Radio Engineers—merged in January 1963. There had been much overlapping of interest in the two organizations and duplication of effort. The IRE, with 100,000 members at the end of 1962, had long since passed the AIEE in membership. The merged organization, the Institute of Electrical and Electronics Engineers, counted some 154,500 members in 1963. Despite slight declines in 1964 and 1967, membership rose until, by 1970, it reached 169,100.

Interest in radio astronomy also accelerated in the 1960s, and some notable radio telescopes were built. They included a dish with a 147-foot diameter constructed in 1962 at Green Bank, W. Va., for the National Science Foundation and a 328-ft dish put up at the same site in 1967 for the National Astronomy Laboratory. But overshadowing all was the dish completed in 1965 on 18.5 acres carved out of a valley at Arecibo, Puerto Rico. A combined radio telescope and radar facility that cost the Advance Research Projects Agency

NASA really had nowhere to go for an encore. From an electronics industry viewpoint, the milestone occurred in the summer of 1966, when the space agency's budget peaked at an annual rate of about \$6 billion. After that the budget began a long downward slide. A follow-on lunar exploration program and ambitious manned missions to Mars were abandoned in the social upheavals of Vietnam and the civil rights movement.

The \$23.5 billion Apollo program lasted 11½ years and landed 12 men on the moon (one mission, Apollo 13, had to be called back without a landing after an oxygen tank ruptured). The missions gathered 840 pounds of moon rocks for scientific analysis and gave the American people one of their few reasons to rejoice in the turbulent decade. Overshadowed by Apollo were some significant achievements in unmanned space flight, notably the applications satellites for communications, meteorology, and earth-resources surveys.

The year 1960 had found the U. S. electronics industry scarcely pausing for breath as it completed a decade of unparalleled growth. Sales of electronic parts and systems had grown fourfold since 1950—to more than \$10 billion yearly. Electronics was now a basic industry in the U. S. economy. Its growth, at a compound rate of nearly 15% yearly, was well above the growth rate of industrial production generally, and it was attracting the attention of Wall Street.

The integrated circuit was on the horizon. Patrick E. Haggerty, president of Texas Instruments, was talking about electronic systems no longer being "circuit-dominated." Rather, an understanding of materials—particu-



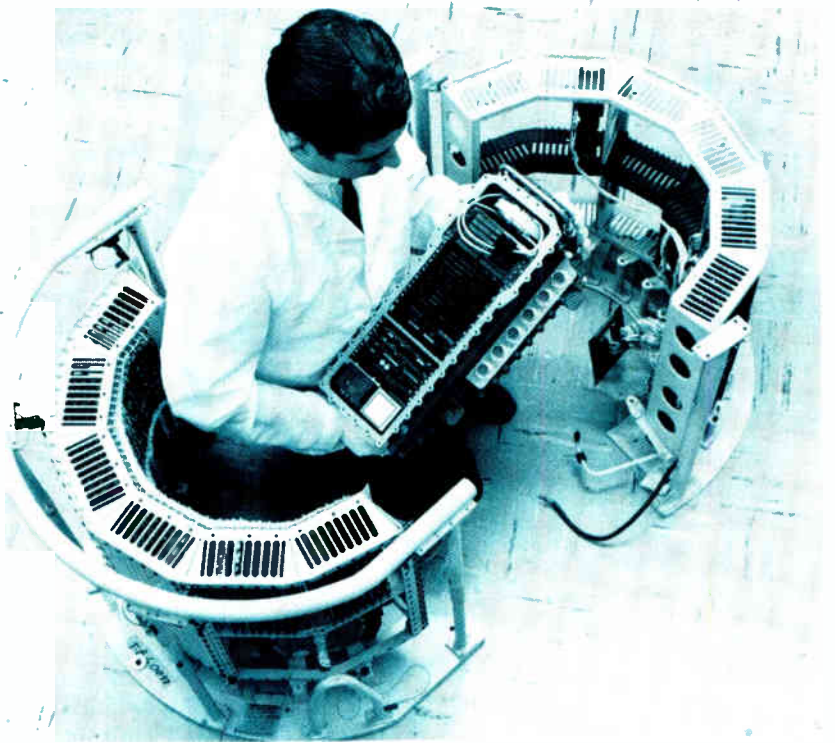

**Shrinking.** Integrated circuits applied in the inertial guidance system of the Air Force's Minuteman ICBM set the pace for small size and reliability. The D37B computer developed by North American Aviation's Autonetics division in 1964 (being held at center) dwarfed Autonetics' older D17 unit.

\$9 million, it had the world's largest antenna: a dish with a 1,000-ft diameter.

The Arecibo radio telescope was 16 times more sensitive than the one at Jodrell Bank, England, and it had 256 times more radar power. Its dish, using a spherical reflector of galvanized steel mesh, could pick up signals 10 to 12 billion light years away, double Jodrell Bank's listening range. It was 10,000 times more powerful than an installation at Milestone Hill, Mass., that had bounced a radar signal off Venus.

**S**ince the formation of the earth, the infinite region called space had been unconquerable. Then the frontier fell virtually overnight. In 12 short years, starting in 1957, man broke the chains of earth's gravity, advanced to scientific and commercial exploitation of space, and also took his first steps on the moon. Few "impenetrable" barriers had collapsed so rapidly in the history of civilization.

The electronics industries led this push into the space age, moving quickly to extract the maximum practical benefit for earth dwellers. The decade of the 1960s saw the orbiting of communications satellites that accommodated radio, telephone, and television services; weather satellites that gave forecasters better information about storms and ice fields than they had ever had before; scientific satellites that yielded a cornucopia of information about the earth, the atmosphere and space; and navigation satellites that allowed pinpointing of positions on earth.

Communications was a fertile and obvious field for early cultivation. Echo I, launched Aug. 12, 1960, from Cape Canaveral (later renamed Cape Kennedy) in Florida, was the world's first passive communications satel-

lite—that is, it reflected passively to receiving stations on earth radio waves that were beamed at it from transmitting stations on earth. The first active communications satellite, Courier 1B, was orbited by the U. S. on Oct. 10, 1960. Active satellites have radio receivers and transmitters on board. They receive radio waves from transmitting stations on earth, amplify the signals and retransmit them to receiving stations on earth.

Active satellite technology took a big step forward in 1962 with the American orbiting of Telstar I, the first satellite to relay television programs between the U. S. and Europe, and Relay I, which retransmitted radio, telephone and television signals. Telstar and Relay were true amplifiers in the sky. They retransmitted communications in real time, unlike some of their predecessors, which just recorded on tape and retransmitted. They also made extensive use of amplification, and this provided higher signal strength at the ground station, thereby simplifying the job of that expensive installation.

The Telstar satellites were designed by the Bell Telephone Laboratories and operated by the American Telephone and Telegraph Co., and they owed some of their origins to AT&T's work with the Echo satellite.

Following the launching of Telstar I by a Thor-Delta rocket, Telstar II—essentially the same satellite—was lofted in May 1963. Like its predecessor, it sent 2.25 watts of power to the receiving station by means of a traveling-wave tube. This microwave vacuum tube was to become a standard for bandwidth, power, and reliability throughout the decade, even while solid-state devices were making inroads into almost every other part of satellite communications equipment.

The Telstars furnished either 600 voice telephone or one television channel—each needed the same bandwidth. But the satellites were still basically experimental

Available from stock . . .

# HI-REL MIXERS with a 3-year guarantee!

**\$7.95** SRA-1

from (50000)



Hi Rel

Five years ago, Mini-Circuits offered a two-year guarantee for its industry-standard SRA-1 hermetically sealed Double-Balanced Mixer. . . now used worldwide for a variety of military and industrial applications.

The two-year guarantee was made possible by the use of an accelerated-life screening test for diodes generally reserved only for space applications. The HTRB-screened Schottky diodes are subjected to a one-volt negative bias at 150°C for 168 hours, a stress designed to accelerate ageing and force time-related failures — thus screening out potentially unreliable diodes.

Mini-Circuits is proud to offer a three-year guarantee for the SRA-1 achieved by further stressing and testing the assembled unit. Each completed SRA-1 experiences:

1. Burn-in for 96 hours at 100°C with 8 mA at 1 KHz.
2. Thermal shock.
3. Gross and fine leak tests (per MIL-STD 202).

And the three-year guarantee SRA-1 is still only \$7.95! Of course, the additional testing adds to our cost, but our continuing commitment is to offer performance and reliability unmatched for off-the-shelf Double-Balanced Mixers.

So, for space or rugged industrial applications, ensure highest system reliability by specifying SRA-1 mixers, the only Doubled-Balanced Mixers with a three-year guarantee. . . from Mini-Circuits where low price goes hand in hand with unmatched quality.

## Model **SRA-1**

Freq. range (MHz)	
LO .....	0.5-500
RF .....	0.5-500
IF .....	DC-500

Conversion loss (dB)	Typ.	Max
1-250 MHz .....	5.5	7.0
0.5-500 MHz .....	6.5	8.5

Isolation (dB)		Typ.	Max
0.5-5 MHz .....	LO-RF	50	45
	LO-IF	45	35
5-250 MHz .....	LO-RF	45	30
	LO-IF	40	25
250-500 MHz .....	LO-RF	35	25
	LO-IF	30	20

Min. Electronic Attenuation (20 mA) 3 dB Typ.

Signal, 1 dB Compression Level -1 dBm

Impedance All Ports, 50 Ohms

LO Power +7 dBm

 **Mini-Circuits**

2625 East 14th Street Brooklyn, New York 11235 (2 2) 759-0200  
Domestic and International Telex 125460 International Telex 620156



The rapid growth of the integrated circuit industry over the past few years has been due, in large measure, to the industry's quality control program. It is strict, exacting, unforgiving.

Now, Nikon instruments are available to help you meet, and surpass, these tough standards.

Examine the Nikon Comparison Microscope, Model 6. It's specifically designed for comparative inspection and measurement of IC and LSI masks by superimposing the images of original and working masks.

The heart of the CM 6 consists of two fixed, high resolution Ultra-Micro Nikkor lenses.

A relay lens allows convenient changes in magnification from 200X to 800X without image shift. Parcentricity and parfocality are maintained at all magnifications.

Masks up to 152.4 mm square (6" x 6") can be measured with a guaranteed accuracy of  $\pm 0.7 \mu\text{m}$  over the full 6" of travel.

Free working distance is greater due to the inverted microscope design, thereby providing added safety for masks and lenses. A digital display printer and built-in Nikon camera complete the system and assure accurate and reliable test reports.

An informative brochure is available to introduce you to the Comparison Microscope, Model 6 and all the other remarkable Nikon IC instruments.

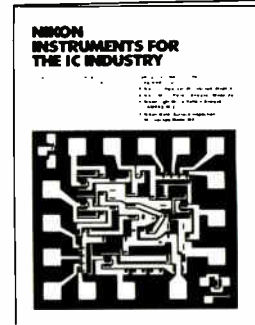

To obtain your copy, please contact:

**Nikon**

Nikon, IC Instrument Division,  
623 Stewart Avenue,  
Garden City, NY 11530,  
(516) 222-0200  
or 1051 Sneath Lane,  
San Bruno, CA 94066,  
(415) 952-8188.

# MEETING THE TOUGHEST STANDARDS OF A VERY TOUGH INDUSTRY.

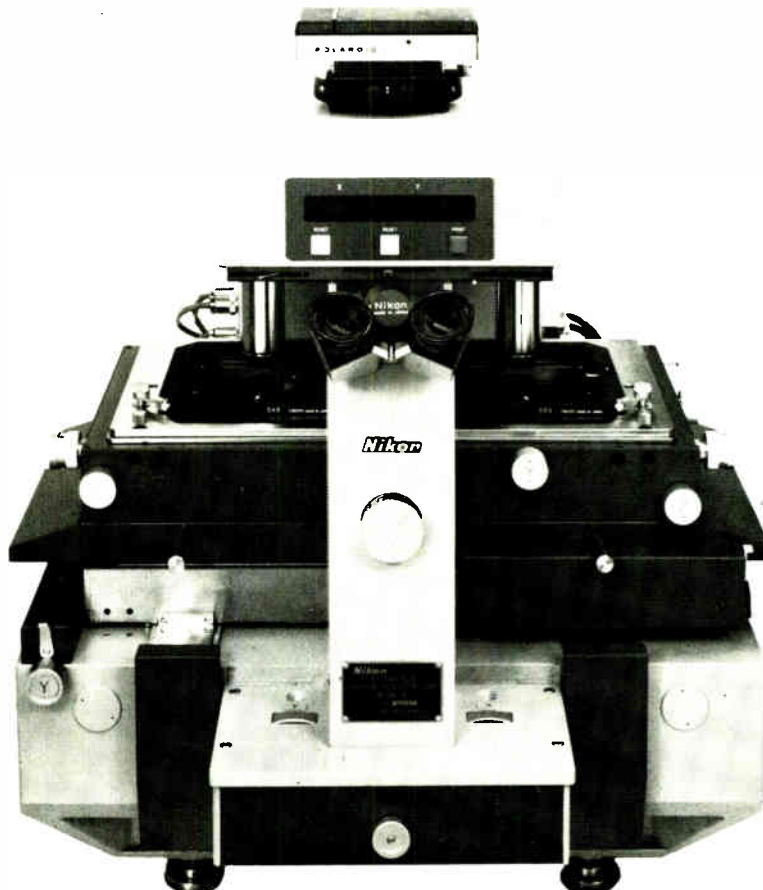

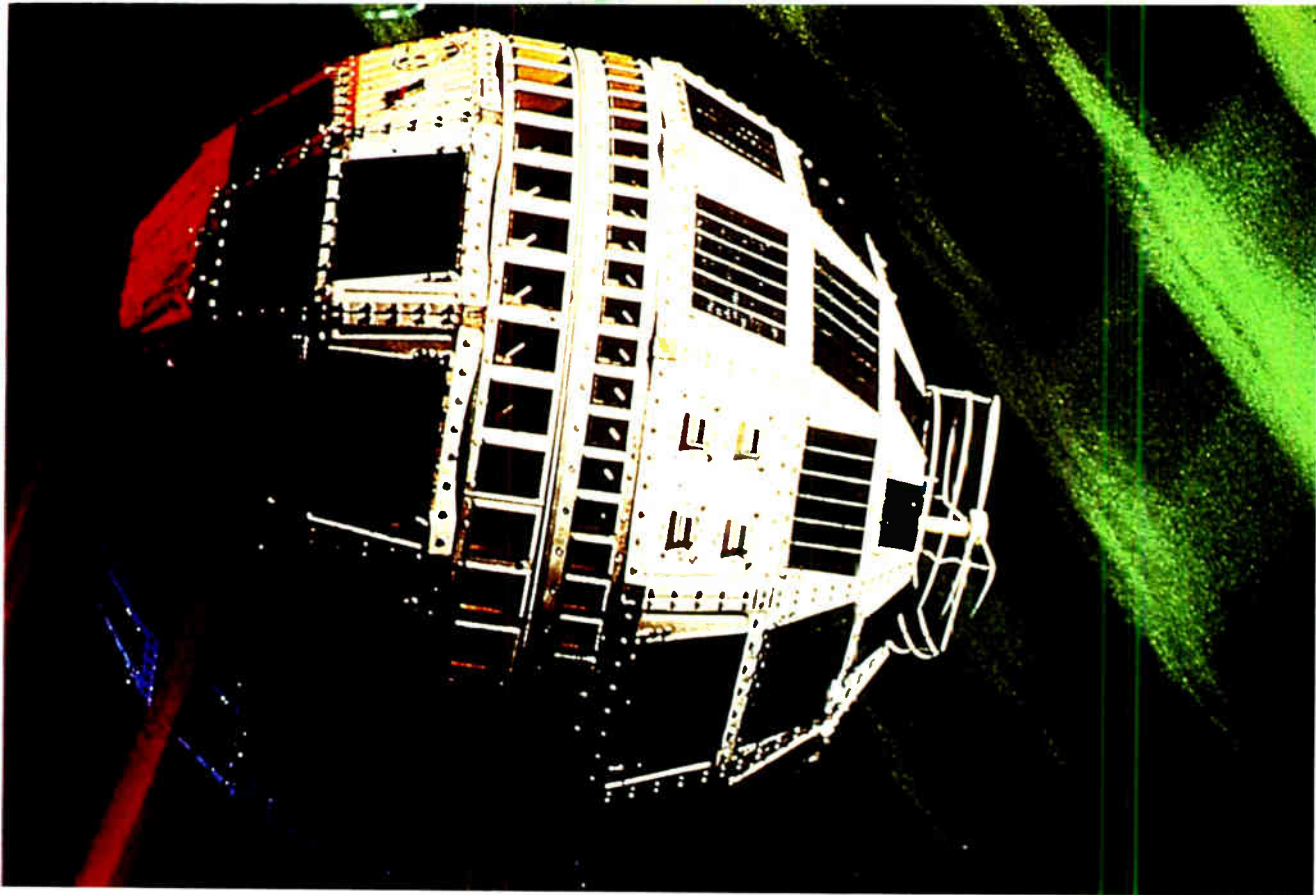

**In space.** The first communications satellite to relay TV signals between the U.S. and Europe was Telstar I, shown in this artist's rendering. The experimental Telstar I and Telstar II, launched in 1962 and 1963, were designed by Bell Laboratories for AT&T.

and not a full commercial success. Relay, a Radio Corp. of America undertaking, was also largely experimental.

The major questions faced by satellite makers, operators, and users in the early 1950s were the political, social, and economic issues of regulation and monopoly. Clearly a number of competing satellites run by separate companies would be as undesirable as a number of separate telephone companies would have been a hundred years earlier.

The U.S. Government considered this issue, and the Communications Satellite Act of 1962 led to the establishment in 1963 of the Communications Satellite Corp. in Washington, D.C. Comsat, as it came to be known, received responsibility for running domestic satellite communications. It became the domestic common carrier.

But what about international satellite traffic? Responding to this challenge, 11 countries set up the International Satellite Telecommunication consortium in August 1964, also in Washington, D.C. Intelsat was charged with designing, developing, constructing, maintaining, and operating the space segment of a satellite-based global commercial communications network. Like Comsat, Intelsat was to succeed commercially: by 1978, direct service had expanded to 124 countries.

The first commercially successful communications satellite was launched by Intelsat at Cape Kennedy in April 1965. Intelsat I—or Earlybird, as it was called—was planned as an 18-month operation. Instead it lasted nearly four years in synchronous orbit, until January 1969. Nothing in the satellite failed. Its place was taken in 1969 by the Intelsat II and Intelsat III series, which covered both the Atlantic and Pacific Oceans.

During this time the U.S. military was not idle; it, too, adopted communications satellite technology. The

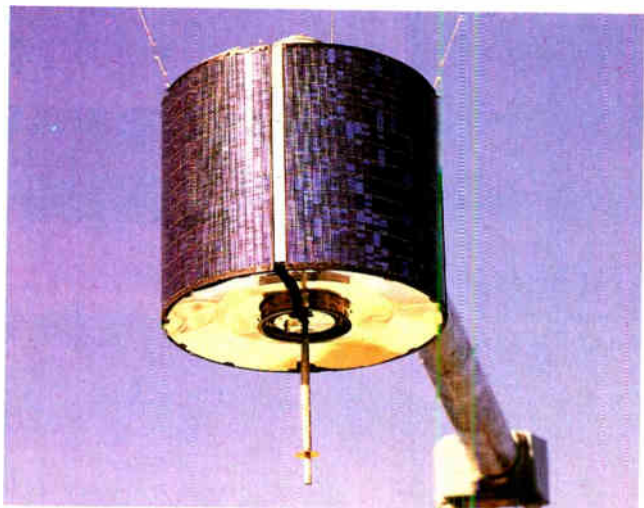

**Farther out.** Intelsat I, or Earlybird, was the first commercially successful communications satellite. Built by Hughes Aircraft for the International Satellite Telecommunications consortium, it operated for almost four years after a 1965 launch into a synchronous orbit.

first military satellite, the DSCS-1, was launched in June 1966 from Vandenberg Air Force Base in California. Military satellites usually had confidential missions. These included not only communications but also reconnaissance of foreign territory by electronic and optical sensors. Orbits were synchronous or nonsynchronous, depending on the mission and the equipment packages.

Meanwhile, starting with Vanguard II in 1959, weath-



# LAMBDA POWER SUPPLIES ARE

Just about everyone in the electronics business knows Lambda power supplies. That's because our Lambda Electronics Division is the recognized leader in the design and manufacture of both switching and linear standard power supplies. Sales are more than double those of our next largest competitor.

Power supplies, however, are only one facet of Veeco's success story. A story that has seen our sales grow from \$34 million in 1975 to \$82.5 million in 1979.

Veeco's Industrial Equipment Division is the world's largest and most experienced producer of mass spectrometer leak detectors. And with recent acquisitions, we're now able to supply a complete line of semiconductor processing equipment. Included are Macronetics' in-line wafer processing systems for cleaning, coating and baking, and Accelerators' ion-implantation systems for laboratory and production applications. We also develop and build Microetch ion beam milling systems, thin film deposition



LAMBDA POWER SUPPLY

MACRONETICS WAFER

Accelerators Ion Im

LAMBDA POWER

Veeco Microetch

VEECO LEAK

# ONLY PART OF THE VEECO STORY.

systems, and a variety of vacuum components.

Lambda also specializes in designing and producing semiconductors for power supply applications, another growing area. Products cover a wide range of monolithic and hybrid voltage regulators, overvoltage protectors and monolithic rectifiers, as well as the industry's broadest line of Darlington transistors.

An important chapter in our growth, too, is the dedication of Veeco's 2100 employees located in 8 manufacturing plants throughout

the United States and 4 overseas.

There's much more worth knowing about Veeco, too. For a more complete story, call or write for our latest annual report, or literature on any products we make, to Veeco Instruments, Inc., 515 Broad Hollow Road, Melville, N.Y. 11747. Phone: (516) 349-8300.



CATALOG  $\Delta$  1980 VOL. 1

PROCESSING SYSTEMS

Plantation Systems

SEMICONDUCTORS

Milling Systems

DETECTORS



er satellites began to give meteorologists reports that much improved long-range forecasting. A long line of Tiros satellites was launched by the U. S. in the 1960s—from Tiros I in April 1960, the first satellite to take detailed photos of weather, to Tiros VIII in December 1963, the first satellite to send photos of clouds automatically to earth. The Tiros series, from Radio Corporation of America, was followed by the Nimbus, and each succeeding launch brought new advances.

Not all of the satellite activity of the sixties was strictly American, though the U. S. dominated the field. In mid-1962, for example, the S-52, a joint project of Britain and the U. S., went into orbit. Built by Westinghouse Electric Corp., it was not designed for communications but for scientific research. Measurements were made of galactic noise, high-altitude atmospheric ozone, and the size and number of micrometeorites in the atmosphere.

The U. S. also cooperated with the West German Post Office, which has responsibility for communications in that nation. The Germans tried out a transportable earth station supplied by ITT Federal Laboratories and installed by Standard Electric Lorenz, an ITT affiliate. The station operated at both the Telstar and Relay frequencies. It was used for West Germany's first direct satellite communication with the U. S.

From the outset, the U. S. placed a high value on the use of satellites for scientific research. The very first satellite it launched, Explorer I on Jan. 31, 1958, discovered the Van Allen radiation belt in space, and subsequent Explorer missions mapped this belt, exploring the region of space between 180 to 47,800 miles from earth.

In March 1962 the U. S. put up the first orbiting solar observatory, OSO-1. Then in September 1964, it lofted the first orbiting geophysical observatory, OGO-1. In February 1965 it began to measure meteorite density in space with Pegasus 1, and in April of that year Snap 10A carried the first nuclear-powered rocket motor successfully into space.

To foster more precise navigation, a series of Transit satellites was orbited, starting in April 1960.

By 1964 the number of objects in earth orbit had reached 400 or so, and the U. S. had a Space Track radar, with a phased-array antenna as high as a 15-story building, to keep track of all the flying objects. The \$30 million Bendix radar, the AN/FPS-85, was at Eglin Air Force Base in Florida. It fed its information into a Space Detection and Tracking System located in Colorado Springs, Colo.

**R**adar evolution was spurred in the 1960s by greatly increased use of the transistor and some complex integrated circuits. On top of this, new families of microwave components were developed that gave the radio-frequency front end of radar sets hitherto undreamed-of capabilities.

Typical of these devices were low-noise parametric amplifiers, transistors in the microwave frequency range up to about 5,000 megahertz, and various Gunn- and avalanche-effect diodes used for oscillators. Before these solid-state devices were available, radar designers had

been prevented from pursuing sophisticated designs by the unreliability of the complex circuits they needed.

A great part of the effort in radar development went into signal processing. Improvements were made in radar resolution—particularly range, the determination of whether or not targets were moving, and background clutter rejection—and in various forms of electronic, rather than mechanical, beam scanning.

These scanning systems worked by distributing many radiators over the scanning aperture and varying the phase of the signal transmitted from each radiator with respect to its neighbors. Inexpensive, readily phase-shifted radiators—perhaps 1,000 in one antenna—as well as simple digital controls were required to make such a system work. Cost was a major problem with these phased arrays, and in spite of the availability of solid-state components, they did not meet wide acceptance in the 1960s.

Many practical mobile radars were developed. Typical was a mortar-locating radar that in its original version weighed 7 tons with an associated power generator. A new semiconductor version weighed 1 ton and had improved performance.

Of course, the most obvious use of the new semiconductor technology was in hand-held radars, which became feasible for the first time. These systems usually generated only about 5 to 500 milliwatts, which, while low-level, was sufficient for a diversity of applications.

**I**n civilian aviation, the 1960s brought planning for an American dream—a supersonic transport that would top the Anglo-French Concorde, which was the first SST on the drawing boards. But the dream turned soon enough into a nightmare of controversy over high costs, not only of development but also in feared damage to the environment.

Boeing, the prime contractor on the American SST, was prevented from building a prototype; the National Aeronautics and Space Administration terminated work after more than four years of Federal funding. However, there was one major benefit from the program: the impact it had on advanced avionics development.

The SST project is credited with spurring the adoption of inertial navigation by the airline industry. The first such systems for jetliners were supplied by Sperry, but the market later was dominated by General Motors' Delco division and Litton. Delco had gained experience with the guidance system it had built for the Apollo satellite program.

The SST project also anticipated the trend to microprocessors and distributed computing. Boeing designed its supersonic aircraft with more than 20 computers embedded in instrument systems. The rationale was simple: the company feared a breakdown of even a redundant central-computer system would create unacceptable risk for a commercial SST.

In other avionics developments not directly related to the SST project, distance-measuring equipment (DME) was introduced on new jetliners in 1961, and the Federal Aviation Agency (later renamed the Federal Aviation Administration) began using DME traffic control proce-

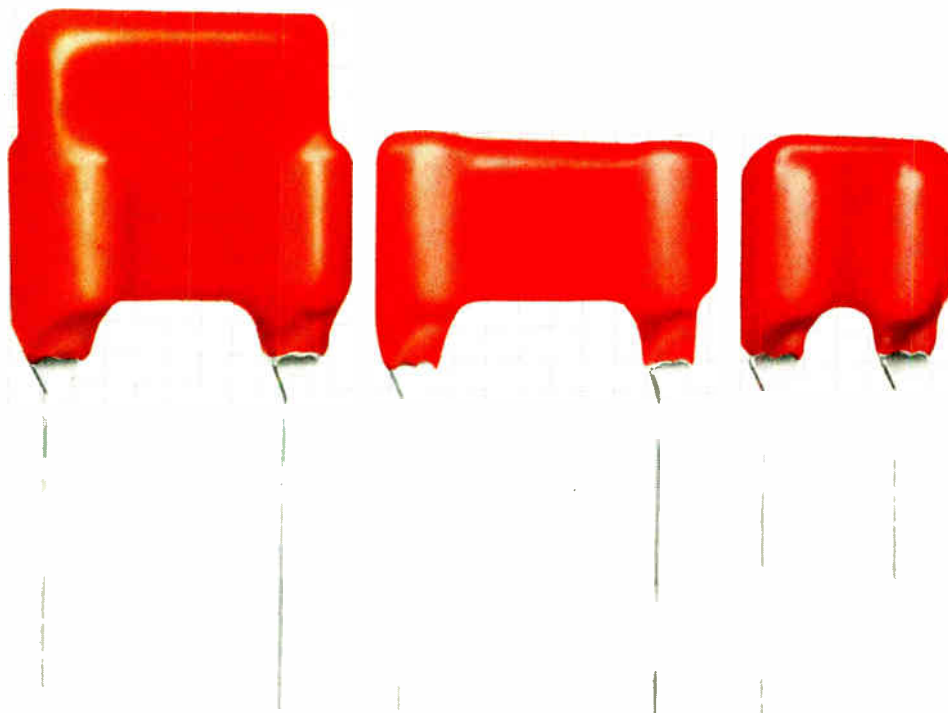

## Introducing "The New Breed" of Monolithic Ceramic Capacitors

Vitramon, Incorporated—which introduced the first monolithic ceramic capacitor back in 1959—is now offering a new breed of high-quality components.

Known as the "VP" Capacitors, they are assembled automatically to reduce your costs—and they have an abundance of key design features.

The heart of each part is a high-quality NPO or X7R capacitor dielectric. The capacitor body, itself, is connected on two surfaces to a pre-formed lead—and the connection is strengthened by high temperature solder.

The rigid leads are short and rectangular for precise centering and positioning on circuit

boards—and have a meniscus-free shoulder to enhance soldering operations.

"VP" Ceramic Capacitors are offered in three body sizes: capacitance values of 1.0 pF to 1.0  $\mu$ F, and ratings of 100 and 50/63 Vdc.

In short, they're the *new breed* of monolithic ceramic capacitors—low in cost, yet they incorporate the highest quality materials.

At Vitramon, Incorporated, we think they're the best monolithic ceramic capacitors available. But don't take our word for it. Call or write for free samples—and judge for yourself.

**Vitramon**<sup>®</sup>

Vitramon North America  
Division of Vitramon, Incorporated  
Box 544, Bridgeport, Conn. 06601  
Tel: (203) 268-6261

Vitramon Limited (London)  
Vitramon GmbH (Stuttgart)

Vitramon France S.A.R.L. (Paris)  
Vitramon Pty. Limited (Sydney)

Vitramon Japan Limited (Tokyo)  
Vitramon do Brasil Ltda. (Sao Paulo)



# Only one 40 column printer has NCR reliability.



NCR's 40 column printer is immediately available in 3 forms: 1) the mechanism by itself, 2) housed in its own cabinet, or 3) in a finished case with its own power supply. Each version is available with optional NCR electronics. And each is field-proven in NCR products. More benefits:

- Works as printer and/or plotter because of unique single wire design
- Multiple copy capability
- Prints up to 120 lines per minute
- Attractive quantity pricing
- Disposable ribbon cassette is operator changeable
- No messy spools or tricky threading

For delivery information, prices, or literature, please contact us at NCR Engineering and Manufacturing OEM Marketing, P.O. Box 627, Ithaca, New York 14850. (607) 273-6066.

**NCR**

Engineering and Manufacturing - Ithaca

## Take your pick.

Circle 366 on reader service card

dures for the first time on a nationwide basis. Also in 1961, the first doppler voice-over-radio (VOR) system was commissioned at Marquette, Mich.

In 1964 automated terminal radar and computer data processing were introduced for evaluation. Field tests led to a decision to replace the existing manual system with the automated terminal radar system. The conversion began in 1966 at Jacksonville, Fla., and continued over the next decade.

**I**n the telecommunications industry, the emphasis was on solid-state electronics. The first effect was felt in 1964 in the New Jersey town of Succasunna (pop. 5,000). The Bell System office there became a pacesetter of the new order that promised to abolish manual and electromechanical switching in all Bell central offices by the year 2000.

According to a Bell spokesman at the time, the system at Succasunna was destined to "open the era of electronic switching, in which high-speed computers run systems that can perform more services faster, more reliably and with greater flexibility than only a few years ago."

The new system, called the ESS-1 (for No. 1 Electronic Switching System), had a stored memory that contained program-switching logic and a temporary memory that stored the transient information needed to process a call. The transient information included the digits being dialed and whether or not a line was busy.

For the telephone company, the ESS-1 meant that the routine chores, such as maintenance and accounting, could be done at less cost. For the customer, the new switching system led to more services, such as conference calls and faster response to the placement of a call.

Adding to the importance of the ESS-1 was the fact that, although it was not totally digital itself (encapsulated dry-reed switches made the actual voice connections under electronic control), it was the forerunner of a family of digital switches that appeared in the U. S. in the 1970s.

In Britain, after some attempts at building an all-electronic switching system in the sixties, the British Post Office, in conjunction with Plessey Communications, designed the TX-E2 system. It used reed relays as the voice switching points, and it was put into service in 1966. Unlike the ESS-1, which could easily serve 10,000 lines, the TX-E2 was set up for either 4,000 or 7,000 lines. More than 1,000 such systems had been installed by the British by April, 1979.

Concurrent with electronic switching in the 1960s was the development of other digitally based telephone equipment built around the transistor and the integrated circuit. Typical of this equipment was the private branch exchange (PBX), which was totally electronic. Also introduced was the so-called repertory dialer, which enabled customers to store numbers in the handset.

And the demand for data services over telephone lines grew in the 1960s to such an extent that the U. S., Britain, and other countries soon developed data modems. The purpose of these mostly transistorized devices was to convert digital data into a form suitable for transmission over the analog phone line.

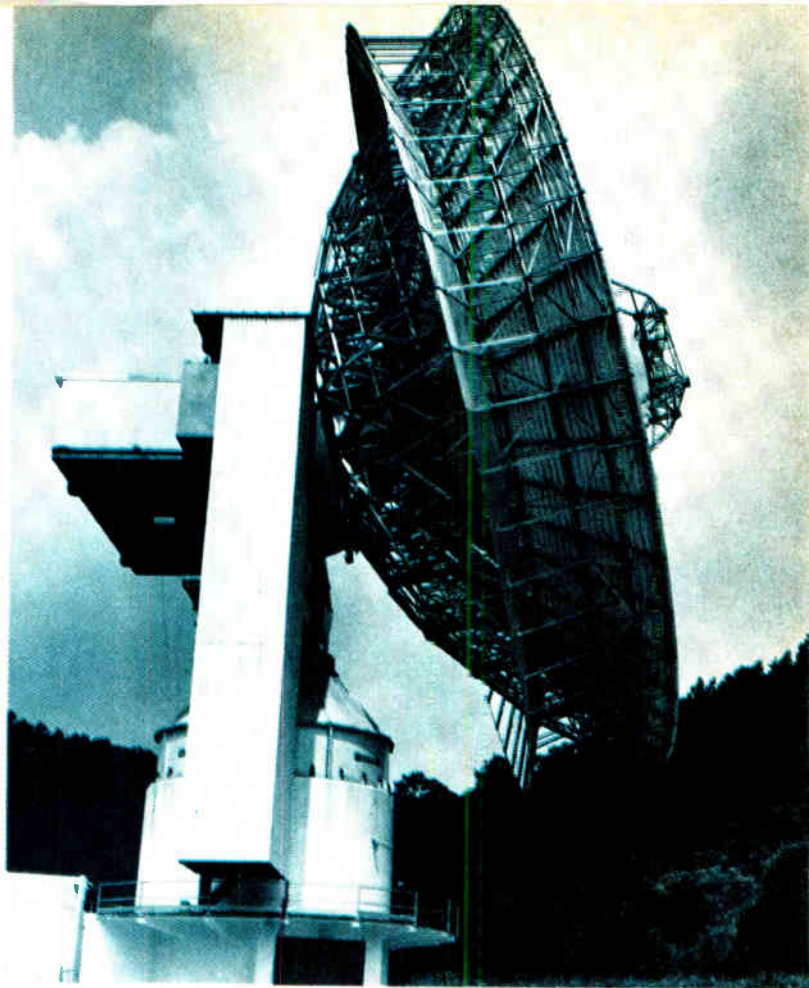

**Towering.** Earth stations, set up in the late sixties to communicate with the new satellites, were big. This one in Morgantown, W. Va., built by Philco-Ford's WDL division for Comsat Corp.'s Intelsat, has a 97-ft-diameter antenna, is 11 stories high, and weighs 470 tons.

Computers meanwhile raced feverishly to greater sophistication and wider use. The pace was such that computer makers were constantly revising their strategies. "Researchers postulate a possible future in which computational power will be available in a wall socket, like electrical power, or where every man who wants one can buy a small computer," wrote Douglas C. Engelbart, a senior research engineer at the Stanford Research Institute, in the April 28, 1961, issue of *Electronics*. "Perhaps the computer builder of 1951 finds it hard to comprehend the development of individually available computer power."

As the decade opened, the last of the first-generation vacuum-tube computers were giving way to the transistorized second generation. By 1964, a third generation was already on its way as the revolutionary integrated circuits began replacing discrete transistors. By the end of the decade, a newer, more compact computer—the minicomputer—was gaining popularity.

In 1960 the value of installed computer equipment was estimated at \$1 billion, up from only \$227 million in 1955. By 1965 that total reached \$6 billion. As the decade closed, almost \$8.5 billion worth of computers and peripheral equipment were shipped in 1970 alone.

The biggest customer became the U. S. Government. From almost a standing start in 1956, when only 90 computers served the Government, the number grew in 10 years to 7,575—more than 30% of the entire





**Trend-setter.** IBM shook up the computer world in 1964 with its new family of compatible computers, the System/360 (the model 30 is above), that made its earlier machines obsolete. IBM opted for hybrid modules (right), rather than still-developing monolithic ICs.

country's installed base. The Federal government's computer budget was about \$50 million in 1959; by 1966 it was \$115 million.

During all of the sixties computer software became ever more sophisticated. There was rapid growth of operating systems that supported a number of innovative features, such as virtual memory and timesharing. Standard programming languages emerged and were accepted by users for their applications.

The recognition that software was an expensive requisite of computer ownership was the death knell for a hodgepodge of incompatible computers on the market. In their places came so-called families of computers, all the members of which used the same architectural features—the same instruction set, addressing schemes, and the like. Hence all understood the same programs.

The space program was a major force in glamorizing the use of computers during the 1960s. Most of the computers used by NASA projects were, in fact, ground-based, general-purpose commercial units. In 1961, for instance, Burroughs ground computers guided the Atlas space missions. NASA used IBM computers to lead Astronaut L. Gordon Cooper on his 22 orbits of the earth in 1963. Burroughs computers guided the Ranger VI and VII unmanned probes to the moon in 1964, as well as Mariner IV to Mars. And IBM's Federal Systems division helped NASA in the Apollo program.

With good economic conditions and Wall Street's in-

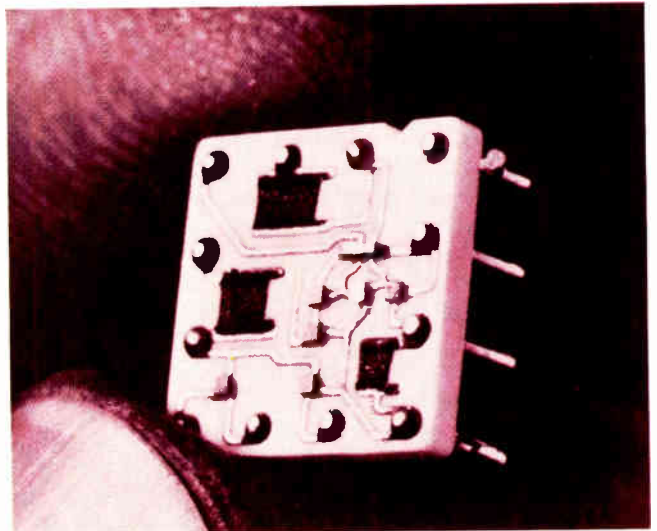

fatuation with high technology, dozens of companies formed or diversified to enter the computer business. Among these were Memorex, Data General, California Computer, Ampex, Storage Technology, Pertec, Data 100, Sycor, and Xerox. Some companies carved market niches for themselves in areas like IBM-compatible peripherals and data-entry devices. Others created entirely new markets, with the minicomputer the best example here. At the same time the strenuous pace of change took its toll. General Electric and RCA were among the dropouts.

At the dawn of the decade, IBM, with its famous "think" slogan, dominated the computer industry the

# RESOLUTION



## When and where you need it.

There are times when a 3½ digit multimeter just can't cut it.

When you really need resolving power, you need a 4½ digit DMM. To illustrate: When measuring a 15VDC supply—a 4½ digit multimeter lets you see each millivolt of change while a 3½ digit instrument would not display a change less than 10 millivolts.

As the leader in 4½ digit multimeters, Data Precision gave you that resolving power 7 years ago with the first truly portable 4½ digit multimeter...our Model 245. Then as your applications became more varied and demanding, we designed other units to meet them. The result is a line of tough, full function 4½ digit DMMs that have given almost 200,000 world-wide users more sensitive measurements.



### MODEL 245

The first of its kind, features high input impedance, 50kHz frequency response, 0.05% basic DC accuracy and a planar gas discharge display...\$345.

### MODEL 248

This high resolution instrument features 10µV and 10 nanoamp sensitivity, True RMS AC measurement, with a basic DC accuracy of 0.05% and an easy to read LED display...\$315.

### MODEL 258

Features True RMS AC measurement, 0.05% basic accuracy, 40 hour battery operation between charges and an LCD display ideal for outdoor as well as indoor applications...\$325.

If your needs are primarily for a bench instrument, Data Precision offers a truly versatile performer — the Model 2480R Bench/Portable with True RMS AC measurement and 0.03% basic DC accuracy. Wide measurement ranges on all functions and a benchtop case make it a logical choice for an in-house DMM...\$309 or the Model 2480 with AC average sensing...\$279. Both feature optional battery pack.

When you need more than a 3½ DMM can give, get a 4½ digit multimeter from Data Precision. We've made more 4½ digit multimeters than anyone else in the world.

For immediate delivery, demonstration, or further information, just contact your local Data Precision distributor or call:

(800) 343-8150

(800) 892-0528 in Massachusetts

Prices USA

Circle 148 for Demonstration  
Circle 162 for Additional Information

 **DATA PRECISION**<sup>®</sup>  
A DIVISION OF ANALOGIC CORPORATION

Data Precision Corporation, A Division of Analogic Corporation, Electronics Avenue, Danvers, MA 01923, (617) 246-1600, TELEX (0650) 921819



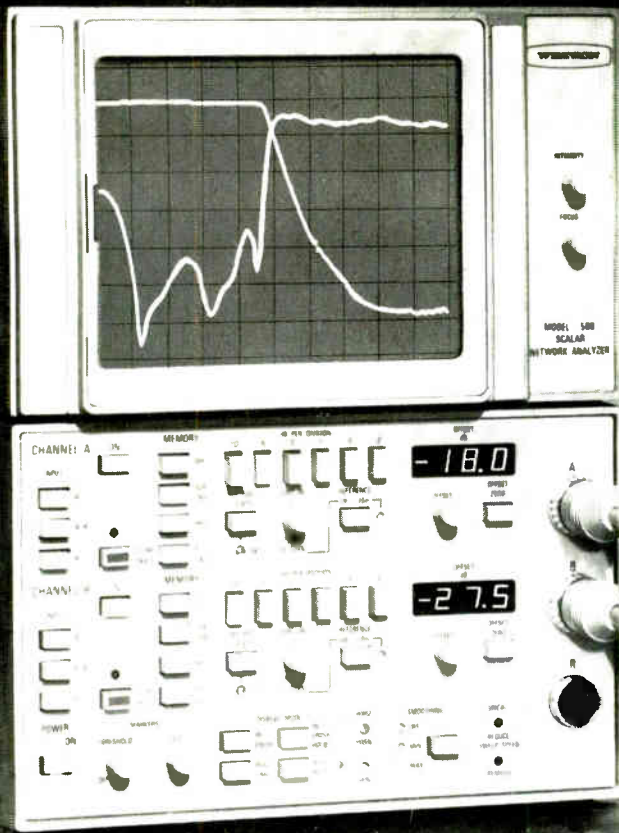

Wiltron Model 560 Network Analyzer with 610D/6247D Sweep Generator (10 MHz to 18.5 GHz) measures transmission and return loss of low pass filter from 4 GHz to 12.4 GHz.

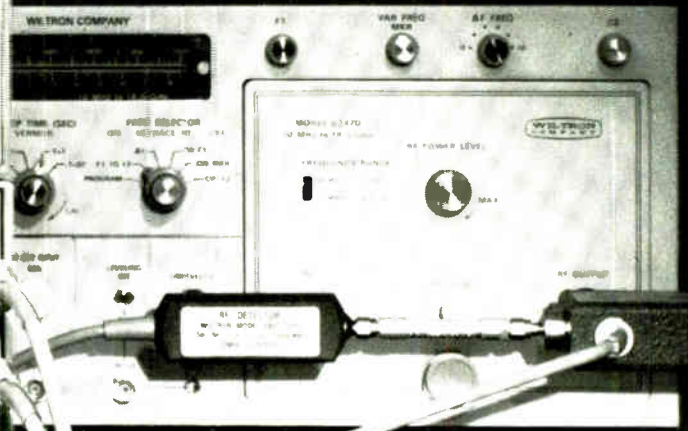

# A new era Network Analyzer. 10 MHz to 34 GHz. It's a Wiltron.

There's a better network analyzer out now. It's the new Wiltron 560 Scalar Network Analyzer for the 10 MHz to 34 GHz range. It's GPIB compatible so you can make both automatic and manual measurements of transmission loss or gain, return loss (SWR) and absolute power. It has a superb dynamic range of 66 dB (+16 dBm to -50 dBm).

## Error proof and so easy to use.

We've done a lot to stop errors and simplify measurements. For instance, there's a display mode for every application. Look at events in Real Time or in the Refresh display mode. In Refresh, data is digitized and updated each sweep for a steady flicker-free display, regardless of the external sweep speed. You can also freeze the display for analysis or photography. Press the X-Y Plot button for a 30-sec. sweep to drive a recorder.

There's memory in the new 560. System residuals, including test-port mismatch errors, are stored and subtracted automatically from test data. Throw away your grease pencil. Memory also automatically averages

open/short reflections, eliminating cumbersome and inaccurate estimates of the 0dB return loss reference.

## Better in a system, better alone.

Wiltron's 560 offers GPIB programmability and 0.01 dB resolution. With 40 dB directivity from a 10 MHz to 18 GHz SWR Autotester, you get unmatched accuracy. Broadband components let you make uninterrupted measurements over more than 10 octaves. A new WSMA (SMA compatible) detector has an upper frequency limit of 34 GHz.

## Prices begin at \$5900.

At \$5900 for the manual unit or \$7250 with GPIB, the 560 is an exceptional value in microwave instrumentation. A fully automated turnkey system (Model 5610) is available too.

For an early demonstration or more data, phone Walt Baxter, (415) 969-6500 or write Wiltron, 825 East Middlefield Road, Mountain View, CA 94043.

WILTRON

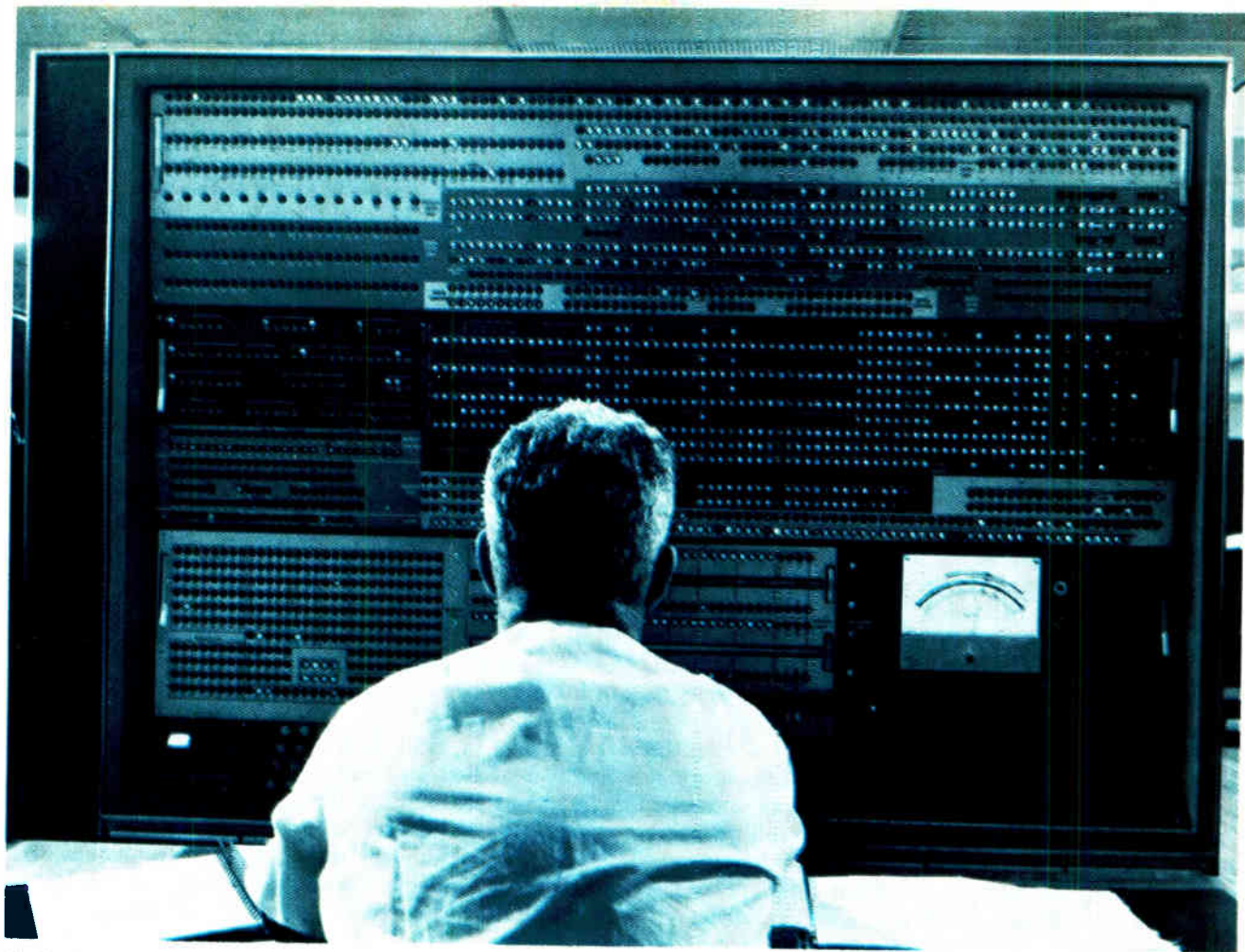

**At the top.** Planned as the most powerful computer of its day, the top of IBM's line, the model 7330 data-processing system also referred to as Stretch, never did live up to its promise after it was delivered in 1961 to the Los Alamos Scientific Laboratory in New Mexico.

way it previously had the punched-card machine market. The marketing prowess of Thomas J. Watson had by then helped IBM gain an estimated 75% of the general-purpose computer market, and it maintained that share throughout the decade.

The IBM product line in 1960 was diverse. At the top was the Stretch machine, planned as the most powerful computer of its day. But when it was delivered to the Los Alamos Scientific Laboratory in New Mexico in 1961, the performance was below the promise of 100 times the performance of the model 709. IBM tried to salvage the machine by lowering the price, but the Stretch was pulled off the market shortly thereafter.

Although a marketing failure, Stretch had several innovative technical features, the most important of which was its instruction "look-ahead," or pipelining. This led to improved performance in other IBM models.

IBM had other, more successful products. The popular model 1401, introduced in 1959, rapidly became a workhorse of its day. It was joined in 1962 by the model 1441 and in 1963 by the 1460, the latter being twice as fast as the 1401. The transistorized 7090 computer line was expanded to include the top-of-the-line and lower-priced 7010 and 7044.

But during this time IBM management began to examine its prospects for the future and did not like what it saw. The low-end 1401 product line, manufactured by its General Products division in Endicott, N. Y., and the high-powered 7000 series from the Data Systems division in Poughkeepsie, N. Y., were beginning to overlap

and to foster severe competition between the two groups.

An internal IBM study of the situation outlined in December 1961 the need for a single, compatible family of computers encompassing the full performance range between the 1401 and 7090. It recommended that the machines be truly general-purpose, having both business and scientific applications and equipped with standard interfaces to peripheral devices. Rather than just replace the 1401 or 7090 computers, the committee suggested that the new machines open new fields of computer applications. Management approved the plan.

The new effort used two of IBM's top computer designers, Gene Amdahl and Gerrit Blaauw, and one of the first decisions made affected the logic circuitry. Researchers reasoned that monolithic integrated circuits would not be available in volume in time to build the new computers. They recommended the use of hybrid ICs, with separate transistors and diodes soldered on a substrate. And, rather than reveal its designs and specifications to outside component suppliers, IBM decided to build the components itself. IBM opened its Components division in East Fishkill, N. Y., in 1963. The plant cost about \$100 million to build.

On April 7, 1964, in its 50th anniversary year, IBM announced six computer models of its new System/360 line. Thomas Watson Jr., who had taken over as chairman from his father in 1956, called it the "most important product announcement in company history."

Writing in the April 20, 1964, issue of *Electronics*, editor Lewis H. Young reported: "With a single new



system, IBM had made every one of its commercial computers obsolete." The System/360 line and its hybrid Solid Logic ushered in the third computer generation.

In addition to the six computers—the models 30, 40, 50, 60, 62, and 70—the company unveiled 19 new memories and 26 input/output devices. The System/360 was also one of the first commercial computer lines to use microprogramming. In this way the various models, with their slightly different hardware, were all made to operate with the same instruction set.

IBM is estimated to have shipped some 33,000 computers during the six-year life of the line. But it required an enormous effort. Whereas Eniac had been developed for about \$600,000, IBM spent over half a billion dollars on research and development for the 360. Between the time the program began and deliveries were in full swing in 1966, the company expanded its work force by more than 60,000 people to 190,000. Capital invested totaled \$4.5 billion. In comparison, the Manhattan Project, which produced the atomic bomb of World War II, is estimated to have cost just over \$2 billion.

But the hardware problems IBM had in building the System/360 were easy compared with the snags it encountered in developing operating system software. The goal was a single operating system for all members of the System/360 family. An operating system gives a computer a "personality"; it administers the supervisory, or housekeeping, chores and thus makes it easier for the user to program the computer.

By the middle of 1965, however, it was apparent that the software development for the System/360's operating system was behind schedule. The first thing the company did was eliminate some of the more elaborate functions. Thirty-one features were "decommitted," as IBM put it.

In the end IBM was forced to deliver two operating systems: the Disk Operating System (DOS) for small-to-medium-sized machines and the more elaborate Oper-

**Tubeless.** All-solid-state computers were being brought to market in the early sixties by several companies. Control Data's desk-sized model 160-A was designed by Seymour Cray and delivered in 1961. It was one of the supercomputer maker's smallest machines.

ating System/360 (OS/360) for large machines.

Eventually IBM overcame many of the problems with the System/360 line and introduced more than 20 models. But in 1970 the family was replaced by the System/370, built entirely from monolithic integrated circuits. Portending the end of core memories, the model 145 of the System/370 was the first commercial computer to use solely monolithic ICs in its main memory. The new computer also incorporated a cache memory and error-correcting circuitry for the main memory.

**D**espite their smaller size, IBM's major competitors—Burroughs, Control Data, General Electric, Honeywell, National Cash Register, RCA, and Univac—were in many cases more technically innovative than IBM. Sometimes they found that their ideas lacked credibility among potential buyers, however. Often it was not until IBM added a technical feature to its product line that the concept was accepted in the marketplace.

Like IBM in 1960, Sperry Rand Corp.'s Univac division in Blue Bell, Pa., had just finished a supercomputer effort, the Larc, built for the Lawrence Livermore Laboratories in California. Where IBM's Stretch had endeavored to employ the most advanced techniques and components available, Univac was more conservative: it built the Larc with readily available components. But the Larc, too, was not the commercial success its manufacturer had envisioned.

Univac was also having trouble in the market because its sophisticated Univac III, introduced in the early sixties, was not price-competitive with other medium-scale machines. In 1962 the company introduced its model 1107. Using a 128-word magnetic thin-film memory for control storage, in addition to traditional magnetic cores, the 1107 offered one of the fastest memory-access times available: three orders of magni-

**On campus.** GE began research in timesharing, a new way for many users to use a single large computer, at Dartmouth College in the early sixties. A key design element was a paging scheme for swapping data between main and peripheral memory.





**With over 30 years of product innovation and integrity,  
Tally just keeps growing, and growing, and growing.**

**TALLY<sup>®</sup>**  
**PRINTERS**  
**WORLDWIDE**

**Tally printers. Quality built on experience.**  
In the forefront of the technological evolution of merging state  
of the art electronics with advanced mechanical designs for  
always improving products.





*Designers Choice*

# KDI PYROFILM

...offers a broad range of thick and thin film resistors. Whether your application calls for a Standard catalog item or for a unique Custom Design, contact a KDI PYROFILM Applications Engineer at 60 South Jefferson Road, Whippany, New Jersey 07981, Tel. (201) 887-8100, TWX 710-986-8220.

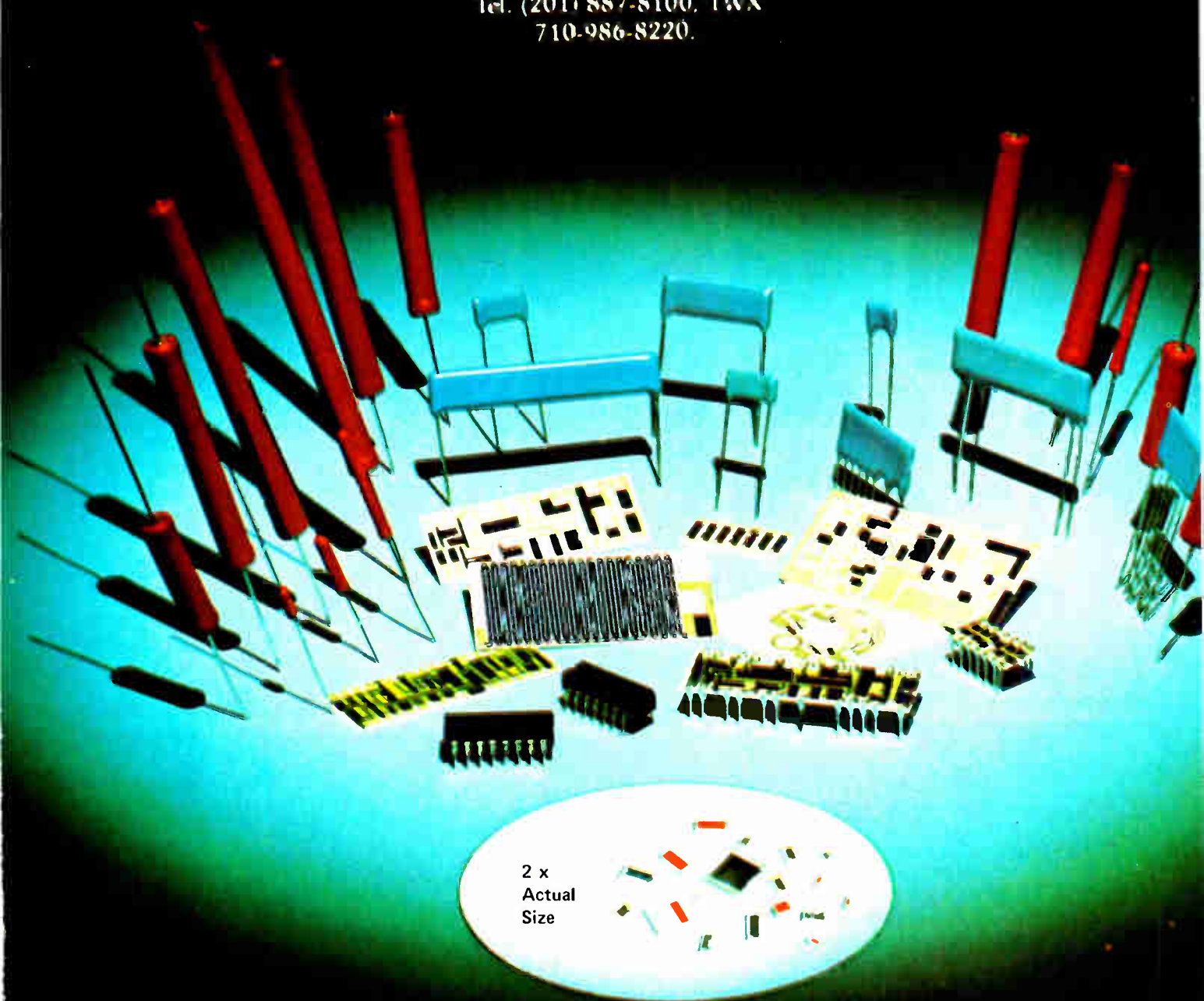

2 x  
Actual  
Size

tude better than the microsecond access with cores. But even with nanosecond access, the 1107 was introduced too late to become competitive.

Univac introduced a third-generation version, the 1108, in July 1964. Since IBM had announced no successor to its large-scale 7090 computers, Univac was able to parlay the 1108 to dominance in the large-scale scientific computer market in the late 1960s.

With the 1107, Univac was on the leading edge of research into what promised to be a better way to build a memory: the thin-film technique. By 1966 the company was plating magnetic films onto wires, a method that was less expensive than making the planar thin films then in use. Univac incorporated the plated-wire memories into its models 9200 and 9300, unveiled in June 1966. The 9200 had a maximum memory capacity of 16 kilobytes, with a cycle time of 1.2 ns, while the 9300 could hold up to twice as much memory with a cycle time of 0.6 ns. Plated wire was eventually replaced by semiconductor memory, however.

Burroughs meanwhile was moving slowly into computers from a well-established position as a supplier of electromechanical business machines. The Detroit company introduced its most dramatic machine in 1961, the large-scale B5000 solid-state computer. The unit used an operating system that provided multiprogramming—one of the first with this capability—and it had an early form of what later became known as virtual memory.

Virtual memory, which did not become popular until IBM introduced it in 1972, was important because it overcame a fundamental obstacle to more powerful computing: restricted main memory. All data and programs must be in main memory for the computer to operate on them. Yet the operating systems, as they became more sophisticated, also became larger, occupying more of that precious memory resource and leaving less for users' applications programs. And because main memory cost so much, it was impractical to add more. The solution was to store the data not immediately being used on slower, less expensive peripheral storage drums and disks and to move the information into main memory only as needed. This obviously made the computer's memory seem larger than it physically was; hence the name "virtual."

When the Burroughs B5000, with its virtual memory, was delivered in 1963, however, it was disappointingly slow. The next year the company introduced the B5500, and this machine offered three times the throughput of the B5000 and a new multiprocessing capability. It became the basis for the so-called 500 family, which was expanded in March 1966 to include the third-generation medium-scale B2500 and B3500 computers featuring monolithic integrated circuits.

At the same time Burroughs introduced the large-scale 6500 computer, which featured a sophisticated operating system called the Master Control Program. It supported multiprogramming, parallel processing, real-time, and timesharing operations.

In 1967 Burroughs got an opportunity to try its hand at the type of supercomputer development attempted earlier by IBM and Univac. Daniel I. Slotnick of the University of Illinois had proposed a new computer

architecture—a machine in which multiple streams of data could be operated upon in parallel by a single set of instructions. The Advanced Research Projects Agency of the U. S. Department of Defense funded the development of the computer, named Illiac IV.

Original proposals called for 256 processing elements, each with its own 2,048 64-bit words of thin-film memory. The elements were to operate in parallel under control of a general-purpose Burroughs 6500 computer. But by the time Illiac IV was finally delivered in 1972 to the Ames Research Center in Mountain View, Calif., it was scaled down to 64 parallel processing elements and 1 megabyte of memory. Still the machine was impressive: it performed 200 million instructions a second.

**T**he vicissitudes of supercomputer design in the 1960s did not keep one company from making a commercial success of its effort. In 1963 Control Data Corp. of Minneapolis announced the model 6600. Designed with multiple arithmetic and logic units coupled with 10 peripheral processors, the machine could perform more than 3 million operations a second. This was more than three times the speed of IBM Corp.'s ill-fated Stretch.

IBM attempted to counter with the models 90 and 95 of the System/360, but after significant development problems, these were withdrawn from the market in 1967. In their place IBM unveiled the model 85 of the System/360 in 1968. It incorporated cache memory (the

**Progenitor.** Digital Equipment Corp. is credited with creating the minicomputer when it introduced its 12-bit Programmed Data Processor, model 8, or PDP-8, in 1965. It had a 4,096-word memory and was the first computer to sell for under \$20,000.

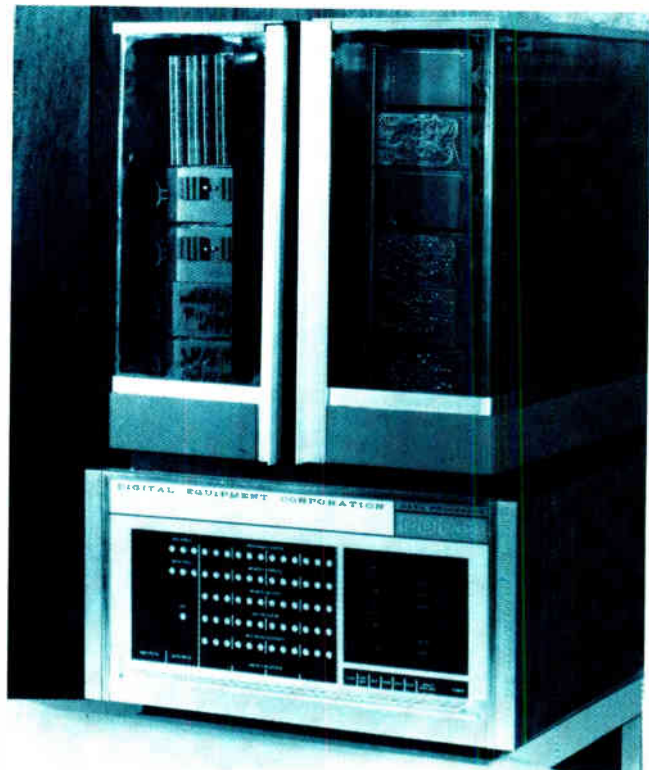



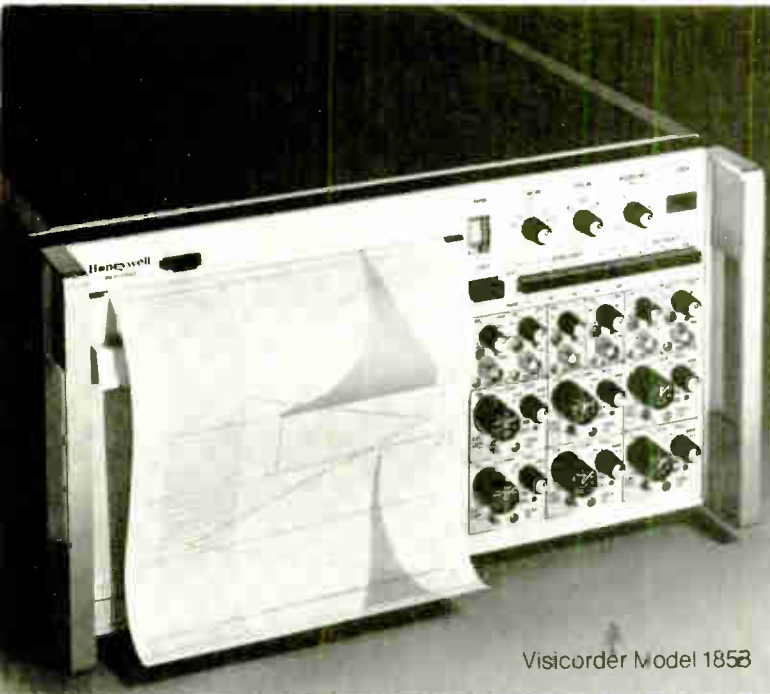

Visicorder Model 185B

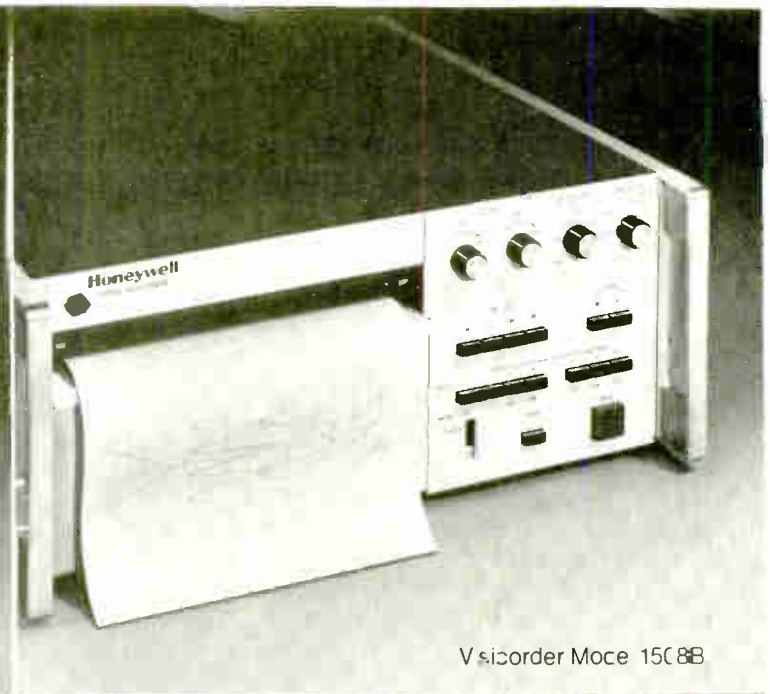

Visicorder Model 1508B



Visicorder Model 1503C

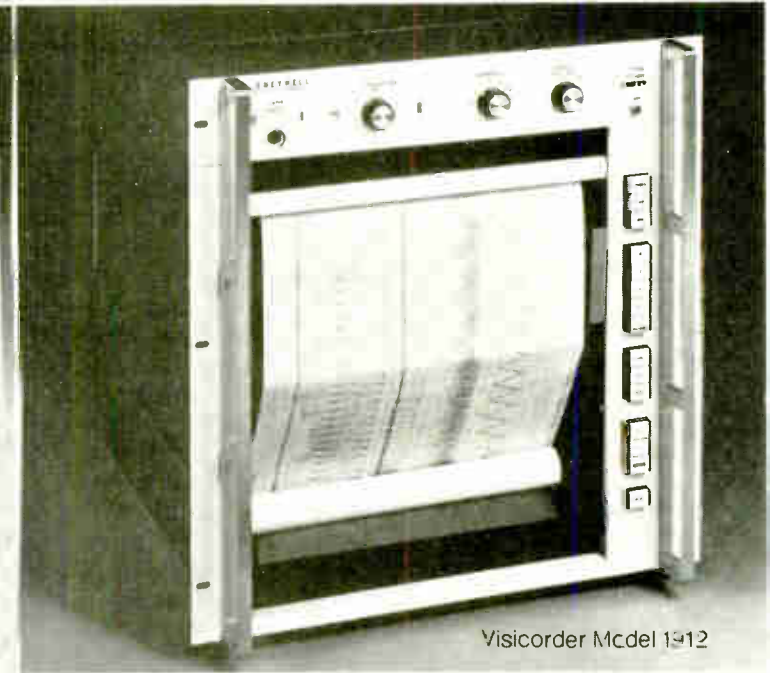

Visicorder Model 1912

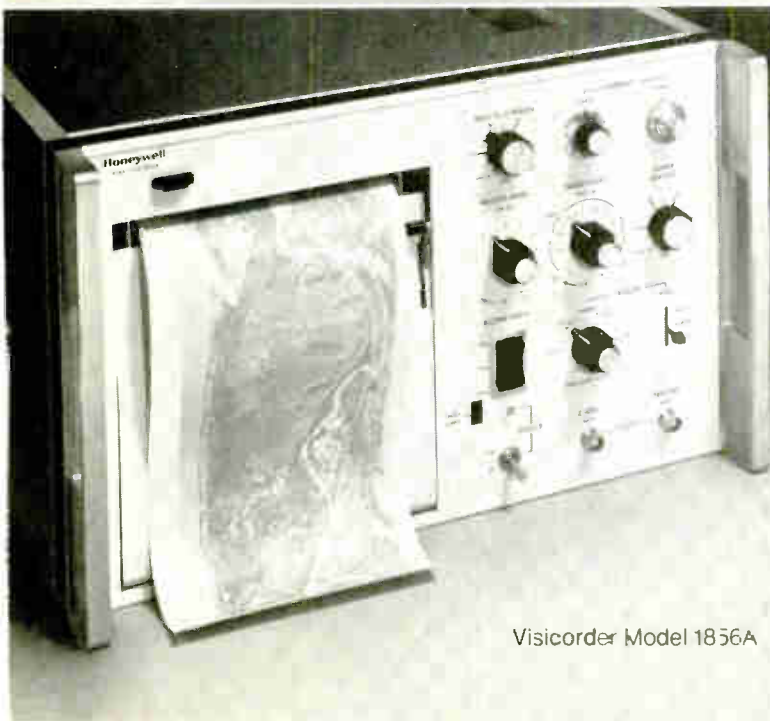

Visicorder Model 1856A

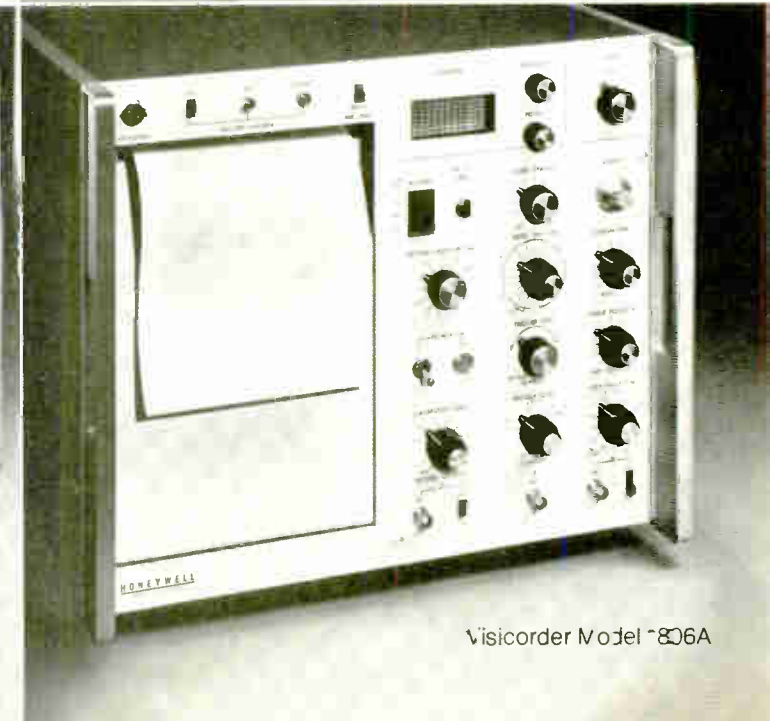

Visicorder Model 1806A

# MEET SIX TOP RECORD MAKERS.

Perhaps the data you need can best be obtained by a high-performance oscillographic recorder with excellent trace resolution. Or you may require a linescan image recorder having very fast scan rates and a broad gray scale. Whatever it takes to get your data, chances are you will get it faster and easier with one of the recorders shown here.

## **These Visicorder oscillographs set the standard for high-performance graphic recording.**

Visicorder Model 1858 is a completely self-contained system with up to 18 channels, yet it stands less than nine inches high. This unexcelled portability, enhanced by a wide selection of miniature, plug-in signal conditioners, makes the Model 1858 ideal for field or mobile use. And its dc to 5 kHz response, wide chart speed range, 100  $\mu$ V-300V input sensitivity, and the ease with which it expands to 32 channels also make it a favorite in the lab. A fiber-optic CRT assures sharp traces of high resolution across the entire 8-inch record.

Visicorder Models 1508B and 1508C offer dc to 25 kHz response, wide chart speed range and writing speeds greater than 50,000 inch/sec. Both combine

high-linearity optical systems with sensitive galvanometers to produce extremely accurate 8-inch-wide recordings. The Model 1508B has 24 data channels plus 4 for event recording; Model 1508C has 12 data channels plus 2 for event recording.

Visicorder Model 1912 offers the most data channels, widest recording paper, and widest transport speed range of all Honeywell galvanometer-type oscillographs. This versatile recorder can handle up to 36 channels of data, in addition to 6 channels of event recording. It accommodates 12-inch-wide paper at speeds from .005 to 200 inch/sec.

## **Do you need 4-axis recording capability? Our linescan image recorders give you the kind of record quality you can only get with a direct writing fiber-optic CRT.**

Visicorder Model 1856A produces 6-inch-wide records that have exceptionally high resolution and wide gray scale. This makes the recorder particularly suited for such applications as facsimile, spectrum analyzer readouts, IR mapping and echocardiography. Z-axis response is dc to 8 MHz, Y-axis is dc to 75 kHz, and the X-axis is capable of scan rates to 18,000/sec. Accessories are available for film records.

Visicorder Model 1806A can record, on 6-inch-wide paper,

high-frequency signals that would otherwise require magnetic tape or oscilloscope camera techniques. It offers Y-axis response from dc to 1 MHz, Z-axis to 10 MHz, X-axis to 1 MHz and writing speeds greater than 1,000,000 inch/sec. The Model 1806A also accommodates accessories for film records.

## **Honeywell's Accudata signal conditioning modules speed most recording and measurement tasks.**

Whether you need to control and amplify strain-gage signals, drive oscillograph galvanometers or magnetic tape recorders, or amplify low-level signals where relatively high common mode voltages are encountered, we have the modules to do the job easily and economically. Just give us your requirements and we'll show you an Accudata signal conditioner than can meet them.

For detailed information on any of these recorders or Accudata modules, call Lloyd Moyer at (303) 771-4700. Or write for our technical data sheets and a free brochure that describes all of Honeywell's Visicorders, magnetic tape systems and Accudata modules. Honeywell Test Instruments Division, Box 5227, Denver, CO 80217.

## **WE'LL SHOW YOU A BETTER WAY.**

# Honeywell



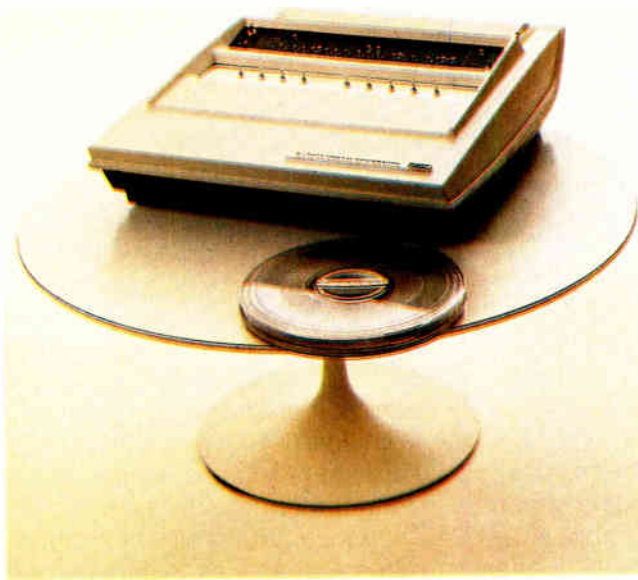

first time this was used in an IBM machine) to improve its speed of memory access.

That same year Control Data announced its large-scale 7600, which executed between 20 million and 25 million instructions a second. IBM followed with its System/360 model 195 in 1969, the first IBM machine to use monolithic integrated circuits, but the machine was never as popular as the Control Data units.

Among the most quiet—and successful—computer makers in the 1960s was the National Cash Register Co., Dayton, Ohio. It stuck with its 300 series, introduced in 1958, until it joined the third computer generation in 1968 with its Century Series, based entirely on monolithic integrated circuits. The new machines used a second generation of thin-film memory.

By now timesharing services had become one of the hottest developments in the industry, and it had all started in the early 1960s with research at Dartmouth College in Hanover, N. H., by General Electric, then headquartered in New York. In the timesharing mode, many users can share a computer by dividing not its hardware but rather its operating time. In this way the

**Powerful.** The Nova entered the minicomputer sweepstakes in 1968, introduced by Data General, a company founded that same year by three ex-DEC employees. Nova's price was low—\$8,000—and it offered mixed and matched RAM and ROM to 32,000 words.

large and relatively expensive computers of the day, kept in special environmentally controlled rooms, could be used via phone lines by many people at once.

General Electric started one of the first commercial timesharing services in 1965. The following year IBM opened its Service Bureau company, which initially linked 125 System/360 computers at over 80 offices, and Control Data opened its Cybernet service. By 1968 dozens of companies were offering remote computing services.

Despite its success in competing with IBM in the timesharing technique, GE found itself spending enormous sums of money on technical development and on financing customers' leases of equipment. GE left the computer business in 1970, selling its assets and installed base to Honeywell Information Systems.

RCA, a pioneer in broadcasting and components making, did not enter the computer business until 1958 with its model 501. To this it added the 301 and 601 in 1960. The New York-based company's most dramatic computer announcement, however, came in December 1964 when it tried to go IBM one better by announcing its Spectra 70 family of computers, based entirely on monolithic integrated circuits instead of the more conservative hybrid technology chosen by IBM. RCA bought its components from Fairchild Semiconductor.

Stressing compatibility, RCA announced that the Spectra 70 computers could run programs from the company's own 301 and 501 computers as well as IBM's System/360 line. The Spectra 70 family was reported to sell well and was expanded to include a total of eight models by 1969. But the stiff competition forced the company out of the computer business by 1972.

One result of the change sweeping the computer industry during the 1960s was the birth of new compa-

**From the Orient.** Japan entered the computer market in a big way in the late sixties. One competitor was Fujitsu and its Facom 230 series. The machines in the series ranged from the multiprogrammable model 60 down to the smallest model 10, shown here.



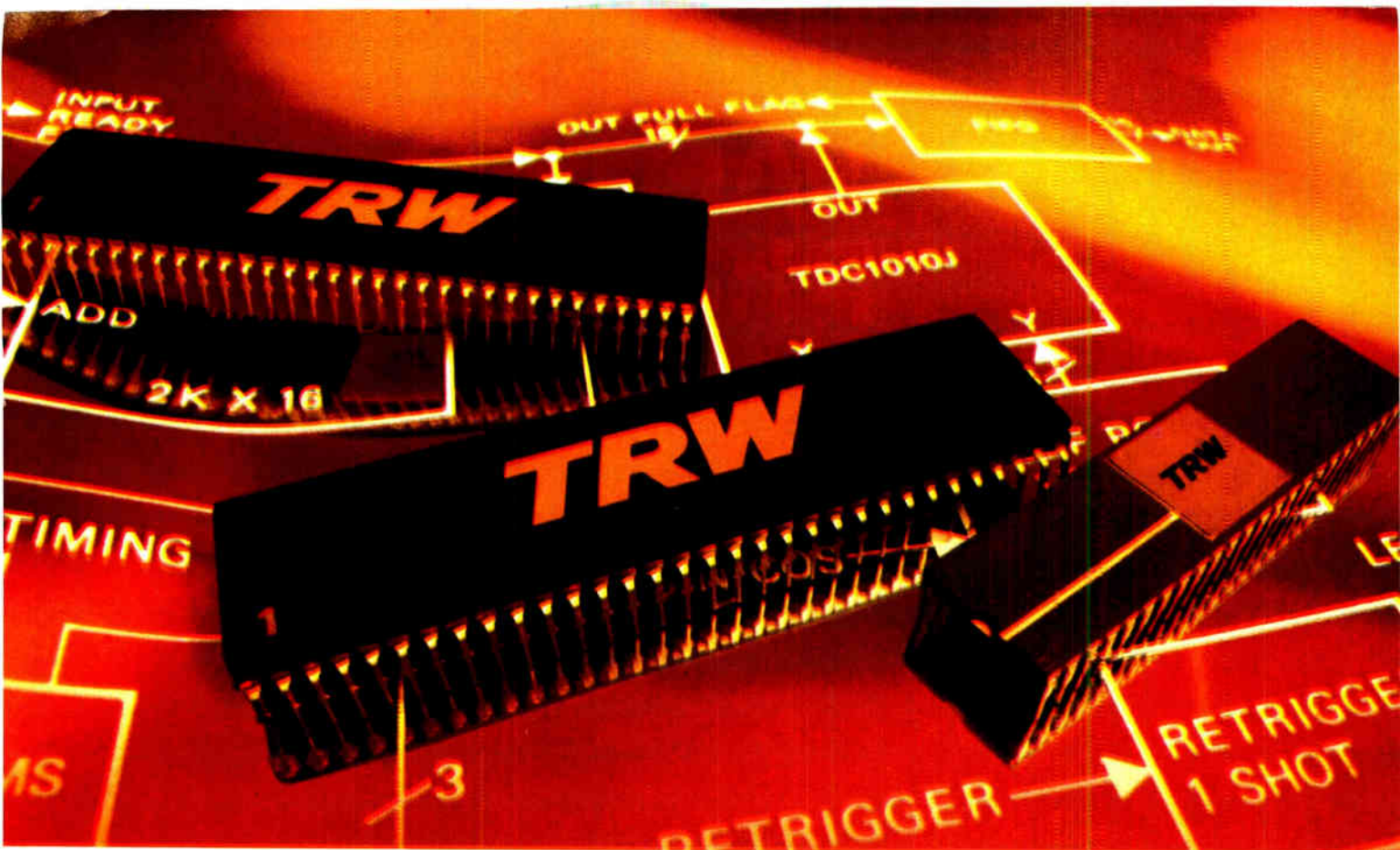

# 16x16-bit multiplication and 35-bit accumulation in 115nsec

(From a single chip.)

The easiest way to boost the number crunching ability of a microprocessor... or to build a high speed, low cost digital signal processor... is to use one of our MACs.

These bipolar, monolithic multiplier/accumulators give you dramatic savings in hardware and dollars. And their power demands are much lower than alternative devices.

The MACs are ideal building blocks for digital signal processing, particularly complex multipliers, filters, and FFT's. If you'd like to extend the capability of your micro/minicomputer, or if you're designing small yet potent signal processors for voice processing,

video processing, communications, or data analysis, look what we have for you:

- On-chip input and output registers with 3-state outputs.
- Subtract, as well as add, in the accumulator.
- Double precision arithmetic.
- Two's complement or unsigned magnitude.
- TTL compatible.
- Ability to operate as conventional n-by-n bit multipliers.
- Single power supply, +5V.

These super-fast multiplier/accumulators are in stock at Hamilton/Avnet.

**For immediate information, call us at (213) 535-1831 or send us the coupon or just attach your business card to this page and mail it back to us.**

Multiplier/ Accumulator	Word Size (Bits)	Sum (Bits)	Speed (nsec)	Power (Watts)	Unit Price (100s)
TDC1010J*	16x16	35	115	3.5	\$205
TDC1009J*	12x12	27	95	2.5	\$120
TDC1008J*	8x8	19	70	1.2	\$ 70

\*Guaranteed operation over  $T_C = -55^\circ\text{C}$  to  $+125^\circ\text{C}$  available for military applications.

**TRW LSI Products**  
P.O. Box 1125  
Redondo Beach, CA 90278

Please send data sheets on the family of multipliers/accumulators. (MAC's).

Name \_\_\_\_\_

Company \_\_\_\_\_

Div/Dept \_\_\_\_\_

Mail Code \_\_\_\_\_

Address \_\_\_\_\_

City \_\_\_\_\_

State \_\_\_\_\_

Zip \_\_\_\_\_

E4

TRW keeps you ahead in digital signal processing

Electronics / April 17, 1980

**TRW LSI PRODUCTS**

An Electronic Components Division of TRW Inc.

Circle 347 on reader service card 347



# VACTEC Photodiodes

Vactec photodiodes are the Gateway\* to solutions for detection problems requiring:  
Blue spectrum response, high signal to noise ratio, excellent linearity, superb stability, high voltage operation, fast rise times, low shot noise, low cost



Just a few of the applications for which Vactec photodiodes have found solutions are:  
light pens, colorimeters, spectrophotometers, analyzers for color film processing, blood analysis, color sorting, camera exposure controls, and hand held exposure meters.

Packages for our photodiodes cover the complete range from hermetic with glass or U-V transmitting windows, isolated detectors, to ceramic headers epoxy coated. Custom arrays are readily fabricated and packaged in dual-inline configuration. Write for Bulletins VTB-1B and VTP-1.

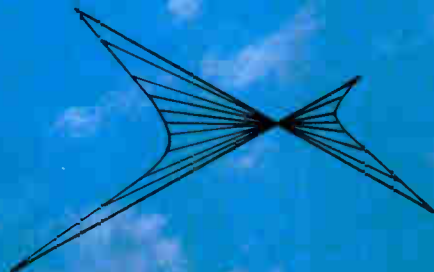

**Vactec, Inc.**

2423 Northline Ind. Blvd.  
Maryland Heights, Mo. 63043  
(314) 872-8300  
TWX 910-764-0811

\*St. Louis Arch in background.  
"The Gateway to the West."

Circle 348 on reader service card

nies formed to bring new technologies to market. Digital Equipment Corp. in Maynard, Mass., is generally credited with creating the market for the minicomputer with the introduction of its Programmed Data Processor model 8, or PDP-8, in 1965. The PDP-8 had a word length of 12 bits and a capacity of up to 4,096 words of memory. It was the first mass-produced computer and the first to sell for less than \$20,000.

Gordon Bell, one of the designers of the PDP-8 and now vice president of engineering, recalls today that the eight-year-old company "was convinced that short-word-length, high-speed machines were needed."

"We built them," he says, "in such a way that other people could use them easily in real-time applications, and we worked a lot on the interfacing so it would be easy to attach other equipment to the unit."

Clearly a distinguishing factor of the new minicomputers was the way they were sold. Instead of legions of support personnel, DEC customers got a minimum of hand-holding. But the customers were primarily engineers and scientists who were using the devices for industrial systems or experiments.

DEC introduced an integrated-circuit version of the PDP-8 in 1967. The mainframe 36-bit PDP-10 came in 1969, and by then the company was fifth in the industry in computers installed. Most significant, however, was the introduction of DEC's PDP-11 line in 1970. It was based on innovative hardware architecture, centered on a single bidirectional asynchronous bus. All processing, memory, and input/output elements were connected to this bus, allowing the computer to be modularly config-

ured in accordance with the user's specific needs.

A number of companies followed DEC's lead into this new, small-computer technology. One of the first was Hewlett-Packard Co. of Palo Alto, Calif., which in 1966 introduced its model 2116A instrumentation computer and a year later its 16-bit general-purpose model 2115A.

And just as computer families begat other computers, so did computer companies beget other computer companies. Most notable of these spinoffs was Data General, founded in April 1968 by three ex-DEC designers. Their first product, called the Nova, was introduced that September.

The new machine was priced at \$8,000 and offered a large computer's features—such as four accumulators, equipment previously unavailable in minicomputers. The Nova also allowed read-only memory to be mixed and matched with random-access memory up to the maximum of 32,000 words. This allowed important programs to be stored on the indestructible braided-core ROM.

Twenty-seven months after the Nova was unveiled, Data General introduced the Supernova, which operated between five and 15 times faster than its predecessor. The line was further expanded in October 1970 with the Nova 1200 and Nova 800 models and the Supernova SC, the first minicomputer to use semiconductor memory.

Seeing the potential, a number of concerns sprang up to offer minicomputers. Among these were Computer Automation and General Automation, Interdata, Modular Computer, Microdata, Datacraft, and Varian Associates. Old-line concerns countered with products of their own. Honeywell, for instance, introduced its

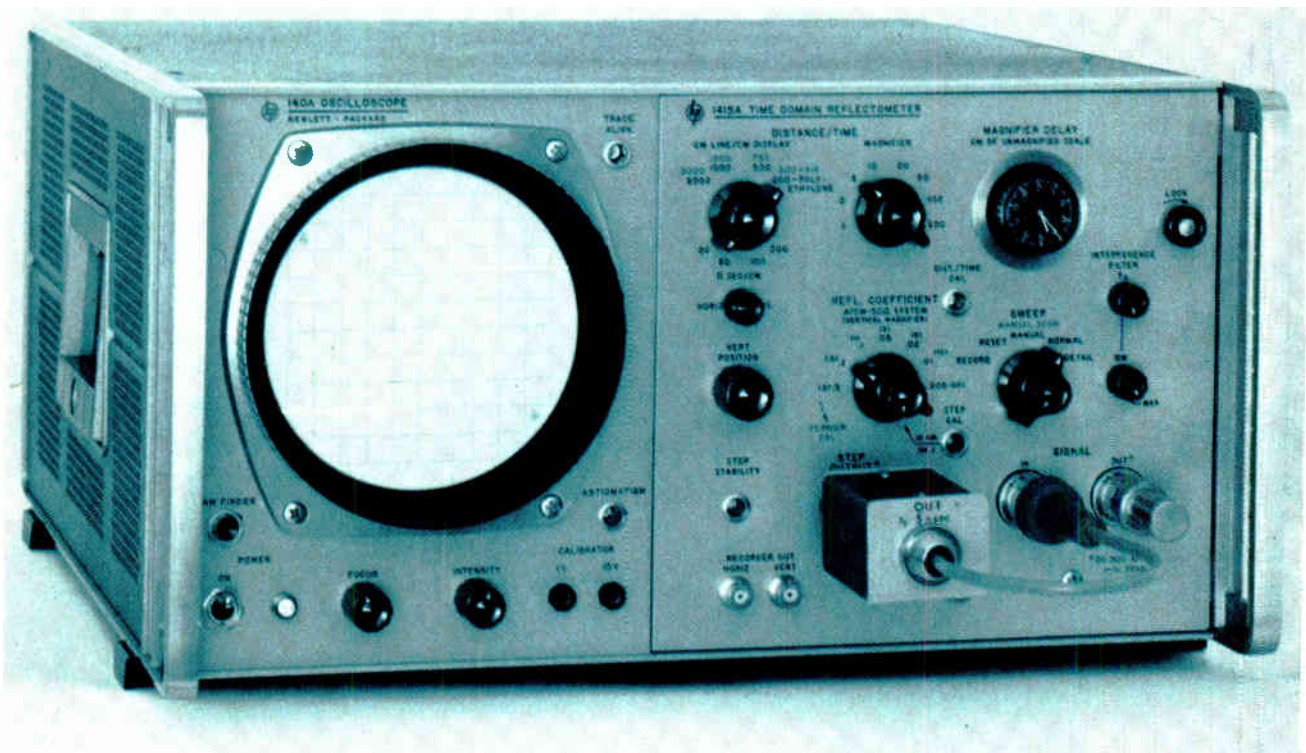

**Reflectometry.** In the early sixties Hewlett-Packard entered the oscilloscope marketplace with a series of innovative designs. For example, it introduced a time-domain reflectometry unit for making characteristic measurements of microwave systems.



under-\$10,000 model 316 minicomputer in 1969.

Computer designers had grown accustomed to using a teleprinter for input and output by people, the most popular being Western Electric's teletypewriter. But during the 1960s the more versatile cathode-ray-tube terminal was developed and gained popularity.

Originally there was concern that the raster-scan tubes, like those in TV sets, would be difficult to use because the wide bandwidth required for the video signal could not be accommodated on telephone lines. In addition, much conversion was needed between the digital information produced by the computer and the analog deflection and intensity-modulated signals needed for the TV-like tubes. By the end of the decade, however, IBM, RCA, and Philco-Ford's Western Development Laboratories were perfecting such terminals.

Another new input/output device devised during the 1960s was a replacement for the ubiquitous punched-card machines. Mohawk Data Sciences Corp., a small company in upstate New York, introduced in 1965 its model 1101 data recorder. The operator used a keypunch-style keyboard, but instead of punching holes in paper cards, recorded the information on seven-track magnetic tape at 200 bits per inch for later processing by a computer.

**A**long with better input/output terminals came improved techniques for connecting remote terminal equipment to a central computer. By 1963 AT&T's Bell System had installed some 5,000 Data Phone modu-

lator/demodulator devices (modems) to transmit digital information over the analog voice telephone lines, and Western Union's Telex was in 3,000 locations for data transmission over telegraph lines.

To simplify the interconnection of digital input/output devices, communications circuits, and computers, the computer industry adopted the American Standard Code for Information Interchange (ASCII) in July 1963. Its 7-bit code represented the alphabet, numerals, punctuation marks, and transmission control characters.

By the end of the decade a number of companies were looking to get a share of the growing data-communications business by operating special digital transmission equipment. Among these were the Data Transmission Co., better known as Datran, and Microwave Communications of America. American Telephone & Telegraph Co. joined the pack in 1970 with a proposal for a digital private line service.

Standard programming languages, especially Fortran and Cobol, were well on the way to becoming accepted at the beginning of the 1960s, and several other key languages were developed during the decade. Kenneth E. Iverson of IBM gave the world APL in 1962. Although this symbolic language was helpful in certain programming applications, its special symbol notation made it difficult to use. In 1963 the IBM users' group, Share, got together with the company to develop a language that would be good not only for mathematics, but also for alphabetic character manipulation, which was difficult to do in Fortran or Cobol. The result in 1965 was PL/1, a general-purpose language with the widest scope of any

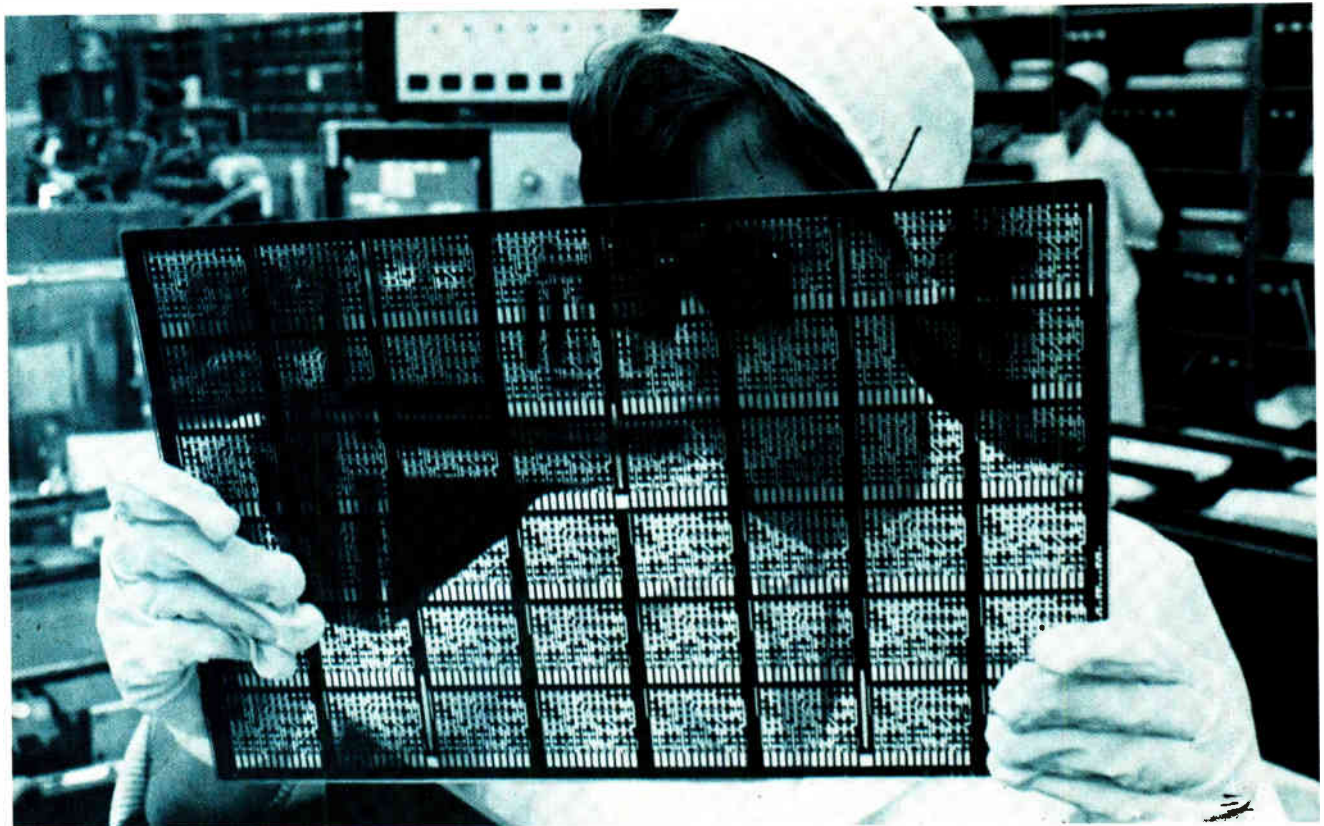

**Master.** Precision glass negative containing circuitry patterns for 48 etched printed-circuit cards for hybrid logic was fabricated for the System/360 line. Here it is inspected by a technician in a clean room before being inserted in an automatic photo-exposure machine.

# When you need illuminated switches, or more than illuminated switches...



Dialight is the first place to look. We make just about any kind of illuminated push button switch that anyone could want . . . Single lamp, dual lamp, neon, incandescent, LED lighted, you name it.

Perhaps you're looking for snap action switches with silver or gold contacts, or wiping action switches with gold contacts for low level application.

And if you're looking for rear panel or front bezel mounting switches, switches with momentary or alternate actions, or high quality switches for computer applications, we have them.

You'll find that Dialight switches are not only available at a reasonable price, they're also available with some very attractive features. Lamp removal is from the front so you don't have to remove

an entire switch just to change a lamp. And you never have to use anything more complicated than your fingers for replacement or installation.

Along with outstanding variety and design, you get superior Dialight quality. Most Dialight switches are Underwriter's Laboratory listed and CSA approved.

And Dialight distributors are widely located throughout the United States, Canada and worldwide.

Call or write Dialight today. We'll send you our free switch catalogs so you can select a quality switch that's American made and Dialight guaranteed.

**DIALIGHT**  
A North American Philips Company

## Dialight meets your needs.

Dialight, 203 Harrison Place, Brooklyn, N.Y. 11237 (212) 497-7600

Circle 351 on reader service card



# 50 YEARS makes a difference... in light measuring instrumentation

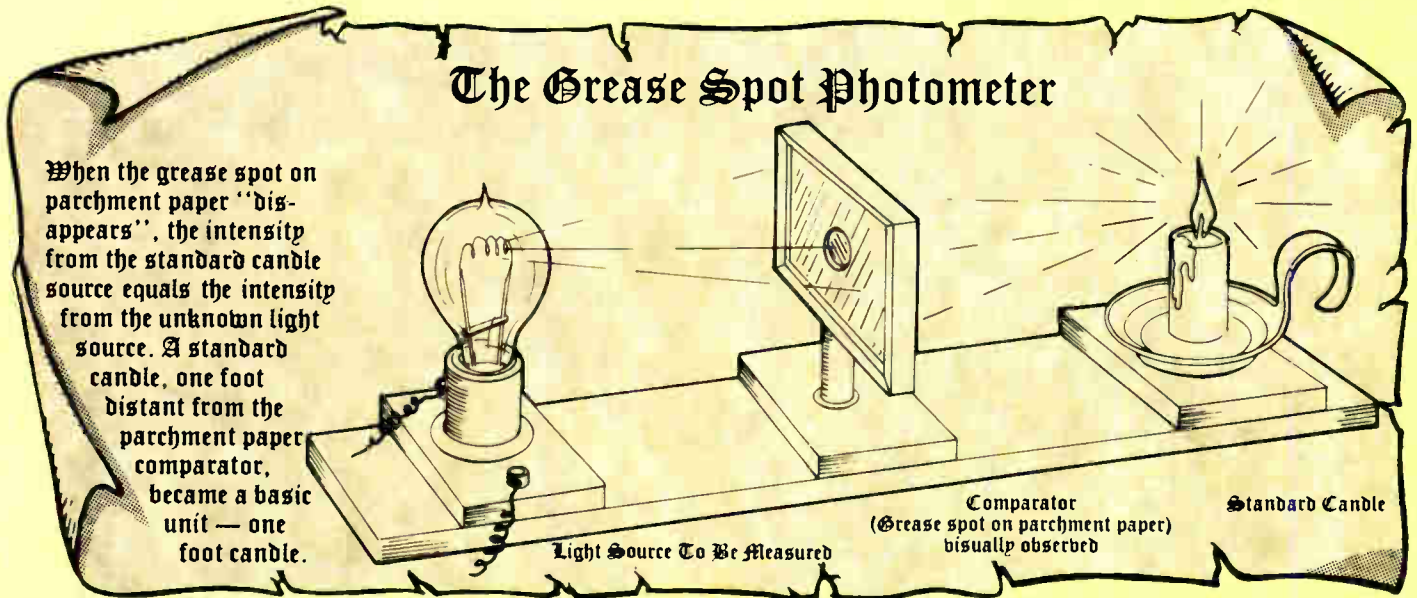

## MODERN PHOTOMETERS AND RADIOMETERS

utilize MOS LSI circuitry and LCD digital indicators to maximize performance and minimize size. Interchangeable solid state sensors provide maximum accuracy, stability, sensitivity, and spectral range.



PHOTODYNE INC. was formed 1 year ago by Dr. Paul Wendland with the aim of producing accurate, sensitive, versatile, and cost effective LIGHT MEASURING INSTRUMENTATION.

### 22XL

Optical Multimeter - calibrates all FIBER OPTIC elements in dB units.

### 66XLA

Optical Energy/ Power Meter measures single pulse energy and CW power from Lasers and LED's.



### 88XL

Radiometer/ Photometer measures light power to 1 picowatt and 1 micro foot candle.

### 99XL

Densitometer/ Reflectometer calibrates spectral transmission and reflection of all optical elements.



**PHOTODYNE INC.**

5356 Sterling Center Drive • Westlake Village, California 91361 • Phone: (213) 889-8770, Telex 18-1159

language that had been created to date.

Meanwhile at Dartmouth College problems in teaching computer programming to large numbers of college students led to the search for an easier language. The result was the Beginner's All-Purpose Symbolic Instruction Code, or Basic, developed in 1964 by John G. Kemeny and Thomas E. Kurtz.

Algol, the programming language first compiled by the Association for Computing Machinery in 1958, was revised and improved during the early 1960s. The language was the first to use a block structure and defined the scope of variables better. It spawned a number of other specialized languages.

By now the American computer industry was firmly entrenched as the world's leader. IBM dominated the foreign markets as much as it did the American. The British industry, which had 12 computer manufacturers at the beginning of the 1960s, underwent a shakeout, leaving it with one major manufacturer by 1970—International Computers Ltd. France's one major computer maker—Compagnie des Machines Bull—received a major infusion of American capital, as did computer companies in Italy and West Germany. The only country outside the U. S. to maintain a position of independence and strength in the computer industry was Japan, which was prodded by its government into grouping its companies and teaming its efforts.

"Japan jumped from nowhere to third place in the world computer industry in six years, ranking behind the United States and West Germany in computer installations," said Katsuhiko Noda, chief of the Electronic Computer division of the Electrotechnical Laboratory in the Japanese Ministry of International Trade and Industry, in the June 27, 1966, issue of *Electronics*. Seven companies were involved: Hitachi, Fujitsu, Nippon Electric, Toshiba, Oki Electric, Mitsubishi Electric, and Matsushita. In 1961 the government created the Japan Electronic Computer Co. to purchase computers from manufacturers and lease them to customers, freeing the makers from the burden of supporting rentals.

Although Japanese computer makers had no trouble with the hardware, the critical software and the lack of trained personnel forced most to produce American computers under license during the early 1960s.

By 1966, however, the Japanese government aimed to make the companies independent of computer imports. Half of the estimated \$190 million in computers to be installed in Japan that year were expected to be domestic. And the Ministry of International Trade and Industry drew up a \$37 million five-year plan for research and development of a large, high-speed computer.

Fujitsu promoted Japan to the big leagues of data processing in 1968 with the announcement of its Facom 230 series. The model 60, introduced in April, was a multiprogramming computer that could be attached to another model 60 to create dual-processor configurations. Other models were added later that year.

In the Netherlands, Philips Gloeilampenfabrieken, the largest electronics company outside the U. S. during the 1960s, established a computer division in 1962. It introduced its first computers six years later. Three third-generation machines in the P1000 series were

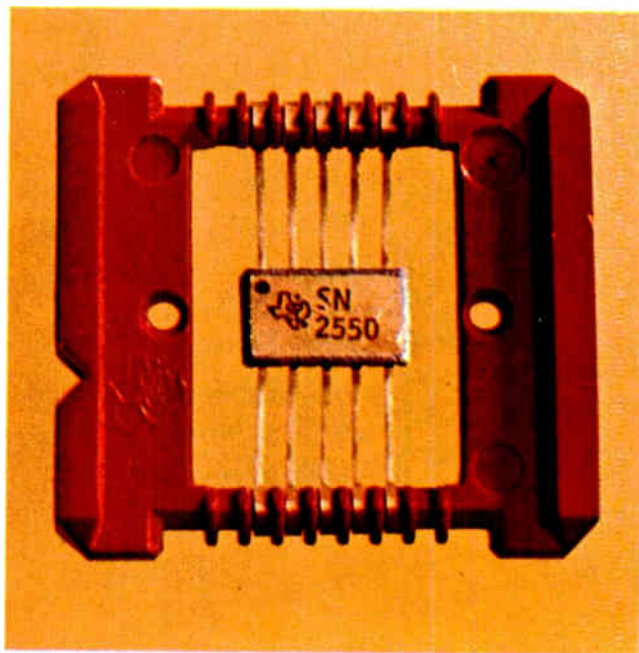

**Flat pack.** Handling tiny integrated circuits was a problem whose solution lay in the flat pack—a ceramic, plastic, or metal unit with flat-ribbon leads jutting from opposite sides. It was invented by Texas Instruments in 1962 and was soon an industry standard.

roughly comparable to the IBM System/360 models 30, 40, and 50.

The Eastern Bloc of Communist Europe was hardly heard from. Although the Soviet Union's success in space was evidence that it had developed computers and the skill to use them, the country was apparently unable to launch a successful general-purpose computer effort.

**C**omputers, of course, fanned the brushfires of automation that swept through the industrial world in the sixties. The National Biscuit Co., for example, bought a Foxboro digital computer to oversee the baking of Saltine crackers and Oreo cookies in its Chicago plant. In April 1961 control of a British chemical plant was turned over to a solid-state Argus 1024 computer by Ferranti Ltd. The following year, at the annual conference and exhibit of the Instrument Society of America, two speakers reported the use of Minneapolis-Honeywell 290 and IBM 1620 digital computers to control American steelmaking furnaces.

While more and more computers were turning up on production lines in 1964, and while engineers were awaiting the next big event in industrial electronics—the debut of integrated circuits in control computers—an important new control concept burst onto the scene: direct digital control (DDC) of industrial plant processes, a technique that timeshared one special-purpose digital computer among hundreds of transducer inputs and actuator outputs, was hailed as a breakthrough in simplicity and cost.

Not only was DDC control hardware cheaper than hundreds of dedicated analog single-loop controllers, it also did not require nearly as much time and money for programming as did the general-purpose mainframe



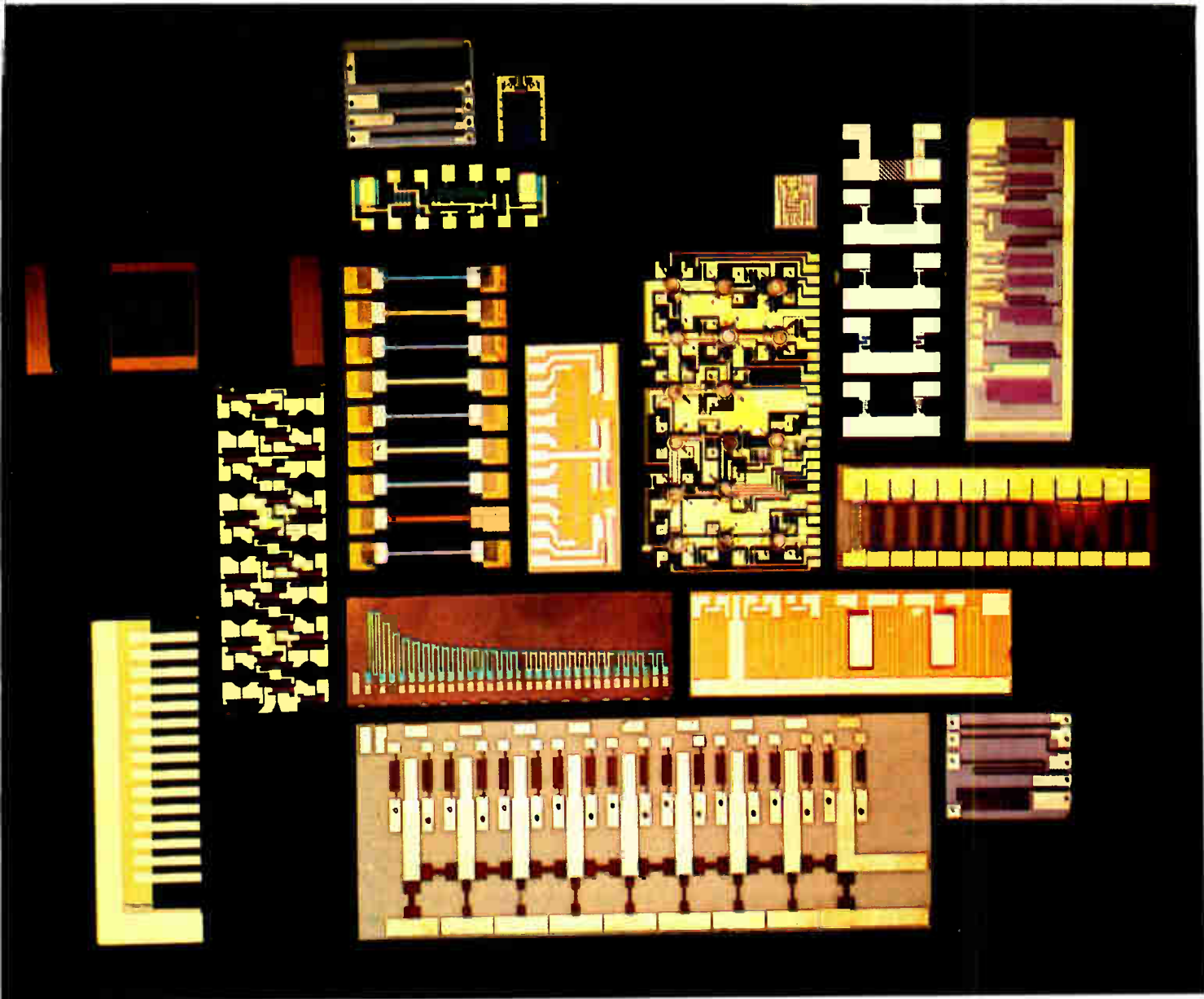

**Shapes and sizes.** Hybrid circuits in a striking variety of sizes, shapes, and colors were developed for the new miniature electronics. Different colors in these 1967 tantalum thin-film circuits from Bell Telephone Laboratories result from different thicknesses of tantalum oxide.

computers, intended originally for data processing. What's more, the new technique permitted plant engineers to optimize a process while the computer controlled it.

The only question about DDC was its reliability: would the whole process shut down if the computer failed? Experts agree that prevention of such an unacceptable event required computers with a reliability of 99.95%.

Seven companies led by 3M Co. soon had DDC systems on the market, all claiming computer reliability of 99.95% or better. Prices were well below those of the general-purpose industrial-control computers. One new system, the SDS-92 by Scientific Data Systems Inc., even pioneered the use of off-the-shelf AND/OR logic ICs for the input/output storage registers in its analog-to-digital converter. The cost of the SDS-92, with 2,000 words of memory, was \$29,000.

America's largest industrial employer, the automotive industry, embraced computers. By 1964 General Motors and Ford were using computer graphics to create perspective drawings of new car models in real time. These drawings were then fed, on punched tape, to a

numerically controlled machine tool that made mockups and actual parts dies.

The auto industry and the aircraft industry were the first to use numerically controlled inspection machines to check the position and to measure the size of holes in engine blocks. These boredom-proof inspectors cut quality-control times by 98%, even while documenting their own work.

Computers penetrated other markets, too. They landed jobs in power plants as training simulators, power-flow controllers, and data links for utility companies thousands of miles apart.

Industry began to explore the use of semiconductor devices as cheaper and more reliable replacements for mechanical and electromechanical hardware. For measurement of position, pressure, and velocity, semiconductor diodes, tunnel diodes, and Hall-effect diodes rapidly made inroads in markets previously dominated by potentiometers, synchros, and accelerometers. Typical of the new devices were new semiconductor strain gauges made of single-crystal p-type silicon; they were 10 to 100 times more sensitive to stress than were metallic or foil wire

# When you look to the future, look into StereoZoom<sup>®</sup> Microscopes.

StereoZoom Microscopes, the world's first zooming stereo microscopes, have played a major role in the production and inspection of micro-electronic components since these innovative microscopes were first introduced by Bausch & Lomb in 1959. In the years to come, the increasing demands placed upon the electronics industry will be staggering.

More than ever, you'll need reliable, versatile StereoZoom Microscopes to meet production quotas, quality levels, and profit expectations.

The future is dawning now. Look into a StereoZoom Microscope today.



**BAUSCH & LOMB**

Scientific Optical Products Division

ROCHESTER, NEW YORK 14602 USA

Circle 355 on reader service card



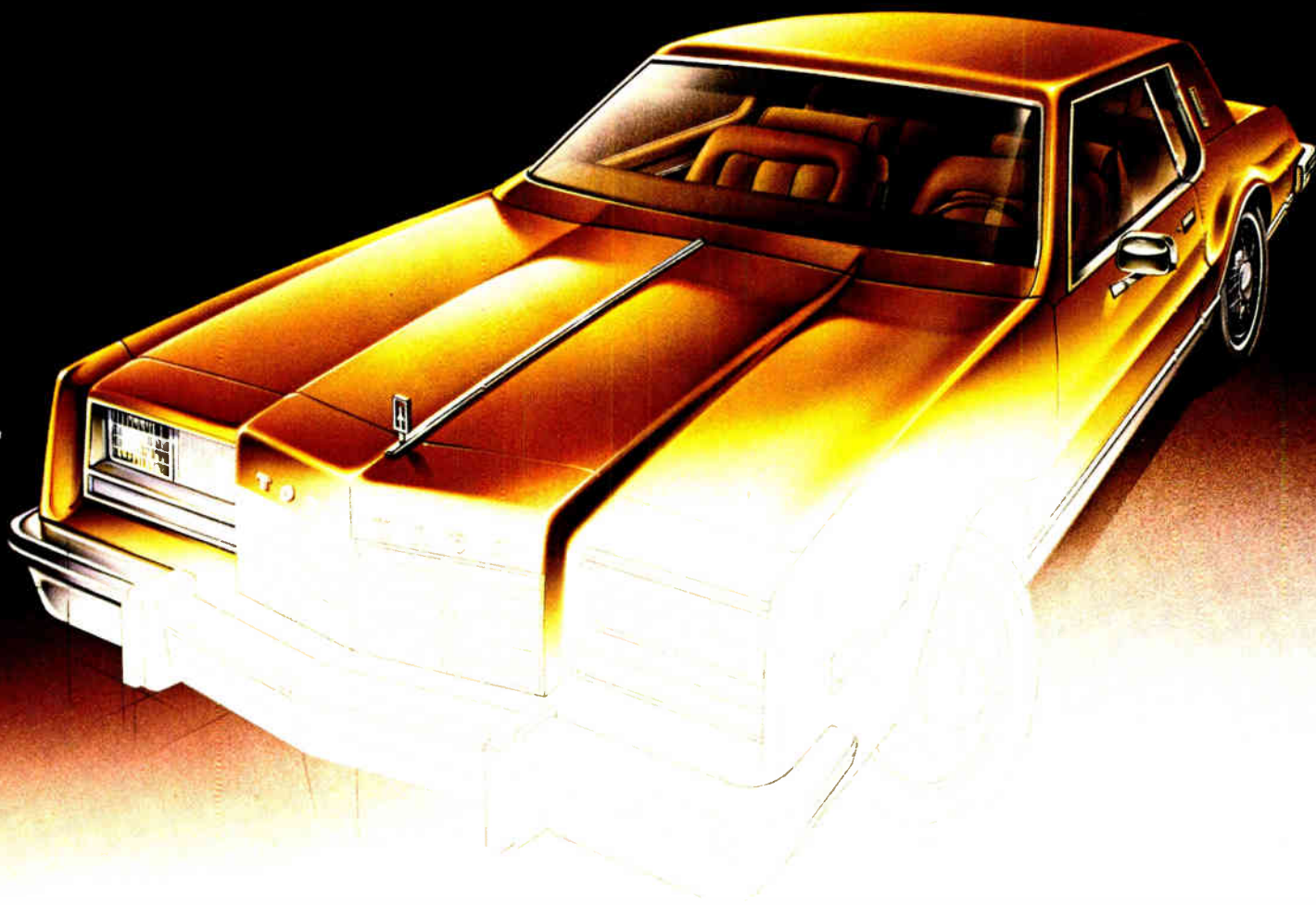

## It takes a comfortable setting to get a great idea rolling.

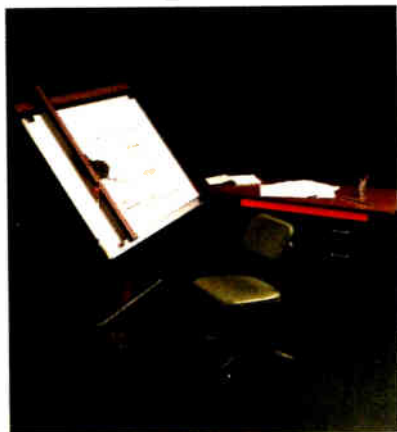

Elegance and comfort. It takes skill to design the fine lines that make beauty functional. It starts with an idea that needs a comfortable setting in which to grow. Bruning understands.

We have a full line of Hamilton engineering drafting furniture and Bruning accessories designed for maximum comfort, efficiency and accuracy.

Our ACCUTRAC™ drafter, for instance, allows you to use 99% of your drafting board. And its head is made with a multiple-tooth index plate that's almost impossible to wear out.

Fact is, Bruning can get you rolling with a complete line of top-quality furniture and supplies.

For more information, call your nearest AM Sales Office. Or write AM Bruning, Dept. E, 1834 Walden Office Square, Schaumburg, IL 60196.

**We help bring your vision to life.**

 **Bruning**  
the Informationists.

© 1979 AM International, Inc.

See our catalog in Sweet's, Sec. 1.4/Er.

Circle 356 on reader service card

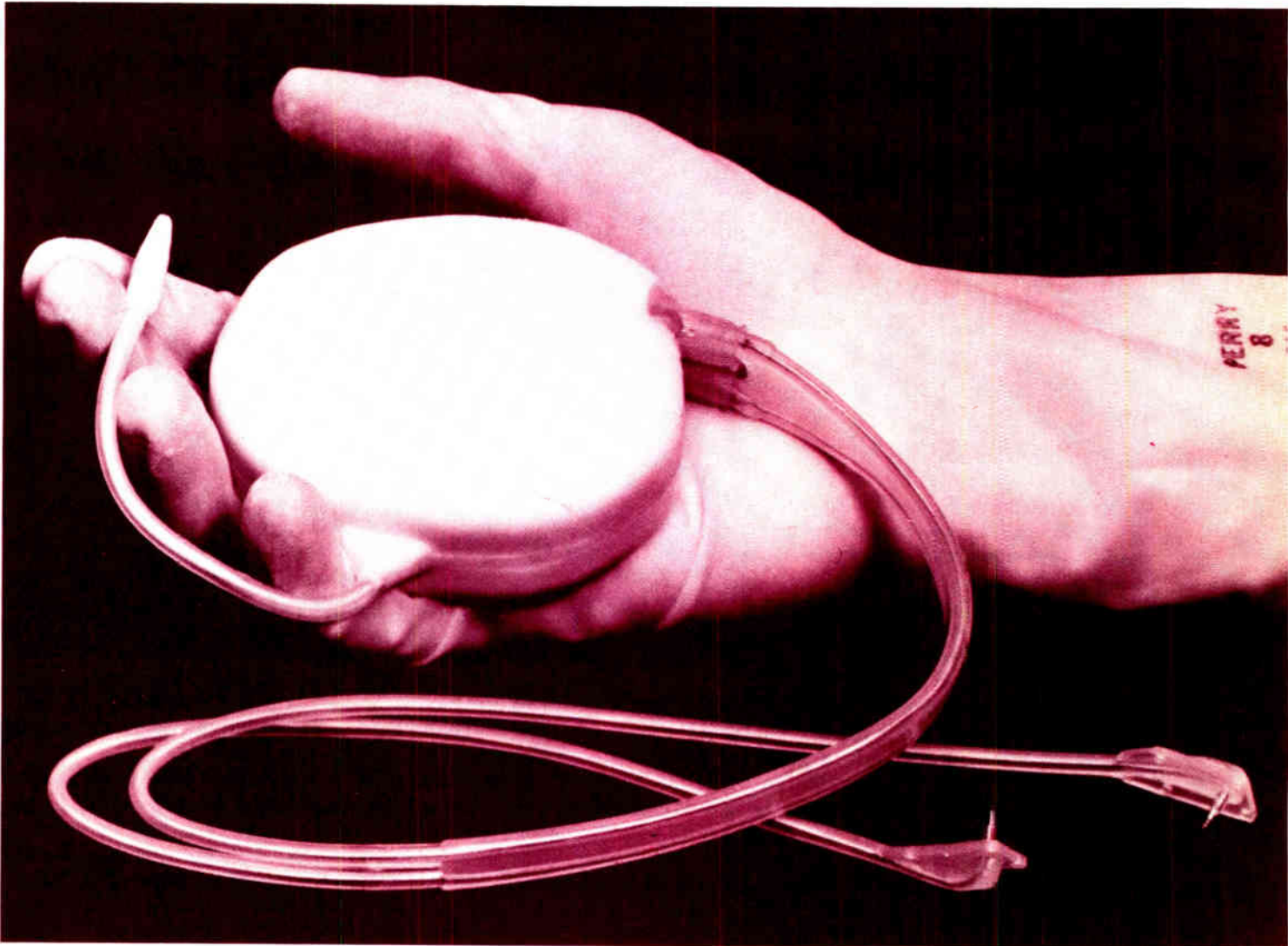

**Lifesaver.** The miniaturization of electronics brought by the integrated-circuit revolution made possible this implantable heart pacemaker developed by Medtronic Inc., Minneapolis, in 1967. As the years passed, the progress in circuit integration would lead to even smaller units.

gauges. In another industrial use of electronics, ultrasonic generators with frequencies in the 20-to-100-kilohertz range cleaned tanks, drilled, welded, and soldered. Power-conversion techniques also improved.

Silicon controlled rectifiers had been invented in 1956 by communications engineers at Bell Telephone Laboratories. They used them as “pnp transistor switches.” But power engineers, led by Gordon Hall at General Electric’s rectifier plant in Clyde, N. Y., developed SCRs into cheap, reliable devices that could control large amounts of electric power.

**V**ideo technology improvements brightened the future of that field. High-resolution vidicon cameras inspected the radioactive interiors of nuclear power plants. Cathode-ray tubes and computers joined forces in photocomposition systems that eventually spelled obsolescence for hot type in the printing industry. Similarly Ampex Corp. started the clock ticking for movie films in broadcasting with its 1967 introduction of a computer-based color video disk recorder that sold for only \$5,000.

Components other than semiconductors had come a long way by the end of the 1960s. The decade had opened with a technology based on tubes and transistors; it ended with linear and digital integrated circuits laying the foundation for the microelectronics revolution of the seventies (see Chapters 5 and 8). A list of significant component developments would have to include:

- The creation of new families of IC packages ranging from beam-lead and flip-chip to the familiar flat-pack and dual in-line versions.
- The emergence, in response to new semiconductor devices, of families of miniaturized passive components plus modular operational amplifiers.
- The birth of components for optoelectronics—light-emitting diodes, fiber optics, optical couplers.
- The arrival of additive technology for printed circuits and heavy use of the multilayer pc board.
- Continued emphasis on automatic assembly and automatic wiring.
- Heavy stress on thin-film and thick-film hybrid circuitry for packaging.

One of the most important improvements in IC



**Fondly displayed.** Cofounders of Tektronix, Jack Murdock, left, and Howard Vollum showed off their new 500-series of general-purpose oscilloscopes in 1964, 17 years after launching the first of the series, the 511. Shown is the 547, which promised crisp display, reliability, and sophistication.

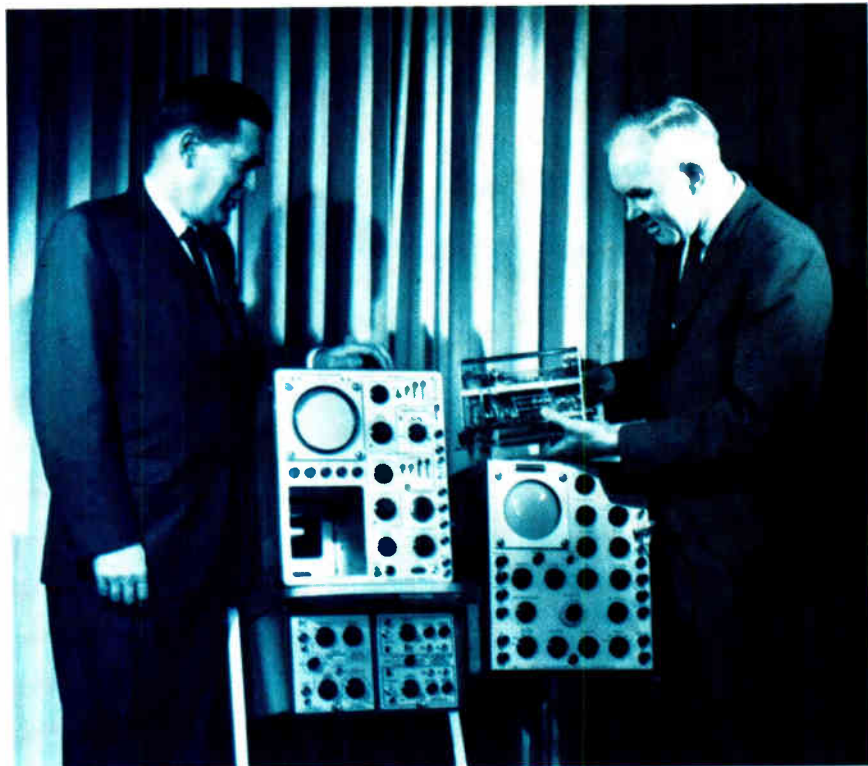

processing was the adoption by semiconductor makers of ion implantation—a technique for modifying the properties of solids by implanting them with ions. The idea had been pioneered in the late 1940s and early 1950s by Russel Ohl and William Shockley of Bell Telephone Laboratories.

Ion implantation was being used in 1963 to make solar cells at a plant of the Ion Physics Corp. in Burlington, Mass. One of the first commercial implanters was reported in 1967; it was made by the same Ion Physics Corp. By 1970 ion implantation was ready to go into the process lines of Hughes and Mostek.

Another important IC fabrication advance was the creation of “clean rooms” to cut contamination of the silicon wafers by dust and other particles. These began to be installed in 1967 by General Instrument, Texas Instruments, American Microsystems, and RCA. The rooms had only one to 100 particulates per cubic foot of air and were the forerunners of today’s super clean rooms, which have proved to be so necessary for large-scale integration.

An article in the July 8, 1968, issue of *Electronics* described Signetics’ use of plasma (a cloud of charged ions) to strip resists from silicon wafers. This technique, a dry etch, became heavily used in the late 1970s for processing large-scale integrated circuits. Another short article in 1969 described a photoresist coater that moved wafers on an air curtain. This technique, designed by Industrial Modules Systems of Cupertino, Calif., was also to reemerge in the late 1970s in fully automated in-line IC processing facilities.

IC lithography methods that were to figure in planning for very large-scale integration in 1980 got their start in the 1960s. A parallel effort was the development of both the IC pattern generator and step-and-repeat camera—

both of which were used to make precise masks for ICs. X-ray lithography, another important technique, did not appear until 1970.

Mask-making, the stimulus for all the lithographies, rapidly became so complex that circuit designers started going to computer-aided design. In 1964 the Norden division of United Aircraft used the technique to do a design analysis and mask layout for a linear microcircuit (a two-stage differential amplifier). The Norden system was centered on an interactive CRT terminal where changes could be made with a light pen.

By 1969 computer-aided design for ICs was in universal use. Computers were now doing everything from turning out logic equations to printing out instructions for fabricating ICs. The use of stored cells (standard subcircuits), partitioning logic, and computer-generated art work became standard.

As the IC evolved, problems arose in attempts to connect the tiny chips to either hybrid or printed-circuit substrates. Packages that were developed for pc boards were the flat-pack, dual in-line, and quad in-line. To attach a bare chip to a hybrid, the following techniques were devised: flip-chip, beam-lead, and spider-bonding.

The first IC package to appear was the flat pack, a ceramic, plastic or metal unit with flat ribbon leads coming out of two opposite sides. Invented at Texas Instruments in Dallas in 1962, it was quickly accepted and standardized, and in 1965 TI developed a socket for use with it.

The dual in-line package, a rectangular ceramic or plastic unit with two rows of pins on 100-mil centers, originated in 1964 at Fairchild Semiconductor in Mountain View, Calif. And in Anaheim, Calif., in 1969 Autonetics, then a division of North American Aviation, designed an interesting variation of the DIP that reap-

# people who play the computer specify Verbatim®

Virtuoso performers at computer keyboards deserve the ultimate in recording quality. That's why you should specify Verbatim brand diskettes, minidisks, cartridges and data cassettes for your computer or word processing system.

At Verbatim, the whole message is quality. We specialize in digital data recording media and have become the world leader by setting the standards for flawless, dropout-free magnetic media. Every size, every format, and available everywhere. Order them from

your computer supplies dealer.  
Simply specify Verbatim.

For the name of your nearest Verbatim distributor, call:

800-538-1793  
In California call:  
(408) 737-7771 collect

Verbatim Corporation  
323 Soquel Way  
Sunnyvale, CA 94086

**In Europe:**

Verbatim S.A.  
Case Postale 296  
1215 Genève 15  
Switzerland  
Telephone: 41(22) 34-90-55  
Telex: 22647 ITGE CH.





# ASTRO-MED



*New! AC-DC*

## DASH II RECORDER

- Take anywhere rugged design
- Rechargeable battery or line operate
- Position feed-back galvos . . . 99.5% accuracy
- DC — 125 Hz.
- Crisp, clear traces . . . low cost thermal paper
- Simple to operate . . . years of trouble free operation

This new Dash II may very well be the final word in portable/lab high speed recorders. With rechargeable batteries and built in charger, you can take it anywhere — land, sea or air, and use it for 4 to 5 hours. Then, you can continue to operate while recharging the batteries. Accuracy? The patented (U.S. #4,134,062) Pathfinder™ galvo is position feedback with better than 99.5% accuracy. High stylus pressure delivers crisp, clear traces on low cost thermal paper.



Get all the facts. Call or write



ASTRO-MED DIVISION  
ATLAN-TOL INDUSTRIES, INC.  
Atlan-tol Industrial Park/West Warwick, R.I. 02893  
401-828-4000

peared late in the 1970s. This was a 42-lead ceramic package with a staggered lead frame that accommodated two rows of pins on 50-mil centers on each side. This has since become known as the quad in-line package.

The flip-chip method of attaching chips to hybrid substrates was first discussed in a 1963 paper from IBM. It proposed that large metal bumps, or balls, be built up on the contact pads of a transistor or IC. The device could then be mounted face down to conductors on a ceramic substrate and reflow-soldered on. Many companies experimented with this method, but from 1970 on, it was almost exclusively used by IBM.

In the beam-lead method, pioneered at Bell Telephone Laboratories in 1964 by Martin Lepselter, a gold metallization system not only interconnected individual gates of an IC chip but also provided beam-like leads to connect to external circuitry. The gold lead was relatively thick and extended beyond the boundaries of the chip like a cantilevered beam to contact the substrate's pads.

The beam-lead process proved to be extremely reliable, and for a while TI and Motorola made commercial beam-lead chips. In time Western Electric became the main advocate of the technology, using it to make its own ICs, in the same way that IBM took to flip chips.

Spider bonding was unveiled in 1968 by Motorola as its way of eliminating wire bonding of the die to a lead frame. A special machine was used to bond the chips to a spiderlike pattern stamped out of a continuous strip of metal. Meanwhile another machine automatically welded the spider-bonded dice and leads to a lead frame. All bonding was done at once, making the process 20 times faster than manual bonding. This process was used by Motorola into the early 1970s but was eventually superseded by more conventional methods like automatic wire bonding and later tape automated bonding.

**T**ubes started strong in the sixties and gradually faded. There was still kick in the tube industry in 1961. News stories that year mentioned companies using General Electric's Compac-tron (several tubes under one envelope) for either TV or stereo applications. A new radar beacon in 1961 used the Nuvistor, a small ceramic tube made by RCA (see Chapter 6). The transistor and a zener diode were available, but not without limitations.

Tubes were still being considered for circuit design in 1963. RCA, for one, thought enough of them to pour \$11.6 million into expanding its tube plant in Lancaster, Pa. However, except for specialized high-power transmitter tubes and replacement tubes for existing equipment, the tube was through for all practical purposes by the decade's end. Silicon devices did it in.

During all this activity, manufacturers of passive and even electromechanical components were not standing still. Miniaturization of resistors for high-density packaging was reported in 1964. The new mini types were mainly films—deposited carbon, metal, and tin oxide. Meanwhile thin films of Nichrome or tantalum were serving as precise resistors on hybrid substrates.

Relays became smaller and faster. Types like the miniature rotary armature, sealed reed, ferreed, tuned



**Laser.** General Electric in 1962 had a new type of laser, one made of gallium arsenide, seen as a small spot between two electrodes within the circles at the lower end of the photograph. Robert N. Hall peers at his discovery, which was cooled in liquid nitrogen.

reed, and mercury-wetted relays emerged in either crystal cans or sealed glass tubes. All could be driven either by a transistor or by certain digital ICs. By 1969, C. P. Claire of Chicago was advertising a relay small enough to fit into a TO-5 transistor can. Inductive devices such as transformers and chokes began to use the now-familiar ferrite core in the move toward size reduction and higher-frequency operation. Tiny cores could be used to make inductors 1/1,000 the size of previous commercial inductors.

Potentiometers were very much in the picture in the 1960s, since most circuitry was analog and servomechanisms required mechanical feedback elements. Wire-wound, cermet, conductive plastic, carbon, and metal-film potentiometers were all in use. Miniaturized versions were used for trimmer applications. Trimmers were now designed to be mounted on a pc board rather than a front panel.

Another important trend of the time was modular components. Companies like Teledyne/Philbrick, Analog Devices, and a host of others came out with small epoxy-coated modules for plugging into pc boards. These modules were mainly high-performance operational amplifiers and a few data converters. Also, some



companies—Beckman Instruments, for one—came out with thick-film hybrid amplifiers and voltage regulators for commercial use. These hybrids could be extremely sophisticated. For instance, in 1968 Philbrick/Nexus put out an operational amplifier in a flat pack, using a thick-film interconnect and thin-film resistors on an alumina substrate. Thick- and thin-film technologies were, in fact, often combined in hybrid designs.

One of the cleverest components of the decade was a Hall-effect key switch—a solid-state contactless switch—made by Microswitch, a Freeport, Ill., division of Honeywell. The heart of this unit was a special IC with a Hall-effect sensor, trigger circuit, and amplifier. Depressing a key lowered a magnet near the device, triggering it. This key switch, by now considerably improved, remains in heavy use on the keyboards of data terminals to this day.

The printed-circuit industry kept up with all the progress. As IC makers went to flat packs and then DIPs, the pc makers found themselves going to finer lines or to multilayer boards to squeeze more DIPs on boards.

Screened-on resists could not be used to make the fine lines needed for the new high-density boards. Dry films filled the need. By 1970 Du Pont and Dynachem had captured 21% of the pc resist market.

**T**he push of instrument designers in the 1960s was in three directions: the definition of more precise standards, the design of new instruments to accommodate growing use of telemetry and digital computers, and the design of automated testers for new integrated circuits.

In 1961 electronic measurement precision took its first great leap of the decade. The National Bureau of Standards applied the electrostatic theorem introduced by A. M. Thompson and D. G. Lampard in Vol. 177 of *Nature* in 1956. The theorem covered the construction of capacitors whose values could be computed if a single parameter—length—was known precisely. The capacitor developed by the bureau made measurement of resistance simpler and more precise.

Using a special quadrature bridge, R. D. Cutkosky of the bureau compared capacitance and frequency to an ac resistance and transferred this measurement to a resistor whose ac/dc difference was calculable. His measurement uncertainty was only 2.3 ppm.

Once instruments could be calibrated easily to more precise electrical standards, NASA and the military could reasonably require their suppliers to use instruments calibrated against standards that could be traced to the National Bureau of Standards. In 1962 this requirement was rigorously imposed by the Government.

The next great improvement in standards came in 1964. The International Committee on Weights and Measures abandoned difficult-to-measure ephemeris time (based on the earth's orbital revolution around the sun) and adopted the standard based on the work of Jerrold R. Zacharias of the Massachusetts Institute of Technology in the 1950s—atomic time. A second of atomic time is defined as the period in which an electron in the shell of a cesium-133 atom, undisturbed by exter-

nal fields, makes 9,192,631,770 transitions between two specific energy levels.

**A**gain, the new standard was critical for the U. S. Government. What was to become the nation's first line of defense, the Polaris submarine, was based on the ability to measure frequency and time precisely, so that the submarine crew could determine their position precisely before aiming and launching a missile.

The great emphasis on rocketry, not only for defense but also for global communications and the exploration of space, also brought telemetry to the forefront. The burgeoning amount of data to be transmitted put a burden on the existing fm/fm telemetry system. At first, the density of data was reduced by processing the data before transmission, so that only changes in the measured value were transmitted. This reduced the power needed in the transmitter, saving space and weight, but soon even this proved insufficient, in terms of not only data density but also data accuracy.

To overcome these difficulties, various pulse transmission techniques were tried with which data could be packed more efficiently. Pulse-code modulation was found to be most efficient.

As a result of the space program, two demands were placed on the instrumentation industry in addition to the need for higher accuracy: to make small sensors to measure a variety of physical parameters, and to provide instruments that could feed measurements directly into a computer. Echoing these demands were the utility and process-control industries, which found telemetering a boon to the management of their facilities, and also the field of medicine, which sought to detect conditions within a patient's body.

In 1960 the Lockheed Missiles and Space division developed a 3-ounce fm transmitter that a patient could wear around his neck while performing routine work. Data from body electrodes was transmitted to an fm tuner to drive a conventional electrocardiograph. Gulon Industries developed an electronic thermometer that used a thermistor in an ac bridge to provide quick temperature measurement. And in 1961 Gulon developed a system for the Air Force that could measure 14 different physiological parameters.

There were other developments, too. Dr. D. H. Howry and Dr. J. H. Holmes of the University of Colorado developed the Somascope, which produced a two-dimensional picture similar to an X ray on an oscilloscope by using ultrasound at a rate of 1,000 pulses per second. A pressure-sensitive radio pill was built by AIL for measuring conditions in the gastrointestinal tract.

Implantable pacemakers were developed by doctors at the University of Buffalo. The Veterans Administration hospital in Buffalo, together with Wilson Greatbatch Electronic Consultants and Medtronics, were licensed to manufacture and market them.

The explosion in information that was taking place called for faster analysis, and this meant getting the data in a form that could be accepted by a computer. The answer was digital instrumentation whose design was

# WE ARE MIDTEX... WE ARE RELAYS...

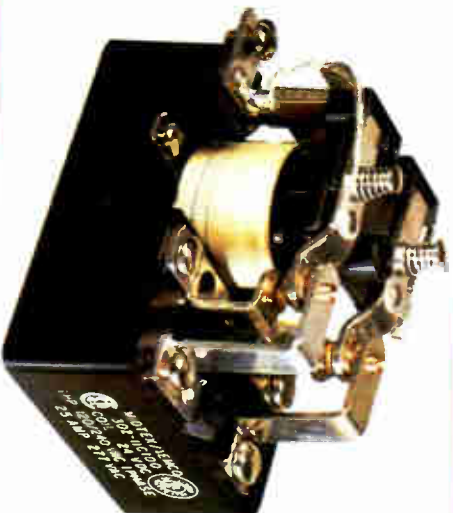
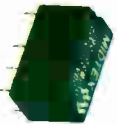
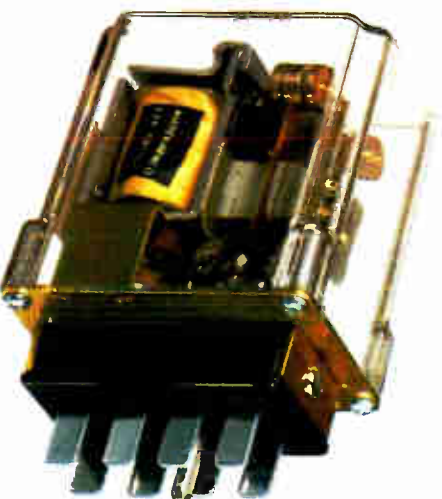
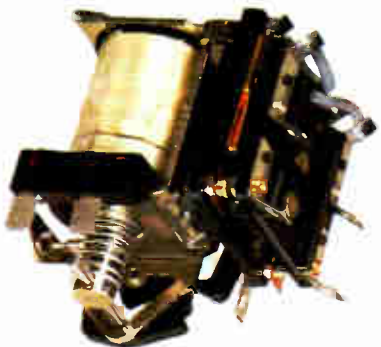

THE TOTAL RELAY COMPANY

**MIDTEX** 

MIDTEX DIVISION / MIDLAND-ROSS CORPORATION

1650 Tower Boulevard  
North Mankato, MN 56001 (507) 625-6521



# Are you on the switching regulator bandwagon?

## We've got just the capacitors you need.

When you use Mallory capacitors you get the features you need in switching regulators: low impedance—low ESR—low inductance. All these qualities combined with high ripple current capability. Besides our recently introduced THF tantalum capacitor, we have

a full line of aluminum electrolytics for these applications.

Let our Mallory Help-Force guide you to the capacitors that fit your needs. Tell us your requirements and we'll help you select the right one. At the right price. Call your local Mallory sales representative. Or contact Help-Force headquarters at (317) 636-5353 for detailed specifications.

Mallory Capacitor Division, Mallory Components Group, Emhart Industries, Inc., P.O. Box 372, Indianapolis, Indiana 46206.

### MALLORY

ELECTRICAL ELECTRONIC GROUP

EMHART



Appearing in ELECTRONICS for 50 years.

# MALLORY

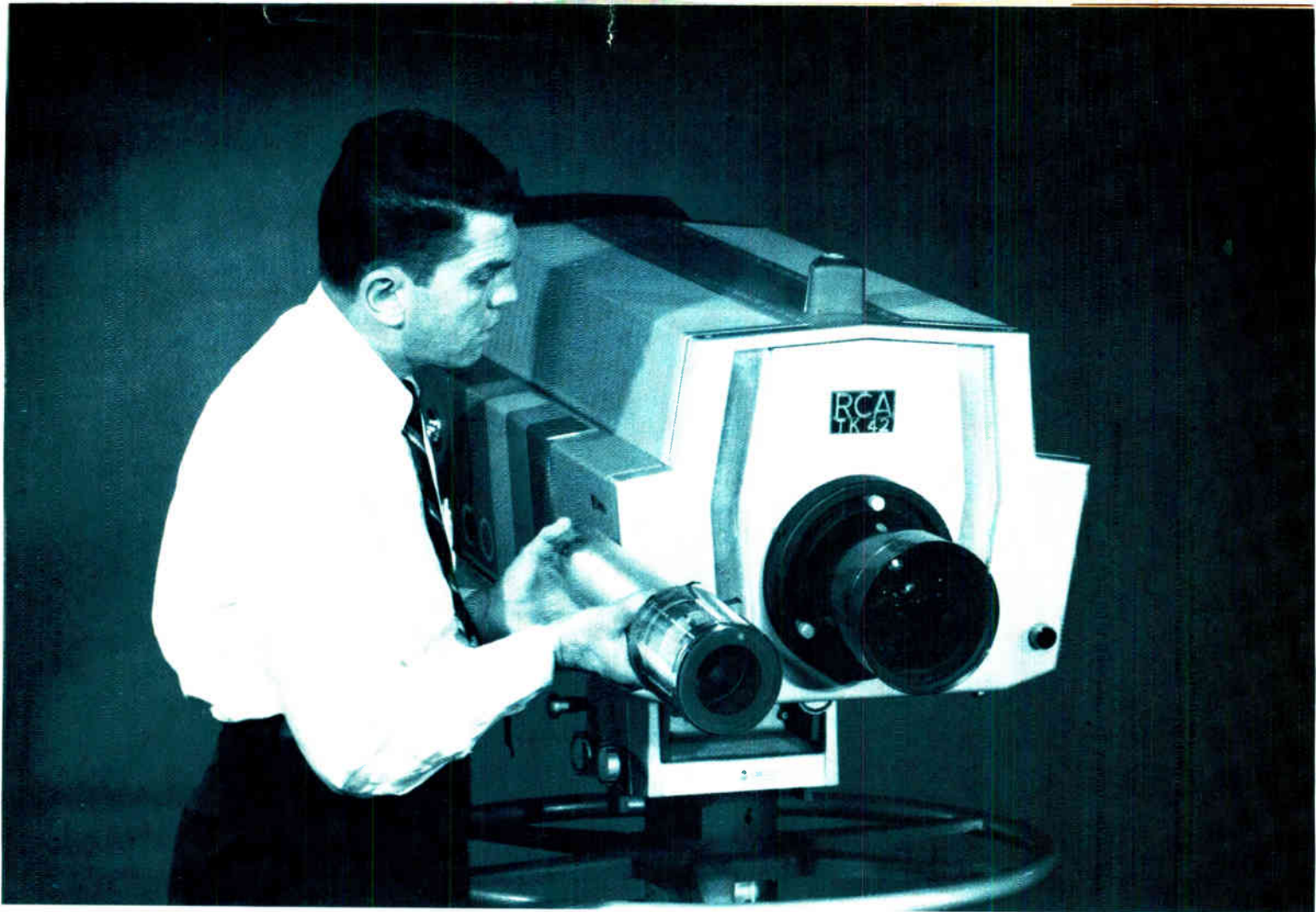

**Camera.** RCA's four-tube color TV camera, the TK-42, was introduced at the 1962 National Association of Broadcasters meeting. A 4½-inch-diameter image orthicon, shown, handled the monochrome channel. Color pickup was with 1-inch image orthicons.

based on the binary counter. Such instruments were more complex than analog instruments and therefore more expensive. But they were also more accurate.

Early digital instruments relied on a variety of display techniques, such as optoelectrical and optomechanical numeric devices and even electroluminescent ones. The Nixie tube, used in Andrew Kay's first digital voltmeter (see Chapter 6), was by far the most popular display, but 1968 was to mark the beginning of its decline. That year Hewlett-Packard unveiled the first commercially available light-emitting-diode matrix, a 28-diode unit developed by the company's components group.

A number of different DVM measurement techniques were also developed at about this time: ramp, integrating, and potentiometric-integrating. But the technique that was to become the standard for DVM design—because it removed errors caused by random noise and hence provided much more accurate results—was dual-slope integration. The technique was first developed by R. W. Gilbert of Weston Instruments in the 1950s but was not thought to be of great use at that time. In the mid-sixties George Armann of Fairchild Camera and Instrument developed refinements of the technique, and Weston and Fairchild shared the patents.

Tektronix dominated in scope sales, and its biggest challenger was Hewlett-Packard. In 1962 Tek introduced a direct-view bistable storage tube, the model 564. HP had a very high-speed oscilloscope, the 185A, which

could display 1-GHz repetitive signals by using a sampling technique that the company had developed. After a two-year effort that began in 1964, HP introduced the 180A, the first solid-state oscilloscope.

This design led to an even stronger foray into Tektronix territory, the laboratory oscilloscope. In 1969 HP unveiled the 183A. While it resembled the 180A in appearance, it was the fastest direct-writing scope of its time.

Tektronix and HP met head on in 1969 at the Western Electronics Show and Convention. While HP was showing off the 183A, Tektronix was unveiling its new 7000-series laboratory scope. The Tek scope, which was also solid-state, had a bandwidth of 150 MHz, and written right on the screen were such things as sweep time and magnification and vertical sensitivity. This feature stemmed from a newly designed medium-scale integrated circuit. Rather than space for two plug-ins, like the 183A, the 7000-series had room for four, so that the dual-beam unit could provide separate vertical amplifiers and time bases for each input.

When the smoke cleared in the 1970s, Tektronix was still dominant in the scope business. But Hewlett-Packard, with its experience, developed other important instruments. It gained a valuable position in spectrum analyzers, first with the introduction of plug-ins for the 410A scope and later with the introduction of the 851A/8551A spectrum analyzer. HP also contributed to



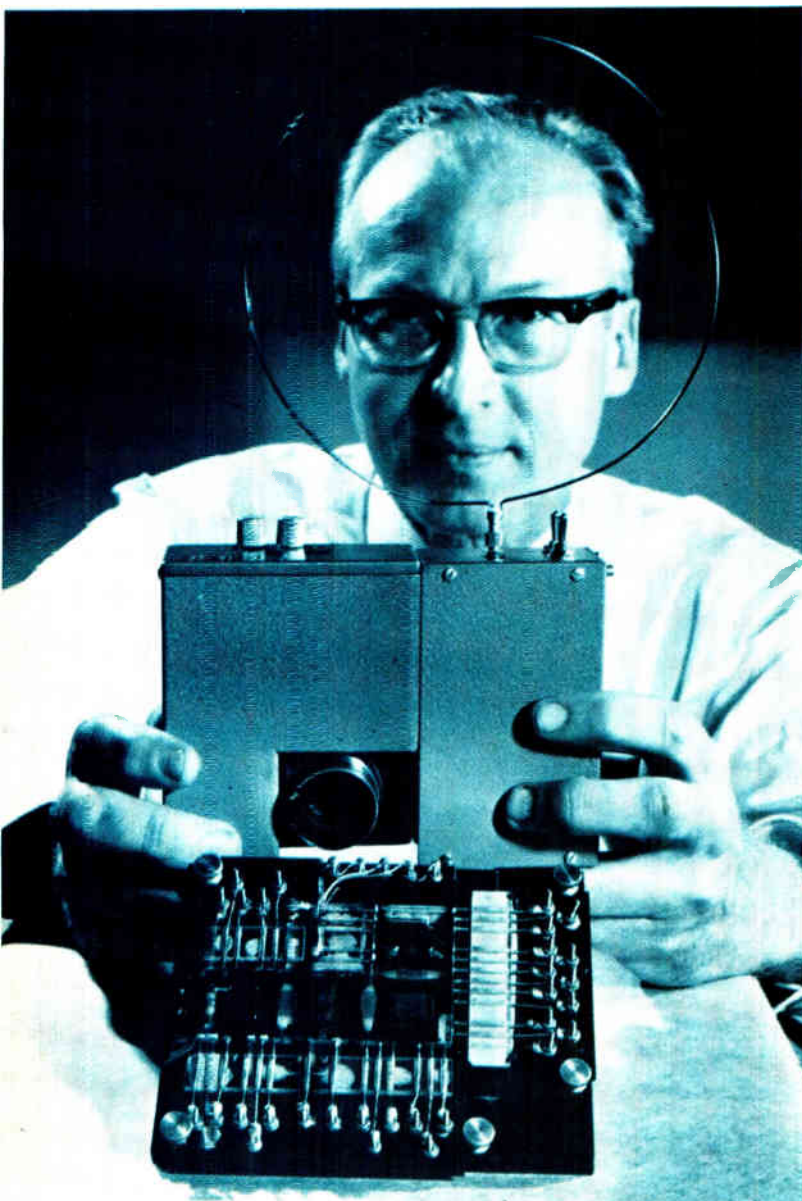

**Solid.** In 1966 RCA displayed a tubeless TV camera, its electronics on the board in the foreground. Held here by Paul K. Weimer of RCA Laboratories, Princeton, N. J., the unit relied on 132,000 thin-film sensors deposited on four 1-inch-square glass slides.

engineering a measurement technique that is still important: time-domain reflectometry.

Noticeable in these and other instruments built in the latter 1960s was the use of integrated circuits. In 1966 the boom in ICs was heard around the world. Not only instrument makers, but everyone in the industry was using them, and so a new instrument market opened for automated equipment to check the parameters of ICs.

Teradyne of Boston was one of the first companies to commit itself to the production solely of automated testing equipment. In 1960 it built the D-131 diode tester. Texas Instruments in Dallas marketed the first IC tester that year, the \$16,500 model 659A. It could perform 36 tests on devices with up to 14 pins. Teradyne then introduced the R105, a go/no-go automatic resistor tester that relied on dial-set tolerances. The tester was

sold in quantity to a component maker, Allen-Bradley, and was a big success! Fairchild had an entire line of transistor testers, starting with the model 50 and progressing through the series 200, 250, 500, and 900.

The need for testing even by users was hammered home in 1969 when many customers who had relied on semiconductor manufacturers to provide good linear ICs were encountering failure rates as high as 1 in 100. By then there were good commercial testers, but under the pressure of intense competition, some IC manufacturers had relaxed their reliability standards. The problems were not found until customers had used the ICs in systems and then had tested the systems.

GenRad provided part of the answer the same year—1969—by introducing the first commercial IC board tester, the model 1790. Now manufacturers could test their boards before system assembly and reduce the cost of faults by a factor of 10. The other part of the solution was to have a forum in which users, test-set manufacturers, and the semiconductor makers could exchange frank views. At Cherry Hill, N. J., the first conference on automated testing was held in the fall of 1969.

**A**n entirely new field of electronics came in with the sixties: optoelectronics. This was a blending of optical components (light pipes, lenses, fiber optics) with light-emitting and light-sensitive electronic components (light-emitting diodes, phototransistors, photodiodes). The result was unique components, such as the optical coupler, with tremendous electrical isolation from noise.

The first breakthrough came with the solid-state light emitter, or light-emitting diode (see Chapter 5). The LED was first thought of as a light source. “Will Gallium Alloys Provide a New Electric Light Source?” was the headline on a product article in the Dec. 28, 1962, issue of *Electronics*. But starting in 1968, LED displays became commercially available. By 1970 an optoisolator in a DIP was being sold by Monsanto, and from then on, optoelectronics started to move.

While the gallium arsenide injection laser was made to work in 1962, actual applications to systems had to wait almost to the end of the 1970s. Only then were fabrication and reliability problems overcome and the working specifications became such that the injection laser would be a natural choice for application to fiber-optical communications.

This laser was a perfect example of how scientific development can occur simultaneously in different laboratories. It was developed twice, at IBM and again at GE, which reported actual stimulated emission on Nov. 1, 1962, in simultaneous publications in the journal, *Applied Physics Letter*. To complicate matters, a paper was received by the same journal, on Nov. 5, 1962, from MIT’s Lincoln Laboratory to announce its successful observation of GaAs emission.

While all this activity was stirring, solar-cell development was striding ahead. Space was again the spur—efficient, lightweight photovoltaic cells were needed to power satellites. By 1960, six years after their development at Bell Telephone Laboratories, single-crystal sili-

# You make the ohms.



# We make them honest.



Today we do more than measure ohms. We tweak them — by laser, the key to high yield production of most precision microcircuits. And around the world, 7 times out of 10, those circuits are laser adjusted by an ESI system.

Attribute it to putting the customer first, working with him to solve his precision needs, from thick film resistance trimming to functional tuning of complex semiconductor devices — even using the laser to repair faulty memory chips during production.

Twenty-five years ago we specialized in measuring ohms, supplying calibration and standards labs with



precision instrumentation. Today, high speed, intelligent impedance meters from ESI are the premier choice of compo-

nent manufacturers for automated resistance and capacitance testing.

As the market grows, we're determined to keep pace — going to the field with a worldwide sales and service network, plus support programs in customer training and applications assistance. It's the ESI way.

Electro Scientific Industries, Inc., 13900 N.W. Science Park Drive, Portland, OR 97229, USA. Phone 503/641-4141. Telex 15-1246.

*Omega outline traced by Model 44 laser trimming system under computer control (ESI Pascal program).*

The proven way to precision



Circle 367 on reader service card



# 20 YEARS AGO, OUR DISCRETE PACKAGE WAS THE STATE-OF-THE-ART.

## IT STILL IS.

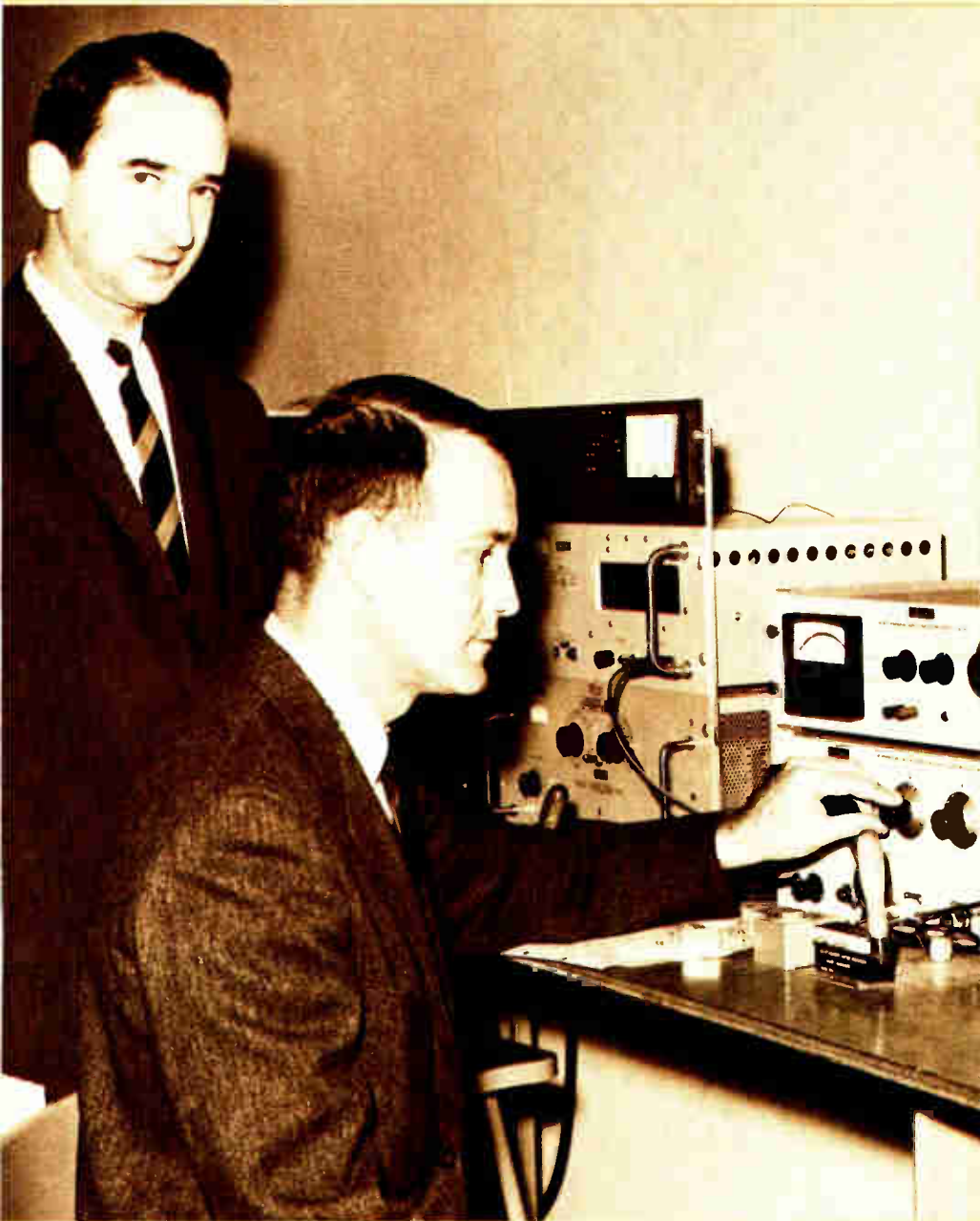

Unitrode's "Fused-in-Glass" package for axial leaded rectifiers. In the military market, it was virtually an overnight success.

And what began as a single product line into a single market has since become an industry-wide standard for reliability. Over the years, we've applied this packaging technology to a range of high-performance semiconductors: Zeners, PIN Diodes, Ultra-Efficient Rectifiers. And soon, our new Super-Efficient Rectifiers.

And not just for the military market, either. Thanks to high-volume production and competitive pricing, the incredible reliability of this package is paying off in applications like computers, telecommunications, industrial control, and instrumentation.

Of course, the Fused-in-Glass package we introduced 20 years ago is not the only reason for our success. Today, we produce a wide range of discrete semiconductors in every important package.

But what we learned from our early success has shaped our corporate philosophy ever since.

And it is simply this: When we design a product, we design it to last.

Unitrode Corporation, 5 Forbes Road, Lexington, MA 02173.



**UNITRODE**

*Unitrode founders Malcolm Hecht, Jr. (standing) and George Berman, testing the original Fused-in-Glass axial leaded rectifier.*

## UNITRODE POWER SEMICONDUCTORS



con solar cells had reached 8% conversion efficiency.

One of the slowest areas to join the trend to solid state was consumer electronics. At the beginning of the decade, color television was still struggling to become a feasible consumer electronics product; there were only 500,000 color sets in use throughout the U. S. in 1960. There were no home video tape recorders, no automobile stereo tape-cartridge or cassette players, and no solid-state wristwatches.

But by the end of the decade, all of these products had been introduced, ICs were turning up in more consumer electronics products, and there were dramatic improvements in color television sales and design.

Although the technical quality of monochrome TV broadcasts at the turn of 1960 was virtually perfect, such was not the case with color TV. In attempting to design a superior system, engineers constructed a number of prototypes, most of which never made it into the marketplace. Nevertheless the components and schemes that evolved from their efforts before the decade ended were used in the first generation of the U. S. color TV system as we know it today.

Color television sets did not begin to sell briskly until 1963 or 1964. Total sales topped 9 million in 1965, and the proportion of color sets to black and white by 1970 was more than 50%.

**W**ith an eye on the American market, the Yaou Electric Co. in Japan introduced a solid-state color set in June 1964. The set had a one-gun, 8-inch picture tube and no convergence circuits. Yaou's tube, developed by the Kobe Kogyo Corp., was an improved Lawrence type that used a color-switching grid to focus the electron beam onto a particular color strip.

The Yaou set notwithstanding, it seemed in 1964 that transistor color television sets were several years away. Fairchild Semiconductor designed and built an almost completely transistorized large-screen color set in 1966 to demonstrate that it was well within the state of the art; the only tubes were the high-voltage rectifier, the vertical-scan output circuit, and the vhf tuner.

In March 1966 RCA put the first IC into a television set; it performed amplification, limiting, balanced frequency-modulation detection and audio preamplification in the 4.5-MHz intercarrier sound channel.

In 1968 Motorola was placing the chassis of its color sets in slide-out frames; the chassis contained plug-in modules that a service technician could replace without soldering a single lead. In England, Thorn Electrical Industries Ltd. said it also would introduce an all-transistor color set that had plug-in modules.

Color television continued to improve. By late 1969 the first sets with electronic tuning came off assembly lines. RCA introduced a set tuned by signals from a hand-held ultrasonic transmitter. The receiver used a MOS FET's gate capacity to develop a voltage in a memory circuit arrangement to control color saturation, tint, and volume in response to a digital signal.

At the start of the sixties the Federal Communications Commission had spent over \$2 million to test the feasibility of uhf broadcasts in a large metropolitan area. The

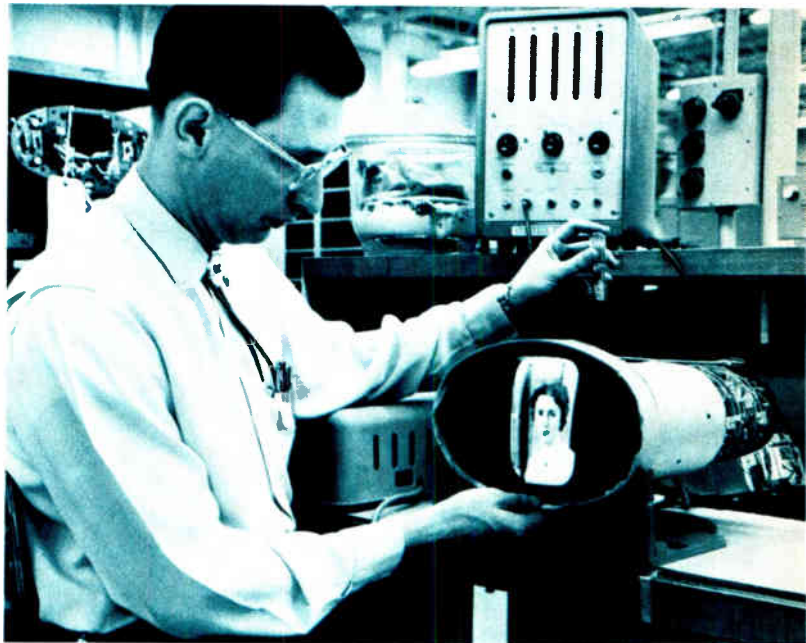

**On the phone.** AT&T thought it had a good thing when it introduced its Picturephone, shown here being checked in 1965 for picture size and quality at a Western Electric plant. But the set's high cost or lack of appeal or both served to keep it from catching on.

tests used an antenna atop New York City's Empire State Building, but before they were complete, one FCC commissioner, F. W. Ford, proposed that all new TV sets moving in interstate commerce be equipped to receive uhf as well as vhf channels. Ford estimated that adding uhf would cost set makers about \$10 a set.

The Electronic Industries Association's Consumer Products division reacted negatively to an all-channel bill that was introduced in Congress. Manufacturers contended that it would penalize set makers and consumers alike with "dubious" results. FCC Chairman Newton N. Minow, however, pressured broadcasters to support the proposed legislation. The House passed the bill in May 1962, and the Senate backed it the following month. The law went into effect April 30, 1964.

Uhf-TV did not take hold initially. However, the number of uhf stations picked up in 1968.

In radio, stereophonic sound offered a way both to enhance reception and retain an audience in the face of increasing competition from television. Extending an idea introduced in 1931 by an English inventor for reproducing live concerts on a disk, Leonard B. Kahn, an engineer in New York, developed in the late 1950s the first system to handle stereo broadcasts.

The English inventor, Alan Blumlein, had used multiple sound channels in a way that recreated concert hall performance. Kahn's system placed both left and right stereo channels on an a-m carrier. Two receivers were required to demodulate the signal, one tuned to a frequency slightly above the main carrier, the other below it.

The first broadcasts came from Station CJAD in Montreal in January 1960, using a system that had been supplied by Kahn. U. S. manufacturers, sensing a major market, rushed to develop systems that might be





**Alchemy.** Liquid-crystal displays turned up in the sixties, promising low power and relatively large areas. RCA scientist Joel Goldmacher in this 1968 photo is pouring together two types of liquid crystal material to produce a quasi-emulsion that retains an image even after power is turned off.

accepted by the FCC. Similar stereo systems proposed by GE and Zenith were eventually accepted by the FCC, and on June 1, 1962, it approved stereo broadcasting.

The FCC had authorized fm broadcasting exactly a year earlier. The first two fm stations on the air were operated by the Zenith Corp. in Chicago and by GE in Schenectady, N. Y. By November 1961 there were 22 fm stereo stations on the air, with 50 forecast by the end of 1961 and 123 by the end of 1962. Manufacturers and distributors reported heavy demand for equipment, and the trend was to buy integrated fm stereo receivers rather than adapters for monaural sets.

**A**utomobile stereo tape cartridge players began to appear in 1964. The original four-track cartridges were followed by more compact eight-track units. The first major marketing effort for cassette tape recorders began in 1966, and by 1969 audio tape recorders were, after color TV, perhaps the hottest item in consumer outlets.

“The cassette is not only challenging the Stereo 8 for leadership in home entertainment outlets,” *Electronics* observed, “but is also going after the huge auto market. Panasonic is reported to be starting production of a cassette player for cars. By next year auto makers will begin offering the motorist a choice. When this happens, it seems likely that the industry will adopt the cassette exclusively within five years.”

The forecast was wrong, primarily because so many Stereo 8 cartridge albums were sold that consumers continued to buy cartridge players.

Although ICs were developed in the late 1950s, they did not begin to appear in consumer electronics until 1966. RCA showed the commercial feasibility of the

microcircuit in an fm receiver in August of that year. The entire unit was built with four chips: one silicon wafer operated as a radio-frequency amplifier, another as a mixer-oscillator, a third as an intermediate-frequency amplifier limiter, and the fourth as an i-f amplifier, limiter, detector, and audio-frequency preamplifier.

Despite this show of confidence, the use of ICs did not catch on immediately in the TV industry. Nor was there a rush to add solid-state controls to large and small home appliances. One of the first appliances to use silicon controlled rectifiers was a Whirlpool laundry dryer introduced in 1963; the SCR provided continuously variable speed.

Perhaps the first use of an IC in a portable appliance was the cycle control in a John Oster Manufacturing Co. food blender. The appliance used a low-cost, plastic-packaged high-threshold-logic IC developed by Motorola’s applications engineering department. The design eliminated push buttons and switches; the ICs formed a shift register. Microwave oven sales also grew through the 1960s, but slowly.

**A**nd so another decade slipped by, with electronics solidly entrenched in the business world and poised for new advances into the home. Already there was talk of expanding the family television set into an electronic information center. With a TV receiver and the proper peripheral equipment, one could get the news on demand or view store advertisements and place instant orders or perhaps conduct banking transactions. With a computer system in the kitchen, one could “program” the oven and stove, leave the house, and find the meal ready to serve on returning. Some of these ideas were to take root in the decade of the seventies.

# Culligan Water: pure economy for critical circuits at Rockwell.

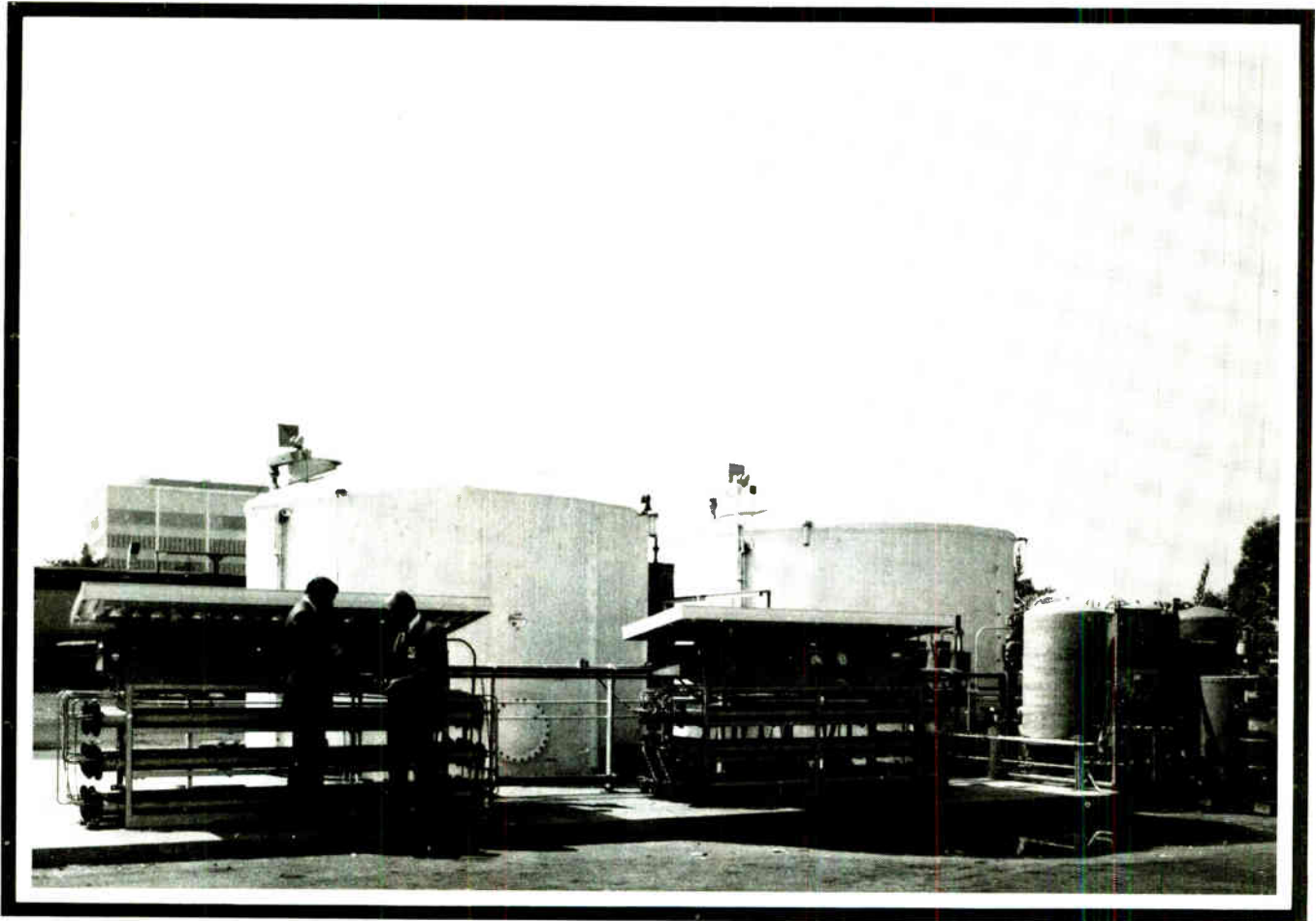

Can Culligan water treatment help a major MOS/LSI manufacturer increase production cost efficiency? Ask North American Rockwell Microelectronics.

Volume manufacturing of MOS/LSI's, with electronic densities of about 400,000 circuit elements per square inch, requires rinsing water as pure as the production tolerances are critical. North American Rockwell Microelectronics, a circuits industry leader, tried to meet the need with bulk quantity distilled water, but production engineers weren't satisfied. Variances in purity increased unit spoilage, and the high cost of trucking in huge quantities of distilled water reduced profits. NRMEC needed a better answer.

**Culligan delivered the solution**—A Reverse Osmosis/Deionization water treatment system was installed at NRMEC's Anaheim MOS/LSI manufacturing plant. Using city water, the Culligan RO/DI system yields product water virtually free of particulate matter, total dissolved solids and bacteria. This results in a process water with a resistivity of 18 megohms. That's about five times as pure as commercial distilled water. And for NRMEC, far more cost effective.

**Your Inquiry is Welcome**—Culligan RO/DI water treatment systems are finding increasingly wide applications in the electronics industry. To find out how Culligan can improve your manufacturing cost efficiency, call your local authorized Culligan dealer. Or contact Greg Montgomery at Culligan USA. Phone 312/498-2000. Or mail the coupon.

Greg Montgomery, Culligan USA  
Northbrook, Illinois 60062

I am interested in knowing more about Culligan water conditioning. 

Have representative call  Send literature

Name \_\_\_\_\_ Title \_\_\_\_\_

Company \_\_\_\_\_ Phone \_\_\_\_\_

Address \_\_\_\_\_

City \_\_\_\_\_ State \_\_\_\_\_ Zip \_\_\_\_\_

**Culligan**  
WATER TREATMENT WORLDWIDE™



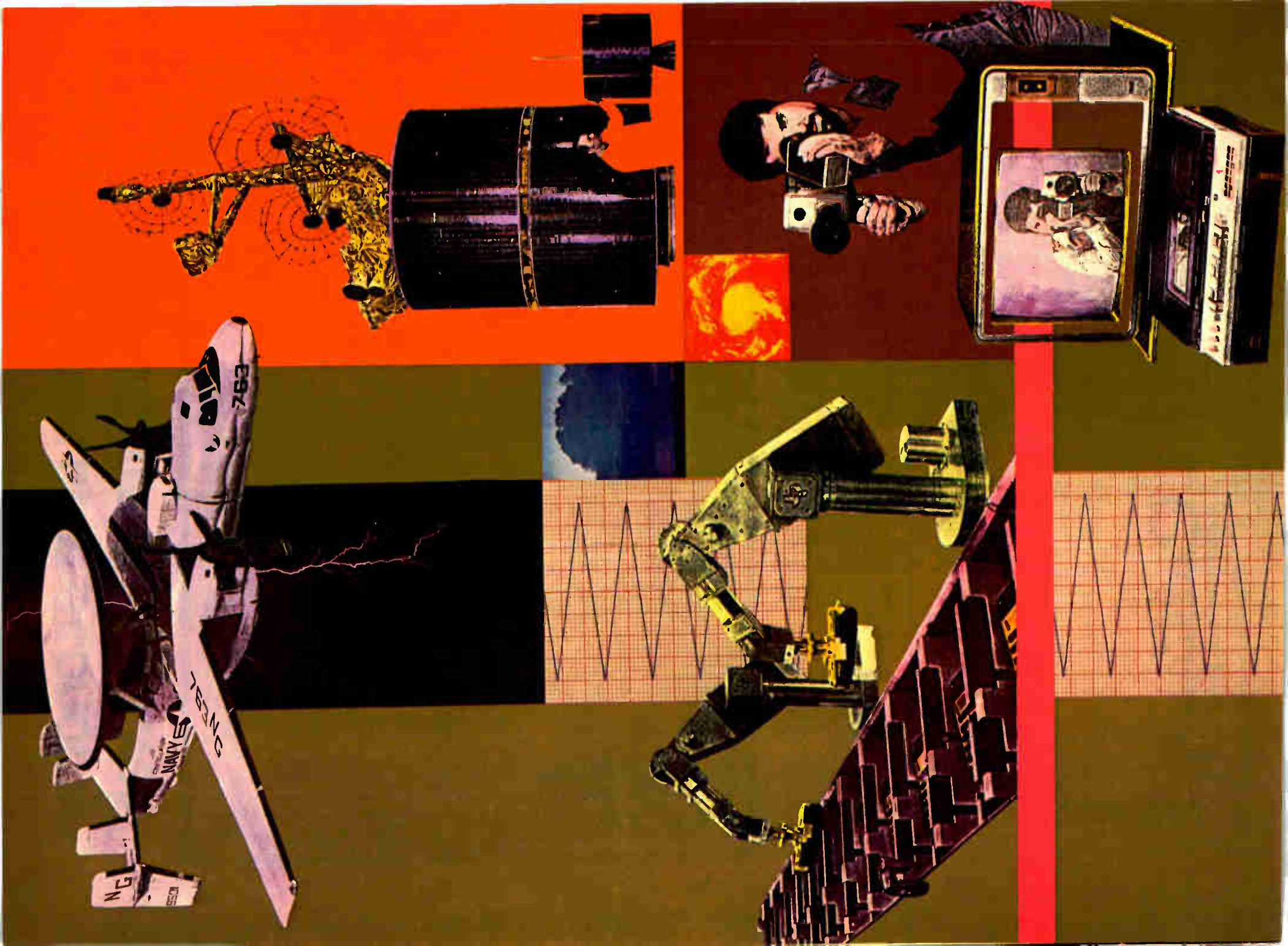

# THE DIGITAL AGE

---



DURING THE SEVENTIES, TWO MAJOR EVENTS

CONVERGED TO LEAVE THE WORLD FOREVER ALTERED: THE END OF CHEAP ENERGY AND THE BIRTH OF THE MICROCOMPUTER. THE FIRST MEANT IMMEDIATE ECONOMIC UNCERTAINTY AND A SERIOUS CHALLENGE TO THE PRODUCTIVE MIGHT OF THE WEST. THE SECOND WAS THE START OF A DIGITAL REVOLUTION THAT SHOULD ULTIMATELY INCREASE HUMANITY'S CONTROL OF THE WORLD IT INHABITS. ALREADY DIGITAL ELECTRONICS IS EXTENDING THE RANGE OF HUMAN COMMUNICATIONS, THE SCOPE OF THE HUMAN INTELLECT, AND THE VARIETY OF GAMES PEOPLE CAN PLAY.

## Chapter 8



**P**ut the 1970s on an analyst's couch, and the diagnosis might well be mixed neuroses. There were years of tension and unwinding. Years of progression and regression. Years of plenty and famine. Aside from war, the big fears were rooted in energy scarcities and inflation. In electronics the integrated circuit was king, and from the look of things, it was going to be a long reign indeed.

Powerful digital computers shrunk midway through the seventies to fit on a tiny chip of silicon smaller than a fingernail. More important even than size, however, was the fact that integrated-circuit computer power was now becoming so cheap that equipment designers in every field had to consider adding it to their products.

Chip-sized microprocessors and microcomputers, and their allied components, were turning up everywhere. Microwave ovens, color TV sets, burglar alarms, toys, stereo systems, electronic organs, food processors, air conditioners, thermostats, and furnace controls, as well as calculators and home computers, were being designed with the new IC elements. So were telephone systems and word-processing and data-processing systems for the office, to say nothing of systems for managing heating and cooling that helped an entire office building operate more efficiently.

The new ICs and their ancillary devices were being used in automobiles, medical diagnostic equipment, prostheses, and surgical aids; at supermarket checkout stands and in gasoline pumps and pleasure boats.

But the activity was accompanied by economic unease. The decade had been born in a recession that ended in 1971. Then, in 1974-75, there was another, more severe, recession as cheap energy ran out.

Starting in late 1973, the Organization of Petroleum Exporting Countries squeezed the supply of crude oil and jacked up prices notch after notch. From \$2.25 a barrel for crude sold to the United States in 1970, prices shot to \$30 by the end of the decade, with oil sold on the so-called spot market at \$40 a barrel and up.

Economic growth slowed as countries spent disproportionate amounts of national wealth on energy. Hundreds of billions of dollars flowed to a handful of developing nations controlling the oil in the Mideast. The New York Times compared 1973 to 1929 and called it "one of the economic turning points of the 20th Century."

The increasing cost of energy affected the price of everything. A pernicious inflation took hold and crept ever higher, reaching 13% in the United States by the end of the seventies. The dollar slid; the mark and yen rose; gold jumped over the moon, soaring to more than \$800 an ounce on one occasion in early 1980, with speculators forecasting that the metal would hit \$1,000 an ounce within a year.

Engineers suffered with each recession. "Some EEs are too proud to apply for unemployment," an official of the Institute of Electrical and Electronics Engineers said in the March 15, 1971, issue of *Electronics*. "They never appear on the rolls. Others hang out a consultant shingle, and some just take their savings and vacation until the job market improves."

The *Electronics* article pointed to "as many as 5,000 unemployed electronics engineers in the greater Boston

area and up to 3,000 more pounding the streets in Southern California's Orange County" in 1971.

Besides the economic worry, many Americans argued bitterly over a war in Vietnam that seemed endless. Finally, sudden escalation of the fighting was followed just as suddenly by a peace treaty and an American pullout in April 1975. Later in the decade, nuclear power became a favorite target of protests, and this opposition reached a climax in March 1979 when a nuclear reactor accident at Three Mile Island in Pennsylvania created wide fear of a catastrophic meltdown of the reactor's radioactive core. The threat was contained, but nuclear power came in for re-evaluation around the world.

The seventies also saw President Richard M. Nixon journey to Peking in 1972 and end more than 20 years of hostility between the People's Republic of China and the United States. Then in 1974 Nixon became the first American President to resign from his office, trapped by his attempt to cover up a break-in two years earlier at the headquarters of the Democratic National Committee in its Watergate office in Washington, D. C.

Earlier, in 1973, Vice President Spiro Agnew had shocked the nation by resigning from office while under investigation for alleged extortion and bribery. Rep. Gerald R. Ford was appointed to Agnew's post, and then he succeeded Nixon as president.

Perhaps equally amazing was the journey in 1977 of Egypt's President Anwar Sadat to Jerusalem to seek peace between his country and Israel. By the end of the decade, following talks involving Sadat, Israeli Prime Minister Menachem Begin, and President Jimmy Carter at Camp David in Maryland, peace agreements were struck.

**T**he decade closed on a note of international anxiety. All through the seventies the U. S. had pressed detente with its old cold war foe, the Soviet Union, and new ties with mainland China. Suddenly detente appeared to have died.

Russian troops entered Afghanistan in December 1979, and President Carter strongly denounced the Soviet Union. Cold war rhetoric was back in style, coupled with a cutting off of cultural exchanges and strategic trade with the Russians.

Through it all, electronics survived handsomely, and many new markets were created. Products that hardly existed one year caught the imagination of consumers in the next year and soon sold by the million—products like video and hand-held electronic games, hand-held calculators, digital watches, and video cassette recorders.

Along with inflation, the engineer's salary rose, too. A survey conducted by the IEEE in 1979 pegged the mean salary for its members at just over \$30,000 a year for the first time, up 15% in a year and a half.

With military events at center stage in the world, President Carter called for a heavy increase in defense spending. Once again opportunities widened for U. S. engineers in this field as the decade ended.

The number of electrical and electronic engineers belonging to the IEEE climbed during the seventies, reaching 200,000 in 1979, with 160,000 in the United

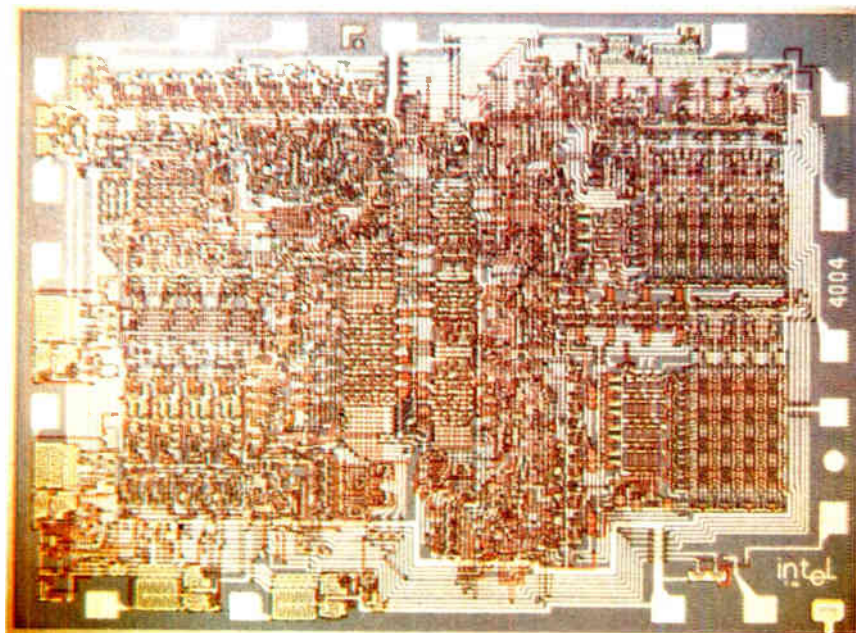

**The first.** It began as a custom design for a Japanese calculator. When Intel unveiled it in 1971 it was the first microprocessor, the 4-bit 4004. One of a five-chip set, the silicon-gate, p-channel MOS chip measured 150 by 110 mils and was almost all random logic.

States. Moreover the IEEE was no longer merely a disseminator of technical information. It had assumed, under pressure from its U.S. members, a role in attempting to influence legislation in Congress, as well in shaping the image that the general public had of engineers and their role in society.

And there were pressures for the IEEE to do even more—for example, help limit the number of engineering graduates. The aim was to make each engineer more valuable, more likely to be used effectively on the job, and not easily turned out of work in a recession.

**C**omputers had indeed come a long way from the days of the room-sized Eniac. The more they matured, the smaller they became. And when it appeared that they had reached the limits of smallness, they became tinier still. The seventies with their advanced ICs rocketed the microprocessor and micro-computer to prominence.

The prerequisites for such advances were in place at the turn of the seventies. Metal-oxide-semiconductor (MOS) technology was workable and improving daily. It was being used in shift registers, multiplexers, and read/write (random-access) and read-only memories (RAMs and ROMs) of modest complexity. MOS sales in 1969, including custom work, ran between \$30 million and \$35 million, and a market in excess of \$100 million was forecast for 1970.

Desktop calculators were selling rapidly, with competitive manufacturers eagerly seeking chips to reduce the bulk and expense of their products. Over 50% of the MOS integrated circuits shipped by the U. S. in 1970 went into calculators, most of which were made in Japan.

The calculator manufacturers insisted upon customized MOS large-scale integrated circuits, but the semiconductor manufacturers pressed for standardized designs. The calculator market demanded proprietary chips. The chip makers did not want to be tied to any one

buyer; they proposed partitioning the calculator architecture in an attempt to isolate circuits that might be attractive to more than one calculator maker.

From this partitioning, it was only a matter of time before the computer-on-a-chip turned up.

In August 1969 Intel Corp., then based in Mountain View, Calif., had been asked by the Busicom Corp. of Japan to design calculator ICs. Marcian E. Hoff, now credited with the development of the first microprocessor, was Intel's manager of applications research. He remembers today that Busicom's requirement was unique, in that it called for a chip set to support a family of calculators.

"They wanted to use ROM programming techniques to customize it," Hoff recalls, adding that "instead of making it look like a calculator with some programming capabilities, I wanted to make it look like a general-purpose computer programmed to be a calculator."

Busicom approved Intel's design in October 1969. But, says Hoff, "Intel recognized that there was a market for computers as components." In June 1971 Intel announced the 4004 microprocessor family.

The 4004 chip set was designed by Federico Faggin, now president of Zilog Inc. It comprised a 256-byte ROM, a 32-bit RAM with a 4-bit output port, a 10-bit shift register and output expander, and a 4-bit microprocessor. All had been made with p-channel silicon-gate MOS technology. The shift register measured 4,505 square mils and each of the three other units roughly 16,500 mil<sup>2</sup>. The CPU could control up to 16 ROMs and 16 RAMs, for a total of 4,096 bytes of ROM and up to 4,120 bits of RAM.

Intel was not the only one to make a processor with large-scale integrated circuits. Fairchild Camera and Instrument, American Microsystems, Texas Instruments, Electronic Arrays, the Autonetics division of North American Rockwell, and Mostek all had contracts to produce calculatorlike chips and chip sets.

Meanwhile Computer Terminals Corp. (now Data-



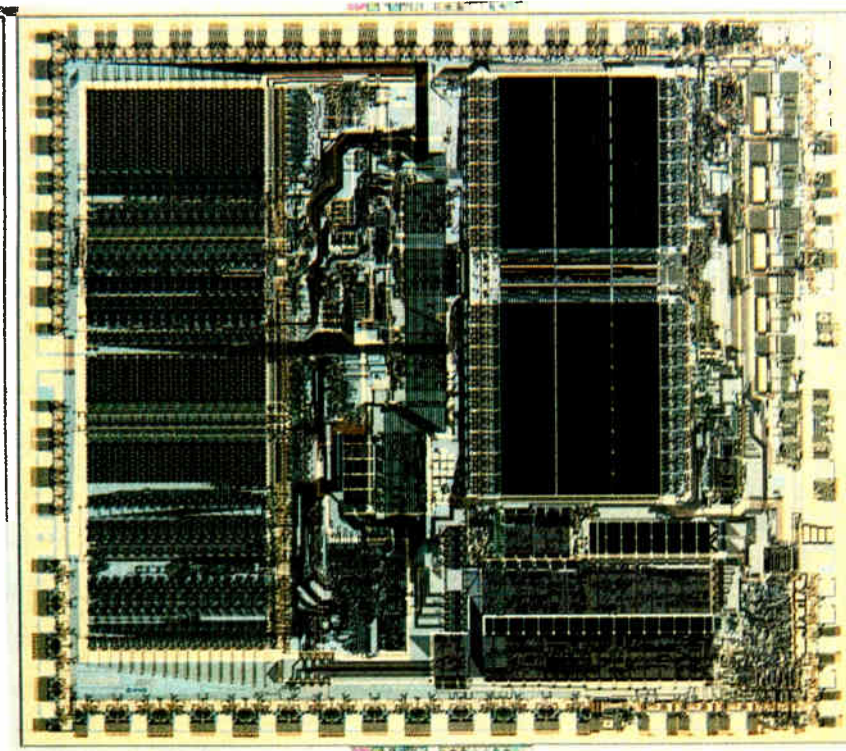

**Advanced.** The end of the decade saw n-channel microprocessors like Motorola's 16-bit 68000, left, with 68,000 transistors and measuring 246 by 281 mils, head for production. Its regular architecture is organized neatly into functions like microcode (two dark areas toward the top).

**Like lightning.** Striving for the exceptional speed needed in scientific applications was the Cray-1 vector processor, right, introduced in 1976. It could handle 80 million floating-point operations per second. Hardware was arranged in a semicircle to minimize interconnection lengths.

point Corp.) had approached Intel two months after Busicom approved what became the 4004 microprocessor. A new challenge was raised. Could Intel integrate the registers and push-down stack of an intelligent terminal that Computer Terminals had designed?

The Computer Terminals processor "was not significantly more complex than the one we had just completed defining for the calculator company," Hoff says. "So we proposed, instead of just building the registers, that they do the entire processor as a single chip."

But when the Intel design team came across an aspect of the architecture that they felt was too limited, they changed the chip. The resulting IC was not compatible with the Computer Terminals' machine architecture, and it never was used in the terminal it was intended for. Instead, Intel put it on the market as the 8008 microprocessor, and Texas Instruments designed a chip to Computer Terminals' specifications.

The 8008 was the first 8-bit microprocessor. Measuring 125 by 170 mils in an 18-pin package, it was offered in sample quantities in early 1972 for \$200. The device contained an arithmetic unit, seven 8-bit data registers, and a memory stack. It used 45 instructions.

More versatile than preceding designs, the 8008 interfaced to standard memory products like the 1101 RAM, 1601 and 1701 ROMs, and the 1400 series of shift registers. Its 14-bit addressing capability enabled it to access as many as 16,384 bytes, and memory types could be positioned anywhere in its maps, as in a von Neumann machine.

By the spring of 1973 Intel was shipping microcomputer kits. In each kit, the microprocessor was supported by more than 10 times its worth in memory and peripheral circuits. Estimates were that by 1975 tens of thousands of such kits would be sold by the industry for a

total market of \$50 million. By 1979 the market had swelled to \$331 million for microprocessors and single-chip microcomputers.

Intel, Fairchild, National Semiconductor, and Rockwell were in the running in 1973. By this time National had introduced its General-Purpose Controller/Processor, a 4-bit device that could be paralleled in bit-slice fashion for word lengths up to 32 bits. The company said that any instruction could be performed if the processor's 23-bit micro-instructions were rearranged in 100-word ROMs. Rockwell's 4-bit Parallel Processor was also microprogrammable. The processor chip used special RAMs and ROMs that could be expanded up to 24,000 words. It had a 5-microsecond cycle time and could execute 50 instructions.

But competition was heating. AMI was readying an expandable kit that could support 8-, 16-, and 32-bit word lengths. It was to have a 600-nanosecond cycle time and 120 instructions. Signetics Corp. had in the works an 8-bit processor, the Pipchip, which used encoding techniques to decrease its memory requirements. Western Digital Corp. was developing an 8-bit, n-channel design that was going to look like a 16-bit one when microprogrammed.

In March 1973 *Electronics* quoted William H. Roberts, then vice president for research and development at Western Digital, as saying: "With good logic organization, n-channel microcomputers could rival today's minicomputers." In fact, minicomputers were beginning to look more like microcomputers. In May 1973 Computer Automation unveiled the Naked Mini/LSI. It had all the capabilities of the Naked Mini computer board but at half the cost, and large-scale integration (LSI) was responsible. The new computer was based on a seven-chip, p-channel MOS CPU that consisted



of four identical processor chips and three identical control chips.

National Semiconductor was also trying to exploit LSI for the minicomputer market. It announced the IMP-16C just prior to the Computer Automation's introduction. This unit included a 16-bit microprocessor chip, a 256-word RAM, a 512-word ROM, and input/output (I/O) drivers, all on an 8½-by-11-inch board.

Microprocessors had clearly shucked off their reputation as being mere programmable calculator replacement parts. Instead, they were assuming a role as general-purpose processing units—only they were slower than minicomputers.

By mid-1973 development aids began to turn up to help engineers, and some of this equipment included software. Intel began offering packaged microcomputers containing the 4004 and 8008, called the Intellec 4 and 8, respectively. Programming packages for the Intellec 4 included assemblers and simulators. The Intellec 8 had these too, plus a text editor and a cross compiler.

The notions of in-circuit emulation and universality were also solidifying. Applied Computing Technology offered a tool for microprocessors called an assembler; it assembled programs that emulated the chip set.

The p-channel microprocessors were, in general, considered the first generation of assemblers. N-channel technology essentially ushered in the second generation, and Intel took a commanding position with its 8080—a 40-pin, n-MOS souped-up version of the 8008 that was to become one of the most sought-after LSI devices in the history of the business.

This is also when Intel went on its crusade of upward compatibility. The address space of the 8008 had been quadrupled—the stack was moved off the chip, so it became limited only by the size of available RAM—but

the 8080 had the same basic instruction set as the 8008. The n-channel, silicon-gate process gave the 8080 a 2-to-6- $\mu$ s instruction cycle time for 10 times the throughput of the 8008. The 8080 was designed by Masatoshi Shima, who later left Intel to join Zilog and there designed the Z80, which had many enhancements over the 8080.

Complementary MOS was also being looked at for microprocessors, and in early 1974 RCA brought out the first C-MOS microprocessor, the 1802. Also in 1974 Texas Instruments introduced its TMS 1000, a 4-bit microcontroller that outsold all other processors—single-chip or not—by millions of units.

Motorola kept a low profile and then bowed in with flair. It introduced its 6800 microprocessor in March 1974. The device needed only one +5-volt power supply, in contrast with the 8080's three. And it had an untangled bus structure like the one the Digital Equipment Corp. put in its PDP-11 minicomputers. In addition, the new device was heavily supported. Along with the 6800, Motorola offered the Exorcisor microprocessor development system, plus four support chips: the 6810, a 128-byte, 500-ns static RAM; the 6816, a 1,024-byte ROM; the 6820, a peripheral interface adapter; and the 6850, an asynchronous communications interface adapter.

In June 1974 Rockwell beat the drums for its PPS-8. The company's earlier PPS-4, a 4-bit parallel processor, was successful, and now Rockwell doubled its word width to compete with Intel and Motorola. Built with p-channel technology, the PPS-8 offered more than 90 instructions and could directly address 16,384 bytes of ROM plus a like amount of RAM.

The first resident high-level language compiler for a microprocessor was supplied by Intel for the language called PL/M. This happened in June 1974. Late that



year Signetics began shipping samples of its 2650 8-bit parallel microprocessor, and National brought out a 16-bit device called PACE (for processing and control element). It was billed as the world's first single-chip, 16-bit microprocessor. It had four accumulators, and it emphasized interrupt control. The designers said they had chosen p-channel technology for PACE because it allowed them an instruction time of 10  $\mu$ s and enabled them to fit all its components on a single chip.

By the fall of 1975 almost 40 different microprocessors crowded the market. But microprocessors were still not that easy to use.

This brought forth a barrage of peripheral and support circuits, like interface adapters and communications controllers. Eventually the chip designers took a systems approach. They studied microprocessor markets and designed the processor, peripheral circuits, and software compilers before they unleashed the device family—not as an afterthought.

Then, with shrinking die sizes, the chip makers saw that some of the peripheral functions could be integrated on the same die as the microprocessor, simplifying the interface. This is how the single-chip microcomputer was born, and it rang in a whole new spectrum of controller applications—from toys and games to engine controls.

The first 8-bit single-chip microcomputer was the

8048 from Intel. But Michael Cochran and Gary Boone of Texas Instruments were awarded the basic patent, filed in 1971, for the single-chip microcomputer.

The Intel unit has CPU, RAM, ROM, and I/O. In late 1976 it was also fitted with an ultraviolet-light-erasable ROM to increase its range of application.

Motorola meanwhile was readying the 6802 controller, Rockwell had out samples of its two-chip PPS 8/2 controller, and Mostek had a single-chip F-8 in the wings that was to turn into the 3870 and be second-sourced by Fairchild. Microcomputers were in—not only single chips, but also single boards. LSI allowed both the chip makers and the minicomputer manufacturers to market complete, ready-to-go computers in the form of small printed-circuit modules.

The single chips became packed with functions. A good example of this came in early 1978 when Motorola announced numerous additions to its 6800 family. The 6801, offered in samples later that year, was really seven integrated circuits in one. Besides the 6800 CPU, the same substrate had the equivalent of the 6875 clock generator, the 6810 128-byte RAM, the 6830 1,024-byte ROM, the 6821 parallel I/O controller, the 6850 serial I/O controller, and the 6840 timer.

Microcomputers also were endowed with the means to make it in the analog world. In addition to all those



**Compatible.** Computers relying heavily on LSI, plug-compatible with but much faster than IBM System/370 models, were introduced by companies like Amdahl Corp. Here, the Amdahl 470V/6 gets checked before delivery to the University of Alberta.

THE  
**ROAD  
RUNNER**  
**ADMM**<sup>TM</sup>

Audio Digital Multimeter

FROM **WESTON**<sup>®</sup>

THE INDUSTRY'S FIRST  
AUDIO RESPONSE<sup>TM</sup>  
DIGITAL DISPLAY  
FIELD SERVICE  
MULTIMETER



*The Measurement People*<sup>TM</sup>

WESTON INSTRUMENTS

a DIVISION of SANGAMO WESTON, INC

614 Frelinghuysen Avenue, Newark, New Jersey 07114 Tel (201) 242-2600

SANGAMO WESTON

Schlumberger

Circle 379 on reader service card



# "At ELPAC we've been building an UGLY™ reputation."

**Ed Blackman**  
Vice President and General Manager  
ELPAC Power Systems

For more than a decade we've been building efficient and economical power supplies. A few years ago we took a long look at them. What could you say? They're UGLY™! But at ELPAC that's only skin deep.

Over 1/2 million UGLIES™ are in the field today with less than a 1% return rate for any reason. What is the key to the UGLIES™ and their success? Simple. It's ELPAC capability. Professionally engineered products built in an automated manufacturing plant. Cost-effective designs perfected throughout the production process. Quality power supplies delivered off the shelf from your local distributor.

ELPAC offers you a full line of power supplies including, open and closed frame, switch mode regulated, series-pass regulated, unregulated, and DC-DC. Computerized designs are applied to standard products as well as custom units for your special needs.

A precision product. Prompt service. Dedicated people. Superior performance. Unmatched reliability. That's our UGLY™ reputation and we're proud of it!

Write or call for complete specifications today. Local, national, and international distribution available.  
**GET UGLY™!**



**ELPAC POWER SYSTEMS**

A DIVISION OF ELPAC ELECTRONICS INC.

3131 S. Stancard Avenue, Santa Ana, CA 92705  
(714) 979-4440 FAX 910-525-1511

internal digital circuits, some single-chip devices were packed with high-current display-driving capabilities, internal timers and event counters, zero-crossing detectors, and even analog-to-digital and digital-to-analog converters. The 8022 from Intel, for example, had two analog inputs. The most comprehensive interfacing reached at this time (1978) was found in Intel's 2920. The microcoded architecture had analog inputs and analog outputs, allowing it to solve complex filtering equations for real-time signal processing.

Then there were the so-called hybrid machines: processors with 8-bit external buses but with 16-bit internal operations. Examples included the 6809 from Motorola, the 9980 from Texas Instruments, and the 8088 from Intel.

Single-chip microcomputers eventually were aimed at two different markets: one for moderately priced 8-bit units and another for 4-bit types with rock-bottom prices. Microcomputer makers learned that their products could not only follow on the heels of the minicomputers, but that they also had a chance to surpass the performance of the bigger machines. That started with the so-called third generation of 16-bit CPUs.

Although Intel was not the first with a 16-bit microprocessor, it was first out with a high-performance 16-bit microprocessor, the 8086. The 51,000-mil<sup>2</sup> chip, built with 4.5- $\mu$ m, high-performance MOS technology, contained over 29,000 transistors.

The 8086 was followed by high-performance 16-bit microprocessors from Zilog (the Z8000), Motorola (the 68000), and National (the 16000). These microcomputer makers were clearly headed for yet another application area: systems. Their products would be used not only to run programs, but also to write programs for data-processing, scientific, and business applications. The new architectures were geared for the compiler writer and could execute a host of high-level languages directly.

But direct recognition of a high-level language and signal processing were not the only functions that microcomputers were designed for. More sophisticated I/O, mathematics, data encryption, and dot-matrix printer control followed. The universal controllers could accept commands from a master processor to link one of several pieces of peripheral equipment to the system bus.

Particularly important to the growth of the microprocessor was the guarantee by semiconductor manufacturers that their chips would be available from more than one source. The 8080, for example, has chalked up the longest list of second sources over the years, including Advanced Micro Devices, Texas Instruments, National Semiconductor, Signetics, Hitachi, and Nippon Electric. And Siemens is licensed to build the device.

**F**or the big computers, the 1970s was a time of consolidation. Instead of the revolutionary changes in fundamental organization or architecture that occurred in the 1950s and 1960s, developments in the 1970s were more evolutionary. They had to be. The architecture of a computer defines how it operates and how it is to be programmed; any alterations in it force the computer user to rewrite the instructions given to the



**Glowing.** The glow of yellow safety lights were features of the special lithography rooms, set up by every semiconductor maker, in which mask patterns were exposed on semiconductor wafers. Technicians in this American Microsystems facility are seen checking wafers.

computer. Computer manufacturers were anxious to avoid making obsolete what by the middle of the 1970s was several billion dollars worth of software.

But some change was inevitable. Continuing improvements in IC technology, reflected in the microprocessor and microcomputer, led to striking innovations in the basic logic and memory building blocks of the big computers. The ability to place more and more logic functions on a single chip forced hardware engineers to re-examine their design procedures. Some designed custom integrated circuits. Others sacrificed some flexibility to gain the reduced cost of industry-standard, such as bit-slice microprocessors. Still others compromised by using gate arrays—mass-produced chips containing hundreds of logic gates with interconnections that could be customized simply by changing the patterns of metalization deposited on them in the final stages of chip manufacture.

The composition of the industry began to change when computer companies established their own semiconductor facilities—as International Business Machines had done in the sixties—and, in turn, semiconductor companies entered the computer business.

Another dramatic hardware change was the shift to semiconductor memory. With declining semiconductor prices came compact, reliable, and inexpensive storage elements for increasingly large main memories.

The combination of semiconductor memory and new logic devices also increased the use of microprogramming in computer design. Instead of hardwiring logic gates to perform a set function, a set of so-called microinstructions could dynamically reconfigure the interconnections between the computer's logic elements. At first these instructions were placed in read-only memories, but later they were stored in random-access memory, so they themselves could be changed easily.

A major beneficiary of all the new advances was data



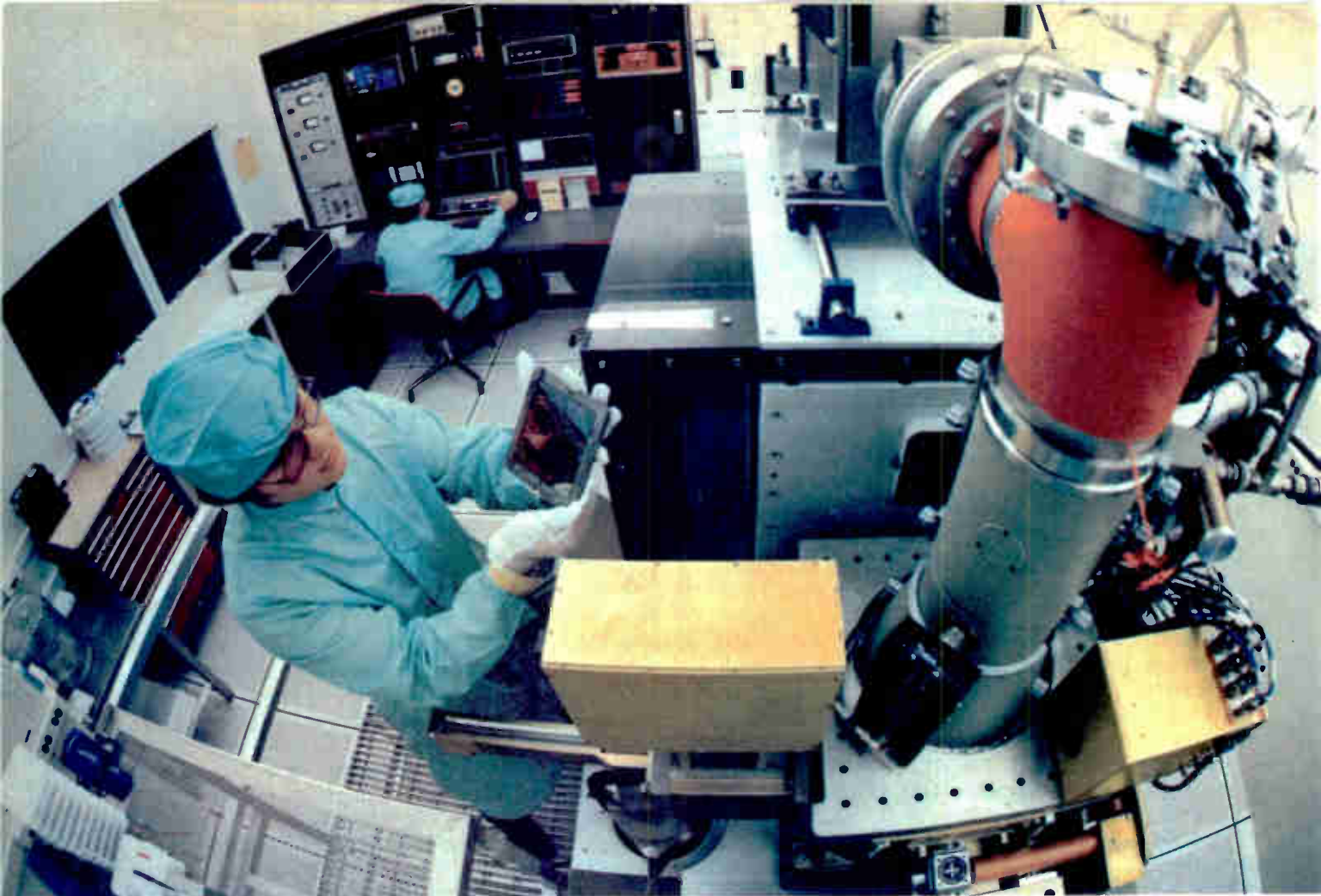

**Electron-beam.** An electron-beam exposure system, or EBES, was developed by Bell Laboratories and licensed to outside manufacturers. Here a technician holds a mask for LSI circuits before inserting it into such a machine at Western Electric's Allentown, Pa., works.

communications. With microprocessors, modems became "smart" enough to perform a variety of line-conditioning, error-checking, and error-correcting chores to make data communications faster and more reliable. And computer manufacturers encouraged data communications with the introduction of front-end processors and special data-communications software. As a result, the remote computing concept pioneered by the time-sharing techniques of the 1960s matured during the 1970s into the possibility of dispersing the data-processing function.

The makers of IBM-compatible peripheral equipment had tough going at the beginning of the decade but bounced back to thrive. This encouraged new manufacturers, led by a former IBM designer, Gene Amdahl, to introduce entire computers compatible with IBM's.

Only five major U. S. mainframe manufacturers were left to compete with IBM: Burroughs, Univac, NCR, Control Data, and Honeywell. They tended to keep pace with IBM product developments and to stay price-performance-competitive, while at the same time using new semiconductor technology to upgrade their third-generation architectures.

At the highest end of the computer power spectrum were the large-scale supercomputers designed for high-speed scientific number crunching. Control Data was most successful here.

Texas Instruments entered the arena in 1971 with its

Advanced Scientific Computer, a progressive pipelined processor, a primary application of which was geological surveying for oil. But after building several, the company discontinued making supercomputers.

More prominent was Cray Research. In 1971 an innovative designer at Control Data, Seymour Cray, left the company to form his own concern dedicated to high-speed scientific supercomputers. The result, delivered five years later, was the Cray-1, a vector processor that could perform 80 million floating-point operations per second—making it the fastest computer in the world. Cray's original hardware design was optimized for speed and physically arranged in a semicircle to minimize the length of interconnections.

At the same time minicomputers, nurtured by the new LSI circuits, experienced tremendous growth through the seventies. The range of developments stretched from single-chip products to computers that overlapped the traditional mainframes. Leading the way was the young company that had invented the minicomputer—Digital Equipment Corp. of Maynard, Mass.

Indicative of minicomputer growth was DEC's growth. At the end of fiscal 1970, the company had revenues of over \$135 million. Seven years later its revenues were almost eight times that—\$1.05 billion.

The minicomputer market attracted dozens of competitors. Among the most successful were Data General, Texas Instruments, General Automation,

A REPORT TO  
INDUSTRY ON  
THE STATE OF  
THE ART  
TEST AND  
MEASUREMENT  
INSTRUMENTATION  
FROM  
FLUKE.

1948: John M. Fluke pioneers high-accuracy voltage, current and true power measurements with the VAW Meter. It's the birth of a major electronics company.

1955: Fluke Differential Voltmeters provide precision high-resolution voltage measurements.

1963: The 540 Thermal Transfer Standard brings NBS traceability to ac voltage and current calibration.



1969: Fluke enters the bench and system DMM markets with the 8100A and 8300A models, priced at about half the price of competitive models.

1972: Fluke's custom IC-based 8000A DMM launches the era of high performance, low-cost digital multimeters.

1973: Fluke enters the digital board test and the electronic counter markets.

1980: Fluke introduces the first instrument controller designed from the boards up to solve the unique problems of IEEE test and measurement systems.

1981 and beyond: Fluke uses their firm foundation in precision instrumentation as a springboard into a full range of electronic solutions from computerized control to digital servicing.

**FLUKE**<sup>®</sup>



# YESTERDAY TODAY &

FLUKE:  
PROVIDING  
STANDARDS  
FOR  
INDUSTRY.



Just a few short years ago, engineers used relatively inaccurate methods of testing. Dry cells and line voltages were often used to calibrate voltmeters. Versatile standards and reliable traceability were only dreams.

Fluke's commitment to improving accuracy, stability, resolution, and sensitivity has played a major role in the evolution of the

electronics industry. Since our beginning, customers have relied on Fluke Instrumentation to establish their own product specifications. From John Fluke's first VAW Meter in 1948, we've continually advanced the frontiers of accurately measured electrical phenomena and precise instrument calibration.

In the 1950's, the standards of precision voltage measurement were Fluke Differential Voltmeters, accompanied by versatile calibrators and power supplies. It was during this period that Fluke firmly established

its position as a leading supplier of metrology instrumentation. The design, manufacturing and service disciplines we acquired provided the expertise to expand into new instrumentation markets during the 1960's and 70's.

FROM MULTI-METERS TO CONTROLLERS: A BROAD LINE WITH A FIRM COMMITMENT.

Today, industry demands accuracies of a few parts per million. Measurements are resolved in microvolts. Fluke has met the challenge.



The theme of Fluke's product engineering has been a price/performance story: thoughtfully applied, state-of-the-art technology that produces trend-setting instrumentation at highly-competitive prices.



We pay a great deal of attention to our customers' needs, striving to make our products easy to operate



and maintain. The 172CA Controller, for example, uses a touch-sensitive video display for simple operator



interface. Yet none of the powerful instrumentation control capabilities have been sacrificed. Our new 8860A DMM links analog measurements to the easy-to-program computing powers of a scientific calculator.

Today, Fluke is much more than a manufacturer of bench and service



THE HIGH-SPEED VOYAGE INTO A DIGITAL WORLD.

**TOMORROW**

programmable instrumentation for production testing and calibration systems. And we now build a revolutionary line of automated circuit board testers.

instruments. We've diversified into industrial products with data loggers and precision digital thermometers. We've developed sophisticated

of Portable Test Instruments (PTI) in interlocking stackable cases that occupy just inches of space. For simple systems without software on an engineer's bench or in low-cost IEEE-488 applications, new PTI products will provide innovative and efficient measurement solutions. Computerized control will be the heart of high-speed data acquisition systems — tools for the researcher of the future.



Future generations of instrumentation will incorporate speed and capabilities far exceeding today's standards. Look for instrumentation that's smaller, lighter, easier to operate, and more interactive.

The benchtops of tomorrow will be populated with Fluke's family

John Fluke Mfg. Co., Inc. looks forward to sharing the future with you as your partner in test and measurement. Look for us at the forefront of tomorrow's technology.



IN THE U.S. AND NON-EUROPEAN COUNTRIES:

John Fluke Mfg. Co., Inc.  
P.O. Box 43210 MS #2B  
Mountlake Terrace, WA 98043  
(206) 774-2481  
Telex: 152662

IN EUROPE:

Fluke (Holland) B.V.  
P.O. Box 5053,  
5004 EB Tilburg,  
The Netherlands  
(013) 673 973 Tlx: 52237

- Please send me the 1980 Fluke Instrument Catalog.
- Please send me a copy of your 1979 annual report.
- I share your commitment to technology. Please have a sales engineer contact me.

Name \_\_\_\_\_

Title \_\_\_\_\_ Mail Stop \_\_\_\_\_

Company \_\_\_\_\_

Address \_\_\_\_\_

City \_\_\_\_\_ State \_\_\_\_\_ Zip \_\_\_\_\_

Telephone ( ) \_\_\_\_\_ Ext. \_\_\_\_\_

For technical data, circle number. 385



# We've Earned Our Stripes

**With The Only Plug Compatible Microprocessor I/O System In The Industry**

Opto 22 combines the latest and best in I/O modules with plug compatibility to single board computers. Opto 22 I/O Systems are available in plug compatible racks holding eight, sixteen or twenty-four modules. These highest quality Input/output modules are available for 5, 15, or 24-volt logic—all employing 2500 volts RMS photo-isolation.

Simplified installation and maintenance are important features of the systems. Barrier-type screw terminals, LED status lights, pull-up resistors and plug-in fuses are mounted on the racks. Changes and replacements are easily made without removing wires.

Because we concentrate solely on photo-isolated SSR's, you get quality, reliability and innovation at the best prices.

Plug compatibility with:

- |  |   |
|--|---|
| <input type="checkbox"/> Intel                         | <input type="checkbox"/> General Automation |
| <input type="checkbox"/> Motorola                      | <input type="checkbox"/> Iasik              |
| <input type="checkbox"/> Burr-Brown                    | <input type="checkbox"/> Mostek             |
| <input type="checkbox"/> Computer Automation           | <input type="checkbox"/> National           |
| <input type="checkbox"/> Control Logic                 | <input type="checkbox"/> Texas Instrument   |
| <input type="checkbox"/> Data General                  | <input type="checkbox"/> Western Digital    |
| <input type="checkbox"/> Digital Equipment Corporation | <input type="checkbox"/> Zilog              |



5842 Research Drive, Huntington Beach, CA 92649, (714) 892-3313

Circle 386 on reader service card

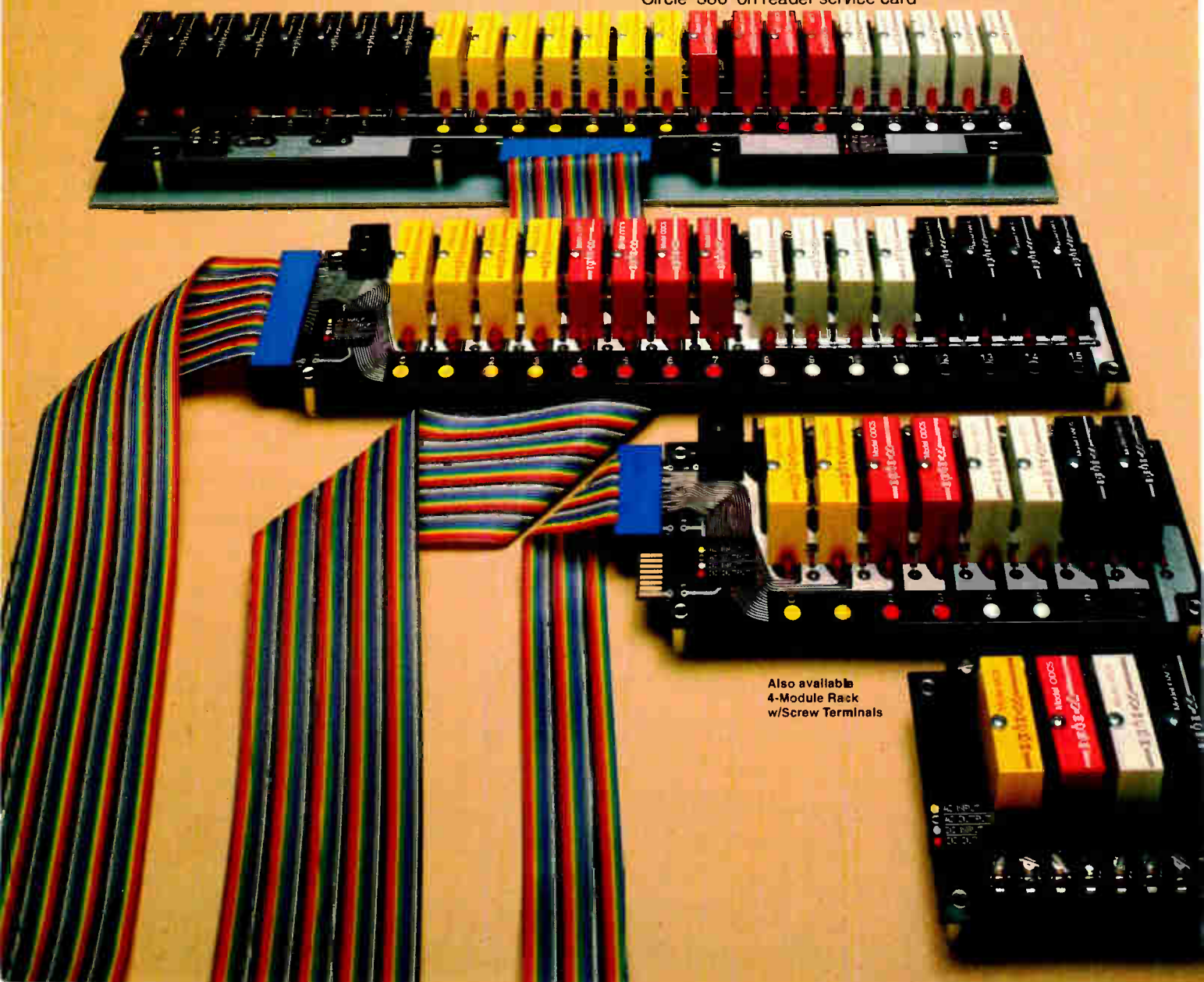

Also available  
4-Module Rack  
w/Screw Terminals

Systems Engineering Laboratories, Interdata, Tandem Computers, Prime Computer, Modular Computer Systems, Harris Computer, and Microdata.

Small businesses, in particular, became fertile ground for new computer applications and a field in which many previously discrete elements of the industry converged. Manufacturers of intelligent terminals and data-entry systems, already selling to office users, realized that the newly miniaturized semiconductors enabled their systems to become more powerful—eventually computer systems unto themselves.

Datapoint was a pioneer with its cassette-tape model 2200, introduced in 1971 and built around a microprocessor chip developed by Texas Instruments. This became the basis for a line of small-business computers that could sit on a desk top and be linked to a full complement of peripheral products. Datapoint's next unique product was the Attached Resource Computing System, unveiled in December 1977. A combination of a specialized software and an innovative coaxial cable network, it allowed users to link the company's various model processors together, so they could share peripherals, data, and the processing tasks.

One specialized office application that attracted computers was word processing. IBM, already a dominant manufacturer of electric typewriters, is credited with creating the market in 1964 when it introduced a magnetic-tape typewriter. This unit could store information on magnetic media for later modification and automatic retyping. Surprisingly it was not the traditional office equipment suppliers that jumped into the new market, but rather a host of new concerns, including CPT Corp., Daconis, Jacquard Systems, Lexitron, Linolex, NBI, Qyx, Redactron, and Vydec. They were joined by minicomputer makers like DEC, Datapoint, and Wang

and by intelligent-terminal vendors like Four-Phase.

Revolutionizing the input/output process during the 1970s, and making the computer generally easier to use, were cathode-ray-tube terminals. The microprocessor brought dramatic innovations. Now it was possible to buffer both the data received by the terminal and that transmitted to the computer; hence the refreshing of the screen display could be handled in the terminal. In addition, information could be edited and verified before transmission to the computer, and this reduced errors.

Some microprocessor-based terminals became so intelligent that it was difficult to separate them from the desktop computers being sold as small-business systems. By the end of the decade almost 90 manufacturers were making CRT terminals, and more than half those on the market were microprocessor-controlled. Close to 2 million CRT terminals were installed by the end of 1979, making them the most common I/O device.

Demand for hard-copy computer output grew, too. For smaller computer systems, one of the more popular printing techniques of the 1970s was the dot-matrix serial printer pioneered by Centronics in 1970.

Toward the end of the decade printers became less complex mechanically. The high-speed nonimpact page printer was invented, and machines such as IBM's 3800, Honeywell's Page Printing System, and Xerox's 9700 could print up to 20,000 lines a minute. In addition, smaller nonimpact printers were perfected, such as IBM's 6670, the Wang Intelligent Copier, and similar units from Japanese manufacturers. And ink-jet printers became more efficient.

Even though the U. S. computer industry had been forced to consolidate, it maintained its dominance in the world market. As a result, many foreign countries either continued or expanded their protection of their domestic

**Homemade.** IBM developed the electron-beam exposure system that its Data Systems division was using in 1978 to expose interconnection lines on bipolar chips for its System/38 small-business computer. Each chip has 704 logic circuits and measures 4.6 millimeters square.





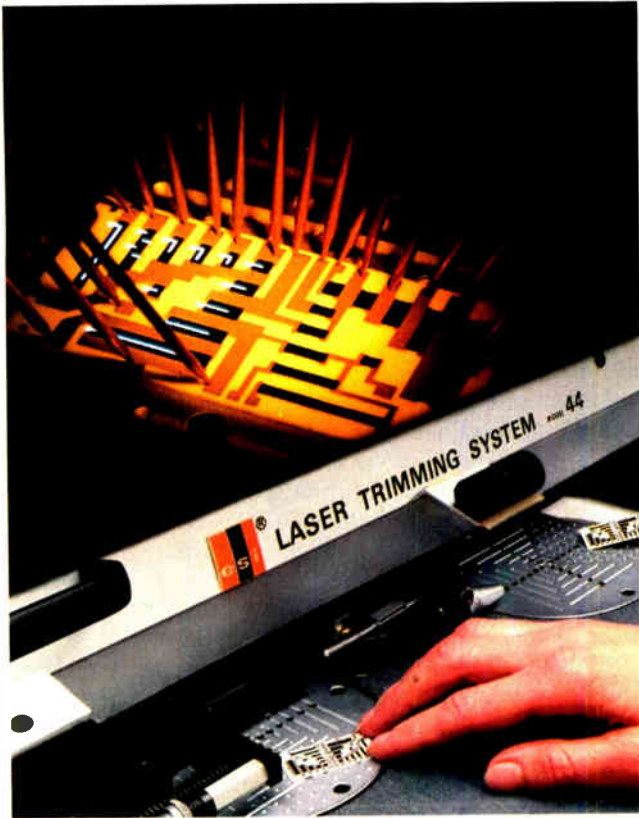

**Trimmer.** Computer-controlled laser trimmers boosted microcircuit yield by precisely removing excess thin- or thick-film resistive materials. A Q-switched YAG laser unit from trimmer pioneer Electro Scientific Industries is shown trimming a thick-film hybrid.

computer manufacturers. And to expand their activities into the highly profitable U. S. market, foreign companies began to acquire American companies.

Plaguing IBM throughout the decade were antitrust charges. Many lawsuits were filed by various competitors, but these were overshadowed by the Federal case. After six years of pretrial planning, a Justice Department antitrust action against the giant corporation went to trial in 1975. The court proceedings dragged on, and by April 1978 IBM was just starting its defense. Industry experts were expecting the 11-year-old case to last for at least another few years.

**E**ver larger-scale integration exerted tremendous influence on techniques for processing ICs and hybrid circuitry, as well as on interconnection in general. As in the 1960s, great advances were made in lithography for increasingly dense ICs. In addition there were these developments:

- IC packaging was revolutionized by film and ceramic chip-carriers.
- Large all-digital, multilayer hybrid circuits emerged.
- The printed-circuit industry developed fine-line boards for speed and four-layer boards for density. For low-cost pc boards, thick-film hybrid techniques were applied.
- Connectors shrunk.
- New automatic wiring techniques emerged as higher-density alternatives to the popular wire-wrap.

■ Data-conversion products gradually evolved from modular to hybrid to monolithic form.

Integrated circuits of the early 1970s had circuit geometries with 20-micrometer line widths. By the mid-1970s these dimensions had shrunk to 10  $\mu\text{m}$ . As the decade ended, 3-to-4- $\mu\text{m}$  details were quite common in production ICs, and prototypes with 1-to-2- $\mu\text{m}$  line widths were readily producible.

As the decade started, practically all IC patterns were exposed to ultraviolet light through masks either in contact with or in close proximity to resist-covered wafers. This system had satisfactory resolution but was hard on masks and also had a low wafer yield.

To overcome these deficiencies, Perkin-Elmer Corp. developed its Micalign optical projection printer in 1973. This noncontact system proved to be an outstanding success at raising IC yield and lengthening mask life. Micalign was a 1:1 optical projection system capable of exposing the entire wafer at one time, with lines and spaces 2  $\mu\text{m}$  wide and an alignment error of  $\pm 1 \mu\text{m}$ —more than adequate for ICs of the 1970s. It was perhaps the dominant lithography machine of the decade.

Electron-beam lithography was the key to making the masks for the optical lithography units. Without its ability to make masks with micrometer-wide lines, no LSI lithography technique based on the use of either masks or reticles would have been possible.

One of the first electron-beam systems came from Bell Laboratories in 1974. Called the Electron-Beam Exposure System, it made masks by using a raster-scanned beam aimed at a continuously moving table. Wafer alignment with the beam was controlled by a laser interferometer. Both ETEC Corp. of Hayward, Calif., and the Extrinsic division of Varian in Gloucester, Mass., were licensed by Bell to develop commercial versions. Their machines gradually became mask-making tools at IC manufacturing plants in the U. S. and abroad.

During this time some of the more sophisticated electron-beam machines were built in house at companies like Hughes, IBM, and Texas Instruments. In fact, in the late 1970s IBM was one of the few companies to write directly on batches of production wafers, eliminating the masking step in its EL1 raster-scanning system.

A third lithographic milestone was reached in 1977 when the Burlington, Mass., division of GCA Corp. announced its Mann 4800 direct-step-on-wafer machine that could expose 1.5- $\mu\text{m}$  lines at a rate of 30 to 60 wafers per hour.

Heavily researched in the 1970s was X-ray lithography, which resembles contact and proximity lithography, but with an X-ray rather than ultraviolet source. X-ray lithography's big advantages were its simplicity and high resolution and throughput. From 1975 on, Bell Laboratories, Hughes Research, General Instrument, the Lincoln Laboratory at the Massachusetts Institute of Technology, and Texas Instruments all had extensive efforts in this field. The first commercial X-ray lithography system appeared in 1978. It was developed jointly in Japan by the Nippon Telephone and Telegraph Public Corp. and Nikon.

The IC packages early in the decade were mainly dual in-line packages of 14 to 16 leads in plastic and ceramic,

plus a small number of flat packs for military and aerospace use. By 1979 this had changed, since the LSI effort required ever larger pinouts. By then 40-, 64-, and 68-pin packages were common.

They included large DIPs, smaller quad in-line packages (rectangular packages with four rows of leads staggered on 50-mil centers), and still smaller ceramic, plastic, and film chip-carriers.

A popular IC package was the ceramic chip-carrier. About one third the size of a comparable DIP, it originated in 1971 at the 3M Co. in St. Paul, Minn. It was a square, multilayered ceramic package whose bottom periphery contained a pattern of gold bumps on 40- or 50-mil centers. The chip was bonded to a gold base pad inside a cavity within the ceramic. The small hermetically sealed package could be easily attached or removed from pc boards and hybrids.

The new, mostly digital LSI chips soon were affecting the hybrid microcircuit field. The extremely dense interconnection patterns required for LSI packages could be achieved only with multilayered ceramic hybrids. Thick-film hybrids were developed with as many as 15 conductive layers on a 2-by-2-inch substrate. Densities ranged from 15 to 20 chips per square inch. To this day, this density can be achieved only with this method.

Multilayer thick-film hybrids were preferred to thin films, which were harder to fabricate. Thin films, although not completely pushed out of circuit work, were used mainly for precision resistors and resistor networks.

Printed circuitry also underwent change in the 1970s. The advances included the creation of fine-line boards, mass molding for multilayer boards, the use of thick-film techniques for simplified pc manufacture, and the use of porcelain-coated steel as a substrate.

As for low-cost pc boards, there were two major advances. The major suppliers of thick-film inks all developed low-cost polymers that could be screened and fired onto standard board substrates. The inks would form conductors, resistors, and insulating crossovers. The method was applied to consumer electronics, especially in Japan and Europe.

Another significant development was the use of cheap but strong porcelainized steel substrates with modified thick-film materials for the circuitry. Early in the 1970s General Electric and GTE/Sylvania screened thick-film conductors onto small porcelain-on-steel boards used in flash-bulb arrays for low-cost cameras. By the late 1970s manufacturers like the Erie Ceramic Arts Co. in Erie Pa., Alpha Metals Inc. in Jersey City, N. J., and General Electric's Lamp Department in Cleveland all produced electronic-grade (low-ion-content) porcelain on steel.

In the early 1970s the main automatic wiring methods for pc boards were Wire-Wrap and Multiwire, with some aerospace work using Stitch Wiring, in which insulated nickel wires were cold-welded to an array of stainless steel pins force-fitted into a glass-epoxy board. As the decade moved along, fast IC logic and high-density interconnects called for shorter wiring paths. Multiwire that embedded the wire in adhesive atop the board was one solution.

Another was Planar Stitch Wiring, announced by Accra Point Arrays Co. of Santa Ana, Calif., in 1973;



**Tester.** As new high-speed processes spawned memories with cycle times pushing 40 ns, ever faster testers were needed. Macrodata in 1979 first introduced a 25-MHz test system, the M-1, shown with its programming terminal, test fixture, and computer rack.

**Attractive.** Low-power liquid-crystal displays found their way into devices other than watches. Here they are being applied to one of the first hand-held digital multimeters to be commercially successful, John Fluke Manufacturing's model 8020, introduced in 1977.





instead of joining wires to stainless steel pins, it used insulated nickel wires that were cold-welded to stainless steel pads on the glass-epoxy card.

A third method, Solder-Wrap, was introduced in 1976 by the United Wiring and Manufacturing Co. of Garland, Texas. It employed a computer-controlled stylus that strung a fine insulated wire to the solder tails or leads of sockets. The wires were soldered by a probe that heat-stripped the insulation away. After soldering, the string was cut automatically.

A fourth wiring method, Quick-Connect, was developed at Bell Laboratories in 1975 and then applied to Schottky TTL circuit boards throughout the Bell system. In this system a computer-controlled wiring head routed and pushed insulated wires into arrays of insulation-piercing contacts on a regularly patterned pc board. Robinson-Nugent Inc. in New Albany, Ind., was licensed to produce boards and hardware in 1979.

**A**s for components, manufacturers pushed ahead with miniaturization in the 1970s. Resistors and capacitors now became the size of IC chips so they could fit on hybrid substrates. All manner of components—resistors, capacitors, networks, reed relays, switches, and nickel cadmium batteries—were squeezed into the dual in-line package (DIP).

Connector technology also had developments that profoundly affected interconnections. Among these were the creation of the first fiber-optic connectors, the first zero-insertion-force (ZIF) connectors, and the use of tin-lead in gas-tight high-pressure connectors.

Fiber-optic communication was one of the great advances of the 1970s. But the technique was held back until 1975 when both the Amphenol Rf division and the ITT Cannon Electric division began to market fiber-optic connectors. Engineers now had the hardware to terminate optical cable and link it to equipment or even other cables.

ZIF connectors, like so many other developments, flowed from the interlinked requirements of LSI and high interconnection density. In 1971 it had become increasingly difficult to mate multipinned ICs to their sockets without damaging the leads of a large DIP. What was needed was a connector with easy entry for the DIP and the ability to lock the DIP to the socket.

One of the earliest ZIF devices to appear was a DIP socket from Textool Products in Irving, Texas, in July 1971. By the late seventies this technique was being adapted to pc-card edge connectors, with many variations of locking actuators.

The rising price of gold was a troublesome problem for connector manufacturers, who employed this precious metal as a contact material. In 1968 Burndy Corp. of Norwalk, Conn., developed a solution. This was a gas-tight, high-pressure interconnection system. The spring force behind a sharply pointed tip caused contact material to flow, or extrude. The contact was composed of a copper alloy base plated with a tin alloy. The contact flow broke down all tarnish and corrosion, resulting in a gas-tight metal-to-metal junction. By the late seventies the company had successfully applied this principle to all

sorts of connectors for all sorts of applications.

A significant development took place in the data-conversion field—the ultimate shrinking of complete systems to monolithic chips. In 1970–71 most digital-to-analog and analog-to-digital converters were large potted modules that used discrete devices and ICs on small pc boards. A sampling of thick- and thin-film hybrid converters was available, along with one lonely monolithic 8-bit d-a converter from Precision Monolithics Inc. of Santa Clara, Calif.

By 1975 the emphasis had shifted from potted modules to hybrid converters. In that year module makers like Datel, Burr-Brown, and Analog Devices came out with hybrid converters, as did National Semiconductor. Later, many module companies opened monolithic facilities. By the decade's end hybrids and monolithics had almost pushed modular converters out of the picture.

The soaring application of linear and digital IC technology shaped instrument design throughout the decade. And the advent of the microprocessor created such shock waves that the full impact had not been felt by the end of the seventies.

There were complaints about the ability of automated test equipment to keep up with the changes in IC design. One solution was offered by Membrain Ltd. of Britain (later absorbed by Schlumberger). Membrain's first product was a functional pc board tester in 1971 that could be expanded to 1,000 pins from a basic 20-pin unit.

Macrodata, another new company, had introduced its first tester, the MD-200 in 1970. It was the first MOS LSI tester to function at 2 MHz, and it placed the pin electronics in the test head, a design that decreased noise and is the major technique in use today. Throughout the decade Macrodata put out state-of-the-art systems, including the first 25-MHz memory test system, the M-1, in 1979.

**A**nother newcomer in 1971 was Trendar (acquired by the John Fluke Manufacturing Co. in 1973). Trendar had the model 2000, which used a new coding scheme—an early form of signature analysis called transition counting—to compare a known good board with a test board.

Faultfinders Inc. and Testline (now part of Fairchild) were also founded during this period and, along with Zehntel Inc., pioneered the in-circuit philosophy for board testing. These testers checked the location and function of components by isolating each device.

Established instrument companies also entered the automated testing business. Schlumberger Ltd., the French oil equipment and electronics conglomerate, introduced a test system, as did Fluke. A highly versatile system, the 4500, was offered by E-H Research Laboratories of Oakland, Calif. Built around an IBM 1130, the tester could function at speeds of up to 1 GHz in a 40-pin configuration. The technology to build the 4500 boosted its price to as much as \$750,000, which few customers cared to pay for a capability that would not be needed for years. In a more down-to-earth vein, Tektronix

THE NEW

# performer.

Model 3400 has features that  
upstage other compact DVOMs.



But to fit your hand and budget, the new Model 3400 (shown actual size) is loaded with features. Like a color coded single range switch for one-hand selection of all functions . . . overload protection for all ranges and 200 hour minimum battery life . . . time-saving automatics including auto-zeroing, auto-polarity, auto low-battery and auto-overrange indication . . . easy to read .5" LCD readout.

Six functions and 24 ranges, typical DC accuracy .5% Rdg, including High and Low Power Ohms for sensitive IC testing, makes the Model 3400 ideal for design, production and maintenance testing, vocational tech training schools, commercial electronic equipment test and measurement use.

1. **HAND SIZE**, 3½ digit, single range switch—6 function, 24 ranges with Hi and Low Power Ohms, Auto-zero and Auto-polarity.
2. **OVERLOAD PROTECTION**—Protected up to 600 volts on all ranges with special 2 fuse arrangement.
3. **BATTERY LIFE**—200 hour minimum with 9V battery, display includes low battery indication.

ONLY **\$140**

Includes test leads, new screw-on insulated alligator clips for the probe, 9V alkaline battery, plus instruction book and 1 year warranty.

For a demonstration, contact your Triplett distributor, Mod Center or representative.  
Triplett Corporation, Bluffton, Ohio 45817  
(419) 353-5015, TWX (810) 490-2400.



Triplett performance... a tough act to follow

**TRIPLETT**

Circle 391 on reader service card  
Circle 250 for FREE Demonstration



# The standard of the industry.

**Snap-on Tools**

Circle 392 on reader service card

Back in 1920, the *Snap-on* Tools founder pioneered the idea of using a single handle with various sizes of socket wrenches. The user simply removed one wrench from the handle and added another. This idea, plus a dedication to excellence in manufacturing and service has made *Snap-on* the largest independent hand tool manufacturer in the world. Today, *Snap-on* ratchets, sockets and related tools are the standard of the industry. Your *Snap-on* tool specialist can show you all the ways *Snap-on* can help you with your tooling needs. *Snap-on* Tools Corporation, Kenosha, Wisconsin 53140.



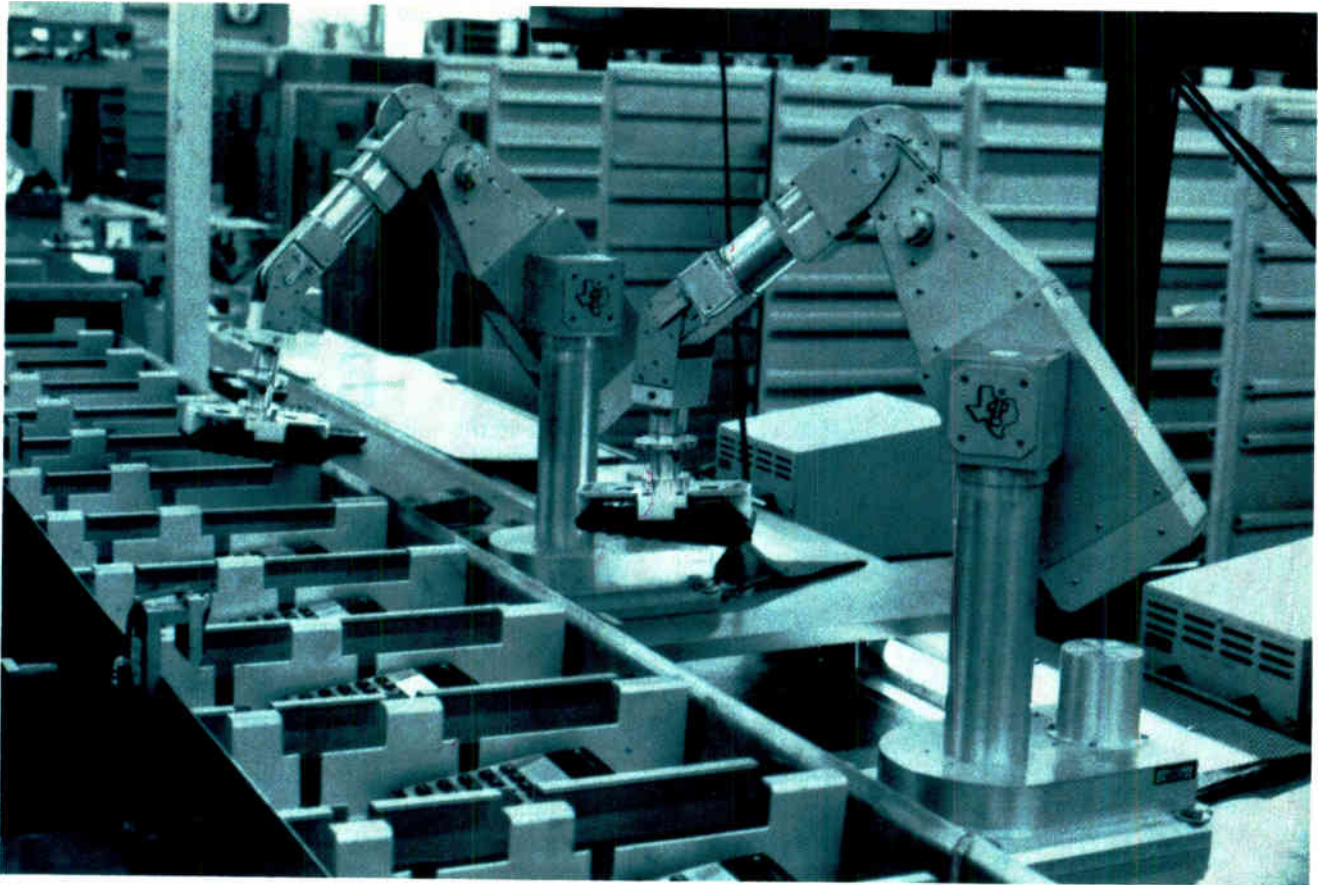

**Pick and place.** Robot arms made some progress during the decade in taking over boring and dangerous jobs. These at a Midland, Texas, plant of Texas Instruments transfer calculators from one conveyor belt to another. Overhead TV cameras help them search for "targets."

marketed the S-3160, a general-purpose LSI tester that worked at speeds up to 20 MHz.

Companies already in the automated test business expanded their lines. In 1970 the Fairchild Semiconductor Test division introduced its Sentry LSI tester, the model 400. The unit was designed to be modular, expandable as testing requirements grew. Teradyne and GenRad also put out IC testers.

Although programmable instrumentation had been built in the late 1960s, the task of integrating such instruments into a system was considered a designer's nightmare. To overcome the problem, Hewlett-Packard attempted in December 1971 to standardize the connectors, cabling, timing, voltage levels, and codes of its future instruments. The company came up with a bit-parallel, byte-serial communications interface, or bus, that eventually was adopted internationally. It is known by a variety of names—HP interface bus (HPIB), general-purpose interface bus (GPIB), IEEE-488, and IEC 625-1. The interface, which first appeared in HP's 3330A/B automatic frequency synthesizer, became common in instruments by the end of the decade.

The oscilloscope competition between Hewlett-Packard and Tektronix led to the development by HP of the first complete data-domain logic analyzer, the 1601L, in 1973. The instrument, which displayed events on several channels as a series of 0s and 1s, actually resulted from an unsuccessful effort to build a digital-processing oscilloscope. That same year Biomation came out with the

first time-domain logic analyzer, the 810-D. It displayed such events as square waves varying between a logic 1 level and a logic 0 level.

That such instruments were immediately popular is not surprising; the use of digital logic was becoming universal. It was evident in digital synthesizers, such as the model 5100 introduced in 1974 by Rockland Systems, and in digital multimeters, such as the 8600A and the 8800A introduced the same year by Fluke. These two DMMs, half the size of previous instruments, were designed around custom digital LSI.

But the greatest impact on instrumentation was made by the microprocessor. In 1973 Intel introduced single-board computers for use in developing programs for its single-chip computer, which the following year began to find its way into instrumentation.

The first oscilloscope to use a microprocessor was the Hewlett-Packard model 1722 in 1974, and the microprocessor was HP's own chip, the 352. Developed for the HP-35 calculator, the microprocessor computed frequency and time intervals, which could be displayed on the scope's light-emitting-diode (LED) readout.

In the same year Fairchild Systems Technology used a microprocessor in its Qualifier 901 IC tester for what was potentially one of its most important roles—performing self-test routines at system startup. The following year the first microprocessor-based synthesized signal generator and counter/timer, Fluke's 6011A and Dana Laboratory's series 9000, respectively, came on the market. Then



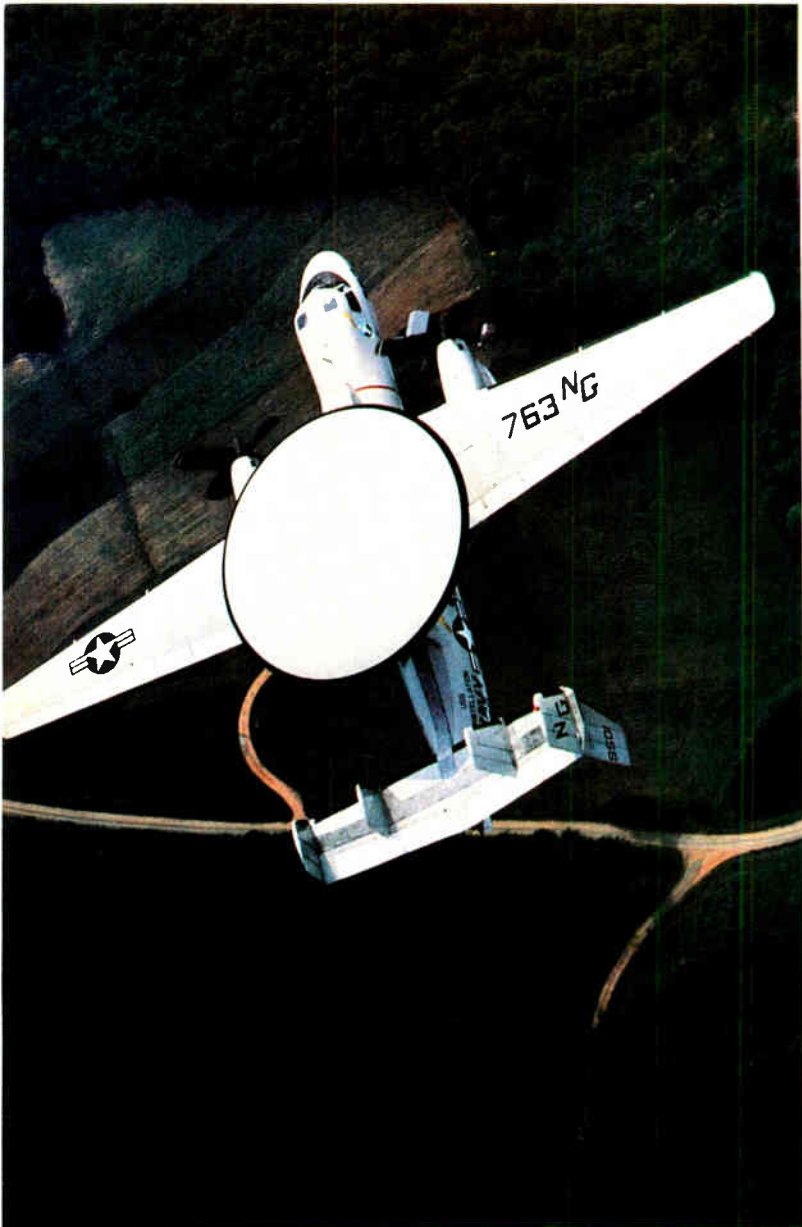

spectrum analyzers, instruments that stood to benefit most by being made easier to operate and read, incorporated microprocessors in 1977. There was the Tektronix 7L18 plug-in for the company's 7000 series; it used the microprocessor to control the setting of frequency and sweep automatically and to manage an MOS memory that stored previous traces so they could be compared to live data. And there was the HP-8586A, which contained three processors to control settings, calculate results, and compute correction factors.

Instruments to help designers build microprocessor-based systems also were developed. The first "universal" system for different microprocessors was Millennium Systems' Microsystems Analyzer in 1977. The instrument was based on one measurement technique developed by HP, signature analysis, and on another developed by Intel, in-circuit emulation.

Signature analysis, based on signal tracing, translates bit streams into hexadecimal codes, or signatures, which are then compared with the correct signatures on a circuit diagram. In-circuit emulation mimics the operation of a microprocessor by using hardware that is linked to a user's prototype system with cabling.

The universal development system was quickly

**Early warning.** Electronics played a continuing role in military aircraft. Grumman's E-2C Hawkeye, deployed in 1974, uses a General Electric radar—its antenna in the circular radome—to automatically track aircraft flying low toward the U. S. Navy's fleets.

adopted by Tektronix, by agreement with Millennium, and introduced as the Tektronix 8001. Another universal system, one that provided a distributed architecture, was built by Futuredata in 1978, and Futuredata then became part of GenRad. In 1979 Hewlett-Packard introduced its first universal development system: the 64000.

**E**ven before computers shrank to chip size in the mid-1970s, industrial electronics found widening use for them. Chemical and petrochemical process control, the largest industrial electronics market, was joined by manufacturing processes in 1971 when programmable controllers made their debut.

The forte of the programmable controller was versatility. With one, a plant manager no longer had to scrap expensive relays and hard-wired logic modules each time production requirements changed. Instead he reprogrammed the controller by replacing one or two braided-wire read-only memories or read/write core memories.

During the early 1970s industrial electronics sales were spurred by Federal legislation that mandated greater safety for factory workers. Farthest reaching was the Occupational Safety and Health Act of 1970 (OSHA), which, among other things, created demand for noise-measuring instruments, like audio dosimeters. The Federal Coal Mine Health and Safety Act of 1969 produced a new market for underground safety equipment that included low-light TV cameras, gas sensors, and dust-particle detectors. Federal standards for automotive emissions and safety further broadened the need for electronics.

In 1972 *Electronics* said that automotive industry analysts were predicting that "by 1980, vehicles will contain as much as \$100 worth of electronics." The predictions were on target with respect to several top-of-the-line models.

Catching on slowly were industrial robots, or automatic manipulators, boosted by robotics pioneer Unimation Inc., Danbury, Conn. Sales of minicomputers to industrial users boomed in the early 1970s. The machines quickly assumed more and more materials-handling chores—from sorting letters to moving air freight and even watching their own operation.

With the advent of microprocessors, designers of industrial equipment could buy a chip set like Intel's 4-bit MCS-4 and then design the circuit boards, systems, and packaging for themselves. This flexibility, plus the high reliability inherent in fewer ICs, allowed inexpensive microprocessors to begin replacing minicomputers and hard-wired controllers in virtually every industrial electronics application.

Microprocessors also permitted distributed control, in which a microprocessor-based controller takes charge of a local control loop, thus freeing a central computer for other duties. One of the first such systems was Honeywell's TDC (total distributed control) 2000 process-

# This book can save your company a lot of money.



**Rental Electronics is renting**

Amplifiers	3
Wave and Distortion Analyzers	3
Logic Analyzers	3
Microvare Link Analyzers	3
Data Link Analyzers	3
Network Analyzers	3
Power Line Analyzers	3
Sound and Vibration Analyzers	3
Spectrum Analyzers	3
Attenuators	3
Calibrators	3
Cameras	7
Counters	3
Couplers	3
Desktop Computers	3
Filters	3
Function Generators	3
Noise Generators	3
Pulse Generators	3
Signal Source Generators	3
Serial Frequency Generators	3
Generators/Synthesizers	3
Analog Voltmeters, Current and Resistance Meters	13
Digital Meters	13
Power Meters and Thermistors	13
Microprocessor Instrumentation	13
Modulators	13
Oscilloscopes	13
Optoscopes	13
Printers	23
DC Power Supplies	23
Probes	23
Digital Penetration Recorders/Plotters	23
Scout Recorders	23
Magnetic Tape Recorders	23
Oscillographic Recorders	23
Strip Chart Recorders	23
Temperature Recorders	23
X-Y Recorders	23
Sources	23
Microscopes	23
Synthesizers	23
Data Terminals	23
Graphics Terminals	23
Test Sockets	23
Test Sets	23
Test Chambers	23

GSA #045-21063 Neg

**1979-1980 Catalog**

**Rental Electronics, Inc.**  
A member of the **EMERSON/CAL** companies

*You can rent just about any electronic instrument -- including data terminals and printers -- off-the-shelf for as short a time as 30 days.*

## Rental Electronics, Inc. (800) 227-8409

In California (213) 993-7368 or (415) 968-8845 or (714) 879-0561

<input type="checkbox"/> Send me a copy of this book. Soon, please. In these inflationary times, my company would like to save money. Your 1979-1980 Rental Catalog might help.	<input type="checkbox"/> I understand you have scads of data terminals and printers for rent off-the-shelf. Send me a brochure.
<input type="checkbox"/> I'd like a copy of your 1979-1980 Equipment Sales Catalog, too.	<input type="checkbox"/> I need immediate assistance. Have someone phone me quickly here: (A.C.) _____ (number) _____ (ext.) _____
<input type="checkbox"/> I'm interested in desktop computers. Send me a copy of your Hewlett-Packard Desktop Computer rental brochure.	<input type="checkbox"/> I have specific interest in the following electronic equipment: _____ _____ _____
<input type="checkbox"/> I'd like to see a brochure on Intel's Intellect® Microcomputer Development Systems now for rent.	
NAME _____	TITLE _____
ORGANIZATION _____	
ADDRESS _____	MAIL STOP _____
CITY/STATE/ZIP _____	
PHONE _____	

E4/80

Please complete this coupon and mail to: Rental Electronics, Inc./19525 Business Center Dr./Northridge, CA 91324





OK MACHINE & TOOL CORPORATION 3455 CONNER ST.,  
BRONX, N.Y. 10475 (212) 994-6600/TELEX 125091



Circle 396 on reader service card

**Downward.** Prices of many consumer electronics items were being drastically reduced in step with the ever higher-volume production of integrated circuits. This photo was taken in 1976 at a store in New York anxious to move its merchandise.

control system, introduced in 1975.

The late 1970s saw the creation of two new industrial electronics markets: lasers and energy-management systems. Low-power (1-to-2-milliwatt) helium-neon lasers proved reliable enough to measure, sort, and inspect components, while larger (1-to-5-kilowatt) carbon dioxide lasers proved faster than induction furnaces for heat-treating such metal parts as the teeth on chain saws. Even more powerful helium-cadmium lasers, with beams expanded to lower and safer power density, were used by the U. S. Coast Guard to monitor oil spills in 1976.

Energy management, a field pioneered by aerospace companies looking for ways to cut the heating, ventilating, and air-conditioning costs of their huge factories, became a lucrative industrial market when oil prices jumped. Tying together technologies from solar heating to load shedding under the aegis of a central computer or distributed microcomputers, energy-management systems often paid for themselves within a year by slashing fuel bills as much as 20%.

**R**adar went digital, too, in the 1970s. It had become deeply involved with information processing and data handling at high rates. Microprocessors and associated memories were sprinkled everywhere in the radar system.

When rain or jamming interfered with signal reception in aircraft, for example, automatic adjustment of the radar threshold and other parameters could avoid false target indications. Such systems were installed in the Grumman F-16 fighter jet and the Grumman EA-6B reconnaissance aircraft.

The decade saw further experimenting with phased-array radar. The Pave Paws long-range search radar built by Raytheon Corp. and installed in Massachusetts was typical. These systems, with their electronically, rather than mechanically, steered antennas, still needed some technological breakthroughs, including cheap computer software control to steer the antenna pattern and cheaper production of phase shifters. Cheap, reliable solid-state oscillators for each element in the array were also needed. By the end of the decade, these problems had not been solved.

High-speed digital processing and low-cost microprocessors and memory made synthetic aperture radars more promising for relatively high-resolution applications. Both range and azimuth resolution of less than 10 feet soon became possible with these systems, which stored the information from multiple scans of a target. This information, in turn, was computer-processed to produce an enhanced picture. Such systems used upwards of 100 megabits of memory for satellite mapping, crash location, and flood control, among other applications. They were used, for example, on the Pioneer-Venus radar mapper, an interplanetary probe built for the National Aeronautics and Space Adminis-



tration by Hughes Aircraft Co.

An experimental microwave radar receiving system front end based on an Intel 8080A processor was developed by GTE Sylvania in 1976. Intended for reconnaissance, it operated in the 0.5-to-40-GHz region of the spectrum and covered just about any frequency an enemy or friend might broadcast on.

In the civilian world, cable television, a novelty and a promise in the 1960s, took off in the seventies. It expanded from a TV subscription service to a two-way data





# Simpson<sup>®</sup> Leading the Industry Since the 30's with the TOTAL Line of Panel Meters and Test Equipment for Industry, Laboratory and Service-Maintenance!



Indicate!  
Monitor!  
Control!  
Record!  
Test!  
Measure!  
Display!

With Simpson  
Digital and  
Analog  
Instrumentation!

For latest full line catalog, see your local Simpson electronic distributor or electrical wholesaler, or write:

**Simpson**  
INSTRUMENTS THAT STAY ACCURATE

SIMPSON ELECTRIC COMPANY

853 Dundee Avenue, Elgin, IL 60120

(312) 697-2260 • Telex 72-2416 • Cable SIMELCO

Circle 399 on reader service card

**KATY**  
SUBSIDIARY



# Hazeltine

**Innovation in electronics  
from the beginning**

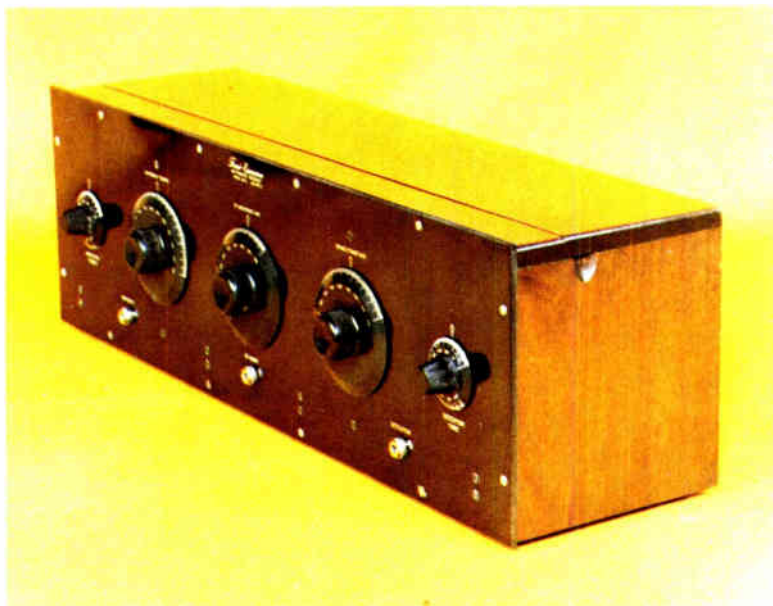

In the early 1920's, Professor Alan Hazeltine received patents on his Neutrodyne Receiver design, which both advanced the state-of-the-art and rapidly found wide use in the manufacture of home radios. It provided a major contribution to the commercial success of radio, and innovative and practical engineering in advanced electronics technology remains a principal strength of Hazeltine Corporation.

Today, we develop and manufacture a diversified range of sophisticated electronics products for government and industry. From Identification Friend or Foe (IFF) Systems, and the Command and Control display systems carried aboard the U.S. Navy/Grumman E-2C and the U.S. Air Force/Boeing E-3A aircraft, to Microwave Landing Systems for airports, power network monitoring

systems for electric utilities, electronic color imaging systems for motion picture film laboratories and for professional printers, and interactive graphic terminals.

We also manufacture a complete line of computer terminals to cover a full range of business applications. Our 1400 Series features technologically advanced, reliable conversational terminals. The Hazeltine 1500 Series offers outstanding performance in conversational editing and printer-controlled terminals. The highly flexible Hazeltine Modular One System designed specifically for editing and polling applications, can be custom configured to your CPU hardware, software and line control discipline with minor alteration to the terminal's resident software. It's the industry's broadest line of video display terminal offerings.

We're a leader in the total field of information electronics, devoting our fifty years of experience to your needs in the decade of the eighties.

Hazeltine Corporation, Commack, NY 11725 (516) 261-7000  
Hazeltine and the Pursuit of Excellence

New York (212) 586-1970 • New Jersey (201) 584-4661 • Chicago (312) 986-1414 •  
San Francisco (415) 342-6070 • Atlanta (404) 952-8444 • Arlington (703) 979-5500 •  
Orlando (305) 628-0132 • Dallas (214) 980-9825 • Los Angeles (213) 553-1811 •  
Columbus (614) 889-6510 • England 01-948-3111 Telex (851) 928572



**Answers for the eighties**

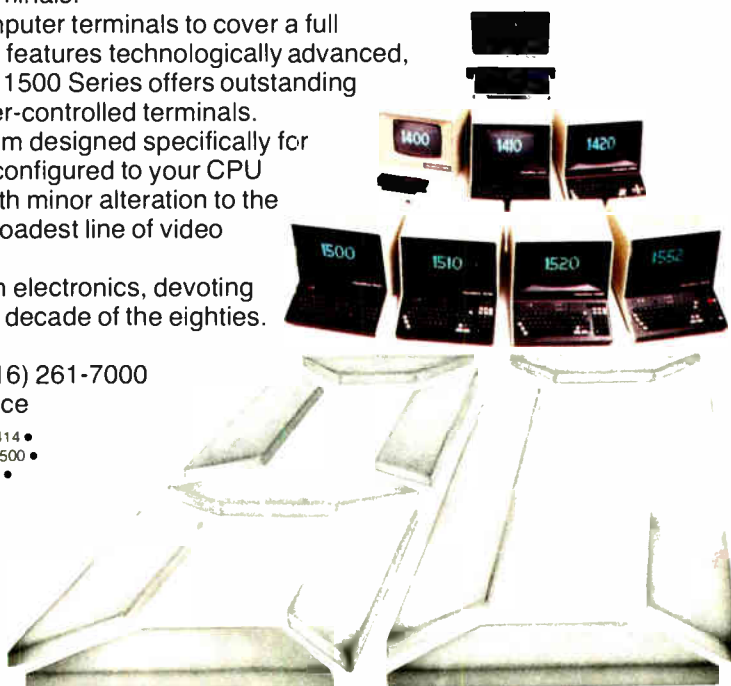



**Stylish.** The ordinary telephone changed significantly as manufacturers and operating phone companies vied to sell sets. This Flip-Phone from General Telephone & Electronics measures 2 by 2 by 7 inches when flipped closed to cover its receiver, transmitter, and push-button keypad.

companies to survive. Among the early casualties were assemblers that bought their components from aggressive semiconductor manufacturers.

One major U.S. calculator maker estimated that about 20 million units were sold in the U.S. in 1975. Domestic production amounted to only about 4 million to 5 million units. Some 6 million were Japanese, who would come to dominate the market, and the rest—almost 10 million—came from other sources.

The first electronic digital watch was introduced in the fall of 1971: the Pulsar, retailing for \$2,000 with an 18-carat gold case bracelet. Touch a button and the light-emitting diodes showed the time. (It took about a year for Pulsar to add the day and date.) Not long after, the manufacturer, Time Computer, came out with a stainless steel Pulsar that retailed for \$275. The company bought the chip from RCA, and one executive recalls, "We held all the original patents, were the innovators, and made a lot of money on it for a few years."

Motorola offered the first integrated electronic watch kit to manufacturers in early 1972. The C-MOS circuit, precision quartz crystal, and miniature microwatt motor sold for \$15, but the company expected the price of each component to drop to \$1. "Watches are going to be in the \$17 range eventually," a spokesman said.

Engineers worked on liquid-crystal watch displays, trying to bring the price down and the reliability up. By

1970, low-temperature crystal materials had appeared that made LCDs practical to manufacture. By May 1974 *Electronics* was asking, "Is 1974 the year of the digital watch?" C-MOS and display suppliers, forecasting sales of 1.5 million units, thought it was, but watch companies were less enthusiastic. The watch companies conceded that semiconductor manufacturers could build watches, but they argued that these manufacturers did not understand styling and also that they did not have jewelry distribution outlets.

**I**n fall 1974 National Semiconductor's Novus Consumer Products division introduced six watches (\$125 and \$220 at retail) and three electronic clocks (\$34.95 and \$60). American Microsystems came out with a redesigned digital-watch module that was smaller and used almost half the power of earlier modules. By February 1975 about 40 companies were offering electronic watches with digital displays.

John M. Bergey, president of Time Computer, in a December 1975 interview with *Electronics*, said: "All the figures we see suggest that there are now some 45 manufacturers and from 70 to 80 nonmanufacturing marketers of digital watches. I believe we'll see this shrink to half that by this time next year. My long-term view is that by 1980, some 20% to 30% of all watches





**Replays.** Video cassette recorders made a hit in the late 1970s. This SelectaVision VCT 400 from RCA, foreground, can be programmed to record up to four TV programs on different channels over seven days. It can be used to tape home TV productions.

sold worldwide will be solid-state digital models.”

Hastening the shakeout was Texas Instruments’ plastic-cased, five-function LED watch that sold for \$19.95. The watch, introduced at the January 1976 Consumer Electronics Show, caused National Semiconductor to reduce its prices in mid-show. Six months later watch-makers were predicting a \$9.95 digital watch would be on the market by Christmas.

As LCD prices dropped, manufacturers used fewer and fewer LEDs. TI introduced a watch with liquid-crystal hands in August 1976. The engineers had to connect 120 separate elements to form the moving hands; the watch retailed for \$275 to \$325, depending on its case.

Electronic games entered a new age when Magnavox put out *Odyssey* in late 1972. An interactive game designed to be played on the screen of the home TV set, it consisted of a master control box, two hand controls, an rf feed line, an antenna switch box, and frosted Mylar

TV-set overlays. *Odyssey* retailed for \$100.

A year and a half later the first coin-operated color game, *Wimbledon*, was marketed. Nutting Associates Inc. of Mountain View, Calif., used a transistor-transistor-logic (TTL) processor and television set to simulate a tennis match—complete with the sounds of play, a grass-green field, white border lines, white ball, tennis rackets in four different colors, and scores displayed on a bright yellow background.

By June 1974 Atari Inc. had been founded and 20 or so companies were manufacturing coin-operated electronic video games. When that market’s growth slowed, it was a natural move into the consumer business. At the end of 1975 General Instrument was offering a chip for \$5 or \$6 that could operate six different games. National Semiconductor was offering a game for \$75, and Magnavox’s *Odyssey 200*, costing \$79, had on-screen boundaries for tennis, hockey, and *Smash*, a combination

# Ittron Advanced Alphanumerics. They'll put your readouts upfront.

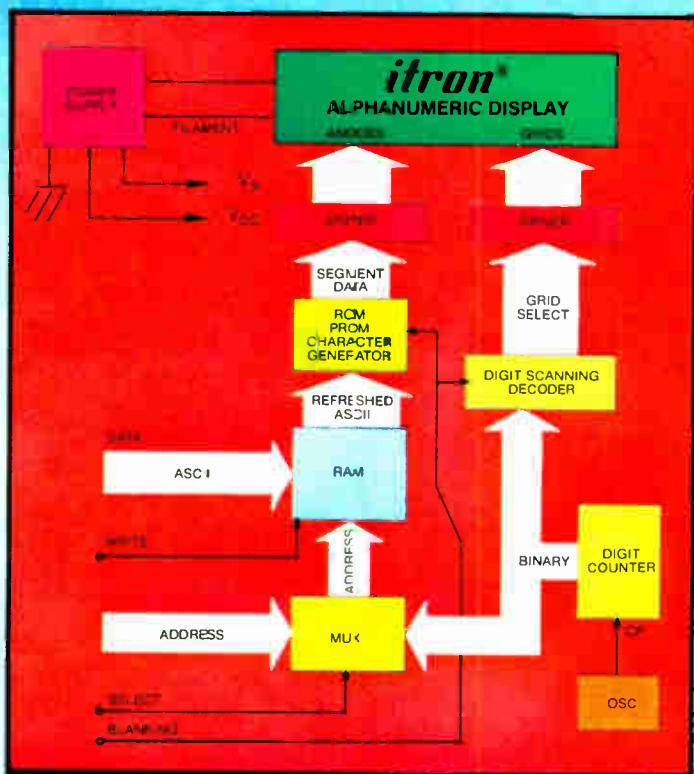

With Ittron's evolutionary 14-segment and dot matrix alphanumeric displays, your readout designs are sure to be front-runners everytime. They're offered for a wide selection of character heights from 5 mm to 15 mm, and character counts that range from an 8-character 14-segment mini-package array, all the way up to the unique 240 character, 5 x 7 dot matrix (6 line x 40 characters/line) plug-in panel—and even 5 x 12 dot matrices for upper/lower case fonts.

Their long-term field-proven reliability, even under severe environments, further enhance their desirability for most every application where bright, easy-to-read legibility (even at a distance and under high ambient light), wide viewing angles and flat-glass simple-to-mount packages—plus low voltage and low current-drain are paramount. So, since brevity is called for, contact us to find out all the particulars on how to put your read-out designs in the forefront with Ittron's Advanced Alphanumerics.

**itron**<sup>®</sup>  
FLUORESCENT DISPLAYS  
Parented and Manufactured by  
ISE ELECTRONICS CORP.

#### INTERNATIONAL REPRESENTATIVES

WEST GERMANY: Neumüller GmbH, Eschonstr. 2, 8021, Taufkirchen, Munich. Phone: 089/6118-245. Telex: 522106

FRANCE: Europavia France, 5 Avenue Leon Harmel 92167 Antony Cedex. Phone: 666-21-10. Telex: 42204381

UNITED KINGDOM: ITT Meridian, West Road, Harlow, Essex CM20 2BP. Phone: 0279-35351. Telex: 817202

SWEDEN: AB Nordqvist & Berg, Box 9145 S-10272, Stockholm. Phone: 08-690400. Telex: 10407

DENMARK: E. V. Johanssen Elektronik A/S, Titagade 15-2200, Copenhagen. Phone: 01/839022. Telex: 16522

HONG KONG: Phone: 5-232420. TAIPEI: Phone: 351-0293

#### NORITAKE ELECTRONICS, INC.

EASTERN OFFICE: 41 Madison Avenue, New York, NY 10010 • (212) 481-3440 • Telex: 12-5469

CENTRAL OFFICE: 16250 Northland Drive, Southfield, MI 48075 • (313) 569-0088

WESTERN OFFICE: 22410 Hawthorne Boulevard, Torrance, CA 90505 • (213) 373-6704 • Telex: 67-4910

#### NORITAKE COMPANY, LIMITED

JAPAN: 1-1, Noritake-Shinmachi, Nishiku, Nagoya-Shi • (052) 562-0336 • Telex: J59738

EUROPE: Burotel Belgium SA, Rue de la Presse 3-5, 1000 Bruxelles • (02) 217-83-60 • Telex: 4625962





## A Name Etched Deep in the Electronic Revolution

With its marriage to solid state physics in the 1950's and 60's, the electronics industry took another cosmic step in service to mankind's needs and wants.

Kepto was a true pioneer in this modern-day Industrial Revolution. Its innovative and imaginative work in etched circuitry is represented in installations of almost

limitless variety and scope throughout the world.

Today, we have everything you need to build your own prototype PC boards. Copper clad laminates. Complete bench-top equipment and facilities. Supporting chemicals. Graphic art supplies. And much more.

Write or call for our free, easy-to-use, illustrated catalog with prices.

**KEPTO CIRCUIT SYSTEMS INCORPORATED**  
630 Axminster Drive Fenton, Missouri 63026, U.S.A.  
Telephone: 1-800-325-3878 (out-of-state)  
1-314-343-1630 (in Missouri)

*Export Sales: Brauner Export Co. • Telex: 442826 • Cable: EBEX STL*

Circle 404 on reader service card

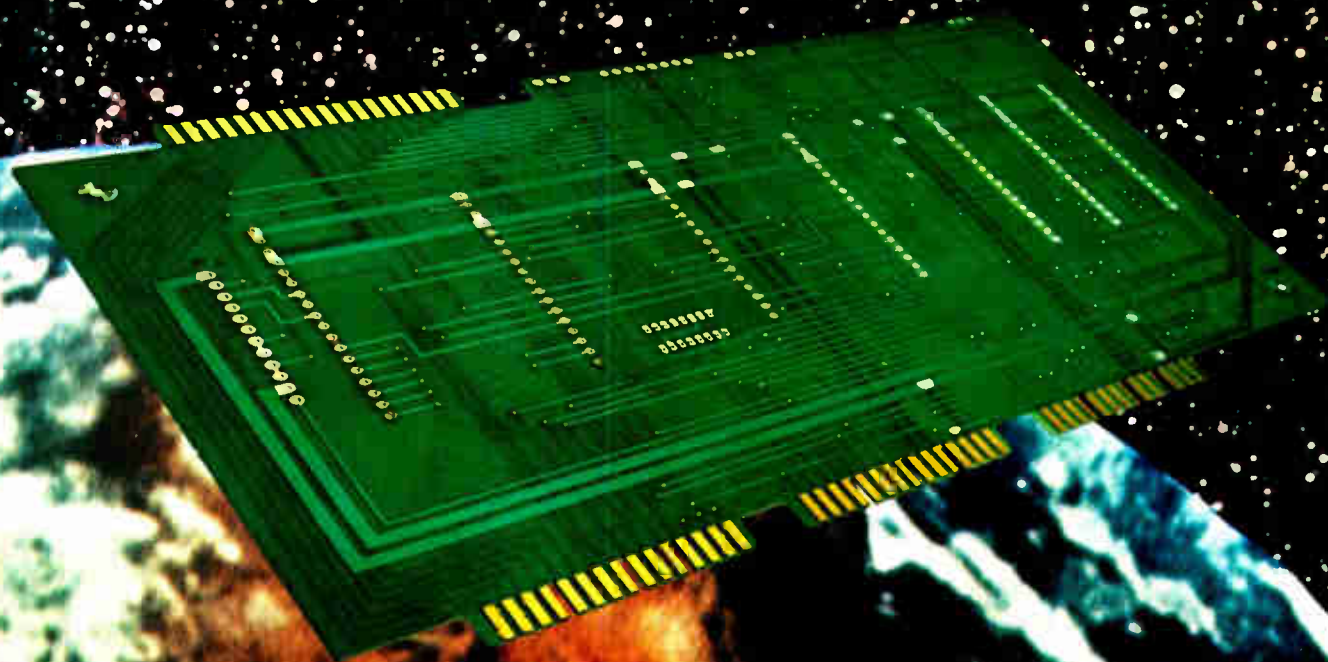

**Picture disk.** Magnavox Consumer Electronics kicked off the video disk sweepstakes late in 1978 with its Magnavision system developed by NV Philips and MCA. The player relies on a laser to scan patterns of bumps and holes stored in a phonograph record-like disk.

of handball and jai alai. Charles Sporek, National's president, expected a market of 10 million units a year for electronic games and an average retail price of \$29.95 by 1980.

But electronic games did not remain tied to the home television set. Mostek Corp. showed an electronic hand-held chess set in March 1976. The set was a calculator in which a chess algorithm had been stored and in which the player fed his moves; it retailed for \$120.

**P**arker Brothers Inc. used a microprocessor in its first electronic board game, Code Name: Sector, a submarine chase-and-sink game that retailed for \$35 to \$40. Mattel Inc. introduced three hand-held games—football, auto racing, and missile attack—all retailing for less than \$30.

Nor was the home television set useful only for games; it could also be employed as part of a home computer system. *Electronics* reported in November 1975 that hobbyists were creating a new industry. "Microprocessor-based computers in packages and kits sell for up to \$1,000; makers have sold 8,000 in the past year," the magazine said. "And manufacturers are offering plug-compatible peripherals."

In August 1977 Radio Shack entered the personal computer market with a \$599.95 system that became a big seller. It had a 12-inch cathode-ray-tube display, keyboard, and cassette tape recorder. The TRS-80 microcomputer system, built around Zilog Corp.'s high-performance Z80 microprocessor, came with 4,096 bytes each of random-access and read-only memory.

Throughout the decade electronics companies flirted with appliance manufacturers. In early 1973, for example, Frigidaire introduced an electric range that incorporated three MOS LSI chips.

Gradually electronic controls were added to other household appliances. In 1974, Whirlpool put an MOS control chip in a Sears Lady Kenmore clothes dryer, the first to use a chip for timing and logic control. In 1976, West Germany's AEG-Telefunken used two ROMs in a microcomputer to store 120 programs that could be used with hundreds of different recipes; the computer controlled baking, frying, grilling, and cooking. In 1978 Hamilton Beach put microprocessors in a food processor and a blender; the electronics not only controlled the machines' speeds but also helped the cook in converting metric measures into English ones.

It was apparent at the beginning of the 1970s that there was a potential market for electronics in the automobile. Safety and pollution laws set engineers to work on electronic fuel-injection and ignition systems, air-bag sensors, electronic antiskid systems, and digital displays. But the auto makers were not satisfied with semiconductors. They complained at the International Solid State Circuits Conference in February 1974 that they needed more cost-effective and more reliable devices.



Federal regulations requiring emission control and fuel economy, however, drove automotive engineers to electronics. Designs included spark-timing control systems; exhaust-gas recirculation; fuel metering, or electronically controlled carburetors; and electronic fuel-injection systems.

By the late 1970s the auto companies were gradually replacing electromechanical parts, such as controls for the headlamp and windshield wiper, with electronics, and electronic ignition systems and voltage regulators were going into second and third LSI generations, primarily to gain greater integration.

It was clear by 1978 that on-board microprocessors were the only available technology able to control an automobile engine precisely enough to make it both cleaner and more efficient. Ford introduced the EEC-II system on 1979 cars; it controlled spark timing, exhaust-gas recirculation rate, and air/fuel ratio, based on inputs from seven sensors. The General Motors C-4 engine control system—introduced first on some Califor-



**Interface.** Connectors that could be handled easily were critical for the new optical-fiber technology to thrive. This connector from Amphenol North America division, Bunker Ramo Corp., illustrates clearly how each "light pipe" replaces the ordinary copper wire.

nia models due out nationally by 1981—kept the air/fuel ratio extremely close to stoichiometric conditions, thereby maximizing the catalytic converter's efficiency.

Color television manufacturers were working on shorter picture tubes at the beginning of the decade by increasing the deflection angle from 90° to 110°; this reduced the length of an 18-inch viewable picture tube some 4 inches. Engineers were also working on solid-state designs, although manufacturers were slow to adopt them because of the higher costs.

**B**ut rising consumerism made more reliable sets important. *Electronics* reported in June 1971 that many set makers were going to all-solid-state in their new models "because they feel the increased costs will be offset by the savings in warranty service bills."

By early 1973, television makers were deeply involved in reliability. Hardly a company failed to revamp its engineering procedures or organization after the advent of solid-state components and especially after linear integrated circuits began to be applied. And 1973 was the year of the picture tube.

Sony Corp. had one-upped everyone else's 110° tube with a 114° device in 1972, and in 1973 the Tokyo Shibaura Electric Co. (now Toshiba) announced a 118° tube for its 16-inch-diagonal receiver. Sony came back and said it could have a 122° tube in a 20-inch-diagonal set. In April 1974 GE-Sylvania introduced a new in-line color tube that could be fitted in existing chassis designs with practically no circuit changes. It was a 110° design with a large neck, in-line gun, striped screen, and slotted shadow mask.

By 1974 most television makers admitted the inevitability of all-electronic tuning. Magnavox reached the market first that June with a top-of-the-line chassis that integrated most remote control, tuning and display functions on a single 200-by-200-mil MOS chip. The Magnavox system featured a 6-inch-high channel number that appeared on the TV screen, then shrunk to a point and disappeared within 3 seconds.

A year later, in June 1975, *Electronics* reported that American TV set makers had three good reasons to design electronic tuners not only into high-priced consoles but also into 19-inch table models:

- The price was just about right.
- Some of the design problems associated with varactor tuners had been solved with new digital ICs.
- New features to attract consumers were more necessary than ever.

Total color set sales to dealers had fallen from 9,263,000 in 1973 to 7,830,000 in 1974 and were off again in 1975—the year-end figure was 6,486,000. Also, according to most estimates, fewer than 10% of the U. S.-made color TV sets in 1975 had electronic tuners, whereas nearly 100% of the color receivers made and sold in Europe had them.

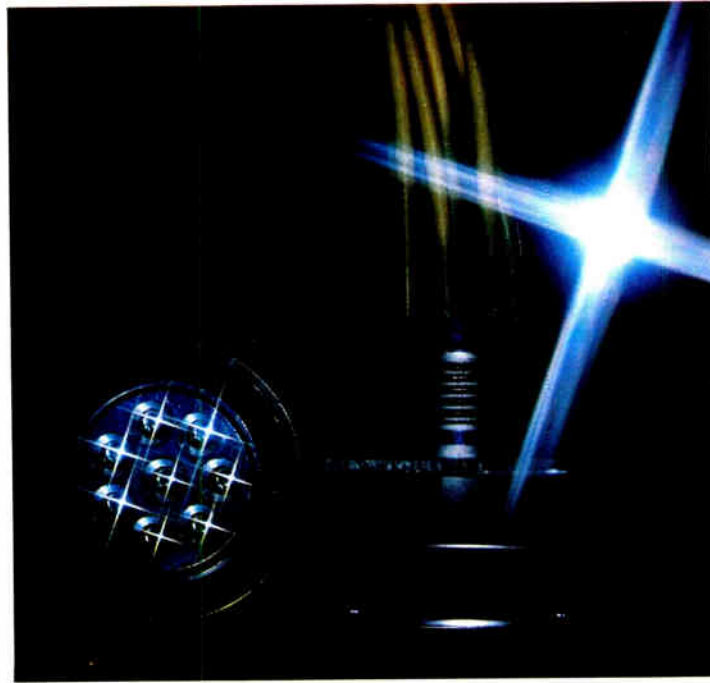

By February 1976, the "electronic magazine" was close enough to reality in Britain that it had a name, Teletext. The system began public trials, permitting home viewers to call up "pages" of printed information, such as news, sports and weather maps, on their specially equipped TV sets.

That fall's color TV sets contained some solid technical advances in station selection, color tuning, and tube designs. There were major changes in channel tuners, led by the German manufacturers. Large-scale integrated circuits were used in digital address systems, often in remote control units. Manufacturers used digital voltage-synthesis and frequency-synthesis techniques, as well as varied digital memory technologies.

In September 1977 Blaupunkt-Werke GmbH unveiled a color television set that turned itself on automatically according to instructions keyed in up to a year in advance. A standard three-chip F8 microprocessor from Fairchild automatically tuned the set's digital tuner to any of 19 channels. The microprocessor stored the dates and hours of as many as 20 TV programs, turning the set on and switching to the desired channel automatically.

In that same month two West Germans—Manfred Ullrich of Intermetall GmbH in Freiburg and Max Hagedorfer of Grundig AG in Fürth—described a way to provide a soundless inset picture on the TV screen along with the standard color picture. By January 1976 Grundig and the Sharp Corp. of Japan were marketing sets with black-and-white inset capability.

The industry knew that if it could solve the home video tape recorder's problems, there was a huge potential market. But in October 1971 a variety of consumer versions were being postponed as a lack of standards, technology problems, and proposed FCC restrictions on the rf radiation that video players could emit at broadcast frequencies all stalled progress. Eight different systems were available, all incompatible. Since the genesis of the industry, two systems have dropped out of the



# Chemicals for a bold new world.

Optical waveguides. Thin film memory. Liquid crystal displays. Wherever today's breakthroughs are shaping tomorrow's world, you'll find EM Laboratories as a source for fine chemicals.

We manufacture chemicals for vacuum deposition, liquid crystal displays, fiber optics, crystal growth... dopants for electronics... that's just the start. And the R&D for tomorrow is bubbling in our labs.

Pure consistency in fine chemicals from EM Laboratories. Whatever you need to frame your future, we produce it. For a better world.

Pure Consistency...



**EM Laboratories, Inc.**

associate of  
E. Merck, Darmstadt, Germany  
500 Executive Boulevard  
Elmsford, N.Y. 10523  
(914) 592-4660

◆ Chemicals for electro optics ◆ Supracpur<sup>®</sup> ◆ Patinal<sup>®</sup>  
◆ Aneron<sup>®</sup> ◆ L-cristal<sup>®</sup> ◆ Selectipur<sup>®</sup>

Circle 407 on reader service card





# Maul-able Memories

**A complete line of core and semiconductor memories that meet Mil-E-5400, 16400, 4158—and more.**

## Into the sea-out to the sun

Our core and semiconductor memories are tough, rugged, reliable, versatile.

They meet MIL-E-5400, 16400, 4158 — and more.

Our memories have been fired into the sea, withstanding over 3,000 G's shock and 300 feet of hydrostatic pressure — and have worked!

They've been blasted 80 million miles into outer space, almost to the sun — and have worked!

## Top companies - top programs

We've been building Severe Environment Memories since 1961, with a customer list that reads like "who's who" in electronics.

You'll find our SEMS memories on the major programs — Sea Sparrow, F-16, F-18, Pershing, SR-71, Mirage, Harrier, and on and on. On commercial jets, too — L1011, DC10, 727.

## Cubic, Planar-large, small

So why re-invent the wheel when we have a complete line of ruggedized memories. Planar and cubic core memories when non-volatility is a must... semiconductor memories when it's not.

We have small memories — 256 x 8 bits, and big memories — 2 megawords x 16. Plus everything in between, in ATR and half ATR compatible packages.

## New products, too

Memories aren't our only business. We now have a ruggedized version of Intel's 80/10A single board micro-computer; D-DAS, a digital data acquisition system for the 1553 bus; and a compact digital tape recorder with 23 megabit capacity.



When you're faced with a tough environment, "buy SESCO... it works!"



**Severe Environment Systems Company**

A Subsidiary of Electronic Memories & Magnetics Corporation

20630 Plummer Street • P.O. Box 668 • Chatsworth, California 91311  
Telephone: (213) 998-9090 • Telex: 69-1404

competition, the Ampex Instavideo and the CBS Electronic Video Recording (EVR).

Meanwhile the Japanese continued to work on video tape recording. At the end of 1974 there were four such home systems: a stripped-down Sony BetaMax for about \$800, with a one-hour tape that sold for \$13; the Video Home System recorder by the Victor Co. for about \$890, with a two-hour cassette for \$20; the VX-2000 by the Matsushita Electrical Industrial Co. for \$730, with a 100-minute cassette for \$26; and the V-Cord II from Toshiba and Sanyo for \$1,150 and \$1,220, with a two-hour cassette for \$24.

In November 1976 the Japanese Government tried to pressure consumer video tape recorder manufacturers to adopt an industrywide standard. The pressure, however, was not strong enough, and in 1977 manufacturers began lining up behind one system or another.

Philips Gloeilampenfabrieken demonstrated a long-playing video disk in September 1972. It was a dramatic improvement over an AEG-Telefunken/Decca black-and-white video disk that had been demonstrated in 1970. Because the Teldec disks had grooves and mechanical tracking, they suffered from short playing time (an 8-inch disk played for only 5 minutes) and high record wear. The Philips disks held 30 to 45 minutes of color material and instead of grooves had submicrometer pits molded into a spiral track; a laser-generated light spot read the patterns.

Two months later Telefunken demonstrated an improved Teldec video disk. The 8-inch disk now played for 10 minutes and produced a color picture, and the

company said the system would be on the market by the end of 1973. Sales started in April 1975.

The Magnavox Consumer Electronics Co. introduced the first video disk system in the U. S.—Magnavision, in November 1978. A Philips design, the player cost \$695 and the disks \$5.95 to \$15.95. RCA and the Japanese also announced systems. Sony had announced the first projection system in early 1972—the Sony Video Color Projection system, a 40-inch screen (50-inch diagonal). The projection unit was \$2,000 and the screen \$250.

The Advent Corp. of Cambridge, Mass., put the projection optics inside each of three color electronic tubes to introduce a large-screen color TV system that did away with the usual shadow masks, color dots, and lattices. Advent's Video Beam screen was 68 by 51 inches, and the price was \$2,495. The first sets went on sale at the end of 1973.

By September 1976 more than two dozen companies were trying to market projection television sets in the U. S. Prices ranged from \$800 to \$5,000, and annual sales were estimated at between 50,000 and 70,000 units.

Audio equipment manufacturers spent the first half of the decade fighting over four-channel sound and the second half recovering from the debacle. *Electronics* reported in March 1971: "Quad sound would help components and IC firms, but conflict between four discrete channels and the matrix approach threatens acceptance. The paucity of four-channel playback material, broadcasts, and equipment has limited public exposure. There's the question of which of several competing quadrasonic techniques will capture the audiophiles

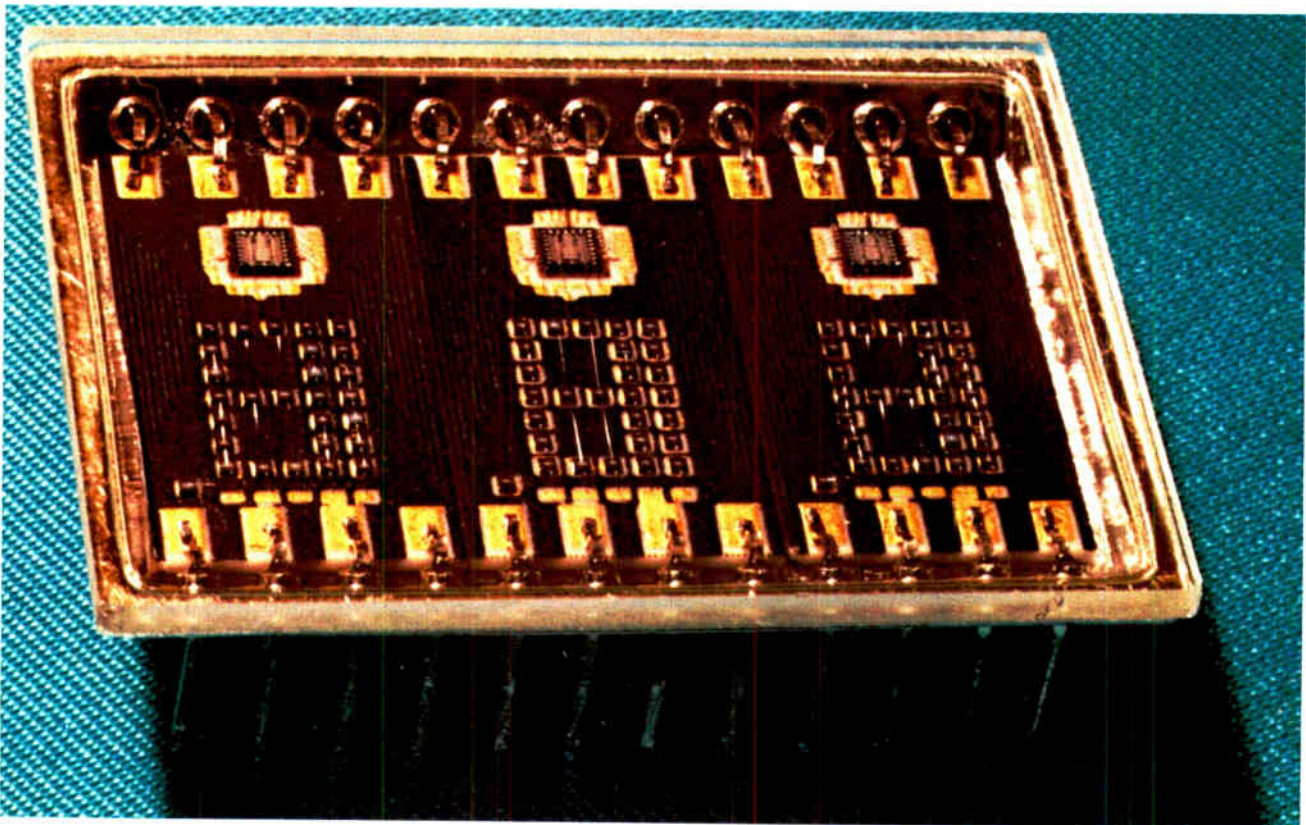

**Indicator.** Light-emitting diodes were being fashioned into rugged displays for industrial environments and the military. This numeric indicator from Hewlett-Packard uses gallium arsenide phosphide emitters in a 5-by-7-dot matrix. Each numeral contains its own decoder/driver.



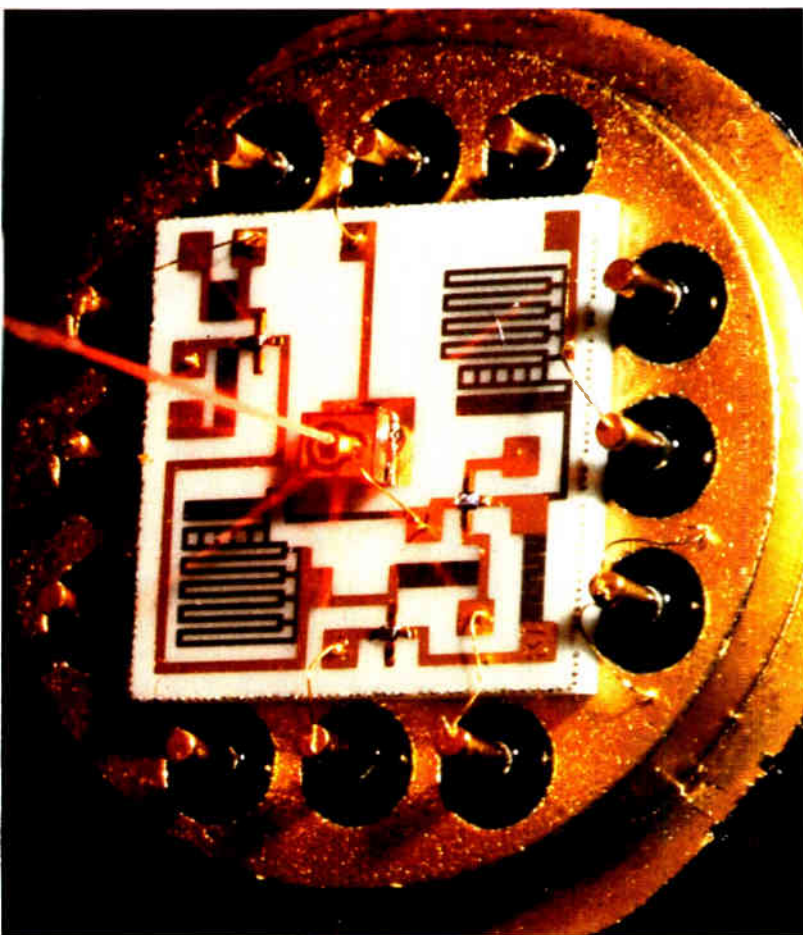

**Talking lightly.** Prototype for Bell System's FT 3 standard fiber-optical system used an avalanche photodetector diode as the receiving element in a thin-film preamplifier circuit in a TO-8 can. Invisible infrared laser will replace helium-neon laser light shown.

first, and whether the mass of two-channel stereo listeners will be willing to spring for the extra speakers and amplifiers." The issues were never resolved. More than a score of audio manufacturers offered four-channel equipment at the June 1971 Consumer Electronics Show, but consumers were unwilling to bet on one system over another. No units were marketed.

Nevertheless there were technological advances in audio equipment during the 1970s. H. H. Scott Inc. of Maynard, Mass., introduced a digital fm tuner in June 1971 that used a phase-locked servo loop to hold firmly onto a carrier. The Dolby B system helped the cassette deck become a true high-fidelity component, and Philips and a Japanese group developed other noise-reduction systems.

Japanese companies developed ultrahigh-fidelity digital stereo phonographs, with the audio signals pulse-code-modulated. Mitsubishi Electric demonstrated in September 1977 the first experimental system with a laser for playback, and it was followed soon by Sony and Hitachi Ltd.

By November *Electronics* was reporting that it was only a matter of time until all stereophonic recording would be done with digital techniques: "One acoustic engineer estimates that it will take three or four years for expensive consumer playback systems to catch on, another five or six more years before the price dips to the average consumer's level."

For radio, the decade brought a new craze that reju-

venated the industry: CB radio. The citizens' band boom flowered in 1973 during the nation's first taste of a gasoline shortage, when long-haul truck drivers used the small transceivers to ask fellow drivers where to locate dwindling fuel supplies. Drivers of private cars then swarmed into the CB market, installed sets, and with a lingo picked up from the truck drivers, began to flood the airwaves with casual conversations.

The Class D citizens' band had been set up in 1957 for quasi-business communications. It had taken 16 years to reach its first million users—this despite the fact that no licensing examination was required to operate the transmitters and receivers. By September 1975 there were 2 million CB users and by March 1976 there were 6 million. By the end of 1976, the total was estimated at 11 million, and potential users were clamoring for space in the crowded 27-MHz band.

But the fad peaked, and the market began to recede in 1977 when the FCC increased the number of available channels from 23 to 40 while a huge inventory of sets was on the shelves. Consumers were becoming increasingly aware at this time that CB was limited in range and that acceptable communication quality was an elusive achievement.

**I**n another area of communications, the combination of smaller, less expensive computers, more sophisticated terminals, and improved data communications led to a trend in the 1970s toward distributed processing. As timesharing in the 1960s had increased access to computers, so did distributed processing, only it went one step further by actually placing a small computer at the user's site.

At first, users—such as service bureau companies—developed their own networking schemes. To assist them, computer vendors began to specify what hardware and software configurations could be constructed and what data communications should be used. Control Data introduced its Cyber 170 Network Products in March 1974, and the Digital Equipment Corp. unveiled its DECnet scheme in April 1974. When IBM introduced its Systems Network Architecture, or SNA, in September 1974, the concept gained momentum. Other mainframe makers soon followed: Univac's Distributed Communications Architecture was announced in November 1976; Honeywell's Distributed Systems Environment came out in January 1977; NCR's Distributed Network Architecture was introduced August 1977, and Burroughs Network Architecture as unveiled in October 1978.

A significant satellite communications development of the seventies was the plan of a new company, Satellite Business Systems, for an all-digital system to handle office communications. Backed by IBM, Comsat, and the Aetna Insurance Co., SBS in December 1975 proposed its satellite system in the 12-to-14-GHz region of the spectrum. The plan called for sending on demand voice,



The only part better is our service.

For a test jack catalog and distributor list, write E. F. Johnson Co., Waseca, MN 56093.  
If you don't find it there, we'll custom design it for you. Just call 507-835-6222.



**JOHNSON**

®  
Your Test Jack Source.



IMPROVED PERFORMANCE

# The "INTELLIGENT" DVM's from Guildline

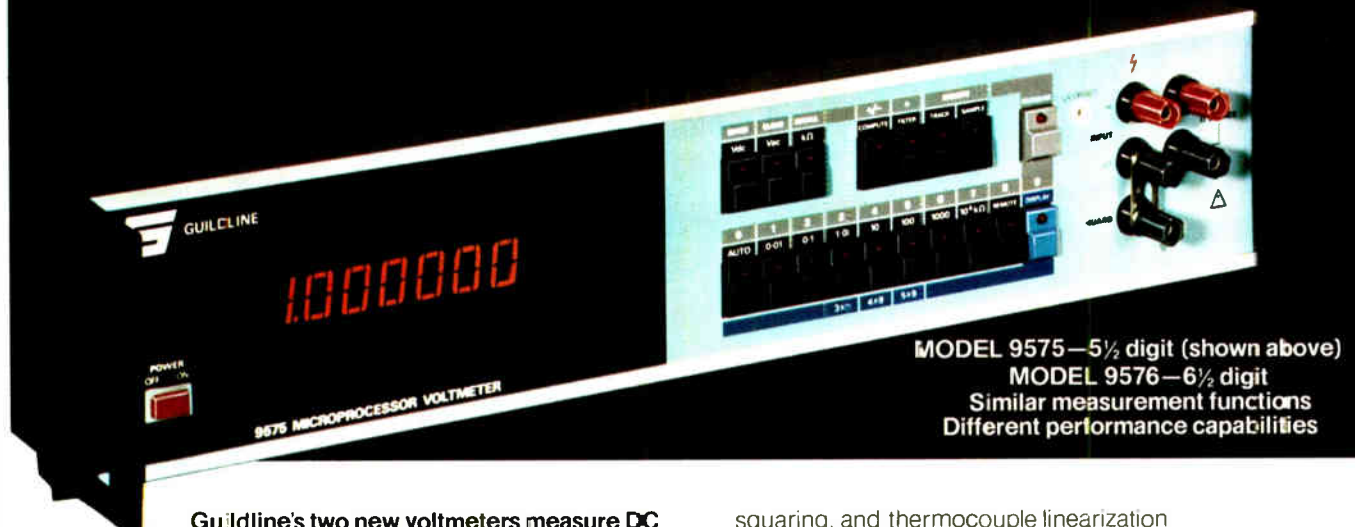

MODEL 9575—5½ digit (shown above)  
MODEL 9576—6½ digit  
Similar measurement functions  
Different performance capabilities

Guildline's two new voltmeters measure DC voltage, AC voltage and resistance **PLUS** they use their measured results as a data base for processing information on a real time basis.

## MEASUREMENT

Conventional measurements can be displayed, processed and displayed, and recalled at the end of each run. **Accuracy**  $\pm 0.0009\%$  • **Stability**—7 ppm/6 months • **Resolution**—1  $\mu\text{V}$  • **Scale length**—3½ digits to 6½ digits • **Ranging**—auto and manual • **400 high speed readings/second**

## PLUS

**Microprocessor Controlled Features** include automatic calibration balance, 9 built-in programs—21 individual calculations. Full math capabilities:  $Y = Ax + B$  or  $Y = A(x + B)$

## PLUS

**Special Processing Power**  
**DATA REDUCTION**—scaling, offset, ratio, logarithmic,

squaring, and thermocouple linearization  
**STATISTICAL**—% deviation, rolling average, updated variance, updated standard deviation, RMS, min., max., peak to peak  
**CONTROL**—high-low limits, real time programmable clock, full internal time control: start, stop, interval between measurements and run time

## PLUS

### Data Systems Options

IEEE—488/1975 RS-232, Binary, BCD  
Independent connectors offer time sharing between GP-IB and RS-232. 10 nanovolt resolution with any interface option to 6½ digits



To get a wealth of information at your fingertips, call or write

 Guildline Instruments, Inc.  
2 Westchester Plaza, Elmsford, NY 10523 (914) 592-9101 • TELEX—GUILDLINEMFD145487

video, or data to anyone hooked into the system, which would bypass the usual common carrier.

Competition was soon promised by AT&T, which announced it would provide its own option, the Advanced Communication Service. The phone would hook up all home and office voice, video, and data machines into one gigantic terrestrial-based system.

The two plans became tangled in a Federal Communications Commission regulation web concerning which should be allowed to do what and for whom. To complicate matters, Xerox got into the act in 1978. It proposed the XTEN system to link office equipment through a combination of land lines, microwave links, and leased channels on satellites. This 10-GHz offering also got tangled in the regulatory system. By the end of the decade, no decision had been reached on any of the new satellite business services.

But satellite communications advanced in other areas. Early in the 1970s there were but two satellite systems serving North America alone: Telesat Canada's Anik and Western Union's Westar. This situation changed rapidly. RCA Global Communications soon launched a satellite. And in another approach to entering the business, the American Satellite Corp. leased channels from Western Union and sold time to customers.

By the early 1970s Intelsat 4 satellites were being launched. These used two separate beams, aimed at the eastern and western regions of the Atlantic Ocean. They provided transatlantic communication by using the same 500-MHz slots at 4 and 6 GHz. There were six Intelsat 4 satellites in orbit in 1975 in response to increasing demand for service. For every transatlantic telephone call made in 1974, 10 were made in 1975. Also in 1975, ships at sea got satellite service when the first Marisat (for maritime satellite) was launched.

To handle cable television, RCA put up Satcom 1 and 2 by the end of 1976, and with the FCC's permission, AT&T and GTE launched a satellite system to handle long-distance phone calls in the U.S. Two of the latter satellites, both named Comstar, were launched in 1976 and a third in 1978. Each operated in the 4-to-6-GHz band, and each could handle 30,000 simultaneous calls.

As the decade closed, still more applications appeared for satellite technology. In Canada, for example, the pages of a weekly newspaper were transmitted from Europe to Montreal via satellite. And in the U.S. the Bell System developed an integrated circuit to remove speech-disrupting echoes from telephone conversations carried by satellite. Previously this had been done by expensive echo-canceling or echo-suppression systems.

In ground communications, the 1970s saw the first practical steps toward fiber-optic systems. Low-loss fibers were invented, and more powerful sources and detectors of light became readily available.

From thousands of decibels per kilometer in the sixties, the attenuation of step- and graded-index fiber had by 1970 dropped to about 20 dB/km at a wavelength of 6,328 angstroms. This feat was accomplished by Robert D. Maurer of Corning Glass Works in Corning, N. Y. At the same time Nippon Electric Co.'s Central Research Laboratory in Kawasaki, Japan, made a graded-index optical fiber with attenuation of approx-



**Decisions.** Microprocessors gave digital communications nets many new capabilities. In 1975, Codex Corp.'s 6000-series Intelligent Network Processor examined data and made transmission decisions without customized programming and at radically lower cost.

imately 20 dB/km. And C. K. Kao at International Telephone and Telegraph's Standard Telecommunications Laboratories in Harlow, England, developed a 100-megabit-per-second transmitter-receiver system wired up with multimode low-loss fiber.

Actual fiber systems were being tested for practicality in the early years of the decade, to see just what the operating tradeoffs might be. Among the most highly interested users were the military services. Besides their need for large bandwidths, which the fibers provided, the armed services were intrigued by fiber's total immunity to electromagnetic interference.

Typical of military interest was work done in San Diego at the Naval Electronics Laboratory Center (later part of Naval Ocean Systems). Early in 1974 engineers there installed a voice-band communications system on a ship. The Air Force that same year test-flew multiplexed data systems that used fiber-optic cables.

Progress in the civilian sector was led by the large companies because of the costs and risks involved with the new endeavor. The Corning Glass Works in Corning, N. Y., experimented in 1973 with fibers that had losses as low as 2 dB/km at a 1-micrometer wavelength. Soon researchers at Bell Laboratories took this figure down to about 0.85 dB/ $\mu$ m. By 1979, Corning was manufacturing fibers with 0.7-dB/km losses at a 1.3- $\mu$ m wavelength.

In mid-decade fiber came out of the laboratory and into the operating environment. Typical was a Bell Laboratories' experiment in January 1976 that demonstrated the feasibility of mass-producing fibers. Bell engineers showed that cables of 144 single fibers could be made and mass-spliced without individual handling. These cables—only 1/2 inch in diameter—could handle almost 50,000 simultaneous telephone conversations.

By this time some smaller, more specialized companies were getting into the act. Teleprompter Manhattan Cable Television capitalized on fiber's broad bandwidth to set up a system to carry multichannel television signals from a studio to a cable television distribution point some 800 feet away.

And in an experiment in the "wired city" concept, the Nippon Telegraph and Telephone Public Corp. in Japan



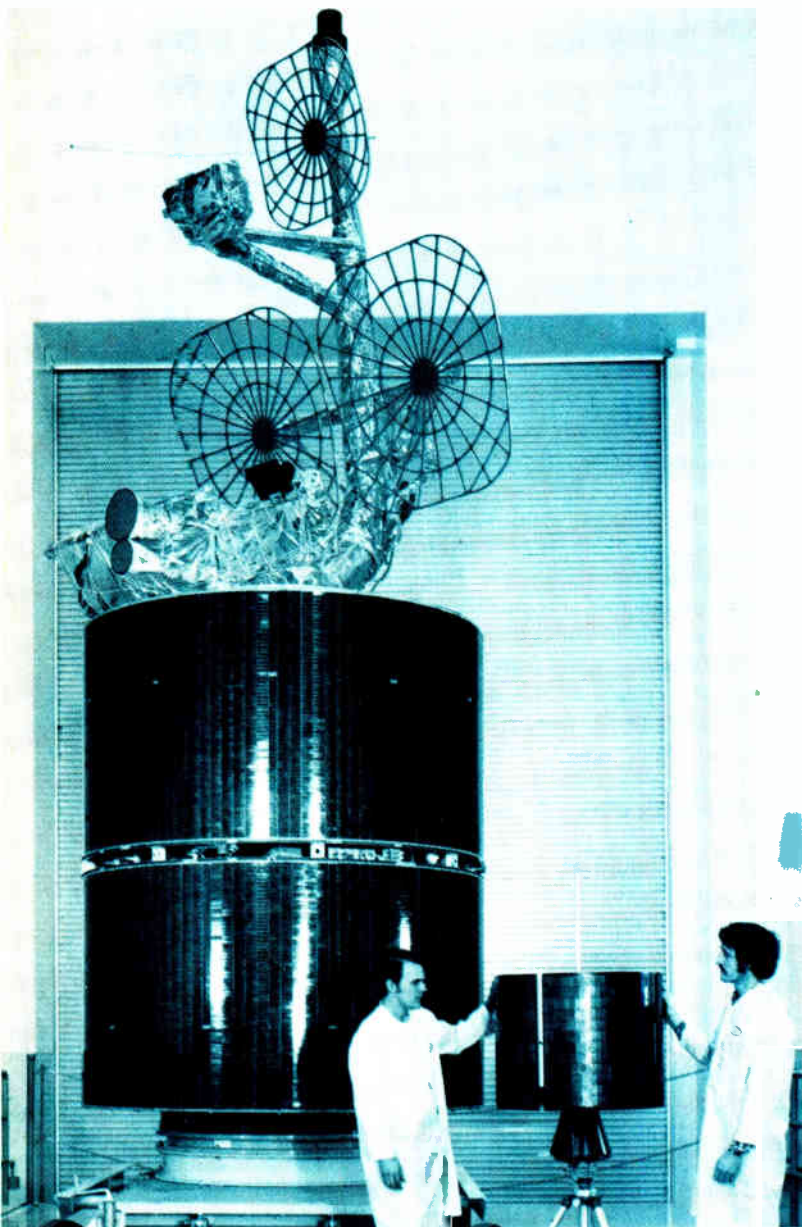

**Related.** As satellite communications grew, so did the satellites. In 1975, Hughes Aircraft engineers showed off two of theirs, the 10-year-old Early Bird, which had 240 two-way channels, right, and the upcoming Intelsat IVA, planned for 11,000 channels.

ter. This was small enough to couple all of the laser power into the thinnest of single-mode optical fibers. These fibers, in turn, had the lowest attenuation, which meant that fewer amplifiers would be needed in the transmission line. The IBM researchers got their laser to handle digital data rates in excess of 100 Mb/s.

By mid-1977 Bell Laboratories was reporting major increases in diode lifetime. This had been a major problem, but now lasers with projected lives of 1 million hours were being made.

RCA announced a planar laser diode in June 1979 that could be mass-produced by integrated-circuit fabrication techniques. It was generally agreed that if optical communications were to become commonplace, the systems would have to be integrated and produced much as ICs are. During the 1970s much research aimed at developing such integrated devices by depositing dielectric layers on glass substrates.

But perhaps the most exciting optical device of all was Bell's experimental Fabry-Perot resonator late in the decade that performed so many tasks it was almost a universal optical element. The lithium niobate-based device could be used as a logic element in memories, since it acted as a bistable switch when driven by suitable optical signals. It also functioned as a pulse shaper, or limiter, or differential amplifier. Furthermore it could work as an optical triode, performing the functions of an electron tube.

**W**ith the closing of the 1970s, the electronics industry could mark 50 years of progress. Starting with expansion of the vacuum-tube radio in the thirties, it had rushed past such milestones as radar, television, analog and digital computing, satellite communications, and semiconductor technology, all the while churning out new ideas and equipment for basic markets like instruments, optoelectronics, industrial electronics, military electronics, consumer electronics, and avionics.

There were no signs of an industry in sedentary middle life or approaching old age. Already there was talk of the "real" electronics era of the coming 50 years:

- The virtual abolition of paperwork in offices by terminals and computer storage.
- The cashless society, with bank computing systems linked to terminals at all the major retail outlets.
- The personalized phone call—the Picturephone would re-emerge in more practical form.
- Electronic mass transit—magnetic levitation and other schemes would receive serious attention as fossil fuels became prohibitively expensive.

There were many more dreams, but these are best left to visionaries and to future generations of practical engineers. The electronic genie was out of the bottle, and further progress was guaranteed. □

set up a fiber-optic network to provide residential video information to 300 subscribers in a model city near Osaka. Not to be outdone, the English ITT subsidiary, Standard Telephones and Cables Ltd., successfully sent 140-Mb/s data over a 9-km link at Harlow in 1977. Similar efforts by Philips Gloeilampenfabrieken and by the Centro Studie Laboratori Telecomunicazioni SpA of Turin were successful in the Netherlands and in an experiment in Italy. All of these systems operated at a rate of 140 Mb/s.

By 1979 NTT had the fiber's loss down to 0.20 dB/km, and Bell Laboratories had its fiber's digital data rate up to 200 gigabits per second—at least in the laboratory.

The usual laser for fiber systems was a gallium arsenide diode. Such a device could convert direct current into highly monochromatic light beams. And this light could be readily modulated by variations in the diode drive. In 1972 IBM researchers produced a GaAs laser that could generate a beam of light only 2  $\mu$ m in diame-

# ALCOSWITCH

## 20 years of dependable leadership.

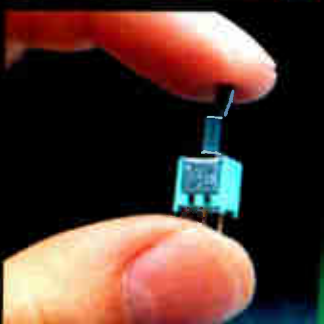
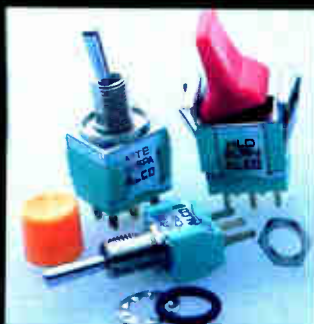

From the beginning, ALCOSWITCH has been the pioneer in miniature electro-mechanical components. Envisioning the need of a smaller toggle switch for commercial applications, in 1961 we introduced our first two switches. Studying customer requirements, making improvements and designing additional models, a complete series of miniatures evolved in 1968. Thus, a new industry of miniature switches was fathered, not only in toggles but pushbuttons and rockers as well. And, further development brought about other related front panel components such as colored knobs and a variety of light products.

Today, ALCOSWITCH upholds its heritage by building the first sub-miniature toggle switches with terminals and mounts which fit the industry's standard 0.1" PC grid pattern. The new ALCOSWITCH TT Series is the new size standard. These switches are produced as a full family, much different than ever before available. Truly ultra small in 1, 2 or 4 poles with terminal varieties such as: wired, PC, right angle and wire-wraps! Our catalog lists hundreds of TT Series toggle switches, slides, pushbuttons, rockers and a variety of lighted types to enhance a design engineer's irragration. ALCOSWITCH will continue to broaden its switch product line and is anxious to accommodate virtually any application. We are dedicated to meet tomorrow's equipment standards, and we will maintain our leadership position as innovators of reliable miniature and ultra-miniature switches and other related front panel components.

For more information, write or call us today and ask for free TT Series sample.

TT Series made in USA  
patented worldwide



# ALCOSWITCH®

Circle 415 on reader service card

ALCO ELECTRONIC PRODUCTS, INC. a subsidiary of AUGAT, INC  
1551 Osgood Street North Andover, MA. 01845 Tel. (617) 635-4371 TWX: 710 342 0552  
EUROPE: Augat France SA (Z.I. Sofilic) B.P. 440-CEDEX 94263 Fresnes France Tel. 668-3090 TWX: 342 201 227  
CANADA: Kaytronics, 375 Norman St. Ville St. Pierre, QUE. H8F 1A3 Te. (514) 487-3434



**Why do people buy Digital's high-performance  
micros more than anyone else's?**

**Maybe it's because there's  
more to buy.**

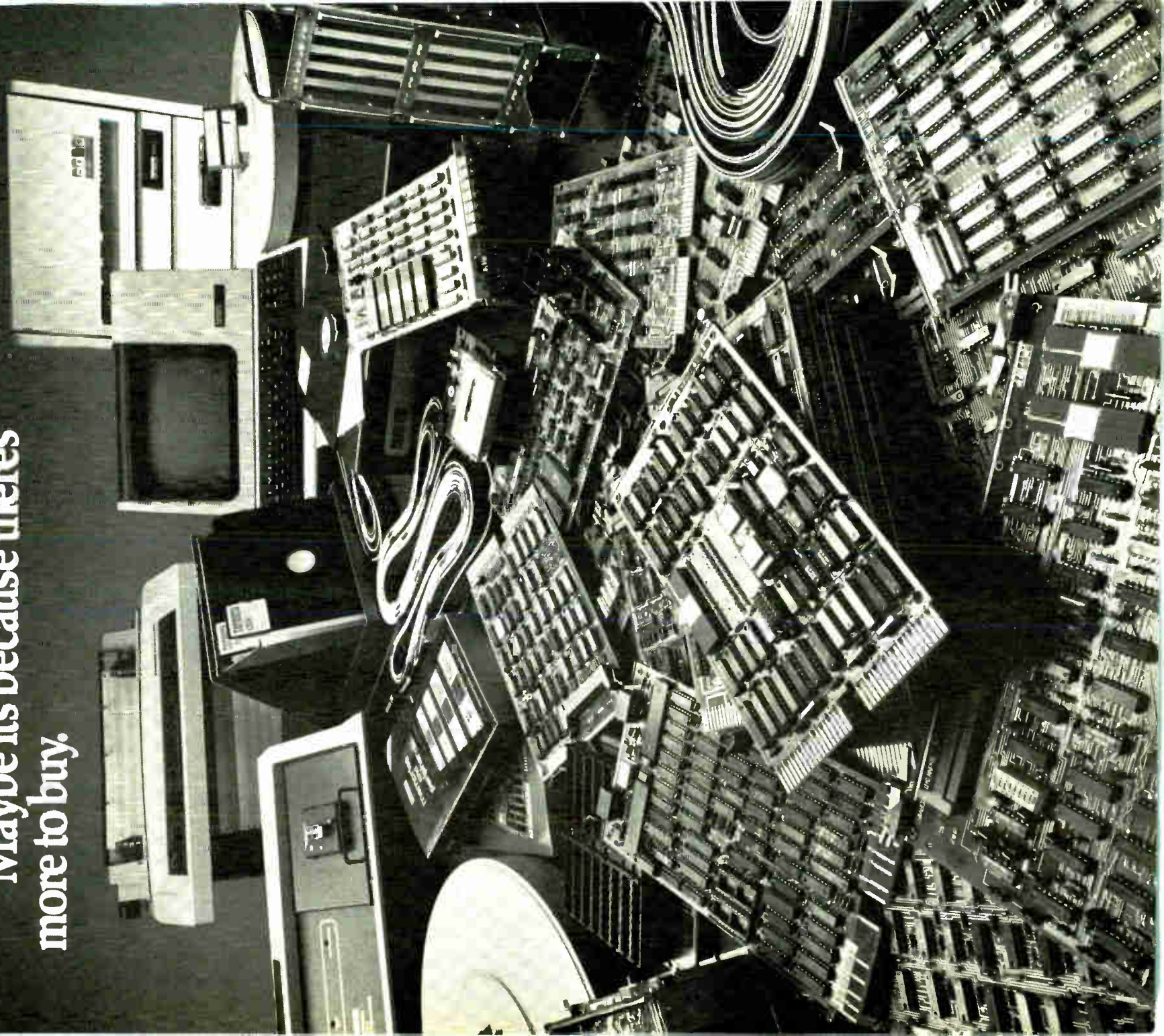



Digital Equipment Corporation has sold more 16-bit microcomputers than any other company in the business.

Over 100,000 of them.

And the reason is simple. We give you more to work with. More hardware, more software, and more true systems capability.

So you can develop your products faster, and offer your customers the right balance of cost and performance every time.

What's more, Digital's micros are software-compatible. Not just with each other, but with our entire PDP-11 minicomputer family as well.

So you'll never run out of ways to expand your business.

Just look at what we offer:

### **Digital's microcomputer family.**

You can choose from eight different configurations of our LSI-11/2 and -11/23 micros, in both boards and boxes. With high-performance features like general-purpose registers. Double-precision floating point processor. Up to 256Kb memory addressing. And the full instruction set of the PDP-11 family.

You also get the best form factor in the industry, because our micro boards measure just 5.2" x 8.9".

### **More options on the industry-standard bus.**

Once you have the micro you want, your possibilities are wide open.

You can choose from dozens of micro products: 9 different memory boards, 11 I/O modules, 9 communications options, even kits for designing your own custom interfacing.

There are also 8 different peripherals, including the TU 58 micro tape cartridge subsystem.

And the whole family runs on Digital's industry-standard LSI-11 Bus, the most widely copied bus structure in micros.

### **The only high-performance hardware with software to match.**

Digital's micro software is literally years ahead of the competition.

There's RSX-11M, the multitasking real-time operating system that sets performance standards for superminis. RSX-11S, a streamlined run-time version of -11M. And RT-11 for smaller single-task applications.

You also get development tools like an optimized FORTRAN IV-PLUS com-

piler and BASIC-PLUS-2. Even a ROM-mable FORTRAN for RT-11.

And Digital's development systems let you break your complex applications into manageable pieces, so several programmers can work on the same application at once.

That can save you plenty of development time.

### **The total approach to micros.**

Behind all Digital's micro products is a support commitment that's unmatched in the industry.

We have 13,000 support people worldwide. Technical consultation and training. And a wide range of support agreements — from do-it-yourself service using our special kits, to full support including coverage for your customers.

It's the total approach to micros, only from Digital.

For more information, contact **Digital Equipment Corporation**, MR2-2/M70, One Iron Way, Marlboro, MA 01752. Or call toll-free 800-225-9220. (In MA, HI, AK, and Canada, call 617-481-7400, ext. 5144.) Or contact your local Hamilton/Avnet distributor. In Europe: 12 av. des Morgines, 1213 Petit-Lancy/Geneva. In Canada: Digital Equipment of Canada, Ltd.

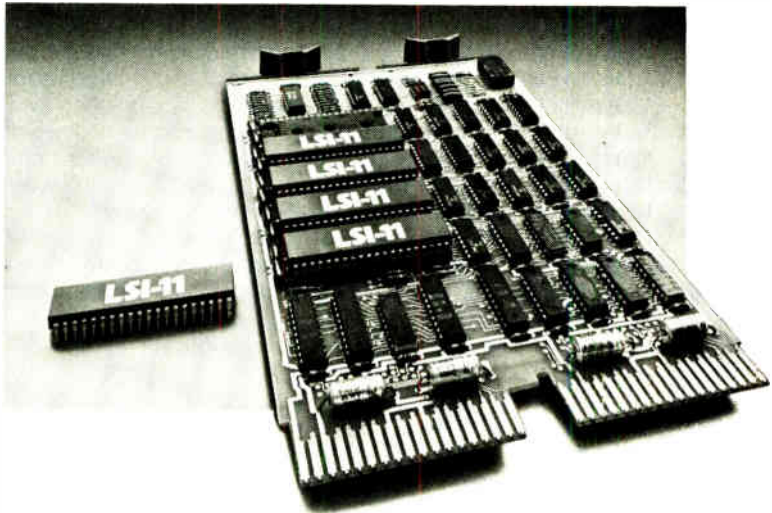

**It took the minicomputer company  
to make micros this easy.**

**digital**



# GREAT INNOVATORS



## VLADIMIR KOSMA ZWORYKIN

"I'm still learning," says Vladimir Kosma Zworykin. Given the hectic pace of developments in his field, that's no mean feat for the 91-year-old inventor of television. "Mostly I'm learning about electronics and electronic applications. What's happened in the last 10 years is just terrific." And the piles of books and journals scattered about his office at RCA Corp.'s research labs in Princeton, N. J., attest to his curiosity and enthusiasm.

In fact, Zworykin, who does not know whether to label himself a salesman or a scientist, has never stopped trying to learn and apply his knowledge to an increasingly complex world. Born in Mourom, Russia, in 1889, he received an undergraduate degree at the Petrograd Institute in 1912. There, under the tutelage of Boris Rosing, Zworykin began his work with an electronic system using cathode-ray tubes for television. "At the institute, there wasn't a lot of interest in electronic TV," he reminisces. "They said, 'you're trying to replace the eye' and I replied, 'can you see the far side of the moon with your eyes?'" These days Zworykin is often at the Jet Propulsion Laboratory to see the photos coming in from various planets in the solar system—all taken with a television camera based on the one he designed over 50 years ago.

Later in 1912 Zworykin began research in X rays under Paul Langevin at the College de France in Paris; he was interrupted by World War I, returning to Russia to serve as an officer in the signal corps. After the war he emigrated to the U. S., becoming a citizen in 1924 and receiving a Ph.D. from the University of Pittsburgh in 1926.

Zworykin did much of the developmental work on the iconoscope (a type of television pickup tube for picture transmission) and the kinescope (the television picture tube itself) while at the Westinghouse Electric and Manu-

facturing Co. In 1929, with the support of David Sarnoff, he joined the then Radio Corporation of America as director of its Electronic Research Laboratory.

Though he retired from the company in 1954, he has been far from idle for the last 25 years. While still actively at RCA, Zworykin had helped to take the electron microscope out of the lab and into medical research centers and hospitals, and this interest in medical electronics has continued. He was director of a medical electronics center at the Rockefeller Institute in New York for a number of years after retiring, as well as national chairman of the professional group on medical electronics of the Institute of Radio Engineers and founder-president of the International Federation for Medical and Biological Engineering. He is keenly aware of how much electronics could improve diagnostic work in medicine. "Some types of electronic equipment would allow measurements of bodily conditions that are much more accurate than those possible now," he observes. "But few are used. Also, excessive use of X rays is not recommended, and doctors can get almost the same results using microwaves."

Holding over 100 patents—for inventions including the snooperscope and sniperscope infrared image tubes developed during World War II, guided missiles, and automatically controlled cars—and nearly 30 awards—including the National Medal of Science and the Founders Medal of the National Academy of Engineering—Zworykin has shown an avid interest in many areas of electronics. He can still be found several days a week at his office at the RCA labs in Princeton corresponding with fellow scientists, reading recently published papers, or consulting with younger RCA researchers. What is he doing? "I'm starting at the beginning again," he says with a twinkle.



## FREDERICK EMMONS TERMAN

What is now Silicon Valley owes a lot to Frederick Emmons Terman. As teacher and administrator at Stanford University for more than four decades, he was the catalyst that transformed the San Francisco bay area into one of the world's leading centers for electronic innovations. Although characteristically he plays down his role, no other academician has proven better able to synthesize the interests of Government and industry with those of a university. He also wrote the standard text of its time on radio engineering.

Terman's tenets were new when he began practicing them after World War II, first as dean of the School of Engineering and later as provost. They were:

- Open the university's research laboratories to Government projects so that students can work on advanced technology.
- Educate good engineers so that local companies can employ them to grow and prosper.
- Respond to local industry needs.
- Attract top-flight faculty.

The emergence of Stanford as an excellent engineering school and the rise of companies like Hewlett-Packard Co. and Varian Associates are but a few of the results. William Hewlett and David Packard were both Terman's students, as are many of the who's who of the electronics industry.

"As a boy growing up, I learned a lot about how a university functions," Terman recalls. He arrived on Stanford's campus as a 10-year-old when his father joined the faculty as a professor in 1910. Since then, he has been away from the campus for only two periods of any length. One was to earn his Ph.D. in 1924 from the Massachusetts Institute of Technology. The other was to run a large top-secret radio research laboratory during World War II in Cambridge, Mass., an experience that crystallized his

thinking on how to integrate technology with Government research and university laboratories.

"I got the benefit of other people's thinking, particularly Harvard's," Terman says, on how to grow a strong engineering school. When he returned to Stanford in 1946 as engineering dean, bringing several laboratory colleagues back with him, he recalls that "there were half-finished jobs at the end of the war, devices weren't perfected. There was a clear need [for the Government] to finish them." He was soon approached by the then new Office of Naval Research and started off with three projects. The one in chemistry flopped, he relates, but the one in physics led to a Nobel prize for Felix Bloch, who discovered nuclear magnetic resonance, and the one in electrical engineering became the start of Stanford's nationally recognized program in engineering research.

However, "I think that the books I wrote had the most influence," Terman declares. They certainly helped him gain a national reputation as an educator. A radio ham in his youth, Terman wrote "Radio Engineering" in 1932—"the first really good textbook in radio engineering," he says proudly. "That book was used everywhere, even translated into foreign languages." Then in 1941, he completed "The Radio Engineer's Handbook," which has often been called the Bible of the field.

In that year, too, he was made president of the Institute of Radio Engineers (now the Institute of Electrical and Electronics Engineers), the first one to be elected from the West Coast.

Retired from the University since 1965, Terman, a widower, lives on campus in his spacious home with its lovely gardens. He believes that electronic technology will keep "steaming right along in integrated circuits, making an honest difference in people's lives."





## MAURICE PONTE

Maurice Ponte, who started his career as a research scientist and eventually rose to the top position in France's premier professional electronics company, contends that the first true forerunners of modern radar technology came out of the laboratories of La Compagnie Générale de Télégraphie sans Fil (CSF) in the early 1930s.

It is Sir Robert Watson-Watt of Britain's National Physical Laboratory who is generally credited with the first use of radio waves in detecting objects at a distance. Watson-Watt began using radio-detection finders to spot for the Royal Flying Corps (later the Royal Air Force) during World War I. Radios then operated in the high-frequency band, where wavelengths are measured in meters; higher frequencies could not be handled.

At this time Ponte was still a boy. By the time he was working on magnetrons in the early 1930s, the frontier for frequency had moved up to the ultrahigh-frequency band of decimeter wavelengths. By 1935, Ponte and his co-worker, physicist Henri Gutton (whose father, also a physicist, had experimented with detection by decimetric waves as early as 1927), had a rudimentary radar aboard the French freighter SS Oregon. Intended mainly to detect icebergs, it operated well up in the uhf band at wavelengths of 80 and 16 centimeters.

Although Watson-Watt and Ponte were working with different frequencies, the two in a sense were on the same wavelength by 1935. In February of that year Watson-Watt submitted to the British Air Ministry, which had asked him to look into the feasibility of an electromagnetic death ray, a memorandum entitled "Detection of Aircraft by Radio Methods." In March, Ponte and Henri Gutton put together a "Note sur le Repérage d'Objets Mobiles par Ondes Ultra-courtes et sur ses Applications Immédiates à la Défense Nationale." They proposed setting up radar bases along the Rhine to pick up movements of German warplanes, using metric waves for detection at ranges out to 100 kilometers and decimetric waves for short-range precision at 10 km.

Throughout the 1930s, Ponte and Gutton kept improving their magnetrons at the CSF laboratory on the

outskirts of Paris at Levallois. Ponte had set it up in 1929, leaving a faculty post at the prestigious Ecole Normale Supérieure—his alma mater—to do so. In 1935, the CSF team turned out what Ponte considers a landmark design—a tungsten cathode surrounded by resonant anode segments. "This tube presaged modern magnetrons with resonant cavities," Ponte explains. "It developed 10 watts continuous wave at 16 centimeters or 7 W at 8 cm—not much now, but very impressive at the time." Further advances in tube technology made it possible for CSF to push the output power of its magnetrons to 50 W peak at 16 cm (1,875 megahertz) by 1939.

Then came World War II and a go-ahead for the radar warning network the Army brass had scoffed at four years earlier. Hitler's blitzkrieging armies overran France before the project was completed, but the high-power magnetrons Ponte and Gutton had developed for precision short-range detection nonetheless aided the Allies against the Germans. On orders from the French High Command, Ponte, mobilized as an artillery captain, carted two tubes across the English Channel in May 1940 and turned them over, with the know-how to build them, to researchers at the Wembley Laboratories of the General Electric Co. (no relation to the similarly named U. S. company).

Back in occupied France, Ponte spent the war clandestinely continuing to improve his magnetrons—in one close call, a German general inspected CSF's tube plant. Nevertheless, Ponte and his crew had CSF ready to become a world-class producer of high-frequency tubes after the war. Thomson-CSF, the organization that resulted when Thomson-Brandt took over CSF in 1968 and made it a division of the parent company, still remains in the top rank today.

Ponte, who had been president of CSF for seven years previous to the merger, left the company then to found the Agence Nationale pour la Valorisation de la Recherche (Anvar), a government agency charged with improving the transition of discoveries made in government laboratories to applications in industrial products. Ponte ran Anvar until he retired in 1971 at the age of 69.

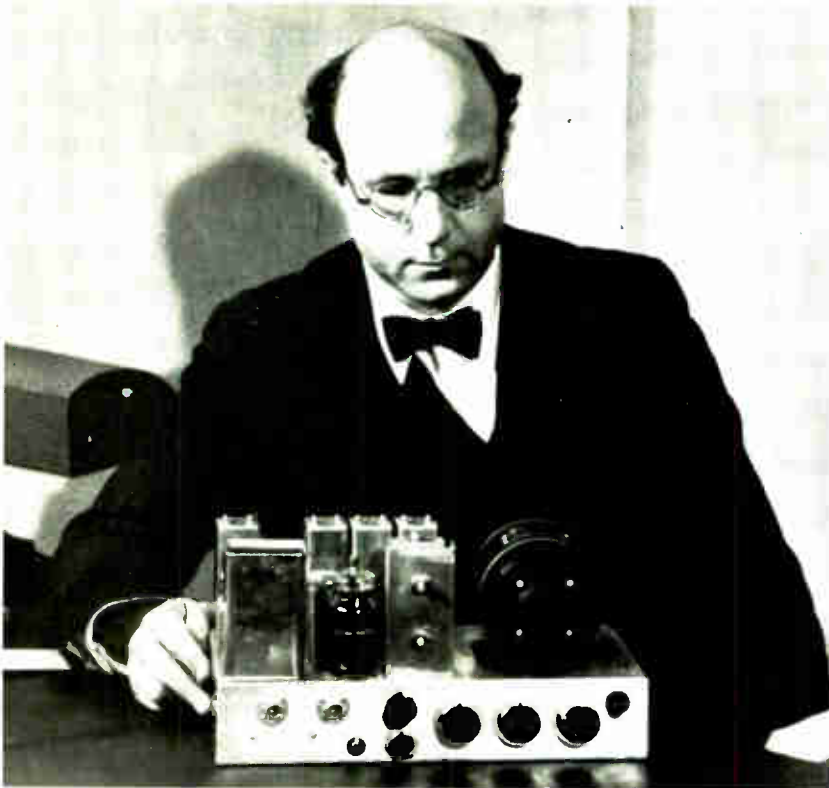

## DANIEL E. NOBLE

Before the advent of the mobile two-way radio telephone system, roadside phones swallowed a lot of nickels from police patrollers and motorists in distress. To Daniel E. Noble, a pioneer in fm radio and solid-state technology, goes the credit for the design and development of the mobile system for the Connecticut State Police in 1940.

Noble's distinguished career in electronics, spanning more than five decades, began in 1923 at Connecticut State College, Storrs (now the University of Conn.), where he received his BSEE degree and spent 17 years as student, teacher, and consulting radio engineer. With additional studies at Harvard University and the Massachusetts Institute of Technology, Noble is remembered for his ground-breaking work in fm radio while at Connecticut. As designer, builder, and operator of the a-m college station that sent programs from Storrs to Hartford over local stations, Noble modified the system to fm between 1936 and 1938. This work was followed by the design of one of the first fm stations for radio WDRG in Hartford.

Noble's work attracted the attention of Paul O. Galvin, owner of the company that was later to become Motorola Inc. Galvin was able to persuade the Connecticut professor to join the Chicago firm in 1940 as director of research. "I didn't know whether I'd like the industrial world or not, so I took a year's leave of absence," the 78-year-old Noble recalls today. "But I soon discovered that I was able to make very real and rapid contributions at Motorola, and it hadn't been six months before I decided to stay."

Noble has spent the remainder of his career with Motorola, where among other things he is credited with:

- The concept and direction of the development of the

U. S. Army's SCR-300 fm Walkie-Talkie in 1942

- The decision initiating Motorola's establishment of major operations in Phoenix, Ariz., where Noble in 1949 set up and headed a research laboratory in the infant field known as solid-state electronics.

- The initiation of work that led to invention of the power transistor.

The holder of nine patents and recipient of numerous engineering awards, Noble stepped down as vice chairman of the Motorola board and chief technical officer in 1970 to move into semiretirement as chairman of the company's science advisory board. He maintains offices in that capacity today in Motorola's original Phoenix plant, erected in 1950.

Noble has been a philosopher and painter in recent years, and his work reflecting his view of man's interaction with technology and today's complex society is prolific. Among the challenges faced by EEs today, he notes "the complexity of a field that has grown so much that it's difficult to know which direction to take. . . . in my day, I was able to contribute because I was effective in identifying patterns that were needed and moving accordingly. But today it's much more difficult."

Noble is not pessimistic, however. In fact, he sees sophisticated computer modeling techniques and the "extension of brainpower" made possible by computers as the ultimate way to regain control of a world that is rapidly growing too complex to handle. Eventually, he says, the electronics industry will "go into fundamentals of molecular and light forces far beyond today's circuitry."

[EDITOR'S NOTE: Daniel E. Noble died at the age of 78 on Feb. 17, 1980.]





## C. LESTER HOGAN

Because C. Lester Hogan has played such an outstanding managerial role, most notably in leadership positions at Motorola, Fairchild, and the Institute of Electrical and Electronics Engineers, his role in research is sometimes overlooked. But in 1950 at Bell Laboratories in Murray Hill, N. J., Hogan built the first microwave gyrator, isolator, and circulator on a single circuit, passive nonreciprocal elements without which microwave communications would be impossible.

A graduate of Montana State University in 1942 with a bachelor's degree in chemical engineering, he served as a Naval Officer in World War II prior to earning master's and doctorate degrees in physics from Lehigh University. In August 1950 he became a member of Bell Laboratories' technical staff where "a guy set out to develop something and did so in a very short period of time," he states.

Working in the Physical Research department, Hogan came across an article written by B. D. H. Tellegen, a member of the Dutch Philips organization, who developed a four-pole network, or gyrator, that was in effect a one-way transmission system. Hogan set out to build some similar devices and found that the physical phenomenon on which Tellegen's work was based was known in optics as Faraday's rotation of planar polarization.

At this point, Hogan sought the help of Bell Labs' William Shockley, who immediately began writing equations that showed him he needed materials with a large rotation at optical frequencies. "Magnetic materials will do it," said Hogan, seeking aid from Bell's chemistry department in developing a very weak magnetic material with low dielectric loss.

"By Nov. 1, all the pieces fit together," he recalls. "They thought I was a genius," he adds, "but I had just put together everything that existed."

Hogan knew the circuit elements were very powerful tools that would be used in microwave systems: "Today, there's not a single microwave system that doesn't use these devices. In fact, there are 200 on Intelsat 5."

Nearly three years later, Hogan accepted the position of associate professor of applied physics at Harvard Univer-

sity, where he extended the knowledge of ferrites. He remained until June 1958, when he joined Motorola Inc. to run its Semiconductor Products division in Phoenix, Ariz., which had had sales of about \$3 million and a similar net loss that year. By the end of 1959, the division had sales of \$10 million and was profitable. "That took me longer than three months, so I must have been getting older and slower," jokes Hogan.

In 1968, the year Hogan left Motorola to become the president and chief executive officer of Fairchild Camera and Instrument Corp. in Mountain View, Calif., Motorola posted a profit of about \$25 million on sales of about \$200 million. Largely responsible for that growth was a gamble Hogan took on epitaxial processing. "Using Bell designs, we made the first commercially available epi devices, Mesa transistors. They were much better than non-epi devices," Hogan says, "and sales skyrocketed."

Today, the 60-year-old Hogan is the technical advisor to the president of Fairchild Camera and Instrument Corp., as well as executive vice president of the Institute of Electrical and Electronics Engineers. He also serves as a member of the board of directors of about half a dozen corporations and on the scientific and educational advisory committees of several universities.

Despite his active schedule, Hogan has time to reflect on his experiences. "It was very exciting and thrilling. None of us visualized the impact we would have on the electronics industry, but we knew it was going to be great." However, he continues, "it wasn't the golden age of electronics. That still lies ahead of us."

"When I went to Bell Labs in 1950," Hogan recalls, "IBM's 701 was the first commercially available computer. Even the simplest of today's microprocessors will outperform that system. Today, the future is overwhelming. My mind is boggled by the potential of VLSI. It is the greatest revolution and it will allow us to do things that were totally impractical before. For years, I've been talking about the pervasiveness of electronics. Finally, it is coming," he states. "A cost barrier had to be broken, and it was done with LSI and the microprocessor."

# Weckesser

Electronic Hardware Since 1932

**POLYVINYLCHLORIDE  
SCREWS NUTS  
AND WASHERS**

**Nylon  
INSULATOR  
TRANSISTOR MOUNTS**

**NYLON  
CIRCUIT  
CARD  
EJECTORS**

**KO-GRIP  
CABLE CLAMPS**

**Nylon  
FLEX-CLIP**

**MOLDED  
NYLON  
METRIC  
SCREWS and  
NUTS**

**SEOLON FLAME-RETARDANT NYLON  
SCREWS and NUTS**

**MOLDED NYLON  
CLIPS  
FOR  
FLAT  
CABLE**

**NYLON CAPTIVE  
STANDOFF**

**NYLON  
FLANGED BUSHINGS**

**MOLDED NYLON PRESS CLIP**  
**MOLDED NYLON HALF PRESS CLIP**

**TEFLON\*  
CABLE CLAMPS**

**NY-GRIP NYLON  
CABLE CLAMPS**

**NY-GRIP  
CABLE TIEZ**

**TAB-LOC  
NYLON  
CABLE CLAMPS**

**PERFORATED  
NYLON STRAPPING  
and accessories**

**MOLDED NYLON  
SCREWS  
and  
NUTS**

**NYLON  
WASHERS**

**NYLON  
SPACERS**

**SNAP-GRIP  
MOUNTING  
STUDS**

**PROPIONATE  
CELLULOSE  
CABLE CLAMPS**

**NYLON  
STRAINBUCK  
BUSHING**

**WASHERS**  
**D WASHERS**

**NYTRIM  
extruded BROWNING**

Write for any of the above catalogs.

**Weckesser COMPANY, Inc.**

4444 West Irving Park Road • Chicago, Illinois 60641 • Telephone: (312) 282-8626

Circle 423 on reader service card



New  
product,  
lower cost



**Seitz, c'est sûr !**

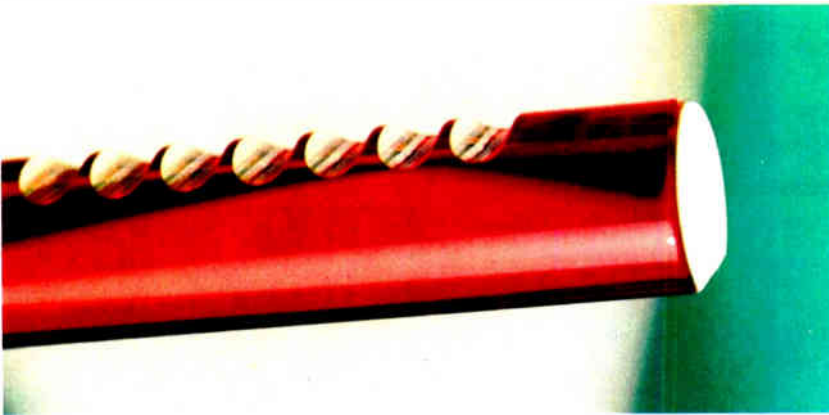

Wire-guide bars for printing heads

All kinds of material have been tried out for the manufacture of wire-guide bars. The corundum in single crystal structure ( $Al_2O_3$ ) still remains the best one. Seitz knows it and uses it in an economic and intelligent way.

The form: a cylindrical bar, which means reduction of friction, improvement of the ribbon guiding, elimination of the wear of the head. Application: in every type of head, thanks to the rigorously respected dimensions and tolerances.

Seitz is the pioneer of wire-guides and is furthermore the most important manufacturer of this product. Seitz has created and fixed its norms.

Seitz wire-guide bars: A technical and economic solution.

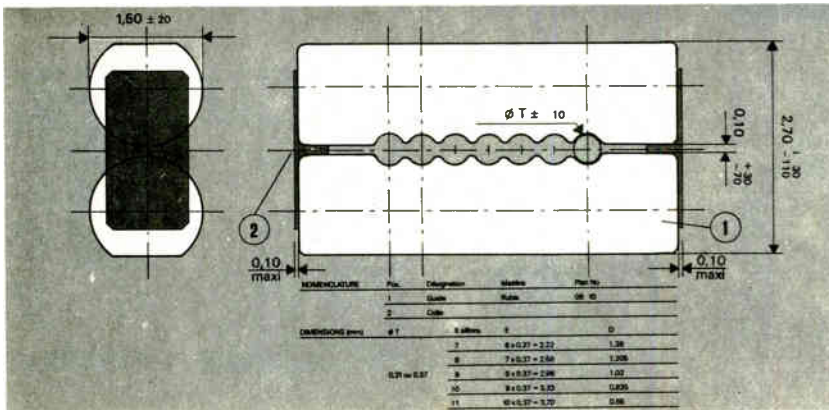



## HAROLD ALDEN WHEELER

"I was born in the year that the Wright Brothers lifted off the ground at Kitty Hawk," says Harold Wheeler. "That was two years after Marconi sent a radio signal across the Atlantic. Those events colored my learning years and destined me to pursue one of those avenues. . . . In the seventh grade I elected radio, and I never swerved from that course."

He began early—the accompanying picture taken by his father in late 1920 shows him at 17 operating his homemade ham radio set. Soon after he met Alan Hazeltine, already a pioneer in radio receiver design: "He became my mentor; I was his understudy."

The understudy, still in college, was the first employee of Hazeltine Corp. in 1924, beginning an association that lasts to this day. In the ensuing 55 years, Wheeler has made major contributions to radio and television receiver design and to microwave, radar, and antenna design. In fact, the mention of his name to a microwave engineer is likely to bring a response such as "Harold Wheeler! I was just reading a paper by him the other day."

In the early days, Hazeltine Corp. was perfecting patentable innovations in receiver design that it then licensed, often designing the units for the licensee. The starting point was Alan Hazeltine's neutralized radio-frequency amplifier, the basis for the Neutrodyne radio that dominated the market in the mid-1920s.

Working independently, the teen-aged Wheeler had also dreamed up the Neutrodyne circuitry. He did not know of Hazeltine's work—still quietly making its way through the patenting process—and the parallel developments were a surprise to both at their first meeting. Hazeltine got the patent, but he granted royalties to Wheeler, as well as taking him under his wing.

Meanwhile, Wheeler was hard at work, obtaining the first BS in physics awarded by George Washington University and then taking graduate courses at Johns Hopkins

University. Summers and spare time were spent at the corporation's first laboratory on the grounds of Stevens Institute of Technology or in his own lab in the basement of his parents' Washington, D. C., home.

It was at home during the Christmas vacation of 1925 that Wheeler came up with the first practical circuit for automatic volume control on receivers. It was a marvel of simple design, because a single triode electron tube was connected as a diode for detecting the signal and for developing the bias voltage controlling the amplification.

"I really didn't appreciate how good it was," says its inventor. "That came on gradually." For years, his invention served as the principal source of income for the corporation. Now known as automatic gain control, the basic circuit is still in use today, notably in a-m radios and TV picture amplifiers.

In the 1930s, television receiver design was the prime object of Wheeler's attention. Then heading Hazeltine's research lab in Bayside, N. Y., he was on his way toward garnering his present total of 180 patents. Among the many awards he also received over the years, the 1940 Morris Liebmann Memorial Prize from the Institute of Radio Engineers for his TV work is particularly dear to his heart.

The World War II years for the corporation were devoted to military electronics, notably radar development. They also marked a turn to microwave and antenna research that continues to occupy him today.

In 1946, he left to form his own firm, Wheeler Laboratories, which did consulting research in communications. Hazeltine bought the labs in 1959, merging them into the parent research group in 1971. The purchase marked a new phase in Wheeler's career, for he served Hazeltine as chief executive officer in 1965-67 and as chairman of the board of directors from 1965 to 1977. He is still a board member and holds the title of chief scientist at the Greenlawn, N. Y., labs.



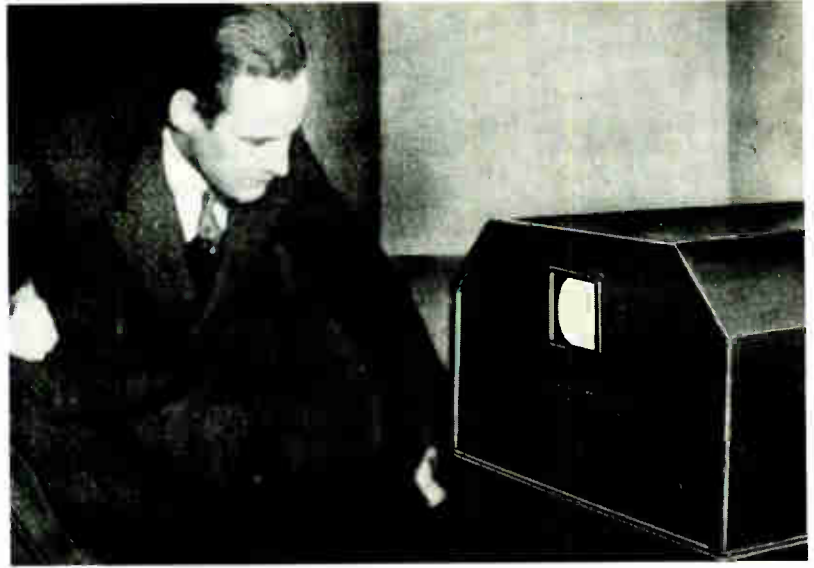

## MANFRED VON ARDENNE

"Make your dreams come true." That's the advice one of Germany's most creative electronics pioneers has for young people aspiring to make a mark on science and technology. For Hamburg-born Manfred von Ardenne, now 73 and since 1955 head of his own research institute in Dresden, East Germany, it has always been the goal of his own technical—and lately medical—efforts.

Fascinated as a youngster by celestial and optical phenomena, von Ardenne soon zeroed in on radio, filing his first patent ("a method for achieving audio-frequency selection, particularly for the purpose of wireless telegraphy") in 1923 at the age of 16. Some 600 more patents as well as nearly 500 published papers and 20 books were to follow. The income derived from the publications and the sale of his developments allowed von Ardenne to finance his private laboratories in Berlin, where his parents had moved just before World War I.

Major inventions in the mid-1920s were the RC-coupled amplifier and a low-distortion tube incorporating three amplifier stages. This multiplexed tube—"in a sense the first integrated circuit," von Ardenne notes—helped cut a third off the price of radios with transformer-coupled amplifiers. Another feat was a 1-megahertz broadband amplifier housing two stages in one tube and using a low-capacitance, gain-boosting design. But it won widespread recognition only many years later when television, radar, and broadband communications came into being.

Not everything went smoothly, however. In 1930, von Ardenne proposed a cable radio broadcasting system analogous to community antenna TV but failed to win industry support for it. Annoyed, he turned to television, "a development whose merits the people and not just industry leaders could assess." Recognizing that the limited-brightness mechanical methods TV specialists were working on in the late 1920s were a dead end, he concentrated on electronic techniques from the beginning. That work culminated in a system using a flying-spot scanner at the pickup end and a cathode-ray tube at the receiving end. Von Ardenne made this purely electronic system work on Dec. 14, 1930, at his Berlin labs.

To give his experimentation a scientific underpinning, von Ardenne studied for four semesters at Berlin University, though he did not earn a degree. In those days, "it was largely an experimenter's realm, a world marked by trial and error," he reminisces. Since a lot of instruments were unavailable, "we had to build them ourselves," he says. "We even had to blow the glass for our tubes." Not surprisingly, his Berlin labs had much equipment not found in today's lab.

After television, he turned to other areas of electron optics. Technical milestones from 1933 to 1937 were the development of a projection electron-beam oscillograph, the invention of the electron-optical image converter, and the development of broadband oscillograph amplifiers (from 0.2 hertz to  $3 \times 10^7$  Hz), the polar-coordinate electron-beam oscillograph, and the scanning electron microscope with beam diameters down to 10 nanometers.

The World War II years were marked by such achievements as improvements in scanning electron-beam methods and were followed by a period in the Soviet Union in charge of a research institute. Then in 1955, he returned to what by then had become East Germany to head "probably the only private institute in our part of the world," he says. His and his co-workers' major electronic feat in Dresden was the development, in 1959, of an electron-beam multichamber furnace for melting heavy blocks of metal in a high vacuum.

Did von Ardenne foresee the importance of his work at the time? "Generally yes," he admits, though he is a beguilingly modest man. "For example, I recognized the significance that the cathode-ray tube would eventually have in oscillograph technology." Some developments, whose importance was not immediately obvious to the German industry, were first perfected abroad. A case in point is the scanning electron microscope.

Like some other electronics pioneers—Zworykin, for one—von Ardenne turned to medicine, specifically to cancer research and therapy, a field which has engaged him since 1959. "I wanted to become active in an area with still many unsolved problems," he says.





*Bendix—We pioneered connector technology. Our Pygmy connectors introduced practical, miniature design and became the world's most copied connector family. Our JT series connectors provided more contacts in less space. And our LJT series were the first 'scoop-proof' connectors that helped prevent blind mating contact damage.*

*Bendix—We've set milestones. Our multipin cylindrical miniature and sub-miniature connectors became national standards. Our Bristle Brush connector brought about a practical solution to the problem of mating and unmating high contact count printed circuit boards with a low mating force connector. And our square cut RF connectors made 30 second assembly a reality.*

*Bendix—We do more than just look to the future. We lead the way. The Bendix Corporation Electrical Components Division Sidney, N. Y. 13838 607/563-5315.*

**We speak connectors.**



Circle 427 on reader service card



# designer collection

by  
WESTON

It's the designer collection of finest-quality cermet trimmers from Weston. It's everything you would expect in a designer collection from expert styling and superior craftsmanship to long-term durability and reliable performance **at competitive prices!** Choose from the 830 ( $\frac{3}{4}$ " rect. multiturn), 840 ( $\frac{1}{8}$ " sq. single turn), 850 ( $\frac{3}{8}$ " sq. multiturn) or the 860 ( $\frac{1}{4}$ " sq. multiturn).

You'll find just the right form, fit and function trimmer for all your demanding applications. Write today for complete specifications, evaluation samples and pricing.

**SANGAMO WESTON**

**Schlumberger**

WESTON COMPONENTS & CONTROLS  
A Division of Sangamo Weston, Inc.  
Archbald, Pa. 18403  
Te. (717) 876-1500  
TWX 510-656-2902  
Telex 83-1873

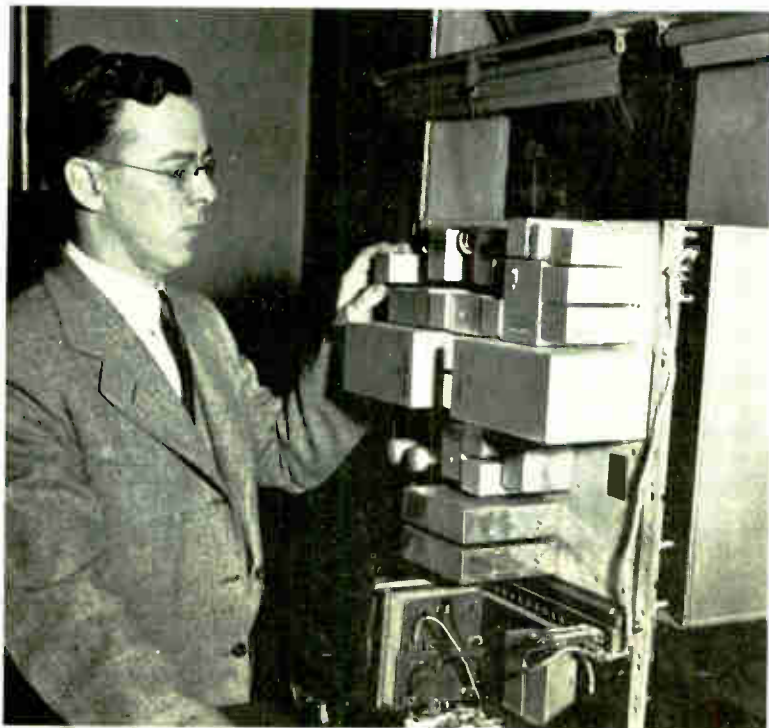

## HAROLD S. BLACK

If Harold S. Black had stayed angry at not receiving a raise in pay soon after starting work at Western Electric Co.'s laboratories—he later went to Bell Laboratories—someone else would probably have had to invent the negative feedback circuit, a development recognized as one of the landmarks in communications.

Black had launched his career at Western fresh out of Worcester (Mass.) Polytechnic Institute. The date was July 5, 1921, and the lab was located near Manhattan's West Side docks, at 463 West Street. He rode the ferry each day from New Jersey, and it was while commuting on Aug. 2, 1927, that the feedback idea came to him "in a flash." Black drew the circuit diagram and some mathematical notations on his New York Times, showed it to his fellow scientists when he got to the lab, and a basic problem of long-distance communication—noise—was solved. Black's interest in the noise problem was long-standing: he had previously worked on reducing hum in phone lines and then on the modification of push-pull amplifiers.

That missing pay increase had almost sent an angered Black to Harvard's business school. But he changed his mind and decided on a different course. "Every memo, written idea, or lab note from the first day of the lab in 1898 had been preserved. So I got them from the library and started coming in on Sundays to read them all. I also found out where all the well-known researchers worked and got to know them," he says. In short, Black became an expert on all the work that had gone on at Western Electric.

Another source of inspiration to the young Black was Charles Steinmetz, the wizard of General Electric. In fact, a lecture by Steinmetz in 1923 led to another Black development: the feed-forward amplifier, also a basic communications breakthrough. In all, Black holds 333 patents—62 in

the United States, 271 granted by 32 foreign nations.

But Black, 82 years old, is excited most by the developmental work that is going on today in communications. "They are moving ahead at an exponential rate," he says. Then, eyes flashing, he says, "I predicted that and helped make it happen."

The key to it all, of course, is digital communications. "In World War II," he recalls, "systems started to be converted partially to digital from all-analog. And I helped make it happen when I was the first one in this country to use pulse-code modulation."

What fascinates Black most about today's digital communications technology is fiber optics. "Its potential is enormous," he says. He compares the improvement still to come with the evolution from his first feedback amplifier and those in use today. "My first one was 9 by 9 by 10 inches," he says. "Now they can get 18,000 feedback transistors in an area about the size of a paper clip."

Black looks back at his Bell Labs years fondly, except for the fact that "they fired me" through the retirement-at-65 rule. So he went to General Precision Inc.—now the Kearfott division—in Little Falls, N. J., as principal research scientist for three years, then did some consulting at Dr. Howard Rusk's New York Hospital for Rehabilitation Medicine by serving on biomedicine and biomedical engineering committees. Today, the still-sprightly scientist does some consulting work from his 30-year-old home perched gracefully on a hill in Summit, N. J., not too far from Bell Labs in Murray Hill.

"I still drop in there once in a while," he smiles. "I can't get over the things they're doing now, especially when I recall I was told not to worry about designing nine-channel systems because the most that Bell System operating companies would ever need was three."





## ROYDEN C. SANDERS

Before Dec. 18, 1950, the safest place on a test range was supposed to be the target. Royden C. Sanders (63 years old this April) can take credit for leading the Navy out of what he calls "the era of unguided missiles" on that date, when a Raytheon Lark scored the first direct hit by a U. S. guided missile on an aircraft in flight.

During 1937-38 Sanders, who had quit college to go into electronics full time, worked on what would become the first practical fm radar altimeter. The Radio Corporation of America invited him to work on the system in its New Jersey laboratories, and eventually—during and after World War II—half a dozen firms turned out more than 300,000 of the devices. The basic design was also modified for use as a radar bombsight.

That was Sanders' first entry into the business, and he had a great future ahead at RCA. He nevertheless left in 1944 because he felt the firm was beginning to divert resources away from the war effort. "I wasn't sure we were going to win that early in the game," he recalls. (RCA was sure, though—it was planning for the postwar boom in television.)

Sanders went to the Raytheon Co. as part of a group that later became the Missile and Surface Radar division; Sanders headed the group, originally known as Lab 16—"because there were 15 others." One of Lab 16's first efforts, missile guidance, continued even after the war.

In 1944, the Navy needed a defense against Japanese kamikaze attacks; out of this requirement came the Lark missile and its successors, the Sparrow III and the Hawk. The original Lark was to have had an active radar guidance system; it might have been the original "fire and forget" missile. But the Navy wanted a longer-range system, where a powerful airborne radar illuminates the target and the missile passively homes in on the reflections. So the design was changed—but not before one of Sanders' Larks scored its direct hit.

Sanders says it scored largely because of his insistence on burning-in each missile's electronics for 24 hours before firing it. He recalls the bemused response of his fellow engineers to the thought of using an entire day's burn-in to assure dependability during a flight measured in

minutes—now a standard reliability technique.

As part of his missile work, Sanders also studied high-density electronic packaging. To offset tube-related thermal problems, he used the missile's skin as a heat sink.

In 1951, feeling that "I had started up two good businesses for other people," Sanders figured it was time to start his own. He and 11 others from Lab 16 mortgaged their homes, pooled resources, and began bootstrapping Sanders Associates into existence.

The company's first contracts were for missile system consulting, so-called Tinkertoy electronic modules, electronic countermeasures (EMC) equipment, electronic intelligence gathering (Elint) gear, and sonar. Sanders' ECM gear is said to have been the first to use an adaptive, broadband repeater approach; formerly ECM had consisted of simple-minded jammers.

Sanders' ECM, Elint, and sonar work led to other efforts in signal and data processing. These resulted in the formation of the Sanders Data System division—a major profit center before his departure in the mid-1970s—which in turn led to Sanders' present interest in work on the office of the future.

This interest is reflected in the goals of his present firm, R. C. Sanders Technology Inc. Sanders views the information explosion both as inevitable and as survivable—with the necessary aids: intelligent printers, display consoles, and word-processing and data-base management equipment. And he has therefore placed his new firm squarely in that market.

Sanders remains concerned with technology, both for personal reasons—"If I don't get to work at the bench once or twice a month, I get edgy"—and out of patriotism: "Today, commercial technology is developing far more rapidly than military. I'm concerned that unless we push military technology development, we risk the survival of the nation." He places the blame for this lag on "woefully inadequate Federal leadership."

Meanwhile, he puts in long hours at Sanders Technology. "We expect to be in the black in 1980," he says, and as for retirement, "my wife says I'll be a retiree when I get my work week down to 40 hours."





Silicon Controlled Rectifiers rated to 1600 Amperes, 3000 Volts

Inverter SCRs rated to 650 Amperes, 1800 Volts.

Silicon Rectifiers rated to 3000 Amperes, 3000 Volts.

Molded Bridge Rectifiers / Power Circuits rated to 100 Amperes/1400 Volts

Power Schottky Rectifiers rated to 150 Amperes, 60 Volts

HEXFET™ Transistors  
Today's most advanced power MOSFETs, rated 2-28 Amperes/60-500 Volts

Bipolar Transistors rated to 50 Amperes 800 Volts

Power Darlington's rated to 25 Amperes, 900 Volts

Since 1947... state-of-the-art power semiconductor devices of every type... every rating... for every application... everywhere in the world.

# INTERNATIONAL RECTIFIER

WORLD HEADQUARTERS: 233 KANSAS ST. EL SEGUNDO, CA 90245, U.S.A. PHONE (213) 772-2000 TELEX 66-4464

EUROPEAN HEADQUARTERS: HURST GREEN, OXTED, SURREY, ENGLAND PHONE 8833-3215 TELEX 95219

Manufacturing Subsidiaries, Sales Offices, Representatives, Agents and Distributors Throughout the World.



Circle 431 on reader service card





## from Datanetics

Many happy line feeds, numerals and alphas, too.

To keep our customers happy, we build the best key switches and keyboards we know how. And we know how a lot better than anybody did 50 years ago — or even one year ago.

We can produce keyboards in a virtually unlimited range of sizes and shapes. They provide extraordinary reliability, yet the economics of the manufacturing process give you custom configurations at unheard of low prices in long runs.

But that's just one reason why the top names rely on Datanetics. Call us today for the whole story.

**ITT** *Datanetics Corporation*  
A Subsidiary of ITT

10840 Talbert Avenue, Fountain Valley, CA 92708. Phone (714) 549-1191, TWX: 910-596-1301.

Circle 432 on reader service card



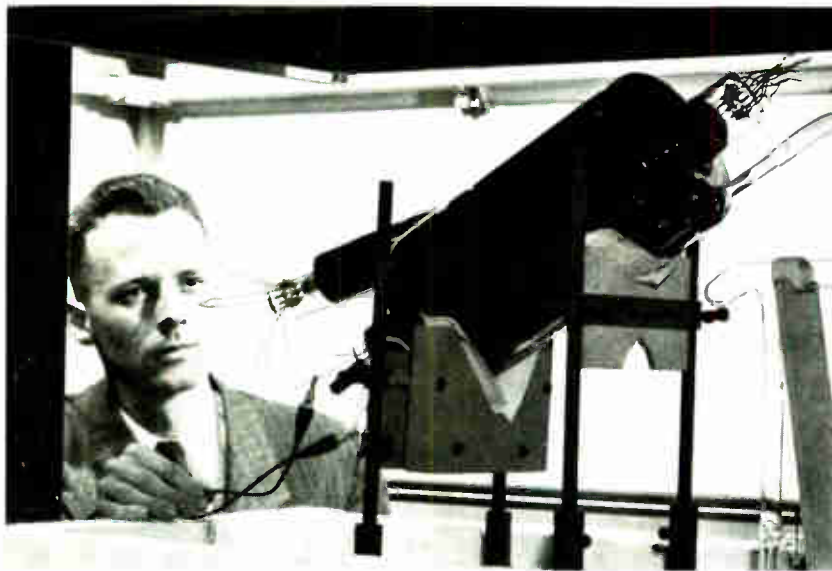

## JAY W. FORRESTER

At age 62, Jay W. Forrester has not only played a major role in the creation of computer technology, he has also applied it in dramatic fashion in recent years as Germeshausen Professor of Management at the MIT Sloan School of Management.

Forrester was director of MIT's digital computer laboratory from 1946 to 1951, responsible for the design and construction of the Whirlwind I, one of the first high-speed digital computers. From 1952 to 1956, he headed the Digital Computer division of the MIT Lincoln Laboratory, guiding and planning the technical design of the Air Force's Sage (for semiautomatic ground environment) air defense system, the most extensive early application of digital computers—and one that might not have been possible in terms of either speed or reliability without his invention of the magnetic-core memory.

Whirlwind was developed using electrostatic storage tubes as memory; experimenters were working with several types of delay lines and with other tube techniques. But these various memory technologies were either slow or unreliable. Forrester had been working on the memory problem since at least 1947. So when in 1949 he happened upon an advertisement for nonlinear magnetic materials, the pieces of the puzzle fell into place. In a few days he had obtained material and had established proof of the principle of the coincident-current magnetic-core memory, laying the groundwork for the memories that were to emerge from development about four years later.

In 1956, Forrester decided to change careers. Though he is still honored for his pioneering computer work, he has become the leading theoretician in the field of complex socioeconomic models—system dynamics.

Forrester notes that his responsibilities at Sage were as much managerial as technical. He came away from them convinced that "technical success could depend more on management than on science" and that "no amount of technical expertise could surmount an unfavorable managerial environment."

With this belief and the feeling that "management was the greater challenge," he moved to MIT's Sloan School in

July 1956. Forrester explains that the Sloan School had naturally taken to the use of computers, especially for operations research and for management information processing. But neither of these was "the correct challenge," in his opinion. "Business data processing was already evolving rapidly outside MIT," he notes, "and operations research dealt with relatively simple problems, not with the keys to success or failure of major efforts."

He combined his thinking with input from managers, finding that executives were concerned with the ebb and flow of capital, fluctuations in inventory, unemployment, and inflation. These and other seemingly cyclic occurrences reminded Forrester—the engineer of oscillations, and he wondered if, through modeling their environments, he might not be able to find a way to apply "negative feedback" to control them. And what better tool for developing such models than the digital computer, which he also had helped develop. He thus midwived a new field of study, system dynamics, or "how . . . policies affect growth, stability, fluctuation, and changing behavior in corporations, cities, and nations."

As his confidence in his models grew, Forrester began speaking out on a variety of issues, most recently innovation, the energy shortage, and long-wave economic cycles—a controversial phenomenon independently predicted by his computer models. He has targeted a number of policies he feels should be pursued. In energy, for example, he would alter price structures so that industry would be forced away from energy-intensive processes.

One of system dynamics' key insights is that the obvious course of action is rarely the correct one; that, in fact, a "logical" course of action can have the reverse of the desired result. Based on the behavior of his models, Forrester often therefore finds himself advocating "counterintuitive" solutions to problems. The moral for social and economic planners is obvious—make it play on the computer first. While no one could call Forrester's pioneering work in data processing unimportant, the potential of system dynamics is so great that it may someday overshadow his engineering achievements.



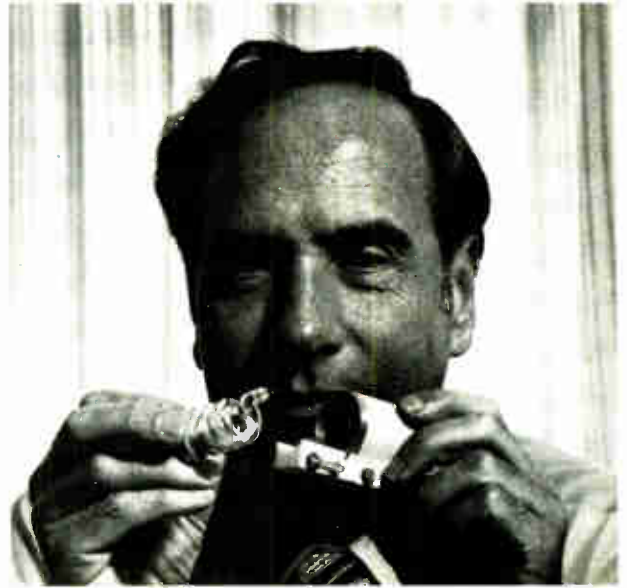

## THEODORE H. MAIMAN

If oddsmakers 20 years ago had handicapped Theodore H. Maiman's chances of coming up first with a working laser, he would have been a long shot. "But I knew something the others didn't," he recalls now about the months preceding May 15, 1960.

Maiman's advantage lay in his knowledge and experience of ruby as lasing material for a coherent light source. He began working with it back in graduate school days in the mid-1950s at Stanford University. He found then and in subsequent R&D projects at Hughes Aircraft Corp. that ruby has much higher fluorescent efficiency—around 75%—than the accepted textbook 1% or so limit. This property is critical to lasing action and meant Maiman could focus his effort—his one assistant and a limited budget—on building a ruby laser. He did not lack confidence: "Once I had the idea, I knew we had the inside track," he says now.

Maiman was bucking the judgment of well-financed programs at some of the most prestigious research firms and institutions in the U. S. and Europe. "There was a worldwide race to make the laser," he points out.

But by the time he had permission from Hughes management to start in August 1959, other scientists were up against a stone wall in building a working model. They based most of their work on a landmark 1958 paper by A. L. Schawlow and C. H. Townes that proposed an optical maser, but one that used a potassium vapor to generate coherent light rather than a solid material.

"I had built an X-band maser in 1958-59 for the Army Signal Corps, which depended on the microwave characteristics of ruby to work," he explains. Already intrigued with the material's optical possibilities, he set about constructing a laser with it, after first looking into the Schawlow-Townes theory and satisfying himself that "it would not work."

Maiman's background turned out to be particularly well suited to implementing the laser. He was familiar with optical energy and instrumentation from his doctoral thesis at Stanford on microwave-optical measurements

and from work in generating electron beams. And at Hughes Research Laboratories, where he headed the quantum electronics section, Maiman already had developed new masers that were coded with liquid helium and liquid nitrogen.

Lending further impetus to his laser experiment was a Hughes management mandate to do it quickly. "Hughes never really thought much of the laser," he says, and almost withdrew funding on advice from Bell Lab consultants. But the nine-month program went smoothly, and the first demonstration was successful.

There were skeptics at first, but now "nobody challenges the fact I made the first laser," observes the 52-year-old scientist. But some confusion, prevailing even today, still rankles. Townes, for example, shared a Nobel Prize in 1964 for theoretical work leading to the maser and laser. Maiman's stock reply to any who try to take credit for his development: "If they did it, where the hell is their laser?" Often he punctuates speeches and appearances by whipping the first laser itself out of his pocket.

In 1961, Maiman left Hughes to set up his own industrial laser company, Korad Corp., sold to Union Carbide in 1968. Since then, serving as a consultant to top industrial firms, he has been "out of the active laser field." But he did aid in developing a large-screen laser-driven color video display.

Maiman joined TRW Electronics in 1976, where today he ranges far afield as vice president of advanced technology. There, among duties like helping guide the company into new ventures, he brought TRW's LSI Products division into the commercial world from a lab beginning.

Contemplating the 20 years since his laser first generated a coherent light beam, he takes strong issue with negative judgments to the effect that the device was "a solution looking for a problem." He had always foreseen industrial uses for the laser and not the flashy communications systems some visionaries predicted right away. "These are just now starting to pick up, which is where they should be."



**TO KEEP  
THE LINES OF  
COMMUNICATION  
OPEN, CALL  
ANRITSU.**

Business runs on communication. That's why it's important to keep the lines of communication open always. And you can be confident of doing just that . . . with Anritsu.

At Anritsu, communication is our business. One that we've been committed to for the better part of a century. In **all** its aspects—wired and radio communications systems, as well as the test and measuring equipment used for them.

Whether it's a public telephone or radio equipment, every Anritsu system is distinguished by precision and reliability. Product excellence that's a testimony to fine workmanship and state-of-the-art electronics.

If you, too, are in the business of keeping communication smooth and efficient, look to Anritsu. After all, we're really in the same business.

The secret behind good communication.

**Anritsu**

**ANRITSU ELECTRIC CO., LTD**

10-27, Minamiazabu 5-chome, Minato-ku, Tokyo 106, Japan Phone: (03) 446 1111/Telex: 0-242-2353

Circle 435 on reader service card



# CLASSIC CIRCUITS

The growth of electronics as a group of industries has resulted from a complex of factors—technical, social, economic, and political. But in the last reckoning, it has been the development of the circuits themselves that has made electronic communication and data processing possible.

Although there have been many innovations over the years, all circuits actually trace their roots back to only a

dozen or so, from which all else was created. Presented here are some of the great circuits, those that *Electronics* feels have been basic to the commercialization of radio, TV, and computers and other data-handling systems. The selection has been difficult, and others indeed might have been chosen, but *Electronics* believes that these truly innovative circuit designs would occupy a spot in just about everyone's all-star list.

## 1. VACUUM-TUBE OSCILLATOR: c. 1912

The vacuum-tube oscillator generated continuous waves at a single frequency, unlike its predecessor, the spark gap, thus permitting communication over a single channel. Using positive feedback and the triode as an energy pump, it provided a sine-wave output at the resonant frequency of its tuned circuit. Several individuals invented the circuit in about 1912 independently, notably Reginald A. Fessenden, Alexander Meissner, H. J. Round, and Lee de Forest, but the arrangements by Edwin H. Armstrong (a) and Edwin Colpitts (b)—a similar circuit was devised by R. V. L. Hartley—were used most widely in the early going.

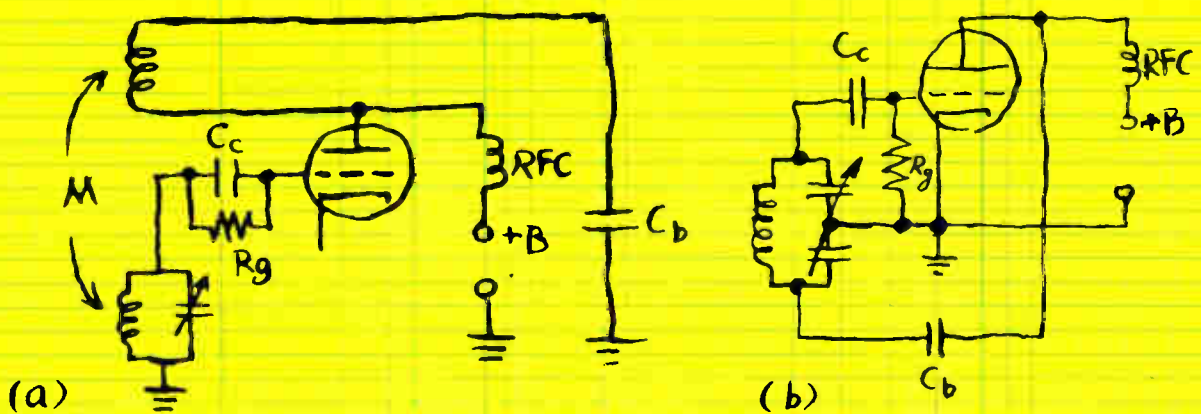

## 2. CONSTANT-CURRENT MODULATOR: 1913

R. A. Heising's vacuum-tube circuit, initially conceived at Western Electric in 1913, was the first modulator capable of working efficiently. With inductor  $L$  preventing any change in the total plate current drawn by  $V_1$  and  $V_2$ , the modulating signal was applied to the plate circuit of the rf oscillator so that audio-frequency variations at the modulator's output would produce similar variations in the oscillator's plate current.

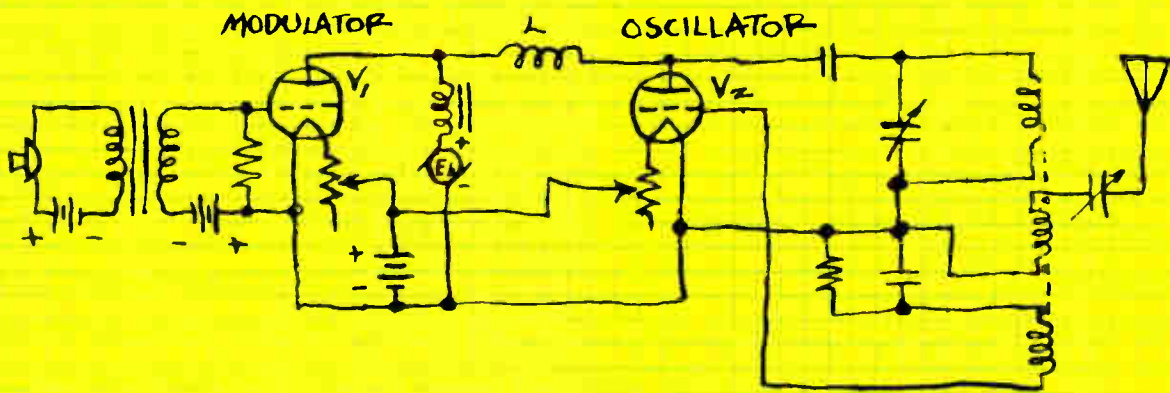

## 3. FLIP-FLOP: 1919

Among the many circuits derived from the general trigger arrangement (a) invented by W. H. Eccles and F. W. Jordan, working in the UK, were the monostable and astable multivibrators and the Schmitt trigger. The bistable latch, or flip-flop (b), is the ancestor of the frequency counter-divider and the computer.

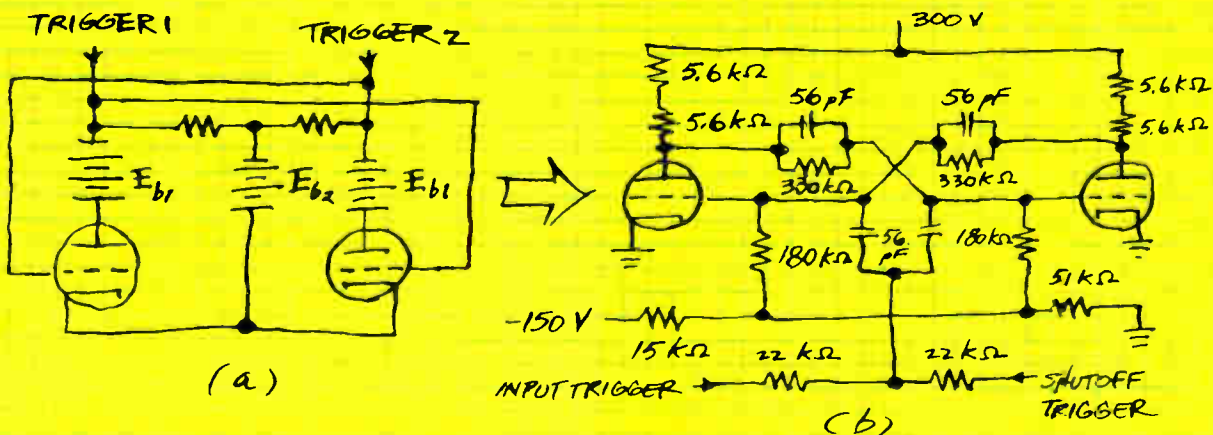



## 4. AUTOMATIC VOLUME CONTROL: 1926

One of the first circuits to utilize the properties of negative feedback, Harold A. Wheeler's automatic gain control for a-m radios provided a substantially constant audio output volume over a wide range of rf signal levels. Wheeler designed the AGC in 1926 at Hazeltine Corp., where he works to this day.

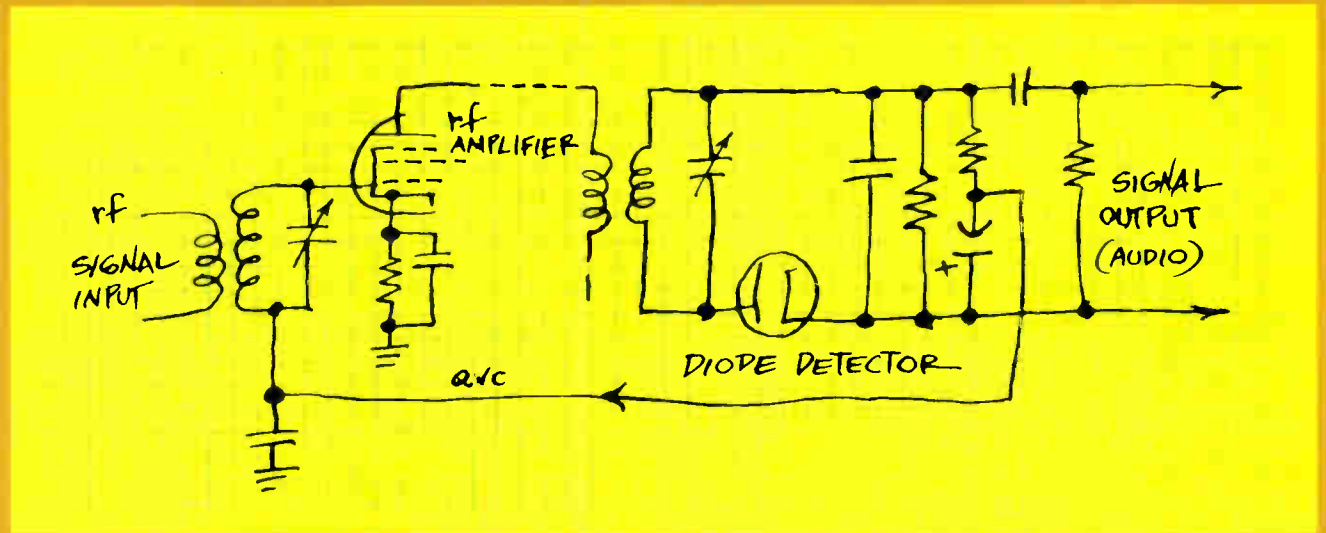

## 5. YAGI-UDA ANTENNA: 1926

Developers of a different kind of circuit—an electromagnetically coupled one having large dimensions compared with the wavelength of interest—H. Yagi and S. Uda of Tohoku University, Japan, were the first to use wave interference to obtain gain and directivity from wire aerials. Although the invention was conceived in 1921, the commercialization of their discovery took place in the West in the late 1920s, after a translation of their paper appeared in the IRE Proceedings for June 1928.

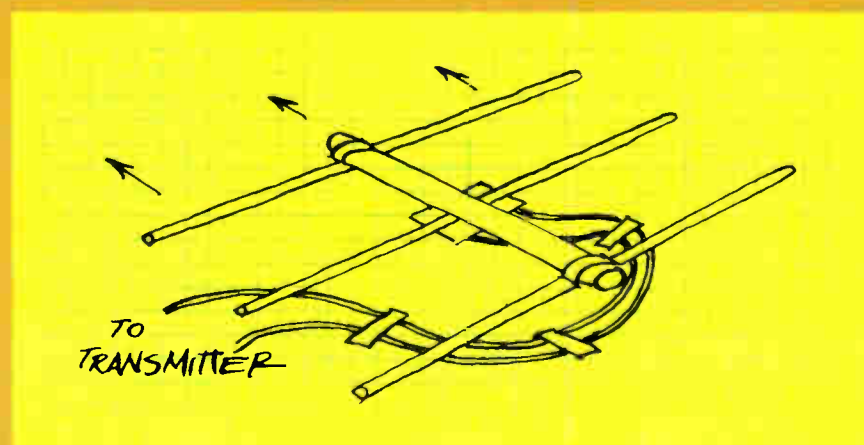

## 6. NEGATIVE-FEEDBACK AMPLIFIER: 1927

In one of the most fundamental developments in the history of communications, H. S. Black discovered that negative feedback could be applied to an amplifier to minimize distortion over a wide band of frequencies and achieve gain stabilization at the same time. This work, performed at Bell Telephone Laboratories in 1927, was different from that of Wheeler, who had earlier used negative feedback for control.

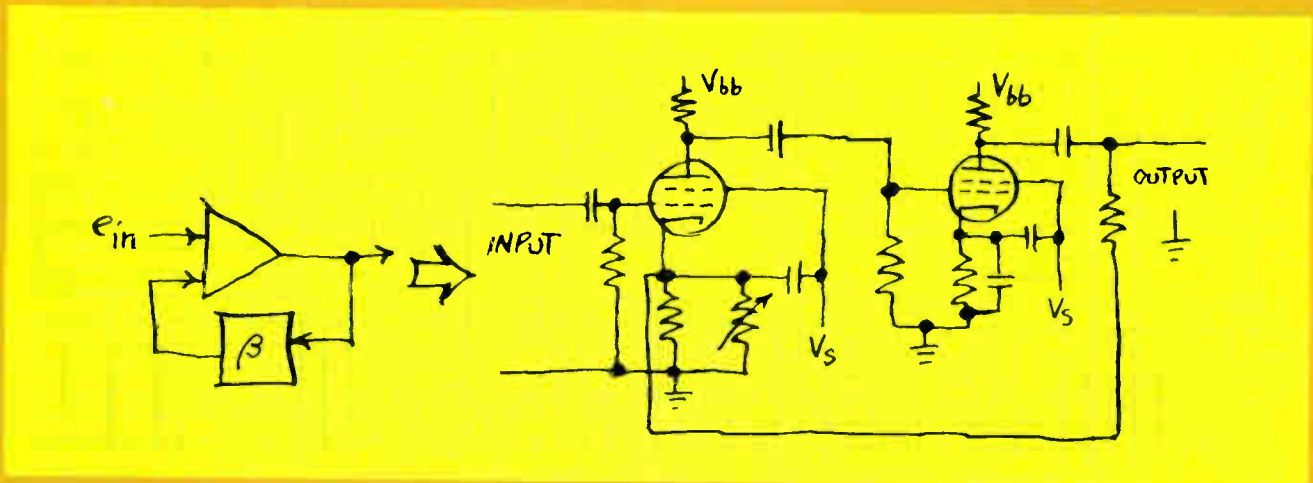

## 7. PHASE-LOCKED LOOP: 1932

H. de Bellescize, working in France, was the first to describe a system for the synchronous reception of radio signals, one that was simpler and more elegant than the superheterodyne approach then used. Using a feedback control loop to adjust a voltage-controlled oscillator to the exact frequency of an incoming signal, the PLL, originated in 1932, is employed widely in many data-processing and communications circuits today.

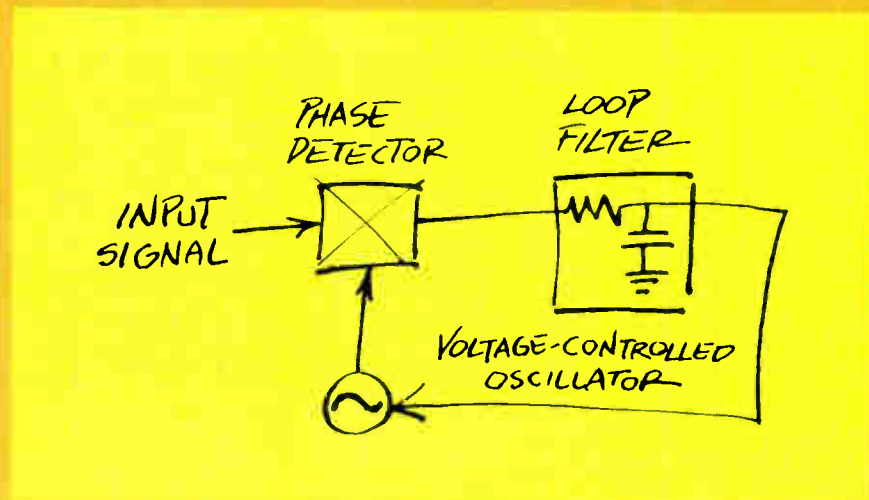



# 8. AUTOMATIC FREQUENCY CONTROL: 1935

Charles Travis's discriminator and reactance-tube circuit (shown here in a modified simplified version by S. W. Seeley), developed in 1935 while he was at RCA, formed the heart of the first automatic frequency control and was the basis of the reactance-tube modulator and the Foster-Seeley discriminator for fm detection.

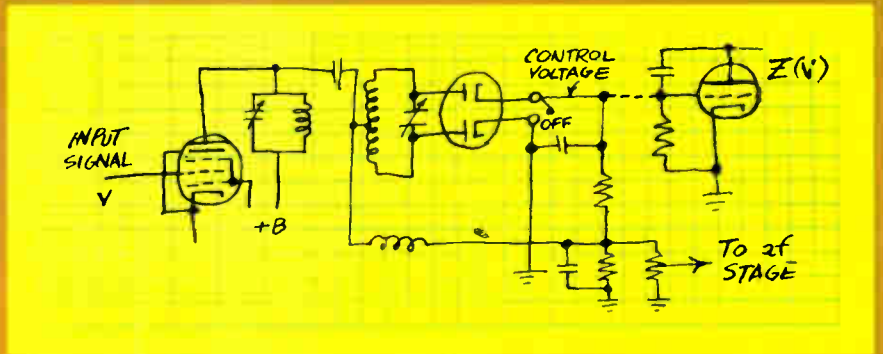

# 9. NOISE BLANKER: 1936

James J. Lamb's noise-silencing circuit (1936) virtually immunized a-m superhet receivers against ignition and pulse noise while drastically reducing other nonrepetitive disturbances—unlike other circuits of the day, which worked on the principle of limiting noise peaks to the level of the received signals. The circuit opened the receiver's signal-handling path during each noise spike, allowing the desired signal through at other times.

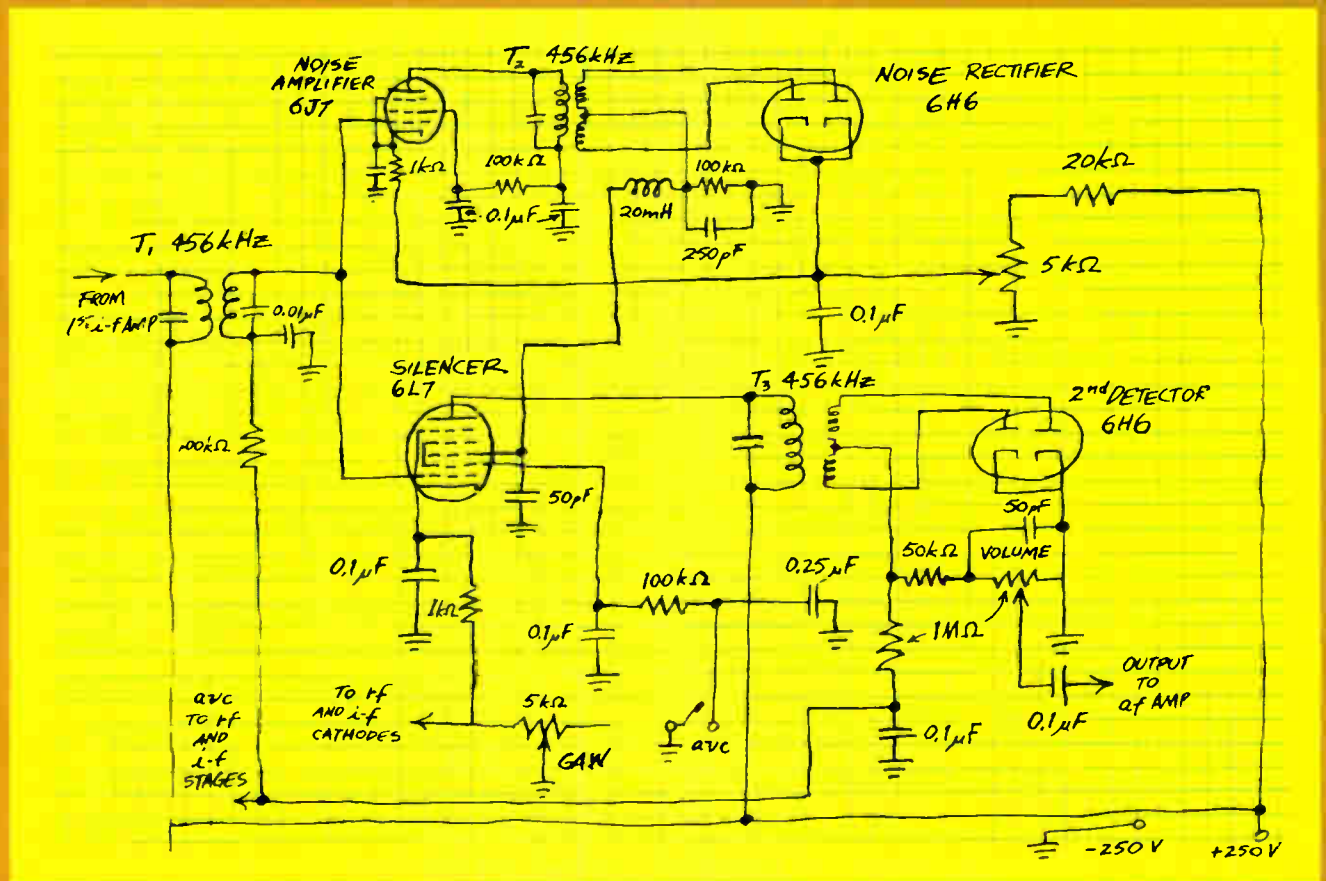

# 10. OPERATIONAL AMPLIFIER: 1938

The discovery by G. A. Philbrick in 1938 of the operational amplifier for performing integration and differentiation by electronic means was not so much the invention of a circuit as it was the development of a concept. Using an odd number of ordinary high-gain vacuum-tube stages for generating the required 180° phase shift between input and output, Philbrick (also, independently, C. A. Lovell) showed that the transfer function of the network could be set with two external elements. This work led to the development of the active filter.

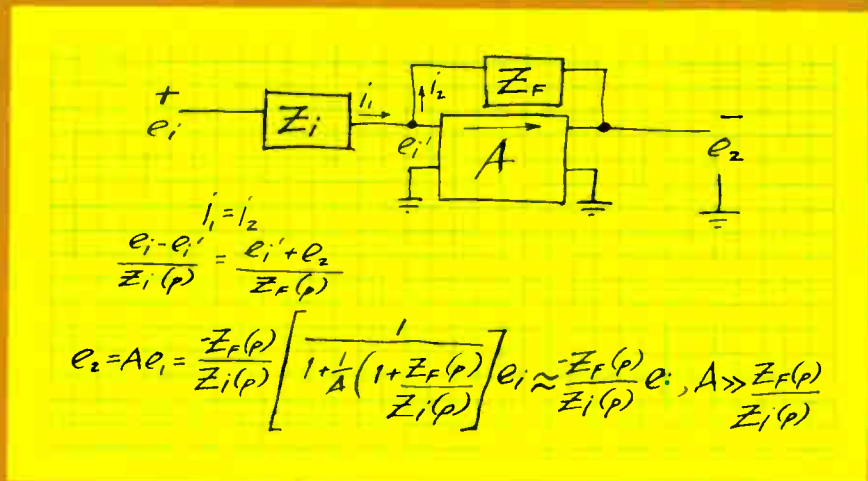

# 11. GYRATOR: 1948

B. D. H. Tellegen's invention in 1948 of the gyrator made unidirectional microwave couplers and inductorless electric-wave filters possible. Having an input impedance proportional to the admittance at its output, this almost lossless nonreciprocal network element was thus able, given a capacitive load, to synthesize the electrical characteristics of an inductor. Developed in 1948 at Philips, this element appears passive, though most configurations contain active components.

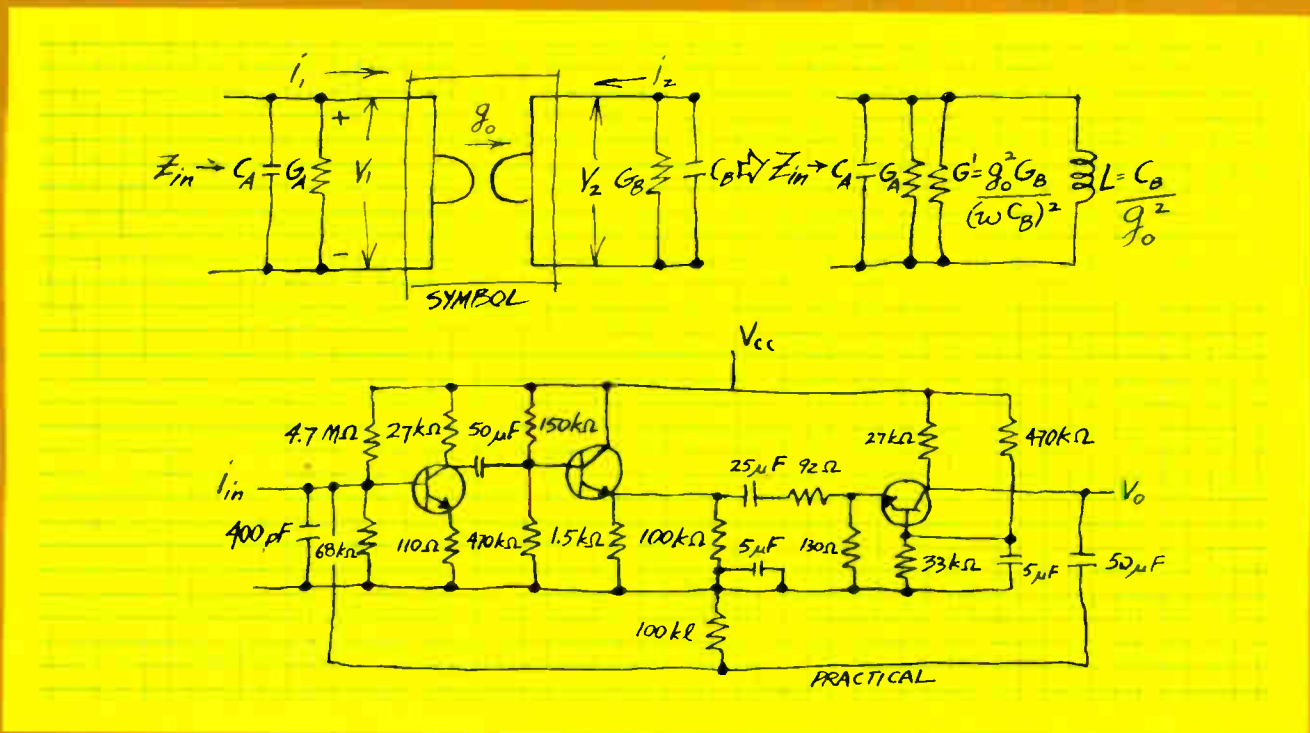



# 12. DUAL-SLOPE INTEGRATOR: 1955

Invented by R. W. Gilbert of Weston Instruments in 1955, the dual-slope integrator greatly simplified the conversion of an analog signal into its digital equivalent and made the accuracy of any measurement done by the relatively new digital voltmeter dependent only upon the accuracy of a reference voltage. Today, this circuit or improved versions of it are used almost universally by makers of digital panel meters and multimeters.

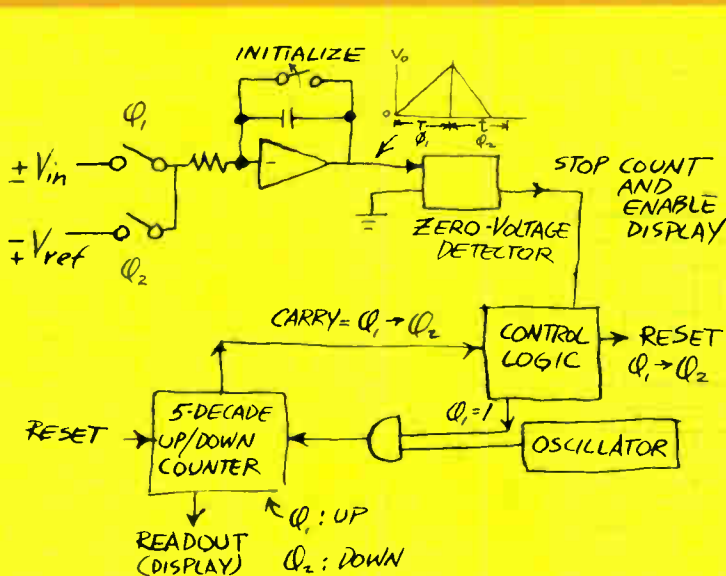

$$\text{during } \phi_1 : V_{o\uparrow} = \frac{1}{RC} \int_0^T V_{in} dt = \frac{V_{in}}{RC} T$$

$$\text{during } \phi_2 : V_{o\downarrow} = \frac{1}{RC} \int_0^t V_{ref} dt = \frac{V_{ref}}{RC} t$$

$$\therefore V_{in} = \frac{V_{ref}}{T} t$$

In saluting the 12 circuits that have had such an impact on the commercialization of electronics during the past 50 years, one fact stands out: most of the important developments took place before 1940. Indeed, it should come as no surprise that today's engineers by and large believe that the day of the pure circuit designer has long past and that the limits of circuit development have been reached.

That engineers have exhausted conventional development there can be little doubt. The first generation is virtually over. But the world has now entered a period

where diminishing natural resources are vitally important to the survival of industrialized society. To that end, engineers—that is, ones of *ingenuity*—will almost certainly be called upon increasingly in the next 50 years to develop circuits that utilize either newly discovered laws or currently little-used but now necessary scientific principles in order to conserve energy. Even circuits for transporting small amounts of matter through space may well be in the offing. Those individuals inventive enough to meet the challenge are likely to earn a place alongside the pioneers of electronics.

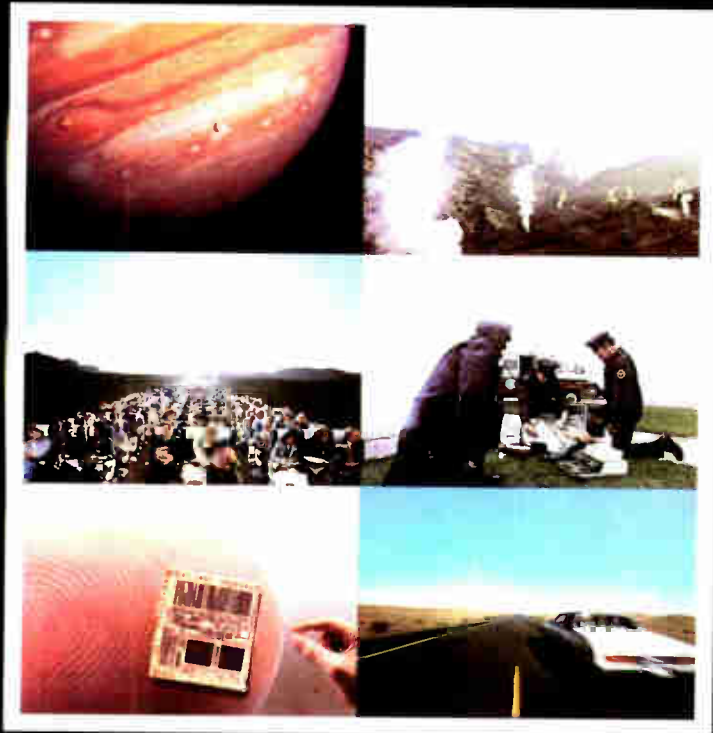

A CELEBRATION OF CREATIVITY.





When Motorola was founded in 1928, it became a pioneer in an industry of the future. An industry that, two years later, would be given both a name and a publication to record its progress.

Our company and **ELECTRONICS** have shared these 50 years of progress together.

And for Motorola, they have been years of dramatic change in the nature of our products, but not in our philosophy of management.

From the beginning, Motorola has sought to create and maintain an environment that is stimulating and evocative. An environment that encourages good people to competence and creativity; that encourages a sense of personal commitment to doing things well.

But results are the true test of any philosophy of management. And results are what the following pages are all about.

A handwritten signature in dark ink, appearing to read "Robert W. Galvin". The signature is fluid and cursive, with the first name "Robert" and last name "Galvin" clearly distinguishable.

Robert W. Galvin  
Chairman of the Board  
Chief Executive Officer



# MOTOROLA BROUGHT HOME

It's not for nothing that Jupiter is named for the mythological king of gods. It's the giant of the solar system, 1300 times the size of Earth. With over a dozen moons and a unique magnetosphere, it's almost a miniature solar system. It swarms with turbulent rivers of color that move at half the speed of sound.

## **ELECTRONIC LINK.**

The flyby of Voyager 1 and 2 has given us the best look we've ever had of this fantastic world. And the only two-way communication link between the Voyager spacecraft and Earth is Motorola equipment: not only for transmitting the

incredible pictures, but for receiving all commands sent to the spacecraft, relaying all scientific and engineering data, and serving as the spacecraft terminal for all tracking and navigation functions. And it's all designed to operate for over a decade on a comparative trickle of power from radioactive isotopes.

## **ELECTRONIC HISTORY.**

Motorola has over twenty years' experience in this esoteric technology, extending back to the earliest unmanned space probes. For example:

America's first venture into space, Explorer 1, in 1958, sent its information to ground-based

Motorola equipment.

Pioneer 5, in 1960, was tracked out to 22.5 million miles with specially-designed Motorola radio receivers.

Motorola's command receivers were on board Alan Shepard's Freedom 7 Mercury spacecraft for the first U.S. suborbital mission in 1961.

In 1965, Mariner 4 made a close flyby of Mars, snapping pictures all the way, and sent them to Earth by a Motorola transmitter.

For the Gemini series, in 1965-66, Motorola developed and produced the spacecraft's digital command system.

Neil Armstrong's historic "one small step for man" was

# PICTURES OF THE GIANT.

elayed from Moon to Earth in 1969 by a Motorola S-band transceiver.

In 1971 the Lunar Rover, first car on the Moon, had a Motorola FM receiver.

The first color photographs from the surface of Mars, in 1976, came to Earth from the Viking orbiter via Motorola equipment.

## IMAGINATIVE ELECTRONICS.

And now, the Voyager spacecraft, pursuing their boomerang trajectories around Jupiter and on toward Saturn. A long way indeed from the time when Motorola put radios into cars fifty years ago, and TV sets in

America's living rooms. We no longer make home TV here at all, but we do make hundreds of models of two-way radios.

We have become one of the world's largest manufacturers devoted exclusively to electronics. We are one of the foremost designers of custom and standard semiconductors. Indeed we are one of the world's greatest innovators in electronic problem-solving.

We have developed systems that cut automobile fuel consumption; systems that

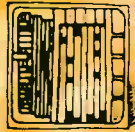

A microcomputer drawn larger than life.

help keep ships from colliding; systems that allow telephones without wires; systems that help keep computers from giving up their secrets to the wrong people—and, of course, systems that bring home to Earth the true face of other worlds.

For further information, write Public Affairs Office, Corporate Offices, Motorola, Inc., 1303 E. Algonquin Road, Schaumburg, Illinois 60196.

Motorola and  are registered trademarks of Motorola, Inc.



## MOTOROLA

### Making electronics history.



# MOTOROLA HELPS GET ENERGY FROM

In northern California, the natural heat of the earth is being harnessed to serve the energy needs of man. Natural steam, heated by the molten rock below the earth's crust, is being tapped, extracted and piped to power some of the electrical generators that help light up San Francisco, 90 miles to the south.

The place is called The Geysers, and it's part of a pioneering

effort by Union Oil Company of California to make geothermal energy a practical alternative to expensive imported oil.

The Geysers may be an unorthodox power source, but it has one thing in common with every other branch of the energy industries: the

need to maintain good, reliable communications, no matter how remote or primitive the site.

At the Geysers, as in many places around the world, the solution to that problem is

Motorola communications.

## **ELECTRONIC PROBLEM-SOLVING.**

One problem at The Geysers, for instance, was the rolling terrain and steep, narrow canyons, among which conventional high-frequency radio signals could get diffused and lost. Motorola solved that one with ingenious simplicity: a low-band two-way radio system that, as one engineer put it, "gets into the nooks and crannies."

## **ELECTRONICS EVERYWHERE.**

But this is merely the tip of the iceberg of Motorola's experience in energy-industry communications.

One of America's largest oil refineries has 35 Motorola



▨ AREAS OF GEOTHERMAL POTENTIAL  
● GEOTHERMAL DEVELOPMENTS



# THE EARTH, THE SEA AND THE SUN.

systems and subsystems, among which are pagers that tell a man he's wanted on the phone; closed-circuit video monitoring systems; and alarm and control systems that not only tell when something is going wrong, but also when everything is working right.

In the North Sea, a Motorola microwave system will provide a data and voice-communication link that will help one person control six unmanned oil-production platforms. He'll be able to check pressures and flow rates, regulate meters, pumps and motors, all by touching a few buttons.

Some of the Motorola equipment on the Alaska Pipeline is so sophisticated that a hard-hat worker in the field can talk directly to an executive in an office a thousand miles away.

In Canada, specially designed

Motorola equipment is in use at an oil mine, an extraordinary strip-mining process for extracting petroleum from tar sands.

Motorola has made the apparently impossible happen by taking radio communication underground into deep-shaft coal mines.

And in solar energy, Motorola has gone beyond communications to actual energy development. Our engineers are producing photovoltaic systems that convert sunlight into electricity.

## ELECTRONICS AND PEOPLE.

Motorola's preeminence in energy-industry communications is as much a matter of people as of technology. We made an early and total commitment to solving energy-industry communications problems, not merely

as suppliers but as participants.

Microelectronics is at the heart of the matter, as it is in many of the things we do today. But if there are similarities among communications devices, there are none at all among the communications systems that the energy industries need in all their activities.

In designing these systems, Motorola brings to bear a combination of expertise and enthusiasm that helps us keep expanding the limits of what's possible in electronics.

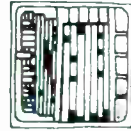

A microcomputer, drawn larger than life.



## MOTOROLA

### Making electronics history.

Circle 152 on reader service card

For further information, write Public Affairs Manager, Corporate Offices, Motorola, Inc., 1303 E. Algonquin Road, Schaumburg, Illinois 60196.

Motorola and  are registered trademarks of Motorola, Inc.



# MOTOROLA HELPS SEAT

Every day, around the world, over a million and a half people make, unmake and change airline seat reservations, some for this evening, some for two weeks from Tuesday, some for as long as a year in advance.

It all depends on computers, of course, but a computer is merely a storehouse for information. To use the information, computers must be able to talk to each other, and to remote terminals miles away, within seconds.

## **ELECTRONIC CONVERSATIONS.**

Such digital dialogue is called

data communications; and in countries around the world, more than half of all airline reservations are now being made through equipment from Codex, the data communications arm of Motorola.

A complete Codex data communications system comprises three key technological tools. First, modems, which translate computer data into signals that can travel over ordinary telephone wires, undersea cables and satellite links.

Second, network processors, which can squeeze the signals from as many as 124 lines through a single telephone wire, without losing the integrity of any one of them.

Finally, network manage-

ment and control equipment, whose job is to supervise, correct and report on the operation of the whole communications network.

Codex has made major contributions to data communications technology, helping improve the reliability, cutting the operating cost, and in some instances quadrupling the speed of data transmission.

## **APPLICATIONS AROUND IN OUR COMMUNICATIONS-INTENSIVE WORLD.**

Fast, dependable real-time data communication is indispensable to an airlines reservation system—or to any communications-intensive industry. For instance, it helps get the very





# 800,000 PEOPLE A DAY.

latest currency exchange information within seconds from places as remote as London and Sydney and Hong Kong. It helps directory-assistance operators in the Los Angeles area handle ten times as many inquiries as they once could. It helps keep stock-market quotations current for brokers; even makes computer time-sharing less expensive by slicing seconds finer.

These electronic miracles are merely representative of what Motorola products are doing every day.

## **A TOTALLY ELECTRONIC INVOLVEMENT.**

From its beginning as a pioneer

in car radios, and later as an innovator in television sets for the home (a product we no longer make or market here at all), Motorola has become one of the world's largest manufacturers devoted exclusively to electronics.

Today, we make hundreds of models of two-way radios, and we're also one of the foremost designers of standard and custom semi-conductors. And with products like the Codex 6000 family of communications processors, and the Motorola MC68000



*A microcomputer, drawn larger than life.*

microprocessor, we are in the leading edge of electronic innovation.

That innovative strength has enabled us to develop systems that can make a home more energy-efficient. Systems that help keep the news new at news services. Systems that transmit color photographs from the depths of space.

And, of course, complete data communications systems that help computers share their information to benefit you.



**MOTOROLA**

**Making electronics history.**

Circle 153 on reader service card

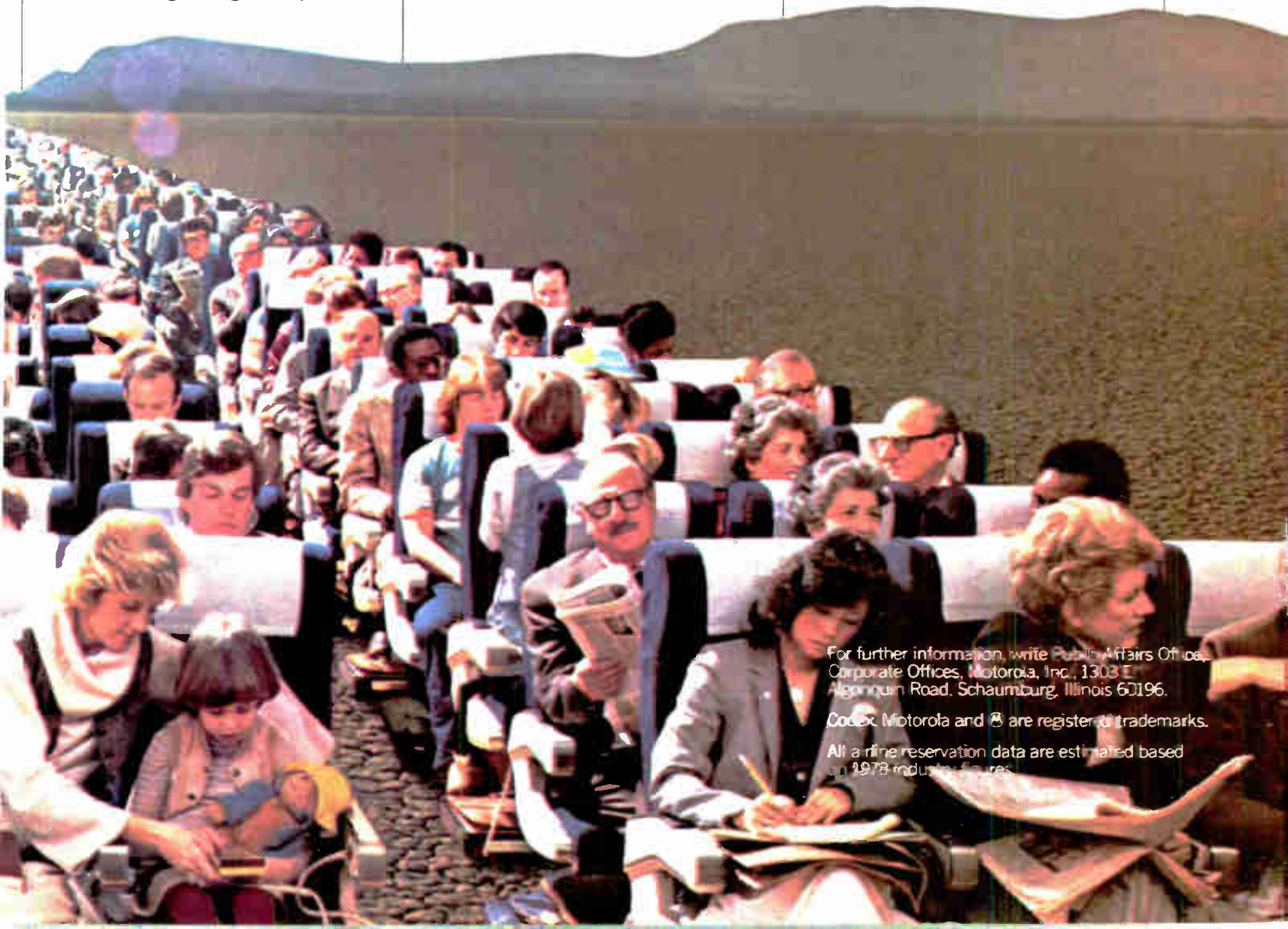

For further information, write Public Affairs Office, Corporate Offices, Motorola, Inc., 1303 E. Algonquin Road, Schaumburg, Illinois 60196.

Codex, Motorola and  are registered trademarks.

All airline reservation data are estimated based on 1978 industry figures.



# MOTOROLA HELPED BRING

His name isn't important.  
His story is.

He was simply walking back to his office when the pain hit him.

In less than three minutes, an ambulance with two paramedics arrived.

But as they began to work, arrhythmia—erratic, wildly uncontrolled heartbeat—set in.

Then his heart stopped altogether.

## A MIRACLE OF ELECTRONICS.

Fortunately, the ambulance was equipped with a Motorola APCOR Coronary Observation unit.

It put the paramedics in immediate touch with an emergency physician at the hospital miles away.

Not just by voice communication; that doesn't give a doctor all the information he needs.

But at the very same instant, by Motorola telemetry, an electrocardiogram of the activity of the man's heart was being transmitted.

A miracle of electronics—

microelectronics—was about to show what it could do.

## TECHNOLOGY DOES THE TALKING.

A lot of things were happening at once.

The medical assistants at the scene were talking to the emergency room at the hospital.

And the Motorola APCOR was also talking to the doctor in a language only a medical professional could understand—by transmitting the patient's EKG.

The doctor could then treat the patient almost as

if he were on the spot.

In a few minutes, the man's heart began to beat. He was once again on his way to being alive, in every sense of the word.

## MICROCIRCUITS MAKE IT HAPPEN.

APCOR is made possible by Motorola microcircuits, tiny information processors that transmit both electronic

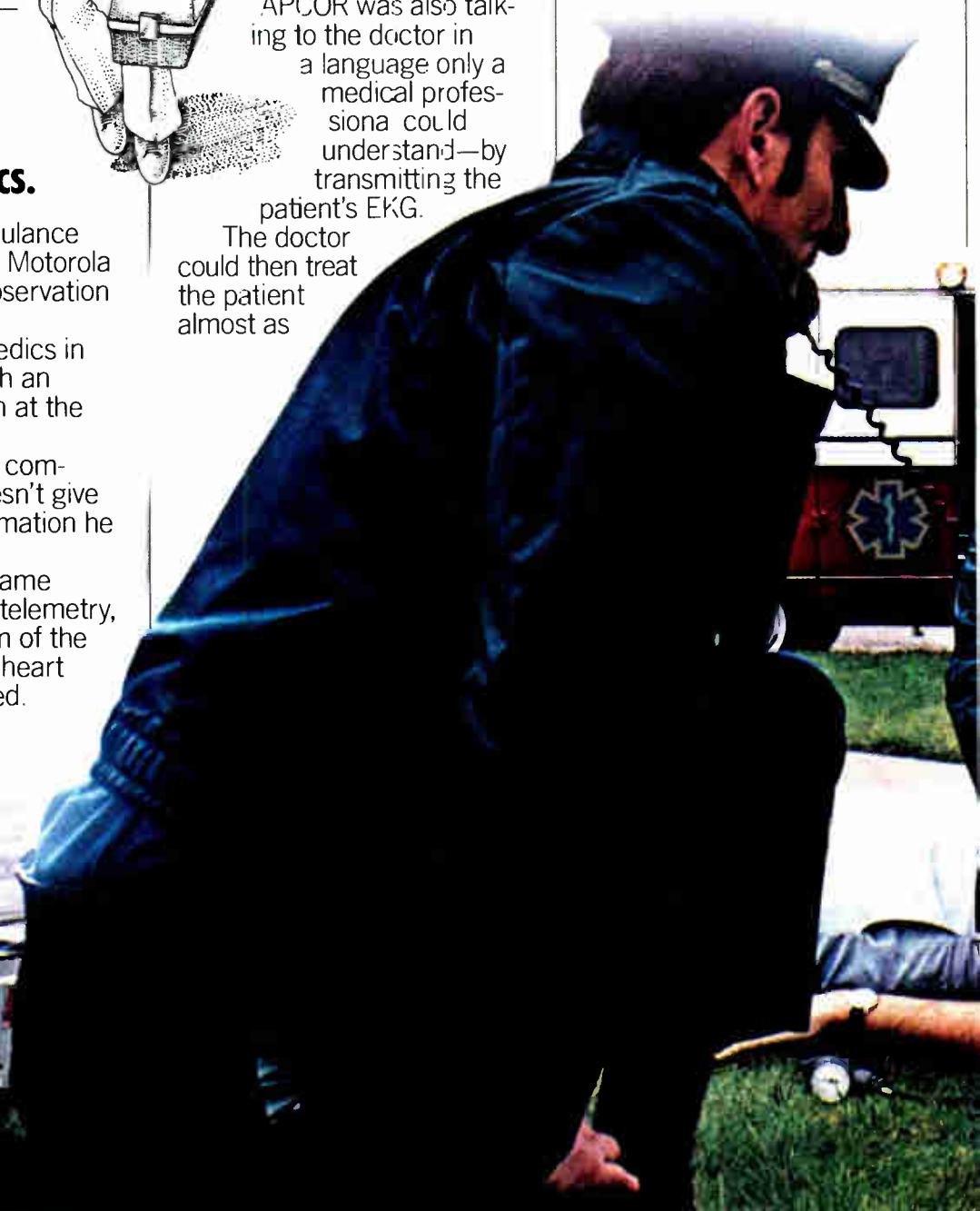

# THIS MAN BACK TO LIFE.

signals and the human voice.

Microcircuitry is also at the heart of the many other kinds of two-way communications equipment we make.



*A microcomputer, drawn larger than life.*

But communications equipment is only one of the ways in which Motorola makes electronics history.

## MAKING ELECTRONICS HISTORY.

Thanks to Motorola microelectronics, we create all kinds of remarkable systems that would

have been inconceivable not long ago.

A system to help power companies handle peak loads without danger of blackouts.

An electronic car-engine management system that can save gasoline.

Even a communications system that helped probe Mars.

But then, we've come a long way from the time we first made history by putting radios into cars (we went on to put alternators and electronic ignitions

into

them) and later put popular-priced TV sets into homes (they're a product we don't make here at all anymore).

Today, Motorola is one of the world's largest manufacturers dedicated exclusively to electronics, as well as one of its foremost designers of custom and standard semiconductors.

Many of the things we make are changing people's lives.

Others are actually saving them.



## MOTOROLA

### Making electronics history.

Circle 154 on reader service card

APCOR, Motorola and  are registered trademarks of Motorola, Inc.

For further information, write Public Affairs Office, Corporate Offices, Motorola, Inc., 1303 E. Algonquin Road, Schaumburg, Illinois 60196.





# MOTOROLA HAS DEVELOPED A

It isn't as if we had invented the wheel, but at Motorola we appreciate some of the feelings of the person who did. Because we have developed a microprocessor—the 16-bit MC68000—of such exceptional speed and capacity that, quite frankly, we don't know all the uses that equipment designers will find for it.

Of course, we know a lot of its applications. And its capabilities are so impressive that we think the MC68000 is authentically a new frontier in electronic innovation. And because we have developed the technology for making the MC68000 in great quantities, we think it may indeed be the great problem-solver of the eighties.

## **ELECTRONIC HORSEPOWER.**

We developed the MC68000 to

handle jobs that benefit from more speed and efficiency than earlier microprocessors could supply. For instance, the additional electronic horsepower of the MC68000 can more cost-effectively turn a typewriter work-station into a complete desktop computer, one with a capacity available only in a room-size computer just a few years ago.

It can give a telephone switchboard the discretion to direct many thousands of phone calls simultaneously, each by the cheapest route.

It can give the auto industry an important increase in the ability to control engine efficiency by giving engines the ability to respond to measurements of such minutiae as air temperature, barometric pressure, altitude, even changes in the chemical composition of gasoline.

It can give the utility industries the ability to distribute electricity in response to second-by-second changes in customer demand.

It can sleeplessly tend scores of patients in intensive care, automatically and instantly responding to critical signs (it can cope with two million instructions per second) with all the relevant corrections.

Even more exciting, however, are the applications we know nothing about.

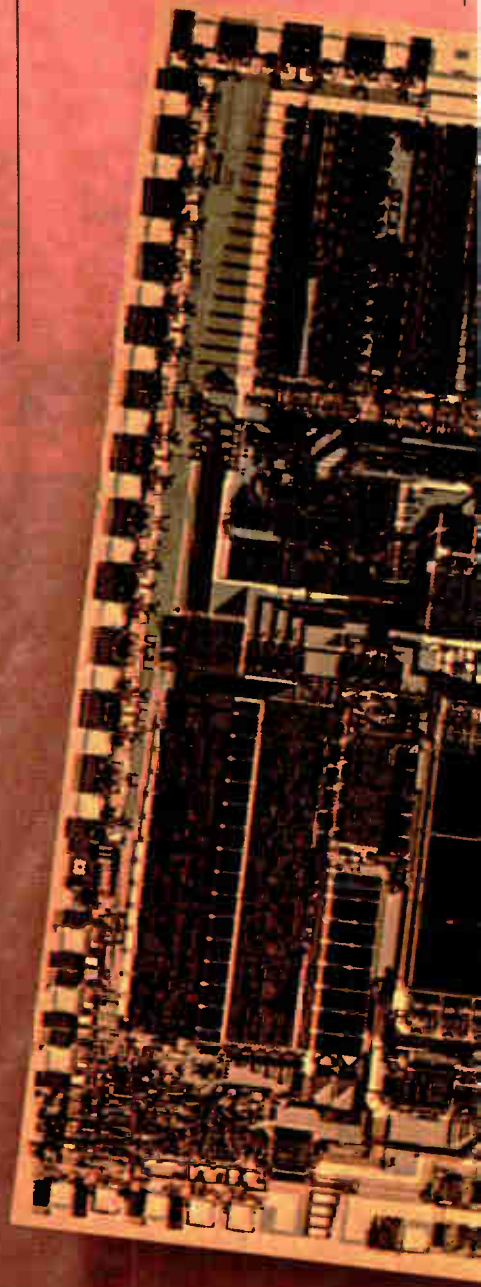



# PROBLEM-SOLVER FOR THE '80s.

## ELECTRONIC HISTORY IN THE MAKING.

What are the applications of a superchip that measures only one-quarter inch square, but has the ability to control a memory containing 128 million bits of data, and can complete a job in microseconds instead of minutes? The mind flies.

Perhaps a worldwide medical diagnostic network that recognizes the symptoms and knows the prescribed treatment for every identified disease on earth. Perhaps computerized machinery to disassemble a space

satellite automatically the moment its orbit begins to decay.

Perhaps an industrial computer that can handle everything, from extraction of raw materials, to packing and shipping to retail outlets. Or an automated national allocation system for home heating fuel, with computers in every city and town to regulate fuel distribution by local temperature fluctuations.

## PUSHING THE LIMITS OF MICROELECTRONICS.

Motorola, of course, makes only the microprocessor and peripheral support

chips. But the MC68000 is a tool of enormous sophistication. In a very legitimate sense, it is a tool for ex-

panding minds, extending possibilities, exciting exactly that sense of practical wonderment that is the real source of all progress.

Motorola's MC68000 is a giant stride even for a company that systematically explores the very limits of microelectronics technology; that has become a foremost producer of semiconductors; that has become one of the world's largest manufacturers devoted exclusively to electronics.

We have been making electronics history since 1928. With the MC68000, we have outdone ourselves.

*For further information, write Public Affairs Office, Corporate Offices, Motorola, Inc., 1303 E. Algonquin Road, Schaumburg, Illinois 60196.*

*Motorola and  are registered trademarks of Motorola, Inc.*



## MOTOROLA

### Making electronics history.

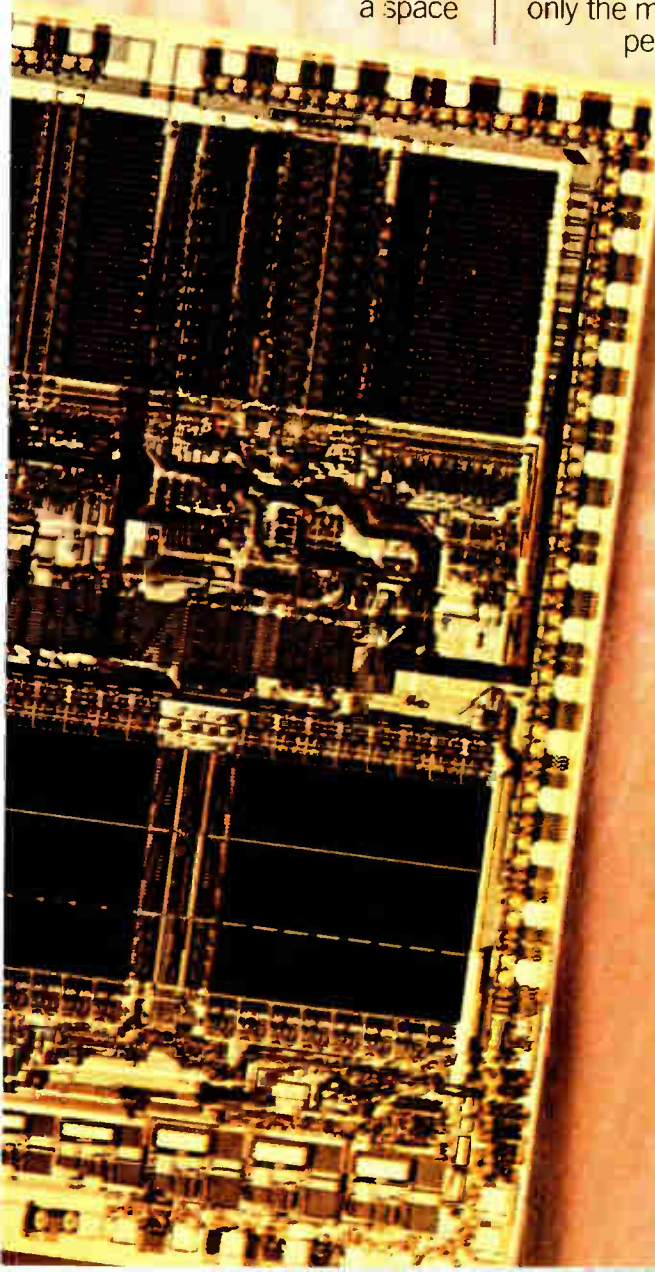



# MOTOROLA HELPS STRETCH GAS MILEAGE

Automotive manufacturers are caught between a rock and a hard place. They are obliged not only to reduce fuel consumption, but also, at the same

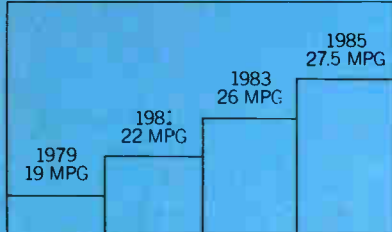

Government mandated Corporate Average Fuel Economy (CAFE) standards. Source: NHTSA

time, to reduce harmful exhaust gas emissions. And these objectives seem to be mutually exclusive.

An engine whose carburetor and spark timing are

adjusted to give high mileage tends to produce unacceptable levels of pollution. The same engine, adjusted for low pollution levels, uses more gas and gives disappointing performance.

The trick is to burn exactly the right amount of fuel at exactly the right moment. But what is "right" depends on a whole complex of constantly changing factors, including terrain, engine and air temperature, barometric pressure, and the load and speed of the car.

It would take a genius to juggle all those factors. Fortunately, Motorola has been working on the problem for some time, and has in fact

produced just such a genius.

## **ELECTRONIC ENGINE MANAGER.**

It's an electronic engine-management system, controlled by a microcomputer that thinks like a first-rate automobile mechanic. It lives inside the car, and because it can make a million calculations each second, it can automatically regulate carburetion, spark timing, and the recirculation of exhaust gases through the engine. It makes all these adjustments continuously, so you get as much performance with as little pollution as possible, whatever the driving conditions are at that particular moment.

It's a real computer in

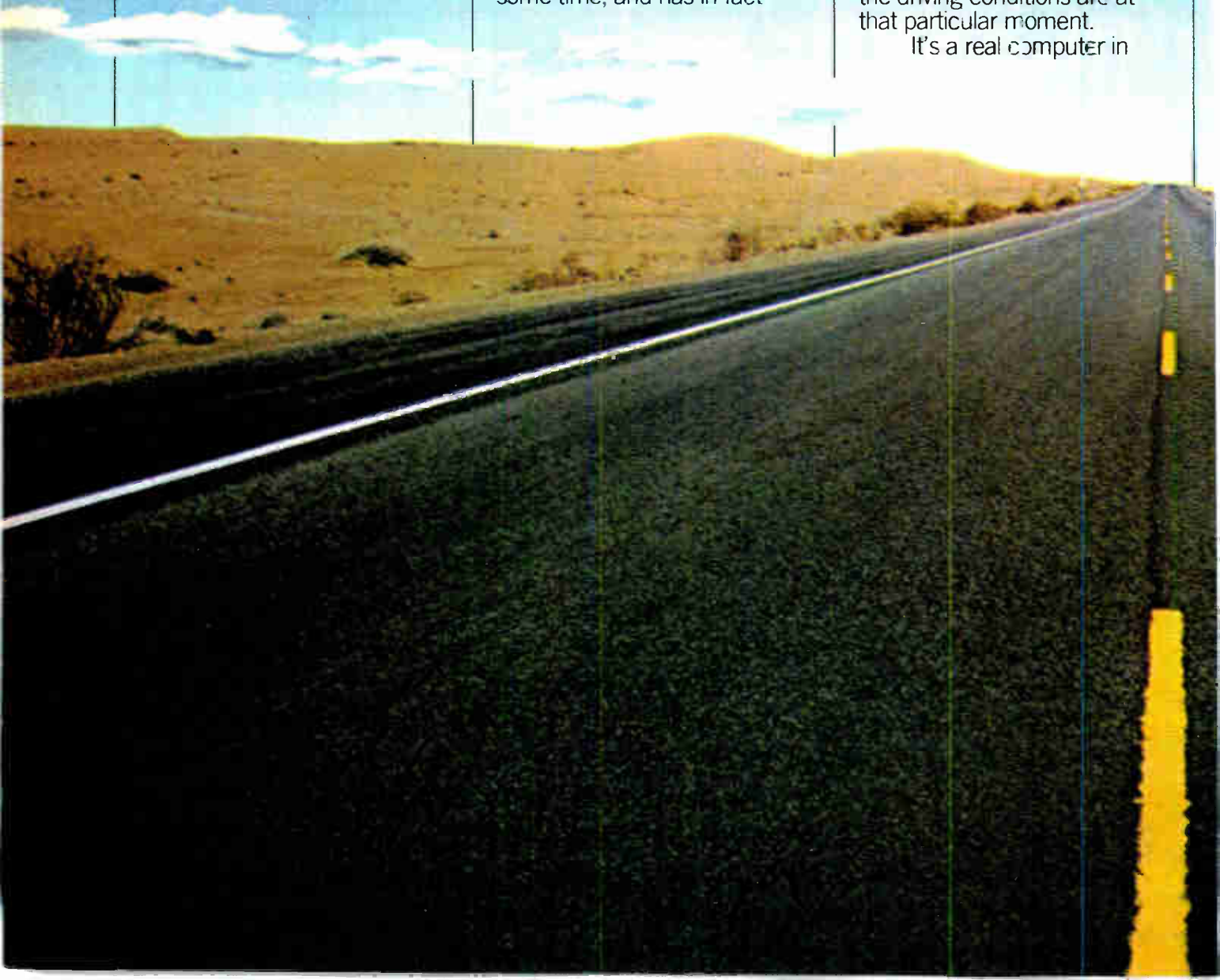

# BY MAKING ENGINES THINK.

miniature, with a memory and the ability to manipulate what it learns in terms of what it already knows. It works so well that car and heavy-duty-equipment manufacturers in America and Europe plan to use it, some as early as the 1980 model year.

## IMPOSSIBLE WITHOUT ELECTRONICS.

Such precise, continuous engine management would be impossible without the integrated circuit, an electronic microcosm that contains the equivalent of twelve thousand transistors and measures about 5mm square. These small miracles are the central nervous system of Motorola's electronic engine-management system,

and they're a remarkable but not unique demonstration of the kinds of things Motorola is doing with microelectronics today.



*A microcomputer, drawn larger than life.*

## IMAGINATIVE ELECTRONICS.

Motorola is not only one of the world's largest manufacturers dedicated exclusively to electronics, but also one of its foremost designers of custom and standard semiconductors.

We've come a long way from the time when we put radios into cars fifty years ago, and TV sets into America's living rooms. Now we make hundreds of

models of two-way radios, and we no longer make home TV sets here at all.

We make microelectronics carry telephone services to places where there are no phone lines. Transmit electrocardiograms and voice messages simultaneously from the scene of an accident to a nearby hospital. Help the energy industries develop the resources of the earth, the sea and the sun.

And we help make automobile engines think about how they use precious fuel.



## MOTOROLA

### Making electronics history since 1928.

Circle 161 on reader service card



For further information, write Public Affairs Office, Corporate Offices, Motorola, Inc., 1303 E. Algonquin Road, Schaumburg, Illinois 60196.

Motorola and  are registered trademarks of Motorola, Inc.





**MOTOROLA**

**Making electronics history.**

# WRESTLING WITH COMPONENT DESIGN AND APPLICATION? LOOK TO STACKPOLE FOR HELP

If you think of Stackpole as just another source of electronic components and materials, you're overlooking one of our most important products. Help.

**Stackpole can help** with your stickiest design and application problems. For example, we can help simplify manufacturing with our enclosed, modular switches. Or can help save board space by squeezing more resistance into smaller thick-film networks. And we can help you meet deadlines, with full stocks and very competitive lead times, even on custom configurations. All this at prices that help *you* stay competitive.

**For over 70 years**, we've been deeply involved in electronic design, product engineering and materials application. As our "Stackpole" shows, our components and materials are used by a wide variety of leading electronic manufacturers. So, the next time you're wrestling with a problem in one of these product areas, look to Stackpole.

**Switches:** slide, rotary, rocker and key-switches; keyboards and custom switches. **Resistors:** fixed-composition, carbon-film, metal-film and special-purpose resistors; thick-film resistor networks. **Ferrites:** ceramic permanent magnets, magnetizable powders and soft ferrite cores. **Get to know Stackpole better.** Write for our new brochure, or call Dauer Stackpole Corporate Marketing Manager, Stackpole Carbon Company, St. Marys, Pa. 15857. Phone: (814)-781-1234.



## STACKPOLE

Get to know us. We can help.





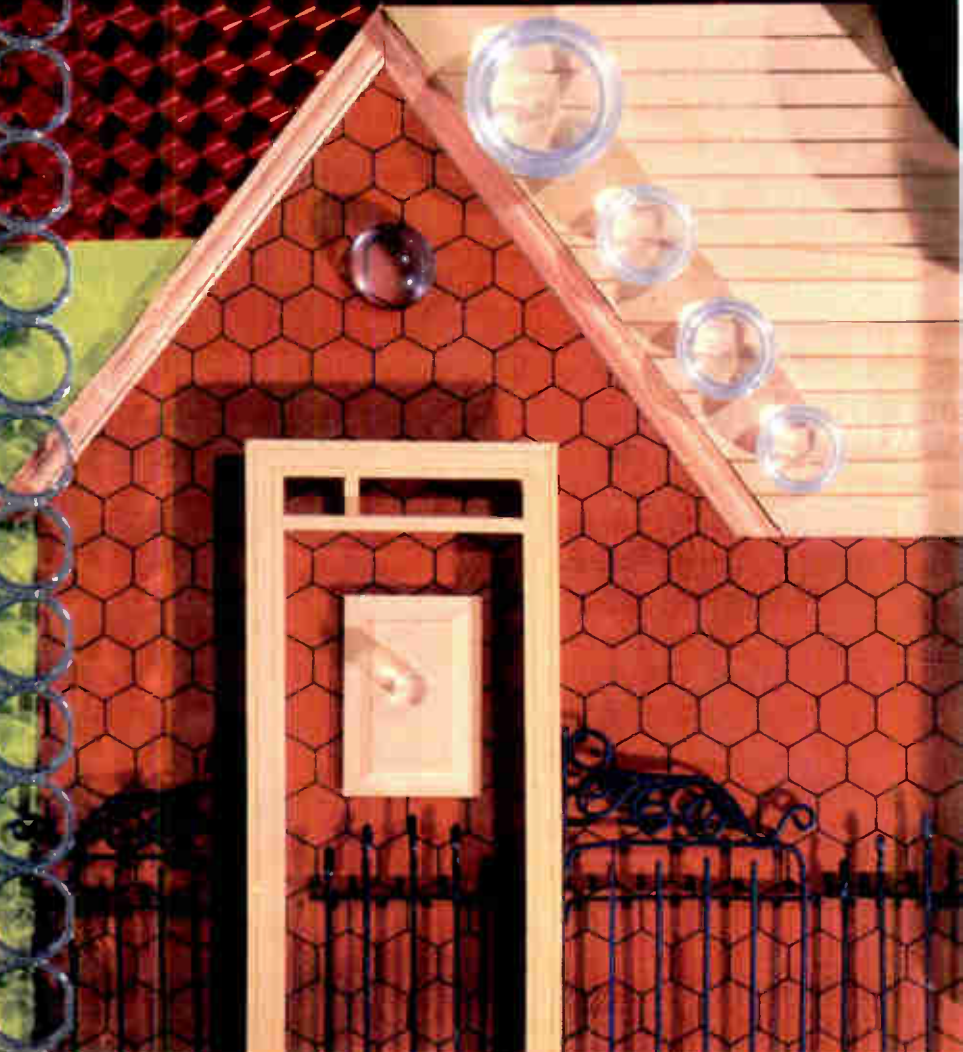



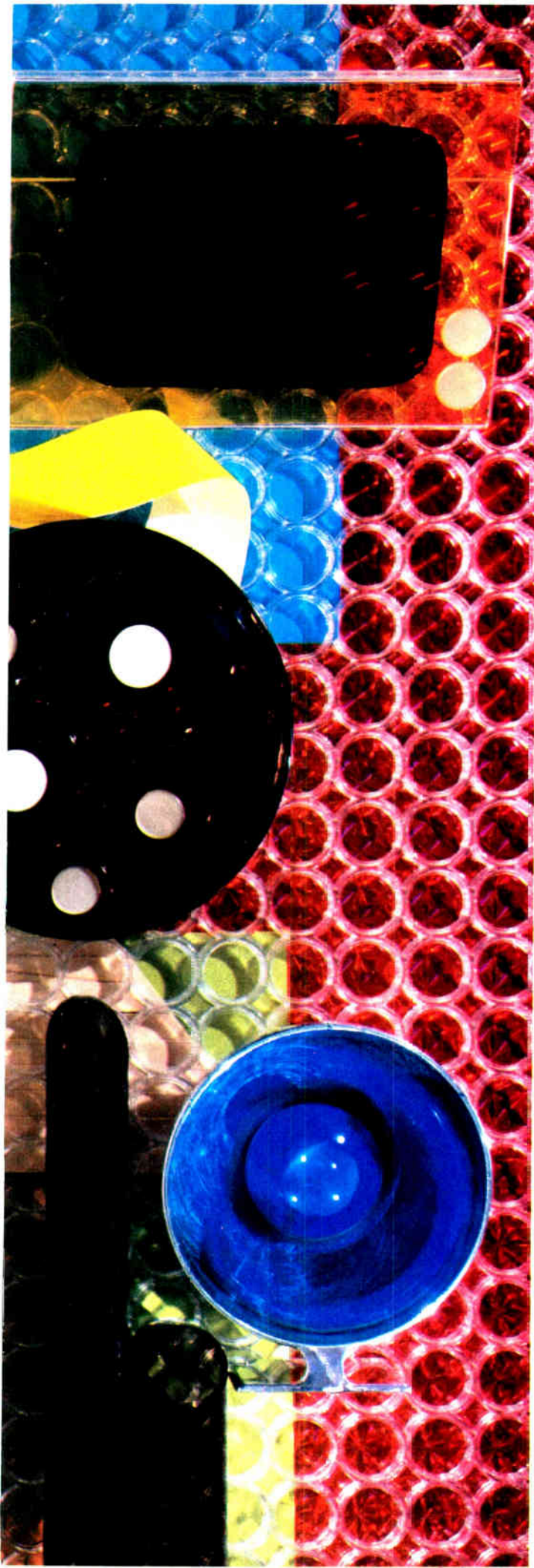

# FUTURE

---



IF WHAT'S PAST  
IS PROLOGUE,  
THE FUTURE OF  
ELECTRONICS

WILL BE ONE OF  
RAPID CHANGE—  
INNOVATION RIDING  
ON THE CREST OF  
TECHNOLOGY. IN  
THE NEXT 20 YEARS,  
SYSTEMS THAT REFINE  
THE RUNNING OF THE  
HOME, THE WORKPLACE,  
AND SOCIETY AT LARGE  
WILL TRANSFORM THE  
ROUTINES OF EVERYDAY  
LIFE. BUT FIRST THE  
LIMITS OF TODAY'S  
TECHNOLOGY MUST BE  
TRANSCENDED. AND  
AS THEY YIELD, THE  
ENGINEER'S CAREER  
WILL UNDERGO  
FORESEEABLE REVISIONS,  
AND THE ELECTRONICS'  
INDUSTRIES COULD  
EXPERIENCE EXTENSIVE  
RESTRUCTURING.  
IN SHORT, THE FUTURE  
PROMISES TO BE EVERY  
BIT AS EXCITING AS  
THE PAST.



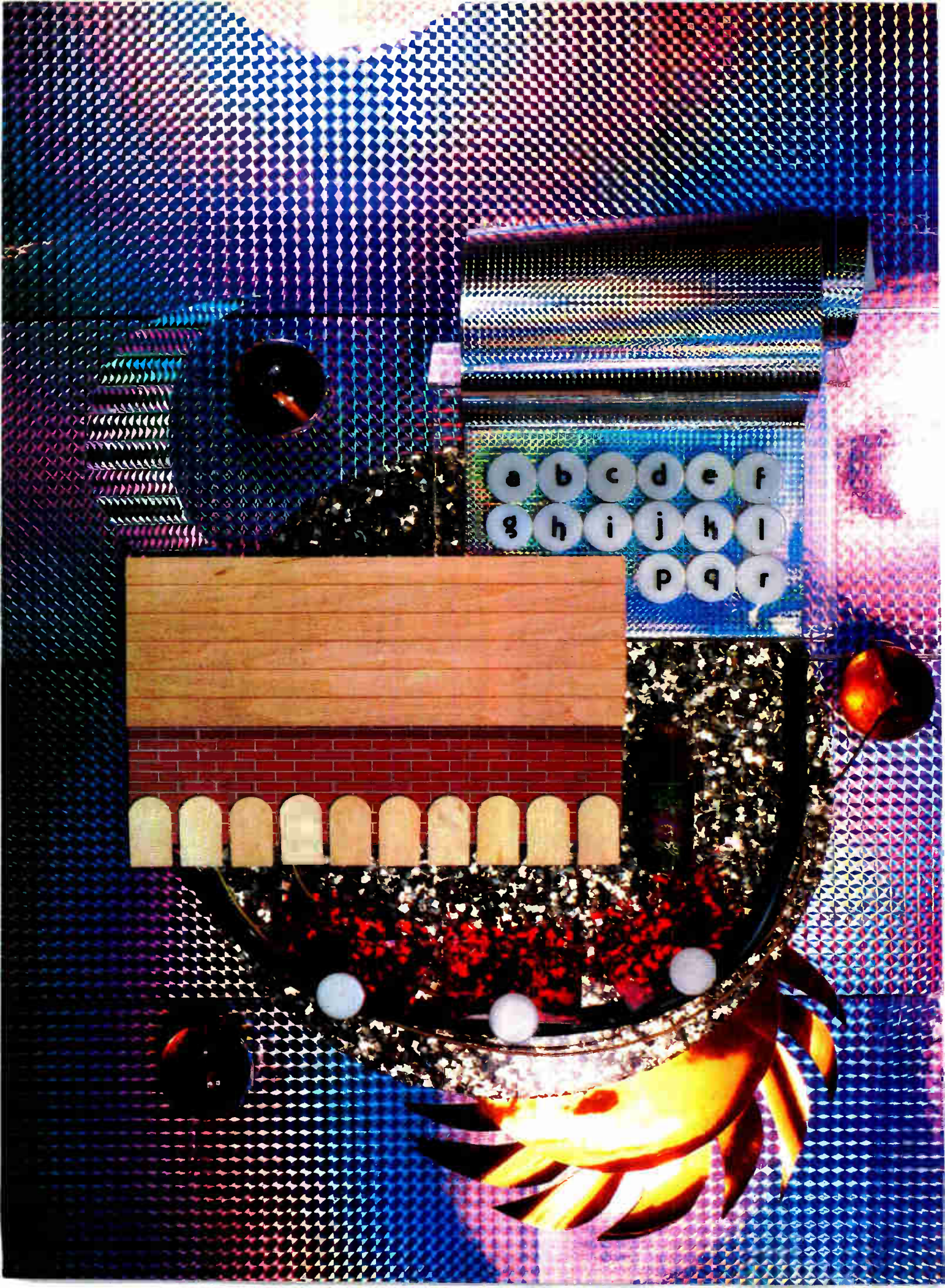

a b c d e f  
g h i j k l  
P q r

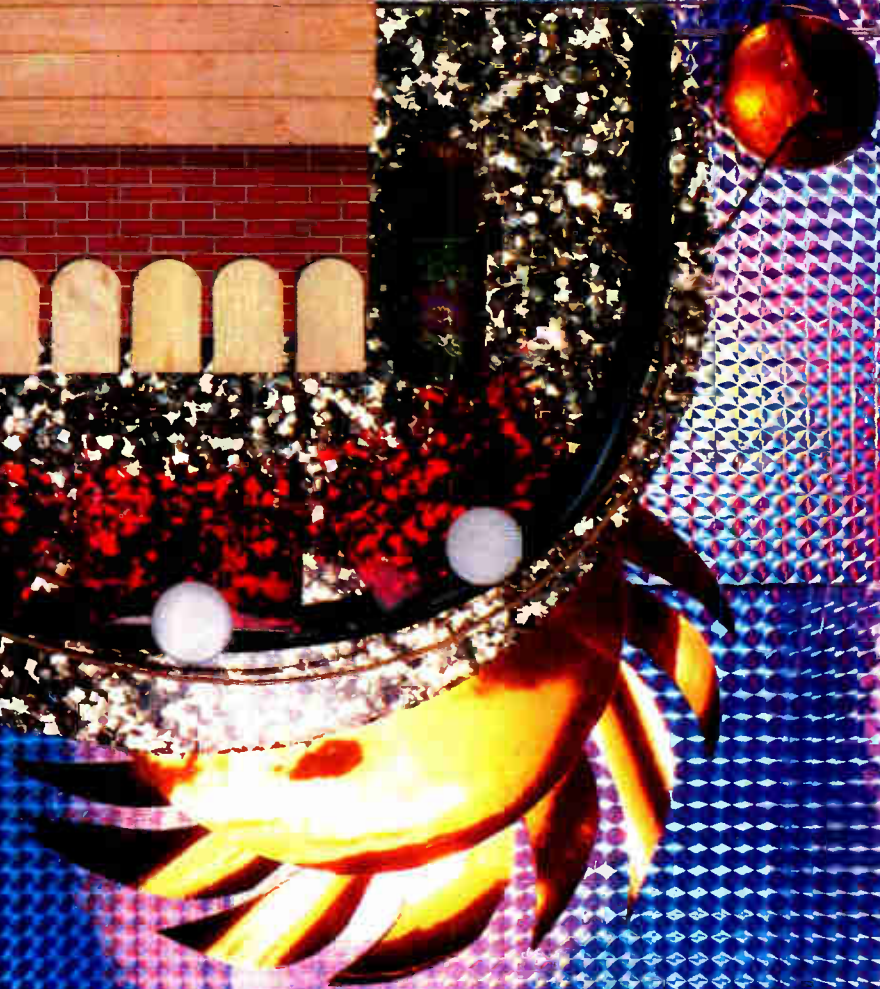



# SYSTEMS

---



THERE WILL BE  
INTELLIGENT  
ELECTRONIC  
SYSTEMS ALMOST

EVERYWHERE—IN  
MOST HOMES, SCHOOLS,  
OFFICES, AND  
FACTORIES, IN HEALTH  
CARE CENTERS,  
DEFENSE ARSENALS,  
AND IN SPACE. THE  
GREAT DIGITAL  
TAKEOVER THAT BEGAN  
IN THE LAST DECADE  
WILL ACCELERATE  
IN THE NEXT TWO  
UNTIL, BY THE YEAR  
2000, THE AVAILABILITY  
OF INEXPENSIVE  
COMPUTING POWER  
COUPLED WITH EXTENSIVE  
COMMUNICATIONS  
NETWORKS WILL HAVE  
WOVEN ELECTRONICS  
INEXTRICABLY INTO  
THE VERY FABRIC OF  
SOCIETY. FOR BETTER  
OR WORSE, THIS  
MARRIAGE OF COMPUTERS  
AND COMMUNICATIONS  
WILL EXPAND A  
PEOPLE'S CONTROL OVER  
ITS CIRCUMSTANCES IN  
A MYRIAD NEW DIRECTIONS.



The most significant coming trend in electronic technology will be the gradual merging of telecommunications and data processing, a meld that by the year 2000 will have profoundly affected many aspects of our daily lives.

There is not yet a generally accepted name in English for this development. But the French, precise in their language, have come up with a term—"télématique"—to suggest a marriage of telecommunications networks with data processing. Perhaps "information teleprocessing" will come to convey the idea of communicating and acting on knowledge from a distance.

Whatever its label, the process will have an enormous impact on the home and workplace. At the heart of this trend will be a combination of inexpensive computer power and ever increasing memory capacity provided by semiconductor technology.

Electronics in the form of dedicated intelligence will be everywhere—in home entertainment, appliances, automobiles, airports, highways, offices, banks, stores, factories, hospitals, schools, and, of course, in space. Prodigious strides have already been made along these lines, but the sheer volume of information processed, stored, and transmitted in the future will be mind-boggling.

The world, then, is entering what one industry researcher terms the "era of computational plenty." But to exploit this new wealth, further advances will have to be made.

One of the obvious requirements will be a means of rapidly extracting desired information from the massive amounts of data there will be on file in the proliferating processors. Thus there will be a need for systems that adapt to the user rather than responding only to programmers.

What steps will have to be taken in a society filled with machines that must "talk" to everyone? For one thing, very large-scale integration (VLSI) will lead to new devices designed specifically to exploit submicrometer spacing and reduce interconnections to maintain speed. Where a prime concern so far has been the reduction of active elements—integration—the emphasis in the future will be on reducing interconnections.

A second key area of development will be interface technology—getting data into and out of the computers. Back when "Star Trek" was a hit show on television, viewers were amused by the easy discussions Captain Kirk and his crew carried on with a computer that replied in a sexy female voice. In Stanley Kubrick's movie "2001: A Space Odyssey," the computer HAL also chatted with the crew matter-of-factly, though it showed definite signs of "emotion" when it tried to take over control of the mission.

So much for science fiction. Verbal communication with processors in natural language via voice recognition and synthesis may become fact in the next decades. Image recognition will also become far more sophisticated than it is today. Actually the term should be image understanding, because the computer will not only identify pictures, including television images, but act on

them. This capability has tremendous implications for the factory, the office, and the home, as well as for intelligence agencies.

Attaining these capabilities will require a great increase in machine intelligence—in the computer's ability to infer and deduce. That intelligence is the basis for speech recognition, image understanding, and automatic programming, and VLSI will ensure the requisite quantity of input/output.

In the systems of tomorrow, the electronic content—processors, memories, and peripheral chips—for the most part will be invisible to the user and taken for granted. Their functions will be paramount, and only the various I/O devices generally will be apparent. To use a favorite analogy of Robert Noyce, chairman of Intel Corp. in Santa Clara, Calif., the electronics will be like the electric motors in today's homes—largely unnoticed.

One of today's fascinating topics concerns the future of the personal computer and its close relative, the home computer. Looking ahead, Michael L. Dertouzos, director of the Laboratory for Computer Science at the Massachusetts Institute of Technology in Cambridge, Mass., defines a personal, or single-user, computer as a machine 64 bits wide containing from 1 to 12 megabytes of storage divided between mainframe and peripheral memory. This unit will almost always be capable of linking with other similar machines to form networks, he says, and will be used in the home, office, or elsewhere depending on its programming.

The availability of such communications linkups will be as important as the availability of hardware and programs. Willis H. Ware, a researcher at the Rand Corp. in Santa Monica, Calif., sees telecommunications support as a major spur to the small-computer market. He predicts the emergence of entrepreneurs who will interface a network of personal computers to offer new services such as electronic messages for subscribers.

Regarding trends in hardware and software, Ware notes that parallel computing—breaking up the workload of the central processor so it can handle data concurrently—is already being tried, and he expects this approach eventually to dominate computer architecture.

Software—instructions and programming of the data processors—will of necessity go back into hardware, where it started, Ware says. The reasons he cites are economic.

As the Rand researcher explains it, hardware was so expensive at the start of the computer era that software's chief role was to keep it running as much as possible. But to minimize system downtime, the software had to become more and more complex to the point where the expense of writing and implementing it soon rivaled hardware costs, which were steadily being pared by large-scale integration. The two cost curves have long since crossed, Ware observes, adding that burying—or re-interring—software in the hardware will also promote security.

What of overall growth prospects for the industry? "Computer people seem year after year to say, 'It can't





## French philosopher of the future

Among practicing futurologists, Robert Veilex of France's Centre National d'Etudes des Télécommunications has an easier job than most who try to predict the future. Veilex is charged with formulating long-range plans for CNET, the research and development arm of the Direction Générale des Télécommunications (DGT), an agency of the Secrétariat d'Etat des Postes et Télécommunications, the organization that is in charge of running the country's telecommunications system.

Veilex is a relatively secure seer because his views carry heavy weight with the postal authority and thus are partially self-fulfilling. "Electronic technology is on the verge of changing society as profoundly as the invention of printing," he states. "Printing multiplied the diffusion of infor-

mation in society; electronics makes possible a greater diffusion in real time."

All the conditions are at hand, he feels, for an explosion of what the French call "télématique," the marriage of telecommunications networks and data processing. The technology to accommodate this explosion is available to those who want it, he points out.

"It takes a couple of decades for people to get accustomed to a major invention," he goes on, "but by the turn of the century 'télématique' will have taken hold. Consumption of paper will fall drastically as people communicate electronically. Books will become deluxe items that people buy to show they're cultivated, much as leather-bound editions are today."

go on forever," says Ware. "But since every level of society consumes information and computing technology spews it forth, that relationship should ensure virtually endless growth."

Agreeing with Ware's assessment, MIT's Dertouzos points out that for the first 15 to 20 years of computing history people tried to develop clever algorithms. The idea was to develop neat tricks to get more out of "the meager hardware resources we had."

But the way to go now, he says, is to put as much knowledge at the disposal of your program as possible and settle for some simple, perhaps redundant rules. "We're moving into the domain of cognition. And instead of making programs smaller and algorithms more clever, we're just pumping in knowledge that can be used in an intelligent terminal."

**S**peech recognition—with very limited vocabulary and syntax—is certainly on the way. But complicated techniques are needed to pick out spoken words from a whole range of sounds and, having done so, identify them from among a whole dictionary of possibilities. Therefore, conversational interface with computers currently requires an unacceptably large amount of

memory and processing power. Nevertheless, the advent of very large-scale integration could swing the tradeoff in favor of such a route.

As for software, most computer makers and users agree that a more productive way to write programs is needed. Says Joel S. Birnbaum, director of computer science at International Business Machines Corp.'s Thomas J. Watson Research Center in Yorktown Heights, N. Y., "There will have to be very high-level languages so people without programming experience as we know it can program future units."

And as the software becomes easier to foist on "friendlier" computers, specialists other than designers will take on a growing role in electronic technology. The mathematician's contribution will certainly gain in importance.

According to Kees Teer, managing director in charge of electronic systems at the Philips Research Laboratories in Eindhoven, the Netherlands, information theorists will play a larger part in the design of data-transmission systems and communications circuits. It is these specialists who will devise ways of monitoring a receiving line to check for signal similarities and cancel echoes. "Companies that know how to merge the various disciplines—engineering, the social sciences, mathematics—and put them to use in systems development will be the most successful," he predicts.

One technology that has relatively little importance today but is going to play a major role in information teleprocessing is micro-optics, Teer says. Miniature semiconductor lasers, fine and highly transparent glass fibers, new ways to manipulate laser beams, and optical imaging methods will yield new techniques for transmitting and storing information. He believes it will be possible to develop more intelligent equipment "that will be operated by verbal commands, announce if there is anything wrong with it, diagnose itself, and tell you how it is to be used."

The driving forces in electronics now and for the foreseeable future—solid-state technology and comput-

**House in the sun.** This Japanese-style home of the future was built to demonstrate the use of solar energy. Operated by Sharp Corp. for a project sponsored by the Ministry of International Trade and Industry, the house uses photovoltaic panels for electricity.

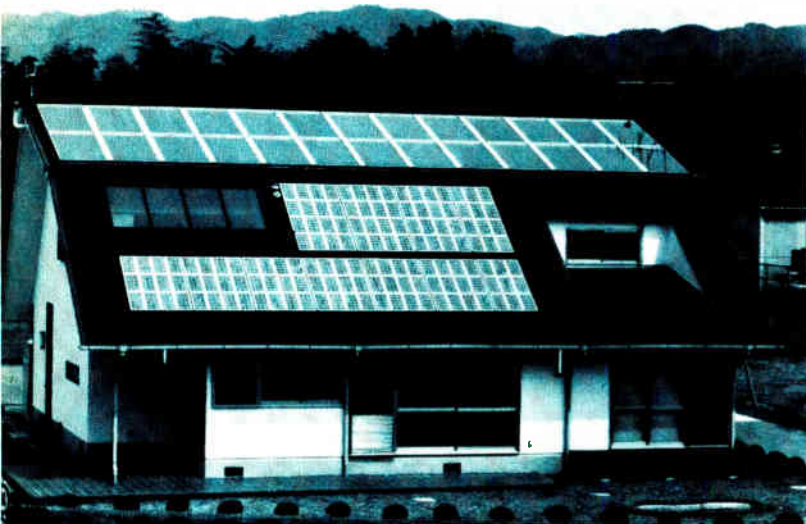

# THE FIRST TO ENTER THE 21st CENTURY.

In this 50th anniversary issue of "Electronics" you will read all about the wonderful and exciting things that happened in the electronics industry during the past fifty years, a half century in which electronics played a major role in changing our way of life so drastically that no preceding half century even faintly compares. But drastic as were the changes in the last fifty years, we may see changes even more dramatic

---

*"The force of ideas is the fuel that leads to innovation; it is this shortage we have to be really concerned about."*

---

in the single decade of the upcoming 80's. By 1990 the electronics industry could reach the sum of \$400 billion and represent 10% of the GNP. Computers, with their uncanny pervasiveness, will invade practically every industrial and consumer activity. The awesome power of electronics and its amazing ability to keep growing as an industry, makes it necessary to step back and reflect on our obligations to society. In fact, that's what anniversaries are for.

Gertrude Stein said, "The Americans are the oldest people in the world because they were the first to enter the 20th century." Electronics was, for Americans, one of the most important gateways into the 20th century. Fifty years ago in April 1930, a magazine calling itself "Electronics" published its first issue and the opening article was entitled "The Future Service of Electronics to Mankind." And this, mind you, appeared 18 years B.T. (Before Transistors) which

---

*"In the 21st century information transfer will become power and electronics will be the dominant resource."*

---

illustrates what Gertrude Stein meant. The three services we would select to head the list, none of which the writers in 1930 foresaw, are the invention of radar (which saved England in WW II), the invention of the transistor, and the development of the computer (which grows more powerful as it gets smaller). These are just three of the milestones in the past fifty years.

Today at the start of the 80's, the biggest threat to our nation economically, socially and politically is "oilflation." It's a threat which engulfs the whole world, hitting at some nations even harder than at our own. In 1974 OPEC increased the price of crude oil by 400%. By the end of 1979 that price doubled, bringing the increase to 800%. Projections for the next five years forecast another doubling, which means that

in a period of ten years the price of oil will rise 1600%! Couple this figure with the ever increasing consumption of oil in all sectors of our society, industry, military, family, and it takes a minimum of expertise to see what persistent oilflation will do to us.

It is the obligation of the electronics industry to be the catalyst that will enable the U.S. to free itself of dependence on oil imports from anywhere in the world except the North American continent. Electronics technology can develop improved instruments in every area where energy is a factor such as the search for new oil and gas fields and the efficient control and management of energy usage in home, office and factory.

The 20th century started out as an electro-mechanical world and we Americans, by inventing, discovering, borrowing and adapting became the world leader. Having only 6% of

---

*"The Americans are the oldest people in the world because they were the first to enter the 20th century."*

---

the population, we used 30% of the world's energy. Energy usage was the yardstick of a nation's progress. Energy was, and still is, power, but in the 21st century information transfer will become power and electronics will be the dominant resource for the generation and storage of information. As an industry, we must lead the world into a workable 21st century. We must realize that the abundance of resources that was perceived in 1880 have become finite, if not scarce, in 1980.

In the fifty years gone by, electronics helped us solve problems from the most mundane to the extraterrestrial. The force of ideas is the fuel that leads to innovation; it is this shortage we have to be really concerned about. In the decades to come, we must identify the crucial needs of society and put our electronics ingenuity to work to bridge the tide that threatens us all. Will we be the first to enter the 21st century?

Sincerely,

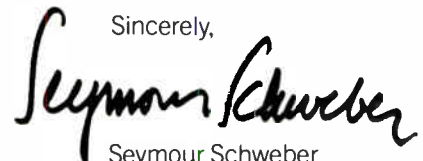

Seymour Schweber  
President  
Schweber Electronics



**Bipolar  
is our business.  
And our  
future.**

# MMI is committed to designing and delivering the bipolar product you want. In volume. On time.

## Continued leadership in bipolar technology.

MMI has grown to become a \$65 million company by consistently designing and delivering state-of-the-art bipolar LSI products. And now we're growing faster than ever.

Our tradition of excellence began with the industry's first 1K PROM in 1971. This was followed by the first 2K, 4K and 8K bipolar PROMs, by the first fast 8x8 multiplier, and then the 15 MHz FIFO. Our latest innovation is PAL™ programmable array logic, the LSI circuit which allows you to program your own logic on a chip.

And we'll continue the tradition, working hard in the future to develop products which are denser, faster and more economical . . . the products you want!

## Delivery that keeps pace with our designs.

MMI has made a commitment to deliver large volumes of bipolar products. We currently ship—and will continue to ship—more bipolar PROMs than anyone else in the world.

Our annual output has tripled during the last twelve months.



MMI was the first to install a 4-inch bipolar wafer fab line. And we will expand that line's capacity by another 80% before the end of 1980. At the same time, we have begun converting

our 3-inch line to 4 inches and will double its output by mid-1981. We have also broken ground on a new assembly facility and expect it to be operational by September of this year. Over the next few years we'll spend 15-20% of every sales dollar on facilities and equipment to assure you volume delivery of MMI's bipolar LSI.

## Let us prove it.

Send for a specially prepared report which details MMI's engineering and production capability and outlines our extensive line of digital bipolar LSI products. Please address your requests to Applications Department, Monolithic Memories, Inc., 1165 E. Arques Ave., Sunnyvale, California 94086.

**Monolithic Memories** 

Circle 453 on reader service card



"You're starting your own farm but you don't have much money. You'd better not plant asparagus. It takes two years to grow. Your money could run out before you've got a crop. That's why we started as an alternate source. Now we're ready for the asparagus business."

W.J. Sanders III, President  
March, 1979

"Asparagus:"

It was just a word, but it stuck.

"Asparagus" symbolizes Advanced Micro Devices' innovative proprietary products.

The Rabbit™, the Am9512, is asparagus. It's the world's fastest TTL multiplier.

The Time Machine™, the Am9513, is. It's the most powerful timing device ever created. Our Am6012 12-bit DAC and our 256x4 RAM, the Am93422, made with the ion-implanted,

oxide-isolated process (IMOX™) certainly are Asparagus.

We brought out some great new products in our growing line of MOS peripherals. We have a new generation of bipolar

**"It was a very good year for asparagus"**

PROM's that utilize platinum-silicide fuses. Every one Asparagus.

As it turns out, our alternate-source business is terrific, from the AmZ8000 16-bit micro-

processor family to the 16K RAMs.

We've given a twenty-million dollar start to our new Technology Development Center, and our new Austin campus is off and running.

Advanced Micro Devices is eleven years old. When we started this business we decided to make building blocks of ever increasing complexity for the communications, computation and instrumentation markets. We made a commitment to excellence and quality. Every part built to MIL-STD-883 or better. Free.

We figured if we stuck to those two basic ideas, we'd pace the industry and become a major factor in integrated circuits world-wide.

And we were right.  
Right, from the start.

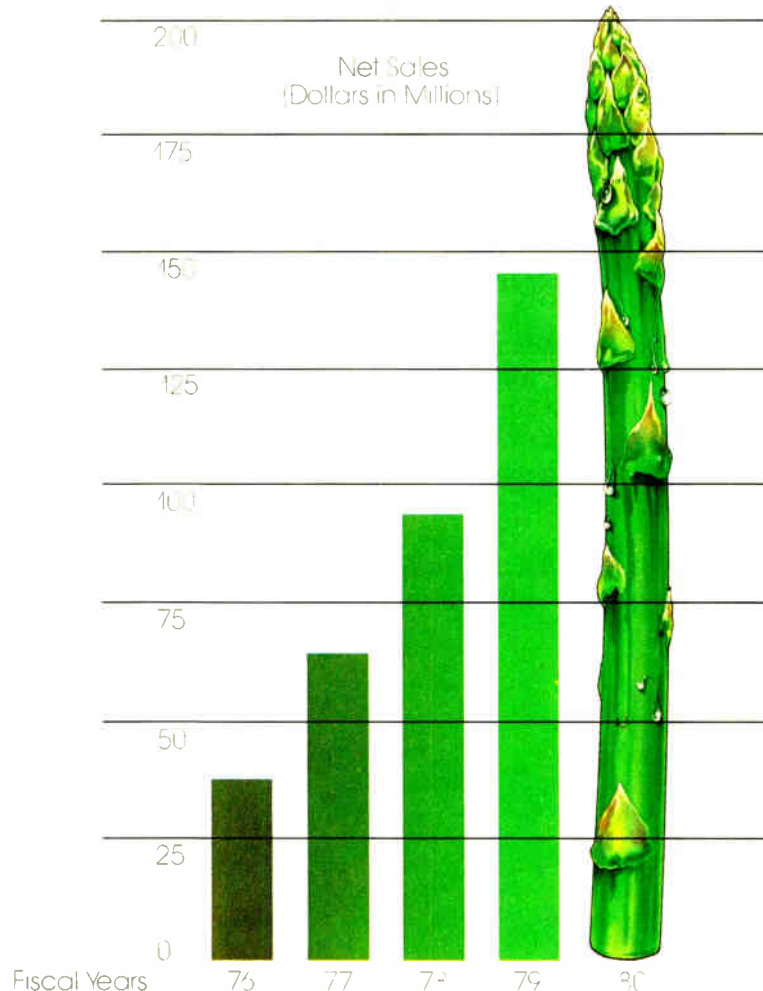

**Advanced Micro Devices** 

4 Thompson Place, Sunnyvale, CA 94085 Telephone (415) 732-2111

FRENCH SURVEY ON IMPACT OF COMPUTERS

	1980	1985	1990	1995	2000	2010	2020	After 2020	Percent	Irrelevant question	Total
Most banks interconnected through a computer network	22	69	23	6	3	—	—	—	—	1	124
Electronic mail the main means of communication in business and industry	1	18	51	25	20	3	—	2	4	1	125
Direct access of individuals to data networks by ordinary telephone lines	16	40	38	18	7	2	—	1	1	2	125
TV-oriented interactive information systems for households	7	33	34	22	17	8	2	—	1	3	127
More than half of manufactured articles produced in plants with automated parts-making operations	1	15	39	29	19	9	2	4	1	—	119
More than half of manufactured articles produced in plants with automated assembly operations	—	1	18	23	37	10	4	13	10	—	116
"Paperless" administration: massive use of computers in offices and administrations	5	16	21	28	25	12	3	4	10	1	125
Automatic translation of unambiguous text	2	17	27	17	26	6	6	9	7	4	121
Computer-aided diagnosis in doctors' offices	9	32	39	24	11	3	—	2	3	1	124
Massive use in higher education of sophisticated computer aids	4	18	38	15	23	11	4	3	4	3	123
Intensive use of medical consultation at home by computer	1	3	11	17	24	15	6	15	18	6	116

Note: Responses from 131 computer users and manufacturers

Source: Frederik R. Bull Foundation

er-communications proliferation—will gain momentum in large part because their economic tradeoffs will continue to be favorable. Higher densities and better performance will mark the semiconductor field for at least the next decade. Thus, integrated circuits' cost will continue to fall while their functions will continue to expand. But, some experts are already wondering how much further integration can be pushed before densities—computing power per chip—approach impractical levels. In other words, the problem arising at some point

in the next decade may be how to exploit the astounding potential of VLSI.

That suggestion seems difficult to accept today when systems designers hunger for more and more intelligence and memory capacity. Indeed, the other side of the coin is a vision in which the total data-handling needs of the world would just begin to be met by the year 2000.

In this view, the level of information teleprocessing today is just a beginning. A planner such as Patricia M. Whiting-O'Keefe, director of SRI International's Infor-

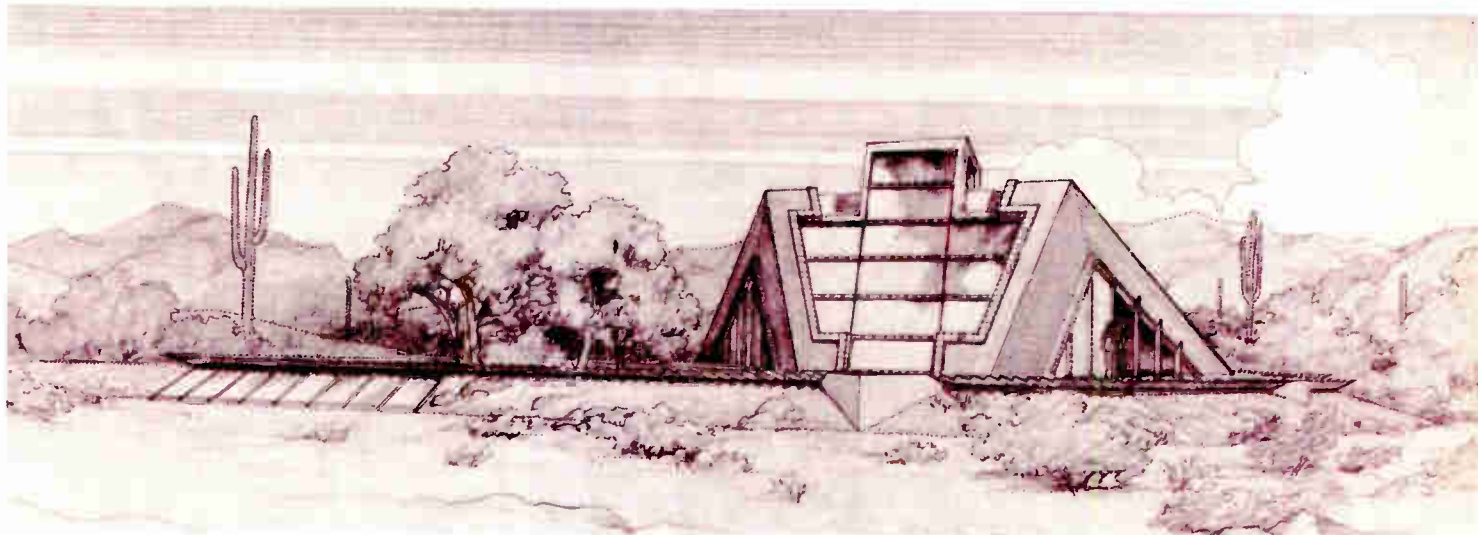

**Shining house of dreams.** Ahwatukee, a Crow Indian word, is the name of a demonstration home run by five interconnected microcomputers. The computer system has five functions: information, electrical-load switching, environmental control, energy management, and security.



mation Sciences Laboratory in Palo Alto, says information management today is "done in bits and pieces, not in a big way. The timeliness of the information is the important thing. The faster you get it, the more successful you'll be."

Another concern only now being appreciated is computer security, or loss control. "These problems are proportional to the amount of data you're storing," explains Tom S. Eason, SRI's assistant director. "As the world moves toward distributed processing, particularly distributed data bases, loss-control problems increase out of proportion to the amount of data stored."

Consequently, Eason thinks it will become universal practice to incorporate loss-control specifications in the design of new computer systems and software.

Companies are becoming aware of security needs in computer-applications programs and planning ahead, he says. Meanwhile, there may be Government regulations requiring such controls and making companies using computers liable for losses. And pressure for loss-control requirements will mount as more and more money or documents convertible to money are represented in electronic form, Eason notes.

But the complexities of information handling have been faced for a long time—actually from the start of the Industrial Revolution. And the union of computers and communications will be reality by the end of this century because society wants it. Given that impetus, technology will solve the attendant problems.



**Computer fun.** The TV set will gradually become a data terminal that displays information as well as broadcasting entertainment. Here a family uses the APF M1000 home entertainment system, which already contains some of the elements of future home computers.

**E**lectronics is now entering the home in the form of various labor-saving and entertainment and educational accessories. Over the next decades, consumers will be offered a mixed bag of home-based products, ranging from personal computers to interactive "entertainment centers." And electronics will be the silent, unseen workhorse in appliances and security systems as well.

Although there has been nowhere near the planning for the "home of the future" that has been lavished on the "office of the future," there are a number of trends today that point to the shape of domestic living circa 2000 A. D. Electronics promises to have an enormous impact on internal environmental controls and external communications. By the year 2000, the television receiver will have long since become a two-way terminal, communicating with various data bases as well as receiving the information and entertainment that has been selected by the consumer.

Actually, two forms of video technology may be involved in communications. Bulk transmissions of information will be largely displayed on the television set, with person-to-person telecommunications being carried via telephone networks linking picture-phones.

Home electronics will be shaped, of course, by the structures that will be housing it—and their design may well reflect a continuing energy pinch.

An impressive example of the direction the use of solar energy for the home is taking can be found in the house constructed by Sharp Corp. at its Central Research Laboratory in Tenri, Japan, as part of a project that was

sponsored by the Ministry of International Trade and Industry.

Energy for that building is captured both by solar cells that convert sunlight directly into electricity and by a solar heat collector that heats water. The house also features a new type of heat-driven air conditioner. It makes use of heat exchangers for both perceptible and latent heat in the air; still another exchanger transfers heat from the solar-heated water to the air. The air conditioner is used for cooling, heating, and humidity control; some of the sun-heated water, logically enough, is also used for bathing.

Sharp's photovoltaic system, consisting of a number of panels tilted at a 36.8° angle, is divided into two parts. The first, with about 90% of the total capacity, operates fans and pumps and is used as an auxiliary power supply for lighting. The second, with the remaining 10%, powers the master bedroom radio, the television set, and all the lighting throughout the house.

The first part has optimum outputs of 33.2 volts and 31.6 amperes. Its panels, covering 23 square meters and weighing 960 kilograms, charge a lead-acid battery with a nominal voltage of 24 v and capacity of 320 ampere-hours. The panels in the other part produce 16.6 v and 5.93 A optimally, total 2.1 m<sup>2</sup>, and weigh 90 kg. They also charge a lead-acid battery, this one with a nominal voltage of 12 v and a capacity of 500 Ah.

An electronic information center in the house monitors the system, providing such data as outside temperatures, solar radiation levels, the power being generated,



## Microprocessor design can be simple...

...with our Series 7000 STD BUS cards. Designed, manufactured, and tested for rugged industrial use.

Our Series 7000 cards handle anything from data processing to instrumentation or industrial control. Take your choice of 2-80, 6800 and 8088 CPU cards. We also have other cards including memory, input/output, industrial control (like TRIAC outputs and AC/DC opto-isolated inputs), and communications interfaces (such as RS-232 and TTY). We also have card racks and compatible power supplies. Our Series 7000 cards conform to the STD BUS, so all of our cards work together. Just plug them into our standard bus mother-board. No messy, inconvenient backplane wiring.

Second-source designed in at every level.

We use all second-sourced parts, parts which have been proven through years of use. Buy 250 of any one card, and we give you free nonexclusive manufacturing rights, photo-ready artwork, a parts list and assembly prints. So you can build your own cards relying on us as your second-source.

Reliability backed by a 1-year parts and labor warranty.

We test every card before and after power-on burn-in. If something does go wrong, our modular, plug-in concept means easy service. Just swap cards.

Our courses and literature show you how easy microprocessor design can be.

Write for a copy of our STD BUS Technical Manual, our Microprocessor User's Guide, and for a schedule of our free half-day microprocessor economics seminars and our microprocessor design courses. Pro-Log Corporation, 2411 Garden Road, Monterey, CA 93940, phone (408) 372-4883.



**PRO-LOG**  
CORPORATION

Circle 457 on reader service card



**“Towering genius disdains a  
beaten path. It seeks regions  
hitherto unexplored.”**

Abraham Lincoln: 1809-1865

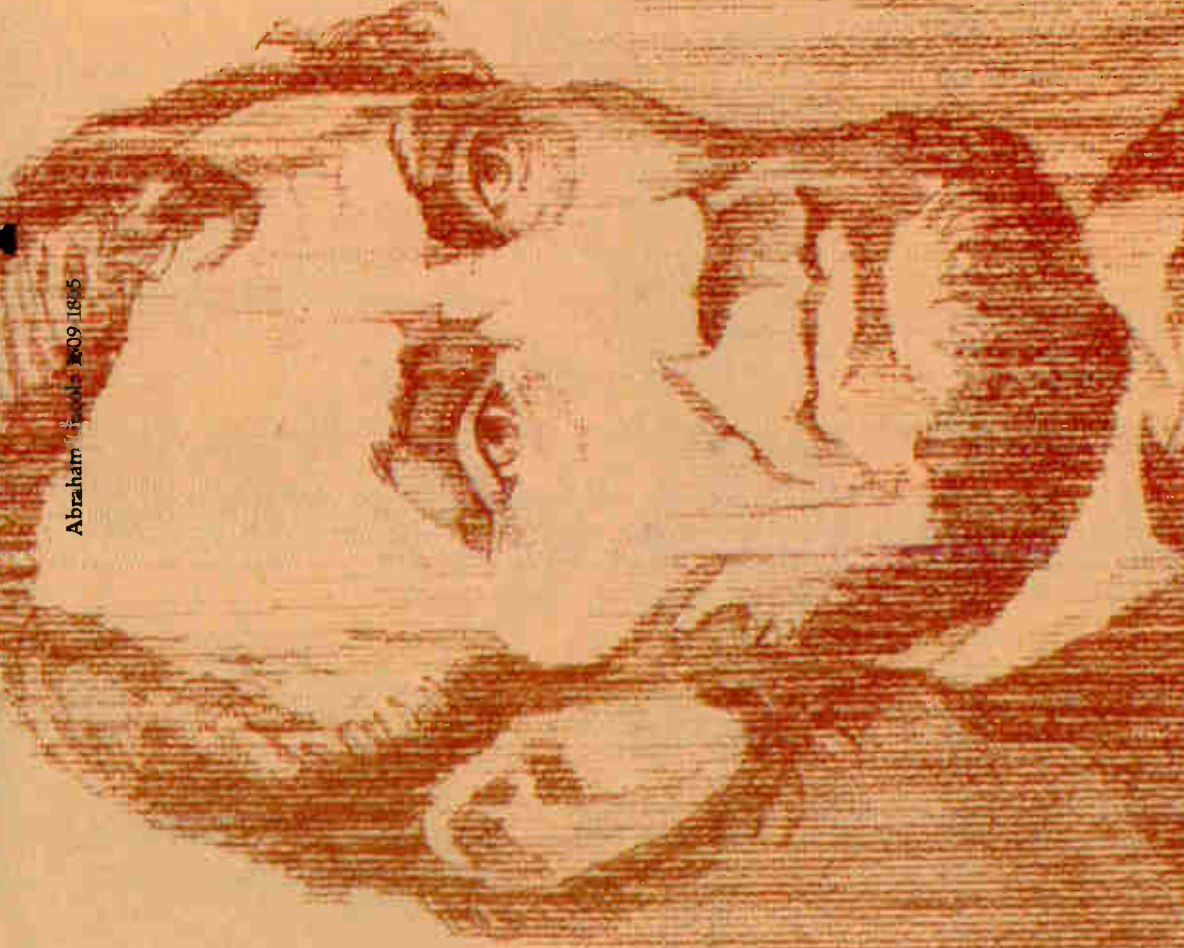

**INTERPOL**



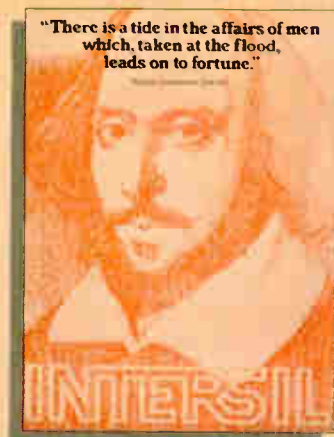

Memory Products

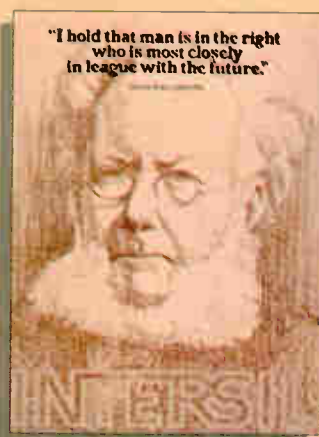

Data Acquisition Products

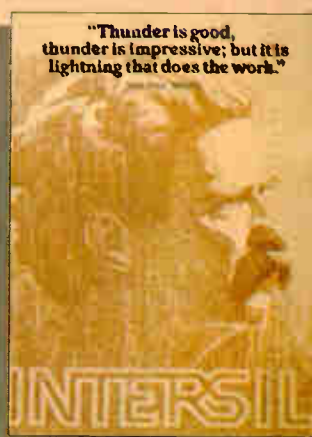

Low Power Products

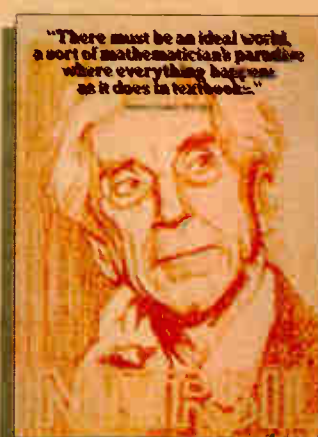

Linear Products

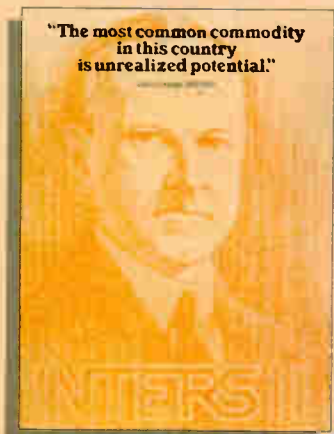

Microcomputers



Memory Systems

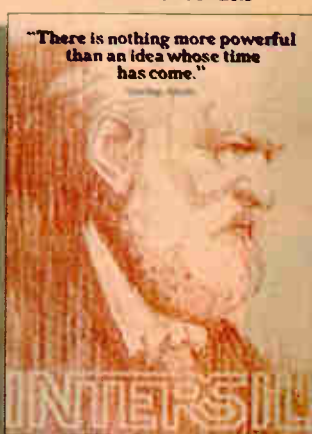

Analog Switches



VMOS Products

## 29 LEADING EDGE PRODUCTS IN '79.

In 1979, Intersil introduced twenty-nine integrated circuits over 7 product lines. Twenty-nine technological firsts. CMOS op amps. Commutating auto-zero amplifiers. An inexpensive CMOS 12-bit A/D converter. 21 deliverable types of VMOS power FETs. A CMOS version of the industry-standard 555 timer. CMOS EPROMs and microprocessors. And, high speed, low power upgrades of the industry standard 2147 Static RAMs.

## TWICE AS MANY IN '80.

In 1980, Intersil will introduce more new high-technology devices than ever before. In processes from Bipolar to CMOS. Voltage converters with 98% efficiency. Monolithic CMOS A/D converters with true 14-bit accuracy and speeds approaching Bipolar devices. Drivers and counters for vacuum-fluorescent displays. VMOS power FETs to 450 volts. Single-chip CMOS microprocessor support systems. The new Intercept III microprocessor development system. And there's a reason for all this.

## WE'RE COMMITTED TO LEADERSHIP.

This business is future-oriented, and so are we. We're committed to the leading edge. To systems thinking, lower costs and reliability. We're committed to ever expanding technological expertise. Expertise in integrated circuits through our Semiconductor division. Expertise in Data Acquisition systems and subsystems through our Datal/Intersil division. And expertise in OEM mainframe memory systems and microsystems through our Systems division.

## WE'RE COMMITTED TO ANSWERS.

We know the future is built on the past. That today's challenges are the groundwork for tomorrow's breakthroughs. Which is why we're committed to answers today. Tough, realistic answers to the critical demands of an industry that long ago departed from the beaten path in favor of regions hitherto unexplored.

For any or all of the posters above, write us on your company letterhead.

**INTERASIL**

10710 No. Tantau Ave., Cupertino, CA 95014 Tel: (408) 996-5000  
TWX: 910-338-0171 (800) 538-7930 (outside California)

# Look to Intersil for answers.





1926 - Società Scientifica Radio Brevetti DUCATI  
is established in Bologna

## DUCATI elettrotecnica s.p.a.

WE PRODUCE CAPACITORS AND OTHER COMPONENTS FOR ELECTRONICS,  
POWER CAPACITORS, R.F. FILTERS, IGNITION SYSTEMS FOR I.C. ENGINES,  
MOBILE COMMUNICATION SYSTEMS AND  
MICROPROCESSOR BASED APPLICATIONS

STUDIO



Bologna

Circle 460 on reader service card

Head office and Management  
40100 BOLOGNA - ITALY - P.O. BOX 588

Cables: ELETTRODUCATI - Phone: (051) 400312 - Telex: 510042 DUCATI



Longarone



**Information center.** An important service in the future will be the availability of data-base information for the home transmitted to the TV set as needed. Viewdata (above) and teletext services are being tried out in the U. S. and are gaining rapid acceptance in Europe.

and collector-tank temperatures. It also shows room temperature and the water level and temperature of the Japanese-style bath. But beyond the functions of a sophisticated thermostat, it displays mail deliveries, heralds the arrival of visitors, and warns of intruders and such emergencies as fire.

**A**hwatukee is a Crow Indian word that means "shining house of dreams." It is also the name of a partially completed 2,000-acre housing development south of Phoenix and of a specific house in that development. Touted as a home of the future, Ahwatukee features a computer system designed around its 6800 microprocessor by Motorola Inc.'s Semiconductor Group.

The system consists of five interconnected microcomputers, called nodes, located in different parts of the house. They divide the overall workload, redundancy being emphasized to minimize the effects of hardware failure. There is even a separate internode communications processor. Input/output is via a keyboard and TV set, while a floppy disk provides data storage.

The computer system at Ahwatukee has five functions: information, electrical-load switching, environmental control, energy management, and security. The information file is of two types—one that holds records such as bank statements, the other acting as a calendar for the storage of important dates.

Electrical-load switching allows the system to control

lights, wall outlets, and other electrical equipment in the house, although the homeowner decides what conditions will cause the different loads to turn on and off. For example, lights are flicked on by a wall switch, but if the owner desires, the computer will lighten the gloom automatically according to the time of day or whether motion detectors indicate someone is in the room. Appliances plugged into wall sockets can also be activated or turned off in this way.

Environmental control is a bit more complicated than it is in a conventional house, because Ahwatukee is divided into three zones—the atrium, the alcove rooms, and the garage—each with its own temperature control. The computer system not only decides when to heat or cool each of these zones but by what means. It is programmed to choose the cheapest method possible. Thus, if the atrium is too warm on a summer evening, the computer weighs opening the windows (after first checking the outside temperature) against turning on the evaporative cooler favored in desert environments or, as a last resort, turning on the air conditioner.

Energy management at Ahwatukee is primarily an information process. The system keeps track of overall energy consumption as it monitors the individual consumption of particular loads. The homeowner can check any of these levels and even get off-site reports on them via telephone lines to a printer.

The security system responds to inputs from smoke and motion detectors located in almost every room to alert the homeowner to fire or intruders. It can also act



in conjunction with the electrical-load switching system to turn lights on and off when no one is at home.

Further, the security program controls the doors of the house at Ahwatukee, which has no keyholes. Instead, a keypad similar to the one on a calculator is used by the homeowner to get into the house; punching in the proper code gets the computer to open the door. The homeowner can change that code at will and even set certain combinations to work only on specified days of the week.

If security detects an alarm condition, its response will depend on the severity of the situation. For instance, a fire will cause the computer to sound alarms in the home, and it can be programmed to send a prerecorded phone message to the local fire departments. But if the problem is minor—perhaps just an improper code entered at the door—it prints a message on the homeowner's printer.

The key to making this project successful—and the critical factor in any home of the future—is the ease of programming these systems. Homeowners will not have to become computer programmers to enjoy their push-button habitat. The system will be transparent to them.

In fact, they will need to know only how to use the keyboard and follow the multiple-choice instructions displayed on the TV screen. Their instructions are converted into reference tables and stored. To prevent unauthorized changes, a password is required before any critical input can be made. The software for the project is written in MPL, a high-level language developed by Motorola and similar to PL/I.

**B**y far the most exciting prospect to most is the availability of computers for personal use. As suggested in the description of the experimental home of the future, most of the applications of at-home computers will be transparent to the user, who will not need to be aware that a computer is at work. Computa-

**Programmable fun.** Equipped with a Texas Instruments microcomputer, "Big Trak" is one of a host of electronic toys that will influence children's ability to program computers. Designed by Milton Bradley, this toy answers to 16 individual commands.



tion, indeed, will be the least of these units' functions, taking a back seat to the jobs of data storage, retrieval, and communications.

Therefore, it is perhaps more accurate to predict that the home computer will be more a terminal for the world of stored information than a processing machine. A new industry will emerge to service what MIT's Michael L. Dertouzos calls the "information marketplace." This he describes as "a business medium in which people will buy and sell information as a commodity. It will become more important as more buyers and sellers join it, and a great part of this business will consist of data bases containing unique information."

The data-base industry has other ramifications, in Dertouzos' view. For one, there will be a need for "yellow-pages entrepreneurs" who will charge a modest fee to tell information seekers what base to tap—a directory-of-directories service.

Another intriguing possibility is "reverse advertising," in which persons needing some product or service will enter requirements into a data base and the suppliers will find these customers by consulting that base. In short, it will be an electronically interactive marketplace.

Another facet of this data marketplace is that it will provide employment for people involved in preparing and maintaining the information that the entrepreneur



**Touchdown.** Mattel's hand-held football game is another popular electronic toy that makes use of a microprocessor to control the action. Hand-held games will become more and more popular as new displays and processors of greater complexity are employed.



Can-type Aluminum Electrolytics



Polyester & Metalized Film



Axial Aluminum Electrolytics



U.S. Corporate Headquarters

Radial Aluminum Electrolytics



Aluminum Etching Facility



Ceramic & Reduced Titanite Discs



# We're Nichicon.

**We make the right capacitor for the product you make  
and the environment it has to work in.**

Nobody goes to extremes for you in capacitors like Nichicon. We have to. We're capacitor specialists. With state-of-the-art capacitor manufacturing plants worldwide. Each a specialist in itself. Special people special equipment, fulfilling the requirements of special customers.

And now we're servicing you better through the largest stocking facility in the United States dedicated exclusively to the warehousing, distribution and marketing of capacitors. We're Nichicon. The name that is synonymous with "capacitors" worldwide. For further information please write or call.



**nichicon**

**We go to extremes for you.**

NICHICON (AMERICA) CORPORATION • 927 E. State Parkway • Schaumburg, IL 60195 • (312) 845-7500  
Division of Nichicon Capacitor, Ltd., Kyoto, Japan

Circle 463 on reader service card



# How Litronix' opens a new world



Rockwell  
AIM 65  
Microcomputer

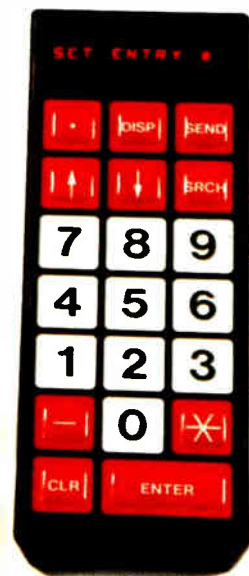

Norand®  
Sprint 100™  
Order entry terminal

**Now designers have a communications peripheral perfectly matched in size and cost to the world of microcomputers.**

Litronix invented the Intelligent Display\* to give microcomputers a new way of "talking" to users in words, numbers or even sentences. And not surprisingly, these displays are already

Part Number	Features	Character Height	Horizontal Row Spacing	Vertical Row Spacing	Viewing Angle	Character Positions	Character Segments
DL-1416	Standard General Purpose Display	.160"	.250"	1.200"	±25°	4	16
DL-1414	Compact Display For Hand Held Equipment	.112"	.175"	.800"	±50°	4	16
DL-2416	Premium Display New Rugged Package	.160"	.250"	.800"	±50°	4	17

\*Intelligent Display is a trademark of Litronix, Inc.

beginning to create a new class of microcomputer-based products.

The Intelligent Display is an alphanumeric LED readout that incorporates ASCII decoder, multiplexer, memory and LED driver in a built-in CMOS IC. It interfaces simply and directly to any microprocessor bus, much like a RAM. Power is from a single +5V supply, and operating current is low enough for any battery powered device.

**Litronix puts intelligent communications in the palm of your hand** or anywhere panel space is limited. Three versions of the Intelligent Display are already available to fit a wide variety of applications. The smallest lets you fit 20 characters side by side in a space of only 3.5 inches.

Litronix' Intelligent Displays are already being used in the portable terminal, the low cost microcomputer and electronic translator above. They're also ideally suited for applications like control panel readouts. Handheld computer

# Intelligent Display™ of microcomputer applications.



Lexicon™  
LK-3000™  
Electronic translator

terminals. "Smart" games and appliances. Educational products, and more.

Use Intelligent Displays in any

product that calls for alphanumeric. They'll reduce component count and cut costs dramatically. Since everything is encapsulated in a single package, design and production costs are

minimal. And because no display interface PC board is needed,

component costs are typically reduced by 25%. Typical OEM volume pricing per digit will range from \$2 to \$5 per digit,

depending on display type. For easy bread-boarding with Intelligent Displays, ask about

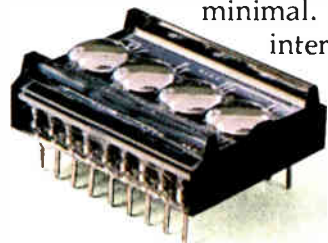

our inexpensive, prewired Evaluation Kit. To get data sheets and a copy of our applications note

**I INTERFACE JUST LIKE A RAM**

on Intelligent Displays, or for a demonstration, phone or write Litronix, Inc., 19000 Homestead Road, Cupertino, CA 95014. Telephone (408) 257-7910.

**litronix**  
AN AFFILIATE OF SIEMENS



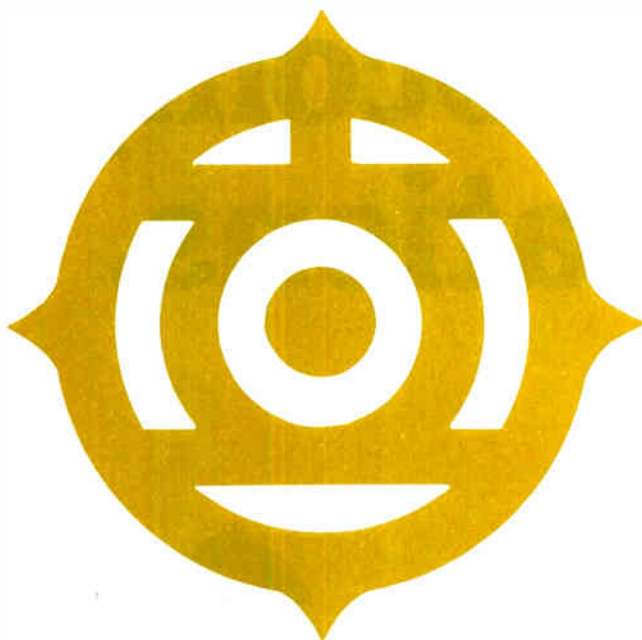

THE  
SYMBOL OF QUALITY  
IN SEMICONDUCTOR  
PRODUCTS...WORLDWIDE



**HITACHI**

HITACHI AMERICA, LTD.  
ELECTRONIC DEVICES SALES AND SERVICE DIVISION  
707 WEST ALGONQUIN ROAD, ARLINGTON HEIGHTS, IL 60005  
(312) 593-7660 TLX 20-6825

**Tokyo**

Hitachi, Ltd.  
Electronic Devices Group  
6-2, Otemachi 2-Chome, Chiyoda-ku  
Tokyo 100  
Telephone: Tokyo (270) 2111  
Cable Address: "HITACHY" TOKYO  
Telex: J22395, 22432, 24491, 26375  
(HITACHY)

**Düsseldorf**

Hitachi Electronic Components  
Europe GmbH  
Königsallee 6  
4000 Düsseldorf  
Telephone: (0211) 80871-80875  
Telex: 8584536  
(HIEC-D)

**London**

Hitachi Electronic Components  
(U.K.) Ltd.  
P.I.E. Building,  
2, Rubastic Road  
Southall, Middlesex UB2 5LF  
Telephone: 01-574-0732 /8  
Telex: 936293  
(HITELECTRO HYES)



**Electronic wash.** The pervasiveness of microprocessors is already apparent in this Whirlpool Corp. electronically controlled washer and dryer combination. Eventually microprocessors will become just as widespread as electric motors are today.

sells. These are jobs that do not exist now.

Dertouzos warns, however, that the information marketplace will also require safeguards in the form of forward-looking regulations backed by comprehensive information laws. These would cover such things as privacy, authentications, protection of the individual, and penalties for abuse.

Perhaps the biggest payoff to society from the eventual development of the information marketplace will be the individualization of products and services, without loss of the cost benefits of mass production. The work of artisans that at one time personalized products has long since disappeared or become too costly for most people to afford.

"But the computer is the first technological artifact capable of individualizing products and services," Dertouzos observes. "Examples go all the way from shoes and clothes to personalized made-to-fit furniture to tailored services and information."

The intelligent terminal in the home, though a relatively simple machine, will be linked by cable, telephone, satellite, or other means to a vast network of computers churning away elsewhere. In effect, a person could order a personal clipping service of facts, delivered in real time, relating to a specific subject. Tapping the data bases, he or she could have a personalized newspaper delivered as well.

As cost barriers tumble, home terminals should proliferate at an astonishing rate. According to Martin L. Ernst, vice president of Arthur D. Little Inc., Cambridge, Mass., there are marketplace parallels to be found in the past. He points to the boom in automobiles in the 1920s, radios in the 1930s and 1940s, and television sets in the 1950s.

The future scenario for information teleprocessing in the home will be written around four technical and economic developments: the introduction of personal

computers to the home; the availability of more intelligent, easier-to-use programs; the spread of "hidden" computers; and the development of distributed processing systems.

Most people would readily admit they would not know what to do with a home computer if they had one. And it is probably true they would not know what to do with any of today's computers. But for those who have projected the role of the computer into the future, the applications are many. Hardware, software, and costs will change, they say, as will the systems' applications.

The personal computer clearly will be used first for recreation and hobbies. The games will be both extensions of traditional favorites—chess and the like—and new ones made possible by electronics.

Hobbies, too, will enter the computer realm. Writes Joel Moses, professor of computer science and engineering at MIT, in a recent book he edited with Dertouzos, "The Computer Age: A Twenty-Year View."

"One effect of the mass media in the past century has been to homogenize experience by providing everyone with the same TV shows or newspaper columns. The mass media also tend to reduce most individuals to insignificance by building up a few personalities to superhuman proportions. Computer-based hobbies can work to reverse this trend by allowing different individuals to specialize in different areas and build up their self-esteem by virtue of their proficiency."

One of television's most serious failures has been its comparatively small impact on education. Indeed, there are some who believe TV has actually set back learning. Computers in the home may do a better job because they are by nature interactive—that is, they require active participation.

The drill-and-practice method of computer teaching is already routine in schools where it has achieved a certain amount of success in imparting specific skills. Whether computers will ever be acceptable teachers of concepts remains to be seen. It will be interesting to see if home use of computers will speed their acceptance in the school, the way hand-held calculators stimulated the development of hand-held teaching aids, such as those produced by Texas Instruments Inc. of Dallas and National Semiconductor Corp. of Santa Clara, Calif. Or it may be the reverse, with computer use in the school having a carryover to the home, just as the educational experience has always prompted the purchase of books outside school.

All those who have projected acceptance followed by explosive growth for the home computer emphasize that this proliferation must be accompanied by a communications hook-up. It appears that the telephone network will be adequate for data communications up to a point. For the transmission of long texts or pictures, however, a broadband conduit will offer a better link than the telephone lines. Chances are that both telephone and broadband will be used, depending on the type of information to be transmitted and the costs.

As a result, the home computer will have a role in



## An intelligent associate for everyone

How will the powerful computer-communications systems of the future benefit man generally? J. Thomas Markley, president of Raytheon Data Systems Co. of Norwood, Mass., believes they will provide us with what he calls "the intelligent associate."

This Markley defines as a device that will take information processing outside glass-enclosed computer centers and beyond narrow services now shared by only a small portion of society.

An associate in this sense of the word is someone who seeks out and reports information and recommends action. Markley's intelligent associate will be a terminal-like device that will hook into data bases at home or at work and solve virtually any information-handling function that needs to be done.

It will be characterized, he feels, by eight principal attributes:

- It will be a display-based terminal that any user can link to a data network. That means—in the U. S.—an English-language-based system in which any terminal built by anyone would react to the same command protocols.
- It will have broad functional capabilities such as data entry, inquiry response, program development, and electronic mail. It will therefore have to store a lot of data.
- It will be of a single, compatible family that can be upgraded from one to dozens of stations. This means communications compatibility as well as distributed processing.
- It will be supported by easily upgradable sets of peripheral devices, implying standardized interfaces. The latest printer or CRT will be capable of being plugged in without inconveniencing the user.
- It will be capable of many network operating modes,

including the selection of transmission paths and data rates. The user will be able to choose the communications path and decide price advantages on the basis of bandwidth or speed.

- It will be rich in software—that is, it will possess all the operating systems and executive software needed for any application. This means the cost of programming will have to be cut by training many entry-level people to program and by increasing the productivity of software specialists.
- It will be available under a variety of labels, which means commonality—several manufacturers producing interchangeable equipment.
- It will become reality only when its potential users are ready for it.

When will that be? "The intelligent associate will arrive none too soon," replies Markley. "The complexity and rate of change of modern life demand that man amplify his ability to apply intelligence to his life circumstances in faster, more effective ways. The intelligent associate will provide this amplification."

Forces he sees shaping the need for this partner are:

- The productivity push. The intelligent associate will do for the office what machine tools and manufacturing processes did for the factory.
- Increasing interdependence. To be effective, information must be shared and shared quickly.
- The growth of technology. The challenge will be to help people understand how and where the new technologies fit into their lives.
- The price-power curve. The economics of computer pricing favor the development of mass markets.
- New directions in the computer industry. The profit potential of hardware for personal units is extremely high.

many forms of communication. Automated mail delivery, for example, becomes feasible when terminals in all households can be economically reached by central processors. Most mail is routine—bills, advertising, magazines, and some personal correspondence that could be delivered by computer. Even paying of bills can be done electronically, as some present bank setups already indicate.

Another benefit afforded by this interwoven system will be the ability to contact others in the net directly, sending either messages for particular persons or general information such as meeting notices.

As for electronic journalism, the resources for establishing the requisite data bases and devising the equipment are near at hand. Electronic news to the home is actually a logical continuation of recent trends in this field—computer typesetting and editing terminals.

Ordinarily the size of the tasks to be performed dictates the size and capacity of the computers to perform them. The situation is somewhat more complicated with the home computer. To MIT's Moses, the basic hardware bottleneck is likely to be the size of the main and backup memories.

"A computer with a main memory of about 10 million bits will probably be satisfactory for most services," he

writes. "A reasonable guess for the sale price of the home computer is about \$500. The current value of a medium-speed computer with the desired memory size is about \$500,000."

Is it reasonable to expect that the latter price will fall by a factor of 1,000 in fixed dollars during the next two decades? Extrapolating the trend in the last two decades would indicate an affirmative answer. Cost per computation has decreased about 30% every year during that time; if that rate is maintained for another 20 years, the 1,000-fold reduction could be achieved.

Then, too, others do not expect the home computer to require all that much memory because its functions will be kept simple, initially at least. Even electronic mail delivery, with all the complexities inherent in setting up the network, would not require a particularly powerful home terminal.

But a strong argument for the hefty machine envisioned by Moses for home use can be made by considering the software. If the computer is to be designed for ease of use, including natural language input and output, there has to be enough capacity to handle the software, the cost of which is already outstripping that of hardware in most installations. To reverse this trend for the home computer, it will probably be necessary to put greater capability into the hardware.

But man does not live by information processing alone

# MATROX MACS®

The OEM Computer — No. 1 Draft Choice of Champions

Matrox  
Advanced  
Computer  
Systems

- Blazing Speed • 4MHz
- Superior Intelligence • Z80-A<sup>2</sup>
- Optimum Size • Multibus<sup>3</sup>
- Sophisticated Execution • CP/M\*<sup>2,4</sup>
- Total Flexibility • Boards/Systems



## BOARDS

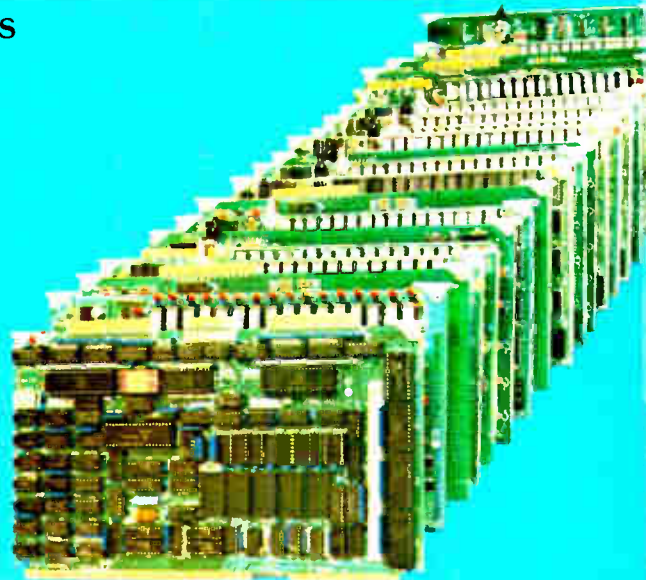

## SYSTEMS

### MACS® — The OEM Computer

Matrox Advanced Computer System is the most advanced 8-bit computer on the market.

By using the best state of the art LSI circuits from leading manufacturers; Z-80A, AmD-9511, FD-1791, 8202, etc., MACS offers the most powerful 8-bit OEM computer available on the Multibus. MACS modular design permits systems ranging from a single board to multi-board computers more powerful than some minis.

MACS gives you MACSimum software support; CP/M2. Over 20 software houses as well as Matrox support CP/M2. Basic, Cobol, Fortran, Pascal, graphics packages, application packages — you name it — are available off the shelf.

CP/M2 plus Multibus ensure your success! Beat the competition by drafting MACS, No. 1 choice of the champions.

1. MATROX™ 2. ZILOG™ 3. INTEL™ 4. DIGITAL RESEARCH™

#### ZBC-80

The CPU board with Z-80A /4MHz CPU, includes 16K or 54K RAM, JART, Arithmetic Chip, 16 level interrupt, 6 timers, Multiprocessor Arbitration, 48 I/O lines and 5 ROM/EPROM sockets.

#### FFD-1

Floppy controller board with FD-1791 chip. Single/Dual density, up to 4 drives, 32K on board RAM with dual port addressing and DMA.

#### MEGA-1

RAM board with up to 128K bytes of memory. Works with any Multibus 8 or 16-bit CPU. Transparent refresh with 350nsec access time. Single 12V battery stand-by. 32/64/128K byte versions.

#### CCB-7

7-slot cardcage with Multibus backplane. Choice of 3 power supplies 5V/5A, 5V/12A and 5V/24A. ± 12V and -5V.

### Other Matrox Multibus Products

- Color graphics RGB-256 • Alphanumeric video MSBC-2480 • Frame grabber FG-01 • High resolution graphics MSBC-512 • Color alphanumerics RGB-2480 • Extender BEX-1 • Prototype board PTB-1 • Dual floppy system DF-28 • CRT terminal CTM-100 • Alphanumerics/Graphics printer PRT 120 • Color monitor MCTV 15 • TV camera • CP/M 2.0 • Pascal • Basic • Cobol • Fortran.

Call or write for complete MACS® catalogue



**matrox**  
electronic systems/ ltd.  
The Visible Solutions Company

US & CANADA:  
5800 ANDOVER AVE., T.M.R., QUE., H4T 1H4, CANADA  
TEL.: 514-735-1182 TELEX: 05-825651

EUROPE:  
HERENGRACHT 22, 4924 BH DRIMMELEN, HOLLAND  
TEL: 01626-3850 TELEX: 74341 MATRX NL

Circle 469 on reader service card



INTERFACE load cells are the most advanced force measurement components in the world. Highly accurate, one part in ten thousand is typical, used in systems that are approved for NIST, OIML, F.G.S, IEC and other national and international tolerance standards, INTERFACE load cells are the modern answer to weighing and force measurement applications. For comprehensive information contact the leader in force measurement.

INTERFACE, INC., 7401 E. Butherus Drive, Scottsdale, Arizona 85260, USA (602) 948-5555 Telex 668-194

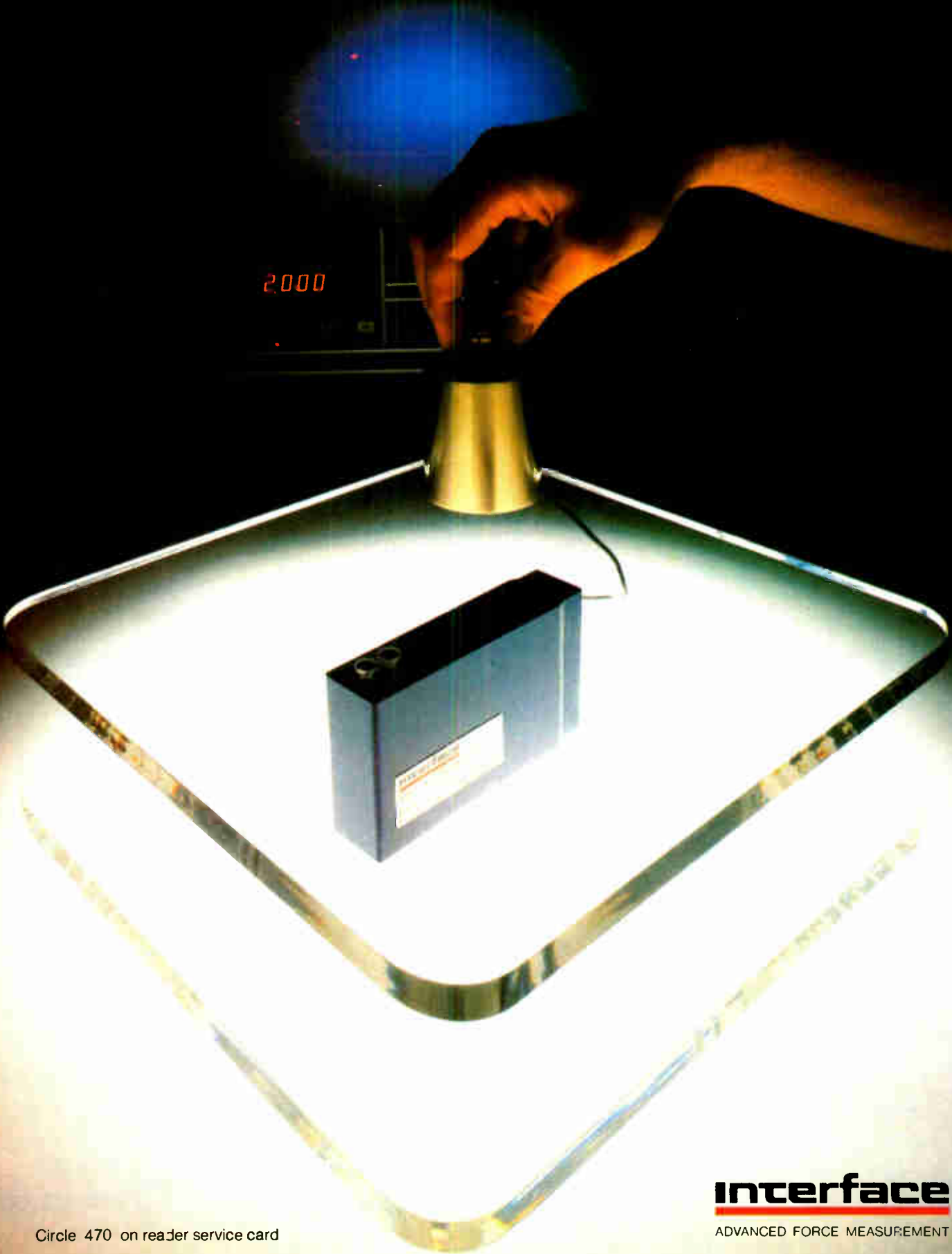

Circle 470 on reader service card

**interface**  
ADVANCED FORCE MEASUREMENT



**Office automation.** The electronic office of the future has started to appear. Management consulting firm Micronet has set up the Paperless Office in which all information and correspondence is handled electronically. Each desk has a variety of displays.

—entertainment will always be a major application of home electronics, as it has been since the beginning of radio and television broadcasting. And the center of home entertainment for the vast majority of consumers right now is the television set. Remarkable changes are taking shape in the way people use their TV receivers.

In a sense, TV viewers are gaining control of their sets, thanks to innovations such as the video cassette recorder, the video disk, and the pay-program selector. Two-way cable television, once thought just around the video corner, will finally emerge in the next two decades. As a result, broadcast television, with its dependence on mass audience acceptance and programs aimed at the lowest common denominator, may be as old-fashioned as an "I Love Lucy" rerun.

**T**hat, in essence, is the thinking of Gerhardt Hanneman, head of the Media 90 project at the University of Southern California's Annenberg School of Communications, which is charged with forecasting changes in television during the remainder of this century.

As associate dean for research at the school and director of the project, Hanneman at this writing is in the first phase of the three-year project. He is working on the premise that the future of TV is being shaped by the development of many alternative uses of the screen and by the public's growing willingness to pay for new video services.

As a result, "the existing network structures are becoming anachronistic," he says. The trend is clear, in his view. About 20% of the nation is subscribing to cable TV, for one thing, and an ever-growing number of these subscribers are attracted to the pay-TV packages that community antenna TV operators offer.

Further, he points out that video cassette recorders are growing in sales and video disks are not far off. "Everyone believes, and so do we, that VCR's impact will be



**Getting the word.** Micronet's future office makes extensive use of dictation equipment. Information may be entered by telephone or from desktop and portable tape-cassette recorders. The system then assigns transcription according to typists' workloads or by priority.

profound." Finally, independent TV stations are going on satellite for nationwide distribution and the high ratings of public broadcasting programs are cutting into network dominance.

"People are going to be using their TV screens a lot more, but they're going to be using them less to watch network TV," Hanneman predicts. He estimates the networks' loss at 20% by 1990, particularly in the big cities. They will then reduce their prime-time offerings, he believes, forcing local broadcasters to buy programming from other sources until they are no longer affiliated with single major networks.

Much of what the Media 90 research is finding reflects a changing attitude toward the role of the TV set, particularly toward displaying information other than standard TV fare. Says Hanneman: "People have become more comfortable with what we call 'mediated communications,' using technology to interact with others. When we first started doing studies in 1973, people were very much against that.

"Now they'll tell you they desire pay entertainment services and interaction for civic functions or to use the TV set to renew a driver's license, say. They're also willing to shop remotely; in the early '70s they wanted to touch the merchandise before buying. And businessmen are particularly willing to use teleconferencing to substitute for routine business travel.

"The fact that people are interested not only in things like shopping but also in two-way picture interaction with their commercial associates, neighbors, friends, and relatives forecasts tremendously increased use of interface units between the TV set and the phone. And what that's going to do is to start devaluing face-to-face interaction. That will have profound implications for society."

Though yet to have a massive effect worldwide, the viewdata and teletext systems developed in Britain are considered models of information services for the home. Britons have had teletext broadcasts for several years,



# OAK INDUSTRIES...

## ADDING NEW DIMENSION TO TECHNOLOGY AND COMMUNICATIONS.

Dramatic changes are taking place at Oak Industries. Oak has totally reshaped its organizational structure. Oak Industries Inc. is now the parent company for Oak Communications Inc. and Oak Technology Inc., which, between them, operate the many Oak divisions.

The first products offered by Oak to the young electronics industry, almost 50 years ago, were switches, sockets, and insulation materials. In the years to come, Oak would fuse its expertise in component technology with the application of that technology. Today, Oak is both a manufacturer of components and materials, and a highly sophisticated user of the fruits of its related technologies.

Rotary switches led to television tuners. From tuners, Oak pioneered converters for the CATV industry, and a short time later, sophisticated decoders for pay cable and over-the-air subscription TV services. Oak is a world leader in this technology.



**Advanced "addressable" decoder systems** from Oak allow pay cable and subscription TV operators to authorize only subscribing viewers to unscramble and watch the premium programming. Any decoder in an Oak system can be remotely switched on or off instantly, at the central control point.

**In switch technology,** Oak has long been the rotary switch leader. Now in the 80's, Oak continues to set trends with its new ultra-thin, touch-sensitive membrane TIP switch. The TIP switch is intended for keyboard-type applications. It has already found its way into the high volume products, from industrial

devices to microprocessor-based toys. Oak also supplies the supporting control interface electronics ... another demonstration of applied technology. For cost-effectiveness and letter-perfect results, an extensive computer-aided design/graphics facility assists Oak engineers in designing new TIP switches.

**Other Oak Technology companies** supply industry with precision crystals, crystal filters and oscillators; miniature potentiometers for guidance systems and computers; and controls for gas and electric appliances.

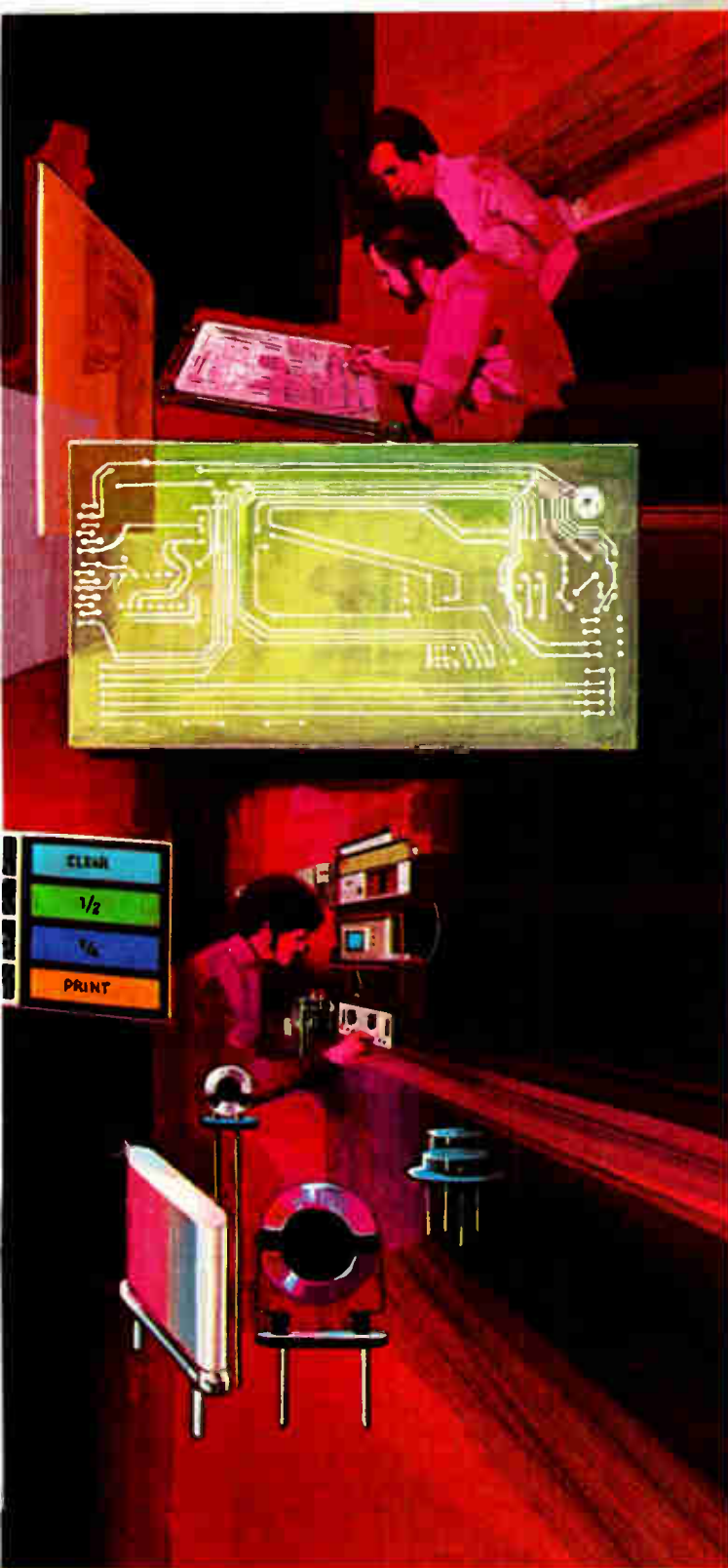

Oak has also earned a leadership position in electronic laminates, with extensive manufacturing facilities for laminates used for printed circuits. Manufacturing technologies developed by the company have increased production capacity for both multi-layer and microwave dielectric board materials, which are expected to be in high demand in future years. Oak continues to advance the state-of-the-art of this technology and already supplies both board types in high volume.

## Technology and Communications... at Oak, they are pathways to the future.

### **OAK** Communications Inc.

NATIONAL SUBSCRIPTION TELEVISION  
CATV DIVISION  
OAK BROADCASTING SYSTEMS, INC.  
HELLER-OAK COMMUNICATIONS  
FINANCE CORP.  
OAK EAST INDUSTRIES LTD.  
OAK RESEARCH & ENGINEERING CENTER

### **OAK** Technology Inc.

**DOMESTIC**  
FLUORGLAS DIVISION  
HARPER-WYMAN COMPANY  
MCCOY ELECTRONICS COMPANY  
OAK-FOTHERGILL INC.  
OAK LAMINATES DIVISION  
OAK-MITSUI INC.  
SWITCH DIVISION  
TECHNO-COMPONENTS CORP.

**INTERNATIONAL**  
DIAMOND H. CONTROLS LTD.  
HARPER-WYMAN de MEXICO  
HARPER-WYMAN LIMITED  
OAK BRASIL INDUSTRIAL LTDA.  
OAK INDUSTRIES HONG KONG LTD.  
OAK INDUSTRIES KOREA  
OAK INDUSTRIES SOUTH AFRICA  
OAK JAPAN LIMITED  
OAK MATERIALS TAIWAN LTD.  
O/E/N INDIA LIMITED

### **OAK** Industries Inc.

Rancho Bernardo, CA 92128



and the post office's Prestel viewdata service—which allows a viewer to contact a computer data bank by phone and receive replies on his television set—is now a public service, though with only a few thousand subscribers so far.

Holding the service back now is price, but that is one problem that developments in microcircuitry will correct over the next two decades. Martin Wolfendon, a product marketing manager for GEC Semiconductors Ltd., predicts teletext decoders will be standard on most British TV sets within five years. Today's \$60 price for a teletext module will drop to \$12, he says, and a combined teletext and viewdata chip set will cost \$120 from the chip maker.

There are other signs that these services will soon have their day. Some 120 information providers are staking out their claims in anticipation of a big market. And subscribers very soon will be able to order goods via Prestel, quoting only their credit card numbers. Also, the viewdata and teletext concepts are spreading from England to the rest of Europe and the U. S.

One add-on for the teletext system is being developed at the British Broadcasting Corporation's Kingwood Warren Research Centre. This new unit incorporates a light-pen bar-code reader attached to a microprocessor, and it can be used to program a week's viewing—switching on and selecting the right channel—when the viewer runs the light pen over a bar code printed alongside each listing in the television program guide.

**E**choing the idea of personalized TV programming, Boris Townsend, head of the Independent Broadcasting Authority's Information Service at its Crawley Court research headquarters, points out that all broadcast material could carry coded classifications for sports, news drama, comedy, and so on and could be used to turn on a smart video recorder to

tape only those shows carrying the selected code.

"Such a recorder could play back to you over breakfast the programming you'd previously chosen. Our studios could run all night churning out recorded, labeled programs mixed with news, while your domestic recorder compiles your own minority-taste program."

Broadcasts from satellites directly to homes will become practical in the next decade. And if all goes well, a pair of European TV satellites will soon be launched jointly by West Germany and France with enough power to reach through much of Western Europe. In preparation for the launching of the two, five television channels in the 12-gigahertz frequency band have been allocated to each European country.

**E**lectronic controls for home appliances are already gaining ground, with the success of programmable microwave ranges an important contributor to acceptance of this approach by the rather conservative home appliance industry. And as microprocessors become cheaper, there is no reason to believe the demand will abate.

Ranges will be programmable to do a series of tasks based on time and temperature. Washing machines will cycle according to the condition of the clothing rather than time. And what homeowner has not dreamed of a programmable lawn mower he can "teach" to cut a specific yard by itself? The big plus here is that the functions of appliances are restricted to well-defined tasks that can be controlled by means of a low-cost microprocessor.

The energy crunch has spurred interest in electronic heating and cooling controls that may be in universal application by 2000, as the cost of the electronic components declines and that of energy increases. Though solar energy, both electrical and thermal, will play an increasingly important part in energy generation, this source

### A reading on the 'electronic book'

Individual access to information takes many forms in the many views of today's prognosticators. To some, it is important that the personal information-processing unit of the future be portable.

For example, Lawrence Seligman, vice president of Data General Corp., Westwood, Mass., envisions a data terminal about the size of a paperback book—something that will fit into a pocket or hang from the belt. It would not have much in the way of mass memory, of course, but could link up with data bases by way of powerful communications satellites.

"As a substitute for the telephone and other instruments, the unit we're talking about would operate at very short wavelengths, very high radio frequencies—perhaps millimeter-wave frequencies," Seligman says.

But he foresees other functions for these book-sized displays. As their data-storage density increases, video disks may serve as the inexpensive "razor blades" of information for the "razors"—that is, the display devices.

"I can see the technology improving to the point where in 20 years something the size of a book, perhaps, could

be inserted in a small video disk and read from the display," says Seligman. Thus, the unit would not only be a portable telephone and computer but a means to read information stored on video disks.

Now assuming that the necessary video disk and replay technology are available, there is another problem to solve before this capability can be realized, and that is retrieval. Seligman expects the answer to lie in disks carrying abstracts of available works, lengthy excerpts, and finally whole articles. Subscribers would then skim the abstracts in much the way they would review technical material today in selecting subjects to read in full. They would not read complete disks but would rather retrieve the desired information with the help of the abstract disks.

Seligman conjures up one other chapter for the "electronic book." Having gained access to the video disk data, the user may even take notes while reading. "You might use the leftover bandwidth on the disk to insert the notes in spaces appropriate to the information you've been reading," he suggests. "You'd then have text and comments together, the equivalent of marginal notations."

# Over 10<sup>9</sup> served.



## The MICROTEMP<sup>®</sup>: the #1 thermal cutoff in the 60° to 240°C range.

OEM's look for reliability in a thermal cutoff. Which is why they've relied on the MICROTEMP<sup>®</sup> over a billion times.

They know the MICROTEMP<sup>®</sup> thermal cutoff is designed to protect the average product for its projected life. And that it will cut off any thermal hazard above

the set temperature instantly.

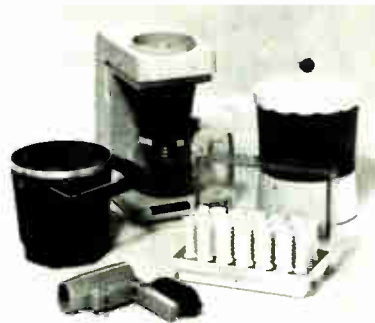

So if you're looking for a low cost thermal cutoff you can really count on, look no further. Go with the one that's #1 around the world. The MICROTEMP.



**MICRO DEVICES**

DIVISION OF EMERSON ELECTRIC CO.  
186<sup>th</sup> SOUTHTOWN BLVD, DAYTON OH 45439  
513-234-0581 TELEX 28 8087  
EMERSON



# “Hey, National Capacitor... Do you really carry every type capacitor and do you really have the largest inventory in the USA?”

**“Absolutely!”**

But don't take our word for it.  
Just check the capacitor lines  
and types we carry listed below.

## CAPACITOR LINES

ARCO • ACI • CALLINS  
• CORNELL-DUBILIER •  
DILECTRON • MALLORY  
• MATSUO • NATIONAL  
CAPACITOR • PLASTIC-  
CAP • NEC • SEACOR  
• SAN FERNANDO •  
SANGAMO • SPRAGUE-  
GOODMAN • SKOTTIE  
• TANSITOR  
• THOMSON-CSF  
• UNITED CHEMICON  
• VARADYNE • WESTCAP

## CAPACITOR TYPES

### Military/Established Reliability

CA • CB • CC • CCR • CDR  
• CE • CFR • CG • CH • CHR  
• CJ • CK • CKR • CL • CLR  
• CM • CMR • CP • CPV • CQ  
• CQR • CRH • CRL • CS •  
CSR • CT • CTM • CU • CUR  
• CV • CWR • CY • CYR •  
CZ • CZR • PC

### Commercial/Industrial

AC Motor Start/Run •  
Aluminum Electrolytic  
• Bathtub • Button Mica  
• Chip • Ceramic Disc  
• Ceramic Monolithic •  
Clamps/Brackets • Computer  
Grade • Dipped Mica • Dipped  
Tantalum • Feed-Thru/Filters  
• Film • Glass • High Voltage •  
Metallized Film • Mica Trimmers  
• Mylar • Nonpolar • Oil Filled •  
Paper • Piston • Polycarbonate  
• Polyester • Polypropylene  
• Polysulfone • Tantalum  
Wet-Slug • Tantalum-Solid  
• Tantalum-Foil • Trimmers  
• Transmitting Mica • Variables

If it's a capacitor, we stock it!  
So if you are looking for  
capacitors, call “*The Buyer's  
Best Friend.*”—National  
Capacitor Supply.

### National Capacitor Supply

11731 Markon Drive  
Garden Grove, CA 92641  
• (714) 892-7749  
• (213) 598-9611  
• Northern California  
(800) 472-1841  
• Outside California  
(800) 854-2451

**NATIONAL**

**CAPACITOR SUPPLY**

will still be primarily employed to augment existing resources.

Electronics will not be expected to generate as much energy as other resources, but it is being counted on to conserve what is used. William George, corporate vice president for product development at Honeywell Inc. in Minneapolis, sees microprocessor-based systems running future residential electrical, heating, and air-conditioning systems in much the way they control those functions in commercial buildings today. The pilot light on a furnace will have gone the way of the buggy whip by 1985, as a matter of public policy, says William McDonnell, vice president and general manager of the Residential Controls Center at Honeywell.

Various metering schemes to reduce residential energy consumption are in place in some cities, like Detroit, but McDonnell's hunch is that Americans will reject the European idea of a central station's automatically shutting off residential water heaters or other appliances to conserve energy. Instead, different rates will be offered for low- and high-demand periods to shave peak power demands and reduce fuel costs.

Eventually, the home appliance and environmental energy control systems, though run by dedicated microcomputers, will be linked in the home information center. Robert Stenstrom, manager of technology planning at Honeywell's Residential Controls Center, sees a future in which "microprocessors will be as common as fractional horsepower motors."

Comparing the spread of microprocessors to the number of motors in the home is a popular theme. It implies an ubiquitous but unseen presence to be felt in the coming years.

**T**he computer-communications marriage will narrow the distance between workplace and home.

Joel S. Birnbaum, director of computer science at IBM Corp.'s Thomas J. Watson Research Center in Yorktown Heights, N. Y., points out that the trend is less a matter of the office moving into the home than of extended electronic offices that executives will be able to take about with them.

There appears to be little inclination, though, to transfer the office *in toto* into the home even if the technology to do so is available. There may be some interest in the next decades in cutting business travel to reduce energy consumption, in which case audio/video conferences will increase. Commuting to and from work may be cut to save fuel, too—again with on-screen, face-to-face interchanges allowing this to be done.

In the factory, productivity and the quality of products are lagging. "Automation" has always been the knee-jerk proposal to solve this problem, but most products (as opposed to processes) do not lend themselves well to automation as we know it today.

Technology's answer is flexible automation, which will be discussed at length later in this chapter. It can be cost-effective even when the number of parts to be made is small or the design or fit changes often. And that suggests intelligent robots, the kind that can sense and respond to a variety of conditions.



**Speaking of computers.** Both speech synthesis, demonstrated above at Bell Laboratories, and speech recognition will be important developments in the future use of computers. They will enable users who have no training to communicate with computers.

These robots will need intelligence and vision-mating to the computer, like charge-coupled-device cameras with microprocessor controls. They will be able to manipulate materials—metal, cloth, leather, plastic, and so on—efficiently even for small production runs.

If plant-productivity statistics can be worrisome, those for the white-collar side of business are downright distressing. Industrialists over the past 30 years invested a yearly average of \$20,000 per blue-collar worker in the form of tools and support systems and realized a 95% improvement in individual output. In the office, business invested a sum equal to approximately \$2,000 for each employee over the same period and squeezed out a mere 4% gain in productivity.

Other versions of these statistics yield the same message. It is estimated, for instance, that while the productivity of the American factory worker increased by 84% in the past decade, the office worker's output inched ahead only 0.4%. One of the reasons for this disparity, of course, is simply that American business spends less per office worker. According to Datapoint Corp., San Antonio, Texas, current capital expenditures to create a U.S. factory job average about \$24,000, against just \$3,000 per office job.

**F**rom another angle, Ing. C. Olivetti & C. of Ivrea, Italy, notes that office staffs in the Western industrialized countries are estimated to have grown by 45% though overall work forces have increased only 6%. According to one study, 51% of the American work force may be grouped in the white-collar category now, up from 42% in 1958.

Raising the productivity of office workers clearly will



# CAMBION. THE RIGHT SOURCE FOR...

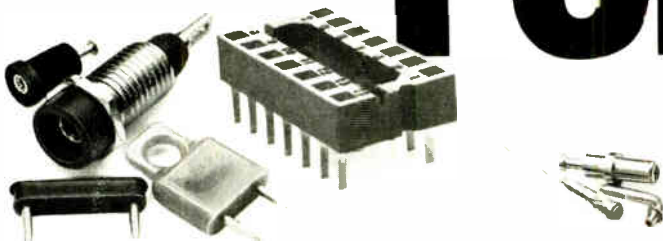

... over 23,000 different, useful electro-mechanical components including SOCKETS: low profile sockets, standard profile sockets, 6 to 64 pin sockets, soldertab sockets, wire-wrappable sockets, tin-plated sockets, gold-plated sockets ... and CONNECTOR JACKS: press mount jacks, solder mount jacks, swage mount jacks, thread mount jacks, combination pin jacks ... and IC PACKAGING: Cambi-Cards®, loaded socket cards, card files, power planes, frames, trays ... and TERMINALS: solder terminals, wire wrap post terminals, insulated terminals ... and HARDWARE: standoffs, battery holders, component clips, handles ... and COILS: shielded coils, unshielded coils, fixed coils, variable coils, custom coils, chokes ... and CONNECTOR PINS ... and CONNECTOR ASSEMBLIES ... and ... and ... and ...

Get all the right connections in Cambion's Catalogs 800 and 121 – the right sources to implement your circuit design and purchasing plans!



**CAMBION®**  
**The Right Connection.**

Cambridge Thermionic Corp., 445 Concord Ave., Cambridge, MA 02238. Tel: (617) 491-5400. Telex: 92-1480. TWX: (710) 320-6399.  
New York State (201) 529-1030 Baltimore/Washington (703) 941-5470 Los Angeles (213) 326-7822  
San Francisco (408) 371-0585 Ontario (416) 671-1588 England 0433 20831

This ad ran in 1930

# HARNESS

*for your tubes!*

Wild tubes, like wild horses, have no value. A harness is essential to put them to useful work. And that harness, in the form of proper controls for various circuits, spells

# CLAROSTAT

Not the name of a product. Nor again a line of products. CLAROSTAT is an engineering service dedicated to the harnessing of vacuum tubes for every conceivable purpose.

The CLAROSTAT line includes VARIABLE RESISTORS—from adjustable grid leaks to wire-wound volume controls, and again to super-power units of 250-watt capacity; FIXED RESISTORS—in strip form and flexible form, tapped or plain; and AUTOMATIC RESISTORS—notably the LINE BALLAST CLAROSTAT, for automatic control of applied voltage irrespective of line voltage fluctuations.

There is no better known name in radio technique than CLAROSTAT. Millions in use bear out that statement. And with the vacuum tube stepping out into new fields, CLAROSTAT joins "Electronics" in enlarging upon the benefits of radio technique.

**WRITE** for data regarding the complete CLAROSTAT line. No matter what your problems, our engineers are ready to serve you.

**CLAROSTAT MANUFACTURING CO., INC.**

Specialists in Variable, Fixed and Automatic Resistors  
294 North Sixth Street, Brooklyn, N. Y.

# CLAROSTAT. WE'VE BEEN DESIGNING THE FUTURE FOR A VERY LONG TIME.

Fifty years ago Clarostat was a small company — a few employees operating from a Brooklyn warehouse — dedicated to developing controls for every engineering design need. Already a leader in radio technology, we stood at the forefront of vacuum tube harnessing.

Physically, we've changed. Over 1200 employees now work at Clarostat. We operate three plants and manufacture a complete line of standard resistive components.

But we're still dedicated to solving engineers unique control problems. Our specialty lines of conductive plastic and cermet resistive elements are designed to meet the demands of a progressive and expanding market.

So when you're designing for tomorrow, let Clarostat help you today. We've been doing it for a long time.

Building the future on a history of success.

# CLAROSTAT

Clarostat Mfg. Inc., Dover, New Hampshire C3820/603-742-1120

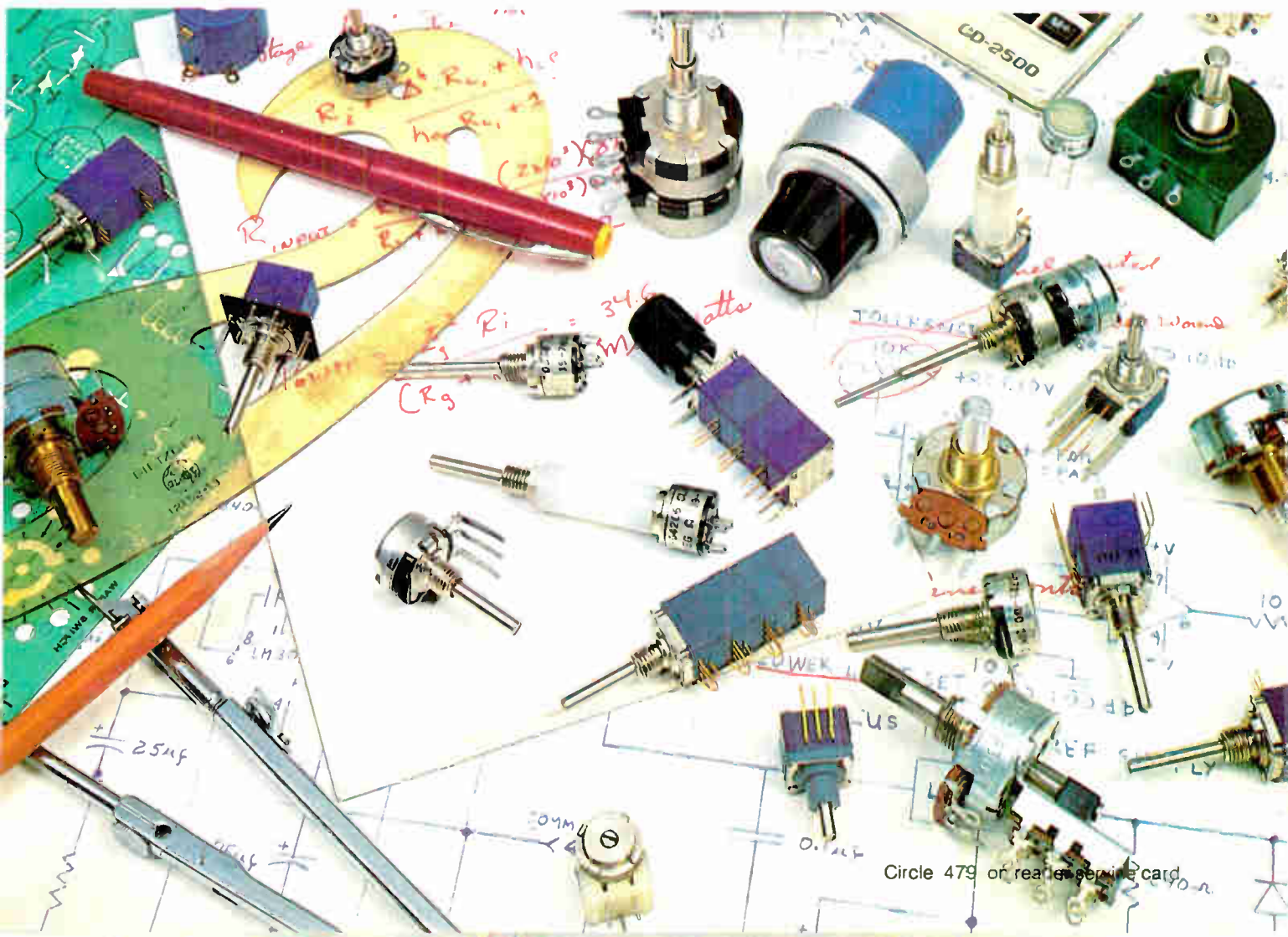

Circle 479 on reader service card



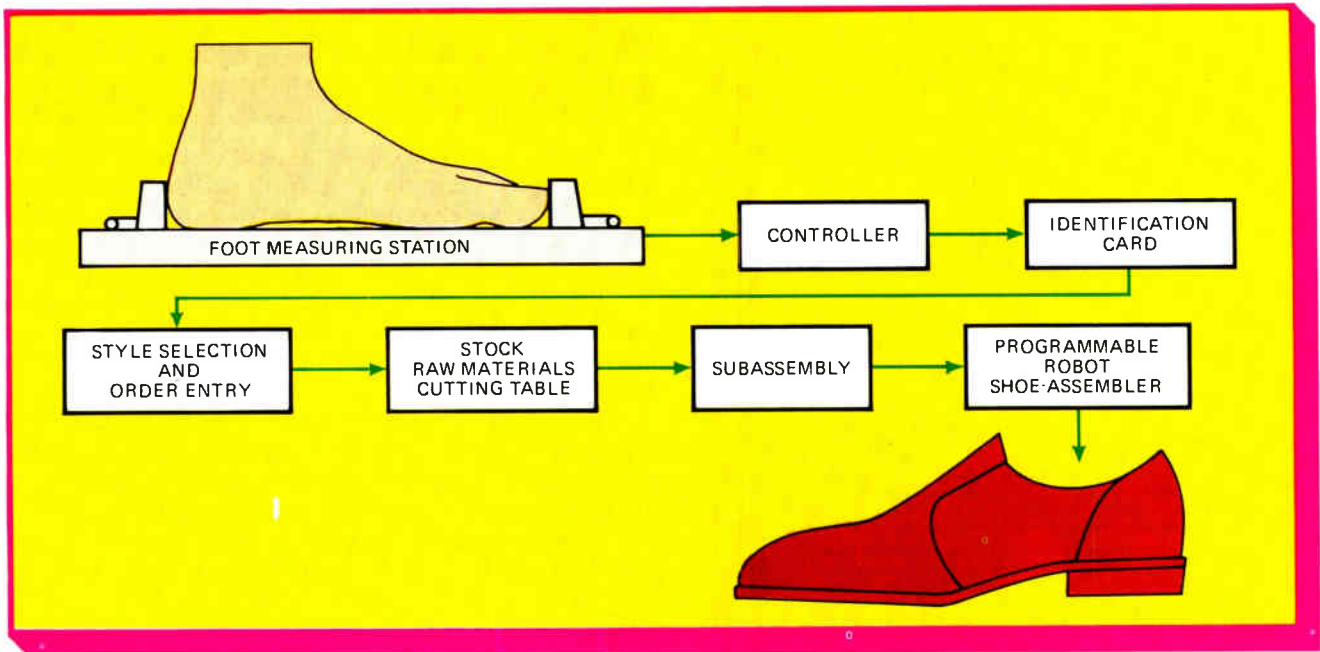

**Shoe store.** As envisioned by Michael Dertouzos in the book, "The Computer Age: A Twenty-Year View," an automated shoe factory will tailor its products to individuals. After a computerized "fitting," the customer will pick a style and robots will make the shoes on the spot.

involve electronics. Earle D. Jones, executive director of SRI's Advanced Development division in Menlo Park, Calif., describes the situation:

"People generally think that the productivity of the American worker is the key to everything, that more output per man-hour is necessary. Consequently, everyone thinks in terms of automation.

"The problem is that only one third of our total GNP is derived from manufacturing. The rest stems from service businesses. . . . Office automation will be the biggest contributor to increasing productivity of this service sector of the GNP."

Many of the technical objectives in gearing up the office of the future will be the same as those involved in establishing access to data bases in the home, except that the office is more concerned with documents and records, of course, and information teleprocessing will be even more important there.

The office-of-the-future concept has been bandied about so long that it has lost much of its power to dazzle. But the recent emergence of a trend to the subtle linking of word- and data-processing functions should succeed in restoring its appeal.

There are two ways of looking at how this trend will develop further. One is to focus on the technology itself and make assumptions about how it will be used. The other is to define the marketplace forces that will push the technology toward specific applications.

Edward P. Gistaro, senior vice president and general manager of the Data Processing division of Datapoint, chooses the latter approach:

"The first major push for the integration of mundane functions—telephone, typewriter, mailbox, and copier—with a common information base would bring a tremendous amount of efficiency to the office," he says. "Ironically we automated all the very complex things in our society first—blast furnaces, industrial processes, tele-

phone switching systems, spacecraft. Yet the office environment, which is so familiar to all of us, we've been content to improve on a piecemeal basis."

Future office automation systems will tend to be distributed processing centers operating from a common data base, Gistaro believes. He sees a close parallel between the emergence of distributed processing in electronic data-processing applications and the way offices will eventually be organized. Each unit of the system, even the mail room, will be able to program procedures to fit its own operation, but each will be tied to the central data base.

The automation of office record keeping will leave another problem to be solved in the next decade: what to do with the paper already on file. Some form of optical character-recognition equipment will be needed to get those records into electronic storage, though, as one observer suggests, close scanning may lead many companies to throw out 90% of them.

The goal then is to integrate data processing and word processing with electronic mail and voice or data communications to form what Datapoint calls the "electronic office." And some form of content-addressable memory system will be a must, according to Gerald L. Cullen, vice president for product marketing. This approach to accessing information may meet a long-time need in office automation—the ability to get at a letter or document filed electronically without a specific tag on it. In other words, the document can go into the data base without an identifying symbol and be retrieved by surveying any number of key words.

For example, say a manager sends out a letter to Mr. Ito Watanabe concerning production of yo-yos in Okura, Japan. That memo could be stored in the system under no particular category and then pulled out by a check of



**AT BELL & HOWELL**

# TODAY IS ALREADY TOMORROW

From the Bell & Howell of yesteryear — then, as now, the recognized leader in the audio/visual field — to a dynamic, diversified firm featuring a dazzling array of electronic products. This is the Bell & Howell Company of the 80's . . . where "tomorrow" R&D, technology and products are already at work today!

As a direct result, you'll find the Bell & Howell logo appearing on a surprising number of new, next-generation items. In such diverse areas as microprocessors, computer output microfilming, automatic mail handling, and remittance processing. In magnetic tape recording, test and recording instrumentation, and patient monitoring for the medical profession. In broadcasting, cable television, closed-circuit TV, video projection movie systems aboard commercial aircraft, and much more.

To underscore our total commitment to the future growth of electronics, we even operate a network of famed Bell & Howell Schools to educate new generations of electronic technicians and engineers.

We are pleased to participate in this exciting golden anniversary celebration for Electronics magazine. It may well be the only occasion when the entire industry pauses for a *backward* glance!



**BELL & HOWELL**  
Information systems for work, education and entertainment.

Circle 481 on reader service card



# Basler Electric Salutes Electronics On Its 50th Birthday

Fifty years of continued growth is a record to be proud of. We hope you'll pardon us if we are a little proud of Basler too....although we're only a little over 35.

From a humble beginning.... Basler started its business winding coils in a small building.... we've grown to a *four* plant operation in three states that manufactures transformers from 5VA to 1500KVA in size. Custom Transformers in Quantity with Quality is our forte. UL and CSA listed products serve many of our North American customers and we build products for international use in equipment conforming to international specs IEC-380, IEC-435, VDE-0730, and VDE-0804.

*Send for our brochure and let us know how we can best serve you.*



*Corporate Headquarters and Main Plant*

**B** Basler Electric  
Highland, Illinois

key words. Given "Ito Watanabe," the system would display a list of all correspondence and memos in which that name appeared. Or it could be possible to get a list of all communications dealing with yo-yos or with Okura. If the user recalls two key words the search is sharply narrowed.

This method of attacking a file sounds rather roundabout, but in fact is the way filing is done now. The difference is that a present search for a key word is done manually and may not produce the correspondence if the secretary who did the filing used a different key.

In a sense office automation is not as simple as pulling together data processing, word processing, and communication. The office is the center of decision making, too. But just as industrial automation has improved the functions of stamping, drilling, and assembling, so office automation should boost the efficiency of decision making and communication.

And, as in manufacturing, automation in the office need not mean a loss of jobs. Jobs will be upgraded so that secretaries will perform administrative tasks and mailroom clerks will become involved in data storage and retrieval.

The office of the future must be as much involved with people and their requirements as it is with equipment. Says Elserino Piol, manager of Olivetti's marketing and product planning department, "When we speak of the office of the future we are talking not so much about technology as we are about people. The human factor, people's willingness to adapt to new modes of behavior, is the unknown variable."

He feels that only through a step-by-step process can automation be applied to the office without meeting resistance from the work force, including the managers charged with implementing the changes.

How much change can we expect in the future? Franco de Benedetti, chief operating officer of Olivetti, says, "The answer lies deeper than technological applications and cost benefits, because the office is ultimately a people-oriented place. Technologically, penetrating the office continues to be an exercise in bridging the gap between promise and reality; the reality remains grounded in an aging, inert structure of patterned relationships."

In other words, the future integrated system can threaten an office's hierarchy. Sounding more like a psychologist than an equipment planner, de Benedetti comments, "A shift from a hierarchical structure to a polarization, with the elimination of intermediate groups and the replacement of higher groups by an oligarchy of specialists, would likely be prejudicial against middle-rank executives."

As for the hardware, the first step will be to link electronic typewriters, copiers, accounting machines, and magnetic filing systems via the office telephone system or a dedicated cable system. But, says de Benedetti, "these improvements in capacity will be useless if no improved access methods are available to the operator. The answer to this problem consists of data-base management systems, advanced structures, and natural inquiry languages."

For Olivetti planners, the term "future office" is

something of an anachronism in that technically the future is now. A company study suggests that though unstructured work comprises 65% of all office activity today, the trend is clearly toward "organizing complexities." Not only is the economics of establishing an integrated office data-processing and communications system becoming more attractive, but workers are becoming more familiar with the tools. Where in 1970 only 25% of the work force operated with computers in any way, it is expected that by 1985 more than 60% will deal with them and another 20% to 25% will have at least some knowledge of their function.

Olivetti believes that while people are growing closer to the computer, the computer itself must grow closer to people. According to Piol, various types of equipment manufacturers will have to mesh their efforts more closely in the future to avoid disillusioning users. "The electronics industry will have to work together as closely and coherently as we are implying others should," he says.

**W**hile outlining their thoughts on what the office of the future will be, most equipment producers and users are careful to point out what it will not be. According to David Klein, vice president for business development at NBI Inc., Colorado Springs, Colo., office automation will be neither word processing nor data processing nor even simply a merger of the two approaches, but rather a new form of more people-oriented automation.

But right now there are two camps: the office equipment suppliers anchored in a word-processing background and the computer hardware producers grounded in data processing. The word-processing companies argue that they understand the needs of the office better than the electronic digital-processing crowd. On the other hand, the data-processing manager in most companies outranks his or her word-processing colleagues and so exercises more sway over buying decisions. Clemenceau is said to have remarked that war is too important to be entrusted to generals. Office automation may prove too important to be left to the data-processing and word-processing managers and perhaps instead should become the direct responsibility of top management. The reason for high-level participation is that office automation is not going to emerge from the random purchase of standard office machines that will be strung together by some loose organizational procedures. Rather, it will have to be a coordinated effort involving the installation of hardware and communication links, development of software support, and employee training.

An example of such all-out commitment is the showcase system installed by Micronet Inc., a Washington, D. C., consulting firm. In operation since May 1979, this Paperless Office has attracted so much attention that Micronet president Larry Stockett has practically made a career out of promoting it. Among its many features is the fact that it represents the pooled resources and equipment of the 17 companies sponsoring the project.

The Paperless Office converts all incoming and original data into either electronic store or microfilm, depending on the nature of the material. All data can



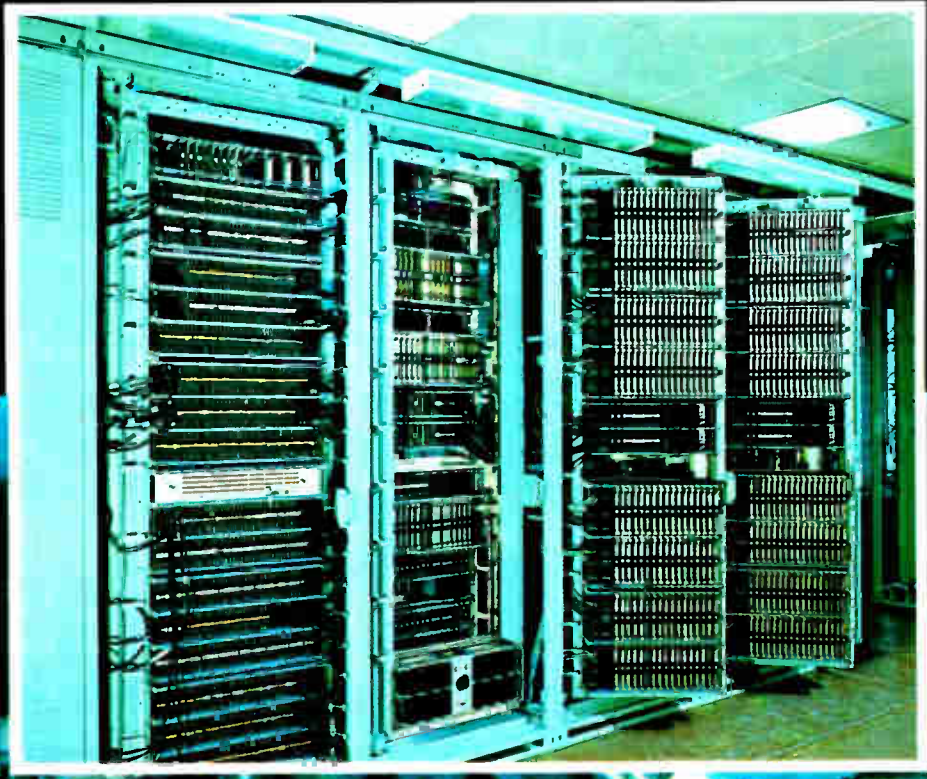

SP 9081/004

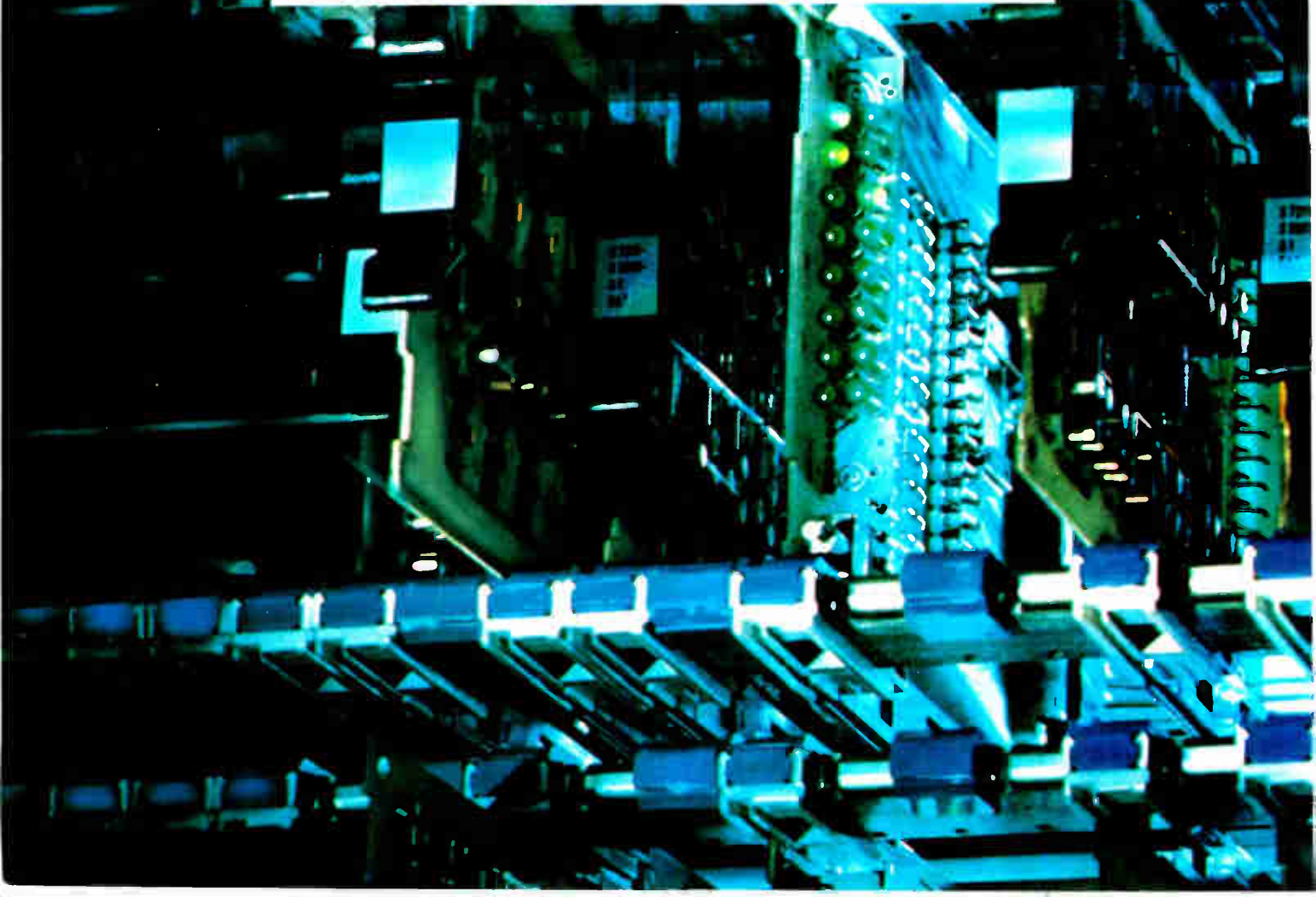

# We know how

## to channel time

Among our advanced systems is "Proteo"  
which uses time division  
for telecom switching.

Made in Italy.



# ITALTTEL

Telecommunications is our business



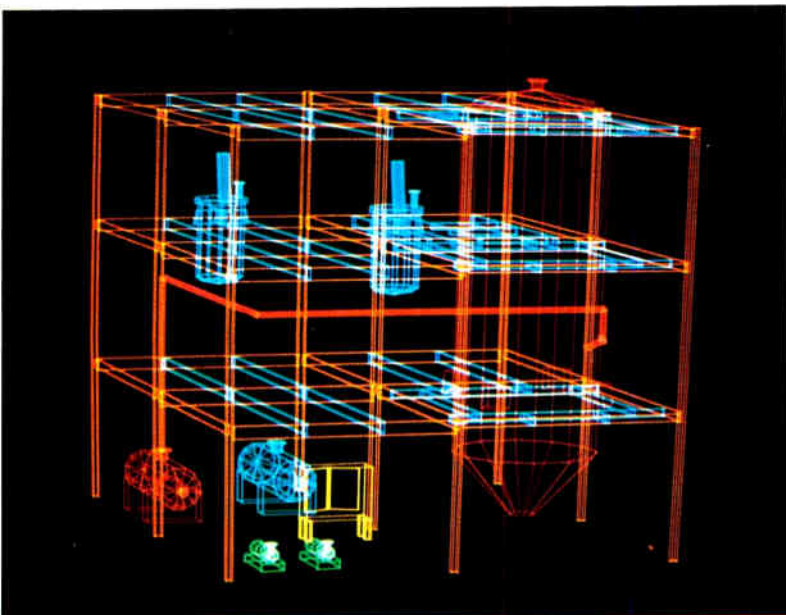

**Floor plan.** Using a computer, Evans & Sutherland has designed this chemical plant. The Multi-Picture System was developed to study the feasibility of designing plants with the aid of computer graphics. Its program was written to demonstrate the use of color in designing.

then be edited, indexed, sorted, retrieved, and converted into paper form, if necessary, to communicate with the "outside world." Correspondence coming into the office is usually stored in the computer system, while documents, catalogues, and other lengthy materials go on film where they can be called up for viewing by an automated microfiche retrieval system.

Information originating in the office often begins at a computerized Thought Tank System 193 from Dictaphone Corp., Rye, N. Y. It accepts dictation via a Touchtone telephone as well as desktop and portable tape-cassette recorders. The system can then distribute this dictation for transcription according to workloads and the priorities of the correspondence.

For word processing, the office has NBI's System 3000, a dual disk-storage unit capable of handling mathematical programs and communications. Data in the word-processing units can be stored on floppy disk or transmitted to a computer for storage or dissemination to other office terminals—again depending on the material.

Facsimile equipment has been supplied by the Qwip Systems division of Exxon Enterprises Inc., New York. And optical character-recognition equipment from ECRM Inc. converts typed copy into computer code.

Even with the minicomputers installed in the office, there is a need for time-shared computer services. Plessey Peripheral Systems Ltd. has installed both the mini- and microcomputer systems, while National CSS's Office Products division in Wilton, Conn., has provided the time-sharing capabilities, as well as access to an electronic mail network. Additional software comes from Microsystems Engineering Corp.

Both the paper and computer-generated data can be put on microfilm. San Diego, Calif.-based Datagraphix Inc.'s AutoCOM converts the computer data into microfiche directly via an interface with the Plessey micro-

computer system. Incoming material is transformed into updatable microfiche by a System 200 Record Processor from the A. B. Dick Co. in Elk Grove Village, Ill.

AM International Inc.'s Bruning division, Cleveland, Ohio, has provided its OP 50 High Speed Microfiche Duplicator with OP 80 Automatic Collator for copying microfiche masters. The Bruning 95 Automatic Cartridge Retrieval Display System lives up to its name by automatically retrieving and displaying microfiche, and there is a Bruning 1830 Enlarger Printer for transforming microfilm back to hard copy.

The office also uses Access Corp.'s computer-controlled storage and retrieval system for microfiche. Thousands of fiches, representing millions of pages, can be indexed, filed, retrieved, and refiled in this unit. For displaying them there are terminals made by Realist Inc., Menomonee Falls, Wis. One of the problems with using both computer and microfilm storage is that it requires two displays at the work station; however, they have been incorporated well in the Hamilton Sorter Co.'s office furniture. The office also uses Zytron Corp.'s computer output microfilm service bureau network.

Stockett of Micronet emphasizes that the Paperless Office will never function without the use of some paper, but it goes a long way toward reducing the shuffle. Another plus in this system is that it automatically keeps track of worker output, something that has not been done very successfully in offices to date. It even monitors the telephones as part of the dictation system. In this way a manager can call in at any time and have correspondence recorded and prepared without being in the office.

There is also a means of recording what has been taken from the microfilm files and when the material is returned. This procedure not only provides a reading on how active the files are, but promotes security. Only about 3% of the files are kept in computer store at any point. The rest is on film.

What about taking work home? This office also has portable film viewers costing about \$200 each, and an enormous amount of microfilmed information can be toted in these briefcase-sized units. The office uses 16 types of microfilm readers, depending on the needs of the viewer.

Stockett believes that past efforts aimed at increasing office productivity have too often focused on the wrong target. It's not the lower-salaried typists and clerks who need the attention, he says, but the high-salaried executives. "If the top manager can improve his or her efficiency by 5%, it can mean an increase on the bottom line of 30%. That easily pays for the system."

**B**ack at the plant, electronics will continue to control more and more processes and machines. And it is solid-state technology that is bringing this industrial automation about. William C. Hittinger, executive vice president for research and engineering for RCA Corp., New York, says production-line activity will be measured and accessed on the spot—permitting rapid correction or adjustment—thanks to microprocessors and their ganglia of sensors. With



**Many of our  
customers  
possess unusual  
powers.**

They couldn't function without them. Take the test engineer who needs to simulate Bombay's electrical system. An Elgar AC Power Source and plug-in oscillator is all it takes. That same Elgar Power Source can take equipment to every kind of electrical system in the world. There are 50 plug-in oscillators to choose from offering frequencies from 15 Hz to 10 KHz. Anything they can't duplicate, an Elgar programmable oscillator can. Single, two, and three-phase outputs are available in ratings from 120 VA to 36 KVA.

If your work calls for unusual powers, come to the source. Elgar. 8225 Mercury Ct., San Diego, California 92111. In California, call (714) 565-1155. Out of state, call 800-354-2213 toll free. (We are also a leading producer of High Isolation Transformers, AC Line Conditioners, and Uninterruptible Power Systems.)



**ELGAR**

an **Onon** power systems company

"Elgar salutes Electronics' 50th Anniversary Issue"



# MLC

## Technology for the 80's.

AVX multilayer ceramic capacitors (MLC's) are ideally suited for the electronics of the 80's. Today's electronic circuits demand superior capacitor performance — performance which cannot be met by yesterday's capacitor styles, but can be met by MLC's.

Future circuit designs will require that even more of the components accommodate increased speeds, while maintaining small physical dimensions. The size and performance



characteristics of AVX MLC's meet these requirements. Ceramic dielectrics cover the widest range of any dielectric from the most stable NPO's to the high frequency, low impedance general application types. This allows AVX MLC's to replace other dielectrics in many applications.

For more information on the advantages of multilayer ceramic capacitor technology write:  
AVX Corporation,  
P.O. Box 367,  
Myrtle Beach,  
SC 29577.

# AVX

Technology for the times

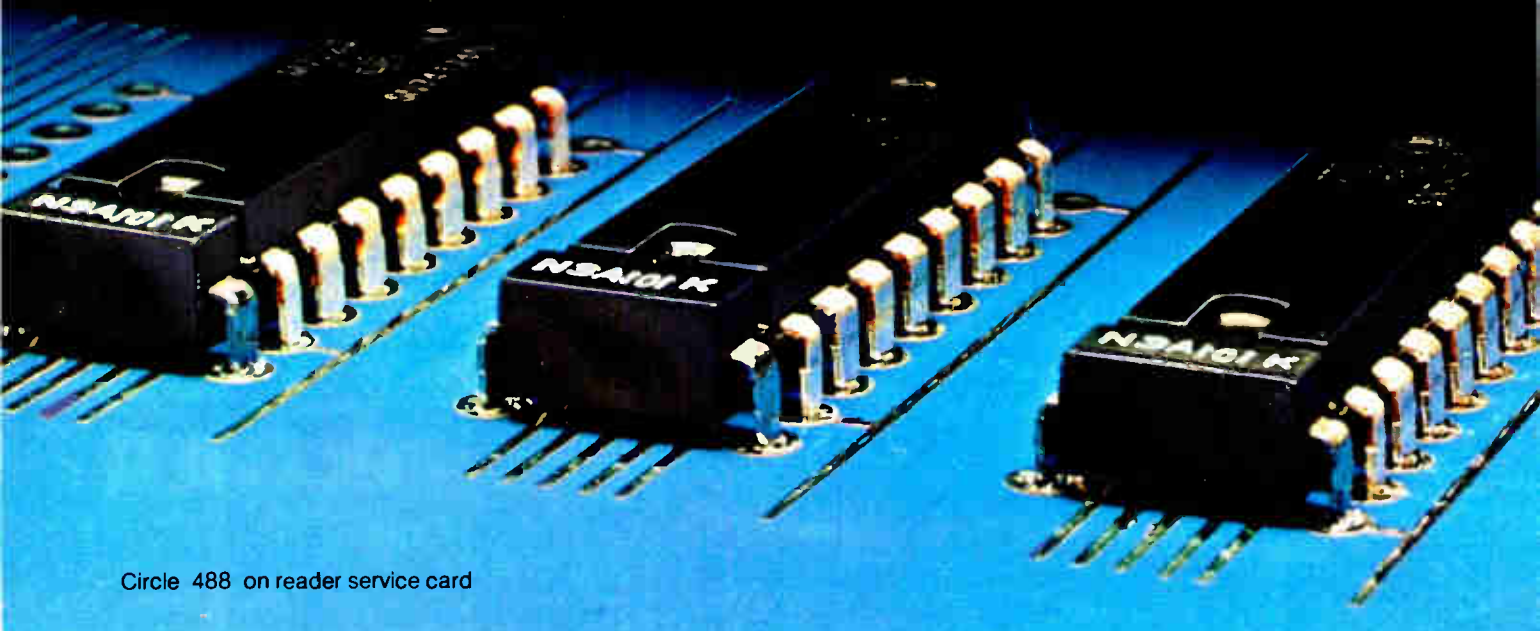

microprocessors used for controllers, robotics will flourish, he adds.

In 20 years there may not be an R-2/D-2 or a C3PO wandering around, but there will be significant advances in the capabilities of robots to distinguish shapes and carry out complex series of instructions.

Also on the horizon is the automation of software production. Earle D. Jones, executive director of SRI's Advanced Development division, says, "You'll just feed the specifications into a computer and get back a program." Small demonstration programs toward this end are going on now, he points out.

One key feature of this concept is that the program is made to develop its own way to access remotely located data. Another is that the user accesses the program in plain language, not a computer language. "That 'front-end' language makes things exciting," Jones remarks. "We may see the worker become tightly coupled with technology."

The programs used to produce other programs have to be tailored to peculiar needs, though, and that is one of the roadblocks. It is impossible to package one program for a broad variety of users or systems.

In the next 10 to 15 years, machines will gain the ability to "see" meanings through the massive use of multiprocessors. For a machine really to understand what it sees or hears will take intelligent programs that are just beginning to be devised.

Regarding intelligent machines and robots, MIT's Dertouzos points out that a whole new approach will accompany the meeting of automation and the information explosion. "It's my contention that it [automation coupled with information capability] will reverse some of the impersonal and dehumanizing consequences of the Industrial Revolution," he states.

Here is how Dertouzos outlines his views in his recent book, "The Computer Age: A Twenty-Year View." In one of his imaginary scenarios, he has the consumer of the future buying a new pair of shoes at a center that will accurately measure his or her feet (filing the results automatically) with an instrument that simultaneously uses the information to code an "order card." Samples of shoes can be inspected, but the bulk of the selections will be looked over on a computer-driven color display. The consumer will pick a shoe model, request alterations to suit personal taste, and have the order card processed along with an automatic payment card.

The order card will program this equipment in the production shop to cut the leather to size and include the requested alterations. And after processing by other special-purpose machines, the shoes will finally be assembled by a robot. The whole procedure will take about 11 minutes, Dertouzos estimates, and its final product will be tailored to the individual, not to a standardized mass market.

"With a few exceptions and qualifications, the technology needed to support this hypothetical automated shoe factory is either here or almost here," Dertouzos declares. "Selection of parts in an automated stockroom has been demonstrated and implemented. Computer-driven sizing and cutting is already being done in certain sections of the garment industry. The conversion of foot

measurements into two-dimensional patterns is straightforward in principle. Perhaps the least practical element is the automated robot that assembles a shoe."

Today's robots essentially repeat prearranged sequences or mimic a series of steps after a run-through. But they are severely limited by lack of sensory feedback and of knowledge specific to the task they must perform. To get greater flexibility into robots it will be necessary to equip them with sensors, particularly for sight, and with programs they can use to handle a variety of tasks.

The tough part will most likely lie in getting the robot to "understand" what its sensors are signaling. Computers help interpret images, but a general-purpose robot would also be required to recognize what action to take—to convert an interpreted image into a course of action, such as inserting a bolt.

Regarding automatic control systems, he observes that they, like robots, depend on sensors as they maintain a temperature or keep a plane on course in the face of disturbances or changes in direction.

The major difference in the control systems of the future will be their use of computers to program and store information, he says. In addition, the control equipment will be able to communicate with other computers, thereby establishing networks of controllers.

"The general-purpose programmable robot and the microcomputer-based controller are two components essential to the future development of automation," Dertouzos writes. "A third is the distributed system or network, which is made up of a number of interconnected robots, programmable controllers, and computer systems."

To the automated equipment in a factory could be added other machines that deal only with such information as order handling, inventory control, accounting, plant maintenance, and the like. Automated networks also could control transportation systems in which a great deal of data must be monitored, processed, integrated, and converted into specific action. The cost/performance capabilities of programmable robots could become competitive with those of unskilled workers by the turn of the century. And as the cost/performance ratio of programmable controllers improves, they will replace today's electronic controllers.

However, Dertouzos cautions, "in spite of the promise that computers offer, the leap in imagination, as has been the case in the past, will probably continue to be bigger than the leap in practice. We should not forget that nearly three decades after the development of modern computers and in spite of intervening promises and successful demonstrations in other domains, we are still using these machines primarily to add and subtract and to store and retrieve information. And even if all of our technological problems are solved, it does not seem likely that workers and employers alike would accept rapid changes that result in massive unemployment."

Of course, labor, plus the skills needed to perform it, has been shifting constantly since the beginning of the Industrial Revolution. There will be such shifts in the



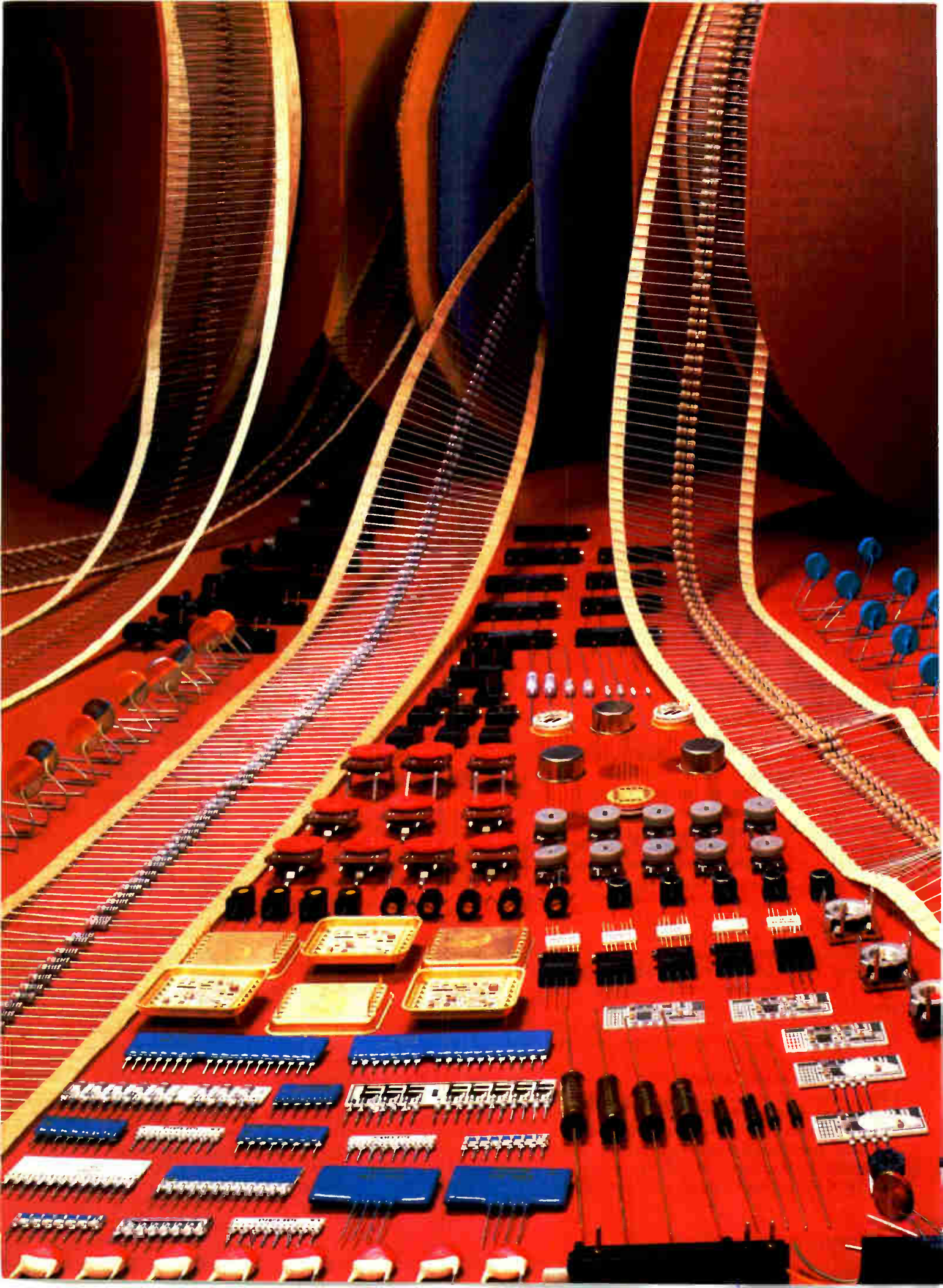



# Mepco/Electra's resistance technology for the 80's...

We've got it. We've got total resistance capability to meet virtually every resistor requirement for your modern electronic equipment.

Resistors like our **General Purpose Resistors** for use in 2% to 5% applications.

Resistors where price is paramount. Resistors chosen using the optimum film technology to provide the best balance between cost and performance. And we've got our **Standard Precision Resistor** line. Made especially for applications where tighter tolerances and temperature coefficients are required.

Add to this the **Ultra Precision Resistor** line which includes the tightest tolerances and temperature coefficients for professional product applications.

Circle 431 on reader service card

## ...and beyond.

Include single and multiturn trimmers, varistors, and thermistors. Products that meet military specifications and resistor/capacitor networks for your custom circuit design. We've got 'em all.

Top it with Resistance technology such as high volume mechanization, more than 20 years of film deposition and formulation research, production applications of laser technology, and computer controlled manufacturing and testing.

We're Mepco/Electra your resistor/capacitor company. Resistor technology for the 80's? We've got it and we make 'em all. Call (201) 539-2000 for all your resistor requirements.



Your resistor/capacitor company with the technology of the 80's edge.

Columbia Road, Morristown, New Jersey 07960  
(201) 539-2000 Telex: 136461

© 1978 Mepco/Electra, Inc.

This is an unretouched Photograph  
of Mepco/Electra's resistors.





information revolution, too, with new jobs emerging as old ones fade away.

"By introducing flexibility, economy, and individualization of goods and services into our way of life, computer-based automation could provide the driving force that insures long-term progress," Dertouzos concludes.

**T**ransportation in the year 2000 may not be much different from what it is today. The automobile should continue to be the principal way of moving people. Mass transit will still be important, with greater strides—as now—being made in Europe and Japan than in the United States.

As for space transportation, unless there is a national commitment—and challenge—equal to putting a man on the moon, manned explorations do not appear to be in the cards. However, there should be considerable activity in satellites to handle the growing need for communications during the information revolution described earlier.

By 2000, the impact of microprocessors will be felt in transportation, particularly in the automobile. At first glance, the typical car two decades from now should look surprisingly similar to the smaller cars of 1980. Underneath the fiberglass shell will be an internal-combustion engine powered by fossil fuel in liquid form.

Ford engineers say they expect two general classes of autos to be on the road: a small model for local use with room for one or two passengers and weighing about a third less than current compacts and a larger, cruising car for long trips. There should be room for smaller manufacturers to fill the gaps left by the major makers.

William Bourke, executive vice president of Ford Motor Co., Dearborn, Mich., explains that the American auto fleet will become "Europeanized," with most vehicles equipped with a four-cylinder engine. In fact, the conversion of American cars to the size and performance

capabilities of European vehicles may mean a significant export market for U. S. producers.

Despite millions of dollars spent to develop such alternatives as diesel motors and improved batteries for electric motors, the internal-combustion engine will remain predominant. Less than 10% of the entire U. S. fleet, which may number more than 120 million by the year 2000, will be powered by other means.

Gould Inc., which has been involved in electric-vehicle development for five years, concedes that less than 5% of the fleet will be electric. "But that's a substantial number," notes Robert D. Carnahan, director of electrical and electronic research at this Rolling Meadows, Ill., firm, because a massive investment in tooling would be necessary to manufacture the hundreds of thousands of vehicles per year that even 1% penetration of the total new-car market would represent.

No matter what kind of power plant is under the hood, it will be controlled by a microcomputer, says Gene Karrer, vice president and general manager of Ford's Electrical and Electronics division. Even electrical vehicles that escape the Government's mandated emission-control and fuel-economy standards need precise electronic controls to conserve battery life.

Automotive engineers say the car of tomorrow will have a level of electronic sophistication common in aircraft today, which means a rapid growth in microcomputer applications. Most autos coming out of Detroit do not have a microprocessor, but that will change this fall when General Motors Corp. includes one on every engine of its 6 million new cars. It will be the mid-1980s before auto makers reach a sufficient IC parts count to support fully these tiny computers.

By then the average car will contain at least 50 ICs and top-of-the-line models will carry more than 100. Many Cadillacs and Lincolns already have half a dozen microprocessors controlling their engines, temperature

## Coast to coast by tunnel

It sounds far-fetched, but a researcher for the Rand Corp. in Santa Monica, Calif., is working on a plan for a magnetic levitation propulsion system that would carry passengers from coast to coast—underground. Robert M. Salter, a senior physical scientist at Rand, points out that the concept—launching a train in a tube and propelling it electromagnetically—is sound but that the costs are staggering.

Others, too, think the idea has merit. The National Academy of Sciences is sponsoring a continuing look at Planetran, as it is called, and Rand has for some years kept the project at the ready, awaiting research funds.

When Salter talks about high speed, he means it. Planetran is seen—grab your hat—as able to hit maximum speeds of 14,000 mph, crossing the country nonstop in 21 minutes. A bidirectional, two-tube tunnel across the continent along a route envisioned by Salter would require a total of 5,440 miles of large tunnels perhaps 40 feet in diameter. This figure sounds outlandish, but he points out that about 8,000 miles of tunnels were drilled in the 1960s in the west alone and twice that distance by the 1970s.

How would the train run? Cars would contain cryogeni-

cally cooled supermagnets for levitation. Traveling electromagnetic waves in Planetran's guideways would oppose magnetic fields in the cars themselves in a way that would provide both support and forward or reverse thrust. For every car being accelerated in one direction, there would be one decelerating in an adjoining tube going the other way. Cars being decelerated would return electrical energy to the system, just as trolley cars did in the past.

The "waves" of energy would then move the car along the way an ocean wave propels a surfboard. The difference is that the extremely high speeds will require very precise controls to maintain the car's stability. In the past, the computers required to handle this task would have taken up all the space in the car, but today's microcomputers make the concept more feasible.

"Is the Planetran far-fetched?" Salter asks rhetorically. "To gain proper perspective, it's instructive to look back over the past 100 years in transportation and see how far we've come. Present travel and freight systems have proliferated without much attention being given to their relationship with integrated plans for the future. Without inspiration, we could have just more of the same in 2080."

Engineering  
Professionals:

We turn imagination  
into tomorrow's technology.

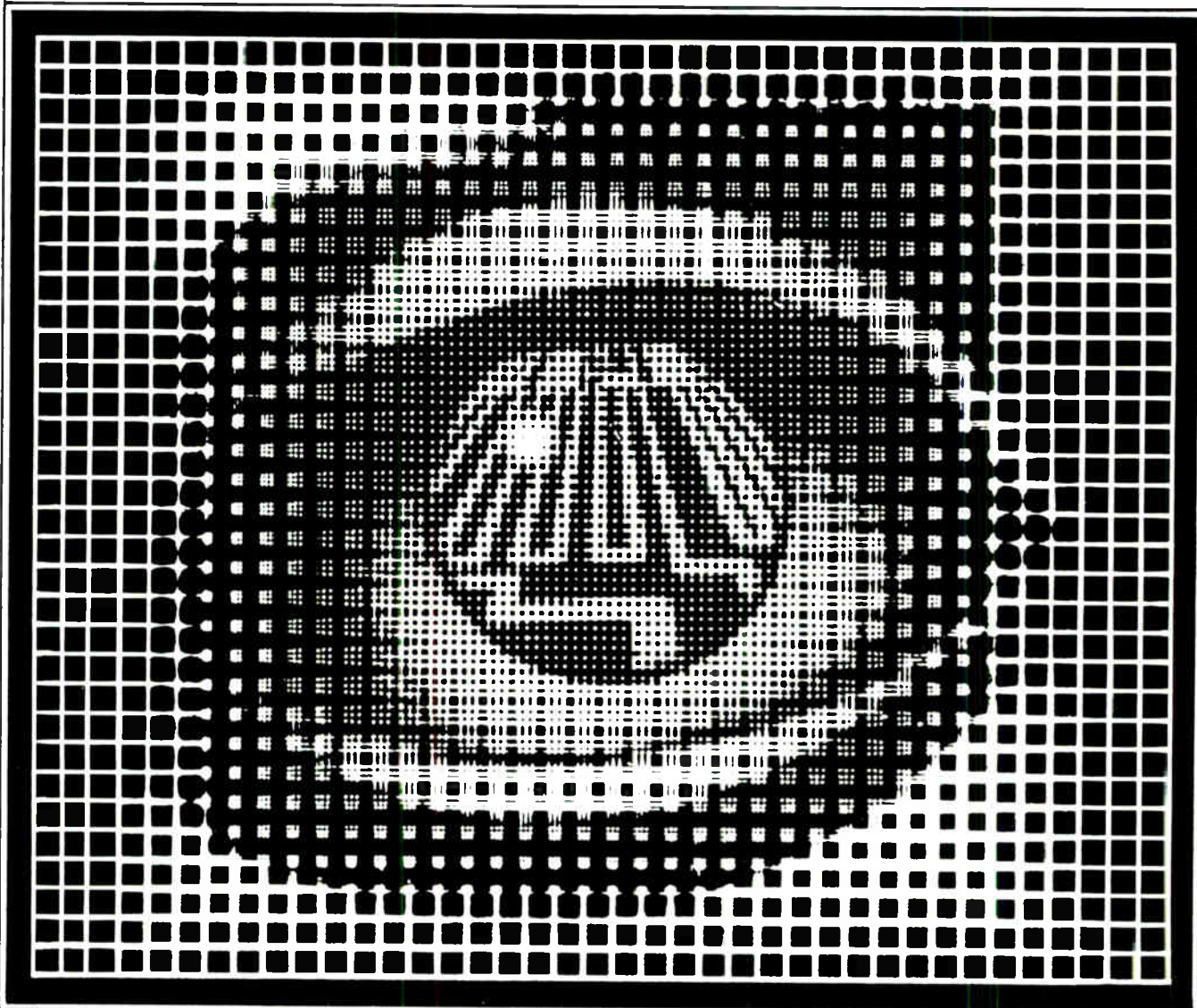

**You.** You're an experienced professional involved in Systems, Communications, Radar, Signal Processing, Antenna Design, or Microelectronics. You've always wanted to perform to your maximum capability, and to be continually challenged, and equally rewarded.

At Lockheed Missiles & Space Company in Sunnyvale, California, you can expect exactly that. A stimulating, varied company that will push you to the limits of your imagination and talents, and give you the recognition and rewards to match.

**Lockheed.** One of the most dynamic and diversified companies in the aerospace industry, continues to excel in growth and technology. Located in the heart of "Silicon Valley", you can expect to work closely with some of the finest, leading professionals in your field, in a team environment. Career growth opportunities are as abundant as your talents and interests, and the excitement of blending your skills and knowledge with our technology is truly a reward unto itself.

**The San Francisco Peninsula.**

Conducive to the type of lifestyle you've always wanted, with year 'round sunny weather, fine schools, plenty of outdoor & indoor activities, plus great cultural and sporting events in nearby San Francisco and San Jose.

Sound interesting? Then we invite you to forward your resume indicating special field of interest to: Employment Office, Dept. E-480, P.O. Box 504, Sunnyvale, CA 94086. An equal opportunity affirmative action employer. U.S. citizenship is required.

**At Lockheed, Technical Excellence is a Way of Life.**

**LOCKHEED**  
MISSILES & SPACE COMPANY, INC.







**On the road.** Transportation in the year 2000 will still depend largely on the automobile. But like this specially built Aston Martin, there will be a great use of electronic controls and displays. Several microcomputers will be installed in each car for a variety of functions.

controls, radios, and instrument panels. And automobile engineers are predicting that as cars become smaller (downsized, as they say in Detroit), electronic features will replace comfort as a key selling point. The increase in popularity of high-priced automobile sound systems is the first evidence of the new attraction that quality audio now has for even the average driver. Electronics will be used as a marketing edge, according to Robert Oswald, executive engineer for instrumentation and features at Ford—a man who has a stake in his own prediction.

Though the number of electronic functions will grow 20% or more, the parts count will stabilize in the mid-1980s and decrease by 2000. For example, the top-line Cadillac this year has 12 large-scale integrated circuits, but Frank Jaumot Jr., director of advanced engineering at GM's Delco Electronics division in Kokomo, Ind., predicts it will have about 10 by 2000.

Three competing schemes for using microprocessors are now being evaluated for the auto of the future: decentralized, with many processors operating basically independently; centralized, with one or two processors; and distributed, with several logic centers all using shared inputs from a variety of sensors in the engine, transmission, and exhaust.

GM, for instance, has established as a corporate policy that each of its cars will have a single computer control center, including a memory section storing a data base of

operating parameters. Elsewhere, however, there is a move toward decentralization because of design efficiencies now possible with lower-cost microprocessors. Also, auto makers fear a backlash from drivers having to replace an entire central computer should it go down, compared to the lower cost of replacing a small module in a distributed system. "We don't want to foist new systems on people that will make their lives more miserable," comments Ford's Oswald.

Another factor in the move away from centralized systems is the problem of designing a single processing unit that can be adapted to the extremely wide variety of engines, transmissions, and body weights available in the typical auto line. Explains Karrer at Ford, "We've looked hard at whether to put all the things together, but we never build the same car twice. We need the flexibility of a modular approach, with different functions for different models."

The first steps in modular electronic controls have already been taken. Ford and GM have designed engine spark-advance and emissions-control systems for a variety of their larger 1980 and 1981 cars, using programmable read-only memory cartridges attached to shared microcomputer controllers. However, the automotive electronic control systems will do more than conserve fuel. They will alert driver and mechanic to impending failures by comparing current operating data with history to pinpoint a decline in performance.

Low-cost mass memory is coming to the auto industry





# 8088: Twin Reality

**Intel unveils the ultimate 8-bit CPU. Powerful. Practical. Beneath the surface, the heart of an 8086.**

True beauty is never skin deep. Such is the case with our new 8088 microprocessor. On first impression, you'll see a powerful third generation CPU with the convenience and practicality of an 8-bit bus. Look closer and you'll discover the remarkable 16-bit internal architecture, megabyte addressability and advanced instruction set of our 8086.

The 8088 is both. Therein lies its ultimate beauty.

When we introduced the 8086 family more than 18 months ago we called it a new beginning, a microcomputer system architecture so advanced it would deliver a dramatic increase in system sophistication, performance and expandability. Now the 8088 delivers the same performance increase for 8-bit designs.

## 8088: Designed with reality in mind.

We built the 8088 to perform in the type of systems you're designing today and well into the future, too.

Advanced arithmetics, including 8- and 16-bit multiply and divide, boost computational thruput for your most complex mathematical and control applications. But the 8088 is much more than a superb number cruncher.

Its byte-wide orientation and extensive string-handling instructions give it unprecedented capabilities—block moves, string comparisons, data scans and translations—that make the 8088

the ideal CPU for your business-oriented applications as well.

The 8088 addresses up to a megabyte of memory, in 64K byte segments. Segmentation and efficient register utilization enabled us to build in the capability for such minicomputer-like features as instruction pre-fetch, re-entrant code, position independent code and dynamic relocation. And 64K I/O space and indirect I/O simplify programming even further.

## Make your own reality.

Any way you look at it, the 8088 is a tantalizing prospect. If you are upgrading your 8080, 8085 or Z80 design, the basic 5MHz 8088 delivers two to five times

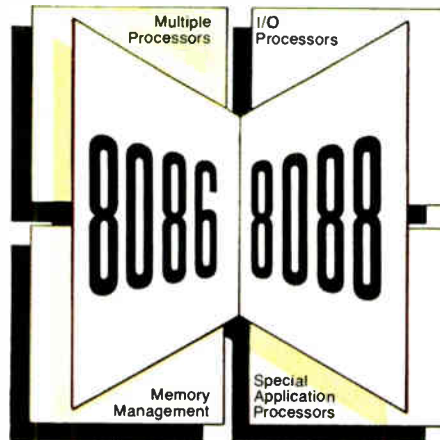

the performance, yet preserves your entire hardware investment. And with the CONV-86 code converter and PL-M/86 compiler, your software can be easily upgraded, too.

The 8088's 100% software compatibility with its 16-bit twin ensures the smoothest possible transition to any future 16-bit processor needs.

Its 16-bit internal architecture

and elegant instruction set are super efficient for implementing high-level, block-structured languages such as Pascal or PL-M/86.

Etched into its HMOS\* circuitry, the 8088 allows compatible interface to multiprocessing configurations with the 8086 and Intel's new generation of I/O processors, math processors, memory managers and distributed intelligence configurations.

For more space—and cost-sensitive applications, though, four other readily available Intel® bus multiplexed peripherals combine with the 8088 for a complete 8-bit system of unprecedented performance.

## The future has arrived.

Because the 8088 shares the instruction set and object code of her more powerful sister, the same Intel® development system and software package you use for 8086 program development fully support the 8088, too.

Put some true beauty into your new designs. You can order the 8088 support components and development system from your local Intel distributor, or with a single call to your Intel sales office. Or write: Intel Corporation, 3065 Bowers Avenue, Santa Clara, CA 95051. Or call (408) 987-8080.

\*HMOS is a patented Intel process.

## intel® delivers.

Europe: Intel International, Brussels, Belgium. Japan: Intel Japan, Tokyo. United States and Canadian distributors: Arrow Electronics, Alliance, Almac/Stroum, Component Specialties, Cramer, Hamilton/Avnet, Harvey, Industrial Components, Pioneer, Wyle/Elmar, Wyle/Liberty, L.A. Varah and Zentronics.

Circle No. 497 for information





**Controlling the wheels.** At a traffic control center, which was used to determine the software needs of a computerized system designed by Sperry division of Sperry Corp., a controller tracks congestion on a major highway and at parallel intersections to divert traffic.

as well. Ford already is using a 64-K random-access memory from Motorola as part of its on-board diagnostic system, and future generations of this equipment will have special input/output ports to interface with a mechanic's test instruments to measure more facets of engine performance. Thus, the same system will tell the drivers their fuel consumption and will allow the mechanic to check specific spark plugs and cylinders.

Besides the engine and exhaust-system sensors already incorporated into electronic controls, others will keep track of the transmission and the interior of the car. Torque and atmospheric sensors and others will be used to monitor spark ignition, fuel injection, and other operations, predicts Patrick Reciputo, assistant chief engineer for automotive electronics at Delco. "It will be an honest-to-goodness closed-loop system."

**W**hile engine-control designers are anxious to link operating functions in the engine, exhaust system, and transmission, others are working on more electronic displays for the driver. But perhaps the most striking change in the passenger compartment will be the

elimination of the accelerator pedal—in the car of the future, voice commands will determine speed, predict Ford engineers. Upon receiving the speed instruction, a microprocessor-based engine-control system will begin acceleration according to a fuel-conservation optimum, explains John Ullrich, a Ford executive engineer for powertrain electronics engineering.

Ford engineers conjecture that the voice-controlled accelerator might eventually be required by the Government to inhibit drunk driving. If the driver's voice sounded slurred, the car would not function. A key-based override would probably be necessary, however, to allow someone else to operate the car.

The instruments in the driver's compartment will probably disappear in time, to be replaced with an electronic display, perhaps a cathode-ray tube. Besides warning about possible equipment malfunction and maintenance needs, the display might be used as a road map generator, engineers speculate.

Oswald of Ford estimates the CRT will cost \$100 and be backed by 256 kilobytes of memory for route guidance, and it may include trending or graphics capabilities to indicate maintenance requirements. Instead of



# WHY EAO SWITCHES?

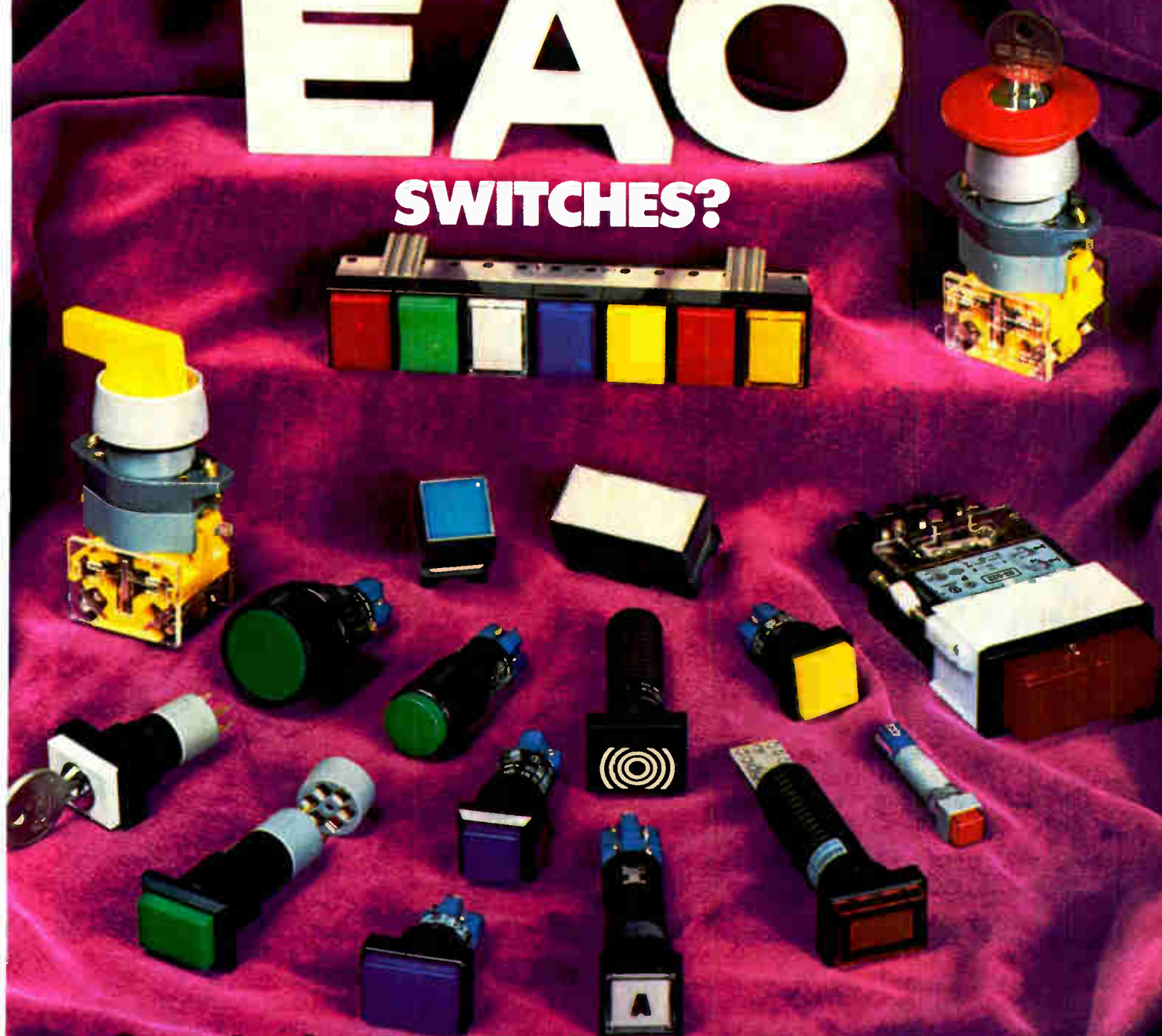

## Great Looks, Great Performance, Great Service.

EAO Switches offer the best performance-per-dollar value on the market today.

**MATERIALS:** Every EAO switch is constructed of the highest grade materials available. Contact blocks are diallyphthalate for dimensional stability under high temperature and humidity. Contacts are hard silver with 10 microns of gold laminate for excellent shelf life and low level operation. Terminals are gold plated for easy solderability.

**ASSEMBLY:** EAO switch assemblies are automatically assembled with every step around the thermostat to prevent movement

of parts internally and to block solder flux that could enter and damage the switch interior.

**TEST & SEGREGATION:** Only switch elements with contact resistance of less than 50 milliohms are accepted. Switches are run-in (actuated 100 times) and re-checked to previous values, then tested for conductivity of each pole.

Other features of EAO switches are:

- To eliminate special panel punches, most EAO switches are designed to fit a round mounting hole.
- Lens and window are designed for

even illumination. Precision fits at the lens virtually eliminates light leakage.

- Secondary latch design reduces stress spending time to set.

EAO switches enhance the look of any panel they are mounted on, with a look of quality when actuated. Since every switch is inspected throughout manufacture and automatically assembled, you can be sure that the millionth you buy manufactured is exactly the same as the first and obeys to the same high performance standards.

EAO offers a wide variety of stock sizes, special sizes, and custom designs.

EAO Switch, you can feel the difference.

# EAO SWITCH CORPORATION

255 Cherry Street, Milford, CT 06460 / (203) 677-4577 / TLX: EAO SWITCH MFRD 8643-7

Circle 400 on reader service card



# Multiwire\* Optimizes ECL.

## These traces tell the story.

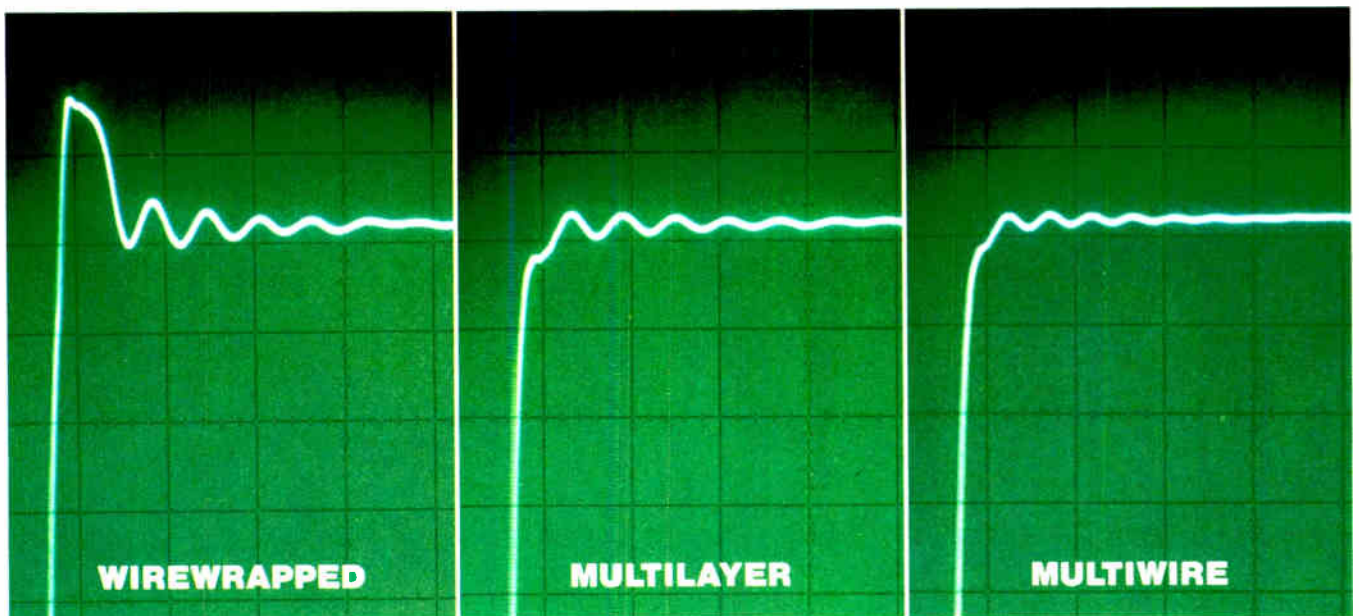

Wirewrapped and multilayer circuit boards can handle the high speeds of emitter-coupled logic. But Multiwire does it better. With Multiwire, *board impedance is precisely controlled to meet circuit specs and is consistent from signal to signal and board to board.* The problem of signal reflections with wirewrapped and multilayer requires the use of discrete series-damping and terminating resistors. Multiwire reduces design problems,

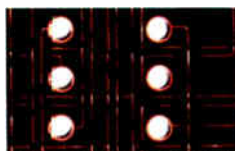

A typical example of the circuit density achievable with Multiwire circuit boards

provides consistent electrical characteristics, and results in lower cost and better circuit performance. Add to that other Multiwire advantages: less design time, shorter lead times, easy circuit changes, reduced inspection costs, and higher production yields. The choice is obvious. Multiwire is the way to go. Write or call today for details.

Multiwire, 31 Sea Cliff Avenue, Glen Cove, NY 11542. Phone (516) 448-1307

\*Multiwire is a U.S. registered trademark for the Kollmorgen Corporation discrete wired circuit boards



**Vite, vite.** The French National Railways has launched a new railway capable of over 160 mph. An elaborate electronic system has been installed to handle the switching of the trains as they rush along. The system also controls the braking action.

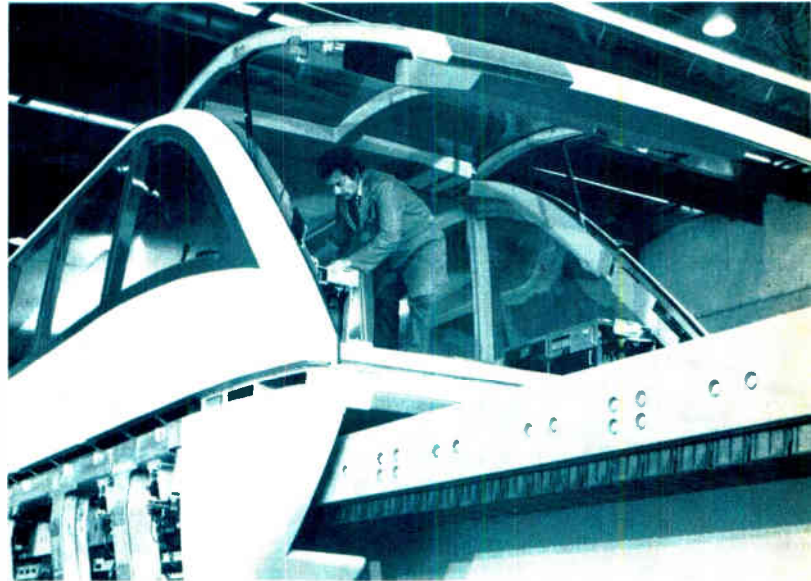

**Magnetic train.** Researchers in Germany have been experimenting with a railroad that would operate on magnetic levitation. Vehicle-mounted magnets lift the car from the rails and a linear induction motor propels it at speeds as high as 400 kilometers an hour.

being scheduled according to time, he says, maintenance will be requested by the engine-control computer on an as-needed basis.

Collision-avoidance systems (CAS) using radar signals have been developed over the years, but engineers are skeptical about them. Will drivers trust such a warning—in other words, will the system be reliable enough to gain the driver's confidence? Unless there is a Government requirement, CAS will be accepted only very slowly. In any case, most accidents involve cars moving in the same direction in the same lane.

**N**ot to be overlooked are the entertainment and comfort functions of automotive electronics. The entertainment center in a future car will be similar in quality to home audio systems, and optical playback units reading digitally recorded sound will be available.

Another form of sound recording will probably be solid-state memories mounted in cartridges to play back audio. Comments Les Wilkinson, general supervisor of communications development at Delco, "We've not seen the impact of inexpensive memories yet."

Electronics will also be used to replace direct driver controls. Instead of a driver-altered thermostat to control heating and air-conditioning, Wilkinson expects "adaptive electronics" to take over. Sensors will detect increased sunlight and temperature in the passenger area and automatically compensate for it. De-icers and windshield wipers will be similarly responsive to sensor-detected conditions.

Despite poor performance and lack of funds to date, computerized traffic control continues to be an idea that occupies transportation planners. One such system is the Integrated Motorist Information System (IMIS) being designed by the Sperry division, Great Neck, N. Y., of

Sperry Rand Corp. for the northern traffic corridor on Long Island, N. Y. IMIS extends from the New York city limits into Suffolk County—a heavily traveled section.

Components of the 35-mile-long system include a central computer, electronic sensors buried at half-mile intervals in the roadways, variable message signs, and computerized traffic signals at key entrance ramps to the expressways, as well as at intersections on parallel arteries and major connectors. Also included will be motorist-aid call boxes at half-mile intervals and near-field radio transmitters to advise motorists of conditions ahead.

The task is to detect congestion quickly enough to divert traffic before a major tie-up develops. Weighing information from the sensors, the computer may someday control various output devices to regulate traffic. Depending on the type of computer finally chosen for the system, it could serve as a central control for the call boxes, notifying the police of congestion and breakdowns and funneling requests for aid to towing services.

The energy supplies of the future will of course be the major influence on public transportation. There is increasing awareness in communities with underdeveloped transportation systems that mass transit is imperative. But all communities are facing a similar dilemma—how to increase transit revenues while lowering costs.

"This means moving to automation as quickly as possible, for only then can the problems of manpower cost, system efficiency, and high passenger volume be accommodated," says Raymond L. de Kozen, vice president of marketing for Cubic Western Data Corp., San Diego.

This is not to imply that mass transit will become entirely computer-operated; rather, the motorman and conductors and so on are to be reassigned to "mainstream" jobs—if their unions are willing to be similarly "reassigned." The technology exists to assure self-ticketing and automatic entry and exit of passengers, with



accounting tied to the system via distributed processing networks.

Actually, Cubic is involved in automatic ticketing for a variety of applications. As more mass transit systems apply this technique to existing or new installations, it will likely spread to airlines and interurban buses. Automatic ticketing may find a role in the entertainment industry as well.

**T**hough passenger rail service in America today is in a depressed state, long-haul freight trains are still profitable. And the railroads have been looking to electronic technology to help solve some of their problems.

"There's a lot of room for microprocessors in rail equipment," declares Ross T. Gill, manager of Research and tests for the Southern Pacific Transportation Co. in San Francisco. For example, "we want to give the engineer more information in the cab, including the forces that are operating on the train, so he can avoid hazardous situations."

One concept in research and development is a microprocessor-based cruise control for diesel locomotives similar to that used in automobiles. These would be add-on black boxes that would optimize throttle settings and fuel consumption and would be based on the type of locomotive and size of the train.

Southern Pacific is looking at diagnostic tools that verify an engine's electrical system, at on-board self-test

units, and at modular electrical components that can be easily tested and replaced. Also in R&D is a remote air responder that would read the condition of the air-brake lines and determine in which car a break has occurred.

Gill also anticipates a great deal of advancement in wayside inspection equipment. His carrier uses infrared gear to spot hot bearings on cars, and similar equipment to identify hot wheels caused by imbalanced loads is in the offing.

Test equipment on wheels will progress, too. To test track specifications, there will be cars of more sophisticated geometry employing laser-beam reference technology, Gill predicts. Rail flaws are detected now at speeds of 20 miles per hour; the goal is to do it at 60 to 70 mph with ultrasound or other technologies.

To get a real picture of the trains of the future, however, one must examine the plans of the railroads overseas. Unless something catastrophic happens in the next year or so, the French National Railways (called SNCF) will be running the world's fastest track service starting in 1981. That's when the SNCF plans to begin full-fledged passenger service with its Train à Grande Vitesse (TGV). It will cover the 266-mile stretch between Paris and Lyons in two hours, hitting top speeds of 162.5 mph and averaging 132.

This tops the pace set by the New Hokkaido line in Japan—though the Japanese are also working on increasing the speeds of the famous Shinkansen, often called the Bullet Train.

Although it clocked over 200 mph with an experimen-



**Space travel.** IBM test engineers check out the instrument panel in the Space Shuttle Orbiter cockpit simulator at NASA's Johnson Space Center. There are two programs: the system services that manage the overall computer operations and their applications programs.

# Iskra - an international electronics company

Significant developments in research, technology and business - Significant developments in research, technology and business

## Building with the future in mind successful in world-wide markets

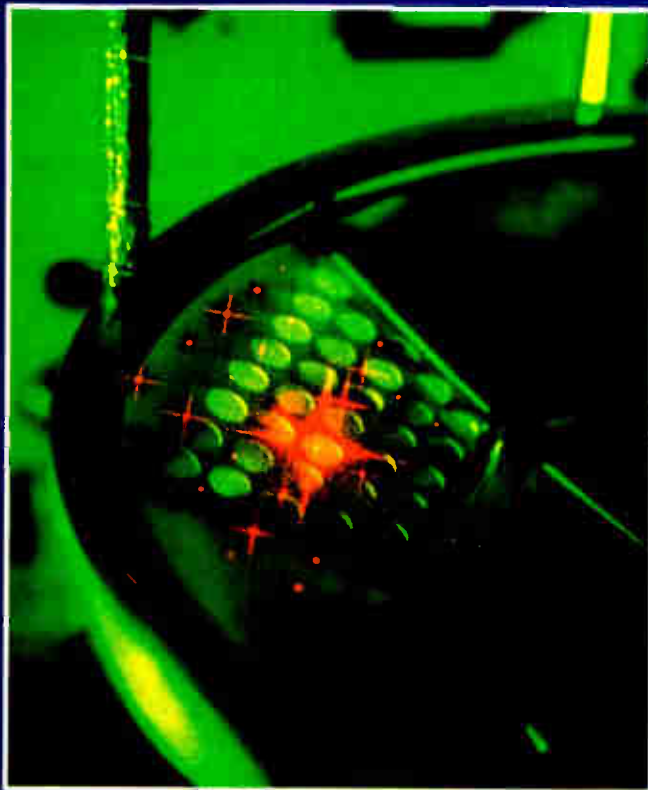

1. Testing of electronic telephone exchanges units.  
2. Telephone "Isicom super".  
3. Factory for the production of automatic telephone exchanges. This is one of the 60 Iskra's factories in Slovenia.



1



2

### Facts about Iskra

The score US\$ 1.233 billion of total revenue per year has brought Iskra to the 58th place in the world's electronics industry, to the 16th in Europe and to the number one place in Yugoslavia. The average exportation rate throughout the last 15 years grew steadily — even in hard times — gaining 27% annually.

The purchasers in several countries extending over four world continents bought for more than US\$ 120 million of Iskra's goods and services in 1979. The major part of the exported goods went for the developed countries of western Europe and USA, 27% were destined for developing countries and 23% of its products were sold to the countries of Comecon.



3

Complete systems and top make products covered 55% of the exported value, industrial cooperation reached 20% while the engineering services, technology transfer and know-how were represented by 5% of the total export value.

However, the share of sold or transferred know-how abroad takes greater dimensions, since it is included in the sales of complete systems as well as in international cooperation activities



# Iskra - an international electronics company

Significant developments in research, technology and business - Significant developments in research, technology

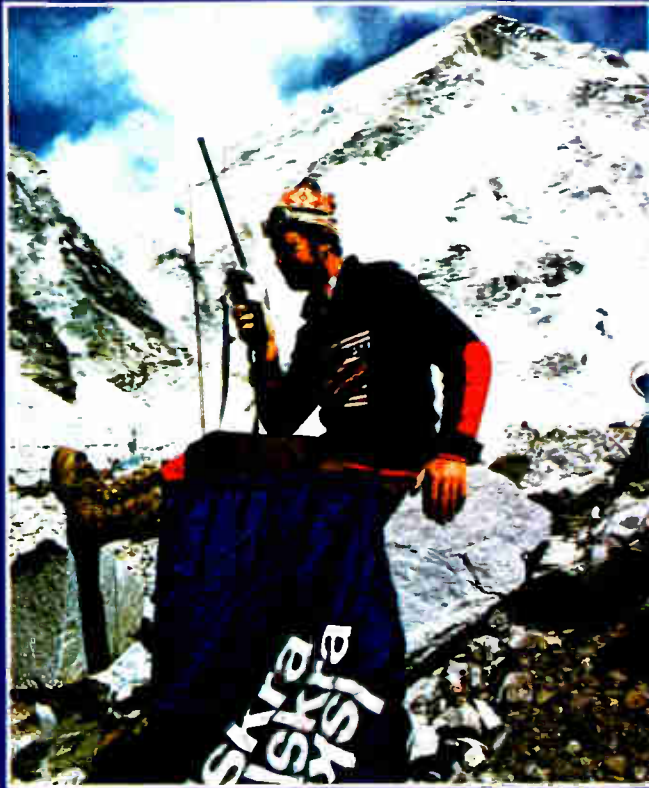

## Some facts about Iskra's relations with the world

The Iskra Co. owns 24 trading companies, production companies, and representative

offices in 17 countries all over the world. The quality of Iskra's products and services is known by its demanding business partners, buying parties and users in New York, Stuttgart, Milan, Paris, London, Biel (Pieterlen), Prague, Warsaw, Berlin, Bucarest, Cairo, Tehran, Caracas, Brussels, Mannheim, Quito, Barcelona and hundreds of other places. The news about Iskra reached as far as Mt. Everest peak as well as many a spot of the world where man seldom sets his foot.

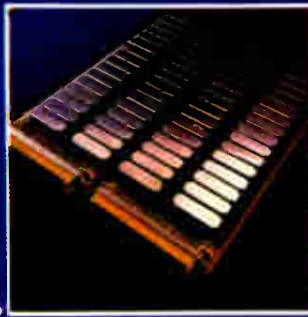

4. Iskra's radio-relay equipment used by Yugoslav alpinists on Mt. Everest.

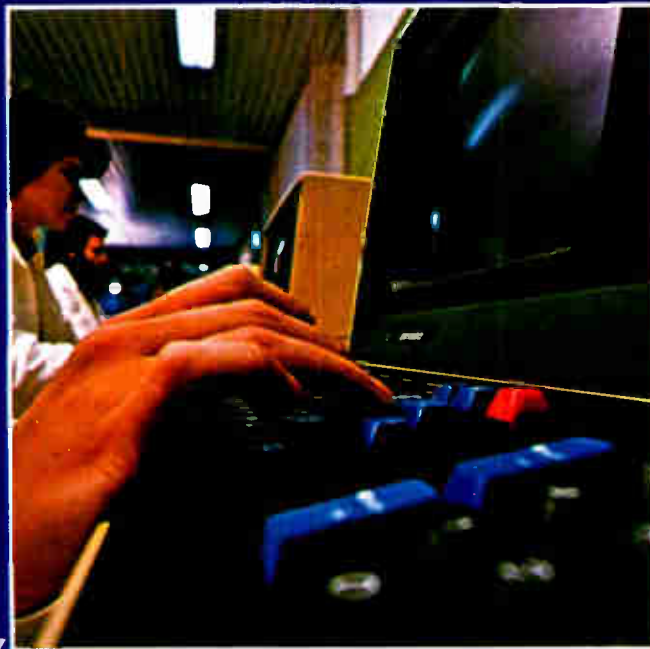

However, in spite of the expansion of Iskra's activity all over the world, the number of biggest importing countries of its products and services is itself limited. These are the states where Iskra Co. has established its own foreign trading firms with steady and long-lasting relations concerning business, technical and scientific collaboration as well as permanent industrial cooperation together with other, more advanced ways of international exchange.



5. Telegraph equipment for remote control and supervision.

6. Module.  
7. Computer center of Maribor University, delivered by Iskra.

8. Automatized marshalling yard "Zalog".



The company has some 29,000 employees including 1,600 research and development engineers in 80 factories, research, marketing and other organizations, and the most up-to-date technologies to work with. In its development, Iskra is oriented toward tomorrow's activities which go far beyond the traditional limits of



electromechanics and extend to the widest application of electronics with priority being given to the development of communications systems and equipment, computers, automation (of traffic power generation and power distribution, and automatic of industrial

processes), security and protection systems and equipment, and engineering activities. All to ensure that every project we handle comes within schedule and budget requirements and meets performance and client expectations.



13. Kilns with regulated temperature and atmosphere for firing thick film layers.

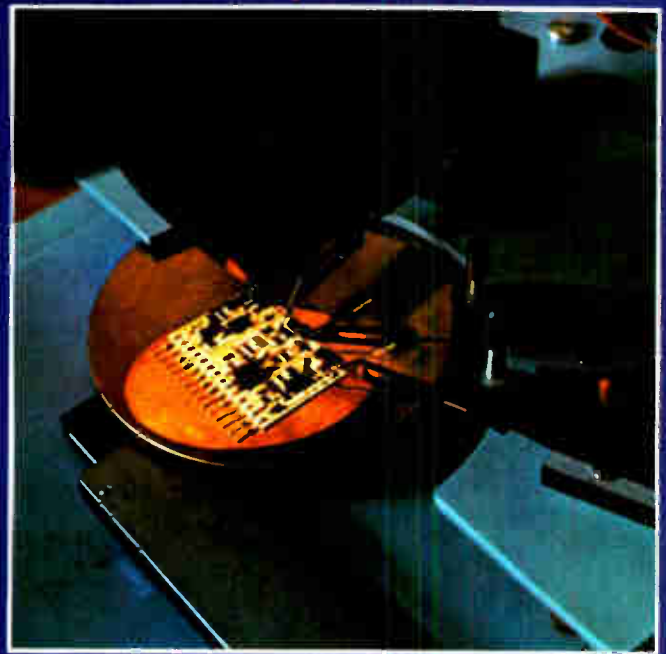

From its wide production programme Iskra invests most in developing the following segments:

Micro-electronics - with all technological variations including thick and thin film technology, the majority of thin films is made in MOS technology. Semiconductor materials and components.

9. Iskra Limited trading company head office in U.K.

10. Laser communication device.

11. Various laser equipment made by Iskra's up-to-date technology are well known in world markets.

12. Iskra company head office in Ljubljana, Yugoslavia.



13



# Iskra - an international electronics company

Significant developments in research, technology and business - Significant developments in research, technology

Business and data processing computer systems and programming equipment, micro computers and micro processors.

Optoelectronics - Development of telecommunication components as optically coupled relays. Holography, mainly for use in memory banks. Optoelectronic for measuring purposes.

Integrated telecommunication systems, based on digital technology as PCM Multiplex and PCM communication equipment.



17



14



15



Engineering activities - Engineering for road and railway automation, for automation of industrial processes, electric power generation and distribution, engineering for communications systems and equipment, for watt-hour meters, consumer goods and various others in the specialised field of technology. Emphasis will be placed on all research and development activities within the company.



18



19

14. Calibration stand for watt-hour meters. These type of stands are also exported to Tunis.

15. Production of TV sets.

16. Production of electrical automobile parts.

17. EPABX 300 type electronic telephone exchange in Holiday Inn hotel in Ljubljana.

18. EPABX 16 electronic telephone exchange.

19. Computer center of an international electronic telephone exchange.



# Iskra

For further information, please contact our head office in Yugoslavia: Iskra Commerce, Trg revolucije 3, 61001 Ljubljana Yugoslavia. Telephone-international: 3861324261, Telex: 31-356 yu iskexp - or our trading companies and representative offices in Czechoslovakia Iskra, Lazarska 5, 11000 Prague, Tel: 202771 - Egypt: Iskra Cairo, 3- Adly Street, P. O. Box 206, Cairo, Tel: 747695 - France: Iskra France S. A., 354, rue Lecourbe 75015 Paris, Tel: 5540427 - GDR: Iskra, Hermann-Maternstrasse 2b, 7000 Stuttgart 1, Tel: (711) 603061 - CEFRA, GmbH, Ungererstrasse 40, 8000 München 40, Tel: 392061 - Italy: Iskra Elettronica Italiana, S.r.l., Piazza de Angeli 3, 20146 Milan, Tel: 4980036 - Iran: Iskra Tehran, 9th Street No. 6, Maydan Sanai, Tehran, Tel: 226765 - Poland: Iskra, Swietokrzyska 36m 15, Warsaw, Tel: 201253 - Romania: Iskra, Str. Visarion nr. 6, Bucharest Tel: 502675 - Switzerland: Iskra Electronics AG, Stalden 11, CH 45000 Solothurn - United Kingdom: Iskra Limited, Redlands, Coulsdon, Surrey CR3 2HT, Tel: 6687141 - Perles (UK) Limited, Rands Lane, Industrial Estate, Armthorpe, Doncaster, Yorkshire, Tel: (032) 832831 - USA: Iskra Electronics Inc., 8 Greenfield Road, Syosset, N. Y. 11791, Tel: (516) 3642616 - USSR: Iskra, Mosfilmovskaja 42, Moscow, Tel: 1478403 - Venezuela: Eurocommerce S.A., Apartado 68 901, Altamira, (Oficinas 19 & 20, Edificio Beca, Chacalto) Caracas, Tel: 728821.

tal train several years ago, the SNCF feels that the TGV will be fast enough for some time to come. Because of the high cost of construction and new rolling stock (about \$1.6 billion), though, there will probably be no extension of the TGV to the rest of France for the foreseeable future.

Naturally, electronics will have a key role in the TGV. A wired-logic control will supervise the engineer at first, but SNCF expects to have microcomputers in some trains by the mid-1980s. "They are essential on lines where headway between trains is less than a minute," explains Jean Plantureux, an executive in SNCF's General Studies and Research division.

At speeds of 162 mph, conventional block signals would be mostly a blur to the TGV engineer, particularly if visibility is poor. So the signals are in the cab; as the train enters a display section, an indicator shows which of five preselected speeds—from 162.5 mph to 0—is authorized for that block. The wired-logic control supervises the engineer, warns him when he is going too fast, and applies the brakes automatically if the speed gets out of hand.

**M**eanwhile, transportation researchers in Germany have begun experimenting with an entirely new means of railroad locomotion called magnetic levitation, or maglev for short. In maglev, vehicle-mounted magnets lift the car away from the rails, thus providing a gap over which it can be propelled by a linear induction motor at more than 400 kilometers per hour (about 248 miles per hour).

To ensure stability, the gap must be kept at a uniform width, and that task is best done by electronic controls.

West Germany's efforts in maglev date back to 1969, when the Bonn government commissioned a large-scale study of new, high-speed train systems. The efforts are now concentrated on a seven-company consortium called Magnetbahn Transrapid, headed by the aerospace firm Messerschmitt-Bölkow-Blohm GmbH (MBB).

Using electromagnetic suspension principles, the consortium's engineers have thus far built a number of experimental carriers, one of which—an unmanned 8.8-ton, 8.5-meter-long instrumentation carrier—reached a speed of 401.3 kmph (about 249 mph) on a 1,300-meter track in 1976. Last summer at the International Transportation Exhibition in Hamburg, a 36-ton, 26-meter vehicle, designated Transrapid 05, shuttled passengers at 90 kmph (about 56 mph) along a 908-meter, pillar-supported track linking two railway stations.

The consortium is now planning a 31-km test track in a sparsely populated area in the northwest of Germany where, by 1982, a follow-up model will be tested. Designed to travel at speeds between 300 and 400 kmph (about 186 to 248 mph), the Transrapid 06 will initially consist of a 100-passenger section and later be expanded to a two-section vehicle.

Such trains will first serve as airport shuttles and the like. By the end of the century, however, maglev trains may be traveling over the first sections of a European rail network. In fact, the experts are investigating the feasibility of a Frankfurt-to-Paris maglev link. The

advantage of this type of train in energy conservation, speed, and ease of construction are obvious.

The electromagnetic suspension system consists of support and guidance magnets on the vehicle and iron rails on the track. The support magnets are arranged so that, when switched on, they attract the vehicle vertically toward a set of rails. The guidance magnets act on another set of rails running along the side of the suspension system to keep the vehicle stable laterally. When the magnets are off, the vehicle rests on a spring-supported glide system, which would also act as a support in the event of magnet failure.

Propulsion is achieved with a linear induction motor, one part of which is mounted on the vehicle, the other along the track. Unlike rotating electric motors, linear induction motors provide translatory motion. They serve not only as propulsion units but also as dynamic contactless brakes. Frequency converters control both propulsion and braking.

The magnet-to-rail gap over which the train travels must be kept as narrow as possible—typically 10 millimeters—to keep the magnets as small as possible. This requirement puts exacting demands on the electronic controls. Inductive sensors integrated into the magnets will keep tabs on the gap. Using as criteria the magnetic-field variations resulting from shifts in distance between the magnets and rails, the sensors can determine the gap to within  $\pm 0.1$  mm. To determine the effects of wind and other forces on the vehicle, and hence the gap, the suspension system employs capacitive pickup acceleration sensors. The outputs of both sensors are fed to a control system that adjusts the voltage on the magnet coils so that the magnetic field reaches the level producing a 10-mm gap.

A computer in the vehicle monitors both drive and guide equipment, checking current through the coils and the gap width and delivering the proper signals to the propulsion mechanism. Computers installed in command and signaling facilities along the route monitor the train's operational status. Communications between train and trackside installations will be via a slotted waveguide running along the track; a train-mounted antenna protruding through a slot into the waveguide will establish the link.

"With no novel components and virtually no fundamental research work required, implementing the system is basically an engineering job," says Eveline Gottzein, head of MBB's Control Dynamics and Simulation Department. Research on maglev is also under way in Japan, France, and the Soviet Union, and it has been proposed in the U.S. as well (see "Coast to coast by tunnel").

**T**hough the science-fiction community will of course be disappointed, many electronics executives who graduated from the space program of the 1960s do not expect there to be much in the way of manned space flights in the coming two decades. Observes Thomas Markley, Raytheon Data Systems president and an Apollo veteran, "There just isn't the confluence of events to force the space programs



**Noninvasive.** Computerized axial tomographic scanners, like this one from EMI in the United Kingdom, will become important tools in medical diagnosis. These complex X-ray machines provide physicians with pictures of cross sections of a patient's anatomy.

to move forward. I just don't see space in 2000."

The major roles for space projects will lie in communications, resource location, weather modification and surveillance, and the like, according to Arthur D. Little's Martin Ernst. The economics of future ventures is still far from settled, he adds.

The power satellite is one of the concepts that should be explored, say some industry observers. Ernst believes there will be some solar-power stations in orbit by 2000—primarily experimental or prototype units sent up to develop performance and cost information.

"There are two times when you ought to run risks," Ernst states. "One is when you can afford to and the other is when you can't afford not to. Some space efforts are beginning to fall into the latter category."

Everyone agrees, however, that communications satellites have a future. Executives of Hughes Aircraft's Space and Communications Group, for example, believe the era of the space shuttle will make an enormous difference in satellites.

Because of the change in launching made possible by this program, tomorrow's satellites will be larger and heavier than present ones, says Albert D. Wheelon, vice president and group executive of the El Segundo, Calif., group. "In a way, this change is like the constraint imposed by the Panama Canal on the size of ships," he remarks. "Satellites had to fit within the shroud diameters and lengths of rocket boosters. In just a few years, those limitations on satellites will be greatly relaxed."

With their greater size, these satellites will be capable of carrying even larger solar-cell arrays and therefore will be able to produce more power for transmission. In addition, extremely large and sophisticated antenna systems will become possible, as Wheelon envisions the scenario. The result will be much greater communications capacity.

Of course, cautions Harold A. Rosen, a vice president of the Hughes group, satellites may increase in size by two or three times, but not by the hundreds predicted by some. It is just too expensive to build these city-sized platforms in space, he says.

"The argument for really gigantic satellites is that you can reuse a frequency not 4 or 10 times, but 100. I think only time will tell if these hopes pan out. From my point of view, the technology of communications satellites has progressed faster than we thought it would—and faster than the institutions that deal with them."

Paul S. Visher, another Hughes vice president and assistant group executive, agrees: "Our experience is that the technology of communications satellites has run something on the order of five years or more ahead of the pace at which market organizations can absorb it usefully." An example he cites is the linking of satellites and cable television. Many expected this connection back in 1965, when it was already feasible, but only now is the idea beginning to take hold.

Nevertheless, new telecommunications concepts in-



volving greater use of satellites may change the economics. One of these emerging changes concerns the theory of economy of scale. Explains Wheelon: "Certainly it is generally more economical to provide an additional unit of service in an existing network than it is to establish a new kind of service. Yet it seems that one can operate more cheaply with a new module than with an increment to an existing system in this field. The leverage of specialization is competing favorably against the economics of scale in the satellite era. It's a simple thing to specialize the configuration of a service provided by communications satellites. It's natural to deploy them as modules in space. These technical facts are changing our economic theorems.

"I believe a new concept of telecommunications will emerge from this decade that will provide direction for the next century of telecommunications—a century that will be dominated by the communication satellite."

The anticipated explosion in the satellite population over the next two decades will undoubtedly tax the frequency spectrum, but Roy Gibson, head of the European Space Agency in Paris, does not see an insurmountable problem in that. Added channels will come from moving up in frequency, he says, noting that ESA already plans transmission experiments in the 20-to-40-gigahertz range and certainly will be exploiting much higher frequencies by the end of the century.

**E**lectronics will expand in health care and education over the next 20 years, though in a continued context of resistance and constraint. Widespread use of

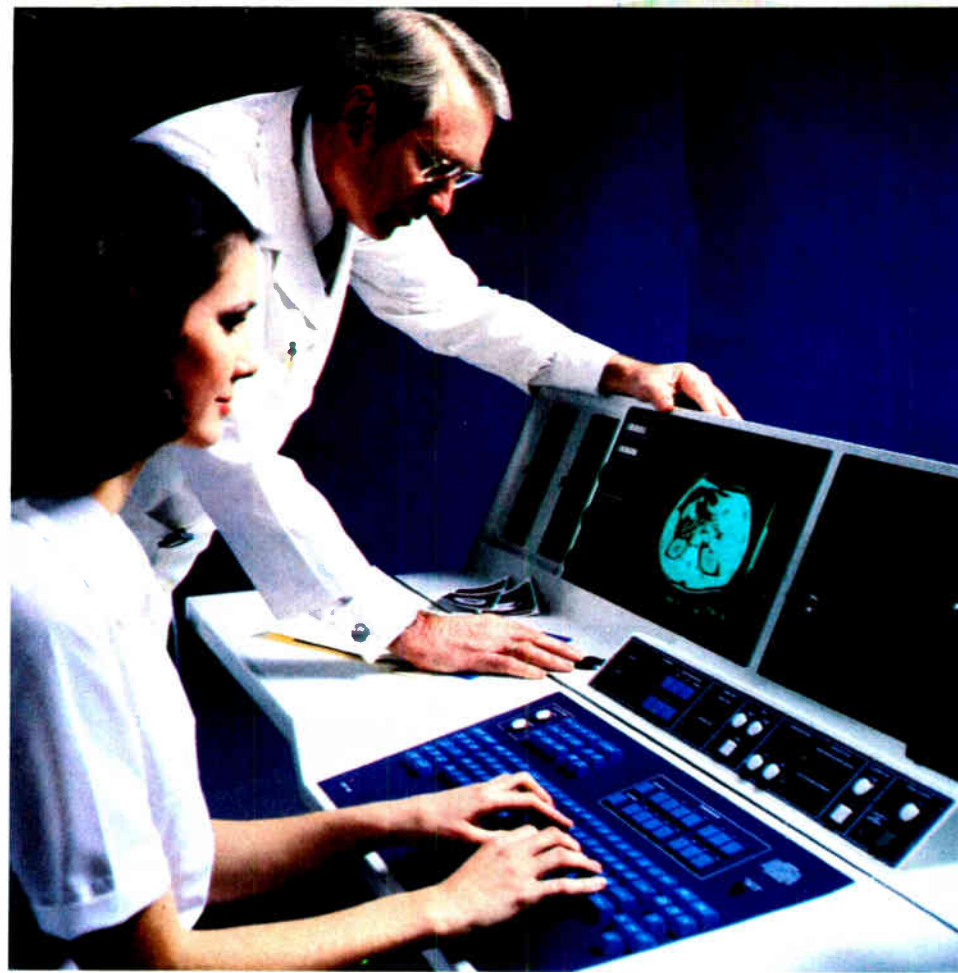

**Diagnosis.** Besides CAT scanners, shown at left, doctors will make increased use of digital nuclear scanners as well as fluoroscopic and ultrasonic scanners. The objective is noninvasive diagnosis that will drastically reduce the number of operations performed. Computers will provide a detailed analysis of the scan pictures in order to pinpoint exactly which are trouble spots.

computers will affect patient care, but these changes will not necessarily be welcomed by a basically conservative medical establishment. And education will still be marked by a lack of understanding of how to use electronics and a chronic lack of money, perhaps exacerbated by further taxpayers' revolts.

Therefore, any view of the future of electronics—specifically computers—in health and education must perforce be blurred at this point. If the home and workplace trends already discussed have any carryover, though, acceptance of electronics in health and education will accelerate. A populace conditioned to computers in the home may demand them in other areas, spurring the timid health and education establishments into joining the 21st Century.

One of the most exciting prospects in medicine is noninvasive diagnosis by means of computerized scanning. Indeed, these techniques could well change the way hospitals are organized and medicine is practiced, according to experts at the University of California's School of Medicine at San Francisco.

The scanning procedures—reflecting advances in computerized nuclear, ultrasonic, fluoroscopic, and X-ray equipment—will cut down the need for exploratory operations, says the UCSF team. Partly because of their cost and complexity, these machines likely will be multipurpose and used around the clock. The current controversy over computerized-axial-tomography (CAT) scanners thus may be magnified, with health insurers and the Government claiming overuse.

But more and more people will be examined on an outpatient basis, freeing more hospital beds for those

actually in need of surgery. Surgical teams, armed with computer-generated diagnostic information, will know precisely where and how to operate, thus increasing the efficiency of the operating room.

Medical costs should decline as a result, and the drop in hospital admissions may permit reductions in staff—moves bound to be opposed by such powerful groups as the American Hospital Association, as well as physicians' and nurses' societies.

“Cardiac diagnostic tests will be totally noninvasive,” declares Dr. William W. Parmley, cardiology chairman at UCSF. “The era of the catheter and its attendant hazards will be over.”

With computerized fluoroscopy, for example, hospitals will be able to perform risk-free coronary angiograms on outpatients, predicts Dr. Alexander Margolis, the school's radiology chairman. And computers will bring to the imaging technologies the promise of enhanced dynamic monitoring and color-coded displays. Here is how these specialists see future developments:

- Computerized axial tomographic scanners. These complex X-ray machines, which gained their developers a Nobel Prize last year, provide images of “slices” of a patient's anatomy and may come close to producing serial pictures of beating hearts, according to Dr. Parmley. The X-ray sources and sensors in current designs have rotation times of from 1.2 to 4.8 seconds, but CAT scanners in development will have 50-millisecond time intervals, Dr. Margolis says. Gated electronic scanning techniques will yield a series of pictures during each cardiac cycle.

The radiologist predicts the development of a special



**Brand-Rex: The state-of-the-art-company in electronic packaging, connector and circuit assemblies and systems.**

At Brand-Rex, we make it our business to be on the growing edge of technology.

That's why we've moved aggressively to electronic packaging, connector and circuit assemblies and systems. That's why we took our wire and cable manufacturing know-how into electronics and telecommunications over a decade ago. A move that has created a company

of more than \$200 million in sales with 8 divisions covering the entire spectrum of the interconnection marketplace. At Brand-Rex we connect genius with common sense. Imagination with experience. Blue Sky product planning with down-to-earth business know-how.

At Brand-Rex we don't just ride the waves of progress into the future. We make the waves.

That's what it means to be a state-of-the-art-company.

**Abbott & Company**, Marion, Ohio. Producer of electrical interconnect-

ing assemblies, harnesses, cord sets, plugs and inserts for the consumer appliance and related industries. Three plants in Ohio and one in Tennessee.

**Electronic & Industrial Cable Division**, Willimantic, Connecticut. Wire and cable for the business machine, utility, military, and industrial process industries. Also, extruded electrical insulating materials. Additional plants are located in Manchester, Connecticut and Glenrothes, Fife, Scotland (Brand-Rex Ltd.).

**Garry Manufacturing Company**,

# SOME RIDE THE WAVES OF

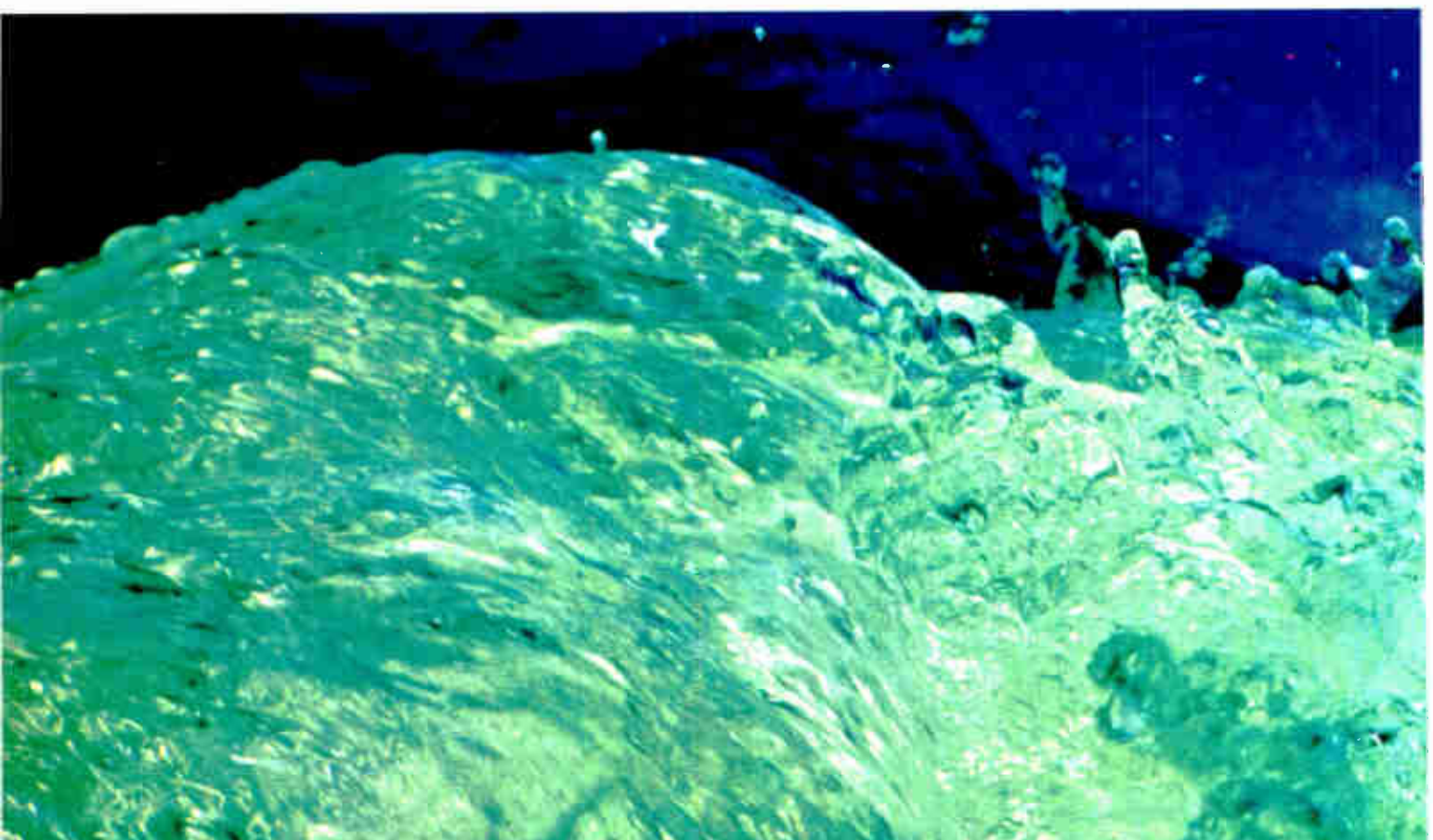

Multi-layer, double-sided and flexible circuit boards are manufactured by General Circuits, Inc.



I.C. Pluggable Packaging Assemblies and Accessories from Garry Manufacturing Co.



Toll Management, Key Station, Coin Telephone and Central Office Equipment from Teltronics.



Pyle-National's C-Line connector designed for the Marine cargo handling industry



New Brunswick, New Jersey. Manufactures a variety of electronic interconnection devices, including integrated circuit logic panels, sockets and related accessories. Also operates a plant in Pennsylvania and at two locations in Switzerland.

**General Circuits, Inc.**, Rochester, New York. Manufactures multi-layered, double-sided and flexible printed circuit boards for the computer and telecommunications markets.

**Nonotuck Manufacturing Company**, South Hadley, Massachusetts. Fabri-

cates uninsulated copper and copper alloy wire.

**Pyle National Company**, Chicago, Illinois. Specializes in commercial and military connectors for aircraft, missile, industrial, railroad and general purpose applications. Has subsidiaries in Mississauga, Ontario, Canada, and Nottingham, England.

**Telecommunications Cable Division**, Willimantic, Connecticut. Producers of a broad line of telephone wire and cable products, including fiber optic cables, at plants located in Asheville, North Carolina, and

Siloam Springs, Arkansas.

**Teltronics, Inc.**, Lakeland Florida. Supplier of a wide range of telecommunications products, including central office, pay station and key system line units, toll restriction devices, and test equipment for the telephone and aerospace industries.

## **BRAND-REX**

BRAND-REX COMPANY, A PART OF AKZONOB INC  
Willimantic, Connecticut 06226

# **PROGRESS. OTHERS MAKE THEM.**



**BRAND-REX.  
THE STATE-OF-THE-ART-COMPANY.**

Circle 3 on reader service card



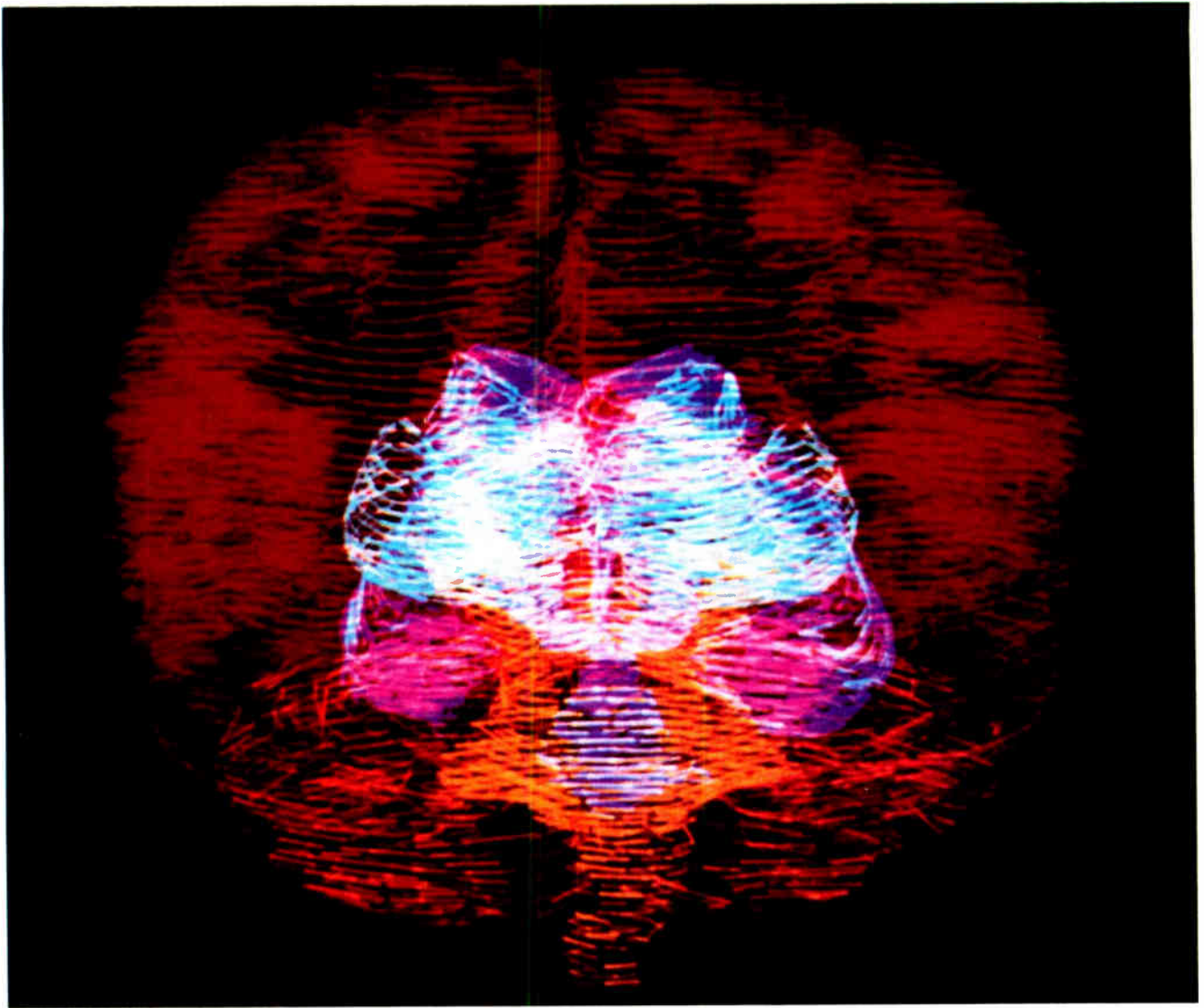

**Brainy.** Another means of extending teaching and research on the human anatomy will be computer-aided graphics like this color rendition of the brain done by Evans & Sutherland. The computer will also become a vital aid in diagnosing ailments outside the hospital.

anode that will drive the X-ray beams much as a TV tube is scanned. Another advance he sees will be the combination of monochromatic beams and new isotope sources for better analyses of living tissue.

■ Nuclear scanners. Now 80% analog, "nuclear imaging systems in 10 years will be 100% digital," states Dr. Robert Hattner, UCSF associate professor of radiology and nuclear medicine. Another emerging technology hailed by some and derided by others is nuclear magnetic resonance, in which signals from atomic nuclei exposed to a powerful magnetic field are used to develop pictures of the chemical makeup of tissues.

■ Fluoroscopic and ultrasonic scanners. These noninvasive imagers also will benefit from increased use of digital techniques. And Dr. Hattner foresees the development of coded apertures to produce three-dimensional sources, array processors to speed processing times, and image reconstruction that will be able to refocus picture information closer to a specific organ. "Ultrasonic and nuclear medicine will revolutionize the way we practice cardiology," Dr. Parmley declares.

Along with these strides in diagnostics, there will be advances in the use of electronics to deal with illness. Implantable devices—pacemakers and prostheses—will perform more functions for more patients and will operate not as individual units but as part of a system, according to designers at Medtronic Inc., a Minneapolis-based manufacturer of pacemakers.

The current trend toward programmability, with post-implant changes to match changes in pulse rate, width, and intensity, will evolve into a fully automatic pacer, they say. And instead of pacing only the ventricular node of the heart, future units will be connected to atrium and ventricle and will trigger a pacing pulse only when necessary. This autopacer will have a significant logic component, dictating pulse stimulation based on a variety of inputs. The goal is to emulate the natural pacing characteristics of the heart, brain, and lungs. For example, sensors will detect oxygen levels in the blood, as well as chemicals such as adrenalin, and cause the heart to respond accordingly.

Closing the loop in this manner has important implica-

**EXXON FORD MOTOR IBM  
GENERAL ELECTRIC BOEING  
LITTON WESTERN ELECTRIC  
McDONNELL DOUGLAS ITT  
RCA ROCKWELL LOCKHEED  
XEROX BENDIX**



## **Why do 52 of the 67 electronics companies in the Fortune 500 buy switchers from LH Research?**

Maybe it's because we offer the broadest selection of switching-regulated power supplies on the market. (We have dozens of models, from 100 to 1000 watts, with single and multiple outputs, both fan- and convection-cooled.) Maybe it's because of our reputation for reliability. (Every LH switcher is burned in at high ambient and computer-checked for 13 key parameters before shipment.)

Maybe it's because switchers are our only product, rather than

a sideline. Or maybe it's because leaders just feel more comfortable dealing with a leader. Which we are, both in technology and sales.

Whatever the reasons, we feel that our association with these prestigious companies says something important about the ability of our products to perform. Would you like to know more about our switchers? Send for a free LH Research Switcher Selection Guide, or contact your nearest LH

Research representative for a copy. It has complete information on our broad line, plus key specifications.

Obviously, buying from LH Research won't get you into the Fortune 500 overnight. But it's a step in the right direction. For more information, call or write: LH Research, 1821 Langley Ave., Irvine, CA 92714, (714) 546-5279.



**The world's largest manufacturer of switching-regulated power supplies.**



# Standard Grigsby... serving the industry with today's finest switches!

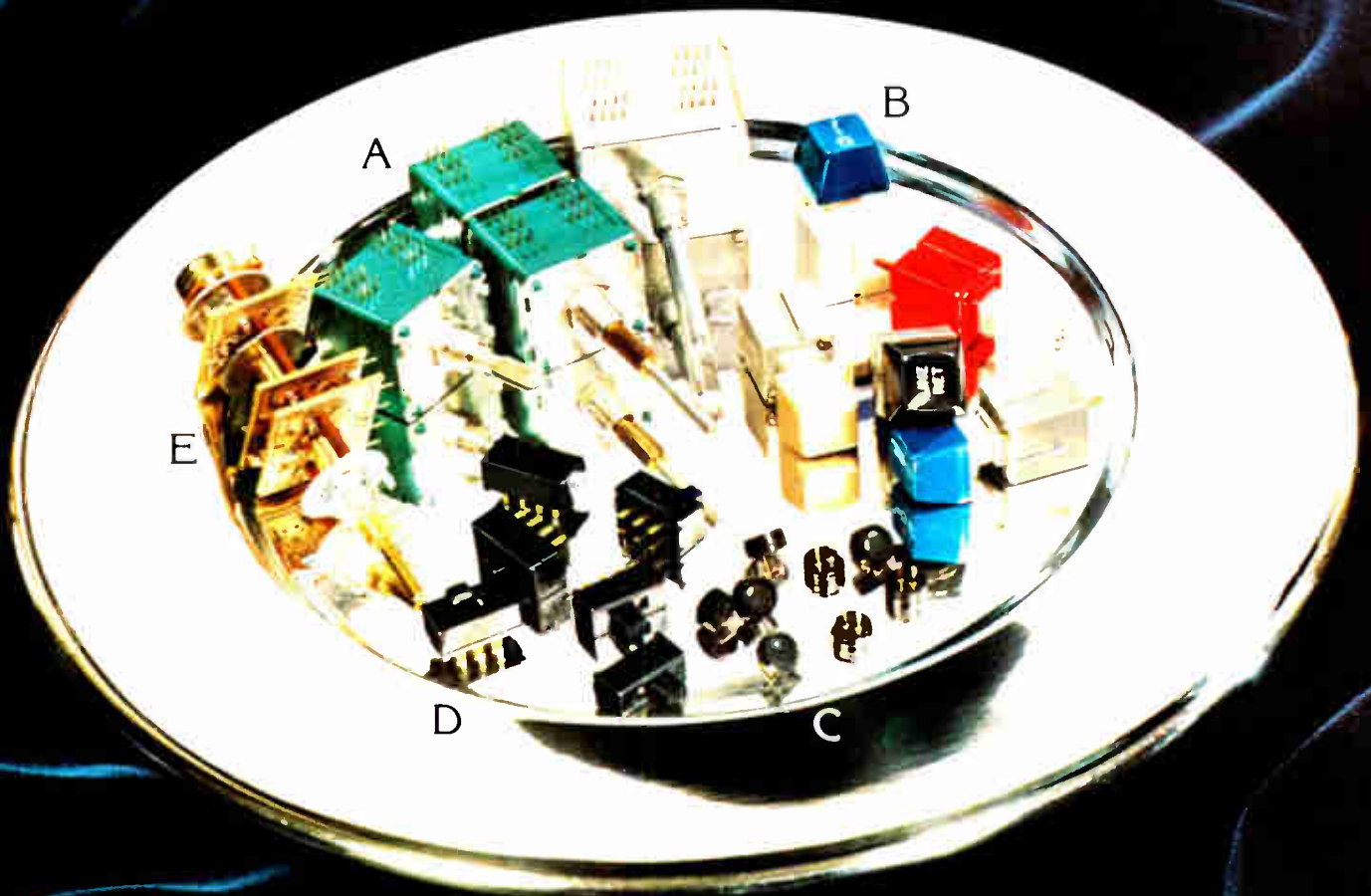

All of our switches are designed to give you the economy, flexibility, reliability and compactness needed in your own finished product:

A) "P/Rel," the industry's first programmable rotary switch. Two sizes 10 through 60 detented positions, up to 20 lines of information per module. B) KS-800 Data Entry Reed Keyboard Switches. C) TL-360 Micro-Miniature Push-Button Switches, with tactile feel. D) Six types of Slide Switches, enclosed and wave solderable. E) Open Frame Rotary Switches, with patented wedge-lock construction. Printed circuit board and wire wrap available.

Let us know how we can serve you.

Please specify type you're most interested in. We'll send the literature.

- A ■ P/Rel, 700
- B ■ Keyboard Switches, KS-800
- C ■ TL-360 Push-Button, No. 90
- D ■ Slide, CAT-SL
- E ■ Rotary, CG-500



"The Switch Experts"

**Standard Grigsby, Inc.**

920 Rathbone Avenue  
Aurora, Illinois 60507  
Phone: 312/844-4300  
TWX: 910-232-3138

IN EUROPE: W. Günther GMBH  
Virrsberger Strasse 51, D 8500 Nürnberg  
West Germany • Phone: 0911/65521  
Telex: 622351 wigu d

Circle 8 on reader service card



**Learning with electronics.** The popularity of these Texas Instruments and other electronic teaching aids will have a growing impact on schools. Teaching will change to make use both of hand-held devices that can be used at home and in school and of large computers. In addition the use of computers to aid in teaching traditional subjects, there will also be increased instruction in programming of computers.

tions. Not only will the intelligent pacer find use in a wider variety of post-attack cardiac patients, but it might eventually help to prevent cardiac infarctions and arrest. Designers now talk about "soft," or prophylactic, applications—the insertion of pacers before the fact. Instead of waiting until patients experience an actual heart failure, they say, cardiologists might use computer analyses to pinpoint those high-risk candidates for electronic pacing.

Such screening, for example, might determine a general weakening of the heart muscle in an elderly man where the heart still responded to pumping signals but not efficiently. If a pacer were implanted to boost the triggering pulse, the heart would pump a larger quantity of blood to the brain, thereby possibly preventing a stroke or even averting senility.

Besides stimulating the heart, the pacemaker of the future will be part of a system that may also include an internal drug dispenser and an emergency device for shocking the heart going into failure.

Computerized medical records will also be a boon to patient care. Enlarged data banks will record individual histories, state- or nation-wide, including treatments and their results. Using a code, a local physician will tap into the bank and, after entering the latest symptoms by voice, will get a recommendation for treatment. The computer will also predict the probable outcome of the doctor's present therapy.

People have always been intrigued by the possibility of developing artificial organs—witness, for instance, the popularity of television's "Six Million Dollar Man." But duplicating the complex functions of human organs is not easy even with the advent of microelectronic controls. Microsurgery has made transplants of certain organs and the reattachment of severed limbs almost routine, but completely artificial organs are still a way down the road. The first steps will probably be partial replacements—devices to help malfunctioning organs perform properly.

Something that might be available fairly soon is a left-ventricular assist device with a synchronizing circuit, according to Dr. Yukuhido Nosé, director of the Cleveland Clinic's artificial organs department. "Any pump we implant will have to synchronize with the remaining natural heart," he explains. "The pumping system is now almost developed; we're just waiting for the electronics."

Dr. Nosé's department is working on an implantable artificial pancreas, but he does not think liver, lung, and kidney replacements will be installed internally.

Hans-Erich Dreyer, director of the electromedical sector at Siemens AG in Germany, predicts that artificial hearts, glands, and kidneys will be common medical items by the year 2000. He too believes the artificial kidney will be external but small enough to carry. Dreyer foresees weak or malfunctioning organs being supported by "auxiliary organs" rather than replaced entirely.

Projects in this field include a battery-driven plastic pump already being tested in animals as an implanted heart pump and an artificial gland that ultimately may dispense insulin into the bloodstream of diabetics. The electronically controlled dosage system will continually supply the insulin in minute quantities according to a preset program. However, artificial glands that are part of a closed-loop system and supply insulin only on demand will not be realized during the next two decades, the Siemens official cautions.

Computers will continue to gain a growing position in education. A recent survey of 1,800 public schools conducted for the National Institute of Education found that about 15% of all U.S. public schools are using computers for applications directly associated with students. These include testing and student administration, teaching data processing, and computer-assisted and -managed instruction. And the study found that of the school districts without computer





**Unmanned spotter.** The military will equip field forces with unmanned aircraft for target acquisition and reconnaissance missions. This 6-foot-long aircraft is part of an aircraft system being developed by Lockheed Missiles & Space to carry spotting equipment.

involvement, 87% are planning to have machines at some time in the future.

Obviously the need and desire exist. But some observers see a necessity to rethink how the computers will be enrolled in the classroom, and once there, how they will be used. Analysts Thomas C. Thomas and Victor Walling of SRI International's Center for the Study of Social Policy in Palo Alto expect these considerations to raise some perplexing problems for local, state, and Federal authorities.

As people begin to turn away from traditional public schools and toward home computers to fill the educational needs of their children, the analysts fear increased strains on community school systems and a widening of the proficiency gap between those who can afford the home computer and those who cannot. How does government cope with the poor and disadvantaged as education for the affluent moves out of the school and back into the home, they ask.

But on the other hand, the idea of superimposing computer systems on an otherwise unchanged school system will probably not work, either. So far, computers in the classroom have essentially been programmed for drill and practice routines, for simulations, and for teaching simple programming languages, usually Basic. All three of these applications are unimaginative and unproductive for they serve only to perpetuate inadequate traditional teaching methods. This criticism comes from Seymour A. Papert, professor of mathematics at MIT, who for many years was co-director of the Artificial Intelligence Laboratory at the institute and head of a project dealing with the use of computers in the education of children.

In subtle and not-so-subtle ways, he says, the present use of the computer programs the child rather than letting the child interact with the computer. How should this approach change?

The computer can enter the educational process in a profoundly different way, Papert writes in his contribu-

tion to "The Computer Age: A Twenty-Year View." One such way has been under investigation at the MIT Children's Learning Lab. There, school children learn a computer language, LOGO, which they then use to program and interact with computer-controlled devices.

One of these devices is the "computer turtle," a cybernetic animal that a child controls by programming the computer. The pupil is in control and works with the teacher to solve a problem, such as getting the turtle to draw a square by writing instructions to the computer. "To square" can then be encoded in the computer's memory so that the child does not have to repeat the long set of instructions originally required for the turtle to trace the shape on the floor.

"For young children, the operation is conceptualized as teaching the computer a new word, and how to teach becomes not only a metaphor for how to program but a theme of the child's activities in the learning lab," Papert reports. The child learns to see formal mathematics as a symbolic language, a style of articulating different from any he yet knows: pupil and teacher work as partners to solve problems set up by the youngster.

**F**ew countries are as sensitized to computers as France. Understanding and support of computers extends from high government circles right down into the school system.

An ambitious part of a five-year program undertaken at the end of 1978 is to put microcomputers into every one of the 7,200-odd secondary schools in France and teach masses of students how to use them. It's a big project, but the government is giving the plan its full financial backing.

A first batch of 400 microcomputers went into the lycées early in the 1979-80 school year. Half were from Logabax Informatique SA, a Paris-based minicomputer house. The other half came from the Société Occitane d'Electronique (OE) of Toulouse, a firm that got its start in video games. Both the Logabax and OE machines are standard models that have 32 kilobytes of random-access memory, twin floppy disks, a full keyboard, and a cathode-ray-tube display, and they sell for about \$4,000.

A second batch of standard microcomputers will arrive in the 1980-81 school year, not necessarily from the two original suppliers. After that, the Ministry of Education may well opt for a special system.

"Experience may show that the instructor needs to have access to each student's working memory so he can check what the student has done," explains Francis Bacon, a consultant in the Mission à l'Informatique, a task force set up in the Ministry of Industry to coordinate the government's program. "Each school could wind up with from four to eight terminals tied to a central unit," he adds.

To make sure the microcomputers get used, the government's program calls for training 10,000 instructors to teach students with them. Software is already available in the form of 400 programs prepared in a pilot program at 58 lycées, and more will be added as the project progresses.

Although this mass effort will be made in the second-

# **“When you’ve got something good to offer, you just don’t sit back and wait for your time to come.”**

Meet Takayoshi Shiina. Age 36. President of SORD Computer Systems, Inc. A man with a purpose.

“In Japan, the conventional route is to enter a well-established company after graduation from college. Then you sit back, be nice to your superiors, and wait for seniority to bring you to a position of leadership and security. But you couldn’t get me to jump on that treadmill for anything.”

In April 1970, at age 26 Takayoshi Shiina established SORD. Initial capital: \$2,600. Total staff: 2.

“I knew that what the public would be looking for in the coming years were general-purpose computer systems that could be operated by just about anybody, with no special training. And I knew that I had the ability to develop both the hardware and software required for such systems.”

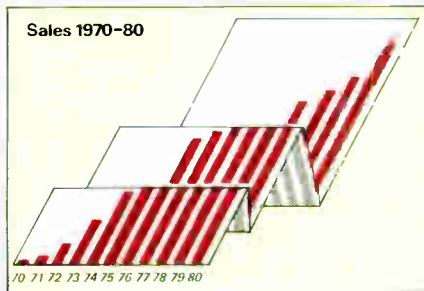

SORD’s first original product was a floppy-disk system introduced in October 1973.

“As the result of years of independent research and develop-



M223 mark VI with hard disk

ment, today SORD offers a full lineup of superior-quality hardware and software products. Our M200 mark Series small professional computers, for example, feature large-capacity memories, outstanding data processing speed and unbelievably easy operability. In software SORD has developed a wide range of unique and highly acclaimed products. Like our brand-new Pan Information Processing System — PIPS for short. PIPS is a data-based general-purpose user’s program that accomplishes simply and quickly the work which used to take a month with BASIC and up to three months with an assembler.

In October 1980 SORD plans to introduce its newest product line: the SORD M-00 Series 16bit supermicrocomputers.

“SORD has come a long way since I started the company exactly 10 years ago this month. We presently have



President Shiina personally conducts overseas visitors around SORD’s facilities.

a permanent staff of 135, and our sales continue to grow by leaps and bounds annually. The reason for our phenomenal success is simple, though. At SORD we know what the people want. And that’s precisely what we strive to give them.”

**SORD. A company with a purpose. To serve you better with the products you want.**

Visit SORD’s display at Stand 1306, Hall 18 (Gulliv’ World) Chicago/80, F.A.R. 80/VEP INCISE, April 18-20, 1980

We have the edge on technology.

# **SORD**

**SORD COMPUTER SYSTEMS, INC.**

42-12 Nishi-Shinkoiwa 4-chome, Katsushika-ku, Tokyo, Japan  
Telex: 2622393 (SORD J) Cable: SORDCOMPSYS TOKYO

**SORD U.S.A., INC.** International Trade Center  
8300 NE Underground Drive, Kansas City, Missouri 64161, U.S.A.  
Phone: (816)454-6300 Telex: 42204(SORDUSA INC KSC)

DISTRIBUTORS WORLDWIDE — ARGENTINA, AUSTRALIA, AUSTRIA, BELGIUM, CANADA, DENMARK, ENGLAND, FINLAND, FRANCE, GREECE, ITALY, LUXEMBOURG, THE NETHERLANDS, NEW ZEALAND, NORWAY, PORTUGAL, SPAIN, SWEDEN, SWITZERLAND, TAHITI, TAIWAN, THAILAND, WEST GERMANY.

Circle 10 on reader service card



# "Eveready" miniature batteries belong...



**AND HERE**

**AND HERE**

"Eveready" is the world leader in the development, design, production and sales of quality miniature batteries. As "Eveready," "UCAR" and Sony/Eveready we service the world with a full line of dependable, reliable, miniature batteries.

So where in the world do "Eveready" miniature batteries belong? In your products, that's where!



**UNION  
CARBIDE**

"Eveready" and "UCAR" are registered trade marks of UNION CARBIDE CORPORATION, BATTERY PRODUCTS DIVISION, 270 Park Avenue, New York, New York 10017

ary schools, the universities have a place in the government's overall plan to speed the application of computers. They have been instructed to prepare to train at least one third of their students, not counting those specializing in computer sciences, in computer applications related to their specialties. Pilot efforts toward this goal started in 1979, and the program should be in full swing by next year.

On top of all this, there will be an adult-education drive to sensitize engineers and technicians, particularly those working in small companies, to the applications of microprocessors. In the next decades, education by and about computers may well prove that over 50 million Frenchmen can't be wrong.

**E**lectronics has held an integral place in national defense since World War II and will certainly continue to do so.

In the 1970s, however, the support of high technology by the Defense Department waned. That is why the very high-speed integrated-circuit (VHSIC) program is regarded by many as so significant, marking the DOD's return to promoting high technology. The applications of VHSIC could become crucial to the defense hardware.

"The watchword in defense studies in the past four or five years has been 'force multiplication,'" says Richard D. DeLauer, executive vice president of TRW Inc., describing what in a previous era was called "more bang for the buck." And how is this accomplished? "We have to do it with equipment."

The keys in tactical defense remain command, control, communications, and intelligence, DeLauer says. "Our present equipment doesn't do the job because we lack devices fast enough for signal processing, which is central to command, control, and communications. That's where VHSIC comes in."

With VHSIC devices designed into equipment, "we can start thinking about new schemes of battlefield management," DeLauer goes on. One example he offers of this type of signal processing is in target acquisition. "A helicopter pops up over a battlefield, takes pictures of targets, and matches them up in a computer, which then predicts their position for firing. This image intensifying will be made possible by VHSIC. We can't do it now."

Implicit in all future military systems is digital communications. In fact, DeLauer considers it a must. The new 1192-93 network for the DOD is a start, he says, the next step being NATO compatibility. Voice communications as well as video transmissions will be secure.

**E**quipment for undersea surveillance will become as sophisticated as airborne detection hardware, predicts Robert Pry, vice president for technology at Gould Inc.

Increased understanding of undersea signal processing will make possible new types of sonar equipment. Inexpensive optical hydrophones will directly transform sound into light, at low energy levels, for transmission to surface or land-based centers, Pry says, while sonobuoys and bottom-sound detection devices will abound.

In the air, he expects that "fly by fiber optics" will be as common as "fly by wire" is now. Actually, he sees a combination of fiber and copper wire for aircraft—wired local actuator-accumulators with command links using optical fibers.

Remotely piloted vehicles (RPVs) for airborne surveillance will continue to be developed. Moreover, Pry anticipates remotely piloted submarines (RPSS) using guidance technology developed for the cruise missile to follow undersea terrain. Like the cruise missile, the undersea version will be a seek-and-destroy weapon.

As for radar—like Kansas City, it seems to have gone as far as it can go. Observers feel that air-defense radars at the end of the century will have substantially no more reach than they do now. For example, the latest long-range radar built by Thomson-CSF in France can spot aircraft as far off as 280 miles. According to Michel Carpentier, general technical director for the company, the successors to the TRS 2230 will not have much increased range but will have markedly superior resolution, antijamming capability, and reliability.

Meanwhile, Carpentier forecasts spectacular advances in the lidar (light detection and ranging), the optical counterpart of radar. "Lidars today are about where radars were in 1934," he says. "They simply send out pulses and detect the return echoes." There will be major developments by the end of the century as lasers become more powerful and such radar techniques as pulse coding and compression, echo processing, and electronic scanning are adapted. Carpentier does not see any insurmountable problem in attaining the submicrometer dimensions needed for the phase shifters in electronically scanned lidars.

**A**side from communications, detection, and command devices, what about guns? The sci-fi set has had plenty of exposure to laser guns, but researchers in the real world have some doubts about developing a portable laser weapon capable of knocking out an enemy plane or ground vehicle. "Is it an efficient weapon, given the amount of energy necessary to generate a potent beam?" one defense contractor asks. "Could you imagine a soldier carrying around an arc welder?" The particle-beam gun, another sci-fi favorite, also does not seem likely in the next 20 years.

More likely will be improvement in the guidance systems of present-day missiles. For example, the Maverick missile initially was homed in by television but is now equipped with forward-looking infrared guidance. In other words, the weapons systems of the 1990s and beyond could look much like today's but have a far greater degree of accuracy, target discrimination, and ease of maintenance.

The enhanced performance of conventional weapons might permit a defense strategy that would not have to depend on nuclear weapons. "By the year 2000 we'll see a leakproof missile-defense system," predicts George Heilmeyer, vice president for corporate research, development, and engineering at Texas Instruments and a veteran of ballistic-missile programs.

Nuclear weapons became a keystone of 1950s strategy



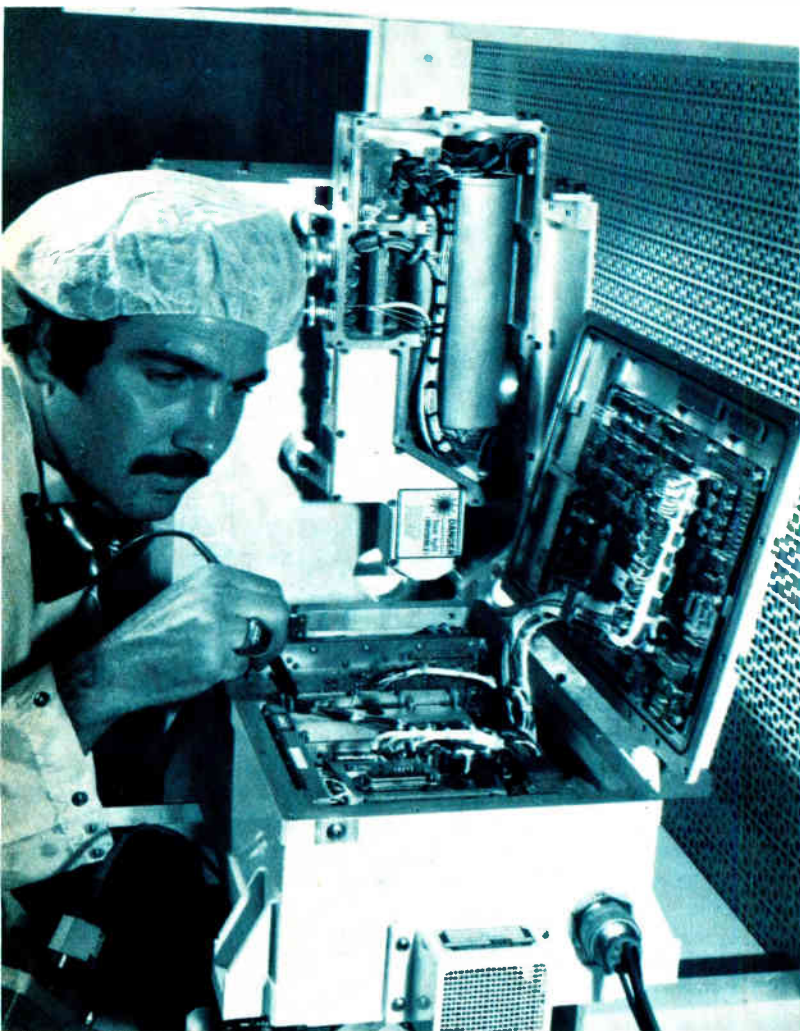

**Laser gun.** Although there is little chance that infantry troops will be armed with laser guns in the near future, lasers will be used in other weapons. Here an engineer tests a laser rangefinder on the Army's Division Air Defense gun at Hughes Aircraft Co.

because aerial bombing was not very accurate. However, extremely precise weapons capable of finding specific targets with zero error probability are definitely in the cards.

As for a "leakproof" missile-defense system, Heilmeier notes that today's tactics are based on intercepting incoming ballistic missiles as they reenter the atmosphere. But a much better time to attack them would be just after they are launched. This objective suggests the need for advanced surveillance systems and a strike mechanism with multishot capability that can be accurate over long distances, Heilmeier points out. Therefore lasers, though not carried by individual soldiers, may very well have a mission after all—mounted on space platforms and standing guard on the horizons.

**T**he computers that are incorporated into weapons systems are usually specially designed. Even the general-purpose processors are more than likely altered to meet environmental specifications. Some military computers are so special that they cannot be sepa-

rated from their weapon system. Because of these specifications, their software is also individualized—created from scratch for each system.

The problems posed by these diverse and special units are important "because they account for a major part of the frustration . . . with which most of the defense community now reacts to computers and software," writes J. C. R. Licklider, former director of the DOD's Advanced Research Projects Agency and now professor of computer science at MIT, in his essay in "The Computer Age: A Twenty-Year View."

The solution could begin with the design of computers applicable to varied weapons systems. Greater engineering discipline in the development of software would be a part of this effort, too, as well as research into the use of high-level languages and advanced software development methods in weapon systems.

However, the Pentagon faces a dilemma in trying to standardize programming languages and methods. On the one hand, it might want to decide on a standard software development system before there are too many different systems. On the other hand, it might decide to defer standardization until the choices are clear.

One solution suggested by Licklider is to have a network-based software center to oversee widely distributed development resources and provide protocols for their use.

**A**nother difficulty cited by Licklider is the fact that military systems, unlike civilian versions, cannot be readily tested under working conditions—in their case, the battlefield. During an actual trial under fire, the results are often too confused to provide a judgment of their effectiveness. However, the computer offers an opportunity, through simulation, to test defense systems—making it possible to exercise the fleet while it is in the harbor, so to speak.

These are just a few of the challenges that will mold the future of computers in national defense. Another problem to be solved concerns controlled information sharing and the equally vital need for computer and network security. Defense systems, like their civilian counterparts, will also be affected by developments in the speech-recognition and self-diagnosis fields.

Still another challenge here is to devise a system giving a commander both rapid access to all raw data at his echelon and below and at the same time the capacity to pass along only his interpretation of that mass of information to his superiors in the chain of command. Besides computer and network security in the command chain, the military will require protection of its communications from such countermeasures as jamming and disruptions of traffic flow. Packet-switching networks are seen as promising in this regard.

Implicit in the outlook for defense electronics, particularly for the development of computer systems, are indications that the Pentagon once again will take the initiative in funding advanced technology. As Licklider suggests, this involvement will be critical not only for national security, but for the advancement of information-teleprocessing technology. □





Tomorrow is an exciting country.  
We can take you there.

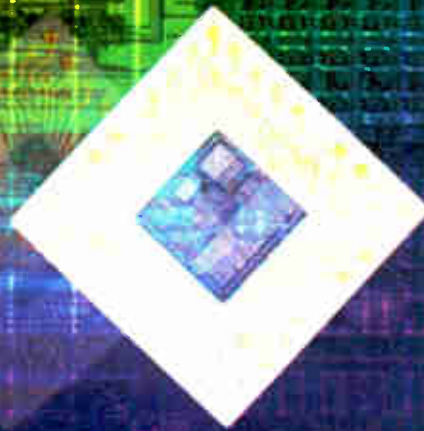

*Fujitsu's state-of-the-art 10,000-gate CMOS 16bit microprocessor*



**FUJITSU**

# State-of-the-art microelectronics—from circuits to bubble memories—headline information processing news.

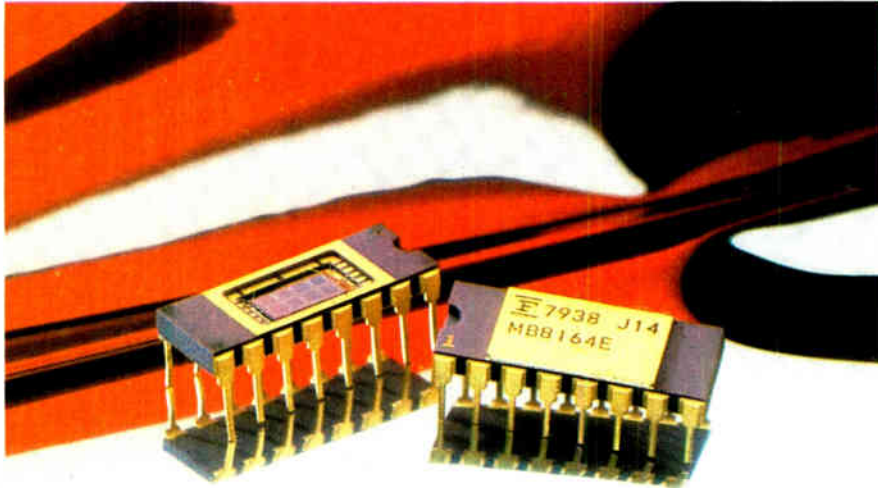

## NMOS 64Kbit DRAM Slated for Expanded Applications

In the early 1970s Fujitsu became one of the first companies in the world to market MOS 1Kbit dynamic random access memories (DRAMs) using N-channel silicon gate technology. Since that time, N-channel silicon gate technology has become the mainstay of semiconductor memories, while DRAMs have advanced significantly in memory capacity and performance specifications.

Over the years Fujitsu has continued to introduce a number of new RAM products, including a 16Kbit DRAM which is the current centerpiece for data processing and many other electronic systems. The 16Kbit DRAM has already received wide recognition for its superior performance and reliability.

In 1979 Fujitsu further expanded the RAM market with the successful commercial introduction of its 64Kbit DRAM. The 64Kbit DRAM is currently in use in a wide variety of memory systems, and based on its proven performance features, it is now slated for use in even broader system applications during the 1980s.

Fujitsu's 64Kbit DRAM features a  $144\mu\text{m}^2$  cell and a  $21.5\text{mm}^2$  chip area. While this represents an area increase of approximately 20% over the 16Kbit DRAM, its memory capacity has been quadrupled.

The 64Kbit DRAM chip is mounted on a 16-pin dual inline package (DIP). Compared with the 1Kbit DRAM, per-

## NMOS 64Kbit DRAM

bit area and energy consumption have both been reduced to 1/100th, while access time has been halved to 150ns.

Circle 216

## 10,000-Gate CMOS 16bit Microprocessor to Serve as Small-Scale Computer CPU in '80s

Using the most advanced semiconductor technology yet developed, Fujitsu has introduced a new CMOS 16bit microprocessor equivalent in complexity to some 10,000 gates on a single chip. Dubbed the FSSP (Future Small System Processor), this advanced LSI is already in use in small-scale computers. With its outstanding processor architecture, the FSSP will become Fujitsu's technically advanced small-scale computer CPU in the 1980s.

The FSSP comprises a microprogram-controlled 16bit processor with a 2bit parity bit. Using high-density, high-speed CMOS technology, data storage RAMs

## 10,000-gate CMOS 16bit microprocessor

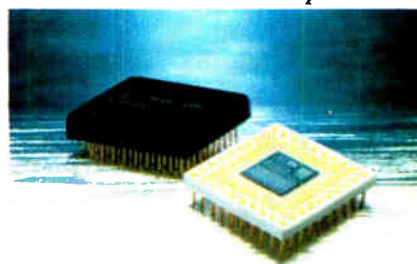

and processor logic are contained on a  $100\text{mm}^2$  chip. The FSSP can also access directly up to 16MB memory, including a virtual storage function. And decimal and floating calculations are processed without software.

Despite its high integration level, the FSSP consumes a low 130mW. Furthermore, internal gate delay time is a rapid 4–7ns with internal calculation speeds as fast as 230ns (memory→ALU→memory).

Circle 215

## Full Family of Semi-Custom LSIs Will Meet Customers' Needs

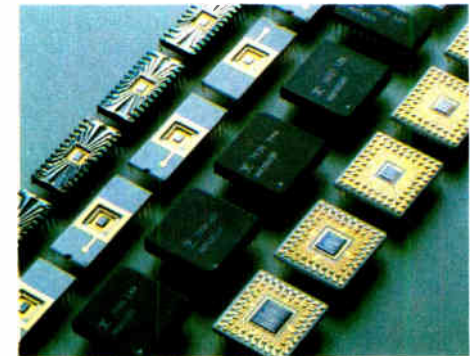

Master Slice Family

Advancing LSI technology has made possible an ever-increasing number of electronic systems offering enhanced performance and unprecedented features. And it is clear that advanced LSI technology is the key to producing the wide variety of highly specialized systems which are needed today.

Despite the recognized advantages of sophisticated LSI technology, the development of full-custom LSIs tailored to each system's needs was difficult to accomplish because of restrictions posed by design procedures, development time and cost. To solve these problems, Fujitsu has developed a complete line of semi-custom LSIs.

This is the Master Slice Family. For high-speed logic circuit applications, a 208-gate array (5ns/gate, 2mW/gate) and 512-gate array (1.8ns/gate, 2.3mW/gate) are available, using SBD (Schottky barrier diode) clamped TTL technology. For high-integration logic circuits, CMOS technology has been applied to produce arrays of 770, 1275, 2000 and 3900 gates (all 8ns/gate,  $20\mu\text{W/gate}$ ). Such LSI gate arrays are manufactured according to user specifications using an advanced double-layer aluminum interconnection technology.

## INTERVIEW: Dr. Bun-ichi Oguchi

Executive Director, Fujitsu Ltd.

Executive Vice President, Fujitsu Laboratories Ltd.

To produce Fujitsu's Master Slice Family of semi-custom LSIs, the design tasks of logic simulation, design rule checking, gate allocation, interconnection, mask pattern generation and LSI test pattern generation can all be accomplished using the customer's logic circuit and Fujitsu's advanced CAD (computer-aided design) system. This simplifies the design task while greatly reducing the turn-around time from product conception to full-scale production.

Circle 217

### 1Mbit Bubble Memory in Preparation

As a fundamental phase of its ongoing development of bubble memories, in 1980 Fujitsu is preparing sample shipment and mass-production procedures for its newly developed 1Mbit bubble memory device. To meet the latest market needs, the new 1Mbit bubble memory device is designed to serve as a program memory, mini-file memory and as a file memory for terminals and other equipment.

Fujitsu entered into bubble memory development in 1970. It currently markets 64Kbit and 256Kbit bubble memory devices which are widely acclaimed for their high reliability, non-volatility and suitability as non-mechanical fixed file memories. In June 1980 Fujitsu will complete its all-LSI support circuitry, thereby permitting bubble memory cards offering enhanced miniaturization and reliability.

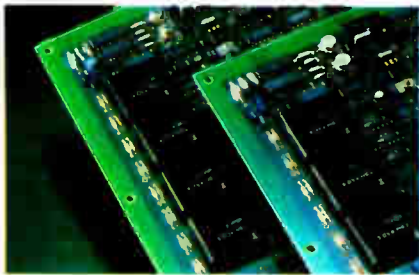

128KB bubble memory cards

Among its unique bubble memory products, Fujitsu was the first company to develop and market a bubble cassette to replace paper tape and card readers as program loaders in testing equipment. This bubble cassette is currently offered in 64Kbit and 256Kbit models.

Following sample shipment and mass-production development of its 1Mbit bubble memory coming soon, Fujitsu is preparing to move next toward the development of a 4Mbit memory.

Circle 218



Dr. Bun-ichi Oguchi

**Q** As Japan's largest computer manufacturer, how does Fujitsu see the present computer situation as we embark on the new decade of the '80s?

During the 1970s, Fujitsu's main concerns were the development of very large-scale computers and of small-scale general-purpose computers offering enhanced performance features. Two factors contributed significantly to such development: the striking progress seen in LSIs, and in software in general. As a result of the trend toward ever more general-purpose systems, computers have emerged from their earlier specialty status to become items which can be operated easily by more and more people. The progress seen in LSIs has been particularly outstanding, with memory capacities advancing at the rapid rate of 400% every two years. Today, in 1980, we are on the threshold of the age of the 64Kbit DRAM. In ultra high-speed logics, logics featuring 100 to 1,000 gates per chip are already in use in large-scale computers. And small-scale systems utilizing 10,000-gate-per-chip CMOS LSIs as the CPU are receiving the benefit of today's sophisticated LSI technology even more directly.

**Q** What direction do you see for future computer LSIs?

As I just mentioned, today we have reached the stage where 64Kbit DRAMs are used in practical applications, and logics offering ultra high rates of speed and high integration are also currently coming into use. Since VLSIs represent the amalgamation of various sophisticated technologies, a great deal of work is required; however, the results of our research will surely be showing up on production lines before long. As a followup to our 64Kbit DRAMs, for example, memories offering four times that capacity will be available in the not too distant future.

Today Japan's LSI mass-production technology is said to be the most advanced in the world. In the future, however, as LSIs come to be used not only in computers but also in a wide range of other products, the emphasis is forecast to change from mass-production of a few varieties of LSIs to limited-quantity production of a wider variety of LSIs. To meet this future shift and yet continue to produce LSIs at moderate cost, at Fujitsu we are currently offering our series of Master Slice Family semi-custom LSIs based on CAD and other technologies.

**Q** What do you see happening in the coming years in terms of bubble memories and other peripheral memory devices?

Fujitsu presently offers 64Kbit and 256Kbit bubble memory devices, as well as 32KB and 128KB bubble memory cards. We have also begun marketing our unique bubble memory cassettes. Looking ahead, by the end of this year we plan to introduce our 1Mbit bubble memory device onto the market.

In disks, we are currently developing models offering several times greater density than disks now available: in other words, disks of 20,000bpi and higher. We are also investigating potential uses for optical disks and proceeding with their development.

(Continued)



**FUJITSU**

# Advanced discrete semiconductors – devices to GaAs FETs – are the inside on the expanding world of telecommun

## Outstanding Lineup of Optical Semiconductor Devices

Based on long years of experience in the development of optical communications technologies, Fujitsu currently offers a wide range of high-performance optical semiconductor devices with proven reliability for a broad spectrum of customer needs.

In the  $0.8\mu\text{m}$  wavelength region, Fujitsu's light source selection includes AlGaAs LDs (laser diodes) and AlGaAs LEDs (light emitting diodes), while in detectors Si APDs (avalanche photodiodes) and Si PIN photodiodes are now commercially available.

Fujitsu's AlGaAs double heterostructure LDs are specially designed as highly reliable light sources for optical communications in the  $0.8\mu\text{m}$  wavelength region. They feature a high 15mW output, stable cw operation over a wide temperature range from  $-40$  to  $+70^\circ\text{C}$ , a long  $10^9$ -hour operating life at an output of 5mW at room temperature, and monitoring optical output for automatic power control. They can also be used in a wide variety of applications such as laser printers, POS terminals and video disks.

Fujitsu's  $0.8\mu\text{m}$  LEDs with a cut-off frequency of 30MHz have an output capability of more than  $200\mu\text{W}$  coupled into a  $0.17$  N.A.  $85\mu\text{m}\phi$  step index fiber at 100mA. The LEDs with a cut-off frequency of 100MHz are also available on request. Their operating life at room temperature is estimated to be over  $4 \times 10^7$  hours.

In optical detectors, Fujitsu's Si APDs are hermetically sealed with a sapphire window for excellent performance and high reliability. An outstandingly high quantum efficiency of 80% has been

### Result of accelerated aging of InGaAsP/InP LED at elevated temperatures

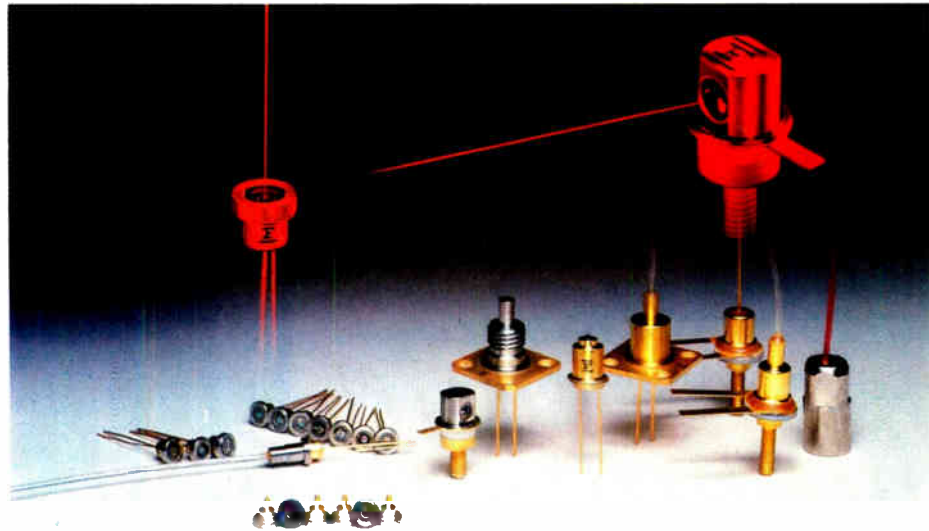
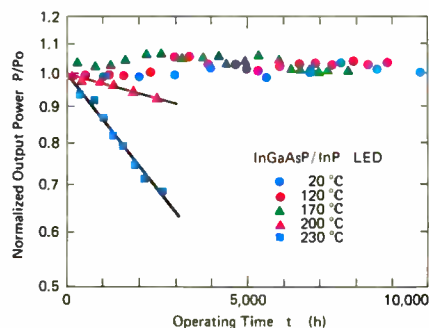

Fujitsu optical semiconductor devices

achieved, with an excess noise factor as low as  $F=4$  at a multiplication of  $M=100$ .

In addition to its excellent selection of  $0.8\mu\text{m}$  region products, Fujitsu is also engaged in the development of a full variety of optical devices for the  $1\mu\text{m}$  wavelength region. InGaAsP LEDs and Ge APDs are already commercially available, and an InGaAsP LD and InGaAs photodiode are presently under development for application in the near future.

Fujitsu's  $1\mu\text{m}$  InGaAsP LEDs are capable of over  $50\mu\text{W}$  output at 100mA when coupled into an  $85\mu\text{m}\phi$  step index fiber. Their cut-off frequency is typically 30MHz. Operated at room temperature, these LEDs offer an expected half-life of up to  $10^9$  hours. And being fiber-coupled, they are extremely easy to use.

For the  $1\mu\text{m}$  wavelength region, Fujitsu's Ge APDs feature a quantum efficiency exceeding 60% and an excess noise factor of  $F=10$  at  $M=10$ . Their cut-off frequency is 600MHz, with a light detecting capability through the  $1.6\mu\text{m}$  wavelength region.

Circle 372

## World's First Integral-Fiber Branching Filters

Integrating its standard optical semiconductor technologies with advanced technologies in the areas of coupling, connectors and peripheral circuitry, Fujitsu has developed a full lineup of optical fiber link modules. These modules are incorporated in Fujitsu's series of optical

fiber link systems, which include 1.5Mb/s–32Mb/s digital models and 6MHz–30MHz analog models. Because of their ease of installation and outstanding cost performance characteristics, these systems are ideal for use as simple transmission links in computer-computer and computer-peripheral data transmission as well as in TV transmission.

Fujitsu has also completed development of a wide range of high-reliability connectors, couplers, branching filters, switches, attenuators and other passive components designed to support its optical transmission systems, such as its ultra high-speed PCM transmission systems. Fujitsu's integral-fiber type couplers and branching filters based on advanced Fujitsu fiber processing technology have won especial acclaim for their compact size, high reliability and low loss characteristics far superior to those of conventional discrete circuitry type optical components. Fujitsu is in fact the world's only manufacturer to offer integral-fiber branching filters, providing sound proof of Fujitsu's outstanding technological achievements in this area.

### Integral-fiber branching filter

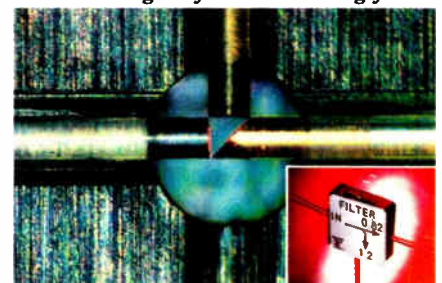

# from optical story cations.

## GaAs FETs Enter IC Age

Since developing the world's first power GaAs FET in 1973, Fujitsu has consistently been a forerunner in this field. Fujitsu developed the world's first normally-off GaAs IC in 1977, and now it is undertaking development of GaAs ICs designed for wide use in the 1980s.

Fujitsu currently offers a broad range of GaAs FETs, from 2 to 20GHz, including power GaAs FETs in the 4 to 12 GHz range. The 8GHz power FET, for example, features a power output exceeding 10W. Fujitsu power GaAs FETs provide a power-added efficiency of greater than 40%, the highest in the world.

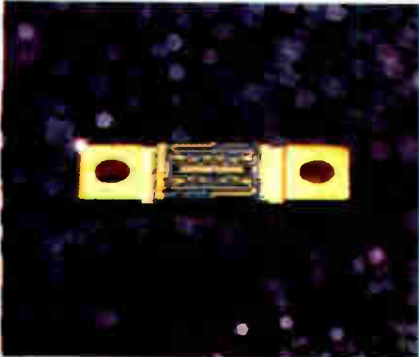

GaAs linear IC

Fujitsu's new devices currently under development are its GaAs linear IC and GaAs digital IC. When completed early in 1981, the GaAs linear IC will be able to serve as a microwave subsystem only 4 x 4mm in size. This will represent a 1,000 times reduction in volume compared with conventional subsystems incorporating discrete GaAs FETs. The new GaAs linear IC will have the additional advantage that it will be applicable to a variety of frequency ranges (2-4 GHz, 4-12GHz, 12-18GHz), thereby achieving subsystem standardization.

Fujitsu's new GaAs digital IC, on the other hand, is being developed as a logic IC for super high-speed digital telecommunications systems and high-speed, large-capacity computer systems. Employing the normally-off operation mode, Fujitsu's GaAs digital IC is to feature 6 to 10 times the speed capability of conventional silicon-based ICs, while further attaining reduced power dissipation. A high performance of 70psec/gate at 100 fJ has already been achieved. Future plans call for development of a GaAs digital IC offering the high speed of the Josephson junction at room temperature.

Circle 374

## INTERVIEW: Dr. Bun-ichi Oguchi

**Q** *What do you see happening in the area of telecommunications during the 1980s?*

The 1980s are generally envisioned as the decade where we will come to see a widespread increase in the use of digital networks and optical communications technologies, combined with the development of new services which these technologies make possible.

In Japan, the everyday telephone may be said to have already permeated throughout all facets of life. The target now is to succeed in converting existing telephone networks to digital ones, in order to introduce a variety of new services. Moreover, this must be accomplished at moderate cost. As the result of recent achievements in semiconductor technology—the introduction of electronic switching systems and solid-state transmission equipment, the advent of LSI coder-decoders, etc.—economical digital telephone communications networks are today approaching a level of practical feasibility. Not only will digital voice transmission thus soon be realized, but great strides will also be made toward practical implementation of transmission of data and video—including facsimile signals—using the same transmission networks used for voice transmission.

In the area of optical communications, owing to the characteristics of lasers, digital systems are judged more suitable than analog systems. With high-speed digital transmission, e.g. video transmission, optical communications technology is viewed as outstandingly practicable, accelerating the development of this technology in the future.

**Q** *Would you agree that Japan leads the world today in the field of optical communications technology? How do you evaluate Fujitsu's role in this area?*

Japan has been right at the top in transmission technology for some ten years already. Naturally our optical communications technology has been at that superior level right from the

beginning. As one of the world's leading comprehensive manufacturers of telecommunications equipment, Fujitsu was a forerunner in optical communications R&D, and today Fujitsu offers a full variety of state-of-the-art optical systems which are highly competitive on the world market.

**Q** *When do you foresee optical communications technology being used in the telephone network, and what problems remain to be solved before this can be accomplished?*



I think we can expect to see optical communications applied to the telephone network for short-haul transmission in the very near future. As for the problems remaining, at Fujitsu we are currently engaged in the development of laser diodes, optical detectors and other components with improved characteristics and longer service lives as required to achieve lower-loss optical transmission. We have already developed such components with 0.8 $\mu$ m wavelength capability, and we are now working toward components for wavelengths exceeding 1 $\mu$ m. Looking farther into the future, one day optical transmission lines will be used not merely over long distances but will also reach subscriber sites for widespread use in video transmission, such as for two-way TV. I think the general public can realistically plan on having such services in the future.

(Continued)



# Product reliability and modern production are today's guarantees, R&D will secure tomorrow's promise.

## New Achievements in Pattern Recognition

Fujitsu has successfully developed a new technique to boost its already impressive lineup of pattern recognition technologies. The latest development is a printed circuit wiring design reading system. Using a grid transformation method, the new technique vastly simplifies printed circuit wiring data input for computer-aided design, accomplishing in but 10 minutes the work formerly requiring several hours.

The new printed circuit wiring design reading system is but the latest development in Fujitsu's continuing program of pattern recognition techniques. Such techniques are beneficial in simplifying computer input of such data as characters, voice and images.

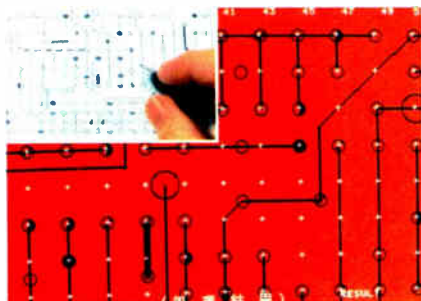

**PC wiring design (above) computer-processed using grid transformation method (below)**

In the area of character recognition, Fujitsu's OCR mechanical printed-character recognition technique currently permits high-speed reading of more than 2,000 different Chinese characters. Hand-written Chinese characters, kana syllabary characters and alphanumerics can also be read.

Fujitsu speech recognition technology presently allows accurate reading of approximately 100 types of spoken words. And in the area of graphic pattern recognition Fujitsu has developed a unique map reading technique using image approximation by polygonal lines. This system is already being applied in actual service.

Circle 375

## 9-Gate 4bit Parallel Full Adder Circuit Developed

The field of Josephson junctions is widely recognized for its overwhelming potential impact on computer systems of the future. Fujitsu has recently achieved yet another milestone in this vital area with the development of the world's first

**Sum generator**

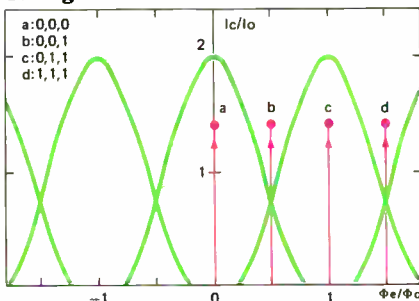

**Movements of the operating points for the sum generator on the threshold characteristics of DC-SQUID type Josephson junctions. Abscissa is indicated by the external flux caused by the input signal currents. Situations a, b, c and d correspond to the logical situations when the number of "1's" is 0, 1, 2 and 3, respectively.**

4bit parallel full adder circuit which uses as few as 9 gates.

Whereas conventional Josephson junction circuits have required 7 gates per bit, Fujitsu's new circuit has reduced this number to 2 gates per bit. This technological development was made possible through utilization of the DC-SQUID type Josephson junction characteristic that the threshold curve periodically changes in response to input signal currents. As a result, Fujitsu's new 4bit parallel full adder Josephson junction circuit requires a total of only 9 gates, an unprecedented achievement.

Fujitsu is currently engaged in the development of new type gates and circuits, aiming toward the realization of Josephson computers. Circle 376

**Experimental circuit of a 4bit parallel full adder using 9 DC-SQUID gates**

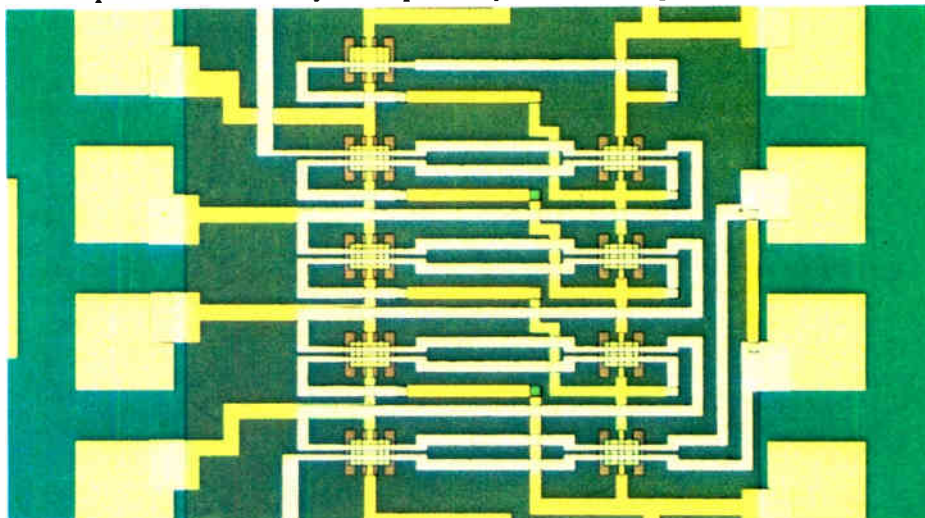

## State-of-the-Art Multilayer Printed Wiring Boards, Microconnectors

Today's high-performance all-LSI computer demands constant improvements in circuit speed and packaging density to enhance its speed and reliability. To meet these requirements, Fujitsu provides multilayer printed wiring boards and microconnectors of superior quality which represent the highest density available today.

In a small 190 x 190mm space, the Fujitsu high-density multilayer printed wiring board contains no less than 400X and 400Y channels, 10,000 through-holes, and 800 I/O terminals. Wiring patterns are only 150μm in width. The aspect ratio, i.e. board thickness vs drill size, is almost 6.

To produce its superior printed wiring boards, Fujitsu has developed a variety of unique production techniques. Its precision technology generates patterns as small as 150μm. Its drilling technique makes possible through-holes as small as 400μm in diameter. Other superior technologies ensure size uniformity combined with a high resistance to heat and flammability. Uniform plating and precise positioning of layers are also Fujitsu's landmark technologies.

The microconnectors used on Fujitsu's multilayer printed wiring boards feature the highest density in the world, with a pin spacing of 1.27mm and 100 pins per connector. To produce the extremely fine male solder leads, Fujitsu has developed a number of superlative production technologies. These include a



low-pressure molding technique and new materials for its use. Fujitsu has also developed a new design system which has substantially improved the reliability of its female contacts. All products are subjected to extremely rigid microscopic inspection to ensure their high quality and precision.

Circle 378

### Submarine Repeater Components Offer Top Reliability

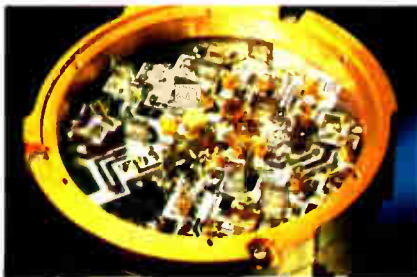

Submarine repeater amplifier

Submarine coaxial cable systems today serve as vital communications links in nearly every corner of the globe. Due to their difficult accessibility, however, such submarine communications systems demand component parts meeting extreme standards of reliability, standards exceeding those for most other components.

Through a stringent series of quality control and reliability tests, Fujitsu has made impressive strides in producing the submarine components in demand. Its submarine repeaters, for example, comprise components manufactured under the most rigorous guidelines to ensure superior quality control and reliability. The failure rate of a Fujitsu submarine repeater is as low as approximately 25 Fits (1Fit=one failure per billion hours). And Fujitsu's submarine repeater transistors—the components most crucial to the smooth operation of the entire submarine system—feature a high reliability rate of 1Fit, the result of rigid manufacturing controls, product screening and long-term aging tests.

Circle 377

### Q *What is Fujitsu's basic policy regarding R&D?*

Fujitsu has achieved and currently maintains a very high level of technological capability in a wide variety of areas. What will be in demand in the 1980s is R&D leading to technologies with more direct practical applications and benefits for the general public. In this respect, it is quite important to bring technological developments to a more generalized level and to create new systems which are designed for use in non-specialized applications. This does not mean, of course, the replacement of sophisticated technologies with those more simplistic, but, instead, the achievement of economical and highly reliable systems on the one hand incorporating the highest technology while at the same time offering complete ease of operation to the non-specialist. For example, in office automation, developing computers permitting input and output of information in the form of voice and images will be a focal point, demanding all-out efforts in the area of pattern recognition technology.

### Q *What do you foresee occurring in the area of office automation?*

At Fujitsu our main goal is to improve data, words and document processing and information retrieval capabilities using office computers



and various I/O and terminal equipment, as well as to improve data, voice and image transmission centering around EPBX's, facsimiles and other telephone-related terminals. In developing new office equipment, we place major importance on such points as meeting office needs, offering ease of operation, compact size, economy, etc. To achieve these, we look toward improved pattern recognition and other man-machine interface technologies, more sophisticated LSIs and other devices, and the development of easier-to-use program languages. We also feel it is particularly important for us to work toward the development of ever more effective Japanese language processing capability. In short, we would like to create a superior system integrating all of these many advantages.

### Q *What is Fujitsu's High Reliability Program, and what has it accomplished?*

Fujitsu's High Reliability Program began in 1966. It extends over the full range of Fujitsu activities: R&D, technology, design, manufacturing, installation, maintenance, etc. Its aims go far beyond merely trying to eliminate product defects and production errors. Instead, the program serves to educate each and every member of the Fujitsu staff concerning the importance of achieving high reliability as part of Fujitsu's responsibility to society. At present our staff members are engaged in some 3,200 different reliability themes. During 1979, as an example, we received 47,800 reliability-related proposals as a result of this program, far more than comparable figures for any other maker.



## And now the rest of the story...



Fujitsu's advancements in semiconductor and component technology have impressed systems manufacturers around the world. Yet equally remarkable are the giant strides made in the field of computers and telecommunications which have brought new dimensions to modern data exchange. Established in 1935, Fujitsu currently has more than 33,000 employees working at 11 plants, a variety of R&D facilities and educational institutions, domestic business offices, and numerous sites abroad. With annual sales approaching US\$2.5 billion and operations spanning the globe, Fujitsu is an international presence.

Operating in an arena which literally has no horizons, Fujitsu has developed, manufactured and site-installed virtually every type of telecommunications system possible today. Moreover it is already in tomorrow developing highly sophisticated systems such as optical communications and digital switching systems which can move data faster, more accurately and with greater efficiency to keep pace with the dynamic growth in telecommunications.



Fujitsu is also Japan's number one computer manufacturer. It developed the nation's first commercial computer, introduced the world's first "fourth generation" all-LSI computer series, and today Fujitsu designs, develops, manufactures and markets a full line of advanced computers—everything from microcomputers to very large-scale systems.

The rapidly increasing pace of our business and daily lives demands that tomorrow's systems be more precise, more complex and assume even greater functions. Fujitsu can answer those needs because it has the capability to integrate computer and telecommunications technologies into one. As a result, it has developed and now offers a diverse selection of large-scale data communications systems, and control and management systems.

Fujitsu's spectacular record in the electronics marketplace has brought it to the forefront of its industry. The story it has written is impressive and the headlines it will create in the future will be no less sensational.

Fujitsu Limited: 6-1, Marunouchi 2-chome, Chiyoda-ku, Tokyo 100, Japan Telephone: 03-216-3211, Telex: J22833  
 •Alger•Amman•Bangkok•Belgrade•Bogota•Buenos Aires•Honolulu•Kuala Lumpur•Lagos•Ljubijana•London•Los Angeles  
 •Madrid•Munich•New York•Paris•Quito•Santa Clara•Sao Paulo•Seoul•Singapore•Sofia•Sydney•Taipei•Zagreb

Main Products•Switching Systems•Carrier & Radio Systems•Computer Systems•Data Communications Systems•Semiconductors•Electronic Components

# New PANDUIT™ MAS-CON™

## Mass Termination Assembly System

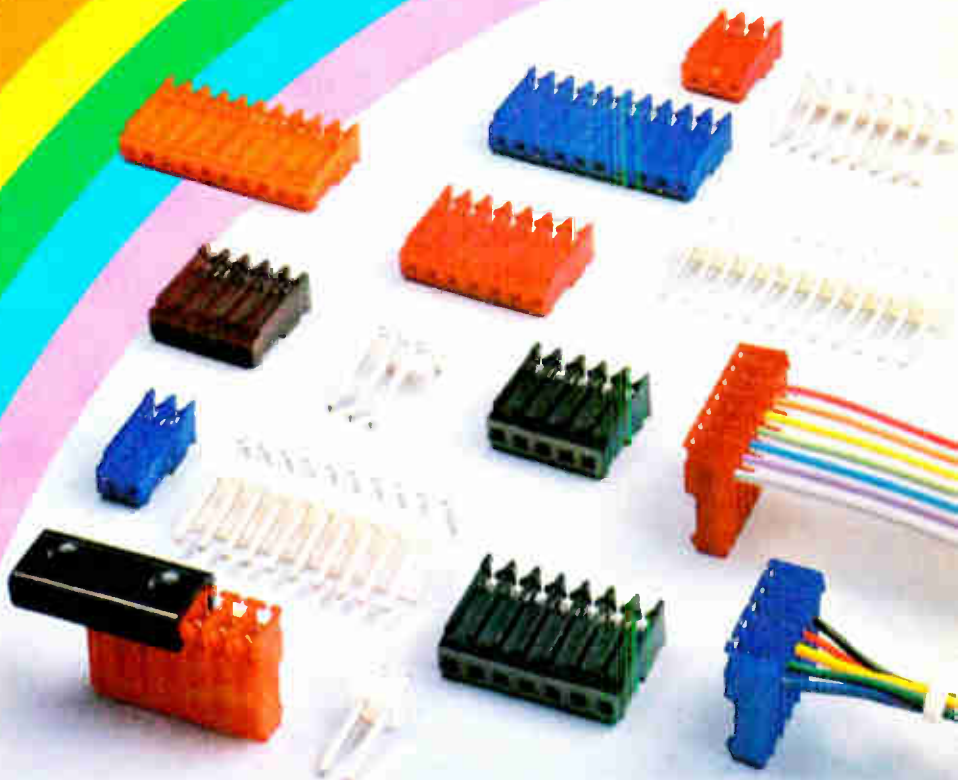

Wires held securely  
in connector



Versatile,  
inexpensive  
bench  
press



## Unique Wire Retention Design Speeds Installation and Reduces Installed Costs

Now you can mass-terminate both discrete wire and notched flat cable without insulation stripping.

- Wires snap quickly into unique wire retainers in each connector. These retainers hold wires securely prior to termination.
- Compact, inexpensive, easy-to-use bench press quickly terminates both through-circuit and end-circuit connectors.
- System includes: Insulation displacement connectors, header assemblies, harness board accessories, polarizing keys, manual and pneumatic hand tools and bench presses.
- MAS-CON is the mass termination system with the flexibility you've been looking for.

**Ask for Free Demonstration  
and Cost Analysis**

**FREE SAMPLES**

Circle 20 on reader service card

The Reliable... Wherever Electricity Is Used



ELECTRONIC PRODUCTS GROUP  
Tinley Park, IL 60477 • Phone (312) 532-1800  
In Canada: Panduit (Canada) Limited



**FAST**

**EST**

**FASTEST**

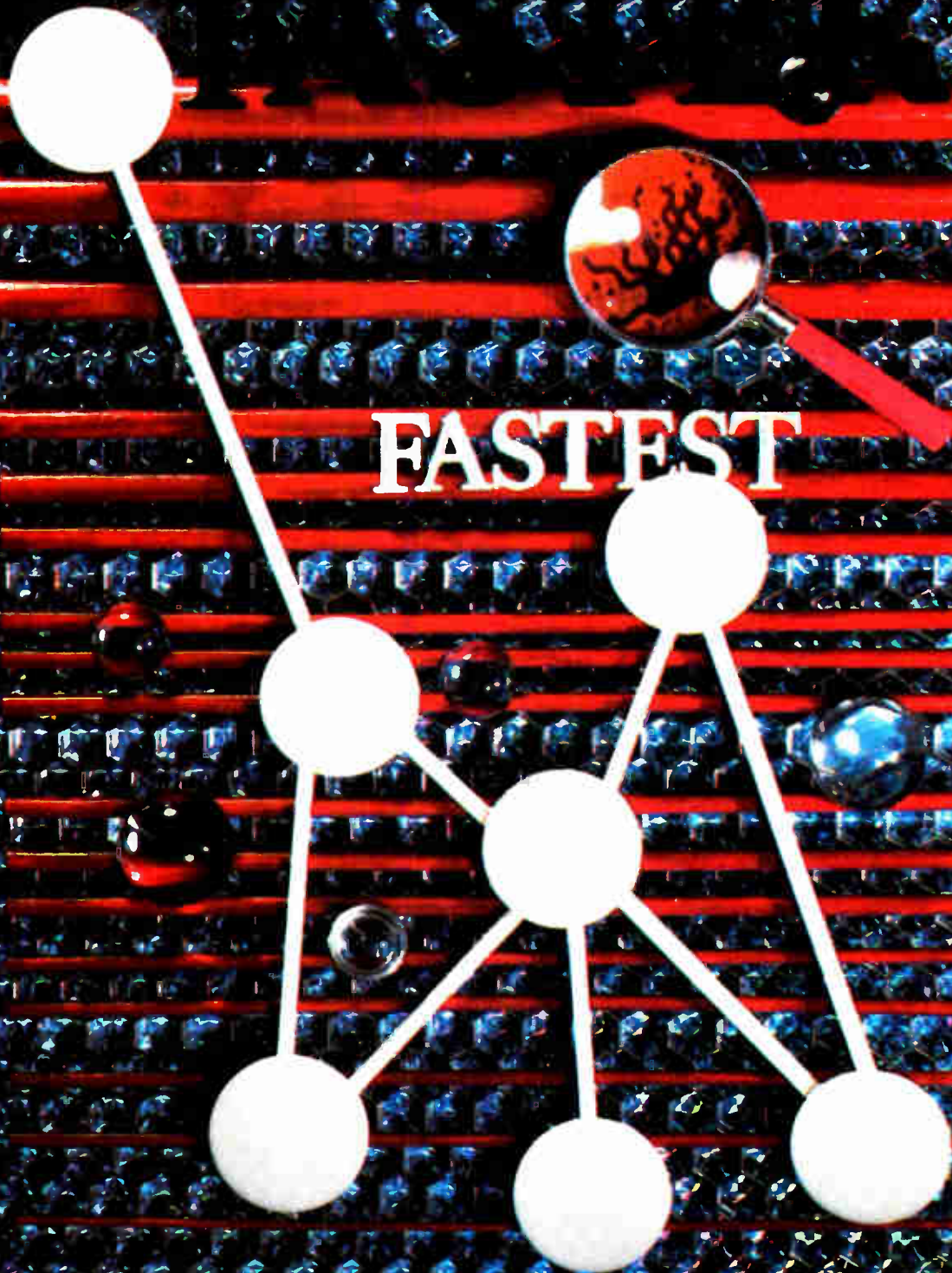



# TECHNOLOGY

---



THE DRAMATIC  
ADVANCES  
PREDICTED FOR  
ALL KINDS OF

ELECTRONIC EQUIPMENT  
OVER THE NEXT TWO  
DECADES WILL DEPEND  
IN LARGE PART ON EQUALLY  
DRAMATIC PROGRESS IN  
SOLID-STATE TECHNOLOGY.  
AHEAD ARE ENORMOUS  
INCREASES IN THE SPEED,  
DENSITY, AND CAPABILITIES  
OF INTEGRATED CIRCUITS,  
MAGNETIC-BUBBLE  
MEMORIES, AND OTHER  
CHIPS. YET ALREADY  
PERCEPTIBLE TODAY ARE  
FUNDAMENTAL LIMITS TO  
THE TECHNOLOGY—LIMITS  
INHERENT IN THE  
LITHOGRAPHIC, PROCESSING,  
AND PACKAGING  
TECHNIQUES AS WELL AS  
THE VERY MATERIALS USED  
TO PRODUCE SOLID-STATE  
DEVICES. THESE LIMITS  
WILL DEFINE THE PATH  
CIRCUIT DEVELOPMENT  
TAKES INTO THE  
NEXT CENTURY.



After 15 glorious years of progress in integrated circuits, the electronics industry finds itself in the position of a good weekend golfer or tennis player: it is just learning how much of the game remains to be mastered. However remarkable the progress so far, it now appears to be only a foundation for enormous increases in the speed, density, and sophistication of logic and memory circuits.

Why?

As circuits become denser, the cost of performing each function goes down because there are more elements on the chip to share in the cost of processing the entire integrated circuit. This means either that more work can be done for less money or that more power and convenience can be made available for the same money. The recent history of technology indicates, if nothing else, that here are the seeds of change, no less so with ICs than with internal combustion engines. The cheaper and more convenient the tool by which the world's work is performed, the more pervasive its application and the greater the demand for it. And with this demand comes the impetus for refinement of the tool, which, in the case of ICs, is expressed by the compulsion to miniaturize.

State-of-the-art devices today are made with minimum features on the order of 2 micrometers. These will seem gross and clumsy compared with what is coming. Integration levels will be extended at least another order

of magnitude, down to where things are measured in angstroms, where light does not reflect colors, where bacteria and DNA molecules crawl around.

In October 1978, the Department of Defense let loose its program for very high-speed integrated circuitry. One of its goals for the six years following that announcement was to establish a minimum feature of 0.5  $\mu\text{m}$  (500 Å) on devices as large as 400 mils on a side. The latest report from the semiconductor companies: "We can do it."

There will be monolithic megabit random-access memories with data accessible in nanoseconds. Bubble memories with several millions—perhaps billions—of bits will be commonly employed in data-processing equipment. There will be mainframe computers on chips. And beyond that, what is known today as electronics will mesh with and cross-fertilize advances in biology to propagate another revolution that deals with organic molecules and living cells. After all, IC features can already be resolved that are smaller than some bacteria.

It will not be easy. This process of increasing sophistication, which the industry calls integration, is now considered "large scale." That is, semiconductor companies are capable of producing commercial quantities of ICs each of which incorporates 100,000 or so components with minimum dimensions greater than 1  $\mu\text{m}$ . Very large-scale integration, on which the industry now verges, indicates the incorporation of many more than 100,000 components with minimum features near to 1  $\mu\text{m}$ . VLSI will be mastered in the next 20 years, but not without sweat off the industry's brow.

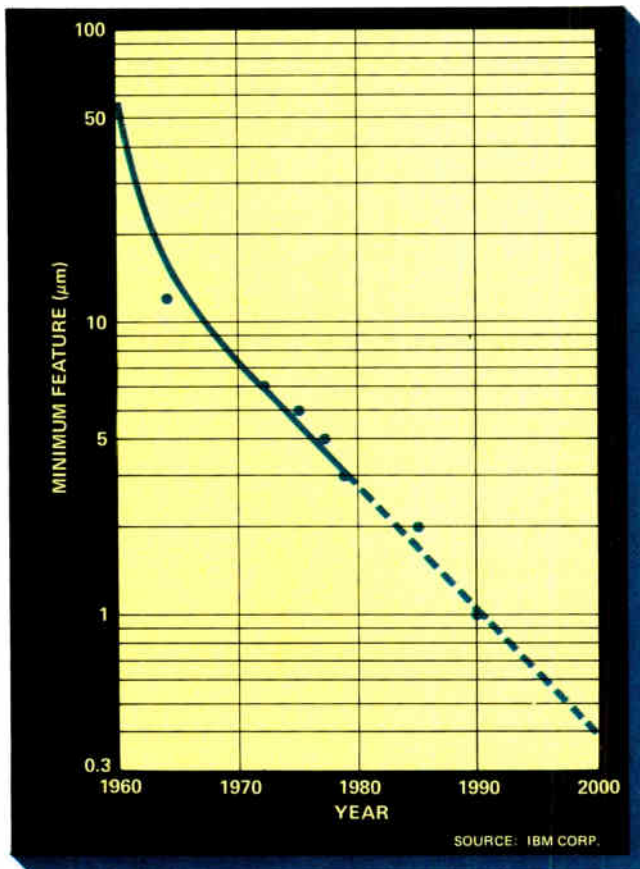

**The big shrink.** Despite the challenges associated with reducing the feature sizes in an integrated circuit, dimensions will continue to shrink. If minimum features follow the curve above, the 1- $\mu\text{m}$  barrier for commercial devices will be broken within a decade.

Expensive—very expensive—machines will have to be developed so that commercial devices can be mass-produced using wavelengths shorter than light. Entire new families of resists will have to be concocted that are sensitive to the electron beams, ion beams, and X rays that will form the basis for the new lithography.

Other fundamental limits will be reached but they, too, will be conquered in order. Parasitic capacitances will be lessened with insulating substrates. Heat will be removed with liquids. More levels of on-chip interconnection will be devised. And when the speed of silicon presents a limit, more emphasis will be given to gallium arsenide or other III-V compounds and possibly to Josephson junctions.

VLSI, however, may be limited by a factor that has nothing to do with the technological ability to produce ultraminiature circuits. That factor is demand. If VLSI devices are too specialized or if yield problems are too restrictive, there will be too few customers to direct such components down the so-called learning curve. This problem is more likely to surface with regard to logic devices, as the demand for memory will undoubtedly increase steadily given the broadening application of computers in industrial society. Beyond memory, says Gordon Moore, chairman of Intel Corp., Santa Clara, Calif., it is quite unclear how to take advantage of VLSI. As he points out, the semiconductor industry is not limited by process technology, and the real problem is how best to use that technology's results.

This is a real question. The dynamics of circuit devel-

opment will obey forces beyond the constraints of laboratory technology. But in the near term, at least, the limits perceived in the laboratory—whether they concern lithography or processes and materials—are likely to be the ones that shape circuit development and with it the architecture of computers.

**L**ithography, the means by which resist chemicals are exposed to define IC device geometries, is responsible for the minimum dimension possible, and this minimum feature in turn determines the extent to which the devices can be squeezed onto a particular size of substrate.

The overall level of integration is also dependent upon the size of the die and the technology chosen; for example, metal-oxide-semiconductor, or MOS, devices may be packed more densely than bipolar devices. The challenge is producing useful VLSI chips in large numbers at high yields so that they are affordable and reliable.

Experimental devices having submicrometer line widths are already being fabricated at Bell Laboratories in Murray Hill, N. J., International Business Machines Corp.'s Thomas J. Watson Research Center in Yorktown Heights, N. Y., and in the research labs of serious semiconductor companies. In fact, IBM researchers have already realized 80-Å (0.008- $\mu\text{m}$ ) lines on thin layers of graphite using electron-beam lithography.

The future course of the minimum feature has been variously predicted. In a paper presented in the fall of 1977 at CompCon 77, the 15th International Conference of the Institute of Electrical and Electronics Engineers' Computer Society, George Marr predicted that minimum features will diminish in accordance with the curve shown the figure on the opposite page. If his assumptions are correct, commercial devices using 1- $\mu\text{m}$  lines may be fabricated by 1990.

Assuming that patterns cannot realistically be resolved that are finer than the wavelength of the light used for exposure, optical lithography loses its effectiveness soon after 1- $\mu\text{m}$  lines are reached. The limit for photolithography is about 0.5- $\mu\text{m}$ , according to M. P. Lepselter, director of the advanced LSI development laboratory at Bell Laboratories in Murray Hill, N. J., and even this requires long exposure to a bright, partially coherent source of deep ultraviolet wavelengths, on the order of 2,000 Å.

Hence, there was a time when 0.5  $\mu\text{m}$  was considered to be the ultimate resolution and the limiting dimension for LSI circuitry, but this was before it was realized that X rays, electron beams, and ion beams could do better. Although these forms of radiation possess effective wavelengths shorter than those of light, they are not without their own drawbacks, not the least of which is the capital needed to buy the machines to generate the radiation. In fact, some industry observers fear the million-dollar-plus pricetags on such equipment may signal industry maturity—in other words, that only the yet-to-be-determined "big four" semiconductor companies will be able to afford to compete in the various VLSI markets of the future.

The limiting factor with X rays, electron beams, and

ion beams is not directly due to their wavelengths. Indeed, electron microscopes have been employed to view individual isolated atoms. Rather, at these higher frequencies, undesirable interactions with particles in the resist and in the silicon substrate come into play. Hence, developing suitable resist chemicals is essential in making these radiation types viable.

With X-ray and electron-beam exposure, secondary electrons are produced in the resist material that have the ability to expose the resist further. Only the side-to-side, or lateral, component of the electron motion has to be minimized, however, since travel directly toward and away from the wafer does not adversely affect resolution.

The lateral range for secondary electron emissions created by X radiation is debatable, but most observers place the distances well below 1,000 Å, more likely between one and several hundred angstroms. X rays are therefore able to resolve features down to at least 0.1  $\mu\text{m}$ . Researchers at the Massachusetts Institute of Technology's Lincoln Laboratory in Lexington, Mass., have recently reported being able to get 200-Å lines using a polyimide mask shadowed with tungsten [Electronics, Oct. 11, 1979, p. 92]. These lines are shown in the photograph immediately below, along with a T4 phage virus for comparison.

Secondary electrons also govern the minimum dimen-

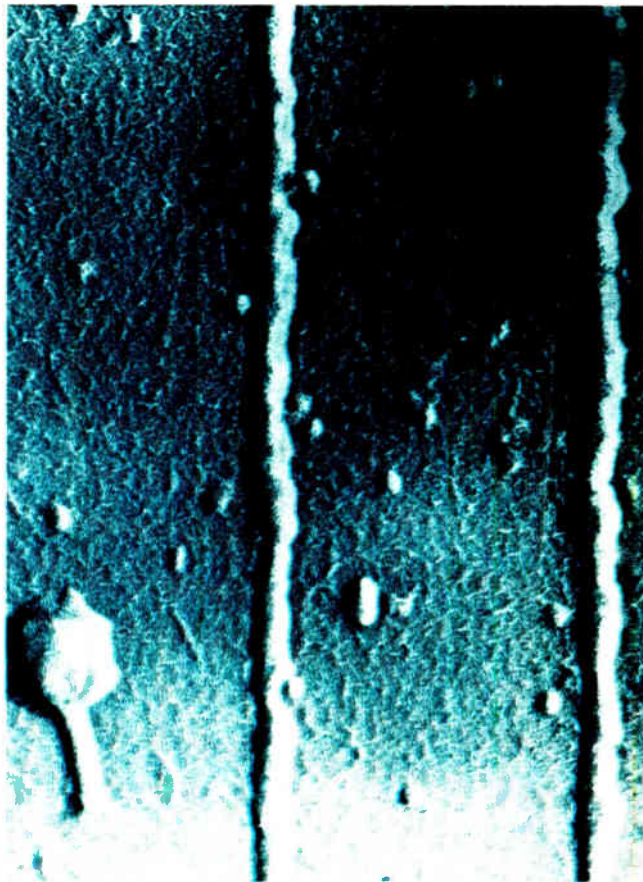

**Slender.** Researchers at MIT's Lincoln Laboratory used a polyimide mask shadowed with tungsten and X-ray lithography to resolve these 200-Å lines of PMMA photoresist on a silicon dioxide substrate. For comparison purposes, a T4 phage virus was placed on the sample.



## Harris Technology: A Progress Report

# Harris highlights of the 70s h

## 70s

"Harris shatters the Op Amp speed barrier!"

"Now . . . Harris offers the most advanced family of high-speed D/A Converters in the industry!"

"Our new UART and BIT RATE GENERATOR . . . the first programmable CMOS Communications System!"

"Breakthrough! Announcing the first all-digital CVSD . . . the only Encoder and Decoder available in a single IC!"

"Designs . . . come to life with the new Harris HA-4900 Quad Comparator!"

"If you compare BIFET Op Amps, there are three good reasons to switch to Harris: 1. Wider bandwidth 2. Faster settling time 3. More stable over temperature."

"Harris was the first to win QPL I Certification for JAN PROMs."

"Sooner or later, you're going to evaluate a CMOS Microprocessor System. The time is now. The Harris Micro-12 is the way."

"Harris high-performance components assure superior speed and accuracy!"

Harris is already working on new ideas for the 80s. They're not here yet, but we can do many things for you now.

Through our divisions, Harris offers a total spectrum of state-of-the-art integrated circuits—*analog, bipolar, CMOS and custom-designed*—to meet your toughest requirements, today and tomorrow. From military electronics to leisure games, and from telecommunications to custom ICs for industry. With expanded output to keep pace with your production.

Harris has been at the forefront of technology throughout the past decade. We intend to maintain this distinction as we continue to work with you — to keep you more competitive in the 80s.

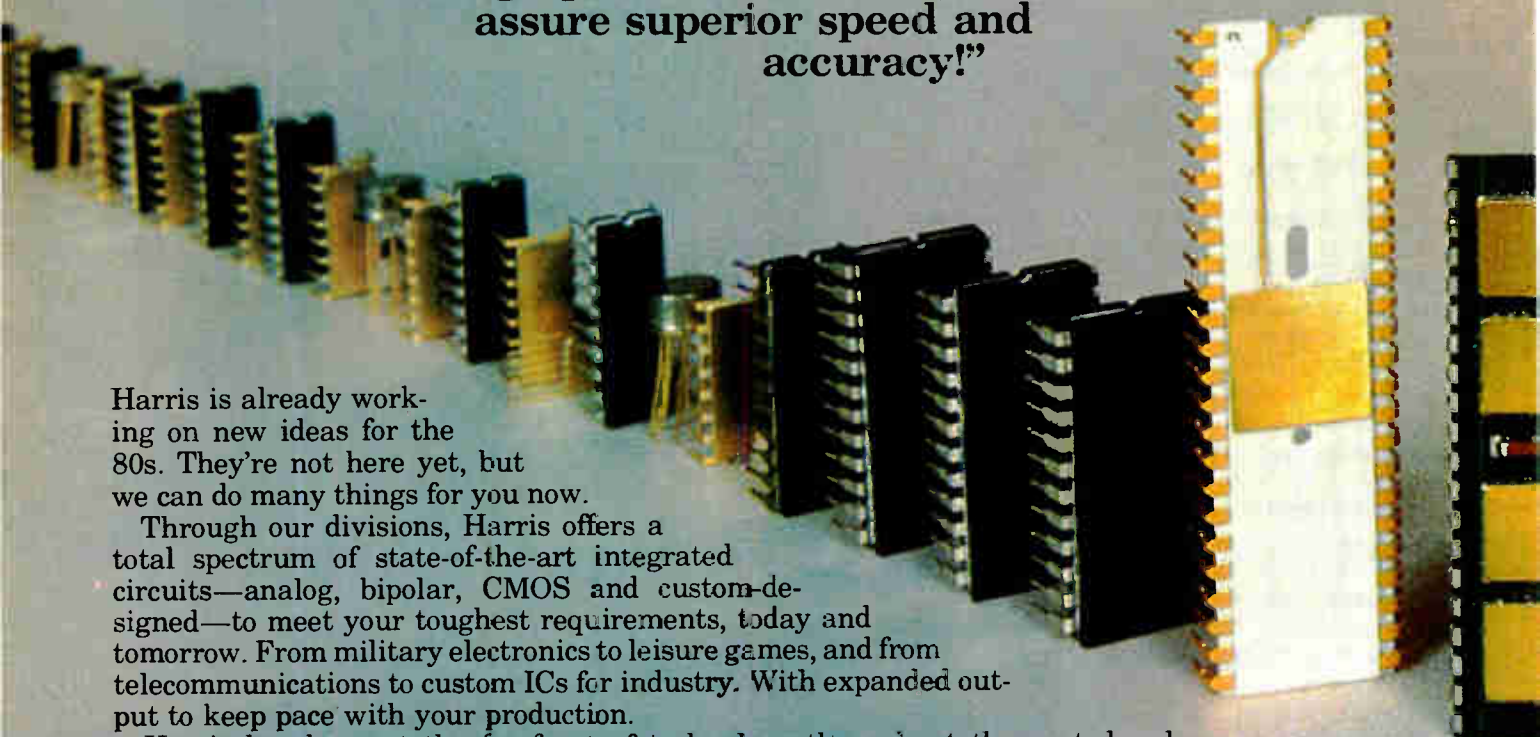

# radical bold advances in the 80s.

**80s** "Harris introduces the world's first 16-bit monolithic A/D Converter!"

"Harris expands levels of technology with development of 64K CMOS static RAM!"

"New Harris monolithic subscriber line interface circuit penetrates telecommunications market!"

"Harris produces industry's first voice-to-hard-copy translator!"

"Megabit array logic opens new design dimensions."

"Harris combines technologies to produce BEGABIT memories."

"Single-chip addressable speech synthesizer now available from Harris."

"Aural interface (response and command) systems now practical through Harris chip."

"Harris produces first totally integrated fiber optic ICs."

"GHz Op Amps now a reality."



Bring your integrated circuit problems to Harris, where high technology is your competitive edge. Write: Harris Semiconductor Group, Advanced Technology Department, MS 53-015, Box 383, Melbourne, Florida 32901.

*Harris Technology  
Your Competitive Edge*



**HARRIS**  
SEMICONDUCTOR GROUP  
DIVISIONS OF HARRIS CORPORATION

Circle 2 on reader service card



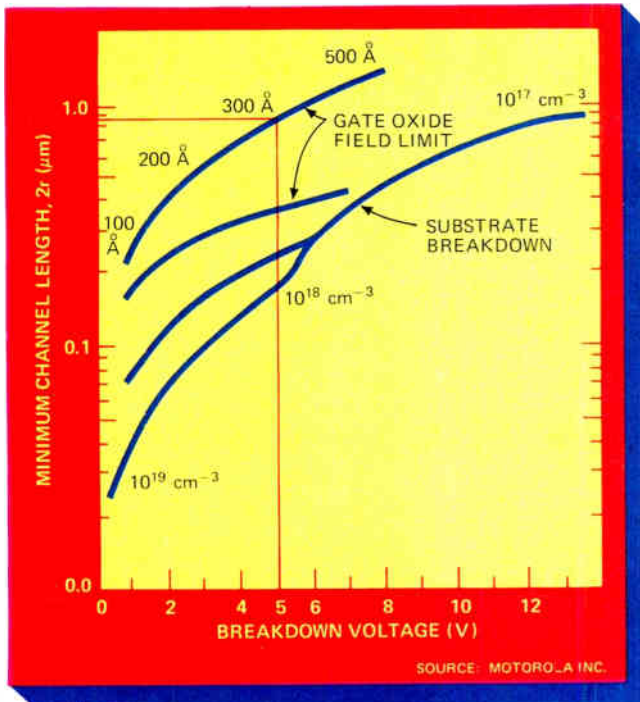

**Breakdown.** As semiconductor devices shrink, electric fields expand because charge tends to collect at small points. Thus a 300-Å gate should break down at 5 V when the channel is slightly less than 1  $\mu\text{m}$ . For VLSI, internal supply voltages will have to be reduced.

sion attainable by writing directly on the wafer with an electron beam. The resist can be applied more thinly, but the electron beams introduce a new pitfall: electrons bounce back off of the silicon itself and expose the resist from the opposite direction. The beam current can be lowered to reduce the range of the reflected particles, but at the cost of stretching out the time that is required to expose a spot and hence the total writing time required for the entire wafer.

The ultimate workable resolution attainable with electron-beam lithography is about a third of a micrometer or less. Direct writing on a wafer with an electron beam has another highly desirable advantage: no masks are needed. The main disadvantage, as just noted, is the writing time required. To expose a 4-in. wafer with an electron beam having a 0.1- $\mu\text{m}$  diameter at present takes about 15 minutes. This delay is probably unsuitable for volume production. However, as electron-beam machines will be used to fashion masks for ultraviolet and X-ray exposure, the equipment will be improved. This, coupled with better resist chemicals, will shorten the writing time and electron-beam lithography will enjoy widespread future use for VLSI.

In place of electron beams, ion beams can be used for micrometer and finer geometries. This concept is exciting because the same machine used for exposure can also be used for ion implantation, ion milling, and mask fabrication. But although the technique can realize resolutions on the order of 0.1  $\mu\text{m}$ , the equipment is expensive and proper exposure calls for sensitive resists because the heavier particles have a shallower range. Moreover, it may be difficult to turn such a beam on and off fast enough to ensure tolerable wiring times.

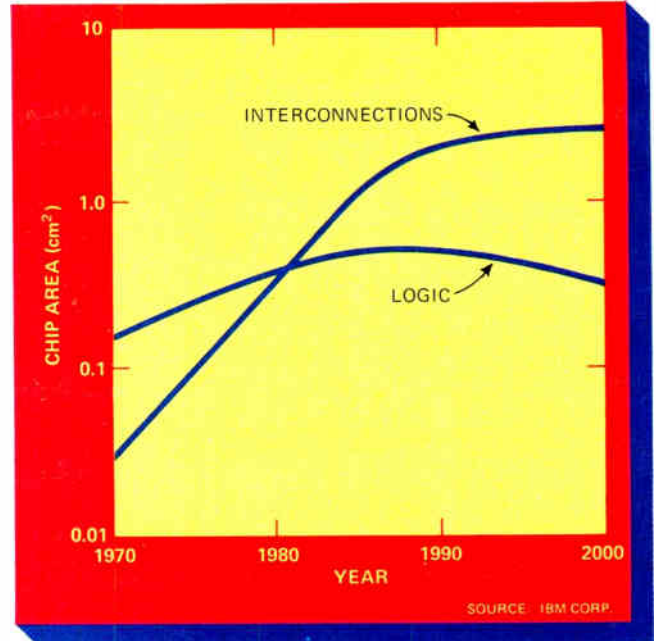

**Wiring worries.** On-chip interconnection of VLSI devices may not seem like a limiting factor, but many semiconductor companies place it at the top of the list of VLSI problems. Interconnections are eating up more space; area for them may equal that for logic very soon.

The time for ion-beam (and electron-beam) exposure can be reduced by using parallel stationary beams (instead of a single, moving beam) and passing them through a mask, just as in X-ray and optical lithography. Preparing the necessary mask is of course tricky, as portions of it need to absorb radiation of a much higher frequency than light, while at other points the rays must pass through easily. And, as usual, the resultant resolution is dependent upon mask-to-wafer spacing. Various companies are toying with parallel-beam exposure, and their conclusions are optimistic; line widths definitely less than 0.5  $\mu\text{m}$  are achievable with masked electron beams or ion beams.

**E**ven if extremely small geometries are defined through exposure, developing the resists creates other technical difficulties. The semiconductor industry today is based almost entirely on what is termed wet processing—that is, the use of liquid developers to induce chemical changes in the exposed resist so that it can be etched.

The wet chemical development process has many idiosyncrasies, says George Heilmeier, vice president for corporate research, development, and engineering at Texas Instruments Inc. in Dallas. One undesirable effect is that the wet chemicals may be absorbed by the resist and thus may undercut it or cause it to swell or both. For the most part, says Heilmeier, wet chemical etching is “an empirical process that is fairly difficult to control.”

Its uncontrollability has led researchers and industry to focus on dry processing, which involves the use of plasma as the etchant. “With dry processing, it is possible to etch very, very steep walls and finer geometries in materials without undercutting,” says Heilmeier. Plasma

# Now available. . .the SMALLEST BROADBAND MIXERS

from Mini-Circuits of course.

## 40 kHz - 3 GHz

**\$11.95**  
MODEL TFM-2  
\$11.95 (6-49)

**ACT NOW TO IMPROVE YOUR SYSTEM DESIGNS,** increase your packaging density, and lower your costs. . . specify Mini-Circuits new microminiature TFM series. These tiny units, 0.5" x 0.21" x 0.25" the smallest off-the-shelf Double Balanced Mixers available today, cover the 40 kHz - 3 GHz range and offer isolation greater than 45 dB and conversion loss of 6 dB. Each unit carries with it a 1-year guarantee by MCL. Upgrade your new system designs with the TFM, rapidly becoming the new industry standard for high performance at low cost.

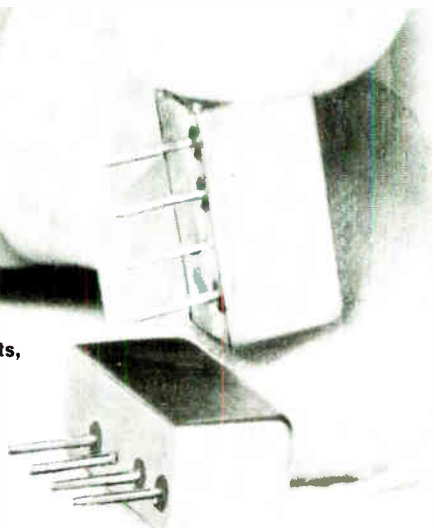

<p>Actual size</p>	Model TFM-2	1-1000 MHz	\$11.95
	Model TFM-3	0.04-400 MHz	\$19.95
	Model TFM-4	5-1250 MHz	\$19.95
	Model TFM-11	1-2000 MHz	\$39.95
	Model TFM-12	800-1250 MHz	\$39.95
	Model TFM-15	10-3000 MHz	\$59.95

40 kHz      0.1 MHz      1 MHz      10 MHz      100 MHz      1 GHz      3 GHz

Simple mounting options offer optimum circuit layout.

Use the TFM series to solve your tight space problems. Take advantage of the mounting versatility—plug it upright on a PC board or mount it sideways as a flatpack.

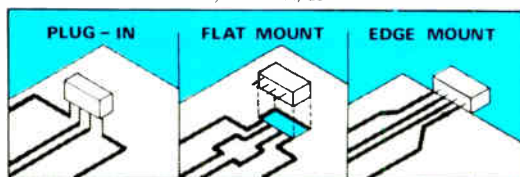

Model	Frequency, MHz		Conv. loss, dB		Isolation, dB						Cost		
	LO	RF	1 Oct. From Band Edge	Total Range	Lower Band Edge To one decade higher	Mid Range	Upper Band Edge To one decade lower	LO RF	LO IF	LO LF	LO IF	Quantity	Price
TFM-2	1-1000	1-1000	DC-1000	6.0-7.5	7.0-8.5	50-45	45-40	40-25	35-25	30-25	25-20	6-49	\$11.95
TFM-3	0.04-400	0.04-400	DC-400	3.0-4.0	6.0-8.0	60-50	55-40	50-35	45-30	35-25	35-25	5-49	\$19.95
TFM-4	5-1250	5-1250	DC-1250	6.0-7.5	7.5-8.5	50-45	45-40	40-30	35-25	30-25	25-20	5-49	\$19.95
TFM-11	1-2000	1-2000	5-1000	7.0-8.5	7.5-9.0	50-45	45-40	35-25	30-20	25-20	25-20	1-24	\$39.95
TFM-12	800-1250	800-1250	50-90	—	6.0-7.5	35-25	30-20	35-25	30-20	30-25	30-20	1-24	\$39.95
TFM-15	10-3000	10-3000	10-800	6.3-7.5	6.5-9.0	30-20	30-20	30-20	30-20	30-20	30-20	1-9	\$59.95

Signal: 1 dB compression level: -1 dBm. Impedance: all ports 50 ohms. Total input power: 50 mW. Total input current: peak 40 mA. Operating and storage temperature: -55°C to +100°C. Pin temperature: 510°F (10 sec).  
\* LO power: +10 dBm. 1 dB compression: +5 dBm.

Mini-Circuits

2625 East 14th Street Brooklyn, New York 11235 (212) 769-0200  
Domestic and International Telex 125460 International Telex 620156

**International Representatives:** □ AFRICA: Afrira (PTY) Ltd. P.O. Box 9813 Johannesburg 2000 South Africa □ AUSTRALIA: General Electronic Service, 39 Alexander St. New South Wales, Australia 2065 □ EASTERN CANADA: B.D. Hummel, 2, 24 Maynard Ave., Utica, NY 13502 □ ENGLAND: Dale Electronics Ltd., Dale House, Wharf Road, Frimley Green, Camberley Surrey, United Kingdom □ FRANCE: S.C.I.E. D.I.M.E.S., 31 Rue George Sand, 91120 Palaiseau, France □ GERMANY, AUSTRIA, SWITZERLAND, DENMARK: Industri Elektronik GMBH, 6000 Frankfurt/Main, Klüberstrasse 14, West Germany □ INDIA: Gokwar Enterprises, Kamal Mahal 17, M.I. Dahanuvar Marg, Bombay 400 026 India □ ISRAEL: Vretronics Ltd., 69 Gordon St., Tel Aviv, Israel □ JAPAN: Denso Kaisha Ltd., Eguchi Building 8-1-1-Chome, Hamamatsuecho Minato-Ku, Tokyo, Japan □ NETHERLANDS, LUXEMBOURG, BELGIUM: B.V. Technische Handelsonderneming COIMEX, P.O. Box 19, B050 AA Hattem, Holland □ NORWAY: Datamatikk As Postboks 111 BRYN, Oslo 6, Osterningsveien 62, Norway □ SINGAPORE & MALAYSIA: Electronics Trading Co. (PTE) Ltd., Suites C13, C22 & C23 (1st Floor), President Hotel Shopping Complex, 181 Kitchener Road, Singapore & Republic of Singapore □ SWEDEN: Integrerad Elektronik AB, Box 43 S, 182 51, Djursnöm, Sweden

**U.S. Distributors:** □ NORTHERN CALIFORNIA: Pen Stock, 105 Fremont Ave., Los Altos, CA 94022, Tel: (415) 948-6533 □ SOUTHERN CALIFORNIA, ARIZONA: Crown Electronics, 11440 Collins St., N. Hollywood, CA 91601, Tel: (213) 877-6950 □ METROPOLITAN NEW YORK, NORTHERN NEW JERSEY, WESTCHESTER COUNTY: Microwave Distributors, 61 Mall Drive, Commack, NY 11725, Tel: (516) 543-4771 □ SO. NEW JERSEY, DELEWARE & EASTERN PENNSYLVANIA: MLC Distributors, 456 Germantown Pike, Lafayette Hills, PA 19444 (215) 825-3177

For other Mini-Circuit Lab Products see ads on pgs. 2, 50, 327

B32/REV E □□□

Circle 22 on reader service card



# S/D



# MONOBRID™

## The New Generation of Custom Monolithic Hybrid Converters from DDC.

By using customized monolithic chips, DDC has taken a giant step forward in converter technology. The new product—Monobrid—is much smaller, less complex, more reliable and requires less power than conventional hybrids.

The first of DDC's new Monobrid series is a *single* 36-pin DDIP module containing a complete 14-bit S/D or R/D converter. At half the size of conventional hybrids the new DDC-8915 Series Monobrid packs the same kind of high

performance. Accurate to  $\pm 2.6$  minutes, the new S/D Monobrid offers tri-state latched outputs in two bytes and continuous tracking, even during data transfer. It accepts broadband inputs of 360 to 1000 Hz, or 47 to 1000 Hz; and is made to order for applications where small size, high MTBF and low power are critical.

For more information about DDC's new 8915 Series Monobrid converter, call or write Department B-7, today.



**ILC DATA DEVICE CORPORATION**

Dept. B-7, 105 Wilbur Place, Bohemia, New York 11716  
516-567-5600, TWX: 510-228-7324

**LOS ANGELES:** ILC Data Device Corporation, Dept. B-7, 7337 Greenbush Avenue, No. Hollywood, CA 91605 (213) 982-6454. TWX 910-499-2674; **LONDON:** DDC United Kingdom Ltd., Dept. B-7, 128 High Street, Hungerford, Berkshire RG17 0DL, England (44) 4886-2141/2142, TLX 851-848826; **PARIS:** DDC Electronique, Dept. B-7, 4 Rue De Abreuvoir, 92400 Courbevoie, France (01) 333-5888, TLX 842-630609

Note: Monobrid™ is a trademark of ILC Data Device Corporation

Circle 23 on reader service card

can be used for much more than resist etching; it can be used to etch silicon and metals as well.

Even if micrometer and submicrometer geometries are exposed and developed, there is no guarantee that chips built to these specifications can be mass-produced. Even before the limits of lithography are reached, device-related problems will need to be subdued. The industry will need to understand and model the behavior of submicrometer structures, find the means to interconnect the enormous numbers of devices that will be fabricated on a single substrate, and develop suitable packages to carry heat away fast enough to make way for high-speed operation.

It is unfortunate, but as dimensions become smaller, electric fields tend to increase because charge tends to collect at small points. If MOS transistors are scaled down enough, the semiconductor junction and gate oxide can both break down. The distance between the source and drain must be greater than the sum of the widths of the depletion regions associated with each of these electrodes if transistor action is not to be lost. And although heavy doping can minimize the degree to which the depletion regions encroach upon the channel, it increases the electric field presented to the gate oxide.

According to William Howard, director of technology and planning for Motorola Inc., Phoenix, "Breakdown is a fundamental problem. As things get smaller, the higher the electric field becomes, and sometime during HMOS [scaled-down and hence high-performance MOS], we're going to have to address the power supply voltage situation." Howard does not claim to know the ultimate solution, but he makes two suggestions: "We could ask customers to adopt a lower voltage, like 2 to 3 V, or we could use on-chip regulation." In either case, the voltage presented to the transistors would be reduced. Referring to Fig. 3, with 2 V applied to the gate, the channel length could be reduced to 0.3  $\mu\text{m}$ . It should be noted that some state-of-the-art MOS devices, like 64-K random-access memories, already operate at internal voltages that are less than +5 V.

The electric fields in a device must be kept down for another reason besides breakdown. If electrons take on enough energy, they may be able to escape the silicon, penetrate the oxide, and become trapped there. As these "hot" electrons, as they are called, carry with them a negative charge, the device's turn-on (or turn-off) threshold voltage can shift. Furthermore, it is expected that advanced processing techniques, such as electron-beam exposure and dry plasma etching, will compound the problem because the higher energies generated by such equipment could create more electron-trapping sites in the gate insulator.

Interconnecting VLSI devices may not seem like a limiting factor, but Motorola, for one, places it at the top of its list of VLSI problems. As a die is stocked with more and more devices, the device connection problem becomes more acute. The interconnections use up more and more of the chip area, and the returns from further integration, especially those of logic circuitry, quickly diminish. Robert Keyes, a researcher

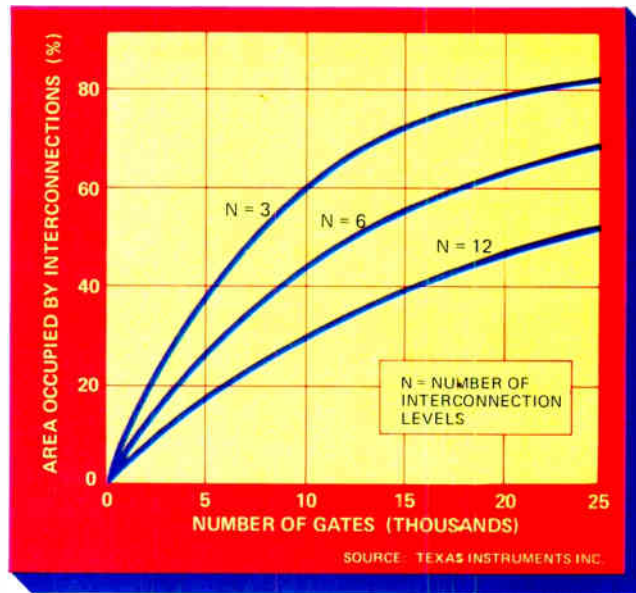

**Solution.** Although on-chip wiring is smothering area that would otherwise be used for logic, there are solutions. One is to increase the number of interconnection levels. But even with 12 levels, wiring will make up half the area of a device having 25,000 gates.

at IBM Corp.'s Watson research center, predicts that the area required to connect logic will grow more rapidly than chip area and that the two areas will in fact be about equal in 1980.

One way to reduce the area required for interconnection is simply to add more levels for this purpose. The graph on the previous page shows how the percentage of the area occupied by the interconnecting wires may be reduced by moving from today's 3 levels to 6 and 12 levels. As the graph shows, even with 12 interconnecting levels, the wiring will still constitute more than half the area of a chip with only 25,000 gates.

The resistance of the interconnecting paths also rises as geometries are scaled down because the cross section of the wiring is reduced. Higher power dissipation or lower speed or both may result, and the desire to prevent such undesirable effects has led to an increased interest in the use of laser annealing and refractory metal silicides. When such a material—tungsten silicide, for example—is deposited atop a polysilicon line, its conductivity is dramatically enhanced. Also, the deposition appears to be completely compatible with the use of silicon gates and VLSI processing.

As if the design of VLSI chips is not already beset with challenges, packaging will not be easy either. "The ultimate limit with VLSI may be getting the signals in and out," says Motorola's Howard. Even if, through on-chip decoding or multiplexing, the number of connections to and from the chip could be kept reasonable, "thermal barriers will come about due to limitations in our ability to conduct heat away from semiconductor devices," says TI's Heilmeyer, adding that ". . . no matter how fine we make the geometries, thermal limits are going to come into play long before the physical limits, the processing limits, or the lithography limits."

Switching from air cooling to liquid cooling can postpone this temperature problem for a long time. But for



Burndy's new GTH™ based IDC II Ribbon Cable Connector System:

# Good as gold...

Burndy IDC Connectors:  
Card Edge, Header and  
Socket types in 20, 26,  
30, 34, 40, 50 & 60 posi-  
tions. Meets or exceeds  
MIL-STD 1344 require-  
ments. Also available  
with gold contacts.



# at a fraction of the cost.



Our new GTH-based IDC II connectors deliver everything you've ever wanted in a ribbon cable interconnect system — convenience features. Ease of installation. Lowest installed cost. And most important — the reliability of gold without the high cost of gold.

That's because our GTH-based IDC II system completely eliminates the need for gold — in both the connector and the circuit board — *without sacrificing reliability!* That can mean a 33% cut in connector costs alone.

Add to that the savings you enjoy by eliminating gold on the circuit board and you're talking about savings of 60% and more. And you get all this in addition to all the convenience features you've always wanted in an IDC connector.

So why settle for less in an IDC ribbon-cable connector system when you can have it all — and save money, too! Check our performance data. Then check our prices. Call me for quick action. Or write: Jack Miller, VP Marketing, Components Group, Burndy Corporation, Norwalk, CT 06856.

**BURNDY**  
Offices in principal cities throughout the United States

## Proof of Performance\* (Contact Resistance based on #28 AWG Str.)

Conditioning	Milliohms		
	Min.	Max.	Avg.
<b>Test Group 1</b>			
Initial C.R.	5.37	6.25	5.54
After Durability (25 Cycles)	5.73	7.23	6.32
After Durability (50 Cycles)	6.89	12.43	7.84
<b>Test Group 2</b>			
Initial C.R.	4.74	6.42	5.23
After Vibration & Shock	5.06	7.63	5.55
After Humidity	5.18	14.50	6.46

Conditioning	Milliohms		
	Min.	Max.	Avg.
<b>Test Group 3</b>			
Initial C.R.	4.83	5.62	5.07
After Thermal Shock	5.08	6.41	5.55
<b>Test Group 4</b>			
Insulation Resistance 1000 VAC for 1 Minute	> 7x10 <sup>4</sup>	> 8x10 <sup>4</sup>	> 7.5x10 <sup>4</sup>
Dielectric Withstanding Voltage Die Breakdown @ 500 VAC	PASSED		

\*Write for complete test data.

IDC II connectors available through your local Burndy Distributor.

Circle 24 on reader service card

INTERNATIONAL SALES AND MANUFACTURING: BRUSSELS, BARCELONA, PARIS, ROTTERDAM, STOKHOLM, STUTTGART, UPPSALA, ZURICH, RIJN, MIAMI, LONDON, TORONTO, BOSTON, TOKYO, MEXICO CITY, SAN PAULI

# BURNDY CONNECTS



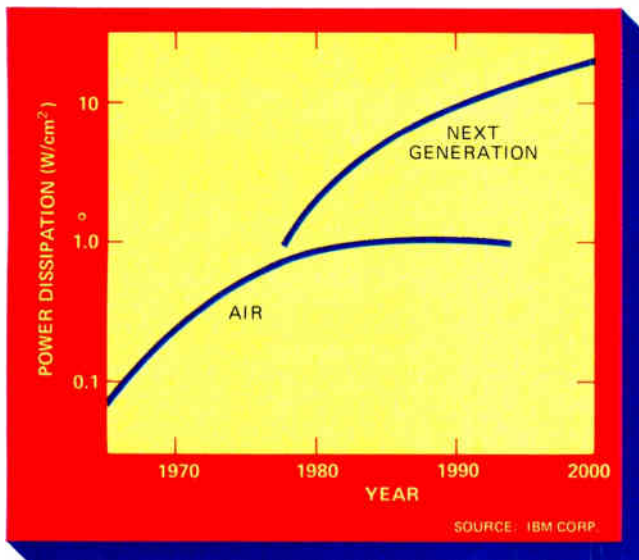

**Cool it.** Another challenge for VLSI is packaging so as to remove the heat generated. Air-cooled packages are capable of dissipating roughly 1 watt without a heat sink. Liquid cooling can be used, though, to raise the limit to about 20 watts per square centimeter.

the next generation of devices, liquid cooling has the ability to raise the power density significantly. The limit with liquid cooling is about 20 watts per square centimeter, at which point Freon will boil. Another solution is to switch to a lower-power technology such as complementary MOS. Many companies are busy investigating this prospect.

**H**aving somehow attained the ability to produce and reproduce very tight circuit tolerances, a semiconductor company is next faced with a choice between technologies. For VLSI, the technology must meet at least a dual requirement: very high packing density and very high speed. As the table shows, the technologies available are many. And this table does not include nonsilicon approaches to logic or memory, such as the use of gallium arsenide or other III-V semiconductor compounds, garnet for magnetic bubbles, and niobium or lead alloys for Josephson junctions.

The primary semiconductor candidates for VLSI are integrated injection logic (or some other form of current-mode logic), n-channel MOS, complementary-MOS, and gallium arsenide. Also, many if not all of these will be fabricated on some form of insulating substrate.

The future of bipolar integration is difficult to predict, as bipolar devices are in general not easily scaled down. Bipolar transistors demand more processing steps than do MOS structures, and too many of these steps involve the introduction of impurities, either by diffusion or through ion implantation. Also, bipolar devices tend to dissipate more power than other technologies, a drawback that so far has kept bipolar integration at relatively modest levels.

On the other hand, integrated injection logic, with its low power-delay product, is one bipolar form that could be made compatible with VLSI processing. As for complexity, current processing and packaging limit the

gate count to some 3,000 gates or less. But, according to Thomas Longo, vice president and chief technical officer for Fairchild Camera & Instrument Corp., Mountain View, Calif., it is reasonable to expect that I<sup>2</sup>L complexity will double every two years.

MOS technologies show much promise for VLSI for many reasons. Device designers have been extremely ingenious at improving speed and density even without adjusting minimum features. MOS devices need little power and are self-isolating; thus, charge can be stored on their capacitive gates, making dynamic logic and memories possible.

Predictions about complementary-MOS point to its widespread use for VLSI circuitry, but not necessarily for memories. "C-MOS will play a role," comments Robert C. Fletcher, executive director of integrated circuits development at Bell Laboratories. "While bipolar and straight MOS are coming closer to the old power versus integration-level dichotomy, there are certain applications where power will be the limiting factor." Fletcher adds that although C-MOS has quite a bit of potential because of its lower power usage, it probably will not be used for memories because it incurs too much of a penalty in chip area. Federico Faggin, president of Zilog Inc., Cupertino, Calif., is in agreement. He says, "You have to use C-MOS above a certain level of complexity—except in memories."

Joseph Borel, director of the Laboratoire de Microélectronique Appliquée in Grenoble, France, makes similar observations. "Power consumption is likely to force the development of a kind of super C-MOS with greatly increased density," he comments. Borel is also a believer in silicon on sapphire because of its immunity to the parasitic effects that, as he notes, cannot be avoided in bipolar devices or MOS devices made in bulk silicon.

Sapphire does indeed make a nice bed for silicon circuitry because the two crystal lattices match. However, the cost of the sapphire remains a limiting factor; after all, natural sapphire is precious. To combat this cost, RCA Corp.'s Solid State division in Somerville, N. J., has been trying to pull sapphire ribbons from the melt. However, it has still not succeeded in bringing the cost of sapphire-based devices down to those fabricated in bulk silicon. Motorola's Bill Howard agrees that an insulating substrate could point the way to lower power consumption, fewer parasitic effects, and high-speed VLSI circuits. But he refrains from saying that sapphire is the right material; indeed, he jokingly refers to SOS as "silicon on something else."

**A**n indirect way to realize single-crystal silicon on an insulating substrate is to laser-anneal polycrystalline material on an insulating substrate. Many researchers are exploring this possibility and obtaining promising results. Polysilicon grown on silicon oxide or nitride has been laser-annealed and devices with good characteristics have been fabricated in the large-grained material. More importantly, however, because polysilicon can be grown over oxides and vice versa, the technique may mean the development of truly three-dimensional structures, as opposed to the planar

**A classy  
alternative  
to  
humdrum  
multilayers.**



Made in U.S.A.

It costs no more to go first class with RMC GOLD-CAPS®. They're unsurpassed for compactness, high mechanical stability and electrical reliability . . . and our patented roll compaction process eliminates pinholes in the ceramic film and subsequent catastrophic failures that could get through the strictest AQL's.

Ideal for filter designs, high frequency bypassing, delay lines, thick film tech-

nology and conventional PC boards, GOLD-CAP® COG, X7R and Z5U leaded and chip multilayers offer high density packaging and rare performance at an affordable price. And we can deliver in 4-6 weeks.

Circle the reader service number, or write for our 36 page designer's guide on ceramics.

RAD O MATERIALS CORPORATION  
4242 West Bryn Mawr Avenue, Chicago, IL 60646  
(312) 478-3600 TWX: 910-221-2915

**RMC®**

RMC . . . components that shape tomorrow's technology.

Circle 25 on reader service card



# Berg's 0.025" PV™ receptacles

## And do it time..after time

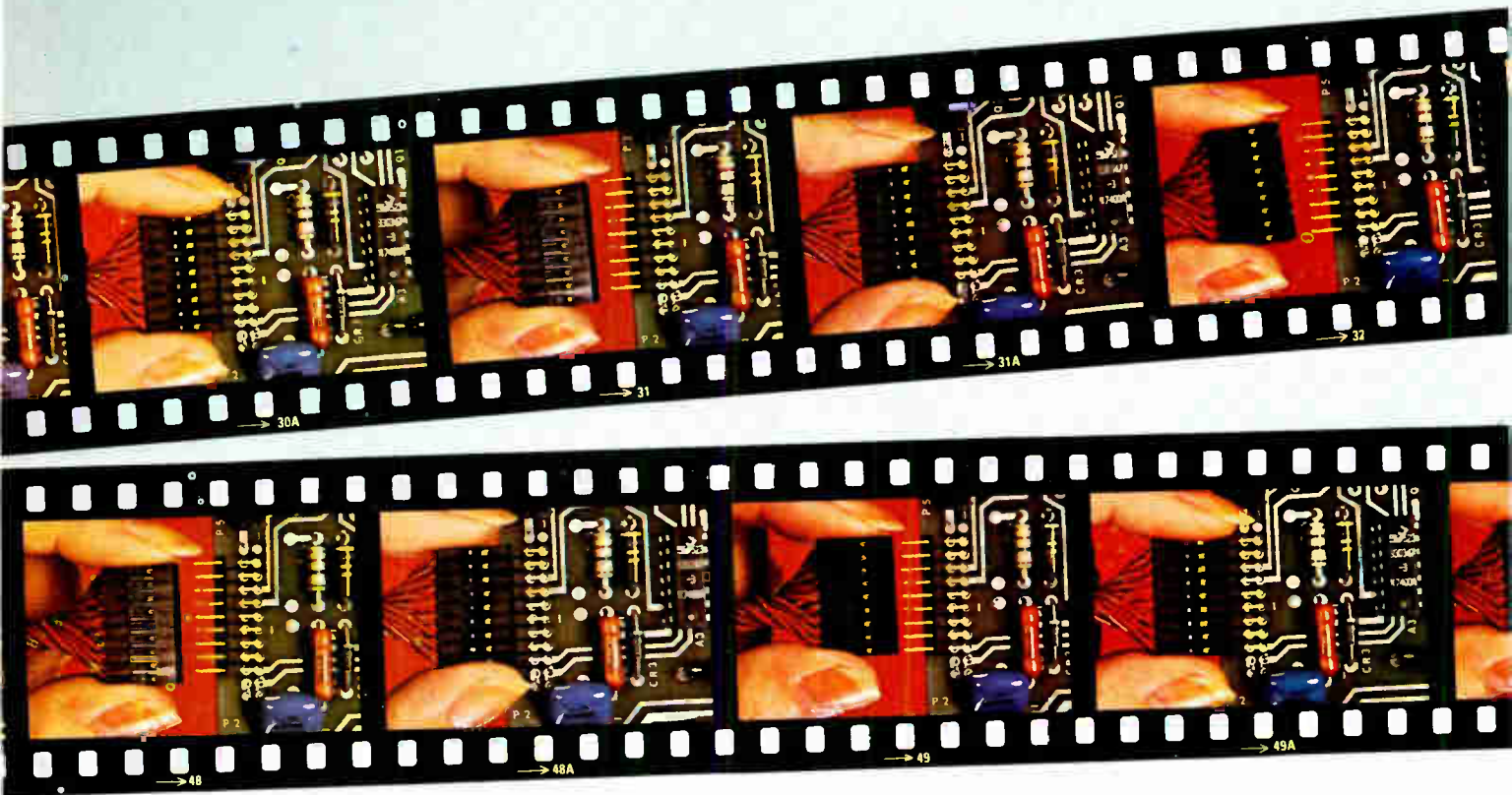

The secret to the durability of the "PV" lies in our unique dual-metal design. This combination of metals results in optimum mechanical and electrical performance.

**A.** The heat-treated beryllium copper spring maintains constant mechanical pressure on pins. Even after repeated insertion/withdrawal cycling.

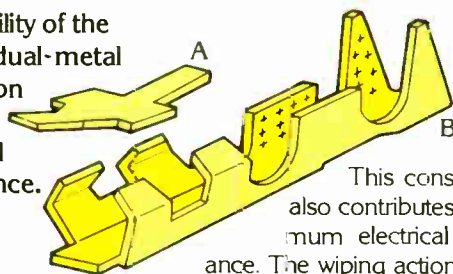

This constant force also contributes to maximum electrical performance. The wiping action between pin and contact area, created by high normal force during mating, cleans the contact surfaces of oxides.

**B.** The brass body, working with the

spring, provides optimum conductivity—an excellent 5 milliohms contact resistance or less. And brass facilitates crimping and extends application tool life.

**The "PV" line allows wide design flexibility.**

A choice of three spring thicknesses are available to help meet specific insertion/withdrawal force requirements. There are four terminal variations in crimp-to-wire sizes from AWG 18-36. The wide variety of

# deliver low contact resistance. ...after time...after time...

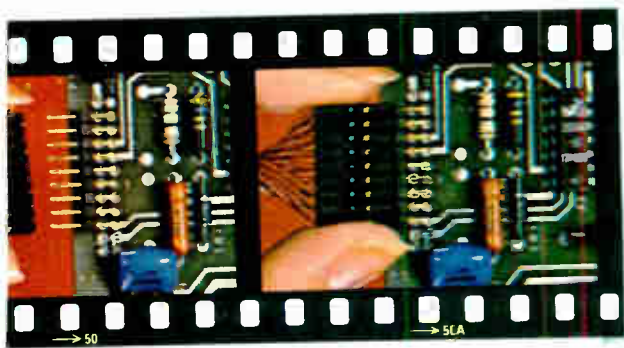
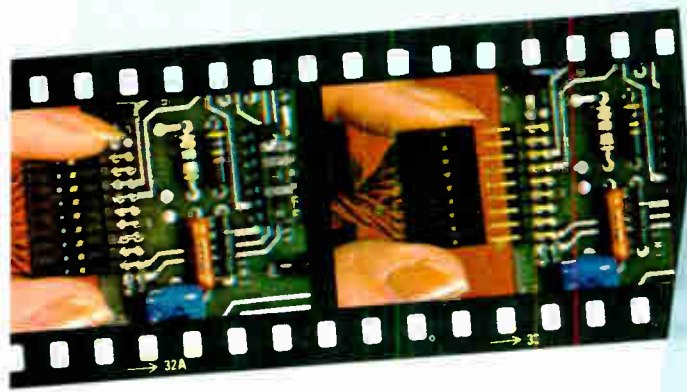

<b>Berg Electronics</b>		<b>PRODUCT EVALUATION</b>
NEW CUMBERLAND, PA.		
REPORT NO.	00447	TEST FILE NO.
		1000-123
<u>SUBJECT:</u> "PV" 0.025" Receptacle.		
<u>PURPOSE:</u> To determine contact resistance after repeated cycling.		
<u>CONCLUSION:</u> After the 50th cycle, no measurable increase in contact resistance.		

types and sizes, and the option of several gold or tin-lead platings, offer maximum design flexibility.

The Berg "PV" is the heart of the most complete 0.025" interconnection system available today. The BergCon™ system.

The "BergCon" system consists of a variety of mateable terminations for board-to-board, cable-to-board, or cable-to-cable packaging:

- BergStik™ pins, conveniently

molded in plastic, can be manually inserted into P.C. boards for on-line production without a machine.

- Standard housings allow simultaneous connection of as many as 72 "PV" terminated connectors.
- Low cost, easy to load hand tools available through distributors make the "BergCon" system practical for even the lowest-volume user. Or a low cost air-operated applicator is available from Berg.

- And the entire "BergCon" system is Underwriters recognized.

For detailed information on the complete "BergCon" system, write or call: The Du Pont Company, Berg Electronics Division, New Cumberland, Pennsylvania, 17070, Telephone: (717) 938-6711. Or contact your nearest Berg Electronics connector distributor.

In Europe: 's-Hertogenbosch, Netherlands, Telephone: (31) 73-215255.

Innovations for Electronics

## Berg Electronics



Circle 26 on reader service card



THIS IS  
THE  
WAY  
IT'S  
DONE!

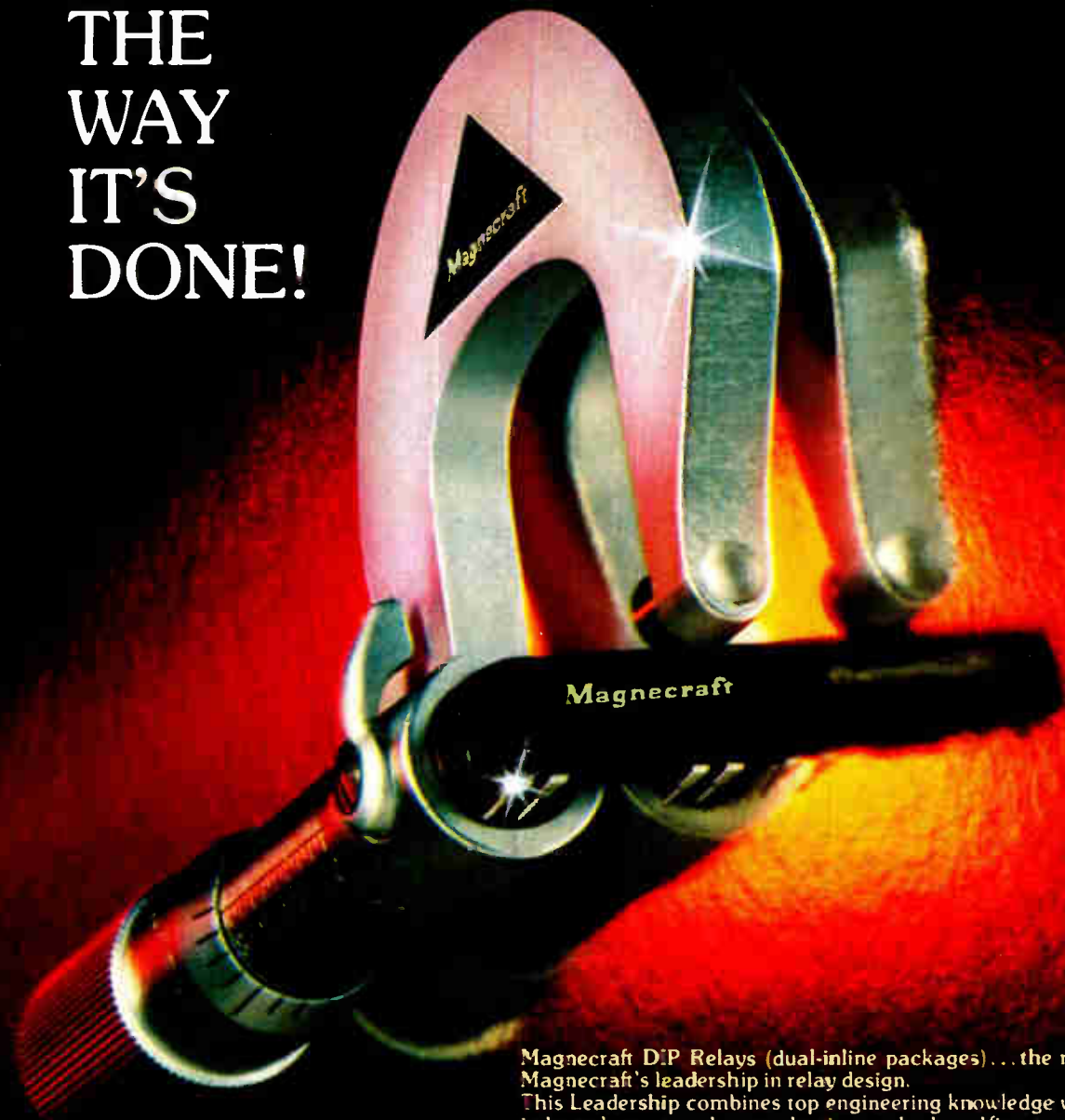

Magnecraft means  
Leadership in Relays

Magnecraft DIP Relays (dual-inline packages)... the result of Magnecraft's leadership in relay design.

This Leadership combines top engineering knowledge with the industry's most modern production methods and finest materials. Magnecraft is proud to supply, from stock, a complete line of DIP relays having exactly the features you want.

**Immersion proof:** Molded in high impact epoxy

**Packaging:** 8 Pin Dual-Inline standard

**Control Voltage:** 5, 6, 12, 24VDC Standard

**Standard Contact types:**

SPST-NO DPST-NO SPST-NC SPDT DPDT

SPST-NO Mercury Wetted SPST-NO Mercury Wetted and Position Free

**Options:** A. Internal Clamping diode B. Electrostatic shielding C. 14 Pin Arrangements

91 DIP Models IN STOCK! Write for your FREE DIP CATALOG!

**Magnecraft**  
ELECTRIC COMPANY

5575 North Lynch Avenue Chicago, IL 60630

312/282-5500

Circle 27 on reader service card

See us at the 1980 ELECTRO SHOW  
Booths 2140-2142 Boston May 13-15, 1980

### TECHNOLOGY CHOICES

Property	Current technology, 1979 - 1980								Future, 1985 - 1990	
	Bipolar				MOS				Silicon on sapphire	Gallium arsenide
	TTL	LS TTL	ECL	I <sup>2</sup> L	p-MOS	n-MOS	C-MOS(bulk)	C-MOS(SOS)		
Process complexity (number of processing steps)	18 to 22*	18 to 23*	19 to 23*	13 to 17	8 to 14	9 to 15	14 to 17	14 to 20	14 to 20	16
Logic complexity (number of components per two-input gate)	12	12	8	3 to 4	3	3	4	4	3 to 4	2
Packing density (gates/mm <sup>2</sup> )	10 to 20	20 to 40	15 to 20	75 to 150	75 to 150	100 to 200	40 to 90	100 to 200	200 to 500	300 to 1,000
Propagation delay (ns)(typical value)	6 to 30 (10)	2 to 10 (5)	0.7 to 2 (2)	7 to 50 (20)	30 to 200 (100)	4 to 25 (15)	10 to 35 (20)	4 to 20 (10)	0.2 to 0.4 (0.3)	0.05 to 0.1 (0.07)
Speed power product (pJ)	30 to 150	10 to 60	15 to 80	0.2 to 2.0	50 to 500	5 to 50	2 to 40	0.5 to 30	0.1 to 0.2	0.01 to 0.1
Probability of improvement	low	low	low	moderate	low	high	moderate	high	high	high

\*Oxide isolation steps are extra

Source: Lockheed Microelectronics Center

devices almost universally used today.

One technology that will definitely be pushed into VLSI is n-channel MOS. Through refinements in circuit design and processing, the complexity of n-channel devices has neatly conformed to Moore's law. This law states that semiconductor device complexity doubles every year. It gets its name from Intel's chairman Gordon Moore, who is credited with having first predicted this relationship.

However, this law is soon to be broken. Due to problems in both lithography and processing, the density of all forms of MOS, including n-channel, is expected to grow less fast and to begin to double only about every two years.

The enormous quantities of n-MOS static and dynamic RAMs shipped annually are a testament to that technology's success—a success that will continue and bring 256-K and 1-megabit dynamic memories in the 1980s.

For packaging considerations, this will require an order of magnitude decrease in the power dissipation per cell down to about 1 microwatt. Most chip companies feel this can be done. And of course, the cell area will need to be very tiny for a high yield.

There are many approaches to very small n-MOS dynamic memory cells. One is quadruply-self-aligned MOS, from the Japan Cooperative Laboratories in Kawasaki. This scheme, discussed at the 1979 International Electron Devices Meeting, lines up the fabrication of the polysilicon gates, source and drain diffusions, deep junction areas, and interconnection areas to attain what the Japanese researchers feel is the smallest dynamic cell possible: 2 by 3  $\mu\text{m}$ . Thus, a monolithic megabit chip could conceivably be made with this technology on a substrate not much larger than 6 square millimeters.

Another approach to the tiniest dynamic RAM cell

comes from Texas Instruments: the taper-isolated cell. The cell can store a 1 or 0 without the need for a storage capacitor. It uses a single-polysilicon process, and n- and p-type implants are adjusted to form a potential distribution that resembles a bowling alley. This distribution is able to trap a packet of holes, and the presence or absence of the holes reflects a 1 or a 0, respectively. Thus, a taper-isolated cell can be made 30% smaller than a one-transistor cell having a capacitor.

If the taper-isolated approach could somehow be applied to the quadruply-self-aligned cell, the resulting cell area would be a mere 1.8  $\mu\text{m}^2$ . This figure is very close to fundamental physical limits, according to Arnold Reisman of IBM's Watson research center. He says that computer simulations show that at about a 0.8- $\mu\text{m}$  gate width there is enough noise to keep the FET switch on all the time.

This limit can be circumvented by cooling down the chip, but another solution is more likely before that happens: static cells will be used instead. Static cells have no gate charge that constantly needs refreshing, so that thermal noise affects them much less. Thus, before the year 2000, a big switch might be made from dynamic RAMs to statics.

Read-only memories, of course, because they are not written electrically, can be made even smaller than RAMs. "The ROM is really an exciting kind of product that hasn't gotten the attention it deserves," states J. Leland Seely, vice president and manager of corporate research and development at American Microsystems, Inc., Santa Clara, Calif. "You can really reduce it to a crosspoint—the intersection of two lines—so a cell area of 1.6  $\mu\text{m}^2$  is a realistic minimum value."

But Seely tacks various caveats on to that prediction. For instance, the sense amplifiers have to "switch from sensing voltage to sensing current," and for high speed, the resistivity of the interconnections have to be considered. "You start to speak of exotic processing technolo-



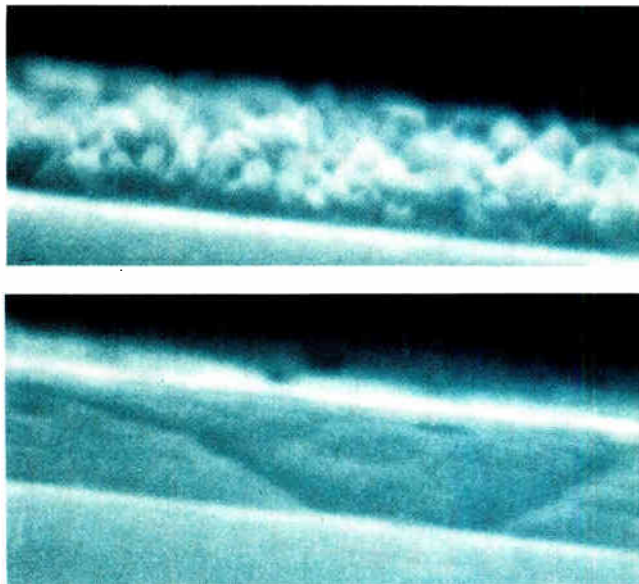

**Soothe it.** Is it possible to build three-dimensional ICs? Sure, and laser-annealed polysilicon may hold the key. In (a), polysilicon on silicon dioxide is shown before annealing; note the rough, pebbly texture. In (b), that polysilicon is annealed; it is much smoother.

gies, such as laser annealing," he warns.

Other changes are in store for memories, be they RAMs or ROMs. Approaches like the taper isolation will allow RAMs to sneak up on the densities of ROMs. But future RAMs will also become similar to ROMs in terms of organization. "In previous generation jumps, we always knew how the next device would be organized; 16-K-by-1-bit, 64-K-by-1-bit, etc.," says TI's Heilmeier. "But for the first time, the issue of what comes next isn't a linear projection any more." Heilmeier points to "interesting new memory organizations" for the microprocessor market for RAMs, which could swell to match the mainframe market in the 1980s. Hence, he sees byte- and word-oriented devices.

Another reason to steer clear of the by-1-bit organizations is that chip-testing times become intolerably long. "How do you test a 500-K-by-1-bit chip?" Heilmeier asks. He predicts that in general, VLSI memory components will be optimized for the system they are being designed for. "There are certain memory-management schemes that we do today off chip in software," he says, adding that "even though you may have the ability to build, say, a half-megabit RAM, you may choose to use up some of that capability in order to add things like self-test fault-tolerance and memory-management features on chip."

One reason to adopt self-testing for fault tolerance is also another reason to switch to static devices. The reason is radiation, such as that embodied by alpha particles. Static cells are less susceptible to the effects of radiation, and many feel the situation will get worse before it gets better. From Gordon Hoffman, manager for memory components and systems at Mostek Corp., Carrollton, Texas, comes this ominous warning: "What I'm afraid of is that, as we get into smaller dimensions, we'll get to other kinds of radiation—maybe cosmic rays. If the particles are energetic and are not stopped by

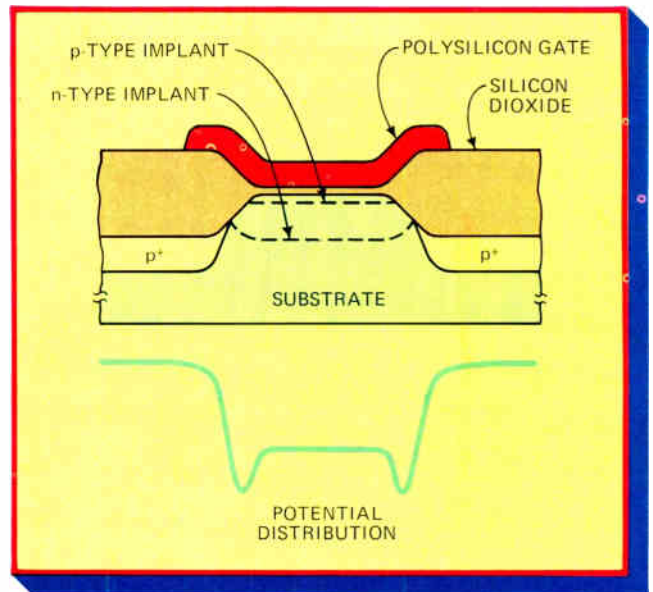

**No capacitor.** Present random-access memories use only one transistor per cell, but a capacitor is also present. Various approaches have been tried to drop that capacitor; this taper-isolated cell is one of them. The potential distribution traps charge.

organic coatings, we're in trouble." Hoffman is not the only one to bring up cosmic radiation, but the general consensus is that radiation will not be a limiting factor. "We will solve the alpha problem as we solve the problems of cosmic and other rays," says Zilog's Faggin. "Silicon processing, packaging, and design all have to converge to solve the [alpha radiation] problem," says Intel Corp. vice president, Leslie L. Vadasz. "Error correction at the systems level would make it a nonproblem, and the same thing would apply to the memory system on a chip."

Advances will also be made with regard to nonvolatile forms of memory, especially the electrically erasable variety. The most promising attempt thus far comes from Xicor Inc., Sunnyvale, Calif. Xicor's nonvolatile RAM uses enhanced electron tunneling to and from a floating polysilicon gate to store 1s and 0s even after the power has been removed. But unlike all other previous approaches, Xicor's memory needs only one supply (+5 V) for all operations and the kind of processing employed in standard n-channel polysilicon gate; no special nitrides are needed nor expensive packages containing quartz windows to let in the erasing energy. Thus this type of memory can be included on the same substrate that holds a microprocessor, and laser annealing might be applied to the cell to stack the polysilicon element vertically for a dramatic reduction in size.

There is a very good reason why silicon is used to fabricate electronic components. Next to oxygen, it is the most abundant material on the earth's surface. More important, it is very easy to grow insulating layers on silicon. But the impulse to higher performance—faster and denser devices—demands that the industry go beyond silicon in both logic and memory device development. For silicon is to semiconductor tech-



## Today's SLIC ideas. Where will they be tomorrow?

They could be tucked away with today's memorabilia.

That's why we are working closely with design engineers today. To meet his needs tomorrow.

Currently, we offer our 3081 and 3082 Subscriber Line Interface Circuits in production quantities. These circuits meet the stringent requirements for Central Office line applications.

They are the best you buy today. And when your specifications change, you can be sure ITT

North will be there to meet those specifications tomorrow.

We have set these industry standards of performance. We will continue to set the standards for C.O., EPABX, and Key Systems.

Specify ITT North.

For more information, write or call: ITT North Microsystems Division, 700 Hillsboro Plaza, Deerfield Beach, Florida 33441. Phone (305) 421-8450, TELEX & TWX: 510-953-7523.

**ITT North**  
Microsystems Division



# Most of our products started as someone else's problems.



*Even our first switch solved a problem. A small company that made incubators for poultry couldn't get the precision they needed in a thermostatic switch. Chickens weren't hatching on time. So we made them a snap-action switch they could count on. And their customers could count on chickens.*



*Recently, a major manufacturer of machine tools needed a solid state proximity sensor. However, this one also had to be rugged, easy to mount and wire, and interchangeable with a traditional limit switch. So we developed the new 2-wire AC proximity switch.*



*Perhaps you remember when the government first cracked down on fuel efficiency in car ignition and timing systems. One auto manufacturer came to us with the problem. The result was our solid state Hall effect vane sensor: A sensor that functioned efficiently and reliably without adjustment, even in the worst driving conditions.*



*In the seventies panel designers couldn't build panels the way they wanted because they couldn't get a variety of manual switches that worked together. Our Advanced Manual Line gave designers switches that were human engineered to look and work like they belonged together, and were easy to mount and wire.*

*In the sixties, a company that made computer terminals and peripherals identified a serious problem. If you needed a keyboard, you settled for the same one everyone else used. Or you had one custom built, which cost a lot of money, and time. We introduced modular design. So everyone could afford reliable, custom keyboards.*

Ever since we made our first snap-action switch, back in 1932, we've been working with customers to develop the best switches for the job.

Because, working with customers early in their design process results in a better product. For them, and for us. That's one of the reasons we have the widest variety of switches and sensors in the world.

And, if we don't already have one that solves your problem, chances are we can design a solution together.

For information about how we can help turn problems into solutions that are cost effective, write MICRO SWITCH, The Sensor Consultants, Freeport, Illinois 61032. Or call 815-235-6600.

MICRO SWITCH products are available worldwide through Honeywell International.

**MICRO SWITCH**  
a Honeywell Division



# Interconnection City News 1980

**M**ethode Electronics, Inc.  
7447 W. Wilson Ave.  
Chicago, IL 60656



## METHODE TAKES LEADERSHIP IN MASS TERMINATED IDC PRODUCTS.

CHICAGO, March 3—The JAGUAR system offers the speed, flexibility and economy that is required in today's new designs. It also provides a cost reduction replacement (with dimensional interchangeability) for existing systems with no sacrifice in performance or reliability.

### WIRE-TO-POST SYSTEM

The original Methode JAGUAR Series is a complete wire-to-post interconnect system combining the proven reliability of the bellows contact, and the labor savings inherent with insulation displacement terminations.

### HIGH CURRENT TYPE

In November, 1979, Methode introduced its IDC power connector with unique modular construction and high current hermaphroditic contacts. For the first time, package designers can obtain the cost effectiveness of mass termination at current ratings up to 9 amps and voltages up to 250 VAC.

### CARD EDGE CONFIGURATION

In February, 1980, Methode introduced its card edge connector version of the JAGUAR IDC family. Depending upon the number of ter-

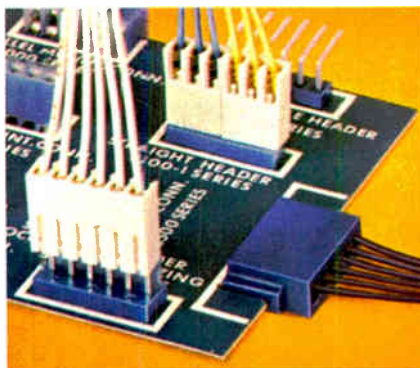
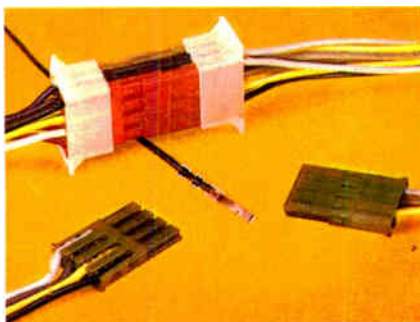

minations on the connector, the JAGUAR card edge system can save from a minimum of 50% up to 90% of the labor time required for termination by solder or crimp type connectors.

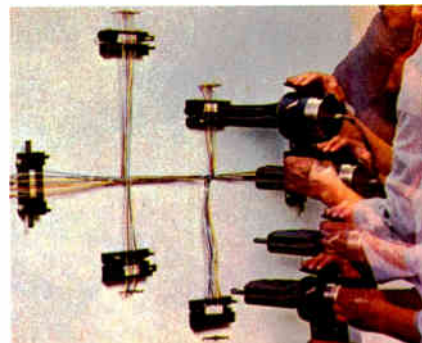

CHICAGO, April 7—Developed for use with the JAGUAR Series mass termination connectors, our new harness terminator gun simultaneously terminates 2 through 24 position circuit harnesses at a rate of 500 assemblies per hour.

The air tool locks easily into IDC connector fixtures arranged to the harness shape on the assembly board . . . then trims and terminates the pre-positioned wires.

## SUPER-PLY FLEXIBLE FLAT CABLE JUMPERS WITH ROUND ENDS OFFER MORE FLEXIBILITY.



CHICAGO, March 31—SUPER-PLY flat wire jumpers offer exceptional flexibility and round-end conductors. Soft tin-plated wire is flattened along the jumper's internal length, however the conductor ends are left round. This provides improved flexibility over ordinary round conductors and eliminates the fragile ends encountered with flat or stranded wire.

## "DELTA-C" COMPLIANT OR PRESS-FIT TERMINALS NOW OFFERED FOR HYBRID RELI-APLANES

CHICAGO, March 24—These new Hybrid RELI-APLANE 200 amp press-fit backpanels permit higher density for faster computer switching . . . provide more critical voltage control at low levels . . . and eliminate the need for bus bars.

The 200 amp capacity is attained by incorporating solid copper plates up to .051" thick into a multi-level laminated or stacked construction.

"DELTA-C" compliant contacts provide a reliable high retention force that does not damage the plated-thru holes of expensive multi-layer backpanels.

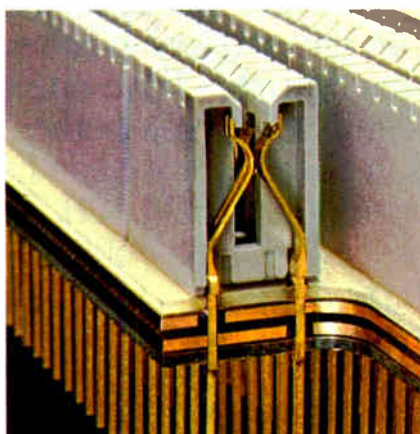



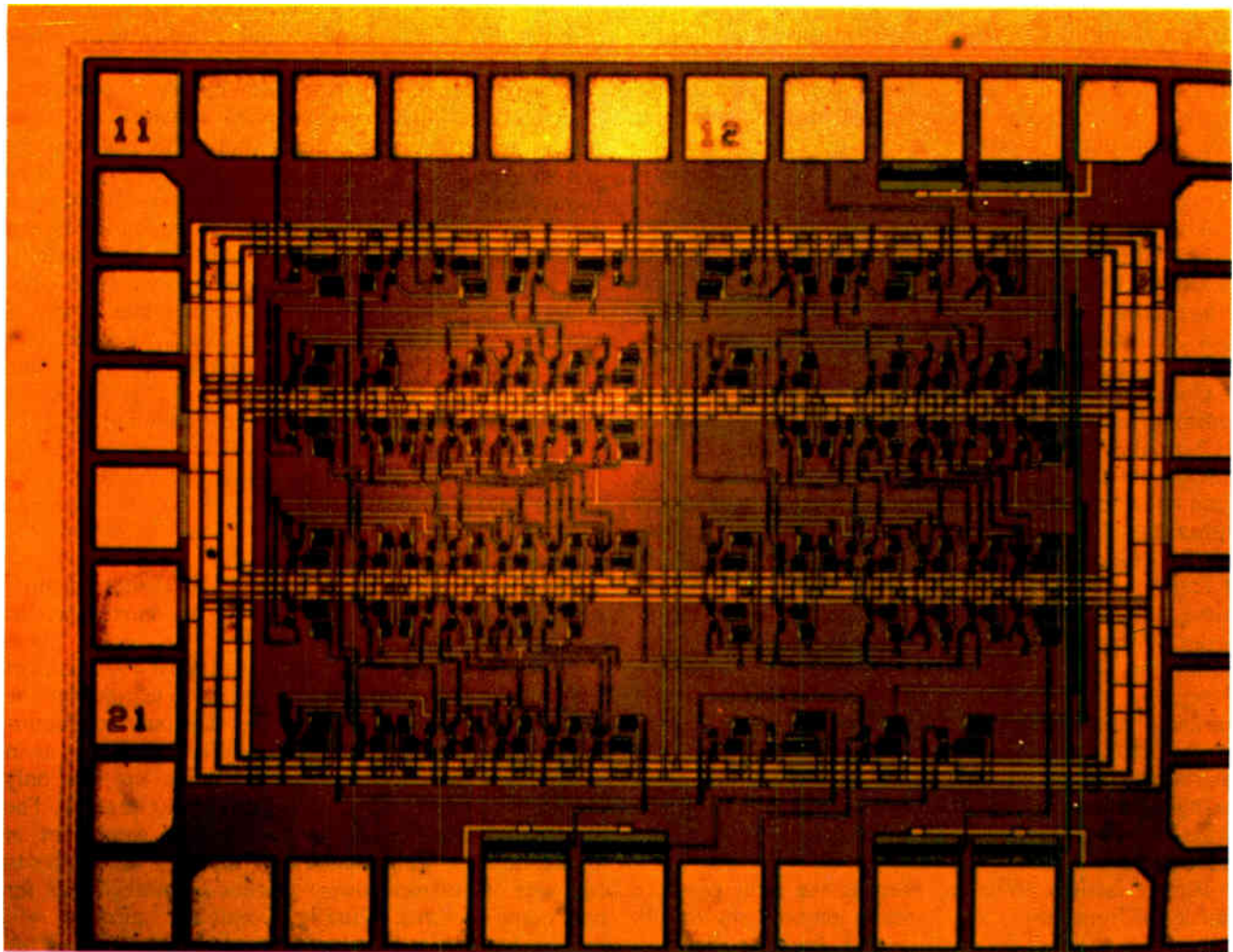

**Gallium arsenide.** To go beyond the speed of silicon, gallium arsenide with its enhanced mobility is one material to use. It has its own set of challenges, one of which is the inability to oxidize it for insulating layers. Still, circuits like this counter have been made.

nology what iron and steel have been to modern metallurgy—enormously useful foundations that served well for relatively unsophisticated demands.

Already silicon has been superseded not simply in laboratory experiment but for commercial production of memory devices with capacities at least four times higher than anything so far realized with silicon: the magnetic-bubble memory. Other technologies are on the horizon that will similarly accelerate speed of computation, although their role in commercial development is as yet uncertain.

These technologies, which include the use of gallium arsenide and the superconducting materials of Josephson junctions, are constrained at present by processing and operating costs. For example, gallium arsenide is highly toxic, and insulating layers are also impossible to grow on it. And Josephson junctions currently must be cooled to near absolute zero to work. (Some theoreticians contend that Josephson junctions can be made to work at room temperature, but this so far has not been proven even theoretically.)

Still, if there is a place where quantum leaps in technology can already be sensed, it is in bubble technology. There was a time when storing information in the form of small magnetic domains in materials such as

garnet appeared as dubious a prospect for commercial production and application as Josephson junctions appear today. But so great is the trust in the new magnetic-bubble technology that some semiconductor companies are producing quarter- and 1-megabit memories reliably and repeatedly, while 4-megabit and larger devices are near-term prospects. The leading applied scientists, indeed, brim over with enthusiasm.

“Bubbles will progress similarly to dynamic RAMs, quadrupling in density every 3 to 4 years, probably for the next 10 to 15 years,” predicts Donald Bryson, formerly of Intel Magnetics Inc. in Santa Clara, Calif. And H. Dean Toombs, a vice president of Texas Instruments, observes: “My feeling is that there will be inventions along the way that will open the door to extremely high-density magnetic bubbles in very small chips. There will be some further fundamental invention or innovation in the area of structures and general technique that will provide a more viable approach than just pushing the presently known structures.”

Today’s quarter- and 1-megabit chips rely on coil-driven, field-access technology. That is, criss-crossed coils of wire carry an alternating current to provide a rotating magnetic field. Present chips and some future chips will also employ easily magnetized and demagne-



tized nickel-iron Permalloy shapes in the form of chevrons. These shapes take on the macroscopic field generated by the coils and become microscopic magnets with poles that rotate so as to be parallel with the coil field. The Permalloy patterns, located directly above the bubbles, attract the minute cylinders of reverse magnetization and pull them through their paces.

Although Permalloy patterns and field-access coils work well for 1-megabit chips, and although it is possible to exploit them for 4-megabit chips, performance and lithography requirements point to alternative technologies for future generations of bubble-device structures. Some real possibilities include:

- **Contiguous disks.** These ion-implanted patterns resemble minute overlapping pennies and can be realized in Permalloy. They have more relaxed minimum-feature lithographic requirements and need fewer masking steps than chevrons do. They also permit bubbles to move in either direction along a bubble-storage loop—an impossibility with chevrons.

- **Current access.** Instead of using field-access coils to move bubbles along their loops, scientists at Bell Laboratories have succeeded in moving them with one or more perforated sheets of conductive materials. Like the Permalloy, these layers are situated over the magnetic garnet where the bubbles reside. The obvious advantage is a simplified package due to the absence of coils. But this scheme can also mean +5-V-only operation, more easily automated testing and packaging, and faster operation because there is no coil inductance to set limits to bubble speed.

- **Bubble lattices.** Whether propagating structures are fashioned from Permalloy shapes or ion implantation, 1s and 0s are stored as the presence and absence of bubbles. However, bubble-lattice files, as they were named by scientists at the IBM Watson research center, store information in the form of wall states present on a single bubble. These states, infinite in number, are caused by twisting the magnetization along the cylindrical wall of the bubbles. Thus, one bubble can store both a 1 and a 0 (as the two lowest-energy wall states, typically), and higher density is an obvious byproduct.

Besides disks, current-access technology, and lattices, improvements in architecture will yield faster access times. That is, the number of loops and their position on the die will significantly improve performance. Also, chances are that improved garnets or completely new materials will be developed and used. And finally, because bubbles exist in very thin layers of magnetic material, the possibility exists that multiple layers can be built up to multiply storage capacity.

One major drawback with repeating patterns like chevrons is the thin gaps that must exist for the bubbles to transverse. Contiguous disks, on the other hand, can manage without gaps, and that is why their lithography requirements are relaxed. Coupling this with the fact that ion implantation could replace masking operations, a consensus has emerged that ion-implanted contiguous disk patterns will be used to construct the next generation of bubble memories. In fact, because of the processing simplification, and in order to become acquainted with the technology, some manufacturers will use disks

in order to build 1-megabit and possibly even 256-K devices.

"Today's generation uses 3- $\mu$ m bubbles," comments Cliff Cullum, director of applied research at IBM's Watson research center, adding that, "The next generation will reach the limits of optical lithography—1½ to 2  $\mu$ m. After that will come contiguous disks." And from Bell Laboratories: "Think in terms of ion-implanted patterns, of which contiguous disks are just one possibility," says H. E. D. Scovil, director of its solid-state laboratory. "There's no question that ion-implanted propagation patterns will succeed," he says, but also warns that there might still remain areas on the chip for which multiple masks would still be necessary, "so the alignment factor could limit chip size even though most of the chip gets only a single mask."

Other schemes like current access and bubble lattices are at more elementary stages. "It is too early to conclude that conductor-access devices will become the technology of the next generation of bubble devices," states Andrew Bobeck, the Bell Laboratories scientist who has done much to improve the current-access scheme for bubble memories.

Nevertheless, writing in the July-August 1979 issue of the Bell Technical Journal, he goes on to summarize the benefits: "There are some features that only conductor-access devices possess. If high speed is a necessity, as in video-based systems, conductor circuits are the only option available to the device designer at present. The anticipated small package size will be significant in applications for which space is a premium. The ability to run with logic-level power supplies is another plus for conductor devices. Finally, conductor circuits will require fewer precision analog control circuits since the critical control function of rotating field timing has been eliminated." Bobeck is also of the opinion that it is possible "that the apertured sheet drive approach applied to the bubble-lattice file will make that structure more attractive."

Ti's Toombs believes that the current-access idea "does have the potential of operating at megahertz kind of propagation frequencies." And it comes about, obviously, because the coils have been eliminated. Although current access is "attractive and has potential," the approach poses materials problems, he says. "You have to produce garnet films with lower dynamic coercivities." This means that the garnet must be more easily magnetized and demagnetized, because the fields produced from the conducting sheets are less than those available from coils. "You've got to produce a garnet film where you can move bubbles with relative ease," says Toombs, and "that's a function of coercivity."

However, the benefits of the current-access approach seem to outweigh the drawbacks, so the idea will undoubtedly be pursued in future bubble chips. Another possibility with the current-access approach is three-dimensional storage: because the field used for movement is very local with regard to the garnet supporting the bubbles, multiple layers of garnet (or some other highly coercive material), metal, and insulator could conceivably be sandwiched for incredible storage.

Bubble lattices offer quadruple the storage density of

**Disks.** Before current-access propagation structures and bubble lattices are put to use, contiguous disks will be. Although they can be made from Permalloy, the best approach is to ion-implant them. They have no gaps, so more bubbles can be stored.

**Josephson.** For the ultimate in speed, super-cooled Josephson junctions can be turned to. These can be switched in less than 10 picoseconds, but fabrication is critical and operation requires temperatures near 0 K. The chip below is a memory.

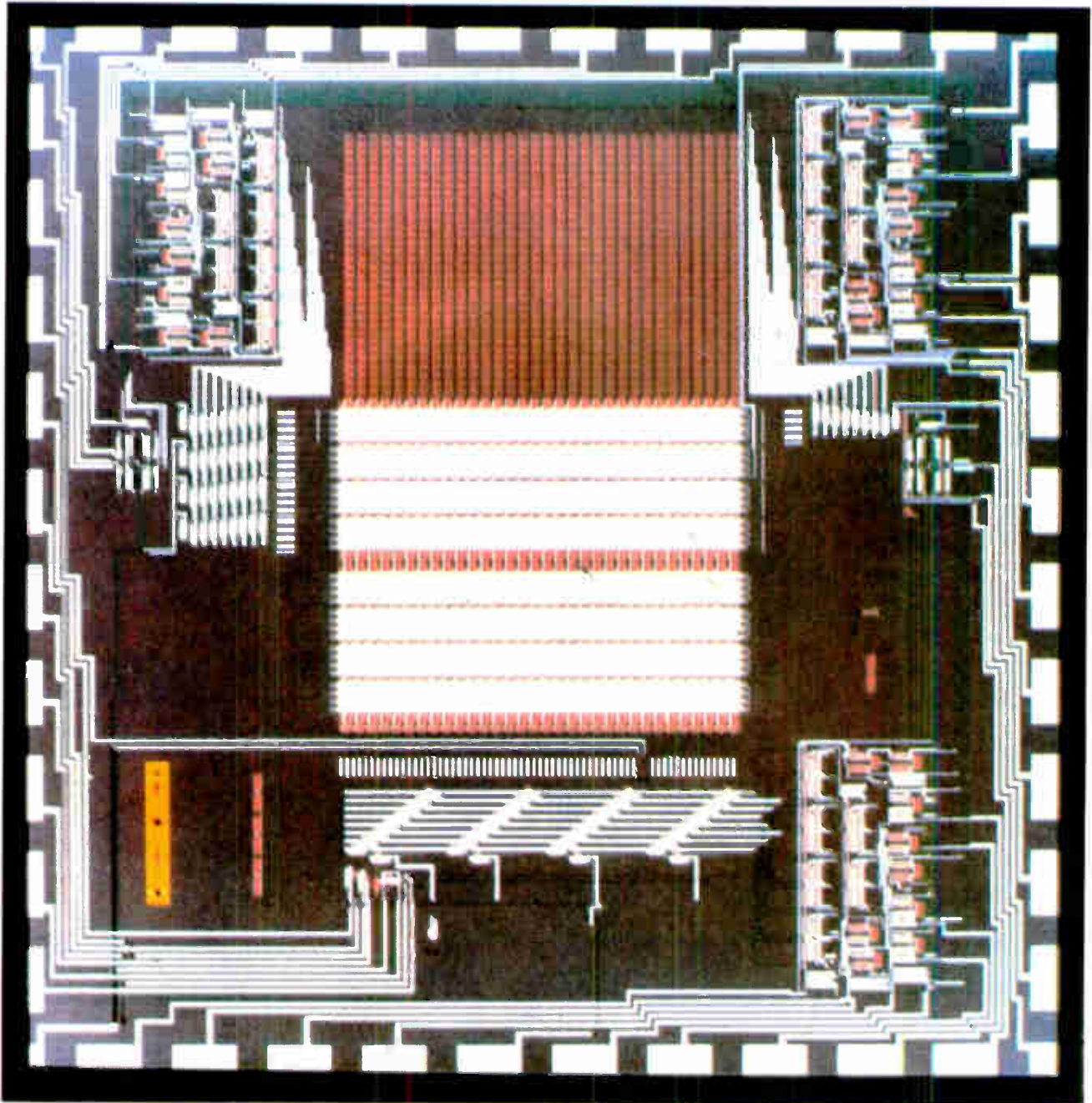
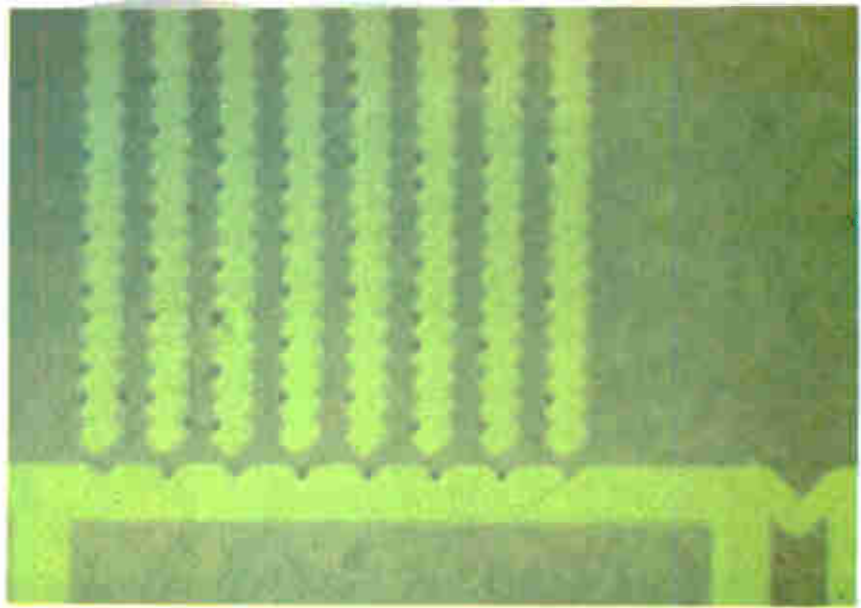



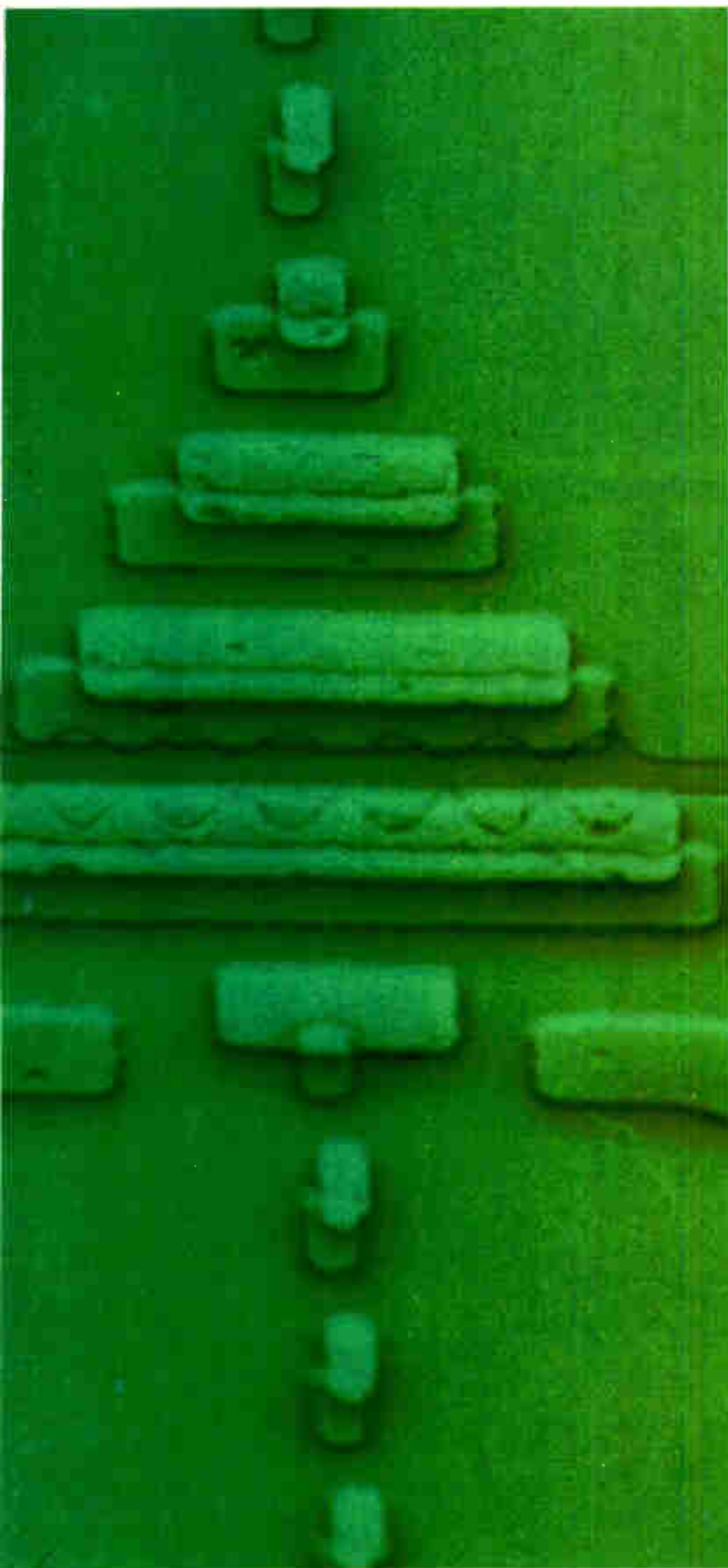

**Current access.** Bubble memories that are said to be field-driven require criss-crossed coils of wire. Current-access devices do not. Instead, they use sheets of conductive material with tiny holes punched in them. At the holes, fields are created that move bubbles.

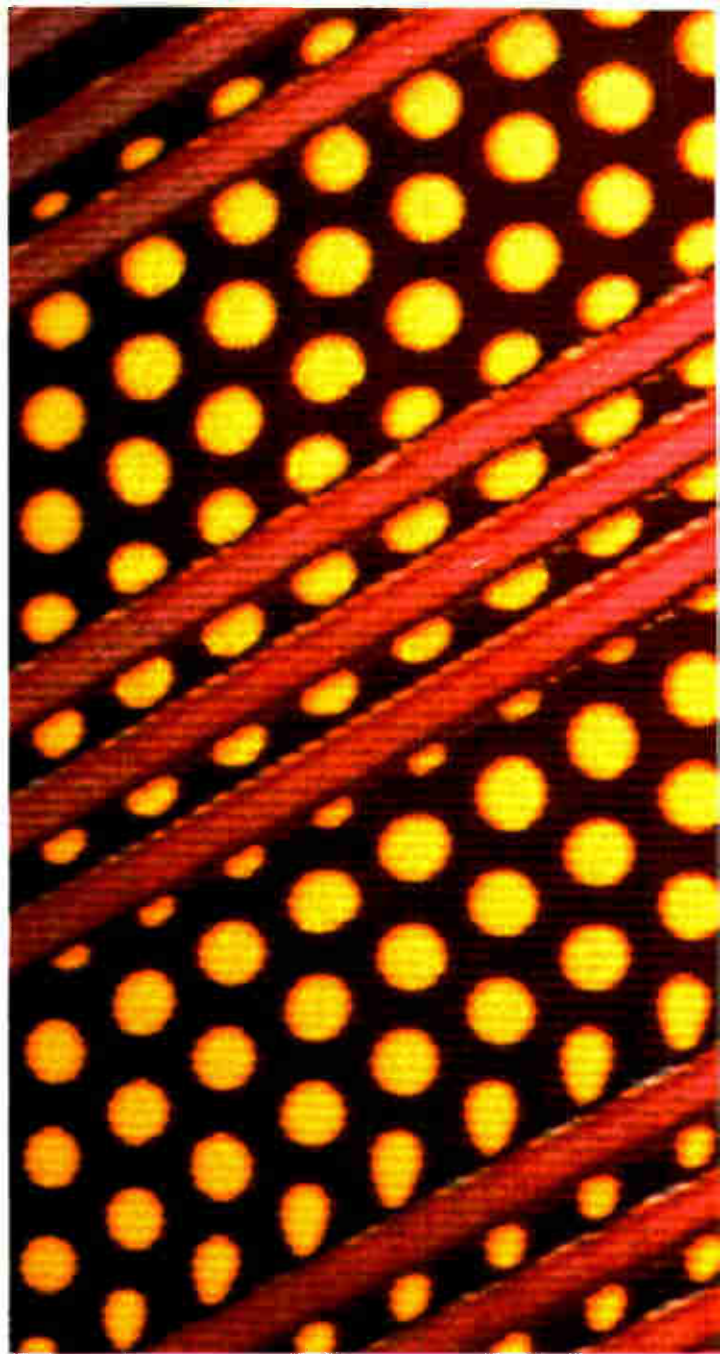

a conventional device having the same bubble diameter and lithographic resolution. But because every bubble stores either a 1 or a 0, there must be a bubble present at every site in the array. This is a benefit as well as a difficult engineering problem. It is a blessing because of the increase in information packing. But bubble spacing is a very delicate matter: too close, and a pair of bubbles may collapse and merge; too far apart, and a bubble may strip out and form two distinct bubbles with unknown wall states.

Perhaps the most recent advance in bubble-lattice technology is the fully functional 14.5-kilobit chip developed at IBM's Research Laboratory in San Jose, Calif. Asymmetric Permalloy chevron propagation patterns and an access channel that reverses the direction of the bubbles permit the chip to be organized into major and minor loops. However, large-capacity



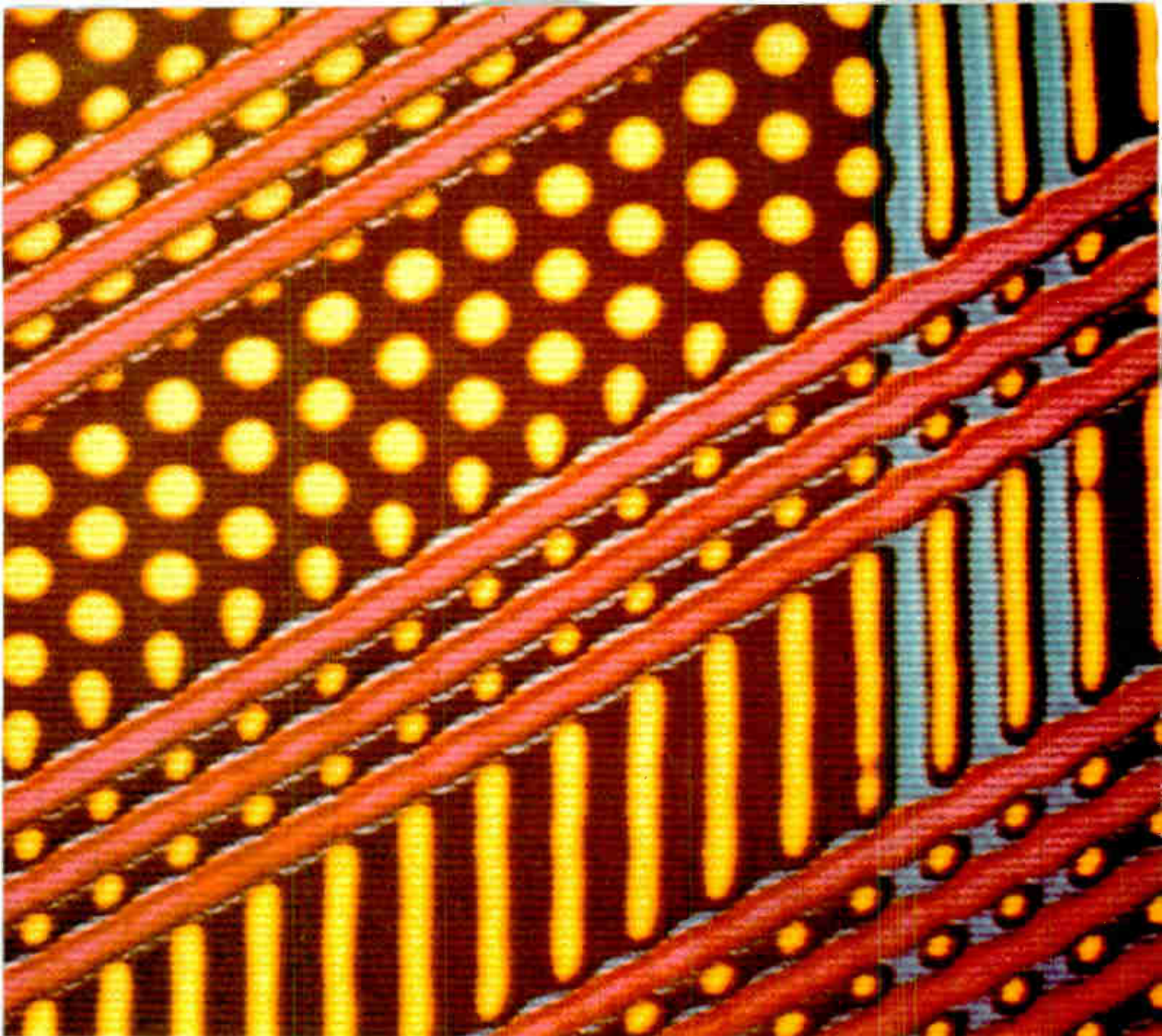

chips demand that some loops be allowed to be nonfunctional or redundant, to increase chip yield and lower cost. In structures other than lattices, such loops can be masked out and not used, but in lattices they are too closely packed for this to be easy. One solution is to have banks of lattices separated by areas where no bubbles are allowed to exist. But this wastes chip area and subtracts from the extra capacity gained by switching to the lattice technology.

While garnet already is outperforming silicon in providing ever greater memory densities, other materials promise also to outdo it by at least an order of magnitude in speed. Among the III-V compounds, gallium arsenide in particular comes to mind, and then there are Josephson junctions, too. As noted, silicon bears much the same relation to future semiconductor technology as iron and steel bear to modern metallurgy: immensely useful structurally and widespread, but just not up to the most sophisticated of requirements.

**Lattices.** This enlarged bubble-lattice device is a piece of art. The bubble lattice can store more information because a bubble is present at every position and 1s and 0s are stored as bubble-wall contortions and not as the presence or absence of a bubble.

Nor is a change from silicon so very radical. Richard Eden, principal scientist for solid-state electronics at the Rockwell International Science Center in Thousand Oaks, Calif., calls it no more drastic than growing silicon on sapphire to reduce parasitic capacitances.

The basic circuit element made with GaAs is the metal-semiconductor field-effect transistor (MES FET). The device is very simple; it consists of a thin low-resistivity layer deposited on a high-resistivity substrate with a Schottky diode gate between two metal source and drain contacts. It operates just like a junction FET or JFET: the voltage on the gate determines the width of the depletion layer, so the voltage on the gate controls the current between the source and drain.

It is possible to make MES FETs in silicon, but silicon's



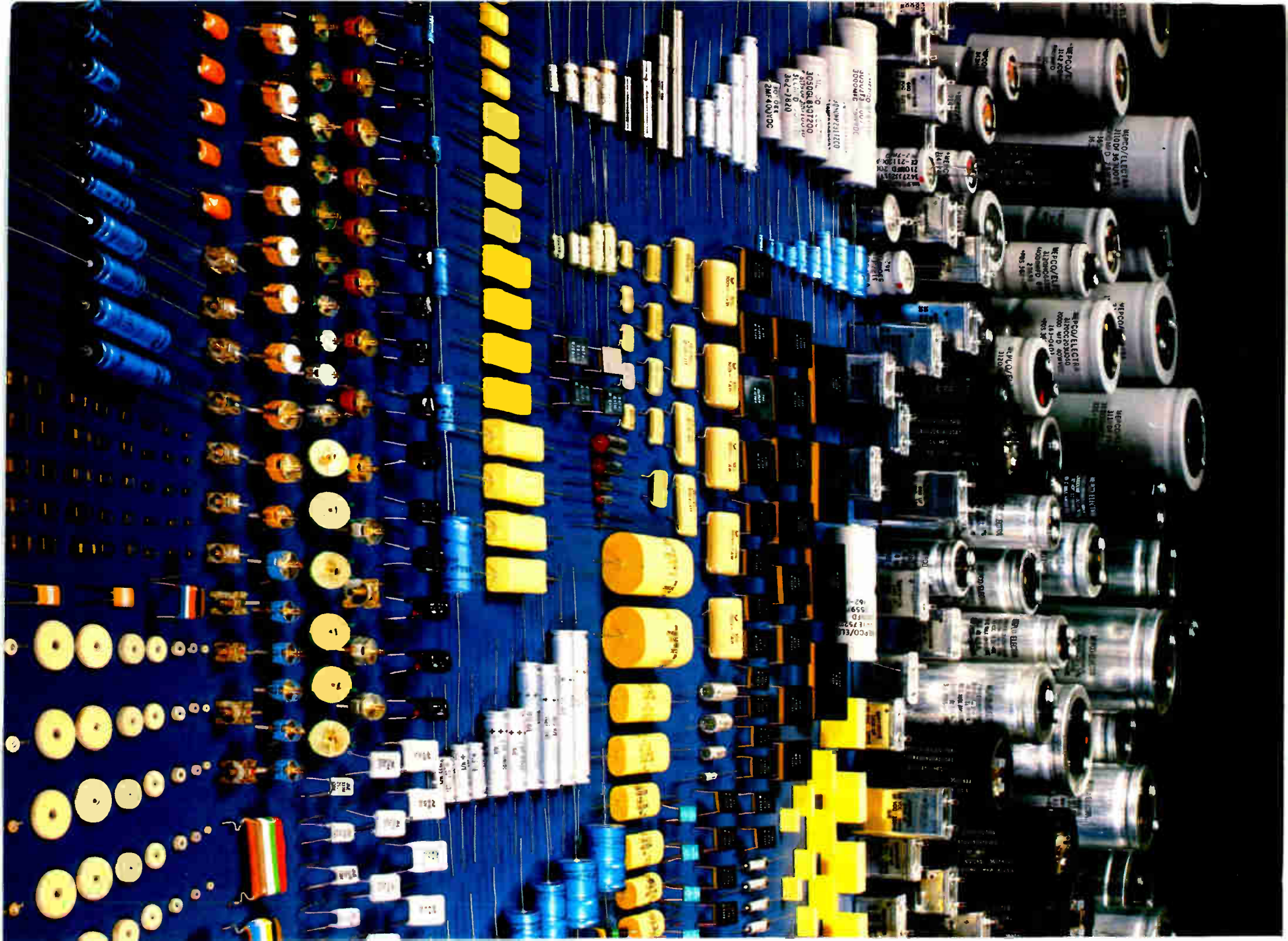



# Mepco/Electra's complete capacitance coverage to 1 Farad.

That's right! Complete capacitance from 1 Picofarad to 1 Farad. And that's the entire spectrum of capacitance values from Mepco/Electra, the resistor/capacitor people. Ceramic Capacitors. Film Capacitors. Tantalum Capacitors. Aluminum Electrolytic Capacitors. Total capacitance for your electronic equipment for the

80's and beyond. Capacitance for Data Processing, Telecommunication, Instrumentation, Consumer, Entertainment, Military and Aerospace markets. Capacitance backed up by tomorrow's technology today. Capacitor technology for the 80's? We've got it and we make 'em all. For your complete capacitor needs call (201) 539-2000.



Your resistor/capacitor company with the technology of the 80's edge.

Columbia Road, Morristown, New Jersey 07960  
(201) 539-2000 Telex: 136461  
Circle 30 on reader service card

© 1978 Mepco/Electra, Inc.

This is an unretouched photograph of Mepco/Electra's capacitors.





lower mobility means there is less of an incentive to do so. Conversely, since insulating layers (like SiO<sub>2</sub>) can be grown on silicon but cannot, at present, be grown on GaAs, GaAs MOS FETs have not yet been fabricated. But JFETs, heterojunction FETs (HJFETs), charge-coupled devices (CCDs), and transferred-electron devices (TEDs) have been made on GaAs. In addition, both enhancement-mode and depletion-mode MES FETs have been obtained with the material.

It is generally agreed, therefore, that gallium arsenide will find its way into integrated circuitry, but when and to what extent is argued. "I'd be surprised if we don't have useful gallium arsenide ICs," says Bell Labs' Fletcher. "But it's not likely to replace silicon in the near future. The higher speed is accompanied by a lower level of integration." "We currently have gallium arsenide devices at frequencies up to about 20 gigahertz," says Michel Carpentier of France's Thomson CSF. "That's just a beginning. It took about 25 years to obtain control over silicon, so there's another 15 to 20 years ahead for GaAs. And indium phosphide will follow. We're not at all squeezed for getting to much higher frequencies."

The last comment, about not being squeezed for higher-frequency performance, is the same reason why another technology—potentially the fastest—has not enjoyed more success. That is the Josephson junction, created by the British physicist Brian Josephson who later shared a Nobel prize for the work. Much of the current investigation is being done at IBM's Watson research center, and so far, the devices still need to be cooled to temperatures near 0 K.

IBM's Cullum summarizes the challenges with Josephson-junction technology:

- **Materials.** Josephson junctions are made with lead alloys—not silicon. A pure lead junction is destroyed after being cycled only once. Hence, the development of suitable lead alloys was a big step along the road to the practical devices of the present, which have undergone hundreds of cycles in the laboratory.
- **Processing.** The junction itself—the barrier between two superconductors—has to be on the order of 50 Å with a few percent tolerance. The properties of the device depend exponentially upon this barrier thickness.
- **Packaging.** The ultimate switching speed for a Josephson junction is around 1 picosecond. At present, too much delay is introduced in going from one circuit to the next and into and out of the device. Thus, Josephson devices must be very small and incorporate entire subsystems to be effective.

The latest Josephson circuit from IBM uses current-injection logic. The circuits operate in as little as 13 ps, but while the actual switching time is 7 ps, it takes another 6 ps to get to the next circuit. AND and OR gates have been constructed.

**R**ecall that Gordon Moore confessed to having little idea how to take advantage of VLSI beyond memory products and that the real problem was how best to use the results of the processing technology. Certainly, in the near term there will undoubtedly be a spillover—as there has been in the past—between

memory technology and processor technology.

And it is safe to predict certain other developments, too, like improved ways of interfacing microcomputer-based systems to real-world variables. Advances in the making of integrated circuits have for too long outdistanced the progress made in sensors and converters, and both will have to make major efforts to catch up.

For instance, two of the transducer's traditional problems—linearity and stability—are no longer serious impediments to its progress, thanks ironically enough to the microprocessor. By statistically processing unstable signals and linearizing them, the microprocessor could make good the transducer's performance, so future sensors are expected to contain microcomputer chips within the same package. And since the microcomputer is already a low-cost item, inexpensive sensors making use of its computational capability can thus be expected to proliferate widely.

As for the analog-to-digital and digital-to-analog conversion devices, current advances in monolithic converter technology can be expected to yield complete a-d and d-a converters with as much as 16 bits of accuracy, within a single chip. Indeed, complete one-chip 8- and 10-bit a-d and d-a converters are already here, and future high-accuracy high-resolution converters are expected to share the same chip as the microprocessor.

**E**lectro-optic devices, too, will play larger roles. Liquid-crystal materials will be perfected to the point where liquid-crystal panels will display multiple lines of dozens of alphanumeric characters at low cost. As for high levels of information display, the familiar cathode-ray tube will likely give way to larger and thinner gas-discharge panels capable of displaying hundreds of alphanumeric characters in color, with near-infinite resolution, at low cost. A leading future contender for computer-output information display is the electrochromic display, which has excellent contrast levels, is aesthetically pleasing, can operate from very low voltages (about 1 to 2 v), and dissipates little power. One possibility is to employ an optical beam to address the electrochromic material in the display for large-screen graphics as well as for alphanumeric information display.

Charge-coupled devices will also do well as infrared imaging and sensing devices. CCD arrays capable of acting as television cameras have already been put to use as industrial surveillance and inspection systems. Focal-plane CCD arrays, with infrared detectors, preamplifiers, and multiplexing circuitry on the same chip, will become a reality. So will monolithic CCD arrays that have both imaging functions and digital signal-processing functions in the same package.

Since CCD arrays can read in data at very high speeds and write it out at much lower rates, they will be ideal as low-cost signal-processing elements for transducers. Typically, CCD arrays operating with input data rates of hundreds of kilohertz per second—orders of magnitude reductions in input/output data rates—will become common and widely used.

Meanwhile, the expanding communications market

# Crystal Clock Oscillators by



**MOTOROLA**

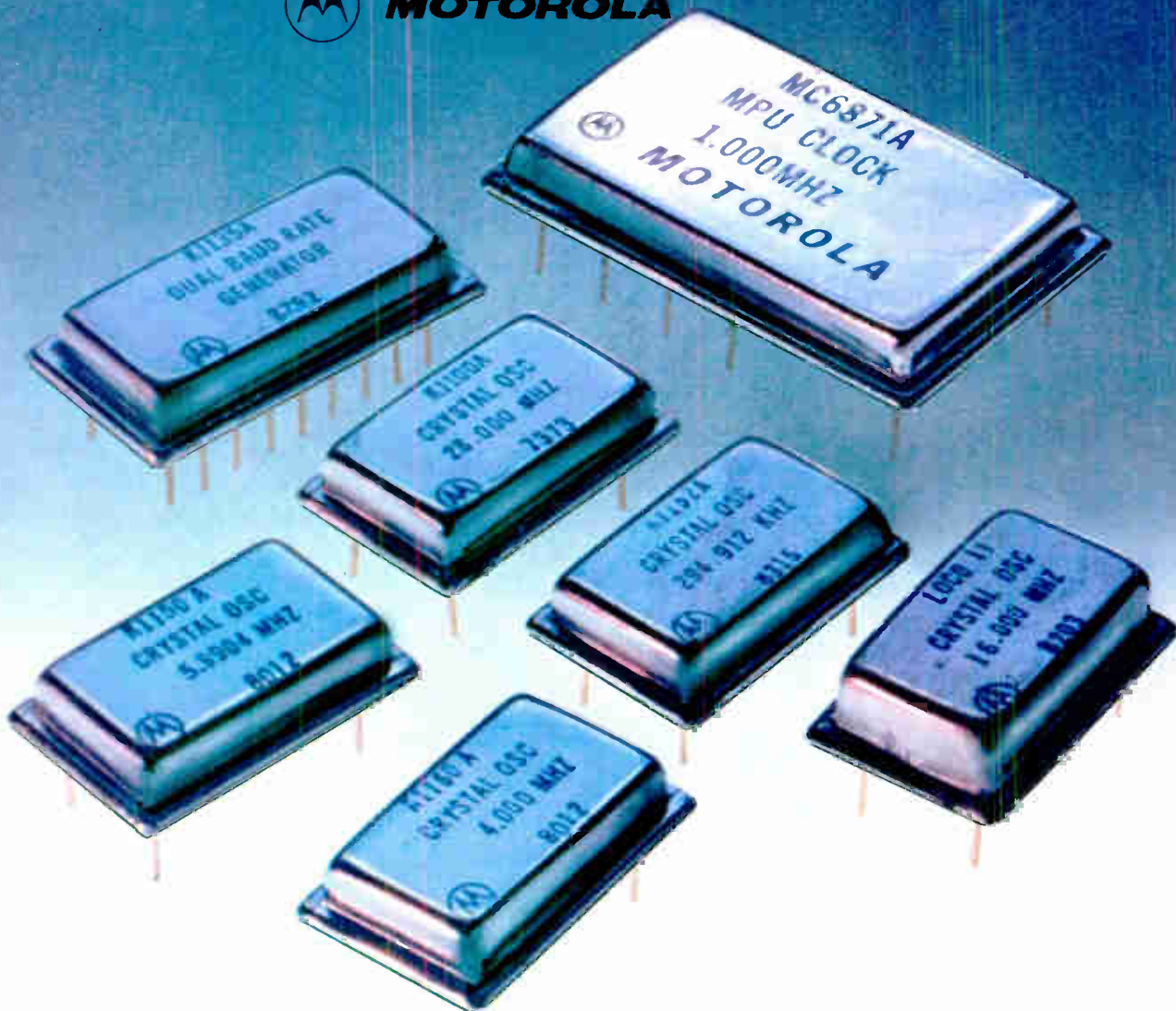

## ...the timing standard of the computer industry

The widest selection of thick film hybrid oscillators available anywhere for computer and microprocessor applications. Logic outputs are available for TTL, CMOS, NMOS, and dual complementary TTL.

Frequencies as low as 25 KHz, and as high as 70 MHz. High stability when you need it, tolerance tradeoffs for applications in which economy is more important.

Complete in-house control, from quartz growing

through thick-film processing enhances reliability.

High volume production capability plus fast prototype delivery helps you meet your own delivery requirements.

DIP packaging saves board space, cuts assembly time over discrete component equivalent. Simply plug a Motorola Clock into your circuit to satisfy all your system timing requirements.

Send today for more information on the clock oscillator to fit your application.



**MOTOROLA INC.**



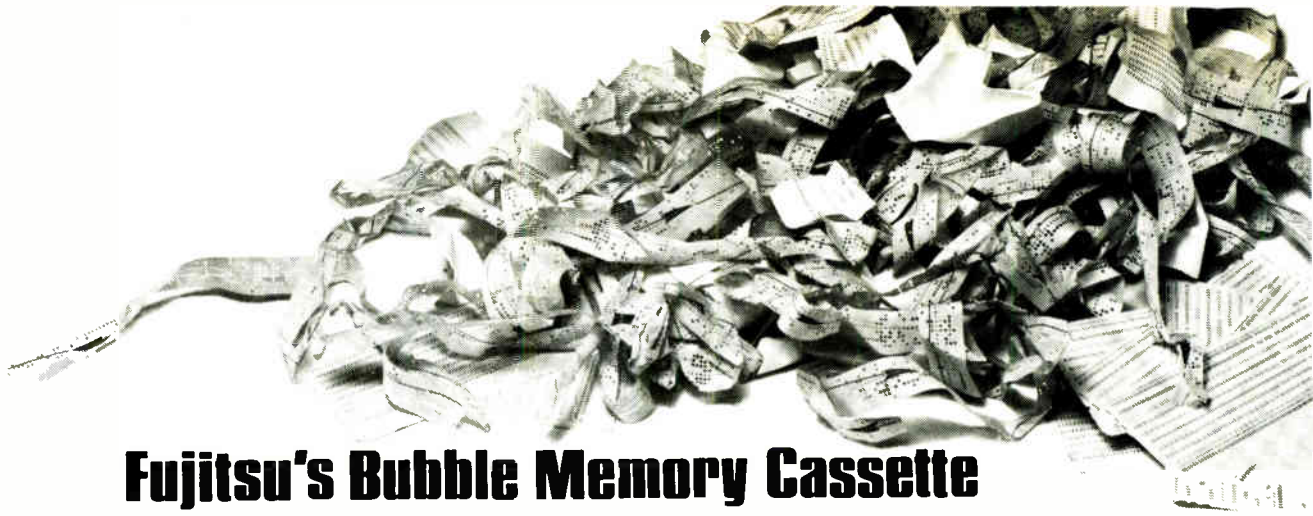

## Fujitsu's Bubble Memory Cassette

# Memory. Remember when it meant reels of paper tape and a huge stack of cards?

At Fujitsu we've changed all that. With our Bubbie Memory Cassette, a portable and detachable bubble memory that gives you a memory capacity equivalent to 20 meters of paper tape or 100 cards in a compact cassette. No wrinkled or dusty tapes. No torn or bent cards. Simply a streamlined cassette which is easy to program, data locate, erase and re-use wherever you need a memory capability. As program loaders and data loggers for testing equipment using microcomputers, numerical controls and numerous other applications.

The Bubble Memory Cassette is a top attraction for a wide

range of OEM equipment. Here are some reasons why:

- 64 Kbit storage capacity
- high speed response — 0.74 sec. access time
- easy to read and write
- non-volatile data storage
- non-destructive readout
- no moving parts for greater reliability
- excellent magnetic shielding

For full details on our Bubble Memory Cassette, contact your nearest Fujitsu representative. It's one memory you won't forget.

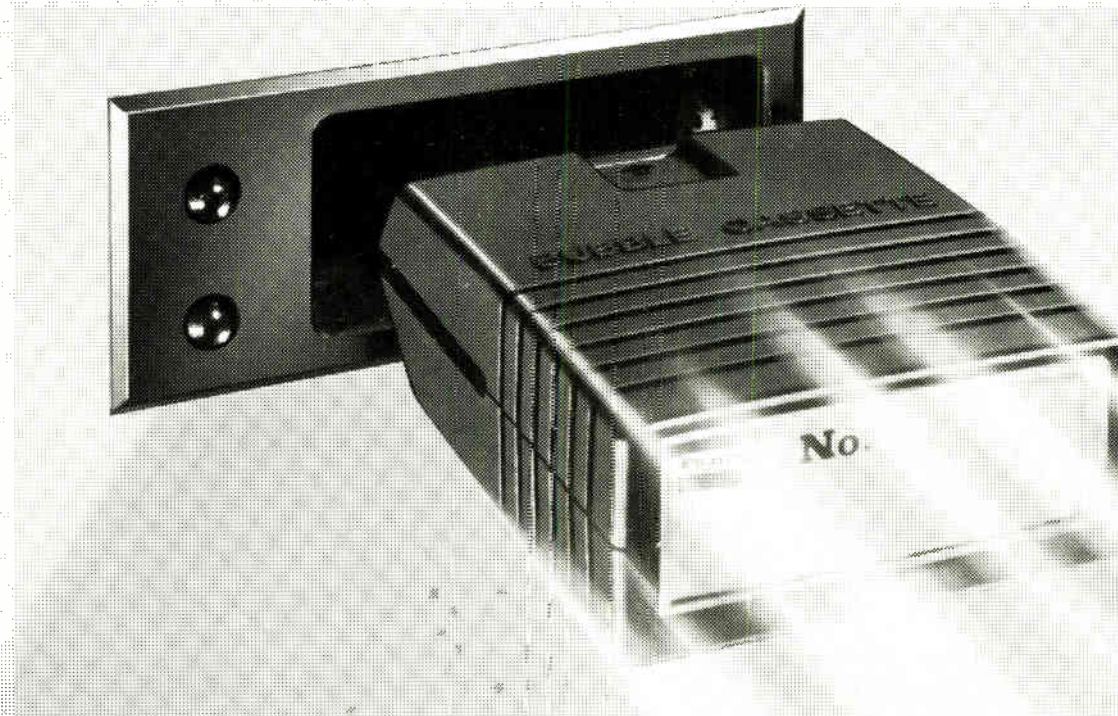

**FUJITSU AMERICA, INC.**

Component Sales Division  
910 Sherwood Drive-23, Lake Bluff, IL 60044  
(312) 295-2610, Telex: 206196, TWX 910-651-2259

will lead to a new class of integrated optical elements. A typical integrated optical IC will contain the light source, modulator, carrier, and detector on the same thin-film chip and will transmit data over fiber-optic cable much faster and more efficiently than now possible. Improvements in the reliability of aluminum gallium arsenide light sources and lifetimes on the order of 40,000 hours will make them the primary candidates for long-distance optical telecommunications in the 0.8-to-0.9-micrometer-wavelength region. Still other integrated optical elements will play a role in data processing, where they can be expected to perform signal transforms, correlation functions, and so on at exceptionally high speeds, for real-time applications.

But the influence of VLSI will undoubtedly be centripetal as well as centrifugal.

"The major impact of VLSI will be on computer architectures. It will affect everyone: mainframe, minicomputer, and microcomputer manufacturers," says Intel's Vadasz. "As microcomputers perform higher and higher levels of functions, the burden is more and more in the cost of the software. Consequently, more and more of the architectural solutions will put the software burden onto silicon. That has to be the major impact of VLSI."

One of the changes in store for microprocessors and single-chip microcomputers—the dramatic increase in on-chip memory capacity—will erase the distinction between the two devices. Every microprocessor will be a microcomputer.

Specialized processors will become more common. They will be designed expressly for data-base management, high-level language execution, distributed processing, and so on. Evidence for such processors can be seen today in the devices built for floating-point mathematics and input and output. However, marketing these processors will require ingenuity because, being customized for a task, they will not enjoy the volume markets of general-purpose chips.

**P**rocessor elements will become more regular architecturally and will therefore make increased use of microcoded control sections and programmable logic arrays. The use of nonrandom circuitry will be the only way to manufacture the chips economically. And when the devices have become completely modularized, the customer will be able to pick and choose functions.

Input and output will become much more intelligent and comprehensive on the microprocessor chip itself. This will be especially true for serial communications, whose protocols and high-level data-link control will be incorporated on chip. Such comprehensive high-speed serial control will help to alleviate the packing problem that is inevitably in store for processing elements.

Finally, on-chip diagnostic features will play a key role in future processors. The complexity of future processors will otherwise present their users with formidable testing difficulties.

Of course, the word width of future processors will grow. But many feel that it will be a long time before 32 bits is exceeded. TI's Heilmeyer says that "as a rule of

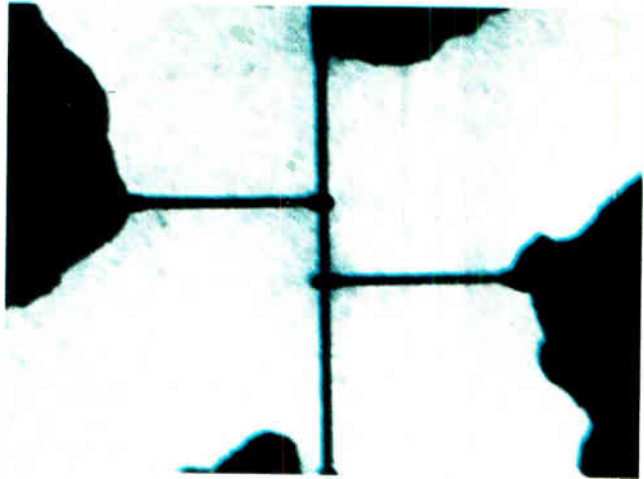

**Even more slender.** An experimental Josephson nanobridge developed by IBM switches without a junction. The lines in the circuit have widths and thicknesses of only 100 to 200 atomic diameters (30 to 40 nanometers). Electron beams exposed them.

thumb, the required word length of a processor goes up by 1 bit every two years." Thus, 32-bit devices will carry the industry through the 1980s, at least. He says that wider words are justified because the problems of each generation need more memory to solve them. One concept in particular that will catch on is machine intelligence, he says, and it will demand wide-word microprocessors. By his definition, an intelligent machine is characterized by qualitative rather than quantitative computation—that is, it is capable of inference and deduction and of answering questions asking how and why certain results occur. "I hesitate to say what comes beyond 32 bits for microprocessors," he adds, "because there are other things to put on the chip."

One of those things is analog input and output. The most efficient way to do this may require the mixing of technologies on the chip, with bipolar around the periphery of the chip to interface with the outside world, MOS on the inside for dense logic. "The microcomputers will go closer to the analog signals that the real world has," says Zilog's Faggin.

And of course, it is this real world of human beings that will in the end determine the path of development of the data-processing revolution that is this generation's gift to posterity. There is no single answer to Gordon Moore's question about how best to use its results, because the answer, of course, depends upon a variety of factors. Not the least of these is how much consumers will be willing to pay for increments in convenience and power that will result from computerizing increasingly large sectors of daily life.

It is clear that daily life will be affected in a myriad ways. The pervasiveness of the image of the robot in mankind's technical imagination guarantees the continued search for the machine that will be the perfect slave. And the guts of such a machine will be the logic devices and memories foreshadowed in the work being done experimentally today. But its impact on society will depend upon where society is going. The dynamics of development that have carried computers thus far are rooted in the competitive nature of an industrial age. □





$$\frac{C(z)}{r(z)} = \frac{G(z)}{1 + G(z)}$$

# ENGINEERS

---



ADVANCES IN  
ELECTRONIC  
TECHNOLOGY  
WILL REDEFINE

THE ENGINEER'S JOB. CLEARLY THE DOMINANCE OF DIGITAL SOLID-STATE TECHNOLOGY DURING THE NEXT TWO DECADES WILL MAKE IT THE MAINSTREAM OF ENGINEERING ACTIVITY. OF GROWING IMPORTANCE WILL BE CAREERS IN SOFTWARE DEVELOPMENT. KNOW-HOW IN COMPUTERS AND COMMUNICATIONS WILL ALSO BE PRIZED. MEANWHILE, NEW TOOLS LIKE HIGHLY SOPHISTICATED COMPUTER-AIDED DESIGN PROGRAMS AND EASILY ACCESSED DATA BASES WILL EVOLVE ALONGSIDE NEW FORMS OF TRAINING. CURIOSITY AND CREATIVITY WILL STILL THRIVE, BUT IN A GREATLY CHANGED ENVIRONMENT.



The men and women who will become newly minted electronics engineers in the year 2000 are just now learning to walk and talk. As they grow up, the profession they will be entering will be growing, too. So when they begin their first jobs, many aspects of what they do, where they do it, and how they will do it will be different from the daily work life of today's EEs.

Conversations with working engineers, engineering managers, electronics executives, and educators disclose broad general agreement on what the changes will be and on what is likely to remain unchanged. Of course, there are some caveats everyone recognizes: the dynamism of the profession will introduce complexities that cannot be predicted; the pace of innovation will be uneven from industry to industry, even from one job type to another; and there is no way of anticipating revolutions in technology.

One point of general agreement: the triad of semiconductors, digital logic, and circuit integration will be the dominant technology until the end of the century and so will offer the key job opportunities. Systems design and software development are going to be hot areas, and new opportunities will arise in energy-related areas in particular. Such developments may not call for a new breed of engineer, but certainly new qualifications will be needed: among them, the ability to develop in-depth specialties,

coupled with the flexibility to learn new fields, and a more keenly developed sense of the relationship between the work and the rest of the world.

The engineer's workplace and the tools that he or she uses are likely to undergo some radical changes—although these are areas where varying rates of change are likely to be most noticeable. And what will be obvious immediately will be the much stronger representation of women and members of minority races. This will be brought about both by the increasing perception of the desirability of electrical engineering as a career and by the realization of EEs' employers that these groups contain vast numbers of potential recruits to fill the probably chronic shortfall of engineering talent.

With all the changes, the educational system is likely to look rather different in 20 years. Still, the same basic teaching method of interaction between the instructor and student is likely to prevail, even with the growth of methods such as computer-aided instruction.

As the sliding scale of integration moves to the million-device chip and beyond, the lives of designers of integrated circuits and of the products using the ICs will change inevitably. It is already widely recognized that the super chips will present staggering problems of design, and that computer-



**Automated workplace.** By the year 2000, most electronics engineers will be using computers in their work. At Bell Laboratories' various locations today, there already is one computer terminal, complete with printer or cathode-ray-tube display, for every two employees.



**Designers needed.** Despite the inevitable growth of highly sophisticated and versatile computer-aided design systems, human designers of very large-scale integrated circuits will still be playing an important role, says L. J. Sevin, the chairman of Mostek Corp.

aided design is likely to rise to the challenge. "The engineer will need all of a computer's resources to handle increasing levels of complexity, with the prospect of encapsulating up to 10 million logic gates on a chip," notes William Gosling, professor of electrical engineering at Bath University, England.

Still, the development of highly sophisticated and versatile CAD systems does not mean that the computer will take over design. "We're always going to need people to come up with the architecture," says L. J. Sevin, board chairman and chief executive officer at Mostek Corp., Carrollton, Texas. "We're even going to need people who do something very like the circuit design that's being done today."

Sevin also believes that CAD will cut the number of jobs available in circuit design—a view not held by some other forecasters of the future. For example, Paul C. Ely Jr., vice president and general manager of Hewlett-Packard Co.'s Computer Group in Palo Alto, Calif., anticipates an increasing need for designers of large-scale ICs, "more so than we need people to work on the processes themselves," although he expects "a relatively small number of people will actually design million-element circuits."

"I don't think circuit designers are going to go away," agrees Stephen A. Szygenda, assistant chairman of the EE department at the University of Texas, Austin. "The job is becoming more complex, so it's reasonable to assume that it's going to evolve into a number of jobs. But the basic building elements are still going to be

circuits, and circuit designers are going to be needed to design them." Szygenda, who also runs a computing systems consulting service, adds that exploding demand, too, will be a big factor. Computer-aided design will not result in fewer jobs, he says. "The only thing CAD does is to provide a repertoire of tools for doing things that we can't do cost-effectively without them."

Of course, LSI has moved chips out of the components category, and very large-scale integration and beyond will move them into the subsystem category. For designers of end products, then, the locus of their work will be on the systems level. Designing at this building-block level may not require the kind of detailed knowledge of circuitry required today. "It won't be important for the average EE to have an intimate knowledge of central processing units, unless he designs CPUs," says Jim Lally, general manager for development systems operations at Intel Corp., Santa Clara, Calif. "It will be important to know how to get the functional building blocks of a system to talk to each other."

What this signifies, Lally forecasts, is the need for an intimate knowledge of software on the part of the systems designer. Agreeing wholeheartedly is Shanda Bahles, a designer at Millennium Systems Inc., Cupertino, Calif. "With the advent of the microprocessor, any hardware designer has to understand software and will be writing a good part of the initial software, if not the production software," she remarks.

**W**hile VLSI and even higher levels of integration portend more complex chips functioning as subsystems, it is equally likely that digital logic will come to be treated as a superior kind of component. "It may very well be that the microprocessor segment of the industry may have matured so much by the year 1990 that you would buy computing power much as you would buy capacitance and apply it in much

**Super problems.** VLSI chip with, say, 10 million logic gates will present formidable design problems, says William Gosling of Bath University. To handle such increasing levels of complexity, engineers will be making use of all of a computer's resources, he says.

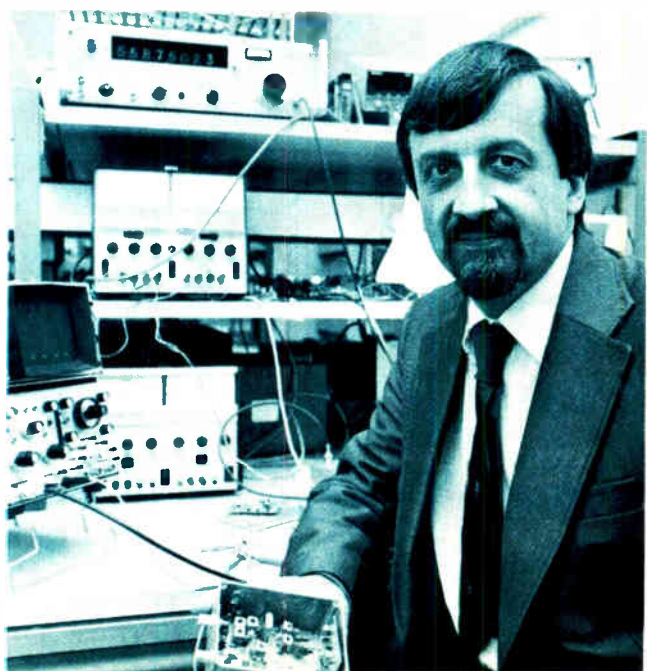



# The one-chip computer: offspring of the transistor

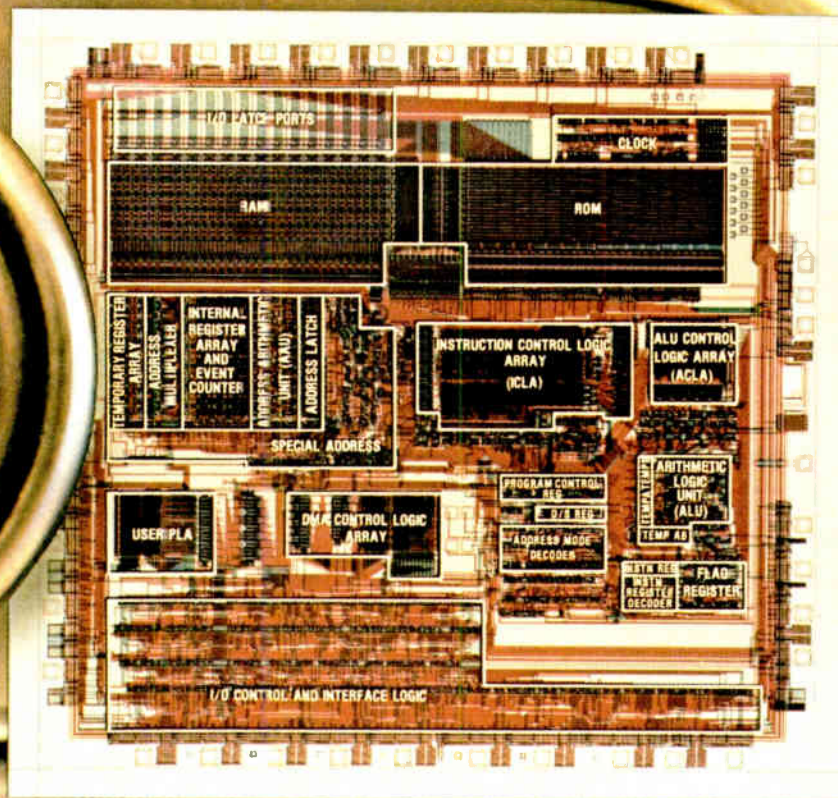

The MAC-4 one-chip computer, developed for a variety of telecommunications applications, is compared to a standard-sized paper clip. The chip's numerous functional areas are labeled.

One of the transistor's latest descendants is the Bell System's 30,000-element MAC-4 "computer-on-a-chip." It's another in a long line of microelectronic developments that have come from Bell Laboratories.

The MAC-4 is so efficient that a program written on it takes 25 percent less storage space than that required by most other microcomputers. Its assembler language, C, also developed at Bell Labs, has features that make MAC-4 easier to program, debug and maintain. And the MAC-4 can handle anything from nibbles to bytes to words with its 4-, 8-, 12-, and 16-bit operations capacity.

Like other one-chip computers, the MAC-4 has sufficient memory to support its varied tasks—3000 nibbles of read-only memory and 200 nibbles of random access memory coupled to 34 input/output ports.

Fabricated with the latest CMOS technology, the MAC-4 needs little power. Thus it is well matched to a variety of telecommunications applications.

#### **It started with the transistor**

MAC-4 is just one current example of the many micro-electronic devices to come from Bell Labs since we started the

solid-state revolution with the invention of the transistor in 1947.

Over the past three decades, our advances in materials, processing, and devices have been vital to solid-state technology. These include:

- The Junction Transistor
- Crystal Pulling
- Zone Refining
- Field-Effect Transistor
- Diffusion
- Solar Cell
- Oxide Masking
- Thermocompression Bonding
- Photolithography
- Epitaxial Film Process
- Magnetic Bubble Memory
- Charge-Coupled Device
- Semiconductor Heterostructure Laser Used in Lightwave Communications
- Electron-Beam Exposure System

#### **Today and tomorrow**

Today, we continue to make important contributions to solid-state technology. For example, we've developed a rugged 65,536-bit RAM that can tolerate processing faults. Corrections can be made on the chip itself, so we can get more usable chips out of each manufacturing batch—and thus lower unit costs.

In materials processing, we've

developed a technique for precisely controlling the growth of successive atomic layers of single crystal materials. This "molecular beam epitaxy" process is finding increasing use within Bell Labs and elsewhere in the electronics industry. We've used it to fabricate a device that permits us to double the speed of electrons by channeling them into crystal layers where they meet less resistance.

Other advances, in X-ray lithography and new resist materials, for example, promise to help place more elements on microelectronic devices and thus enhance their ability to perform important tasks.

As the solid-state revolution continues, these and other developments from Bell Labs will play an important part in it. What's important to us is the promise these advances offer for new telecommunications products and services. Like the transistor, MAC-4 and its solid-state relatives will find more and more applications in the nationwide telecommunications network.

*For information about employment, write:  
Bell Laboratories, Room 3C-303,  
600 Mountain Avenue,  
Murray Hill, N.J. 07974.  
Please include a résumé.  
An equal opportunity employer.*



# **Bell Laboratories**

**From Science: Service**





**Coding's cost.** Already software development is expensive, but the costs are likely to become even greater, says Steven A. Szygenda of the University of Texas. The reason is evident: complex chips will require complex test programs to exercise them fully.

the same way—that is to say, using a known and very clear-cut set of ground rules,” predicts C. Gordon Bell, vice president for engineering at Digital Equipment Corp., Maynard, Mass. Thus end-product design need not entail sophisticated knowledge of electronics, and indeed, as applications spread into yet untouched fields, designers may well not be EEs at all, he forecasts. In such fields, “EEs will work in the interfacing domain: they’ll work on problems of getting information into and out of computers, even though computers will be quite small in the perspective of large systems,” Bell says.

Another aspect of the computer or subsystem as a component will be the dramatic improvements in efficiency that it will bring to the design task, almost across the board. The change is already beginning to appear in the design shops of state-of-the-art companies. “A good illustration that strikes home with me as the general manager of an operating design systems group is that the productivity of a product design engineer has increased five times in the last few years,” says Intel’s Lally. “Before, designing a floating-point processor to increase the capability of a computer substantially would take five design engineers along with three product engineers, two draftsmen, and four technicians 12 to 15 months to come up with three to four boards loaded with TTL. Now you can buy one chip that will do 90% of the job.” Such advances not only make the life of the engineer easier, but they also will offer a partial answer to the shortage of design talent that shows no signs of abating.

**A**lready industry savants are aware that programming the systems of the future will be a tremendous task. As the University of Texas’s Szygenda points out, cost is a major factor; for a considerable time now the expense of software design has outstripped that of the hardware design. (A not incidental reason, of course, is the rapidly dwindling cost of the hardware.)



**Disciplines melding.** Watch for a growing need for systems designers to understand software, says Shanda Bahles of Millennium Systems Inc. Moreover, programmers will need to know more about hardware design in order to write effective software, she says.

The highly complex chips that will offer vast new capabilities will undoubtedly require highly complex new programs to put them through their paces.

Certainly software development will benefit from improved tools that will increase productivity. Still, there will be plenty of work for the engineer interested in programming as a career. The explosion in applications is another factor insuring the growth of the field.

The widening range of applications will mean that programmers will increasingly need an understanding of hardware as well as of software, says Roger R. Bate, manager of the advanced software technology department in Texas Instruments Inc.’s Equipment Group, Lewisville, Texas. He cites the TI experience with large military software projects. Often these programs must be designed with an eye towards interaction with various sensors and the like. Thus the software developer must work much more closely with the hardware than when he simply programs large machines with sophisticated operating systems.

Bate foresees a problem looming: “The explosive growth in the application of computers will require an increasing number of people who can make those applications work.” Unfortunately the demand will outrun the supply of qualified programmers, and this shortage will begin to limit the application of computers within about five years, he feels.

A strong dissent comes from Mostek’s Sevin, who argues that, in the VLSI era, programming requirements will ease as software packages for dedicated processors head toward standardization. Also, languages will be block-oriented and very simple, so that secretaries and other nontechnical personnel will be able to do their own applications programs, he says. However, for the fewer

*We listened. Here it is!*

# Easy Insertion ...High Retention

## "Lo-Rise"™ DIP Production Socket

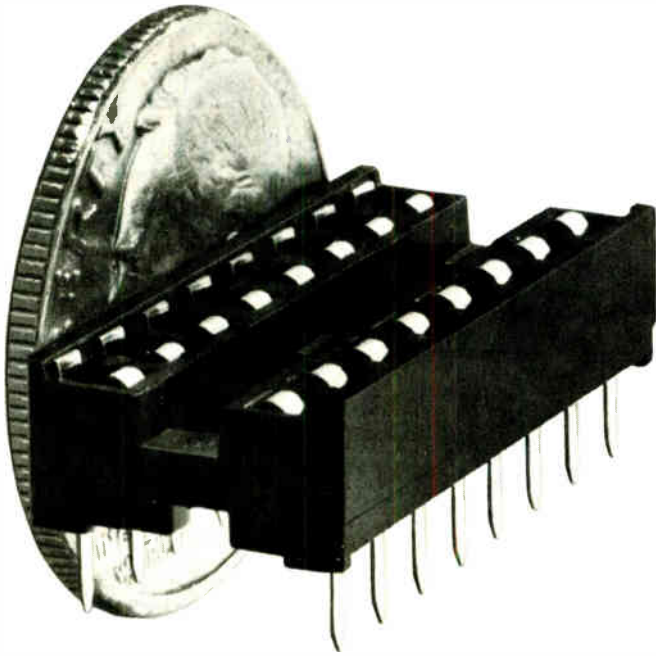

**Now... performance and reliability features you asked for in a production socket, from a proven leader in test/burn-in sockets.**

We've put two years of design effort into our new lo-rise production socket... and we're proud of it! The 802 Socket has a low average insertion force of only 39.91 grams per pin. High extraction force of 72.90 grams that resists shock and vibration. Widest entry area ever. Dual side wiping contacts. Easy-to-clean open frame. Orientation and air circulation groove. Protective sealed bottom that eliminates solder wicking. End-to-end and side-to-side stackability. Available in 8 to 40 pinouts. Material meets U.L. 94 V-O Spec. Competitively priced, it's a total package of recognized Welcon™ socket reliability.

We deliver too. Quickly. Dependably. We make it easy for you to find the right person with the right socket information. We're small enough to be customer oriented, with service people willing to discuss your special socket requirements. Give us a call, and discover just how responsive a company can be. For full details, contact Wells Electronics Inc., 1701 South Main, South Bend, Indiana 46613 U.S.A. Phone: 219/287-5941.

# Welcon™

Wells Electronics Inc., 1701 So. Main, So. Bend, IN 46613 U.S.A.

Electronics / April 17, 1980

### DUAL, SIDE WIPING CONTACT



Low contact resistance. High retention force. Will not damage I/C lead.

### CLOSED BOTTOM

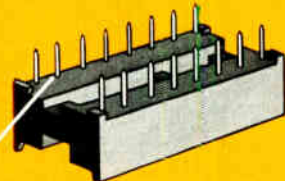

Top loaded contact. Press-fit into socket housing prevents solder wicking.

### WIDE TARGET AREA



Dual-sided contacts, ramped in. Handles splayed leads or off-center insertion.

### ANTI-OVERSTRESS BARRIER



Protects contact from overzealous probing or clumsy insertion.

### OPEN FRAME CONSTRUCTION

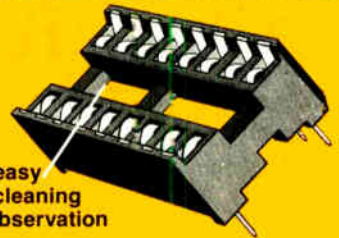

Allows for easy P.C. board cleaning and trace observation or repair.

### END AND SIDE STACKABLE



On .100" centers. Provides for high density packaging. Also machine insertable.

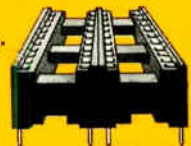





**W**hen Mrs. Barton turned on her new microwave oven, she got The Galloping Gourmet Show, because one of its PC boards wasn't performing properly, because the leads on two of its components were bent, because the VCD insertion machine inserted the wires off center, because there was no Optical Correction System to determine the dead centers of the holes, because the VCD insertion machine wasn't a Dyna/Pert.

Announcing Dyna/Pert's revolutionary new Optical Correction System. OCS is a new system which can precisely determine centers of PC board holes after mounting on either our VCD or DIP. The benefits? First of all, greater insertion reliability. By programming to the dead center of the hole, you get fewer errors, fewer bent leads. And since more accurate programming means smaller holes, you can design for greater circuit density. Next, the OCS lets you rewrite programs automatically for different board lots. And totally eliminate machine-to-machine and fixture-to-fixture variables. Finally, the OCS greatly reduces program writing and debugging time. All of which means greater productivity for you. Our Optical Correction System. Now you're cooking.



We help you do it right the first time.

**DYNA/PERT**

programming jobs available, "the sophistication and technical requirements will increase without bounds."

Sevin's position may be a minority one (and a minority of one, albeit from a man with a good track record on charting the future). Among the prognosticators in the majority camp, discussion is already under way on ways to meet the forthcoming shortage. Bate, for example, foresees the appearance of the software technician to relieve program writers of many tedious routing tasks. Typically, he says, the graduate software engineer will do the design and definition work, then turn the project over to the technician for the actual program writing. "The technician will play an especially important role in software testing and maintenance," he notes.

**T**he software technician's job, for example, is one that will grow almost organically from the present organization of work in the electronics industries, but many other new job categories will appear in the next 20 years. The opportunities will be in the applications of electronic technology. Such use can already be seen in medicine, where the electronics revolution is only starting, and in the home and the office that will be the major beneficiaries as the post-industrial society moves into the Information Age. Moreover, it may be, as Gordon Bell suggests, that many applications will take plug-in computing power, so they will not require an EE's expertise.

One vast applications area, which overlaps almost all others, should predominate in the next 20 years: energy. It is hardly necessary to point out why the swift, sure control of digital logic will play so vital a role in solving the energy crisis that is gripping the world. For example, look for "a resurgence of the power side of electrical engineering" that will intimately involve the practitioners of advanced electronics, asserts Robert C. Seamans Jr., dean of engineering at the Massachusetts Institute of Technology. Just a few of the technologies subject to intensive research are magneto-hydrodynamics, cryogenically cooled power generation, and fusion energy, he says. There will be many opportunities for EEs because the complexities of the technical problems involved may be amenable only to electronic solutions. A case in point is nuclear power, Seamans says, where the Three Mile Island crisis laid bare the need for vastly more intelligent instrumentation and for better training in crisis management, inevitably involving better electronic simulators.

Moreover, power electronics will be only the tip of the iceberg, as illustrated by the work on environmental management in building and on pollution and fuel controls in automobiles. The synergistic nature of solutions to the energy crisis may be glimpsed in the mushrooming developments in communications technology. "A lot of our travel, which consumes energy at a high rate, could be replaced by much more effective communication," Seamans says.

It may be that communications will prove as fertile an



**New opportunities.** The world's energy crisis calls for intensive application of electronic technology to the power side of electrical engineering, says MIT's dean of engineering, Robert C. Seamans Jr. Building environment management is another promising market.





**Multidisciplinary EEs.** With hardware and software design merging, electronics engineers will become systems designers, says Paul C. Ely Jr., vice president of Hewlett-Packard's Computer Group. They will need both hardware and software expertise to function well.

area for EEs as will energy. Jean-Loup Delcroix, director of France's prestigious Ecole Supérieure d'Electricité, Gif-sur-Yvette, near Paris, notes that much work will be done in fiber optics and lasers. Also, says Seamans, "I expect that toward the end of the century you will not be able to determine directly where the communications system begins and ends and where the electronic data-processing system begins and ends."

Industry observers shy away from predicting the demise of any EE specialties. In one way they are saying that the next two decades will not represent so great a break with the past, but they are also saying that certain technical problems will endure. "Analog design will remain pretty much the same—we will probably always need an analog interface," remarks Thomas Slade, a microprocessor applications engineering manager at General Instrument Corp.'s Microelectronics Group in Hicksville, N. Y. Thus he sees a need for "classical analog engineers."

Nor do the demands of technology remain static, points out Liselotte Schulz, head of the error analysis group in the quality control section of Siemens AG's Semiconductor division in Munich, West Germany. "With solid-state devices becoming more and more complex, there will always be a need for painstaking testing by analytical techniques," she says. "In answering questions as to why there is a hole in the oxide or why ions travel under certain conditions, a computer is of little help. It does not replace the human mind with its capacity to analyze a problem."

**A**n emphasis on applications will mean more across-the-board emphasis on marketing skills. Jim Lally of Intel notes that the systems area will certainly become more market-driven because micro-computer makers will need to solve a larger extent of the

applications' design to be successful in the business.

In agreement are Ray Stata, president of Analog Devices Inc., Norwood, Mass.; Millennium Systems' Shanda Bahles; and Hewlett-Packard's Paul Ely. "I think an important element will be a strategic marketing understanding of how to mesh technology with its application in the marketplace," says Stata. "So I think the premium will come to companies that understand how the technology can be applied. The strategy used will be more technology-intensive."

Thus the EE will need a greater understanding of the interrelationship between user and machine than he had before, or what Steve Szygenda of the University of Texas calls human engineering. "Until now, human needs could readily be identified, and the engineer struggled to meet needs that were obvious," says William Gosling of Bath University. "In the future, increasing amounts of the engineer's time will be devoted to the perception of human needs and wants, perhaps in close collaboration with psychologists." Such a view puts the emphasis where it belongs, according to Dean Seamans of MIT: "I wouldn't necessarily call it a marketing orientation so much as a people orientation."

Kees Teer, managing director of electronic systems at the Philips Research Laboratories, Eindhoven, the Netherlands, expands on this point. He argues that marketing success will depend on the expertise of specialists in human behavior. "Human appreciation is a big question, and it is the job of the behavioral scientist to help answer that question," he says.

However, it is likely that EEs will move toward greater involvement with the results of their work, for that is increasingly the way of the world. Despite fluctuating political tempers and harsh economic times, a new spirit is loose that will not be quenched: a belief that the quality of life is a foremost consideration. "The engineer will have a lot more concern about how what he does affects his environment and about his relationship with society," says John F. Wilhelm, director of educational services for the Institute of Electrical and Electronics Engineers in New York. "Of course, this must be tempered with the employer's goals."

**P**erhaps it is beginning to seem as if the EE of the future will have to be a Renaissance man or woman, with talents and skills that span the universe of work. Actually, the engineer's qualifications in the next 20 years will differ little from those of today, although there is a distinct possibility that increasingly tough challenges will require increasingly well-qualified engineers.

One possibility is the development of the engineer as a multidisciplinary problem solver fueled by the trend towards more complex electronic solutions to more complex problems. The predicted merger of hardware and software design tells it all: the EE "will have to be a systems designer, an architect who knows how to design VLSI devices and who is competent in software," says HP's Paul Ely.

On the other hand, some observers see increasing specialization as the norm—a feature that has long been

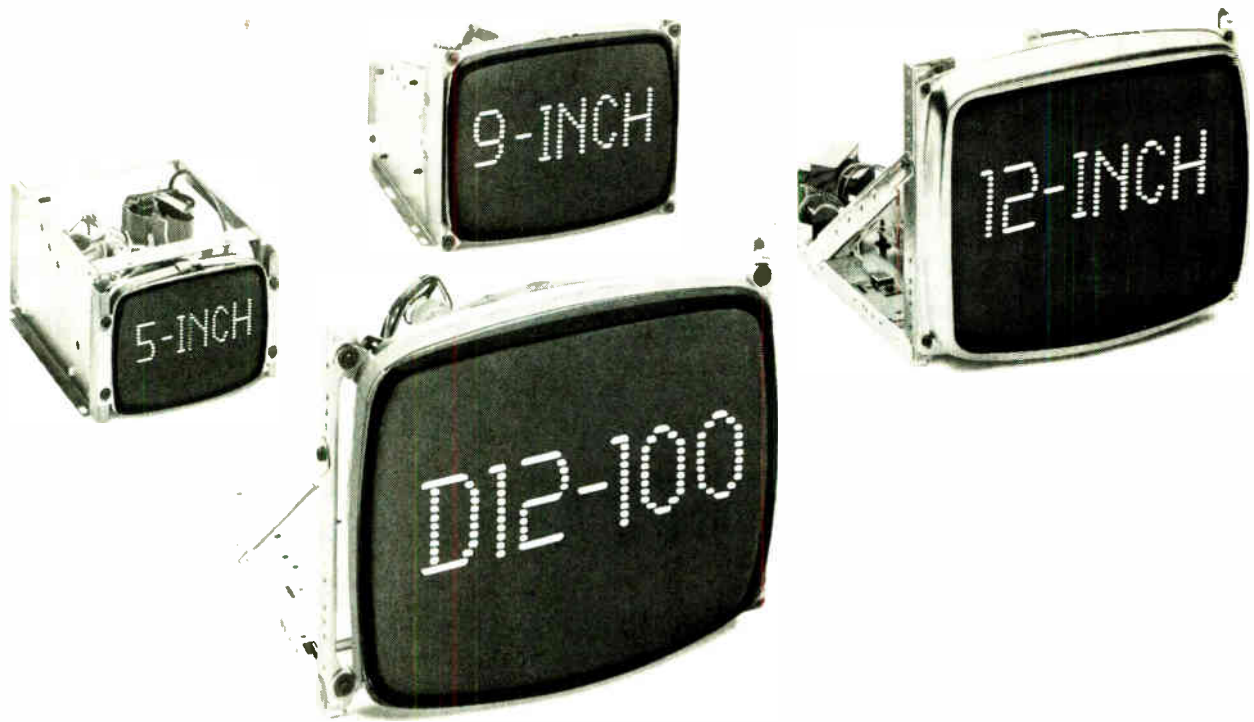

# NOW ZENITH GIVES YOU A BRAND NEW WAY TO MEASURE CRT DISPLAY QUALITY.

Now Zenith technology comes packed into a brand new CRT Display format. Introducing the D12-100. This new model in our expanding line has a diagonal measurement of 12 inches. But the story is much, much bigger.

## THE D12-100

To deliver maximum performance at lower cost, our new D12-100 is designed with a 4x5 aspect ratio rather than the currently used 3x4 aspect ratio. In those applications where the D12-100 is appropriate, it offers all the reliability and dependability of our fully featured, top-of-the-line 3x4 aspect ratio models.

No wonder. The D12-100 is designed and tested to meet the same quality and reliability

standards established for all Zenith CRT Displays. Thousands of test hours under extreme humidity, vibration, altitude and temperature conditions. And exhaustive analysis, including electron microscope and thermograph scans in the Zenith Reliability Lab.

## APPLICATION ENGINEERING

The D12-100, like every Zenith CRT Display, can be designed to meet your own specifications, as well. We'll meet with you to determine your exact requirements. And then custom build a D12-100 to fit. Since the D12-100 is also the start of a new series of CRT Displays, we'll be happy to talk about

other screen sizes as well.

## ZENITH TRADITION

At Zenith, we're building CRT Displays with the same commitment to excellence that's made us number one in the television industry. When you want a product that works, with delivery on *your* time schedule, plus proven reliability and dependability... you want what we've been giving our customers for over 60 years.

More big ideas are coming. For further information and specifications, write: CRT Display Engineering Division, Zenith Radio Corporation, 1000 Milwaukee Avenue, Glenview, Illinois 60025, or call (312) 773-0074.



The quality goes in before the name goes on.



# BONANZA!

## For **PDP-11**\* users, the most cost effective, "no-compromise," SMD disc controller

Maximize your system's cost performance factor with the full capability DC-233 Disc Drive Controller. Its unique master-slave bit slice micro-processor architecture provides total DEC software transparency with up to eight drives. Use it with the CDC 9762 80mb drive to emulate DEC's RM02/03 (67mb of formatted capacity per drive). Or—use it with the Memorex 677 Series 100/200mb drives to emulate DEC's RP05/06 (up to 176mb of formatted capacity per drive). Or—use it with eight 300mb drives for up to 2.1 billion bytes of formatted data in non-software compatible mode.

### AND THERE'S MORE

- Embedded design fits all PDP-11's\*
- Dual drive porting
- Optional dual unibus porting
- Automatic NPR throttling
- ECC fully implemented
- Media compatible

### SEND FOR COMPLETE INFORMATION

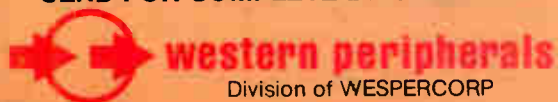

(714) 730-6250 — TWX 910-595-1775  
Cable WESPER  
14321 Myford Rd., Tustin, Calif. 92680

\*Trade name of Digital Equipment Corporation

Circle 36 on reader service card





a fact of engineering life, says Analog Devices' Ray Stata. "One way we've dealt with the problem of technological expansion is to specialize in one small slice of it in terms of your productive work for a company."

As Stata is the first to acknowledge, specialization need not be a straitjacket, especially for the highly motivated engineer. General Instrument's Tom Slade joins him in anticipation of a broadening of the individual EE's vision by his switching specialties. "I think specialist areas don't take that long to learn," he says. Every few years the engineer could rotate, perhaps switching among related jobs. "When he returns to former specialties he could catch up with very little effort," Slade remarks.

John Wilhelm of the IEEE raises a related point: "The job assignments can be very specific, but they will change and probably at a much faster rate because technology is going down the learning curve." Stata agrees, although he sees much more of a challenge in specialization than Slade does: "I think the degree of that specialization will be more intense in the future."

**A**s mentioned earlier, the trend towards the use of building blocks obviates the need for detailed knowledge of the circuitry. DEC's Gordon Bell says it is already leading to what he calls "upward integration of engineering skills." He adds, "Engineers seem to be moving from the domain of discrete component design continually upward to high levels of integration, and that refers not just to the components with which they make their design decisions, but also to the sort of skills they apply to the design problems at hand."

Millennium Systems' Shanda Bahles reports that from her perspective as a systems designer, there is no longer any need to know more than the rudiments of physics. "The IC houses are taking care of all analog problems," she states. "We can essentially ignore the electrical characteristics of TTL, for example, and treat the signal as a 1 or 0." Similarly, she believes it generally unnecessary for a computer designer to understand solid-state LSI processes. "But if you'd like to design a system with a view to an eventual changeover to an LSI chip, it would be nice if whoever is designing the system had some insight into some of the problems that are going to arise," she adds.

If such concerns as electrical characteristics and production processes become less important on the systems level, they will undoubtedly continue to be crucial at the chip level. Also, of course, IC designers will combine hardware and software expertise. One way to put it, says Jean-Claude Six, head of a design group at the applications laboratories of RTC-La Radiotechnique Compélec in Paris, is that "they will be specialists in functions and optimize them with a mix of microprocessors, software, and complex components. Engineers at nonelectronic companies like appliance makers will define the functions they want as black boxes, and the components suppliers will work out the best way to implement them."

In such fields as artificial intelligence, EEs will find themselves working with scientists from quite different

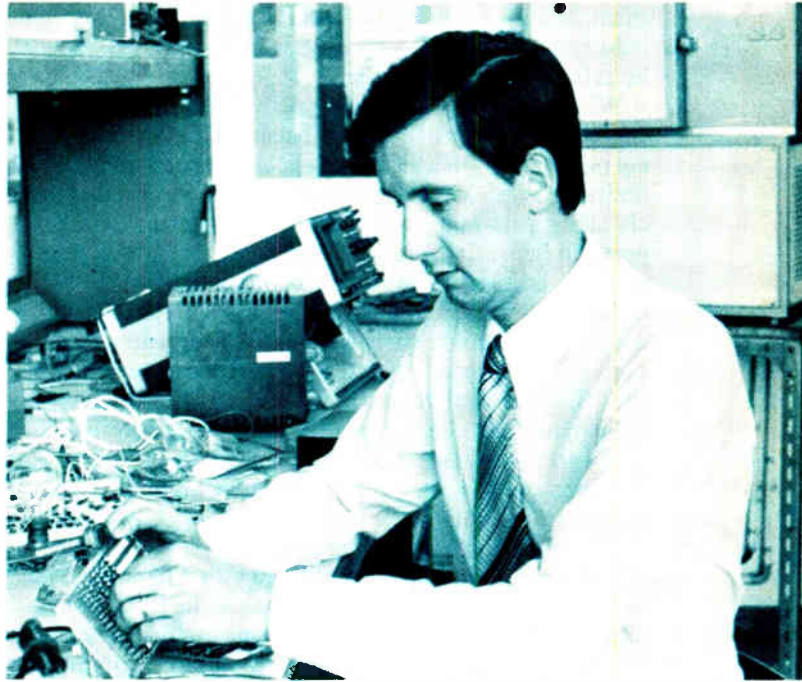

**Chip designers.** When it comes to designing the integrated circuits of tomorrow, it will take designers who are specialists in functions, combining hardware and software knowledge to realize the new chips, says Jean-Claude Six of RTC-La Radiotechnique Compélec.

fields, such as biology. "The mix will be an interdisciplinary one, with specialists from a number of different fields working on the same project," predicts Isolde Dietrich, a physicist who heads a team at Siemens' research facilities in Munich. Such a mix is not unheard of today; what will be exciting for EEs is the growing number of opportunities for them in such basic research.

**One** way to look at the interplay between expanding career opportunities and an individual engineer's qualifications is to argue for an increasing bias towards tailoring a person's talents to the job. Still, that requires a healthy supply of EEs, and many industry observers are wondering if the manpower shortage of today is likely to become chronic. An important factor, in the U.S. at least, is demographic: zero population growth means relatively fewer candidates for engineering careers. Moreover, a shortage today has important long-term effects.

"When I think of the problems we're having today in terms of the scarcity of technical managers and engineers, I begin to realize that the really good ones have taken from 15 to 25 years of either education or related work experience to reach maturity as engineers," says Ray Stata of Analog Devices. "This means that 15 to 25 years ago, the education requirement had to be anticipated and clearly wasn't—and I think if we look ahead to 15 or 25 years from now, we'll have the same situation."

One interesting development, then, could be a change in the public's perception of the engineer—that is, to move the status of the job up to the level of a profession, like physicians, comments Tom Slade of General Instru-



ment. Stata argues that especially within the electronics industries, greater social value will be assigned to what he calls "the guru engineer."

What one finds now, he says, is that bright young engineers are motivated to become tomorrow's managers, primarily because these jobs are seen as the most desirable for career enhancement. Two factors will change this: "The scientific and engineering gurus are going to be so few and far between in the future, and so valuable as a result, that their contributions will come to be seen as more precious. . . . Beyond that, I think within companies there is getting to be a greater recognition that the product and technology decisions really are the fundamental underpinnings of high-technology industries, and the companies that have continued to show great success and progress tend to be companies where there is a very high level of achievement in the technological skills some place."

Of course, such a development will have considerable fallout among the general public, which will enhance the trend that Tom Slade sees developing. In fact, Siemens' physicist Isolde Dietrich sees a change in attitude developing towards basic research. "People are beginning to

hold research activities in higher esteem and are recognizing the importance such activities have for society as a whole," she says.

One important direction in which this leads will be the engineer's role as ambassador of technology to the general public, says the IEEE's John Wilhelm. Bob Seamans of MIT agrees; he spends a lot of time doing just that and finds his speeches warmly welcomed.

The need for this role arises out of the increasing importance of technology in everyday life. More and more, political issues are likely to involve technology, and where public debate comes into play, people must decide technological issues.

"Unfortunately they are being forced to select among technological alternatives with very little technological knowledge and of course, this is where the engineer comes in—in the role of educator," Seamans says. "I think an engineer who goes out with the goal of helping people understand technological problems, as opposed to a sort of urge to uplift the masses, will find a sympathetic audience. I think he can be very candid and help a great deal."

With enhanced public respect for engineers, the desirability of the field may grow. John Wilhelm believes that and says: "I think the climate is going in that direction." Perhaps then the shortage of talent will not be as extreme as it now looks.



**Basic prestige.** The general public is beginning to look with more favor on basic research in the sciences, believes physicist Isolde Dietrich of Siemens in West Germany. The reason is a greater appreciation of the important benefits to society of such research.

The lure of an engineering career will be more likely to attract more women and members of racial minorities than has been true in the past. Already there are signs that this is happening. The University of Texas's Steve Szygenda reports his school's enrollment is now 10% female, and that EE schools in general are beginning to respond to the pressure of the times by active recruitment of women.

It is not easy to guess how many minority EEs there will be, but the National Fund for Minority Engineering Students in New York can offer some interesting figures on the trend in all engineering schools. Of the 46,091 engineering undergraduates receiving degrees in 1978, 2% were black, 1.6% were Hispanic, and 0.1% were American Indian. However, of the 95,805 freshmen entering engineering school that fall, 5.7% were black, 2.8% were Hispanic (the University of Puerto Rico is not included in either Hispanic figure), and 0.2% were American Indian.

Of course, more is at work here than interest among the prospective engineers and pressure from the Government and representative groups. Companies are perceiving that they can help overcome the manpower shortages by encouraging a broader pool of applicants. "I think industry will be trying to do things that don't screen out women and minorities," says Ray Stata of Analog Devices. And TI software technology manager Roger Bate sees minorities and women as a way to fill the gap in program development; he notes that there is already a comparatively higher percentage of women in the field than before—"perhaps because it requires less in the way of heavy-duty engineering courses." As DEC's Gordon Bell points out, software engineering is an exam-

# New from Pyramid Optical.

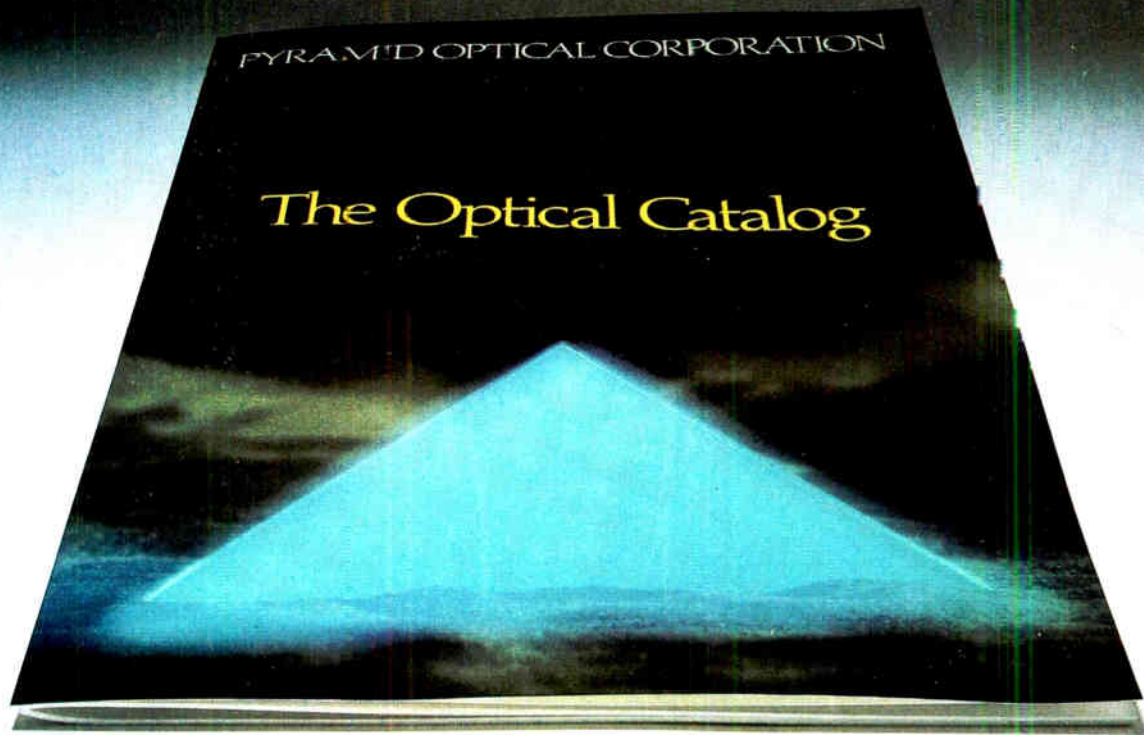

## An optics catalog you'll want to keep handy all the time.

### Prepared with your needs in mind.

Our goal was to create a useful tool for the user of flat optical components.

We think we succeeded.

### Reference material you won't find in any textbook.

In addition to brief descriptions accompanying each product category, we have included a Design Hints section. Here you'll find detailed explanations and illustrations that will help you in

your work. Especially useful if your background is electronics rather than optics.

### Catalog information that's really complete.

You'll discover a wide variety of prisms, flats, windows and beamsplitters listed. Along with something you normally don't get—expected delivery times and prices.

Each component is shown in a dimensioned drawing. What's more, there's a ray diagram that

shows you clearly how the beam changes direction and is rearranged as it passes through an optic.

### Call or write if you can't wait.

If you're in a hurry to get your copy of our catalog, call Ken Panique at 714/557-2414. Or write Pyramid Optical Corporation, 1732 McGaw Avenue, Irvine, CA 92714.

If you're a bit more patient, circle the reader-response number below.



PYRAMID OPTICAL CORPORATION





## Norplex<sup>®</sup> multilayer materials make your ideas work.

Norplex base materials can help put your circuitry concepts into working order. Our product philosophy is to develop laminates and prepregs needed for today's generation of multilayer interconnections.

We stress the involvement of our advanced engineering groups in the design of all multilayer materials. Using segregated production facilities, specially-designed impregnation treaters and sophisticated laminating press lines, Norplex combines top-grade materials into superior multilayer laminates. We also maintain a vigorous program for survey and evaluation of new technologies.

The excellent dimensional stability of Norplex laminates is demonstrated by proper registration of layers after lamination. Laminate integrity is also maintained

throughout board fabrication.

Norplex prepregs are characterized by consistent resin flow and rheology. Conductor encapsulation and void expulsion results in superior resistance to thermal degradation. Precision thickness tolerances and controlled electrical properties also contribute to high production yields and consistent performance in the application.

So, if you've got a multilayer application to be transformed from design to working reality, talk with the man who can help make it happen: your Norplex Technical Representative.

Norplex Division, UOP Inc., La Crosse, WI. European Headquarters: Wipperfürth, West Germany. Pacific Headquarters: Kowloon, Hong Kong.

**Norplex laminates**  
by **uop**



One of The Signal Companies



**Trying harder.** Even in the most socially enlightened companies, professional women must try harder than their male counterparts in order to make equal gains in terms of promotions, says Hanni Kelle of Siemens' semiconductor quality control operation.

ple of the type of work that could be performed easily in the home once the wired nation truly arrives. Such a setup could also benefit another minority beginning to make itself heard: the physically handicapped.

Now that the walls are breached, what welcome are the new groups of engineers finding? Shanda Bahles, who has worked for two young companies besides Millennium Systems, believes that of all the professional fields, "engineering has the least amount of bias. Engineers tend to judge on merit and technical ability."

However, Bahles goes on to argue, in effect, for Superwoman. "If they [women engineers] make it a point to excel, there will be no opportunities for those few [men] who are biased and are waiting to throw stones." Three women who have worked many years at Siemens support that argument. Isolde Dietrich and Liselotte Schulz report similar experiences to those of Hanni Kelle, a group leader in the quality control section of the semiconductor division, who says, "Women are not equal to men" when it comes to promotions. "One must try harder than men."

All three group leaders lay the blame on a lack of experience with women professionals; in fact, fewer than 1% of West Germany's engineers are women. Siemens has a little better than 200 women among its 20,000 engineers and researchers in domestic and foreign facilities, but that still makes the female engineer a rarity. Even so, the situation for women has improved, Schulz suggests. Throughout the industry only two or three decades ago, it was virtually inconceivable for a woman

to hold a management position. That is still the case in France, where women engineers do not have the same career opportunities as do men, says Claude Iroulart, a group head at RTC-La Radiotechnique Compélec's Paris applications laboratory. "They get lower pay for the same job and cannot move up as easily because men don't want to work for women," he reports.

At the technician's level, Siemens is training a healthy number of women. At its Munich school for technical assistants, some 250 young women are attending two years of training. Those with degrees from junior colleges graduate as engineering assistants, and those with high school diplomas graduate as technical assistants. They follow courses in either communications or computer technology.

Of course, few other countries have the healthy percentage of racial minorities among their populations that the U. S. does. So there are hardly any movements afoot elsewhere to develop opportunities for minority engineers. The American push is going to reach fruition in about eight years, says Thomas L. Martin, president of the Illinois Institute of Technology, who recently completed a 2½ year stint as chairman of the National Research Council's Committee on Minorities in Engineering. Then the level of minority and women freshmen in engineering colleges will equal the level of minorities in the total population. It may take until 2010 for them to reach that level of representation in the engineering professions, he predicts.

Martin affirms the importance of the changing attitudes of the employers. The perception of discrimination discouraged minorities and women. "There was very little motivation to take the hard courses in high school and to take a hard program in college if you know you were not going to get the job anyhow," he says.

He also blames the high schools for inadequate preparation, particularly of minorities and women, a point on which he is supported by MIT's Seamans—who also singles out "inept guidance" in most secondary schools as a contributing factor. Even more critical is Gordon Bell, who is serving DEC while on leave as professor of computer science and electrical engineering at Carnegie-Mellon University, Pittsburgh, and who has a daughter in high school. Of the schools, he says, "I believe in fact that they can harm students. For example, there is a stereotyping of women with respect to mathematics: a negative stereotyping. . . . Now when you consider that engineering is based inherently on physics and mathematics, that says something about women and their entry as a group into the career of engineering. It's going to be impeded . . . by the parents, by their childhood environment, and it is certainly not going to be helped by secondary schools."

A number of observers see a related problem of a lack of role models because of the near invisibility of women and minority men in electrical engineering. Obviously, that lack is being corrected. No one mentions the success of Oriental men within the profession, perhaps because they have long since become part of the work landscape. If that is so, it augurs well for the acceptance of women





**On the way up.** That women are finding their way up the electronics career ladder is in evidence at Siemens, where a number hold important jobs. One is Liselotte Schulz, head of the error analysis group in the quality control section of the Semiconductor division.

and minority men in the engineering work force of 2000.

One notable obstacle for minorities is inadequate preparation, and Martin pleads for support for the special programs designed to overcome that problem: "These programs aren't something you start and think they are going to fuel themselves," he says. Retention rates at the college level are a related problem, observes John Wilhelm, who reports that the IEEE is focusing its minority effort on that and on identification of likely prospects for college entry.

**T**here will be more than new faces around the offices and laboratories 20 years from now; the facilities themselves will look different. Again, this development is one that will occur unevenly, but by 2000, many EEs will work in a fully automated, highly computerized space—most likely still at central facilities, but perhaps with some spillover into their homes.

It takes no particular prescience to predict that the profession that spawned the computer, the minicomputer, and the microcomputer will capitalize upon its progeny. It is not just a matter of familiarity; it is the promised improvement in productivity. A consensus among industry oracles holds that computer-aided design and other computer-based tools are the answer to the twin dilemmas of too few engineers and increasingly complex design tasks. The computer will come to the rescue in both hardware and software design.

"Automation can reduce the ratio of drudgery to inspired work and the ratio of routine to judgmental activities," says Analog Devices' president Ray Stata.

"Without that, there are some things that could never be developed within the lifetime of an engineer—they are just so complex." It is more than a matter of using a computer to model various alternative device configurations, emulate their performance, and aid in the layout, he argues. "You get into questions of a tradeoff of market requirements versus price elasticity—for instance, considering, as a function of various parameters, user options, which are things that can be in many ways modeled and can be more analytically factored into the design process than is the case today."

So computing power will pervade every aspect of many EEs' jobs. The workspace will probably be a work station not unlike those that are the forerunners of the office of the future, says HP's Paul Ely. "The EE will have a computer terminal and an experiment station with a number of computer-based instruments. Close by, there will be specialized laboratories with a few specialists in each. There will also be a place to take designs and have unique VLSI circuits made."

Because of the multidisciplinary nature of future jobs, "I see the EE of the future reading often. And when he is working, he will spend about half his time sitting at his computer terminal. I also see him writing and drawing a lot less than he does today, and a lot of things he used to look up in a file cabinet will be available to him in a computer." Nor will tomorrow's EE need a workbench or technicians' assistance as much as today, Ely says. "He can build a model or a product in software and test it in software from his terminal. All this will be an enormous assistance in reduction of documentation."

**W**hat goes for the future of hardware design also goes for the future of programming—and just in time, says Intel's Jim Lally. "The software engineer needs the same kind of advance as the hardware engineer got with VLSI." It will take computing power to bring that advance about; for example, Lally forecasts that the major tool that will increase productivity will be the increased use of high-level languages by software engineers.

Far down the road will come automated generation of software. "People have been working in this area for years, though we haven't had much success," says the University of Texas's Steve Szygenda. "But as the cost goes up and the pressures get greater, more emphasis will be put in this area."

If the next 20 years do not hold the promise of automated software generation, they will still see important advances in the art, both in terms of the tools that the engineers use and in the programming concepts from which they work. Among the former, Lally mentions automated performance-measuring tools; and among the latter, he includes structured programming, which imposes a discipline for error-free coding, and modular design, which links functional blocks by such design tools as linkers and locators, to permit more debugging.

At TI, Roger R. Bate and his associate in the advanced software technology department, Douglas S. Johnson, speculate that a special design language might evolve, and that it might include many English and high-level





# ELECTRONIC COMPONENTS DESIGNED TO SURVIVE

Call on Hi-G, and you call on an electronic components source whose products are designed and built for high reliability. Providing a blend of specialized skills and technologies throughout its divisions, Hi-G offers a broad and still expanding electronic component line. Hi-G products are distinguished by quality, dependability, systems compatibility. A company-wide commitment to technological service, offers today's original equipment designer the help he needs in getting the job done. To see how Hi-G can help you, turn to the appropriate pages in EEM, or contact: Hi-G Incorporated, 580 Spring St., Windsor Locks, CT 06096; (203) 623-2481.



## MINIATURE HIGH-PERFORMANCE RELAYS

A broad line of hermetically-sealed electronic miniature relays. Includes full-size and half-size crystal cans, as well as TO-5 type. Offered in both military and commercial versions.

Relay Division, Hi-G, Inc.

See Pages 3420-3437 for product line data.

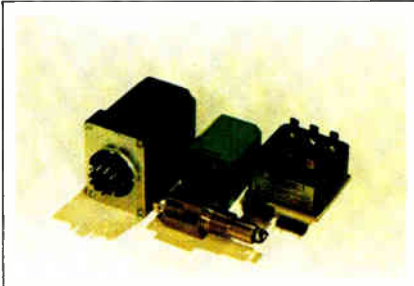

## ELECTRONIC TIMING & SENSING CONTROLS

A broad line of time-delay and voltage-sensing relays for military and commercial applications. Includes plastic dust-case, octal plug devices, as well as OEM products.

Hi-G Electronics Division, Hi-G, Inc.

See Page 3432-3435 for product line data.

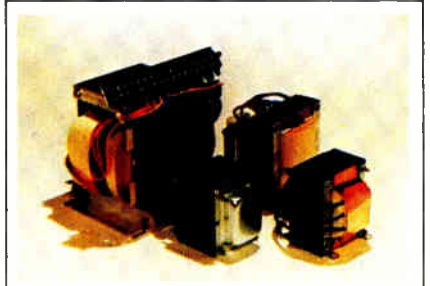

## POWER TRANSFORMERS

The product line includes linear, ferro-resonant (constant voltage — CVN type) and switching-mode (15 kHz and up) power transformers. Capable of power output up to 2 kVa. All devices professional-grade quality and custom-designed by computer to meet specific equipment specifications.

Merrimack Magnetics Div., Hi-G, Inc.

See Page 4207 for additional product information.



## LINEAR SOLENOIDS

The product line includes both dc and ac versions. Offered in open, box frame and tubular versions. Customized linear actuators of all types also available.

Magnetec Corp., Division, Hi-G, Inc.

See Page 3438 for product line data.



## PRINTED CIRCUIT BOARDS

Includes single-sided, double-sided and multi-layer boards. Fine line and high volume capability available. Prototype service also offered.

Deflance Circuit Corp., Division, Hi-G, Inc.  
12 Sheppard St.  
Lawrence, Mass. 01843  
Tel. 617-688-1856

Contact factory for product line data.



## RADIO-FREQUENCY CONNECTORS

A broad line of RF connectors. Male and female types up to 2 GHz. Patented FASTFIT™ connectors for field-installable applications. Special line of broadcast-application connectors also offered.

Cambridge Products Corp., Division, Hi-G, Inc.  
244 Woodland Ave.  
Bloomfield, Conn. 06002  
Tel. 203-243-1761

Contact factory for product line data.



DESIGNED TO SURVIVE.

programming language characteristics. (They also caution that while it is easy to invent a new programming language, it is hard to bring it into general use because of such factors as the high cost of development and training.)

Another possibility is text editors for program entry and management. These tools will be sensitive to the programming language in use and will check punctuation and syntax, thus relieving the programmer of that overhead. These tools will also track the changes made to program texts and will aid in the overall task of configuration management.

Also likely is a sophisticated assortment of testing tools. Today, testing complex software poses problems in selecting what data to put in in order to ensure that all branches that could possibly be traversed are checked. The programmer will need all the automated help he can get with the more complex programs of the future. According to Johnson, another testing tool (and one that will be one of the first to appear in common usage) will be source-level-language debugging tools—that is, software that can snapshot a running software program and transform the memory image into the symbols the programmer originally used.

Debugging also is an increasing problem with hardware, says Millennium Systems' Bahles. With more and more devices on a chip with a limited number of output

pins, "the designer needs a more sophisticated debugging tool that is multifunctional and automatically refines data for the user so that he or she is not faced with a mass of signals that have to be interpreted."

The changing life of EES certainly will affect their education through different curriculums, different study tools, and perhaps more time in schools. Some features of academia will not change, however, and one that industry forecasters almost unanimously see in the school of the future is an undergraduate education that emphasizes the fundamentals of engineering.

One problem that several of them foresee is that the list of basics will expand continually. With fabrication, design, testing, and software development coming together on the job, universities will be called on to produce "broadbased EEs who are going to have to know a lot about all of these areas," observes the University of Texas's Steve Szygenda. Of course, course content would have to be revamped, but it could be largely a matter of dropping the old in favor of the new. "We have gone from relays to tubes to solid-state devices, and we have changed our programs," he notes. "We don't teach much about tubes anymore."

Student engineers might indeed devote some time to a

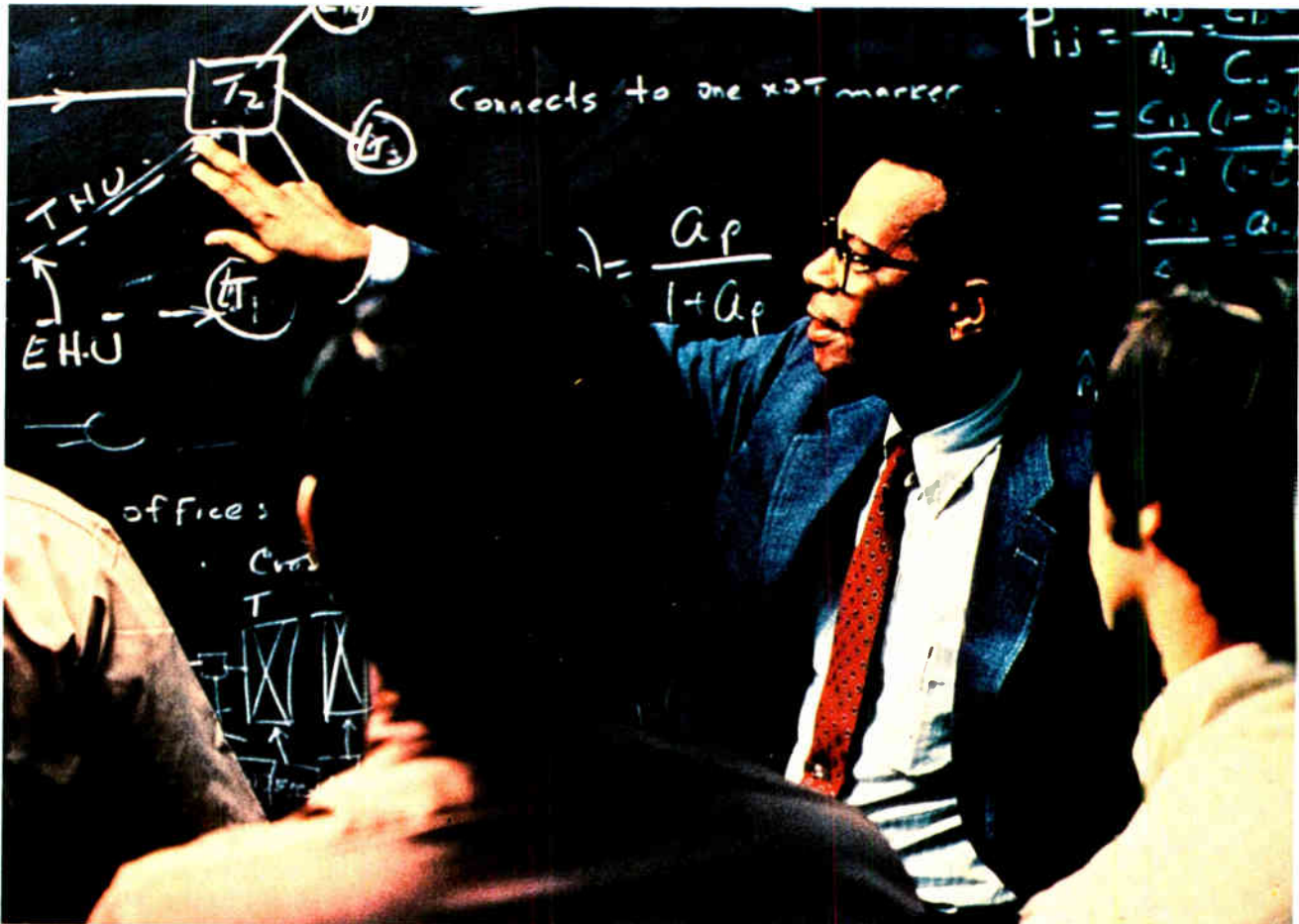

**Well-equipped.** Not only will systems EEs need a broad-based technical education, but they must be prepared to disseminate their knowledge, as Bell Labs' Victor Ransome does in explaining an internal measuring system for the operating companies' traffic departments.



specialized area of knowledge, but they would have to be cautious, urges HP's Paul Ely. The content of most specialized courses will be obsolete by the time the students are through them, he says. "I see no letdown in the rate of technological change. In fact, there will probably be an acceleration." GI's Tom Slade agrees heartily and remarks, "It takes us six months full time to train a guy to become an MOS designer. So how can you do that in one course that meets once a week?"

One interesting direction towards which curriculums may move is "what you might call the engineer in society, and the question of to what extent in the undergraduate curriculum do we treat management, economics, environment, politics, geopolitics, and so on," says MIT's Bob Seamans. Similarly Tom Slade and the IEEE's John Wilhelm see a need for teaching communications and management skills.

Talks with educators suggest that the best picture of the new undergraduate curriculum will come from looking at today's graduate courses. They point to what might be called the trickle-down effect. "Many courses that were taught to graduate students only in the forties and fifties are now considered quite routine undergraduate courses," remarks Seamans. Not only is that true of computer programming, for example, but more than half of the University of Texas's freshman EE students have had some programming experience in high school, says Szygenda. Thus while there will be more to learn, the students may come better prepared.

A subject on which there is anything but a consensus is the amount of time the student EE will be spending in school by 2000. Will the undergraduate years stretch to five? Will the master's degree come to be the entry level into industry? Will there be more engineers with Ph. D.s? On all these questions, both positive and negative answers roll forth. One key factor, however, is identified by several observers, including Shanda Bahles, who says "undergraduate education won't last much

longer because it already costs too much." Expensive though it is, extended education is likely to be as important in 20 years as it is today. It is perhaps noteworthy that the two youngest EEs interviewed for this chapter are enrolled in graduate school: Bahles is on leave from Stanford University's master's program, where her emphasis is on computer hardware; and Tom Slade, whose undergraduate degree is in physics, is working on a doctorate in operations research.

Given that the working EE's tools will be undergoing some changes, the student's tools will probably follow. Educators expect the wide use of individual computer terminals or portable data bases, and these will—to a degree—change the nature of education. "I can foresee as a teaching aid something that would combine computational ability and data-base access and a certain element of interaction with a student," says Gordon Bell of DEC and Carnegie-Mellon University. "Conceivably, the knowledge the student EE could call on would be much broader than that he calls on today. On the other hand, he would have to spend much less time learning it and would probably spend more time learning how to find or look up certain pieces of knowledge. . . . I believe the revolution is almost here right now, and that revolution consists of algorithms being in place so that information can be derived rather than stored."

Computing power may become as ubiquitous as the pencil, but a strong sentiment remains for the continuation of traditional teaching methods. Bell rather grimly attributes it to entrenched interests: "Schools have to put people in classrooms because they have classrooms, and people have to go to lectures at certain hours because there are lecture hours and schedules to fill." Seamans argues for the importance of the interaction possible in the classroom: "Obviously something is lost when you physically separate the instructor from the class—and when you tie the instructor down to something like video tape, there is still less flexibility in the learning situation." Along with other educators, however, he does anticipate more use of all forms of electronic delivery of information and of computer-aided instruction.

While Bell talks of a revolution, he makes it clear that he agrees with Seamans in rejecting the idea of what has been called the computerized campus. Such a scenario envisions a vast communications network linking myriad data bases, with every student and teacher gaining easy access through individual computers or smart terminals. Bell points to the size, complexity, and regimentation of such an undertaking, noting that "it will require too much agreement among a population composed of scholars preoccupied with intellectual freedom." Seamans asserts once again that the setup would replace actual experience with an unsatisfactory alternative. "Anything that is in the can is not the real world."

Another problem with the computerized campus and with sophisticated new educational tools is a longstanding headache for academia: cost. Not only do courses require increasingly expensive laboratory equipment, Seamans says, but more and more "require far more



**Career preparation.** One way for companies to ensure women are educated for engineering jobs is to make a special effort to train them. Siemens' School for Technical Assistants prepares young women for jobs in the communications and computer divisions.

# Design in speed not cost with Fujitsu's new 16K dynamic RAM

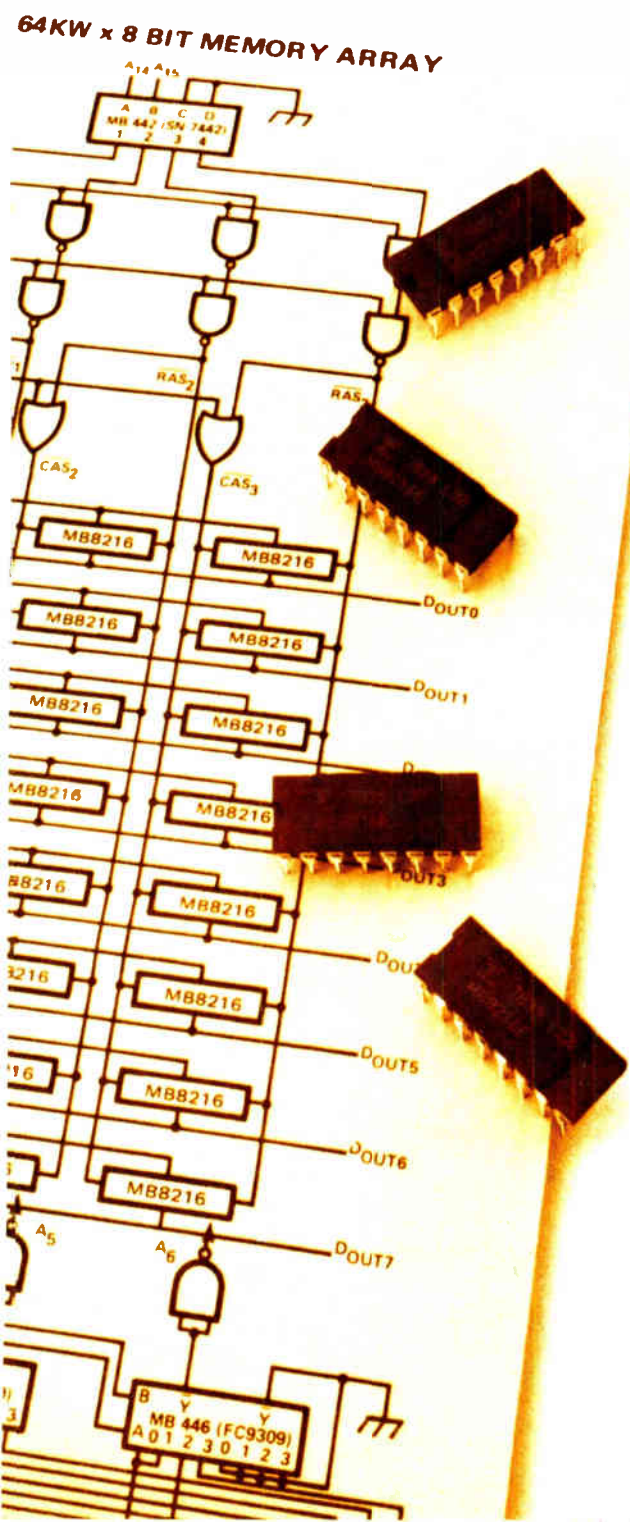

The MB8216 is a new generation 16K MOS Dynamic RAM. Its Access Time of 120 ns (max) makes it the fastest three power supply 16K Dynamic RAM available.

This all-new 16K Dynamic RAM is specifically designed to give Memory System Engineers a cost-effective, high-speed alternative. In your existing boards, the MB8216 can improve performance up to 50% with no increase in power requirements. System upgrading is simplified because the MB8216 is pin compatible with the 4116 and our MB8116.

The MB8216 is built with the same proven Double-Poly, N-Channel, Silicon Gate Process as our popular MB8116. Small die size and the highest reliability available anywhere are achieved with this process.

The MB8216 is available now in production quantities. For complete information about this new 120 ns Dynamic RAM, write or call. We've got data and samples to back up everything we say.

**FUJITSU** **MICRO  
ELECTRONICS, INC.**

2945 Oakmead Village Court, Santa Clara, CA 95051  
(408) 727-1700, Telex 171182, TWX: 910-338-0047

- I want to know more about the MB 8216
- Send me your complete information package.
- Have a sales engineer call.

Name \_\_\_\_\_ Title \_\_\_\_\_

Company \_\_\_\_\_

Address \_\_\_\_\_

City \_\_\_\_\_ State \_\_\_\_\_ Zip \_\_\_\_\_

Phone \_\_\_\_\_

E3-80

Circle 48 on reader service card



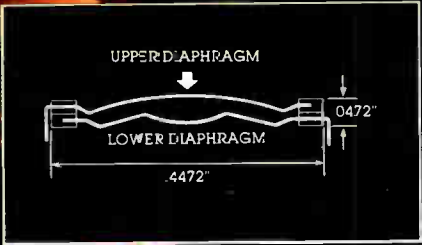
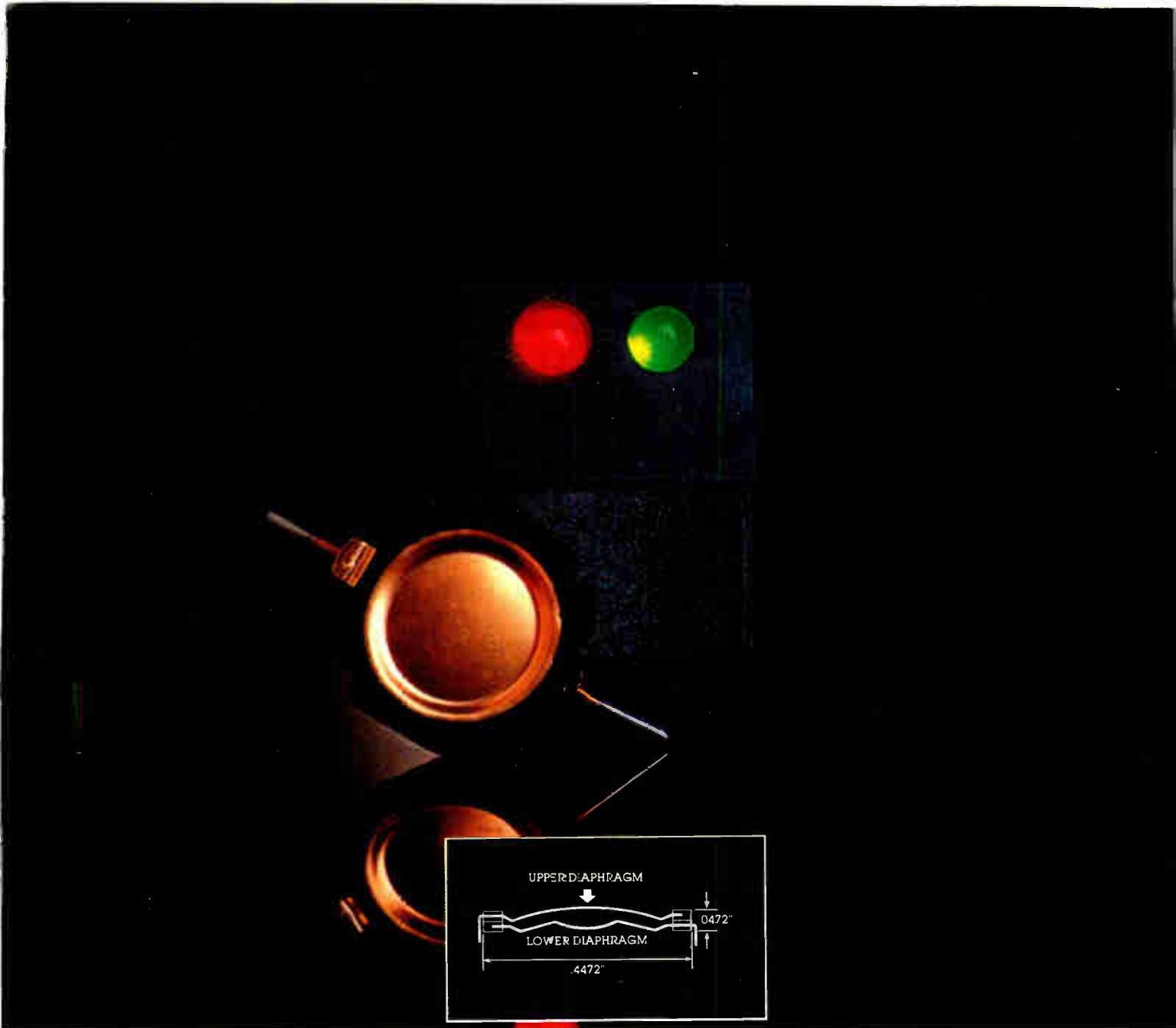

**The assignment: offer a reliable switch element capable of evolving into a variety of specialized key- and rocker switch designs.**

**The result ITT Schadow's Disc Switch.**

At ITT Schadow, we specialize in taking basic switch designs and changing them to fit your specific applications. We've built a reputation on our awareness that the first two syllables of "customer" are "custom."

Customized adaptations work best when they're based on products with a proven record of reliability. Our popular Disc Switch is a case in point. When depressed, its upper dome-shaped diaphragm flattens to make positive contact with a lower diaphragm over a broad circular con-

tact area. This simple, sturdy design has a rated service life of up to 10,000,000 cycles. Schadow's Disc Switch is available as a basic switch element, in a variety of standard packages as shown, and in custom packages. You can choose

from a selection of colors and graphics.

Over the past two decades, we've made millions of pushbutton, key-, rocker, and rotary switches for some of America's largest consumer and industrial OEM's. We are your "creative

switchmaker" with the ability to design, adapt, and manufacture switches for nearly every requirement.

Your ITT Schadow manufacturer's representative or distributor can tell you more. Or contact ITT Schadow Inc., a subsidiary of International Telephone and Telegraph, 8081 Wallace Road, Eden Prairie, MN 55344. Phone 612/934-4400, TWX 910-576-2469, Telex 29-0556.



Circle 51 on reader service card

**ITT Schadow**

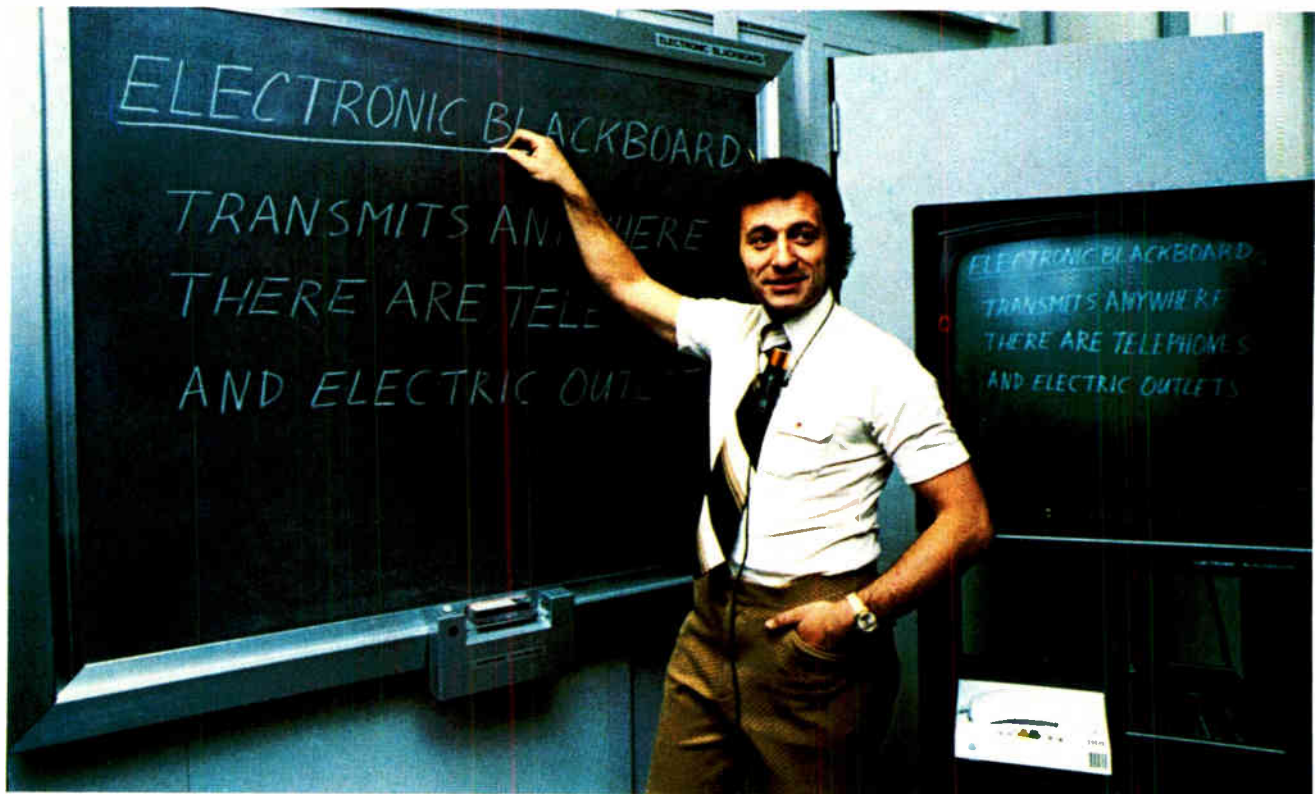

**Electronic aid.** Likely to become familiar in far-flung companies is such equipment as AT&T's Gemini 100 electronic blackboard. Behind the surface are pressure-sensitive plates that convert chalk marks into electric signals for transmission over phone lines to video monitors.

computer time than is presently easily available."

What all this means, according to the MIT dean, is that labs "are not at the cutting edge of technology in many cases." Tom Slade says that computer experience is the crucial factor, especially for developing programming skills and systems analysis. But he dismisses the rest of the equipment problem; he argues that student laboratories are little more than a taste of the real thing. "Labs are a waste of time until you get into industry where you spend eight hours a day in them," he says.

A number of observers anticipate that the zooming costs of education will be met in part by a variety of industry contributions. For starters, both Shanda Bahles and Steve Szygenda say, companies could donate advanced equipment for the labs. Of course, the geometrical increases in equipment costs are making many companies wonder how they can afford them for themselves. The alternative, suggested by Seamans, is to take the student to the equipment. Internships can give access to state-of-the-art tools; moreover, they give "a chance first of all to learn about the real world and how things are done, while they are still undergraduates and able to structure their electives to suit themselves better to life in the real world." Tom Slade thinks internships or some equivalent could be equally valuable on the graduate level, and could replace the dissertation, of which he says, "The absolute specialization of this is useless."

Opinions are mixed on whether companies will move beyond equipment donations to more active financial involvement. Analog Devices' Ray Stata looks for increasing interaction in order for industry to get across its educational needs. Alumni participation is one route,

but even more important are industry funds for consulting services and for research. Such money has been coming mostly from the Government, he says, so it "has had an incredible influence on the direction academia has taken." On the other hand, Steve Szygenda argues that companies traditionally have been reluctant about financing university research for fear the results would enter the public domain.

Across the Atlantic, Great Britain may well be moving towards a closer interrelationship between industry and academia, says Bath University's William Gosling. The impetus might be a major overhaul of the educational and professional structure of engineering, says Gosling, who is serving as president of the Institute of Electronic and Radio Engineers. The root of the problem is Britain's emphasis on pure science and a consequent downgrading of application. What is needed, he says, is the creation of a highly rewarded engineering elite.

What Gosling and many in British industry hope for is a three-tiered educational structure for engineers, technician engineers, and technicians educated by, respectively, universities that become centers of technical excellence, colleges of technology, and polytechnic schools. He also argues for a measure of flexibility in the framework and in careers to avoid the rigidity of educational qualifications that is so strong a part of Britain's class structure.

For an example of the involvement industry might have with educational institutions, Gosling points to the cooperation between his university and General Electric Co. Ltd. A master's in engineering program, an intensive 4½-year course, mixes carefully structured internships



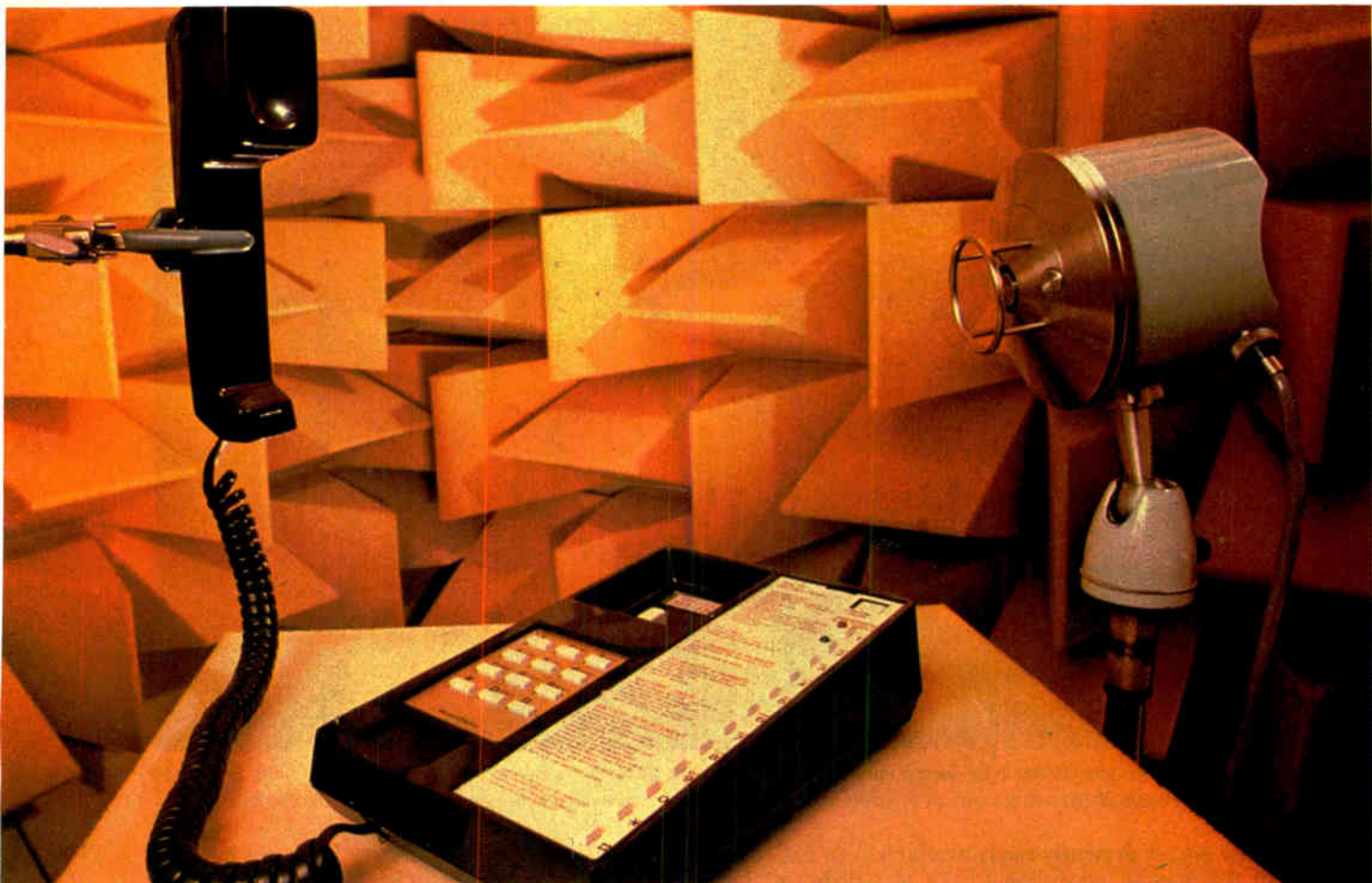

**Easy dialing.** For a true hands-off phone, Bell Labs is working a voice-actuated rotary dialer. The unit will store some two dozen numbers, referenced by the words the user stores with them. Marrying the analog and digital worlds will be an important design area.

with GEC and classroom work. The impetus for GEC was its strong dissatisfaction with shortcomings in the average undergraduate's education.

In the U. S., dissatisfaction is not with postsecondary education but with the quality of high schools and presecondary schools. Seamans reports that MIT tests incoming graduate students for ability in reading, writing, and speaking English, "and the percentage who are lacking in these communications skills is incredible. We are talking about 20% or 30% of students at the *graduate* level needing remedial work in English." And Tom Slade reports with dismay that the high-school calculus course he took no longer exists.

There is a desolate joke to the effect that the 21st Century will be called off, due to lack of interest. The optimists in the industry do not see that happening, for they expect interest in such demanding work as engineering to rekindle with an increase in the students' demand for tough preparatory courses. A good lodestar may be the use of scientific calculators and home computers. If high school students take to them and if they seek courses that use them in significant new numbers, then secondary science education in the U. S. may well flourish.

Even with the problem of ill-preparedness solved, the postsecondary schools face another critical obstacle in the opposite direction. Steve Szygenda says that the

massive needs of industry mean that universities are unable to attract qualified new faculty members because of salary differentiation. Not only are few bright young EES choosing careers in education, but few engineers with industrial experience are opting to move into the universities, he says.

**W**hat he sees as a solution is for engineering schools to move to professional status, like law and medicine. (Of course, some forecasters already see engineering as a career moving in the direction of professionalism.) With separate status like this, faculty salaries can be much higher than in other disciplines, he maintains. Without it, the quality of graduates will fall drastically, and industry will be forced to pick up more of the educational burden in house.

John Wilhelm of the IEEE has noted discussion of what some engineering professors see as the first wave of the problem. It is the increasing presence of foreign-educated teachers. Without experience in U. S. schools or companies, their understanding of American industry is questionable—or so the argument runs.

For many EES, education continues as they advance in their careers, and that feature of their worklife will still be around at the turn of the century. As the microprocessor has boomed, continuing education has boomed; as

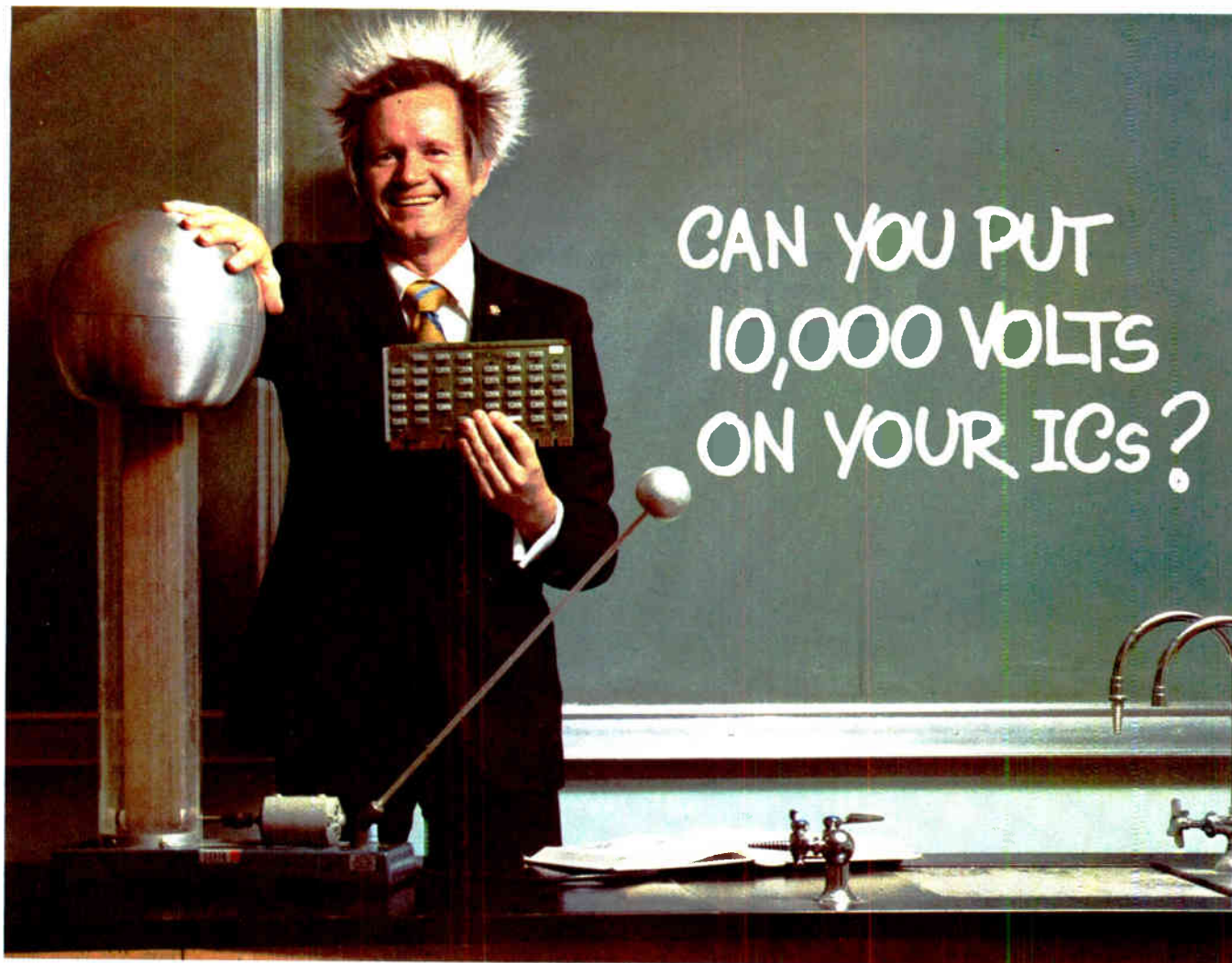

CAN YOU PUT  
10,000 VOLTS  
ON YOUR ICs?

**WE DID!!!**

But first we protected the  $V_{cc}$  line with our ICT Series (5 thru 45 volts) TransZorb<sup>®</sup> Transient Voltage Suppressors and the signal lines with our new GHV Surge Arrestors.

In most situations you will never have to worry about 10,000 volt transients but "we did it" in order to demonstrate both the speed ( $1 \times 10^{-12}$ sec) and the effectiveness of General Semiconductor Industries TransZorb Transient Voltage Suppressors.

For an actual demonstration or complete technical information call or write:

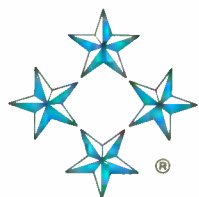

**GENERAL  
SEMICONDUCTOR  
INDUSTRIES, INC.**

2001 West Tenth Place • P.O. Box 3078 • Tempe, Arizona 85281 • 602-968-3101 • TWX 910-950-1942

TransZorb<sup>®</sup> is a  
registered trademark of  
General Semiconductor  
Industries, Inc.







# AEG-TELEFUNKEN.

## Working For The Future of Electronics

For almost a century, AEG-Telefunken has made history in electronics searching for new, innovative ways to control, process and utilize electric energy.

Today, closing in on our first centennial, we still endure our commitment to the advancement of the frontiers of semi-

conductor technology.

Our engineers and scientists throughout the world continue their search for ever faster, denser and more powerful semiconductor devices—always ready to meet the challenges of our demanding, complex times.

## AEG-TELEFUNKEN CORPORATION

U.S. Headquarters/Route 22-Orr Drive/P.O. Box 3800 Somerville, NJ 08876 (201) 722-9800 TELEX: 833409

Circle 54 on reader service card



the digital revolution rolls on, engineers will continue to go back to school, or take short courses, or sign up for self-study courses.

Ray Stata of Analog Devices points out that reeducation sponsored by companies could become a key ingredient in meeting the manpower shortage. Right now it may be cheaper to hire a new college graduate and fire the experienced but unprepared man, but increasingly companies will not have that choice, he predicts. "The issue of obsolescence as a result of changing technology and opportunity is one that has been with us all along and is still with us, perhaps to an accelerating degree," he says. "But I think the answer to it is . . . continuing education." Tom Slade disputes this viewpoint. He says that in his experience of interviewing job candidates at GI, "The ratio of good to bad EEs is running 50:50. . . . Age matters very little; I'll bet the obsolete engineers were obsolete when they left school."

What counts, says Stata, is the self-motivation of the individual engineer. Both Paul Ely of HP and Shanda Bahles of Millennium Systems see a lot of motivated EEs out there. They do not foresee significant increases in time spent on continuing education, simply because engineers are already putting as much time as they can spare into studying. Bahles expects company-sponsored education to continue to be popular, but new emphasis to go to self-study programs. She thinks formal continuing education will become less important because "five years out of school, whether you have a master's or a bachelor's degree makes no difference."

John Wilhelm confirms that the IEEE sees its members' acceptance of home-study courses growing but so is interest in any type of class that offers leading-edge technology. Another possibility would be midcareer internships, with both teachers and employed EEs moving into the other sphere of activity for a while.

Yet something else might happen, says DEC's Gordon Bell. "There will come a time when there will be

**Strange bedfellows.** One educational trend likely to pick up speed is increased use of computers. Rensselaer Polytechnic Institute, for example, installed a major new computing center, ingeniously converting a former church (and then a library) to house it.

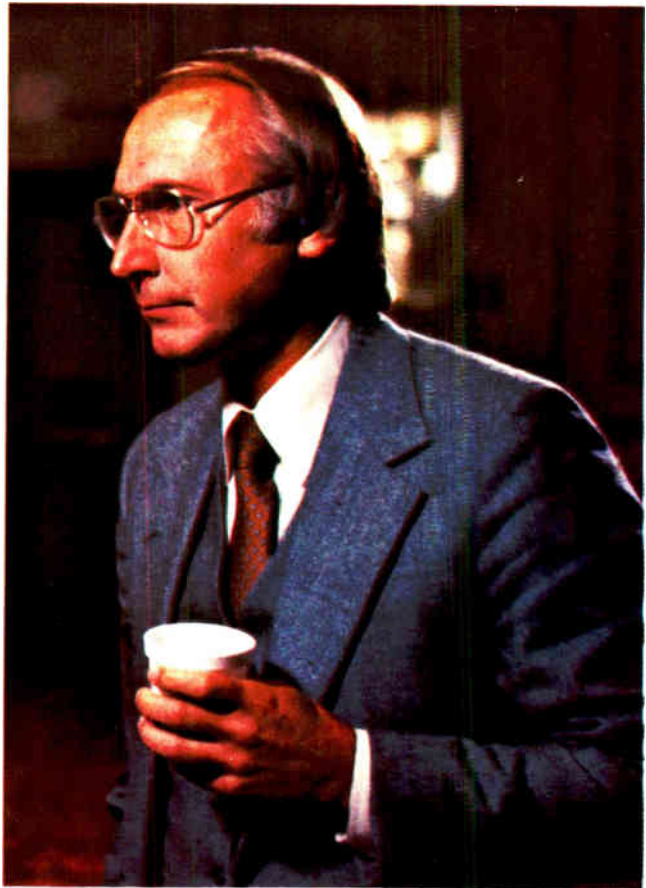

**Retraining a key.** What with the shortage of electronics engineers, companies will find it wise to invest in retraining, says Analog Devices' president Ray Stata. In fact, the troubling notion of an obsolescent EE itself will become outmoded, he maintains.

programs available—software, that is—that are of such sophistication and utility that they might make continuing education much less necessary than it is today." The hard work has already been done and need only be reduced to software. "One way of dealing with a lot of these very complex problems like continuing education and like the problems that engineering has solved is by packaging them and treating them like black boxes."

What Bell suggests has crucial, perhaps frightening, implications for the EE of the future. "I think that an engineer is basically a person with great intellectual curiosity whose skills lie in structuring complexity—solving problems in that fashion," he says. "I think his skills and his intellectual curiosity may be all he needs in the next 20 years to carry him through. He will either educate himself if he needs to be educated or learn to use the black-box, algorithmic approaches I've just mentioned to solve problems."

Yet, how alive will skills and intellectual curiosity stay if the person possessing them is simply plugging in software? Will not technological advance deteriorate if the collective level of intelligence atrophies? Perhaps Bell is only painting a picture of the routine, and the technological and social problems that remain will challenge the truly skilled and truly creative engineer—and with any kind of luck, perhaps there will be enough of these EEs to go around. □



# SUPERIOR

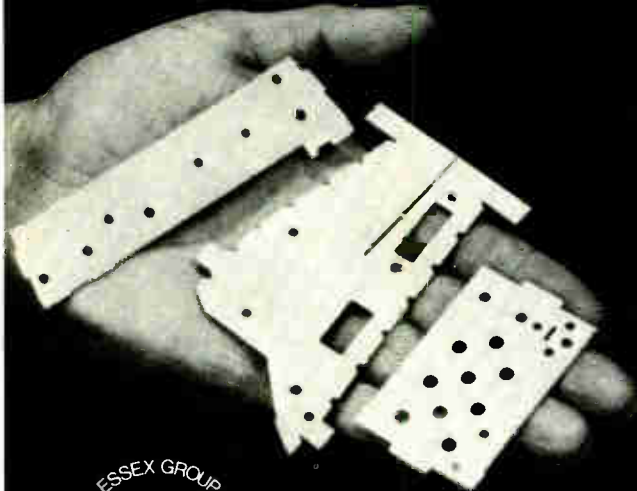

## ESSEX/MACALLEN Inorganic Micapaper Heater Plate

The superior technology of Essex/Macallen has led to the development of heater plates which feature high thermal properties; moisture, oil, and solvent resistance; improved mechanical strength and punching characteristics.

This same technology makes it possible for Macallen to offer micapaper high-temperature material as a replacement for asbestos-based materials both flexible and rigid.

Give us a call and we'll show you how Macallen micapaper heater plates fit your application. Available from Essex/Macallen, Newmarket, NH, 03857. Phone — 603/659-5555.

Circle 448 on reader service card

# RESISTS

ESSEX/SUFLEX Acryflex® FR sleeving is flexible 155°C. Underwriters Laboratories listed.

- RESISTS — solvent, varnish and oil attack.
- RESISTS — flame
- RESISTS — dielectric breakdown
- RESISTS — cracking from bending when hot or cold
- RESISTS — abrasion and cut through
- RESISTS — inventory build-up because it's used for Class 105, Class 130 and Class 155 applications

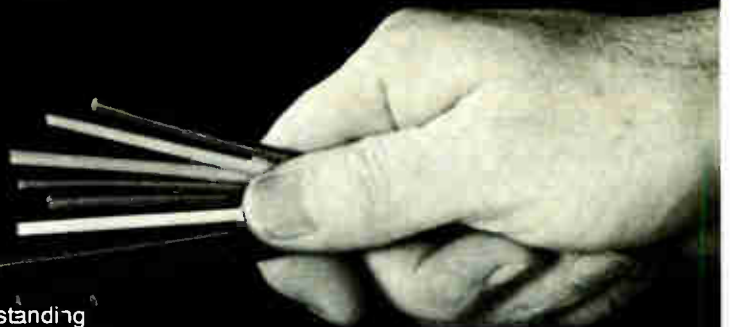

Acryflex FR — UL listed as FR-1 (VW-1) — is an outstanding sleeving for appliance, home entertainment and medical equipment manufacturers. All ASTM-D372 grades are available.

Samples, property data and prices available from the Essex/MWI Warehouse/Sales Centers or contact: Essex Magnet Wire & Insulation Division, Essex/Suflex, Newmarket, N.H. 03857. Phone: 603/659-5555.

**ESSEX GROUP**  Subsidiary of **UNITED TECHNOLOGIES**

**ESSEX/MWI Stocking/Sales Centers...The Distributor with Thoroughbred Lines**

Atlanta 404/482-8806 • Baltimore 301/644-C140 • Charlotte 704/394-1315 • Chicago 312/254-8787 • Cincinnati 513/771-6500 • Cleveland 216/781-2310 • Dallas 214/339-8346 • Denver 303/399-7782 • Detroit 313/772-264C • El Paso 915/545-1312 • Fort Wayne 219/461-4000 • Houston 713/680-1082 • Kansas City 816/842-1613 • Los Angeles 213/264-7000 • Lubbock 806/745-5733 • Memphis 901/775-1681 • Minneapolis 612/378-1111 • Nashville 800/343-0934 • New Orleans 504/522-3188 • Oklahoma City 405/236-5411 • Peabody 617/531-7100 • Philadelphia 215/647-8686 • Phoenix 602/258-4589 • Pittsburgh 412/242-5560 • Portland 503/665-0138 • Salt Lake City 801/972-2806 • San Francisco 415/692-5344 • Seattle 206/244-8986 • St. Louis 314/371-2516 • South Hackensack 201/621-4400 • Tampa 813/621-5545.

Circle 449 on reader service card

0-320

# In the past 20 years we've produced over 1,000,000 watts of solar electric power

And yet some of you haven't heard of us.

## From milliwatts to kilowatts

As we said, our business is providing solar electric power. It's been our major effort since 1958 when Vanguard I went into orbit. The solar cells that powered that grapefruit-sized satellite produced 6 milliwatts of electricity. Enough for Vanguard but not for its many offspring. Skylab, for example, consumed 11.5 KW.

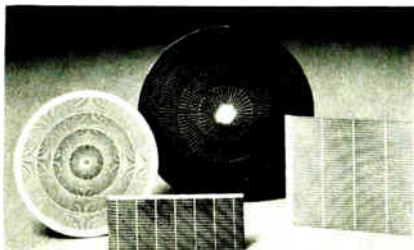

One sun, concentrator and space cells — all from Applied Solar Energy

Satisfying this fast growing need for solar power was no accident. It took some clever and innovative efforts by our scientists and engineers. The results of those efforts are now available for those of us with our feet planted firmly on the ground.

Applied Solar Energy is meeting earthbound challenges for solar power up to 110 KW with a full array of flat plate and concentrator cells, modules and engineered systems. The criteria for these products and services remain the

**We're Applied Solar Energy Corporation**, formerly the Photoelectronics Division of OCLI. The world's oldest and most experienced supplier of solar power for space and terrestrial applications. In fact, if you connected all the cells we've produced during the past two decades, you would generate over one megawatt of electricity.

Despite this record, we have something of an identity problem. And that disturbs us. So we'd like to take this opportunity to tell you briefly who we are.

same as those we meet for space ...high efficiency and reliable performance.

## Some straight talk on performance

Applied Solar Energy produces the most efficient photovoltaic cells available. No brag. Just fact. Proven time and again in government and private tests.

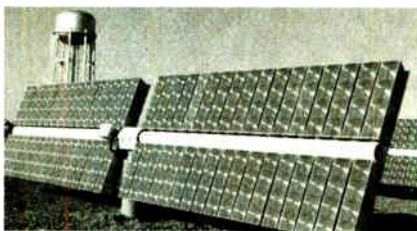

2 1/4" diameter concentrator cells from Applied Solar Energy are the heart of this point focus fresnel system

The reasons we are best are simple. We use the same high technology processing techniques for our terrestrial cells that we use for our space cells.

The result is more power from fewer cells with a longer service life. In fact, many of the thousands of solar panels we've put to work



Remote electrical packages are available in a wide range of power outputs

have been in constant use over 15 years. If this is the type of high efficiency and reliability that's important to you, let's discuss how we can put our solar electric power products to work for you. Call or write:

Applied Solar Energy Corporation  
15251 E. Don Julian Road  
City of Industry, CA 91749  
Phone (213) 968-6581  
TWX 910-584-4890

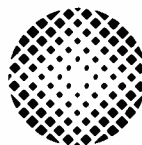

Applied  
Solar  
Energy  
Corporation





# Imagine the Synertek Z8.<sup>™</sup> A single-chip microcomputer with no limits.

For today's complex applications, other single-chip microcomputers are limited. Limited in architecture. Limited in instruction set. Limited in ROM/RAM addressing space. Limited in flexibility. Not so the Z8.

The incredibly sophisticated Z8 is the most powerful single-chip microcomputer available today. It combines the architecture of high-end general-register microprocessors with near limitless flexibility. Flexibility in addressing modes. Software configurable I/O ports. Multi-level programmable priority interrupts. Two 14-bit counter/timers. Integral UART/baud-rate generator. 144 registers. 32 I/O lines. And no limits on ROM and RAM expansion — up to 124K bytes! With processing power and addressing space like this, the Z8 is really a fully expandable microprocessor. And — at 8MHz — it's got the speed to match.

Everything you need to get up and running is available now: A complete floppy-based development system

with Z8 assembler and simulator. Comprehensive data sheet. Technical manual. And the 64-pin Z8-02 works

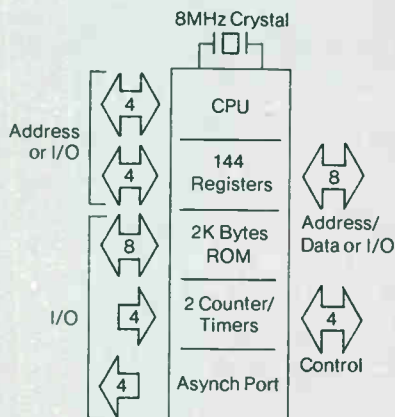

with external EPROM to allow full software/hardware testing and debugging — before you commit to mask ROM 40-pin Z8s. A host of additional development tools are in the works right now. The Z8 is here and now. Alternate

sourced, too. When it comes to production quantities of the amazing Z8, find out how our unique capabilities in high-volume MOS LSI manufacturing work for you. For samples and our complete Z8 information packet, contact Microprocessor Marketing direct at (408) 988-5614. TWX: 910-338-0135.

**Synertek performs** as a major MOS supplier of high volume parts with advanced technologies and techniques behind everything we make. ROMs. Static RAMs. EPROMs. Custom circuits. Single-chip Microcomputers. Systems. 6500 Microprocessors and Peripherals.

Z8 is a trademark of Zilog



**SYNERTEK**

3001 Stender Way, Santa Clara, California 95051  
(408) 988-5600. TWX: 910 338-0135.

Circle 59 on reader service card



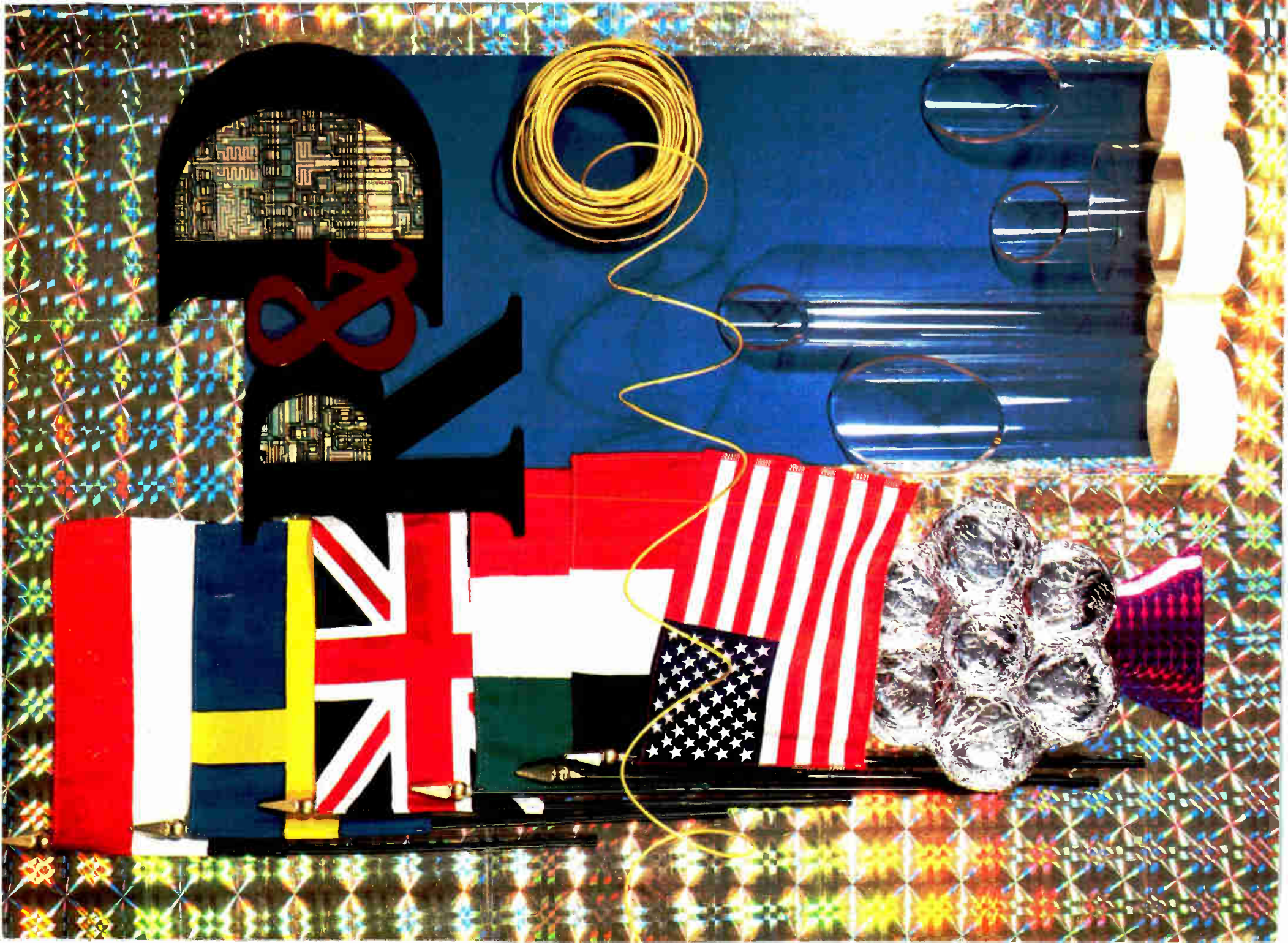

# INDUSTRIES

---



IN SHAPE AS  
WELL AS IN  
SUBSTANCE THE  
ELECTRONICS

INDUSTRIES WILL  
CHANGE BY THE TURN  
OF THE NEXT CENTURY.  
THE MOST DISCERNIBLE  
MOVEMENT WILL BE  
AN ACCELERATED  
INTERNATIONALIZATION.  
A CONSOLIDATION  
INTO A FEW LARGE  
ACROSS-THE-BOARD  
MULTINATIONAL  
COMPANIES COULD  
HAPPEN, WITH NICHE  
LEFT FOR SOME SMALL  
SPECIALTY HOUSES.  
ALMOST CERTAINLY  
THERE WILL BE A  
ROUTINE EMPHASIS ON  
WORLDWIDE SALES BY  
COMPANIES OF  
ANY SIZE. NORTH  
AMERICA'S GRIP  
ON INNOVATION  
WILL LOOSEN,  
AND ELECTRONIC  
TECHNOLOGY WILL  
BECOME TRULY THE  
PROPERTY OF NO  
SINGLE NATION OR  
GROUP.





**Getting together.** Panelists are (standing, left to right) Standard Microsystems' Paul Richman, Bell-Northern's Gordon B. Thompson, and Intel's Gordon Moore. Seated are (left to right) IBM's Ralph E. Gomory, TRW's Simon Ramo, Carl Carman, and TI's George Heilmeier.

The electronics industries will look different 20 years from now, at the start of the 21st Century. That is an easy prediction, in the light of the last 50 momentous years.

Now comes the difficult part: just how different will the electronics industries look? Will the structure be close to today's, with recognizable companies making recognizable products, or will there be an evolution toward just a few large, broad, and all-encompassing supercompanies dominating every market from consumer to communications, industrial to defense? It can be argued that such a movement is already under way, what with semiconductor makers spreading into the computer business and computer manufacturers extending into the communications industry, and so on.

Here is another conundrum with which to wrestle: were such consolidations to happen, where would the innovation come from? Traditionally, advances in electronic technology have emerged from the small, shoe-string operation started by an entrepreneur who had an idea and wanted to bring it to the marketplace. If such operations no longer flourish, will there be room for such pioneering in a supercompany with its carefully structured parts and its zealously guarded table of organization? Is not the nature of such concerns to busy themselves with making and selling many products rather than to nurture innovation?

Another current is running strong through electronics: internationalization. The world of technology is shrinking. Roughly 50% of the advances are now coming from

the U. S., but that is a sharp reduction from the years when the rest of the world was years behind the Americans in introducing new ideas. Japan and Western Europe are no longer imitators; what will they be at the turn of the century?

With all these forces for change, it may seem that evolution is inevitable. Yet there are certain limitations that must be taken into account: limitations to what people can accomplish, to what the industries can do, and, of course, to what the technologies can do. The question is whether any of these limitations is insurmountable, or if any will hinder progress.

There is no question that the fields to watch will be computers, communications, and semiconductors. Within these fields, however, there are manifold considerations to ponder when forecasting the shape of things to come. Advances there will be, but what kinds and how significant?

This is where we stand as the ninth decade of the 20th Century begins. Things are changing: just how much will they change in the next 20 years?

**P**rognostication is at best a chancy business. However, the people best qualified to foretell the shape of the future are those who have done so much to mold the present. *Electronics* has asked some of those leaders of the electronics industries to look 20 years down the road. The magazine's editors interviewed

them around the world, at their workplaces, on the move between cities, and even in their homes.

The centerpiece of those efforts, however, was an extraordinary convocation in New York. In an all-day discussion with the editors on Sept. 13, 1979, they offered their vision of what the electronics industries will be like in the early years of the 21st Century. Those industry heavyweights were:

■ Carl D. Carman, then vice president for engineering at Data General Corp. in Westboro, Mass., where his responsibility was the engineering of computers, peripheral equipment, and related products for the minicomputer maker. He is now vice president for engineering at NBI, a Boulder, Colo., word-processor vendor. He has served as assistant to the president of Storage Technology Corp. in Boulder and as director of engineering at Inforex Inc. in Burlington, Mass. He has bachelor's and master's degrees in electrical engineering from the University of Kentucky.

■ Ralph E. Gomory is responsible for International Business Machines Corp.'s Research division laboratories in Yorktown Heights, N. Y.; San Jose, Calif.; and Zurich, Switzerland. A mathematician, he has been with IBM since 1959 and was appointed director of research in 1970. He has published more than 40 papers in pure and applied mathematics and in 1964 was winner of the Lanchester Prize of the Operations Research Society of America. Also in 1964, he was named an IBM Fellow. He was a member of the council of the National Academy of Sciences in 1977-78. He received his BA from Williams College and his Ph.D. from Princeton.

■ George H. Heilmeier, vice president of research, development, and engineering at Texas Instruments Inc. in Dallas. He holds 15 patents in molecular and liquid crystals. As assistant director of defense research and engineering for the Department of Defense from 1971 to 1975, Heilmeier formulated major new initiatives in microwave tubes, fiber optics, infrared systems, charge-coupled devices, and radiation-hardened complementary-MOS devices on sapphire; he then served as director of the Defense Advanced Research Projects Agency from 1975 to 1977. Before those stints, he was at RCA Laboratories in Princeton, N. J., from 1958 to 1970. He holds a bachelor's degree in electrical engineering from the University of Pennsylvania and a master's and Ph.D. from Princeton.

■ Gordon E. Moore, chairman and chief executive officer of Intel Corp., Santa Clara, Calif. He was a member of the technical staff at Shockley Semiconductor Laboratory and director of research and engineering for Fairchild Semiconductor before going on to found Intel with Robert Noyce. He holds a bachelor's degree from the University of California at Berkeley and a Ph.D. from California Institute of Technology. He received the first *Electronics* Award for Achievement.

■ Simon Ramo, vice chairman of TRW Inc. in Cleveland and chairman of its executive committee. He served as the chairman of the President's Committee on Science and Technology, 1976-77; on the Advisory Council to the Secretary of Commerce, 1976-77; and as a member of the White House Energy Research and Development Advisory Committee on Science and Foreign Affairs,

1973-75. He is the author of "Cure for Chaos" (1969), "Peacetime Uses of Outer Space" (1961), and "Guided Missile Engineering" (1959). He holds a BS from the University of Utah and a Ph.D. from California Institute of Technology. He has been president of Space Technology Laboratories and chief scientist of the U. S. intercontinental guided missile program and was a founder of the Ramo-Woolridge Corp. He is a 1979 winner of the National Medal of Science.

■ Paul Richman, president of Standard Microsystems Corp., Hauppauge, N. Y. He holds the basic patents for the Coplamos and Clasp MOS technologies and is author of "MOS Field-Effect Transistors and Integrated Circuits" (1974) and "Characteristics and Operation of MOS Field-Effect Devices" (1967). He was vice president for R&D at Solid State Data Sciences Corp. and a senior development engineer at General Telephone & Electronics Corp.'s central research laboratories. With a BS in electrical engineering from Massachusetts Institute of Technology and a master's from Columbia University, he is a visiting professor of electrical sciences at the State University of New York at Stony Brook. He received *Electronics'* 1978 Award for Achievement.

■ Gordon B. Thompson, manager of communications studies at Bell-Northern Research Ltd., Ottawa, and the holder of 13 Canadian and 11 American patents. In his career with Bell-Northern Research and Northern Electric, he has worked as development engineer for communications equipment and a supervisor of audio and video products and systems design and has made studies of information technology and socioeconomic systems.

In evolving a scenario for the next 20 years, the participants in the forum managed to arrive at a consensus. Since no one can predict revolutions, what emerged is a belief that change would be evolutionary, a continua-



**World competition.** TRW's Ramo sees a "contest between a free world economy, in which money and resources move freely around the world, and the isolation and protectionism of some national groups" still going on 20 years from now.



tion of forces already set in motion by the enormous technological impact of solid-state circuitry and, more particularly, the computer and the microprocessor.

Intel's Gordon Moore perhaps put it best when he said that the structure of the electronics industries would not change so much that it would be unrecognizable.

"I see a general split between companies whose principal business is in making the hardware and companies whose principal business is in applying it to the solution of the problems. It's not going to be a clean split: most companies will have some distribution across the entire spectrum. But companies will tend to peak their capability in one direction or the other."

However, Moore expects that technologies will not be restricted to just a few companies apiece. "I'm sure we'll see the general technologies that are important much more broadly diffused through the industry. Any significant systems company will have a significant solid-state electronics operation, for example, and vice versa. But the electronics industry is going to be very, very diverse. While it's going to have a number of large companies, it's still going to have a very large number of relatively small companies that will specialize in particular areas."

This setup will carry over even into the components business, says Moore. In semiconductors, for example, "there will be a number of producers of relatively large quantities of standard products; there will be a lot of companies producing more for their internal systems. This will result in a lot of different companies doing semiconductor work. That's been a dramatic change over the last half dozen years already."

**B**ut will there be any major technological changes in the next two decades? The answer, says Gordon Thompson of Bell-Northern Research, may be economic: "The higher the inflation rate, the faster new technology will be sucked into use." TRW's Simon Ramo points out, though, that new technology is not product development. Nevertheless, Ralph Gomory of IBM thinks that "we're going to wiggle our way to an awful lot of advances."

Of course, the wide diffusion of technology predicted for the decades ahead is already under way. Such diffusion and diversity, however, are not limited to individual industries: they are proceeding apace, with the planet itself providing the only boundaries. In the past five years, news of another step forward coming from, say, Japan or West Germany has received the attention that used to be reserved for U. S. developments only. That is a major change.

Gomory warns that while other people have been used to getting ideas from abroad, the sensation is a new one for Americans but one that they had better become accustomed to. For example, he says, "the pace of discovery in Europe is equal to that of the U. S., whereas it wasn't a short time ago. We may have ideas, but other nations sometimes apply them faster."

Such technological parity is accompanied by increased investment of foreign firms in American companies, as well as takeovers by big U. S. firms. "I don't see it going completely that way," says Moore, "but there are rela-

## Europe looks toward the 21st Century

With advanced electronic technology becoming a worldwide phenomenon, any prediction of the shape of the next 20 years must include the views of overseas industry leaders. In Europe, for example, many leaders expect consolidation and internationalization to shape the electronics industries—but many also think the U. S. will comfortably maintain its technology lead through 2000.

One of the best-qualified companies to undertake such prognostication must be NV Philips Gloeilampenfabrieken of Eindhoven, the Netherlands. With sales in 1979 of more than \$17 billion, Philips is a multinational company—it prefers to call itself a "federation of companies"—that is by far the largest of the electronics conglomerates outside of the U. S.

The most striking change, as enunciated by Winfried van 't Hoff, director of the firm's components division, Elcoma, is one of maturation. "The stage when a few geniuses set the pace has long since passed," he says. "Solid-state production has become too capital-intensive and the market positions too entrenched for a new small company to find an opening." Leo Heesels, a member of Philips' 11-man board of management, agrees with this point of view. "For many advanced products, an integration of several technologies is needed," he says, "and small companies don't have broad enough applications know-how to embrace them all."

Ferdinand Rauwenhoff, Elcoma's managing director for production, believes that the increasingly sophisticated solid-state technologies seem sure to be worked only by giant companies. But that is where the smaller firms also will find a niche: they will be able to strike oil where the software content of a system or product is high.

At ITT-Europe headquarters in Brussels, Karl M. Schmidt, audio product line manager, predicts that if the U. S. does not have another space program, "its technology lead could be cut from 50% to 30% by 2000." Speaking of semiconductors, Jack Shields, technical director, pinpoints first-class manufacturers of production equipment as the pacing factor in the U. S. dominance. The Japanese? "I don't see them gaining the upper hand in semiconductors," says Schmidt, "because in Japan demands for better living will increase and costs will go up."

Marketing director D. M. Hamm thinks that if the U. S. can still nurture small companies it will maintain its semiconductor lead because smaller companies are so close to the marketplace.

In computers, the ITT officials see changes coming about because of software costs. "I see a shift in training engineers from hardware to software," says Schmidt, adding that the costs will mean that software will no longer be a free service.

ITT-Europe vice president Heinz Roessle has a slightly different view of the shape of the industry. "The trend toward diversified company structure will accelerate," he says. Member companies of large international organizations—like ITT—will increasingly cooperate across national boundaries. This will make sense because national markets will be too small to support the companies.

Such strategy, adds Roessle, also will benefit small companies "if they are prepared to take risks and think international." He points to Intel Corp., the Santa Clara, Calif., semiconductor leader, as one that has succeeded with just such a strategy. He is convinced that the U. S. will maintain its lead in electronic technology for some



**Philips seers.** Ferdinand Rauwenhoff (left) says new solid-state technologies will emerge from big companies. Winfried van 't Hoff believes that small firms will not find an opening.



**Bigness will win out.** Leo Heesels, a member of the Philips board of management, thinks that small companies will be unable to handle the needed integration of several technologies.

time to come because it has "the kind of society that fosters innovations, a society that rewards those who advance technology and open up new frontiers." As for Japan, Roessle believes that it will play a pace-setting role in many technical fields.

In France, opinion also leans toward the consolidation scenario for the electronics industries. Erich Spitz, director of Thomson-CSF's central research laboratory in Orsay believes that "real, serious research will be done almost exclusively in large labs." The reason: "Everything will be conceived in terms of large complex systems," making it virtually impossible for small or even medium-sized companies to carry out major research programs.

On the whole, he believes that the U. S. will keep its position as the technological leader, even though internationalization is inevitable. "The differences between American and European companies will grow smaller and smaller. In 20 years, all large companies will be international companies," he says. The Czech-born research chief says that electronics will play a major role in solving problems that threaten the very existence of mankind. "It may stem from an energy crisis, or something else. In 20 years, hundreds of thousands of electronics engineers may be working on solutions to energy-related problems. As a spur for new technologies, "the energy crisis might well turn out to be akin to World War II."

For Jean-Claude Pelissolo, director of the French government's electronics and computer industry agency, the Direction des Industries Electroniques et de l'Informatique, it is a foregone conclusion that the future will hold

more multinationalization. Pelissolo, who is also a member of the board at CII-Honeywell Bull, the large French computer maker, adds that many of the largest groups will be based outside the U. S. — possibly in France or other European countries.

The European data-processing market is growing faster than that in the U. S., he says, and should constitute 30% of the world market by 1990. Pelissolo sees Europe shrinking the U. S. technological lead in coming years because Europe is becoming more like America in building markets that encourage innovation.

In Britain, an expert on silicon technology sees a different sort of picture for 2000. He is Derek Roberts, director of research at General Electric Co. Ltd., Britain's largest electrical company and a former managing director of Plessey Microsystems Ltd. Talking about the advances in microcircuits, he says, "The technology is running ahead of our ability to exploit it."

Though the million-device chip promises an era of runaway computer power, Roberts cautions that it is not that easy to see markets and applications for such devices that are wide enough to recover the design cost of such complex products. Also, they create a testing problem.

As a result, he sees the semiconductor industry polarizing in two directions. First, the traditional vendors will specialize in very large-scale integrated products, with high-volume potential "producing silicon by the square mile." Second, an increasingly significant sector of the industry will provide job-shop services for devices needed in medium- and small-scale integration.



**PROJECTION MASK ALIGNER**

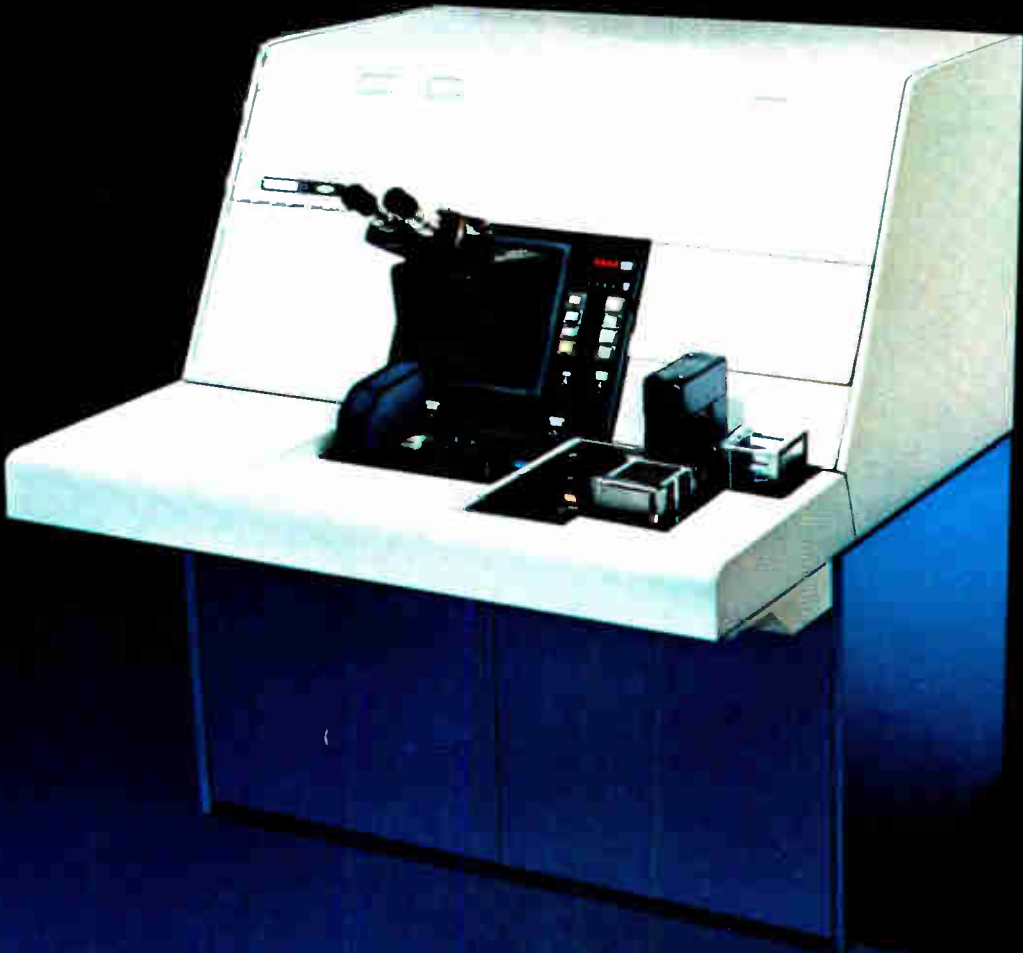

# Introducing the Micralign<sup>®</sup> 200 Series. Higher throughput than step-and-repeat at a much lower price.

Perkin-Elmer designed the new Micralign Model 200 to be the most cost-effective projection mask aligner available. In performance, it achieves 2-micron geometries or better in production, distortion/magnification tolerance of 0.25 micron, and 4 percent uniformity of illumination. Options available include automatic wafer loading and automatic alignment. Soon to be available: deep UV optical coatings for still smaller geometries.

Compared to the leading step-and-repeat aligner, the Micralign Model 200 delivers outstanding performance for not much more than half the cost. It takes about a quarter of the floor space. It provides consistently higher throughput regardless of die size.

The Model 200's remarkable performance is the result of a number of major innovations.

#### **Improved optical design and fabrication**

We improved the optical design to provide increased resolution

and depth of focus. Optical manufacturing tolerances are five times tighter to ensure precise overlay from aligner to aligner.

#### **Near-zero vibration**

We minimized vibration. We constructed the Model 200 with two frames—one inside the other. The inner frame, which carries the projection optics and carriage drive, is completely isolated from the outer frame.

We incorporated a superb linear motor carriage drive with air bearing slide. This drive does more than eliminate vibration. With the air bearing feature there's no contact and no wear. And no limit to carriage drive durability.

#### **Built-in environmental control**

We provided the Model 200 with a built-in environmental chamber. External air, supplied by you or from our optional air conditioning system, is blown through a HEPA filter and heating elements built into the Model 200 top cover. A positive-pressure, class 100 environment is carefully controlled to better than 1°F.

We included a separate thermal control for the mask, to compensate for mask run-out.

#### **No mask contamination**

We designed a sealed mask carrier for the Model 200. You put the mask in the special carrier right in the mask department. Seal it. When you load the sealed carrier in the Model 200, the cover plates are automatically removed. After use, the cover plates are automatically replaced.

#### **Proven production capabilities**

Perkin-Elmer, the leader in projection mask alignment systems, offers six years of proven production capability, with an excellent training and service record.

#### **Get all the facts**

These are just a few of the features that make the Micralign Model 200 Series a completely new concept in projection mask aligners. Get more details on how these and other improvements in design can translate into improvements in your production. For literature, write Perkin-Elmer Corporation, Electro-Optical Division, 50 Danbury Road, Wilton, CT 06897. Or phone (203) 762-6057.

**PERKIN-ELMER**

Circle 60 on reader service card



**ELECTRONIC SYSTEMS · OPTOELECTRONICS ·  
MICROWAVE · ASSESSMENT SERVICES ·  
RADAR · MARINE & SONAR SYSTEMS ·  
COMMUNICATIONS · MILITARY COMMUNICATIONS ·  
TELECOMMUNICATIONS · OFFICE SYSTEMS ·  
MICROSYSTEMS · COMPONENTS · RESEARCH ·  
COMMAND & CONTROL · CAPACITORS ·  
SEMICONDUCTORS · CONNECTORS ·  
MATERIALS · PERIPHERAL SYSTEMS ·  
TRAFFIC CONTROLS · MILITARY COMMUNICATIONS ·  
INTEGRATED CIRCUITS · RADAR · MARINE & SONAR ·  
CAPACITORS · SEMICONDUCTORS ·  
ASSESSMENT SERVICES · ELECTRONIC COMPONENTS**

Plessey is a world leader in electronics and communications, operating internationally from its base in the United Kingdom. In the United States Plessey activities are concentrated in the areas of integrated circuits, precision metals, computer peripheral systems, electronic and electrical systems and electronic components.

Plessey Incorporated, 277 Park Avenue, New York, New York 10017.

ONICS · AVIONICS · COMMUNICATION  
S · WOUND PROTECTORS · SATELLITE S  
· OFFSHORE · AEROSPACE  
MUNICATIONS · SYSTEMS · O  
TEMS · FACTORS  
SISTO  
S · W  
LECT  
CONN  
MUNIC  
INE & SUB  
VIONICS · COMMUNICATIONS · CONN  
E SYSTEMS · COMPONENTS · OFFICE S

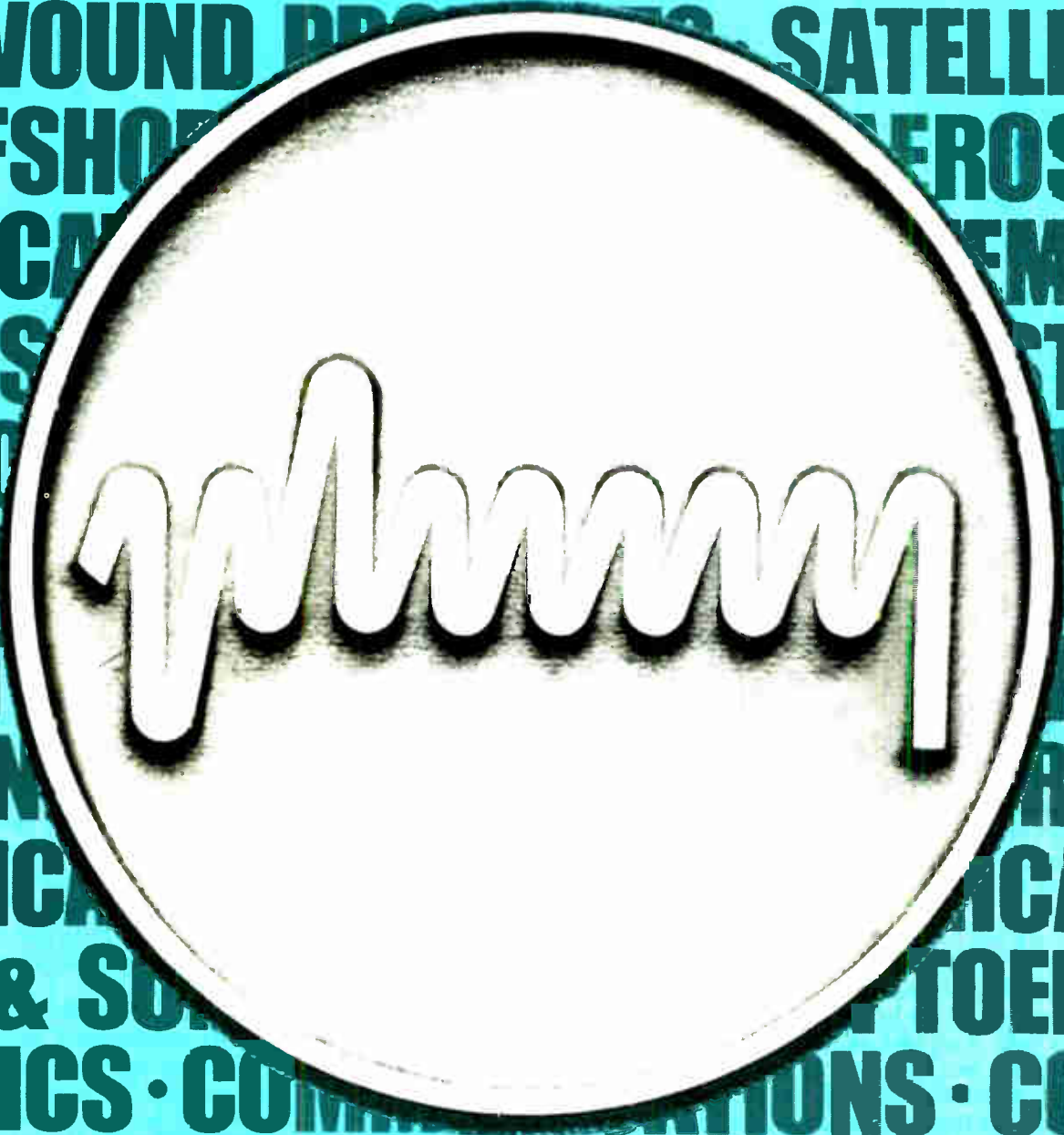

# **PLESSEY GROUP**

*keeping ahead in Electronics*

The Plessey Company Limited, Ilford, Essex, United Kingdom IG1 4AQ.

Circle 61 on reader service card





**More in less.** TI's Heilmeier expects nonmilitary spread-spectrum communications to proliferate. With everyone using the entire band instead of dividing it along time or frequency lines, every school could have its own uhf channel to broadcast homework.

tively few semiconductor companies, for example, that do not have some ownership by either a large U. S. or a large foreign systems house these days. Of itself, I see the trend as neither healthy nor unhealthy. I would like to see more independent semiconductor companies around, but that may be too much to hope for. It is getting harder and harder to start a new semiconductor company these days because the costs have risen so much in the last 10 years." The upshot, then, is that large systems houses, looking for semiconductor capability, will continue to buy into existing enterprises rather than embrace the capital risk of launching their own.

Ramo views the movement toward internationalization as a battle for technological supremacy, one that will still be going on in 2000. "Twenty years won't see completion of the contest between a free world economy, in which money and resources move freely around the world, and the isolation and protectionism of some national groups. The U. S. can at most hope to provide 50% of the technological advance over the next 20 years rather than the 90% or 95% it has become accustomed to," he says. Any new companies in the future will be set up with world marketing ambitions right from the start. "In 2000, the thinking of American companies will be required to be more international, but the idea that the U. S. is losing creativity is nonsense," he maintains.

Gomory sees as one of the important questions in the

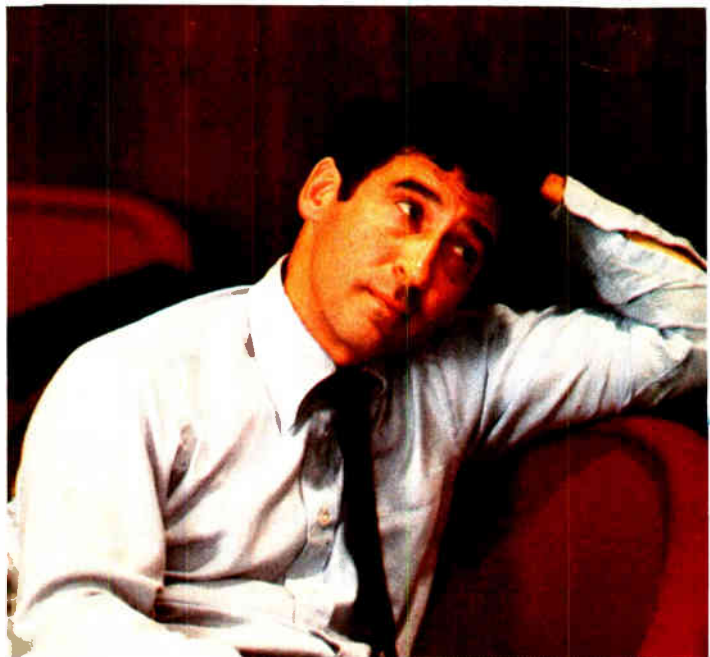

**A new receptiveness.** IBM's Gomory says the experience of getting ideas from abroad is a new one for Americans, but they had better get used to it. He says that "the pace of discovery in Europe is equal to that of the U. S., whereas it wasn't a short time ago."

future: "How are we going to do against the Japanese? I think we do pretty well against controlled economies, but the problem is how are we going to do against another free economy like the Japanese?"

The answer, as he sees it, must take into account the difference between Japanese and American approaches to technology. "Those viewing the Japanese scene tend to see it, from a very great distance, as the degree of cooperation of the government with their various industries. But my impression is that they have very, very good engineering and that they are dedicated people who take great pride in designing good products. They simply get a lot of terribly good engineering per dollar. It's those people we're competing against, as well as the Japanese government."

Texas Instruments' George Heilmeier maintains that technology always was an international property. From the economic and marketing standpoint, internationalization may be a fairly recent phenomenon in the widespread form that we know it, he says. "From a technology standpoint, we might think today that we're seeing a diffusion of electronics know-how around the world and that represents the internationalization of technology. But that's just a part of an ongoing saga; it's been happening since the dawn of technology—it has always been international." Still, the bottom line is the same: it would appear that for electronics companies, the world will become a smaller place by the time the 21st Century is rung in.

One element in that picture that deserves more than just passing mention, says Paul Richman of Standard Microsystems, will be the role of government. "Something that will be fundamental in determining the shape of the electronics industries in the year 2000 is the relative mix of large and small companies," he says. "Also, one of the things that has resulted in the tremendous amount of progress that the industry has made over the last few years is something that is highly American, and that is the free-enterprise system and the ability of



**Mass termination from AMP.  
Technology's most economical  
connection to the future.**

Circle 62 on reader service card



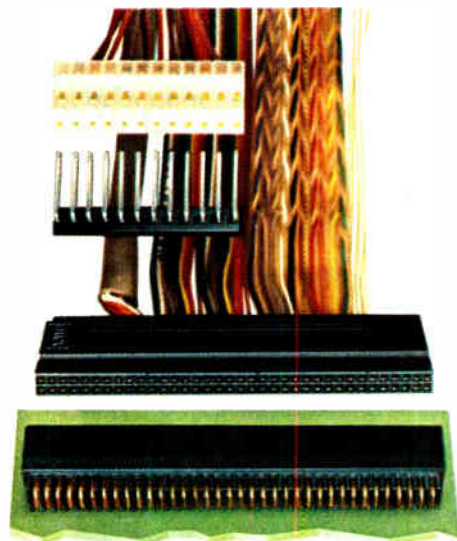

**Mass termination leadership:  
Total system capability  
for discrete wire and  
twisted pair cable.**

When your design calls for discrete wire or twisted pair cable, we have three complete mass terminated interconnection systems that are designed to give you reliable connections and save you money in the process. Namely, the **MTA .100" and .156"  $\phi$  single row interconnection system, featuring:**

- reliable wire-to-post or card edge interconnects
- capability to mix wire and cable
- high speed application tooling for complete harnesses in seconds
- tin or gold plate
- power capability

**.100"  $\phi$  double row AMPMODU interconnection system, with features like:**

- higher density capability
- capability to mix wire and cable in the same assembly
- unique contact design which incorporates insulation support
- modular housing designs
- complete line of headers with over 4,000 variations.

**For .085" centerline applications, use the CHAMP connector system, which features:**

- telecommunications-style housings
- wire-to-wire, wire-to-panel, or pc board application capability
- IEEE #488 interface
- jacketed cable capability

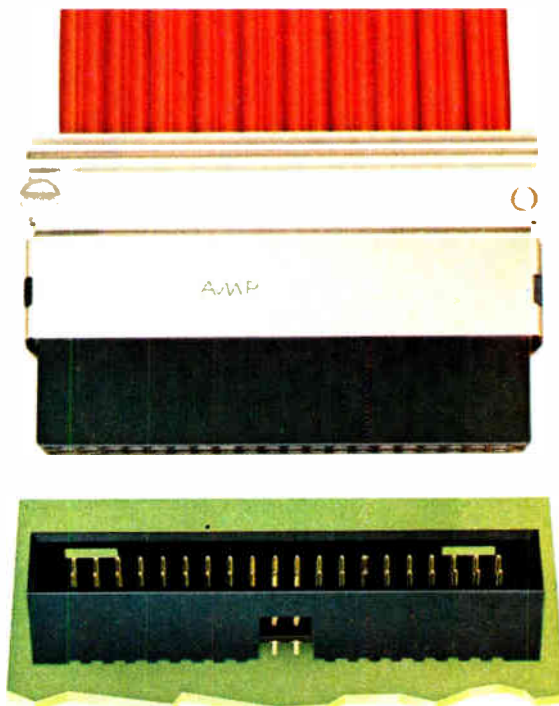

**Mass termination leadership:  
The only mass terminated  
coaxial cable  
in the world.**

Thanks to an AMP breakthrough in ribbon coaxial cable design, you can cut your coax cost with mass termination. In any length assembly you require, and without degradation of system performance or the need for board redesign.

The reason is that our ribbon coax cable is made up of individual coaxial cables, each with a solid center conductor and a foil wrapped drain wire shield. Enabling you to make reliable mass terminations anywhere along the cable.

**We also have a complete line of ribbon coax cable and connectors that feature:**

- 50, 75, or 93 ohm ratings on .100" centers
- 95 ohm rating on .125" centers
- standard .0252" post mating and paddle board types
- board mount pin headers and I/O post compatibility

Together, our connectors and cable provide a reliable, multiple circuit assembly that is unmatched in simplicity of design and ease of termination. So whether you order complete assemblies, or opt for the cable, connectors, and tooling to make your own, your coax applied costs go down.

For more information on this and other mass termination capabilities, call the Mass Termination Information Desk at (717) 780-8400. Or write us. AMP Incorporated, Harrisburg, PA 17105.

AMP has a better way.

**AMP**

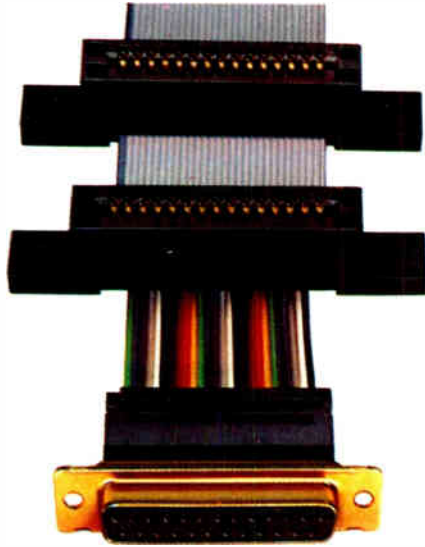

**Mass termination leadership:  
Total system capability for  
.050"  $\Phi$  Ribbon Cable.**

Four complete assembly systems give you all the capability you'll ever need in .050" ribbon cable.

**The AMP-LATCH and AMPMODU .100"  $\Phi$  two row interface systems, featuring:**

- compatibility with over 4,000 header variations
- post, receptacle, paddleboard, DIP, and card edge styles
- capability to mix wire and cable in the same assembly
- mass terminated shielded cable capability without cable preparation
- daisy chain capability
- precision tooling and cable for lower rejection rates
- assemblies on quick delivery
- compatibility with 20 to 30 AWG cable

**For RS 232 applications, there are AMPLIMITE HDF connectors, which feature:**

- subminiature D configuration
- choice of 9, 15, 25, or 37 positions and mating headers
- daisy chain capability
- compatibility with AMP filtered connectors

**And, for .085"  $\Phi$  application, there are CHAMP connectors, featuring:**

- telecommunications-style housings
- wire-to-wire, wire-to-panel, or pc board application capability
- IEEE #488 interface
- jacketed cable and discrete wire capability

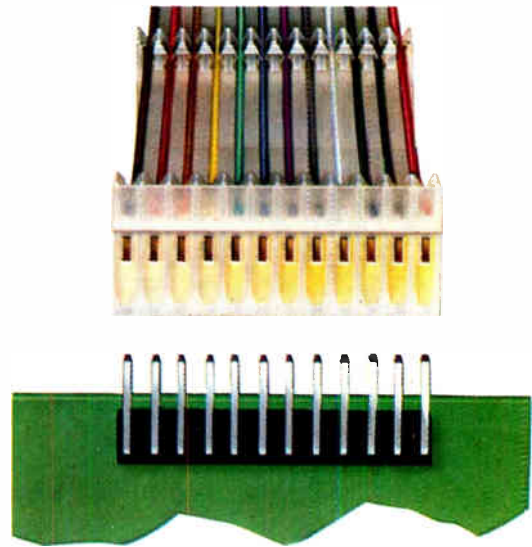

**Mass termination leadership:  
Total system capability  
in webbed cable.**

AMP gives you three complete interconnection systems that cover every conceivable application. With the tooling, headers, mounting hardware and technical support that goes with them.

**MTA is our .100" and .156"  $\Phi$  single row connector family. And it features:**

- reliable wire-to-post connections
- capability to mix wire and cable in the same housing
- tin or gold plate

**Choose the AMPMODU system for .100"  $\Phi$  double row applications. With these features:**

- higher density capability
- wire and cable in the same assembly
- unique contact design which incorporates insulation support
- modular housing designs
- complete line of headers—over 4,000 variations
- compatibility with 20 to 30 AWG cable

**The CHAMP connector system is also available for webbed cable applications, featuring:**

- telecommunications-style housings
- wire-to-panel or wire-to-wire capability
- IEEE #488 interface
- jacketed cable and discrete wire capability

Together, these three systems give you all the capability you'll ever need in webbed cable applications. Plus the cost-effectiveness of mass termination every time you apply them.

For more information on these and other mass termination capabilities, call the Mass Termination Information Desk at (717) 780-8400. Or write us. AMP Incorporated, Harrisburg, PA 17105.

AMP has a better way.

**AMP**

Circle 62 on reader service card



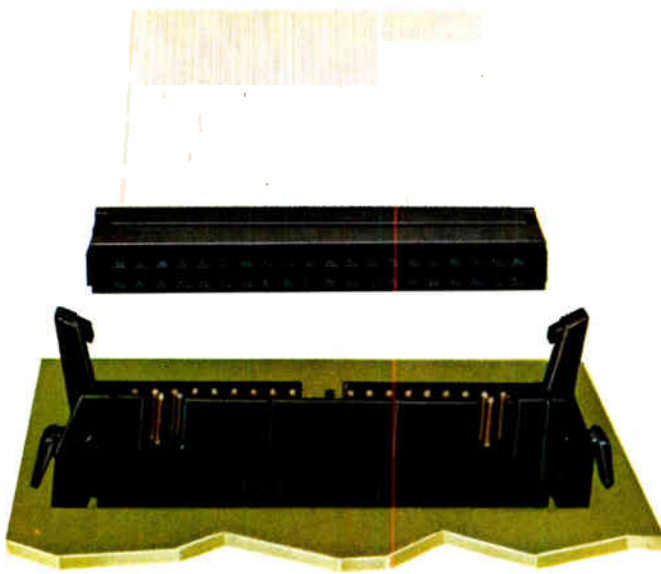

**Mass termination leadership:  
Unmatched cost-effectiveness  
in transmission  
cable assembly.**

Now you can have all the performance advantages of transmission cable—and the cost-saving advantages of mass termination in one easily applied, completely solderless assembly.

We can offer you these benefits because when we mass terminate, it's done with slotted-beam technology. That means you can use a more economical cable because the need for expensive heat resistant dielectric is eliminated.

**Here are some of the features you get with our transmission cable connectors:**

- designed for 50, 75, 90, or 100 ohm cable on .025"  $\text{C}$
- compatible with shared or separate ground cables
- redundant dual gold-plated spring members at the contact/post interface.
- .100" x .100" or .125" x .250" industry standard interface
- common grounding buss
- selective ground pin out with programmable application tooling that terminates in 40 seconds

The features of our connector combine to give you an assembly with more controlled impedance. And that means you've got the extra signal integrity to run higher data rates. Reliably. And with the kind of cost-effectiveness never before available.

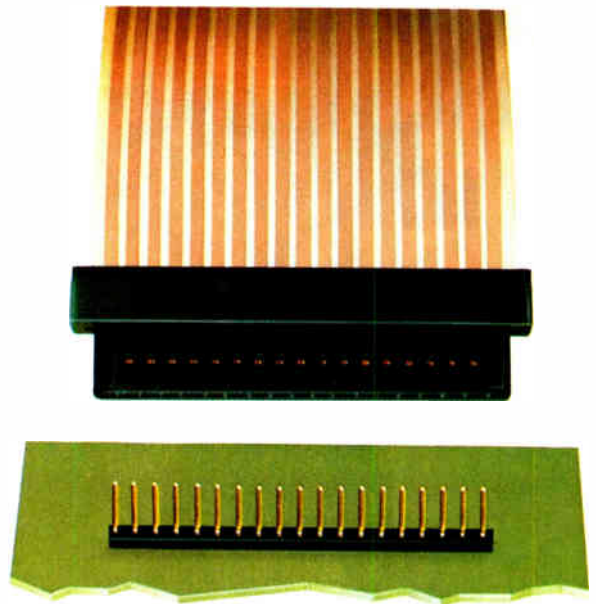

**Mass termination leadership:  
Ideal solutions in 3 amp flat  
cable, and flexible circuitry.**

The advantages of Flat Flexible Conductor cable—greater vertical density, flexibility to stress, and 3 amp capability—are almost as obvious as the need for a cable to deliver these advantages consistently. Our solution to this need is just such a cable. And the interconnection system to match. Together they constitute a better way in FFC assemblies.

Beginning with the cable, AMP developed a unique manufacturing process. Instead of electrodeposition or etching, we use a superior bonding technique to bond the conductor to the insulation. We then score it and strip off the excess conductor. This results in precisely controlled width, thickness and spacing. And that means unprecedented quality and variety in conductor configuration.

**But that quality doesn't stop with the cable. We also offer the high quality connectors to match. They feature:**

- intermateability with AMPMODU headers
- insulation displacing contacts for greater reliability and no cable preparation
- single or double row housings
- pin, receptacle, card edge, and solder tab styles
- capability to mix flat cable and discrete wire in the same housing
- conductive ink capability

Of course, we also provide all the application tooling and technical assistance you need. Or you can opt for completed FFC assemblies made by AMP. Either way, we've got a better way.

For more information on this and our other mass termination capabilities, call the Mass Termination Information Desk at (717) 780-8400. Or write us. AMP Incorporated, Harrisburg, PA 17105.

AMP has a better way.

**AMP**

## The coming VLSI industry

One man especially well equipped to look to the year 2000 is Richard L. Petritz. A long-time electronics venture capitalist and entrepreneur, he was a principal founder of Mostek Corp. in Carrollton, Texas, which today is one of the leading semiconductor memory makers. Most recently he organized Inmos Corp., another semiconductor maker, this one with the backing of the British government. So when Petritz talks about the integrated-circuit business, everyone listens.

He maintains that what has been seen so far is just the prelude to the glittering era to come. "The real industry is just getting under way, and that's the microcomputer industry," he says. The world has finally discovered "the universal component" in the single-chip microcomputer.

The solid-state world has gone through three ages, Petritz believes. First was the age of the transistor, a circuit component requiring engineers to specify voltages, waveforms, and other parameters. Second was the age of the IC, in which engineers worked with logic modules and the specifications of 1s and 0s instead of voltages and the like. Emerging now is the third age, that of the microcomputer, described by Petritz as a system component, requiring designers to deal basically with interfaces.

In the next two decades, the system will be the largest element that must be dealt with, he says, and "it's hard to comprehend a system that can't be implemented on silicon in a microcomputer" in that time. Demand will mean that owning a company producing very large-scale integrated circuits will be like owning an oil well, he reasons. He expects that by 2000 there will be only 10 vendor companies left worldwide, and because of capital requirements to stay in the business, they will be very large and very profitable. "There won't be any system house that will be able to afford to buy less than 50% of its VLSI requirements from those 10 outside vendors," because the volume of the vendors' sales will put them so far ahead on the VLSI learning curve. The other source of devices will be in-house divisions started or maintained by users for their own needs. But those captive operations will move out to the VLSI mainstream with specialty devices needed by the parent also.

Who will those lucky 10 vendors be? In Petritz's view, some, and maybe all of them, are around today. Some, like Texas Instruments and Motorola, will likely not be purely semiconductor houses. Some will deal exclusively in VLSI—and Petritz, naturally, counts his Inmos among

those. He also predicts that a half dozen or so attempts will be made to start new companies, but these efforts will not take the traditional venture-capital route. They will be started with the kind of major backing possessed by Inmos itself or by Zilog Corp. (from Exxon).

Paradoxically, he believes that money will not be a problem: "There's plenty of it around—look at the Arabs." Instead, he feels that the critical limiting factor is people: finding entrepreneurial types who can work full time for years to put a new venture together and then staffing it with technical personnel.

At any rate, he sees 5 or 6 of his big 10 in the U. S., 2 or 3 in the Far East (and he includes South Korea as a possibility), and 2 or 3 in Europe. He expects to see the U. S. continue to supply about 50% of all technology advances: "The U. S. is not going to roll over and play dead." Being on the front edge of technology "appeals to the American ego," and since the U. S. has the people, the money, and the world's largest market, there is every reason for it to come up with half the advances.



**The best is ahead.** Richard Petritz says IC innovation to date is just a prelude to the excitement of the microcomputer age.

entrepreneurs to come out with products and processes and new developments spurred by the profit motive. So one of the key things is going to be government involvement over the next 20 years in the shaping of what that mix is going to be."

It is vital, says Richman, that government not tamper with the innovative cycle that starts with a small, entrepreneurial company that grows to large corporate status on the strength of innovation and creativity. "If you look at the microprocessor revolution, it came out of companies like AMD, Mostek, Intel—all small companies 10 years ago. They made major contributions. One of the main problems recently has been that the cycle has been interrupted—venture capital over the last five years has been virtually nonexistent. If we don't watch out with

respect to government involvement, we may find that in the year 2000 the electronics industries will be dominated by a few major large corporations and international cartels. If that is the case, American industry will certainly be in great difficulty."

Carl Carman believes that "in the last few years, creativity hasn't had the same spark." Therefore, "if we have only 50% of the people in the world who implement technology, we'll probably have only 50% of the exploitation of that technology. What has changed those numbers is that the diffusion of technology throughout the world scientific community is so much quicker. If foreign companies can diffuse their technology faster than we can diffuse ours, then we're going to come out on the negative side. But in the end, it's not how many





**Getting the work out.** Standard Microsystems' Richman notes that multinational companies will probably base decisions on which countries in which to invest their resources to a great extent on the productivity of any particular nation's engineering talent pool.

points you have on the scoreboard that counts—that is, what percentage of the ideas originated where. What counts is the economic reduction of that technology.”

Moore sees the international diffusion of electronic technology as inevitable. In fact, he recalls, a Japanese official speaking at Caltech once enumerated the troubles of his nation as including the relocation of much of the native textile industry to South Korea. The official even sadly predicted that one day Japanese would be driving Toyotas made in Korea. “That is a natural evolution,” says Moore. “The countries that are developing are picking up the technology and entering at a fairly high level. Electronic technology will diffuse as lesser developed countries with lower labor costs pick up the technology and run. Eventually it will be diffused out to where it can be produced least expensively.”

Thompson points out that such diffusion, or transfer, of technology is the best way to give foreign aid. “It’s a lot easier to export, say, the textile industry than to give money. Just give them an industry.”

Ramo singles out the cooperation between government and free enterprise that exists in Japan and Western Europe as a prod for the U.S. “Maybe in the next 20 years we’ll manage to get rid of some of the government constraint on growth. Here, small companies can’t get cash, larger ones don’t have the cash flow. Our rivals overseas don’t face those problems. I’m confident that by the year 2000 we’ll see a trend toward government-private relationships that are superior to what is emerging from the present trend.”

In any event, “a meeting such as this one in 2000 will find itself talking half the time as if there are no separate American and Japanese companies and half the time as though there are,” Ramo says. “The typical company

may be one that is heavily involved with investments in various countries and getting the benefits of those investments. I think many multinational corporations are that way today; it certainly is partially true of the one I know most about. So when you ask, ‘How are we going to do against the Japanese?’ you have to have in the back of your mind ‘What do you mean by the Japanese; what do you mean by we?’ ”

**T**oo often, when the pace of innovation is discussed, the role of the military is ignored, Ramo argues. Its influence on technology may have shrunk somewhat since the heady days of the 1950s and 1960s when decisions in the Pentagon charted the course of electronics. But he thinks the trend is toward a renewal of that steering power.

“In the year 2000 we will discover that military technology all over the world will be a very big factor in what happens in electronic technology. And the proliferation of nuclear technology that enables threats to the world to be made by small nations, and even by groups within nations, and the energy instability that adds to the conflict between the haves and the have-nots—all of those problems will not get solved in the short term. They create an instability that makes military strength a necessity.” Ramo adds that West Germany and Japan in particular will do more militarily than they have in the recent past.

Looking back on his years at the Pentagon, Heilmeyer agrees that the military and space communities lost the initiative in the 1970s. But “there’s no evidence that they’re going to recapture that initiative any time soon. There is a tremendous cultural barrier in the Depart-

# Your telecommunications future belongs with Avantek.

Over fifteen years of microwave product experience from transistors to transmitters.

Avantek's vertically integrated microwave product line spans the range from sophisticated GaAs FET transistors to turnkey digital microwave telephone systems.

We've developed and manufactured products that have increased the quality of transmission, reception and processing of wideband or high speed information in telecommunication. Avantek's products have provided quality solutions to a variety of problems in the defense, satellite communication, instrumentation, telephone and cable television industries. And, we're committed to meeting the future needs of the tele-



communications industry with a strongly focused research and development program.

If you would like more information on Avantek's full range of products, please write: Avantek, 3175 Bowers Avenue, Santa Clara, California 95051. Or telephone (408) 727-0700.

## Avantek

Avantek has employment opportunities for sales engineers, design engineers and manufacturing professionals.

© 1980 Avantek, Inc. Avantek is a registered trademark of Avantek, Inc.

Circle 69 on reader service card



# Matsuo Electronics Congratulates Electronics Magazine on their 50th Anniversary

---

For 31 of those 50 years MATSUO led the world by developing the first resin dipped capacitor.

Since that time many unique physical and electric innovations have been incorporated to assure our continued leadership.

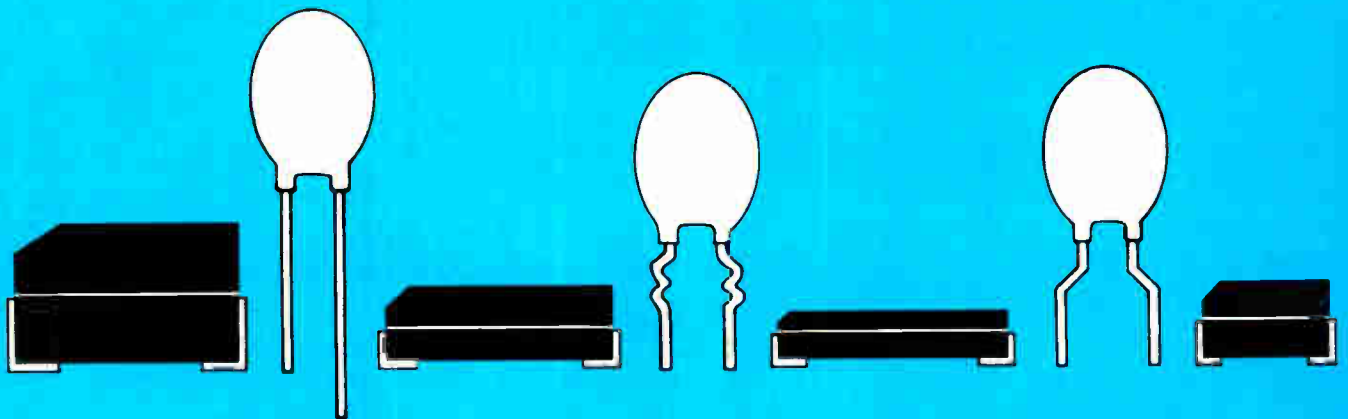

*For prices, literature, engineering samples, write or call*

**MATSUO**  
ELECTRONICS

12831 Western Avenue, Garden Grove, California 92641 • (714) 898-0707, (213) 594-6659

We start  
your car,

operate  
your TV,

protect  
your home,

and print  
your check.



Wabash coils start your car. Run your factory. And your home appliances. Because Wabash is one of the nation's major producers of molded coils. Through its IPM subsidiary, Wabash has also become a major supplier of electro-mechanical devices for the automotive market.

Wabash transformers operate your TV. And your radio. Photocopier. And air cleaner. And they are now being used in Wabash battery chargers sold throughout the world. Because Wabash is one of the country's major manufacturers of transformers and power supplies.

Wabash relays monitor your security system. Telephone system, medical equipment, TV and video equipment and mobile communications (for police, fire and EMS services). Because Wabash is one of the largest integrated producers of reed switch and dip relays.

Wabash computer tape directs computers how to print your check. Operate plants. And run businesses. Because Wabash is one of the nation's major manufacturers of magnetic media (computer tape, flexible disks and digital cassettes).

Isn't it time we met?  
**wabash**

For additional information contact Wabash, Inc., 200 East Daniels Rd., Palatine, Ill. 60067  
Wabash/Transformers(219)356-8300, Wabash/Relays(219)563-2191, Wabash/Tape(312)298-8585 (Canada 416-625-9533)

Wabash/IPM (312) 359-4710, Wabash/Coils (219) 563-3111,  
Listed N.Y. Stock Exchange WAB



# Cominco American

- Die attach preforms
- Lids and lid seal preforms
- Brazing alloys
- Bonding wire and ribbon
- Custom alloys and other specialized metallurgical products
- High purity metals
- Vacuum evaporation materials
- Sputtering targets
- Compound semiconductors



For details on pricing, delivery information or our new product brochure, call or write:

Cominco American Incorporated  
East 15128 Euclid Avenue  
Spokane, WA 99216  
TLX: 326492 CAI VELCX SPK  
Tel: (509) 924-2200

Cominco American Incorporated  
Suite 615, 8550 W. Bryn Mawr  
Chicago, IL 60631  
TWX: 910-2535253 CAI CGO  
Tel: (312) 693-7770

Cominco American Incorporated  
15070 Stratford Court  
Monte Sereno, CA 95030  
TLX: 171107 COMINCOAM MTSR  
Tel: (408) 395-7100

Cominco (UK) Ltd., Crown House  
550 Mauldeth Road West  
Chorlton-Cum-Hardy  
Manchester M21 2SJ  
ENGLAND  
TLX: 851-669567 COMMAN G  
Tel: 061-881-0111

Tokyo Cathode Laboratories Co. Ltd.  
1-10-14 Itabashi  
Itabashi-Ku  
Tokyo, JAPAN  
TLX: 2722842 TCLAB J  
Tel: 03-962-3311

D & R Associates  
228 Franklin Avenue  
Nutley, NJ 07110  
TWX: 710-9691420 D/R ASSOC NULY  
Tel: (201) 667-5900

Microdon Incorporated  
150 Speen Street  
Framingham, MA 01701  
TLX: 948316 MICRODON FMH  
Tel: (617) 879-3800

Feikert Associates Incorporated  
202 Blackberry Road  
Liverpool, NY 13088  
Tel: (315) 632-5577

ASM B.V.  
Soestdijkseweg 328  
3723 HH Bilthoven  
THE NETHERLANDS  
TLX: 47374  
Tel: (30) 78 76 84/78 50 45

ASM Southern Europe SARL  
Rue du Caducée, Zolad,  
34100 Montpellier  
FRANCE  
TLX: 480381  
Tel: (67) 63 30 30

ASM Germany Sales B.V.  
Elisabethstrasse 81  
8 München 40  
GERMANY  
TLX: 5 22 320  
Tel: (089) 18 80 41

ASM Asia, Ltd.  
Hang Fung Ind. Bldg.  
2G, Hok Yuen St.  
Hung Hom, Kowloon  
HONG KONG  
TLX: 83361 ASMAL HX  
Tel: 3-652222



ment of Defense to implementing the type of technology in which the U.S. leads the world: sophisticated command, control, and information-handling techniques.

"For that reason I don't think that we'll see the Department of Defense take, any time soon, a leadership role in information technology, for example. I think

they'll continue to be behind the power curve. It's not really a technical problem; it's a cultural problem, and usually cultural problems get solved in large bureaucracies by traumatic events—and that's what's most disturbing to me."

Taking the concept of a cultural factor further, Gomo-

## The view from the Northeast

In 2000, as now, it is likely that the information-processing industry clustered around Boston's universities will flourish. Officials at consulting firms and computer manufacturers agree that business will boom, but there are some differences of opinion on the shape of the industry.

At Arthur D. Little Inc., the world-renowned consulting firm, Guy L. Fougere is a vice president and head of the physical sciences group and a director of Cambridge Consultants Ltd. in England, a Little subsidiary. He foresees a "steady increase in the number of companies appearing, rather than a decrease or conglomeration," but expects there to be fewer semiconductor startups because of the capitalization costs.

He does expect more widely distributed creativity in the next 20 years because of the advent of the microprocessor. "Products emerging from a thousand different garages and basements strike me as being very plausible in the next 10 or more years," he says. "The telephone

system has what seems to be an almost magnetic attraction for these budding entrepreneurs: each socket in the wall is a market."

At Prime Computer Inc. in Framingham, Mass., director of research David Nelson sees few indications that there will be a great number of small companies by the time 2000 rolls around. The best prospect for a small company in the computer industry, he says, lies not in manufacturing but in the area of value-added software. In fact, he believes that software and services will draw more emphasis from both large and small companies. For the large companies, Nelson sees a great deal hanging on an upcoming legal battle over information distribution that can be summed up as IBM versus AT&T versus the U.S. government. The trend he sees there is toward deregulation of telecommunications—in fact, the Federal government would like to deregulate the area now if it could figure out how, he says.

A pair of scientists from GTE Laboratories Inc. in Waltham, Mass., vice president and director of research Paul E. Ritt Jr. and director of technology William F. Nelson, understandably have something to say about the conduct of research and development at the turn of the century. Ritt thinks the outlook for small R&D companies is not good because venture capital is tight, compared to the 1950s and 1960s when "someone with a good idea could just go down to the corner, talk to someone in a large company, and get the money he needed to bring his innovation to market."

Nelson feels that the relative percentage of U.S. contributions to R&D will decline because the rest of the world is coming up so fast. He believes that technology will be more expensive because the social and political problems it is being asked to tackle will present the need for more expensive solutions. Though industry efforts may be organized in consortium form with the Government leading the way, Nelson says, the Government will begin to reduce its share of support of innovation.



**Big and small.** For small companies, Prime's David Nelson sees the best opportunities in the computer industry lying in value-added software rather than traditional manufacturing.



**Steady growth.** ADL's Guy Fougere foresees a "steady increase in the number of companies appearing, rather than a decrease or conglomeration," except in the semiconductor industry.



# ENOUGH IS

## IT'S TIME SOMEONE ESTABLISHED 'INDUSTRIAL GRADE' COMPUTER SPECS

**It's Time Someone Established 'Industrial Grade' Computer Specs.** Computers started in clean rooms and then moved into offices. Soon people tried to put them out in the plants where they couldn't stand up to the heat, humidity and other hostile environmental factors.

But, just because a computer is smart enough to run a machine doesn't make it an 'industrial grade' computer. Too much computer hardware that is billed as 'industrial' breaks down in the real world of the plant.

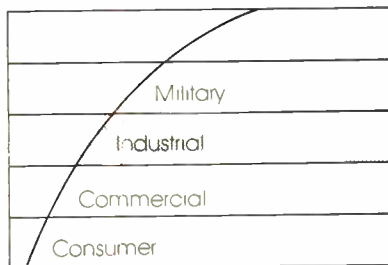

Industrial specifications for military computers are too stringent and too costly to be practical for industrial applications.

**Temperature.** We believe that the minimum acceptable 'industrial grade' temperature specification should be 60°C. Factories are not comfortable like offices. The temperature inside sealed enclosures is usually 15°C higher than the ambient plant temperature. XYCOM's '180+' line carries a 65°C specification.

**Relative Humidity.** In a plant, a computer should have a tolerance to relative humidity levels from 0% to 100%. They should also have resistance to condensation. The new XYCOM '180+' line with XYCOAT™ meets this stringent demand.

**Vibration.** Failures due to vibration are virtually always the result of faulty connections, boards or chips. To meet 'industrial grade' spec, chips should be soldered to the board and EPROMs clipped to their sockets. In addition, units should be subjected to 100% full vibration stress and subsequent testing to ensure maximum product integrity.

**Contaminant Protection.** Salts, dust, dirt and oils are enemies of computers. They even find their way into sealed cabinets in plants. The XYCOM '180+' line is XYCOATED to keep contaminants from the boards. (See corrosion.)

**Corrosion Protection.** Plants are killers when it comes to atmospheric contaminants that corrode and destroy. XYCOAT utilizes a specially formulated shield that protects module components from moisture, fungi, grease, oxidation, salt spray, acids, alkalis, and many other harmful elements. In addition, XYCOM connectors are industry proven gold.

**Testing Standards.** A computer failure is always bad, but in an industrial situation it can be disastrous. Testing Standards for 'industrial grade' should be higher than for 'commercial grade'. All components and assemblies should be tested at all stages of production. They need to be subjected to the full range of dynamic testing which includes power cycling and stress testing under extreme temperatures under

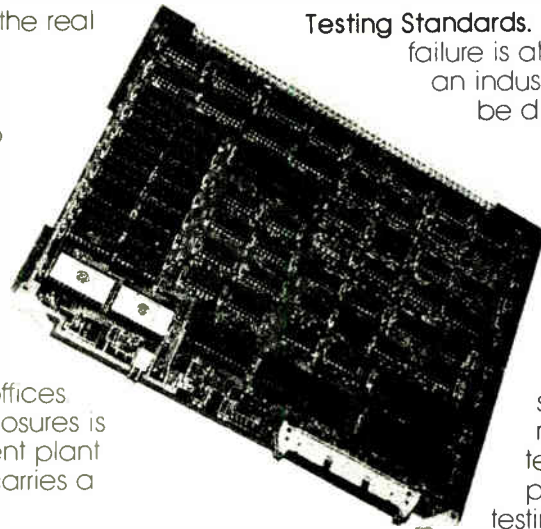

microcomputer control for up to 72 hours. This is in addition to our stress vibration cycle. All XYCOM products are tested to our 'industrial grade' standards.

**Warranty.** For industrial purposes a warranty needs to cover the period soon after installation when most failures will occur. We believe that a year warranty offers the most desirable cost to reliability ratio for both manufacturer and user. It is our philosophy that, although the extent of our testing is extensive, the resulting savings due to greatly reduced warranty claims keeps XYCOM products competitive and your plant operating.

# ENOUGH!

## ...AND STOP SENDING BOYS TO DO MEN'S WORK

Introducing the XYCOM 180+ Line. Now, we are setting a new standard for the others to match. Every '180+' module is XYCOATED and uses gold connectors. Our regular 180 line meets

most 'industrial grade' specs which is sufficient for most factories. The '180+' line exceeds 'spec' and is for even tougher environments.

### COMPARE 180+™ 'SPEC FOR SPEC'

We've told you what we think 'spec' should be. Look at how our '180+' line shapes up and compare us with any other product that espouses to the 'industrial grade' designation.

Common Features	Intel	DEC	Motorola	Others	XYCOM 180+
Temperature					65°C
Relative Humidity					0% - 100%
Vibration					100% Vibration Stress
Contaminant Protection					XYCOAT meets petroleum industry standards
Testing Standards					100% Accelerated burn-in with power cycling, full dynamic testing
Warranty					1 year

#### Specific '180+' Features

**Digital I/O:** T<sup>2</sup>L I/O, 64 channel  
64 channel power out

**CPU:** Minimum Cost CPU.  
High Performance CPU.

**Memory:** Multiple 65k EPROM cards.  
Multiple 65k RAM cards

**Analog I/O:** 12 bit, 300 v common mode  
integrating A/D  
8 channel, 4 to 20 ma isolated D/A

**Software:** Multitasking Runtime Executives,  
Assembly Fortran IV, Industrial Pascal.

## Accept the XYCOM Challenge (You could win a week for two to Club Med, Cancun.)

We want you to compare the XYCOM '180+' line with any other product that aspires to the 'industrial grade' designation. Just fill in the specifications for any competitive industrial computer, fill in your name and address and send your entry to us. Everyone that makes a comparison gets a gift. One entry per person. The grand prize winner will be selected by drawing before September 30, 1980. Entries must be received by July 31, 1980. The trip must be taken between January 1, 1981 and May 31, 1981.

Name \_\_\_\_\_ Title \_\_\_\_\_

Co \_\_\_\_\_ Address \_\_\_\_\_

City \_\_\_\_\_ State \_\_\_\_\_ Zip \_\_\_\_\_

P.O. Box 984  
Ann Arbor, Michigan 48106  
Phone (313) 429-4970  
TWX 810-223-8153

**xycom**<sup>TM</sup>

The Hardhat Computer People



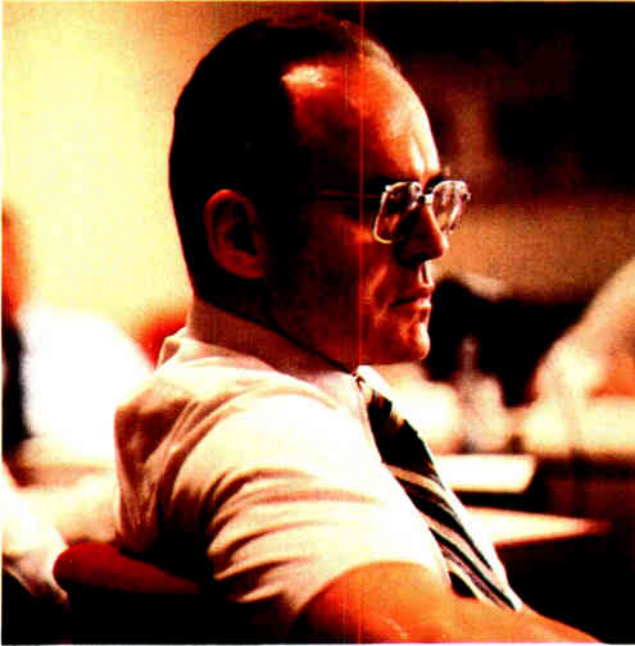

**Slower movement.** Intel's Moore thinks that the semiconductor industry, with more and more capital invested in it, will change more slowly. "Some of the problems associated with inertia will come into the business," he says, and it won't be able to change models fast.

ry spreads it around the world. Although he agrees that a meeting of industry thinkers in 2000 could have an international makeup, he also can foresee "very strong, nationally oriented, industries." The reason, he says, lies in the strong pull that is exerted by cultural ties and by nationalism.

**S**uch a development could be viewed as a brake on growth or progress, but what other barriers to the evolution of the electronics industries could pop up in the next 20 years? The panelists agree that such hindrances could take the form of shortages of the properly educated and trained people, difficulties in realizing fully the advances that innovation will make possible, and poor government-business relations.

For Heilmeier, prime among the limitations is the problem of finding the people. "In the VLSI era, where will all the designers that will be required come from? And where will all the software people come from to service the 'era of computational plenty' made possible by VLSI?" Unless there is some sort of new approach, he says, some sort of innovation, the crisis is going to be over getting the trained people needed to fulfill the promise of VLSI.

Thompson returns to the problems of culture. "Without some significant change in the technological base, problems of complexity are going to create, in turn, those cultural and management problems that are going to end up stifling an awful lot of activities. I really hope that we can find some way to keep the small thing alive and vigorous because that's the only way tomorrow can be a successful tomorrow," he says.

Thompson continues: "The problem that Heilmeier attributed to the DOD is present in any large organiza-

tion—and with more and more things going to be done by large organizations, I'm worried. The cultural orientation of a large multinational company frightens me. The culture of IBM, the culture of ITT, the culture of DOD—they start to become very meaningful things. It's almost as strong as the culture of being an American or being a Japanese in terms of trying to get change to happen within the organization."

By contrast, Gomory classifies himself as very optimistic on the management of innovation. "The tough part of making technical progress is on the software end, but I do think that there is a learning process. People will find a way to do it—and I think they're going to manage to go right on."

Moore sees a problem looming in the match between design resources and the super chips that must be designed. "The total number of electronic functions produced by the semiconductor industry roughly doubles every year. Project that trend for 20 years, and the limitations that you come up with are apt to be ridiculous. So design questions are a real problem."

He also sees hardware becoming more like software, with the expense of design high and the price of reproduction low. "The cost of design is increasing linearly with the complexity of design of the product," he says, "but the cost of reproducing the product is remaining essentially constant. So the software cost dominates, and the hardware cost becomes trivial. The productivity problem of software is exactly the one we're going to have to deal with in defining and designing the functions we're going to make."

Richman sees a lesson for the future in some of the problems experienced by the semiconductor manufacturers over the years. Most of these problems come in a time of "severe manufacturing overcapacity, which results from slackening user demand and overambitious plant expansion. But as we approach 2000 we may have another major problem to deal with: if the semiconductor industry does not focus its resources on the development of computer-aided-design techniques to keep up with the process development," then it might create manufacturing problems.

"The biggest limitation, particularly in America, is in government-private relationships," says Ramo. "But I'm optimistic because the nature of that limitation is going to be understood rapidly over the next few years, and innovative, economic, and international forces will be applied to it. However, while I'm optimistic about all forms of innovation, I'm least optimistic about that limitation because we have invented in the wrong direction here in America. Our response to economic, political, and social forces has been to create a confusion and a wrong trend in the proper role of government *vis à vis* the private sector, and we have been developing a hybrid of government control and a free economy that isn't the right mix."

Carman believes that if anything is going to limit advances in the next 20 years it will be human resources. But he is also worried about another form of government regulation: that coming from the courts. "If liability is going to be assigned to computers, all of a sudden a lot of the techniques we've used in the past to put out machines

## 440 ELECTRONICS COMPANIES MAKE THEIR HOME HERE.

"It used to be hard to get people to come here. Now it's hard to get them to leave." So said a Minnesota corporate recruiter recently. And for many people who don't live and work here Minnesota is a mystery.

Why is it headquarters for 14 of FORTUNE's top 500? Companies like Control Data, Honeywell, 3M, General Mills and Pillsbury? Why is it that 440 electronics companies and nearly 100,000 people employed in electronics-related industries call Minnesota home?

Simple. People like it here. Our "quality of life" ranking is one of the highest in the country.

Minnesota has 4 major league sports teams. Is second only to New York in attendance of the performing arts. Has 60 colleges. Our residents rank second in the country in the number of school years completed.

So, if they're so smart, how come they live where there's winter? Because they enjoy the variety of four separate seasons. They like space. Clean air. Clean water. Midwestern stability along with plenty of diversity, challenge and competition.

## MINNESOTA

DEPARTMENT OF ECONOMIC DEVELOPMENT  
480 CEDAR STREET, ST. PAUL, MN 55101

Mail to: Minnesota Department of Economic Development  
480 Cedar Street, St. Paul, Minn., 55101

Will you please inform me about job opportunities in Minnesota. I'm particularly interested in \_\_\_\_\_

Name \_\_\_\_\_

Address \_\_\_\_\_

City \_\_\_\_\_

State \_\_\_\_\_ Zip \_\_\_\_\_

Phone \_\_\_\_\_



**I care about your business. That's why I put a tough guarantee on every instrument.**

Good service and dependable delivery are important to me, because they are important to you. That's why I've put a tough guarantee on every instrument. Either we live up to our guarantee or you get 25% of your first month's rental fee back for that unit.

**Here's what I promise:**

1. The instrument will arrive on the day we say it will.
2. It will work properly, be calibrated and have everything you need right down to the operator's manual.

**Choose from the industry's largest pool of general purpose test instruments.**

USIR stocks more than a thousand models of instruments from more than one hundred leading manufacturers. We add more every day as new instruments are introduced. No one else offers you this much to choose from.

**See what a difference caring makes.**

Systems and computers don't solve your test and measurement problems. People do. At USIR we have people who are willing to try just a little harder to get you the instrument you need, when you need it. In short, we care.

Call or write for a complete 92-page, illustrated catalog today.  
2121 S. El Camino Real,  
San Mateo, California,  
94403, (415) 574-6006



**United States Instrument Rentals, Inc.**

**US**

A U.S. Leasing Company

Circle 78 on reader service card

**"GET THE TEST INSTRUMENTS YOU WANT.  
ON TIME. OR GET MONEY BACK."**

*—Anthony Schiavo, President.*



are going to be very difficult to use. That will be especially so if, say, you come along with a very large-scale integrated machine and you suddenly have huge amounts of software that go out hardened and therefore you have to accept liability" because a court decides that the computer is to blame. Such a trend will significantly limit a computer company's options on how it can distribute intelligence, he says. "Maybe it will mean that we can't go to VLSI with lots of outboard or hardened functions. If we make a mistake and have liability for that mistake, we may not be able to afford to use that technique—and it has nothing to do with technology."

Laying aside the unanswerable question of whether demand will motivate technologists or technology will create demand, it is still possible to study the role that various specific electronic solutions will play. First on the list is the computer, and the prime question is what level of performance the ubiquitous machines will reach.

"We won't count in instructions per second," Gomory reckons, "we'll just be thinking in other terms. I'm sure, also, that there will be a lot more parallel processing because it will be harder to make progress in raw speed: price-performance is easier to push than speed, and I think that will push us in the long run in the direction of distributed functions."

Carman believes that, for economic reasons, a way will be found to increase computing power without forcing designers to change circuit technology. "Let's take the example where I'm in MOS or TTL and I want to double my performance. Say I accomplish it by going to emitter-coupled logic. Then all my test equipment, in the factory as well as the field, will have to be changed because of the change in circuit technology. Therefore, I will use all the techniques available to me—parallelism, multiprocessing, or whatever—to try to prevent changing the basic technology. So in 20 years we'll still be using n-MOS, or an evolutionary technology from that," he predicts.

Gomory adds that there will be big machines and small machines and that "we will gang them." But whatever is used and whatever is done will be largely invisible to the user. Agreeing that people will use computers without knowing exactly what it is they have in their hands, Heilmeier says that the big impact in the future will be made by the interface between the user and the machine. "If computers are to become pervasive, that's vital," he says.

The computer also must become easier to use if it is to become the universal tool that some observers predict. Heilmeier says that first "people must be able to interact with the machine on their terms, rather than vice versa. We're going to be deluged with data, and people will want to extract information from that data—but they're not going to want to memorize protocols or data-base structures or anything of the sort. The sophistication of the machine is not going to be in the trivial amount of computation needed to get the answer, it will be in organizing the data to do that trivial computation."

Gomory holds that one "increasingly do-able" tech-



**Information for all.** With computers becoming more pervasive, Carman would not be surprised to see them generate a new utility—he calls it an information-bank utility—in which national data banks would spread information via satellite and rooftop antennas.

nique will have the computer generating an image that shows what the user would see if he or she were looking at ledger sheets. In fact, he sees no reason why the top of a desk could not some day be a giant display, with "piles" of certain papers in one corner and others "stacked" elsewhere.

Moore wonders if, by 2000, it will be possible to use conversational English to communicate with a data base or with an automated typewriter. Richman is convinced that such a thing will come to pass. However, he believes that progress will be made not so much in the industrial sector as in the home. "You're going to see computers there with speech-recognition capability and speech-synthesis capability. You may even see personal computers evolving to the point where they're actually handheld or like a wristwatch, so that you can carry around your bank book or even your medical records."

There will be a great deal more voice input, says Heilmeier. However, he adds, "general speech recognition, unconstrained speech where it's not speaker-specific, is quite a ways off."

Gomory agrees: "Unconstrained speech with any speaker and some background noise is very hard to do. However, I'm not sure it matters that much, because before you come to that you can go through so many gradations of constrained speech. It is relatively easy to get, say, 95% or maybe 98% of the words right—but to get from 98% to 100%, which is what you need if you want to dictate a letter to a typewriter, really is the difficult thing."

Whether or not computers will be able to carry on useful conversations with the world at large, Carman believes that they may generate a new utility, one that he dubs an information-bank utility. Here, information would reside in a large national data bank and will be



## Light talk

With the world turning into the information society, dissemination of speech and data will become even more crucial. That is the view of the scientist generally credited with being one of the fathers of fiber-optic communications, Charles K. Kao of International Telephone and Telegraph Corp.



**Tough fiber.** Charles Kao believes that fiber-optic communication will be the ideal method for handling the coming information explosion.

To handle all that data, he says, "we already have developed the means of processing it, but we will need a more efficient transmission medium. That medium is fiber optics." Kao, a 46-year-old British-educated scientist, has been with ITT for more than 20 years and now works in the firm's Roanoke, Va., facility. He started work on fiber optics in 1964 and published his first paper on the subject two years later, in 1966.

More complex electronic circuits will be required to manipulate, store, and process information, but the use of fiber optics—"it will be all over the place"—will not directly affect circuit design, says Kao. "However, by 2000 the terminal will be more complex and the central switching office will be radically different," he adds.

He also foresees a "separate packet-switching network for data because it is much faster than voice: 1-millisecond segments versus segments of perhaps three minutes for voice. Fiber optics will become cheaper and cheaper, though it will not replace copper completely—"after all, copper can conduct electricity," he notes.

disseminated via satellite and rooftop antennas.

But how will all these computers, both visible and transparent, in the factory and at home, be built? Will VLSI make it possible for designers to use a wide range of architectures for their computers? No, says Heilmeier. To be sure, he says, there will be more than one architecture, but the extreme—"where everyone has his own architect—is not going to happen."

However, the key element in the eyes of Carman will not be hardware or architecture but software. "It would be interesting to be able to have different machines that run on standard software," he says. Heilmeier's feeling is that software will continue to develop along familiar paths, "but I see a much more extensive use of nonprocedural languages." His definition of such languages is that they tell a computer what to do, not how to do it. Today's languages tell both.

Such a change would also alter the relationships of designer and programmer. "In the future," he says, "the role of the programmer may be to create a formalism or structure by which the system engineer can interact directly with the computer" instead of using the programmer as a go-between. "The system engineer will input the rules of the game, and the programmer will give him the structure by which he can do that. That may be one of the ways we can get around the bottleneck that looms in software development."

The only way this will come to pass, he says, is another cultural revolution, a radical change from the first 30 years of the computer's history in which the programmer was constantly exhorted to write software that used as little memory hardware as possible. As the software bottleneck becomes more restrictive, "people might say, 'I'm spending too much money on this front-end process—if you guys want to use 30% more memory, go right ahead'."

Ramo believes that the tremendous investment in already installed technology will preclude major changes to new and better equipment. "Our own Govern-

ment, the biggest user of computers, is using computers that are out of date so badly that if you could imagine buying up-to-date ones, it would save so much money that in a very short time it would more than make back the cost," he says. However, the American political system is one that favors expediency over such farsightedness, he adds.

As for the general populace's acceptance of computers, none of the electronics executives sees any problems—not even with questions of invasion of privacy. Carman says the tradeoffs will tip the balance in favor of computers. Referring to TRW's credit-verification services, Ramo says, "We have found that if someone wants more privacy, we can do it more easily by applying technology than by limiting the application of technology. There are concerns, but the way to meet the concerns is to do the right job with the technology and not to look at it as a limitation."

Summing up, Gomory says, "One thing we can say is that by the year 2000 a very sizable slice of the population will be comfortable with computers."

**M**uch of the future structure of the electronics industries will depend on the shape of the information explosion, a phenomenon nurtured by electronic technology. Communications is the key, since in recent years its costs have become the greatest component of computing expense.

An important consideration, says Thompson, is whether the communications network will link individuals to computers or computer users to each other. As one of the small band trying to study the future seriously, he has applied his vocation as a communications engineer to his avocation as a futurist—and he sees two possible scenarios for the information explosion.

His first he calls the every-man-an-island scenario. "It is essentially a downplaying of the concept of networks. One might expect an increased use of broadband. And

# AN EYE-OPENER IN MODULAR PACKAGING

Our new 16 bit 990-E industrial microcomputer system offers these packaging firsts: pre-connectorized boards . . . separate bus and I/O connectors to prevent mishaps . . . 16 board slots in a compact 19" chassis . . . board fasteners to prevent walk-out.

The 990-E provides a TMS-9900 bit, byte and word oriented CPU and is fully expandable to 4096 I/O lines in up to 8 Chassis. It offers 20 **individual function** digital & analog interface boards for a myriad of industrial OEM or end-use applications.

Just circle the reader service number to get an eyeful.



## ERNI & COMPANY

3316 Commercial Avenue  
Northbrook, IL 60062  
(312) 480-9240

Circle 79 on reader service card

Circle 425 for FREE Demonstration



No matter what size LCD is in design . . .  
 Our ZEBRA LCD connectors are on the line.



LCD Microsystems, Inc.  
 Clock



J. Fluke  
 Mfg. Co., Inc.  
 8020A DMM



Beebe Electrical  
 Instrument, Co., Inc.  
 Tachometer

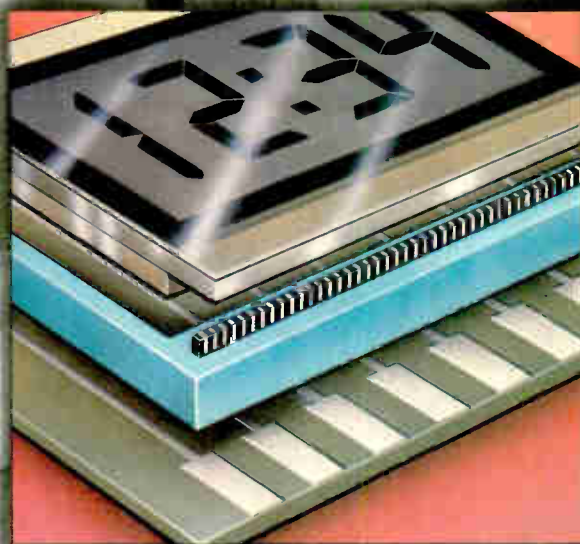

T mex Corp.  
 Watch

Texas Instruments, Inc.  
 TI-1030 Calculator

- ZEBRA LCD connectors offer design flexibility to accommodate any size LCD.
- ZEBRA LCD connectors are available for shipment within one week for any size LCD.
- Over one billion reliable contacts made in the field.

**TECKNIT**<sup>®</sup>  
 129 DERMODY ST., CRANFORD, N.J. 07016 (201) 272-5500

*The Conductive People*



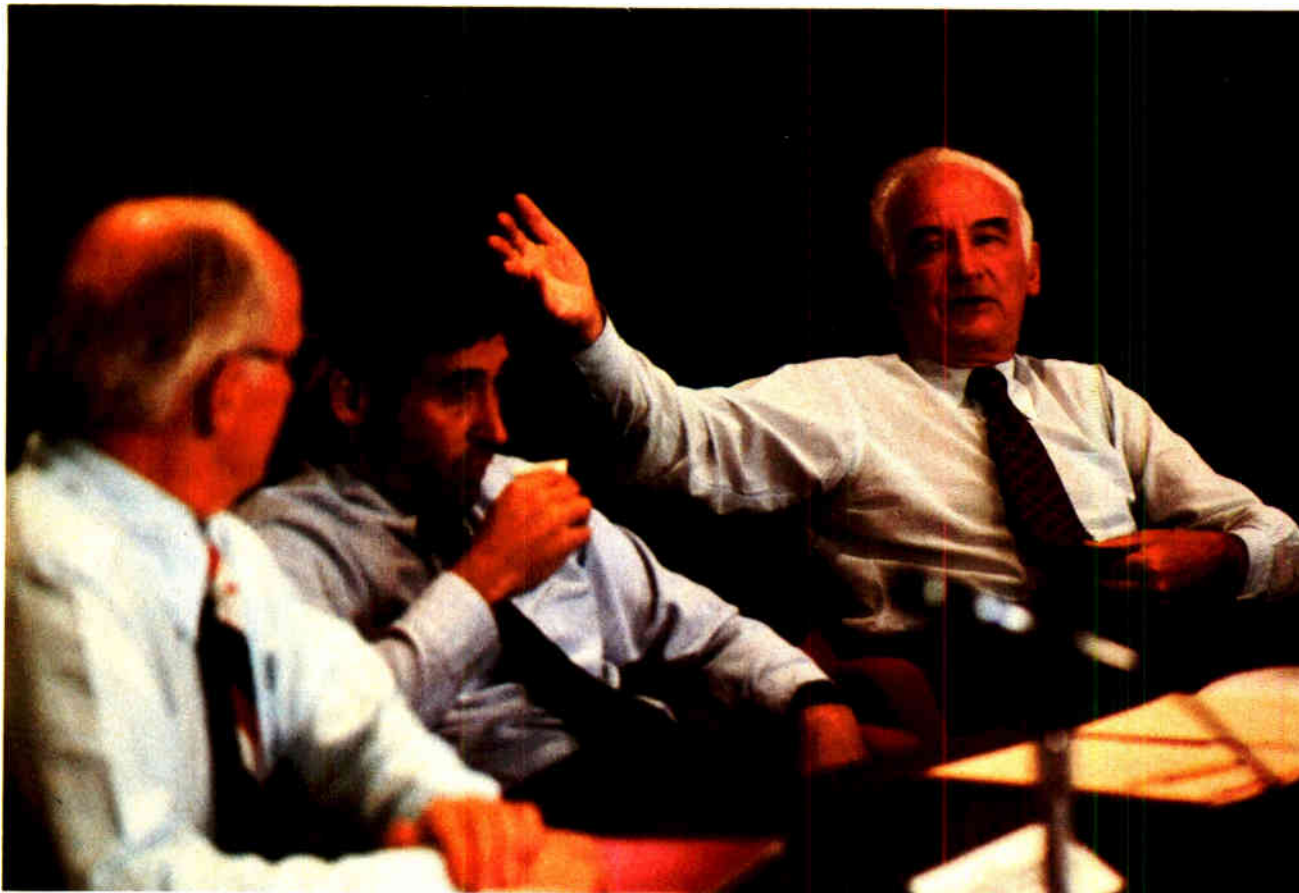

**Defense comes back.** TRW's Ramo gestures toward the military and his expectation that it will regain some of its former influence on the shape and direction of technology. It is his opinion that West Germany and Japan will become more active than they have been recently.

there would be a lot of stand-alone memory for processing in the home—it wouldn't be a case of which 10 channels but of which 500. This scenario will evolve if we move in the direction of working for short-term economic benefits."

Thompson's alternative is what he calls the every-man-a-node scenario. "It is conditioned on being able to deal with the constraints which seem to be forcing us to use this new computer-communications technology in ways that predominantly appear to be extensions of industrial technology." That task accomplished, "I would expect to see evolve a network that has some very interesting highly intelligent characteristics in terms of interfacing with the user. The network would start to exhibit the kind of properties that would make it seem aware of the context of the traffic it's handling."

An example of such a network, he says, is the modern computer-aided learning system. Here, the path a student takes through the material is given some kind of mathematical definition, letting the computer respond to the student's responses. Moreover, for students taking the same paths, the system sets up communications links between them. Thus individuals are linked automatically on the basis of the activities in which they are engaged.

Such a system would be about the only way to move toward an information society with two kinds of characteristics, says Thompson. "The first is that information can be meaningfully evaluated, integrated, and synthesized within the network directly." In other words, no

surrogates would be necessary: a computer model of an IC would also tell the designer whether the circuit would work—he or she would not have to build one. The second characteristic is present already: information is treated as a private economic good that can be traded like any other commodity.

The problem is, says Thompson, that unless there is some sort of payoff for looking at the long-term significance of such an alternative, short-term expediency "will move us toward the every-man-an-island scenario with considerable haste. So I'm not completely optimistic about the every-man-a-node scenario. This kind of intelligent network is really essential if we're going to get that kind of convivial entrepreneurship and if we're going to deal with the information explosion that is going to result from it."

To tell which way society and the technology are going, he says, watch to see if the broadband approach, delivering many TV channels and the like, gains ascendancy. Also, "one would expect to see an increase in paranoia," he says, "as it would become necessary to engage in sharp practices to continue to win the right to have a significant role in such a society. So you can expect that if encryption devices for telephones start to become a common product, we are on our way to the first scenario." Thompson says he sees emerging a value set that indicates people are moving that way.

On the other hand, Heilmeier believes that both scenarios will come to pass. "If you want to get a





**At a crossroad.** Bell-Northern's Thompson points to two directions for communications: broadband for short-term gains, or an emphasis on "intelligent characteristics in terms of interfacing." But, based on present tendencies, he expects the former to predominate.

broadband link to everyone," he says, "one of the routes is to do that in a guided mode—and look at the impact of fiber optics. If you want to do that in the unguided mode, look at the impact of very large antennas in space—adaptive antennas. The day is not far off, if it isn't already here, when we'll be able to put a very, very high-gain adaptive antenna in space. And you'll be able to think about everybody having a small satellite antenna on the roof." The technology to do that will surely be here by 2000, he adds.

But Thompson is holding out for more than a mere ability to see and hear someone or something else on a display. "What I really want to do is find someone I don't know about whose ideas happen to have some resonance with my ideas. The network should be smart enough to say, 'You guys are doing similar things and ought to get together.' That is, my telephone number should be more than just my address—it should be my interest profile, my behavioral use of information, and that kind of thing."

Ramo, turning to what he calls the more mundane aspects of communications in 2000, remarks that the basic vehicle for electronic information exchange already exists—the telephone network—even if it will be some time before it is ready to meet the full demands of the computer age. "It will take 20 years for AT&T, the French, the Germans to take even today's technology and make it available," he says. So by 2000 "we will have begun to use digital techniques extensively and we

will have installed the infrastructure for it. Most of the time, if we want to communicate, we will just pick up the phone as we do today."

Heilmeier predicts a three-legged stool of fiber optics, large adaptive antennas in space, and—a new development—nonmilitary spread-spectrum communications instead of frequency- and time-division multiplexing modes. In the future, he believes, this kind of scheme, where with proper coding everyone uses the entire band instead of dividing it along time or frequency lines, could result in "lots of different users residing in the same band." For example, every school could have its own ultrahigh-frequency channel with a radius of, say, three miles around the school, and if every child had a book-sized TV set, homework could be sent over this channel. What will make such communications happen, he adds, is surface-acoustic-wave technology married to integrated circuits.

But a smothering influence on that kind of progress, says Richman, is the Federal Communications Commission. "The role of the FCC will have to change," he says. "Computers, semiconductors, and so on have made giant strides because they are unregulated. But the FCC as it is now structured is the biggest obstacle to such progress."

If one development can be singled out as the seminal electronic invention of the past 50 years, it would be the semiconductor. Advances in design, fabrication, and application of the devices since they first appeared seem to be unending—but how long can that continue? For





# What you don't know about static is costing you plenty!

## THE PROBLEM

Static electricity is more serious than ever. Static damages and affects the operation of electronic equipment—from the smallest component to the most sophisticated computer. Static attracts and holds dirt, dust and bacteria to all surfaces. A static spark will readily ignite combustible vapors and dust. Static causes machines and equipment to jam, resulting in costly downtime, waste, poor quality and lost profits. In short, static is dangerous and expensive.

There are several devices available to temporarily eliminate static. These devices deal with static after it is generated, rather than preventing it from reaching harmful levels. What's really needed is long term static prevention.

## THE SOLUTION

The only product that effectively deals with long term static prevention is **STATICIDE™** antistatic solution. **STATICIDE™** is an easily applied topical coating that provides optimal static control without the necessity for material modification or substitution. **STATICIDE™** is non toxic, non flammable, biode-

gradable, inexpensive and performance guaranteed.

**STATICIDE™** easily complies with the electrostatic criteria outlined in MIL-B-81705B and NFPA 56A specifications. **STATICIDE™** is the only EPA registered antistatic/bacteriostatic compound available today. For these reasons, **Staticide** is used by thousands of companies to eliminate critical static problems.

## THE COMPANY

The manufacturer of **Staticide** is Analytical Chemical Laboratories, a truly unique company. For over 30 years we've specialized in industrial static control, including the design and production of antistatic chemicals, instruments and static control programs.

Widely recognized as consultants to industry, ACL has solved a wide variety of static related problems... and we can solve yours. To help you control environmental and material static, we offer the only complete line of static measuring, monitoring, analysis and process control equipment available today. Also, we provide our clients with electrostatic material testing in our laboratory at no cost.

Isn't it time you cut the lid on costly static problems... with **STATICIDE™**?

**CONTACT ACL TODAY!**



## ACL

**ANALYTICAL CHEMICAL LABORATORIES**  
2424 Pan Am Blvd., Elk Grove Village, IL 60007  
(312) 595-1242

*In Japan contact: TDK ELECTRONICS CO., LTD., 13-1, 1-Chome, Nihonbashi Chuo-Ku, Tokyo 103 Japan*

Circle 82 on reader service card



# The worldwide switch is at hand.

Manufacturers of computers and computer peripherals throughout the world use C&K switches. Producers and designers of test instrumentation, panel boards, word processing, and telecommunication equipment are switching our way too.

And here's why. Our line of mini, submini, and microminiature switches is literally hundreds of thousands of models long. Quality is incredibly high because we specialize exclusively in switches and have developed our own specialized engineering techniques. C&K switches are readily available, at highly competitive prices and with no minimum order requirements.

If you're not with us yet, start switching. Send for our complete new catalog and see for yourself. We give you more to switch about than anyone in the world.



The Primary Source Worldwide.

**C&K Components, Inc.**

15 Riverdale Avenue, Newton, MA 02158  
Tel: (617) 964-6400, TELEX: 92-2546. TWX: 710-335-1163

See us at Electro/80 Booth 2252-2254

Circle 84 on reader service card

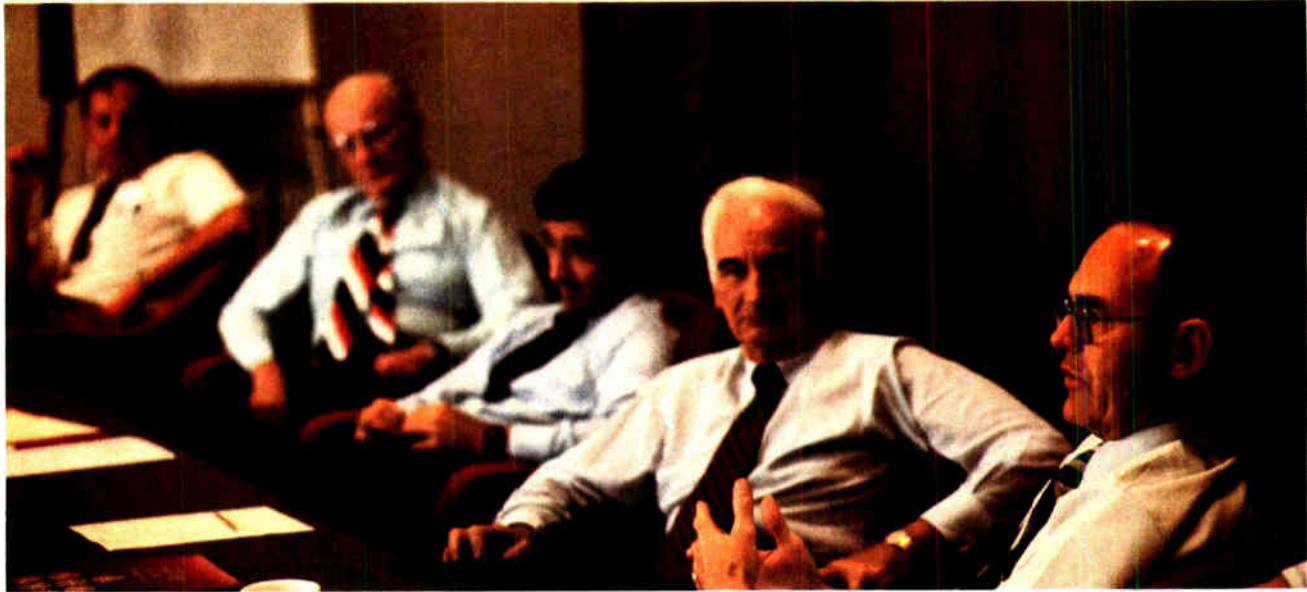

**Wrapping things up.** Fellow panelists listen as Intel's Moore says that device packages of 2000 will not change. The world will continue to operate on a 5-volt standard, he believes, because a change to a 1.5-V standard would mean huge costs for new ancillary equipment.

there is a growing school of thought that the rest of this century may see semiconductors reach their physical limits: for example, highly concentrated electric fields with submicrometer structures. However, the history of technology is seeded with examples of apparent barriers reached and then breached by new approaches in design or material.

Heilmeier notes various intermediate barriers in MOS technology—in patterning, design, and interconnection, for example. If these are overcome, some people expect problems when channel lengths reach 0.2 micrometer because of oxide integrity, he says. But Moore maintains that silicon will still be the main material, though it may “sit on other substrates.”

More to the point, says Heilmeier, is the still broad potential for semiconductors. For example, he expects by 2000 to see high-temperature superconductors “accessible to liquid helium or liquid nitrogen.” Moreover, he says, the IC business does not get very far from the surface—“we’re basically a two-dimensional world”—so someone might get smart and might exploit the third dimension. In addition, what would happen, he asks, “if we learned how to passivate the surface of compound semiconductors?”

**T**hen there is design automation. Heilmeier believes that “we will have a new concept that will be much more deeply rooted in machine intelligence and image understanding than the current systems are.” He also expects there to be more mixed-material chips—for example, devices made of silicon and gallium arsenide—more knowledge about defects, increased use of energy beams in fabrication, a true nonvolatile random-access memory, and solid-state technology applied to solar energy. And, he adds, “I won’t rest until we have a book-sized solid-state TV.”

Focusing on the semiconductor industry itself, Moore foresees a tremendous amount of evolutionary improve-

ment taking place—but with the industry becoming more capital-intensive, such movement will occur more and more slowly than in the past. He also sees “some of the problems associated with inertia coming into the business.” As the semiconductor industry becomes a larger part of the total economy, “we get sunken investments, we can’t change models much faster than the auto industry can, and that kind of thing.”

Conceding that there still will be a great many advances, Richman also says semiconductors are moving from a revolutionary to an evolutionary mode. Still, he adds, “we are going to see a lot of advances that look evolutionary but are really revolutionary.” He heartily seconds Heilmeier’s motion of use of the third dimension to build devices. “We’re seeing it already in things like V-groove MOS; we’re seeing double poly and triple poly; in the static RAM area we’re seeing high-resistivity polysilicon folded on top of the active transistors to increase the density in respect to RAM size.”

Look also for multilayer silicon structures, with the multilayers containing active components, he advises. In random-access memories, or RAMs, there will be increased evolution in processes. For example, titanium silicide and molybdenum silicide have “all the advantages of polysilicon, but offer lower sheet resistivity,” he says. Also, gallium arsenide devices are finding more and more proponents.

With all this, though, Carman believes that “the number of things we can get on a chip will continue to outpace the ability of systems to implement them.” For his part, Gomory points out that though “things can continue to be made tinier and tinier,” they must be evaluated from the system level. Looming here are such limitations on bit rates as packages and the problem of power in, heat out, he points out. Speaking of packages, Moore says they can not be changed because that would require monumental change. “It’s a 5-volt world,” he insists, “and to change to 1.5 v would mean that the whole world would have to change.” □



# Active Filters

## Frequency Selection Where You Need It



Frequency Devices offers expanding families of over 100,000 unique active filters. These filters are designed to meet the broadest possible range of application requirements.

- Fixed, tuneable and programmable frequencies
- Lowpass, Highpass, Bandpass and Band Reject transfer functions
- 2, 4, 6, 8, and 10-Pole designs
- Tchebyscheff, Elliptic, Butterworth and Bessel characteristics

- Passbands from DC to 1 MHz
- Corner frequencies from 0.001 Hz to 50 KHz

For special needs Frequency Devices manufactures a host of application-specific active filters.

- EEG, EKG and EMG for biomedical work
- C-Message, Phosphometric, FSK, CCITT and PCM for tele- and data communications applications
- Anti-Aliasing for A/D conversion

- ANSI 1/Nth Octave for broadcasting, aircraft vibration and OSHA noise standards
- Filters for elimination of powerline interference and harmonics
- Filters for tone control, demodulation, comb filtering, phase lock control and many more.

Frequency Devices designs, manufactures, and delivers active filters to industrial, federal or military specification.



25 Locust Street, Haverhill, MA 01830  
Tel: 617-374-0761 TWX: 710-347-0314

# DC-500 Mbits/s

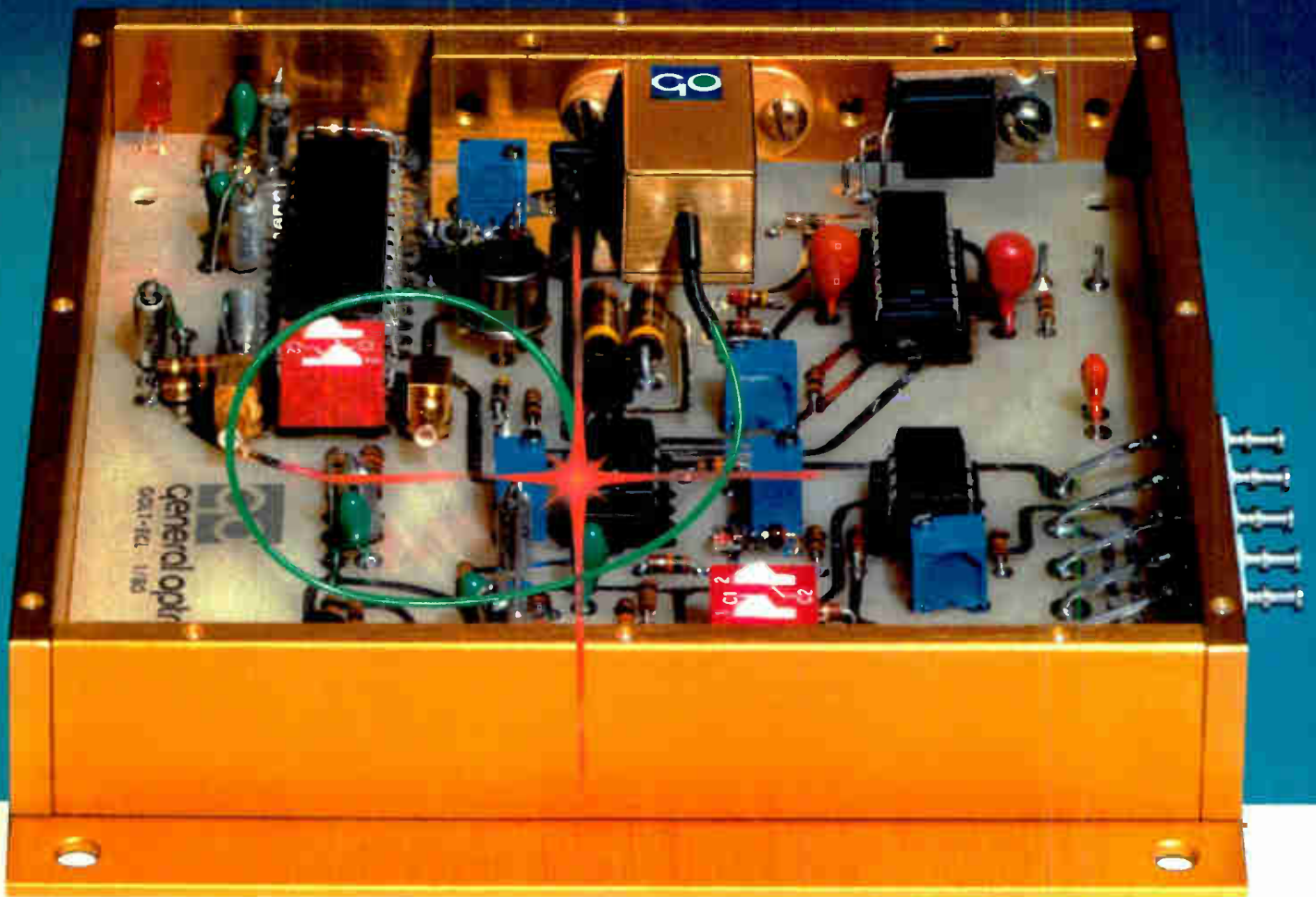

## General Optronics sets the standard for Digital Laser Transmitters...

- GENERAL OPTRONICS Hermetically Sealed Laser Diode
- Performance Warning Alarm
- Remotely Programmable
- Differential or Single Ended Input
- Available in OEM or Self Contained Configurations.

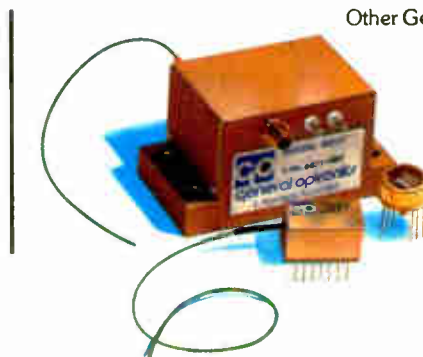

Other General Optronics products include

- Laser Diodes
- Analog Optical Transmitters
- Laser Diode in DIP with pigtail
- Optical Transmitter with Hybrid circuitry in TO-8 Package.

 **general optronics**

Circle 88 on reader service card

General Optronics Corp. • 3005 Hadley Road, South Plainfield, NJ 07080 • Tel. 201-753-6700 • TWX 710-997-9556



# Announcing a NEW GENERATION of Airborne Yokes from THE GREAT AMERICAN YOKE COMPANY.



CELCO Airborne Yokes are designed for aircraft information displays, orbiting satellite, hand-carried and helmet displays, or wherever airborne and portable yoke applications require extremely small size and light weight without sacrificing high performance.

The highly efficient design of CELCO Airborne Yokes translates into space and power savings so critical to the airborne environment.

For three decades CELCO has met the demands of research in all fields of science and industry where high resolution CRT deflection components are required. CELCO YOKES are well known and respected throughout the Free world where they are the choice for military, medical, environmental, space, nuclear, earth resources and commercial applications.

Designing a high resolution Airborne CRT Display? CELCO engineers will help you select the correct combination of deflection components from among our standard catalog units. Or, we'll design custom production yokes to meet your most precise display requirements. Call or write CELCO today for your FREE CRT Display Computer and your complete CELCO Display Engineering Catalog.

**CONSTANTINE ENGINEERING LABORATORIES CO.**  
70 Constantine Drive  
1150 E. Eighth Street

**Celco**

Mahwah, NJ 07430  
Upland, CA 91786



# Index

## Index of people

Affel, H. A., 51  
Aiken, H., 44, 142  
Alexanderson, E. F. W., 100, 112  
Allen, J. W., 246  
Amdahl, G., 339, 382  
Anderson, A., 319  
Anderson, H., 300  
Andrews, E. G., 185  
Armann, G., 365  
Armstrong, E. H., 17, 18, 37, 51, 78, 100, 106, 436  
Arnold, H., 60  
Atalla, M. M., 263  
Atanasoff, J. V., 186, 191  
  
Babbage, C., 44, 66, 69, 142  
Bachman, W. S., 285  
Backus, J., 300, 304  
Bahles, S., 567, 570, 577, 581, 585, 586, 589, 593  
Baird, J. L., 75  
Baker, W. R. G., 45, 115  
Ballantine, S., 103, 136  
Bardeen, J., 217, 229, 230, 233, 236, 249  
Bate, R. R., 570, 573, 578, 582  
Batt, W. L., 158  
Batts, R., 109  
Becker, J. A., 220, 223  
Becquerel, A. E., 216  
Bell, A. G., 70, 236  
Bell, C. G., 349, 570, 573, 577, 578, 581, 586, 593  
Bergey, J. M., 401  
Birnbaum, J. S., 450, 477  
Blaauw, G., 339  
Black, H. S., 37, 46, 96, 118, 136, 429, 438  
Blank, J., 249  
Bloch, F., 419  
Bloembergen, N., 307  
Blood, W. B., 276  
Blumlein, A., 369  
Bobb, H. S., 266  
Bobeck, A., 554  
Boole, G., 69  
Boone, G., 378  
Borel, J., 542  
Bourke, W., 492  
Bowen, E. G., 161  
Boyle, W. S., 270  
Brattain, W. H., 217, 220, 223, 226, 229, 230, 233, 236, 249  
Braun, K. F., 75, 130, 216  
Braunstein, R., 243  
Breuche, E., 141  
Brown, J. E., 195  
Bruch, W., 118  
Brunetti, C., 210  
Bryson, D., 553  
Bucy, F., 269  
Buie, J. L., 236, 263  
Burroughs, W. S., 69  
Bush, V., 44, 70, 141, 142, 161  
  
Caldwell, O. H., 12, 16-19, 44, 185  
Campbell-Swinton, A. A., 75  
Carlisle, S. F. Jr., 209  
Carman, C. D., 601, 613, 622, 625, 626, 633  
Carnahan, R. D., 492  
Carpentier, M., 519, 560  
Carson, J. R., 75, 78, 96, 100  
Carter, J., 249, 269  
Christiansen, D., 19, 20

Clarke, A. C., 210  
Clements, M., 16  
Cochran, M., 378  
Colpitts, E., 436  
Compton, K. T., 161  
Conant, J. B., 161  
Cornelius, E., 210  
Craven, T. A. M., 284  
Cray, S., 300, 303, 340, 382  
Cullen, G. L., 480  
Cullum, C., 554, 560  
Cuming, W. R., 311  
Cutkosky, R. D., 362  
  
Davidson, C. J., 223  
Davydov, A. S., 217, 220  
de Bellescize, H., 439  
de Benedetti, F., 483  
de Forest, L., 44, 46, 59, 60, 69, 96, 97, 216, 436  
de Kozen, R. L., 501  
DeLauer, R. D., 519  
Delcroix, J.-L., 574  
DeLoach, B. C., 246  
Dertouzos, M. L., 448, 450, 462, 467, 480, 489, 492  
Dietrich, I., 577, 578, 581  
Dodd, S. H., 195  
Doerfer, J. C., 284  
Dotson, C. P., 269  
Dreyer, H.-E., 515  
Dreyer, J., 142  
Dryden, H. L., 185  
DuBridge, L. A., 161  
Ducas, C., 51  
Dummer, G. W. A., 251  
Du Mont, A. B., 112, 115, 133  
  
Eason, T. S., 456  
Eccles, W. H., 437  
Eckert, J. P., 186, 191, 295  
Eckert, W. J., 142  
Eden, R., 557  
Edison, T. A., 59, 60, 61  
Einstein, A., 216  
Ely, P. C., 567, 574, 582, 586, 593  
Engelbart, D. C., 335  
Erllich, H., 17  
Ernst, M. L., 467, 508  
Esaki, L., 243  
Espenschied, L., 51  
  
Fabrikant, V. A., 307  
Faggin, F., 375, 542, 548, 563  
Faraday, M., 60, 61  
Ferguson, J. P., 266  
Fessenden, R. A., 75, 436  
Fink, D. G., 17, 18, 19  
Fleming, J. A., 60, 66, 216  
Fletcher, C., 542, 560  
Fluke, J., 319  
Ford, F. W., 369  
Forgue, S., 284  
Forrester, J. W., 192, 195, 295, 433  
Fougere, G. L., 619  
Franck, J., 220  
Frenkel, Y. L., 220  
Fuller, W. F., 316  
  
Gabor, D., 307  
Gady, W., 136  
Galvin, P. O., 421  
Gamow, G., 243  
George, W., 477

Germer, L., 223  
Gibbons, P. E., 246  
Gibson, R., 508  
Gilbert, R. W., 365, 442  
Gill, R. T., 502  
Gill, S., 300  
Gilruth, R. R., 303  
Gistaro, E. P., 480  
Glenman, T. K., 303  
Goddard, R. H., 303  
Goldmacher, J., 370  
Goldmark, P. C., 200, 206, 285  
Goldstine, H. H., 185  
Gomory, R. E., 600-602, 608, 619, 622, 625, 626, 633  
Goodrich, R., 284  
Gordon, J. P., 307  
Gosling, W., 567, 574, 589  
Gottzein, E., 507  
Gould, R. G., 307  
Griffin, D., 206  
Grinich, V., 249, 250  
Grove, A. S., 259  
Gunn, J. B., 246  
Gutton, H., 420  
  
Haef, A., 192  
Hagendorfer, M., 406  
Haggerty, P. E., 325  
Hall, R. N., 361  
Hamm, D. M., 602  
Hammond, R., 319  
Hanneman, G., 471  
Hartley, R. V. L., 436  
Hattner, R., 512  
Hawkins, L. A., 161  
Hazeltime, A., 425  
Heesels, L., 602, 603  
Heil, O., 106, 220  
Heilmeyer, G., 519, 520, 536, 539, 548, 563, 600, 601, 608, 608, 614, 622, 625, 626, 629, 630, 633  
Heiman, F. P., 240, 263, 266  
Hertz, H., 60, 66  
Hewlett, W., 203, 206, 209, 398  
Hittinger, W. C., 486  
Hoerni, J., 249, 250, 251, 260  
Hoff, M. E., 375, 376  
Hoffman, G., 548  
Hofstein, S., 240, 263, 266  
Hogan, C. L., 269, 421  
Hollerith, H., 44, 69, 70  
Holmes, J. H., 362  
Holst, G., 103  
Hopper, G., 300, 304  
Horton, J. W., 136  
Howard, B., 539, 542  
Howry, D. H., 362  
Hull, A. W., 103, 185  
Hyland, L. A., 121  
  
Iroulart, C., 581  
Israel, D. D., 278  
Iverson, K. E., 350  
Ives, H., 112  
Ivrea, C., 477  
  
Jacquard, J. M., 69  
Jaumot, F. Jr., 495  
Jewett, F. B., 161  
Johannson, H., 141  
Johnson, D. S., 582, 585  
Johnston, R. L., 246  
Jones, E. D., 480, 489



## Index

- Jordan, F. W., 437  
Josephson, B., 560
- Kahn, L. B., 369  
Kao, C. K., 413, 626  
Karrer, G., 492  
Kay, A., 316  
Keithley, J., 206, 319  
Kelle, H., 581  
Kelly, M., 223, 226  
Kelvin, Lord, 70  
Kemeny, J. G., 353  
Keyes, R., 539  
Khouri, A. S., 210  
Kilburn, T., 295  
Kilby, J., 251, 252, 259, 260  
Klein, D., 483  
Kliner, E., 249, 250  
Klipsch, P. W., 203  
Knoll, M., 141  
Kurtz, T. E., 353
- Lake, C. D., 142  
Lally, J., 567, 570, 574, 582  
Lampard, D. G., 362  
Langevin, P., 418  
Langmuir, I., 60, 69, 103  
Lark-Horowitz, K., 226  
Last, J., 249, 250  
Law, H. B., 196, 200  
Lee, R. E., 284  
Leibniz, G. W., 66  
Lepselter, M., 361, 533  
Lessing, L. P., 276  
Lewis, B., 185  
Licklider, J. C. R., 520  
Lilienfeld, J. E., 106, 217, 236, 240  
Little, J. B., 239  
Longo, T., 542  
Lonsdale, K., 295  
Lovell, C. A., 441  
Lowell, A. C., 266
- McDonald, W. W., 19  
McDonnell, W., 477  
McGraw, J. H., 16  
McMillan, D., 19, 20  
Maiman, T. H., 307, 434  
Mallina, R. F., 312  
Marconi, G., 59, 60, 61, 96, 106, 425  
Margolis, A., 509  
Markley, J. T., 468, 507  
Maron, W., 195  
Marr, G., 533  
Marrison, W. A., 136  
Martin, T. L., 581, 582  
Mauchly, J. W., 186, 191, 295  
Maurer, R. D., 413  
Maxwell, J. C., 60, 66  
Meissner, A., 436  
Millman, J., 209  
Miner, W., 200  
Minow, N. N., 369  
Moore, G. E., 249, 250, 259, 269, 532, 547, 560, 563, 600, 601, 602, 614, 622, 625, 633  
Morgan, S. O., 229  
Moses, J., 467, 468  
Moskowitz, S., 209  
Mott, N. F., 217, 220  
Mundel, A. B., 209  
Murdock, J., 206, 209, 358
- Nelson, D., 619  
Nelson, W. F., 619
- Nipkow, P., 70, 75  
Noble, D. E., 421  
Noda, K., 353  
Norman, R. H., 260, 266  
Norris, W. C., 300  
Nosé, Y., 515  
Noyce, R. N., 249, 250, 251, 252, 259, 260, 269, 448, 601  
Nyquist, H., 46
- Ohl, R. S., 223, 226, 358  
Olivetti, C., 477, 483  
Olsen, K., 300  
Olsen, S., 300  
Oswald, R., 495, 498
- Packard, D., 203, 206, 209  
Papert, S. A., 516  
Parmley, W. W., 509, 512  
Pascal, B., 59, 66  
Pearson, G., 229, 230  
Pelissolo, J.-C., 603  
Petritz, R. L., 613  
Philbrick, G. A., 441  
Pierce, J., 233, 236  
Piol, E., 483  
Planck, M., 216  
Plantureux, J., 507  
Pohl, R. W., 216, 220, 236  
Pollard, B. M., 295  
Ponte, M., 420  
Popov, A. S., 59, 60  
Post, E. L., 142  
Potter, J. T., 206, 315  
Powers, J., 70  
Pry, R., 519
- Rabi, I. I., 161, 185  
Rajchman, J., 192  
Ramo, S., 600, 601, 602, 608, 614, 622, 626, 629, 630  
Randolph, C. C., 19  
Ransome, V., 585  
Rauwenhoff, F., 602, 603  
Reciputo, P., 498  
Reeves, R. H., 103  
Reisman, A., 547  
Richman, P., 600, 601, 608, 613, 614, 622, 625, 630, 633  
Richmond, H. B., 277  
Ritt, P. E. Jr., 619  
Roberts, D., 603  
Roberts, S., 249, 250  
Roberts, W. H., 376  
Roessle, H., 602, 603  
Röntgen, W. K., 216  
Rose, A., 196, 200  
Rosing, B., 75, 418  
Round, H. J., 103, 436  
Rudenberg, R., 141  
Ruska, E., 141  
Russel, H. N., 185
- Salter, R. M., 492  
Sanders, R. C., 430  
Sarnoff, D. L., 38, 51, 109, 121, 418  
Scaff, J. H., 223  
Schadow, A. L., 307, 434  
Scheutz, P. G., 69  
Schickard, W., 66  
Schmidt, K. M., 602  
Schottky, W., 103, 217, 220, 223  
Schrödinger, E., 220  
Schulz, L., 574, 581, 582
- Schwinger, J., 173  
Scovil, H. E. D., 554  
Seamans, R. C. Jr., 573, 574, 578, 581, 586, 589, 590  
Seeley, S. W., 440  
Seely, L., 547  
Seligman, L., 474  
Sevin, L. J., 567, 570, 573  
Shannon, C. E., 103, 142, 304, 307, 311  
Shepherd, M., 260, 269  
Shewart, W. A., 51  
Shields, J., 602  
Shima, M., 377  
Shockley, W., 217, 223, 226, 229, 230, 236, 249, 250, 358, 421  
Siegel, M., 249, 250  
Six, J.-C., 577  
Slade, T., 574, 577, 578, 586, 589, 590, 593  
Smalley, N., 206  
Smith, G. E., 270  
Smith, W., 216  
Snepvangers, R., 285  
Snow, H. A., 103  
Sommerfeld, A., 220  
Southworth, G., 124  
Spitz, E., 603  
Sporck, C. E., 269, 405  
Stata, R., 574, 577, 578, 582, 589, 593  
Steinmetz, C., 429  
Stenstrom, R., 477  
Stibitz, G. R., 142, 185  
Stockett, L., 483, 486  
Stratton, J. A., 174  
Swigget, R., 312  
Szygenda, S. A., 567, 570, 574, 578, 582, 585, 586, 589, 590
- Taylor, A. H., 118, 121, 127  
Teal, G., 239, 246  
Teer, K., 450, 574  
Tellegen, B. D. H., 103, 421, 441  
Terman, F. E., 161, 419  
Tezner, S., 240, 263  
Theurer, H. C., 223  
Thomas, C. X., 66  
Thomas, T. C., 516  
Thompson, A. M., 362  
Thompson, G. B., 601, 602, 614, 622, 626, 629, 630  
Thomson, J., 70  
Tolman, R. C., 161  
Toombs, H. D., 553, 554  
Townes, C. H., 307, 315, 434  
Townsend, B., 474  
Turing, A. M., 142
- Uda, S., 438  
Ullrich, J., 498  
Ullrich, M., 406  
Urey, H. C., 185
- Vadasz, L. L., 548, 563  
van't Hoff, W., 602, 603  
Van Vleck, J. H., 229  
Veblen, O., 185  
Veilex, R., 450  
Visher, P. S., 508  
Vollum, H., 206, 209, 319, 358  
von Ardenne, M., 112, 133, 141, 426  
von Karman, T., 185  
von Neuman, J., 185, 186  
von Zeppelin, F., 217
- Wallace, M., 209

*Meeting industry  
display needs for  
three decades*

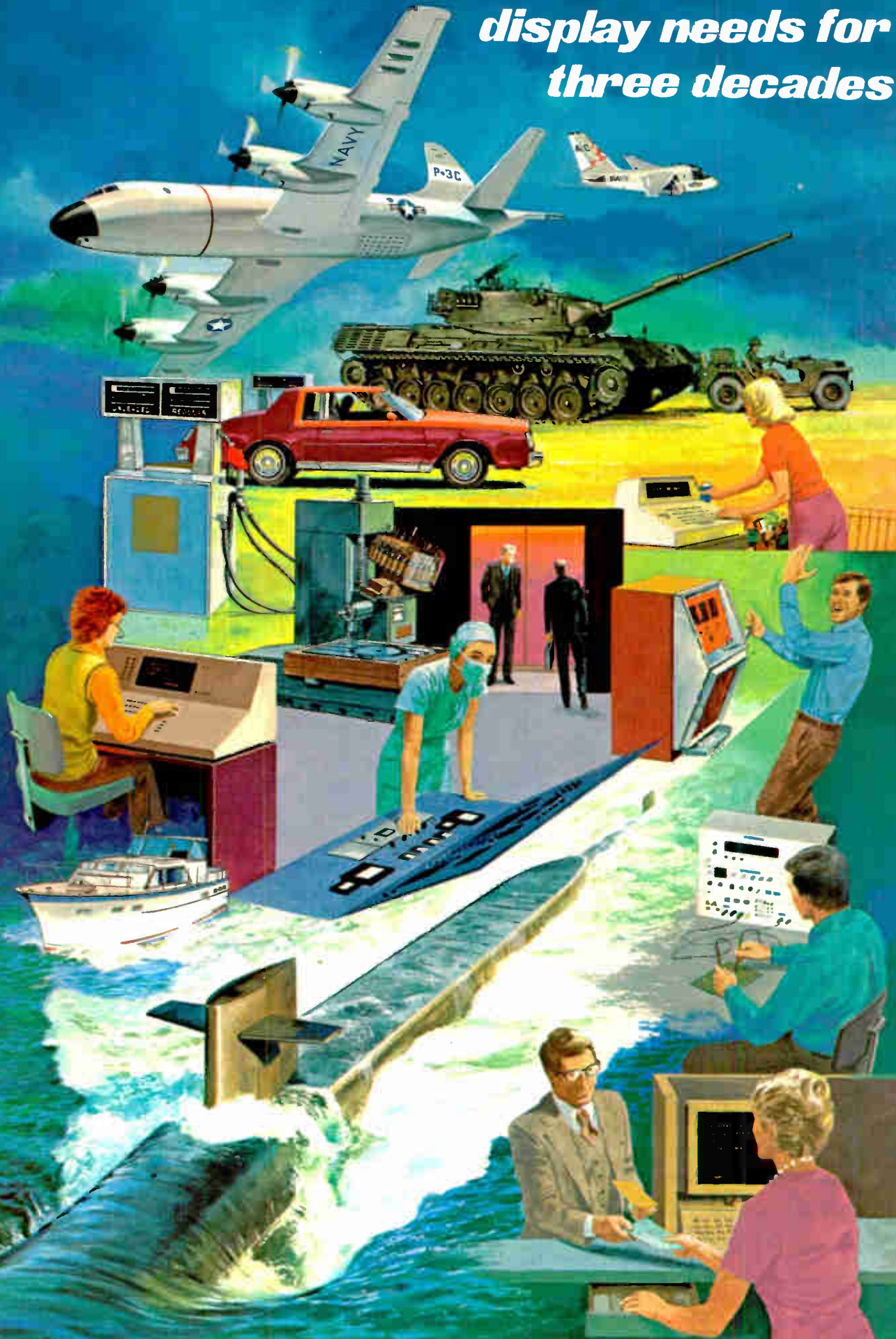



# Index

Walling, V., 516  
Wallmark, J. T., 263  
Wang, A., 295  
Ware, W. H., 448, 450  
Watson, T. J., 44, 69, 142, 339  
Watson-Watt, Sir Robert A., 127, 158, 161, 168, 420  
Weaver, W., 304  
Weimer, P. K., 196, 200, 263, 284, 366  
Wheeler, D. J., 300  
Wheeler, H. A., 17, 425, 438  
Wheeler, A. D., 508  
Whiting-O'Keefe, P. M., 455  
Widlar, R., 266  
Wilhelm, J. F., 574, 577, 578, 582, 586, 590, 593  
Wilkes, M., 192  
Wilkes, E. V., 303  
Wilkinson, L., 501  
Williams, F. C., 191, 192, 295  
Williams, S. B., 142  
Wilson, A. H., 220  
Wolfendon, M., 474  
Woo, W. D., 295

Yagi, H., 438  
Youtz, P., 195  
Young, L. C., 118, 121, 127  
Young, L. H., 19, 20, 339

Zacharias, J. R., 362  
Zeiger, H. J., 307  
Ziller, I., 300, 304  
Zornig, H. M., 185  
Zworykin, V. K., 18, 37, 51, 75, 78, 418, 426

## Index of companies

A. B. Dick, 486  
Accra Point Arrays, 389  
Admiral Radio, 277, 285  
Advanced Micro Devices (AMD), 381, 613  
Advent, 409  
Aetna Insurance, 410  
Allen-Bradley, 366  
Allen B. DuMont Laboratories, 115, 118, 133, 278, 385  
Alpha Metals, 389  
Amdahl, 378  
American Microsystems (AMI), 358, 374, 376, 401  
AM International's Bruning division, 486  
American Satellite, 413  
American Telephone and Telegraph Co. (AT&T), 44, 276, 325, 350, 369, 413  
American Television, 118  
Ampex, 286, 336, 357  
Amphenol North America division, 406  
Amphenol Rf division, 390  
Analog Devices, 361, 390  
Andrea Radio, 118  
Applied Computing Technology, 377  
Atari, 402  
Autonetics, 269, 358, 375

Beckman Instruments, 362  
Bell System, 413  
Bell Telephone Laboratories, 37, 38, 46, 133, 174, 185, 216, 220, 223, 229, 236, 239, 250, 251, 266, 269, 307, 312, 316, 325, 329, 350, 357, 361, 366, 382, 388, 390, 413, 414, 421, 438, 477, 533, 554  
Bendix, 315  
Berkeley Instrument, 316

Blaupunkt-Werke, 406  
Bosch, 109  
Bowmar/ALI, 398  
Bunker Ramo, 406  
Burlington division of GCA, 388  
Burr-Brown, 390  
Burroughs, 69, 299, 316, 340, 343, 382, 410

California Computer, 336  
Capehart, 203  
Centralab, division of Globe Union, 210, 311  
Centro Studie Laboratori Telecommunica-  
zioni, 414  
Centronics, 387  
Compagnie Générale de Télégraphie sans Fil  
(CSF), 420  
Compagnie des Machines Bull, 353  
Computer Automation, 349, 376  
Comsat, 329, 410  
Control Data, 300, 343, 346, 382, 410  
Corning, 413  
C. P. Claire, 361  
CPT Corp., 387  
Crosley Radio, 44  
Cubic Western Data, 502

Daconis, 387  
Dana Laboratory, 393  
Data 100, 336  
Datacraft, 349  
Data General, 336, 346, 349, 382  
Datapoint, 375, 376, 387, 477  
Data Systems division, 339  
Data Transmission Co. (Datran), 350  
Datel, 390  
De Forest Radio Corp., 44, 46, 96  
Delco, 332  
Device Manufacturers, 240  
Dictaphone Corp., 486  
Digital Equipment Corp. (DEC), 300, 343, 349, 377, 382, 387, 410

Eckert & Mauchly Computer, 192, 296  
ECRM, 486  
E-H Research Laboratories, 390  
Electro Scientific Industries, 388  
Electronic Arrays, 375  
El-tronics, 316  
Emerson Radio and Phonograph, 278, 285  
Erie Ceramic Arts, 389  
Evans & Sutherland, 486, 512

Fairchild, 233, 249, 250, 259, 260, 263, 266, 269, 346, 358, 365, 366, 369, 375, 376, 378, 390, 393  
Faultfinders, 390  
Ferranti, 296, 353  
Fisher Radio, 286  
Ford, 354, 405, 495, 498  
Four-Phase, 387  
Franklin Airloop, 210  
Frigidaire, 405  
Fujitsu, 346, 353  
Futuredata (see GenRad)

Garrard, 203  
General Automation, 349, 382  
General Electric (GE), 44, 106, 109, 118, 206, 210, 239, 240, 246, 276, 299, 312, 315, 336, 346, 361, 366, 370, 389  
General Electric Co. Ltd., 589, 590, 603  
General Instrument, 266, 358, 388, 402  
General Microelectronics, 266  
General Mills, 312

General Motors (GM), 354, 492, 495  
GenRad, 133, 136, 366, 393  
General Telephone & Electronics (GTE), 401, 413  
GTE Laboratories, 619  
Gould Inc., 492  
Grundig, 406  
Gulton Industries, 362

Halske, 142  
Hamilton Beach, 405  
Harris Computer, 387  
Hazeltine, 17, 284, 285, 425, 438  
Hewlett-Packard (HP), 203, 209, 263, 266, 316, 349, 365, 393, 394, 398, 409, 419  
H. H. Scott, 410  
Hoffman Electronics, 285  
Honeywell, 299, 340, 349, 362, 382, 410  
Hughes Aircraft Co., 329, 358, 388, 397, 520

Industrial Modules Systems, 358  
Inmos, 613  
Intel, 259, 260, 269, 270, 375, 376, 377, 378, 381, 393, 394, 613  
Intelsat, 329  
Interdata, 349, 387  
International Business Machines (IBM), 44, 69, 70, 142, 185, 229, 270, 286, 296, 299, 300, 312, 336, 339, 340, 343, 346, 350, 353, 361, 366, 381, 382, 387, 388, 410, 533, 556  
International Computers Ltd. (ICL), 353  
International Semiconductor, 266  
Ion Physics, 358  
ITT Cannon Electric, 390  
ITT Federal Laboratories (West Germany), 332

Jacquard Systems, 387  
Japan Electronic Computer, 353  
John Fluke Manufacturing, 319, 389, 390, 393  
John Oster Manufacturing, 370  
John Sargrove, 210

Keithley Instrument, 206  
Kobe Kogyo, 369  
Korad, 434

Lexitron, 387  
Linolex, 387  
Logabax Informatique, 516

Macrodata, 389, 390  
Magnavox, 285, 402, 406, 409  
Mallory, 109, 312  
Marconi, 44  
Matsushita, 353, 409  
Mattel, 405  
Medtronic, 357, 362, 512  
Membrain Ltd. (see Schlumberger)  
Memorex, 336  
Messerchmitt-Bölkow-Blohm GmbH (MBB), 507  
Metropolitan-Vickers Electric, 142  
Microdata, 349, 387  
Micronet, 471, 483  
Microsystems Engineering, 486  
Microwave Communications of America (MCA), 350, 405  
Mitre, 398  
Mitsubishi Electric, 353, 410  
Modular Computer Systems, 349, 387  
Mohawk Data Sciences, 350

# He's one reason the electronics industry is taking off in Northern Ireland.

Sam Harper puts his skills to work for AVX, the world's largest manufacturer of multilayer capacitors. Other highly trained technicians staff a growing number of firms in Northern Ireland's electronics industry.

Companies headquartered in the U.S., Europe, and Great Britain have all opened plants here. Manufacturing is solidly supported by research and development services, including a specially dedicated unit at Queen's University. And generous grants are available to turn R&D into profitable products.

From Northern Ireland it is easy to do business in the Common Market or anywhere else in the world.

Transportation and communication links are first-class. Investment incentives have been judged

the best overall in the EEC and include provisions for joint ventures, buy-back equity, and licensing.

But the best reason for locating here is the work force. Experienced, productive, and loyal, with a good labor relations record.

Put our people to work for you. Talk to Reg Browne or Marcus Robinson at the Northern Ireland Industrial Development Office. They can quickly put together a package of incentives to fit your plans. Call (212) 593-2258. Or write: NIIDO, British Consulate-General, 150 E. 58th St., New York, NY 10022.

Sam Harper works. A service engineer at AVX, he restores and flies small airplanes in his spare time.



## Northern Ireland works.

Circle 92 on reader service card





# Index

Monsanto, 366  
Mostek, 252, 269, 358, 375, 378, 405, 613  
Motorola, 109, 266, 278, 285, 361, 369, 370, 376, 377, 378, 381, 401, 421, 461, 462, 498, 539

National Biscuit Co., 353  
National Broadcasting Co., 44, 115  
National Cash Register (NCR), 299, 340, 346, 382  
National Semiconductor 252, 269, 376, 377, 378, 390, 401, 402, 467  
National Union Radio, 44  
New Hokkaido Line, 502  
Nikon, 388  
Nippon Electric, 353, 381, 413  
Nippon Telegraph and Telephone Public, 388, 413  
Non-Linear Systems, 316  
Northrop Aircraft, 295  
Nutting Associates, 402

Oki Electric, 353  
Olympic, 285

Parker Brothers, 405  
Perkin-Elmer, 388  
Perryman Electric, 44  
Pertec, 336  
Philbrick/Nexus, 362  
Philco, 19, 115, 118, 240, 243, 246, 269, 276, 281, 299, 335, 350  
Philips, 353, 405, 409, 410, 414, 441, 602  
Photocircuits, 312  
Plessey Peripheral Systems, 486  
Potter Instrument, 315  
Powers Tabulating Machine, 70  
Precision Monolithics, 390  
Prime Computer, 387

Qyx, 387  
Qwip Systems, division of Exxon Enterprises, 486

RCA, 17, 39, 44, 100, 103, 109, 112, 115, 118, 133, 196, 200, 203, 226, 239, 240, 243, 246, 266, 269, 276, 281, 284, 285, 286, 299, 300, 315, 319, 332, 336, 340, 346, 350, 358, 361, 366, 369, 370, 377, 401, 402, 409, 413, 414, 542  
RCA Global Communications, 413  
R. C. Saunders Technology, 430  
Radio Shack, 405  
Ramo-Woolridge, 601  
Raytheon, 106, 168, 174, 175, 239, 240, 246, 276, 397  
Realist, 486  
Redactron, 387  
Remington-Rand, 70, 296, 299  
Robinson-Nugent, 390  
Rockland Systems, 393  
Rockwell International Center, 376, 377, 378, 557

Sanders Associates, 311  
Sanyo, 409  
Satellite Business Systems, 410  
Scientific Data Systems, 354  
Schlumberger Ltd., 390  
Sentinel, 285  
Sharp, 406, 450, 456  
Shockley Transistor Laboratories, 249  
Siemens, 142, 381, 581, 582

Signetics, 376, 378, 381  
Société Nationale des Chemins de Fer (SNCF), 502, 507  
Société Occitane d'Electronique, 516  
Sony, 281, 406, 409, 410  
Southern Pacific Transportation, 502  
Sperry, 70, 168, 290, 295, 322, 498, 501  
Sprague, 312  
Standard Telephones and Cables, 414  
Storage Technology, 336  
Submarine Signal Co. (see Raytheon)  
Sycor, 336  
Sylvania, 240, 246, 263, 266, 276, 389, 397, 406  
Systems Engineering Laboratories, 387

Tandem Computers, 387  
Teledyne, 192, 240, 361  
Telefunken, 118, 405, 409  
Teleprompter Manhattan Cable Television, 413  
Television Laboratories, 115  
Tektronix, 206, 209, 365, 390  
Teradyne, 393  
Testline (see Fairchild), 390  
Texas Instruments (TI), 230, 246, 252, 259, 260, 263, 266, 325, 353, 358, 361, 366, 375, 376, 377, 381, 382, 387, 388, 393, 398, 402, 467, 547  
Textool Products, 390  
Thomson-Brandt, 420  
Thomson-CSF, 420, 519  
Thorn Electrical Industries Ltd., 369  
3M Co., 354, 389  
Time Computer, 401  
Toshiba, 353, 406, 409  
Transitron, 246  
Trendar (see John Fluke Manufacturing)  
TRW Semiconductor, 236, 263

Unimation, 394  
United Shoe Manufacturing, 312  
United Wiring and Manufacturing, 390  
Univac, 296, 340, 343, 382, 410

Varian Associates, 349, 388, 419  
Varo, 312  
Victor, 409  
Victor Comptometer, 246, 266  
Vydec, 387

Wang Laboratories, 295, 387  
Western Digital, 376  
Western Electric, 66, 196, 239, 290, 361, 437  
Western Union, 413  
Western Union's Telex, 350  
Westinghouse, 44, 106, 168, 266, 276, 285, 332  
Weston, 365  
Whirlpool Corp., 405, 467  
Wilson Greatbatch Electronic Consultants, 362

Xerox, 336  
Xicor, 548

Yaou Electric, 369

Zehntel, 390  
Zenith, 44, 276, 370  
Zilog, 377, 381, 673

## Index of subjects

Adding and Listing Machine, 69  
Alexanderson alternator, 75, 103  
Alpha particles, 548  
American Institute of Electrical Engineers, 45, 136, 161, 278, 325  
Antennas, 112, 115, 173, 425, 438, 625-626, 630  
Apollo program, 243, 325, 332  
Appliances, 210, 405, 474, 477  
Atomic Energy Commission, 303, 312  
Audio development:  
  digital fm tuner, 410  
  equipment, 409-410  
  high-fidelity, 276, 285-286  
  oscillator, 203  
  phonograph industry, 203  
  quadraphonic sound, 409-410  
  stereo tape cartridge players, 370  
  stereophonic sound, 203, 286, 369  
Automation, 353  
  of assembly, 311, 312, 389, 390  
  of circuit design, 566-567, 582, 633  
  in software design, 582  
Automobiles, electronics in, 370, 405-406, 492-498, 501  
Aviation:  
  air traffic control, 308, 332-335  
  inertial navigation, 332

Ballistic Research Laboratory, 185-186  
Bipolar technology, 236, 263, 542  
  I<sup>2</sup>L, 542  
  RTL, 233, 243, 260  
  TTL, 236, 263, 390, 625  
Britain, electronics in, 142, 167, 191, 192, 295, 300, 303, 335, 420, 474, 567, 574, 589

Calculator chips, 375  
Calculators, 66, 44, 355, 398-401  
California Institute of Technology, 142, 601  
Capacitors, 312  
Cathode-ray tube (CRT), 75, 130-133, 173, 284, 316, 387, 498, 560  
Cat's whisker, 60, 216, 217, 236  
Ceramic tubes, 312  
Charge-coupled devices (CCDs), 266, 270, 560  
Columbia University, 44, 142, 167, 168, 601  
Components as subsystems, 336, 390, 567, 570  
Computers, 66-69, 290-300, 375-388, 600  
  analog, 142, 192, 290-295  
  Binac, 295  
  Bizmac, 299, 300  
  Colossus, 191  
  Complex Number Calculator, 142  
  Cray-1, 382  
  data base, communication with, 625  
  disk-storage units for, 299  
  distributed processing, 332, 410, 563  
  early digital, 142, 290-300  
  Edsac, 192, 295  
  in education, 398, 467, 515-516, 629  
  Edvac, 191  
  Eniac, 186, 295, 340  
  Erma, 299  
  in Europe, 353  
  home, 448, 456, 467, 468  
  Iliac IV, 340  
  in industrial electronics, 353-354, 394-397  
  interface with, 448-450

# Dedicated to custom IC's. Committed to excellence.

**Item:** The only difference between a typical IC company and SSi is our attitude and their catalog—they sell you what they've got... we give you what you want.

**Item:** 92% of all the integrated circuits we now have in production were custom designed for individual clients.

**Item:** MOS, Bipolar, Linear, Digital, combinations on a single chip—we give you exactly what you need.

If you want it your way, call SSi, Director of Marketing; or send for our capabilities brochure today.

Silicon Systems incorporated, 14351 Myford Road, Tustin, California 92680. Phone: (714) 731-7110 or TWX 910-595-2809.

## Silicon Systems

incorporated



# Index

- Larc, 340  
magnetic thin-film memory, 340-343  
Mark I, 66, 295, 296  
personal, 405, 448, 467, 625  
programming languages for, 300, 304, 350-353  
Stretch, 337, 339  
timesharing, 346  
Univac series, 296, 340, 343, 410  
Whirlwind I, 295
- Connecticut State College, Storrs, 421  
Converters, a-d and d-a, 388, 390, 560  
Cornell University, 240  
Counters, 69-70, 206, 315, 316
- Dartmouth College, 142, 346, 353  
Data-base management, 563  
Data communications, 410, 450, 480  
  modems, 335  
  packet-switching network, 520  
Digital watches, 401-402  
Direct digital control (DDC), 353  
Display technologies, 142, 370, 389, 401, 560  
Double-bass diode, 240  
Dry (plasma) processing, 358, 536-539
- Electric eye, 106  
Electron-beam exposure system, 382  
Electron microscope, 141-142, 426  
Electron countermeasures, 430  
Electronic Industries Association, 115, 277, 364, 369  
Electronics, employment in, 45, 277-278 (see also Future engineers, employment and)  
Energy management, 397, 461, 573, 603  
European Space Agency (France), 508
- Federal Aviation Administration (FAA), 39, 289, 290, 308, 332-335  
  precursors of, 39, 290, 308, 332-335  
Federal Communications Commission (FCC), 78, 100, 109, 195, 200, 281-285, 307, 364, 369, 370, 398, 406, 410, 413, 630  
Federal Radio Commission, 39, 78  
Feed-forward amplifier, 429  
Fiber optics, 357, 390, 413, 414, 563, 626  
Field-effect transistors (FETs), 252, 547, 557  
  HJFETs, 560  
  insulated-gate, 220, 263  
  JFETs, 106, 263, 557-560  
  MES FETs, 557-560  
  MOS FETs, 266  
Flip-flop, 191, 233, 252, 259, 437  
France, electronics in, 127, 167, 418, 420, 450, 502-507, 516-517, 542, 574, 603  
Frequency modulation (fm), 100, 195, 370, 421  
Future:  
  automobile in, 492-501  
  computers and communications in, 448-456, 629  
  computers and education in, 515-519  
  computers for personal use in, 462-471  
  European technology of, 602, 613  
  health care in, 508-515  
  home electronics in, 456-462, 474-477  
  national defense and, 519-520  
  office automation in, 477-486  
  railroads of, 502-507  
  research and development in, 619  
  space exploration in, 507-508  
  telecommunications and data processing in, 448-486  
  television of, 471-474  
  transportation in, 492-501  
  workplace of, 477-492
- Future engineers, 566-593  
  analog design and, 574  
  communications and, 573-574  
  computer programming and, 570-573, 582-585  
  education and, 581-582, 585-593  
  employment and, 567, 570, 573, 577-578, 626  
  energy and, 573  
  integrated circuit design and, 566-567  
  microprocessor industry and, 567-570  
  minorities as, 578-582  
  racial minorities as, 578  
  software development and, 566, 570  
  specialization and, 574-577  
  systems design and, 566  
  technology application and, 574  
  women as, 578-582  
  workspace and, 582
- Future industries, 600-633  
  communications and, 626-630  
  computers and, 625-626  
  government role in, 608-614, 622  
  internationalization of, 602-614  
  invasion of privacy and, 626  
  military role in, 614-622  
  problems of, 622-625  
  small companies and, 619
- Future technology, 531-563  
  bubble technology and, 553-560  
  electro-optical devices and, 560-563  
  integrated circuitry in, 532-536  
  lithography in, 533-534  
  semiconductor industry and, 536-553  
  VLSI devices in, 532, 539-542, 547, 563
- Games, electronic, 62, 402-405  
Geiger-Muller tube, 315  
General-purpose interface bus, 393  
Germany, electronics in, 141, 173, 332, 507, 614  
Ground communications, 413-414  
Gunn diodes, 246, 266
- Hall-effect key switch, 362  
Harvard University, 66, 75, 168, 185, 229, 307, 316, 422  
High-level languages, 350-353, 462, 563, 582  
  Algol, 300, 353  
  Cobol, 300, 304, 350  
  Fortran, 300, 350  
Hollerith counter, 69-70  
Holography, 307
- Ignitrons, 315  
Impatt diodes, 246  
Industrial electronics:  
  automatic controllers, 315  
  computers and, 353-354, 394-397  
  safety equipment and, 394  
  sonic generators and, 357  
Information teleprocessing, 448, 450, 455  
Information theory, 103, 304-307, 311  
Innovation management, 622  
Institute of Electrical and Electronics Engineers (IEEE), 19, 325, 374, 375, 419, 422, 533, 574, 582, 586, 590, 593  
Institute of Radio Engineers (IRE), 44, 45, 96, 124, 158-161, 195, 203, 239-240, 259, 277-278, 325, 425
- Instruments, 203-210, 315, 362-366, 390-394  
  digital, 315-319, 389, 393  
  integrated-circuit board tester, 366  
  programmable, 393  
  signature analysis in, 394  
  standards for, 362  
  time-domain reflectometry, 349, 366
- Integrated circuits (ICs), 251-269, 325, 357-362, 366, 370, 375, 388-390, 492, 532-563, 633  
  design of, 577  
  early history of, 230, 233, 251-263, 325, 326  
  future improvements in, 566-567, 633  
  hybrid circuits, 312, 339, 362, 388, 389  
  invention of, 252-260  
  linear, 266, 269  
  micrologic, 260  
  organic coatings, 548  
  processing, 252, 358, 536, 539, 542  
  clean rooms, 251, 358
- Integration, medium- and small-scale, 603  
Internationalization, 600, 608  
Iowa State College, 186-191
- Japan, electronics in, 353, 410, 438, 456, 608, 614  
Jet Propulsion Laboratory, 418  
Josephson junctions, 553, 555, 560
- Laser, 246, 250, 307, 361, 366, 388, 397, 414, 434, 450, 519, 520  
Light-emitting diodes (LEDs), 246, 263, 365, 366, 402  
Lithography:  
  electron beam, 266, 388, 533-536  
  ion-beam, 533-536  
  X-ray, 358, 388, 533-536
- Logic analyzers, 393  
Loran (Long-Range-Navigation), 175  
Los Alamos Laboratory, 186, 337
- Magnetic bubbles, 269, 270, 553-557  
Magnetic components, 312  
Magnetic-core memory, 295, 340  
Magnetic levitation, 507  
Manchester University, 191-192, 295-296  
Marconi Laboratories, 142  
Massachusetts Institute of Technology (MIT) 44, 70, 142, 158, 167, 168, 173, 174, 175, 192, 195, 223, 295, 362, 419, 433, 448, 462, 467, 468, 516, 519, 573, 578, 586, 589, 590, 601  
  Lincoln Laboratory, 366, 388, 433, 533  
  Radiation Laboratory, 18, 153, 158, 161, 162, 168, 173-175  
Maser, 246, 307, 315, 434  
Medical electronics, 362, 509, 512, 515  
  computerized axial tomographic (CAT) scanners, 508, 509  
  pacemakers, 357, 362, 512, 515  
Memory, 295, 343, 495-498, 501, 548  
  random-access (RAM), 269, 270, 346, 375, 376, 378, 498, 547, 548, 553  
  read-only (ROM), 260, 269, 346, 375, 376, 378, 547, 548  
  erasable programmable, 260  
  programmable, 495  
Microcomputers, 378-381, 486, 495, 563, 613  
Microprocessors, 259, 376, 378, 461, 467, 486, 489, 502, 560, 563

- high-level languages and, 377
- in industrial electronics, 394-397
- systems, 377, 394, 477
- Military role in U. S. electronics, 121-127, 130, 153-162, 167, 180-185, 192, 229, 236, 240, 289-290, 295, 300, 303-304, 312, 325-326, 343, 413, 419, 421, 519-520, 532, 614, 619
- Minicomputers, 349, 377
- MOS technology, 239, 246, 249, 252, 259, 269, 375, 533-539, 625, 633
  - C-MOS, 270, 377, 401, 542
  - HMOS, 539
  - MOS FETs, 266
  - n-MOS, 269, 270, 377, 547
  - p-MOS, 269
  - quadruply self-aligned MOS, 547
- Mott-Schottky theory of rectification, 229
- National Advisory Committee for Aeronautics, 303
- National Aeronautics and Space Administration (NASA), 185, 263, 303-304, 324, 325, 332, 336, 362, 397, 502
- National Astronomy Laboratory, 325
- National Science Foundation, 325
- Negative feedback, 46, 51, 118, 429, 439
- Nixie tube, 316
- Operational amplifiers, 192, 266, 441
- Optical computers, 357
- Optoelectronics, 357, 366, 560
- Oscilloscopes, 130, 133-136, 206, 316, 349, 365, 426
- Packaging of integrated circuits:
  - beam-lead, 357, 361
  - chip-carrier, 388, 389
  - dual in-line package (DIPs), 266, 357, 358-361, 388-389
  - flat pack, 353, 357, 358
  - flip-chip, 357, 361
  - micromodule program, 311
  - polystyrene cast resins, 311
  - Project Tinkertoy, 311
- Photoelectric effect, 216
- Photovoltaics, 456
- Positive feedback, 60
- Potentiometers, 312, 361
- Printed-circuit (pc) boards, 51, 312
  - multilayer, 312, 389
- Project Mercury, 303-304
- Proximity fuse, 180
- Pulse-code modulation, 103, 362
- Purdue University, 109, 226-229
- Quartz clocks, 136-141
- Quartz crystals, 195
- Radar, 10-11, 70, 118-133, 153, 162, 167-174, 289-295, 332, 335, 420, 501, 519
  - Ballistic Missile Early Warning Systems (BMEWS), 289, 290
  - chirp, 174
  - collision-avoidance systems (CAS), 501
  - digital, 397
  - Distant Early Warning (DEW) line, 289, 290
  - European development of, 127-130, 167
  - fm altimeter, 430
  - ground-controlled approach (GCA), 290
  - magnetrons, 168, 173, 276, 420
  - phased-array antenna, 332
  - pulse-doppler, 289, 290
  - Sage system and, 289
  - Silent Sentry, 290
  - Radar plan position indicator, 173
- Radio, 44, 46, 60, 78, 96, 103, 115, 118, 195-196
  - automobile, 106, 109
  - broadband amplifier, 426
  - citizens' band (CB), 307, 410
  - frequency modulation (fm), 78, 100, 195, 370, 421
  - mobile, 51, 109
  - shortwave, 39, 100
  - single sideband modulation, 78
  - telephone, 421
  - waveguides, 124
- Radio astronomy, 325-326, 343
- Radio Manufacturers Association, 45-46, 115, 158
- Rectifiers, 223, 217
- Robots, 394, 477, 489
- Satellites, 210, 303, 304, 308, 508
  - earth stations and, 332, 335
  - communication, 326-332, 410-413
  - research, 303, 308, 332
  - weather, 329-332
- Semiconductors, 216-270, 600, 633
  - in industry, 354
  - learning curve and, 251
  - strain gauges, 354
  - surface state theory and, 229-230
  - theoretical work on, 220-226
- Semiconductor materials, 216, 226, 263, 557, 560
  - gallium arsenide, 246, 250, 361, 414, 553, 557, 560
  - germanium, 174, 226, 229, 230, 243
  - silicon, 223, 229, 230
- Sensors, 486, 489, 498, 501, 507
- Silicon controlled rectifier (SCR), 240, 357, 370
- Silicon-on-sapphire (SOS), 269
- Software, 336, 448, 489, 585, 602, 619, 622, 626
- Solar cells, 358, 366-369, 508
- Sonar, 174-175
  - antisubmarine warfare, 161
- Space shuttle, 502, 508
- Spectrum analysis, 209, 365
- Speech recognition, 448, 450, 625
- Speech synthesis, 448, 625
- Standards:
  - atomic time, 362
  - Federal Bureau of Standards, 141
  - frequency, 136
  - National Bureau of Standards, 209, 210, 295, 311, 362
- Standardization, 158
- Stanford Research Institute (SRI), 335, 455-456, 489, 516
- Stanford University, 203, 419, 586
- Superheterodyne receiver, 51, 78, 97, 127, 196
- Surface-acoustic-wave technology, 630
- Tape recorders:
  - audio, 286 (see also audio development)
  - color video, 286-289
- Telemetry, 362
- Telephone, 118, 335, 401
  - network communication, 630
- Television, 17, 51, 70-78, 109-118, 124, 196-203, 276, 278, 406-409, 418, 426
  - battery-operated, 278-281
  - cable, 397-398, 413
  - color, 278-285, 364, 369, 406, 409
  - as data terminal, 456, 461
  - electronic tuning, 369
  - engineering standards for, 281
  - future of, 471-474
  - iconoscope, 75, 78, 418
  - image orthicon, 196
  - kinescope, 75, 418
  - Nipkow disk, 70-75
  - receivers, 425, 456
  - role of, 471
  - scanning standards for, 281-284
  - selenium detectors, 70
  - teletext, 406, 461, 471, 474
  - vhf channels, 281
  - vidicon cameras, 357
  - viewdata systems, 471, 474
- Television tubes, color, 281, 284-285
  - dot-sequential, 203, 206, 284, 285
  - field-sequential, 200-203, 206
  - line-sequential, 200, 284
  - vidicon, 284
- Thermionic integrated micromodules, 312
- Thick- and thin-film hybrid circuits, 312, 362, 388, 389
- Thyratrons, 315
- Transistors, 216, 226, 229-236, 240-251, 276, 286, 290, 421
  - diffused-base, 250
  - epitaxial method and, 251
  - field-effect (see field-effect transistors)
  - mesa process, 250
  - planar process, 229, 251
  - point-contact, 217, 236
  - power, 421
  - silicon grown-junction, 246-249
  - unijunction, 240, 266-269
- Traveling-wave tube, 326
- Triacs, 269
- Triodes, 230
- Tunnel diodes, 243
- Uhf broadcasts, 369
- Ultrasonics, 362, 512
- University of Pennsylvania, 601
  - Moore School of Electrical Engineering, 185-186, 192, 295
- Vacuum tubes, 51, 60, 66, 97, 103-107, 133-136, 216, 220, 223, 276-277
  - Compactron, 361
  - Nuvisor, 361
  - pentodes, 103
  - tetrodes, 103, 106, 136
- Van Allen radiation belt, 303, 332
- Very high-speed integrated circuit (VHSIC), 519
- Very large-scale integration (VLSI), 270, 448, 532, 533, 536, 539-542, 547, 548, 560, 563, 603, 613, 625, 626
- Video cassette recorders, 402, 471
- Video disk recorder, 357, 409, 474
- Voltmeters, 136
  - differential, 319
  - digital, 316, 365
  - vacuum tube, 133-136
- Williams tube, 178, 192
- Word processing, 387, 480, 483



# Credits and acknowledgments

## Illustration and photography credits

- COVER: Richard Krepel  
14: Jackie Vican  
36: collage by Fred Sklenar  
38-39: Culver Pictures  
44: courtesy of IBM Archives  
45, 46: Culver Pictures (all)  
51: courtesy of General Electric  
58: collage by Fred Sklenar  
61: Culver Pictures (top right)  
61: Science Museum, London, Crown copyright (top left)  
61: Edison Institute (bottom right)  
66: Science Museum, London, Crown copyright (all)  
68: courtesy of Bell Laboratories  
69: courtesy of General Electric  
70: Science Museum, London, Crown copyright  
75, 78: collection of Dipl.-Ing. Gerhart Goebel (all)  
94: collage by Fred Sklenar  
96, 97: Culver Pictures (all)  
100, 103: courtesy of RCA (all)  
106: Wide World Photos  
109: courtesy of Motorola (both)  
112: courtesy of Bell Laboratories (top)  
112: courtesy of RCA (bottom)  
115: courtesy of RCA (top)  
115: Wide World Photos (bottom)  
118: courtesy of AEG Telefunken  
121: courtesy of RCA  
124: courtesy of Bell Laboratories  
124: courtesy of AEG Telefunken (bottom)  
127: National Archives (both)  
130, 133: Department of the Army  
136: courtesy of GenRad  
141: MIT Historical Collections  
150: collage by Fred Sklenar  
152: courtesy of Western Electric  
154: MIT Historical Collections  
158: MIT Historical Collections (left)  
158: National Archives (right)  
161: Wide World Photos  
162: National Archives (all)  
167: U. S. Naval Historical Center (top)  
167: Wide World Photos (bottom)  
168, 173: Wide World Photos (all)  
174, 175: National Archives (both)  
180: courtesy of Centralab  
185: courtesy of Sperry Univac  
186: courtesy of Bell Laboratories  
191: courtesy of Prof. J. V. Atanasoff (top)  
191: University of Newcastle-upon-Tyne Computing Laboratory (bottom)  
192: Department of Computer Sciences, University of Manchester  
195: MIT Historical Collections  
196: courtesy of Western Electric (top)  
196: courtesy of Motorola (bottom)  
200: courtesy of RCA  
203: courtesy of Motorola  
206: courtesy of RCA (both)  
209: courtesy of Hewlett-Packard  
209: courtesy of Tektronix  
210: courtesy of Centralab  
214: collage by Fred Sklenar  
217, 220: courtesy of Bell Laboratories  
223, 226: courtesy of RCA (both)  
229: courtesy of Fairchild  
230: courtesy of Texas Instruments  
233: courtesy of Fairchild  
236: courtesy of TRW  
239, 240: courtesy of RCA (both)  
246, 249: courtesy of Regis McKenna (all)  
250, 251: courtesy of Bell Laboratories (both)  
252: courtesy of Mostek  
252: courtesy of National Semiconductor  
259: courtesy of Intel (both)  
260: courtesy of Texas Instruments  
260: courtesy of Intel  
263: courtesy of Hewlett-Packard  
266, 269: Courtesy of Bell Laboratories  
270: courtesy of IBM  
274: collage by Fred Sklenar  
277: Wide World Photos (both)  
278, 281, 285: courtesy of RCA  
286: courtesy of IBM  
289: courtesy of Bell Laboratories  
290: courtesy of Western Electric  
295: Army News Features (top)  
295: Ferranti (bottom)  
296: Department of Computer Sciences, University of Manchester (left)  
296: courtesy of Sperry Corp. (right)  
299: courtesy of IBM  
300: courtesy of RCA  
303: Science Museum, London, Crown copyright (right)  
303: courtesy of Control Data (left)  
304: courtesy of Sperry Univac (left)  
307: courtesy of IBM  
308: courtesy of NASA (both)  
311, 315, 316: courtesy of Bell Laboratories (all)  
319: courtesy of RCA  
322: collage by Fred Sklenar  
324: courtesy of NASA (both)  
326: courtesy of Autonetics  
329: courtesy of Bell Laboratories (top)  
329: courtesy of Hughes Aircraft (bottom)  
335: courtesy of Philco-Ford  
336, 339: courtesy of IBM (all)  
340: courtesy of Control Data (left)  
340: courtesy of General Electric (right)  
343: courtesy of Digital Equipment Corp.  
346: courtesy of Data General (top)  
346: courtesy of Fujitsu (bottom)  
349, 350: courtesy of Hewlett-Packard  
353: courtesy of Texas Instruments  
354: courtesy of Bell Laboratories  
357: courtesy of Medtronic  
358: courtesy of Tektronix  
361: courtesy of GE Research & Development Center  
365, 366: courtesy of RCA (both)  
369: courtesy of Western Electric  
370: courtesy of RCA  
372: collage by Fred Sklenar  
375: courtesy of Intel  
376: courtesy of Motorola  
377: courtesy of NCR  
378: courtesy of Amdahl  
381: courtesy of AMI  
382: courtesy of Western Electric  
387: courtesy of IBM  
388: courtesy of ESI  
389: courtesy of Macrodata (top)  
389: courtesy of John Fluke Manufacturing (bottom)  
393: courtesy of Texas Instruments  
394: courtesy of Grumman Aircraft  
397: Fred Sklenar  
398: courtesy of Hewlett-Packard  
401: courtesy of GTE  
402: courtesy of RCA  
405: courtesy of Amphenol North America Division  
409: courtesy of Hewlett-Packard  
410: courtesy of Bell Laboratories  
413: courtesy of Intel Net. Processors  
414: courtesy of Hughes Aircraft  
418-434: pictures supplied by the interviewees or their companies  
444, 446: assemblages by Ann Dalton  
449: R. J. Muna, courtesy of IBM  
450: courtesy of Sharp Corp.  
455: courtesy of Frederik R. Bull Foundation (top)  
455: courtesy of Motorola (bottom)  
456: courtesy of APF  
461: courtesy of Bill Loveless, KSL-TV  
462: courtesy of Mattel (right)  
462: G. Walker (left)  
467: courtesy of Whirlpool Corp.  
471: courtesy of Micronet (both)  
477: courtesy of Bell Laboratories  
480: adapted from Michael Dertouzos and Joel Moses, "The Computer Age: A Twenty-Year View," The MIT Press, copyright © 1979 by The Massachusetts Institute of Technology  
486: courtesy of Evans & Sutherland  
495: courtesy of Aston-Martin  
498: courtesy of Sperry division of Sperry Rand  
501: courtesy of Messerschmitt-Bölkow-Blohm/Transrapid E-M-S (right)  
501: courtesy of SNCF (left)  
502: courtesy of IBM  
508, 509: courtesy of EMI  
512: courtesy of Evans & Sutherland  
515: courtesy of Texas Instruments  
516, 520: courtesy of Hughes Aircraft (both)  
530: assemblage by Ann Dalton  
533: MIT Lincoln Laboratory  
548: courtesy of Texas Instruments (all)  
553: courtesy of Rockwell International Science Center  
555: courtesy of IBM (both)  
556: courtesy of Bell Laboratories (left)  
556: courtesy of IBM (right)  
557, 563: courtesy of IBM  
564: assemblage by Ann Dalton  
566: courtesy of Bell Laboratories  
567: courtesy of Mostek (top)  
567: courtesy of Bath University (bottom)  
570: courtesy of the University of Texas (left)  
570: courtesy of Millennium Systems  
573: courtesy of MIT  
574: courtesy of Hewlett-Packard  
577: courtesy of RTC-La Radiotechnique Compélec  
578, 581, 582: courtesy of Siemens  
585: courtesy of Bell Laboratories  
586: courtesy of Siemens  
589, 590: courtesy of Bell Laboratories (both)  
593: courtesy of Analog Devices (top)  
593: courtesy of Rensselaer Polytechnic Institute/Gehring Associates (bottom)  
598: assemblage by Ann Dalton  
600-633: text photographs by Jim Luke  
603: Philips (left)  
603: CII-Honeywell Bull (right)  
613: Inmos  
619: Prime Computer (left)  
619: Arthur D. Little (right)  
626: ITT

## Acknowledgments

The quotation from Sir Winston Churchill on page 152 comes from "Their Finest Hour," published by Houghton Mifflin Co., Boston, 1949, page 41.

The paragraphs from the New York Times of July 1, 1948, quoted on page 216, are copyrighted © 1948 by The New York Times Company and reprinted by its permission.

The Bell Laboratories document excerpted on page 229 is copyright © 1973 by the Institute of Electrical and Electronics Engineers Inc. and reprinted by permission from IEEE Spectrum, Vol. 10, No. 1, 1973, pages 25-26.

Thanks are also due to Jerry Eimbinder for permission to use material researched by him for parts of Chapter 5.

The passages on pages 461, 467, 489, 516, and 520 from "The Computer Age: A Twenty-Year View" by Michael Dertouzos and Joel Moses are reprinted by permission of The MIT Press, Cambridge, Mass., copyright © 1979 by The Massachusetts Institute of Technology.

# Who stole page 39?



This whodunit happens all the time. By the time the office copy of Electronics Magazine gets to your name on the routing slip, a page is missing. Or maybe the reader service cards. Or an entire article has been clipped. Sometimes you never get the magazine at all.

Other times the magazine is (glory be!) intact. But dogeared. Or otherwise abused. Or at the very least, you get it late.

O.K., we'll grant that a second-hand, third-hand, or maybe seventh-hand copy of Electronics is better than none. But it's no substitute for the copy that comes directly to you—to your home if you wish—with up-to-the-minute news and information of the technology in this fast-moving field.

To get your very own subscription to Electronics send in a subscription card from this magazine. And if they are missing, write to subscription department, Electronics, McGraw-Hill, 1221 Avenue of the Americas, New York, N.Y. 10020.

## Electronics Magazine. The one worth paying for.



## FREE

**Brochure**  
describes Electronics editorial  
reprints, services, books...

- More than 70 article reprints in 15 subject categories
- Handy wall charts
- Custom-made reprint services
- Books especially for Electronics' readers
- Convenient postage-paid order cards

For your free copy, circle #275 on  
the reader service card.

For faster response, write directly to  
**Electronics Reprints**, P.O. Box 669,  
Highstown, NJ 08520, or call  
(609) 448-1700, ext. 5494.

## this publication is available in microform



Please send me additional information.

**University Microfilms International**

300 North Zeeb Road  
Dept. P.R.  
Ann Arbor, MI 48106  
U.S.A.

18 Bedford Row  
Dept. P.R.  
London, WC1R 4EJ  
England

Name \_\_\_\_\_  
Institution \_\_\_\_\_  
Street \_\_\_\_\_  
City \_\_\_\_\_  
State \_\_\_\_\_ Zip \_\_\_\_\_



<b>Able Computer Technology</b>	125	<b>Brand Rex</b>	510, 511	<b>Dyna / Pert Div. USM Corporation</b>	572
<b>Adtech Power</b>	187	<b>Bruning Corp.</b>	356	<b>EAO Switch Corporation</b>	499
<b>Advanced Micro Devices</b>	454	<b>Bud Industries</b>	169	<b>Eaton Corporation (Cutler Hammer Inc.)</b>	242
<b>Advanced Microtechnology</b>	222	<b>Burndy</b>	540, 541	<b>EDAC Connectors</b>	208
<b>Advant</b>	247	<b>Burroughs</b>	212, 213	<b>Electro Scientific Industries</b>	367
<b>AEG Telefunken</b>	188, 189, 592	<b>Bussmann Mfg. Div. McGraw Edison Co.</b>	232	<b>Electromask</b>	190
<b>Afga-Gevaert</b>	310	<b>California Computer, Inc.</b>	128, 129	<b>Electronic Navigation Industries</b>	15
<b>Ailtech</b>	262	<b>Cambion</b>	478	<b>Electronics Processors</b>	302
<b>Alco Electronic Products (Sub. of Augat)</b>	415	<b>Carroll Manufacturing</b>	253	<b>Elgar Corporation</b>	487
<b>Allen-Bradley</b>	3C	<b>CELCO (Constantine Engineering Labs. Co.)</b>	636	<b>Elpac Power Supplies</b>	380
<b>Amp Incorporated</b>	609-612	<b>Century Data Systems</b>	62, 63	<b>EM Laboratories Inc.</b>	407
<b>Amphenol North America Div., Bunker Ramo Corp.</b>	228	<b>Cherry Electrical Products</b>	40, 41	<b>EMM SESCO</b>	408
<b>Analytical Chemical Laboratories</b>	631	<b>Circuit Technology Inc.</b>	227	<b>Erni &amp; Company</b>	627
<b>Anritsu Electric Co. Ltd.</b>	435	<b>C &amp; K Components</b>	632	<b>Essex Group (Sub. of United Tech)</b>	594
<b>Applied Solar Energy Corporation</b>	595	<b>Clarostat</b>	479	<b>Everett / Charles Test Equipment Corp.</b>	184
<b>Astro Med</b>	360	<b>Cominco American</b>	618	<b>Fairchild (Semiconductor Operations Divisions)</b>	42, 43, 182, 183
<b>Augat, Inc.</b>	137-140	<b>Corcom</b>	131	<b>Fairchild Test Systems</b>	54, 55
<b>Avantak</b>	615	<b>Creative Micro Systems</b>	160	<b>Fairchild Test Systems</b>	198, 199
<b>AVX Materials Division</b>	488	<b>Cromemco</b>	201	<b>Ferranti Electric Inc.</b>	47-49
<b>Basler Electric Company</b>	482	<b>Culligan USA</b>	371	<b>First Computer Corporation</b>	76, 77
<b>Bausch &amp; Lomb Scientific Optical Products</b>	355	<b>Dale Electronics, Inc.</b>	98, 99	<b>John Fluke Advertising</b>	383-385
<b>Beckman Instrument Advanced Electro Products</b>	159	<b>Data Display</b>	67, 71	<b>Forth Inc.</b>	132
<b>Beckman Instruments, Helipot</b>	163	<b>Data General Corporation</b>	146, 147	<b>Frequency Devices Inc.</b>	634
<b>Belden Corporation</b>	102	<b>Datanetics</b>	432	<b>Fujitsu America Inc.</b>	562
<b>CEC Division / Bell &amp; Howell Co.</b>	481	<b>Data Precision</b>	337	<b>Fujitsu Limited</b>	521-528
<b>Bell Laboratories</b>	568, 569	<b>Datel-Intersil</b>	306	<b>Fujitsu Microelectronics, Inc.</b>	587
<b>The Bendix Corporation Electrical Comp. Div.</b>	427	<b>Dialight</b>	351	<b>Gates Energy Products, Inc.</b>	268
<b>Berg Electronics</b>	544, 545	<b>Digital Equipment Corporation</b>	244, 245	<b>GCA Corporation</b>	166
<b>Bishop Graphics</b>	221	<b>Digital Equipment Corporation Microcomputer</b>	416, 417	<b>General Electric A&amp;Sp. Operations Semiconductor</b>	305
<b>Blue M Electric</b>	172	<b>Dit-MCO</b>	207	<b>General Electric Company Semiconductor Dept.</b>	143-145
<b>Bourns Inc.</b>	291	<b>Ducati Elettrotecnica</b>	460	<b>General Electric Instrument Rental Div.</b>	204, 205

<b>General Instrument Microelectronics</b>	119	<b>E.F. Johnson Company</b>	411	<b>NCR</b>	334
<b>General Dptronics</b>	635	<b>Kepron Circuit Systems, Inc.</b>	404	<b>NEC Electron</b>	264, 265
<b>General Semiconductor Industries</b>	591	<b>Kollmorgen</b>	224, 225	<b>Nichicon America Corporation</b>	463
<b>Genrad Incorporated</b>	164, 165	<b>Kollmorgen Multiwire Division</b>	500	<b>Nicolet Instrument Corporation</b>	272, 273
<b>Gould Inc., Instruments Division</b>	64, 65	<b>Lambda Electronics Corporation</b>	330, 331	<b>Nikon Incorporated Instrument Division</b>	328
<b>Gould Inc., Portable Battery Division</b>	294	<b>Leader Instruments Corporation</b>	74	<b>Non-Linear Systems Inc.</b>	197
<b>Gould Santa Clara Division</b>	116, 177	<b>Lear Siegler, Inc. Data Products Div.</b>	107	<b>Noritake Electronics Inc.</b>	4W3
<b>Guildline Instruments Inc.</b>	412	<b>LH Research Inc.</b>	513	<b>Norpflex Division UDP Inc.</b>	5W0
<b>Hamilton Avnet</b>	320, 321	<b>Litronix</b>	464, 465	<b>Northern Ireland Development Organization</b>	641
<b>Harris Semiconductor</b>	534, 535	<b>Lockheed Missiles &amp; Space Co., Inc.</b>	493	<b>Oak Industries</b>	472, 473
<b>Hazeltine Corp.</b>	400	<b>Magnecraft Electric Company</b>	546	<b>Ohio Scientific</b>	79-92
<b>Hewlett Packard</b>	2nd Cover, 1, 21-34	<b>Malco</b>	193	<b>O. K. Machine &amp; Tool Company</b>	396
<b>Hi-G Incorporated</b>	584	<b>Mallory Capacitor Company</b>	364	<b>Opto 22</b>	386
<b>Hitachi America</b>	466	<b>Matrox Electronic Systems</b>	469	<b>Panasonic Industrial Division</b>	287
<b>Honeywell</b>	108	<b>Matsuo Electronics</b>	616	<b>Panduit Corporation</b>	529
<b>Honeywell TID</b>	194, 234, 235, 344, 345	<b>Mepco/Electra</b>	490, 491, 558, 559	<b>Perkin-Elmer Corporation</b>	604, 605
<b>Hysol</b>	179	<b>Methode Electronics</b>	552	<b>Philips Elcoma</b>	170, 171
<b>IEE Industrial Electronic Engineers, Inc.</b>	639	<b>Micro Devices Division of Emerson Electric</b>	475	<b>Photodyne, Inc.</b>	352
<b>ILC Data Device Corp.</b>	538	<b>Microsoft</b>	317	<b>Plastics Engineering Company</b>	126
<b>Instrumentation Engineering</b>	301	<b>Microswitch Division of Honeywell</b>	550, 551	<b>Plessey Company Ltd.</b>	606, 607
<b>Intel Corporation</b>	496-497	<b>Midtex, Inc.</b>	363	<b>Plessey Semiconductors</b>	104, 105
<b>Interdesign, Inc.</b>	176, 177	<b>Mini-Circuits Laboratory</b>	2, 50, 327, 537	<b>Precision Filters</b>	68
<b>Interface Incorporated</b>	470	<b>3M Company Electronics Division</b>	292, 293	<b>Pro-Log</b>	457
<b>International Rectifier Corp. Semi. Div.</b>	431	<b>State of Minnesota</b>	623	<b>Pyramid Optical</b>	579
<b>Intertel</b>	460, 461	<b>Mitel Semiconductor Incorporated</b>	120	<b>Pyrofilm Corporation</b>	342
<b>Iskra Commerce Marketing</b>	503-506	<b>Mitsubishi Industrial Division</b>	288	<b>RCA Solid State</b>	4C
<b>Italtel/SIT</b>	484, 485	<b>Molex Incorporated</b>	114	<b>Rental Electronics</b>	395
<b>Ithaco, Inc.</b>	258	<b>Monolithics Memories</b>	452, 453	<b>RMC-Radio Materials Corp.</b>	543
<b>ITT Cannon Electric</b>	148, 149, 248	<b>Monolithics Systems</b>	113	<b>Rockland Systems Corporation</b>	314
<b>ITT Electro Optical Products</b>	56, 57	<b>Mostek Corporation</b>	313	<b>Rohm Corporation</b>	181
<b>ITT North Microsystems Div.</b>	549	<b>Motorola Inc. Component Products</b>	561	<b>Rotron Incorporated (Commercial Product Division)</b>	17B
<b>ITT Schadow Incorporated</b>	588	<b>National Capacitors</b>	476	<b>Schweber Electronics</b>	451



Seitz SA	424	Thomson CSF/DRP	254, 255
Semtech Corporation	271	Thomson CSF/GCT	256, 257
Sepa	231	Trio Tech	280
Sharp Corporation	494	Triplett Corporation	391
Sheldahl Inc.	211	TRW Electric Components	122, 123
Siemens Corporation	52, 53	TRW LSI Products	347
Signal Transformers	318	TRW Power Semiconductor	110, 111
Signetics Corporation	5-11	Tunisia Investment Promotion Agency	261
Silicon Systems	643	Union Carbide Corporation	518
Siliconix	134, 135	Unitrode Corporation	368
Simpson Electric	399	US Instrument Rentals	624
Snap-on Tools Corporation	392	Universal Instruments	202
Sola, a unit of General Signal	218, 219	Vactec Inc.	348
Solid State Scientific	309	Varo Semiconductor	279
Solitron Devices Inc.	297	Verbatim Corporation	359
Sord Computer Systems	517	Victor Dats Products	237
Spectrol Electronics	238	Vitramon	333
Sperry Univac	282, 283	Wabash Tape Corp.	617
Sprague Electric	101	Wavetek San Diego	241
Stackpole	443	Weckesser Company Incorporated	423
Standard Grigsby Inc.	514	Wells Electronics	571
Standard Microsystems	298	Wesper Corporation, Western Peripherals	576
Statek Corporation	583	Weston Sangamo	428
Synertek	596, 597	Weston Instruments	379
Tally Corporation	341	Wiltron	338
TDK Electronics Co., Ltd.	35	Xycom	620, 621
Technit (Technical Wire)	628	Yokogawa Electric Works	267
Texas Instruments Semiconductor	154-157	Zenith CRT Display Engineering	575

## Advertising Sales Staff

### Advertising sales manager: Paul W. Reiss

1221 Avenue of the Americas, New York, N.Y. 10020  
[212] 997-3468

**Atlanta, Ga. 30309:** Peter Stien  
100 Colony Square, 1175 Peachtree St., N.E.  
[404] 892-2868

**Boston, Mass. 02118:** Frank Mitchell  
607 Boylston St., [617] 262-1160

**Cleveland, Ohio 44113:** William J. Boyle  
[716] 248-5620

**Fort Lauderdale, Fla. 33308:** Peter Stien  
3000 N.E. 30th Place, Suite #400  
[305] 563-9111

### New York, N.Y. 10020

1221 Avenue of the Americas  
John Gallie [212] 997-3616  
Matthew T. Reseska [212] 997-3617

**Philadelphia, Pa. 19102:** Matthew T. Reseska  
Three Parkway, [212] 997-3617

**Pittsburgh, Pa. 15222:** Matthew T. Reseska  
4 Gateway Center, [212] 997-3617

**Rochester, N.Y. 14534:** William J. Boyle  
Powder Mill Office Park, 1163 Pittsford-Victor Rd.,  
Pittsford, N.Y. 14534  
[716] 248-5620

### Advertising sales manager: Norm Rosen

(Western)

3200 Wilshire Blvd., South Tower  
Los Angeles, Calif. 90010 [213] 487-1160

### Chicago, Ill. 60611

645 North Michigan Avenue  
Jack Anderson [312] 751-3739  
Robert M. Denmead [312] 751-3738

**Detroit, Michigan 48202:** Jack Anderson  
1400 Fisher Bldg., [313] 873-7410

**Costa Mesa, Calif. 92626:** Edward E. Callahan  
3001 Red Hill Ave. Bldg. #1 Suite 222  
[714] 557-6292

**Dallas, Texas 75201:** John J. Uphues  
2001 Bryan Tower, Suite 1070  
[214] 742-1747

**Denver, Colo. 80203:** Harry B. Doyle, Jr.  
655 Broadway, Suite 325  
[303] 825-6731

**Houston, Texas 77002:** John J. Uphues  
601 Jefferson Street, Dresser Tower  
[713] 659-8381

**Los Angeles, Calif. 90010:** Chuck Crowe  
3200 Wilshire Blvd., South Tower  
[213] 487-1160

**San Francisco, Calif. 94111:** Don Farris,  
Larry Goldstein, 425 Battery Street,  
[415] 362-4600

**Paris:** Michael Sales  
17 Rue-Georges Bizet, 75116 Paris, France  
Tel: 720-16-80

**United Kingdom:** Simon Smith  
34 Dover Street, London W1  
Tel: 01-493-1451

**Scandinavia:** Andrew Karnig and Assoc.  
and Simon Smith  
Kungsholmsgatan 10  
112 27 Stockholm, Sweden  
Tel: 08 51 68 70 Telex: 179 51

**Milan:** Ferruccio Silvera  
1 via Baracchini, Italy  
Phone 86-90-656

**Brussels:**  
23 Chaussee de Wavre  
Brussels 1040, Belgium  
Tel: 513-73-95

**Frankfurt/Main:** Fritz Krusebecker  
Liebigstrasse 27c, Germany  
Phone 72 01 81

**Tokyo:** Akio Saijo, McGraw-Hill  
Publications Overseas Corporation,  
Kasumigaseki Building 2-5, 3-chome,  
Kasumigaseki, Chiyoda-Ku, Tokyo, Japan  
[581] 9811

## Business Department

### Thomas M. Egan

Production Director  
[212] 997-3140

### Carol Gallagher

Production Manager  
[212] 997-2045

### Betty Preis

Production Manager Domestic  
[212] 997-2908

### Thomas Kazich

Production Manager Related Products  
[212] 997-2044

### Karen Walpole

Production Assistant  
[212] 997-2843

### Frances Vallone

Reader Service Manager  
[212] 997-6057

## Electronics Buyers' Guide

**H.T. Howland,** General Manager  
[212] 997-6642

**Regina Hera,** Directory Manager  
[212] 997-2544

## Classified and Employment Advertising

**Frank Eberle,** Manager  
[212] 997-2557

# We've been in Electronics for over 75 years!

When Electronics magazine began in 1930, Allen-Bradley already had 25 years of carbon resistor manufacturing experience. And through the years, the A-B line of carbon composition fixed and variable resistors became the quality standard of the industry. Today, the demand for A-B electronic components continues to soar—requiring massive investments in new plants to keep pace. The success of A-B resistive components is due to innovations, that today, far exceed those of early times: MOD POT<sup>®</sup> modular potentiometers, I-DIP and I-SIP resistor networks. Specify Allen-Bradley... there's 75 years of cost-effective electronic component quality behind us!

## *Bradleystat*

early A-B variable resistor used in the fledgling electronic communications industry.

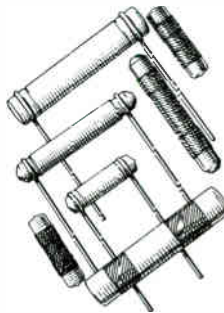
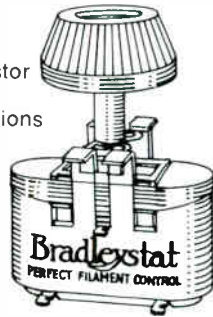

## *1930 fixed resistors*

advertised by Allen-Bradley in the first issue of Electronics magazine.



## Quality in the best tradition.



**ALLEN-BRADLEY**

Milwaukee, Wisconsin 53204

Circle 901 on Reader Service Card



# Like Electronics, we were born at the dawn of a new age.

Magazine

## We've been a pioneer in solid state since 1948.

Founded in 1919, RCA was an established leader in the "electronics" industry even before McGraw-Hill coined the word.

Our solid state research and development began in 1948, the same year the transistor was developed at Bell Labs.

Since then, RCA has been at the forefront of the semiconductor revolution. Here are some of the highlights of our contributions to the electronics industry.

**1948:** RCA begins research and development on point-contact and alloy-junction transistors.

**1953:** RCA introduces its first commercial semiconductors, the 2N31 series of germanium devices.

**1956:** RCA opens its 175,000-square-foot Solid State headquarters in Somerville, New Jersey.

**1962:** RCA develops the first commercially practical silicon power transistors.

**1963:** RCA's Princeton Laboratory begins development of what was to become the first successful CMOS process.

**1965:** RCA pioneers the first integrated circuits for the consumer television industry.

**1966:** RCA produces the first cost-effective ICs for broad use in sound IF stages.

**1968:** RCA announces the first CMOS ICs capable of operating over a range of 6 to 15 volts.

**1970:** RCA establishes the first practical rating for thermal fatigue in power devices.

**1974:** RCA introduces the world's most complex semiconductor, a CCD image sensor for television cameras, with approximately 164,000 elements on a single chip.

**1975:** RCA produces the first commercial 525-line CCD image sensor and TV camera.

**1976:** RCA announces the

industry's first CMOS micro-processor, the CDP1802.

**1976:** RCA pioneers the BiMOS op amp, featuring PMOS input and bipolar output.

**1979:** RCA designs and builds a color CCD video camera especially for a National Geographic underwater expedition.

The camera descends 8,000 feet beneath the sea and brings back vivid pictures of previously unknown forms of life.

**1980:** RCA expands its Micro-board line to become the industry's widest line of CMOS single-board computers.

RCA Solid State would like to commend Electronics for publishing an excellent magazine, and McGraw-Hill for naming an industry that has changed the way we live.

**RCA Solid State**

