

hifi

JUNE 2000

£2.75

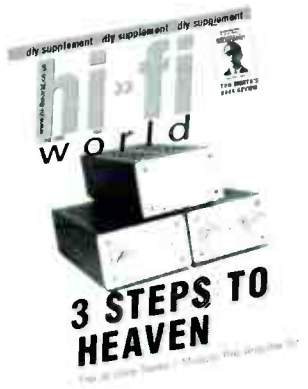

**DIY SUPPLEMENT NO.51
FREE WITH THIS ISSUE**

world

6 TO GO

WE TEST six ultimate portables from Aiwa, Diamond, Pioneer, Select and Sony.

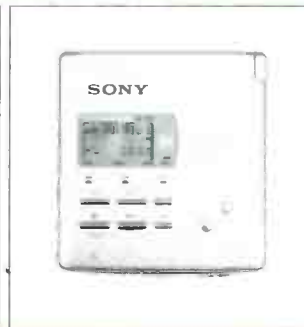

NAD S500 SILVERLINE CD PLAYER

Plus:

- Monrio MP1 monoblocs
- Hadcock GH242 SE Tonearm
- ALR Jordan Note 3 Loudspeakers

Final 0.3 Electrostatic Loudspeakers

100s of classified ads full of secondhand bargains!!!

World Radio History

JUNE 2000



9 770961 766093



NO HINT OF HISS



On a Hi-Space™ recordable MiniDisc, you can cut, paste, divide, erase and record a million times. One thing alone will never change. The digital quality of the recording. Just pure sound, no hiss.

TOMORROW'S MEMORY TODAY



Web Site: www.hi-space.com - E-mail: info@hi-space.com
UK Office - Tél: 0281 961 99 06 - Fax: 0281 961 92 99



HI-FI WORLD
 IMEX HOUSE,
 THE PARK BUSINESS CENTRE,
 KILBURN PARK ROAD,
 LONDON, NW6 5LF

Web Site
 www.hi-fiworld.co.uk

Subscriptions & Back Issues
 9-30am - 2.30pm
 +44 (0) 1923 270833.
 e-mail: subs@hi-fiworld.co.uk

Private & Trade Classified Ads
 +44 (0) 207 625 3134
 Fax: +44 (0) 207 328 1844
 e-mail: class@hi-fiworld.co.uk

Contact Numbers
 Mon-Fri 9am - 5pm

General Editor
 Simon Pope
 +44 (0) 208 789 7344
 edit@hi-fiworld.co.uk

Technical Editor
 Richard White
 Fax: +44 (0) 207 328 1844
 Individual queries cannot
 be answered by telephone.

Design & Production Editor
 Faiza Chunara
 +44 (0) 207 625 3129
 Fax: +44 (0) 207 328 1844
 e-mail: ads@hi-fiworld.co.uk

Contributors
 Jon Marks
 David Price
 Dominic Todd

Advertising Designer
 Faiza Chunara
 +44 (0) 207 625 3129
 Fax: +44 (0) 207 328 1844
 e-mail: ads@hi-fiworld.co.uk

Production Editor/Photography
 David Noble
 +44 (0) 207 625 3134
 e-mail: class@hi-fiworld.co.uk

Sales and Marketing Manager
 Amanda Sweeney
 +44 (0) 208 864 4760
 Fax: +44 (0) 208 864 4780
 e-mail:
 amanda.sweeney@virgin.net

Accounts
 Michael Ogazi
 +44 (0) 207 289 3533
 Fax: +44 (0) 207 328 1844

Credit Control
 Louise Palfrey
 +44 (0)1923 270833
 Fax: +44 (0)1923 270833
 e-mail: subs@hi-fiworld.co.uk

Publisher
 Noel Keywood

WORLD AUDIO DESIGN
Technical Manager
 Nick Lucas
 Tel/Fax: +44 (0) 207 625 8032
 nick@worldaudiodesign.co.uk
 website: worldaudiodesign.co.uk

Distributed by
 Comag Magazine Marketing,
 Tavisstock Road, West Drayton,
 Middlesex UB7 7QE
 Tel: +44 (0)1895 444 055

Printed by
 Southernprint, Dorset.
 Tel: +44 (0)1202 622 226

All unsolicited submissions are made at the owner's risk. We accept no responsibility for such submissions, nor do we undertake to return them.

No material may be reproduced from this magazine without the publisher's written permission.

© A 0 194 114 .td

First it was vinyl, then cassette, now the consumer electronics industry will have you believe that CD is dead on its feet. The amount of DVD players now available at a fraction of the cost of a £1000 CD player can be counted on, oh... twenty five hands and feet. There is, however, one fundamental problem with this. Few of them will play music as well as a similarly-priced, dedicated CD player. After the past few weeks of listening I've come to a conclusion that won't really surprise the majority of our readers. If you want to get the best from your CDs at present, stick to something that plays CDs - and only CDs - alone.

But it seems that the larger manufacturers are abandoning the production of CD players and concentrating their efforts on DVD audio and video players. At the moment there's still a market for new CD players, and it will

continue for some time to come. After all, there are apparently many people who buy DVD players not realising they will actually play CDs as well! The fact of the matter is that many people both in and out of the 'hi-fi as a hobby' school still use vinyl and cassette. This goes to show that CD has many years left in it still. This may start to change with the introduction of a reliable, quality sounding, and more importantly, affordable format with plenty of software to choose from. We'll then have a transitory period as people gradually change their consumer electronics purchasing habits.

With the current situation involving the progression (or stag-

naion) of future audio formats, it seems that there's plenty of life left in the silver disc yet. And even though we have a deep interest in the technology, MP3 still has a long way to go in the sound stakes. Remember though: it took at least eight years to get CD sounding right!



Simon Pope

How we test the products

- Hi-Fi World has its own advanced test laboratory and acoustically treated listening room.
- Hi-Fi World has a dedicated in-house team of experienced listeners. We review thoroughly by extensive auditioning, rather than by quick-fire group listening tests.

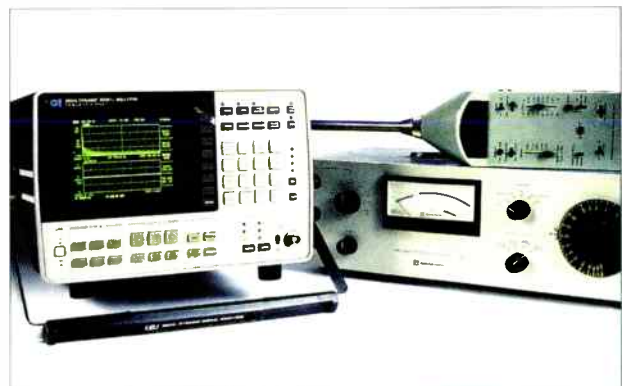

- Hi-Fi World's engineering team designs a wide range of products in-house. No other hi-fi magazine is so expert and dedicated.

 NICE PRICE - Represents excellent value for money	 EXCELLENT - Superb sound, among the best available	 VERY GOOD - Well worth a listen	 ADEQUATE - Room for improvement	 POOR - Seriously flawed. forget it!
---	--	---	---	---

Half globes are added for those products that we feel are between categories

contents



23...NAD S500 CD Player

11...Ultimate Portables

7...
NEWS

11...
NEXT ISSUE

42...
READERS' LETTERS

53, 55, 57...
COLUMNS

59...
SUBSCRIPTIONS

60...
HI-FI WORLD KITS

64...
SPECIALIST HI-FI
DEALERS

REVIEWS

13...GROUP TEST

This month, to greet the warmer weather, the World Team escape from the stuffy office to try out some portable sound sources. Undaunted by the slush and sleet of a typical English summer, we bring you our verdict on the best carry-ons on the market.

AMPLIFIERS

25...MONRIO MP1 MONOBLOCS

There is still a good case to be made for monobloc power amplifiers, especially if unmeasurable crosstalk is your aim. Richard White wires up these modest looking boxes from Monrio to discover whether two amps are still better than one.

27...MVL A2+

With their previous models still basking in the plaudits of the hi-fi press, MVL unveil their substantially updated A2+. Deja vu all over again, or will the improvements make themselves heard? Jon Marks investigates.

CD PLAYERS

23...NAD S500

This £1000 player is the CD spinner in the top of the range Silverline series. Simon Pope listens in.

41...MYRYAD MCD500

Another top of the range player comes under the scrutiny of Mr Pope . . .

LOUDSPEAKERS

37...ALR JORDAN NOTE 3

An old idea brought up to date; the ALR Jordans use a passive bass radiator to help shift air at the lowest frequencies. Richard White hangs on to his hat whilst giving these solidly built 'speakers their head.



37...ALR Jordan Note 3 'speakers

volume 10
issue no 4
June
2000

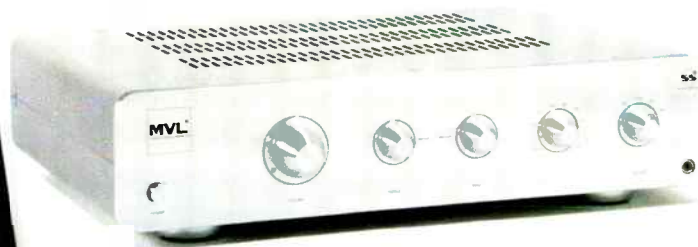

27. . .MVL A2+ Integrated Amplifier

25. . .Monrio MP1 Monoblocs



39. . .Final 0.3 Electrostatics 'speakers

39...FINAL 0.3 ELECTROSTATICS

In the eyes and ears of many people, hybrid loudspeakers are a mixed blessing. Simon Pope takes a long hard listen at these stylish-looking electrostatic/reflex 'speakers from Final. Powerful bass and sparkling treble, or just a 'curate's egg' - good in parts? Find out on page 39.

VINYL

35...HADCOCK GH 242SE TONEARM

With the year 2000 still ringing in everyone's ears, George Hadcock offers a new tonearm to greet the Millennium.

With re-optimized geometry and stylish

chrome-plated bodywork, will the new model catch the buyers' ear? Richard White threads his needle.

49...COMPUTER AUDIO

Three pages of wonders from the fast-growing computer audio sector. David Price taps in to the web consciousness for more thrills and spills in the world of on-line digits.

ACCESSORIES

47...CLEAR SOUND SPEAKER HOODS & CHORD COMPANY'S CLEARWAY

We test out two ways of enhancing your system with these audiophile goodies.

FEATURES

20...PORTABLES FEATURE

Noel Keywood and David Price give you a taste of portables past and present.

35. . .Hadcock GH 242SE Tonearm

68... HI-FI WORLD LIBRARY

70... DIAL-A-DEALER

74... MEET YOUR MAKER

75... HI-FI WORLD BUYING GUIDE

111... MEASURED PERFORMANCE

119... READERS' CLASSIFIEDS

130... ADVERTISERS' INDEX

High Quality Recordings

New LPs, Used LPs, 180g LP Pressings, 24kt Gold CDs, 24/96 DAD, DTS E Channel Surround, HDCD, SACD, XRCD, Accessories

www.vivante.co.uk

Vivante Music Ltd

Unit 4, 60 High Street, Hampton Wick, Surrey, KT1 4DB
tel: 0208 977 6600 fax: 0208 977 4445

AUDIO ILLUSION

23 Langley Broom
Langley
Berkshire SL3 8NB
TEL: 01753 542761 FAX: 01753 772532

Mirage

*This system also won best buy in
What Video & TV and
Home Cinema Choice*

£399

**HOME CINEMA
BEST CHOICE
BUY**

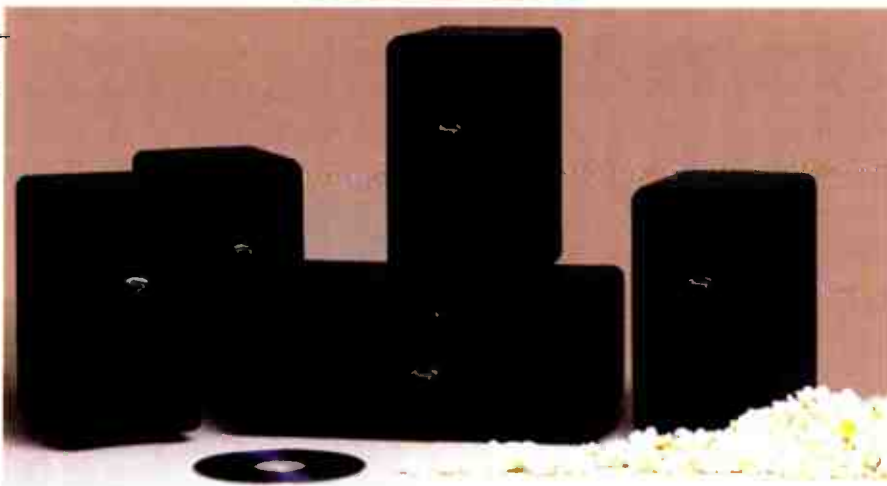

Systems of the Future



Elegance & Simplicity
by **THULE**
AUDIO

Audio Reference
IMPORT & DISTRIBUTION

Unit 8, Enterprise Park, Slyfield Industrial Estate,
Guildford, Surrey GU1 1RB
Tel: (01252) 702705
email: info@audioreference.co.uk

campaign audio design



Getting a better, more involving sound often means spending a lot of hard earned money. It's such a waste, because every system can benefit from our cables and accessories, at a fraction of the cost of some new "black box". Here are some of the ways we can help.

We have Linear Crystal Oxygen Free Copper interconnects (£12.48) up to High Purity Silver cables (£89.00) and high definition loudspeaker cables in Silver Plated Copper or Pure Silver. Our mains cables add weight, power and scale,

and with non-inductive RF filtering (£10.00) and over-voltage protection (£3.00) enhance performance still further. Gold plated AV cables, both RF (£17.95) and OFC Seat (£19.21), help bring picture quality in line with NICAM sound resolution. Valves, capacitors and transistors are all microphonic. They cannot perform optimally if vibrated. Our set of three brass isolation cones are worth their weight in gold - revealing low level resolution and dynamics hitherto hidden beneath electronic noise. We also have a cure for your noisy fridge or central heating motor (£3.50), enabling you to throw away your big mains noise suppressor, which has been giving you that "sat upon sound" for years. There's lots we can do to bring you closer to the emotion and energy of the performance. So confident are we, that we offer a 14 day money back guarantee.

Ring or write for details:-

CAMPAIGN AUDIO DESIGN
Llandudno Road (HW)
Cardiff CF3 8PG
Tel:- 01222 779401

Website: <http://business.virgin.net/cad.cables/>



Trade and International Enquiries Welcome.



THE LINKS EFFECT

IXOS have a new digital coaxial interconnect to show off. The 1051 Argento is the latest version of the award-winning 105 interconnect. It's priced at £39.95 per metre and features a new silver-plated, oxygen-free-copper solid-core conductor with twin oxygen-free-copper braid screens designed to increase noise rejection. IXOS also claim that it's engineered to deliver a "pure 75ohms impedance across the bandwidth".

It's designed to be used with latest generation DVD players for connection to DTS/Dolby Digital receivers and processors and "top line" CD transports to DACs.

**Path Group Plc,
Unit 2, Desborough Industrial Park,
Desborough Park Rd.,
High Wycombe,
Bucks HP12 3BG
Tel: 01494 441736**



RECORDED MESSAGE

TEAC have two new compact disc recorders on the market which are new additions to the 300 and 500 Reference Series. Both, however, are available separately.



The RW-H300, priced at £399.95, for the 300 Reference Series features an on-board frequency converter (32 or 48 kHz to 44.1 kHz). Erase function for CD-RW-DA, CD sync. recording, auto or manual

Track Increment, TOS-Link optical digital input and output and independent left/right recording level control. The RW-H500 CD recorder, for the Reference 500 series, is priced at £449.95 and features the same facilities as the 300.

**Teac UK Ltd,
E Martin House,
The Crowley Centre,
Watford,
Herts,
WD1 8YA
Tel: 01523 815630**

PASS THE BUCKS

These brutes are the new X1000 Monobloc amplifiers from Passlabs of California. The Passlabs X Series consists of the biggest and most powerful amplifiers the company has ever made (and they've made a few heavyweights). They claim to have a tremendous dynamic range of >150 dB to do justice to the 24 bit recordings of the 21st Century.

The X1000 monobloc has only two gain stages: a single-stage front end which provides all of the voltage gain, and a high current follower stage.

The output follower stage consists of four banks totalling 80 power Mosfets, rated at 12 kilowatts for class A operation to 120 watts peak. The input and output of the amplifier is direct coupled, and the connection is by balanced output only. For higher power operation, X1000s can be operated in an array producing up to 2000W per chassis. Two X1000s can therefore deliver a claimed 4000W into 8 ohms or 2 ohms. Four X1000s can deliver 8000 watts into 4 ohms, and, if you're really rich and hard of hearing, sixteen X1000s can deliver 32,000W into 1 ohm(!)

The X1000 is provided with a dedicated high current 20-amp power cord that mates to a standard receptacle at the rear of the amplifier and it needs a high current wall socket. The cash required for such powerful luxury - £10,500 for each monobloc.

**Zentek Music Ltd.
Lizanne House,
Mount Sion,
Tunbridge Wells,
Kent,
TN1 1YQ
Tel: 01892 616383**



The Best Speaker Just Got Better

Severn 2SE

Why change the most successful loudspeaker we've ever made?

How could we improve the 1997 What Hi-Fi? Award winner?

The answer: two years' hard work and technical development - not to mention hours and hours of critical listening.

Castle's core values remain unchanged. Our speakers are still handbuilt by craftsmen using Castle-designed and built drivers, assembled into immaculately-finished cabinets - built in the same factory - in England.

The technical benefits:

- new 19mm soft dome tweeter
- new 150mm bass/mid unit
- specially-shaped T-pole phase plug
- improved crossover components

The musical benefits:

- improved transparency
- improved image focus
- improved dynamics
- greater musicality

for only £699

That's why, what - and how much.

Plus - as always, Castle's renowned fine furniture finish in no less than nine real wood veneers.

And the best-looking sound around.

The Classic Range includes:

Howard S3

Harlech

Severn 2SE

Pembroke

Classic Sub

Richmond

Keep 2



Castle Acoustics Limited

Park Mill, Shortbank Road, Skipton,
North Yorkshire BD23 2TT, England

T: 44 (0) 1756 795333 F: 44 (0) 1756 795335

Email: sales@castleacoustics.co.uk www.castle.uk.com



Classic

JOIN THE Q

KEF have a new loudspeaker range in full production. The KEF Q.2 Series attempts to bring new aesthetics to the ever-popular Q Series. The patented Uni-Q technology is now in its fourth generation. For those unaware of the technology, it features a tweeter that is mounted at the "exact" acoustic centre of the midrange cone.

This is to apparently create a broader and more detailed sound stage throughout the whole listening area. This, claim KEF, makes the 'speaker less directional and an easier load to drive. The Q.2 Series features an improved tweeter with a larger magnet and a new midrange unit in a new silver finish.

Prices start at £199.99 for the Q15.2 two-way compact, through to £699.99 for the Q65.2 three-way floor-stander. There's also a rear surround closed box model, the Q85s, at £179.99



and the Q95c two-way centre channel at £199.99.

**KEF Audio Ltd.,
Eccleston Rd.,
Tovil, Maidstone,
Kent ME15 6QP
Tel: 01622 672261**

Panasonic

LIFE BEGINS AT FORTY!

Panasonic has re-focused itself on the CD-ROM market with a new 40X speed drive. The CR-593 is available for just £29.99 and comes supplied with an ATAPI interface and uses Constant Linear Velocity and Constant Angular Velocity techniques, which apparently achieve data rates of up to 6000kbytes per second.

Panasonic Tel. Information Line: 0845 600 3535
www.panasonic-storage.com

Samuel Johnson Audio
creators of definitive premium audio



Voted one of the
"TOP 50 MUST HAVE"
items of the New Millennium
by The Independent Newspaper
March 2000



SJ audio

• no compromise - just music •

www.sjaudio.com

World Radio History

KARMA CHAMELEON

At a recent Frankfurt show Chameleon Audio displayed their new rugged-looking D777 power amplifier. This can apparently deliver - surprise, surprise - 777W per channel into 4 ohms. Surprisingly for such a powerful beast it weighs less than 10 kilos and fits easily into a standard size equipment rack.

The 777 features a lightweight linear power supply which they claim will be hard matched by even switch-mode amplifiers with similar dimensions. There's also variable forced heatsink cooling and quadruple bi-phase rectification for a quicker current delivery. They are very proud of their new baby, with designer Paul Houlden describing the D777 as a real breakthrough and an "ultra-compact package with high reliability levels, producing the best sound around."



Chameleon Audio Limited,
Whimsey Industrial Estate,
The Mews,
Brook Street,
Cinderford Mitcheldean,
Glos,
GL14 3JA
Tel: 01594 827602
e-mail: cameleon@ftch.co.uk

MONITOR WIZARDS

The Professional Monitor Company have launched their first compact monitor. The AML1 boasts an impressive build quality with custom drive units and OS-Con capacitors used in key design areas. The bass driver is a flat, piston design made from carbon fibre and a Nomex honeycomb. In a break from the professional monitor norm, the tweeter is a soft dome model. Quoted sensitivity is 106dB with the amplification - 100W - being supplied by none other than Canadian professional amp designers, Bryston. There are also three by-passable user controls for input level, LF roll-off, LF tilt and HF tilt. The AML1 is available now priced at £3000 plus VAT.

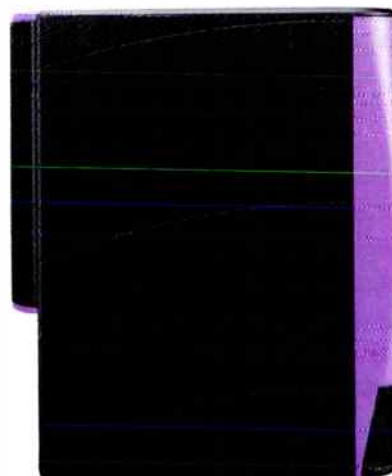

PMC Ltd.,
Unit 72 Haslemere Industrial Estate,
Tewin Rd.,
Welwyn Garden City,
Herts AL7 1BD
Tel: 01707 393002

NEXT MONTH'S ISSUE

A selection of some of the goodies we hope to bring you next month:

Samuel Johnson Audio pre/power amps

This new high-end company have launched themselves onto the market with a very stylish pre/power combination. Will they sound as grand as they look?

Tannoy mx2 loudspeakers

Tannoy have updated and re-designed their budget models, building on the success of the m Series. We give a listen to the middle-priced speaker.

Zingali Overture 0.3 loudspeakers

These chunky floorstanders hail from Italy and feature beautiful cabinet work and a horn tweeter. Read what we think of them in four weeks time!

Wooden't it be lovely

...if all your hifi looked this good



Pro-ject Classic Cherry
From around £450

...or was such great value



"Product of the Year"



Pro-ject Debut
From around £110

Superb record playing systems from

Henley Designs

The Old Coach House, The Street, Crowmarsh Gifford
Wallingford, Oxfordshire, OX10 8EH. Tel: 01491 834700 Fax: 01491 834722
www.henleydesigns.co.uk



KEEP ON MOVIN'

Summer's here and the time is apparently right for dancing in the street. So Simon Pope and David Price round-up six portable players and boogie on down the road!

Portable audio players have changed a lot since their inception. Gone are the days when portable meant something that was either very small, expensive and unreliable or something that was reliable but resembled a Revox A77 strapped tastefully to your trouser belt - and wore all for the humble cassette.

Portable now means digital, very light, very small and mostly affordable. After the initial plague of portable MiniDisc recorders, to quench the thirst of those who require ever decreasing size, we now have a trend for beautifully sleek and sexy player-only models. Many people now have a dedicated MiniDisc recorder firmly settled between their other ancillaries at home and crave something they can plop in their pocket with out inviting the question "Is that a MiniDisc recorder in your pocket or are you just..."

Portable also now encompasses two of the fastest growing mediums in consumer electronics, DVD and MP3, both of which are featured here. There are a number of portable DVDs on the market, perhaps the most stylish of which we have captured for this little round-up. And David Price gives his valued opinion on two of the most popular portable MP3 players.

Make no mistake, portables will be around as long as music itself exists, which is some time yet. Their ever-developing attraction and quality make sure of this, and with MP3, for example, they are also at the forefront of new technology. And partnered with a decent £40-50 pair of headphones such as those from Grado or Sennheiser, the sound can be spot-on. As a current advert for an international bank rightly says, we as customers always want the biggest of everything. This may be so, but we also want the smallest.



AIWA AM-H50 MINIDISC PLAYER

It's now that portable MD players are coming into their own. Rather than purchase a more chunky recorder, more people now have full-size recorders at home and are plumping for portable MD players as their preferred choice for music on the move.

It's hard to imagine a portable MiniDisc player being any smaller than this sexy little number from Aiwa.

Described as Ultra Slim, you can literally slip it in your shirt pocket without creating a bulge or a sag as it's almost as light as a feather. If your top criteria for a portable is sheer portability, you can't get much better than this. The problem that can occur with ultra thin and light gear is that often something has been sacrificed for size, and it can often be sound quality. In this case, it's a display window on the main body of the player. It's found instead on the small and functional remote con-

trol which has slightly more usable buttons than the necessarily miniscule offerings found on the player itself. A blue velvet bag of the expensive Scotch whisky

hefty battery life of fifty hours playback time (rechargeable Ni-MH battery included, plus attachable AA battery pack), forty seconds anti-shock and Aiwa's Dynamic Super Linear bass. Dealing with the digits inside the casework is a 1bit D/A converter.

As far as sonic performance is concerned, the AM-HX50 keeps up the tradition of Aiwa's high quality performance in the portables market.

The supplied earphones are some of the better examples of the in-ear genre and

deliver a bright and exciting sound with a sensible bass balance - as long as they stay in your ears, that is! Excerpts of Bach's B Minor Mass gleaned from vinyl sounded refreshing and clear, with space and air. This is a great little player, tiny enough to be stored almost anywhere. It has the knack of looking sexy and sleek and also delivering the goods in the sound stakes.

variety is supplied to plop the whole shebang into for transportation purposes.

A host of functions are crammed into such a small space. There is a



SONY MZ-R55

Personal MiniDisc players and recorders have a short shelf-life. They may sell like hot cakes and have the most up to date features but manufacturers can't resist trying for improvement by adding maybe one more feature, reducing the size by 2mm or the weight by 2 grams. As it goes this excellent little recorder will probably be replaced in the near future by something only marginally different. Manufacturers should get a grip on this. I really can't see a personal MiniDisc recorder getting beneficially any smaller or more feature-packed than this, and it's also coupled with a light-weight stylish design. The phrase "if it ain't broken, don't fix it" springs to mind.

The MZ-R55 is as stylish, if maybe a fraction more functional-looking, as the sexy little Aiwa player expect that it has slightly more girth to accommodate the recording technology. Features abound, including an optical digital input, a microphone input and also a 'proper' line out for linking to a hi-fi system. There's also a

switchable volume limiter for protecting one's lugholes. As far as recording facilities go, most of the facilities to be found on a full-size recorder are present in

miniature form here, including editing and track naming.

Apart from the functions, the other area in which the Sony shines is sound quality. It has an open and clean sound that manages also to be smooth and sophisticated. Harpsichord and strings, for example, possess none of the brittleness that digital compressed sound can sometimes bring. The Mega Bass Boost (in two stages) benefits from not being too Mega. Hence the tight and controlled low end that never becomes over-balanced against the rest of the sound. Chuck in a remote that manages to be sleek and modern without looking like an unused prop from Blake's Seven and you have a very sensibly-priced package, not particularly cheap, but very good value when it comes to features and sound quality. This has to be a 'must buy' if you require a portable recorder, and although there's some strong contenders out there, not much on the market can touch it.



ultimate



PHILEX MPRESS3

Although it arrived at the same time as the new Rio, the MPress3 is more of a swish first generation machine than a true second waver. One for iMac fans, its silver and translucent blue front panel make it look sweet as cherry pie. Unfortunately its overall build and durability don't seem as hot as comparable MD portables which routinely sport metal casings. Nor are the ergonomics quite so good, but in defence, the MPress3 costs just £149 and comes with a handy 128 minute voice recorder.

It also comes supplied with a manual in PDF format which you can read with the aid of the also-supplied Adobe Acrobat reader! The MP3 files are opened into the software database and can be loaded from it in any desirable order. The clear LCD indicates track number and the remaining playing time,



whilst smaller icons are present for volume level, battery level, bass and treble. There are also the various preset EQ modes and a user mode can be set, also.

Sound is comparable to cheap MiniDisc portables - a touch cold and unforgiving but still listenable. Indeed, get yourself a decent Fraunhofer CODEC-equipped ripper (like MusicMatch Jukebox 4.1) and use the preset EQs sparingly, and you'll find it quite musically engaging. It's a neat little player with an excellent selection of features, and the supplied earphones are one of the better examples on the market.

The only real downer is the paltry 32MB of memory - the player is near-useless without the optional 32MB add-on card available from:

www.input.solutions.co.uk

DIAMOND MULTIMEDIA RIO PMP500

The first true second generation MP3 portable - lighter, smaller and better made than its rivals - the new Rio combines top ergonomics and fine sound. Its high £230 retail price buys you a nifty backlit alphanumeric display, 'turn and press' jog dial, separate bass and treble controls, decent headphones, plus a superb direct-connect USB interface which gives blazing download speeds. Most important of all though is its standard 64MB of memory - the bare minimum for half-decent playing times from 128kbps MP3s (which is the lowest sampling rate giving near-hi-fi sound).

Something also that raises the quality of this player is the excellent software and connections supplied. When the cable is plugged into your computer it's

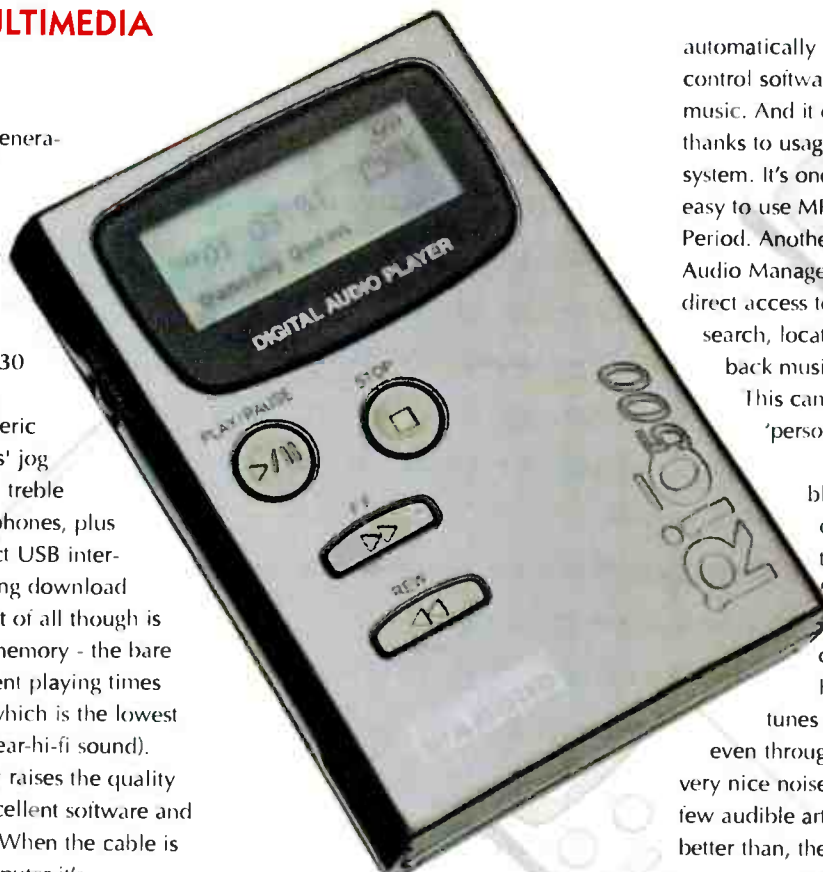

automatically recognised and the Rio's control software is ready for downloading music. And it does this with great speed thanks to usage of the direct-connect USB system. It's one of the fastest loading and easy to use MP3 players on the market. Period. Another great bonus is the Rio Audio Manage software which gives direct access to RioPort.com. This lets you search, locate, locate create and playback music in a simple application.

This can then be stored in your 'personal jukebox'.

As with all MP3 portables, sound quality comes down to a combination of the CODEC used to rip the MP3 and the player's on-board DAC and analogue output stage. Give the new Rio 192kbps (or better) tunes and it positively sings - even through high end hi-fis you get very nice noises. Warm, sweet and with few audible artifacts, it's as good as, if not better than, the latest MiniDisc portables.

statement



Full 4 way system • 5th generation Uni-Q® technology • 15" dual suspension LF driver
individually selected crossover components • 3 dedicated separate enclosures • 25mm
braced MDF construction • bespoke gold plated hardware • fine veneer and lacquer finish

Designed on computer • fine tuned by ear • hand built by music lovers

REFERENCE SERIES MODEL 109 THE MAIDSTONE



© 2009 KEF Reference Series. All rights reserved. KEF AUDIO (UK) LIMITED, DEPT HEWLETT FREEPOST MAIL 32, ECCLESTON ROAD, TOVIL MAIDSTONE, KENT ME15 8BB. TEL: 01795 460071. WWW.KEF.COM

WorldRadioHistory

PIONEER PDV-LC10

This, basically, has to be the ultimate portable. Not perhaps in its capacity for being carried around, as if you used it on the move you'd either get very tired or be run over by a vehicle. But when it comes down to sheer versatility, the PDV-LC10 takes some beating.

What we have here is, by all means, a toy for the upwardly-mobile, thirty-something Clapham bachelor (not that I'm one to stereotype). It's without doubt the best looking portable DVD on the market. Slimline, with a 7" 'wide-screen' flip-up LCD screen, it's the epitome of technological cool; and - take it from first hand experience - is a very desirable gadget. I'm not particularly upwardly-mobile, nor do I dwell in Clapham and I'm married, but it's firmly established on my wish-list just for the sheer hell of it.

As well as the slimline casework, there is a credit card-thin remote that deals with the usual array of DVD functions. If you're a portable audiophile with money to burn, this is the ultimate 'take where

you want' digital playback machine. It will play DVD video discs, VCDs, CDs and CD-Rs. With the inclusion of a



24/96 DAC it also

means you can play high resolution audiophile DVD-V audio-only discs! The quality of both video and audio playback is excellent for a portable. With a good pair of headphones, both CD and 24/96 discs (such as Rachmaninov's Symphonic Dances on the Classic DVD 24/96 label) are played with control and a rare sophistication. Although a little 'dry' at times there is detail relayed (especially with 24/96 discs) that other portables can only dream of. The supplied multitude of cables mean that connection to a hi-fi is easily achieved. And, although the sound isn't as good a full sized £500 player, it's better than most other digital portables

I've put through a hi-fi. The screen also, considering the size, is clear and detailed with good resolution.

It comes with a chunky-ish (yet stylish) battery pack, which the unit fits into (supplying three-and-a-half hours of continuous play with screen). The price isn't cheap but even the most cynical and doubtful among you could well succumb to its charm!

SONY PBD-V30

This portable DVD player has been on the market for a while now, and we reviewed it last year, but it still remains the best screenless DVD portable on the market. It's a small and functional little machine with lid-mounted controls that are easy to use - indeed, it's an all-round user-friendly machine. Weighing in at just over a kilo with the 7.2v lithium battery pack, the case encloses a twin laser mechanism and Dolby Digital output (no DTS - this shows its age). There's an A/V out socket with supplied cable for connecting up to your hi-fi and telly, and a full remote control

The performance using the lithium battery is very good indeed and it seems that Sony's experience in all things portable really pays off. Playing audio discs it's a surprisingly musical customer with both



CDs and, even more, with audio only 24/96 DVDs. Using Musical Fidelity's A1001 integrated and a pair of Tannoy mx2s, basslines were delivered with tautness and depth. The top end could sometimes err a bit on the shrill side with violins and strong female voices, but overall the V30 does a very good job with musical playback. With video discs, the result is a clean and detailed picture but can't quite compete with the results supplied by a full size player.

With miniturisation there's usually a sacrifice to be made somewhere, and whilst it's a very small sacrifice it comes in the form of pictures with the V30, as the Sony's sonic performance is very good indeed, with the emphasis on phrasing, making it very well suited to vocal music of all kinds.

CONCLUSION

Times change, of course, and now we have a whole host of portable audio items that reflect the fast-developing world of consumer electronics. Zippy, jelly-coloured personal cassette players sit on the shelves alongside portable DVD players, which in turn sit alongside watches that will download and play MP3 files as well as tell the time. The theme of our round-up was ultimate portables, so we picked the best available of each type and assessed them in their

own right, so there's neither a winner or a loser, as such. One of the items that stood out for its sheer 'wantability' is the Pioneer portable DVD complete with LCD 'widescreen' monitor. This played movies and audio discs (including CDs!) with equal aplomb and really impressed us with both its performance and sexy looks. Yes, it may be a rich boy's toy, but who cares?

On the MiniDisc side of things, the two samples we managed to listen to

were both exemplary. The Aiwa player has a style that's sleek and cool and sounds equally sophisticated, whilst the Sony is probably the best personal MD recorder around at present - it's easy to use with excellent facilities, great sounding and as small as you'll ever need a recorder to be!

And the two MP3 players here are, we think, the best currently available. Check out our World Verdicts.



Sony PBD-V30 £700
Sony: 01932 816000



Select MPress 3 £150
www.inputsolutions.co.uk



Aiwa AM-H50
Aiwa: 0208 897 7000

WORLD VERDICT



Great performer, attractive but a little dated compared to the competition.

Measured Performance see page 111

WORLD VERDICT



Style, sound and speed make it one of the best at the price.

WORLD VERDICT



If you're after a player in this price range this could well be the one to go for.

Measured Performance see page 111



Pioneer PDV-LC10 £1000
Pioneer: 01753 789789



Diamond Rio PMP500 £200
Diamond: 01189 444477



Sony MZ-R55 £250
Sony: 01932 816000

WORLD VERDICT



One of those, 'must have' executive toys. Great if you can afford it.

Measured Performance see page 111

WORLD VERDICT



Superb look, software and sound make it the best all-rounder.

WORLD VERDICT



Stylish and small, yet feature-packed. Highly recommended.

Measured Performance see page 111

PORTABLES PAST AND PRESENT

The act of taking recorded music with you wherever you may tread has been around in one guise or another for a very long time indeed. Think of Edison's early machines or, going back even further into the eighteenth century, musical boxes.

The main development was the inception of the Sony Walkman nearly twenty years ago, which heralded the dawn of the personal "hi-fi" (as it used to be known) phenomenon. Whilst the original Sony was sleek, sophisticated and sounded great, there were the minor reliability problems that come with being the smallest and first of anything.

Times change, of course, and now we

have a whole host of portable audio items that reflect the fast-developing world of consumer electronics. Here we highlight two classic bits of portable kit. One is something that could shape the future of how we listen to music on the move, and the other is a piece of pure portable history - the recorder that showed the world excellent things can come in small packages!

CASIO MP3 WATCH

Noel Keywood lends a critical ear to Casio's answer to music on the move - and ends up pleasantly surprised!

We couldn't pass up the opportunity to have a quick listen to Casio's new MP3 watch for this report. It's one of those 'must have' gadgets - 'till you've got it perhaps. At 19mm thick you'll need to consult your tailor about this one, or stick to tee shirts. It's not as if the rest of the

with a USB connector. You'll need Windows 98 or higher for USB, plus USB sockets on

The buttons are small, need a firm push and were fiddly.

Our first question was "where's the headphone socket". Then we noticed that it's on a carrier that clips on separately. The reason for this escapes us. Our early sample came without handbook or software so mysteries like this remain unexplained for the time being. It could just be that Casio are planning to supply alternative output connectors on different pods.

Who knows, perhaps you'll be driving your hi-fi from a watch soon!

Without software we were unable to load music or test files, which limited our assessment. The watch had just one music track onboard to prove it worked and, with decent hi-fi headphones, quality seemed very good.

There was deep bass and quite definitely some sweet sounding high treble. A few minutes hooked up to our spectrum analyser was enough to show that the WMP-1 delivers musical energy from 30Hz up to 16kHz, the full musical range. It's fine as a minimum standard, so quality wise the WMP-1

looks good - it's no toy. Full volume was loud but clean, tests showing the player didn't overload and distort like some MP3s we've reviewed.

The Casio's 16MB doesn't give much playing time and you can't pop another tape in when the music stops, but it is a bold attempt that delivers a decent sound. So plug your hi-fi system into your watch, sit back and enjoy! The idea might just catch on.

world won't notice of course: the £230 WMP-1 looks like a divers watch complete with emergency oxygen supply onboard. It's not fresh air you'll find inside though but 16MB of computer memory, enough to hold 16 minutes of music encoded at 128kbts/sec, so called CD quality. Halving the data rate extends this to 30 minutes, with loss of quality.

Our review sample came with a docking station, which also serves as a charger when connected to a 7.5V power supply unit. The station has a cradle for the watch and hooks up to the computer through a lead

your motherboard of course, or MAC OS8.6 or higher and an iMac or G3 with USB sockets.

The watch's fascia has a Mode button that toggles from Time to Alarm to Stopwatch and back. Hold it down and the display suddenly animates with a dancing icon, plus MP3 track number and playing time. A Play button gets things going; it also serves to Pause. Track Skip buttons reset to zero (i.e. Stop) and there are small volume 'up' and 'down' buttons.



UNBIASED REPORTING

Nothing added, nothing taken away, promised Sony's WM-D6C 'Walkman Professional' cassette portable. David Price investigated.

It was dark, windy night in 1986 when I first identified the suspect in a Tottenham Court Road shop window. It was an unassuming little thing, giving no obvious visual clues as to its capability. Only on second appraisal, some days later, did I realise what this machine was capable of.

Consider the evidence - a black, brick-like 180x90x40mm Walkman with a metallised case, when all others were smaller, brighter and plasticky. Then there was the extra Record button - something you almost never saw on a cassette portable of this type. The Dolby selector was another give-away, offering both B and C noise reduction systems on a little slider switch. Then there was the bank of little oblong LEDs, with peak indicators flashing at +3dB and +6dB. Hell, three out of the five meter segments weren't even in the minus zone! What did it all mean?

Looking around the back was no less intriguing - a facility to switch off the quartz-lock speed control to allow variable pitch playback. Variable pitch? Quartz lock? What would these be doing on a Walkman? You don't even find them on two head Nakamichis! Then there was the mechanical tape counter, the large battery box packing four AA cells, and a long volume slider controlling one of the beefiest headphone amps I'd heard. Forget the overgrown earphones of other walkies, this output stage could drive the meanest of high-end hi-fi cans. It was a highly suspect device. After much head scratching, I was forced to conclude it was not actually a Walkman at all, but a real hi-fi cassette deck in disguise.

Inserting a pre-recorded cassette

into the Sony's transport only served to confirm my suspicions. The transport, with its beefy capstan and expensive looking heads, seemed quite unlike those of other portables. Indeed it proved clunky in an over-engineered sort of way. Just as

switched off the Dolby B, whacked the record level up until the +6dB was flashing on and off like a Christmas tree, and cued up my turntable. The results were little less than astounding - so tight, so powerful, so clean, so dynamic, so musical. The usual cassette nasties (wow and flutter,

tape hiss, compression) seemed comprehensively banished. I was amazed, I'd only ever heard the top, three-head Nakamichis do better.

It was all becoming clear, and the facts slotted in to place. I realised the Walkman Professional was Sony's very best high end hi-fi cassette trans-

port, squeezed into a box and run from batteries. Its record/replay head was also a top dollar laser amorphous affair, and to compensate for the lack of dual capstans (too tricky to fit into such a small box), the WM-D6C had the first quartz-lock servo control to grace a Sony cassette deck. This explained its superb speed stability and fantastic overload figures.

These days, I see large numbers of Sony Walkman Professionals in the course of my investigations. The lagging popularity of cassette means people are selling them on the second-hand market. But it's a shady business, buying a used example. Despite the beefy build, they still aren't quite man enough for the punishment the pro audio guys hand out. The transport breaks easily, the lack of proper auto-stop can wreck the motor and the heads don't last forever either. So be warned. A newish, mint, low use example is worth £200, but there are dodgy characters out there passing off fifteen year old nails for upwards of £150 - don't even think about it. Case closed.

From the moment my pre-recorded tape spooled off its leader, I detected something distinctly different. Instead of the usual splashy, mushy treble, it was sparkingly clear and vivid. Gone was the traditional wobbly walkman midband with vague imaging and fuzzy detail, in its place a clean, confident soundstage with bold lateral and front-to-back imaging. Whatever could be going on? Then there was the bass, oh that bass! Run from batteries or a high quality DC supply, low frequencies had a speed and power like few other cassette machines I'd heard. The facts, ma'am, were plain to hear.

A lucky break, I thought, so I swapped to a Sony Metal ES blank, slid the little tape selector over to Type IV,



R.E.S.P.E.C.T

By Grahams



You've heard it a million times before. It's one of your all-time favourites. But whether that's Aretha Franklin, The Rolling Stones, Blur or Beethoven, you'll never have heard it sound quite as good as through a Grahams Hi Fi system. Why? Because at Grahams we really sit and listen to what you want from your hi-fi. And only then will we use all our expertise to recommend a system that's right for you and your tastes.

We won't sell you a system, we'll give you the information you need to buy one. Now that's what we call RESPECT.

Grahams Hi-Fi Canonbury Yard
190a New North Road London N1 7BS
Tel: 020 7226 5500 Fax: 020 7319 7620
E-mail: enq@grahams.co.uk
www.grahams.co.uk

definitive audio

...land of opportunity and adventure...



Definitive Audio has a long standing reputation for producing leading edge and innovative audio solutions. We use a strict selection of components from the worlds finest designers. These include Border Patrol, Canary Audio, Art Audio, SJS, Electrofluidics, SME, Wadia, Western Electric, Vitavox, DNM, Lowther, Nottingham Analogue and, of course, Living Voice.

"Definitive Audio...continues to put on spectacular demonstrations"

Jason Kennedy HFC 2000

Stiff brush clearout of part exchanged and ex-dem items source	Sale	New
Roksan Xerxes Alphason HR100MCS	£500	£1500
Nottingham Analogue Space Deck - Mentor tonearm	£900	£1550
Wilson Benesch Full Circle - 0.5 tonearm, Goldring Excel	£1300	£2600
Linn LP12, Avondale PSU	£300	£1300
Helios Stargate CD player. Ex Dem	£1750	£2900
Audio Note Dac3 Signature	£1300	£2850
amps		
Jadis JA80 monos - boxed perfect. Two years old. Mad price!!!	* £3500 *	£10000
Cary 300 SE Integrated (comes with two spare sets of tubes)	£2000	£4000
Cary 805 50w SE Monos Crated, perfect. 2 yrs old. Mad price!!!	* £3300 *	£8500
Audio Innovations Series 1000 Silver monos	£900	£2250
Croft Series V monos	£600	£1600
Audio Innovations Series 800 Mk3	£450	£1000
Audio Note P4 Monos	£1500	£4000
Sugden C128 Pre, P128 Monos SPX1A PSU	£400	- - -
SJS Arcadia 300B Single Ended - 18watts	£4000	£6500
Art Audio Symphony 300B Single Ended - New	£2100	£2500
Art Audio Diavolo SE integrated - chrome/gold	£3500	£4500
Musical Fidelity A2 - ex dem	£250	£800
speakers		
Living Voice Auditorium - Maple (second hand)	£900	£1500
Snell Type K Mkt, Type J MkII (x2)		£300 / £400

Our stock of part exchanged items is constantly changing. Most items come and go before they can be included in these monthly ads. Call for specific requirements

AMEX • VISA • MASTERCARD

Tel 0115 973 3222 Fax 0115 973 3666

internet: www.definitiveaudio.co.uk email: shout@definitiveaudio.co.uk

Living Voice • Helios • Border Patrol • Art Audio • SJS Electroacoustics • Wadia • Vitavox • Lowther • MF • Nottingham Analogue • Western Electric • SME • Canary

5 MINS FROM M25

MATRIX HI-FI

VALVE AMP REPAIRS

NEW HI-END HI-FI

Michell Gyro Deck/Bronze/RB300	£1,199.00
Micro Deck/RB250	£ 549.00
Delphini Phono Stage/Large PSU	£ 895.00
Orca Pre-Amp/Large PSU	£1,650.00
Henley Pro-ject Classic/Cherry/9 Arm/510	£ 449.00
Alchemist Nexus CD 24Bit DAC	£ 599.00
Rothwell Indus Pre-Amp, Passive	£ 499.00
Rubicon Power Amp	£ 949.00

PREVIOUSLY CHERISHED HI-FI

Quad 77 Pre-amp	£ 395.00
77 Power Amp	£ 395.00
77 Tuner	£ 395.00
Including Remote, All boxed and MINT	
Magneplaner SMGa Pair, Oak/Brown	£ 420.00
Apogee Minor Ribbon Hybrid, Pair	£ 600.00
Quad 33/303	£ 150.00
Tripletone valve amp, 4 watt per chan.	£ 85.00



• NEW HI-END HI-FI

• VINTAGE HI-FI FOR SALE & WANTED

MICHELL - ALCHEMIST, CELESTION, QED, AUDIOQUEST, TARGET - ETC...

NEW AND VINTAGE VALVES - INTERCONNECTS & SPEAKER - OFC & SILVER

WEALTH OF KNOWLEDGE SPANNING OVER 30 YEARS, FOR ENQUIRIES OR

A CONTROVERSIAL CHAT, ASK FOR DAVE OR LEE.

PHONE: (01322) 292391

FAX : (01322) 229908

E-MAIL: MATRIXHIFI@HOTMAIL.COM

WEB: WWW.MATRIX-CS.CO.UK

FREE -EASY PARKING

SHOWROOM -

65 DARENTH ROAD

DARTFORD

KENT DA1 1LU.

HI-HO SILVERLINE!

The Silverline Series marks a distinct change from the usual marquee of NAD. The familiar functional grey box has been replaced by a white matt box of fairly substantial build that, yes, does bear a passing resemblance to silver in a certain light. Actually the whole design looks a little classier in it's chosen hue than it would in stainless steel. It's a very streamlined look with heat

sinks incorporated into the side panels, a thick, overlapping fascia and a matching slim-line drawer. Adding to the style appeal is the simple-but-effective blue dot-matrix display window which spells out operational instructions, such as play or pause, plus the time durations. It's a committed progression towards the high-end for NAD, and I think it works. Indeed, the only recognisable bit of NAD the S500 has is the familiar 'pregnant rhomboid' grey remote supplied.



Simon Pope takes a trip down memory lane with the flagship CD player from NAD - the Silverline S500.

took me a while to put my 'air-violin' down and remember that I was supposed to be reviewing the CD player rather than the recording. There was a rich and natural tone to the instruments, that seemed untouched by any deliberate internal component tweaking to give the player a 'distinctive' sound. The S500 brought me into the music with its simplicity of performance, the highlights of which included natural sound staging and a intricately detailed midrange.

Lose. The clean sounding drum kit and bass guitar powered the groove through the 'speakers to create a real drive to the open and spacious sound. Similarly uncompressed was the Cleveland Orchestra with Mahler's Seventh Symphony. The orchestra had space and transparency which helped to deliver all the intricacies found in the orchestration. Tonal balance was excellent, with violins and brass rich, yet detailed, whilst woodwind floated weightlessly over the double basses, growling for all they were worth. Great stuff.

I can highly recommend the S500. Even though it has recently taken a price drop, it's still quite an expensive player. It's a tough job for a budget/mid price company to take the plunge and go for the upper scale of the market, but in this instance NAD have made a good shot at it. The S500 will play all CDs with excitement, good tonal balance, an open and spacious sound and, above all, simplicity.

NAD S500 £1000

Lennbrook UK Ltd.

Tel: 01296 482017



Balanced outputs are just one of the S500's high-end features

I've found throughout my time in the hi-fi reviewing business that very often the best equipment is not that which grabs you immediately with its out-and-out glitzy sound and wacky styling; these are undoubtedly the fun items. But when I want to listen to music at home, I tend to choose something that's reliable in sound and simply plays music without any raised eyebrows or sharp intakes of breath. The NAD S500 is one such bit of kit.

I have a recording of Mozart String Quartets played by the Franz Schubert foursome that has some wonderfully delicate and balanced playing coupled with so-so recording quality. On hearing it through the S500, I wasn't listening to flaws in either the player or the recording but my attention was instead grabbed by notes, phrasing and musical dynamics. It

The way in which the S500 will play both rotten and demonstration recordings with equal attention was brought to light with Radiohead's OK Computer, the opening track of which - Airbag - sounds like it was recorded in a bungalow garage with the aid of My First Mixing Desk. Again, my attention was taken away from the highly compressed recording and focussed upon the music, which was opened up by the S500. The drum kit powered away skillfully and Thom Yorke's whines seemed, for once, to actually mean something. All the aspects of the muddled mix were as discernable as intended by the engineer, and there was an excitement and frisson to the sound which is often lost on lesser players.

This excitement remained with the excellent rock-out recording of the Foo Fighter's latest album, Nothing Left To

WORLD VERDICT



A great little player with excellent performance and sleek looks. Highly recommended.

Measured Performance see page 111

Qtrax -

*The Innovative
answer to
Cable Chaos*



Prices from £149
(3 shelf glass system
shown £294)

Features include:

- Durable anodised finish
- Integral cable channels
- Modular construction
- Fully adjustable shelves
- Design registered

**Qtrax - 14 Valeside, Hertford,
Herts, SG14 2AR.**

Tel: 01992 551484

Fax: 01992 551092

Email: Qtraxshelf@aol.com

**Callers by appointment please.
(Mail Order only)**

Mail Order



Quote Ref: HW

pear audio

presents

Shahinian DYNAVECTOR Well Tempered

Stockists and Information from
**Pear Audio Ltd. 7 Prospect Place,
Alnmouth, Northumberland, NE66 2RL**
Tel: 01665 830862 Fax: 01665 830051

MICHELL ORBE

Millennium Special Edition

A SYMBOL OF PRECISION



Michell will be offering **50**
numbered Limited Edition
Gold plated Orbes
complete with SME V Gold
Plated tonearms,
to commemorate the coming
Millennium....

For details contact:

Michell Engineering Ltd, 2 Theobald St, Borehamwood, Herts, WD6 4SL

Tel: 0181 953 0771 Fax: 0181 207 4688

e-mail: john@michell-engineering.co.uk Website: www.michell-engineering.co.uk

THE ROAD TO MONRIO

Monobloc power amplifiers have an enthusiastic following in hi-fi. Richard White listens to Monrio's MP1s to decide whether these two can tango.

It is very tempting to describe these monoblocs as grey lumps and let it go at that. Not that I see any reason to be ashamed of their appearance. After all, a power amp is intended to perform a task which doesn't of necessity include looking pretty. Anyway, grey lumps.

Solid ones, mark you with an encouraging weight to them and a well-crafted face plate containing only a couple of LED beacons and the standby/on switch. Things aren't much more crowded on the back, with just the rocker power switch, kettle socket, phono input and loudspeaker terminals. As regards setting up, the Monrio's are one of the simplest jobs I've tackled - apart from lifting the things!

The Monrio MP1s can deliver of a very capable 120W each of solid state power. As the switching from 'standby' to 'on' is accomplished internally by a buffered relay, there's little danger of unwanted surges escaping in the direction of your loudspeakers.

Having had such an easy job installing the amps, I had plenty of time to give them a thorough gallop through the riches of the musical spectrum. First stop, pot luck on the radio. With "In Tune" presenter Sean Rafferty on holiday, there was time for more music and less chat; the first movement of the recently re-constructed Third Symphony of Elgar providing a good solid meal for any amplifier to deal with. Central to Elgar's orchestrations is the wonderful 'thickness' of the string texture, a satisfying feast provided it doesn't overstep the mark into muddiness. Happily the Monrios were well up to this; the enormous textures washing out of the loudspeakers still kept all components distinct. 'Cellos and double basses particularly benefitted from the breadth-with-detail which the amps were providing. Needless to say, you can't churn out Elgar, or any of the Late Romantic masterpieces with a two-valve Dansette - you need assured

power. Even with the volume turned up uncomfortably high, there was no sign of breathlessness.

Finding some fusion rock on the go (not on Radio 3 you understand) gave the Monrios the chance to demonstrate their speed. We've noted before how certain amplifiers (Musical Fidelity's for example) always impress with the immediacy of their performance, and the Monrios seem set fair to join this nippy club. Although I couldn't entirely agree with the sentiments of the track being broadcast - indeed I doubt if it's physically possible - nevertheless the message came over good, fast and clear!

Vocal music next: Linn's HDCD Airs de Cour, a collection of 16th and 17th Century courtly songs, has

Back with more customary sources, I wheeled out some Haydn string quartets on Naxos to see if the amplifiers would communicate the slightly Fortnum and Mason sound to my loudspeakers. Here, with music of limited dynamic range, the Monrios perhaps felt a little under-used. To describe the sound as grey is an overstatement but there was certainly a shadow of a shade about it. Not enough, it is true, to fundamentally detract from one's enjoyment, but just a hint of not quite getting the full story of the music. As I've remarked, these amplifiers excel on beefier material, so perhaps it's just a question of horses for courses.

As regards, speed, power and sheer push, the Monrio monoblocs leave little to be desired. They are a convenient and compact way to follow the monobloc route, but they do not sound valve-like - indeed why should they? Putting

aside my reservations - all of which might be modified with a different pre-amp and/or loudspeakers - the Monrios are well constructed and competent beasts and will suit a wide variety of systems.



Monrio MP1s monoblocs £600 each

some very carefully recorded examples of both male and female voices, with a range of detail which makes for an excellent test for hi-fi, regardless of the at times rather samey musical content. Here the voices, accompanied only by a lute, were clear certainly; possibly there was also a hint of the slightly metallic sheen which the very richness of what I'd listened to earlier had masked. Ears out on strings, I listened further. This sort of recording is not common. In other words, there is a touch of the metallic to the amps' sound but I think it's only with this sort of source material that it would irritate, so it's probably nothing to worry about.

UKD

23 Richings Way,

Iver,

Bucks,

SLO 9DA

Tel: 01753 652669

WORLD VERDICT



Solid and dependable way to monobloc a system. Fast and powerful solid-state sound. Slightly metallic with small-scale works.

Measured Performance see page 111

More **Bass**
More **Volume**
More **Music...**

Only
£24.95

Looking for **better sound** from your Hi-Fi?

We can help! Established specialists in Hi-Fi cables and accessories, we can show you how to get more from your equipment. Much more.

Get More...

Most Hi-Fi, Midi Systems and Portable Stereos are only performing at a fraction of their full potential. That's where our cables and accessories come in. Our **Yello Power** mains cable brings you deeper tighter bass, higher volume without distortion and lots more detail. More music in fact. Pretty clever... and a 1m length only costs £24.95.

How does it do that?

The **Yello Power's** unique weave removes interference from your mains. Interference that would normally cause loss of information and increased distortion.

But that's not all...

For full information of our extensive range, including Hi-Fi and Home Cinema cables, CD and contact cleaners, and equipment supports... contact us for our **FREE** catalogue.

Order NOW on UK FREEPHONE 0800 373467
or phone for our full product catalogue quoting ref: AHW0600

Internal section showing the unique woven cable construction which effectively removes mains interference



"I have never bought a cable which made such an obvious & significant improvement to the sound of my Hi-Fi system." Nir R

Qureshi Bucks

Russ Andrews Accessories Ltd.,
FREEPOST NWW881A,
KENDAL, LA8 9ZA
www.russandrews.com
E-mail: info@russandrews.com
Fax: 01539 825540

Lifetime
Guarantee

30 Day
Home Trial

Free
Delivery

Freephone
Ordering



**ORANGES
& LEMONS**

Juicy fruit from London's freshest hi-fi / home cinema retailer. Free home installation + credit cards. 0% credit finance available (subject to status).

ARCAM. B&W. CABLETALK. CASTLE. CHORD CO. DENON. EPOS. KEF. LINN. MARANTZ. NAD. NAIM. NEAT. QUAD. REGA. ROKSAN, ROTEL. ROYD. RUARK. SOUNDSTYLE. STANDS UNIQUE. YAMAHA

Our Sixth succulent year

**THE INNOVATIVE
AUDIO RETAILER**

0171-924 2040

61/63 WEBBS ROAD, CLAPHAM. SW11

www.orangesandlemonshifi.com

five star
performance
in audio equipment support

Hi Fi Choice

An earth-shattering upgrade for your Hi Fi system
Best Buy September 1999

Customer Selection

The BASE platform must rank as one of the great bargains in Hi Fi



WHAT HI-FI?

extract from June 1999

This nicely finished platform works superbly and for sheer value for money, the Audiophile BASE 01 takes top honours.
★★★★★

**Top Accolades for
BASE Audio Supports**

Stereo (Germany) Feb 97 Maximum ★★
Hi Fi World Feb 98 Outstanding ●●●●
What Hi Fi July 98 ★★★★★
Home Entertainment Oct 98 ★★★★★
Stereoplay (Germany) Feb 99 Outstanding
What Hi Fi June 99 ★★★★★
Hi Fi Choice Sept 99 Best Buy

AUDIOPHILE FURNITURE LTD

The Square, Forest Row, East Sussex RH18 5ES
Tel: 01342 826262 Fax: 01342 824845

hey, good looking...



Can MVL keep their footing in the hi-fi world with the updated A2+ integrated? The odds are in their favour, reckons Jon Marks.

Looking fetching in its upmarket satin steel garb decorated with chunky, machined knobs, the latest of MVL's A2+ integrateds has been working out in the FET gym - an increase in the number of output devices means a satisfying jump in maximum power from 100watts to 150watts.

The extra grunt on offer took barely a bar or two of the sound track CD from the film *Run, Lola, Run* to show through. Whereas the first A2+ into HFW's listening room had failed to really get Magneplanar's MG12/QR panels properly fired up, this newcomer injected much more impact and speed into their music making. Apparently, some would-be fans of the MVL sound felt there was a certain, vital something missing from the bottom-end of the original models, an ingredient which is definitely not lacking in the new recipe.

Mixing it up with this greater control was an improvement in clarity of the 'grimy window freshly cleaned' variety. Desmond Decker's *Rude Boy Ska* compilation is a fine example of content over presentation. The tonal richness which characterises this amp made easy work of turning these tracks into gems of the Ska world, rather than an obstacle course for the ears.

On the other hand, if the recording happens to be something along the lines of Eric Bibb And Needed Times' *Good Stuff* - captured with crystal clarity by Opus 3 - then you're in for a seriously life-like listening session. Spartan arrange-

ments such as 'Saucer And Cup' highlighted the natural, unprocessed way in which the MVL handled string instruments in particular, Bibb's guitar possessing a rare harmonic complexity and transient speed.

The A2+ came up trumps on every input (each of which features the company's Sound Sentinel system, which "improves" the signal passing into it). Showing the biggest gains were the inputs for CD, LP and FM. The first had a refreshing freedom from typical digital failings that flow undisguised through the majority of amps - deficiencies in tonal colour, sound stage depth and image precision to name the worst offenders.

Plying the Phono stage with millivolts from a Technics SL-7 direct-drive parallel-tracker in addition to a Music Maker on an SME V/Trio L-07D, I discovered low background noise married to a real ability to swing dynamics and keep the musical heart of a song beating. But even more successful were the sockets for Ye Olde wireless transmission, where humble solid-state tuners from the Seventies shed their thin and crispy or fat and bloaty colorations to give an altogether more involving, balanced picture of the ether.

The changes wrought inside the A2+ are more of everything desirable in the bass, increased three-dimensionality and wider compatibility with tough speaker loads. Seeing as a plain black A2+ will still set you back the £1250 of the original, it looks as if MVL have succeeded in making a fine amp even more versatile.

THE TECHNOLOGY

The A2+ amplifier has MVL's own Sound Sentinel enhancement circuits that, they told us, improve the sound quality of sources.

Measurement with noise, impulse and sine wave test signals showed Sound Sentinel applies bass and treble boost under all circumstances, gently with the bass control turned fully anti-clockwise, which also negates treble control action. With full bass dialled in the treble control would then alter treble lift, so these controls are confusingly interactive.

Subjectively, small amounts of bass and treble lift add presence, but detract from fundamental accuracy and are very much a matter of taste.

MVL A2+ (Satin steel finish) £1450

MVL A2+ (black finish) £1250

MVL Technology Ltd

Northfield Mill,

Wymondham

Norfolk,

NR8 0DF

Tel: 01953 850800

WORLD VERDICT



A controlled, powerful sound ensures that the A2+ remains well up in its price range

Measured Performance see page 111

absolute sounds

compact disc players
digital & analogue recorders

ARCAM Alpha 7SE

- ◆ 24-Bit Converter
- ◆ Coaxial Digital Output
- ◆ Upgradeable to Alpha 8, 8SE or Alpha 9 Specification
- ◆ **What Hi-Fi?** Award Winner 1999

£349



sevenoaks sound & vision

why choose sevenoaks for compact disc?

As the main source component in most dedicated hi-fi systems, the quality of the CD Player is vital, as any musical information lost at this stage cannot be retrieved later. **Sevenoaks** Sound & Vision have chosen models from all the leading manufacturers which, in our opinion, provide the very best performance, reliability and value for money. All CD players are sold with a minimum two year warranty, with extended warranties available, for peace of mind.

selected cd players

Arcam FMJ CD23	£1099
Denon DCD835	£279
Musical Fidelity X-Ray	*Claim Free VDH D102 £799
Rotel RCD951	£349
Rotel RCD991	£749
Roksan Caspian	£895

**When purchased together with the X-A1 Amplifier*

also available at **selected outlets**

Marantz CD17Ki Signature, Meridian 506 & 508, Naim CD3.5, Cyrus DAD1.5 & 3-Q24 and SACD.

Please Note: Advertisement valid until at least 7th June 2000, E&OE
Mail Order not available on Arcam and Marantz Products

marantz



**When purchased together with the PM6010 OSE Amplifier*

CD6000 OSE CD Player



What Hi-Fi? Sept 1999

£299

ROKSAN Kandy



Kandy KC1 CD Player



What Hi-Fi? May 2000

£475

MUSICAL FIDELITY

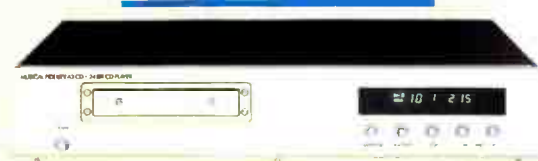

A3 CD Player



What Hi-Fi? May 2000

£799

essential accessories

We carry a wide range of interconnect cables, speaker stands, equipment supports and other performance enhancing accessories at all outlets.



SONY MDSJA20ES MiniDisc

- ◆ Digital Record Level
- ◆ Coaxial & Optical Input & Output
- ◆ Black or Gold Finishes Available
- ◆ **What Hi-Fi?** ★★★★★ Dec 98

£299

Pioneer
PDR509

- ◆ CD-R & CD-RW Recorder
- ◆ Coaxial & Optical Input & Output
- ◆ Digital Record Level
- ◆ **What Hi-Fi?** ★★★★★ Dec 99

£269



minidisc, cd-rw or cassette
a **bewildering** choice?

With the bewildering choice of high quality recording formats available it makes sense to choose **Sevenoaks** Sound & Vision. With knowledgeable staff and a comprehensive range of MiniDisc, CD-RW and Cassette Recorders available, you will be guaranteed to find the format most suited to your needs.

sevenoaks selected
minidisc, cd-rw, and
cassette **recorders**

Denon DRM555	Cassette Deck	£159
Pioneer PDR555RW	CD-RW	£259
Sony MDSJE330	MiniDisc	£119
Sony MDSJE530	MiniDisc	£149
Yamaha CDRS1000	CD-RW	£399
Yamaha KX580SE	Cassette Deck	£199

also available at **selected outlets**

The Award Winning Project Debut Turntable and a selection of Tuners including the Award Winning Arcam Alpha 10 DAB Digital Radio.



marantz
DR700 CD-RW Recorder

★★★★★ **What Hi-Fi?** Nov 1999

£399

SONY



MDSJB930 MiniDisc

What Hi-Fi? Award Winner 1999

£249

YAMAHA



KX393 Cassette Deck

★★★★★ **What Hi-Fi?** Sept 1990

£119

absolute sounds

two year warranty for **peace of mind**

As the UK's largest independent specialist hi-fi retailer, all home cinema and hi-fi separates come with a minimum two year warranty and ten day exchange.

massive performance

a **selection** from our **unbeatable** range



MUSICAL FIDELITY A3 Amplifier

"Playing Bob James' *Joy Ride* disc, with its laid back jazz feel, the A3, fed from the Marantz CD-7 and driving Monitor Audio Studio 20SEs, reveals that it's an amplifier truly capable of performing way beyond its price."

£849



sevenoaks sound & vision

daunted by **amplifiers?**
sevenoaks can help
you choose

With complicated and often meaningless technical specifications, choosing the right amplifier can be really daunting. **Sevenoaks** Sound & Vision will help you choose from our unbeatable range. With inexpensive integrated models to esoteric pre/power combinations, all of which have been selected for their performance and flexibility, you can guarantee finding an amplifier ideally suited to your requirements.

selected amplifiers

Arcam Alpha 8R	£379
Denon PMA250SE	£139
Marantz PM6010 OSE	Claim Free QED Qunex®** £229
Musical Fidelity X-A1	Claim Free VDH D102* £479
Rotel RA931/II	£175
Roksan Kandy KA1	£475

* When purchased together with the X-Ray CD Player
** When purchased together with the CD6000 OSE

also available at **selected outlets**

Marantz PM17Ki Signature, Myryad MI120,
Naim Nait 3R and Tag McLaren F3-60i RV.

Please Note: Advertisement valid until at least 7th June 2000. E&OE
Mail Order not available on Arcam, B&W, Marantz and Monitor Audio Products

ARCAM



A22 Amplifier

Available at selected outlets

£999

ROKSAN Caspian



Caspian Amplifier

★★★★★ What Hi-Fi? Nov 1999

£799



Cyrus 5 Amplifier

★★★★★ What Hi-Fi? Apr 2000

£499

Please Note:
Cyrus Products only
available at selected outlets



demonstration rooms in all stores

Everything we stock is available to audition in our dedicated hi-fi and home cinema demonstration rooms.



Studio 20SE

"They're what we use every day in our top reference system - that's how good they are."

The Ultimate What Hi-Fi? Guide to Audio 1998

- ◆ Gold Anodised Reference Tweeter
- ◆ Ceramic Coated Metal Alloy Mid/Bass Unit
- ◆ Internally Wired with QED Silver Profile Cable
- ◆ Cherry, Black or Rosemah Finishes Available



Also Available:

Silver 4i £349 Silver 5i £449
Silver 8i £699 Silver 9i £999

what hi-fi?
reference loudspeakers

£1299 SAVE **£1000**



which **loudspeakers?**
sevenoaks can help
you decide

As the final component in any hi-fi or home cinema system, the loudspeakers determine the way sound is presented. However, not only is it imperative that the loudspeakers work correctly with the amplifier and source components, but also do not react adversely with your room. With such a variety of bookshelf, stand mounted and free-standing loudspeakers available, it make sense to choose **Sevenoaks** Sound & Vision, where we can help you find the perfect solution - all you need to do is listen!

selected **loudspeakers**

Acoustic Energy Aegis 1	£149
KEF Cresta 2	£129
Mission 773E	£399
Monitor Audio Studio 50	£1999
Ruark Prologue Reference	£949
Tannoy MX2	£149

also available at **selected outlets**

Other models from the above ranges, B&W CDM-SE, Castle Classic & Inversion and Jamo Concert Series.

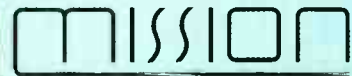

New 78 Series

- ◆ Includes Highly Reviewed 780 & 782
- ◆ Keraform Bass/Mid Units
- ◆ 25mm Silk Dome Tweeter
- ◆ 30mm MDF Cabinets
- ◆ 782 & 783 Feature Additional Nomex Bass Units
- ◆ Beech, Rosewood and Black Ash Finishes Available

Please Note:
78 Series only available at selected outlets

600 Series 2

- ◆ Includes Award Winning DM601 Series 2
- ◆ New Nautilus Technology Tweeter
- ◆ Kevlar Mid/Bass Units
- ◆ Stand Mounting, Floor-standing, Centre and Rear Models Available



massive performance

the ultimate **buying guides**

Our friendly and experienced staff will be happy to assist you through every step of your purchase and will, when appropriate, deliver and install your equipment.



The North

ABERDEEN

491 Union Street
E-Mail: sevenoakshifi@btconnect.com
9.30-5.30 Monday-Saturday
9.30-7.00 Thursday
01224 587070

LEEDS

112 Vicar Lane
E-Mail: sevenoakshifi@btinternet.com
10.00-6.00 Monday-Friday
9.30-5.30 Saturday 12.00-4.00 Sunday
0113 245 2775

PRESTON

40-41 Lune Street
Air Conditioned
9.00-5.30 Monday-Saturday
01772 825777

GLASGOW

88 Great Western Road
10.00-6.00 Monday-Saturday
12.00-4.00 Sunday
0141 332 9655

MANCHESTER

69 High Street, City Centre
sevenoaks.manchester@btinternet.com
10.00-6.00 Monday-Friday
9.30-5.30 Saturday
0161 831 7969

SHEFFIELD

635 Queens Road, Heeley
Air Conditioned
E-Mail: SevenoaksSheffield@bun.com
9.30-5.30 Monday-Saturday
10.00-4.00 Sunday
0114 255 5861

HULL

1 Savile Row, Savile Street
9.30-5.30 Monday-Saturday
01482 587171

NEWCASTLE

19 Newgate Street
E-Mail: 7oaks@btconnect.com
9.30-5.30 Monday-Saturday
0191 221 2320

Midlands & East

BEDFORD

29-31 St Peters Street
E-Mail: sevenoaks.bedford@lineone.net
10.00-6.00 Monday-Friday
9.30-5.30 Saturday
01234 272779

IPSWICH

12-14 Dogs Head Street
9.30-5.30 Monday-Saturday
01473 286977

OXFORD

41 St Clements Street
E-Mail: 7oakshifioxford@btconnect.com
10.00-6.00 Monday-Friday
9.30-5.30 Saturday
01865 241773

CAMBRIDGE

17 Burleigh Street
E-Mail: 7oakshifiscam@aol.com
10.00-6.00 Monday-Saturday
01223 304770

LEICESTER

10 Loseby Lane
10.00-6.00 Monday-Saturday
0116 253 6567

PETERBOROUGH

36-38 Park Road
sevenoaks@peterborough00.freerve.co.uk
9.30-5.30 Monday-Saturday
9.30-7.30 Thursday
01733 897697

ESSEX

1 The Grove Centre, Witham
E-Mail: 7oakshifiwitham@btconnect.com
9.30-5.30 Monday-Saturday
Late Night Thursday by Appointment
01376 501733

NORWICH

29/29a St Giles Street
E-Mail: sevenoaks.hifi@virgin.net
9.30-5.30 Monday-Saturday
01603 767605

Midlands & West

BIRMINGHAM

12 Queensway Arches, Livery Street
9.30-5.30 Monday-Saturday
0121 233 2977

CHELTENHAM

14 Pittville Street
9.30-5.30 Monday-Friday
9.00-5.30 Saturday
01242 241171

SWANSEA

24 Mansel Street
Air Conditioned
10.00-6.00 Monday-Saturday
11.00-5.00 Sunday
Late Night Wednesday by Appointment
01792 465777

BRISTOL

92b White Ladies Road, Clifton
Air Conditioned
9.30-5.30 Monday-Saturday
0117 974 3727

EXETER

28 Cowick Street
9.30-5.30 Monday-Saturday
01392 218895

WORCESTER

2 Reindeer Court
E-Mail: sales@sevenoak.demon.co.uk
9.30-5.30 Monday-Saturday
01905 612929

CARDIFF

104-106 Albany Road
E-Mail: 7oakswales@compuserve.com
9.30-5.30 Monday-Saturday
029 2047 2899

PLYMOUTH

107 Cornwall Street
9.30-5.30 Monday-Saturday
Late Night Thursday by Appointment
01752 226011

demonstration rooms in all stores

Everything we stock is available to audition in our dedicated hi-fi and home cinema demonstration rooms.

outlets nationwide



At **Sevenoaks Sound & Vision** you'll find the widest range of quality products anywhere in the UK. Everything from the latest DVD players and Plasma Televisions to amazing special offers all with our outstanding service. From Aberdeen to Plymouth, we're great value nationwide.

London & South East

SEVENOAKS

109-113 London Road
Air Conditioned
9.30-5.30 Monday-Friday
9.00-5.30 Saturday
01732 459555

BRIGHTON

57 Western Road, Hove
E-Mail: 7oakshifibrighto@btconnect.com
10.00-6.00 Monday-Saturday
01273 733338

BROMLEY

39a East Street
Air Conditioned
E-Mail: 7oakshifibromley@btconnect.com
9.30-5.30 Monday-Saturday
020 8290 1988

CHELSEA

403 Kings Road, Worlds End
Air Conditioned
E-Mail: 7oakshifichelsea@btconnect.com
10.00-6.00 Monday-Saturday
020 7352 9466

CRAWLEY

32 The Boulevard
E-Mail: Sevenoakscrawley@aol.com
9.30-6.00 Monday-Saturday
01293 510777

CROYDON

369-373 London Road
E-Mail: 7oakshificroydon@btconnect.com
9.30-5.30 Monday-Saturday
11.00-4.00 Sunday
020 8665 1203

EPSOM

12 Upper High Street
E-Mail: sevenoaks.epsom@virgin.net
9.30-5.30 Monday-Friday
9.00-6.00 Saturday 11.00-4.00 Sunday
01372 745883

GUILDFORD

73b North Street
Air Conditioned
E-Mail: 7oakshifi_gford@btconnect.com
9.30-5.30 Monday-Friday
01483 536666

HOLBORN

144-148 Grays Inn Road
10.30-6.30 Monday-Friday
10.30-4.30 Saturday
020 7837 7540

KINGSTON

43 Fife Road
Air Conditioned
9.30-5.30 Monday-Saturday
9.30-7.30 Thursday
020 8547 0717

MAIDSTONE

96 Week Street
Air Conditioned
E-Mail: 7oakshifimstone@btconnect.com
9.30-5.30 Monday-Saturday
01622 686366

READING

3-4 Kings Walk Shopping Centre
9.30-5.30 Monday-Saturday
0118 959 7768

SOUTHAMPTON

33 London Road
Air Conditioned
E-Mail: 7oaks_soton@breathemail.net
9.30-5.30 Monday-Saturday
023 8033 7770

SOUTHGATE

79-81 Chase Side
E-Mail: NEILEP1@eggconnect.net
10.00-6.00 Monday-Saturday
020 8886 2777

SWISS COTTAGE

21 Northways Parade, Finchley Road
Air Conditioned
E-Mail: furrukh.hasan@virgin.net
10.00-6.00 Monday-Saturday
12.00-4.00 Sunday
020 7722 9777

TUNBRIDGE WELLS

28-30 St Johns Road
Air Conditioned
E-Mail: 7oakshifitw@btconnect.com
9.30-5.30 Monday-Saturday
01892 531543

WATFORD

478 St Albans Road
E-Mail: 7oakshifiwatford@btconnect.com
10.00-6.00 Monday-Saturday
11.00-4.00 Sunday
01923 213533



outlets nationwide

Opening in 2000

The North

LIVERPOOL

London & South East

EAST LONDON

Midlands & East

NOTTINGHAM

The North

EDINBURGH

the ultimate buying guides

Our friendly and experienced staff will be happy to assist you through every step of your purchase and will, when appropriate, deliver and install your equipment.



essential *stimulation*

European amplifier of the year

Audio specialists of nineteen European countries concluded: "TAG McLaren Audio has succeeded in developing an extremely refined integrated amplifier which combines truly high-end technology, audiophile components, engineering and, most important, audiophile sound - all at a reasonable price."

The 60iRv is shown here with TAG McLaren Audio's ground-breaking analog and digital tuner T32R, both in silver



www.tagmclarenaudio.com

TAG McLaren



TAG McLaren Audio, The Summit, Latham Road, Huntingdon, Cambs. PE29 6ZU
freephone: 0800 783 8007 tel: 01480 415600 fax: 01480 52159
e-mail: helpdesk@tagmclarenaudio.com

World Radio History

PUT THE RIGHT ARM IN

Richard White sticks his arm out to hail the latest unipivot offering from G. C. Hadcock, the GH242 SE.

Unipivot arms have, as the name implies, one universal pivot which permits the arm to rock about the bearing in any direction. It's an attractive arrangement in many ways: for a start it is simple; second, provided that the bearing is properly designed and made, friction can be minimized to exceptionally low figures. Lastly, the set-up is inherently self-balancing - there is no tendency for gravity, acting through a fixed-axis pivot, to push the arm across the record in either direction.

Of course, it can't be all smiles: the very fact that the arm is not rigidly mounted means that portability tends to go out the window, although what portability has to do with a hi-fi set-up is open to question. A unipivot's self-balancing properties can also mask a deck not strictly on the level. In short, a unipivot tonearm needs careful setting up and careful checking from time to time - but don't they all?

General considerations aside, back to the arm in question, the GH242 SE (£689.73). At the centre of the design is George Hadcock's patented bearing, a component of his tonearms for decades now. This elegantly simple device ensures minimal friction and consequent wear, in addition to accurately centring the main components on the hardened needle point. Encasing the bearing is a massy cylinder of chromium-plated brass, into which are fitted the arm proper, the counterweight stub and the anti-skate out-rigger.

Two weights are provided for adjusting playing force. The larger of the two provides both the coarse adjustment and, being underslung, the dynamic balance. The smaller weight is for the fine adjustment. In use I found no difficulty in repeatedly setting the playing weight

within a tenth of a gramme with this arrangement. Both weights are 'O' ringed to the stub, which in turn is decoupled from the main bearing housing. The jury is still out on the practise of decoupling counterweights - some arms, notably the Rega, seem to benefit from a completely rigid coupling - but with the Hadcock (a much lighter device) the results are

beneficial. A simple weight and pulley arrangement serves to set the anti-skate bias.

The playing arm itself is manufactured from seamless drawn stainless steel, critically damped and wired with van den Hul silver leads. As can be seen in our photograph, a plug and socket arrangement makes it a simple matter to completely detach the arm while leaving the base and pivot in place; a major boon when it comes to setting up different cartridges.

It is in the geometry, perhaps, that the latest Hadcock edition breaks with its antecedents. For more years than we need recall, the 228 bit of a Hadcock arm has stood for 228mm - in other words, about 9 inches. The new 242 chimes in at about

half an inch longer. There is no 'right' answer to tone arm configuration but a moment or three I spent with the back of an envelope and the set-up instructions showed me that the latest Hadcock has been shrewdly re-optimized for minimal tracking error and well-placed null points. This

isn't just a question of 'longer tonearms are better'; the theoretical benefits of increased length are often cancelled out by the commensurately greater mass involved. The Hadcock 242 treads this fine line very gracefully.

All this care in design and manufacture need not, of course, produce a listenable result. How does it sound? Properly speaking, it doesn't. For an arm which will happily carry rather stiff MCs right the way to exceedingly compliant (30c.u.+ variable reluctance types, the

Hadcock 242's modesty is startling. Having tried it out with an extensive variety of cartridges, from a £30 MM Stanton to a £1,700 MC van den Hul,

all I can report is that, if the Hadcock is adding any coloration, the result is only an improvement. As regards its tracking ability, the new geometry is spot on, with the inner zero error point coinciding with the 'worst' groove on most LP records - a very happy result.

The Hadcock's price is roughly comparable with the Rega 900 and the SME300 range and, in my opinion, it is both more versatile and more able than either. In truth its performance places it in a higher class altogether. All-in-all, whether you view it as a bargain high-end or as an improbably musical medium-pricer, the GH242 SE deserves a long, blissful listen.

Hadcock GH242 SE £689.73
Tcl: 01889 569166

WORLD VERDICT

£ 

Utterly musical high-end performance, with a very tempting price tag attached. Very little serious competition at the price.

Measured Performance see page 111



X-A RANGE.
MACHINED, MIL-SPEC ALUMINIUM
FRONT PANEL.

MILLED METAL KNOBS.

RUGGED, NON-RESONANT
METAL CASEWORK.

JUST IMAGINE HOW GOOD
THE ELECTRONICS MUST BE.

MUSICAL FIDELITY

INTEGRATED AMPS, PREAMPS, POWER AMPS, TUNER, AND CD PLAYER. FOR DETAILS OF YOUR NEAREST STOCKIST RING 0181 900 2866.

CROSSING THE JORDAN

Richard White looks at ALR-Jordan's Note 3 loudspeakers, which feature a new form of an old idea.

AL R-Jordan's Note 3 loudspeakers incorporate an update of an old idea in the form of a passive bass radiator sited on the rear baffle. Although they were never universal, various applications of this idea were popular in the early seventies - Celestion made some prime examples. After the truly horrendous reflex designs of the 1950s, the so-called infinite baffle cabinet had come as a breath of comparatively undistorted air and before many years had passed, bass-reflex designs had been chopped up for firewood and every maker had at least one 'box' in its range - even Tannoy!

The only problem with an infinite baffle cabinet is its woeful lack of efficiency - 3% is good! - and ideas were investigated to keep the well-behaved response of the enclosed box whilst beefing up the output a little. ABRs (auxiliary bass radiators) are one such method - in essence a loudspeaker cone and surround bereft of coil and magnet. Inasmuch as they are coupled to the air mass in the cabinet, they behave a little

like the air mass in a reflex port - at certain frequencies their mass is too great to permit significant movement, whilst in the nether regions the cone moves with the air, either in or out of phase with the main driver, depending on the resonances of the various masses. An interesting refinement adopted by ALR-Jordan is a method by which the mass of the ABR can be trimmed; a selection of washers are supplied to be fixed on to the centre of the cone with the thumbscrew arrangement shown in our picture.

Auxiliary radiators aside, the ALR-Jordans are an exceedingly solid job - they certainly won't blow away! Two drivers do the main work, with the tweeter one of the now favoured soft-dome types.

Provision is made for bi-wiring with heavy duty cable terminals properly anchored to the back panel.

I don't know whether it was the weight of the Note 3s which made me think of Wagner, but the Philips recording of Siegfried was close to hand so I tried out the inevitable sword-forging sequence. It was obvious from the word go that these 'speakers are capable of a real sense of



grandeur; the descending scale passages were rendered with an entirely appropriate primeval feel, and Wagner's enormous orchestra threw out crushing blocks of sound: all quite exhilarating.

Staying literally with the big guns, I tried a dose of Tchaikovsky's 1812 as a cross reference. There's no doubt about it, these 'speakers can put over some very powerful arguments when fed with the might of 19th Century orchestral pieces. Experiments with the washer arrangements on the passive radiator proved a little inconclusive. Musical signals are such fleeting things that it is difficult to say whether changes in the perceived bass response were due to the variation in cone weight or just our old enemy psy-

cho-acoustics. Certainly the Jordans are not lacking in bass response; if anything they are inclined towards over-emphasis, although with an effective doubling of the cone area at the resonant frequencies, this shouldn't come as a surprise.

Away with the heavy artillery and on with The Art of Fugue, with Neville Marriner's very satisfying orchestration of Bach's masterpiece on Philips. With all the subtleties that the small-scale mix of strings, woodwind and harpsichord provides, accuracy is the main desideratum rather than power. Here there was a slight hitch. Whether or not it was the fractionally overweight bass or something more difficult to pinpoint, the Note 3s tended to sound just a bit 'lazy' on these pieces; some slight lack of presence and incisiveness left me feeling that I was 'thinking' the music rather than actually hearing it.

If power and weight are high on your wants list, these 'speakers are a strong possibility; well-made and with an appropriately weighty sound. If chamber music is your tittle, though, the slightly 'recessed' treble sound might become irritating after a time.

ALR-Jordan Note 3 £1000

**ALR-Jordan
Audio Plus Distribution Ltd.,
PO Box 902,
Sutton, Surrey SM1 2UQ
Tel: 0208 642 4436**

WORLD VERDICT



An intriguing 'speaker with plenty of bass power and weight. Rocks aplenty, but the balance isn't ideal for classical chamber music.

Measured Performance see page 111

replay



The now-classic Sugden A21a is, as far as we know, the only Class A, single ended solid state integrated amplifier available. Don't be fooled by other so-called Class A amps; they usually switch to class B after a few watts! The warm, lucid sound of the A21a is way ahead of these pretenders and costs a very reasonable £850. There is also an excellent CD player to match it, the CD21 at £899. For Sugden's ultimate Class A amplifier, there is the Masterclass pre/power, a genuinely world-class system for £4995.

**64 Flixton Road
Urmston
MANCHESTER
M41 5AB
0161 202 9922
email replay@dial.pipex.com
website www.replay.dial.pipex.com**

CD/DVD from Audio Analogue, Creek, LFD, Meracus, Musical Fidelity, NAD, Onkyo, Pink Triangle, Samuel Johnson, Sugden, Teac
Ampifiers from Audio Analogue, Bryston, Creek, Crimson, LFD, Musical Fidelity, Pathos, Rothwell, Samuel Johnson, Sugden, Teac, Trilogy, Unison.
Loudspeakers from Acoustic Energy, A.R.T. AVI, Audio Physic, Avantgarde, Final Electrostatics, Heybrook, Monitor Audio, Neat, Opera, Royd, Ruark, Sequence, Triangle, Veritas etc

WILMSLOW AUDIO LIMITED



The name in loudspeakers for over 30 years

As well as being the largest supplier of loudspeaker kits in the UK we are also renown for our comprehensive range of drive units, accessories and components. Our stock profile includes units of the highest quality such as:-

ATC,
KEF,
Morel,
Peerless,
Scan-speak,
Volt
and Vifa.



Our stock list of components is equally as impressive with capacitors from **Ansar, SCR** (Solen) and **Hovland Musicap**. We have ceramic wire wound resistors and air-cored inductors from Volt. We have spent hour upon hour listening to cables and interconnects from all manner of manufacturers and have settled on a range to suit all budgets and hopefully all tastes.

So if you are thinking of building your own loudspeakers or refurbishing your cherished but ageing speakers you should contact us for all your requirements. Our aim is to provide you the customer with the best service possible at the fairest price.

Phone for your FREE catalogue or check out our website: www.wilmslow-audio.co.uk

WILMSLOW AUDIO LIMITED

50 Main Street. Broughton Astley. Leicester
Tel: 01455 286603 Fax: 01455 286605

SOUNDS PERFECTION

THE SOUTHWESTS PREMIER RETAILER

e-mail:- nigel@soundsperfection.co.uk

web:- www.soundsperfection.co.uk

AUDITION THE FOLLOWING PRODUCTS HERE:-

AMPLIFIERS:- ALCHEMIST * AUDIO ANALOGUE * AUDIO NOTE * BORDER PATROL * CANARY AUDIO * ELECTROCOMPANIE * GRAFF * MUSICAL FIDELITY * PARASOUND * PRIMARE * SONIC FRONTIERS * SUGDEN * UNISON RESEARCH

SPEAKERS:- ARCAVYSIS * AUDIO NOTE * AUDIO SPECTRUM * B. C. ACOUSTICS * BOSTON ACOUSTICS * J.M. LABS * MONITOR AUDIO REL SUBWOOFERS * TOTEM * TRIANGLE * TSUNAMI * VIENNA ACOUSTICS

CD PLAYERS:- ALCHEMIST * AUDIO ANALOGUE * AUDIONOTE * ELECTROCOMPANIE * MUSICAL FIDELITY * SONIC FRONTIERS * TEAC * TRICHORD

HOME THEATRE:- PARASOUND * PRIMARE * SONIC FRONTIERS * BOSTON ACOUSTICS * J.M.LAB'S * LEXICON * NAKAMICHI * REI * TSUNAMI * TRIANGLE * TEAC * VIENNA ACOUSTICS * YAMAHA

ANALOGUE:- AUDIO NOTE * AUDIO DESIGNS (THE GROOVE) * AVID * HENLEY DESIGNS * MICHELL * MUSICAL FIDELITY ORTOFON * PROJECT * SME * VOYD

ANCILLARIES:- ATACAMA * AUDIOQUEST * CABLE TALK * EINSTEIN * PHILOSOPHY CABLES * SONIC LINK * STANDS UNIQUE * STRAIGHT WIRE * TARA LABS CABLES * TARGET * UNDERSTANDS

FULL HOME THEATRE DEMONSTRATIONS NOW AVAILABLE

WE HAVE THESE SECOND HAND/EX-DEM PRODUCTS

Audionote Ongaku New Boxed Once Only	£24950
Conrad Johnson Premier 8 Mono Blocks Mint Boxed 4 Mths Old Only	£12995
Audionote M5 Pre - Amplifier Phono Mint Dem Norm £6000 Only	£3995
Audionote An-S7 Mk II Moving Coil Transformer	£2995
Audionote An-J Spx Speakers Boxed (Customer Sale) Mint Inc Stands	£2395
3 Quad ESL 63 Speakers Inc Special Stand	£1495
Alchemist Kraken Pre / Power & 2 Box Cd (System) Ex Dem	£1395
Monitor Audio Studio 20 Ann Piano Black New Unwanted Prize	£1395
Alchemist SS Power Amplifier Mint Boxed	£1375
Sonic Frontiers Anthum Integrated 2 Boxed Ex-Dem Mint	£1295
Audionote An-Vz Interconnect 1.5m Length	£995
TDL Monitor Transmission Speakers Walnut Mk1 Mint Cond.	£895
Macomack Phono Pre Amp V.G.C. Quite Rare Unit Excellent Pre	£695
Impulse H6 Speakers Black Finish with Light Oak Cabinet Wood Trim	£675
Electrocompaniet ECI 2 Integrated Amp Mint Boxed	£649
Meridian 508 Cd Player Mint Boxed 4-5 Years Old Below Av. Use	£649
A.E. 509 Speakers (New Boxed Unused) Black Ash Finish	£595
Musical Fidelity X - P100 Pre - Amp Boxed Mint	£575
Audio Research BL1 S/L Converter to Balanced Line	£449
Parasound PLD 1500 Pre-Amp	£425
Rothwell Rubicon Valve Power Amplifier Mint	£395
Hart (Lindsey Hood) 2 Box Pre - Amplifier Amazing Kit Performance	£395
Understand X-Wing With Wood Plinths 3 Months Old	£375
MicHELL ISO Hera Phono Stage Only	£375
Madrical 1m Pair Y Balanced Cz Jel Cables Only	£349
Arcam Digital Pre-Amplifier Marked Hence	£299
Kinshaw Perception Dac	£275
Triangle Lunns Ex Dem Boxed	£275
JPW Ruby 2 Speakers	£275
Henley HMC 100 Phono Stage Ex-Dem Boxed	£275
VDH The Second 1metre Balanced Interconnect	£195
XLO Reference Digital Cable	£149
Audio Synthesis Balanced Silver Cable 2 Now Available	£95

**SOUNDS PERFECTION & SOUND ACADEMY OFFER
UPGRADE YOUR CD PLAYERS PERFORMANCE
£99 ONLY**

**CONTACT NIGEL ON:- 01326 221372
OR MOBILE 0498 554357**

**CONTACT US FOR UP TO THE MINUTE PRICES
OF SECOND-USER EQUIPMENT
AND SPECIAL OFFERS**

**FOR FRIENDLY ADVICE AND 7 DAYS A WEEK
8AM to 10 PM**

MAIL ORDER THROUGHOUT UK

VISA/ACCESS/SWITCH

THE FINAL FRONTIER

From the land of Tulips, windmills and liberal attitudes comes the Final range of electrostatic speakers. Simon Pope goes Dutch with the baby's of the range.



Firstly, I have to admit to being a bit of a panel fan. Like many of my fellow flat-heads, I bought a pair simply because they looked and sounded different. I soon began to appreciate the benefits that can be reaped from a pair of electronic ironing boards at their best, such as beautiful transparency, air, space and detail. However 'pure' panels - such as Quad electrostatics and Magneplanars have a tradition of quirks that some consider problems. Low sensitivity (necessitating powerful amplification), positioning sensitivity (they can be very directional) and a lack of bass. On the other hand, in my opinion nothing can play unaccompanied sacred choral music (my Desert Island genre) quite like panel 'speakers. Others may consider that all the detail and refinement from a single radiator won't compensate for the sheer kick that a drive unit can deliver. Hence what is commonly known as the 'hybrid'. This is a design used by the Finals, among others, in which a powered electrostatic panel is used in conjunction with a bass drive unit. In the case of the Finals, the drive unit is intriguingly on top of the cabinet, which is situated behind the main panel at an angle.

On first listening to these 'speakers I immediately noticed they have one of the traits I mentioned earlier, namely directionality. There was undoubtedly a 'hot-spot'. With the vast spacial effect of Messiaen's Chronochromie on DG with Pierre Boulez and the Cleveland Orchestra, the Finals did a grand job of relaying the shimmering upper treble of the vast percussion section, but I felt the spacious nature of the recording was being held back. A quick tweak, as suggested by the distributor, worked wonders, however. By changing the phase of the bass drivers via the cable at the 'speaker end, the Finals made a grand job of the air and space in this marvellous

recording. This demonstrated the benefits of the electrostatic sound. Flutes and other woodwind floated naturally in the room, no matter where you stood or sat, and the violins were as transparent as possible.

The firm lower strings and percussion showed that the bass driver delivers the goods. Good extension was present, accompanying the spacious, open sound of the panels with bass depth. Maybe the two didn't amalgamate quite as naturally as you'd wish, but the bass certainly wasn't ploddish, which kept the sound as a cohesive whole.

Playing rock music in the form of Soundgarden's Superunknown CD saw the Finals reacting in quite an unexpected way. Feeling that the nature of the sound suited classical and light jazz music far better than rock music, I was pleasantly surprised that they fared very well with Soundgarden. This CD has a very complex and at times confused mix, with heaps of studio compression - not ideal panel material. But the bass driver took hold of the bass guitar and drum kit to deliver an infectious, driving groove to the music. I have rarely heard the drum kit on this album with such detail and excitement, it was a complete surprise. The only small gripes I would have here were that there were definitely two elements to the music, and you could hear at which point the bass driver took over.

If you want to invest in something entirely different from the square cabinet with drivers norm, then you should without doubt give these a listen. Yes, they take a bit of driving and are placement sensitive to a point at which you may pull

your hair out, but a little perseverance and changing the phase of that bass driver will bring a civilized and spacious sound to acoustic recordings. The sound is very different from that of a cabinet and leans towards the upper end of the frequency range, but is nonetheless a breath of fresh air in the otherwise rather stale loudspeaker world.

U.K.D.
23 Richings Way,
Iver,
Bucks,
SL0 9DA
Tel: 01753 652669

WORLD VERDICT

A civilised, open sound with oodles of space to the sound. Could integrate a little better.

Measured Performance see page 111

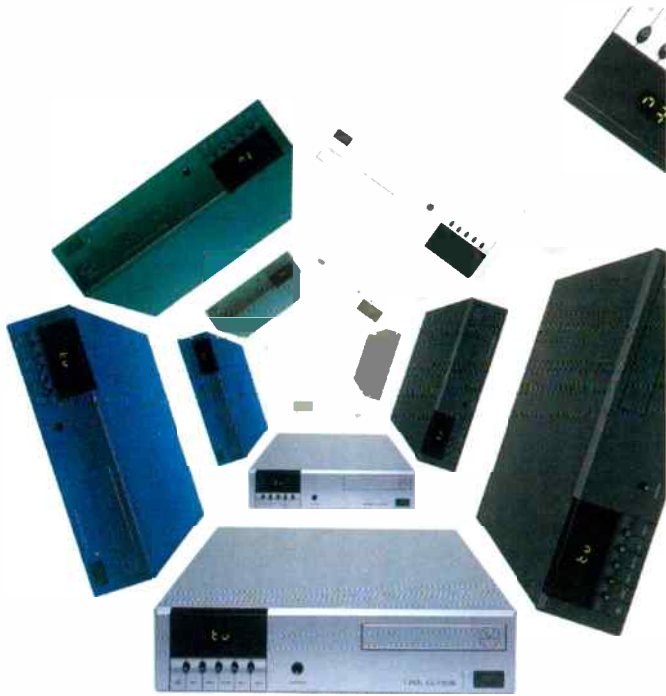

100%
value

with a real Linn
hi-fi system

A new category of independent product, offering a supremely elegant, neat and complete, CD and AM/FM radio music system combining power, performance and style. Now with the added ability to control lights, TV and home security devices

a **classik** by Linn®



LINN
the only sound®

Linn is available from the very best hi-fi retailers and Linn at Harrods. For further information simply see our website on www.linn.co.uk or call 0500 888909

York...
a great place for...

Cyrus

Meridian

Martin-Logan

Krell

Monitor-Audio

AE
Atacama
Cable Talk
Copland
Cyrus
Epos
Harman-Kardon
JBL
KEF
Krell
Marantz
Martin-Logan
Meridian
Michell
Mission
Monitor Audio
Musical-Fidelity
Pickering
Pink Triangle
Pioneer
Primare
Project
Quad
REL
SME
Sonus-Faber
Spendor
Tannoy
Thorens
Yamaha
& lots more

• Widest choice in the area
• Independent advice
• Qualified staff
• Comfortable dem rooms
• Superb showrooms
• Main road location
• Major car parks nearby
• Insurance estimates
• Over 30yrs experience
• Service Dept
• Delivery & installation
• Part Exchange
• Open 10.30-5.30 6 days

**Up to 3 yrs.
Interest Free
Credit**

deposit only 20% of
£500+ for 12 months
£1500+ for 24 months
£3000+ for 36 months
subject to status

PS if you're making a special trip
it's best to book, weekdays

Vickers Hi-Fi

24 Gillygate, York
Tel. 01904 629659
High Fidelity Specialists est. 1967

More info.+sale items at... www.Vickers-HiFi.co.uk

TUBE AMPLIFIERS

Music

音楽

SHINDO LABORATORY

Sound Create Professor

16-11, Hongo 2Chome Bunkyo-ku Tokyo 113-0033, Japan FAX. 81-3-3818-6873
Information : <http://www.shindo-laboratory.co.jp/index.html>

In The Classical Style

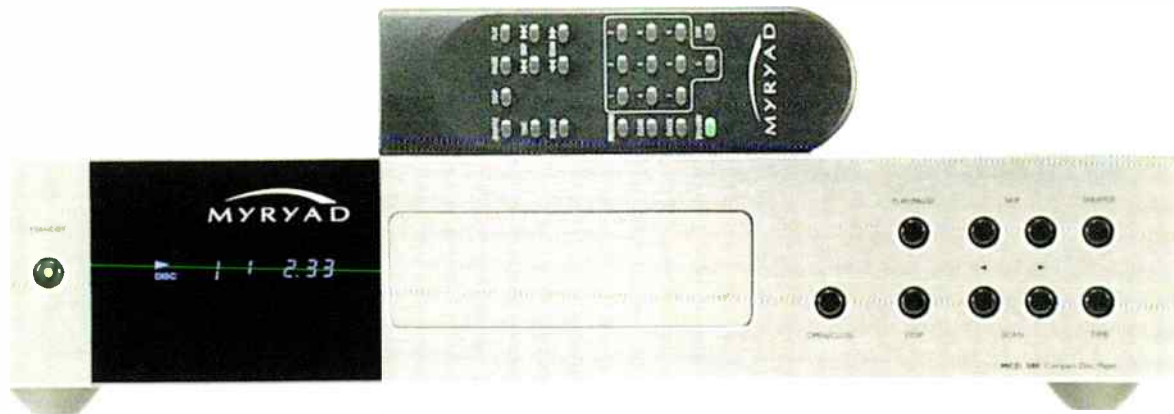

Simon Pope encounters the dark horse that is Myryad's MCD500 top of the range CD spinner.

The Myryad M Series are flagship products. Integral to the design is their quality build and distinctly attractive black and silver styling. Inside the MCD500's casework we have a high quality 24-bit DAC made by Crystal that deals with the number-crunching. This is accompanied inside by no less than 13 separately regulated power supplies with dual transformers. The front panel consists of thick brushed aluminium with the M Series trademark display window to the left and nine simple operation buttons to the right. Although all this is crammed inside it weighs a sensible 6Kg, so a block and tackle followed by few days aromatherapy massage on the lower back isn't necessary. Also included is a comprehensive and slimline remote control - ideal for listening-chair potatoes out there.

The MCD500 took a while to run in. After a week or so of regular play the sound began to warm up and gain more depth until it was ripe for review. The main characteristics of this player are its smoothness and musicality. Other players will have more air and space with bog-standard recordings but may not have the art of carrying a phrase like the MCD500 does. This meant that the Myryad excelled with music played on 'proper' instruments, rather than a computer in some fella's spare room. So dance music was out and classical and jazz was in. And large scale classical too!

Playing Mahler's second symphony in a remastered 1977 DG version by the Chicago Symphony Orchestra under Claudio Abbado gave very musical

results. Starting with the beautifully lyrical mountain waltz second movement, rather than the aural assault of the opener saw the MCD500 picking up the subtleties of string playing, such as vibrato and pizzicato from the Chicago fiddlers. Also demonstrated was the deep soundstaging that the player has True, most aspects of soundstaging are present in the recording itself, but a good player is needed to highlight them. Through the MCD500 the massive orchestra had weight and presence, especially in the larger scale movements, and the ability to play music without worrying too much about the electronics in the box - always a good sign.

The MCD500 is especially good with voices, whether it be the massed choir of the Mahler or the soloists in Berlioz's massive opera *The Trojans*. Good singers carry phrases through to the death (listen to Fischer-Diskau) so every part of the phrase - and the notes that make it - are heard. The MCD500 plays music, especially opera, like this. It's a very musical player in this respect. Tonally there are no problems either. Treble is suitably sweet and bass has, rather than out and out kick, a smooth and tuneful presence.

The only slight problems come with rock music, which could sound compressed with compressed tracks, yet open with well recorded music such as Paul Weller's *Stanley Road*. The MCD has the art of exaggerating bad rock recordings in a way that strangely didn't occur with classical CDs of a similar nature. It creates much more space with acoustic music than it does with studio-based multi-track

recordings.

This is not a cheap player and there is strong competition from other similarly priced machines from people such as T&A whose players may give more demonstration fireworks and analytical performances. The MCD500 holds its own in the market by playing music - especially classical - very well indeed. You can compare it to performers. Some good orchestral conductors such as Carlo Maria Giulini rely more on richness of tone and phrasing rather than heart-stopping excitement to create a performance. The effects of this are long-term rather than merely immediate. It allows the music to seep into you. The MCD500 is the Giulini of £1000+ CD players!

Myryad MCD500 £1299

Myryad Systems Ltd
2 Pipers Wood,
Waterberry Drive,
Waterlooville,
Hants.
PO7 7XU
Tel: 01705 265508

WORLD VERDICT



Excellent with large scale classical or opera. Lacks a bit of clout with rock or dance music.

Measured Performance see page 111

letters & e-mails

Visit our website at www.hi-fiworld.co.uk or send your e-mails to edit@hi-fiworld.co.uk

LETTER OF THE MONTH

THINKING ALOUD

Can you please help with a problem I have with my recently purchased system which consists of:

Arcam Alpha 7SE,
Sound Audio VP-3a tube line amplifier,
Arcam Alpha 8P,
Mission 750LEs hi-wired with VDH Cleartrack.
Interconnects VDH D102 Mk111.

The pre-amp was bought second-hand without manuals and although it has thirty-one steps on the volume control I can only use the first five before noise levels get too loud for the neighbours and harshness sets in. Attenuators supplied by Audio-T have not made any difference and Arcam have sug-

gested that the pre-amps input stage is being overloaded and I should get an engineer to fit one with less gain.

Do you have any information on this amplifier or any suppliers/engineers who are familiar with them as I do like the sound it produces up to volume notch four and would rather pay for it to be modified than ditch it if it is a viable exercise? Or have you had any customer reports back from people who have bought the variable attenuators advertised in the back of your magazine and could these help or is there a drop in sonic quality when using them?

Any advice you can give me will be greatly appreciated.

Yours sincerely...

David Parfitt

This is a problem I know very well of old, particularly when trying to match any other pre-amp to a Leak power amplifier. Because of the excessive sensitivity of the old Leaks, most pre-amps thump out about eight times more volts than the amp needs with inevitable overloading.

I am curious that you say your attenuators have made no difference - they must have made some, surely. or again, why does a line amp find itself pushed into overload - outputs nowadays tend not to do this, at least not to the extreme levels you mention. Anyway; to business . . .

If it turns out to be question of attenuating the input level of the

pre-amp, here's what to do: you will need a selection of half-watt resistors. Values of 1k Ω , 4.7k Ω , 10k Ω and 100k Ω will probably do you for starters. If we manage to hit on the right combination, you'll need two of each - one for each channel. Separate your pre-amp entirely from the mains and open the box. Unsolder the internal lead from the input phono socket and fit the resistor network as shown:

This arrangement means that the pre-amp is being fed from a potential divider and thus receives an attenuated but proportionate signal from the CD. If the trial values of 1k Ω and 100k Ω make things too quiet (ie the fault is now in the opposite direction) substitute the 4.7k Ω for the 1k Ω . Still too quiet? Try 10k Ω and 100k Ω . By the time you've tried this, you will have a good idea of the sort of attenuation required and may feel that an intermediate value of the smaller resistor will give optimum results.

Although this is a fiddly process, the plain resistors will give a much more determinate result than trying to set a potentiometer, measuring the result etc. In any case, buying a few shillings' worth of resistors is a much cheaper option than variable attenuators or repairers' bills. If the 1:100 ratio I've suggested you begin with leaves things still too loud, then there's problem 1:100 gives about 40dB of attenuation, quite a bit. If you need more than this, there is a serious mismatch somewhere (it's supposed to be line amp after all) and it's time to wonder if something is seriously at fault. Then ring the engineer.

RMW

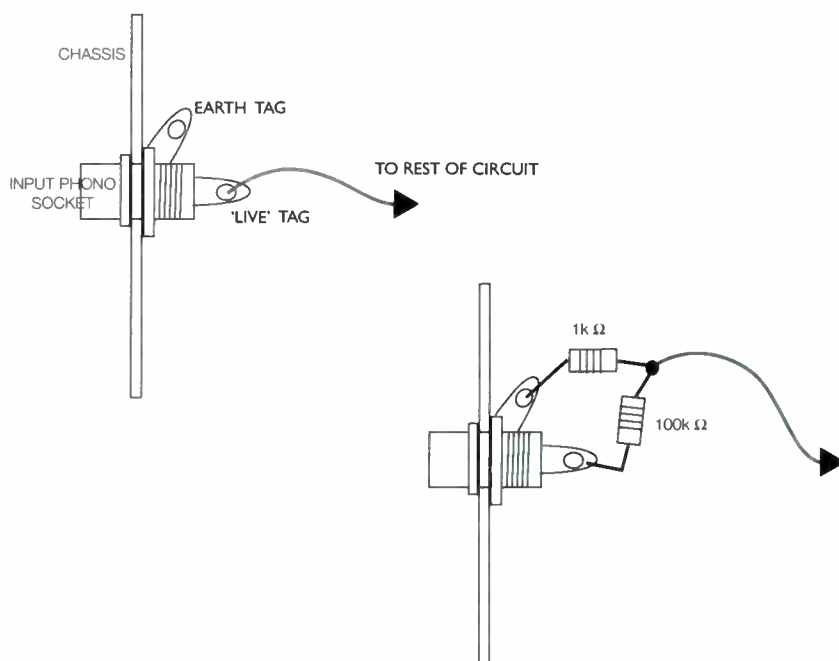

SECONDS FIRST

I'd appreciate some advice, please. A dealer in your mag has for sale a Michaelson Odyssey integrated valve amp. advertised for £700 compared with the original 1992 price of £1150. I understand that Anthony Michaelson now runs Musical Fidelity, and that this amp was highly rated in its day. But your guide to buying second hand valve kit advises novices to avoid amps above 15W - and the Odyssey is 45!

Does the fact that Mr Michaelson clearly knows his business outweigh your general advice? I have no previous experience of valves, and would be grateful for any additional advice either generally on buying a valve amp or specifically on the Odyssey.

In case it's of help, rest of the system is Marantz 63 KI-slg mk 2, Mission 780 SEs, Goertz M1 speaker cable, Cambridge Audio Silver Spirit interconnect. Current amp is an Alchemist Kraken class A integrated, which does everything well except low bass, so I'm looking for a replacement which will retain the clarity of the midrange and top, but add some bottom end.

Thanks a lot,

Bob Connell

First things first: the caveat against valve amplifiers with greater than 15W output was intended especially to warn people off vintage stuff in this category; excrescences like the Leak TL50+, for example. Since those days (late 1950s), improvements in components and refinements of circuit design have made powers up to, say, 45W from a push-pull pair quite practicable hi-fi, so as regards power there's nothing to worry about with the Odyssey. What might weigh more with you is that although Mr Michaelson is one and the same, Michaelson Audio and Musical Fidelity are not, and MF can not undertake to provide service for equipment which, in truth, they did not make. This is a problem that affects any gear from a now-defunct maker, so it is not just the Odyssey; if you're new to valves, you may want to tread more carefully. In any case, the price you quote for what is now a ten-year old amplifier seems a bit steep - halve that again at least and you might have a deal.

*Two more general points concern me here: low bass is not specifically an amplifier matter and valve amplifiers are not particularly bass beasts. As you suggest, you should benefit enormously from valve midrange, so it's worth making the change in any case. You might consider re-positioning your loudspeakers - an ounce of acoustic enhancement can be worth a ton of electrical assistance. **RMW***

PLANARS PLAIN CAN BE

I am in the market for a new system CD/AMP/Speakers. I listen to orchestral music mainly but would like the system to cope with other "types" too. The high frequencies of most speakers I have auditioned seem "detached" and little too "Hi Fi" for my taste. I heard a pair of second hand Magneplaner panel speakers and was quite enchanted with the thinks that they did well - size of "image", midrange smoothness etc. but was less impressed with the bass - not the lack it but it seemed "slow" on rock music, fine on classical. I have been unable to find a dealer who can demonstrate these products in the UK, can you recommend one? Or is it a case of auditioning in the US on the next visit and getting them sent home.

Thanks for your help.

Graham

Graham Simpson

I have good news for you, Graham. As a fellow Magneplaner user I can agree your comments, but personally find the bass on rock music not particularly slow, but a bit shallow. To conquer this problem I sometimes put into use a good subwoofer. Magneplanars are a very 'fast' and open speaker and they need a fast sub to integrate with. My personal recommendation is a REL Strata III which can shake the floorboards with the frequencies unattainable by the Magneplanars and match a MacLaren F1 over 200 metres!

*As far as getting a pair within the UK, RT Services (tel no: 01235 810455) are the UK distributors for Magneplanar and should be able to help you out. **SP***



**The Strata III:
bass instincts!**

THE SPIRIT OF MUSIC

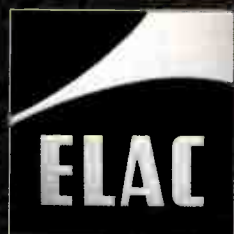

CL 310i JET



Distributed by
Sennheiser UK Ltd.
FREEPOST High Wycombe, Bucks HP12 3BR.
Tel: 01494 551 571 Fax: 01494 551 549
email: info@sennheiser.co.uk Web: www.sennheiser.co.uk

Hi-Fi Choice June 99 ★★★★★ (Build Quality)

Hi-Fi World July 99 ●●●●●

ELAC Electroacoustic GmbH, Rendsburger Landstr. 215, D-24113 Kiel,
Tel: +49 (431) 64 774-0 Fax: +49 (431) 68 21 01 Web: www.elac.com

No good advice this month – just top goods at good prices. All sold with guarantees and our help with critical system matching. Benefit from one of our occasional clearouts.

Bargains

bargains, bargains

All these items are in nearly new or very good condition. Most are sold with boxes and instructions and all are guaranteed by us.

		Was	Now
Wadia 22 CD transport	<i>slh</i>	2240	1125
Theta Pro Basic III DAC	<i>slh</i>	2990	1395
Linn Karik CD player	<i>slh</i>		695
Linn Numerik DAC	<i>slh</i>		275
Wadia 830 CD player	<i>dem</i>	3000	2495
Orelle DA188 DAC	<i>dem</i>	450	175
Jeff Rowland Consummate phono stage + separate PSU	<i>slh</i>	3000	995
Lumley PVI.5 phono preamp	<i>dem</i>	1500	795
Adyton Opera integrated amp	<i>dem</i>	2600	1895
Lumley PS2 s/state phono preamp	<i>dem</i>	3550	1295
Lumley 120 valve power amps	<i>dem</i>	3500	1795
Mirage 890si A/V speakers	<i>dem</i>	995	595
Lumley 3.5 floor speakers	<i>dem</i>	1050	625
Promenade 2 stand speakers	<i>dem</i>	365	275
Ethos L55/12B stand speakers	<i>dem</i>	1500	1095
Ethos 202 floor speakers	<i>dem</i>	2600	1725

Customers say we make some of the best sounds they have ever heard, so you know we can do the same in your home.

Our advice will take account of your best components and guide you where change is needed, in stages you can afford.

You **AVOID EXPENSIVE MISTAKES**, enjoy music along the way and save money in the long run.

JUST LISTEN AND YOU'LL KNOW

The
Right
Note
A Note to the Music

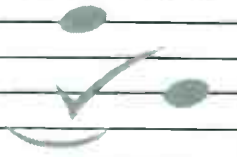

BATH

01225 874728

CD: ACCUPHASE, ADVANTAGE, AUDIO SYNTHESIS, BALANCED AUDIO TECHNOLOGY, dCS ELGAR, MERACUS, PASS, SUGDEN, WADIA. **VINYL:** BASIS, CLEARAUDIO, CROWN JEWEL, DNM, GRAHAM, LEHMANN, MICHELL, STRATOSPHERE, SUMIKO BLUE POINT SPECIAL, TRANSFIGURATION. **AMPLIFIERS:** ACCUPHASE, ADVANTAGE, BALANCED AUDIO TECHNOLOGY, CAT, DNM, GAMUT, LUMLEY, MERACUS, NAGRA, PASS, SONNETER. SPECTRAL, SUGDEN. **LOUDSPEAKERS:** AUDIO PHYSIC, BKS, CHARIO, ETHOS, LUMLEY, MAGNEPLANAR, NEAT, TOTEM, VERITE AUDIO. **TUNERS:** ACCUPHASE, MAGNUM DYNALAB. **CABLES:** ARGENTO CHORD CO., DNM, NORDOST, SILTECH, YAMAMURA CHURCHILL ETC. **SUPPORTS, STANDS:** UNIQUE, VIBRAPLANE ETC.

NOW IN THE UK FOR THE 1ST TIME World Radio History

HIFI WORLD

BASS UP THE CREEK!

While searching for the meaning of life and everything, I found another reason why CD's don't always sound as pleasant to listen to you would expect or want.

Certainly, resolution is missing compared to good old fashioned vinyl, but one area where they are supposed to excel is in the region of low bass. There is no technical reason why they shouldn't be capable of reproducing extremely low bass (down to almost DC) if it is recorded and transferred onto the media.

It would appear that recording studios, be design or mistake have not always used capability. In fact, from disc to disc, track to track and recording label to recording studio, there is a conspiracy to remove or "scrub" all the bass off certain popular recordings. Please check this out on a site that has been set-up to "out" this error or deliberate corruption of the original recordings. We have confirmed this on our own test equipment and it appears to be absolutely true. see:

<http://WWWWebTown.Net/NoLowBass/>

I can go further than these Grateful Dead fanatics and say that after checking many and varied titles there is a worrying number that have been messed around with, to presumably make the recordings better suited to midi systems or in-car use.

Please let me know if you want more information. We should try and get this practice stopped.

Best regards,

Michael Robert Creek
Creek Audio Ltd.

Interesting points brought up here. Many recordings for CD are specifically mixed or mastered for use with tranny radlos, midi systems, in-car stereos and the like. I can say, though that I've often heard bone-shaking low bass both left and EQ'd out of various CDs in mastering studios. So it does exist, but rarely with rock music and more with dance tracks (also mastered on vinyl for club PA use).

When, on occasion, a CD has remarkably low and powerful bass - such as The Prodigy's Fat Of The Land or Massive Attack's Mezzanine - the only equipment that will handle the frequencies properly are dedicated hi-fi separates. For example, playing these recordings in my car results in it transforming into a mobile rattle-shack.

The situation reminds me a little of the hey days of Vinyl, such as

the 'Decca period' of the 60s and 70s. These early Decca recordings were simply far too good for the majority of equipment they were played on. The knitting needles that most vinyl reproduction systems used for picking up information simply ignored a lot of the detail found in the ambient nature of the discs. So the full sonic advantage of these magnificent records were reserved for the privileged few.

Nowadays most people have CD players that will capture most of the information on a disc but the problem lies with the quality of engineering inside mass produced systems and their matching loudspeakers. Unfortunately some of these, if fed with the Prodigy would probably shake to pieces at a certain volume level.

*Hence, the majority rule over the minority yet again and your bog standard rock CD can often be compressed beyond musical recognition. This means that they will sound OK in your car, over the engine level, but on a decent hi-fi are like bathing with your socks on! **SP***



That ear trumpet won't help much!

Every letter we print wins a superb prize! On offer are The Chord Co. interconnects, Audio Electronics books, Ringmat Statmats, and a **FREE** subscription to **Hi-Fi World** for the best letter of the month! Please write, fax or e-mail to **Hi-Fi World** Mail, Suite G4, Imex Hse, The Park Business Centre, Kilburn Park Road, London NW6 5LF. Fax: +44 (0)171 328 1844

E-mail: edit@hi-fiworld.co.uk

Experience a fresh, new clarity from your hi-fi

You may have some of the greatest musical performances ever recorded in your cd and record collection, but are you experiencing the full 'live' effect when you listen to them?

All hi-fi systems are subject to vibration and static build-up, which take more than an edge off the sound before it reaches your ears. Their effects are insidious because you are not always consciously aware of them until they have been removed. Yet a purer, cleaner, more dynamic reproduction that will surprise and delight can be achieved easily and cost effectively by using our products with your existing hi-fi system to minimise those distortions.

We are the world's leading specialists in the geometry of sound and resonance in materials. Thousands of our products are in daily use with music lovers around the world, including musicians and music and hi-fi reviewers and are recommended by hi-fi companies.

www.ringmat.com

www.statmat.net

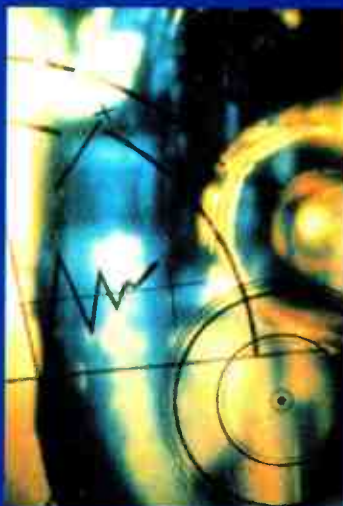

STATMAT

"I now instinctively use the device all the time".

Christopher Breunig Music Editor
Hi-Fi News & Record Review

RINGMAT SUPPORT SYSTEM

"Already I'm wondering how I ever listened to music without it".

Jimmy Hughes Hi-Fi Choice

RINGMAT FEET

"... the effect on the music was magical."

Jimmy Hughes Hi-Fi Choice

Our products are available through good hi-fi retailers or via mail order and cost from as little as £20. For more information, including reviews and brochures, or to order with a money-back guarantee, contact:

RINGMAT DEVELOPMENTS

PO Box 200 Brentwood Essex CM15 9FB

T: ++ 44 (0) 1277 200 210

F: ++ 44 (0) 1277 201 225

E-mail: enq-hifiworld@ringmat.com



FOR MORE DETAILS PLEASE CONTACT:

Ultimate Sonics

36 Hurstbourne Road,
London SE23 2AB

Tel: 0208 699 2446

Famous for their loudspeaker and interconnect cables, The Chord Company have naturally joined the list of companies offering cables to polish the performance of the National Grid. Except that they haven't. Instead, Stage 1 of the Clearway process turns out to be an unlikely black plastic box sprouting at one end a few inches of wire

opting for curiosity before scepticism, I plugged the Clearwater in ahead of my LAT International distribution block and fired up my system.

"Well I'll be b..." accurately describes the impact of The Chord Company's new component. The Cardigan's 'Erase/Rewind' single had so much more bottom-end welly, so much

more clarity and detail that I had to reach for more recordings to confirm I wasn't imaging things. Nope. Every CD inside the T+A CD 1210 R, every LP on the Trio L-07D benefitted to the same extent, and the gains were even more evident through Magneplanar MG 12/QRs rather than Jamo Concert 8s.

A change of address and an equip-

RUBBISH COLLECTOR

Is the quality of the electricity coming out of your wall socket holding your hi-fi back? Jon Marks searches for a remedy with the Clearway Stage 1 System Enhancer from The Chord Company.

terminated in a single trailing mains socket, at the other an IEC mains input. The second item in the pack that looked suspiciously as if it might have an audio purpose was a very standard IEC cable.

Hmm, I scratched my head – things weren't getting off to the start I'd expected. And I hadn't had many promising experiences in the past with 'lumps in leads' intended to purify the ubiquitous 240V product. However,



ment shuffle proved the Clearway remained consistent in its effect. Removing it from the supply equation left the sound quality suffering, as imaging lost focus, bass its punch and the overall presentation closed in and became congested. Good things do come in small packages, it seems.

Clearway Stage 1 Mains Enhancer £200
The Chord Company, tel: 01722 331674

HOOD VIBES

Richard White encounters Clearsound's Speaker Hoods for the ultimate sonic cover-up.

Gadgets come and gadgets go – here's an idea which may have a modicum of common-sense behind its design. It would be idle to pretend that all loudspeakers give such astounding results as to be unsusceptible of improvement. In the dim and distant past, items such as 'acoustic lenses' and 'slot filters' were marketed in the interests of improving things, without the necessity of incurring the greater expense of starting from scratch with new 'speakers.

Clearsound's Speaker Hoods are clearly distant relations of this established line. In essence, a Speaker Hood is an additional box which fits snugly but not tightly to an existing loudspeaker and claims to improve the tone. Actually, the Hood itself at no point contacts the 'speaker cabinet; it is lined with what the manu-

facturer designates a 'sound-absorbing composite comprising a lossy membrane . . . separated from the hood by layers of acoustic foam'. On the specimen we inspected, a tailor-made hole cut in the back made connecting the actual 'speaker easy enough, and the Clearsound Hood is not so heavy as to make the combined unit too cumbersome.

Even at first glance this idea may have something to recommend it, if it achieves a degree of damping with a too-lively cabinet – a by no means uncommon phenomenon, especially at the cheaper end of the market. With the sample submitted to us for listening, the hood when fitted made a worthwhile improvement to the host loudspeaker; so much so that our initial scepticism was noticeably less-



ened. Whether or not you like the change is a matter of taste; to our ears a somewhat forward budget 'speaker gained a rather more musical and neutral voice.

Clearsound are intending to make the Speaker Hoods in limited runs; in other words, if they can establish a demand for a particular model they will make a batch. One-off jobs are not invited at present, but it might be worth enquiring – who knows?, you may not be the only one.

Clearsound Speaker Hood £99
Tel: 01684 833155

Give your music a
New Dimension.

SilverLine



'Sell your soul to buy this, or suffer in eternity.
The best Hi-fi we've heard this year'.

T3 June 1999

'I have to applaud NAD for doing such a nice job with SilverLine'.

Hi-fi Choice April 1999

'Gorgeous build quality and a lush, smooth but close-detailed sound'.

What Hi-fi? May 1999

A new NAD for a new millennium

A stunning new range of true audiophile components which set new standards - even for NAD.

The SilverLine remains faithful to the traditional NAD philosophy of high performance and sound quality combined with excellent value for money and ease of use.

Contact us at the address below for more information.



New Acoustic Dimension

World Radio History

Lenbrook UK Limited

15 Faraday Road
Aylesbury HP19 3RY

Tel 0700 00 AUDIO
0700 00 28346

UK www.lenbrook.co.uk

Worldwide www.nadelectronics.com

www.hi-fiworld.co.uk

hi-fi

JUNE 2000

No51

World



THIS MONTH BOOK REVIEW.

*The Life and
Works of Alan
Dower Blumlein*
by Robert Charles
Alexander



3 STEPS TO HEAVEN

The all Valve Series II Modular Pre-Amplifier

ACTIVE CROSSOVER MODULES

- A true reference for other active crossovers.
- Individually calibrated in our workshop for your loudspeaker. Analogue phase linear.
- User adjustments - Instructions supplied.
- More accurate than the best loudspeaker computer software.
- Built using audiophile components.
- Fully alterable for future loudspeakers.
- Available for 2 way, 3 way, satellite and subwoofer systems.
- Specifications:
 <math> < 0.0002\% </math> Distortion
 >110dB S/N Ratio
 <math> < 0.5\mu s </math> Rise Time
 0Hz to 450kHz Bandwidth.

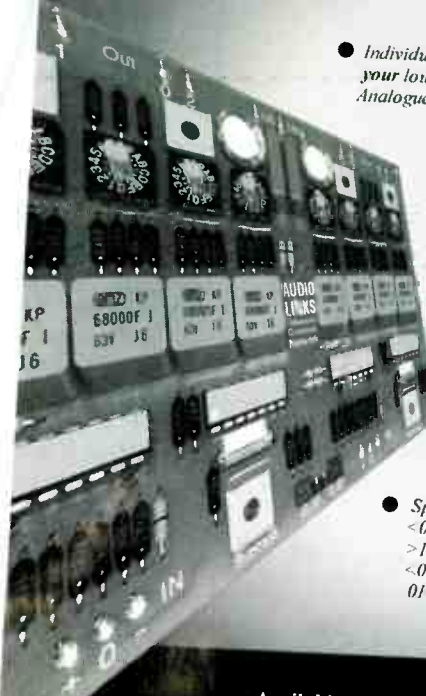

Available exclusively from

AUDIO LINKS

7 Fairmont Crescent, Scunthorpe, North Lincolnshire DN16 1EL
 TEL (+44) 01724 - 870432 FAX (+44) 01724 - 875340

PRICE VALIDITY TO END APRIL 2000 - ASK ABOUT ANY TYPES NOT ON THIS LIST



CHELMER VALVE COMPANY

for High Quality Audio Tubes

Everybody in the tube business knows that the justly famous Brand names of yesteryear like BRIMAR, GEC, MULLARD, RCA & TELEFUNKEN Etc. are scarce and often very expensive. Although we supply all major brands when available (and have many in stock) our policy is to offer a range of tubes, mostly of current manufacture, the best we can find from factories around the world, which we process specially to suit audio applications. The result - CVC PREMIUM BRAND. Our special processing includes selection for LOW NOISE, HUM & MICROPHONY and controlled BURN-IN on all power tubes to improve STABILITY and select out tubes with weaknesses Etc.

A selection of CVC PREMIUM Audio Tubes			
PRE-AMP TUBES	POWER TUBES	SOCKETS ETC.	
ECC81 5.20	EL34G 7.70	(continued)	B9A (Chassis or PCB) 1.60
ECC82 5.20	EL34 (TESLA) 8.20	6336A 46.00	B9A (Ch or PCB) G/Plated 3.00
ECC83 5.20	EL346CA7 (Large Dia.) 10.70	6550A 11.00	Octal (Ch or PCB) 1.80
ECC85 6.00	EL84/6BQ5 4.80	6550WA or WB 13.50	Octal (Ch or PCB) G/Plated 4.20
ECC88 5.00	EL509519 9.50	7581A 11.00	4 Pin (For 2A3, 300B etc.) 3.30
ECH82 5.00	E84L7189A 6.50	807 9.00	4 Pin (For 2A3, 300B etc.) G/Plated 5.00
ECL82 5.20	KT66 22.00	811A 11.00	4 Pin Jumbo (For 211 etc.) 11.00
ECL86 5.20	KT66R 12.00	845 34.00	4 Pin Jumbo (For 211 etc.) Gold Plated 15.00
EF86 5.60	KT77 12.50	KT88 (Standard) 21.00	5 Pin (For 807) 3.00
E80F Gold Pin 10.00	KT88 (Gold Special) 30.00	KT88 (GL Type) 9.00	7 Pin (For 6C33C-B) 4.50
E81CC Gold Pin 6.80	PL509/519 9.00	EZ80 4.20	9 Pin (For EL, PL509, Ch or PCB) 5.00
E82CC Gold Pin 8.00	2A3 (4 or 8 Pin) 14.50	EZ81 4.70	Screening Can (For ECC83 etc.) 2.00
E83CC Gold Pin 7.50	211 22.00	GZ32 12.00	Anode Connector (For 807 etc.) 1.50
E88CC Gold Pin 8.00	300B 50.00	GZ33 10.00	Anode Connect: (For EL509 etc.) 1.70
6EU7 6.00	6C33C-B 27.00	GZ34 6.70	Retainer (For 6L6WGC etc.) 2.00
6SL7GT 8.50	6L6GC 6.50	GZ37 8.70	
6SN7GT 4.60	6L6WGC/5881 8.00	5U4G 5.50	
6922 5.50	6V6GT 5.00	5Y4GT 7.00	
7025 6.50	6080 11.50	5Y3GT 7.00	
	6146B 10.50	5Z4GT 4.70	

and a few "Other Brands" (inc. Scarce types).

BRAGY 7.00	684G / SYLVANIA 27.00	6SN7GT 10.00	6X4 11.00
BRIMAR CHATHAM USA 10.00	68W6 BRIMAR 5.00	12AT7A (MULLARD) 7.00	6X4 STC 50.00
ELMGR RCA or GE 12.00	6EY1 GT GE 8.50	12AY7 GE-SYLVANIA 7.00	6X4A GEC 15.00
SYNMT SYLVANIA 5.00	6C78P or SYLVANIA 7.50	12AZ7 GE 7.50	6X4A TUNGSTOL 12.50
BASTG RCA or SIEMENS 12.00	6CL6 RCA or GE 5.00	12BH7A GE or RCA 13.00	8550A GE 23.00
BAU6W SYLVANIA 3.50	6CW4 RCA 11.00	12BY7A GE 9.00	6146B GE 17.00
	6SL7GT STC 8.50	12E1 STC 12.50	

ALL PRICES IN U.K. POUNDS £
 Please note carriage charge extra + VAT (EEC Only) - When ordering state if matching required (add £1.00 per tube).
 Payment by CREDIT CARD (ACCESS, VISA, MASTERCARD) or BANKERS DRAFT, TRANSFER or CHEQUE (UK ONLY).
 FAX or POST your ORDER - We shall send PROFORMA INVOICE if necessary.

Value Amplifiers sound better still fitted with CVC PREMIUM Valves!
 Chelmer Valve Company The Stables Baddow Park, Great Baddow
 Chelmsford, Essex, CM2 7SU, England.
 email: sales@chelmervalue.com © 44 (0)1245 241301 Fax: 44 (0)1245 241309 www.chelmervalue.com

LANGREX SUPPLIES LTD

DISTRIBUTORS OF ELECTRONIC VALVES, TUBES AND SEMI-CONDUCTORS AND I.C.S.
 1 MAYO ROAD • CROYDON • SURREY CR0 2QP

PHONE
 0181 684 1166

24 HOURS EXPRESS MAIL ORDER SERVICE ON STOCK ITEMS
 E-MAIL LANGREX@AOL.COM

FAX
 0181 684 3056

A selection of our stocks of New Original Valves / Tubes.
 Many other brands available.

STANDARD TYPES		SPECIAL QUALITY TYPES		AMERICAN TYPES		OTHER TYPES	
ECC83	E.I	A2900/CV6091	GEC	5R4GY	RCA	ECC81	RFT
ECC85	RFT	E88CC/CV2492	BRIMAR	5U4GB	SYLVANIA	ECC82	RFT
ECC88	BRIMAR	E88CC/CV2492	MULLARD	5Y3 WGT	SYLVANIA	ECC83	RFT
ECC88	MULLARD	ECC81/CV4024	MULLARD	6BX7GT	GE	EF86	USSR
ECH81	MULLARD	ECC81/M8162	MULLARD	6B4G	SYLVANIA	EL84	USSR
ECL82	MULLARD	ECC81/6201	MULLARD	6FQ7	SYLVANIA	EL34G	SOVTEK
ECL86	PHILIPS	ECC82/CV4003	MULLARD	6L6GC	GE/SYL	EL34	E.I
EF86	MULLARD	ECC82/M8136	MULLARD	6L6WGB	SYL	6SL7GT	USA
EL36	MULLARD	ECC83/CV4004	MULLARD	6SN7GTB	GE	6SN7GT	USA
EZ81	MULLARD						
EZ80	MULLARD						
GZ33/37	MULLARD						
5Z4G	BRIMAR						
6V6GT	BRIMAR						
12E1	STC						
13E1	STC						
807	HYTRON						
811A	RCA						
6080	MULLARD						

THESE ARE A SELECTION FROM OUR STOCK OF OVER 6000 TYPES. PLEASE CALL OR FAX FOR AN IMMEDIATE QUOTATION ON ANY TYPES NOT LISTED. WE ARE ONE OF THE LARGEST DISTRIBUTORS OF VALVES IN THE UK. SAME DAY DESPATCH VISA/ACCESS ACCEPTABLE. OBSOLETE TYPES A SPECIALITY.
 CREDIT CARD MIN ORDER £10.00.



OPEN TO CALLERS MON.-FRI. 9AM - 4PM. CLOSED SATURDAY
 U.K. P&P 1-3 VALVES £2.00, 4-6 VALVES £3.00 ADD 17.5% VAT TO TOTAL INC P+P. O'SEAS P & P PLEASE ENQUIRE



HI-FI WORLD
IHEX HOUSE,
THE PARK BUSINESS CENTRE,
KILBURN PARK ROAD,
LONDON, NW6 5LF

Web Site
www.hi-fiworld.co.uk

Subscriptions & Back Issues
9.30am - 2.30pm
+44 (0)1923 270833
e-mail: subs@hi-fiworld.co.uk

Private & Trade Classified Ads
+44 (0) 207 625 3134
Fax: +44 (0) 207 328 1844

Contact Numbers
9am - 5pm Mon - Fri

Editor
Nick Lucas
+44 (0)171 328 8387
nick@worldaudiodesign.co.uk

Sub Editor
John Marks

Design & Production Editor
Faiza Chunara
+44 (0) 207 625 3129
Fax: +44 (0) 207 328 1844
e-mail: ads@hi-fiworld.co.uk

Contributors
Richard White
Gary Devon

Advertising Designer
Faiza Chunara
+44 (0) 207 625 3129
Fax: +44 (0) 207 328 1844
e-mail: ads@hi-fiworld.co.uk

Production Editor/Photography
David Noble
+44 (0) 207 625 3134
e-mail: class@hi-fiworld.co.uk

Sales and Marketing Manager
Amanda Sweeney
+44 (0) 208 864 4760
Fax: +44 (0) 208 864 4780
e-mail:
amanda.sweeney@virgin.net

Accounts
Michael Ogazi
+44 (0) 207 289 3533
Fax: +44 (0) 207 328 1844

Credit Control
Louise Palfrey
+44 (0)1923 270833
Fax: +44 (0)1923 270833
e-mail: subs@hi-fiworld.co.uk

Publisher
Noel Keywood
WORLD AUDIO DESIGN
Technical Manager
Nick Lucas
Tel/Fax: +44 (0) 207 625 8032
e-mail: nick@worldaudiodesign.co.uk
website: worldaudiodesign.co.uk

Distributed by
Comag Magazine Marketing,
Tavisstock Road, West Drayton,
Middlesex UB7 7QE
Tel: +44 (0)1895 444 055

Printed by
Southernprint, Dorset
Tel: +44 (0)1202 622 226

All unsolicited submissions are made at the owner's risk. We accept no responsibility for such submissions, nor do we undertake to return them.

No material may be reproduced from this magazine without the publisher's written permission.
© Audio Publishing Ltd

ALL RIGHTS to the designs are reserved by World Audio Publishing Ltd. They are published for single use by private individuals. They are not to be used for commercial gain without prior permission from World Audio Publishing Ltd.

World Audio Publishing Ltd accept no responsibility for accident or injury arising from the construction or use of any of the designs published. All of the projects in this supplement have gone through rigorous listening and test procedures. The performance and specification of these projects can only be guaranteed on kits bought directly from World Audio Publishing Ltd.

diy supplement/contents

No51



NEWS	5
<i>Our newshounds scour the world of the DIYer in search of tasty news morsels.</i>	
PRE-PARATION	7
<i>Nick Lucas sets the scene for the arrival of our new three-box pre-amp, which offers high-end sound without damaging your bank balance.</i>	
MASTER CLOCK WORK	11
<i>Jon Marks tries a little CD surgery with replacement master clocks from Acoustic Precision and Daniel Espley, one of our readers.</i>	
BOOK REVIEW	17
<i>ROBERT CHARLES ALEXANDER - The Life and Works of Alan Dower Blumlein</i>	
WEBSITE LAUNCH	18
<i>Presenting www.worldaudiodesign.co.uk</i>	
TONING UP	19
<i>Doing the DIY thing for most hi-fi components means simply a bag of bits, a spot of solder or a little woodwork. However, building a tonearm is tougher. In this article, Richard White shows you how to design one of your own.</i>	
DIY LETTERS	21

Watford Valves

7 DAYS A WEEK 9AM - 9PM THE AUDIOPHILES CHOICE

All output valves multi-tested and digitally matched

Full no quibble guarantee. Expert advice on all valve amps

		£			£
ECC81	Philips	5.00	GZ32	Harma	9.00
ECC82	Philips	5.00	GZ32	Philips	25.00
ECC83	Philips	6.00	GZ34	Harma	8.00
ECC83	RFT	8.00	KT66	Harma	25.00
ECC83	Tungstram	15.00	KT66	GEC	80.00
ECC803S	Tesla	20.00	KT88	Sovtek	20.00
E83CC	Siemens	25.00	KT88	Svetlana	32.00
ECC85	RFT	5.00	300B	JJ/Tesla	68.00
ECC88	Siemens	20.00	5687WB	Philips	5.00
E88CC	Tesla	6.00	5881WXT	Sovtek	5.00
ECL85	Polam	5.00	6550C	Svetlana	18.00
ECL86	Harma	6.50	6550WE	Sovtek	16.00
EF80	Mazda	5.00	6AU6WC	Philips	3.50
EF86	Tesla	10.00	6B4G	Sovtek	28.00
EL34WXT	Sovtek	6.00	6C33C-B	Russian	28.00
EL34EH	Sovtek	10.00	6CG7	EI	8.00
EL34	Svetlana	8.50	6CG7	GE	14.00
E34L	JJ/Tesla	8.50	6GK5	GE	7.00
EL84	Sovtek	4.50	6L6GC	Svetlana	12.00
E84M	Russian	6.00	6SL7GT	Sylvania	8.00
EL84	Philips	15.00	6SN7GT	Tungsol	18.00
EL519	Tungstram	9.00	7119	Amperex	12.00
EL519	EI	12.00	7199	G.E.	15.00
EZ81	Tesla	7.00	12AX7LPS	Sovtek	8.00

SOVTEK EL34EH

By using a special tri alloy plate material Sovtek have eliminated the odd order harmonics resulting in tighter bass and smoother treble. This valve is now comparable with the famous Mullard making it an instant upgrade at only £10 each.

NEW SOVTEK 2A3

For triode lovers the new Sovtek 2A3 has received rave reviews in America. It is praised for its superb sonic purity and large sound stage. They are now in stock and we consider this a great value tube at £18 each.

WATFORD VALVES 3 RYALL CLOSE,
BRICKET WOOD, ST ALBANS, HERTS AL2 3TS



01923 893270

Fast mail order/next day delivery/World Wide shipping
1000's more valves stocked. Prices exclude VAT and carriage.

Fax: 01923 679207

www.watfordvalves.com



Lockwood Audio

SPEAKER MANUFACTURERS'
SURPLUS DRIVERS

Examples:

25mm	Tweeters	Soft or Anodised
110mm	ICT;MF; Bass	
120mm	Bass/Mid	Shielded
135mm	Bass/Mid	
165mm	Mid;Bass/Mid	
172mm	Bass Long throw	
200mm	Bass;Mid/Bass*	
386mm	Bass	
Various	Ellipticals	
4/6/8/16 ohm		pressed/cast/moulded frames

Crossovers: Termination Panels:Spikes & sockets etc.

*as used in HI FI WORLD Horn Enclosure !

AT A FRACTION OF ORIGINAL COST

Phone Fax email for details

Lockwood Audio

email: sales@lockwood-audio.co.uk

Unit 8, 724 Field End Road, Ruislip, Middlesex, HA4 0QP
Phone +44 (0)20 8864 8008 Fax: +44 (0)20 8864 3064
credit & debit cards welcome



BRITISH SUB BASS
OMP 100 WATT SUB BASS
Loudspeaker Amplifier
Panel. WWW.BKELEC.COM/SUB.HTM



Ideal for
building
Audiophile
and Home
Theatre
subwoofer
loudspeaker
Projects

FEATURES:- *100W R.M.S. into 8 ohm *High and Low Level Input *Toroidal Transformer *Short Circuit Protection *D.C. Speaker Protection *Frequency Roll Off, Lower 10Hz, Upper 60Hz to 240Hz(Fully Adjustable) *AC3 Compatible Filter can be by passed for 5-1 Formats. *Airtight Construction *Tens of Thousands of our panels already in use. *Complete with Leads
SPECIFICATION:-*Power 100W RMS @ 8 ohms*F.Resp 10Hz-15KHz -3dB *Damping Factor >200 *Distortion 0.05% *S/N A Weighted >100dB *Supply 230V. A.C. *Weight 2.7Kg *Size H254 W254 D95mm

The above item may be ordered by post, fax, e-mail or phone and payment is welcome by cheque or credit card. **PRICE: £117.44 + £5.00 P&P incl VAT**

B.K.ELECTRONICS
UNIT 1 COMET WAY
SOUTHEND-ON-SEA
ESSEX SS2 6TR

Web: <http://www.bkelec.com>
E-mail: Sales@bkelec.com
TEL: 01702-527572
FAX: 01702-420243



A TOUCH OF GLASS



**Electro-Harmonix
6V6EH**

Another twist to the design consists of a heater twisted into a spiral, which is claimed to reduce leakage between it and the

History can be a fickle thing. Just as turntables and the LP were once supposed to be on the verge of extinction, so it was too with the valve, and yet new and improved versions of classic types are still appearing regularly. This month sees two such tubes released by Sovtek and Electro-Harmonix, a pair of firms under the New Sensor corporate umbrella.

Sovtek's latest is the 12AX7LPS, the 'LP' suffix standing for Large Plate. Taking a lead from respected predecessors like the Telefunken and Mullard 12AX7s, Sovtek say that increasing the size of the plate gives a smoother, more linear performance.

cathode, thereby lowering noise created by AC heaters. For more information, pay a visit to Sovtek's website at: www.sovtek.com.

Electro-Harmonix' contribution to the thermionic cannon is the 6V6EH 'Super Tube'. Aimed mainly at musicians plugging into vintage amps, the 6V6EH has been crafted to take a full 475volts of HT and provide a sweeter tone thanks to lower odd-order harmonics. E-H have achieved this by using a secret-recipe cathode coating, carefully aligning the grids and employing 6550-grade tri-alloy plate material. If that little lot hasn't sated your curiosity, the Electro-Harmonix website is at: www.ehx.com



Sovtek 12AX7LPS

New Sensor Corporation
20 Cooper Square,
4th Floor,
New York
NY10003
Tel: (212) 529 0466

HIGH-END CROSS-OVER INDUCTION COILS

No chain is stronger than its weakest link. This is especially so with loudspeakers, where there is often a cost reduction

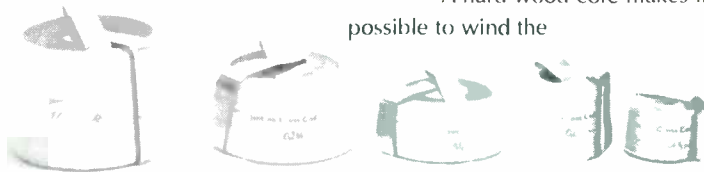

for the crossover inductors. High-End loudspeaker manufacturers overcome this problem by using foil coils where the copper is flat instead of round. And why is this an advantage?

We know that with a rising frequency the electrons will reach for the surface. This phenomenon is known as power distortion, and that is why a larger surface is preferred.

The small value Cross Coil are from 0.01 mH to 0.05 mH, ideal for digital

amplifiers. Larger Cross Coils range from 0.01mH to 12.0 mH.

The disadvantage of foil inductors have, until now, been the price. But with Jantzen Audio's new production methods and special constructed machinery the costs have been greatly reduced. Every single Jantzen Cross Coil goes through specially developed Jantzen Anti-oxidant treatment and measurement, which guarantee a life long top performance.

A hard-wood core makes it possible to wind the

coils extra close. This results in very low magneto shrinking factor and virtually zero FM distortion. This is very close to the "ideal inductor" in all respects. The tolerance is +/-3% where the normal industry standard is set at +/-5%. Copper purity is 99.99%.

This product is also an eminent opportunity to upgrade an existing loudspeaker system.

For more info look at:
www.jantzen-audio.com

MAP READING

As well as being April Fool's day, the 1st of said month also heralds the arrival of the latest issue of Maplin's chunky catalogue. Supplied in both traditional paper and new-age CD-ROM formats, the new product line-up comes with £50 of vouchers and better photography. For on-line info, the place to be is: www.maplin.co.uk, while dialling 01702 554000 will put you in touch telephonically.

Maplin Electronics
PO Box 777
Rayleigh
Essex SS6 8LU



Ansar Supersound Polypropylene Axial Capacitor



Audio specific. For transparent & detailed sound with EXTREMELY low distortion. High purity imported metallised polypropylene Tol 5%

Part no.	Description	L x D mm	Price
CPW100N	Ansar 100nF 630V	32 x 6.5	1.60
CPW150N	Ansar 150nF 630V	32 x 7.5	1.60
CPW220N	Ansar 220nF 630V	32 x 9.0	1.60
CPW330N	Ansar 330nF 400V	32 x 8.0	1.60
CPW470N	Ansar 470nF 400V	32 x 9.0	1.80
CPW680N	Ansar 680nF 400V	32 x 10.5	1.80
CPW110U	Ansar 110uF 400V	32 x 12.5	1.80
CPW115U	Ansar 15uF 400V	32 x 14.7	1.80
CPW2U2	Ansar 2.2uF 400V	43 x 14.8	1.80
CPW3U3	Ansar 3.3uF 400V	43 x 17.6	2.20
CPW4U7	Ansar 4.7uF 400V	43 x 20.7	2.50
CPW6U8	Ansar 6.8uF 400V	43 x 22.8	3.00
CPW8U0	Ansar 8uF 400V	43 x 26.5	4.00
CPW10U	Ansar 10uF 400V	43 x 29.5	4.00
CPW15U	Ansar 15uF 400V	55 x 34.1	5.50
CPW22U	Ansar 22uF 400V	55 x 39.3	7.00
CPW25U	Ansar 25uF 400V	55 x 42.0	7.50
CPW30U	Ansar 30uF 400V	55 x 44.7	8.50
CPW50U	Ansar 50uF 400V	83 x 46.0	11.50
CPW60U	Ansar 60uF 400V	83 x 51.7	13.50
CPW75U	Ansar 75uF 400V	83 x 55.1	19.00
CPW80U	Ansar 80uF 400V	83 x 56.8	19.50
CPW100U	Ansar 100uF 400V	115 x 55.2	20.00
CPW125U	Ansar 125uF 400V	115 x 60.9	26.00

Dual Polypropylene Smoothing Capacitors

To replace old electrolytics or for new designs. Wire tails.

Part no.	Description	L x D mm	Price
CPW1616	Propyl 16-16 400V	100 x 50	25.00
CPW3232	Propyl 32-32 400V	115 x 61	30.00

Philips Polypropylene Axial 1%

Blue coated Film & Foil. Epoxy coated, low inductance metal foil & film. Supremely stable. Tolerance 1%

Part no.	Description	Price
CPW47P	Propax 47pF 630V	0.40
CPW100P	Propax 100pF 630V	0.40
CPW150P	Propax 150pF 630V	0.35
CPW220P	Propax 220pF 630V	0.35
CPW330P	Propax 330pF 630V	0.35
CPW470P	Propax 470pF 630V	0.35
CPW680P	Propax 680pF 630V	0.35
CPW1N0	Propax 1nF 400V	0.45

CPP1N5	Propax 1.5nF 250V	0.45
CPP2N2	Propax 2.2nF 250V	0.45
CPP3N3	Propax 3.3nF 250V	0.45
CPP4N7	Propax 4.7nF 160V	0.50
CPP6N8	Propax 6.8nF 160V	0.50
CPP10N	Propax 10nF 63V	0.65
CPP22N	Propax 22nF 63V	0.75
CPP33N	Propax 33nF 63V	1.10
CPP47N	Propax 47nF 63V	1.30

Audio Electrolytics Radial 105 deg C +PLUS- low impedance.

These superior electrolytics offer a low impedance path to the signal, resulting in a very open & detailed sound. The use of high temperature materials ensures that these capacitors enjoy a long & stable life.

Part no.	Description	Price
1150	Lo Imp Hi Temp 1uF 50V	0.25
202Y50	Lo Imp Hi Temp 2.2uF 50V	0.25
407Y100	Lo Imp Hi Temp 4.7uF 100V	0.25
10Y63	Lo Imp Hi Temp 10uF 63V	0.25
22Y63	Lo Imp Hi Temp 22uF 63V	0.30
47Y63	Lo Imp Hi Temp 47uF 63V	0.35
100Y63	Lo Imp Hi Temp 100uF 63V	0.50
220Y50	Lo Imp Hi Temp 220uF 63V	0.75
470Y63	Lo Imp Hi Temp 470uF 63V	1.25
1000Y35	Lo Imp Hi Temp 1000uF 35V	1.50
2200Y50	Lo Imp Hi Temp 2200uF 50V	2.25
4700Y25	Lo Imp Hi Temp 4700uF 25V	2.50

Trobo High Ripple Reservoirs

Excellent for Audio. Long life. High reliability 100VDC caps with screw terminals

Part no.	uf/Voltage	Price
10000C100	10000uf 100V	20.00
22000C100	22000uf 100V	30.00

Alcap Bipolar Electrolytics

Axial leads 50V Tol. 10%

Primarily for use in speaker crossovers.

Part no.	Description	Price
CAB1	Alcap 1uF	0.25
CAB2U2	Alcap 2.2 uF	0.40
CAB3U3	Alcap 3.3uF	0.40
CAB4	Alcap 4uF	0.40
CAB5	Alcap 5uF	0.40
CAB6U8	Alcap 6.8uF	0.50
CAB8	Alcap 8uF	0.50
CAB10	Alcap 10uF	0.50
CAB16	Alcap 16uF	0.65
CAB20	Alcap 20uF	0.65
CAB25	Alcap 25uF	0.65
CAB35	Alcap 35uF	0.65
CAB50	Alcap 50uF	0.75
CAB60	Alcap 60uF	0.85
CAB80	Alcap 80uF	1.00
CAB100	Alcap 100uF	1.10

Monacor Air Cored Inductors.

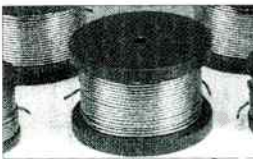

A range of professional air cored inductors for 80 or 40 crossovers/filters for use up to 300W. 1.2mm enamelled copper wire wound on air spaced plastic bobbins

Part No.	Specification	Price
#15	150uH 0.15 Ohm 8x19mm	£2.00
#22	220uH 0.15 Ohm 48x19mm	£2.50
#33	330uH 0.20 Ohm 8x19mm	£3.00
#47	470uH 0.25 Ohm 50x19mm	£3.50
#68	680uH 0.35 Ohm 59x19mm	£4.50
#100	1mH 0.40 Ohm 59x19mm	£5.50
#150	1.5mH 0.50 Ohm 70x30mm	£6.50
#220	2.2mH 0.60 Ohm 70x30mm	£8.00
#330	3.3mH 0.75 Ohm 70x30	£10.00

Monacor Ferrite Inductors



A range of professional high efficiency ferrite cored inductors with very low ohmic losses for 80 or 40 crossovers or filters for use up to 400W. 1.4mm enamelled copper wire (1.3mm on F1000) wound on plastic bobbin.

Part No.	Specification	Price
F220	2.2mH 0.15 Ohm 400W	£6.50
F330	3.3mH 0.20 Ohm 330W	£9.50
F470	4.7mH 0.25 Ohm 140W	£11.00
F680	6.8mH 0.35 Ohm 120W	£12.00
F1000	10mH 0.45 Ohm 100W	£13.50

High Quality Valves

Part No.	Description	Price
6550C	OUTPUT VALVE	£26.00
6L6GT	OUTPUT VALVE	£4.50

6SN7GT	OUTPUT VALVE	£4.50
6V6GT	OUTPUT VALVE	£3.95
ECC81	TRIODE	£4.50
ECC82	TRIODE	£4.50
ECC83	TRIODE	£4.50
EF86	LOW NOISE PENTODE	£9.50
EL34	OUTPUT VALVE	£8.50
EL84	OUTPUT VALVE	£3.50
GZ34	RECTIFIER	£6.50
KT88	OUTPUT VALVE	£20.00

Valve Holders - High Quality Valve Bases. Chassis Mounting With Screw Fittings.

Part No.	Description	Price
B9AC	B9A VALVE HOLDER CERAMIC	£1.50
B9AG	B9 VALVE HOLDER PORCELAIN PLUS GOLD PLATED PINS	£3.00
OCTC	OCTAL VALVE HOLDER CERAMIC	£2.00
OCTG	OCTAL VALVE HOLDER PORCELAIN PLUS GOLD PLATED PINS	£4.00

Fully Gold Plated Phono (RCA) Plugs with spring coil cable grip.



Part No.	Description	Price
PPG5A2	PAIR GOLD PLUGS for up to 5mm CABLE	£1.50 pair
PPG8A2	PAIR GOLD PLUGS for up to 8mm CABLE	£1.50 pair

Very High Quality Phono (RCA) Plugs



Part No.	Description	Price
6550C	OUTPUT VALVE	£26.00
6L6GT	OUTPUT VALVE	£4.50

Very high quality satin grey metal with heavy gold plated connections. Top collet cable grip & PTFE insulators. Very low noise.

Part No.	Description	Price
PPG6H2	GOLD PTFE PLUGS for up to 6mm CABLE	£3.50 pair
PPG8H2	GOLD PTFE PLUGS for up to 8mm CABLE	£3.50 pair

Extra High Quality Gold Plated Phono Oxygen Free (RCA) Leads (pairs)



Highly flexible oxygen free cable with extra moulded in control / grounding wire

Part No.	Length/Colour	Price
LPP1GG	0.8 Metres/Green	£5.50
LPP2GG	1.5 Metres/Green	£6.50
LPP5GG	5 Metres/Green	£11.00

Bass Reflex Tuning Ports



A range of adjustable plastic ports for use in various sizes of loudspeaker cabinets. d=diameter L=adjustable length (mm)

Part No.	Dimensions	Price
R35	d=35L=110-210	£2.50
R50	d=50L=150-280	£3.50
R70	d=70L=120-245	£3.50
H100	d=110L=160-122	£9.50
R85	d=85 angled 45° for narrow cabinetsL=210-310	£6.50

High Quality Components at the right price. Please add £3.00 carriage + VAT to all orders. Credit Card phone orders accepted.

Cricklewood Electronics Ltd, 40 & 42 Cricklewood Broadway, London NW2 3ET. Tel: 0208 452 0161 Fax: 0208 208 1441



Vacuum Tubes for Audio Are Back!

Glass Audio brings together yesterday's tube with today's improved components, voltage control, and the exciting new Soviet tubes, to make smooth sound in your livingroom possible again!

YES!

Please send my first issue of *Glass Audio*. I'll pay just \$45.00 for six issues (1 year); \$80.00 for 12 issues (2 years) of the best information on tubes to be found anywhere. I understand that my satisfaction is guaranteed!

Name _____

Street & Number _____

City _____ Postal Code _____

Country _____

REMIT IN US \$ DRAWN ON A US BANK ONLY. PRICE GOOD THROUGH DECEMBER 31, 1995.

We Accept MC/VISA.

Glass Audio

PO Box 176, Dept. HFWS, Peterborough, NH 03458-0176 USA
Phone: (603) 924-9464 or FAX 24 hours a day (603) 924-9467

TRIPLE WHAMMY

Nick Lucas and Gary Devon introduce the latest addition to HFW's kit family, a high-performance, three-box valve pre-amplifier.

Anachronistic we may be, but then we're not the only ones. Judging from letters and conversations at hi-fi shows, plenty of our readers fly the valve flag rather than the transistor one. This isn't a problem-free allegiance, though, as getting the most from the beloved bottle can be a real design challenge, especially when you're concerned with phono stages.

One problem we had to overcome during the development of our KLPP1 line/phono pre-amp was how to keep the noise and hum levels down. This was a difficult proposition considering the phono stage has a gain of 1300 and the power supply unit and signal circuitry are housed in the same case. The solution we opted for was to use a highly-regulated supply for both the HT line and heaters. This time, we've decided to go all the way and house the PSU, pre-amp and phono stages in their own dedicated cases.

The beauty of this system is that noise and hum are kept to extremely low levels. There is more than enough room inside for the space-hungry valve circuitry too, and if you don't use a turntable, you only need shell out for the PSU and the line stage. (On the other hand, if you only want to upgrade your existing cartridge amp, you'll need just the PSU and phono stage).

STYLUS MAXIMUS

Kits have to look as good as they sound now – it's no longer acceptable for an amp to sound superb but resemble a ploughing implement or a metal breeze-block. After the success of our stylish KiT88 and KaT88 integrated/power amps, we chose similarly svelte casework for our

new pre, adopting the 6mm silver-anodised fascia and chrome knobs of the 88 series. The chassis top features staggered cooling vents which are not only highly effective but very eye-catching as well. The final touch is a blue LED power indi-

they're unlikely to come loose thanks to their twist-and-lock action.

THE INS AND OUTS

Common to all modules is an earth post at the rear of the chassis. Both the line and phono sections utilise gold-plated RCA sockets ready-equipped with insulation (no need for M6 fibre washers

this time). The former's six inputs are controlled by a fascia-mounted selector switch and joined by a single tape loop, activated by the

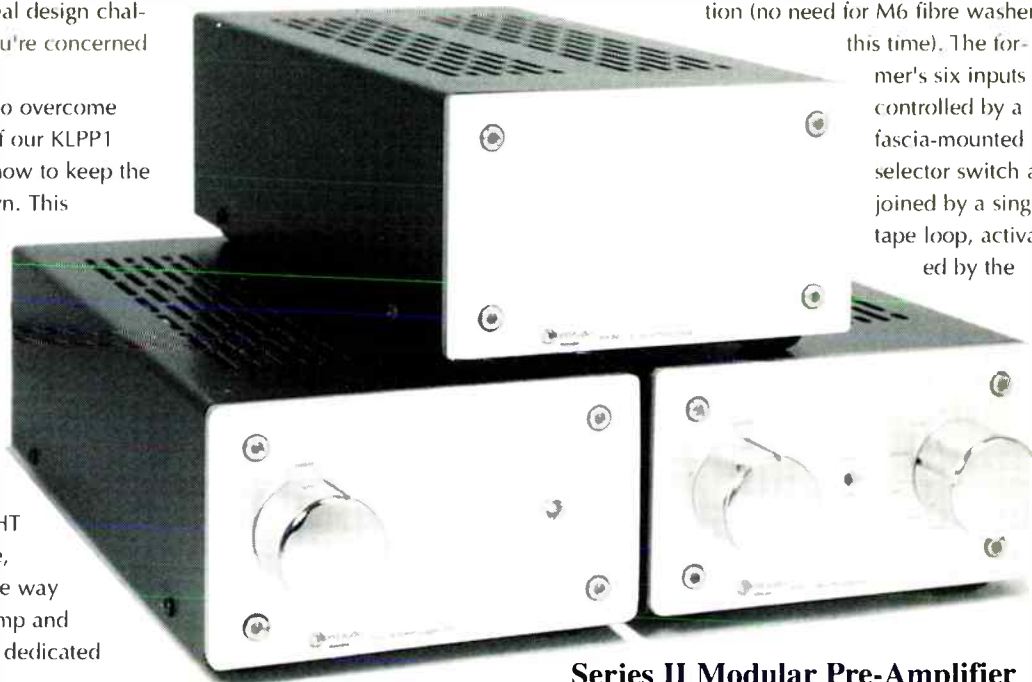

Series II Modular Pre-Amplifier

cator on the PSU module.

THE CABLE BUY

The National Grid's product enters the PSU module via the customary IEC lead. The next question was how to feed the power on into the line and phono stages given that both require different HT voltages. Step forward detachable umbilical cabling, which will allow you to pick up one module without the rest following off the shelf.

After an extensive search for a suitable plug and socket, we arrived at a new pairing. The Clifcon connectors from Cliff Electronics offer a high voltage and current rating on their four gold-plated pins to suit both the HT and heater lines. And

Tape/Source switch. There are two pairs of outputs to enable bi-amping.

The Phono module offers phono in and phono out. All MC users will need a pair of step-up transformers (available from us at £49 per pair) if they want to interface their favourite pick-up with this pre. Otherwise, the phono module is suitable for any MM cartridge.

BOARD GAMES

Owing to the importance of the layout of valve circuitry (particularly where the gain is very high) and the large numbers of components, we have employed PCBs throughout the pre-amp, which makes the Series II fairly easy to construct. The build procedure for the kit will be discussed fur-

**SERIES II
PHONO-STAGE
MODULE
CIRCUIT DIAGRAM**
SIGNAL CIRCUIT
(ONE CHANNEL)

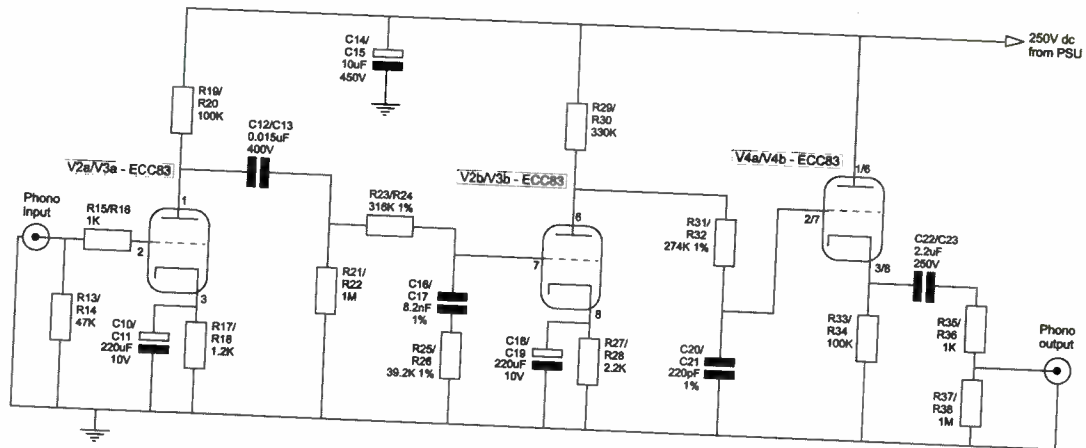

V2V3V4 - ECC83

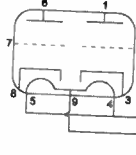

Views are from underneath valve or valve holder
h = heater hct = heater centre tap c = cathode a = anode nc = no connection

ther in the second part of this article (see August 2000's Supplement No.52), as will be the delicious sound of these magic boxes. Now, it's over to Gary Devon, our designer, for a word on the circuit itself.

SERIES II PHONO MODULE

The phono stage uses three ECC83 sections per channel for amplification and output buffering. The first two valve sections of each channel (V2a/V3a) and (V2b/V3b) provide the necessary gain. The final stage of each channel (V4a/V4b) is used as a cathode-follower buffer, which reduces high-frequency signal loss due to the capacitance of the interconnect cable between phono and line amp sections. The RIAA equalisation is performed in two separate stages - first low then high-frequency compensation is applied. V2a/V3a, the input section, is connected as a conventional amplifying stage with its associated anode and bias resistors. This is then AC coupled to the first equalisation stage (formed by R23/R24, R25/R26

and C16/C17), which includes the output impedance of the first amplifying stage. This EQ circuitry provides the low-frequency time constants of 318 and 3180 microseconds.

Coupling capacitor C12/C13 can be chosen to introduce an extra degree of bass roll-off to reduce the amplitude of sub-sonic signals. As it stands, the roll-off is set to -3dB at approximately 10Hz. A value for C12/C13 of 8.2nF or 3.9nF would set this to 20Hz or 40Hz respectively. Personally I prefer to set the limit to around 10Hz, otherwise the bass begins to sound thin and light.

The next amplification stage, formed by V2b/V3b, is again conventional, but here the output is DC coupled to the EQ network and to the output cathode follower. The EQ network R31/R32 and C20/C21 (plus the output impedance of the preceding stage) produces the necessary 75 microsecond HF compensation. The cathode-follower buffer has been added to interface the high-impedance

circuitry with the outside world. An ECC83 used in this way couldn't drive a long cable due to its low operating current, and it wouldn't make a very good line stage, but it performs superbly as a buffer where the load is easy to drive.

SERIES II LINE MODULE

The line stage is a little different from the norm as it's transformer coupled. A big problem with valve pre-amps is the inability of the line stage to drive a low-impedance load, whether this is formed by the input resistance of the following power amplifier or the parasitic capacitance of a long length of cable. All single-stage line pre-amps are phase inverting as well, an inherent characteristic of the anode follower. If a cathode follower is used, phase accuracy is maintained but there is no gain. Some manufacturers have resorted to using far more complex circuitry in order to achieve a decent drive capability. One pre-amp even has a plethora of ECC88 sections in parallel to reduce the

output impedance, which quite frankly is a very inelegant solution. The circuitry of the Series II is very simple - basically one half of an ECC88 or 6922 is used per channel. This is a superb valve as long as it is used properly; it doesn't like very high voltages on its anode, so here 100V is used. The mu of the 6922 is approximately 32, and as the transformer offers the valve a very high impedance load, most of this gain is available for use. The step-down ratio of the transformer is 6:1, thereby giving an overall gain of approximately 5. The grid of the 6922 is connected to the volume control, and there's selector switching of sources in the usual manner.

SERIES II PSU MODULE

There's nothing unusual about the Series II's Power Supply Unit. Four low-noise diodes take care of rectification before handing over to reservoir capacitors. The first stage of smoothing is performed by L1 and C2, which remove most of the ripple. The line stage draws its power from a zener-stabilised 100V rail. The phono stage's HT line is further smoothed by R5 and C4 to bring the ripple down to the very low levels necessary for a phono stage. The heater supply is elevated on a DC potential to protect the cathode-follower section of the phono stage. This is accomplished through a potential divider network, R2 and R3, on the HT power supply.

**SERIES II
PRE-AMPLIFIER
MODULE
CIRCUIT DIAGRAM
SIGNAL CIRCUIT
(ONE CHANNEL)**

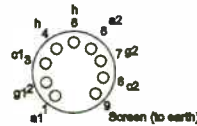
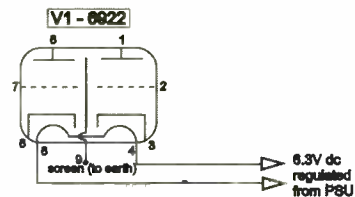
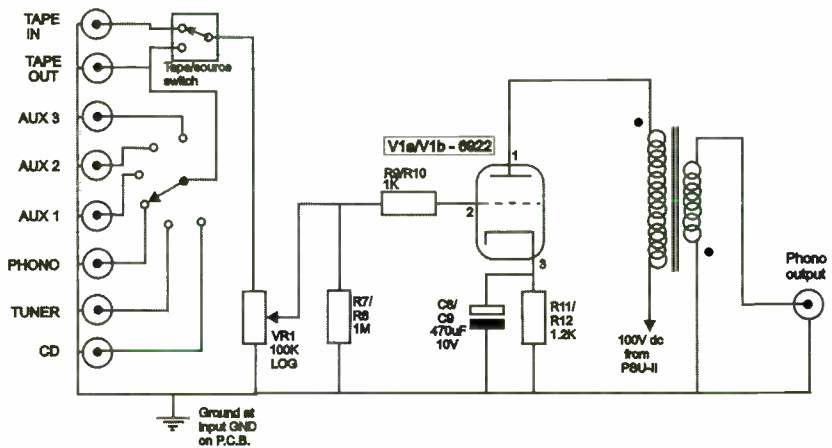

Views are from underneath valve or valve holder
h = heater c = cathode a = anode g = grid nc = no connection

**SERIES II
POWER SUPPLY UNIT
MODULE
CIRCUIT DIAGRAM
(SUPPLY COMMON TO
BOTH CHANNELS)**

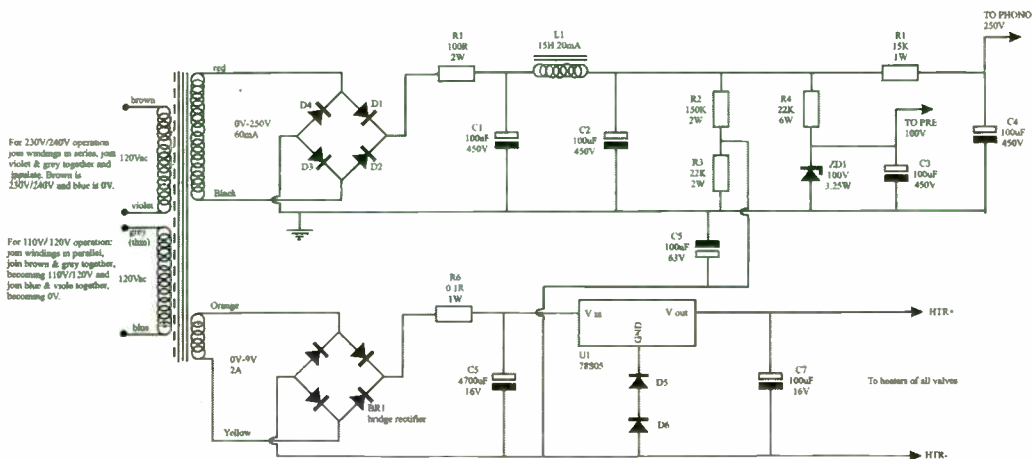

PARTS LIST FOR SERIES II PSU MODULE

RESISTORS

R1 100R, 2W	1
R2 150K, 2W	1
R3 22K, 2W	1
R4 22K, 6W	1
R5 15K, 1W	1
R6 0.1R, 1W	1

CAPACITORS

C1 100uF, 450V	1
C2 100uF, 450V	1
C3 100uF, 450V	1
C4 100uF, 450V	1
C5 100uF, 63V	1
C6 4700uF, 16V	1
C7 100uF, 16V	1

DIODES / BRIDGE RECTIFIERS/ VOLTAGE REGULATOR

D1, BYV96E	1
D2, BYV96E	1
D3, BYV96E	1
D4, BYV96E	1
D5, 1N4001	1
D6, 1N4001	1
BR1, KBU4K	1
U1, 78SO5	1
heatsink	1

TRANSFORMERS

mains transformer	1
L1 15H, 20mA	1

HARDWARE

power switch	1
Cliffcon socket	2
Cliffcon plug	4
IEC mains socket	1

IEC leads	1
fuse 500mA	1
FEET	4
wire	assorted
M4 x 10 screw	2
M4 nut	2
transformer fittings	1
M3 x 6 screws	12
M3 x 10 standoff	4
M3 fibre washers	8
M4 x 12 hex screw	4
terminal pins	10
LED	1
KNOBS (chrome)	1
PHONO CHASSIS	1
PHONO FRONTPLATE	1
PCB	1

PARTS LIST FOR SERIES II PHONO MODULE

RESISTORS

R13/14	47K, 0.5W	2
R15/16	1K, 0.5W	2
R17/18	1.2K, 0.5W	2
R19/20	100K, 0.5W	2
R21/22	1M, 0.5W	2
R23/24	316K, 1% 0.25W	2
R25/26	316K, 1% 0.25W	2
R27/28	2.2K, 0.5W	2
R29/30	330K, 0.5W	2
R31/32	274K, 0.5W	2
R33/34	100K, 0.5W	2
R35/36	1K, 0.5W	2
R37/R38	1M, 0.5W	2

CAPACITORS

C10/11	220uF 10V	2
C12/13	0.015uF 400V	2
C14/15	10uF 450V	2
C16/17	8.2nF 1%	2
C18/19	220uF 10V	2
C20/21	220pF 1%	2
C22/23	2.2uF 250V	2

HARDWARE

SELECTOR	1
BLK PHONOS	2
RED PHONOS	2
Cliffcon socket	1
earth post	1

FEET	4
wire	assorted
M3 x 6 screws	12
M3 x 10 standoff	4
M3 fibre washers	8
M4 x 12 hex screw	4
B9A PCB mount valve base	3
terminal pins	10
PHONO CHASSIS	1
PHONO FRONTPLATE	1
PCB	1
ECC83	3
*step up transformers	2
*Please add £49 to cost for one pair	

PARTS LIST FOR SERIES II PRE AMP MODULE

RESISTORS

R7/8	1M, 0.5W	2
R9/10	1K, 0.5W	2
R11/12	1.2K, 0.5W	2
VR1	100K LOG POT	2

CAPACITORS

C8/9	470uF 10V	2
------	-----------	---

HARDWARE

driver transformer	2
selector	1
tape/source switch	1
black phono insulated sockets	10
red phono insulated sockets	10
Cliffcon socket	1
earth post	1
feet	4
wire	assorted
grub screw	1

M3 x 6 screws	12
M3 x 10 standoff	4
M3 fibre washers	8
M4 x 12 hex screw	4
B9A PCB mount valve base	1
terminal pins	10
KNOBS (Chrome)	2
PHONO CHASSIS	1
PHONO FRONTPLATE	1
PCB	1
6922 valve	1

**The Series II Modular Pre-amp Kit is available as a kit from Hi-Fi World
(available from June 30th 2000)**

	UK (inc. vat & p&p)	Overseas (exc. vat & p&p)
Power Supply Unit (PSU-II)	175.00	150.00
Pre-amplifier (PRE-II)	175.00	150.00
Phono Stage (PHONO-II)	100.00	85.00
Moving coil step-up transformer	49.00	42.00

**Call or fax Nick Lucas on: +44 (0) 207 328 8387 (9am-5pm, Monday-Friday) orders@worldaudiodesign.co.uk
For overseas freight charges, please call, fax or e-mail.**

IT'S HIP TO BE SQUARE

Iron-wielder Jon Marks continues his search for superior CD sound with Acoustic Precision's master-clock upgrade, and tries out a DIY solution from Daniel Espley

SEE SAW

If the main bug-bear of analogue for most users (especially those on the professional side of the fence in studios) is noise, then the corresponding weak point in digital's performance is timing. We're not talking here about the kind of timing that keeps feet tapping (even if the silver disc is often acknowledged to be less than perfect in this respect). Instead, the subject under examination is the very heart of digital audio electronics, the master clock. This high-frequency quartz oscillator synchronises the operations of all the various digital circuits and ensures that all the '0s and 1s' arrive at their destinations exactly when they're supposed to.

Well, the theory looks fine and dandy, but in the real world things don't run quite so smoothly. The ideal master clock would produce a pure square wave, the spacing between each of the peaks or troughs identical every time. Take a squint at your average clock output through an oscilloscope, however, and you'll most likely find a range of traces from the vaguely square-like to simply saw-tooth. On top of that, noise will roughen the trace and further degrade the signal. And these problems effect expensive machines just as much as cheaper components.

THE JITTER BUG

The timing errors caused by mediocre master clocks are called 'jitter'. This term has been around for a good few years now, and yet the quality of the clocks in most commercial players remains unim-

pressive (in spite of the fact that a useful tidy-up of the timing signal would add very little to a product's budget).

This is where replacement clocks such as Acoustic Precision and AudioCom's come in. They have been designed to output a square wave as free from noise and

The main PCB bears a large, low-profile crystal and a pair of surface-mount chips. Mounted on a tiny daughter board is a high-speed regulator said to minimise phase noise, thereby reducing jitter. Apparently, a lot of time and effort went into optimising the PCB's layout in order

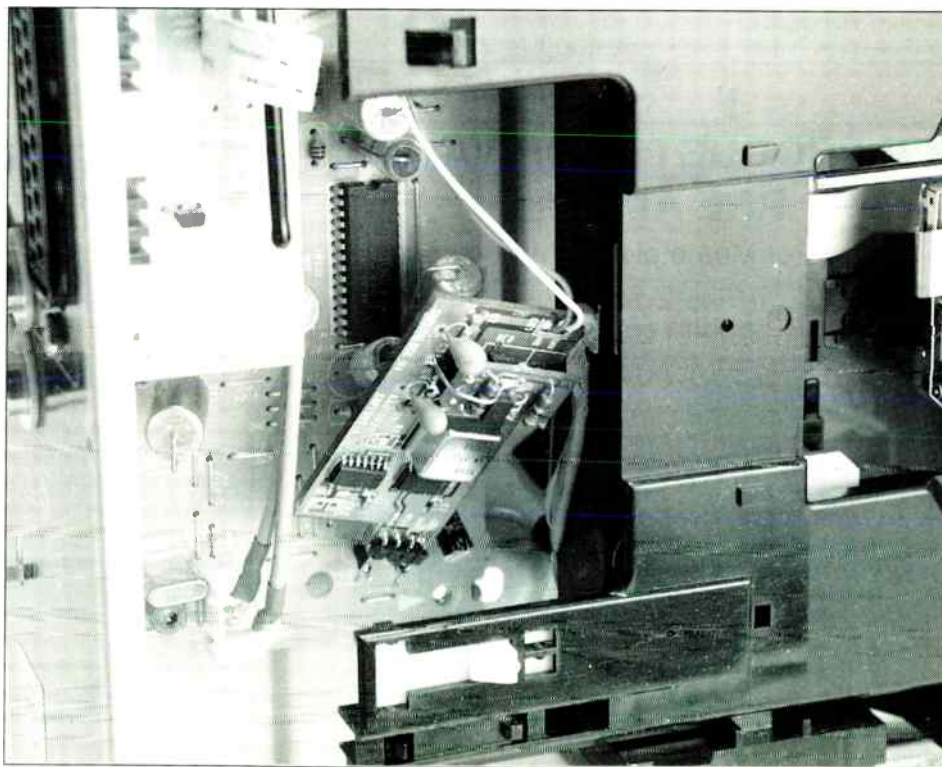

Acoustic Precision's Super Clock 4 fits easily behind the DV-505's transport

jitter as possible. In addition to these two, one of our readers, Daniel Espley, has sent in his own DIY clock, which is both cheap and easy to put together.

ACOUSTIC PRECISION SUPERCLOCK 4

Although it shares its nomenclature with AudioCom's clock (reviewed in the last Supplement), Acoustic Precision's device is a more petite but less crowded affair.

to reduce RF emission, and this seems to have paid dividends.

AERIAL VIEW

One problem encountered when you're working with the sort of very high frequencies found in digital equipment is that even very short pieces of wire or track will act as aerials, spraying RF frequency interference all over th

Falcon Acoustics Ltd

Falcon Electronics, Basically Sound

<http://www.falcon-acoustics.co.uk>

DRIVE UNITS: by FOCAL & Seas, and a pick of the best from other manufacturers.
100+ CROSSOVER NETWORKS: - Active & Passive, Components, Accessories,

COMPONENTS

SOLEN Polypropylene capacitors, 0.1mFd. to 100mFd.

Polyester and Polycarbonate Film Capacitors, 0.1mFd. to 10mFd.

ALCAP Reversible Electrolytic Capacitors (Non-Polar): 50v, 100v & Low Loss, 2mfid. to 600mFd

FALCON Custom-wound Inductors.

FERRITE:- Standard, High Power, Super Power, Super Super Power + AIRCORED 0.56-1.25mm wire

NEW IRON DUST. 1mm wire

TAPPED INDUCTORS:- 0-10mH in 1mH steps & 0-1mH in 0.1mH steps

AUDIO AMATEUR PUBLICATIONS

NEW- Valves for Audio Frequency Amplifiers from Philips Technical Library plus lots in PL.

Back year sets of Speaker Builder, Audio Amateur & Glass Audio, plus the Audio Anthology Set.

Altogether 50+ books and 50+ Audio Amateur's magazine year sets, 1999 sets available

FOCAL® 'State of the Art' Units & Kit Designs

C800 Mk II

82 litres

3 way floor standing

92 dB/watt system

-3dB point of 32Hz.

PolyKevlar 10" bass & 5" midrange

Titanium dioxide dome tweeter



From a wide range of High-Tech Loudspeaker units.

Unit Spec Booklet available 30p.

Please send A4 SAE with 40p stamp (66p with PL) +30p extra stamps.

SUPPLIERS TO THE TRADE SINCE 1972

Send for our FREE price list PL29: Just send a large S.A.E. (44p stamp) or US\$2 bill overseas.

Europe US\$1 bill or 3 International Reply Coupons (IRC) to:- (Dept HFV) Tabor House,

Norwich Road, MULBARTON, Norwich, Norfolk, NR14 8JT Tel (0)1508 578272

NEW PRODUCTS FOR VALVE PRE AMPS

Full range of Mumetal input and output transformers for balanced and unbalanced pre-amps, microphone amps, equalizers etc.

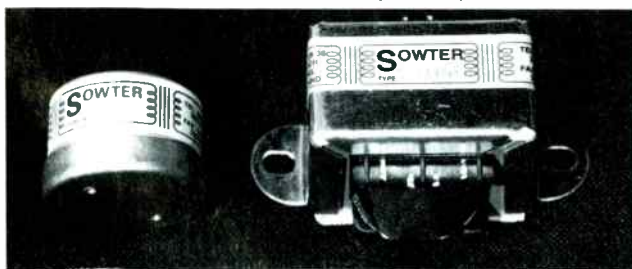

SOWTER EST. 1941
TRANSFORMERS

For the true "valve sound" and elimination of hum and interference in your own or vintage designs. A new range and custom service for low power transformers to complement our power amplifier products. Transformers built to order 2-4 weeks delivery. Full technical support. Free catalogue. Visa, MasterCard, JCB etc.

E A Sowter Ltd
PO Box 36 IPSWICH
IP1 2EL England

Tel: (+44) (0) 1473 252794

Fax: (+44) (0) 1473 236188

E-Mail: sales@sowter.co.uk
techsupport@sowter.co.uk

Call or visit our Website for
catalogue and information

<http://www.sowter.co.uk>

A MESSAGE.....

from the U.K.'s Premier Valve-equipment Repair & Restoration Centre:

* * * * *

"IT DOESN'T MATTER whether your equipment is
Old, New, in Kit form, Valve, Solid-state, Audio or R.F."

We...

Repair, Restore, Re-calibrate, Re-align:-

Tape recorders by *Revox, Tascam (up to 1"), Teac, Akai* ;

Valve amps., pre-amps., tuners, cinema amps.,
theatre-organ amps., industrial p.a. amps. from *Radford, Quad, Leak,*

Kalee, Clarke & Smith, Compton, Parmeko, RCA, Altobass etc;

Valve Communications Receivers and Transmitters

(to 30 MHz/2kW/6'6 tall) by *KW, Marconi, Labgear, Eddystone,*
Rediffon, Ajax, RCA, Tiger and so on.

We will...

Build that Kit for you or

Re-build it if you've had a go but it's gone pear-shaped.

We will...

Custom-build for you a published Classic design or

Design something special and build the prototype

(A 250-watt AB2 high level modulator, Sir? No problems!!)

All this,

as well as being an Authorised Service Centre for such respected
names of the Digital Era as *Denon, Pioneer, Kenwood, Yamaha.*

* * * * *

Overall, some pretty comprehensive facilities.... and it will take only
a few minutes of your life plus a few pence from your pocket to call/fax
and discuss your requirements: **0113 244 0378**

We are:

AUDIO LABORATORIES (LEEDS)

3 Kildare Terrace Industrial Estate,
Leeds LS12 1DB, England

Website: www.audiolabs.co.uk

TECHNICAL & GENERAL

SOME NECESSITIES - FROM THE ORIGINAL CLASSIC TURNTABLE SPECIALISTS

CONNOISSEUR			£	P&P
	BD1/2 Drive Belt		£11.60	£1.90
	BD1/2 Motor Suspension kit		£14.50	£2.50
	SAU.2 Headshell		£17.50	£2.90
	SAU.2 Connecting Lead		£16.50	£3.20
GARRARD Standard Models			£	
	Wired arm tubes	from	£14.50	£2.90
	Cartridge carriers (sliders)		£12.50	£1.90
301/401 Transcription models			£	
Original	Thrust pad assembly		£12.50	£2.50
Original	Idler tension spring		£3.25	£1.90
Original	Brake pad		£2.40	£1.90
Xeroxcopy	Owners Manual 301 incl. full size mounting template		£9.30	£1.90
	401 " " " " " "		£7.20	£1.90
Replacement	301 control knobs On-Off/Speed select	pair	£21.50	£2.00
Replacement	301 suppressor unit		£6.20	£2.50
Replacement	301 motor pulley (-2%), (-1%), (Std), (+1%)	each	£16.20	£2.50
Replacement	301 Chrome plateu mounting bolts	set	£7.20	£2.50
Recommended	Lubrication set - early 301 or 301/401	(specify)	£6.20	£1.90
GOLDRING/LENCO			£	
	Idler wheel (lock-nut or clip fixing)		£21.20	£2.90
	Tension spring		£3.25	£1.90
	Arm pivot bearings - with fitting instructions		£9.25	£1.90
	Spindle/Main bearing assembly complete	GL.69/72	£21.00	£3.90
		GL.75/78	£25.00	£3.90
	Chassis suspension springs (set of 4)	set	£19.50	£3.90
	Headshells	from	£22.25	£2.80
	Instruction books	from	£4.50	£1.90
THORENS			£	
TD.124 series			£	
	Idler wheel original		£28.50	£2.90
	Idler wheel our redesigned replacement		£16.50	£2.90
	Drive belt		£17.50	£1.90
	Suspension rubbers ('mushrooms')		£16.50	£2.90
TD.150/160			£	
	Drive Belt		£14.70	£1.90
	Suspension springs (-1%), (Std), (+1%) (set of 3) set		£13.50	£2.90
	Suspension - main bushes (set of 3)	set	£13.50	£2.90
	Armboards TD.150 blank		£12.50	£2.50
	" " TD.160 " "		£10.20	£2.90
CECIL WATTS Dustbugs & spares - incl. Preener wicks				

Cartridges and styli for 78s and Mono LPs in addition to current Stereo LPs

TECHNICAL & GENERAL

PO BOX 53, CROWBOROUGH, EAST SUSSEX, TN6 2BY
TELEPHONE: 01892 654 534

For this reason, the leads from the signal terminals of any master clock should be kept as short as possible. Still, you might find it necessary to use coax cable to wire the clock into the circuit: as I discovered when AudioCom's Superclock went into the PD-91, RF radiated by the clock can interfere with other areas of digital circuitry. This is, in fact, what happened when I first fired up Daniel Espley's clock inside the Pioneer DV-505 DVD player. And, as had been the case with the AudioCom and PD-91, both

machines worked perfectly with their lids off, but as soon as the lids were screwed in place, spanners started appearing in the works. Speaking to Tom Evans, the man behind Acoustic Precision, I was told that putting the lid on the chassis completes what is effectively a transformer winding around the clock – not a good idea! That said, I never experienced any difficulties with the AP, whether it was resident in the 505 or the 91, so I stuck to using extremely short (10mm) twin runs of solid-core when connecting it up.

WE'RE GOING IN!

Seeing as the procedure for grafting the Acoustic Precision into the Pioneer is the virtually the same as it was for the AudioCom, this section of the article is simply a repeat for those who missed the last Supplement. If you just want to know how the Superclock 4 sounded, skip to sound quality.

Gaining access to the relevant board in the DV-505 is a rather fiddly affair. Having removed the lid, undo the two screws which hold the SCART socket onto the rear panel and lift the metal clip above it which will still be holding it in place. Next, take out all the screws remaining on the rear panel and lift it up and off.

To fit the new clock, you'll have to take out the beige PCB with the output socketry on it. This entails disconnecting CN301, which is located beside crystal 301 (not the one you should replace, by the way, as it operates at 18MHz, not

16MHz!) This leaves two ribbon cables hooking the output board to the main PCB, but these are fairly flexible and won't hamper the clock-fitting process. Once the four screws holding the board down have been removed, you can lift it gently away from the chassis.

SOLDER SURGERY

Now it's time to get down to the real modifications. Once you've warmed up your soldering iron, use it to remove R320

although a standard iron – and some solder braid will also work). Crystal X302 has to go as well.

One point which clock manufacturers all agree on is that the signal leads from their devices to the relevant ICs inside the players need to be kept as short as possible. By putting a link across C322, you can simply connect the Acoustic Precision's signal + and – PCB pins to the pads which used to be occupied by the original crystal via 10mm runs of solid-core cable. The AP's clock ground should go to the pad between C322 and R322, whereas the signal should go to the other pad between C320 and R320.

The only other connections to make are the power supply + and -. The best place to hook up in this case is the main power supply board, where the negative terminal of C711 is connected to ground. P211 (one of the two small, yellow fuses near the PSU board's front edge) has +12V flowing

through it, so connecting to either side of it will provide the AP with a suitable voltage. (By the way, +20VDC is the maximum the regulator can handle). I also assessed sound quality with the Superclock 4 wired to the same power points as the AudioCom clock in the pre-

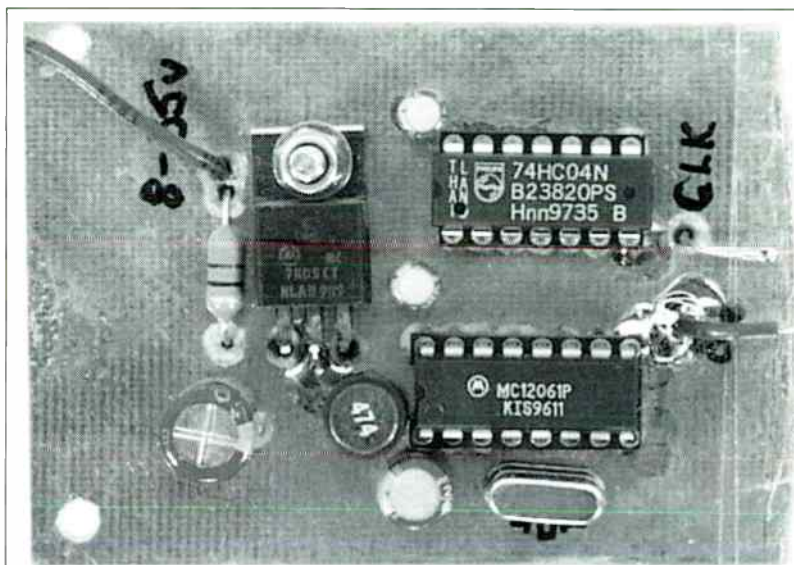

Daniel Espley's DIY master clock can be built onto either veroboard or a homemade PCB

(1Mohm), R322 (910ohm), C320 (27pF) and C322 (12pF), all of which are located on the underside of the output board. (Beware, as these are very small surface-mount parts which are most easily removed with the appropriate bit,

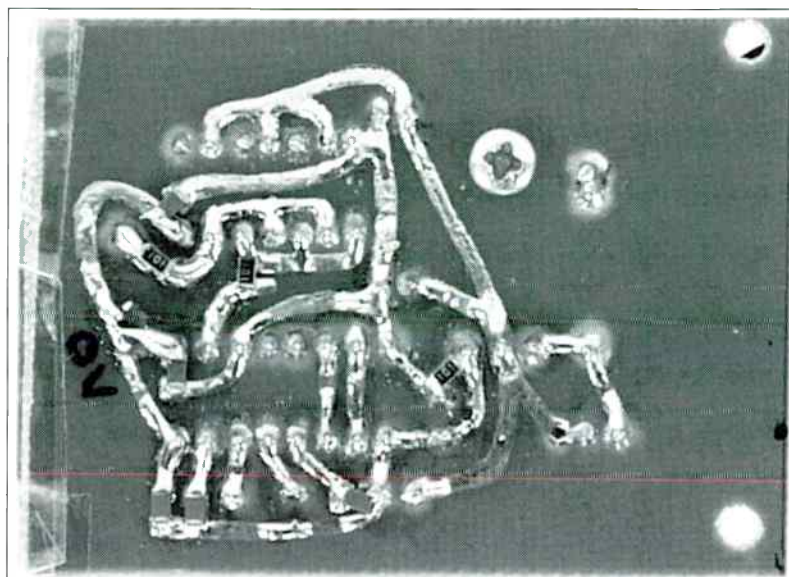

Underside of Daniel Espley's PCB's

Audiophile Sound • Professional Finish • Affordable

Our aim at Riverside Audio is to enable the home constructor to build valve amplifiers which combine true audiophile sound quality with the professional finish of high-end products at an affordable price.

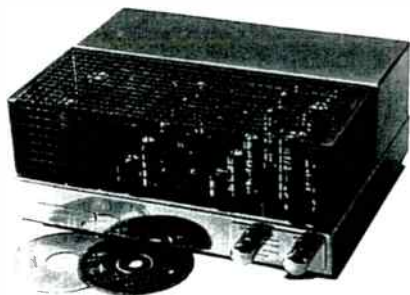

The Riverside 4040 is an integrated amplifier featuring dual mono construction, five line level inputs and both 4 and 8 Ω outputs. The chassis is hand polished stainless steel and includes a matt black valve cover. The amplifier delivers 40 Wrms per channel at less than 0.1% distortion. Kit £625, fully built £725.

The Riverside P2 moving magnet phono amplifier is designed to partner the Riverside 4040 for those who enjoy the vinyl sound. High accuracy equalization is provided for a moving magnet input to a generous line-level output. Kit £225, fully built £275.

Contact Riverside Audio for further information and pricing. Most parts are available separately - even down to individual components. Riverside Audio can also design special audio mains and output transformers.

Riverside Audio, 18 Riverside, Cambridge CB5 8HL
Telephone (01223) 512253 Facsimile (01223) 572629
Internet—<http://www.riverside-audio.demon.co.uk/>

Speaker Kits From IPL Acoustics



IPL Acoustics are pleased to announce their latest range of speaker kits which include no less than seven transmission lines, three conventional speakers, two AV centre speakers, and an active subwoofer kit.

IPL kits are designed to the very highest specification using sophisticated Audiosuite testing system to ensure smooth response, correct phase, and low distortion. Only the best drivers and crossover components are utilised.

Our two new flagship transmission line kits include the:

S3TLM RIBBON which incorporates a superb custom built aluminium coned 6.5" bass mid unit and the unique new IPL Ribbon tweeter.

S5TL GOLD which incorporates the Audax 10" HDA bass unit, the 5" HDA mid unit, and the highly acclaimed Audax piezo GOLD dome tweeter in a transmission line enclosure. The sound quality of all IPL speakers compare well with commercial speakers costing 3-4 times the cost of the kit and are tunable to suit your room and system.

If you would like further details of our range, which includes drivers, Quality components, and Silver PTFE cables, please send a 40p A4 S.A.E. to **IPL Acoustics, Chelsea Villa Torrs Park, Ilfracombe, Devon, EX34 8AY. Tel: 01271 867 439**
Website: www.marketsquare.co.uk/ilfracombe/iplacoustics.htm



WIRE & INSULATION

introduce **DESKADEL** Products

731/733 Ormskirk Road • Pemberton
Wigan • Lancashire • England • WN5 8AT
TEL/FAX 44 - 1 - 942 887171

The **DESKADEL** range of Hi-Fi interconnect, speaker cables, hook-up wires and tone arm wires are precision manufactured featuring **PURE SILVER** conductors insulated with **PTFE** in a variety of designs to suit all applications. Using only the finest materials and the latest manufacturing techniques we aim to provide a selection of quality products for superb natural sound reproduction on a scale previously unheard.

DISTRIBUTORS:

Switzerland
ARBELOS

Tel/Fax: 41-613616466

UK

AUDIO SYNTHESIS
Tel: 44-1-159224138
Fax: 44-1-159229701

Holland
ANALOGUE AUDIO PRODUCTS
Tel/Fax: 31-30-6044342

Belgium
DESKADEL INT BVBA
Tel: 32-3-8892231
Fax: 32-38609181

INTERNATIONAL TRADE ENQUIRIES WELCOME

vious Supplement.

With all the mods inside the DV-505 completed, all that remains is to double-check your work before firing up. I can't emphasise how important this is, as the urge to just whack the lid back on and get a CD in the drawer as swiftly as possibly can be very strong. Unfortunately, it's this classic situation which tends to lead to more barbecued equipment than any other. Check the polarity and position of all the connections from the clock, and only when you're 100% satisfied that you've made no errors, reassemble the player and power it up.

SOUND QUALITY

No doubt about it, this clock pays its way very handsomely indeed when you consider that it can be had unfitted for only £89 including postage (£152 including postage if factory fitted). The 505 was obviously happy with its latest addition judging from how much clearer, firmer and more revealing its presentation was on the sound track from the film 'Run, Lola, Run'.

Take track 6, 'Running Three', as a prime example of the AP's virtues. What had once been a flabby bottom-end was toned-up Schwarzenegger-style to yield far more rhythmic, weighty basslines. While the low frequencies were thundering away, the midrange and treble showed what they had gained. Aside from large steps forward in terms of resolution, sound staging and image clarity, there was a major boost to the solidity and realism of vocals, cymbals – everything, really. These made for much more convincing replay on every disc the Pioneer handled.

Through a DPA 50S and Trio L-08D monoblocs (on top of an MVL A2+ integrated) the DV-505 fed my old Ferrograph S1 monitors and Magneplanar MG12/QR loudspeakers with music of surprising scale and dynamics. Because of that extra solidity and smack, even relaxed, simple numbers like some of those on Beth Orton's Trailer Park album had more life and emotion to them.

Whether its quality or quantity you look for in your record collection, the Superclock 4 is able to strike a satisfying balance between the two. The extra sound stage width and depth along with increased clarity meant that the Reggae compilation, The Best Of Bob Marley And The Wailers – The Early Years – actually sounded much closer to what must have

been heard in the studio than the bottom-of-a-wet-cardboard-bucket scenario which emerges from a lot of budget CD players, DVD-capable or not.

91 NOT OUT

It was a similar story when it came to the PD-91. The older machine was beginning to look distinctly lacklustre in original guise when compared to how it sounded with the AP in place. It managed the same trick as the AudioCom – beefed up basslines, much greater control and clarity, and a more enjoyable way with whatever CD lay in the drawer.

Classical pieces, whether major or minor in scale, demonstrated the broader spread of tonal colour that came as standard with this little green PCB. Violins had presence and power without the glassy sheen and harmonic homogenising that still goes on inside too many players these days.

in a velvet glove, which is just as happy to provide filigree detail as it is floor-board-shaking pyrotechnics. The AP is a cheaper tweak too, and it's diminutive size makes fitting it a piece of cake.

I DID IT MY WAY

Of course, if you happen to be a hard-core DIYer who has to construct everything from scratch, then Daniel Espley's circuit could be the answer. Inexpensive and simple to build (either on veroboard or a home-made PCB), Daniel's clock is another design that leaves standard circuits lagging.

Although it's relatively large and proved tough to squeeze into the DV-505 with a coax connection (without which RF pollution occurs), this home-brew confection sharpened up imaging and sound staging, and gave a firmer, crisper overall portrayal. The sample supplied to HFV boasted a couple of Os-Con caps and a standard 7805 regulator on its board. The

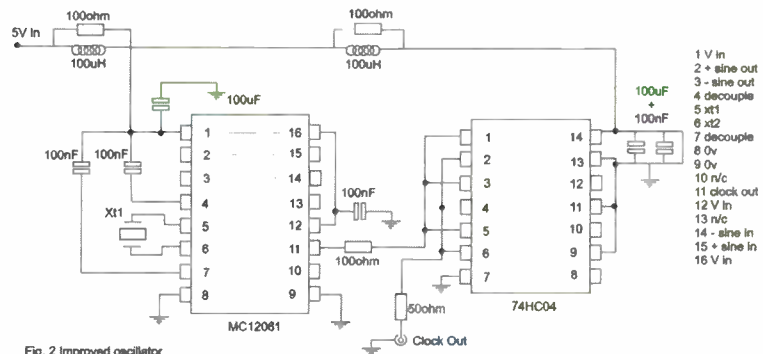

Fig. 2 Improved oscillator

Daniel Espley's improved clock

SHOWDOWN TIME

It's always unfair to put two hi-fi components side by side and say that one's better than the other as so much depends on system synergy, positioning, cabling, etc. And it became evident after fitting the commercial clocks (and Daniel Espley's DIY version) that location, choice of wiring (coax or solid-core) and its length, as well as the power supply link-up points all play a part in deciding the final sonic results.

While the ready-made clocks both improve what comes out of the back of a CD player, they do so in subtly different ways. The AudioCom seems to tilt its balance marginally in favour of the 'wham, bam' approach over delicacy. In its own right it's an eminently successful upgrade, but the AP possesses an iron fist

crystal's position was left unfilled, as the machine's own should be soldered in here (whereas the AC and AP types are optimised for individual frequencies). While the enhancements might not have been as 'night and day' as the other clocks, the unmodded DV-505 was more sluggish and less involving to listen to.

Acoustic Precision Superclock 4 £89 (unfitted)

£152 (fitted)

**Acoustic Precision
50 Bedwlwyn Road
Ystrad Mynach
Mid-Glamorgan
CF8 7AE
Tel: 01483 267516**

KIT & COMPONENT SUPPLIERS

LOUDSPEAKER KIT SUPPLIERS

**Wilmslow Audio, 50 Main Street,
Broughton Astley, Leicester LE9 6RO
Tel: (01455) 286603
Fax: (01455) 286605**

UK distributors of Drive Units from ATC, COLES, DYNAUDIO, KEF, MOREL, PEERLESS, RCL, SEAS, SCANSPEAK AND VOLT. Comprehensive range of high quality crossover components, acoustic damping products, connectors and veneers. Over 20 different D.I.Y. loudspeaker kits on demonstration, including ATC 50 & 100.

**Audio Note (UK Ltd)
Unit C, Peacock Ind. Est.
125-127 Davigdor Road
Hove, East Sussex BN13 1SG
Tel: 01273 220511
Fax: 01273 731298**

Suppliers of a large amount of components for the Audiophile Kit builder. Valve amplification data and vintage circuits also available. See the double page spread in the back section of the main issue for extra & more detailed information.

**European Precision Mouldings Ltd
Highwyck, Sawbridgeworth,
Herts, CM21 0JS
Tel: 01279 600428
Fax: 01279 723846**
Manufacturers of the Red Scorpion range of loudspeaker terminals and binding posts.

**Falcon DIY Speakers
Falcon Acoustics Ltd., Tabor House,
Norwich Road, Mulbarton,
Norfolk NR14 8JT.
Tel: 01508 578272**

UK distributors of FOCAL drive units & Kits, plus SOLEN (SCR - Chateauroux) polypropylene capacitors and the largest specialist Audio inductor manufacturer in the UK. Stocking Audio Amateur Publications and Audio Computer Software. Comprehensive range of D.I.Y. Speaker kits, Parts, Accessories and Books. Please send large SAE (38p) for free price list. "Everything but the wood."

**IPL Acoustics, Chelsea Villa, Torrs Park
Ilfracombe, N.Devon EX34 8AY.
Tel: 01271 867439**

IPL supply a range of eight speaker kits using drive units from SEAS, Morel, Audax, Visaton etc. including four transmission lines to suit all room sizes. We also supply a full range of drive units, capacitors, and cabinet accessories as well as silver plated P.T.F.E. insulated cables.

**South Coast Speakers Ltd
326 Portwood Road,
Southampton, Hampshire.
Tel: 01703 559312**

UK suppliers for High-Quality Driver Units from: SEAS VOLT VISION SCAN-SPEAK also MOREL RCL & many more. Accessories/Components all of the Highest Quality inc. ProAudio MKT Capacitors. Inductors wound to order for any values. Many DIY Kits always on demonstration in our comfortable listening area. Custom design services & friendly advice!

VALVE AND OUTPUT TRANSFORMER SUPPLIERS

**Chelmer Valve Company
130 New London Road,
Chelmsford, Essex CM2 0RG.
Tel: 01245 265865 Fax: 01245 490064.**

Supplier of premium range of audio valves, other valves and components also available. (Please see our main advertisement in this supplement).

**Wilson Valves, 28 Banks Avenue,
Golcar, Huddersfield,
West Yorks HD7 4LZ.
Tel: 01484 654650
Fax: 01484 655699
E-mail: wilsonvalves@surflink.co.uk**

We stock over 2,500 different types of valves, N.O.S. and New. Please send a S.A.E. for full list. No charge for matching. Most major credit cards accepted.

**Billington Export Ltd.
1 E Gillmans Trading Estate,
Billingshurst,
West Sussex RH14 9EZ
Tel: 01403 784961
Fax: 01403 783519**

Billington Export Ltd. holds large stocks of audio valves including many obsolete brands such as Mullard, GEC, Brimar etc. as well as Sovtek, Thermionic Gold Brand and the recently introduced Billington Gold range. Also Cathode Ray Tubes (eg. used in Marantz tuner 10B). 50 page catalogue available, tel or fax for a quotation. Minimum order £50.00 UK, £100 export.

**Langrex Supplies Ltd
1 Mayo Road, Craydon,
Surrey CRO 2QP
Tel: 0181 684 1166
Fax: 0181 684 3056**

One of the largest distributors of electronic valves, tubes and semi-conductors in the UK by original UK and USA manufacturers. Obsolete types are a speciality. Telephone or fax for an immediate quotation.

**Watford Valves
3 Ryall Close, Bricket Wood,
St. Albans, Herts AL2 3TS
Tel: 01923 893270
Fax: 01923 679207
www.watfordvalves.com**

Specialist in new old stock and current production valves. Sole UK distributor of the Harma Diamond range selected for their superior performance. Huge range held, stockists of Mullard, GE, Phillips, National, Brimar, Sylvania, Telefunken, RCA, MOV and many more. All valves are new boxed and guaranteed. For free price list and specialist advice call or fax Derek Rocco, Watford Valves.

**PM Components
Springhead Enterprise Park,
Springhead Road, Gravesend,
Kent DA11 3HD
Tel: 0474 560521**

PM Components Ltd are the specialist component company for High End Audio enthusiasts. We have a design and manufacturing base for audio valves and associated products and have a capability to produce custom tubes for major manufacturers. Our 70 page catalogue is available at £2.50 including U.K. postage. P.M. Components are major stockists for Golden Dragon, Mullard, GEC and Teonex valves and have a vast archive of vintage tubes gathered from every manufacturer in the world.

**Woodside Sound Engineering,
Arfryn, Llanboidy, Whitland, SA34 0EY
Tel: 01994 448271 Fax: 01994 448665
E-Mail: woodside@tesco.net**

As well as producing transformers for our own products, we can now offer an expanding range of audio transformers for new ventures and Renovations. We can wind transformers for most RADFORD amplifiers to original specification. Contact us with your requirements or a list of standard items is available on request.

CLASSIC TURNTABLES

**Technical & General
P.O. Box 53, Crowborough,
East Sussex TN6 2BY.
Tel: 01892 65 45 34.**

The original specialist source of spares, replacements and expertise for the classic turntables. Years of actual experience and comprehensive range of parts (originals and re-manufactures), manuals, ancillaries, No dubious 'improvements' - no harmful 'modifications'. Our specialities: Connoisseur: Garrard: Goldring: Lenco: S.M.E.: Thorens: Watts: Ortofon: Shure: Cartridges and styli for 78s, Mono LPs, Stereo LPs.

COMPONENT SUPPLIERS

**Avondale Audio,
The Hollis, Avondale Road
Chesterfield S40 4TF
Tel: 01246 200096
Fax: 01246 207240**

Audio Engineers: upgrades, Improvements & servicing to both static and moving parts of the hi-fi chain. (amps as well as turntables). Also bespoke range of own equipment and an extensive range of parts & components available.

**White Noise
11 Station Road, Bearsden
Glasgow G61 4AW
Tel: 0141 942 2460**

Specialist supplier of the highest quality, solder masked, silkscreened, PCBs and kits for audiophile grade, solid state power amplifiers, power supplies, MM/IC phono stages, and active crossovers, with many more to come. We also supply a wide range of top quality audiophile passive and active components, specialising in the latest high performance Japanese transistors and UK lateral power mosfets. Write for a free catalogue. Mail order only.

**Audio-Links
7 Fairmont Crescent, Scunthorpe,
North Lincolnshire DN16 1EL.
Tel: 01724 870432 Fax: 01724 875340**
Large range of specialist audiophile components for solid state and valve enthusiasts. Friendly mail order service. Monday to Saturday, 9am - 6pm. 30 Page Catalogue - £3.00.

**AudioCom (UK),
Unit 4 & 6, Tindle Centre
Warren Street, Tenby
Pembrokeshire, SA70 7JY
Tel: 01834 842803
Fax: 01834 842804**

E-Mail: audiocom@scotnet.co.uk
Audiocom are international suppliers of premium grade components. We stock a large range of specialist parts which include: ALPS, Black Gate, Elna SLIMIC & CERAFINE, Danish Audio Connect CT1, Holco, REL-CAP, Sanyo OS-CON, MIT MultiCap, Sfernice, Vishay, plus top grade OFC Inductors & RCA connectors. Our full colour 1999 catalogue is available at £2.50 (UK), & £3.50 overseas.

**Hart Electronic Kits Ltd
Penylan Mill, Oswestry,
Shropshire SY10 9AF
24 Hr salesenquiries Tel: 01691 652894**

A range of Audiophile kits for 80 watt Power Amplifiers, Tuners, Pre-Amps and Moving Coil/Moving Magnet RIAA Pickup Preamps. All kits are fully engineered, with our thirty years design experience, for easy constructions from circuits by John Lindsey Hood, the most respected designer in the field. Send for lists.

**AP Electronics
20 Derwent Centre, Clarke Street,
Derby, DE1 2BUT**

Check out the AP ELECTRONICS catalogue. It's free with every order of over £40.00 or can be purchased for a £4.95 cheque payable to 'AUDIOKITS'. Over 80 pages include pre and power amplifier kits, high grade audiophile resistors, capacitors and semiconductors, audio and mains cables, gold and rhodium plated connectors and COMPONENT NOTES on using high grade parts. A quarterly newsletter 'AP PERFORMANCE AUDIO' has been recently launched and your first issue is free.

**Cambridge Scientific Supplies
12 Willow Walk,
Cambridge CB1 1LA.
Tel: 01223 811 716
Fax: 01223 501 833**

Specialist wire products for the knowledgeable audiophile including:- Silver wire (>99.99% purity, stress free) unique quadruple PTFE insulated Silver wire, Silver loaded solder, PTFE sleeving and Nylon braid sleeving, premium Gold plated connectors and plugs. Custom assembly available. Call Peter Bullock for a catalogue and application note.

RESTORATION

**Audio Laboratories (Leeds)
3, Kildare Terrace, Whitehall Road,
Leeds, LS12 1DB
Tel: 0113 244 0378**

Have your pet hi-fi project professionally done. With over 20 years experience in factory-grade kitbuilds and overhauls, to both valve and solidstate equipment, our good reputation stems from meticulous engineering coupled with superb measurement facilities.

VINTAGE DIY

**Loricraft Audio
4 Big Lane, Goose Green,
Lambourn, Berks RG16 7SQ.
Tel: 01488 72267**

Specialist restoration of 301's and 401's using genuine spares and re-manufactured parts to original pristine standards in our newly built workshops designed primarily for these purposes.

WELDING

**N.Clark Welding & Fabrications
14 Redhills Road
Easton Industrial Estate
Southwoodham Ferrers
Essex CM3 5UP
Tel: 01245 323336**

Precision welding and sheet metal work TIG/MIG welding, CNE Punch and Press Milling and Turning Fine Limit and General Engineering Prototype work and batch work undertaken.

SPECIALIST UPGRADE SERVICES

**AudioCom (UK),
Unit 4 & 6, Tindle Centre
Warren Street, Tenby
Pembrokeshire, SA70 7JY
Tel: 01834 842803
Fax: 01834 842804**

E-Mail: audiocom@scotnet.co.uk
Professional modifications using leading edge components. Modifications are carried out by engineer with 30 years experience in the field of analogue and digital electronics. Upgrades available to all types of audio equipment including CD players, Transports, D-A converters, Pre & Power Amplifiers. Call us today for more information.

INVENTOR OF STEREO -

The Life and Works of Alan Dower Blumlein

by Robert Charles Alexander

Alan Dower Blumlein was a legend in his own short lifetime. Few who swam into his orbit were untouched by what all and sundry unanimously call his genius. In the fields of microphone design, cable technology, television, radar and, most famously, binaural recording, his contributions were at the very least significant; more often they were immense. Which raises a question: if the man made such a mark, why is so little known about him? Four photographs are known to exist - four! For a man born in the 20th Century, that is perilously close to being undocumented.

The reasons for this state of affairs are various. When Blumlein died in an air-crash in 1942, he was part of a team testing what was to become radar. In time of war, such work was top secret so, not unnaturally, a veil was quickly drawn over both the accident and the type of work being attempted.

This can of course be redressed in peacetime. Unfortunately, Blumlein's self-appointed official biographer proved himself monumentally incapable of the task: much of the archive of documents this person hoarded so greedily from the 1970s until his death in 1998 has yet to be recovered. He died without publishing a line, but his dog-in-the-manger approach meant that by the time other hands had taken up the task, many of those who could have made significant contributions had died, including Blumlein's widow and his close colleagues.

From the foregoing it will be seen that RC Alexander has faced an uphill task in producing this work. Having of necessity to side-step the meandering path of his predecessor, Mr Alexander has been obliged to undertake much original research and it is probable that the result is the richer for it.

Alan Dower Blumlein's parents met in South Africa. His father was from the then-German province of Alsace and his mother was a Scot. The couple moved to England and in 1904, a year after Alan's birth in Hampstead, his father became a



naturalised British subject. This did not prevent the young Blumlein being subjected to the usual bullying at school on account of his German surname - especially during the Great War. This may have contributed to the fact that nearly into his teens he was unable to read. Whatever the shortcomings of his reading abilities, Alan was seemingly always fluent in the language of mathematics. It is possible that his slow start in written English aided rather than hampered his manipulation of the abstracts of numbers.

Sent to a crammer, Blumlein caught up quickly and he was awarded a Governors Scholarship to the City and Guilds, where he gained First Class Honours as a BSc. All this speaks of rare ability but does not of itself portend genius - it is notoriously difficult to sustain a sprint.

By the end of the 1920s, Blumlein was working for Columbia, soon to become part of the giant EMI conglomerate. Early on, he was placed with the team who were attempting to develop a new recording and record-cutting system in order to break the commercial strangle-hold which the Bell company's patents had on the industry. Blumlein's ideas on the use of electromagnetic damping to control resonances and his intuitive grasp of electro-mechanical equivalence in cutter-heads proved invaluable. Within a remarkably short time, the Columbia system was

patented and the company was itself granting licenses to other manufacturers wanting to use it.

According to his wife, Blumlein conceived what he termed binaural sound while they were at the pictures one night. Why shouldn't the sound follow the picture? As with most of his work, there is a breath-taking simplicity about his attempts to apply the idea. Indeed, with many of his 128 issued patents, Blumlein expressed surprise that no-one had done before. In 1931, a series of patents covering practically every salient point of what was to be known later as stereo reproduction was granted to ADB and other members of the EMI team. It was so ahead of its time that when Decca later tried to patent various bits of their new stereo system they discovered ruefully that Blumlein had beaten them to it by about 20 years.

There is much more of absorbing interest in this book. For a semi-technical work, it is well-written by one who clearly understands what he is writing about. The account of the early television service from Alexandra Palace, with both the Baird company and EMI broadcasting the same programmes alternately via their respective systems gives a fascinating insight into quite how incidental pure science can be to a development which has changed the world.

Centimetric radar, on which Blumlein was working when he met his death, helped in no small degree to win the war, whatever we may now think of the bombing of cities and their populations.

For a full and detailed account of a genuine genius, I cannot recommend this book too highly. One anecdote I personally find irresistible: Finding a metal No Smoking sign in a colleague's office, Blumlein bent it up into an ashtray for his pipe! Of this stuff are heroes made. **RMW**

This book and other titles are available from the World Library, page 68-69.

Alternatively you can order on-line:
www.worldaudiodesign.co.uk

Code No: 1660 £14.99 + £2.50 P&P (UK)

World Audio Design goes Dot.Com

Yes, hold on to your mouse -

www.worldaudiodesign.co.uk has arrived. After sharing the well-established magazine website, www.hi-fiworld.co.uk, for some years, we felt it was high time for our kit company to go it alone with a fresh new presence.

The site is a cinch to navigate as it follows the three-click rule. The home page provides links to five sections: Company Profile (a brief history of our outfit plus a description of the site and how it works); Tube Pre-amplifier and Amplifier Kits; Speaker Kits; Books and Ordering.

As this is quite a technical site, there is plenty of data available. For example, if you click on the Tube Pre-amplifier and Amplifier icon on the home page, it provides a view of all our valve kits. Click on an individual item and you'll find a small picture with a brief description and a table

of five further links to pages about the kit in question. Click on these and you'll get larger internal and external pictures, or you can read a more detailed description of the kit and even an explanation of the circuit design. A look at the circuit diagram or the full instruction booklet are also only a click away.

As is so often the case with technical websites, we have utilised PDF (Portable Document Files) for the circuit diagrams and instructions. To view such files you need to have a copy of Adobe Acrobat Reader installed on your computer. This is available free from www.adobe.com and only takes a few minutes to download. Once it has been installed, your browser (be it Netscape Navigator or Internet Explorer) will open it automatically so you can view the files. It's often a good idea to print off such schematics as there is a lot of information to digest whilst you're sitting online.

Our Speaker Kit section is presented in a similar way, and the Book section shows over 40 titles, each with a picture of the front cover and a brief description of the contents.

With the explosion of e-commerce, we could hardly launch our site without the provision of ordering facilities. All our products are now available for purchase directly from the site.

We cater for orders placed anywhere in the world, so it is essential you select your postal region correctly from the 14 zones so you incur the right postal charges. Then, just choose one of the four purchasing categories and order away. All your details arrive encrypted via e-mail to be unencrypted and then processed. Rest assured your card information is safe. You will receive an order confirmation and an estimated time of despatch of your purchase via return e-mail.

One thing we want to make clear is that worldaudiodesign.co.uk is an active site - our web designer, Andrew Mains, will be working continuously on it. We are thinking of adding to the home page an archive section, which will detail some of the original DIY Supplement articles of yes-

teryear, not to mention some of the more recent ones. Additionally, we will be setting up a chat room where all you DIYers can bat e-mails back and forth within the site on topics such as valve amps, speakers and the like.

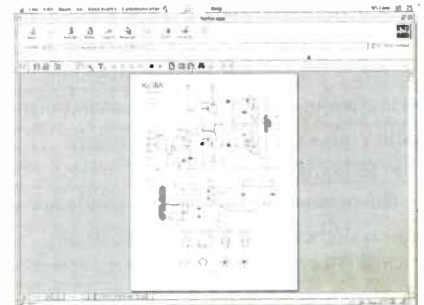

Example of PDF document



Postal zone page

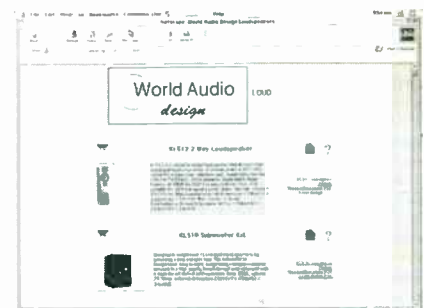

Speaker page

As no self-respecting site would be complete without links, a link page will be available so you can travel direct to other sites of interest. Come what may, worldaudiodesign.co.uk will be a true hi-fi DIYer enthusiast's site that will surely grow and grow.



Home page



Tube Amplifiers & Pre Amplifiers page



The books page

SHOT IN THE ARM

Richard White explodes the 'black art' of tonearm geometry.

It sometimes happens that one wishes to fit a tonearm to a turntable without having any of the manufacturer's instructions to hand. Rather than work by guess-work or those wretched bits of cardboard laughingly called 'alignment protractors', it is a better exercise altogether to set up from scratch. The following formulae enable the optimum tracking parameters to be set for any tonearm. There is no absolute answer to this problem but the method below gives a very good compromise: no well-designed arm should give results radically different to those you can calculate from the formulae. For simplicity, I have assumed for the purposes of this article that the reader is actually designing an arm, but obviously by algebraic substitution, it is easy to use the instructions for checking and setting up a 'shop-bought' arm.

Using the formulae below ANY ARM designed using the same values of I and O will have the same points of zero tracking error, regardless of arm length or offset angle, so a protractor made to suit one will suit all.

Note: In the following description, all measurements and values are given in inches, for no better reason than that inches are a convenient-sized unit for this exercise. You may work in mm, or for that matter cubits or ells if you choose, the 'real' dimensions remain the same. Given that pocket calculators will give at least six places of decimals, I recommend that answers are rounded to the nearest hundredth of an inch. Similarly, if working in millimetres, it is simply labour lost to calculate finer than about .25mm. Whichever base unit is adopted, it must be used throughout the calculations - beware cm/mm muddles!

To begin with, you need to decide upon the position for the 'worst case' places on the arm's sweep, in other words, the points at which tracking error matters least. Although there are other possibilities, I have found, after exhaustive calculation of alternatives, that radii of 2" and 6" approach the ideal compromise. 6" radius has only the run-on grooves to worry about and 2" is practically on the label. With other parameters, improvements in one area tend to be wiped out by excessive errors in another, but once you master the following method, it is easy enough to try them and see for yourself.

In the formulae which follow, any pair of factors of the product of our initial choices will have the same degree of tracking error although of different sign (+ or -). If we adopt 2" and 6", pairs of factors of the product 12 will have the same degree of error. As an hypothetical example, if a radius of 3" gives an error of +2°, 4" (the complementary factor of 12) will give -2°.

For purposes of algebraic convenience, we shall call these chosen points I (for Inner) and O (for Outer).

We derive a trigonometric constant from these two in the formula shown below:

$$\frac{(\sqrt{I} + \sqrt{O})^2}{4} = \kappa$$

Substituting our values for I and O gives:

$$\frac{(\sqrt{2} + \sqrt{6})^2}{4} = \kappa$$

which gives us the answer, constant $\kappa = 3.732$

In many respects, this constant is the answer; it is the distance measured at right angles from the cartridge axis to the arm pivot, and from it we calculate all the other dimensions we require to set up a tonearm for optimum tracking. The diagram below shows the various points and construction lines to which the next processes will refer:

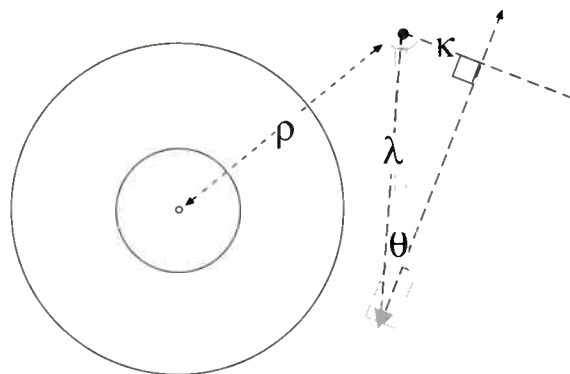

Having derived a sort of geometric mean of the two values I and O, we use the result κ to calculate arm length and/or offset angle. Of these two, it is usually easier to vary the arm length λ (by virtue of the cartridge fixing slots) than the offset. I do not recommend setting the cartridge askew in the headshell to vary the offset θ ; except in the case of uni-pivot arms, this procedure prevents the proper alignment of the cartridge axes with the arm pivot for optimum vertical tracking.

$$\frac{\kappa}{\sin \theta} = \lambda \quad \text{or} \quad \frac{\kappa}{\lambda} = \sin \theta$$

Having now related both our arm length λ and the headshell offset θ to the limits of our required geometry, we can now derive the distance from the record centre to the arm's horizontal pivot. This distance we shall call ρ . The square of ρ should be equal to the square of the arm length λ minus the product of I and O:

$$\lambda^2 - IO = \rho^2$$

We have now found values of arm length, pivot-to-record-centre and headshell offset which will give minimal tracking error between our chosen radii I and O. What we have not yet covered is the calculation of exactly where the points of zero tracking error will occur.

If we treat things as essentially a 'solution of triangles' problem, we can get at the answers by a practical application of the sine rule. The case of tonearm geometry is what is called an ambiguous case; there are always two possible solutions to the problem which give us our two zero error points. The points of zero tracking error will be found where the length of the radius makes an angle with the arm equal to 90° less the offset angle.

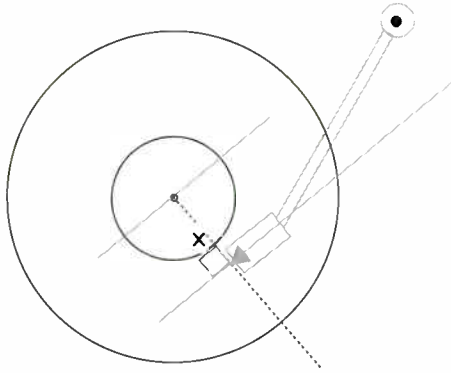

So we are looking for the missing side of a triangle having two sides of λ and ρ and another angle (not included) of 90° less θ .

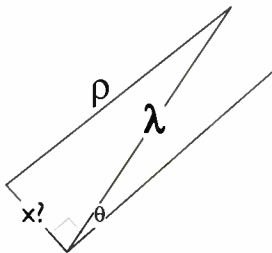

The above diagram extracts the basic problem. Note that the angle opposite λ at the record centre is *not* a right angle - this can be deceptive.

Since by the sine rule

$$\frac{a}{\sin a} = \frac{b}{\sin b} = \frac{c}{\sin c}$$

We know that ρ divided by $\sin \rho$ (which equals $90^\circ - \theta$) is equal to both λ divided by $\sin \lambda$, and 'x' divided by $\sin x$, we can readily fill in a few of the blanks:

$$\frac{\rho}{\sin \rho} = z \quad \text{therefore} \quad \frac{z}{\lambda} = \sin \lambda$$

'z' is a flag of convenience for the sine rule constant.

Turning $\sin \lambda$ to degrees and adding our angle ρ figure, we know that angle x is equal to 180° minus the sum of the other two angles.

$$\text{angle } x = 180^\circ - (\lambda + \rho)$$

and so $\sin x$ multiplied by $z = x$

which gives us one of the values of x which will have zero tracking error.

To find the other, we simply divide the product of I and O by x_1 which gives our inner zero radius, x_2 . One other value is handy to know: the point of maximum tracking error in the arm's journey across the record. This is very simple to calculate; it is the square root of the product of I and O , which a moment's

thought will show will be the same as the square root of x_1 times x_2 as well - and indeed of any complementary pair of factors of I multiplied by O .

It's easy, isn't it ?

Actually it looks frightfully complex like this. To show how readily applied all of the geometry really is, let's look at a worked example.

We wish to find the optimum set-up for an arm having an offset angle which we have measured at 24° .

κ divided by $\sin 24^\circ$ equals 9.175, so the length of the arm measured from pivot centre to stylus tip should be this (remember we're working in God's own inches). If this is impossible within the available range of adjustments on the arm, let's say things could be better, at any rate as far as this method is concerned!

Having derived the arm length, we square it and subtract the product of our two chosen values I and O , which is $2 \times 6 = 12$. Arm length 9.175 squared = 84.189; subtract 12 = 72.189. Find the square root and there's the pivot to record centre distance, 8.496".

Without going any further, we can set up the arm by these figures in the certain knowledge that tracking error will on average be as low as possible. We now may want to know the zero error points which will enable us to make a protractor for checking things afterwards.

90° minus 24° gives us value of angle opposite the pivot-centre line ρ when error is zero, in other words 66° . Applying the sine rule to find the length of side opposite the arm pivot (effectively the zero error radius) goes like this: ρ divided by $\sin 66^\circ$ gives constant $z = 9.300$. Dividing arm length λ by z gives the sine of the angle opposite the side we want to find, so λ divided by $z = 0.987 = \sin 80.595^\circ$. Adding this angle to the 66° and subtracting them from 180° gives the angle 33.405° .

$\sin 33.405^\circ$ multiplied by z equals zero error point: $\sin 33.405^\circ \times 9.300 = 5.120$ ". This is the outer zero. To find the other one nearer to the label, divide $I \times O = 12$ by 5.120 which gives inner zero at 2.344".

To reiterate: ANY tonearm set up by the same values of I , O and κ will have the zero points at the same radii, no matter what its length or offset angle; this must be so, because all values are in fact derived from our first choice of two parameters I and O , so even such nonsense as a twenty foot arm, if set up by this plan, will have null points at 5.120" and 2.344".

I see I've gone back on my earlier advice and worked to the nearest thou rather than hundredth of an inch, but that's just my youthful zeal. Have a look at a vernier or micrometer to gauge your chances of setting up to the nearest thou or .0254mm!

I hope this article will be of interest. There are so many nebulous quantities in hi-fi, it is refreshing to find a subject which yields concrete results with just pencil and paper. **RMW**



QUAD A DIFFERENCE A CLEAN MAKES

Mike Gerrard, a die-hard fan of Quad electrostatics, passes on some cleaning hints (undertaken at your own risk!)

My wife and I bought our ESL57s second-hand some 25 years ago, so when one died of constant abuse (my Naim power amp is capable of stunning our neighbouring farmer's prize bull), I was down but not out, although we did have a mono Millennium.

Enquiries suggested that repairs could be long-winded and the costs prohibitive. However, research in the pages of this most august of organs and elsewhere led me to another 25-year-old pair. 450 miles and £300 later I had quad Quads. The new ones were dusty but tidy, untouched since Huntingdon waved them good-bye.

The audition was promising - no noise, crackles, spitting or other nasties. So, having been temporarily estatic, I was ecstatic and if they could turn in a performance as well as they did after our trek, what would they do after a clean?

Reflect on this for a moment. If you don't clean your TV screen, you won't realise its full potential. Colour and picture nuances will be lost (not that there is much nuance to lose these days). Wipe it over and the crow you've been watching turns into a peacock. Your TV screen is subject to high voltages, and when you put your hand close to the screen, you sometimes hear a fizzing sound. That is static build-up on the glass, and you're dispersing it with your hand.

So in effect we are going to wipe over the Music Screen and reveal the peacocks in our music collection. As the sonic improvement was such a revaluation, I began to wonder just how many Stat owners are listening through a thick layer of dirt. All that filth virtually negates the point of having an ultra light membrane as the transducer/air interface. If you can't change a light bulb or fit a 13A plug, don't bother reading on. If you can, learn and inwardly digest this lot. Look at your speakers to see what is being discussed and above all, be honest with yourself. I can assure you that we are not in the realms of rocket science here. Do use the correct tools, do carry things out in the prescribed order, take your time, be patient and use delicacy as your watchword.

If you have a partner and kids, despatch them for the day, assemble your tools, fully engage your brain and in good heart start.

TOOLING UP

You will need: a 4mm-blade engineers screwdriver (for the small screws); a larger 6mm woodworking driver (for the side cheeks); a smallish pair of wire cutters and pliers (for removing the staples); a soldering iron or 6BA/small adjustable spanner (for the earth tag, see text), and 0.5in./3in. clean paintbrush. It is worth buying new ones - the cheap, thin, soft bristle types are ideal. Also necessary are a staple gun; maybe a small hammer; a vacuum cleaner with a nozzle attachment; an old hand towel, dampened but not wet; a few cotton buds; some contact cleaner, and some Elastoplast. Find a few empty yogurt pots for screws, etc.

STEPS TO HEAVEN

1) Unplug your speakers a good two hours before you start - as I've said, there is a few thousand volts floating around in there. Don't forget you're doing this for yourself, your wife and your children, not your widow and orphans!

2) Prepare yourself a work surface at least 3ft. by 2ft. You will have to turn the speakers easily and lay them on their backs. Tape some felt over the foot ends - this will help them slide easily and work at a comfortable height.

3) With the speaker facing you, remove the six screws holding the side cheeks and mark appropriately, left and right. Place away from the work area, and remove the screws and cups from the cheeks (yogurt pot No1). Be careful now, you have exposed the raw edge of the expanded aluminium fret and it's sharp!

4) Look down the exposed edge and you will see several staples. Remove them. Carefully lay the unit on its back, feet towards you and the rear foot over the edge of your work surface. Remove the fret-securing screws along the bottom edge (yogurt pot No2). You will find that there is an earthing wire attached to the fret via a solder tag (it is towards the left-hand side).

This has to be disconnected. Desolder the wire and leave the tag in place. If you don't have a soldering iron, use a spanner to undo the 6BA nut. (Ensure that you remake the joint on reassembly).

5) Whilst you have the speaker on its back, remove the bottom securing screws for the back cover. These are chrome and round-headed as opposed to the countersunk steel ones you have just removed from the fronts. They should also have washers under them (yogurt pot No3). You will meet your earth wire again, this time for the back panel.

Observe the same procedure and precautions as previously recorded.

6) Stand the unit up again, facing you. You now have the first tricky bit. The fret is made of expanded aluminium and is easily dented, so take your time and be careful.

Ease the bottom edge away from the frame. As it comes free, progressively work up each side, gently parting the fret from the frame, until it is free all the way up. You now have to free the top edge. This, as you will observe, rolls around the frame top and slots into a groove. Hold the fret at about 45 degrees with one hand and ease the fret out of the groove, starting at one side. Take care here, for over-exuberance could fold your fret in half. A gentle poke with a screwdriver on the side may help to get it started. When one side is free, do the same for the other. Once it is dislocated on each side, gently move the fret up and down, rocking it slightly as you work the still-captive section free. For this manoeuvre, hold the fret about half way up. When free, lift it off, place it away from the work area, and put the kettle on.

PANEL BEATING

You will now be faced with the three panels. The two outer ones are the bass radiators; the middle, slightly recessed one, is the treble unit. If you are faced with three rectangular, grey rugs, then you're in for a treat when you have finished. The bass panels will be worse than the tweeter as their polarising voltage is greater. Don't worry if the panels don't look like carpet underlay, there is bound to be some muck around, and every bit you shift will liberate more music.

If, on inspection, any of the membranes are damaged in any way ie, ripped - I'm sorry, but you're out of this game. In fact, you're just where I was before Christmas. However, if they aren't, read on.

6) Turn the speaker so the back is facing you. Before we start the clean up, let's have a look at the rear membrane - there is no point creating a lot of dust if the problem is around the back. Remove the remainder of the back screws and pop them in pot No3. The back fret is again

expanded material, only more open this time and of steel. If you've already cut yourself on the raw aluminium edges of the front fret, I should wear protective gloves if I were you don't bleed all over the membrane (this is where the Elastoplast in the tool list comes in).

To make matters even more awkward, the backs are sprung into the frames. Start in a top corner, with your 4mm screwdriver blade through one of the perforations (make sure it doesn't go right through). Bias the fret down and out towards you. Work your way along until you reach what passes for the handle.

Repeat from the other corner. Pop your driver blade into a central hole, bias it down and out again; the top should now spring out. Juggle the folded-under-and-box section away from the frame. Now you can see the business bit.

Most of the gubbins are easily seen, apart from the bits behind the treble unit wadding and transformers. I wouldn't disturb the wadding - that should be fine - but squint around everywhere else. A torch is helpful here. Having satisfied yourself that you're clear, make that brew and ponder why it's cleaner in there.

One reason is the felt wadding over the inner face. This reduces dust ingress, and as the speaker is angled towards the back, heavier dust particles fall away rather than being attracted onto the membrane. Fine particles still get pulled through, though. The wadding is in there to attenuate some of the sound radiation from the rear. This should make the Quads more room tolerant. After I had pair No1 for a while, a magazine article implied that overall performance could be miraculously improve, by removing the wadding, which I did. I can't remember if I thought there was any improvement; I probably did, as this was a period of wonderment and hyperbole. Some audio journalists, cranks and an odd manufacturer or two were trying to tell us that our systems would sound dire if you had a phone in the same room, or you didn't use copper pipe and plumbing fittings for speaker leads. Degradation would be noticed if your auntie had a poodle or you wore a wrist-watch whilst listening to your records (unless, of course, it was a gold Rolex!)

My surviving aunt doesn't have a poodle, so I've left the felt in the No2s.

Mike Gerrard

Gerrards@pict Thorn.freereserve.co.uk

FOR THE FINAL DETAILS ON QUAD CLEANING, SEE OUR NEXT SUPPLEMENT



Quad ESL57 Electrostatics

All contributors to the letter pages of the DIY supplement will receive a book of their choice (under £25.00) from our World Library. Please send your letters to: Hi-Fi World DIY Supplement, Suite G4, Imex House, Kilburn Park Road, London, NW6 5LF. Alternatively you can e-mail your letter to letters@worldaudiopublishing.co.uk. We look forward to receiving them. Thank you.

ADVERTISERS INDEX

Audio Link	IFC	Falcon Acoustics	12	Riverside Audio	14
Audiolab Leeds	12	Glass Audio	6	Sowter Transformers	12
Billington Export	IBC	IPL Acoustics	14	Sugden	IBC
BK Electronics	4	Langrex Supplies	IFC	Technical & General	12
Chelmer Valve	IFC	Lockwood Audio	4	Watford Valves	4
Cricklewood Electronics	6	PM Components	BC	Wire & Insulation	14

**COMPETITIVE WHOLESALE PRICES
BILLINGTON EXPORT LTD**

New old stock - Government or Original boxes unless marked * which are White box

On these types **ONLY** you can obtain these **WHOLESALE** prices for a **MINIMUM ORDER ONLY £50**

	1-19	20-49	50-99	200-299	200+
3D21 STC Data available	£12.00	£9.50	£9.50	£7.50	£7.00
6AK5 Mullard	£1.95	£1.95	£1.95	£1.95	£1.30
6AM5 Mullard UK	£3.00	£2.00	£1.60	£1.35	£1.25
6AK6 Brimar UK	£1.00	£0.65	£0.45	£0.38	£0.38
6AU6WC * USA	£1.43	£1.43	£0.95	£0.85	£0.66
6AU8A GE/RCA USA	£0.75	£0.75	£0.75	£0.75	£0.75
85A2 * East European 90 day guarantee	£1.80	£1.20	£1.20	£1.20	£1.10
807 Russian	£6.60	£4.40	£3.00	£2.90	£2.70
5644 Raytheon	£3.90	£2.60	£2.50	£2.40	£2.30
5755 Raytheon USA	£2.63	£2.63	£2.63	£2.63	£1.75
7327 Sylvania. may be similar to ECC82	£1.35	£1.35	£0.90	£0.90	£0.90
ECL86/6GW8. Try PCL86 which is a similar valve at an amazing low price! Data available					
EF86. Use EF95 which is a similar valve. EF95 is B7G base. EF95 is recommended in Glass Audio. Data available					
EF95 Mullard UK	£1.95	£1.95	£1.95	£1.95	£1.30
EL34 See 3D21 possible alternative					
EL84 near equivalent try 6CH6	£1.95	£1.95	£1.40	£1.30	£0.80
6CH6 Brimar UK. similar to EL84 Mullard but different pin out.					
No discounts possible. Data available.	£1.95	£1.95	£1.40	£1.30	£0.80
PC86 Zaerix East Europe	£3.68	£3.68	£2.45	£2.45	£2.45
PC900/4HA5 East European	£1.72	£1.72	£1.15	£1.15	£0.90
PCC84/7AN7 Mullard UK	£1.50	£1.00	£1.00	£0.90	£0.80
PCC89 Russian	£1.50	£1.00	£0.90	£0.75	£0.65
PCL86/14GW8 Polish or Russian made using					
Philips technical expertise	£0.53	£0.53	£0.53	£0.53	£0.37
SV811-3 Svetlana	£19.50	£16.00	-	-	-
TT21 Billington Gold Chinese	£27.00	£18.00	£18.00	£16.00	-
UCL82 * Russian	£1.80	£1.20	£1.20	£1.10	£1.00

1,000,000 valves in stock including E88CC, ECC81, ECC82, ECC83, EF86, EL34, EL84, KT66, KT88, 6SL7, 6SN7, 300B, 807, 845, 6080 and sockets. Please inquire for RETAIL or WHOLESALE prices. We also stock the excellent BILLINGTON GOLD brand and limited quantities of Mullard, GEC, etc. MASTERCARD, VISA and most credit/debit cards accepted.
IE GILLMANS ESTATE • BILLINGSHURST • SUSSEX RH14 9EZ UK

Visitors by Appointment only

Tel: (0) 1403 784961 • FAX: (0) 1403 783519 • E-MAIL: billingtonexportltd@btinternet.com

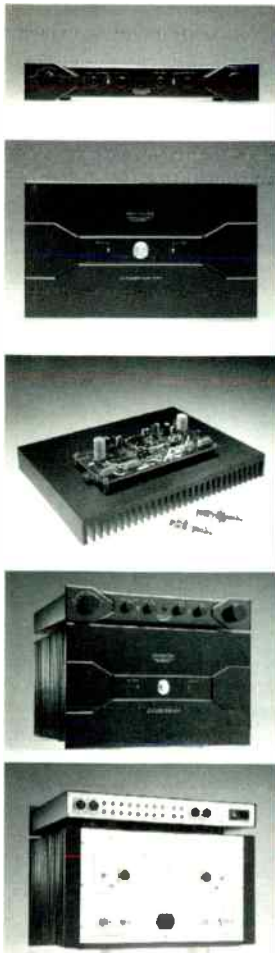

SUGDEN audio products



Masterclass from the original CLASS A company

New products from Sugden

Wide-bandwidth d.c coupled high current class A power amplifier and matching pre-amplifier. Available as a stereo power amplifier you can upgrade or balanced monoblocks.

Handcrafted from the finest materials and components, Sugden guarantee to add an extra dimension to your listening pleasure. Our superior wide-bandwidth designs will increase the dynamic range and sonic accuracy of your audio system - without fatigue.

With over thirty years experience in design and manufacturing Sugden has become a reference for reviewers, musicians and audiophiles around the world. Prices start at £549.00 for the Audition series so why settle for anything less?

J. E. Sugden & Co Limited
Valley Works, Station Lane, Heckmondwike,
W. Yorks. WF16 0NF
Tel. 01924 404088 Fax 01924 410069
Email jesugden@compuserve.com



Golden Dragon

Precision Audio Tubes

Please enquire for any tube not listed. We have an inventory of over 2,500 different types in stock.

Golden Dragon High Quality Pre-amplifier Tubes

12AT7A/E81CC/ECC81	£ 6.95
12AU7A/E82CC/ECC82	£ 6.95
12AX7A/E83CC/ECC83	£ 6.95
12BH7A	£ 9.95
6DJ8/E88CC/ECC88	£10.95
6SN7GT/ECC33	£ 8.95

KT66R	£69.95 pr
KT88R	£69.95 pr
6550WA	£67.95 pr

Golden Dragon Special Quality Pre-amplifier Tubes

E81CC-01	Gold Pins Low Microphony Low Noise	£10.50
E82CC-01	Gold Pins Low Microphony Low Noise	£10.50
E83CC-01	Gold Pins Low Microphony Low Noise	NEW £ 9.50
E88CC-01	Gold Pins Low Microphony Low Noise	£14.50

Golden Dragon Triodes

	Singles	Per matched pair	Per matched quad
2A3 4 pin	£22.50	£50.00	£100.00
2A3 Octal	£22.50	£50.00	£100.00
211	£28.50	£60.00	£120.00
811A	£11.50	£25.00	£50.00
845	£36.50	£75.00	£150.00
805	£36.50	£75.00	£150.00

Golden Dragon T300B Range

300B Super	£79.00	£160.00	£320.00
4.300B	£84.00	£170.00	£340.00
4.300B LX Super	£124.00	£250.00	£500.00

Golden Dragon Power Tubes

	Matched Pair	Matched Quad	Matched Octet
EL34 Super	£25.00	£50.00	£100.00
EL34M	£25.00	£50.00	£100.00
E84L (special quality EL84)	£12.50	£25.00	£50.00
EL156 Octal	£75.00	£150.00	£300.00
6L6WGB	£25.00	£50.00	£100.00
KT66	£25.95	£52.00	£104.00
KT66 Super	£65.00	£130.00	£260.00
KT88	£57.95	£116.00	£232.00
KT88 Special (Gold plated)	£67.95	£136.00	£272.00
KT90	£65.00	£130.00	£260.00
KT90LX	£75.00	£150.00	£300.00
350B	£29.95	£60.00	£120.00
6L6GC	£19.95	£40.00	£80.00
6550A	£42.95	£86.00	£172.00
6550A Special (Gold plated)	£64.95	£130.00	£260.00
50CA10	£84.95	£170.00	£340.00
807	£25.00	£50.00	£100.00

We have a vast range of tubes available from manufactures all over the world including rare and vintage types. an 80 page booklet of valves available is updated monthly and can be provided at a cost of £2.50 per copy U.K. £4.00/\$7.00 rest of world or you may telephone our Sales Desk for a prompt quotation.

Prices exclude VAT and Carriage. Please add carriage charge of £2.50 for UK orders and VAT at 17.5%

P.M. COMPONENTS LTD, Selectron House, Jenkins Dale Industrial Estate, Chatham, Kent. ME4 5RD
Tel 01634 848500, Fax 01634 848676, e-mail: 101650,2424@Compuserve.com

The Valve. Golden Dragon



Simply, The Best.

For more information contact:

PM Components Ltd, Selectron House, Jenkins Dale Industrial Estate,
Chatham, Kent. ME4 5RD

Tel 01634 848500, Fax 01634 848676, e-mail: 101650,2424@Compuserve.com

Magic Moments?

David Price spent a long weekend with Emagic's Audiowerk2 soundcard. Pure enchantment or just another brief encounter? Read on...

Emagic is a new name to me, although my computer musician friends say the company has a fine pedigree. Founded in Hamburg in 1992, its founders reputedly played a major part in developing Notator, the first sequencing program with interactive real-time notation. Without them, it seems, a million Atari-based bedroom house records would never have been made! Based on this product's world-wide success, Emagic was formed.

In 1997 they launched the Audiowerk 8, an 8 channel digital audio recording PCI card designed for pro and semi pro use.

Then, last year came the Audiowerk2 Production Kit, which is a more home-oriented computer based digital recording system, working in conventional 2 channel stereo. It comprises the Audiowerk2 digital audio recording card (PCI, for both Windows and Mac platforms), plus Logic Audio Composer and MicroLogic AW2 (custom sequencing software derived from the industry renowned Logic Audio package).

The Audiowerk2 card itself is an unassuming little number, with two RCA phono analogue inputs at the back, adjacent to similarly configured analogue outs. Two S/PDIF digital connectors (one in, one out) complete the package. The card itself is tidy looking affair with a Philips SAA7146A 18 bit, 128x continuous calibration DAC and Bitstream ADC. Installation was pretty straightforward, being the usual case of snapping the main card into a PCI slot on the motherboard, and screwing it to the chassis. You then switch on and plough through Windows' autoinstall routine with the supplied Audiowerk disk in your CD-ROM drive. When the driver has loaded, you're greet-

ed by an icon in your system tray, which you can click on to control the action of the card.



The Audiowerk MME Driver Properties application gives full software control of Volume, Recording, Digital I/O and Performance settings. You can select the sampling rate you want the card to use (it supports 32kHz [recording only], 44.1kHz [default playback rate] and 8kHz recording which it defaults to), or press the Auto button if you don't want to worry yourself.

The Audiowerk performed faultlessly in use, both as a soundcard (for Windows sound effects) and as an audiocard for number crunching digital audio in and out. The only blemish on its copybook was the quality of the onboard digital convertors, which although just about up to the job of monitoring, were hardly the last word in sound quality. Compared to my budget reference Cambridge DACMagic 2, the DAC sounded rather hard and steely. The upper midband definitely suffered from a touch of digititis, treble was splashy and harsh and the bass lightweight and unengaging. Overall, not a great sonic performance, and actually inferior to Yamaha's WX-192 at one third

of the price. Ho hum!

Used purely as a digital card and without recourse to its onboard convertors - in conjunction with RME Audio's superb AD-1 for example - things were much better. Given a 44.1kHz the card does bit-for-bit recording with no automatic resampling - this keeps the data integrity of CDs you may be recording, for example. The Driver software proved simple and effective to use and there were no other major problems to report.

Emagic's new Audiowerk2 Production Kit is a fine package with much to recommend it, providing you've already got an off-board DAC plumbed into your sound system.

Emagic Audiowerk2 £199.95
Sound Technology PLC 01462 480000
www.soundtech.co.uk

THE FACTS

PCI Card, 7" depth 32 Bit Busmaster audio co-processor Windows 95/98 & Mac compatible 2 record channels, 4 playback channels RCA unbalanced phono connectors quoted max output level (@ 0dBFS): 1.5 VRMS Bitstream A-D convertor with 18 bit resolution 18 bit, 128x oversampling DACS/P DIF digital I/O via RCA phonos Max sample rate 16bit, 48kHz

WORLD VERDICT



Strong in all respects except its mediocre onboard digital convertors.

NEW MUSIC

Philips' DSS370 USB multimedia monitors could be a blueprint for twenty first century hi-fi, says Nick Tate.

Universal Serial Bus is an interesting format for audiophiles.

Although not directly designed with audio in mind, it just happens to run a direct datastream out of the back of your computer and into the peripherals it controls. In the case of multimedia loudspeakers, that means digital conversion is done in the speaker enclosures themselves, right next to the drive units. As all hi-fi nuts know, this is a good thing.

The £140 package comprises two digital speakers and a single 30-watt ported active subwoofer with a claimed power handling 15W RMS per channel. While this may not seem a lot, it's plenty loud enough for any multimedia application. The two way bass reflex satellites are quite sizeable at 270mm high, and feature 100mm bass drivers and 50mm tweeters with a single 140mm woofer in the sub. At over 7kg for the whole package, the system is fairly sturdily built and certainly looks very swish. The ergonomics are excellent, and certainly raised the tone of my run-of-the-mill PC.

If your PC is USB equipped, which all recent models are, you can install the DSS370s using hot plug'n'play which eliminates the need to install drivers, sound cards, adjust switches, or reboot your PC. "Sound cards and complicated installation are now a thing of the past", says the Philips press release, and amazingly they're right! Unlike Roland's MA 150U USB monitors the DSS370s literally did plug in and play. If you're not USB equipped you can still use these speakers by taking a Line Out from your PC's soundcard into the DSS370's aux input, but you'll lose both the flashy software controls and the theoretical sound quality benefits of doing everything

in the digital domain.

On audition the DSS370 displayed the happy combination of refinement and brio. While ultimately lacking in power compared to hi-fi separates, they still went very loud for their size. Indeed they proved remarkably unconstrained even at near full volume, positively refusing to sit

on musical peaks. Always detailed and clean, the whole package worked well



together and never gave the impression of being out of its depth with demanding full-range recordings. Instead the DSS370s seemed to capture the spirit of every recording they played, even if they couldn't quite convey the scale. Highs were admirably clean, if a little dry, the mid-band well proportioned with secure stereo imaging and a decent amount of stage depth.

The subwoofer generally worked well too, providing you didn't turn it up past about half volume. Set any higher than this, it would begin to intrude on, rather than complement, proceedings by descending in to one note boom. The switchable Dynamic Bass boost proved okay for recordings lacking in bass, but decent full range hi-fi programme simply didn't need it. The other optional effect, Incredible Sound (who writes this stuff?), was literally correct. By boosting the mid-band and playing havoc with the phase,

you got sound from all around, even if it was akin to listening from your bathtub, under water.

It was interesting to hear these Philips USB speakers so soon after the Rolands, which share their fast musical sound - those theoretical benefits of USB really do work in practice. But there are differences too, the Philips being more refined and even handed, the Rolands more muscular and energetic. It's like the difference between German and Italian cars - you pay your money and take your choice.

Overall I was surprised by Philips' DSS370. They really are up to serious monitoring use, providing you stay in the digital domain, keep the sub at bay and avoid the silly DSP effects. Their polished musical sound, plus excellent ergonomics, good looks and decent build add up to a lot for your money.

PHILIPS DSS370 USB £140

**Philips +44 (0)181 665 6350
www.pcstuff.philips.com**

WHY USB?

- Universal Serial Bus is a new standard for controlling PC peripherals like loudspeakers, monitors, key boards and joysticks.
- USB is a medium speed data bus with a 6Mbps (Megabits per second) bitrate, which is easily capable of handling high quality digital audio in all its forms.
- USB speakers take the direct digital audio bitstream from the mother board, and do all digital to analogue conversion onboard the speakers themselves.

WORLD VERDICT



Impressive at the price, with a clean and powerful sound that's addictively musical. Useful facilities and ease of installation a bonus. Recommended.

First came Diamond Multimedia's Rio PMP300 MP3 portable, the player the US music biz tried to ban. Then came a host of pretty undistinguished rivals, offering an extra feature here and there but nothing to write home about. Then the Rio PMP500 arrived, which arguably did for MP3 what Akio Morita's original Sony Walkman did for cassette - turned it into a practical, viable, day-to-day music machine with great son-

heart's delight without so much as a reboot or reinstall. This, plus its fast 1.3Mbps file transfer speeds, makes downloading music from your computer to the player so much easier it's hard to imagine life with parallel ports ever again!

The Samsung software installed effortlessly onto my P166 notebook, and was as easy to understand as any MP3 managers I've tried - it's the usual drag and drop affair, perfectly intuitive and

powerful sounding with little sign of compression. Treble was sweet and clean, bass surprisingly forceful and midband smooth with convincing depth perspective. In absolute terms (compared to my reference Sony CDP-X77ES CD player) the Yepp sat on dynamics a touch, rolled off the frequency extremes and chrome-plated the upper midband slightly, but I must say how surprised I was with how subtle its colourations were.

YEPP, CAN DO!

With its slick sound and swish ergonomics, Samsung's YP-E64 'Yepp' portable makes a great case for MP3 as the format that can do anything.

ics to boot. Now we have Samsung's answer in the shape of the second generation Yepp, threatening to do the same at a lower price. At £199 the YP-E64 is around £30 cheaper.

What's so great about the Yepp? It's only the second player after the Rio 500 boasting the heady combination of 64MB of flash card memory as standard (giving just under an hour's playing time at MP3's standard 128kbps resolution) and proper, MiniDisc portable-style ergonomics and functionality. Other MP3 walkies might offer one or the other for a few pounds less, but you'll need both if you're going to do serious MP3 playing out on the town.

The Yepp's build is light years ahead of any MP3 portable I've tried to date - its aluminium fronted, plastic backed case weighs just 75g without batteries and is impressively small at just 65x87x17.2mm. In addition to its MP3 playing duties, it can also record up to 128 minutes of voice messages via its built-in microphone (perfect for lectures or interviews) which it can upload to a PC at a later date for storage or editing. Oh, and it also remembers 350 names and numbers too!

The Yepp comes with a parallel port data transfer cable, installation CD containing Yepp Explorer software, two AAA batteries, belt clip, earphones, user guide and optional USB adaptor. This last option is the mark of true second generation MP3 portables - USB offers 'intelligent plug and play', meaning you can plug in and unplug the Yepp to your

unfussy to use. Listening to the music you've just downloaded to the player is simply a matter of pressing the play button, whereupon the YP-E64 displays the track number, name, time and EQ setting. This latter feature is disappointing - separate treble and bass as the Rio 500 are forsaken for four pretty hapless NORMAL, JAZZ, ROCK and CLASSIC presets, with the option of '3D enhancement' which just puts a gaping hole in the stereo image and boosts the presence region. My only other criticisms with the Yepp's otherwise excellent modus operandi is the lack of a backlit display - a big disappointment at this price.

Through a decent hi-fi the Samsung sounded great. Feeding a pair of Musical Fidelity XA200 monoblocks driving Yamaha NS1000Ms the YP-E64 was extremely smooth and refined, running good CD portables very close at 256kbps. Even at hog standard 128kbps MP3 (coded using the Fraunhofer CODEC-equipped MusicMatch Jukebox 4) the Yepp was mightily impressive - Be Bop Deluxe's Modern Music was fast, full and

Overall then, the Yepp has a DAC and analogue output stage as good as any MP3 portable around today and far better than most - given properly encoded MP3s I really believe it's got the measure of MiniDisc. The problem is that the bundled RealJukebox MP3 ripping software isn't adequate, offering as it does a maximum of 96kbps encoding. This is fine for speech, but hi-fi music needs a bare minimum of 128kbps. The answer is to buy some decent MP3 software liked MMJ4.0, with a superb coding engine that runs up to 320kbps! Splash out on a decent ripper and a worthy set of in-ear headphones (the supplied ones look better than they sound), and Samsung's new Yepp is a top way of taking your music on the road.

SAMSUNG YP-E64

MEMORY: 64MB SmartMedia, optional 32MB £79

WEIGHT: 75g

POWER: 2xAAA batteries

SIZE: 65x87x17.2mm

PRICE: £199

WHERE FROM:

www.samsungelectronics.co.uk

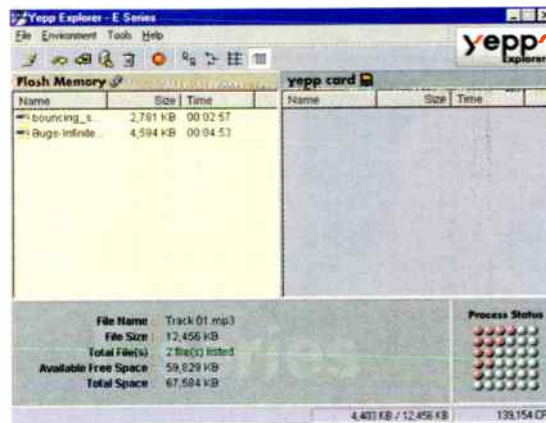

WORLD VERDICT

With great build, generous spec and superb sonics, Samsung's new yepp advances the state of the MP3 art.

marantz®

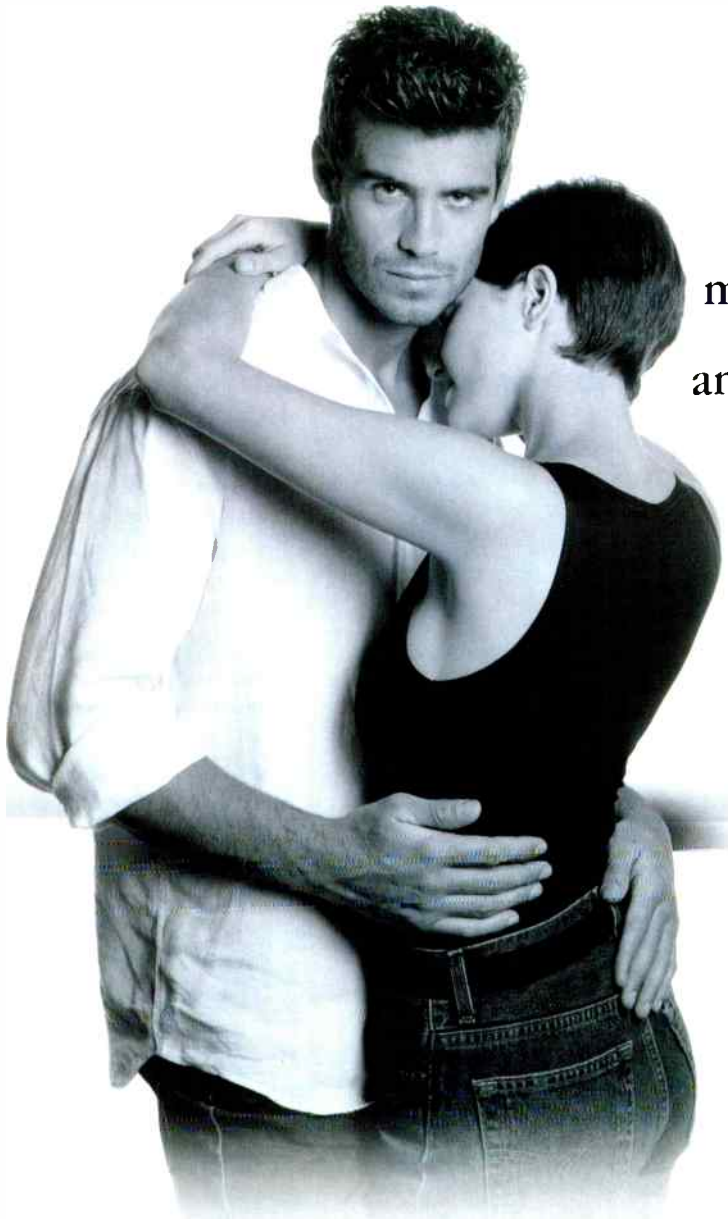

I like my cars fast,
my beer cold,
my women exciting,
and my music played
on Marantz



Telephone: 01753 680868 Internet: www.marantz.com

"Search for H.J. Leak" and you should find it, Richard said. Sure enough, typing the name into Alta Vista brought up the site straight away (<http://home.mira.net/~kiewavly/Leak.html>). Of the hi-fi sites this is one of the most interesting I have seen. It's a fascinating history of one of the earliest and most innovative hi-fi manufacturers. Such histories still being made today but, the way things are going, not for much longer. High fidelity as we know it is becoming progressively more commoditised and as this happens small, specialist companies are less able to make a useful contribution.

The process started with Compact Disc. Until it appeared in 1983, the turntable reigned. The LP - in fact the whole idea of mechanical recording - was born out of experiment rather than science.

Grooves were cut and played first; theories about their behaviour developed afterward.

Science never caught up with the turntable. Vinyl and polished diamonds were honed to produce a performance somewhat better than CD in many areas, such as frequency response and distortion, but improvements couldn't easily be wrought by hard science because the whole system was too approximate. This made the LP fertile territory for small, specialised companies, Linn being just one of course.

For the hi-fi business Compact Disc was a bombshell. It was born from advanced research carried out by Philips and Sony. The outcome of hard science and awesome production engineering across many differing technologies, such as lasers and optics, reflective coatings, servo systems and digital signal processing within dedicated silicon chips, CD players are technologically just about out of reach to small companies. The first ones seemed absurdly complex to me. Little did I realise at the time that the Japanese would find a way to mass produce CD transports to bring their price right down. Back in the early eighties no such thing was ever envisaged or talked about. The sheer complexity of CD seemed enough to be

thinking about, not the impact it would have on the future of high fidelity.

Nowadays, when you buy a CD player from a specialist audio manufacturer it is, at best, built from a medley of bought-in parts. Knowledgeable designers will choose a transport mechanism, use the associated servo-electronics but design the digital and analogue audio processing stages, using a proprietary chip set from Burr Brown, Philips, Crystal or similar. Whilst I can't say there's no skill or experience needed for this, equally there's only a limited amount that can be done to advance sound quality.

A product as complex as a CD player effectively limits the influence of specialists. It is the province of advanced high volume manufacturing techniques in which the Far East specialises. Japan

” A product as complex as a CD player effectively limits the influence of specialists.

moved its manufacturing plants into neighbouring territories with lower labour costs during the late 1980s and everyone else followed them. Intel built a chip fab plant in Malaysia and Sony has its largest overseas manufacturing plant there. Similarly, Philips has factories in Malaysia and its audio headquarters is in Singapore. This is where CD is manufactured, not in specialist Western hi-fi companies.

Deltec almost managed to turn CD back into an area of specialised audio manufacturing by designing their own digital-to-analogue converters. They got as close as you can nowadays to emulating the innovation and quality demonstrated by Leak, if not the breadth of product range. But Deltec, which later became DPA, never managed to get out of their small niche to appeal to a wider audience. In some ways it isn't surprising because commoditised products are sold on features and low price. Deltec could not compete with mass produced CD on price and, in any case, sound quality from Compact Disc has always been strictly limited by its

old late 1970s coding scheme. Unlike analogue systems, digital systems have brick wall quality limits that are difficult to overcome.

As DVD, a highly complex technology, takes over from CD, specialist audio manufacturers will become even more marginalised. Already, tuners and CD players are mass produced from building blocks that exclude the specialist skills that once so distinguished Leak, Quad and others. Solid-state amplifiers are cursedly difficult to improve significantly (although again Deltec managed to be the exception). There's too little latitude here, I feel.

That leaves us loudspeakers. This used to be a fertile area for specialists and Britain especially had a large number of companies. Again, the creeping commoditisation of audio has seen price become ever more important here, putting quality under pressure. Slowly loudspeaker companies are finding it ever more difficult to stay afloat, Mordaunt Short, Epos and TDL all calling it a day. Looking at the history of innovation of Leak and knowing how good their products were (I still use a Troughline tuner) I feel saddened that the days of talented individualist engineers are largely over and histories like this won't happen again. Thankfully we now have a well researched and illustrated appreciation of Leak and Co. on the internet to remind us how the hi-fi business came about. ●



Noel Keywood

506.24 CD Player

From Meridian Audio, the inventors of MLP –
the code chosen by the world's experts for DVD-Audio,
our new updated CD player, now 24 bit.

Who else would you trust?

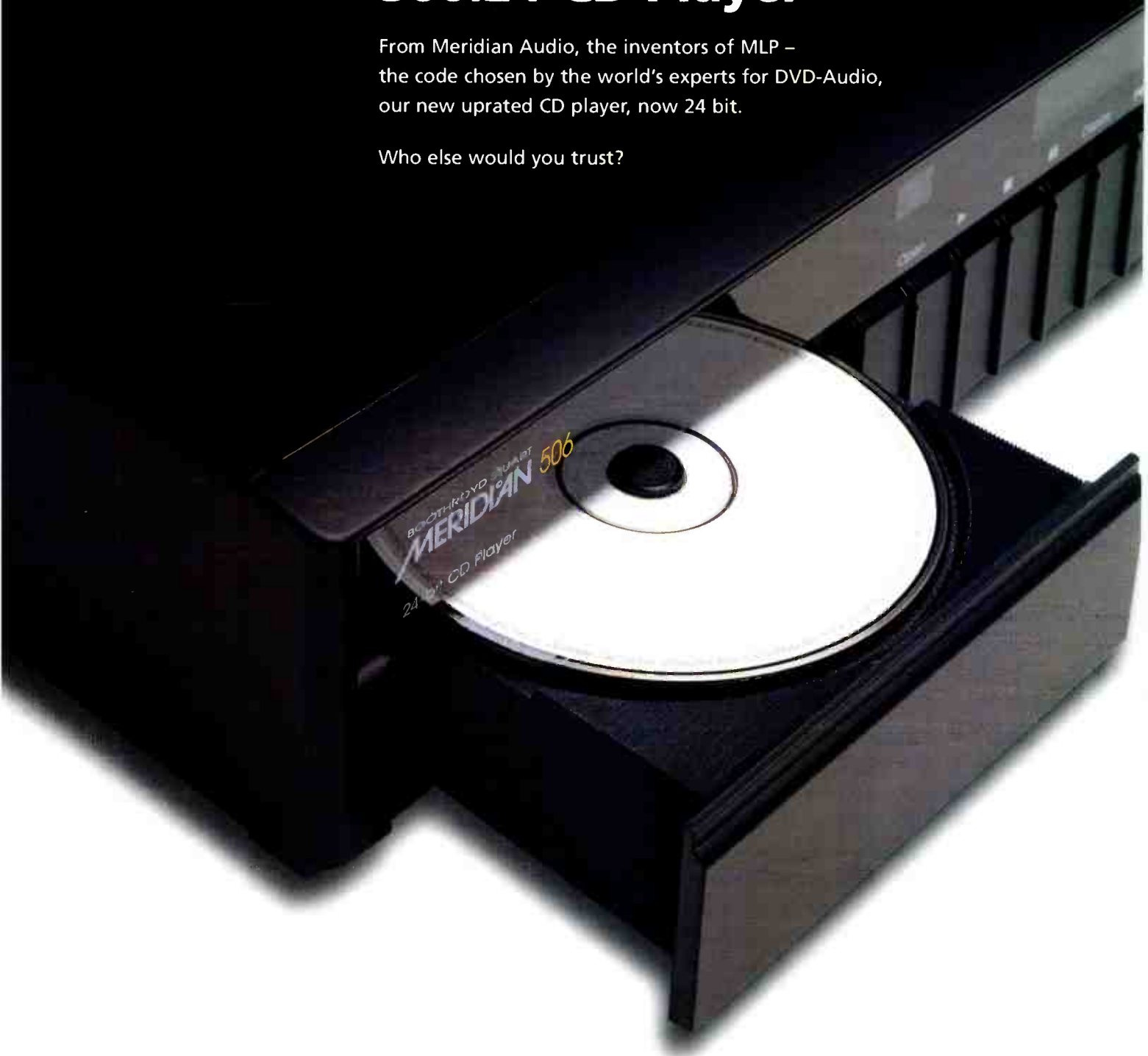

Meridian Audio Ltd

Stonehill Stukeley Meadows Huntingdon England PE18 6ED
T 44 (0)1480 52144 F 44 (0)1480 459934

Meridian America Inc

3800 Camp Creek Parkway Building 2400 Suite 122 Atlanta GA 30331
T (404) 344 7111 F (404) 346 7111

BOOTHROYD STUART
MERIDIAN[®]

<http://www.meridian-audio.com>

Recently I had an exchange with a manufacturer who was looking for a review of his product - an audio accessory. On several occasions during the past eighteen months or so, one or other of the 'World editorial team have held long telephone conversations with said person. Our views were thoroughly sounded out on the likely validity of the product and, by means of rather leading questions, we were able to agree that things had every chance of prospering. Our usual parting remark - you must picture each of us having several of these conversations over the months - was that we should be happy to consider the items for review when we received them.

Upshot - nothing received. So it went on, with each of us in turn giving patient attention to the rather long-winded birth-pangs of the product-to-be. Since negotiations had started, much had changed in the editorial office, with different working procedures in place.

Once the product had arrived, a whole eighteen months later, the calls started again: when would it be reviewed? who was doing it? when were they doing it? Not content with one answer, the manufacturer started the old blanket bombing routine again. Getting an honest 'I can't say as yet' from one of us, the ball bounced straight over to someone else on the team. I'll be perfectly frank: having waited a year-and-a-half for the sample to arrive, we were not minded to drop everything else at once.

Once we'd got past this stage, the tone of the calls took a turn for the worse. The old leading-question routine began again, this time the burden being on the lines of "is it usual for . . ." I'm sure you can imagine the rest. It wasn't long before the recriminations began. Putting the railings into a nutshell (sounds like a conjuring trick), it turns out that the Editorial staff are too young to know anything about anything. And in any case the item was already on sale so our review wouldn't necessarily be

needed anyway and (a more pointed barb, this one) everything would be different if only we (the Hi-Fi World staff) had been wined and dined like we are by all the big manufacturers.

Once you've made this sort of accusation there's really not much point continuing; the light touch has been lost. I won't pretend I didn't give the matter some thought, though. In order to profit by what would otherwise have been wasted time and breath, I thought I'd touch on the matter in a future column, and offer my thoughts on the matter, both for and against. To be even-handed about this, I admit I can readily imagine getting no response from a magazine for a while would be irritating. Never mind that we can hardly move in the main

“ I should say that accumulated years do not necessarily aid effective reviewing

office for stuff either awaiting review or awaiting collection, it's not pleasant to feel shunted into a siding. Similarly, if I felt (whatever I might say to the contrary in the heat of the moment) that a review would be of use to me in getting a product off the ground, I'd be anxious - possibly even a little pushy - too.

There are ways and means. A few years ago I was involved in a production at the Edinburgh Fringe. The 'occasion' was a new musical which had been performed a few times in the community theatres of north Surrey but would here be subjected to its first really critical review in the make-or-break atmosphere of the Fringe. The cast, of which I was one, were all excited; naïf talk of agents with pockets bulging with contracts for West End premieres abounded. If we

were excited, the author/composer was in orbit: a good review in *The Scotsman* and move over Harold Lloyd-Webber, the future has arrived.

To help with this apparently imminent contingency, the author/composer made a tactical blunder: not only did he badger the Scotsman's review staff into attending the show, he then rang the paper's Fringe desk every day at least once to remind them that a review was due. The result? A hammering: "trite lyrics . . . plagiarized tunes . . . will appeal only to deaf relatives of members of the cast . . ."

Going back to our manufacturer, the moral of this tale is painfully obvious. To tie up the odd loose end, I should say that accumulated years do not necessarily aid effective reviewing; if anything, ears are much sharper in youth (pardon? - ed) and the critical faculties have had fewer opportunities of being blunted. Nor are we in the habit of exchanging hospitality for globes; by other names that's bribery and corruption. I assure you if any of that sort of thing had come my way, you wouldn't find me still among the dark, satanic mills of Tooting. Oh no! A few heavy back-handers and I'd have moved up in the world, to Balham. ●



Richard White

Audio Analogue

Puccini Remote & Puccini S.E. Remote



What have the boffins been up to now?

When the boffins at Audio analogue came out with the Puccini and Puccini Special Edition, they grabbed 'Best Buy' status virtually everywhere. They set the standard by which other integrated amplifiers were judged. For build quality, sheer musicality and value for money they were simply unsurpassed. And you might think that all that success would have gone to their heads.

But those boffins at Audio Analogue don't believe in resting on their laurels. They wanted to prove that they could do it again. So they took a fresh look at the Puccini and S.E., and made them into something really special.

First they made them remote controlled. And we're not talking about just any old remote control. They made theirs out of stainless steel, with the smartest little handset you've ever seen. Gave them remote volume and remote electronic input switching, so couch potatoes everywhere can sit back and relax.

Those hyperactive boffins didn't stop there. They added bigger power supplies to give more punch to that lovely natural Puccini sound, fitted a pre-out facility to allow bi-amping, and gave them sophisticated protection circuits.

So now the Puccini and Puccini S.E. are right back on top, where they belong. And those hard-working boffins at Audio Analogue can take a well-earned rest.

For more details and a list of stockists please contact



23 Richings Way, Iver, Bucks, SLO 9DA, England
Tel: 07000-853443 Tel: 01753-652669 Fax: 01753-654531

www.ukd.co.uk

World Radio History

Modem. It's a term that ten years ago most of us had never heard of. Further more, flicking through my fifteen-year-old dictionary it's not even there at all! Which is exactly what I found my computer advising me of when I tried to "log on" the other day. "Could not detect modem. Is it connected and properly installed?" Rebooting and reinstalling the modem proved fruitless. I was on the verge of attacking the computer, John Cleese-style with a broken branch, when the idea came into my head that I should perhaps take a look inside. Now, with hi-fi this has usually proved a disaster, so you can understand my concern. However, I know a little about the workings of the inside of hi-fi separates, but absolutely nothing about computers. On the basis that a little knowledge is a dangerous thing, which explained my cack handedness with hi-fi gubbins, I thought no knowledge whatsoever should be harmless! All I need to do is go in there, wiggle some boards about, and blow the dust out. Imagine my surprise when opening the computer I found it to be a neat, modular stack of boards and drives; just like a hi-fi separates system!

Speaking to friends far more involved with computers than me, I've realised that the whole culture of computer hardware is very much a separates culture (which explains where all those lost hi-fi fanatics of the 70s and early 80s turned to!). Again, as with hi-fi, this has the effect of polarising people in turning them on or off the technology. There are those who love to tweak and try out new cables, modems or what ever it may be, whereas others simply want it all together in one easy package. With computers that means a ready prepared package and an expensive "homeware" back up system. With hi-fi, a mini or "lifestyle" system will do the trick.

The element of Heath Robinson is implicit with both technologies. Less predictable is the influence that the burgeoning computer market has had in the

field of hi-fi separates and accessories. In retailing I've recently been aware of a younger affluent audience that before wouldn't have considered a hi-fi unless it said Sony and came in the box wrapped in brushed aluminium with twinkling blue lights. This new audience is partly here because of sexy new technology, such as MiniDisc, but often I find it's their primary interest in their computer that's brought them here. Certain crossover elements are obvious. A phono lead to connect the hi-fi to computer, or even a basic amp and 'speaker set up purely for the computer.

Then there's MP3. Any hi-fi retailer interested in the budget and accessory end of the scale really should be starting

computer hardware is very much a separates culture (which explains where all those lost hi-fi fanatics of the 70s and early 80s turned to!)

to stock these now. There may be those who consider them to be lo-fi (and they most definitely are at the moment), and to be left to the computer stores but this could have serious implications for their future survival. Hi-fi products are, more and more, relying upon some form of computer software, and there has to be a crossover point in retailing. If you don't believe me take a look at products such as the Philips Pronto remote control. At one time, a £250 remote control would be the preserve of the exclusive high-end hi-fi shops. Now, this particular model is widely sold, not because of a great resurgence in the interest for remote controls, but because it can be connected to a computer to download different screens via Windows. Not only that, there are various, both official and unofficial, Internet sites that can provide even more screen options. You may ask what rel-

evance this has. Well, my feeling is that if software can be downloaded to a remote control now, what's to say that this won't be the case with a CD player in the future? Agreed, there's no miraculous way of downloading an improved digital to analogue converter, or transport mechanism, yet as many hi-fi manufacturers begin to use more computer software in their machines, the possibilities become greater. It may begin by the user being able to add new screen displays or features to their MiniDisc, CD or whatever the prevailing source turns out to be in five years time yet, in time, it could be possible to download sonic upgrades to. The catch is whether or not manufacturers will actually want to do this. Whilst they may be able to profit from upgrades on the web, there are plenty of others out there willing to offer hacks for less or even free.

Whether sonic web upgrades come about or not, there's no denying that the interest in computers looks set to continue for some time, and the influence on hi-fi will prevail even if it's just as a means of connecting the two together and searching for DVD hacks via the web. Which brings me nicely back to my modem. Unplugging it, dusting it down and plugging it back in did the trick! Who said new technology was complicated? ●



Dominic Todd

A Perfect Ten...

For the past 10 years the Wharfedale Diamond has been the UK's most popular loudspeaker. In contrast to almost every other speaker manufacturer, Wharfedale designs all its own components and builds almost every part in its own factories.

These award winning speakers incorporate the finest acoustic engineering that Britain can offer. The advanced technology of the decoupled cabinets; the 'Audio Stealth' moulded rock front and back; elliptically cut mineral loaded sandwich cones; magnetically linearised pole pieces; double wound voice coils all continuing the dominance of Wharfedale's technological leadership since 1932.

Across the world, the UK's No. 1 best selling loudspeaker enjoys the same reaction.

Sound Quality



Value for money



Again confirming that in every way she's a perfect ten.



Wharfedale

Wharfedale International Ltd.
Ermine Business Park
Huntingdon
Cambs PE18 6WA
Tel: 01480 447700
www.wharfedale.co.uk

World Radio History

Diamond 7.1*	£99.9
Diamond 7.2*	£129.9
Diamond Anniversary	£149.9

SUBSCRIPTIONS

**GET TO THOSE CLASSIFIED ADS EARLY AND GRAB A BARGAIN !!!
SUBSCRIBE TO HI-FI WORLD !!!**

UK SUBSCRIPTION £27

Get to our amazing classified ads first and grab a bargain.
Run by dedicated hi-fi engineers and enthusiasts, Hi-Fi World has become famous for its informative reviews and radical kit designs.

MISSED AN ISSUE?

Back issues also available at a cost of £3.50 only (includes P&P), payment by cheque only - overseas please contact for details.
Send cheque to Suite G4, Imex House, The Park Business Centre, Kilburn Park Road, London NW6 5LF

OVERSEAS SUBS RATES

Surface Mail	£40
Airmail Europe	£50
Airmail Middle East & South-East Asia	£60
Airmail USA, Canada, Australia, Japan, Korea and China	£70
<input type="checkbox"/> Airmail	<input type="checkbox"/> Surface mail

NEWS;

**DIY; VALVE AMPS/PRE-AMPS;
SPEAKER KITS; REVIEWS
+ lots more information not published in the magazine.**

VISIT OUR WEBSITE:

WEBSITE: www.hi-fiworld.co.uk

Credit card hotline 9.30AM - 2.30 PM: (44) 01923 270833

Fax: (44) 01923 260 588 (Please fax form below)

By post: Make cheque or postal order payable to Audio Publishing Ltd, sent in an envelope marked Hi-Fi World, FREEPOST LON3478, LONDON, W9 1BR



HI-FI WORLD SUBSCRIPTION CARD

PLEASE REGISTER ONE YEAR'S SUBSCRIPTION FOR HI-FI WORLD

WOULD LIKE TO PAY BY CHEQUE MADE PAYABLE TO AUDIO PUBLISHING LTD CREDIT CARD

DEBIT MY MASTERCARD/ACCESS/VISA ACCOUNT NO:

EXPIRY DATE: SIGNATURE _____ DELIVERY ADDRESS IF DIFFERENT _____

NAME _____

ADDRESS _____

DAYTIME _____

TEL NO _____

START ISSUE _____

Airmail Surface mail

KITS HAVE NEVER

Ki88 VALVE INTEGRATED AMPLIFIER KIT & Ka88 VALVE POWER AMPLIFIER KIT

Here is the amazing Ki88. The circuit is similar to that of the ever popular KEL 34 with a few changes to incorporate the Tesla, JJ branded KT88 power tetrode. This is a pure Class A push-pull design providing 36 watts into an 8ohm load. Gary Devon has come up with a gem of an output transformer (E1). Combined with the KT88 it offers a virtually unmatched result for a valve amplifier. Frequency response measured 11Hz to 75kHz, separation 71dB, noise 98dB, sensitivity 400mV and distortion 0.03%. "As valve amplifiers go, the Ki88 is one of the best measured performances I have ever come across", says Noel Keywood. Jon Marks says, "The Ki88 pulled a series of surprisingly fast, meaty basslines out of its trickbag when dealing with Suzanne Vega's Nine Objects Of Desire album. As if this wasn't enough, the mid and treble were nice too -

THE Ka88, THE POWER AMPLIFIER VERSION OF THE Ki88



£425

NEW!

cymbals had a deliciously natural, golden shimmer without sounding soft, and vocals were extremely transparent and crisply defined. Ki88 didn't hang around when it came to exploiting the virtues of its four output valves on numbers such as 'Leaves' and 'Suspect Sustain' from Cirrus' Land's End Jazz CD. Saxophone had a wonderfully smooth, realistic character, and acoustic guitar mixed speed with harmonic richness to very impressive effect. Asian Dub Foundation and Moloko showed no sign at all of the sluggish, woolly bottom-end and poorly-delineated bass beats that most valve amps are to blame for. Which makes the Ki88 an all-round, high-end bargain." Weight 16kg, external dimensions with valves are 300mm(w) x 300mm(d) x 190mm (h).



£440

KEL34 E&I VALVE INTEGRATED AMPLIFIER KIT

The KEL 34 E&I version is our second generation budget stereo integrated valve amplifier, providing a massive 40 watts of pure valve sound. With 4 line level inputs and one tape output. The KEL 34 E&I is a simple and elegant circuit design using a 6AU6 pentode input valve, an ECC82 double-triode phase splitter and a push-pull pair of Tesla, JJ branded EL34s. The result is a typically sweet, open valve sound with atypical bass control and power. The KEL34 E&I will work its magic into 'speakers of average sensitivity too. Jon Marks says, "tonally the KEL34 E&I is a bit of a smoothie. It has a fast, dynamic sound, plucked guitar strings and bass drum enjoy crisp

leading edges and great impact. Clear imaging and spacious sound staging meant voices and instruments really jumped out of the loudspeaker boxes. Overall the KEL 34 E&I is a beautiful power amp." At the price, this kit is second to none and will open up the benefits of valve amplification to a whole new class of audio nuts! Weight 12kg. External dimensions with valves: 33cm(w) x 27.5cm(d) x 18cm(h).



KEL34 Facelift - if you want your KEL34 to look like the Ki88 this is what you need - £75.00

KEL34 Upgrade Kit - with a superb Panasonic volume control, stargate electrolytics & paper in oil capacitors and fast recovery diodes.

£175

£315

HD83 VALVE HEADPHONE AMPLIFIER KIT

The HD83 is our new headphone amplifier, a beautifully simple design using Mullard ECL83 valves, a triode and power pentode housed in the same envelope. It works directly from any source, be it CD, tape, tuner etc., or from an amplifier's tape out or pre-amp sockets. The circuit utilises high specification output E/I output transformers that will drive any headphone load from 16 ohms to over 300 ohms depending on how the secondaries are wired up. The HD83 is a single-ended design with the power pentode wired up in triode configuration for that added purity and is as quiet as a mouse. For sound quality Jon Marks says, "The bass is punchy and controlled without becoming artificial, while treble has the crispness of the best solid-state, with the tonal purity, delicacy and speed associated with valves. External dimensions 18cm(w) x 30cm(l) x 8cm(h) weight 4kg.



K5881 MkII VALVE AMPLIFIER KIT

A 20watt, Class A power amplifier that uses reliable Russian 5881 output valves, a military version of the American 6L6, designed for low distortion audio work. Now with a super shunt regulated push-pull (SRPP) input stage K5881 offers amazing sound quality. It can be used with a simple passive pre-amp or one of our own pre-amplifiers, and it matches modern loudspeakers well. Weight 15kg external dimensions with valves 40cm(w) x 32.5cm(d) x 17cm(h).



£395

MkII with SRPP input stage! World Radio History

KEL80 MONOBLOCK AMPLIFIER KIT

Following the success of our budget KEL 34 40watt kit amplifier, we have come up with a 'bigger brother' design. The output stage utilises two pairs of TESLA EL34 pentodes in parallel-push-pull mode, allowing KEL80 to turn out 80 watts into an 8ohm load. Heading up the input stage we have the wonderfully linear Russian 6AU6 working into an American 5687 phase-splitter. KEL80's output transformers are 4ohm and 8ohm tapped. With an input sensitivity at around 380mV for full output, it will happily partner both passive and active pre-amplifiers. It is easy to assemble. Simon Pope says, "The proof of the pudding is in the eating and the KEL80 is a feast for the ears, with solid bass attack, lightning fast reactions, that emphasises musicality as well as power, at 590.00 GBP a pair, a definite valve winner. Each monobloc weighs 12kgs., external dimensions with valves: 14cm(w) x 8cm(h) x 11.5cm(d).

£590
A PAIR



BEEN SO GOOD!

KLS10 HIGH TECHNOLOGY COMPACT MONITOR



Our mini-marvel uses an Audax carbon fibre bass/midrange unit, married to the world's most advanced tweeter, the piezo-electric gold dome HD3P from Audax. KLS10 offers high performance from a small package. The main speakers are designed to work alone, or with a dedicated subwoofer to extend their bass. Alone, they are suited to near-wall mounting and can be tuned by port adjustment to suit personal taste and location.

£394

They are easy to drive and need just 30-60watts. KLS10 is unique. Technically advanced, yet compact and relatively inexpensive. There is little to match it. Sensitivity 89dB 1W/1m, 15mm MDF, internal volume 9Ltrs, external dimensions 19cm(w) x 31cm(h) x 23cm(d).

DRIVE UNITS & CROSSOVER KIT £394.00
DRIVE UNITS ONLY £358.00

KLS10 GOLD SUBWOOFER



£149.95

Designed to compliment KLS10 Gold stand mounters by providing a deep and open bass. The subwoofer is inexpensive, easy to build, comprising a simple crossover network to a high quality 8 inch Aerogel dual voice coil unit. A must for all KLS10 Gold customers. Sens. 89dB, volume 25 litres, external dimensions 28cm(w) x 43cm(h) x 34cm(d).

DRIVE UNIT & CROSSOVER KIT £149.95
DRIVE UNIT ONLY £71.00

KLS9 TWO WAY FLOORSTANDER



£230

Here's a storm for you - KLS9, with its BB4 alignment bass cabinet and Audax High Definition Aerogel 8in bass/midrange unit. Designed by Noel Keywood to possess optimal bass damping and a clean step response. Aided by a teensy bit of bass lift, KLS9 really thunders; it will re-arrange your furniture. But it does not waffle, falling silent when there's no bass in the music. Aided by a high power 1in fabric dome tweeter, KLS9 is detailed, evenly balanced and images superbly. It is an easy 12ohm load and is 88dB sensitive. For amps up to 60W. Easy to build and great for beginners. Internal volume 70Ltrs, 18m MDF, external dimensions 25cm(w) x 93cm(h) x 40cm(d).

DRIVE UNITS & CROSSOVER KIT £230.00
DRIVE UNIT PACK £160.00

ALL NEW SERIES II MODULAR PRE-AMP KIT

NEW



The PRE-II is a valve pre-amplifier with six inputs, tape monitor and two sets of output sockets. It utilises a high quality line driver transformer and x5 gain.

The PHONO-II is a dedicated valve phono stage that incorporates a step up transformer for MC users.

Finally, PSU-II is a power supply unit that feeds both the PRE-II and PHONO-II.

POWER SUPPLY UNIT (PSU-II) £175.00
PRE-AMPLIFIER (PRE-II) £175.00
PHONO STAGE (PHONO-II) £100.00
LINE DRIVER STEP UP TRANSFORMER £49.00

KLS12 TWO WAY FLOORSTANDER/STANDMOUNTER



£175

KLS12 is a versatile budget loudspeaker that delivers fine sound quality at a low low price. It utilises Audax's HT210F0 woven fibre glass cone, mid/bass unit, beautifully married with the TW034X0, 34mm diameter doped fabric dome tweeter. Noel Keywood says, 'The KLS12 is a transparent, vividly detailed transducer with fine projection. It has tight well defined bass, which means it is best positioned close to a rear wall. Vocals possess a clean outline with an intense clarity.' At 89dB the KLS12 is easy to drive, thus, it is suitable for 20W and upward power amps. Internal volume = 34.1 litres standmounter external dimensions = 58cm(h) x 24.2cm(w) x 34cm(d) floor stander external dimensions(with sand filled space cavity) = 58cm(h) x 24.2cm(w) x 34cm(d)

DRIVE UNITS & CROSSOVER KIT £175.00
DRIVE UNIT PACK £100.00

KLS3 3 WAY CARBON-FIBRE DRIVER LOUDSPEAKER



£350

KLS3 uses extremely light and stiff carbon-fibre cone drive units for a fast, accurate sound. A dedicated 4inch carbon-fibre midrange drive unit provides the clean, smooth and detailed midrange characterised by superb projection. Its high 90dB sensitivity and near flat 8ohm impedance make it one of the easiest loudspeakers to drive. An ideal loudspeaker for high-end valve amplifiers. 25mm MDF, internal volume 60Ltrs, external dimensions 26cm(w) x 100cm(h) x 35cm(d).

DRIVE UNIT & CROSSOVER KIT £350.00
DRIVE UNIT PACK £230.00

KLS8 TWO WAY HIGH SENSITIVITY

With a sensitivity of 94dB, KLS8 needs very little power. Its 10in. professional bass driver and horn loaded tweeter give it a BIG sound. Ideal for low power amplifiers. Internal volume 50.5Ltrs, external dimensions 29cm(w) x 65cm(h) x 36cm(d).

DRIVE UNIT & CROSSOVER KIT £260.00
DRIVE UNIT PACK £175.00

KLS3 GOLD MK II



£575

ADVANCED TECHNOLOGY THREE WAY LOUDSPEAKER

KLS3 Gold uses the latest version of Audax's innovative oval gold dome piezo electric tweeter, giving it the sweetest and most extended treble. Married to a 4in. carbon fibre cone midrange driver for neutral and clear reproduction, and a powerful 8in. bass driver for superb depth, this is our top-of-the-line reference speaker. Sensitivity 90dB at 1W/1m, 25mm MDF, internal volume 60Ltrs, external dimensions 26cm(w) x 100cm(h) x 35cm(d).

DRIVE UNIT & CROSSOVER KIT £575.00
DRIVE UNIT PACK £450.00

Upgrade your KLS9s to Gold status. Includes latest oval gold dome piezo tweeter and all components.

£330

KLS7 2 WAY CARBON-FIBRE DRIVER FLOORSTANDER

Compact and affordable two way reflex loudspeaker. KLS7's slim dimensions make it easy to accommodate, but it uses top quality carbon-fibre drivers, so performance isn't compromised. An audiophile bargain. Sensitivity 86dB at 1W/1m 12mm MDF, internal volume 18Ltrs, external dimensions 15cm(w) x 80cm(h) x 22cm(d).

DRIVE UNIT & CROSSOVER KIT £195.00
DRIVE UNIT PACK £110.00



PURE



UNCUT



SOUND

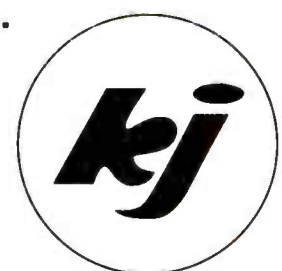

The World's Finest Hi-Fi Systems.

NORTHAMPTON
01604 637871

PETERBOROUGH
01733 341755

LONDON
0171 486 8262/3

WARNING

THESE ARE EXPERT KITS, NOT FOR THE INEXPERIENCED. YOU MUST BE ABLE TO SOLDER AND READ A CIRCUIT DIAGRAM. THE VALVE KITS CONTAIN LETHAL VOLTAGES. WE CANNOT BE HELD RESPONSIBLE FOR ANY ERRORS ARISING FROM THE CONSTRUCTION OF THESE KITS.

ORDER FORM

Please send your completed order form to: **WORLD AUDIO PUBLISHING LTD, Suite G4, Imex House, The Park Business Centre, Kilburn Park Road, London, NW6 5LF Tel/Fax: 0207 328 8387 Order on-line: www.worldaudiodesign.co.uk Website: www.worldaudiodesign.co.uk E-Mail: nick@worldaudiodesign.co.uk**

240/120 option - delete the voltage NOT required. If you wish for a built item, please phone for a quote.

IF YOU WOULD LIKE A DATA SHEET ON ANY OF THE KITS, PLEASE WRITE A 'D' IN THE QTY BOX

WARNING - World Audio Publishing Ltd accept no responsibility for kits, parts or modifications made or supplied by third parties.

Far-East Distributor:
Millennium Hi-Fi & AV
137 Jalan Pendekar 2
Taman Skudai Baru
81300 Skudai, Johor DT
Malaysia
Tel: 07 554 5171
Fax: 07 554 7645
E-mail: mhab@pdjaring.my

DESCRIPTION	ORDER No.	QTY	UK	OVERSEAS
			(inc VAT & carriage) (exc. VAT)	

AMPLIFIER KITS

Series II Pre-amp modules available from 30th June 2000

Power Supply Unit (PSU-II)	<input type="checkbox"/>		£175.00	£150.00
Pre-amplifier (PRE-II)	<input type="checkbox"/>		£175.00	£150.00
Phono Stage (PHONO-II)	<input type="checkbox"/>		£100.00	£85.00
Moving coil step-up transformer	<input type="checkbox"/>		£49.00	£42.00

Kit88 Valve Integrated amplifier kit (with valves).....Kit88-K240/120	<input type="checkbox"/>		£440	£375
Kit88 Valve Integrated amplifier kit (without valves)..Kit88-K240/120	<input type="checkbox"/>		£325	£275
KaT88 Valve Power amplifier kit (with valves).....KaT88-K240/120	<input type="checkbox"/>		£425	£365
KaT88 Valve Power amplifier kit (without valves).....KaT88-K240/120	<input type="checkbox"/>		£310	£265
HD83 Valve headphone amplifier kit.....HD83-K240/120	<input type="checkbox"/>		£175	£150
KEL80 Valve Monoblock Amplifier kit (with valves) ...KEL80-K240/120	<input type="checkbox"/>		£590	£500
KEL80 Valve Monoblock Amplifier kit (without valves) ..KEL80-K240/120	<input type="checkbox"/>		£520	£445
KEL34 E&I 40W push-pull integrated amplifier.....KEL34 E&I -K240/120(with valves).....	<input type="checkbox"/>		£315	£270
KEL34 E&I (without valves)	<input type="checkbox"/>		£270	£230
KEL34 E&I Transformer set (1 main & 2 outputs).....KEL34 E&I -K240/120(T. set)	<input type="checkbox"/>		£130	£110
KEL34 E&I Output Transformer (pair)	<input type="checkbox"/>		£80	£68
K5881 MkII 20W push-pull valve amplifier	<input type="checkbox"/>		£395	£350

LOUDSPEAKER KITS

KLS12 2-way fibreglass driver standmounter/floorstander loudspeaker				
Drive Units + Crossover kit etc	<input type="checkbox"/>		£175	£150
Drive Units	<input type="checkbox"/>		£100	£85
KLS11 3-way aerogel standmounter loudspeaker with piezo gold tweeter				
Drive Units + Crossover kit etc	<input type="checkbox"/>		£595	£505
Drive Units	<input type="checkbox"/>		£470	£400
KLS10 2-way carbon-fibre standmounter loudspeaker with piezo gold tweeter				
Drive Units + Crossover kit etc	<input type="checkbox"/>		£394	£343
Drive Units	<input type="checkbox"/>		£358	£311
KLS10 SUBWOOFER Drive Unit + Crossover Kit etc	<input type="checkbox"/>		£149.95	£130
KLS10 SUBWOOFER Drive Unit.....KLS10-SubD (1 x HM210Z2)	<input type="checkbox"/>		£71	£61
KLS3 3-way carbon-fibre driver floorstanding loudspeaker				
Drive Units + Crossover kit etc	<input type="checkbox"/>		£350	£300
Drive Units	<input type="checkbox"/>		£230	£200
KLS3 Gold 3-way carbon-fibre driver floorstanding loudspeaker with piezo tweeter				
Drive Units + Crossover kit etc	<input type="checkbox"/>		£575	£500
Drive Units	<input type="checkbox"/>		£450	£392
KLS7 2-way carbon fibre driver floorstanding loudspeaker				
Drive Units + Crossover kit etc	<input type="checkbox"/>		£195	£170
Drive Units	<input type="checkbox"/>		£110	£95
KLS8 2-way high sensitivity standmounting loudspeaker				
Drive Units + Crossover kit etc	<input type="checkbox"/>		£260	£225
Drive Units	<input type="checkbox"/>		£175	£150
KLS9 2-way HDA driver floorstanding loudspeaker				
Drive Units + Crossover kit etc	<input type="checkbox"/>		£230	£200
Drive Units	<input type="checkbox"/>		£160	£140

AUDAX DRIVE UNITS

Carriage and packaging please add £6.00 for one unit or a tweeter pair, otherwise add £15.00 for 2-6 units
* Not applicable to overseas prices

High Definition Aerogel Drivers

3inch midrange, 93dB	<input type="checkbox"/>		£35	£30*
4inch midrange, 92dB	<input type="checkbox"/>		£47	£40*
6.5inch bass/mid, 91dB	<input type="checkbox"/>		£53	£45*
8inch bass, 91dB	<input type="checkbox"/>		£64	£55*

Carbon Fibre Drivers

4inch midrange, 90dB	<input type="checkbox"/>		£41	£35*
6.5inch bass/mid, 90dB	<input type="checkbox"/>		£47	£40*
8inch bass, 90dB	<input type="checkbox"/>		£58	£50*

Fabric Dome Tweeters

25mm 92dB for 2 way systems	<input type="checkbox"/>		£15	£13*
25mm 92dB for 3 way systems	<input type="checkbox"/>		£16	£14*
25mm horn loaded 97dB	<input type="checkbox"/>		£25	£21*
34mm 93dB - powerful sound	<input type="checkbox"/>		£26	£22*
Oval Gold Piezo electric dome tweeter, 89dB	<input type="checkbox"/>		£130	£110*

NAME: _____

ADDRESS: _____

POST CODE: _____

COUNTRY: _____

TEL. (DAY): _____

24 hour Credit Card Hotline: Tel: 0207 328 8387

I enclose cheque/postal order for £_____ made payable

to World Audio Publishing Ltd. I wish to pay by Mastercard / Visa /Switch/ Solo.

Please debit my account no:

--	--	--	--	--	--	--	--	--	--	--	--	--	--	--	--	--	--	--	--

Expiry Date: _____ **World Audio History** Signature _____

OVERSEAS PRICES & DETAILS

Please allow for your own local import taxes (customs duties) and for carriage charges, which must be added to the net price.

METHODS OF PAYMENT

International money order in Sterling, Mastercard or Visa.



LONDON

SPECIALIST HI-FI DEALERS

AudioVenue
Respect Audio Visual Consultants
— ONCE IS NOT ENOUGH —



Nakamichi REIO Receiver
X-PIIO & X-ASIO pre power amplifier
Ortophon SIO Cartridge

► Export Orders Welcome ► Home Demonstrations
 ► Multi-Room Design & Installation Service

We at AudioVenue are committed to providing an unrivalled service together with state of the art equipment to achieve the ultimate in home entertainment so whether you are buying, selling, exchanging or just looking for unbiased advice, ensure your first call is to AudioVenue.

Components from £120 - £72,000
0% Credit available. Written quotations on request. Subject to status.

Tel/Fax: +44 (0)181 707 4849 Mobile: +44 (0)973 471 426
email: info@audiovenue.co.uk



think audio think...
Auditorium

0171 384 3030

THE HI-FI SHOP 112 NEW KINGS ROAD LONDON SW6

Soundcraft
INSTALLATIONS

VISIT THE LEADING HI-FI DEALER IN THE SOUTH EAST
"SEE & HEAR THE DIFFERENCE REAL HI-FI MAKES"

LINN NAIM ARCAM REGA
HELPLINE: 01233 624441



AUDIO CONCEPT

27 BOND STREET, EALING
LONDON W5 5AS
TEL: 081 - 567 8703

Audio Analogue, Art Glass, Ash Designs, Avik, B&O, B&W, Cabeltalk, Chord Company, Creek, Denon, Epos, Harman Kardon, Infinity, KEF, Lat, Marantz, Musical Fidelity, NAD, Nakamichi, Nordost, Orelle, Onkyo, Primare, Quad, Roksan, Rotel, Ruark, Sennheiser, SonicLink, Sound Style, Stands Unique, Striaghtwire, Supra, Tag McLaren, Target, Teac, Thorens, van den Hul

10 - 6 pm Mon, Tues, Friday, & Sat
Late night Thur, closed Wed.

Two demonstration rooms
Free local delivery and installation
Repairs and Services

ORANGES & LEMONS

INSTANT 0% FINANCE AVAILABLE
SERVING LONDON FROM BATTERSEA

Juicy fruit from London's newest, freshest hi-fi/home cinema retailer. Telephone demonstrations or just pop in. All the usual, i.e. friendly and efficient service, free home installation - credit cards

THE INNOVATIVE AUDIO VISUAL HI-FI RETAILER ARCAM CABLETALK CHORD CO DENON EPOS MARANTZ NAD NAIM REGA ROKSAN ROTEL ROYD RUARK SOUND-STYLE STANDS UNIQUE YAMAHA

NOW IN OUR FIFTH FLAMBOYANT YEAR.
0171- 924 2040
61-63 WEBBS ROAD, SW11
Visit www.orangesandlemons.co.uk

O'Brien Hi-Fi



MARTIN LOGAN LINN

ARCAM · ANALOGUE · AND ORGAN · AUDIO RESEARCH · AUDIO TECHNICA · BEYER · CABLETALK · CHORD · CREEK · DENON · DEFINITIVE · JAD · JELLY · JMWELL · MUSICAL FIDELITY · NAD · NAIM · OPERA · PIONEER · REGA · ROKSAN · ROTEL · ROYD · SENNHEISER · SHARP · TAG MCLAREN · TARGET · TEAC · TANNAY · THORENS · VAN DEN HUL · YAMAHA

Specialist Hi-Fi, Stereo, Home Cinema, Digital Equipment

0% Instant Finance Available

Free Demonstration Rooms · Free local delivery · Major credit cards · Personal Finance · Mail Order · Installation service · Repair facilities · Sunday and Evening Part BR · 20 min Carriage · 30 min Inst. All Major Part BR · 20 min Carriage

60 Durham Rd, West Wimbledon, London SW20 0TW
Est 1966
Tel: (0181) 946 1528 Fax: (0181) 946 0331

ZEBRA

18-24 Brighton Road,
South Croydon
CR2 6AA
0181 688 2093

NORTH

FRANK HARVEY The Midlands Largest Choice
HI FI EXCELLENCE of Specialist Hi Fi & Home Cinema

163 Spon Street, Coventry
Tel: 01203 525200
Web: http://frankharvey.co.uk

For real choice and the largest range of Hi Fi & Home Cinema products in the Midlands

Acoustic Energy · Atacama · Arcam · Audio Quest · Alphason · Apollo · Bang & Olufsen · B & W · Castle · Cabeltalk · Celestion · Chord · Cyrus · Definitive Technology · Denon · IXOS · Kef · Marantz · Meridian · Monitor Audio · Miller & Kreisel · Mission · Mitchell Gyrodek · Musical Fidelity · NAD · Optimum · Panasonic · Pioneer · Quad · QED · REL · Rega · Rotel · Sennheiser · Sharp · Tag McLaren · Target · Teac · Tannoy · Thorens · Van Den Hul · Yamaha

Much more in store on 3 Floors with 3 dedicated Hi Fi demonstration rooms of the very best Hi Fi
Plus our new Home Cinema Room. Very nice Staff and excellent coffee. Appts Req
Opening Hours 9-30 to 5-30. Tues to Sat Closed all day Monday



INVEST IN OUR EXPERIENCE

CYMBIOSIS
AUDIO & VISUAL SOLUTIONS

6 HOTEL STREET
LEICESTER
TEL: 0116 262 3754

ARCAM · ACOUSTIC ENERGY · CASTLE · CHARIO · CURA
CHORD CO. · DENON · LINN HI-FI & KNEKT · LOEWE
LUTRON · MUSICAL TECHNOLOGY · NAIM · NORDOST
REGA · REVOX · ROTEL · TAG MCLAREN · WADIA

"Customer care at it's best"

e-mail: shop@cymbiosis.com
website: www.cymbiosis.com



Basically Sound
NORWICH ● NORFOLK

Arcam, Audio Analogue, Cabeltalk, Chario, Chord Co., Denon, Epos, Naim Audio, ProAc, Rega, Royd, stax, Talk Electronics, Teac, UKD Opera, Audio Note and many others

The Old School
School road, Braxton Ash
Nr Norwich, Norfolk, NR14 8HG
Tel (01508) 571829



NORTH

THE hi-fi ROOM

50 BRIDGE STREET, MANCHESTER M3 3BN. TELEPHONE: 0161-832 0888/0161-835 1366

An Oasis of Sound

EXCLUSIVE HI-FI AND AUDI VISUAL SYSTEMS

GLASGOW 0141 248 2857 EDINBURGH 0131 220 0909 NEWCASTLE 0191 230 3600 LEEDS 0113 242 7777

THE LEAMINGTON HI-FI COMPANY THE LEADING HI-FI SPECIALIST

ARCAM AUDIOLAB QUAD MERIDIAN MARANTZ DENON PIONEER
YAMAHA NAD MICROMEGA MISSION KEF CELESTION ATACAMA
TECHNICS TRICHORD TDL REL DCS
SINGLE SPEAKER DEM ROOM WHO DO NOT USE ANY COMPARETORS
WE ALSO HAVE FULL DEMONSTRATION OF PROJECTION TV WITH
LASERDISC AND FULL PRO LOGIC SYSTEMS
PART EXCHANGE WELCOME
PLEASE PHONE OR E-MAIL FOR PRICES
WE HAVE IN STOCK OVER 200 LASERDISCS
CALL FOR OUR LATEST CATALOGUE
THE LEAMINGTON HI-FI COMPANY
23a Regent Street, Leamington Spa, Warwickshire CV32 5EJ
Phone: 01926 833644 Fax: 01926 837488 E-mail: k.browne@lembcc.org.uk

audio excellence

WHERE THE MUSIC MATTERS
CHESTER PRESTON
86-90 Boughton, 131 Friargate
Chester CH3 5AQ Preston, PR1 2EE
(01244) 945576 (01772) 263057
TUESDAY - SATURDAY 9.00 - 5.30
CLOSED MONDAY

Demonstrating some of the worlds finest HI-FI
Home Demonstrations a speciality
(see Dial-A-Dealer for complete product range)
Tel/Fax 0161 304 7494 Mobile: 07801 498934
Evening calls welcome
Input to the Pleasure of Music

SERIOUS KIT

The finest range of Hi-Fi in the north.
Stockists of Audionote, Sugden, Impulse, Pro-Ac, Harbeth, Stenfort, Target, Neat, Trichord, Systemdek, Lyra, Proceed, SME, Michell, Heart, Keswick etc etc
Open 10-6pm Mon-Fri
10-5pm Sat
10-2pm Sun
Phone 0161 793 6742
Fax: 0161 727 7042

EAST

The Audio File

AWARD WINNING DEALER
COME AND EXPERIENCE HI-FI AND HOME CINEMA AT ITS BEST
ARCAM ■ AUDIOLAB ■ CYRUS ■ CASTLE ■ B&W
YAMAHA ■ RUARK ■ KRELL ■ AUDIO RESEARCH
SONUS FABER ■ MARTIN LOGAN ■ MARANTZ ■ LINN
NAIM ■ LOEWE ■ DENON ■ ROTEL ■ MICROMEGA
MISSION ■ SOUNDSTYLE ■ QED
THE AUDIO FILE, 41 VICTORIA ROAD,
CAMBRIDGE CB4 3BW
TEL: 01223 368305 FAX: 01223 354975

INTUNE

PROFESSIONAL AUDIO
MAIN AGENTS FOR:
A.T.C. • SONY • NAD • DENON • QUAD • TEAC •
PROJECT • YAMAHA • MONITOR AUDIO •
ROGERS • MISSION • MUSICAL FIDELITY •
PIONEER • MERIDIAN • ALCHEMIST
Also Quality In-Car and Computing
19c East Street, St. Ives, Cambridge PE17 4PD
Tel: 01480 465888

UNIVERSITY AUDIO

EST 1945
MAIN AGENTS FOR
ARCAM, MERIDIAN, B&W, DENON,
MARANTZ, YAMAHA
FOR ALL YOUR HI-FI NEEDS CONTACT
01223 354237
3 PEAS HILL, CAMBRIDGE

Rayleigh Hi-Fi

THE SPECIALISTS
HI-FI HOME CINEMA & MULTI-ROOM SPECIALIST

216 MOULSHAM ST CHELMSFORD 01245 265245	44A HIGH ST RAYLEIGH 01268 779762	132-134 LONDON RD SOUTHEND-ON-SEA 01702 435255	AT DANES WORLD OF FURNITURE LAKESIDE RETAIL PARK W. THIRROCK 01708 680551
---	---	--	--

Apollo, Arcam, Atacama, Audio Technica, Beyer, Bose, Chord, Copland, Creston, Cyrus, Delinive, Technics, Denon, KEF, Krell, Lexicon, Linn Products, Loewe Televisions, Lutron Lighting Controls, Marantz, Micromega, Miller, K. Kreisel, Mission, Naim Audio, Ortofon, Parasound, Pioneer, Proceed, QED, Quad, Rega, Revox, Roksan, Rotel, Ruark, Seleco, Sennheiser, Stands Unique, Stax, Stuart Screens, Tag McLaren, Target, Van den Hul, Wilson Benesch, XLO etc
www.rayleighhifi.com

Johns

Audio & Visual Specialists
Technics Yamaha Sony
Panasonic Kenwood Aiwa
Toshiba Pioneer Mission
*Low, low prices
all year round!!!*
(Established 1959)
142 High St
Seunthorpe, Nth Lincs
01724 843800

STOWSOUNDS

audio consultants
Quality Equipment Available From:
Acoustic Solutions J. M. Labs
Alchemist Neat Acoustics
Atacama Nordost
Audioquest QED
Beyer Sonic Link
Cable Talk Sonneteer
DPA Soundstyle
Electrocompaniet Stands Unique
Exposure Van den Hul
For A Demonstration & Expert Advice Call
Stowmarket (01449) 675060
Stone Farm, Borough Lane, Gt. Fenborough, Stowmarket

BG Audio Visual

9 Hatter Street
Bury St Edmunds
Suffolk
01284 765 227
Bang & Olufsen, Sony,
Technics, Denon,
Yamaha, Rotel, Linn,
Mission, KEF, Jamo,
JBL, Harman, Boston

Lend us your ears and we'll blow your mind . . .
Arcam, A.T.C., B & W, Celestion, Denon, Kenwood, Kef, Marantz, Michell, Mission, Meridian, NAD, Panasonic, Philips, Pioneer, Quad, REL, Rotel, Ruark, Sony, TAG McLaren, Teac, Technics, Yamaha and more
Audition the very best at Lincolnshire's premier Hi-Fi dealer . . .
MANDERS HI-FI LTD
2-4 EDWARD STREET (Off Pasture St.)
GRIMSBY. TEL (01472) 351391

GRAYSTON sound&vision

Alchemist Arcam B&W Boston Acoustics
Castle Acoustics Denon Harman Kardon
KEF Reference Linn Loewe Meridian Musical Fidelity
Philips Pioneer Project Rotel Sennheiser Thomson
Sugden Technics TDL Trichord TDL Trichord
Regular musical and surround sound evenings
Exhibiting Hi-Fi accessories Home Demonstration
33 Sir Isaac's Walk, Colchester
Tel: 01206 577682

SPECIALIST HI-FI DEALERS & SPECIALIST HI-FI DEALERS

SOUTH



Soundcraft

The best in sound advice from Kents premier audio dealer

Telephone our Customer Orderline: 01233 624441

Take advantage of our ex demonstration clearance stock this month. Now is the time to buy that system you always dreamed of. All items listed are individuals sold with warranty, so you need to be quick!

We are even selling our reference Linn Kellik Aktiv system to make way for the new Climax power amplifiers. To guarantee your complete enjoyment some of our equipment may need to be delivered by our qualified installers. There may be a small additional charge for this service, but we will discuss that fully when you call.

Remember you can try before you buy in our period style listening and cinema rooms which are the perfect places to enjoy the delights of quality audio and video entertainment with your favourite recordings. Sit down, relax, trust your own ears and eyes, and our 30 years of experience.

Ex-display stock Loewe TV's: Calida 33inch (silver) £1195, Calida 21 (blue) £485 & Profil (black) 28 £985 + Sony KV28 WF1 widescreen £550 & Sony KV14 Portable £149

Ex-dem Summer Madness Clearance Sale ! July 1999

AE 120 Loudspeakers	£375	Musical Fidelity X-DAC	£199
Castle Avons (Birch)	£650	Musical Fidelity X-Pre&2 X-A50	£500
Denon AV/C 2800 amp	£400	Musical Fidelity KT3 Spks	£950
Linn Majk	£450	Musical Technology Hawks	£350
Linn Kabers (black)	£1000	Musical Technology Condors	£800
Linn AV 5140 Speakers	£1400	Naim IXO Cross over	£350
Linn AV 5120 Centre	£495	Naim SBL Speakers	£1450
Linn LK100	£485	Naim Intro Speakers (black)	£499
Linn LP12/LVII/Cirkus/K9	£900	Naim Credo Spks (black)	£900
Linn Isobariks (Walnut)	£1200	Naim NAF 180 Pwr amp	£350
Linn Kellik Aktiv System	£1200	Rega Brio amplifier	£199
3Clouts, Kaim + Kelliks	£7500	Sony S315 DVD with free discs	£399
Linn Karik III CD	£1350	Sony DBR-925 AV amp	£450
Linn Numerik DAC	£1000	Shahinian Arc Loud speakers	£850
Linn Sara 9s (walnut)	£400	TDL T-Line 2 speakers (cherry)	£399

At 40 High Street, Ashford, Kent TN24 8TE. Our exciting range includes Arcam, Ruark, Linn (CD12 in stock), Loewe TV, Naim, Rega, Rotel & Musical Fidelity. We're open 9-5.30 Mon-Sat. Tel: 01233 624441 Fax: 01233 640333. All items come with a warranty for your security & peace of mind. Why not check out our web site: <http://www.soundcraft-kent.ltd.uk>

SPALDINGS

THE SOUTH EAST'S LEADING HI-FI COMPANY

3 DEM ROOMS A.V.
HOME DEMS., 0% CREDIT
FREE INSTALLATION

LINN . NAIM . MISSION . KEF
DENON . TAG MCLAREN
MARANTZ . MUSICAL FIDELITY
CASTLE

MON TO SAT 9.00 to 6.00, TUE 9.00 to 8.00 Closed
WEDNESDAYS

SEVICE DEPT

325-354 Lower Addiscombe Road, Croydon, Surrey CRO

7AF

Telephone: 0181 654 1231/2040 Facsimile: 0181 655 3922

Stockists of: ARCAM • CREEK • EPOS • LINN •
MERIDIAN • NAIM AUDIO • NAUTILUS 800 •
NEAT • REGA • ROTEL • ROYD • SHAHINIAN •
STAN • YAMAHA •

Infidelity
indecently good hi-fi

9 High Street, Hampton Wick, Kingston upon
Thames, Surrey KT1 4DA. Tel: 081-943 3530
Open Tues - Sat 10.30am - 7.00pm.



Best place in town for Hi Fi and Home Cinema

- * Three demonstration rooms
- * All leading brands
- * Interest Free Credit
- * Good parking facilities

UNILET SOUND & VISION

24-26 UNION STREET, MAIDSTONE ME14 1ED

Tel: 01622 676703 Fax: 01622 676723

ADAMS & JARRETT

East Sussex Leading Hi-Fi Specialists

- Agents for: • REL • KEF • RUARK • CABLETALK
• B&W • ROTEL • TANNOY • MERIDIAN • MARANTZ
• YAMAHA • TALK ELECTRONICS • DYNAUDIO and more
- PLUS - HOME CINEMA SPECIALISTS WITH LISTENING ROOMS
PROFESSIONAL, FRIENDLY ADVICE AND SERVICE -
COME TO THE HI-FI DEALER THAT PUTS YOU FIRST

Tel: 01424 437165/432398

Norman Road, St. Leonards on Sea, East Sussex

JAYSOUND AUDIO

- AUDIO TECHNICA • BEYER • BLAUPUNKT •
 - DENON • DUAL • JBL • JVC •
 - MARANTZ • NAD • ORTOFON •
 - PIONEER • QED • SAMSUNG •
 - SENNHEISER • SHURE • TANNOY •
 - TARGET • TATUNG • TDL • TOSHIBA •
- Free 2 year guarantee on hi-fi & speakers.
- Part exchange welcome.
- Hi-Fi and Car Audio Repairs.
Licensed credit brokers

5 WATERLOO SQUARE

(Opposite Pier)

BOGNOR REGIS WEST SUSSEX

TEL: 01243 828366



Best place in town for Hi Fi and Home Cinema

UNILET Sound & Vision

- * Six demonstration rooms
- * All leading brands
- * Interest Free Credit
- * Free Parking
- * Open 10-4 every Sunday

UNILET SOUND & VISION

35 HIGH STREET, NEW MALDEN,
SURREY, KT3 4BY

Tel: 0181 942 9567 Fax: 0181 336 0820

WORTHING AUDIO

20 Treville Gate, W.Sussex BN11 1UA
(01903) 212133

The friendly shop with the best sound system in the South.
Talk Electronics - Friendly Advice - 3 Year Guarantees
Easy Parking - Open Mon-Sat. 10am-6pm.
Late Night Wed 7.30pm.

Agencies include: Dynaudio, Ruark, Gradient, Marantz,
Restek, Orelle, Sonneteer, Kora, Cymbol, Talk Electronics,
and many more.....

SOUTH WEST ANALOGUE

SME MODEL 10/20/30 Turntables

Michell • Northman Analogue • Garrard • Proest •
Ortofon • Eminent • Rega • Tube Technology • Cables •
Vibex • Rega • Unifon • I.D. Supplies • Esoteric Cables •

01643 851351

Garage, Velthuis, Non S. in de buurt
Recent Closing Service - Quality guaranteed items

WEST



PRICE CHECK
WE WILL NOT BE BEATEN

- AUTHORISED DEALER FOR ALL TOP MAKES
 - EASY PAYMENT TERMS • DEMO ROOMS
 - MAIL ORDER • SERVICE DEPARTMENT
- PHOENIX WAY, ENTERPRISE PARK, SWANSEA (Just off Junc 45, M4)

01792 773644
OPEN 7 DAYS A WEEK

audio excellence

WHERE THE MUSIC MATTERS

Bristol 65 Park Street
Bristol BS1 5PB
(01179) 264975

Cardiff 134/6 Crwys Road
Cardiff CF2 4NR
(01222) 228565

Gloucester 58 Bristol Road
Gloucester GL1 5SD
(01452) 300046

Swansea 9 High Street
Swansea SA1 1LE
(01792) 474608

Exeter
156 Sidwell Street, Exeter, EX4 6RT
(01392) 491194

TUESDAY - SATURDAY 9.00 - 5.30
CLOSED MONDAY

The HiFi Centre

- DEMONSTRATION FACILITIES
- MAIL ORDER
- FINANCE AVAILABLE
- STOCKISTS FOR OVER 70 BRANDS
- CINEMA SURROUND SPECIALISTS
- NORTH WALES LARGEST YAMAHA CINEMA SURROUND SPECIALISTS
- ARCAM, B&W, CASTLE, DENON, MARANTZ, MISSION, QUAD, ROTEL, RUARK, TANNOY, TEAC AND UKD

Have a cheerful chat with Chris, Mike or Steve on:

01978 364500

ACTON GATE AUDIO
RUABON ROAD, WREXHAM, CLWYD



NORTH WALES' LEADING HI FI & HOME CINEMA SPECIALIST
BEST SERVICE • BEST PRICE • BEST ADVICE

50 Victoria Buildings,
Mostyn Avenue,
Craig - Y - Don, Llandudno
Tel: 01492 876788



30 Lord Street, Wrexham, L11 1 LR Tel: 01978 364168

Over 40 years experience



O'Callaghan

TV VIDEO & HI-FI

62 Oliver Plunkett St.,
Cork.
Tel. (021) 273433

ARCAM, CASTLE, B&W,
TECHNICS, PIONEER, SONY

SPECIALIST HI-FI DEALERS * SPECIALIST HI-FI DEALERS

IRELAND

KRONOS HI-FI
 7 Scotch Street Centre, Dunganon, N. Ireland BT70 1AR.
 Tel. 01868 753606
<http://www.kronos-hi-fi-demon.co.uk>
 Open Mon-Sat 9.30-5.30, closed Wednesdays
 Agencies include: Absolute Sounds, Arton, Audion, Audiomea, Cadence, Densen, Ellax, Frameworks, Harman Kardion, JBI, Kabelwerk, Klipsch, Living Voice, Lyrx, LFD, Marantz, Mitchell, MIT, Musical Fidelity, Nottingham Analogue, Oracle, Orelle, Raksan, Rotel, Rmark, Silver Sound, SMF, Sonic Link, Triangle, Trichord, Umson, UKD, VPI, Wilson Benesch, Yamaha.

Hearing is Believing

CLONEY Audio
30 years of Excellence

55 Main Street, Blackrock, Dublin.
 Tel: (01) 2889449/2888477
 Open: Tues - Sat 10 am to 6 pm.
 Thur - Fri 10 am to 6 pm

Arcam
 B&W
 Tag McLaren
 Castle
 Meridian
 Classé
 Copland
 Marantz
 Jadls
 Naim Audio
 Sony
 REL

VALVES & TUBES

CVC Chelmer Valve Company
for audio valves

Buy CVC PREMIUM HI-FI valves direct from us. All valves processed for improved performance. We also have stock of MAJOR BRAND types inc. MULLARD, GEC, BRIMAR, RCA, GE, PHILIPS, etc.

130 New London Road Chelmsford Essex CM2 0RG
 Tel 01245 265865/355296 Fax. 01245 490064
 e-mail :- sales@chelmervalue.com

MISSION YOU MUST LISTEN TO MISSION

THE HI-FI SHOP

AUDIOLAB, B&O, B&W, CASTLE, MERIDIAN, MICROMEGA, ROTEL

OPEN TUES SAT 10.6

PHONE: (01232) 327604 BELFAST

MAIL ORDER

VINYL

REPAIR & DIY

TECHNICAL & GENERAL
 THE ORIGINAL TURNTABLE SPECIALIST

for the Great Classical Turntable, Arms, Cartridges, Styli

CONNOISSEUR • GARRARD • GOLDRING • Lenco • ORTOFON • SHURE • S.M.E • THORENS • WATTS

All available Genuine spares and our own re-manufacture of obsolete parts

NO ILLUSORY 'IMPROVEMENT' NO DUBIOUS OR HARMFUL MODIFICATIONS

Cartridges and stylis, correct radius diamonds, for early recordings - 78s & Lps

TECHNICAL & GENERAL
 P.O.Box 53 Crowborough East Sussex TN6 2BY
 Tel: 01892 65 45 34

MUSONIC STYLE
 SPECIALIST MANUFACTURER & SUPPLIER FOR MORE THAN 40 YEARS REPLACEMENTS & ORIGINALS MANY OBSOLETE 78 VERSIONS PICK UP CARTRIDGES & RECORD ACCESSORIES

MUSONIC (UK) LIMITED
 Unit 13 The Wenda Business Centre Colne Way Watford Hertfordshire WD17 4ND
 Tel: 01927 213942 Fax: 01927 213988
 E-mail: sales@musonic.co.uk Website: www.musonic.co.uk



THE DIRECT DISC
 VINYL VINYL VINYL

Thousands of records always in stock.
 + a full range of sought after compact discs.
 Extensive search service for wanted albums.
 Comprehensive 96 page full catalogue available at £1.50
 Telephone / Fax 01992 447764
 Or visit our web site on www.walrus.co.uk

Looking for **better sound** from your Hi-Fi? **We can help!**

Established specialists in Hi-Fi cables and accessories, we can show you how to get more from your equipment. Much more.



For full information of our extensive range, including Hi-Fi and Home Cinema cables, CD and contact cleaners, and equipment supports... contact us for our **FREE** catalogue quoting ref: ABHW0600.

FREEPHONE 0800 373467
Russ Andrews Accessories Ltd.
 FREEPOST NLW881A, Kendal LA9 9ZA
 Tel: +44 (0)1524 825500
www.russandrews.com
 e-mail: products@russandrews.com

Lifetime Guarantee
30 Day Home Trial
Free Delivery
Freephone Ordering

SERVICES & CONSULTANTS

Front End Problem?
contact
The Cartridge Man

It doesn't have to cost an arm and a leg to get the best - listen to my Koetsu - and Decca - eater.

Also agents for Croit, Hadcock, E.A.R, Michell & Moth.

plus cartridge re-tipping service
0181 - 688 6565
 Website: LISTEN.TO/THECARTRIDGEMAN

atv

- Service & Repairs
- Valve & transistor amplifiers
- Vintage valve Radios
- Hi-Fi VCR's
- Valves Tested

ATV SERVICES
 LEATHERHEAD
 01372 456921

TO REACH 78,000 READERS CALL AMANDA NOW ON 0208 864 4760

"SYSTEM HARMONISING"
 Balance your Sound Reproduction System and extract its **full** potential.

Three-Dimensional Natural Swedish Recordings
 OPUS3 ("Eric Bibb") PROPRIUS ("Cantate Domino")
 PROPHONE ("Jazz at The Pawnshop") Swedish Society. ("Jussi Bjorling")

OPUS3/PENTACONE
 4, Cross Bank Road, BATLEY, W.Yorks.
 Tel FAX: 01924 445039 Email: Peter@pentacone.freeserve.co.uk
<http://www.go.to/pentacone>

STUDER REVOX
 SALES, SERVICE, SPARES
 SERVICE & REPAIR OF
 A77, B77, A700, PR99 &
 36 SERIES
 HI-FI SPARES TO ORDER
 SERVICED MACHINES IN STOCK
 APPROVED CONVERSIONS
E.M.A.S.
 TEL: 01246-275479
 FAX: 01246 550421

SPECIALIST HI-FI DEALERS * SPECIALIST HI-FI DEALERS

WORLD LIBRARY

OVER 40 TITLES ON OFFER!!!

LOUDSPEAKER BOOKS

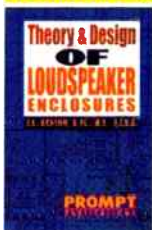

Theory and Design of Loudspeaker Enclosures by **J. E. Benson**
Covers infinite baffle, reflex, passive radiator etc. in great detail with a highly mathematical approach, making it unsuitable for beginners but highly authoritative for experienced designers.
244pp 6" x 9"
Paperback Code: 1140
£23.95 + £2.50 P&P (UK)

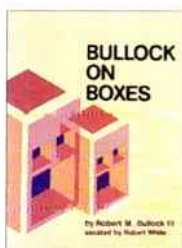

Bullock On Boxes by **Robert M. Bullock III**
Using Thiele-Small parameters clearly, it offers lots of helpful tables and graphs to get to grips with the sizing of the box and part of a reflex loudspeaker.
72pp 8 1/2" x 11"
Paperback Code No. 1100
£12.95 + £2.00 P&P (UK)

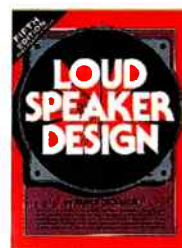

The Loudspeaker Design Cookbook, 5th edition by **Vance Dickason**
This best seller offers up-to-date design information for the home constructor. It uses modern Thiele-Small theory and parameters.
185pp 8 1/2" x 11 1/2" Paperback
Code No. 1090
£22.95 + £3.25 P&P

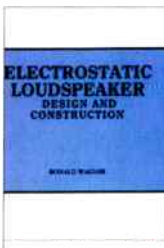

Electrostatic Loudspeaker Design and Construction by **Ronald Wagner**
Step by step guide to the design and construction of a full range electrostatic loudspeaker, including basic operating principles. Strongly recommended for those wanting to either build, repair and/or restore, or who are just interested in electrostatics.
243pp 7" x 9 1/4"
Paperback Code No. 1080
£16.95 + £3.25 P&P (UK)



Testing Loudspeakers+ by **Joe D'Appolito**
Joe D'Appolito, loudspeaker designer and consultant, has written the definitive text on testing loudspeakers. Dr. D'Appolito brings his expertise to the subject and provides you with a hands-on discussion of testing drivers and systems. He brings you the theory and physics behind loudspeaker testing in this volume.
Paperback Code No. 1580
£24.95 + £2.50 P&P (UK)

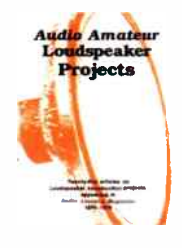

Audio Amateur Loudspeaker Projects
A collection of the 25 best speaker articles published in the Audio Amateur throughout the 1970s, this popular book is proof that great designs are never out of date. This volume is a rich source of theory, practice and design.
135pp 8 1/2" x 11" Paperback
Code No. 1550
£16.95 + £2.50 P&P (UK)

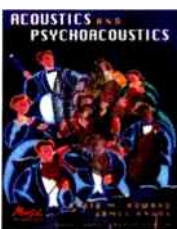

Acoustics & Psychoacoustics by **David M. Howard & James Angus**
An introduction to acoustics, covering human perception of sound, notes and harmony, musical dynamics, timbre of musical instruments, acoustic model for musical instruments, hearing music in different environments, deciving the ear and processing sound electronically
224pp 244 x 189mm
Paperback Code No. 1370
£25.00 + £3.25 P&P (UK)

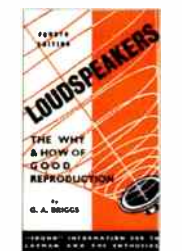

Loudspeakers: The Why and How of Good Reproduction by **G.A. Briggs**
An easy to understand book on building loudspeakers, using empirical techniques that pre-date computer analysis. Strongly recommended for beginners.
88pp 5 1/2" x 8 1/2"
Paperback Code: 1070
£10.95 + £1.50 P&P (UK)

ORDER 4 BOOKS & OVER & PAY ONLY £7.00 P&P (UK ONLY)

AUDIO ELECTRONIC THEORY BOOKS

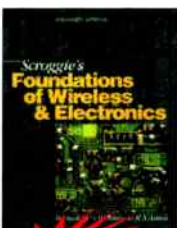

Scroggie's Foundations of Wireless & Electronics by **Roger Amos**
A classic text based on his experience since the dawn of the electronic age. It covers both the theory and practical aspects of a huge range of topics from valve technology, and the application of cathode ray tubes to radar to digital tape systems and optical recording technique.
400pp 234 x 156mm Paperback
Code No. 1590 **£19.99 + £3.00 P&P (UK)**

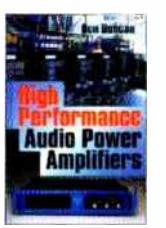

High Performance Audio Power Amplifiers by **Ben Duncan**
This handbook links analog electronics, acoustics, heat and music technology - high-end hi-fi and professional PA and recording studio use; theory, modelling and real-world practice; design and repair: the old and the new, the mainstream and the specialised.
288pp, 234x156mm, Hardback
Code No.1460 **£40.00 + £3.25 P&P (UK)**

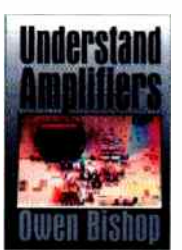

Understand Amplifiers by **Owen Bishop**
Here's a readable introduction for those with little previous knowledge of the subject. The theme of amplification is central to many branches of electronics. The book describes amplifier types, how they work, their properties, advantages and disadvantages, and applications. Amplifiers are treated with the minimum of mathematics and lots of illustrations.
Paperback Code No. 1560
£16.99 + £2.50 P&P (UK)



Inventor of Stereo - The Life and Works of Alan Dower Blumlein by **Robert Charles Alexander**
At last! An authoritative biography of one of the seminal figures in electronics. In addition to inventing stereo, Blumlein made significant contributions to, recording, television, cable and radar. A well informed work, a must for all enthusiasts.
448pp 234mm x 156mm Paperback
Code No: 1660 **£14.99 + £2.50 P&P (UK)**



Electronics made Simple by **Ian Sinclair**
This book covers the basic theory and principles of electronics. A good read for the beginner.
Code No 1420 **£12.99 + £2.00 P&P (UK)**



Build your own High-End Audio Equipment by **Elektor**
Build your own High-End Audio equipment contains construction projects for solid state preamplifiers and power amplifiers, active cross-over filters, an active subwoofer, a mono/stereo compressor and a headphone amplifier.
Code No. 1390
£14.95 + £2.25 P&P (UK)



Audio Electronics by **John L Hood**
The contents are as follows: Tape recording, tuners and radio receivers, preamplifiers and input signals, voltage amplifiers and controls, power output stages, the CD and digital audio, test instruments and measurements, loudspeaker crossover systems, power supplies. Index.
240pp, 246 x 189mm Paperback
Code No.1480 **£19.99 + £3.00 P&P (UK)**



Practical Electronic Fault-Finding and Troubleshooting by **Robin Pain**
This book explains the basic techniques needed to be a troubleshooter, using only basic equipment: a digital multimeter and an oscilloscope. Simple circuit examples are used to illustrate principles and concepts fundamental to the process of fault finding.
240pp 235mm x 156mm Paperback
Code No. 1430
£19.95 + £2.25 P&P (UK)

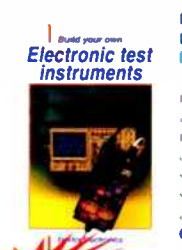

Build your own Electronic Test Instruments by **Elektor**
This book contains designs for 17 measuring instruments, seven generators and analysers, ten miscellaneous instruments and a number of test antennas and auxiliaries. The designs range from a simple multi-core cable designs contain a special printed circuit, drawing of which are given in an appendix.
Code No. 1400 **£15.95 + £3.25 P&P (UK)**

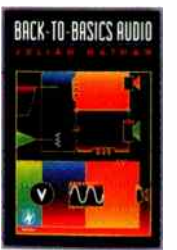

Back To Basics Audio by **Julian Nathan**
A first class reference book covering electrical principals, meters & measurements, amplifiers, transmission lines, sound waves & decibels, loudspeakers, tape recorders, transformers, PSUs, mixers, acoustics, audio cabling assembly methods, installation planning and home cinema. An excellent read.
341pp, 234 x 152mm Paperback
Code No.1610 **£25.00 + £2.25 P&P (UK)**



The LP is back by **Audio Amateurs**
Your complete guide to LP care and maintenance designed to offer you everything useful for those who love and enjoy this older music medium. This covers the theory and care of LPs and the electronics and mechanics of its players.
154pp Paperback Code No.1620
£9.00 + £1.50 P&P (UK)



The Joy of Audio Electronics by **Charles Hansen**
This is a fail-safe guide to the pleasures of hands-on electronic construction. This book covers test and measurement projects, how to build simple kits, safety issues, the workplace, theory and resources. A must for the beginner who plans to build more advanced electronic projects in the future.
124pp Paperback Code No.1650
£10.50 + £2.25 P&P (UK)

VALVE BOOKS

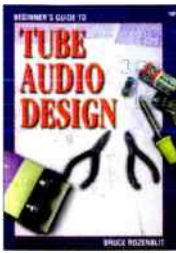

The Beginner's Guide to Tube Design
by **Bruce Rozenblit**
This book takes a comprehensive look at tube audio design. It explains how vacuum tubes work and how to design with them. Rozenblit covers stabilisation and testing, a description of 11 famous and classic amps and preamps and how to work effectively as a designer. A hands-on guide to construction techniques, tools and choosing components and tubes is provided.
1997, 132pp., 8" x 11"
Paper back Code No. 1340
£15.50 + £2.25 P&P (UK)

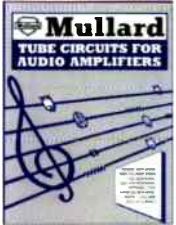

Mullard Tube Circuits for Audio Amplifiers
Includes full designs for eleven power and control amps, including 5-20, using valves. Begins with a four chapter tutorial on getting the best sound from valve amplifiers.
142pp 8" x 10"
Paperback Code 1030
£13.95 + £1.50 P&P (UK)



Radio Designer's Handbook 4th Edition
by **Fritz Langford Smith**
This is a classic reference handbook for all who are interested in the design and application of audio amplifiers and radio receivers, and deals with basic principles and the practical design of all types of classic audio amplifiers, radio receivers and record-producing equipment up to the invention of the transistor, covering valves, valve testing, general theory and components; audio and radio frequencies; power supplies; design of complete AM and FM receivers, and reference information.
1498pp 216mm x 138mm **Hard back Code No. 1600 £35.00 + £6.00 P&P (UK)**

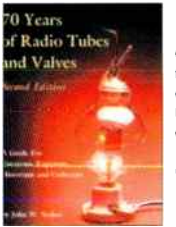

70 Years of Radio Tubes and Valves
by **John W. Stokes**
Outlines the evolution of radio receiving tubes and the part they played in the domestic radio receiver. A reference for those interested in the history and development, and collectors alike.
256pp 8" x 11" **Paper back Code: 1050 £24.95 + £3.50 P&P (UK)**

Valve Amplifiers
by **Morgan Jones, Audio Engineer**
This book allows those with a limited knowledge of the field to understand both the theory and the practice of valve audio amplifier design, such that they can analyse and modify circuits, and rebuild an amplifier. Construction techniques are also provided so readers can build from scratch designs that actually work.
174pp 6" x 9"
Paperback Code No. 1330
£25.00 + 2.75 P&P (UK)

AUDIO ANTHOLOGY BOOKS

Audio Anthologies - When Audio Was Young
Volume One: May '47 to Dec '49
Contents: 9.5W, 5W and 6.5W 6AS7G amps., 30W 300B amp., valve FM tuning indicator, 30W 211 power amp., cathode follower amp. using 6V6, an adaptation of the Williamson amp., valve phono pre-amp., several horn and reflex loudspeaker designs.
Code No. 1150 £14.95 + £2.00 P&P (UK)

Volume Two: Jan '50 to Jul '55
Contents: Ultra linear 6L6 design and operation of the Williamson, a direct coupled amp., Williamson type amp using 6A5s, 40W 845 push-pull amp., valve phono and line pre-amps, valves and loudspeaker damping, design and construction of reflex, horn loudspeakers.
Code No. 1160 £14.95 + £2.00 P&P (UK)



Audio Reality
by **Bruce Rozenblit**
A fine read that investigates conductors, skin effect, impedance, interconnects, speaker cables, balanced lines, transmission lines, power cords, isolation transformers, damping systems, tubes, acoustics and much more. Also, includes 6 excellent detailed valve design projects, 80Watt OHT, 25Watt OTL, grounded grid pre-amp, 150Watt amp., 6550 SE amp, and a grounded grid cast code phono preamp.
Paperback 128pp Code No 1640
Price 21.50 + 2.25 postage (UK)

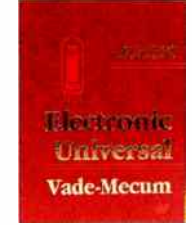

Electronic Universal Vade-Mecum
by **Piotr Mikolajczyk & Bohdan Paszkowski**
This Data book comprises 5693 valves divided into 442 groups. A comprehensive book which contains connection details, operating parameters, load lines and example circuits.
Hard back Code 1060
£49.95 + £ 8.50 P&P (UK)

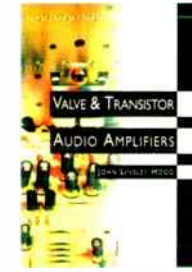

Valve & Transistor Audio Amplifiers
by **J.L. Hood**
This is J.L. Hood's greatest work yet, describing the milestones that have marked the development of audio amplifiers, from the earliest valve amps to the latest solid state design. It is the complete world guide to audio amp design. Other contents: active & passive components, amplifiers, pre-amplifiers and power supplies.
Paperback 250pp. 176mm x 232mm
Code No. 1530 £19.99 + £2.50 P&P (UK)

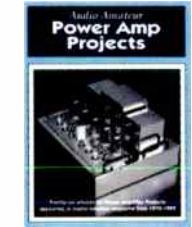

Audio Amateur Power Amp Projects
by the editors of **Audio Amateur**
This illustrated handbook features 26 of the best articles on power amps from 1970-89. Authors from six countries offer an array of designs. To provide almost any level of high-quality audio power needed by the resourceful amateur who prefers the pleasure of building his or her own equipment.
205pp, 8" x 11" **Paper back Code No. 1300 £14.95 + £2.25 P&P (UK)**

Principles of Electron Tubes
by **Herbert J. Reich**
A textbook for beginners starting with the basics of how a vacuum tube actually works. Shows how a simple circuit is designed including amplifiers, transformers and power supplies. A must for both enthusiasts and hobbyists.
398 pp 6" x 9" **Paperback Code No. 1010**
£27.95 + £3.00 P&P (UK)

An Approach to Audio Frequency Amplifier Design
Seventeen circuits from 5 to 1100watts - General Electric Co. High quality amp. designs using KT66s, KT88s, DA100s etc. Includes two valve pre-amps complete with phono stages.
126pp 6" x 9" **Paper back Code No. 1020**
£19.95 + £1.75 P&P (UK)

Volume Three: Aug '52 to Jun '55
Contents: Simple valve phono stage, transformer less amplifier using 60B2, 20W 5881 amp., 10W 6V6 amp., stereo valve pre-amp., high quality valve phono stage, a pre-amp for the Williamson, low distortion tone control pre-amp., binaural or stereophonic, transistor phono amp., corner & concrete horn loudspeaker.
Code No. 1170 £14.95 + £2.00 P&P (UK)

Volume Four: Jul '55 to Dec '57
Contents: 18W 5881 amp., 4W single-ended tweeter amp., budget 11W amp., versatile bass/treble control, transistor theory, transistor pre-amp., transistor techniques, battery powered transistor phono pre-amp. and loudspeakers explained.
Code No. 1180 £14.95 + £2.00 P&P (UK)



Tube Amplifiers
by **Kavek & Kavek**
The most beautiful tube amp book in the world. No specs, no test, just 215 gorgeous four colour photos of 654 amps with a short description of each. Including a 12 page explanation of the history of tubes and tubeamps. Appendix with addresses with tech. data.
167pp 9" x 12"
Hard back Code No. 1310
£47.95 + £5.50 P7P (UK)

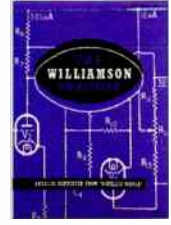

The Williamson Amplifier
by **D.T.S. Williamson**
Offers practical advice on how to build and set up the amplifier for best results.
40pp 8" x 11"
Paper back Code No. 1040
£9.95 + £1.50 P&P (UK)



Build your own Audio Valve Amplifiers
by **Rainer Zur Linde**
This book covers construction projects for pre-amplifiers, power amplifiers and two amplifiers for musical instruments aimed at the practical audio/hi-fi enthusiast, it offers much information on the operation of electron tubes, while the first chapter gives a short history of the thermionic valve.
paperback, 251pp, 235mm x 133mm
Code No.1320 £14.95 + 2.25 P&P (UK)



Fundamentals of Radio-Valve Technique
by **J. Deketh**
This is part of the philips technical series written in 1947 it was one the most authoritative and comprehensive treatments of the nature and function of the vacuum tube.
334pp 6" x 9" **Paper back Code No. 1630**
£21.50 + £2.50 P&P (UK)

Electronic Valves in Audio Frequency Amplifiers
by **E. Rodenhuis**
Originally published in 1954 by Philips, this book encourages amp. builders to experiment with design elements. Discussing the use of valve data, the function of different amplifier stages and includes detailed descriptions of eight designs. A wealth of practical data, measurements and interesting features will be found. A very good read.
Paperback 147pp Code No. 1520
Price £12.95 + £2.00 P&P (UK)

Volume Five: Jan '58 to Dec '59
Contents: Stereo valve multiplex decoder, 7W EL84 amp., valve active crossover and 20W treble amp/50W bass amp., monaural, binaural, monophonic and stereophonic explained, heterodyne FM multiplex adaptor, transistor pre-amp., 60W EL34 amp., high power audio amps, hi-fi loudspeaker enclosure.
Code: 1190 £14.95 + £2.00 P&P (UK)

Volume Six: Jan '60 to Dec '61
Contents: Transistor pre-amps., feedback techniques, the coming of FM stereo, FM multiplex adapters, Tape recorders; distortion, frequency response and noise, 120W 6550 amp., loudspeaker efficiency.
Code No. 1200 £14.95 + £2.00 P&P (UK)

ORDER FORM

Please send (Code No.) _____ (enter codes clearly)

Pay: World Audio Publishing Ltd. £ _____ or debit my Mastercard/Visa/Switch/Solo (Card No) _____

Expiry date: _____ Name: _____ Signed: _____

Delivery Address: _____

Tel: (Day) _____ Please return to: W.A.P. Ltd, Suite G4, Imex House, The Park Business Centre, Kilburn

Park Road, London NW6 5LF, ENGLAND TEL/FAX: 0207 328 8387 Website: www.worldaudiodesign.co.uk E-Mail: nick@worldaudiodesign.co.uk

Please contact us for overseas P&P charges. Allow 28 days for delivery. All orders subject to availability. If further space is required please attach separate sheet.

WELCOME TO DIAL A DEALER

This is a comprehensive directory of Hi-Fi Dealers throughout the UK and Ireland. For your local dealers refer to our County mapguide for your requirements

BEDFORDSHIRE

RICHARD'S AUDIO VISUAL 4 Grayfriars Bedford. Tel: 01234 365165. Stockists of Arcam, Audioquest, Beyer, B&W, Bose, Cable Talk, Celestion, Cyrus, Denon, Heybrook, Marantz, Mission, Moth, Nakamichi, Ortofon, Pioneer, Pro-Ject, Quad, REL, Rotel, Royd, Ruark, Sennheiser, Sound Style, Systemdek, Target, Teac, Thorens, von der Hul & more! Expert friendly service - Listening room, Pioneer Reference Point Visa Access

BIRMINGHAM

SEVENOAKS HI-FI 3 & 4 Kingswalk Shopping Centre, 19-23 King Street, Reading, Berks. RG1 2HG. Tel: 0118 9597768. A specialist Hi-Fi store with two demonstration rooms. The audio visual room is complete with Meridian Digital Surround Sound. Major brands stocked are: Arcam, Audioblab, Cyrus, Denon, Marantz, Meridian, Rose, Yamaha, Acoustic Energy, Castle, B&W, Kef Reference, Monitor Audio & Ruark.

BRISTOL & BATH

THE RIGHT NOTE Tel: Tel.No. (01225) 874728. Just think: most audiophiles listen for most of the time to systems that are 'not quite right'. Are you happy with yours? Forget the reviews and trying to put together a system like a patchwork quilt with the best bits around. It's our job to do the assessing, you judge our results. We'll help you to plan a system for the future, even if you spread the purchases. Leave the 'up-grade-itis' behind, save money and enjoy music all the time. Just listen, and you'll know. CD Acuras, Audio Synthesis, Classe, DCS, Enlightened Audio Design, Meracus, Orelle, Wadia, XTC. Vinyl: Basis, Crown, Jewel, Graham, Michell, Sumiko, Transfiguration, Amps: Acuras, Audio Sculpture & more. Speakers: Audio Arastry, Audio Physics & more. Tuners: Finfare, Magnum Dymtab & many more. Cables: Chord, DMM, Silver. Sounds & more. (Credit Cards Accepted).

VAUDIO HiFi Consultants 36 Druid Hill, Stoke Bishop, Bristol, BS9 1EJ. Tel: 0117 968 6005. ATC, AVI, Alon, Audio Analogue, Audiomeca, Cadence Valve, Chord Amps, Electrocompaniet, Harman Kardon, Heybrook, Jamo, LFD, Lyra, Opera, Ortofon, Pink Triangle, Ruark, Mark Levinson, Michell, REL, SME, Shocore, Sonic Link, Sugden, Townshend, Triangle, Unison Research, Valve Amps. Home Cinema demonstrated including, A/V Amps, DVD Players, Video Projectors and Screens. Demos by appointment only. Home trial facilities. Free installations. We are not a shop.

GLoucestershire

HAZLEMERE AUDIO CONSULTANTS To hear how realistic music can sound please call for an appointment (day or evening). Objective advice, comfortable listening, home demonstrations, free installation, part exchange, repairs and superb service. Acoustic Precision, Air transport, ATC, Audiomeca, Basis, Classe, EAD, Finfare, Henley, Magnipiana, Mirage, Monrio, Muse, Nottingham Analogue, Opera, Ortofon, SD, Sirius, Straightwire, Tice Triangle, Triology VPI. Based in High Wycombe. Please call: 01494 437892.

TECHNO SOUND/ AUDIO INSIGHT 7 Granville Square, Willes, Milton Keynes MK15 9JL. Tel: (01908) 604949. Audiophile Hi-Fi and Home Cinema Specialists. All major brands stocked from Arcam to Yamaha. Home and Digital Home Theatre dealer. Custom home cinema and music room installation. 4 dem rooms and expert advice. Audiophile CDs, LPs and LaserDiscs to buy. Open late on Fridays.

NORTHWOOD AUDIO 98 Cambridge St. Aylesbury, Bucks HP20 1BA. Tel: 01296 428790. Selected sounds from Acoustic Energy, Alchemist, Audio Note, Audio Note, Boston, B & W, Caberick, Carver, Emerson, Chord, The Chord Company, CR Developments, DNM Virtual Reality, Denon, DPA, Epos, Exposure, Gyndel, Harman Kardon, Heybrook, Kef, Klipsch, Marantz, Micromega, Monitor Audio, Moth, Musical Technology, NAD, Nakamichi, Pioneer, PMC, Proac, Rega, Rel, Rose, Rotel, Ruark, Stax, Tannoy, Teac, Talk Electronics, Thorens, Triangle, Tube Technology, and a range of quality pre-used equipment. Export orders welcome. - The ultimate Hi-Fi Specialist experience... a mere phone call away.

CAMBRIDGESHIRE

THE AUDIO FILE 41 Victoria Road, Cambridge. Tel: 01223 368305. For the best in British Hi-Fi and Home cinema entertainment. Visit or call to arrange a dem with products from Audioblab, Arcam, Mission, Linn, Naim, Rega, Cyrus, Absolute Sounds, Kef, Sony, Yamaha, Rel, Quad, Ruark, Denon.

THE HI-FI COMPANY PETERBOROUGH The region's largest range of enthusiast hi-fi. Arcam, Audioblab, B&W, Cyrus, Denon, Kef, Kenwood, Krell, Marantz, Martin, Logan, M&K, Mendian, Mission, NAD, NAIM, Pioneer, Quad, REL, Rotel, Yamaha and many more. Excellent hi-fi and A/V demonstration facilities. Part exchange welcome. Huge selection of top quality, carefully used equipment, telephone for mailing list. 35-42 COWGATE, Peterborough. Phone: (01733) 341755. Fax: (01733) 358141.

CHESHIRE

ACOUSTICA 17 Hoole Rd, Chester CH2 3NH. www.acoustica.co.uk. Tel: 01244 344227. All that's best in HiFi & Home Cinema from quality manufacturers including Naim, Rega, Arcam, Musical Fidelity, Rotel, Seleccion Projectors, Kef, Ruark, Densen, Primare, Teac, JIM Lab, Nakamichi, Quadraspire, Celestion & Crinson. We offer friendly, helpful advice, interest free credit & trade-in facilities, and deliver & install systems throughout Cheshire, Merseyside & North Wales. Opening hours are Tuesday to Saturday 10.00 until 5.30, evenings by arrangement.

ACTON GATE AUDIO 4 Ruabon Road, Wrexham, North Wales. Tel: 01978 364500. Audio Visual Specialists. Arcam, Audio Analogue, Bose, B&W, Celestion, Castle, Denon, Harmon Kardon, Jamo, Marantz, Michell, Mission, Onkyo, Pro-Ject, Musical Fidelity, NAD, Micromega, Myrad, QUAD, Radford, Rotel, Ruark, Tannoy, TDL, Teac, Thorens, UKD, Unison Research, Yamaha, DSP Club Member. Demo Room, installation service. Easy Parking and Motorway access. All major credit cards accepted. 9.30 - 5.30 daily. Closed Weds pm.

INPUT AUDIO Dukinfield, Cheshire. Tel/Fax: 0161 304 7494. Mobile: 07801 498934. We have the time, we have the patience, we have the desire, and we have the products to help you reach your musical goals. featuring: Adyton, Altis, Art, Audiogram, Audio Analogue, Puccini, Audiomeca, Audio Physic, Audio Vector, Base, B.C.D., Chord, Diapason, Graaf, Insert Audio Immedia, Meracus, Monrio, Neat, P.A.D., Siemel Silver Sounds, Stands Unique, System Audio, Triangle UKD Opera, Unison Research, Yamamura-Churchill, YBA. And much more arriving soon, specialising in home demos. Please phone for more information or friendly chat. All usual facilities. Input for the pleasure of music.

DOUG BRADY HI-FI Kingsway Studios, Kingsway North, Warrington, WA1 3NU. Tel: 01925 828009. Fax: 01925 825773. Visa, Mastercard, Lombard Tricity. 2 dem rooms, home trial. Agencies include: Arcam, Tag McLaren, AVI, B&W, Castle, Caspian, Chord Electronics, Exposure, Harbeth, Heybrook, Krell, LFD, Michell, Meridian, Musical Fidelity, Monitor Audio, Naim, Nautilus 800 series, Pink Triangle, ProAc, Roksan, SME, Wilson Benesch, XTC and many more.

PRACTICAL HI-FI 88 Bridge Street, Warrington, WA1 2RF. Tel: 01925 632179. See our main entry under Preston, Lancs.

REPLAY AUDIO CONSULTANTS Tel/Fax Chester (01244) 401290. Cheshire's alternative hi-fi specialists. Honest advice and personal service. We can demonstrate Alchemist, AVI, Henly, Heybrook, LFD, Michell, Moth, Musical Fidelity, NAD, Neat, Origin Live, Ortofon, Pink Triangle, Royd, Sonneteer, Totem, Trichord. Demonstrations by appointment in Chester or in your own home. Delivery & installation available. Mastercard, Visa, Switch, Delta.

SWIFT HI-FI St. Annes Parade, Wilmslow. 01625 526213. Aura, B&W, Denon, Kenwood, Marantz, Nad, Pioneer, Rotel, Systemdek, Tannoy, Revolver, J.P.W., M. Short, Mission, Celestion, Technics, Audioblab, Castle. Open 9.30-6. Dem room. No pressure. BADA member.

CORNWALL

SOUNDS PERFECTION Cornwall's most exclusive Audio retailer. Agencies include: Alchemist, Audio Analogue, Audio Note, Audio Spectrum, Border Patrol, Boston, Electrocompaniet, Elemental Audio, Henley, JIM Labs, Michell, Monitor Audio, Musical Fidelity, Ortofon, Parasound, Sonic Frontiers, Primare, Project, Nordost, Philosophy, REL, Tsunami, S.M.E., Sugden, Stands Unique, Teac, Vienna Acoustics, Triangle, Trichords, Tara Labs, Sonic Link. Home Demonstrations by Appointment. Tel/Fax: 01326 221372. Mobile 0468 754353. E-mail: soundsperfection@mailcity.com

CUMBRIA

MISONS SOUND & VISION Viaduct House, Victoria Viaduct, Carlisle, CA3 8AN. Tel: (01228) 22620. Exposure, Heybrook, Aura, Bang & Olufsen, B & W, Castle, NAD, Quad, Rotel, Sony, Sugden,

Yamaha, Demo Suite. No appts nec. Home trial facilities. Free installation. Service Department Mon - Sat. 9 - 5.30. **PRACTICAL HI-FI** 106 English Street, Carlisle, CA3 8ND. Tel: 01228 44792. See our main entry under Lancaster.

DORSET

MOVEMENT AUDIO 588 Ashley Road, Poole, Parkstone, Dorset BH14 0AQ. Tel: (01202) 730865. Arcam, Audioblab, B&W, Castle, Cyrus, Denon, Kef, Marantz, Meridian, Michell, Micromega, Pioneer, Ruark, Shearpe Audio. 2 Dem rooms. Listen to the available choice and decide at your leisure - no pressure, no obligation. Our staff enjoy music, with our choice of products, you can too! Service Department. Free installation. Home trial facilities. Access, Visa, Amex, Diners Card. Credit facilities available. Open Mon-Fri 10-6. Sat 9-6.

MOVEMENT AUDIO 336 Wimborne Road, Winton, Bournemouth, Dorset. BH9 2HH. Tel: (01202) 529988/520066. Arcam, B&W, Denon, Kef, Marantz, Meridian, Mission, Pioneer, Sony, Yamaha. Full dem facilities available, also home dem. Friendly expert advice. Service Department. Free installation. Home trial facilities. Access, Visa, Amex. Open Mon-Fri 9-5.30.

DAWSONS OF WESTBOURNE Home Cinema Specialists. Main agents for Bang & Olufsen, Harman Kardon, JBL, REL, Mordaunt Short, Sony, Technics and TDL. Demonstration facilities include our unique Dolby pro-logic system comparator for the ultimate way to choose the perfect system. Also on demonstration large screen televisions from Thomson, Sony and Ferguson with video projectors from Sharp and Seleccion. Dawsons, 23 Seamoor Road, Westbourne, Bournemouth 01202 764965.

SUTTONS HI-FI 18 Westover Road, Bournemouth, Dorset. Tel: 01202 555512. You will find the very latest in superb Hi-Fi facilities with stocks to include: Arcam, Cabeltalk, Celestion, Denon, DTS, Kef, Linn, Marantz, Meridian, NAD, Pioneer, QED, Rotel, Sennheiser, Sony, Sound Organisation, Tag McLaren, Target, Teac, Technics, Yamaha, and many more. If you're serious about Hi-Fi you've probably heard of all these brands and probably heard of Suttons too! We've been around for over 45 years. Please call for expert knowledge and friendly advice.

WEYMOUTH HI-FI 33-35 Maiden Street, Weymouth, Dorset DT4 8BA. Tel: (01305) 785729. Arcam, Aura, B&W, Denon, Kenwood, Marantz, Micromega, Musical Fidelity, Panasonic, Quad, Sony, Technica, Yamaha. Dem room. Friendly professional advice. Only quality hi-fi dealer in Weymouth area. Service Department. Free installation. Home trial facilities. Access, Visa, Amex, Switch, Delta Mastercard. Interest free credit. Instant credit. Open Mon-Fri 9.30-5.30 Sat - 9.30-5.30.

ESSEX

GRAYSTON SOUND & VISION 33 Sir Isaac's Walk, Colchester. (01206) 577682. Alchemist, Arcam, B&W, Boston Acoustics, Castle, Denon, Harman Kardon, Kef, Linn, Loewe Opta, Meridian, Michell, Musical Fidelity, Philips, Pioneer, Project, Rotel, Sennheiser. Superb demo rooms, free regional delivery and installation. Regular musical and surround evenings, home demonstrations. Excellent credit facilities.

GLOUCESTERSHIRE

THE RIGHT NOTE - BATH For specialist advice and home demonstrations. See Bristol & Bath.

HAMPSHIRE

HAMPSHIRE AUDIO LTD. 2-12 Hursley Road, Chandlers Ford, Hants, SO53 2FU. Tel Southampton (01703) 252827/265232. 3 Hi-Fi and 2 Home Cinema/Dolby Surround Sound Demonstration Rooms, one with Projection TV and an 8' wide screen. Brands stocked include ARCAM (incl. Xeta), Audioblab, Audioquest, Celestion, Cyrus, Denon, Gradient, Infinity, Kef, Marantz, Meridian, Mission, Polk, Quad, Rotel, Seleccion, Sennheiser, Soundstyle, Tannoy, Target Audio, Thorens, & Yamaha. Established 1969, we offer a 2-year Guarantee covered by our own well-equipped Service Dept. We have a large FREE car parking facility and we are located within 3 miles from Junction 14 (M3/M27 Interchange) and Junctions 13 (M3) and 5 (M27). Closed Mondays, except in December. Late Night: Thurs to 8pm BADA Founder Member. All deposits fully covered by BADA Bonding.

NOW THATS HI-FI 32 Arundel Street, Portsmouth Tel: (01705) 811230. Pioneer, Yamaha, Marantz, Kenwood, Mission, TDL, REL, Attacama and much more. Laserdisc and AC3 specialists. Accessory center at 24 Arundel Way, Portsmouth. Tel: (01705) 811618.

DIAL A DEALER

SOUTH COAST SPEAKERS Ltd 326 Portwood Road, Southampton, Hampshire. Tel: 01703 559312. Hand made Loudspeaker Systems! Tailored to your individual tastes. Many real world veneers. Any colour finish available. U.K. suppliers of Driver Units for: SEAS, VOLTA, MOREL, VISATION, RCI, SCAN-SPEAK & MORE. Home builder kits always on demo. High quality accessories/components, comfortable listening area, ample free parking, friendly advice.

HEREFORDSHIRE

ENGLISH AUDIO 37 Whitecross Road, Hereford, HR4 0DE. (01432) 355081. Arcam, A.T.C., B&W, Castle, Cura, Cyrus Centre, Denon, Dynaudio, JM Lab, KEF, Marantz, Mission, Musical Fidelity, MVL, Naim, ProAc, Pink Triangle, Pioneer, Project, REL, Rotel, Ruark, John Shearner, Stax, System Audio, Tag McLaren, Teac, Vienna Acoustics, Wadia, and Yamaha. Single speaker dem room, home trial facilities, free installation, service dept, Access/Visa. Credit arranged. Open Mon-Sat, 9.30-5.30pm. BADA members.

HERTFORDSHIRE

ACOUSTIC ARTS LTD 101 St Albans Road, Watford, Herts. Tel: (01923) 245250 Fax: (01923) 230798 Audio Research, B&W, Boston, Castle, Celestion, Chord, Copland, Denon, Denison, DPA, Jads, KEF, Krell, Marantz, Martin Logan, Michell, Micromega, Rel, Roksan, Ruark, SME, Sonus, Faber, Theta, Thorens, Wilson. 4 demonstration rooms. Purpose built AV studio. Credit available 100 yards from Watford Junction station. Open Tues-Sat 10-5.30 (Thursday open by appointment until 8pm).

AUDIO FILE (THE) 27 Hockerill Street, Bishops Cleeve, Herts. Tel: (01279) 506576. Please see main ad under Cambridgeshire.

AUDIO FILE OBJECTIVE 37 Tower Centre, Hoddesdon, Hertfordshire, EN10 8UD. Tel: 01992 478666 Fax 01992 440431. Selected British and specialist brands. New, Ex-demon, and S/H. Mail order Hi-Fi Purchased. Free Parking.

DARBY'S OF ST ALBANS. 6 Market Place, St Albans, Herts. Tel: (01272) 851596. Hertfordshire's premier Hi-Fi/Audio Visual specialists established 1946. Full Home Cinema demonstration suite. Whether your needs are large or small, we stock it all: Arcam, Yamaha, Quad, Denon, Sony, Bang & Olufsen, Pioneer, REL, KEF, Mission, Ruark, Celestion, Polk, and many more. Free planning service. Free Delivery and basic installation. Full workshop facilities. Open 9-6 Mon-Sat.

KENT

ASHFORD SOUNDRAFT HI-FI 40 High Street, Ashford. Seeking music lovers, male or female, any age, to share common interest in musical Pro-aktiv Hi-Fi Systems. Multi Room of Home Cinema. Attractive unusual equipment in unusual setting, your place or ours, we guarantee lasting pleasure. Open Mon-Sat. Appointment Service or just pop in. Tel: (01233) 624441

DOVER HI-FI 43 High Street, Dover. Tel: 01304 207562. Suppliers of quality hi-fi equipment including, Arcam, Akai, B&W, Denon, Jamo, Mordaunt Short, NAD, Panasonic, ProAc, Quad, Rotel, Ruark, TDL, Technics, Tannoy. Part exchange. Listening room. Service and repairs. Credit facilities. Access/Visa. Open 6 days 9.5-30.

THE LINN STUDIO Sondek LP12 'knekt' Karik Kairn Klout' Kremlin' Keltik' Kaber Keilled' Numerik' Tukan' Wakonda' Majik' Mimik' LK100 'Ekos' Kudos' Arkiv' Brilliant' Lingo' Valhalla' Solkit' Aktiv'...Dream systems for everyone from £2,000 to £30,000+. A new dealership from a specialist family business, established in 1948. Outstanding service and facilities. Multi-room specialist. 123 Snargate Street, Dover, Kent. CT17 9AP. Tel: 01304 201525, Fax: 01304 240135

KIMBERLEY HI-FI 193 Broadway, Bexleyheath, Kent. Tel: 0181 304 3272. Sep dem rooms, Denon, Technics, Kenwood, AiW, NAD, Dual, Wharfedale, Mission, Marantz, Tannoy, Castle, Monitor Audio, Heco, Jamo, Cerwin Vega and many more.

PROGRESSIVE AUDIO 2, Maryland Cr. Rainham, Kent. ME8 8QY. Tel: 01634 389004. Agencies include: Audio Innovations, Audio, Audionote, Audio Mecca, Audio Systems, Audio Static, Audio Technica, Chord Amps, Cogan Hall, Conrad Johnson, Convergant, Denson, Goldring, Impulse, Koetsu, Levinson, IFD, Lyr, Moth, Nordost, Origin Live, Pink Triangle, Proac, SD Acoustics, Silversounds, SME, Sugden, Sumiko, Systemdek, Snell, Target, TDL, Transfiguration, Townsend, Tube Technology, Unison Research, UKD, Voyd, VPI, etc. Demos by appointment.

MATRIX HI-FI SHOWROOM - 65 Darsanth Road, Dartford, Kent DA1 1LU Tel: 01322 292391 Fax: (01322) 229908 E-mail Matrixcomputers@compuserve.com Hi-end, Home Dem. By appointment, over 30 years experience, for enquiries or a chat, give us a ring.

LANCASHIRE

CLEARSTONE 235 Blackburn Road (1/2 mile from city center on the A 666 Blackburn Road) Bolton, Lancs BL1 8BH Tel: (01204) 531423. Bolton's biggest Hi-Fi superstore. Every top brand & all the best buys at guaranteed unbeatable prices. Aiwa, Akai, Arcam, Audiolab, B&W, Bose, Celestion, Denon, Hitachi, Infinity, JBL, JVC, KEF, Kenwood, Marantz, Meridian, Mission, Mordaunt Short, NAD, Panasonic, Pioneer, Rotel, Sony, Tannoy, TDL, Technics, Toshiba, Yamaha. 2 dedicated Hi-Fi Demo rooms and 2 A/V Demo rooms, no appointments necessary. Service department, free installation, home trial facilities, free parking, Access Visa, Amex, Diners. Interest free credit. Open Mon-Wed 10.00-6.00. Thurs-Fri 10.00-7.00. Sat: 9.00-6.00. Sun 11.00-5.00

MARTON MUSIC S Masterson Ave. Read, Burnley, BB12 7PL. for audition of the best stereo and surround sound equipment from BRYSTON (20 yr guar.), MYRAD, PMC, RUARK, YAMAHA, and the latest WILMSLOW-HART electronics, in a comfortable demonstration room through commercial and custom-built speakers including Transmission Line, Open Baffle and Reflex designs. Home demos encouraged for complete satisfaction. Also main agent for Liberty Audiosuite loudspeaker audio measurement system, ETF4.0 room measurement system and LspCAD room/box design/crossover package. Call Tony Seaford anytime for an appointment, a chat or free advice on 01282 773198 (fax 776413), or e-mail 106505.251 @compuserve.com.

ORPHEUS AUDIO Tel: 01257 473175 See our main entry under Greater Manchester.

PRACTICAL HI-FI 43 Friargate, Preston. Tel: 01772 883958. The audio visual specialist, expert advice, instant demonstrations, best prices, instant free credit, part exchange welcome. Extended warranty. Stockists of Yamaha, Castle, Teac, NAD, Lexicon, Arcam, Kenwood, Denon, Sony, Technics, Onkyo, Marantz, Pioneer, Mission, Kef, Celestion, B&W.

PRACTICAL HI-FI 84 Penny Street, Lancaster, LA1 1XN Tel: 01524 39657 See our main entry under Lancaster.

PRACTICAL HI-FI 33/35 Knowsley Street, Bolton, Lancs Tel: 01204 395789 - See our main entry under Lancaster.

PRACTICAL HI-FI 81 Whitegate Drive, Blackpool, FY3 9DA Tel: 01253 300399. See our main entry under Lancaster.

ROMERS HI-FI, 94-96 High Street, Rishton, BBI 4LQ. Suppliers of quality hi-fi equipment including: Linn, Arcam, Cyrus, Quad, Yamaha, Mission, Ruark, Sony, Monitor Audio, NAD, Onky, Bose, Castle, Nordost, Straightwire, Panasonic, Pioneer, Loewe, TDL, JVC, Target, Stands Unique. Specialists in multiroom installations. Access/Visa/Switch. Credit facilities. Open 9.00 - 5.30 Mon-Sat (5.00pm Wed & Sat). Tel: 01254 887799 Fax: 01254 876866

LEICESTERSHIRE

ZOUCH AUDIO Suppliers of quality Hi-Fi, Apollo, Audio Analogue, AVI, Bow Technologies, C.A.T., Celestion, Chord Electronics, Creek, D.C.S., Dyalab, Graham, John Shearn, L.A.T., Lumley, M.I.T., Magnum, Munrio, Musical Fidelity, Musical Technology, Neat, Opera, Orchid, Orelle, Sirius, Stands Unique, Sumiko, Teac, Tice, Townshend, Transfiguration, Unison Research, Wilson Benesch, X.T.C. Open 10.00-5.30. Closed Monday. Zouch Audio, The Old Coach House, off South Street, Ashby De La Zouch, LE65 1AN. For further information call Michael on 01530 414128 or 0976 571875

CYMBIOSIS 6 Hotel Street, Leicester, LE1 5AW. Tel: (0116) 2623754. Email: shop@cymbiosis.com. Arcam, Acoustic Energy, Cable Talk, Castle, Chario, Chord Company, Cura, Denon, Linn Hi-Fi, Linn Knekt, Loewe Televisions, Lutron Lighting, Musical Technology, Naim, Nordost, Projekt Furniture, Rega, Rowox, Rotel, System Audio, Tag McLaren, and Wadia. Multi room design & Installation Service. 4 listening lounges. Installation Service, Finance Available. Open 10-5.30 Monday to Saturday

LEICESTER HI-FI 6 Silver Walk, St Martins Square, Leicester LE1 5EV. Tel: (0116) 2539753. Fax: (0116) 2626097. Arcam, B&W Nautilus, Mission, Cyrus, Marantz, Pioneer, Quad, Tannoy, Copland, Pink Projects, Michell, Technics, Rotel, Rogers, Yamaha, Acoustic Energy, Chord Electronics, Teac, Miller & Kreisler, DPA., Talk Electronics, Greg Loudspeakers, E.T.C. 4 Listening areas over 3 floors. We can demonstrate, deliver and install. Including A/V and Multiroom. Credit Facilities. All cards taken, open 6 days 9.30-5.30.

STEREO SHACK 1-3 Guildhall Lane, Leicester. Tel: (0116) 2530330. Fax: (0116) 2626097. Yamaha, Kenwood, NAD, Mission, Teac, Aiwa, Cerwin Vega, Pioneer, TDL, Thorens, JBL, Rotel, Celestion, Jamo & many more. We are A.V. specialists, 2 dem rooms. We can demonstrate, deliver and install. Credit facilities and all cards taken. Open 6 days 9.30-5.30

LONDON

AUDIOJOY LIMITED Run by enthusiasts for the enthusiasts, in search of a natural and musical sound. Lavardin Technologies amplifiers in synergy with LS3/5a and Harbeth Speakers. Clearaudio turntables, Transfiguration cartridges and Graham tonearms in syntonic systems. Stands Unique, Target, Nordost, Michell, Trichord Research, and finally Rockport fo that little bit extra. www.audiojoydemon.co.uk Tel/Fax 0181 363 4963. Enfield London.

BABBER ELECTRONICS SERVICE CENTRE 158 Uxbridge Road, West Ealing, London, W13 8SB. Tel: 0181 579 6315 Akai, Aiwa, A&R, Celestion, Dual, Goodmans, Harman Kardon, JBL, JVC, Kenwood, Marantz, Panasonic, Sennheiser, Sony, ES range, Tannoy, Technics, Wharfedale, Yamaha and many more. Auth. Service Dept. Credit Facilities. Open 10.30 - 5.30 Mon-Sat.

BILLY VEE SOUND SYSTEM 248 Lee High Road, Lewisham, London SE13 5PL. Tel: 0181 318 5755/0181 852 1321. Arcam, Denon, Marantz, Linn, Mission, Naim, Tag McLaren Pioneer-DVD, Rega, etc 7 domestic style listening lounges. Appts required, service dept, home trial facilities. Interest free credits, Access, Visa, Amex cards accepted. Opened Mon-Sat 10-6.30, Closed Thursday.

CHOICE HI-FI Tel: 0181 392 1959. Specialist dealers in high end quality second-hand equipment. All main brands in stock including Krell, Audio Research, Wadia, Mark Levinson, Sonus Faber, Linn, Naim, SME & many more. Generous price given on trade-in. Part exchange welcome. Also dealers for Trichord, SME, Gamma, Trilogy, Lumley, Boulder & many more.

INFIDELITY 9 High Street, Hampton Wick, Kingston-upon-Thames. Tel: (0181) 943 3530. Full demo suite entry under SURREY

HIFI EXPERIENCE 227 Tottenham Court Road, London W1P 0171 580 3535. Arcam, Audiolab, Mission, Cyrus, Quad, Celestion, Kef, Meridian, Rogers, Tannoy, Yamaha, TDL, Thorens, Marantz, Nakamichi, Musical Fidelity and many more. Open 10.00-7.00 Mon-Fri. 9-6 on Sat. Service dept. Credit facilities. Delivery and free installation.

K J WEST ONE 26 New Cavendish St., London W1M 7LH. 0171 486 8262/63. Fax 0171 487 1432. Two hi-fi & two home cinema dem studios. Appts pref. Home trial. Installation by arrangement. Service dept. Major credit cards. Interest free credit on selected items. Major brands, including Arcam, Audio Alchemy, Audion, Audiolab, Audio Research, B&W, Castle, Chord, Copland, DPA, Epos, Groat, Harbeth, KEF, Klipsch, Krell, Levinson, Marantz, Martin Logan, Meridian, Michell, Micromega, Mission, Musical Fidelity, Nitry Ginty, Pink, ProAc, Quad, Rel, Rega, Sonus, Sonus Faber, Stax, Tannoy, Theta, Unison Research, Vienna Benesch. Open 6 days.

THE LISTENING ROOMS 161 Old Brompton Road, London SW5 0LJ (0171) 244 7750/59. Fax (0171) 370 0192. Linn, Quad, Meridian, Nakamichi, Arcam, Audiolab, Acoustic Energy, SME, Audio Research, Krell, Wadia, Theta, Apogee, Marantz, Mission, Pioneer, Tannoy, Systemdek, Stax, Pink Triangle, Michell, Monitor Audio, Yamaha, Marantz, KEF, Bose, Celestion, Epos, Mission, Denon, Neat Petite. Mon-Sat 10-6pm.

ORANGES AND LEMONS 61-63 Webb's Road, Brixton, SW11. Tel: 0171 924 2040. Visit www.orangeandlemons.com. Juicy fruit from London's freshest Hi-Fi Home Cinema retailer. Our sixth succulent year. Telephone demonstrations, or just pop in. All the usual, i.e. friendly and excellent service, free home installation, credit cards, 0% credit finance available. Subject to market plus... all the very best from Arcam, Cable Talk, Castle Acoustics, The Chord Co., Denon, Epos, Kef, Linn, Marantz, NAD, Naim Audio, Neat, Quad, Rega, Roksan, Rotel, Royal Kean, Sansui, Stands Unique, Yamaha and more.

THOMAS HEINITZ LTD 35 Montagu Road, Balwyn VIC, London, W2 4AH. Tel: 0171 229 2077 Fax: 0171 727 9348 Email: info@thomasheinitz.com. Web site: www.thomasheinitz.com. Established in 1956 Thomas Heinitz has a long history of installing the best music and visual systems available. We continue to offer the highest standard of service in the most relaxed atmosphere. If you require multiroom, AV system or just a high quality audio system then we can supply systems that are tailored to your exact requirements. For more information contact Mike or Alister.

TIME & TUNE For TV, video Hi-Fi, and hi-Ci Hi-Fi we are dealers of: Aiwa, Bose, Hitachi, Jamo, Kenwood, Marantz, Mitsubishi, Nad, Panasonic, Pioneer, Sansui, Technics. For stereo and more come and see us at Time & Tune, 218-222 Whitechapel Rd, London E1 1BJ. Or call 0171 377 3000

GREATER MANCHESTER

ORPHEUS AUDIO. Passion for Total Sound. A renowned Dealer for: Acoustic Precision, Art Audio - Audio Analogue, Audiomeca, Audio Physics, Audio Synthesis, Boulder, Burmester, Cabasse, Conrad Johnson, Croft, DPA, E.A.R., Electrocompaniet, Forsell, Gamma Acoustics, Golden Tube, Groat, Klipsch, Living Voice, Lothar Voigt, Magnum, Meracus, O.M., Ortofon, Ortofon, Ortofon, Papworth, Project, Pentachord, Pink Triangle, Penta, QED, Sequence, Stax, Teac, Triangle, Trichord Research, Tannoy, Unison Research, VPI, Yamamura Churchill, YBA and others. Free delivery/installation. Call for list of part exchange. Demonstrations by arrangement in Standish (17 of the M6) or in your own home without obligation. Tel: 01257 473175 (evening calls welcome).

PRACTICAL HI-FI 65 Bridge Street, Manchester M3 5BQ Tel: 0161 839 8869 See our main entry under Lancaster

SWIFT OF WILMSLOW, 4-8 St. Annes Parade, Wilmslow, Tel: (01625) 526213. Aura, B&W, Denon, Kenwood, Marantz, NAD, Pioneer, Rotel, Tannoy, Revolver, JPV, Open 9.30-6.00pm. 2 dem rooms. No pressure!

MERSEYSIDE

ACOUSTICA 17 Hoole Rd, Chester CH2 3NH. Tel: 01244 344227. See our main entry under "Cheshire".

MIDDLESEX

MUSICAL IMAGES 45 High Street, Hounslow, Middlesex. Tel: (0181) 569 5802. Fax: (0181) 569 6353.

MUSICAL IMAGES 173 Station Road, Edgeware, Middlesex. Tel: (0181) 952 5535. Fax: (0181) 952 5535. Most brands available - see full page advert. Interest free credit, ask for details. Demo rooms. Repairs & Service. Sunday opening - Open all week. A Home Cinema Specialist. Mail order. Part exchange.

OPAL DESIGNS LTD. Rockware Business Centre, 5 Rockware Avenue, Greenford, Middlesex. UB 8 3AA. Tel: (0181) 930 7972. Fax: (0181) 930 7876. Email: jas@opal.co.uk. Home Page: www.opal.co.uk. Hi-Fi and Audio & Home Theatre Consultants. Authorised dealers: Mark Levinson, Proceed, Linn Hi-Fi, Linn Knekt, Runco, Prologos, Faroudja, Stewart Film Screen, Revel Loudspeakers, Stax, Wilson Audio, Martin Logan, Sonus Faber, MIT, Transparent, B&W. Mail order welcome. Credit cards accepted. Please for latest brochure.

DIAL A DEALER

RIVERSIDE HI-FI 422 Richmond Road, East Twickenham, Middlesex. TW1 2EB. Tel: 0181 892 7613 Fax: 0181 892 7749. www.riversidehifi.co.uk Arcam, Bose, B.O. Castle, Copland, Denon, Krell, Marantz, Martin Logan, Michell, Monitor Audio, Musical Fidelity, NAD, Pioneer, Project, Rel, Sonus Faber, Sony, Tag McLaren Audio, Tannoy, Teac, Theta, Wilson. Finance available. Subject to status. Written details available on request. Export orders welcome. UK mail order available. 3 demonstration rooms. All major credit cards. Open 10am-5.30pm Mon-Sat.

NORFOLK

BASICALLY SOUND The Old School, School Road, Bracon Ash (Nr Norwich) Norfolk, NR14 8HG. Tel: (01508) 570 829. Stockists of the following leading Hi-Fi: Arcam, Audio Analogue, Beyer, Denon, Dynavector, Epos, Grado, Naim, ProAc, Rega, Royd, Sennheiser, Talt Electronics, Teac and more. Bada members, 2 comprehensive demo rooms

NORTHAMPTON

CLASSIC HI-FI At Classic Hi-Fi we cover the best in quality sounds. Be it a question of taste, a question of balance or a question of price, we're the ones to help. We stock: Marantz, Nad, Pioneer, Roksan, Yamaha, Heybrook, LFD, Sugden, Rotel, Kenwood, B & W, Kef, Rogers, Monitor Audio, Musical Fidelity, Tannoy, Shearpe Audio, Royd, Audio Alchemie, Teac and many more. For more details call: 01536 310855

LISTEN INN 32 Gold Street, Northampton, NN1 1RS. Tel: (01604) 637871 Making Music with help from Linn, Naim, Rega, Myrrad, Arcam, Denon, Rotel, Yamaha, Marantz, Castle, Shahinian, Epos, KEF, Mission, Tannoy, Chord Company, Cable Talk, Dynavector, Sumiko and others. 2 listening rooms, Open 10am-5.30pm (closed Thursday)

NOTTINGHAMSHIRE

CASTLE SOUND & VISION 48-50 Maid Marian Way, Nottingham, NG1 6GF. Tel: 0115 958 4404. Nottingham's leading hi-fi, multi-room and home cinema store, serving the whole of the East Midlands. Brands stocked include: Alchemist, Audio Valve, Bose, Boston Acoustics, Chaste Acoustics, Chord Electronics, DMP, Denon, Jolida, KEF, Klyne, Linn, Linn Knekt, Lexicon, Loewe, Monarchy, Musical Fidelity, Naim, Nordost, Pink Triangle, Pioneer, Project Turntables, Precious Metals, REL, Rega, Revox, Seleco Projectors, Sheffield Lab, Solidsteel, Sony, Stand Unique, Stereophile, Talk Electronics, TEAC, Wavac, Wilson Benesch and XLO. Large showroom including purpose built home cinema room as well as three demonstration rooms. Home demonstrations and a full installation service available, including multiroom systems. Open 10.00 am - 6.00 pm Tuesday, Thursday, Friday and Saturday. 11.30am - 7.30pm Wednesday. Appointments out of normal shop opening hours can also be arranged

NOTTINGHAM HI-FI CENTRE 120-122 Alfreton Road, Nottingham. Tel: 0115 9786919. Multi-room specialists. Hi-Fi, Home cinema. All leading brands stocked. Three superb demonstration areas. Two year parts and labour guarantee. Home trials. On site service facility. Full delivery and installation service. Easy free parking. BADA Dealer. Established 1968. Mon-Sat 9.00-5.30

OXFORDSHIRE

HI-CAM Buy, Sell, Part Exchange. Good Quality Audio Products. Equipment includes: Naim, Linn, Audioball, Kef, Mission, Krell, Meridian, Rel, Epos, Also Project Equipment. Open Mon-Sun 10.00am - 8.00pm. For genuine & friendly service Tel/Fax 01844 260182 Mobile 0973 233380.

OVERTURE HI-FI, 3 Church Lane, Banbury, Oxon OX16 8LR. Tel: (01295) 272158. Email sales@overture.co.uk Arcam, Bose, B&W Solid, Cura, Denon, KEF, Linn Products, Miller and Kriesel, Mission, NAD, Naim Audio, Yamaha. For sensible unbiased advice, call Oxfordshire's audio experts. Superb demo facilities. No appts. necessary. Home Cinema, MultiRoom and Commercial installations. Access Visa, instant credit. Mon-Fri 10-6 Sat 9.30-5.30

SHROPSHIRE

ADAMS & JARRETT HI-FI and Home Cinema Specialist. Phone or visit us at 6-18 Norman Road, St. Leonards-on-Sea, E Sussex (01424) 437165/432398. Stockists of quality equipment including Audio Innovations, Meridian, KEF, Ruark, Marantz, NAD, JBL, Royd, Dali, Jamo, Onkyo, Rel, Traget, Cable Talk, Technics, TDC, Yamaha, Kenwood. Air conditioned listening rooms, on site service & repair facilities

MID SHROPSHIRE AUDIO 24 Peveril Bank, Dawley, Telford, Shropshire, TF4 2BU. Tel/Fax: 01505 502097 OR mobile: 07930 913536 E-mail roybaggott@hotmail.com Used and ex-dem Hi-Fi equipment, call for current list. Also agent for Audionote, Alchemist, Apollo, Herley, Des gns, Michell, Ortofon, Project, Rothenel Electronics, SME, Stands Unique etc. I will give you top part/ex allowance against any new product. Home dems always a pleasure (I will travel any reasonable distance).

APPOINTMENTS ONLY.

SHROPSHIRE HI-FI St. Michael Street, Shrewsbury, Shrops. SY1 2ES. Tel: 01743 232065. Stockists of Musical Fidelity, Mordant, Short, Sony, Kenwood, Pioneer, Rotel, Denon, B&W, Project, Audio Visual. Products available. Open 9.30 - 5.30pm Mon-Sat.

SOMERSET

SOUTH WEST ANALOGUE Quality British and European Hi-Fi. SME specialists. Mix 2 turntable on demonstration. Michell, Garrard, Project, Ortofon, Tube Technology, Tesseract, Castle, Ensemble Cables. 01643 851351 anytime.

STAFFORDSHIRE

ACOUSTICA 114 Wolverhampton Rd, Stafford ST17 4AH. www.acoustica.co.uk. Tel 01785 258216. All that's best in HiFi & Home Cinema from quality manufacturers including Naim, B&W, Musical Fidelity, Rotel, Seleco Projectors, Kef, Ruark, Densen, Primare, Teac, JM Lab, Nakamichi, Quadraspire, Celestion & Crimson. We offer friendly, helpful advice, interest free credit & trade-in facilities, and deliver & install systems throughout Staffordshire & the Midlands. Opening hours are Tuesday to Saturday 10.30 until 6.00, evenings by arrangement.

SOUND OF MUSIC The alternative Hi-Fi shop. 01270 214143. A.K.G., A.V.I., Alchemist, B.C.D., Blueprint, Castle, Chord Co., Deva, Dynaudio, Dynavector, Electrocompaniet, John Shearn, Kef, Lexicon, Linn, Loewe, Michell, Myrrad, Nordost, Ortofon, Project, Projekt Stands, Q.L.N., Restek, Roksan, Stands Unique, Teac.

SUFFOLK

AANVIL AUDIO, Tel/Fax 01359 240687 Mobile 0467 404874 Music from the Sound Foundry! Suppliers of: [Audio Physic]: loudspeakers, Adyton: amplifiers, Meracrus: CD transports, players, DAC's pre and power amplifiers, Yamamura Churchhill: cables and accessories, ART: Accessories Mail Order Accessories/CD's Cable/Amp Stock Clearance: Phone or fax for further details and ex-demo hardware offers. Most major credit cards accepted

ANGLIA AUDIO The Street, Hessett, Bury St Edmonds, Suffolk. IP30 9AZ. Tel. 01359 270212. "Hi-Fi and speaker centre dedicated to quality hi-fi since 1971. Open 10-6. Closed Weds and Sundays. Evening and Sunday Demos by appointment.

AUDIO IMAGES 128 London Road North, Lowestoft, Suffolk. NR32 1HB. Tel: 01502 582853. Arcam, Acurus, Castle, Rotel, Moch, Triangle, QTA, Sugden, Denon, Yamaha, Mirage, M & K, Definaute, Musical Fidelity, plus the incredible Rothwell range. Refreshingly different selection. Dem Room, Professional AV installer's from budget to high end. Full credit facilities. 9.30 to 5.30 Mon & Sat ~ 9.30 to 6.00 Tues to Fri.

EASTERN AUDIO 41 Bramford Road, Ipswich, Tel. 01473 217 217. Fax 01473 215705. Quad, Arcam, Audioball, Meridian, Mission, Denon, Rotel, Marantz, NAD, Sony, Rogers, Nakamichi, Systemdek, Technics, Celestion, B&W, Tannoy, Morel Thorens and Top Tape. Also stock a wide range of accessories, usual credit facilities. A BADA dealer.

STOWSOUNDS audio consultants, Stone Farm, Borough Lane, Great Finborough, Stowmarket. Tel: 01449 675060. We offer genuine impartial advice and demonstrations of quality audio equipment, racks and accessories. Demonstration by appointment here or in your own home. Some ex-demo and second-hand equipment. Phone for a consultation, demonstration, or price lists and product information.

SURREY

INFIDELITY 9 High Street, Hampton Wick, Kingston upon Thames, Surrey, KT1 4DA. Tel. 0181 943 3530. Stockists of: Arcam, Creek, Epos, Linn, Meridian, Naim Audio, Nautilus 800, Neat, Rega, Rotel, Royd, Shahinian, Stax, Yamaha. Open Tues - Saturday, 10.30am - 7.00pm.

SPALDINGS HI-FI 352-4 Lower Addiscombe Rd., Croydon, Surrey. CR0 7AT. 0181 654 1231/2040. 3 dem rooms and home dem. Free installation/credit. Meridian, Linn, Naim, Quad, Arcam, Audioball, Mission, Denon, Tannoy, Marantz, Ruark. Mon-Sat 9-6, Tues 9-8. Service dept. (3 Dem rooms incl. A.V. 0% credit).

SUSSEX (EAST)

ADAMS & JARRETT For the best Audio Visual Specialist with friendly helpful staff phone or visit us at 6-18 Norman Road St. Leonards-on-sea, East Sussex. Tel. 01424 437165/432398. Meridian, Kef, Ruark, JBL, Marantz, NAD, Dali, Jamo, Onkyo, Rel, Target, Technics, Yamaha, Kenwood, Musical Fidelity, Dynaudio, Denon, Tannoy, B&W, Rotel, Thorens. Interest free credit available subject to status. Visa, Mastercard.

THE POWERPLANT "Brighton's Leading HiFi Shop". 66 Upper North Street, Brighton, Tel. 01273 775978. Fax. 01273 748419. email@powerplant.co.uk. Open 10am-6pm Tues-Sat. Comfortable listening rooms. Experienced and friendly staff. ATC, Arcam, B&W, Cyrus, Rega, Linn, Pro-Ac, Tag McLaren, and much more.

WARWICKSHIRE

LEAMINGTON HI-FI CO 23a Regent Street, Leamington Spa, Warks. CV32 5EJ. Tel: 01926 888644 Fax: 01926 887486 E-mail: thehificompany@dial.pipex.com Web: <http://www.hificompany.co.uk> Arcam - Quad - Marantz - Denon - Pioneer - Yamaha - NAD - Mission - KEF - Celestion - Atacama - Technics - TDL - REL Ixos Single speaker dem room. Permanent Dolby Digital Demonstration with rear projection televisions + DVD laserdisc hardware and software in abundance. Part exchange and credit available - subject to status.

SOUNDS EXPENSIVE 12 Regent St. Rugby, Warwks CV21 2QF. Tel. 01788 540772. Agents for: Arcam, Audioball, B&O, Castle, Celestion, Denon, Dual, Kef, Mission, Marantz, Meridian, Pioneer, Quad, Rotel, Sony, Tannoy, Yamaha & many more. 2 year warranty on all hi-fi separates. 2 Demonstration rooms. Home Trials, All Major Credit Cards Accepted, Mail Order Welcome. Ring Now For Keenest Prices. Open Monday - Saturday 9-5.30. Closed Wednesday. If We Haven't Got It It's Probably Not Worth Having.

STRATFORD HI-FI 10a Chapel Street, Stratford upon Avon, Warwickshire. Tel: (01799) 414533. Arcam, B&W, Bose, Cyrus, Denon, KEF, Marantz, Micromega, Mission, Monitor Audio, NAD, Panasonic, Onkyo, Pioneer, Rotel, Sony, Technics, Yamaha. Demonstration room. Service facilities. Mail order, interest free credit. Open 9.30-5.30 Monday to Saturday. All major credit cards.

WEST MIDLANDS

ACOUSTICA, 114 Wolverhampton Rd, Stafford ST17 4AH. See our main entry under "Staffordshire".

MUSIC MATTERS

Birmingham - 363, Hagley Road, Edgbaston, B17 8DL. Tel. 0121 429 2811.

Soilhill - 93-95, Hobs Moat Road, B92 8JL. Tel. 0121 342 0254.

Stourbridge - 9, Market Street D48 IAB. Tel. 01384 444184.

Sutton Coldfield - 10, Boldmere Road, B73 5TD. Tel. 0121 354 2311. Arcam, Alchemist, Apollo, Audioquest, Audio Research, B&W, Cable Talk, Castle, Celestion, Chord, Copland, Cyrus, Denon, DPA, JBL, Kef, Krell, Marantz, Martin Logan, Meridian, Musical Fidelity, Panasonic, Pioneer, REL, Rotel, Ruark, SME, Sennheiser, Sonus Faber, Tag McLaren, Teac, Theta, Yamaha etc. Classical CD's available at Birmingham only. Demonstration rooms, service and installation. BADA member. VISA / MASTERCARD / AMEX / SWITCH. Open: 10-5.30 Tuesday to Saturday. Late night Thursday till 7.00 (not Stourbridge).

FRANK HARVEY HI FI EXCELLENCE 163 Spon Street, Coventry, CV1 3BB. Tel: 01203 525200. Web Site: <http://www.frankharvey.co.uk>. Much more in store on 3 floors with 3 dedicated Hi-Fi demonstration rooms of the very best Hi-Fi. Plus our new Home Cinema Room. Appts Req. Open 9.30 to 5.30, Monday to Saturday. Authorised agencies include: Acoustic Energy, Atacama, Arcam, Audio Quest, Bang & Olufsen, B&W, Castle, Cable Talk, Celestion, Chord, Cyrus, Definitive Technology, Denon, KEF, Marantz, Meridian, Monitor Audio, Miller & Kreisel, Mission, Michell Gyrodek, Musical Fidelity, NAD, Optimum, Panasonic, Pioneer, Quad, QED, REL, Rega, Rotel, Sennheiser, Sharp, Tag McLaren, Target, Teac, Tannoy, Thorens, van den Hul, Yamaha. Interest free credit and part exchange. Wide screen TV. Projection and Multi room specialists.

SOUND ACADEMY For the Midlands. The Parade, Sutton Coldfield. Tel 0121 321 2445 & High Street, Bloxwich, Nr Wallsall. (sharing the ASDA shopping centre) Tel 01922 493499. Hosts 4 private studios plus a Home Theatre Cinema with Tube & LCD Projectors. The best hi-fi from Naim, Arcam, Audioball, Chord, Meridian, Monitor Audio and many more. So... if you've taken time to read this, please let us make you welcome. Phone 0121 321 2445 for Sutton or 01922 493499 for Wallsall. Call in and to browse our exciting display of hi-fi and home cinema equipment. Mail order available. interest free credit S.T. Status. Open 6 days, 9am to 5.30pm. Please call for late night. Expert Advice. Cable Dressing and Installation.

WILTSHIRE

SALISBURY HI-FI LTD, 15 Catherine Street, Salisbury, Wiltshire SP1 2DF. Tel: (01722) 322169. Arcam, B&W, Celestion, Denon, KEF, Kenwood, Marantz, Meridian, Micromega, NAD, Ruark, Sony, Yamaha, 2 Dem rooms. Friendly, relaxed atmosphere. Professional advice. Home dem available. Service department. Free installation. Home trial facilities. Access, Visa, Amex. Interest free credit. Instant credit. Open Mon-Sat 9-5.30.

THE RIGHT NOTE - See under BATH & BRISTOL heading.

WORCESTERSHIRE

MAX - MIDLAND AUDIO X-CHANGE 181 Franche Road, Kidderminster, Worcs. DY11 5AD. Phone: 01562 822236 • Mobile: 0421 605966 • e-mail: john.roberts20@virgin.com Analogue Hi-end specialist • Open Monday to Saturday 9.30 to 6.00 • Part exchange always welcome • Evening demos arranged by appointment • Service facilities • Free delivery. Suppliers and installers of high quality audio systems, including: Audio Note • Basis • BAT • Densen • Dpa • Electrocompaniet • Mark Levinson • Michell • Nagra • Pass • Primare • ProAc • Rega • Revel • Roksan • SPM • Sugden • UKD • Unison Research • Wadia. Access, MasterCard, Visa and Switch.

YORKSHIRE (EAST)

THE AUDIO ROOM 2 George Street, Hedon, Hull, HU12 8JH. Tel: 01482 891375. Hi-Fi - Home Cinema - Multiroom. Authorised agents for:- Linn Products, Cyrus, Musical Fidelity, B&W, AVI, Marantz (including premium), Denon, NAD, Royd, Quad, Helios, Nakamichi, Tannoy, Sonic Link, QED, Quadraspire, Stands Unique, Soundstyle, Cable Talk, Grado, Sound Organisation, Exposure, Talk Electronics and more. Open Mon-Sat 9am-7pm, 0% Finance Available, 4 Demonstration rooms, home demonstrations available, friendly relaxed atmosphere guaranteed.

ZEN AUDIO 35 George Street, Hull Tel. 01482 587397. "Comfortable listening rooms; Home dems; Personal, friendly service; Free installations. Agencies include: Arcam, Audioball, Atacama, Audio Innovations, Audio Note, Audion, Alchemist B&W, Cable Talk, Chord CO, DPA, Densen, Denon, DNK, EAR, Exposure, Fi-Rax, Harbeth, Heybrook, Impulse, KAR, KEF, Michell, Micromega, Monitor Audio, Musical Technology, Myrrad, NAD, NAIM, Pioneer, REL, Rehdelto, Rotel, Royd, Ruark, Shearpe Audio, Stands Unique, Sugden, Sponsor, Sonic Link, TEAC, TDL, Tube Technology, Vivanco and many others.

YORKSHIRE (SOUTH)

THE HIFI STUDIOS DONCASTER Sunnyfields, Doncaster, DN5 8SA. Tel: (01302) 781387/391193. Fax: (01302) 781387. *HIFI, HOME CINEMA AND MULTI-ROOM EXPERTS* Musical Fidelity, TAG McLaren, Electrocompaniet, ProAc, Ruark, Castle, TEAC, Unison Research, John Shearner, T & A, Impulse Horns, Monitor Audio, Harbeth, Alchemist, Michell Turntables, Nottingham Analogue Studios, Blueprint Audio Analogue, Exposure, Living Voice, Densen, Celestion (A Series only), Opera, Audio Physic, Trichord Research, Nordost, Stands Unique, Stav Electrostatics, Ortofon, Goldring, REL Subwoofers, Yamaha AV, Proceed Digital Cinema. Viewing and demonstration by appointment. Home trials and free installation. Access: Visa and credit facilities. Phone for more information. 10-8pm Tues - Fri, 10-6pm Sat. Closed Monday.

MOORGATE ACOUSTICS 8 Westgate Chambers, Rotherham Tel: 01709 370666, 184 Fitzwilliam Street, Sheffield Tel: 01142 756048 - Audio Alchemy, Arcam, Arcam, Audio Lab, Audio Quest, Beyer, Bose, Canon, Castle, Cyrus, Celestion, Denon, Jamo, John Shearner (Amplifiers), Linn, Marantz, Mission, REL (Sub Woofers), Rogers (Speakers & Amplifiers), Royd, Sennheiser, Spendor, Tannoy "D", T.D.L., Technics, Yamaha. Demo rooms (6), Home Cinema, Access, Visa, Switch, Interest free credit (details available upon request), up to 5 years guarantee.

SOUND ORGANISATION YORK, 2b Gillygate, York YO3 7EQ Tel: (01904) 627108. Carefully chosen Hi-Fi and AV equipment includes Arcam, B&W, Denon, Linn, M&K subwoofers, Naim, Rega, Rotel, Royd, etc 3 dem rooms incl. Home Cinema and Multi-room facilities. Service Department. Home installations. Instant Credit and major credit cards. Closed Mondays. Phone for chat and more details.

YORKSHIRE (WEST)

HUDDERSFIELD HI-FI CENTRE 4 Cross Church St. Huddersfield. (01484) 544668. B&W, Cyrus, Kenwood, Denon, Rotel, Arcam, Musical Fidelity, Quad, Audio Lab, Marantz, Mission, etc. Dem facilities - appointment reqd. Mon-Sat 9-5.30, Thurs 9-8. Closed Wed. Free installation, credit facilities. Access, Visa

HUDDERSFIELD HI-FI CENTRE HALIFAX 3-5 King Cross St. Halifax. 01422 366832. Audio Analogue, Arcam, B+W, Castle, Cyrus, KEF, MF, Mission, NAD, PRO-AC, Sugden, Quad, 2 Dem rooms Mon - Sat 9-5.30 closed Thursday. Credit facilities.

PREMIER AUDIO Wakefield (01924) 255045. A brand new company offering a range of exciting Audiophile products carefully selected and professionally demonstrated. Equipment includes Audio Synthesis, Chord Company, Classe, cable Talk, DPA, EAD, Exposure, Harbeth, Kora, Mirage, Myrrad, Orrelle, Trichord and many others, demonstration facilities, Home demonstrations & free installation. Part Exchange & used equipment Available. telephone for details and opening offers.

SCOTLAND**CENTRAL**

COLIN MACKENZIE'S HIFI CORNER 52 Gordon Street Glasgow 0141 248 2840. Rose St Edinburgh 0131 220 1535, 1 Haddington Place, Edinburgh 0131 556 7901 and 44 Cow Wynd, Falkirk 01324 629011. Audioblab, Cyrus, Sound-Bytes, Meridian, etc. Most major Brands stocked. Free five year guarantee on all loudspeakers, keen prices.

JAMES KERR & Co., 145 Bath St, Glasgow 0141 226 5711. Glasgow's oldest established hifi specialist, now at new larger premises.

LOTHIAN

COLIN MACKENZIE'S HIFI CORNER 52 Gordon Street Glasgow 0141 248 2840. Rose St Edinburgh 0131 220 1535, 1 Haddington Place, Edinburgh 0131 556 7901 and 44 Cow Wynd, Falkirk 01324 629011. Audioblab, Cyrus, Sound-Bytes, Meridian, etc. Most major Brands stocked. Free five year guarantee on all loudspeakers, keen prices.

JAMES KERR & Co., 145 Bath St, Glasgow 0141 226 5711. Glasgow's oldest established hifi specialist, now at new larger premises

MUSIC MILL 72, Newhaven Road, Edinburgh EH6 5QG. Tel: 0131 555 3963 Fax: 0131 555 3964. Audio Research, Copland, Naim Audio, Krell, Roksan, Rotel, DNM, Marantz, AVI, Martin Logan, Pro-Ac, Wilson Audio, Wilson Benesch Theda Digital, Transparent Audio, Alchemist, Quadraspire, Stands Unique. Listening Rooms, Free Parking, Full Workshop, Delivery and Installation. Open Mon-Sat 10-6.00 pm. Please phone for a map or contact Raoul, John, Mark, or Mike.

GRAMPIAN

HOLBURN HI-FI 441 Holburn Street, Aberdeen. Tel: 01224 585713. Arcam, Audioblab, B&W, Celestion, Denon, Dual, Epos, Heybrook, ION, Kenwood, Creek, Marantz, Meridian, Mission, Cyrus, M.S., NAD, Nakamichi, Pioneer, QED, Quad, Revox, Rotel, Ruark, Tannoy, Technics, Wharfedale, Yamaha. 9.30-5.30 Mon-Sat.

STRATHCLYDE

COLIN MACKENZIE'S HIFI CORNER 52 Gordon Street Glasgow 0141 248 2840. Rose St Edinburgh 0131 220 1535, 1 Haddington Place, Edinburgh 0131 556 7901 and 44 Cow Wynd, Falkirk 01324 629011. Audioblab, Cyrus, Sound-Bytes, Meridian, etc. Most major Brands stocked. Free five year guarantee on all loudspeakers, keen prices.

KEVIN GALLOWAY AUDIO. Audio Physic, Accuphase, Audio, Basis, DCS, JM Lab, Pink Triangle, Electrocompaniet, Sugden, Nagra, Tara Labs. Nationwide delivery and installation. Demonstration by appointment. Tel: 01563 574185. Fax: 01563 573207

JAMES KERR & Co., 145 Bath St, Glasgow 0141 226 5711. Glasgow's oldest established hifi specialist, now at new larger premises

LOUD & CLEAR 520 St Vincent Street, Finnieston, Glasgow G3 8XZ. Tel: (0141) 221 0221 or visit us at www.loud-clear.co.uk. Glasgow's finest and friendliest Hi-Fi store, combining knowledgeable advice with specially selected products and the best of service. Three comfortable demonstration rooms, full service and installation facilities, interest free credit on selected products. Product lines include Naim Audio, Exposure, Alchemist, Rega, Tag McLaren, Musical Fidelity, Marantz, Denon, Rotel, Acoustic Energy, KEF, KEF Reference, Monitor Audio, Tannoy, ProAc, VdH, Chord Co., DNM, Ash Design, Stands Unique. Open Tues-Sat 10am-6pm Thurs till 7pm. Complimentary parking at PC World, Finnieston Street.

STEREO STEREO 278 St Vincent Street, Glasgow, Tel: 0141 248 4079 E-mail Stereo @ cix.compinlink.co.uk We will supply the most musical sound for your budget and if you take the time to visit us we will take the time to return the compliment with free installation of your chosen equipment. Open 10-6.00pm closed Sunday. Tuesday Installation Nationwide Interest free credit available

AUDIO NOTE SALON Five dem rooms in Glasgow's peaceful west-end: free parking, relaxed atmosphere, serious equipment. Unique in the north, we specialise in Audio Note (entry level to Ongaku), Bow Tech and Mark Levinson, speakers include ProAc and Zingali. Large second-hand stock and cost-effective cables. Established 1979 as the original Music Room, we invented the dem room, matching, and consultancy rather than selling hype gear. We save you a lot of disappointment. See our full page and half-page ads in this issue. Visit us online, HYPERLINK <http://www.audiosource.co.uk> www.audiosource.co.uk. Phone or fax for advice, info sheets, lists, or appointment. Fax: 0141-339 9762. E-mail HYPERLINK mailto:jack@audiosource.co.uk jack@audiosource.co.uk. Phone 0141-357 5700.

WALES**NORTH WALES**

ACOUSTICA 17 Hoole Rd, Chester CH2 3NH. Tel: 01244 244227. See our main entry under "Cheshire".

ACTON GATE AUDIO 4 Ruabon Road, Wrexham, North Wales, Tel. 01978 364500. See our main ad under Cheshire.

GLAMORGAN (SOUTH)

SOUND DR. JULES SWANSEA, 01792280 061. Call now for price list, UK or overseas. Hi end new and pre-owned hi-fi at an affordable price. Home trial prior to purchase. Reliable courier service and repair service. Friendly and enthusiastic advice, day or evening seven days a week. A service to suit you.

IRELAND

AUDIO AUDIO HIFI SPECIALISTS 15 Mansfield Heights, Portlennoe, Co. Antrim, N. Ireland BT44 8JR. Telephone 01266 822128/ Fax 01266 822128. Products include Totem, Sugden, Denon, Ortofon, Project, Alchemist, QED, Chord Co., Arcam, Quadraspire, Audioquest, Rega, Soundstyle, Apollo, Grado, Ixos, Sonace, Optimum, Acoustic Energy, Tangent, Mighty, Sound Organisation, Jamo. Free installation. Please ask about our FREE customer care package.

CLONEY AUDIO 55 Main Street, Blackrock, Dublin, Tel: 2889449/2888477 Fax: 2834887. Products include: Arcam, Classe, Phillips, B&W, Naim Audio, Meridian and others. Open Tues/Sat 10am-6pm, Thurs/Fri till 9pm Closed Mondays.

DUBLINN HI-FI 38 Augier Street, Dublin 2. Tel: (00 353) 1 4785205. Fax: (00 353) 1 4785219. We all have two ears and one mouth - use them accordingly. We only stock the best products, based on performance and reliability - not reviews or sales patter. Call Mark or drop in for a listen. Three single speaker demo rooms. Free delivery and installation. Full service department. Open Mon-Fri 10-7, Sat 10-6

NORTHERN IRELAND

KRONOS HI-FI 7 Scotch Street Centre, Dungannon, BT70 1AR. Tel: (01868) 753606. Fax: 753006. Email: David@KronosHi-Fi.demon.co.uk. website <http://www.Kronos-Hi-Fi.demon.co.uk> We have one of the largest ranges of quality Hi-Fi in Ireland. Our agencies include Absolute Sounds, Apogee, Audio, Audiomecc, Blueprint, BOW Technology, Cadence, Copeland, Denson, Frameworks, Harman Kardon, Helios, JBL, Kelly, Kimber, Klipsch, Living Voice, Lyra, LFD, Marantz, Micheli, MIT, Musical Fidelity, Nottingham Analogue, Oracle, Orelle, QLN, Rogers, Roksan, Rotel, Ruark, Silver Sounds, SME, Triangle, Trichord, Unison, UKD, Wilson Benesch, YBA and much more. Demo rooms for Hi-Fi and A.V. Free installation, home demos and home trial. Access and Visa. Credit including instant and interest free. Multi-Room specialists. Open Mon-Fri 9.30-5.30. Closed Wed. Sat 10-5. We are also open an evening by appointment.

VINYL RECORD MAIL ORDER

AUDIOPHILE UK LTD 214 Station Road, Addlestone, Surrey, KT15 2PH. Specialise in high quality new and used vinyl & CD. Telephone order 01932 761248 Fax order: 01932 761162. E-mail order: sales@audiophile.co.uk. Order your copy of our free monthly flyer and get the most up to date information on new releases plus the mechanics of mint used LPs we hold in stock. As well as this we stock interconnects, record cleaning materials, isolation feet and many more accessories. Callers welcome by appointment. Hours: Mon-Fri 9.30am - 5.30pm and occasional Saturdays.

ABERGAVENNY MUSIC 23 Cross Street, Abergavenny, S. Wales. NP7 5EA. Tel: 01873 853374. 9am - 5pm Monday-Saturday. E-mail abermusic@compuserve.com. All major credit cards accepted. Abergavenny Music is a specialist classical music shop carrying a wide stock of CDs & Tapes. We accept your vinyl stock - please phone for prompt personal service. Any item to reach customers by post sent immediately. First class free P&B. We welcome any enquiry or order.

DIVERSE MUSIC 12 Upper Dock Street, Newport, Gwent. NP9 1DF. 9am-5.30pm Mon-Sat. Internet site <http://www.diversemusic.co.uk>. Phone/fax 01633 259661 / 256261. E-mail: sales@diverse-music.co.uk. Catalogues available. Mastercard, Visa, Amex, Switch, JCB. New and forthcoming releases: Blue Note 180gm LPs - re-issued on 14th April (very limited) also large current and back catalogue stock selection. P&P £1.00. 1st LP, additional LPs 50p each (max £3.50). Please contact us for more details and catalogues.

SILVERNOTE PO Box 158, Cheshunt, Herts EN7 6UH. Always wanted: Vintage and Modern Equipment, Records & CDs. Tel: fax Steve on 01992 620905.

VINYL DEMAND Stockists of VPI record cleaning machines and the widest range of audiophile vinyl in the UK - at the best prices. Living Stereo, Verve, Musical Fidelity, Decca, Absolute Analogue, Testament, MCA, DCC. Also a vast range of analogue accessories. Phone 01425-654545 or Fax 01425-654400 for orders or catalogues.

VIVANTE - Unit 4, 60 High Street, Hampton Wick, Surrey KT11 4DB. Tel: 0181 977 6600. Fax: 0181 977 4445. One of the UK's largest importer and distributor of audiophile and conventional vinyl is now operating a mail order service specialising in jazz and classical reissues. Labels include Decca, London, Deutsche Gramophon, Archiv, EMI, Telefunken, Testament, Verve, MPS, Milestone, Fantasy, Pablo and more. Extensive catalogue available. Access/Visa accepted.

WOODSTOCK RECORDS, The regions largest new and used vinyl specialist catering for all musical tastes - classical; jazz & blues; rock; sixties; indie; funk; soul; reggae; soundtracks; disco, deep house; hip hop; drum & bass; breakbeat; electronica and much much more. Plus extensive 7" section and a wide range of accessories. Internet site coming soon! Shop details: 22 Heritage Close, St Albans, Herts AL3 4EB Tel/Fax 01727 846 907. E-Mail: woodstockrecords@LineOne.net. Shop hours: Mon 10.30-6.30 Sat 9.30-5.30.

VINTAGE

AUDIO CLASSICS 18/20 Chapel Green Road, Hindley, Wigan, WN2 3LL. Tel: 01942 257525. Fax: 01942 207089. Mobile: 0585 476574. Hi-Fi bought, sold, repaired and renovated. Mail order and vintage specialists. Please see our main ad (look under the ad index to find) for further information.

EX DEMONSTRATION

AFFORDABLE AUDIO. (Northampton) Pre-Owned Hi-Fi Specialists. 168 Wellingborough Road, Northampton, NN1 4DU. Tel: (01604) 231261/845138. Mobile: (0370) 877893. Urgently required: compact disc collections, 1/2 separates, especially Linn products, Naim Audio, Cyrus Electronics, Musical Fidelity, Quad Electronics almost anything British/American. Cash waiting, part exchange welcome. We also stock lots of audio accessories, compact discs, vinyl, Naim video recorders, DAT players. Single speaker demo room. All equipment is sold with warranties. All Credit Cards accepted. Please phone anytime for stock update.

AUDIO CLASSICS 18/20 Chapel Green Road, Hindley, Wigan, WN2 3LL. Tel: 01942 257525. Fax: 01942 207089. Mobile: 0585 476574. Hi-Fi bought, sold, repaired and renovated. Mail order and vintage specialists. Please see our main ad (look under the ad index to find) for further information.

CHOICE HI-FI Hi-Fi Specialists. Open 10am-8pm, 7 days a week. Tel: 0151 392 1959/1963 Fax: 0151 392 994. Agencies for Acoustic Energy, A&A, ATC, Boulder, Beyer, Cyrus, Chord, Harbeth, Grylls, Harbeth, Harman, Harman, JME, Sennheiser, Sonos, Tripp, Tichord, Trilog, VPI, XLO and many more. We offer generous part exchange, your equipment purchased, free home trial from large specialist demo rooms, trade in points credit card facilities, mail order prompt service, finance available.

HAZELMERE AUDIO The best hi-fi specialist music centre, please call for an appointment, day or evening. Objective advice, comprehensive home demonstrations, free installations, part exchange, repairs and support service. Absolute Precision, Air Tagent, ATL, Audiomeca, Basis, Classe, EAD, Fröhner, Hindley, Marantz, Mission, Monitor Music, Naim, Analogue, Opera, Ortofon, SD Series, Straightwire, Tice Triangle, Tripp VPI, High Wycombe. (01494) 437892.

DIAL A DEALER

HI-FI WORLD

Buying Guide

Our comprehensive new guide contains over 1000 hi-fi components, all tried and tested by Hi-Fi World's listening team. Backing up each one is our performance verdict to help you select the perfect upgrade or first purchase. Happy reading!

Contents

Loudspeakers	70
Integrated amps	80
Pre-amps	81
Power amps	81
CD players	82
Turntables	85
Phono stages	85
Cartridges	85
Tone-arms	87
Tuners	87
Cassette decks	87
DVD players	88
MiniDiscs	88
Headphones	88
CD transports	89
CD converters	89
Classics	90

buying guide

Loudspeakers £ Year Verdict

Under £300

Model	Price	Year	Verdict
Acoustic Energy AE100	£200	Jan 96	Reasonably neutral but ultimately lacklustre. Control of treble and mid-range poor.
Acoustic Energy Aegis One	£150	Sep 99	Weighty, powerful performers with plenty of character. Exceptional value for money.
Audio Gem Opals	£240	Dec 97	Partner the Opals with warm ancillaries and you get an involving sound. Avoid bright amps and sources.
Aura LSB-627M	£230	Aug 98	Energetic, bold and highly detailed, the Aura is one to consider for the budget-conscious.
Aura LST-627	£299	Oct 98	Like Aura's matching stand mounters, the 627Ms are lucid and controlled. Treble is brightish.
B&W 601	£200	Jan 96	Unrestricted and clean sound with satisfying musicality. An engaging subtlety not common at the price.
B&W DM302	£130	Apr 96	Clear open and detailed sound but balance too forward and weak bass.
B&W DM602	£250	Nov 96	Excel with taut hard-hitting bass with dynamic and uncoloured midrange. Metal dome tweeter bleaches out the treble.
Boston CR6	£150	Sep 98	With simple music, the CR6s work well, but not quite as well as the best of the competition.
Castle Isis	£230	Jan 96	A lively little animal, well worth the money.
Celestion 12i	£119	Feb 98	The 12is' powerful, confident sound belies a rather poor measured performance.
Celestion Impact 15	£200	Jan 96	Big presentation but a rather distant quality. Could sound boomy and confined.
Celestion Impact 23	£299	Nov 96	Sterling performance in the bass with speed and control. Good midrange projection.
Chario Hiper 1000	£235	Feb 99	Quality construction and sound marry to produce a very capable 'speaker. Open treble and firm bass for the size.
Eltax Liberty 3+	£150	Jan 98	A lot of loudspeaker for the money. Punch and slam in the bass but sometimes thin in the treble.
Eltax Liberty 5+	£200	Sep 99	Immediate 'hi-fi' sound with little subtlety or finesse. Bass inclined to boom, although mass-loading helps.
Eltax Symphony 6	£240	Nov 96	Although bright, the Symphony 6s score for clarity and power. Bass is fast and accurate.
Gale 2i	£140	Feb 97	Smooth, balanced performers that do a good job on any genre. Free from the nasties that afflict many at the price.
Gale Mini Monitor	£50	Apr 97	Not the last word in midrange or bass clarity, but gives real hi-fi results for a paltry £50.
GLL ICT100	£170	Nov 95	For their size and price they offer some super qualities, especially stable imaging.
Heybrook Heylette	£199	Sep 99	Better suited to Classical than Rock or Heavy Metal. Smooth and refined sound will appeal to many.
Heybrook Optima	£259	Oct 98	Capable all-rounders, the Optimas combine smoothness, insight and control to great effect.
Heybrook HB1 S3	£269	Nov 96	Excellent imaging with clear treble and midrange. Bass slightly dry and boxy but would suit a smaller room.
Jamo CS5 Actives	£200	Oct 98	In spite of a few colorations, the Jamos are fine examples of budget active operation.
JPW ML510	£130	Jan 98	With greater transparency and a bit more get-up-and-go, the 510s could be leaders of the budget pack.
Kef 60S	£200	May 96	The 60S is open and detailed but coloured too.
Kef Coda 7	£129	Apr 95	Rhythmic push and tuneful bass are the plus points of these small standmounts.
Kef Coda 8	£200	Jan 96	Breezy presence, good dynamics and a sense of fullness. Not the utmost in clarity, some box colouration.
Kef Coda 9	£299	Jul 96	Strong bass can get out of control, as can treble. This tends to overpower the midrange.
KEF Cresta 2	£150	Oct 99	A highly entertaining bi-wire budget mini. The only slight let-down is sound staging.
Kef Q15	£199	Feb 97	Impressive bass and a sweet clarity make the Q15s 'speakers that'll put a smile on any audiophile's face.
Kenwood LS90UK	£129	Jul 98	The LS90UKs have dry bass and limited tonal colour, but staging and imaging are superb.
Linn Sekrit	£298	Apr 96	Well-behaved and with a decent tonal quality.
Mission 700	£130	May 98	The 700s are easily outclassed by Mission's own superb 731 Pros at a £10 premium.
Mission 702e	£199	Sep 99	Well constructed and engineered but top-heavy balance lets the side down with its lack of subtlety.
Mission 731	£129	Apr 95	An initially impressive, up front sound but ultimately a little uninvolved.
Mission 731 Pro	£139	Jul 97	Musical makers with a clean, punchy sound. Real value for money.
Mission 731i	£130	Nov 96	Mission's babies are a truly worthwhile improvement on the original 731s.
Mission 731LE	£150	Nov 95	Excellent sound puts the competitors in the shade. Well built and pretty too!
Mission 732i	£200	Aug 97	If you've got £200 with 'loudspeaker' written on it, then the 732i should be on your shopping list.
Mission 771	£170	Jul 98	Superb stand mounters of real refinement and musicality. A touch bass light.
Mission 772	£230	Apr 99	Civilised standmounters which lack nothing in control, finesse or transparency.
Monsoon MM-1000	£200	May 99	A novel multi-media two-satellites-and-sub which nevertheless demands to be taken quite seriously.
Mordaunt-Short MS20i	£200	Jan 96	Very tight bass and an all-round big sound. Some sharpness in the treble but assertive and clear.
Nad 801	£100	Jun 97	Impressive bass with midrange clarity are pluses. Prominent treble stops the 801 from challenging the best.
Paradigm Mini Monitors	£230	Aug 97	The Paradigms have a generally enjoyable sound but treble is sharp and midrange recessed.
QLN 122	£270	Jun 96	Solid bottom end will drive a large room well, but they're a bit bright too.
RDL RA Labs Mini Ref	£99	Jul 95	Engineering is not tip-top, but with a smooth system they will produce a clear and open, if bright, sound.
Revolver Purdey	£200	Jan 96	Rather small sound for a big cabinet. Absence of deep bass hard to forgive.
Richard Allen Minette 3	£159	Sep 99	Very individualistic loudspeakers will need careful auditioning to ensure that they're right for you.
Rogers LS1	£149	Feb 96	Clear, bright and open but with weak bass. Best used close to or against a wall.
Rogers LS33	£250	Nov 96	Detailed and clear with a forward midrange. Could be a little rough on vocals; bass extension is limited.
System Audio 1005	£299	Aug 96	Excellent all-rounder that provides a real open window into almost every genre of music.
Tangent Monitor 11	£200	Nov 97	The Tangents' bass has attractive speed and impact, matched with smooth treble and open midband.
Tangent Monitor 2	£60	Jul 96	Good imaging as well as control. Tweets a bit too much but more than fine for the money.
Tannoy Mercury m1	£120	Jun 98	The best at the price and capable of embarrassing many more expensive 'speakers.
Tannoy Mercury m2	£140	May 97	For £140, you get a 'speaker with transparency and enjoyability unmatched at the price.
Tannoy Mercury m2.5	£160	Sep 99	A little brittle in the upper midrange but the virtues outweigh the faults many times over. Budget bargain.
Tannoy Mercury m3	£240	Nov 97	Even overall balance and taut secure bass, if not the deepest ever. Slightly lightweight and uninvolved.
Tannoy R1	£199	Nov 98	Worth an audition if you need to balance a bright source and amp, but treble lacks clarity.
TDL NFM 1	£120	May 97	Bright treble is partially balanced by taut, well integrated bass, but outclassed by the competition.
TDL Nucleus 1	£60	Apr 97	Clean, incisive, detailed and revealing, especially in the bass.
TDL Nucleus 3	£200	Sep 99	The more you listen, the more you appreciate them. Best with smaller scale music - not for headbangers.
W'dale Active Diamond	£180	Mar 99	Great value introduction to active. The sound is deep and powerful but could be a little coloured for some.
Wh D'm'd Anniversary 7.2	£150	Sep 99	Honest reproduction, but with a suspicion of bass boom. Lacking in finesse; little dated now.
Wharfedale Valdis 300	£150	Jul 96	Can work well if partnered to give weighty bass and smooth treble.

Prices shown are those at the time of review



Heybrook Heylette



Mission 772

Billy Vee

SOUND SYSTEMS

248 Lee High Rd, London SE13 5PL (Mon-Sat 10am to 6.30pm Closed Thurs & Sun)

You can't touch it but you sure can feel it
You can't see it but you really can hear it
Call 0181 318 5755 & join us for true -

HI-FI PERFORMANCE



Here's looking at you kid!

There's many a catch phrase for describing how good something looks and sounds but here's a simple truth. You can believe what you read but you will never really know how good something is until you listen. Why just read before you buy when you can listen and when you hear what we mean, you will never look back. Honest!



Loudspeakers £ Year Verdict

£300-£799

Model	Price	Year	Verdict
Alesis M1 (active)	£549	Jul 99	Almost worthy of domestic bargain status, the M1s lack just a little smoothness and finesse.
Arcaydis AS2	£700	Oct 99	Quality drive units give smoothness, detail and imaging. Require hefty amplification and finish could be better.
Arcaydis ASC	£399	Jun 99	The ASCs have natural warmth and good imaging. Inclined to be a little power-hungry.
B&W CDM1SE	£600	Apr 98	Tuneful and confident, these 'speakers are well suited to Pop and Dance music.
B&W DM305	£350	Mar 97	All the ingredients for listening fun are in the DM305. Overall presentation could be more cohesive though.
B&W DM602 Series 2	£300	Aug 99	A fair design that needs partnering with smooth amplification in a well-furnished room.
B&W P4	£600	Mar 95	Good-looking solid 'speakers with great spirit and tenacity but with a dry treble. Not fans of classical music.
Blue Room Minipod	£400	Jan 97	Arresting style allied to an engaging sound makes the Minipods attractive. Best with smooth amps and source.
Castle Avon	£699	Dec 96	Taut, dry bass and lucid midrange but need matching to warm ancillaries to avoid sounding bright. Castle
Castle Harlech	£799	Aug 96	Bass power and extension will impress but overall sound is uneven and rather sterile.
Castle Inversion	£425	Aug 99	Unusual styling will polarize opinion, but sonically the '15s are fair performers. Imaging could be better.
Castle Kendal	£450	Mar 98	The Kendals have great clarity but need coupling to warm ancillaries.
Castle Severn II	£579	Jul 98	Apart from some hardness in the tweeters, the Severn 2s are accomplished all-rounders.
Chario Hiper 1	£399	May 95	Music makers through and through with a great feel for rhythm and dynamics.
Charlo Lynx	£549	Apr 99	The Lynxes are superbly built but their rising bass and treble suit home cinema more than hi-fi.
Dali 450	£700	Feb 96	A powerful and rich sound from these competitively priced floorstanders makes them worth a recommendation.
Epos ES12	£495	Oct 96	Strong, punchy bass allied to detailed and articulate midrange and treble.
Heybrook Heylios	£339	Mar 97	The Heylios stand out for their bass depth, dynamics and sound staging. Overall balance prefers Classical to Rock.
Heybrook Heylio	£389	Oct 95	Posses a neutral, fast and dry sound. A good match for soft sounding systems.
Jamo 307	£300	Apr 95	Delicate, detailed sound, albeit with rather imprecise imaging. Will work well on a bookshelf.
JPW ML910	£300	Nov 97	The 910s aren't perfect but make music fun. Quality, power and extension, the Millenniums are worth a listen.
JPW Ruby 2	£395	Oct 98	Once allied to warm electronics, the Ruby 2s mix insight with plenty of involvement.
Kef LS3/5A	£599	Jul 95	Partnered with the Rogers AB1, this is a substantial marriage.
Kef Q35	£350	Nov 97	Very accomplished midrange and treble but the dry in the bass. For Rock fans the upper bass speed is appealing.
Kef Q55	£499	Aug 97	The Q55s look rather expensive at £500 with their 'boom and tizz' presentation.
Kef RDM1	£499	Oct 97	The RDM1s soundsstage well thanks to their Uni-Q drivers. Can be uninvolved because of a lack of scale and impact.
Linn Tukon	£389	Dec 95	Highly musical standmounters that give similarly priced floorstanders a great deal to worry about.
Meridian A500	£750	May 95	Very polite and many will appreciate their civility. Deep powerful bass.
Mission 733	£300	Apr 95	Captivating floorstanders that bring music to life - what good hi-fi should do.
Mission 773e	£400	Nov 99	Nicely engineered slimline model. Some sonic trade-offs with the compact size.
Mission 734	£430	Sep 95	Engineered for low price and showroom appeal rather than absolute sound quality.
Mission 751 Freedom	£350	Apr 97	Charming little stand-mounters with a sweet, warm, musical sound.
Mission 752 Freedom	£578	Jan 97	Dynamic, punchy, and musical yet refined like few at the price. Bass lacks a little depth.
Mission 774	£500	Feb 99	With the right ancillaries, the 774s have a clarity and lack of colouration still rare at the price.
Mordaunt-Short MS25i	£300	Nov 96	Sweet sounding metal dome tweeter although the dry bass and rather plasticky midrange work against it.
Musical Technology PM15	£474	Jan 99	Sophisticated, neutral sound and fine musicality put the PM15s near the head of the class.
Near 10M	£500	Jan 96	A thin and hard sound but precise with it!
Neat Critique II	£445	Jan 99	Deserving 'speakers with good looks and build. Can fail to shine with over-polite equipment.
NHT 1.3	£389	Aug 95	Very crisp sounding 'speakers best suited to smaller rooms.
Opera Mini	£300	Nov 99	A mini 'speaker made for music. Well built and versatile. At worst, ponderous, at best, immense.
Opera Prima	£495	Feb 99	The Primas offer a taste of the high-end at a sensible price. They are more fans of Classical than Rock though.
Ortofon ConCorde 6	£329	Oct 95	Good value floorstanders with clean enjoyable sound - not quite supersonic, though.
Poik PSW150	£500	Jul 97	The PSW150 adds depth to a system but can sound obvious at times.
Proac Tablette	£600	Aug 98	Amp-sensitive and slightly boxy in the lower treble, the ProAcs are still highly musical.
Rel Q Bass	£350	May 96	Needs care in setting up but this subwoofer offers serious quality bass for not a lot of money.
REL Q100E	£500	Apr 98	Another capable sub from REL that boosts bass and improves sound staging.
Rogers AB 1	£499	Jul 95	When used with the Kef LS3/5a this sub delivers the goods, beyond a doubt.
Roksan RokOne	£595	Feb 97	Musically involving 'speakers that many will enjoy, but a little unrefined at times.
Sequence 400	£329	Apr 96	Good at orchestral scale but coloured in the midband.
Soundcraft Absolute 4P	£799	Oct 97	The Absolute 4Ps excel in all areas except for the rather bright, hard treble. Bass is exceptional.
Spendor 2030	£599	Jun 96	Smooth and coherent in their delivery with deep and taut bass extension. Not the most spacious sound.
Systemdek 165	£400	Feb 96	Dry and clean sound, but can become hard and confused when pushed.
Tannoy Precision P10	£300	May 98	Though very even in their performance, the P10s lack ultimate clarity and punch.
Tannoy Profile 633 plus	£300	Nov 96	Weighty bass and rhythmic detail work well on dance. Less satisfying with classical music. Firm imaging.
Tannoy Revolution r2	£350	Oct 99	Lively and exciting, will appeal to many. Solid built and confident sound makes them well worth the money.
TDL RTL 4	£650	Feb 95	Easy going with plenty of detail and timbral richness. Better with classical fare.
TDL T-Ilne 2	£550	Jan 97	Midrange and treble have good tonal colour, detail and speed. Bass is slow and blurred.
Technics SB-M01E	£400	Nov 99	Punchy and dynamic, yet refined. In a small environment, these highly detailed 'speakers are excellent.
Technics SB-M300	£350	Nov 95	A great sound with solid bass from a compact and well priced 'speaker.
Technics SB-M500	£450	May 96	Clean, dry and taut with good imaging and sound staging. More neutral than Mission's 752s but less euphonic.
Titan Mini T2B	£600	Dec 99	Heftily built standmounts with terrific punch and attack. The metal drivers might make classical a bit harsh.
Triangle Comete TZXe	£475	Jan 95	Quite pleasant, inoffensive sound but others costing less can offer more.
Wharfedale Valdue 500	£300	Oct 95	Good for adding scale and power to a weak system or budget separates.
Yamaha MSP5	£449	Jun 99	Ruthless to poorly-produced material and can sound cold, but their detailing is impressive.



JPW Ruby 2.



Opera Prima

Prices shown are those at the time of review

Billy Vee

SOUND • SYSTEMS

SAVE £££'S ON OUR DISPLAY CLEARANCE

SOME AS NEW WITH 1 YR WARRANTY. 24HR DEL ONLY £5. CHECK AVAILABILITY BEFORE ORDERING

CALL SALES: (0208) 318 5755 or 852 1321 - 248 Lee High Road, London, SE13 5PL

0% APR is available on purchases of more than £660. Please call for details. * These products Shop callers only

Arcam Alpha 8 Amp* (2Yr G/tee)	£349.00	£229.00	Linn Isobarik Active Speakers (Latest spec) (3500.00)	£1395.00
ArcamAlpha 8se CD Player* (2Yr G/tee)	£499.00	£369.00	Linn Helix 2 Spkrs inc stands S/H	£249.00
Arcam Alpha 9 Amp* (2Yr G/tee)	£499.00	£369.00	Naim NAT 03 Tuner (1Yr G/tee)	£475.00
Arcam Alpha 9P Power Amp* (2Yr G/tee)	£399.00	£299.00	Naim NAP180 Power amp S/H	£750.00
Arcam Alpha 8 Tuner* (2Yr G/tee)	£279.00	£199.00	Naim NAP140 Power Amp (1Yr G/tee)	£595.00
Cyrus 2/PSX Amplifier S/H	£649.00	£349.00	Naim AV1 Surround Processor (1Yr G/tee)	£895.00
Epos ES22 Speakers (Light Cherry)	£1185.00	£799.00	Pioneer 515 DVD Player (NEW)	£249.00
Linn Kudos Tuner (2Yr G/tee)	£775.00	£489.00	Quad ESL63 Electrostatic Speakers S/H	£995.00
Linn Kaber Passive (Black)	£2000.00	£1195.00	TAG 60i Integrated amp	£499.00
Linn Kaber Aktiv (Walnut/Grey) inc cards	£2850.00	£1095.00	TAG T20 Tuner (2YR warranty)	£749.00
Linn Wakonda Preamp S/H(1Yr G/tee)	£750.00	£399.00	TAG PA10 Pre Amp (2YR G/tee)	£499.00
Linn Wakonda/Kudos Phono S/H	£1400.00	£799.00	TAG 60P Power Amp (2YR warranty)	£579.00
Linn LK140 Power Amp (2Yr G/tee)	£750.00	£469.00	TAG 125 Mono P/Amps pair (2Yr G/tee)	£1695.00

WE SELL THE FINEST PRODUCTS

and we bring you the benefits and security of buying from a larger dealer, yet each of our stores is run as an individual specialist shop. We are enthusiastic and friendly, with the knowledge and experience to satisfy your expectations.



BOW
T E C H
N O L O
G I E S

BOW Technologies was founded in 1994 by Bo Christensen and since its inception has pursued the holy grail of combining wonderful aesthetics and good sound quality. BOW Technologies is a master of the art. It's electronics have won many awards around the world and much praise for their stunning looks and superb engineering. The range consists of the ZZ Reference Series and newly introduced W Series.

Available at OXFORD, WEST HAMPSTEAD, HIGH WYCOMBE, EPSOM



Wilson Benesch has, in less than ten years, earned a world wide reputation for producing innovative, elegantly designed audio equipment. From turntables to tone-arms and in 1995 – the A.C.T. One – the World's first curved floor-standing loudspeaker. With its multi alloy baffles and advanced carbon fibre composite structures, it remains as contemporary and successful today as it was five years ago.



Available at BRENTWOOD, BRISTOL, CARDIFF, EPSOM, READING, SOUTHAMPTON, SWINDON, WEST HAMPSTEAD

CHORD



Chord Electronics has become synonymous with outstanding performance. The company's range of products fulfils every stereo or multi-channel system requirement. Continual dedication to research and innovation, combined with excellence of build and sterling reliability have been rewarded by continued growth. Chord users include many of the most demanding customers in the audio world, both from professional and high-end customer domains.

Available at BASINGSTOKE, BRENTWOOD, BRISTOL, CARDIFF, CHELTENHAM, EPSOM, EXETER, READING, SOUTHAMPTON, SWANSEA, SWINDON, WEST HAMPSTEAD

- 53 YEARS JOINT EXPERIENCE • 3 YEAR GUARANTEE ON HI-FI SEPARATES
- FULL DEMONSTRATION FACILITIES • PRICE PROMISE • 10 DAY EXCHANGES
- 30 DAY NO COST PENALTY UPGRADES • PART EXCHANGES
- INTEREST FREE OPTION Subject to status. Written details on request
- HOME LOANS AND HOME DEMONSTRATIONS
- EVENING DEMONSTRATIONS BY APPOINTMENT

BASINGSTOKE 4 Feathers Lane
01256 324311

BRENTWOOD 30 Crown Street
01277 264730 Open late Thursday

BRISTOL 65 Park Street
0117 926 4975 Open late Thursday

CARDIFF 134/136 Crwys Road
029 2022 8565 Open late Thursday

CHELTENHAM
40/42 Albion Street
01242 583960

EPSOM 15 Upper High Street
01372 748888 Open late Thursday

EXETER 156 Sidwell Street
01392 491194

HIGH WYCOMBE
30-32 Castle Street
01494 558585 Open late Thursday

LONDON: W. HAMPSTEAD
190 West End Lane
020 7794 7848 Open late Thursday

OXFORD 19 Old High Street
Headington
01865 765961 Open late Thursday

READING 4 Queens Walk
Broad Street Mall
0118 958 5463

SOUTHAMPTON
2-12 Hursley Road
Chandlers Ford
023 8025 2827 Open late Thursday

SWINDON 60 Fleet Street
01793 538222 Open late Thursday

SWANSEA 9 High Street
01792 474608

All shops are closed on Mondays



FREEPHONE
0500 101501

(quoting WHE1)
and ask for a **FREE** copy of
our **MUSIC AT HOME** Guide



For the very latest information
please check our web sites:
www.audio-t.co.uk
www.audio-excellence.co.uk

Loudspeakers £ Year Verdict

£800-£1499

Acous.Precn Elkos RF1	£800	Nov 99	Bass-light, but excellent in every other area. A sub is on the way. Very revealing of ancillary components.
Audionote E	£1450	Mar 95	Big, bulky and ultra-sensitive with quick pace and a well balanced sound, but not without flaws.
Audiovector M1 Sig.	£1479	Aug 98	The M1 Sigs may be a little laid-back, but they have a pleasant and involving sound.
Audiovector M2	£1499	Jun 98	The M2s are marred by a boom 'n' tizz presentation that suits Heavy Metal but not much else.
B&W CDM7	£999	Feb 98	With warm ancillaries the CDM7s produce a weighty, open sound. Bass could be faster.
Castle Howard S2	£1099	Mar 96	Fantastically deep and tight bass but some treble sharpness requires careful matching.
Celestion A2	£1499	Jun 98	Focus is not a strength, but bass extension and even tonality are. Metal tweeter can be bright.
Chario Academy One	£1199	Dec 95	Musical realism and a great real-wood finish make these 'speakers enjoyable, if not perfect.
Dipason Karls	£1250	May 99	Small cabinet precludes the deepest bass, but a sweet little act for all that. Seriously imaging abilities.
ELAC Jet 310i	£800	Jul 99	Lovely fast, clear sound majors on musicality. 10 year guarantee too.
Epos ES22	£1185	Jun 98	Aside from a slightly cool balance, the ES22s shine. Dynamics, bass depth and control are tops.
Event 20/20BAS	£829	Sep 98	Warm, detailed and well-endowed in the bass, the Events lack only a touch of overall control.
Harbeth DPM1 Active	£849	Sep 98	Now HHB's Circle Actives, these loudspeakers mix the best of pro and domestic to produce first-class results.
Harbeth HL Compact 7	£1329	Jun 96	Dry and analytical but truthful with it. A first class monitor ideally suited to acoustic or classical music.
Harbeth HL K6	£975	Dec 96	Clean, musical and classy - Harbeth have done themselves proud again!
KAR Torino	£895	Jan 97	The Torinos' stylish sound won't shame any system. That powerful bass does need space to breathe properly though.
Kef Reference 1	£995	May 95	Beautifully fluid and integrated mid band and treble but can be slow, with a little loss of bass control.
KEF Reference 2	£1499	Jan 95	Handles rock and classical with equal aplomb, with the ability to reproduce detail that flummoxes many other models.
Klipsch Heresy II	£1150	May 99	Horn and infinite-baffle hybrid with power to spare. Phasing and frequency accurate beyond belief.
KRK V8	£995	Sep 98	Ultra-detailed and revealing, the V8s are true pro more than domestic transducers.
Magneplaner MG 0.6 SE	£1370	Mar 95	Very clear detail and separation, but just fails to produce a fully 3-dimensional sound.
Magneplaner MG12/OR	£1200	May 99	Lightness of touch, dynamics and clarity in trumps. Needs powerful amplification for 77dB/W/m. Not a valve 'speaker.
Mirage 890i	£1075	Oct 95	An easy going, open and natural sound makes the mirages an attractive proposition.
Mission 754 F5	£1299	Sep 96	Articulate and informative sound with fine imaging and tight, deep bass.
Mordaunt Short 860	£1450	Dec 95	Fast, tight and informative, but a poor tweeter casts a grey shadow.
Musical-Tech. Falcon	£955	May 96	Give a big sense of scale on rock and jazz but not subtle and even enough for the critical classical listener.
NEAR Soundmast	£1199	Aug 95	An interesting, musical floorstander that's good value even at this price.
Origin Live Sovereign	£1225	Jun 98	The OLs have transparency and detail in considerable amounts. Bass can be loose though.
PT Ventricle	£896	Aug 95	Smooth and refined floorstanders that some listeners will find captivating.
QLN Signature	£1499	Mar 96	Super sound staging, openness and detail. Well worth seeking out.
REL Stadium 2	£995	Aug 95	Excellent bass performance means that this subwoofer is no toy.
Roksan Ojan 3	£1000	Jan 98	Unusual 'speakers with great rhythmic capabilities and bass. Could be more transparent.
Ruark Paladin	£1099	May 95	The Paladins possess a detailed and expansive soundstage but also a rather dry character
Spendor 2040	£899	Oct 96	The tweeter works well but a recessed midband and one-note bass are the Achilles heels.
Spendor FL8	£1275	Jun 98	The FL8s are warm, mellow performers which prefer Classical to Rock.
Tannoy D300	£1000	Apr 97	Impressive bass extension and control go hand in hand with precise imaging to make the D300s a snip at £1000.
Totem Model 1 Sig.	£1250	Sep 97	Good but the move from standard to Signature has taken speed and punch out of the Model 1s
UKD Callas Gold	£995	Jun 96	A rich and open sound, extremely musical if not strictly accurate. Great bass extension for their size.
UKD Divina	£1390	Jun 95	Not the most neutral 'speakers but they are extremely smooth with an overall coherence to the sound.
Veritas 7	£1000	Jun 99	The Veritas 7s combine neutrality and detail with fluidity and sophistication.
Zingali Concerto .1	£1100	Dec 99	Beautiful cosmetics but poor frequency balance. May be a partner for a subwoofer: otherwise too bass-light.



Klipsch Heresy

£1500-

Audiovector 6	£4600	Jun 95	If you have enough room and money the 6s are capable of a highly musical, involving performance.
BKS 107 Mikil	£1500	Dec 98	The 107 Mk2s may look slim but they have a solid sound and are fabulously revealing.
Cadence ES	£3500	Sep 95	Interesting design that incorporates an electrostatic tweeter. An impressive sound but an inconsistent performer.
Celestion A3	£1800	May 97	The A3s are quite simply superb. All you'll need to enjoy them is a large enough listening room.
Epos ES25	£1505	May 95	An extremely coherent and focussed sound; these are true audiophile speakers. Captivating with classical music.
Harbeth HLS8	£1999	Mar 97	Glassy clarity, bright treble, with bass that comes alive when given welly. Expensive though.
Heybrook Octet	£1800	Jul 98	The Octets are smooth, laid-back floor standers. Lack speed and transparency.
Jamo Concert 11	£2000	Dec 97	A worthy bigger brother for the Concert 8s, with a fast, transparent and even sound.
Jamo Concert 8	£1500	Jun 97	The Concert 8s are superbly clean and transparent. Their nature will show up any source shortcomings.
JBL S2600	£3500	Jul 96	Smooth, detailed and spacious with great scale and imaging. Capable of producing a real performance.
Kef Reference 3	£2000	Nov 95	For superb reproduction within large rooms, the 3s are a force to be reckoned with.
Kef Reference 4	£3099	Oct 96	Superb bass and near-electrostatic soundstaging make these involving 'speakers a bargain.
Living Voice Auditorium	£1500	May 99	Their strengths suggest a Classical 'speaker but they suit electronic compositions better. Rich tone but loose bass.
Proac Studio 150	£1500	Mar 99	Musically engaging but the tall ProAc's brightness suits them best for smooth valve amplification.
Slate Audio Stormforce	£8000	Feb 99	The best home for a reflex-loaded Tannoy dual-concentric, but they don't come cheap!
Spendor SP7/1	£1970	Jan 95	Gorgeously looking. Listening becomes an enjoyable experience, full of surprises from subtleties.
Spendor SP9/1	£3400	Apr 96	One of the clearest and most expressive loudspeakers you'll ever find for a large room. Easy to drive, too.
Tannoy AMS8	£2702	Aug 96	Bold, powerful sound with solid bass, focussed midrange and delicious treble. Well worth tracking down.
Tannoy D900	£3999	Sep 97	£4000 may be a lot to pay for a pair of 'speakers, but the Tannoys deliver to great effect in all areas.
Technics SB-M1000	£1500	Nov 96	Materially excellent value. Sound clean and extended but can lack involvement.
Thomas Transducers Brio	£4750	Feb 95	Capable of producing a captivating performance of lifelike proportions with a great air of naturalness.
Thomas Virtuoso Gold	£3395	May 98	Impressive horns that combine lightness of touch with power and clarity.



Jamo Concert 8.

Prices shown are those at the time of review

Billy Vee

SOUND SYSTEMS

"TAG McLaren Audio engineers have spent thousands of hours in listening tests to guarantee compatibility between all components within the F3 Series, as the sensitivity of the human ear outperforms the ability of the engineers to specify an audio product in technical terms alone." Now it's your turn to test drive the superb New F3 Series. Call the sales numbers above to book an audition & set your pulse racing, start to finish!

SET YOUR PULSE RACING WITH TAG McLAREN

Call 0181 318 5755/852 1321

248 Lee High Road, London SE13 5PL

email: sales@billyvee.demon.co.uk



In Stock - available for audition

CD20R CD Player	£1249.00
CDT 20R CD Transport	£1499.00
DAC 20sl	£1249.00
T20 Tuner	£1099.00
PPA 20sl Phono Preamp	£1499.00
60IsI Integrated amp	£799.00
60IRvsl Integrated remote	£999.00
PA10 Preamp	£849.00
PA20Rsl Remote Preamp	£1499.00
60Psl Power Amp	£849.00
100Psl Power Amp	£1099.00
125Msl Monoblock Amp	£1199.00

If you would like any further information on the new TAG range, we will be pleased to send you a full range booklet.

Prices correct at time of press. E&OE

buying guide

Integrated £ Year Verdict

under £300			
Alchemist Maxim	£299	Mar 96	Fluid and musical but upper bass is a little dry. Useful phono stage with but with a little sibilance and ringing.
AMC 3025	£150	Nov 96	A lot for very little money - sweet sound and good build make the AMC 3025 a great starter amp.
AMC 3050A	£170	Feb 98	Offers plenty of power for the money but sound quality is not class leading.
Arcam Alpha 5 plus	£250	Oct 96	Good with efficient loudspeakers but generally needs more power and control.
Arcam Alpha One	£230	Jan 99	In a smooth system with a warmish bias the Alpha One makes a strong case for itself.
Aura VA80	£279	Apr 95	Excellent value for money and will get the best from any component. Needs a separate phono stage.
Aura VA80 SE	£250	Mar 96	The Aura has a smooth, civilised sound with fine detail. Bass punch really rolls along. Good phono stage.
Cambridge A1 MkIII integ	£100	Jul 98	Involving and finely detailed, the Cambridge pushes forward the boundaries for inexpensive amps.
Denon PMA 250SE	£160	Feb 97	A mix of control, delicacy and detail allows it to excel with any music.
Denon PMA 425R	£230	Sep 96	Good drive, punch and an open soundstage, but suffers from confusion plus a thin midrange and treble.
Harmon Kardon HK610	£180	Jun 95	Thorough-going down to earth liveliness. Bright but clean which gives appealing vivacity.
Harmon Kardon HK620	£280	Oct 95	Not quite a giant killer, the Harman is nevertheless a good solid budget buy.
Musical Fidelity E11	£299	Feb 98	A very capable integrated with a smoothness and warmth predisposed to classical rather than rock.
NAD 304	£239	Apr 95	Fine quality bass but rather lackadaisical as regards timing. Phono stage moderate. Needs careful matching.
NAD 310	£130	Jan 95	Good detail and a spacious open sound gives acoustic music and the majority of rock superb clarity.
NAD C320	£200	Apr 99	Younger sibling of the famous 3020 with many of its virtues to boot. Pre-eminently balanced and natural.
Pioneer A103	£130	Mar 95	Luxuriant presentation doesn't compensate for the tendency to un-rhythmic effects. MM phono stage.
Pioneer A300X	£230	Apr 95	Another highly capable all-rounder although a touch sterile sounding for some tastes.
Pro-ject 7	£259	Apr 95	On a budget, the Pro-ject has strong merit, including an excellent phono stage. Not for all systems.
Rotel RA 970BX	£250	Oct 96	Fresh sound with sharp attack. A slight midrange emphasis can make certain music sound rather forward.
Rotel RA 931	£150	Dec 98	For the money there's no faulting such a gifted performer.
Sony TAF446E	£250	Aug 95	Bright clear and detailed, but needs a touch more refinement to prevail.
Teac A-E2000	£180	Sep 99	Unusual power supply and very clear treble. Mid and bass so-so hot but the Teac's not expensive considering.
Technics SU A700 mk3	£250	Jan 97	A smooth unassuming sound misses out on the subtlety which brings music to life.

Prices shown are those at the time of review



Audio Analogue Puccini.

£300-£799			
Affordable Valve EL34	£600	Feb 00	Low feedback integrated with plenty of slam. Not the ultimate in refinement but good value.
Alchemist APD43A Nexus	£799	Dec 99	A good looker with a smooth and powerful sound, if a tad sterile. Competition is strong at the price.
Alchemist Axiom	£300	Sep 95	Musically rewarding; deserves serious audition. Great British hi-fi on a budget.
AMC 3150A	£329	Nov 98	Not the most musical amp ever but good value. The tone controls and balance adjustment will appeal to some.
Arcam Alpha 6+	£350	Jan 96	Full and smooth sound, unfortunately with loose bass.
Arcam Alpha 9	£500	Dec 96	Excellent value. A detailed and open sound gives great atmosphere to all types of music
A. A. Puccini SE	£595	Dec 97	All the main ingredients like rhythm and dynamics present and correct. Natural smoothness and transparency.
Audio Analogue Puccini	£595	Sep 97	Excellent sound quality outstrips the competition at up to £1000.
Audiolab 8000S	£700	Dec 97	Powerful hefty sound which doesn't blench when driving awkward loads.
Calim Aria	£450	Oct 99	Looks great and Rocks with the best of them, but treble could be smoother.
Cyrus 3	£500	Oct 96	Highly refined and detailed performance with a clear well-proportioned soundstage.
Cyrus Straight Line	£398	Nov 96	A good, honest bit of kit with a fine musical sound and no glaring vices.
Densen Beat	£650	Dec 97	If a musical adrenaline rush is what you seek, fine. Listening in bulk, rather clinical and cold sounding.
Edmund ESI 10	£400	Apr 99	Solid build and a big sound make the ESI 10 worthy of audition. Not perhaps the transparent at the price.
Holff Audis	£750	Jun 98	Powerful and refreshingly pure; a sound investment.
Kenwood KA-7090R	£400	Apr 98	Excels with sound staging but lacks subtlety and tonal colour.
LFD Mistral	£499	Jun 97	An extremely enjoyable, lucid little amplifier that really gets to the heart of the music.
Marantz PM-66 KI-S	£400	Nov 97	An enjoyable and rhythmic sound but may be too lean for some bass-light speakers.
Monrio Asty RM	£500	Aug 99	Attractive integrated that offers a glimpse of real high-end performance. A touch bass light, though.
Monrio MJ	£695	Jan 97	An engaging musical performance; sweet overall sound. Doesn't cope with difficult loads so well.
Moth 30 Integrated	£320	Jul 95	A big open sound sound sets the Moth apart at this price. Low powered, though. Distinctly amateurish looks.
Musical Fidelity X-A1	£480	Dec 98	Two boxes don't form a pre and power in the X-A1 but the result is nevertheless a winning combination.
Myryad T-40	£399	Nov 98	Couple the Myryad with a warm system and enjoy. Possibly a little lightweight on the Reggae & Rap side.
Nad 317	£470	May 97	With 80 watts on tap, the NAD has power aplenty but is rather dynamically limited and ultimately uninvolving.
Naim Nait	£500	May 95	Rather monochromatic with midband emphasis and slightly dry bass. Good imaging but smallish soundstage.
Nakamichi RE-10 (receiver)	£400	Jul 99	A powerful performer in a competent package that is good value for money. Bettered by good separates though.
Orelle SA 100	£449	Jul 96	Clean, open, active sound. Smooth and detailed with good punch too. One of the best at the price.
Pioneer A-300R Precision	£400	Aug 97	A bargain at £400 pure and simple. Outclasses the competition in every area.
Pioneer A400X	£300	Oct 96	Complements all sorts of music with power and confidence. Outstanding value for money.
Quad 77	£595	Feb 95	Although classically orientated, the Quad will rock too. Precise and stable imagery and fidelity to tonal values.
Roksan Caspian	£695	Jun 97	Mixes the best of solid state and valve worlds (without valves!) to produce a seductive sound.
Rose Scion	£615	May 97	Great packaging and super sound make the Scion a winner.
Sonnesteer Campton	£579	Jan 96	Highly detailed and smooth sound. Worth searching out.
Sony TA-FB920R	£300	Feb 99	Partnered correctly to counterbalance its forwardness, the Sony offers a fast, rhythmic presentation.
Teac ABX7R	£700	Jun 96	Big and powerful sound, but a little unsubtle with it.
Technics SE-A900 MkII	£300	Mar 99	Nominally a separate pre and power, but the pre can't work alone. Exciting but unsubtle.
Thule Spirit IA60	£450	Nov 99	Benefits from a calm, controlled presentation. Could ideally do with more fire in its veins.
Token K50	£345	Nov 99	Well-specified low-feedback design gives punchy results, if a little unrefined. Well sustained power.
Valve Audio Exclamé	£310	Dec 99	The Exclamé does an excellent job of being all things to the the audiophile on a budget.



EL34 - £600

Affordable Valve Co
Tel: 01634 373 410

Trichord Research

Tel: +44 (0)1684 573524
Fax: +44 (0)1684 577380

Convert your CD player to a high performance transport with our Digital Output Board
Genesis Mk3 CD Player, Digital Turntable CD Transport, Pulsar Series One DAC with HDCD
High performance 75 ohm Digital Interconnect suitable for CD and DVD Transports
Upgrade your CD player with Clock 3 and dedicated Power Supply
Mains Conditioners, Cables and Accessories

Visit our Web Site @

www.trichordresearch.com



We are a
Which? Web Trader
www.which.net/webtrader

Integrated £ Year Verdict

£1500-

Audionote Soro Se	£1999	Mar 95	Needs the right loudspeaker but a good musical presentation is in there somewhere.
Copland CSA 14	£1099	Apr 96	A sweet and subtle sound. Fine midrange; transparent and open with vocals.
Densen DM 10	£1299	Jun 95	Dual mono construction gives strong stereo separation. Brutal resolution of detail but not the clearest ever.
Exposure Super XV	£800	Oct 95	A stringy-sounding transistor amp for rock. Build and finish could be better and price lower.
Gamma Rhythm	£2499	Jul 96	Partnered with sensible loudspeakers of good bass depth, the Rhythm is capable of impressive performance.
Lavardin IT	£3200	Apr 99	Has clarity in spades and an extremely rare tonal purity. Outclasses many transistor alternatives with ease.
Mcintosh MA8000	£3735	Sep 95	A mighty confection of power, facilities and style, and it sounds good to boot.
Musical Fidelity A1001	£2499	Jun 98	Awesome power and seismic bass. A very good all-rounder with super-clean sound.
Musical Fidelity A300	£1400	Oct 99	High power integrated with phono. Exquisite manners and power to spare. Sets new standards at the price
MVL Integral A2	£850	May 99	An excellent performer with any music. Adept at handling subtle details. Difficult to beat at the price.
Papworth MVH-200	£1200	Jun 99	Very solid, enjoyable amp but not the smoothest top end or the most open sound-staging.
Shearne Phase 2	£800	Apr 97	Even-handed performer deals confidentially with music regardless of genre. Not as smooth as the best.
Sonic Frontiers Anthem	£1295	May 98	A characteristically competent and musical integrated. Prefers fairly efficient loudspeakers though.
Sonneteer Alabaster	£900	Oct 97	Excellent high-end integrated with a real love of music and plenty of poke.
Teac AB X10	£1000	Sep 95	Very strong all round performer with excellent build and finish. Verging on the expensive though.
Unison Res. Simply 845	£2950	Mar 98	Allied to all the right 'speakers will handle all musical genres with smoothness and power.

Prices shown are those at the time of review

Pre-amps £ Year Verdict

Under £300

AMC 1100	£150	Mar 99	Tone controls cannot be defeated and the sum total is a little metallic but value in spades.
Creek OBH-11SE	£199	Apr 99	A very lucid, natural headphone amp which scores as highly on acoustic and Classical as it does on Rock.
Creek OBH-12	£200	Jul 98	Only poor cosmetics mar the Creek. Sonically it's a gem.
Moth 30 Passive	£149	Mar 99	Won't win prizes for best build but a flexible effort for a passive. Somewhat dry presentation overall.
Musical Fidelity X-Cans	£130	Mar 99	If you haven't yet experienced the world of quality headphone listening, the X-Cans is the way to start.
Musical Fidelity X-Pre	£200	Jan 98	A smooth, sweet and musical performer.
Musical Fidelity X-Tone	£120	Mar 99	Easy-to-use stand-alone modern tone control with subtle effect. At present deleted, worthwhile 2nd hand.
Project 7	£259	Feb 95	Immensely enjoyable and listenable. A rare mixture of sophistication and fun.
Rotel RC-971	£150	Mar 99	Five line-level inputs and tone controls make for flexibility. Partnered by the RB-971 power amp, good value.
Technics SU-C1000MkII	£299	Apr 98	Needs slightly more taut bass and a less grainy midrange to bring it up with the best.



Musical Fidelity A300

£300-£799

Audio Analogue Bellini	£475	Apr 98	Organic and transparent. Free from transistor hardness.
Aura CA200	£749	Mar 97	A smooth and sweet sound devoid of roughness.
Crimson CS610C	£440	Nov 98	The phono stage is the main area of weakness. Can sound a touch muddled at times.
Croft Epoch	£600	Jun 96	A fine sounding preamp, but the phono stage is weak in the bass.
Cyrus Pre	£650	Feb 96	Pre-amplifier has plenty of facilities, but sounds a little unexciting and 'conventional'.
Heybrook Signature II	£549	May 97	Impressive smoothness and tonal colour, transparent as well.
Meridian 501.2	£750	Nov 99	Impressive with high octave music, but lacks that bit of warmth to bring out the best in laid-back material.
PM Audio Lab L1S	£650	Dec 95	This valve pre-amp is very good value indeed.
Rothwell Indus	£499	May 99	Passive pre of box-of-switches, whichever way you look at it the Indus is stylishly finished and well conceived.
Sumo Athena II	£767	May 96	More valve-like than transistor in sound; highly competent if not spectacular.
Talk Hurricane 1	£500	Jun 97	Flexible with a strong controlled sound, but won't suit all tastes.
Technics SU-C1000	£350	Feb 97	Good when mains powered, even better running on its batteries. One to consider at the price.
Thorens TTA2000	£550	Jul 95	Poor sound quality and engineering let this pre-amp down. Pricy too.
Unison Res. Feather 1	£795	Aug 98	Warm but still exciting, it is only let down by a slightly recessed midrange



Croft Epoch Elite

£800-£1499

Audiolab 8000Q	£999	Jun 95	Highly recommended for its blend of operational sophistication, build and sound quality.
Croft Epoch Elite	£950	Oct 99	Fast and detailed with a breathtaking clarity and sweetness. Well worth saving up for.
Etalon PreampII	£1095	Feb 98	Smooth, even and transparent. Well worth the outlay.
John Shearne Phase 6	£895	Sep 96	Matched with a smooth amp and 'speakers the Phase 6 is capable of a transparent and rewarding performance
Linn Wakonda	£900	Apr 98	In terms of musicality and involvement it falls short.
Meridian 502	£1295	Dec 96	Transparent, detailed sound with good tonal range and very natural presentation.
Musical Fid. Nu-Vista	£1200	Sep 98	A truly competent pre-amp whose high-end sound comes with a very reasonable price tag.
Musical Fidelity X-P100	£800	Jul 99	Clear, fast and flexible. 'Son of NuVista' is a substantial chip off the same block.
Naim NAC102	£999	Apr 97	This even-handed performer images well and deals confidently with music regardless of genre.
Quad 7741	£850	Jul 96	Bright and detailed, but phono stage is inadequate at this price.
TAG McLaren PA10	£850	Nov 98	Justifies its price with a very musical and revealing performance.
XTC Pre-1	£1000	Nov 96	This pre-amp is highly detailed and spacious.

£1500-

Audiovalve PPP30	£1995	Mar 95	A bright and lean approach to the valve sound.
Canary 601 MkII	£1600	Apr 99	Very musical, very revealing. A credit to the valve tradition with considerable kick in reserve.
Chord CPA 1800	£1774	Mar 98	Has it all - detail, transparency, slam and rhythm. In a word excellent.
Final Music 5	£1500	Feb 99	Partner for the Final Music-6 power amp. Battery powered.
Focusrite Red 4	£2345	Feb 96	Smooth and detailed sound. Not as clinical as some professional amps can be.
Galactron Pre	£1630	Nov 95	Smooth, but dull balance makes it suitable for bright systems.
Marantz 7	£3500	Mar 97	Superb, combines delicacy and power, especially with a vinyl source.
Michel Orca	£1650	Oct 98	With its Panasonic pot, the Orca reaches new standards of transparency and involvement.
Unison Res. Mystery 2	£1750	May 98	Offers finesse, control and clarity for a very reasonable outlay.



AMC 2200

Power amps £ Year Verdict

Under £800

AMC 2200	£150	Mar 99	Super value separate with first-rate sound staging. Midrange subtleties sometimes suffer but at this price ...!
Arcam 9P	£400	Dec 96	A detailed and open sound gives great atmosphere to all types of music.
Arcam Alpha 10P	£600	Jul 98	This power amp lags behind the best of the competition, and the build is flimsy.
Audio Analogue Donizetti	£575	Apr 98	As smart as an Armani suit, they sound powerful in a natural, organic manner
Aura PA100	£749	Mar 97	A smooth, sweet powerful sound free from the rough brightness that afflicts many solid-states.
Creek A43	£399	Mar 99	Shows what a skilled designer can do, even when hooked up with a passive pro. A very realistic approach
Cyrus Power	£449	Feb 96	The Cyrus Power is simply impressive in all respects.
Linn LK100	£650	Apr 98	Well built, but judged purely on a musical basis they fall short.
Linn LK240	£750	Aug 97	The LK240 plays tunes exceptionally well, tonal colour and image precision are not its forte though.
Meridian 505	£795	Aug 97	Crisp, clear images are set in a broad spread between the 'speakers but the 505 lacks stage depth and grunt.
Monarchy SM-70	£595	Jan 99	The Monarchy is a smooth, warm amp most at home with 'speakers that are easily driveable.
Moth 30 Power	£249	Mar 99	Refined approach with the lighter acoustic music but lacking a little in overall clout.
Moth Stereo 60	£549	Dec 95	This power amp unfortunately suffers from sharp sounding treble and poor depth.
Musical Fidelity X-A50	£500	Jan 98	Very smooth, sweet and musical performers, not over-analytical but very involving.

Power amps £ Year Verdict

under £800

Quad 77/67	£600	Jul 96	With good punch, speed and attack its not bad at all but can be a little uninspiring.
Rotel RB-971	£225	Mar 99	70 Watts a channel helps give lucid presentation with deep sound staging. Perhaps on the bright side.
Shearman Phase 3	£689	Apr 97	The Phase 3 possesses impressive clarity, detail and dynamics.
Talk Tomado 1	£500	Jun 97	A flexible power amp with a strong, controlled sound, but won't suit all tastes.
Technics SE-A1000	£400	Feb 97	Smooth, warm sound has plenty of grunt when needed and is very enjoyable to listen to.
Thorens TTP 2000	£500	Jul 95	Its best feature is the key on/off switch, otherwise its a case of poor sound quality and engineering.

£800-£1499

Chameleon Ruby	£995	Jan 96	Well specified and powerful, but dry and short of life. Suits Rock on bass-heavy 'speakers.
Chord SPM 400	£1325	Mar 98	This amp has it all - detail, transparency, slam and rhythm. In a word, excellent.
Crimson CS630C	£800	Nov 98	These monoblocs have a tonal richness and bass speed rare amongst powerful amps.
Croft Series V	£800	Jun 96	Fast, clear and detailed sound will win friends in both the transistor and valve camps.
Delph Da Capo	£1469	May 95	Quality bass and a clear midband but the treble can be harsh at high volume.
DPA 200S	£1245	Jul 93	Serious audiophile product at an affordable price. Well constructed, pleasant to use and fine sounding.
Galactron Power	£1200	Nov 95	Smooth sound but dull balance make the Galactron suitable for bright systems.
HD Audio Duo	£1185	May 95	Not dissimilar to the Audiolab monoblocs, the sound has a sweet top and amazing clarity.
Heybrook Signature II	£1051	May 97	Not quite as transparent as it could be but impresses with its smoothness and tonal colour.
Meridian 556	£950	Nov 99	Impressive with high octave music, but lacks that bit of warmth to bring out the best in laid-back material.
Meridian 557	£1400	Dec 96	Great control and dynamics allied to seductive smoothness. A rare combination of power and delicacy.
Musical Fidelity X-A200	£1000	Aug 98	Hugely powerful and controlled, the X-A200s are still superbly musical.
MVL Integral A2	£895	May 99	An excellent performer with any music. It is hard to imagine the A2 being beaten at the price.
Myryad MA120	£1000	Apr 96	The sound is a somewhat acquired taste and a little rough in places.
Omak Jewel One	£899	Jul 95	A lot of amplifier for the money. Big, warm, sweet sound places it ahead of most.
Quad 707	£800	Jul 97	The 707 embodies a rare blend of grace and power in its sleek grey casework.
Rothwell Rubicon	£949	May 99	Low on power at 8 watts but fairly musical for all that. Good resolution of detail and texture.
Sumo Polaris III	£898	May 96	More valve-like than transistor in sound; highly competent if not spectacular.
TAG McLaren 60P	£850	Nov 98	Fully justifies the cost with a very musical and revealing performance.
VRR Adur	£1495	Jun 95	Lovers of light piano-based fare and Baroque music will appreciate this amp's delicacy.

£1500-

Audiovalve LC8	£1995	Mar 95	Eschews the traditional lavish tube sound for a brighter and leaner approach.
Canary 301	£3055	Nov 98	The 301 puts the 300B's traditional virtues to good use in a push-pull design that will drive most loudspeakers.
Cary 300B SE	£3975	Feb 95	Cary have a winning amplifier that is a prime example of how a 300B can sound.
Cyrus aPA7	£2000/pr	Jul 99	There's no shortage of clarity and control here, but the aPA7s don't come cheap.
Etalon Ampli	£2925	Feb 98	Very natural, substantial presentation with lots of power on tap.
Final Music 6	£1500	Feb 99	Battery powered amp puts convincing scale and three-dimensionality into suitably sensitive loudspeakers.
Focusrite Red 5	£2057	Feb 96	Powerful, smooth and detailed sound. Not as clinical as some professional amplifiers can be.
Gamma Aeons	£4999	Apr 97	Sound quality of these monoblocs is impressive but marred by a rather obvious hum. Build could be better.
Marantz 9	£8000	Mar 97	These monoblocs are superb, producing a beguiling performance of great control and verve.
Micheli Alecto	£1989	Oct 98	The new Alecto is crisper, cleaner and more controlled than earlier incarnations.
Musical Fld NuVista 300	£3300	Dec 99	Simply beautiful sound and inexhaustible power. Higher price than usual for MF gear - limited edition product.
Orchid RC750	£6600	Aug 96	A powerful grip on music, but articulate and detailed too. A rare combination.
Shearman Phase 1	£1999	Oct 94	Good sound quality and an impressive tonal balance.
Sugden Symetra	£1550	Oct 96	The Symetra monoblocs impress with their grip. They run hot and sound warm.
Tube Technology Genesis	£2599	Jun 94	Valve monoblocs that produce explosive bass, midrange as clear as a bell and shimmering treble.
Unison Res. Smart 300B	£4250	May 98	Powerful, neutral sounding amps thanks to their modified 300B valves, but a little expensive for the same reason.
Unison Res. Power 35	£1525	Aug 98	A great compromise between delicacy, power and practicality. Very musically satisfying, too.
Vadis S15	£2350	Jul 98	The S15's purity and clarity are impossible to beat for the money. Bass is not brilliant, but still better than most.
XTC POW-1	£2000	Nov 96	This power amplifier is smooth and seductive, although a little pricey.

CD Players £ Year Verdict

under £300

Aiwa XP-V74 portable	£80	Aug 99	Natural rendition uncommon amongst portables but a little compressed with it.
AMC CD8	£150	Oct 97	The CD8 is free from grain but can sound too polished at times.
Cambridge CD4SE	£200	Feb 98	Natural and very life-like, the CD4SE embarrasses many pricier players.
Denon DCD-425	£150	Apr 97	Crisp, up-beat player which is inconsistent in its overall presentation.
Denon DCD-635	£180	Feb 98	Rhythmically slick and dynamic, the Denon errs to the cool side of neutral.
Denon DCD-835	£280	Nov 98	Warm and smooth, the 835 is laid-back rather than in-your-face.
Goodmans Delta CMD	£199	Jun 99	Well-tailored CD/MD pairing and a doddle to use. Sound quality is spot-on for the price.

Prices shown are those at the time of review



MVL A2+



Focusrite Red 5

WORLD'S BEST AMPLIFIER UNDER £1,000?



WORLD VERDICT

An excellent performer with any music. At present, it would be hard to imagine the A2 being beaten at the price.

HI-FI WORLD MAY 1999



MVL

For more information ring 01953 850800 (See our main ad)

MVL Technology Limited, Northfield Mill, Wymondham, Norfolk NR18 0DF. Tel: +44 (0) 1953 850800 Fax: +44 (0) 1953 851022
Sound Sentinel[®] manufactured under licence from Sound Sentinel Systems. Sound Sentinel[®] is a registered trade mark.



CD Players £ Year Verdict

under £300

Boommans GCD90K	£170	Aug 99	Portable. A secure performer thanks to its 20 second anti-shock system. Sound quality good.
Grundig CD3	£240	Sep 94	Great for simple Jazz and Folk, but soft bass slows things down.
JVC XL-VZ20	£157	Jan 99	Slightly muddled in the bass, the '230 isn't the most rhythmic of players.
Kenwood DP-306/II	£180	Feb 98	One of the best budget all-rounders there is. A shade treble-heavy.
Kenwood DP-5050	£250	Aug 93	Waffly bass and enthusiastic treble mean the Kenwood prefers Classical to Rock.
Kenwood DIF-2010	£180	Jan 99	A fine performer. Lacks only some of the spirit of its predecessors.
Kenwood DPC-395	£100	Aug 99	Portable. Has build and appearance on its side but not the greatest sonic performer in portables.
Marantz CD-53	£249	Jun 94	Upholds the Marantz tradition of lively CD players.
Marantz CD-67	£270	Nov 96	Fine vocal projection and treble. Bass is deep if not that tight.
NAD 510	£200	Oct 95	Hard to criticise at the price, with a typically smooth, fluid NAD sound.
NAD 522	£170	Jan 99	Warm and smooth, this is a cultured player. Can be over-civilised at times.
Parasound SL-00410 port	£100	Aug 99	Portable with limited dynamics but nonetheless musical and finely detailed.
Philips CD721	£130	Feb 96	Not the most accurate machine, but holds its own at the price.
Pioneer PC-133	£140	Feb 95	Rolled-off treble limits detail. Light bass retains foot-tapping ability.
Quad 67	£7	May 93	One of the top players at the price with great speed and grip.
Royal RCD 9400K	£230	Oct 94	Controlled and invigorating player albeit a touch sterile.
Teac CD-P3450SE	£200	May 97	Refuses to become flustered. Can lack emotion as a result, though.
Teac CD-P4100	£249	Nov 92	Like many of its contemporaries, the Teac is too smooth to shine.
Technics SL-PG490A	£100	Jan 99	In spite of a bias towards bass and treble, this machine remains a bargain.
Technics SL-PS-10D	£200	Feb 98	Typical Technics' bright and bassy sound. Prefers Dance and Rock.
Yamaha CDX-480	£200	Mar 95	Mature, laid-back machine drops points for inferior timing and imaging.
Yamaha CDX-590	£230	Feb 98	Detailed, refined but not particularly engaging or exciting.
Yamaha CDX-593	£180	Jan 99	Lean and up-front, the Yamaha is involving on Rock but can sound rough.

Prices shown are those at the time of review



Technics SLPG490 CD

£300-£799

Alchemist Nexus	£599	Jul 99	Listening is 'sumptuous' but perception of fine detail a little more difficult.
AMC CDM7	£340	Jun 96	Very musical outfit which gains sweetness with optional valve output stage.
AR-07	£300	Jan 92	The '07 is even-handed but has no real forte.
Arcom Alpha 7	£320	Jan 97	Superbly-designed, instinctively musical player destined for success.
Arcom Alpha 7SE	£330	Nov 99	Refinement comes second to speed in the 7SE, so careful cabling is required for the best results.
Arcom Alpha 8SE	£599	Jun 98	The 8SE builds on the strengths of the standard 8 with HDCD filtering.
Arcom Alpha 9	£799	Dec 98	Apart from its tonal brightness, the Alpha 9 is a very capable machine.
Audie Analogue Paganini	£749	Apr 99	Effortless, wholly musical delivery. The Paganini does for CD replay what the Puccini does for amplification.
Audio Innovations Avo	£449	May 96	Grainless treble is detailed but the Alto misses that vital emotional spark.
Auris CD66	£450	Jul 93	High measured distortion mars the treble and bass is dry.
Ortek CD45	£499	Oct 98	A competent player with a musicality that will seduce any music-lover.
Cyrus 6AD 1.5	£398	May 99	Great detail and imaging. Classical and Jazz suit the 1.5 down to the ground but Rock can sound harsh.
Cyrus 6ADS	£598	Dec 96	Lacklustre with Classical, dramatic and lively on Dance and Rock.
Denon DCD-1550AR	£350	Jul 98	Clean and precise, the Denon lags only in warmth and openness.
Denon DCD-1650A/R	£700	Jul 99	Refined and enjoyable. Its in-built smoothness can get in the way of absolute transparency.
Harman/Kardon HD730	£300	Aug 96	Strong on dynamics and drive, but lifeless treble can dampen music.
Harman/Kardon HD740	£300	Jun 99	A smooth, musical and rhythmic player, but midrange best suits Classical rather than Rock.
Helios 3	£700	Jul 99	It is unusual to find a player with such definite loves and hates. First class with acoustic, otherwise maybe!
Linn MkII	£798	Apr 95	Tonally hard but possesses many, if not all of the Linn rhythmic strengths.
Marantz CD-92 KI-Sig	£500	Sep 96	This is a rare player, greater than the sum of its parts.
Marantz CD-63SE	£350	May 95	Taken as a whole, the CD-63SE is one hell of a CD player. No digital nasties.
Myriad T20	£600	Dec 98	With its brightness balanced by warm ancillaries the T20 will win friends.
Ortek CD-1300	£650	Mar 97	Clean and tidy on electronic music. Not so good with acoustic material.
Pioneer PD-1804	£400	Sep 96	Fluid midrange leads a dry bass and tonally-limited treble.
Pioneer DV-717	£550	Sep 99	Detailed and sweet-sounding, the DV-717 brings out the best in most discs. Not the last word in neutrality.
Royal RCD-911	£300	Aug 99	Good with ordinary CDs, excellent on HDCD. Construction is very solid too.
Royal RCD-905A Diacryl	£375	Dec 94	Fast, clean sound verges on the clinical at times.
Royal RCD-921	£350	Sep 98	Refinement is a plus point, but lack of vitality holds the Royal back.
Royal RCD-975	£450	Sep 96	Tuneful, pungent bass are the pros, flat sound staging and tone the cons.
Sony CDP-K3000ES	£500	Mar 98	Neutral, dynamic and stylish but not quite up with the best.
Sony CDP-XB300E	£300	Dec 99	A classy customer with a sophisticated and smooth sound that's very hard to fault.
Sony CDP-K6000E	£300	Mar 97	In spite of fine sound staging and clarity, the Sony fails to involve.
Teac CD-8	£350	Jan 96	Clean and dry, the Teac is rather sterile compared to the competition.
Technics SL-PS-10	£450	Sep 95	Not the last word in bass control. Midrange is more persuasive.
Teac CD100	£600	Apr 99	A very smooth and refined player with the added bonus of good detailing. Can lack rhythmic bite at times.
Triforce Genesis	£549	Sep 96	Warm and bassy, but extremely natural. Not the most consistent player.
Triforce Revelation	£799	May 97	When it's good, it's very good indeed. Can get confused on dense mixes.



Marantz CD63 KI-Sig.

£800-£1499

AudioLab 8000	£1000	Dec 96	Sweet treble and full midrange give the 8000CD a lucid sound.
Cosmos CDA 260	£1199	Feb 99	Perhaps lacks the last ounce of strength on Rock, nonetheless has winning all-round ability.
Symbol CDP12	£1279	Dec 97	Its warm, musical sound plus HDCD compatibility are a strong combination.
Cyrus 6AD-7	£899	Jan 95	Up with the best at the money, the Cyrus simply sounds 'right'.
DPA Renaissance	£895	Jun 95	Breath-taking imagery and dynamics. Not strictly accurate, but who cares?
Hilmar/Kardon HD7720	£800	Jan 94	Construction is price-correct, but not the excessively relaxed sound.
Heybrook Signature	£989	Oct 97	The Heybrook loses out because of its rough treble and lack of clarity.
Just Xara	£950	May 98	It's not cheap but the Xara scores for firm bass and exciting presentation.
LFD Mistral	£999	Nov 97	The Mistral is outclassed in areas like pace and bass depth.
Marantz CD-17	£800	Jul 99	Commendably solid build, smooth top-end and velvety overall sound.
Marantz CD-17 KI-S	£1300	Sep 97	The KI-S has a valve-like smoothness and clarity.
Meridian 506	£875	May 95	Characteristically dry Meridian balance which could do with more emotion.
Musical Fidelity X-Ray	£800	Feb 99	Bright, clear and well-built, the X-Ray's transparency can be hard on poor recordings.
Ork Thrasos Humana	£1099	Apr 98	This very natural one-box fully justifies its £1000 price tag.
Quad 77	£850	Nov 95	Competent, entertaining machine with neat styling and remote.
Roksan Caspian	£895	Aug 97	The Caspian is a gifted player well worth its asking price.
Shinn Audio Phase 7	£1499	Dec 99	The Phase 7 leads the pack for smoothness and tonal colour more than for detail and excitement.
Sugden 60T-1	£850	Mar 93	A superb all-rounder with particularly convincing rhythms.
Teac CD 1210 R	£1150	Sep 99	Outstanding build married to outstanding build, at a price which isn't expensive considering what's on offer.
Teac VRDS-10SE	£850	Apr 96	Draws you into the music. Soundstaging fine but treble is a little bright.
Teac VRDS-95	£1300	Aug 96	Solid build doesn't make up for sound which lags in integration and detail.
XFD CDP 1	£1250	Dec 97	Rhythmically satisfying, but can sound hard in the wrong system.



Roksan Caspian CD.

£1500-

Anthem CD1	£1600	Mar 98	Sweet sound and numerous features make the Anthem fine value for money.
Numatics 837	£5460	Sep 94	Amongst the best with its belt-drive transport.
McIntosh CDM-7109	£2635	Dec 95	Unmatched quality from CD at a high but fair price.
Meridian 508.24	£1995	Jul 98	The 508.24 is one of the top performers at its price.



A selection of our ever changing offers for sale
(all fully guaranteed)

Equivalent
New Price

Sale
Price

A selection of our ever changing offers for sale
(all fully guaranteed)

Equivalent
New Price

Sale
Price

AMPLIFIERS

LFD Mistral Line-Level Int. MINT / LIKE NEW Boxed /Manuals	500.00	369.95
Croft Vitale Valve Pre-Amp. The NEW Pre-amp. (Superb at this price) Available to Special Order Only NEW Standard 350.00 *Deluxe *(Timber Fascia / Brass Control Knobs)		400.00
NAD 3130 Int. 2 x 30 Watts / Phono-Stage Etc: VGC / Manuals	250.00 +	119.95
Musical Fidelity X-A1 2x50 Watts Int. Amp. NEW	N/A	479.00
Musical Fidelity B-1 2 x 40 Watts Int. VGC	300.00	149.95
Papworth Audio M-100 Valve Mono-Blocs MINT / Boxed / 2x 100 Watts (EL-34's)	3800.00	1995.00
Audion Premier Silver Night (2-Box Valve Pre. with Phono-Stage) MINT	1500.00	795.00
Audion Silver Nights Valve Mono-Blocs (300B's) MINT / Boxed / New 300B's Fitted	2300.00	1195.00
Revox B-750 2x75 Watts Int. VGC	800.00	299.95
Marantz PM-66 Kl Signature Remote Etc:MINT / Boxed Etc.	400.00	249.95
AMC 3050A 2 x 45 Watts / Full Remote Etc: MINT / Boxed Etc.	300.00 +	169.95
Quad 405 Mk1 Power Amp.G.C 2 x 100 Watts	N/A	179.95
Technics SU-A800 Rem. Int. Amp.MINT	350.00	189.95
Technics SU-C1000M Remote / Battery Pre.MINT	350.00	199.95
Pioneer A-656 Int. (2 x 100 Watts / M.M./M.C. Phono Etc:) VGC (Inexpensive Power-House Amp.)	500.00	169.95

PRODUCT OF THE MONTH

KEF CONCERTO TWO

Brand new model speakers NEW, MINI, & BOXED of course
NEW PRICE £800.00 AA PRICE £649.95

Wharfedale 304 GC	160.00	79.95
Castle Tay Bi-Wire (Rosewood) (MINT / AS NEW)	350.00	199.95
Rega Ela Floorstanders (Black) MINT	500.00	£249.95
Celestion 7 II (Black) MINT	250.00	£119.95
APOGEE CALIPER FULL RANGE RIBBON SPEAKERS (Restoration project/need finishing) SOLD AS-SEEN or "reasonable" offers Lots of Leadspeaker Cables in Stock both New & Used	3500.00	500.00

Meridian 207 / 209 C.D / D.A.C. / Pre-Amp.VGC	1500.00	495.00
Mission DAD-5 Remote / DAC-5VGC	600.00	269.95
Micromega Stage One Full Remote / Digital out etc:	550.00	229.95
Micromega Logic Remote Etc: G/C	N/A	99.95
DPA Renaissance 24-Bit / Remote /Deltran-Sync-Lock MINT	950.00	595.00
DPA Enlightenment DAC Digital To Analogue Convertor MINT	850.00	425.00
Audiolab 8000 DACMINT / AS NEW	900.00	549.95
Harman Kardon HD-7500 Remote VGC	350.00	149.95
Musical Fidelity X-Ray (24/96) (Superb Player) NEW Ex-Dem.	799.00	699.00
Musical Fidelity X-100 Missing-Link C.D. Line-Buffer / VGC / Boxed	120.00	59.95
Musical Fidelity DigiLog DAC Cosmetically Challenged But Works Perfectly	350.00	99.95
Sony CDP-XE 900 E RemoteMINT / AS NEW	300.00	169.95
Philips CD-830 Remote VGC / Digital Out (Surprisingly Musical)	400.00	129.95
Philips Cdl 210 (Interactive) Remote MINT	400.00	59.95
Nad Monitor 5000 VGC / Digital Output	310.00	149.95
Nad 5420 VGC	150.00	79.95
Marantz CD-67 Rem. MINT	250.00	169.95
Marantz CD-63 SE Rem. / Digital Out Etc: VGC / Boxed/Manual	300.00	159.95
Marantz CD-63 SE Rem (Another One) MINT / Manuals Etc:	300.00	159.95

Hundreds Of Compact Discs In Stock And Always WANTED
(Complete Collections Purchased - JAZZ in particular)

Quad FM-3 GC	N/A	79.95
A.V.I. S200 MT MINT /As New (Deposit On) Sugden FM VGC	600.00	349.95
Sugden R-51 VGC	N/A	90.00
Sugden T-48 VGC	N/A	95.00
Leeson FM1 F.M. Tuner (Very Rare) VGC	N/A	89.95
Nytech CT-206 VGC	N/A	449.95
Q.E.D. T-231 VGC	N/A	99.95
Meridian 104 VGC	N/A	89.95
Musical Fidelity T-1 VGC	N/A	149.95
Yamaha TX-470 Remote FM / Pre-Set VGC	N/A	229.95

Project 0.5 / Ortofon OM-10 G / C	170.00	85.00
Manticore Mantra c/w Rega RB-250 / Linn K-5 VGC	500.00+	199.95
Linn Armboard (Cut for Linn) (2 In Stock) VGC	N/A	Each 10.00
Mission 775 SM / 774 Arm / Ortofon VMS-20EII M.M Cartridge VGC	N/A	£249.95
Monacor SPR-6 M.M Phono-Stage / P.S.U (Brilliant Value) NEW	N/A	26.95
Musical Fidelity X-LP (The One At This Price) M.M / M.C Phono-Stage	NEW	N/A
Musical Fidelity XL-P2 Mono-Bloc Phono-Stage/ X-PSU NEW and Superb (M.M /M.C) (Switchable Impedance)	N/A	499.90
Revolver Rebel c/w Arm / A.T M.M Cartridge MINT	N/A	129.95
Audio Technica AT 1005 II Tonearm VGC	N/A	69.95
Linn Ittok LV II VGC / Boxed	N/A	199.95
Linn Bassit Plus Tonearm MINT	N/A	79.95

Denon DRM 10. HX 3 Motor Etc: VGC	N/A	119.95
Denon DRM 550. HX-PRO Etc:MINT/AS NEW	160.00	129.95
Denon DRM 800A. 3-Head / C.D Direct Etc: MINT	300.00 +	169.95
Denon DRS-640. Front-Loader / HX-Pro Etc:VGC	200.00 +	109.95
Denon DRM-24. HX 3-Head Etc:VGC	250.00	90.00
Marantz DCC-82 Digital Recorder MINT / Boxed /Some Tapes	650.00	249.95
Nakamichi BX-100E. 3-Motor / 2-Head Etc: VGC	500.00 +	199.95
Nakamichi 581. Variable Bias / Variable Gain Etc: VGC	Loads	199.95
Sony TC-KE 400S Dolby S Etc: MINT / AS NEW	250.00	149.95
Yamaha KX-500 HX-Pro / Vari-Bias Etc: VGC	160.00	99.95
Aiwa ADF-640 3-Head / 2-Motor Etc:MINT	300.00	119.95
Technics RSB-565 Direct-Drive / HX-Pro etc: G/C	250.00	99.95
Technics RS-TR 373 Tone / Arm Reverse Etc:VGC	230.00	119.95

Yamaha DSP-E1000 Remote Pro-Logic Processor / DSP VGC	700.00	249.95
R.A Labs Shielded Centre-Speaker NEW / Boxed	139.95	119.95
TDL CSS Shielded Centre-Speaker MINT	150.00	89.95
Jamo Shielded Centre-Speaker VGC	80.00	39.95
Solid S-100 Surround Speakers VGC / Boxed	130.00	89.95
Musical Fidelity X-Tand Stacking Blocks NEW	N/A	29.00
Cable Talk L.S / Incon Cables Now In Stock "NEW"		P.O.A.
Golden Dragon 300B Valves (4 Of / All Good) (prices are for each)	90.00	30.00
Sound Organisation L.S. Wall Brackets MINT	N / A	40.00
Lovan Trisolator Isolation Platform (Adds Mass-Loading to C.D Players Etc:) NEW	99.95	79.95
Lovan Classic II Stand (For Power Amps. Etc:) NEW	50.00	40.00
Target B-5 (5-Shelf Stand) VGC	220.00	139.95
LFD Power - Cord VGC	60.00	30.00
Roni IS4W Input Expander (4-Way Line-Level Expander)	NEW	15.00
Chord Siren Incon 1x Metre	70.00	35.00
Cable Talk Broadcast 2 Incon 1x Metre NEW	99.95	79.95
Cable Talk Broadcast 2 Incon 1/2 x Metre NEW	79.95	59.95
Cable Talk Monitor 2.1 Incon 1x Metre	49.95	34.95
Ixos Gamma L.S Cables 2 x 3.5 Metres (Unterminated)	40.00	19.95
Soniclink Bi-Wire L.S Cables 2 x 3.5 Metres (Terminated)	N / A	50.00
Roni 4 m.m Banana Plugs (Gold Plated)		6.95
(Screw-Type, Don't Require Soldering NEW (prices for 4)		10.00
Roni Optical Linc Cables (C.D / Minidisc to D.A.C. Etc:) NEW		
Monacor SPS-20 Anodised Adjustable Polished Cone Equipment Supports NEW (Superb Spike System at a very good price) Set of 4	19.95	11.95
Ixos Sorbothane Feet Set of 4 NEW	N / A	10.00
AQ Sorbothane Feet Set of 4	N / A	5.00
Parastatic Disc Preener 3 In Stock (price is for each)	N / A	5.95
Kontakt 60 Contact Cleaning Spray 100 ML NEW		
A Few Left Reel to Reel Tapes (71/2) Please Phone for details!		N / A
Various. Prices on application (71/2" only left)		
B-Tech BT 928 Stereo Headphone Amp. C/W Tone / Volume Control /P.S.U (Excellent Value) NEW	200.00	60.00
Hi-Q (By Chantry) Headphone Amp. Volume Control / P.S.U / VGC	200.00	60.00
Monacor DC-100 Carbon-Fibre Brush NEW (A must)		5.95

PLEASE VISIT OUR WEB-SITE (UPDATED DAILY)
WWW.affordable-audio.CO.UK E-MAIL: Sales@affordable-audio.CO.UK

***** GOOD HIFI SEPARATES WANTED *****
Phone anytime with your wants, stock changing daily. All equipment is sold with warranties.
Don't forget we can offer mail order.
All major credit cards accepted.
We welcome part-exchange on any of the above Affordable Audio is always keen to buy, (or part-exchange) Good quality Hi-Fi separates in good condition. Especially top

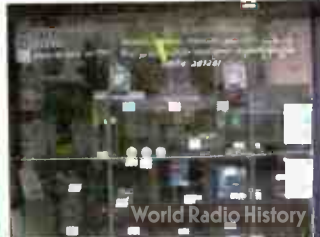

We can also sell your equipment for you on a commission basis.
(Lowest rates/best return)
(Please phone Paul for details!)

CD players £ Year Verdict

£1500-

Naim CD2	£1998	Apr 97	CD2 excites at the expense of subtlety. More at home in a Naim system.
Philips Compact Disc	£2099	Feb 98	One-box player with sound capable of mixing it with the best.
Teac CD-X1	£2300	Jun 92	You'll either love or hate this machine's great flair and confidence.

Turntables £ Year Verdict

Under £800

Clearaudio Soutron	£750	Feb 99	If you seek a powerful presentation where musicality takes precedence over absolute finesse, this could be the answer.
Linn Saali	£400	Sep 94	Definitely a turntable for devotees of attack and strong bass lines. Not strong on imaging.
Mitsubishi CD-2000	£775	Apr 99	Great sound, superb build and excellent upgradability make the 'spider' a wonder at the price.
Michael Meyer	£539	Jan 94	Silent and beautifully made, with transparent reproduction.
Rega 333	£200	Nov 94	Based on a Rega Planar 2. Both pleasant to use and look at with a mature sound, all for £200.
Pink Triangle Tantalus	£575	Oct 97	Simply the best at the money. Combines PT's customary transparency with real authority.
Project 1.2	£200	Jun 97	A bargain at £200 with its substantial and involving sound.
Project 4	£350	Dec 93	Involvement and rhythm are priorities. Highly recommended.
Project 6.1	£435	Sep 94	The 6.1 gives a very full, strong sound. A very exciting deck.
Pro-ject Classic Cherry	£450	Jul 99	Emminently capable player that can be upgraded with superior cartridges.
Pro-ject Debut	£109	Dec 99	Produces an enjoyable and confident sound on a budget. There are better turntables around, but not at this price!
Systemdek 232	£500	Aug 96	Clear and precise sound through midrange and treble puts it up with more expensive rivals.
Systemdek 3300	£415	Sep 94	Detailed sound stage and broad imaging with a good, even range of tonal colour.
Systemdek 333	£450	Jan 93	Combined with an SME 309 it achieves great results, with a massive sound stage.
Thomas TD165 MK2	£405	Sep 94	Tonally smooth with a warm midrange, but a little too laid back.
Thomas TD180	£180	Feb 95	A good, basic budget bargain.
Thomas TD250 MK4	£199	Jun 93	Superbly lucid and clear midrange, but lower reaches are a little lightweight.
Vestax SDT-2000	£225	Sep 99	Price includes cartridge and phono stage. A fit-and-forget solution to LP replay, of exceptional versatility.
Vinyl Ready Resonance 1	£600	Nov 95	With fine detail resolution, transparency and a neutral balance the Resonance 1 represents super value.
VPI Junior	£500	Oct 97	The Junior is a very good deck indeed, with an assured and involving sound.

£800-

Aphoton Symphony	£1860	Nov 92	The Symphony has to be one of the best the British can offer. It's expensive, but a true sophisticate.
Basis 2001	£2995	Jun 99	It's not cheap, but the 2001 shows just why vinyl is still a sonically viable format.
Michael Orto	£1950	Apr 95	Fast and detailed with crisp sheer treble and clean, deep bass.
Orto 3 CommensCarbis	£900	Oct 95	Solid as a rock and almost as heavy, it's a satisfying performer, but not quite the best.
Orto Live Cassa-A	£950	Dec 98	Nice looks and a good sound, but can be bettered on price.
Orto Live Cassa-S	£2250	Oct 98	The Oasis-S is a cool, lean but very transparent performer thanks to battery power. Up against strong competition.
Pro-ject Perspective	£900	Aug 98	Aesthetically, the Perspective is a winner, but better sound can be had from cheaper decks.
PT Anniversary	£2390	Oct 96	With its battery supply and ultra-quiet DC motor, the Pink displays great accuracy and neutrality. A top-flight deck.
Robson X Series X	£1295	Jan 97	An undoubted bargain and class leader in all areas with a precise, confident and well-balanced sound.
SME Model 20	£2500	Oct 92	This is a deck for those with a substantial record collection who demand the best. Exemplary sound.
Technics SL-1200 LTD	£1000	Apr 97	Looks expensive at £1000, but don't let that put you off the capable standard version.
Wilson Hornet	£1775	Jul 96	Gives a technically excellent rendition but fails to really communicate the emotion in music.
Wilson Bahdach Full Circle	£2000	Mar 98	Offers clarity in abundance with a natural ease. Looks gorgeous too.

Phono stages £ Year Verdict

Under £500

Orto OB1/2/3/4	£160	Nov 97	One of the best MC phono stages on the market at the price
Orto OB1/3/4/5	£110	Nov 97	Smooth and truly musical, exceedingly worthy entry-level phono stage.
Orto OB1/3/4/5	£350	Sep 97	A beautifully made, fine sounding device that looks great too.
Lehmann Black Cube	£395	Oct 98	Capable of involvement, neutrality and insight usually the preserve of stages three or four times the price.
LPJ Mito	£299	Sep 97	The most lucid and musical budget phono stage around - a true audiophile bargain.
Musical Fidelity X-LP	£130	May 99	First-class inexpensive phono. MM and MC inputs catered for. Low on distortion, high on clarity.
NAD PH1	£40	Sep 98	At this price the NAD is an accomplished all-rounder. Slowish bass will suit leaner systems though.
Pro-ject Phono Box	£40	Dec 99	Very competent little MM & MC stage at an astonishing price. First-rate starter package.
SED Discman	£35	Jan 97	A bargain. Beguilingly musical presentation, with more than enough detail and power for a mere £35.
Tronix RO 970BX	£130	Nov 94	Combine with a good cheap line level integrated and it will show you how good vinyl can be.
Sumner Sedyly MC2MM	£399	May 98	The Sedley combines transparency and fine dynamics with excellent rhythmic ability.

£500-

Anthem Pro 1P	£899	Aug 98	Despite a sizeable price tag the Anthem offers a smooth, lucid sound and superb build quality.
Audio Innovations P2	£749	Feb 96	Fantastic bass and super insight make this one of the best phono stages around.
Axentia 8000PPA	£800	Oct 94	Instruments can have a somewhat flat perspective, but excellent clarity.
Orto OB1/3/4/5	£495	Oct 94	Could be too forceful for some, but with excellent detail and extremely powerful bass.
Kimber Perception	£525	Oct 94	Extremely impressive results, especially with MM cartridges.
Linn Linn	£850	Oct 97	Marries beautifully into the Linn family, but not too hot with other components.
Michael Leo	£528	Oct 94	Gives a thoroughly cohesive picture of a recording with a very tight and rhythmical bass.
Michael Leo HR	£850	May 93	Perhaps too good for some record collections. Extremely revealing.
Robson Anniversary D58	£945	Oct 97	Doesn't worry about genre, it just gets on with the job of making music in an enjoyable way.
Sonic Frontiers Phono 1	£2000	Apr 98	Expensive, yes, overpriced, no. The Phono 1 is a superb all-round phono stage.
Sumner Sedyly Phono	£495	Mar 96	Liquid sound with great dynamics, but a little hissy and muddled too. Beguiling, but not perfect.

Cartridges £ Year Verdict

Under £200

Clearaudio Alpha	£130	Apr 99	Tends to sound quite hard at the top but imaging and detail are good. Best in a warm system.
Denon DL183M	£110	Aug 97	First manufactured in 1963, it sounds mature and sure-footed rather than over the hill.
Denon DL110	£65	Mar 94	May be a little soft-natured for some. Splendid dynamics and an even tonal balance.
Orto OB1	£185	Feb 98	Better Goldring's 1042 without difficulty. MC quality from an MM.
Orto OB1	£90	Jan 93	One of the best MMs at the price with strainless delivery.
Shure 1012GX	£60	Jul 93	Great with Rock music, the 1012GX is the best value low-price MM.
Grado Prestige Silver	£119	Apr 97	Good tracking and inoffensive sound, but somehow lacks sparkle in any department.
Linn RS	£58	Sep 94	Rhythmic bite compensates for a lack of vibrancy in music (MM).
Orto OB1 (10 Mill)	£40	Jul 99	Excellent tracker at a good price. Warm amplification is needed to tame this sure-footed budget entry.
Orto OB1	£100	Jan 93	Smooth operator and very good value for money (MM).
Orto MC15 Super II	£110	Mar 95	In the right system, can be masterful with its dry and accurate response.
Orto MC25E	£170	Sep 95	A considerable achievement that adds true verve a pizzazz to the MC15 Super II
Orto MC25E	£120	Jan 93	Light and dry presentation with good presentation (MM).
State Brass MM	£185	Sep 97	If you like the V15 you'll love the Brazen. Works well with an SME 3009.
Sumner Sedyly Phono	£100	Oct 92	Excellent value for money. It does its job of transcribing the information on the disc without fuss or bother.

Prices shown are those at the time of review



Pro-ject Classic Cherry



Lehmann Black Cube



Clearaudio Alpha

Audio Direct (UK) - the best audiophile components at the best prices !

Goertz Cables - world class audiophile cables now available at genuine US retail prices
The best value cables at the most affordable prices - Quiet, dynamic and natural, with incredible imaging and detail!

MI 1 "Centre Stage" speaker cable, 13 AWG OFC, sample price £115.00/3m pair terminated in Rhodium spades/bananas
MI 2 "Veracity" speaker cable, 10 AWG OFC, sample price £165.00/3m pair terminated in Rhodium spades or bananas
MI 3 "Divinity / Big Boy" speaker cable, 7 AWG OFC, sample price £375.00/3m pair with choice of factory termination
AG 1, AG 2 and AG 3 Solid Fine Silver Cables available to order only please inquire for our best prices and availability
"Micro Purl" pure copper interconnect, a superb budget cable at £42.50/1m pair "Smooth and natural presentation"
"Tourmaline" pure copper interconnect, on special offer at only £49.50/1m pair "Dynamic and powerful presentation"
"Micro Purl" fabulous pure Silver Interconnect, superb value at £84.95/1m pair "Open and very natural presentation"
"Triode Quartz 2" improved pure Silver interconnect, top end bargain at £124.95/1m pair "An absolute must for valve users"
"Sapphire" pure silver interconnect, Goertz's best high-end cable at £199.50/m pair "Superb with solid state equipment"
Cables offered on 21 day trial basis subject to normal conditions (exc. MI 3/AG1,2,3) - termination service available.

Nordost Cables & accessories - Full range now available directly from Audio Direct (UK)

Considered by many to be the best range of speaker cables and interconnects available on the market today!

- Please inquire for generous part-exchange allowances against either of the above leading cable brands.

- Also note that we can offer many part-exchange and second-hand bargain cables as they become available!

Selected Valves - super quality premium valves only- offered at the best available prices

ECC82 JJ	£4.95	300B JJ	£62.95	6L6GC JJ	£8.95	6B4G new Sovtek single-late	£19.95
ECC83 JJ	£4.45	(the best 300B available)		KT88 JJ	£19.95	2A3 new Sovtek single-plate	£19.95
E88CC JJ	£4.95	6SN7/6SL7	£4.95	EL34L JJ	£5.95	6AU6WC Jan Philips nos.	£4.50
ECC99 JJ	£9.95	EL84 JJ	£4.45	(a superb EL34)		5814a (ECC82) Jan Philips nos.	£5.95

Full matching and burn-in service available @ 80p/valve. Factory selected pairs and quads also available

JJ Capacitors - superb new caps for valve power supplies, quiet, transparent & dynamic
100 uF 500/550V £4.95 500uF 500/550V £8.95 These new caps will rival the best at a fraction of the price!

Panasonic pots. 100k dual log stereo pot offered at £29.95 including free Wonder solder Unbeatable value!

InfiniCap SETI (0.01 through to 10 uF) Sample price 0.47 uF £8.95 Probably the best cap available!

Kiwame carbon resistors Best quality Japanese carbon Film resistors - sweet, open & very natural
Available in 2 watt and 5 watt ratings. Priced at 95p/2 watt and £1.90/5 watt Superb for crossovers and valves!

Nordost hook-up wires - only available from Audio Direct! Totally stunning cables of the
very highest quality- guaranteed to blow away any other copper or silver wires currently available!
Silver Note - multi purpose paralleled pair 8 nines copper/silver 20 AWG cable with pure Teflon dielectric £6.95/m
Blue Vulcan 2 - screened twisted pair with drain wire, 8 nines copper/silver 26 AWG cable with pure Teflon £14.95/m

Customers have been astounded at the available performance in amps, speakers & signal applications.

New Vibropods - "Stereophile" recommended isolation mounts for amps, CD players and speakers
Five models available covering 2 to 30 lbs.each. Amazing value at only £3.95 each Don't waste money - these really work!

New UIC Wonder Solder the best available - no sonic degradation, easy to use. £1.95/m (heavy gauge)

Audiolinx Power Cords a new range of cables that outperform everything up to £400.00!
Audio power cords designed specifically for Hi Fi, using the best materials available. They have a full Military Spec. screen and are fitted with top quality hardware and feature non-invasive protection against noise, spikes and any damaging surges
1.2m/15 amp cord for CD, preamps etc. £69.95 1.2m/25 amp for poweramps, A.V etc. £89.95, other specifications to order.
Quiet, dynamic, very detailed presentation with a tight bass and improved soundstaging and transparency!

All major credit cards accepted Please add Vat @ 17.5% to the above prices. Insured carriage extra at cost.
2 Craigs Road, Carlisle Park, Ballynahinch, Co.Down, BT24 8PQ - UK.

Audio Direct(UK). Tel 02897 561348 Fax 02897 564063 Email audioduk@cs.com

Total customer care

1. Expert, impartial advice on all aspects of audio & video, given by trained staff
2. Products specially selected for quality, performance and value
3. Personal demonstrations - Listen before you buy!
4. A home delivery and installation option - for optimum performance



BADA
BRITISH AUDIO DEALERS ASSOCIATION
the symbol of security

BRITISH AUDIO DEALERS ASSOCIATION

P.O. Box 229 London N1 7UU Phone: 0171 226 4044

Fax: 0171 359 7620 E-mail: bada1@compuserve.com

For further information please see our web site: <http://www.bada.co.uk> or ring for our information pack

BADA acknowledges the support of the following Associate Members: Alphason The Chord Company, Dolby Labs, Heybrook Jamo, KEF Kenwood Meridian NAD Pioneer Polk Sennheiser Sony Vivanco

Total peace of mind

1. A 10-day purchase exchange programme (returns as new & excluding special orders)
2. BADA's Free extended 2-year Guarantee on all new hi-fi and home cinema separates
3. The option to transfer the Guarantee to any one of 120 BADA members nationwide
4. Deposits safeguarded by the BADA Bonding Scheme

Cartridges £ Year Verdict

£200-

Cartridge Man Music Maska	£549	Feb 99	Good price, high output and a winning musicality make this Moving Iron cartridge the one to beat.
DNM Lens	£1300	Jan 99	A Goldring make-over that tracks well and sounds good. Pricey, though.
DNM Rice MM Cartridge	£255	Jun 98	This betters the Mica, has super-MM virtues.
Dynavector DV30X-H	£299	May 99	Delightfully musical sound makes the Dynavector a very strong contender in the budget MC stakes.
EMT 1873	£850	Oct 96	Solid bass and smooth, musical sound make this rare MC cartridge worth the money.
Golding Excel VX	£495	May 97	Has fine midrange clarity, but is bettered in other areas by cheaper competitors.
Linn Arko	£1200	Dec 97	Linn fans will love it but it's up against strong competition.
Linn Klyde	£489	Jun 95	Sumptuous sounding cartridge that borders on the bass heavy but has a good feel for music.
Linn Lydon	£649	Jun 95	Externally smooth, civilised MC with no obvious weaknesses.
Ortofon Jubilee	£1250	Mar 99	Detailed, musical and sure-footed, the Jubilee goes a long way towards justifying its elevated price tag.
Ortofon MQ25F	£225	Sep 95	Delightfully sweet, musical sound with added refinement on FL that takes some beating.
Ortofon MC20 Supreme	£450	Jun 95	Involving yet refined presentation but some could feel it's slightly coloured.
Ortofon MC7500	£2000	May 94	Conveys the full gamut of emotion from A-Z with the fervour of a live concert. Expensive, but the business.
Ortofon Rohmann	£1000	Apr 96	A top quality MC with superb tonal quality and excellent imagery.
Shure V15VMR	£295	Mar 97	Warm, dynamic rendition of music with great detail and Impact (MM).
Transfiguration Spirit	£1000	Jul 98	A balanced all-rounder that misses out only on the last ounce of detail and bass weight.
Van De Hul MC10	£840	Jun 95	The MC10 is very hard to fault. A honey, pure and simple.
VHM Grasshopper IV	£3750	Dec 95	Allows music to flow with superb fluidity and reveal things which were previously unheard - at a price!

Prices shown are those at the time of review



Ortofon Jubilee

Tonearms £ Year Verdict

Hadcock GH 228 SG	£595	Dec 98	Construction won't worry SME but its sound quality will unsettle a lot of the competition.
Origin Live RB250RB300	varies	Nov 97	These modified arms are a considerable improvement on the originals
SME 206	£689	Jan 93	Tight, neutral sound with good tonality, but lacks the IVs pace and precision.
SME3V	£828	Mar 92	Sexy chassis and staggering engineering along with potent performance earn it a place in audio history.

Tuners £ Year Verdict

Under £200

AAC T7	£130	Jul 97	Although it has a tempting price, its sound quality is poor compared with its rivals.
Arcam Alpha 7	£230	Mar 97	An attractive, smooth sounding tuner that won't break the bank.
Cambridge T500	£180	Feb 99	The T500 is one of the most gifted tuners under £500; a very accomplished all-round performer.
Denson TU-200L Mini	£130	Jun 99	With its smooth, inoffensive sound and abundant facilities, the MkII is a worthy addition to the tuner line-up.
Herman/Kardon TU 950	£1200	Jul 96	Sound quality is generally impressive. Let down by a rather constricted sound stage, but still good value.
Kelwood KT-2080	£130	Feb 97	Smooth, even balance allows the KT-2080 to convince with whatever it's receiving. £130 well spent.
Marsatz ST-57	£150	Oct 97	The ST-57 is a smooth, warm tuner but lacks a little clarity and transparency.
Mission Cyrus FM7	£299	Apr 94	Musical, communicative and extremely detailed and a steal at the price.
NAD 412	£190	Jun 96	A remarkably musical and natural sounding tuner. Unbeatable at the price, or even twice the price for that matter.
Origo T401	£160	May 94	A competent machine, but time has taken its toll on the sound quality.
Opera Radio	£230	Jan 95	Sounds on the whole more than its price, but in other respects it isn't especially competitive.
Hotel RT-930AX	£175	Aug 94	The RT-930AX is a glowing little bargain. real quality at a very realistic price.
Sony ST-545E3	£250	Apr 97	The Sony is worth every penny of its asking price. If you're a fan of radio this is one to go for.
Shny ST-SE700	£180	Aug 97	The ST-SE700 is one of the best at this price. LW reception is a welcome bonus.
Teac T-460	£120	Oct 99	An inexpensive and versatile tuner, difficult to fault as such. Sound quality on the dryside.
Technics ST-GT-350L	£140	Jun 95	Not a bad buy at all and a very good fit for budget and mid-price systems.
Yamaha T3500 ROS	£200	Feb 95	If you want something for casual listening with superior aesthetics, this might be the one for you.



Hadcock 228SG

£200-

Arcam GFT 885 L2	£399	May 93	Quite musical but does not rejuvenate the waves! Good solid performance but less than luxurious.
Arcam Alpha 10 DRT		Jul 99	Arcam's digital radio couldn't be simpler to use. Compared with good FM the benefits are marginal as yet.
Summaster 931	£4347	Nov 94	This is not a cheap tuner, but its cheaper than buying a radio station, which is the only possible alternative.
Cross T43	£399	May 98	A great little tuner. This is the one in the price bracket.
Cyrus FM2.5	£400	Oct 99	Fine, smooth and musical; commendably simple in style and operation. Only its price counts against it.
Denson TU-910	£400	Mar 98	A stylish, well-built tuner which has a detailed sound but needs careful partnering
Fanfare FT 1	£1350	Mar 95	Whether it's sweaty disco or symphony hall, the Fanfare comes up to scratch.
Kelwood KT-8500L	£300	Oct 95	A good value, excellent sounding rds tuner, but lacks full EON facilities
Linn Krenalin	£1645	Mar 92	Commendable basic performance but, considering the price there are limitations.
Magnon Cyrus FT101A	£749	Apr 92	Worth auditioning but bass rather dry and light.
Marsatz ST-17	£600	July 99	Knock-out build quality and rich velvety sound. Poor-signal mute a bit too enthusiastic.
Merrill SD4	£660	Mar 96	A clear, natural sound with good punch. Has strong rivals at the price, but acquits itself well.
Micromega Tuner	£700	Jul 95	An unusual design from Micromega that's well built but sonically unrewarding and expensive.
Myriad ST100	£530	Nov 99	Low on facilities, but when it comes to looks and sonic performance, it's the business.
NAD 702	£330	Jul 94	Well worth auditioning, even if you've never previously considered a receiver.
Naim N4T (3)	£499	Sep 93	Soft and pure, especially across the midband. Speech very well reproduced plus solid weighty bass.
Nitaramini ST35	£350	Dec 94	Looks good, but the sound quality isn't really worth the asking price.
Pioneer F-504SD75	£300	Dec 98	One sole mark against the class-leading transparency is its slightly dry character.
Pioneer F-504RDS	£350	Nov 95	Well engineered and competent tuner, but a little uninspiring.
Real Music RH110	£895	Mar 94	This classy looking tuner can hold its head up high amongst the best tuners at the price.
Real RT-990BX	£500	Apr 95	The price of twenty concert tickets, and for that you can listen as if you were there. A bargain.
Teac McLennan T20	£1100	Mar 99	Extremely well built with a lucid if slightly dry sound. The only real drawback is the high price.
Thorens TRT-2095	£500	Dec 97	An otherwise competent tuner is let down by a rather processed character.



Marantz ST-17

Cassette £ Year Verdict

Under £300

Aiwa AD-F380	£150	Apr 98	No Dolby S, but three heads and two capstans make the Aiwa a bargain.
Denon DFM-550	£160	May 96	Good enough for the price and no worse than the competition.
Denon DFM-555	£150	Jul 99	Its slant towards features prevent the Denon taking the audiophile honours at the price.
Denon DM8-6505	£230	Aug 96	Top sound quality with ferric and chrome makes this deck a steal.
Grundig CF4	£250	Jan 95	Fair on pre-recordeds, OK when recording, but speed stability isn't great.
JVC TD-V862	£300	Sep 98	Only the lack of Dolby S conspires against the otherwise excellent JVC.
Kelwood KK-5000S	£200	Jan 97	Stable transport gives fine results on metal and chrome. Rough on ferrics.
Nad 613	£230	Jan 96	Decent playback and good recording when used carefully.
NAD 614	£270	Sep 95	Excellent electronics are let down by a low-grade transport.
Notat RD-908BX	£230	Oct 95	A solid, competent machine which is reasonable value for money.
Sony TC-K011	£150	Dec 93	Auto-tuning is mediocre and the general results are unexceptional.
Sony TC-K480	£170	Jan 93	A mix of average heads and electronics doesn't make for happy taping.
Teac V-610	£100	Apr 97	The V-610's performance matches its price well, but audiophile it isn't.
Teac V-600	£150	Sep 94	Satisfactory for in-car recordings, but the low price shows.
Yamaha KC-580 SE	£250	Sep 97	The '580 lives up to its SE tag with a fine performance in all areas.

Prices shown are those at the time of review

Cassette £ Year Verdict

£300-

Model	Price	Year	Verdict
Alwa AD-S950	£300	Feb 95	Vice-free playback is mirrored by impressive recording.
Denon DR19-B10	£300	Jan 92	On the right tapes, the Denon repays with delightful sound quality.
JVC TD-V1010	£400	Sep 92	Disappointing on replay but recording is another kettle of fish altogether.
Kenwood KX-7060S	£330	Dec 94	Convincing all-rounder except for heavy-handed noise reduction.
Nakamichi 1.5	£500	Jan 92	The Cassette Deck 1.5 has no rivals in its ability to recreate a realistic performance.
Nakamichi DR-1	£780	Jun 93	Not perfect but as close as you can get for the money.
Nakamichi DR-3	£300	Mar 93	Unfortunately keeping the price down keeps performance below Nak's norm.
Onkyo TA250	£350	Oct 94	Top transport but the electronics aren't on a par.
Pioneer CT-95	£1000	Mar 97	On chrome and ferric, the '95 is smooth and natural. Not so good with metals.
Pion'r CT-S550S Precision	£340	Feb 99	Three heads, ease of use and high quality make the Dolby S equipped Precision a strong contender
Pioneer CT-S740S	£430	Jun 96	Complex but superb in every important area.
Sony TC-K611S	£330	Feb 94	A little muffled on pre-recordeds but pulls out all the stops on recordings, esp. with metal tape.
Teac V-6030S	£550	Nov 97	Solid build and solid sounds. Top-notch at the price.
Teac V-8030S	£650	Aug 95	One of the highest quality Dolby S decks available.
Technics RS-AZ7	£300	Jul 96	Excellent bass but mid and treble lack dynamics. Auto-tunes poorly on metal.



Sharp 772

Minidisc £ Year Verdict

Model	Price	Year	Verdict
Alwa AM-F70	£250	Oct 99	Solid all-rounder that doubles as a superb dictaphone. Not No 1 as regards MD portables though.
Denon DMD-1000	£300	Nov 99	Sound quality up with the rest, wears its years well. Beginning to look expensive.
Goodmans GMD 520	£160	Nov 95	Very good value, built quality a touch plastic-y but stylish with it. Sonically very worthy.
JVC XM-228	£230	Sep 99	Well-built recorder. Good but not exceptional as Minidisc improves generally.
Kenwood DMF 9020	£500	Aug 99	An excellent tool for home recording; combines convenience, superb sound and a fair price.
Pioneer MJ-D508	£200	Nov 99	Sensible and well featured MD. Excellent transcriber of digital, shows up on analogue a little.
Sharp 722 portable	£230	Aug 99	Flash looks with solid build. First-class portable with domestic potential, but it isn't cheap.
Sony MDS-JB930	£300	Nov 99	UK Special Edition, so it sounds alright! Keyboard compatible with no difficulties in operation.
Technics SJ-MD100	£230	Nov 99	Solid, obviously meant for serious use. Excellent editing features. Sound up with the rest.

Recordable CD £ Year Verdict

Model	Price	Year	Verdict
Marantz DR700	£600	Oct 99	A very solid all-rounder with impressive playback sound quality. Dearer than many though.
Philips CD-R 880	£500	Oct 99	Spot on with digital sources and impressive with analogue; playback a touch cold sounding.
Philips CDR-765	£360	Oct 99	Big value package. Whether the 'free' CD player function will earn its keep is a moot point.
Pioneer PDR-555RW	£500	Oct 99	Worthy of consideration but a bit of a mixed bag all round. Plenty of drive.
Traxdata Traxaudio 900	£500	Oct 99	Not the cheapest on the market but has an obliging way with playback which may turn the scale.

DVD £ Year Verdict

Model	Price	Year	Verdict
DVD-3000	£700	Aug 98	The Denon is a fine performer with CD and better still with 24/96.
Denon DVD-5000	£1500	Mar 99	Build is second to none. Sound is very solid convincing, but not as musical as the 3000.
Panasonic DVD-A350	£700	Jul 98	The A350 wipes out the CD-only competition at the price and threatens players up to £2000.
Panasonic DVD-L10	£1000	Nov 98	Isn't cheap, but it's an outstanding portable and a capable domestic device.
Sony DVP-S715	£700	Aug 98	The Sony is warm and smooth but lacks clarity and precision.
Sony DVP-S7700	£700	Oct 99	Looks good, sounds better. Deserves very serious consideration.
Sony PBD-V30 (portable)	£700	Jun 99	The Sony is an engrossing performer in a sturdy and attractive design.

Headphones £ Year Verdict

Model	Price	Year	Verdict
Ergo Model 2	£140	Apr 99	Wonderfully lucid and transparent panel-like sound.
Jackin Float 2	£100	Apr 99	Clarity and openness are their traits, rather than slamming bass, but still good value.
Sennheiser HD-580	£200	Nov 98	In the company of a smooth, warm system the 580s can shine.
Sennheiser HE50/V70	£1000	Feb 95	Electrostatic that set a class standard and can put a case for chucking out your power amp and 'speakers.
Vivanco FMH-6800	£80	May 98	Have a lot of potential but basic operating problems have to be cleaned up first.
Vivanco SR850	£50	Nov 95	Excitement that is rarely heard in headphones, but have a little trouble with heavy orchestral loads.



Sony PBD-V30



TEMP-O

Low Thermal Noise Interconnects

Listen to the Music - not the background noise and interference !

TEMP-O Interconnects are manufactured from a highly specialised cable, which has been treated to remove sources of thermal noise within the cable. Terminations are made with a unique Sn/Cd low thermal solder.

To further enhance noise rejection, the signal is carried by a twisted pair of conductors, with an overall grounded screen. To make full use of the quality of the cable, TEMP-O interconnects are terminated with the acclaimed NEUTRIK PROFI sliding shield Phono Plugs.

Price per M/Pr. £98.00 inc. P&P (U.K.) CONTACT US FOR FURTHER DETAILS

POWERSAFE specialised electronics

13, Lloyd Street, Heaton Norris, Stockport SK4 1QP

Tel/Fax 0161-477-8670

Email bernard@psafe.u-net.com

CD Transports £ Year Verdict

Audiolab 8000 CDM	£1249	Aug 94	Distinguished by a wide array of facilities, Thoughtfully designed and high quality.
Cyrus Disc Master	£1800	Jul 94	Smooth and cohesive. The Disc Master looks good and comes with the Disc Master within the price.
DPA Enlightenment	£695	Mar 95	Solid and lifelike sound with Rock music and full bodied on Classical.
Kierwood DP-X9010	£530	Feb 92	Superb build for the money and a very musical sound. Benefits greatly from clocking.
Micromega Duo	£3435	Apr 93	Excellent build quality and a sound quality to match.
Monarchy DT-40A	£1595	Jun 94	Isn't cheap but has a solid dependable sound with a big, powerful presentation.
Parasound C/BD-2000	£1695	Jun 97	The belt drive is an interesting idea but the Parasound is bettered by cheaper transports.
PT Cardinal	£1440	Feb 95	Heart-stopping speed and impact contribute to what is an exceptionally good machine.
Rotel RDD-980	£450	Jul 96	Good, clean dynamic sound with a neutral and pure midrange tone.
Sonic Frontiers 3	£6999	Sep 98	A handsome machine both sonically and aesthetically. We love the camera aperture-style loading system.
Sonic Frontiers SFT-1	£2295	Aug 96	Top flight machine with an easy, musical and enjoyable sound, for those that can afford it.
Teac P-30	£2500	Jun 97	Costs a lot of money and sounds nothing short of superb.
Teac VRDS T1	£499	Feb 95	Enjoyable player with good insight. Good finish and keen pricing make it a thoroughly good buy.
Thorens TCD 2000	£900	Jun 96	A soft and warm sound will please vinyl lovers, but it's not the last word in detail.
XTC CDT1	£1200	Apr 96	A warm and musical sound with a taste of high-end refinement and detail.



Sonic Frontiers 3

CD Convertors £ Year Verdict

Alchemist TS-D 1	£300	Jan 99	Smooth, natural and relaxed on the ear, highly persuasive with acoustic material. A bit soft on Rock and Dance.
Arcam BB500	£750	Aug 97	Smooth and accurate treble and easy-going rhythm. Measured and engaging; good value too.
Audiolab 8000DAC	£900	Aug 97	Treble roll-off serves to remove some of the music's sparkle; lags behind the group leaders somewhat.
Cambridge Dacmagic	£150	Jun 95	Instant upgrade for a budget player but out of its depth with In a properly designed hi-fi CD player.
Chord DSC 900 DAC	£1700	Dec 98	The Chord combines smooth composure with musicality and transparency. Fort Knox build and priced to match.
Creek OBH-14	£239	Jun 99	Combined DAC and passive pre-amp; at the money there is no competition.
DPA Digital SX64	£800	Aug 99	Combines lack of grain and tonal richness with typical DPA speed and lucidity.
DPA Enlightenment dac	£795	Mar 95	Powerful, taut bass and remarkably solid higher frequencies. A nice touch with acoustic music especially.
DPA Enlightenment	£825	Aug 97	An engrossing listen with good manners to boot. Never uninvolved or lacklustre, plays with realism.
DPA Little Bit 3	£300	Nov 95	Don't be misled by the name - it's the budget convertor to have. Impossible to criticise for the money.
DPA SX512 DAC	£8000	Jun 98	A real smoothie for high-end digital conversion. Given the right transport, an outstanding sound is on the cards.
Link DAC 2	£300	Nov 99	Bargain price, priceless performance. A DAC to take very seriously indeed.
Manson Silhouette PSU	£895	Aug 97	If detail is high on your list of priorities, with a more forceful, hard-edged presentation, this looks like a very good bet.
Midiman Flying Calf	£109	Feb 99	A great little DAC which simply can't be beaten at the price. A bargain in all areas.
Midiman Flying Calf	£300	Jun 98	First-class as a DAC; doubles as an ADC for archiving to CDR - great value.
Monarchy Audio Delux 18	£595	Aug 97	Never offensive; its multi-bit convertor packs a mighty bass punch. Useful analogue volume control.
Monarchy Delux 18	£795	May 95	Delicate brightness does a lot to open out music and create a sense of space.
Musical Fidelity X-24K	£300	Jan 99	Crisp, detailed and dynamic, the MF is a genuine music maker, if a touch hard and bright at times.
Musical Fidelity X-DAC	£300	Nov 97	Outstanding value for money. Excellent sound in the usual attractively styled package.
Orella DA188	£399	Jun 95	Nicely built with quality components, the DA-188 has a lively sound. Solid bass, tidy midrange and crisp treble.
Pink Triangle Da Capo	£1400	Feb 95	Old hand at the game. One of the first HDCD-compatible convertors still a fine piece of gear.
Pro Audio	£699	Nov 95	A fine musical performance makes this idiosyncratic CD convertor worth searching out.
RDP 980	£450	Jul 96	An affordable route into two-box players. Good, clean dynamic sound with a neutral and pure mid-range tone.
Sonic Frontiers DAC kit	£240	Jan 95	Easy and fun to build, competitively priced and delivers fine sonic results.
Sonic Frontiers Processor 3	£7000	Sep 98	An awful lot of money - use it forever. Quality which can outlive any amount of cheaper purchases.
Sonic Frontiers Transdac	£699	Jul 95	The transdac has a smooth and focussed sound, but partnered with the Ultra Jitterbug looks expensive.
Thorens TDA2000	£700	Jun 96	Partnered with the TCD 2000, produces a sound that is certainly focussed, detailed and spacious.
XTC Dac	£1200	Apr 96	A taste of the elegantly smooth, slightly laid-back sound - the epitome of American good taste.

Prices shown are those at the time of review



Midiman Flying Calf

To advertise in the
Hi-Fi World Buying Guide
 please call Amanda Sweeney on
 0208 864 4760



Nu-Vista 300
power amplifier



X-PI00
X-AS100
pre/power amplifiers



X-A50
also available
X-A200
monoblock power amplifiers



X-AI
also available
X-A00R
integrated amplifiers



X-RAY
24 bit integrated
CD player



X-24K
digital analogue
converter



X-UP
phono stage

Hi-End Audio & Home Theatre

Home Demonstrations

Unbiased Advice & Support

0% credit available. Written quotations on request. Subject to status.

Multi-Room Design & Installation

Export Orders Welcome

Part-Exchange Available

Tel/Fax: +44 (0)181 707 4849 • Mobile: +44 (0)973 471 426 • email: info@audiovenue.co.uk

Other ranges available... Audio Analogue • Boston • Bow Technologies • Chario • Diapason • Graaf • Michell • Monitor Audio • MRS • Opera • Proceed • Project • QED • Straight Wire • Stax • Target • Unison Research & other leading components & accessories

MUSICAL FIDELITY

X SERIES
at

AudioVenue

Bespoke Audio Visual Consultants



World Classic

Cassette

Nakamichi (various)
Yamaha TC-800GL

See main Guide

Early classic in serious cassette. Its ski-slope looks got it a cult following once it had ceased to be simply ugly.

CD Players

Meridian 207
Pioneer PD-91

Beautifully-built two-box with pre-amp stage. Very musical although not as refined as modern Bitstream gear. No digital output. Built-to-last player with easy upgrade routes for modifiers. Not knockout as it stands but get one cheap and have a go!

Amplifiers

Leak Point One, TL12 & TL10
Leak Pre-amps
Leak Stereo 20
Leak TL12+
NAD 3020
Quad 33
Quad II
Sugden A21
Technics SE-A5 Mk2

Ancestors of hi-fi, consequently expensive nowadays. As with all vintage stuff, overhauling is de rigueur before use. Line of 'good for their time' pre-amps. Use of **6F86** pentode for high gain rules out ultra performance. Not the highest-fi. Excellent workaday classic. In good order the 20 will not disgrace itself. Various upgrades are available from specialist repairers. Plentiful monobloc equivalent of Stereo 20. Reasonably inexpensive and a tweakers' dream. Genuine hi-fi on a budget. You can't argue with success! NAD's budget integrated gave thousands their first taste of hi-fi and remains great value. By no means a bad job and value for money. With its matching 303 pre-amp makes a good introduction to audio classics. One of the all-time classic mono amplifiers. Unusual circuit but it works beautifully. 22 pre-amp not up to today's standards. Seventies transistor integrated has an eminently likeable smoothness and musicality. Limited inputs via DIN sockets. Nice transformer and electronics, shame about the casework. With tweaking, this 150watt can sound sweet.



Leak TL12 Point One.

Loudspeakers

Klipschorn
Leak Sandwich
Lowther PM6A
Magneplanar SMGa
Mission 770
Quad ESL57
Tannoy GRF & Autograph
Wharfedale Super 8 RS DD
Yamaha NS1000M
TannoyYork, Lancaster etc.

Not exactly plentiful or cheap but a splendid beast. For efficiency they have seldom been equalled. Space hungry! Rather warm sounding big infinite baffle but cheap with it. With reasonably powerful amp can sound quite satisfying. High quality full-range driver; still manufactured. High sensitivity, as fitted to many classic horn designs. Touch dry in the bass but a technological 'speaker with genuinely musical abilities. Usual warnings re: dipoles apply. Father of the 77 range which continues to this day. Well mannered with a warm sound and a kind load to amplifiers. Unrivalled. Properly serviced there is nothing like 'em. Their natural presentation may make them caviar to the general. Folded horn monsters which certainly sound good if you have the space. For Tannoy vintage see HFW November 1998. Ideal experimenters' driver. High sensitivity -14,000 Gauss magnet and extended frequency range. Inexpensive tool. Hi-tech favourites of the Japanese and Americans. Viewed more warily in the UK but can give excellent results. Many similar models of infinite baffle or reflex design. Not the last word in tautness but the drivers work well in modern cabinets.

Vinyl

Acos Lustre
Alphason HR100S
Ariston RD11
Garrard 301 & 401
Goldring Lenco 00 & 99
Haddock 228
Linn Axis
Michell Focus One
Shure M75
SME 3009 IIS
Thorens TD124
Thorens TD150
Trio L-07D

Very honest piece of kit, well made and easily adjusted. Vinyl beginners could do very much worse. First class arm, up to present-day standards. Buy carefully, though, as there's no service available now. A one-time king of turntables very similar to the Linn LP12. Now deposited but worth a look at the right price. Legendary and fairly plentiful. Excellent back-up available; many different custom plinths available. High quality. Great deck for the kitchen table enthusiast. Garrard fans won't look at 'em but cheap and capable. Servicing available. Recently out-classed by Haddock's updated 228 Special Edition but a proper hi-fi arm for all that. Makers still service. Uncomplicated, lower-price version of the famous Sondak. Considerably less expensive than some of its stablemates. 20 years and still going strong. Early runner in the 'modern' turntable cycle with a first class arm. Factory servicing available. Recent line-contact improvements have left the M75 behind but the wide range of needles make it a handy tool. Everlasting classic tone-arm. Spares permanently available from SME. No longer the last word but peanuts second-hand. Best classic deck ever? Judging by the prices they fetch it's possible - 78rpm too! Mid-price deck with a keen following. No real difficulty with servicing - novices may find the suspension system unnerving. Knockout heavyweight from 1980 with stainless bearing and 11lb platter! Not a give-away and beware! - spares scarce.



Thorens TD124.

Tuners

Leak Troughline (original)
Leak Troughline II & III mono
Leak Troughline III Stereo
Marantz ST-0

Interesting ornament but no longer hi-fi. Bandwidth limited to 55MHz to 100MHz only. Arguably the best-sounding tuners ever. Adaptation for stereo easy via phono multiplex socket. Excellent tuner with indifferent stereo decoding circuit. Best when adapted to use modern outboard decoder. Possibly the ultimate Tardis console, including an oscilloscope for checking the strength of signal. Expensive even now.



WELCOME TO OUR MARKET PLACE



Here you will find a variety of stalls offering you a wide range of products.

Look out for our regulars, some of which have sales on this issue with some real bargains to be had.

So if you're looking for a great deal this spring then look no further.

HAPPY HUNTING!!!



Previously Cherished Items, Or something new from Choice

Clearance Items

	Our Price	Original Retail Price
McCormack DAC	£ 395.00	£ 995.00
Cambridge Dac Magic	£ 75.00	£ 150.00
Audio Alchemy DDS 2	£ 395.00	£ 900.00
Exposure V Active x over (3 Way)	£ 295.00	£ 905.00
EAD 7000 Transport	£ 795.00	£ 2495.00
Magnum P200 pre amp	£ 795.00	£ 1895.00
Gale 401	£ 150.00	£ -
Alchemist Kraken	£ 195.00	£ 580.00

New in This Month

	£2995.00	£ 3999.00
POWER AMPLIFIERS		
Tube Tech. Synergy 1	£ 275.00	£ 400.00
Exposure IX Power supply	£ 795.00	£ 1500.00
Krell KSA 80	£1795.00	£ 3800.00
Jadis JA500	£8995.00	£21,000.00
Restek Monoblocks Exponent (1.2kw)	£8495.00	£12,000.00
NRG 401M	£5495.00	£13,000.00
Naim Nap 135	£1995.00	£ 3500.00

	£ 295.00	£ 600.00
PRE AMPLIFIERS		
Exposure VII	£ 295.00	£ 600.00
Mark Levinson No 26 S + Phono	£2795.00	£ 5400.00
Electrocompaniet EC4.5 (New)	£ 895.00	£ 1195.00
Naim Nac 52	£3495.00	£ 5500.00

	£1795.00	£ 2995.00
SPEAKERS		
Acoustic Energy AE2 Sig + Strnd	£ 795.00	£ 1500.00
Acoustic Energy AE1 P/Blik + Strnd	£1200.00	£ 3200.00
Quad ESL 63	£ 985.00	£ 1800.00
QLN Sig. + Stands	£1995.00	£ 2800.00
Shahinian Obelisk	£2995.00	£ 8500.00
Apogee Mini Grand		

AV COMPONENTS

	£ 495.00	£ 1000.00
C.D PLAYERS & DACS		
Meridian 206 Delta Sigma	£2495.00	£ 3000.00
Wadia 830	£1895.00	£ 2599.00
Krell KAV 250 C.D.	£2495.00	£ 4290.00
Krell KAV 300 C.D.		

TURNTABLES/ ANALOGUE/ VARIOUS

	£ 185.00	£ 240.00
Thorens TD206 mk IV	£2250.00	£ 4000.00
LP12/ Lingo/ Ekos/ Arkiv Cirkus	£ 650.00	£ 1185.00
Naim Nat 02 Tuner	£ 550.00	£ 800.00
Audiolab 8000T Tuner		

Power Amplifiers

	£ X-Dem	£ 995.00
Meracur Intrare	£ 5500.00	£12,000.00
Audio Research Classic 150 M/blocks	£ 1595.00	£ 3000.00
EAR 861 Power amp	£ 450.00	£ 600.00
Linn LY100	£ 1295.00	£ 2645.00
Audio Research VT60	£ 1295.00	£ 2200.00
Arccom GF565	£ 1495.00	£ 1848.00
Rogers E40A (new)	£ 1495.00	£ 2000.00
Linn Kloufs	£ X-Dem	£ 850.00
Musical Fidelity A3 Integrated	£ 795.00	£ 1100.00
Restek Integrated	£ 450.00	£ 900.00
Quad 77 Integrated	£ 795.00	£ 1895.00
Acuphase E203 Integrated	£ 3795.00	£ 5180.00
Jadis JA30 Monoblocks (latest)	£ dem	£ 2350.00
Cary 572 SE Monoblocks	£ 9995.00	£16,500.00
Audio Note Neiro (as new)	£ 1650.00	£ 2150.00
Graff 50/50	£ 4950.00	£ 7900.00
Graff GM 200	£ 2850.00	£ 3450.00
Plinius SA 100	£ 9995.00	£20,000.00
Cello Performance 2 Monoblocks (4 chassis)	£ 9995.00	£18,000.00
Krell KAS 2 Monoblock	£ 6995.00	£21,000.00
Jadis JA500	£ 2650.00	£ 3400.00
Boulder 102 AE	£ 4995.00	£10,000.00
Jadis JA 80 Monoblocks	£ 1995.00	£ 4000.00
Audion Golden Knights	£ 3250.00	£ 4790.00
Jadis Defy 7 mk III	£ 450.00	£ 900.00
Micromega Tempo 2 Integrated	£ 8995.00	£12,900.00
Krell FPB 600	£ 2750.00	£ 6700.00
Krell KSA 250	£ 1995.00	£ 3690.00
Krell 50S	£ 495.00	£ -
Exposure XII psu	£ 2250.00	£ 4000.00
Musical Fidelity F19	£ 1295.00	£ 3000.00
Audion Silver Knights	£ 699.00	£ 799.00
Musical Fidelity XAS 100 (X-dem)	£ 225.00	£ -
Quad 405	£ 795.00	£ 1400.00
Counterpoint SA12	£ 1495.00	£ 3500.00
VTL 125	£ 550.00	£ 800.00
Exposure Super VIII	£ 450.00	£ 700.00
Exposure VIII		

Pre Amplifiers

	£ 795.00	£ 2000.00
Audio Research SP9	£1195.00	£ 1845.00
Audio Research LS3	£ 475.00	£ 767.00
Naim Nac 72	£ 1995.00	£ 2500.00
Audio Research LS9	£ 1850.00	£ 3750.00
Graff GM 13.5	£10,995.00	£28,000.00
Cello Audio Suite + master supply	£ 9995.00	£25,000.00
Cello Audio Palette + master supply	£ 3995.00	£ 8000.00
Jeff Rowland Constatate + Phono (3box)	£ 650.00	£ 1095.00
Meridian 541 Dolby Surround	£10,995.00	£17,000.00
F M Acoustics 266 Resolutio	£ X-DEM	£ 5750.00
C.A.T. SL1 Ultimate	£ 2995.00	£ 6900.00
CAT SL1 Sig mk III	£ 699.00	£ 799.00
Musical Fidelity X-P 100	£ 695.00	£ 995.00
Meridian 562 V	£ 795.00	£ 1500.00
Exposure XI pre XII psu		

Quality Speakers

	£ Special	£ 2499.00
Audio Physic Tempo II	£ 895.00	£ 1175.00
Naim Credo	£ 450.00	£ 600.00
Proac Tablette 2000	£ 1295.00	£ 1980.00
Sonus Faber Minima Amators Iron Wood Stands	£ X-Dem	£ 1748.00
Audio Physics Spartak	£ 2750.00	£ 3800.00
Meridian DSP5000 Rosewood	£35,000.00	£80,000.00
Wilson Grand Slam mk II	£ On Dem	£ On Dem
JM Lab Grande Utopia	£ 495.00	£ 900.00
Mission 733 Rosewood + base	£ 2500.00	£ 4000.00
Monitor Audio Studio 50 SE Piano Black	£ 895.00	£ 1500.00
Proac Resp 1 SC + Stands	£ On dem	£ 3400.00
Audio Physics Virgo	£ 585.00	£ -
Linn Isobariks	£ 1285.00	£ 2288.00
Martin Logan Aerius	£ 4995.00	£12,000.00
Souf Lab A3		
Cello Stradivari Grand Master	£22,000.00	£80,000.00
(Rosewood and Piano Black)	£ 2750.00	£ 4250.00
Audio Static DC1+ (Audi Silver)	£24,995.00	£33,000.00
Wilson Audio MAX	£ 995.00	£ 3000.00
Apogee Stage	£10,500.00	£18,000.00
Wilson System V.1 (Black)	£ 575.00	£ 798.00
Rogers LS3/ 5A Black (NEW)	£ 395.00	£ 598.00
Rogers AB1 Sub (NEW)	£ 330.00	£ 430.00
Rogers LS55 (New)	£ Special	£10,000.00
Alon Adriana (New)	£ Special	£ 5500.00
Alon V mkIII	£ 1095.00	£ 1800.00
Meridian M 2500 Sub	£ 495.00	£ 800.00
Jamo SW3105 active sub	£ 795.00	£ 1200.00
Orelle Swings	£ 695.00	£ 1200.00
Dynalab 2.8 Ref (New)	£ X-DEM	£ 5000.00
Audio Physics LIBRA		

CD Players & DACS

	£ 1795.00	£ 3800.00
Pink Triangle Da Capo 24 bit Battery PSU	£ 595.00	£ 900.00
Pink Triangle Ordinal 1307	£ 395.00	£ 600.00
Teac P500	£ 95.00	£ 130.00
Musical Fidelity X-ACT	£ On Dem	£ 1095.00
YBA Integre	£ P.O.A.	£ 7299.00
Oracle CD2000 Transport	£ X-Dem	£ 850.00
Musical Fidelity A3 CD	£ 995.00	£ 2000.00
Micromega Duo 3.1	£ 95.00	£ 200.00
Audio Alchemy DDE 1	£ 6500.00	£ 7500.00
Wadia 860 X (24/96)	£ 4250.00	£ 5000.00
Mark Levinson No 39	£ 4995.00	£ 8000.00
Forsell Air Ref Transport mk II	£11,500.00	£24,000.00
Mark Levinson 30.5/31	£13,995.00	£19,995.00
Krell KPS 25s	£ 495.00	£ 700.00
Quad 77 CD Player (Quadlink)	£ 225.00	£ 500.00
Meridian 203 dac	£ 195.00	£ 500.00
Arcam Alpha plus	£ 495.00	£ 850.00
Meridian 563 dac 20 bit	£ 1495.00	£ 2500.00
Meridian 565	£ 895.00	£ 1300.00
Helios Model 1	£ 495.00	£ 700.00
Helios Model 3	£ 699.00	£ 799.00
Musical Fidelity X-Ray (X-Dem)	£ 89.00	£ 119.00
Musical Fidelity X-HDD (X-Dem)		

Turntables & Analogue

	£ 99.00	£ 129.00
Musical Fidelity XLP	£ 8995.00	£30,000.00
Goldmund Ref Turntable	£ 1995.00	£ 5000.00
Air Tangent 2B Arm	£ P.O.A.	£ 4199.00
Oracle Mk V Turntable	£ 495.00	£ 950.00
Pink Triangle PT Too Ref Bearing, platter, clamp	£ 2500.00	£ 4000.00
Linn LP12/ARC/Armedgeddon/ Prefix/ Hi Cap/ 17 DMS	£ 1095.00	£ 2000.00
Linn LP12/ LVIII Lingo Cirkus K9	£ 375.00	£ 500.00
Linn Klyde		

STOCKIST OF:

- Acoustic Energy, Advantage, Alon, ATC, Audible Illusions, Audio Physics, Boulder, Bryston, Cary, C.A.T., Chord, ClearAudio, Denon, Dynavecator, Egglaston Works, Graham, Michell, Musical Fidelity, Oracle analogue and digital, P.M.C,
- Plinius, Rockport, Shahinian, SME, Tara Labs, Target, Totem, Transfiguration, Trichord, Trilogy, Van den Hul, VPI, XLO,
- DVD Players now available from Sony, Panasonic and Pioneer, and many more.

- ⦿ In-depth experience on high end new and used equipment
- ⦿ Best prices paid for top quality equipment
- ⦿ Generous part exchange
- ⦿ Show room/dem room
- ⦿ Long term trade in policy, to allow continual upgrading
- ⦿ All credit cards inc. Amex
- ⦿ Mail order
- ⦿ Export service
- ⦿ Finance arranged subject to status
- ⦿ Widest range available
- ⦿ Unbiased advice
- ⦿ Unique 'Hi-Fi Exchange' - a computerised database of sales and wants - will put you in touch

Choice hi-fi make it easy for you to fulfil your sonic dreams. Quality hi-fi is not just about expensive brandnames, it's about aspiring to the very best sound, about choosing your ideal system from the widest selection in the country, in a unique no-pressure environment. It's about taking advantage of our unrivalled knowledge and being given the freedom to choose and upgrade the audio equipment you want, when you want. Others may sell you hi-fi, Choice hi-fi will sell you solutions.



tel 0181 392 1959 & 0181 392 1963

fax 0181 392 1994 e-mail choice_hifi@msn.com open from 10am to 8pm by appointment
All previously cherished items in mint, second hand or as new condition - guaranteed

Grandjix

Sound & Vision

71 HIGH STREET, NEW MALDEN
SURREY, KT3 4BT

TEL: 020 8336 0012
FAX: 020 8336 2703

TEL: + 44 (0) 20 8336 0012
FAX: + 44 (0) 20 8336 2703

WORLDWIDE MAIL ORDER

14 DAY HOME TRIAL - EXCHANGE SYSTEM ● FULL DEMONSTRATION FACILITIES ●
0.0% INTEREST FREE CREDIT (subject to status) ● PART EXCHANGE WELCOME ● MON TO SAT

SOME OF OUR MOST POPULAR BUYS

SOURCE - COMPONENTS

MONRIO ASTY PLAYER CD	£795.00
AUDIO ANALOGUE PAGANINI	£745.00
SONNETEER BYRON CD	£795.00
AVI S2000 24BIT REFERENCE CD - NEW	£995.00
LINN GENKI CD	£995.00
COPLAND CDA266	£1295.00
MARANTZ DR17 CD/CDR	£1495.00
ELECTROCOMPANET EMC I- CD - NEW	£2249.00

INTEGRATED - AMPLIFIERS

ROTEL RA-972 - NEW	£495.00
AUDIO ANALOGUE PUCCINI R - NEW	£575.00
SONNETEER CAMPION	£595.00
AUDIO ANALOGUE PUCCINI SE R - NEW	£795.00
REDGUM RG1 120	£795.00
SONNETEER ALABASTER	£895.00
ELECTROCOMPANET EC1-3	£995.00
ATC S1A2-150 INT AMP	£1984.00

PRE/POWER - AMPLIFIERS

CREEK P43/A52SE	£849.00
LINN KOLECTOR/LK85	£950.00
AUDIO ANALOGUE BELLINI/DONIZETTI	£1095.00
COPLAND CSA303/CSA515	£2835.00
REDGUM RGM300 PRE+MONOBLOCKS	£2995.00
ATC SCA2/SPA2-150	£5295.00

SELECTED - LOUDSPEAKERS

AVI NU-NEUTRON	£495.00
AVI BIGGATRON	£595.00
VIENNA ACOUSTICS HAYDN	£649.00
CASTLE SEVERN 2 SE	£699.00
VIENNA ACOUSTICS MOZART	£1500.00
JM LAB ELECTRA 905	£1195.00
SONUS FABER SIGNUM	£1249.00
GRADIENT EVIDENCE	£1650.00

CLEARANCE BARGAINS

		WAS	NOW
AUDIO ANALOGUE PUCCINI SE	XD	£635	£469
ACOUSTIC ENERGY AEGIS SUBWOOFER	XD	£300	£199
AVI NUNEUTRON	XD	£499	£389
AVI BIGGATRON	XD	£600	£469
ALR JORDAN NO 4	NEW	£1200	£719
ALR JORDAN TAKE 2	NEW	£1700	£995
ANTHEM CD1 CD	XD	£1700	£899
ANTHEM INT2 AMP	XD	£1800	£995
AIC SCM10 YEW	XD	£1240	£849
ATC S1A2-150 INT AMP	SH	£1195	£1449
CASTLE HOWARD S2 MAHOGANY	XD	£1299	£799
COPLAND CSA28 INT	XD	£1349	£1049
CHARIO ACADEMY ONE	XD	£1450	£799
CHARIO ACADEMY TWO	XD	£1700	£919
CHARIO ACADEMY THREE	XD	£8500	£3995
CREEK T43 TUNER	XD	£400	£299
DIAPHASON ADEMANTES III INC STANDS	XD	£2450	£1795
INFINITY KAPPA 80S	XD	£995	£649
PIONEER PDS505 PRECISION	XD	£460	£249
PIONEER PDS904 CD	XD	£400	£199
PIONEER CLD515/2 LASER DISC	XD	£550	£249
PIONEER PDR509 CDR	XD	£300	£219
LEXICON DC1 PROCESSOR	XD	£5000	£2500
MARANTZ CD-17KI GOLD	SH	£1100	£799
MARANTZ CD67 OSE	XD	£300	£199
MARANTZ SD57 TAPE	XD	£200	£129
MUSICAL FIDELITY X-PRE	SH	£200	£129
MUSICAL FIDELITY X-LP	SH	£129	£79
MUSICAL TECHNOLOGY HARRIER	SH	£649	£299
NAD C540 CD PLAYER	XD	£330	£249
NORDOST BLUE HEAVEN 1.0M PAIR XLRNEW		£180	£119
PROJECT CLASSIC CHERRYWOOD	XD	£449	£339
QUAD 909 POWER AMP	XD	£900	£719
ROTEL RA971	XD	£250	£149
ROTEL RC972 PRE	XD	£250	£169
ROTEL RB971 MK2 PWR	XD	£225	£179
ROTEL RCD951	XD	£350	£259
TANNOY REV R1	XD	£199	£129
TANNOY REV R2	XD	£350	£250
TANNOY REV R3	XD	£550	£399
TANNOY CANTERBURY 15HE	XD	£8500	£5995
TEAC REFERENCE 500	SH	£800	£549
TEAC AV H500	XD	£380	£249
SONUS FABER CONCERTO W	XD	£945	£745

EX = EX DISPLAY, SH = SECOND HAND, NEW = BRAND NEW BOXED

MASSIVE CABLE CLEARANCE NOW ON ... UPTO 50%
OFF CABLETALK, AUDIOQUEST, IXOS, QED, VAN DEN
HUL, NORDOST, SONICLINK AND MORE.
CALL FOR DETAILS

MARK LEVINSON NO0380s Pre amplifier
c/w MARK LEVINSON No 334 Power amplifier
NORMALLY £11990 EX-DISPLAY £8395
Only 1 set available so hurry!

AGENCIES INCLUDE: ACOUSTIC ENERGY ● AUDIO ANALOGUE ● AVI ● ATC ● ANTHEM ● APOLLO ● ATACAMA ● AUDIOQUEST ●
ALPHASON ● BEYER ● CASTLE ● CABLETALK ● CREEK ● COPLAND ● CYMBAL ● CHARIO ● DIAPHASON ● EPOS ●
ELECTROCOMPANET ● GRADIENT ● HARBETH ● HARMON KARDON ● HEYBROOK ● IXOS ● INFINITY ● JBL ● JAMO ● JM LAB ●
KRELL ● LINN ● LOEWE ● MARANTZ ● MICROMEGA ● MICHELL ● MUSICAL TECHNOLOGY ● MYRYAD ● MONRIO ● NAD ● NORDOST ●
OPTIMUM ● ORTOFON ● OPERA ● PIONEER ● PANASONIC ● PRECIOUS METALS ● PROJECT ● QED ● ROTEL ● REDGUM ● RESTEK ●
SME ● SHURE ● SONY ● SONUS FABER ● SENNHEISER ● STANDS UNIQUE ● SOUND ORGANISATION ● SONICLINK ● SONIC
FRONTIERS ● STAX ● SOUNDSTYLE ● SONNETEER ● TANNOY INC PRESTIGE ● TDL ● TEAC ● TECHNICS ● UNISON RESEARCH ●
VAN DEN HUL ● VIENNA ACOUSTICS ● YBA AND MORE

WE REGRET WE ARE UNABLE TO MAILODER MARANTZ AND LINN PRODUCTS

PREVIOUSLY OWNED AND EX DISPLAY HI-FI EQUIPMENT

PREVIOUSLY OWNED EQUIPMENT

Acoustic Energy Aegis One (Rosewood)	£ 79.00
Arcam Alpha 8 CD Player	£ 299.00
Audiolab 8000A	£ 329.00
Audiolab 8000C (vgc, boxed)	£ 349.00
Dynaudio Contour 1.3 mkl (inc. stands)	£ 799.00
Exposure 20 Integrated amp	£ 349.00
Harman Kardon AVI 250/ADP303	£ 499.00
Marantz CD 52 se	£ 119.00
Marantz CD17 KI Signature	£ 599.00
Mordaunt Short MS20i Pearl	£ 99.00
Musical Fidelity B1	£ 99.00
Naim NAC72/NAP180 (optional Audioquest Quartz interconnects, please telephone for details)	£1149.00
Quad 34/405 (inc. phono boards)	£ 379.00
Talk Electronics Hurricane/Tornado 3 Pre/Power	£ 899.00
Thorens TD 160s Mk V (selling on behalf of customer)	£ Offers

EX DISPLAY EQUIPMENT

2 x 5m lengths of Audioquest Midnight biwire (£475.00)	£ 359.00
Arcam Alpha 10 DAVE inc. 3 ch power amp (£2500.00)	£1999.00
Arcam Alpha 9 CD player (£800.00)	£ 679.00
Pioneer DV717 DVD Player (multi-region, black)	£ 449.00
Tag McLaren 60iRV Integrated amp (£1000.00)	£ 649.00
Tag McLaren T20 Tuner ex display (£1100.00)	£ 769.00
Tag McLaren 60 P Stereo power amp (£850.00)	£ 549.00
Talk Electronics Cyclone 1 integrated amp (£550.00)	£ 469.00
Talk Electronics Thunder 3 CD player (ex display)	£ 849.00
Talk Electronics Hurricane/Tornado 4 Pre/monos	£1999.00

Sevenoaks hi-fi (Peterborough)
36-38 Park Rd,
Peterborough. PE1 2TG
Tel 01733 897697

www.sevenoakshifi-peterborough.co.uk

the Audio Experience 14th May 2000

Vintage Audio • Classic Hi Fi • Tuners • Turntables
Amplifiers • Loudspeakers • CD Players • Valve Equipment
Records • CDs • Cables • Accessories • Components

**THE GUILDHALL
CAMBRIDGE CITY CENTRE
10.30 - 4.00**

A must for all audio enthusiasts !

(with plenty of local attractions for the rest of the family)

Admission: £2.50 OAPs/Students £1.50 Children (under 16) free

Further details : Audio Ex. Tel. / Fax. 01992 447764

E - Mail: audioex@directdisc.demon.co.uk

AUDIO ILLUSION

23 Langley Broom

Langley

Berks SL3 8NB

TEL: (01753) 542761 FAX: (01753) 772532

OPENING HOURS:

10am - 8pm Monday - Saturday (By appointment)

SPRING
SALE

*Mail Order Service * Export Facilities: * All Major Credit Cards Accepted

AWARD WINNING MIRAGE AVS-500 MICRO SYSTEM

£399

MIRAGE SPEAKERS

Ex. Demo/Pre-owned Equipment for Sale

NEW SALE

ACURUS RL II Classe A Linestage Preamplifier (Black)	Ex.Demo/Mint	£765	£375
AUDIO RESEARCH LS3B Linestage Preamplifier	Mint S/Hand	£2250	£1395
CLASSÉ CP-50 including Phono. Fully Balanced Remote Preamplifier (Black)	Mint Ex.Demo	£3190	£1995
DIRECTOR Electric Screen: 7' 4..3	Ex. Demo/Mint	£800	£395
GRAHAM 1.5 Tonearm	Mint Ex. Demo	£3000	£1495
KORA D50 50w Pure Class A Integrated Line Tube Amplifier	Mint Ex. Demo	£2700	£1795
KRELL KST 100 Power Amplifier (Grey)	Mint S/Hand	£3000+	£1595

MIRAGE:-

M-390is 2-Way Tuned Vent Floorstander (Black Ash)	Mint Ex. Demo	£550	£295
FRX-3 2-Way Bookshelf Monitors (Black)	Mint Ex. Demo	£330	£195
FRX-5 2-Way Floorstander Loudspeakers (Cherry)	Mint Ex. Demo	£510	£325
FRX-7 2-Way Floorstander Loudspeakers (Black)	Mint Ex. Demo	£700	£420
OM-6 3-Way Semi Active Omnipolar Radiators (Black)	Mint Ex. Demo	£2750	£1995
OM-14 2-Way Omnipolar Radiators (Black)	Mint Ex. Demo	£650	£395
FRX-R Spherical Radiating Surround Speakers (Black)	Mint Ex. Demo	£335	£199
BPS-400 400w Active Bipolar Subwoofer (Piano Black)	Mint Ex. Demo	£1300	£895

MUSICAL FIDELITY F18 200 wpc Power Amplifier Mint S/Hand £4000 £1995

PARASOUND HCA 1205A THX Ultra Power Amplifier S/Hand/Mint £1700 £1150
(HCC - Multi-Channel Amplifier of the Year 2000)

ROTEL RB 985 Multi-Channel Amplifier As New S/Hand £725 £495

SONY VPHD50QM CRT Multi-Scan Projector with Linedoubler Ex.Demo/Mint £10500 £6995

acurus : aragon
AERIAL ACOUSTICS

Barclay : Classé Audio

EZO : PIEGA

MIRAGE LOUDSPEAKERS

Renaissance Audio

Oxford Audio Consultants HI-FI SPECIALISTS

WE'VE MOVED RIGHT NEXT DOOR TO
MUCH BIGGER PREMISES WITH SUPERB
PURPOSE BUILT DEM ROOMS



NOW DEMONSTRATING

- MARTIN LOGAN PRODIGY** - a fabulous new speaker from this world-class company
- KRELL KPS 28 CD PLAYER** - a fantastic new CD player from our favourite manufacturer priced at £7777
- WILSON AUDIO SYSTEM 6** - a major advance on what was our benchmark
- LOEWE TELEVISIONS** - we now stock this premium range incl the top of the range ACONDA
- MARANTZ CD7 CD PLAYER** - outrageous value for money
- LEXICON MC1 HOME THEATRE PROCESSOR** - superb quality
- THETA DREADNOUGHT POWER AMP** - awesome!!
- SONUS FABER AMATI HOMAGE** - a sensational world-beating product from our favourite Italian company
- KRELL KPS25 CD PLAYER** - just upgraded and now sounding even better
- B&W NAUTILUS 804 LOUDSPEAKERS** - a genuine bargain at £2500
- NAIM AUDIO CDS MK 2** - a sensationally good CD PLAYER for the money - audition an absolute must!
- NAKAMICHI SOUNDSPACE 8** - perfect on the wall
- DENON AVC-A10SE HOME THEATRE AMPLIFIER** - a knock-out for £1300
- SHARP LCD MONITORS** - 15" AND 20" ON DEM
- NEC 4210 42" GAS PLASMA MONITOR** - just brilliant!!
- SONUS FABER SIGNUM** - a replacement for the wonderful MINIMA AMATOR at £1249
- ROTEL RDV285** - sets the DVD standard at £985 - multi-region to boot
- AUDIO ANALOGUE MAESTRO CD PLAYER** - staggering build quality and unrivalled sound; on dem at last after a long wait
- GRAAF 13.5B2 PREAMPLIFIER** - a great sound
- CABLES & ACCESSORIES** FROM TRANSPARENT, NORDOST, CABLE TALK, GM AUDIO, STANDS UNIQUE, SOUNDSTYLE, TARGET, KONTAK etc
- GM AUDIO EQUIPMENT TABLES** - the elite - now even better looking and superb value

*****MAIL ORDER INTEREST FREE CREDIT AVAILABLE*****

EX DEM & P/EX BARGAINS

AUDIO RESEARCH SP14 BLACK	£ 895	SH
TEAC VRDS25 CD PLAYER EX DEM	£ 895	XD
KRELL FPB200 POWER AMP	£4295	SH
PROAC RESPONSE TWO S BIRDS EYE MAPLE	£ 895	SH
NAIM CDS MK 1 CD PLAYER	£2195	SH
VIDIKRON HELIUS PROJECTOR - OUR DEMONSTRATOR	£7995	XD
TEAC 8030S CASSETTE DECK GOLD AS NEW	£ 395	
THETA PEARL CD TRANSPORT OUR DEMONSTRATOR	£995	XD
NAIM CD3	£ 695	SH
AUDIO RESEARCH VT100 MK 1	£2995	SH
LINN MIMIK II CD PLAYER	£595	SH
WILSON AUDIO SYSTEM 5 MINT BLACK	£9995	SH
STAX NOVA SIGNATURE SYSTEM NEW	£950	NEW
THETA JADE CD TRANSPORT OUR DEMONSTRATOR	£1950	XD
REVOX B77	P.O.A.	
MUSICAL FIDELITY A1001	£1495	XD
DAVIS LITEBEAM PROJECTOR	£2295	XD
PROAC STUDIO 100 YEW	£395	SH
RUARK TALISMAN	£ 395	SH
ROKSAN CASPIAN POWER AMP	£ 395	SH
GRAAF WFB TWO PREAMP	£ 950	SH
AUDIO RESEARCH LS8 PREAMP	£ 995	XD
AUDIO RESEARCH VT60	£1395	XD
KRELL FPB300 POWER AMP	£5495	SH
NAIM CDI CD PLAYER	£995	SH
ATC SCA 2 PREAMPLIFIER	P.O.A.	
B & W SILVER SIGNATURES BOBINGA WOOD	£2495	SH
WILSON SYSTEM FIVE EX DEM	£9995	XD
AUDIO ALCHEMY DDS 3	£ 250	SH
UNISON RESEARCH SMART 845 - OUR DEMONSTRATORS	£1995	XD
NAIM IBL SPEAKERS	£295	SH

0% INTEREST FREE CREDIT

Licensed Credit Broker

Agencies include: Audio Analogue, Audio Research, Audio Technica, B&W, Cable Talk, Castle, Copland, Denon, Graaf, Goldring, Jamo, Jadis, Koetsu, Krell, Lexicon, Loewe TV & Video, Lyra, Marantz, Martin Logan, Michell, Musical Fidelity, MRS, NAD, Naim, NEC Gas Plasma Screens, Nordost Cables, Onkyo, Opera, Ortofon, Pioneer, Proac, Pro-ject, QED, QUAD, REL Subwoofers, Rotel, Speakercraft, Sennheiser, SME, Sonus Faber, Sonance, Stands Unique, Stax, Target, TEAC, Thela, Thorens, Transparent Cables, Unison Research, van den Hul, Vidikron, Wilson, Yamaha.

TAX-FREE EXPORT SERVICE
MAIL-ORDER AVAILABLE ON MANY ITEMS

Open Mon-Sat 10am-6pm

Oxford Audio Consultants

Oxford Audio Consultants, Cantay House, Park End Street Oxford OX1 1JD
Telephone: Oxford (01865) 790879 Facsimile: Oxford (01865) 791665
E-MAIL: Oxford.Audio@btinternet.com
WEBSITE: www.oxford-audio.co.uk

HICAM

CHERISHED PRE-OWNED HI-FI EQUIPMENT SOLD, PURCHASED, P/X.
WE URGENTLY REQUIRE NAIM, MERIDIAN, AUDIOLAB, LINN EQUIPMENT
MAIL ORDER ALWAYS A PLEASURE

DESCRIPTION	PRICE	£
AVI S2000 MONOBLOCKS/BOXED	1400	850
AVI S2000 PRE AMP BOXED	950	550
BOSE AM5 SPEAKERS/WHITE/BOXED	500	325
EAR 834P MM/MC PHONO STAGE/VOLUME CONTROL NEW	529	375
HENLEY DESIGNS HMC 50 MM/MC PHONO STAGE	150	80
KEF 104/2 REFERENCE LOUDSPEAKERS WALNUT FINISH	1500	495
KEF Q55 LOUDSPEAKERS BLACK	499	275
KRELL 3001 INT AMP/BOXED/MINT	2400	1800
LFD MC1 PHONO STAGE INC PSU	930	375
LINN LP12/VAHALLA/TITTOCK/AFROMOSIA	N/A	395
MARK LEVINSON 23.5 (200 WATT) POWER AMP	7400	3195
MERIDIAN 200/203 TRANSPORT/DAC	1300	495
MERIDIAN 541/REMOTE CONTROL	1100	450
MICHELL ELECTO MONOBLOCKS	2000	1195
MICHELL ARGONHEIRA	950	525
MONFIO AST INT AMP/BOXED	425	300
MUSIC FIDELITY A1000 CLASS A INT AMP/PSU MINT	1500	895
MUSIC FIDELITY X ACT BOXED	200	120
NAD C340 INT AMP 5 MONTHS OLD	270	150
NAIM 180 POWER AMP BOXED	1090	750
NAIM 32 PRE AMP	N/A	75
NAIM 42 PRE AMP SERVICED NAIM JAN 2000	N/A	75
NAIM 72 PRE AMP MM BOARDS BOXED	750	395
NAIM 92 PRE AMP	495	295
NAIM CDS CD PLAYER BOXED	1080	550
NAIM CDS PSU BOXED MINT	1995	
NAIM HICAP NEW STYLE BOXED	780	495
NAIM42.5PRE AMP	N/A	95
NAKAMICHI BX150E TAPE DECK	N/A	195
PRECIOUS METALS SS202 1 METRE PR INTERCONNEC	290	175
PROAC TABLETTE 50 LIGHT OAK/BOXED	600	375
QUAD 306 POWER AMP BOXED	N/A	225
SEQUENCE 200 CENTRE SPEAKER	100	50
SONETEER CAMPION INT AMP BOXED/MINT	550	295
SONICLINK BLUE NICKEL 1 METRE PR NEW	150	90
SONICLINK MAROON 1 METRE PR NEW	125	75
SONICLINK VIOLET 1 METRE PR NEW	85	60
SONETEER ALABASTER INT AMP	900	525
SPENDOR 2/2 LOUDSPEAKERS CHERRY FINISH	595	295
SUGDEN SIGNATURE 41 PRE AMP	740	425
SUGDEN SYMETRA CLASS A MONOBLOCKS	1550	925
THETA TLC/GOLIATH PSU (LINEAR CONDITIONER)	500	275
VARIOUS SONICLINK/PRECIOUS METALS SPEAKER/INTERCONNECTS		

WE OFFER DISCOUNTS FOR CASH PURCHASES

OPEN MON-SUN 10AM-6PM

FOR FURTHER DETAILS: TEL/FAX 01844 260182 MOBILE 0973 233380

E-MAIL HICAM1@FREENETNAME.CO.UK

OR VISIT OUR WEBPAGE HICAM.CO.UK



VINTAGE AND MODERN HI-FI BOUGHT, SOLD.

WE BUY: VALVE AMPS: QUAD I and II; BEAM ECHO; CROFT amp/preamp; DECCA; LEAK (any model), LOWTHER (any model), PYE (any model) RADFOR (any model); SOUND SALES; RGD and DYNATRON radiograms;
AUDIO VALVES new/used: 300B WE, ACO44, DA30, DA60, DA100, ECC32, ECC83, ECC88, EL34, GZ32, GZ34, KT66, KT88, PX4, PX25, PP3/250, PP5/400, RS241 any triode.
TONEARMS: SME 3012 and 3009; GARRARD 301; 401; MICHELL Gyrodeck/Orbe; any EMT plus other vintage GEAR!
LOUDSPEAKERS/Drive units: GOODMAN'S Axiom 80 and other models; QUAD ESL57; ROGERS LS 3/5 (15 Ohm only); TANNOY Lancaster, York, Autograph etc. Westrex etc. VITAVOX

WE SELL: SONUS FABER New/ex demo. Concertino £430; Concerto £ 750; Concerto Gran Piano £ 1,290; Electa Amator 2 £ 1,950; Guarneri Homage £ 3,750; Amati Homage £ 8,750; LOWTHER Belcanto £ 1,500 (piano finish); MAUHORN cabinet £ 1,000.
Amplifiers: UNISON RESEARCH SMART 845 £ 2,850 (new boxed); LEAK TL10 POA; Leak TL12+ (pair) £ 400; Leak Stereo 20 POA; QUADII amps POA; Pye HF25; Rogers HG88; Cadet III stereo etc. Also list of other amps please send fax for details.
TURNTABLE/CARTRIDGE/ARMS: Garrard 301/401; NOTTINGHAM Analogue Mentor £ 2,000; Interspace £ 350; Spacedeck £ 550; Hyperspace £ 1,190; also ORTOFON all models including Rohmann cartridge mint £ 750; SME 309 £ 550; SME 3009 and 3012 POA;
AUDIO VALVES: BOXES OF RADIO and AUDIO VALVES (8,000) from 1930's- 1950's please ask for list! 6L6; 6V6 Brimar; ECC81, 82, 88, 88; GZ32; GZ34; GZ37; 5U4G; KT61; KT66; EL34; EL84; PX4; PP3/250. Brands: Brimar/Cossor/Mazda/Mullard/Sovtek/Zaerix.

A ▶ Lto Tel/Fax: 0181 343 0533

◀ J Tel: 07901 976 441 A!l!ap! ◀ J



THE EMPORIUM

28 St Nicholas Street, Diss, Norfolk IP22 3LB
Tel/Fax: 01379 650744 email: emporium@dircon.co.uk
www.emporium.dircon.co.uk



	COST	PRICE		6200	3800
VALVE AMPS					
AMC power amps hybrid with el34 op valves		250	PINK TRIANGLE PIP TWO PREAMP two box with dry cell psu serviced last year	2000+	1200
AUDIO INNOVATIONS CLASSIC 25	1000	400	PINK TRIANGLE PIP preamp original in oak		500
ART AUDIO QUINTET stereo power amp	1500	750	PRIMARE A20 MK1	700	350
AUDIO NOTE M2 RIIA phono stage EX DEM	1050	550	PLINIUS SA 50 new class a power amp boxed	2800	1800
AUDIO NOTE M2 PRE	1500	800	PLINIUS 8150 remote integrated with phono 150 watts	1800	1200
AUDIO NOTE P2 amp	1200	550	PS AUDIO TWO PLUS C power amp		250
AUDIO NOTE p2se power amp	1500	800	QUAD 34/306 grey 400 will split		200 each
AUDIO NOTE P4 monoblocks	4200	2400	QUAD 66/606with remote		800
AUDIO NOTE KASSAI SILVERparallel single ended 300B 18watts per channel silver wired output tx	32000	9500	QUAD 77 int.no remote	700	300
AUDIO RESEARCH SP8		850	QUAD 77pre carbon with system remote mint boxed 100		120
AUDIO RESEARCH CLASSIC 30		1000	REGA LUNA		275
AUDIO RESEARCH SP11	5311	1750	ROTEL RC 872/ line pre		125
AUDIO RESEARCH VT100	5500	2750	SUGDEN OPTIMA 200 line integrated	900	450
AUDION SILVER NIGHTS	2250	1350	SUGDEN C1285L PRE/P28 Power	800	400
AUDIO INNOVATIONS 1st Audio monoblocks		600	SUGDEN AS1 original class A power amp with C51 pre	350	900
BEARD BBA100 line integrated	1500	450	Toca 22 class a power amp	1900	
BEARD P35 MKII power amp		400	LOUDSPEAKERS		
BEARD P500A PREAMP	1000	300	ALIANTE LINEA (sonus faber electas clones)	2500	1100
CONCORDANT EXCELSIOR phono pre with psu	1500	500	ATC SCM10 black boxed ex dem	1080	600
CONCORDANT QUAD II		400	AUDIOPLAN KONTRAST MARK 2	2800	1200
CONRAD JOHNSON PVS PREAMP with phono	2000	800	AUDIO PHYSICS TEMPOS with Essex digital equalizer	4000	1250
COUNTERPOINT SA100 100 watt valve/mosfet hybrid excellent sound	2000	900	BANDORA BANDORA in light oak	1350	500
EAR 834L line pre black case	450	270	CADENCE ES mk 1	3500	1000
EAR 834L deluxe	800	400	CASTLE SEVERN mk 1 floorstanders	579	300
EDISON 12 power amp 12 watts class A		200	Celestion 5000 with ribbon tweeters	700	250
GAMMA RYTHM INTEGRATED needs attention	2500	500	CHARIO HYPER 2 with matching stands	850	425
GAMMA AEON MONOBLOCKS latest version	5500	2500	JR 149 round version of Is3/5a		150
GAMMA ERA REFERENCE preamp with phono	3500	1500	KEF Is3/5a raymond cookie ltd edition piano black	900	900
GOLDEN TUBE AUDIO SE40 power amp	1200	600	KLIPSCH LA SCALAS, black, deluxe, boxed	2500	1350
LUMILEY M75 monoblocks 75 watts		1000	LIN KANS MK 2 black biwire		200
MELOS 222 two box pre with phono	3000	700	LINN KANS MK1		1200
MORE FIDELITY 300B single ended stereo power amp	2200	700	LINN KANS before MK1 serial 0037 in Is3/5a cabinets, nice museum piece		1750
ORANGE VALVE PRE with Phono		300	LIVING VOICE AUDITORIUM with bases	1750	200
RADFORD STA 25 RENAISSANCE		700	RUARK EQUINOX boxed 2250 1000		900
RADFORD RENAISSANCE SC25 Pre Amp		500	SONUS FABER CONCERTO GRAN PIANO	2000	1400
SONIC FRONTIERS SF5 40 POWER AMP	2000	1000	SONUS FABER MINIMA AMATOR		950
TRILOGY 948 Stereo power amp.	2000	900	SONUS FABER MINIMA FM2		600
VTL 50 WATT MONOBLOCKS		700	SPENDOR SA1 mini monitors		150
TRANSISTOR AMPS					
ARCAM ALPHA old model		80	TANNOY ARDEN objective audio rebuild (twice as heavy as the originals with 158quots; hpds. Awsome sound		900
AVIS2000MP preamp	950	450	TANNOY BERKLEY excellent	700	700
AVI phono stage		150	TANNOY LANCASTERS with 12" & 15" Gold POA		900
AUDIOLAB 8000C pre grey colour	450	200	TOWNSEND GLASTONBURY MK II (new drive units)	900	900
AUDIOLAB 8000A BLACK		250	UKD CARUSO ltd edition, four way floorstanders	2500	1250
BURMESTER 838 Mk V silver front	1500	400	TUNERS, CASSETTE DECKS & REEL TO REEL		
CYRUS pre/power	1100	700	FERROGRAPH SFM1 FM Tuner		80
CYRUS STRAIGHT LINE integrated amp	400	150	LEAK TROUGHLINE III STEREO	120	120
Cyrus two	650	150	NAIM NAT101 TUNER with psu	170	450
CRIMSON 610 battery powered Pre/630 monoblocks grey finish		400	Nakamichi 700 tritracer	100	200
CRIMSON 610C/630 MONOBLOCKS chrome finish		1050	REVOX A77 2 track	200	100
DENSEN D200/D300 pre/power & " "	1850	1080	YAMAHA t1 fm tuner black analogue tuner	100	100
DPA DSP2005 pre amp	800	450	TECHNICS 9600 tuner top of the range 20 years ago	100	100
EXPOSURE SUPER XV111 POWER AMP		200	NAKAMICHI BX2cassette deck	180	180
ELITE TOWNSHEND 85 watt monoblocks		700	CD & DACS		
HARMON KARDON PA2200 Poweramp		3000	AUDIO ALCHEMY DIGITAL DRIVE 3	700	350
HEYBROOK C3/P3 Pre/Power	1400	750	AUDIOMECA mephisto top loading cd transport	2000	1000
KRELL KSA1005	5735	400	AUDIOLAB 8000 transport & 24 bit DAC	2200	1200
LINN KAIRN PROwith brilliant psu	1500	400	ARCAM DELTA 70.2 CD player	800	275
LINN WAKONDA pre		400	CYRUS DISCMASTER/DACMASTER transport/dac	1750	800
LINN MAJIK	800	700	DPA bigger bit	700	250
LUXMAN C12/M12/T12 pre/power and tuner		400	DPA little bit three	350	125
MERIDIAN 101/105 monos boxed		750	KRELL KPS20i CD PLAYER	10995	6500
MERIDIAN 201pre/205 monoblocks 100 watts with 209 remote	1800	850	LINN KARIK CD PLAYER	1500	700
MERIDIAN 205 MONOBLOCKS 1000 500 excellent 400 average		350	MARC LEVINSON 39 cd player mint boxed	3600	1800
MICHEL ISO with HERA		750	MARANTZ CD12 le cd transport & dac mint and boxed	4000	1200
MOTH 60 WATT power amp wood mint boxed	650	300	MERIDIAN 506 20 bit cd player	1200	750
MUSICAL FIDELITY E100amp	700	350	MERIDIAN 206 DAC7 CD PLAYER		400
MUSICAL FIDELITY MA50 MONOBLOCKS	850	400	MERIDIAN 203 dac	500	150
MUSICAL FIDELITY A2	500	300	PIONEER DVL909 DVD player!	900	300
NAIM NAC 32		150	QUAD 66cd		300
NAIM NAC 92/NAP 90/NAP 90/FLATCAP		1250	ROTEL 980 TRANSPORT & DAC	700	350
NAIM NAIT ONE " "		150	ROKSAN DPI TRANSPORT upgraded with DAC1 & DSP1	2700	900
NAIM SNAPS		350	TURNTABLES, ARMS & CARTRIDGES		
NVA passive pre		200	ALPHASON SOLO + BASIK arm	450	150
NAIM 42.5/110 OLD STYLE	350	350	AUDIO NOTE TT2	425	200
NAIM NAC125		75			
NAIM NAIT 32/140 OLD STYLE 450					
PASS LABS ALEPH 2 MONOBLOCKS 100 WATTS CLASS A zero feedback single ended besr solid stateamp i've ever heard					
Audio Note ans2 step up tx					
ARISTON RD1 I ELECTRONIC with arm					
CLEARAUDIO EVOLUTION TURNTABLE with rb 250 arm 1300					
DECCA LONDON cartridge					
ERA with SME 3009 imp					
GARRARD 301 in Classicue sounds plinth with sme 3012/11					
HADCOCK CH228 ARM unipivot					
KISEKI BLUE SILVERSPOT just rebuilt by Expert stylus					
LINN AXIS					
LINN LP12 ITTOK					
LINN LP12/BASIK/Linn cartridge					
LINN LP12 SONDEK EARLY MODEL excellent					
LINN LP12 slight blemish to wood					
MICHEL SYNCHRO tweaked with rb 250					
MICHEL GYRODECK with rega arm and QC psu					
ORTOFON spu ge					
PINK TRIANGLE pt too with rb 300 arm					
PINK TRIANGLE PT00/RB300					
ROCKPORT TECHNOLOGY CAPELLA turntable with ROCKPORT 7000 arm. Ex. Dem.					
REGA PLANAR 3 WITH RB200					
REGA PLANAR 3/RB250/ATHOE					
SME 312 silver wired ex dem 1 year old					
TRANSCRIPTORS SATURN with ORIGINAL ARM & LID					
TRANSCRIPTORS MICHEL HYDRAULIC REFERENCE					
VPI HW16.5 RECORD cleaning machine new/ex dem					
CABLES					
Please note orig prices are approximate, I can't be bothered to look them up					
AUDIO QUEST STIRLING hyperlitz2M spades					
XLO TYPE 5 1.5m spades					
GOERTZ M1 centre stage 5m bananas					
GOERTZ					
HARMONIX STRINGS hs101 1.9m biwire bananas					
QCOS DC SERIES 8 2.2m single/bi or tri wire 50					
PURIST AUDIO COLOSSUS 1.9M water filled spades					
SYMIO L55-Sx swiss made 2 of 2m pairs with bananas/spades					
TRANSPARENT MUSIC WAVE SUPER 5m					
TRANSPARENT MUSIC WAVE SUPER 5m biwire					
VAN DEN HULL SC54 1.5M					
YAMAMURA MILLENIUM 5000 2.5m bananas bit tatty					
FURAKAWA PS-2T15S PC-OCC 3.5m bananas and 2mm					
AUDIOQUEST DIAMOND 1m					
" " " " " 0.5m					
SONIC LINK LILAC 1m phonos					
VAN den HULL gold 1.2m					
LFD bi-wire cable 6metre rb					
SONIC LINK CABLE RANGE NOW IN STOCK					
SOLID STATE AMP					
AUDIOLAB 8000c/8000p grey					
EXPOSURE SUPE RXV111 POWER AMP					
VINTAGE					
AUDIOMASTER 11A PAIR WITH MATCHING PREAMPS					
CLASSIQUE SOUNDS 301 PLINTH					
GREEN MARBLE PLINTH cut for TD 124/SME 3012 PLINTH ONLY					
LEAK STEREO 50 REBUILD					
LEAK TL12+ PAIR					
LEAK TL25+ PAIR for rebuild					
RESPRAYED QUAD II pair					
QUAD ESL57					
QUAD 22 serviced					
QUAD FM2 matches 33 in looks					
ARMSTRONG STEREO 222 AMP for rebuild					
HEATHKIT MA12 monoblocks					
ROGERS CADET 111 pre/power					
SME 3012 arm					
TANNOY SPEAKERS					
In addition to the above we have loads of cheap stuff - come and have a look!					
NEW EQUIPMENT available for Home Demo					
AUDIONOTE ZERO SYSTEM LAVARDIN IT AMPLIFIER LAVARDIN IS AMPLIF					

LAVARDIN

MODEL IT INTEGRATED AMPLIFIER £3200



"I was mesmerised" HiFi +
"Natural, Fabulously neutral"



"Outclasses alternatives at the same price easily" HiFi World Apr 99

DISTRIBUTION: K. WALKER/N. BESLEY 01895 253340

Dealers:

Audiocraft - Uxbridge	01895 253340
Audio Matters - Surbiton	0181 2550572
Audio Rooms - Hull	01482 891375
Kevin Galloway Audio - Killmarnoch	01563 574183
Kronos - N. Ireland	01868 753606
Movement Audio - Dorset	01202 730865
Progressive Audio - Kent	01634 389004
The Listening Rooms -	0171 2447750
The Emporium	01379 650744

S/hand and ex-demo clearance items - June '00

	Was	Now		Was	Now
CD Players & DAC'S			Amplifiers		
Audio Alchemy DDE1.0V D/A Converter	399	149	Audion Sterling Power amplifier	599	349
Audio Alchemy DDE1.1V D/A Converter	399	179	Audion Sterling Integrated Line	799	449
Audio Alchemy Power Station 2	250	99	Beard M1000 125W Monoblock 6550 Triode	6500	2250
Deva 600 CD Player	699	349	Bartolomeo Trasparenza ST140 Stereo Power amplifier	1499	699
Deva DAC	495	199	Conrad Johnson MV55 Power Amplifier	1995	1199
DPA Enlightenment CD Player	995	695	Graff 50/50 Push Pull Power amplifier (New & Boxed)	2100	1795
DPA Enlightenment SX 64 DAC	850	499	Plinius 5150 Remote Integrated Phono (New & Boxed)	1900	1299
Mark Levinson No39 CD Player	4999	3950	Radford STA 35 Valve Power Amplifier	1000	499
Meridian 203 DAC	499	119	Roksan Caspian Integrated (New & Boxed)	795	595
Micromega Stage3	999	495	Quad 33/303 Amplifiers (New caps fitted)	N/A	250
Monrio Bit Match Transport	950	650	Unison Research Pentode 35 Valve Integrated (4xEL34)	1500	995
Monrio 18B2 DAC	950	599	Unison Research Smart 845 Monos	3500	1799
Nakamichi DV10 DVD DTS/5.1	799	599			
Primare D20 24/96 CD Player	695	575			
Quad 67 CD Player	950	549			
Turntables Tonearms & Cartridges			Loudspeakers		
Aphelion Audio 401 Plinths (New & Various Finishes)	250	169	Acoustic Energy Aegis 2 Beech	299	199
Decca London Gold (Garrot Re-build)	N/A	195	Audio Note AN-E/L Rosewood Loudspeakers	1680	950
Decca London Gold (J.Wright Re-Built/Podded)	N/A	250	Audio Note AN-J/SP Light Oak Loudspeakers	1230	750
EMT HSD15 Special MC phono Cartridge (New)	995	650	Audio Note AN-K/SP Light Ash Loudspeakers	1070	629
Linn Troika (No cantilever)	N/A	150	Celestion SL600 Loudspeakers	675	275
Linn Ittok LVII Tonearm	N/A	325	Impulse Maya Loudspeakers	695	399
Linn LP12 Valhalla/Basik Plus/K9	650	299	Impulse Lali Cherry	1895	999
Lyra Parnassius 600 hrs	1895	599	Opera Callas Gold Mahogany	1050	599
Michell ISO/IIera phono Stage MC (Lyra)	599	329	ProAc Studio 100 Cherry	749	499
Roksan Radius 3 Tabriz/DSU	1170	499	Ruark Solus Yew Monitors (New & Boxed)	1299	995
Roksan Xerxes Black Ash/Tabrizi/XPS2	1795	595	Snell J MK2 Loudspeakers Black / Huygens Stands	900	349
Roksan Xerxes Piano Lacquer Cognoscenti/Artemiz	3000	995	Totem Arrow Cherry	950	699
Roksan Xerxes Rosewood/Artemiz XPS3.5/DSU	2400	795			
Roksan Xerxes X Black/Tabriz/Corus (New & Boxed)	2072	1200			
Tubaphon TU2 MC Phono Cartridge 50hrs	695	425			
Preamplifiers			Cables & Accessories		
Audio Note M1 Phono Preamplifier	750	599	Air Sus Cherry Platform	169	99
Audio Note M2 Line Preamplifier	999	750	Cetech AV Carbon Platforms	250	169
Audio Research LS2 Hybrid Preamplifier	2890	1299	Einstein Octopus 8 Way Main Block (Ex-demo)	199	149
Conrad Johnson PV10A Phono Preamplifier	1395	750	DPA White Slink 1M	99	45
DPA Enlightenment New Style	799	599	DPA The Power / Power Slink	199	125
Gate Audio Line Valve Preamplifier	1699	650	Foundation FRED 21" Stands	179	89
Nagra PLP Battery/Valve Preamplifier	6995	5385	Nordost Elderado 2M Mains Cable	400	259
Rotel RC850 Preamplifier	199	69	Roksan Turntable Stand / Tall	169	99
Unison Research Mystery One Valve Preamplifier	1795	1399			
			Tuners & Tape Decks		
			JBL ESC 200 Surround Package	299	149
			Meridian 565 DTS/AC3 7.1 Processor	2850	1499
			Revox B77 fi Track 3fl - 7fi MK1 Reel to reel	1600	549
			Roksan Caspian Tuner AM/FM	599	449

Midland Audio X-change is looking for good used British & American Hi-fi, cash paid call John Roberts on 01562 822236

Martin Logan

Martin Logan Prodigy speakers available exclusively from Midland Audio X-change

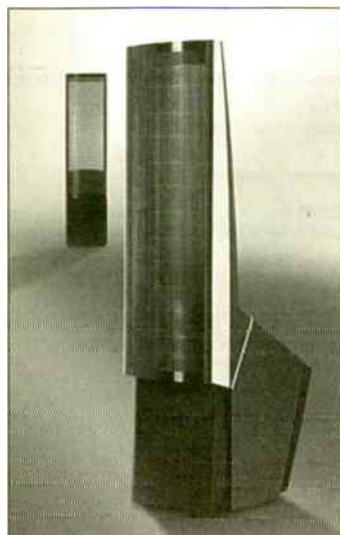

Suppliers and installers of High Quality Audio Systems

Accuphase	Audio Note
Audio Research	Avid
Basis	Cabasse
Cardas	Clearaudio
Conrad Johnston	Copland
Densen	DNN / Reson
Einstein	Electrocompaniet
Final	Finite Elemente
Graff	Mark Levinson
Martin Logan	Michell
Nagra	Primare
ProAc	Rega
Resolution Audio	Roksan
Sonus Faber	SPM
Sugden	UKD
Wadia	47 Laboratory

www.midlandaudiox-change.co.uk

call John Roberts Tel / Fax 01562 822236

181 Franche Rd • Kidderminster • Worcs • DY11 5AD

e-mail sales@midlandaudiox-change.co.uk

Mobile 0421 605966

BETTER OFF DEAD

no vibrations dead sounds perfect

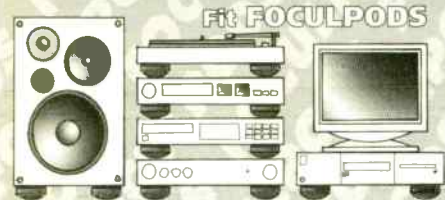

WHAT THE PRESS HAVE TO SAY
 "...I thought they worked very well on some low-cost CD players I had Knocking About..."
Hi-Fi Choice
 July 1995

FOCULPODS & POLIPODS are high performance vibration absorbing supports designed to be placed under Compact Disc Players, Turntables, Amplifiers, Loudspeakers and all other Audio & Video equipment. Designed using computer modelling techniques the spherical surface provides even contact and uniform energy distribution

4 FOCULPODS will support a maximum of 20 Kilos



50 mm dia. x 20 mm

£14.95
per pack 4

available from most good Hi-Fi dealers

NEW POLIPODS

Designed to support a pair of bookshelf speakers or 2 items of lightweight Hi-Fi equipment



40 mm dia. x 14mm

4 POLIPODS will support a maximum of 5 Kilos

WHAT THE PRESS HAVE TO SAY
 "...We found they worked best with CD players; allowing the transport to run more smoothly to give a more open and natural sound, and better stereo imaging..."
WHAT HI-FI - 1996

£14.95 per pack 8

available from most good Hi-Fi dealers

For a **FREE** information pack and details of other products from **SPECTRA DYNAMICS**

Tel (01745) 360070 Fax (01745) 360086 www.spectradynamics.co.uk

Unit A1, Ffordr Denwen Industrial Estate, Rhyll, Denbighshire, LL18 2YR

TEL: 01428-651554

P.G. Hi-Fi

FAX: 01428-654592

Buying & Selling Vintage HiFi, Valves, Classical LP Records & Spare Parts.

Quad

Multiplex Decoder to fit Quad FM1	£50
Quad ESL57 Electrostatics (pair)	£500
Quad FM1 Tuner	£50
Quad 33	£60
Quad 44	£150
Quad 303	£100
Quad FM3	£80
Quad 405-2	£225

Leak

Stereo 20 (mint)	£250
Stereo 60	£550
Stereo 70 (mint)	£50

Valves (G.E.C. Mullard etc.)

PX25, KT66, ECC81/84, EF80
 Many Others.
 Please Phone For Details.

Most Models Of Leak Mono + Stereo Pre-Amps In Stock.

Radford STA25 III + SC22 (serviced) £700

BARGAIN BASEMENT

NAD 5120 Turntable + Nagaoka MP15	£20
NAD 7125 FM/AM Receiver	£60
Tannoy 3LZ (cabinets only) for 10" monitor golds	£30
Ortofon Hi-Jack arm lifter in original box	£15
Stentorian column speakers (pair)	£10
Myst Pre-amp + power supply (boxed)	£75
PM6 drive units (3) the lot	£150

VALVE ALERT

ORIGINAL MULLARD ECC83
LAST BATCH MADE IN UK
BLUE BOX - N.O.S.
£15 EACH INC P&P

FOREIGN ORDERS WELCOME
MINIMUM ORDER 10 VALVES
ALSO ECC81 £8 EACH
Servicing for Quad II + Leak Amplifiers

Photocopies Of Circuit Diagrams + Vintage Hi-Fi Literature
 Spare Parts For Quad + Leak - Transformers etc.
 Garrard 301 spares
 All spares available for Quad II and Quad 22

Garrard 301 motor	£50
Quad II mains transformer	£100
Quad II output transformer	£100
Quad II choke	£30

Please phone for details of other Quad/Leak/Garrard spares

Speakers

Mordaunt Short MS600's with Decca Kelly ribbons (pair)	£200
Kef Concord speakers (early type/B139+T15) (pair)	£75
Tannoy 15" monitor golds with crossovers (pair)	£450
Lowther Audiovector in burr walnut with original (serviced) ALNICO PM4 drive units (pair)	£2,200
Lowther Acoustas in Teak with original PM6 Alnico drive units (pair)	£250
Tannoy 12" full range drive units (early 60's) (pair)	£200

DECCA DECOLA RADIOGRAM (Stereo) mahogany with rosewood inlay, original, rare & beautiful £2,500

DEFLEX[®] By SPECTRA Dynamics

Deflex material is a specially formulated low resilience polymer with exceptional shock absorbing properties. Loosely grouped molecules within the material rub together and transfer vibrations into heat. In its soft form the material has a texture similar to plasticine but with a high memory characteristic. The mechanical properties of the material guarantee to reduce unwanted noise.

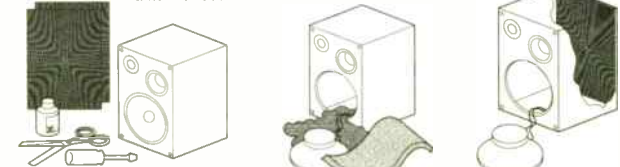

You need at least 2 Deflex panels for a pair of small bookshelf speakers, 4 panels for a pair of Tannoy 6's, and at least 6 panels for larger cabinets.

Once you have gained access to the inside of the cabinet, remove foam and/or wool damping from the inside of the speaker (if fitted)

Place the flexible Deflex panel thru' the speaker cut-out and stick to the inside of the cabinet using the recommended adhesive

DEFLEX ACOUSTIC PANELS

The simplest and most cost effective way to upgrade your existing system

"Deflex panels seemed to give greater tightness and control, improved internal clarity, and pitch definition - all without deadening the sound in any way."
 Audiophile - January 1994

"the result was sharper imaging, wider dynamics and a more natural sound..."
 Hi-Fi Choice - January 1994

CHOICE VERDICT

Sound Quality ■■■■■
 Value for money ■■■■■

"...a marked improvement was obvious from the first few bars of REM's Automatic for the people album..."
 Hi-Fi News & Record Review - March 1994

"...But one thing for sure - the Deflex panels are no gimmick. They work..."
 Audio Video - December 1994

Now sit back and listen to the extra detail in sound, and far less distortion when played loud.

PANEL PRICES

Standard Panel	£5.00	(28cm x 21cm)
Medium Panel	£4.00	(28cm x 18cm)
Small Panel	£3.00	(24cm x 13cm)
Sub-Woofers Panel	£12.00	(34cm diameter)
Adhesive	£3.50	
Delivery	£3.00	

"The only world acclaimed flexible acoustic damping pad for lining loudspeakers"
 (UK PATENT N° GBPT 2277008)

For a **FREE** comprehensive information pack & details of other products from **SPECTRA DYNAMICS**

Tel. (01745) 360070
 Fax. (01745) 360086
 Website: www.spectradynamics.co.uk

Unit A1, Ffordr Denwen Industrial Estate, Rhyll, Denbighshire, LL18 2YR, UK



H-F Audio Consultants
 Sales and Service

CODE KEY:- N = NEW X = EX DEM S = SECOND HAND

MAKE	MODEL	TYPE	WAS	NOW ONLY
ARCAM	170.3 & BLACK BOX 5 CD TRANSPORT & DAC		£1,000.00	£300.00
ARCAM	ALPHA 8 CD	CD PLAYER	£450.00	£350.00
ARCAM	XETA 2	AV PROCESSOR		£250.00
CASTLE	EDEN	LOUDSPEAKER	£600.00	£350.00
BOOKSHELF LOUDSPEAKER - ANTIQUE OAK				
CASTLE	TAY	LOUDSPEAKER	£350.00	£225.00
BOOKSHELF LOUDSPEAKER - WALNUT				
CASTLE	INVERSION 15	LOUDSPEAKER	£515.00	£300.00
BOOKSHELF LOUDSPEAKERS - FINISHES INCLUDE WALNUT, MAHOGANY & CHERRY				
CASTLE	INVERSION 15	LOUDSPEAKER	£515.00	£350.00
BOOKSHELF LOUDSPEAKERS - DELUXE ROSEWOOD FINISH				
CELESTION	A 1	LOUDSPEAKER	£900.00	£500.00
BIG BOOKSHELF LOUDSPEAKER - BLACK				
JAMO	CONCERT 8	LOUDSPEAKER	£1,350.00	£800.00
EX DEMONSTRATION SLIGHT DAMAGE TO CABINET				
LOGIC	DM 101 + RB 300	TURNTABLE	£800.00	£350.00
MERIDIAN	565	PROCESSOR	£2,850.00	£1,750.00
DOLBY DIGITAL, DTS & MLP PROCESSOR - LATEST SOFTWARE FITTED, EX DEMONSTRATION				
MERIDIAN	DSP 5000	LOUDSPEAKERS	£3,300.00	£1,900.00
DIGITAL ACTIVE LOUDSPEAKERS - SUPERB CONDITION				
MERIDIAN	DSP 6000	LOUDSPEAKERS	£9,995.00	£6,250.00
DIGITAL ACTIVE LOUDSPEAKERS - SUPERB CONDITION				
QUAD	77	POWERAMP	£600.00	
YAMAHA	DSPA 2	AV AMPLIFIER	£1,000.00	£700.00
DOLBY DIGITAL & DTS				

12 Regent Street, Rugby, Warwickshire, CV22 5LP
 Tel: 01788 540772 Fax 01788 542170

www.soundexpensive.co.uk

RETRO REPRODUCTION

Exclusive Scottish dealer for
E.A.R./Yoshino, Croft, Cary, Nottingham Analogue, Creek,
Triangle, B.C. Acoustique



The Outstanding V20 Integrated Amp

V20

Introducing Tim De Paravicini's latest masterpiece, the outstanding V20. Using no less than 20 ECC83 triodes operating in Class A with no overall feedback, the result is the most natural and uncoloured sound available today.

HI-FI NEWS: Ken Kessler: 'What I think we're witnessing here is Tim De Paravicini's finest moment and that's scary, when you consider that even his disasters are better than most designer's triumphs!'

WHAT HI-FI: Verdict *****

Leading French magazine Diapason voted the V20 Amplifier of the year. To hear what all the fuss is about phone now for a personal home demonstration

Used Equipment For Sale

Gold Lion KT88 Tubes 2 of	each £95
Tannoy little red monitors	£595
TDL RTL 3	£250
Rega Planer 3 Turntable boxed	£175
Gamma Rhythm 211 int valve amp with phono stage	£1195
SMF 309 Tone boxed new	£495
Trilogy 900 valve pre with phono stage	£350
Trilogy valve MC head amp	£195
Tube Technology Prophet 2 box and pre with phono stage	£795
Arcam Two + speaker complete with stands	£145
Onyx integrated amp with Tuner	£350
Linn LP12 with lingo black boxed	£695
Roksan Xerxes walnut with Tarentz xps usu	£495
Neat Petite loudspeaker black boxed	£295
Mission Cyrus 2 & PSX boxed mint	£295
Quad 66 Pre & Tuner with remote	£595
Quad 77 Pre & 707 Power Amp with remote	£895

CROFT PRODUCTS

Croft's new Vitali Valve Pre with Phono Stage an ideal partner for Vintage Amps or a upgrade from solid state £350.00

Systemdek II Round chassis type	£225
Thorens TTA2000 Class A Power Amp	£295
Nytech 202 Int amp	£95
Denon CA202 DP-3000 DD Turntable	£250
Luxman Z501 Class A Power Amp	£195
Michel ISO hr with hera	£395
Michel ISO with hera	£295
Michel Argu with hera	£295
SonyTan 55ES poweramp 250 watt per channel mint	£250
Sugden MMMC phono stage, Optima	
Audion single ended EL34 int. amp	£395
Audio Innovations Series 800 MC step up	£95
Ferroglyph seven open reel with Dolby	£150
Golden Tube SE 40 power amp 12 mths old	£795
Crimson monoblocks 100 watts 6 mths old	£495
Audio Research V70 pwr amp 3yrs old boxed new £5000	£1495
ATC SCM 10 spks black finish	£995
Heybrook Sextet Ribbon tweeter rosewood	£595
Apogee Centaur Hybrid ribbon spks boxed	£995
Cary SP301 Floorstanders piano black 91.5 db ideal match fro single ended amps new	£2300 - £995
Michelle QC power supply	£325
Audio Research D250 power amp 20x 6550 Awesome	£1995
E.A.R. V20 integrated amp 4 months old still under guarantee BARGAIN	
Tannoy III LZ 10" Monitor golds	£1995
Fisher x 100 Integrated valve amp	£350
Rodgers Cadet III valve amp mint	£145.00
EAR R34 L valve line stage	£145
Lamley 120 valve monoblocks Triode/Petode 120 watt chrome black finish mint. fantastic drive £3700 new	£275
Quad 77 Integrated amp with quad system remote	£1995
Pye FM Tuner valve with rose gold finish	£399
Leak stereo 60 mint & professionally rebuilt	£95



Small but perfectly formed MC3

MC3

Producing the very best from vinyl has long been a black art and it's no wonder with so many permutations involved. Most people agree that Moving Coil cartridge design is technically superior than the Moving magnet but demands much more from it's ancillaries, especially the phono stage.

E.A.R./Yoshino have just launched the MC3 Cartridge Transformer with a band width of 3Hz-100kHz, facilities for a wide range of quality cartridge outputs and twin isolated earth terminals for maximum noise reduction.

The MC3 captures all the subtleties from the most complex recording without resorting to thrusting or spitting it out. Its extreme clarity and grainless presentation makes for a superb vinyl experience.

ART DUDLEY: Leading American hi-fidelity critic.

'I'm impressed with the MC3, and from a musical point of view, I think it's worth every penny of the price. Those of you who have tube-based systems & can afford it should pester your local dealer until he lets you take one home and try out Value/Quality *****

Meridian 602 Transport	£595
Meridian 601 PRE/DAC	£595
Meridian 604 Tuner	£695
Leak Stereo 30 amp mint	£50
Quad 101 spendor spks as new	£395
Quad II pair various	£300
Leak TL12+ pair	£300.00
EAR R34P	£235.00
Revox B77 Open Reel mint	£495.00
Leak Throughline 3 Tuner	£95.00
STD Turntable	£145.00
Cary 300b kit amp professional build	£495.00
Stax head phones and enginers various models	(phone)
Various Open Reels, Revox, Ferroglyph, Sony	(phone)

NOW DEMONSTRATING
AUDIO ANALOGUE PUCKINSE INT AMP
& PIGANINI CD PLAYER

NEW SHOWROOM NOW OPEN
103 Henderson Row, New Town, Edinburgh, EH3 5BB
Phone / Fax 0131 558 9989
open 11.00-5.30 everyday closed Wednesday

VALVE FRIENDLY SPEAKERS
NOW IN STOCK FROM B.C. ACQUSTIQUE & TRIANGLE 90
DB SENSITIVELY AND ABOVE. PRICES START AT £199.00



2nd User Hi-Fi & audio

01376 521132

0802 483698

CHELMSFORD, ESSEX

E-MAIL: soundstage@netlineuk.net

BY APPOINTMENT ONLY

SUMMER MADNESS-1 MONTH ONLY

ACOUSTIC ENERGY AE2 BLACK WITH AE CUSTOM STANDS (HEAVY)	£695
ARCAM ALPHA 5 CD	£159
ARCAM ALPHA 9P x 2	£269
ARCAM ALPHA + CD PLAYER	£159
ARCAM ALPHA+ CD	£139
CAMBRIDGE AUDIO P50 INTEGRATED AMPLIFIER	£99
CYRUS PSX BLACK CASE OLD STYLE	£179
CYRUS SL INTEGRATED AMPLIFIER	£249
ION OBELISK 2 INTEGRATED AMPLIFIER	£129
JVC RX508V PRO-LOGIC AMPLIFIER	£39
KENWOOD KAV3700 PRO-LOGIC AMPLIFIER	£69
KENWOOD SS3300 PRO-LOGIC AMPLIFIER	£49
LINN AV 5140 CHERRY WOOD WITH FULL LENGTH GRILLE	£1299
LINN AV 5120 CHERRY CENTRE SPEAKER WITH FULL GRILLE	£329
LINN LK1 PRE AMP	£179
LINN AXIS TURNTABLE WITH BASIK ARM	£249
LINN SARA BLACK ASH LOUDSPEAKERS	£249
LINN SONDEK AFROMOSIA WITH BASIK+ TONEARM	£399
MARANTZ PM66SE INTEGRATED AMPLIFIER	£119
MARANTZ CD63 CD	£89
MICROMEGA STAGE 4 CD	£329
MICROMEGA PREMIUM 18 CD PLAYER	£399
MICROMEGA STAGE 5 CD	£379
MONITOR AUDIO R 252 WALNUT LOUDSPEAKERS	£59
MORDAUNT SHORT MS25 BLACK ASH	£59
NAIM NAC42 PRE AMP	£69
NAIM NAC62 PRE AMP	£139
NAIM NAC42.5 PRE AMP	£89
NAIM NAC 92 PRE AMP	£269
NAKAMICHI BX125E RECENTLY SERVICED	£179
NAKAMICHI 582	£199
REVOX B261 TUNER	£349
REVOX B77 MK1 REEL TO REEL LOVELY CONDITION	£349
ROTEL RCD 950 CD	£109
ROTEL RA930AX INTEGRATED AMPLIFIER	£69
RUARK SABRE BLACK ASH LOUDSPEAKERS	£199
SONY TC-FX420R CASSETTE DECK	£59
YAMAHA DSP A590 PRO LOGIC AMPLIFIER	£59
YAMAHA NSE80 SURROUND SPEAKERS	£39
YAMAHA DSP-E390 PRO LOGIC 3CH ADD ON AMPLIFIER	£49

PROFESSIONAL RECORD CLEANING SERVICE - KEITH MONKS MACHINE - PLEASE RING FOR FURTHER DETAILS AND PRICES.

**THREE MONTH WARRANTY ON ALL ITEMS
PART EXCHANGE WELCOME - RING FOR DETAILS**

serious kit ltd

*if you feel like
turning your
hi-fi off after
an hour give me
a call, I have a
cure.*

sugden
pro-ac
totem
harbeth
michell
lyra
s.m.e.
grado
audionote
rothwell
canary audio

*full range of accessories
431 Bury New Road, Prestwich,
Manchester*

0161 798 9649

e-mail seriouskit@aol.com

*open 10-5 mon to sat
fatigue free hi-fi*

SUPPORT YOUR HI-FI/HOME CINEMA

There are many ways of improving the sound your hi-fi equipment makes, including the type of interconnect, speaker cable, speaker stands etc., that you use, but one of the most effective, though not the cheapest, can be the equipment stand you sit your components on. There are numerous models on the market but most are simply variations on the same theme, but two of them stand out as being different by isolating the shelves from the floor using air suspension. The most common of these is the various types made by Max Townsend, starting off with the single 3-D Seismic Sink (£234), which can be placed on your normal existing rack, to the Seismic Sink stand (from 1 to 6 shelves between £1000 and £1500), and now also available in a stackable modular form at around £400/module.

Equally impressive are the speaker stands, which are a variation on the above 3-D Sink, working in just 2D (vertical and in the cone movement direction), which amaze everyone who hears them (£500/£600 a pair). Works equally well on stand or floormounted. Add the Isolda transmission line speaker cable which matches the impedance between the amp/cable and cable/speaker and you're another step up. Alternatively there is another excellent rack by Arcici from America which has the advantage that shelves can be spaced to your requirements and being more stable could be more suitable for some turntables. You will be amazed that these stands do just to the sound of your video recorder, or DVD player, and of course home cinema systems can benefit just as much (think of all those sub-woofer frequencies) and Townsend now do a cheaper A/V range to carry TV sets etc. Do phone!

V'audio Hi-Fi Consultants
36 Druid Hill, Stoke Bishop, Bristol BS9 1EJ
Tel/Fax: 0117 968 6005

MERIDIAN AT SALE PRICES

	<u>NEW PRICE</u>	<u>SALE PRICE</u>	
DSP5000 CHERRY LATEST SPEC	3885.00	2950.00	D pair
DSP5000 CENTER CHANNEL	1995.00	799.00	D
500 CD TRANSPORT	1325.00	899.00	D
562V DIGITAL CONTROLLER	995.00	399.00	D
506.24 CD PLAYER	1195.00	995.00	N
551 INTEGRATED AMP	845.00	599.00	N
M33 ACTIVE SPEAKERS	1495.00	1195.00	N pair

D = DISPLAY/DEMO UNITS. ALL ARE CLEAN & MOST ARE UNMARKED & AS-NEW CONDITION, **N** = FACTORY SEALED STOCK

PLEASE RING FOR DETAILS

UNIVERSITY AUDIO
3 PEAS HILL
CAMBRIDGE CB2 3PP
01223 354 237

Sound Investment

If you have invested expertise and money in building up a sound system to your own unique specifications, then why compromise with indifferent housing units?

Fi-Rax offers a new dimension in audio visual racking - from a range of standard designs to the flexibility to custom create a unit to suit your particular sound system and lifestyle.

- *High quality aluminium construction.
- *Finishes available to your choice.
- *Fully adjustable 6mm glass shelving.
- *Sound isolation on shelving/feet.
- *Custom created to suit your system.
- *Free delivery throughout the UK.

Fi-Rax - a sound investment for those who want the best from their equipment.

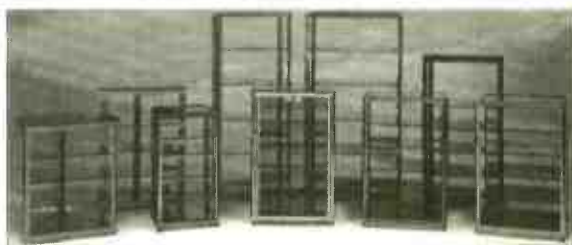

Audio Visual Furniture

For further information or a free brochure contact: JEM Distribution, Springfield Mills, Spa Street, Ossett Wakefield WF5 0HW.
Tel: 01924 277626 Fax: 01924 270759

Wide range of popular, classic, vintage, rare Electron Tubes from STOCK.

E.T.O.L.S

Electronic Tube On Line Shopping

Division of HALFIN
50 years of experience.
We ship worldwide.



Free membership gives access to the gateway of the world.

Web site

www.halfin.com/shop

37/39
Quai aux
Pierres de Taille
B-1000 Brussels
BELGIUM

Phone: +32.2.218 10 11 Fax: +32.2.218 69 98
E-Mail: etols@halfin.com

MANTRA AUDIO

Specialist Suppliers of Audio Accessories

CARTRIDGE SELECTION	STYLUS	REPLACEMENT STYLUS
Audio Technica		
AT 95 E	£22 £14	Swiss Copy Diamond Styl
AT 110 E	£27 £14	ADC XLM IIIK IIII £14.00
AT OC 9 ML	£300 £226 EX	Akai AN 5, AN 60 £10.00
AT33 PTG (new)	£465 EPOA EX	AN2, AN 70 £12.00
Denon		
DL 110	£75 £59 EX	DN 145 E, DN 165 E £14.00
OL 304	£200 £170 EX	Dual Goldring G800 Super E £14.00
Goldring		
1012 GX	£76 £50	JVC DT 55, DT 60 £10.00
1022 GX	£94 £62	National EPS 24 GS, P 30 D, P 33 D £10.00
1042	£115 £76	Ortofon FF 15 E II, VMS 20 E II, DM 20 £14.00
Eroica (LX or H)	£108 £78 EX	Pioneer PN 210, PN 220, PN 240 £10.00
Elite	£212 £153 EX	Shure N 75 C, SC 35 C, £10.00
 Grado		
Prestige Black	£44 £24	N 75 ED T2, N 75 EJ T2 £12.00
Prestige Gold	£134 £74	N 95 ED, N 95 EJ, N 75 3 (78) £14.00
Reference Series	EPOA EPOA	VN 35 E £16.50
Ortofon		
510 Mk II	£34 £22	N 95 HE, N 97 HE, VN 35 HE £22
MC 15 Super II	£120 £102 EX	ND 142 G, ND 150 G, ND 155 G £10.00
MC 25 FL	£226 £190 EX	CN234 £12.00
MC 10 Supreme	£283 £240 EX	
MC 20 Supreme	£355 £300 EX	
MC 30 Supreme	£420 £358 EX	
Rohmann	£779 £690 EX	
Jubilee	£950 £850 EX	
Shure		
V 15 V XMR	£265 £189	
SC 35 X	£32 £24	
*** OVER 500 STYLUS TYPES STOCKED ***		
See our Website for full selection and Special Offers		
http://www.mantra-audio.co.uk		
HEADPHONE SELECTION		
GRAOO		
Prestige Series	SR-60 £75	
	SR-80 £90	
	SR-125 £135	
	SR-225 £180	
	SR-325 £270	
Reference Series	RS-1 £590	
	RS-2 (new) £425	
RECORD CLEANER KIT REFILL		
Milly Permaclean Record Cleaner	£13.00	£9.00
Permastat Anti-static Spray	£13.00	£9.00

MAIL ORDER (1-10 DAYS) PRICES (INC P&P) ARE BEST WE CAN OFFER THROUGH COMPETITIVE SOURCING UK & MAINLAND EUROPE - ALL ITEMS CARRY FULL MANUFACTURERS GUARANTEE - OVERSEAS CUSTOMERS PLEASE ADD £5.00 TO ORDERS OVER £50 IN VALUE TO COVER INSURANCE

Tel/Fax (01757) 288652 e-mail: enquiry@mantra-audio.co.uk

MANTRA AUDIO (HFW), 22 GARTH AVENUE, NORTH OUFFIELD, SELBY NORTH YORKS YO8 5RP

ALCHEMIST

DISTRIBUTOR CLEARANCE

Henley Designs are no longer distributing Alchemist, to make way for future products we have decided to offer our last few remaining items direct to our customers at distributor cost, this offer will never be repeated and there are only a few items available.

Model	Normal price	Clearance
Kraken pre amp (demonstrator)	550.00	250.00
Kraken power amp (demonstrator)	550.00	250.00
Forseti r/c integrated amp (review model)	1250.00	500.00
Forseti pre amp (demonstrator)	1000.00	350.00
Forseti pre amp (new)	1000.00	400.00
TSD1 outboard dac (review model)	300.00	100.00
TSD1 outboard dac (new)	300.00	125.00
Forseti Signature Series power amp (demo)	2000.00	750.00
Forseti Signature Series pre amp (demo)	1500.00	550.00
Nexus r/c integrated amp (new)	800.00	325.00

Prices include UK mainland delivery, all models are covered by a three month warranty, further products / service may be obtained direct from Alchemist UK

For more information call Henley Designs on 01491 834700

HEATHERDALE AUDIO LTD.

HEATHERDALE PRE-OWNED GUARANTEED EQUIPMENT EXPORT FACILITIES AVAILABLE

SPEAKERS		Exposure 18 Stereo Amplifier	£495
TDL Studio 11 speakers with stands (Black Ash)	£495	Exposure 18 Stereo Power amplifier NEW	£720
Light isobars with stands	£285	Luxman M2000 Power Amplifier	£495
ATC Towers 7's	£795	Rotel RT18 350 Tuner/pre-amp	£395
Audionote ANE/SE (Rosewood) F Veener	£3995	Adcom GFA-5000 Power amp	£295
Dillon 15's Speakers	£195	Naim Nap 180 Power amplifier	£750
Kel 1012 speakers	£475	CD PLAYERS & TRANSPORT	
Magnaphone 1.5's	£995	Proced PC-3 CD player	£1595
Mirage M-15 Piano black	£2995	Audio Research CD11 CD transport	£1295
Mission 782 Loud Speakers (Stand mount model)	£750	Mendian 200 CD transport	£395
Monitor Audio Subwoofer Rosewood	£195	Arcam 170 3 Transport with Arcam black box 5 DAC	£475
Solstice AAD speakers with stands	£495	DACS	
TANNIY 15" dual concentric speakers in superb oak cabinets	£2995	Mark Levinson 30.6 Reference DAC (HDCD-24/96khz)	£11995
Selection of Thiel ex Demo Speakers All with 10 year guarantee	£950	Mark Levinson 30.3 Reference DAC (HDCD)	£6750
PRE AMPS		Ref Reference DAC	£2995
Naim HCC 102 with display power supply	£995	LFJ DAC 3	£1195
Audio Research phono 1 phono stage MM & MC	£1495	Mendian 203 DAC	£195
Audio Research SP 14 Pre-amp (with phono stage) boxed	£995	Mendian 263 DAC	£195
Audio Research LS8 Black Pre-amplifier	£795	Sonic Frontiers SF01 DAC	£1195
Electrocompaniet EC4.5 balanced Pre-amp with remote	£495	Vac DAC Valve DAC	£895
Exposure 17 Pre-amp	£890	MISCELLANEOUS	
Exposure 21 Pre-amp NEW with remote	£495	Naim Hi-Lap psu	£450
Mendian 501 Pre-amplifier with phonostage	£2799	Naim Snaps psu	£250
Passlabs Alpha P Pre-amp	£1195	Nakamichi Cassette deck 1 (3 head recorder) Mint condition	£395
Great WFB two Pre-amp		Nakamichi EX 506 3 head auto reverse cassette deck	£695
AMPLIFIERS		Nakamichi 1000 ZXL Cassette deck very rare Excellent cond	£1495
Mark Levinson 332.200 wpc power amplifier	£3995	Mobile Fidelity Philes of Rome UHQD Sealed box	£200
Mark Levinson ML29 Power amplifier	£1695	Michell ISO Phonostage	£249
Audionote P4 Monoblocks	£3395	Revox PR99 MK2 tape deck trolley mounted	£1495

202 FINDON ROAD, WORTHING, WEST SUSSEX, BN14 0EJ
TEL: 01903-872288 OR (AFTER HOURS) 0860 660001 FAX: 01903-872234
e-mail: heatherdale@hifi-stereo.com http://www.hifi-stereo.com

Sonic Frontiers Jitta Bug	£495	CEC Turntable & PSU	£495
Vanden Hul CS122 Hybrid speaker cable 2.5 meter sets	£500 set	Relius Silver wired tonearm	£395
Teac A-33405 Tape recorder	£595	Rolsan Xerxes The mechanic pick-up arm Linn Tnoka cartridge	£795
Henley HMC 50 MC phono stage	£75	Rolsan Xerxes Turn table	£395
Stax Lambda Nova Electrostatic headphones and energizer	£795	VPI TNT Turntable	£3495
Naim NAT 11 FM Tuner (arriving shortly)	£150	Rolsan Xerxes with Linn tonearm (boxed)	£650
TURNTABLES, CARTRIDGES & TONEARMS		Rolsan turntable with SME 1V tonearm	£995
SME series 1V Tone arm	£1295	Ortofon MC 7500 Full guarantee (new)	£1495
Audio Technica OC9 MC Cartridge NEW/ BOXED	£475	SME 3009 ser 111 Tonearm Boxed	£150
CEC Turntable & PSU	£495		
Relius Silver wired tonearm	£395		
Rolsan Xerxes The mechanic pick-up arm Linn Tnoka cartridge	£795		
Rolsan Xerxes Turn table	£395		
VPI TNT Turntable	£3495		
Rolsan Xerxes with Linn tonearm (boxed)	£650		
Rolsan turntable with SME 1V tonearm	£995		
Ortofon MC 7500 Full guarantee (new)	£1495		
SME 3009 ser 111 Tonearm Boxed	£150		

A RARE OPPORTUNITY

CELLULOSE DA CONVERTER £2995
MARK LEVINSON 30.6 DAC 24/96 plus HDCD £11995

NOW DEMONSTRATING THE MARK LEVINSON 30.3 INTEGRATED AMP

WE NOW OFFER 0% FINANCE (subject to status)

PLEASE PHONE TO ARRANGE AN AUDITION

MAIN DEALERS FOR MARK LEVINSON, THIEL AND ABSOLUTE SOUNDS

VISA - SWITCH - MASTER CARD - AMEX - DINERS CLUB WELCOME.
WE TAKE PART EXCHANGE ON NEW & USED STOCK AND BUY IN FOR CASH

Are you making the right connections?

Send for Britain's biggest catalogue of specialist cable and connections.

All available by mail order.

Phone 0181-942 9124 or clip the coupon for your Free copy

CUSTOM CABLE SERVICE

PO Box 4007, London SW17 8XG

Please send me your FREE Custom Cable Catalogue

Name _____

Address _____

Postcode _____

NO FURTHER INFORMATION REQUIRED

Send to: Custom Cable Service
PO Box 4007
London SW17 8XG

HFW 06/00



*An Outstanding
Selection of Carefully*

USED HI-FI

All Fully Guaranteed!

The Trading Station specialises in superior quality, previously used hi-fi. As part of a leading group of retailers (established more than twenty-five years) our lists can also include display and ex-demonstration items, as well as used equipment bought in or part-exchanged.

VISITORS WELCOME

All of the products listed here can be auditioned in our showrooms (subject to availability - please phone to check).

FULLY GUARANTEED

All products are fully inspected and tested before being offered for sale and a comprehensive three months warranty (with an option to extend) is included.

NEXT-DAY DELIVERY

As mail-order specialists, consignments are always carefully packed and fully insured. Next day delivery is guaranteed on all purchases made by credit card.

Our couriers can also collect any 'trade-ins' or items you wish to sell

NEW AND USED EQUIPMENT

We also stock a huge range of new hi-fi and AV equipment, against which we can be especially generous with our P/X allowances. Please call for details.

GOOD AS NEW!

If your unwanted hi-fi is in excellent condition, a classic or collectable, we'll ensure you get the best market price; by cash purchase, part-exchange for new or used equipment, or commission sale.

So...avoid all the hassle - call us now!

HOURS OF BUSINESS

Tuesday - Saturday 10.00am - 5.30pm
Closed Mondays.

**DON'T MISS A BARGAIN - PHONE
01733 555514**

TURNTABLES - TONEARMS

Air Tangent 1B Air Bearing Tonearm	£NA	£890
AR EB10 T/table	£NA	£148
AR P77 MM Cartridge	£NA	£48
Ariston RD40 - SME 3009 MK 2i	£NA	£325
Audio Technica AT OC5 MC Cart	£NA	£78
Dunlop System Deck 3, Basic LVX - K5	£NA	£379
Dynavector DV505 (Arm)	£NA	£558
Grace G707 Mk 2 Tone Arm	£NA	£139
Linn LP12 + Basic Plus (Sounds Great)	£1600	£399
Linn LP12 + Lingo + Ittock	£3200	£1648
Linn LP12 (Rosewood,Cut for Linn Arm)	£NA	£398
Luxman PD 300 T/Table Choice of Two	from	£350
Nottingham Analogue Hyperspace + Arm	£NA	£1398
Nottingham Analogue Space Deck + Arm	£NA	£998
Oracle Alexandra (Piano Black)	£NA	£499
Oracle Delphi II/Linn Ittock II	£NA	£1299
Pink Triangle LPT + Roksan Tabriz +	£1500	£499
Pink Triangle LPT2 (SME-cut)	£NA	£299
Pink Triangle Tarantella + Rega RB300	£NA	£698
Rega Planar 2 T/Table RB300	£NA	£189
Revolver With Linn Basic - NAG MP11	£NA	£199
Revox B795 T/Table	£NA	£499
Roksan Radius + Tabriz	£800	£449
Roksan Xerves + Tabriz (Walnut)	£NA	£600
Roksan Xerves (Black) Choice Of Three	from	£499
Roksan Xerxes (Rosewood) Alphason Arm,		
SME Series 3 Tone Arm	£NA	£140
Sumiko BP	£2400	£999
Technics SL150 + SME 3009	£NA	£228
Thorens TD125 + SME3012 + SME Plyth	£NA	£428
Thorens TD316 Mk2 T/Table (Black)	£NA	£169
Thorens,Garrard and other Classic Turntables Changing Weekly Please Call!		
Wilson Benesch Act 2 Arm (Ex-Demo)	£NA	£798

CD PLAYERS - TRANSPORTS - DACS

Arcam Delta Black Box 3 DAC	£449	£99
Audio Alchemy ACD2 CD Player (Ex-Dem)	£499	£389
Audio Alchemy DAC in a box	£250	£159
Audio Alchemy Drive 3	£649	£449
Audio Alchemy Power Station 2	£NA	£109
Audio Alchemy V1 + PSU	£NA	£298
Audio Alchemy V3 DAC + PSU	£900	£549
Audio Lab 8000 CD	£1000	£648
Audio Mecca Kreaturea + Elixir	£NA	£POA
Audio Synthesis DAX (DAC)	£NA	£548
Audio Synthesis DAX - 2 (DAC)	£NA	£1298
AVI 2000 CD	£950	£648
Cambridge Audio CD 2 CD Player	£NA	£149
Cambridge Audio DAC Magic 1 DAC	£NA	£95
Cambridge Audio DAC Magic 2 DAC	£NA	£108
Conrad Johnson DF2 (CD Player)	£2000	£1398
DPA Bigger Bit 2 DAC 7	£800	£429
DPA Little Bit 3 DAC	£NA	£298
DPA PCM Series 2 DAC	£NA	£438
Kenwood DP9010 CD Transport	£500	£269
LFD Minstral CD Player	£650	£350
Linn Karik CD	£1850	£1098
Linn Mimick CD Player	£880	£599
Marantz CD 17 KI SIG (CD Player)	£NA	£848
Marantz CD 63 (Clock 2) CD	£340	£198
Marantz CD 94 CD Player	£NA	£498
Mark Levinson 360s DAC (Months Old)	£NA	£4998
Marston Audio Research Silhouette DAC (Ex-Demo)	£NA	£428
Meridian 200 Transport	£999	£399
Meridian 203 DAC	£NA	£258
Meridian 206 CD Player	£999	£398
Meridian 207 CD/ Pre	£1200	£548
Meridian 208 Tricord 3 CD	£1300	£898
Meridian 263 DAC	£650	£248
Meridian 500 Trans	£1325	£870
Meridian 518 DAC	£NA	£698
Meridian 563 DAC	£NA	£498
Meridian 563 DAC 18 Bit	£899	£449
Meridian 566 20 Bit DAC	£980	£599
Micromega DAC 1 (DAC)	£NA	£320
Micromega DAC 2	£NA	£499
Micromega Drive 3 Transport	£NA	£529

Micromega Stage 2 CD Player	£700	£399
Micromega Stage 5 CD Player (Ex-dem)	£750	£549
Monarchy DIP (De-gitterer)	£NA	£198
Musical Fidelity Electra E624/24 Bit	£500	£299
Musical Fidelity X - DAC New hdcd	£300	£199
Naim CD 3.5	£NA	£898
NVA Emotive Statement CD Player	£NA	£900
Pink Triangle DaCapo DAC	£1500	£548
Pink Triangle Ordinal DAC	£800	£399
Pioneer PDS 505 Precision CD Player	£549	£299
Primare D320 CD Player	£NA	£438
Proceed DAP (DAC)	£NA	£1198
Proceed PD2 / PT2 (DAC + Trans)	£NA	£2498
PS Audio Lambda CD Drive (Trans)	£NA	£1098
PS Audio Ultralink (DAC)	£NA	£998
QED Digit Reference DAC (Chrome)	£450	£199
Quad 66 CD Player	£NA	£458
Radford WS2 CD Player	£NA	£698
Radford WS1 CD Player	£NA	£489
Revox B225 CD Player	£1100	£459
Sugden SDT-1 CD Player	£NA	£798
Teac TI (Trans)	£NA	£389
Teac VRDS 10 CD Player	£770	£459
Technics SHZ 1000 + SHX 1000 Transport	£5000	£2500
Theta Data Basic II + 0.5 Siltech (Trans)	£2497	£1698
Theta TLC (Line Conditioner)	£NA	£148
Trichord Pulsar DAC 20 Bit, Blue Marble	£1450	£789

AMPLIFIERS - SOLID STATE

Accuphase 200 Pre Amp	£NA	£698
Accuphase 266 Power Amp	£NA	£858
Aragon 24k Pre Amp	£1600	£799
Audiolab 8000 5 Int Amp	£649	£548
Audiolab 8000a (Grey Top) Int Amp	£NA	£278
Audiolab 8000a Int Amp	£NA	£378
Audiolab 8000LX (Amp)	£NA	£348
Audio Research BL1 - SE to Bal (Ex-dem)	£799	£549
AVI 2000 MP Pre Amp	£1100	£679
Chord 1400B Mono's (Inc Ampstand + Trager)	£11730	£7448
Chord CPA 2800 Pre Amp	£NA	£1398
Chord SPM 1200 B Power Amp (Mint)	£3790	£2799
Counterpoint Solid One Power Amp	£NA	£690
Cyrus AV Master Dolby Prologic Processor	£699	£299
Cyrus 1 Int Amp	£275	£159
Cyrus 2 Int Amp	£350	£179
Cyrus Power Amp	£499	£319
Cyrus Pre-Amp	£650	£399
Cyrus PSX-R Power Supply Unit	£329	£219
Cyrus Straight Line Int Amp	£399	£249
Denon AVP 1A Processor	£2500	£1499
DNA Pre 2-PA1 Pre-Power	£2800	£1099
DPA Renaissance Int Amp (Ex-demo)	£599	£399
Electrocompaniet Two Channel Power Amp	£NA	£398
Fisher 440 Solid State Reciever (1960's Classic)	£159	
Galactron MK 2121	£NA	£848
Haffer DH101 Pre Amp	£NA	£149
Harmon Kardon AVP1A Processor	£2000	£459
Harmon Kardon AVP1A Pre	£NA	£248
Harmon Kardon Citation 17 Pre Amp	£NA	£199
Harmon Kardon PA 2200 Power Amp	£NA	£198
Ion Obelisk (Int Amp)	£NA	£197
Krell KAV 250a Power Amp	£3498	£2649
Krell KMA 100 MK2 (Mono pevels)	£5999	£2798
LFD Line Stage LS1 Pre Amp	£NA	£498
Linn Kairn (Pre)	£1700	£1098
Linn Klout (Power)	£NA	£1348
Linn Wakonda Pre Amp	£1200	£579
Fisher 440 Solid State Reciever (1960's Classic)	£159	
Galactron MK 2121	£NA	£848
Haffer DH101 Pre Amp	£NA	£149
Harmon Kardon AVP1A Processor	£2000	£459
Harmon Kardon AVP1A Pre	£NA	£248
Harmon Kardon Citation 17 Pre Amp	£NA	£199
Harmon Kardon PA 2200 Power Amp	£NA	£198
Ion Obelisk (Int Amp)	£NA	£197
Krell KAV 250a Power Amp	£3498	£2649
Krell KMA 100 MK2 (Mono pevels)	£5999	£2798
LFD Line Stage LS1 Pre Amp	£NA	£498
Linn Kairn (Pre)	£1700	£1098
Linn Klout (Power)	£NA	£1348

Linn Wakonda Pre Amp	£1200	£579
Magnum MP250-MF125 Pre Power	£750	£349
Marantz PM66 KI Sig (Int Amp)	£400	£248
Mark Levinson 23.5 Power Amp	£NA	£3698
Mark Levinson 26 Pre + 25mc + 266 Phono PSU	£NA	£3898
Meridian 101 Pre + 105 Mono Blocks	£NA	£348
Meridian 201 Pre-Amp	£760	£329
Meridian 502 Pre (Inc Phono Stage)	£1385	£999
Meridian 562 V-2 (Inc Phono)	£1478	£1000
Meridian 565 V.7.1	£2850	£1498
Michell Argo + Hera Pre Amp	£NA	£598
Micromega Tempo 2 Amp	£900	£499
Moth 30 (Pre + Power)	£NA	£148
Muse 1/5 Mono Powers	£3700	£1899

Muse Model 300 Mono's (300 WPC - Bal Solid State Superb)	£4400	£2199
Musical Fidelity 3a Pre Amp	£379	£229
Musical Fidelity E100 Int Amp	£700	£399
Musical Fidelity F19 Power Amp (Mint)	£4000	£2399
Musical Fidelity F25 (Pre)	£NA	£1500
Musical Fidelity MVX Pre + PSU	£2200	£839
NAD 208 THX Power Amp - (Ex-dem)	£1100	£799
Naim 32 Pre Amp	£NA	£199
Naim 32.5 Pre Amp	£NA	£229
Naim Flatcap PSU	£NA	£298
Naim NAC 42 Pre	£NA	£200
Naim NAC 72 Pre Amp	£750	£489
Naim NAC 92 Pre Amp	£499	£299
Naim NAIT 2 Int Amp	£NA	£298
Naim NAP 140 Power Amp	£NA	£398
Nakamichi IA3 Int Amp	£300	£129
NVA A60 Power Amp As New	£495	£329
NVA A80 Mono Blocks New (Pair)	£1460	£959
NVA TIS Int Amp	£NA	£800
NVA TSS Second State Stereo Power	£3700	£1799
Nyteck CPA 602 Power Amp	£NA	£120
Nyteck CTP 102 Pre/Tuner	£NA	£120
Onix CA 30m Int Amp	£350	£238
Orelle SP150 Power	£500	£298
Parasound 2200 Power Amp	£NA	£1248
Pass Labs Aleph 3 Power Amp vgc.	£2200	£1499
Quad 33 Pre Amps	from	£69
Quad 34 Pre Amps	from	£159
Quad 66 Pre Amp	£NA	£498
Quad 77 Int Amp	£NA	£348
Quad 303 Power Amp	£NA	£120
Quad 306 Power Amp	£NA	£229
Quad 405 Power Amp	£NA	£220
Rappaport Pre 2 Pre Amp	£NA	£395
Revox B250s (Amp)	£NA	£798
Sonographe SC1 Pre Amp (By Conrad Johnson)	£399	
Stemfoot SF 60 Int Amp	£NA	£368
Tesseract Monitor Pre Amp	£1500	£798
Thorens TTA 2000 Power Amp (Ex-dem)	£599	£499
Townsend Elite 600 cll Pre Amp	£NA	£230
Trio Lo7c II Pre Amp	£NA	£198
Yamaha DSPE492 Av Processor	£250	£169

AMPLIFIERS - VALVE

Audio Innovations Series 700 Int Amp	£1100	£599
Audio Research LS5 Mk 1 Pre Amp	£5995	£2999
Audio Research LS3 Pre Amp	£NA	£POA
Audio Research LS7 Pre Amp	£NA	£1098
Audio Research SP9 Pre Amp	£1700	£878
Audio Research SP14 (Pre Valve Phono)	£NA	£1398
Audion Silverlight 2x 300b SET Mono Pwrs	£NA	£1198
Audion Sterling SET Power Amps (Pair)	£NA	£598
Conrad Johnson PV11 Pre Amp	£NA	£1099
Counterpoint SA12 (Hybrid Power)	£NA	£900
Croft Epoch Pre Amp	£NA	£499
Croft Micro 5 Pre Amp	£NA	£240
Croft Series 3 OTL Power Amp	£NA	£699
Croft Series 5 Power Amp	£NA	£425
EAR 802 Pre Amp	£2200	£1299
EAR 859 Power Amp	£1599	£899
Edison Technology HPA12 Power Amp	£NA	£229
Elector MFJ Pre Amp	£NA	£299
Gamma Aeon 20w SE-Triode Mono's	£4999	£2299
Golden Tube SEF1 Pre	£1100	£698
Golden Tube Audio, SEP1 Pre + 2x SE40	£NA	£1998
Lumley Megavox 75 Valve Mono's	£NA	£1179

Lumley Megavox (Pre)	£NA	£1198
Lumley Reference ST70 (Power)	£NA	£998
Manley VTL Tandard Pre Amp	£NA	£290
Michealson Odysseus 40w Int Amp	£1150	£699
Musical Fidelity F22 Pre	£NA	£898
Musical Fidelity X-A1 Int Amp	£485	£328
Musical Fidelity X-A50 Mono Powers	£500	£348
Papworth TVA50 Int Amp (Ex-dem)	£NA	£1948
SJS Electroacoustics Arcadia Pre	£1000	£750
Sonic Frontiers Anthem Int Amp	£2000	£1398
Sonic Frontiers Assemblage ST40 Power	£NA	£698
Trilogy 902 Pre Amp (Chrome)	£2000	£1399
Unison Research Feather 1 (Pre)	£800	£558

TUNERS

Audiolab 8000T	£800	£529
Braun 301 Tuner	£NA	£99
Cyrus Tuner	£NA	£1/8
Harmon Kardon TU-9400	£NA	£128
Harmon Kardon TU-950 Tuner	£250	£149
Leak Troughline + De Paravacini valve decoder	£NA	£289
Luxman T210L Classic Tuner	£NA	£159
Micromega Tuner	£550	£398
Quad 66T	£NA	£345
Quad FM3 Tuner	£Please call	
Quad FM4 Tuner (Beige)	£NA	£238
Revox B260S Tuner (Black)	£1100	£699
Revox B760	£NA	£598
Revox H6	£NA	£948
Sansui TU-710 Tuner (Black)	£NA	£149
Trio KT 9xl	£NA	£128
Yamaha CT 7000 Tuner	£NA	£430
Yamaha T80 Tuner	£NA	£159

LOUDSPEAKERS

Acoustic Energy AE120 (Rosewood)	£NA	£348
Acoustic Precision Eikos RF1 Mini Monitors	£800	£599
Apogee Centour Minor (Ribbon Hybrid)	£NA	£798
Apogee Stage Rosewood Trim	£4700	£1999
ATC SCM-20T (Rosewood)	£NA	£1298
AVI Newtron (Cherry)	£NA	£328
B&W DM 601 (Black)	£NA	£148
B&W P4 (Cherry)	£NA	£448
Castle Avon Speakers (Ex-dem)	£729	£549
Castle Chester Speakers (Mahogany)	£750	£479
Celestion 3000 Ribbon Hybrid	£NA	£299
Celestion 7000	£NA	£748
Celestion CS7, 12" Bass	£NA	£169
Epos ES14 (Walnut)	£700	£388
Epos ES30 (Rosewood) (Ex-dem)	£2550	£1699
Gale GS 301	£NA	£118
Gammo Acoustics Epoch Ref 5 (Cherry)	£3000	£1599
Harbeth HL-P3	£699	£430
Heybrook HB200 (Teak)	£NA	£139
Heybrook Sextets (Yew)	£1199	£698
IMF Domestic Monitor Speakers	£NA	£399
Jamo Concert II (Maple)	£2250	£1598
JBL Control 5	£NA	£198
Kef Model 100 (Centre)	£NA	£198
Kef Model 105 (Walnut)	£NA	£338
Kef Model 200c Reference Centre VGC	£699	£500
Kef Q30	£350	£248
Kef Reference 101 - UniQ	£600	£249
Leak 3090 (One ribbon tweeter out)	£NA	£350
Linnaem LFX, Ribbon Mini Monitors	£600	£399
Linn Isobarik	£Please Call	
Linn Kan (Teak)	£NA	£295
Linn Nexus (Grey)	£450	£249
Magna Planar MG 0.6 (Black)	£NA	£898
Magna Planar SMGA (Oatmeal / Teak)	£900	£449
Martin Logan Arius	£NA	£POA
Meridian DSP 5000 (Rosewood)	£4125	£2200
Meridian M10	£NA	£998
Mission 752	£580	£348
Mission 753F (Black)	£NA	£498
Morel Bass Master 602 Inc Stands	£1600	£748
Musical Fidelity Ref 2 Mini Monitors	£NA	£149
Naim Creda Cherry finish v.g.c	£1250	£749
Naim SBL Various,	£Fram	£699
Note Perfect Virtuoso (Ex-dem)		£1399

Opera Callus Gold (Mahogany)	£NA	£868	
Opera Platea (Cherry) (Ex-dem)	£800	£639	
Pro-Ac Response 3.5 (Walnut) (Ex-dem)	£4250	£2699	
Pro-Ac Response 4 (Maple) (Ex-dem)	£13000	£7499	
Quad ESL57	£NA	£POA	
Quad ESL63, Just Serviced	£500!	£3500	£1850
Rel Stadium Sub-Woofer (Black)	£NA	£698	
Rel Storm Sub-Woofer (Black)	£NA	£498	
Rogers LS33 + Sub-Units (Black)	£600	£299	
Rogers LS4A Speakers (Teak)	£400	£199	
Rogers Studio 1 Teak v.g.c	£620	£369	
Royal Eden (Black)	£NA	£148	
Shahinian Super Elf	£790	£499	
Shahinian Obalisk	£NA	£1198	
Snell J3 High Efficiency Monitors	£770	£449	
Snell Type E2	£NA	£698	
Sonus Faber Concertino (6 Month Old)	£599	£478	
Sonus Faber Electra Amator (Walnut)	£NA	£1598	
Sonus Faber Minuetta	£NA	£648	
Soundlab Dynastat Hybrid Panels	£3750	£2349	
Soundlab Quantum Electrostatic Hybrid	£2250	£1448	
Spendor SP 2/2	£800	£498	
Spendor SP 2/2 (Walnut)	£NA	£498	
Spica TC50 + Sub	£NA	£898	
Tannoy D50 (Black)	£NA	£328	
Tannoy D300 (Walnut)	£NA	£748	
Tannoy Devon Speakers	£NA	£329	
Tannoy R2 (Cherry)	£NA	£258	
TDL RTL 3 (Black)	£400	£199	
Thiel CS 1.5 (Black)	£2700	£1699	
Triangle Graphite (Black)	£800	£499	
Wilson Audio System 5.1 (Graphite Finish)	£18000	£11999	
Wilson Audio Witt Mk1 Ex Demo	£8888	£6499	
Yamaha NS1000M (Black) Ref Monitors	£NA	£898	

CASSETTE - TAPE RECORDERS

Aiwa AF 850 Cassette Deck 3 Head	£250	£129
Denon DRM 650's Cassette Deck	£NA	£129
Nakamichi 582 (Cass)	£NA	£368
Nakamichi 700zxe (Cass)	£1200	£698
Nakamichi BX1 Cassette Deck	£NA	£249
Nakamichi CR2E (Cass)	£499	£200
Nakamichi Dragon (Cass)	£NA	£1098
Nagra EL Portable Mono Reel to Reel	£4000	£1399
Pioneer CT8305 Cassette Deck, Dolby S	£550	£329
Pioneer CT5830 (Cass)	£369	£198
Revox A700 3 Speed (Reel to Reel)	£NA	£798
Revox A77 Reel to Reel (2 Available)	£Please Call	
Revox D36 Reel to Reel	£NA	£348
Revox G36 Valve Reel to Reel	£NA	£399
Revox PR99 Pro Tape Machine	£NA	£899
Rotel RD955 Cassette Deck	£300	£99
Sony Pro Walkman D6c (Cass)	£330	£168
Tanberg 3034 Silver Cassette Deck	£NA	£189
Tanberg TCD 320 AV Cassette Deck	£NA	£149
Tascam 22-4 4 Track Reel to Reel	£NA	£398
Teac CX650R Cassette Deck	£300	£129
Uher 4400 Report Monitor, Portable	£NA	£799
Yamaha KX 580 Cassette Deck (Used Once)	£250	£149



35 - 42 COWGATE

PETERBOROUGH PE1 1LZ

www.audiotrader.co.uk

01733 555514
fax 01733 315079

UPGRADE YOUR TURNTABLE

"If you are thinking of upgrading your system.....the Origin Live dc-motor kit should be high on your list for consideration" TNT AUDIO internet magazine April 2000.

"The single most important upgrade you can ever make to any record deck concerns the motor drivenothing can compare you for the shock of going DC, in a word Gobsmacking" COMMON GROUND MAGAZINE

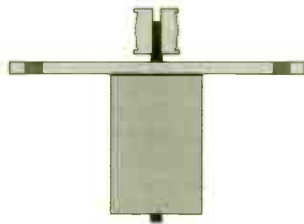

Whether you own a Linn Lingo or a Rega, the results of upgrading to the Origin Live dc motor and advanced power supply are simply astounding. This high grade motor kit is designed as a drop in replacement for almost all turntable motors. Decks benefiting so far from this ultimate of upgrades include Linn, Roksan, Michell, Systemdeck, Rock etc. With a 12 Volt power supply it is safe and easy to fit. Guidance instructions are provided. At £250 with money back guarantee if not impressed this is a bargain out of all proportion to it's value in terms of performance. An optional, larger purpose made transformer is also available as an add on at £175

TURBOCHARGING YOUR REGA ARM

"Nothing less than total dynamite!"

If you are the proud owner of any Rega arm, why not utterly transform it into the league of super arms with the Origin live structural modification:- £75 inc post & packing.

This modification will enable your Rega to perform at a level exceeding that of arms costing over £1200. Internal rewiring with high grade litz cable is also offered at an additional £70, and external rewiring is £70.

"I have to say the Rega modifications turn this humble arm into a real Giant killer. Gone is the rather grey, sterile sound of the cooking Rega. Instead, tonal colour is fresh, dynamics have great speed and impact, and the sound stage is huge." HI-FI WORLD SUPPLEMENT (structural modification to a RB250) WHAT HI-FI gave this modification a 5 star rating.

For arm modifications we normally return your arm in 2-3 days

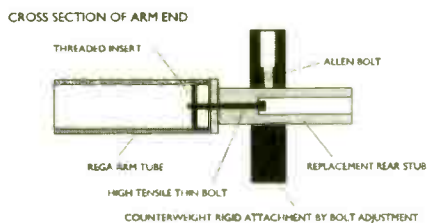

For further information contact:-

Origin Live, 87 Chessel Crescent, Bitterne, Southampton, SO19 4BT

Tel: 01703 442183 / 578877 Fax: 01703 398905

Email: origin.live@virgin.net

WEB SITE: <http://www.originlive.com>

ORIGIN LIVE TURNTABLE KITS Standard & Ultra

Now you can save money and build your own high performance deck. The standard kit version is offered at £195, and the ultra version at £279. Both decks come with a full set of drawings and guidance instructions. The kit allows for your creativity or there are optional parts that will enable you to assemble a tried and tested design within 1-4 hours. This is probably the easiest kit you will ever make.

"this Vinyl font end had my jaw heading towards the floor with the solidity and transparency of the music it was making"...
" the standard came up with crystal clear images set in a broad sound stage"... "With all these goodies in place, the standard would give turntables at the £1200-£1400 mark a hard time."

HI-FI WORLD SUPPLEMENT

"is exceptionally easy to build and professional in both sound quality and appearance"

HI FI NEWS SUPPLEMENT

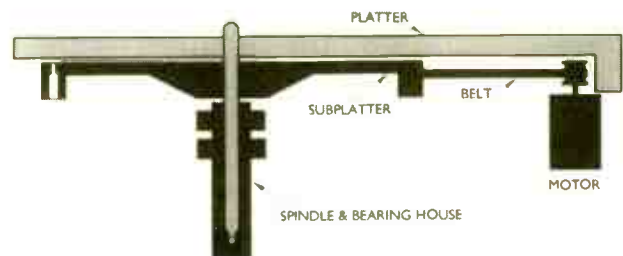

listening
rooms

PHONE FOR LATEST LIST

	RRP	SALE	
AMPS/PRE-AMPS/TUNERS			
AUDIO RESEARCH PRE AMP	1999.00	1499.00	D
AUDIO RESEARCH D130	1995.00	1295.00	S/H
AURA AUT50 TUNER	259.00	189.00	D
CYRUS 31	598.00	399.00	D+N
MERIDIAN 501 PRE	695.00	489.00	D
MICHELL. J.A. ALECTO stereo	1,150.00	849.00	D
MICROMEGA TEMPO2 int	899.90	599.00	D
MUSICAL FIDELITY E10		249.00	S/H
CD PLAYERS/TRANSPORTS/DACS			
MERIDIAN 506	1195.00	849.00	D+N
MICROMEGA STAGE 2	549.00	299.00	D
MICROMEGA STAGE 1	499.00	279.00	D
THETA CHROMA HDCD	899.00	579.00	D
TRICHORD GENESIS	549.00	349.00	D
TRICHORD REVELATION	799.00	479.00	D
SPEAKERS			
ACOUSTIC ENERGY AE1 2/2 MKII ROSEWOOD MINT	995.00	699.00	D
B&W 601	199.00	129.00	D
B&W 302	149.95	95.00	D+N
KEF CODA 7		59.00	D
LINN KEOSA	499.00	329.00	D
MONITOR AUDIO STUDIO 20SE. PIANO BLACK MINT	2500.00	1395.00	
NEATE PETITE 2	800.00	495.00	MINT
NEATE CRITIQUE	440.00	299.00	D
NEATE MYSTIQUE	735.00	539.00	D
PROAC TABLETTE SIGNATURE BIRDS EYE MAPLE	900.00	649.00	D
OTHER ITEMS			
DENON DF10 SYSTEM (AMP, CD, CASSETTE, TUNER SPEAKERS)	1199.00	799.00	D

D = EX DEMONSTRATION, N = NEW, S/H = SECOND HAND

THE LISTENING ROOMS LTD

161 OLD BROMPTON ROAD LONDON SW5 0LJ

TEL: 0171 - 244 7750/59 FAX: 0171 - 370 0192

www.listeningrooms.com

E-mail: tlr@dial.pipex.com

Mon-Sat 10-6pm

Valve Amplifier Power Supply

Fitting a BorderPatrol power supply to your valve amplifier will solidify the bass, improve the dynamics and power delivery, increase clarity and resolution, and improve the sound stage. You will recognise your old amp but you will not believe it's the same one.



'In every instance the Border Patrol effect was nothing short of a transformation. Bass solidified, imaging became significantly more three-dimensional and substantial, and the power-supplied amp made the regular version sound, quite literally, a mess.'

Jason Kennedy *Hi-Fi Choice* April 1997

Models converted to date:

Audio Note	Meishu, P3, P4, Quest, Conquest, Conqueror, Oto, P1SE, Kit1, Kit3
Audio Innovations.	S500, 700, 800, 1000, S200, 300, 1st, 2nd Audio Amplifier.
Art Audio:	Quintet, Concerto, Tempo, Diavolo
Audion:	Silver Night, Golden Night
Leak	Stereo 20
Unison Research:	Simply 2, 4
World Audio Design	K5881(mk1&2)

A complete transformation for £595.00

For more information contact

BorderPatrol Brighton UK
Tel/Fax +44 (0)1273 276716
E-Mail bp@borderpatrol.net
Web Site www.borderpatrol.net



diverse vinyl

01633 256261 / 259661

10 Charles Street Newport South Wales NP20 1JU.
sales@diverse-music.co.uk

Forthcoming Releases

Captain Beefheart	Grow Fins Volume 3	£18.90
Captain Beefheart	Unconditionally Guaranteed	£19.90
Elvis Presley	Elvis Presley (Simply Vinyl)	£TBC
Led Zeppelin 1	(Classic Records 180g)	£25.90
Smashing Pumpkins	Machina: Machines Of God	£18.90
The Who	Tommy (Simply Vinyl)	£TBC
Tom Waits	Swordfishtrombones	£TBC
XTC	Apple Venus Volume 2	£TBC

New Stock And Recent Reissues

STEELY DAN	TWO AGAINST NATURE	£16.90
EXCLUSIVE 180G	PRESSING - BEWARE OF THIN IMITATIONS!	
Alexander Spence	Oar	£14.90
Beck	Midnight Vultures	£TBC
Broadcast	The Noise Made By People	£12.90
Captain Beefheart	Bluejeans/Moonbeams	£19.90
Captain Beefheart	Ice Cream For Crow	£19.90
CSNY	Looking Forward	£19.90
Eels	Dasies Of The Galaxy	£14.90
Embrace	Drawn From Memory	£15.90
Gentle Giant	In A Glass House	£16.90
Gonzalez	Uber Alles	£8.90
Guns And Roses	Live Era 87-93	£21.90
John Lennon	Imagine (New Mix)	£15.90
Lambchop	Nixon	£10.90
Love	Forever Changes	£15.90
Macy Gray	On How Life Is	£12.90
Matt Doughton	You Are The Healer	£12.90
Neil Young	Silver And Gold	£15.90
Paul Weller	Heliocentric	£14.90
Pretty Things	Parachute	£9.90
Santana	Supernatural - 180g	£17.90
Six By Seven	The Closer You Get	£10.90
Smog	Dongs Of Sevotion	£12.90
Ten Benson	Hiss	£10.90
Tosca	Suzuki (Richard Dorfmeister)	£15.90
West Bruce And Laing	Whatever Turns You On	£9.90
Yo La Tengo	And Then Nothing	£12.90

P & P £1.00 1st LP; 50p each Additional LPs (up to 5 LPs)
Call For Rates On Larger Orders. 24hr Service Now

WWW.DIVERSE-MUSIC.CO.UK



Vacuum Tubes for Audio Are Back!

Glass Audio brings together yesterday's tube with today's improved components, voltage control, and the exciting new Soviet tubes, to make smooth sound in your livingroom possible again!

YES!

Please send my first issue of *Glass Audio*. I'll pay just \$45.00 for six issues (1 year); \$80.00 for 12 issues (2 years) of the best information on tubes to be found anywhere. I understand that my satisfaction is guaranteed!

Name _____

Street & Number _____

City _____ Postal Code _____

Country _____

REMIT IN US \$ DRAWN ON A US BANK ONLY PRICE GOOD THROUGH DECEMBER 31, 1995.

We Accept MC/VISA.

Glass Audio

PO Box 176, Dept. HFWS, Peterborough, NH 03458-0176 USA
Phone: (603) 924-9464 or FAX 24 hours a day (603) 924-9467

AUDIO MATTERS

NEW EX-DEM & PART EXCHANGE
EQUIPMENT FOR SALE
0181 255 0572/0973 436135

	LIST	SALE
Alchemist Forsetti pre + power	£2398	£POA
Alchemist Kraken Anniversary MkII	£599	£POA
Audiolab 8000 CDM + DAC	£2300	£1050
Anthem CD player (5 star What Hi-Fi)(ex/d)	£1699	£1150
Audio Research D240 Mk.II	£3500	£1195
Audion Black Shadows 845 valve monoblocks	£4000	£POA
Audion Silvernight 300B monoblocks	£2250	£POA
Audio Alchemy drive 3 + V3DAC + 3PSU	£1649	£759
Chario Academy 1 solid walnut (ex/d)	£1299	£800
Chario Academy 2 solid walnut (ex/d)	£1649	£1100
EAR 859 pwr. amp	£1599	£750
Krell Kav 300I	£2495	£POA
Krell KSA 80 pwr. amp	£3498	£1495
Krell KSA 250 pwr. amp	£6700	£2500
Krell KSL pre amp	£2298	£995
Krell MD 10 CD Turntable	£7990	£1995
Krell Studio DAC	£4450	£1295
Krell KAV-S Prologic. AC3. DTS. THX PRE	£13500	£6500
Monitor Audio 703 PMC	£800	£400
Macintosh 7106 6ch. THX pwr. amp	£4000	£1999
Meridian 207 CD + PRE		£350
Proac Response 4 spks	£12000	£3995
Pass Aleph LFP PRE	£3800	£2195
Pass Aleph 2 100 watt class A pwr amp	£6200	£3800
Quad 66 pre + remote	£850	£450
Spendor SP7/1 spks.	£1995	£650
Tannoy D700 spks. rosewood	£2500	£1250
Theta pearl transport + Progeny dac	£2448	£1250
Wilson watts system 6 piano black spks.	£18450	£14450

Wazoo integrated amp from Bow Technologies now on Dem

A NEW RANGE OF VIENNA ACOUSTICS SPKS. NOW ON DEM - ALSO
PERREAUX EQUIPMENT AVAILABLE ONLY FROM AUDIO MATTERS
ON DEM -

Alchemist. Anthem. Audiomeca. Audion Valve Amps. Cadence Spks., Chario. D.P.A.,
Goertz cables. Monarchy. Ortofon. Pink Triangle. Project T-T. Sonic Frontiers.
Triangle Spks., Trilogy Valve Amps. Vand den Hul.

VISA/MASTERCARD ACCEPTED

ENGLISH audio

All the following new, ex dem or second-hand (S/H) Mostly mint
condition but please enquire

	WAS	NOW
AMPS		
Cynis ACA7 Pre		399
Musical Fidelity X-PRE	199	119
Musical Fidelity X-A1 Integrated	479	289
John Shearne Phase 2 Integrated	689	399
John Shearne Phase 2 Reference	799	479
John Shearne Phase 3 Power	639	389
John Shearne Phase 3 Reference	749	449
John Shearne Phase 6 Pre	999	599
Tag McLaren 60iRV Integrated	999	599
Tag McLaren 60i Integrated	799	479
Tag McLaren PA10 Pre	849	499
Tag McLaren 100P Power	1099	659
Tag McLaren PA20R Pre	1499	899
Tag McLaren PA20R pre	1499	899
CD		
WAS		
NOW		
Trichord Digital Turntable/Pulsar 1 DAC/PSU S/H	2700	1350
Tag McLaren CDT20R Transport	1499	749
Tag McLaren DAC20 DAC	1249	625
Tag McLaren CD20R	1249	625
Pink Triangle da Capo		699
SPEAKERS		
Dynaudio 1.8 MKII (cherry)	1895	1299
Naim Intro (black, old model)	699	399
Arcadyis ASC/rosewood	399	149
Ruark Prelude/rosewood	749	449
Dynaudio Audience 60	729	449
Castle Inversion 50/maple	875	525
Castle Inversion 15/maple	599	399
Castle Severn/mahogany (s/h)	599	349
Castle Avon/mahogany (s/h)	799	449
Castle Kendal/walnut (s/h)	399	249
Dynaudio Audience 50/rosewood	599	399
Dynaudio Contour 1.3 MKII/cherry	1200	799

37 Whitecross Road, Hereford, HR4 ODE
Tel 01432 355081 Fax: 01432 354302
www.sales@englishaudio.com

Now in Stock

Lyra Clavis DC evolve99

moving Coil Cartridge

Very Limited Edition

£695.00 inc Vat

THE

powerplant

66-67 Upper North Street,
Brighton

Tele: 01273 775978 Fax:
01273 748419

email@powerplant.co.uk

hi-fi, home cinema & multi room systems

Arcam. ATC. B&W. B&O. Cyrus. Epos. M&K. Mission. Mark Levinson. Linn.
Lutron. Pro Ac. Rega. Rotel. Ruark. Tag McLaren. XLO. Yamaha and more



PROGRESSIVE AUDIO



2 Maryland Court, Rainham, Kent, ME8 8QY
Telephone / Fax No. 01634 389004
WEBSITE: www.progressiveaudio.co.uk
E-MAIL: dave@progressiveaudio.co.uk

We now have the following new products on permanent demonstration. PROAC Tablette 2000, Studio 125, Response 3.8 and 1.5 loudspeakers, VERITAS loudspeakers including the H3 horns, the complete AUDIONOTE Zero system, SUGDEN Masterclass pure Class A amps - In fact the whole SUGDEN range, the complete AUDIO SYNTHESIS range, GRAAF GM 20 OTL valve amplifier, PATHOS Twin Towers amplifier, INNERSOUND Eros and Isis hybrid loudspeakers, MUSIC FIDELITY A3 CD player, A3 and A300 integrated amps, BOW TECHNOLOGY Wizard and Wazoo CD and amp, CHORD 1200C power amp, 3200 pre amp and DSC 1500E Dac plus of course all our regular range of products. Please call for more information. We now have DNM Electronics and Rhedeko Speakers plus ART Loudspeakers on permanent dem.

We have the following ex demonstration and secondhand equipment for sale:

- Accuphase P450 power amp. Absolutely mint. Boxed. £2250.
- Acoustic Energy AE109 loudspeakers. Mint. S/H. £225.
- Musical Fidelity Nu Vista pre amp. Absolutely mint. Boxed. S/H. £1095.
- Audion Golden Knights. 9w single ended 300B monoblocks. Absolutely mint.Boxed. £2500.
- Sugden 5DT1 CD player. Absolutely mint. Boxed. £695.
- Much sought after. S/H. £1800.
- Muse Model 18 subwoofer. S/H. £2200.
- Graaf GM20 OTL power amp. Stunning. Mint. Boxed. S/H. £2500.
- Gamma Aeons 211 valve monoblocks. Virtually mint . Boxed. Spare valves.S/H. £795.
- Exposure Pre XIX and PowerXVIII amp combo complete with a 1m balanced interconnect cable. Mint. S/H. £495.
- Teac P500 and D500 CD transport and dac combo. First class condition. S/H. £3450.
- Bow Technologies ZZ eith CD Player. Brand new in manufacturers sealed carton RRP £5000 £900.
- DNM series 3 twin pre amp £450.
- Mission 753 loudspeakers. Mahogany. mint. boxed. £650.
- Golden Tube Audio SI 50. 50 watt integrated amp. £350.
- Acoustic Energy AE1 loudspeakers with stands



TEL/FAX
0121 747 4246

URGENTLY REQUIRED
LINN, NAIM,
MERIDIAN, QUAD,
CASH WAITING

RRP NOW £

APOGEE STAGE (MINT / BOXED)	4700	995
ALCHEMIST NEXUS CD	600	295
ALCHEMIST KRAKEN MK11 POWER	550	295
ALPHASON ALCAEUS POWER SUPPLY	N/A	95
ATC SCM 20 BLACK	1600	850
ATC SCM 20 TOWER SL (WALNUT)	2400	1695
AUDIOSTATIC DC1	2800	1595
AUDIONOTE P2SE	1500	795
AUDIONOTE ANJL + STANDS OAK (4 MTHS OLD)	1300	795
AUDIO RESEARCH DI15 MK II	2500	1195
AUDIO RESEARCH SP8 MKII	2000	850
AVI S200 MI INTEGRATED	1000	650
BOSE 901 SERIES VI	1650	795
BOSTON VR960 WITH ACTIVE SUBS	850	550
BOSTON VRS DIPOLE SURROUNDS	300	195
BOSTON VR12 CENTRE	300	195
CONCORDANT QUAD II	N/A	450
CABLE TALK REFERENCE 2	150	75
CARDAS QUADLINK IM	200	125
EPOS ES 22 CHERRY	1350	695
EXPOSURE XX INTEGRATED	800	250
EXPOSURE CD	1000	650
GAMMA GEMINI 12 WATT SE CLASS A INTEGRATED	700	250
LEAK ST 20 REBUILD £400 KIMBER CAPS ETC	N/A	295
LINN LP12 EKOS CIRKUS LINGO LYRA LYDIAN	4000	1695
LINN AXIS AKITO K5	N/A	295
LINN LP 12 ITTOK PINK LINK AT OC9	N/A	695
MADRIGAL LEARNING REMOTE CONTROL	300	195
MANA REFERENCE TABLE	350	250
MANA 3 TIER	450	295
MARK LEVINSON NO 39 CD	5000	3795
MERIDIAN 541 PLUS PHONO	1180	495
MERIDIAN 500 TRANSPORT	1350	695
MERIDIAN 518 PROCESSER	1000	695
MERIDIAN 563 (UPGRADED TO 24 BIT)	1380	695
MERIDIAN 600 TRANSPORT (MERIDIAN SERVICE 7/99)	1800	595
MERIDIAN 563 DAC	900	395
MICHELL ALECTO MONOS	2000	1295
MICROMEGA STAGE 4	500	295
MONARCHY M18 DAC (NEW SEALED BOX)	800	450
NAIM CD 3.5 (5 MONTHS OLD)	1080	795
NAIM SNAPS	N/A	75
NAIM 42	N/A	50
NAIM 140	N/A	350
NAIM CD3	1080	550
NAIM CDI	2000	995
NAIM NAIT 1	N/A	150
NAIM SBL WALNUT (6 MTHS OLD EX DEMO)	2395	1695
NAIM 42.5	280	95
ONIX SOAP POWER SUPPLY	N/A	95
PASS ALEPH P PREAMP	3900	2295
PROAC TAB 2000 SIG + STANDS (4 MTHS OLD)	1250	895
PROAC TABLET II	550	295
QUAD ESL 63 BLACK BOXED (QUAD SERVICE 3/99)	3500	1495
REVOX G36	N/A	295
ROTEL RB 985 THX 5 CHANNEL	625	425
ROKSAN TABRIZ	350	95
SOMETHING SOLID 5 TIER	360	150
SONY SDP-EP9ES AC3 DECODER	600	195
TAG MCLAREN PA 10 PRE	850	595
TAG MCLAREN T 20 TUNER (NEW SEALED BOX)	1100	695
TRANSPARENT MUSIC WAVE 2/4 FT	280	195
WIREWORLD EQUINOX 2/3MTR	N/A	195

CABLES HALF PRICE SALE

OPEN MON-SUN 10.00 TO 8.00

Website: www.centralaudio.co.uk

E-mail: tony@centralaudio.co.uk

CLASSIQUE SOUNDS. (LEICESTER) INC ONE THING VINTAGE HIFI & VALVE SPECIALIST

FOR SALE PRE/POWER AMPLIFIERS

Michaelson & Austin TNA 1, 50W channel valve power amplifier in chrome. Big, bold, and very rare. Only	£ 695
Quad 34 pre-amplifier. Brown. Mint. Boxed/inst.	£ 225
Yamaha DSP580 Dolby prologic digital sound-field processor. CW centre and rear spks & remote. Mint. Boxed	£ 250
Tro KA990 integrated amplifier. 100W/CT. Huge	£ 100
Mission Cyrus 1 MK1 amplifier. Boxed	£ 95
Mission Cyrus 2 amplifier. Good condition	£ 175
Rotel RB981 power amplifier. Mint. Boxed. Cust. 350	£ 195
Audio Innovations S/800 integrated valve amp	£ 295
Audio Innovations S/800 Anniversary power amp	£ 795
Quad 405/1. Good condition. £ 185. Leak Stereo 50 power amplifier. Very rare	£ 190
Technics SL3610 new class A amplifier	£ 95
Cambridge 125 integrated amplifier. Ex condition	£ 99
Rogers HG88 MK2 integrated valve amplifier	£ 125
Arcam Zeta 1 Pro Logic Cinema amp. Cost £999.00	£ 450
VAc line level valve pre-amplifier. Mint. Boxed	£ 350
Leak Stereo 20 valve power amplifier from	£ 200
Musical Fidelity Electra F10 int amplifier. Boxed	£ 195
Quad 11 Various. From £350 a pair	£ 350
Creek 4040 MK1 amplifier. Excellent condition	£ 600
Naim Nac 42.5K pre amplifier with MC board	£ 195
Harman Kardon HK610 integrated amplifier	£ 790
Musical Fidelity £200 pre amp with remote	£ 299

TURNTABLES

Notis Analogue Hyperspace deck with Rega RB300	£ 695
Dunlop Systemdeck Turntable Complete with Synms 2 pick up arm the original & the best. Excellent condition	£ 299
Anston RD110 turntable Cut-out for SME 3009	£ 75
Rega Planar 3 good condition. RB 300 arm	£ 159
Strathelyne 305M Transcription turntable C/W Ultratract tone-arm. Chrome front. In nice condition. Bargain	£ 140
Garrard 401 in SME 2000 plinth system. Good	£ 200
Anston R1800 turntable C/W Linn Basik 1 vs Boxed	£ 149
Aphelion plinth for Garrard 401. New. Cost £199	£ 140

SPEAKERS

Quad ESL 57 speakers. All fully serviced with full 3 months warranty. Hear what ESL 57s should sound like. From	£ 700 pr
Living Voice Auditorium speakers. Complete with purpose built stands. Beech finish. Boxed. New. Price £1750	£ 895
Acoustic Energy AF109 Rosewood. Mint. Boxed	£ 195
BRW DM3 speakers. Cabs marked. Hence only	£ 95
Ruark Sabre. Black finish. Mint condition	£ 170
Lumley Reference 3 speakers. Absolute bargain	£ 250
Base powered Acoustims. 3 Spks. Unused. Boxed	£ 895
BRW DM14 loudspeakers. A real hi-fi speaker	£ 199
Pair Rogers Studio 5 speakers. Rosewood finish	£ 250
Highbrook H181 speakers. Black	£ 500
Pair HKW DM3 speakers. Sounds like a Snell	£ 95
Mission 702 speakers. Good condition	£ 49

OTHER ITEMS

Celestion digital processor. For use with 6000 spks	£ 100
Linn Asaka moving coil cartridge. Little use	£ 175
Rotel 965BX ed player. Mint. Boxed. Cost £300.00	£ 125
Morantz CD52 MK2 CD player. Mint. Boxed	£ 100
Cambridge CD4 ed player. With remote	£ 79
Repa RB300 tone-arm. Origin. Live modified	£ 195
Haddock tone-arm with Linn armboard	£ 149
Decca London Blue cartridge. Unused. Boxed	£ 100
Decca London Gold. Needs re-tip	£ 40
Tapet. Stand 3 shell W20" X H34" X D16"	£ 55
Quad FM3. Mint. Serviced & realigned	£ 95
Technics Class-AA 3 head cassette deck. Dolby. B/C. Hi pro adjustable. Bias control. Good condition	£ 80
Arwa X1950 tuner. Unused. Boxed. Frn. Lw/Mw	£ 75
Quad FM4. Mint. Boxed	£ 250
Supex SM 100 MM cartridge. Good condition	£ 35
Leak Troughline 2 & 3 Mono/Stereo. From	£ 75

QUAD ESL57 PANELS/SERVICING ETC

Fully reconditioned Quad ESL57 speakers from only £700.00.pr. why spend £4000
 Rebuilt & soak tested treble panels. Fitted new dustcovers. Exchange £100
 Rebuilt and soak tested bass panels. Fitted new dustcovers. Exchange £120
 New high spec rectifier boards. Pair £ 80
 Clamp boards. (price per pair). £ 45
 New dust covers bass or treble panels. Fitted Pair £ 20
 Treble protection boards (before S/N 16800) price each £ 20
 Refurbish Grille with fabric overcover. Black or brown. Each £ 30
 Stands for ESL 57 speakers. Wood finish. Pair £150
 Full servicing facilities available.
 "Classique Sounds servicing restores the Quads to a position where they can hold their head high", Jon Marks. HIFI WORLD. April 1999
 12 months warranty on all panels/parts

One Thing stereo decoder MK2.

(lets a tuner speak for itself). Awarded 4 globes. Hifi World, June 1999. Only £175.00
 Troughline tuner service & realignment £75.00. (excludes valves. Rarely needed)
 subject to tuner being in a serviceable condition, with no major faults or modifications

TRANSLUCENT. (somewhat of a bargain) Hifi World, Jan 1999

PURE SILVER INTERCONNECT CABLE

99.99% pure silver conductors. Quality gold plated RCA phono plugs.
 Half Metre terminated £60.00 One metre terminated £80.00
 7 day money back guarantee if not better than existing cable. Regardless of price or quality
 99.99% pure silver wire 5mm (unsleeved). Only £4.95M

NEW EAR/YOSHINO EQUIPMENT

Ear 834P MM/MC phono stage with/without volume.	Brand new. Boxed at only £529
Ear 834P MM phono stage. No volume control	Brand new. Boxed at only £379
Ear 834L Line only valve pre-amplifier. Amazing.	Brand new. Boxed at only £479

301/401/124 PLINTHS (lets the Garrards inherent quality show through) Hifi World, Oct 98
 *Units @ only £199 unfinished or £299 finished (veneered). Awarded 4 Globes October 98 (HIFI WORLD)
 Choice of veneers available. Extra for special finishes

WANTED VINTAGE & MODERN HIFI EOPT.

Tel/Fax 0116 2835821 or 0802 213740 (Mobile). Callers by appt only.
 Opening times 10.00am-6.00pm Mon-Friday, 10.00am-2.00pm Saturday.
 Classique House, 61 Aylestone Drive, Aylestone, Leicester, LE2 8QE

MUSICAL IMAGES

PRODUCT	LIST	NOW
ACOUSTIC ENERGYAE2 blk speakers	S/H £1,000	£400
CABASSE FARELLA 400 beech speakers	EX/DEMO £1,000	£500
CHORD SPM1400B Mono power amplifiers inc Tragger feet	EX/DEMO £10,550	£7,000
CHORD SPM5000 Power amplifier inc Tragger feet	EX/DEMO £16,900	£12,000
CHORD DSC1100 DAC inc Tragger	EX/DEMO £3,815	£2,700
CHORD SPM1900 Black	S/H £4,210	£3,000
CYRUS DAD3 cd player	EX/DEMO £600	£400
DEFINITIVE TECHNOLOGY BP2000 Speakers	S/H £3,600	£1,000
DEFINITIVE TECHNOLOGY CLR1000 Centre	S/H £900	£300
DEFINITIVE TECHNOLOGY BPX Surrounds	S/H £1,100	£500
Linn Mimik2 CD Player	EX/DEMO £875	£500
MERIDIAN 561 Processor	S/H £2,850	£1,900
MICROMEGA PREMIUM DVD	EX/DEMO £1,500	£750
MICROMEGA AMP power amp	EX/DEMO £1,250	£600
MICROMEGA TEMPO P pre amp	EX/DEMO £1,250	£600
MONITOR AUDIO MA705PMC blk speakers	EX/DEMO £1,150	£650
ROTEL RB985 5 CHANNEL THX Power amp	S/H £625	£350
TEAC P30 CD Transport	EX/DEMO £2,500	£1,800

Special Kef Reference Old Range Demo Offer

KEF MODEL 1 Rosetta speakers	NEW £1,550	£1,075
KEF MODEL 1 Classic Rosewood speakers	NEW £1,450	£950
KEF MODEL 1 Black speakers	NEW £1,350	£875
KEF MODEL 2 Rosetta speakers	NEW £2,150	£1,425
KEF MODEL 2 Classic Rosewood speakers	NEW £1,850	£1,225
KEF MODEL 2 Black speakers	NEW £1,750	£1,175

Special TAG McLaren Demo Stock Clearance

TAG McLaren T20 Tuner	EX/DEMO £1,100	£650
TAG McLaren 60P Power Amp	EX/DEMO £850	£500
TAG McLaren 60i Integrated Amp	EX/DEMO £800	£450
TAG McLaren PA10 Pre Amp	EX/DEMO £850	£500

PLEASE VISIT OUR SHOWROOMS OR CALL OUR HOTLINE NUMBER FOR DETAILS. HURRY, THESE ARE ONE-OFF ITEMS!!

SEE IT! HEAR IT! BUY IT!

**HOTLINE NUMBER:
0171 497 1346**

14-18 Monmouth Street, Covent Garden, London WC2H 9HB
E-Mail: sales@musical-images.co.uk

Beckenham Edgware Hounslow

0181 663 3777 0181 952 5535 0181 569 5802

NOT VALID WITH ANY OTHER OFFERS OR PROMOTIONS E&OE

WANTED

HI-FI & accessories any make, any age

BUY • SELL • TRADE

OPEN 7 DAYS 10am - 8pm

Please bring official ID with address & signature when selling or exchanging

MUSIC & VIDEO EXCHANGE

56 Notting Hill Gate, London W11

☎ 020 7792 3474

480 Fulham Rd (Broadway), London SW6

☎ 020 7385 5350

95 Berwick St, Soho, London W1

☎ 020 7434 2939

www.buy-sell-trade.co.uk

LARGE SELECTION ON SALE

ALSO BUY, SELL, TRADE MUSICAL & PHOTOGRAPHIC EQUIPMENT

IAN HARRISON HI-FI

TEL: 01283 702875

9am - 9pm

INCLUDING SUNDAYS

HIFI AT DISCOUNT PRICES. FREE NATIONWIDE DELIVERY

TRADE IN YOUR OLD MOVING COIL CARTRIDGE & SAVE UP TO 45% OFF THE RRP.

CARTRIDGES & STYL	TONEARMS	CASSETTE DECKS	COMPACT DISC
DENON SHURE AUDIO TECHNICA GOLDRING AUDIOQUEST TRANSFIGURATION LONDON (DECCA) ARCAM GRADO ROKSAN VAN DEN HUL ORTOFON AUDIO NOTE DNM CLEAR AUDIO KOETSU	ROKSAN SME MOTH CLEAR AUDIO TURNTABLES TECHNICS MICHELL CLEAR AUDIO HIFI FURNITURE APOLLO SOUND STYLE PROJEKT SOUND ORGANISATION	PIONEER TEAC SONY DENON YAMAHA MARANTZ TASCAM DAT PIONEER TEAC TASCAM SONY FOSTEX MINI DISC SONY DENON	PIONEER TEAC SONY DENON YAMAHA MARANTZ PHILIPS CREEK TUNERS SONY DENON PIONEER YAMAHA MARANTZ PHILIPS AMPLIFIERS DENON MARANTZ PIONEER YAMAHA PHILIPS SONIC LINK & OTHERS
LOUDSPEAKERS HARBETH ATC SONY ROYD	CABLES	CDR PIONEER	REEL-REEL STUDER TASCAM
HEADPHONES SENNHEISER BEYER SONY AKG GRADO AUDIO-TECHNICA	SONIC LINK AUDIOQUEST AUDIO-TECHNICA VAN DEN HUL GOLDRING QED ORTOFON NORDOST	ACCESSORIES DISCWASHER MELBY OED GOLDRING TDK	MAXELL SONY ANTIFERRE MAXREW PIVOTELLI
TEST CASSETTES TEST CD'S TEST RECORD OPUS 3 *PHONE OR WRITE FOR DETAILS	BLANK TAPES / DISCS TDK SONY MAXELL BASF	AMPEX JVC SCOTCH FLU	

*ALL GOODS ARE BRAND NEW & BOXED WITH FULL U.K. GUARANTEES. NO EX/DEM OR EX DISPLAY GOODS. NO GREY IMPORTS.

PLEASE PHONE TO CONFIRM PRICE & AVAILABILITY PRIOR TO ORDERING. GOODS ARE NOT SUPPLIED ON APPROVAL. SORRY, NO GENERAL CATALOGUES. PLEASE PHONE OR WRITE FOR SPECIFIC REVIEWS, BROCHURES OR PRICES.

MAIL ORDER ONLY FROM: IAN HARRISON, 7 MILL HILL, REPTON, DERBY, DE65 6GQ. TEL: 01283 702875. 9am - 9pm INCLUDING SUNDAYS.

Measured Performance

loudspeakers

ALR JORDAN

The ALR Jordan has a smooth frequency response from 16kHz down to 100Hz, our response analysis shows. With a rise in output below 1kHz it will have a full-bodied sound, but should also come across as accurate, cohesive and detailed due to lack of a crossover suckout. The tweeter looks like a good one, since there is no peakiness in its response.

The rear-firing, mass-loaded bass radiator works from around 80Hz downward, peaking at 50Hz and running usefully down to 25Hz or so. It should give this 'speaker some deep, solid sounding bass.

The impedance curve has some steep slopes, meaning there's a lot of energy-storing reactance here, not a good thing. It looks as if a notch filter is operating at 3kHz or so, to cause such behaviour. Overall impedance measured a healthy 7 Ω , making the current draw reasonable

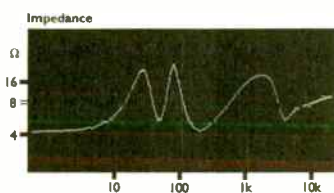

for most amplifiers.

This is a well engineered loudspeaker that should give good subjective results. NK

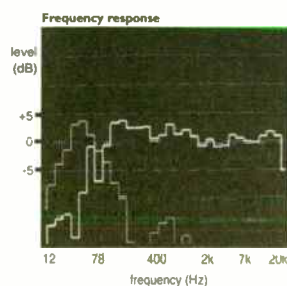

FINAL 0.3

It isn't easy to match an electrostatic panel to a conventional cone bass unit. The Final managed this better than I expected, although measured frequency response does have its peculiarities. Not all of them are matching phenomena either.

The panel itself has a hump from 600Hz-1kHz which will push vocals forward a bit. The bass unit comes in progressively below 600Hz, taking output down to 60Hz. There's a suckout from 80Hz-100Hz though, likely to make the bass sound boomy. Bass output rolls down slowly below 500Hz or so, which is likely to make the overall balance seem a bit bass light.

The electrostatic panel peaks up at 10kHz, which may add a little sharpness

or bite to the treble. However, electrostatics are usually so smooth this may not be unpleasant. Above 12kHz output drops away quickly, but this will probably have little affect subjectively.

The Final has an evil impedance curve that plunges down to 2.5 Ω at 150Hz and below 2 Ω above 5kHz. Overall impedance measured a very low 2.2 Ω , so an amplifier with real current delivery is needed. Above 2kHz or so the electrostatic unit acts as pure capacitance, with little

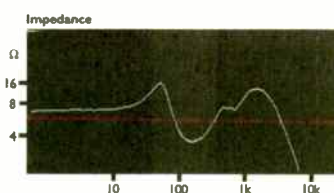

sign of a 1 Ω or so limiting resistor. Producing just 83dB from 2.8V input (much more than one watt in this case) efficiency was low, as was sensitivity. An amplifier of 60W or more is needed.

Like most electrostatics the Final is a difficult load and 'speakers like this tend to highlight amplifier differences. Otherwise it manages reasonably well as far as things go. NK

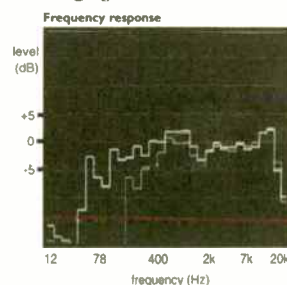

amplifiers

MONRIO MP1

The MP1 produces plenty of power, 120W into a normal 8 Ω load and no less than 210W into a low 4 Ω load. This is plenty enough to go very loud even though the case is quite compact.

Distortion levels were held well in check, with little rise from 0.02% at high frequencies and at high power outputs.

Low input sensitivity means the Monrio needs a preamplifier with gain, the usual x3 figure being about right.

Frequency response was broad and

flat. I'd expect good bass delivery and clean treble.

This power amplifier measured well in all respects. NK

Power	120W
Frequency response	4Hz-180kHz
Noise	-116dB
Distortion	0.02%
Sensitivity	1.2V
dc offset	3mV

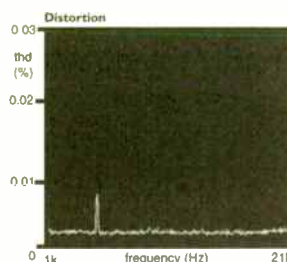

LAT AC2 POWER CABLES AND DISTRIBUTION BOXES ARE AVAILABLE FROM:

- Audio Concept - Ealing - 0181 567 8703
- Audio Reflections - Wakefield - 0113 252 8850
- Audio Venue - Cranford, Middx - 0181 707 4849
- Custom Cable Service - (mail order) - 0181 942 9124
- HiCam - Oxon - 01844 260182
- KJ West One - London - 0171 486 8262
- Musical Images - Covent Garden - 0171 497 1346
- Musical Images - Edgware - 0181 952 5535
- Orpheus Audio - Lancs - 01257 473175
- Sound Academy - Bloxwich - 01922 493499
- Sounds Of Music - Tunbridge Wells - 01892 547003
- Sounds Of Music - London SE1 - 0181 357 8882
- The Listening Rooms - London SW7 - 0171 244 7750
- The Right Note - Bristol - 01225 874728
- Unilet Sound & Vision - New Malden - 0181 942 9567
- Unique Audio - Neasden, London - 0181 450 7384
- Kronos Hi Fi - N Ireland - 01868 753 606

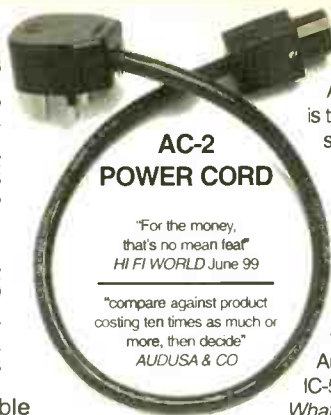

L A T INTERNATIONAL

World Class Cables Made in U.S.A

AC-2 Power cable - Silver clad, Teflon insulated at 10awg; this is the largest gauge of power cord we know of. The design of our shielding system effectively eliminates interferences from RF and EMI sources. Fitted with a MK Tough plug and IEC or Fig of eight connector. European connectors also available. Solder connections with Wonder Solder. 2ft £49, 3ft £59, 4ft £69, 6ft £89. Other lengths to order. 4, 6 and 8 way all steel distribution boxes with 3 ft of cable & MK Tough plug £149, £179, £209.



Analogue Interconnects, IC-50, IC-80, IC 100, IC, 200. - refer What Hi Fi for review ratings. Hi-Fi World Sep 99 - IC-50 "this months bargain". Speaker cables - SS800, BIWIRE, SS1000

Hi-Fi World Aug 99
"gained speed, control & involvement. Improved cohesion and musicality"

Taperwire

flat speaker cable

418 -★★★★★ WHAT-HIFI, What Hi Fi Ultimate Hi Fi Guide

Sunfire Corporation

....from the mind & soul of Bob Carver



CLASSIC TUBE PRE AMP, optional all valve phono stage (MM/MC) with CD input (reverse RIAA equalisation)



STEREO POWER AMPLIFIER 300 wpc HEXFET with no heat sinks

FIVE CHANNEL POWER AMP 200 wpc x 5 - HEXFET with no heat sinks
THEATRE GRAND PROCESSOR PRE-AMP- phono stage, tuner, Dolby Digital, DTS, auto source sensing, intelligent remote

2700 watt TRUE SUB-WOOFER
11 inch cube 18Hz
Patent No 4218660 & 4484150
2700 watt SIGNATURE SUB-WOOFER 13 INCH CUBE 16Hz



4 Arundel Road Kingston Upon Thames
Surrey KT1 3RZ
Tel 44 (0) 181 241 9826
Mobile 07967 652629
Fax: 44 (0) 181 241 0999
E-Mail cweare @mcmail.com

AUDUSA & Co



From Ohlo, USA a polymeric, mat with a uniform multilayer of a specially formulated mixture of organic compounds. Clarity and depth in music from CD's, sharper picture and brilliant colours from DVD £25-14 day money back warranty

Cable Talk
— Interconnects & Speaker Cables —

- 1994  Best Speaker Cable
- 1995   Best Interconnect & Highly Recommended Speaker Cable
- 1996   Best Interconnect & Best Speaker Cable
- 1997   Best Speaker Cable & Highly Recommended Interconnect

Interconnects Speaker Cables

Doesn't Your System Deserve The Best?

FOR FURTHER INFORMATION

Please telephone, fax or write to

Cable Talk,

Unit J, Albany Park, Camberley, Surrey, GU15 2PL

Tel (UK ONLY): FREEPHONE 0808 - 100 - 6868

TEL: (+44) (0) 1276 686717.

FAX: (+44) (0) 1276 686353

(CT HFW 06/00)

Natural sounding audio systems based on **valve amplifiers** and **efficient loudspeakers** that major on **tone, dynamics** and **musical** expression

Selected products from.

BorderPatrol • Living Voice • SME • Audio Note
SJS Electroacoustics • Cartridge Man • Goldring

Used equipment for sale

- Audio Note CD2 boxed new £695
- Audio Research D125 £1800
- Audio innovations 1st Audio with BorderPatrol PSU £850
- Audio innovations S500 integrated. 7 months old excellent £650
- Huygen K 4-leg (very) high mass loudspeaker stands £150
- Snell type J11, Oak £375
- Snell type K, Walnut AudioNote AN SPx internal wiring (excellent condition) £395
- Voyd Reference 0.5, Helius Cyalene, ClearAudio Gamma S £2500
- Selection of cables (Audio Note etc) (please enquire for details)

Rare, classic and eclectic corner

- EMI pre-amp £250
- Horning Agathon Mahogany PM4 midrange/PM2C bass £1500
- Horning Agathon Walnut PM2C midrange/PM2C bass (later version) £1500
- Garrard 401. Custom laminate ply plinth, arm board but no arm £450
- Lowther TP1 London. PM2C drive units £995
- Trio L02 T tuner. Excellent condition £1250

Services

Audio innovations valve amplifier **repair, service and spare parts** (most parts available including replacement mains and output transformers)

definitive audio
BRIGHTON

Tel/Fax: +44 (0) 1273 276716 e-mail: bp@borderpatrol.net

MVL A2+ AMPLIFIER

The A2+ exhibits bass lift of +2dB at 33Hz and treble lift of +4.5dB at 70kHz in its frequency response. In effect it has a built-in loudness control that emphasises low and high frequencies, something that will give it obvious presence in a show-room comparison with other amps. The tone controls altered matters little and had no proper zero point, what's more the characteristic was also independent of volume control position, unlike modern loudness controls. Asked about this, MVL claimed sine wave tests would not show behaviour with music. However, noise and impulse tests gave a similar result: bass and treble lift. Fundamentally then, the MVL A2+ isn't accurate.

Power output was a massive 153W into 8Ω and 225W into a low 4Ω load, so the amplifier will go very loud.

Power tests showed the A2+ has very soft clipping (output overload), suggesting low feedback. Sure enough, although distortion was low in the midband it rose to no less than 0.8% at high frequencies (10kHz), from low right up to high power outputs. MVL claim in their handbook that this amplifier has "extremely low distortion", but it does not: anything past about 0.3% at 10kHz is usually audible as roughness or coarseness to the treble, so the A2+ may well start to sound fatiguing after a while. Only listening tests can assess this.

The disc stage was very insensitive, needing 9mV for full output, against a usual value of 3mV. It displayed similar amounts of bass and treble lift as the CD input.

The MVL A2+ has MVL's own Sound Sentinel dynamic enhancement circuits that impose considerably upon performance. It is not technically an accurate unlike the simpler A2 without Sound Sentinel. Whether the A2+'s sound is preferable can only be a matter of taste.

THE TECHNOLOGY

The A2+ amplifier reviewed here has MVL's own Sound Sentinel enhancement circuits that are intended to improve the sound quality of sources. Specifically, a poor sounding CD player would experience greater enhancement than a high quality player.

In truth, Sound Sentinel applies bass and treble boost under all circumstances, most subtly with the bass control turned fully anti-clockwise, which also negated treble control action. With full bass dialled in, the treble control seems to alter treble lift, so these controls are confusingly interactive. Subjectively, small amounts of bass and treble lift do add presence, but detract from fundamental accuracy and are very much a matter of taste.

MVL claim that Sound Sentinel works

differently with music than test signals. However, we used music-like noise and impulse test signals as well as conventional sine waves; there was little difference.

The A2+ will certainly have a distinctive sound. Just bear in mind that it is not technically accurate. NK

Power	153W
CD/tuner/aux.	
Frequency response	135Hz-16kHz
Separation	33dB
Noise	-90dB
Distortion	0.8%
Sensitivity	400mV
dc offset	1mV
Disc	
Frequency response	28Hz-4kHz
Separation	30dB
Noise	-79dB
Distortion	0.8%
Sensitivity	9mV
Overload	70mV

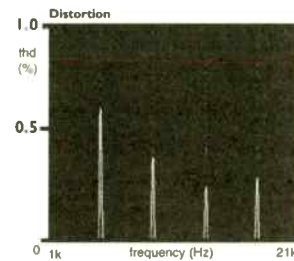

cd players

MYRYAD MCD500

Our response analysis shows the Myryad MCD500 CD player has a ruler flat frequency response that extends right up to 21kHz, the upper limit for CD. The lower limit measured 5Hz, plenty low enough for good subsonics. The Myryad measured academically well in terms of frequency response.

Distortion was low right down through the dynamic range, our analysis showing a complete absence of distortion harmonics at -30dB. The low -60dB value of 0.04% contributes toward a high EIAJ dynamic range figure of 109dB, putting the Myryad up with the best in this area.

With good channel separation and low noise this CD player measures impeccably in all areas. NK

Frequency response 5Hz-21kHz

Distortion	left	right
-6dB	0.006	0.007
-30dB	0.006	0.006
-60dB	0.038	0.04
-90	29	30

Separation	left	right
1kHz	120	119
20kHz	102	101

Noise	-103dB
with emphasis	-103dB

Dynamic range	109dB
Output	2.38V

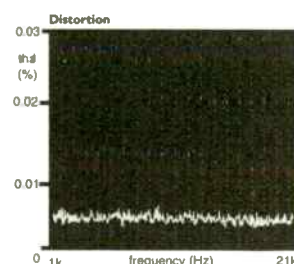
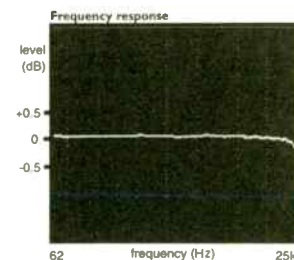

Tel.
01834 842803

AUDIOCOM

Fax.
01834 842804

SUPERCLOCK (S-Clock) The Definitive CD Upgrade

If your CD Player relies on a standard clock, then it is limited by inherent problems like jitter, slow rise time which means timing errors, and interference with the DAC conversion process. Low level information is lost and irretrievable.

These standard clocks do not generate an initial sine wave for conversion, they just produce a waveform similar in shape to a sawtooth.

Now picture this...

- High accuracy oscillator ± 2 ppm master clock.
- Negligible levels of power supply and data related jitter.
- Low distortion sine wave, virtually free of phase noise.
- Fast rise time resulting in greater data accuracy retrieval.

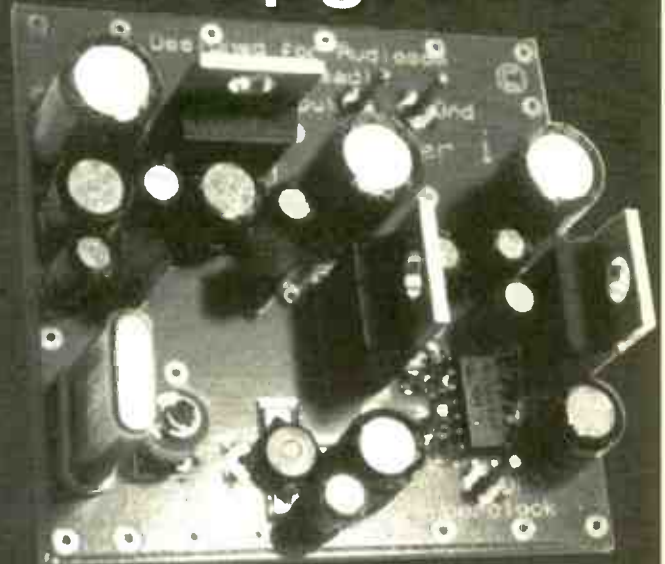

www.audiocom-uk.com

For further information on S-Clock, other components and upgrades: Tel. 01834 842803 Fax. 01834 842804 E-Mail: audiocom@scotnet.co.uk
Most Major Credit/Debit Cards Accepted



RECORD STORAGE

Shoanne's front elevation is here compared with one of IAN EDWARDS' larger units, the 40" 5-tier LP unit which is drawn to the same scale & which holds 1250 LPs.

This is our way of letting readers know that IAN STILL MAKES LP RECORD HOUSING in ALL SORTS of wood finishes from pine to rosewood, as well of course as racks & drawer-chests for CDs, video tapes or cassettes, Hi-fi units & bookshelves, etc, etc, etc and Specials.

For the BEES KNEES in this type of furniture, in Modern or Georgian styles, ask for the Brochure from

IAN EDWARDS

The Old Chapel, 282 Skipton Road, Harrogate,
North Yorkshire, HG1 3HB.
Telephone: 01423 500442

Note Ian Edwards

SALE

of many superb items.

Reduced Prices & Quick
end-of-month delivery

Write or phone now for brochure
& sale notice

Q.S. KITS.

DESIGNS ENGINEERED FOR
EXCELLENCE WITH:-
POLYPROP CAPS
AIR CORED COILS
HI-TEC DRIVERS
TOP GRADE
COMPONENTS



CABINETS
INCLUDED WITH
OPTIONS ON FINISH
NOTES AND SPECIFICATIONS
COMPREHENSIVE INSTRUCTIONS
AVAILABLE AS COMPLETED UNITS
WITH STANDARD OR EXOTIC VENEERS
DISCRETE COMPONENTS
CUSTOM MACHINING SMALL PANELS,
JOINTS & CUT-OUTS
FOR FURTHER DETAILS:-

Q.T.A. Systems
2 Wheatsheaf Way
Linton - Cambs CB1 6XB
Tel: 01223 891091

NAD S500

NAD have given this flagship CD player a near-perfect measured performance as far as 16-bit CD players go. The frequency is as flat as you can get, distortion as low as possible (discounting Denon's Alpha Processing scheme) and channel separation wide. Noise was low too and output normal at 2.25V. The S500 measured impeccably and should sound smooth and refined. NK

Frequency response	5Hz-21.1kHz	Dynamic range	109dB
		Output	2.38V
Distortion	left	right	
-6dB	0.006	0.006	
-30dB	0.007	0.007	

	left	right
-60dB	0.39	0.38
-90	29	29
Separation	left	right
1kHz	107	109
20kHz	102	105
Noise		-103dB
with emphasis		-103dB

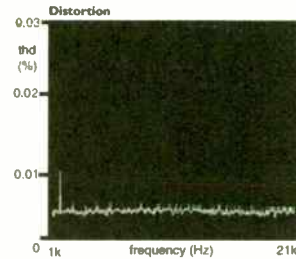
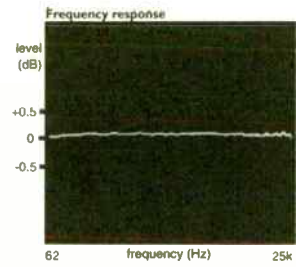

portable players

AIWA HM-AX50

The AM-HM50 produces the sort of flat frequency response expected from a good CD player, so as an MD it's right up to the mark, reproducing all frequencies from the lowest to the highest evenly.

Like many battery driven portables though it has less dynamic range than a full size player, noise measuring -70dB below full output. That's quiet enough, but it means that low level signals sink below noise and indeed I couldn't get the Aiwa to reproduce much below -70dB or so. Bear in mind that rock music is generally compressed up to the 0-30dB range so whilst this player wouldn't rival a full size machine it's quite good enough for portable use.

Maximum undistorted output was a loud 300mV with distortion at around 0.05%.

The tiny Aiwa works well, giving a measured performance good enough for portabe hi-fi. NK

Frequency response	20Hz -	
	20kHz	
	left	right
Distortion		
-6dB	0.05	0.05
-30dB	0.05	0.06
-60dB	1.6	1.7
-90	-	-
Separation	left	right
1kHz	93	93
20kHz	89	90
Noise		-70dB
Output		0.3V

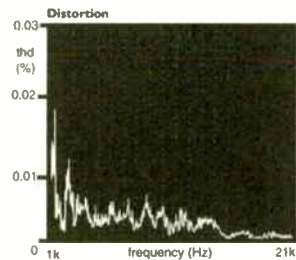
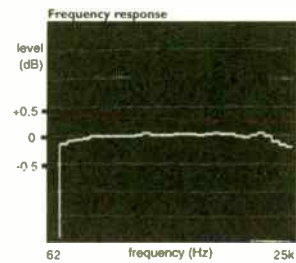

CASIO WMP-1 MP3 WATCH

We could not load test files into this watch for measurement, because software wasn't supplied. Casio told us it was an early working 'photographic' sample. However, long term averaging of the single music track onboard revealed a few useful indicators of performance.

Frequencies from 30Hz up to 16kHz were being output with an even energy distribution, so this is a minimum likely frequency response. MP3 files are commonly performance-limited by the encoding software, so much better might be possible. It's a good performance for a watch!

Maximum output was 260mV, similar to larger portables, giving plenty of volume with most headphones.

Always bear in mind the biggest limiting factor to sound quality are earpieces. Use hi-fi headphones, like lightweight Sennheiser HD40s or such like and a watch that measures like this will impress. NK

Frequency response (min)	30Hz-16kHz
Output	0.26V

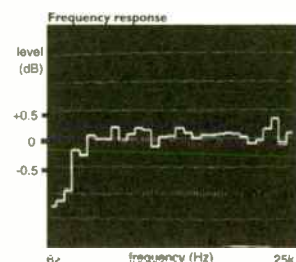

cartridges

denon
dnm
goldring
lyra
ortofon
sumiko

cables

audioquest
cable talk
chord company
dnm
heybrook
ixos
kortak
lfd
nordost flatline
ortofon
qed
sonic link
trichord
van den hul
xlo

headphones

beyer
ergo
grado
jecklin
sennheiser
stax

stands

alphason
frameworks
sound org'n
something solid
soundstyle
stands unique
target

accessories

audioquest
creek
densen demagic
discwasher
earmax
goldring
ixos
kortak
michell
mitty
monarchy
moth
musical fidelity
nordost
pixall
qed
rms
shure
trichord
zerostat

hardware

atc
audiomeca
audio physic
audio synthesis
densen
harbeth
jm labs
michell
nva
nordost
qln
royd
sequence
sugden
teac
thorens
totem
trichord

audio, cables and accessories available by post

(post haste)

phone, fax or

write for latest

price list / newsletter



Second hand & ex dem deals

- Quad FM4 tuner. Brown with DIN socket. S/H good ... \$175
 - Audio physic** Spark 2 loudspeakers. Cherry veneer. Excellent condition. One owner S/H (\$1700) ... **\$450**
 - Nordost** Flatline gold superflat bi-wire cable. Mk1 version with Chord Co plugs. 5m pair in excellent condition... **\$95**
 - Moth** thirty series 60 watt three box pre / power amplifier (black ash front) S/H (well, the "pre" bit is brand new) excellent (\$749) **\$395**
 - NVA** Cube 1 loudspeakers. Black of course. Perfect. ex demo. (\$700)..... **\$375**
 - Stemfoot** (Sugden) SF100 line level amplifier. 100 WPC S/H. Two years old, one owner, boxed as new (\$900) **\$465**
 - ATC** SCM 10 loudspeakers. Brand new, box opened. Rosewood veneer (\$1195) Full warranty as new **\$650**
 - NVA** CD70 CD player. Excellent condition (\$950) S/H one owner \$900 **\$650**
 - Teac** Ref 500 system. Amplifier, CD player, tuner and cassette deck. Ex demo (\$800) good condition **\$475**
 - Neat Critique** loudspeakers. Cherry veneer, perfect, boxed ex demo (\$650)..... **\$275**
 - Trichord** Pulsar DAC. HDCD, balanced digital input. Latest spec. Ex demo, excellent (\$1395+) **\$875**
- on behalf of customers
- Trichord** Revelation CD player. Perfect, boxed (\$800)..... **\$375**
 - DSD** DAC (by the people who set up Audio Alchemy). 3 digital inputs(selectable on front panel), one digital output. Includes free Siltech phono - BNC cable. Cost over \$600 new..... **\$195**



hi-fi for grown-ups



ipswich(01473)622866
 signals martlesham heath
 ipswich suffolk IP5 3UA
 fax (01473) 631588
 email: enq@signals.uk.com
 www.signals.uk.com

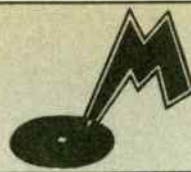

MUSONIC STYLI

**SPECIALIST MANUFACTURER &
SUPPLIER FOR MORE THAN 40 YEARS**

REPLACEMENTS & ORIGINALS

MANY OBSOLETE/78 VERSIONS

PICK-UP CARTRIDGES

RECORD/TAPE/CD ACCESSORIES

**WHY NOT TRY US AND HEAR THE
DIFFERENCE !!**

For prices tel/fax/e-mail to:-

MUSONIC (UK) LIMITED
Unit 13 Wenta Business Centre Colne Way
Watford Hertfordshire WD2 4ND

Tel: 01923 213344 Fax: 01923 213355

E-mail:sales@musonic.co.uk

Website:www.musonic.co.uk



Trade and Export enquiries welcome



English Analogue

Supplier of quality second-hand classical records
Reasonable prices for truly collectable original vinyl from
the 1950s to the 1970s. Labels include:

- DECCA** - SXL, SDD, SET, RCS, SPA, PFS
- HMV** - ALP, ASD, SAN, SLS
- COLUMBIA** - 33CX, SAX
- RCA** - SB - 2000/6000, VICS, SER
- DEUTSCHE GRAMMOPHON, PHILIPS**
etc, also available

If you are unfamiliar with classical music,
recommendations are available of great recordings to
enhance the enjoyment of your Hi-Fi and enter you into
the vast world of Classical Music. Just as there are good
recordings or Rock, Pop or Jazz, the same applies to
Classical.

To increase your satisfaction, all the records sold are
cleaned and audibly checked before being sold, free of
charge, as well as a guarantee. The records are also
supplied with a new innersleeve, as well as the old, to
ensure a high standard. In addition, if you have any
classical LPs or CDs you wish to sell or want a free
catalogue, please write, phone or fax to:

3 Naseby Rise, Newbury, Berks, RG14 2SF, England
Tel: 44 (0) 1635 40242. Fax: 44 (0) 1635 524239

www.multiplex.co.uk/Records

PIONEER PDV-LC10

Our analysis clearly shows early top end roll-off from the PDV-LC10, meaning it will give a softer sound than a conventional CD or DVD player. This is not to say "dull" however. Connected to a hi-fi system frequency response is wide enough to reproduce all audio frequencies up to 15kHz.

Distortion levels were a little above the norm for CD too, about double what is expected. Again, this won't make a huge difference in the context of what it is, a portable where sound quality is not a primary concern, but it won't help home hi-fi use.

Noise was similarly higher than the theoretical maximum, but it was with most of the portables and at -82dB still low enough to be inaudible.

It doesn't compare with full sized DVDs but the PDV-LC10 still turns in a respectable measured performance. NK

Frequency response	6Hz-15kHz	
Distortion	left	right
-6dB	0.01	0.01
-30dB	0.04	0.04
-60dB	1	1.1
-90	45	39
Separation	left	right
1kHz	96	96
20kHz	94	94
Noise	-82dB	
Output	1.5V	

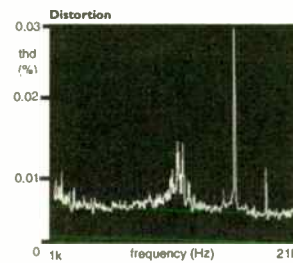
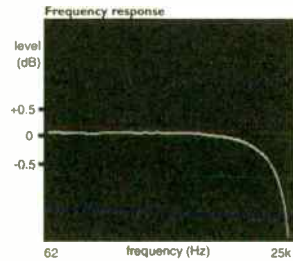

SONY MZ R55 portable MD

Sony's MZ R55 miniature MD recorder follows in the wake of the recording Walkman, offering a level of performance that's almost good enough for professional use. This recorder resolved a very low level -90dB test signal - unusual for a machine of the type. From -70dB up to 0dB there was minimal distortion, like full sized MD recorders. Our analysis clearly shows that at -30dB the spectrum analyser was measuring noise rather than real distortion when it returned a value of 0.02%.

Noise was a little higher than than the theoretical minimum for a 16-bit system but at -88dB still low enough to be inaudible.

Frequency response measured flat to 20.5kHz, with a small roll-off at the top end; just enough to ensure a smooth sound.

The MZ R55 has an excellent measured performance, better than CD in terms of low distortion. NK

Frequency response	6Hz-21kHz	
Distortion	left	right
-6dB	0.01	0.01
-30dB	0.014	0.014
-60dB	0.07	0.068
-90	32	31
Separation	left	right
1kHz	88	89
20kHz	87	88
Noise	-88dB	
Output	0.76V	

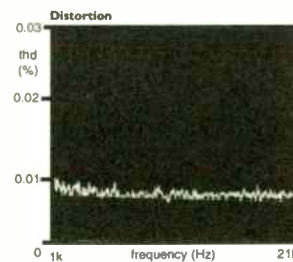
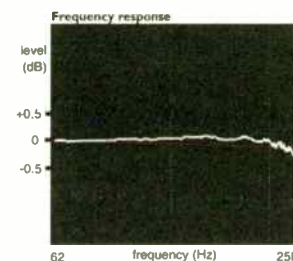

Orpheus Audio

**We are proud to introduce "Oxyzen"
a single-ended, pure class A triode power amplifier
with volume control unbelievable at £595 new
"the closest approach to the original emotion"**

Turntables

VPI TNT Junior & JMW Memorial 12" Arm & Lyra Lydian	£3000
Technics SL-1200 Ltd	£600
Technics SL-1200	£275

CD Players

Meridian 500 CD Transport with remote	£550
Meridian 203 DAC	£150
Audio Alchemy D1TB	£100
Kinshaw Overture DAC	£75

Pre Amplifiers

Audio Research LS7 (Silver)	£675
Conrad-Johnson Sonographe SC26	£600
LFD MC-1 Phono Stage	£400
Audio Synthesis Passion	£350
Michell Argo with Hera power supply	£300
Harmon Kardon Citation 21	£250
QED Reference	£200

Power Amplifiers

Cabasse AM1000 Monoblocks	£1100
Pass Labs Aleph 3	£1000
Chord SPM 800B	£900
Conrad-Johnson Sonographe SA250	£600
Quad 405-2	£300

Integrated Amplifiers

EAR 859	£950
Magnum Class A SE	£450
Musical Fidelity A-X1	£350
Arion Electra	£350
Triangle TE60	£200
Sanyo Plus A35	£50

Loudspeakers

Cabasse Skiff 301 (Beech)	£1000
Klipsch K65.5 (Light Oak)	£650
Cabasse Farella 401 (Bubinga)	£600
Triangle Scalene (Black)	£300
JBL LX-66 (Black Ash)	£300
Mordaunt Short MS3.10	£50
Target HH16 Stands	£35

All the above come with 12 months warranty
tel: 01257 473 175
evening calls welcome
email: orpheusaudio@freeuk.com

For a full list of our agencies please see: ORPHEUS AUDIO
(GREATER MANCHESTER) in the DIAL-A-DEALER Section

Audio Synergy



LIMITED AVAILABILITY

The HeadMaster is a new headphone pre-amplifier manufactured by SUGDEN. Not only will it satisfy the demands of headphone users, it is also a high quality Class A pre-amplifier with three inputs, tape-out/pre-out and is fully relay switched. The case construction is solid aluminium plate, finished in superb black chrome.

Contact us now for further details
Audio Synergy Limited
Tel. 01924 406016
email audiosynergy@easynet.co.uk

NEWS FLASH! ERGO headphones now available in the UK. Made in Switzerland these headphones are simply the best. Prices start from £149.00 for the Model 1.

NEW EX - DISPLAY & PART EXCHANGE CLEARANCE SALE

Castle Avon	Mahogany(Part.Ex)	£ 399.00
Arcam Alpha 10 DAVE	+ 10 3 Ch.Power	£ 1999.00
Castle Inversion 100	in Yew (£ 2375)	£ 1699.00
Castle Inversion 50	in Yew (£ 1045)	£ 749.00
Exposure CD	CD Player	£ 699.00
Exposure 21RC	Pre - Amp	£ 549.00
Exposure Super 18	Power Amp	£ 539.00
Jamo Concert 11	Stunning Floorstander	£ 1799.00
Monitor Audio PMC703	Black Wood (Part.Ex)	£ 399.00
Monitor Audio Studio	20SE (Still boxed)	£ 1299.00
TAG McLaren 60i	Integrated	£ 559.00
TAG McLaren 60iRv	Integrated	£ 699.00
TAG McLaren PA10	Pre - Amp	£ 599.00
TAG McLaren PA20r	Pre - Amp	£ 1049.00
TAG McLaren 60P	Power Amp	£ 599.00
TAG McLaren 100P	Power Amp	£ 789.00
TAG McLaren 125m	MonoBlocks(Pair)	£ 1679.00
TAG McLaren CD20R	CD Player	£ 899.00
TAG McLaren CDT20R	CD Transport	£ 1049.00
TAG McLaren DAC20	DA Converter	£ 875.00
TAG McLaren T20	Tuner	£ 775.00
Yamaha DSP A1	AV Amp(Black)	£ 996.00
Tsunami TS300L	Active.Sub (Cherry)	£ 269.00

**All Units sold with Packaging ,Instructions Etc.
Ex-Display Products include Full Manufacture's
Warranty.Next Day Delivery Available(UK only)**

TEL 01603 767605

29 ST. GILES ST. NORWICH . NR2 1JN

E-mail: sevenoaks.hifi@virgin.net

Speaker Kits From IPL Acoustics

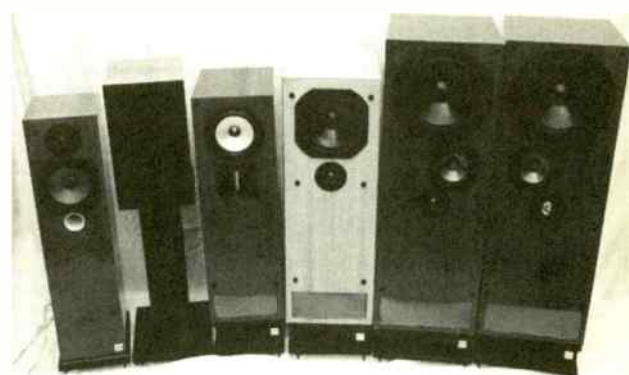

IPL Acoustics are pleased to announce their latest range of speaker kits which include no less than seven transmission lines, three conventional speakers, two AV centre speakers, and an active subwoofer kit.

IPL kits are designed to the very highest specification using sophisticated Audiosuite testing system to ensure smooth response, correct phase, and low distortion. Only the best drivers and crossover components are utilised.

Our two new flagship transmission line kits include the;

S3TLM RIBBON which incorporates a superb custom built aluminium coned 6.5" bass mid unit and the unique new IPL Ribbon tweeter.

S5TL GOLD which incorporates the Audax 10" HDA bass unit, the 5" HDA mid unit, and the highly acclaimed Audax piezo GOLD dome tweeter in a transmission line enclosure. The sound quality of all IPL speakers compare well with commercial speakers costing 3-4 times the cost of the kit and are tunable to suit your room and system.

If you would like further details of our range, which includes drivers, Quality components, and Silver PTFE cables, please send a 40p A4 S.A.E. to IPL Acoustics, Chelsea Villa Torrs Park, Ilfracombe, Devon, EX34 8AY. Tel: 01271 867 439
Website: www.marketsquare.co.uk/ilfracombe/iplacoustics.htm

www.hi-fiworld.co.uk
hi-fi
 world

Private Ads

Special Internet offer
 see page 130 for details

Dealers must not advertise in the Private Classified section. Monthly consecutive insertions will be considered Trade advertising. The Publisher reserves the right to judge submissions.

MUSICAL FIDELITY MX preamp. Musical Fidelity P180 poweramp, both with outboard P.S.U. Vgc £1300 brand new, accept £600 ono. May split. Tel: 0115 840 0047 (Jun/I)

RUARK SOLSTICE (Yew Finish) £3200. KEF Reference Model Four (rosewood) £2250. All as new, complete with boxes/packaging etc. Tel: 0973 899 651 (Jun/I)

AUDIONOTE TYPE E/SP silver wired light oak £675. Matched Quad Golden Dragon 300Bs low hours use £185. Audionote AU32BSL super 300B matched Quad low hours use £150. World Audio KLSB speakers built but require cosmetic finishing £175. Tel: 01483 534 795 (Jun/I)

NAIM 92R + MM phono £345. NAP 90/3 £295. Nait 3 £295. NAC 102 + NAPSC + MC phono £865. NAP 180 (3 months old) £845. Naim CDi £795. All excellent condition. Tel: 0117 977 0317 (Jun/I)

PASS ALEPH O monoblocks. Stereophile Class A rated. Mint, boxed with manuals £3500. Also Pass Aleph P preamp. Mint, box etc £1000. Superb Hi-end sound and Battleship build quality. Tel: 020 7636 9464 (day), 01582 629 556 Eves (Jun/I)

LOWTHER PM6s in need of re-foaming in custom built Sapele cabinets (Accousta style) £280 ono Tel: 0115 950 6790 (Jul/I)

SONY 557 CD player. 38Lbs! Superb sound and Battleship construction excellent condition. Box and Manual £350. Tel: 020 7636 9464 (day) 01582 629 556 (Jun/I)

MARK LEVINSON 332 200W and 333 300W power amps. Each Class A dual mono block, fully balanced, award winning power and refinement, immaculate, boxed, full documentation, guarantee. £4250 (£6500 new) and £5600 (£8500 new). Tel: 0171 706 8838 (Jun/I)

HI-FI HOUSE clearout! DNM 3C Primus pre-amp, as new, under warranty, £1500 (£2300). Muse Model 300 monoblock power amps, 300wpc, silver, as new, under warranty, £1750 (£4200). ProAc Response 3, oak, Vdh rewired, excellent, £1500 (£3600). ProAc Response 2S, cherry, mint with RS2 stands, £1200 (£2600). Copland CSA28 amp, mint, £850 (£1400). Infinity Modulus spkrs, piano black with stands, vgc, £275 (£1000). All with original boxes. Tel: Adil 0208 673 3850 or 0207 919 8559 (London) (Jun/I)

'STANDS UNIQUE' high AV support. Mahogany legs, adjustable 6mm glass shelves, spikes, as new. £190. Tel: Nick (home) 01908 696 869, (work) 01908 356 205 Milton Keynes (Jun/I)

MISSION 752 loudspeakers (not Freedom), (£495), £225. EMT 950 turntable, collectors item (£?), £800ono. Marantz CD67SE (£350), £110. Marantz CD54 champagne gold, collectors item (£395), £60. Sony XL-55 Pro MC, virtually new (£250), £65. Pioneer A400X amp (£295), £95. Aiwa ski-slope cassette deck with dustcover (£180), £55. Aiwa mini system, optical digital out (£500), £65. All mint, boxed, carriage arranged. 07939 084514 anytime. (Jun/I)

NAIM SBL. Latest spec with new crossover. Black. As new. £1100 Tel: 01227 830 286 or email: nm1@ukc.ac.uk (Kent) (Jun/I)

BLACK METAL Sound Organisation style racks hold 160 records and approx 100 CDs. Four available. Cost £300 each. Plus Soundstyle X250 revolving CD rack 250 CD's. Offers invited. Tel: Andy 0121 631 2631, email: amcgowan@kibham.hlbkidsons.co.uk (Jul/I)

SME 3009/52 arm in original packing. Technics SL150 turntable with strobe, boxed. Neither used, both as new! £120 each or £200 together ono. Tel: 0208 504 0595 (Woodford Green) (Jun)

QUAD CD67 £450, MSB Link DAC Audio Alchemy power supply £300. KEF 104/2 Kube rosewood £400. Chameleon Ruby power amplifier £300. Buyers collect. Tel/Fax: 0116 235 7083 (Leicester) (Jun/I)

PINK TRIANGLE Ordinal DAC (1307) chip boxed £295. Trichord digital pulsewire 1 metre £30. Celestion 3 (II) speakers boxed £45. Hi-Fi World October '92 to Feb 2000 (most issues) £25 ono. Tel: 01908 260 112 (Jun/I)

VERSALABS woodblocks £50 each, Red Rollers £20 each, OnAir Support Systems Airpod II's £40 each, Solid Glass Support Platform (18mm thick) £60, Audionote ANV Interconnect 1 Mtr (RCAs) Pair £50, Audionote ANV Digital 0.75 Mtr (RCAs) £25, Siltech Digital 1 Mtr x 2 (1 with gold BNCs, 1 with WBT RCAs) £50 each, CAD Anacreaon; Silurian; Czar (ask for prices). Tel: 00 3520 2128 5621, Email: barig@sbx.com (Jul/I)

Classified Ads

Classified Ads

ARCAYDIS

HAND CRAFTED SPEAKERS TO SUIT
ALL MUSICAL TASTES AND POCKETS

ARCAYDIS ASC



*As reviewed by Richard White
Hi-Fi World June 99*

ARCAYDIS AS2



*As reviewed by Simon Pope
Hi-Fi World October 99*

Unit 4 -19 Lisle Avenue, Kidderminster, Worcs. DY11 7DF
Tel: 01562 865 788 Fax: 01562 865466

MIDLAND STUDIO 2

HI-FI CONSULTANTS. 9 FINCHFIELD ROAD WEST, FINCHFIELD, WOLVERHAMPTON, WEST MIDLANDS, WV3 8AY
FAX/TEL. (01902) 380083 V.A.T. Registration No. 333 9324 60

HIGH END STAR BUYS

ex dem	Magneplanar MG20 black c/w electronic X over	£5900
s/h	Magnaplanar MG 1 imp	£350
s/h	Magnaplanar SMGa oatmeal	£295
s/h	WILSON AUDIO WATT & 2 PUPPIES	£6490
s/h	Quad ESL. 57 black	£450
ex dem	Clements 600i black	£600
ex dem	Sequeria MET 7 walnut	£475
ex dem	Mirage centre	£120
ex dem	Royd Minstral cherry (metal feet)	£375
ex dem	Royd Doublet black	£450
ex dem	OCM 500 200 watt power (£2800)	£1995
ex dem	pre & power	£2500
ex dem	OCM 55 preamp (£1700)	£995
s/h	Quad 405 1 power	£200
s/h	Quad 34 preamp	£200
s/h	Counterpoint SA 3 valve preamp (much sought after)	£595
s/h	Audio Research LS1 preamp silver	£850
New boxed	Alchemist Forseti AP15 intergrated amp	£695
New boxed	Alchemist Kraken pre & power	£750
ex dem	DPA 200s preamp	£325
s/h	Cambridge P100 power	£199
s/h	Radford STA 25 MkIII	£600
	Radford preamps various available soon	
	Leak TL 30 plus monoblocks	SOON ASK
	Stax SR 34 electret headphones	£90
	Sharp MDR1 Minidisc	£150
	Revox PR99 playback reel to reel (high speed)	Just in
ex dem	Teac Reference TBX10 tuner	SAVE £100 OFF
ex dem	T1/D1 reference Transport and DAC	SAVE! SAVE!
	Roksan DAC 1	£250
	Thorens TD126 unused boxed MKV	£375
	As above used no cover c/w SME det 3009	£350
	Systemdeck 2 turntable good s/h belt drive	£125
	Well Tempered Turntable	£950
	Grace pickup arms	various
	Mission 774 pickup arm	£99
	sony HA55 Step up arm	£99
	Various rare steps ups	
	STAD S turntable	COMING SOON
	TRIO LO7D turntable	
	Many alternatives ASK	
	TRADE INS A SPECIALITY	

Unbeatable value!

Style, performance, value; get
more for your money at **AV Zone**

Cable Zone

up to Nordost | QED | van den Hul
35% off

van den Hul

Magnum HB
RRP £40/m
Our Price £26/m

CS122 HB
RRP £13.49/m
Our Price £11.80/m

Revelation HB
RRP £60.00/m
Our Price £45.00/m

First Classic
RRP £159.99 (0.6m)
Our Price £139.99

D102iii HB
RRP £79.99 (0.8m)
Our Price £69.99

Accessory Zone

Atacama | harman/kardon

Atacama SE20 & SE24 stands
RRP £74.99
Our Price £63.74

harman/kardon
TC1000 uni-learning remote
RRP £300
Our Price £249

Atacama Nexus 5 & 6 stands
RRP £49.99
Our Price £42.49

**Call us or visit our
website for details**

- Accessories
- Cables
- Hi-Fi
- Home Cinema
- Lifestyle

Telephone
020-8931 1206
website
avzone.co.uk

Special Internet offer
see page 130 for details

ARCAM ALPHA 10 amp £500. AVI Nuneutron speakers marble steel stands separate spiked plinth £300. Yamaha digital surround processor £492 £120. Marantz 63K1 Signature CD player £150. Tel: Brian 01461 203 190 (Jun(I))

LUX 304 valve preamp. Lux MQ 3600 60wpc £1100. Sony 338 ESD CD £190. Citation Twelve Amp Delux £330. B&W speakers DM5 £80. Tel: 01932 889 547 (Jun(I))

LINN KEILIDH speakers, walnut with plinths K400 biwired cable. As new £500. Tel: 01751 431 032 (Jun(I))

CYRUS Q module for dAD3 CD player £75. Syrinx PU3 tonearm, boxed, £45. Tel: 01642 559 204 (Jun(I))

NAIM ARO mint, boxed, with arm board £525. Naim Armagedon mint, boxed £400. Naim 250 early type mint £575. Naim tuner, NAT 101 with Snaps, mint £375. Tel: 0191 281 0260 (Jun(I))

HARBETH HL Compact 7SE latest edition £700. Ariston RD40 turntable RB250 Sumiko Blue Point £290. Celestion Ditton 66 studio monitors £390. Creek OBH9SE phono-stage £95. Atacama 12" stands £35. All mint/excellent. Tel: 0208 952 2044 (Jun(I))

KIMBER 0.5m PBJ CD interconnect £40, DBF FPTHOM speaker cables 2m bi-wire £30, DBF black velvet 1m £20, DBF Azure 0.5m £30. Tel: 01293 786 453 evenings or weekends (Jun(I))

ROKSAN CASPIAN CD player with remote control. Boxed with manual, recently serviced by Roksan Audio with new laser. Immaculate condition. As new. £500. Reason for sale, upgrading. Tel: 01335 370 594 (Jun(I))

IMPULSE H6 speakers, rare Burr Oak finish, excellent condition. Boxed. £550. VDH CSI22 HB 2x6 metres speaker cable £60. Tel: 0141 339 7387 evenings (Glasgow) (Jun(I))

MOTH PHONO amplifier MM/MC mint £130 ono. Moth active line level pre-amp & matching power supply, mint £160 ono. Tel: Alex 0208 985 4452 or Email: alexkirkham@yahoo.com (Jun(I))

AUDIO RESEARCH SP9.II £1000 ono. Helius Orion 2 £260. Michell Iso with Hera £300 ono. Audion Intro Pre Valve Phono £300. System Deck turntable £120. Snell Type E.II Silver wired with stands £900 ono. Tel: 0956 301 065 (Jun(I))

IMPULSE H2 loudspeakers. Awesome dynamics. Beautiful condition. Boxed. £1150 ono. Audionote Miraa "Special" phono stage. MM/MC. 10 hours use only. £525 ono. Tel: 01785 677 639 evenings and weekends (Jun(I))

GAMMA ACCOUSTIC Space Reference pre and power valve amps. Mint condition. Light use. 18 watts per channel. New valves. Any inspection. Cost new £8000 will accept £2750. Tel: 01726 824 114 (Jun(I))

ROKSAN DP1.5 transport and XLO interconnect £275. Tel: 01984 629 086 (Jun(I))

WANTED WELL used Dynavector cartridge, any model. Cash waiting or exchange various Shure Ortofon models. Tel: 01772 432 263 Jun (I)

REVOX B77 One owner from new, immaculate condition, two speed, Nab reel adaptors, Variable speed control £650. Revox Tuner 261 as above condition, high blend separation, Threshold station stereo control, manual/auto tuning £350. Tel: 01305 772 150 (Jun(I))

ACOUSTIC STUDIO monitor loud speakers, 12 inch polywoofer, 5" liquid cooled mid-range, 3" liquid cooled tweeter, 125 watts, 95db per watt, hardly used, with boxes and warranty. Cost new £1795, sell £800 ono. Tel: 07939 238 954 (Jun (I))

PINK TRIANGLE DaCapo DAC with 1307 filter, good condition £450. Pioneer CLD 600 Laserdisc CDV/CD player v.good condition £400. Tel: 01303 863 424 (Jun(I))

REVOX B77 Tape reels "new never used" Aluminium & Black, Nab & Cinecentre fixing 10 each, £65. Revox B77 Tape reel "Library box's" New condition" 12 each, £75. More details Tel/Fax 01305 772 150 (Jun(I))

TRIO L-07CII 150 watt monoblocks £375. QED silver profile 12 2m £20. Pickering 75000s £65. Early Linn arm £30. Decca International £20. Tel: 01273 727 476 (Jun(I))

LINN SYSTEM, Karik/Numeric, Kairn, 2No Klouts, Keilidhs £4850, Keswick Audio Figaro speakers Rosewood £450, Tannoy P4 Speakers in Cherry £500, Gale 401 speakers in Walnut £275. Tel: 01977 643 629 (Jun(I))

MUSICAL FIDELITY XA50 £325, X-Pre £120, X-PSU £85, X-Cans £85, Opera Prima £395, Alchemist Kraken Power £350, Helios Model 3 £475, AVI NuNuetron £380, Rotel RC/RB850 £175. Tel: Darren 01482 891 375 (Jun(I))

QUAD 34 Pre Amp with 405/2 power amp £300, AVI Pre Amp, latest spec £450, AVI Stereo Power Amp £400, Teac P500/D500 2 Box CD Player £475, Linn Keilidh Speakers £350, Audio Innovation 400 integrated valve amp £300. Tel: 01977 643 629 (Jun (I))

REVOX B710 Cassette recorder, Muxplex filter, Dolby, Tape bias, memory select, Superb condition £450. Revox Furniture, Stacking system in Walnut, Base unit storage with glass doors. 2 of £85 each. Tel: 01305 772 150 (Jun(I))

BEAUHORN VIRTUOSO Gold fully horn loaded speakers "be there" (£3395) bargain £1995. Audio Innovations 'First Audio' monoblocks 7.5 WPC £750. Second Audio's £1195. Move forces sale (may part-x). Tel: 01472 329 668 (Cleethorpes) (Jun(I))

KLIPSCH CF3 Epic loudspeakers rosewood finish original boxes and manuals £750. Tel: 01463 222 088 (Jun(I))

CANARY AUDIO

Hear what you've been missing...



300B Single Ended Monoblocks 9 watts per channel

CANARY PRODUCTS ON DEMONSTRATION BY APPOINTMENT AT THE FOLLOWING OUTLETS

The Audio Consultants	LONDON	0207 380 0866
River Crossing Audio	NORFOLK	01263 741230
Better Hi-Fi	LIVERPOOL	0151 227 5007
Sounds Perfection	CORNWALL	01326 221372
Definitive Audio	NOTTINGHAM	01159 733222
Serious Kit	MANCHESTER	0161 798 9649
Walrus Systems	LONDON	0207 724 7224
Orpheus Audio	LANCASHIRE	01257 473175
Kevin Galloway Audio	AYRSHIRE	01563 574185

DISTRIBUTED BY AUDIO CONNOISSEURS
TEL/FAX +44 151 645 0007

AUDIOVECTOR

FINAL REDUCTIONS on ex-demonstration loudspeakers

C Series	Condition	Original Price/£	Sale Price/£
C1 (bookshelf)	xd	399.95	sold
C2 (floorstander)	xd	799.95	369.95
M Series (UPGRADEABLE)			
M1 Black Ash veneer	xd	759.95	349.95
M1 Cherry veneer	xd	789.95	359.95
M1 Rosewood veneer	xd	819.95	369.95
M1 Super Cherry veneer	new	1029.95	549.95
M1 Super Rosewood veneer	xd	1059.95	569.95
M1 Signature Cherry veneer	xd	1479.95	669.95
M1 Signature Rosewood veneer	new	1509.95	769.95
M2 Cherry veneer	xd	1499.95	849.95
M2 Rosewood veneer	xd	1599.95	949.95
M3 Signature Beech veneer	xd	2699.95	1399.95
M3 Signature Rosewood veneer	xd	2699.95	1399.95
AV3C Black Ash veneer	xd	499.95	229.95
AV3C Super Cherry veneer	xd	799.95	379.95

5 year transferable guarantee. Upgrades available for M Series.
Magazine comments: C1 "over-riding musicality" (Hi-Fi News 05/99), "affordable...musical excellence" (Hi-Fi Plus 08/99), C2 "Recommended" (Hi-Fi Choice 05/99), M1 Signature "worth consideration" (Hi-Fi World 08/98), M2 "Recommended" (Hi-Fi Choice 07/98). All offers subject to being unsold. Limited stock available only through Glaive Limited, the sole UK distributors. Offer not available elsewhere. UK Delivery £10 per carton. E & O.E.
For further information and a brochure, please return the coupon.

Post to: Glaive Limited, Unit 7, Wren Industrial Estate, Coldred Road, Maidstone, ME15 9YT. Tel/Fax: 01622 66 40 70. Web: www.glaive.co.uk
Please send me info on: Audiovector

Name:
Address:
.....
.....
Post code: HFW0004

Colomor (Electronics) Ltd

Unit 5 Huffwood Trading Estate, Brookers Road, Billingshurst, West Sussex RH14 9RZ Tel: 0 (44) 1 403 786 559

Fax: 0 (44) 1 403 786 560 E MAIL - sales@colomordemon.co.uk

VALVES

	£p each
DET19 CERAMIC BASE	14.00
DG7-32 MULLARD	10.00
E55L 8233 AMPREX	16.00
E80F	15.00
E180CC	2.50
ECC81	2.15
ECC81 CV4024	6.00
ECC82	2.50
ECC82 MULLARD	8.00
ECC82 CV4003, MULLARD	12.50
ECC83 SOVTEK	3.35
ECC83 MULLARD	15.00
ECC85	2.30
ECC88 TESLA	2.00
ECC88 MULLARD	10.00
ECC88 TELEFUNKEN ORIGINAL	30.00
E88CC MULLARD	10.00
E88CC/01 MULLARD	16.95
ECL82 GERMAN	4.50
EF37A MULLARD, GREY	2.50
EF86	4.35
EF86 MULLARD	11.00
EL34 SOVTEK	6.00
EL37 MULLARD	45.00
EL84 SOVTEK	2.15
EL84 MAZDA	5.10
ELL80	25.00
EZ80 MULLARD	6.00
EZ81 MULLARD	6.00
GZ33 MULLARD	13.00
GZ34	3.50
GZ37 MULLARD	7.00
KT61 GEC	25.00
KT66 GEC ORIGINAL	65.00
PCL86 14.SV, HTR, ECL86	0.50
£35 / 100; £250 / 1000 PT15 MARCONI	
35.00	
PX4 POA	
VT4C 211. GE, USED, TESTED & GUARANTEED	45.00
VT4C GE	120.00

3C24	EEV	20.00
5R4GA		6.15
5R4GY		5.80
5U4G		4.95
5Z3GT		3.60
5Z4GT		1.90
5Z4G		6.00
6CH6	Brimar	2.50;
		£200 for 100
6FQ7		9.45
6L6G	CV1947	30.00
6L6	METAL	9.80
6L6GC	SYLVANIA	14.90
6L6GT/C		2.50
6L6WGA	SYLVANIA	12.00
6L6WGB		12.00
6SL7GT	BRIMAR	8.00
6SN7GT	BRIMAR	8.00
6V6GT		5.10
6X4WA		3.30
12BH7	BRIMAR, BLACK PLATE	15.00
12E1	STC	10.00
807	CERAMIC BASE	20.00
807	USA	5.00
808	POA	
813	RCA	35.00
6072A		7.45
6336A	USA	49.00
6550A	GE	24.15
6550A	MATCHED PAIRS	32.00
6550-B2	SVETLANA	12.75£EA
B4 BASES		1.00
B5 BASES		1.50
INTERNATIONAL OCTAL, CERAMIC		3.00
B9A, CERAMIC,		2.00
UX4 / UX5, CERAMIC		2.50

TRANSFORMERS, CHOKES & BLOCK CAPACITORS

Oil filled block capacitors
by TTC Dublier
.5uf, 1uf, 2uf, 4uf all at 600V £6.00 ea.

.8uf, 600V; .5uf, 1KV; 1uf, 1KV; 2uf, 800V; 4uf, 1KV £8.00 ea.

.8uf, 800V £10.00 ea.

10 uf. Oil filled, 2000V, GE USA £20

RCA Heater transformer for 211VT4C
Primary 190-210-230-250
Secondary 10V centre tapped @ 3.25A X 2
Fully enclosed, £20

RCA transformer
Primary 110-125-150-210-240
Secondary 345-0-345 @100Ma
5V 2A 6.45V @ 4.5A
Fully enclosed £25

Oil filled Transformer, Gardeners
Primary 110-240V;
Secondary 250-0-250; 180mA 6.3V, 7A, 5V, 3A £50.00 EA

Primary 115-250-440V Secondary 640-0-640V
160mA 330-0-330 225mA £50.00

Oil filled Chokes by Parmeko/ Gardeners
2.5H, 220mA; 2.5H, 350mA; 4.5H, 150 mA; 4.5H, 220mA; 4.5H, 280mA; 5H, 110mA; 5H, 200mA; 5H, 250mA; all at £30.00 ea.

5H 100mA Oil, Parmeko, £15.00

5H, 400mA £38.50 ea; 7.5H, 250mA £30.00ea

10H, 75mA £23.50 ea; 10H, 170mA £33.00ea

10H, 75mA Varnished £10.00

TEL FOR CARRIAGE

VAT @ 17.5% TO BE ADDED TO ALL UK & EEC VATABLE ORDERS
Payment by Cheques, PO's, Banker's Draft sent to address above.
Goods sold over the counter. Please telephone ahead for a more efficient service.
PLEASE SEND LARGE 1st CLASS STAMPED SAE FOR OUR FREE VALVE CATALOGUE.
P & P UK 1-3 valves £2.00; 4-6 valves £3.00; 7-10 valves £4.55.
Other countries please apply for tariff.

Special Internet offer
see page 130 for details

RATA 2 way speakers plus stands £550. Leak Stereo 20, Troughline MkII, Syrac 50W KT88 amplifier, Musical Fidelity preamp 8, Hi-Fi World Audio KL3 speakers, Neat Petite's plus dedicated stands, Tannoy Berkleys, Thoren TD160 B MkII, Linn K9 (20 hrs), various Hi-Fi magazine sets. Ring for details: Tel: Graham 01273 691 776 (Jun/I)

WANTED ORIGINAL Lowther TP1 corner horn with PM3 drive unit. Any condition considered. May be interested in anything Lowther. Private enthusiast. Tel: 01886 853 385. Email: a.j.king@tesco.net (Jun/I)

KRELL PAM 7 preamp with power supply £450. Quad 510 monoblocks 125 watts £495. Celestion Ditton 66 Studio monitors teak £395. All items mint or near as. Tel: Brian 0208 908 4633 or 0208 952 2044 (Jun/I)

SNELL K's Huygens £395. Vintage Rowe 7868 valved amplifier £295. Audioplan silver interconnect £70. Dean Alto's £145. Audio Innovations 800 preamp £175. Matching power amplifier £350. Walker CJ55 SME MP II £170. Wanted: Source/ well tempered turntable. Tel: 0113 255 9475 (Jun/I)

LINN KABERS ash black active cards, latest spec, unmarked, boxed, passive crossovers available, demo if required. £795. Tel: Jerry after 7pm 01702 545 622 (Jun/I)

STUDER 1/4" tape recorders EMT turntables. Very good condition Tel: 0121 356 9636 (Jun/I)

EAR 519 monoblocks pair £2300. Ear 802 preamp £590. Magneplanar MG1 speakers £550. Black Slink 4m interconnects offers accepted for parts or whole superb range. Tel: 01305 262 359 Email: rolandtarr@mon-mouthroad.freeseerve.co.uk (Jun/I)

UNISON RESEARCH Mystery One preamp; Unison Research 845 monoblocks twenty four watt per channel; Unison Research Simply phono stage; Tim DeParavicini's "The Head" amp. New price £6100. Bargain £3600 mint. Stunning Italian amps, beautifully carved wood and they synergise gloriously with Quad Electrostatic ESL 63's. Not only can you have great valve sound but gorgeous looking Hi-Fi as well. Tel: 02891 461 603 (Jun/I)

SUGDEN SIGNATURE AU41 remote pre AU41 power £600. Naim MC (separate MM boards) two box phono stage £200. Both for £750. No boxes. Tel: 01733 810 516 (Peterborough) (Jun/I)

SPENDOR SP9/I loudspeakers big elegant floorstanders, cherry veneer. New 1997. High efficiency plus easy load. One of the best big speakers. A true bargain £1400 (£3400). Tel: 0208 325 2585 (Jun/I)

QUAD 34 preamp with phono stage and MC module £175. Mint. Quad 606 £375. Mint. £500 both. Celestion Ditton 25 floorstanders walnut excellent condition original packing £175. Tel: 0208 952 2044 (Middx) (Jun/I)

LOWTHER ACOUSTAS - early original - Birch ply throughout. Professionally renovated, finished in satin dark oak. New DX3 drivers. Total renovation cost = £1600. For Sale @ £895. Also new/ as new Lowther drivers. Half Price. Quad II Stereo complete. Recently overhauled by ATV to Quad spec. @ = £450. Tel: 01483 268 804, Email: ***@thinktank.soft-net.co.uk (Jul/I)

MICHELL ALECTO monobloc amplifiers, wide band width, low distortion, 125w 8ohm, 200w 4ohm, boxed, £1250 (£1950). Audioquest 3.5m Midnight £149 and 3.5m Cobalt £199 speaker cables. Tel: David 01296 747 852 (evenings) (Jun/I)

PROAC STUDIO 100 cherry excellent condition £400 ono. Celestion SL700 speaker stands fantastic quality £100 ono. Tel: Pete 01582 467 021 (Herts) (Jun/I)

VOYD TURNTABLE Cylene II arm Japanese 10 cartridge natural wood finish with torelite stand £2000. Altec Ay Vot speakers, newly built, boxes £1000. Tel: 01189 310 410 (Jun/I)

A GOOD starter system? For sale. CD player - Rotel RCD955 AX (£100). Amplifiers - Cyrus SL (£300) and XPA (£200). Speakers - Ruark Templars (£300). Tuner - Sony ST-SE500 (£50). vdH cables (£100). Tel: 0207 564 3819 (Jun/I)

REVOX B77 MK 2 one owner from new £395. Tel/Fax: 01202 291 435 (Jun/I)

AUDIOLAB 8000 DAC £350 (£900). Arcam Delta transport and black box 50 DAC £550 (£1280). Castle Howard S2's oak finish £750 ono. Nordost flatline gold bi-wire 2x2m £35. Tel: 01202 381 413 (Jun/I)

CELESTION DITTON 66 Studio monitors teak, excellent condition £395. Creek OBH 9SE phono stage virtually unused £95. Tel: Brian 0208 952 2044 (Jun/I)

WADIA 22 CD transport 4 digital outputs AESIEBU coaxial (BNC) toslink ATT glass optical extremely low jitter boxed in mint condition £980. Tel: 01626 352 682 (Jun/I)

MICROMEGA STAGE II, CD player, boxed £135. Nakamichi MR2, professional tape deck, just had complete overhaul by Nakamichi costing over £100+, £195. Cambridge Audio DAC, Dacmagic II £90. Kenwood KA-3700 Dolby decoder/amplifier £75. Tel: 01484 846 253 (Huddersfield) (Jun/I)

NAIM NAC 52 supercap latest spec immaculate condition £3150 ono. Tel: 01444 418 984 work 01276 472 386 home (Surrey) (Jun/I)

SME MODEL 20 turntable last MK1, Mint, boxed; £1600. Naim NAC 82 pre. 16 months old mint: £1600. Linn Sara 9s with stands, boxed: £340. Tel: 0208 337 1725 or 0976 695 218 (Jun/I)

LINN LK2 power amp and interconnect, very good condition, genuine reason for sale £250. Price includes carriage if required. Tel: 01383 416 263 (Jun/I)

HI-FI EXCHANGE

Previously abused items
and objects of desire

	NEW	USED
Neat Critique (cherry)	£445.00	£300.00
Meridian 201 Pre inc remote	£760.00	£375.00
Meridian 205 monoblocks (pair)	£1,050	£595.00
UKD Opera Callas, Boxed	£1,000	£649.00
Ruark Prologue I cherry	£900	£575.00
Ear 859 integrated	£1,750	£950.00
Exposure XV integrated	£650	£350.00
Spendor SP2	£550	£350.00
Marantz CD80 Serafine caps	£550	£325.00
Nakamichi cassette deck II	£350	£175.00
Denon DRM/800A 3 head	£300	£150.00
Linn Basik/Akito/ATFS MC	£400	£220.00
Acoustic Energy AE2 inc stands	£1,400	£875.00
Lowther Acoustas PM6s	-	£250.00
TDL RTL3	£400	£249.00
Audiolab 8000A integrated	£500	£250.00
Hitachi D-5500 M inc remote 3 head cassette deck	£440	£200.00

"Let us sell your old Hi-Fi for you"

commission sales our speciality
ring for details

01325 241888

30a, Larchfield Street, Darlington, Co. Durham. DL3 7TE

Rothwell

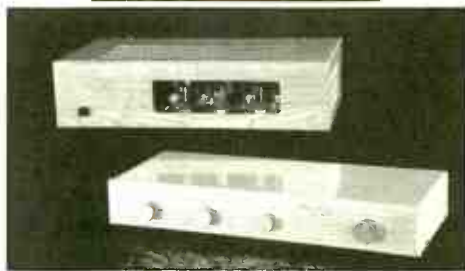

Valve Amps of Distinction

This pre/power combo has been winning admiration and praise from satisfied customers throughout Britain and abroad for over five years. Many are so impressed with the performance that they have invested in a second Rubicon, running the two amps as monoblocks. To find out for yourself why these music lovers are so dedicated to Rothwell, contact your nearest dealer for a dem.

The Rubicon is a stereo valve power amp using triode configured EL84s to give a remarkably delicate sound, guaranteed to captivate. Bridgeable for monoblock operation. **£949**

The Indus is the ultimate passive pre-amp, based on Rothwell's unique stepped attenuator. This precision device has fine and coarse volume controls to give 132 volume settings and unbeatable sonic accuracy. **£499**

Audio Images Lowestoft, Suffolk 01502 582853
Kronos Hi-Fi Dungannon, N.Ireland 01868 753606
Serious Kit Prestwich, Manchester 0161 798 9649
Sounds Perfection Helston, Cornwall 01326 221372
Shadwell Hi-Fi Studios Leeds, Yorkshire 0113 237 1019
Input Audio Dukinfield, Cheshire 0161 3047494
Kevin Galloway Audio Killmarnock, Ayrshire 01563 574185
Romers Hi-Fi Rishton, Lancashire 01254 887799
Hazlemere Audio Consultants High Wycombe, Bucks 01494 437892
Audio Illusion Langley, Berkshire 01753 542761
Mid Shropshire Audio Telford, Shropshire 01952 502097
Rothwell Electronics 60 Pennington Road, Great Lever, Bolton BL3 3BR
Tel/Fax 01204 654614

AudioSource

TRY AN £800 INTERCONNECT IN YOUR SYSTEM ... AND KEEP IT FOR £125

Most cables have a sonic signature or tonal character to match specific components. In well-matched systems these cables are often found to be harsh or dull.

Petros cables were designed for AudioSOURCE to complement transparent components in a well-matched system: the goal was neutrality - musical flavour transmitted as water flows along a smooth pipe. If our cables sound bright or blurred, be confident that it is the equipment that you are hearing! Stratos cables have the greatest differentiation of all interconnects we have compared, that is to say that different recordings and different components just yield their own characters, transparently.

The design is the attention to many details, based on simple physics and many listening tests. We are now so far ahead of the game - and still moving the goal posts - that we will disclose the basic principles. The two major principles are conductivity and contamination. **Conductivity:** low resistance, capacitance, etc, using the highest purity copper (silver content acid-free solder) in very fine but many strands. In outer space, such cables would transmit Nothing But Signal (hence the esteemed American NBS brand! Incidentally, we have some of their amazing cables for sale at half-price). **Contamination:** since the invention of radio we are aware that your wires act as aerials. Designers cannot eliminate this in the equipment without serious degradation of the music signal. Planet Earth is now contaminated with EMI, RFI, you name it fields from cellular phones to AC mains. Coming from your neighbours, factories, and your own hi-fi and non-hi-fi devices. Our cables use twin axial (quasi-balanced) plus and minus wires, inside a triple-shielded braid earthed at source only and taken through to the plugs. We also apply Kontak cleaner to greatly reduce RF rectification and enhance surface conductivity. It lasts for about six months. If you haven't tried it, you don't know

what you are missing. £14.95 per bottle.

Stratos Series II (launched in August) is a major leap forward in interconnects which exceed the sonic performance of all but one extremely expensive (NBS) digital and stereo interconnects we have tried in a wide variety of equipment. Series two features our own RCA state-of-the-art phono plugs which use our tried materials (solid phosphor bronze, not bent copper) for enhanced contact and noise rejection. **Do not judge the performance by the price.** Customers are disposing of major brands now shamed by Stratos II because our cables are sold direct to end-users without marketing costs. This saves at least 75% when you consider that packaging and promotion double the cost of cables and dealer margins and vat double it again. One stereo metre of Stratos II thus sells for only £125. Stratos II Digital costs £59. Terminations are RCA or Neutrik Black Gold XLR from stock; others to order.

"These cables are everything you said they were ... this has been the cheapest and by far and away the most significant upgrade I've done to my hifi in years. I ordered cables, and when I opened the box, the contents looked like cables but these Stratos cables are much, much more than that. They have made such a huge difference to my listening pleasure that it's the equivalent of replacing one or more of the key items of hardware. At £120 [series II now £125] a 1 metre pair, they are the cable bargain of the decade." - Mr E.H., Aberdeen, 12/08/99.

Dirty mains has been neglected for too long in the UK but conditioners can degrade sound by limiting speed and power. The best place to clean up your mains is between your wall and the equipment. We are at beta test stage on effective AC mains cords, and can advise you on high-end products from America before you invest. Advice on speaker cables freely available.

PHONE 0141-357 5700. FAX 0141-339 9762.

E-MAIL:jack@audiosource.co.uk The web is at www.audiosource.co.uk.

Special Internet offer
see page 130 for details

MUSICAL FIDELITY
A1000 £750. Meridian 563 (20bit) £375. Sony STSA3ES £150. Sony CDPX55ES £200. Nakamichi CR2 £175. Soundstyle XO53 five shelf rack plus additional shelf £150. Dynaudio Audience 70 £700. Tel: 01276 685 793 day or 07879 477 782 eve (Jun/I)

PIONEER RT707 reel to reel. Good condition £250. Ferrograph 633 mono £50. Box of mixed audio and other valves (includes two new Amperex 6550) £50. Tel: 0116 255 4619 (Jun/I)

PROAC STUDIO 100 with Foundation stands £450. Would swap for power amp. Phillips digital compact cassette recorder with 30 tapes £125. Moth record cleaning machine £125. Tel: 01604 661 052 (Jun/I)

SUGDEN 51 pre amp with 51 power amp £850, Lowther Horn speakers £375, Gale 401 speakers in walnut £275, AVI Pre with Mono Block Power Amps £750. Tel: 01977 643 629 (Jun/I)

AUDIOLAB 8000Q pre-amp £730. 8000A int-amp £280. DPA PDM1 Series 2 DAC £130. VDH CS112 speaker cable 2x10m £100. Ixos 100.X03 0.6m interconnects £50. Technics SL1700 turntable £80. Tel: 01889 882 551 (Jun/I)

LINN LP12, Aro, Lingo, Circus £950. Audionote Meishu amp (phono version) £1800. Audionote type E/SP inc. stands £900. Mana Reference table £250. Mana Mini table £100. All mint. Tel: Nick 0114 245 4601 (Jul/I)

CONRAD JOHNSON Premier Two pre-amplifier. The first Premier pre-amp and a classic, good condition. Noisy transformer hence £450. Be quick! Tel: 01509 215 230 (Jul/I)

KRELL KRC-HR pre-amp stunning transparency. Mint. Can demonstrate £3495 ono. Also Wadia 6i CD player. Mint. Expensive Wadia upgrade from 6 £2495 ono. Tel: 01234 713 199 (Bedford area) (Jun/I)

WANTED. Linn Akito ton-earm vgc. For Sale Sennheiser headphones HD565 Ovation boxed mint condition £50. A&R C77 magnesium bodied cartridge £10. Rega Elys cartridge £30. Both boxed. Tel: 01709 547 176 (Jun)

REVOX B760 tuner £400. Revox B710 II £300. Mission Cyrus 2 + PSX Mark 1 £150. Wharfedale 510 spks £70. Sony 915E CD player £120. Mint Thorens 160B Mk2 + Mayware TMC cart £50. Sonamp power amp £250. Dual 505 vg £20. QED headphone amp £30. Creek 4040 £40. Pioneer TX7500 tuner £80. Wharfedale 50 spk £50. Philips 4506 reel to reel £50. Tel: 0207 394 0870 (Jun/I)

V.D.H. THE Second interconnects (phono), 1.0 metre £140 (£275). 0.6 metre £100 (£200). Goldring Excel VX MC cartridge, very low mileage £160 (£525). All in mint condition. Tel: Rod 0208 205 6778 (NW London) (Jun)

CASTLE AVON floor-standers - yew - boxed - v.g.c. £425. Cable Talk Reference interconnect 1m pair £75. Cable Talk Concert 3m bi-wire £75. Tel: Chris 01296 661 105 (Jun/I)

THETA PRO-PRIME DAC mint condition, boxed. Original owner from new. Big effortless sound. £750. Tel: 01509 215 230 (Jul/I)

HEYBROOK SIGNATURE amplifiers including two power amps, two power supplies and preamp, on Signature stand £900. Heybrook Sextets (perfect match for Signatures) £400. Heybrook Quartets including matching stands £250. Tel: 0113 269 6570 (Jun/I)

TECHNICS SU-A900 Mk2 £190. Rotel 820BX4 £75. Marantz CD50SE and Dac-in-the-box with extras £120. Ixos 105 £12. Chord solids £50. Brother Electronic Notebook £90. All mint, boxed with instructions. Tel: 01253 500 881 (Jun/I)

ROTEL MICHl RHA10 'hi-end' pre-amp. Superb. Still mint after 6 years cossetting. (£999) £230. Musical Fidelity X-Cans headphone amp with Golden Dragon valves. Mint but minus power supply (available from MF) hence £35 only. Tel: 01752 773 369 (Jun/I)

HP3561A DYNAMIC signal analyzer frequency 0.000125Hz - 100kHz. Full specification upon request. As featured in April 2000 Hi-Fi World. Price £3000. Tel: Daytime 01952 605 451, evening 01952 253 515 (Jun/I)

CROFT SERIES 3 OTL monoblocks 45w per ch. Upgraded using premium parts. Fantastic open sounds. £800. Tel: 01384 271 571 (Jun/I)

KRELL KSA50 £750. Rappaport Pre 1A £200. Spica Angelus loudspeakers £500. Marantz CD700 recordable £250. Sony professional portable cassette £150. Audio Research SP9 Mk II pre-amp £800. D115 MkII power amp £900. Arcam C200 pre £150. Tel: 01704 530 928 (Jun/I)

REVOX B760 amplifier £200. Marantz SP50 surround processor £75. Sony STS-700ES tuner £75. Denon DRM33HX cassette £75. Thorens TD160 LVX £100. Mission Cyrus amplifier £75. Yamaha 410 tuner £40. Tel: 01704 530 928 (Jun/I)

SHAHINIAN HAWKS, 2 years old, walnut finish. In excellent condition, boxed. Can demonstrate. Tel: Andy 07776 218 951 (Jun/I)

FOR SALE, drive units in pairs, Scanspeak 25w 8561 bass/mid £110. Scanspeak 25w 8565 bass £155. Scanspeak 13M 8636 Kevlar midrange £75. Scanspeak 13M 8621 midrange £50. Dynaudio T330D tweeter £150. Tel: 01664 851 217 (Leics) (Jun/I)

NAKAMICHI DRAGON 1994/5 serviced mint (£2200) £1100. Studer A80 1/4" reels (£1000s) £380. Ultimate machines. AVI pre and monoblocks latest remote £800. Boxed Spendor BC1's BBC monitors £115. Tel: 0161 764 8888 or 0161 762 9884 (Jun/I)

Classified Ads

Van den Hul:

(all new, unused)

Loudspeaker-cables:

CS-122 Hybrid: £ 9.50 m
Teatrack Hybrid: £ 16.50 m
New Royal Jade Hybrid: £ 7.50 m
Magnum Hybrid: £ 25.- m
Revolution Hybrid: £ 59.- m
Revelation Hybrid: £ 69.- m

Interconnect-cables:

The First Ultimate: £ 189.- 0.8m p.
MC Gold: £ 299.- 0.8m pair
MC Silver IT: £ 999.- 0.8m pair

Cartridges:

MC One Super: £ 639.-
The Frog HO: £ 1099.-
Grashopper IV GLA: £ 1999.-

C.E.C. TL-5100 CD-Transport



belt-drive, black coloured, Digital-out:
Cinch+AES/EBU, 2 years warranty, new, boxed
was: £ 900.- now: £ 499.-

Sonic Frontiers SFD-2 MK II

Tube DA-Converter, 20 Bit Ultra Analog, ex-demo

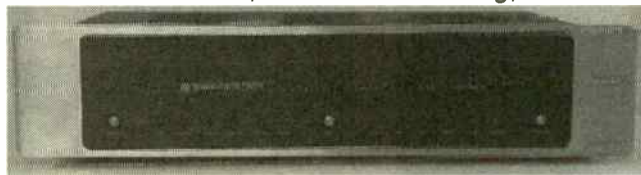

was: £ 5.700.- now: £ 2.600.-

NBS-Cable (new, boxed)

Interconnects:

NBS Statement:

XLR 2,4m was:£ 7.500.- now: £ 2.900.-
XLR 1,8m was:£ 6.250.- now: £ 2.500.-
XLR 1,2m was:£ 5.000.- now: £ 2.200.-
RCA 1,8m was:£ 6.250.- now:£ 2.500.-
RCA 1,2m was:£ 5.000.- now:£ 2.200.-

Digital-Connects:

NBS Statement:

AES/EBU 1,0m
was: £ 2.500,- now: £ 1.250,-

NBS Professional:

AES/EBU 1,0m
was: £ 1.500,- now: £ 750,-
RCA 1,0m
was: £ 1.500,- now: £ 750,-

Burmester 935 II+933 II

Pre- and Poweramplifier, new, boxed



was: £ 5.000.- now: £ 3.250.-

VAC Renaissance 70/70

8 x 300 B Tube, used, good condition



**was: £ 8.350.-
now: £ 3.000.-**

B+W MPA-810

Big Monoblocks, used, good condition, with box, price is for both



**was: £ 5.350.-
now: £ 2.000.-**

**Ask for over 800 more used items,
bargains, specials,...**

Or look at: www.hifi-classics.com

☒ These items are just a small selection of our large stock. Please check out our complete range (updated daily)

at www.springair.de

☒ Looking for rare items ?

Please phone us & we will register your demand in our search database (FREE SERVICE).

☒ 6 months warranty on all items !

☒ S.R.P. are based on former German price-lists

☒ Mail order specialists - worldwide shipment

☒ Trade - in welcome

☒ Credit Cards accepted: VISA, EUROCARD, MASTERCARD, AMEX

☒ Orders will be charged by COD, or can be paid by credit card or bank transfer

☒ Shipping costs are about £20 for an average 20 lbs. item. Loudspeakers and "heavyweights" on request.



q e

Office Hours :

Monday - Friday : 9 A.M. - 6 P.M.
Saturday : 10 A.M. - 2 P.M.

WWW.SPRINGAIR.DE

email : info@springair.de

SPRINGair

Hifi Produktions- und Vertriebsgesellschaft mbH
Alte Andernacher Str. 21, D-56637 Plaidt

Tel. : +49 (0) 26 32 / 93 75 - 28 or 29
Fax : +49 (0) 26 32 / 93 75 - 11

Special Internet offer
see page 130 for details

AUDIOLAB 8000CDM £600. Cyrus III £350. Musical Fidelity X10D £45. Harman Kardon TC1000 £150. VDH First £80. VDH CS122 4x5m £140. VDH First Ultimate £130. VDH Teatrack 2x2m £50. Tel: 07971 810 145 (Jun/I)

AUDIOLAB 8000 DAC, mint condition, £375. Naim 62 preamp, new style, £175. Naim 32.5 preamp, superb sound, £175. Tel: 01275 543 447 after 6pm (Bristol area) (Jun/I)

NAIM 180. 12 months old. First offer £795. Naim 72/90 £550. All excellent condition. Epos 11's with stands. Minor repair required. £165. Naim phono boards. MM/MC £30. Tel: 0141 641 0496 (Jun/I)

SD1 ACOUSTIC Two's speakers floorstanders vgc. Panel like sound excellent with vocals, £475. Tel: 01634 723 223 (Medway) (Jun/I)

AUDIO ANALOGUE Bellini/Donnizetti pre/power amps boxed £600 (£1095). Linn Akito tonearm £130 (£300) pair. Siltech interconnects 0.5m £100 (£210). Tel: 0208 926 6916 ansaphone (Jun/I)

UNISON RESEARCH Simply Two £550. Klipsch KG 4.5 floorstanding loudspeakers £300. Micromega Stage One CD player £100. M&K LCR 55 speakers £250. All boxed mint. Tel: 0208 654 9850 (Surrey) (Jun/I)

NAIM NAP 140, NAC 62 vgc, boxed, one owner £450 ono. Marantz CD85, good condition £200. Tel: 01943 607 336 (W.Yorks) (Jun/I)

MERIDIAN 501 pre amp. Excellent condition. Boxed. Manual. TV CD tape plus many other inputs great sound. Giveaway price. (upgrading) £340 ono. Tel: 01633 254 673 (Jun/I)

FISHER X100 valve amp FM50 tuner and MPX200 decoder £150. Goldring Lenco 88 deck £40. Cerwin Vega AT20 speakers £75. Tangent RS4 speakers £150. Designwise Glen speakers £70. Tel: 01379 898 676 evenings (Jun/I)

NORDOST CABLE. 4 metre stereo pair flatline twin bi-wire boxed £65. Chord interconnects Cobra phono to din £20. Phono to phono £20. Tel: 01895 235 547 (Jun/I)

QUAD ESL 63. 97 Spec. Special Piano laquer finish. Black wood also available. Including stands. Mint, boxed. Reluctant sale. £1300. Aura Evolution 100 chrome amplifier £200. Tel 01376 329 499 (Essex) (Jun/I)

WANTED: Linn Isobarik, latest spec, must have external X/over and panel stands. Tel 01376 329 499 (Essex) (Jun/I)

RUARK TALISMAN-II. Biwireable floorstanders plus 4 litre tub of Soundbytes. Boxed, mint. Still under warranty £400 (£749 + £25). Impeding house move allows upgrade to more amps and bigger Ruarks. Tel: 01483 281 234 (Surrey) (Jun/I)

GARRARD 401, SME 3009II, SME plinth. Good condition, £135 ono. Tel: 01503 250 679 (evenings or weekends) (Jun/I)

SME SERIES V tonearm. Perfect, boxed, with full toolkit and manual. Legendary quality. Sensible offer secures. Wanted: REL Stentor subwoofer (black). Tel: John 01865 862 745 (leave message) (Jun/I)

WANTED: WORKING or for spares. Rogers A75 amp, A100 amp, Pantera tuner. Tel: 01938 553 559 (Weshpool) (Jun)

AUDIO INNOVATIONS P2 phono stage, heavily upgraded, new caps, silver wire etc. £600. Lumley M120 valve mono blocks, boxed, £1150. Michell Alecto mono blocks, new model, boxed £1500. ATC 10's, black ash, boxed £400. all excellent condition. Tel: 01844 347 729 (Jun/I)

1m TRANSPARENT ULTRA interconnect £400. 1m Cable Talk Gold interconnect £150. 2.5m Harmonic Strings loudspeaker cable £200. 1m Renaissance Audio Silver digital cable £100. 0.6m Renaissance Audio Silver blue interconnect £200. 2 way switching box, silver wired £45. Solid Link yellow mains cable £30. Kimber mains cable £30. Tel: 01844 347 729 (Jun/I)

SILVER WIRED Nuance pre-amp/psu, very detailed £375. Lowther Acoustas, silver voice coils, vgc, nice cabinets £350. Dynavector 17D/2 (£450) little use £175. S.D. Ribbon speakers (£2400+) £500. The 'Source'. Odessey arm, 3-D psu £650. AR Legend, RB300 £150. Audion-Silver-Nights mono's £750. Tel: 0151 353 0930, mobile 07720 636 678 (Wirral area) (Jun/I)

QUAD 63's pair, mint condition, recent Quad service, very reluctant sale, boxed, £1250 ono. Roksan DP1 CD transport + Roksan DA1 and power supply. Mint condition, boxed £700 ono. Tel: 01446 418 207 (Jun/I)

QUAD 67 CD, new laser and service 3/4/00, £650. 66 preamp, never used £450. 66 tuner £300. Stands Unique sound support with isolation platform £150. Wanted: Tannoy Buckingham grills. Tel: 0121 742 2015 (Jun/I)

SUGDEN MASTER-CLASS Pure Class A power amp. Mint, boxed £2000 (£3000) One year old. Sugden AU51C pre-amp £550 ono (£995) Two years old. Tel: 0385 771 819 or 01293 611 293 (Jun/I)

AUDIO SYNTHESIS transcend Decade transport, 9 months old, cost new £3295, asking £1900. Audio Synthesis Dax Decade, balanced output dac/digital preamp, cost new £3490, asking £1900. Tel: 01296 437 314 (Aylesbury Bucks) (Jun/I)

WILSON BENESCH Asside hi-fi stands. 4 tier version, asking £400 inc 4x shelves. 2 tier version, asking £200, inc 2x shelves. Target R5 speaker stands £140. Tel: 01296 437 314 (Aylesbury Bucks) (Jun/I)

TRIANGLE ANTAL Loudspeakers, Audio Note silver wired, cost new £900, asking £450. Stands Unique tuned speaker supports. Cost new £300, asking £140. Tel: 01296 437 314 (Aylesbury Bucks) (Jun/I)



WIRE & INSULATION

introduce **DESKADEL** Products

731/733 Ormskirk Road • Pemberton
Wigan • Lancashire • England • WN5 8AT
TEL/FAX 44 - 1 - 942 887171

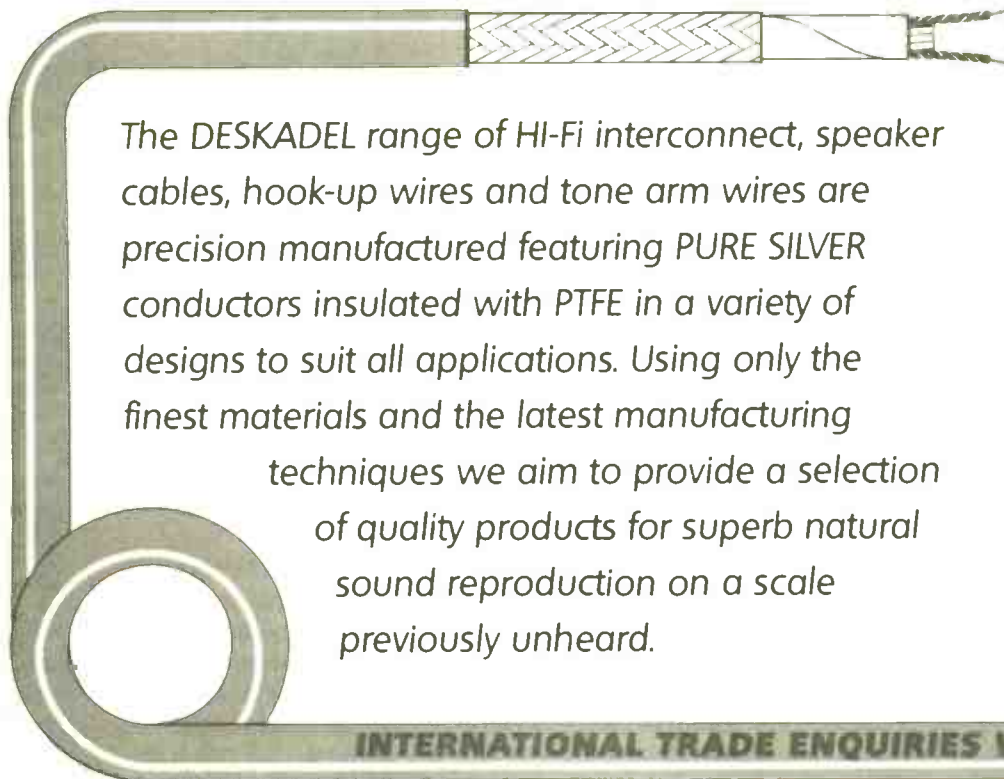

The DESKADEL range of Hi-Fi interconnect, speaker cables, hook-up wires and tone arm wires are precision manufactured featuring PURE SILVER conductors insulated with PTFE in a variety of designs to suit all applications. Using only the finest materials and the latest manufacturing techniques we aim to provide a selection of quality products for superb natural sound reproduction on a scale previously unheard.

INTERNATIONAL TRADE ENQUIRIES WELCOME

DISTRIBUTORS

Switzerland

ARBELOS

Tel/Fax: 41-613616466

UK

AUDIO SYNTHESIS

Tel: 44-1-159224138

Fax: 44-1-159229701

Holland

ANALOGUE AUDIO
PRODUCTS

Tel/Fax: 31-30-6044342

Belgium

DESKADEL INT BVBA

Tel: 32-3-8892231

Fax: 32-38609181



SUGDEN audio products



Masterclass from the original CLASS A company

New products from Sugden

Wide-bandwidth d.c coupled high current class A power amplifier and matching pre-amplifier. Available as a stereo power amplifier you can upgrade or balanced monoblocks.

Handcrafted from the finest materials and components, Sugden guarantee to add an extra dimension to your listening pleasure. Our superior wide-bandwidth designs will increase the dynamic range and sonic accuracy of your audio system - without fatigue.

With over thirty years experience in design and manufacturing Sugden has become a reference for reviewers, musicians and audiophiles around the world. Prices start at £549.00 for the Audition series so why settle for anything less?

J. E. Sugden & Co Limited
Valley Works, Station Lane, Heckmondwike,
W. Yorks. WF16 0NF
Tel. 01924 404088 Fax 01924 410069
Email jesugden@compuserve.com

hi-fi world Trade Ads

Special Internet offer
see page 130 for details

Dealers must not advertise in the Private Classified section. Monthly consecutive insertions will be considered Trade advertising. The Publisher reserves the right to judge submissions.

WANTED - EARLY HI-FI LOUDSPEAKERS
Tannoy, Lowther, Parmeko, Voigt, Vitavox, RCA WE etc
TURNABLES
Garrard, BBC301, EMT SME, Ortofon, Decca, etc.
VALVE AMPLIFIERS
AEI, EMI, Leak, Rogers, PYE-Quad, WE etc
AUDIO VALVES
DA30, KT66, KT88, PX4, PX25, PP3/350, WE300
CLEAR CRYSTAL SYSTEMS
John Petrie-Baker
Tel: 0171 328 9275

ROGERS E-40a pure Class 'A' valve amplifiers - BRAND NEW. Latest improved version, 40 watts per channel. High quality phono stage plus four line inputs. Great styling, superb sound and VERY RARE. 12 months warranty. Only £998. Tel: Stirling Broadcast 01256 851 001 (Jul/I)

MERIDIAN 506.2 CD £650 boxed manuals as new. Papworth Audio MVH200 integrated amp £525 (£1200) boxed excellent condition. Conrad Johnson PV10A and MV55 pre-power £1850 boxed manuals excellent condition. Proac Response 1SC speakers and dedicated Target stand £875 boxed mint condition. Castle Clifton speakers and Atacama stands £135 boxed. Two sets Mit Terminator2 interconnects £135. Mit Terminator2 speaker cable biwire 8 foot £180 boxed. Nordost Blue Heaven interconnect £75. Aiwa ADF450 cassette deck £35 boxed manuals. Assorted speaker cables and power leads available. Phone for details. Apex Acoustics. Tel: Steve 01527 450 500 Email: apexnm@aol.com (Jun/I)

CASTLE LOUDSPEAKERS
New. Discounts available. Deliver Anywhere UK. Please telephone for details. Five Ways Hi-Fidelity Ltd (Est 1972), 12 Islington Row, Edgbaston, Birmingham B15 1LD Tel: 0121 455 0667. Tues-Sat 10.30-6.00 (Jun/I)

BUY-SELL-EXCHANGE. Vintage wireless and classical audio. Repairs, spares, restoration, modification to all valve equipment. Quad II, Leaks etc, shipped worldwide, best prices, call us at 17 Bell Street, NW1 5BY. Tel: 0171 258 3448 Fax 0171 258 3449 (Jul/I)

AFFORDABLE VALVE COMPANY Model EL34. Quality 30 watts Class A valve amplifier £600. Thick aluminium front panel. Detachable safety cage for hot valves. FREE colour literature. 1 month HOME TRIAL. Tel: 01634 373 410 anytime (Oct/I)

ANALOGUE ELECTRONICS Engineer BSc(Hons). Repair, restoration and modification. Also: equipment designed and built to your specification. Please ring between 9.30-6.30 Mon-Fri. Tel: Theo 0181 881 1623 (Jun/I)

TECHNICS SP-10 Mk2 turntables £248. Revox PR 99 Mk3 £648. Studer A80 VU £398. Studer A810 £348, EMT 950 £498. Rogers brand new DB-101 £148, LS3/5a £398, AB-1 £298. Tel: Stirling Broadcast 01256 851 001 (Jul/I)

CD IN Line attenuators. Fixed -12dB £25/pair. Variable -8dB to -18dB £47/pair. Improve volume control and remove input overload. Tel: Grant 01752 202 841 (Jun/I)

LOW COST, high performance stereo decoder for the Troughline, Quad etc. Cased, mains powered outboard unit £58.50 inc P&P. Decoder board only £18.50. Studio 12. Tel: 01736 798 393 (Aug/I)

NAGRA IVS £1200, EMT 948 £450, 950 £750, Technics SP10 £260, SLP1200 CD £500, Revox G36HS £500, PR99 MkII £850, B126 £450. Studer A810 £600, B67 £500, A710 £550, B62 £500, A807 £750, A80 £650, Rogers LS5/8 £250, Nagra T £1500. Uher RM £160. Tel: 01246 235 024 Fax: 01246 550 421 (Jun/I)

AUDIO SYNTHESIS Passion pre-amplifier (passive) & Audio Synthesis Desire power-amplifier RRP £2250 - £1300ono, Audio Research SP9 mk1, boxed, as new £750, Audio Research LS15, boxed, as new £2,200 ono. Krell KSA50 Mk2 power-amp, as new £1,100. DPA Enlightenment Drive plus DAC, 24bit 96khz technology, guaranteed, (new £1,900) £1,000. ATC SCM20 speakers, in yew, immaculate, boxed £900. U.K.D. Opera Callas Gold speakers, immaculate, RRP £1500 - £500. Denon DCD1520, manual, bargain - (New £500) £100. Yamaha DSP A990 AV amp, as new £230. Transparent balanced interconnect, RRP £300 - £120 ono. Transparent power cable, including 3 RF boxes, new £250, accept - £150. XLO 4.1 DIGI cable 0.5m, new £350, - £170 ono. Transparent power cable, 2 RF boxes - RRP £150 - £90. Nordost Blue Angel balanced cables, 1mtr, RRP £128 - £70 ono. Deltac Black Slink, 0.5mtr pair, RRP £147 - £70. Ortofon 7 nine's cable 1mtr, RRP £250 - £170. Tel: Jules 01792 280 061 (Jun/I)

CLASSE CA100 amplifier £925. CAV75 £1495. B&W 610 £130. Arkaydis ASC with matching rosewood stand £525. Quality mains cables and interconnects for home trial. Contact Audio Visual Concepts 01628 440 873 (Jun/I)

PRIMARE D30-2 CD player (new) £1100. Primare D20 CD (new) £600. Primare A30.1 amp (new) £1000. Primare A20.1 amp (new) £600. Magnaplaner SMGa speakers, boxed as new £250. Tel: 01952 502 097 (Telford) (Jun/I)

REPAIRS, MODIFICATIONS, restorations and upgrades to all amplifiers, ancient and modern. One offs built to order, kits debugged, power supplies etc. Quad 303's turned into 'super amps'. Design work undertaken. Ex-Alchemist products and Musical Fidelity engineer. Tel: Arkless Electronics 01642 860 881 (Sep/I)

KRELL FPB600 £8000. Krell KSA300S £5000. Krell FPB650m x2 £offers. Krell KST100 (grey) £1495. M/Levinson 23.5 £3995. Mark Levinson 20.6 monos £5500. Krell KRC-3 £2795. Krell Pam-7 £995. M/Levinson 31.5 CD £7500. Wilson Watt 5.1 £18000-£8500. Sonus Faber Amati Homage £9500. Rogers LS3/5 15 ohms £350. Tannoy 15" Gold x2 £850. Tel: 0207 349 9675 or 0958 607 613 (Jun/I)

HOME CINEMA, brand new Dolby pro-logic surround processors by Onkyo, WHF five star stunning at £300 our price only £99. Hi-Fi purchased. Free parking. Major brands stocked. Tel: Audiofile Objective 01992 478 666. (Jun/I)

AUDIO SELECTION - Showroom - come & listen - generous part exchange. incs. coffee - Available - Audiolab 8000AII, NAD312, Marantz CD63II KISI, CD42, TDL T-Line 2's. Manufacturers-your Hi-Fi sold on commission! Tel: Jim, 01206 510 392 (Colchester) (Jun/I)

EX-DEM SPECIALS Meridian 502-557 pre-power £2149. Meridian 501.2-556 pre-power £1259. Meridian 551 £599. Meridian 504 £569. Cyrus AEQ7 phono stage £349. Cyrus ACA7 pre-amp £559. Monitor Audio Studio 60 (black) £3495. Meridian DSP5000C centre £1399. Tag McLaren 60i integrated £499. Tag McLaren PA10 pre-amp £549. Tel: 02380 337 770 (Jun/I)

VALVE PREAMPS! Best selection of sensibly priced valve amplifiers in England. New valve preamps from £250. New class 'A' valve powers from £350. Stockists of Croft, EAR, Loudspeakers for valves! A C. Acoustics 'Chester'. High efficiency bookshelf design, specially tailored low mass cones for valve amplification. For more info or a demo Tel: Audio Classics 01942 257 525. Email: audio-classics@hotmail.com (Jun/I)

HI-FI WORLD CLASSIFIED ADS ORDER FORM

Dealers must not advertise in the Private Classified section. Monthly consecutive insertions will be considered Trade advertising. The Publisher reserves the right to judge submissions

RATE

Maximum length per advert is 30 words, each additional word is 50p extra.
Telephone and model numbers are treated as one word, i.e. Quad 303 = two words

PLEASE TICK BOX FOR TYPE OF ADVERT REQUIRED

Private:	Free Internet	£10.00 per month	<input type="checkbox"/>
Private:	Display Black Box - Free Internet	£15.00 per month	<input type="checkbox"/>
Trade:	Free Internet	£10.00 per month	<input type="checkbox"/>
Trade:	Display Black Box - Free Internet	£15.00 per month	<input type="checkbox"/>

PLEASE TICK HERE IF YOU DO NOT WANT YOUR FREE INTERNET ADVERT

Please write neatly or type your advertisement copy in block capitals with one word per box.
Please continue on a separate sheet if necessary. WE WILL ACCEPT PHOTOCOPIES OF THIS FORM

1	2	3
4	5	6
7	8	9
10	11	12
13	14	15
16	17	18
19	20	21
21	23	24
25	26	27
28	29	30

Name _____
Address _____

SPECIAL OFFER
BOOK A PRIVATE OR TRADE
CLASSIFIED AD. AND GET ONE
MONTH'S FREE INTERNET AD.

Post Code _____ Daytime Tel No: _____

I enclose cheque/postal order for £ _____ Made payable to: **Audio Publishing Ltd.**



Please debit my VISAMASTER/SWITCH CARD Card No.

<input type="checkbox"/>	<input type="checkbox"/>	<input type="checkbox"/>	<input type="checkbox"/>	<input type="checkbox"/>	<input type="checkbox"/>	<input type="checkbox"/>	<input type="checkbox"/>	<input type="checkbox"/>	<input type="checkbox"/>	<input type="checkbox"/>	<input type="checkbox"/>	<input type="checkbox"/>	<input type="checkbox"/>	<input type="checkbox"/>	<input type="checkbox"/>	<input type="checkbox"/>	<input type="checkbox"/>	<input type="checkbox"/>	<input type="checkbox"/>
--------------------------	--------------------------	--------------------------	--------------------------	--------------------------	--------------------------	--------------------------	--------------------------	--------------------------	--------------------------	--------------------------	--------------------------	--------------------------	--------------------------	--------------------------	--------------------------	--------------------------	--------------------------	--------------------------	--------------------------



Expiry Date _____ Cardholders Signature _____

Send in your private classified ads with our NEW Freepost service. No need for a stamp!
Send this form together with your payment in an envelope marked:
Hi-Fi World, FREEPOST LON3478, LONDON W9 1BR

ADVERTISERS INDEX

Affordable Audio	84	Custom Cable	112	Michell Engineering	24	Sennheiser UK Ltd	44
Alto Fidelity	97	Definitive (Brighton)	107, 112	Midland Audio Exchange	99	Serious Kit	101
Arcaydis	120	Definitive (Notts)	22	Midland Studio	2, 120	Sevenoaks 28, 29, 30, 31, 32, 33	33
Audio Connoisseurs	122	Emporium (The)	98	MPO	IFC	Shindo	40
Audio Direct	86	English Analogue	116	Music & Video Exchange	110	Signals	116
Audio Experience	96	English Audio	108	Musical Fidelity	36	S J Audio	10
Audio Illusion	6, 97	Glaive	122	Musical Images	110	Sound Perfection	38
Audio Matters	108	Grahams Hi-Fi	22	Musonic	116	Sound Stage	101
Audio Reference	6	Grandix	95	MVL	82	Spectra Dynamics	100
Audio Room	94	Halfin	102	NAD	48	Spring Air	126
Audio Source	124	Henley Designs	12, 103	Oranges & Lemons	26	Sugden	128
Audio Synergy	118	Hi-Cam	97	Orelle	120	Tag McLaren	34
Audio T	78	Hi-End	93	Origin Live	106	The Listening Rooms	106
Audio Venue	89	Hi-Fi Company	104-105	Orpheus Audio	118	The Power Plant	108
Audiocom	114	Hi-Fi Exchange	124	Pear Audio	24	The Right Note	44
Audiophile Furniture	26	Ian Edwards	114	P G Hi-Fi	100	Trichord	79
Audusa	112	Ian Harrison	110	PowerSafe	88	UKD	56
BADA	86	IPL Acoustics	118	Progressive Audio	108	University Audio	102
Billy Vee	76, 77, 79	Jem Distribution	102	Q.Trax	24	V'Audio	102
C.A.D.	6	KEF	15, 17	QTA	114	Vickers Hi-Fi	40
Cable Talk	112	K J West One	62	Replay	38	Wharfedale	58
Castle Acoustics	8	Linn Products	40	Retro Reproduction	101	Williams Hart	94
Central Audio	109	Mantra Audio	103	RJF	94	Wilmslow Audio	38
Choice Hi-Fi	92	Marantz	52	Roksan	IBC	Wire & Insulation	128
Classique Sounds	122	Matrix Hi-Fi	22	Rothwell	124		
Crystal Cloud	94	Meridian	54	Russ Andrews	26		

DEADLINE FOR JULY 2000 ISSUE IS FRIDAY 5TH MAY 2000

Caspian
catch the wave

- DSP Surround sound processor
 - 5 Channel AV Amplifier
- also...
- Integrated CD Player
 - Integrated amplifier
 - Tuner
 - Power amplifier

Finish: silver or matt black



Roksan was formed in 1985 to offer sound reproduction systems of the highest quality for the most discerning of music lovers.

Today... nothing has changed, except of course the products... same standards – but now more affordable.

ROKSAN

ROKSAN Audio Limited
Unit 6 • Northfield Industrial Estate
Beresford Avenue • Alperton
Middlesex • HA0 1NW
Tel: +44 (0)7000-ROKSAN (765726)
Fax: +44 (0)7000-ROKSA (765726)

Email: info@roksan.co.uk
www.caspiansystem.co.uk



MISSION



*Beauty is not
only skin deep.*



The new **78** series

Mission Group, Huntingdon, PE18 6ED England. Tel: 01480 451777 Fax: 01480 432777 email: info@mission.co.uk <http://www.mission.co.uk>