

www.hi-fiworld.co.uk

hi-fi



DIY SUPPLEMENT No. 62
INSIDE THIS ISSUE!

JANUARY 2002

UK £2.75
Malaysia Rm18

WORLD

& computer audio

ONE FOR ALL



Tested - Panasonic's brand new DMR-E20 DVD recorder

plus

- Four stylish sub/sat systems tested
- Sony MDS-JE770 MD recorder
- Harman Kardon CDR30 CD recorder
- Clearaudio Champion turntable
- Sugden Masterclass CD player
- Exposure 2010 power amp
- Unison Research S2K integrated amp
- Buying secondhand hi-fi: our guide to the best bargains

Computer Audio World

- Cool Edit 2000 and Steinberg's Cubasis VST
- Frontier Labs' NEX II and Ziplabs Zappee
- Plextor PlexWriter S88TU

COMPETITION
Get your complete system re-cabled by the Chord Company!

JANUARY 2002



+ 100s of classified ads full of secondhand bargains!!!

Small change

RECORD



Big difference

Introducing the Philips DVDR 1000: The biggest small change in DVD technology. Thanks to its red record button, you can now capture your favourite films and TV programmes in the highest digital picture and sound quality. Up to 4 hours recording per side of a Re-Writable disc.

Your recordings will play perfectly on most DVD players and the Philips DVDR 1000 will play DVD-Video movies too. This two-way compatibility is achieved without any compromise on picture quality, recording time and ease of use.

And now preserving your home movies is simply a matter of connecting your camcorder to the Philips DVDR 1000 via the i-Link digital connection. Your recording will be saved forever on DVD.



The new Philips DVD Recorder.



For more details, call 020 8665 6350 or visit our website
www.ce.philips.co.uk/dvdrw



PHILIPS

Let's make things better.

World Radio History

In what was an otherwise ordinary evening in the capital, I experienced a strange phenomenon at the Barbican Hall in London a few months ago that gave me hope for the future of the hi-fi industry. Attending the final of the Masterprize composition competition

I expected to see the hall half-filled with plenty of stuffed shirt sponsors, a few die hard classical music industry bods and not much else, apart from a conductor and an orchestra.

After all this was 'difficult' music that hardly packs in the crowds and what's more, a whole evening of it. Contemporary pieces are usually surrounded by crowd pleasers from

Tchaikovsky or Sibelius, the sugar coating around the bitter pill so to speak. Not here. There wasn't even a 'big name' to help out either - another way of getting the punters in.

I actually found a packed hall filled with, unsurprisingly, sponsors (the money has to come from somewhere) and, here's the crunch, scores of young schoolchildren. It turned out that they were members of various UK youth orchestras that had taken part in a little 'sub competition' of their own performing one of the finalists' compositions.

This gives me hope for a couple of reasons. Firstly, classical music, like hi-fi, is allegedly a declining market. As fewer people take time to understand it - especially contemporary music - so the cultural life of our nation takes a backward step. Getting kids involved at school level is an invaluable and essential way to get things back to a forward momentum. Secondly, if kids are into music they will often be into reproducing it to a high standard.

I first encountered 'real' hi-fi at school. My particular Alma Mater had a Garrard turntable, a Leak Stereo 20 amp and a pair of fine Leak Sandwich 'speakers' sat in room 7, the main music room. As my music teacher got us to shut up by playing loud music in the Stravinsky mould, I wanted to go home and recreate this sound as best as I could, much to the annoyance of my parents - this was my first step on the hi-fi ladder.

It's rare that schoolchildren, for a number of reasons - but mainly money - get this kind

of experience these days and it's a shame. Getting the younger generation into hi-fi is essential for the future of the business and believe me, as long as kids listen to music the potential is there. Even if they download the music in MP3 form, there's still the urge to hear it through decent gear.

Schools, homes (and friends' homes) apart, where do the younger generation get the opportunity to listen? No retailer wants a time wasting youth with no wonga armed with 'crap' CDs ploughing through their demo stock on a Saturday afternoon. And manufacturers spending money exhibiting only want immediate sales from such a venture.

Maybe shows ought to bite the bullet and charge a quid or so more for the public and let accompanied children in free, or have special time period preserved for this purpose. And what's more, let them play what they want to hear, which isn't the usual well-recorded Radio 2 reject tunes. They'd be a lot more appreciative and positive than many that turn up to such events. You never know, the sales could come flooding in, albeit at a later date. Even in these financially unstable times, isn't a bit of a risk worth the possible recoup? ■ ▲



Simon Pope

how we test the products

- Hi-Fi World has its own advanced test laboratory and acoustically treated listening room.
- Hi-Fi World has a dedicated in-house team of experienced listeners. We review thoroughly by extensive auditioning, rather than by quick-fire group listening tests.
- Hi-Fi World's engineering team designs a wide range of products in-house. No other hi-fi magazine is so expert and dedicated.

£ ——— NICE PRICE - Represents excellent value for money.

●●●● EXCELLENT - Superb sound, among the best available.

●●●● VEEERY GOOD - Well worth a listen.

●●● ADEQUATE - Room for improvement.

●● POOR - Seriously flawed. Forget it!

● Half globes are added for those products that we feel are between categories

HI-FI WORLD

SUITE G4, IMEX HOUSE
KILBURN PARK ROAD
LONDON, NW6 5LF

www.hi-fiworld.co.uk

Contact Numbers

Mon-Fri 9am-5pm

Editor

Simon Pope
tel/fax +44 (020) 8786 8141
e-mail: editorial@hi-fiworld.co.uk

Computer Audio World Editor

David Price
email: editorial@computeraudio.co.uk

Graphic/Advertising Designer

Faiza Chunara
tel: +44 (020) 7625 3129
fax: +44 (020) 7328 1844
e-mail: adproduction@hi-fiworld.co.uk

Production/Photography Editor

David Noble
tel: +44 (020) 7625 3134
fax: +44 (020) 7328 1844
e-mail: classifieds@hi-fiworld.co.uk

Advertising

Ewan Hawkes
tel: +44 (020) 7624 9022
fax: +44 (020) 7328 1844
e-mail: adsales@hi-fiworld.co.uk
Amanda Sweeney
tel/fax +44 (020) 8864 4760
e-mail: advertising@hi-fiworld.co.uk

Accounts

Michael Ogazi
tel: +44 (020) 7625 8032
fax: +44 (020) 7328 1844

Credit Control

Louise Palfrey
tel: +44 (0) 1923 270833
fax: +44 (0) 1923 260588
e-mail: subscriptions@hi-fiworld.co.uk

WORLD AUDIO DESIGN

Technical Manager - Nick Lucas

www.worldaudiodesign.co.uk

tel/fax: +44 (0) 1908 218 836
e-mail: nick@worldaudiodesign.co.uk

Publisher

Noel Keywood
e-mail: publisher@hi-fiworld.co.uk

Private & Trade Classified Ads

tel: +44 (020) 7625 3134
fax: +44 (020) 7328 1844
e-mail: classifieds@hi-fiworld.co.uk

Subscriptions & Back Issues

9:30am - 12:00 noon
tel: +44 (0) 1923 270833
fax: +44 (0) 1923 260 588
e-mail: subscriptions@hi-fiworld.co.uk

Distributed by

Comag Magazine Marketing,
Tavisstock Road, West Drayton,
Middlesex UB7 7QE
Tel: +44 (0) 1895 444 055

Printed by

Southern Print, Dorset
Tel: +44 (0) 1202 622 226

Our Agents in Malaysia

Millennium Hi-Fi & AV
Simon Chang
Showroom & office, 500-1-3 First Floor
Wisma Indah (Shen Court), Jalan Tun Razak
50400 Kuala Lumpur, Malaysia
Tel: 603 9283 8171 Fax: 603 9281 3762
e-mail: info@millennium-audio.com

All unsolicited submissions and goods are at the owner's risk. We accept no responsibility for such submissions, nor do we undertake to return them.

No material may be reproduced from this magazine without the publisher's written permission.
© Audio Publishing Ltd



contents

reviews

amplifiers

EXPOSURE 2010 POWER AMPLIFIER 25



David Price gets to hear the hot new power amplifier from the re-vamped amp specialists. Will he be impressed?

UNISON RESEARCH S2K 42



This stylish Italian valve integrated uses KT88 valves in a single ended design. Andy Grove listens in.

loudspeakers

SUB/SATELLITE GROUP TEST 12



Hi-Fi World listens to four of the most stylish two channel 'speaker combinations available. Which will get the seal of approval?

digital source players

REGA JUPITER CD PLAYER 22



This is the £1000 CD spinner from the Essex company. Will it follow the fine tradition of its cheaper stablemate, the Planet?

SUGDEN MASTERCLASS CD PLAYER 55



Simon Pope gets first crack at the new flagship CD player from the Yorkshire hi-fi stable.

digital recorders

HARMAN KARDON CDR30 34



This is the new £600 twin deck CD recorder from the re-launched Harman brand. How will it fare in this competitive market?

PANASONIC DMR-E20 50



DVD recordable is the new big thing. Panasonic stake their claim with this new recorder that employs the DVD-RAM format. Noel Keywood does the honours.

SONY MDS-JE770 MINIDISC RECORDER 59



Is MD dead and buried? It appears Sony don't think so with this new budget recorder, says David Price.

vinyl

CLEARAUDIO CHAMPION TURNTABLE 63



Simon Pope spins the new entry level vinyl reproduction source player from the German analogue maestros.

features

CLASSIFIED SOURCES 37

David Price compares four ways of getting the best sound per pound, by buying a second-hand source from the back pages of this very magazine.

regulars

WORLD NEWS 6

NEXT ISSUE 11

READERS LETTERS 44

Hi-Fi World's team reply to your letters and e-mails.

SUBSCRIPTIONS 56



Hi-Fi World is second to none for news and reviews. Subscribe today!

HI-FI WORLD KITS 64

HI-FI WORLD LIBRARY 68

A comprehensive selection of titles covering audio, valve amplifiers, loudspeakers, solid state electronics and more.

CLASSIC CUTS 70



This month Andy Giles chooses the elegiac Cello Concerto by Edward Elgar.

COMPETITION 72



Get your system re-cabled by the Chord Company in this month's superb Christmas competition.

OLDE WORLDE 74



This month David Price looks at Nakamichi's "budget" 480 cassette deck.

COLUMNS 71,73,75

The World team get to grips with issues facing both the industry and hi-fi alike.

SPECIALIST HI-FI DEALERS 76

Got a problem? - see a specialist.

DIAL-A-DEALER 78

Who sells what, and where to find them.

MEET YOUR MAKER 80

Who makes what, and how to get in touch.

WORLD FAVOURITES 87

Components which we know to be truly worthy of audition.

WORLD CLASSICS 92

Our list of products that have stood the test of time.

MARKETPLACE 107

READERS CLASSIFIED 123

The definitive place to find classic audio components.

ADVERTISERS INDEX 130

computer audio world

FRONTIER LABS NEX II V ZIPLABS ZAPPEE 81



David Price puts these two new Asian MP3 players in a head to head. Which will he recommend?

SYNTRILLIUM'S COOL EDIT 2000 & STEINBERG'S CUBASIS VST. 84

CAW encounters the latest versions of these two audio editing packages.

PLEXWRITER S88TU 86



David Price checks out the latest portable CD burner from Plextor.

DIY SUPPLEMENT NO.62 95

Upgrades for our KiT6550 and KiT34 integrated amps.

world news

▶▶ MISSION'S ULTIMATE STATEMENT

At a recent launch - over asparagus tips and sushi at London's chic One Aldwych hotel - Mission showed to the UK press their new high-end loudspeaker, the Pilaastro. And what a beautiful brute it is - with a cabinet constructed of granular structure to mimic granite, each Pilaastro weighs a reviewer's back-breaking 160 kilos! With a phenomenal price tag of £20,000, this is a design statement as well as a fine sounding high-end product that's clearly aimed at those with a worryingly high disposable income who are free from recession worries.

The Pilaastro has an impressive quoted sensitivity of 95dB and features side mounted bass units in parallel. Each bass unit is horizontally opposed by its partner and linked by a force rod to reduce vibration. The multitude of drive units results in a quoted frequency range of 22Hz up to 56kHz (the upper frequencies are delivered by a high quality Scanspeak tweeter). Recent lottery winners or those wishing to make a musical investment will be pleased to know the Pilaastro is available from the end of November 2001.

Symphonix Ltd.
Stonehill
Huntingdon
Cambs PE29 6EY
Tel: 01480 451777



▶▶ RADIO GOES RETRO

Here's something decidedly different for the UK market. This humble looking box of tricks is the Model One radio from the sprightly named Tivoli Audio. Designed by US Audio Hall of Fame member Henry Kloss - famed for his designs in acoustic suspension 'speaker systems, radio and tv projection - the Model One measures a miniscule 8" x 4" x 5" (W x H x D) and claims to pull in more FM stations than more costlier receivers. Attempting to produce the finest possible sound quality from a small box, the Model One has allegedly been a hit in its US homeland with "massive sales and tremendous acclaim" and has hitherto been available in only mainland Europe. Stripped of unnecessary bells and whistles, the mono AM/FM radio features three controls - one for volume, one for power and band switching and the other for tuning the analogue dial. The Model One uses a new discrete component developed for cell phones and not used previously in FM technology. This device, the company claim, is responsible for the unusually high number of FM stations that can be pulled in for a product at this price level. There's also an input for an external source and outputs for headphones or recording. The tuning dial is a 5:1 gear ratio design for more precise movement of the tuning mechanism; a green LED indicates when the station is tuned on-centre. Finished in a furniture quality wood and available in three



colours the Model One is to retail for £99.99. The Tivoli Audio radio is available from UK dealers or from selected mail-order specialists.

Tivoli Audio Freephone 0800 0930426



THE KOMRI. PREVIOUSLY UNHEARD TECHNOLOGY.

This uncompromising full-range loudspeaker is designed to let you hear every pure note and every subtle nuance of the live musical performance captured by the recording.

The Komri five-way loudspeaker utilises newly developed loudspeaker technology for the sub-bass, bass, midrange, high-frequency and super high-frequency drivers. Two completely independent servo controlled bass drivers incorporating Linn's Class-V Active Servo Bass technology drive the lowest frequency range. The four upper range drivers have been mounted closely together in an optimised acoustic array.

To find your nearest Linn specialist where you can experience the Komri for yourself visit www.linn.co.uk or call the Linn Helpline on 0500 888 909.



LINN

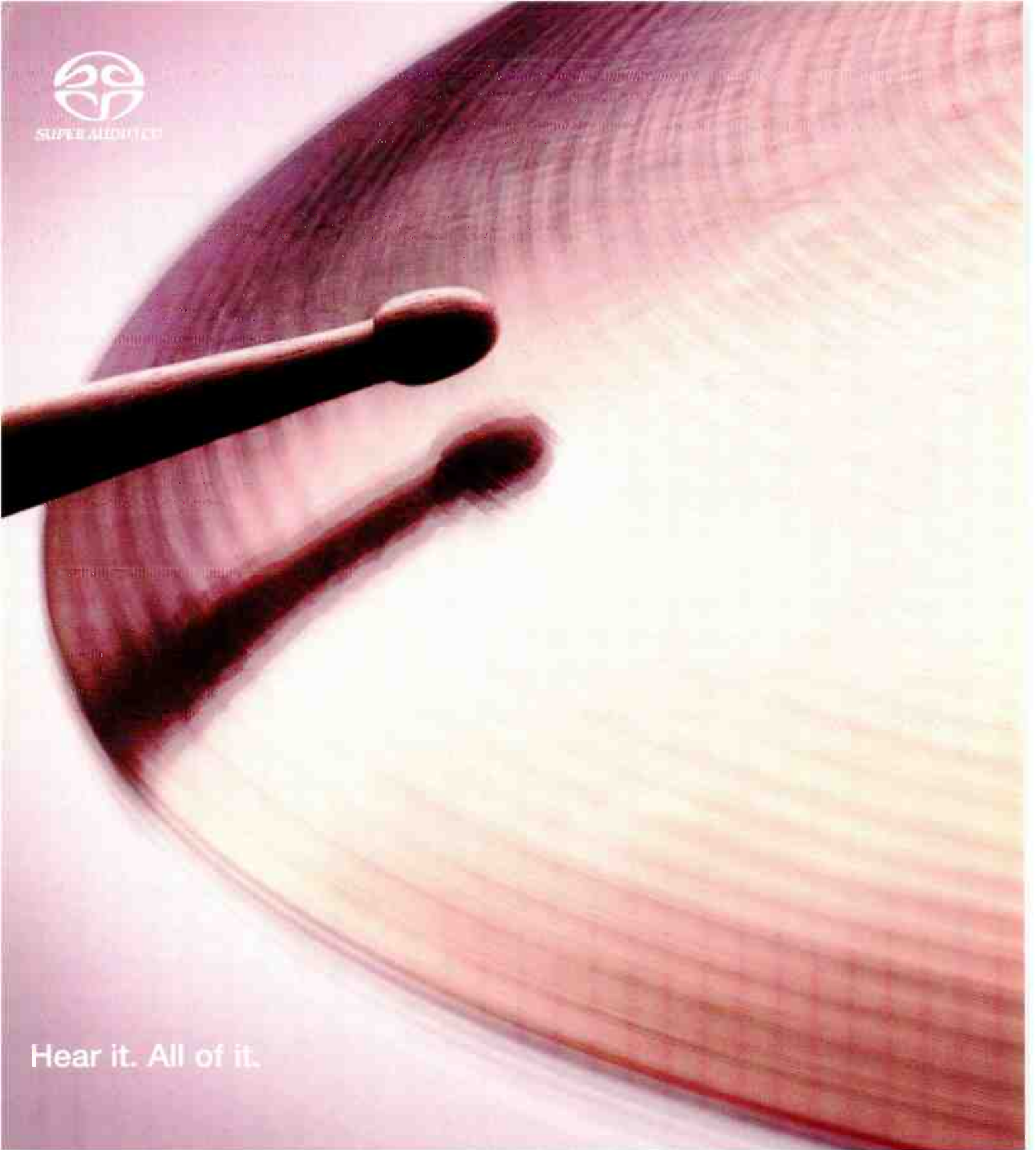

Hear it. All of it.

Sony Super Audio CD.

With Super Audio CD, you'll hear sounds almost beyond the range of human hearing. How? Because Super Audio CD uses completely new technology called Direct Stream Digital (DSD), which gives you sound quality unmatched by conventional CD systems, bringing the finest details into sharp relief. With Super Audio CD's new multichannel capabilities this sonic purity can now surround you, recreating the atmosphere of a live performance or recording. But Super Audio CD is not restricted to pure Super Audio CD players alone – Sony has now incorporated this breakthrough sound technology in selected DVD-Video players and Digital Audio Video systems. So if you truly want to hear what you are listening to, listen to Super Audio CD from Sony.

www.sony.co.uk

Customer information centre 08705 111 999

Sony, Super Audio CD and Direct Stream Digital are registered trademarks of the Sony Corporation, Japan.



go create

SONY

▶▶ NAIM VISUALISE THE FUTURE

Hitherto firmly established as a world leading stereo hi-fi company, Naim Audio have announced details of their first official AV products. The AV2 is a multichannel processor and preamp that promises to have all the facilities and versatility of AV equipment with Naim's attention to detail and sound quality. The AV2 can be used with the NAPV 175 power amplifier for a multichannel experience in the traditional Naim sound mould.

The AV2 is designed to be used either in addition to an existing Naim stereo system or in a dedicated home theatre set up. For example, the Nait 5 integrated has a dedicated AV input which can be used in conjunction with the AV 2 which will power the right and left stereo channels - a NAPV175 can be used for the remaining channels. For dts use a NAP 150 stereo power amp will also be required for the extra channels. Finished in the company's 5 Series

design it possesses the rest of the range's low vibration chassis, anti resonance circuit board mounting pillars and compliant feet. On the technological front, there are time aligned analogue filters and independent power supplies for analogue and digital circuitry.

Priced at £2200 and using a Motorola DSP5632 digital processor, it can decode and support Dolby Digital, Dolby Prologic and dts formats and downloadable upgrades will be available soon for Dolby Prologic II and dts-ES. There are two coaxial digital inputs, two optical, Toslink, six stereo (three RCA and three DMS) VIPS, one tape loop, two coaxial digital outputs and one optical RCA RS232 port for upgrades.

Naim Audio
Southampton Road
Salisbury
Wilts SP4 7LW
Tel: 01292 252525
www.naimaudio.co.uk

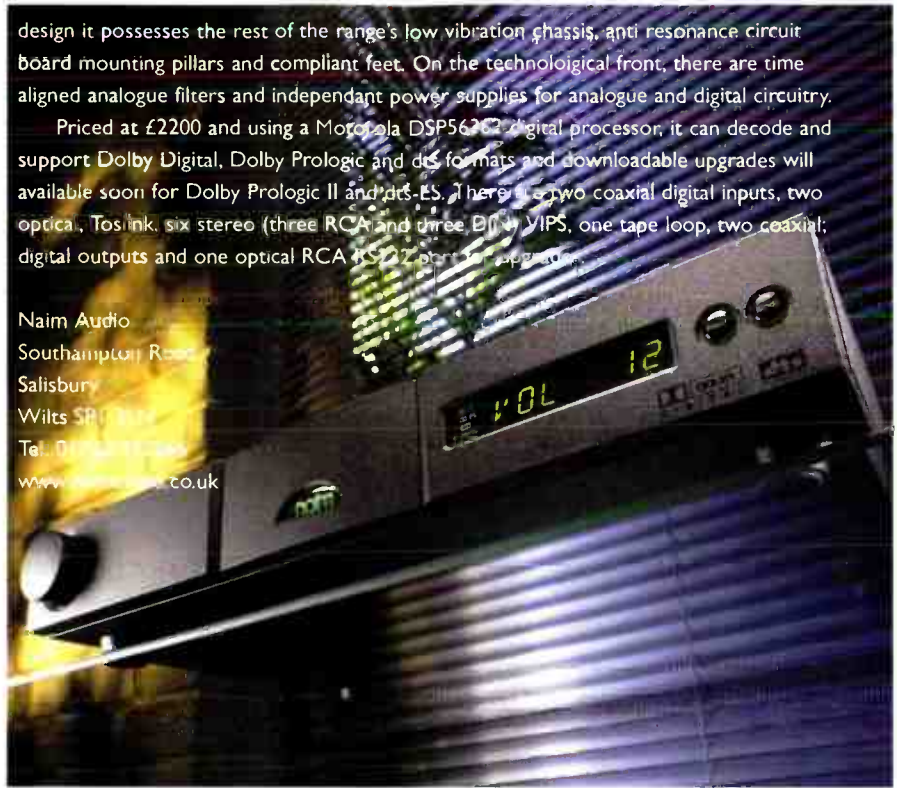

▶▶ KEF'S NEW RANGES HIT THE RETAILER

The boys at KEF have certainly had their heads down recently. The company have announced details of a whole variety of new models that span the price range. At the top end we have the introduction of a new model in the acclaimed Reference Series. The £2999 Model 203 is the first of the range in production and continues the evolution of the series with the incorporation of new technologies. It's a floorstanding 4-way design using computer matched four-way crossover that features a new "hyper-tweeter" unit plus the latest generation Uni-Q midrange/high frequency unit and two six-inch woofers. The newly designed cabinets feature curved sections with massive bracing and an open chassis design with vented cones is employed to eliminate trapped air noise.

Also new to the KEF ranks is the latest Q Series. There are a total of six new models in the pipeline which all feature design and technology features found in the flagship Reference range. At the heart of the range is the latest generation Uni-Q drive units - noted for their wide dispersion and imaging - with a new "Uni-Q pod" in the curved section of the cabinets. The range starts with the Q1 compact standmount featuring a new metal dome tweeter at the acoustic centre of the Uni-Q drive unit which is priced at £250.

Finally we have three models in the new Coda Range, the floor standing Coda 90 which features a side firing sub-woofer, the Coda 80 which is a two-way centre-channel, and

the Coda 70 bookshelf 'speaker - a direct descendant of the Coda 7. All three of the new Codas have a new low distortion bass driver derived from those used in the Reference Series. Prices are £200 for the 70, £380 for the 90 and £150 for the 80. Finishes: Real Wood Black Ash Veneer and Real Wood Maple Veneer.

KEF Audio Ltd.
Tovil
Maidstone
Kent ME15 6QP
Tel: 01622 672261
www.kef.com



Pascal



You won't want to look at anything else.

It's rude to stare. But who can blame you? Our tiny Pascal 815ED hi-fi speakers are designed for eyes as well as ears. Their pure aluminium cases produce a sound so clear a Soprano would be jealous. And thanks to Extended Definition (ED) Tweeters they're perfect for Super Audio CD as well as Home Cinema. With a range of Pascal speakers to suit any budget, it all sounds very impressive. Unless you're a fish.

www.sony.co.uk

Customer information centre 08705 111 999

Sony, Super Audio CD and Pascal are registered trademarks of the Sony Corporation, Japan.

World Radio History



go create

SONY

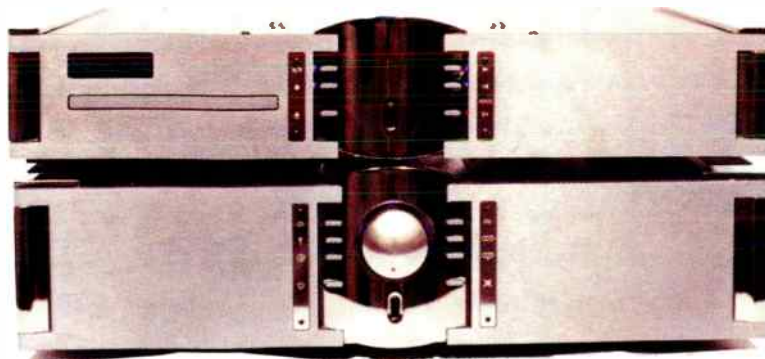

IN THE PINK AGAIN

Pink Triangle are once again back in the hi-fi race with the launch of two new high end products. First is the company's long awaited integrated amplifier, the Integral. Derived from the PIP preamp, the Integral uses the PIP's line level stages and the development which went into the "unfinished" POP power amp. The chunky construction is made from tool plate alloys and finished in anodised aluminium and nickel silver plating. The internals employ an "extremely" linear complex cascode circuit

which is apparently suited to driving loudspeakers with a difficult low impedance load. It uses forty banked ultra-high speed low ESR capacitors to smooth the dual-mono power supply. Power rating is 100W per channel into 8ohms and 200W into 4ohms. The Integral comes with a remote for switching and volume functions and the amp features one pair of balanced inputs and three single ended RCA analogue inputs. Retail price is £3995. A PIP III phono stage is to follow.

Secondly, we have the £4300 DaCapo II CD player. The original digital to analogue

conversion system in this new player was first seen in the original 1-bit DaCapo DAC and the Litaural CD player. The DaCapo II is built using full modular construction, meaning that it is fully upgradable for future formats such as SACD or DVD-A. Whatever takes the lead from CD, the technology can be factory installed in the DaCapo II at a later date. Inside the player is the latest version of the 1-bit digital 3Gem2 and the player features two selectable filter choices: 24-bit processing with 20-bit output, and HDCD. The DaCapo II is "battery driven" for maximum signal-noise performance and isolating sensitive sections from the mains. The integrated power supply with its "battery subsystem" automatically self-monitors the battery status to dispose of user intervention. The finish mirrors that of the new Integral amplifier.

The Pink Triangle Partnership Ltd.
99-103 Lomond Grove
Camberwell
London SE5 7HN
Tel: 020 7703 5498
www.pink-triangle.com

THE SWEETEST BITE

Apple's brand new iPod is a significant product for computers, hi-fi and multimedia. A stunningly styled digital music player 'the size of a deck of cards', it stores 1,000 songs on its hard drive and costs £329 for the stainless steel cased version. Like Creative Labs' original DAP Jukebox launched last year, it has a 5GB hard drive (offering around 1,000 'CD quality' songs), but importantly it connects to Macs only, using FireWire via Mac OS 9 and Mac OS X. It includes a 10-hour lithium polymer battery and offers 20 minutes of anti-skip protection. Look out for next month's Computer Audio World for a detailed overview, and check out Apple's website for more information at

www.apple.com/ipod.

BURNING BRIDGES

Roxio, formerly known as Adaptec, has announced new updates for its Easy CD Creator series of software, allowing it to work hand in hand with Microsoft's new Windows XP operating system. Easy CD Creator 5 Platinum customers can freely download a plug-in from Roxio's website (www.roxio.com). Users of earlier versions of Easy CD Creator Deluxe 3.x or 4.x, will need to purchase Easy CD Creator 5 Platinum for a special limited time upgrade price of £30 and download the free update for compatibility with Windows XP. Customers can purchase direct from

Roxio at sales@roxio-shop.com.

THE SPACE RACE

Why ever would Creative Labs be adding value to its already impressive DAP Jukebox? Could it be Hango's move to cut the price of its impressive PJ-Box, or the newly announced Apple i-Pod? Surely not! Anyway, the DAP Jukebox now comes in a mind bogglingly capacious 20GB version. Available alongside the original 6GB Jukebox, the new 20GB version can store, play, compile and index the equivalent of 500 CD albums, that is 5000 tracks in MP3, WMA and other digital formats. The price is just £339 and it's in the shops now. For more info, point your browsers at

www.europe.creative.com.

next issue

here's a little taster of what we hope to bring you in February's issue

NAIM ALLAE LOUDSPEAKERS

Hi-Fi World get first crack at the new floorstanding 'speakers from Naim Audio. Find out what we make of them next month.

ROGUE AUDIO 99 & M120 PRE/POWER AMPLIFIERS

These valve amplifiers from across the pond promise to be a real find. Read all about them in just four weeks time.

BOOKSHELF LOUDSPEAKER GROUP TEST

A selection of the latest budget bookshelf loudspeakers get the HFW treatment next month.

SUB STANDARD!

So you want bass but you haven't the space. What are your options? Simon Pope picks out four of the most stylish satellite and subwoofer sets on the market.

“Gone are the days when a wardrobe with woofers in each corner of the room was not only domestically acceptable but the only way to get bass. With today's increasing obsession with everything to do with home interiors, even some die-hard hi-fi fanatics are tempted to go for something a little less intrusive - and more partner pleasing - as long as it doesn't sacrifice sound quality for social acceptability. The good news is that with the exposure of home theatre more and more high quality speaker systems are flooding the market. The four examples that we review here are all super chic looking but also claim to deliver the goods when it comes to true high fidelity sound quality - narrowing the gap between hi-fi and 'lifestyle' product in a way that more man-

ufacturers are now believing is the way forward for financial success. There are both pros and cons to sub/sat systems. Pros are obviously the fact that oodles of bass and depth can be administered in a visually tidy way, taking up relatively little space. Cons usually come in the sonics - good systems need to integrate well, leaving no gaps in the frequency band and delivering bass which is tight and tidy as opposed to ragged and woolly. Comprehensive research and development and plenty of listening time is essential for manufacturers to get this right and when they do, the sound can be very impressive. Let's hope that the four parties here have put the effort in. If so, it could be RIP for the corner coffins of yesteryear!



Final 0.2/10 subwoofer



Linn Katan/Sizmik



Cabasse Systeme iO/Jupiter subwoofer



Blueroom Minipods/Bass Station

Blueroom Minipods/Bass Station £828

Another contender for hi-fi's weirdest shaped components. If the Cabasse iO system resembles elephants' eyeballs on sticks, then this Minipod set up looks like two blue Eskimos with a bongo! The Minipods have, of course, been around for a few years and we first reviewed the original models way back in 1998, discovering that despite their obvious novelty appeal they also offered surprisingly decent sound quality. Now, of course, the Minipods have found a wider audience and greater fame, featuring as a visual device for many a TV program and advert.

Although I said we were "surprised" by the Minipods audiophile credentials when we first came across them it should have been taken as read that the company wouldn't sacrifice sound for looks, as there is a distant but none the less important link with the 'speaker giant B&W here, as Blueroom are the only company to use their neighbours (both companies are based in Worthing, Sussex) drive units. The design of the satellites hasn't changed much over the years (hardly at all cosmetically) but this latest generation unit has a few internal alterations from the first model.

The striking, drum-like bass station uses a driver which fires upwards as opposed to many subs, that have a downward firing unit. Positioning here was more important than with the other subs tested. It took a few attempts to gain the best performance from the system, so it's not the easiest of the group to set up. The ideal for my humble (13'x13') listening room was about a foot away from the rear wall and about one foot

behind the satellites towards the middle right! The power isn't in the mega standards but effective at 75W. Quoted crossover is from 40-120Hz and there is the usual gain and phase control. One small gripe is the below par 'speaker connections on both the sub and Minipods.

The sound is actually a lot bigger and warmer than the dimensions suggest. Firstly, the satellites have a commendably high sensitivity which adds to the immediacy of the sound and the bass unit, whilst not the speediest around is nonetheless tuneful and deep. The fast, pounding bass line of Underworld's Push/Upstairs erred to the sluggish at times although the notes were discernable. Because of this, speed integration wasn't as sharp as I'd have liked but a little tweaking of the filters ensured that little was missing when it came to frequency band integration. This is quite a warm sounding sub woofer that matches the smoothness (sometimes almost veiled) sound of the Minipods. Consequently the treble is often a little covered, resulting in a loss of detail in the high and upper midrange frequencies.

Classical music sounded good. Mahler's 7th symphony on DG had space and depth, in a commendable attempt to convey the (admittedly very large) scale of the orchestration - by no means easy with these type of 'speaker set-ups. Strings a had good



tone and warmth and basses had depth and scale. Dynamics weren't the most reactive I'd heard and the complexity of the scoring often sounded swamped at climaxes. Still, these 'speakers are by no means shoddy. Despite the deliberately untraditional design of this system, it performs with a kind of old fashioned, smooth sound more akin to a Leak Sandwich sound than a thrusting, modern sound system for the young urban dweller! By no means bad, the Minipods and bass Station are good, well rounded performers, though integration and a softening of the sound means that detail could often be better.

Blueroom Loudspeakers Ltd.
6c Littlehampton Road
Worthing
West Sussex
BN13 1QE
Tel: 01903 260033
www.minipod.com

MEASURED PERFORMANCE

This satellite and subwoofer combination returned one of the flattest response traces of the group, as our analysis shows. There are no suckouts and little peaking, but treble output is very well maintained up to 20kHz which is likely to give the speakers a touch of brightness compared to many.

The satellites were flat and integrated well with the subwoofer,

without peaking between them. The main point to note here is that the subwoofer does not go especially low. It turns out quite a lot of bass but cuts off steeply below about 35Hz. This isn't a subwoofer so much as a powered bass unit that in effect lends bass weight to the small, light satellites. It is an accurate system all the same. **NK**

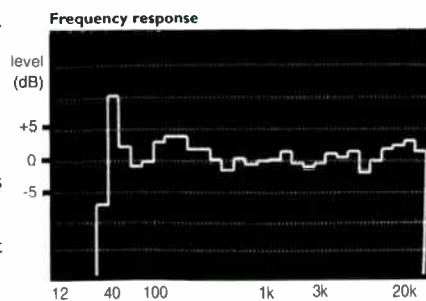

World Verdict



Fairly good value for a stylish system with a warm and generous sound. A bit too woolly at times, though.

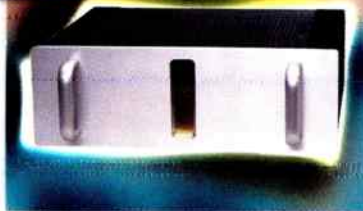

Gamut amplifiers "Sweet and seductive in that nearly ineffable way the real thing is" - Harry Pearson. The Absolute Sound



Start from Clearaudio's basic turntables and trade up to their award winning Master Reference.



Cabasse Kl loudspeakers delivering audiophile performance with style, and a life time guarantee



Transfiguration Spirit Mk3, rendering faithfulness to the original recorded sound



Alolia Italian tube timbre amplification featuring their 'Inductive Power Supply'



Audio Reference are the UK Distributors for Acapella, Alolia, Argento, Cabasse, Clearaudio, C.A.T., Gamut, Graham, Halcro, Shakti, Shun Mook, Transfiguration and Thule. For a free information pack contact us on, Tel: 01252 702705, e: info@audioreference.co.uk

campaign audio design

Hi-Fi Cables Manufacturer and Supplier

"Love Hertz"

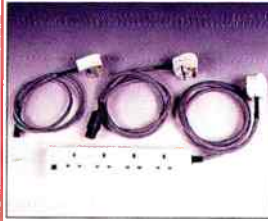

Getting a better, more involving sound often means spending a lot of hard earned money. It's such a waste, because every system can benefit from our cables and accessories, at a fraction of the cost of some new "black box". Here are some of the ways we can help.

We have Linear Crystal Oxygen Free Copper interconnects (£12.48) up to High Purity Silver balanced cables (£99.00) and high definition

loudspeaker cables in Silver Plated Copper or Pure Silver. Our mains cables add weight, power and seal, and with non-inductive RF filtering (£10.00) and over-voltage protection (£3.00) enhance performance still further. Gold plated AV cables, both RF (£19.95) and OFC Scart with PTFE insulation (£30.19), help bring picture quality in line with NICAM sound resolution.

We also have a cure for your noisy fridge or central heating motor (£3.50), enabling you to throw away your big mains noise suppressor, which has been giving you that "sat upon sound" for years. There's lots we can do to bring you closer to the emotion and energy of the performance. So confident are we, that we offer a 21 day money back guarantee.

Ring or write for details:-

CAMPAIGN AUDIO DESIGN
Llandudno Road (HW)

Cardiff CF3 3PG

Tel:- 02920 779401

Website: <http://business.virgin.net/cad.cables/>



Trade and International Enquiries Welcome.



definitive audio

Part exchanged and ex-dem clearance.

Sale New

Digital

Sugden Masterclass CD - new - boxed	£1990	£2500
Helios Model CD2i - new	£890	£1200
Helios Model CD3i - ex-dem	£690	£900
Linn Genki - 1yr - boxed	£650	£1000

Analogue

Nottingham Analogue Mentor - with reference platter	£1900	£2900
- Reference power supply for above	£490	£800
Nottingham Analogue 'Foot' - 12" carbon fibre tonearm - new	£700	£1100
Nottingham Analogue Space Deck - with SME arm mount	£650	£850
Helios Cyalene - tonearm	£590	£1350
Hadcock GH228 Super - 9" tonearm - nearly new	£440	£640

Loudspeakers

Living Voice Auditorium - Hi-Fi Choice 'Best Buy'		
4 pairs - Walnut - ex-dem	£1150	£1500
Cadence DS	£750	£1750
Dali 104 (MS)	£390	£650
Lowther Bi-Core 2000	£500	
Klipsh LaScala Black	£1750	£3500
Quad ELS63 - fully reconditioned by Quad	£1500	£3000
Quad ELS63 - fully reconditioned by Quad	£1300	£3000

Amplifiers

Border Patrol 300B SE - with new Western Electric valves.		
Light Oak - the best SE available - ex-dem	£3750	£4500
Canary Audio 301 - 24 watts stereo power amp with 2 matched pair Western Electric 300B - fabulous	£3900	£5200
Art Audio Concerto - integrated 40 Watts Class A. V.good x2	£1500	£2650
Audio Innovations S1000 - 50 watt class A monos	£790	£1550
Joule Electra 2 box phono pre-amp	£800	£2000
Art Audio VPS - valve line pre-amp	£600	£1400
Sugden A21 - integrated (line only) ex-dem - mint condition	£750	£900
Musical Fidelity A1000 - 'super pre main' class A	£850	£1800
Cary '2A3' 7 watt power amp 1992	£850	
Cary 5500 Line pre-amp. 1992	£550	
Unison Mystery One PR+	£950	£1750
Tube Technology MAC phono pre-amp. Fully refurbished by manufacturer. Including Hovland film and foil capacitors.	£900	£1400
Tube Technology line pre-amp with separate power supply Fully refurbished by manufacturer.	£850	£1450
Tom Evans Groove - phono stage - new	£490	£750

Tel 0115 973 3222 Fax 0115 973 3666

internet: www.definitiveaudio.co.uk email: shout@definitiveaudio.co.uk

► Cabasse Systeme iO/Jupiter subwoofer £1230

Eye, eye what have we here then? Probably the most bizarre looking speakers that have ever graced my listening room, the iO system is the work of Cabasse, the French high end 'speaker manufacturer famous for high sensitivity cabinets with balls! The balls in question have lost their cabinets (the company's Baltic loudspeaker) and are to be found atop metal poles. They still retain a sensitivity quoted as 93dB.

Looking like they've been prised from an elephants skull, these contraptions use the company's SCS (Spatially Coherent Source) technology and consist of a midrange 13cm Duocell membrane with a treble dome unit centrally placed as the balls-eye! The satellites are solidly built, the actual balls themselves have a metal cabinet that is integrally linked with the stand itself, so 'speaker connections are actually found beneath the base of the stands, making things nice and tidy on the cable front. If you don't fancy the stands, then a wall mounted base can be substituted into which the spherical oddities magnetically clamp with a strong 'thock' (so 'fall out' should be a rarity!)

The Jupiter subwoofer is a bit of a beast. Weighing a fair amount it features a horn design and a power output of a healthy 170W. It features a horn loaded unit and has gain control plus an adjustable crossover ranging from 35-200Hz - the iO balls take over from 180Hz.

The sound of the iO system far outperforms its diminutive appearance. There's a nice dispersion to the satellites that spreads the sound throughout the listening room and whilst they image quite well, this isn't what they are especially about. Put on some bass heavy dance music and you'll find this system kicks like an angry mule. Underworld's Push/Upstairs powered through the drive units with authority and grip with the bass full and fast and upper frequencies and midrange detailed, if a little hard in true French style. This is a system that can really be caned without it becoming highly unpleasant or particularly strained - looks are deceptive and the sound is big.

Mahler's large scale music is a good test for such systems, few of which can recreate the sheer space of the orchestra. The iO did a commendable job with a fairly large 'out-of-the-ball' sound and the sub helped create a full and ambient acoustic. The innate sharpness of the top end made the upper strings, brass and woodwind stick out too much but overall their good integration, with plenty of midrange detail, was discernable. Take away the sheer novelty factor of this system and you'd still be left with a pretty impressive sound, albeit one that could perhaps grate over long listening periods.



Audio Reference
Unit 8, Enterprise Park
Slyfield Industrial Estate
Guildford
Surrey
GU1 1RB
Tel: 01252 702705
www.audioreference.co.uk

MEASURED PERFORMANCE

The small Cabasse satellite loudspeakers have none too smooth a frequency response. There are plenty of ups and down, characteristic of a mediocre quality drive unit. Although not smooth by modern hi-fi standards it does all the same cover the audio band well enough. A midband hump will aid vocal projection. A small lift above 6kHz of +3dB, taking output strongly up to 16kHz, will likely add audible brightness to the sound. I'd expect the satellites to sound clear, but possibly sharp and a bit coloured.

The single mono subwoofer crosses over at 125Hz to the satellites and it reaches down to a low 20Hz. Our analysis, distant from the subwoofer to show integration with the satellite, shows a large peak, but this is a room mode. A separate near-field analysis, not shown, revealed a flat enough frequency response with good extension downward and an effectively adjustable upper limit.

Although the Cabasse system will have plenty of deep bass the satellites do not look very refined and will likely come over as bright. **NK**

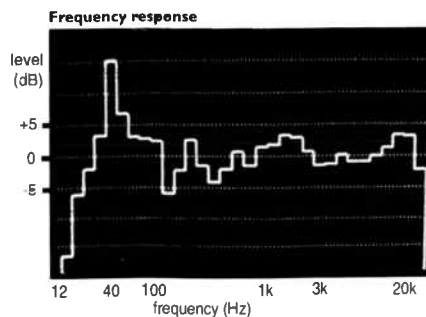

World Verdict



Uniquely engaging looks and very space friendly. A good hi-fi sound with plenty of drive that's just let down by the edgy treble.

►► Linn Katan/Sizmik £1595

This is a very neat looking combination with a visual appeal that's easily accommodated in most environments. We've reviewed the Katans on their own previously and whilst they need a fairly powerful amp to drive them, they give an accurate and rhythmically involving sound with a quick and colourless response to most music and recordings. Due to their sheer size (or lack of it) low bass isn't exactly forthcoming, so the new Sizmik is a perfect match for those who require a little more bass grunt but wish to retain a stylish and compact looking package - perhaps the most conservative in the test.

The Sizmik is the odd one out when it comes to the subs in this test. Instead of the usual potentiometer controls for filters and gain, mm, the Sizmik's operations are electronically adjusted and there is a tiny but significant green LED display. We have the usual line level and speaker

connections but the filters and gain are altered by using three discrete buttons at the bottom rear of the sub. This design allows for a whole host of parameters (eight in all) such as two modes of gain (coarse and fine), internal and external high pass filter, an internal low pass filter as well as phase adjustment. The drive unit is a 10" long throw design and the cabinet a very solid 38mm MDF construction. Power rating is a hefty 500W.

Setting up this system was by far the most difficult of the four, mainly due to the various parameters of the sub. However, these parameters also make it one of the best to integrate. The initial sound was loose and flabby, with a heavy one-note bass, this became gradually more and more subtler until after a good thirty minutes or so the sound miraculously tightened and became highly cohesive. The result was one of the best 'hi-fi' sounds heard in this group test. Underworld's Push/Upstairs' had muscle and drive, plus a good spread

of frequency range that was impressively seamless. Detail in the Katans was excellent and the rhythmic drive of the track was brilliantly portrayed. With classical in the form of Mahler, everything was well proportioned and balanced but the Linn set up just failed to create the space and depth of the recording, although instrumental colour was very fine and phrasing well relayed.

Whereas the Sizmik sub may not suit other manufacturers' speakers quite so well, partnered with the Katans the combination is very convincing, giving a true high fidelity sound totally bereft of the 'boom and tizz' factor that can often creep in. You have to work hard on integration with plenty of tweaking and to-ing and fro-ing (set it up with a pall!) but when this is completed it's a solid, fast and detailed sound you'll be greeted with - although not one of the most spacious or airy available.

Linn Products Ltd.
Floors Road
Waterfoot
Eaglesham
Glasgow G76 0EP
Tel: 0141 307 7777



MEASURED PERFORMANCE

The Linn Sizmik subwoofer has a lot of on-board filters to control behaviour, but under near-field measurement it had a fairly rounded response no matter what setting was used, preventing it from going too low unless gain was cranked up. The gain at 30Hz had two settings, rather than the three alluded to in the handbook, and even at maximum there did not appear to be too great a lift at this frequency. The problem with going really low at constant acoustic amplitude (i.e. SPL) is that

cone excursion must increase progressively, so e.q. often must be limited and this appears to be a concern with the Sizmik.

Our overall response shows the Katan satellites have a smooth response, as you'd expect from a real hi-fi loudspeaker. The Sizmik integrates in well but at -9 gain there's some bass peaking. It reaches down to 30Hz (-6dB), output rolling off steeply below this frequency. This is not

especially low for a dedicated, powered subwoofer. **NK**

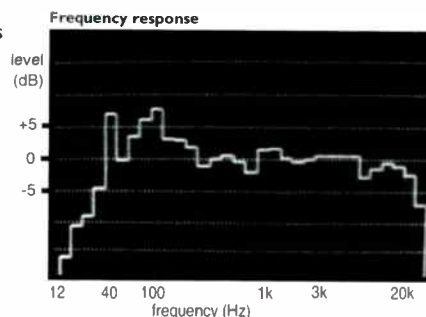

World Verdict



When properly set up this combination delivers a cohesive and well balanced sound. Good with rhythm and speed.

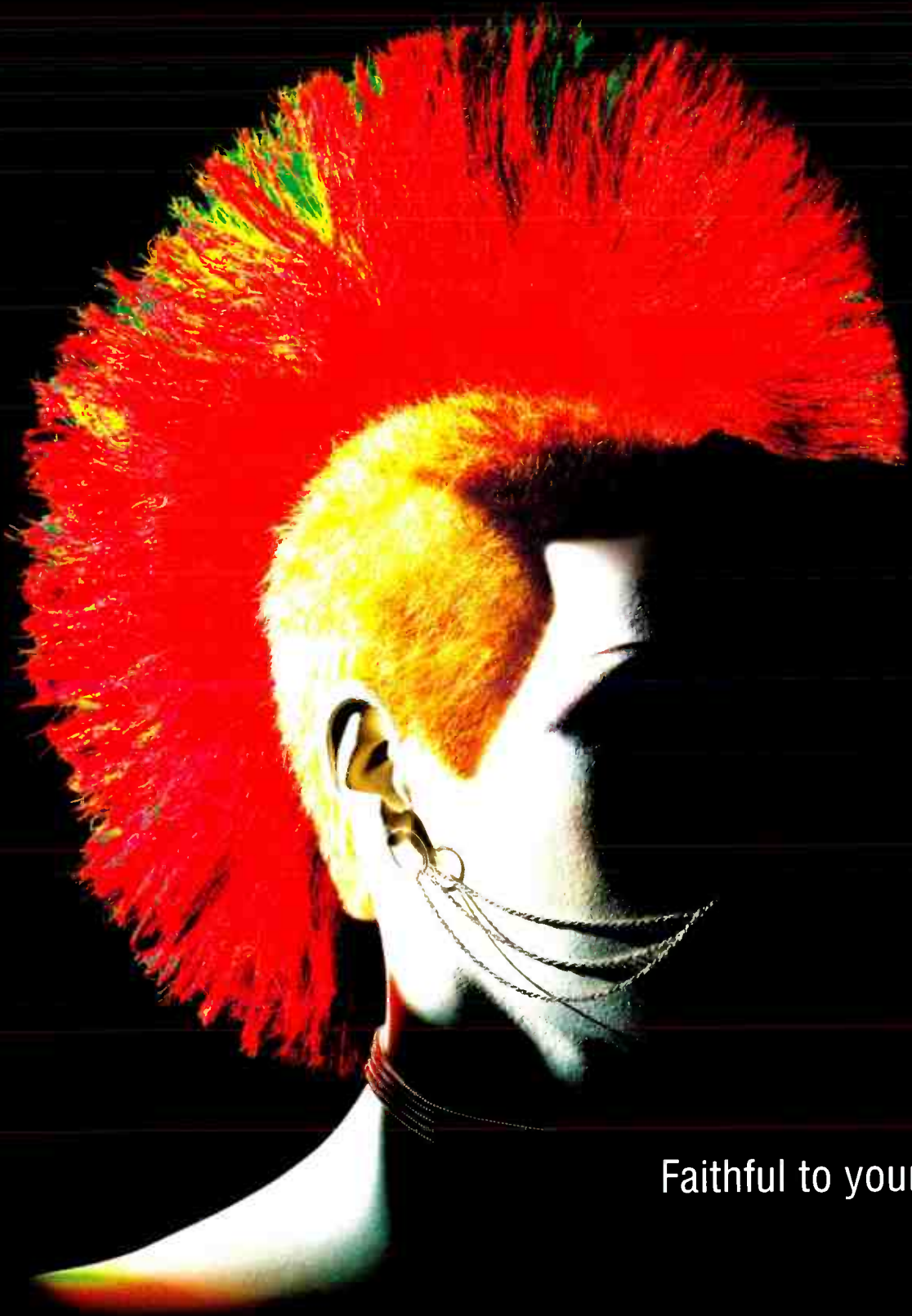

Faithful to your music



Music as it was meant to be heard • Systems start from £3000

For your nearest stockist call +44 (0)1722 332266. Or visit www.naim-audio.com

World Radio History



Final 0.2/10 subwoofer £1875

Like the Linn Katan 'speakers, we've encountered these electrostatic panels from the Netherlands before, although that time they were attached to a vertical cylinder with an up firing bass unit in a hybrid design - the 0.3. Here with the 0.2 the sleek panels have lost their chunky Siamese twin and look all the better for it. We now have a less esoteric 'hi-fi' product and a more appealing system that would catch the eye of many more interior conscious buyers than the 0.3 perhaps would. Intended as a modular system the panels can be bought in pairs with the sub and central unit (more of which later) for a stereo set up and further panels - including a shorter, horizontal 'centre' panel - for surround sound applications. Wall mounting brackets are also available for that extra aesthetic appeal.

With the panels and subwoofer, a central unit that resembles an amplifier is also supplied. The 'speaker outputs from your power amplifier or receiver are connected into the 4mm banana plug sockets of the centre unit (there are five pairs in total) next to which there are three pin sockets into which the panels are connected to receive the signal. Sounds confusing but its a fairly simple process and one that is actually quite sensible - as it can make things a little more neat and tidy in the home. The sub is connected as per usual with either line or speaker connections straight from the amplifier/preamplifier. There's nothing out of the ordinary when it come to the subwoofer's features and controls

but it does have two drive units in a kind of 'dipole' configuration.

Little set up was needed. With only a little filter and gain tweaking the sound was soon well integrated and filling the room with a light and spacious sound. Due to the thin nature of the electrostatics, as we found before, they are somewhat directional and don't have as wide a dispersion, as say, a Quad but the sound is nonetheless very transparent and detailed and refreshingly different from most sub/sat systems on the market. You're not going to rock the house's foundations with this system but it's revealing and rich. Underworld's pumping dance music failed to have ultimate drive and power overall (although the sub was fast enough to keep up with the panels - no mean feat) but it was responsive and well detailed with plenty of upper frequency intricacies revealed. The Final system was well suited to the classical sound, with strings in Mahler's 7th symphony transparent and natural sounding, free from scratchiness. Woodwind was suitably ethereal and lively and added to the sense of space and ambience. Imaging is fairly good with the orchestra spaced out well, with a good sense of perspective although the pinpoint accuracy found with more conventional 'speakers is somewhat lacking.

For those who like a refined and spacious sound with plenty of



transparency and neutrality the 0.2/10 combination could fit the bill. You get a true hi-fi sound with stylish minimalist appeal - it's something different that's also effective but also pretty expensive.

UKD
23 Richings Way
Iver
Bucks
SL0 9DA
Tel: 01753 652669

MEASURED PERFORMANCE

This unusual satellite and subwoofer system comprises an electrostatic panel and a small powered subwoofer. Unfortunately, the panel had a noticeably hollow resonance sound under test with pink noise, and the spectrum analyser clearly shows there's a very large peak at 200-250Hz - an odd effect.

The other effect of significance is a smooth roll down in high frequency energy above 4kHz, which became steeper as the measuring microphone was moved off-axis. The Final will

have a smooth sound that will lack really high treble, but it might not sound too dull in the conventional sense because open electrostatics like this often seem very clear.

The subwoofer reaches down to around 38Hz, which is not especially low. Much like the B&W system the subwoofer here is a powered bass unit rather than a true floor shaking sub. There is a benefit in that musical bass notes can seem cleaner and faster when not accompanied by rumbling subsonics.

The Final 0.2 system is a bit idiosyncratic, shall we say. It will doubtless have some beguiling properties, but there are a few significant weaknesses in there too, so listen and see. **NK**

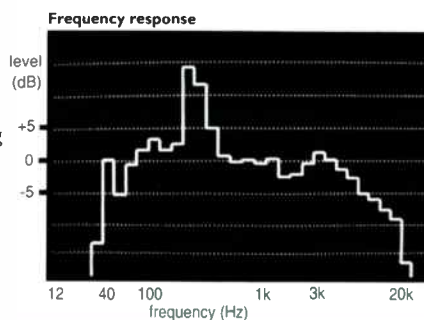

World Verdict



very different to the usual sub/sat sound. This is an airy, spacious and civilised sound but it doesn't come cheap.

conclusion

Sonics apart, many prefer a sub/satellite option for questions of practicality. Family homes appreciate more space and a hefty floorstander can be toppled over - spikes and all - quite easily by a young child, for example. Judging by the amount of letters and emails we get on this very subject, it's obviously a concern of many audiophiles.



▶▶

One factor that was consistent with all the systems here was that with a bit of time spent on proper tuning resulted in a very cohesive sound - far better than expected. You may not get the ultimate cohesion and seamlessness found in the best floorstanders at the price but in some cases there's not much in it. What system you'd choose actually depends on which characteristics you want from the sound. If you're into classical, for example, the Final system would be your cup of tea. Being an electrostatic design there was transparency and space in abundance. Strings and

woodwind, for example are as clean as a whistle and there's a keen sense of ambience. You also get a very refined overview of most other music, although those into dance or rock may wish to look elsewhere. Unless you like the look, of course which is genuinely engaging and modern without being too wacky.

Talking of wacky, we then have the Cabbasse iO/Jupiter system. This wasn't a bad sound at all but it's geared for those into studio music rather than acoustic or classical, as scale is quite hard to create here. It certainly kicks like a mule, with a forward and sometimes disconcerting sound but there's plenty of presence and drive here - ideal for dance music. The down side to this, though is that typically French edge to the treble which, because these go relatively loud could be a tad wearing at extended listening periods. It was a good out-of-the-box sound though, with decent dispersion. Looks-wise it's an acquired taste but love it or loathe it, it certainly turns heads.

The other two systems are less genre fussy than the Final or Cabbasse 'speakers. The Linn Katan/Sizmik combination was perhaps



the fussiest to set up but is also the most versatile. It's very important to set up the sub well, using all of the

parameters to tweak carefully, as when it was incorrectly set, it sounded loose.

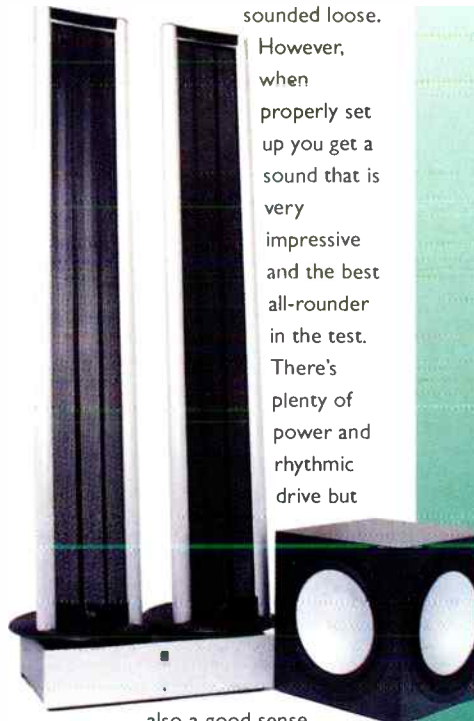

However, when properly set up you get a sound that is very impressive and the best all-rounder in the test. There's plenty of power and rhythmic drive but

also a good sense of detail and cohesion to all aspects of the sound. Integration is very good. It is the choice for those who wish to play anything and everything.



The cutie Minipods and Bass Station definitely have the novelty appeal, although the sound is far from the novelty dept. It's a good, solid, sound but not quite up to the best here - as the lower price suggests. Still, many will find the warm and accommodating sound pleasant and, again it's a good all rounder with all types of music. The looks make them a highly distinctive choice, although I wouldn't expect to find them in the front room of many pensioners! ■ ▲

Heard the impossible?

It sounds amazing –

but what exactly is 1-Bit audio?



SHARP

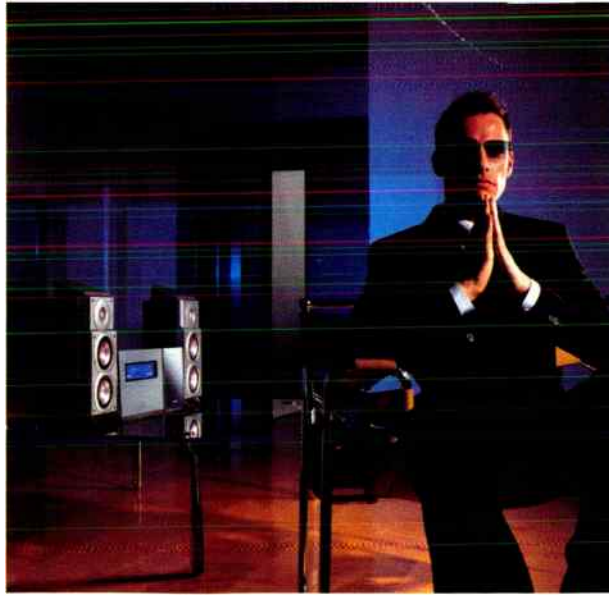

HOW 1-BIT BREAKS WITH CONVENTION

It's important to realise that there's a very big difference between amplifiers processing analogue signals and those that process digital signals. In conventional amplifiers – like the ones you're used to – there's an inherent problem and it's this. The signal being processed from digital encoding to analogue has to pass through a number of complex stages. Inevitably, this may mean that the signal becomes more and more untrue at each stage.

In perfecting 1-Bit audio Sharp has broken away from convention to use an advanced and unique digital processing, known as Delta Sigma technology. It's this technology that makes the ultra-high speed sampling possible, and the difference is awesome.

The digital process ensures that the dynamic range of the reproduced audio signal remains true, keeping the resolution of the original audio signal in both the high and low frequency areas.

A brilliant purity of sound is achieved by a simplified sound transmission circuit that doesn't add or remove anything from the original signal. This is true whether the source is existing CDs or new digital technology.

EVERY SO OFTEN, along comes one of those events that completely transforms our enjoyment of music. Think of the impact that stereo must have had. Or more recently, the advent of the compact disc. Well, be prepared now to hear the impossible, because the introduction of 1-Bit audio by Sharp is nothing less than the sound of the new century. A breathtakingly pure sound that reproduces the original so faithfully, you'll believe you're actually at the performance. Impossible? Not when you hear it, and not when you hear how it's done.



1-BIT AUDIO LOOKS AS GOOD AS IT SOUNDS

Apart from the incredible sound quality, there's another significant advantage with this innovative technology. Being more efficient, the 1-Bit amplifier takes up less space.

This means Sharp have been able to revolutionise the product appearance to create ultra-compact, slim models that strike a note in sophisticated lifestyle design. So they are as attractive to the eye as they are to the ear.



THE SECRET'S IN THE SAMPLING

Unique to Sharp, the revolutionary technology behind this new 1-Bit audio is pretty amazing, and it's all to do with the way it processes the signal from a CD. If you're ready for the technical stuff, here's how Sharp define it. 'An ultra-high sampling speed of 2.8MHz (2,822,400 times per second) gives unrivalled time accuracy and resolution resulting in faithful reproduction of the original signal. As 1-Bit signals are digital, there is virtually no noise or sound degradation during signal transmission or amplification process.'

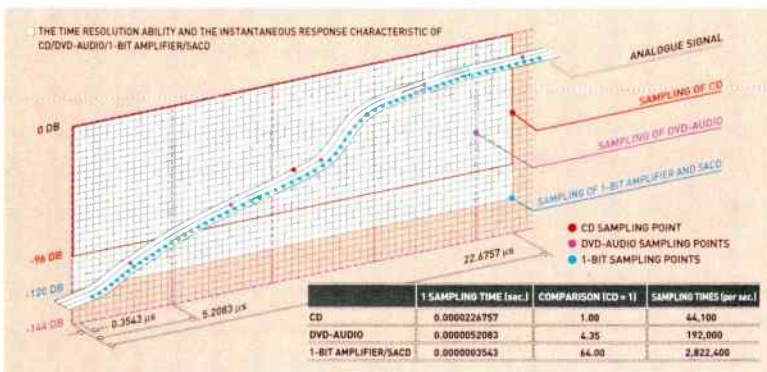

Let's look a little more closely at what that means exactly. To put the high speed sampling rate into perspective, compare it with the sampling rate of a CD. No contest, as 1-Bit audio samples at an incredible sixty four times the rate – and remember, we used to think that sound couldn't get much better with CD.

Quite simply, the higher the sampling rate, the more faithful the result. Slower sampling can actually add sound that may not have been present in the original recording. With 1-Bit audio, you hear the most accurate sound performance ever reproduced, because Sharp has completely re-invented the amplification process.

WANT TO HEAR MORE?

With this new 1-Bit audio Sharp really have achieved the impossible. Audio that delivers the warmth and ambience of analogue, yet with the clarity and purity of digital sound. You actually experience the entire atmosphere, all the passion and all the excitement of being right there with the performer. Making you wonder if you're in your living room or at a live performance.

But if hearing is believing, why not listen for yourself? You'll find these new Sharp 1-Bit systems at Currys, Dixons, Comet and all good audio specialists.

Sounds like the best idea is to go and ask for a demonstration. Or, if you can't wait to see them, Sharp have a website at www.sharp.co.uk that features the whole range.

MORE IN TUNE WITH THE ENVIRONMENT

1-Bit audio has superior power efficiency in comparison with conventional amplifiers – consuming only around half the power, and radiating only one fifth the heat.

In the manufacture of all its products, Sharp uses recycled materials wherever possible. All of these factors strike the right note environmentally, which is something we all have to be mindful of today.

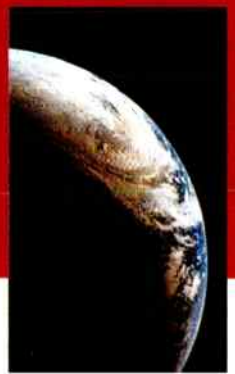

INTERS'



Rega's Jupiter 2000 is the company's beefed up, cost-no-object version of its cracking Planet CD player. David Price does some space exploration.

It's all very well doing a class leading mid-price CD player - and make no mistake, Rega's Planet 2000 is such a product - but things get a little trickier when you move into the 'junior high end' category. Whereas the Planet is fighting it out with warmed up Philips players and liberally tweaked Sonys, the £998 Jupiter finds itself playing with big boys like Meridian, Linn and Naim. This is where it's harder to judge how to voice your design, thanks to the better, more neutral partnering ancillaries it's likely to be used with - not to mention the wider tastes of discerning audiophiles.

Enter Jupiter, a silver disc spinner from the genius of Rega's valve-loving designer Terry Bateman. It shares the Planet 2000's externals - which means a smartly finished extruded aluminium (435x100x 270mm) case with cantilevered, top loading disc cover, four frontal transport controls and a circular backlit power switch and matching (CD Text-compatible) crimson red Sony fluorescent display. Underneath there's the same Rega VCS feet (viscous coupled system) to give it a degree of mechanical isolation from its environs, and round the back the usual fixed audio line

outputs, plus optical and coaxial digital outputs, and an IEC mains socket. Like the Planet, the optional remote control adds a host of features, including Program, Repeat and - most usefully to me - Display Off functions.

Inside, the Jupiter 2000 uses the same basic circuit topology as the original Jupiter and lo that preceded it, but with improvements in the digital converters, power supply and clocking stages. The dual differential DAC is based around two custom built Rega IC40 DACs (24bit Delta Sigma affairs, said to be a Burr-Brown modified to Rega's specifications), with separate converters for the left and right channels. DC servo control is used in the post-DAC amplifier and filter stages, to keep the number of capacitors in the signal path as low as possible. Seven separate power supplies feed the transport, digital and analogue sections, micro controller, display, analogue amplifier and filter. All stages for the clock PLL and signal path are double regulated, and there are two physically separate power feeds for the noisy stages (i.e. motor drivers) and clean stages (DAC, clock, etc.). All this comes from the Jupiter's generously rated toroidal

transformer. Finally, Rega says the player uses a high stability oscillator module for the main clock.

I kicked off the listening with New Order's 'True Faith', which is a murky recording that can sound a little lost in the hands of lesser players. Some cheaper models give it some pep thanks to their hard, forward edge, whereas many more expensive ones sound too soft and woolly. The Jupiter, by contrast, got things just right. A wide soundstage issued forth from my Mission 782 speakers, which was alive with little bits of low level detail that other players struggle to resolve.

The recorded acoustic (if you can call it that) was surprisingly deep and capacious - but more impressive was the way the different tracks in the mix played together. Everything cohered better even than Cyrus's superb CD7/PSX-R, which seemed rather cerebral by comparison. The Rega just got on with the job of conveying the music's emotional impact, making a poorly recorded piece of electronic pop sound dramatic, expansive and anthemic. While bass was tight and reasonably tuneful, it wasn't quite in the Naim CD5 league thanks to a lack of dynamic power. Peter Hook's

TELLAR

basslines didn't really punch out at you, but rather bounced up and down the scale breezily.

Next into the Rega was Donald Fagen's 'Tomorrow's Girls', which showed the player up as the smoothie that it is. Whereas the Naim CD5 and Linn's Genki seem better at catching the leading edges of notes, the Jupiter was the king of the tune. It went straight to the heart of the melody, really emphasising Fagen's subtle but incredibly effective chord progressions and laconic, plaintive vocals. Whereas the CD5 would focus on the bassline, pushing to the fore its importance in the song's structure, the Jupiter was much more preoccupied with the keyboard playing - which was never less than beautifully syncopated.

This Rega is king of the midband - its soundstage is cavernous from left to right (and quite deep too), with a lush tonality that reminds one of its designer's beloved tube amplification. Joan Armatrading's 'Love and Affection' showed it to be punchy too - although the bass isn't as tight or controlled as Cyrus's CD7/PSX-R, it's

decently weighty and ever-so slightly warm.

True, compared to the likes of Naim's CD5 it's just a tad polite, but the overall effect blends well with the Jupiter's sweet, clean and enveloping mid-band. Indeed, female voices are a joy - there's no hint of shrillness and this player gets surprisingly close to their grains and textures.

Very 'analogue', the Jupiter goes deep to the heart and soul of the music, leaving very little to criticise behind. The treble is possibly a little over-sweet, and the bass is a tad overblown and detached - but the mid-band is a joy to behold.

The biggest problem I have with the new Jupiter 2000 is its Planet 2000 little brother. Although the former has a noticeably more generous bass and a more organic mid-band, the latter is just so ridiculously good at the price that it almost makes you want to pocket the cash and go for the cheapie. On its own terms though it's superb - one of the very best at the price, especially if you're into a more 'analogue' rendition of the music. ■ ▲



Rega Jupiter 2000 £998

Rega Research Ltd
119 Park Street
Westcliff-On-Sea
Essex
SSO 7PD
Tel: 01702 333071

MEASURED PERFORMANCE

Rega like to make their products look and feel a little different, the Jupiter being a great example. Luckily, under the skin there are fewer surprises, or at least no nasty ones. This player returned respectable results all round, a smooth wide frequency response being one plus point. Our analysis shows just a slight movement down in high frequency energy but, not enough to add any dullness.

The noise floor was very low in our -30dB distortion analysis - and there's no distortion as such in there either. It's a very good result, up with the best.

Linearity was good right down the player's dynamic range, helping toward a high EIAJ dynamic range value of 110dB. With output set at

the usual level of 2V this player returned a neat, conventional performance that should see it producing a clean sound with good balance. **NK**

Frequency response 5Hz - 21.1kHz

	left	right
Distortion		
-6dB	0.01	0.01
-30dB	0.015	0.015
-60dB	0.34	0.36
-90	28	27
Separation	left	right
1kHz	-11	-116
20kHz	-91	-92
Noise		118dB
Output		2.02V

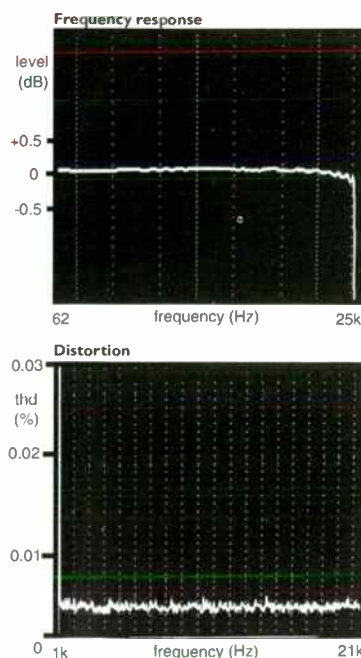

World Verdict



Superbly musical and engaging player that's voiced for real music rather than hi-fi demo discs - a fantastic new contender and top value too.

ROKSAN

The full picture.....

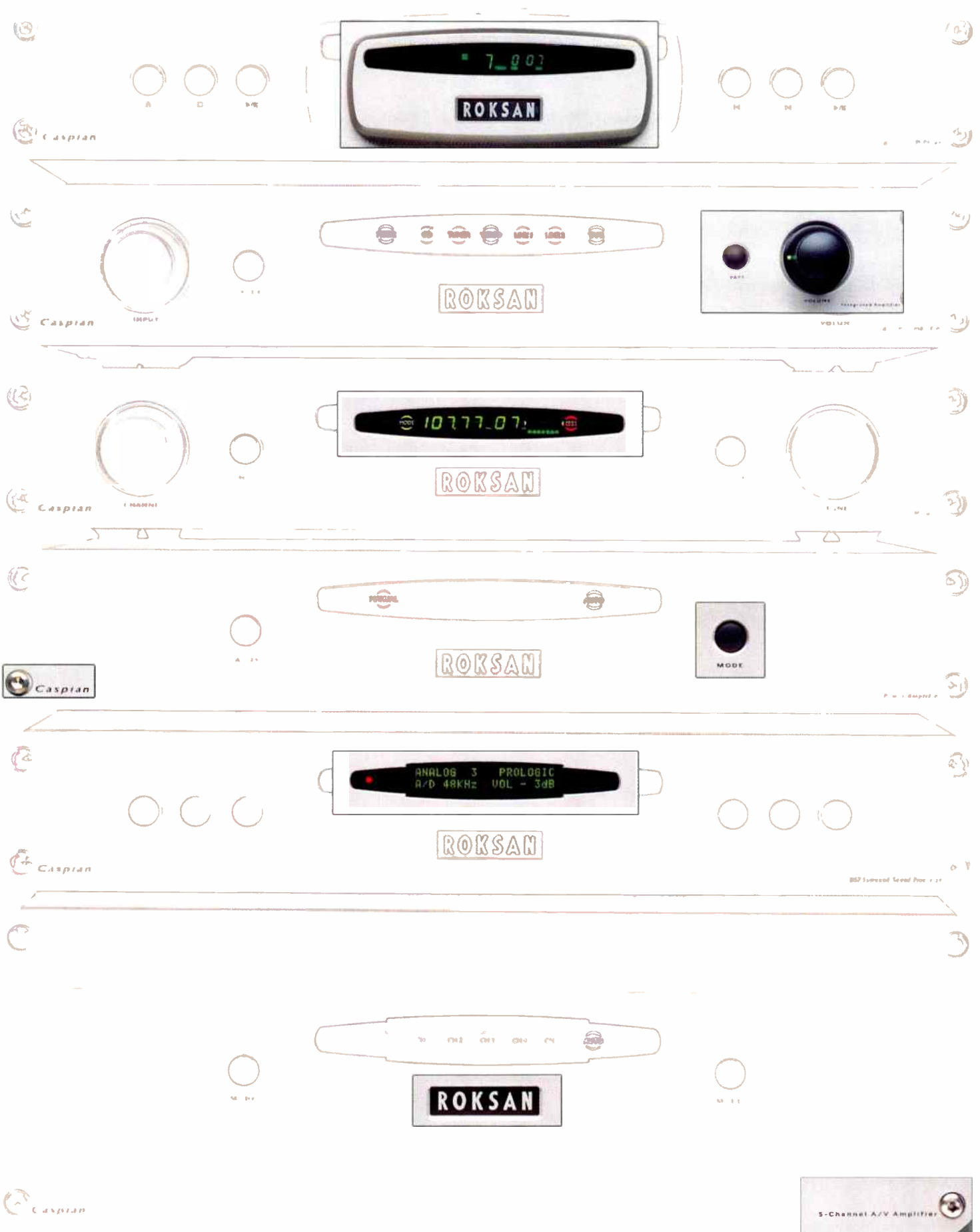

Distributors: Henley Designs Ltd
Unit 10 Moorbrook, Southmead Industrial Park, Didcot, Oxon, OX11 7HR.
Tel: 01235 511166, E-mail: henley.designs@virgin.net, WWW.henleydesigns.co.uk

MORE EXPOSURE



David Price tries out Exposure's latest 2010 power amplifier, paired up with the company's well respected 2010 integrated.

The nineties were a hard time for Exposure Electronics. In the decade previously, the company found a large and willing customer base in people who liked the Naim sound but ultimately couldn't live with it. To wit, Exposure electronics gave much of the Salisbury firm's grippy, punchy sonics with just a touch more smoothness and refinement. In the nineties however, a new, more couth generation of Naim amps rained on Exposure's parade, and the brand seemed to lose direction.

The noughties, however, have seen Exposure back on track. The new 2010 range - and in particular the integrated amplifier tested recently in Hi-Fi World - is a persuasive package. Gone is the dodgy black box styling, and in its place a more sleek and attractive case (in optional Titanium finish) that's better finished and more generously specified. Exposure's own X, launched back in 1986, was one of the very first 'super-integrateds' (and very fine it was too) - and the £599 2010 is a worthy successor.

To recap briefly, its plain Jane front panel (volume and source selectors only, plus - heaven forsend! -

a remote sensor) hides a high capacity toroidal transformer, special power supply capacitors, and shunt regulated pre and power amp stages. Specially selected audiophile passive components, including polystyrene and solid aluminium electrolytic caps feature in the short signal paths, and cascade driver circuit topology is used for improved linearity. All this, plus a lateral MOSFETs output stage, adds up to 50W RMS per side with a useful 12A peak current capability.

For the purposes of this review at least, a key feature of the 2010 Integrated is the provision of a separate pre-amp output. This makes for easy connection to the new £499 Exposure 2010 power amplifier you see before you. Housed in a complementary rigid aluminium chassis (a la 2010 Integrated), it puts out a claimed 75W RMS at the crank, thanks to another high performance toroidal transformer and special power supply capacitors.

Working in conjunction with the 2010 Integrated in bi-amp mode, the Power Amplifier does the lion's share of the business driving the mid/bass frequencies, with the Integrated left to take care of the highs. Should you

wish, you can also switch the Power Amplifier to monoblock mode, which doubles the peak current output from 12 amps to 24 amps. Exposure says that this throws open the possibility of running monos for the low frequencies, whilst the 2010 Integrated drives the high frequencies by itself.

The Exposures were given a generous burn-in period - past experience says they don't give of their best fresh out of the box. Connected to a pair of Mission 782 loudspeakers and driven by a Cyrus CD7/PSX-R they made particularly nice noises with Mercury Rev's 'Goddess on a Highway'. The song is a clean - if slightly anaemic - recording that works as a great 'universal indicator' to an amp's character. The 2010 combo proved just a little softer and more euphonic than I remember 1980s Exposures - with a big hearted and (dare I say it) even fulsome sound. Although we're not getting into lilted, beguiling Class A territory here, it showed up the reference Cyrus 7/PSX-R amplification as slightly clinical - forensic, even. Where the Exposure shone was its ability to 'get the message' of the



Probably the best CD Player money can buy.

Creek CD53 reference standard CD Player



You've heard the rest, now hear the best

With the advent of SACD and DVDA, you may be wondering why Creek have designed a new high-end CD player. Research has shown that while these new technologies allow for increased resolution, when plying discs recorded in the new formats, they are not so convincing at extracting the best from CD's. As CD has been around for 20 years, many people have built up large libraries of discs and want to get the best from them for years to come. Creek feel that a statement product is required to achieve this and have left no stone unturned in their attempt to achieve it. The CD53 is the ultimate reference standard, achieving the best performance money can buy. The CD53 uses a Philips transport, custom Creek software, ultra-low jitter master clock and waveform shaping, for maximum signal retrieval. In addition to its no compromise power supply circuitry, it uses professional standard balanced audio output filtering and buffer circuitry to provide the lowest noise and highest fidelity signal available.

Contact us for more details or visit our web site:-

Creek Audio Ltd, 2 Bellevue Road, Friern Barnet, London N11 3ER
Tel # +44 (0)20 8361 4133 Fax # +44 (0)20 8361 4136

email: info@creekaudio.co.uk internet: www.creekaudio.co.uk

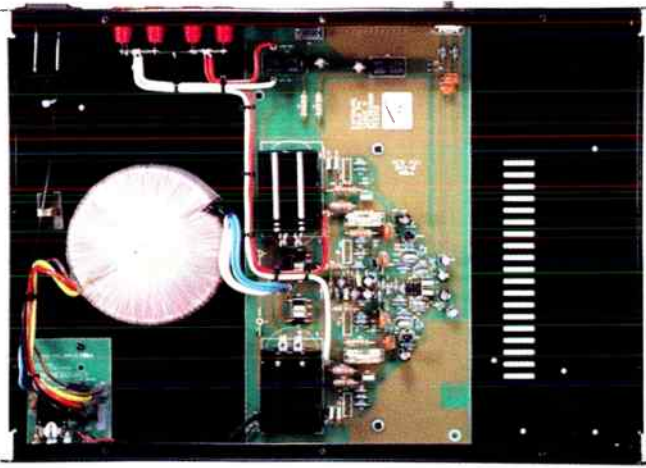

entry-level integrateds as I'd agree wholeheartedly. But take the 2010 Integrated/Power combo as an entity and it's playing with much bigger boys. Here, it falters very slightly. The 2010 Power is a very worthwhile upgrade to the basic amp, but should only be bought outright as a pair if you're after a very specific sort of sound that suits your taste and system. This combo is smooth and has plenty of power, and offers a lively punch that makes it a pleasantly musical listen. The trouble is it falls a little awkwardly between several established and very accomplished

music and convey it without fuss to the listener. Rather than falling over itself to impress with pin-point imaging, thunderous bass or lightning dynamics, it just dived into the music's heart and soul and issued it forth from the loudspeakers. As Editor Pope said in his review of the 2010 Integrated, this is a great rock amp.

Great rock amps often tend to be terrible jazz amps, so I was intrigued to try it with Special EFX's 'Masterpiece' - a sleek piece of modern fusion. Here it again impressed with an expansive soundstage brimming with energy and strong image projection. Treble wasn't slick in the hi-fi sense (i.e. Japanese/US high end), but was nevertheless quite smooth through the Missions' tweeters. There was a good deal of air, but the reference Cyrus combo bettered the Exposures by a way here, letting a lot more ambient information flood out. Moving down to the bass and again the Exposures lacked the reference amps' tautness and grip, but was no

less well articulated - you still got the feeling of a real musician pushing out a supple, fluid bassline.

Classical music was a slightly less happy experience - an eighties Karajan recording of Beethoven's Ninth (on DG) showed a tonally constrained amplifier.

Musically it was a hoot - nice and rhythmic with plenty of life and a surprisingly deep and airy acoustic - but it simply lacked the Cyrus's wider tonal palette or meticulous low level detail portrayal. Whereas the Cyrus did tonal textures ranging from hard and steely to smooth and sweet, everything through the Exposure sounded simply 'warmish'. Although accurate tonality is usually the preserve of the high end, the fact that some rival mid-price designs 'do it' makes competition stiff for Exposure's 2010, especially in costlier bi-amped guise here.

Simon recommended the 2010 Integrated as a great step up from

rivals. It's certainly no slouch and represents good value, but if you want more accuracy get a two-box Cyrus, for more dynamics buy an entry level Naim pre-power or for more sweetness try Sugden.

EXPOSURE 2010
INTEGRATED/2010 POWER
£599/£499

Exposure Electronics Ltd
The Works, 59 North Street
Portslade
East Sussex
BN41 1DH
01273-423877
www.exposurehi-fi.com



MEASURED PERFORMANCE

The 2010 power amplifier and the integrated were very similar in measured performance. The figures discussed here apply equally to both. Power output was 60W into 8ohms but line volts of both units drooped significantly into low loads (i.e. under higher current draw), giving the same power of 60W into 4ohms.

Bandwidth was a normal enough 10Hz-33kHz, channel separation wide and noise low. Input sensitivity was also normal at 280mV, high enough to accommodate low-ish output sources such as legacy tuners, cassette decks.

The output stage produces

predominantly odd-order distortion components under all conditions, at all frequencies, which is not a good sign. Third order distortion is dominant and may give the Exposure a slightly sharp or perhaps fast sound.

Producing 60W the 2010 power and integrated amplifiers have enough power to go loud with most loudspeakers. They both look a little less happy than rivals when it comes to low 4ohm loads and, these days, most loudspeakers use 4ohm bass units to maximise their voltage sensitivity, apparent and measured. The 2010 isn't optimised for such loads. **NK**

Power	64watts
CD/tuner/aux.	
Frequency response	10Hz-33kHz
Separation	75dB
Noise	-99dB
Distortion	0.02%
Sensitivity	280mV

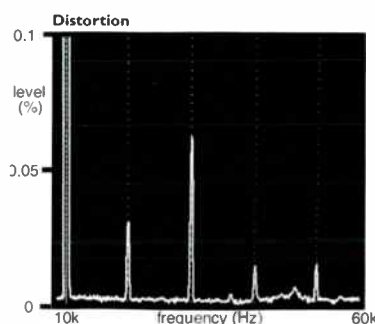

World Verdict



A fine sounding, powerful and musical combination, but faces stiff competition.



PRO-JECT

Debut II Turntable £109.95

"The original Debut turntable romped away with a Product of the Year Award in 1999, and the MKII version continues the extremely good work. It's a simple affair, that's easy to set up, but don't let the price fool you - it sounds a whole lot more expensive than that. This is a fine turntable, and it clearly reveals the benefits of listening to vinyl, with a rich and detailed soundstage, and a good dynamic response.



It's available in six funky colours, so you should find one to suit your decor, and at just a smidge over £100, you can have no excuse not to keep that old vinyl collection in employment for a good few years yet." ★★★★★ What Hi-Fi? | Awards 2000

marantz® DR6000 CD Recorder £349.95

"Most CD recorders make excellent copiers but are less than brilliant as plain CD players. Not so this Marantz: the DR6000 is a recorder you can also use as your main CD player, using your existing machine as a source for recording, for unless you have a very good machine in the £400+ league, chances are the Marantz is going to outperform it.

Whether playing its own recording or standard CDs, the DR6000 sounds big, confident and highly detailed, delivering a sound with real presence and few sonic foibles. Fast rhythms are delivered with terrific conviction, and the way the Marantz digs out detail of percussion and brass instruments knows no rival at the price. What's more, recordings made on this machine have bags of punch and impact, sounding virtually identical to the original discs.

The work that has gone into making the Marantz a good CD player has resulted in a fine recorder that also earns its keep as a system upgrade. No, it's not the least expensive recorder around, but it's one of the best, and worth every penny." ★★★★★ What Hi-Fi? | Awards 2000



Videologic DRX-601ES Digital Tuner £349.95

"New name, new format, new winner: the Videologic story is as simple as that. The £299 DRX-601E digital tuner came out of nowhere to establish the firm as a major player in the digital tuner market. With this upgrade, Videologic goes one step further: it's still a DRX-601E at heart, but quite apart from the sleek silver styling and sexy blue LEDs it now has a better, white-on-blue display, and what the company calls 'Psycho-acoustic Compensation' - a form of signal processing designed to make the tuner sound less digital.

And it works: the DRX-601ES has a presentation that's rich, clean and extremely informative. Bass is big and powerful, while the midband and treble are well controlled. The style alone would justify the slight price rise; the sound quality makes it a Product of the Year."

★★★★★ What Hi-Fi? | Awards 2001



Turntables, Tuners and Recorders

Denon TU260L MKII Tuner	£119.95
Linn LP12/Basik/Akito Turntable	£1749.95
Michell Gyro SE Turntable inc RB300	£974.95
Pioneer MJ-D508 MiniDisc	£179.95
Pioneer PDR609 CD Recorder	£199.95
Project Debut Phono Turntable	£139.95
Sony ST-D777ES AM/FM/DAB Tuner	£449.95
Sony MDS-JE770 Mini Disc	£229.95
Yamaha KX393 Cassette Deck	£119.95
Yamaha KX580SE Cassette Deck	£199.95
Videologic DRX-601E DAB Tuner	£299.95

Sevenoaks Pricing Policy
see page six for details



more entertaining

World Radio History



CD Selection

Arcam DiVA CD92T	£849.95
Arcam FMJ CD23	£1099.95
Linn Ikemi	£1949.95
Marantz CD5000	£149.95
Marantz CD6000 OSE LE	£299.95
Meridian 588	£1949.95
Musical Fidelity NuVista 3D	£2999.95
Marantz CD17Ki Signature MKII	£1199.95
Sony SCD-XA333ES SACD	£1099.95
Sony CDP-XE570	£119.95



DiVA CD72T CD Player £399.95
DiVA A85 Integrated Amplifier £749.95

ARCAM *DiVA CD72* "The CD72 will have you jumping out of your seat from the very first notes. Both powerful and punchy, it delivers every ounce of air and detail present from detailed midrange to smooth, singing treble. Sometimes a product comes along that sets new standards..." ★★★★★ What Hi-Fi? | Awards 2001

DiVA A85 "You'll have realised by now that we rather like this amp. It took us completely by surprise, and further strengthens Arcam's already impressive product range... The A85 is superb, and we can't wait to put it up against its peer in a group test." ★★★★★ What Hi-Fi? | March 2001

0% Finance Option

see page six for details



MISSION

78 Series

782 bases its performance on a 165mm Nomex bass unit fitted to a reflex enclosure ensuring excellent low frequency extension from a graceful and compact cabinet. The *783* houses a larger 200mm bass unit with massive motor system, capable of floor shaking, yet tightly controlled low frequency extension. Both use Keraform midrange drivers for outstanding clarity and midrange detail coupled to superb dynamic range together with Mission's silk dome tweeter.

The *780* and *781* are the pinnacle of Mission's research into creating a three dimensional soundstage, extensive bandwidth and dynamic range from the smallest possible cabinet dimensions. The *780* is massive in its sonic capabilities. Its 130mm Keraform bass unit is carefully matched to a novel reflex enclosure for full bodied bass extension, the qualities of Keraform produce a dynamic and ultra detailed midrange. In the *781* a 165mm Keraform driver takes advantage of a larger cabinet to extend bass performance and increase efficiency whilst maintaining that superb midband transparency and finely detailed treble.

780 "Versatile and with a sound that works well with a wide variety of hi-fi kit, these speakers were worthy of this title last year, and this year have achieved the tough task of making it the double." ★★★★★ What Hi-Fi? | Awards 2001

marantz®
CD6000 Ki Signature CD Player £449.95
PM6010 Ki Signature Amplifier £349.95

CD6000 Ki Signature "The result is a player of real power and grace, and one that sounds dynamic, exciting and fresh. Rhythms are tight and clean while the live atmosphere of discs is conveyed with a real 'you are there' feeling. Even massive scale and weight isn't beyond the Marantz: it delivers all the bass your amp and speakers can handle without ever drowning out the high stuff. The audiophile bargain of the Nineties is back, and it's even better!" ★★★★★ What Hi-Fi? | Awards 2000

PM6010 Ki Signature "Yes, this is the most expensive amplifier in this group, but provided you like its bright yet weighty, detailed yet wide-open sound, it's still something special." ★★★★★ What Hi-Fi? | September 2001

Please Note: Some products may not be available at all outlets. Advertisement valid until at least 13th December 2001. E&OE.





CD Players
Best Buy £501-£800

CYRUS

CD7 CD Player £799.95
7 Integrated Amplifier £699.95

Cyrus 7 CD "This player is just as convincing with thundering orchestral strings and brass, making a great job of Bernstein's recording of *Mahler's Symphony No 5* and it has the definition to unravel the instrumental strands in the Kronos Quartet's disc of Phillip Glass string quartets... It's that that makes it special - and this is a very special player indeed." ★★★★★ What Hi-Fi? | November 1999

Cyrus 7 Amplifier "This is a fabulous amplifier. It's fast, punchy and has bags of power on tap but crucially delivers huge sackfuls of subtlety when the music requires. Some of the other amplifiers in this group may be better with particular genres of music but as an all-rounder it takes some beating." ★★★★★ What Hi-Fi? | November 1999



LINN
Genki CD Player £994.95
Majik Line Amplifier £694.95
Katan Speakers Maple £634.95

Genki "Tempting though it is to think of Genki as a Glaswegian word, it's actually Japanese, and the nearest definitions we could find involve vitality, vigour and spirit. And used as adjectives, these words go a long way towards describing the sound of the Genki, which always manages to communicate the music first and foremost, and let the rest of the hi-fi thing look after itself.

It's a very well-thought-out player, too, from its clear and simple control layout to the provision of four sets of analogue outputs, two at fixed level, and two with level control. Completing the package is a 24-bit Burr-Brown DAC and Pacific Microsonics HDCD filter.

Few owners will worry about all that stuff, however, as they'll be too busy enjoying the way Genki plays music, its purity of tone and sense of drama on Mozart's *Don Giovanni* being a fine example of its talent.

By any standards this is a superb player, and not just one for the army of Linn enthusiasts." ★★★★★ What Hi-Fi? | March 2000

Majik The Linn Majik is a sophisticated control amplifier complete with on-board stereo power amplifiers. A core entry-level product for powerful and flexible control of hi-fi, video or multi-room installations. "Sneaky" add-on modules expand its functions. It can accommodate many source components. The Majik is available in two versions: The 'Phono' version has five line-level inputs and one Moving Magnet phono input and the 'Line-level' version has six line-level inputs.

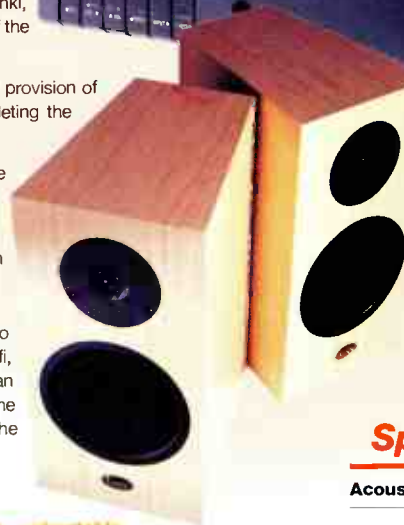

The **Katan** loudspeaker is an attractive, compact, two-way bass reflex loudspeaker. The Katan offers pitch accurate sound quality with substantial power handling, and it outperforms the similarly-sized and award-winning Tukan.

Speaker Selection

Acoustic Energy Aesprit 300	£399.95
B&W DM303	£179.95
B&W DM601S3	£249.95
Cyrus CLS50 (Black)	£449.95
KEF Q3	£399.95
Mission M71	£129.95
Monitor Audio Silver 8i	£699.95
Ruark Epilogue II	£344.95
Wharfedale Diamond 8.1	£119.95

Sevenoaks Pricing Policy
see page six for details



The CDM™NT series from B&W combines the unbeatable sound purity of their highly acclaimed Nautilus 800 Series and the classic looks of their predecessors, the CDM SE. Complete in both looks and sound quality, this is one of B&W's finest loudspeaker ranges to date. The CDM™NT Series is available in a choice of beautifully finished real wood veneers.



Loudspeakers
Best Buy £601-£1000

CDM™1NT £749.95

"Here's a great example of trickle-down engineering, in that all of the technology of B&W's £1400 Nautilus 805s has been transferred to the CDM 1NTs... The CDM 1NTs are superbly built for their class. Their insight and resolution are simply terrific, ensuring levels of precision and clarity no rival in their class can match." ★★★★★ What Hi-Fi? | Awards 2001

CDM NT Series:
CDM 7NT £1249.95, CDM 9NT £1799.95
CDM CNT Centre £399.95
CDM SNT Surround £749.95

Please Note: Some products may not be available at all outlets. Advertisement valid until at least 13th December 2001. E&OE.

more entertaining

World Radio History





Amplifier Selection

Arcam DiVA A65 Plus Integrated Amplifier	£349.95
Arcam DiVA A75 Plus Integrated Amplifier	£449.95
Arcam FMJ A22 Integrated Amplifier	£999.95
Linn Kolector Pre Amplifier	£494.95
Linn LK85 Power Amplifier	£494.95
Cyrus ACA7.5 Pre Amplifier	£699.95
Cyrus Smart Power Power Amplifier	£549.95
Marantz PM4200 Amplifier	£159.95
Musical Fidelity A3 Pre Amplifier	£999.95
Musical Fidelity A3 Power Amplifier	£999.95
Musical Fidelity NuVista M3 Integrated Amplifier	£2974.95

0% Finance Option *see page six for details*



Caspian MKII CD Player **£894.95**

"If you can stretch to it, though, Roksan's Caspian the player to go for. Yes, it's the most expensive here, but no rival can touch it when it comes to bringing music to life - regardless of genre. And that's what hi-fi is all about." **★★★★★** What Hi-Fi? | May 2001



A3 CD Player **£799.95** Integrated Amplifier **£849.95**

MUSICAL FIDELITY

A3 CD Player "OK, so not everyone will be drawn to the styling, but when it comes to turning on the sonic fireworks, few players come even close at this price... A class act and a worthy winner." What Hi-Fi? | Awards 2000

A3 Amplifier "The A3 does a wonderful trick of conveying a great romantic sweep of music while at the same time delivering as much internal detail as anyone could possibly want... This is an amplifier capable of performing well beyond its price. We guarantee you won't be disappointed." What Hi-Fi? | Awards 2000



MONITOR AUDIO

Gold Reference Series

GR10 Speakers Ex-Stands **£799.95**

"We like the GR10s a lot: Monitor Audio has long been making beautifully upmarket standmounters, and this new model is no disappointment." **★★★★★** What Hi-Fi? | August 2001

GR20 Speakers **£1499.95**

"Monitor Audio has made an immensely accomplished pair of speakers in the *Gold Reference 20*. In sonic and physical terms there is little to criticise; even the price is highly competitive. We have no choice but to recommend them highly." **★★★★★** What Hi-Fi? | March 2001

ROKSAN

Founded in 1985, Roksan's objective has always been to bring high-end specialist hi-fi to every home. Today with the Caspian range, that goal has been fully achieved.

Caspian MKII Amplifier **£794.95**

"The Caspian has been around for a few years, but Roksan has developed it to a point where it now leads the class in all-round terms. In specific areas other amps equal it, but overall none can beat its combination of clarity, timing and dynamics. The Caspian is a worthy winner." **★★★★★** What Hi-Fi? | February 2001





who are sevenoaks?

Founded as Sevenoaks HI-Fi in the summer of 1972, the original shop, in the market town of Sevenoaks, Kent, quickly gained a reputation for offering a wide range of products at competitive prices, and providing excellent service.

Exciting new technologies like compact disc, meant that throughout the 1980's there was considerable interest in hi-fi and Sevenoaks were able to grow. By 1990, the company was established as one of the leading independent hi-fi specialists in the country.

More stores were opened and a number of the original shops were relocated. In 1995 the important decision was made to change the name to Sevenoaks Sound & Vision, reflecting the wide appeal of new audio visual products.

After twenty-nine years of trading, the company has more than forty outlets nationwide, and is for many of the UK's leading manufacturers of electronics and loudspeakers, their largest and most successful retailer.

The people at Sevenoaks appreciate that customers have a choice. This appreciation has meant that over the years Sevenoaks have had to adapt.

As new products and technologies have arrived, the staff have been trained to ensure that they can explain the issues, simply and informatively.

This orientation to customer service remains, and the implementation of a company charter is one example of this commitment.

By staying true to the original ideals of offering a wide range of the latest products, at competitive prices, and providing superb service in pleasant surroundings, Sevenoaks are able to listen, recommend, demonstrate and supply the products that best suit the needs of their many customers.

As the world becomes a more complex place and people search for entertainment and relaxation, Sevenoaks Sound & Vision believe that whatever the requirement, they have the solution.

sevenoaks online

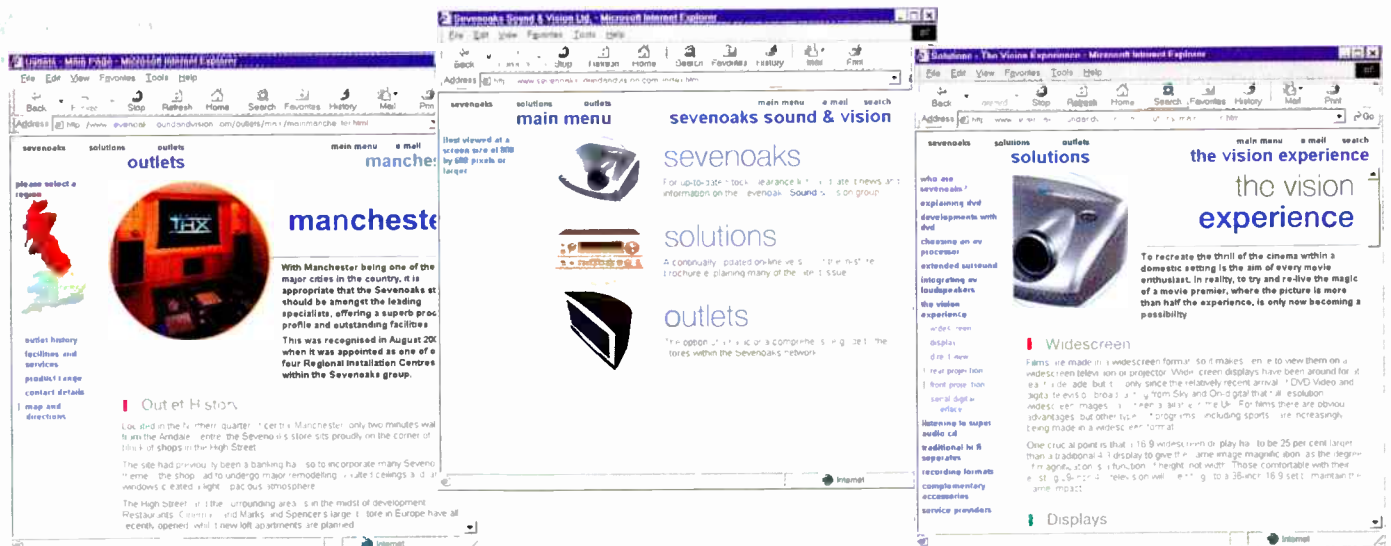

www.sevenoakssoundandvision.com

The Sevenoaks Sound & Vision website has news and information on the Sevenoaks group and its 44 outlets nationwide. The website is designed to provide you with answers to the questions everyone has when buying new equipment.

The site has comprehensive guides to a range of products and technologies from vinyl, compact disc and audio accessories to all the latest formats, including DVD Audio, SACD, widescreen televisions and projectors.

There are regularly updated stock clearance lists with hundreds of products on offer and detailed pages to help you locate your nearest store.

For unbiased advice and information, just click on sevenoakssoundandvision.com.



more entertaining



scotland and north

Aberdeen 491 Union Street **01224 587070**
aberdeen@sevenoakssoundandvision.com

Edinburgh 5 The Grassmarket **0131 229 7267**
edinburgh@sevenoakssoundandvision.com **Open Sunday**

Glasgow 88 Great Western Road **0141 332 9655**
glasgow@sevenoakssoundandvision.com **Open Sunday**

Hull 1 Savile Row, Savile Street **01482 587171**
hull@sevenoakssoundandvision.com

Leeds 112 Vicar Lane **0113 245 2775**
leeds@sevenoakssoundandvision.com **Open Sunday**

Liverpool 16 Lord Street **0151 707 8417**
liverpool@sevenoakssoundandvision.com

Manchester 69 High Street, City Centre **0161 831 7969**
manchester@sevenoakssoundandvision.com

Newcastle 19 Newgate Street **0191 221 2320**
newcastle@sevenoakssoundandvision.com **Open Sunday**

Preston 40-41 Lune Street **01772 825777**
preston@sevenoakssoundandvision.com **Open Sunday**

Sheffield 635 Queens Road, Heeley **0114 255 5861**
sheffield@sevenoakssoundandvision.com **Open Sunday**

midlands and east

Bedford 29-31 St Peters Street **01234 272779**
bedford@sevenoakssoundandvision.com

Cambridge 17 Burleigh Street **01223 304770**
cambridge@sevenoakssoundandvision.com **Open Sunday**

Ipswich 12-14 Dogs Head Street **01473 286977**
ipswich@sevenoakssoundandvision.com

Leicester 10 Loseby Lane **0116 253 6567**
leicester@sevenoakssoundandvision.com

Lincoln 20-22 Corporation Street **01522 527397**
lincoln@sevenoakssoundandvision.com

Norwich 29/29a St Giles Street **01603 767605**
norwich@sevenoakssoundandvision.com

Nottingham 597-599 Mansfield Road **0115 911 2121**
nottingham@sevenoakssoundandvision.com

Oxford 41 St Clements Street **01865 241773**
oxford@sevenoakssoundandvision.com

Peterborough 36-38 Park Road **01733 897697**
peterborough@sevenoakssoundandvision.com **Open Sunday**

midlands and west

Birmingham 12 Queensway Arches, Livery Street **0121 233 2977**
birmingham@sevenoakssoundandvision.com

Bristol 92b White Ladies Road, Clifton **0117 974 3727**
bristol@sevenoakssoundandvision.com

Cardiff 104-106 Albany Road **029 2047 2899**
cardiff@sevenoakssoundandvision.com

Cheltenham 14 Pitville Street **01242 241171**
cheltenham@sevenoakssoundandvision.com

Exeter 28 Cowick Street **01392 218895**
exeter@sevenoakssoundandvision.com

Plymouth 107 Cornwall Street **01752 226011**
plymouth@sevenoakssoundandvision.com

Swansea 24 Mansel Street **01792 465777**
swansea@sevenoakssoundandvision.com **Open Sunday**

london and south east

Brighton 57 Western Road, Hove **01273 733338**
brighton@sevenoakssoundandvision.com

Bromley 39a East Street **020 8290 1988**
bromley@sevenoakssoundandvision.com

Chelsea 403 Kings Road **020 7352 9466**
chelsea@sevenoakssoundandvision.com

Crawley 32 The Boulevard **01293 510777**
crawley@sevenoakssoundandvision.com

Croydon 369-373 London Road **020 8665 1203**
croydon@sevenoakssoundandvision.com **Open Sunday**

Epsom 12 Upper High Street **01372 720720**
epsom@sevenoakssoundandvision.com **Open Sunday**

Guildford 73b North Street **01483 536666**
guildford@sevenoakssoundandvision.com

Holborn 144-148 Grays Inn Road **020 7837 7540**
holborn@sevenoakssoundandvision.com **Open Sunday**

Kingston 43 Fife Road **020 8547 0717**
kingston@sevenoakssoundandvision.com **Open Sunday**

Maidstone 96 Week Street **01622 686366**
maidstone@sevenoakssoundandvision.com

Reading 3-4 Kings Walk Shopping Centre **0118 959 7768**
reading@sevenoakssoundandvision.com

Sevenoaks 109-113 London Road **01732 459555**
sevenoaks@sevenoakssoundandvision.com

Southampton 33 London Road **023 8033 7770**
southampton@sevenoakssoundandvision.com **Open Sunday**

Southgate 79-81 Chase Side **020 8886 2777**
southgate@sevenoakssoundandvision.com **Open Sunday**

Swiss Cottage 21 Northways Parade, Finchley Road **020 7722 9777**
swisscottage@sevenoakssoundandvision.com **Open Sunday**

Tunbridge Wells 28-30 St Johns Road **01892 531543**
tunbridgewells@sevenoakssoundandvision.com

Watford 478 St Albans Road **01923 213533**
watford@sevenoakssoundandvision.com **Open Sunday**

Witham 1 The Grove Centre **01376 501733**
witham@sevenoakssoundandvision.com

stock clearance

With more than forty outlets nationwide, the Sevenoaks Sound & Vision group stock and display a wide range of products. As technology delivers improvements in performance, so individual models and product ranges are changed or superseded. The preceding models are made available at a reduced price, for clearance. Visit our Website for an up-to-date list of the clearance stock, listed by outlet, within the Sevenoaks Sound and Vision group.

0% finance option

Spread the cost of buying. 0% finance option is available on the vast majority of products we stock. Please ask in-store for details.

sevenoaks pricing policy

Whilst we do not claim always to be the cheapest, we try to ensure our prices are highly competitive. Take into account the expert advice, unrivalled product selection, demonstration facilities and excellent pre, during and after sales service and the lower price might not look such good value.

In the event you can find the same products and excellent service at a lower price, please bring it to our store managers' attention. We will always endeavour to offer you the best deal.

FULLY LOADED



Dominic Todd listens to the feature-packed CDR 30 from Harman Kardon.

Let's get the two bits of bad news out of the way first. The first is that the Harman Kardon CDR 30 costs £589. Stiff money when one considers Marantz's excellent DR-W 6050 twin CDR is available for just £450. The second is that at any price range, audiophiles have traditionally always been rather sceptical of any twin deck machine.

That aside, the CDR 30 offers great appeal to serious home recording fans. If there's a CD-R feature that the Harman doesn't have, then I've yet to find it. As well as recording CD-Rs and CD-RWs at normal, 2x or 4x speed, it will also record MP3s onto CD-R. Furthermore, there's CD Text and ID information on MP3 discs. It will even decode HDCD discs.

There's a sampling rate converter to make it possible to record from DAT and, joy of joys, adjustable recording levels for both analogue and digital recordings.

As far as socketry goes, Harman really do have every eventuality covered. Both units output independently via analogue, optical or co-axial outputs. In terms of inputs there's the choice, again, of analogue, optical and coaxial. Furthermore, there are even front mounted optical and coaxial inputs; perfect for recording from portable units. It's good to see that an effort has been made internally too,

especially at this price. Whilst there's nothing inside that would put a similar CD player of this price to shame, the unit is well engineered. Good quality Delta-Sigma DACs feature on both transports.

With such good technical and feature packed credentials, it's a shame to find the plastic casing rather letting the side down. Whilst the CDR 30 looks impressive enough, the plastic front panel and under-damped controls are disappointing from a company who used to make some of the most solid kit around.

I chose, 'Your Song' from the 'Moulin Rouge' album, as it's quite a busy and complex track that would be a good test of dynamic scale and detail resolution. The original recording on my own equipment suffered the usual slight blurring of definition and reduced height of sound stage. The Harman impressed in its slightly more 'breezy' presentation. Detail retrieval was good, although there was still a slight constriction of the sound staging. Unfortunately, there was also a slight splashiness to the sound and some emphasis of sibilance.

Using the CDR's own playback draw actually improved the sound in some respects, no doubt due to the guaranteed compatibility of the two mechanisms. There was a very slight loss of depth and definition, yet there

was less sibilance, and the CDR 30 kept a tight grip upon the music when the more complex orchestration kicked in. At twice the speed, I found it very difficult to discern a noticeable difference between that of the original real time recording. If one was to be extremely critical, then one could point to a very slight loss of decay with cymbals, and a slight loosening of grip in terms of the track's dynamics. In most cases though, the differences were so small that it would take an extremely analytical system to pick up upon them at all. It's worth noting that I used Sennheiser HE60/HEV70 electrostatic headphones to eke out these differences.

Recording at 4x speed was more revealing. Here, a slight lack of clarity and impact was more noticeable and blurring of definition more prevalent during the busier passages. I wouldn't, therefore, recommend the setting for archive use. For making copies for the car or a portable, however, this feature will literally save hours of time, and the loss of sound quality is still quite slight in the scheme of things.

In terms of playback, the HK is from the 'clean and detailed' school of sound, although a decent £200 CD player would still give it a good run for its money. The main concern centres on a rather mechanical

oaded

balance that can spoil the timing and flow of music. The bass response is also rather lacking in terms of punch and depth.

On the plus side, the CDR 30 has good resolution, and a response that's seamless enough not to make it uncomfortable to listen to over long periods of time.

It's quite clear that the HK CDR 30 is suited to a particularly specialised market. It's a good quality recorder that can easily hold its own against well-regarded single CDR machines. The trouble is that such machines are often considerably cheaper, and offer superior playback. Although many may well have a second CD player for playback, the whole idea of a twin deck machine is that it's not necessary. To be frank,

the £200 NAD C521 would have no problem in out-classing the HK in terms of playback. Yet, what the NAD can't do, of course, is record. Neither can it replay HDCD - or record MP3 either. Here the CDR 30 is truly unique, and unrivalled as a compact, multi-purpose recording solution. If space is tight, and you'd use all of the HK's many features, then this is the machine for you. If not, then best stick to separate boxes if sound quality is the primary concern. ■ ▲

Harman Kardon CDR 30 £589
Harman Consumer UK
Unit 2 Borehamwood Industrial Park
Rowley Lane
Borehamwood
Herts WD6 5PZ
Tel: 020 8731 4670



MEASURED PERFORMANCE

The Harman CDR30 CD recorder has a reasonably flat, wide frequency response that is much the same via the D/A converter (i.e. replay only) or via the A/D and D/A converters (record-replay). As always there's a little bit more noise and distortion when the record chain is included, but not a lot with a worst case result (max gain in record mode) being a respectable -89dB.

Through the replay D/A the distortion and noise figures were good, with little noise or distortion visible in our -30dB spectrum analysis. There's no quantisation noise either. The Harman should sound clean enough replaying CDs. With the record A/D converter in line distortion at -30dB - typical music level - jumped from 0.017% to 0.05% and down at -60dB noise contributed mainly to a recorded distortion value of 1.5%. However, noise in a digital system dithers the signal, lowering distortion and producing a smoother sound, so small amounts of noise are

no bad thing.

Input sensitivity was high at 230mV, allowing this recorder to record from even quite old tuners and cassette decks. The only strange point was an output level of 0.977V - 6dB lower than Philips standard 2V that every other manufacturer uses. This has no direct impact but it will make the HK sound quieter in comparative demos.

This is a well engineered CD recorder with good digital-to-analogue and analogue-to-digital converters. **NK**

Frequency response 5Hz-21.25kHz

Distortion	left	right
-6dB	0.006	0.006
-30dB	0.017	0.016
-60dB	0.4	0.38
-90	29	28
Separation	left	right
1kHz	-96	-96
20kHz	-92	-92

Noise	89dB
Output	0.977V
Sensitivity	230mV

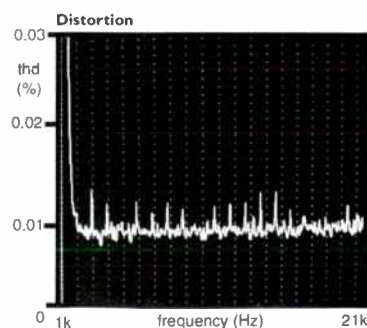
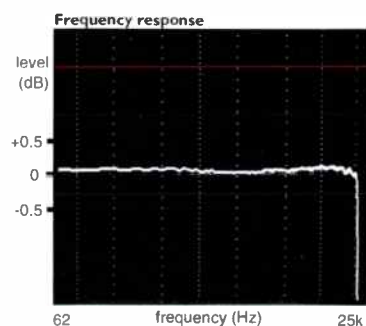

World Verdict



A truly versatile machine with little in the way of competition. Great for a recording solution but lets the side down a little when it comes to playback.

Walrus Systems

11 New Quebec St, London W1

air tight
allaerts
amazon
apollo furniture
argento
audible illusions
audio note
audio physic
audio synthesis
avantgarde
breuer dynamic
brinkmann
canary audio
cartridge man
cat
cawsey cables
clearaudio
coph nia
decca london
dnm
duevel
dynavector
ear yoshino
ergo
final lab
graham
incognito
lyra



No home cinema, multi-room, or computer audio.
No sir, just good old fashioned superb sound from
Walrus, the premier Valve and Vinyl specialist!

(clockwise) Michell Gyro SE / RB300 (£975)
Notts Analogue Spacedeck / Spacearm (£1380)
SME Model 10 (£2643 - arm extra)
EAR V20 amplifier (£2699)
Papworth SE amplifier (£1700)
EAR 834P MM phono stage (£380)
Musical Fidelity Nuvista CD (£2999)
(NB: Check availability - limited edition model)
Brinkmann amplifier (£2000, or £2500 inc DAC)
Spendor SP2/3 (£1295)
Avantgarde Uno (£6809, in midnight blue)

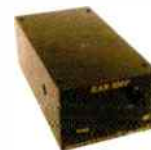

Don't delay. Give Les or Pete a call now!

michell engineering
morch
musical fidelity
nordost
nottingham analogue
ortofon
papworth
phy cables
pluto
pro-ject
reference 3a
rega turntables
ringmat
shun mook
sme
spendor
stax
sugden
sumiko
tci cables
tom evans
townshend audio
transfiguration
trilogy
tron
vaessen
van den hul
verdier
yamamura churchill



For info on these, and much more, including our numerous second-hand items,
please visit our popular website: www.walrus.co.uk

* interest free credit available on most items, subject to status *

tel: 020 7724 7224

fax: 020 7724 4347

email: mail@walrus.co.uk

web: www.walrus.co.uk

UP TO ...3 YEARS INTEREST FREE CREDIT* from...

Vickers Hi-Fi

The North of England Hi-Fi Specialist

- ▶ Quality Hi-Fi separates from £100 to £10,000
- ▶ Widest choice in the area ▶ Independent advice
- ▶ Consumers Choice gold Award Winners
- ▶ Over 30yrs experience. ▶ Qualified staff
- ▶ Comfortable dem room Superb showroom
- ▶ Main road location Major car parks nearby
- ▶ Insurance estimates ▶ Service Dept.
- ▶ Up to 3 years Interest Free Credit* only 20% deposit
- ▶ Carriage Free Mail Order (inc. credit) *subject to status
- ▶ Deliver & Installation ▶ Part Exchange
- ▶ Open 10.30am - 5.30pm 6 days: Mon. to Sat.
- ▶ Visa, Access, Switch etc.

24 Gillygate, York YO31 7EQ

01904 629659

www.Vickers-HiFi.co.uk

specialists in high fidelity sound reproduction - since 1967

Classified Sources

David Price compares four ways of getting the best sound per pound, by buying a second-hand source from the back pages of this very magazine.

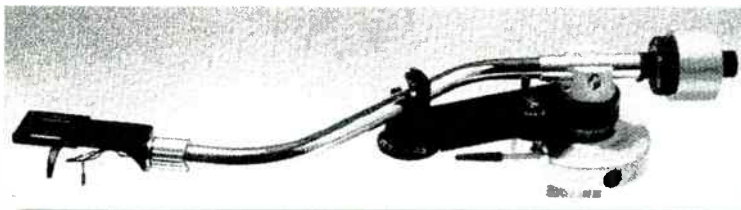

▶▶ ARISTON RD40SL £125

There are literally millions of old turntables lying around in people's spare rooms, lofts, garages, basements and sheds - all going for pennies, but if you're after a respected British design you'll have to fork out at least £100 for something in decent condition.

Ariston's RD40 was one of the many 'nearly men' of the early eighties vinyl scene. It was a fine piece of kit, but somehow failed to capture the imagination of journalists and buyers alike. Nothing wrong with that, because you can pay much more for a trendy deck that's only half as good as this. An 'old skool' suspended

subchassis design, there's nothing remarkable about it at all - anyone who's ever seen a Thorens TD160 will find nothing new here. The joy of the Ariston is that it cost over £200 in 1984 (a lot of money) and as a consequence is built very sturdily. Not as good as an LP12, but not that far off either.

This improved SL model comes complete with a thick, correctly shaped platter mat and a dinky little alloy record clamp.

The arm often fitted was Linn's very first Basik - a popular partner for decks such as the Ariston, Thorens TD160, Heybrook TT2 and STD 305S. It's a Japanese built affair with many trademark Audio Technica signs - although Linn never stated that this is where the Basik was sourced, I'd bet money on it! This is no bad thing, because you get a decently finished, nicely aligned middle of the road S-shaped tonearm which sounds surprisingly musical. Because LVVs are objects of derision to the hi-fi cognoscenti, they're cheap as muck and therefore a fine starter arm. The origin Linn Basik cartridge (reputedly an Audio Technica AT93) was fitted, but in the interests of my record collection this was junked in favour of a shiny new AT110E (£25).

To ears that spend far too much time listening to CD these days, this deck sounded incredibly warm and powerful. Bass was fat and full (incredibly so, compared to CD!), midband clean with impressive depth

PUTTING SOUND INTO FOCUS

ORDER NOW FOR CHRISTMAS

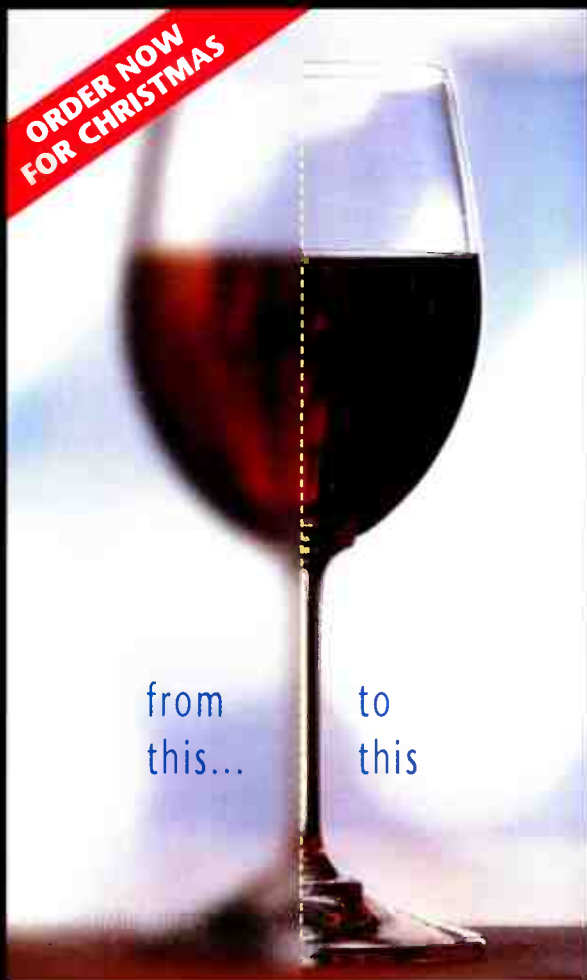

from this... to this

YES, YOU CAN IMPROVE THE SOUND FROM YOUR HI-FI OR A/V SYSTEM, EASILY, AT RELATIVELY LITTLE COST PLUS MONEY BACK GUARANTEE

- ANNIVERSARY RINGMAT, LP BLUE STATMAT and STATCAP for your LPs
- CDi BLUE STATMAT for your CDs, DVDs, SACDs, and CD-ROMs
- UPGRADE PRICES ON ABOVE
- AUDIOPHILE CABLES
- EQUIPMENT SUPPORTS - Ringmat Feet, Domes and Statfeet



our unique add-on RINGMAT and STATMAT products are **used** and **recommended** by music lovers, musicians, music critics and hi-fi reviewers the world over

DON'T MISS OUT!

dial 01277 200 210 NOW
or visit www.ringmat.com

 **RINGMAT**

New – two landmark digital players: one playing SACD and CD at the highest level, the other bringing more affordable high quality CD replay.

Digital

dream machines

When British **dCS** and US **WADIA** – world leaders in the fiendishly complex field of digital replay – bring out new models it's time to take a close look.

In their different ways the **dCS VERDI** SACD/CD transport and the **WADIA 301** CD player are class leaders.

The Verdi plays SACD, CD and CD-R with a **DUAL LASER** mechanism which gives fast track access. CD replay has *not* been compromised to favour SACD, unlike some players.

Great care has been taken to control digital replay's big bugbear – **JITTER**, more than anything else responsible for "digital" sound – with a high precision clock and a "slave" link to dCS Elgar or Delius DACs.

This combination gives "the closest to the **ORIGINAL MASTER** recording so far achieved with audiophile equipment", claims dCS.

Verdi's key functions are software-based and simply **UPDATED** from a dCS CD played in the transport.

The Wadia 301 has been completely re-designed and uses "trickle-down" technologies from their awesome **POWER DAC** digital amplifier and the top **27ix DAC**. Also software-upgradeable, the 301 gives CD a natural, musical sound which will bring smiles to faces for years.

Customers say we make some of the **BEST SOUNDS** they have ever heard, so you know we can do the same in your home. Our advice will take account of your best components and guide you where change is needed, in stages you can afford.

You **AVOID EXPENSIVE MISTAKES**, enjoy music along the way and save money in the long run.

JUST LISTEN AND YOU'LL KNOW

The
Right
Note
Music in the home

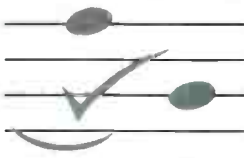

BATH

01225 874728

CD: ACCUPHASE, ADVANTAGE, AUDIO SYNTHESIS, BAT, dCS (ELGAR, DELIUS, PURCELL, GRIEG, VERDI) MERACUS, PASS, SAT, SUGDEN, WADIA. **VINYL:** BASIS, CLEARAUDIO, CROWN JEWEL, DNM, GRAHAM, THE GROOVE, LEHMANN, MICHELL, SUMIKO BLUE POINT SPECIAL, TRANSGURATION. **AMPLIFIERS:** ACCUPHASE, ADVANTAGE, BALANCED AUDIO TECHNOLOGY, CAT, DNM, GAMUT, HOVLAND, NAGRA, PASS, SAT, SONNETEER, SPECTRAL, SUGDEN. **LOUDSPEAKERS:** AUDIO PHYSIC, AUDIOSTATIC, BKS, ETHOS, LUMLEY, NEAT, TOTEM, VERITY AUDIO. **TUNERS:** ACCUPHASE, MAGNUM DYNALAB. **CABLES:** ARGENTO, CHORD Co., DNM, HOVLAND, NORDOST, SILTECH, SPECTRAL, YAMAMURA CHURCHILL ETC. **SUPPORTS:** ARCICI, KINABALU, STANDS UNIQUE

◀ perspective and treble silky and deliciously smooth. Properly set up and aligned, the Ariston gave a more natural, organic sound than practically any CD player I've ever heard. It was truly big hearted and involving, and just seemed to connect on an emotional level in a way that no digital audio can. The downside was its slightly compressed dynamics (thanks to the LVV methinks), vague imaging and loose, spongy and overblown bass. So if it's classical music you love then look you'll probably want to look elsewhere, but with jazz and rock this was dynamite. Not brilliant in absolute 'hi-fi' terms then, but if it's music you're into then a well preserved turntable is incredible value right now.

both worlds - it has the superb build of all Pioneer's late seventies products (possible thanks to the weakness of the Yen at that time), yet was just about modern enough to feature metal tape compatibility. This was an important leap for Philips once all-conquering Compact Cassette format - allowing far high levels and crisper high frequencies.

At the time this machine was made, the British hi-fi press largely overlooked the superb sonic performance afforded by the high end cassette decks of the day. It was Nakamichi, more than any other company, which proved how good pre-recorded cassette decks could sound - but the likes of Pioneer took up the gauntlet and produced some beautifully made dual capstan, three

down the wide scale, and you're in business. Although seventies pre-recorded cassettes aren't much to shout about, eighties and nineties ones are far better and the Pioneer is capable of quiet surprising fidelity. The Sendust heads take ages to wear out (beware decks with Permalloy heads - these suffer severe HF droop after a few years) and offer surprisingly sweet and extended highs. Bass is full and powerful - if not the tautest around and there's plenty of midband detail and even a half decent soundstage.

In 2001, it's fascinating listening to high quality cassette decks. In today's CD-dominated world, they sound so obviously warm and coloured, yet thanks to their complete lack of digits, give an extremely fluid and listenable sound. You can hear a minute touch of pitch instability and wobble on piano notes, a slight 'cracking' of high frequencies, a bit of compression and even (that old enemy) hiss - but musically they're still no poor relation to a CD player. Best of all, both cassette decks and pre-recorded cassettes are absolutely dirt cheap these days. This deck cost £100, and I picked up some great titles (from Pink Floyd to Kate Bush) at Oxfam for 50p a go - can't argue with that! As well as Pioneers, look also for baby Nakamichis, top Aiwas, JVCs and Sonys for cheap thrills.



PIONEER CTF950 £100

These days, it's pretty common knowledge that Pioneer is one of DVD's most passionate proponents. The company dedicates much of its creative energies - not to mention its R&D budget - into the new format. Back in the seventies, Pioneer's heart was in cassette decks. The company produced a range of best selling designs - from budget, entry-level fare like the £100 CT-F500 to massive behemoths such as the £400 CT-F1250. All shared superb construction quality and were impressively well set up. The CT-F950

motor transports, such as the one fitted to the CTF-950.



MARANTZ CD54 £80

The first Compact Disc players arrived in 1982 and finally reached British punters a year

you see here occupied the upper echelons of Pioneer's range in 1980, selling for around £250 (which was about the same as a Linn LP12). With hindsight could be said to offer the best of

Slot in a tape, lightly touch PLAY button and there's a quiet solenoid click before the reels start spooling. The ridiculously bright fluorescent bar graph meters start darting up and



AV32R: maybe the most versatile av processor ever?

"Most home cinema processors can also double as component preamplifiers, but they are rarely transparent enough for serious use in quality systems. However, the AV32R is... This processor is a tour de force."

What Video & TV - 8/01

"Few processors can match the AV32R and none at the price comes close."

Hi-Fi Choice - 6/01

"I can endorse the AV32R whole heartedly... It would be very difficult to improve on its thoughtful design, basic performance, and craftsmanship, and its inherent simplicity appeals to me strongly."

Stereo Reviews Sound & Vision - 6/00

"Performance lives up to very high expectations, thanks to combination of finesse, clarity and control. Advanced software and full upgradeability protect substantial initial investment."

Audio Video - 4/01

"The AV32R can lay claim to being one of the very best audio products on the market. This machine will not only provide you with high-grade audio reproduction, it should also remain at the cutting edge for some time to come."

Essential Home Cinema - 7/01

"Flexibility is built into the AV32R at every level. Unlike others of this type, however, the processor is particularly well adapted to the task. Using stereo source material, it is particularly transparent and clean, easily matching many component two-channel audiophile preamplifiers... The AV32R is an equally excellent multi-channel processor too. Image steering is smooth, and imagery is generally seamless and homogeneous."

Home Entertainment - 9/00

Processing Formats

Mono, Direct, Pro Logic, Dolby Digital, DTS, TMS 7, DTS-ES Matrix, THX, THX Surround EX (Dolby EX)

Optional Formats

HDCD, Pro Logic II, DTS ES 6.1 Discrete, DTS Neo:6, MPEG-2

Upgrades via the Internet

PC owners can download software, incl. new sound formats, from the Internet

Latest DSP Technology

The field-leading 32-bit Analog Devices Sharc 21065L allows processing at all native sampling rates, incl. 96kHz/24bit

Minimal Jitter for superb sound

A twin phase-locked loop reduces jitter to a minimum, resulting in crisp sound

TAGtronic Sync Link

Allows the DVD32R to synchronise its clock to the AV32R, resulting in the lowest jitter technically possible

Enhanced TAGtronic Bus

This multi-device network allows information to be shared between products and can interface with multi-room systems

Best components

Multi-layer glass epoxy pcbs, soldered using a nitrogen filled reflow oven & wave soldering are combined with ultra stable Vishay resistors and ultra low noise Elna Cerafine and Wima capacitors

Proven Upgradability - not just promises

Nine upgrades since launch, for all AV32R - old and new- including:

- Dolby Pro Logic II
- THX Surround EX (Dolby EX)
- HDCD
- TMS 7
- DTS-ES + Matrix
- Remote controller I/O
- Automation triggers

And more are coming:

- DTS-ES 6.1 Discrete
- DTS Neo:6
- DTS 96/24
- 5.1 analog bypass
- Second 21065L DSP
- Second stereo zone
- Balanced (XLR) outputs
- Comp. video switching
- Internal video scaler
- Digital Video Interface
- DVD-A digital interface
- Precision tuner module



TAG McLaren Audio Latham Road, Huntingdon PE29 6ZU

tel: 0800 783 8007 e-mail: helpdesk@tagmclaren.com

To book an audition contact one of these authorised AV32R stockists:

Beds: Sevenoaks Sound & Vision, Bedford	01234 272779	Hants: Audio T Ltd, Cheltenham	01242 583960	Merseyside: Sevenoaks Sound & Vision, The High End, Barnes	0207 722 9777	Sevenoaks Sound & Vision, Glasgow	0141 332 9655
Berks: Audio T Ltd, Reading	0118 958 5463	Audio T Ltd, Basingstoke	01256 324311	Sevenoaks Sound & Vision, Liverpool	0208 876 3355	Stereo Stereo Ltd, Glasgow	0141 248 4079
Sevenoaks Sound & Vision, Reading	0118 959 7768	Audio T Ltd, Chandler's Ford	02380 252827	Audio T Ltd, Enfield	0151 707 8417	Shropshire Hi-Fi, Shrewsbury	01743 232065
Audio Excellence Ltd, Clifton	0117 926 4975	Sevenoaks Sound & Vision, Watford	01923 213533	Frank Harvey Hi-Fi Excellence, Coventry	0208 367 3132	Rodfords, Bath	01225 446245
Sevenoaks Sound & Vision, Clifton	0117 974 3727	The Audio File, Bishops Cleeve	01279 506576	Music Matters Ltd, Stourbridge	02746 525200	Sevenoaks Sound & Vision, Ipswich	01473 286977
Audio T Ltd, High Wycombe	01494 558585	HiFi Corner, Aston Quay	00353 1671 4343	Music Matters Ltd, Sutton Coldfield	01284 444184	Audio T Ltd, Camberley	01276 685597
Martin Kleiser Ltd, Beaconsfield	01494 681300	Sherwoods, Waterford	00353 5187 2622	Music Matters Ltd, Solihull	0121 354 2311	PJ Hi-Fi, Guildford	01483 504801
Sevenoaks Sound & Vision, Cambridge	01223 304770	The Hi-Fi Shop, Belfast	02890 381796	Sevenoaks Sound & Vision, Birmingham	0121 212 0254	Sevenoaks Sound & Vision, Epsom	01372 745883
The Audio File, Cambridge	01223 368305	Sevenoaks Sound & Vision, Sevenoaks	01732 459555	Sevenoaks Sound & Vision, Kingston	01922 473499	Sevenoaks Sound & Vision, Kingston	0208 547 0717
Ouag Brady Hi-Fi, Warrington	01925 828009	Sevenoaks Sound & Vision, Tunbridge Wells	01892 523548	Unitel Sound & Vision, New Malden	01926 886644	Capital Sound & Vision, Crawley	01273 459352
Peter Tyson Hi-Fi, Carlisle	01228 546756	Sevenoaks Sound & Vision, Preston	01772 825777	Audio Designs, East Grinstead	01228 546756	Audio Sound & Vision, Swanscoe	01342 314569
Audio Excellence Ltd, Exeter	01392 491194	Audio Concept, Ealing	0208 567 8703	Stratford HiFi, Stratford upon Avon	01926 886644	Capital Sound & Vision, Crawley	01273 459352
Sevenoaks Sound & Vision, Plymouth	01752 226011	Audio T Ltd, West Hampstead	0207 294 7848	Lintane Audio Ltd, Metro Centre	0191 460 0999	The Powerplant (Hi-Fi) Ltd, Brighton	01273 775978
Suttons Hi-Fi, Bournemouth	01202 555512	Billy Vee, Lewisham	0207 318 5755	Martins HiFi, Norwich	01603 627010	Gilson Audio, Middlesbrough	01642 248793
Audio T Ltd, Brentwood	01277 264730	Cornflake.co.uk, West End	0207 631 0472	Nottingham HiFi Centre, Nottingham	0115 978 6919	Audio Excellence Ltd, Cardiff	0292 022 8565
Rayleigh Hi-Fi, Chelmsford	01245 265245	Harrods, Knightsbridge	0207 730 1234	Sevenoaks Sound & Vision, Nottingham	0115 911 2121	Audio Excellence Ltd, Swansea	01792 474608
Rayleigh Hi-Fi, Lakeside	01708 680551	Harrow Audio, Harrow	0208 930 9933	Audio T Ltd, Headington	01865 765961	Audio T Ltd, Swindon	01793 538222
Rayleigh Hi-Fi, Rayleigh	01268 779762	Listening Rooms, Chelsea	0207 244 7750	Oxford Audio Consultants, Oxford	01224 585713	Worcester HiFi, Worcester	01905 612929
Rayleigh Hi-Fi, Southend	01702 432525	Martin Kleiser Ltd, Chiswick	0208 400 5555	Halburn Hi-Fi Ltd, Aberdeen	01421 221 0221	Moorgate Acoustics, Sheffield	0114 275 6048
Sevenoaks Sound & Vision, Witham	01376 501733	Prestige Audio Ltd, Harrow	0208 060 2977	Sound and Clear, Glasgow	0131 229 7267	Sevenoaks Sound & Vision, Hull	01482 587171
Audio Excellence Ltd, Gloucester	01452 300046	Sevenoaks Sound & Vision, Southgate		Sevenoaks Sound & Vision, Edinburgh		The HiFi Studios, Doncaster	01302 727274

◀ later. The UK hi-fi press promptly split straight down the middle over the new formats relative merits relative to established superdecks of the day such as the Linn and Oracle. To the poor customer, it was a wall of confusion - some journalists celebrated CD uncritically, apparently ecstatic that it had banished all of analogue's traditional bugbears like hiss, wow and flutter.

The result was that the first generation of silver disc spinners has become largely forgotten. Shame, because many of the very first players had a sound quite unlike any others that followed, and one that was - ironically - far more analogue and musical than most of today's high end esoterica.

The Marantz CD54 you see here is practically a museum piece. Made in 1984, it's a late first generation design using Philips' exquisite CDM-1 Pro metal die-cast transport mechanism and the same company's Palaeolithic 14bit, 4 times oversampling DAC/filter package. Despite its midi size, the thing weighs a ton - evidence that the consumer electronics giants built their very first generation players to last. As they cost CD's 'early adopters' a packet, it was only right that they weren't plastic boxes full of air, I guess!

Using it is a riot - it feels as clunky as the Pioneer cassette deck, but slower to respond! Press the Open button and a CD drawer the size and mass of the Clifton Suspension Bridge lumbers out to greet you. Put the disc in and press PLAY and you can go off and make brew before the music's started. When it does finally see it's way to reading the disc's table of contents, the digital time display starts (hurrah!) and the fun begins.

Anyone who thinks big is better, and more bits and oversampling maketh a superior silver disc spinner will learn something playing this baby. It sounds incredibly analogue for something so self-avowedly digital - bass isn't far off the Sansui turntable in its warm and softness, and is barely any tighter either. The mid band doesn't have much in the way of level detail, but what instruments you do hear have a beautifully rich and sonorous texture. Treble is the biggest disappointment - what there is sweet and silky, but it sounds rather

perfunctory. Interestingly though, it isn't harsh and painful as you'd expect from its meagre 14bit DAC - quite the reverse in fact, it's fluffy and vague and cloudy.

The CD54 is an incredibly musical way of listening to digital discs - it's obviously a long way off the likes of even a good mid-range modern machine (i.e. Rega's Planet 2000) in many hi-fi respects like dynamics and detailing, but is still a hoot to listen to. The fact is that there are lots of machines still going that use this transport/DAC/digital filter combination - from Philips' original CD100 to its CD104B - and all are reasonably priced. If you can live without a remote, programming facilities and S/PDIF digital outputs, then they're well worth searching out. Likewise, pathological CD haters may just find them an acceptable way into the delights (?) of the digital disc!

steep learning curve with the new technology, the result being that the first examples, such as the one you see here, had far from perfect sonics.

This Sony ST-J60 is one of the sleekest and most ergonomically successful hi-fi tuners I've ever used. It is beautifully built inside and out, with a thick but tasteful brushed aluminium front panel with a long sleeve of Perspex inset. The switches, buttons and legends wouldn't look out of place on an S-class Mercedes, and are a joy to use. You can ever slide in little labels behind the presets to denote the station you've chosen. The signal strength doubles up as a multipath indicator, and the fluorescent tuning display dims automatically in low light. Wonderful stuff - but it's a shame about the sound. Lightweight, coarse and mushy, sonically it's a million miles behind the high end analogue tuners just three



SONY ST-J60 £60

For whatever reason, used tuners are hardly the sexiest bit of kit for hardened hi-fi nuts, and tend to be very cheap as a result. While you're struggling to get any sort of serviceable turntable, CD player or tape deck for under £100, there's a wide choice of weird and wonderful tuners.

The big issue here is analogue vs. synthesiser tuning - round about 1981 there was a mass migration away from big dials, knobs, levers and pulleys to fully digitally synthesised tuners, which famously 'locked on' target, never to drift off station again. The problem was that designers were on a

years previous.

This one cost £60 - which still makes it brilliant value for a once top of range model - but if you do anything more than casual listening and want a digital then you'd do far better with a NAD 4130, Creek T40 or Denon TU260 for under £100. As far as analogue radios are concerned, there a welter of late seventies analogue NADs, Pioneers, Sonys and Trios going for a song, all of which sound surprisingly open and airy. In this case however, budget for a decent aerial - the old wet string won't work well with these less sensitive designs. ■ ▲

2 ALL GETHER, NOW

Andy Grove encounters the Unison Research S2K integrated amplifier. Using the KT88 valve in an unusual single-ended design, will he be impressed?



Whether you think “yum” or “yuk” to the styling of Unison Research’s amplifiers they are certainly distinctive. The addition of wood to an otherwise dull crackle finish box, I suppose, does add a more organic note to the product. I think the S2K is more front room friendly with its laquered cherrywood fascia when compared to the macho lab equipment look, and the stainless steel plate below the valves shows them off well. The volume and selector knobs are large, curvy machined items which protrude through the fascia. A remote control is provided (also made from wood!) which operates the motorised volume control. Round the back are four line level inputs and a tape in and out. No monitor facility is provided, ‘tape’ is selected via the selector knob. The

single set of speaker terminals are good quality WBT types which accept banana plugs. The power bulge at the rear of the amp contains the mains and output ironwork, all of which was of a healthy size.

Single-ended amplifiers require large output transformer cores due to the static DC magnetic flux. The output transformers in the S2K have dimensions similar to those found in 60W push-pull amplifiers. I had a quick peek under the bonnet; the build quality was good, the components are also of good but not exotic quality and are mounted onto a PCB. The amplifier’s topology is of stereo single-ended design using one KT88 and one ECC82 per channel. The output valves are operated in Ultra-Linear mode where a proportion of the anode signal is fed into the screen grid, giving “partial

triode” characteristics to the KT88 beam tetrodes. The power output may seem diminutive on paper but experience tells us that although this type of amplifier may not be suitable for an open-air Motorhead concert, the achievable volume belies the power rating. This may be due to the relatively benign overload characteristics of low feedback valve amplifiers.

I found that the S2K drove my QUAD 989s okay. I couldn’t achieve ear splitting levels but under regular day to day listening conditions I never seemed to over stretch the amp. My very first impression was that the amp had a kind of light, delicate presentation. Opening with Tchaikovsky’s Piano Concerto No1 Martha Argerich’s piano was portrayed with a precisely etched dynamic envelope, there was no sense of the amp smoothing the

◀ leading edge of transients. The orchestra had a light, airy quality with a fine, shimmery treble, the opening horns had a silvery rather than brassy tone, but were still fat and rambunctious. The effect was in no way unpleasant, the general tone of the amp was light and glittery with no sense of grit or dirt.

I popped on Vaughan Williams' Thomas Tallis Fantasia and once again that very musically appealing light was present. In all of the classical music I listened to I found that the S2K gave a very airy performance with fine staging and hall ambience. Maybe with the heaviest of passages at high volume the sound could become a little confused. The strings would jam together - maybe I was pushing the amp a bit too hard though.

To see if the little amp could boogie I tried James Brown's 'Shoot Your Shot' from his LP, The Payback. Out came some seriously groovy tunes. The Godfather's voice was precisely positioned within the mix as he whooped and growled. The complex bass and percussion lines

were fleetfootedly followed and explored. Sax, Hammond and guitar stabbed out of the mix, punctuating the bassline. The bass quality was quick and extended but it didn't hold the spotlight in the way the mid and treble did. While on the subject of the Seventies I gave 'Kung Fu' from Curtis Mayfield's Sweet Exorcist LP a spin, plus a few tracks by Parliament - the result: funky brother! I then gave the Mediaeval Baebes a quickie (so to speak); the girl's voices were highlighted in the same way as the strings in the orchestra. Their voices never compressed together into a disharmonious chord. The excellently recorded acoustic drums had a great, elastic, resonant quality with good depth.

The S2K is a great little amp with a bright, chirpy personality. I have spent quite a while listening to it with a variety of music and I never found myself complaining. The slight "silvering" effect may not be to

everyone's taste but it does give the amp a light, easy going character. Maybe it picked up some of the Italian sunshine when it was being built? It drove the QUAD 989 electrostatics fine, so I would expect it to work with a fair number of speakers as long as they are reasonably sensitive (89dB plus) to make the most of the low power output. ■ ▲

Unison Research S2K £1295

UKD
23 Richings Way
Iver
Bucks SL0 9DA
Tel: 01753 652669
www.ukd.co.uk

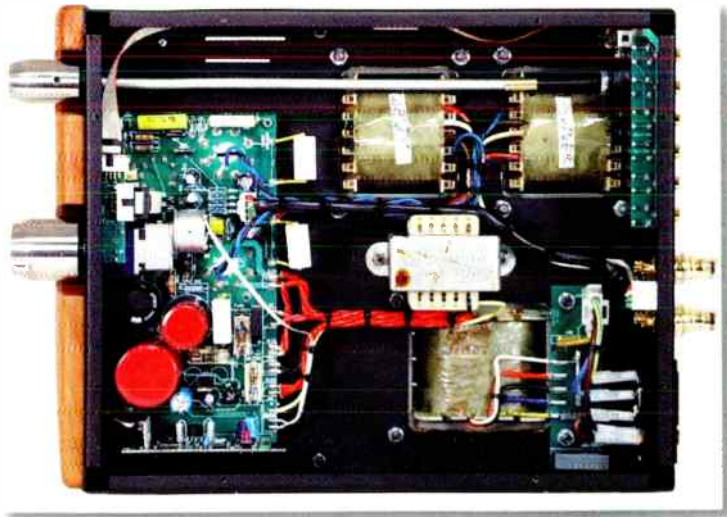
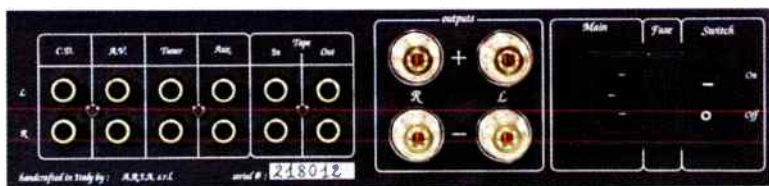

MEASURED PERFORMANCE

Being a single-ended amplifier with just one valve per channel the Unison S2K will not be producing much power and it measured out at just 4.5W per channel, for 3% distortion. However, amplifiers like this overload gently and the distortion they produce is predominantly second harmonic, which is just about inaudible to the ear below 5% or so. Above this it merely lightens timbre, rather than producing anything nasty in the sound. So 3% distortion from this amplifier is a lot more tolerable than 3% from most. Pushed harder it would actually deliver 10W before serious clipping set in, so subjectively there's a bit more available than you might think from the official specification, as it were (3% being the usual measuring limit used for this sort of amplifier).

Obviously, the S2K won't go very

loud but it will give a reasonably good account of itself. As always though, it does need sensitive loudspeakers and this really means good, modern floorstanders with an 8ohm bass driver - rare these days; most are 4ohm.

Bandwidth was very wide for the species, stretching from 8Hz-47kHz. Sensitivity was high at 130mV and channel separation wide at 70dB. There was a little hum though. Distortion characteristics were good, second harmonic dominating even at high frequencies, showing the transformers do not possess excessive reactance, as many poor designs do.

The S2K is neat enough in its performance. Amps like this do really need to have a proper matching loudspeaker to really show what they can do and nowadays there aren't so

many around. Matched with care it should give a sweet and balanced sound. **NK**

Power	4.5watts
CD/tuner/aux.	
Frequency response	8Hz-47kHz
Separation	70dB
Noise	-71dB
Distortion	1.6%
Sensitivity	130mV

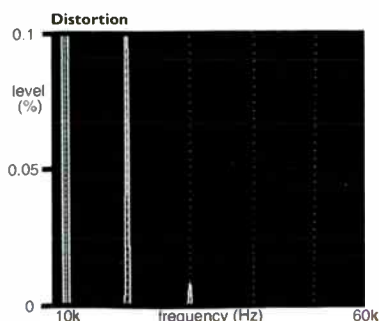

World Verdict



A cracking looking and airy sounding valve amp, though low output means partnering with more sensitive 'speakers.

letters & e-mails

Visit our website at www.hi-fiworld.co.uk or send your e-mails to letters@hi-fiworld.co.uk

Every letter we print wins a superb prize including Precious Metals interconnects and a **FREE** subscription to **Hi-Fi World** for the best letter of the month!!

LETTER OF THE MONTH

LASER GUIDED MELODIES?

A few years ago, BBC TV's Tomorrow's

World programme presented a record player which read vinyl using three lasers, which could read over scratches, static etc. and sounded like something I would definitely like to own. They said it cost about £2000 at the time, but such a product would surely drop in price like all other technology. But no - I have tried in vain to track down such a unit and can only conclude that the patent for the unit was bought and the unit withdrawn from the market. I can't also help but think that remastered CDs are merely digitally read vinyl transferred to CD using this withdrawn unit. Prove me wrong! If you own such a unit or know someone who does, then please let me know.

Will Stevens

This 'laser turntable' you mention has become something of a hi-fi legend - or should I say 'myth'. As far back as

twenty years ago, there was a prototype in existence that claimed to play vinyl using lasers, thus eliminating record wear. It was developed in America by Finial but getting the lasers to track the groove was a problem. A Japanese company bought the design and ironed out the bugs but it had a peculiar problem. The lasers read all the damage and rubbish in the groove, producing a noisy and rough sound! Styli plough through unwanted detritous, pushing it aside.

If you want scratch free vinyl, there are several far better and more realistic options. First is to buy a top quality turntable (such as a Linn LP12 Lingo, Michell Orbe or Origin Live Oasis-S) - you'll be amazed by how superior decks seem to let the arm and cartridge track through the noise rather than get caught up by it.

Second is keep your records clean, use a carbon fibre dust brush every time you play them and always put them back into polythene lined, anti-static treated inners (such as

Goldring's Exstatic sleeves, for instance). Really noisy records can be transformed by a blast on Keith Monks record cleaning machine, or on one of the excellent smaller Moth or VPI home designs.

Third, you could make your own remasters by recording your vinyl onto your computer, processing it with Cool Edit's de-scratcher and de-noiser, and then burning the result direct to CD. This option will give you the quietest recordings, but the first two will offer better sonics - a combination of all three gives very impressive results, however.

As for your suspicions about the use of the aforesaid laser disc spinner in the remastering process of many CDs, I'm sorry to say that chance would be a fine thing. Judging by the sonics of many so-called 'remasters' (especially those done from the mid-eighties to the mid nineties), I suspect a bag of spanners, a lump of two-by-four and a few rusty nails were the mainstays of the operation.

DP ■

ARCAM

Visit www.arcam.co.uk

for Arcam news, product information, technical support and advice on how to get the best from your system

Arcam, Pembroke Avenue, Waterbeach, Cambridge, CB5 9PB, England

Tel: +44 (0) 1223 203203 Fax: +44 (0) 1223 863384

support@arcam.co.uk www.arcam.co.uk



The laser turntable was first designed by Robert Stoddard and the Finial company back in 1988. It took 13 years for the product to eventually reach the market and is now hand made in Japan to order by the company ELP. Called the LT-1A, it plays vinyl records via lasers and is operated and programmable like a CD player, skipping and repeating tracks for example. It uses two laser beams to read the stereo audio signals, two to maintain the beams in their proper channels and one more controls the distance from the LP. Priced at \$13,500 in the USA, you can find out more about the product on the company website at www.elpj.com

VIDEO CAPTURED

Since the advent of DVD I have been waiting for the day when recording machines would become available, my idea being that I could buy something to replace my VHS tape recorder and play all other CD type formats. This one box solution would be connected to my vinyl only system as a means of listening to digital audio. Well, I have become tired of waiting for this machine to materialise. Even if it does exist I feel sure it would not be the flexible play-anything machine I am looking for.

This got me thinking that maybe it would be possible to leapfrog over this problem and go the computer route? I was thinking of being able to record audio/video to a hard drive. Also to have both DVD and CD burners for saving purposes, both of which presently exist in the computer world. With a top quality sound card I could play audio through my vinyl system and use, say, a Pinnacle DV500 card to connect the TV and any digital photo equipment.

I agree it's a very rough idea but there are couple of points I'm not sure of. Would I be able to use the TV as a monitor when accessing the computer or is there another way around this? Is it possible to programme the computer to record on hard drive by timer (i.e. same process as on home taping with VHS)? I guess you can see the basic outline of what I am thinking. Is this possible and if

so could you flesh it out a bit for me? Loved the CD12/ LP12 contest but the result was a foregone conclusion to anyone who listens to vinyl!

**Graham Jelley
Taiwan.**

To my mind, there's no doubt that DVD is the missing link between computers, hi-fi and video. By the end of 2001 Philips estimates that there will be around 160 million DVD players & DVD-ROM players in use, and this is no insignificant point. As you rightly say, they've reached computers faster than the domestic market, and offer greater flexibility and lower costs too. Amazingly, it looks like your prayers have just been answered in the shape of Philips' brand new DVDR 1000 home DVD recorder, which can record and play TV programmes in high-quality MPEG2 format, as well as write in real time onto DVD+RW discs.

Besides being rewritable up to 1,000 times, DVD+RW's biggest plus is its compatibility with existing home DVD players and PC-based DVD-ROM drives. Philips' offering is expected to be incompatible with only a small number of first-generation DVD devices. It also features a built-in TV tuner that can record TV programs onto high-quality DVD+RW discs, just like a videocassette recorder and has a

programming mode that allows preset timed recordings. This could be just what you're looking for, at a cost of £1200.

Going the computer way is a more complex but far more powerful option. For complete video and audio editing and mastering, you'll need Hauppauge's (£90) Win TV card (letting you watch TV on your PC and record it to hard drive), plus a video capture card like VideoLogic's £100 Vivid XS (which has a TV output, letting you use your telly as a monitor). Then you'll want a beefy hard drive (at least 40GB), a fast processor, a decent soundcard (such as Guillemot's £250 Isis) and a PC DVD-RW, such as LaCie's new external unit.

For around £650 this offers 4.7GB of storage capacity per disc, DVD-RW/-R and CD-RW/-R capabilities combined in a single drive, universal CD/DVD reading and a powered FireWire port for mobile use. The drive records to 4.7GB DVD-R General Use discs at 2x speed (2.6 MB/sec) and to 4.7GB rewritable DVD discs (-RW) at 1x speed. It provides 6x (7.8 MB/sec) read performance for DVD-R and DVD-ROM discs. Smaller files can also be stored on lower-cost 700MB CD-Rs at 8x speed or on CD-RW discs at 4x speed, while CD playback is at 24x. These DVD-R General Use discs can be played back on most DVD-ROM drives and home DVD players. Once the DVD-R disc is burned it becomes either a DVD-ROM or a DVD-Video disc.

The total cost of the computer set-up would be around £2,000, but would effectively let you record and edit your own audio and video, then burn it onto either DVD or CD at your leisure. Thanks to the bundled software with the Hauppauge, you'd get all the timer recording facilities of the Philips DVDR1000 - and a whole lot more. The choice is yours! **DP**

Philips DVDR 1000 is in the shops now, accompanied by Panasonic and Pioneer DVD recorders. The DVD recorder drives for computers from Pioneer, Panasonic, Hewlett Packard and Philips all record audio to CD as well as DVD. Any of these machines could well fit your criteria. It may be worth hanging on if you favour a dedicated unit! **SP**

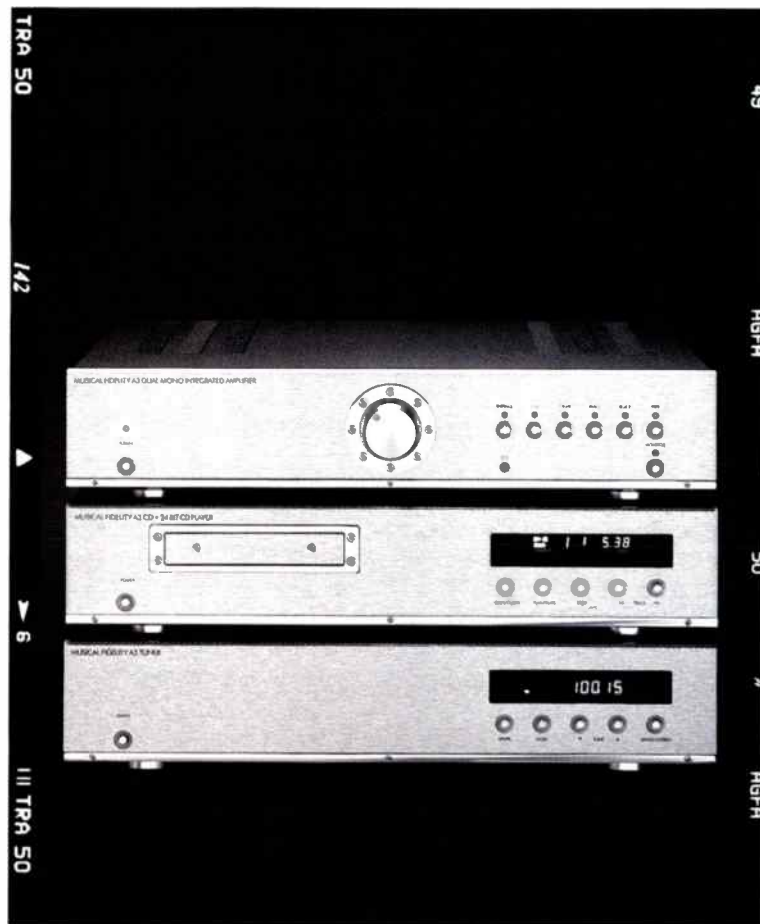

A3 RANGE.

MACHINED, MIL-SPEC ALUMINIUM
FRONT PANEL.

TWENTY-FOUR CARAT GOLD
PLATED FITTINGS.

REMOTE CONTROLLED.

PHONO STAGE.

POWERFUL, ROBUST, BUILT.

MUSICAL FIDELITY

A3 RANGE: INTEGRATED AMPS, PREAMPS, POWER AMPS, TUNER, CD PLAYER AND HOME CINEMA DECODER. FOR DETAILS OF YOUR NEAREST STOCKIST RING 020 8900 2866.



The Philips DVDR 1000 may be answer to your sleepless nights!

► **CARTRIDGE CORNUCOPAEIA?**

I hope you can help me with some advice about a cartridge for the excellent Michell GyroDec SE, which I hope to buy shortly to upgrade my Rega Planar 3/ Linn K9. The rest of my current system comprises a Denon DCD1700 MkII, Nakamichi CD1, Yamaha TX-950, Hart Linsley Hood 1400 series preamp, Hart Linsley Hood monoblocks and B&W CDM7NT's. The power amps are bi-wired with 1 metre lengths of Sonic Link horizon cable and the pre-power interconnects are made from Maplin high quality cable and gold phonos.

The Rega will migrate to the remains of my old system of Radford ZD22/ ZD100 pre/power, KEF 104ab speakers and Aiwa AD1800. I also have all my old cartridges - Shure M75EDII, A&R P77 and Goldring Eroica H - which may or may not have any life left in them? I'm thinking along the lines of a Dynavector DV10 or 20, Shure V15, or even part exchanging the Eroica for a new version. Any suggestions?

Brian

Wow, what a veritable treasure trove of stuff you have there, Brian! I'd agree that the Gyro SE would make a fine upgrade to the Rega (especially in its new DC guise), so what pick-up to partner it with? Unfortunately you haven't told me your budget, so assuming money's tight this is how I'd proceed. Buy a new C77 stylus for your A&R cartridge (£20) - just to get you back on the road with a working pick-up that isn't going to recut your discs. Then, spend all the money you've saved by not buying a Dynavector DV20X-H (i.e. £299) on an Origin Live modded RB250 tonearm to partner it.

When you've saved up some more dosh, go for a Dynavector DV10X4 (or the DV20X-H if you can possibly afford it). Next, borrow a Trichord

Dino phono pre-amp from a sympathetic dealer and see if it makes any improvement over your phono stage (and it should!). If so, buy it when funds permit. This done, you'll have a fantastic vinyl source. When your boat comes finally in, I'd suggest an Ortofon Kontrapunkt B as the missing link in your dream vinyl front end. As for cartridges deteriorating with age, as with everything it depends how they're kept - essentially though, the suspension holding the cantilever eventually fades - hence a brand new cheapo MM is often better than an older, part-worn MC. **DP**



At £300 the Dino is a superb vinyl upgrade

► **SOME THICKENING'S REQUIRED**

Dear World,
I have a Roksan Xerxes XPS2 /Artemiz/DynaVector 20H mounted on a target wall shelf and Mana soundframe. This is amplified by an Exposure 15 integrated and a pair of Kef Concerto 2 speakers. Speaker cable is VDH CS122. My musical tastes include Jazz, Female vocal, some dance and a wide range of other styles. Overall I am very happy with the sound of my system although it sounds a little thin at low volumes.

I wondered if you could offer me some advice regarding CD players. My old Arcam alpha + is sounding a bit harsh. I wanted to replace it with

something a little better but am struggling to understand the best way forward due to all the new formats. I have very few CDs.

In addition I am considering replacement of my amplifier. I would like an integrated that will meet my desire for better performance at low volumes and also has better imaging than my Exposure as I feel this is somewhat lacking. I have a maximum of £1500 to spend and am happy buying second hand.

Thanking you in advance.
Julian Shuttle

That thin sound you appear to get at low volumes could be sorted out a number of ways. A little moving around of your Concerto 2s could solve part of the problem, placing them closer to a rear wall could 'blossom out' the sound a tad more without creating too much boom. The art to it is to take time over positioning. It may seem a tedious job but it often pays surprisingly good dividends.

On the equipment front, it would seem that the slightly grey sounding Arcam is perhaps contributing towards this lack of body. Ideally you need a rich and smooth sounding player but unfortunately these rarely come cheap (considering you have very few CDs). Meridian's entry level 506.24 at £1200 is ideal. You don't get oodles of high frequency detail - which in certain respects is great for CD and all its digital nasties - but you get a full and broad picture of the music with a deep perspective - it will warm up the sound no end. You could always take this route and change the Exposure later.

However, if you'd rather change both then there are a few pairings which could well be worth auditioning. Two smooth sounding options further down the price scale

are a pair of chic Italians - Monrio's Asty Player at £695 and Audio Analogue's Paganini at £795. These can be paired with the Asty integrated at £450 or the excellent Audio Analogue Puccini Remote, which also has a fine MM/MC phono stage. An extra £200 or so gets you the SE version, which has a little more power and finesse with the same phono stage! I'd recommend that you give all of these options a listen and decide which works best for you.

On the new formats front, you may well find that the various SACD or DVD-A player options available may not quite have the smoothness you require, as these players are geared towards the extra high frequency detail that the new formats deliver and can consequently sound a little bright with Compact Discs. **SP**

IMAGE CONSCIOUS

I have a system comprising Denon DVD5000, Linn AV5103, Naim HI-CAPIS-NAXO/3 x NAP250, Naim NAP140, Linn Isobariks and Linn Sekrits. The problem with my system is that the imaging is poor and sounds ponderous, so I want to upgrade the speakers but am unsure what to buy. I was thinking of Yamaha NS1000s, as I listen to a lot of rock music, but my hi-fi dealer said they have a very hard sound. In David Price's review of a Naim system in the August 2000 issue he used NS1000 speakers, so I was wondering what he suggests?
Jonathan Smith

Frankly Jon, I'm not surprised that you've got an image problem. Not you personally, of course, but your system. Any sentence with the magic words 'Linn Isobarik' and 'imaging' is

bound to end in a plea for help. The 'Bariks are brilliant speakers, if you like that kind of thing - they come from another age when Linn was producing very eccentric and often totally bonkers kit that appealed to total dyed-in-the-grain enthusiasts seeking one kind of sound (dare I say it, "the only sound"!).

Unfortunately, Linn's particular take on this didn't display exhaustive attention to detail in the imaging department. Indeed, back in the days of the nineteen eighties, many 'flat earthers' denied that such a thing really exists. Well, I don't want to go down that particular ontological dark alley - suffice to say that many people like to get a reasonable sense of a recorded acoustic from the general direction of the music they're hearing.

The problem with the Bariks was that they're a long, long way from a point source. Think about one of Tannoy's modern dual concentric designs - the combination of the single coaxial driver and tall, narrow front baffle gives images that hang in space as if by magic. Consider now the Isobarik - about twenty five different drive units of wildly differing



The Asty integrated could be the ideal Italian job!

Enjoy music more

Forget all you know about valve amplifiers. Ask for a home trial of the RA-01 and prepare to be delighted.



RA-01 monoblock from £6995 per pair
Full-range, natural, detailed and expressive

*Renaissance
Amplification*

RA-01
22W triode amplifier

Available from:

Acoustic Arts – 01923 245250

audio solutions - 07787 543031

Sounds of Music - **01892 539245**

stoneaudio UK – stoneaudio.co.uk

Walrus Systems - 020 7724 7224

"These amplifiers really are a bit special." – *Andy Grove, hi-fi world December 2001*
 "Here was a sound you could leave playing all day." – *Martin Colloms, Hi-Fi News September 2001*
 "The measured performance of this 300B amplifier is as good as it gets." – *Noel Keywood, hi-fi world*
 "The whole performance was reproduced with musicality and emotion ..." – *Andy Grove, hi-fi world*

Distributed by Integrated Engineering Solutions Ltd - 023 8090 5020

www.higheaudio.co.uk

designs, laid out higgledy-piggledy in baffles as wide as a bus and pointing every which where but here. Hmmm. doesn't exactly come as a shock that they don't image with rifle-bolt precision...

The Yamahas image far, far better than the Bariks, but they're still not perfect - (one of) the great thing(s) about the NS1000Ms is that they have dome midrange drivers as well as tweeters. The latter are essentially smaller versions of the former, hence they share near identical phase and dispersion characteristics - making for far tighter images. The problem is that to get the bass response down to 30Hz, the Yams use 12 inch bass units, necessitating a wide front baffle and cabinet, which we now know isn't ideal for image location. This is why many modern designs use two or more 6 inch woofers in series (rather than one 12), permitting the use of far slimmer baffle.

Moving to your predicament - if you like the muscular, ballsy sound of your Isobariks, you'll love the NS1000Ms which are the same, only more so. They're also far tighter and more transparent too. The problem is that your front end may not be quite up to it - I'd be happier with you using a dedicated hi-fi CD player for serious audio use - a smooth sounding Meridian 588 or 506.24 would do the trick, or ideally a Marantz SA-1 or Linn CD12. The NS1000Ms aren't hard so much as revealing - put a fierce source in and you'll be scraping yourself off the walls - feed them with a smoothie and you'll be swimming in sweet, warm sound. I'd try to source a pair of NS1000Ms for sale at a dealer, and get a dem to see what you think first. As always with speakers, you should ALWAYS try before you buy! **DP**



Yam up the NS1000s for a taste of speed and slam!

SMALLER IS SOMETIMES BETTER

Dear HFW, I have been reading your magazine on and off for years (spring/summer equals outdoor pursuits) and always come back for inspiration for upgrades etc. Twenty years on my system consists of: Nottingham Analogue Spacedeck, Mentor Arm, One of Cartridge Man's Music Maker Cartridges Silver wire from Cartridge to amp. Helios one CD (mk1), Audio Note Meishu 300B single ended (power supply upgrade) Cable Talk 4 bi-wire, Epos E11 on Epos stands.

The problem is that I hate demoing equipment. So what I need advice on is, a short list so that all my spare moments are not sitting in stuffy dem room, sipping foul coffee with the knowledge that the speakers now in front of me will not sound this good in my very compact flat. Yep, the ES11s after 10 or so years service are still lovely but are damaged (drive unit distortion on certain low frequencies), so your advice for a short list would be appreciated.

When I first wanted speakers I spent months listening to everything up to £1500, but always came back to the ES11s, why? Because to my ear they are musical and have good timing. No screaming treble (tiring) or booming bass (I have neighbours). Not perfect but the Hi-Fi stays on. . .late, 'nuff said.

A minor problem is that on paper they should not work with the amp but only on high volumes do they scream, due to the amp working hard (I assume). The list I have compiled - ES12s (87db?) Jamo Concert 8s, ESL63s (ok with the amp?). Budget, still £1500. Taste in music is from Be-Bop to Funk to Hip -Hop anything with a Soul. Any other changes?

Grant Beerling

Right, Grant, let's presume you ideally don't wish to part with your Epos 'speakers but have to. The first thing to do is to arrange for a decent retailer to give you a home demo of the Epos M12s. Now owned by Creek Audio, the brand has retained . You get a big sound from the 12s, with a fine treble and dynamics and scale rarely associated with stand mounts, especially at £430 - well below your price point. You can keep your Epos stands, saving even more money which can be re-channelled elsewhere in the system, should you

so wish. The M12s, though, are around 88dB, which isn't exactly perfect for an 8W valve amp such as the Meishu! I presume your volume control is permanently cranked to 1!!

Should you wish to consider a pair of 'speakers with a higher sensitivity which would be a closer match (on paper at least) to the valve sound there are a few options around £1500. The Jamo Concert 8s (or D830s as they're known now), whilst having a fairly highly rated sensitivity of 90dB are actually quite a handful to drive and, although a valve sound could calm down the slight top end edge they can acquire, it may not be a marriage made in heaven. Again, although valve amps are well suited to Quad electrostatics, they need a bit more oomph than can be delivered from the Meishus - you'd end up with a pretty thin sound (although someone from the company recently told me they heard a 1W valve amp driving a pair of ESL-989s in China recently. Although the only music played was - tellingly - solo violin!)

I'd recommend getting a home trial for a pair of Diapason Karis standmounts for £995. These are of bookshelf dimensions yet are designed to work with valves, with their transparent and refined sound. Sensitivity is suitably high and they have an excellent real wood cabinet resulting in a beautifully eye catching finish, unlike another possibility - the Klipsch Heresy IIs. Although these hefty standmounts aren't the prettiest puppy in the litter, they have a very high sensitivity and the appeal of a horn loaded design. Give them a good listen, as they are undoubtedly different to the sound you've been used to with your Epos models. **SP**



Not cheap but beautifully finished, the Diapason Karis is great with valves.

FOR ALL



Have you been waiting for the one bit of kit to replace that pile of black boxes in your front room? Your prayers could be answered in the shape of Panasonic's DMR-E20 DVD recorder.

Last month I tested Philips DVDR1000, a DVD recorder you can connect into the hi-fi to play CDs. You get DVD movie sound and tv sound channelled through the hi-fi system too. A big disappointment of the Philips was that whilst it can record movie audio, Philips had not configured it to be used as an audio-only recorder. Now here's Panasonic's brand new DVD recorder and it will record audio. So is this, their DMR-E20, a better choice for audio buffs than the Philips?

DVD video recorders are the latest big thing. They not only play DVD movies, but record tv and video to a CD-like 12cm DVD disc, ousting the VHS video recorder which has long reigned supreme in this role. You might be surprised to learn there are three competing DVD recording systems: Philips DVD+RW, Pioneer's DVD-RW and, represented here, Panasonic's DVD-RAM. Behind each of these manufacturers lie a group of industrial allies of course, but

Panasonic are largely going it alone with DVD-RAM. The reason is that DVD-RAM was intended to be a durable, high capacity computer storage format. It stores video on a relatively expensive caddy protected disc, currently priced at around £25 for 4.7GB. Japan's DVD committee designated DVD-R as the domestic recording format and these discs cost around £15 for 4.7GB.

As a result Panasonic have faced difficulties devising a recorder like the DMR-E20 which will appeal to the man in the street who will likely want to record the footie and watch movies. The solution is this: the DMR-E20 records both to expensive rewritable DVD-RAM cartridges and write-once DVD-R discs. It's an ingenious solution, made better by the fact that Panasonic supply a pack of three 4.7GB cartridges with each recorder. If you use these for recording programmes you will erase later, three could be enough. Permanent recordings can be made to less expensive DVD-R discs; the

DMR-E20 has an unusual disc tray that can load caddy DVD-RAM discs or naked DVD-R discs (12cm and 8cm). Since all DVD recorders must be able to produce a disc that will play on any DVD player, in other words a compatible disc, it has to be able to write to a conventional DVD blank like this.

The poser for Panasonic was how to keep this a RAM recorder that basically supports their own video disc format. Their solution is to prevent the DMR-E20 writing to rewritable DVD blanks, in other words DVD-RW discs. If you want to lend your recording of the footie to a friend or play it elsewhere on a DVD player, then you'll have to record to a £15 DVD-R disc that cannot be erased, unlike Pioneer and Philips recorders.

Two mitigating factors are that DVD-R blanks cost £15 whatever format you use and that this price will surely come down pretty fast as demand rises. Also, not all DVD players can play rewritable DVD-RW

& ALL FOR

discs in any case, so you might not be able to transfer a DVD-RW recording from a Philips or Pioneer player either!

So there's a pretty good case in favour of the new dual-format DMR-E20 reviewed here. How does the machine fare in performance terms? Panasonic have had time to develop DVD-RAM; it has been on sale for many years, for computer storage, and for domestic recording in their Japanese home market, with models prior to this one. And it shows. Picture quality was excellent in high quality XP mode, which gives one hour recording time on a 4.7GB disc. It was all but identical to the original.

Standard Play (SP) mode gives two hours on 4.7GB and it too was very easy to watch, with good levels of detail and sharpness. There was a little blandness in people's faces, but their hair wasn't smudgy; grass and trees looked real.

Even in Long Play mode, giving four hours, the picture still looked less coarse and jagged than Philips format, remaining quite easy to view, if obviously of low-ish quality. Down at Extended Play level (6hrs) things were getting rough but the picture



was viewable. It seems that Panasonic have had time to hone their video compression techniques, giving a picture that really is of excellent quality and easy to watch. The machine has plenty of trick modes of course: you can stop, start, pause, move slowly frame by frame, move fast at a variety of speeds and I was surprised that sound output was maintained even in what looked like x2.

Initially, my recorder did not auto-tune and the factory AV1 output was composite video. I connected up an aerial and a SCART lead to the tv, which took just a few minutes. No tv pictures appeared though, until I manually tuned (unlike the Philips), which was odd because Panasonic claim it does auto-tune. Getting to manual tune is not easy until you understand the menu system - and all

DVD recorders face you with a fierce number of confusing options.

Initially, picture quality from DVD movies wasn't particularly good, looking grainy, which was puzzling. Then I remembered seeing a small note in the 95 page manual about optimising picture quality. I re-set the AV1 output from composite to RGB, then the DMR-E20 gave fine results. This is a first class video recorder and, once you get the hang of it, quick and easy to use. Recording to RAM cartridges does not require finalising, so there's no delay between making a quick recording from tv and replaying it. The recorder was slick in this important area.

This machine can also be used as an audio recorder and it is relatively easy to use. The only difficulty lies again in the handbook which does not identify this as an individual function. Selecting AV4, the rear audio inputs, allows it to record audio, with or without a video signal being present. Record level cannot be set, but our tests show there's plenty of dynamic range and a maximum input level of 2V is enough to avoid overload from all sources.

Audio sound quality was very good, from CDs and from recordings. Bass drive was reasonably firm, if quite not up to the Philips, and there was quite a good sense of clarity and time domain resolution. I really couldn't seriously fault the machine in this area, even though audio is not its primary function. It is a very respectable recorder all the same, far



Behind the fascia lies a whole host of function controls

DESKADEL

When only the best will do!

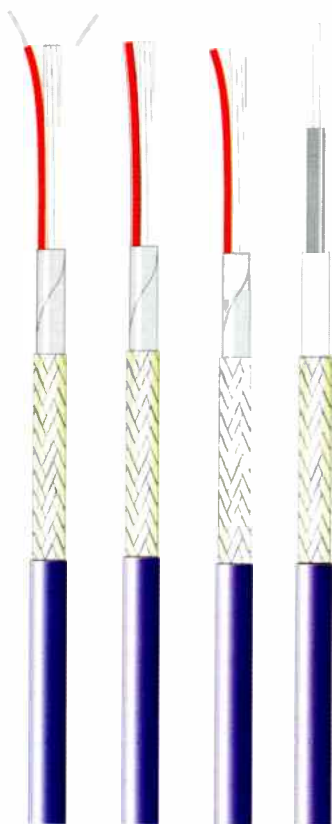

Conductor
Reference Cables
and Connectors
in PURE gold and PURE SILVER

Worldwide Distribution

Wire & Insulation Tel/Fax: 00-44-1-942-887171

Agents

1	Arbelos	Switzerland	Tel: 00-41-718586282
2	Analogue Audio	Netherlands	Tel: 00-31-306044342
3	Audio Synthesis	United Kingdom	Tel: 00-44-1159224138
4	Deskadel International	Belgium	Tel: 00-32-3-8892231
5	Audiophile	Spain	Tel: 00-34-963331156
6	Lothar Hoffman	Germany	Tel: 00-49-60298107
7	Christou Laertis	Greece	Tel: 00-30-17773208
8	Lowweld Audio	South Africa	Tel: 00-27-137511485
9	Samhouse	Hong Kong	Tel: 00-852-254457

DESKADEL

MOERPLAS 53 2870 PUURS - BELGIUM

Telephone: +32 3 8892231 Fax: +32 3 8609181

web: <http://www.deskadel.com> e-mail: kdelaet@deskadel.com

Hazlemere Audio

We offer music lovers the opportunity to increase their enjoyment of music.

Objective advice, comfortable listening rooms, home demonstrations, superb customer services and some of the world's finest equipment.



Now
Demonstrating
the Full Range of
Oracle Products

Come and hear
Nirvana Cables
Where less is more.
Less Noise, More Signal



Also demonstrating in the new showroom and studios
Accuphase, ART, ATC, Audio Analogue, BKS, Creek, Crimson, DNM, Epos,
Gamut, Harmonic Technologies, Nagra, Plinius, Opera, Ortofon, Resolution, Reson,
Rockport, Sugden, Totem, Triangle, Trilogy, Unison Research

For an appointment (day or evening)

Call High Wycombe

(01494) 865829

campaign audio design

Hi-Fi Cables Manufacturer and Supplier

“Love Hertz”



Getting a better, more involving sound often means spending a lot of hard earned money. It's such a waste, because every system can benefit from our cables and accessories, at a fraction of the cost of some new "black box". Here are some of the ways we can help.

We have Linear Crystal Oxygen Free Copper interconnects (£12.48) up to High Purity Silver balanced cables (£99.00) and high definition

loudspeaker cables in Silver Plated Copper or Pure Silver. Our mains cables add weight, power and scale, and with non-inductive RF filtering (£10.00) and over-voltage protection (£3.00) enhance performance still further. Gold plated AV cables, both RF (£19.95) and OFC Scart with PTFE insulation (£30.19), help bring picture quality in line with NICAM sound resolution.

We also have a cure for your noisy fridge or central heating motor (£3.50), enabling you to throw away your big mains noise suppressor, which has been giving you that "sat upon sound" for years. There's lots we can do to bring you closer to the emotion and energy of the performance. So confident are we, that we offer a 21 day money back guarantee.

Ring or write for details:-

CAMPAIGN AUDIO DESIGN

Llandudno Road (HW)

Cardiff CF3 3PG

Tel:- 02920 779401

Website: <http://business.virgin.net/cad.cables/>



Trade and International Enquiries Welcome.



◀ better than cassette and little different from a normal CD recorder, excepting good ones costing £350 or more. Most people will not want to record a few megabytes of audio permanently to a £25 4.7GB cartridge I'm sure. However, it has the flexibility to provide audio-only recording, whilst also acting as a good quality CD player, as well as a video



The front of the machine houses the analogue and S-Video sockets

player and recorder. That's a lot of ability and it's all handled very slickly.

This is a well honed, quality DVD recorder at a competitive price. Whether buyers will accept DVD-RAM cartridge prices, which remain stubbornly high, is the big question hanging over this DVD recording format. ■ ▲

Panasonic DMR-E30 £999.99

Panasonic UK Ltd.
Panasonic House
Willoughby Road
Bracknell
Berks
RG12 4PF
Tel: 01344 862444

MEASURED PERFORMANCE

The DMR-E20 was detectably different from a normal CD recorder. For a start its bandwidth was fractionally wider, terminating with a 'brick wall' filter at 22.4kHz (-1dB). You can see also a peculiarly bumpy response with some high frequency roll-off - not at all CD like in its bumpiness, although you have to bear in mind this analysis has a very high amplitude resolution of 0.5dB/division, so even the smallest departures from flatness are amplified. Most suspicious - and not shown here - was the way the recording system de-cohered the test signal, much like a cassette recorder! However, in this case it could not have been fm modulation (i.e. wow and flutter) so much as the presence of Dolby signal processing.

Noise was very low yet the noise floor in the presence of a signal was CD like, suggesting a -96dB or so noise floor when the actual measurement was -115dB. The important point to note here though is that there are virtually no distortion or quantisation products; the spectrum analyser was in fact measuring noise in the harmonic frequency bands.

There was no audio recording level control and maximum input

before overload measured 2V, just like recordable CD. The DMR-E20 is linear and has plenty of dynamic range so this is not a problem, since no conventional hi-fi source (e.g. tuner, CD player) delivers more than 2V.

In a nutshell the Panasonic measures well as an audio recorder. There is extra processing going on so it isn't as pure as a CD recorder, but its measured performance fully meets audio requirements, being a little worse than recordable CD in some areas but better in others. It's very respectable and Panasonic have obviously paid attention to audio quality. **NK**

Frequency response 6Hz - 22.4kHz

	left	right
Distortion		
-6dB	0.025	0.025
-30dB	0.027	0.027
-60dB	0.77	0.77
-90	24	24
Separation	left	right
1kHz	71	70
20kHz	65	64
Noise		-115dB
Output		2V

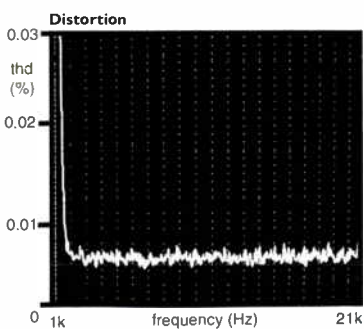
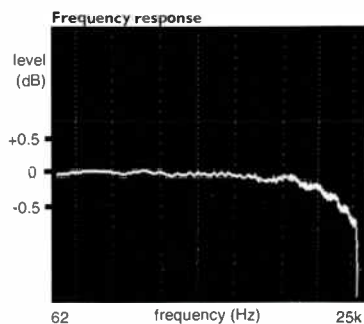
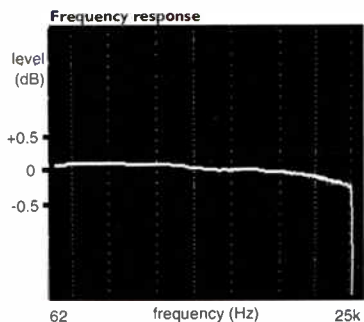

World Verdict



High quality player and recorder, the DMR-E20 is a fine breakthrough machine that offers excellent value when all is considered.



freedom of choice in Glasgow and Edinburgh

LOUD & CLEAR @ THE MILL NOW OPEN FROM WEDNESDAY – SATURDAY 10.00am – 6.00pm

AVI • Crimson • Chord Co. • Denon • DNM • Epos • JM Lab • Kef • Kef Reference • Krell • Living Voice • Marantz
 Martin Logan • Michell • Monitor Audio • Moon Electronics • Musical Fidelity • NAD • Naim Audio • Nakamichi • Nordost
 Primare • PMC • ProAc • Rega • Rel • Roksan • Ruark • Seleco • Sonus Faber • Tag McLaren • Tannoy • Transparent
 Van den Hul • Velodyne, etc

- Eight dedicated demonstration rooms across three stores
- Home theatre specialists
- Multi room audio and video
- Delivery and installation
- Turntable service and set up
- Full service and repair facilities
- Range of credit terms
- Tuesday – Saturday 10am – 6pm



**Loud
& Clear**

HI-FI AND HOME CINEMA

www.loud-clear.co.uk

520 St Vincent Street, Finnieston, Glasgow G3 8XZ 0141 221 0221 26 Hamilton Place, Stockbridge, Edinburgh FH3 5AU 0131 226 6500
 Loud & Clear @ The Mill, 72 Newhaven Road, Leith, Edinburgh EH6 5QG 0131 555 3963

Second hand and ex-dem items:

Musical Fidelity HTP200	£1200	Linn Sara loudspeakers	£300	JM Lab 905 ex dem	£900
Musical Fidelity XA50 (pair)	£300	Rotel RCD991	£500	TAG CD 20R	£999
Audio Research LS9 pre-amp	£1300	B & W Matrix 805v (black)	£600	Ruark Prologue R (cherry)	£845

To view our full range of second hand, ex-dem and trade-in items, please check www.loud-clear.co.uk/offers

IN A CLASS OF ITS OWN



Sugden's top range of the Masterclass 16-bit CD player is the latest in a line of high-end CD players from the industry. Will it be yet another excuse to keep hold of your CD library, asks Simon Pope?

This Masterclass CD player is the latest in a line of CD players from big-time audio specialists such as Linn with the fantastically expensive CD 12, Marantz with the CD 7 and Musical Fidelity with their NU-Vista 3D that claims to alter the way we think of CD these days. Instead of a withering digital format on its last legs, the CD 7 and 3D played the old dog with such a 'fresh' approach, giving new life to the format, that many of us spent hours upon end 're-discovering' our often scant regarded CD library. It became a music collection as opposed to merely a professional necessity.

What is the appeal of such players that we feel the urge to listen to what many audiophiles consider one of the most unmusical (but convenient) reproduction formats ever to succeed? Apart from the fact that these players not only looked good and were fantastically built they also sounded what can only be described as different. Yes, you may well think, but how different. Well, they sound analogue, in as far as digital can ever sound analogue. Here

is the organic fluidity and smoothness of LP with the black silence background and detail of digital. As SACD and DVD-A struggle to get the backing of the public as a format, so companies make the most of what we have and Sugden are the latest to do so with their Masterclass CD player. Yet another call to the masses to invest in the musical future, which many still see as being primarily CD based.

The Masterclass CD player matches the rest of the Masterclass range of Class A amplification with its tank-standard metal front plate (which must weigh a fair amount of the total 5.5kg!) and styling. It's big, but not up to the chunky dimension standards of the MF 3D. It's a strikingly no-nonsense look with a basic green display window - nothing as pie-and-mash as dot matrix here - and an absolute minimum of controls. At the heart of the player is the highly regarded 16-bit TDA1541 Crown DAC much beloved of many designers (such as Ken Ishiwata, apparently, as this was the chip used in the CD 7), along with the SAA7220 digital filter

and SAA7274 digital interface. The traits of this high voltage chipset are its incredibly musical voice which favours smoothness and phrasing, along with depth of field and speed. The power supplies for analogue and digital domains are divided with front-end segregation in two multi-wound toroidal transformers. Five separate power supply rails are split for analogue output, transport and motor operation, display and driver, microprocessor, digital conversion and control.

Taking the bonnet off the player shows the detail that's gone into this design. There are four circuit boards in the player, the microprocessor and display board is unusually shaped as a large 'C' enabling the transport mechanism to sit closely to the high frequency digital signal processing, and as far from the analogue circuits as possible. There are two digital inputs (the internal DAC can be used by an external source), one line level out and a balanced XLR output.

Sugden have long been believers in wide bandwidth technology and in the Masterclass CD a new current

SUBSCRIPTIONS



UK SUBSCRIPTION £27

VISIT OUR WEBSITE: www.hi-fiworld.co.uk

Get your issue of **hi-fi** straight to your door!
world
& computer audio

Get to our amazing classified ads first and grab a bargain!!

Run by dedicated hi-fi engineers and enthusiasts, Hi-Fi World has become famous for its informative reviews and radical kit designs.

MISSED AN ISSUE?

Back issues also available at a cost of £3.50 only (includes P&P), payment by cheque only - overseas please contact us for details.

Send cheque to: Hi-Fi World, Freepost LON3478, London, NW6 6YR.

OVERSEAS SUBS RATES

Airmail Middle East & South-East Asia	£60	Airmail Europe	£50
Airmail USA, Canada, Australia, Japan, Korea & China	£70	Surface Mail	£40

Credit Card Hotline Monday - Friday 9.30am - 12.00 noon: Tel: +44 01923 270 833 Fax +44 01923 260 588

By post: Make cheque or postal order payable to: Audio Publishing Ltd, sent in an envelope marked: Hi-Fi World, Freepost LON3478, London, NW6 6YR

HI-FI WORLD SUBSCRIPTION FORM

I would like to pay by cheque made payable to Audio Publishing Ltd. Credit Card Airmail Surface Mail

Please debit my VISA/MASTER/SWITCH Card No. (Switch card issue No _____)

Expiry Date: _____ Cardholder Signature: _____



Name _____

Delivery Address (if different) _____

Address _____

Post Code _____

Daytime Tel: _____

Start Issue _____

feedback DC coupled analogue output stage is put in place to aid this belief. The sonic design aim was to basically create a natural sound and to offer audiophiles a "more enjoyable" level of involvement in digital audio.

And it succeeds. I used the Masterclass CD player in balanced mode feeding the company's matching pre and power amps and also in line mode with a pair of Quad's new Two-forty monoblocks with a Creek passive preamp. In both instances the player showed a winning way with CD. The unaccompanied ethereal masterpiece 'Spem In Alium' by Thomas Tallis floated through my Quad ESL-988s with grace and fluidity - far away from the mechanical edge that's often inherent in CD.

The voices of the Tallis Scholars had body and depth, with an impressively deep stage, but most importantly had fine cohesion and balance. Likewise, a recording of Mahler's 'Das Lied von der Erde' on reference recordings (a fine example of what can be achieved with CD) was finely reproduced, not perhaps with the absolute detail of the Musical Fidelity 3D - the player's only real rival - but with a great sense of dynamics and scale. Strings had a lovely lyrical quality to the playing and

woodwind phrasing was equally impressive.

With rock and jazz in the form of Paul Weller's 'Stanley Road' and Miles Davis's 'Kind Of Blue' the Sugden showed its mettle equally as well as it did with classical, making it a fine all rounder. Imaging and depth to the Weller CD was very fine, with everything rhythmically together and a good kick in the bass, that was firm and powerful yet warm and free from sterility. Vocal lines were detailed and clean, yet rounded and natural.

'Kind Of Blue' was a great CD to put in the drawer of the Masterclass. This showed off its way with phrasing and lyricism in Coltrane's smooth as silk tenor and Bill Evans's introspective piano accompaniment, which was showed as an essential element of the music - after all, what goes on behind is as crucial as what goes on in front! These traits became more obvious when I returned to my £1000 - and excellent - Meridian reference 506.24 player which lacked the immediacy of the playing that I found with the Masterclass.

What is important to note about this player is that, just like its matching amps, it takes away a certain extent of the sterile 'hi-fi' traits that often distract from the music. In this

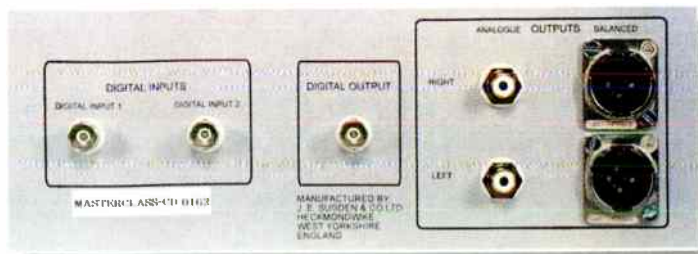

respect it resembles both the main competition in the shape of the 3D and the CD 7. The 3D perhaps give more insight into the recordings whilst retaining the musical elements but the Sugden is to a certain extent smoother, lacking the extreme upper frequency detail but having a more organic appeal to the sound. It's fine example of what can be done with CD if you try. It's a very close call between this and the 3D and anyone in the market for a player at this price should look no further than these two. They both resoundingly show that there's life left in the old dog yet. ■ ▲

Sugden Masterclass CD player £2700

Audio Synergy
Valley Works,
Station Lane,
Hecmondwyke,
W. Yorks. WF16 0NF
Tel: 01924 404088

MEASURED PERFORMANCE

That this CD player uses an early 16-bit D/A convertor is obvious just from our distortion analysis. A spectrum of harmonics can be seen stretching from the test signal at 1kHz right up to the player's upper limit of 20kHz, not something seen much nowadays, as comparison with other players tested in this issue shows. Lower distortion equals a smoother sound, but some feel modern convertors sound too soft and slow. It might seem as if the difference in sound is due solely to measured differences but this is not automatically the case. Differing circuit topographies may also have an impact. At 0.06% at -30dB this player produces around 3x more distortion than normal and the same situation exists at -60dB.

Frequency response was flat, our analysis shows, so there should be a good sense of tonal balance, although the Sugden will not sound soft or

warm. All other parameters measured normally.

Sugden know what they are doing as far as sound quality is concerned, being one of very few companies able to get almost unanimous approval. This player will definitely have an interesting sound, using components not commonly encountered nowadays. **NK**

Frequency response 5Hz - 21.1kHz

	left	right
Distortion		
-6dB	0.006	0.007
-30dB	0.06	0.07
-60dB	1.26	1.3
-90dB	52	50
Separation	left	right
1kHz	120	120
20kHz	96	97
Noise		109dB

with emphasis	109dB
Dynamic range	99dB
Output	2.1V

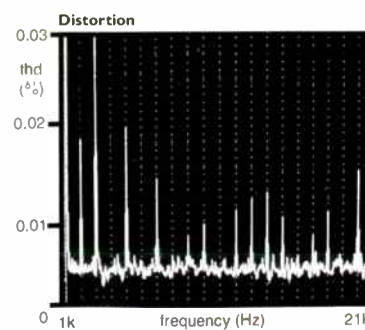
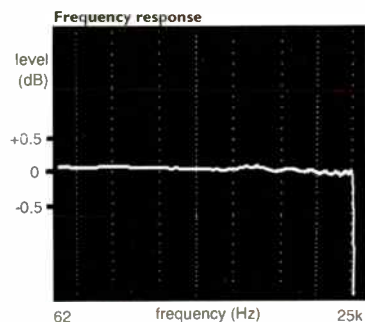

World Verdict

A high end player in a different mould. Concentrates on the organic rather than the mechanical making it a fine 'analogue' CD player.

fig.1. AV receiver that sounds great in Dolby Digital.



"A strong budget contender for forward thinking music fans" **Hi-Fi Choice September 2001**

"Great stereo performance; commendably solid build" **What Hi-fi? Sound and Vision September 2001**

"At this price point, nothing sounds better than NAD" **Essential Home Cinema October 2001**

fig.2. AV receiver that sounds great in stereo.



"A strong budget contender for forward thinking music fans" **Hi-Fi Choice September 2001**

"Great stereo performance; commendably solid build" **What Hi-fi? Sound and Vision September 2001**

"At this price point, nothing sounds better than NAD" **Essential Home Cinema October 2001**

Sounds obvious, doesn't it?

Unfortunately, AV products have always been a trade-off, usually sacrificing musical finesse in favour of brute strength and making too many compromises for them to ever find a place in an audiophile system. Now, NAD brings its wealth of experience in producing award-winning, no-nonsense stereo products to the world of home cinema, and the same principles of simplicity and value that make our amplifiers and CD players world-beaters, are now producing truly earth shattering AV receivers, DVD players and multi-channel amplifiers.

Contact us for your nearest NAD Home Cinema dealer, and figure it out for yourself.

MINI-LITE



Sony's MDS-JE770 is the MiniDisc recorder for serious audiophiles on a budget. David Price takes the test drive.

In a convoluted way, this is today's direct descendent of the MiniDisc machine that started it all for Sony. Warp back to 1997 and remember the (£250) MDS-JE500; Hi-Fi World had the scoop and yours truly got the review. I still remember listening to it and wondering if I'd lost the plot - after half a decade of dreary sounding MD recorders, here was a warm, smooth and big-hearted performer that didn't compare too badly with my DAT! Such was the format's dire reputation back then that I was frightened of giving it a rave review, lest readers think I didn't have both oars in the water.

The rest, as they say, is history - sales soared and 1998 became MiniDisc's harvest year. 1999 saw the advent of the (£300) MDS-JB920 - a real budget blockbuster - and last year Sony treated us to the (£700) MDS-JA555ES, which is the best sounding MD I've heard by a long chalk. These days, Sony MiniDiscs run across several different ranges. The ES (Extremely high Standard) series is the 'high end' range, the QS (Quality Standard) series is a budget audiophile range and the entry-level E series is the budget line into which the MDS-JE770 fits. Its mission - which Sony has obviously chosen to accept - is to keep the format alive.

It's no secret that in 2001, MD

sales have been plummeting - as far as pre-recorded discs go, they're down 67% (year on year, Q1 2001, source: BPI) and the machines themselves haven't exactly been vanishing off dealers' shelves. The MDS-JE770 is all about keeping punters on a budget happy, and staving off the onslaught from CD-R just a little longer before Sony can get its corporate house in order with this particular format. As if Philips, Marantz and Pioneer CD-R recorders weren't enough to worry about, MiniDisc's traditionally thriving home (Japanese) market now has internet audio portables (i.e. MP3 and AAC players) to contend with. The format's diminutive size was what won it so many friends at home a few years back, and now - in a country where less is more definitely more - the likes of Panasonic's SV-SD75 and Sony's MS Walkman are giving it a right kicking.

So, it's all about value, convenience, ease of use and flexibility - all heartland stuff for any Sony MD recorder - and just as you'd expect, the JE770 has all this in spades. Okay, at 3.1kg it's hardly built like the Japanese giant's best SACD players, but its 430x95x285 case is still passably well finished for the price. It's dripping with features, from MDLP (giving up to four times the playing time of a standard 80 minute

disc, albeit at the expense of sound quality) to a PC Link kit option (part # PCLKMN10) which lets you hook up your computer for easy titling and editing. And, should you lack the aforementioned IT facilities, you can always simply plug in a cheapo (£15) PC keyboard to help with your Disc and Track labelling exploits!

The deck offers optical and coaxial digital inputs, along with digital and fixed audio outputs - plus headphones. There's timer recording, 'time machine recording' (which records anything that went into the deck up to six seconds before you press the record button), a handy digital volume control, a variable pitch facility, a clock and date stamp function, mono recording and of course, Sony's exhaustive (and indeed exhausting) editing facilities. Virtually any bit of your recording can be rearranged, renamed, moved or cut to your heart's delight.

While the player lacks most of the trick audiophiles goodies of its bigger brothers, it still claims 'high quality components' including the mains transformer, chemical condensers and op-amps. ATRAC 3 is used for recording, with ATRAC DSP TYPE-R for playback, with full sample rate conversion from 32 or 48kHz sampling frequencies. Sony's proprietary 24-bit Hybrid pulse DAC

MICHELL GYRODEC SE

A SYMBOL OF PRECISION



WHAT HI-FI?
June 1999

Michell Engineering Ltd, 2 Theobald St, Borehamwood, Herts, WD6 4SE
Tel: 0208 953 0771 Web: www.michell-engineering

Why settle for
anything else
when you can **OWN** something
this good!

Mail Order Direct on UK Freephone

0800 373467

quoting: AH12

and request a FREE catalogue or visit our website at
www.russandrews.com



The NEW *Crystal* Interconnect Range

Prices from £88 for 0.5m pair

These unique cables will give you a more relaxed and musical sound, improved soundstage and better bass. In the 'sound per pound' stakes they really are hard to beat!
The Crystal-Cu from £88,
The Crystal-H from £211 and
The Crystal-Ag from £322.

Crystal-Ag
Interconnect

Sole UK Distributor
for KIMBER KABLE



• 15TH ANNIVERSARY •

**Russ Andrews
Accessories**

*"for the best cables,
CDs and accessories"*

Full Refund
Cable Upgrades
•
Lifetime Guarantee
•
30 Day Home Trial
•
Expert Advice

Russ Andrews Accessories Ltd.,
FREEPOST NWW881A,
KENDAL, LA8 9ZA.

Tel: +44 (0)1539 825500

Fax: +44 (0)1539 825540

E-mail: AH12@russandrews.com

www.russandrews.com

and VC Digital Filter are fitted. Hooked up to the optical digital output of my reference Linn CD12 CD player, the Sony made very acceptable recordings. Make no mistake, its MDS-JB940QS has noticeably more clarity, treble detail, bass tautness and overall grip - but despite its sins of omission, this 'E-type' Sony covers its tracks well. The result is a smooth, warm and rather sumptuous sound which at times veers on the uninvolved, but it's never hard to listen to.

Compare this deck to one of Sony's cheaper midi sized MDs, or even its more expensive MDS-PCI reviewed last year, and you're instantly reassured that this is a hi-fi rather than an audio separate. Sade's appropriately named 'Smooth Operator' showed the 770 to be crisp and open sounding, with decent bass weight and a fair smattering of stereo soundstaging. By contrast, the cheaper midi decks sound harder and thinner, whereas its 940 big brother

sounds tighter and punchier, with a lot more treble definition.

High hat cymbals on the 770 don't have any nasty compression artefacts, but do sound just a touch fluffy and rolled off. Likewise, the bass sounds just a tad too bland and unarticulated, like the bass player is going through the motions. Its midband is surprisingly good though - again there's a loss of the 940's vice-like grip on stereo imaging, but nothing too much to worry about.

The overall effect is nine tenths of the QS machine at considerably less money. The only area where it falls down is the A-D converter (used when recording from analogue sources) but frankly its bigger brother's ADC isn't too hot either. If its serious vinyl recording you're wanting to do, look at least to the MDS-JA333ES.

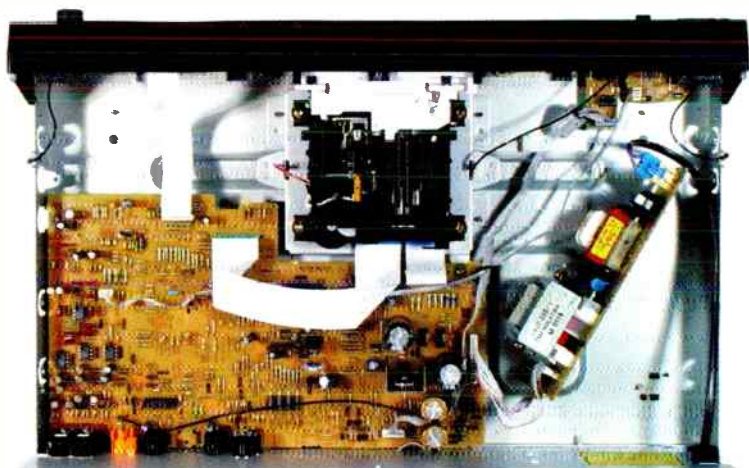

Overall, it's a very sensibly judged package with everything your average MD user is likely to need. Sound is perfectly pleasant, inoffensive and listenable but if it's sonics you're into then you really wouldn't be spending this little on an MD anyway. A brilliant slice of budget MiniDisc hardware then, but whether it's attractive enough to stave off the format's decline remains to be seen. 🟡 🟢

Sony MDS-JE770 £229.95

Sony UK Ltd
The Heights
Brooklands
Weybridge
Surrey KT13 0XW
Tel: 01932 816000

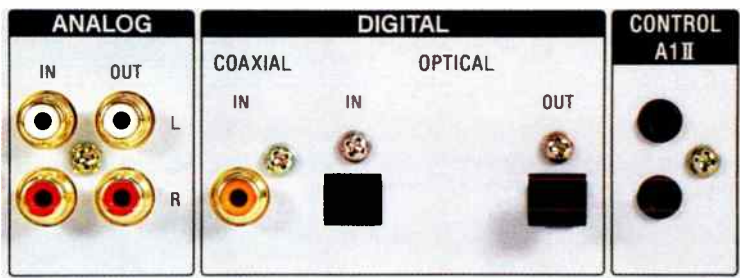

MEASURED PERFORMANCE

The MDS-JE770 MiniDisc recorder has a smooth, wide frequency response that extends from a very low 2Hz right up to 20.8kHz. There's a slight roll off at the top end, our analysis shows, which will help to give this recorder a smooth and cohesive sound.

Noise within the digital side of the signal chain helps dither the digital code, improving linearity. This means MiniDisc has a little more noise than the theoretical 96dB limit of a 16bit system; but also the benefit of minimal distortion at all signal levels. There were few distortion products to be seen in the analyses. Our analysis at -30dB is fairly typical, with just a few noise spikes visible.

Channel separation was wide and output normal at 2V. There's a limited amount of input gain, sensitivity measuring 500mV.

Sony are pretty consistent in marketing products that measure well and this recorder is no exception. **NK**

Frequency response	2Hz - 20.8kHz	
	left	right
Distortion		
-6dB	0.006	0.006
-30dB	0.026	0.026
-60dB	0.7	0.7
-90	24.2	25
Separation	left	right
1kHz	98	-99
20kHz	-92	-93
Noise		92dB
Output		2V
Sensitivity		500mV

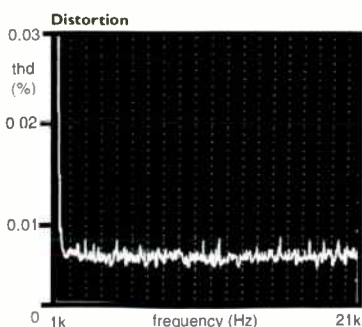
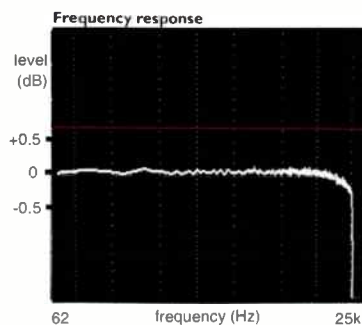

World Verdict
£🌐🌐🌐🌐

Great value budget blockbuster from Sony, with all you could possibly want - except superb sound.



SOUNDS PERFECTION



BAT VK 5i REMOTE PRE / VK60 POWER MINT BOXED £6495
 AUDIONOTE M3 PHONO EX CON MILITARY SPEC VALVES £2495
 SUGDEN MASTERCLASS POWER AMP BOXED MINT £1895
 AUDIONOTE QUEST MONOBLOCKS EX-DEM £1895
 PARASOUND DAC 2000 (JOHN CURL SPECIAL) ONLY £995
 VIENNA ACOUSTIC MOZART SPKS ROSENUIT BOXED £1095
 AUDIONOTE OTO SE PHONO MINT BOXED £1095
 J.M.LABS ELECTRA 905 SPEAKERS BLACK SUPERB AT £795
 PARASOUND AVC 1800 BOXED HARDLY USED ONLY £695
 AUDIONOTE PI SE POWER AMP BOXED £695
 REL ACOUSTICS Q201E WOOD VENEER HARDLY USED £595
 TRIANGLE ZEPHYRS XS MINT BOXED £495
 VIENNA ACOUSTICS HADYNS BOXED MINT £475
 PRIMARE A 20 AMP BOXED MINT £449
 PARASOUND CD-P 1000 CD PLAYER £295

ARCAYDIS BABY 2 NEW BOXED £400 NOW ONLY £295
 MUSICAL FIDELITY CDT PLAYER TOP LOADER NEW LASER £249

SPECIAL OFFER ON DEMO UNITS

LEXICON MC 1 PROCESSOR MINT BOXED £2995
 PARASOUND AVC 2500 MINT BOXED ONLY £1495
 LEXICON DC 1 LEVEL 4 SOFTWARE BOXED £1495
 ELECTROCOMPANIET DMB 120 POWR MINT £1395
 ELECTROCOMPANIET 4.6 PRE-AMP BOXED £775
 BOSTON ACOUSTIC 10X SATS SET OF 4 MINT BOXED £795
 AUDIONOTE CD 3 PLAYER BOXED £775
 SONIC FRONTIERS ANTHUM II AMP BOXED £875
 AUDIONOTE ZERO PRE & MONOBLOCKS MINT BOX £795
 ALCHEMIST 2 24BIT CD PLAYER BOXED £695

SPECIALIST IN ANALOGUE AND DIGITAL WE STOCK

J.M.LABS * LEXICON * PARASOUND PRIMARE *
 PROJECT * TRIANGLE * REL SUBWOOFERS *
 VIENNA ACOUSTICS AVID * PROJECT * SME *
 ROKSAN STRAIGHT WIRE * MICHELL
 ACOUSTIC DESIGN * AUDIONOTE
 MONITOR AUDIO * BOSTON * SUGDEN
 AUDIO ANALOGUE * GRAFF
 PLUS MANY OTHER TOP BRANDS

NORDOST VALHALLA CABLES

FOR FRIENDLY SERVICE CALL NIGEL

01326 221372

MOBILE:- 07798 554357

Email :- nigel@soundsperfection.co.uk

kathryn@soundsperfection.co.uk

Web :- www.soundsperfection.co.uk

THE NEW AFFORDABLE PHONO AMPLIFIER FROM TRICHORD RESEARCH

DINO



Moving Coil
 Moving Magnet
 Switchable Gain
 Switchable Loading
 Super Regulators
 Discrete Output Stage
 Upgradeable Power Supply

Tel: +44 (0)1684 573524

Fax: +44 (0)1684 577380

WWW.TRICHORDRESEARCH.COM

Super Champ

Clearaudio are the passionate advocates of German high end vinyl but they're just as keen to get beginners on the path to righteousness. Simon Pope spins the entry level Champion turntable.

Those readers who are either moviephiles, computer game geeks or both could well have witnessed probably the world's largest and meanest looking turntable had you seen the otherwise disappointing Tomb Raider flick at your local picture emporium. Those of you with a life would have missed the close up of the £10,000 Clearaudio Master Reference turntable in Lara Croft's manor house spinning to the mathematical strains of Bach.

For those of us with a less esoteric taste and much shallower pockets the company have recently introduced a 'real world' turntable, the entry level Champion. Headed by Peter Suchy, Clearaudio continue to er, champion the black stuff for all they're worth, creating a full range of weird and wonderful turntables and arms, plus an army of cartridges to suit most pockets.

Although described as entry level, it's worth remembering that £930 is at the top end of the price list from the much respected likes of Rega for example, and being so

priced, the Champion does indeed look like a serious bit of kit. Below the plinth are three chunky cones to assist stability and the simple nature of the design means that a good, level base is needed for the Champion to perform.

Setting up is a doddle, as the plinth thoughtfully houses a natty spirit level for correct levelling and the arm attaching rigmarole is greatly reduced due to the basic, no-nonsense design. The motor unit is separate from the plinth in the company style and is placed into a cut out at the top right of the design. This helps eliminate vibration and possible motor noise.

Atop the heavy motor unit is a stepped pulley for manually changing the speed by moving the belt between the two wheels. The arm is Clearaudio's tweaked Rega RB 250 called the 250ST. The cartridge is Clearaudio's own entry level moving magnet Alpha Mk2.

The Champion delivers a sound that's worthy of a serious price tag in as much as it's very revealing and detailed, exactly what many would hope to glean from a high end bit of

kit, and undoubtedly a step up from your Planar 3 (as fine as it is) in all respects - just as the price should dictate. An original pressing of Bob Marley's 'Exodus' showed that the Clearaudio set up had a fine ear for intricate detail as the smooth strains of Natural Mystic faded in. There was a good bass response as the odd dub boom dropped into focus and the high frequency detail in the cymbals, for example was very impressive - perhaps not as smooth as could be reached with an MC cartridge but this can easily be fixed.

Pitch control was perfect, as a quick, skeletal tinkle of the ivories along with Barenboim's (far, far superior) playing of Chopin Nocturnes revealed. These were played by the Champion with insight and poise which also showed a good sense of dynamics and attack - all good hi-fi traits.

The Champion has the ability to glean so much detail from vinyl that I personally found it sometimes took the emphasis away from the job of making music, creating at times a slightly 'cold' sound. - a trait that its major competitor, the Michell Gyrodec SE doesn't have. However, if you favour this the Champion offers a good dose of high end vinyl replay for relatively sensible money. Recommended heartily. ■ ▲

Clearaudio Champion/RB 250ST/Alpha Mk2 £930

Audio Reference
Unit 8, Enterprise Park
Slyfield Industrial Estate
Guildford
Surrey
GU1 1RB

Tel: 01252 702705
www.audioreference.co.uk



World Verdict



Attractive and well built, the Champion is an accomplished turntable in its neutrality and detail. Some could find it too sterile.



SALE NOW ON!! SALE N

SALE! SALE! SALE! SALE! SALE! SALE! SALE! SALE! SALE! SALE!

NEW DEMONSTRATION ROOM NOW OPEN AT 12A SPRING GARDENS, NEWPORT PAGNELL,

KIT6550 VALVE INTEGRATED AMPLIFIER KIT & KAT6550 VALVE POWER AMPLIFIER KIT

~~£535~~

£549

NEW KITS

£535

~~£580~~



These are our new 6550 series amplifiers. A pure class A design providing 40 watts into a 8 ohm load. (available in a 4 ohm version if required) A truly high end design by Andy Grove, using Svetlana 6550Cs in push-pull (any 6550 or KT88 tube can be used with this amp). It features valve rectification (5U4) a choke pi filter power supply and is hard wired. Weighs 19kg with dimensions 390mm(w) x 330mm(d) x 190mm(h)

with valves or 220mm(h) with cage. Simon Pope says - "If you favour attack and rhythmic grip, together with a smoothness of sound that's incredibly easy to live with, the KIT6550 could well be the kit amp for you. The 6550 is one for those who like a valve sound married to the attack and clout of a good quality solid state design".

Kel84 VALVE INTEGRATED AMPLIFIER KIT

This is our brand new, low cost, beginner level amplifier kit. It features a pair of EL84 valves per channel in push-pull configuration. They give 15 watts into an 8 ohm load - plenty for medium sensitivity loudspeakers. The output transformers are Ultra Linear, keeping distortion down to a minimum. Up front the ECF80 input/phase splitter valve has an extremely smooth sound.

The Kel84 has very low hum, to solid-state standards. For simplicity the kit is built on a printed circuit board. A strong steel chassis is fronted by a 3mm anodised front panel and attractive chromed custom made knobs. There are five line level inputs, plus one monitor input, with a tape output included, all controlled from the front panel. The phono input sockets and 4mm banana socket speaker terminals are gold plated.

At rear is a mains switch, an IEC power input and an earth post. This kit is aimed at beginners. The instructions include pictures as well as diagrams, making them very easy to follow. At a UK price of £278.00 all inclusive you cannot ignore Kel84. Simon Pope says, "The quality that can be gleaned from this amp is a fine introduction to the joys of the valve sound. The Kel84 will highlight all the intricacies and depth of detail in your favourite recordings whilst retaining a warmth and fullness that is almost exclusive to pure valve amps and is rare at this price point." Kel84 weighs 10kg. External dimensions with valves are 300mm(w) x 270mm(d) x 150mm(h).

£250

~~£278~~



KAT88 VALVE POWER AMPLIFIER KIT

Here is the amazing KaT88. The circuit is similar to that of our popular KEL34 with a few changes to incorporate the Tesla, JJ branded KT88 power tetrode. This is a pure Class A push-pull design providing 36 watts into an 8ohm load. Andy Grove has come up with a gem of an output transformer (E/I). With the KT88 it offers a virtually unmatched result for a valve amplifier. Frequency response measures 1Hz to 75kHz, separation 71dB, noise 98dB, sensitivity 400mV and distortion 0.03%. "As valve amplifiers go, the KaT88 is one of the best measured performances I have ever come across", said Noel Keywood. Jon Marks said, "The KaT88 pulled a series of surprisingly fast, meaty basslines out of its trickbag when dealing with Suzanne Vega's Nine Objects Of Desire album. As if this wasn't enough, the mid and treble were nice too - cymbals had a deliciously natural, golden shimmer without sounding soft, and vocals were extremely transparent and crisply defined. KaT88 didn't hang around when it came to exploiting the virtues of its four output valves on numbers such as 'Leaves' and 'Suspect Sustain' from Cirrus' Land's End Jazz CD. Saxophone had a wonderfully smooth, realistic character, and acoustic guitar mixed speed with harmonic richness to very impressive effect. Asian Dub Foundation and Moloko showed no sign at all of the sluggish, woolly bottom-end and poorly-delineated bass beats that most valve amps are to blame for. Which makes the KaT88 an all-round, high-end bargain." Weight 16kg, external dimensions with valves are 330mm(w) x 300mm(d) x 190mm (h).

£425

~~£468~~



KIT88 upgrade kit now available £150

KaT88 upgrade kit now available £140

£135

£126

NOW ON!! SALE NOW ON!!

MILTON KEYNES, BUCKS MK16 0EE - CALL FOR DETAILS ON 01908 218836

ALL NEW SERIES II MODULAR PRE-AMP KIT

The PRE-II is a valve pre-amplifier with six inputs, tape monitor and two sets of output sockets. It utilises a high quality line driver transformer and x5 gain. The PHONO-II is a dedicated valve phono stage that incorporates a step-up transformer for MC users. Finally, PSU-II is a power supply unit that feeds both the PRE-II and PHONO-II.

Power Supply Unit (PSU-II)	£195.00	£175.00
Pre-amplifier (PRE-II)	£195.00	£175.00
Phono Stage (PHONO-II)	£110.00	£100.00
Moving coil step-up transformer	£77.00	£70.00
Passive pre-amplifier (PAS-II)	£215.00	£195.00

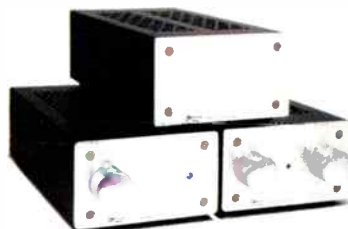

KAT34 VALVE POWER AMPLIFIER KIT & KIT34 VALVE INTEGRATED AMPLIFIER KIT

~~£440~~ **£432**

NEW KITS

KaT34 upgrade kit now available £120

KIT34 is a 32 watt stereo valve integrated amplifier, featuring a pair of EL34s, in push-pull mode, per channel, plus an ECF80 pentode/triode as input/phase splitter. The power supply is valve rectified (2 x 5U4), using a heavy duty choke to achieve exceptional smoothing. The output transformers are 14% Ultra Linear tapped to keep distortion down to its lowest level and the kit is totally hard wired utilising three tag boards. It has five line level inputs, plus a tape-in and tape out, all controllable from the front.

~~£445~~ **£446**

KIT34 upgrade kit now available £130

Simon Pope says, "This integrated bring together the best sonic virtues of our KIT88, kel34 and top of the range 300B PSE in an affordable package. The highlights of the sound are a deep and taut bass response, together with an open and highly detailed mid and high frequency response that only the best valve designs can achieve... a true valve classic" Weight 22kg, External dimensions with valves fitted - 390mm(w) x 360mm(d) x 210mm(h)

300B PSE MONOBLOC KIT

Our Parallel Single Ended amplifiers offer ultimate sound quality Each monobloc has two of the beautifully linear 300B directly heated triode in its output stage, producing 20 watts into an 8 ohm load. At the front we have a 6AU6 pentode and an ECC82 as the driver valve. This design utilises a 5U4 rectifier valve in the power supply, in combination with a 10H choke, giving an extremely quiet supply. Both mains and output transformers we E/I pattern.

For purists, feedback is switchable and the kit is totally hard-wired. For those that require valves we provide the superb Tesla 300Bs, Russian 5U4s and European 6AU6s & ECC82. Simon Pope says, "Not to put too fine a point on it, the sound these monoblocs create is among the finest that can be encountered in hi-fi." Our 300B PSE kit bears an affordable price of £875.00 (UK price) excluding valves. Each monobloc weighs 23kgs., external dimensions with valves: 25cm(w) x 38cm(h) x 22cm(d) per monobloc.

~~£875 A pair~~ **£780**

£126

300B PSU upgrade kit now available £120

KEL80 MONOBLOC AMPLIFIER KIT

Following the success of our budget KEL34 40watt kit amplifier, we have come up with a 'big brother' design. The output stage uses two pairs of TESLA EL34 pentodes in parallel-push-pull mode, allowing KEL80 to turn our 80 watts into an 8ohm load. Heading up the input stage we have the wonderfully linear Russian 6AU6 working into an American 5687 phase-splitter. KEL80's output transformers are 4ohm and 8ohm tapped. With an input sensitivity at around 380mV for full output, it will happily partner both passive and active pre-amplifiers. It is easy to assemble. Simon Pope says, "The proof of the pudding is in the eating and the KEL80 is a feast for the ears, with solid bass attack, lightning fast reactions, that emphasises musicality as well as power. At £649.00 a pair, a definite valve winner. Each monobloc weighs 12kgs., external dimensions with valves: 14cm(w) x 8cm(h) x 43.5cm(d).

~~£649 A pair~~ **£585**

HD83 VALVE HEADPHONE AMPLIFIER KIT

The HD83 headphone amplifier is a beautifully simple design using Mullard ECL83 valves, a triode and power pentode housed in the same envelope. It works directly from any source, be it CD, tape, tuner etc., or from an amplifier's tape out or pre-amp out sockets. The circuit uses high specification E/I output transformers that will drive any headphone load from 16 ohms to over 300 ohms depending on how the secondaries are wired up. The HD83 is a single-ended design with the power pentode wired up in triode configuration for added sonic purity, and it is as quiet as a mouse. For sound quality Jon Marks says, "The bass is punchy and controlled without becoming artificial, while treble has the crispness of the best

solid-state, with the tonal purity, delicacy and speed associated with valves." External dimensions 18cm(w) x 30cm(l) x 8cm (h) weight 4kg.

~~£175~~ **£175**

SALE OFFERS FROM 1/12/01 - 31/12/01

World Audio design

SALE NOW ON!! SALE NOW ON!!

NEW DEMONSTRATION ROOM NOW OPEN AT 12A SPRING GARDENS, NEWPORT PAGNELL, MILTON KEYNES, BUCKS MK16 0EE. CALL FOR DETAILS ON 01908 218836

KLS10 HIGH TECHNOLOGY COMPACT MONITOR

Our mini-marvel uses an Audax carbon fibre bass/midrange unit, married to the world's most advanced tweeter, the piezo-electric gold dome HD3P from Audax. KLS10 offers high performance from a small package. The main 'speakers are designed to work alone, or with a dedicated subwoofer to extend their base. Alone, they are suited to near-wall mounting and can be tuned by port adjustment to suit personal taste and location. They are easy to drive and need just 30-60watts. KLS10 is unique. Technically advanced, yet compact and relatively inexpensive, there is little to match it. Sensitivity 89dB 1W/1m, 15mm MDF, internal volume 9Ltrs, external dimensions 19cm(w) x 31cm(h) x 23cm(d).

Drive Unit & Crossover kit ~~£433.00~~ **£390.00**
Drive Unit only ~~£394.00~~ **£333.00**



~~£433~~
£390

KLS10 GOLD SUBWOOFER

Designed to complement KLS10 Gold stand mounters by providing deep and open bass. The subwoofer is inexpensive, easy to build, comprising a simple crossover network with a high quality 8 inch Aerogel dual voice coil unit. A must for all KLS10 Gold customers. Sens. 89dB, volume 25 litres, external dimensions 28cm(w) x 43cm(h) x 34cm(d).

Drive Unit & Crossover kit ~~£164.00~~ **£148.00**
Drive Unit only ~~£76.00~~ **£71.00**



~~£164~~
£148

KLS3 GOLD MK II ADVANCED TECHNOLOGY 3 WAY LOUDSPEAKER

KLS3 Gold uses the latest version of Audax's innovative oval gold dome piezo electric tweeter, giving it the sweetest and most extended treble. Married to a 4in. carbon fibre cone midrange driver for neutral and clear reproduction, and a powerful 8in. bass driver for superb depth, this is our top-of-the-line reference 'speaker. Sensitivity 90dB at 1W/1m, 25mm MDF, internal volume 60Ltrs, external dimensions 26cm(w) x 100cm(h) x 35cm(d).

Drive Unit & Crossover kit ~~£633.00~~ **£570.00**
Drive Unit Pack ~~£496.00~~ **£485.00**



~~£633~~
£570

Upgrade your KLS3s to Gold status. Includes latest oval gold dome piezo tweeter and all components.

for ~~£327~~
£327

Mains transformers & Chokes

KIT6550/KAT6550 mains transformers
2 inch stack, 130mm(h)x120mm(w)x135mm(l) drop through fitting with zinc cap. Secondaries: 425V-0V-425V, 350mA, 0V-5V, 6A, 3.15V-0V-3.15V, 9A. Suitable for 120V & 240Vac operation

KEL84 mains transformer
1.5 inch stack, 90mm(h)x80mm(w)x95mm(d) drop through fitting with zinc cap. Secondaries: 0V-240V 300mA, 3.15V-0V-3.15V, 5.5A, suitable for 120/240V operation

KIT88/KAT88 mains toroidal transformer
120mm dia. x 60mm(h). Secondaries: 195V-0V-95V, 450mA/0V-27V, 100mA/3.15V-0V-3.15V, 9A, suitable for 120/240V operation

KIT34/KAT34/KIT6550/KAT6550 choke
1.25 inch stack, 65mm(h)x105mm(w) with fitting holes x 60mm(d), clamp fitting, 2.5 H, 350mA

300B PSE mains E/I transformer
130mm(h) x 95mm(w) x 115mm(d). drop through fitting with zinc cap. Secondaries: 380V-0V-380V, 180mA/150-0V-150V, 25mA/0V-5V, 1.2A/0V-5V, 1.2A/0V-5V, 3A/3.15V-0V-3.15V, 0.4A suitable for 120/240V operation

KEL80 mains toroidal transformer (encapsulated)
130mm dia. x 65mm(h). Secondaries: 195V-0V-195V, 390mA/0V-27V, 100mA/3.15V-0V-3.15V, 7.5A, suitable for 120/240V operation

HD83 mains toroidal transformer
80mm dia. x 35mm(h). Secondaries: 0V-165V, 75mA/3.15V-0V-3.15V, 1A, suitable for 120/240V operation

PSU-II mains toroidal transformer
80mm dia. x 35mm(h). Secondaries: 0V-270V, 60mA/0V-10V, 2A, suitable for 120/240V operation

TRANS1 mains toroidal transformer
95mm dia. x 50mm(h). Secondaries: 0V-370V, 150mA/0V-6.3V, 3.5A 300B E/I choke 65mm(h) x 70mm(d) x 80mm(w) open frame fitting, 10H, 180mA.

KEL84 E/I choke
0.5 inch stack, 40mm(h)x35mm(d)x70mm(w) clamp fitting, 1H, 250mA

PSU-II E/I
40mm(h) x 35mm(d) x 70mm (w) clamp fitting, 15H, 20mA

KIT34/KAT34 mains transformer
2.5 inch stack, 120mm(h)x115mm(w)x95mm(d), drop through fitting with zinc cap. Secondaries 365V - 0V - 365V, 300mA/0V - 5V, 6A/3.15V - 0V - 3.15V, 7.5A. Suitable for 120/240V operation.

Output transformers

KIT6550/KAT6550 E/I 16% TAPPED UL push-pull output transformer
2 inch stack, 80mm (w) x 95mm(l) x 100mm(h), drop through fitting with zinc cap. Primary-secondary 4.5K, 16% UL tapped. Secondary 4 Or 8 ohm, pls specify on order. max output 45 watts, max current 180mA, valves, K188, 6550 etc

KEL84 E/I Ultra Linear push-pull output transformer
1.25 inch stack, 76mm(h)x65mm(w)x76mm(d) Primary - secondary, 8K with 12.5% UL tap - 8ohms, max o/p-15watts, max current 150mA valves EL84 etc

KIT88/KAT88 E/I push-pull output transformer
80mm(w)x95mm(l)x100mm(h). Primary-secondary 10K - 8ohms, max o/p-40watts, max current-160mA valves-K188, 6550, EL34

KIT34/KAT34 E/I 14% tapped Ultra Linear push-pull output transformer
2 inch stack, 80mm(w)x95mm(l)x100mm(h), drop through fitting with zinc cap. Primary-secondary 6.4K, 14% UL taps. Secondary 8ohm, max output 34watts, max current 150mA, valves EL34, 6L6, 6CA7

KEL80 E/I parallel-push-pull output transformer
95mm(w)x115mm(l)x133mm(h). Primary-secondary 4.6K - 8 & 4ohms, max o/p-80watts, max current-250mA valves-EL34, 5881, 6L6

HD83 E/I single ended output transformer
40mm(w)x50mm(l)x55mm(h). Primary-secondary 4K - 4 x 64ohms windings, max o/p-1watts, max current-25mA valves-ECL83 etc

Pre-II E/I driver transformer
80mm(w)x60mm(l) x65mm(h), 6:1 step down transformer, max current-10mA valves-6922 etc pre-amp stage

300B PSE E/I parallel single ended output transformer
130mm(h) x 95mm(w) x 115mm(d). drop through fitting with zinc cap. Primary 1K5 Secondary 8R, output .

Printed circuit boards

- Kel84 Printed Circuit Board 280mm(w) x 135mm(l) x 1.6mm(d).
- KIT88/KAT88 Printed Circuit Board 140mm(w) x 310mm(l) x 2.4mm(d)**
- Kel134 Printed Circuit Board 140mm(w) x 310mm(l) x 2.4mm(d).
- Kel180 Printed Circuit Board (a pair) 120mm(w) x 215mm(l) x 2.4mm(d)**
- HD83 Printed Circuit Board 140mm(w) x 160mm(l) x 1.6mm(d).
- PSU-II Printed Circuit Board 105mm(w) x 130mm(l) x 1.6mm(d)**
- PRE-II Printed Circuit Board 105mm(w) x 130mm(l) x 1.6mm(d).
- PHONO-II Printed Circuit Board 105mm(w) x 130mm(l) x 1.6mm(d)**

Hi-Fi World in Malaysia at Millennium Hi-Fi & Av. Kuala Lumpur, Malaysia

Hi-Fi World is now distributed through good bookshops and newstands in Malaysia. For back issues, general enquiries and advertising, contact Simon Chang at Millennium Hi-Fi & Av.

Also available are products by World Audio Design, Michell, Trichord, Lowther and ReThm loudspeakers.

Millennium Hi-Fi & Av
500-1-3 First Floor, Wisma Indah (Shen Court),
Jalan Tun Razak 50400 K.L.

tel: 603 9283 8171 fax: 603 9281 3762

137 Jalan Pendekar 2, Taman Skudai Baru, 81300 Skudai, Johor DT
tel: 607 554 5171 fax: 607 554 7645

e-mail: info@millennium-audio.com



SALE! SALE! SALE! SALE! SALE!



order on our website @

www.worldaudiodesign.co.uk

amplifier kits description

Table with 2 columns: amplifier kits description and order No. listing various kits like KaT6550, KAT34, Kel84, etc.

order No.

Table with 2 columns: order No. and qty, listing corresponding order numbers for the kits.

qty

Table with 2 columns: qty and uk, listing quantities and prices in UK pounds.

uk (inc vat & carriage)

Table with 2 columns: uk and overseas, listing prices in UK pounds and overseas prices.

overseas (exc. vat & carriage)

Table with 2 columns: overseas and uk, listing overseas prices and UK prices.

loudspeaker kits

Table with 2 columns: loudspeaker kits description and order No. listing kits like KLS3, KLS10, etc.

order No.

Table with 2 columns: order No. and qty, listing order numbers and quantities.

qty

Table with 2 columns: qty and uk, listing quantities and prices in UK pounds.

uk (inc vat & carriage)

Table with 2 columns: uk and overseas, listing prices in UK pounds and overseas prices.

overseas (exc. vat & carriage)

Table with 2 columns: overseas and uk, listing overseas prices and UK prices.

parts description

Table with 2 columns: parts description and order No. listing various components like transformers, chokes, PCBs, etc.

order No.

Table with 2 columns: order No. and qty, listing order numbers and quantities.

qty

Table with 2 columns: qty and uk, listing quantities and prices in UK pounds.

uk (inc vat & carriage)

Table with 2 columns: uk and overseas, listing prices in UK pounds and overseas prices.

overseas (exc. vat & carriage)

Table with 2 columns: overseas and uk, listing overseas prices and UK prices.

World Audio Design Amplifiers fully built from Malaysia

Table with 4 columns: Title, Description, Price (exc. VAT + Carriage), and Title, Description, Price (exc. VAT + Carriage).

Order from our Far East Distributor: Millenium Hi-Fi & AV

137 Jalan Pendekar 2, Taman Skudai Baru, 81300 Skudai, Johor DT, Malaysia Tel: 07 554 5171 - Fax: 07 554 7645 - email:mha8@pd.jaring.my

order information

Form fields for NAME, ADDRESS, POST CODE, COUNTRY, TEL. (DAY), and Expiry Date.

Tel/Fax: 01908 218 836

I enclose cheque/postal order for £ made payable to World Audio Publishing Ltd. I wish to pay by Mastercard / Visa /Switch/ Solo. Please debit my account no:

Form fields for account number, Signature, and Valid Date.

Prices were correct at time of print, 01/12/01 they are subject to change. If you wish for a built item, please phone for a quote / Valves included except where otherwise stated. If you would like a data sheet on any of the kits, please write a 'D' in the qty box

WARNING - World Audio Publishing Ltd. accept no responsibility for kits, parts or modifications made or supplied by third parties. Order on our website www.worldaudiodesign.co.uk Please send your completed order form to: WORLD AUDIO PUBLISHING LTD, 124 Spring Gardens, Naxos Park, Milton Keynes, Bucks MK16 0UE Tel/Fax: 01108 218836 e-mail: orders@worldaudiodesign.co.uk



SALE OFFERS FROM 1/12/01 - 31/12/01 World Audio design

World Audio Library

WE HAVE OVER 30

AUDIO ELECTRONIC THEORY BOOKS



Electronics made Simple
by Ian Sinclair
This book covers the basic theory and principles of electronics. A good read for the beginner.
Code No 1420
£12.99 + £2.00 P&P (UK)

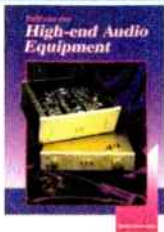

Build your own High-End Audio Equipment
by Elektor
Build your own High-End Audio equipment contains construction projects for solid state preamplifiers and power amplifiers, active cross-over filters, an active subwoofer, a mono/stereo compressor and a headphone amplifier.
Code No. 1390
£14.95 + £2.25 P&P (UK)

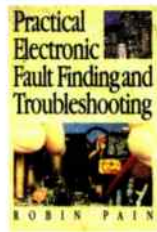

Practical Electronic Fault-Finding and Troubleshooting
by Robin Pain
This book explains the basic techniques needed to be a troubleshooter, using only basic equipment: a digital multimeter and an oscilloscope. Simple circuit examples are used to illustrate principles and concepts fundamental to the process of fault finding.
240pp 235mm x 156mm Paperback
Code No. 1430
£19.95 + £2.25 P&P (UK)



Build your own Electronic Test Instruments
by Elektor
This book contains designs for 17 measuring instruments, seven generators and analysers, ten miscellaneous instruments and a number of test ancillaries and auxiliaries. The designs range from a simple multicore cable designs contain a special printed circuit, drawing of which are given in an appendix.
Code No. 1400
£15.95 + £3.25 P&P (UK)



The LP is back
by Audio Amateurs
Your complete guide to LP care and maintenance designed to offer you everything useful for those who love and enjoy this older music medium. This covers the theory and care of LPs and the electronics and mechanics of its players.
154pp Paperback
Code No. 1620
£8.00 + £1.50 P&P (UK)



The Joy of Audio Electronics
by Charles Hansen
This is a fail-safe guide to the pleasures of hands-on electronic construction. This book covers test and measurement projects, how to build simple kits, safety issues, the workplace, theory and resources. A must for the beginner who plans to build more advanced electronic projects in the future.
124pp Paperback
Code No. 1650
£10.50 + £2.25 P&P (UK)

VALVE BOOKS

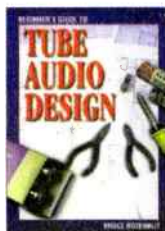

The Beginner's Guide to Tube Design
by Bruce Rozenblitz
This book takes a comprehensive look at tube audio design. It explains how vacuum tubes work and how to design with them. Rozenblitz covers stabilisation and testing, a description of 13 famous and classic amps and preamps and how to work effectively as a designer. A hands-on guide to construction techniques, tools and choosing components and tubes is provided. 1997, 132pp., 8 1/2" x 11"
Paper back
Code No. 1340
£15.50 + £2.25 P&P (UK)



NEW TITLE
VACUUM TUBE AMPLIFIERS

REPRINTED AND REDESIGNED BY AUDIO AMATEUR PRESS

Vacuum Tube Amplifiers
by Valtek & Walkman
This book is a well known reference valve text book and is assembled from pieces by ten knowledgeable authors. An absolute bible when it comes to valve electronics.
734pp 140mm x 210mm
Paperback
Code 1770
£29.95 + £ 4.00 P&P (UK)

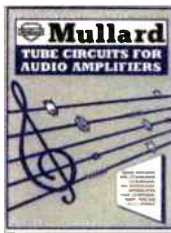

Mullard Tube Circuits for Audio Amplifiers
Includes full designs for eleven power and control amps, including 5-20, using valves. Begins with a four chapter tutorial on getting the best sound from valve amplifiers.
142pp 8" x 10" Paperback Code 1030
£13.95 + £1.50 P&P (UK)

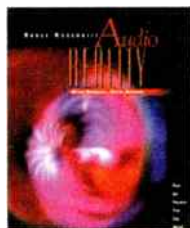

Audio Reality
by Bruce Rozenblitz
A fine read that investigates conductors, skin effect, impedance, interconnects, speaker cables, balanced lines, transmission lines, power cords, isolation transformers, damping systems, tubes, acoustics and much more. Also, includes 6 excellent detailed valve design projects, 80watt OTL/25watt OTL, grounded grid pre-amp, 150watt amp., 6550 SE amp. and a grounded grid cascode phono preamp.
Paperback 128pp
Code No 1640
Price 21.50 + 2.25 P&P (UK)



An Approach to Audio Electronic Valves in Audio Frequency Amplifiers
by E. Rodenhuis
Originally published in 1954 by Philips, this book encourages amp. builders to experiment with design elements. Discussing the use of valve data, the function of different amplifier stages and includes detailed descriptions of eight designs. A wealth of practical data, measurements and interesting features will be found. A very good read.
Paperback 147pp
Code No. 1520
Price £12.95 + £2.00 P&P (UK)



Build your own Audio Valve Amplifiers
by Rainer Zur Linde
This book covers construction projects for preamplifiers, power amplifiers and two amplifiers for musical instruments aimed at the practical audio/hi-fi enthusiast, it offers much information on the operation of electron tubes, while the first chapter gives a short history of the thermionic valve.
paperback, 251pp, 235mm x 13mm
Code No.1320 £14.95 + 2.25 P&P (UK)



Radio Designer's Handbook 4th Edition
by Fritz Langford-Smith
This is a classic reference handbook for all who are interested in the design and application of audio amplifiers and radio receivers, and deals with basic principles and the practical design of all types of classic audio amplifiers, radio receivers and record-producing equipment up to the invention of the transistor, covering valves, valve testing, general theory and components; audio and radio frequencies; power supplies; design of complete AM and FM receivers, and reference information.
1498pp 216mm x 138mm Hard back
Code No. 1600
£35.00 + £6.00 P&P (UK)

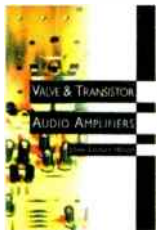

Valve & Transistor Audio Amplifiers
by J.L. Hood
This is J.L. Hood's greatest work yet, describing the milestones that have marked the development of audio amplifiers, from the earliest valve amps to the latest solid state design. It is the complete world guide to audio amp design. Other contents: active & passive components, amplifiers, pre-amplifiers and power supplies.
250pp., 156mm x 232mm Paperback
Code No. 1530
£19.99 + £3.50 P&P (UK)



Fundamentals of Radio-Valve Technique
J. Deketh
This is part of the Philips technical series written in 1947 it was one the most authoritative and comprehensive treatments of the nature and function of the vacuum tube.
534pp 6' x 9" Paper back
Code No. 1630
£21.50 + £2.50 P&P (UK)

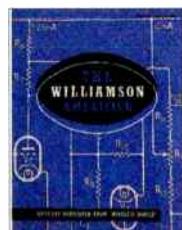

The Williamson Amplifier
by D.T.N. Williamson.
Offers practical advice on how to build and set up the amplifier for best results.
40pp 8 1/2" x 11" Paper back
Code No. 1040
£9.95 + £1.50 P&P (UK)

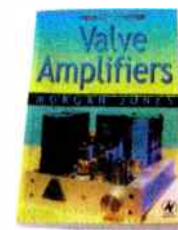

Valve Amplifiers (second edition)
by Morgan Jones, Audio Engineer
This book allows those with a limited knowledge of the field to understand both the theory and the practice of valve audio amplifier design, such that they can analyse and modify circuits, and rebuild an amplifier. Constructional techniques are also provided so readers can build from scratch designs that actually work.
488pp 6" x 9 1/4" Paper back
Code No. 1330
£25.00 + 3.50 P&P (UK)



The Best of Audion
editorial projects
by Luciano Marci
This book contains six excellent audio projects - a high sensitivity speaker, a superb tube pre-amp, a 2A3 amplifier design, a project using the Russian 6C33CB and two projects using 300Bs as output valves. Overall the book is a fabulous read.
62pp. paper back
book code 1750
£12.00 + £2.00 UK p+p

ORDER 4 BOOKS & OVER & PAY ONLY £7.00 P&P (UK ONLY)

World Audio Library

TITLES ON OFFER!!!

NEW TITLE

Manuale HI-FI a valvole Schemario 2°
 An Italian publication with all circuit diagrams in standard conformation, therefore, all circuits are easy to follow. This book is dedicated to self makers and to HI-FI tube engineers. With a wealth of circuit diagrams from some of the best valve amplifiers, pre-amplifiers and phono equipment producers in the world. Including, Audio Research, Altec, Conrad Johnson, Art Audio, Luxman, Carver, Dynaco, Electrovoice, Leak, McIntosh, Marantz, Quad, Radford, Quick Silver, numerous OTL designs, Verdier, VTL and Western Electric. Well worth the money.
208pp 210mm x 300mm Paperback
Code No. 1720
£44.00 + £4.00 P&P (UK)

NEW TITLE

First in High Fidelity The Products and History of H. J. Leak & Co. Ltd.
 by **Steven Spicer**
 This book is the unique and comprehensive story about one of the world's best high-fidelity audio companies. Contained are 300 pictures, 30 circuit diagrams for classic designs of the day. There are also numerous anecdotes and contributions from ex-employees. A wonderful historical read.
270pp 195mm x 264mm Paperback
Code no. 1740
£19.95 + £3.25 p+p UK

NEW TITLE

VACUUM TUBES
 by **Robert B. Tomer**
 From the cover, "Types and causes of tube failures, what to expect from tubes, testing methods and all about tube maintenance programs." This book is intended to offer explanations of why tubes fail and what to do about it. Discussions of catastrophic and degenerative failures; selecting tubes and tube types and testing and predicting tube performance.
160pp 140mm x 216mm Paperback,
Code No. 1710
£13.95 + £2.00 P&P (UK)

NEW TITLE

BASIC THEORY AND APPLICATION OF ELECTRON TUBES
 A US Army & Navy Publication
 This book is an excellent introduction into valves. It does just about everything its title suggests. Written in 1957 it was used by the US military as a text book in their electronics department. Superbly written it contains all you need to know.
215pp
200mm x 260mm Paperback
book code 1760
£17.95 + £3.25 P&P (UK)

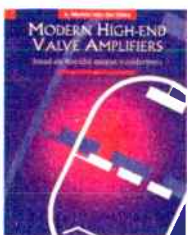

Modern High-End Valve Amplifiers Based on Toroidal Output Transformers
 by **Menno van der Veen**
 Explains the whys and wherefores of toroidal output transformers at various technical levels. Discussed extensively within this book are designs for amplifiers from 10 to 100 watts. Finally, the author gives some attention to a number of special valve amplifiers, and to the theory and practice of negative feedback.
250pp 170mm x 240mm Hard back
Code No. 1670
£24.95 + £2.50 P+P (UK)

NEW TITLE



Sylvania Technical Manual
 by **Sylvania Electric Products Inc.**
 This 13th edition contains data on more than 3300 electron tubes and semiconductor devices. Reprinted here without the TV picture tube section, this manual contains detailed information on Sylvania's devices including charts and diagrams. A master index is found in the front of the book for reference.
516pp 140mm x 216mm Paper back
Code No. 1700
£16.95 + £3.50 UK p+p

LOUDSPEAKER BOOKS



Testing Loudspeakers+
 by **Joe D'Appolito**
 Joe D'Appolito, loudspeaker designer and consultant, has written the definitive text on testing loudspeakers. Dr. D'Appolito brings his expertise to the subject and provides you with a hands-on discussion of testing drivers and systems. He brings you the theory and physics behind loudspeaker testing in this volume.
Paperback
Code No. 1580
£24.95 + £2.50 P&P (UK)

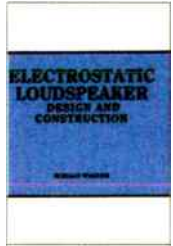

Electrostatic Loudspeaker Design and Construction
 by **Ronald Wagner**
 Step by step guide to the design and construction of a full range electrostatic loudspeaker, including basic operating principles. Strongly recommended for those wanting to either build, repair and/or restore, or who are just interested in electrostatics.
243pp 7" x 9 5/8" Paperback
Code No. 1080
£16.95 + £3.25 P&P (UK)



The Loudspeaker Design Cookbook, 6th edition (new)
 by **Vance Dickason**
 This best seller offers up-to-date design information for the home constructor. It uses modern Thiele-Small theory and parameters.
288pp 8 1/2" x 11 1/2" Paperback
Code No. 1090
£29.50 + £4.00 P&P (UK)

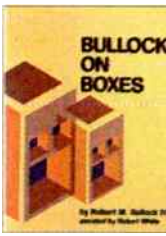

Bullock On Boxes
 by **Robert M. Bullock III.**
 Using Thiele-Small parameters clearly, it offers lots of helpful tables and graphs to get to grips with the sizing of the box and port of a reflex loudspeaker.
72pp 8 1/2" x 11" Paperback
Code No. 1100
£12.95 + £2.00 P&P (UK)

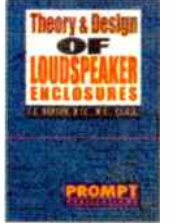

Theory and Design of Loudspeaker Enclosures
 by **J. E. Benson**
 Covers infinite baffle, reflex, passive radiator etc. in great detail with a highly mathematical approach, making it unsuitable for beginners but highly authoritative for experienced designers.
244pp 6" x 9" Paperback
Code: 1140
£23.95 + £2.50 P&P (UK)

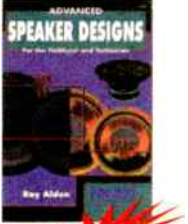

Advanced Speaker Designs
 by **Ray Alden**
 One for the mathematical minded with all the equations one would need for speaker design. Driver parameters are discussed. Sealed & Vented Enclosures have a chapter to themselves. Crossover design is covered as well as measuring speakers. At the rear there are seven projects that rely upon American sourced drivers (Radio Shack). The book offers concise technical explanations of how speakers work.
128 pp 230mm x 150mm Paperback
Code No. 1680
£14.99 + 2.00 P&P (UK)

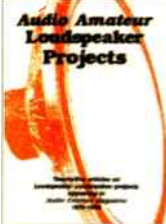

Audio Amateur Loudspeaker Projects
 A collection of the 25 best speaker articles published in the Audio Amateur throughout the 1970s, this popular book is proof that great designs are never out of date. This volume is a rich source of theory, practice and design.
135pp 8 1/2" x 11" Paperback
Code No. 1550
£16.95 + £2.50 P&P (UK)

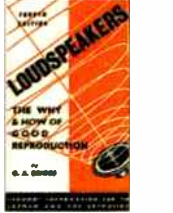

Loudspeakers: The Why and How of Good Reproduction
 by **G.A. Briggs**
 An easy to understand book on building loudspeakers, using empirical techniques that pre-date computer analysis. Strongly recommended for beginners.
88pp 5 1/2" x 8 1/2" Paperback
Code: 1070
£10.95 + £1.50 P&P (UK)



Horn Loudspeaker Design
 by **Mr J. Dinsdale**
 A collection of papers by Mr J. Dinsdale, that discuss the design and theory of this wonderful breed of loudspeaker. The book contains detailed drawings of numerous design, including some Lowther classics. Also, included with the book is a 3.5inch floppy disc with straight-forward software to assist in the design process. A serious reference for those with an interest in horn speakers.
112pp paperback & 3.5 floppy disc
210mm x 300mm
Code: 1730
£29.50 + £2.50 P&P (UK)

ORDER FORM

Please send (Code No.) _____ (enter codes clearly)
 Pay: World Audio Publishing Ltd. £ _____ or debit my Mastercard/Visa/Switch/Solo (Card No) _____
 Expiry date: _____ (Switch/Solo only) Valid Date: _____ Issue No. _____ Name: _____ Signed: _____
 Delivery Address: _____
 Tel: (Day) _____ Please return to: W.A.P. Ltd. 12A Spring Gardens, Newport Pagnell, Milton Keynes, MK16
 SEE ENGLAND TEL/FAX: 01908 218836 **ORDER ON LINE** Website: www.worldaudiodesign.co.uk E-Mail: nick@worldaudiodesign.co.uk
 Please contact us for overseas P&P charges. Allow 28 days for delivery. All orders subject to availability. If further space is required please attach separate sheet.
 TICK BOX IF YOU HAVE ORDERED BEFORE

ORDER 4 BOOKS & OVER & PAY ONLY £7.00 P&P (UK ONLY)

classic cuts

Andy Giles asks you to forget Pomp, Circumstance, The British Empire, Jingoism, Women's Institute jam and a funny old chap with a silly moustache – Edward Elgar's Cello Concerto is quite sublime.

Edward Elgar was arguably the leading English composer of his generation and a significant figure among late Romantic European musicians. Yet, for many, he is still seen as an icon of imperialism and a symbol of what England once purported to stand for. He is intrinsically linked to things like The Last Night of the Proms, Armistice Day dirges and a fair bit of pomping and circumstancing. Splendid and worthy as all that is – it's a shame. One listen to his sublime Cello Concerto in E Minor (Op.85) will reveal a great deal more about the man and his music than the standard perception. Born in 1857, Elgar first earned his living as an organist, violinist and teacher. After his marriage in 1889 he moved to London as a composer, but success only came later, confirmed by the Enigma Variations, first performed in London in 1899.

Elgar wrote his Cello Concerto throughout the late spring and summer of 1919 and may have intended the work as an elegy to those who had died in the Great War of 1914 to 1918. The England, which he knew before it, was no more. The death of his wife, in 1920 dealt Elgar such a deep emotional blow that he was unable to compose anything of similar creativity thereafter, thus making the Cello Concerto his last major work.

The opening movement is marked Adagio-Moderato, and is one of fury and vigour. It opens dramatically and angrily, *ff* with a flourish on a chord, which provides the material for the introduction. The orchestra supports the cello in its opening chords and it then leads to the lyrical and poignant main theme of the movement played

by the orchestra alone. The tension rises and ebbs continually. As the second theme is developed further, it gets more and more agitated, until the point where it plays a continuous ascending minor scale in despair. The whole orchestra then plunges into a tumult of grief and sorrow. Stark orchestration such as the use of timpani with the solo cello adds to the extreme loneliness.

The second movement begins with pizzicato chords played forte by the solo cello, followed by an exclamation from the orchestra. The cello then tentatively introduces a theme that becomes a frivolous scherzo. It plays without much of a break in-between, always saltando (a continuous staccato). There are parts where the cello has to play in very high positions, with harmonics. Occasionally it breaks into a sweeter, lyrical theme, which the orchestra remarks on, but it quickly then reverts to the original frivolity. The movement ends in a rather light-hearted mood with vigorous cello pizzicati.

The third movement is very short and concise - not really a true slow movement, but rather somewhat like an interlude of sorts - an Adagietto. Nevertheless, it is full of heartfelt emotion, though distant in an English manner.

The fourth and final movement commences with a brief introduction from the orchestra, followed by an angry but lyrical intrusion from the solo cello. This gives way to a short impassioned cadenza, after which the movement truly starts, with a sturdy determined theme which gives way to an episode of tragic humour and fun.

Again, frivolity (in the form of



ricochet notes) is never far away from tragedy and optimism, and the mood of the movement changes abruptly, and often. The movement is the most complex of the four and in using themes from previous material, makes the work a 'cyclic' one. For example, the theme from the third movement is brought up again, expressing regret and longing, and leading to resignation.

The concerto concludes with the abrupt recall of the angry chords from the first movement, and the music rages towards... despair? Optimism? Whatever it is, the listener is kept wondering. The music speaks so personally to the heart that one must wonder.

Sir John Barbirolli's recording of the work with Jacqueline du Pré and the London Symphony Orchestra is hailed by many as its definitive interpretation.

The Cello Concerto has become a favourite with audiences, and it was a favourite of Elgar's, too. During his final illness in 1933, Elgar hummed the concerto's first theme to a friend and said, "If ever after I'm dead you hear someone whistling this tune on the Malvern Hills, don't be alarmed. It's only me." He died the following year. ■ ▲

You need buy only one version of Elgar's Cello Concerto. Recorded in 1965, the original Barbirolli/du Pré EMI pressing is faultless. Available on CD - EMI CDC 7473292.

Philips new DVDR1000 DVD video recorder fascinated me. It's possible impact upon audio came up again recently when I was asked to write a piece for a newspaper about hi-fi. The commissioning editor quite firmly told me she wanted to know what sort of hi-fi you could get that wasn't ugly and intrusive in the home and could be moved easily too. It just so happens that there are some new consumer electronics products coming to market that could change the face of a typical domestic system, meeting this woman's requirements neatly.

Although I run large valve amplifiers and sand filled loudspeakers that are better rooted to my floor than the pyramids to Gaza, I sympathise with this editor's views. There's nothing more depressingly ugly than a lounge full of, well, CE (consumer electronics) boxes. I have installed four-channel audio many times, as well as large, high-tech. televisions, only to become disenchanted by both. The end result, I felt, never justified the intrusion. But new technologies could change all this, if not tomorrow, then very soon after.

As wonderful an invention as the CRT of a television is, being historically and physically linked to the valve of course, it sits uneasily in most homes. There have been no end of alternatives. The most attractive nowadays is the plasma display screen, but at £5000 or more I could equally well take up residence in the local cinema. Projectors offer a bigger picture for less money and are gaining in popularity, but they are difficult to accommodate in most homes. Then there is the LCD flat screen, which to date has been used solely in computer monitors. Neat and compact, although prices range from £500-£1000 their popularity suggests this is a price people are prepared to pay for a screen that, at last, fits into the home and is easy to move if need be.

So why, I have asked myself, are LCD screens not being seen in the television market where televisions just seem to get ever bigger, more hideous and more expensive? The current crop

of large screen cinema ratio tvs look like neolithic monuments. Televisions and computer monitors may look alike, but they operate under different conditions and fulfil different requirements. Computer screens are for close viewing and television screens for far viewing. Computer screens have high resolution for fine text and smooth image edges, but lower brightness. Television screens have low resolution but greater brightness for far viewing. Try moving up close to your tv screen and you'll see how coarse looking and bright it appears compared

” The DVD recorder is potentially an all-in-one wonder machine for anyone who hate multiple boxes

to a computer screen.

What we need is a brighter LCD for television use and this is what's coming. Sharp have three models, the 15in LC-15B2U being available discounted for around £1000. Sharp have little competition at present but Philips will be releasing two models at the start of 2002, one a computer monitor with a tv tuner, the other a tv that can be used as a computer monitor. I presume the latter has higher brightness and perhaps a slacker specification for non working pixels, LCD screen manufacture suffering quite high reject rates at present from this cause. I'd guess Philips will price them below £1000. Bear in mind that LCD screens reach 21in maximum at present and that large sizes are disproportionately expensive. A 15in LCD tv is relatively light, portable (10lbs/4.5kgs) and can be hung on the wall.

How does this relate to hi-fi? It relates in terms of being a modern, truly complementary technology to the DVD video recorder, which itself can form the heart of an interestingly different and impressive hi-fi system. Although Philips new DVDR1000 domestic video recorder doesn't record audio (except as video soundtrack), which I think is an unfortunate omission, computer DVD+RW drives from Philips and

Hewlett Packard do. They will record audio CDs (CD-R/RW) in addition to video DVDs (DVD+RW).

We can expect to see this ability coming to the domestic DVD recorder pretty quickly as manufacturers realise it is potentially an all-in-one wonder machine for anyone who hates multiple boxes in their lounge. As a centrepiece in your hi-fi system it could play audio CDs and record them too. CD replay sound quality from the Philips recorder was excellent; there are no innate weaknesses in its audio performance. The same box will also play DVD video discs of course, as well as record tv programmes. Ultimately it will make the CD player/recorder, DVD player and video tape recorder obsolete, so although fairly expensive in absolute terms DVD recorders are cheap against the collection of boxes they replace. Complement them with a hi-fi amplifier and a pair of high quality compact loudspeakers, plus a neat LCD tv, and you have a system that is neat, unobtrusive and easy to move – just what the editor ordered. ●



Noel Keywood

HI-FI WORLD'S GREAT COMPETITION GIVEAWAY

GET YOUR HI-FI SYSTEM CABLE CUSTOMISED BY THE CHORD COMPANY IN OUR SUPERB CHRISTMAS COMPETITION!!

"F"ather Christmas has got something decidedly different for one reader this year! The lucky winner of our January competition will be getting a visit not only from Santa but from the Chord Company, who will subsequently cable customise your system. Those who have multiple hi-fi systems scattered throughout various rooms, take note - you will unfortunately have to choose only one system to get the makeover! A member of Chord Company's experienced team will visit your home, assess your hi-fi and choose a combination of interconnects, 'speaker cable and mains conditioning to make your hi-fi truly sing. And not only that, they will be accompanied by the esteemed editor of this very publication to record the event for posterity. That should give any doubtful reader extra incentive to enter!

The Chord Company are one of the most respected and dedicated manufacturers not only in cable production but also in the whole UK hi-fi industry. With a deep commitment to music, as well as a dedication to its reproduction, the Chord Company constantly produce and develop cable that not only performs outstandingly but also represents great value.

The company was formed in Salisbury (a home town they share with Naim) in 1986 by Sally Kennedy and prides itself on customer satisfaction from personal contact as well as quality of product and after sales service. This results in a very loyal and repeat customer base. The company now have a much larger range of products than the first cable that started it all off, the Chrysalis interconnect - however, this very product still graces the catalogue today, which if anything is testament to the quality of the cable.

That quality has been established by tireless research and development

in all areas of cable design such as the relationships between conductor and dielectric materials or signal screening design. Further concentration is paid to the performance of terminations and the solder used to connect them. As new products are developed, so new ideas are incorporated into existing products to increase performance, as in the case of the Cobra and Chameleon interconnects, among others.

Cable synergy is an important area for the Chord company, for which they see two areas: the matching of cables to equipment and the matching of interconnects to 'speaker cable. They recommend experimentation with cable that has the same design principles and matching dielectric and conductor materials.

In the words of Sally Kennedy "our philosophy is quite simple, but surprisingly unique. All the staff at Chord hold the same vision; we enjoy life, we enjoy music, and we enjoy making and designing cables that increase this delight." This philosophy is carried through from the entry level Calypso interconnect and Carnival 'speaker cable up to the high-end Anthem and Signature interconnects and Odyssey 'speaker cable.

The winner of this month's competition will get a taste of this philosophy as the Chord Company will evaluate which of their products best suit your particular system and give it the cable makeover of a lifetime.

Simply answer the questions below on a postcard and send it to



the address below by December 31st. The first correct answer picked out of our very large hat will be the lucky winner. ■ ▲

NB. As well as your answers and address, a simple outline of your system, plus a contact telephone number would be appreciated on the postcard, too.

Hi-Fi & Computer Audio World Competition rules and conditions of entry

1. Only one entry per house hold.
2. Multiple entries will be automatically disqualified.
3. Purchase of the magazine is not a pre-condition of entry.
4. No correspondence will be entered into.
5. The Editor's decision is final.
6. No employees of Audio Publishing Limited, or of any companies associated with the production or distribution of the prizes may enter.

CONGRATULATIONS!
...to Mr. Daniel Crossfield of Uxbridge, the winner of our November competition. A Cyrus Quattro system is on its way to you!

Competition Questions

[1] Who was the founder of the Chord Company?

- [a] Sally Kennedy
- [b] Jackie Kennedy
- [c] Sally Burton
- [d] Aunt Sally

[2] In which year was the company founded?

- [a] 1981
- [b] 1886
- [c] 1996
- [d] 1986

[3] Which other famous music reproduction company mentioned in the text is based in Salisbury?

- [a] Linn
- [b] Naim
- [c] Aiwa
- [d] Ted Heath

[4] Which interconnect was the Chord Company's first product?

- [a] Chameleon
- [b] Carnival
- [c] Chrysalis
- [d] Carnivore

Please send all entries to:

January Competition
 Hi-Fi World Magazine
 Unit G4 IMEX House
 The Park Business
 Centre
 Kilburn Park Rd.
 London
 NW6 5LF

September is always a time that's greatly anticipated within the hi-fi retail sector. As well as being the time when manufacturers launch new products and showcase new technologies it gives the industry its first glimpse of how business is going to pan out over the 'season'. Broadly speaking the season runs from September to January peaking, as you read this, in December and early January.

This September and October has proved most surprising to me in the number of young people and, specifically students, who have purchased hi-fi. Although I have only anecdotal evidence, there appears to be far greater numbers of students buying hi-fi from the store I work in, than ever before. Although I've only ten years experience of hi-fi retail, it's a trend I've heard from other hi-fi store managers and owners across the country.

Although this is excellent news for all involved in the business of hi-fi, it does pose the question as to why student interest in hi-fi appears to have escalated? It seems to me that the reasons could be one, or more, of four - increased population, affluence, new technology or a changing affinity to music. The last of these I think I'll disregard as it's an almost impossible trend to speculate upon, yet the other three aspects are worthy of investigation.

A trip to the National Statistics web site proved fascinating, yet far from conclusive in terms of population. Birth rates fell from 1968 to 1978. There were mini 'baby booms' in 1980, 1985 and 1990, yet nothing like to the extent of 1964. Hence, we can rule out this as a major cause. One factor we do hear much of is the increasing percentage of younger people entering higher education. However this years figure isn't exceptionally higher than that of previous ones. As for affluence, yes we are becoming a richer nation and there is, again anecdotal, evidence that parents support students more. One only needs a quick tour around some of the pubs, supermarkets and restaurants in your local university City to see that

students also seem more likely to hold down part time employment these days. Yet this doesn't fully explain the seemingly sudden jump from last year.

Of more relevance to this publication is that of hi-fi technology. In short, is there a particular product that has sparked the interest of a new breed of hi-fi separates fans (I'm going to stop short at the term audiophiles, as it's too early for that!)? At this point I'd love to be able to say how it was all down to x technology or y product, but I can't. Student purchases are far more diverse than that. A few years ago

there appears to be far greater numbers of students buying hi-fi than ever before.

I had feared that future generations would abandon traditional hi-fi separates altogether as they downloaded MP3 files off the internet, to be played back through a ghastly set of active computer 'speakers, or portable MP3. Yet, despite the growing ownership of Internet ready PCs, this doesn't seem to have become reality, at least not yet in a widespread manner. As far as I'm concerned, students are buying amps, 'speakers, CD players, MiniDisc players, tuners and the occasional DVD player. In short they are buying pretty much everything that goes to make up a hi-fi separate system. This includes half-decent cables and stands too, which I would hope proves a more than cursory interest. Unsurprisingly what they are not buying are tape decks, but then who does these days? More surprising is that interest in DJ equipment such as turntables and mixers seems to have tailed off this season. It would appear that this year's freshers are more interested in listening to music than producing it (a blessing, no doubt, for those living next to student households across the country!).

As I've mentioned in previous columns, portable MiniDisc players still have a strong following amongst both young students and workers. Despite sales having reached a plateau last year, and the fact that prices have stabilised

too, they remain a popular product. Remarkably, no doubt thanks to Sony's ingenious marketing machine and huge financial clout, they remain a trendy 'must have' product, despite having been around for almost nine years now. As many regular readers will be aware, there are a plethora of recording formats just waiting in the wings, yet none have yet managed to wrestle the recording king mantle away from MiniDisc. Perhaps 2002 will be the year when MiniDisc finally loses its hold yet, then again, the same thing has been said for several years previous now.

In conclusion then, the apparent upturn in student hi-fi interest is uncertain and most probably multi-faceted. Now the responsibility lies with all sections of the hi-fi community to 'keep the buzz' and ensure that in five to ten years time the same students don't simply dump their separates and resign themselves to mini systems in order to maintain domestic harmony. In the mean time, if anyone has any ideas as to the present trend, then answers on a postcard please! ●



Dominic Todd

Head 2 bseH

Not all Nakamichis were high end, fire-breathing Dragons. David Price looks at one of the company's classic 'budget' babies, the 480.



It's easy to think of Nakamichi as purveyors of frighteningly expensive, telephone number price tag esoterica. Thanks to its much vaunted Dragon and MusicLink ranges, the company has achieved legendary status. Like Luxman, MacIntosh, Revox or Goldmund, its brand name enjoys guilt-edged, 24 carat gold-plated surety. The chances of Nakamichi doing anything even remotely affordable are less than seeing flying pigs, right?

Wrong. In truth, the 480 is not a budget product by normal standards - when launched in 1978 it cost more than most companies' all-singing, all-dancing range toppers. But selling for just £220 - mere Linn Sondek money!

Purists may decry it for being 'just' a two head design (and therefore lacking the all-important split record/play head so beloved by serious tape worms), but this is to misunderstand the Nakamichi tradition. Some ten years earlier, the company wasn't building unfeasibly expensive audio esoterica, but learning its craft doing a vast range of OEM gear for others.

How does a Fischer Nakamichi (1969's RC-70) sound - or a Marlux (1972's 5000), or a Motorola (1970's NR-147), or a Sansui (1973's SC-700), a Sylvania (1971's SY-32) or a Concord (1971's MK-1X)? Then there was a Harman Kardon (1967's CAD-4a), a Saba (1974's CR835), a Norelco (1971's 2100), a Sonab (1977's C-500) and a Leak (1973's 2001) - yes really! Add Goodmans, Philips and Elac to the list of names Nakamichi designed and manufactured cassette decks for in its

early years, and you soon see that there's

more to this company than a few eighties Yuppie fashion accessories.

All this work gave Nakamichi the resources to develop its own components. Where other cassette deck manufacturers bought in motors and tape heads off the shelf from OEM manufacturers, Nakamichi developed their own bespoke designs at great expense. In practice, this meant quieter, torquier motors and heads with higher MOLs and lower distortion. The result was clear to hear, as well as resulting in some pretty impressive measured specifications.

The 480 then, despite its relatively modest feature set, was packed with only the finest ingredients - a Nakamichi RP-9E record/ replay head and E-8L erase head, plus 3 bespoke Nakamichi motors that ran silent and smoothly. In addition, the deck got a superbly

No variable bias was offered - it came preset for the company's own brand of EX, SX, ZX tapes - that's Ferric, Ferrichrome and Chrome to you and me - but could of course be re-set by your friendly local Nakamichi dealer. Tape counter, record level sliders and fast acting meters aside, that was your lot. Compared to equivalently priced high end Jap designs, it was a model of simplicity and ergonomic purity - you put the tape in, waited for a second as the auto tensioner took up the slack, and then pressed record. No setting up, fiddly adjustments or tape

calibration - it just got on with the job. And being a Nakamichi, who needed a third head anyway, because you just knew the recording would turn out perfect?

Sound is superb even by today's standards. It's clean and crisp, with powerful, well articulated and tuneful bass, a wide and expansive midband with bold imaging and a clear, bell-like treble. Wow, flutter, crackle, hiss, break-up, distortion? Of course not - this isn't an Aiwa, Sony or JVC we're talking about here! The major drawback is that being a late seventies design, there was no metal tape facility - at a stroke limiting tape choice today. Still, if you can live with TDK SA, you'll be amazed by the results.

In 1980, the 480z arrived with the addition of a fine bias adjuster, and the 482 appeared with a discrete 3-head transport. These are equally desirable second-hand acquisitions, but somehow dilute Nakamichi's pure, bare-bones, 'less is more' concept that the 480 so eloquently espoused. Today, all are available for between £150 and £200 in mint condition. They're all beautiful bits of kit, showing a crispness of design and ergonomic brilliance that today's CD recorder manufacturers could do well to emulate. The face that they're built so well makes them a safe used bet, too - which is something you can't say about cassette decks very often. Like a classic 1970s Mercedes, the quality remains after the fashion has gone. ■ ▲

Visiting Naim Audio's Salisbury factory was an experience not to forget. Any British hi-fi nut who's followed the scene for over a decade will have the company's design ethos indelibly stamped deep into their psyche. So famous is it, that it's very hard not to know at least something about Naim's products, philosophy and history.

As a gauge to the company's significance, think of another successful manufacturer, of roughly similar age, size and/or niche - can you say the same about Meridian or Musical Fidelity, for example? No disrespect to Messrs Boothroyd, Stuart or Michaelson, but they have got on with the business of designing, manufacturing and selling hi-fi whereas Naim has done all this - and more. Like Linn, to which the Salisbury-based company was once famously allied, it has been spreading a philosophy too.

The cynics will say that Naim is just like any other brand, and that all its eccentricities (okay - here we go - unipivot tonearms, DIN plugs, weird speaker cables, exhaustive power supply options, no digital outputs on CD players, SNAIC shakers, non-biwireable speakers) are just clever marketing touches. Indeed, even I have to admit to having thought that treacherous thought too, at one time or another! But visiting the company and seeing what goes on dispelled any conspiracy theories I may have had in an instant. The frightening thing is - they really mean it, man!

The result is a range of charismatic (and rather eccentric) products which - more than almost any other brand - do what it says on the label. It is unlikely that people who've spent the last forty years listening to Leak valve amplifiers will be hankering after a brace of Naim NAP250s - but for those wanting kick-ass dynamics and dizzying levels of grip, punch and control from their sources and amplification, Naim simply has no rivals.

Still, all the hocus-pocus stuff can be a bit annoying - why oh why can't a CDX be specified with a digital out for me to record CDs for the car? And

does the ARO really have to have a non-adjustable headshell, with holes pre-drilled for just one cartridge? And couldn't we have at least one AUX input on the preamp using RCA phonos? Frankly, installing and using Naim gear can be a right pain in the posterior - but then again it's worth it. Like a petulant classic car with a useless heater, twitchy handling and no boot space to speak of, you kind of grow to love its quirks.

Paul Stephenson is an unlikely but brilliant new supremo for the company - he's the yin to Julian Vereker's yang

” Frankly, installing and using Naim gear can be a right pain in the posterior - but then again it's worth it.

(or is it the other way round). Whereas Naim's founder was an outspoken and sometimes abrasive character, Paul is a bridge over troubled water. He knows Naim has had a bit of a hard time from the UK press, but he's happy to let the products speak for themselves, simple as that.

The most impressive part of editor Pope and my visit to Naim Audio was being whisked back to Paul's pad for a quick listening session. No time for speech-making or grandiose presentations - he just hit the volume control and we were off (Naim devotees will know the equipment was already turned on, of course!) The sound through those DBLs was awesome - power and punch without any of the Naim nasties you get if the system's mis-matched or poorly set up.

As PS ran through a range of CDs, including some very impressive recordings on Naim's own label, you couldn't help thinking, 'well, this is what all the fuss is about'. This towering, magnificent sound is why some people spend half their lifetimes working their way up the Naim upgrade ladder, why people buy all the special speaker cables, bespoke equipment supports

and wretched stupid bloody DIN interconnects. If this is the result, I found myself thinking, I'd probably go through it all too.

Right now, Naim is moving into multichannel. They're not pious about stereo hi-fi - the philosophy is to get a good a sound as possible from all formats - which is why they still make the ARO! That's why you can expect to see some distinctly 'epoch-making' products from the Salisbury veterans in the not too distant future. Naim fans are set for the biggest surprise they've had since the company introduced its first remote control pre-amp. Watch this space unbelievers, because even you too could be - sooner or later - Naiming that tune! ●



David Price

SPECIALIST HI-FI DEALERS * SPECIALIST HI-FI DEALERS * SPECIALIST HI-FI DEALERS

LONDON

ORANGES & LEMONS

INSTANT 0% FINANCE AVAILABLE SERVING LONDON FROM BATTERSEA

Juicy fruit from London's newest, freshest hi-fi/home cinema retailer. Telephone demonstrations or just pop in. All the usual, i.e. friendly and efficient service. Free home installation + credit cards.

THE INNOVATIVE AUDIO VISUAL HI-FI RETAILER ARCAM CABLETALK, CHORD CO. DENON EPOS MARANTZ NAD NAIM REGA ROKSAN ROTEL ROYD RUARK SOUNDSTYLE STANDS UNIQWE YAMAHA

NOW IN OUR SEVENTH SPARKLING YEAR.

020-7924 2040

61/63 WEBBS ROAD, SW11
Visit www.orangesandlemonshifi.com

LONDON

We aim to provide a well chosen selection of quality hi-fi and accessories including FMJ, ARCAM, B&W, NAUTILUS, DYNAVECTOR, LINN, LOEWE, MERIDIAN, M&K, NAIM, PIONEER, PROCEED, NEAT, REGA, ROTEL, SHAHINIAN, YAMAHA + more

www.infidelity.co.uk

Infidelity
INDECENTLY GOOD HI-FI

9 High Street, Hampton Wick,
Kingston upon Thames, Surrey KT1 4DA
Tel: 020 8943 3530

Open:
Tues-Fri 10.30am-7pm,
Saturday 10am-6pm

WEST

audio excellence 

WHERE THE MUSIC MATTERS

Bristol 65 Park Street Bristol BS1 5PB (01179) 264975	Cardiff 134/6 Crwys Road Cardiff CF2 4NR (01222) 228565
Gloucester 58 Bristol Road Gloucester GL1 5SD (01452) 300046	Swansea 9 High Street Swansea SA1 1LE (01792) 474608

Exeter
156 Sidwell Street, Exeter, EX4 6RT
(01392) 491194

TUESDAY - SATURDAY 9.00 - 5.30
CLOSED MONDAY

O'Brien Hi-Fi

ARLAM • ANTHEM • AUDIODESIGN • AUDIO RESEARCH • AUDIO TECHNICA • BEYER • CABLETALK • CHORD • CREEK • DENON • DEWEE • DENON • JADIS • JEDRUS • MICHELL • MUSICAL FIDELITY • NAD • NAIM • DPLRA • PRECIOUS METALS • QED • REGA • ROGERS • ROYD • SENNHEISER • SILTECH CABLES • SIME • SONNETEER • SONUS FABER • TICAL • THORENS • TRANSPARENT CABLES • UNISON • RESEARCH • WILSON

MARTIN LOGAN
AUDIO ANALOGUE

Clearance, Special Offers, • Direct Equipment, • Detailed enquiries

0% Instant Finance Available

New Demonstration Room • Free car parking • Major Credit Cards
Personal Export • Mail Order • Installation Service • Repair facilities
5 mins walk Raynes Park BR • 10 mins Waterloo
5 mins from A1 (Kew) Park BR exit • 20 mins M25 exit 10

60 Durham Rd, West Wimbledon, London SW20 0TW
Est 1966
Tel: 020 8946 1528 Fax 020 8946 0331

AUDIO CONCEPTS

27 BOND STREET, EALING
LONDON W5 5AS
TEL. 081 - 567 8703

Audio Analogue, Art Glass, Ash Designs, Avik, B&O, B&W Cabletalk, Chord Company, Creek, Denon, Epos, Harman Kardon, Infinity, KEF, Lat, Marantz, Musical Fidelity, NAD, Nakamichi, Nordost, Orelle, Onkyo, Pmware, Quad, Roksan, Rotel, Ruark, Sennheiser, SonicLink, Sound Style, Stands Unique, Straightwire, Supra, Tag McLaren, Target, Teac, Thorens, van den Hul

10 - 6 pm Mon., Tues., Friday, & Sat.
Late night Thur., closed Wed.

Two demonstration rooms
Free local delivery and installation
Repairs and Services

NORTH



Unison Research 845

ZENAUDIO

Stockists of:
Naim, Densen, Dynaudio, Ruark, JMLab, Proac, Craft, Sugden, Sme, Michell, Unison Research, Nad, Teac, and many more.

35 George Street Hull. tel 01482 587397

SOUTH

WORTHING AUDIO

20 Treville Gate, W.Sussex BN11 1UA
(01903) 212133

The friendly shop with the best sound system in the South.
• Electronics - Friendly Advice - 3 Year Guarantee
Easy Parking - Open Mon-Sat. 10am-6pm.
Late Night Wed 7.30pm.

Agencies include: Dynaudio, Ruark, Gradient, Riddim, Proac, Onkyo, Sonneteer, Kora, Cymbol, Talk Electronics, and many more.....

Basically Sound

NORWICH • NORFOLK

Audio Analogue, Bryston, Cabletalk, Chango, Chord Co., Denon, Epos, Final, Isobule, Naim Audio, PMC, ProAc, Rega, Slax, Talk Electronics, UKD Opera, Audio Note and many others



The Old School
School Road, Bracon Ash
Nr Norwich, Norfolk, NR14 8HG
Tel (01508) 570829

SOUTH WEST

SOUTH WEST ANALOGUE

SME - MICHELL - NOTTINGHAM ANALOGUE - LORICRAFT GARRARD - PROJECT - ORTOFON - TUBE TECHNOLOGY 64bit Valve CD Player, Remote Control Hybrid Integrated Valve Amplifier VOODOO Isolation platforms/Loudspeakers, Equipment Stands and T/Turntable lift off Perspex Covers.

Record cleaning service - Secondhand equipment
01643 851 351
graham@southwestanalogue.fsnet.co.uk

audio excellence 

WHERE THE MUSIC MATTERS

CHESTER 86-90 Boughton, Chester CH3 5AQ (01244) 345576	PRESTON 131 Friargate Preston, PR1 2EE (01772) 253057
--	---

TUESDAY - SATURDAY 9.00 - 5.30
CLOSED MONDAY

TO ADVERTISE

HERE

PLEASE CALL

EWAN HAWKES

ON

020 7624 9022

EAST

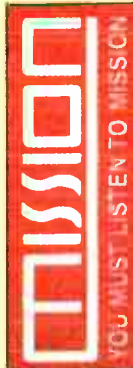

BG Audio Visual

9 Hatter Street
Bury St Edmunds
Suffolk

01284 765 227

Bang & Olufsen, Sony,
Technics, Denon,
Yamaha, Rotel, Linn,
Mission, KEF, Jamo,
JBL, Harman, Boston

GRAYSTON
sound & vision

Alchemist Arcam B&W Boston Acoustics
Castle Acoustics Denon Harman Kardon
KEF Reference Linn Loewe Meridian Musical Fidelity
Philips Pioneer Project Rotel Sennheiser Thomson

33 Sir Isaac's Walk, Colchester
Tel: 01206 577682

Lend us your ears and we'll
blow your mind . . .

Arcam, A.T.C., B & W, Celestion, Denon,
Kenwood, Kef, Marantz, Michell,
Mission, Meridian, NAD, Panasonic,
Philips, Pioneer, Quad, REL, Rotel, Ruark, Sony,
TAG McLaren, Tannoy, Technics, Yamaha and more.
Audition the very best at Lincolnshire's
premier Hi-Fi dealer . . .



2-4 EDWARD STREET (Off Pasture St.,)
GRIMSBY. TEL: (01472) 351391

STOWSOUNDS
audio consultants

These And More Available From:

Creek	JM Labs
Epos	Living Voice
Exposure	Neat Acoustics

For A Demonstration & Expert Advice Call
Stowmarket (01449) 675060

Stone Farm, Borough Lane, Gt. Finborough, Stowmarket



Johns
Audio & Visual
Specialists

Technics Yamaha Sony
Panasonic Kenwood Aiwa
Toshiba Pioneer Mission

Low, low prices
all year round!!!
(Established 1959)

142 High St
Scunthorpe, Nth Lincs
01724 843800

SERVICES & CONSULTANTS

Front End Problem?
contact
The Cartridge Man

It doesn't have to cost an arm and a
leg to get the best - listen to my
Koetsu - and Decca -eater.

Also agents for Croft, Haddock,
E.A.R, Michell &
Moth.

plus cartridge re-tipping service
020 8688 6565

Website: www.thecartridgeman.com

**TO ADVERTISE IN
SPECIALIST
HI-FI DEALER
PLEASE CALL
EWAN HAWKES
ON
020 7624 9022**

atv

ATV SERVICES
LEATHERHEAD
01372 456921

- Service & Repairs
- Valve & transistor amplifiers
- Vintage valve Radios
- Hi-Fi VCR's
- Valves Tested

VINYL

THE DIRECT DISC
VINYL VINYL VINYL

Thousands of records always in stock.
+ a full range of sought after compact discs.
Extensive search service for wanted albums.
Comprehensive 96 page full catalogue
available at £1.50

Telephone / Fax 01992 447764

Or visit our web site on

www.directdisc.demon.co.uk

VINYL CLEANERS

**CHERISHED
RECORD CO**

UK SUPPLIERS OF
VPI TURNTABLES,
RECORD CLEANING
MACHINES AND ACCs.
HUGE SELECTION OF
NEW & USED LPS & CDS

www.cherished-record-company.co.uk

01579 363 603

MAIL ORDER



**Russ Andrews
Accessories
Mail Order Direct**

Q. How do I get the best
sound from my system?

A. Order our free booklet!
It's essential reading for anyone
who wants to hear the best
music their system can deliver,
and it's full of free tips and advice
on how to upgrade your system.
Call and request your free
copy quoting ref. AH12 or
visit our website where you can
download it now

UK FREEPHONE
0800 373467

Russ Andrews Accessories Ltd.,
FREEPOST NWW881A, Kendal LA8 9ZA
Tel: +44 (0)1539 825500 Fax: +44 (0)1539 825540
E-mail: AH12@russandrews.com
www.russandrews.com

VALVES & TUBES



Buy CVC. PREMIUM HI FI valves direct from us.
All valves processed for improved performance.
We also have stock of MAJOR BRAND types inc.
MULLARD, GEC, BRIMAR, RCA, GE, PHILIPS, etc.

The Stables, Baddow Park, Great Baddow,
Chelmsford, Essex, CM2 7SY
Tel: 01245 241301 Fax: 01245 241309
Email: sales@chelmervalve.com



£600

Mr. Andrew Everard in Gramophone Magazine
"delivers a sound that's both smooth and refined
... allied to a good degree of clarity and finesse"
Hi-Fi Choice "it's a 'classic valve sound'... warm and
cuddly... vocals are generally lifelike and involving"
FREE colour literature. £600 with free delivery
Phone 01634 373410 anytime. 1 month home trial
www.affordablevalvecompany.com 40 watts

**TO ADVERTISE IN
SPECIALIST
HI-FI DEALER
PLEASE CALL
EWAN HAWKES
ON
020 7624 9022**

DIAL-A-DEALER

This is a comprehensive directory of Hi-Fi Dealers throughout the UK and Ireland.

BEDFORDSHIRE

RICHARD'S AUDIO VISUAL 4 Greyfriars Bedford. Tel: 01234 365165. Stockists of: Arcam, Audioquest, Beyer, B&W, Bose, Cable Talk, Cyrus Denon, Marantz, Mission, Moth, Ortofon, Pioneer, Pro-Ject, Quad, REL, Rotel, Ruark, Sennheiser, Sound Style, Stands Unique, Teac, van den Hul & more! Expert friendly service: Listening room, Pioneer Reference Point, Visa / Access.

BRISTOL & BATH

THE RIGHT NOTE Tel: (01225) 874728. Just think: most audiophiles listen for most of the time to systems that are 'not quite right'. Are you happy with yours? Forget the reviews and trying to put together a system like a patchwork quilt with the 'best' bits around. Its our job to do the assessing, you judge our results. We'll help you to plan a system for the future, even if you spread the purchases. Leave the 'up-grade-itis' behind, save money and enjoy music all the time. Just listen, and you'll know. CD: Accuras, Audio Synthesis, Classe, DCS, Enlightened Audio Design, Meracus, Orelle, Wadia, XTC. Vinyl: Basis, Crown, Jewel, Graham, Michell, Sumiko, Transfiguration. Amps: Accuras, Audio Sculpture & more. Speakers: Audio Artistry, Audio Physics & more. Tuners: Fanfare, Magnum Dynalab & many more. Cables: Chord, DNM, Silver Sounds & more. (Credit Cards Accepted).

V AUDIO HiFi Consultants: 36 Druid Hill, Stoke Bishop, Bristol, BS9 1EJ. Tel: 0117 968 6005, A.T.C., AVI, Alon, Audio Analogue, Audiomeca, Cadence Valve, Chord Amps, Electrocompaniet, Harman Kardon, Heybrook, Jamo, LFD, Lyra, Opera, Ortofon, Pink Triangle, Ruark, Mark Levinson, Michell, REL, SME, Shearpe, Sonic Link, Sugden, Townshend, Triangle, Unison Research Valve Amps. Home Cinema demonstrated including, AV Amps, DVD Players, Video Projectors and Screens. Demos by appointment only. Home trial facilities. Free installations. We are not a shop.

BUCKINGHAMSHIRE

NORTHWOOD AUDIO 98 Cambridge St. Aylesbury. Tel: 01296 428790. Established since 1992. Independent specialist retailer. Extensive Hi-Fi, AV and Multiroom experience catering to your needs. From Vinyl to SACD, Valve to Solid State, from LCD to Plasma. Audiomeca, Audio Note, Cable Talk, Castle, Chord, The Chord Company, Cura, Denon, Elac, Epos, Exposure, Heart, JM Labs, KEF, Linn, Marantz, Michell, Micromega, Monitor Audio, NAD, Nakamichi, PMC, ProAc, Quadraspire, Rega, REL, Revox, Roksan, Rose, Rotel, Ruark, Sony, Sennheiser, Sonus, Talk Electronics, Tannoy, Teac, Tube Technology, Videologic, Vienna Acoustic. Export orders welcome. 2 demo rooms. Credit facilities available. Website: www.northwoodaudio.co.uk Email: info@northwoodaudio.co.uk

TECHNOSOUND 8 Granville Square, Willen, Milton Keynes, MK15 9JL. Tel: (01908) 604949. Fax: (01908) 202166. Audiophile Hi-Fi and Home Cinema specialists. All major brands stocked from Arcam to Yamaha. Meridian Digital Home Theatre dealer. Video projection, Plasma screens. Custom installation. 2 dem rooms and expert advice. Email: hifi@technosound.co.uk www.technosound.co.uk

CAMBRIDGESHIRE

THE AUDIO FILE 41 Victoria Road, Cambridge. Tel: 01223 368305. 'For the best in British Hi-Fi and Home cinema entertainment'. Visit or call to arrange a dem with products from: Arcam, Linn, Naim, Rega, Cyrus, Absolute Sounds, Kef, Sony, Yamaha, Rel, Ruark, Denon.

CHESHIRE

ACOUSTICA 17 Hoole Rd, Chester CH2 3NH. www.acoustica.co.uk. Tel: 01244 344227. All that's best in HiFi & Home Cinema from quality manufacturers including Naim, Rega, Arcam, Musical Fidelity, Rotel, Selecio Projectors, Kef, Ruark, Densen, Primare, Teac, JM Lab, Nakamichi, Quadraspire, Celestion & Crimson. We offer friendly, helpful advice, interest free credit & trade-in facilities, and deliver & install systems throughout Cheshire, Merseyside & North Wales. Opening hours are Tuesday to Saturday 10.00 until 5.30, evenings by arrangement

ACTON GATE AUDIO 4 Rubon Road, Wrexham, North Wales. Tel: 01978 364500. Audio Visual Specialists. Arcam, Audio Analogue, Bose, B&W, Celestion, Castle, Denon, Harmon Kardon, Jamo, Marantz, Michell, Mission, Onkyo, Pro-Ject, Musical Fidelity, NAD, Micromega, Myrad, QUAD,

Radford, Rotel, Ruark, Tannoy, TDL, Teac, Thorens, UKD, Unison Research, Yamaha, DSP Club Member. Demo Room, installation service. Easy Parking and Motorway access. All major credit cards accepted. 9.30 - 5.30 daily. Closed Sunday & Monday.

DOUG BRADY HI-FI Kingsway Studios, Kingsway North, Warrington, WA1 3NU Tel: 01925 828009 Fax: 01925 825773. Visa, Mastercard, Lombard Tricity. 2 dem rooms, home trial; Agencies include: Arcam, Tag McLaren, AVI, B&W, Castle, Caspian, Chord Electronics, Exposure, Harbeth, Heybrook, Krell, LFD, Michell, Meridian, Musical Fidelity, Monitor Audio, Naim, Nautilus 800 series, Pink Triangle, ProAc, Roksan, SME, Wilson Benesch, XTC and many more.

CORNWALL

SOUNDS PERFECTION 'Cornwall's most exclusive Audio retailer'. Agencies include: Audio Analogue, Audio Design, Audio Note, AudioQuest, Audio Spectrum, AR, Avid, Border Patrol, Boston, Dynavector, Electrocompaniet, Graaf, Henley, JM Labs, Lexicon, Michell, Monitor Audio, Musical Fidelity, Ortofon, Parasound, Primare, Project, NAD, Nakamichi, Nordost, Philoshophy, REL, Roksan, Ruark, Rotel, Totem, Tom Evans, Tsunami, S.M.E., Sugden, Stands Unique, Unison Research, Teac, Vienna Acoustics, Triangle, Trichords, WBT, Sonic Link. Home Demonstrations by Appointment. Tel/Fax: 01326 221372 Mobile: 07798 554357 email: nigel@soundsperection.co.uk website: www.soundsperection.co.uk

DORSET

MOVEMENT AUDIO 588 Ashley Road, Poole, Parkstone, Dorset BH14 0AQ. Tel: (01202) 730865/380018. Arcam, B&W, Castle, Chord Electronics, Cyrus, Denon, Marantz, Michell, Mission, Pioneer, Tannoy Dimension, Yamaha. 2 Dem rooms. Listen to the available choice and decide at your leisure - no pressure, no obligation. Our staff enjoy music, with our choice of products, you can too! Service Department. Free installation. Home trial facilities. Access, Visa, Amex, Diners Card. Credit facilities available. Open Tuesday-Saturday 10-5.30. www.movement-audio.co.uk

MOVEMENT AUDIO 926 Wimborne Road, Winton, Bournemouth, Dorset, BH9 4DH. Tel: (01202) 529988/520066 Arcam, B&W, Denon, KEF, Marantz, Mission, Musical Fidelity, Opera, Pioneer, Quad, Roksan, Ruark, Yamaha. Full dem facilities available. also home dem. Friendly expert advice. Service Department. Free installation. Home trial facilities. Access, Visa, Amex. Open Tuesday-Saturday 9.30-5.30

DAWSONS OF WESTBOURNE Home Cinema Specialists. Main agents for Bang & Olufsen, Harman Kardon, JBL, REL, Mordaunt Short, Sony, Technics and TDL. Demonstration facilities include our unique Dolby pro-logic system comparator for the ultimate way to choose the perfect system. Also on demonstration large screen televisions from Thomson, sony and Ferguson with video projectors from Sharp and Selecio. Dawson's, 23 Seamount Road, Westbourne, Bournemouth 01202 764965

WEYMOUTH HI-FI 33-35 Maiden Street, Weymouth, Dorset DT4 8BA. Tel: (01305) 785729/766345. Arcam, B&W, Denon, KEF, Marantz, Mission, Musical Fidelity, Panasonic, Pioneer, Quad, Sony, Tannoy, Yamaha. Dem room. Friendly professional advice. Only quality hi-fi dealer in Weymouth area. Service Department. Free installation. Home trial facilities. Access, Visa, Amex, Switch, Delta Mastercard. Interest free credit. Instant credit. Open Mon-Sat 9.30-5.30

ESSEX

GRAYSTON SOUND & VISION 33 Sir Isaac's Walk, Colchester. (01206) 577682. Alchemist, Arcam, B&W, Boston Acoustics, Castle, Denon, Harman Kardon, KEF, Linn, Loewe Opta, Meridian, Michell, Musical Fidelity, Philips, Pioneer, Project, Rotel, Sennheiser. Superb demo rooms, free regional delivery and installation. Regular musical and surround evenings, home demonstrations. Excellent credit facilities.

GLOUCESTERSHIRE

THE RIGHT NOTE - Bath. For specialist advice and home demonstrations. See **BRISTOL & BATH**.

HEREFORDSHIRE

ENGLISH AUDIO 37 Whitecross Road, Hereford, HR4 0DE. (01432) 355081. Arcam, A.T.C., B&W, Castle, Cura, Cyrus Centre, Elac, Denon, JM Lab,

KEF, Loewe, Marantz, Mission, Musical Fidelity, NAD, Naim, Pink Triangle, Pioneer, Project, QED, Systemline, REL, Rotel, Ruark, John Shearpe, Stax, System Audio, Teac, Vienna Acoustics, Wadia, and Yamaha. Single speaker dem room, home trial facilities, free installation, service dept, Access/Visa. Credit arranged. Open Mon-Sat. 9.30-5.30pm. BADA members.

HERTFORDSHIRE

AUDIO FILE (THE) 27 Hockerill Street, Bishops Stortford, Herts. Tel: (01279) 506576.

DARBY'S OF ST. ALBANS, 6 Market Place, St Albans, Herts. Tel: (01727) 851596. Fax: (01727) 812217) Email: sales@darbysvhifi.co.uk Hertfordshire's premier Hi-Fi/Audio Visual specialists established 1946. Full Home Cinema demonstration suite. Whether your needs are large or small, we stock it all: Arcam, Cyrus, JVC, Yamaha, Quad, Denon, Sony, Bang & Olufsen, Pioneer, REL, KEF, Mission, Ruark, Celestion and many more. Free planning service. Free Delivery and basic installation. Full workshop facilities. Open 9-6 Mon-Sat.

LANCASHIRE

ADVENTURES IN HI-FI 5, Bishopgate, off Hallgate, Wigan, WN1 1NL. Tel: 01942 234202. For the best hi-fi and home cinema products from quality manufacturers including Naim, Rega, Cyrus, NAD, KEF, Denon, Dynavector, Rotel, Shahinian, JM Lab, PMC, Project, Quadraspire, Selecio and Sanyo projectors. We offer friendly advice, excellent demonstration facilities, 0% finance, free delivery and installation throughout the North West. Opening hours 10.00 - 5.30pm Tuesday to Saturday evenings by appointment.

LEICESTERSHIRE

LEICESTER HI-FI 6 Silver Walk, St Martins Square, Leicester LE1 5EW. Tel: (0116) 2539753. Email: info@leicesterhifi.co.uk www.leicesterhifi.co.uk Arcam, B&W, Chord Electronics, Copland, Cyrus, Denon, Greig Loudspeakers, KEF, Marantz, Michell, Miller & Kreisel, Musical Fidelity, NAD, Nakamichi, Nautilus, Mission, Project, Rotel, Sanyo Projection, Talk Electronics, Teac, Technics, Yamaha, and many more. 4 Listening areas over 3 floors. We can demonstrate, deliver and install. Including A.V. and Multiroom. Credit Facilities. All cards taken. open 6 days 9.30-5.30.

LONDON

BABBER ELECTRONICS SERVICE CENTRE 158 Uxbridge Road, West Ealing, London, W13 8SB Tel: 020 8579 6315 Akai, Aiwa, A&R, Celestion, Dual, Goodmans, Harman Kardon, JBL, JVC, Kenwood, Marantz, Panasonic, Sennheiser, Sony, ES range, Tannoy, Technics, Wharfedale, Yamaha and many more. Auth. Service Dept. Credit Facilities. Open 10.30 - 5.30 Mon-Sat.

INFIDELITY 9 High Street, Hampton Wick, Kingston-upon-Thames. Tel: (020) 8943 3530. for full details see entry under **SURREY**

HIFI EXPERIENCE 227 Tottenham Court Road, London W1. 020 7580 3535. Arcam, Cyrus, Denon Gold, Quad, Kef, Meridian, Yamaha, Marantz, McCormack, Mirage, Nakamichi, Musical Fidelity, PAFF and many more. Open 10.00-7.00 Mon-Fri, 9-6 on Sat. Service dept. Credit facilities, delivery and free installation.

THE LISTENING ROOMS 161 Old Brompton Road, London SW5 0LJ. (020) 7244 7750/59. Fax (020) 7370 0192. Linn, Quad, Meridian, Nakamichi, Arcam, Audiolab, Acoustic Energy, SME, Audio Research, Krell, Wadia, Theta, Apogee, Martin Logan, Pioneer, Tannoy, Systemdek, Stax, Pink Triangle, Michell, Monitor Audio, Yamaha, Marantz, KEF, Bose, Celestion, Epos, Mission, Denon, Neat Petite. Mon-Sat 10-6pm.

THOMAS HEINIZ LTD 35 Moscow Road, Bayswater, London, W2 4AH. Tel: 020 7229 2077. Fax: 020 7727 9348. Email: info@thomasheinitz.com. Web site: www.thomasheinitz.com. Established in 1952, Thomas Heinitz has a long history of providing the best music and AV systems available. We continue to offer the highest standard of service in the most relaxed atmosphere. Whatever your needs, from multiroom and home cinema to a high quality stereo system, we offer consultation, design specification, architect liaison and installation in order to ensure your system is tailored to your exact requirements. For quotes contact our manager Johnny Drum.

GREATER MANCHESTER

ADVENTURES IN HI-FI 5, Bishopgate, off Hallgate, Wigan, WN1 1NL. Tel 01942 234202. See our main entry under LANCASHIRE

MANCHESTER

REPLAY AUDIO 64 Flixton Road, Urmston, Manchester. M41 5AB Tel 0161 202 9922. Audio Analogue, Bryston, Creek, DNM, Exposure, LFD, Michell, Myryad, NAD, Onkyo, Ortofon, Pink Triangle, Project, Sonneteer, Sugden, Trichord, Unison Research, Teac. Loudspeakers from Acoustic Energy, A.R.T. Audio Physic, AVI, Blueroom, Epos, Harbeth, Living Voice, Monitor Audio, Neat, PMC, Royd. Lots of cables and accessories available. We are just off Junction 10 of the Manchester Ring Road (M60), five minutes from The Trafford Centre. Our demonstrations are relaxed and informal and help and advice is free! Phone or visit our web site www.replaydialpipex.com or email replay@dialpipex.com

MERSEYSIDE

ACOUSTICA 17 Hoole Rd, Chester CH2 3NH. Tel 01244 344227. See our main entry under "Cheshire".

MIDDLESEX

RIVERSIDE HI-FI 422 Richmond Road, East Twickenham, Middlesex, TW1 2EB. Tel: 020 8892 7613 Fax: 020 8892 7749. www.riversidehifi.co.uk Arcam, Bose, B&O, Castle, Copland, Denon, Krell, Marantz, Martin Logan, Michell, Monitor Audio, Musical Fidelity, NAD, Pioneer, Project, Rel, Sonus Faber, Sony, Tag McLaren Audio, Tannoy, Teac, Theta, Wilson. Finance available. Subject to status. Written details available on request. Export orders welcome. UK mail order available. 3 demonstration rooms. All major credit cards. Open 10am-5.30pm Mon-Sat.

NORFOLK

BASICALLY SOUND The Old School, School Road, Bracon Ash (Nr Norwich), Norfolk, NR14 8HG. Tel: (01508) 570 829. Stockists of the following leading Hi-Fi: Audio Analogue, Beyer, Bryston, Denon, Dynavector, Epos, Grado, Naim, PMC, ProAc, Rega, Royd, Sennheiser, Talk Electronics, Teac and more. Bada members. 2 comprehensive demo rooms.

NORTHAMPTON

CLASSIC HI-FI At Classic Hi-Fi we cover the best in quality sounds. Be it a question of taste, a question of balance or a question of price, we're the ones to help. We stock: Marantz, Nad, Pioneer, Roksan, Yamaha, Heybrook, LFD, Sugden, Rotel, Kenwood, B & W, Kef, Rogers, Monitor Audio, Musical Fidelity, Tannoy, Shearpe Audio, Royd, Audio Alchemy, Teac and many more. For more details call: 01536 310855

LISTEN INN 32 Gold Street, Northampton, NN1 1RS. Tel: 01604 637 871. The World's Finest Hi-Fi from Arcam, Audio Analogue, Chord Company, Copland, Denon, FMJ, Fujitsu, KEF, Krell, Linn, Loewe, Martin Logan, Meridian, Miller & Kreisel, Mission, NAD, Naim, Proac, Rega, Rotel, Sennheiser, Sonus Faber, Wilson, Benesch, Yamaha. Dedicated Viewing & Listening Rooms, Friendly Staff, Fresh Coffee, 2 Full Years Warranty, Part Exchange Welcome, Free Car Parking, Interest Free Credit, Members of BADA. Open 10am-5.30pm (Closed Thursday).

NOTTINGHAMSHIRE

NOTTINGHAM HI-FI CENTRE 120-122 Alfreton Road, Nottingham. Tel: 0115 9786919. Multi-room specialists. Hi-Fi, Home cinema. All leading brands stocked. Three superb demonstration areas. Two year parts and labour guarantee. Home trials. On site service facility. Full delivery and installation service. Easy free parking. BADA Dealer. Established 1968. Mon-Sat 9.00-5.30

OXFORDSHIRE

OVERTURE HI-FI 3 Church Lane, Banbury, Oxon OX16 8LR. Tel (01295) 272158. Email sales@overture.co.uk Website: www.overture.co.uk Arcam, Bose, Cura, Denon, KEF, Linn Products, Miller and Kriesel, Mission, NAD, Naim Audio, Yamaha. For sensible unbiased advice, call Oxfordshire's audio experts. Superb demo facilities. No appointments necessary. Home Cinema, Plasma TV, Projectors, Lutron Lighting, MultiRoom and Commercial Installations. Access/Visa, instant credit. Mon-Fri 10-6. Sat 9.30-5.30.

SHROPSHIRE

ADAMS & JARRETT Hi-Fi and Home Cinema Specialist. Phone or visit us at 6-18, Norman Road, St Leonards-on-Sea, E.Sussex. (01424) 437165/432398. Stockist of quality equipment including: Audio Innovations, Meridian, KEF, Ruark, Marantz, NAD, JBL, Royd, Dali, Jamo, Onkyo, Rel, Traget, Cable Talk, Technics, TDC, Yamaha, Kenwood. Air conditioned listening rooms, on site service and repair facilities

STAFFORDSHIRE

ACOUSTICA 114 Wolverhampton Rd, Stafford ST17 4AH. www.acoustica.co.uk. Tel 01785 258216. All that's best in HiFi & Home Cinema from quality manufacturers including Naim, B&W, Musical Fidelity, Rotel, Seleco Projectors, Kef, Ruark, Teac, JM Lab, Rega, NAD, Yamaha, REL, Sanyo projectors, Fujitsu. We offer friendly, helpful advice, interest free credit & trade-in facilities, and deliver & install systems throughout Staffordshire & the Midlands. Opening hours are Tuesday to Friday 10.30 until 6.00, Saturday 10.30 until 5.00.

SUFFOLK

ANGLIA AUDIO The Street, Hessay, Bury St Edmunds, Suffolk, IP30 9AZ. Tel. 01359 270212. "Hi-Fi and speaker centre dedicated to quality hi-fi since 1971. Open 10-6. Closed Weds and Sundays. Evening and Sunday Demos by appointment.

AUDIO IMAGES 128 London Road North, Lowestoft, Suffolk, NR32 1HB. Tel: 01502 582853. Arcam, Acurus, Castle, Rotel, Moth, Triangle, QTA, Sugden, Denon, Yamaha, Mirage, M & K, Definitive, Musical Fidelity, plus the incredible Rothwell range. Refreshingly different selection. Dem Room. Professional AV installer's from budget to high end. Full credit facilities. 9.30 to 5.30 Mon & Sat ~ 9.30 to 6.00 Tues to Fri.

EASTERN AUDIO 41 Bramford Road, Ipswich, Tel: 01473 217 217. Fax 01473. 215705. Quad, Arcam, Audioblab, Meridian, Mission, Denon, Rotel, Marantz, NAD, Sony, Rogers, Nakamichi, Systemdek, Technics, Celestion, B&W, Tannoy, Morel Thorens and Top Tape. Also stock a wide range of accessories. usual credit facilities. A BADA dealer.

SURREY

INFIDELITY 9 High Street, Hampton Wick, Kingston upon Thames, Surrey, KT1 4DA. Tel. 020 943 3530. Email: infidelity@compuserve.com - Web Address: infidelity.co.uk Stockists of: Linn, Naim, Arcam, Meridian, Rega, B&W Nautilus, Neat, Proceed, Royd, M&K, Rotel, Stax, Shahinian, Dynavector. Open 10.30 - 7.00 Tues - Fri, 10.00 - 6 Sat.

SUSSEX (EAST)

ADAMS & JARRETT For the best Audio Visual Specialist with friendly helpful staff phone or visit us at 6-18 Norman Road St. Leonards-On-Sea, East Sussex. Tel. 01424 437165/432398. Copland, Castle, Denon, Densen, Dynaudio, Jamo, Kef, Kenwood, Marantz, Meridian, Musical Fidelity, NAD, Onkyo, Primare, Rel, Rotel, Ruark, Tannoy, Technics, Yamaha. Interest free credit available subject to status. Visa. Mastercard.

WEST MIDLANDS

ACOUSTICA 114 Wolverhampton Rd, Stafford ST17 4AH. See our main entry under "STAFFORDSHIRE".

MUSIC MATTERS

Birmingham - 363, Hagley Road, Edgbaston, B17 8DL. Tel: 0121 429 2811.

Solihull - 93-95, Hobs Moat Road, B92 8JL. Tel: 0121 342 0254.

Stourbridge - 9, Market Street D48 1AB. Tel: 01384 444184.

Sutton Coldfield - 10, Boldmere Road, B73 5TD. Tel: 0121 354 2311. Arcam, Alchemist, Apollo, Audioquest, Audio Research, B&W, Cable Talk, Castle, Celestion, Chord, Copland, Cyrus, Denon, DPA, JBL, Kef, Krell, Marantz, Martin Logan, Meridian, Musical Fidelity, Panasonic, Pioneer, REL, Rotel, Ruark, SME, Sennheiser, Sonus Faber, Tag McLaren, Teac, Theta, Yamaha etc. Classical CD's available at Birmingham only. Demonstration rooms, service and installation. BADA member. VISA / MASTERCARD / AMEX / SWITCH. Open-10-5.30 Tuesday to Saturday. Late night Thursday till 7.00 (not Stourbridge).

SOUND ACADEMY For the Midlands. The Parade, Sutton Coldfield, Tel. 0121 321 2445 & High Street, Bloxwich, Nr Walsall, (sharing the ASDA shopping centre) Tel 01922 493499. Hosts 4 private studios plus a Home Theatre Cinema with Tube & LCD Projectors. The best in hi-fi from Naim, Arcam, Audioblab, Chord, Meridian, Monitor Audio and many more. So...if you've taken time to read this, please let us make you welcome. Phone 0121 321 2445 for Sutton or 01922 493499 for Walsall. Call in and to browse our exciting display of hi-fi and home cinema equipment. Mail order available. Interest free credit S.T. Status. Open 6 days, 9am to 5.30pm. Please call for late night. Expert Advice, Cable Dressing and Installation.

WILTSHIRE

SALISBURY HI-FI LTD 15 Catherine Street, Salisbury, Wiltshire SP1 2DF. Tel (01722) 322169/330841. Arcam, B&W, Celestion, Denon, KEF, Marantz, Meridian, Mission, Musical Fidelity, NAD,

Opera, Pioneer, Ruark, Tannoy, Yamaha, 2 Dem rooms. Friendly, relaxed atmosphere. Professional advice. Home dem available. Service department. Free installation. Home trial facilities. Access. Visa, Amex. Interest free credit. Instant credit. Open Mon-Sat 9-5.30.

THE RIGHT NOTE - See under BATH & BRISTOL heading.

YORKSHIRE (NORTH)

SOUND ORGANISATION YORK. 2 Gillygate, York YO31 7EQ. Tel (01904) 627108. Carefully chosen Hi-Fi and AV equipment includes: Arcam, B&W, Nautilus, Denon, Linn, Naim, Rega, Rotel, Stax etc. 3 dem rooms incl. Home Cinema and Linn connect. Service Department. Home installations. Instant Credit and major credit cards. Closed Mondays. Phone for chat and more details. www.soundorg.co.uk

YORKSHIRE (EAST)

ZEN AUDIO 35 George Street, Hull Tel. 01482 587397. "Comfortable listening rooms; Home dems; Personal, friendly service; Free installations. Agencies include: Arcam, Audioblab, Atacama, Audio Innovations, Audio Note, Audion, Alchemist, B&W, Cable Talk, Chord CO, DPA, Densen, Denon, DNM, EAR, Exposure, Fi-Rax, Harbeth, Heybrook, Impulse, KAR, KEF, Michell, Micromega, Monitor Audio, Musical Technology, Myryad, NAD, NAIM, Pioneer, REL, Rehdeko, Rotel, Royd, Ruark, Shearpe Audio, Stands Unique, Sugden, Spendor, Sonic Link, TEAC, TDL, Tube Technology, Vivanco and many others.

YORKSHIRE (SOUTH)

THE HI-FI STUDIOS

Hi-Fi - Home Cinema - Custom Installation
Tel: Doncaster 01302 727274 or 01302 725550.
E-Mail: info@thefiistudios.freeserve.co.uk
Web Site: www.thefiistudios.co.uk
Musical Fidelity, Electrocompaniet, ProAc, PMC, JM Lab, Ruark, Castle, TEAC, Unison Research, Monitor Audio, Impulse, Primare, Harbeth, NAD, Michell Turntables, Nottingham Analogue Studios, Audio Analogue, Living Voice, Densen, Celestion, KEF, Opera, Trichord Research, Nordost, Stands Unique, Ortofon, Project, Goldring, REL, Denon, TAG McLaren, Rotel, Yamaha. Proceed - plus many more. Viewing & Demonstration by appointment in a unique setting. Home trials and installation. Card facilities and 0% available. Please phone for more information. BADA, CEDIA.

YORKSHIRE (WEST)

HUDDERSFIELD HI-FI CENTRE

**Hi-Fi • AV • Widescreen
Plasma • Installation Service**
4 Cross Church St, Huddersfield. 01484 544668. Brands inc: Arcam, B&W, Castle, Cyrus, Denon, KEF, Marantz, Mission, Musical Fidelity, NAD, Project, Sony etc. 3 Dem Rooms, Mon-Sat 9-5.30, Thurs 9-8. Closed Wed.

HUDDERSFIELD HI-FI CENTRE HALIFAX

3-5 King Cross St, Halifax. 01422 366832. Brands inc: Arcam, B&W, Castle, KEF, Marantz, Mission, Musical Fidelity, NAD, PRO-AC, Project, Sugden etc. 2 Dem Rooms, Mon-Sat 9-5.30, Closed Thursday.

WALES

NORTH WALES

ACOUSTICA 17 Hoole Rd, Chester CH2 3NH. Tel 01244 344227. See our main entry under "Cheshire".

ACTON GATE AUDIO 4 Ruabon Road, Wrexham, North Wales, Tel. 01978 364500. See our main ad under Cheshire.

VINYL/RECORD MAIL ORDER

DIVERSE VINYL 10 Charles Street, Newport, NP20 1JU. Tel/Fax: 01633 259661/256261. Email: sales@diverse-music.co.uk Probably the most varied and impressive selection of brand new LPs you'll find anywhere: international new releases, reissues and audiophile products. Also UK distributor of the Disco Anti Stat LP Cleaning Device. Call for a free catalogue, or visit www.diverse-music.co.uk

PRE-OWNED MAIL ORDER

AFFORDABLE AUDIO (NORTHAMPTON) Pre-Owned Hi-Fi Specialists. 168 Wellingborough Road, Northampton, NN1 4DU. Tel/Fax: 01604 231261 or Tel: 01933 273281 Mobile: (0370) 877893. Email: sales@affordable-audio.co.uk Website: www.affordable-audio.co.uk Urgently required: compact disc collections, hi-fi separates, especially Linn products, Naim Audio, Cyrus Electronics, Musical Fidelity, Quad Electronics, almost anything British/American. Cash waiting, part exchange welcome. We also stock lots of audio accessories, compact discs, vinyl, DAT players. All equipment is sold with warranties. All Credit Cards accepted. Please phone anytime for stock update.

MEET-YOUR-MAKER

A reference guide to Britain's manufacturers and distributors

MEET-YOUR-MAKER

AFFORDABLE VALVE COMPANY £600 Valve amplifier. Powerful 40 watts. Powerful bass. See colour photograph in 'Specialist Hi-Fi Dealers' section. Mr Andrew Everard in Gramophone Magazine "delivers a sound that's both smooth and refined...allied to a good degree of clarity and finesse". Free colour literature. Telephone 01634 373 410 anytime. Website: www.affordablevalvecompany.com

ALCHEMIST PRODUCTS Call us and allow us to transform your life with products from an acclaimed range of Amplifiers, CD's and Pre/Power combinations including such models as 'Kraken' and 'Forsetti' right through to our award winning 'The Alchemist' range (Winners 1996 C.O.T.Y. Japan) Unit 1, Furzewood House, Cranbourne Ind Est. Potters Bar, Herts. EN6 3JN. Tel: 01707 664607 (for enquiries) Tel: 01753 889949 (for UK Sales) Fax: 01707 664207 (for enquiries) Fax: 01753 889636 (for UK Sales).

APOLLO The UK based designers and manufacturers of high quality speaker stands and equipment racks have now added to their comprehensive range a modular system ideal for housing audio visual products and CD storage. Please send for our free brochure to Zenith Crown Ltd, Tipton Rd, Dudley, West Midlands. DY14 Tel: 0121 520 5070. Fax: 0121 522 2055. All export trade enquiries welcome.

AUDIOPHILE FURNITURE LTD The Square, Forest Row, East Sussex RH18 5ES Tel: 01342 826262. Fax: 01342 824845. Manufacturers of the patented BASE Vibration Control Platforms and the Modular Audio Support System. These Products are endorsed by Hi-Fi World. Also newly introduced are the Resonance Controlled Hi-Fi Cabinets which are multi level modular design and available in various sizes and wood finishes. Please telephone for more details and a product portfolio.

AUDIO SYNTHESIS Manufacturers of the the outstanding DAX digital to analogue converter, comes DAX-2, a new Hi-End reference converter able to dig deeper into the digital source than ever before! A new addition to the superb PASSION series of all Vishay controllers has just been introduced in the form of PASSION 8, a fully remote controlled uniquely transparent passive preamplifier, the perfect match for DESIRE. By word of mouth our DESIRE power amplifier is rapidly convincing listeners, whether passive or active! New for 1997 is TRANSCEND a state of art CD transport with AES, coaxial, AT&T glass and Toslink outputs. Audio Synthesis, PO BOX 50, Nottingham, NG9 1DZ. Tel: (+44) (0)115 922 4138. Fax: (+44) (0)115 922 9701.

BORDER PATROL 63 Berriedale Avenue Hove BN3 4JD Tel/Fax 01273 276716. Manufacturers of Power Supply Units for valve amplifiers, Single-Ended Power Amplifiers and high quality Transformers. The Border Patrol PSU: valve-rectified choke input filter power supply units which dramatically improves the sound of valve amplifiers; models available to suit Audionote, Audio Innovations, Audion, Art Audio, Cary, Unison Research, World Audio Designs. The Border Patrol 300B SE single-ended valve amplifier featuring interstage driver transformers and valve rectified choke input filter power supplies. Border Patrol transformers: high quality output (PP and SE), interstage and pre-amp output transformers and high value Inductors.

CREEK AUDIO LTD 2 Bellevue Road, Friern Barnet, London N11 3ER. Tel: 020 8361 4133. Fax: 020 8361 4136. E-mail: info@creekaudio.co.uk Internet: www.creekaudio.co.uk - Creek Audio build stylish Hi-Fi products in the UK, combining state of the art electronic design, with full bodied, accurate and musically rewarding sound. Our standard size products come in two award-winning ranges, the entry level 43 series and higher priced S3 series. These include: CD43 Mk2 - CD player with 24 bit resolution DAC, T43 AM/FM Tuner, Integrated Amps - 5350, 5350SE and 4330 Mk2 (described by Stereophile Magazine as the best amp under \$1000). Our A43 Mk2 and A53 Power Amps range from 50 to 250 Watts and both P43 and P53 Pre-Amps offer passive and active operation with remote control. In addition we have an award winning OBH range of small products: OBH-8/BSE MM and OBH-9 MC Phono Pre-Amplifiers, OBH-11 and 11 SE Headphone Amplifiers, OBH-10 and 12 Remote Control Passive Pre-Amps and OBH-14 - 24 bit DAC. See our home page for further details or call us for leaflets.

DBS AUDIO, PO BOX 91, Bury St Edmunds, Suffolk, IP32 7JU. Phone: 01284 723933 Fax: 01284 723933. Suppliers of Electro-Acoustic measuring equipment and CAD software to the audio industry. NEW: Clio win and Clio win Lite, the latest Windows versions of the Globally-established Clio Electro-Acoustic measuring system, used for loudspeaker design, Quality Control and electronics testing by many major audio companies. Clio win is the full (lab) system and Clio win Lite a lower-cost version for smaller companies and serious hobbyists. Both use the same purpose-built Clio HR200 ISA card, with its in-built mic, preamp and phantom powering. The matching Mic 01 (or Mic Lite) plugs straight in to make a com-

plete system. Both versions offer the same high accuracy and ease of use: Clio win Lite simply has fewer functions. Common features include MLS testing (to eliminate sound reflections), sine and third-octave analysis, impedance, Thiele Small Parameters, LC meter, software and manual on CD ROM -- plus much more. Measurements may be exported to our Netcalc software for accurate and easy crossover design. Also available: Boxcalc and Boxdraw bass optimisation packages and Outline speaker measuring turntable. Write or E mail and we will send fuller information and prices. Also, visit Audiomatica's new Website at: www.audiomatica.com

EMINENT AUDIO Distributor of Croft Valve Amplification Tel 01902 656517. Fax: 0121 681 8772 Mobile 0956 921740 U.K. Stockists are: Classique Sounds (Leicester) GT Audio (London NW) Nottingham Analogue. Punst Audio. The Cartridge Man (Len Gregory - Croydon), call for overseas distributors.

EPOS ACOUSTICS 2 Bellevue Road, Friern Barnet, London N11 3ER. Tel: 020 8631 8864. Fax: 020 83614136. Email: info@epos-acoustics.com Website: www.epos-acoustics.com. Innovative design and superior sound distinguish EPOS speakers from other brands in a similar price category. Adhering to the EPOS tradition of musicality and communication, the new M12 follows closely the style of the successful ES12, and was awarded five gold stars in the March 2001 edition of *What Hi-Fi!* For more information about the M12 or the new M15 please see our home page or call us for leaflets.

FALCON ACOUSTICS LTD Tabor House, Norwich Road, Mulbarton, Norwich, Norfolk, NR14 8JT. Tel: (01508) 578272. U.K. distributors of FOCAL driver units and SOLEN (Chateauroux) polypropylene capacitors and the largest inductor manufacturer in the U.K. Comprehensive range of DIY Speaker Parts and Kits, Sub-Bass and Electronic Filters. "Everything but the wood" Enquiries should be accompanied by a 44p stamped addressed envelope.

IAN EDWARDS The Old Chapel, 282 Skipton Road, Harrogate, Yorks. Tel: 01423 500442. Somebody Somewhere must make better storage units for CDs, Music, LPs, HiFi, Books, etc. than Ian Edwards. BUT until he appears, why not send for the brochure showing a selection of HAND MADE units. To do this please send 3 x 2nd class stamps.

JEM DISTRIBUTION (FI RAX) Springfield Mills, Spa Street, Ossett, Wakefield, WFS OHW. Tel: 01924 277626. Fax: 01924 270759. Fi-Rax offers a new dimension in audio visual racking. High quality aluminium construction. Finishes available to your choice. Fully adjustable 6mm glass shelving, sound insulation on shelffice. Custom created to suit your system. Free delivery throughout the UK. For further information or a free brochure contact JEM Distribution.

LANGREX SUPPLIES LTD 1 Mayo Road, Croydon, Surrey, CR0 2QP. Tel: 020 8684 1166. Fax: 020 8684 3056. One of the largest distributors of electronic valves, tubes and semi-conductors in the UK and USA manufacturers stock. We specialise in obsolete types including original UK and USA made audio valves. Telephone or fax for an immediate quotation.

MICROMEGA distributed by Surrey Sounds, 32-33 Enterprise House, Terrace Road, Walton On Thames, Middlesex. KT12 2SD. Tel: 01932 254297. Fax: 01932 230174. For dealer and product info on the fantastic Minium compact system, up to the Solo and Data and Dialog Also the new 24bit audio and video DVD player and the outstanding new premium range of CD players. All Micromega CD players play CDs like Vinyl!

NORTON TECHNOLOGIES LTD Manufacturers of the acclaimed AirPower LP12 Power Supply. 14 Rothsday Avenue, Chelmsford CM2 9BU. (01245) 283125

NOTTINGHAM ANALOGUE STUDIO Tel: 01773 762947. Design and manufacture of quality analogue audio. We're in the business because we realise how important music is. Our turntable arms and cartridges sell the world over. Our Main UK Dealers: Radlett Audio. Tel: 01727 85577. The Audio Consultants. Tel: 020 7380 0866. Wairus Systems: Tel: 020 7724 7224.

PLATFORM 7 High density marble ISOLATION PLATFORMS for all makes of equipment RACKS/STANDS. An elegant way to UPGRADE improves clarity; better BASS control. 3 Abbotts Drive, North Wembley, Middlesex HA0 3SB. Tel: 020 8904 2646. Also NEALGAR DISTRIBUTION Tel/Fax 01296 24756.

PMC/BRYSTON Emmy award winning manufacturers of the highest quality loudspeakers and amplification. Industry standard in Mastering, Film Scoring, Broadcast and Post Productions. (S.I & Stereo) PMC Products: Compacts, Floorstanders, and Large passive & active monitors. Prices range from £500 to £32,0000. Finished in a large selection of exquisite real wood veneers. All PMC loudspeakers are available in horizontal mirrored pairs, centre channels and complementary subs for 5.1 surround systems.

Bryston's balanced range of products include R/C Preamps, Integrated, Amp modules for all the PMC range, Mono, Stereo 150W to 800W per ch, 3 Ch, 4 ch and 5 channel THX amplifiers, Surround processors, all with distortion figures and build quality to die for. Every product is available in silver or black backed by a 20 year warranty. PMC Ltd 43-45 Crawley Green Road, Luton, LU2 0AA. Tel: 08704 441044 Fax: 08704 441045 Email: sales@promonitor.co.uk Web: www.pmc-speakers.com

REL ACOUSTICS North Road, Bridgend Ind Est, Bridgend, Mid Glamorgan, CF31 3TP UK. Tel: 01656 768 777, international +44 656 768 777. Fax: 01656 766 093. international: +44 656 766 093. Email: contact@rel.net Web: <http://rel.net> The UK's only specialist sub-bass speaker manufacturer. "The only one that works". Get your dealer to give you a home demo and find out what the fuss is all about.

RDE TANDBERG HI-FI SERVICES Holly Tree House, The Green, Full Sutton, YORK YO4 1HW. Tel: 01759 372795. The service, overhaul and reconditioning of all Tandberg hi-fi products regardless of age.

SONIC LINK The Derwent Business Centre, Clarke Street, Derby DE1 2BU. Tel: 01332 361390. Fax: 01332 200698. "Makes the World's Finest Hi-Fi Cable From the Highest Quality Materials". SonicLink Black Rhodium interconnect uses Rhodium plated wire. Vermilion uses pure Titanium wire. S-Gold mains cable improves the picture quality in TVs, computer monitors and home cinema as well as sound in hi-fi systems. Best selling products include Red, Silver Pink and Violet interconnects. AST75x2 AST200x2 and S130x2 Bwire loudspeakers cables and Green digital 75 ohm interconnect.

SOUND BYTES 72 Novar Drive, Hyndland, Glasgow, G12 9TZ. Tel: 0141 339 7595. Fax: 0141 339 7592. e-mail bytes@colloquium.co.uk We specialise only in mass loading material. After hours exhaustively testing SOUND BYTES with various types of speakers, we know it works and so do you - we have never had a single complaint. Call us for advise on how much to add to your equipment for the best performance and the location of your nearest dealer.

SOUND IMAGE UK LTD 52 Milton Road, London SW14 8JL. Tel: 020 -8255-6868. Importers and distributors of the finest audio equipment, featuring the stunning Boulder 2,000 series and the complete range from Norwegian manufacturer Electrocompaniet.

J E SUGDEN & CO LTD Valley Works, Station Lane, Heckmondwike, West Yorkshire, WF16 0NF. Tel: 01924 404088. Email jesugden@compuserve.com. Superb amplifiers and compact disc players from the original class A Company. Our unique wide-bandwidth Masterclass series sets new standards in sound reproduction and can be upgraded to 180 Watt balanced monoblocks. Prices start from £549.00 for the incredible Audition-T and £649 for the legendary A21a. Contact us now for Brochures, reviews and purchase details. British owned - British built.

TALK ELECTRONICS Unit 12, Farnborough Business Centre, Eelmoor Road, Farnborough, Hampshire, GU14 7XA. Tel: 01252 378383. Please ring for details

TAG McLAREN AUDIO - The Summit, 11 Latham Road, Huntingdon, Cambs, PE18 6ZU. Tel: +44 (0) 1480 415600 Fax +44 (0) 1480 52159. Combining science and technology with distinct style. TAG McLaren Audio's complete range of audio and audio-visual products are designed to bring maximum pleasure to the discerning listener. To find out more visit our website at www.tagmclarenaudio.com, email us on HelpDesk@tagmclarenaudio.com or contact our helpdesk on freephone 0800 783 8007.

TARGET AUDIO PRODUCTS PLC Britannia House, Leagrave Road, Luton, LU3 1RJ. The Audio equipment, rack and speaker stand specialist. For information on our products please telephone or write.

TECH-LINK distributes some of the best performing hi-fi and a/v accessories currently available in the UK. These include Puresonic, best known for its range of high performance interconnects and connectors, and cable adapters for a wide variety of hi-fi and a/v applications in its range. Tech-Link's own brand Switch Boxes are the perfect solution to multiple applications - for example, its highly acclaimed TAS-1 is a very practical and inexpensive way of switching your speakers between hi-fi and home cinema systems; and Shark - a range of very exclusive high quality cables, interconnects and connectors. For more information contact: Tech-link at Units 1/2, 76a Farley Road, London, SE25 6NX. Tel: 020 8771 8388, Fax: 020 8771 1840.

To advertise in Meet Your Maker please call Ewan Hawkes on 020 7624 9022

computer audio world

advertising@computeraudio.co.uk

editorial@computeraudio.co.uk

news@computeraudio.co.uk

Asian Tigers?

David Price pits two MP3 players designed and built in the Far East against each other, Frontier Labs' NEX II and Ziplabs Zappee.

FRONTIER LABS NEX II \$110

From North Point, Hong Kong comes Frontier Labs new NEX II. Being one of the first to review the original model, looking at this one is a sober reminder how the market for digital audio portables (as they're now called) has developed since 1999. To be blunt, the NEX I was an aesthetic and ergonomic disaster. Still very much wrapped up in the exigencies of 1980 street style, it was bluff, brick-like and had as much sex appeal as a mains plug. Ironically, despite being way off the pace in this respect, it actually worked superbly - it had 64MB of memory, giving up to 2 hours playing time - and better still sounded great.

Compared to old NEX, new

NEX seems light years ahead. Considerably smaller and lighter, it comes in a new hue (the almost compulsory silver - this is getting boring) and boasts a radically redesigned control system. Even by the standards of its latest rivals, its 90x60x20mm vital statistics are good, as is the 65g weight. It uses two AA batteries to give an extremely impressive 15 hours-plus playing time.

EASY DOES IT

By pushing its 'jog lever' you can access all the operation controls (pause play, fast-forward, fast-reverse, track search) - it sounds complex but

works very intuitively. Volume control is courtesy of large + and - buttons on the right side, and there's a stop/power off button to the left. There's the usual five position EQ too, but requiring two pushes of the volume buttons, it's a tad fiddly for people on the move. Best of all

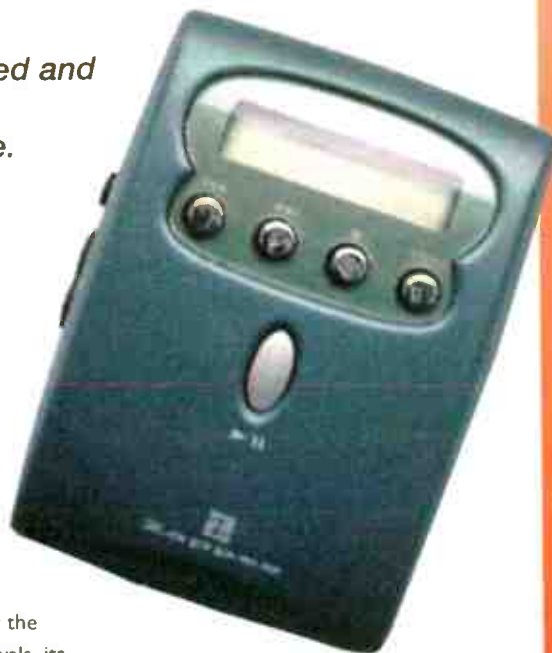

◀ though is the neon blue backlit LC display, which has a fine (112 x 64) pitch and shows comprehensive information.

Another clever feature is the fact that PCs recognise it as an external drive, so you can copy files to and from it at will. This means the NEX II doesn't just function as an MP3 player, but can also be used to store and back-up any other computer data, as well as transfer information from PC to PC. It comes with a 32MB CompactFlash card, which is a shame considering its predecessor had twice as much, but memory prices are tumbling so this is no longer so important. It also supports IBM's Microdrives, which hold between 340MB and 1GB of data (giving plenty of music), although these are expensive and fussy. More useful is the fact that the card slot will in future accommodate Iomega's cheap PocketZip disks, which hold up to 40MB each. The new NEX is also Transfer2Device compatible, so you can copy any song available for download on MP3.com directly into the NEX II from your My.MP3 account.

Other features? Usefully it's 320kbps MP3 and VBR compatible, and WMA is also supported, although sadly no AAC as yet. It uses a quick, efficient USB connection system but no Mac drivers are provided so it's PC only right now. It comes bundled with Windows Media Player, which is excellent although a little too close for comfort to Microsoft for some tastes. NEX II also comes with a foam-padded carrying case, with openings for both the (dire) in-ear headphones and jog lever, plus a strong belt clip and three spare NEXkins, which are a development of the removable plastic inserts the original model had, and can be changed to suit your taste.

LUSH SOUNDS

The new NEX sounds much like the old one, which is no bad thing. Essentially it has a warm and sumptuous sound - not a million miles from Philips' Rush SA126 in fact - which makes MP3s of all qualities and bitrates perfectly listenable. Crank up your ripper to 320kbps and use a Fraunhofer codec, and Bob's your Chinese Uncle - the sound becomes sweet, clean and very

powerful with fine imaging and a good, musical character. There are far more expensive players which impress less. A fine design then, and incredibly cheap if you buy it online (via secure server) from www.frontierlabs.com.

ZIPLABS ZAPPEE \$129

From Singapore comes the curiously named Ziplate Zappee. Very much a third generation machine, it's a bit smaller than SONICblue's new Rio and also boasts a built-in digital FM tuner. The test unit came with a 16MB MultiMedia Card for \$129, but can be bought without any memory for just \$99, or with 32MB or 64MB for \$179 or \$239 respectively.

It's a pretty little thing and weighing just 74g doesn't give much away to the NEX II, especially when you remember it's got an FM tuner built in. It uses 2 AAA batteries which last for around 12 hours. Ergonomically pretty solid, the controls are easy to use on the move, excepting the MP3/FM tuner button which is annoyingly obscured by the headphone jack. The small, 18 character alphanumeric LC display is crammed with information, including file name, track number, bitrate and elapsed time. It's a shame it's not backlit though. As always there are preset EQ settings (jazz, pop, rock, classical) and a useful user-defined bass and treble facility which the Zappee will remember when you shut it down.

GETTING CONNECTED

The Zappee isn't as easy to connect as the NEX II, thanks to its pain-in-the-butt parallel port connector. This works okay, but after the 'hot pluggable' convenience of USB is a real chore. Nor is it the fastest way of transferring data ever devised. The package includes in-ear headphones (get yourself some Sonys or Sennheisers!), the aforesaid parallel-port multimedia card adapter, and Ziplate's own MP3 Creator Software. This offers a CD player, Ripper, MP3 Player, MP3 Encoder, MP3 Decoder, ID3 Tag Editor, Playlist builder and the parallel port interface program etc. It isn't bad, but it's hardly Windows Media Player 7.



After you've transferred your music from your PC to the MMC using the supplied software, you simply plug in the dinky little card and go. You'll be greeted by a surprisingly clean and clear sound that simply doesn't reflect the bargain basement price tag of the Zappee. Treble is crisp, although a touch more pointed than the NEX II, and there's plenty of air and space at 320kbps (using the aforementioned Fraunhofer Professional codec). Midband is detailed although less three dimensional than the Hong Kong rival, and there's a less organic, more mechanical feel to proceedings. Still not bad though - I've heard a lot worse. Bass is light and tight and dry, good for classical but jazz and dance prefer fuller bottom ends such as that of the NEX. It's a good performance at its (low, low) price, but unless the FM tuner is important, I'd go for the Frontier Labs on the grounds of sound quality and better connectivity. In the pan-Asian MP3 wars, today at least, Hong Kong has the better of Singapore. If you want to find out more, click on: ■ ▲

www.zappee.com

World Verdict

FRONTIER LABS NEX II
Stunning value, nice ergonomics, USB link and great sound make it a true bargain.

World Verdict

ZIPLABS ZAPPEE
Great value thanks to its built in FM tuner, but lack of USB and mediocre ergonomics make it a little off the pace in other respects.



just compare OUR prices for the BEST deals.



A selection of our ever changing offers for sale
 (All fully guaranteed)

Equivalent Sale
 New Price Price

A selection of our ever changing offers for sale
 (all fully guaranteed)

Equivalent Sale
 New Price Price

AMPLIFIERS

Audionote OTO SE (Phono) (2 x 10 Watts Single-Ended Triode Valve Int. Amp. c/w M.M. Phono-Stage) MINT / As New / Manuals	1500.00	795.00
Sunfire (Bob Carver) Classic Pre. (Valve) / Phono-Stage c/w Load-Variant Power-Amp. (2 x 300 Watts into 8 Ohms / 2 x 600 Watts into 4 Ohms Etc.) (See "Star Product") VGC / Boxed / Manuals	6400.00	2995.00
Croft Epoch Elite Valve Pre-Amp. (M.M. Phono-Stage) MINT / As New	995.00	
Croft "C-Core" Valve Power-Amp. MINT / As New	1200.00	
Thermionic OutLaw Transformerless Int. Valve - Amp. (2 x 18 Watts / Push-Pull) MINT / As New	1200.00	795.00
Audio Innovations Series 500 (2 x 25 Watts Class A Valve Int. / Phono-Stage) VGC	1000.00	
Classé CAP-80 Remote Int. (2 x 80 Watts / Balanced-Inputs Etc.) MINT / Manual	1300.00	749.95
A.V.I. S-2000P Pre-Amp. / 52000M Mono-Blocs. (2 x 150 Watts / Remote Control) MINT / Manuals	2350.00	1195.00
Musical Fidelity Pre-3A / 2 x P-140 Power-Amps. (120 Watts Bi-Amp System) MINT / Boxed	1100.00	595.00
John Shearman Phase 6 Pre-Amp. / Phono-Stage MINT / Boxed / Manuals	1100.00	449.95
John Shearman Phase 3 (2 x 50 Watts Power-Amp.) MINT / Boxed / Manuals	620.00	329.95
John Shearman Phase 3 (2 x 50 Watts Power-Amp.) (Another One) MINT / Boxed / Manuals	620.00	329.95
Micromega Tempo 1 Int. (2 x 50 Watts) MINT / Manuals	700.00	369.95
Micromega Tempo 1 Int. (2 x 50 Watts) (Another One) MINT / Manuals	700.00	369.95
(Buy The Two And Bi-Amp. For £700.00) Saving £39.00		
Audiolab 8000A Int. Amp. (DIN Version) VGC	500.00	179.95
Linn Intek Int. / Phono-Stage MINT / Boxed / Manuals	500.00	
Exposure XII Pre. / XII Power Supply MINT / Boxed	1300.00	595.00
Exposure VFSU / VII Pre. / VII Super Power (2 x 63 Watts 3-Box Amp With M.M./M.C. Phono-Stage) VGC	1100.00	100.00
Rotel RA 840BX4 (2 x 50 Watts / M.M. / M.C. Phono-Stage) VGC / Boxed / Manual	270.00	139.95
Crimson Elektrik Series 500 Pre-Amp. (Battery-Powered / P.M. Phono-Stage) MINT	250.00	129.95
Quad 34 Pre. (Buff) / DIN / (Discrete C.D. Input / M.M. / M.C. Phono-Boards) MINT / Boxed / Manuals	400.00	229.95
Quad 405 I Power Amp. Fair C.	500.00	179.95
Quad 77 Pre / Remote-Station / 77 Power-Amp. (Carbon Finish) MINT / Manuals	1600.00	849.95
Kenwood KA-5040R Remote Int. MINT	350.00	
Sugden A-48 (2 x 40 Watts Class A/B) VGC	N / A	
Denon PMA-250 SE MINT	200.00	
Proton 520 Int. Amp. With M.M. / M.C. Phono-Stage VGC	200.00	
Cambridge A-1 / II Int. Amp. MINT / Boxed / Manual	120.00	79.95

PRODUCT OF THE MONTH

Sunfire Classic Pre-Amp. / Load Invariant Power-Amplifier (By Bob Carver) (Valve Pre-Amp. With 2 x 300 Watts Solid-State Power Amplifier) In VGC With Boxes.
Last Retail Price £6,400.00 affordable-audio price £2995.00
Priced To Sell @ £2295.00

RECORDING EQUIPMENT

Denon DR-M34 HR (3-Head) (HX-Pro / Variable Bias Etc.) VGC	300.00	
Revox B-77 Mic. II High-Speed / 1/2 Track Reel to Reel (7 1/2 / 15 i.p.s. / Vari-Speed) VGC / NABs /	549.95	
Tape (Recent Service)	2500.00	
Nakamichi DR-3 (2-Heads) MINT	450.00	229.95
Nakamichi BX-1 (2-Heads) VGC / Manual	N/A	159.95
Nakamichi BX-150E (2-Heads / Dolby B / C) VGC	N/A	159.95
Nakamichi BX-155E (2-Heads / Dolby B / C) VGC / Manuals	N/A	149.95
Rotel RD-865 (2-Motor / HX-Pro) MINT / Boxed	230.00	109.95
Cambridge CT-50 (2.0-Motor / HX-Pro) VGC / Boxed / Manual	130.00	
Yamaha RX-300 Remote / HX-Pro Etc.) VGC / Boxed / Manual	200.00	89.95
Aiwa AD-WX909K Twin (3-Heads / Auto Reverse / HX-Pro Etc.) G/C	N / A	69.95
Sony TCW-R690 Twin Cassette-Deck (Auto-Reverse / HX-Pro Etc.) VGC	200.00	69.95

DIGITAL

Meridian 200 Transport / 263 DAC (2-Box Player) MINT / As New / Boxed / Manuals	1800.00	
Meridian 207 C.D. Player / Pre-Amp. c/w 209 Remote Control Station VGC / Manuals	1500.00	449.95
Classé CDP-3 HiDCD / Remote / Balanced-Out. MINT / Boxed / Manuals	1400.00	725.00
Sugden Steamfrost PDA-10 DAC (Arcam Chips) VGC	1500.00	550.00
Musical Fidelity X-24K 24-Bit Digital-to-Analogue Converter MINT	300.00	
Arcam Alpha 9 (HiDCD / Remote Etc.) MINT / As New	900.00	549.95
Arcam Alpha 5 Remote Player VGC / Boxed / Manuals	450.00	
Arcam Black Box 50 D.A.C. (Sync-Lock) MINT / Boxed	500.00	229.95
Technics SLP-1000 Remote Etc. MINT / Boxed / Manuals	800.00	199.95
NAD C-520 (Remote Etc.) MINT	200.00	129.95
Marantz CD-17 Remote MINT / Boxed	800.00	495.00
Marantz CD-67 SE Remote / Digital-Out. Etc. MINT / As New / Boxed / Manual	350.00	189.95
Marantz CD-52 II Remote VGC / Manual	400.00	119.95
Marantz CD-52 SE Remote VGC	450.00	99.95
Marantz CD-55 II SE Remote VGC	250.00	99.95
Marantz CD-73 Frontloader (Gold) VGC	N / A	69.95
Mission DAD-5 / DAC-5 (Two-Box Player) MINT	600.00	219.95
Mission PCM-7000 Remote Etc. VGC	600.00	119.95
Sony CDP-C245 (5-Disc Multi-Player) MINT	230.00	129.95
Sony CDP-XE330 Remote MINT / Boxed / Manual	120.00	
Denon DCD-620 Remote 18-Bit C.D. Player VGC	200.00	69.95

SYSTEMS

Bang & Olufsen Beomaster 5000. Comprising: C.D. Player / Amplifier / Tuner / Loudspeakers / Remote Control Station. VGC / Manuals 1200.00 + Cash Price £350.00

affordable-audio will happily "build" Systems to your individual requirements, and if you purchase three or more components, i.e. (C.D. Player, Amplifier, & Loudspeakers), we will give you a 15% Discount on the total price! Please enquire for further details.

TUNERS

Quad FM-4 (Buff) VGC / Manuals	500.00 +	
Sugden R-21 FM Tuner VGC N / A		
Arcam Alpha 3 (Digital-Display) MINT	159.00	
Denon 701 (2-Way Reflex / 100 Watts) MINT	150.00	
Rotel RT-820L 3-Band Tuner VGC	N/A	59.95

TURNABLES

Voyd (The Voyd) c/w Helios Orion Silver - Wired Tonearm / Koetsu Black M.C. (Standard PSU) VGC / Manuals	2800.00	1295.00
Notes Analogue Spacedek / Spacemarm / Stanton 681EE M.M. Cartridge MINT / As New	1200.00 +	
Linn Axis / Basik Plus / K-9 MINT	600.00 +	299.95
Dunlop Systemdek / Syrinx PU-2 / Nagaoka MP-11 Boron (Original And The Best Systemdek) VGC	1000.00 +	249.95
Dunlop Systemdek IX 900 / Rega RB-300 / Ortofon 510 Cartridge VGC / Scratched Lid	5000.00 +	249.95
Thorens TD-160B / II / SME 3009II (Fixed) / Linn K-5 Cartridge VGC / Manual	400.00	149.95
Garrard 401 Transcription Motor-Unit VGC / Manuals / Templates	N / A	
Nottingham Analogue Mentor Tonearm (Linn Fix Option) MINT	800.00	495.00
SME 3009 II Fixed-Head / FD-200 Fluid Damper VGC	340.00	109.95
Acos Lustre Tonearm (Detachable) VGC / Manuals	400.00 +	229.95
Michell Iso Phono-Stage (Set For Low-Output M.C.) MINT	45.00	30.00
Project "The Phono Box" (M.M. / M.C.) MINT	300.00	
Shure V-15 Type IV MINT / Boxed / Manuals	29.95	
Monacor SPR (M.M. Phono-Stage) NEW / Excellent Value N / A	25.00	
BiB Groov-Start (Gum / Pad Etc.) MINT / Boxed		

(Lots of Vinyl in Stock and always WANTED)

LOUDSPEAKERS

Celestion "Art" 5000 Ribbon Hybrids / K-Stands (American Walnut) MINT / Boxed / Manuals	1500.00	495.00
Audionote ANJD 94db / Bi-Wire Etc. (Black-Ash) MINT / Boxed / Manuals	930.00	599.95
Audionote ANJ Stands (For The Above) MINT	300.00	149.95
B&W 805 Matrix VGC / Boxed / Manuals	1000.00	595.00
Pro-Ac Tablette 2000 Signature (Target R-I Stands Available) MINT / Boxed / Manuals	900.00	499.95
Naim SBL Double-De-Coupled LS. VGC / Boxed	1800.00	895.00
Castle Sevm 2 (Carbon Drivers Etc.) MINT / As New Boxed / Manuals	600.00	
Mission 752 Freedom (Hi-Fi Choice "Best Buy") MINT / As New Boxed / Manuals	600.00	399.95
Mission 701 (2-Way Reflex / 100 Watts) MINT / Boxed	160.00	89.95
Epos ES-14 Bi-Wire / Linn Kis-Stone Stands MINT	750.00	
Chario Syntar 100 / Stands MINT / Boxed	500.00	229.95
Ruark Epilogie Minis / Bi-Wire MINT / Manuals	325.00	189.95
Harbeth HL-5 2-Way Monitors VGC / Boxed	1200.00 +	399.95
Spendor 2020 MINT / Boxed	400.00	179.95
Kef 105 / II Monitors VGC / Manuals	2000.00 +	429.95
Kef Reference 101 / II Uni-Q Etc. MINT / Boxed / Manuals	300.00 +	139.95
Heybrook HB-2R / Stands (Black-Ash) VGC / Manual	160.00	89.95
Etax Liberty 3 Plus (Bi-Wire Etc.) MINT	N / A	89.95
Calef Domestic Monitor (2-Way LS / Stands) Fair C.	N / A	129.95
Linn Helix / Stands (Bi-Wire) GC / Some Marks	N / A	
Mordaunt Short MS-3.10 Minis / Stands GC / No Grille Cloths	180.00	
Lots of Loudspeaker Cables in Stock, both New & Used.		

MISCELLANEOUS

Sony DVP-5725D Remote DVD Player (Region Two) MINT / Boxed / Manuals Etc.	500.00	229.95
Yamaha DVD-5700 Remote DVD Player (Region Two) MINT / Boxed / Manual	600.00	229.95
(DVD's In Stock And Always Wanted)		
Cambridge Audio V-500 Dolby-Digital Processor With Remote VGC	200.00	69.95
Bell Acrylic (5-Shelf Audio Stand) Alternative Colours Of Acrylic Available To Order		
Expandable Spiked Equipment Stand New-Line Just In	329.95	
Foundation-15 (Lead-Shot Filled) VGC	130.00	69.95
Atacama SE-20 Spiked-Stands (Lead-Shot Filled) MINT	70.00	45.00
Target R-1 Super-Heavies (Lead-Shot Filled) (For Tablettets Etc.) MINT / Boxed	300.00	189.95
Target HJ-18 "Heavy" Spiked LS. Stands VGC	100.00	49.95
Target 18" Column Stands VGC	60.00	34.95
Target 24" Spiked Stands (Electric Orange) MINT	90.00	
Stands For LS-35a, Kans or Pro-Ac Tablettets Etc. (Homemade) GC	N / A	15.00
Monacor SPS-35 Spike Kit (Gold or Anodised Black Finish) Loudspeaker Spikes NEW 9.95 (Per 4)	7.95 (Per 4)	
Monacor SPS-45 Spike Kit (Small) Loudspeaker Spikes NEW		
Monacor SPS-65 Spike Kit (Large) Loudspeaker Spikes NEW 9.95 (Per 4)		
Roni LSS 2 (2-Way Speaker Swtch-Box)	NEW	18.95
Vivanco PHC (Optical to Co-Axial Converter) MINT / As New	30.00	15.00
Roni 4 m.m Banana Plugs (Gold Plated) (Screw-Type, No Soldering) NEW 6.95 Per Four		
Roni Optical Line Cables (C.D. / Minidisc to D.A.C. Etc.) NEW	10.00	
Scart to Scart 21-Pin / Gold-Plated High-Grade Scart Cables Screened OFC / 1.5 Metres	NEW Only	10.95
Linn Incon MINT	30.00	18.00
Exposure Incon VGC	25.00	15.00
Cable Talk Advanced 3 Incon (1.0M) (New)	NEW	34.95
Cable Talk Monitor 3 Incon (1.0 M) MINT	60.00	30.00
XLO/VDO Digital Incon. 4 Metres / MINT / Boxed	70.00	
Monacor 75 Ohm. Digital Incon. NEW	N/A	8.95
Nexera Gold 5-Pin DIN To 4 Phono NEW	N/A	9.95
Monacor SPS-20 Anodised Adjustable Polished Cone Equipment Supports NEW (Superb Spike System at a very good price) 1995 Set of 4 (Black Anodised Or Gold Finish) dishwasher CD Radial Cleaner VGC / Boxed N / A	8.00	
Monacor Power Concept Incons (0.8M. / 1.5M / 5.0M) Excellent Value Interconnects NEW Only 7.95 0.8M. 10.95 1.5M. or 14.95 5.0M. (Blue And Black)		
affordable-audio Bi-Wire LS. Cable (In Brown or White) NEW Only 3.50 Metre		
79-Strand LS. Cable (Black-Round-Section or White-Flat-Section) NEW Only 1.25 Metre		
Allsop Carbonoptic Record Brush VGC N/A	5.00	
Monacor DC-100 Carbon-Fibre Brush NEW	6.95 (Essential)	
Various Plugs (R.C.A. / DIN / Cannon Etc.) Various NEW / S/H P.O.A.		

PLEASE VISIT OUR WEB-SITE (UPDATED DAILY)
E-MAIL: Sales@affordable-audio.CO.UK
WWW.affordable-audio.CO.UK

*** GOOD HiFi SEPARATES WANTED ***
 Phone anytime with your wants, stock changing daily. All equipment is sold with warranties.
 Don't forget we can offer mail order.
 All major credit cards accepted.
 We welcome part-exchange on any of the above.
 Affordable Audio is always keen to buy, (or part-exchange) Good quality Hi-Fi separates in good condition. Especially top British manufacturers products!



We can also sell your equipment for you on a commission basis. (Lowest rates/best return) (Please phone Paul for details!)

THE CUTT

Audio editing software has never been better, and there's more to choose from than ever. David Price tries out two of the best, Syntrillium's Cool Edit 2000 and Steinberg's Cubasis VST.

SYNTRILLIUM COOL EDIT 2000

This is a cut-down version of the awesome Cool Edit Pro, which can count no less than the BBC as one of its corporate users. The version you see here - Cool Edit 2000 v1.1 - is the 'consumer' version which costs \$69 to download from the company's website (www.syntrillium.com). Just in case you don't want to splash out in one go, you can always download the cut-down 30 day demo version for free. The main difference between 2000 and Pro is that the latter is a full-blown multichannel recorder offering 64 track recording and mixing, over twenty extra effects, and support for ActiveX/DirectX plug-ins from a number of third-party developers.

Cool Edit 2000 is an audio recorder, which lets you store music from an analogue or digital source (depending on your computer soundcard) on your PC and manipulate it in the digital domain using the program's powerful digital signal processing functions. It works on virtually any Pentium PC but needs at least a PIII 500 with 128MB and decent sized (10+GB) hard drive to give of its best.

The 8.5MB program takes around 20 minutes to download via a standard 56kbps dial-up modem, whereupon it starts up automatically and self installs. The program auto configures itself to use your PC's soundcard as its recording and playback devices, but if you've got several soundcards fitted you can select your desired one by going into the OPTIONS/ SETTINGS menu. Recordings are known as sessions - to start one you click on the red

RECORD button, whereupon you're asked to choose the sampling frequency and word depth for the recording you're about to make. To sync with DV, you'd go for 32 or 48kHz sampling frequencies, with 16bit words. One of CE 2000's great features is its sample rate conversion, which will shift it to any chosen rate up to 192kHz (which is DVD Audio's maximum theoretical limit).

Thus selected, the session duly starts and the levels are displayed on wide bar-graph meters running all the way along the bottom of the screen. The range of these can be changed by right clicking on them (meaning you can read high levels or low levels more easily, should you need to), and there's selectable peak and valley displays. As with Cubasis, if the levels are too high or low, you'll need to go into Windows' own volume control (accessible by clicking on PROGRAMS/ACCESSORIES/ENTERTAINMENT VOLUME CONTROL from the Start bar). When the session's finished, you click the STOP button and CE 2000 displays the recording graphically as a wave ($x=time$, $y=amplitude$), giving visual confirmation that everything has been recorded properly. It's then a good idea to save it by going into the FILE menu, selecting SAVE and specifying a filename and format (in this case .WAV, which is Windows' word for PCM audio).

Once your recording is committed to disc, it's safe to edit it. This is simply a case of locating the start and stop points of the bits in your recording you wish to cut, paste or delete. At this point you use the ZOOM IN and ZOOM OUT buttons to display your edit. Cool Edit's timecode is accurate to one thousandth of one second, making it a



breeze to tie into your video via your digital editing software. If you mess up, you can always hit the UNDO button and try again.

After chopping out the bits you don't want and getting everything into the right sequence, you can apply digital signal processing to parts - or all - of the recording. It's here that things get really clever - the program offers a vast range of 'effects' (some of which are optional) including noise reduction, click and pop elimination, clip restoration, compression, convolution, delay, sustain, echo, chorus, expanding, FFT, distortion, normalisation, phasing, vocoding, sample rate conversion, time stretching, tempo compression, parametric equalisation and DC bias adjustment. The Studio plug-in pack (\$49) adds four-track mixing, punch-in recording and other facilities, while a Pro-EQ plug-in (\$49) pack offers multi-band equalisation and powerful filtering. Audio quality is superb - they really do let you make a silk purse of a sonic sow's ear. Be careful though, because the DSP effects are so powerful and configurable that you can find yourself making swingeing tonal changes. Luckily you can preview the effects, which is where a top quality pair of near field monitor loudspeakers come in handy.

Cool Edit 2000 is an extremely powerful audio recording and editing

ING EDGE

package. It's surprisingly easy to use and supports an extensive range of file formats (including an extremely high quality MP3 encoder) and will freely convert between them. There's virtually nothing to complain about, save the absence of a facility to slave digital audio to MIDI timecode, which web developers would doubtless appreciate. For video soundtracks, it's a damn near indispensable.

STEINBERG CUBASIS VST 3.0

Something of a legend amongst musicians of both pro and amateur varieties, Steinberg Media Technologies AG is known the world over for its professional audio software. It has been going since 1984, during which time its Cubase sequencing and recording package has become something of an industry standard. Cubasis VST is another 'lite' product, this time of the aforementioned Cubase VST 5.0.

A mere £59.95 buys you a superbly written manual and 2 CDs of software and samples. Cubasis VST actually comprises a suite of programs including WaveLab Lite 2.0 (which is comparable to Cool Edit 2000), and goes beyond audio editing into the realm of sequencing and mixing a proper. And while its parent Cubase doesn't really touch on video, Cubasis comes with a video monitor for post-production and audio dubbing. This in turn lets it hook up with the supplied AIST Movie Xone software which allows cutting and editing of video material. Essentially then, Cubasis is a bridge between WaveLab (sound) and Movie Xone (vision), and as such is a more all-embracing package than the audio-only Cool Edit even attempts to be.

So how well does it bring these two very different things together? Steinberg says Cubasis is designed to allow music to be produced straightaway, without having to spend

hours studying the manual - thanks to a clever online tutorial which navigates the user through all of Cubasis's main functions while a song is playing, letting you learn as you listen. It's an ambitious claim, but not far off the truth.

First and foremost, you have to get your audio recorded - for which you'll need WaveLab. This is an excellent application, which is far prettier to look at than Cool Edit 2000, but rather less intuitive to the non-musicians. It loads up with a host of minimised tool bars - offering things like effects processing and transport controls (i.e. RECORD, PLAY etc). Once you've repositioned them in a convenient place on your workspace, you can start a recording.

Very usefully, WaveLab offers a mixer which lets you control all the levels without resorting to Windows' Volume Control. This aside, it works similarly to CE 2000 but looks nicer and offers some interesting features such as dither (which improves the sound of digital audio) and standard parametric equalisation. In other respects, WaveLab is markedly inferior - the DSP effects are less numerous and the design of the workspace simply feels more cluttered. 'Techies' and studio jockeys might like, but those of us with real lives will find it fussy.

Once you've made, edited and processed your recording(s), you save your work as a WAV file and click on Cubasis VST3.0. This loads up to offer a window displaying a blank 16 track 'arrangement', into which you can load your audio track(s) created in WaveLab as well as pull in music tracks and sound effects. A modest music library comes supplied, complete with some basic synth riffs, drum patterns, loops and vocal takes. If you want more you can always add ones you've recorded in WaveLab or generate them via the MIDI music

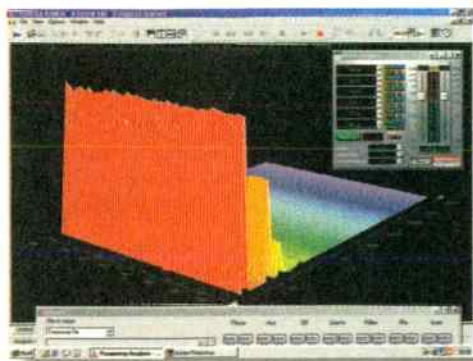

generator. Cubasis can then match the audio files and tempo of the song automatically, using the QUANTISE option.

It's true that Cubasis can be used without recourse to the instruction manual, but if

you're doing anything seriously then a bit of bedtime reading is definitely in order. Once you've added all your tracks, sounds and MIDI music parts, you save it as a song, arrangement or part, which can then be burned onto CD using the supplied Master Unit software. With up to 48 audio channels and 64 MIDI tracks, you do need some practice to get to give its best.

Essentially then, Cool Edit 2000 and Cubasis VST 3.0 are designed for subtly different users. DV jockeys already using serious video editing applications - and who want the audio equivalent - will love Cool Edit.

Steinberg's Cubasis VST does far more - it's all you need for quite intricate soundtracks for your video masterpiece. It combines audio recordings with MIDI and music pretty seamlessly, then lets you burn it to CD. It will even make straight digital copies of music and import MP3 files. That it isn't too far behind CE 2000 in the pure audio stakes is a tribute to the depth and breadth of this package. ■ ▲

www.steinberg.de



World Verdict



SYNTRILLIUM COOL
EDIT 2000

Brilliantly capable and focused audio-only package. Great value for money.

World Verdict



STEINBERGCUBASIS
VST 3.0

Amazingly thorough product that's tailored to multimedia rather than stereoaudio. Tremendous range of facilities and a bargain price makes it unbeatable value...

ON THE MOVE

Not content to rest on its laurels, Plextor has just launched its first portable CD burner. David Price takes the test drive.

Plextor makes some of the very best computer CD burners - the quality is always high, the reliability excellent and the performance superlative. The only problem is that its products hardly capture the imagination - what's so interesting about being so competent? Well, the brand new £290 PlexWriter S88TU portable CD writer is a total stunner.

The specs are superb - it's capable of 8x Writing, 8x Re-Writing and 24x Reading, is fully Windows XP compliant, features the all-important BURN-Proof Technology to stop buffer under-run errors, and is USB 2.0 compatible. The USB Hi-Speed (as it's also known) specification was released in April 2000, but is only just filtering onto CD-R portables now. With a raw data rate of 480Mbps, it's 40 times faster than the previous USB 1.1 (now called USB Basic), which tops at 12Mbps. Don't worry though, because USB 2.0 is backwards compatible, so you can connect all previous USB devices to the new interface (but you won't get the speed benefit, obviously). Also, the

maximum length of a USB 2.0 cable is 5m, making it ideal for external portable recorders.

I reviewed Sony's Digital Relay a few months back, and was impressed by the concept but had reservations about the execution. It's a fine product, brilliantly packaged, but it was hardly the sturdiest of things - this didn't exactly bode well for a hard life on the road. Happily, Plextor's new portable is far better built. The package includes the drive itself, two excellently written printed manuals, quick reference guide, blank CD-R and CD/RWs, USB 2.0 cable, AC (110-240V) adapter and power cord. Ahead Software's Nero and Plextor's Manager 2000 software is bundled, along with USB 2.0 drivers for Win98SE. The unit comes with a two year 'on site collect and return' warranty. The Plextor supports 8cm (CD single sized) data CD-Rs, but for some reason it drops its reading speed down to 18x, and recording speed down to 4x. Usefully, CD-Text is included.

The Plextor feels so much nicer

than the plasticky Sony Digital Relay. The disc tray in particular is quiet and smooth and doesn't feel like it's going to fall off at any moment - which bears out Plextor's claim that it's been tested 20,000 times! Its silver and blue casing is neat looking and even smaller than the Sony at just 141x22x171mm. The front carries an Eject button, power LED (showing power on, disc access, and/or writing) and the all-important emergency eject hole. On top there's a handy viewing window for checking to see if there's a CD inside - and if so, whether it's spinning or not. Round the back there's the 5.25V DC power socket and USB port. The right side carries a volume control and on/off switch, plus a headphone jack (claimed to give 0.8V at 32 Ohms) for monitoring purposes only - don't expect it to get the best out of your Sennheiser HD590s!

The Plextor works superbly, making excellent recordings time after time with no apparent signs of distress even with very heavy, repeated burning. Even with budget blanks, the discs it burns sound extremely crisp, clear and smooth - especially at 4x recording or under. It's also very good at Digital Audio Extraction, running up very high speeds with faultless results (providing the disc isn't scratched). It's very hard to fault Plextor's new PlexWriter S88TU - it's a beautiful piece of kit and incredibly handy for those who use their notebook computers for audio and multimedia work. If pressed, I could say that it's just a little heavier than it needs to be (at 500g it's 65g heavier than Sony's Digital Relay), and of course the high retail price hardly makes it available to everybody. Nevertheless, if you want the best CD-R portable around right now, this is very probably the one. ■ ▲



World Verdict



Plextor PlexWriter
S88TU

Brilliant all rounder that's a joy to use - but it will cost you!

Plextor PlexWriter S88TU £290

www.plextor.com

welcome to world favourites

Here's a list of products that are a good buy. We've tried to cater for a range of tastes, identifying strong products in every area. We're agnostic so you'll find a wide range of products, from valve pre-amps through to MiniDisc players. Products marked * are recently out of production but make a good second-hand buy.

Prices shown are those at the time of the review



Roksan Caspian CD player
Solid as a ROK

COMPACT DISC

ARCAM FMJ CD23 £1100
This British-built player is extremely versatile. Controlled and detailed with a musical insight that few match. (Jul 2000)

CAMBRIDGE CD4SE* £200
A touch soft in the treble but outstanding in every other respect. (Feb 98)

KENWOOD DP-3080/II* £180
Has great clarity and presence for the price. Not as naturally expressive as the CD4SE though. (Feb 98)

LINN KARIK III* £1775
Under rated and overlooked, the final Karik was a gem. Superb transport gives a brilliantly tight, grippy dynamic sound, albeit tonally rather dry.

MARANTZ CD-17 KI-S £1100
The Marantz excels in all areas. Without doubt this is one of the most involving CD players on the planet. Build quality is also exemplary. (Sep 97)

MARANTZ CD-63 MKII KI-S* £400
Similar to the CD-63SE but more powerful bass and an all-round smoother sound. The famous KI tweaks pay off again. Whether or not it is still pre-eminent against the vastly improved competition is a matter of opinion.

MERIDIAN 506 20-BIT* £1100
Very detailed and revealing player. More cerebral than visceral sounding, however. (May 95)

MUSICAL FIDELITY X-RAY £800
Commonsense sturdy CD player of exceptional ability. Clear and detailed with high quality internal processing system. The X-Ray is inclined to show up poor recordings, but it's only doing its job! (Feb 99)

NAD S500 £1000
This dynamic top of the range Silverline spinner delights with any type of music. Exciting, sophisticated sounding and highly recommended. (Jun 2000)

ROKSAN CASPIAN £895
The Caspian has a smooth, slightly bright sound with some of the clearest treble in the business. Very engaging, dynamic character. (Aug 97)

ROTEL RCD 951 £300
HDCD capability at a midrange price. Plain Jane looks but solid construction. There is some higher than average measured distortion which may take the edge off this otherwise tempting product. (Aug 99)

COMPACT DISC TRANSPORTS

SONIC FRONTIERS TRANSPORT £6999
Cutting-edge design and technology combine to make this one very desirable product. The only problem is the fantasy hi-fi price. (Sep 98)

TEAC P-30 £2500
Cheap it isn't, but then it sounds like a million digital dollars. Nothing short of superb. (Jun 97)

TEAC VRDS-T1 £600
Excellent mid-price silver disc spinner with a powerful, expansive and warm sound. Easily beats most sub-£1000 designs. A good choice for the budget conscious who want the best. (Feb 95)

DACs

CAMBRIDGE AUDIO DACMAGIC 3* £99
Superb value for money with extensive facilities and solid, detailed sonics. Upgrades any sub-£300 player.

DCS ELGAR £8500
Future-proof convertor which will handle 24/96 and 24/192. Extremely open and natural performer. (Nov 97)

DPA LITTLE BIT 3* £299
A taste of the high end on a budget. Rich, clean, punchy sound transforms budget CD players.

MIDIMAN FLYING COW £299
Excellent as a DAC and doubles as an ADC for archiving to CDR. (Jun 98) Great value, as is junior version Flying Calf at £109. (Feb 99)

MUSICAL FIDELITY X-DAC* £300
A bargain for normal CDs and even better with HDCDs. (Nov 97)

SONIC FRONTIERS PROCESSOR 3 £6999
Quality never comes cheap! This DAC oozes class and when matched with the Transport 3 is certainly up with the best. (Sep 98)

TURNTABLES

LINN SONDEK LP12 BASIK £1100
Off the pace these days in many respects but still an extremely sweet and engaging listen with a quintessentially analogue sound.

MICHELL GYRODEC SE £775
Exquisitely built, infinitely upgradeable deck that gives true high end sound at mid-fi prices.

MICHELL ORBE £2000
Fantastically capable all rounder with commanding, powerful, detailed sound that gets the best from almost any arm and cartridge. Supreme build, brilliant value. (Apr 95)

ORIGIN LIVE STANDARD (KIT) £145
Good in standard form with AC motor; frighteningly good with a DC motor and battery PSU.

PINK TRIANGLE TARANTELLA £680
Not only does the Tarantella have more style than a catwalk full of models, it also combines PT's usual clarity with real authority. (Oct 97)

PRO-JECT DEBUT £110
Straight out of the box and onto the shelf! Nothing short of a bargain. Vinyl's never had it so good, so cheaply!

REGA PLANAR 2 £214
Brilliant starter deck with extremely polished manner. Better built £274 Planar 3 is a great all-in-one package that eats mid-price CD players for breakfast.

ROKSAN XERXES X £1295
DSU or XPS 3.5 power supply £150/170 extra. Excellent pitch stability from a new Swiss motor and outboard power supply. Very tight bass, fine dynamics and revealing clarity. (Jan 97)

SYSTEMDEK IIX900*/RB250 £330
A fine all-rounder and easy to upgrade too. More depth and breadth than Rega Planar 3. (Sep 94)

VESTAX BDT-2000 £225
A stylish looking deck with infinitely variable speed 16-90 rpm, DC belt drive and built-in MM phono stage. Good value, with plenty of chassis room for alternative arms, if required. (Sep 99)

TONERMS

HADCOCK 242 SE £649
Latest of a long line of unipivot arms. Added mass makes the 242 suitable for both low compliance MCs and straw-in-the-wind high compliance types. Revised geometry and chromium plating completes a first-class job. (Jun 2000)

NAIM ARO* £975
Truly endearing and charismatic performer - wonderfully engaging mid-band makes up for softened frequency extremes

REGA RB300 £180
Some may prefer the simpler RB250 at £130. Detailed, tight, rhythmic sound but tonally rather grey and cold-sounding. Still excellent value, though.



Distributed by
Henley Designs Ltd
 Unit 10 Moorbrook, Southmead Industrial Park, Didcot, Oxon, OX11 7HR.
 Tel: 01235 511166 E-mail: henley.designs@virgin.net
WWW.henleydesigns.co.uk

MANTRA AUDIO
 Specialist Suppliers of Audio Accessories
www.mantra-audio.co.uk

CARTRIDGE SELECTION		STYLUS		REPLACEMENT STYLUS	
Goldring					
1006	£74	£51	GEX	£51	Swiss Quality Diamond Stylus
1012 GX	£93	£65	GEX	£65	ADC XLM Mk III £15.00
1022 GX	£122	£84	GEX	£84	Akai AN 5, AN 60 £11.00
1042	£140	£98	GEX	£98	AN2, AN 70 £13.00
Eroica LX/H	£123	£93	GEX	£93	Dual DN 145 E, DN 165 E £15.00
Elite	£232	£163	GEX	£163	8800 Super E £15.00
GEX - Exchange price for a Goldring Any make/model of cartridge accepted					
Audio Technica					
AT 95 E	£23			£15	JVC DT 55, DT 60 £11.00
AT 110 E	£28			£16	National EPS 24 CS, P 30 D, P 33 D £11.00
AT OC 9 ML	£330	£280	EX		Ortofon FF 15 E II, VMS 20 E II, OM 20 £15.00
Denon					
DL 110	£79	£62	EX		Pioneer PN 210, PN 220, PN 240 £11.00
DL 160	£95	£74	EX		Shure N 75 C, SC 35 C £11.00
DL 304	£210	£179	EX		N 75 ED T2, N 75 EJ T2 £13.00
Grado					
Prestige Black	£46			£25	N 95 ED, N 95 EJ, N 75 3 (78) £15.00
Prestige Gold	£140			£78	VN 35 E £18.00
Ortofon					
510 Mk II	£34			£22	N 95 HE, N 97 HE, VN 35 HE £25
MC 15 Super II	£130	£110	EX		ND 142 G, ND 150 G, ND 165 G £11.00
MC 25 FL	£227	£193	EX		CN234 £13.00
MC 10 Supreme	£304	£258	EX		*** OVER 500 STYLUS TYPES STOCKED ***
MC 20 Supreme	£382	£323	EX		HEADPHONE SELECTION
MC 30 Supreme	£452	£385	EX		GRADO
Rohmann	£837	£742	EX		Prestige Series
Shure					
SC 35 C	£35			£27	SR-60 £77
V 15 V XMR	£298			£199	SR-80 £93
EX - Exchange price against any Audio Technica, Denon, Goldring or Ortofon moving coil type cartridges					
GRADO Reference Series					
SR-125 £139					
SR-225 £186					
SR-325 £279					
RS-1 £609					
RS-2 (new) £439					

All items guaranteed authentic new originals see our website for full selection of accessories order direct from our secure online catalogue

MAIL ORDER (1-10 DAYS) PRICES (INC P&PI) - INSURANCE FOR UK DELIVERY - £6 - FOR EUROPE DELIVERY & £12 FOR US-WORLDWIDE DELIVERY TO COVER INSURANCE ON ORDERS OVER £50 VALUE

Tel/Fax (01757) 288652 e-mail: enquiry@mantra-audio.co.uk

MANTRA AUDIO (HFW), 22 GARTH AVENUE, NORTH DUFFIELD, SELBY, NORTH YORKS YO8 5RP

Acoustic Energy, Acoustic Zen, Advantage, Aloga, Argento, Audio Physics, Audio Refinement, Audio Synthesis Avantgarde, Apollo, Audion, Audio Note, Audio Research, Atacama, Buse, Balanced Audio Technologies, Beyerdynamic, Chord, Chord Audio Technology, Chord, Copland, Cadence, Cable Tail, Echo Busters, Eggleston Works, Electrocompanient, Graham, Goertz, Jango, JM Labs, Khurma, Koetsu, Krell, KEF, Klipsch Lumley, Lyra, L.A.I., Lavardin, Meadowlark, Musical Technology, Magnum Dynalab, Marsh, Marantz, Martin Logan, Mitchell, Musical Fidelity, Near, Nordost, Opera, Optimum, Ortofon, Orchid, Parthos, Project, Pro-acc, Pink Triangle, Quad, Rel, S.A., Shun Mook, Shun Shun, Sisonic Link, Soundstyle, Suis, Sonus, Tannoy, Tali, Wansley, Irar, Hull, VTL, Wisdom, Wilson, Wilson Benesch, Wadia, XTC, XLO, Acoustic Energy, Acoustic Zen, Aloga, Argento, Audio Physics, Audio Refinement, Audio Note, Audio Research, Avantgarde, Buse, Burmester, Cabasse, Anthem, A.V.I., A.I.C., Ar

Sounds of Music

Xmas & New Year Sale

Call us on: **01892 547003** or **539245**
 Fax us on: **01892 547004** or **616383**
 Check out our web site at: **www.sounds-of-music.co.uk**

STARTS 27 - 12 - 01

Call for our latest list today

TUNBRIDGE WELLS KENT

Prices shown are those at the time of the review



Musical Fidelity X-Cans2
Warm, sumptuous, sweet sound

SME 3009SII £309
Once state of the art, but no longer. Weak at frequency extremes and detail, but its legendary serviceability makes it a cult in Japan. Can be picked up for peanuts second-hand. (Jan 93)

SME 309 £689
A down-market version of the IV and V with aluminium armtube and detachable headshell. Tight, neutral sound with good tonality, but lacks the IV's pace and precision. Like the older SME 3009 series, this arm is also available in 10" and 12" versions. (Jan 93)

CARTRIDGES

AUDIO TECHNICA AT-110E £30
Great starter cartridge that's refined, detailed and musical beyond its price. Best value MM under £50

GOLDRING 1012GX £74
An accomplished MM with a solid bass, slightly forward midband and clean transients. Very reasonable price for such an able performer. (Jul 93)

DNM MICA £185
Better than Goldring's 1042 and costs only £135 on trade-in. An assured and transparent MM. (Feb 98)

DYNAVECTOR DV20X-H £299
The best modern budget MC combines deliciously sweet sound with fantastic get-up-and-go. High output version works a treat with valve phono stages too.

MUSIC MAKER £575
When mated with a good quality arm, this hand finished high-output pick-up gives an ear-boggling account of itself. Very high compliance ensures maximum information retrieval. An absolute (grain orientated) gem. (Feb 99)

ORTOFON MC 7500 £2000
Conclusive proof that there's hope for the world. It's a long time ago now but this high-priced favourite still earns its niche - CD lovers would die if they heard it. (May 94)

ORTOFON MC 15 SUPER II £140
Not quite as good as the dearer Supremes but the Super II is a splendid introduction to the joys of moving-coil cartridges.

GOLDRING 1042 £130
One of the best Moving Magnet cartridges going, with beautiful treble and muscular bass. New low price makes it a bargain.

ORTOFON ROHMANN £1000
In a way it's MC 2000 meets MC 7500 with great tonal strengths and a dynamo sound. (Apr 96)

INTEGRATED AMPLIFIERS

AUDIO ANALOGUE PUCCINI SE £595
This superbly-built Italian integrated has a lucidity and control which leaves others nowhere. Sound stage a wow. (Dec 97)

AUDIOLAB 8000a * £495
Well rounded integrated with smooth and detailed sound plus a huge feature count. Great build makes later versions a top used buy.

DENON PMA-250SE £160
It might not have bags of grunt but the Denon can sound exceedingly natural and open. (Feb 97)

McINTOSH MA6800* £3735
The MA6800 not so much plays music as takes control of it, with effortless bass drive. (Sep 95)

MISSION CYRUS 2 * £299
Classic eighties minimalism combines arresting styling with clean, open, lively sound. Further upgradable with PSX power supply.

MUSICAL FIDELITY X-CANS2 £160
Warm, sumptuous, sweet sound h/phone amp. gives startling results with a decent set of headphones.

NAIM NAIT 3 * £575
Superb rhythms and dynamics make for great music making, but tonally monochromatic. Super optional phono stage makes it ideal for vinyl junkies.

ROKSAN CASPIAN £695
Smooth, warm integrated with remote control that works happily into most 'speakers. (Dec 97)

SONNETEER ALABASTER £995
Builds on the strengths of the Campion with ample control, colour and drive. (Oct 97)

PHONO STAGES

CREEK OBH-8 SE £180
Punchy, rhythmic character with oodles of detail makes this a great budget audiophile product.

LFD MISTRAL PHONO STAGE * £300
The Mistral has a warmth and involvement that make many pricier stages sound overpriced.

MICHELL DELPHINI MONOBLOCS £1995
Analogue tour-de-force gives supremely clean, detailed and finely resolved sound with breathtaking dynamics. Great value, even at this price.

MUSICAL FIDELITY X-LP £125
One of the famous MF X series. Full marks throughout for clarity and detail. Switchable between MM and MC. Indestructible build! (May 99)

PRO-JECT PHONO BOX £39
Not the last word in many respects but a thoroughly honest piece of work. Inexpensive introduction to all that vinyl has to offer. MM and MC provision plus choice of two impedances.

ROKSAN ARTAXERXES X £950
With the Attesa PSU the Artaxerxes X MM/MC stage still shines. Great stage depth, neutrality and tonal colour. (Oct 97)

Billy Vee
SOUND • SYSTEMS

248 Lee High Rd, London SE13 5PL (Mon - Sat 10am to 6.30pm Closed Thurs & Sun)

NOT ONLY A CLASSIK BUT MUCH MORE

Call 020 8318 5755 or 8852 1321 now!

Save over £300 on this Linn/Celestion System

This is just one of the fabulous systems available during our Autumn promotion. The offer may be limited in quantity but you can be sure that any product or system we stock is available for audition and backed by experienced staff who work to fulfill the Billy Vee pledge - to give the ultimate in musical satisfaction

- Free delivery (U.K. Mainland) & local installation included
- Five year parts and two year labour warranty on this system
- Deferred & Interest Free Credit available 0% APR - Call for details.
- Arcam, B&W, Linn, Naim, Rega, TAG & more available for audition

Complete with speaker leads - just plug & play only :-



£1290

Individually, Linn Classik - any colour £995. Celestion Compact A £599

world favourites |

SONNETEER SEDLEY £399
Combines transparency and fine dynamics with excellent rhythmic ability. (May 98)

PRE-AMPLIFIERS

AMC 1100 £150
Suffers from un-defeatable tone controls but an extremely good value piece of kit. Partners the similarly budget level AMC 2200 power amplifier, also at £150. Comfortable beginners' choice. (Mar 99)

AUDIO ANALOGUE BELLINI £475
Showcases AA's characteristic mix of clarity and musicality and blasts the competition. (Apr 98)

CHORD CPA1800 £1800
Clarity, insight and control are second to none - an addictive mixture. (Mar 98)

CROFT VITALE £350
A modestly priced valve pre-amp with exceptionally transparent performance. MM phono stage plus three line stages are standard. Volume controls are separate for each channel, thus giving balance adjustment. A remarkable item in all respects. (Feb 2000)

XTC PRE-1 * £1000
Almost valve-like in its smoothness, the line-level Pre-1 is warm and seductively clear. (Nov 96)

POWER AMPLIFIERS

ARCAM 9 * £400
With 70W on tap, the 9P will drive most loudspeakers with a spacious and detailed sound. Good bass welly too. (Dec 96)

CHORD SPM400 £1400
There's a sense of effortless power to the Chord that gives music real scale and presence. (Mar 98)

MARANTZ MODEL 9 * £8000
Authentic reproduction monoblocs still more than cut the sonic mustard. Highly expensive and highly sought after. (Mar 97)

MICHELL ALECTO £1989
Crisp, clean and beautifully controlled with gorgeous styling. Partnered with the £1650 Orca this is a superb winning combo. (Oct 98)

MUSICAL FIDELITY X-A200£1000/pair
200W of high-end monobloc power in a grooved tube. (Aug 98)

NAIM NAP180 £1060
Partnered with a NAC82, this has classic Naim control, and a superbly rhythmic presentation.

TUNERS

CAMBRIDGE T500 £180
An extremely engaging tuner with a performance at odds with its low price. Not exactly a Troughline, but you may not notice... (Feb 99)

CREEK T43 £399
Excellent detail, separation and dynamics. A great little tuner and unbeatable at this price. (May 98)

MARANTZ ST17 £600
A positive dreadnought of a tuner. Sweet and refined but with a heavy punch when needed. A tuner of this quality demands a decent aerial. (Jul 99)

MISSION CYRUS FM7* £300
Clear and lucid sound puts it up with the best. Superb build too. (Apr 94)

NAIM NAT03 £595
The NAT03's warm, atmospheric sound is further proof of Naim's proficiency with tuners. (Sep 93)

SONY ST-SA3ES* £250
Beguiling RDS tuner for the sonically discerning. Good ergonomics and sensitive too. (Apr 97)

CASSETTE DECKS

AIWA AD-S750* £200
Sonically a very decent machine at the price. Comes fitted with Dolby B, C and the dead handy Dolby S. (Apr 96)

AIWA AD-S950* £300
A stable transport, superb head and Dolby S make the AD-S950 an excellent all-rounder. (Feb 95)

KENWOOD KX-3080* £160
A simple deck, but excellent-quality head and transport give top quality sound. (Oct 96)

PIONEER CT-S740S £430
A great piece of engineering from Pioneer, with first-rate sound. (Jun 96)

YAMAHA KX-580SE* £250
The 'SE' tag is more than a marketing gimmick. Sound is solid and clear with Dolby S. (Sep 97)

LOUDSPEAKERS

CASTLE EDEN £469
Impressively vice-free 'speakers that offer great transparency and involvement. One of a select band that simply makes music regardless. (Mar 97)

EPOS ES12 * £495
Strong, punchy bass is allied to finely detailed, articulate midrange and sparkling treble. (Oct 96)



Kef Cresta I loudspeakers
A very musical sound

KEF CRESTA I £100
Delightfully sophisticated presentation for the price. Won't blow the roof off, but will deliver a very musical sound. (April 2000)

KLIPSCH HERESY II £1100
An outstanding high sensitivity loudspeaker with midrange and treble horns coupled with infinite baffle 12" bass driver. Effortless, fast and accurate. (May 99)

MISSION 752 * £495
Cracking mid-price mini towers combined HDA drive units and metal dome tweeters with surprisingly warm results. Benign load characteristics makes them great for valves.

MISSION 771 £170
Characteristically fast, punchy Mission sound from the Aerogel mid/bass and silk-dome tweeter. (Jul 98)

Billy Vee
SOUND SYSTEMS

248 Lee High Rd, London SE13 5PL (Mon - Sat 10am to 6.30pm Closed Thurs & Sun)

isn't it time you upgraded your naim?

Call Sales: 020 8318 5755 & 8852 1321

Would you like to upgrade to a new 112/150?

If you are already a Naim Nait owner or an aspiring Naim owner now is the time to talk to us. During our Naim promotion in October, we can offer the opportunity to upgrade to the 112/150 pre-power combination for £100 less. How? Call our sales team on either number above to find out - and upgrade *your* musical satisfaction.

- Local delivery and installation included in purchase price
- 3 year warranty for all 5 Series products - part exchange available
- Deferred and Interest Free Credit available at 0% APR - Call for details.
- Complete Naim range available for audition inc NAP500 & NBL

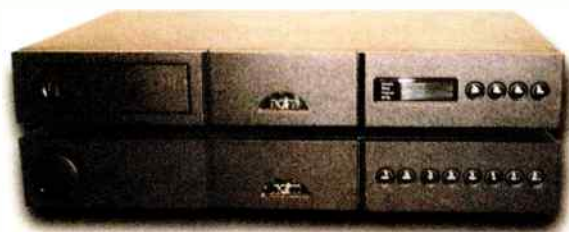

Featured - CD5 Player (Top) & Nait 5 (Bottom)

QUAD ESL 63 * £3450
A reference against which all other loudspeakers are judged, the '63s have superb imaging and genuine transparency.

TANNOY AMS8 * £2700
Bold sounding pro active monitor with solid bass, clear midrange and delicious treble. (Aug 96)

TANNOY MERCURY m2 * £140
A true audiophile bargain which embarrasses many more expensive boxes. Never mind the price, let your ears decide. (May 97)

MINIDISC PLAYERS

KENWOOD DM-9090 £500
One of the best MD players yet. ATRAC 4.5 gives clean and very musical recordings from this Kenwood. (Jan 98)

SONY MDS-JB930Q £250
Great mid-price machine that adds better build and facilities to the '530's already excellent sonics.

SONY MDS-JA50ES * £1300
This Sony can put the wind up Nakamichi cassette decks when used with better blank MDs. (Apr 98)

SONY MDS-JE55ES MiniDisc recorder £520
The best sounding MD deck made so far, thanks to awesome build and heroic ATRAC-DSP Type R coding.



Alesis Masterdisk
A glimpse of the future

SONY MDS-JE510 £300
An impressive sound and unmatched convenience make this MiniDisc player an excellent buy.

DIGITAL RECORDERS

ALESIS MASTERDISK £1400
A groundbreaking hard disc recorder with a built-in CD drive. An amazing bit of kit, and a glimpse of the future. (July 2000)

KENWOOD DMF-9020 £500
An excellent tool for home recording, combines convenience, superb sound and a fair price. (Aug 99)

MARANTZ DR-17 £1100
Probably the best sounding CD recoder on the market. Built like a brick out house with a true audiophile sound. HDCD compatible. (July 2000)

PHILIPS CDR-765 £360
One of the first twin deck recorders/players that boasts high speed dub facility. Playback could be warmer, but still a bargain. (Oct 99)

PIONEER PDR-555RW £480
Excellent mid-priced CD recorder that both plays and records with equal panache. (Oct 99)

SONY TCD-8 DATMAN * £599
Super clean and detailed sound makes this an amazing portable. Not as robust as it should be though.

DVD PLAYERS

DENON DVD-5000 £1600
Monster build, as you'd expect at this price. Facilities and gadgets galore and drop-dead high end looks. A very smooth and sophisticated sound, although not as good as similarly-priced CD players. (Mar 99)

PIONEER DV-717 £700
Well built and a solid performer, with a 'true' 24/96 digital output. Facilities in abundance and a controlled, exciting way with CD replay. Shame it lacks a Dolby Digital decoder! (Sep 99)

SONY DVP-S725 £490
One of the best buys in the DVD market. Available in a dodgy white case, but the facilities and performance more than make up for this. Excellent with both music and visuals, and a whole host of up to the minute facilities to keep you occupied. (Mar 2000)

HEADPHONES

JECKLIN FLOAT MODEL TWO £99
Wonderful panel-like and open sound from these esoteric-looking headclamps. Do not wear in public unless you like being made a fool of!

SENNHEISSER HD-490 £50
Good value cans with an exciting and bassy sound. Everything one should look for in headphones at a sensible price.



Nordost Blue Heaven
A simple and effective upgrade

INTERCONNECTS

CHORD COMPANY CHAMELEON 2 £90/m
One of our favourite favourites, the Chameleons are musical performers with a smooth yet open sound.

DNM RESON £40/m
Neutral and transparent, and a steal at forty quid!

NORDOST BLUE HEAVEN £150/m
Some of the fastest and most transparent cable around. A simple and effective upgrade.

VAN DEN HUL ULTIMATE THE FIRST £260/0.6m
Carbon interconnects that help you forget the electronics and concentrate on the music. Miraculous transparency.

LOUDSPEAKER CABLE

CHORD COMPANY RUMOUR £9.95/m
The Rumour is our reference at the price. Tight and tuneful bass mixed with air and space results in a cracking cable for the money.

DNM RESON £6.95/m
This cable has a transparency of sound that's rarely heard at the price. Excellent value for money.

NORDOST BLUE HEAVEN £375/3m pair
This isn't cheap, but it sounds absolutely fab. An open and spacious sound that simply carries music.

Billy Vee SOUND SYSTEMS

SAVE £££'S ON OUR DISPLAY CLEARANCE
SOME AS NEW WITH 1 YR WARRANTY. 24HR DEL ONLY £5. CHECK AVAILABILITY BEFORE ORDERING
CALL SALES: (020) 8318 5755 or 8852 1321 - 248 Lee High Road, London, SE13 5PL
0% APR is available on purchases of more than £660. Please call for details. * Prices Correct at 12/06/01 E&OE

Arcam AV50 Amplifier	(699.00)	£179.00	Naim NAC72 Preamp (1Yr G/tee)	(760.00)	£449.00
KEF Concerto 1 Spkrs (5Yr G/tee)	(599.00)	£249.00	Naim NAT 02 Tuner (2Yr G/tee)	(1240.00)	£849.00
KEF Concerto 2 Spkrs (5Yr G/tee)	(799.00)	£369.00	Naim AV1 Surround Procs E/D (2Yr G/tee)	(1835.00)	£659.00
Linn Karik CD Player S/H (1Yr G/tee)	(1498.00)	£895.00	Naim SBL Passive Speakers S/H (1Yr G/tee)	(2475.00)	£1495.00
Linn 5120 Centre Spkr (1Yr G/tee)	(725.00)	£395.00	Naim CD2 CD Player S/H (1Yr G/tee)	(1995.00)	£1199.00
Linn AV5140 Speakers (Cherry)(2Yr G/tee)	(2150.00)	£1395.00	Naim Intro Spkrs - Beech (1Yr/Gtee)	(790.00)	£590.00
Linn 5150 Subwoofer-Cherry (2Yr G/tee)	(2999.00)	£1995.00	Naim Credo Speakers (2Yr G/tee)	(1285.00)	£895.00
Linn Kairn Line Preamp (1Yr G/tee)	(1400.00)	£799.00	Naim NAP 250 Power amp (1Yr G/tee)	(1855.00)	£1390.00
Linn CD12 CD Player E/D (2Yr G/tee)	(12000.00)	£7995.00	Naim Flat Cap Power Supply (1Yr G/tee)	(370.00)	£249.00
Linn Keilidh Active Spkrs inc Stands & cards	(1135.00)	£695.00	ProAc Response 2 Spkrs S/H (1Yr G/tee)	(1995.00)	£1175.00
Marantz DV4100 DVD Player (1Yr G/tee)	(399.00)	£299.00	PMC TB2 Spkrs S/H - Cherry (1Yr G/tee)	(700.00)	£549.00
Marantz DV7000 DVD Player (1Yr G/tee)	(599.00)	£449.00	PMC LB1 Speakers (2Yr G/tee)	(1150.00)	£825.00
Marantz SR5000 AV Receiver (1Yr G/tee)	(499.00)	£375.00	Rega Jura Speakers (2Yr G/tee)	(498.00)	£329.00

World classics

CASSETTE

NAKAMICHI DR-2

A great machine with Nakamichi's legendary heads. The lowest cost 'true' Nakamichi at the time, retailing for £600.

NAKAMICHI CR-7

The last of the great ones, and definitely the best Nakamichi ever (yes, better than a Dragon)

YAMAHA TC-800G

Early classic in serious cassette. Its ski-slope looks got it a cult following once it had ceased to be simply ugly.

CD PLAYERS

MERIDIAN 207

Beautifully-built two-box with pre-amp stage. Very musical although not as refined as modern Bitstream gear. No digital output.

PIONEER PD-91

Built-to-last player with easy upgrade routes for modifiers. Not knockout as it stands but get one cheap and have a go!

CAMBRIDGE CD1

The first two box player with weighted mechanics and even an optional Dropout/error counter. Radical and effective at the time - a classic.

AMPLIFIERS

LEAK POINT ONE, TL12 & TL10

Ancestors of hi-fi, consequently expensive nowadays. As with all vintage valve stuff, overhauling is de rigueur before use, using original parts if possible.

LEAK PRE-AMPS

Line of 'good for their time' pre-amps. Use of EF86 pentode valve for high gain rules out ultra performance. Not the highest-fi.

LEAK STEREO 20

Excellent workaday classic valve amp. In good order the 20 will not disgrace itself. Various upgrades are available from specialist repairers.

LEAK TL12+

Plentiful monobloc equivalent of Stereo 20. Reasonably inexpensive and a tweekers' dream. Genuine valve hi-fi on a budget.



Garrard 401
A legendary turntable.

NAD 3020

You can't argue with success! NAD's budget transistor integrated gave thousands their first taste of hi-fi and remains great value.

QUAD 33/303 PRE/POWER

Great style and construction, also bullet proof. Warm and wooly sound, but easy going. A good introduction to early transistor audio classics.

QUAD 22/II PRE/POWER

One of the all-time classic valve amplifiers. Unusual circuit but it works beautifully. 22 pre-amp not up to today's standards.

SUGDEN A21

Seventies transistor integrated has an eminently likeable smoothness and musicality. Limited inputs via DIN sockets.

TECHNICS SE-A5 Mk2

Nice transformer and electronics, shame about the casework. With tweaking, this 150watter can sound sweet.

LOUDSPEAKERS

KLIPSCHORN

Not exactly plentiful or cheap but a splendid beast. For efficiency they have seldom been equalled. Space hungry!

LEAK SANDWICH

Rather warm sounding big infinite baffle but cheap with it. With a reasonably powerful amp can sound quite satisfying.

LOWTHER PM6A

High quality full-range driver; still manufactured. High sensitivity, as fitted to many classic horn designs.

MAGNEPLANAR SMGa

Touch dry in the bass but a technological loudspeaker with genuinely musical abilities.

MISSION 770

Father of the 77 range which continues to this day. Well mannered with a warm sound and a kind load to amplifiers.

QUAD ESL57

Unrivalled. Properly serviced there is nothing like them. Their natural presentation may make them caviar to the general.

YAMAHA NS1000M

Hi-tech favourites of the Japanese and Americans. Viewed more warily in the UK but can give excellent results.

TANNOY GRF & AUTOGRAPH

Folded horn monsters which certainly sound good if you have the space. For Tannoy vintage see HFW November 1998.

WHARFEDALE SUPER 8 RS DD

Ideal experimenters' driver. High sensitivity ~14,000 Gauss magnet and extended frequency range. Inexpensive too!

TANNOY YORK, LANCASTER

Many similar models of infinite baffle or reflex design. Not the last word in tautness but the drivers work well in modern cabinets.

VINYL

ACOS LUSTRE

Very honest piece of kit, well made and easily adjusted. Vinyl beginners could do very much worse.

ALPHASON HRI 00S

First class arm, up to present-day standards. Buy carefully, though, as there's no service available now.

ARISTON RD 11

A one-time king of turntables very similar to the Linn LPI2. Now deposed but worth a look at the right price.

LINN AXIS

Uncomplicated, lower-price version of the famous Sondek. Less expensive than some of its stablemates.

GARRARD 301 & 401

Legendary turntables, once fairly plentiful. Excellent back-up available; many different custom plinths available. High quality.

GOLDRING Lenco 88 & 99

Great deck for the kitchen table enthusiast. Garrard fans won't look at 'em but cheap and capable. Servicing available.

HADCOCK 228

Recently out-classed by Hadcock's updated 228 Special Edition but a proper hi-fi arm for all that. Makers still service.

MICHELL FOCUS ONE

20 years and still going strong. Early runner in the 'modern' turntable cycle with a first class arm. Factory servicing available.

SHURE M75

Recent line-contact improvements have left the M75 behind but the wide range of needles make it a handy tool.

SME 3009 IIS

Everlasting classic tone-arm. Spares permanently available from SME. No longer the last word but peanuts second-hand.

THORENS TD124

Best classic deck ever? Judging by the prices they fetch it's possible - 78rpm too!

THORENS TD150

Mid-price deck with a keen following. No real difficulty with servicing - novices may find the suspension system unnerving.

TRIO L-07D

Knockout heavyweight from 1980 with stainless bearing and IIIb platter! Not a give-away and beware! - spares scarce.

TUNERS

LEAK TROUGHLINE (ORIGINAL)

Interesting ornament but no longer hi-fi. Limited coverage of 88MHz to 100MHz only.

LEAK TROUGHLINE II & III MONO

Arguably the best-sounding tuners ever. Adaptation for stereo easy via phono multiplex socket.

LEAK TROUGHLINE III STEREO

Excellent tuner with indifferent stereo decoding circuit. Best when adapted to use modern outboard decoder.

MARANTZ ST-8

Possibly the ultimate Tardis console, including an oscilloscope for checking the strength of signal. Expensive even now.



“Two more firsts from Sounds Of Music”

At both ends of the specialised high-end market. These amazing new products are absolutely unbeatable. They set new standards and are already references in many other countries around the world. The Halcro is the lowest distortion amplifier currently available by a huge margin undisputedly acknowledged by reviewers and laboratories alike and their sound is on a different planet to practically all others. Both these fabulous music producers are on demonstration along with the most comprehensive range in the UK. Call for a demonstration and further details on these or any of our other products.



Aloia



Halcro

“you won't do better anywhere else”

Sounds Of Music, 10 - 12 Chapel Place, Tunbridge Wells, Kent TN1 1YQ Tel: 01892 539245 Fax: 01892 616383
Check out our web site at www.sounds-of-music.co.uk



**Choice
hi-fi**

you choose

Choice hi-fi make it easy for you to fulfill your sonic dreams. Quality hi-fi is not just about expensive brandnames. It's about aspiring to the very best sound, about choosing your ideal system from the widest selection in the country, in a unique no-pressure environment.

your choice

- Acoustic Energy
- Advantage
- Alon
- ATC
- Audible Illusions
- Audio Physics
- B.A.T
- Boulder
- Bryston
- Cary
- C.A.T.
- Chord
- Clear Audio
- Denon
- DNM
- Dynavector
- Egglaston Works
- Electrograph Delphi
- Genelec
- Gryphon
- Graham
- Helios
- J M Lab
- John Shearn
- Krell
- Lexicon
- Loewe
- Mark Levinson
- Michell Eng.
- Musical Fidelity
- NEC
- Nordost
- Oracle
- Plinius
- P.M.C.
- Primare
- Quadraspire
- Selego
- REL
- Rockport
- Roksan
- Ruark
- Shahinian
- SME
- Straight Wire
- Sugden
- Tara Labs
- Teac
- Thule
- Totem
- Transfiguration
- Trichord
- Trilogy
- Van den Hul
- VPI
- Wilson Audio
- Wilson Research
- YBA

H I - F I

HOME
CINEMA

MULTIROOM
INSTALL

BUY / SELL

Quarterly Sale items

	Our Price	Original Retail Price
Burmester 850 Monoblocks	£950.00	£3,000.00
Trilogy 948 Stereo	£850.00	£2,000.00
Exposure IX Power supply	£595.00	£1,500.00
Exposure VIII	£325.00	£700.00
Kenwood L1000C pre/ L1000M Power Amp	£795.00	£2,500.00
Pioneer A300 Int	£90.00	£180.00
Exposure VII	£195.00	£600.00
Exposure XI pre XII psu	£595.00	£1,500.00
Orelle Swings	£495.00	£1,200.00
Cyrus Dac Master & Cyrus Disc Master	£695.00	£1,798.00
Harmon Kardon AVPI	£175.00	£ -
Pioneer CLD 2850 Laserdisc	£175.00	£ -
Cary 572 se Monoblocks	£1,495.00	£2,350.00
Counterpoint SA12	£595.00	£1,400.00

New this month

POWER AMPLIFIERS	Our Price	Original Retail Price
Krell FPB 200	£4,995.00	£8,450.00
Bryston 7 BST Monoblocks	£2,750.00	£4,000.00
Cary SLA 70 mk II Silver	£1,295.00	£2,250.00
Linn LK100	£345.00	£650.00

SYSTEMS	Our Price	Original Retail Price
Cello Audio Suite/ Palette/ Performance 2 Monoblocks/ Grand Master (Piano Black) Speakers	£38,000.00	£120,000.00
Nakamichi PA7/ CAS/ 5T5	£1,395.00	£3,300.00

PRE AMPLIFIERS	Our Price	Original Retail Price
Krell KRC 2	£1,995.00	£3,400.00
CAT SL1 Sig Pre Amp	£2,495.00	£5,995.00

LOUDSPEAKERS	Our Price	Original Retail Price
Wilson System 5.1	£8,500.00	£18,000.00
B & W CDM1 se + Stands	£495.00	£900.00
Acoustic Research LST	£495.00	£ -
Thiel 7.2	£7,995.00	£14,000.00
Wilson Benesch ACT 1	£4,495.00	£7,000.00
Infinity Kappa 9	£1,295.00	£2,100.00
ATC SCM 20 SL (black)	£1,495.00	£2,051.00

CD PLAYERS & DACS	Our Price	Original Retail Price
Oracle CD1000 Transport	£On Dem	£3,950.00
Oracle CD2000 Transport	£On Dem	£7,500.00
Sony CDPRI/ DAs R1	£2,995.00	£6,000.00
Audio Synthesis DAX 2	£995.00	£2,000.00
Audiomeca Mephisto CD Transport	£1,200.00	£2,000.00
Audio Research CD2	£2,395.00	£3,400.00
Krell KPS 25s	£14,995.00	£22,500.00
Audiomeca Kreature Transport/ Elixir DAC	£1,495.00	£2,800.00
Micromega CD3.1/ Duo BS DAC	£1,295.00	£2,400.00

TURNTABLES, ANALOGUE, VARIOUS	Our Price	Original Retail Price
Ortofon Kontrapunkt	£375.00	£500.00
Michell Gyro SE RB300	£On Dem	£1,100.00
Pink Triangle Anniversary/ SMEIV	£1,495.00	£2,500.00
Sony SA3ES Tuner	£295.00	£ -
Elemental 4 Tier (Individual)	£1,695.00	£2,500.00
Elemental 4 Tier (Fixed)	£1,295.00	£2,000.00
Roksan Shiraz	£495.00	£1,000.00
Transparent Audio Cables Various	£ POA	£ -
Nakamichi Dragon	£1,395.00	£2,200.00

Power amplifiers

Boulder 500 AE	£2,850.00	£5,500.00
Acuphase E203 Integrated Amp	£795.00	£ -
Mark Levinson 331	£3,250.00	£4,995.00
Melos 402 Monoblocks	£4,495.00	£9,000.00
Krell FPB 300	£5,995.00	£9,990.00
Krell KAS 2 Monoblocks	£9,995.00	£20,000.00
Linn Klassik	£895.00	£1,030.00
Boulder 1060 Power	£On Dem	£16,500.00
Copland CTA 501	£895.00	£1,800.00
Cary Audio 300 SE Sig. WE300B	£3,495.00	£5,304.00
VTL 120	£1,495.00	£3,500.00
Primare 30.1 Integrated	£1,195.00	£1,500.00
Copland CTA 402	£1,395.00	£1,800.00
Plinius SA100	£On Dem	£3,400.00
Krell FPB 600	£7,500.00	£12,000.00
Copland CTA 402	£1,395.00	£1,700.00
Krell 250 A/3 3 Chanel amp	£2,995.00	£4,698.00
Audio Note P2 SE	£695.00	£1,500.00
Graff GM200	£4,750.00	£8,000.00
ML 436 Mono Power Amps	£10,500.00	£12,000.00
Cary SLA 70 mk II	£995.00	£2,250.00
Audio Refinement Complete Amp	£695.00	£895.00
Audio Research VT200 mk II	£6,995.00	£9,998.00
Audio Research Ref 600 mk II	£29,995.00	£40,000.00
YBA Passion Monoblocks	£On Dem	£8,995.00
YBA Passion Stereo	£On Dem	£5,995.00
Krell FPB 300c	£8,500.00	£9,998.00
Sunfire 300 Power Amp	£995.00	£2,400.00
Plinius 250 mk IV	£On Dem	£6,000.00
Audio Note Kasi	£12,495.00	£30,000.00
Cary 805 C Monoblocks	£On Dem	£8,250.00
Cary 300 se LX20 Monoblocks	£3,750.00	£5,250.00
John Shearn Reference Phase 3 Power Amp	£495.00	£749.00
Krell FPB 600 c	£9,995.00	£14,994.00
Sugden AU51	£995.00	£1,500.00

AV components

AV COMPONENTS	Our Price	Original Retail Price
Krell HTS (AV Processor)	£4,495.00	£6,498.00
Thule PR250B DTS/ Dolby	£On Dem	£1,549.95
Thule PA250B 5 Channel Amp	£On Dem	£1,549.95
Audio Refinement Pre 5	£On Dem	£895.00
Audio Refinement Multi 5 (Power)	£On Dem	£2,250.00

TELEVISIONS & DVD PLAYERS BY LOEWE	Our Price	Original Retail Price
Loewe Xamix DVD	On Demo	£495.00
Loewe Aconda	£POA	£ -
Loewe Planus + Std	£POA	£ -
Loewe Xelos + Std	£POA	£ -
Loewe LZA Active Speakers	£POA	£ -

PLASMAS	Our Price	Original Retail Price
From NEC/ Panasonic	£ -	£ POA
From Electrograph Delphi	£ -	£ POA

Pre amplifiers

Audio Research LS2	£1,795.00	£4,000.00
Hovland HP100 Line Pre	E.P.O.A	£4,950.00
Audio Synthesis Passion 8M bal/ remote	£1,095.00	£1,895.00
Audible Illusions Modulus P3A mm	£1,795.00	£2,565.00
BAT VK505E	£5,295.00	£6,500.00
Krell KSL 2 Pre	£1,795.00	£3,000.00
Cary SLP98L Remote Pre	£1,495.00	£2,794.00
BAT VK5i + remote	£2,350.00	£3,995.00
Audio Research 5P9	£895.00	£ -
Cary SLP 74 pre	£695.00	£1,500.00
Conrad Johnson PV10 AL	£695.00 *	£1,200.00
Boulder 1012 (pre amp/ 24.96 dac/ Phono)	£ On Dem	£3,000.00
Krell KRC3	£1,995.00	£3,250.00
Trilogy 901 Pre	£495.00	£995.00
Krell KSL + Phono	£1,295.00	£ -
YBA I Alpha Pre mm/mc + psu	£ On Dem	£4,900.00
YBA Passion Pre + mc	£ On Dem	£5,595.00
Boulder 2010 Pre	£p.o.a.	£30,000.00
Plinius 16L	£ On Dem	£3,200.00
C.A.T. ultimate reference Pre Amp Inc/ Phono Stage	£ On Dem	£5,750.00
Tube Tech 5er Pre Amp	£595.00	£935.00
Audible Illusions P3A Pre MM/MC mk II	On Demo	£3,140.00
Electrocompaniet EC 4.5 (new)	£595.00	£1,195.00
Mark Levinson No 28	£1,495.00	£4,000.00
Naim 42.5	£150.00	£450.00

Quality speakers

Magneplanar 2.5R	£1,100.00	£2,500.00
Martin Logan CL5 llz	£1995.00 *	£ -
Soundlab A3 Plus	£3,995.00	£12,000.00
Apogee Mini Grand	£2,500.00	£4,500.00
Wilson Max (new)	£29,995.00	£39,000.00
JM Lab Utopia (Ex Dem)	£12,495.00	£16,999.00
Vienna Acoustics Mozart	£1,095.00	£1,500.00
Audio Physic Avanti	£ On Dem	£7,500.00
Kef 104.2	£695.00	£1,200.00
Audio Physic Steps and Stands	£899.00	£1,300.00
Audio Plan Contrast 3	£1,395.00	£3,200.00
Proac Studio 3 Rosewood	£750.00	£ -
Avalon Ascents	£6,995.00	£12,000.00
JM Lab Micro Utopia	£ On dem	£3,899.00
JM Lab Mini Utopia	£ On dem	£4,500.00
JM Lab Mezzo Utopia	£ On dem	£7,300.00
JM Lab Electra 915.1 (ex dem)	£850.00	£1,895.00
Audio Physic Tempo III	£ On Dem	£2,000.00
Naim SBL's	£1295.00 *	£2,225.00
BC Acoustics Tibre	£795.00	£1,100.00
ClaraVox Magnifica	£6995.00 *	£14,500.00
BC Acoustics Araxe	£895.00	£1,195.00
Ensemble Speakers PA1	£995.00	£2,000.00
Audio Physic Caldera	On Demo	£10,000.00
Audio Physic Libra	X-demo	£4,799.00
Audio Physic Rhea Sub	£1850.00 *	£3,099.00
Audio Physic Spark	On Demo	£1,749.00
Audio Physic Steps	On Demo	£999.00
Audio Physic Virgo	£2,395.00	£3,000.00
Rogers LS55 (new)	£330.00	£430.00

CD players & DACS

Acuphase DP70V	£1,895.00	£ -
DCS Elgar	£6,500.00	£8,500.00
Linn Karik CD Transport	£795.00	£1,500.00
Linn Numerik	£895.00	£1,800.00
Pink Triangle 24 bit Module	£395.00	£645.00
Mark Levinson No 39	£3,995.00	£5,000.00
Copland CDA 266	£995.00	£1,199.00
Acuphase 90/91	£6,999.00	£16,000.00
YBA CD Speciale	£495.00	£675.00
Theta Data II/ Progen III Bal	£2,750.00	£8,500.00
Thule Spirit CD 150B	£ On Dem	£899.95
Audio Refinement CD Complete	£650.00	£875.00
Boulder 2020 dac	£p.o.a.	£24,000.00
Krell KPS 25sc	£18,995.00	£23,498.00
Pink Triangle Da Capo (1307)	£695.00	£1,595.00
Theta Data II Transport AT + link	£1,995.00	£4,000.00
YBA CD Integre	On Demo	£1,195.00

Turtables & analogue

Michell Orbe/QC/SME VI Koetsu Urushi	£3,500.00	£5,800.00
Koetsu Onyx	£1,195.00	£2,200.00
Van den Hul Grasshopper	E.P.O.A	£4,000.00
Audio Synthesis Phono Eq mm/mc	£795.00	£ -
Koetsu Urushi	£1,195.00	£2,200.00
Voyd Valdi/ Orion	£695.00	£ -
Gryphon Phono Pre-Amp (dual mono)	£795.00	£1,600.00
Parasound TQ1600 (remote tuner)	£295.00	£400.00
Air Tangent 2B	£1,995.00	£ -
SME Series V Arm	£895.00	£1,650.00
Wilson Benesch Act 2	£895.00	£1,400.00
Rotel Michi Phono	£695.00	£1,200.00
Roksan Tabriz	£150.00	£300.00
Audio Technica AT33	£offers	£ -
Rockport System II c/w Air stand, vac hold and arm	£18,000.00	£33,000.00
Musical Surroundings Phenomena Phono Stage	£495.00	£ -
Pink Triangle PTTO SA/RB300S/W	£795.00	£ -
Ortofon MC 3000 mk II	£695.00	£1,000.00
Plinius 14 Phono	£ On Dem	£2,750.00
Transparent Audio Music Wave Ultra XL Bi-Wire	£2,100.00	£4,000.00
Cary PH301 MM/MC	£895.00	£1,695.00
Nakamichi DR 3	£225.00	£400.00
Tom Evans - The Groove	£ On Dem	£1,500.00
Clear Audio Reference Mc phono stage X-demo	£1,695.00	£2,065.00
Rega Planer 3 + Hi Fi News Out Board Power Supply	£320.00	£423.00
Clear Audio Symphono phono stage X-demo MM/MC	£640.00	£740.00
Lavardin Reference Phono	£ On Dem	£2,500.00

* Reduced this month

tel: 020 8392 1959 & 020 8392 1963
fax: 020 8392 1994 info@choice-hifi.com

Open from 10am to 6pm Mon-Sat and other times by appointment.

Buy sell exchange quality hi-fi equipment.

We accept all major credit cards. Finance available subject to status



Full Price List and Focal details on Web Site

DRIVE UNITS: by FOCAL & seas, and a pick of the best from other manufacturers.
Coming:- ETON HEXACONE Range of units

100+ CROSSOVER NETWORKS: - Active & Passive, Components, Accessories,
COMPONENTS

SOLEN Polypropylene capacitors, 0.1mFd. to 100mFd.

Polyester and Polycarbonate Film Capacitors, 0.1mFd. to 10mFd.

ALCAP Reversible Electrolytic Capacitors (Non-Polar): 50k, 100k & Low Loss, 2mfd. to 600mFd.

FALCON Custom-wound Inductors.

FERRITE:- Standard, High Power, Super Power, Super-Super Power

AIRCORED 0.56 - 1.25mm wire: IRON DUST, 1mm wire

TAPPED INDUCTORS:- 0-10mH in 1mH steps & 0-1mH in 0.1mH steps

AUDIO AMATEUR PUBLICATIONS

NEW- First in High Fidelity - The story of H. J. Leak & Co., plus lots in P/L.

Back year sets of Speaker Builder, Audio Amateur & Glass Audio, plus the Audio Anthology Set.

Altogether 50+ books and 50+ Audio Amateur's magazine year sets.

2001 year sets available. Feb

FOCAL 'State of the Art' Units & Kit Designs'

Long Awaited 'W' Glass-Sandwich
Focal Unit Range

as pioneered in the Utopia range of systems.

Unit Spec Booklet available 30p. OR FREE on Web Site available in pdf format
Please send A4 SAE with 44p stamp (66p with PL) +30p extra stamps.

SUPPLIERS TO THE TRADE SINCE 1972

Send for our FREE price list PL30. Just send a large S.A.E. (44p stamp) or US\$2 bill overseas.
Europe US\$1 bill or 3 International Reply Coupons (IRC) to: (Dept HI-W) Tabor House,
Norwich Road, MULBARTON, Norwich, Norfolk. NR14 8JT Tel (0)1508 578272



IT DOESN'T MATTER whether your equipment is
Old, New, in Kit form, Valve, Solid-state, Audio or R.F.

We will....

Repair, Restore, Re-calibrate, Re-align:-
Tape recorders by Revox, Tascam (up to 1") and Teac
Valve amps., pre-amps., tuners, cinema amps.,
theatre-organ amps., industrial p.a. amps. from Radford, Quad, Leak,
Kalee, Clarke & Smith, Compton, Grant, Pameko, RCA, Altobass etc.

Valve Communications Receivers and Transmitters
(to 30MHz/2kW/6'3" tall) by KW, Marconi, Labgear, Eddystone,
Redifon, Ajax, RCA, Tiger... and so on.

We will....

Build that Kit for you or
Re-build it if you've had a go but it's gone pear-shaped.

We will....

Custom-build for you a published Classic design.
(Fancy a Williamson?? Or a 912+? A 3-3, maybe? No problem)
Design something special and build the prototype.

All this,

as well as being an Authorised Service Centre for such respected
names of the Digital Era as Denon, Pioneer, Kenwood, Yamaha.

Overall,

some pretty comprehensive facilities....and it will take only
a few minutes of your life plus a few pence from your pocket to call/fax
and discuss your requirements: 0113 244 0378. Or write!

AUDIO LABORATORIES (LEEDS)

3 Kildare Terrace Industrial Estate,
Leeds LS12 1DB, England.

audioXpress... It Just Sounds Better

Your Favorite Audio -
One New Magazine!

- PROJECTS
- REVIEWS
- THE NEWEST TECHNOLOGIES
- AUDIO CLASSROOM
- and Much More!

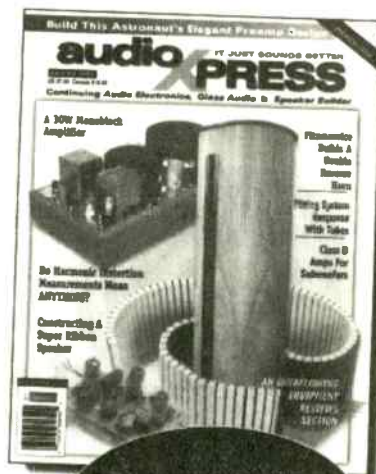

Subscribe To This
Great Monthly
Publication Today!

Only \$59.95 US
for 12 Issues!

audioXpress • PO Box 876 • Peterborough, NH
03458-0876 USA • Phone: 603-924-9464

Fax: 603-924-9467 • E-mail: custserv@audioXpress.com

ORDER ONLINE AT: www.audioXpress.com

WHITE NOISE

AUDIO KITS, MODULES, COMPONENTS

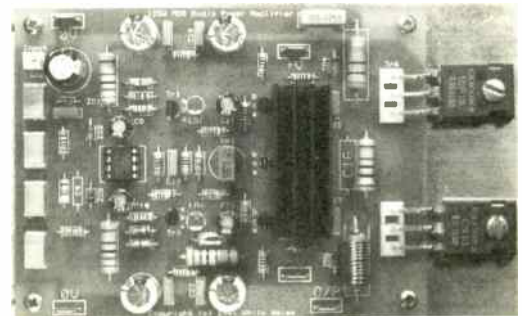

PRODUCTS INCLUDE:- Power Amplifiers 30-
250W, Preamplifiers, Phono stages, Active
Crossovers, Power Supplies, Buffer Amplifiers,
Balanced line drivers / receivers, Stepped attenua-
tors, Gold plated connectors, Cables, Capacitors,
Resistors, Semiconductors, Transformers,
Subwoofers, Loudspeaker drive units

WHITE NOISE
11 STATION ROAD
BEARSDEN
GLASGOW
G61-4AW

<http://homepage.ntlworld.com/david.white38>
Email:- david.white38@ntlworld.com
Tel:- 0141-942-2460 (until 9pm)
Fax:- 0141-587-7377

e-mail us with news at - diynews@hi-fiworld.co.uk

KIT & COMPONENT NEWS

► A PROFUSION OF GOODIES

Here's an interesting supplier of parts with many audio goodies in their range, many quite esoteric. How about an Alesis 24bit ADC for super high quality recordings? Or a Wolfson 24bit 192kHz stereo D/A converter, for which there is an evaluation board available? Many smaller manufacturers use evaluation boards and application note circuits to produce products quickly and cheaply. This is one way to approach commercial use, as well as domestic DIY use. In addition to parts like this Profusion also stock a wide range of audio power transistors, MOSFETs,

special audio connectors, balanced input transformers, special electrolytic capacitors and what have you. There aren't many suppliers who are so tuned into audio. If you want to see their product range go to :-

www.profusionplc.com.

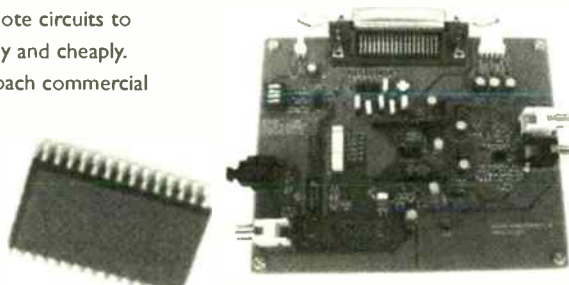

► AMPLIFY YOUR AERIAL

Philex tell us they have a new range of aerial amplifiers with a digital bypass path to accommodate the Sky Digieye. Their new SLxP range is compatible with Sky Digital, they say, and are suitable for professional installers or get-out and get-up-there DIYers who like to fit their own kit. There are 2-way, 4-way, 6-way and 8-way versions, the 2-way jobbie having variable gain, whilst the others have 10.5dB fixed gain. For more information go to :-

www.philex.com

KIT & COMPONENT SUPPLIERS

CLASSIC TURNTABLES

Technical & General
P.O. Box 53, Crawborough,
East Sussex TN16 2BY.
Tel: 01893 65 45 34.
The original specialist source of spares, replacements and expertise for the classic turntables. Years of actual experience and comprehensive range of parts (original and re-manufactured), manuals, ancillaries. No dubious 'improvements' - no harmful 'modifications'. Our specialities: Connoisseur; Garrard; Goldring; Lenco; S.M.E.; Thorens; Wtatts; Ortofon; Shure; Cartridges and stylus for 78s, Mono LPs, Stereo LPs.

COMPONENT SUPPLIERS

AudioCom (UK),
Unit 14 Pier Road
Pembroke Dock
Pembrokeshire, SA72 6TR
Tel: 01646 685601
Fax: 01646 685602
Website: www.audiocom-uk.com
E-Mail: enquiries@audiocom-uk.com
Massive range of audio components and accessories available including Black Gate electrolytics, Elna SILMIC (Silk Fibre) electrolytics, Audyn-Cap film and foil capacitors, OFC air core and copper foil inductors, high power resistors, loudspeaker crossovers, high-end cable, Vishay & Holco resistors, 99.9999% pure Silver wire, DACT CT1 & CT2 attenuators, audio connectors, spikes & damping materials, plus over 50 loudspeaker kits. Active products include the SUPERCLOCK master clock plus super-low noise PSU & Q-power super-low noise discrete regulators. A new, 365 page 2001 handbook is available for £3.50 (UK) and £5.00 (overseas).

White Noise
11, Station Road, Beardsden
Glasgow G61 4AW
Tel: 0141 942 2460
Fax: 0141 587 7377
E-Mail: david.white38@ntlworld.com
Supplier of the widest range of standard and audiophile kits for solid state preamplifiers, power amplifiers, headphone amplifiers, power supplies, MM/MC phono stages, active crossovers, balanced I/O modules, and stepped attenuators; more kits in the pipeline. All kits use the highest quality glass fibre, solder masked, silkscreened, PCBs. We also supply a wide range of active (esp. Japanese transistors and Edoon mosfets) and passive components, gold plated connectors, and silver plated wires. Write, phone or email for a free catalogue. Mail order only.

Audio-Links
7 Fairmont Crescent, Scunthorpe,
North Lincolnshire DN16 1EL

Tel: 01724 870432
Fax: 01724 875340
Email: audiolinks@europa.com
Extensive stock of specialist audiophile components for valve and solid state enthusiasts. Supplier of the largest range of high-end audio volume controls in Europe. 30 Page Catalogue - Free via e-mail or £3.00 posted.

LOUDSPEAKER KIT SUPPLIERS

Audio Note (UK Ltd)
Unit C, Peacock Ind. Est.
125-127 Davingdon Road
Howe, East Sussex BN13 1SG
Tel: 01273 220511
Fax: 01273 731298
Suppliers of a large amount of components for the Audiophile Kit builder. Valve amplification data and vintage circuits also available. See the double page spread in the back section of the main issue for extra & more detailed information.

Falcon DIY Speakers
Falcon Acoustics Ltd,
Tabor House,
Norwich Road, Mulbarton,
Norfolk NR14 8JT.
Tel: 01508 578272
UK distributors of FOCAL drive units & kits, and ETON loudspeakers, plus SOLEIL (SCR-Chateauroux) polypropylene capacitors. We are the largest specialist Audio inductor manufacturer in the UK. We also stock Audio Amateur Publications and Audio Computer Software and a comprehensive range of DLY speaker kits, parts, accessories and books. Please send large SAE (44p) for free price list. "Everything but the wood".

IPL Acoustics, Chelsea Villa, Torr's Park, Ilfracombe, North Devon, EX34 8AY
Tel/Fax: 01271 867 439
Website: www.iplacoustics.co.uk
IPL Acoustics supply a range of 7 transmission line, 3 conventional, speaker kits, and kits for centre speakers and active subwoofers. We also supply a full range of drive units from Audax, SEAS, Morel and Legend Acoustics (Ribbon Tweeters) as well as custom built metal coned drivers. Also included is a range of capacitors, inductors and quality cabinet accessories as well as Silver Plated PTFE insulated cables.

SPECIALIST UPGRADE SUPPLIERS

AudioCom (UK),
Unit 14 Pier Road
Pembroke Dock
Pembrokeshire, SA72 6TR
Tel: 01646 685601
Fax: 01646 685602
Website: www.audiocom-uk.com

E-Mail: enquiries@audiocom-uk.com
Release the full potential of your digital source with CD/DVD upgrades from audiocom. Available is the highly acclaimed SUPERCLOCK master clock oscillator. (Dave Bennin fits the S-Clock to the Teac VRDS-10SE and comments... there was not one area of music reproduction which didn't improve!) SUPERCLOCK super low noise power supply, & Q-power ultra-low noise discrete regulators. Why not contact us to see how this service can be adapted to suit your requirements?

Rush Communications, 10 Chestnut Avenue, Clocton on Sea, Essex, CO15 2BQ
Tel: 01255 224 041
Fax: 01092 260 243
E-Mail: rcom@lineone.net
Website: www.rcom.connectingbusiness.com
VALVES VALVES VALVES
Audio Engineer with 35 years experience can repair, modify or upgrade any valve amplifier or pre-amplifier

VALVE AND OUTPUT TRANSFORMER SUPPLIERS

Wilson Valves, 28 Banks Avenue, Galilee, Huddersfield, West Yorkshire HD7 4LZ.
Tel: 01484 654650
Fax: 01484 655699
E-mail: wilsonvalves@surflink.co.uk
We stock over 2500 different types of valves, N.O.S. and New. Please send a S.A.E. for full list. No charge for matching. Most major credit cards accepted.

Worford Valves
3 Ryall Close, Bricklet Wood,
St. Albans, Herts AL2 3TS
Tel: 01923 893270
Fax: 01923 679207
Specialist in new old stock and current production valves. Sole UK distributor of the Harma Diamond range selected for their superior performance. Huge range held, stockists of Mullard, GE, Philips, National, Brimar, Sylvania, Telefunken, RCA, MOV and many more. All valves are new boxed and guaranteed. For free price list and specialist advice call or fax Derek Rocco, Wadford Valves.

Chelmer Valve Company Ltd
The Stables, Baddow Park
Great Baddow, Chelmsford, Essex
CM2 7SY
Tel: 01245 241301
Fax: 01245 241309.
Email: sales@chelmervalve.com
Web Site: www.chelmervalve.com
Supplier of premium range of audio valves, other valves and components also available. (Please see our main advertisement in this supplement).

Longrex Supplies Ltd
1 Mayo Road, Croydon,
Surrey CR0 2QP
Tel: 020 86841166
Fax: 020 86843056
One of the largest distributors of electronic valves, tubes and semi-conductors in the UK by original UK and USA manufacturers. Obsolete types are a speciality. Telephone or fax for an immediate quotation.

Billington Export Ltd.
1E Gillmans Trading Estate,
Billingshurst,
West Sussex RH14 9EZ
Visitors by appointment only please
Fax: 01403 783519
E-Mail: sales@bel-tubes.co.uk
Website: www.bel-tubes.co.uk
Minimum order - UK£100.00 + VAT + Carriage
Export £150.00 + Carriage
Specialists in guaranteed new/old stock, current production valves & tubes. Also CRT for audio, hi fi (as well as industrial uses). A vast archive of vintage and obsolete types including limited quantities of Mullard, GEC, Sylvania, Philips, Brimar, Telefunken, RCA and others. Large stocks of Chinese, Russian, El and Tesla etc. A 50-page valve catalogue is available on request. Major stockists of the excellent Billington Gold brand. Contact us for quotations - attractive price on larger orders.

Audio Specialist,
W. Marriott
73 Station Road,
Sturry-in-Ashfield,
Notts,
NG17 2DL
Tel: 01623 461128
Email: wasmarricott@talk21.com
Transformers. One of the world's widest range manufactured. Mains choice's, output transformers etc. From the standard IE M6 to the awesome Hi-B nickel double C-Core's wound with the superb 6N cardas copper cable. All types of transformers manufactured. One of a speciality. A superb range of accessories and components supplied. Solder copper, brass etc. cases available for that special project. All types of repairs, modification undertaken. Rebuilds, kits built to both thermionic solid state. Classic vintage equipment always sought, working or not. Catalogue £2.50 redeemed on first order over £30.00

TO ADVERTISE IN THE
KIT & COMPONENT
SUPPLIERS PAGE
PLEASE CALL
020 7624 9022
Email:
diyadvertising@hi-fiworld.co.uk

Upgrading our & 34 Series

Nick Lucas guides you through our upgrade package for the KiT6550 and KiT34 integrated amplifiers

Our KiT6550 integrated amplifier and KaT6550 power amplifier, and the 34 Series comprising KiT34 integrated and KaT34 power amplifier are based around the same circuitry, with slight changes to suit the operating conditions of the 6550 and KT88 tetrode power valves for the former, and the EL34 pentode power valve for the latter. All these amps use the triode/pentode ECF80 as input/phase splitter instead of the two valve arrangement of their predecessors. As there are many similarities with these two ranges we thought it would be a good idea to carry out upgrades on both at the same time. Following the tried and tested formula of our previous upgrade kits, we selected Rubycon's amazing Black Gate, high performance, graphite foil electrolytic capacitors in the position of the output valves' cathode by-pass capacitors, C15, C16, C17 and C18, and as the low frequency component feedback capacitor C9 and C10. Being electrolytic these capacitors are polarised, so they have positive and negative leadouts. They are clearly marked and follow the same orientation as the original components.

The signal capacitor that blocks the d.c. voltage component from the anode of triode section of the ECF80 contributes significantly to the sound. Consequently, we have gone for a change here, substituting Jensen's paper-in-oil capacitors. Jensen make a range of paper-in-oils. The capacitors we have chosen are their aluminium foil type, hermetically sealed in an aluminium tube. The terminal leads are tinned copper, solder-sealed to eyelets in the end-discs. The capacitor element is insulated from the tube. The terminal in contact with the outer foil (i.e.

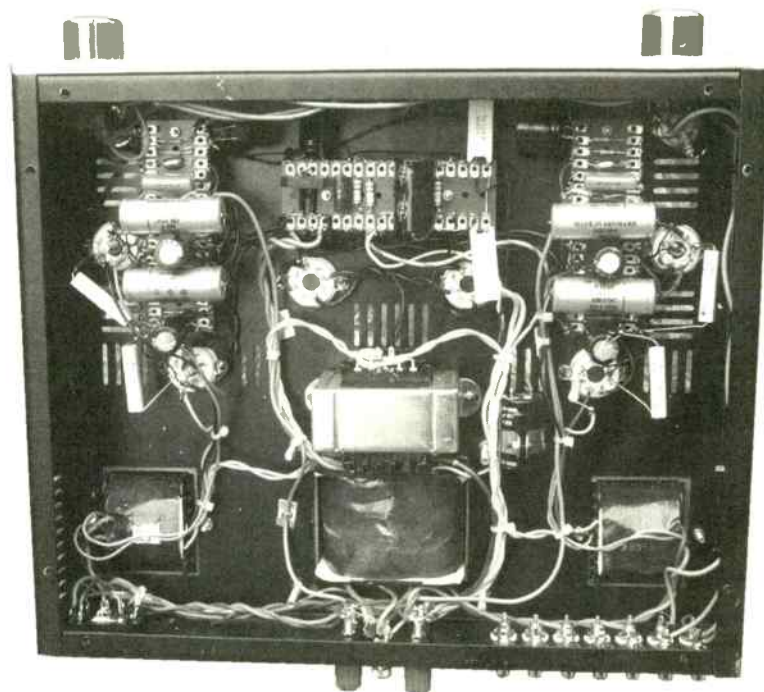

closest to the can) is always marked with a vertical line on the body of the capacitor. To ensure best performance, this terminal must be connected to the grid stopper end, R31, R32, R33 and R34 (2.2kohm resistor that feeds the input grid of the output valves.) We chose the aluminium foil construction capacitor from Jensen's range because the copper foil, silver leadouts type cost around £60 each, which leads to enormous cost for four items.

The volume potentiometer of the integrated versions is an obvious target for improvement. The original carbon track unit has a good sound, but we chose to put a 100k specialised Alps in its place. This high-grade potentiometer offers comfortable operation and possesses high precision characteristics, ideal for audio applications.

DIFFICULT TO UPGRADE?

If you built the kit, then you will have no trouble with the upgrade:

The Alps 100k potentiometer has a small orientation lug that needs to be removed in order that it fits flush. This can be easily done with a pair of cutters. The shaft of the potentiometer fits in the hole of the old one,

although it is tight. You will find it easier to do the wiring while the potentiometer is free of the chassis front.

As the components sit on tag boards and all solder points are accessible there is no need to remove the boards, unlike PCBs. Make sure all Black Gates are correctly orientated.

The Jensens are much larger than the original Philips 486 orange coloured capacitors. Even though there is a lot of available space for fitting, you need to be able to get the iron in to solder component side without burning the capacitor body. Plan it before fitting. The capacitor's outer foil end, signified by a line on the component body, needs to be soldered to the join that relates to the 2.2k grid stopper that feeds directly into the grid of the output valves - this ensures the best performance. Their long leads need to be isolated with rubber sleeving to avoid unwanted contact with other parts of the circuits.

Now over to Simon Pope for the sound quality. We have concentrated on the integrated version for the listening test. The power amplifier versions will be sonically similar.

6550 Series amplifiers

KIT34 basic version

Our Kit 34 offers great insight into music, a typical trait of the valve amp, with the added bonus of the excellent grip and dynamics associated with solid-state designs. Playing an LP of Paul Weller's Greatest Hits the Kit 34 sounded full and warm with a good amount of high-end detail, yet also a good balance of all frequencies. Bass was firm and musical and the midrange information of the guitars and vocals was clear and well defined.

KIT34 with Alps potentiometer

Here the inclusion of the Alps brought out some finer details and nuances of the midrange and added more punch to the bass and drums. Weller's voice became slightly warmer and more forward in the sound stage and the accompanying guitars had more body.

KIT34 with Alps potentiometer and Black Gate capacitors

The Black Gates add a touch of smoothness to the overall sound, making drums richer and vocals warmer. Upper frequency detail still remained but was partnered with a sweeter sounding treble, making cymbals sparkling and life like.

KIT34 with Alps potentiometer, Black Gate and Jensen capacitors

This inclusion of the Danish made capacitors tightened up the grip of the music, creating what seemed a faster and more immediate sound but with all the traits of the above

upgrades also present. Bass was tuneful and tight, midrange open and spacious and treble sweet and detailed.

KIT6550 basic version

This amplifier has fine control of bass, concentrating on an infectious mixture of rhythm and detail. 'Underdog' by Turin Brakes, with its copious acoustic guitar strumming sounded warm and lucid, with the male vocals clear. Bass drum had a nice sharp 'thud' to it and treble was open and detailed.

KIT6550 with Alps potentiometer

The Alps pot added more bass response to the bottom-end and pushed the bass drum further back, and vocals further to the front of the sound stage. Imaging improved, too, with the accompanying guitar strumming more intricate on either side of the picture.

KIT 6550 with Alps potentiometer and Black Gate capacitors

The Japanese Black Gates, with their innate smoothness of sound, made the vocals richer and warmed up the guitar timbre. The sound was also slightly fuller bodied, creating a 'fatter' image through the 'speakers which added more involvement to the music.

KIT6550 with Alps Potentiometer, Black Gate and Jensen capacitors

The Full Monty upgrade resulted in a very involving sound, with a high degree of detail and a full and exact sound stage. Imaging was

greatly improved and the mix became wholly cohesive and communicative. Upper band detail was excellent and the bass very tuneful and taut.

FURTHER UPGRADES

Obviously there is no limit as to how far you can take an upgrade. If you decide that you wish to take it further here are a few pointers.

- a) We have heard many good things about Tantalum resistors, so you could try swapping all grid stoppers - R9, R10, R31, R32, R33 and R34 and possibly the feedback resistor R45 and R46. A word of warning though: it is never a good idea to swap all resistors, especially if you go to high-end metal film type. They can sound a touch too bright, with diminished bass output.
- b) Swap C19/C20 for high quality polypropylene.
- c) Invest in some Aerovox or Cerafine electrolytics to replace C1, C2, C3, C4 and C5. Watch out on room as the original components sit on the tag board. The new type are usually clamp fittings so the chassis needs to be drilled and clamps purchased. Even better, get some Ansar polypropylene capacitors. These work wonders in power supplies but are generally quite large, so make sure they will fit before you purchase.
- d) C16/C17 These capacitors in the feedback network are key components. Try swapping them to Scan-Ex polystyrenes. These are available from Audio-Links 01724 870432. Enjoy upgrading. ■ ▲



KIT34 INTEGRATED VALVE AMPLIFIER

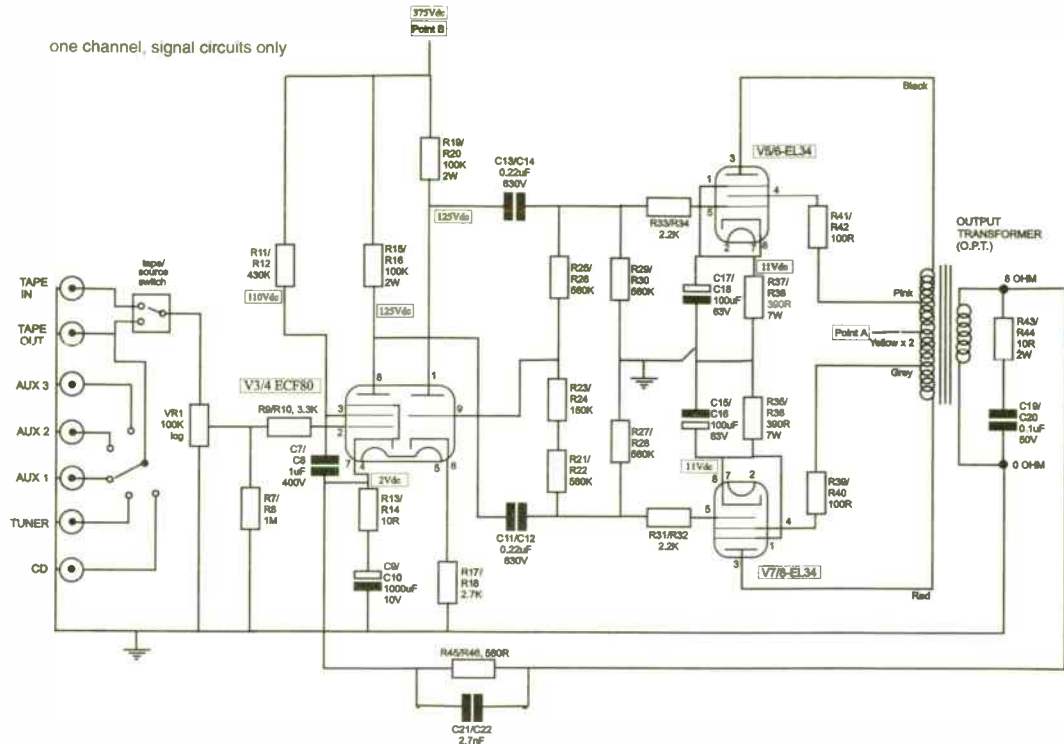

Valve pin layout

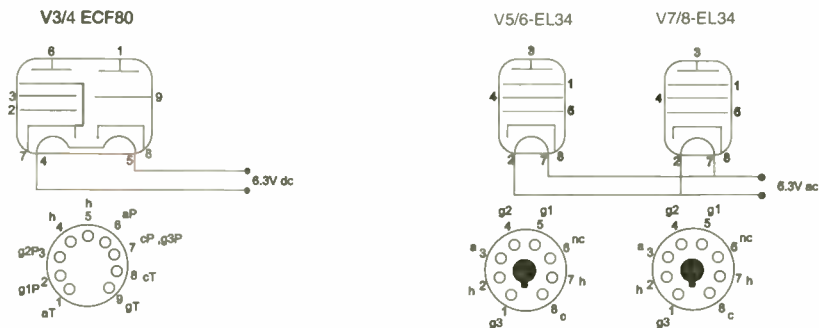

Views are from underneath valve or valve holder
 h = heater hct = heater centre tap c = cathode a = anode g1 = grid 1 g2 = grid 2 g3 = grid 3 nc = no connection (T=triode P=pentode for V1)

KIT34 UPGRADE KIT

KiT34 upgrade kit	£130.00	£110.00
KaT34 upgrade kit	£120.00	£105.00
KiT6550 upgrade kit	£130.00	£110.00
KaT6550 upgrade kit	£120.00	£105.00
or		
100k Alps Pot.	£14.00	£12.00
Jensen 0.22uF, 630V	£16.00	£14.00
Black Gate 1000uF, 16V	£8.00	£6.80
Black Gate 2200uF, 16V	12.00	£10.00
Black Gate 100uF, 50V	£6.00	£5.20
Black Gate 100uF, 100V	£8.00	£7.00

Call or fax Nick Lucas on: +44 (0) 1908 218836 (9am-5pm, Monday-Friday)

e-mail: nick@worldaudiodesign.co.uk

For overseas freight charges, please call, fax or e-mail.

order online - www.worldaudiodesign.co.uk

NEW PRODUCTS FOR VALVE PRE AMPS

Full range of Mumetal input and output transformers for balanced and unbalanced pre-amps, microphone amps, equalizers etc.

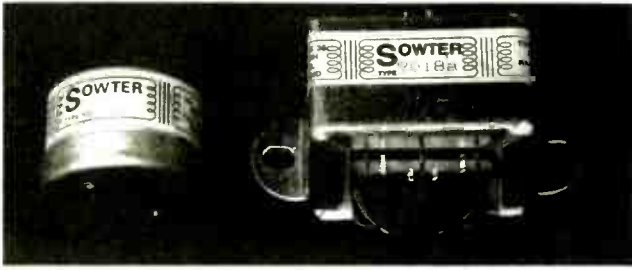

For the true "valve sound" and elimination of hum and interference in your own or vintage designs. A new range and custom service for low power transformers to complement our power amplifier products. Transformers built to order 2-4 weeks delivery. Full technical support. Free catalogue. Visa, MasterCard, JCB etc.

E A Sowter Ltd
PO Box 36 IPSWICH
IP1 2EL England
Tel: (+44) (0) 1473 252794
Fax: (+44) (0) 1473 236188

E-Mail: sales@sowter.co.uk
techsupport@sowter.co.uk
Call or visit our Website for catalogue and information
http://www.sowter.co.uk



Music's Finest Conductor Test & Quality Control Engineer

The Audio Note Co. is a specialist hifi company making both analogue and digital products for the music enthusiast. we are world leaders in several areas of valve amplification and digital technology.

For our expanding plant soon to be set up in Newhaven, we are looking for one and possibly more qualified electronics engineers with hands on experience in both test and quality control procedures.

The applicant must have proven experience in test and fault finding to component level and general quality control procedures, be able to work independently, liaise with production and research & development on all matters concerning design changes, updates etc.

If you fit this bill, regardless of age, you should apply for this position. we operate a friendly no smoking environment and provide a good competitive salary structure with longterm prospects.

Apply to.

P. Quortrup
Managing Director

Audio Note Co Ltd. Unit C, Peacock Industrial Estate, Lyon Close,
125 - 127, Davigdor Road, Hove, BN3 1SG, East Sussex, England.
Tel. +44 (0) 1273 220511 Fax 731498
Email: info@audionote.co.uk Company Reg. No. 3357356.
Vat Reg. No. 699 3396 60

Ansar Supersound Polypropylene Axial Capacitor



Audio specific. For transparent & detailed sound with EXTREMELY low distortion. High purity imported metallised polypropylene Tol 5%

Part no	Description	L x D mm	Price
CPW100N	Ansar 100nF 630V	32 x 6.5	2.00
CPW150N	Ansar 150nF 630V	32 x 7.5	2.00
CPW220N	Ansar 220nF 630V	32 x 9.0	2.00
CPW330N	Ansar 330nF 400V	32 x 8.0	2.00
CPW470N	Ansar 470nF 400V	32 x 9.0	2.00
CPW680N	Ansar 680nF 400V	32 x 10.5	2.00
CPW1U0	Ansar 1uF 400V	32 x 12.5	2.00
CPW1U5	Ansar 1.5uF 400V	32 x 14.7	2.00
CPW2U2	Ansar 2.2uF 400V	43 x 14.8	2.50
CPW3U3	Ansar 3.3uF 400V	43 x 17.6	3.00
CPW4U7	Ansar 4.7uF 400V	43 x 20.7	3.00
CPW6U8	Ansar 6.8uF 400V	43 x 22.8	3.50
CPW8U0	Ansar 8uF 400V	43 x 26.5	4.00
CPW10U0	Ansar 10uF 400V	43 x 29.5	4.00
CPW15U0	Ansar 15uF 400V	55 x 34.1	6.00
CPW22U2	Ansar 22uF 400V	55 x 39.3	7.50
CPW33U5	Ansar 33uF 400V	55 x 42.0	7.50
CPW30U3	Ansar 30uF 400V	55 x 44.7	9.00
CPW50U0	Ansar 50uF 400V	83 x 46.0	12.00
CPW60U0	Ansar 60uF 400V	83 x 51.7	13.00
CPW75U0	Ansar 75uF 400V	83 x 55.1	18.00
CPW80U0	Ansar 80uF 400V	83 x 56.8	18.00
CPW100U0	Ansar 100uF 400V	115 x 55.0	20.00
CPW125U0	Ansar 125uF 400V	115 x 61.2	26.00

Dual Polypropylene Smoothing Capacitors

To replace old electrolytics or for new designs Wire tails

Part no	Description	L x D mm	Price
CPW1616	Propyl 16-16 400V	100 x 50	25.00
CPX 1616	Propyl 16-16 630V	115 x 63	30.00
CPW3232	Propyl 32x32 400V	115 x 61	30.00

Philips Polypropylene Axial 1%

Blue coated Film & Foil Epoxy coated, low inductance metal foil & film. Supremely stable. Tolerance 1%

Part no	Description	Price
CPW47P	Propax 47pF 630V	0.40
CPW100P	Propax 100pF 630V	0.40

Part no	Description	Price
CPP150P	Propax 150pF 630V	0.40
CPP220P	Propax 220pF 630V	0.40
CPP330P	Propax 330pF 630V	0.40
CPP470P	Propax 470pF 630V	0.40
CPP680P	Propax 680pF 630V	0.40
CPP1N0	Propax 1nF 400V	0.40
CPP1N5	Propax 1.5nF 250V	0.50
CPP2N2	Propax 2.2nF 250V	0.50
CPP3N3	Propax 3.3nF 250V	0.50
CPP4N7	Propax 4.7nF 160V	0.50
CPP6N8	Propax 6.8nF 160V	0.50
CPP10N	Propax 10nF 63V	0.60
CPP22N	Propax 22nF 63V	0.70
CPP33N	Propax 33nF 63V	1.00
CPP47N	Propax 47nF 63V	1.50

Audio Electrolytics Radial

185 deg C -PLUS- low impedance
These superior electrolytics offer a low impedance path to the signal, resulting in a very open & detailed sound. The use of high temperature materials ensure that these capacitors enjoy a long & stable life

Part no	Description	Price
1Y50	Lo Imp Hi Temp 1uF 50V	0.30
2U2Y50	Lo Imp Hi Temp 2.2uF 50V	0.30
4U7Y100	Lo Imp Hi Temp 4.7uF 100V	0.30
10Y63	Lo Imp Hi Temp 10uF 63V	0.30
22Y63	Lo Imp Hi Temp 22uF 63V	0.30
47Y63	Lo Imp Hi Temp 47uF 63V	0.40
100Y63	Lo Imp Hi Temp 100uF 63V	0.60
220Y50	Lo Imp Hi Temp 220uF 63V	0.80
470Y63	Lo Imp Hi Temp 470uF 63V	1.50
1000Y35	Lo Imp Hi Temp 1000uF 35V	1.50
2200Y50	Lo Imp Hi Temp 2200uF 50V	2.50
4700Y25	Lo Imp Hi Temp 4700uF 25V	2.50

Alcap Bipolar Electrolytics

Alia leads 50V Tol .10%
Primarily for use in speaker crossovers

Part no	Description	Price
CAB1	Alcap 1uF	0.40
CAB2U2	Alcap 2.2 uF	0.40
CAB3U3	Alcap 3.3uF	0.40
CAB4	Alcap 4uF	0.40
CAB5	Alcap 5uF	0.40
CAB6U8	Alcap 6.8uF	0.50
CAB8	Alcap 8uF	0.50
CAB10	Alcap 10uF	0.50
CAB16	Alcap 16uF	0.80
CAB20	Alcap 20uF	0.80
CAB25	Alcap 25uF	0.80
CAB35	Alcap 35uF	0.80
CAB50	Alcap 50uF	1.00
CAB60	Alcap 60uF	1.00
CAB80	Alcap 80uF	1.50
CAB100	Alcap 100uF	1.50

Monacor Air Cored Inductors.



A range of professional air cored inductors for 8u or 4u crossovers/ilters for use up to 300W 1.2mm enamelled copper wire wound on air spaced plastic bobbins

Part No	Specification	Price
P15	15uH 0.15u 8x19mm	£2.00
P22	22uH 0.15u 48x19mm	£2.50
P33	33uH 0.2u 8x19mm	£3.00
P47	47uH 0.25u 50x19mm	£3.50
P68	68uH 0.35u 59x19mm	£4.50
P100	1mH 0.4u 59x19mm	£5.50
P150	1.5mH 0.5u 70x30mm	£6.50
P220	2.2mH 0.6u 70x30mm	£8.00
P330	3.3mH 0.75u 70x30	£10.00

Monacor Ferrite Inductors



A range of professional high efficiency ferrite cored inductors with very low ohmic losses for 8u or 4u crossovers or filters for use up to 400W 1.4mm enamelled copper wire (1.3mm on F1000) wound on plastic bobbin

Part No	Specification	Price
F220	2.2mH 0.15u 400W 55x31mm	£6.50
F330	3.3mH 0.2u 330W 65x39mm	£9.50
F470	4.7mH 0.25u 140W 65x30mm	£11.00
F680	6.8mH 0.35u 120W 65x39mm	£12.00
F1000	10mH 0.45u 100W 65x39mm	£13.50

High Quality Valves

Part No	Description	Price
5881	BEAM TETRODE	£9.00
6550C	BEAM PENTODE	£26.00
6L6GT	TETRODE	£4.50

Part No	Description	Price
6SN7GT	TRIODE	£4.50
6V6GT	TETRODE	£4.50
E88CC	RUGGED DOUBLE TRIODE	£11.00
ECC81	DOUBLE TRIODE	£5.00
ECC82	DOUBLE TRIODE	£5.00
ECL82	TRIODE PENTODE	£4.00
ECL86	TRIODE PENTODE	£4.00
EF86	LOW NOISE PENTODE	£10.00
EL34	PENTODE	£8.50
EL84	PENTODE	£3.50
EM84	MAGIC EYE	£9.00
GZ34	RECTIFIER	£7.00
KT66III	BEAM TETRODE	£25.00
KT88	BEAM TETRODE	£20.00

Valve Holders - High Quality Valve Bases. Chassis Mounting With Screw Fittings.

Part No	Description	Price
B9AC	B9A VALVE HOLDER CERAMIC	£1.50
B9AG	B9 VALVE HOLDER PORCELAIN PLUS GOLD PLATED PINS	£3.00
OCTC	OCTAL VALVE HOLDER CERAMIC PLUS GOLD PLATED PINS	£2.00
OCTG	OCTAL VALVE HOLDER PORCELAIN PLUS GOLD PLATED PINS	£4.00

Fully Gold Plated Phono (RCA) Plugs with spring coil cable grip.



Part No	Description	Price
PPG5A2	PAIR GOLD PLUGS for up to 5mm CABLE	£1.50 pair
PPG8A2	PAIR GOLD PLUGS for up to 8mm CABLE	£1.50 pair

Very High Quality Phono (RCA) Plugs



Very high quality satin grey metal with heavy gold plated connections. Top collet cable grip & PTFE insulators. Very low noise

Part No	Description	Price
PPG6H2	GOLD PTFE PLUGS for up to 5mm CABLE	£3.50 pair
PPG8H2	GOLD PTFE PLUGS for up to 8mm CABLE	£3.50 pair

Extra High Quality Gold Plated Phono Oxygen Free (RCA) Leads (pairs)



Highly flexible oxygen free cable with extra moulded-in control / grounding wire.

Part No	Length/Colour	Price
LPP10G	0.8 Metres/Green	£5.50
LPP20G	1.5 Metres/Green	£6.50
LPP50G	5 Metres/Green	£11.00

Bass Reflex Tuning Ports



A range of adjustable plastic ports for use in various sizes of loudspeaker cabinets. d=diameter L=adjustable length (mm)

Part No	Dimensions	Price
R35	d=35L=110-210	£2.50
R50	d=50L=150-280	£3.00
R70	d=70L=128-245	£3.50
R100	d=100L=160-122	£5.50
R85	d=85 angled 45 for narrow cabinets L=210-310	£6.50

High Quality Components at the right price. Please add £3.00 carriage & VAT to all orders. Credit Card phone orders accepted.

www.cricklewoodelectronics.co.uk
email sales@cricklewoodelectronics.com

Circuit of 6550 integrated power amplifier (one channel)

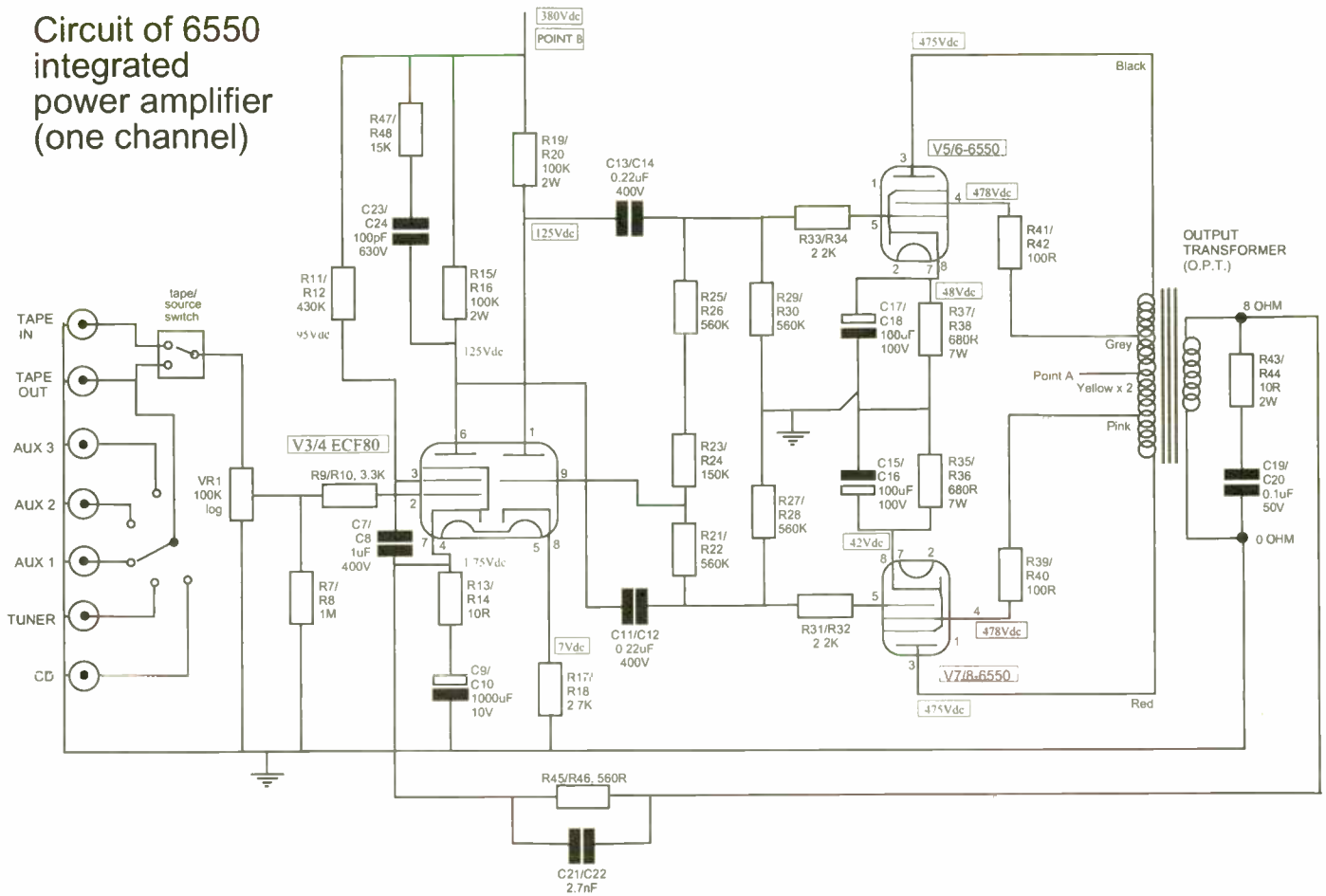

KiT34 & 6550 PARTS LIST

34 Series Parts List

Part No.	Description	Quantity
VR1 (KiT34 only)	Alps 100k dual log potentiometer	1
C9/10	Black Gate 1000uF 16V	2
C13/14/15/16	Jensen paper in oil 0.22uF 630V	4
C15/16/17/18	Black Gate 100uF 50V	4
rubber sleeving	20cm	

6550 Series Parts List

Part No.	Description	Quantity
VR1 (KiT6550 only)	Alps 100k dual log potentiometer	1
C9/10	Black Gate 2200uF 16V	2
C13/14/15/16	Jensen paper in oil 0.22uF 630V	4
C15/16/17/18	Black Gate 100uF 100V	4
rubber sleeving	20cm	

**All upgrade kits mentioned are available from
World Audio Publishing Ltd
UK (inc. vat & p&p) Overseas (exc. vat & p&p)**



EAR 834P Signature - MM/MC as new only
£390



Manley Labs 50w mono blocks. The most Dynamic 50w valve sound you will ever hear On demo
£2250



The stunning Unison research S8. Using the legendary 845 valve, they are the sweetest cleanest sound you will hear
£2950 £2495



PINK TRIANGLE PT Export fitted with SME 309. Best based as new
£2000 £795



EAR V 20 - Great reviews and a visual masterpiece - on demo
£2799



AUDIO PHYSIC Virgo II Class A Stereophile Class A rated on demo
£3000 £1999

NEW & EX DEMO EQUIPMENT

	NEW	£		NEW	£		NEW	£
EAR			Conrad Johnson			Opera speakers		
NEW DEALERS FOR THE FULL EAR RANGE			PV-108L vacuum tube line pre amp	1195		Pavarotti on demo	695	595
EAR V20 integrated, great reviews & a visual masterpiece - on demo	2799		PV-108L with all valve - on demo	1495		Super Pavarotti on demo	995	895
EAR 861 power amp. Great reviews - on demo	3799		PV-14 pre amp - on demo	2200		Callos Gold on demo	1095	895
EAR 864 pre. Balanced inputs/outputs - on demo	1529		MV-60 VT power amp 60w - on demo	2695		Final Electrostatics		
EAR 834P deluxe. MM/MC phono stage - on demo	779					0.3 ex demo	1495	995
MCE MC step up transformer. Probably the best available - on demo	659		Plinius			0.4 NEW - on demo	2500	2195
PLEASE ASK FOR THE MODEL YOU ARE INTERESTED IN IF IT IS NOT LISTED ABOVE						Triangle Loudspeakers		
Veritas			8100 100w on demo	1450		Zephyr XS on demo		590
P400 Digital power amp 240w - on demo	2995		Jorah Phono stage on demo	599		Ittoh XS		725
Manley Labs			8200 Integrated 175w with phono stage	2250		Antol XS		875
Stingray Integrated Valve amplifier - on demo	2195					Zays XS		1195
Purist pre amp on demo	1650		Pathos			Celius 202 6x on demo new model, Stereophile Grade A		1250
50w Monoblocks on demo	2250		Classic One - on demo	995		Lyrr XS		1650
Unison Research			Twin Towers RR - Hybrid valve & solid state the best of both worlds. HiFi News loved it, so will you - on demo	3250		Ventis		2195
NEW MODEL : DM Dual mono power amplifier 150w per channel, can be bridged to form a 500w mono block !!! ON DEMO -	850					Loth-X		
S2K Pure Class A using the legendary KT-88 power valve. Single ended heaven. ON DEMO	1300		Audio Analogue			Othello precision turntable on demo		1145
S2 single ended ultralinear Class A - on demo	975		Belini remote pre-amplifier, superb on demo	560		Ion BS-1 speakers, 94db		
SR1 valve & solid state ex demo	1250		Donizetti 100w monoblocks - on demo - pair	920		Great HiFi news review		400
S6 single ended pure Class A ex demo	1600		Maestro CD player - 24 bit 96 Khz upsampling - on demo	1500		The all new Amaze on demo		750
S8 single ended Class A 24w - on demo	2950		Puccini SE Integrated amp - on Demo	635	540	All new Auro floorstander on demo		1600
Simply Phono, stunning all valve NEW - on demo	510		Paganini 24 bit CD player	795	695			
PSU for simply phono NEW	400		latest model on demo	795	695	Benz Micro of Switzerland		
Smart 845 mono blocks on demo -	3450		Maestro 150w integrated amp on demo	2500		'The Glider' on demo		650
Kuzma			Audio Physic Loudspeakers			MC Silver		165
Stabi S with Stagi S tone arm on demo	1245		Virgo II Class A Stereophile rated on demo	2799	1999	MC Gold		165
HEART			Spark III on demo	400		Ace 2mv MC on demo		395
CD 6000 valve CD player. If you can find a better sounding CD player for up to £1,000 we would like to know what it is!! - on demo	590		Tempo III	1999		Lavardin - Newly appointed dealers for this superb brand		
			Avanti III - on demo	7599		Lavardin IS integrated - incredible HiFi review. On Demo		1495
			Croft			Lavardin IS Reference amplifier - new model on demo		2295
			Vitale pre amp NEW on demo	379				
			Epoch Elite pre amp, reference quality, valve regulated psu. In new aluminum chassis - on demo	1000				
			Apparition Elite 15w per channel OTL power amp - on demo	1600				

improve your listening pleasure

CARED FOR USED EQUIPMENT

Turntables/Cartridges/Phono stages	NEW	£
EAR 834P Signature MM/MC all valve phono stage		390
Mitchell Gyrodec SE with acrylic cover and record damp R8300 boxed new	1175	795
Ortofon Jubilee boxed unused	1250	699
Ortofon Rohmann boxed new	1200	649
SME 309 Boxed New		629
SME IV - Boxed NEW		890
Pink Triangle PT Export. Fitted with SME 309, Boxed as new	2000	795
Linn Ekos tone arm. Boxed as new. Latest specification	1500	790
Audio Note R-Zero phono stage. Boxed new. Unused	450	350
Linn LP12, Valhalla, Ittoh, boxed		690
Amplifiers		
Lavardin IT, boxed as new. Very rare	3250	2600
Quad 405 Boxed. Manual as new		250
Moon i5 Boxed NEW - black facio	2600	1999
Jadis Orchestra Reference, Boxed New	2495	1795
Electrocompaniet AW60FTT power amplifier. Boxed (we also have matching pre amp for above)	1200	650
Pre - amplifiers		
Parasound PLO 2000, balanced inputs & outputs boxed	1695	795
Quad 34 - Boxed unused. Very rare		275

Pre - amplifiers	NEW	£
Quad 44 boxed with manuals		175
Electrocompaniet EC4.7, reference quality, balanced inputs & outputs	1200	699
EAR 834L, all valve line stage, unmarked & boxed	550	350
Speakers		
Audio Physic Virgo 11 - ex demo	3000	1999
Quad ESL 63's, boxed	3300	1595
Quad ESL 57 Electrostatics, Black panels, amazing condition		675
Gershman Avantgarde RX-20. Boxed	4900	2990
Verity Fidelio in Makore finish. One owner. Boxed	7300	5900
Wilson Watt/puppies 5.1	18000	6900
JM Labs Mezzo Utopia - boxed	7000	4500
CD Players/Transports/DAC's		
Marantz SA-1 super audio CD player. 3 months old still under warranty	5000	3500
Mark Levinson No 39, 2 years warranty left	5200	3500
Copland CDA 288 HD/CD. Boxed as new	2000	999
Audio Note CDT Zero. Boxed new unused	500	450
Audio Note DAC One 1X Boxed new unused	750	650
Electrocompaniet EMC-1 balanced outputs and RCA, boxed	2400	1500
FULL SYSTEM - SPECIAL		
Quad 77/707 system - 77 pre, 77 CD & 707 Power boxed as new with Quad controller	2650	1250

appointed dealers

- Manley Labs
- Croft
- Kuzma
- Conrad Johnson
- Benz Micro
- Cardas
- Loth-X
- Unison Research
- Opera
- Audio Analogue
- Final
- Pathos.
- Graaf
- LAT
- Monrio
- Diapason
- Esopower
- Ecosse
- Veritas
- Plinius
- Triangle
- Michell
- Audio Physic
- Lavardin
- EAR

OUR GUARANTEE: If for whatever reason you are not entirely satisfied up to 14 days from purchase for any reason, you may return it (in as condition supplied with original packaging etc) in exchange at FULL purchase value for any other stock item whether it be cheaper or more expensive.

Full stock list of New & Used products plus reviews and much more on our web site 24 hrs a day
www.connoisseuraudio.co.uk

01592 630652

E mail : info@connoisseuraudio.co.uk
Open Mon - Sat 9.30 - 5.30

Connoisseur Audio



**High end Hi-Fi
from Etalon of Hungary**

Leather handbags by Arrogance, Bosboom
and Tula **Hand Blocked Soft Furnishings**
Miniature Swords by Wilkinson
a very large selection of Brio Railway
over 150 different Beanie Babies
Mamod and Wilescio Working
Steam Engines Meccano
Collector's Playing Cards
Chess Mah Jong and
Backgammon Juggling gear



For something a little different

Salago

The Old Butterwalk, Totnes, Devon, TQ9 5NP
Telephone (24hr) 01803 866981

Or buy from our web site
www.salago.co.uk

*The shop
that is
a little
different*

Valve Amplifier Magic!

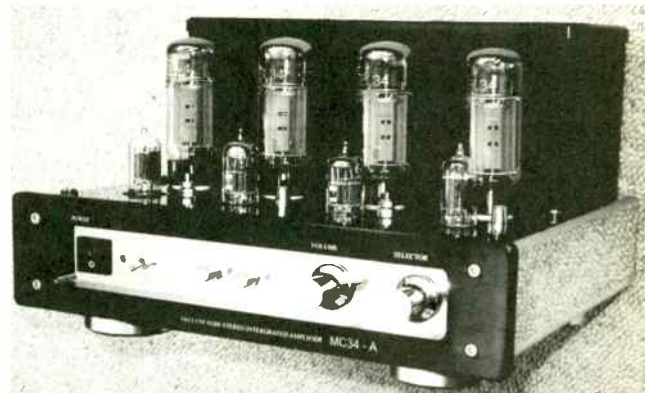

Icon Audio MC34-A

Simply a very beautiful hand made amplifier using point-to-point wiring, top quality components and superb construction.

We believe that old-fashioned values like solid build quality coupled with good design and audiophile components makes a difference you can hear.

Go on read our spec, but what it does not tell you is the wonderful sound stage, and the detail you can hear even in complex passages. The passion comes through in all kinds of music. And this is a 'Listening Fatigue' free amplifier.

Look at the excellent specification...

- 4x EL34 output valves
- 2x 12AU7 for pre-amp
- 2x 12AX7 phase-splitter
- No printed circuit board
- Hand wired point to point
- 30 Watts RMS per channel
- Signal to noise level 86db
- Power bandwidth 20hz-40khz
- 45 watts peak per channel
- 4 and 8 ohms output taps
- Japanese EI transformers
- Attractive safety guard included in the price
- Minimal feedback
- Ultra-Linear operation
- High quality carbon & metal film resistors
- German audio capacitors
- Japanese ALPS volume pot.
- Black Diamond power caps.
- Internal wiring using silver gilt cable
- Valves carefully matched & burnt in up to 100 hours
- Attractive safety guard included
- Polished stainless steel chassis
- 30 day money back trial
- Gold plated Input & speaker terminals
- Inputs for CD, Tape, Tuner, Aux
- 200mv sensitivity, can be used with or without a pre-amp
- 240volts, 135watts
- 320W, 250D, 180H, 14.6kg
- 12 months full Guarantee **including valves**

Even our price is beautiful ...only £599.95
Including delivery and 12 months guarantee including valves.

But don't take our word for it, try it for yourself for up to 30 days, full refund if not delighted. Please visit our website for full description and detailed photo's (inc internal) www.iconaudio.co.uk or send now for our free info sheet, by phone or email.

Icon Audio

351 Aylestone Road Leicester LE2 8TA
Phone 07787 158791.

email sales@iconaudio.co.uk



We accept Visa and MasterCard.
CE certified



**64 FLIXTON ROAD
URMSTON
MANCHESTER
M41 5AB
0161 202 9922**

SECOND HAND AND EX DEM ITEMS FOR SALE

	RRP	SALE PRICE
CD PLAYERS		
Myryad T10 silver, as new	£400	£350
NAD S500 Silver Series	£1000	£850
AMPLIFIERS		
Audio Analogue Bellini/Donizetti (silver)	£1100	£700
Crimson 610 preamp with MM/MC phono stage	£450	£200
Exposure 2010 integrated	£599	£499
LFD Mistral pre amp	£450	£300
LFD PAO power amp	£650	£300
Myryad T50/T70 pre/power with prologic	£949	£600
NAD S300 silver series	£1500	£1099
Unison Research S2K valve integrated	£1295	£1095
LOUDSPEAKERS		
Acoustic Energy Aego 2 (NEW)	£300	£250
Acoustic Energy AE100	£229	£99
Audio Physic Step inc stand	£1299	£499
Epos M12 cherry	£499	£375
Monitor Audio Gold Reference 20	£1499	£1250
Monitor Audio Silver 3i	£279	£225
Naim SBL walnut	n/a	£599 ono
Neat Mystique II (natural ash) as new	£795	£650
Neat Petite III (rose)	£845	£499
Opera Platea (mahogany)	£795	£499
Totem Model One	£1249	£599
MISCELLANEOUS		
Onkyo TX DS595 dolby digital/pro logic II	£495	£395
Onkyo TX DS777 THX receiver	£799	£499
Project RPM Four	£300	£249
Sonus Systems 5 shelf "Excel" rack	£269	£200
Teac Reference 100 system	£420	£349
Teac Reference 300 system	£599	£450
Teac DV3000 DVD player	£229	£189
Teac RW800 CD recorder	£349	£275

check out our website for up-to-date list : www.replay.dial.pipex.com

Oxford Audio Consultants Ltd.

OUR SUPERB SERVICE IS THE SAME REGARDLESS OF PRICE



Now Demonstrating



Ex-Demonstration & Previously Owned Equipment

SALE LIST - November 2001

COPLAND 266 CD PLAYER	£795	SH
MUSICAL FIDELITY X RAY CD PLAYER	£495	SH
LINN LP12/LVX	£350	SH
MUSICAL FIDELITY XP100 PREAMP	£495	SH
JADIS ORCHESTRA CD PLAYER EX DEM	£695	XD
TRANSPARENT INTERCONNECTS	P.O.A.	
KRELL 300I AMPLIFIER	£1795	SH
MARANTZ CD17 KI SIGNATURE GOLD	£695	SH
MARANTZ CD7 EX DEM	£2795	XD
SHAHINIAN OBELISK WALNUT	£2195	SH
AUDIO RESEARCH LS9 PREAMPLIFIER	£1095	SH
THETA PROGLNY	£695	SH
KRELL KAV300CD CD PLAYER	£1995	SH
COPLAND CDA288	£995	SH
LOEWE PLANUS 32" WITH CABINET ARCTIC EX DEM	£1350	XD
COPLAND CSA 8 AMPLIFIER	£799	XD
ARCAM 290 P POWER AMPLIFIER	£295	SH
ARCAM 290 INTEGRATED AMP	£295	SH
KRELL KAV300CD AS NEW	£2995	SH
KRELL 250P PREAMPLIFIER	£1795	XD
KRELL 300CD	£2495	SH
AUDIO RESEARCH VT50 POWER AMP AS NEW	£2295	SH
AUDIO RESEARCH D130 POWER AMPLIFIER EX DEM	£1495	XD
REGA PLANAR3	£150	SH
NAIM SBL BLACK EX DEM PASSIVE	£1295	XD
NAIM 90.3 POWER AMP	£ 350	SH
NAIM 72 PREAMP	£ 450	XD
PATHOS ACOUSTICS TWIN TOWERS AMPLIFIER	£2495	SH

0% INTEREST FREE CREDIT

Licensed Credit Broker

REFER TO OUR WEBSITE FOR THE LATEST UPDATED SALE LIST.

Agencies include: Acoustic Energy, Alphason, Atacama, Audio Analogue, Audio Research, Beyer, BOSE, Castle, Chord Company, Copland, Crestion, Denon, Diapason, Dwin Electronics, Einstein Fujitsu, GM Audio, Goldring, Graaf, Integra Systems, IXOS, Jadis, Jamo, Kef, Koetsu, Krell, Lovicon, Loewe TV/Video, Linn Classic, Lyrx, Marantz, Martin Logan, Michell, MFS, Multiroom Systems, Musical Fidelity, NAD, Naim, NEC Gas Plasma Screens, Nakamichi, Nordost, Onkyo, Opera, Ortofon, Parasound, Pioneer, ProAc, Project Turntables, QED Multiroom Quad, Quadraspire, REL Subwoofers, Rotel, Sennheiser, Sharp LCD TVs, SME, Sonus Faber, Sonus Systems, SoundStyle, Standesign, Stands Uniquo, Stax, Stewart Screens, Tag McLaren, Tannoy, Teac, Theta, Transparent, Unison Research, Van den Hul, Vibe Acoustics, Vitwoofers, Videologic, Vienna Acoustics, Wilson, Yamaha.

TAX FREE EXPORT SERVICE
MAIL-ORDER AVAILABLE ON MANY ITEMS

Cantay House, Park End Street
Oxford OX1 1JD

Telephone: Oxford (01865) 790879

Facsimile: Oxford (01865) 791665

E-MAIL: Oxford.Audio@btinternet.com

WEBSITE: www.oxfordaudio.co.uk



V.A.T. No.
729580013



QUALITY USED
EQUIPMENT,
BOUGHT, SOLD,
PART EXCHANGE

TEL/FAX
0121 747 4246



URGENTLY REQUIRED
LINN, NAIM,
MERIDIAN, QUAD
CASH WAITING

	RRP	NOW £
ADVANTAGE P1 PRE	1600	895
ADVANTAGE A300 POWER	2600	1495
ART AUDIO DIAVLO 300B SE CHROME & GOLD		
POWER AMP	4500	1995
AUDIO RESEARCH LS7	1600	795
AUDIO RESEARCH VT60	3000	1195
BASIS 1400 REGA RB300	1300	795
BOW TECHNOLOGIES WAZOO XL INTEGRATED AMP	2500	1595
CAL CL15 hdcd digi vol bal NEW SEALED BOX	2195	895
CAL DX-2 CD EX DEM	650	395
CAL ICON MK 11 CD EX DEM	1100	595
CAL ALPHA 20 BIT DAC VALVE EX DEM	1495	795
CAL SIGMA DAC VALVE EX DEM	1100	595
CELLO STRADAVARI GRANDMASTERS ROSEWOOD	60000	14995
CELLO PERFORMANCE 11 MONOS	30000	7995
CELLO AUDIO SUITE PLUS MASTER SUPPLY	30000	7995
CELLO DAC 5.1	8000	2495
CHARIO SYNTAR 100 TOWER BLACK	450	250
COPLAND CTA 505 POWER AMP	1900	995
COUNTERPOINT BIJOU-MYSTIC-ORPHEUM 5 SPK SYSTEM	N/A	295
DENSEN DP DRIVE PHONO STAGE	350	250
DYNAVACTOR KARAT 17D2 MK11 BOXED LOW HOURS	450	195
ELECTROCOMPANET EC1.3 2 MONTHS OLD	1000	695
JEFF ROWLAND MODEL 1 POWER AMP	3000	1195
KRELL KAV 250P PRE	2400	1495
KRELL MD10 SIG TRANSPORT	10000	3495
KRELL FPB 600C POWER	15000	8995
KRELL KPS 20i/L CD/PRE	11000	3995
KRELL FPB 600 POWER	13000	6995
LINN TROIKA	850	195
LINN KARMA	500	95
MAGNUM DYNALAB MD100R SILVER EX DEM	2050	1395
MAGNUM DYNALAB MD10 VIRTUAL DECODER EX DEM	N/A	5
MAGNUM DYNALAB SIGNAL SLEUTH EX DEM	350	195
MANA MINI TABLE	170	95
MARANTZ SA-1 SACD PLAYER	5000	3695
MARK LEVINSON 380 PRE 6 MONTHS OLD	4450	2995
MIT 330 MK11 INTERCONNECT	300	150
NAIM NAC 72	850	395
NAIM 62 NEW STYLE	450	195
NAIM 250	1800	995
NAIM SBL WALNUT LATEST MID/BASS	2400	895
NAIM 05 TUNER	800	495
NAIM BLACK SNAIC 4 PIN	55	35
NAIM 102 + NAPSC + PHONO	1350	850
NAIM CD2	2000	1095
NAIM CDX	2400	1695
NAIM 82	2500	1695
NAIM 140	850	450
NAIM HICAP	750	495
NAIM CD3	1000	450
NAIM NAP 140 OLD STYLE	N/A	350
NAIM 92	520	295
NAIM CD 3.5	1100	695
NAIM 90/3 X2	550	295
NHT 1.3A SPEAKERS PIANO BLACK EX DEM	500	295
NHT 1.1 SPEAKERS PIANO BLACK EX DEM	400	195
NEAT MYSTIQUE CHERRY	750	250
OPERA DUETTO CHERRY	430	295
PROAC TABLET 50 WALNUT	650	350
PRIMARE T20 TUNER	550	395
PROCEED AMP 2 (2 channel) THX	2000	995
PROCEED AMP 3 (3 channel) THX	3000	1495
REVEL ULTIMA GEM PIANO BLACK	7000	3500
ROKSAN XERXES ARTEMIZ REGA ELYS ROSEWOOD	N/A	495
ROKSAN XERXES ARTEMIZ BLACK	N/A	395
SIM AUDIO CELESTE 4000 INTEGRATED	N/A	295
SONIC FRONTIERS ANTHEM INTEGRATED AMP 2	2000	995
SONY ESPRIT TA-E900 PREAMP	2600	595
TANNOY ARDENS MK11 15 INCH DUAL		
CONCENTRIC (reconed)	N/A	695
TECHNICS SLPG440A CD	300	25
THETA PRO PRIME 11	1600	695
VAN DEN HUL THE SECOND DIGITAL XLR	150	95
VAN DEN HUL REVELATION HB 2X 1.5 PAIR	800	395
XLO 4.1 SIGNATURE DIGITAL CABLE RCA	325	175

OPEN MON-SUN 10.00 TO 8.00

Website: www.centralaudio.co.uk

E-mail: tony@centralaudio.co.uk



HEATHERDALE AUDIO LTD.



202 FINDON ROAD, WORTHING, WEST SUSSEX. BN14 0EJ
TEL. 01903-872288 OR (AFTER HOURS) 07860 660001 FAX. 01903-872234
e-mail: heatherdale@hifi-stereo.com // www.hifi-stereo.com

HEATHERDALE PRE-OWNED GUARANTEED EQUIPMENT EXPORT FACILITIES AVAILABLE

SPEAKERS

Dynaudio Audience 10 Speakers
John Bowers Active Speakers
Mendrian A500 Speakers
KLH Speakers
Kef 1012 speakers
Mission 782 Loud Speakers (Stand mount model)
Selection of Thiel ex Demo Speakers. All with 10 year guarantee
MAIN DEALER FOR ORCHID SPEAKERS
Yamaha NS1000 Ebony (rare) Speakers
AVI Nutron 111 Speakers

PRE AMPS

NAD 114 Stereo Pre-Amp £99
Perreux SM6P Pre-amp 350P Power Amplifier £2750
Naim NAC 42.5 Pre-Amp £150
Musical Fidelity MVT Pre Amplifier with Phonostage + PSU £495
Musical Fidelity "The Pre-amp" £175
Exposure 21 Pre-amp NEW with remote £890
Mark Levinson ML 26 Balanced Pre-Amp £1995
Classe Audio DR6 Pre-Amp with PSU & Phono Stage (cost new £3900) £1995
Sugden A21A Line Level Integrated Amp £600
Krell KSL Pre-Amp £695
DAX Passion Pre-Amp £395

ALL USED CARTRIDGES ARE CHECKED UNDER A MICROSCOPE BEFORE BEING OFFERED FOR SALE.

AMPLIFIERS

Mark Levinson ML 383 Integrated Amp (3 months old) £195
Audio Note Niro Power Amp £695
Perreux SM6P Pre-Amp 350P Power Amplifier £995
Naim 120 Power Amplifier £195
Sugden AUSTp amplifier £475
Rogers E40a Integrated Amplifier with phono-stage (NEW) £250
Exposure 11/12 Super 8 £250
Audionote P4 Monoblocks £phone
Sugden A21A Line Level Integrated Amp £phone
Audio Research VT60 Power Amp £895
£350

CD PLAYERS & TRANSPORT

Theta Jade CD Transport £1295
Classe CDP 5 CD Player £995
Rotel BX 970 CD Player £130
Teac VROS 9 CD Player (mint) £650

DACS

Mark Levinson ML30 Reference DAC (ex demo) £495
MSB Link DAC 111 with PSU, Base, HOCB and upsampler £890
Mark Levinson ML360s OAC (5 year guarantee) £1995

MISCELLANEOUS

Beyer 811 Headphones £600
Musical Fidelity X Cans Headphone Amp £695
Musical Fidelity X Cans Headphone Amp £395

Teac A-33405 tape recorder £595
Quad 77 System Power Amp, Pre-Amp, CD Player and Tuner £2995
Audio Note ANS7 MC Transformer with Phono-Phono Stage £8495
Selections of MIT cables available at discounted prices
TURNABLES, CARTRIDGES & TONEARMS
Haddock Tonearm (mint) £445
Michelle Gyro Deck with out-board power supply £895
Project Debut Gloss Black Turntable £99
Koetsu Urushi Cartridge (unused) £1995
Koetsu Itoigawa Diamond Cartridge (unused) £4495
Helus Silver wired tonearm £995
VPI TNT Mk3 Turntable £2695
Thorens TD125 Turntable £295

BRAND NEW BOW WAZOO
INTEGRATED AMPLIFIER NORMAL PRICE £2500 OUR PRICE £1995

NOW DEMONSTRATING THE MARK LEVINSON 383 INTEGRATED AMP

WE NOW OFFER 0% FINANCE (subject to status)
PLEASE PHONE TO ARRANGE AN AUDITION
MAIN DEALERS FOR MARK LEVINSON, THIEL, AND ABSOLUTE SOUNDS

VISA - SWITCH - MASTER CARD - AMEX - DINERS CLUB WELCOME
WE TAKE PART EXCHANGE ON NEW & USED STOCK AND BUY IN FOR CASH



Soundcraft HiFi.com

At 40 High Street, Ashford, Kent. TN24 8TE

SPECIAL New Year's CLEARANCE SALE January 2002

Hi-Fi Separates (! = Ex - demonstration)

Arcam CD-72 Ex-Dem	£349!	Linn 5105Power Amp	£899!
Arcam Alpha 10P3 pwr amp	£650!	Marantz PM6010K1 Amp	£299!
Audiolab 8000A	£249	Marantz DR4050 CD recorder	£249!
Castle Harlechs ant/oak	£850!	M/F X-Ray/X-A1/X-Plora	£1199!
Castle Harleth (cherry)	£700!	M/F A3 Amplifier	£599
Castle Richmond ant/oak	£199!	Naim NAC-62/ NAP 90/3	£499
Castle Severn 2's (Birch)	£499	Naim CDS and CDPS	£2995
Jamo Concert Centre	£349	Naim AV-1 processor	£650
KEF Concerto 1	£399!	Pioneer VSX 859 THX receiver	£599!
Linn Numeric	£499	Rega Planar 25 Turntable & Cart	£550!
Linn Karik CD	£799	Ruark Solus speakers rosewood	£899!
Linn Kairn Phono Pre-amp	£849!	Ruark Prologues	£795
Linn Mimik CD	£499	Ruark Dialogue Centre	£250!
Linn Axis Turntable	£250	Yamaha MDX 596 mini Disk	£150!

Our exciting range includes: Arcam, DiVA & FMJ, Chord Electronics, Linn (CD12), Naim (NAP 500 & NBL), Rega, Musical Fidelity, Denon, Yamaha, Rotel, B&W Nautilus, PMC, Ruark, Castle, Kef, Loewe TV, Pioneer Plasma, Sim 2 DPL!
HOTLINE: 01233 624441 Fax: 01233 640333.

AV Separates (! = demonstration)

Arcam AVR 100 Receiver	£650	Pioneer NS-DV1DVD System	£999!
Denon DV-2500 DVD player	£399!	Pioneer XV-DV55 + S-59 spkrs	£649!
Denon DVD 5000	£799!	Sony DVPS 335	£199
Denon AVC-10 AV reciever	£999!	Sony DVPS 900 ES	£999
H/K AVR-45 receiver	£200!	Yamaha DVD-S510 zone free	£230!
Marantz DV-4100 zone free	£299!	Yamaha RXV-395 receiver	£199!
Pioneer 502 50" Plasma	£6995!	Yamaha DSP E 800 processor	£279!
Pioneer DV-535 DVD zone free	£199!	Yamaha AX-1 Amplifier	£1199

Check our web site: www.soundcraftthifi.com

Sound Investment

If you have invested expertise and money in building up a sound system to your own unique specifications, then why compromise with indifferent housing units?

Fi-Rax offers a new dimension in audio visual racking - from a range of standard designs to the flexibility to custom create a unit to suit your particular sound system and lifestyle.

- *High quality aluminium construction.
- *Finishes available to your choice.
- *Fully adjustable 6mm glass shelving.
- *Sound isolation on shelving/feet.
- *Custom created to suit your system.
- *Free delivery throughout the UK.

Fi-Rax - a sound investment for those who want the best from their equipment.

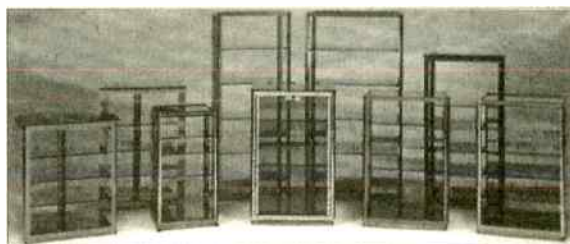

Audio Visual Furniture

For further information or a free brochure contact: JEM Distribution, Springfield Mills, Spa Street, Ossett Wakefield WF5 0HW.
Tel: 01924 277626 Fax: 01924 270759

Are you making the right connections?

Send for Britain's biggest catalogue of specialist cable and connections.

All available by mail order.
Phone **020-8942 9124** or clip the coupon for your Free copy
www.custom-cable.co.uk

CUSTOM CABLE SERVICE

PO Box 4007, London SW17 8XG

Please send me your FREE Custom Cable Catalogue

Name _____

Address _____

Postcode _____

NO FURTHER INFORMATION REQUIRED

Send to: Custom Cable Service
PO Box 4007
London SW17 8XG

HFV 01/02





S/hand and ex-demo clearance items - January 2002

	Was	Now
CD players DACs & Transports		
Audio Analogue Maestro CD Player Ex-Demo	1200	799
Audio Note CD1 S/H	695	299
Audio Note CD2/ Border Patrol PSU Fitted S/H	1699	999
Audio Note CD3 S/H	1600	749
Naim Audio CDI Integrated CD Player 96 S/H	1990	1099
Roksan DA2 DAC S/H	599	299
Roksan DS5 PSU S/H	579	325

	Was	Now
Turntables Tonearms & Cartridges		
Audio Note IO (Kondo built)S/H	2499	799
Audio Note AN-S3 Transformer S/H	1300	599
Basis 1400/RB250 (New & Boxed)	1300	899
Benz Micro Gold MC Cartridge S/H	169	99
Decca London Gold (J.Wright modded)	N/A	299
EAR MC3 Transformer (3 Months old)	625	499
Kuzma Stogi/Stabi S Turntable (New & Boxed)	1299	1099
Linn Axis Turntable S/H	N/A	249
Nottingham Analogue Tracer MM Cartridge	99	50
Pink Triangle Export/RB300/EroicaS/H	N/A	399
Rega Planar 3 Green Turntable S/H	298	175
Roksan Shiraz Black 50 hrs Ex-Demo	995	599
Roksan DS1.5 PSU Ex-Demo	695	499
SME 20/2 Turntable S/H	3657	2499

	Was	Now
Preamplifiers		
Audio Note M1 Phono Preamplifier S/H	750	349
Audio Note M Zero S/H	449	275
Audio Note M Zero R Ex Demo	599	449
AVI 2000 Line Preamplifier S/H	850	449
Electrocompaniet EC4R Preamplifier S/H	1250	599
DPA Enlightenment R/C Preamplifier S/H	795	399
Krell KSL-2 inc KPE phono board S/H	5989	1995
Naim Audio NAC 92/N Preamplifier S/H	598	325
Roksan L1.5 Reference Line Preamplifier S/H	2250	1395
Roksan L2.5 Preamplifier S/H	1295	599
Spectral DMC10 Phono Preamplifier	N/A	995

	Was	Now
Amplifiers		
Audio Note Otto SE Phono S/H	1600	799
Conrad Johnson MV 55 Valve Power Amplifier S/H	1995	1099
Conrad Johnson Premier 11 Power Amplifier (New&Boxed)	3695	2799
Copland CTA505 Power Amplifier S/H	1899	1099
Densen Beat 300 power Amplifier Ex-demo	795	599
DPA Enlightenment 100w Stereo Power Amplifier S/H	999	599
Golden Tube Audio SI-50 MKII Valve integrated (New&Boxed)	1100	699
Graaf Venticinque 25 Watt Integrated S/H	1795	995
Naim Audio NAP 90.3 Power Amplifier S/H	487	295
Roksan Rok S1.5 Power Amplifier S/H	1499	949
Unison Simply 4 Valve Integrated Ex-Demo	1600	999

	Was	Now
Loudspeakers		
Acoustic Energy AE1 MKII Rosewood S/H	849	599
Audio Note AN K-SPx Blk S/H	1395	599

	Was	Now
Loudspeakers (con't)		
Boston Acoustics VR 10 Centre Channel (New&Boxed)	250	175
Infinity Outrigger jr Outdoor Speakers (New&Boxed)	249	129
Opera Duetto Mahogany Speakers Ex-Demo	395	289
Totem Mani 2 Mahogany S/H	3200	2250
Totem Tabu Mahogany Ex-Demo	2300	1599
Totem Arro MKII Cherry New& Boxed	1095	849
Totem Model One Signatures Cherry Ex-Demo	1695	1199
VelodyneTX810MK2 Subwoofer S/H	695	349

	Was	Now
Cables & Accessories		
Black Diamond Racing "The Pits" (New&Boxed)	180	99
Bow Technologies Wand Remote S/H	349	199
G- Flex isolators (New & Boxed)	199	75
Goertz AG-2 2x10ft silver speaker cable S/H	1643	799
Golden Sounds Ceramic Cones (New & Boxed)	85	49
Naim Audio2x5m Speaker cables white S/H	N/A	45
Roksan HA01 1M Interconnect S/H	99	49
Shakti Stone (new & boxed)	199	140
Sound Style 4 Tier in Green S/H	325	159
Transparent Music Link Balanced 1m S/H	349	199
XLO 2X7m Type 0.6 Speaker Cables Shotguned S/H	750	399
VanDenHul Thunderline 1.0m RCA Interconnect S/H	99	49

	Was	Now
Tuners & Tape Decks		
Magnum Dynalab FT-R Remote Switcher for FT101A/Etude (New)450		299

	Was	Now
Clearance Items Under £100		
Leak Stereo Troughline MK3 Tuner S/H	N/A	99
Thorens TD125 Turntable S/H	N/A	99

Midland Audio X-change are looking for Audio Research, Krell, Mark Levinson, Naim Audio, Theta, Wadia, cash paid call John Roberts on 01562 822236 now!



- Suppliers and installers of High Quality Audio Systems
- 47 Laboratory
 - Accuphase
 - Audio Note
 - Audio Research
 - Avid
 - Basis
 - Cabasse
 - Cardas
 - Clearaudio
 - Conrad Johnston
 - Copland
 - Dcs
 - DNM / Reson
 - Einstein
 - Electrocompaniet
 - Final
 - Finite Elemente
 - Graff
 - Gryphon
 - Lavardin
 - Mark Levinson
 - Martin Logan
 - Michell
 - Nagra
 - Primare
 - ProAc
 - Rega
 - Resolution Audio
 - Sonus Faber
 - Spectral
 - SPM
 - Sugden
 - UKD

www.midlandaudiox-change.co.uk

call John Roberts Tel / Fax 01562 822236

181 Franche Rd ¥ Kidderminster ¥ Worcs ¥ DY11 5AD

e-mail sales@midlandaudiox-change.co.uk

Mobile 07721 605966

www.midlandaudiox-change.co.uk

Midland Audio X-change is looking for good used British & American Hi-Fi cash paid call John Roberts on 01562 822236

- cartridges
- denon
- dnm
- goldring
- lyra
- ortofon
- sumiko
- cables
- audioquest
- chord company
- dnm
- ixos
- kontak
- lfd
- nordost
- qed
- sonic link
- trichord
- van den hul
- headphones
- beyer
- ergo
- grado
- sennheiser
- stax
- stands
- frameworks
- sound org'n
- something solid
- soundstyle
- stands unique
- target
- accessories
- audioquest
- creek
- densen demagic
- earmax
- goldring
- ixos
- kontak
- michell
- milty
- monarchy
- moth
- musical fidelity
- nordost
- pixall
- qed
- rms
- shure
- trichord
- zerostat
- hardware
- atc
- audio physic
- boston
- bow technology
- creek
- densen
- genelec
- harbeth
- michell
- nordost
- primare
- qln
- sme
- sugden
- teac
- trichord

audio, cables and accessories available by post

(post haste)

phone, fax or write for latest price list

/ newsletter

Second hand & ex dem deals



ATC SCM20 Pro Active loudspeakers. Perfect, ex demo, complete with "flight case" pods. (£3050). Full 6 year warranty. **£2350**

ATC SCM10 loudspeakers. Rosewood veneer, s/h, good condition but no boxes. (£1200) **£475**

AVI nuNeutron III loudspeakers. Cherry. S/H boxed as new (£500) **£275**

EAR 859 integrated valve amplifier. S/H in pristine condition, boxed. About 4 years old. (£2200 new) **£1095**

Linn Sondek / Naim Aro / Naim Armageddon PSU. All parts in mint condition. Willing to split, **£1500**

Michell Mycro turntable with RB250 tone arm. Good condition, secondhand (£583) **£300**

NVA AP50 amplifier. S/H, excellent, boxed (£625) **£300**

Sugden Masterclass CD player. Ex dem. Unmarked, boxed etc (£2500) **£1750**

Target R1 stands. S/H good condition. Very heavy, so carriage is extra! **£175**



hi-fi for grown-ups



ipswich (01473) 655171
 fax (01473) 655172
 bucklesham ipswich suffolk IP10 0DY
 email: enq@signals.uk.com
 www.signals.uk.com

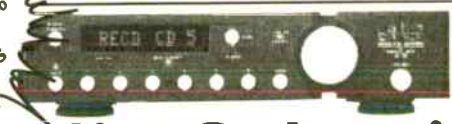

Audio Selection

Demonstration studio/mail order
 (N) New (SH) Second hand (ED) Ex. Demonstration

Buy/Part Exchange your unwanted Hi-Fi - Audiolab, Linn, Quad, Meridian, Cyrus, Arcam, Rel, Kef, Spendor etc.

Tel: 01206 510392 - Jim

CD Players		Price	New
Meridian 206B	(SH)	£450	(£995)
Meridian 506	(SH)	£650	(£1200)
Pink Triangle Ordinal DAC	(SH)	£395	(£795)
Arcam Alpha one	(SH)	£179	(£300)
Sony CDPXE220	(ED)	£60	(£120)
Amps			
Meridian 201/205'S 100w monoblocs	(SH)	£995	(£2300)
Meridian 501/557 200VVRMS	(SH)	£1795	(£2325)
EAR-YOSHINO 8L6 50w integrated class A valve amp. can be used as power amp/pre amp. 5 line input. Shimmering highs-liquid midrange - excellent!!			
Pioneer VSA303 5 stars AV + Sub output	(ED)	£200	(£300)
Quad 33/303 (HIOVUSA version)	(SH)	£120	(-)
Speakers			
Kef Cresta 3's cherry floorstanding	(N)	£220	(£250)
Paradigm PDR10 sub 100w SUB	(ED)	£220	(£250)
IMF TLS80 II Teak pair + stands	(SH)	£500	(-)

Collection or Mail Order Delivery order form UK. Overseas Tel /write first
 Please supply equipment:-----
 Add £10 delivery charge each item. I enclose a Personal/Credit Card Cheque (not cards) or P.O./M.O/registered cash payable to 'J. Derrick'
Audio Selection, 'Firtrees' Howe Close, Colchester, CO4 3XD UK
 Name:-----
 Address:-----

Please allow 28 days delivery - although most orders arrive within 10 days.

MUSONIC STYLI

SPECIALIST MANUFACTURER & SUPPLIER FOR MORE THAN 40 YEARS

- REPLACEMENTS & ORIGINALS
- MANY OBSOLETE/78 VERSIONS
- PICK-UP CARTRIDGES
- RECORD/TAPE/CD ACCESSORIES
- WHY NOT TRY US AND HEAR THE DIFFERENCE !!

NAGAOKA CARTRIDGES NOW IN STOCK

For further information tel/fax/e-mail to:-

MUSONIC (UK) LIMITED
 Unit 13 Wenta Business Centre Colne Way
 Watford Hertfordshire WD24 7ND

Tel: 01923 213344 Fax: 01923 213355
 E-mail:sales@musonic.co.uk

VISIT OUR NEW WEBSITE
www.musonic.co.uk

Trade and Export enquiries welcome

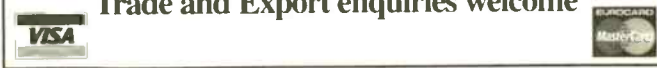

AUDIOJUMBLE

"2002"

Tenth Year Anniversary Special

Vintage valve amplifier display

ANNUAL SALE OF VINTAGE AND MODERN HI-FI EQUIPMENT AT:- THE ANGEL LEISURE CENTRE TONBRIDGE, KENT.

SUNDAY 17TH FEBRUARY 2002
10.30AM - 4.30PM

STALLS £25-00 ADMISSION £3-00
9:30am Early Entry £10-00
BOOKINGS/ENQUIRIES 01892-540022

LARGE CAFETERIA SERVING HOT AND COLD MEALS ALL DAY
MAIN LINE RAILWAY STATION WITHIN WALKING DISTANCE

* VALVE AMPS * TUNERS * RECORDS *
* SPEAKERS * COMPONENTS *
* BOOKS * CASSETTE DECKS * C.D. PLAYERS *

www.audiojumble.co.uk

WILLIAMS HART ELECTRONICS

HART ELECTRONIC KITS TRADED FOR OVER 30 YEARS



NEW LAYOUT

80Watt Mosfet Stereo Power Amp Kit
110Watt Mosfet Monoblock Power Amp Kits
ONE OF THE BEST AMPLIFIERS YOU WILL FIND REGARDLESS OF PRICE
ON DEMO @ Wigan, Southend, Peterborough and Burnley



Single Ended Class A Valve Sound
15Watt Power Amp modules
FOR THOSE WHO WANT THAT VALVE MIDBAND BUT BASS AND TREBLE TO MATCH

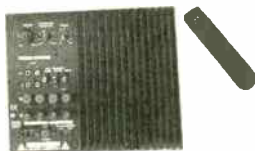

ACTIVE RC/CONTROL SUBWOOFER MODULE £177.50



Range of speaker Kits
Passive and Active

Advertise your Hi-Fi on my website (£2.50 admin charge)
Also Award Winning Phono Stage Kit, Active Crossover Modules, Speaker Drive Units,
M Cap Capacitors, Caddock Resistors, Remote Control Volume and much more

WEB SITE www.williamshart.com

e-mail: williamshart@classicfm.net

or Tel/Fax for catalogue 01942 253647 121 Long Lane, Hindley Green, Wigan, W24 4XD
PERSONAL VISITORS SHOULD PHONE FIRST TO AVOID DISAPPOINTMENT

Run by former Technical Director of Wilmslow Audio



MUSICAL IMAGES

PRODUCT		LIST	NOW
HOUNSLOW			
ACOUSTIC ENERGY AE 120SE Speakers	EX/DEMO	£600	£375
ACOUSTIC ENERGY AE 509 Speakers	EX/DEMO	£850	£425
DENON AVC-A1SE Gold AV Amp	EX/DEMO	£2,000	£1,300
DENON AVR3300 AV Receiver	EX/DEMO	£800	£475
DENON DVD3300 Black or Gold DVD Player	NEW	£650	£550
SONY MDSJB940 Black or Silver Mini-Disc Player	NEW	£330	£250
EDGWARE			
DENON DVD3300 Black or Gold DVD Player	NEW	£650	£550
JAMO CONCERT 11 American Cherry Speakers	EX/DEMO	£2,300	£1,200
JAMO CONCERT 8 Speakers	S/H	£1,350	£850
KEF TDM45 Subwoofer	S/H	£800	£550
MARANTZ CD17 Black CD Player	EX/DEMO	£800	£500
MARANTZ CD17KI Gold CD Player	EX/DEMO	£1,200	£750
MARANTZ PM17 Gold Amp	EX/DEMO	£1,000	£600
SONY MDSJB940 Black or Silver Mini-Disc Player	NEW	£330	£250
COVENT GARDEN			
CASTLE SEVERN2 Speakers	EX/DEMO	£700	£300
DENON AVR3300 AV Receiver	EX/DEMO	£800	£475
DENON DVD3300 Black or Gold DVD Player	NEW	£650	£550
NAD 533 Turntable	S/H	£220	£150
PRO-AC RESPONSE 3.8 Cherry Speakers	EX/DEMO	£3,990	£2,800
PRO-AC STUDIO 125 Yew Speakers	EX/DEMO	£1,100	£750
ROKSAN RADIUS Turntable + PSU	S/H		£200
THORNS TD166 MK6 Turntable, Arm & Cartridge	S/H	£500	£350
BECKENHAM			
CHORD DSC1100 Silver DAC inc Trigger	EX/DEMO	£2,815	£2,300
CYRUS AVMASTER+ Processor	EX/DEMO	£800	£400
DENON AVC-A1 Gold AV Amp	EX/DEMO	£2,000	£1,300
DENON DVD3300 Black or Gold DVD Player	NEW	£650	£550
MARANTZ CD17 Black CD Player	EX/DEMO	£800	£500
MARANTZ CD17KI Gold CD Player	EX/DEMO	£1,200	£750
MARANTZ PM17KI Gold Amp	EX/DEMO	£1,500	£1,000
MUSICAL FIDELITY XA-1 Amp	EX/DEMO	£480	£350
PRIMARE A30.1 Amp	S/H	£1,500	£950

ALL BRANCHES KEF REFERENCE SPEAKERS SPECIAL OFFER

MODEL 1-2 Black/Cherry/Rosenut/Rosetta Burr	NEW	£1,350	£1,000
MODEL 2-2 Black/Rosenut	NEW	£1,750	£1,400
MODEL 3-2 Black/Albina Burr/Classic Rosewood	NEW	£2,750	£2,000
MODEL 4-2 Black/Cherry/Classic Rosewood	NEW	£3,650	£2,800

PLEASE VISIT OUR SHOWROOMS
OR CALL OUR HOTLINE
NUMBER FOR DETAILS. HURRY, MANY ARE
ONE-OFF ITEMS!!

SEE IT! HEAR IT! BUY IT!

Beckenham
126 High Street
Beckenham, Kent
BR3 1EB
Tel: 020 8663 3777
Fax: 020 8663 3555

Covent Garden
18 Monmouth Street
Covent Garden
London, WC2H 9HB
Tel: 020 7497 1346
Fax: 020 7497 9205

Edgware
173 Station Road
Edgware, Middlesex
HA8 7JX
Tel: 020 8952 5535
Fax: 020 8951 5864

Houslow
45 High Street
Houslow, Middlesex
TW3 1RH
Tel: 020 8569 5802
Fax: 020 8569 6353

E-Mail: sales@musical-images.co.uk

NOT VALID WITH ANY OTHER OFFERS OR PROMOTIONS E&OE

We are best known for our single-ended 300B power amplifiers and power supply upgrades for valve amplifiers, but did you know that we supply complete systems, new and used equipment, and components? We also provide support and servicing for Audio Innovations valve products. For full information visit www.borderpatrol.net or ring 01273 276716.

passion, grace & fire

www.borderpatrol.net

Selected products from:

BorderPatrol • Living Voice • SME • Audio Note • Cartridge Man • Goldring
Western Electric • Electrofluidics

BorderPatrol Brighton UK
Tel/Fax +44 (0)1273 276716
e-mail: bp@borderpatrol.net
www.borderpatrol.net



BorderPatrol

AUDIO MATTERS

NEW EX-DEM & PART EXCHANGE
EQUIPMENT FOR SALE
020 8255 0572/0973 436135

	LIST	SALE
Alchemist Kraken Anniversary MkII	£599	£POA
Alchemist Product 8 pre & pwr (on dem)	£2047	-
Alchemist Product 8 dac & drive (on dem)*	£1898	-
Alchemist The Statement pre amp ex/dem	£4999	£2295
Alchemist The Statement Stereo pwr ex/dem	£3999	£1995
Audion Black Shadows 845 valve monoblocks	£4000	£POA
Audion Silvernight 300B monoblocks	£2250	£POA
Audion Golden Nights	£4000	£2200
Bow Technology Wazoo (ex/d)	£2195	£1595
Bryston BP ST4 pwr	£2100	£1195
Chario Academy 1 solid walnut (ex/d)	£1299	£800
Classe DR 6L pre	£3400	£1295
DPA Renaissance CD player ex/d	£995	£595
Krell 250 CD Player	£2592	£1795
Krell Kav 3001	£2495	£POA
Linn Karin pre	£1400	£595
Mark Levinson 331 pwr	£4500	£2695
Mark Levinson 23.5 pwr	£7500	£3195
Meridian 551 int. amp	£845	£425
Meridian 555 pwr. amp	£750	£395
Naim 72 pre	£800	£395
Naim 90 pwr.	£487	£250
Perreux AC 3 pre ex.d	£1700	£1195
Perreux 6 ch. pwr amp	£2500	£1695
Roksan Caspian (AC3 DTS) pre & 5 ch. pwr amp (on/dem)	£2290	-
Ruark Prologue re 1 spks.	£999	£595
Monitor Audio 20SE	£2200	£950

A NEW RANGE OF VIENNA ACOUSTICS SPKS. NOW ON DEM

*New Product 8 from Alchemist Dac & Drive with 192 sampler in-built ON-DEM

Also On-Dem: Alchemist, Anthem, A.R.T. spks., Audiomeca, Audion Valve Amps, Cadence Spks., Chario, D.P.A., Goertz cables, Lavardin., Monarchy, Ortofon, Pink Triangle, Project T.T., Roksan., Sonic Frontiers, Triangle Spks., Van den Hul., Rogue Audio Valve Amps., Amphion Spks.

VISA/MASTERCARD ACCEPTED



PROGRESSIVE AUDIO



2 Maryland Court, Rainham, Kent, ME8 8QY
Telephone / Fax No. 01634 389004

WEBSITE: www.progressiveaudio.co.uk E-MAIL: dave@progressiveaudio.co.uk

We have the following ex demonstration and part exchange items for sale :

- ANTHEM (by Sonic Frontiers) amp 2 (silver) Mint £1200 S/H
- FINAL 0.3 Hybrid loudspeakers (cherry) mint £1150 S/H
- DNM series 3 pre amp with twin power supply £750 S/H
- PROJECT perspective turntable £650 Ex Dem
- ALON Lii Rascal loudspeakers £325 Ex Dem
- Van den Hul the second i/c cable 1m £165 S/H
- TOM EVANS groove micro plus phono stage £495 S/H
- THETA D5 pro progeny DAC. Mint £850 S/H
- YBA CD2. As new. Silver. £2250. X/D.
- LFD LS1 Line stage. £525. S/H
- REGA Jupiter /lo CD Transport and DAC with digital interconnect. £795. S/H.
- VERITAS H3 Horns. Piano black. As new. £4600. X/D.
- VERITAS 20'S. Piano Black. With stands. As new. £1250. X/D.
- BLACK Rhodium interconnect. 1.5m. Boxed as new. £795. S/H.
- ALON Petite loudspeakers. Walnut. As new. Boxed. £850. X/D.
- ALON 1 loudspeakers. Walnut. Excellent condition. Boxed. £795. X/D.
- ELEMENTAL Audio monoplith. (£499) £300. X/D.
- ELEMENTAL Audio speaker stands (the best ever ?) £1500 new. £850. X/D.
- SONUS FABER concerto loudspeakers (walnut) with Partington stands £650 S/H
- MICHELL Argo HR Line pre amp. With Hera P/S. £650. X/D.
- MICHELL Iso HR phono stage. With Hera P/S. Excellent condition. £495. S/H.
- ORIGIN LIVE Sovereign loudspeakers. Cherry. Good condition. £650. X/D.
- ACOUSTIC SOLUTIONS "Eight" loudspeakers. Oak. As new. With stands. £1200. X/D.
- LINN Kaber loudspeakers with stone stands. £825. S/H.
- JEFF ROWLAND Model 2 power amp with BPS 2 battery power supply plus
- SYNERGY 11 pre amp. £6000. S/H.
- AUDIONOTE AN-KSp speakers (Oak) with matching Audionote stands. £725. S/H.
- REGA EOS m/m +m/c phono stage. £250. S/H.
- CASTLE Harlech speakers (Natural Oak) Mint. Boxed. £525. S/H.
- AUDIONOTE AN-SPx reference speaker cables. 7 ft bi-wire set. £1650. S/H.
- LAVARDIN IT Integrated amp. Mint. Boxed. 1 year old. £2250. S/H
- AUDIO MECA Mephisto CD drive Mint. Boxed £1250. S/H
- SUGDEN AU51 DAC Mint. Boxed. £750. S/H

NOW ON PERMANENT DEMONSTRATION THE SUGDEN MASTERCLASS INTEGRATED AMP AND CD PLAYER, RED ROSE ROSETTA AND ROSEBUD, MOON ELECTRONICS, VELODYNE SUBWOOFERS, WADIA CD PLAYERS, AUDIO ANALOGUE MAESTRO CD PLAYER AND AMP MUSICAL FIDELITY 3D CD PLAYER, LIVING VOICE AND AUDIO PHYSICS LOUDSPEAKERS, AVID TURNTABLES AND CHAPTER AUDIO POWER AMP

UPGRADE YOUR TURNTABLE

"If you are thinking of upgrading your system..the Origin Live dc-motor kit should be high on your list for consideration" TNT AUDIO internet magazine April 2000.

"The single most important upgrade you can ever make to any record deck concerns the motor drivenothing can compare you for the shock of going DC, in a word Gobsmacking" COMMON GROUND MAGAZINE

"Its value is nothing short of tremendous" LISTENER MAGAZINE

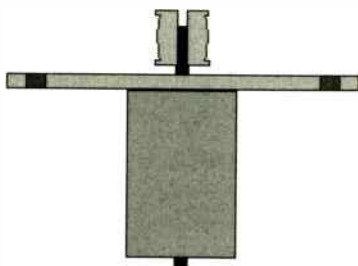

Whether you own a Linn Valhalla/Lingo, Rega or any other deck, the results of upgrading to the Origin Live dc motor and power supply are simply astounding. This high grade motor kit is designed as a drop in replacement for almost all turntable motors. Decks benefiting so far from this ultimate of upgrades include Linn, Roksan, Michell, Systemdeck, Rock, Rega etc. With a 12 Volt power supply it is safe and easy to fit. Guidance instructions are provided. At £262 with fully soldered and tested regulator board plus money back guarantee, this is a bargain out of all proportion to it's value in terms of performance. A larger purpose made transformer is also available as an optional extra at £175.

Why pay 4 times the price for less performance ?



LAMINAR FLOW ULTRA

"A high end sound with a sensible look and price tag"
HI-FI WORLD July 2001

"The Ultra's are a deeply satisfying musical product and supreme bargain"
Stereo Times August 2001

Laminar flow cable is a groundbreaking new design of cable. The "Ultra" version is guaranteed to outperform all other interconnects up to 4 times it's price and the "Reference" is a cable that reviewers use to judge other cables due to it's incredible transparency and musicality.

With a money back guarantee if not satisfied you have nothing to lose. Why not order a pair or see your local Origin Live dealer.

Advanced interconnect: £45 per stereo pair
Laminar flow Ultra Interconnect: £85 per stereo pair
Laminar flow Reference Interconnect: £159 per stereo pair

Make cheques payable to Origin Live and send to address shown We can take credit card orders if you wish. Remember there is a no risk money back guarantee if not entirely satisfied.

EMAIL: origin.live@virgin.net

ORIGIN LIVE TURNTABLE KIT

Now you can save money and build your own high performance deck. The standard parts kit is offered at £282 and is complete apart from a plinth. The kit comes with a full set of drawings and guidance instructions. It allows for your creativity or there are optional parts that will enable you to assemble a tried and tested design within 1 - 4 hours. The optional parts include plinths for suspended and non-suspended designs along with sub-chassis etc. The optional parts upgrade the standard kit to high end performance levels and is probably the easiest kit you will ever make.

"this Vinyl front end had my jaw heading towards the floor with the solidity and transparency of the music it was making"...
"the standard came up with crystal clear images set in a broad sound stage"... "With all these goodies in place, the standard would give turntables at the £1200-£1400 mark a hard time."

HI-FI WORLD SUPPLEMENT

"is exceptionally easy to build and professional in both sound quality and appearance"

HI-FI NEWS SUPPLEMENT

In group comparison test of 8 turntables, WHAT HI-FI MAGAZINE stated "the origin live turntable is the best sounding deck here... if sonic ability is your top priority just go ahead and buy it... the origin live ultra sounds fantastic"(FIVE STAR RATING)

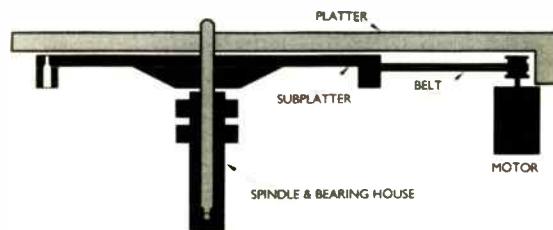

TURBOCHARGING YOUR REGA ARM

"Nothing less than total dynamite" HI-FI WORLD

If you are the proud owner of any Rega arm, why not utterly transform it into the league of super arms with the Origin live structural modification:- £75. This modification will enable your Rega to perform at a level exceeding that of arms costing over £1200.

Rewiring with high grade litz cable is also offered at an additional £70, and external rewiring is £70.

"I have to say the Rega modifications turn this humble arm into a real Giant killer. Gone is the rather grey, sterile sound of the cooking Rega. Instead, tonal colour is fresh, dynamics have great speed and impact, and the sound stage is huge." HI-FI WORLD SUPPLEMENT NOV 97 (structural modification to a RB250)
WHAT HI-FI gave this modification a 5 star rating.

For arm modifications we normally return your arm in 2 - 3 days

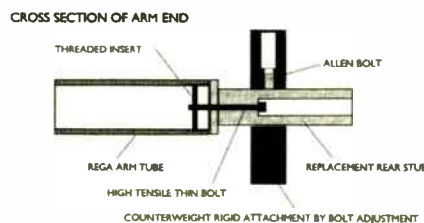

For further information contact
Origin Live, 87 Chessel Crescent, Bitterne,
Southampton, SO19 4BT
Tel: 02380 442183 / 578877 - Fax: 02380 398905

WEBSITE: <http://www.originlive.com>

HEATHCOTE AUDIO

TEL: 01992 653999 MOBILE: 07860 511111 E-MAIL ADDRESS: HeathcoteAudio@aol.com

VALVE AMPS

AUDIO INNOVATIONS SECOND AUDIO TRIODE MONO'S NEW 2A3 VALVES
 JADIS JA80 CLASS A MONOBLOCKS (WERE £10 000) RE-VALVED/SERVICED SUPERB
 RAYMOND LUMLEY M-150 MONOBLOCKS (MONSTERS!)
 CONRAD JOHNSON P-10AL PRE AMP
 AUDIO INNOVATIONS 300 INTEGRATED MM/MC PHONO (SUPERB)
 AUDIONOTE OTD SE INC. PHONO STAGE
 COPLAND CT-401 INTEGRATED INC. PHONO STAGE
 LUMLEY REFERENCE 120 MONOBLOCKS (NEW VALVES) TRIODE SWITCHABLE
 MONRIQ ASTY VALVE PRE (VERY PRETTY)
 CARY AE- ONE P LINE PRE AMP (EXPOSED VALVES)
 ROTEL MICHI RHC10 PASSIVE PRE
 MICHAELSON & AUSTIN/MORE TVA-1 KT88 POWER AMP CHROME CHASSIS
 HEAVILY MODIFIED QUADS EL34'S RECTIFIED PSU.S ETC BUILT FROM NEW PARTS
 EAR-834P MM/MC 8VOLUME CONTROL

SOLID STATE

ELECTROCOMPANET EC-1 REMOTE INTEGRATED WITH PRE OUT EX-DISPLAY
 ELECTROCOMPANET AW-50 POWER AMP 60 WATTS CLASS A EX-DISPLAY
 AUDIO RESEARCH LS7 PRE AMP
 KRELL KS80 POWER AMP (PROBABLY THE NICEST EXAMPLE AVAILABLE)
 ECA VISTA PRE AMP (SUPERB)
 TAG MACLAREN 60-I INTEGRATED FEW HOURS USE ONLY
 TECHNICS SUC 3000 PRE/SEA3000 POWER AMPS CHAMPAYNE GOLD ROSEWOOD CHEEKS
 BATTERY POWERED PRE AMP ETC STUNNING LOOKS BRAND NEW! (WAS £3000)
 E20 ARIA REMOTE INTEGRATED (VERY PRETTY) AS NEW- FEW HOURS USE
 MVL A2- VERY HEAVY 100 WATT X 2 INTEGRATED VERY LITTLE USE (WAS £12-1400)
 MUSICAL FIDELITY XA2 INTEGRATED AS NEW
 ALCHEMIST FREYA PRE AMP & 2 GENESIS MONOBLOCKS EXTREMELY RARE/BEAUTIFUL
 ROTEL MICHI RHC10 PASSIVE PRE
 QED VECTOR REFERENCE REMOTE ACTIVE/PASSIVE PRE-AMP
 MUSICAL FIDELITY P180
 MUSICAL FIDELITY 3A PRE AMP
 MUSICAL FIDELITY 3A PRE AMP
 MUSICAL FIDELITY MA50 CLASS A MONOBLOCKS
 DENON POA 4400 160 WATT MONOBLOCKS
 LINX STRATOS PRE AMP & 2X 120 WATT MONOBLOCKS MM/MC ETC (VERY RARE/GOOD)
 MUSICAL FIDELITY ELECTRA E200 REMOTE PRE AMP & E300 POWERAMP
 DPA ENLIGHTENMENT REMOTE PRE AMP (LIGHT DEM USE ONLY SUPERB)
 AUDIOLAB 8000A INTEGRATED LATE MODEL
 TECHNICS SUC 2000 REMOTE PRE AMP/SEA-2000 POWER AMP VERY HIGH QUALITY
 TECHNICS SEA2000 POWER AMP VERY HIGH QUALITY
 MAGNUM REFERENCE MP 125 PRE & 2 X MF125 MONOBLOCKS(140WATTS)
 MUSICAL FIDELITY THE PRE-AMP & 2 TYPHOON BRIDGEABLE POWER AMPS(BALANCED)
 MERIDIAN MCA
 THRESHOLD FET 2 PRE-AMP
 LINN PRETEK PRE AMP
 LINN LK1/LK2 REPOWEROR + REMOTE
 LINN LK2/280 UPGRADE
 ION SP1 PRE-AMP & X-PACK-2 SEPERATE POWER SUPPLY
 MISSION 776/777 BATTERY PRE & MATCHING POWER (VERY RARE INC MANUALS)
 NAKAMICHI IA3 INTEGRATED EXCELLENT SOUNDING AMP
 SUGDEN CS1/PS1/TS1 PRE/POWER/TUNER CLASSIC KIT! RECENT £200 SERVICE
 AMC AVB1HTC PRE-AMP/PROCESSOR STEREO/PRO LOGIC/PBX
 SONY TDA 8 ES 5 CHANNEL AMP
 SONY SDP-EP95 DOLBY BY DIGITAL PROCESSOR AC-3 ETC
 REVOX A-78 AMP COLLECTORS ITEM
 EXPOSURE 4 POWER AMP

CD
 MERIDIAN 506-20 BIT & MSR REMOTE
 MARANTZ 17 KI SIGNATURE
 WADIA WT3200 TRANSPORT COAX/OPT/GLASS/8 DELTRAN OUTPUTS
 DPA PDM 2 LEGENDARY 2 BOX DAC (VERY LATE MODEL WAS £2500)
 DPA PDM 2 2 BOX DAC
 DPA ENLIGHTENMENT DAC
 THETA CHROMA 396 DAC HDCD (£1000 NEW)
 MICROMEGA T DRIVE TRANSPORT & T DAC (WAS £2080) PHONO&BALANCED
 ROKSAN DP1.5 TOP LOADING TRANSPORT
 MYRIAD T-10 CD PLAYER
 SONY 502ES CLASSIC EARLY BATTLESHIP BUILD
 PIONEER PD-S505 PRECISION
 ORELLÉ DA-188 DAC (VERY SOUGHT AFTER)
 WOODSIDE DAC 1
 PINK TRIANGLE ORDINAL DAC
 ROTEL RDD/980 TRANSPORT
 ROTEL RDP/980 DIGITAL PROCESSOR
 TECHNICS SLPS 800 REMOTE VOLUME ETC
 ARCAM DELTA 70.2 CD PLAYER DIGITAL/VOLUME OUT
 ARCAM DELTA 170 TRANSPORT
 ARCAM BLACK BOX 3 DAC
 AMC CDA0 BALANCED&PIONO OUTPUTS
 PIONEER PD 9700

VINYL

LINN LP12 /LINGO/ITOK ONE OWNER
 TOWNSEND ROCK WITH FLUID DAMPER
 MISSION 775S TURNTABLE ALL PACKAGING BOOKS ETC
 TECHNICS SL-7 ONE OWNER ORIGINAL BOOKS PACKAGING ETC
 REGA PLANER 2 RB250 ARM/BIAS CARTRIDGE
 STD 305M TURNTABLE & MAYWARE ARM
 TECHNICS SL-110 CLASSIC TURNTABLE
 TECNICS SL-110 STAINLESS FINISH AUDIO TECNICA ARM
 DAIS TURNTABLE (GOLD STUNNING LOOKS VERY RARE)
 AUPHELIAN PLINTH SUIT GARRARD 301/401 LIGHT OAK VENEER
 PROJECT 6 TURNTABLE & ARM/ NEW GOLDRING 1022 CARTRIDGE
 ALPHASON XENON
 ALPHASON DELTA

PS AUDIO 11B MM. PHONO STAGE VGC £195
 COUNTERPOINT SA2 VALVE STEP UP SEPERATE PSU(WAS £1700 NEW) VGC £575
 MISSION 773 LC. MC. CARTRIDGE BRAND NEW NEVER USED NEW/BOXED £175
 SHURE REALISTIC RXT6 (EQUIVALENT V15-47) BRAND NEW NEW/BOXED £125
 SHURE N75ED-T2 BRAND NEW NEW/BOXED £50
 MISSION 773 LC. MC VERY LITTLE USE MINT £75
 GOLDRING 1020/1022/1042 ALL NEW STYLUS £65/70/80
 DENON DL-103 USED TWICE AS NEW £95
 DENON DL-110 LITTLE USE AS NEW £95
 AUDIO TECHNICA AT20SLA LTD EDITION GOLD (NEW STYLUS) MINT/BOXED £95
 AUDIO TECHNICA AT-F30CC MC.(APPROX.5HOURS USE) MINT/BOXED £75
 TOM EVANS MICROGR00VE PHONO STAGE MM/MC MINT £400

LOUDSPEAKER

SONUS FABER MINIMA AMATORS FEW HOURS USE ONLY AS NEW MINT/BOXED £1175
 BKS 107 MK.2 RIBBON FLOORSTANDERS MINT/BOXED £1250
 MAGNAPLANER SMG C SE HARDLY USED MINT/BOXED £695
 SNELL TYPE E MK3 VERY RARE MINT/BOXED £995
 ROGERS STUDIO 7 ROSEWOOD MINT £395
 INFINITY REFERENCE STANDARD KAPPA 5 EMIT RIBBON TWEETER SANTOS ROSEWOOD MINT/BOXED £475
 TANNAY ARUNDEL 15' DRIVERS 95/98 DB SENSITIVE VERY RARE MINT £1095
 TANNAY PAIR CORNER SPEAKERS 12 INCH DRIVERS £375
 AUDIO NOTE AN/SP SILVER WIRED & AUDIONOTE MATCHING HEAVY STANDS MINT/BOXED £875
 CELESTION 7000 4FT. HIGH RIBBON TWEETER VERY RARE MINT/BOXED £675
 WHARFADALE OPTION 1 HUGE ACTIVE ONLY 4 PAIRS MADE (WERE £8000NEW) £1500
 MIRAGE FXR-3 STANDMOUNT FEW HOURS USE ONLY AS NEW/BOXED £195
 WILMSLOW AUDIO VORTEX VOLT DRIVERS PIANO BLACK EXT X OVER VGC £475
 KEF CONCERTO.S GC £150
 ROYD EDEN'S SUPERB MINI MONITORS VGC £275
 PROAC TABLETS GGC £225
 CELESTION SL 600 SI (AEROLAM ENCLOSURES) MINT/BOXED £395
 CASTLE EDEN

TUNERS /TAPE

LINX AUDIO THETA TUNER FULL WIDTH (WAS EXPENSIVE) VERY HIGH QUALITY MINT £275
 SONY ST-SE 300 AS NEW MINT/BOXED £70
 SONY TCK 700ES TAPE DECK LITTLE USED 3 HEAD SUPERB ES BUILD MINT £350
 SONY TCD-68 PORTABLE DAT MACHINE AS NEW MINT £475
 AWA HDS100 PORTABLE DAT MINT £250

RACKS/STANDS

SOUNDSTYLE X5 105 NEW STYLE (CURVED GLASS) 5 SHELF BLACK OR SILVER EX DIS BOXED £195
 SOUNDSTYLE X100 4 SHELF STAND SILVER/BLACK EX DIS BOXED £145
 SOUNDSTYLE AV/TABLE SILVER EX DIS £150
 TARGET 5 SHELF HEAVY DUTY STAND BLACK VGC £85
 TARGET 5 SHELF STAND BLACK GLOSS/SMOKED GLASS VGC £120
 SOUND ORG. Z530 AUDIO VISUAL STAND SILVER NEW NEW/BOXED £110
 TARGET 28 INCH SPEAKER STANDS SAND FILLED SATIN BLACK MINT £75
 KUDOS S50? 18 INCH SPEAKER STANDS SAND FILLED GC £50
 SOUNDSTYLE SELECT 4 PILLAR 22 INCH SPEAKER STANDS SATIN SILVER/BLACK NEW/BOXED £75
 ACOUSTIC ENERGY AE-1 DEDICATED LOUDSPEAKER STANDS MINT £175
 ACOUSTIC ENERGY AE-1 DEDICATED STANDS BRAND NEW BOXED 2 PAIRS ONLY NEW £250

CABLES

QED SILVER ANNIVERSARY AWARD WINNING BI-WIRE CABLE (LTD STOCK) PER METRE £6.50

LOUDSPEAKER CABLE

MIT MH-50 BI-WIRE 2.5 METRE PAIR (WAS VERY EXPENSIVE \$2500+) £750
 VAN DEN HUL MCD.352 1.5 METRE PAIR (TERMINATED) £45
 DPA IS19 4.5 METRE PAIR £195
 NORDOST FLATLINE GOLD BI-WIRE 4.5 METRE PAIR EX DEM. £150
 NORDOST FLATLINE GOLD BI-WIRE 3.7 METRE PAIR £125
 ROKSAN HDC 815 2.9 METRE PAIR X 2 NEW £35
 ROKSAN HDC 815 2 METRE PAIR NEW £25
 SILVER SONIC (AMERICAN) 2.4 METRE LENGTH £50
 CEHLEBACKEABEL (SWISS) 11 METRE LENGTH BRAND NEW UNUSED (WAS £15.M) £100
 AUDIOQUEST INDIGO BLUE 3 METRE PAIR (BI-WIRE) £75
 CABLE TALK 3 BI-WIRE 6 METRE PAIR £35

INTERCONNECT

AUDIOQUEST EMERALD 1 METRE PAIR £150
 DPA BLACK SLINK 6 METRE PAIR (BALANCED XLR) £650
 DPA BLACK SLINK 1/2 METRE £90/95
 LINDSAY AUDIOPHILE SATIN GRAY (AMERICAN NEW/PACKED WAS £480) £200
 ROKSAN HDC 01A ANALOGUE INTERCONNECT 1 METRE PAIR £50
 ROKSAN HDC 02A ANALOGUE INTERCONNECT 1 METRE £35
 AUDIOQUEST INDIGO BLUE 3 METRE PAIR (BI-WIRE) £75
 ROKSAN ISODA 1/2 METRE £45
 IXOS 104 2 X 1 METRE PAIRS £20
 YFERA 1.5 METRE PAIR £60
 SHARKWIRE BRAND NEW 1 X 3FT 1 X 2FT 2 X 1/2 METRE ALL NEUTRIK XLR BALANCED TERMINATIONS £200 THE LOT £60

DIGITAL

ILLUMINATIONS KIMBER CABLE ORCHID AES/EBU 0.6 METRE (WAS £300+) BOXED £200
 VAN DEN HUL AES/EBU £40
 AUDIOQUEST AES/EBU PRO £60
 AUDIOQUEST OPTILINK X TOSLINK £80
 AUDIOQUEST AES/EBU PRO BALANCED 14 INCHS £75
 BELDEN-M DATATWISTER AES/EBU 1 METRE £65

SPECIAL OFFER

SOUNDSTYLE SPEAKER STANDS SOLID PILLAR ATECAMA STYLE . SATIN BLACK OR SILVER FINISH SAND FILLABLE 18" OR 24" LOOK SUPERB LIMITED NUMBERNEW/BOXED WHILE STOCKS LAST ONLY £75
 MOST EQUIPMENT STOCKED IS ONE OWNER MINT/BOXED, SIMILAR QUALITY VINTAGE AND MODERN EQUIPMENT REQUIRED FOR IMMEDIATE CASH PURCHASE. PLEASE PHONE GEORGE 01992-653999 / 07860-511111



RESERVE YOUR COPY TODAY!

Distributed to the news trade by



Complete this form and hand to your local newsagent

Please reserve/deliver*(delete as appropriate)
 Hi-Fi & Computer Audio World on a regular basis, commencing with the next issue, until further notice.

Name _____
 Address _____

Signed _____ Date _____

**CLASSIQUE SOUNDS.(LEICESTER) INC ONE THING.
VINTAGE HI-FI & VALVE SPECIALIST**

FOR SALE, PRE/POWER AMPLIFIERS

Linn LK1 pre-amp and remote. Good condition.	£ 249	Linn LK2 power amplifier. Good condition.	£ 299
Naim 180 power amplifier. Ex condition. Boxed.	£ 699	Naim 72 pre-amplifier. Boxed MM Boards.	£ 349
Naim Flatcap power supply. Ex condition. Boxed.	£ 199	Musical Fidelity A1000 integrated amplifier.	£ 849
Nad 1140 pre-amplifier. MM/MC. Slightly scruffy.	£ 80	Musical Fidelity B1. Nice condition.	£ 130
Quad 77 pre-amplifier with large LCD remote.	£ 495	Quad 77FM tuner with RDS. Good condition.	£ 395
Sugden A48 integrated amplifier. Nice condition.	£ 150	Harmon Kardon integrated valve amp. 110V. V rare	£ 299
AudioLab 800QC pre-amp. Mint/bxd/inst. Cost £1250	£ 649	Nad 1130 pre-amplifier. Excellent condition.	£ 79
Obelisk 2 integrated amplifier. Good condition	£ 150	AudioLab 800C pre-amplifier. Boxed/instructions.	£ 299
Grant 60S integrated valve amp. 60W. A monster!	£ 599	Townsend 60XC pre-amp with MM/MC stage.	£ 99
DPA Renaissance integrated amplifier. Mint. Boxed	£ 299	Mission Cyrus2 amplifier. Mk1. Ex condition.	£ 169
Quad 303 power amplifiers from	£ 125	Arcam 290 integrated amp & remote. Small dent	£ 175
Nad 2140 power amplifier. Good condition.	£ 99	Alchemist Forsetti pre-amp. Mint. Boxed.	£ 599
Nakanichi CA5 pre-amplifier. Ex cond. Cost £750	£ 375	Nakanichi PA5 100W/CH power amp. Cost £1,300	£ 650
Proton AP1000 pre-amplifier. Cost £299.00. G/cond	£ 110	Proton DP1200 Power amp. Cost £499. G/cond	£ 220
Linn Wakonda pre-amp + remote. Mottle finish	£ 399	PS Audio Model two power amplifier. 230V model	£ 200
NVA A80 mono power amplifiers X 2. Good cond.	£ 799	NVA A60 stereo power amplifier. Good condition.	£ 295
AVI S2000 MI int amp & remote. Cost £999. Mint	£ 549	Linn LK100 power amplifier. Excellent condition.	£ 395
Musical Fidelity Pre-8 pre-amplifier. Mint. Boxed	£ 159	Arcam Alpha 3 amplifier. Mint. Boxed/Instructions	£ 100
Naim Nac 42.5 pre-amplifier with MC boards.	£ 150	Creek 4040 integrated amplifier. 5 pin din version.	£ 79
Pair Heathkit MA12 mono valve amplifiers.	£ 249	Quad 34 pre-amplifier. 5 pin din. Boxed. Ex cond	£ 225
Musical Fidelity The Pre-amplifier. with MM/MC	£ 199	Technics SHG70 Graphic Equaliser. 12 presets	£ 80
Scott 410A integrated transistor amplifier.	£ 99	Mission Cyrus 1 amplifier. Good condition.	£ 120
Arcam Zeta 1. Pro logic Cinema amp. Cost £999.00	£ 450	Quad 33 pre amplifiers. From.....	£ 75
Leak Stereo 20 valve power amplifiers from	£ POA	Audio Innovations L2 Valve pre-amplifier. Lane.	£ 399
Arcam Alpha 2 amplifier. Mint. Boxed/instr	£ 95	Conosur/Sugden stereo valve pre/power amp. mint	£ 249

TURNTABLES

Revolvers turntable and Linn LVX basic arm. 33/45	£ 150	Ortofon MC10 super MC coil cartridge. G/cond	£ 40
Thorens TD125 Audio Technica 1100 arm/plinth	£ 250	NVA phono 2 MC pre-amp + 2 X PSU. Awesome	£ 499
Mission electronic 7755M turntable. Rare & heavy	£ 399	Thorens TD125 Chassis only	£ 59
Dual 5054 record deck. Good condition/instr	£ 100	Trio KD550. Direct drive turntable.	£ 95
Ariston RD110 turntable. Cut-out for SME. 3009	£ 75	Technics SL150 DD deck C/W SME3009 imp arm	£ 150
Thorens TD166BC. Deck only. Cut-out for SME. Bxd	£ 150	Thorens TD166 MK2 with thorens arm.	£ 89
Ariston RD50 turntable. Boxed. Good condition	£ 99	Dual CS05-2 turntable. Mint condition. Boxed	£ 89
Rega planer2/Rega RB200. Wood plinth.	£ 95	Garrard 301 & 401 motor units all serviced from	£ 125

SPEAKERS

Mirage OM6 loudspeakers. Built in active subwoofer. Goes down to 18Hz. Cost new £2800. Bargain for only	£ 1299
Quad ESL57 speakers. All fully serviced with full 3 months warranty. Hear what ESL57s should sound like. From	£ 750 pr
Pair Quad ESL57 spkrs. Fully rebuilt. 1c 4 Recon bass & 2 recon treble units. All new electronics. 12m warranty.	£ 1199
Heybrook Heylins. Black. Boxed. Ex condition	£ 199
Kei concertos in super condition. Teak cabinets	£ 225
Pair Linn Keilish in black with Kustone stands. Absolutely mint. 6 months old 4 yrs warranty left. (£300) Bxd	£ 595
Naim Int speakers in black ash. Mint. Boxed	£ 450
Dynalab 2.8 ref speakers. Cost \$1200 were £450.	£ 249
B&W DM220. slight cabinet marks. Boxed	£ 79
Mordaunt Short MS201 Pearl. Black finish. New.	£ 169
Roksan Ojan3 speakers. Good condition.	£ 449

OTHER ITEMS

Hart MM/MC Line level phono stage & PSU.	£ 199	Goldring Electro 11 MC cartridge. In case.	£ 60
Musical Fidelity. Digital Digital-analogue converter	£ 89	Ortofon MC10 MC cartridge. Good condition.	£ 30
Pioneer CT93 reference Dolby S cassette deck. Mint	£ 449	Nakanichi Cassette deck 1, 3 heads. Mint condition	£ 349
Nad 4020 tuner. Scratch on top hence	£ 35	Linn Mimik ed player and remote.	£ 380
Marantz CD50 Cd player. Ex condition.	£ 79	Chord Chameleon interconnect. For nam eqpt. Bxd	£ 49
Audio Alchemy Dac in the box with separate psu	£ 99	2 X 6M lengths of Linn K400 Biwire spkr cable	£ 70
Cogan Hall loudspeaker cable. 1.5 metre pair.	£ 150	Cogan Hall interconnect. Very high end. Amazing.	£ 150
Sme3009 series 3 arm. Mint. Boxed	£ 150	Nakanichi CDP 21: CD player. Ex condition.	£ 250
Linn Basik plus tone-arm. Good condition.	£ 75	Rotel 950 CD player. Ex cond. Boxed.	£ 100
Michell Iso Phono pre amp and PSU. Ex condition.	£ 249	Nakanichi CR3e Cassette deck. 3 heads. Ex cond	£ 299
Goldring Electro 11 MC cartridge. Boxed. Ex cond	£ 60	Sme series 3 arm. Black. Boxed with damping prof.	£ 150
Sugden SDT1 & SDA1 Transport & Dac/remote.	£ 849	Sony S770ES award winning tuner. Ex condition	£ 100
Rotel R0970 MM/MC phono pre-amplifier.	£ 89	Marantz 105B arm/fm tuner. Ex condition.	£ 69
Rotel 965 BX CD player. Excellent condition	£ 150	Spare arm tube for SME series 3. New. Unused. Boxed	£ 55
Leak Troughline 3 stereo valve tuner. Fully serviced	£ 195	Teac TR450 tuner. AM/FM synthesized/RDS. Boxed	£ 69
Linn Tuner. Mint. Boxed. Very unusual. Cost £549	£ 249	Quad FM3 tuner in excellent condition.	£ 99
Arcam Alpha 5 cd player. Mint. Boxed/remote	£ 195	Marantz CD63 top loader cd player. Collectable.	£ 125
Arwa AD-S750 Dolby B-C-SHs pro Cassette. Mint.	£ 75	ADC ALT-1 tone-arm. Mint. Boxed. Unused.	£ 100
Avantic Beam Echo valve tuner. BM61 L. AM/FM	£ 149	Trio KT800L synthesiser tuner. AM/FM. Black.	£ 75
Hackrock tone-arm with Linn arm-board.	£ 149	Technics SL-PS620A CD player/remote.	£ 75
Quad 34 moving coil module. Mint. Boted	£ 40	SME 3009 tonearms from	£ 125

QUAD ESL57 & ELS63 PANELS/SERVICING ETC

Reconditioned Quad ESL57 speakers from only £750.00.pr. Why spend £4000+?
 Have your ESL57s refurbished for only £349.00/Pair. Ring for full details.
 Exchange/ recon ESL57 bass panel £120. Treble £100. ESL63 panels £100 Refurbished.
 New socks for ELS63s £38 pr. Many other spare parts available. Please ring.
 "Classique Sounds servicing restores the Quads to a position where they can hold their head high", Jon Marks. HIFI WORLD. April 1999. Full servicing facilities available.

Troughline tuner service & realignment £95.00. (excludes valves. Rarely needed). Subject to tuner being in a serviceable condition, with no major faults or modifications. One thing stereo decoder (back in stock) £175.00 Ex review Hifi world.

TRANSLUCENT. (somewhat of a bargain) Hifi World. Jan 1999

PURE SILVER INTERCONNECT CABLE
 99.99% pure silver conductors. Quality gold plated RCA phono plugs.
 Half Metre terminated £60.00 One metre terminated £80.00
 7 day money back guarantee if not better than existing cable. Regardless of price or quality.

One Thing Mains cables. Class 1 RFI suppressed. Silver plated conductors. Voltage spike protection. only...£55.00

NEW EARLYOSHINO EQUIPMENT

Ear 834P MM/MC phono stage with/without volume. Brand new. Boxed at only £529
 Ear 834R MM phono stage. No volume control. Brand new. Boxed at only £379
 Ear 834L Line only valve pre-amplifier. Amazing. Brand new. Boxed at only £479

NEW... Classique sounds 6 way heavy duty 13A mains blocks. Only £99.00
WANTED Vintage and modern hifi eqpt. Part exchange welcome.
 Tel 0116 2835821 or 0/802 213/40 (Mobile). Callers by appt only.
 Opening times 10.00am-6.00pm Mon-Friday. 10.00am-2.00pm Saturday.
 61 Aylestone drive, Aylestone, Leicester. LE2 8QE. Email
 classique_sounds@yahoo.co.uk

Supradirect

The ONE STOP website for Supra cables to improve your Hi-Fi and/or Home Cinema system.

- 1 - VISIT www.supradirect.co.uk
- 2 - VIEW the range online (or download the PDF catalogue)
- 3 - SELECT from a wide range
- 4 - SAVE money when you make your purchase
- 5 - ENJOY

Home Cinema Users - Choose from Supra's range of composite, s-video, or RGB/Component video cables to improve your picture quality. Or use Supra co-ax digital or fibre optic cables from DVD to AV amp/receiver. DIY'ers - Fit Supra Boxcon 4mm terminals to your amp or speakers. Hi-Fi Nuts - Upgrade your existing cheap cables and enjoy better sound quality with Award-winning Supra speaker and interlink cables!



EFF-ISL - Hi-Fi Choice "Best Buy". Classic 4 - What Video "Best Buy". Ply 3.4 - Hi-Fi Choice "Recommended". Ply 3.4/S - Hi-Fi Choice "Recommended"

We belong to the Which? Webtrader Code of Practice

Bocchino Audio Connectors

Australia's finest range of high-end phono connectors
 Upgrade your phono cables from the **cheap, gold-plate on brass types** (as normally fitted) to these luxurious gold & silver-plated, pure copper, one-piece phono plugs.

Brenda™ B7 - £109/pair

Brenda™ B9 - £149/pair

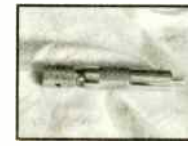
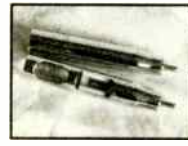

Common features: Each plug machined from a solid billet of 99.94% pure High Conductivity Oxygen Free Copper then plated with 15+ micron silver and 1.0+ micron hard gold. Signal tips plated with 3.0+ micron hard gold.

Now available from specialist accessory dealers.
 Or visit our website at: www.bocchino-audio.co.uk

Also available for OEM customers - please contact sole UK distributor:
 Bocchino Audio UK, PO Box 364, Maidstone, ME15 9FE

V'AUDIO Hi-Fi Consultants

Sale of Ex-Demo & P/E equipment	Ex-demo (x) or P/E	Approx New price	Sale price
Ruark Solstice Reference monitors (light oak, as new)	X	4000	2700
Triangle ZAYS (91db) black/walnut	X	1200	500
Castle Howard MKII (cherry, as new)	P/E	1100	600
Linn Sondek/Lingo/Mission Mechanic/ Kiesikl Blue (V.D. Hul new)	X	N/A	1000
Oracle Delphi MKII/Rega 250(+)	X	N/A	1500
Davis Home Cinema 1 (DLP)	X	4200	2500
ATC SCA 2/SPA2-150 pre/power	P/E	6800	3700
Proceed Audio-Video pre-amp	P/E	4700	3000
Rotel 991 THX 200w/ch power (2 off, still under guarantee)	P/E	650	350
Audioplan Kontrapunkt speakers	P/E	1100	450
Rotel RB 981 power amp 130w/ch		450	250
Rotel RB 971 power amp 70w/ch		250	140
Rotel RCD 971 HDCD CD player		475	250
B&W 601 S2 speakers		200	100
AVI NU-Neutron (cherry)		500	250
ECA Vista/Lectern pre/power, 50w/ch		1200	700

(Note: offers on the above may be considered)

New Generation Power Amps

As we are becoming increasingly surrounded by a digital world. It's interesting to follow development of digital power amps. Back in May Hi-Fi News reviewed the British Veritas P400 enthusiastically, and in the Nov. issue has "eulogised" over the ESLAB DS-X4 from a new British company Control Q. At £2495 it is not expensive for 200w/ch into 8 ohms, 90% efficiency, lower noise, lower weight, and negligible heat. Only available through a few select dealers, so phone for information and/or a demo.

www.vaudio.co.uk

V'audio Hi-Fi Consultants
 36 Druid Hill, Stoke Bishop, Bristol BS9 1EJ
 Tel/Fax 0117 968 6005

Sound of Music

Rotel RCD 965BX CD Player(SH) - £200
 Myriad MT100 Tuner (XD) - £300
 Beard P500 Pre & P50 Power(Valve)(SH) - £875
 Myriad MC100 CD Player (XD) - £350
 LoewePlanus&Base32"WideScrn(XD) - £1200
 Castle Severn Speakers (Maple) (XD) - £500
 Nakamichi CMS 5 System (XD) - £300
 Nakamichi Soundspace 5 (XD) - £375
 Nakamichi Soundspace 8 (XD) - £700

Loewe System Tuner/Amplifier & CD Player
 **** With Stand/CD Rack(XD) - £1200 ****

Arcam AT51 Diva Tuner(Silver)(New) - £200
 Arcam AVR100 Surround Amp(New) - £500
 John Shearne Phase 2 Amplifier(SH) - £350
 Roksan Kandy Tuner(XD) - £200
 Marantz CD 63 Ki Sig (SH) - £200
 Arcam Alpha 7 CD Player (SH) - £200
 Energy Encore AV Sub & Sats (XD) - £850
 Musical Technology Kestrel Spkrs(XD) - £350
 Proac Studio 150 Speakers(XD) - £650
 Jamo E800 Speakers(XD) - £125
 Jamo Home Cinema Spkr System(XD) - £300
 Quad 44Pre & 405Power Amplifiers(SH) £400
 NAD 216 THX Power Amplifier(XD) - £200
 Cyrus Discmaster/Dacmaster (SH) - £750
 Cyrus Pre-Amplifier (SH) - £400
 Musical Fidelity A3 Int. Amplifier(XD) - £700
 Meridian DSP 5000 Speakers(XD) - £3000
 NAD 319 Integrated Amp(XD) - £250

**Sound Of Music, 93-95 Nantwich Rd.
 Crewe, Cheshire. CW2 6AW**
Tel: 01270 214143
 For : Linn, Arcam, Musical Fidelity, Castle, Roksan,
 Onkyo, Monitor Audio, Quad, NAD, Wharfedale,
 Loewe, Project, Meridian, S.M.E., & Many Others.

AUDIO MATTERS

NEW EX-DEM & PART EXCHANGE
 EQUIPMENT FOR SALE
 020 8255 0572/0973 436135

	LIST	SALE
Alchemist Kraken Anniversary MkII	£599	£POA
Alchemist Product 8 pre & pwr (on dem)	£2047	-
Alchemist Product 8 dac & drive (on dem)*	£1898	-
Alchemist The Statement pre amp ex/dem	£4999	£2295
Alchemist The Statement Stereo pwr ex/dem	£3999	£1995
Audion Black Shadows 845 valve monoblocks	£4000	£POA
Audion Silvernight 300B monoblocks	£2250	£POA
Audion Golden Nights	£4000	£2200
Bow Technology Wazoo (ex/d)	£2195	£1595
Bryston BP ST4 pwr	£2100	£1195
Chario Academy 1 solid walnut (ex/d)	£1299	£800
Classe DR 6L pre	£3400	£1295
DPA Renaissance CD player ex/d	£995	£595
Krell 250 CD Player	£2592	£1795
Krell Kav 300I	£2495	£POA
Linn Karin pre	£1400	£595
Mark Levinson 331 pwr	£4500	£2695
Mark Levinson 23.5 pwr	£7500	£3195
Meridian 551 int. amp	£845	£425
Meridian 555 pwr. amp	£750	£395
Naim 72 pre	£800	£395
Naim 90 pwr.	£487	£250
Perreux AC 3 pre ex.d	£1700	£1195
Perreux 6 ch. pwr amp	£2500	£1695
Roksan Caspian (AC3 DTS) pre & 5 ch. pwr amp (on/dem)	£2290	-
Ruark Prologue re 1 spks.	£999	£595
Monitor Audio 20SE	£2200	£950

A NEW RANGE OF VIENNA ACOUSTICS SPKS. NOW ON DEM
 *New Product 8 from Alchemist Dac & Drive with 192 sampler in-built ON-DEM

Also On-Dem: Alchemist, Anthem, A.R.T. spks., Audiomeca, Audion Valve Amps, Cadence Spks., Chario, D.P.A., Goertz cables, Lavardin, Monarchy, Ortofon, Pink Triangle, Project T-T, Roksan., Sonic Frontiers, Triangle Spks., Van den Hul., Rogue Audio Valve Amps., Amphion Spks.

VISA/MASTERCARD ACCEPTED

IAN HARRISON HI-FI TEL: 01283 702875

HI-FI AT DISCOUNT PRICES. FREE NATIONWIDE DELIVERY 9am-9pm
SALE NOW ON! INCLUDING SUNDAYS

TRADE IN YOUR OLD MOVING COIL CARTRIDGE & SAVE UP TO 60% OFF THE RRP.

CARTRIDGES & STYL	HIFI FURNITURE	HEADPHONES	DVD
DENON SHURE AUDIO TECHNICA GOLDRING SUMIKO TRANS-FIGURATION LONDON (DECCA) GRADO ROKSAN VAN DEN HUL ORTOFON AUDIO NOTE RESON CLEAR AUDIO KOETSU	APOLLO SOUND STYLE SOUND ORGANISATION ALPHASON CABLES SONIC LINK AUDIOQUEST VAN DEN HUL QED ORTOFON NORDOST ARGENTO AUDIO	SENNHEISER SONY AKG GRADO AUDIO-TECHNICA DAT TASCAM SONY PANASONIC CASSETTE DECKS PIONEER TEAC SONY DENON MINI DISCS SONY DENON	SONY DENON PHONO STAGE MICHELL CREEK NAD AUDIO NOTE EAR ROKSAN LOUDSPEAKERS HARBETH CABASSE SHUN MOOK EPOS AMPLIFIERS DENON AUDIO NOTE C.A.T. GAMUT ALOIA EAR
TONEARMS	TURNTABLES	TUNERS	
ROKSAN SOUTHER GRAHAM MOTH CLEAR AUDIO	ROKSAN MICHELL CLEAR AUDIO AUDIO NOTE	SONY DENON	

ACCESSORIES

Hifi News Cartridge Alignment Gauge	£5	Milty Zerostat 3	£30
Hifi News Test Record & Alignment Gauge	£15	Audion Technica Stylus Cleaning Fluid	£5
Shure SFG/2 Tracking Force Gauge	£25	Clearaudio Carbon Fibre Record Cleaning Brush	£14

PLEASE PHONE TO CONFIRM PRICE & AVAILABILITY PRIOR TO ORDERING.
 ALL GOODS ARE BRAND NEW & BOXED WITH FULL U.K. GUARANTEES.
 NO EX. DEM OR EX DISPLAY GOODS. NO GREY IMPORTS. GOODS ARE NOT SUPPLIED ON APPROVAL. SORRY, NO GENERAL CATALOGUES. PLEASE PHONE OR WRITE FOR SPECIFIC REVIEWS, BROCHURES OR PRICES.
 MAIL ORDER ONLY FROM: IAN HARRISON, 7 MILL HILL, REPTON, DERBY, DE65 6GQ. TEL: 01283 702875. 9am - 9pm INCLUDING SUNDAYS.



Hi-Fi & Audio Consultants
 Sales and Service

Model	Was	Now
ALPHA 1 AMPLIFIER	X £230	£190
ALPHA 10 DAB TUNER	X £800	£675
BOSE 501 LOUDSPEAKERS	X £600	£350
CASTLE INVERSION 15 LOUDSPEAKERS	X £425	£275
CASTLE SEVERN II LOUDSPEAKERS	X £700	£495
CASTLE SEVERN II LOUDSPEAKERS	N £700	£495
DENON AVP-1, POA-T3 & POA-T2	S £4,950	£1,000
JAMO CONCERT 8 LOUDSPEAKERS	X £1,400	£900
JAMO CONCERT 11 LOUDSPEAKERS	X £2,300	£1,500
MUSICAL FIDELITY A 1 AMPLIFIER	S -	£175
SONY TAN 55 ES POWERAMPLIFIER	S -	£195
YAMAHA DSPE 492 PROCESSOR	S £400	£125

12 Regent Street, Rugby, Warwickshire, CV22 5LP
 Tel: 01788 540772
www.soundexpensive.com

5 MINS FROM M25

MATRIX HI-FI

VALVE AMP
REPAIRS

CURRENT HI-FI STOCK

VALVE CD PLAYERS FROM £330.00 ON DEMO - PLEASE PHONE FOR DETAILS.

AUDIO NOTE ANJ/SPE INC STANDS BLK	750.00
AUDIO NOTE OTO SE - MINT	799.00
BEARD P35 CHROME - MINT	450.00
CELESTION A1 SPEAKERS BLACK - NEW	499.00
CROFT SERIES 4S - ABSOLUTELY MINT	795.00
GOLDRING Lenco '88' RECORD DECK WITH SME 3009 ARM ADC CARTRIDGE.	150.00
HEART/MARANTZ VALVE OUTPUT CD PLAYER (INC CDRW) LEAK TL25 PLUS PR.	590.00
LINN CLASSIC VARIOUS COLOURS	800.00
LINN KEOSA FLOOR STANDERS - BLACK/MAPLE/CHERRY	995.00
MARANTZ CD-63	399.00
MARANTZ PM-6010 AMPLIFIER KI- SIGNATURE - BLK	90.00
PIONEER ER-420 VALVE RECEIVER	240.00
PRECIOUS METALS COPPERTECH DELTA	225.00
	59.00

PRECIOUS METALS SILVER SS200 SIGNAL	187.00
PRECIOUS METALS SILVERCOPPERTECH 102 SIGNAL	110.00
PRECIOUS METALS SILVERTECH 52 SIGNAL	81.00
PROJECT 2.9 RECORD DECK WITH ORTOFON CART. CHERRY	399.00
PS AUDIO 5.6 PRE-AMP WITH MM/MC PHONO	550.00
QED PASSIVE CD PRE AMP ALPS POT.	65.00
QUAD II PAIR. Nr. MINT	700.00
RADFORD MA50 MONOBLOCS - MINT	1,699.00
ROGERS JUNIOR + PRE AMP - RARE	350.00
ROTHWELL INDUS PASSIVE PRE AMP STEPPED CONT.	399.00
ROTHWELL RUBICON POWER VALVE AMP	799.00
SONY MDS-JE320 MINI DISK PLAYER-NO REMOTE	120.00
SOUND ORGANISATION RACK - SILVER 4 SHELVES 40% OFF	120.00
SOUND STYLE XS RACK - ICE BLUE GLASS - 5 SHELVES	299.00
THORENS TD126 MKIV ELECTRONIC WITH SME 3009/PLINTH	260.00
TRIPLETONE STEREO INTERGRATED	95.00
VAL.20WATT INTERGRATED VALVE STEREO EL.34	399.00
VERDIK QUALITY 10 VALVE MONOBLOCS	350.00



● NEW HI-END HI-FI ● VINTAGE HI-FI FOR SALE & WANTED

MICHELL - ALCHEMIST, CELESTION, QED, AUDIOQUEST, MARANTZ - ETC...
NEW AND VINTAGE VALVES - INTERCONNECTS & SPEAKER - OFC & SILVER
WEALTH OF KNOWLEDGE SPANNING OVER 30 YEARS, FOR ENQUIRIES OR
A CONTROVERSIAL CHAT, ASK FOR DAVE OR LEE.

PHONE : (01322) 292391

FAX : (01322) 229908

E-MAIL: INFO@MATRIXHI-FI.CO.UK

WEB: WWW.MATRIXHI-FI.CO.UK

SHOWROOM

65 DARENTH ROAD

DARTFORD

KENT DA1 1LU

FREE EASY PARKING



01376 521132

07802 483698

CHELMSFORD, ESSEX

E-MAIL: soundstage@netlineuk.net

BY APPOINTMENT ONLY

PRE-OWNED EQUIPMENT

AUDION SILVER KNIGHTS 300B MONOBLOCS NEW VALVES 3 YRS OLD	£995
B & W DM601 BLACK ASH VGC	£129
BEARD CA35/P35 II VALVE PRE/POWER (€2500 APPROX NEW)	£1295
DENON AVC A1 GOLD BOXED AND IMMACULATE (€2000 NEW)	£795
DENON AVP A1 GOLD BOXED AND IMMACULATE (€3000 NEW)	£995
DENON DVD-5000 GOLD WITH MULTI REGION CHIP FITTED SUPERB MACHINE	£995
DENON AVR 3800 DOLBY DIGITAL DTS BLACK BOXED IMMACULATE	£449
EPSON ES12 DARK CHERRY BOXED WITH INSTRUCTIONS	£349
EPSON ES14 WALNUT SUPERB CONDITION	£349
EPSON ES11 LOUDSPEAKERS BLACK ASH WITH HARD COVERS	£199
HARD WIRE UPGRADES AND WBT BINDING POSTS SAVE OVER £500	£1995
KIE REFERENCE MODEL 100 CENTRE LOUDSPEAKER BLACK	£199
LINN AV5103 AC3 RF LASER DISC INPUT DD PRE AMP IMMAC (€4750 NEW)	£1995
LINN ISOBARIKS DMS WALNUT LOVELY CONDITION BUYER CONDITION	£695
LOEWE PLANUS 32 WIDE SCREEN ARTISTS BOXED AND IMMACULATE	£895
MERIDIAN 500/566-20 BIT TRANSPORT/DAC BOXED AND IMMACULATE	£1495
MERIDIAN 602/606 TRANSDAC BRAND NEW LASER BOXED IMMACULATE	£1495
MICROMEGA STAGE 6 IMMACULATE AND BOXED	£529
MICROMEGA DRIVE 3/DAC BOXED AND IMMACULATE	£995
MONITOR AUDIO MA1800REF GOLD TEAK	£595
MUSE MODEL 3 PRE-AMP REMOTE BLACK BOXED AND IMMACULATE	£1295
MUSICAL FIDELITY TFM ONLY TUNER BOXED AND IMMACULATE	£199
NAIM SAC32/SNAPS/NAP250 OLD STYLE SUPERB CONDITION	£995
NAIM SAC 72 PRE AMP BOXED AND IMMACULATE (€790 NEW)	£449
NAIM SAC 92 PRE AMP BOXED AND IMMACULATE	£279
NAIM NAIT3/PRE OUT MODIFICATION BOXED AND IMMACULATE (1999 MODEL)	£399
NAIM IVO 2 WAY ACTIVE X OVER WITH VARIABLE FREQUENCY	£399
NAIM NAP10 OLD STYLE SUPERB CONDITION	£399
NAIM NAP90/3 BOXED AND IMMACULATE	£329
NAKAMICHI CR2 CASSETTE DECK	£175
NORTON AIR POWER LP12 POWER SUPPLY EX DEM	£595
PIONEER CL1995 ELITE LASER DISC PLAYER (€2000 NEW)	£395
PROCEED PCD SERIES 3 CD PLAYER (€3500 NEW)	£1695
QUAD ES163 ATC MODEL APPROX 1992/93 BLACK WITH STANDS SUPERB	£1395
RIGA PLANET CD PLAYER BOXED AND IMMACULATE	£299
ROKSAN CASPIAN CD PLAYER SILVER OR BLACK AVAILABLE	£495
RUFARK CL30 CHERRY WOOD (NEW £2500) WITH SH TECH AND XLO INTERNAL	
RUFARK CRUSADER II SPECIAL ORDER YEW VENEER BOXED & IMMACULATE	£1295
SME V TONEARM BOXED MINT CONDITION	£995
TDL RTL 2 BLACK ASH LOUDSPEAKERS	£189
YAMAHA DSP-A1 BLACK (€1800 APPROX NEW) BOXED AND IMMACULATE	£595

PROFESSIONAL RECORD CLEANING SERVICE - KEITH MONKS MACHINE -
PLEASE RING FOR FURTHER DETAILS AND PRICES

THREE MONTH WARRANTY ON ALL ITEMS

www.sound-stage.co.uk

STOWSOUNDS

Stonfarm Borough Lane, Great Finborough, Stowmarket, Suffolk, IP14 3AS

We have the following equipment to clear:

ENGINES	
Rega RB 300	£150
Creek CD 43 mk2	£500
Creek CD 53	in
Michell Gyrodek	poa
Nakamichi BX 2	£175
DPA Renaissance CD	£550
Trichord Revelation CD	£500
YBA CD 3	£1500
Marantz 6 dic changer	150
GEARBOX	
Creek 5350SE	£725
Cyrus 2	£150
Exposure 25 Integrated	£850
Michell Hera/Argo	poa
Michell Alecto monoblocks	poa
Naim various	call
Sonneteer Campion Integrated	£425
YBA 3 Pre Power	£1725
EXHAUST	
Epos M12	£385
JM Lab Tantal 515	£325
JM Lab Cobalt 810	£525
JM Lab Electra 905	£795
Rogers LS4a	£150
Martin Logan Aerius	£1250
Naim SBL old	£300
FURRY DICE	
Quad FM 4	£175
Yamaha DSP E492 Processor	£150
Tripod Rack	£100
Sound Organisation Z565	£100
Linn Classic	£825
Rotel RT 950BX	£125

Various interconnects, supports, cables at reduced prices.

Phone for details

Sale of CDs. Phone for latest list.

TEL: 01449 675060

HICAM

**CHERISHED PRE-OWNED HI-FI EQUIPMENT SOLD, PURCHASED, P/X.
WE URGENTLY REQUIRE NAIM, MERIDIAN, AUDIOLAB, LINN EQUIPMENT
MAIL ORDER ALWAYS A PLEASURE**

	WAS	NOW		WAS	NOW
ALCHEMIST NEXUS APO32A 24 BIT CD PLAYER NEW	599	425	INTERCONNECT NEW	60	50
ALPHASON ANKROS 2 SPEAKER STANDS BOXED	60	40	PRECIOUS METALS SILVER SIGNAL 202B BALANCED NEW	500	425
ATACAMA SE 24 SPEAKER STANDS NEW	75	65	PRECIOUS METALS SILVER SIGNAL 204 INTERCONNECT	1	
AUDIIONOTE QTD INT AMP LINE LEVEL	999	595	METRE	490	425
LYRA HELIXON SL MC CARTRIDGE NEW	1249		NAIM 32.5 PRE AMP EXCELLENT CONDITION	150	
EAR HEADPHONE AMP HP4 NEW	1695		PROJECT CLASSIC/PROJECT9/510 PIANO BLACK NEW	450	325
AV1 S2000 MM MONDBLOCKS NEW	1399	POA	NAIM NAIT 3 INT AMP/BOXED/MINT	600	325
AVI S2000M11 AM/FM REFERENCE TUNER NEW	899	POA	PSB ALPHA 6 ACTIVE SUBWOOFER AS NEW	500	425
AVI PRO NINE SPK NEW	699	625	ELAC CL 330 JET INC STANDS NEW	2499	
AVI S2000MC REFERENCE 24/96 CD PLAYER NEW	999	625	RUARK CL10 CHERRY FINISH (NEW) SLIGHT MARK	900	695
AUDIOQUEST INDIGO 1X2 METRE PAIR	90	45	RUARK DIALOUGE R ROSEWOOD (NEW) SLIGHT MARK	380	305
AUDIOUSA EUPEN POWER CABLES FULL RANGE		POA	RUARK PROLOGUE CHERRY (NEW) SLIGHT MARK	995	795
EARV 20 INTEGRATED CLASS A NEW	2798		RUARK VITA 100 5.1 SYSTEM BEECH (NEW)	1500	1095
RUARK 100 VITA ACTIVE SUB BOXED/AS NEW	550	450	STAX SRS 4040 SYSTEM SIGNATURE 2 NEW	1195	1195
EAR 861 POWER AMP CLASS A 1 MONTH OLD	3599	2995	SONETEER BYRON CD PAYER AS NEW	795	695
DALI ROVAL METET MK2 CHERRY FINISH NEW	400	325	SONETEER CHAMPION INT AMP AS NEW	599	495
EAR 815 INTEGRATED/PRE-MAIN AMP NEW	2299		AUDIIONOTE AHS1 CARTRIDGE TRANSFORMER	400	300
EAR 834P CHROME DELUXE MM/MC PHONO AS NEW	778	695	SME 300312 ARM/BOXED MINT	1000	695
EAR 834P MM/MC PHONO STAGE	549	475	TRICHORD DINO PSU NEW		225
EAR MC3 MC TRANSFORMER 1 MONTH OLD	658	595	SONICLINK AST200 BIWIRE SPK CABLE NEW	10	8
EAR 834 INT AMP NEW	2198		SONICLINK THE BASE 1 METRE PAIR INTERCONNECT NEW	25	18
HEYBROOK QUARTZ ROSEWOOD FINISH	595	275	SONICLINK THE REBEL SPK CABLE NEW	7.56 PER METRE	
JBL CONTROL 1 SPEAKERS		40	SONICLINK 8 WAY DISTRIBUTION BLOCK 2 METRE CABLE		
LAT SS800 SPEAKER CABLE 5MTR NEW	206	175	NEW	299	250
LAT 8 WAY DISTRIBUTION BLOCK 3 FT NEW	226	195	SONICLINK SIMPLICITY 1 METRE PAIR INTERCONNECT NEW	35	27
LAT AC2 6 WAY DISTRIBUTION BLOCK 3 FT NEW	195	160	SONICLINK VIOLET 1 METRE PAIR INTERCONNECT NEW	85	40
LAT AC2 POWER CABLE 3 FT NEW	68	63	SONICLINK VIOLET INTERCONNECT (OFF THE REEL)		
LAT IC100 MK2 1 METRE BOXED NEW	105	90	15 PER METRE		
SONICLINK 8 DISTRIBUTION BLOCK NEW	299	250	STAX SRS 2020 MK2 EAR SPEAKERS MINT	449	375
AUDIIONOTE ZERO TRANSPORT/DAC NEW	1048		TAG McLaren IDDP X2 PURCHASED MARCH 2001	1100	
MERIDIAN DSP 5500 24/96 SPEAKERS	7000	4500	EACH	625	
MERIDIAN D500 CONVERTED TO M60 ACTIVE	2000	1195	SUMIKO PEARL MM CARTRIDGE NEW		79
MERIDIAN 565 AV PROCESSOR/DTS.7.1 ETC	2800	1695	SUMIKO BLUE POINT SPECIAL MC NEW	279	249
MERIDIAN 562V MULTIMEDIA CONTROLLER	1395	850	TALK ELECTRONIC CYCLONE 1 INT AMP R/C	595	495
LYRA LYDIAN BETA MC CARTRIDGE NOT USED	599	525	TALK ELECTRONIC THUNDER 1 CD PLAYER		
MERIDIAN 506 CD PLAYER	1200	795	TARGET Mx100 SPEAKER STANDS PIANO BLACK		
MERIDIAN DSP 5000C 24/96 CENTRE SPEAKER	1995	1195	TRICHORD PSU FOR DINO PHONO STAGE NEW		225
MICHELL LARGE PSU NEW	399	399	TOM EVANS MICROGROOVE MM PHONO STAGE	400	295
MICHELL ALECTO MONDBLOCKS AS NEW	1989	1800	TRICHORD RESEARCH 500 POWERBLOCK	299	275
MICHELL GYRO 6E/RB300 ARM	976	976	TRICHORD RESEARCH DINO MM/MC PHONO STAGE NEW	299	299
MICHELL ORBE SEALED BOX	2095	POA	NEC 42 IHD1 PLASMA TV NEW	6600	POA
MICHELL ORCA PRE AMP	1251	POA	VOH INTEGRATION 1 METRE PAIR BOXED	300	350
MYRYAO INT 100 FIA TUNER NEW	599.95		NEC 50 INCH PLASMA TV NEW	9995	POA
MICHELL GYRODECK RB 300 ARM AS NEW	1190	1095	VOH MC 10 MC CARTRIDGE NEVER USED	700	600
STAX OMEGA REFERENCE SR 007/SRM 717			MYRYAO MD 600 CD PLAYER NEW		1299
TUBE ENERGISER		2795	AUDIIONOTE ANCO 3 1X CD PLAYER NEW		1499
PRECIOUS METALS GAMMA 1 METRE			VOH FIRST ULTIMATE 0.6 METRE NEW		220
			VOH THE SOURCE HB 0.8 METRE NEW		65
					57.5

OPEN MON-SUN 10AM-6PM
FOR FURTHER DETAILS: TEL 01726 74474 / FAX 01726 70387
MOBILE: 07973 233 380
E-MAIL: hicam1@freemtnname.co.uk
OR VISIT OUR WEBSITE www.hicam.co.uk



AWARD WINNING SUPPORT RANGE

You've read about it for years.
You've seen it on TV.

Now experience The Mana Effect™
at your local retailer...

- BRISTOL AUDIO EXCELLENCE 0117 926 4975
- CARDIFF AUDIO EXCELLENCE 029 2022 8565
- CHELTENHAM AUDIO T 01242 583960
- CHESTER AUDIO EXCELLENCE 01244 345576
- EDINBURGH LOUD AND CLEAR 0131 226 6500
- EXETER AUDIO EXCELLENCE 01392 491194
- GLASGOW LOUD AND CLEAR 0141 221 0221
- GLOUCESTER AUDIO EXCELLENCE 01452 300046
- HARROW HARROW AUDIO 020 8930 9933
- HIGH WYCOMBE AUDIO T 01494 558585
- HULL ZEN AUDIO 01482 587397
- LEEDS IMAGE AUDIO 0113 278 9374
- LONDON THE CORNFLAKE SHOP 020 7631 0472
- SWANSEA AUDIO EXCELLENCE 01792 474608
- WIGAN ADVENTURES IN HI-FI 01942 234202

Mana Audio LTD

Unit E, Amlwch Industrial Estate, Anglesea LL68 9BX
Tel: 01248 450472 or 01407 830 530 Fax: 01407 830 535
E-mail: post@mana.co.uk www.mana.co.uk
Visit the Mana forum: www.manaforum.atinfopop.com

SALE!!

UNREPEATABLE
PRICES ON
CLEARANCE STOCK!

		RRP	SALE
ASK C1 COMPACT LCD PROJECTOR 10FT IMAGE	NEW	£3,500	£1,800
B&W CDM1SE BOOKSHELF SPEAKER (CHERRY)	NEW	£600	£375
B&W CDM2SE BOOKSHELF SPEAKER (RED ASH)	EX DEMO	£400	£250
B&W CDM7SE FLOOR STANDING SPEAKER (RED ASH)	EX DEMO	£1,000	£600
B&W DM601 S2 BOOKSHELF SPEAKER (BLACK)	NEW	£230	£150
B&W DM602 S2 BOOKSHELF SPEAKER (BLACK)	NEW	£300	£200
B&W LM1 LEISURE MONITOR (PEARL WHITE)	NEW	£200	£150
DENON DCD-1500AR CD PLAYER	NEW	£350	£195
KEF REFERENCE 105 FLOOR STANDING SPEAKER (BLACK)	S/H	£2,000	£700
LINN CENTRIK SINGLE CHANNEL SPEAKER (BLACK)	NEW	£345	£250
LINN CLASSIK INTEGRATED CD PLAYER	NEW	£995	£600
LINN CLASSIK INTEGRATED CD TUNER (BLUE)	NEW	£995	£650
LINN IKEMI CD PLAYER	NEW	£1,950	£1,500
LINN KEILDH FLOOR STANDING SPEAKER (WALNUT)	EX DEMO	£850	£500
LINN KOLEKTOR PREAMPLIFIER WITH MM PHONO STAGE	NEW	£495	£250
LINN POLYMER STANDS	EX DEMO	£135	£80
LINN TUKAN BOOKSHELF SPEAKER (WALNUT)	EX DEMO	£600	£300
LINN WAKONDA PHONO PREAMPLIFIER	NEW	£945	£500
LINN SONDEK LP1 2 TURNTABLE, AKITO TONEARM, K9 CARTRIDGE	NEW	£1,790	£1,100
LINN LINGO POWER SUPPLY	NEW	£750	£500
LINN 5110 ON WALL SPEAKERS (WHITE)	NEW	£195	£130
LINN SIZMIK ACTIVE SUBWOOFER (CHERRY)	NEW	£1,000	£650
LOEWE 4236H VIEWVISION VIDEO RECORDER (ARTIC)	NEW	£250	£150
LOEWE 4236H VIEWVISION VIDEO RECORDER (GRAPHITE)	NEW	£250	£150
LOEWE 6336H VIEWVISION VIDEO RECORDER (GRAPHITE)	NEW	£300	£190
M&K SW95 IN WALL SPEAKER (WHITE)	EX DEMO	£550	£320
MISSION 773e FLOOR STANDING SPEAKER (ROSEWOOD)	NEW	£400	£250
MISSION 774 FLOOR STANDING SPEAKER (ROSEWOOD)	NEW	£500	£300
MISSION M71 BOOKSHELF SPEAKER (BEECH)	NEW	£130	£80
NAKAMICHI AV-10 DOLBY DIGITAL AMPLIFIER	EX DEMO	£1,000	£600
TAG McCLAREN 100P POWER AMPLIFIER	NEW	£1,000	£600
TAG McCLAREN 60i INTEGRATED AMPLIFIER	NEW	£500	£370
TAG McCLAREN 60iRv INTEGRATED AMPLIFIER	NEW	£1,000	£600
TAG McCLAREN 60P POWER AMPLIFIER	NEW	£600	£400
TAG McCLAREN APHRODITE CD TUNER (BLUE)	NEW	£3,000	£2,250
TAG McCLAREN APHRODITE STAND	NEW	£380	£330
TAG McCLAREN CD20R CD PLAYER	NEW	£1,250	£700
TAG McCLAREN DAC20 DA CONVERTER	NEW	£500	£300
TAG McCLAREN PA10 PREAMPLIFIER	NEW	£500	£390
TAG McCLAREN PA20R PREAMPLIFIER	NEW	£700	£500
TLC CLASSIC 2 FLOOR STANDING SPEAKER (PIANO BLACK)	NEW	£950	£450
TLC MAESTRO 70S BOOKSHELF SPEAKER (CHERRY)	EX DEMO	£220	£130

- FINANCE AVAILABLE
- 12 MONTH WARRANTY ON ALL EQUIPMENT
- DEMONSTRATION AVAILABLE
- AUTHORISED DEALER ON ALL STOCK



3-5 Village Way East
Rayners Lane • Pinner • Middlesex • HA2 7LX
Tel: 020 8868 3300 • Fax: 020 8868 9593
E-mail: info@prestige-audio.co.uk
Web: www.prestige-audio.co.uk

AudioSource Stratos Series III Interconnects



Stratos Stereo, Fully Balanced, and Digital Audio Cables

MARKET POSITIONING Affordable excellence: designed as a high-end, high resolution cable, not a designer "house" timbral signature as normally aimed at the mid-price market

! Exclusively manufactured for sale mail order direct to end-user: you don't pay a multiplier for development, marketing or middlemen

! Designed by a leading audio engineer and refined with a wide variety of leading brands; regularly used in The Audio Salon's reference valve and solid-state systems.

PUREST COPPER CONDUCTORS Highest grade OFC in 140 strand x 0.07mm assures ultra smooth response, DC to multiples of highest audio frequency, thus no HF harmonics

! Lowest plate capacitance assures no audible treble roll off even over 10 metres

! Copper crystal conditioning forms long grains for optimum phase response before burn-in

! Age annealed against long-term degradation of skin effect due to air and moisture ingress.

INDUSTRY HIGHEST RFI and EMI REJECTION Triple shielding results in greater than 85% airborne and common mode rejection; custom phono plug with reflector shield throughout

! Unique earth drain XLR configuration with RCA plug system grounds antenna and contamination collected by shielding to source, not target

! Surface cleaning applied immediately before all plating and soldering avoids diodic (non linear) RF stripping

! These features yield close to perfect square wave (high rise time) ideal for our digital cable

3-T SOLDER TECHNIQUES Etc. Time, technique and temperature developed by listening test, not neatness of join. Twinning: AudioSource silver and tin solders made in Japan were developed by 17 of our 87 logged listening tests. Applied to combine maximum adhesion and permanent interface current transfer). Pure materials, airtight storage, and hygiene result in highest purity signal transfer.

***FULLY BALANCED STRATOS CABLES USE SWISS BLACK GOLD NEUTRIK CONNECTORS**

NO QUIBBLE 28-day refund policy, less £5 handling charge, providing cable is undamaged.

AudioSource Purist Audio Mains Products

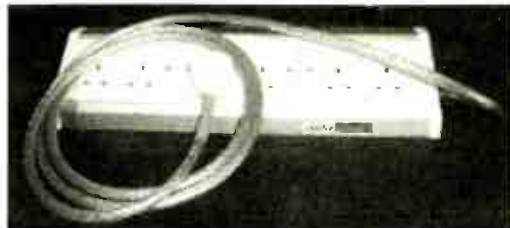

Model E4/6-outlet 13amp (UK) with Premium Filter Board

CAPTIVE INPUT CORD

! Hard-wired direct to filter Low inductance, shielded by outer braid (isolates adjacent cables)

! High gauge, high purity for near instantaneous current delivery

ALUMINIUM EXTRUSION

! Non-ferrous (no back EMF); also, non plastic (no electrostatic induction)

! Farady shield around internal double-helix OFC wiring

! Sockets inline eliminate Line and Neutral terminals EMI

MULTI-PURPOSE FILTER

! Medical instrument grade integral design, not radio shop components soldered in standard mains filter circuit

! LCR Values chosen to gently filter incoming sinewave without compression, optimising all proprietary AC cords

SAFETY AND CONSISTENCY

! All units are auditioned against prototype s/n 001 itself tested with wide variety of systems

! All UK components CE approved, hand-assembled in UK.

! Superior design and construction outperforms similarly-priced rivals

VALUE FOR MONEY

! Equivalent to a very substantial component upgrade for the price of a good interconnect your music collection is renewed!

! Sold mail-order direct to end-users, no middleman!

! No quibble 21-day refund less cost of £12 includes carrier collection for return. No hassle, no unwanted product sale due to inertia.

The Double Helix "british braided cord" - UK made

! 1.5 metre double wound, high current OFC wire cancels RFI without slowing or compressing sound. **£45-00**

"Certainly, BBC is revealing rather flattering, but at £45 it's very good value." H-Fi Choice, September 2001

Buying & Selling Vintage HiFi, Valves, Classical LP Records & Spare Parts.

Quad		Valve Alert	
All spares available for Quad II and Quad 22			
Quad AM2 Tuner	£40	iviatard ECC81 Genuine N.O.S Blue Box, Made In England	each £8
Quad QC II Pre-amp	£40	Valves N.O.S	
Quad FM1 Tuner	£40	ECC84 Mullard	£6
Quad II Mains Transformer	£120	ECC84 Bnmar	£6
Quad II Output Transformer	£120	EF80 Mullard	£5
Quad II Output Transformer (100v Line)	£50	ECC81 CV455 Mullard	£8
Quad II Choke	£30	ECC81 CV4024 Haltron	£5
Quad II Fuse Holder	£10	ECC81 CV4024 White Box?	£5
Quad II Chassis + Wiring Loom	£35	Photocopies Of Circuit Diagrams + Vintage Hi-Fi Literature Spare Parts For Quad + Leak - Transformers Etc. Garrard 301 Control Levers	
Quad FM1 + Decoder	£75		
Quad 33/303/FM3	£300		
Quad 33/303 (33 needs service)	£170		
Please Phone For Details Of Other Quad/Leak/Garrard Spares			

Leak		Cartridges & Arms	
Leak TL12.1 (Pair)	£1500	Shure V15 III cartridge (No Stylus)	£20
Leak Stereo 20	£250	Shure V15 II cartridge (With Stylus)	£20
Leak Stereo 60	£550	Goldring 10-10 cartridge (As New)	£50
Most Models Of Leak Mono + Stereo Pre-Amps In Stock.		Ortofon SPU-TE (built-in transformer) needs re-tipping	£100

Speakers	
Nakamichi 610 Pre-amp/ 620 Power-Amp/ 630 FM Tuner	£500
Tannoy HPD15 gold crossover (Single)	£50
HMV 555 Stereoscope Amp with cathode ray tube	£450
Garrard RC88 Autochanger Turntable	£25
Sound Sales D X plus one tuner SW/MW/LW (approx 1946) very rare	£200
Garrard 401 (Chassis only) (mint)	£200
Garrard 401 +SME 3009 II improved in SME 2000 plinth (mint)	£375
Decca MK1 arm with Microlift	£30
Goodmans Triaxiom 12" drive units with crossovers model 1220 (pair) £200	
Wharfedale Super 3 drive unit needs new surround (single) £20	
KEF K1 Slimline Monitors (pair) £25	
Leak Sandwich Bohm (pair) £100	
Please phone for details of Tannoy speakers, stock often changes before the next advert.	

Valves (G E C. Mullard etc.)		Hammond/Everett organ model S3000 (valve)-two keyboards with Vibrato + Reverb + Bass pedals Overall size 35" h x 39" w x 22" d £100	
KT66, ECC81 84, EF80 Many Others Please Phone For Details			

Quad ESL57 Electrostatic Loudspeakers
 2 pairs both in excellent condition and sounding superb. £600 (pair)
 Pair 1. Bronze, Serial No.s. 35882 + 35906
 Pair 2. Black, Serial No.s. 11031 + 7143
 Packing available in tailor-made export quality cartons £70 (pair)

WANTED : LARGE COLLECTIONS OF CLASSICAL LP'S

A
p
e
x
A
c
o
u
s
t
i
c
s

Musical Fidelity A3 CD Player Silver Trim B/M/MT	£595
Arcam Alpha 9 CD Player B/M/MT	£525
Meridian 506.18 CD Spec'd to 24 Bit Serviced B/MT	£685
Rega Planet CD Player X1	£450
Cyrus Disc/Dac Master Transport Dac B/EX	£875
Naim CDI CD Player 1994 B/M/MT	£825
Quad 34 Pre Amp Phono B/M/EX	£190
Rega Mira Int. Amp X1	£450
Manley Stingray Integrated Amp X1	£1625
Musical Fidelity F16 Power Amp B/M/EXC	£1000
Musical Fidelity A3 Int. Amp Silver Spec. New	£725
Musical Fidelity XA1 Integrated Amp B/M/MT	£300
Musical Fidelity X Plora Tuner B/M/MT	£375
Cyrus XPA Power B/M/MT	£250
Cyrus AV Master/Pre B/EX	£300
Cyrus Power (Slight Mark Front) B/M	£300
Exposure 17 Pre Exposure 18 Power Balanced Leads B/MT	£800
Audio Analogue Bellini Pre B/M/MT	£335
Exposure 21 Pre Exposure Dual Reg 4 Power B/MT	£1600
B & W CDM7NT Cherry Floor Standing Speakers B/M/MT	£995
Linn Keilidh (Granite Plinths) Rosewood Speakers B/M/MT	£590
Veritas 7's & Stands Satin Oak XD	£795
Veritas 7's Cherry SH	£550
Veritas 25 Floor Standing Speakers Cherry XD	£1030
Quad ESL 63's Serviced With Report	
Re-Clothed In Black MT	£1295
Chord Chorus/Connect 1m XD	£170
Vdh The First Ultimate 1m XD	£260
Vdh The First 0.8m XD	£150
Ecosse Reference Conductor CA1 1m New	£40
Ecosse Reference Maestro 0.8m MA2 XD	£135
Ecosse Reference Quartet 0.8m XD	£160
Vdh The Wind 3m Factory Terminated XD	£200
Vdh Tea Track 3m Bi Wire 2x4 Factory Ter XD	£130
NEW PRODUCTS	
Geist Interconnects 99.99% Silver Featuring The Eichmann Bullet Plugs 0.85m Stunning!	£150
Townshend Interconnects Isolda Deep Cryogenic From	£250
Townshend Isolda Deep Cryogenic Speaker Cables 3m From	£300
Sonic Link Power Blocks 8Way WOW!	£300
Sonic Link Power 25 Leads 1m Rhodium Plugs IEC's From	£79
Dino Phono Amp On Dem £299 PSU Upgrade	£225

XD=Ex Dem
 B=Boxed
 M=Mass.
 MT=Mint
 EXC=Excell

PHONE STEVE ON 01527 450500 / MOBILE : 07773198336 E-MAIL Apexnm@aol.com

diverse vinyl

10 charles st newport south wales np20 1ju
 01633 259661/256261 sales@diversevinyl.com

Forthcoming Releases

Beatles	Live At The BBC (Reissue)	£TBC
Byrds	Live At The Filmore	£TBC
Eva Cassidy	Songbird	£TBC
Fun Lovin Criminals	Loco (on vinyl at last!)	£TBC
Louis Armstrong And	Duke Ellington (ClassicRecords)	£TBC
Love	Forever Changes (Sundazed)	£15.90
Mick Jagger	Goddess In The Doorway	£18.90
Mott The Hoople	All The Young Dudes	£TBC
Pete Townsend	Scoop - 3LP (ClassicRecords)	£49.90
Pink Floyd	Echoes (Best Of) 4LP Set	£33.00
Robbie Williams	Swing When You're Winning	£15.90
Sarah Vaughan	You're Mine You (Roulette)	£16.50
Stephen Stills	Manassas (Classic Records)	£41.90

ALBUM OF THE MONTH

Sir Paul McCartney "Driving Rain" £15.90

New Stock And Recent Releases

4 Hero	Creating Patterns	£19.90
Aphex Twin	Drukqs - 4LP Set	£25.90
Basie/Bennet	Basie Swings Tony Sings	£26.90
Beechwood Sparks	Once We Were Trees	£12.90
Billy Mahonie	What Becomes Before 2LP	£12.90
Dilated Peoples	Expansion Team	£15.90
Dinosaur Jr	BBC Sessions	£16.90
Graham Nash	Songs For Beginners	£26.90
James Carr	You Got My Mind Messed Up	£10.90
James Carr	A Man Needs A Woman	£10.90
Kinobe	Versebridgechorus?	£13.90
Led Zeppelin	Presence (Classic Records)	£26.90
Leonard Cohen	Ten New Songs	£12.90
MC5	Kick Out The Jams	£15.90
Michael Jackson	Invincible	£14.90
Ride	OX4 - The Best Of Ride	£18.90
Silver Mount Zion	Born Into Trouble	£13.90
Starsailor	Love Is Here	£15.90
Talvin Singh	presents Back To Mine 3LP	£16.90
The Clangers	Original TV Soundtrack	£10.90
The Fall	Are You Our Missing Winner	£15.90
Tindersticks	Trouble Every Day OST	£13.90
Todd Rundgren	Something/Anything?	£15.90

SIMPLY VINYL & S125 TV & FILM SOUNDTRACKS
 Titles include: Lost In Space, Star Trek, Best Of Godzilla 54-75
 The Time Tunnel, They Call Me Mr Tibbs, Across 110th St

DISCO ANTI STAT LP CLEANER

Probably the most economical LP cleaning device on the market
Only £41.95



Call for details

Call for a catalogue of over 3500 brand new LPs, or visit

www.diversevinyl.com

RETRO Reproduction

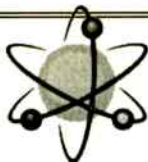

New Showroom & Dem rooms now open
28a Haddington Place Edinburgh EH7 4AF Phone/Fax 0131 558 9989
Open 11.00am - 5.30pm - closed Monday & Sunday



PS When Tim de Paravicini does a job, he does it properly, whether it is a custom studio installation or an affordable phono pre-amplifier like the EAR 834P. With years of experience in design and manufacturing, nobody can come close to the unique point of view and life experience he puts into all of his designs.

When first launched, the 834P was the only valve phono stage you could buy with facilities for both good quality moving coil (MC) and moving magnet (MM) cartridges. In addition, the unit could be purchased with a volume control, allowing direct connection to a power amplifier. Now in its seventh year of production it still sets the standard with fantastic soundstaging that all transistor phono stages can just dream off, coupled to low background noise and enviable reliability.

There are now four models in the EAR lineup:

The classic 834P uses the same circuit architecture as its more expensive brothers, and shares the same high quality sound through MM type cartridges. It is enclosed in a tough, rigid metal case and is fully "CE" type approved. price £380.00

The signature builds on the Classic 834P specification by adding a superb moving coil (MC) input stage, as well as the no-extra-price option of a high quality volume control. price £530.00

Top of the range, the Deluxe 834P comes in stunning chrome and gold cabinet, and has extra attention and quality control. With different moving coil input options, this unit will fit the most demanding of audiophile systems. For the true vinyl enthusiast, price £800.00

MC3 - The ultimate stage for MC matching with 3 fixed transformer taps to cover all types of moving coil cartridges, and separate left/right grounding. MC3 in used in the new £10,000 312 pre. price £6,300.00



PS Ear Yoshino New Models

Ear 869 single ended triode integrated amplifier
 Improved version of the classic 859 with revised output transformers modified input stage with the addition of a extra signal valve which has allowed an increase to 15watt of single ended power, also the 869 can be used as a power amp. Don't be fooled by its modest power output this amp drives real world speakers. price £2100.99

Ear 8L6 Integrated/Pre-main amplifier

Using 8 EL34 power valves to produce 50watt per channel in push pull class A with in-house designed output transformers. The 8L6 has been designed to meet a wide variety of needs from the most demanding of audio files to the professional seeking high quality monitoring equipment in the studio field. Valve life is long and replacement cost are modest. There is also a balanced power amp version with monoblocking capabilities to produce 100watt per channel. Price £2199.00

LIMITED PERIOD

Part Exchange your existing equipment against any Ear product and it will be valued at private prices not usual dealer rates.

NOW DEMONSTRATING

LEN GREGORY'S AMAZING MOVING IRON CARTRIDGE ON THE NEW NOTTINGHAM ANALOGUE CARBON SPACE ARM

HARMONIC TECHNOLOGY SINGLE CRYSTAL CABLE
 NOW IN STOCKS - WE WANT YOU TO HAVE A CABLE TO DO ALL THE THINGS THE MANUFACTURE CLAIMS AND AT A RIDICULOUS LOW PRICE. PHONE FOR MORE DETAILS

Used Equipment For Sale

Primare A20 MKII integrated amp new £700
 System Deck NX turntable UPGRADE YOUR REGA from Art Audio valve headphones amp & line stage without board PSU new £750
 Arcam BR integrated amp as new
 NAD 312 integrated amp boxed mint
 Epos M15 floorstanding speakers cherry new model
 B&W 603S2 floorstanding speakers cherry
 Musical Fidelity E10 integrated amp
 Sugden A21 new model integrated amp silver finish
 Luxman valve D105 CD player
 Rogers LS1 bookshelf speakers
 Rogers LS33 with AB33
 Quad ESL63 black mint with stands
 Solstice Advanced Acoustic Design open baffle design speakers outdoor crossover with stands new £1000's?
 SME V tonearm boxed
 ProAc response 25 loudspeakers burr oak finish new £2300 with Target R stands
 Crimson battery 610
 Rogers LS5 speakers
 QLN signature speakers with crossover and stands
 Musical Fidelity F25 remote pre
 Radford TRI Star 3 way speakers
 Pink Triangle Ordinal DAC
 Quad 33 wooden sleeve boxed as new
 Tube Technology Genesis 100watts monoblocks re-valved
 Musical Fidelity P270 MKII power amp with MX pre

Kel Reference 1.2 roseout finish new mint £995
 Cyrus III integrated amp £395
 Sugden T48 stereo tuner £195
 Pioneer PD5703 CD player £350
 Sansui Faber Signum boxed new £195
 Audion golden knights 300b mono blocs new valves £95
 Revox G36 open reel mint £595
 Conrad Johnson PV10 pre amplifier as new £295
 Audio Research SP14 valve pre amp £175
 Audio Research CD11 cd player £595
 Audionota K speakers with matching stands £195
 Kel Concerto speakers £95
 SME 309 tonearm £295
 EAR V20 integrated amp bargain price £995
 EAR 834P £995
 Quad 77 integrated amp with Remote carbon finish £695
 Trilogy valve MC head amp £995
 Michelle QC power supply £1195
 EAR 834 L valve line stage £95
 Revox A77 Open Reel £175
 Amcron DC-300A Power Amp £995
 Linn Wakanda MM & MC phono stage £795
 Counterpoint SA 5000 Pro - the ultimate Valve Pre Amp (very rare) £795
 Audio Research LS2 one of the world's finest line preamps £195
 Pioneer PD93 CD player battleship build quality with rosewood and stops new £1500 £250
 Pioneer CT-93 tape deck dolby s cost new £600.00 - £1350
 QED T-237 tuner £750
 Dynalab Etude tuner "the best" new £1400

Sennheiser HD500 headphones boxed as new £95
 Chord Clearway mains conditioner new £225 £95
 Croft OTL power amp 10 months old £595
 Philips CB304 heavy weight build £75
 Audiolab 8000A int amp various from £195
 Linsley Hood 75 de-lux int amp £75
 Linsley Hood power tran tuner £75.00
 Celestion Dittan 10 bookshelf spk's £495
 KEF K2 bookshelf spk's £1250
 Leak Sandwich 250 spk's £95.00
 Marantz 105 tuner £750
 Hytech power amp £125
 Meridian 206 CD player £450
 Audio Innovations L2 valve line stage £1795
 Audio Innovations S200 pre-amp with valve phono stage £375
 Croft original micro valve pre-amp superb phono stage £195
 Pioneer 93 reference tuner rosewood side panels £225

Due In

Audio Research remote integrated amp £295
 Linn LK100 £350
 Quad 606 £295
 Quad II monoblocks consecutive serial numbers £1495
 various centre speakers £1250
 Sonab omni directional speakers £495
 Selected products from: Audio physic speakers, Ear Yoshino, Croft, Cary, Nottingham Analogue, Creek, Triangle, Sugden, AVI, £195
 £75
 £795

ERGO ago-go

Mail order service for quality Swiss headphones
 Free next day delivery hotline 01924 406016

ERGO MODEL ONE	£109.00	=====
ERGO MODEL TWO	£149.00	=====
ERGO MODEL AMT	£599.00	=====

ERGOPHONES are designed for fatigue free listening and can be used for many pleasure filled hours without discomfort. Acting as a true earspeaker, they have a wide bandwidth capability coupled with low distortion figures of less than 0.30%.

All music types are replayed beautifully, offering a remarkable near-field listening experience. We guarantee superb sound quality at sensible price points.

More info available at www.precide.ch and info@audiosynergy.co.uk

Distributed in the UK by Audio Synergy Limited

SUGDEN HEIL AMT PRECIDE MDM ACE ERGO JECKLIN FLOAT

Special Internet offer
 see page 130 for details

Dealers must not advertise in the Private Classified section.
 Monthly consecutive insertions will be considered Trade
 advertising. The Publisher reserves the right to judge submissions.

RUARK EXCALIBERS (Black Piano Lacquer) £4,995.00 Musical Fidelity 3D-CD Player £2,450.00. Musical Fidelity A300-CR Power-Amp £1,495.00. Can deliver - all are as new with their boxes / manuals etc. Tel: 01622 721011 or 07973 899651 (Mar/I)

TEAC VRDS 10 Trichord Clock 2 £370. Audio Synthesis Passion £350. Ear 834P MM/MC £375. Avantgarde Sub 217 BR pro active subs £750 pair. Rogers LS55 rosewood £120. Tel: 01922 477 682, Walsall (Jan/I)

PROAC RESPONSE 2 'S' with Target stands £895. AVI Neutron III Red Spot £325. Quad 606 and 34 £550. Genuine reason for sale. Lovely condition. Tel: 01455 212 977 or 212 671 (Jan/I)

MUSICAL FIDELITY E20 E30 pre power 100wch phono headphone remote 4 line 2 tape black hi-gloss finish excellent boxed condition, terrific bargain at £395. Tel: 01371 850 665 (Essex) (Jan/I)

AUDIONOTE MEISHU valve amplifier inc phono input little used £1500, Linn Karik with power supply £500, Snell J2's imported £400, dedicated stands £100, tuner £45. (£2250 the lot). Tel: John 01344 640 070 evenings (Jan/I)

CELESTION C3 speakers (pair) won in competition, hardly used (unboxed) worth £1000 total, will accept £600 cash. Will deliver in Yorkshire. Tel: Alan Carnley, Kirkbymoorside, N.Yorks 01751 432 270 (Jan/I)

SONY CDP-101 (Very rare, 1st generation) CD player, £150. Musical Fidelity A1, £165. Mission Cyrus II (final alloy cased version), £150. Nakamichi 480 cassette deck (silver), £150. Pioneer CTF-850 high end cassette deck, £95. All mint, boxed. Tel: 07870 657 173 (Jan/I)

BEAUTIFUL ROSEWOOD Thorens TD321 turntable, Syrinx, AT110 £175 (£400+). Marantz PM47 integrated phono amplifier £50. SD50 Dolby B&C HX-Pro cassette, ST50 AM/FM Synthesis tuner £40 each. B&W 302 bookshelf speakers £45. Tel: 01709 555 403 (Jan/I)

MERIDIAN 500 Mk1 CD transport (swinging arm model) £550 (£1325). Cyrus Pre, balanced in/out, phono stage, full remote control, volume/inputs £295 (£650). Wanted: d-to-d upsampler. Tel: 01273 325 901 (Brighton) (Jan/I)

LINN AKTIV System. Kairn Pro pre-amp, Mimik CD player, 3 x LK100 amplifiers, Kaber speakers. All boxed in mint condition £2650. Tel: 01332 541 389, (Mob) 07903 112 386 or email: lifestyled@lineone.net (Jan/I)

LEAK FM Troughline 3 mono tuner, Radford FM7 stereo tuner, Quad FM3 stereo tuner, Quad 33, Teac tape recorder, Meridian p/amp also Sansui Sony A&R Cambridge Mission 771 amplifiers, chokes available for vintage amps EMI BTR2 ex BBC offers. Tel: 0131 332 7536 (Jan/I)

ATC 50ASI loudspeakers in rosewood with custom slate stands £3600. Tact Millennium digital amplifier £3600. Audio Synthesis DAX (balanced version) £750. Meridian 200 (full Trichord modifications) £350. Tel: 0131 225 9002 or email: s.hussain@ed.sac.ac.uk (Jan/I)

MUSICAL FIDELITY Nu-Vista M3 integrated amplifier (275wpc), asking £2250. Audioquest 5 metre bi-wire speakers cable, cost new £800, asking £175. Tel: 01296 437 314 (Aylesbury, Bucks) (Jan/I)

QUAD ESL63 speakers, serviced by Quad, £1195. 66 preamp and control panel, 606 poweramp £750. 44 preamp £195. FM4 tuner £195. Tel: 01993 883 523 (Jan/I)

ARMSTRONG 621 amp, 624 tuner £70 the pair. Cyrus I, Cyrus 2, first generation £60, £80 respectively. Old Goodmans Maxim loudspeakers £50. Goodmans Maxim II £40. Armstrong 521 amp £25. Philips 850 II CD player £60. All in very good condition. Tel: 01254 397 015 (Jan/I)

TANNOY BERKELEY reconed with receipt, Unison Research Simply 4P, Mission CD player PCM 7000, all boxed £1600 ono. Tel: 01463 236 211 or 01463 715 428 or Mobile 0771 230 9139 (Jan/I)

SWISS ENSEMBLE speakers, PA Reference Silver, excellent condition, £1150. Audio Innovations 800 Series 1 valve amplifier £235. Sonic Link Silver Aero S130 3m bi-wire speaker cables £75. Tel: 01202 767 873 (Poole) (Jan/I)

ROKSAN ROKI Original slate CD transport, DAI DAC, excellent condition, original boxes £450 ono. Nordost Silver Shadow digital interconnect, phono to BNC, best there is, £150 ono. Tel: 0794 136 8479 (Plymouth) (Feb/I)

PINK TRIANGLE DaCapo Dac, 22 bit filter and DC power supply with recent batteries. Rare combination, £1100 ono. 24 bit filter also available (£650 new) £300 ono. Tel: 0794 136 8479 (Plymouth) (Feb/I)

RUARK EQUINOX Loudspeakers (walnut), mint condition with new stands from factory. Stereophile recommended component. Deep bass from a small loudspeaker, £750 ono. Just upgraded to Dunley's. Tel: 0794 136 8479 (Plymouth) (Feb/I)

WILSON BENESCH Actor speakers, pristine condition, boxed, upgrading forces sale, £2000. Tel: 01480 393 298 (evenings) (Jan)

ROTEL RB991 power amp 200wpc, recommended Hi-Fi Choice, £325 (£599). Marantz DD82 DCC recorder £120 (£600). Hardly used. Tel: 01332 842 220 (Jan/I)

HELIOS 1, £650 (£1500). Musical Fidelity X-Cans II, £75 (£145). Sennheiser HD600 £80 (£250). Rotel RQ970 BX Phono £35 (£120). All boxed, vgc, sale due to upgrade. Tel: 01732 840 265 (Kent) (Jan/I)

LINN SONDEK LP12, black ash, Ittok tonearm, new Linn K9 cartridge, has just been fully rebuilt and refurbished by Linn technician, £1100. Tel: 01753 851 429 after 7pm (Jan/I)

THORENS TD160 turntable with Hadcock G228 Unipivot tonearm and brand new Audio Technica moving coil cartridge. Has just had expert turntable rebuild, £350. Tel: 01753 851 429 after 7pm (Jan/I)

EXPOSURE ACTIVE electronic crossover for Linn Isobarik. Very rare unit with a special history. £400 ono. Also Naim 32.5 and 42.5 pre-amps, just serviced. Tel: 01753 851 429 after 7pm (Jan/I)

EKOS ARM £550. Naim CD5, boxed, mint £695. Ruark Talisman speakers £250. Linn Sondek, late spec £200. Quad ELS 57 G.W.O. £300. Marantz CD10 £375. Linn Karma MC £50. Tel: 0114 221 5271 (Jan/I)

MICROMEGA TEMPO 'P' (pre-amp) + Tempo 'Amp' (power) 120wpc (1998). Top of range inc. 2 pairs van den Hul Source interconnects. Full remote, as new, boxed (£2500 new) £795 ovo. Yamaha KXW 482 twin tapes cassette deck (seperate). Full logic remote, boxed as new £125 ovo. Tel: 0121 358 0459, mobile 07960 945 994 (Jan/I)

AUDUSA EUPEN CSA 2.5 MAINS CABLE - HI FI CHOICE SEPT 2001 BEST BUY AWARD



AUDUSA-Eupen CSA 2.5



AUDUSA EUPEN GNLN 5.0 mains cable

CSA and GNLN Cable with FERRITE TECHNOLOGY - A polymer material mixed with a considerable quantity of homogeneously fine high quality ferrite powder. This compound is called EMC/COM and it can be extruded around copper conductors. The ferrite itself is a non-conducting material, but it has a very interesting magnetic behaviour. As a ferromagnetic material, it will go through hysteresis loops whenever it is under influence of an alternating magnetic field. Consecutively magnetizing and demagnetizing the material will cause considerable losses of high frequency energy. This energy is absorbed in the ferrite grains and converted into heat. This effect is more or less proportional to the field frequency. By coating conductors with a thin layer of ferrite compound, high frequencies will be strongly attenuated, because their energy will be absorbed by the ferrite powder. This applies to high frequency disturbances that are propagating on the conductor and which we don't want to disturb the environment, as well as to surrounding interferences, which we want to prevent from disturbing the signals on our cable. The CSA cable which in addition to the above described ferrite technology is further protected with a foil shield and a drain wire and specifically manufactured for High End audio use.

£48 for 1.0m
£58 for 1.5m
£68 for 2.0m
off the reel £30
for 1st meter, £20
per m thereafter.

Fitted with IEC (Martin Kaiser) and MK Tough Plug. Figure of eight, 16 amp IEC, Bulgin etc also available as well as USA, European Schuko, and other mains plugs. Cable can be supplied fitted to our all steel 4, 6 and 8 way distribution blocks. We can rewire the distribution blocks with Eupen cable as an extra cost option. Refer to our web site for details.

L A T INTERNATIONAL NJ USA - all cables now with SILVERFUSE conductors

LAT AC-2 HI-FI CHOICE - SEPT 2001 - RECOMENDED MAINS CABLE

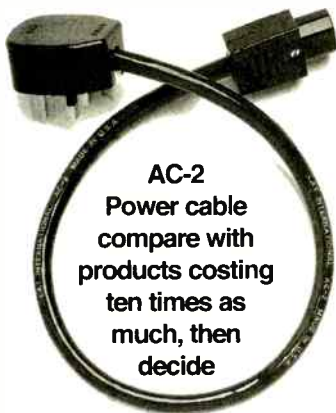

AC-2
Power cable
compare with
products costing
ten times as
much, then
decide

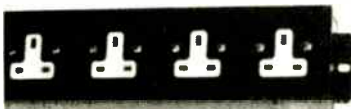

LAT AC-2 Power cable. We have developed a cabling (weaving) pattern along with an unusual shielding/filtering system that gets rid of the garbage that contaminates your components. The difference you hear with our cord is astounding. Our power cord takes advantage of silver in its design through use of our proprietary Silverfuse conductors. The conductors are 10 gauge and insulated with Teflon; the best insulation available. Fitted as standard with an IEC and MK Toughplug. Other connectors are available incl Schuko, 16 amp IEC, Figure of eight etc. 60cm £56, 90cm £68, 1.2m £78, 1.8m £99. other lengths available and off the reel at £39 per meter. SE version available with GP Tough plug and IEC , outer black braid all for an extra £12 irrespective of length **4,6 and 8 way all steel mains distribution blocks** fitted with UK, Schuko or USA type sockets. CE tested and approved mains distribution units manufactured out of heavy gauge steel, finished in black and fitted with high quality Wadsworth 13amp sockets. It has no filters, circuit breakers, surge protection, transformers, resistors, capacitors, LED's, on/off switches, chokes, regulators, just fitted with 1m of LAT AC-2 mains cable. From £161 for 4 way, £194 for 6 way, £226 for 8 way.

NEW GOLD MK Tough plug with gold plated pins (£14)
Otto Heil IEC with gold plated contacts (£10).

SILVERFUSE is a near alloy of silver and copper. IT IS NOT SILVER PLATED OR SILVER CLAD. Plating (or clad, which is the same thing as plating) causes a dioding effect when signal is passed through resulting in brightness and distortion. The Silverfuse process starts with seven nines OFHC copper wire with a diameter that is slightly larger than the required size. It is then pulled through a trough of molten silver. The wire with a silver deposit, is then forced through a compacting die where it is subject to tremendous pressure. The silver and the high purity copper are fused together into a near alloy. The compacting fusion also reduces the wire diameter to the desired size. No dioding subsequently occurs with this process. The result provides for the benefits of silver; which are excellent definition and clarity, with the high purity copper benefits of warmth and mellowness.

LAT AC-2 mains cable available with 16 amp IEC (MF, KRELL etc), Figure of eight, Bulgin etc sockets. UK, USA, Australia, European and Schuko plugs. Check our web site for available variants.

LAT INTERNATIONAL - Analogue, Digital and Video interconnects and Speaker cable. Refer to www.audusa.com for further details or ask for reviews etc



3D-LABS CDP, DAC, TRANSPORT AND DVD's

with SRC sampling rate and bit converter translates 16,18 and 20 bit inputs to 24 bits format. All 32, 44.1 and 48kHz frequency is re-sampled to 96kHz. This is known as upsampling. The SRC is comparable with that used by DCS in the Purcell unit. Prices start from £1245 for a CDP with SRC. Later this year the SRC will re-sample to 192 kHz.

DVD with SRC and CV2. CV2 Video system for unmatched picture quality - best with projection systems . DVDS with SRC and CV2 start from £1730. DVD with CV2 £1245.

SUNFIRE CORPORATION

New Sunfire True Sub Woofer MKIV 11 inch cube 220v

Signature True Sub Woofer 13 inch cube 220v. Junior Sub Woofer 9 inch cube, Classic Tube Pre-amp, solid state power amps 2 channel and 5 channel and processor pre-amp.



Special Internet offer
see page 130 for details

CROFT SERIES V poweramp. Newer type with horizontal valves, burr oak fascia, top class condition and sound, £275 ono. Tel: 01270 251 837 after 6pm (Jan/I)

TRICHORD PULSAR DAC and power supply plus jitter reduction unit. New £2193, will accept £800. Tel: 01732 88 3950 after 7pm (Jan)

CASTLE HOWARD S2 rosewood finish, excellent condition. What Hi-Fi 5 star award, £550. Elemental Isotube SZse stands, £350. Harbeth 6ES Nextel grey with dedicated black ash stands £625. Tel: 01202 871 603 (Jan/I)

MUSICAL FIDELITY Nu-Vista CD player, 20 hours use £2500 ono. Tel: 01943 864 097 after 7pm (Jan/I)

WANTED: CELESTION System 6000 Dipole sub woofers or REL Stadium sub woofer also Celestion Ditton 88 or any information on these. For cash. Tel: 07932 768337 or 0207 480 7964 Email: amw@amwi.fsnet.co.uk (Jan/I)

PS AUDIO P600 power plant, UK model 240v new in unopened box, c/w full multiwave options, (financial problems after ordering cause sale). New price £2800. Bargain at £2000. Tel: 01923 256 071 or 07957 855 787 (Jan/I)

SWAP CHARIO Academy 1's speakers, matching stands, solid walnut, cost £1200 plus Soundstyle 5 shelf rack, blue marbled shelves, for Castle Howards etc. Must be light wood finish. Tel: 01243 869 698 (Jan/I)

NAIM CDX and Chord Solid interconnect £1450. Naim XPX £1300. NAC 82 £1400. Hi-caps £400 each. Nap 250 £900. All mint and boxed. Tel: Chris 07718 267 988 or 0208 592 9797 (Jan/I)

FOR SALE: Mark Levinson Proceed power amp 2. 150wpc. £950 (£2500). Meridian 566.20 dac. £450 (£1250). Stereophile recommended. Yamaha E390 prologic processor £50 (£250). Mint. Boxes. Manuals. Tel: Bill 01993 851 508 (Oxford) (Jan/I)

KEF REFERENCE Series Model 100 speaker £100. Arcam Xeta One A/V amplifier with remote £60. Arcam Delta 70 C/D player, no remote £40. Quad 303 amplifier £50. Tel: 0131 229 8514 (Jan/I)

YAMAHA NS1000M speakers £600. Linn Sondek Valhalla £450. Quad 34 preamp £250. Leak TL12+ power amps matched pair £400. Tel: 01926 887 506 or 07949 006 832 for further details (Jan/I)

AUDIOLAB 8000 PX power amp 100wpc mint condition, boxed, owned from new. £495. Tel: Mike on 0208 363 8350 or 07973 671 915 (Jan/I)

PAIR REVAMPED Leak TL25 Mk II's excellent £500. Pair Tannoy 15" Arden's need surrounds. Offers. Croft Micro pre amp small fault £70. Also Denon PMA 250 II amplifier £60. Bargain. Tel: 01453 752 226 evenings after 6pm. (Jan/I)

NORDOST SOLAR Wind speaker cable bi-wire. 2 x 3.5 metres. 2/4 termination £200, mint, boxed. Tel: 07941 213 107 (Norwich) (Jan/I)

TWO GENUINE Voigt corner horns with PM2 and PM4, very rare pair £1000 ono. Pioneer tuner TX 540 L £70. Marantz player CD 63 £130. Denon cassette DR MR 414 £80. Sony cassette TCX 6116 £60. Pioneer cassette CTF 500 £80. Revox A77 four track 1224 (speakers amplifiers) £200. Sony turntable PSLX 210 £50. Quad 33 & 303 £150. Connoisseur turntable SME & Ortofon pick up £50. Tel: 01924 463 031 (Yorks) (Jan/I)

3 PAIRS prototype horn cabinets. Unique construction. Can be dismantled for transport. Various Lowther units if required. H.1200mm W. 425mm D. 920mm £400 - £500 - £950. Can demonstrate. Tel: 01763 269 613 (Jan/I)

LUMLEY ST70 valve amplifier, chrome, switchable triode/pentode operation £895. Golden Tube SEPI valve preamp £450. Soundstyle four shelf rack £90. Tel: 01452 612 640 or Email: andy@admckenzie.fsnet.co.uk (Jan/I)

MERIDIAN DSP 5000 24 bit (black) 9 months old, absolutely mint. Still under 3 year warranty. Quick sale, hence £2850. Tel: 07802 828 266 (Jan/I)

WANTED QUAD 405 dead or alive, or replaced 405 amp modules. For sale: Mission Cyrus I £70. Tel: 07790 880 328 (Yorks) (Jan/I)

NAKAMICHI CR7-E cassette, ultimate, serviced, mint £890. Cyrus 2 + PSX classic amplifier superb phono stage manual £320. Studer A710 cassette X-BBC serviced excellent condition £280. Wanted: Tannoy 12" silver Leak TL10. Tel: 07764 408 756 (Jan/I)

TDL ELECTRONICS RTL4 floor-standing speakers (rosewood) boxes. Very little used £200. Sale due to house move. Tel: 01883 627 185 (N.E. Surrey) (Jan/I)

QUAD FM3 £75. Rotel power amp RB980BX £180. Boxed, with manuals, both excellent condition. JBL Control 5's, monitor speakers, SB5 subwoofer, both very loud sound. Both boxed £300 ono. Tel: 01903 501 061 (Jan/I)

ARCAM DELTA Equipment: 250 transport/black box 50, £495. D290 integrated (phono) £200. D290-P power amplifier £180. Linn Keilidh with stands £350. Tel: 01384 395 967 evenings or 07740 245 984 anytime. (Midlands) (Jan/I)

NAIM HI-CAP £450 (£750), NAP 140 £400 (£700). NAC62 including MM/MC boards and Din/phono adaptor £150 (£650). All latest backlit cases. All excellent condition. Original packaging, manuals. Careful owner upgrading. Tel: 01761 221 168 (Jan/I)

HARBETH HLK-6 walnut stand-mount speakers mint bi-wire (£1000) £599. Mission 754 Freedom 5's oak floorstanders (£1400) £649. Marantz PM 17 KI gold remote boxed (£1100) £649 Tel: 0115 960 3934 or 07779 045 059 (Jan/I)

MYRYAD MDV 200 DVD player £695 (£1000). Van Den Hul The First Ultimate II c 0.6m £125 (£220). Van Den Hul CS122 3.0m pair speaker cable BFA amp end banana plugs speaker end £55 (£115). Tel: 023 8087 2620 (Jan/I)

LINN KLIMAX'S (2000) £7250, LK140 (2001) £575, Espeks (American Cherry, Aug 01) with supplied stands £2000. Espek/5140 Kustone stands £125. Stereo Aktiv cards for Espeks/5140 £225. All in mint condition and boxed. Tel: 01622 858 085 (Jan/I)

ACOUSTIC ENERGY AEI Series II standmount speakers, 6 months old, cherry (£800) £499. Sony TA-FAS0ES amplifier black remote, 6 months old, boxed (£850) £449. XLO Ultra .5 mtr interconnect (£125) £75. Tel: 0115 960 3934 (Jan/I)

SME 309 Immaculate - boxed, manual, tools £425 ono. Audio Synthesis Passion Vishay-Holco version as new £275. Also Passion equivalent as kit. Elna switches, silver wire, gold phonos etc, bargain £100, details on 01624 817 230 eves (Jan/I)

MARANTZ CD17 KI Signature, gold finish, mint condition, boxed £550 for quick sale (£1100 new). Tel: Tony 0151 236 7120 Email: tony@pmedia.demon.co.uk (Jan/I)

KRELL 250P pre-amp £950 (£2250). Krell KMA-100 monoblock power amps £1750 (£6000). Wadia WT3200 CD transport £850 (£1800). Audio Synthesis ultra-analogue D/A converter £500 (£1250). All mint, boxed. Tel: 07768 938 867 (London area) (Jan/I)

MIRAGE M1 loudspeakers £1600. Naim NAP250 £900. NAP140 £400. Linn Active Isobariks (black-1988). S-Naxo (1996). Hi-Cap (1990) £1400. DMS Isobariks (black 1980), £450. Tel: 01233 626 163 or Email: john.isobarik@virgin.net (Kent) (Jan/I)

AUDIO INNOVATIONS 500 integrated valve amplifier with border patrol valve rectified power supply. Amp in excellent condition, power supply mint. Boxed, can be heard, buyer collects. £475. Tel: 0161 624 8856 (Jan/I)

SNELL ACOUSTICE Type A/MC III 2 box loudspeaker mint condition boxed £3500. Sunfire true sub woofer MkII 11 inch cube two drivers 2700 watt amplifier £750. Tel: 01527 459 274 (Jan)



PHONE FOR LATEST LIST

NEW, ED-DEM AND CLEARANCE ITEMS

	RRP	SALE	
Arcam Alpha 10	£799.00	£549.00	D
Arcam Alpha 8R Amp.	£350.00	£259.00	N+D
Arcam Alpha 7R Amp.	£280.00	£229.00	N+D
Arcam Alpha 9P Pre. Amp.	£400.00	£300.00	N+D
Acoustic Energy AE1 MKII	£995.00	£695.00	D
Copeland CDA266	£1,399.00	£1,195.00	D
Copeland CDA289	£1,985.00	£1,295.00	D
Krell KAV 500i Int. Amp.	£5,498.00	£3,895.00	D
Mission 701 speakers	£160.00	£119.00	N
Linn Kaber	£1,995.00	£695.00	D
Linn Keosa	£499.00	£369.00	D
Mission X space speakers	£199.00	£95.00	N+D
ProAc 3.8	£3,990.00	£2,990.00	D
Neate Mystique	£735.00	£499.00	D
Cyrus SL Amp	£400.00	£250.00	D
Cyrus AV Master Processor		£200.00	D
Audio Research VT50	£3,499.00	£2,279.00	D
Rotel RX965RDS A/V receiver	£950.00	£695.00	D
Tannoy Revolution R3 speakers		£249.00	S/H
Meridian 500 Transport (mint)	£1,350.00	£849.00	D
Meridian 502 Pre. Amp	£1,385.00	£995.00	D
Meridian M33 Active speakers	£1495.00	£995.00	N+D
Quad 77 Integrated Amp.	£700	£350	D

D = EX DEMONSTRATION, N = NEW, S/H = SECOND HAND

Hi-Fi Multiroom and home cinema

ACOUSTIC ENERGY ARCAM ASH DESIGN AUDIO
 RESEARCH CELESTION COPELAND CYRUS
 DENON KEF KRELL LINN TAG MCLAREN MARTIN
 LOGAN MERIDIAN MICHELL MISSION MONITOR
 AUDIO MUSICAL FIDELITY NEAT ACOUSTICS
 PIONEER PROAC QED QUADRASPIRE REL SONUS
 FABER SME STANDS UNIQUE STAX THETA
 WILSON AUDIO ETC...

THE LISTENING ROOMS LTD

161 OLD BROMPTON ROAD LONDON SW5 0LJ
 TEL: 020- 7244 7750/59 FAX: 020 - 7370 0192
 www.listeningrooms.com E-mail: tlr@dial.pipex.com
 Mon-Sat 10-6pm



64 FLIXTON ROAD
 URMSTON
 MANCHESTER
 M41 5AB
 0161 202 9922

SECOND HAND AND EX DEM ITEMS FOR SALE

	RRP	SALE PRICE
CD PLAYERS		
Myryad T10 silver, as new	£400	£350
NAD S500 Silver Series	£1000	£850
AMPLIFIERS		
Audio Analogue Bellini/Donizetti (silver)	£1100	£700
Crimson 610 preamp with MM/MC phono stage	£450	£200
Exposure 2010 integrated	£599	£499
LFD Mistral pre amp	£450	£300
LFD PAO power amp	£650	£300
Myryad T50/T70 pre/power with prologic	£949	£600
NAD S300 silver series	£1500	£1099
Unison Research S2K valve integrated	£1295	£1095
LOUDSPEAKERS		
Acoustic Energy Aego 2 (NEW)	£300	£250
Acoustic Energy AE100	£229	£99
Audio Physic Step inc stand	£1299	£499
Epos M12 cherry	£499	£375
Monitor Audio Gold Reference 20	£1499	£1250
Monitor Audio Silver 3i	£279	£225
Naim SBL walnut	n/a	£599 ono
Neat Mystique II (natural ash) as new	£795	£650
Neat Petite III (rose)	£845	£499
Opera Platea (mahogany)	£795	£499
Totem Model One	£1249	£599
MISCELLANEOUS		
Onkyo TX DS595 dolby digital/pro logic II	£495	£395
Onkyo TX DS777 THX receiver	£799	£499
Project RPM Four	£300	£249
Sonus Systems 5 shelf "Excel" rack	£269	£200
Teac Reference 100 system	£420	£349
Teac Reference 300 system	£599	£450
Teac DV3000 DVD player	£229	£189
Teac RW800 CD recorder	£349	£275

check out our website for up-to-date list : www.replay.dial.pipex.com



4 Ruabon Road, Wrexham, LL13 7PB
 Tel: 01978 364500

email: sales@acton-gate.com
 website: www.acton-gate.com

Autumn sale

REL Q100e	£250
TEAC vrds7 cd	£225
Tdl RTL 3 Speakers	£200
Marantz cd17ki	£700
Quad 405 MK1	£175
Arcam cd92	£690
Rotel RC980/RB980/RB980	£650
Audio Analogue Donizetti Power	£475
Audio Analogue Bellini Pre-amp	£395
Quad 99 Pre & CD	£1125
Rotel 951 CD Ex.Disp.	£275
Quad 50e (pair)	£350
Linn Classik (silver.ex-dem)	£800
Michell Alecto Stereo	£999
Quad 44 pre-amp (mint condition)	£200
Quad 988 speakers	£3000
Michell Gyro SE with RB 300	£785

Good prices paid for used Quad equipment.

Special Internet offer
see page 130 for details

GARRARD 401 Aphelion plinth just serviced not usual rubbish £475. Hadcock GH 242 SE 3 months old £450. Cartridge Man cartridge 3 months old £295 – or £1150 everything. Dynaco Stereo 70 recent GT Audio service £500. Tel: 0208 952 2044 (Jan/I)

COPLAND CDA 266 £750.
Copland CSA 28 £750. Both boxed as new also new Grado SR80 £50. Tel: 0798 458 0389 (Jan/I)

STACKED QUADS! Black. Oak stained frames. Sound superb! Storage several months £695 pair. Technics SL1000 plinth and SP10 motor. Offers. Valve Rogers radiogram tudor cabinet mono classic. RGD Radiogram. Tel: 07989 401 489 (Jan/I)

DENON DCD-715 CD £60. Sub bass for Wilmslow micro monitors (LS3/5A) £50. Linn LP12, Ekos, Klyde, Lingo. Little use £1300. Tel: 01635 299 244 (Jan/I)

LINN SONDEK, black with black Itok/P77E cartridge, £600. Nakamichi cassette deck 2 £100. Both little used. Arcam Alpha CD £75. Tel: 01606 301 398 or Email: ian.bowley@ntlworld.com (Jan/I)

47 LABORATORY Gaincord 4706 plus power Humpty 4700 amplifier. New perfect condition. Lovely sounding, cost £2800, accept £1900. Tel: 0208 994 2030 evenings (Jan/I)

LINN IKEMI CD hardly used £1450. No offers, no timewasters. Audiolab 8000T tuner £350. Quad 34-306, Quad serviced £350. All items mint, boxed, one owner. Tel: 01482 842 740 (Jan/I)

STIRLING LS3/5A's brand new walnut £495. Exposure CD 4 years old, mint £450. Atacama stands (£150) £65. Incatech Claymore mint £165. Rogers A100 superb £140. AR Cambridge tuner classic £60. Tel: 0208 952 2044 (Jan/I)

PINK TRIANGLE Export, light ash, SME and Rega armboards £350. Arcam Alpha 6 CD £200. Denon DCD825 £100. Royd Minstrels, black £100. All mint boxed. Tel: Mark 01543 414 936 (Staffs) buyer collects (Jan/I)

ABSOLUTE 4P Active monitors. 200W internal amps, great review in Hi-Fi World £450 (£800). Opera Super Pavorotti – beautiful slim floorstander, 1 month old, just run in. Quick sale £750 (£1000). Tel: 0207 613 0136 (Jan/I)

BEARD MKII valve power amp P100. Beard MkII valve preamp P505. £1200 both. Tel: 020 8386 4753 (Jan/I)

IPL ACOUSTICS S4 transmission line speakers, professionally built out of 25mm H.D.F. glued and screwed cabinets, black ash, superb sound, genuine reason for sale £475 ono. Tel: Glyn 01709 524 575 (Jan/I)

TOWNSHEND ELITE pre/power ampl incl. phono stage. 85wpc dual monobloc design £300 ono. Ruby Chameleon 200wpc power amp. phono/balanced inputs. £400 ono. Tel: 01302 370 578 (Jan/I)

TARGET WALLSHELF £40. VPI magicbricks £35 each. Mission Isoplat £27. Tel: 07905 186 575 (Jan/I)

PINK TRIANGLE Cardinal CD player mint (£1400) £550. Ordinal 24 bit Dac £245. Illuminations digital cable boxed £100. Nordost Blue Heaven interconnect 0.6 £75. Tel: 07773 060 254 or 01709 511 220 evenings (Jan/I)

AUDIO RESEARCH SP8 Mk2 pre amplifier £850 ono. Musical Fidelity A3CR dual mono amplifier £550 ono. Tel: 0161 764 2069 (Bury) (Jan/I)

PINK TRIANGLE DaCapo with 24 bit filter and Cardinal re-clocking board, excellent condition £650. Cardinal Transport £350. Transparent PDL digital interconnect £100. Tel: 01592 772 806 (Fife) (Jan/I)

QUAD 77 CD Player plus integrated amplifier bus system plus remote £500. Buyer collects. Tel: Charlie 01524 848 621 (Lancaster) (Jan/I)

ONE PAIR of speakers Celef LC1 no base units cases unmarked £40. One Technics cassette deck RS-B40 £25. One Garrard 401 turntable with arm & plinth very clean. Offers. Fax: 01623 862 400 (Jan/I)

NAIM NAC32.5 with phono cards. NAPI60 HiCap. Good condition, boxed. Circa 10 Years old. £675 the lot. No splits. Tel 01628 781 253 or 07881 782 662 (Jan/I)

KINSHAW OVERTURE matched pre and power amps rare and sought after, can demo £350. Tel 0207 284 2393 or 01494 762 574 (Jan/I)

SONY DTC-55ES DAT player/recorder, mint condition C/W 13 tapes £195. Wanted: PX my M.F. A300 for Beard P100 MkII power 506 pre. Tel: Steve 01429 268 218 or Email: stephen.petch@ntlworld.com (Jan/I)

REL STORM MkIII £999 new accept £575 ono, good condition, only months old. Tel 07751 874 816 or 0208 488 5302 anytime (Jan/I)

AVANTIC SPA21 valve amps (2) £110 each. Decca tone arm new £50. NAD 3020A amp £70. JBL SVA 1600 horn speakers superb £800 new £260. Tel 01827 261 082 (Staffs) (Jan/I)

MUSICAL FIDELITY Nu-Vista CD player, mint condition, boxed with manuals £2800. Musical Fidelity XPI100 pre-amp, mint condition, boxed with manuals £600 ono. Tel: 07958 552 671 or Email: rorrdeen@yahoo.com for details (Jan/I)

WANTED: MUSICAL Fidelity X-PSU must be complete with leads, instructions and preferably boxed. In good condition. Tel: 07940 494 447 (Jan/I)

AEI SPEAKERS with dedicated stands. Boxed, superb condition and sound. £400. Tel: 01432 275 203 (Hereford) (Jan/I)

CONRAD JOHNSON PFIL FET pre amplifier, excellent condition, cost new £1200 sell £475 ono. Manual. Boxed. Tel: 0131 332 4478 (Jan/I)

LINN KLOUT amplifier £1200. Linn Keltik loudspeakers black £2200. Includes Aktiv cards. Linn external Keltik crossover £200. All as new. Tel: 01763 262 493 (Jan/I)

GAMMA ACOUSTIC speakers Epoch 5 black with oak cheeks £850. Wanted: Audiolab 8000 MX's or 8000 M's would swap money either way. W.H.Y. Tel: 01395 275 698 (Devon) (Jan/I)

LUX L100 int/amp 110W channel, rosewood, £250 Lux T88V tuner £55, Dynavector DV17D2 MkII £100, JR 25w 70Hz amp/x-over for sub £20. Homemade loudspeakers, Linnaeum, Volt, Coles, tri-wired £90. Tel 01474 708 631 (Jan/I)

KOETSU RED cartridge bought as spare in October. Unused, not needed. Retail at £1500. Sell £750. Quad 303, just serviced £100. Tel: 01424 755 375 (Jan/I)

AUDIOLAB 8000PX Sept 98 mint £425 ono. Audiolab 8000Q vgc £375 ono. Meridian 566.20 DAC superb sound mint £395 ono. Tel: Alan 01992 576 551 (Essex) (Jan/I)

ARCAM ALPHA 9 CD/HDCD player £475 ono. Arcam Alpha 10, Dave, Alpha 10P, 3 Dolby Digital DTS 5 x 100w cinema system superb £2500 new. £1200 ono. KEF Reference 1 to 2's speakers, rosewood veneer finish, beautiful, over £1400 new (recent What Hi-Fi winner). £899. KEF Q95 centre channel speaker £90 ono. Sound Organisation 5 tier stand, black glass shelves £75. Tel: 01753 623 813 or 01628 604 455 ext. 385 (Jan/I)

REGA PLANET CD player, Rega Elex amplifier, Acoustic Energy AE109 (black) connecting leads, boxed. Consider splitting. All A1 condition £699 ono. Tel: 0118 934 9370 (Reading) (Jan/I)

LEAK STEREO 20 plus Varislope preamp, grey silver £300. Pair Leak Mini Sandwich speakers £100. Pair Kef Corelli speakers £100. Goldring GL75 turntable plus 2 Shure cartridges £125. Audiolab 8000C and 8000P £500. No split. Pair Tannoy Little Gold monitors 10 inch dual concentrics £600. All GWO. All ono. Tel: 0118 973 2059 or Email: johncaswell@compuserve.com evenings/weekends

ARCAM ALPHA 9 integrated £250. Sony SA3 ES tuner £130. Both mint) Tel: 01992 719 320 (Jan/I)

Classified Ads

Classified Ads

AUDIO ILLUSION

23 Langley Broom

Langley

Berkshire SL3 8NB

Tel: 01753 542761 Fax: 01753 772532

Open: Monday – Saturday 10am – 8pm (By appt.)

www.audioillusion.co.uk

<mailto:audioillusion@btinternet.com>

HI-END AUDIO VISUAL

0%
FINANCE
ON ALL
OUR
BRANDS
(Subject to Status)

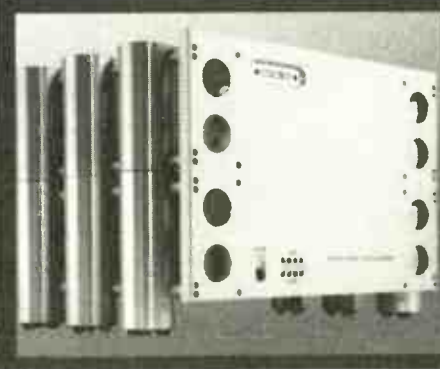
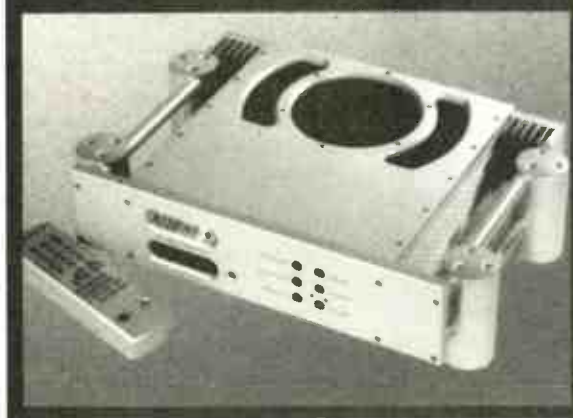
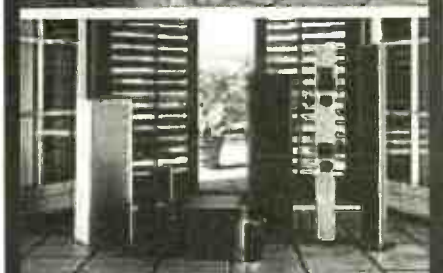
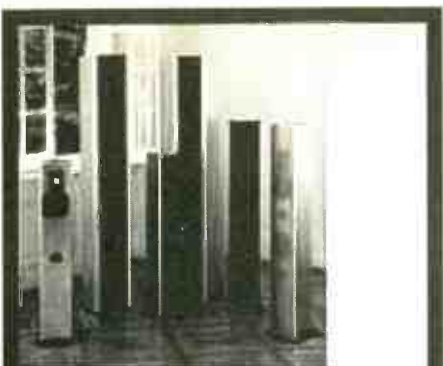

We've lost the INTEREST so you don't have to!!!!
ARAGON CHORD MICHELL
MIRAGE RENAISSANCE AUDIO
PIEGA SIM2 & SONY PROJECTORS
STEWART SCREENS TRICHORD

www.hifiworld.co.uk
hi»fi
 WORLD
 & computer audio

Trade Ads

Special Internet offer
 see page 130 for details

Dealers must not advertise in the Private Classified section.
 Monthly consecutive insertions will be considered Trade
 advertising. The Publisher reserves the right to judge submissions.

VINTAGE WIRELESS
 COMPANY LONDON
 Website: www.vintagewirelesslondon.co.uk
 Buy-Sell-Exchange. Vintage wireless and classical audio. Repairs, spares, restoration, modification to all valve equipment. Quad II, Leaks etc, shipped worldwide, best prices, call us at: 17 Bell Street, London, NW1 5BY. Tel: 020 7258 3448
 Fax 020 7258 3449 Email: vwirelesslondon@aol.com (Oct02/1)

THE DEMO ROOM - For new, ex-demo & used ex trade quality audio amplifiers, CD's, loudspeakers etc. Visits by appointment only. Tel: 0131 430 7817 (South Birmingham) (Feb/1)

AMAZING INTERCONNECTS!
 Hand built pure silver cables with world class connectors. Fantastic performance, money back guarantee. £105 per metre pair, £5 p&p, longer lengths available. Details: 0115 982 5772 after 7pm, Email: Bob@skydivers.co.uk (Jan/1)

SONY CDP R1 Reference.
 Transport Das R1 Dac as new. (£6000) £2650. Audio Analogue Bellini preamp, Donizetti power-amp, Boxed with manual, £550. Revox B215 Reference cassette deck, excellent condition, (£1200) £450. Please telephone Jules on 01792 280061, E-mail: sales@sounddrjuleshifi.co.uk
 Web: www.sounddrjuleshifi.com (Jan/1)

LINN SONDEK, early 1980's £300. Myriad T20 CD player, as new £250. Transparent Music Link Super 25ft, interconnect RCA £600. Transparent Music Wave Plus Bi Wire Speaker cable 8ft £300. Musical Fidelity XLP-S, phono stage, £100. Please telephone Jules on 01792 280061, E-mail: sales@sounddrjuleshifi.co.uk
 Web: www.sounddrjuleshifi.com (Jan/1)

KRELL KRC-2 pre-amp as new £1990. Michell ISO / Hera £330 ono. Krell CD 10 Signature Transport. Approx 5 yrs old. mint. (£10,000) £4000 Please telephone Jules on 01792 280061, E-mail: sales@sounddrjuleshifi.co.uk
 Web: www.sounddrjuleshifi.com (Jan/1)

AUDIO TECHNICA OC9 cartridge brand new exchange £240. Crimson 610 / 620 pre / power £300. Delttec Black Slink 0.75 interconnect £90. Delttec Black Slink 1.0 mtr WBT's, £100. Denon POA660 mono blocks £650. telephone Jules on 01792 280061, E-mail: sales@sounddrjuleshifi.co.uk
 Web: www.sounddrjuleshifi.com (Jan/1)

REPAIRS, MODIFICATIONS and upgrades to all amplifiers. Design work undertaken. One offs built to order. Almost any analogue electronic problem solved! Power amps, PSU's pre amps etc. M.C. only phono stage now available for £175, compare with others at up to £800! Ex Alchemist products and Musical Fidelity engineer. Tel: Arkless Electronics 01642 860 881 (Jan/1)

WWW.AUDIOATMOSPHERE.COM for new, exclusive products Gutwire, Pierre Gabriel, Power Snakes, Extensive range of equipment and accessories. Service, spares, mods including fabled Black Gate capacitors. Please Email: stuart@audioatmosphere.com or telephone 01785 711 232 (Jan/1)

REPAIR, RESTORATION, modification, custom design and construction of audio equipment. Theo Argiriadis BSc Hons. Phone 020 8881 1623 Mon-Fri 9.30am to 5.30am. Website: www.tube-electronics.com (Jan/1)

REVOLUTIONARY SINGLE-Ended amplifier runs on 2 AA batteries! Sub-watt design with DC-DC converter. See www.bigvalveamplifiers.co.uk for details. Type described is BVA Type '0'. Contact: BVA, 21 Gloucester Street, Norwich. NR2 2DX (Jan/1)

RUARK EQUINOX, slight cosmetic mark, new £1299. Accolades (£2699) £899. Proac Response One SC £699. Tablettes £229. Quad ESL63 vgc £1599. Castle Howard S2, x-display £899. Inversion Centres (£500) new £349. Neat Mystiques £399. Michell Mycro/RB300 £299. Quad 34/306 £339. Others available. Tel: Audiofile Objective 01992 478 666 (Jan/1)

AUDIO RESEARCH LS 25 MkII £3995. Audio Research LS15 £1995. Wadia 21 CD £2495. Sirius D200 power amplifier £1995. Sirius pre-amplifier £395. Revox B26 FM tuner £495. Audio Analogue Puccini SE £450. Tel: Horsham Hi-Fi 01403 272 931 or Email: info@homecinema.uk.net (Jan/1)

TWO KIMBER hi-current one metre powercords £50 each or £90 for two. Acoustic Precision black box £50. Naim speaker cable 3.5 metre bi-wire lengths £20. Chord Cobra 2 interconnects £20. Tel: 01457 834 465 (Jan/1)

FOR SALE Moth Record cleaning machine kit £150 ono. One Linn LPI2 circuit board with switch for 33 1/3 and 45 £20 ono. Tel: 01482 641261 (Jan/1)

EMT 950 £850, Studer A80 VU £850, Nagra T-Audio £1500, IV-Stereo £1200, E-Mono £400, Uher RM Stereo £250, Technics SP10 MkII £250, SLP1200 CD £450, Revox PR99 MkIII £950, PR99 MkII £750, G36 MkII £450. Tel 01246 275 479 or Fax 01246 550 421 (Jan/1)

WANTED - EARLY HI-FI LOUDSPEAKERS
 Tannoy, Lowther, Parmeko, Voigt, Vitavox, RCA WE etc
 TURNTABLES
 Garrard, BBC301, EMI SME, Ortofon, Decca, etc.
 VALVE AMPLIFIERS
 AEI, EMI, Leak, Rogers, PYE-Quad, WE etc
 AUDIO VALVES
 DA30, KT66, KT88, PX4, PX25, PP3/350, WE300
 CLEAR CRYSTAL SYSTEMS
 John Petrie-Baker
 Tel: 020 7328 9275

WYCHWOOD DESIGN.
 Specialist Hi-Fi furniture for audio equipment. Hand crafted in solid English oak with carved panels, finely laid Italian 23 carat gold leaf. For details telephone: 01935 825220 or 078 12345 169

MARTIN LOGAN owners, SL3 Sequel II. Bass problems - booming overbearing? Using cut to no good effect. For the solution and total transformation. Please Tel: 01226 764 272 (Jan/1)

REPAIRS, MODIFICATIONS and upgrades to all amplifiers. Design work undertaken. One offs built to order. Almost any analogue electronic problem solved! Power amps, PSU's pre amps etc. M.C. only phono stage now available for £175, compare with others at up to £800! Ex Alchemist products and Musical Fidelity engineer. Tel: Arkless Electronics 01642 860 881 (Jan/1)

REPAIR, RESTORATION, modification, custom design and construction of audio equipment. Theo Argiriadis BSc Hons. Phone 020 8881 1623 Mon-Fri 9.30am to 5.30am. Website: www.tube-electronics.com (Jan/1)

HIGH EFFICIENCY monitor loudspeaker, for valves or Class "A" transistor. Full range of Croft & EAR valve amplifier. 01942 257525 www.audioclassics.co.uk (dealer enquires welcomed on Model 'C') (Jan/1)

UNISON RESEARCH

For a lifetime of musical enjoyment



S6

Single-ended pure Class-A integrated amplifier. This is how Hi-Fi World (April 2001) described it:”Strong, confident power delivery, wide tonal palette, with sweetness, warmth, rhythmic alacrity and a deliciously clean, open sound.....

“At the price, It’s easily the best tube amplifier I’ve heard...Superb value for money”.

S2K

Pure Class-A all-tube amplifier using the legendary KT-88 power valve in single-ended mode for maximum transparency and detail. The sound it gives is delightful, unforced and natural. S2K is truly a machine for making beautiful music.



SR1

Combines the virtues of valve and solid-state in a thoroughly modern, fuss-free design. With 80 watts per channel dynamic Class-A power, plus the grace and delicacy you would expect from triode valves. The SR1 really gives you the best of both worlds.



For more information on the range of Unison Research Products please contact:



23 Richings Way, Iver, Bucks, SL0 9DA, England
Tel: 01753 652 669 Tel: 07000 853 443 Fax: 01753 654 531
www.ukd.co.uk email: post@ukd.co.uk

*models illustrated: S6, £1600. S2K, £1295. SR1, £1250. All complete with radiowave remote control.

MISSION

F5 SERIES

Imagine...

...a discreet loudspeaker system that adapts to any living space, with a room filling sound for both movies and music.

Imagine no longer... **F52**



"LOUDSPEAKER SYSTEM OF THE YEAR..."



AV Speaker Packages
Best Buy £500-£800

Home Entertainment
AWARDS 2000
WINNER

"PRODUCT INNOVATION..."



"HI-FI COMPONENT OF THE YEAR..."

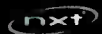

NXT is a registered trademark of New Transducers Limited

Tel: +44 (0) 1480 423 700 Fax: +44 (0) 1480 423 701
email: info@mission.co.uk web: www.mission.co.uk

World Radio History