

THE JOURNAL FOR PROFESSIONAL ENGINEERS

# ELECTRONICS & WIRELESS WORLD

OCTOBER 1987

£1.95

**V.K.Zworykin:  
catalyst of  
television**

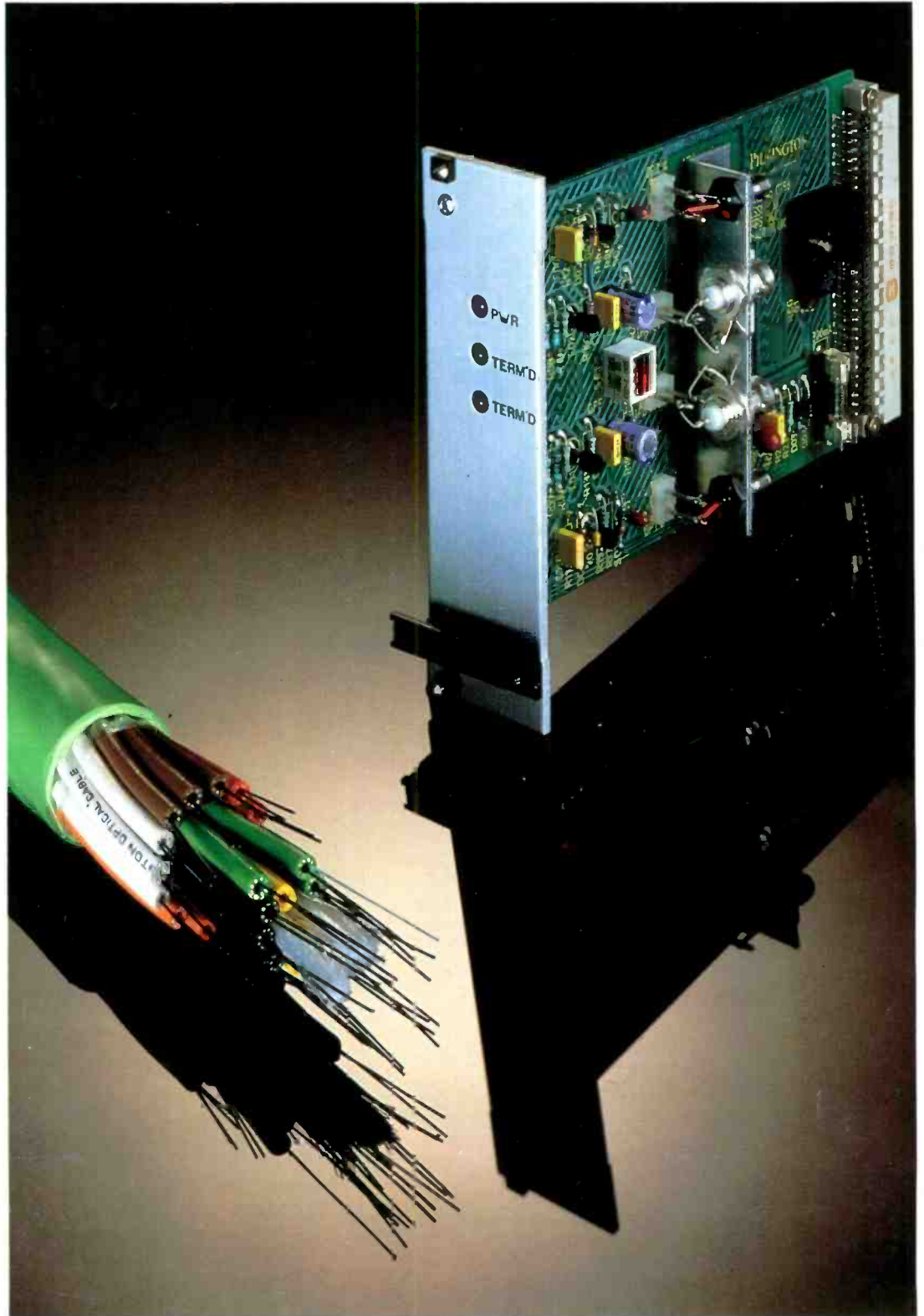
**Oscillators  
using unity-  
gain op-amps**

**Harmonics —  
the French  
connection**

**Relativity:  
a critique**

**Commercial  
signal  
generators**

**Semiconductor  
analysis using  
glow-discharge  
spectrometry**



Denmark DKr. 63.00 Germany DM 12.00 Greece Dra. 680 Holland Dfl. 12.50 Italy L 6500 IR €2.86  
Spain Ptas. 700.00 Singapore S\$ 11.25 Switzerland SFr. 8.50 USA \$ 6.50

# BEFORE BUYING YOUR NEXT SIGNAL GENERATOR

...compare the price, performance and facilities of the new Farnell PSG1000 with the competition.

1GHz without doubling

1 volt to 0.05  $\mu$ V

AM/FM/PM and pulse mod. option

AF synthesizer for all tone calls

DC coupled AM and FM

SINAD facility

10Hz resolution, 100 memories, IEEE 488 and HPIL, sweep, AC line or 12VDC operation, 50W reverse power protection, portable: 145 x 330 x 405mm 8.5kg.

Colour brochure from:

FARNELL INTERNATIONAL · WETHERBY · LS22 4DH · UK · INT. TEL. +44 937 61961 · TELEX 55478 FARINT G · FAX +44 937 66487

AVAILABLE THROUGH A WORLD-WIDE  
NETWORK OF AGENTS



**Farnell  
International**

contact us at **TELECOM 87, THE FIFTH WORLD TELECOMMUNICATION EXHIBITION,  
GENEVA, SWITZERLAND, 20-27 OCTOBER, 1987**

# CONTENTS

OCTOBER 1987 VOLUME 93 NUMBER 1620

## FEATURES

### COVER

The world's largest in-building optical-fibre installation is now up and running in Shearson Lehman Bros' New York dealer room. Using 3000 miles of Pilkington p.c.s200 fibre, the system feeds 500 dealer desks from 12,700 video modules (as shown) and 5000 data modules, requiring a grant total of 60,000 connectors. The £3 million project was managed by Pilkington Communication Systems Ltd of Rhyl.

### PROGRESS IN SIGNAL GENERATORS

978

A look at the state of signal-generator design, which is now largely digital in concept  
by *S.J. Gledhill*

### RADIO FREQUENCIES – A NEW GENERATION

984

Some representative instruments from the major manufacturers  
by *David Scobie*

### THE ELECTRONIC CAR – MYTH OR REALITY?

990

If it is to be a reality, companies in this field need to invest now  
by *Paul Bastock*

### CAPACITORS FOR SUPPRESSING RADIO FREQUENCIES

991

Choosing the most appropriate type of capacitor for r.f.i. suppression  
by *R. Hanson*

### ANALYSIS OF SOLIDS BY GLOW-DISCHARGE MASS SPECTROMETRY

997

G.d.m.s. offers the semiconductor industry a method of bulk analysis with uniform sensitivity and no-standards operation  
by *P.M. Webb and N.E. Sanderson*



### A SERIES OF REMARKS ON FOURIER

1000

Waveform analysis and the Governor of Lower Egypt  
by *Joules Watt*

### SINGLE-CHIP DATA ACQUISITION SUBSYSTEM

1013

This highly integrated device offers better performance than board-level systems and cuts the work-load of the controlling c.p.u.  
by *Charles Yager and Harlon OHara*

### PIONEERS – 10

1019

Vladimir Kosma Zworykin: the catalyst of television  
by *W.A. Atherton*

### TOWARDS THE INTELLIGENT RADIO

1023

The v.h.f. Radio Data System (RDS) and the progress towards its implementation  
by *Simon Shute*

### NOISE RESISTANCE IN MAINS SIGNALLING

1040

New methods of producing signals with tightly controlled bandwidths to reduce interference between data transmissions  
by *N.A. Young*

### RELATIVITY – A CRITIQUE

1026

A scrutiny of a typical relativist's exposition of the "twins effect"  
by *Stephen Grieve*

### CD – THE 600 BYTE ROM

1046

Error correction by interpolation works well enough on audio Compact Discs. But to exploit CD's potential for data storage, more precision is needed  
by *J.R. Watkinson*

### TEN FASTER OP-AMP OSCILLATORS

1053

Connecting op-amps for unity gain increases oscillator frequency  
by *M.T. Abuelma'atti and N.A. Humood*

## REGULARS

COMMENT 977

CIRCUIT IDEAS 1007

RESEARCH NOTES 1009

LETTERS 1030

SATELLITE SYSTEMS 1031

TELECOMM TOPICS 1035

APPLICATION NOTES 1037

NEW PRODUCTS 1057

RADIO BROADCAST 1063

TELEVISION BROADCAST 1066

RADIO COMMUNICATIONS 1067

UPDATE 1071

# ELECTRONIC BROKERS

This is just a sample of our huge inventory – contact us with your requirements.

## OSCILLOSCOPES

**Hewlett Packard**  
180 TR 100MHz Scope Mainframe (Mint) £1500

**Philips**  
PM3266 100MHz Storage Scope £3950  
PM3305P 35MHz Digital Storage. 1 only £2140  
PM3540 Logic Anal/Scope £1500

**Tektronix**  
465B/DM44 100MHz Scope/DMM £1650  
465B 100MHz Scope £1450  
475A/DM44 200MHz Scope/DMM £1950  
485 350MHz Scope £3000  
608 Monitor £995

634 opt 1,20 Display Monitor £500  
5223 Scope M/F (Mint) £2500  
7104 1GHz Scope M/F £16000  
7603 100MHz M/F £1500  
7704A 200MHz Mainframe £2500  
7834 Fast Storage Scope M/F £6900  
R7603 100 MHz Rack MINT M/F £1950  
7904 500 MHz Scope M/F £4250

A large selection of 7000 series plug-ins available at up to 60% saving on list. Please call for quotations.

## ANALYSERS

**Hewlett Packard**  
141T Display Mainframe £1950  
3580A Spectrum Analyser £3000  
3582A Spectrum Analyser £7500  
4193A Impedance Analyser £4750  
8552B IF Section £1850  
8553B RF Section, 110MHz £2550

**Marconi**  
TF2300A Mod Meter £495  
TF2370 110MHz Spectrum Analyser £7500  
TF2371 200MHz Spectrum Analyser £6500

**Tektronix**  
7L14 Spectrum Analyser P.In £8750  
308 Data Analyser £700

## SIGNAL SOURCES

**Hewlett Packard**  
4204A Digital Oscillator £375  
8007B Pulse Generator £950  
8011A-001 Pulse Generator 20MHz £695  
8601A Sweep Generator £1750  
8640B/001/002 Signal Generator 1024MHz £3950  
86260A Sweep Gen. Plug-in 12.4-18GHz £3500

**Marconi**  
2015-1 AM/FM Signal Generator £750  
TF2002B AM/FM Signal Generator £995

**Philips**  
PM55191TV Pattern Generator £600

**Wavetek**  
184MHz Sweep Generator £650  
10801GHz Sweeper £1500

## HEWLETT PACKARD COMPUTERS

9845A Desk Top Computer £1650  
9816A Personal Computer £2250  
9825A opt 001-002 Desk Top Computer £700  
98256A 256K RAM board, series 200 £275  
9915A Computer £750

## GENERAL PURPOSE T & M

**Farnell**  
SSG 520 + TTS 520 Transmission Test Set £3500

**Fluke**  
7220A Comms. Freq. Counter £350

**Hewlett Packard**  
4282A-001 Digital High Capacitance Meter £750  
436A Power Meter £1200  
467A Amplifier £600  
3403C True RMS Voltmeter £795

3406A Sampling Voltmeter £995  
3465A 4½ Digit D.M.M. £150  
5300B + 5305B 1300 MHz Counter £350  
5381A 80 MHz Counter £225  
8447A Amplifier £400  
8447D Amplifier £500

**Marconi**  
TF1245A Q meter £750

TF 1246 Oscillator £500  
TF 1313A LCR Bridge 0.1% £350

TF 2173 Synchroniser for 2016 £250

TF 2603 RF Millivoltmeter £395  
TF 2604 Voltmeter £395

TF 2702 Inductor Analyser £550  
TF 2905/8 TV Pulse Generator £650

TF 2915 Data Monitor £1200  
TF 2950/5 Mobile Radio T.S. £995

**Philips**  
PM5580 IF Modulator £3000  
PM5581 RF Converter £1000  
PM5582 RF Converter £1000

**Tektronix**  
520A Vectorscope (NTSC) £3750  
521A PAL Vectorscope £3950  
S1 Sampling Head £1100  
S.3A Sampling Head £1500  
1411C opt 03 TV Signal Generator £4950  
A6901 Isolation Monitor £275  
4041 System Controller £4500  
P6451 DA Probe £375  
PM102 Personality Module £400  
PM108 Personality Module £500

**SEND NOW FOR OUR LATEST BROCHURE**



85A Microcomputer £600  
86A Microcomputer 110(45710BU) 'The Portable' £1100  
150B Touchscreen £450  
2673A Thermal Printer £550  
6940B Multiprogrammer £950  
7470A opt 001/002 A4 2-pen plotter £600  
7475A opt 002 A3/A4 6-pen plotter £1050  
7910H opt 015 Disk Drive £395  
82913A 12 inch Monitor £75  
82938A HPIL Interface £150  
82939A Serial Interface £100  
82940A GPIO Interface £250  
9111A Graphics Tablet £795  
9121D Single-sided Disc Drive £525  
9122D Dual Double-sided Disc Drive £875  
9133XV 15MB & 270KB Disk Drive £600

All prices are exclusive of VAT and correct at time of going to press • Carriage and packing charges extra • A copy of our trading conditions is available on request

**Electronic Brokers**

ENTER 61 ON REPLY CARD

**Electronic Brokers**

140-146 Camden Street, London NW1 9PB  
Fax: 01-267 7363. Telex: 298694. Tel: 01-267 7070

## Multiplexed analogue confusion

EDITOR  
Philip Darrington  
DEPUTY EDITOR  
Geoffrey Shorter, B.Sc.  
01-661 8639

TECHNICAL EDITOR  
Martin Eccles  
01-661 8638

PROJECTS EDITOR  
Richard Lambley  
01-661 3039

NEWS EDITOR  
David Scobie  
01-661 8632

DESIGN & ILLUSTRATION  
Alan Kerr  
01-661 8676

Roger Goodman  
01-661 8690

ADVERTISEMENT MANAGER  
Martin Perry  
01-661 3130

ADVERTISEMENT EXECUTIVE  
James Sherrington  
01-661 8640

CLASSIFIED EXECUTIVE  
Susan Platts  
01-661 3033

ADVERTISING PRODUCTION  
Brian Bannister  
(Make-up and copy)  
01-661 8648

Jackie Perry  
01-661 8649

PUBLISHER  
Shobhan Gajjar  
01-661 8452

 REED  
BUSINESS  
PUBLISHING

**T**his time next year, direct tv broadcasting by satellite will be almost with us. After years of false starts and second thoughts by the broadcasters, British viewers will find their choice of channels nearly doubled overnight. Receivers will come at a cost which promises to fall comfortably on the right side of the traditional £400 cut-off level for family spending on consumer durables.

All the major details of the new service appear to have been sorted out by the IBA and its contractor. Nevertheless, the television industry now finds itself in the middle of yet another standards battle.

For just as BSB is readying its new service, the European Astra satellite will appear on the scene with a further 16 d.b.s. channels. Among them will be at least another three in the English language, plus a clutch of all-day music and sport channels with appeal for British viewers.

Unfortunately, it looks as though consumers who want both services will need two sets of equipment; still more, perhaps, if they want to sample Europe's other d.b.s. offerings. To receive Astra they will need a larger dish, a more elaborate mount for it and a separate front-end for the lower frequency band.

Indoors, satellite decoder units represent yet another battleground. Britain may opt for the IBA's D-MAC, but France and West Germany's d.b.s. groups are wedded to the cut-down D2-MAC format because it will fit their existing cable networks.

Multi-standard decoder chips which will cope with this diversity are on the way. But compatibility problems will undoubtedly return with renewed vigour when high-definition tv arrives.

Marketing people say that when the consumer is confused, he keeps his cash to himself: as evidence they can cite examples such as the quadraphonic sound fiasco of a decade ago. And when BSB and Astra's UK partners British Telecom each begin spending millions of pounds promoting mutually incompatible satellite transmissions, there should be plenty of opportunity for confusion.

Among engineers it tends to be an occupational disease to want to keep the thing in the lab just that bit longer; and in the present case the advertising interests which will pay for satellite tv just couldn't wait. But signal formats for satellite and cable broadcasting have evolved so rapidly that it's fair to wonder what we might have had in a couple of years more if they had been allowed to develop further. It's true that Shoenberg, Blumlein and the others produced their 405-line standard in a matter of weeks, but they did not have EBU and CCIR committee meetings to worry about.

Incidentally, readers who remember the colour tv standards battles of the 1960s may recall the popular parlour game of reverse-engineering the acronyms. So, for example, we had Never Twice the Same Colour, a System Essentially Contrary to the American Method and, of course, Peace At Last. What are we bid for their MAC successors?

*Electronics & Wireless World* is published monthly USPS687540. By post, current issue £2.25, back issues (if available) £2.50. Order and payments to 301 *Electronics and Wireless World*, Quadrant House, The Quadrant, Sutton, Surrey SM2 5AS. Cheques should be payable to Reed Business Publishing Ltd. **Editorial & Advertising offices:** EWW Quadrant House, The Quadrant, Sutton, Surrey SM2 5AS. **Telephones:** Editorial 01-661 3614 Advertising 01-661 3130 01-661 8469 **Telex:** 892084 BISPRS G (EEP) **FaX:** 01-661 3948 (Groups II & III) **Beeline:** 01-661 8978 or 01-661 8986 300 baud, 7 data bits, even parity, one stop-bit. Send ctrl-Q, then EWW to start. NNNN to sign off. **Subscription rates:** 1 year (normal rate) £23.40 UK and £28.50 outside UK. **Subscriptions:** Oakfield House, Perrymount Road, Haywards Heath, Sussex RH16

3DH Telephone 0444 59188. Please notify a change of address. **USA:** \$116.00 airmail. Reed Business Publishing (USA) Subscriptions Office, 205 E. 42nd Street, NY 10017. **Overseas advertising agents:** France and Belgium: Pierre Mussard, 18-20 Place de la Madeleine, Paris 75008. **United States of America:** Jay Femman, Reed Business Publishing Ltd, 205 East 42nd Street, New York, NY 10017. Telephone (212) 867-2080 Telex 23827. **USA mailing agents:** Mercury Airfreight International Ltd, Inc., 100b Englehard Ave, Avenel N.J. 07001 2nd class postage paid at Rahway NJ. Postmaster - send address to the above.

© Reed Business Publishing Ltd 1987 ISSN 0266-3244

A synthesized signal generator covering to 1GHz.



# Progress in signal generators

The current state of signal generator design which, in common with most measuring equipment, takes full advantage of digital technique.

S.J. GLEDHILL

To appreciate the modern signal generator it is instructive first to review the evolution of signal generators.

## FUNDAMENTAL-OSCILLATOR SIGNAL GENERATORS

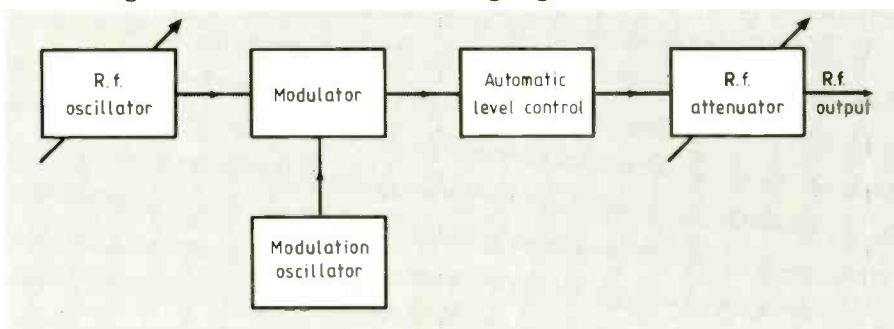
The earliest signal generators were of the fundamental-oscillator type as shown in Fig.1. A single r.f. oscillator was used and the

frequency was changed by changing the capacitance or inductance of the tuned circuit. In the 1960s, transistorized instruments appeared for the first time: mechanical tuning was still retained, but the instruments became more sophisticated and less clumsy. Electronic tuning has subsequently largely replaced unreliable mechanical methods.

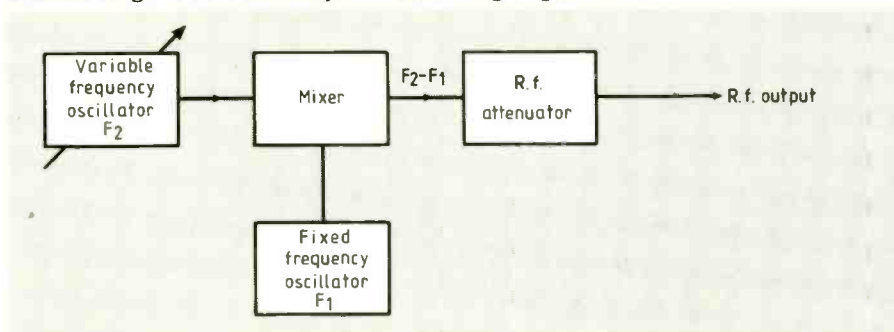
Level control on very early instruments was not automatic. The operator had to reset the carrier level whenever the frequency was changed by an appreciable amount, a level control and meter being provided for this purpose. More recent instruments include automatic level control: a detector is used to derive control voltage, which adjusts the oscillator level or the gain of a variable-gain amplifier, to maintain a level output.

Frequency stability is poor and the signal generator can drift out of the pass-band of the receiver whilst a measurement is performed. Fundamental-oscillator signal generators do have their advantages however: there are no non-harmonically related spurious signals such as those experienced in other signal generator types.

1. Block diagram of a fundamental oscillator signal generator.



2. Block diagram of a heterodyne oscillator signal generator.



## HETERODYNE-OSCILLATOR SIGNAL GENERATOR

The problem with a fundamental oscillator is that it is difficult to cover a wide frequency range, particularly at the low-frequency end. Incorporating many different oscillators into the design is possible, but this is expensive and, furthermore, the associated band switching is cumbersome.

A solution is to mix or combine two signals together. This technique is used in the heterodyne-oscillator type of signal generator, a simplified block diagram of which is shown in Fig.2. A variable frequency oscillator ( $F_2$ ) is mixed with a fixed frequency oscillator ( $F_1$ ). The output signal is either the sum or difference of the two oscillator frequencies, the difference frequency ( $F_2 - F_1$ ) always being used. Wider

tuning ranges are thus possible and band switching is reduced by using this type of design.

Although heterodyne oscillators can cover a wide frequency range, they can often also suffer from poor frequency stability. The output signal is not absolutely pure, since it is derived from two other signals which will be present to some degree at the output together with intermodulation products, even if filtering is used.

### MULTIPLIED AND DIVIDED OSCILLATOR SIGNAL GENERATOR

To give a signal generator a wider frequency coverage the multiplier and divider concept was developed. The descriptions are largely self-explanatory.

With a multiplied-oscillator signal generator, only one low-frequency variable oscillator is used, so the cost and complexity is reduced. Cascaded tuned multipliers are used to provide the higher frequency ranges and a switch is used to select the required frequency range. A variable-frequency band-pass filter may be tuned in synchronism with the frequency of the r.f. oscillator to select the required frequency. Frequency stability is poor, especially at the higher frequencies, since the effect of drift in the variable frequency oscillator is multiplied. A further limitation is that the output signal contains many unwanted sub-multiple frequency components.

Figure 3 illustrates the principle of the divided-oscillator signal generator. This technique superseded the multiplied oscillator type when high-speed dividers became widely available. Like the multiplied oscillator type there is only one variable-frequency oscillator, so cost and complexity is reduced. Signal purity can also generally be better because fairly simple filtering can be used to remove unwanted high-frequency components.

### DIGITALLY-CONTROLLED SIGNAL GENERATORS

A solution to the drift problem is to digitally lock the r.f. oscillator to a stable crystal reference using a synchronizer. The inherent frequency stability of a crystal oscillator is thus imparted to the r.f. signal.

A variable-ratio divider synchronizer operates by dividing the signal generator output frequency down to the frequency of the crystal oscillator. The two frequencies are compared and, as the frequency of the signal generator drifts, a correction voltage is applied to the voltage-controlled oscillator in the signal generator.

Another method of synchronizing is to use a frequency counter to determine the current output frequency of the oscillator and to compare this with the required frequency, again a correction voltage being used to correct the tuned frequency.

Synchronizers were introduced in the early days of digital technology, but were soon to be superseded by fully synthesized signal generators. For stringent applications, where low sideband noise and spectral purity are critical, a fundamental cavity oscillator and synchronizer still provides the

purest possible signal with no non-harmonically related signals. Such a generator is shown in Fig.4. The mechanical oscillator tuning is controlled by an electric motor, so the tuned frequency can be entered from the keyboard or through remote control. This provides the best instrument for testing receiver spurious responses in a programmable system or to provide a stable low noise signal.

### SYNTHESIZED SIGNAL GENERATORS

Most current signal generators now use one of several synthesizer techniques. Frequency drift is reduced and the frequency of tuning is set digitally to give precise rapid tuning. There are no moving parts, so size, weight and cost is reduced.

The heart of the majority of synthesizers is a phase-locked loop, working on the principle shown in Fig.5. Frequency  $F_{out}$  is divided by the variable divider to give a frequency of  $F_{out}/N$ : this frequency is compared with  $F_{ref}$  by the phase-sensitive detector and a correction voltage is applied to the voltage-controlled oscillator via a low-pass filter. Locking of the phase locked loop is achieved when  $F_{out}/N = F_{ref}$ . This method is known as indirect synthesis.

Unlike fundamental frequency oscillators, which have no spurious frequency components and a low level of noise, synthesizers generally have a number of spurious frequency components and noise is normally higher, although recent design advances have improved matters. A further limitation of a synthesizer is that the tuning changes in steps equal to  $F_{ref}$ , which can be a major problem for receiver testing.

The indirect synthesizer detailed in Fig.5 can be made more versatile by including what is known as a sum loop in the correction loop, further benefits including a wider frequency coverage and superior frequency resolution. This is an adaptation of the heterodyne method described earlier. Figure 6 illustrates a simplified example, in which two indirect-synthesis loops are both referred to the crystal oscillator: the mixer in the output loop allows the two frequencies to be added. In practice three or more loops may be added together and programmable dividers also incorporated. On p.978 is shown an example of a recent synthesized r.f. signal generator which covers to 1000MHz.

Synthesizer design is a classic example of compromise since there are two conflicting requirements. Good sideband noise performance is achieved by making the control-loop bandwidth wide, but resolution suffers.

High resolution can only be achieved if the control-loop bandwidth is narrow. A solution is the fractional-N method of synthesis which is used in many modern signal generators. A wide-bandwidth control loop is used, but to achieve high resolution the divider is rapidly switched between two integer division ratios.

By switching the dividers with different mark-space ratios, a range of frequencies between the two that would only be attainable without switching is obtained: sidebands at the switching frequency are removed by cancellation methods. Figure 8 shows a signal generator using the fractional-N synthesis method.

### SIGNAL GENERATOR SPECIFICATIONS

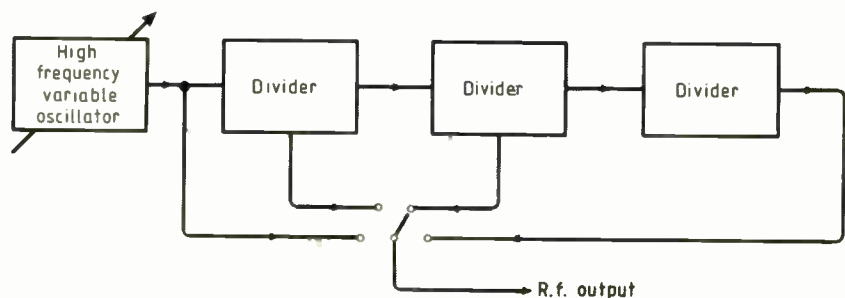
R.f. signal generators are available from many different manufacturers, covering similar frequency ranges, but with a bewildering variety of specifications. Inevitably, the quality of the specification of an instrument will generally affect the purchase price and the complexity of the instrument. It is therefore important to select the right instrument with the right specification for a particular application. The main specification points are reviewed

**Frequency range.** A typical r.f. signal generator will cover from 10kHz to 500MHz or 1GHz. Inevitably the user will select an instrument to cover the appropriate h.f., v.h.f. or u.h.f. bands in question. An instrument covering to only 500MHz may be less expensive than one covering to 1GHz, but with increasing use of the 800-960 MHz band for mobile communications it may be unwise to restrict future applications.

The low-frequency range is important, since i.f. frequencies down to at least 450kHz may need to be covered. Certain radio receivers operate as low as 10kHz, so this aspect may also have to be considered.

**Frequency resolution.** A resolution of 100Hz is typical at v.h.f. and u.h.f. frequencies for an inexpensive synthesized instrument, but this can be a limitation when measuring the bandwidth of a highly selective circuit. 10Hz resolution is common on most mid-range signal generators; higher resolution is achievable but this inevitably leads to a high price, so it is wise to consider carefully what is adequate. 100Hz resolution is often more than adequate for routine production and maintenance tests on receivers, whereas higher resolution may only be necessary for research or development use.

### 3. Block diagram of a divided oscillator signal generator.



**Frequency accuracy and stability.** As we have seen, most modern signal generators are either synthesized or locked to a reference crystal oscillator. Key specification points of the crystal oscillator are: Temperature stability, warm up and ageing rate.

Short-term stability and noise are very important when evaluating the performance of single sideband (s.s.b.) radio receivers. Audio signals in the receiver are generated by setting the signal generator to a frequency offset from the tuned frequency, an offset of 1kHz thus generating a 1kHz signal from the receiver. Any short term instability and noise in the signal generator will be apparent in the audio output and may invalidate a measurement.

**Modulation.** Most r.f. signal generators include amplitude modulation and frequency modulation as standard. Low-cost instruments may have just one modulation frequency, generally 1kHz. Mid-priced instruments may have five or six modulation frequencies, ranging from 300Hz to 6kHz, so that the extremes of the voice-frequency band can be evaluated. More sophisticated and expensive instruments include modulation oscillators with a much wider range of internal modulation frequencies. External modulation inputs are generally provided in all types of signal generator so it may be preferable to use an external audio oscillator rather than selecting a more expensive instrument with a wide-ranging oscillator built in.

Mixed a.m. and f.m. may also be required, especially in research and development laboratories, for the measurement of such parameters as the f.m. rejection of an a.m. radio. Phase modulation may also be required and signal generators increasingly offer this facility. Pulse modulation is also available for certain applications such as testing microwave radar systems at the i.f. (intermediate frequency) stages.

Modern radio receivers employ digital modulation techniques to a greater or lesser extent; military radios, for example, use digital techniques for encryption and data. To test such a digitally modulated receiver a digital test signal is applied to the external modulation input of the signal generator. A restricted modulation bandwidth may distort the pulse waveforms.

Modulation accuracy also needs to be considered, since errors in the measurement of the signal-to-noise ratio of a radio receiver can be considered if accuracy is poor. Modulation inaccuracy of the order of +5% is typical and this is generally acceptable. Some lower-quality signal generators have

an inaccuracy of up to  $\pm 20\%$ , which can give errors of up to  $\pm 2\text{dB}$  when measuring signal-to-noise ratio.

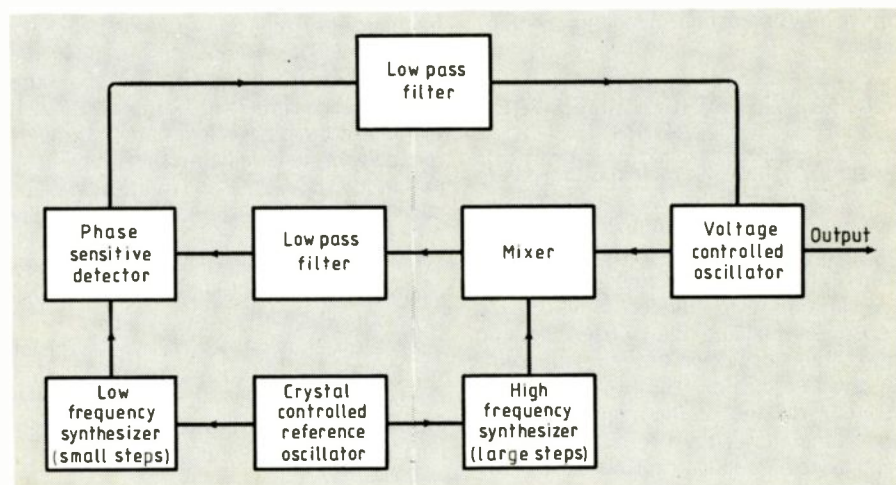
**Output level range.** Maximum and minimum output levels both need to be considered. Most signal generators will be used to measure the sensitivity of radio receivers, so a minimum output level of at least  $-127\text{dBm}$  (0.2 microvolts e.m.f.) is commonly available.

The maximum output level may be important for certain applications such as measuring receiver blocking or measuring mixer intermodulation intercept points. For routine production and maintenance maximum levels of  $+6\text{dBm}$  or  $+13\text{dBm}$  will generally be adequate.

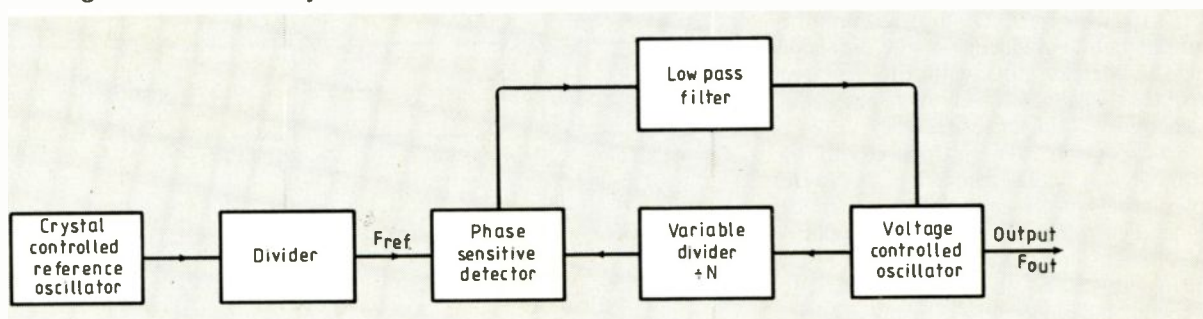
**Output-level accuracy.** Level accuracy is most important, especially since the sensitivity of a radio receiver will be specified according to the indicated output level of the signal generator. A typical specification is 1dB total level accuracy. Unfortunately, level accuracy can be misleading, so it is important to read the manufacturer's specification carefully. For example, the quoted level accuracy may only apply at one frequency, and frequency response uncertainty may also have to be added to obtain the total level uncertainty.

Another potential pitfall is that some manufacturers incorporate exclusion clauses such that the accuracy only applies over certain level and frequency ranges. Finally, it is also important to study the output impedance specification, since a poor v.s.w.r. can lead to errors when measuring receiver sensitivity.

### 5. Block diagram of a simple indirect synthesis signal-generator oscillator using a phase-locked loop.



6. A sum loop adds together two indirect synthesis loops to provide a wide frequency range and superior resolution.







then used to measure the output from the discriminator.

Since the output of the discriminator is noise, the measurement bandwidth has to be specified. Some manufacturers specify the noise over a band from 300Hz to 3kHz or from 50Hz to 15kHz, the former being applicable to communication receiver measurements, the latter to broadcast receiver measurements.

Another method of measuring the noise is to pass it through a psophometric filter, which has a frequency response tailored to

#### 4. Synchronized cavity tuned signal generator covering to 1024MHz with very low sideband noise.

simulate the sensitivity of the human ear to noise. A typical specification would thus refer to a CCITT telephone psophometric weighted filter.

Specifications differ between different types of signal generator but spurious f.m. figures of less than 10Hz are readily achievable on most modern signal generators,

whilst 1Hz is available on expensive instruments.

**Single-sideband phase noise.** This is a very important parameter, to be considered if the signal generator is to be used for adjacent-channel rejection measurements. This test measures the ability of a radio receiver to reject a high-power signal in the adjacent channel. To carry out a measurement, two signal generators are used; one at the tuned frequency of the receiver and one set to a frequency one channel spacing above or below the receiver frequency, as shown in Fig.9.

The level of the off-channel signal generator is increased until the signal-to-noise performance of the receiver is degraded by a specified amount, usually from 12dB to 9dB. The single-sideband phase-noise specification is critical because unwanted noise sidebands give rise to erroneous results, as illustrated diagrammatically in Fig.10.

Only higher-quality signal generators have specifications sufficiently good to allow sideband noise measurements to be made. Measurements are generally only carried out during development, and not as a routine test, so it is not always necessary to have excellent sideband noise performance

A typical, modern high-quality signal generator has a sideband noise specification of between  $-135\text{dBc/Hz}$  and  $-145\text{dBc/Hz}$

## Gould OS300 versus Douglas DC3

OS300	DC3
Proven worldwide	Proven worldwide
Inexpensive	Inexpensive
Fugged construction	Rugged construction
Go anywhere	Go anywhere
Piece of cake to fly	Piece of cake to fly
NATO approved	NATO approved
Two year guarantee	
U.K. design and manufacture	
Modern spec*	
Available off-the-shelf	



### The Gould OS300 dual-trace 20MHz 'scope

For £342 + VAT.

Gould Electronics Ltd., Instrument Systems, Roebuck Road, Hainault, Ilford, Essex IG6 3UE. Telephone: 01-500 1000. Telex: 263785.

#### HIGH-FLYING TECHNOLOGY YOU CAN TRUST.

\*Much as we admire the Dakota's traditional hard-working virtues, sadly its last spec. update was in 1945. The Gould OS300, on the other hand, offers 1980's features - dual-trace with true 20MHz operation, continuously variable amplifier sensitivity to eliminate loss of bandwidth over the 2mV to 5V/cm, X-Y operation, P43 phosphor and quick heat cathode for rapid set-up and brighter displays.



ENTER 11 ON REPLY CARD

### MARCONI INSTRUMENTS

10KHz to 1024MHz  
AM/FM SIGNAL GENERATOR



µP controlled, synthesized 10KHz-1024MHz signal generator MARCONI TF2017. Superb specification, in mint condition. One only available from stock at under half current list price.

TF2006 AM/FM Signal generator 10-1000MHz	£950
TF2011 FM Signal generator 130-180MHz	£325
TF2905/8 Sine squared pulse and bar generator	£350
TF2908 Blanking and sync mixer	£250
TF995A/5 AM/FM signal generator 1.5-220MHz	£195
2017 AM/FM signal generator 0.01-1024MHz Superb spec	£8,000
TF2170 digital synchronizer (for 2002 series)	£250
TF2300S modulation meter 35-1000MHz AM/FM	£495
TF2303 Modulation meter 2.5-520MHz AM/FM	£325
TF1313 1/4% RCL Universal Component Bridge	£250
TF1245A/1 Q-Meter 1246 & 1247	£550/£250/£150
TM4520 Standard inductor set	£250
TF893A Audio power meter 1mW-10W 1sd	£75
TF1020A 100W 250MHz RF power meter	£75
TF1152A/1 25W 250MHz RF power meter	£75
TF2604 Electronic multi-function meter	£150
TF2430 80MHz Frequency counter	£95
TF2807A PCM multiplex tester	£450
2829 PCM digital analyser	£750
2833 PCM digital line monitor	£275
2828A Digital simulator	£750
TF2356 20MHz level oscillator	£650
TF2167 RF amplifier 0.05-80MHz 47db gain	£450
TF1263S 1GHz attenuator 142db 1db steps	£250
TF2092C noise receiver	£350
TF2910/4 non-linear distortion analyser	£750
TF2162 MF Attenuator 0-111db in 0.1db steps	£100

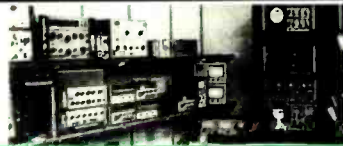
### BRUEL & KJAER

1042 Random noise generator	£200
2209 Precision sound level meter	£495
2113 Audio frequency spectrometer	£495
1607 Frequency and distortion measuring bridge	£195
2305 Level recorder	£250
1022 BFO with 2305	£600

### RALFE ELECTRONICS

10 CHARL STREET LONDON NW1  
TEL 01-238 53 1100

EST.  
35  
YEARS



### TEST & MEASUREMENT EQUIPMENT

DL905 transient recorder with XY display	£350
AMBER 4400 Multipurpose audio test set	£750
TEKTRONIX 475 200MHz oscilloscope with DM44	£1500
TEKTRONIX P6202 active oscilloscope probe 500MHz	£195
TEKTRONIX 1L5 spectrum analyser plug-in	£250
AVO B151 RCL bridge	£325
MEGURO 2-Channel automatic distortion meter	£295
TELEONIC 1019 sweepers Band II (83-115MHz)	£150
PHILIPS PM5509 TV Pattern generator colour	£200
FLUKE D.M.M. 8800A 5 1/2 digit	£200
FLUKE D.M.M. 8840A 5 1/2 digit + GPIB and true RMS opits	£400
GREEN 2601 Wattmeter 0.3-300W to 500MHz	£250
TELETYPE Terminal model 43 RS232 i/face	£295
TELEQUIPMENT CT71 transistor curve tracer	£600
TEKTRONIX 575 Transistor curve tracer	£250
TELEQUIPMENT D83 Oscilloscopes 50MHz	£350
TELEQUIPMENT DM64 Storage scopes	from £225
OSCILLOSCOPE - stock, phone for best quote.	
BRYANS 22020 XYT Plotter A3	£175
DYMAR 785 modulation meters. 30-480MHz AM/FM	£125
GPW 7620 Telegraph & Data generator	£195
AVO VCM163 Valve characteristic meter	£350
RACAL 383 4-Trace display oscilloscope	£175

### ★ MAINS INVERTERS ★

VALRADIO 24V DC Input to 230V 50Hz output 120W Sine Wave	£185 (new); £125 (used)
150W Square wave £75 (used) 24V 5A chargers	£45

ALL OUR EQUIPMENT IS SOLD IN EXCELLENT, FULLY FUNCTIONAL CONDITION AND GUARANTEED FOR 90 DAYS. MAIL ORDERS AND EXPORT ENQUIRIES WELCOMED. PLEASE TELEPHONE FOR CARRIAGE QUOTE. ALL INSTRUMENTS ARE AVAILABLE EX-STOCK AS AT COPY DATE. GOOD QUALITY TEST EQUIPMENT ALWAYS WANTED FOR STOCK. PRICES QUOTED ARE SUBJECT TO ADDITIONAL VAT.

### HEWLETT PACKARD

8007B Pulse generator	£500
400F Voltmeter 100µV-300V 4MHz	£225
738BR Calibrator	£195
4800A Vector impedance meter	£750
11602B Transistor fixture for 8745A	£450
1630D Logic analysers	£2,500
5300A 6 digit measuring system with 50MHz counter	£110
3300A Function generator. Rack mount versions	£100
5110B Driver with synthesizers 5105A and 5100B covering from 0.01Hz-500MHz extremely accurately	

Prices : 5110B £250 Synthesizers £100 each

5326A 50MHz counter timer 8 digits	£150
1740A 100MHz Oscilloscope	£850
8745A S-Parameter test set 11602B trans fixture	£550
8004 pulse generator	£225
355E Programmable attenuator 1GHz 0-12db	£95
355F As above but 0-120db in 10db steps	£95
3490A Digital Multi-meter	£450
8733A Pin modulator	£450

### ★ HP141T SPECTRUM ANALYSER ★



HEWLETT-PACKARD Spectrum Analyser system to 110MHz comprising 141T main-frame, 8552B, I.F. plug-in and 8553B 110MHz RF Plug-In Unit. Excellent condition throughout. £3250

### µP DEVELOPMENT SYSTEM

Hewlett-Packard model 64000 microprocessor development system with 2 5/4" FDD's, 10MB Winchester, erom programmer. Software for 8048 offers invited

### FREQUENCY COUNTERS

MARCONI 2430A 80MHz 7 digit	£100
MARCONI 2435 2GHz 8 digit	£750
HP5300A 6 Digit system unit with 50MHz counter	£110
HP 5326A 8 Digit 50MHz counter timer	£150

### NETWORK ANALYSER



HP  
8407A

Hewlett-Packard 8407A 110MHz Network analyser with types 8412A Phase-magnitude and 8414A Polar display units £1750 S-Parameter test set with 11602B transistor fixture £500

\*\*\* or COMPLETE KIT - £2000 \*\*\*

ENTER 41 ON REPLY CARD

## Conventional Printed Circuits

More people are turning to us because we are one of the most knowledgeable and experienced companies in NON PTH circuits in the U.K. (Established 1983)

**Quality in design**  
B.S.I. 6221 pt. 3 Artworks; Precision Photography and a Prototype board - The full package - Guaranteed

**Quality in manufacture**  
Prototypes; Small to Medium Run and VOLUME PRODUCTION  
Choice of materials including B.S.I. 4584 stock; Screenprinting.

**Competitive Prices; Deliveries - 2 to 3 Weeks - average or Scheduled.**

Talk to our skilled technical sales staff  
send for 5% our quoted price on your OFF Name Business Tel

Tel: 0226 200717

Unit 4, Grange Lane  
Industrial Estate,  
Carrwood Road, Barnsley,  
South Yorkshire  
S70 1SE England

**Slee Electro**  
Products  
complete  
the circuit.



ENTER 57 ON REPLY CARD

## ELECTRONICS & WIRELESS WORLD

### COMPUTER AIDED DESIGN DECEMBER ISSUE

The December issue of Electronics & Wireless World, on sale 19 November, reviews Computer Aided Design.

C.A.D. plays an ever increasing role in the design of circuits and systems. P.c.b. design can be improved dramatically by the use of a computer. Most large scale integrated circuits are too complex to be designed without one.

Electronics & Wireless World explains the processes involved and describes some of the available systems.

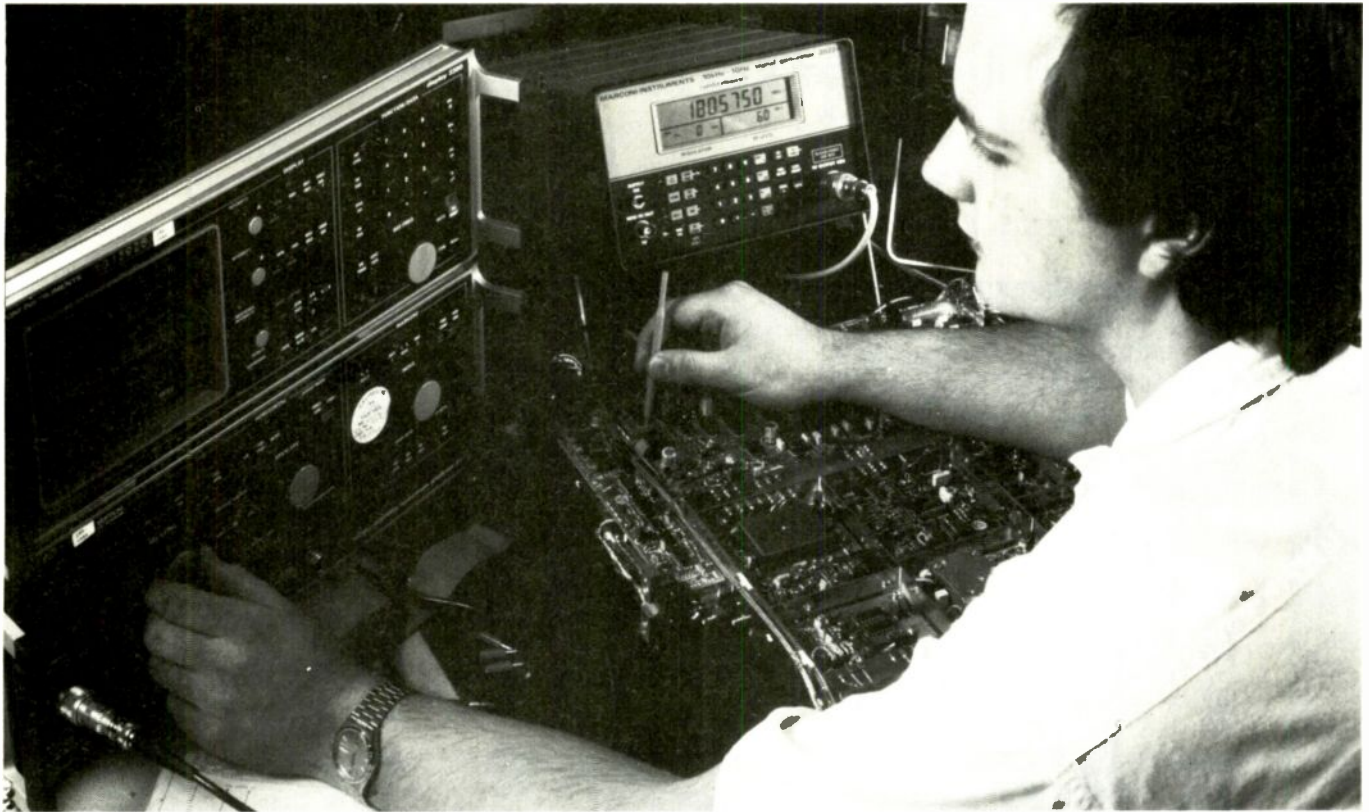
TO ADVERTISE WITHIN THIS FEATURE

CONTACT

MARTIN PERRY on 01 661 3130

or

JAMES SHERRINGTON on 01 661 8640



a 20kHz offset from the carrier, permitting the measurement of adjacent channel rejection to better than 70dB.

**Overload protection.** When testing transceivers it is important to be aware of the fact that the same antenna connection is used for transmitting as well as for receiving and that it is very easy accidentally to turn the transmitter on while it is still connected to the signal generator. Many signal generators have been destroyed by an accident such as this – it only takes a momentary loss of concentration. Modern signal generators now incorporate reverse power protection to eliminate the problem.

#### SIGNAL GENERATOR FACILITIES

Microprocessors have had a dual impact on signal generator design. Ease of use is increased due to digital setting of parameter values, and specifications have been improved due to software correction and control of parameters.

To be able to enter the frequency of tuning directly would have been an expensive luxury 10 years ago. This has now become commonplace and is taken for granted. The user now demands additional facilities to improve ease of use, the two main ones being incremental control and storage of control settings.

Incremental controls are generally available to increment or decrement any parameter by an amount entered on the keyboard. Holding a key down will increment the parameter continuously, – invaluable for tuning rapidly across a band or for changing output level when determining receiver sensitivity. A 'total shift' display which indicates the total increment is especially useful when measuring bandwidths, since calculation is not required.

Storage of complete front-panel control settings can be a great time-saver. Not only

**8. Compact low-cost signal generators are possible using fractional-N synthesis. Coverage of this instrument is 10kHz to 1GHz with 100Hz resolution.**

can the frequencies of a multi-channel receiver be recalled by simple key-strokes but complete settings, including incremental values, can be recalled as well.

Software is used to correct for frequency response variations and to linearize frequency modulation. A further useful facility which is becoming increasingly popular is a software-controlled clock, which can indicate elapsed time. This may be used to monitor instrument reliability or to schedule re-calibration only when absolutely necessary.

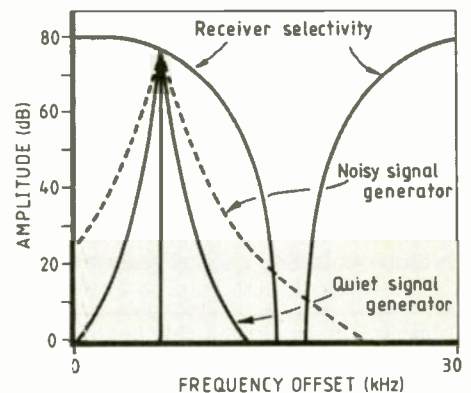
#### CONCLUSION

Signal generators have changed dramatically in recent years. Very high performance and extreme precision are available, but at the other end of the market low-cost, high-performance instruments are readily available. Perhaps the most dramatic illustration of the current state-of-the-art is that ten

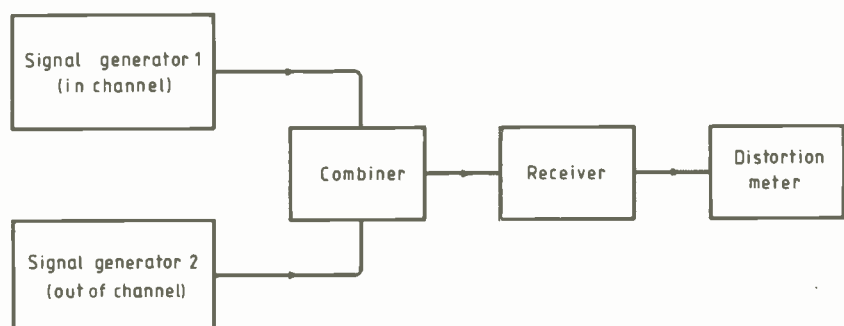
years ago a synthesizer was found in only a few development laboratories. Modern synthesizers are now so affordable that they become universally used for service and maintenance as well as for more demanding applications.

*S.J. Gledhill is with Marconi Instruments at St. Albans*

**10. Sideband noise on a noisy signal generator introduces noise into an out-of-band channel measurement.**



**9. Two signal generators used to test FM adjacent channel selectivity.**



# Radio frequencies — a new generation



Radio frequency signal generators have taken on new roles. As well as testing radio performance they are now used for testing a variety of equipment from optical-fibre networks to satellite systems.

Signal generators, for any frequency, are part of a test chain. They inject a signal into a component or system that can then be measured for power or purity at various stages along a transmit/receive system. As the complexity of the medium increases, by using high frequencies or further distances, so the quality of the test equipment must increase. It should be noted that the test equipment should be a degree of magnitude better than the system under test in order to obtain meaningful measurements. So r.f. signal generators, as the first link in the test chain, have had to be

Synthesized generators, like the one above, offer low noise high frequency stability and remote control and monitoring.

improved over recent years to include microwave frequencies and achieve even lower distortion figures to test equipment which is itself of very high quality.

Perhaps the biggest change in recent years is due to the microprocessor and to digital electronics generally. It is now possible to synthesize signals of high speed and high purity without the delicate tuned analogue circuits of previous generations. It has

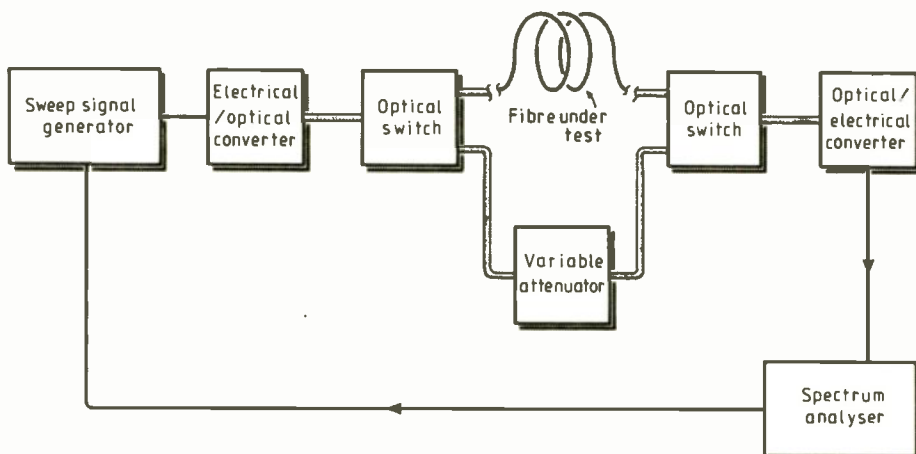
also led to remote and automatic testing and, like much other test equipment, the signal generator can be controlled from a computer and can communicate its status and operations back to the remote controller. Because it is the essential front end of a test system, it can be incorporated into that system and becomes just one part of, say, a spectrum analyser or an r.f. 'test set'. This has the advantage that the signal generator and the measuring instrument are combined and the receiving instrument is automatically set up to 'expect' a signal that its own generator is sending. Alternatively a generator can be rack-mounted and integrated into a complete test set-up. However, it should be noted that the test chain is only as strong as the weakest link, so it is unnecessary to use a high-performance generator if the rest of the equipment is not up to its standard.

A typical test set-up is shown in Fig.1, where an optical-fibre cable is being tested and compared with a known, adjustable, level of attenuation. A similar technique is used to test a single component or a whole system.

## SYNTHESIZED R.F. GENERATORS

The performance requirements of modern radar and communications systems call for high-frequency signals with particularly good spectral purity. Hewlett Packard produce two synthesized signal generators with

A test set-up. The attenuation in an optical fibre is compared with a known level. The technique is used to test a single component or a whole system.





Equipment Sales Division of Instrument Rentals (U.K.) Ltd.

01-897-2434

**AT LAST!**

**THE SINGLE SOLUTION TO YOUR TEST EQUIPMENT NEEDS**

**HEWLETT PACKARD  
6033A  
GPIB POWER SUPPLY  
MLP £2237  
OUR PRICE £1250**

**HEWLETT PACKARD  
7550A  
A3/A4 PLOTTER  
MLP £3813  
OUR PRICE £2350  
\*\*UNUSED\*\***

**HEWLETT PACKARD  
8568A  
SPECTRUM ANALYSER  
MLP £37,000  
OUR PRICE £25,000**

**MARCONI  
2019  
SIGNAL  
GENERATOR  
OUR PRICE £2750**

**HEWLETT PACKARD  
7440A-001  
COLORPRO PLOTTER  
MLP £995  
OUR PRICE £750  
\*\*UNUSED\*\***

INSTRUMEX, the newly formed subsidiary of Instrument Rentals, offers the widest available selection of second-user equipment in Europe. Through its direct access to over \$150 million worth of stock, it is able to buy and sell more equipment than other "market leaders". The items shown above are a very small example of what we carry, why not 'phone now for a quotation?

European Distribution Centre :

Dorcan House  
Meadfield Road  
Langley, Berks  
England SL3 8AL

Regional Offices :

Munich : 089-2021021  
Paris : 1-69285829  
Aberdeen : 0224-899522  
Manchester : 061-973-6251

ENTER 39 ON REPLY CARD

especially low noise characteristics: the HP8662A operates up to 1.280GHz, while the HP8663A covers an additional octave up to 2.56GHz. Phase noise (or s.s.b. phase noise) is a measurement of the short-term stability of a frequency source. It is important because it can affect the performance of receivers, particularly where the desired signal is of lower strength but close to another source. The selectivity of a receiver can be reduced because of phase impurities in local oscillators. HP, therefore, have designed their generators especially with low phase noise, so that they can be used to measure the phase noise in communications systems.

The block diagram (Fig.2) shows three main sections: reference, phase-locked loops and output sections. The reference section synthesizes many different frequencies from a high-stability 10MHz quartz oscillator. Phase-locked loops use these reference frequencies to generate output frequencies of 320 to 640MHz in 0.1Hz steps. The output section modulates and amplifies the output signal and translates this to the required output frequency.

The reference section not only produces the frequencies that are used to derive the output waveforms, but also several local-oscillator frequencies for internal use by the p.l.l. and output sections. All these are directly derived from the quartz oscillator, so the long-term stability of the instrument depends on this internal reference which is specified at  $5 \times 10^{-10}$  per day after a ten-day warm-up. This represents a maximum drift of 0.25Hz/day. The reference frequency can be adjusted mechanically within a range of 20Hz to allow close calibration against a standard. For even greater stability, an external reference, such as a caesium or

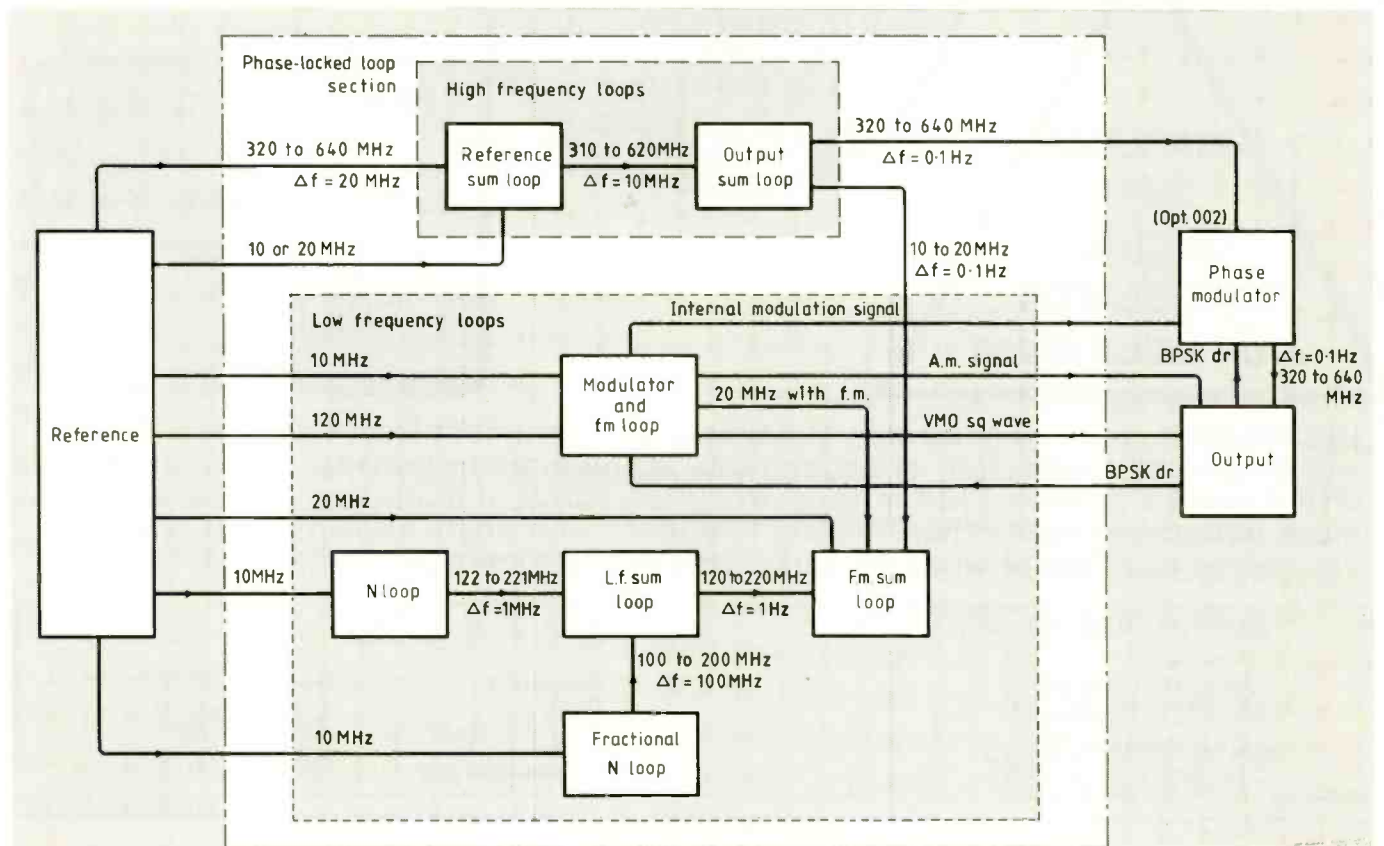
rubidium clock, can be used to give a stability of  $1 \text{ in } 10^{11}$ . Short-term stability or phase noise is kept to a minimum by the use of monolithic crystal filters in the reference multiplier chain. The mechanical mounting of these crystals is critical because any vibration can be translated into spurious noise microphonically. Typically, cooling fans in the instrument can cause offset sidebands, so the filters are mounted in special shock absorbers.

There are seven p.l.l.s in the loop section. Indirect-synthesis techniques are used (con-

trasting with the direct synthesis of the reference section, which derives its signal by mixing, multiplying or dividing.)

One of the high-frequency loops, the 'reference sum loop' tunes over a 310 to 620MHz frequency range, improves the resolution from 20MHz to 10MHz steps and provides 60dB of spectral filtering, reducing the spurious sideband levels from  $-40\text{dBc}$  to  $-100\text{dBc}$  (dBc - dB rel. to carrier). The 'output sum loop' is virtually identical and sums the 310 to 620MHz output from the reference sum loop with a 10 to 20MHz signal from the low-frequency loops, which provides the output sum loop with 0.1Hz steps. Frequency modulation of the signal can be added to the waveform at this stage. Both high-frequency loops use a special

**Internal workings of a Hewlett Packard 8663A generator. Three sections are the reference oscillator, phase-locked loops and output.**



voltage-controlled oscillator, a switched-reactance oscillator consisting of five inductors switched in and out by pin diodes. This reduces the bandwidth needed for the varactor tuning diode and again helps to reduce noise. The signal from the output loop is directed to the output section by way of any modulators (a.m., f.m., p.m., p.c.m., or b.p.s.k.) used for the final signal.

The output stage translates this signal from the p.l.l. section into the desired output frequency by frequency doubling, dividing and mixing. Phase noise is increased in the multiplying stages and reduced in the dividing stages, but is kept to a minimum by careful design of the a.g.c. circuits and the input levels to the heterodyne band mixer. Noise is better than  $-90\text{dBc}$  anywhere in the spectrum and is typically better than  $-148\text{dBc}$ .

Hewlett Packard produce a wide range of signal generators and much of this information was taken from their application note on phase noise measurement.

#### LOW-COST GENERATOR FROM ROHDE & SCHWARTZ

The latest signal generator from Rohde & Schwartz is the SMX, which at £4,300 incorporates GPIB remote control and r.f. overload protection to 30W and a memory capacity for up to 50 front-panel set-ups. The frequency range is 100kHz to 1GHz and so covers all frequency bands from l.f. to u.h.f., with a resolution varying between  $<10\text{Hz}$  and  $<100\text{Hz}$ . Output level can be set with high accuracy from  $-137\text{dBm}$  to  $+13\text{dBm}$  with a total error level of  $<\pm 1.5\text{dB}$  down to  $-127\text{dBm}$ . Non-interrupting levels of settings over a range of 10dB can be used for squelch hysteresis measurements or testing a.l.c. characteristics with a level setting time of 10ms.

The instrument features versatile modulation capabilities; a.m. or f.m. separately or combined in a two-tone modulation; the a.m. mode also allows external pulse modulation. A modulation source is fitted as standard with a range of frequencies. The unit is shielded against received or transmitted r.f.i. at a level well below recognized standards.

Another instrument from R & S is the SMG low-noise signal generator which shares many of the specifications of its fellows but offers a total error level of  $<1.5\text{dB}$  and very high spectral purity with s.s.b. phase noise of  $-140\text{dbc}$  at 20kHz from a carrier of 100MHz, and residual f.m. of  $<2\text{Hz}$  at frequencies up to 500MHz. The SMG also features a sweep with selectable start and stop frequencies, step size and timings for phase-continuous frequency changes.

#### SWEEPER FROM MARCONI INSTRUMENTS

A programmable sweep generator with applications in scalar network analysis, active measurement and ATE testing, the 6311, has been introduced by Marconi Instruments. It offers an extended frequency range of 10MHz to 20GHz in a single sweep. Features of the generator include high signal purity coupled

with low harmonics, high power level accuracy, fast sweep and low residual f.m. It also provides a frequency accuracy of  $\pm 3\text{MHz}$  typically in c.w. mode,  $\pm 20\text{MHz}$  over any sweep width is provided for precision swept measurements by digital control circuitry. The instrument can be calibrated in 15 minutes using only a power meter and counter connected on the internal GPIB. In conjunction with the 6500 automatic amplitude analyser and an autotester, the 6311 forms part of a complete scalar network analyser system. Uses of the 6500/521 system are for microwave component and system manufacturers for testing cables, connectors, amplifiers, pin switches etc, and test applications in radar, telecommunications and satellites.

The high-purity signal coverage required for scalar analysis has been incorporated in the design of the 6311 to guard against serious errors in filter measurement caused by harmonics and subharmonics. Between 2 and 20GHz, harmonics and subharmonics are  $-40\text{dBc}$  and  $-60\text{dBc}$  respectively. Coverage of 10MHz to 2GHz is provided with low harmonics of  $-30\text{dBc}$  with spurious signals below  $-40\text{dBc}$ .

Digital control of the 6311 is of use in active-device measurement, since the power level accuracy of  $\pm 0.5\text{dB}$  over 10MHz to 2GHz and  $\pm 0.4\text{dB}$  for 2 to 20GHz is necessary for the effective testing of the devices. Microwave transistor and mixer manufacturers require accurate input-level measurements on amplifiers to compare gain compression, and mixer sensitivity for local oscillator drives with conversion loss.

For a.t.e. testing, where speed of switching signals is important, the instrument has a fast sweep of 15ms across its full range. This meets the requirements for t.w.t. testing, radar system performance and military sub-system test racks.

The 6311 can also be used in calibration laboratories with such features as precision power resolution of 0.01dB, low harmonics and low spurious signals, rapid calibration and stable output power and frequency. The instrument incorporates a 68000 processor with programming facilities, either from the

front panel or through the GPIB. The sweep generator has internal and external GPIB links and includes comprehensive commands for operation over the system bus. Manual operation of the 6311 is simplified by a 'soft-key' operation, from instructions on the instruments' back-lit l.c.d. Up to 20 sets of start-up modes can be stored in the non-volatile memory and quickly reviewed and selected.

#### GENERATORS FOR RADIO AND TV TESTING

Two synthesized generators from Philips are intended especially for radio and tv testing and are probably nearest to what a traditionalist might call a "sig. gen." They are intended as signal sources for testing v.h.f./u.h.f. receivers. Frequency increment settings allow random or sequential testing of a wide range of tv channels, irrespective of standards and including cable tv 'S' channels. They can also be used for testing domestic radio receivers and as a video modulator or signal source for testing video equipment. With a frequency range of 0.1MHz to 0.102GHz, the PM5390 has a resolution of 1kHz up to 1GHz and of 10kHz above that. It takes 80 minutes after switch-on to settle in, after which its setting error is  $<1 \times 10^{-6}$ . Harmonic impurity is typically  $-35\text{dB}$  and non-harmonic  $-45\text{dB}$ . S.s.b. phase noise is  $-100\text{dBc/Hz}$  at 20kHz from the carrier. It offers a wide range of modulations, including a.m., f.m., video and sound carrier. There is an input for external a.m. or f.m. and for an external video source or sound carrier. Easy-to-use front panel controls can select frequency, increment, sweep time, level and change in level. Each of these selections has its own display. The instrument has a built-in GPIB and can be controlled remotely.

The PM5326 is especially suitable for radio and tv development laboratories and those involved in sensitivity and selectivity measurements. For service workshops and educational purposes it has four wobblers (sweep generators) for i.f. alignment and f.m. receivers. The 5326 offers a frequency range of 0.1 to 125MHz in nine



push-button ranges. The frequency can be set on the 5-digit display to an accuracy of 1 in  $10^4$ . The r.f. output is electronically stabilized to 50mV into 75Ω, and can be calibrated and continuously attenuated to over 100dB. Variable and fixed markers can be added to a wave to positively identify reference frequencies. The built-in frequency counter can be used to measure external sources.

### MICROWAVE FREQUENCY SYNTHESIZER

Frequency synthesizers covering up to 500MHz bandwidth at frequencies between 0.5GHz and 4GHz, with high spectral integrity, are produced by Scitec Electronics Inc. and distributed by Lyons Instruments. The modular design enables even unusual requirements to be met. The VDS-G's design makes use of new techniques and devices to achieve excellent performance without signal multiplication, cavities, mechanical tuning, or crystal oscillators. It uses little power, and is simple, reliable and less vulnerable to shock and vibration. Exploration of surface acoustic wave devices make it a highly cost-effective system.

Construction takes the form of four modules, mounted on a fifth mother module. The reference generator module uses a s.a.w. resonator and also produces the step-size reference. The comb generator module drives the r.f. output module via a tubular bandpass filter mounted in the mother module. The r.f. module includes the v.c.o.

and r.f. signal processing devices. Finally, the signal processor modules uses a combination of programmable dividers, low-noise loop amplifiers and a loop parameter network to accommodate changes in loop characteristics such as v.c.o. constants and division ratios.

This modular approach makes it easy to meet customers' specific requirements. All output frequency-determining elements are contained in the r.f. module and tubular filter. Similarly, the signal processing module circuitry determines user requirements, such as step size, frequency control word and the like.

Typical performance specifications include bandwidth of 20% standard, up to the 500MHz available, and step size of 500kHz, 1MHz, 5MHz or 10MHz. Switching speed is less than 1ms, spurious signals typically less than -70dBc and the s.s.b. phase noise floor -146dBc/Hz. The instrument is controlled through binary-coded decimal signals.

### RACAL-DANA INSTRUMENTS

Racal-Dana manufactures a comprehensive range of synthesized signal generators offering a broad spectrum of performance and capability. Indeed the company pioneered the synthesized signal generator concept. Their range combines stability, resolution, accuracy, and programmability of synthesizers as well as the low noise offered by more conventional analogue generators.

These generators are designed for a wide range of general and systems applications

associated with radio communications testing, including selectivity and sensitivity testing of ultra-sensitive r.f. receivers. The Racal-Dana products are particularly suited to these applications because of their calibrated output-level characteristics, low v.s.w.r. and automatic levelling circuits. In addition, the overall design has been engineered to reduce leakage and r.f.i. to extremely low levels, typically less than 0.5μV. The generators offer a wide range of functions which allow their use for signal-to-noise ratio measurements, as drive sources for mixers and bridges and for many other applications including automatic test systems. Frequency selection, spin-wheel tuning, and a choice of internal reference oscillators make the Racal-Dana synthesized signal generators a cost-effective solution to measurement and stimulus requirements in the h.f., v.h.f. and u.h.f. bands. Probably the best known of the Racal-Dana signal generators is the 9087, the highlights of which are: 10kHz to 1.3GHz with 1Hz resolution; exceptional spectral purity; internal and external modulation a.m., f.m., phase, pulse and f.s.k. with simultaneous combinations; ±19dB dynamic range with 0.1dB resolution; level accuracy better than ±1dB; full GPIB control; and self-check and diagnostic routines.

Because of their low noise performance, the 9087 and its sister model the 3101, a low noise frequency-agile synthesizer, are ideal for use as local oscillators in satellite communications and for testing of v.h.f./u.h.f. receivers. High switching speed also enables

# TAYLOR

## VESTIGIAL SIDEBAND TELEVISION MODULATOR C.C.I.R/3

CRYSTAL CONTROLLED OSCILLATOR  
19" RACK MOUNTING, 1u HIGH, 205mm DEEP



#### C.C.I.R/3 SPECIFICATION

Power Requirement	- 240V 8 Watt (available in other voltages)
Video Input	- 1V Pk-Pk 75 Ohm
Audio Input	- .8V 600 Ohm
F.M. Sound Sub-Carrier	- 6MHz (available 5.5MHz)
Modulation	- Negative
I.F. Vision	- 38.9MHz
I.F. Sound	- 32.9MHz (available 33.4MHz)
Sound Pre-Emphasis	- 50us
Ripple on I.F. Saw Filter	- 6dB
Output (any channel 47-860MHz)	- +6dBmV (2mV) 75 Ohm
Vision to Sound Power Ratio	- 5 to 1
Intermodulation	- Equal or less than 60dB
Spurious Harmonic Output	- 40dB (80dB if fitted with TCFL1. Filter or combined via TCFL4 Combiner/Leveller

#### CHANNEL COMBINER/FILTER/LEVELLER

to combine outputs of modulators

TCFL2	2 Channel Filter/Combiner/Leveller. Insertion Loss 3.5dB
TCFL4	4 Channel Filter/Combiner/Leveller. Insertion Loss 3.5dB
TSKO	Enables up to 4 x TCFL2 or TCFL4 to be combined.

C.C.I.R./3.1

- Specification as above but output level 60dBmV  
1000mV

**TAYLOR BROS (OLDHAM) LTD**  
BISLEY STREET WORKS, LEE STREET,  
OLDHAM, ENGLAND.  
TELEPHONE: 061 652 3221 TELEX: 669911

ENTER 24 ON REPLY CARD



their use for frequency-hopping radio testing.

As well as manufacturing signal generators, Racal-Dana also distributes equipment including products manufactured by Adret Electronique. Among the range of signal generators which Adret manufacture is the 742A, a 2.4 GHz high spectral-purity instrument. Launched as a high-performance generator available at a modest price, its excellent pulse modulation capability makes it ideal for certain radar applications.

#### PORTABLE GENERATOR FOR MOBILE TESTING

New from Farnell Instruments is the PSG1000 synthesized signal generator, a compact, lightweight, fully portable instrument for use in the frequency range 10kHz to 1GHz. The unit is designed to operate from an external 12V d.c. supply or any standard a.c. mains supply and its small size and light weight make it eminently suitable for field or bench use.

Full +13dBm (1V) output is available from 10kHz to 1GHz and an integral modulation synthesizer (10Hz to 10kHz) is provided. The instrument can also sweep carrier frequency/level and modulation frequency/level between set limits. The generator has microprocessor control and can achieve the entire frequency range of the PSG1000 by direct r.f. synthesis with a resolution of 10Hz up to 128MHz and 100Hz from 128MHz to 1GHz.

Controls are of the sealed tactile membrane type. This results in increased reliability, prevents the ingress of dust or moisture and reduces r.f. leakage.

The front panel includes high-visibility led displays of output frequency, output level, modulation rate and modulation level. An automatic sinad facility is included which provides a quick, simple and unambiguous method of measuring receiver sensitivity. A.m. f.m. and p.m. are available and other features include facilities for external modulation, external reference frequency, reverse power protection to 50W, patented r.f. screening techniques and 100 non-volatile memories for front panel set ups or user defined modulation tones and selcal tone sequences for radio-telephones. In addition to manual data entry and updating, the PSG1000 is programmable via the standard IEEE488 bus or Hewlett Packard Interface Loop (HPIL).

Amongst other generators from Farnell are two synthesized signal generators, designated the SSG1000 (1GHz) and SSG2000 (2GHz). These two models also use microprocessors and offer 10Hz resolution, low r.f. leakage, 1GHz testing of cellular radios, wideband coverage for testing aeronautical and marine communications, low phase noise for radio astronomy and ranging and location equipment, wideband phase modulation for satellite communications, sweep facilities for component testing and channelled operation for multichannel radio, with a fast lock speed for frequency-hopping transmission.



**SMX generator from Rohde & Schwartz covers frequencies from l.f. to u.h.f. and offers highly accurate output levels.**

The entire range of the SSG1000 is covered without using doublers or multipliers with a frequency resolution of 10Hz: the SSG2000 achieves 2GHz by means of an internal active doubler system. Three manual methods of data entry and data updating are provided and the instruments are programmable via the standard IEEE488 or Hewlett Packard Interface loop. This is a low-cost serial twisted pair link that can communicate to a controller, which can be as small as a Hewlett Packard hand-held programmable calculator.

#### FUNCTION GENERATOR UP TO 2MHZ

An audio-style function generator has a frequency range of 0.1Hz up to 2MHz and so can be used for some r.f. applications. The Black Star Jupiter 2000 offers sinewave distortion of less than 1% at frequencies below 200kHz, with all harmonics below -30dB in the upper range. The frequencies are in seven overlapping bands with a vernier adjuster which can set the frequency to within 5%. Output levels are also in switched bands with vernier adjustment and the claimed level flatness is  $\pm 0.2$ dB up to 200kHz and  $\pm 1\%$  to 2MHz. A sweep facility is provided. The instrument has also triangle waves and pulse trains ("square waves") and a t.t.l. output with a fan-out of 20 standard t.t.l. loads. The instrument is marketed in the UK by Altek Products.

#### RADIO FREQUENCY TEST SETS

Wandel and Goltermann make a range of level generators, but these are designed to work with their level meters and make up test sets. They are tuned externally through the meter, though some of them can have their output levels and frequencies set by front panel keypads or be controlled through a GPIB. They make a whole series of test sets that do incorporate r.f. signal generators. Typically there is a spectrum and network analysis system that covers a frequency range of 100Hz to 180MHz and includes a sweep generator of a high specification. There is also a range of distortion measurement sets for cable, radio links and satellite

systems. The RK-100 white noise measuring set up can cope with up to 10,800 channels in a frequency range of 6kHz to 100MHz.

#### PULSE MODULATION AND 2.1GHz FROM FLUKE

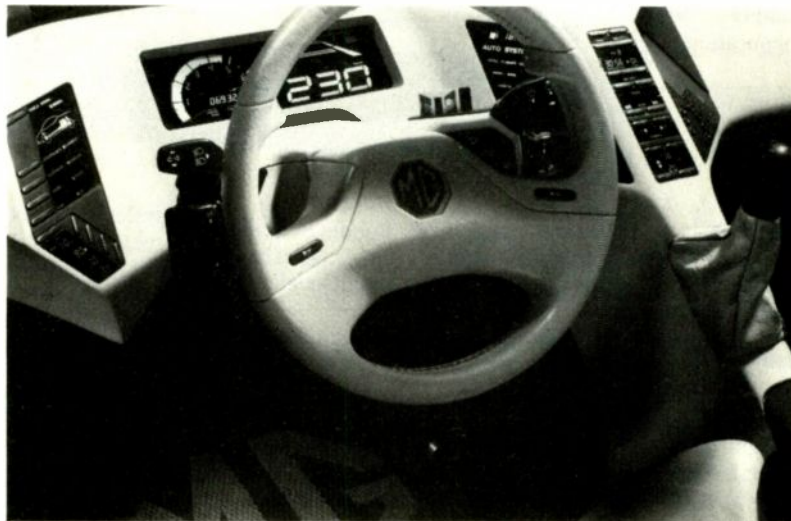
The latest signal generator from Fluke has a frequency range from 0.1MHz to 2.1GHz; In addition, the 6062A incorporates a pulse modulator which uses GaAs switch technology to achieve rise/fall times of 15ns and on/off ratios of 80dB. The 6062A is designed for L-band testing in avionics communications and navigation.

Specific applications include secondary-surveillance radar, i.f.f. microwave links, global positioning systems and satellite communications.

The 6062A adds extended frequency to Fluke's family of low-cost signal generators and complements the performance of their general purpose 6060B and the low noise 6061A models, both of which operate to 1.05GHz. Its output level is adjustable over the range of +16 to -137dBm to 1050MHz, and +13 to -137dBm to 2100MHz. Absolute accuracy is  $\pm 1.5$ dB. Amplitude can be displayed in volts, dBm, dB  $\mu$ V, or relative to any specific reference. The 6062A increases the modulation capabilities of the 6060 line with f.m. deviations to 400kHz. The pulse modulation on the 6062A has the high on/off ratio (80dB minimum) that is needed for radar simulations. Fast rise and fall times permit quality pulses of less than 50ns duration. The low-noise capabilities of the 6061A are incorporated in the 6062A. Residual f.m. is guaranteed to be less than 6Hz (0.3 to 3kHz) and less than 4Hz in the frequency range of 245 to 512MHz. Non-harmonic spurious products are less than -60dBc to 1050 MHz, -54dBc to 2100 MHz; typical s.s.b. phase noise is -123dBc at 20kHz offset from a 500MHz carrier frequency. Other standard features on the 6062A include: a.m. f.m. and phase modulation; a.c./d.c. coupled a.m.; full talk-listen IEEE 488 interface; 400 kHz f.m. deviation on 1050 to 2100 MHz range; relative frequency and amplitude nodes; step programming; a 50 location non-volatile memory; 25W reverse power protection; sub-harmonic external reference; Low microphonics due to robust construction; and self-diagnostics.

# The electronic car — myth or reality?

BY PAUL BASTOCK



Until about twenty years ago, the average car contained only one capacitor, fitted across the contact breaker points to reduce arcing. Today, the figure has grown to around 100 capacitors per vehicle, due mainly to the meteoric growth in the number and complexity of in-car entertainment systems. At present, about 30% of new cars are equipped with some form of audio equipment, predicted to rise to approximately 70 per cent by the start of the next decade. There is every reason to suppose that the number of capacitors in these units will increase as more and more features are incorporated. Already, push-button radio tuning is accomplished by electronics rather than a mechanically-variable inductive tuner.

But this market is a rather static one; in-car entertainment is the biggest user of capacitors at the moment, but this isn't where expansion will take place. Driver surveys commissioned by the car industry have revealed, not surprisingly, that the average car owner regards electronics as something of a gimmick. This hasn't been helped by the introduction of voice synthesizers and difficult-to-read liquid crystal displays on some up-market cars. Electronics is chiefly of interest to the driver if it brings improved performance, better fuel economy or increased reliability; it interests the manufacturer if it achieves these goals profitably. However, the appeal of gadgets to the potential car buyer must not be forgotten. In the US, strict emission control requirements have provided an impetus to the development of engine management systems which until recently has been lacking in Europe\*.

**Greatest growth for components will not be in-car entertainment, as this EX-E panel hints.**

## ELECTRONIC INROADS

One of the first areas to move away from mechanical and electromechanical operation into electronics was electronic ignition. This apparently simple function gave manufacturers and designers their first taste of the problems involved in installing electronic units in the electrically noisy, hot and vibratory environment of a typical engine compartment. Capacitor discharge units dominated this application at first, but failures due to the extreme stresses imposed on the output capacitor, both in terms of voltage and current handling, gave electronic ignition an undeserved reputation for unreliability. Now, most such units use inductive energy storage, coupled with a Hall-effect magnetic field sensor to give feedback control for spark optimization.

Fuel-injected cars also require electronic control systems, ranging from simple program controlled open-loop networks to more complicated feedback systems. Some manufacturers have used electronic fuel management successfully on cars using carburetors.

Currently, some 60% of new cars have some form of electronic engine management. Indications are that by 1992, all vehicles sold in the EEC will have some form of electronic engine management, particularly as EEC pollution regulations favour electronic control rather than catalytic systems.

Some analysts include automatic transmission systems under the heading of engine management. The traditional automatic gearbox uses a complex series of

pressure-sensitive valves to determine when to change gear, but there is a new breed of transmission units which employ power fets under the control of a microprocessor for improved reliability. The next decade should see about 40% of cars with this variety of automatic transmission.

**Safety and security.** The principal use for electronics in safety is in the control unit for anti-lock braking (ABS), which many car makers are offering as an, albeit rather expensive, option. This is another field in which electromechanical systems are being supplanted by electronic control. It is feasible to implement a self-adjusting servo-actuated suspension system; indeed this is already being done, but the extremely high cost of the sensors will limit this aid to road-holding to very expensive vehicles, unless there is a major technology breakthrough in the near future.

More likely to expand is the area of electronic security. Indeed, electronic lock encoding and security marking of stereo equipment is present-day rather than future technology, even for medium-priced cars.

**Comfort and convenience.** Electronic 'C & C' systems are almost unknown, but prestige cars are beginning to use various means of electronic driver environment control. Some particular models feature a microprocessor unit which governs the operation of the air-conditioning, a task formerly entrusted to relays and bimetallic sensors. The driver's seat position and shape can also be controlled by an electronic system via electric or hydraulic actuators. Inevitably, this category of equipment will remain a fitment for only the most expensive vehicles. The best predictions currently available indicate that around 25% of new cars will have some electronic comfort control by 1990.

\*See Microprocessor-controlled engine management, by Pat Jordan, *EW* September 1987.

**Dashboard instrumentation.** Despite a number of widely-differing high-tech dashboard layouts seen on cars in the last couple of years, driver reaction has not on the whole been favourable, so the market has yet to find a direction when it comes to digital or liquid crystal information displays. Possibly a quarter of all cars will have an electronic dashboard within the next few years, but this is a very debatable figure.

#### THE MARKET FOR CAPACITORS

Assuming that all the trends mentioned are accurate, the average car in 1990 should have some 500 capacitors fitted by the factory. With an estimate of 10 million new cars on the roads in Europe by then, this makes for a very large volume of capacitor production to very exacting quality standards. None of the above arguments takes into account the growing use of plastics for body panels, which will inevitably degrade the screening between different electronic units within the car, so these figures might even represent an underestimate, assuming that decoupling remains cheaper than using screened cable. A modern car uses up to 5km of wiring, so screening is certainly an expensive option.

**Problems for component suppliers.** Few applications require such a large volume of production as does the automotive industry. A typical production line will consume many thousands of electronic units per week, even in medium-volume manufacture; mass-market cars are made at even higher rates. It is this sheer volume which has tended to exclude the small component manufacturer for very high reliability, one-per-car units like ABS control boxes. There

is room for the small supplier, but generally they must be capable of producing components in huge numbers. For a car manufacturer, price is all-important, with assured quality a very close second. Most car producers will expect a product specifically tailored to his own need, with SPC (Statistical Process Control) figures supplied well in advance of a firm order. It can easily take two years to develop a component exactly to the buyer's requirements, and there is no guarantee that any other manufacturer will be interested in the same component as his rival. But having designed the component and assuming that failure levels of a few parts per million can be achieved, the component supplier is usually rewarded with a four-year contract with production quantities scarcely dreamed of in other fields.

**Space for electronics.** Although the number of electronic functions is increasing, the size of the car into which units must be fitted isn't changing appreciably. Already there is strong competition for the prime spots, such as under the dashboard where temperature ranges are restricted, so units are being sited under wings, in the boot, anywhere in fact but in the electrically noisy and hot area under the bonnet. The tendency to overheat is exacerbated by present-day drag reduction programmes, which reduce the volume of air flowing into the engine compartment.

This places a premium on small size, so surface mounting of devices has caught on in the automotive sector much faster than in some other industries. This is good news for multilayer ceramic capacitor makers, since today's plastics-film capacitors are difficult to surface-mount without the risk of thermal damage to the dielectric. Surface mounting brings other advantages, of

course, chiefly that of reduced r.f. pickup brought about by minimal lead length and therefore minimal inductance.

#### THE FUTURE

The automotive market represents one of the few areas in which really high-volume electronics production is likely to continue to expand. The workhorse at the moment is the eight-bit microprocessor, though the newer microcontrollers with their on-chip ram and multiple i/o ports are ideal for this type of process control and are rapidly gaining ground. Sixteen-bit processors will probably not be used in the near future as eight-bit accuracy is sufficient for all present needs in a car.

Mechanical and electromechanical units will continue to be replaced by electronics, with closed-loop control and its attendant advantages in the majority of applications. This will mean an enormous market for low-cost, reliable sensors of every type, provided that they can be made cheaper than and at least as reliable as their electromechanical counterparts. All kinds of passive components, with particular emphasis on capacitors and resistor arrays in surface mountable form, will be needed in vast quantities. Almost every control box will have at least one power mosfet to do the mundane but necessary job of switching the solenoid valves and electrical actuators. Companies prepared to invest the large sums needed to make components in millions at high reliability will benefit immensely from this expanding industry.

*Paul Bastock works at the newly acquired AVX plant in Paignton, Devon.*

# Capacitors for suppressing r.f. interference

How to choose the best capacitor type for use across the a.c. mains supply.

R. HANSON

**T**here is a growing need to fit interference suppression filters to electronic and electrical equipment, either to prevent the equipment malfunctioning due to noise on the mains or to prevent noise generated by the equipment going back into the mains supply. The last-mentioned requirement is governed by EEC directives and regulations in many countries.

Interference filters consist of one more capacitors used either alone or in conjunction with chokes in series with the supply leads. These assemblies can consist of individual components on a printed board or an encapsulated assembly in a box. These filters can present a safety hazard, the primary cause of which is the capacitors. Properly made chokes are an insignificant hazard. To

make economical and physically small capacitors the dielectric within them is stressed at potential levels of 40V/ $\mu\text{m}$ , which equates to 400kV/cm – sufficient to make one's hair stand on end. No other electrical or electronic components are stressed at such levels.

It is because r.f.i. capacitors are stressed so highly and operated from low impedance sources that they are a safety hazard. The numerous regulations around the world covering their use and operation testify to numerous capacitor failures. The failures have led to equipment fires and the possibility of electrical shocks to operators.

#### DESIGN OF X AND Y CAPACITORS

There is no way that millions of capacitors

can be made without having some failures in the field, albeit only one or two per million. Having accepted that failures are going to occur the capacitor designer must design the capacitors to be intrinsically safe in that if short circuits do occur in the capacitor during use they should clear themselves – in other words the capacitor self-heals. In the event of the capacitor permanently going short circuit the component should preferably be made of fire retardant materials which do not sustain burning.

This doesn't mean that the capacitor will not burn, only that the burning will extinguish when the prime cause of ignition is removed by the circuit protection device. It is unfortunate that many of the capacitor designs on the market are not intrinsically

safe. In the United Kingdom, unlike other countries, capacitors for r.f.i. suppression do not have to be approved, and only need to comply with the regulations (BS2135).

There are two basic classes of suppression capacitors, namely X and Y. The last type is for use where failure of the capacitor could lead to danger of an electric shock, and as a consequence is made to much higher standards than X capacitors and designed to withstand much higher test voltages. Class X capacitors are normally in the capacitance range of 0.01 to 1 $\mu$ F and go straight across the mains to filter symmetrical interference. Class Y capacitors are normally in the capacitance range 1 to 4.7nF and go between live and neutral and earth and neutral to filter asymmetrical interference. Because Y capacitors are connected from the mains lead to earth they are limited to 4.7nF for most domestic equipment to prevent more than 0.5mA flowing to earth. (If the equipment is permanently connected to the mains the 0.5mA limit does not apply.)

Class X capacitors are mostly wound capacitors using either paper, polyester, polycarbonate or polypropylene as the dielectric. Class Y capacitors may be either wound units using the previously mentioned dielectrics or ceramic capacitors.

Most countries have their own specifications and regulations relating to X and Y capacitors to maintain safety standards but sometimes they are used as import controls. Specifications do not always keep in touch with the times and are sometimes written around a previous generation of capacitors, for instance the German specification VDE0560/7 for X capacitors.

Originally published in 1967 before metal-



ized capacitors came to the forefront for suppression purposes, the specification was very good but 10 years later when metallized capacitors were used across the mains some types of approved capacitors failed disastrously. This was because on the 240V a.c. mains, there are present transient voltage spikes many hundreds of volts greater than the peak a.c. voltage of  $240\sqrt{2}$ . Some lesser makes of early metallized capacitors had a very low tolerance to transients and as a consequence the VDE specification was withdrawn and replaced by another, VDE0565/1, published in 1979. This required 1kV a.c. to be applied to class X2 and Y capacitors for 0.1 second every hour of the endurance test at the rated temperature. These tests were also called up in IEC specification 384-14, published in 1981.

The problem of designing intrinsically safe X and Y capacitors depends on econo-

mics and physical constraints of size as well as the parameters of the design materials. As stated, given that millions of capacitors are in use and some are left on continuously 24 hours a day (tv sets which leave the filaments warm for instant picture, even some electric kettles), some capacitors are going to short. Short-circuit failures in metallized capacitors are reduced because even if voltage transients cause the capacitor to short the component clears itself.

This clearing or self-healing depends on metallized electrodes, burnt away around the short-circuit area enabling the capacitor to function normally. The self-healing is a complex physical and chemical process which even today is not fully understood, but will be described later. The metallized plastics paper capacitors are the only types that have this self-healing function, other types such as ceramic capacitors cannot recover.

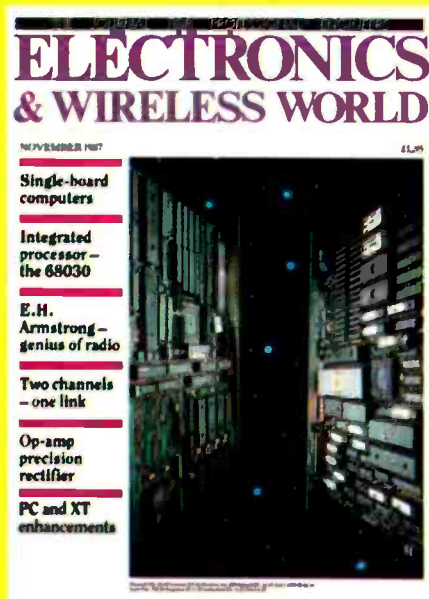
## NEXT MONTH

**Single-board computers.** Computers on one board have long been regarded as components to be incorporated in larger systems. Since our last look at these devices, development has proceeded apace; we therefore review the latest techniques and survey the available boards.

### Edwin Armstrong – genius of radio.

Eleventh in our series on the pioneers of radio and electronics, this piece describes the life and work of the American engineer who is known for his invention of the superheterodyne principle and for the development of f.m. radio.

**32-bit micro.** Production of Motorola's MC68030 begins this month. This a second-generation, enhanced, 32-bit microprocessor in which the functions of memory management are integrated with the c.p.u. on the same chip, as well as a data cache, instruction cache and Harvard architecture. Our authors Burns and Jones describe the device.



**The Janus link.** P.E.K. Donaldson of the Medical Research Council shows how two independently adjustable outputs can be derived from one pulse or r.f. The circuit was designed for a radio-coupled stimulation system, but is adaptable for more general applications.

### Fast, current-mode precision rectifier.

John Lidgley and Chris Toumazou describe a novel precision rectifier circuit using op-amps with supply-current sensing. It is simple to design and provides a performance which is claimed to be superior to conventional op-amp rectifiers over a large bandwidth.

**Elliptic low-pass filter.** Kamil Kraus presents a simple method of design for elliptic filters using op-amps in the form of a ladder network. The design of a 5th order filter is shown as an example.

While ceramic capacitors have a major disadvantage their basic construction does make them flame retardant; but providing selected materials and additives are used metallized plastics and paper capacitors can also be made flame retardant.

The two main problems encountered with capacitors for use at 240V a.c. on the mains are

- ionization within the capacitor
- inability to clear faults.

### IONIZATION IN VOIDS

All capacitors contain voids and these are a cause of ionization within the capacitor. The void which contains air has a lower dielectric constant than the surrounding dielectric and is therefore subjected to a greater voltage stress. Additionally the air in the void has a lower breakdown voltage than the surrounding dielectric. The minimum breakdown voltage for air under ideal conditions is approximately 340V and as the peak voltage of the 240V a.c. mains exceeds this, ionization can occur in all mains capacitors. Once started it can rapidly degrade the dielectric and this in turn can cause the onset of ionization to start at a lower voltage than that which was first required. This is positive feedback, which leads to the dielectric breaking down and a short circuited capacitor.

The way to eliminate ionization within a capacitor is to

- make the air gaps very large
- make the air gaps very small
- reduce the voltage on the capacitor below the minimum to start ionization.

Obviously the first choice is possible, but makes for unacceptably large capacitors. The second is also possible and while all wound capacitors contain air voids due to irregularities of the winding materials, these can be eliminated by vacuum impregnation of the capacitor with an oil. This was the traditional method but the requirement to have oil-tight seals and cases made the capacitors expensive and bulky. The modern version of oil impregnation is to use epoxy resin which is then cured to a solid. By impregnating the capacitor in a suitable mould the resin can be made to completely encase the capacitor element and no additional case is needed and this method becomes economical. The method is not a complete answer to all types of capacitors - only capacitors using paper dielectrics are sufficiently porous to impregnate properly.

Plastic films, because they have smoother surfaces which are more difficult to wet and inherently non-porous, cannot be satisfactorily impregnated to avoid ionization. Because of shrinkage of the resin when it cures, even paper dielectric capacitors contain some small voids which cause some ionization, but if metallized paper is used the ionization burns away the metallizing at these potential fault sites and in practice the fault sites are isolated. That is, the ionization within a metallized paper capacitor, providing it is below a specific level, does not increase with time but reduces.

The third method of preventing ionization is to reduce the peak voltage below the

critical voltage of 340V. This is done in practice by winding the capacitor as two elements in series such that there is only 120V a.c. across each capacitor element. This method is done on several commercial designs and is very effective.

### CLEARING ABILITY

The clearing ability of metallized capacitors, that is their ability of self-heal and to clear short circuits due to transient voltage or dielectric faults, is a complex physico-chemical process. While the number of clearings or self-healing operations occurring during the life of a properly designed capacitor is minimal they do occur in service. The clearing ability depends on electrode metal, electrode thickness, and dielectric film. The metal electrodes almost universally used for metallized film capacitors are aluminium evaporated on to the dielectric films, about 30nm thick in a high vacuum.

The films commonly used in mains capacitors are polyester, polypropylene, polycarbonate and paper. These dielectrics all have different clearing abilities which are also dependent on the metal film used. When a clearing occurs in a capacitor, the energy discharged through the short circuit causes the electrodes around the fault site to be evaporated away. This evaporated metal can still cause short circuits or low resistance paths unless it is oxidized to an insulating film. The only places that the oxygen can come from are either the entrapped air in the winding, and to prevent ionization this should be negligible, or from the dielectric itself. It has been found that those dielectrics which contain a high proportion of oxygen in their molecules do in fact have superior clearing ability to dielectrics which have little oxygen.

Another important criterion is to have a high hydrogen to carbon ratio as this prevents carbonization which can in turn lead to low resistance paths in capacitors and additional clearing discharges. The temperatures reached during self healing are in the

order of 600K and at these temperatures the aluminium electrodes are easily evaporated and can react with oxygen in the film to form an insulating oxide.

The empirical formulae for the commonly used capacitor dielectrics are:

- paper (cellulose)  $C_6H_{10}O_5$
- polyester (polyethylene terephthalate)  $C_{10}H_8O_4$
- polypropylene  $C_3H_6$
- polycarbonate  $C_{16}H_{14}O_3$
- polystyrene  $C_8H_8$

Paper has the highest oxygen content followed by polyester, and experience confirms that paper has the best clearing properties, followed by polyester.

Polystyrene has a low hydrogen to carbon ratio, no molecular oxygen, and as a consequence is not used as a metallized dielectric. Polypropylene has a high hydrogen to carbon ratio but no oxygen. It clears moderately well but the lack of molecular oxygen creates other problems. When plastic films are metallized with aluminium, the aluminium adheres by reacting with the molecular oxygen within the film. The absence of oxygen within polypropylene prevents good adhesion between the metallizing and the film and metallizing is easily rubbed off. To improve the adhesion to acceptable standards polypropylene films have to be pre-treated prior to metallizing.

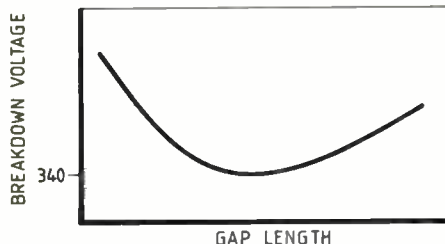
This pre-treatment consists of subjecting the film to a corona discharge, which physically abrades the surface and oxidizes the outer layers of film. While this process allows the aluminium metallizing to bond to the polypropylene, the excellent electrical properties of polypropylene are degraded only slightly.

The material requirements of an intrinsically safe capacitor or at least a very safe capacitor can now be defined:

- metallized paper dielectric
- epoxy resin vacuum impregnation
- flame retardant epoxy resin.

As well as meeting these material requirements the capacitor manufacturer must exercise rigorous quality control steps at each stage of production. There are differences between each manufacturer's own techniques. A significant improvement in reliability can be achieved by pre-clearing the metallized dielectric at a voltage in excess of what is seen by the dielectric in practice i.e. typically three times rated voltage. This pre-clearing is done by the better manufacturers before the film is wound into capacitors and effectively isolates all weak spots due to inclusions or holes. The pre-clearing eliminates or reduces to very low orders clearings which occur in the wound capacitor and this aids reliability as major clearings in a finished capacitor can damage adjacent layers which in turn causes other clearings to occur.

Another major problem of all metallized capacitors is the method of making contact to the metallizing. This is done by spraying metal from either a flame spray gun or an arc spray gun. Some manufacturers spray one layer of metal while others spray at least twice and sometimes three separate spray



**At large gap lengths the potential gradient is reduced and few free electrons are available. At small gap lengths the gradient is high but the mean free path of the free electrons generated is comparable to the gap length and no additional ionization is caused by the electrons striking other molecules. At intermediate gap lengths free electrons are generated by the voltage gradient and these travel sufficiently far to strike and ionize the air molecules. This generates other free electrons and an avalanche effect occurs causing large current to flow.**

. These layers are different alloys chosen initially to bond to the paper/film metallizing while the final layer is chosen to be weldable to the lead wires.

While there are differences between manufacturers of plastics-film and paper capacitors with regard to reliability and performance, these differences – especially those of r.f.i. suppression performance – are marginal compared to the differences between different types of ceramic capacitors. Ceramic capacitors are normally used as Y capacitors i.e. values up to 4700pF. To make economical and physically small capacitors, ceramic manufacturers have to use semi-stable ceramic formulations with high dielectric constant. These ceramic formulations are based on barium titanate dielectrics with a dielectric constant in the region of 1000, compared to four for an impregnated paper capacitor, three for a polyester capacitor and 2.2 for a polypropylene capacitor. This high constant is obtained by having a highly polar dielectric but as a consequence its properties and dielectric constant vary with time, frequency, applied voltage, and temperature.

The variation with time is of the order of 1% per decade and this change is trivial compared to the other changes. At first sight it would appear that as X and Y capacitors are designed for use across the mains at 50Hz, the variation of capacitance with frequency of a ceramic capacitor is of no consequence, but the frequency of operation of X and Y capacitors is not 50Hz but any frequency up to 300MHz or more. RFI capacitors are designed to suppress noise and if their capacitance falls with frequency their ability to suppress noise also falls.

The variation of dielectric constant and hence capacitance of ceramic capacitors with voltage is different for each capacitor manufacturer and the capacitance may increase or decrease by as much as 20% from 1V a.c. to 250V a.c. and this should be taken into account when selecting capacitors for use as Y capacitors. ◻

By far the major cause of variation of capacitance is temperature with ceramic capacitors. Again these variations differ widely from different producers and compared to the room temperature capacitance some types may lose as much as 80% of their capacitance at  $-40$  or  $+100^{\circ}\text{C}$ . Alternatively at these extremes the capacitance can increase.

The performance of the other commonly used dielectrics such as polypropylene, polyester, paper are a model of stability compared to the semi-stable ceramics. Polypropylene has the best frequency stability and has a capacitance stability of  $\pm 2\%$  over the temperature of  $-40$  to  $+85^{\circ}\text{C}$ . While polyester and paper lose a few percent of capacitance at 1MHz, their capacitance over the temperature range can vary by as much as 10%. These dielectrics are in a different class to ceramics where stability is concerned.

Where Y capacitors are concerned one essential requirement for intrinsic safety is capacitance stability. As previously stated many countries specify a maximum leakage current to earth of 0.5mA at 240V a.c. This

corresponds to a capacitance of 6600pF. To allow for  $\pm 20\%$  tolerance on capacitance, and tolerance on the mains voltage, a safe capacitance value is 4700pF. This capacitance value will give a certain performance of r.f.i. suppression and at room temperature there will be little difference between the performance of any of the plastics, paper or ceramic capacitors.

Over the working temperature range of  $-40$  to  $+100^{\circ}\text{C}$  plastics and paper capacitors will all have sufficient capacitance stability to maintain the r.f.i. suppression and keep the leakage current to earth below the regulation limit of 0.5mA. The ceramic capacitors, depending on the ceramic formulation used, will either have a markedly inferior r.f.i. suppression performance at some temperatures or alternatively they will allow the earth leakage current to exceed 0.5mA. It must be stressed that there are many ceramic formulations and it is conceivable that some types marketed may be able to maintain a reasonable r.f.i. performance over the temperature while at the same time keeping the earth leakage current within the allowed limits.

The main parameters for designing intrinsically safe capacitors or at least the safest possible capacitors can now be defined. They should be

- stable; or at least the changes should be predictable and small with variation in temperature.
- stable with changes of applied voltage.
- predominantly fail-safe i.e. as open circuits. This requires good clearing properties.
- flame retardant in the event of a short circuit failure due to misapplication or a manufacturing defect.
- free from internal discharges.

The design which comes closest to meeting all the above parameters is the metallized paper capacitor encapsulated in a flame-retardant epoxy resin. These capacitors cover both X and Y applications and because of their excellent capacitance stability the r.f.i. suppression capabilities of Y capacitors do not have to be compromised against their safety requirements. These designs can meet all the current specifications but it is probably time that these specifications were re-examined and rewritten to assess the effects of capacitors over their full working temperature range and to recognise that semi-stable ceramic dielectrics can have capacitance variations with voltage and frequency.

Metallized paper capacitors have been available in various forms since the early 1900s. The modern form using metallized electrodes deposited by vacuum evaporation originated in Germany in the late 1930s while the aluminium metallized paper capacitor became available in the 1960s. The metallized paper capacitor has stood the test of time. Very few technologies have a 40-year production history in the electronics industry. But with the increasing emphasis on product safety, the metallized paper capacitor will undoubtedly be in production for the next 40 years because of its intrinsic safety advantages.

Ron Hanson is Waycom's product manager for capacitors.

# BOOKS

**Compendium of Active Devices** compiled by W.S.E. Mitchell, A. Milward and G.A. Taylor. IEEIE Monograph, 82 pages, soft covers, available at £4.50 including postage from the Institution of Electrical and Electronics Incorporated Engineers, Savoy Hill House, Savoy Hill, London WC2R 0BS. Splendid crib for the engineer or student, or in fact anyone who feels in danger of being left behind by the proliferation of misfets, mesfets, mosfets, vrams, scrams and other novel semiconductor devices. The text provides an outline of fabrication techniques and a description of each device, with numerous diagrams and photographs. At the end are tables of standard letter symbols and acronyms, and an outline of the Alvey, Esprit and Map programmes. This volume is the second in a series of monographs from the technicians' professional body; the first, published last year, was entitled *Interfacing Standards for Computers*.

**Programmable Logic Handbook** by Geoff Bostock. Collins Professional Books, 234 pages, hard covers, £25. Authoritative survey of this fast-growing device family. The final part of the book deals at length with a wide diversity of logic elements showing how they may be fitted into p.l.d.s. Appendices list p.l.d. manufacturers and companies offering c.a.e. support.

**The Loudspeaker Design Cookbook**, third edition, by Vance Dickason. The Marshall Jones Co., Franconia, New Hampshire: 77 pages approximately A4 size, soft covers; distributed by Old Colony Sound Lab, P.O. Box 243, Peterborough, New Hampshire 03458-0243, USA, price \$14.95 excluding postage. Despite the title, this is hardly a book for the amateur constructor – it is more a reference manual for the small-scale production of loudspeakers of very high quality.

A chapter is devoted to each of the basic enclosure designs; for each type the author discusses possible variants and provides tables, design equations, references and much other information, including practical advice on overcoming likely problems. Other sections deal with driver units, crossover design and methods of testing.

**Introductory Technology: Book 2**, by O.D. Ogbonna. Macmillan, 132 pages, soft covers, £2.95. Well-illustrated basic course designed for Nigerian junior schools, but suitable for wider use. Topics covered by this volume included simple mechanisms, basic electricity and electrochemistry. Other chapters deal with technical drawing and metalwork. Language and vocabulary have been kept simple.

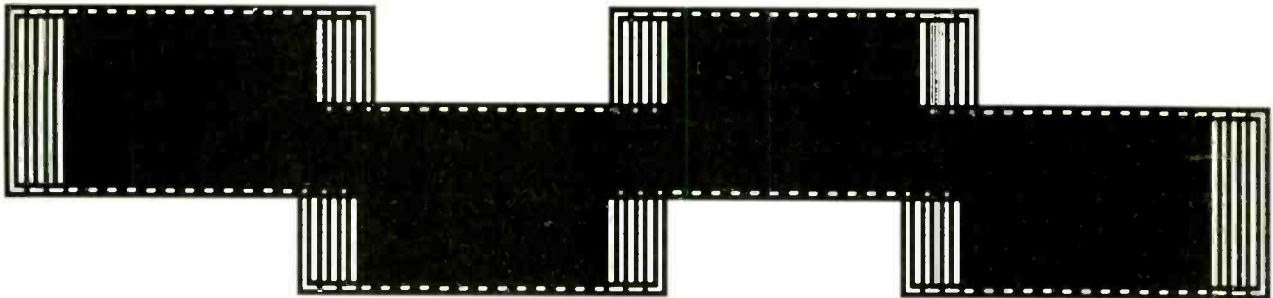
# Carstonsell

☎ 01-943 4477

Carstonsell Carstonbuy

## Carston

2nd USER  
TEST EQUIPMENT  
& COMPUTER PRODUCTS



WHATEVER YOUR EQUIPMENT NEEDS ARE,  
DO PLEASE CALL US!

FOR LATEST STOCK  
INFORMATION .....RING 01 943 4477

CARSTON ELECTRONICS LTD.  
2-6 QUEENS ROAD, TEDDINGTON, MIDDLESEX, TW11 0LR  
TELEPHONE: 01-943-4477. TELEX: 938120 CARLEC-G

ENTER 21 ON REPLY CARD



# FIELD ELECTRIC LTD.

3 Shenley Road, Borehamwood, Herts WD6 1AA.  
01-953 6009

*We would like the opportunity to tender for surplus equipment*

Official Orders/Overseas Enquiries Welcome/Order by phone or post. Open 6 days, half day Thursday. Please ring for C/P details not shown. Postal rates apply U.K. mainland only. All test equipment carries warranty. All prices incl. 15% VAT & c/p unless stated

## SPECIAL OFFER

TTL 7" Green Phosphor Monitor Chassis. 22MHz bandwidth 12V DC input new and boxed. Complete with data, circuit diagram compatible to BBC, IBM computers, diagram supplied for connection to BBC, 75Ω comp video circuit supplied. **£19.95** inc c/p.

Card No 1 1×Z80A DMA, 1×Z80A CPU, 1×D8255 AC-5 in holders, 1×5MHz Xtal, 8×MB8264, 15+53, 1×SN74198N various chips new ex-equip. **£15.95.**

Card No 2 1×WD 1933B-01 in holder + 16 various chips, new ex-equip. **£15.00.**

8" Winchester, 20MB hard disk drive, c/with manual taken out of working equipment. We cannot of guarantee. **£125.00**

IDC Connectors 26 way, 270mm cable **£2.20.** IDC Connector 20 way 45mm cable **£2.00.** IDC Connector 50 way to IDC card edge Connector 50 way 520mm cable **£4.20.** Cables have connector on each end.

Dryfit A200 by Sonnenschein 12V DC 5.7AA **£16.95**

5V 20A SMPSU **£18.00.** 5V 40A SM **£25.00.** Farnell SM +5V 10A +24V 4A +12V 500MA-5V 1A new data **£27.75.** Farnell SM 12V 2.5A **£38.00.** Ultra small Farnell fan-cooled SM +5V 10A, -5V 1A +12V 3A, -12V 1A **£32.00.** 12V 10A SM **£38.00.** 12V 30A SM **£69.00.** 12V 3A Linear **£16.95.** All PSU units are 240V input. Many more in stock.

Gould Advanced OS1100A Dual Beam 30MHz Delayed Oscilloscope c/w manual **£325.00.** Cossor CDU 150 35MHz Delayed Dual Beam Oscilloscope c-w manual **£195.00.** Tek 545B Oscilloscope from **£46.00** buyer collects c/p can be arranged. Tek RM556 50MHz Dual Beam Oscilloscope. Over 50 Display modes including dual beam display with one input 7ns risetime **£85.00.** Accepts multitrace sampling and spectrum analyser plug ins. C/p please ring.

Solartron 7055 Microprocessor Voltmeter **£230.00** c/p please ring.

Solartron Metered PSU ×2 0-60V 0-1A 240V input **£45.00** c/p 6.75.

## SPECIAL OFFER

Disk drives full height. Full height 40 Track single side ex-equipment **£19.95.** Toshiba 1/2 height 40 track d/sided new **£35.00.** No information, no guarantee. Full height 40 track double side ex-equipment **£25.50.**

8" Winchester 10MB Hard Disk Drive, new and boxed, manual etc **£75.00.**

**ALL OUR PRICES INCLUDE 15% VAT & CARR/PACKING UNLESS STATED. SAVE TIME PHONE YOUR ORDER FOR QUICK DELIVERY WITH ACCESS, AMERICAN EXPRESS OR VISA CARDS**

ENTER 65 ON REPLY CARD

# SATELLITE TV EQUIPMENT

## SYSTEMS

1. Telecom Satellite. (French TV & Radio). 90cm fixed dish, LNB, SR1000 Rx..... **£310.00**
2. Eutelsat F1. (French, German, Italian, English). 1.3m fixed dish, LNB, SR1000 RX..... **£375.00**
3. Tracking System (Basic). 1.6m dish, feedhorn, Motor Drive, LNB. SR 1000 RX..... **£685.00**
4. Full I.R. Remote control System. 1.6m dish, Motor, Polorotor, LNB, SR4500 RX/DRIVE..... **£885.00**
5. GORIZONT (Russian). 1.3m dish, Feedhorn, LNB, SR1000 RX. Depolariser Block..... **£475.00**
6. INTERNATIONAL C BAND System. 2.7m dish, AZ+EL Motor drives, LNB, RX, I.F. Active Filter, P.T.F.E..... **£2200.00**

## EQUIPMENT

- 'C' Band LNA + BDC. 10.9 - 11.7 Ghz LNB's, 1.9, 2.0, 2.1, 2.2, 2.3 dB. Telecom + DBS.
- Motor Drives. Tracker 2, SP3000, 12, 18 & 36" Arms.
- Receivers. Echosphere. 1000, 3000, 4500, Luxor Mk 2.
- Dishes. 90cm, 1.3m 1.6m, 1.8m, 2.0m, 2.7m.
- Spectrum Analysers for TVRO use. Luly..... **£575.00.** Avcom..... **£1560.00**
- Transcoder. SECAM to PAL video..... **£105.00**
- 'F' Connector Crimp tool and 100 connectors..... **£39.00**
- Line amplifiers, line switches (50dB isolation. D.C. Path to be specified)
- Line splitters N or F connectors. 11 Ghz O.M.T.'s
- Polorotor problems. The grey Taiwan product with white plastic cover. Modification for low loss..... **£10.00 + p.p.**

## TRAINING

Engineering Courses in all aspects of Satellite Reception covers both theory and practice of L, S, C, Ku bands LNA, BDC, LNB operation. Feedhorns, Polorotors, Receivers, Motor Drives. Dish Theory and operation, Test Equip Involves 'Hands On' experience with dishes from 90cm to 2.7m, C & Ku Band systems, Practical experience with Luly & Avcom Spectrum Analysers, Sat Sig Strength Meter. Setting up receivers from basic Vari-cap through remote control to on Screen Graphics with built in drive controller and programming of system. Practical tests of LNB

Noise figure, Polorotor Loss, Dish efficiency, etc.

This two day course is limited to 6 students and runs twice a month depending on weather..... **£100.00**

The course will shortly be extended to an optional third day to include theory and operation of Remote Weather sensing Primary data satellite reception high resolution. Giving Visible, I.R. Water Vapour pictures from any predetermined point within satellite viewing area. 2.7m dish, L band operation..... **£50.00**

Not to be confused with METEOSAT secondary user, PRIMARY user data is under the receive station software control.

## MICROWAVE PRODUCTS

Mainly intended for the professional user.

Data Communications LNB's in the band 9-13 Ghz input. External Oscillator required for low phase noise applications.

External multipliers for 2Ghz input of low phase noise source, output with SMA to feed above LNB.

Low phase noise drive sources can be supplied.

Low noise amplifiers to customers requirements 1-14 Ghz.

Microwave filters for specified frequencies

Noise sources

Orthomode Transducers

Microwave splitters & amplifiers

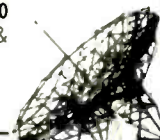
Items are manufactured to specific customer requirements hence no data or specifications are available, telephone your requirements for price & delivery.

Available shortly....10.3Ghz amateur TV band Low noise downconverters 2.3dB N.F. approx..... **£178.00**

METEOSAT PRIMARY USER IMAGE DATA SYSTEM. **£5000.00**

Design service available for your specific Project. P.C.B. & Prototype for production use.

All prices are exclusive of VAT & Carriage.



# North East Satellite Systems

Manufacturers of Microwave Dishes, Feed Horns and Specialised Electronics  
Suppliers of Satellite Systems and Closed Circuit T.V. Equipment

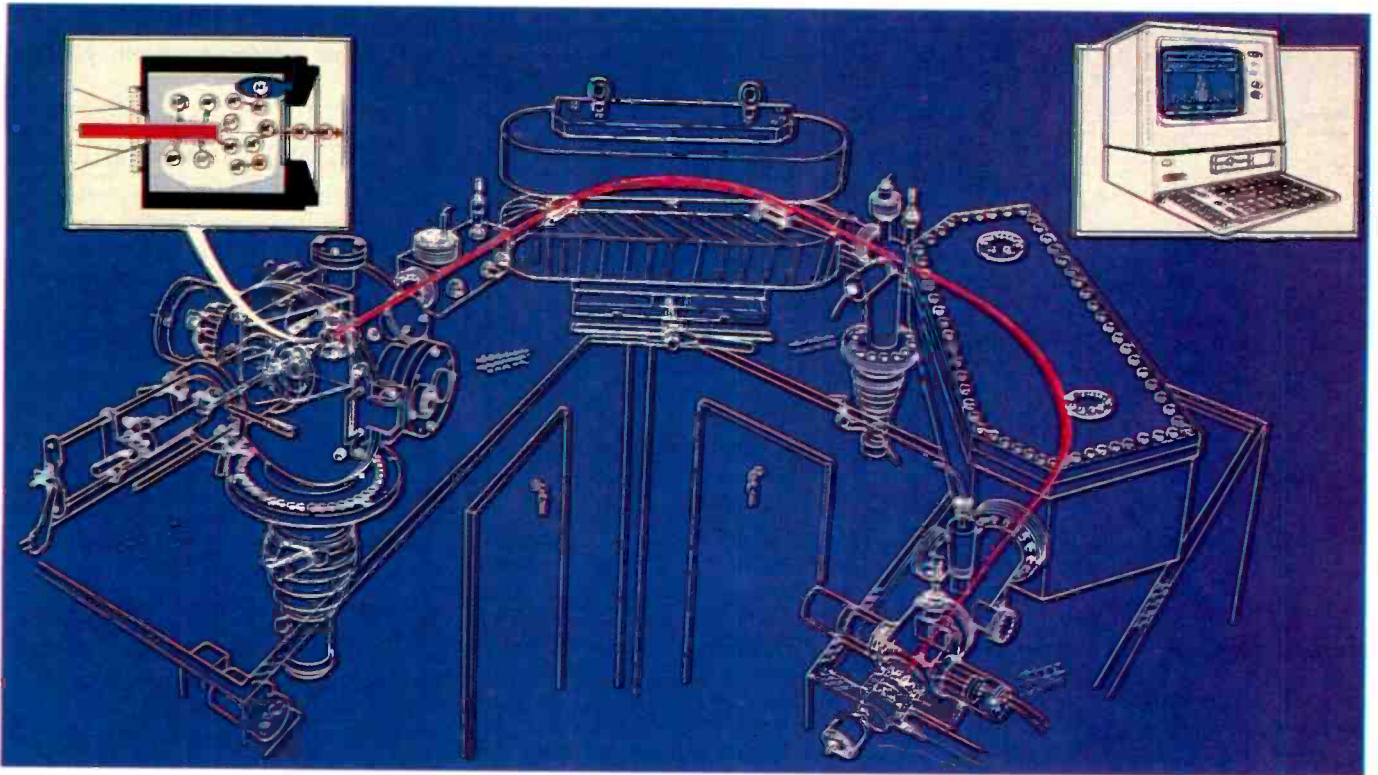
**CROPTON, PICKERING, NORTH YORKSHIRE YO18 8HL**  
**TEL: LASTINGHAM (07515) 598**  
**VAT No. 347 557132**



# Analysis of solids by glow-discharge mass spectrometry

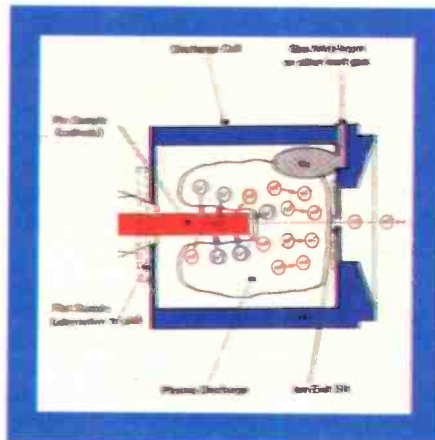
G.d.m.s. offers the semiconductor industry a method of bulk analysis with uniform sensitivity and no-standards operation

P.M. WEBB, N.E. SANDERSON.



**G**low discharge mass spectrometry (g.d.m.s.) has stimulated considerable interest in the ultra-high purity material and semiconductor industries in recent years. The technique has been seen as a natural successor to spark source mass spectrometry (s.s.m.s.) for the bulk analysis of solids due to the considerable benefits imparted by the glow discharge source. The features of particular note are good, uniform sensitivity across the periodic table and an inherent lack of matrix effects, resulting in an excellent capability for no-standards analysis. This feature is of key importance in the semiconductor industry, where there is a lack of well characterized, multi-element standards available to the analyst.

In this article, the significance of g.d.m.s. to the semiconductor industry will be discussed, with reference to the only commercial instrument capable of attaining the required sensitivities for semiconductor materials characterization, the VG 9000 from the Elemental Analysis Division of VG Isotopes.



**Fig.1.** The major components of the system: from left to right, glow discharge source, analyser and detector.

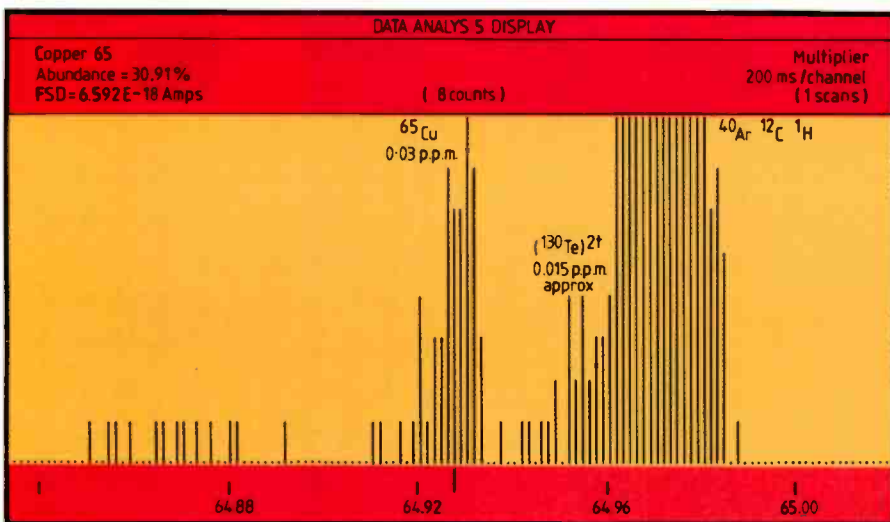
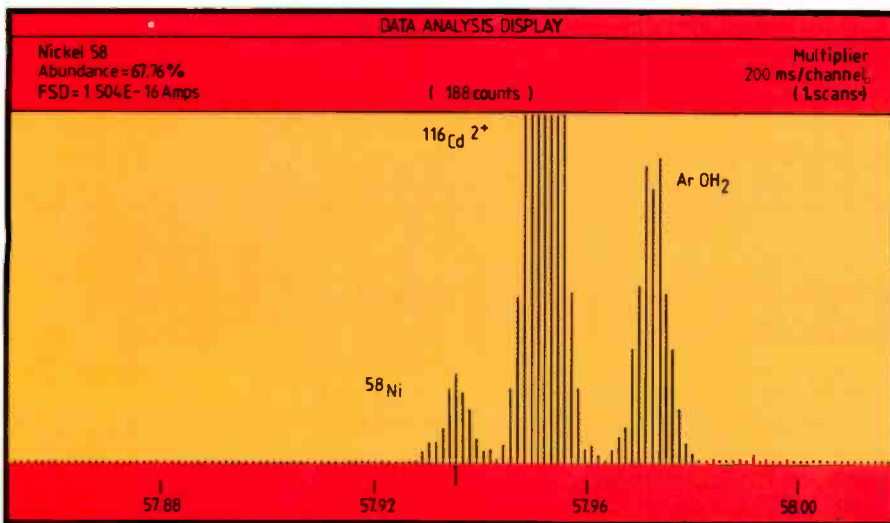
**Fig.2.** Section through the glow discharge source.

## PRINCIPAL COMPONENTS OF A GDMS SYSTEM

The system can be considered to consist of four major components, the glow discharge source, a mass analyser, detector system and control computer as shown in Fig 1. The source produces a stream of ions which are subsequently separated on the basis of their mass to charge ratio by a double focussing mass spectrometer. Electronic detection of the ions is by a Faraday/Daly dual detector system.

Operation of the instrument is accomplished by a powerful PC-based system which also serves to acquire data and perform the data reduction and formatting.

**The glow discharge source.** The sample serves as a cathode in a low pressure (0.5m bar) argon plasma in a small tantalum discharge cell (the anode). The sample is inserted into the cell and several hundred volts potential applied between the sample (cathode) and the cell (anode) causing the



breakdown of the argon gas to form a plasma. Argon ions impact upon the surface of the sample, resulting in the generation of sputtered neutral species of the sample atoms. Any positive ions produced are attracted back to the sample surface, whilst the neutral atoms diffuse into the central column of the plasma where they are subsequently ionized by collision with metastable argon atoms or electron impact. (Fig.2)

The reaction with metastable argon atoms is termed Penning exchange, and leads to a uniform ionization sensitivity (within a factor of 3) over the periodic table; hence true multi-elemental analysis is attained even in the absence of calibration standards. The separation of the sputtering and ionization process has considerable benefits over direct ionization at the sample surface (e.g. secondary-iron mass spectrometry or laser-ionization mass spectrometry), giving a response almost totally independent of the matrix. Hence, the combined effect provides for a powerful no-standards analysis.

**The mass analyser.** The output from the glow discharge source consists mainly of singly charged analyte ions, with some background of doubly charged ions and singly charged molecular species. These potentially interfering ions range from a few parts per billion to around 100 parts per million in concentration relative to the matrix.

To ensure that none of these potentially interfering ions cause problems, the mass

analyser of the VG 9000 is double focussing. It consists of a combination of magnetic and electrostatic analysers producing high resolution. Without this geometry, certain determinations would be background limited by the presence of one or more interfering ions. Figures 3 and 4 illustrate the analyser's ability to separate these species from the singly charged ion of analytical interest.

Thus, the molecular species, whilst they are obviously present, do not hamper the correct identification and determination of trace impurities. However, without a double-focussing geometry analyser, a glow discharge source coupled to a low resolving-power (e.g. quadrupole mass filter analyser) would be subject to background limitations at levels of a few p.p.m. and lower.

**The detection system.** The instrument uses a unique Faraday/Daly dual-detection system, having a combined linear dynamic range of more than 10 orders of magnitude. Since the Daly detector has a background of 1 count per second, p.p.b. concentration measurements are obtained in short integration times simply by direct ratio of the ion-beam intensity to the matrix. Typically, the Faraday is used to monitor the major components above 1000 p.p.m. whilst the Daly measures minor and trace components down to sub-p.p.b. concentration levels. Switching between the detectors is under computer control, enabling all measure-

ments to be ratioed to the matrix signal in a single analytical cycle.

## SAMPLE PREPARATION AND ANALYTICAL CONDITIONS

The g.d.m.s. source will accept conducting and semiconducting samples directly, with provision for accepting pelletized non-conductors or powders. Surface contamination can be removed by a combination of chemical etching prior to loading the sample and pre-sputtering in the discharge cell. The rapid analysis and real-time data display enable the operator to track or profile compositional changes from the surface to the bulk of the material, as successive layers of material are sputtering away. In the normal bulk analysis mode of operation, this erosion rate is of the order of 1µm/min, but adjustment of the source pressure enables this to be controlled down to around 0.1 µm/min for quantitative depth profiling studies.

## G.D.M.S. IN THE SEMICONDUCTOR INDUSTRY

Impurities in semiconductor materials can be classified into two categories, those deliberately introduced, as in the case of dopants such as boron or phosphorus, and those arising from impure raw materials or contamination from processing chemicals and equipment.

When studying the profile of a deliberately introduced dopant, it is essential to be able accurately to monitor the concentration of single elements (usually in the 1-40+ p.p.m. range). However, in the analysis for inadvertent contamination it is essential not only to maintain accuracy but also to do this across the entire periodic table. This comprehensive elemental coverage is a major advantage of g.d.m.s. over other techniques such as s.i.m.s., where not only is coverage much reduced but the sensitivity from element to element may vary by as much as three orders of magnitude. The other major technique for bulk analysis, spark source mass spectrometry (s.s.m.s.), is much slower in operation than g.d.m.s., shows less precision and provides inferior detection limits.

The capability of g.d.m.s. can be illustrated by a study of trace level determinations of transition elements in cadmium telluride, silicon and depth-profiling of gallium arsenide.

## CADMIUM TELLURIDE

Cadmium telluride is used extensively in the electronics industry, either directly as a gamma-ray detector or as a raw material in the production of cadmium mercury telluride (CMT) which is used as an infra-red detector. In both these roles, the trace element composition is vital to the performance of the device and the transition element concentration is of particular importance. The elements Fe, Ni and Cu have been difficult to determine by traditional techniques such as s.s.m.s. The reason for this is the high-level of doubly charged matrix ions (~10 - 20%) produced in s.s.m.s. Thus the Cd<sup>2+</sup> and Te<sup>2+</sup> peaks swamp the Fe, Ni and Cu peaks, making analysis difficult or im-

possible. A similar difficulty is seen with s.i.m.s., so that the effective limit of detection with this technique for these elements will be around the p.p.m. level.

Determination of trace levels of transition elements in cadmium telluride by g.d.m.s. is made practical due to the ionization process employed, which produces very low levels of doubly charged ions (typically <100 p.p.m. of the singly charged level) in combination with uniform element-relative sensitivity factors and small matrix effects.

Table 1 illustrates the results of g.d.m.s. in the determination of transition elements in the cadmium telluride sample as well as the concentration of the major components. Element identification confirmation is illustrated by isotope ratio checks for Ni and Cu. In general, detection limits of around 10 p.p.b. are obtained, based on 10 seconds integration time per peak.

TABLE 1

Analysis of cadmium telluride by VG 9000 g.d.m.s. — concentrations from ion-beam ratios

Element	Isotope concentration	Element concentration
Ti48	0.074	0.100
V 51	0.005	0.005
Cr52	0.037	0.004
Mn55	0.005	0.005
Fe56	0.150	0.164
Ni58	0.020	0.03
Co59	0.003	0.003
Ni60	0.007	0.025
Cu63	0.029	0.042
Cu65	0.009	0.030
Zn66	0.003	0.010
Zn68	0.010	0.056

Figures 3 and 4 illustrate the value of the excellent resolution obtainable by the high-performance mass spectrometer. The element ions of <sup>58</sup>Ni and <sup>65</sup>Cu are clearly resolved from adjacent doubly charged species, oxides and other molecular species. In all cases it can be seen that the doubly charged species are less than 1p.p.m. in concentration, thereby enabling precise identification and measurement of the transition metal isotopes at a nominal 4000 resolving power.

### IRON AND OTHER TRANSITION METALS IN A SILICON MATRIX

In the analysis of a silicon matrix, a similar problem arises, as is shown with cadmium telluride, whereby transition elements can

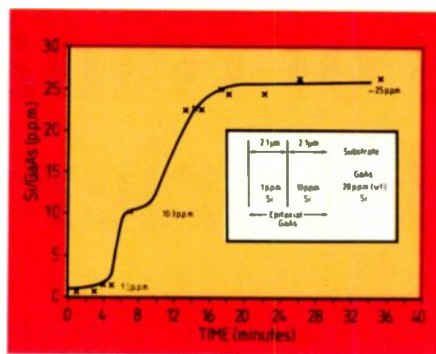


Fig.6. Analysis of silicon surface films on GaAs substrate.

be overlapped by neighbouring species. In this case the problem is caused by the high relative concentration of the dimers (species formed by the union of two like atoms) of silicon 28, 29 and 30 at the same nominal mass as <sup>56</sup>Fe, <sup>58</sup>Ni and <sup>60</sup>Ni, making analysis difficult by s.s.m.s and s.i.m.s.

In the analysis of silicon by g.d.m.s. the silicon dimers are at a level as low as 1p.p.m. and when a resolution of 6000 is used it is more than adequate to resolve these dimers from the associated isotopes of interest.

Figure 5 shows <sup>56</sup>Fe at the 6p.p.b.a. level after normalization, clearly resolved from the <sup>28</sup>Si-<sup>28</sup>Si dimer at the same nominal mass; this was produced using an integration time of approximately 15 minutes. Similar detection limits of a few p.p.b.a. parts per billion (atomic) have been achieved for other transition elements namely Cr, Mn, Co, Ni and Zn.

### DEPTH PROFILING ANALYSIS

The controlled precise sputtering of the g.d.m.s. source enables both surface and bulk analysis of silicon. Table 2 shows the results of the analysis of another silicon sample where column 1 indicates the surface composition immediately after introduction and column 2 the bulk of the material after a period of sputter etching. This ability to determine trace composition at certain depth resolution in the sample is of consider-

Fig.5. Showing <sup>56</sup>Fe at the 6p.p.b.a. level after normalization and the <sup>28</sup>Si-<sup>28</sup>Si dimer at the same nominal mass.

able interest and recent advances in the technique herald its increasing importance in depth profiling studies.

TABLE 2

Analysis of high purity silicon

Element (isotope used)	I	II
B 10,11	—	0.022
Mg 24,25	1.05	0.056
Al 27	3.12	0.125
V 51	0.013	0.009
Cr 52,53	0.391	0.008
Mn 55	0.012	0.010
Fe 56,57	0.236	0.010
Co 59	—	0.009
Ni 60	10.4	0.035
Cu 63,65	0.40	0.007
Zn 65,66	0.19	0.016

All concentration parts per million:

Run I was acquired immediately after starting the discharge and is representative of the surface.

Run II was acquired after a sputter-etch period and is representative of the bulk of the sample.

The bulk analysis determinations described above have been carried out using the standard pin sample configuration (15mm × 2mm diameter) and a pressure of around 0.5 to 1 torr of argon in the discharge cell. This results in an erosion rate of around 1 µm per minute.

Using an alternative cell geometry, flat samples, for example semiconductor wafers around 10-25mm diameter, can be run directly. By reducing the argon pressure in the discharge cell the erosion rate can be controlled to below 0.1 µm per minute. This enables the analysis of thin surface films for impurity determinations and depth profiling analysis.

A sample of GaAs was doped with silicon in two epilayers:

- (a) at 1 ppm for a depth of 2.1 µm;
- (b) at 10 ppm for a further 2.1 µm;

and (c) at 20 ppm approximately in the substrate. The results in Fig. 6 show excellent agreement between the VG 9000 and the quoted values.

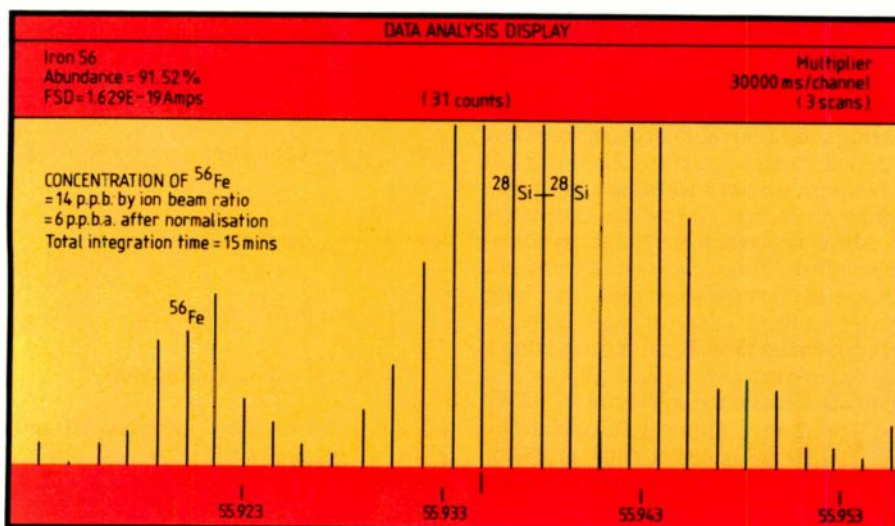
### CONCLUSIONS

Glow-discharge mass spectrometry possesses several unique properties and shows considerable benefits over other techniques for the analysis of semiconductor materials. These major benefits are:

- \* Full element coverage with approximately equal sensitivity for metals and non-metals
- \* Freedom from spectral interferences allowing determinations at trace levels which are impossible with other techniques
- \* Excellent limits of detection (p.p.b.)
- \* Minimum matrix effects
- \* Good semiquantitative analysis without the need for standards
- \* Quantitative depth profiling.

This comprehensive range of attributes should see g.d.m.s. becoming more widespread in both manufacturing processes and QA laboratories and it can be expected that further new applications will arise.

The authors are with VG Elemental — a division of VG Isotopes, Ltd



# A series of remarks on Fourier

Waveform analysis and the Governor of Lower Egypt

JOULES WATT

“It all started with the French Connection”, I said.

Once again my discussion group buzzed a little and conjectured about the cryptic beginnings that seemed to grow more and more common in our revisionary topic sessions. By this time I had drawn Fig. 1 on the board. “You might remember that the elementary trigonometric functions have three constants or parameters in their expressions which set the vertical height, the rapidity of oscillation and the position along the axis.” Then I asked if Fig. 1 was a sine wave or a cosine wave. The replies varied: some people thought it was a sine wave; others said, “Cosine, because the peak starts nearer the origin.” One bright student suggested that, because neither the peak (which would be a plot of cosine) nor the rising zero crossing (which would characterize sine) was at the origin, the plot was neither a sine nor a cosine wave. “On the other hand”, he said as an afterthought, “it might be a mixture of both.”

Later, I appreciated this last suggestion, because it is nearest to our purpose here. Figure 1 does show a combination of a sine and a cosine wave. If you consider,

$$v = \hat{V} \sin(\omega t + \phi) \quad (1)$$

$t$  is the independent variable of the function, and  $v$  the dependent variable. The  $\hat{V}$ ,  $\omega$  and  $\phi$  parameters respectively fix the vertical scale, the rapidity with which the graph oscillates as  $t$  increases, and whereabouts the sine curve starts relative to the origin.

If the symbols stand for familiar quantities in our subject, we know that  $v$  relates to an instantaneous value, usually a voltage. For current,  $i$  and  $I$  appear in place of the  $V$ s.  $t$  indicates time ticking by.  $V$  gives the peak value or *amplitude* and  $\omega$  is the *angular frequency*, with  $\phi$  indicating the *phase angle* relative to the sine wave origin.

## SINE AND COSINE ARE 'ORTHOGONAL'

You might remember that at about the end of “O” to the start of “A” level maths studies, trig. expansions of compound angles turned up, much to the bane of young students. Here they are:

$$\begin{aligned} \sin(A + B) &= \sin A \cos B + \cos A \sin B \\ \cos(A + B) &= \cos A \cos B - \sin A \sin B \end{aligned} \quad (2)$$

Use the first relation to expand equation (1),

$$\therefore v = \hat{V}(\sin \omega t \cos \phi + \cos \omega t \sin \phi). \quad (3)$$

The sine and cosine of the phase angle  $\phi$  must have a right-angled triangle interpretation. This means that from the triangle in Fig. 2 we can write,

$$v = \hat{V}_1 \sin \omega t + \hat{V}_2 \cos \omega t \quad (4)$$

where  $\hat{V}_1$  and  $\hat{V}_2$  are new amplitudes, both smaller than  $\hat{V}$ , the original. So the single wave in Fig. 1 obviously contains a sine wave and a cosine wave, called its sin and cos components.

Everything about sine compared to cosine has a right angle about it – the sides of the triangle from which they arise – the phase angle between them, which is  $90^\circ$  or  $\pi/2$  radians – and even the fact that combining them gives the tangent (=  $\sin \phi / \cos \phi$  which as a trig. function measures how much ‘up’ for so much ‘along’; in other words the slope or gradient).

We are dangerously near  $j$  and the work Euler did at this point, a topic we have discussed<sup>1</sup>. In fact,  $j$  entering on the scene gives yet another orthogonality relationship. Orthogonal means ‘at right angles to . . .’

## FOURIER

Where does the French Connection arise? As you might have guessed, through the work of J. B. Fourier<sup>2</sup>, (see box). Fourier analysis’ came into being from his work. In it, he showed not only that the general sinusoidal waveform had a sine and cos component, but *all* periodic waveforms of any shape also had a whole series of sine and cosine components making them up. Making up a complex waveshape (as certain electronic organ designs still do) from the basic sin and cos components naturally receives the term Fourier synthesis. Current ways of synthesizing complex waveshapes include using a look-up table in a rom, repeating the cycle at the fundamental rate you require and using a d-to-a converter. Although this clouds the basic Fourier series components, programming the original table contains the relevant information.

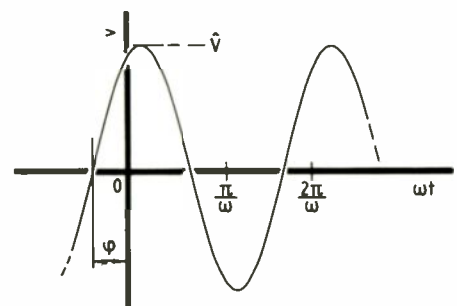


Fig 1. A typical ‘sine’ wave starting at an arbitrary point, or *phase* relative to 0 as shown, has a true sine and cosine component.

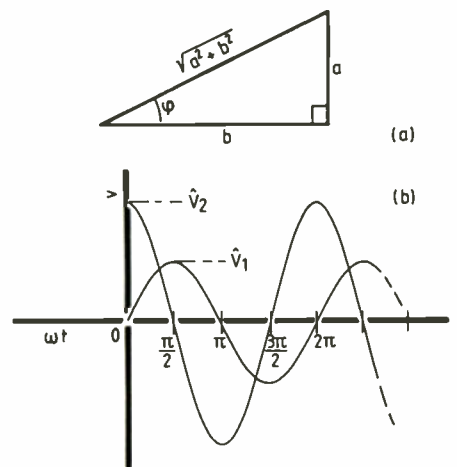


Figure 2. A right angled triangle gives the ordinary definition of the sine and cosine of an angle we all meet with at school. Hence,

$$\sin \phi = \frac{a}{\sqrt{a^2 + b^2}} \text{ and } \cos \phi = \frac{b}{\sqrt{a^2 + b^2}} \text{ so that,}$$

$$\hat{V}_1 = \frac{\hat{V}a}{\sqrt{a^2 + b^2}} \text{ together with } \hat{V}_2 = \frac{\hat{V}b}{\sqrt{a^2 + b^2}}$$

$$\phi \text{ is } \tan^{-1} \frac{a}{b} \text{ or } \tan^{-1} \frac{\hat{V}_2}{\hat{V}_1}$$

(the  $\sqrt{a^2 + b^2}$  cancelling out).

(b) shows the results of equation (4) and gives us explicitly the sine and cosine components mentioned in the caption to Fig. 1.

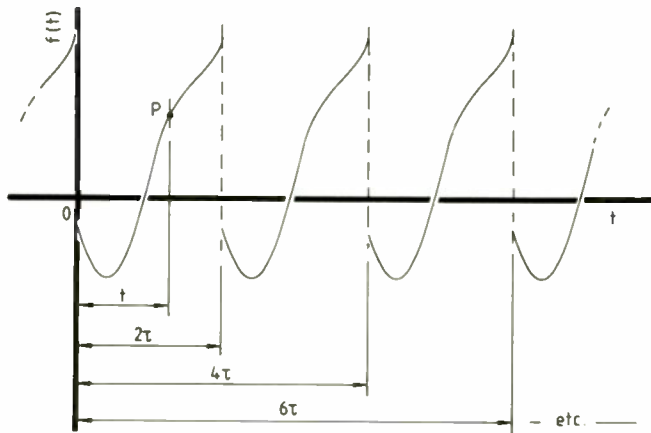


Fig. 3. Any repeating function yields sine and cosine components when Fourier analysed. The period is the shortest interval over which  $f(t)$  varies through a complete cycle, shown as  $2\tau$  here.

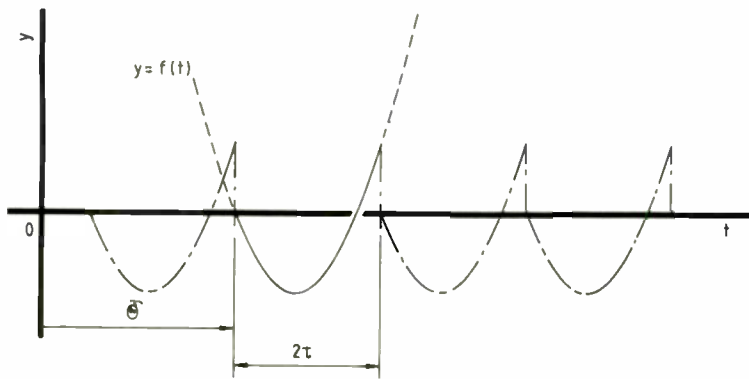


Fig. 4. If you carry out a Fourier analysis on a segment of a non-periodic function, then the piece is 'reproduced' ad-infinitum. In other words, the analysis makes the function periodic with the interval of the piece as the period.

INFINITE SERIES AGAIN

When  $j$  was on the agenda<sup>1</sup>, I remember discussing Colin Maclaurin's series, which 'expanded' a function about the origin, (the point where the independent variable equals zero), so that it could be represented by an infinite series of terms added together. Perhaps you remember sine and cosine themselves had an infinite series, obtained by that technique. The main difficulty with infinite series methods is that you have to keep an eye on them to see that the series converges to a finite sum.

Fourier used the same method to expand functions<sup>2</sup>, but went further, ending up with

an infinite series containing sines and cosines of all harmonic frequencies. Earlier, Daniel Bernoulli had attempted using a similar series in work on how a string vibrates, but was unhappy about the rigour. Also Leonhard Euler had written a more limited version of such series, but again mistrusted the rigour. Fourier acknowledged Euler's contribution, increased the rigour of the derivations and ended up with integrals, including the ones we still call 'Fourier integrals'. All modern work commemorates his remarkable contributions to mathematical theory under the titles Fourier series and Fourier transform methods.

A closer look shows us that such series arise from a special class of functions – the periodic functions. Imagine you are moving along with the independent variable  $t$  in the function  $y = f(t)$ , say, and you look at what  $y$  is doing. Your observations might show that  $y$  has moved back to, or jumped back to its starting value at some stage in the journey, then went on to repeat the same pattern again.

If  $y$  keeps doing this, your function is periodic.  $\sin\theta$  and  $\cos\theta$  typically show periodicity. In fact, they are the archetypes of periodic variations and, as you probably know, the physicists' name for such oscillation is Simple Harmonic Motion. But we term periodic any other function which repeats itself at intervals. From this reasoning, if any arbitrary function  $f(t)$  repeats itself every  $2\tau$  like that shown in Fig. 3 then,

$$f(t) = f(t + 2\tau) \quad (5)$$

The constant  $2\tau$  is the period.

If any other function, not necessarily periodic, has a piece chopped out of it whose width is  $2\tau$ , then we can do a Fourier analysis on this segment as if it is repeated indefinitely each way – that is, as if it is periodic, as Fig. 4 shows.

I have made the tacit assumption in talking about oscillations and in using  $t$  as a variable, that  $y$  is a function of time. But we do not limit Fourier analysis to time variables only: space variables arise in some applications.

Fourier must have asked himself something like, "Can any periodic motion, however complicated, be made up the sum of simple motions of the sine and cosine types?" This question asks that, since

$$\cos \frac{n\pi(t + 2\tau)}{\tau} = \cos \frac{n\pi t}{\tau} \quad (6)$$

$$\sin \frac{n\pi(t + 2\tau)}{\tau} = \sin \frac{n\pi t}{\tau}$$

for all  $n = 0, 1, 2, 3$  etc. as illustrated in Fig 5, could a periodic function be expanded as,

$$f(t) = \frac{a_0}{2} + a_1 \cos \frac{\pi t}{\tau} + a_2 \cos \frac{2\pi t}{\tau} + \dots + a_n \cos \frac{n\pi t}{\tau} + \dots + b_1 \sin \frac{\pi t}{\tau} + b_2 \sin \frac{2\pi t}{\tau} + \dots + b_n \sin \frac{n\pi t}{\tau} + (7)$$

... which is the usual daunting series expression quoted early in the "Fourier" chapters of textbooks.

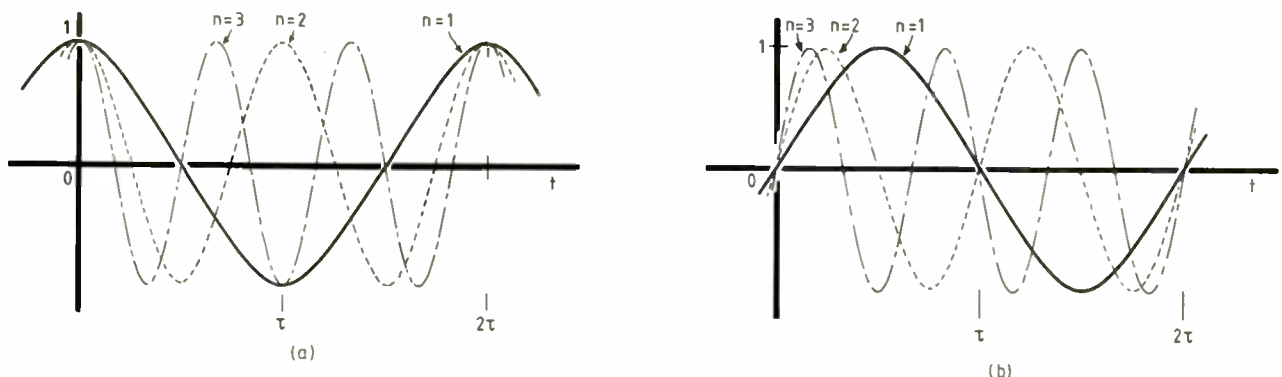


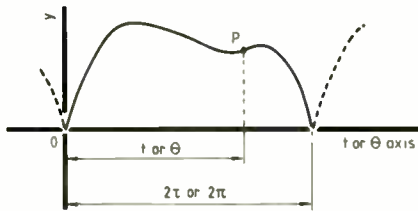
Fig. 5. Equations (6) can be hard to visualize. This attempt shows that whatever  $n$  is, all the component waves in the cosine and sine harmonic series start at 0. They then go on to repeat the same pattern every  $2\tau$ .

Of course, as in all these series methods we immediately have to face the awkward question, "What are all those  $a_0, a_1, a_2 \dots b_1, \dots b_n \dots$  numbers?" In this instance, as Fourier established, we must use certain integrals to find these coefficients. If you are rusty on evaluating the trigonometrical integrals, a quick glance into a book<sup>3</sup> will remind you that integrating sin and cos over complete periods produces a zero result, because there is as much positive area (above the axis) as negative (below the axis) in the summation,

$$\int_{\Theta}^{\Theta+2\pi} \cos n\theta d\theta = 0, \text{ with the proviso for this one that } n=0 \text{ and } \int_{\Theta}^{\Theta+2\pi} \sin n\theta d\theta = 0 \quad (8)$$

In the limit, the  $\Theta$  is an arbitrary start and  $2\pi$  is the angular period.

The arguments of the sines and cosines I wrote earlier, for example in equations (7), vary with  $t$ . Yet they are angles and I have switched to angles in equations (8). You can see the equivalence of this from  $t/2\tau$  being the fraction of the period that 0 to  $t$  repre-



**Fig. 6. The fundamental angular periodicity in the trigonometrical functions amounts to multiples of  $2\pi$  radians. Generalizing to any interval is useful and necessary and we do it as shown here.**

sents and  $\theta/2\pi$  indicating the same fraction of the period, written as an angle. Figure 6 shows that these two fractions describe the same point P and so are equal,

$$\frac{t}{2\pi} = \frac{\theta}{2\pi}, \quad \theta = \frac{\pi t}{\tau} \quad \text{radians} \quad (9)$$

We need one or two more integrals that look even more off-putting but you should find them fairly straight forward when you get down to it<sup>3</sup>.

$$\begin{aligned} & \int_{\Theta}^{\Theta+2\pi} \cos m\theta \cos n\theta d\theta = 0 \quad m \neq n \\ \text{but } & \int_{\Theta}^{\Theta+2\pi} \cos^2 n\theta d\theta = \pi \text{ when } n = m, \text{ but not } 0 \\ \text{also } & \int_{\Theta}^{\Theta+2\pi} \cos m\theta \sin n\theta d\theta = 0 \quad \text{always} \\ \text{again } & \int_{\Theta}^{\Theta+2\pi} \sin m\theta \sin n\theta d\theta = 0 \quad m \neq n \\ \text{with } & \int_{\Theta}^{\Theta+2\pi} \sin^2 n\theta d\theta = \pi \text{ when } m = n \text{ but not } 0 \end{aligned} \quad (10)$$

With these, we can go back and integrate term by term throughout the series, hopefully getting the  $a_n$ 's and the  $b_n$ 's.

First, simply integrate right through the series with the limits set as before from end to end of the period,  $\Theta$  to  $\Theta + 2\pi$ ,

$$\int_{\Theta}^{\Theta+2\pi} f(t) d\theta = \frac{a_0}{2} \int_{\Theta}^{\Theta+2\pi} d\theta + a_1 \int_{\Theta}^{\Theta+2\pi} \cos \theta d\theta + \dots + a_n \int_{\Theta}^{\Theta+2\pi} \cos n\theta d\theta + \dots + b_n \int_{\Theta}^{\Theta+2\pi} \sin \theta d\theta + \dots \quad (11)$$

We have assumed  $f(t)$  can be integrated. In other words, we do not expect the range of  $f(t)$  to go roaring off to infinity, or oscillate infinitely within the domain  $2\pi$ , so endangering the existence of the integral. Engineering waveform functions certainly do not produce any funny business like that, so we have no worries.

By the first two integrals above, all the cosine and sine integrations on the right vanish away. This leaves only the first term, which is,

$$\frac{a_0}{2} \int_{\Theta}^{\Theta+2\pi} d\theta = \pi a_0, \text{ so that } a_0 = \frac{1}{\pi} \int_{\Theta}^{\Theta+2\pi} f(t) d\theta \quad (12)$$

This gives us  $a_0$ , often called the 'constant' term, or the d.c. term (if the function is an electronic waveform).

We also want the  $a_n$ 's and  $b_n$ 's, for all the values of  $n$  as it steps 1, 2, 3, ... etc. For the  $a_n$ 's, multiply right through the series by  $\cos n\theta$  and integrate everything again,

$$\begin{aligned} \int_{\Theta}^{\Theta+2\pi} f(t) \cos n\theta d\theta &= \int_{\Theta}^{\Theta+2\pi} \cos n\theta d\theta + a_1 \int_{\Theta}^{\Theta+2\pi} \cos \theta \cos n\theta d\theta + \dots + a_n \int_{\Theta}^{\Theta+2\pi} \cos^2 n\theta d\theta + \dots + b_1 \\ & \int_{\Theta}^{\Theta+2\pi} \sin \theta \cos n\theta d\theta + \dots + b_n \int_{\Theta}^{\Theta+2\pi} \sin n\theta \cos n\theta d\theta + \dots \end{aligned}$$

A careful look on the right shows all the integrals equal to zero except the one containing  $\cos^2 n\theta$ , which equals  $\pi$ .

$$\therefore \int_{\Theta}^{\Theta+2\pi} f(t) \cos n\theta d\theta = a_n \pi \quad (14)$$

so we have found the  $a_n$ 's.

In the same way, multiplying right through the series with  $\sin n\theta$  and integrating again, we obtain  $b_n$ . You will find only the  $\sin^2 n\theta$  integration survives to contribute something,

$$\therefore b_n = \frac{1}{\pi} \int_{-\Theta}^{\Theta+2\pi} f(t) \sin n\theta d\theta \quad (15)$$

#### WE STAY NEAR THE ORIGIN

Most often, instead of the general start, the interval over which the cycle of calculation takes place is 0 to  $2\pi$ , or  $-\pi$  to  $\pi$ , so that we take  $\Theta$  either as 0 or as  $-\pi$ . In other words, we stay around or near to the origin.

We calculated  $a_0$  separately, but in the cosine part of the series, which gives the  $a_n$ 's,  $a_0$  turns up automatically by putting  $n = 0$  into the integrated result. You might find an occasional problem in doing this – if a denominator went to zero, for example, then the separate calculation for  $a_0$  would need doing.

What we have assumed is that a periodic function  $f(t)$  has a Fourier series. All we can say is *if*  $f(t)$  has a Fourier expansion, *then* we find the coefficients  $a_n$  and  $b_n$  as above.

Some of the conditions for the existence of a Fourier series arose from the work of Peter Dirichlet. In a famous theorem he proved,

"If a bounded function has at most a finite number of maxima and minima and a finite number of points of discontinuity, without infinite jumps, then the Fourier series of  $f(t)$  converges onto  $f(t)$  where it is continuous and on to the average of the right and left handed limits of  $f(t)$  at each discontinuity."

What Dirichlet said means that waves such as those in Fig. 7 have a Fourier series and at each discontinuity the value tends to  $1/2(f(t+) + f(t-))$ . Although none of the physically real waveforms with which we have to deal do awkward things, there are relatively simple-looking functions that behave in ways Dirichlet would not have liked, for example,

$$y = \sin \frac{1}{t} \quad (16)$$

However small the interval 0 to  $t$ , say at the origin,  $y$  oscillates infinitely, see Fig. 8, and there is no Fourier series.

#### R.F.I.

As an example, suppose you had a half-wave rectifier performing in some application. The radio across the room might produce a buzzing mains hum on the long-wave band every time you had your rectifier system on. "Ah-hal, you say, "the jerky diode current turning on and off in the rectification, produces harmonics." This is a typical Fourier situation and we can find the harmonics.

Figure 9 illustrates the usual half-wave rectifier current waveform. Dirichlet would

be happy with it; there is only one maximum and one discontinuity (the cusp at the origin) in the domain  $-\pi$  to  $\pi$ .

The piecewise function is 0 from  $-\pi$  to 0 and  $\sin \omega t$  from 0 to  $\pi$ . Therefore to find the  $a_n$ s, we write

$$a_n = \frac{i}{\pi} \int_{-\pi}^{\pi} f(t) \cos n\omega t d(\omega t) = \frac{i}{\pi} \int_{-\pi}^0 0 \cdot \cos n\omega t d(\omega t) + \frac{i}{\pi} \int_0^{\pi} \sin \omega t \cos n\omega t d(\omega t) \quad (17)$$

The first integral on the right contributes nothing, the second gives

$$a_n = \frac{i}{\pi} \left[ -\frac{1}{2} \left( \frac{\cos(1-n)\omega t}{1-n} + \frac{\cos(1+n)\omega t}{1+n} \right) \right]_0^{\pi}$$

$$= \frac{i}{2\pi} \left( \frac{\cos(\pi-n\pi)}{1-n} + \frac{\cos(\pi+n\pi)}{1+n} - \frac{2}{1-n^2} \right)$$

$$\therefore a_n = \frac{(1+\cos n\pi)}{\pi(1-n^2)} i$$

As you can see, we have no result possible for  $n = 1$ , and we must do the integral directly. This shows  $a_1 = 0$ . Now let  $n$  run. 0, not 1, but 2, 3, 4, 5, and so on, are alright, therefore  $a_0 = 2i/\pi$ ,  $a_1 = 0$ , already found,  $a_2 = 2i/3\pi$ ,  $a_3 = 0$ ,  $a_4 = -2i/15\pi$ ,  $a_5 = 0$  and so on.

If you go through the calculation for the  $b_n$ s, only one survives and that is  $b_1$ . All the rest go to 0.

$$b_1 = i/2.$$

Therefore the final expansion of the half-wave rectifier waveform into its Fourier series is at our disposal,

$$i = i \left[ \frac{1}{\pi} + \frac{\sin \omega t}{2} - \frac{2}{\pi} \left( \frac{\cos 2\omega t}{3} + \frac{\cos 4\omega t}{15} + \frac{\cos 6\omega t}{35} + \dots \right) \right] \quad (19)$$

The first term is your d.c. component. The second term shows you have a considerable amount of the fundamental a.c. wave present. Then, in the bracket, appear all the harmonics with their amplitudes, that give rise to the radio-frequency interference.

Synthesizing back, term by term, shows how the Fourier components build up the original function. Figure 10 shows that even with only three terms, we get a good approximation to the original half wave, and that not a great deal of energy actually goes into the higher harmonics—which is some relief.

### THE GIBBS PHENOMENON

On the other hand, the departure from the original waveform is worst near the discontinuities. We see overshooting at these positions. Radio engineers call such transients 'ringing', from their decaying oscillatory nature. Figure 7 shows them. If we take more terms of the Fourier series, the rate of oscillation increases and the amplitude of

the overshoot declines somewhat, but even with an infinite number of terms, the overshoot still holds up at some 9% of the jump.

We call this seeming imperfection in the Fourier synthesis of a function, the Gibbs phenomenon. In engineering practice, the energy in the smaller spikes vanishes away and we therefore lose interest in them. But mathematically the stubborn refusal of these spikes to disappear in the limit caused a flurry of interest.

### ONLY A START

Of course, I have only scratched the surface of such a large subject. Yet many more detailed textbooks are vague and even misleading, so that the beginner becomes rapidly confused. However, we have pointed up some of the more intriguing little facts about Fourier, so if you are in the middle of a struggle with learning it all, or about to start, (or even if you are an old hand, but never really got to grips with it!) then go

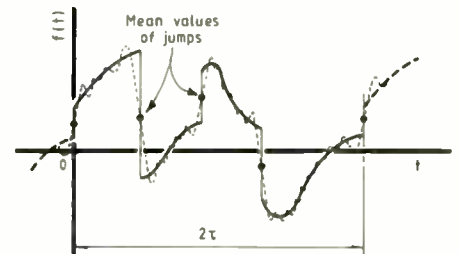


Fig. 7. Dirichlet proved that functions, even arbitrary and discontinuous like this one, possess Fourier series. The 'error' in the operation of synthesizing back by adding a finite number of terms of the series results in oscillations near the discontinuities. The oscillations persist, which is known as the Gibbs phenomenon (see text). Nevertheless, the synthesized result passes through the mean points halfway along the discontinuity jumps.

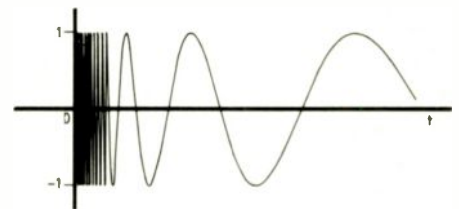


Fig. 8. This function has an infinite number of oscillations in any interval, however close to the origin. No real physical function behaves like this.

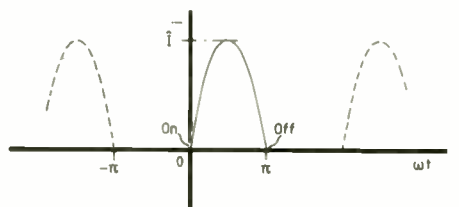


Fig. 9. The typical half sine 'caps' of a rectified a.c. source shown here illustrate the sharp corners where the diode turns on and off.



Jean Baptiste Joseph, Baron de Fourier, had a humble start, but gained honours at the military school in Auxerre. Later he joined the staff of the École Normale and then the Polytechnique in Paris.

Fourier went to Egypt with Napoleon, who made him Governor of Lower Egypt after the 1798 Expedition. Returning to France after the withdrawal, he was made Prefect at Grenoble and then Baron in 1808. He ended up secretary of the Académie des Sciences in 1816 and the following year the Royal Society elected him Fellow.

In 1822, appeared his monumental *Théorie Analytique de la Chaleur* in which he expanded the theory of trigonometrical series expansion of periodic functions. He died in 1830.

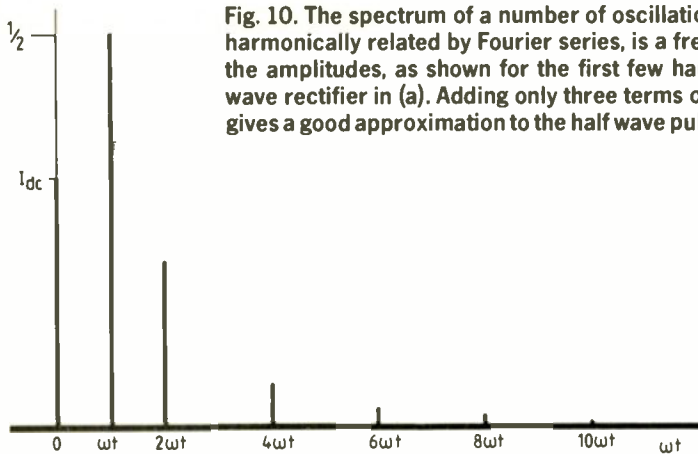
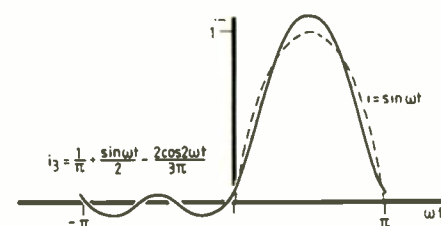
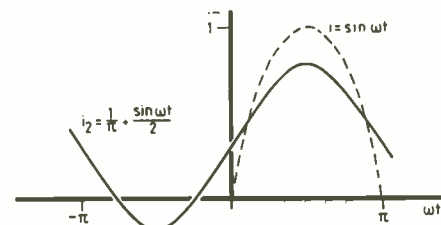
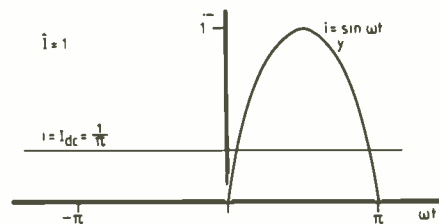


Fig. 10. The spectrum of a number of oscillations, including those harmonically related by Fourier series, is a frequency axis plot of the amplitudes, as shown for the first few harmonics of the half wave rectifier in (a). Adding only three terms of the series already gives a good approximation to the half wave pulses, as in (b).



ahead with perhaps a little more confidence.

I will leave you with a little thought. Suppose you had a periodic function like the half-wave rectifier output, but instead of starting the period at  $-\pi$  through  $0$  to  $+\pi$  you found the negative start at say,  $-2\pi$  or  $-3\pi$ , but the half sine or whatever still started at  $0$  and finished at  $\pi$ ? Or further, suppose you saw the half wave at  $0$  to  $\pi$ , but however far you looked along the axis – both ways – you never found another one. In other words, you only had pulse, at  $0$  to  $\pi$ . Would this have a Fourier series? (The first good explanation might enable me to talk

the Editor into producing a book token. But you must be just starting as a student – no cheating from Ph.D mathematicians please!)

#### References

1. Joules Watt, "j" *Electronics and Wireless World*, September, 1987.
2. J. B. Fourier, *Analytical Theory of Heat*, English Translation, Freeman. See Sir Harold and Lady Jeffreys, *Methods of Mathematical Physics*, page 436 for a critical comment on Fourier.
3. G. Stephenson, "Mathematical Methods For Science Students" Chapters 4 and 15. (Longmans).

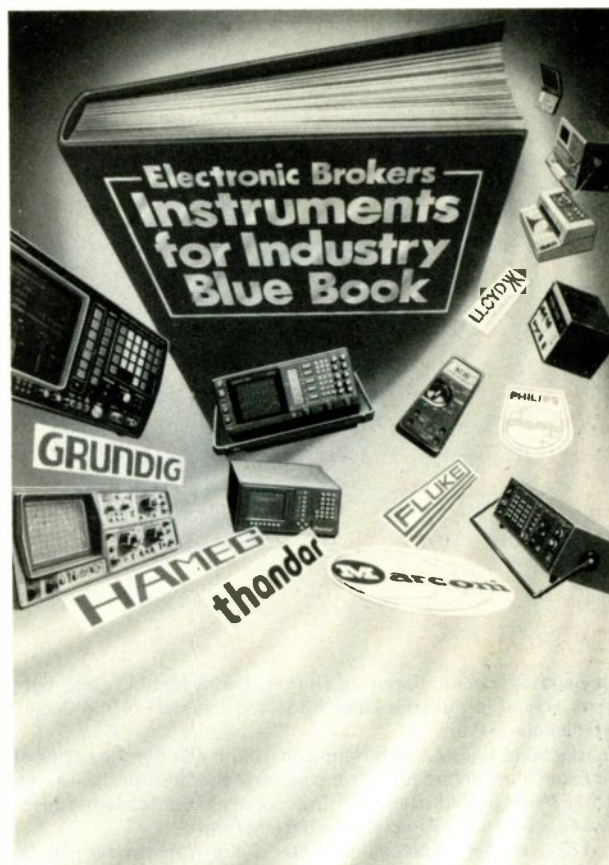
## INSTRUMENTS BLUE BOOK

The search for the appropriate instrument to specify for a particular application can be a frustrating business. Gathering together data sheets on anything up to a dozen possible instruments eats into an engineer's time and store of patience.

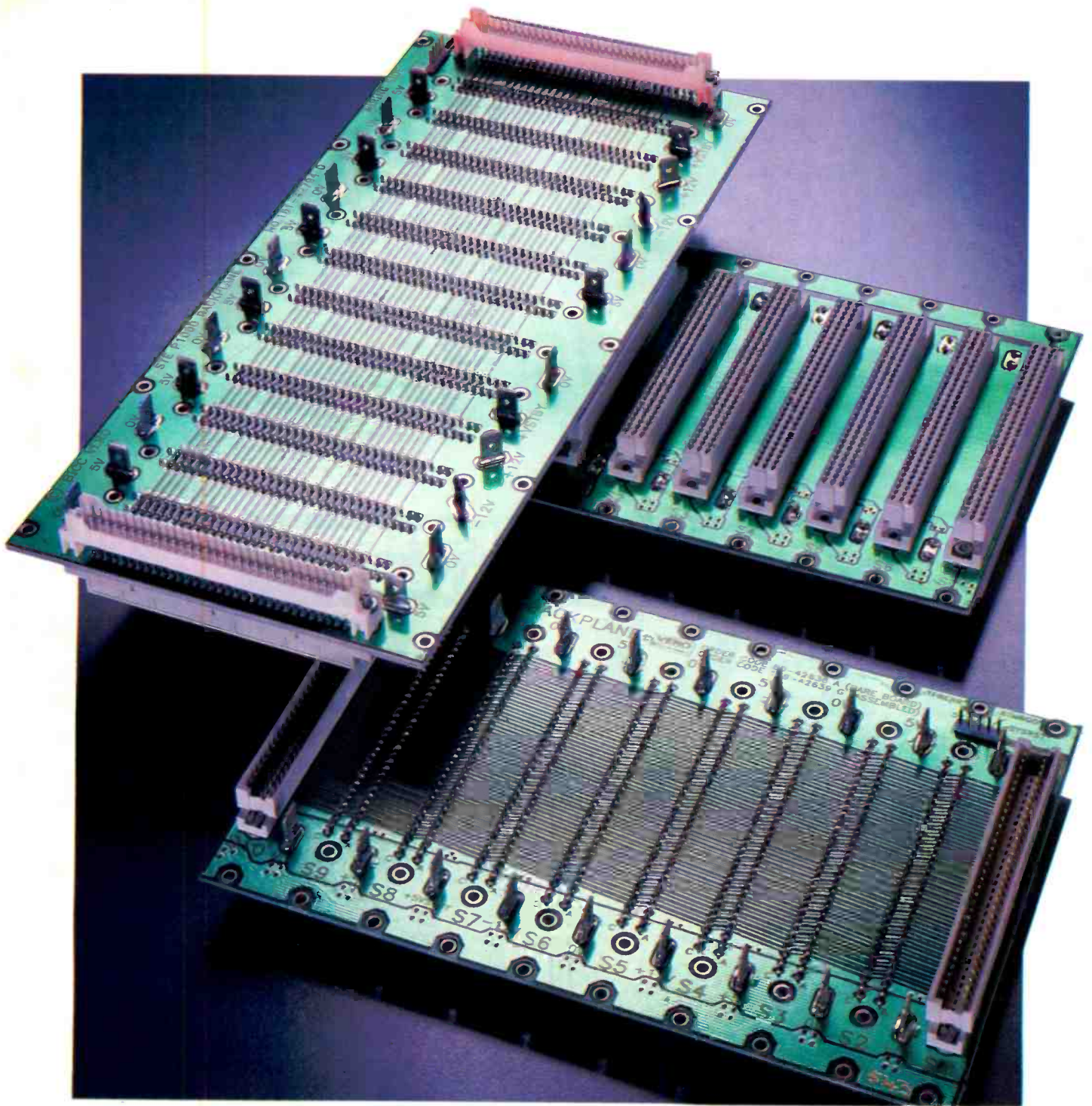
In an effort to ease the problem, and also to emphasize the direction in which the company is committed to progress, Electronic Brokers has published its Blue Book – a most unusually comprehensive catalogue of test and measurement equipment.

It is easy to use, consisting of separate sections for each of sixteen types of instrument, each section containing a general introduction to the equipment, a list of types offered and a catalogue page for each type, which includes the price. Full technical information is provided on the instruments from twenty-one manufacturers, including makers of computers and peripherals, and each section contains a comparative guide to characteristics.

The Blue Book is obtainable free from Electronic Brokers, 140-146 Camden Street, London NW1 9PB, in response to requests on company headed paper.







## COMPREHENSIVE STE bus HARDWARE SUPPORT

As you'd expect from a company with BICC-VERO's reputation we're supporting fully the increasingly recognized STEbus architecture.

We offer you STEbus backplanes, terminators, extenders, and prototyping boards with interface, all complying fully with IEEE Standard P1000, Draft 3.2. And – better still – our comprehensive range of STEbus support products includes all the additional hardware, fully compatible with STEbus, you need to build your STEbus system. The range includes:-

**Power supplies:** Single or multi-output plug-in modules, or open frame switchers, up to 500W.

**Prototyping boards:** A wide range of general purpose boards, plus PTH microboard and Speedwire

with STEbus interface.

**Cardframes:** Choose from the well-known industry standards, KM6 or KM7.

**Racks and enclosures:** Of all types, to suit your STE application.

**Connectors:** An extensive selection of two-part IEC 603-2 (DIN 41612) connectors, including pressfit.

Contact us now for more information on our STEbus hardware support products.

For immediate action, phone: 0703 260211 (South) or 0744 24000 (North). Or write to:



BICC-VERO Electronics Limited, Flanders Road, Hedge End, SOUTHAMPTON, SO3 3LG. Tel: 0703 266300 Fax: 0703 264159. Telex: 477984.

LEADERS IN STE bus TECHNOLOGY

A MEMBER OF THE STE MANUFACTURERS AND USERS GROUP

ENTER 19 ON REPLY CARD

**Our HM205-2 must be an award winner...**

# Masterclass OSCILLOSCOPES

*For those who compare*

With the phenomenal success of the HM205, with its Component Tester feature, pioneered by Hameg, we now take pleasure in introducing the HM205-2. This improved version contains all the previous features, but has increased capabilities in the following areas:

**Increased sampling rate of 5MHz** giving a digital timebase range of 20µs/cm to 5s/cm, with automatic refresh every sweep.

**Dot joining facility** as a front panel push button, combines the waveform samples to form a solid continuous trace.

**Memory of 1024 x 8 bits per channel** provides high resolution capture of complex signals, for as long as required.

**20 MHz analogue bandwidth** for full general purpose applications, providing any signal shape, large or small.

**A digital timebase of 5s-2µs per division** makes it possible to see a solid picture of a signal from kilohertz right down to .05 Hertz.

**Maximum sensitivity of 2mV per division** means even the smallest signals can now be seen, triggered and stored for careful examination.

**because at £527 it deserves the prize of the year!**

# HAMEG

74-78 Collingdon Street, Luton, Bedfordshire, LU1 1RX Telephone (0582) 413174 Telex 825484

ENTER 40 ON REPLY CARD

## Quarhand DEC Bought and Sold

### PLUG-INS

TEK7A22 Diff. Amplifier £600  
TEK7A26 Dual Trace Amp 200MHz £800  
TEK7B53A Dual Time Base £950  
TEK7B80 Delayed Timebase 400MHz £850  
TEK7B85 Delaying Timebase 400MHz £950

### DVM's

Datron 1051 5 1/2 Digit Autorange £650  
Solartron 1765 £350  
Solartron 7050 £450

### VARIOUS TEST EQUIPMENT

HP3400A RMS Voltmeter £425  
HP5326A Counter Timer £175  
Fluke 895A Differential Voltmeter £200  
Marconi TF2162 Attenuator 0-111dB £100  
Marconi TF2430 Freq Counter 80MHz £200  
Rocal Dana 9500 Counter Timer £250  
HP59401A IEEE Analyser £550  
HP5004A Signature Analyser £395  
HP105B Quartz Oscillator £150  
HP612A UHF Sig Generator £375  
HP1602A Logic Analyser £375  
Texscan V560B Sweep Generator £450  
Texscan DU120 Display £375  
Solartron 3430 Portable Data Logger £850  
Radford DM52 £275  
Marconi CT452A Sig Gen £250

### COMPUTER EQUIPMENT

Tektronix 4051 £400

### UNIBUS

11/34A, DL-11W, KK11-A, FP-11 £750  
DZ-11A Mux £375  
RL-11 RLO Controller £475  
DR-11C Gen Purpose I/F £75  
DN-11 Telex I/F £450  
LP-11 Printer I/F £200  
RX01 Floppy drives £300  
RK-11 + 2 RK051 Drives vgc £250  
RX-211 RX02 Controller £210

### Q-BUS

BA-11NF Box, psu (new), H9273 B/pace £175  
PDP 11/03, Dual 8", 64KB £450  
DLV-11J 4-port serial £230  
11/34A £575  
11/03 DLVII-J, RX01 £600

**ENVIRONMENTAL CHAMBER** for component testing, etc. -55° to 200°C £500

### MISCELLANEOUS

CDC Lark + PIO Module NEW £400  
Mitsubishi 1/2Ht 96ipi DSDD Floppy £70

### MODEM

Case 480-24 Modems £270  
Case 480-48 Mo dems £350  
Case DCX 815-4 Star Mux £375

### WINCHESTER DRIVES

10MB Full Height ST506 (New) £150  
CORVUS 10MB/M for Apple £100  
45MB Full Height Voice Coil Atasi 4036 } £300  
7 Heads 40 mSec Average Access  
Seagate ST225 20MB 1/2 height £160

### DAISY PRINTERS

Diablo 630RO Serial (New) £650  
Diablo 630RO Sheet Feeder £175  
Olympia ESW3000 Parallel £450  
TEC Stowriter F10/40 (New) 12Bit 1/4 } £550  
Olivetti PR430 Serial £375  
Diablo 1345A 12 Bit I/F, + Tractor £175  
NEC Spinwriter 3510, as new, RS-232 £375

### MATRIX PRINTERS

Texas Silent 700 Serial 80 Col £95  
Dec LA36 with Datsouth Board £100  
AJ650 Ink Jet £50

### PLOTTERS

HP9872S with Feed & Cutter £720  
Calcomp 1012 Serial 4 Pen £120

### ODU's

Televideo 925 £160  
Televideo 950 £220  
Pericom 6803 £125  
HP2624 with Thermal Printer £275  
HP2621 £150  
HP2647A Graphics Terminal £350

### PSU's

Gould MG12-10 Switch Mode £25  
Gould MG24-5 Switch Mode £25  
Gould Triple Output 15V11A, 5V40A-12V4A £100

## EPROM PROGRAMMER



### AT LAST ! Over 50 Generic Device Types

1 - 2508 / 10ms	15 - 2764	29 - 8749	43 - 8744
2 - 2508 / 50ms	16 - 2764A	30 - 8750	44 - 8051 *
3 - 2516 / 10ms	17 - 27128	31 - 8748H	45 - 8052 *
4 - 2516 / 50ms	18 - 27128A	32 - 8749H	46 - 8044 *
5 - 2532 / 10ms	19 - 27256	33 - 8750H	47 - 87C51
6 - 2532 / 50ms	20 - 27256 / 21V	34 - 8741	48 - 63701V
7 - 2564 / 10ms	21 - 27512	35 - 8742	49 - 63701X
8 - 2564 / 50ms	22 - 27513	36 - 8041 *	50 - 63705V
9 - 2758	23 - 87C64	37 - 8042 *	51 - 63705Z
10 - 2716	24 - 87C256	38 - 8048 *	
11 - 2732	25 - 8755	39 - 8049 *	
12 - 2732A / 10ms	26 - 8755A	40 - 8050 *	
13 - 2732A / 50ms	27 - 8355 *	41 - 8751	
14 - 2764 / 50ms	28 - 8748	42 - 8752 / 21V	* READ ONLY

... at a price to suit any budget !

### THE MQP ELECTRONICS MODEL 18 PROM PROGRAMMER

- \* Automatic Data Rate setting 300 - 19200 Baud
- \* Two independent Communications Protocols built in
- \* Terminal Mode Protocol
  - Use any host computer with RS232 port and Terminal Emulator
- \* Host Computer Protocol
  - Use our PROMDRIVER Advanced Features User Interface Package available for all MS-DOS, PC-DOS, and CPM-80 computers.
- \* No personality modules to install, no switches to set.
- \* Fast interactive algorithms automatically selected as appropriate
- \* Upgradable for future types.
- \* Designed, Manufactured, and Supported in the UK. \* EX STOCK 1
- \* Comprehensive 60 page User Manual.
- \* n.b. Devices other than 24/28 pin require low cost socket adapter.

£189-95  
+ VAT

Write or telephone for further details:

**MQP**

ELECTRONICS, 22, RINGSBURY CLOSE, PURTON, SWINDON SN5 9DE.

TELEPHONE 0793 770555

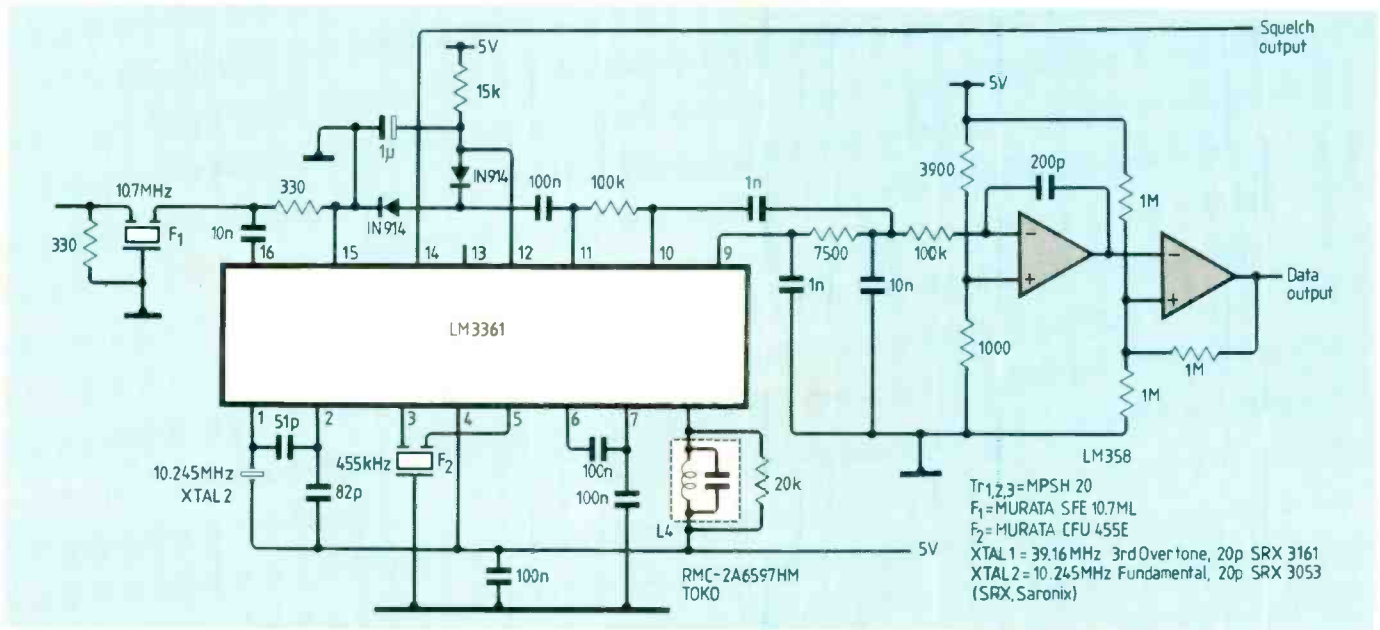
ENTER 58 ON REPLY CARD

ALL PRICES PLUS VAT AND CARRIAGE  
**Ring Colin, 01-885 5522**

Unit 4, Hotspur Estate, West Road, Tottenham, London N17 0XJ.

ENTER 54 ON REPLY CARD

# CIRCUIT IDEAS



## FSK data receiver

Digital communications and telemetry are popular uses of the American 49.82 to 49.9MHz band\* for low-power devices operating up to about 30m. A simple yet effective f.s.k. receiver for this band can be made from an LM3361 narrow-band f.m. i.f. amplifier/detector.

Incoming carrier centred at 49.86MHz is converted to two intermediate frequencies of 10.7MHz and 455kHz. Both i.f.s include readily available ceramic filters to increase selectivity while reducing coil count. Baseband data is recovered using quadrature detection and an integrator/Schmitt-trigger filter demodulates output. The squelch circuit also functions as a status indicator; when signal is present, its open-collector output switches high.

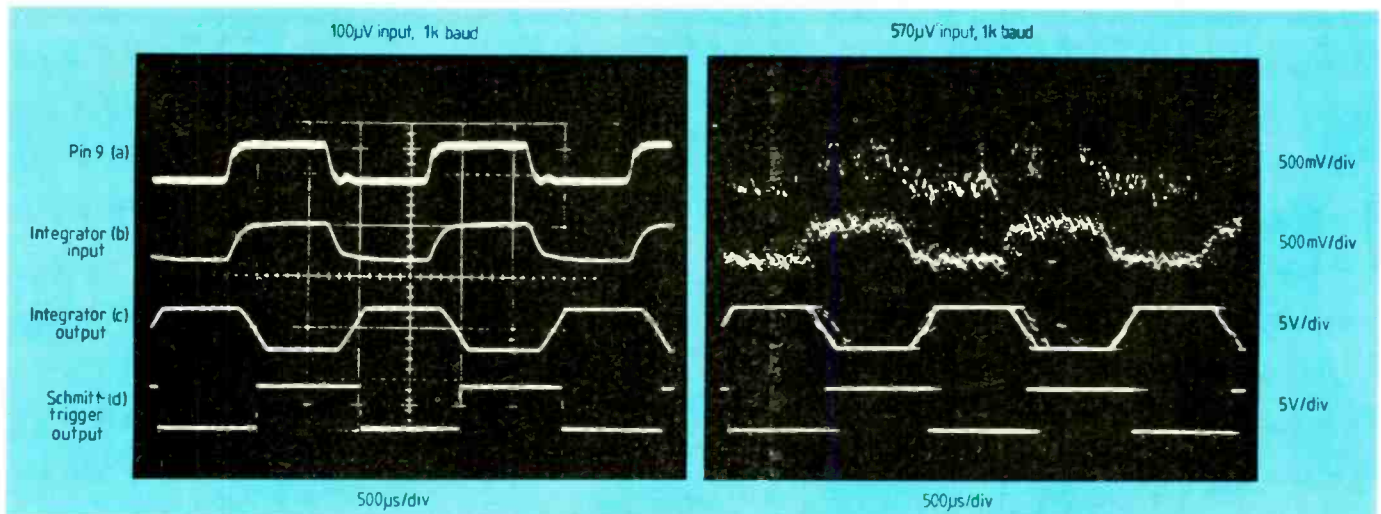
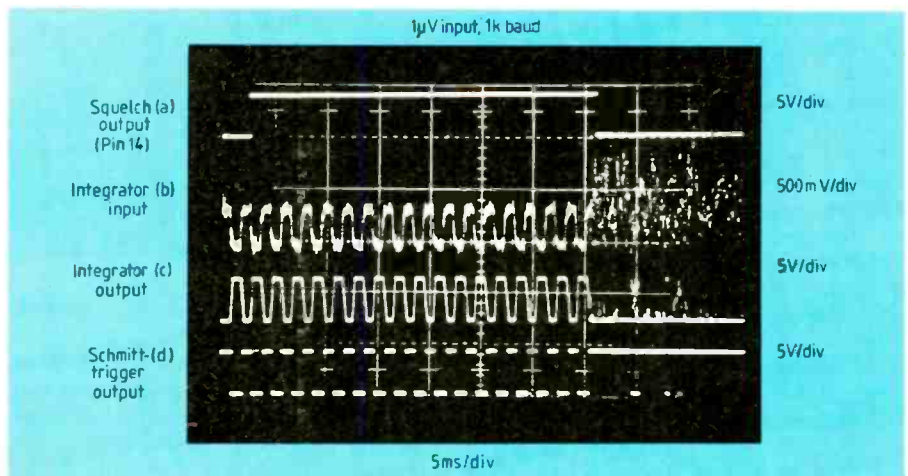
Consumption of the 3361 is 4mA at 5V – the entire circuit consumes about 10mA. With components shown, typical detector conversion gain is 150mV for each kilohertz of carrier shift. Frequency shift of 3.3kHz results in 500mV pk-pk detected output at

pin 9. Increasing the Q-setting resistor at pin eight gives higher gain.

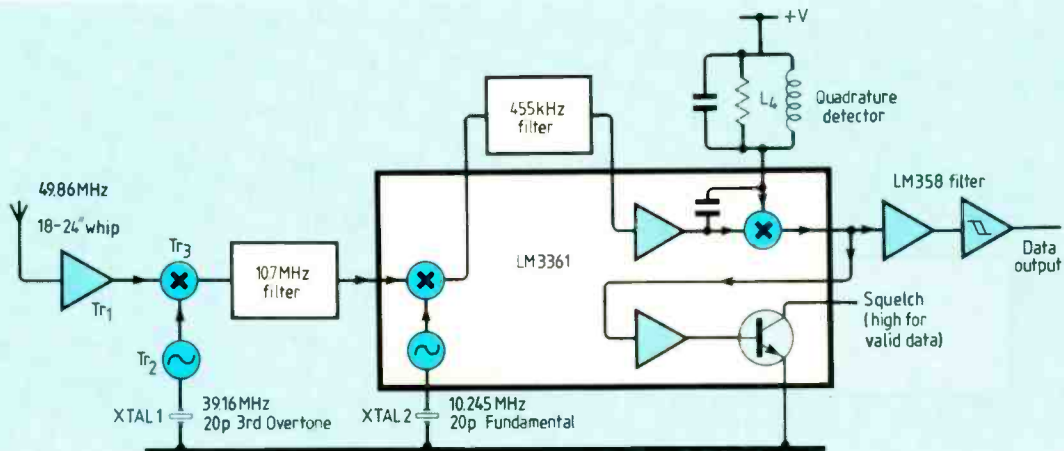
Many transmitters have a 16.62MHz master oscillator tripled to 49.86MHz. Modulation is carried out by pulling the 16.62MHz fundamental crystal; pulling of more than 1kHz is possible, which gives 3kHz when

tripled. By comparison, a 49.86MHz third-overtone crystal could only be pulled by a few hundred hertz because crystal Q increases as the square of the harmonic order.

Significant baseband filtering is illustrated in the first (lower) oscillogram. Twice-i.f. product of the quadrature detec-



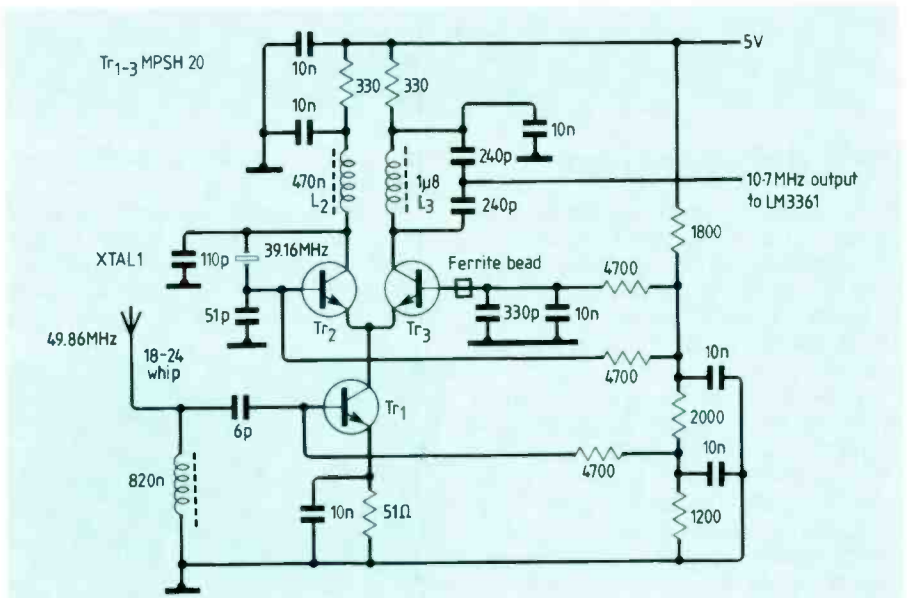
# CIRCUIT IDEAS



tor, evident in the top trace, is removed by RC filtering at pin nine. Weak-signal performance is shown in the second oscillogram. Input of slightly less than 570nV results in about 10% jitter at 1kbaud. At 500nV, the occasional bit is lost and at 300nV the squelch line goes low, although data is still visible at the output. On and off times of the squelch switch are 3 and 1ms respectively. Despite the squelch on time, data at pin nine appears almost immediately, as shown in the top oscillogram. Correction of the d.c. output shift occurs within 1 or 2ms.

Bandwidth limitations of the 455kHz filter, integrator, transmitted signal and  $L_4$  limit the data rate to 1.2kbaud. Long strings of ones and zeros are not a problem since the circuit is d.c. coupled. When testing the circuit note that r.f. generators with f.m. input, like the Boonton 103/1020, cannot produce f.s.k. because their f.m. input is a.c. coupled.

A relatively short whip antenna of 460 to 610mm, is matched to r.f. amplifier  $Tr_1$  by an 'L' network of 4-6pF and 50-100 $\Omega$  in series. It is a common misconception that a short 49MHz whip exhibits just a few ohms. While this may be true, impedance measured from the base of the whip to ground is 50 to 200 $\Omega$  in series with a capacitive reactance of about 4-6pF. High driving-



point resistance is a result of a lossy ground, not the whip.

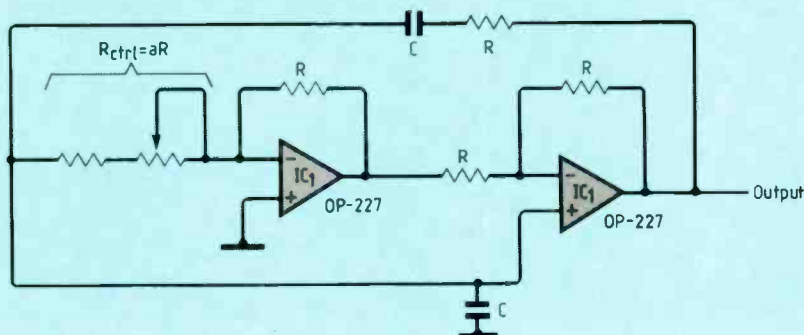
To tune the circuit, connect a carrier of <math>2\mu V</math> modulated by alternating ones and zeros and adjust the quadrature coil while observing integrator output. Tune  $L_4$  for symmetrical trapezoidal waveform at the

integrator output. With crystal tolerances of 0.005%, no other adjustments are necessary. Receiver sensitivity can be peaked by adjusting  $L_1$ .

Mitchell Lee  
National Semiconductor  
Santa Clara

\* FCC rules for low-power communication devices operating in the 49.82 to 49.90MHz band, part 15.117.

## Frequency control in Wien-bridge oscillators



Adding an op-amp inverter to the conventional Wien bridge oscillator provides frequency control.

For a normal Wien bridge oscillator, the condition for oscillation is  $R_1 C_1 R_2 C_2 = 1$ . By adding an inverter it is possible to change current through one of the bridge resistors. If inverter gain is  $1/a$  then the left part of the expression, the condition for oscillation, is multiplied by factor  $a$ .

In this oscillator,  $R_1 = R_2 = R$ ,  $C_1 = C_2 = C$  and the condition for oscillation is

$$aR^2 C^2 \omega^2 = 1 \Rightarrow \omega = \frac{1}{RC\sqrt{a}}$$

Frantisek Michele  
Brno, Czechoslovakia

# RESEARCH NOTES

## Optical fibres: bandwidth breakthrough

Researchers at West Germany's Standard Elektrik Lorenz AG have constructed an optic-fibre system that will transmit data at a rate of 5Gbit/s for 90km without any intermediate amplification. Until now, such distances could only be achieved at much lower data rates because of dispersion within the fibre. The problem is the difficulty of constructing a fibre in which the wavelength of minimum dispersion coincides with the wavelengths for minimum attenuation. It is therefore usually something of a trade-off between distance and bandwidth.

What the West Germans have done is to adopt a special doping profile to increase the wavelength of minimum dispersion to a point at which it is almost coincides with the wavelength of minimum attenuation. These figures are now respectively 1525nm and 1550nm.

The result of this research is a system with a single optimum wavelength and a distance/bandwidth product about an order of magnitude better than anything in commercial operation.

## Atomic bonding for reliability

Mitsubishi's quarterly publication *Advance* Vol. 38, 1987, contains details of a new technique for welding together dissimilar materials without the need for heat or high pressures. This development is significant in view of the number of solid-state device failures that can be attributed to defective bonds.

Conventional welding, whether arc, resistance or beam, depends on extremely high temperatures to induce localized melting. This in turn can create thermal stresses or even destroy semiconductor materials. High processing temperatures can also cause chemical effects and molecular migration, leading to chip diseases such as the once-dreaded 'purple plague'.

Diffusion welding is a more recent technique in which heat is partially traded for pressure. Nevertheless it still requires many materials to be heated to temperatures at which thermal degradation occurs.

Mitsubishi's atomic joining process gets round the problem by reference to the fundamental physics of bonding. If one imagines a typical solid material such as a metal, each atom is closely and tightly joined to the next by means of chemical bonds made up of clouds of electrons. In any solid these bonds are by definition strong, otherwise the material would liquify or vaporize. In theory, therefore, all that is necessary to create a strong bond between two lumps of solid material is to create two adjoining surfaces that closely replicate the inter-atomic structure.

The problems in practice are firstly the need to polish the surface to a mirror-like finish and then the need to avoid any chemical contamination. Even the oxygen in the atmosphere can bind with the free chemical bonds at the surfaces and deactivate them. If it were not so, any fracture could be repaired merely by pressing the broken pieces together.

To achieve atomic bonding, Mitsubishi first polish the surfaces under atmospheric conditions. Then in an ultra-high vacuum, better than  $10^{-9}$ Pa, the surfaces are bombarded with argon ions that perform a sort of atomic-scale sandblasting function. These ions are themselves too big to embed themselves in the atomic lattice, but carry away any contaminants from the free chemical bonds. If two surfaces that have been treated in this way are pressed together, they then unite instantly with a bond strength as great as that of the bulk material.

The secret of the whole process is partly the initial polishing process, which can remove surface atoms down to an accuracy of about  $10^{-9}$ m. Then, if the bond is to be as strong as the parent material, the vacuum must be of an extremely high quality. Mitsubishi use a combination of sputter-ion and titanium-evaporation pumps which act as sacrificial surfaces to absorb gases left behind by conventional pumps.

Although the process may

seem more suited to the laboratory than to chip production it does open up possibilities denied to conventional welding. Amorphous materials such as ceramics can easily be atomically joined to metals. Heat-sensitive semiconductors can also be joined reliably to each other and to various substrates. Moreover, as Mitsubishi point out, the whole process would be very much simpler and more economic if it were carried out on board a space station where the necessary vacuum comes free.

## Plastics hold the record

ERA Technology has developed a novel technique to ascertain the thermal history of samples of most common plastics. Given a few milligrams of polyethylene, polypropylene, nylon, p.t.f.e. for example, they can reveal the maximum temperature to which it has been subjected during service.

The technique depends on the fact that all these plastics consist of long-chain polymer molecules that take up different configurations when held for a certain time at a particular temperature. When cooled down, the plastic holds a memory of the maximum temperature reached.

ERA has now solved the problem of how to decode the information locked away in the molecular structure using a differential scanning calorimeter. This is simply a device which plots temperature rise against heat input. When a sample of plastic reaches again the maximum temperature it attained in service it exhibits a phenomenon analogous to latent heat of fusion; there is a non-linear relationship between heat input and temperature rise.

This technique of retrospective temperature measurement is likely to have numerous applications in practice. It is possible, for example, to dispense with sensors during a product's testing and development; it is merely necessary to cut up a moulding or a bearing or an insulator afterwards and test samples taken from different areas. In the case of a component that has failed, the technique can estab-

lish the maximum temperature of the material at the very point of fracture.

Although ERA's thermal analysis procedure requires a sample to be taken from a component, this can be obviated in some cases by building a sacrificial element into the original component design. This element could be made of a plastic specially chosen for its maximum sensitivity over the temperature range of interest.

The test has already been applied to ascertain the maximum temperature reached by high-voltage power cables. It also has possible interesting applications in forensic science or industrial espionage. In the case of a fire, it should be possible to determine from a sample of cable whether it was the cause or the result of the fire. In the first case a sample of the plastic insulation will show a temperature gradient from the inside out; in the latter case it will be the other way round.

As for discovering other people's secrets, it should be possible to find out the temperature at which a sample of a special plastic has been treated during manufacture. This can often be the clue to its particular properties.

ERA are, needless to say, not too keen on this last possibility, but they are interested in hearing from anyone with a legitimate application for this technique.

## New superconductivity puzzle

An unexpected and unexplained property of the new ceramic superconductors is reported by a group of physicists from the University of Wellington, New Zealand and from the Department of Scientific and Industrial Research in the same country, but with the assistance of AB Kaiser from the West German Max-Planck Institute of solid state physics at Stuttgart (*Nature* Vol. 328 No 6127). What A. Mawdsley and his colleagues have done is to measure the thermoelectric power of several samples of superconducting ceramic oxides of the yttrium-barium-copper-oxide type. Thermoelectric power is a measure of

# RESEARCH NOTES

the voltage generated when there are differences of temperature between one part of an electrical conductor and another, except that the thermoelectric power of superconductors is expected to be zero (as confirmed by the New Zealand experiments).

The surprise that now emerges from the measurement of several samples of yttrium-barium-copper-oxide, all of which became superconducting between 91 and 93 degrees above absolute zero, is that the thermoelectric power seems to increase dramatically as samples are cooled to the temperature of the transition to superconductivity, before plunging to zero at the onset of the superconducting stage.

The thermoelectric power of a material arises from differences in the way electrons are distributed between the various energy states accessible to them at different temperatures. The New Zealand authors say that measurements like theirs, apparently the first of their kind to have been carried out with the new superconducting materials, should throw light on several still puzzling features of electrical conduction in the ceramic superconductors. But they confess that they had expected the thermoelectric power of their materials to decline steadily towards zero as their materials were cooled to the superconducting point.

## Superconductivity: the temperature keeps rising

One of the best attested hints of superconductivity near room temperature (at minus 43 degrees Celsius) is reported (*Nature*, Vol. 328 No 6129) by Professor C. W. Chu from the University of Houston and a group of his colleagues there and the Lockheed Palo Alto Laboratory and the National Magnet Laboratory at MIT. In an accompanying editorial note, Dr David Caplin from Imperial College, London, says that the report from Chu

and his colleagues may be best explained if the high conductivity of the specimens resides only in the boundaries between grains.

The material used in the experiments at Houston contains the rare earth element europium, and is chemically similar to the more familiar ceramic superconductors of the yttrium-barium-copper-oxide type, but with the replacement of yttrium by europium, Chu and his colleagues describe how the electrical resistance of one of the samples decreased at least 10,000-fold as it was cooled over an interval of 10°C beginning at minus 35°C. The current used in these measurements was kept small to "avoid damaging the sample". Even so, these hints of some kind of superconductivity disappeared after the sample was heated and cooled a number of times.

Caplin says in his comment on Chu's research that reports of "possible, if transient, superconductivity" at these higher temperatures "should not be pushed aside", but that the successful search for room-temperature superconductors may require that people should replicate on a "macroscopic scale the molecular structure of grain boundaries".

## Groundplanes and interference

ERA Technology Ltd has undertaken a detailed study of the effect of p.c.b. ground-planes on the susceptibility of microprocessor circuitry to electromagnetic fields. The purpose of this research was to try and discover what could be achieved without the cost penalty associated with filters, screened cables and metal enclosures. As ERA point out in their report (87-0096R), microprocessor-based control systems are increasingly finding their way into industrial and domestic environments where hostile fields exist and where cost constraints are severe.

The work on which this latest paper is based is an extension of an earlier study at the Research Laboratories of the British Gas

Corporation in which different p.c.b. designs were compared for their susceptibility to transient over-voltages on the supply leads. ERA Technology have now looked at how different boards compare in the presence of high r.f. fields.

Two circuit boards were constructed, each carrying an 8040 microprocessor, a crystal oscillator, a circuit to monitor oscillation and a fibre-optic output device. Component layouts were nominally identical, except that one board had a copper ground-plane on the upper side to provide all the zero-voltage returns. Power in each case came from the a.c. mains via a filter.

Each board was subjected on its own to a range of frequencies from 10MHz to 500MHz with and without a square-wave modulation at 2.5kHz. Tests were then repeated with a 2m length of twin cable connected to the output of the circuit and resistively terminated to simulate a practical working load.

As might have been predicted, the presence of an output lead reduced the level of external r.f. field at which problems began to occur and also created a few 'problem' frequencies due to resonances. Taking the results as a whole, however, it was immediately apparent that, with or without external connections, the circuit employing a ground-plane was consistently 6dB more immune to electromagnetic fields than the conventional single-sided circuit board. ERA Technology add that with ground-plane construction it is much easier to retro-fit additional suppression components if they should prove necessary.

## Success for deep-frozen squid

A team from the department of physics at Birmingham University has developed what is probably the first practical application for the recently discovered yttrium-barium-copper-oxide high-temperature superconductors. It is a sensitive magnetometer called an r.f. SQUID (Su-

perconducting Quantum Interference Device).

Conventional r.f. SQUIDS consist of a metal ring made superconducting at liquid helium temperatures. This ring which has a gap analogous to the gap in a tape head, is coupled to a tuned LC circuit and fed from a constant current r.f. source of around 20MHz. At particular r.f. current levels the voltage across the LC circuit becomes critically dependent on changes in the magnetic flux entering the SQUID's gap. This is due to changes in the hysteretic losses in the ring.

As a sensitive detector of magnetic fields there is nothing to beat a SQUID; it can pick up the fields due to the tiny electric currents that flow in the human brain. It also offers immense possibilities for navigation, especially in the tiny magnetic fields of space and for military applications such as submarine detection. The only snag is the need to cool the metal of the SQUID ring to within a few degrees of absolute zero. At least that was the case until the Birmingham group made a ceramic SQUID.

In their recent paper (*Nature* Vol.328, No. 6125) they describe a SQUID ring made of a material with the composition  $Y_{1.2}Ba_{0.8}CuO_4$  that works, albeit with reduced efficiency at temperatures up to 45° K. At the lower temperature of 4.2°K, the ceramic SQUID exhibits a novel and unexpected property. Unlike the metal version it requires no gap to intercept the external field.

The implications of this finding is that, unlike a bulk metallic superconductor which is impervious to magnetic fields, the ceramic material can be penetrated to a significant extent, even at high frequencies.

As yet the Birmingham team has no fully developed theory to explain the behaviour of the novel ceramic r.f. SQUID. They think, however, that in some way the ceramic has built-in magnetic 'weak links' that disappear as the temperature is raised. At the moment they are testing out other SQUID geometries in order both to optimize performance and also to elucidate precisely what is happening at the molecular level.

*Research notes is compiled by John Wilson.*

# TELESCOPIC MASTS



- Pneumatic
- Hydraulic Ram Operated
- Winch Operated



## Hilomast Ltd.

THE STREET - HEYBRIDGE - MALDON  
ESSEX - CM9 7NB - ENGLAND  
Tel: (0621) 56480 Telex: 995855

ENTER 13 ON REPLY CARD

## TWIN TWIN PPM



Comprising two PPM9 boards, featuring inherent stability with law under microprocessor control, the unit gives simultaneous monitoring of A/B on red/green and M/S on white/yellow pointers. Together these provide complete information about stereo signals, in contrast to the ambiguous readings of phase meters. Manufactured under licence from the BBC.

ALSO: PPM7, highest specification single channel driver on the market; PPM3, unbalanced; PPM5, 20-pin DIL hybrid; PPM8, IEC/DIN -50/+6 dial; Illuminated Twin Boxes and movements.

**SURREY ELECTRONICS LTD**  
The Forge, Lucks Green, Cranleigh, Surrey GU6 7BG.  
Tel: 0483 275997

## QUALITY QUARTZ CRYSTALS QUICKLY

Our frequency ranges are:



We also supply quartz crystal filters, oscillators of all types and communication antennae.



**Webster Electronics**

ILMINSTER, SOMERSET TA19 9QA, ENGLAND  
TEL: (0460) 57166 TELEX: 46571 FRONCY G  
FAX (0460) 57865

ENTER 46 ON REPLY CARD

# TEST METERS

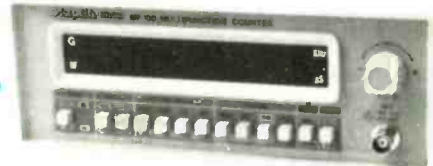
*Realistically priced  
for your workbench*



ONLY  
**£86.91**  
YMG8Y

**SWEEP FUNCTION GENERATOR** Range 0.2Hz to 2MHz. Sine, square, triangle, rectangular, pulse, ramp, sawtooth, and slewed sine wave can be generated. Variable duty cycle, push button range and 1 function selection switches.

ONLY  
**£104.30**  
YJ62D



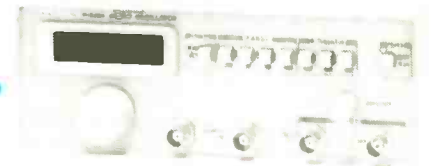
**100MHz MULTI-FUNCTION COUNTER TIMER** 10Hz to 100MHz with 8-digit LED display, frequency counter, period counter with a range down to 400ns, and a totalise (event counter) mode. 10MHz crystal oven time base.



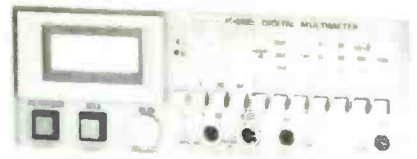
ONLY  
**£130.39**  
YMG5V

**1GHz MULTI-FUNCTION COUNTER TIMER** 10Hz to 1GHz with 8-digit LED display, freq. counter, period counter with a range down to 400ns, and a totalise (event counter) mode. 10MHz and 3.90625MHz crystal oven time base.

ONLY  
**£164.30**  
YMG5W



**AUDIO OSCILLATOR 20Hz to 200kHz** Low distortion sine & square wave outputs. Synchronisation input. Output frequency displayed on 4-digit LED display. Output 2.5V r.m.s. into 600Ω with continuous and fixed-step output attenuator.



ONLY  
**£139.08**  
YMG7X

**4 1/2-DIGIT DIGITAL MULTIMETER** Reads DC volts from 10μV to 1000V, AC volts 10μV to 750V. DC and AC current 10nA to 10A and resistance 10mΩ to 20MΩ. Basic DC accuracy ±0.05% (+2 digit). Continuity and diode test ranges. Similar specification (100nF. min. current) hand-held type also available YJ81C ONLY £66.82.

**MPS** MAPLIN PROFESSIONAL SUPPLIES  
P.O. Box 777, Rayleigh, Essex. SS6 8LU.  
Telephone 0702 552961. Telex 995695. Fax 0702 553935.

**Maplin PRECISION GOLD** In meters... we're miles ahead.

All prices are net trade exclusive of VAT. Lower prices are available for quantities of 5 or more per item. All meters 240V mains operated in attractive grey boxes with tilt stand except YJ81C.

ENTER 9 ON REPLY CARD

# PINEAPPLE SOFTWARE

Programs for the BBC model 'B', B+, Master and Master Compact with disc drive

## DIAGRAM II

Diagram II is a completely new version of Pineapple's popular 'Diagram' drawing software. The new version has a whole host of additional features which make it into the most powerful and yet quick to use drawing program available for the BBC micro. The new features mean that 'Diagram II' can now be used for all types of drawings, not just circuit diagrams. Scale drawings are possible and the facilities for producing circles and rubber banded lines together with the pixel drawing routines make any type of drawing possible. This advert has been produced completely using Diagram II.

### Summary of Diagram II features:

1. Works on all model BBC computers and makes use of Shadow memory if poss.
2. Rapid line drawing routines with automatic joins for circuit diagrams.
3. Rubber band line and circle drawing modes.
4. Makes use of the Acorn GXR rom to produce ellipses, arcs, sectors, chords and flood filling.
5. Pixel drawing mode allows very fine detail to be added.
6. Defined areas of screen may be moved, copied, deleted or saved to disc.
7. On-screen cursor position indication allows scale drawings to be made.
8. Keyboard keys may be defined to print User defined Characters allowing new character sets to be used.
9. Wordprocessor files may be loaded and formatted into defined areas.
10. Up to 880 UDC's if shadow memory available, 381 without shadow.
11. Compatible with Marconi Trackerball and most makes of 'mouse'.
12. All 'Diagram Utilities' are included.
13. Completely scaleable print routines allow any area of the diagram to be printed either horizontally or through 90deg, in scales that may be varied in 1% steps allowing up to 18 mode 0 screens to be printed on an A4 sheet (still with readable text).
14. Smooth scrolling over the whole area of the diagram.

Diagram II consists of a set of disc files and a 16k Eprom. The disc is formatted 40T side 0 and 80T side 2. Please state if this is unsuitable for your system, or if you require a 3.5" Compact disc

DIAGRAM II - £55 + VAT p&p free

## MARCONI TRACKERBALL

For Model 'B' and B+ (with Icon Artmaster)  
For Master 128 (with Pointer Rom)  
Bare Trackerball (no software)  
Pointer Rom (available separately)  
Trackerball to mouse adapters  
Postage and packing on Trackerballs

£60.00+VAT  
£60.00+VAT  
£49.00+VAT  
£12.50+VAT  
£8.00+VAT  
£1.75

All orders send by return

## PCB

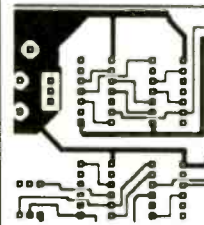
Pineapple's now famous PCB drafting aid produces complex double sided PCB's very rapidly using any model BBC micro and any FX compatible dot-matrix printer.

The program is supplied or Eprom and uses a mode 1 screen to display the two sides of the board in red and blue either separately or superimposed. Component layout screens are also produced for a silk screen mask.

The print routines allow a separate printout of each side of the board in an expanded definition high contrast 1:1 or 2:1 scale. The print time is typically about 5 minutes, for a 1:1 print of a 7" x 5" board. This program has too many superb features to adequately describe here, so please write or 'phone for more details and sample printouts.

Price £85.00 + VAT

## PCB PLOTTER DRIVER



A new addition to the PCB software is the PCB plotter driver programme. This enables files produced by PCB to be used in conjunction with most types of plotter to produce plotted output rather than the normal dot-matrix printer output. The program is suitable for use with most makes of plotter including Hewlett Packard, Hitachi and Plotmate M. The program can also be configured to work other plotters by entering suitable plotter instructions.

All the features of the printer driver are included, such as the automatic thinning down of tracks between rounds. Mirror image plots are also available.

Price £35.00 + VAT

## ADFS UTILITIES ROM

ADU is an invaluable utility for all ADFS users. It adds over 20 new commands to the ADFS filing system as well as providing an extensive Menu facility with over 35 sub commands covering areas such as repeated disc compaction, saving and loading Rom Images, auto booting of files and many more.

Copying of DFS discs onto ADFS discs can be made in one pass with automatic creation of the required directories on the ADFS disc. All functions are fully compatible with Winchester drives, including BACKUP which allows backing up of Winchesters onto multiple floppies.

New commands are as follows: ADU, BACKUP, CATALOG, CHANGE, DFSADFS, DIRALL, DIRCOPY, DIRDESTROY, DIRRENAME, DISCEDIT, DRIVE, FILEFIND, FORMAT, KILLADU, LOCK, MENU, PURGE, PWRBRK, UNLOCK, VERIFY, VFORMAT.

Price £29.00 + VAT

MITEYSPICE - Powerful AC & DC, circuit analyser package with Graphics output. Send for more details - £119.00+VAT



39 Brownlea Gardens, Seven Kings, Ilford, Essex IG3 9NL. Tel: 01-599 1476



ENTER 8 ON REPLY CARD



for universal application.

Advantages: Low losses, broad voltage range, high resistance to interference, wide temperature range from -40 to +85°C.

Low-power Schottky TTL-compatible.

These ICs are fully compatible with and equivalent to international types.

Please ask us for detailed specifications.



Agents: Edicron Ltd  
1-7 Wesley Avenue London NW10 7BZ

Alexanderplatz 6  
1026 Berlin, DDR.  
Telex: 114721

elektronik  
export-import

ENTER 28 ON REPLY CARD

## Valradio

50 YEARS OF EXPERIENCE  
IN POWER CONVERSION  
1937-1987



DC-AC Inverters (Transvertors)

SINE/SQUARE WAVE INVERTERS 30 to 2000 watts, 50 (or 60) Hz, 115/230V, single phase AC. From 12, 24, 50, 110 or 220 Volts DC.

AC POWER FROM DC SOURCE

DC-DC Converters

AC-DC Power Supplies

AC-AC Frequency Changers

Battery Chargers

Standby/UPS Systems

Line Conditioners

For details:

VALRADIO POWER LTD  
LAWRENCE ESTATE, GREEN LANE, HOUNSLOW TW4 6DN, UK  
Tel: 01-570 5622

ENTER 48 ON REPLY CARD

IN VIEW OF THE EXTREMELY RAPID CHANGE TAKING PLACE IN THE ELECTRONICS INDUSTRY, LARGE QUANTITIES OF COMPONENTS BECOME REDUNDANT. WE ARE CASH PURCHASERS OF SUCH MATERIALS AND WOULD APPRECIATE A TELEPHONE CALL OR A LIST IF AVAILABLE. WE PAY TOP PRICES AND COLLECT.

## R. Henson Ltd.

21 Lodge Lane, N. Finchley, London, N12 8JG.

5 mins. from Tally Ho Corner

Telephone: 01-445 2713/0749

ENTER 47 ON REPLY CARD



# Single-chip data acquisition subsystem

This highly-integrated device offers better performance than board-level systems and cuts the workload of the controlling c.p.u. to manageable proportions.

CHARLES YAGER AND HARLAN OHARA

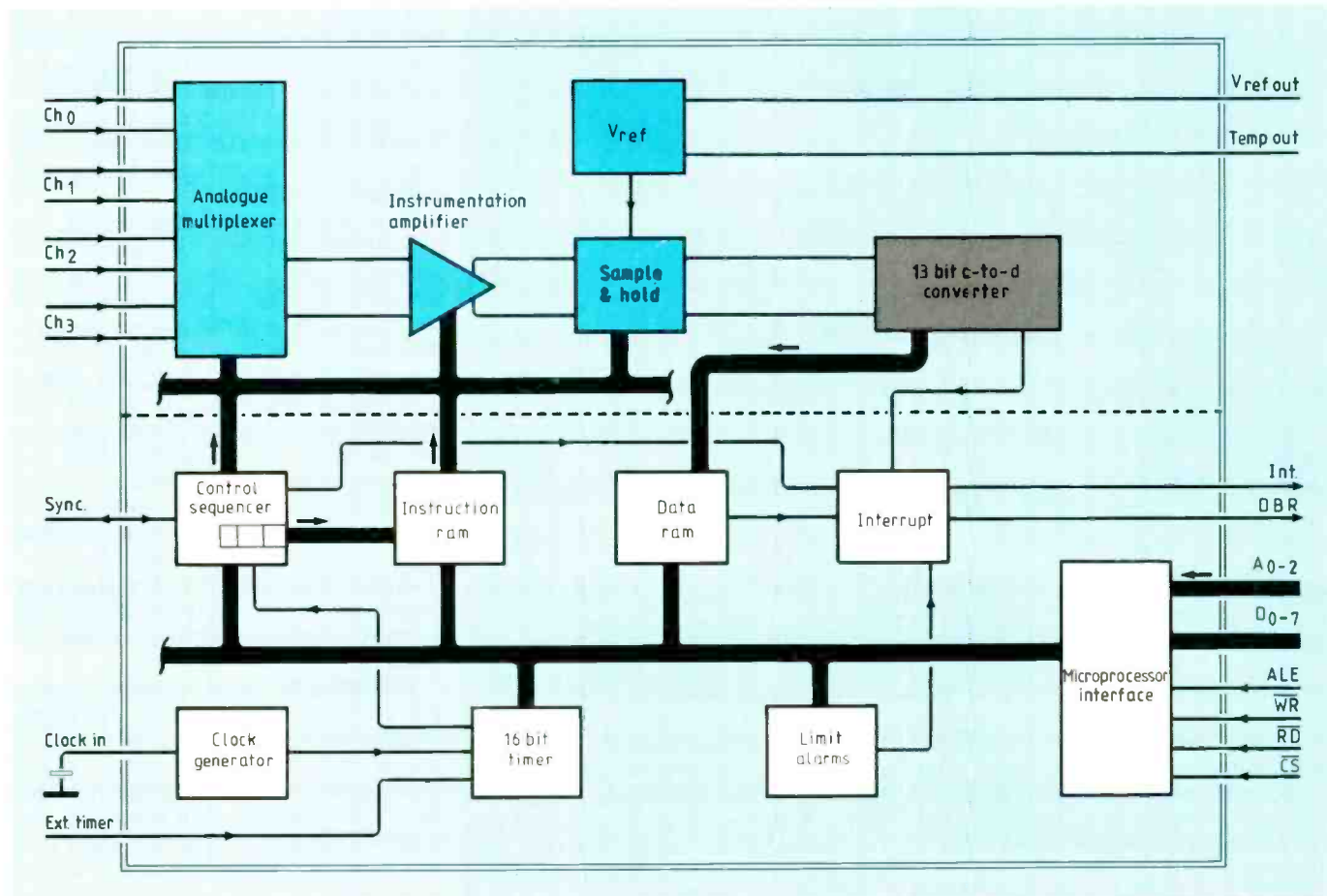


Fig. 1. The ML2200 data acquisition peripheral is a complete data acquisition subsystem on a single low power chip. It offers high performance at a lower overall than for board-level systems cost.

Until now, designing a data acquisition subsystem has called for a design engineer experienced in both analogue and digital circuitry. Usually the task begins with the selection of the a-to-d converter; however, with 12 to 13 bit a-to-d converters, little system support is provided other than the converter itself. A myriad of both analogue and digital components still needs to be added to complete the interface.

Designing the analogue section of a data acquisition system requires several i.c.s and in many cases a number of precision discrete components. A typical analogue section consists of an input multiplexer, a sample-and-hold amplifier, a programmable-gain instrumentation amplifier and a voltage reference, in addition to the converter. While several 12 to 13 bit a-to-d converters offer some combinations of the above capabilities, none offers them all. This leaves the designer with the formidable task of matching the right

analogue components with the converter and the thorny task of achieving a low noise layout.

Once the analogue components of the system have been matched, stability must be considered. Generally, the current crop of converters requires external trimming for both bipolar offset and full-scale error. While external trimming does improve the offset, recalibration is needed periodically during the life of the system. Schemes have been devised for self-calibrating bipolar offset and full-scale error, but they come at the cost of special calibration software and additional board space for the extra circuitry. Even the

addition of gain and offset auto-calibration circuitry cannot improve linearity specifications, which are inherent in the converter and subject to temperature and time variations.

Currently, 12 to 13 bit a-to-d converters provide little digital capability other than a double-buffered generic microprocessor interface. With this low level of digital capability at high sampling rates, a considerable load is placed on the microprocessor, exhausting it with the i/o task and effectively rendering it useless for application processing. Additional digital logic can be designed into the subsystem to offload the microprocessor; however, again, this requires extra circuitry.

## TWO-IN-ONE CHIP

These design problems have found a solution in a single, integrated component that uses a systems-oriented approach to data acquisi-

**Algorithmic a-to-d conversion** is one of many successive approximation techniques. One popular technique uses a d.a.c. to feed back the approximated signal. The difference between the approximated signal and the original signal is used to convert the next bit. This solution requires more circuitry since each bit in the d.a.c. requires two resistors, and the resistor values need to be matched to within the accuracy of the number of bits of the a-to-d converter.

The algorithmic converter only uses a  $2\times$  amplifier (using input and feedback capacitors to realize the gain of 2) and a sample-and-hold amplifier. The algorithm employed is basically binary division where the input voltage is divided by the reference voltage ( $V_{in}/V_{ref}$ ).

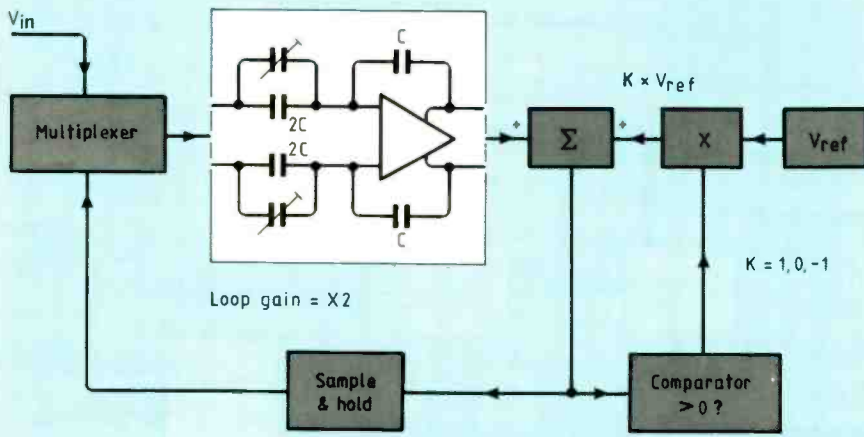
Conversion begins by multiplying the input signal by two. The reference is then subtracted from this signal and the difference is compared to 0V. If it is greater, the m.s.b. is 1 and the difference is stored in the sample-and-hold circuit. If the difference is less than 0V, the m.s.b. is 0 and the reference voltage is added back to the difference and stored in the sample-and-hold circuit. During the second and subsequent times around the loop, the sample-and-hold voltage is multiplied by two and the reference is subtracted from it. The algorithm is a slightly modified for negative input voltages.

**Algorithmic converter algorithm**

Step 1. If  $(V_{in}\times 2) - V_{ref} > 0$  then m.s.b. = 1  
 $(V_{in}\times 2) - V_{ref} \rightarrow s/h$   
 else m.s.b. = 0  
 $(V_{in}\times 2) \rightarrow s/h$

Step 2. If  $(s/h \times 2) - V_{ref} > 0$  then next bit = 1  
 $(s/h \times 2) V_{ref} \rightarrow s/h$   
 else next bit = 0  
 $(s/h \times 2) \rightarrow s/h$

Step 3. repeat step 2 until done.



Micro Linear's ML2200 data acquisition peripheral (d.a.p.) offers an entire 13-bit data acquisition subsystem on a single c-mos chip which provides higher throughput and better analogue specifications than conventional designs (Fig. 1).

At the heart of the d.a.p. is a 13 bit self-calibrating a-to-d converter (12 bit plus sign). Complete conversions, including the sample and hold, run at 40kHz for 13 bits, and 50kHz for eight bits. The ML2200 requires no external components – including trimming devices – which can drift over temperature and time.

The four-channel differential input multiplexer feeds the input signal into a high-precision, programmable gain, instrumentation amplifier. Each channel can have a different gain selection, which is automatically controlled by the on-chip processor.

Completing the analogue section is a sample-and-hold amplifier and an on-chip voltage reference. The sample-and-hold amplifier allows programmable acquisition time for high-impedance input signals. However, with only a  $2\mu s$  acquisition time – the default – output impedances of up to  $10k\Omega$  can be accommodated while still maintaining 13 bit accuracy.

Following transfer of the input sample,

this same amplifier samples the reference source selected in software. Since both the reference and the signal pass through the same sample-and-hold, there is no gain error between the source and reference; thus full-scale accuracy is guaranteed by design.

The internal voltage reference is a 2.5 volt bandgap reference with an accuracy at room temperature of  $\pm 5mV$  and a maximum temperature coefficient of 50 p.p.m. per degree Celsius. When performing a conversion, the ML2200 provides the option of using the internal source or one of the four external channels as a voltage reference. This allows ratiometric conversion between any two of the four channels. Ratiometric measurements can also be taken without sacrificing an input channel using the  $V_{ref}$  output pin. For example,  $V_{ref}$  could be used as the supply voltage for a resistive bridge type of sensor, such as an i.c. pressure transducer.

The  $V_{ref}$  circuit also produces a TEMP OUT signal, a voltage proportional to the die temperature. Because of the low chip power dissipation, the die temperature is only 10-15°C above ambient. Therefore TEMP OUT could be fed into one of the input channels, informing the microprocessor of the system temperature. If excessive temperature con-

ditions are important to know, the ML2200 could detect this condition via the on-chip level alarm and generate an interrupt for the microprocessor.

**A-TO-D CONVERTER**

Choosing an algorithmic converter for the 13 bit a-to-d was a critical part of the ML2200's design. There are several advantages to using an algorithmic converter (see box):

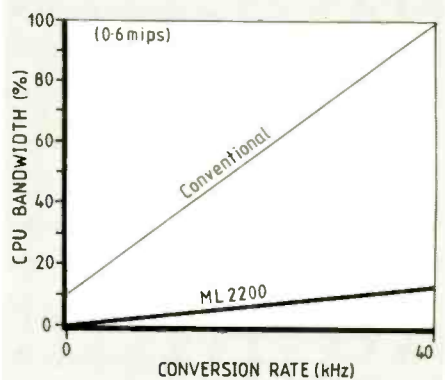
- it uses relatively little die area, therefore allowing room for other functions
- it is easily made fully differential, removing the effects of power supply coupling
- linearity of the converter depends on only two parameters: the gain error in the loop and the offset error in the loop. The offset error is eliminated by the autozeroing circuits in the sample-and-hold and  $2\times$  operational amplifiers: this is done at the beginning of each conversion. The  $2\times$  gain of the loop is precisely controlled by the self-calibration circuitry.

Once the offsets have been nulled, the algorithmic converter is calibrated by measuring the  $2\times$  gain of the loop and adjusting it. Gain can be measured by converting the internal voltage reference. The result, in the ideal case, is all 1s. If the loop gain is slightly less than 2, the resulting l.s.b. of the conversion will be 0. If the resulting conversion is all 1s, the gain may be too great and is reduced until the threshold of the l.s.b. is reached.

Adjusting the gain of the loop is done by tuning the binary-weighted trim capacitor array for each of the  $2C$  input capacitors. This must be used differentially so that it can either increase or decrease the  $2C$  value by being connected as positive or negative feedback.

Calibrating the a-to-d converter is a simple matter of programming. Once the ML2200 has been powered up, the c.p.u. sets the CAL bit in the control register and the device goes into its self-calibration mode. Since calibration takes 2ms to perform, the ML2200 generates an interrupt when it is complete, allowing the c.p.u. to execute

**Fig. 2. A conventionally double-buffered a-to-d converter requires an order of magnitude more c.p.u. bandwidth than the ML2200. For a standard 0.6 mips microcontroller at a conversion rate of 40kHz, the entire bandwidth is consumed by the overhead of interrupt processing.**



other tasks while calibration is executing.

Self-calibration should always be executed on power-up before the chip is placed in the run mode. Re-executing self-calibration can be done at any time.

### ON-CHIP DIAGNOSTICS

The d.a.p.'s built-in diagnostics provide a way for the system to ensure that the chip is fully operational and meeting specification.

To test the digital paths within the chip a digital loopback is provided, guaranteeing that the internal data paths and registers are fully functional. The analogue section provides several diagnostic features testing linearity, bipolar offset, full-scale error and common mode rejection ratio. To ensure that the self-calibration circuitry is functional, the user can read the calibration code result. This code informs the system that the calibration circuitry was able to adjust the linearity to within  $\pm 1/2$  l.s.b. at 13 bits.

Converting with the inputs shorted to ground provides system offset values, ensuring bipolar offset is within specification. Converting the internal voltage reference provides the full scale error. Converting with both inputs shorted to  $V_{ref}$  provides a common mode test. No external circuitry is required to support diagnostics.

### DIGITAL SECTION

The digital section of the ML2200 was designed with three basic goals in mind: to offload the microprocessor, provide a high-performance standard peripheral interface requiring no external support circuitry, and offer a highly-programmable solution for maximum flexibility.

To accomplish these goals a programmable processor is integrated into the nucleus of the chip, autonomously controlling the entire operation of the d.a.p. The on-chip processor contains eight instruction ram

locations, or operations. Upon system power-up, the microprocessor loads the ML2200's instruction ram with a particular system configuration. The microprocessor can dynamically change the instruction ram to adapt the ML2200 to changing environments or system configurations.

Once the d.a.p. has been initialized, it can run autonomously without c.p.u. intervention. As conversions are completed, data is buffered in the on-chip data ram. Up to eight conversions can be buffered before the chip notifies the c.p.u., through an interrupt or d.m.a. request, that the buffer is full. The double-buffered architecture allows eight more conversions to be taken while the previous series of conversions is being read.

On-chip limit alarms provide even more opportunity to off-load the c.p.u. These can generate interrupts based on two programmable voltage levels as well as in-range and out-of-range detection. Interrupts can also be generated if the a-to-d converter goes into overrange or underrange. Having the ML2200 automatically scan for a-to-d saturation or programmable voltage levels frees the microprocessor from having to scan each converted data word for these conditions.

Programmable timing control is achieved using the on-chip 16 bit timer: this can be used for a variety of data acquisition functions. In one of its modes it acts as a programmable sampling clock, generating precise sampling rates independent of microprocessor control. Programmable sample-and-hold acquisition times are another feature of the 16 bit timer - this feature is handy when input channels coming from a high-impedance source require longer acquisition times.

The 16 bit timer can receive its clocking source from either the internal clock, running at 4MHz, or an external input pin ( $\tau_{CLK}$ ). Therefore, if the internal clock cannot provide an exact enough frequency, or if the timer must be synchronized from an external source, the  $\tau_{CLK}$  pin is available. This pin can also be used as an event counter, counting  $n$  events before triggering a conversion.

### C.P.U. OFFLOADING

The combination of autonomous operation, eight word double buffering, level alarms, and the 16 bit timer dramatically reduces c.p.u. loading, freeing the microprocessor for other tasks.

As an example, consider a design using a single-chip microprocessor for the c.p.u. of a data acquisition system. Typical performance of a standard single chip microprocessor is about 0.6 million instructions per second (mips). Conventional a-to-d converters provide only double buffering; therefore an interrupt would be generated for each sample. Since the ML2200 contains an eight-word double-buffered data ram, the interrupt frequency is reduced by a factor of eight.

A typical interrupt service routine would take 9-15 instructions, not including the time taken to read the data and store it, which is equal in both cases. Assuming an

Fig 3. Each instruction from the instruction ram causes an a-to-d conversion. Up to eight conversions can be stored on chip before a request to read the buffer is issued. The double buffered architecture allows up to eight more conversions while the previous series of conversions is being read.

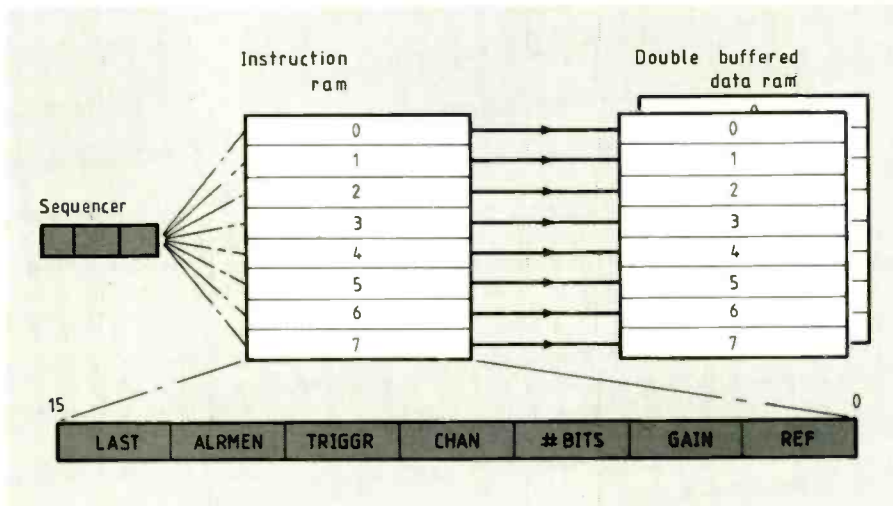
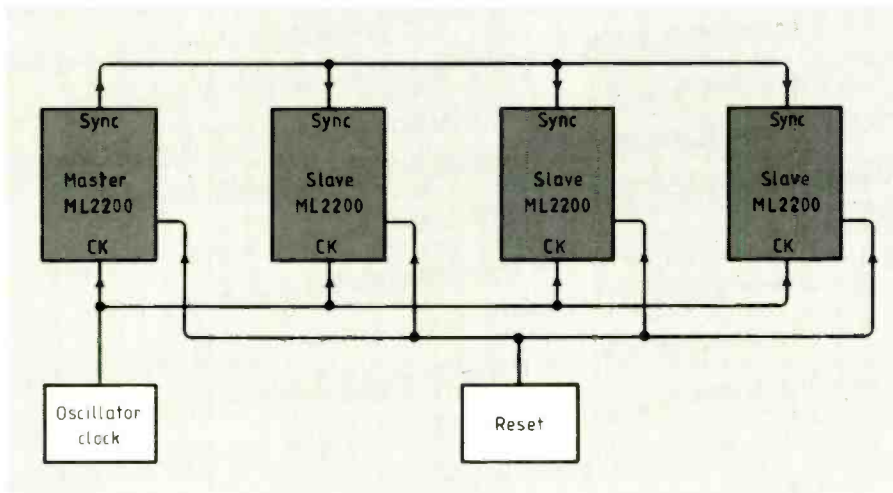


Fig. 4. Several ML2200s are easily synchronized by tying the sync pins together and running them off of the same clock. The c.p.u. can internally program the sync pin to be an output (master) or an input (slave). One application of this technique is to achieve higher order sampling. The master d.a.p. issues a sync pulse which triggers the slaves to sample the same signal. Each slave uses the internal 16 bit timer to delay the appropriate amount before sampling the input signal.



alarm feature is incorporated, another 3-5 instructions would be required with a conventional a-to-d. The ML2200 handles this automatically. Thus, using a 40kHz sampling rate, a conventional converter would take between 0.48 and 0.8 mips (40kHz × 9-15 instructions), which is 80% of the c.p.u.'s bandwidth. The ML2200 requires 0.045-0.075 mips (Fig.2).

Considering the amount of c.p.u. bandwidth consumed by i/o for a conventional a-to-d converter, it is plain to see that no capacity remains for application processing.

### C.P.U. INTERFACE

As the frequency of peripheral interrupts increases, so does the value of a high-performance bus interface. Adding wait states to i/o cycles wastes c.p.u. time and slows overall throughput. Micro Linear's d.a.p. provides an 8MHz no-wait-state interface, which maintains system performance and eliminates the need for wait state glue logic.

Other ways to enhance system performance via the microprocessor interface include a variety of high-performance i/o methods. The three standard types of i/o, from the lowest to highest performers, are polling, interrupts and d.m.a. The ML2200 offers all three.

Polling is by far the most inefficient i/o method, consuming the most c.p.u. bandwidth; however it also requires the least amount of logic. Interrupts provide the next level of performance, because the c.p.u. is relieved of polling on-chip registers, but the c.p.u. still needs to do a fair amount of processing for each interrupt request.

One of the tasks involved in interrupt processing is determining the source of each interrupt request. Since the d.a.p. contains seven internal interrupt requests, the c.p.u. would have to read the interrupt status register and execute a routine to resolve which interrupt was being requested. However, the routine would have to be executed every time an interrupt occurs. By far the highest frequency of interrupt requests comes from the data.

For this reason, the d.a.p. has two interrupt request i/o pins: one for data (data buffer ready - *DBR*) and another for the less frequent interrupt requests (*INT*). If the system cannot afford two separate interrupts, the data buffer ready request can be mapped into the *INT* pin.

Direct memory access provides the highest performance i/o. When the ML2200 is placed in d.m.a. mode, the *DBR* pin serves as the d.m.a. request while the *INT* pin serves as the interrupt request. The *DBR* pin is activated when the data ram is full and remains active until the data buffer is empty, thus allowing burst-mode d.m.a. (back-to-back cycles).

The peripheral interface on the ML2200 is no different from any other microprocessor peripheral such as a u.a.r.t. or a floppy disc controller. The only external component required is a crystal, which can be substituted for a t.t.l.-compatible clock input.

Saving external logic is the main reason for including an address latch enable (*ALE* pin.) The ML2200 has the ability to operate

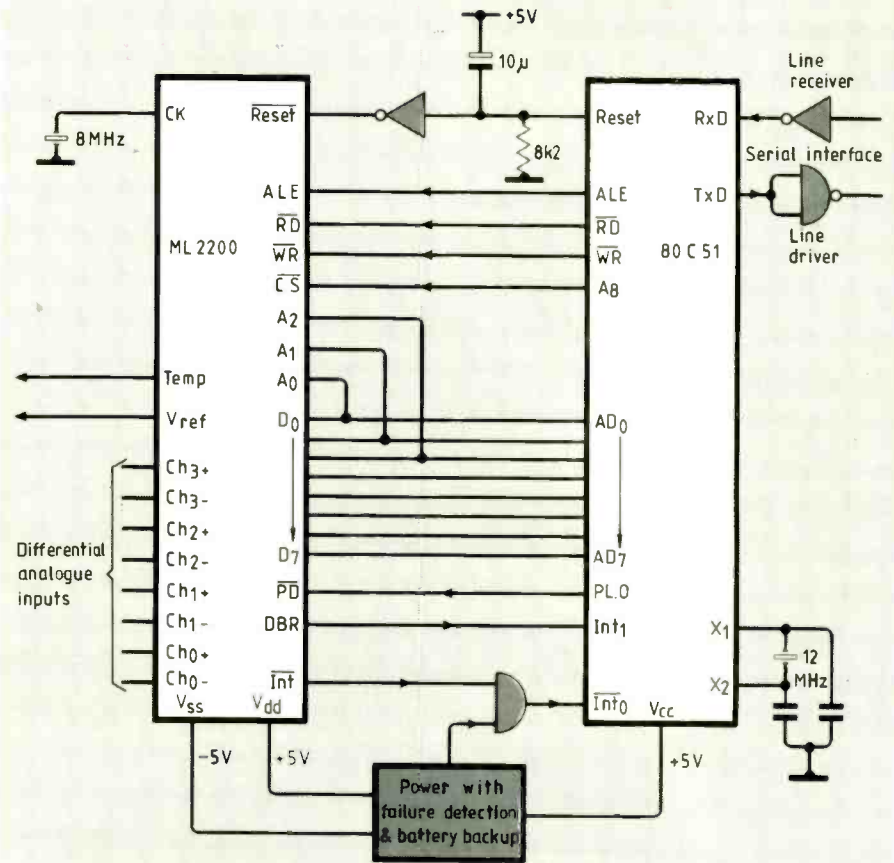


Fig. 5. A direct interface to standard microcontroller provides a highly-integrated solution for a remote data acquisition system. Since both chips are in cmos, this application consumes very little power and can even accommodate a power-down mode.

on multiplexed or non-multiplexed buses with no additional glue logic. When the d.a.p. is used with multiplexed buses, *ALE* removes the need for an external latch. Address information is latched on the address pins on the falling edge of *ALE*. For non-multiplexed buses, *ALE* is simply tied high.

Another cost-reducing feature of the ML2200 is its power consumption, which is about a quarter of a watt, or less than one eighth of the power of equivalent discrete solutions. In addition, the chip can be placed in a power-down mode, by pulling the *PD* pin low, which consumes less than 1mW. All register contents are retained, even without a clock input. Restoring the power fully restores and operation of the chip without the need to reinitialize it.

### PROGRAMMABLE PROCESSOR

In the d.a.p.'s programmable processor is a sequencer that sequentially executes instructions from the on-chip instruction ram. There are eight programmable instruction ram locations where each is an operation (Fig. 3). On initialization the microprocessor loads the instruction ram with the desired operations by writing to the on-chip instruction ram registers.

After the ML2200 has been initialized, it is placed in run mode where the sequencer cycles through the instruction ram, decoding and executing the operations. Each

operation stores converted data in the corresponding data ram location.

The eight instruction ram locations are 16 bits wide and are broken up into seven different fields:

**LAST:** indicates that this is the last operation.

**ALRMEN:** arm the limit alarm for this operation.

**TRIGGR:** start conversion criteria -

- immediate execute (full speed mode)
- pause and wait for microprocessor to initiate start
- start on next timer timeout
- preset timer and wait for timeout
- wait for external sync signal
- preset timer by sync signal and wait for timeout

**CHAN:** channel to be converted.

**BITS:** number of bits to convert - 8 bits (7 bits plus sign) or 13 bits (12 bits plus sign).

**GAIN:** gain select: 1, 2, 4, 8.

**REF:** reference to be used - internal *V<sub>ref</sub>* (2.5V) or external channels 0 to 3.

The rate at which the sequencer cycles through the instruction ram is a multiple of the channel sampling rate. If a channel is sampled only once per cycle, then the cycle frequency is also the sampling frequency. However, the same channel can be sampled more than once per cycle, which is impor-

tant when channels have different bandwidth requirements.

When the sequencer is free-running at its maximum speed (immediate execute), several signals can gate or inhibit the sequencer from executing the next operation, which effectively lowers the sampling rate even though the conversion time remains the same.

One of these is the external sync pin. This feature allows the d.a.p. to synchronize conversions to an external event. The pin can be programmed to be an output or input. When SYNC is an output, the ML2200 becomes the master and a positive going pulse is activated just before the beginning of each operation. As a slave, the ML2200 waits for the SYNC input before executing the next operation.

#### MULTI-CHIP SYNCHRONIZATION

Several ML2200s can be synchronized by tying their SYNC pins together (Fig. 4). In this wiring scheme, all the devices should be running off the same clock and the same reset pin. The reset signal initializes this synchronization.

Two types of synchronization can be accomplished. Several ML2200s can be triggered to sample at the same time, or they can be sequentially triggered to sample. The first method calls for the TRIGGR field (in the instruction word) to be set to 'wait for external sync signal'. Sequential sampling requires the instruction set 'preset timer by sync signal' and 'wait for timeout'.

One application of sequentially-synchronized sampling is higher-order sampling of the same signal, thus achieving sampling rates higher than 40kHz. The internal 16 bit timers are individually programmed to delay the appropriate amount. For example, if four ML2200s are used, the second chip should delay taking a sample from the master sync pulse for a quarter of 25µs; the third chip should delay half of 25µs, and the fourth chip should delay three quarters of 25µs. In this example a sampling rate of 160kHz is achieved.

*Charles Yager is technical marketing manager for Micro Linear's data acquisition products. He spent eight years at Intel in d.s.p. and datacom developments including the 2920 d.s.p. program. He holds a BSEE from Arizona State University and an MSEE from the University of Santa Clara.*

*Harlan Ohara is the project leader for the ML2200. Before joining Micro Linear he worked at Intel designing memories and telecommunication devices. Harlan holds a BSEE and an MSEE from the University of Washington.*

*Micro Linear Corporation is at 2092 Concourse Drive, San Jose, California 95131, tel. (408) 262-5200. The company, founded in 1983, produces a variety of standard and custom devices in c-mos and bipolar technologies. It also offers c.a.d. packages for the IBM p.c. for designing semi-custom linear i.cs.*

# BOOKS

**Proficient C** by Augie Hansen. Microsoft Press, Penguin Books, 494 pages, paper covers, £19.50. Extensive handbook for the intermediate or advanced programmer working in a DOS environment. Sections deal with DOS and program development, using standard libraries and interfaces, file utilities, the ANSI device driver and screen routines. Attractively presented. The many example programs are also available on two discs, as source code or as executable programs.

**Private Mobile Radio – a system planner** by John Davies; 48 A4 pages ring-bound, soft covers. Available direct from the author, price £8.50 inclusive (Europe £9.50, overseas £11), at 26 Walnut Close, Penwortham, Preston, Lancashire. Do-it-yourself kit for prospective users, to be used in conjunction with the author's Private Mobile Radio: a practical guide (Heinemann). Contents in-

clude a questionnaire designed to establish basic system requirements, a preliminary specification for discussion with equipment suppliers, draft form of tender, guidance notes and so on.

**CD ROM 2: Optical Publishing**, edited by Suzanne Ropiequet with John Einberger and Bill Zoelick. Microsoft Press, Penguin Books, 358 pages, soft covers, £19.95. Handbook for paperless publishers, describing all aspects of working in the new medium in an accessible and generally non-technical way. Sections cover the CD rom itself, text preparation and indexing methods, working with images and sound, disc production and data protection. Two case studies are included: one is of a medical data retrieval system, the other a bibliographical index of publications in the US Library of Congress. The book is a companion to CD ROM: the new Papyrus, which was published last year.



## Telecommunications converges on Geneva

Telecom 87, the fifth in a series of four-yearly world telecommunications exhibitions, will be held in Geneva, Switzerland from 20 to 27 October. In parallel with it will be the World Telecommunications Forum.

These events are organised by the International Telecommunications Union (ITU), the specialised agency of the United Nations for the planning, coordination, regulation and standardisation of telecommunications worldwide. As such, they have the support of its more than 160 member countries. Consequently, major vendors, especially those wishing to do business with Governments and PTTs, feel under an obligation to give very full support. In addition, the conference attracts both very high level speakers and delegates.

Under the theme "Communications Age: Networks and Services for a World of Nations", Telecom 87 will bring together some 750 exhibitors from nearly 40 countries from all parts of the world who will display, on some 88,000 square metres of indoor and outdoor space, state of the art equipment and technology. The previous exhibition, held four years ago in 1983, attracted around 200,000 visitors and delegates.

As telecommunications is a growth industry it is to be expected that at least this number will converge on Geneva where they will also get a glimpse of the future in telecommunications through demonstrations of prototype equipment yet to come to the market – such as those related to ISDN and the X.400 message. The Forum is attended by policy makers, engineers, scien-

tists, regulators, industry leaders, bankers, researchers, users and, indeed, all those with an interest in the telecommunications sector as it becomes one of the main focal points of consideration in the move towards the Communications Age and greater independence.

It consists of five separate symposia concentrating on specific issues: executive telecommunications policy; technical; legal, the harmonisation of global telecommunications systems; economic and financial, the role of telecommunications in the infrastructure and its impact on economic growth; and on regional network development and cooperation.

France and the USA, each with over 5,000 sq. metres, have the biggest presences at the exhibition, closely followed by Japan (4,600) and the UK with 4,500 sq. metres. They provide the opportunity for the display of national themes so as to promote technological competence and so obtain a marketing edge for their products. Vast sums of money are spent both by individual companies and by national bodies because this opportunity only occurs once every four years.

This is a vitally important time because, even though equipment must be compatible, each manufacturer is striving to ensure that it will be his system that is adopted. Thus, as purchasing decisions in telecommunications require a long-term strategic overview, the planners and decision makers in attending Telecom 87 and The Forum are looking to identify the long-term trends and winners so as to avoid costly mistakes.

# IMAGE-10

## HIGH PERFORMANCE SINGLE BOARD GRAPHICS COMPUTER

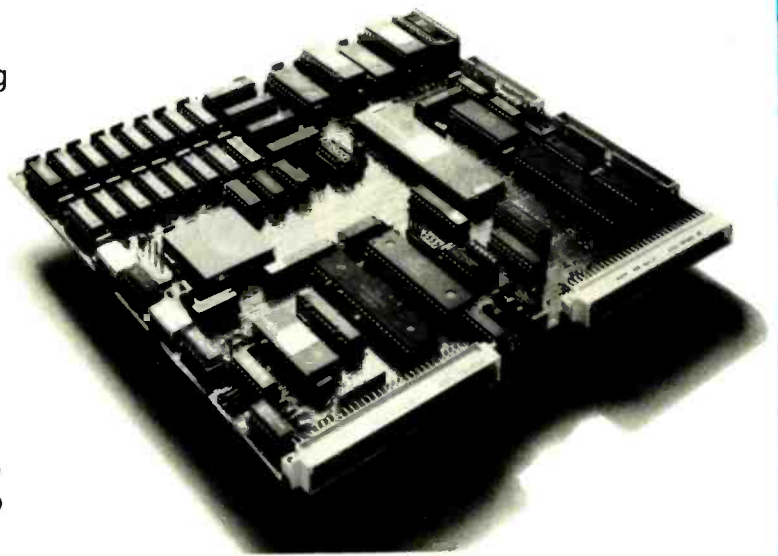
High performance? they all say that.  
Ah yes, but. . . .

Image-10 has three 16 bit processors working concurrently for dazzling speed  
*and*

Image-10 has a resolution of 768 by 576 pixels for intricate detail  
*and*

Image-10 has 256 on-screen colours giving photographic quality.

In fact Image-10 has all of the refinements asked of graphics intensive applications. Like hardware windows, hardware drawing, hardware zoom and pan, hardware character generation and hardware block moves. The only thing the cpu has to do is to run your applications.



### Board Price £1295

Image-10 includes:

- ★ 68010 cpu      ★ 82786 gdc
- ★ Floppy disc controller
- ★ Dual RS232   ★ Centronics
- ★ Battery backed clock
- ★ 512K dram    ★ 64K sram
- ★ Winchester disc controller
- ★ Mouse
- ★ transputer ports
- ★ Stereo sound generator
- ★ 256K eprom

### SOFTWARE DEVELOPMENT SYSTEMS

Versatile, low cost, development systems based on Micro Concepts' single board computer, Microbox 3. A choice of powerful disc operating systems is available including Os-9/68K, TRIPOS, and CP/M-68K

Features include:

- 68000 microprocessor, 8MHz clock.
- 512K dynamic ram, 64K static ram, 128K eprom
- On-board graphics controller offers:
- 80 column, 24 row, 16 colour text.
- 640 by 480, 4 colour graphics.
- 320 by 480, 16 colour graphics.
- Floppy disc controller.
- Winchester disc controller.
- Dual serial RS232 ports.
- Centronics printer port.
- Up to 48 lines of parallel input/output.
- Battery backed clock/calendar.
- I/O expansion capability.
- Double eurocard board format.

Hardware prices:

- Fully built and tested Microbox 3 single board computer ..... £650
- System with dual 1M byte floppy disc drives ..... £1195
- System with 20M byte Winchester and single floppy drive ..... £1895

### UNIVERSAL CROSS ASSEMBLERS for all MSDOS OS-9 FLEX computers

Supports the following devices

1802	809	8049
6502	8022	8080
6803	8039	8751
6808	80C48	6303
8021	8051	6802
80C35	8749	68HC05
8048	68000	8020
8050	6301	8035
8748	6801	8040
Z80	6805	80C49
1805	68HC11	8085
6800	8031	Z8
6804	80C39	

Extensive directives support modular, conditional and structured programming. Powerful Macro Pre-processor, xref generator and output conversion utilities provided.

COMPLETE SUITE ..... £295  
INCLUDES FULL 'C' SOURCE CODES (NOT 68000)

### MICROPROCESSOR CONTROLLED EPROM EEPROM and SINGLE CHIP MICRO PROGRAMMER

Programs the following devices:

2508	2516	2532
2564	27(C)16	27(C)32
2732A	27(C)64	2764A
27(C)128	27128A	27(C)256
57(C)256	27(C)512	27513
2758	27011	2816A
2817A	2864A	28256
48Z02	52B13	52B23
52B33	68732	68764
68766	8741	8742
8744	8748	8749
8748H	8749H	8751
8755	9761	CY7C282
CY7C292		DS1225
AT-ROM	PC-ROM	XT-ROM

No Personality Modules required.

Controlled via RS232 interface.

Accepts Intel, Motorola, Ascii-hex and binary data. Ultra-fast, fast and standard programming modes.

Low and high byte programming supported.

Completely self contained but uncased.

Price £295

All prices shown exclusive of VAT and carriage

VISA

Micro Concepts

2 St. Stephens Road, Cheltenham, Gloucestershire GL51 5AA  
Telephone (0242) 510525

ENTER 20 ON REPLY CARD

# Pioneers

W.A. ATHERTON

## 10. Vladimir Kosma Zworykin (1889 – 1982): catalyst of television

**B**ugs scurry in panic when a stone is lifted. Technical historians do a fair impression of the same thing when anyone asks who invented television. Nevertheless, when Vladimir Zworykin died in New York on July 29, 1982, one day short of his 93rd birthday, he was acknowledged internationally as *the great pioneer of electronic television.*

His obituary in *The Times* credited his work on television as "the basis for virtually all the later technical advances in the science".

However, Zworykin himself disclaimed the title Father of Television on the grounds that television had many fathers: no single person could be so regarded, he maintained, because a great many inventions had led to modern television.

He was best known for his invention of the iconoscope, the first practical electronic television camera tube. Shortly before that invention he had developed a television picture tube which he called a kinescope.

Together these two developments made good-quality television a reality in the 1930s.

### IN RUSSIA

Zworykin spent his formative years in Czarist Russia. He was born on July 30, 1889 in Murom, a small town on the Oka river which lies to the south-east of Moscow. His father was a shipowner who ran a passenger service along the river.

Later he recalled that he was eight years old when he first became aware of electrical engineering, after seeing his father press a button and receive a response from elsewhere in the ship.

After leaving school he entered the Institute of Technology at St Petersburg (now Leningrad) from where he graduated with a degree in electrical engineering in 1912. Whilst there he was a student of Professor Boris Rosing, probably the first man to achieve television.

It was Rosing who did so much to inspire Zworykin with an interest in electronics and television. Rosing in Russia and A.A. Campbell Swinton in Britain both foresaw the



Institution of Electrical Engineers

possibilities of electronic television as early as the first decade of this century, well before better known names such as Baird.

In 1908, and again in 1911, Campbell Swinton published his ideas for electronic television for which he specified cathode-ray tubes at both the camera and the receiver, both using electromagnetic scanning. The details bear close comparison with Zworykin's later successful tubes.

Though Campbell Swinton had the right ideas he was unable to transform them into reality. But in Russia, Rosing, with more limited aims, met with some success. At the camera he used the spinning mirror-drum technique to achieve horizontal and vertical scanning together with a photoelectric cell. The result was displayed on a cold-cathode Braun tube (c.r.t.) using magnetic coils to achieve scanning.

Zworykin recalled that during his time with Rosing (1910-1912) they constructed a cathode-ray picture tube and achieved "stationary geometrical figures, very fuzzy, like a triangle and some kind of distorted circle and so on but with very, very intense light"\*.

Though Rosing did not achieve moving

pictures (selenium cells have a slow response time) he did inspire Zworykin. "He started me to dream about television so when I succeeded to reach the United States which was in 1919, I started to look for a place where I could work in television," said Zworykin.

### SOMETHING MORE USEFUL

Zworykin's arrival in the USA was not his first foreign travel.

After graduating from St Petersburg he moved to Paris where he did X-ray research at the College de France under Paul Langevin. The outbreak of World War I brought him back to Russia and into the army signal corps.

After the war he travelled around the world and settled in the USA. He became an American citizen in 1924.

With help from Russian friends he gained a position at Westinghouse where, apart from a brief interlude, he stayed until joining RCA in 1929.

In 1923 he applied for his first patent covering a complete electronic television system. This application was amended considerably over the years. Another was filed in 1925 and that covered an essential part of the camera tube, a part which was to be important in the future iconoscope.

In the next two years he actually built an electronic television system using a converted oscillograph tube for the receiver and a specially-made tube for the camera. This, the first electronic television camera tube, is still held by RCA.

A demonstration was given to the Westinghouse management. The date is uncertain but it was probably early in 1925. The stationary picture was poor and Zworykin was advised to work on "something more useful". Meanwhile the University of Pittsburgh awarded him a doctorate in 1926.

### AT RCA

After a tour of Europe in which he visited Germany, Hungary, Belgium, France and

\* B. Norman, *Here's Looking at You*, BBC/Royal Television Society, 1984.

Britain, Zworykin moved to RCA in 1929 as director of an electronics research group. By this time several other pioneers had made names for themselves in television.

John Logie Baird had achieved many firsts with mechanically-scanned television including a transatlantic transmission. In America C.F. Jenkins had actually begun what were to be short-lived broadcasts. Others in France, Germany and the USA were hard at work on television.

When Zworykin returned to the USA in September 1928 he had ideas for a much improved cathode-ray picture tube. Work began almost immediately. Shortly afterwards he was able to convince David Sarnoff, the Executive Vice-President of RCA, that a workable television system could be produced in two years. Sarnoff gave the go-ahead and the funds.

Sarnoff later called Zworykin a great salesman. "He told me it would cost \$100,000 to develop television, but RCA spent \$50 million before we ever got a penny back."

Zworykin's picture tube was called a kinescope. It had a hard vacuum, an indirectly-heated cathode and a grid for beam current modulation. Electrostatic focusing gave a sharp spot and this has been claimed as the first application of electron optics to a television picture tube. It was the basis of all future tv picture tubes.

This kinescope was announced in November 1929, by which time work was in progress or completed on a radio transmitter and six receivers.

### THE STORAGE PRINCIPLE

It was time to return, once again, to the redesign of the camera tube. The first of the new tubes had a double-sided target and 12-line pictures were obtained. It proved the novel principle of temporarily storing the charge generated by the received light. This storage principle, used in the iconoscope and in every television camera tube since, solved the biggest problem of all. Zworykin called it "my principal contribution to television".

Previous workers had scanned the image part by part on to a single photocell. Each picture element was seen by the photocell only momentarily. Consequently little charge was generated per picture element and very, very intense illumination of the subject was needed to produce a usable signal.

Instead Zworykin projected the image on to a mosaic of photocells laid on a sheet of mica. The mica had a conducting plate on the back. Each photocell, insulated from its neighbours, became a capacitor.

Each cell continuously received light from only one part of the subject and so continuously generated and stored charge. A video signal was induced into the conducting plate when the scanning electron beam discharged the capacitors in sequence.

The idea of a mosaic of photocells was crucial. It was not in the original 1923 patent application but was in the 1925 version (as "globules" of photosensitive material) even though storage was not mentioned. The 1929 tubes achieved this mosaic by having rivets pinned into holes in a screen.

In June 1931 Zworykin and his team turned to single-sided insulated targets and made the mosaics by ruling or by evaporating the photosensitive material. It was these tubes that Zworykin called iconoscopes. An RCA chemist developed an easier method of producing the mosaics. After other improvements the iconoscope was announced on 26 June, 1933.

Meanwhile, at EMI in Britain, J.D. McGee and W.F. Tedham independently invented a similar camera tube based on Campbell Swinton's 1911 suggestions. Much to their annoyance some of their patent applications were rejected on the grounds that RCA had already filed for patent protection. (EMI were receiving information about RCA patents through a patent exchange agreement.)

The EMI group constructed their first tube, contrary to the instructions of their management, in autumn 1932. Zworykin's first single-sided mosaic dates from June 1931 and his globules (mosaic) from the 1925 patent. Zworykin clearly had priority.

### LATER WORK

Zworykin's group continued to improve the iconoscope and it was RCA that produced subsequent tubes: the image iconoscope, the orthicon, the image orthicon and the vidicon.

Zworykin's own interests developed wide-

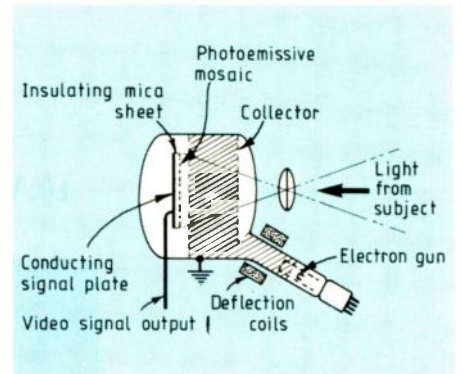


Fig.2. Zworykin's iconoscope, announced on June 26, 1933. Its charge-storage principle, which has been used in every camera tube since, greatly reduced the lighting level needed to produce a usable picture.

ly. His laboratory produced the first commercial electron microscope for industry (1941). During World War II he directed work on aircraft fire control, tv-guided missiles, a sniperscope and radar. After the war he worked on high-speed electronic memories and later took a great interest in medical electronics.

Dr Zworykin retired from RCA on 1st August 1954 but it was a nominal retirement. He kept an office there, became Honorary Vice President and also became a director of the Rockefeller Institute Medical Center in New York. As late as 1981 (when he was 90 years old) one writer reported "he still goes to work every morning on his latest project". He continued to read scientific journals and enjoyed swimming every day if the weather permitted.

Amongst the 27 major honours he received were the IEE Faraday Medal (1965) and the American National Medal of Science (1966). In 1959 he was an honoured guest in Moscow at the first post-Cold War cultural and scientific exchange between the USA and the USSR, organized by Eisenhower and Krushchev.

He was described as a gregarious individual with a mischievous twinkle in his eyes. Apparently he enjoyed telling jovial anecdotes about himself, including the tale of how on the voyage which took him to America in 1919 he took all his meals alone in his cabin. Dinner jackets were the rule in the dining room and he did not have one.

He held a low opinion of many modern television programmes, believing them to have a bad influence on viewers, especially children. His preference was for cultural and educational material rather than "mindless mayhem".

Vladimir Zworykin was survived by Katherine, his wife of 30 years, a daughter and seven grandchildren.

Next in this series of pioneers of electrical communication will be Edwin Armstrong – the man who invented the superhet and made f.m. radio work.

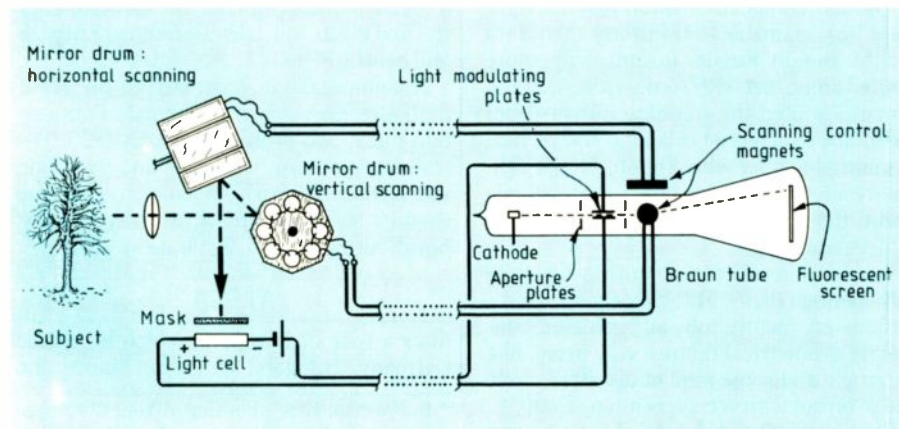
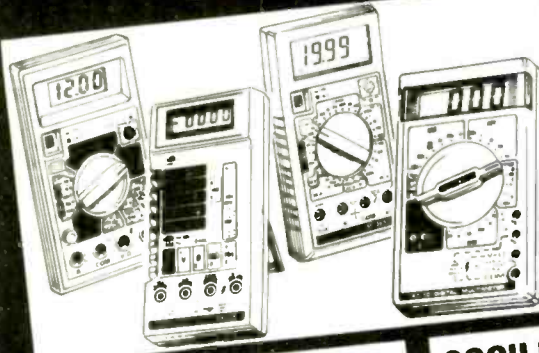


Fig.1. Rosing's television system. First transmission was probably on May 9, 1911 when Zworykin was a student under Rosing at St Petersburg.



# UK'S LARGEST IN-STOCK RANGE OF INSTRUMENTS

FOR TRADE, EDUCATION AND INDUSTRY - ALL STOCKS ON DISPLAY FOR CALLERS



## DIGITAL MULTIMETERS

3: Digit unless stated † with continuity buzzer  
 (R) Rotary, (P) Push Button, (S) Slide  
 † Includes carry case Case £3.91

**KT305** † † 26 range plus Hfe test 10A AC/DC 20 meg buzz 0.5% (R) **£37.00**  
**KT110** † † 31 range incl. 5 range CAP 10A AC/DC 20meg buzz 0.5% (R) **£36.00**  
**KT5005** † † 4% digit 28 range plus Hfe 10A AC/DC 20meg C 0.7% (PB) Extra AC/DC Current ranges **£83.00**  
**M3800** † † 30 range plus Hfe 20A AC/DC 20meg 0.5% (R) **£35.00**  
**M3610** † † 28 range plus Hfe 20A AC/DC 20meg 0.3% (R) **£43.00**  
**M3530** † † 28 range incl. 5 range CAP plus Hfe 10A AC/DC 0.5 (R) **£53.00**

**M4630** † † 4% digit 30 range incl. CAP Hfe data hold 20A AC/DC (0.05%) (R) **£77.00**  
**M3650** † † 30 range incl. Hfe CAP freq. count. 20A AC/DC 0.3% (R) **£57.00**  
**K0508** † † 15 range AC/DC volts 0.2A DC 2 meg (S) **£19.96**  
**K0578** † † 20 range 10A AC/DC auto range display hold 0.8% (R) **£34.50**  
**TM357** † † 30 range 10A AC/DC 20 meg 0.5% (R) **£39.00**  
**6010** † † 28 range 10A AC/DC 20 meg 0.25% (PB) **£33.50**  
**7030** † † 28 range incl. CAP Hfe temp etc 0.25% (R) **£39.50**  
**501DEC** † † 34 range incl. CAP Hfe temp etc 0.25% (R) display hold 0.5% (R) **£48.00**  
**HC779** † † 20 range 10A AC/DC auto range & Hfe & memory/ **£41.00**  
**DM205** † † 14 range 10A DC Display hold 0.5% (R) **£21.50**  
**KC909** † † 19 range 10A DC Hfe test 0.8% (S) **£29.00**  
**H5010** † † 31 range 10A AC/DC. High accuracy 0.25% (R) **£36.50**

## COUNTERS & TIMERS

### ALL BENCH MODELS FREQUENCY COUNTERS

**MET100** 220/240V AC 8 digit LED 0.1Hz RESOLUTION **£99.00**  
**MET600** 5mv min Sensitivity **£126.00**  
**MET1000** 5mv min Sensitivity **£175.00**  
**MET1500** 5mv min Sensitivity **£199.00**  
**TF200** 8 digit LCD batt 200MHz **£175.00**  
**COUNTER/TIMERS 8 DIGIT LED** 0.001Hz RES 100MHz 5mV sens. **£219.00**  
**APPOLLO 10 STANDARD MODEL** **£285.00**  
**APPOLLO 100 PLUS DISPLAY HOLD RPM STOP WATCH ETC.**



## OSCILLOSCOPES (★ with probes)

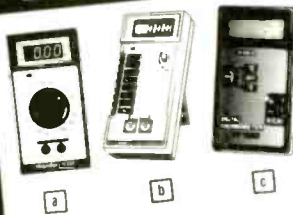
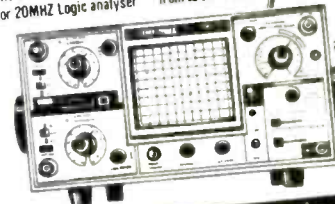
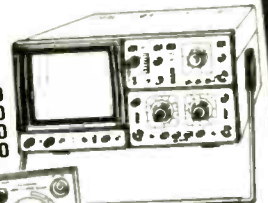
### HAMEG ALL WITH COMPONENT TESTERS

(8 x 10cm CRT) **£314.00**  
 ★203/6 Dual 20MHz **£418.00**  
 ★204/2 Dual 20MHz - sweep delay **£527.00**  
 ★205/2 Dual 20MHz - digital store **£583.00**  
 605 Dual 60MHz - sweep delay

**HUNG CHANG** (6" FLAT screen 615 3% CRT) **£295.00**  
 ★620 Dual 20MHz - comp test **£399.00**  
 ★635 Dual 35MHz sweep delay **£579.00**  
 ★650 Dual 50MHz sweep delay **£399.00**  
 ★615 Dual 15MHz Batt/mains **£195.00**  
**THANDAR SC110A** Batt mini 10MHz **£199.00**  
**CROTCHM 3031** 20MHz single track **£139.09**  
**GENERAL O5T5m** 5MHz bench **£320.00**  
**HITACHI V212** Dual 20MHz

### SCOPE ADD ON'S

**TD201** 200K sampling storage **£195.00**  
**HZ65** Component tester **£26.00**  
**DM358** Convert to 8 channels **£179.00**  
**LA160** 10 or 20MHz Logic analyser from **£395.00**



## POCKET SIZE INSTRUMENTS

(\*with case †case £3.91) (Digitals 3 1/2 digit)

(a) † **TC200** LCR Digital cap/res/ind. meter LCD **£85.00**  
 (b) † **KT905** 7 range digital cap meter LCD (PB) **£40.00**  
 (c) † **TH301** Digital temperature meter with probe LCD **£59.50**  
 (d) † **555** 20Hz to 150KHz audio generator **£47.50**  
 (e) † **K0m6** 1.5MHz to 250MHz TR dip meter **£43.04**  
 (f) † **KT50** 7 range digital CAP meter LCD (rot) **£40.00**  
 (g) † **2030ET** 27 range analogue meter 10A AC/DC - Hfe - cap **£37.90**  
 (h) † **5050E** 41 range FET m. meter 0.1µA 1000 meg etc **£28.65**  
 (i) † **102BZ** 19 range meter 10A DC 20K/V buzzer 10 meg **£12.61**

(j) **07** 20MHz logic probe TTL CMOS bleeder **£9.52**  
 (k) † **PFm200A** 200MHz LED 8 digit Freq. counter **£75.00**  
 (l) † **ST300** 0/300Amps AC 5 range 0/600V AC 4 ranges **£32.83**  
 1KOhm Res clamp meter **£65.00**  
 (m) † **501** Electronic insulation tester 500V DC 100 meg **£63.04**  
 (n) † **6060** Digital power meter 2Kw/4Kw true power 10A AC/DC - volts LCD **£11.50**  
 (o) † **X1/X10** Scope/inst probe kits X1/X10 250MHz BNC. **£22.95**  
 (p) **625** 50MHz logic probe plus logic pulser 0.5/400Hz

## DC POWER SUPPLIES

240V AC input  
 Stabilised variable output voltages. Direct meter reading volts and amps.

243 0/24 volts 0/3 amps DC **£43.26**  
 245 0/24 volts 0/5 amps DC **£56.26**  
 154 5/15 volts 0/4 amps DC **£33.26**

**DIGITAL/ANALOGUE** stockists for Thurlby, Thandar & GW psu's

## BENCH DIGITAL MULTIMETERS

3 1/2 digit LCD 100µV AC/DC 100mA 100m Ohm con buzzer **£89.00**  
 batt operated 20A AC/DC **£119.00**  
 3225 0.25% basic **£85.00**  
 3210 True RMS Version 0.1%  
 Tm355 3 1/2 digit LED 10A AC/DC 0.25% (Batt operated) **£99.00**  
 Tm351 LCO 0.1% £115.00; Tm 35L LCO 0.25% £95.00

**AC MILLIVOLT METERS** (10Hz - 1MHz) **£99.00**  
 416 1mV - 300V **£110.00**  
 417 300µV - 100V **£110.00**  
 427 2 channel version of 417 **£250.00**

## SIGNAL SOURCES

AC 220/240V operation:  
**FUNCTION SINE/ΣQ/TRIANGLE/TTL 0/p**

**Jupiter 500** 0.1Hz to 500KHz **£110.00**  
**TG101** 0.02Hz to 200KHz **£110.00**  
**TG102** 0.2Hz to 2MHz **£160.00**  
**Jupiter 2000** 0.2Hz to 2MHz **£149.00**

**TV-VIDEO** PAL VHF/UHF 5.5/6/6.5MHz Fm SOUND RGB 2 SYN/p/s Colour - B/W etc. **£199.00**  
**DIGITAL DISPLAY** (0.2Hz - 2MHz) **£165.00**  
 40 4 digit 0.2Hz - 2MHz Function **£215.00**  
 80160 6 digit 0.2Hz - 2MHz Function **£250.00**  
 8019 5 digit 0.2Hz - 2MHz AM/FM Function **£190.00**  
**SWEEP FUNCTION** (0.2Hz - 2MHz)  
 8016S FM mod. 6 types of wave-form **£190.00**  
 8019 see above

PRICES EXCLUDE UK VAT

ORDER BY PHONE OR POST OR CALL IN

MEASURING INSTRUMENTS SECURITY COMMUNICATIONS PUBLIC ADDRESS TOOLS AUDIO/TV/VIDEO/COMPUTER ACCESSORIES - SEE CATALOGUE

CATALOGUES TRADE, EDUCATION, INDUSTRY FREE ON WRITTEN REQUEST ON OFFICIAL LETTERHEAD

OPEN 6 DAYS A WEEK

RETAIL, MAIL ORDER SEND SAE (min 12" x 9") WITH £1.00 STAMP UK. EXPORT £2.00

TRADE, EDUCATION EXPORT AND ACCOUNT ENQUIRIES 01-258 1831. TELEX 298102 (TRANS G)

**AUDIO ELECTRONICS** 301 EDGWARE RD, LONDON W2 1BN 01-724 3564  
 ALSO AT HENRY'S 404 EDGWARE RD, W2 01-724 0323

ENTER 33 ON REPLY CARD

# RAE DEK ELECTRONICS

102 PRIORY ROAD, SCRIBERS LANE, HALL GREEN, BIRMINGHAM B28 0TB, ENGLAND

Telex No 333500 CROSAL G

Tel 021-474 6000

**Electron Tubes**

AMPEREX      AMPERITE

CETRON      CTC      Du MONT      EIMAC

ELECTRONS      GENERAL ELECTRIC      GENALEX

ITT      LITTON      MACHLETT      MULLARD

NATIONAL      OMNI WAVE      R.C.A.      RAYTHEON      STC

SIEMENS      SYLVANIA      TELEFUNKEN      THERMOSEN

VICTOREEN      VARIAN      TUNGSOL      BURROUGHS      WESTINGHOUSE

**R.F. Power Transistors**

MOTOROLA      GENERAL ELECTRIC      R.C.A.      JOHNSON

AEROTRON      THOMSON - CSF      REGENCY      WILSON      T.R.W.      MSC

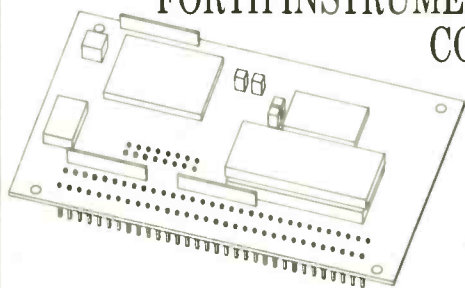
ACRIAN      TOSHIBA      NEC      MITSUBISHI      PHILIPS      AMPEREX

**CCTV EQUIPMENT · PA SYSTEMS · RADIO MICROPHONES**

ENTER 17 ON REPLY CARD



## FORTH INSTRUMENTATION COMPUTER



**TDS  
9090**

A powerful control computer based on the new Hitachi 6303Y and high level language Forth. 100mm x 72mm. 30K bytes RAM, 16K dictionary RAM/PROM, 256 bytes EEPROM, 16K Forth. You can attach 64 key keyboard, LCD and I<sup>2</sup>C bus peripherals. Built in are interrupts, multitasking, time of day clock, watchdog timer, full screen editor and symbolic assembler. 32 parallel and two serial ports. Single power supply and low power 3mA operational mode.

1 off £194.95 including manual and non-volatile RAM.

**Triangle Digital Services Ltd**  
100a Wood Street, London E17 3HX

Telephone 01-520-0442 Telex 262284 (quote M0775)

ENTER 25 ON REPLY CARD

## RUGBY TIME?

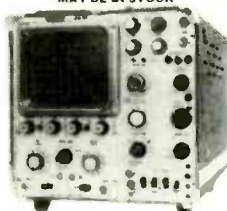
### MSF CLOCK IS EXACT

- 8 DIGIT display of Date, Hours, Minutes and Seconds.
- SELF SETTING** at switch-on, never gains or loses, automatic GMT/BST and leap year, and leap seconds.
- EXPANDABLE** to Years, Months, Weekday and Milliseconds and use as a STOPCLOCK to show event time.
- COMPUTER** or **ALARM** output also, parallel BCD (including Weekday) and audio to record and show time on playback.
- DECODES** Rugby 60KHz atomic time signals, superhet receiver (available separately), built-in antenna, 1000Km range.
- LOW COST**, fun-to-build kit (ready-made to order) with receiver
- ONLY £97.90** includes ALL parts, pcb, 5x8x15 cm case, by-return postage etc and FREE 'Kit News'. Get the **RIGHT TIME**.

## CAMBRIDGE KITS

45(WX) Old School Lane, Milton, Cambridge, Tel 860150

**SMALL SELECTION ONLY LISTED  
RING US FOR YOUR REQUIREMENTS WHICH  
MAY BE IN STOCK**



**Latest bulk Government release** - Cossor Oscilloscope CDU150(CT5312) £150 only. Solid state general purpose bandwidth DC to 35MHz at 5MV/cm. Dual Channel. High brightness display 18" x 10cm. Full delayed time base with gated mode. resolution 10NS. illuminated graphics. Beam finder. Calibrator 1KHz squarewave power 100 120V 200V 250 volts AC size W 26CM H 4CM deep WT 12.5 KG carrying handle. colour blue. projection cover front containing patented viewer and camera adaptor plate. probe (1) meters lead. Tested in fair condition with operating instructions. £150.00

**Racal Solid State Communication Receivers** - RA1217 Mechanical dept. readout 1 30MC S 1300 Racal RA17L Communication Receivers 500KCS to 30MC S in 30 bands 1MC S Wide - £175. All receivers

are all tested and calibrated in our workshop. supplied with dust cover. operation instructions. circuit. all fair used condition. **Racal Synthesizers** (Decade frequency generators) MA250 10MC S to 31.6 MC S £100 MA1350 for use with RA17 receiver £100 MA259Q precision frequency standard 5MC S 1MC S 100KHz £100 for £150 RA137 and RA37 LF converters 10 to 90K C S £40 to £75 RA98 5SE-15B converter £50 RA121 55B-15B converter £75 Plessey PR155G Solid State receivers 50K C S 30MC S £300 Transet Matrix Printers AF11R 5 level baudot code up to 300 bauds for print out on plain teleprinter paper £50 Army field telephone sets type F L and J large quantity in stock - 6 to £15 depending on type and quantity P.O.R Don 10 Telephone Cable full mic camera lenses £20 Night Viewing infra - red periscopes twin eyepiece 24 volt DC supply £100 EA (original cost to Government over £11000 EA. Static invertors 12 or 24 volt input 230 volt AC sine wave output various wattages P.O.R XY Plotters and pen recorders various P.O.R Signal Generators various P.O.R TF 893A Power meter £30 Racal frequency counter type 836 £50 Tektronix plug-ins 1A1 £50 1A2 £40 1A4 £100 M £50 All items are bought direct from H.M. Government being surplus equipment price is ex works. S.A.E. for enquiries. Phone for appointment for demonstration of any items. also availability or price change. V.A.T. and carriage extra

**EXPORT TRADE AND QUANTITY DISCOUNTS**  
JOHNS ROAD, WHITEHALL WORKS,  
84 WHITEHALL ROAD EAST, BIRKENSHAW,  
BRADFORD, BD11 2ER TEL NO. (0274) 604007.  
**WANTED: REDUNDANT TEST EQUIPMENT -  
VALVES - PLUGS - SOCKETS, SYNCHROS  
ETC. RECEIVING AND TRANSMITTING  
EQUIPMENT**

# Towards the intelligent radio

## RDS – the v.h.f. Radio Data System and its implementation in the UK.

SIMON SHUTE

Radio receivers have been with us now for getting on for seventy years, and the technological developments which have led to the present variety of models, ranging from the wrist-watch and credit-card sized miniatures, through the vast range of 'portables', to the sophisticated hi-fi tuners and communications-type receivers, are well known to the readers of a magazine such as this one.

The fact remains, however, that most present-day receivers would be instantly recognizable to our great-grandfathers, who would find the tuning knob and scale quite familiar, albeit lacking the evocative inscriptions *Allouis*, *Hilversum*, and *Droitwich!*

We take radio broadcasting very much for granted, the overwhelming majority of the UK population tuning in at some time in any given week, but there is nevertheless a massive lack of understanding of such matters as waveband, frequency and modulation system among most members of the public. Most people seem to find their chosen station by trial and error, and are understandably reluctant to risk disturbing the tuning to find another one.

Contrast this with television. A television receiver is invariably equipped with some kind of preset tuning, in many cases gives a visual indication of the selected station and in no case that I have ever seen mentions Megahertz anywhere on it! As a result, viewers are entirely adept at dipping into the offerings of all four channels without giving it a thought – or at least not a technical one.

As more and more radio stations come on the air, and as the emphasis is increasingly on v.h.f./f.m. where the potential is so much greater, it can only get more difficult for the listener to find the signal of his choice. There are several separate but related problems:

- with many transmitters required to provide a national service, inevitably with overlapping service areas, how to identify the best signal;
- with many stations playing similar music, how to tell which station has been selected;

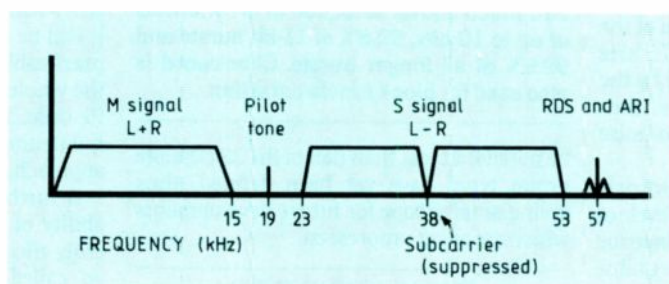


Fig.1. RDS data subcarrier is centred on 57kHz, precisely three times the pilot-tone frequency.

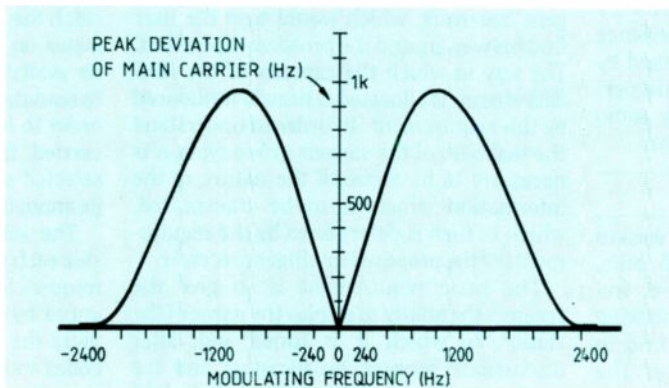


Fig.2. Modulation system used gives a null at 57kHz, ensuring compatibility with ARI system.

● for the mobile listener, how to benefit from the increasing number of 'filler' transmitters which are being built to fill in the remaining holes in the national v.h.f./f.m. services;

● again particularly for the mobile listener, how to find the local station serving the area he is passing through to get the benefit of the local information services;

● starting with a desire to listen to a particular station, how to find it without resorting to tables of frequencies.

It has been evident to engineers for many years that there was at least a potential solution to these problems, certainly on the v.h.f./f.m. band. Subcarriers of various kinds have been used for some time alongside the audio signals, and have provided several different applications. The idea that such a subscriber could carry coded information to identify the transmitter from which it emanated is not new, but no serious attempt had been made at drawing up the framework of international standards which would be an essential prerequisite for the

receiver industry, which must look at a supra-national market for its products to be viable, until the European Broadcasting Union addressed the task in the mid 1970s.

The v.h.f. Radio Data System which will be described in this article is the product of the international working group which was set up by the EBU and in which the BBC was an active participant. The development and experimental period spanned the years 1974-1982, and several countries participated in the work. The objective was to develop a system which would be rugged enough to provide a viable service under all practical reception conditions, but would be compatible with the millions of receivers which already existed in the hands of the public to the extent of not generating any audible interference. Experimental transmissions over the last decade have proved the viability of the chosen system, which was formerly endorsed by the EBU in 1984, and which was adopted as a recommendation by the CCIR in 1986. The internationally agreed designation for the system is RDS.

### DATA SUBCARRIER

The frequency chosen for the data subcarrier is 57 kHz – exactly three times the frequency of the transmitted stereo pilot-tone, and synchronized to it in quadrature to its third harmonic for stereo broadcasts. In the case of monaural broadcasts, the data subcarrier 'free runs' but with the same tolerance on its frequency as for stereo ( $\pm 6$  Hz).

This fixed relationship to the pilot tone is an important contribution to compatibility, minimizing the audibility of any beats being generated under multipath reception conditions or in receivers which are not properly aligned. The subscriber is modulated by shaped biphasic-coded symbols which represent the 0s and 1s of the raw data-stream. The modulation system used is two-phase phase-shift keying with a phase deviation of  $\pm 90^\circ$ , giving rise to a null at the sub-carrier frequency itself, with all the energy concen-

trated in an upper and a lower sideband, separated from the centre frequency by the data rate. It is this spectrum-shaping arrangement which ensures compatibility with the ARI system<sup>3</sup> which itself uses tones around 57 kHz. Figure 1 shows the baseband spectrum of the resulting composite signal including RDS, and Fig.2 shows the detail of the spectral components around 57 kHz.

Another important decision to be taken was the level at which the data subcarrier was to be injected. Clearly, an error-free signal will be easier to receive if the subcarrier is injected at a fairly high level. Equally, a high level of injection is bound to make it more likely that the data signal will interfere with the audio channel under non-ideal reception conditions, and of course the fact that the peak deviation of the radiated f.m. carrier is limited to  $\pm 75$  kHz means that any deviation that is used by the data signal is not available for audio, thus marginally worsening audio signal-to-noise ratio.

Extensive laboratory tests and on-air trials have confirmed that the chosen level of about 3% gives satisfactory performance for data decoding, and is compatible with unimpaired audio reception, although a somewhat lower level is required for full compatibility with ARI. The system specification allows the injection level to be between  $\pm 1$  and  $\pm 7.5$  kHz, and the BBC's experience indicates that there is little to be gained by using more than the minimum value permitted, with consequent benefits for audio compatibility under adverse conditions.

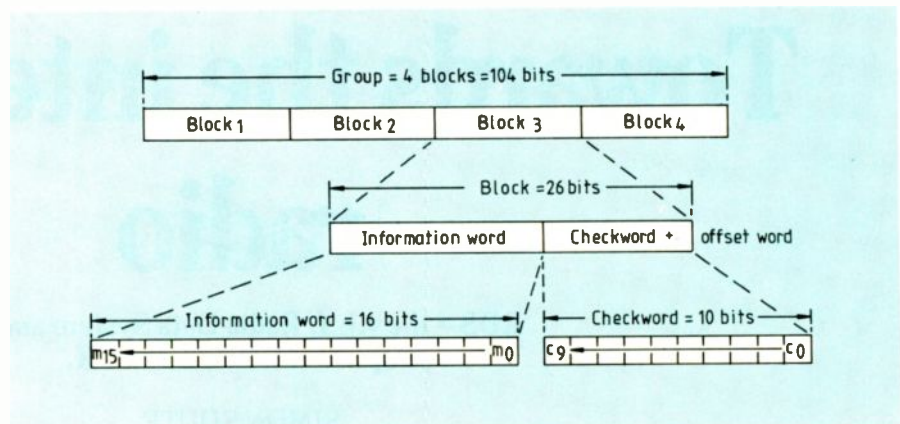
#### DATA SIGNAL

The 'raw' data rate of the data signal used to modulate the sub-carrier is 1187.5 bit/s, which is derived from the sub-carrier frequency itself by division by 48. Phase locking of all the signals in this way can lead to simplification in the design of decoders. The data-rate itself was constrained by considerations of compatibility and ruggedness, but the chosen figure gives adequate capacity for the various planned applications as well as allowing scope for future developments.

Data is transmitted as 16-bit words, each of which is associated with a special 10-bit checksum for error control. Four such 26-bit blocks form a 'group' and various types of group are specified to cover the various applications of the RDS system (Fig. 3). No additional bits are required for framing or other synchronization since this information can all be derived from the data stream itself by use of the special checksums.

An important feature of RDS is the flexible way in which the different group types can be inserted in random order to suit the requirements of the particular set of applications chosen. Each group is an entity in itself and can be decoded without reference to any other group.

Several group types are specified to cover all the defined data patterns, and it is up to the broadcaster to determine which groups, and in which order, he needs to transmit to satisfy the needs of the particular RDS service which he is implementing. It should



**Fig.3. 10-bit checksum provides information which allows detection of error bursts of up to 10 bits, 99.8% of 11-bit bursts and 99.9% of all longer bursts. Checkword is also used for block synchronization.**

be noted that less than half of the 32 possible group types have yet been defined, thus giving ample scope for future developments which are as yet unforeseen.

#### RDS AS A TUNING AID

The original primary objective of RDS was to open the way to the development of 'intelligent' receivers, which would help the user find his way around the broadcast spectrum. The way in which the capacity of the RDS data stream is allocated is heavily influenced by this requirement. In order to understand the make-up of the various group types it is necessary to be aware of the nature of the information which is to be transmitted, which in turn is determined by the requirements of the proposed intelligent receiver.

The basic requirement is to give the receiver the ability to display the name of the station to which it is tuned and, after discussions between broadcasters and the receiver industry, it was agreed that eight alphanumeric characters would be used. This eight character designation is known as the Programme Service Name, abbreviated to PS. The coding used is in accordance with ISO 646, which makes provision for the various accented letters, as well as the Greek and Cyrillic alphabets required in some European countries. For the Roman alphabet the coding is effectively the same as ASCII.

To allow a receiver to find a station that the listener has selected, it is desirable to have a more compact and differently structured code. This requirement is met by the Programme Identification code, (PI), which is a sixteen-bit code, unique to each radio station or network. Of the sixteen bits, the first four represent the country or origin of the broadcast, and the second four the service area (local, regional, national etc.). The remaining eight allow for 256 separately identifiable stations in each category.

The PI code is backed up by the addition of Alternative Frequency (AF) codes. These, each of eight bits, give the receiver information about other frequencies on which the same programme can be found in adjacent areas. By doing this, the mobile receiver can keep its memory updated and be ready to

retune to one of relatively few other frequencies when the one to which it is tuned fades. It will be apparent that this is a much more practicable operation than having to rescan the whole band, looking for the appropriate PI code. Each possible v.h.f., m.f. and l.f. frequency is coded using a look-up table approach.

A further improvement to the potential ability of an RDS receiver to offer its user truly effective automation is provided by the so called Other Networks (ON), feature. Consider the case of a receiver which is in use on a particular station, and the listener wishes to retune to another, perhaps to catch the News, having noticed that the time is just on the hour. With the information so far available, the receiver would again have to scan the band from one end to the other in order to identify the strongest signal which carried the appropriate PI code for the selected station. The time taken could well be annoyingly long.

The solution lies in transmitting alongside each station's signal, information about frequencies on which other services, referenced by their PI codes, can be found. ON gives the receiver a sequence of related PI codes and associated frequencies for each of the other services available in the service area of the transmitter in question.

An RDS receiver asked to tune to another station will therefore know where to look!

#### OTHER RDS APPLICATIONS

After allowing the requisite capacity for the above mentioned primary applications, it was evident that there would still be a considerable amount of spare capacity in the data stream. Various other potential applications for broadcast data alongside a radio service were identified and their formats standardized by the EBU working group. The flexible nature of the RDS coding strategy means that unwanted features can be omitted by the broadcaster with negligible penalty, and conversely that they can be added later in a compatible way.

The specified features are as follows.

**Clock time and date (CT).** A binary coded representation of time and date using Coordinated Universal Time (UTC) and calendar date. A local offset is appended to allow the RDS receiver to generate an appropriate display of local time.

**Programme type (PTY).** By allocating a different code to each of the various types of

programme – news, drama, pop-music etc. – it would be possible for a receiver to display the programme type, or even to search for a particular type among the available broadcasts.

**Decoder identification (DI).** A code could indicate which of various kinds of signal processing was in use so that the receiver could switch in the appropriate decoder, for example noise reduction.

**Music/speech switch (MS).** Broadcasters are well aware that it is impossible to satisfy the requirements of all listening conditions with a single speech/music balance. By identifying which is being broadcast, it would be possible for a receiver to switch between two volume settings which could be independently set by the user.

**Programme identification number (PIN).** By giving each programme a unique code, the receiver could be pre-programmed by the user to respond to it. An obvious application would be for unattended recording, but this would have copyright implications in most cases.

**Radiotext (RT).** Perhaps the most obvious of all, the datastream could be used to transmit text messages to the receiver for display. Newsflashes, sports results, titles of music are among the possible applications. The RDS specification gives a format for a 64-character display.

**Transparent data channel (TDC).** The RDS specification anticipates the requirements to download generalized data (e.g. computer software) via the RDS channel.

**Traffic information: RDS and ARI.** ARI (Autofahrer Rundfunk Information)<sup>3</sup> is in use in a number of European countries and provides a simple way of signalling broadcast traffic flashes to suitably equipped receivers. Although RDS as a system can coexist with ARI – the signals do not interfere with each other – it is recognised that the availability of the RDS datastream will make the ARI signalling tones redundant. An RDS receiver would be able to extract the necessary switching information from the digital stream with no additional circuitry, thus

saving the cost of a ARI demodulator. Codes have therefore been allocated in the RDS system which allow the precise emulation of the ARI functions:

**traffic-programme identification (TP)** is an on/off switching signal to indicate to the receiver that this is a programme which carries announcements for motorists;

**traffic-announcement identification (TA)** is also an on/off switching signal, but which indicates that a traffic announcement is actually on the air, thus allowing automatic switching away from another radio station or cassette listening.

It will be clear that as the RDS signal is digital, each of these codes represents no more than a single bit in the bitstream. It is thus practicable to repeat the codes frequently in order to give the required rapid response. Countries which use the ARI system are planning that the tone signalling arrangements will ultimately be phased out as RDS receivers become the norm.

### RDS GROUP STRUCTURES

Now that the various specified RDS applications have been described, the actual arrangement of the codes within the various different group types can be understood.

A group comprises 104 bits, made up of four 16-bit words, each with its own 10-bit checksum. As the bit rate of the signal is 1187.5 bit/s, it will be apparent that a little over eleven blocks are transmitted each second. Every block starts with the 16-bit PI (Programme Identification) code so that the repetition rate of this important part of the RDS signal is guaranteed to be sufficiently high to ensure satisfactory operation of automatic receivers. The second 16-bit word contains five bits which define the group type, and thus point to the nature of the contents of the other bits in this word, and the other two words in the group. The five

bits describe an A and a B version of each of sixteen group types. Of these 32 possibilities, only about half have been defined, leaving considerable scope for the development of new applications in a compatible way. The essential difference between the two main group types is that the B version includes a repeat of the PI code in the third word of the group. This clearly raises the repetition rate, but reduces the rate at which other RDS information can be transmitted.

By way of example, Fig. 4 shows the make up of a type OA group. After the PI code, the first four bits of the second word define this group as a Type 0 group, and the fifth B<sub>0</sub>, as the 'A' version of it. The microprocessor in the receiver will therefore 'know' what the meaning of the following bits is. It can be seen from the diagram that the next bit is the TP (Traffic Programme) code, and the next five, the PTY code. The TA (Traffic Announcement) flag is then followed by the M/S (music/speech) switch. The last two bits of this word are used to set up a four-block sequence, so that the 4-bit Decoder Identification code, and the eight character PS (Programme Service Name) can be spread over four consecutive OIA groups as shown. The fourth 16-bit word contains the ASCII characters for this PS code, and the third, two coded 'Alternative Frequencies'. The way in which these AF codes are used is given in full in the published specification but essentially a look-up table is specified to convert between the eight bit binary numbers and the actual frequencies in use.

It can be seen from the above example that not all the various RDS features are accommodated in a single group. It is therefore necessary to transmit a mixture of group types to suit the applications in use by a particular broadcaster. By adjusting the repetition frequency of the different group types, the appropriate data capacity can be allocated to the various functions. For example, the group type containing the Clock Time code (CT) only needs to be repeated once each minute.

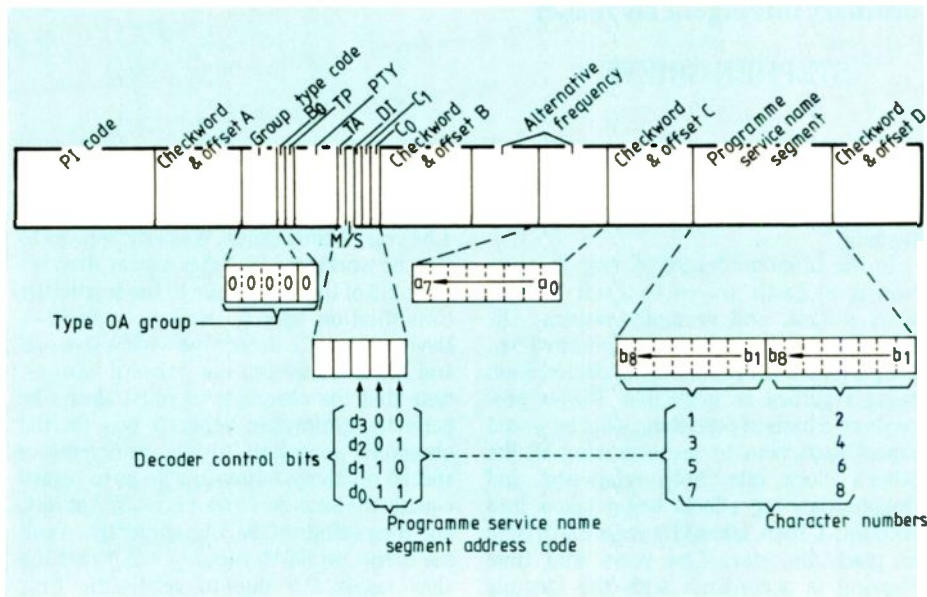
### IMPLEMENTATION OF RDS BY BBC

Once the specification for the RDS system had been finalized and agreed, there then existed a 'chicken and egg' situation. Receiver manufacturers were not keen to undertake expensive development work on receivers for a service which did not exist, and broadcasters were reluctant to spend similar large sums on starting a service when there no receivers purchasable by the public.

To unlock this position, the BBC was involved in informal talks with a wide range of manufacturers through 1984 and 1985, and through these contacts, a level of confidence was built up which allowed the BBC to start detailed planning for a service. As details of the plan began to emerge, the receiver industry demonstrated a corresponding increase in confidence, and by March 1986, the BBC felt able to give the formal go ahead to the first phase of the implementation programme in the certain knowledge that there would be at least some receivers available at or around the announced start date of October 1987.

**The plan.** In determining the precise details

Fig.4. OA group provides capacity for features shown. Other groups are specified to include the remaining features.



of implementation, it was necessary to balance a number of factors. The RDS specification provides for a wide range of features, many of which would require a considerable continuing input to render a viable service. Similarly, receiver manufacturers were feeling their way, and looked for a package of features which would get the service off the ground, without involving an excessive amount of development.

It was also becoming clear that the first RDS receivers were going to be car radios. Accordingly, the BBC planned to implement a set of features which would optimize the benefits obtainable from an automatically tuned car radio. In fact, these are the same features which would be required by an intelligent receiver, and so are in no way dedicated to in-car application. Additionally it was decided to implement the Clock Time and Date feature, since this could be done at little additional capital cost, and involved no continuous operating expenditure.

The RDS codes involved in automatic tuning are PI, AF and ON and of course PS is also included to give a positive read-out of the station name. In the case of the BBC networks, the information for these codes is generated centrally, and fed to the RDS encoders at transmitters by data links. In this way, the codes can be changed dynamically, which is necessary when, for example, the v.h.f. and m.f. services are 'split'.

CT is derived at each encoder site from a clock circuit which derives its reference from the low-frequency 'MSF' transmissions from Rugby.

**Phased implementation.** It became clear early in the planning period that it would not be practicable to muster the necessary re-

sources to equip the whole of the BBC's network simultaneously. However, the nature of RDS is such that it is vital for all the services receivable in a particular area to be coded, otherwise the intelligent receiver will have 'blind spots'. Having made the decision to spread the implementation geographically, rather than by service, it followed that the logical first phase was to cover England. In England, the pattern of broadcasting is less complex, with four national networks almost universally available, and the local radio chain forming an effective 'fifth network'.

Now that this first phase is virtually complete, planning effort is being devoted to solving the complexities of coding the various regional and 'opt-out' services which are broadcast in the national regions (Scotland, Wales, Northern Ireland) with a view to completing the installation programme in a single second phase through 1988/9.

**Travel information and RDS.** The possibility of providing an ARI<sup>3</sup>-type travel information service using the RDS equivalent codes has been mentioned earlier, and the BBC has been conscious of considerable interest by the car radio industry in this feature. From the BBC's point of view of course, the car radio audience is a minority, albeit an important one, and it would not wish to commit itself to providing a service which did not measure up to the normal yardsticks of a public-service broadcasting organization. The use of the ARI system in West Germany has been studied, and of course an important difference is the way in which all radio broadcasting is regionalized. This allows stations to broadcast traffic flashes which are at least partially localized.

In the case of BBC Radio, the obvious channel to use as the primary channel for traffic flashes is local radio, and it is along these lines that preliminary planning is taking place. It is planned to conduct a limited experiment next year whereby a group of local radio stations will be equipped to radiate the TA and TP codes, which will also be linked into the BBC network services, so that a listener to, say Radio 3, could choose to have the programme interrupted by traffic flashes from the local stations in the area he was passing through. There are various technical and editorial problems to be solved, but if successful, there is no reason why the service should not be extended nationwide in due course.

**Acknowledgement.** The author acknowledges the contribution of colleagues in BBC Engineering Division and in BBC Radio to the work described in this article, and wishes to thank the Director of Engineering for permission to publish it.

#### References

1. Design Principles for the VHF-FM radio receivers using the EBU radio-data system RDS. S.R. Ely and D.Kopitz. *EBU Review* April 1984.
2. Specifications of the Radio Data Systems RDS for VHF-FM Sound Broadcasting. EBU Technical Centre, Brussels. March 1984.
3. ARI Automatic Radio Information. H.G. Duckeck. Proceedings of SAE Conference on Audio Systems, Detroit. February/March 1984.

*Mr Shute is General Manager, Engineering, BBC Radio.*

# Relativity — a critique

**A typical relativist's exposition of the twins effect is scrutinized with a greater attentiveness than could normally be expected of either a confirmed relativist or the ordinary intelligent lay reader**

STEPHEN GRIEVE

In his book *Space and Time in the Modern Universe*, Paul Davies gives a detailed exposition aimed at showing the layman that the twins 'paradox' is not in fact paradoxical. As an authority on special relativity, Professor Davies is surely as recognizable as most are (at the very least, for the purposes of such an exposition), and does give an impression of total confidence in knowing exactly what he is saying and why he is saying it. Or at least, this would probably be the impression for most or all lay readers, while specialists confident in his qualifications would in general probably feel little if any need to read the exposition at all. Nevertheless, there are certain criticisms that one could at least seem justified in

putting to him, or to a similar authority: and in such a connection, perhaps merely to seem justified is to be so, if only educationally.

In the situation described, twin A leaves twin B on Earth, travels to a star 10 light years distant, and promptly returns. His relative speed throughout is a uniform  $0.9c$ , the periods of acceleration and deceleration being regarded as negligible. Davies proceeds on a basis of describing what he would expect each twin to see occurring to the other's clock rate, both relativistic and Doppler/time-lag effects being taken into account. A, then, takes 11.1 years Earth time to reach the star, 4.84 years ship time elapsing in accordance with the formula

$\sqrt{(1-v^2/c^2)}$ ; his arrival there being seen by B 21.1 (i.e.  $11.1 + 10$  signal-lag) years after his departure. Since in this 21.1 years B sees 4.84 years A time elapse, A's clock appears to B to be working 4.36 times slower than his own; 2.3 of this being 'due to the relativistic time-dilation effect'. Now, on pp.42-3, Davies states: 'To determine what A sees of B and his clock during the outward journey, note that the observations must always be perfectly symmetric between two inertial observers according to the principles of special relativity, which enable us to regard equally the situation that it is really A at rest, and B receding at  $0.9c$ . Consequently, A will see events on Earth running 4.36 times too slow (again 2.3 due to relativistic time

dilation). Because A reaches his destination after 4.84 years on his clock . . . should he look back at Earth at the moment of arrival, he will observe events occurring only 4.84/4.36=1.1 years after his departure.'

This is a very interesting passage. One can agree (see presently) that there is symmetry in the sense that each observer sees a reduction by a factor of 4.36 in the other's clock rate: but this symmetry is of a secondary nature, being in respect of the extent to which different amounts of observed time evince reduction – A, as indicated, seeing 1.1 years Earth time elapse in 4.84 years space-ship time and B seeing 4.84 years ship time elapse in 21.1 years Earth time. The layman at least could be forgiven, were he wrong, for remarking that a principle of perfect symmetry – and so special relativity, assumably – should require that each observer, during the periods of uniform relative motion, sees the same reduced-amount of time elapse for the other. Even could no other criticism be made, one could feel justified in suggesting that Davies has a case to answer. He could be accused of keeping mentally separate the idea of perfect symmetry he asserts and the manifest asymmetry he describes. However, he would perhaps be unlikely to feel that his position was seriously threatened. He himself finally acknowledges that an asymmetry is involved, as of course he must if he is to have an asymmetric outcome and not have a paradox. He ascribes this outcome to the fact that it is only A who undergoes acceleration and velocity reversal. The question of whether he is right to do so, which is not quite a straightforward one, will be treated of after further asymmetric aspects of his exposition have been pointed to – aspects upon which this question would seem to have no bearing.

According to Davies, as noted, A on arriving at the star sees 1.1 Earth years having elapsed. Considering 4.84/4.36, one can say that he indisputably does involve the formula  $\sqrt{(1-v^2/c^2)}$  in obtaining this apparent period; and thus he gives the impression of obtaining it by doing so. However, (as will be seen forthwith) 1.1 years can be expected solely, merely, on account of being the difference between A's transit time and that of light, under an implicit assumption on Davies's part that real values for these times are those according to B, 11.1 and 10 years respectively, rather than to A. While 4.84/4.36=1.1 may be seen simply as the division of a given period by a given reduction factor, it is surely far from irrelevant to note that 4.84 years is itself derived by application of  $\sqrt{(1-v^2/c^2)}$ , i.e. to 11.1 years B time. Taking account of this (and choosing to express 1.1 as 11.1–10), one may say that 4.84/4.36=1.1 expresses:

$$\frac{11.1 \cdot \sqrt{(1-v^2/c^2)}}{(11.1+10) \cdot \sqrt{(1-v^2/c^2)}} = 11.1-10, \quad (1)$$

i.e. a relation of 11.1+10 to 11.1–10; which simplified, and substituting t for 11.1 and k for 10, is:

$$\frac{t^2(1-v^2/c^2)}{t+k} = t-k \quad (2)$$

Now, it is a quite general truism that any pair of quantities x+y, x–y are related thus:

$$\frac{x^2z}{x+y} = x-y$$

where z (since  $x^2z=x^2-y^2$ )

$$\begin{aligned} &= \frac{x^2-y^2}{x^2} \\ &= 1-y^2/x^2; \end{aligned}$$

which in the case of t+k, t–k is  $1-k^2/t^2$ , which in turn must of course equal  $1-v^2/c^2$ , since v varies as 1/t. One may say that Davies's implicit application of  $\sqrt{(1-v^2/c^2)}$  to A's transit time is no effective application of this factor as such, being effectively merely part of an application of  $1-v^2/c^2$  to 11.1<sup>2</sup>, as (1) and (2) imply.

Even if the asymmetry of transit times is ignored, Davies can still be seen to treat A and B in qualitatively different ways. If A is really granted his relativistic right to say that 4.84 years is indeed 'B's travelling time', and exercises it, and agrees that the relative speed is 0.9c, then he must assume that light's transit time is  $0.9 \times 4.84 = 4.36$  years. Were Davies to treat A as he treats B, he would have A seeing B's completion of the outward phase after  $4.84 + 4.36 = 9.2$  years A time,  $4.84/2.3 = 2.1$  years B time. The apparent-retardation factor 4.36 would still apply, in this case resulting from  $9.2/2.11$ . So:  $(4.84 + 4.36)/4.36 = 2.1$  years, as would correspond to  $(11.1 + 10)/4.36 = 4.84$  years in the case of what B sees: but of course, Davies divides just 4.84 by 4.36.

Were Davies's treatment of what A should see thus similar to his treatment of what B should see, he would of course then be faced with two different amounts of Earth time elapsing on Earth during the outward phase of the experiment. Clearly, one may say that of these values, 11.1 and 2.1 years, only the former need be seriously considered, seeing that the latter is ultimately derived from it: but to deny thus the reality of the latter is to deny A his relativistic right to say that it is B who recedes at 0.9 c, and so is implicitly to deny the relativity postulate. What also would be incompatible with Davies's treating A in the manner in question, of course, is that for A's observation of B's clock rate to be uniform for 9.2 years, he would like B (B for 21.1 years, i.e.) have to remain unaccelerated for this period. This alone would violate the definition of the experiment, as also would what would make it seem otherwise the same, namely appropriate acceleration of the Earth and the star (ignoring the rest of the universe) so as to achieve velocity reversal relative to A. This serves to confirm the importance of the question of who undergoes acceleration(s); an importance, however, then, associated with an apparent implicit denial of the relativity postulate.

By now, anyway, one can readily appreciate that the 1.1 years A sees having elapsed on Earth cannot be derived through treating A in the same manner as B: so it is reasonable

to assume that this value will not be obtainable in any way other than that conveyed in equation (1) above, and that that equation is indeed the only true expanded version of 4.84/4.36=1.1. In other words, 1.1 years really does represent 11.1–10 years, so that A's observation depends entirely on periods occurring in B's reference frame; 11.1–10 years, moreover, necessarily considered as a natural concomitant (in the situation described) of B's observed period of 11.1+10 years. Regarding  $21.1/4.84 = 4.36 = 4.84/1.1$  in the light of these considerations, one may say that the secondary 4.36 symmetry actually depends upon the primary asymmetry Davies allows.

One further asymmetric feature to note is a simple qualitative difference between A and B as regards the way in which the  $\sqrt{(1-v^2/c^2)}$  clock-slows contributes to the factor 4.36 – which without it would be greater for A (i.e. 11.1/1.1) and smaller for B (i.e. 21.1/11.1). And of course – the very obviousness of which perhaps has tended to help it evade subtle scrutiny – only A is affected by this real retardation, in the situation described, as described, by Davies.

The impartial reader may now feel that Davies does have some explaining to do, regardless of whether he is right to ascribe the asymmetric outcome to A's changing reference frames through acceleration; that whilst he is describing an effect predicted by special relativity, he is not doing so in such a way as could be said to illustrate Einstein's (special) relativity postulate, for all his assertion of symmetry. During an instance of uniform relative motion, 11.1 years elapse in one reference frame and 4.84 in the other. In a more technical work, his ascribing the asymmetry to acceleration would presumably have involved invoking general relativity (though if he would have been right to do so, he could at least be censured on educational grounds, for stating: 'acceleration is absolute in special relativity' (p.44): thus conveying to the lay reader the impression that acceleration is indeed in special relativity, when it is not). But invoking general relativity could not have vindicated him, if one may judge from David Bohm's corresponding discussion in his own *The Special Theory of Relativity*.<sup>2</sup> Bohm (who in contrast to Davies stresses asymmetry throughout) says: 'The conclusions of (special relativity) evidently cannot be applied symmetrically in the frames of both observers, since one of them is accelerated and the other is not', and goes on to say: '... the different degree of "agings" (*sic*) of the two twins is fully compatible with the principle of relativity, when the theory is generalized sufficiently to apply to accelerated frames of reference' (pp.166-7). His speciousness, such as it is, can be said to depend upon an ambiguity of the word accelerated: which can mean either 'being accelerated now' or 'moving faster, having been accelerated' (in this case, i.e., faster than zero speed). The first meaning, at least, affords apparent justification for invoking general relativity; but only the second can apply to the whole experiment considered, since Bohm too specifies negligible acceleration periods. He cannot be actually using the first meaning, since he

states that special relativity holds for the Earth observer: as it could not do, were the slower-aging effect confined to the acceleration periods (as anyway, of course, would be out of the question). So, he is definitely using the second meaning: but this cannot justify invoking general relativity, since the 'accelerated' spacecraft is in uniform motion. Or if he is saying that general relativity has to be applied even in this case, then he implies that special relativity may never be symmetrically (and so never properly) applied: since the spacecraft, its uniform transit speed attained, could not be different from one that happened to be passing Earth at the same speed. How could it 'remember' that *its* was the accelerated frame?—Unless the absolute difference arising during acceleration were retained during uniform motion: as, then, Bohm implies, and as indeed Davies does. Both authors are compelled by special relativity's internal logic to say that there will be differential aging due to relative motion *per se*: but to get an asymmetric result, they are also compelled to associate this effect causally with the only apparent kinematic difference between the twins, namely the traveller's acceleration(s). But if they say that it is due to acceleration *per se*, they make relative motion *per se*, and thus special relativity even for the Earth observer, redundant. A solution to their problem is not hard to see, but for them as relativists may be so unwelcome as to be very much so. Namely, that what they have implied is indeed the case: the acceleration does render the resulting two inertial reference frames non-equivalent: as suggests the idea of absolute motion, upon an assumed meaninglessness of which, of course, special relativity as such depends. Let the prospect, then, be considered as unequivocally as possible:

(i) The relativistic or 'relativistic' clock-slowness effect, of which the differential aging of A and B is a manifestation, is due to relative motion.

(ii) This differential ageing, being an absolute effect, must be causally associated with the only other perceptible absolute difference between A and B, namely the former's being accelerated.

(iii) Regarding (i) and (ii), it could tend to seem that the differential ageing is being ascribed to two different causes in a way implying that (i) and (ii) cannot both be right: but given that both are right, such contradiction cannot be the case. The 'different causes', then, must be regardable as aspects of one causation. The only imaginable way in which this can be so appears in that, quite simply, A's acceleration is the cause of his motion relative to B. I.e., merely, acceleration has its effect through the relative motion it creates; an effect that persists after it itself has ceased and the motion is uniform. But this effect is an absolute one. One should, then, see no option but to say that an absolute effect is being had by uniform relative motion.

(iv) Such motion, therefore, here, cannot validly be regarded as merely relative, of A to B, in the orthodox Einsteinian sense: there is about it, however elusive, something corresponding to the idea of absolute motion.

Davies is right about acceleration: but not as a relativist.

Lastly as regards acceleration, a few words on the question of velocity reversal; which is of course but an aspect of the acceleration question, since the real clock-slowness is the same in both directions. Davies, however, tends to give the impression that it has some independent or additional significance, when on p.44, concerning the return journey, he says: 'The abrupt reversal of A's velocity means that although the clock rates are equally slowed and speeded by a factor of 4.36 for both A and B, A sees the speeded-up period occur for half his journey, whereas B sees this period occur for only the last 1.1 out of the total 22.2 years' trip. Hence their clocks must get out of step'. But since they must get out of step in any event, owing to relative motion, the observational circumstances determined by the velocity reversal must be regarded as incidental, if inevitable; they would get out of step even could B observe the speeded-up period for half the 22.2 years. The 1.1 year period is of course the inevitable natural compensation for the 21.1 year slowed-down period of B's observing the outward journey, ensuring that the clocks get out of step to no other extent. By stressing as he does the importance of what is seen by A and B, here, Davies tends to give the impression—to the lay reader at least—that the illusory Doppler portion of observed retardation contributes to the end result.

The implication that Davies is effectively not a relativist at all, in his exposition, and that the correctness of his description actually depends on his not being one, may tend to

**“What is also surely a valid option is the naive inference by one from whom light rays are receding in opposite directions, that they are at 2c relative to each other”**

seem incredible to much of a non-specialist readership in spite of the criticisms conveyed. He might, then, rely on silence in the face of them, so as to imply that they are beneath authoritative refutation. However, he surely can be said to have an educational duty to show clearly, if he can, that they are ill-founded and that he can indeed properly be called a relativist, in the sense of one who rigorously applies the relativity principle; for even if he does not imply absolute motion, it is clear that the impression of his doing so could be given to at least some readers of his exposition, especially the forewarned. No relativist, as such, would wish this impression to be given: if Davies cannot be seen successfully to defend his own position, perhaps other authorities will feel constrained to show that they themselves are relativists. But if it is the case not only that he implies absolute motion, but also that his exposition is essentially such as would be given by any similar professional and that paradox can be avoided in no other way, then

one will be justified in saying that there have never really been any true relativists. Their dealing with real effects predicted by special relativity would surely not be sufficient reason for retaining the title 'relativist', if the idea of absolute motion were reinstated and (so) the relativity postulate abandoned.

There seems no good reason for regarding this abandonment as incompatible with the experimental evidence to the prediction of which it leads. It is possible to make the right prediction for the wrong reason. In any event, the idea that this evidence as such confirms special relativity as such is demonstrably muddle-headed. The latter entails a symmetry of counterbalancing asymmetries; and Earth clocks and masses have not been observed from the reference frames of high-velocity particles in the experiments in question. To take the evidence from only Earth's reference frame as confirming special relativity as such is implicitly to adopt the argument:

(i) if both the required asymmetries are the case, then that for this reference frame is so;

(ii) the asymmetry for this reference frame (as the evidence shows) is the case;

(iii) therefore, both asymmetries are the case

—which is a straightforward instance of that quite basic error in logic, 'the fallacy of affirming the consequent'.

If absolute motion is the case, no other situation would seem imaginable than that the Earth has such a low absolute speed compared with light as to be virtually at absolute rest by this comparison, which of course is the one that matters where  $\sqrt{1-v^2/c^2}$  is concerned: which situation coincides, for terrestrial observers, with the relativist idea that any inertial observer's claim to be at rest is as good as that of any other moving uniformly relative to him. Considering the enormous and contrived energy expenditure required to accelerate even moderately sizable bodies to significant fractions of  $c$ , it would hardly be surprising if in the case of planets such speeds were virtually or altogether absent from the universe. In immediate response to this, it might be said that such speeds, and of whole galaxies relative to each other, are very common — i.e., where these galaxies are greatly separated even by cosmological standards. But if the implication of absolute motion is unavoidable, then the idea (or fact-image) of cosmological red-shift's betokening recession of galaxies itself falls under the gravest suspicion: since it would then imply, unconsciously, that our galaxy is at or near a centre of cosmic expansion. That the expanding-universe model has for so long been generally regarded as factual, and that so much professional theorizing has involved its assumption, could be expected significantly to augment whatever resistance there would anyway be to a re-acknowledgement of absolute motion. But some alternative interpretation of the red-shift is surely possible\*: will be necessary, unless relativists can show that they are indeed properly so called. And if it is the case that they cannot be so, † then any sense of great loss as regards special relativity itself,



at least, will be essentially an illusion.

Changes that would have to be made may or may not be thought self-evident. For one thing, the speed of light would have to be conceived of as absolute in itself (i.e. relative to whatever elusive 'medium-ness', \*or restingness; the idea of some sort of which is surely inseparable from the idea of absolute motion) and thus variable relative to observers at various absolute speeds, despite measured invariance – to regard which as an illusion, rather than as a bizarre-and-fundamental fact of nature, has surely always been a valid option. The limiting real relative speed would then naturally be  $2c$  (not, of course, that anything could approach any resting entity at faster than  $c$ ). What is also surely a valid option is the 'naïve' inference by one from whom light rays are receding in opposite directions, that they are at  $2c$  relative to each other. It is possible to imagine that that is the situation: whereas if one says that their relative speed must rather be  $c$ , according to the formula  $u+v/(1+uv/c^2)$ , one is implying that the value for  $c$  obtained by the observer in question is illusory (i.e., that though it is measured as  $c$  in each direction, it is really  $0.5c$ ), while relativists would also hold that the value  $c$  obtained in any reference frame is not illusory.

Still regarding what may or may not be illusory, there is the question of the dependence of apparent spatial separation of two entities upon the relative speed of their recession or approach. Davies (*ibid.*, p.44, italics his) says: '... this distance must appear to A to be only  $0.9 \times 4.84 = 4.36$  light years, rather than 10 light years as measured by B. The spatial distance, therefore, has shrunk ...'. First he stresses appearance as though to suggest that the shrinkage is an illusion, then he definitely implies that it is real. One may suspect that in this he is unconsciously taking advantage of the fact that the word observation is neutral in this respect. Or, since observation is regarded as the only means of direct access to physical reality, and all inertial frames are regarded as equivalent, the relativistic requirement here is that what may seem to be an illusion must nevertheless be real.

For such spatial variance to be real, however, space *per se* must consist in nothing but the separation of entities: may not be validly imagined as devoid of them, as would imply its absoluteness: must have an objective reality in its own right – which denial relativists may explicitly convey. One

\*The writer uses this expression rather than just 'medium' on account of the likely necessity of some more subtle idea than that of an ether, as such.

\*For instance, it could perhaps betoken a very gradually increasing charge-to-mass ratio of electrons.

†The writer has found nothing in other relativist expositions to discourage him from taking this view. (Apart from Bohm, e.g., Lewis Epstein: 'Danny has used some of his speed to carry him through space, and thus he fell behind Peter who used all of his speed for time travel.'<sup>3</sup> This need not be in context for one to see the implication of an absolute difference between reference frames.) He has found that Harald Nordenson has accused Einstein of unconsciously assuming classical time. Nordenson, though, rejects the  $\sqrt{(1-v^2/c^2)}$  effects altogether; and his work is perhaps too abstruse, and extensive in presentation, to hold the full attention of most of those tending to assume that he must be wrong.<sup>4</sup>

might ask how what is unreal can be really variable – which question, however, a relativist could simply reject, saying that what is variable in the sense conveyed is spatial separation, as distinct from the space-as-such to the idea of which it has given rise. But then the question arises of whether one can talk of real spatial separation without implying space as such. What can spatial mean, if there is no real space? – It can only be referring to an illusory feature of what is really a temporal separation only: so, if space as such is unreal, then so is spatial separation, as such, as termed. This might be compatible with mysticism, but clearly is incompatible with observational physics – for the purposes of which, then, one must regard space as having physical reality, being there, in its own right, and the apparent distance contraction as illusory (as distinct, one must expect, from length contraction of moving bodies\*). It is true that per a disembodied visual consciousness in a space devoid of entities, the idea of space could not arise. In the light of the foregoing, though, one may say that spatial separation of entities betokens space *per se*. Acknowledging

**“There seems no good reason for regarding this abandonment (of the relativity postulate) as incompatible with the experimental evidence to the prediction of which it leads”**

the reality of space, however, does not in itself help one in trying to imagine kinematic relation thereto.

And still on the question of medium-nature; if there is no such nature associated with space, or space-time, then light must be regarded as, in the words of George Gamow: 'vibrations taking place within the lumps of a certain physical entity (i.e., electromagnetic field) flying freely through the empty space.'<sup>5</sup> The writer has not discovered what response to expect if one asks a relativist how a physical entity can not only travel at  $c$  but also vibrate when  $\sqrt{(1-v^2/c^2)}$  indicates zero frequency. To note that zero frequency would mean zero quantum energy would be no explanation. Perhaps it might involve an assertion that light has 'zero rest mass', and so is not subject to relativistic mass increase, and that this effect is of course linked to clock-slowness... again no explanation, even were it not evasive. Anyhow, this idea of zero rest mass derives from the idea that the rest mass of an entity corresponds entirely to

\*Davies notes that this should not be imagined as a forcible squashing, but as a property of space itself. However: if a body is shortening as it undergoes acceleration, the trailing edge must gain on the leading edge: since this is incompatible with the single acceleration rate implied by a single engine, one would seem justified in regarding it as effectively forcible. Moreover, given that the space in which the body moves is not in itself affected, the body's consisting of fundamental particles plus ill-defined interstices/bondings may mean that the effect on the body as a whole, unlike that on the particles themselves, will be less than according to  $\sqrt{(1-v^2/c^2)}$ .

the kinetic energy of its internal motions (as tends to imply an indefinite series of sub-particles), the zero value being associated with a total externalization of such motion. But if all the motion is externalized in the sense conveyed, the entity is left with no sub-entities: one may then ask how it can still be an entity—Bohm (*ibid.*, p.118) does say: 'light... does not possess any such inner movements' (though cf. Gamow quotation). But light does have associated energy, so one may ask: 'How can it not be an entity?' And: 'Since it travels, how can it not be a travelling entity?' The problem as such disappears, if one acknowledges that its wave-aspect cannot but imply some medium-nature. Clearly, no material entity travels when a wave travels: the only such (at any rate physical) entity involved being the medium. So light, *qua* entity may be regarded as a transient form of resting matter, continuously created and then decreed at successive points in, and from, whatever medium-aspect is the case.

The view that the idea of absolute motion is meaningless is bound up with the assumption (in relativists perhaps an unconscious wish) that there is no possibility of detecting it. Still, if its, at least implicit, assumption is essential to describing potentially real instances of clock-slowness without paradox, then the idea of it surely must be somehow meaningful in spite of undetectability (or the fault is in the mind). But is it undetectable? Clearly, if realized, Davies's experiment would itself afford indirect detection. Moreover, if the Earth and the star (or far more likely, a pair of relatively slow spacecraft) happened to have significant absolute speed in A's or the opposite absolute direction, then A's absolute speed would be greater or less than the observed relative speed (this itself different from the real relative speed, owing to the absolute effect on B): so that the journey would take either less or more ship time than the predicted 4.84 years. Regret as one may that the situation should be thus complicated, such results would surely demonstrate beyond reasonable doubt the reality of absolute motion, whether or not they were a basis for accurate indirect measurement. These aside, though; if it is true to say that Davies's experiment as described would afford evidence of an absolute difference between inertial reference frames, then (considering that acceleration is of only secondary relevance) so does all the existing evidence that has been seen as corroborating special relativity.

#### References

1. Davies, P. C. W.; Space and Time in the Modern Universe (Cambridge University Press, 1977).
2. Bohm, David; The Special Theory of Relativity (New York: W. A. Benjamin, 1965).
3. Epstein, Lewis; A Myth for Special Relativity *New Scientist*, 8th. Sept. 1983, p.691).
4. Nordenson, Harald; Relativity, Time, and Reality (London: Allen & Unwin, 1969).
5. Gamow, George; Matter, Earth, and Sky (London: Macmillan, 1959), p.177.

Stephen Grieve was born in 1947 and took a degree in botany at the University of Hull.

# FEEDBACK

## Newton's Principia

I am astonished that T. Theocharis and M. Psimopoulos (August letters) should have interpreted my piece on Newton's *Principia* (February issue) as some kind of belittlement of that great work. The item was written to draw attention to and celebrate this scientific masterpiece, as any balanced reading of it will show. Einstein's relativity was mentioned once, and in parenthesis, purely as a matter of historical perspective.

In quoting Bertrand Russell's remark that force is "a mathematical fiction, not a physical entity" (from his *Principles of Mathematics*) I was certainly not trying to make any point about relativity, but rather a point about reality.

Before Newton defined force in the way he did, I imagine most people used the term, and understood its meaning, in much the same way as we do today in common parlance: the force of an explosion, the force of a blow, the force in a mechanical press, etc. These common-or-garden phrases, and the ideas behind them, represent our direct experience of energy as it manifests itself in the real world.

The world is as it is, and no amount of human analysis, definition, or verbal or mathematical description will make any difference to it. As soon as we invent a precise scientific definition like that for force we are producing an abstraction, for force cannot exist in isolation from the real phenomena of the world – just as voltage cannot exist in isolation from real electrical energy, temperature in isolation from real heat, or speed in isolation from something or other real moving about. These physical quantities are all abstractions, products of the mind, or *a priori* concepts. In that very abstraction lies their usefulness.

If, as your correspondents suggest, a champion boxer hit somebody (a relativist) in the face with considerable force (say 100 newtons), but a 'pure' force independent of any specific physical phenomenon, as in its scientific definition, if that were possible, the victim would not feel anything because there would be no energy delivered, just a "mathematical fiction".

I was under the impression that the inevitable chasm between the wonderful, brute reality of the world and the tidy mental framework that humans seek to impose on it was well understood by all scientists, artists, poets, philosophers and others who strive to express, describe or explain. Forgive me, then, if your correspondents make it necessary to labour the obvious fact that the map is not the territory.

Tom Ivall  
Staines  
Middlesex

## Oscillator amplitude stabilization

In the July issue, R. Shankar invites comments from readers to his proposed method of obtaining a ripple-free, rectified output from a sinewave oscillator, for use in the amplitude control circuit. A quadrature signal of the same amplitude is derived, the two signals are squared and then added. Since  $\sin^2 x + \cos^2 x = 1$ , the output will be d.c. proportional to the square of the peak amplitude.

This technique is not new; it is described in Burr-Brown's "Applications of Operational Amplifiers" from 1972. I tried the idea a few years ago and found that in spite of its apparent elegance, it is not a very practical method. As pointed out by Mr Shankar, squaring circuits are expensive and, for a low distortion, they also require careful offset and gain trimming, in order to completely balance out all a.c. components.

There is another principle, however, which may be put into practice without too many problems. What is required is a voltage which represents the waveform amplitude, which has no a.c. component in the steady state, yet still tracks the sinewave envelope during transient states with a minimum of delay. These conflicting requirements rule out the use of a straightforward rectifier. A sample-and-hold circuit, however, with a sinewave supplied to its input, will store the peak value of the waveform if its control terminal is driven by narrow pulses derived from the zero-crossing of a cosine (quadrature) waveform.

A fast-acting and accurate control loop is established as follows. The staircase envelope supplied by the sample-and-hold circuit is subtracted from a d.c. reference. The difference (the error voltage) is fed through a circuit which provides both the integral of the error voltage and the error voltage itself, the sum of these controlling the loop-gain in the feedback oscillator. By properly choosing integration time and gain constants, the amplitude can be made to settle within a few cycles of oscillation. With a well-designed amplifier, the distortion obtainable depends solely on the linearity of the gain control element, and figures below -90 dB (0.003%) are not unrealistic.

The principle described here was first put into commercial use in the Radford Low Distortion Oscillator (type LDO3) which I designed in 1972. This instrument was based on the parallel-T resonator while subsequent versions have employed the more modern state-variable filter structure, still with a sample-and-hold control loop.

Jens Langvad  
Solrod Strand  
Denmark.

## Flow diagrams

The article by David Sweeney on flow diagrams in your August issue rather underlines the drawbacks of using flowcharts instead of promoting their use. Flowcharts do not lend themselves to structured programming and, although his examples may be more flexible than usual, they are just as poorly structured.

Mr Sweeney tries to show that his method clarifies decision nesting (Fig.1.). In doing so, he compares his example to a Pascal fragment which he has listed without indentation. There is no way of working out which BEGIN goes with which END just by looking at it, so the nesting is indeed hidden. However, this fragment may be written out with normal indenting and, (surprise, surprise) decision nesting becomes quite clear again.

Mr Sweeney mentions escape routes and gives a really poor example as an illustration (Fig.4.). I have rewritten this example in pseudocode, which shows up two points: (a) there is a logical error in his example – if

Z is 20 then control passes to a test for  $Z > 50$ ; and (b), written out in this form, there is no need for an escape route at all. The use of an escape route as indicated is suspiciously like the Basic habit of sprinkling GOTOs around instead of trying to structure the code.

I would contend that pseudocode techniques may be of more benefit to well structured programs than Mr Sweeney's altered flow-chart method. As a final comparison, I give a pseudocode version of the CIRCGEN algorithm used in Fig.5 of the article, which was itself shown against the original type of flow chart. I wonder which readers would prefer.

I too started off learning computing with flow charts – the pseudocode came later. These days, I use pseudocode for all my programming projects in both high and low-level languages. Coupled with top-down design techniques, readable programs that work can be produced. How many people could adopt Mr Sweeney's method and say the same?

**Example PASCAL fragment, rewritten with normal indentation:**

```
IF B > 27 THEN
  BEGIN
    IF I < 50 THEN
      CALCVAL(Q)
    ELSE
      BEGIN
        B:=9
        I:=5
      END;
  END;
ELSE
  BEGIN
    B:=B+1
    C:=I+B/5
    X:=B*7
    CALCZFACT(X)
  END
```

**Fig.4, rewritten in pseudocode:**

```
BEGIN
  set A to B*2
  IF Z=20 THEN
    IF Z<=50 THEN
      set C to Z/7
    ENDIF
  ELSE
    set A to A/9
  ENDIF
  set I to I+1
```

END  
The above is exactly equivalent to the flow diagram, logical error included.  
Stewart Ross  
Inverness

# SATELLITE SYSTEMS

## Sputnik's 30th anniversary

October 4 this year is the 30th anniversary of the launching of the first artificial satellite of the Earth—Sputnik-1. The Soviet Union sent this small, spherical device into orbit at 1930 hours GMT on 4 October 1957. It was launched by a powerful, 27.5-m high rocket, with a lift-off thrust of 4.9 MN, from a missile test range a few miles north of the small town of Tyuratam in Kazakhstan. This town (about 63°E and 45°N) is just east of the Aral Sea and lies near the Syr Daria river flowing into that Sea. Nowadays a new town built to the north of Tyuratam is one of the permanent launching centres for the Russian space programme.

Our planet's first artificial satellite was an aluminium alloy sphere, only 580mm in diameter and weighing 83.6 kg. Much of this weight was made up by batteries for powering the two radio transmitters carried in the spacecraft. Projecting from the metal sphere were four whip antennas, with lengths ranging from 2.4 to 2.9 metres.

The satellite was propelled into a low elliptical orbit with an apogee of 942 km, a perigee of 228 km and an inclination (to the equatorial plane) of 65°. It was spinning at a rate of about 7 revolutions per minute. The orbital period was approximately 90 minutes, and so, with the rotation of the Earth, its radio signals were soon heard all over the world.

These signals were on frequencies of 20.005 MHz and 40.002 MHz and were keyed to give pulses of carrier about 300 ms in duration. The p.r.f. was initially about 108 pulses/s and gradually increased to 150 pulses/s until October 7, when the keying stopped altogether. Received signal strength was occasionally in the region of 35  $\mu$  V/m but much of the time was only just above the noise level. With the 90-minute orbital period the reception time for each pass of the satellite was usually not more than about 5 minutes, though some observers recorded times as long as 30 minutes – possibly the result of ionospheric refraction.

This journal published a detailed, five-page report (written

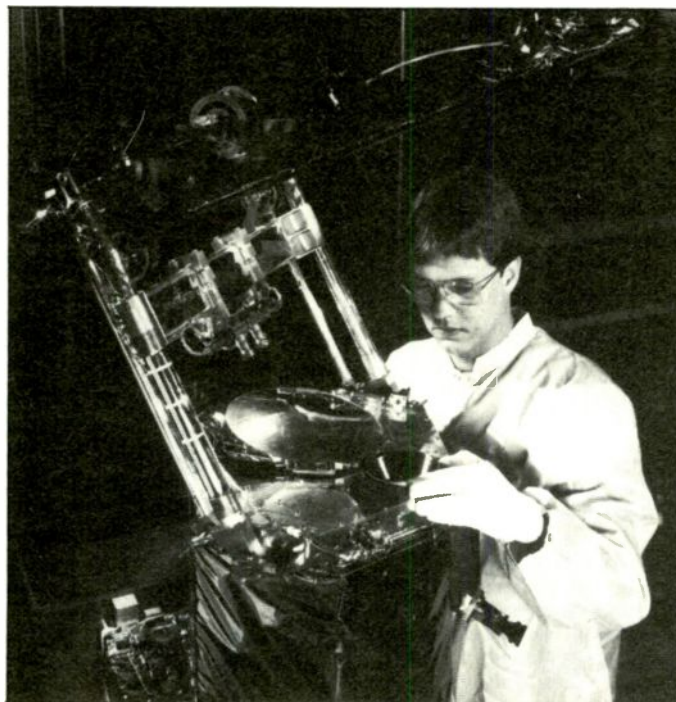
by the undersigned) on the observations made, in the December 1957 issue, pp. 574-578. In the UK these included measurements by the DSIR (now SERC), BBC, Post Office (now BT), RAE, RRE (now RSRE) and the Cambridge and Manchester universities' radio astronomy observatories. Using mainly Doppler and interferometric techniques, the observers were able to derive measurements of Sputnik's range, height and velocity and to calculate its track in terms of orbital period and inclination and the altitudes of its apogee and perigee.

When the radio transmissions ceased after 21 days, measurements were continued by means of radar. The spacecraft went on orbiting for 92 days. Atmospheric drag in the upper atmosphere reduced its orbital velocity and as a result it descended into denser

air and burnt up on 4 January 1958.

The decision to launch Sputnik-1 on 4 October 1957 was determined by several events – a combination of a natural phenomenon, human ambitions and historical circumstances. First of all, it took place in the International Geophysical Year (actually 18 months from July 1957 to December 1958) when many countries collaborated in studying the effects of a peak of solar activity on the Earth. The IGY planning committee had already passed a resolution recommending the use of artificial satellites for this research if they could be launched. So Sputnik was to some extent a response to a scientific initiative. In fact the satellite provided measurements of temperature in the thermosphere and exosphere, while its radio signals allowed ground

**The microwave imaging sensor shown here being adjusted at Hughes Aircraft is now orbiting the Earth at an altitude of 850 km in a US military weather satellite. Among other things it is designed to detect where rain is falling over land. With visible and infra-red imaging from meteorological satellites this is not normally possible because the rain-clouds themselves block the e.m. emissions at such wavelengths coming from below them. But the parts of the clouds not producing rain can be penetrated by the longer wavelengths in the microwave region. (In meteorology this normally means a range of frequencies at e.h.f. between about 20 GHz and 200 GHz.) The underlying rain structure thus observed may prove useful for forecasting hurricanes and typhoons. Operated by the US Air Force, the new metsat is also being used to measure wind speeds over the sea, moisture content in the ground and mountain snow packs, and the extent and thickness of ice coverage. Information obtained is being shared with international civilian weather agencies.**



observers to measure electron densities in the ionosphere.

But probably more influential in fixing this date was technological rivalry with the USA. The Russian team of experts, led by the aircraft and rocket engineer Sergei Korolev, were well aware that the Americans, under Wernher von Braun, were planning to launch a scientific satellite in September 1957. In the event von Braun's plan was turned down by the US authorities. Had it been accepted the USA might well have been the first country to go into space. As things turned out America became No. 2, when its Explorer-1 satellite was sent into orbit on 31 January 1958.

Another important stimulus was national prestige, and this has several strands to it. October 1957 was the 40th anniversary of the Bolshevik revolution in Russia and thus an appropriate time to draw the world's attention to the scientific and technological achievements of the regime that came out of it. Secondly, 1957 was the centenary of the birth of Russia's greatly revered space theorist, Konstantin Tsiolkovsky (1857-1935). Korolev had visited him shortly before he died. And thirdly, Nikita Krushchev, then First Secretary of the Communist Party of the Soviet Union, badly needed to generate some national, and hence personal, prestige to boost his declining position in the Politburo of that time. He had some powerful opponents. So it was Krushchev who was responsible for providing the necessary human and technical resources for the satellite project and giving approval for the launch.

Finally, the time at which Sputnik arrived can be seen as the result of a complicated interaction between engineering progress and historical accident. Here an important factor was the career and character of the project leader himself, Sergei Korolev (1906-1966). As well as being an aeronautical engineer, Korolev was privately a life-long enthusiast for rocketry and space flight. To begin with there was no official outlet in the USSR for this interest and Korolev pursued it through a small, private group of like-minded scientists and engineers who had got together to study rocket propulsion. Later this group was taken up and given government

# SATELLITE SYSTEMS

support by the then armaments minister Mikhail Tukhachevsky, and in 1933 the first Russian liquid-fuel rocket was built and flown.

But in 1937 Tukhachevsky fell victim to one of Stalin's notorious political purges, and with him his whole rocket team including Korolev. From then on Korolev was held in various grades of prison, including the special ones for scientists and engineers (as described in Solzhenitsyn's novel *The First Circle*), until Stalin died in 1953. He was then rehabilitated and soon afterwards elected to the Soviet Academy of Sciences as a reward for his work. Krushchev was impressed with Korolev's achievements in rocket research and promoted him under the new post-Stalin regime. As a result Korolev was now, in the mid-1950s, in a strong enough position to press for permission for a satellite project, and this was eventually obtained in the summer of 1957.

From the successful debut of Sputnik-1 followed the whole Soviet space programme. Recently the USSR has been launching satellites at an average rate of about two per week.

## Anglo-Japanese X-ray astronomy

The largest X-ray sensor to be carried in a satellite has just started a five-year programme of celestial observations. Called a large-area counter, it is the result of a collaborative research project in X-ray astronomy by British and Japanese scientists. In the UK, Leicester University and the SERC's Rutherford Appleton Laboratory built the detector proper, which has a sensitive area of 0.5 m<sup>2</sup>, and its analogue signal-processing electronics. In Japan the Institute of Space and Astronautical Science (ISAS) and Nagoya University provided the advanced, digital data-processing unit and the interfaces between the detector payload and the satellite. The UK work was funded by the British National Space Centre.

Japan also provided the satellite itself, called Astro-C, and launched it, in February this year, from ISAS's Kagoshima Space Centre at the south-

ernmost tip of the country's four main islands. Astro-C has a fairly low elliptical orbit with an apogee of 670 km and perigee of 505 km.

X-ray astronomy started about 25 years ago, using balloons and rockets to take the detectors as far as possible beyond the shielding effect of the Earth's atmosphere. It is one of several modern branches of astronomy which have extended our knowledge of the universe by making observations at wavelengths beyond the visible part of the electromagnetic spectrum. At the long-wavelength end of the spectrum there are infra-red and radio astronomy; at the short-wavelength end, ultra-violet, X-ray and gamma-ray astronomy. Satellites were a boon for X-ray observations and started to be used in 1970. Britain's Ariel-5 X-ray satellite was launched as early as 1974 and contributed to the general mapping of X-ray sources.

The significance of the large-area counter in Astro-C is that it is very sensitive and is being used for a kind of observation that has not been done before. It is measuring the intensity variations of celestial X-ray sources over different intervals of time, ranging from under a second to several months. These variations provide information on the size of the sources. The size information is important in studying those X-ray sources which are associated with black holes or neutron stars. Here the X-rays are thought to be the result of dust or gas accelerating spirally into the intense gravitational fields of these centres and becoming enormously hot in the process. Temperatures of 10<sup>8</sup> or 10<sup>9</sup> K are estimated and such high energy would result in the emission of X-rays.

Astro-C also carries two other astronomical instruments, an all-sky X-ray monitor from Osaka University, Japan, and a gamma-ray burst detector from Los Alamos, USA.

*Satellite Systems is compiled by Tom Ivali*

### Satellite Systems Correction

To those readers who might have been worried by a reference, on p.832 of the August issue, to the apparent transference of French Guiana from South America to Africa, an apology is due. French Guiana is quite stably based in South America. The error was not Tom Ivali's, but entirely ours.

## Second User Sales means First Rate deals...

when you buy our re-furnished, re-calibrated instruments from the world's leading manufacturers.

### MICROPROCESSOR DEVELOPMENT SYSTEMS

		Manuf Price £	Our Price £
<b>AMD</b>			
AM2940B	8080/Microprocessor System with Dual Floppy Disk Unit	-	1,900
AM29/6310	10MHz High Speed Trace Unit	-	550
AM29/6312	High Speed Trace Expansion	-	385
AM29/2065	64K High Speed Writable Control Store Board	-	300
AM29/8230A	System VDU	-	95
AM2945	Microprogram Control Store Emulator	-	1,750
AM8/8142	Development System with Dual Floppy Disk Unit	-	1,225
AM16/8050A	Real Time Emulator	-	POA
AM16/8002A	Z8002 Emulator Pod	-	POA
AM16/8064A	Emulation RAM Expansion	-	POA
<b>MOTOROLA</b>			
EXORSET 100	Software Development System	4,410	1,600
EXORSET 165	Software Development System	3,580	2,300
EXORMACS 68000	Multi-User Development System	21,830	1,100
M68KJUSE	68000 Emulator	1,400	100
M68SX010255	Exoterm 155 Terminal	1,120	150
EXORCISOR II	Single User Development System	5,200	800
EXORDISK IV	Dual Disk Subsystem	2,800	365
HDS 200	8-Bit Stand Alone Emulator	1,890	310
MEX146805 USE	6805 Emulator	2,350	100
MEX68120EVM	Stand Alone Evaluation Unit	500	50
MVME10	Single User 680X0 Development System including Integral Winchester Drive. Various options also available	14,000	POA
<b>ZILOG</b>			
ZDS 1/40	Development System including: Dual Disk Drive/Z80/Z80A Emulator and ASPIO option	7,800	1,400
ZSCAN	Z8001/2 Stand Alone Emulator	3,500	2,100
<b>GPTE</b>			
<b>HEWLETT PACKARD</b>			
HP1630D	43 Channel Logic State and Timing Analyser	-	3,500
HP4951A	Protocol Analyser (c/w I/F Pod and Integral Tape Drive)	4,200	2,300
HP3770B	Telephone Line Analyser	5,290	3,500
HP3777A	Channel Selector	-	2,250
<b>TEKTRONIX</b>			
318	Logic Analyser 16 Channel 50MHz	-	1,300
4041	System Controller (IEEE488)	9,300	5,400
2445	Oscilloscope, 150MHz, 4 Channel with probes	-	2,100
<b>FLUKE</b>			
1722A	Instrument Controller C/W Rackmount kit, options 2/6/8 parallel port, extra memory, IEEE 488/R232	-	5,750
<b>STAG</b>			
PP28	Portable Eprom Programmer. Full edit facility, RS232 I/O and 64K RAM for devices up to 2764	650	150
PPX	Universal PROM Programmer. Full edit facility, Integral CRT, 128K RAM, RS232 and TTL I/O	2,212	680
PP16A	Ganged Eprom and Micro Tester and Duplicator	1,031	350

Note: The various modules that are required with the above programmers are available on request. Please phone our sales team for further details.

For up-to-date list and prices contact Chris Griffin.

# TechniRent

## SECOND USER SALES

Park House, Downmill Road, Bracknell, Berks.

# 0344 411011

ENTER 36 ON REPLY CARD

# ADCOLA

THE ALL BRITISH  
SOLDERING EQUIPMENT  
MANUFACTURERS

## SOLDERING STATION 1456



**COSTS LESS  
THAN £60**  
plus p & p and VAT.

- adjustable temperature in handle
- electronic thermostat control — no moving parts
- spike and potential free
- simple plug in 4.75mm tips
- full supporting tip range
- low voltage power pack 24v 50v AC

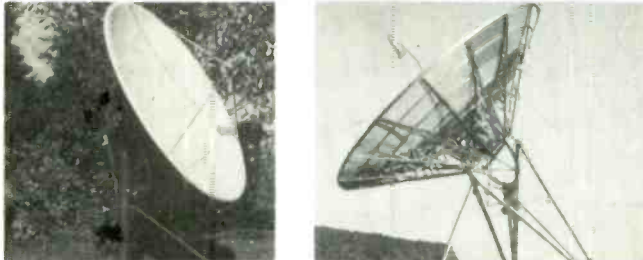
**ADCOLA**  
(Regd Trade Mark)  
**ELECTRONIC PRODUCTION EQUIPMENT**

FOR FULL DETAILS  
on all ADCOLA equipment  
contact Sales Department...

ADCOLA PRODUCTS LIMITED Gauden Road London SW4 6LH  
Telephone Sales (01) 622 0291 Telex 21851 Adcola G  
Sales Offices also at Bristol · Bournemouth · Preston · Glasgow

ENTER 6 ON REPLY CARD

## HIGH QUALITY — LOW PRICES



**4+11GHz SATELLITE TV RECEIVING EQUIPMENT**  
RECEIVERS, LNB's, LNC's, FEED HORNS,  
ANTENNAS, ANTENNA POSITIONERS,  
POLOROTORS, LINE AMPLIFIERS, ETC.

For further details contact:  
**HARRISON ELECTRONICS**  
Century Way, March, Cambs. PE15 8QW Tel: (0354) 51289

17/1/88

## EMS Power Systems



EMS manufactures DC Power Supplies and Battery Chargers both linear and switch mode in a range from 5 VA to 3.2 KVA.

Also a complete range of Standby, UPS and Mains Stabilizer Systems 35 VA to 1 KVA. EMS specialises in the manufacture of customised products and has a full design and development facility.

**EMS (Manufacturing) Limited,**  
Chairborough Road,  
High Wycombe,  
Bucks HP12 3HH.  
Tel: (0494) 448484

ENTER 26 ON REPLY CARD

## IEEE488

Technology that hits the mark

ines

Measstechnik  
Datenverarbeitung

- For IBM-PC/XT/AT/IC/RT6150 and all other compatible computers
- For PHILIPS PC :YES
- HP commands (enter, clear etc.) implemented
- SRQASYST compatible
- 64 kByte memory capacity
- DMA and INTERRUPT can be activated by simple commands
- HELP functions, SYNTAX monitoring in clear text
- BASIC, BASIC(compiled), (TURBO-)PASCAL, MODULA-2, FORTRAN, C, ASSEMBLER
- DOCUMENTATION-ANALYSIS-software for IEEE-488 systems e.g. transient-recorder, PHILIPS-memory oscilloscope

DEALER + OEM WELCOME

ines GmbH  
Neuenhofer Allee 45 Phone: +49-221-43 88 5E  
5000 Köln 43 Telex: 2627-221-42 33 gsklin  
West-Germany FAX: +49-221-49 18 71

ENTER 16 ON REPLY CARD



# TELECOMMS TOPICS

## Radiopaging by satellite

British Telecom Mobile Communications is to start trials of a radiopaging service by satellite at the end of the year. Claimed to be a world-first, it will enable drivers of long-distance lorries to be contacted immediately by their companies while they are on the road. This will be of particular value to road haulage firms operating on routes across Europe, the Middle East and Africa. It will provide an international extension to the existing radiopaging service operated in the UK by BT. Earlier this year BTMC announced that it would provide a transatlantic paging service through a joint operation with US-based paging company, Metrocast.

Customers taking part in the trials will make their satellite paging calls in exactly the same way as an inland paging call. Short messages of up to 90 characters can be sent with the characteristic bleep-tones.

Messages will be routed via the BT International earth station at Goonhilly Down to an Inmarsat satellite. The receiving equipment consists of a purpose-built flat-plate antenna, approximately 120 mm square and 100 mm thick, mounted on the lorry cab roof. It is wired to a small low-noise receiver mounted in a box underneath to form the most compact, mobile, receive-only satellite earth terminal yet designed and only consumes 6 watts. The associated combined alphanumeric page and printer fits conveniently on the parcel shelf in the cab.

## Diversity to the Channel Islands

A new 140Mbit/s digital route is to be provided across France to augment existing direct cable and microwave links between the Channel Islands and the United Kingdom. It is scheduled to enter service in November 1988, to provide greater diversity and security of communications.

The route will consist of a microwave link across the Channel from Dover to Boulogne, cable across the Normandy region of France and then, finally,

by microwave to Jersey, where it will link into the Channel Islands' own microwave system.

At present the Channel Islands are linked to the UK by three cables, having a total capacity of 3,240 telephone circuits, and by a standby microwave radio link, between the Isle of Wight and Alderney, able to carry 960 simultaneous calls. This standby link spans 120km (75 miles) and is affected by weather conditions while the existing cables are liable to damage by shipping.

A new submarine cable with optical fibres is planned to be brought into service by early 1989. Initially it will operate at 140Mbit/s with two fibre pairs to provide a 4,000 circuit capacity.

## Cellular anti-dumping action by EEC

The European Economic Community (EEC) has initiated an anti-dumping proceeding against Japanese and Canadian cellular car-telephone manufacturers, following a complaint brought before it by Motorola Ltd. The complaint is that they are selling cellular car telephones and transportable units in the UK at lower prices than they sell such products in their home markets.

Companies named in the complaint include JRC, Kokusai, Matsushita, Mitsubishi and NEC, all of Japan, and Novatel Communications of Canada.

In its complaint, Motorola said that dumping by these manufacturers is severely injuring the European cellular car-telephone industry during its early growth stage. Although it recently reported strong demand for its new cellphones manufactured and sold in the UK, Motorola said that the underlying price structure of the industry has been driven down to levels where it will be difficult or impossible to achieve a reasonable rate of return on its investment due to this dumping.

According to Motorola, Japanese and Canadian producers have sold cellular car telephones in the UK at dumping margins (the difference between home market and export market price) of as much as 200 per cent

or more. If its complaint is upheld by the EEC, special dumping duties will be imposed on cellular car telephones brought into the EEC by manufacturers currently dumping products. When Motorola successfully pursued a similar anti-dumping proceeding in the US in 1984-85 the result was anti-dumping duties of 58 to 108 per cent imposed on Japanese exports to the US.

## Ferranti voice messaging for Sweden

Swedish Telecom Radio has purchased a Ferranti VM Director voice messaging system for use on the Nordic Mobile Telephone Network. It will provide voice messaging for users of both the long established NMT 450 system and new NMT 900. It will be sited with the Ericsson AXE10 exchange at Sundsvall where the NMT900 trial was carried out.

Ferranti claims that its success with Swedish Telecom follows on from the experience that it has gained in providing equipment to the UK cellular telephone networks.

## Voice and data switch for the smaller user

Ericsson has staged the European launch of a small version of its MD110 digital PBX, which is claimed to make integrated voice and data communications economic for the small business. Known as the MD110/20, it is cost-efficient for just 40 extensions whereas previously digital voice/data PBXs have only been economic for users needing over 100 lines. Consequently, the new switch is expected to open a significant market for the company among small businesses as well as to national organizations, where it will allow them to connect even the smallest branch offices into a single network.

As well as providing advanced telephone facilities, such as automatic call-back, the MD110/20 can simultaneously carry point-to-point digital data communications and local area net-

works. It transmits all traffic via standard telephone wiring, thus eliminating the need for dedicated data networks for office automation systems. It also makes a new lan-type voice networking practice economic for high-rise buildings. The MD110/20 is small enough to serve individual floors with the PBXs on each floor being linked to form a single exchange using channels on an optical backbone. This mirrors current lan practice, and means that all of an organization's lan and PBX networks can be economically carried on a single cabling system, relieving congested ductwork.

## BT managed communications services

British Telecom International has purchased a System 400 integrated communications system from System Designers Ltd. BTI will use it for its Primex facilities managed service. This provides a secure, 24hour availability network configured to meet the needs of large users. It gives these customers a private, international packet-switched network for integrating facsimile, teleprinter, teletex and data transmissions. These networks incorporate a new technique which automatically converts telex messages to fax format as well as supporting the CCITT X.400 MHS (message handling service) recommendations.

BTI's first Primex customers, who will be using it as a stand-alone system for internal communications only, are Japanese business houses Matsushita and Marubeni. It was announced several months ago that these two companies had entered into contracts worth £4m with BTI for the provision of these services between Tokyo, London and New York.

The integrated communications market is assuming an ever greater importance for business with the markets for such systems expected to grow to around £1000 million per annum by 1990.

According to SDL, System 400 is the only fully integrated, fault-tolerant system currently available which is capable of handling

# TELECOMMS TOPICS

the message volumes required by the PTTs, the very large multinational companies, and the international banks. It is a family of products which enables different makes of computer and different communications methods to be linked on a worldwide basis.

In terms of pure volumes of communications, store and forward messaging switches carry the heaviest traffic with many thousands of messages being transmitted every day within some organizations. SDL believes that the message switching module build into System 400 is likely to be one of the most widely used in the growing markets.

## Largest ever opto order

In the largest ever order placed in Europe for optical fibre cables, BICC has won a contract worth £6.5 million from British Telecom. The order is to supply over 41,300km of optical fibre cable for BT's junction network linking the main trunk and local exchanges.

All the optical fibres for the cable will be manufactured at the Optical Fibres factory at Deeside, a joint venture between BICC and Corning and the largest optical fibre manufacturer outside the USA.

BICC will supply both its proprietary ribbon product as well as the more traditional loose tube cable. Both products are specified for operation at both the second and third "windows" of silica glass where optical fibres achieve their highest transmission capacity and optimum transparency, respectively.

## Secure voice and data network for RAF

British Telecom is to supply the Royal Air Force with a secure voice and data network and Honeywell Bull has been awarded a £7.5million contract for the message handling sub-system. The network, to be known as Uniter, will consist of 90 PBXs

servicing 14,000 extensions serving more than 50 user sites in the UK.

BT will act as sub-contractors to the Defence Systems division of GEC Telecommunications under the contract, believed to be worth in excess of £100 million, for the network which is to be designed, installed and commissioned by BT between now and 1990. The switching equipment to be supplied is a military variant of the BTeX digital BPX, with a number of added special facilities, as well as hardening against electromagnetic pulse (e.m.p.).

British Telecom's director of customer marketing, Nick Kane, said that "This is one of our largest defence contracts yet and a milestone in the development of British Telecom's strategy as a supplier of large integrated networks."

The message handling sub-system contract involves the supply of 40 DPS6 minicomputers, 500 terminals and a range of applications software. While Honeywell Bull will build the minis itself it will obtain the application software from System Designers Scientific, who will bring to the project experience in message switching and communications systems; and the terminals will come from Lynwood Scientific Developments, both companies acting under sub-contracts from Honeywell.

## Inmarsat simulator for Finland

Finland's Rauma Nautical College has ordered a Racal Marine Systems' SC9050 satellite communications simulator. It is a procedural and protocol trainer designed to make students familiar with the Inmarsat maritime satellite system. Developed in conjunction with Inmarsat, it has full compatibility with the "live" satellite system and incorporates several features which have still to become operational in the real system.

The simulator consists of a number of student "ship station" positions with both telex and voice communication facilities together with an instructor's

position with hard copy recording facilities for later evaluation and appraisal.

The advantage of the SC9050 is claimed to be its low cost and flexibility, ideal for nautical colleges and training schools. If an operational ship earth station were used, only one student at a time could be trained and expensive charges would be incurred. This simulator is a development of the first generation system installed and operating in Leith Nautical College in Scotland.

## Increased System Y capacity

With the recently completed expansion to its Scunthorpe factory, Thorn Ericsson now has a capacity to manufacture 700,000 lines of AXE 10 equipment per annum. AXE 10 is often referred to as 'System Y', because it is the public telephone switching system adopted by British Telecom as the alternative to System X.

When Sir George Jefferson, BT's chairman, recently opened the £14 million extensions to the Scunthorpe factory he said that "British Telecom's procurement policy is to support British excellence and efficiency whenever we can. In simple terms, that means that we always look at the benefits of buying British as part of our procurement decisions – and Thorn Ericsson's Scunthorpe manufacturing operation is clearly seen as a benefit to British Telecom. It certainly proves that our critics were wrong in suggesting that our digital exchange purchasing policy would drive orders and jobs out of Britain."

He went on to say that "Competition does produce benefits for all concerned, and I believe that System X is today a more effective and attractively-priced product on world markets as a result of our decision to place orders, on a continuing basis, with the manufacturer of an alternative system here in the UK.

"So, like our customers, British Telecom now has a choice. Inevitably, orders for each system will vary from time to time, according to such factors as, for

instance, the competitiveness of the tenders, the capacity of the respective manufacturers and the amount of work they already have in hand."

## Plessey launches signalling systems

Plessey has launched two signalling systems for use in telephone switching systems. One links a PBX to ISDN while the other gives an organization the opportunity to provide transparency of voice features across its network without having to resort to digital trunks.

The former, DASS II (Digital Access Signalling System), allows the PBX to take full advantage of all the power of the public network. Current digital PBX's, such as the Plessey ISDX, share many of the characteristics of System X as used in the public ISDN – digital switching, an integration of voice and data switching, many added-value features and great flexibility.

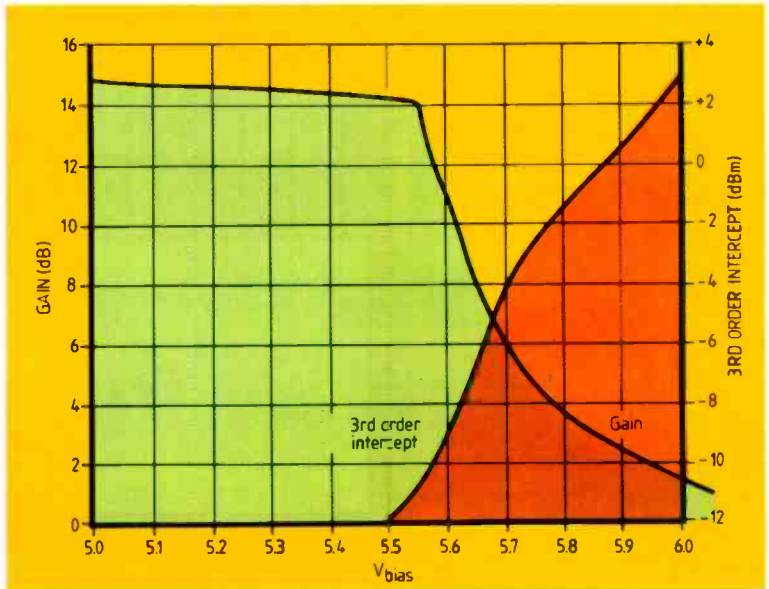
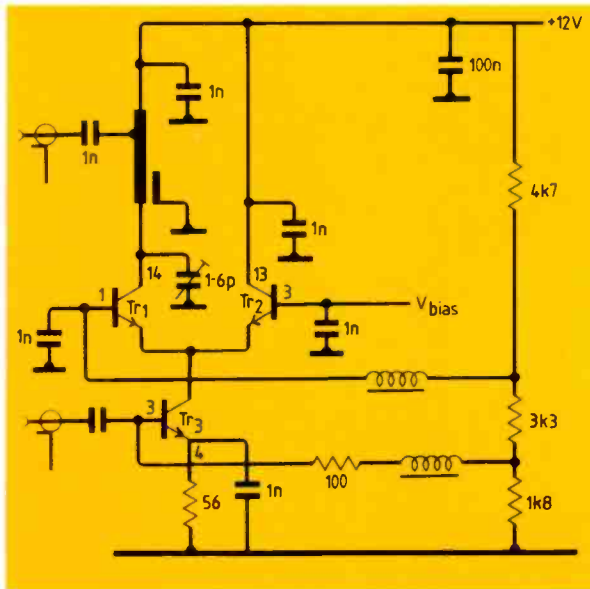
The signalling protocol employs the DPNSS (Digital Private Network Signalling System) hardware together with appropriate firmware to terminate the 2Mbit/s link from the ISDN. This provides up to 30 64kbit/s information 'B' channels which may be employed for speech or modemless data transmission. Control information relating to all the channels in the ISDX/network link is aggregated into a common signal channel.

APNSS (Analogue Private Network Signalling System) was developed from DPNSS. It provides a number of networking solutions to the end-user. Applications will vary from organizations with growth in mind and requiring APNSS as an interim solution, to businesses such as banks, insurance companies or travel agents requiring transparency to be extended to their sub-branches but are unable to justify the expense of a digital link.

*Telecomms Topics was written by Adrian Morant*



# APPLICATIONS SUMMARY



## 900MHz gain- controlled amplifier

Transistors in this 900MHz amplifier with voltage-controlled gain are all from one i.c. Plessey's SL2364/5 arrays consist of two long-tail pairs whose tail transistors are internally current-mirrored to similar transistors. Typical  $f_t$  of the bipolar devices is 5GHz.

Collector load in the amplifier is a 14mm length of 75Ω stripline resonated with a 1-6pF capacitor. A small loop of stiff wire grounded at one end and located a few millimetres above the stripline forms the transformer secondary winding. Graphs for gain and third-order intercept versus voltage

bias are shown. At full gain, noise is 9dB.

Other circuits in the SL2364/5 application note are a 150-300MHz frequency doubler, a 100-300MHz frequency tripler and a single-balanced mixer. These circuits have neither coil winding details nor explanatory text.

## Mixer design using admittance parameters

Using small-signal admittance parameters simplifies transistor mixer design. Note AN238 from Motorola details the technique and presents three design examples including this mixer for converting 30MHz r.f. to 5MHz i.f. using a 35MHz local oscillator.

Both local oscillator and r.f. signals are base injected. For the 2N2221A working at 2mA collector current and 10V collector-emitter voltage,

$$Y_{11e} = (6.25 + j9.5) \text{ mmhos (30MHz)}$$

$$Y_{22e} = (0.027 + j0.28) \text{ mmhos (5MHz)}$$

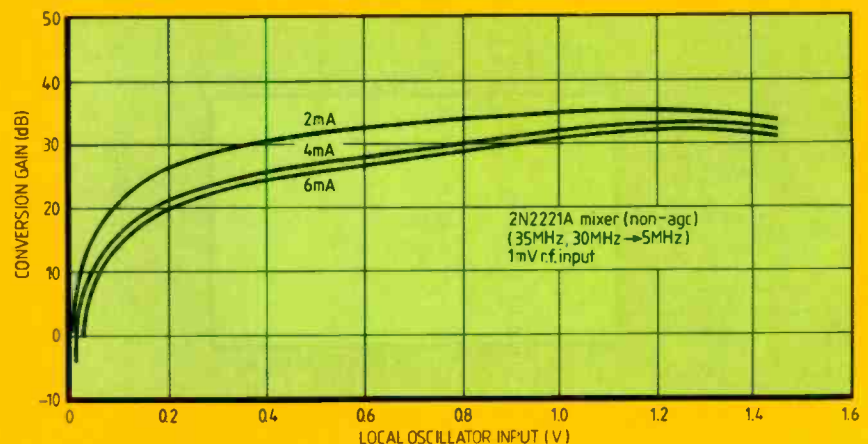
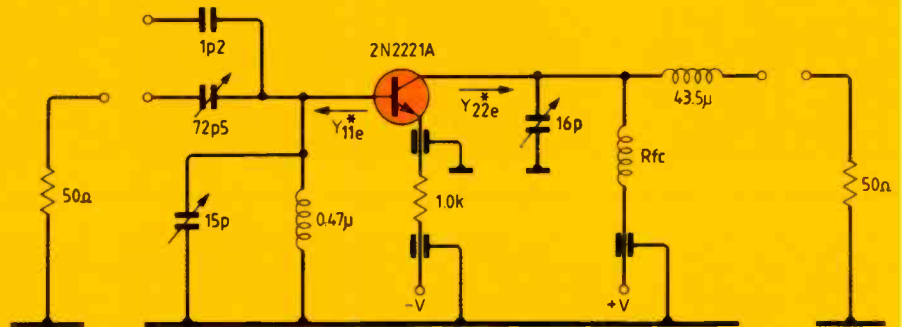
Consequently, design criteria for the input network are,

$$\frac{1}{Y_{11e}^*} = (160\Omega \parallel -50.5\text{pF})$$

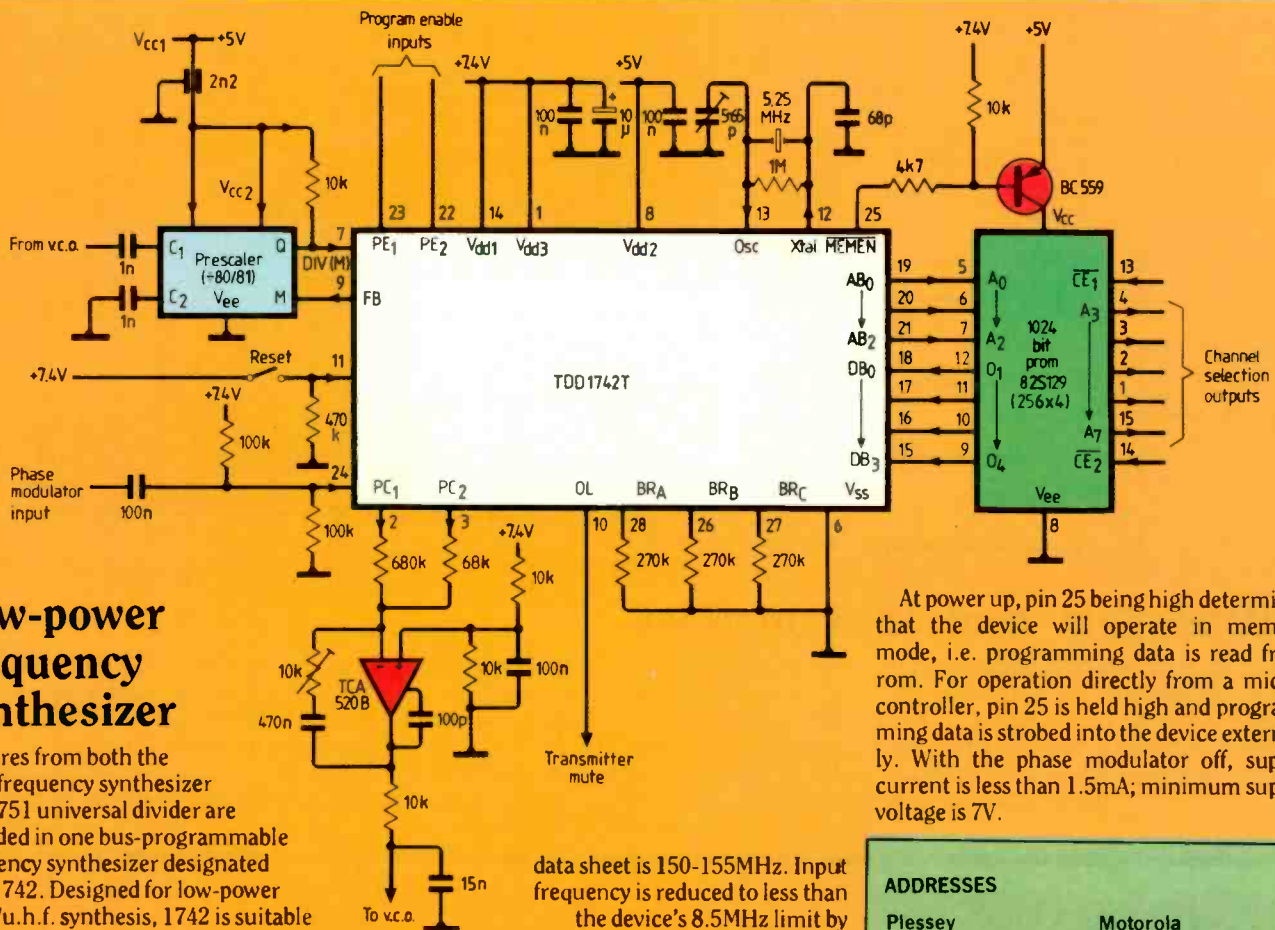
and for the output network,

$$\frac{1}{Y_{22e}^*} = (3700\Omega \parallel -0.9\text{pF}).$$

Full equations for obtaining component values are included in the note. Characteristics of two further mixer circuits, both for 250MHz conversion to 50MHz output, are also given.



# APPLICATIONS SUMMARY



## Low-power frequency synthesizer

Features from both the 4750 frequency synthesizer and 4751 universal divider are included in one bus-programmable frequency synthesizer designated TDD1742. Designed for low-power v.h.f./u.h.f. synthesis, 1742 is suitable for portable and mobile radio applications. It has a high-gain phase comparator with sample-and-hold capacitor and phase-modulation circuits.

Frequency range of this application circuit from Mullard's TDD1742 development

data sheet is 150-155MHz. Input frequency is reduced to less than the device's 8.5MHz limit by an external prescaler. Fixed and programmable dividers reduce 5.25MHz crystal frequency to a 12.5kHz reference which feeds the device's two phase comparators. Sensitivity of the v.c.o. is 1MHz/V and loop bandwidth is 300Hz.

At power up, pin 25 being high determines that the device will operate in memory mode, i.e. programming data is read from rom. For operation directly from a micro-controller, pin 25 is held high and programming data is strobed into the device externally. With the phase modulator off, supply current is less than 1.5mA; minimum supply voltage is 7V.

### ADDRESSES

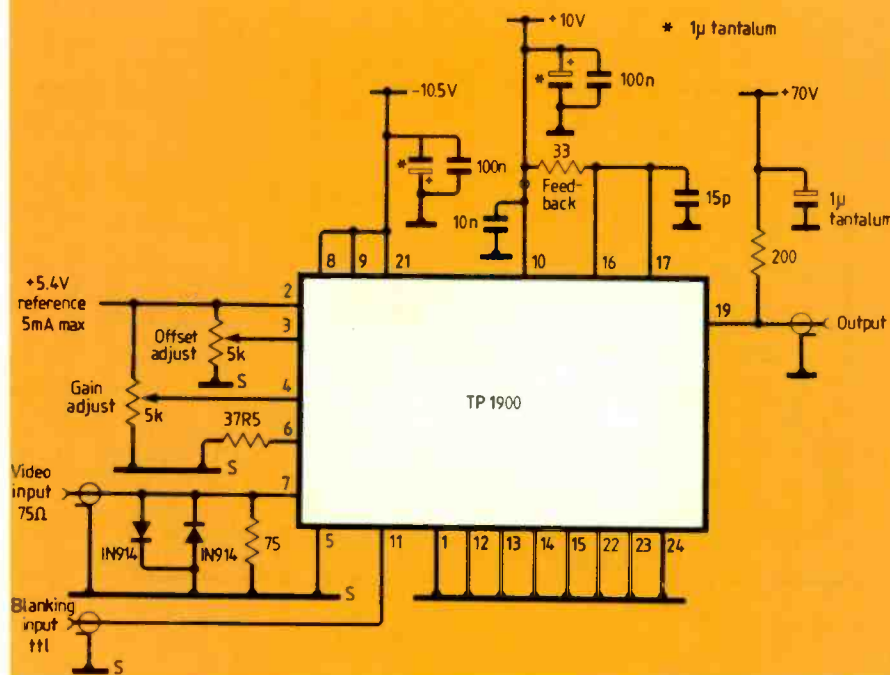
Plessey  
Cheney Manor  
Swindon  
Wiltshire SN2 2QW  
0793 36251

Motorola  
STC Electronic Services  
Edinburgh Way  
Harlow  
Essex CM20 2DF  
0279 442971

Teledyne Philbrick  
Microcircuits  
MCP Electronics  
26-32 Rosemont Road,  
Alperton  
Wembley  
Middlesex HA0 4QY  
01,902 6146

Mullard  
Mullard House  
Torrington Place  
London WC1E 7HD  
01 580 6633

## 175MHz video amplifier/driver

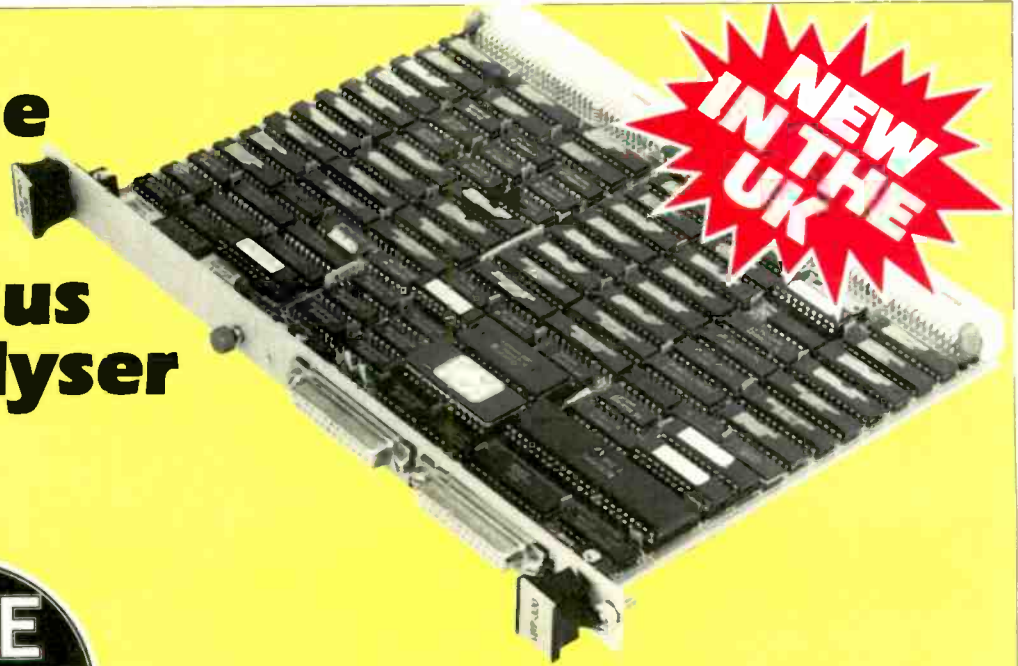


A differential preamplifier, variable-gain stage and class-A output stage within the TP1900 convert 75Ω video input at 714mV (RS170) to c.r.t. cathode drive. For a 55V swing into 200Ω and 6pF, output rise time is 2.5ns so the device is suitable for high-resolution monitors; gain is variable from 0-85V/V.

Here the device is shown connected for 0.5V common-mode input, and output from a 5.4V buffered zener reference feeds gain and offset potentiometers. Blanking input sets output to 2V below the black-level, which is set using the offset control. This circuit is from the preliminary data sheet for the Teledyne TP1900.

# The VMETRO VME Bus Analyser

The Board Level  
Specialists



Available from Dean Microsystems is the VMETRO VME Bus Analyser. Ideal for solving VME Bus problems and an ideal tool for the system integrator, it combines all the important features of an expensive Logic Analyser dedicated to the VME Bus in one simple to use menu driven VME Module.

DEAN MICROSYSTEMS LIMITED  
7 HORSESHOE PARK, PANGBOURNE, BERKSHIRE RG8 7JW. Tel. 07357 5155 Telex 846396

ENTER 18 ON REPLY CARD

## KESTREL ELECTRONIC COMPONENTS LTD.

- All items guaranteed to manufacturers spec.
- Many other items available.
- Exclusive of V.A.T. and Post and Package\*

74LS00	0.13	0.09	6821	1.40	1.00	2764-25	2.40	2.30
74LS04	0.13	0.09	6502	3.10	2.50	27C64	3.00	2.60
74LS08	0.13	0.09	6522	3.10	2.50	27128-25	3.70	3.40
74LS74	0.13	0.10	6809	3.00	2.50	27C128-25	3.40	3.00
74LS86	0.13	0.10	6810	0.70	0.60	27256	3.70	3.50
74LS138	0.20	0.16	8085A	1.30	1.10	6116LP-3	1.30	1.10
74LS139	0.20	0.16	8255-5	1.90	1.60	6264LP-15	2.20	1.95
74LS244	0.40	0.25	LM386N	0.50	0.40	62256LP-12	7.50	7.00
74LS245	0.40	0.25	LM2901	0.80	0.50	4164-15	0.80	0.75
74LS273	0.40	0.24	LM2917N-8	1.60	0.70	41256-15	2.30	2.25
74LS373	0.35	0.24	LM393	0.25	0.20	Z8DACPU	1.20	0.75
74LS374	0.35	0.23	8251	1.90	1.50	Z8DACTC	1.20	0.75
74LS393	0.40	0.25	8253-5	1.50	1.30	Z8DAP10	1.20	0.75
74LS399	0.25	0.20	4 meg Crystal	0.30	0.25	Z8DAS100	2.50	2.00

All memory prices are fluctuating daily, please phone to confirm prices.

178 Brighton Road,  
Purley, Surrey CR2 4HA  
Tel: 01-668 7522

ENTER 45 ON REPLY CARD

## IEEE 488.2 SYSTEMS

NEW... Controller using APRICOT Xen 386 or Xen i  
The best controller yet?

### IBM or Compatible Computers

Advanced IEEE 488.2 controller using Turbo Pascal or QuickBASIC makes it both powerful and easy to use.

### Acorn 'B' or Master Computers

Believed to be the best IEEE 488.2 controller for these computers. Available as a complete controller or as a software package to update your Acorn interface.

### All controllers use IEEE 488.2 Commands

making programming easy and effective while offering unbeatable value for money.

Consultancy work undertaken. Specialising in IEEE 488 and Ethernet Systems.

Dealers welcome.

M A INSTRUMENTS LIMITED  
Moordene, Axtown Lane, Yelverton, Devon PL20 6BU.  
Tel: (0822) 853585

ENTER 31 ON REPLY CARD

# ICOM Communications



ICOM introduces the IC-R7000, advanced technology, continuous coverage communications receiver. With 99 programmable memories the IC-R7000 covers aircraft, marine, FM broadcast, Amateur radio, television and weather satellite bands. For simplified operation and quick tuning the IC-R7000 features direct keyboard entry. Precise frequencies can be selected by pushing the digit keys in sequence of the frequency or by turning the main tuning knob. FM wide/FM narrow/AM upper and lower SSB modes with 6 tuning speeds. 0.1, 1.0, 5, 10, 12.5 and 25kHz. A sophisticated scanning system provides instant access to the most used frequencies. By depressing the Auto-M switch the IC-R7000 automatically memorises frequencies that are in use whilst it is in the scan mode, this allows you to recall frequencies that were in use. Readout is clearly shown on a dual-colour fluorescent display. Options include the RC-12 infra-red remote controller, voice synthesizer and HP-1 headphones.

Please rush me details of the IC-R7000 and my nearest ICOM dealer.

Name \_\_\_\_\_

Address \_\_\_\_\_

Tel: \_\_\_\_\_

Post to: ICOM (UK) LIMITED, Dept WW, FREEPOST,  
Herne Bay, Kent CT6 8BR (no stamp). Tel: 0227 363859.

ENTER 27 ON REPLY CARD

# Noise resistance in mains signalling

Research into noise-resistant mains signalling reveals new methods of producing signals with tightly controlled bandwidths which reduce interference between data transmissions.

N.A. YOUNG

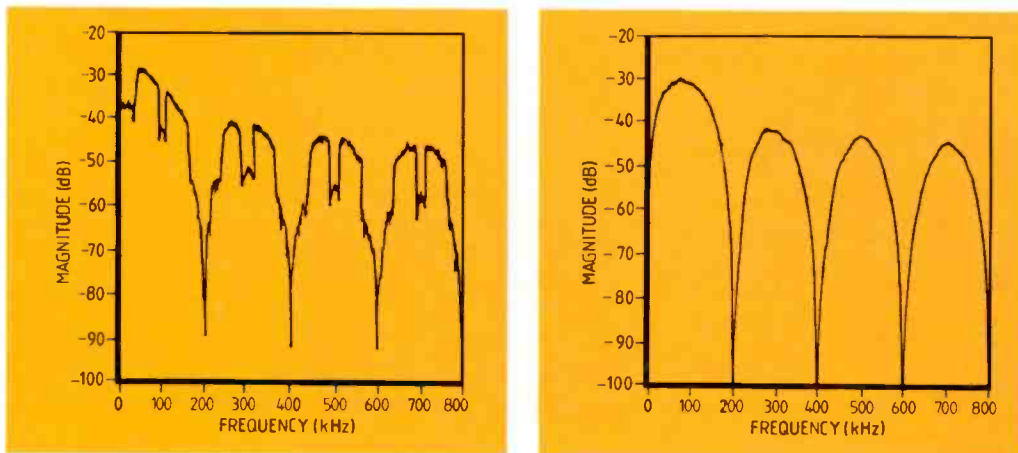


Fig.1. Spectrum of an up-converted m sequence (left) and Fig.2. K-sequence spectrum.

At the MATES 1982 conference two papers<sup>1,2</sup> were presented describing a system for low-voltage mains signalling. This article describes further research done on that mains-borne system, the expertise gained in signal processing and the improvements to the system that resulted, both in communications performance and in spectral control.

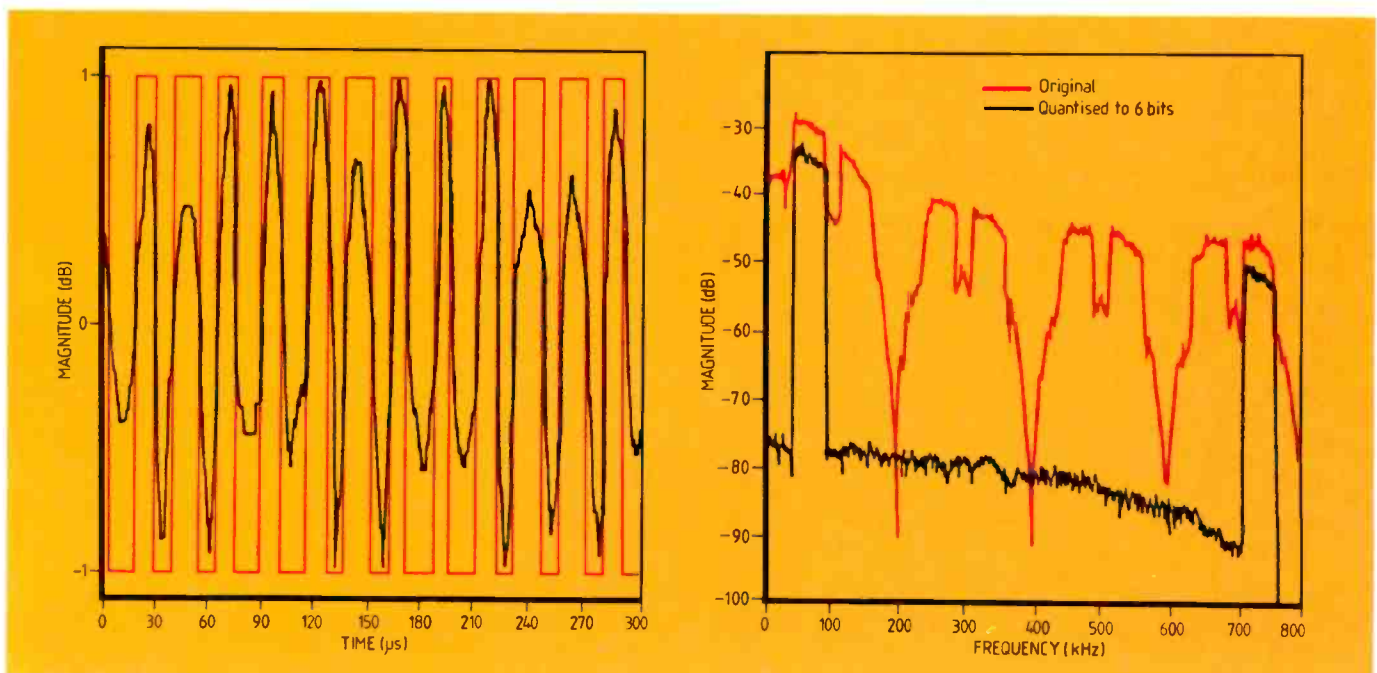
Although the techniques developed are primarily applicable to mains signalling and similar noisy environments they have wider uses, and interest has been shown from

people in many different areas of signal processing. The two areas of research described in this article are reduction of the spread-spectrum bandwidth and improvements in communication performance.

Over the four or more years since the system was first proposed, extensive research has been done at THORN EMI, supported by field trials, into various aspects

of communication over the electricity mains. A 19-month 1000-house trial has recently finished, using the spread-spectrum signalling technique referred to at the 1982 conference. During that time further investigation was carried out into some of the fundamental theory of communicating in a noisy environment, in particular under the limitation of restricted bandwidth. Much of the work was done first on a computer, using a simulator and other programs, and then validated in the field. Early in the 1000-house trial the BISMA\*

Fig.3. K-sequence in time domain, left, and Fig.4, the K-sequence spectrum. These show the effects of quantization.



control-manufacturers body recommended that the spread-spectrum bandwidth for ESI use should be restricted to 40-90kHz instead of the current 50-150kHz, with negligible signal outside these limits. This paper describes research done into meeting that specification, and the new sequences and signal-processing techniques that resulted. A further, separate improvement in performance was also achieved using the same basic tools – the computer simulation and other programs – and it is also described briefly here. The spectral content of the transmitted signals is shown to be very sharply defined, and the communications performance of the system is shown to be improved also in spite of the reduction in bandwidth.

### PRESENT COMMUNICATION SYSTEM

Understanding of the techniques and results described below requires some knowledge of the current communication methods. A very brief outline is therefore given here, the system described being that actually used in the 1000-house trial.

Spread-spectrum transmission is used for two reasons: firstly because it results in a low spectral power density, thus reducing interference; and secondly because mains characteristics change significantly with time due to electrical interference and notches in the frequency response caused by loading. Spreading the spectrum reduces the probability that the chosen frequency of operation can suddenly become completely unusable for a significant length of time.

The current mains-borne system uses the direct-sequence baseband method of spreading the spectrum. Binary sequences used are derived from m-sequences, up converted so that the nominal 3dB bandwidth is 50-150kHz, see Fig.1.

Two 1024-chip† sequences are used, one for data zero and the other for data one, and the appropriate one is transmitted in response to the controlling data line. They are stored in read-only memory and are clocked out at about 200kHz to give a data rate of 200Hz. The rom output is filtered to reduce out-of-band noise (which changes the rectangular shape of the sequence to a considerable extent) and fed into a power amplifier, then onto the mains through a capacitor and transformer.

Reception and decoding of the data is quite complex, using a fast hardware correlator followed by substantial software processing. Before the correlator, the incoming signal is filtered to reduce out-of-band noise and then hard clipped since the correlator works in binary data. It is then correlated in eight positions at once with both reference sequences (data one and data zero) and the results are analysed and compared to determine which data bit has been transmitted.

The magnitudes of the correlations are also used to determine whether genuine data

The K sequence, developed as part of the noise-resistant mains signalling project, reduces interference between adjacent transmissions by reducing out-of-band noise.

There are a number of possible variations on the basic K sequence which is named after Ian Kimber, the THORN EMI scientist who invented it. Notches or other differences can be introduced in the pass band for special purposes; indeed the spectrum can be tailored to practically any extent, depending on the system requirements.

Usually a fairly straightforward shape is needed, with a flat pass band and negligible noise outside, cutting off sharply at the edges. Generation of this basic sequence is described below, using as an example the mains-borne system with 1024-chip sequence, a clock rate of 200kHz and a bandwidth of 40-90kHz.

A fairly even flat-topped spectrum in the pass band is desired since otherwise the advantages of the spread-spectrum technique are reduced as single-frequency or f.s.k. transmission is approached. Thus the sequence has to contain frequencies from all the way across the band, each with an individual bandwidth large enough to ensure that there are no significant gaps in the spectrum. On the other hand the bandwidths must not be too great as the cut off obtained becomes less sharp as they increase.

Thus the best compromise is to set the individual bandwidths to a value that is about the same as the distance from one of the component frequencies to the next. Choosing the nearest power of two for the number of frequencies since gives an exact number of chips for each one.

Assume that there are N frequencies in a 1024-chip sequence. Each sequence period is 5ms so each frequency lasts for 5/N ms. This makes bandwidth roughly N/5kHz, which is actually the distance to the first null since the spectrum of a single frequency transmitted once is a sinc function. Distance between frequencies is (90-40)/N kHz so the two can be equated to give 50/N=N/5 or N<sup>2</sup>=250. This results in N=16 so there must be 16 component frequencies in the sequence, each 64-chips long.

Generation of the sequence is quite simple. The frequencies are selected in an arbitrary order – 16 frequencies gives over 2x10<sup>13</sup> possible sequences, though they will not all have good cross-correlation functions with each other. For each frequency a sinewave is calculated and sampled at the clock frequency to give a set of 64 chips of 5/16ms total duration.

At the boundary between frequencies the phase is kept constant to reduce discontinuities as far as possible. On each sample the sinewave is quantized to one bit, i.e., set to either one or zero depending on whether the waveform is positive or negative.

This gives the K sequence. It is fairly easy to show that its spectrum G(f) is given by

$$G(f) = \sum_{p=-\infty}^{\infty} F(f - pf_s) \cdot \frac{\sin \frac{\omega T}{2}}{\frac{\omega T}{2}} e^{-\frac{j\omega T}{2}}$$

which is the characteristic sinc function where F(f) is the basic flat-topped spectrum desired, f<sub>s</sub> is the sampling frequency and T = 1/f<sub>s</sub>. Factor

$$e^{-\frac{j\omega T}{2}}$$

is a phase factor whose modulus is always 1.

This spectrum is shown in Fig.2, though since it is plotted as a power spectrum the envelope is actually sinc<sup>2</sup>(x). Note both the reflections of the main lobe about the sampling frequency and the quantization noise between the lobes. Both of these need to be removed by the next stage of processing.

### DIGITAL FILTERING

Sequences and waveforms generated are held in the computer to a precision of eight samples per chip in time and to the limit of its resolution (32 bits) in amplitude, so that there is plenty of scope for processing. Also, all necessary operations can be performed in the frequency domain, which makes processing the spectrum very much easier. Thus the digital filtering, like the sequence generation, is done off line on the computer, and the problems of causality do not arise.

The easiest way of achieving the sharp cut off required is simply to set the spectrum to zero outside the required band and transform back to the time domain. This however produces an analogue waveform that cannot be transmitted in the same way as before, and so quantization is necessary if it is to be stored in memory.

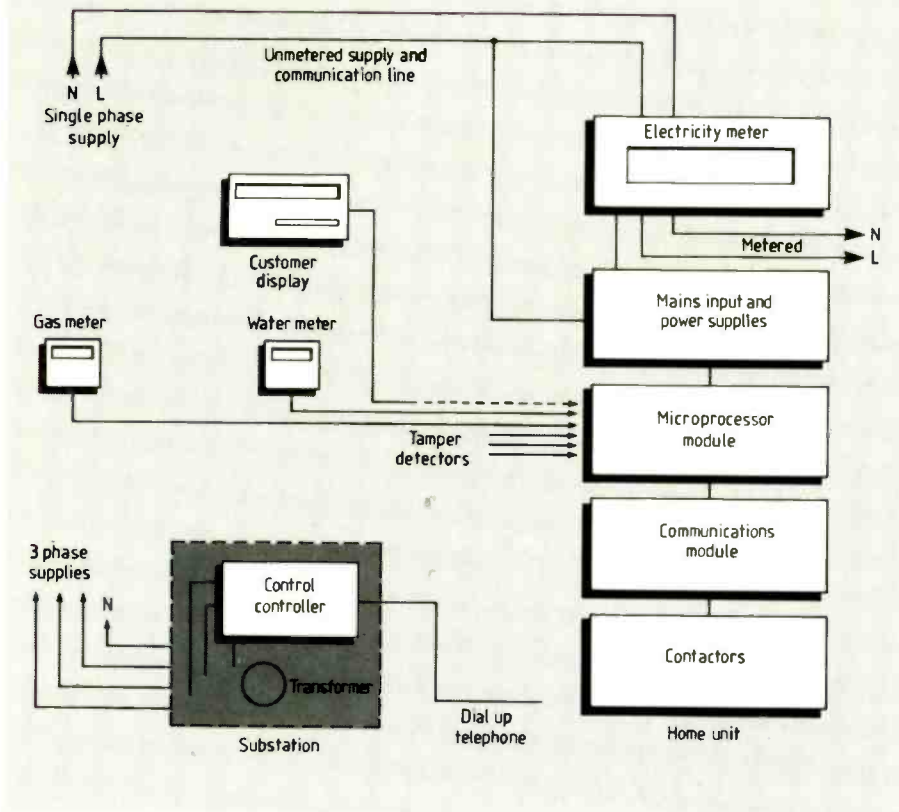
Choice of the number of bits N is dictated by the trade off between the amount of cut off required and the available bits of memory. The numbers resulting from the quantization are normalized to 2<sup>N-1</sup> so that they can be stored in memory. It can be shown that the signal-to-quantization-noise ratio achieved by this method is 6dB/bit (over the whole band, i.e., up to half the sampling frequency).

To move the side lobes far enough away so that the analogue front-end filters can remove them it is only necessary to sample at a high enough frequency. Since all the processing is done at eight samples per chip, the sampling frequency of the transmitted waveform can be up to 1600kHz. This does not mean altering the chip rate or the data rate, but simply transmitting to a greater precision in time.

\*BISMA is the BEAMA interactive and mains systems association, formerly called BMSA.

† A chip is a component of the 1024 binary-digit sequence which makes up a data bit. It is actually a bit but since it is a bit that makes up a bit, the term chip is used to avoid confusion.

**Household units will give customers much more useful information about energy and water consumption than simple meters.**



or pure noise is being received. On receiving noise, the receiver goes into search mode, that is, it searches for the best position on the correlation function to lock onto and analyse.

For the correlation process to be effective the auto-correlation function of each sequence must have no significant peaks ('noise') anywhere away from the central one that the system could lock onto since this would degrade performance. Also the cross-correlation function with noise and with the other sequence must have no significant peaks at all to avoid data errors.

M sequences are known to have the best available auto and cross-correlation functions with each other and with random noise, and the derivative that is presently used is almost as good. The complete auto-correlation function of this derivative is almost completely 'clean' – the reason for the small amount of 'noise' that exists is that an extra chip has been added to the m sequence to make its length a power of two.

In designing a new sequence for the system care must be taken to ensure that the correlation characteristics are equally satisfactory.

### REDUCTION OF SPREAD-SPECTRUM BANDWIDTH

When mains-borne communication was first proposed the only bandwidth consideration was that of efficiency. Compliance with existing legislation was not seen as a problem. However, early on in the trial, BISMA produced an interim document (BMSA<sup>3</sup>) proposing division of the spectrum into bands, of which the relevant one for this purpose is 40-90kHz. There is a limit on the power that may be transmitted outside this

band, and the restrictions imposed are very stringent.

In the current system there is far too much signal outside these limits to satisfy the proposed regulations, and so some modification would be required if the system were to go ahead and comply with the standard.

The analogue filters presently on the transmitter output are insufficient for this purpose, though it would be possible to use much higher-order filters to produce the desired effect. However, such filters would be expensive and elaborate, would require much physical space and would introduce unacceptable phase shift into the pass band. Thus any effective methods needs to be basically digital, leaving at most a very small amount of interference for the analogue filters to cope with.

To achieve the aim of drastically reducing unwanted noise two procedures were used: firstly the generation of a suitable digital sequence with roughly the right frequency characteristics, and secondly digital filtering of the sequence to achieve the sharp cut off required. As a result of this processing a somewhat more complex transmission method is required since digital filtering turns the binary sequence into an analogue waveform. However, the reception and correlation process is still the same, which means that the only change is that the system has to store and transmit this waveform instead of the original sequence.

### THE K SEQUENCE

The 'suitable sequence' mentioned above is one which fulfils two criteria: it must possess a satisfactory auto-correlation function with no spurious peaks, and it must be substan-

tially unaffected by the digital filtering as far as correlation is concerned. Additionally the digital filtering process must not produce too uneven a waveform as this would reduce signal-to-noise ratio on reception.

A sequence fulfilling these qualifications is the so-called K sequence, the generation of which is described fully in the panel and whose spectrum is shown in Fig.2. Note that well over half of the energy is in the main 40-90kHz lobe, which means that subsequent digital filtering has only a small effect on the time-domain distribution of the sequence.

This represents the limit of the spectrum tailoring available using binary sequences and a 200kHz clock, so the sharp frequency cut off desired required a different approach – hence the digital filtering.

The important and unusual feature of the K sequence is that its spectrum can be very tightly controlled. Because of the sharp edges of the spectrum a very large 'brick-wall' cut off can be applied by a filter without altering the basic shape of the sequence.

Since the filter is digital no phase shift is introduced in the pass band, so the resulting analogue waveform follows the outline of the original sequence; in particular the zero crossings are still the same, which is important for correlation purposes.

Additionally, if the waveform is normalized after filtering so that the highest peak is at the original magnitude of the binary sequence, less than half the energy is removed from the sequence which is an important consideration for transmission. Since it is then practically unaffected by the output filters, the transmitted power is comparable with that of the binary sequence used in the trial, which is severely altered by these filters.

### DIGITAL FILTERING

Digital filtering, done off line, introduces the sharp cut off required into the spectrum. It consists of two parts: firstly a 'brick-wall' filter in the frequency domain, and secondly, back in the time domain, a requantization to as many levels of output as desired and a resampling at a higher clock frequency. The second stage is required to enable the analogue result to be digitally stored and transmitted. These two processes are explained in detail in the panel and the results are described below.

An essentially analogue waveform (actually multi-level quantized) is produced which follows the original binary sequence shape but has rounded edges. Its spectrum consists of the main lobe of the original sequence, sharply defined to an extent that depends on the number of quantization bits (roughly 6dB cut-off per bit).

There is a side lobe further up, which is a reflection of the main lobe about the new clock frequency. This is inevitable in a digital system but can be moved far enough away so that the ordinary analogue output filters can remove it on transmission.

Figures 3 and 4 show the original K sequence and a six-bit quantized version in the time and frequency domains respectively. Note the side lobe at just below 800kHz (the new sampling frequency), and the fact that the spectrum is clean between the two lobes. Theoretically, there is no limit to the cut off that can be achieved by this method—the limitations are likely to be the output amplifiers and other analogue devices.

This multi-level waveform's auto-correlation function is also essentially that of the original sequence, the only difference being that it changes shape gradually as the sequences drift past each other (as they do in a real system because of unsynchronized clocks). This produces no problems, and indeed is used in one method of analysing the incoming data described below.

The auto-correlation function is slightly different from that of an m sequence or its derivative, but just as good for locking on to. In many respects it is better because at one

stage of the clock drift cycle the auto-correlation function of the filtered m sequence becomes very small.

### TRANSMISSION OF THE FILTERED K SEQUENCE

The original 1024-chip binary sequence was held in rom and clocked out at approximately 200kHz, producing the spectrum shown in Fig. 1 with 50-100kHz 3dB bandwidth. Only three bits of each byte were used, one for each sequence (data one and data zero) and one for an end-of-sequence marker which is required by the hardware.

To be reasonably simple and compatible with the existing system the same basic method is used, but some alterations are required. Considerably more memory is

**Customer display and home unit similar to those used in the 1000-house trials. Substations have a central controller.**

needed and using byte-wide read-only memory limits quantization to six bits, though more could easily be used by placing two roms in parallel.

The two signals are held in two separate areas of memory, and the most-significant address line is switched as required. Six bits are used for the transmitted signal, one is the most-significant bit of the other waveform, which is used for correlation, and the eighth bit functions as the end-of-sequence marker. If desired this marker could be produced using hardware.

Rom clocking is at four times the previous rate, i.e. approximately 800kHz. This speed is necessary to achieve the desired spectrum, and does not alter the effective chip rate of 200kHz — there are simply four cycles per chip instead of one.

Six bits representing the signal to be transmitted are latched into a d-to-a converter and the resulting analogue signal feeds an output amplifier, which of course is a linear device and therefore maintains the shape of the waveform.

Since the output filters have negligible effect on the main lobe, what appears on the mains is the exact spectrum required, with the side lobe down by more than 50dB. Any other noise can only come from the amplifier or the main itself.

This system was implemented in hardware, which involved minor changes to the existing mains-borne equipment. For a continuous transmission of one

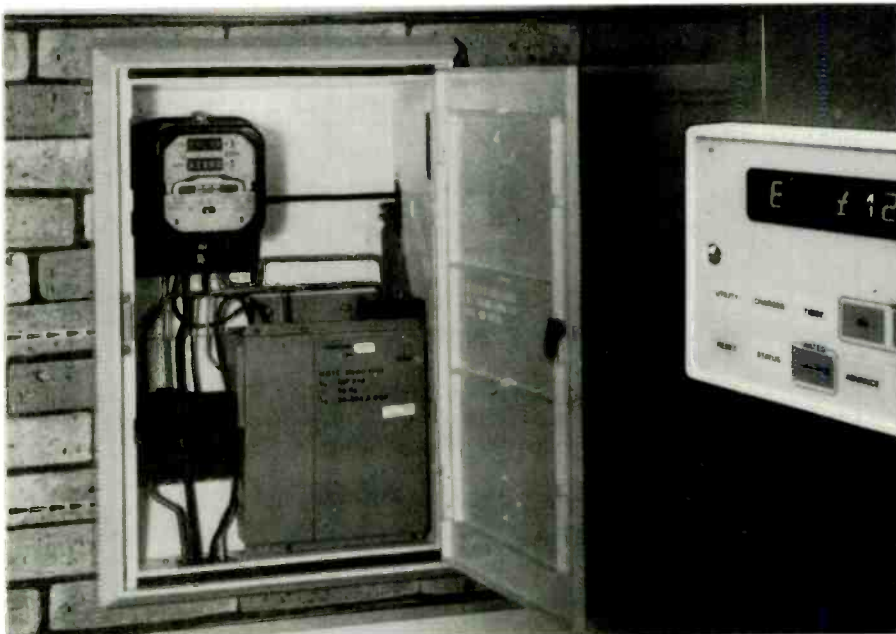
sequence the results are

identical to the theory as far as can be measured, except for an insignificant quantity of extra noise introduced by the power amplifier at around 1MHz.

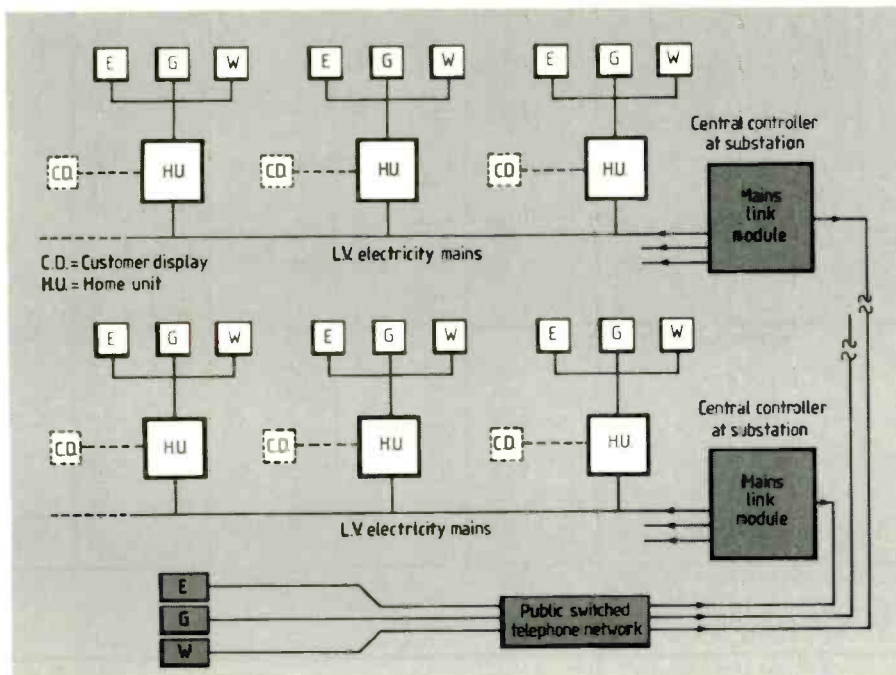
Transmitting different sequences spreads out the spectrum somewhat, the spreading becoming noticeable at about -30dB. This is due to edge effects which appear when the line spectrum of a continuous transmission changes to the continuous spectrum of a pulse transmission. It is a relatively small effect, extending for only a few tens of kilohertz before being lost in the general noise, though it does not depend on the amount of quantization. If necessary, further filtering of the sequences could be performed on the computer to reduce or eliminate this, at the expense of a slight degradation in performance.

The system has also been tested in the field to a limited extent. It had been feared that a degradation in performance might have resulted from the bandwidth reduction; in fact this new system actually communicates noticeably better than the current system.

This improvement is due to the fact that the K sequence conforms to the sampling theorem by having all but a negligible proportion of its energy at less than the Nyquist frequency of 100kHz. This is not true of m sequences, which are in very



Mains signalling network for domestic gas, water and electricity supply information.







common use in communications at the moment, though not generally in environments with such a high degree of phase distortion. Even so, it is possible that problems could result from this fact, which does not appear to have been recognized in the literature. The effect is more pronounced in the up-converted version, which has almost half its energy above 100kHz, causing the correlation function to become very small at certain points on the clock drift cycle; using K sequences removes the problem and therefore improves communications performance.

#### IMPROVEMENTS IN PERFORMANCE

The computer model of the mains-borne communications module used extensively in the reduced-bandwidth work is a detailed simulation of the system. It is a continuous hardware model using the clock rate as the basic unit of time, and it is interruptible after each cycle so that the system parameters can be changed or examined.

These features of the model simplify assessment of the effects of changes made to the software and hardware of the front end, and so the simulation was also used for work on improving the communications performance of the system.

Various methods of improvement were considered, including an analogue correlator and low-level error correction, some of which can potentially yield a several decibel increase in s-to-n ratio. One method is described below.

The method of processing the results

obtained from the fast correlator is important, and changes here can alter the performance of the receiver considerably. Our current system simply adds together the squares of the values of the eight results from the correlator, separately for each reference sequence (data one and data zero), producing two numbers that are compared to determine which data bit has been received. Instead of this, a matched filter can be used for the eight correlation results, which makes it possible to take the transmitted signal characteristics into account.

Using a matched filter gives an improvement of 10dB over the current method; if desired, the channel characteristics could also be allowed for, and thus the effects of any known distortion could be minimized, resulting in a further improvement in performance.

#### CONCLUSIONS

A new method of generating and transmitting spread-spectrum signals has been devised and implemented. Bandwidth can be tightly controlled, and the main lobe can be placed wherever it is wanted. There is no theoretical limit to the sharpness of the cut off that can be obtained by this method, at least with one sequence continuously transmitted.

As implemented, the system comes close to complying with the BISMA specification. If required, further improvements could be made using the same basic techniques. The new signalling system works at least as well as the present one: however it has been field

tested to only a limited extent, and more trials are needed to be certain of its performance.

System performance has been enhanced by a new method of analysing the correlation results which can improve s-to-n ratio by up to 10dB. Being general in nature, the techniques devised and the results obtained from the research on spread-spectrum communication are applicable to areas other than mains-borne signalling. In particular the methods of generating signals with tightly-controlled bandwidths should be of interest wherever spectral efficiency is an issue.

#### References

1. Cooper, M.F., Kimber, I.D. and May, I.G., 1982, Fourth International Conference on 'Metering apparatus and tariffs for electricity supply', Conference Publication 217, p.100.
2. Chapman, N.R., Eyre B.E., Goodwin, S.J. and Wiener, A., 1982, Fourth International Conference on 'Metering apparatus and tariffs for electricity supply', Conference Publication 217, p. 108.
3. The Association of Control Manufacturers (TACMA), Dec. 1982, 'Industry interim document draft for v.l.f. mains signalling code of practice', SSC39. (note - BMSA replaced TACMA).

#### Further reading

Eyre, B.E., 1987, 'Results of a comprehensive field trial of a UK customer telemetry system using mains-borne signalling', Proceedings, Fifth International Conference on 'Metering apparatus and tariffs for electricity supply', IEE.

N. A. Young is with THORN EMI Central Research Laboratories UK

# REDUCED SUBSCRIPTION

Make life easier and save money at the same time by accepting our offers of reduced-price subscriptions.



A one-year subscription of £19.50 brings 12 issues to your door for the price of 10, saving nearly 17%. But for £53, you can have a three-year subscription and save nearly 25% - eight free issues.

And you won't have to keep on ringing up to ask for photocopies of articles you've missed.



## REDUCED SUBSCRIPTION ORDER FORM

Please send me Electronics & Wireless World for one year at the special price of £19.50 \*

Please send me Electronics & Wireless World for three years at the special price of £53.00\* \* Inclusive of postage and packing.

I enclose a cheque/PO to the value of £ made payable to Reed Business Publishing Limited.

Please debit my credit account.

Expiry date:

Access  Barclaycard/Visa.

Diners Club  American Express

Signed

Name

Job Title

Address

Please return to Electronics & Wireless World, Room 316, Quadrant House, The Quadrant, Sutton, Surrey SM2 5AS.

# CD: the 600 megabyte rom

Error correction by interpolation works well enough on audio Compact Discs. But to exploit CD's potential for data storage, more precision is needed.

J.R. WATKINSON

By storing digital audio in a highly durable medium convenient for mass duplication, the Compact Disc has overcome the major drawback of analogue audio recording. Its tremendous success as a consumer product has brought down the cost of the player and made it attractive as a computer peripheral.

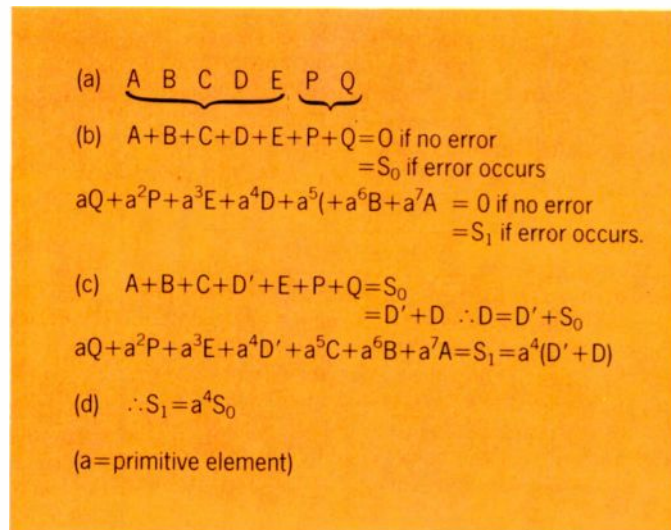
The Compact Disc is an optical disc which cannot be recorded by the user, since it is designed for mass duplication of pre-recorded music. It has many advantages as a storage medium. No contact is made between the disc and the laser pickup; and as there is no wear mechanism, life is indefinite. The principle of reading through the thickness of the disc reduces the effect of surface contamination. Random access to any part of the disc is easy because it is only necessary to move the pickup radially to reach any part of the recording.

CD's main advantage in a data storage application, however, is its capacity in relation to cost. Digital audio requires about one megabit per second per audio channel. Since CD can hold at least one hour of stereo, the capacity is staggering – about 600 megabytes. This is the equivalent of about five reels of half-inch computer tape, or some 200,000 pages of text. A CD player costs about the same as the floppy disc drive in a home computer, but has about 1500 times the capacity.

Publishing houses are therefore exploiting the use of Compact Disc as a read-only memory – hence the name CD-rom. Technical databases are already being made available for commercial, financial and medical use. Several years' issues of all the major journals in a given discipline can be carried on a single disc, making optical disc publishing a reality. For companies, the cost of a suitable computer and CD-rom drive is trivial, and the cost of the discs is reasonable considering the storage space which is released. For the consumer, encyclopaedias are a natural application.

## ADAPTATION FOR DATA

Compared to the heads used in magnetic disc drives, the laser pickup of a CD player is much heavier. Access speeds will therefore be slower than for hard discs, although similar to the speed of floppy disc drives. The track spacing of only 1.6 micrometres means that the destination track has to be approached slowly.



(a)  $A \ B \ C \ D \ E \ P \ Q$

(b)  $A+B+C+D+E+P+Q=0$  if no error  
 $=S_0$  if error occurs

$aQ+a^2P+a^3E+a^4D+a^5C+a^6B+a^7A=0$  if no error  
 $=S_1$  if error occurs.

(c)  $A+B+C+D'+E+P+Q=S_0$   
 $=D'+D \therefore D=D'+S_0$

$aQ+a^2P+a^3E+a^4D'+a^5C+a^6B+a^7A=S_1=a^4(D'+D)$

(d)  $\therefore S_1=a^4S_0$

(a=primitive element)

**Fig.1. A simple Reed-Solomon code over GF(8). At (a) two check symbols and five data symbols of three bits each form a code word. The code word will satisfy the equations of (b) if P and Q are correctly computed. If at (c) there has been an error, symbol D becomes D', and the syndrome S<sub>0</sub> becomes the difference between what D should be and what it was. Syndrome S<sub>1</sub> becomes the same quantity, but multiplied by a to some power. When the correct power is used, equation (d) is satisfied, and the power of a becomes the position of the error.**

Unlike magnetic discs, CD uses a continuous spiral track. Once the beginning of a file has been located, the transfer of contiguous blocks can be completed without a seek. The spiral track and constant linear velocity principle of CD means that there is no such thing as the physical cylinder address which magnetic discs use to locate data. Data on CD-rom is addressed as a function of time along the track. If the pickup is at a given place on the disc and a different physical address is given, the time difference is easily computed; but this does not readily translate to a number of tracks to skip. As the track speed is constant, a track skip near the edge of the disc will cause a larger time jump than a track skip near the centre. The number of tracks to be skipped can be estimated from the starting radius.

During a seek, the tracking error becomes approximately sinusoidal and it is an easy matter to count the cycles in the same way as a servo surface magnetic disc decrements the cylinder difference during a seek. However, since the number of tracks to skip is approximate, it is necessary to read the

actual address arrived at and to compute a short correction seek to reach the correct place.

In magnetic discs, data becomes scattered all over the disc surface as files of different sizes are erased and written. With CD-rom, a different approach is required. CD-rom cannot erase or record, and so the disc format never changes. To minimize the number of seeks necessary, it is essential to order the data into physically contiguous files before the disc is mastered.

A further problem is the error rate of Compact Disc. This is perfectly adequate for audio applications: on the rare occasion that an audio sample is not correctable, the previous and next

samples can be averaged to conceal the error. This works in audio because there is a degree of redundancy in the signal.

For storage of computer data, interpolation cannot be used, since the average of two instructions is meaningless. The error rate of the normal CD must be reduced for CD-rom applications. This is achieved by adding an extra layer of error correction on top of the existing error correction system of CD.

## ERROR CORRECTION

Two basic error mechanisms are at work in CD. Small random irregularities in the ends of the bumps where the disc is stamped can cause one 14-channel bit pattern to become another, corrupting eight data bits. Fingerprints on the disc surface can make the track less distinct and large debris can obscure it, causing errors of many bits known as burst errors.

All error correction techniques work by adding to the data extra bits which have been calculated from the data. These extra bits convey no more information than is already contained in the data, and so they are said to be redundant. The addition of redundancy produces a data block which always has some special characteristic irrespective of the actual data content. In error correction, a block having such a characteristic is called a code word. If on replay the data block does not have the special characteristic, it is not a code word and there has been an error.

The redundancy added to the data is calculated mathematically from that data. For simplicity of hardware implementation, the mathematics used is modulo-2, where there are no borrows or carries between different powers. In modulo-2, addition and

subtraction mean the same thing. In a digital circuit operating with a finite number of bits, say eight, there can only be 256 different numbers, whereas conventional mathematics allows an infinite range.

In error correction, the more appropriate mathematics of finite fields is used because it makes the hardware simpler. Finite field mathematics was first developed by Evariste Galois (pronounced Galwah), so the term Galois Field is usually used. In a Galois Field, the finite number of states (known as elements) can all be obtained by raising the so called primitive element to successively higher powers. Whether two elements are added, subtracted, multiplied or one raised to the power of the other, the result can only be another element, which makes life very easy for the hardware designer.

In the Reed-Solomon codes used in the Compact Disc and in many other error correction systems, the principle of finite element fields is used exclusively. The size of the Galois Field is a function only of the number of bits in the data words used. Compact Disc uses bytes, so that the field has  $2^8$  power elements, abbreviated to GF(256). Every possible data byte is now an element of the Galois Field, or to be more precise, some power of the primitive element.

For the purpose of this explanation, a much smaller field, GF(8), will be used, because it keeps the examples to manageable

size. The data symbols will be of three bits because  $2^3$  is eight. The principles of the Reed-Solomon codes remain the same whatever the size of the field. The number of symbols in a code word cannot exceed one less than the appropriate power of two, so in the examples there will be seven three-bit symbols.

The correcting power of a Reed-Solomon code is determined by the number of symbols in the code word that are allocated to redundancy. In Fig.1, two symbols are redundant, leaving five data symbols. The two redundant symbols P and Q are calculated so that the two checks shown will succeed if they are made on an error-free replay. The P check is simply a modulo-2 sum of all the symbols, and so if one symbol is wrong, the P check equation will give a non-zero syndrome  $S_0$  which will be the error pattern. The P check cannot, however, decide where the error was.

The Q check is subtly different because it multiplies each code word symbol by a different power of the primitive element. If one symbol is wrong, the syndrome of the Q check,  $S_1$ , will be  $S_0$  which has been raised to

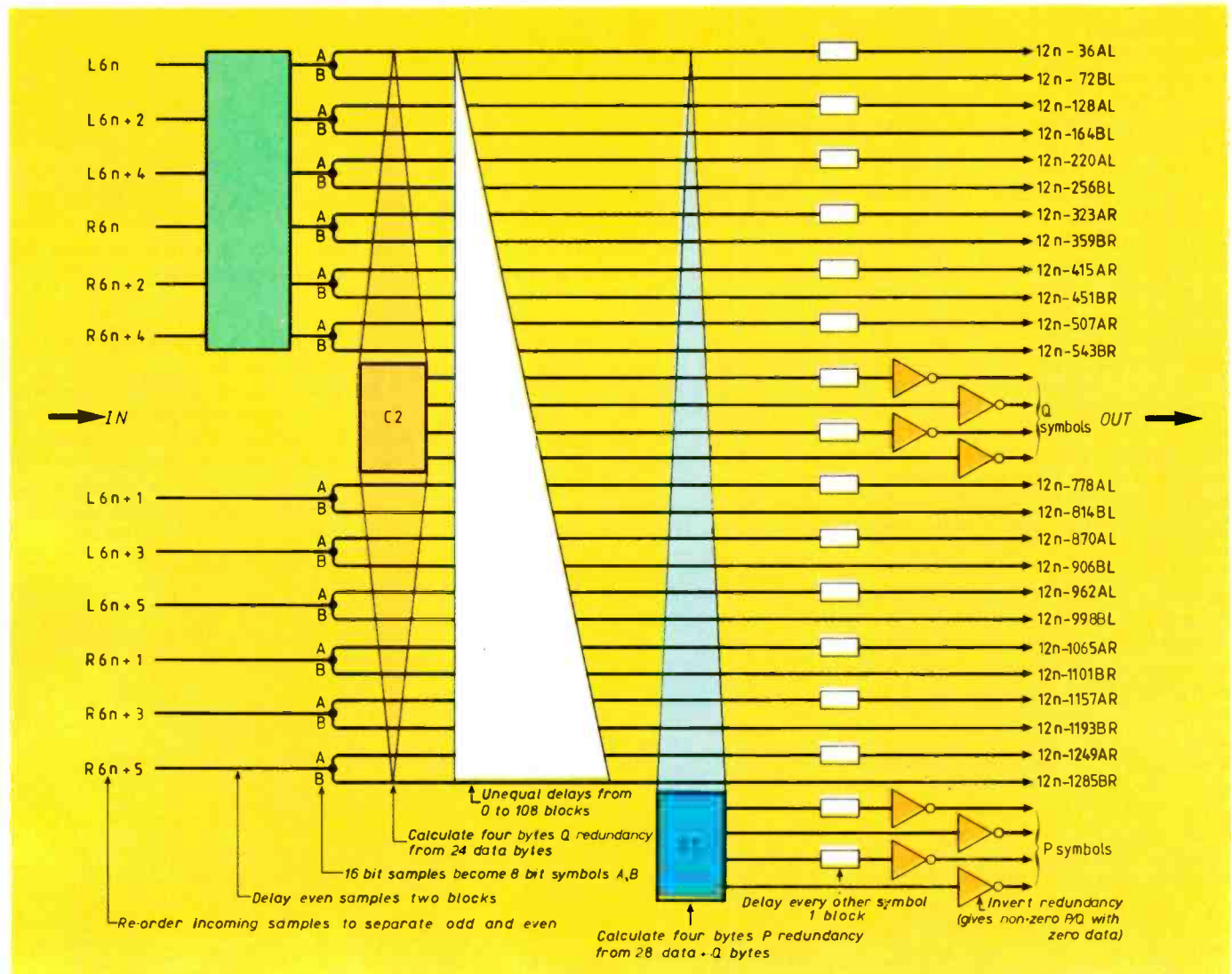
a different power depending on the error position. If for example the middle symbol was wrong, the  $S_1$  syndrome would be the error pattern multiplied by the primitive element raised to the fourth power. It is only necessary to multiply  $S_0$  by ascending powers of the primitive element until the result is the same as  $S_1$ , and the power needed gives the position of the error. In this manner, the Reed-Solomon codes can determine the nature of the error and its position. Adding  $S_0$  achieves the correction.

Effectively the system has solved two simultaneous equations to find the two solutions, which are the position and nature of the error.

There is an alternative mechanism which illustrates the power of the Reed-Solomon codes. If the position of an error symbol is already known by some separate means, then only one equation need be solved to find what the error is. Thus if the positions of two errors in the code word are known, then two redundant symbols are enough to correct them.

For example, if the fifth and sixth symbols are known to be wrong, the syndrome  $S_0$  will be the modulo-2 sum of both errors, whereas the syndrome  $S_1$  will be the sum of the errors multiplied by the fifth and sixth powers of the primitive element. Solving these two equations will now give the two error terms known as correctors, which can be added to

**Fig.2. The convolutional cross interleave of a normal Compact Disc. A random error near a burst error can be corrected by the interleaved code word, leaving the burst to be corrected after de-interleaving.**



the offending symbols. The significance of this method will become clear when interleaving is discussed.

If four redundancy symbols are used in each code word, then four simultaneous equations can be solved, with some difficulty, to locate and correct two erroneous symbols. But the complexity is considerable and there is some danger of miscorrection if the error is greater than two symbols.

### INTERLEAVING

Using Reed-Solomon codes over GF(256) it is possible to correct errors of byte size, but much larger burst errors may occur because of contamination. The solution to these bursts is to use interleaving. Data is formed into code words, but these code words are not recorded one after the other on the track: they are woven together so that a large error causes slight damage to many code words instead of severe damage to one. In the convolutional interleave of Compact Disc, sequential sample bytes are formed into code words which become the columns of a rectangular array, which is then sheared by subjecting each row to a different delay. The data bytes are again read out in columns, when they will have been interleaved. If a burst error occurs, when the data is deinterleaved on replay there will be separate single symbol errors in several different code words, which can easily be corrected.

The problem with this simple system is that the occurrence of a random error near a burst can still result in excessive errors in one code word after de-interleave. The solution adopted is to use the so-called cross interleaving technique. In this approach, code words are formed on input data columns as before, but further code words are also formed on columns after interleave. A random error near a burst error is corrected by the interleaved code word, leaving the burst to be corrected after deinterleaving.

There is a further and powerful consequence of using cross interleaving. If a burst error occurs, the interleaved code will be overwhelmed and powerless to correct it, but it serves the purpose of detecting the error by declaring every sample in the code word to be bad by attaching a flag bit to them. After de-interleave, the burst error will have been converted to single errors in many code words, but with the significant advantage that the position of the error is already known. As before, if the position is known, twice as many errors can be corrected and so the de-interleaved code is made more powerful.

Figure 2 shows the interleaving arrangement used on the Compact Disc. Prior to interleaving, four bytes of redundancy Q are included in each codeword; and after interleaving, another four bytes of redundancy P are included in the resultant diagonal code words. On replay, the four P check symbols will be used to correct random single byte errors with high reliability since all four equations must agree on the correction. The probability of making a miscorrection is very slight here. The presence of random errors is thus prevented from reducing the efficiency of the interleave.

In the case of a burst error, the P code is

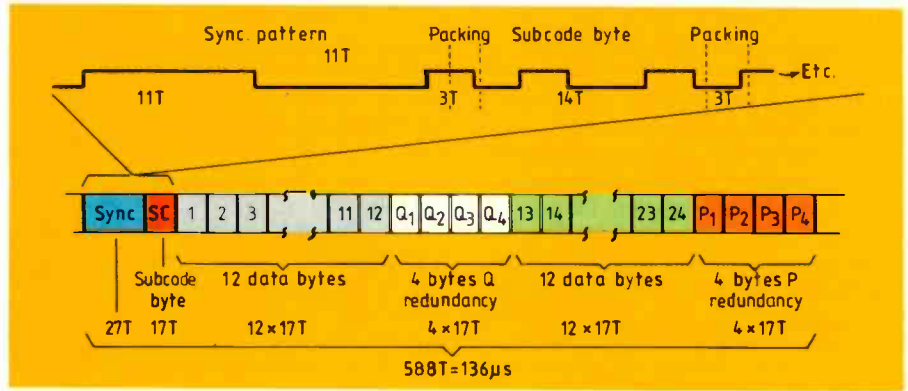


Fig.3. One CD sync block begins with a unique sync pattern and one subcode byte, followed by 24 data bytes and eight redundancy bytes. Note that each byte requires 14 channel bit periods, with three packing bits between symbols.

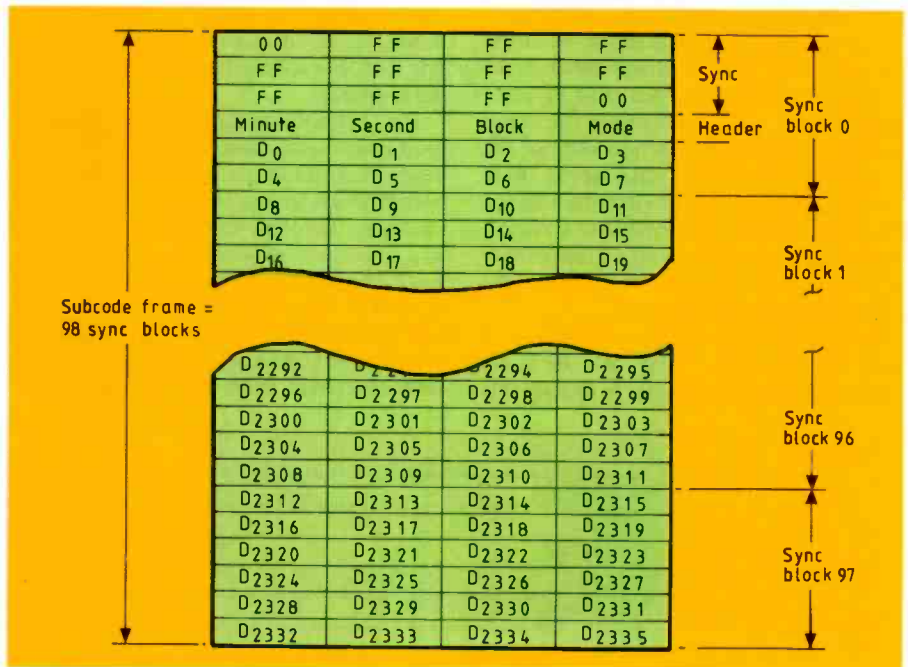


Fig.4. Arrangement of CD-rom data corresponding to 98 sync blocks, or one subcode block. There is a 12 byte sync pattern and a four-byte header, leaving 2336 bytes for user data and redundancy.

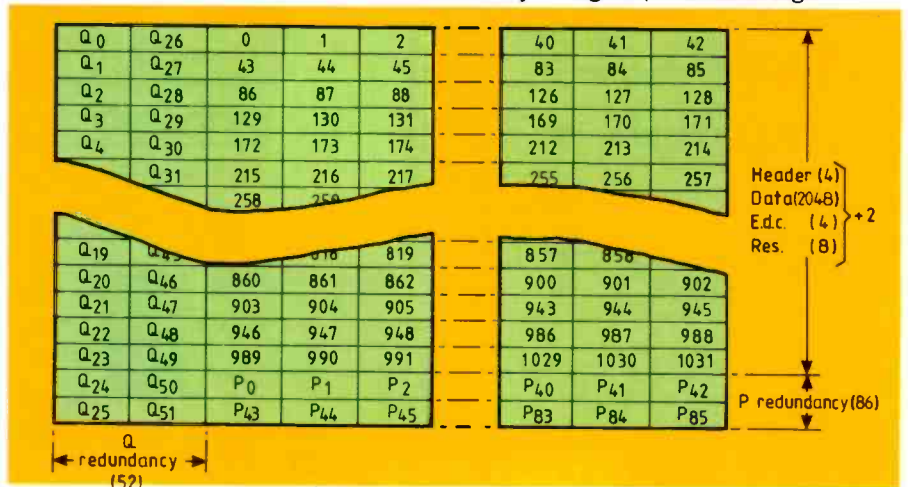
overwhelmed and attaches error flags to every symbol in the codeword, such that after de-interleave the four Q redundancy bytes can correct up to four errors. The way in which the two code words assist each other using the geometry of the interleave is

what makes the cross-interleaved Reed Solomon code so powerful.

Under extreme circumstances the error correction system will be unable to correct properly. Suppose that after de-interleave, five or more error flags appeared in one code

Fig.5. The additional error correction of CD-rom. The P redundancy is formed on

columns of the array, whereas Q redundancy is diagonal, as shown in Fig.6.



word. The correction system would have to declare all of the flagged symbols uncorrectable, and the only course of action available in a CD player is to use concealment. But in CD-rom this approach cannot be used. Further error correction is necessary, which implies that more redundancy is needed.

### CD-ROM BLOCK STRUCTURE

The sync block structure of the CD track is shown in Fig. 3. This is maintained in CD-rom so that the mastering equipment and playback processing can be identical. Following the sync pattern, there is a single byte of subcode, then a total of 24 data bytes and eight redundancy bytes. The subcode bytes in a CD build up into a subcode block after 98 such sync blocks. This apparently strange number was chosen so that with the standard sampling rate of 44.1kHz the subcode block rate would be 75Hz. The subcode contains flags which assist the player to find the beginning of a particular recording. In CD-rom, the same subcode structure must be retained and so the data corresponding to the audio samples for one subcode block is made into one codeword block for error correction and addressing purposes.

One block contains  $98 \times 24 = 2352$  bytes. The structure of this block is shown in Fig. 4 in a way which relates to the original audio application of stereo samples of 16 bit word length. At the beginning is a sync field, which is all ones except for the first and last bytes which are zero. The next four bytes specify the time along the track from the beginning in minutes, seconds and subcode blocks (1-15) and the mode.

The track timing would normally be the same as the track timing carried in the Q subcode, but repeating it in the data field means that the player does not need to communicate subcode to the computer. A further convenience is that computer tapes generated for disc cutting have a time reference, since Q subcode is put on by the disc cutter.

Next there follow 2048 bytes (2K) of user data, which is a convenient size in computer terms. The remaining 288 bytes are occupied by additional redundancy and eight bytes reserved for future use.

It is now possible to deduce the actual user data capacity of CD-rom. Playing time is restricted to one hour, which brings a reduction in the raw random error rate by virtue of longer recorded wavelengths than for the audio disc (for which the maximum is 75 minutes). Since the subcode block rate is 75Hz, it is easy to obtain the user data rate as  $2K \times 75$  bytes per second, or 150Kbyte/s.

The overall capacity of the disc is then given by multiplying this rate by the playing time:  
 $60 \times 60 \times 150K\text{byte} = 540M\text{byte}$ .

### EXTRA ERROR CORRECTION

The additional error correction needed by CD-rom also uses Reed-Solomon coding over GF(256) which means that the symbols are byte size. Figure 5 shows how the data corresponding to the subcode period is arranged. The 16-bit words from the CD are split into high byte and low byte and formed

into two separate arrays which are identical in size and structure.

Each array is 43 columns wide. The first 24 rows contain the four-byte header, the 2Kbytes of user data and four-byte cyclic redundancy check character calculated over the header and user data. This serves as a final error detection stage after all the correction processes, to give a reliable indication that the corrected data is error free.

Each column of the array is then made into a P code word by the addition of two bytes of Reed-Solomon redundancy. The P redundancy occupies another two rows of the array.

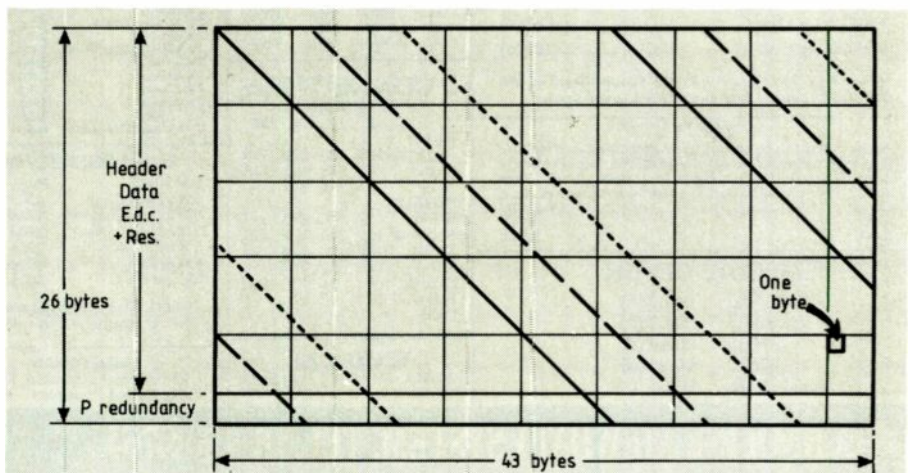
To give a cross interleaved structure, Q code words are then generated on diagonals through the array. Figure 6 shows how these diagonals wrap around the array to form what is known as a block completed interleave. As one diagonal begins in each row of the data and P redundancy, there are 26 diagonal code words. The two bytes of Reed-Solomon redundancy for each code-word occupy the first 26 positions of the last two rows of the array.

$$2048 + 4 + 4 + 8 + 172 + 104 = 2340$$

data   hdr   e.d.c.   res   P   q   total

The action of the system is as follows. When the disc is played, random errors are corrected before de-interleave and burst errors are detected. The error flags accompany the data through the de-interleave process to act as flags for correction by erasure. Up to four erasure corrections can be made by the standard CD player chip set, but if this number is exceeded the player declares them uncorrectable and in an audio application would use concealment. In CD-rom, however, the second layer of error correction operates on the residual errors. Each of the additional codes can locate and correct single errors, but erasure correction can double this power if the uncorrectable flags from the CD player are used. These are not always available, however. The block completed cross interleave of the additional correction system has as its input errors which are random, since the interleave of the CD player broke up all but the largest burst errors on the disc track. In some

**Fig.6. In the block-completed cross interleave of CD-rom's additional error correction, diagonal Q code words wrap around so that 26 of them cover all of the block's contents.**



systems the additional error correction is performed in software, and this allows an iterative process to be used where P and Q codewords are used alternately to maximize the probability of correction. Finally the c.r.c.c. is tested, and if this is satisfactory, the data is assumed error-free.

### SOFTWARE

The CD-rom standard specifies only how user data shall be stored reliably on disc and so each individual organisation is free to use any directory structure under any convenient operating system. This is not necessarily a good thing, because it means that there is no such item as a standard CD-rom. A given disc will be accessible only by the software it was designed to work with. The penalty of premature software standardization is that applications of CD-rom which are still emerging might conflict with it.

One solution which has been proposed is for CD-roms to contain several versions of retrieval software as well as the actual data. Each disc would carry a standard boot block, which would allow a computer to read the appropriate control software from the CD-rom itself.

Since the capacity of CD-rom is so large, the performance of retrieval software is crucial. Data on the disc must be indexed such that keyword searches can be undertaken in the shortest possible time. In a relational database on a magnetic disc, the location of the physical address of the required data will need a path through a decision will result in a seek to the next linked file. But CD-rom seeks quite slowly, and retrieval software based on magnetic discs would be clumsy. The high capacity of CD-rom can be used to enable fewer layers of decisions to be made, out of more possibilities.

An extensively-indexed database might require as much storage for the index as for the actual data. There is, of course, a tradeoff, as the index size can be reduced if slower access is acceptable.

*John Watkinson, M.Sc., is senior technical support engineer and educational consultant with Ampex Great Britain Ltd.*





## ANALOGUE METERS

**LEVELL AC MICROVOLTMETERS TM3A/B** £159/179  
16 ranges 15 $\mu$ Vfs/500Vfs, accuracy 1% + 1%fs + 1 $\mu$ V.  
- 20dB/ + 6dB scale.  $\pm$ 3dB 1Hz-3MHz. 150mVfs output.  
TM3A: 83mm scale. TM3B: 123mm scale and LF filter.



**LEVELL BROADBAND VOLTMETERS TM6A/B** £249/279  
16 LF ranges as TM3A/B + 8 HF ranges 1mVfs/3Vfs,  
accuracy 4% + 1%fs at 30MHz.  $\pm$ 3dB 300kHz-400MHz.

**LEVELL DC MICROVOLTMETER TM8** £135  
28 linear ranges  $\pm$ 3 $\mu$ V/ $\pm$ 300V and  $\pm$ 3pA/ $\pm$ 300nA plus 2  
log ranges for nulling. Output  $\pm$ 300mV at fs.

**LEVELL MULTITESTER TM11** £179  
50 $\mu$ A/500Vfs ac, 50pA/500mAfs ac, 150 $\mu$ V/500Vfs dc,  
150pA/500mAfs dc, 0.2 $\Omega$  to 100G $\Omega$ , lin/log null.  
Diode/LED test. Optional RF, HV and Temperature.

# LEVELL

for INSTRUMENTS

**LEVELL TRANSISTOR TESTER TM12** £199  
Transistor, diode and zener leakage to 0.5nA at 2V 150V.  
Breakdown to 100V at 10 $\mu$ A, 100 $\mu$ A, 1mA. Gain at  
1 $\mu$ A-100mA. Vsat and Vbe at 1mA-100mA.

**LEVELL INSULATION TESTER TM14** £210  
Log scale covers 6 decades 10M $\Omega$ -10T $\Omega$  at 250V, 500V,  
750V, 1kV; 1M-1T $\Omega$  at 25V-100V; 100k-100G $\Omega$  at  
2 5V 10V; 10k-10G $\Omega$  at 1V Current 100pA-100 $\mu$ A.

## BENCH POWER SUPPLIES

**THURLBY SINGLES PL154/310/320** £159/125/155  
0.5" LED digit meters, acc 0.1%, resoln. 10mV, 1mA.  
<0.01% change for 50% load change. Remote sense.  
154: 0-15V 0-4A. 310: 0-30V 0-1A. 320: 0-30V 0-2A.

**THURLBY DUALS PL310QMD/320QMD** £269/339  
Two 0-30V 0-1A (2A on 320) with isolated, series  
tracking, series or parallel modes of operation.

**THURLBY TRIPLES PL310K/320K** £275/345  
310K: 0-30V at 0-1A, 0-30V at 1/2 A & 4V-6V at 3/2 A.  
320K: 0-30V at 0-2A, 0-30V at 1A & 4V-6V at 7A.

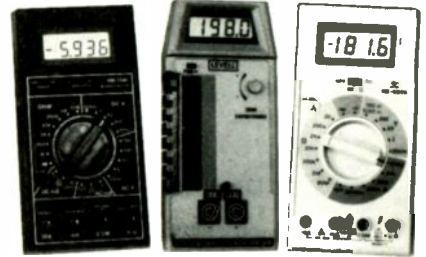
## LEVELL DECADE BOXES

**C410** : 10pF to 111, 110pF, acc 1% $\pm$ 2pF. £49  
**R401/410** : 4 decs. 1 $\Omega$  or 10 $\Omega$  steps, acc 1%, 2.5W £49  
**R601/610** : 6 decs. 1 $\Omega$  or 10 $\Omega$  steps, acc 1%, 2.5W £63  
**R601S** : 6 decades. 1 $\Omega$  steps, acc 0.3%, 2.5W £75  
**R701** : 7 decades. 1 $\Omega$  steps, acc 1%, 2.5W £72

## DIGITAL METERS

**COUNTERS MET100/600/1000/1500** £99/126/175/199  
8 digit 0.5" LED. 5Hz up to 100/600/1000/1500MHz.  
Resolves 0.1Hz. Sensitivity 5mV up to 10MHz. Low pass  
filter. Mains/rechargeable battery powered.

**LEVELL DIGITAL CAPACITANCE METER 7705** £49  
0.1pF-2000 $\mu$ F, acc 0.5%. 3 1/2 digit 12.7mm LCD.



**HC DIGITAL MULTIMETER HC4510** £69  
4 1/2 digit 11mm LCD. Up to 1kVdc, 750Vac, 10A, 20M $\Omega$ .  
Resoln. 10 $\mu$ V, 100nA, 10m $\Omega$ . Buzzer. dcV 0.05%.

**HC DIGITAL MULTIMETERS HC5040/5040T** £37/39  
3 1/2 digit 12.7mm LCD. Up to 1kVdc, 750Vac,  
10A, 20M $\Omega$ . Resolution 100 $\mu$ V, 100nA, 10m $\Omega$   
(5040T: 100m $\Omega$ ). Buzzer. dcV 0.25%. Battery life  
2000hrs. 5040T: has a TR test.

**THURLBY DMMs 1503/1503HA/1504** £169/185/199  
4 1/2 digit 9mm LCD. Up to 1.2kVdc, 750Vac, 10A, 32M $\Omega$ ,  
4MHz. Resoln. 10 $\mu$ V, 10nA, 10m $\Omega$ . Mains / battery.  
1503: dcV 0.05%. 1503HA: 0.03%. 1504: True rms ac.

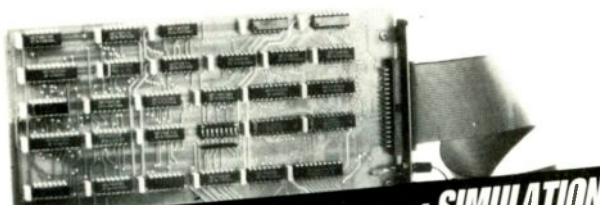
**THURLBY INTELLIGENT MULTIMETER 1905a** £349  
5 1/2 digit 13mm LED. Up to 1.1kVdc, 750Vac, 5A, 21M $\Omega$ .  
Resoln. 1 $\mu$ V, 1nA, 1m $\Omega$ . dcV 0.015%. Computing and  
storage functions. RS232/IEEE interface options.

OTHER INSTRUMENTS AVAILABLE - FREE DELIVERY MAINLAND UK - QUANTITY DISCOUNTS - VAT EXTRA

**LEVELL ELECTRONICS LTD.**

Moxon Street, Barnet, Herts., EN5 5SD, England  
Telephone: 01-440 8686 & 01-449 5028

ENTER 37 ON REPLY CARD



**OCTAGON ES-1 SIMULATION SYSTEM**

From £399

## Turn your IBM-PC into an EPROM Simulator

Now you can develop programs for any microprocessor system using your IBM-PC (or compatible) without the high cost of an in-circuit emulator.

- Octagon add-in card simulates up to 4 x 32k bytes of EPROM
- Unique de-bug window
- Ribbon cables connect to your target microprocessor's EPROM sockets
- Accepts binary or hex load files

We can also supply most cross-assemblers/compiler to make a complete low cost development system. For more details contact:



Engineering Solutions Limited  
King House, 18 King Street, Maidenhead, Berks. SL6 1EF  
Tel: (0628) 36052 Telex: 849462 Fax: (0628) 74928

ENTER 29 ON REPLY CARD

## Toroidal & E.I. Transformers

As manufacturers we are able to offer a range of quality toroidal and laminated transformers at highly competitive prices

### Toroidal Mail Order Price List

prices inclusive of VAT & Postage  
15va 7.95, 30va 9.18, 50va 10.16, 80va 11.36, 120va 12.07, 160va 14.20, 225va 15.21, 300va 17.04, 500va 22.10, 625va 24.66, 750va 28.75, 1000va 44.82.

Also available 1k2, 1k5, 2k, 2k5, 3k. Prices on request.

Available from stock in the following voltages: 6-0-6, 9-0-9, 12-0-12, 15-0-15, 18-0-18, 22-0-22, 25-0-25, 30-0-30, 35-0-35, 40-0-40, 45-0-45, 50-0-50, 110, 220, 240. Primary 240 volt.

Quantity prices and delivery on request



**Air Link Transformers**

Unit 6, The Maltings, Station Road,  
Sawbridgeworth, Herts. Tel: 0279 724425

ENTER 14 ON REPLY CARD

## Quarhand

74LS00	0.18	74LS164	0.50	74LS670	1.00
74LS02	0.18	74LS174	0.30	4116	1.60
74LS03	0.18	74LS191	0.50	4164-120	1.20
74LS04	0.18	74LS193	0.50	4164-150	1.00
74LS08	0.18	74LS221	0.50	4164-15	1.50
74LS10	0.18	74LS240	0.55	41256-12	2.50
74LS123	0.36	74LS244	0.55	41256-15	2.30
74LS138	0.36	74LS245	0.70	8284	3.60
74LS139	0.36	74LS259	0.36	8255AC-5	2.90
74LS151	0.18	74LS374	0.60	8255A-5	2.90
74LS157	0.18	74LS393	0.50	280 CPU	2.10
MK3880U	} 2.10	FD1793-02	12.00	FD1793B-02	16.00
Z80 CPU		LF351N	0.40	2716	3.20
LF 351	0.40	2732-2D	4.00	2764-25	2.25
2732	3.20	2764	3.00	27128	3.60
2732A	3.50				

All prices exclusive of VAT. Add £1 for package and postage  
Call for volume discount and unlisted items.

Please ring tel: (01) 885 5522

ENTER 49 ON REPLY CARD



# Ten faster op-amp oscillators

Connecting op-amps for unity gain increases oscillator frequency by minimizing gain-bandwidth product restrictions.

MUHAMMAD TAHER ABUELMA'ATTI AND NOURIA ABDULLAH HUMOOD

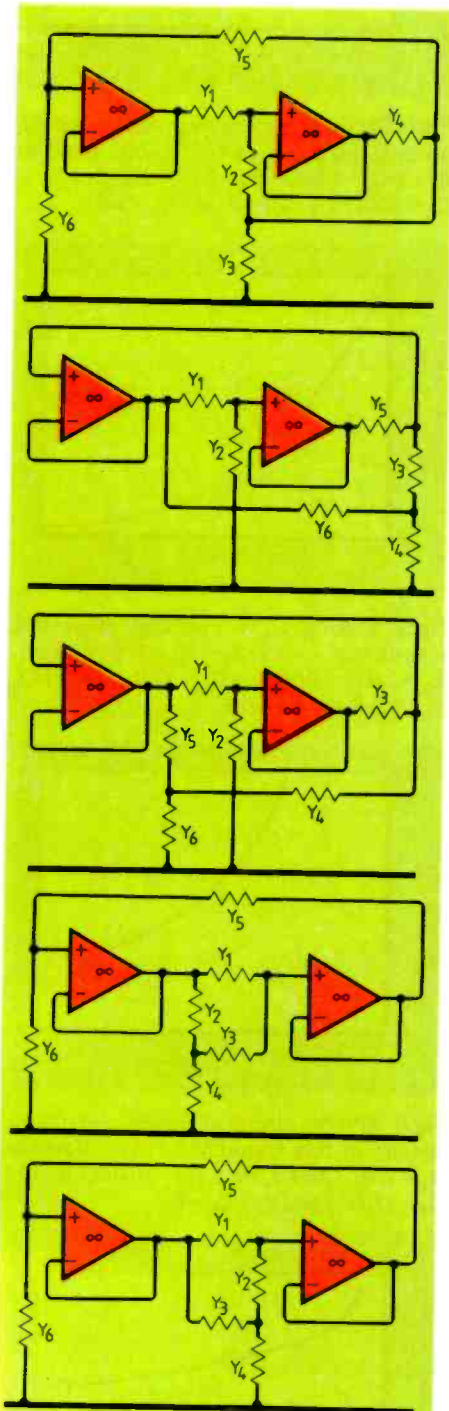


Fig.1. Five oscillator configurations using op-amps connected for unity gain to achieve higher oscillation frequencies.

In 1985, Senani\* proposed a new sinusoidal oscillator based on unity-gain op-amp configurations. Compared with oscillators using op-amps as finite or infinite-gain voltage-controlled voltage sources, this new approach produces circuits that work at much higher frequencies.

Consider the five configurations of Fig. 1. Assuming ideal unity-gain amplifiers, routine analysis yields the characteristic equations of the circuits which are, respectively,

$$Y_1 Y_6 (Y_2 + Y_3 + Y_4 + Y_5) + Y_2 Y_3 (Y_5 + Y_6) + Y_1 Y_3 Y_5 + Y_2 Y_5 Y_6 = 0,$$

$$Y_3 (Y_1 + Y_2) (Y_4 + Y_6) + Y_2 Y_5 Y_6 = 0,$$

$$Y_2 Y_3 (Y_4 + Y_5 + Y_6) + Y_4 Y_6 (Y_1 + Y_2) = 0,$$

$$Y_1 Y_6 (Y_2 + Y_3 + Y_4) + Y_3 Y_6 (Y_2 + Y_4) + Y_3 Y_4 Y_5 = 0$$

and

$$Y_1 Y_6 (Y_2 + Y_3 + Y_4) + Y_2 Y_6 (Y_3 + Y_4) + Y_2 Y_4 Y_5 = 0.$$

By performing all possible permutations of these five configurations, two oscillator circuits result from each configuration, Fig. 2. Oscillation conditions and frequency equations for each circuit are summarized in Table 1. Sensitivity is calculated using,

$$S_y^{\omega_o} = \frac{y}{\omega_o} \cdot \frac{\partial \omega_o}{\partial y}$$

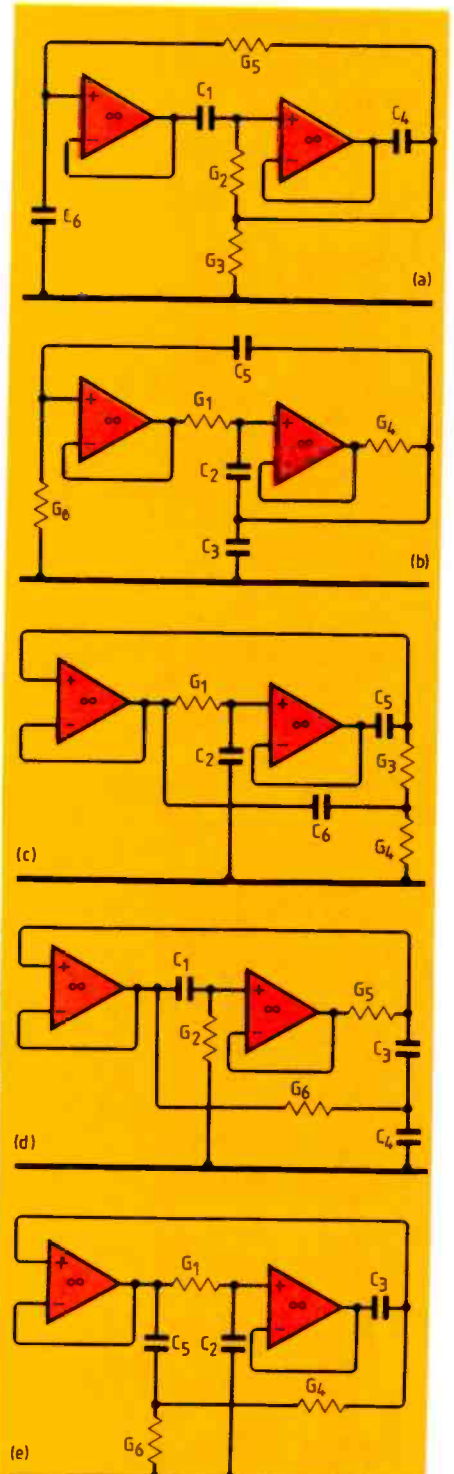
where  $\omega_o$  is the oscillation-frequency parameter and  $y$  is the element of variation. From Table 2 it is clear that the ten oscillators have low sensitivity characteristics.

Results are presented for only four of the oscillator circuits, Figs 3-6, but all ten designs have been built and tested using  $\mu$ A741 op-amps. Good quality oscillations have been successfully produced and sustained at up to approximately 295kHz.

Each of the ten new active-RC oscillators shown uses two op-amps connected for unity gain, three capacitors and three resistors. Connecting the op-amps for unity gain minimizes the effects of gain-bandwidth product, so higher oscillation frequencies are easily obtained. All ten circuits have low sensitivity characteristics.

Muhammad Abuelma'atti and Nouria Humood are with the Department of Electrical Engineering and Computer Science at the University of Bahrain.

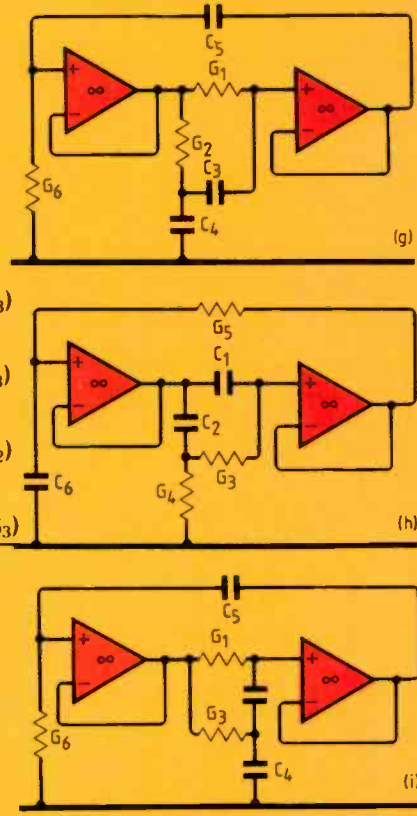
\* Senani, R. New RC active oscillator configuration employing unity gain amplifiers, *Electronics Letters*, Vol. 21, pp. 889-891.



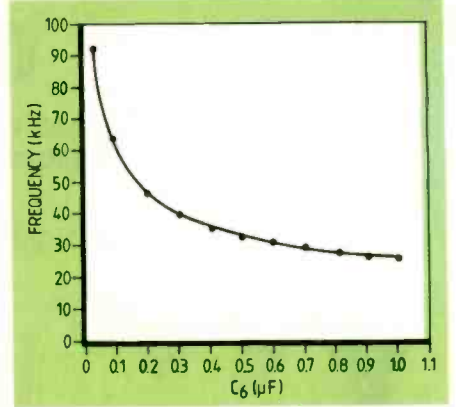
(Fig.2. see over)

**Table 1. Frequency and condition of oscillation for circuits of Fig. 2.**

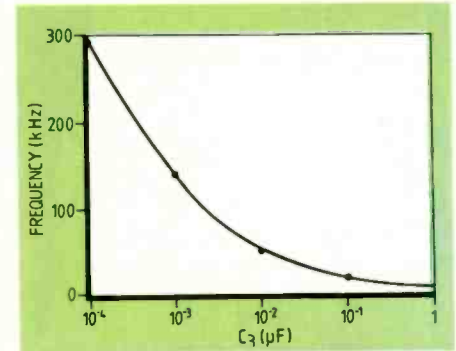
Circuit Fig. 2	Oscillation frequency $\omega^2$	Condition of oscillation
a	$\frac{C_2 C_3 C_5}{(G_2 + G_3 + G_5) C_1 C_6}$	$G_2 G_3 G_5 C_4 = (G_2 + G_3 + G_5) [C_1 C_3 C_5 + C_2 (C_3 C_6 + G_5 C_6)]$
b	$\frac{G_1 G_6 (C_2 + C_3 + C_5)}{C_2 C_3 C_5}$	$C_2 C_3 C_5 G_4 = (C_2 + C_3 + C_5) [G_1 C_3 C_5 + C_2 (C_3 G_6 + C_5 G_6)]$
c	$\frac{G_1 G_4}{C_2 C_6}$	$G_1 G_4 C_5 = C_2 G_3 G_4 + G_1 G_3 C_6$
d	$\frac{G_2 G_6}{C_1 C_4}$	$C_1 C_4 G_5 = G_2 C_3 C_4 + C_1 C_3 G_6$
e	$\frac{C_4 G_6}{C_3 C_5}$	$G_1 C_3 C_5 = C_2 C_3 G_4 + C_2 C_3 G_6$
f	$\frac{G_3 C_5}{G_4 C_6}$	$C_1 C_3 C_5 = G_2 G_3 C_4 + G_2 G_3 C_6$
g	$\frac{G_1 G_2}{C_3 C_4}$	$G_1 G_2 C_5 = G_6 (G_1 C_3 + G_1 C_4 + G_2 C_3)$
h	$\frac{G_3 G_4}{C_1 C_2}$	$C_1 C_2 G_5 = C_6 (C_1 G_3 + C_1 G_4 + C_2 C_3)$
i	$\frac{G_1 G_3}{C_2 C_4}$	$G_1 G_3 C_5 = G_6 (G_1 C_2 + G_1 C_4 + G_3 C_2)$
j	$\frac{G_2 G_4}{C_1 C_3}$	$C_1 C_3 G_5 = C_6 (C_1 G_2 + C_1 G_4 + C_2 C_3)$



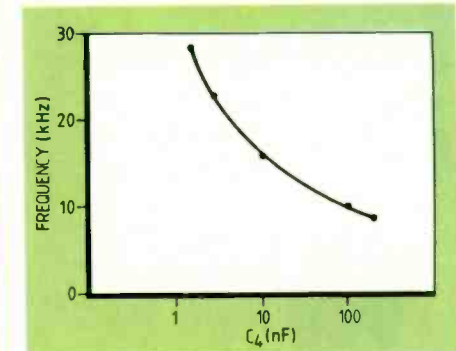
**Fig. 3.** Variation of oscillation frequency with capacitance  $C_6$  for the circuit of Fig. 2(c). Resistor  $R_1 = 1/G_1 = 2.6k\Omega$ ,  $R_3 = 1/G_3 = 129\Omega$ ,  $R_4 = 1/G_4 = 147\Omega$  and capacitor  $C_2 = C_5 = 1nF$ .



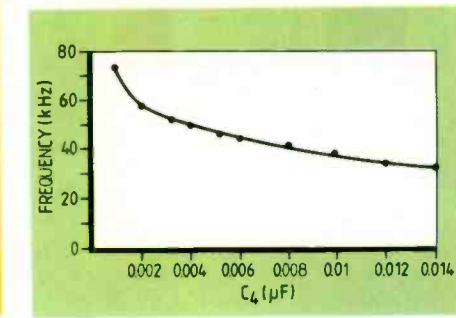
**Fig. 4.** Oscillation frequency versus capacitance  $C_3$  for the circuit of Fig. 2(e). Resistor  $R_1 = 1/G_1 = 1.8k\Omega$ ,  $R_4 = 1/G_4 = 900\Omega$ ,  $R_6 = 1/G_6 = 200\Omega$ ,  $C_2 = 100pF$  and  $C_5 = 5nF$ .



**Fig. 5.** Varying  $C_4$  in Fig. 2(g) gives this frequency curve for  $R_1 = 1/G_1 = 166\Omega$ ,  $R_2 = 1/G_2 = 200\Omega$ ,  $R_6 = 1/G_6 = 112k\Omega$ ,  $C_3 = 10nF$  and  $C_5 = 1nF$ .

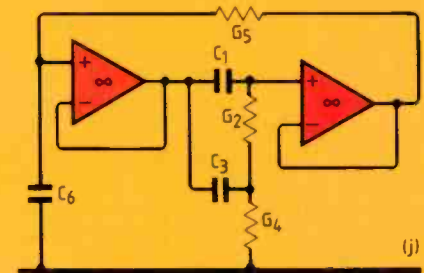


**Fig. 6.** With the circuit of Fig. 2(i), varying  $C_4$  results in this frequency curve. Resistor  $R_1 = 1/G_1 = 289\Omega$ ,  $R_3 = 1/G_3 = 300\Omega$ ,  $R_6 = 1/G_6 = 17.7k\Omega$  and  $C_2 = C_5 = 1nF$ .



**Table 2. Sensitivity equations for the ten oscillators.**

Circuit Fig. 2	Sensitivity
a	$S_{C_1}^{\omega_0} = S_{C_5}^{\omega_0} = -\frac{1}{2} \cdot S_{G_2}^{\omega_0} = \frac{1}{2(1 + \frac{G_2}{G_1 + G_5})} \cdot S_{G_3}^{\omega_0} = \frac{1}{2(1 + \frac{G_3}{G_2 + G_5})} \cdot S_{G_5}^{\omega_0} = \frac{1}{2(1 + \frac{G_5}{G_2 + G_3})}$
b	$S_{G_1}^{\omega_0} = S_{G_6}^{\omega_0} = -\frac{1}{2} \cdot S_{C_2}^{\omega_0} = \frac{-1}{2(1 + \frac{C_2}{C_3 + C_5})} \cdot S_{C_3}^{\omega_0} = \frac{-1}{2(1 + \frac{C_3}{C_2 + C_5})} \cdot S_{C_5}^{\omega_0} = \frac{-1}{2(1 + \frac{C_5}{C_2 + C_3})}$
c	$S_{G_1}^{\omega_0} = S_{G_4}^{\omega_0} = -S_{C_2}^{\omega_0} = -S_{C_6}^{\omega_0} = \frac{1}{2}$
d	$S_{G_2}^{\omega_0} = S_{G_6}^{\omega_0} = -S_{C_1}^{\omega_0} = -S_{C_4}^{\omega_0} = \frac{1}{2}$
e	$S_{G_3}^{\omega_0} = S_{G_6}^{\omega_0} = -S_{C_3}^{\omega_0} = -S_{C_5}^{\omega_0} = \frac{1}{2}$
f	$S_{G_3}^{\omega_0} = S_{G_5}^{\omega_0} = -S_{C_4}^{\omega_0} = -S_{C_6}^{\omega_0} = \frac{1}{2}$
g	$S_{G_1}^{\omega_0} = S_{G_2}^{\omega_0} = -S_{C_3}^{\omega_0} = -S_{C_4}^{\omega_0} = \frac{1}{2}$
h	$S_{G_3}^{\omega_0} = S_{G_4}^{\omega_0} = -S_{C_1}^{\omega_0} = -S_{C_2}^{\omega_0} = \frac{1}{2}$
i	$S_{G_1}^{\omega_0} = S_{G_3}^{\omega_0} = -S_{C_2}^{\omega_0} = -S_{C_4}^{\omega_0} = \frac{1}{2}$
j	$S_{G_2}^{\omega_0} = S_{G_4}^{\omega_0} = -S_{C_1}^{\omega_0} = -S_{C_3}^{\omega_0} = \frac{1}{2}$



**Fig. 2.** These ten new oscillators derived from the configurations of Fig. 1 each have two op-amps connected for unity gain, three resistors and three capacitors.

# ● DATABANK ●

## CARSTON ELECTRONICS

We sell a wide range of 'second user' computer equipment, microcomputers, computer terminals, peripherals and development systems.

We also sell test equipment – all fully guaranteed.

We buy good quality under utilised equipment.



**CIRCLE 59**  
FOR FURTHER DETAILS.

## THE ELECTRONIC SOURCE

*The Electronic Source*  
Sales Catalogue - Spring 1987



**CIRCLE 15**  
FOR FURTHER DETAILS.

Has access to in excess of £100m. worth of Second User General Purpose Test Equipment, P.C's, Instrument Controls, Dataloggers, MDS Systems and Audio Visual Equipment. Our latest catalogue indicates price and specification of our more readily available items.

Without reference to this Catalogue, can you really be sure that you have secured the best possible deal?

## CIRKIT



A new product catalogue containing the most comprehensive range of passive and electromechanical components yet offered by CIRKIT. Major franchises featured are ALPS, ARROW HART, BULGIN COMPONENTS, COOPER WELLER, FKI KEWSWITCH VARLEY, HARWIN, IVO, RICHIO and TOKO. WAYCOM To complement the tools and components available, an entire range of test equipment from THANDAR, HAMEG and HUNG CHANG is included. Service products from MULTICORE SOLDBERS and ELECTROLUBE complete the line up.

**CIRCLE 42**  
FOR FURTHER DETAILS.

## ELECTRONICS & WIRELESS WORLD DATA BANK

let your brochure do the selling

If you want to get your product information into the right hands fast,  
call Martin Perry on 01-661 3130.

## COUNTER TIMERS



**PFM200A** £175.50 + VAT

20Hz – 200MHz in 2 ranges, 4 gate times. 10mV sensitivity. 8-digit LED display. Battery/mains operation.

**TF200** £175 + VAT

10Hz – 200MHz in 2 ranges, 5 gate times. Frequency, period, period average, totalize. 10mV sensitivity. 8-digit 0.5" LCD. 200 hour battery life.

**TF600** £135.50 + VAT

5Hz – 600MHz in 3 ranges, 3 gate times. 10mV sensitivity. 8-digit 0.5" LED display. Battery/mains; complete with adaptor/charger.

**TF1000** £495 + VAT

DC – 100MHz on both channels, 6 gate times. Frequency, period, period average, time interval, time interval average, frequency ratio and totalise. 20mV sensitivity. HF filter, attenuator, trigger controls, trigger hold-off. 8-digit 0.6" LED display. Mains operation.

**TF1100** £595 + VAT

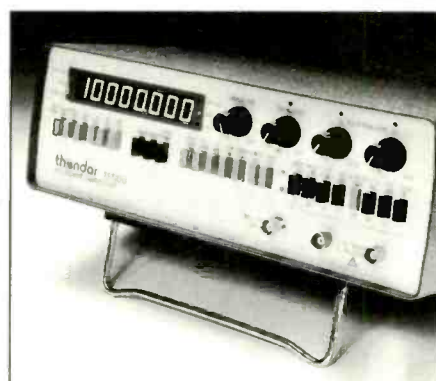
As for TF1000 but with 70MHz to 1GHz prescaler (frequency only); 10mV sensitivity.

**TP600** £45 + VAT

+ 10 prescaler, 40MHz – 600MHz. 10mV sensitivity.

**TP1000** £75 + VAT

+ 10 prescaler, 100MHz – 1GHz. 10mV sensitivity.



**thandar**  
ELECTRONICS LIMITED

Thandar Electronics Limited,  
London Road, St. Ives, Huntingdon  
Cambridgeshire PE17 4HJ, England  
Telephone (0480) 64646 Telex 32250 Test

THE LOGICAL CHOICE

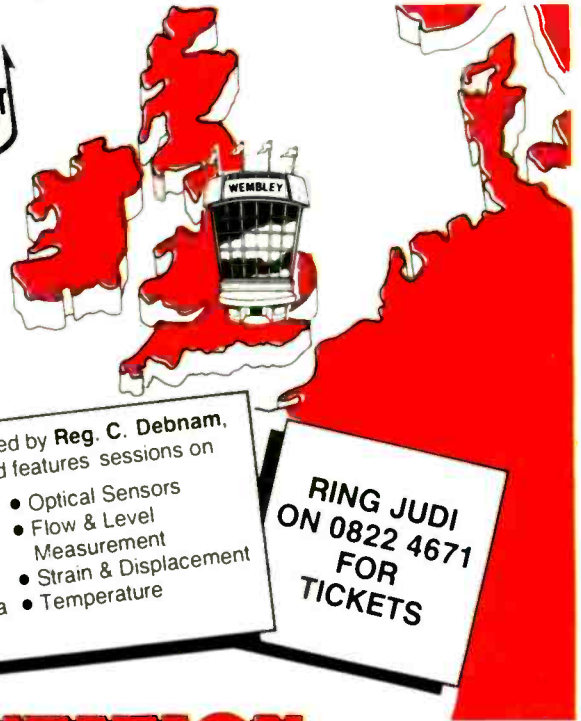
ENTER 53 ON REPLY CARD

# TEST+TRANSDUCER

THE MEASUREMENT EXHIBITION & CONFERENCE, WEMBLEY, LONDON, OCTOBER 20•21•22 1987

## THE EXHIBITION

Test+Transducer Instrumentation offers you the very latest from over 250 suppliers. It's the complete event for sensors and instrumentation for measurement, control, electronic and environmental test, data acquisition, recording and analysis. And it's all in Wembley's magnificent new exhibition hall.



## CONFERENCE HIGHLIGHTS

- FET silicon sensors, batch manufactured using techniques developed for the electronic industry.
- Application of optical fibres in automobiles.
- Imaging processing as a practical measurement tool.
- QuaT, a unique digital temperature measurement system.

The Conference is chaired by Reg. C. Debnam, C.Eng., M.I.Mech.E. and features sessions on

- Chemical Sensors
- Humidity
- Pressure & Vacuum
- Force & Mass
- Data Acquisition/ Data Processing
- Optical Sensors
- Flow & Level Measurement
- Strain & Displacement
- Temperature

**RING JUDI  
ON 0822 4671  
FOR  
TICKETS**

## LONDON'S INSTRUMENTATION EVENT

TRIDENT INTERNATIONAL EXHIBITIONS LTD, 21 PLYMOUTH ROAD, TAVISTOCK, DEVON PL19 8AU, ENGLAND. TEL: 0822 4671. FAX: 0822 4818

ENTER 51 ON REPLY CARD

## The Archer Z80 SBC

The SDS ARCHER – The Z80 based single board computer chosen by professionals and OEM users.

- ★ Top quality board with 4 parallel and 2 serial ports, counter-timers, power-fail interrupt, watchdog timer, EPROM & battery backed RAM.
- ★ **OPTIONS:** on board power supply, smart case, ROMable BASIC, Debug Monitor, wide range of I/O & memory extension cards.

ENTER 22 ON REPLY CARD

## The Bowman 68000 SBC

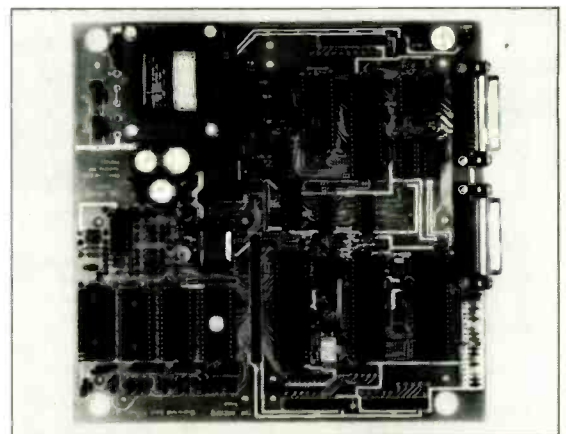
The SDS BOWMAN – The 68000 based single board computer for advanced high speed applications.

- ★ Extended double Eurocard with 2 parallel & 2 serial ports, battery backed CMOS RAM, EPROM, 2 counter-timers, watchdog timer, powerfail interrupt, & an optional zero wait state half megabyte D-RAM.
- ★ Extended width versions with on board power supply and case.

ENTER 23 ON REPLY CARD

## Sherwood Data Systems Ltd

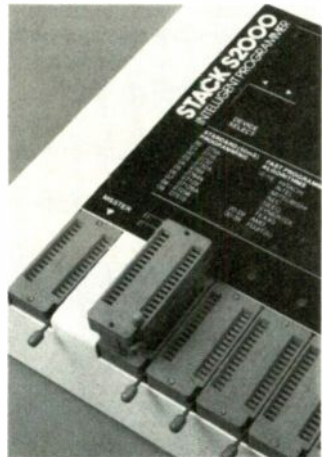
Sherwood House, The Avenue, Farnham Common, Slough SL2 3JX. Tel. 02814-5067



# NEW PRODUCTS

## Adaptor for 32-pin eproms

Any eprom programmer which can program a 28-pin 27011 'paged' 1Mbit eprom can also be used for 32-pin devices if the stack adaptor is used. The adaptor plugs directly into the 28-pin socket and no modification is necessary. Adaptors can be fitted in adjacent sockets for gang programming and will cope with 2Mbit devices when they become available. Stack Ltd, Unit 8 Wedgewood Road, Bicester, Oxon OX6 7UL. Tel: 0869 240404.



## Programmable random logic

A Signetics device offers the capability of performing more than two-level logic functions without incurring i/o buffer delays.

The PLHS501 programmable macro logic unit is field programmable and has 24 dedicated inputs. The user can embed logical operations or macro structures relating to the input/output pins. Such functions are independent of any i/o buffers and can therefore be performed at much higher speeds than with conventional logic.

The organization of the internal matrix of fused-logic gates allows the direct interconnection of any number of logic nodes. Several such nodes can be combined to form a macro. The speed of the device reflects the complexity of the function: a single logic function has a short path through the matrix and can therefore be very fast. Additional levels will add one gate-delay per level but still do not suffer from the delays normally caused by i/o buffers. The device is programmed by routing the circuits with blown fuses. The built-in test circuitry allows the device to be thoroughly tested prior to programming. Available from a number of Signetics/Mullard distributors including Celdis, 37 Loverock Road, Reading, Berks RG3 1ED. Tel: 0734 585171.

## Fuselinks for p.c.b. mounting

A range of subminiature fuselinks (Beswick series TDC 483) resemble resistors in appearance, having an insulated ceramic body and axial leads, and comply with international standards. The fast-acting fuses, type

f, are available in values ranging from 63mA to 15A. Up to 10A they have an operating voltage of up to 125V and 10A, 32V. Available from RR Electronics Ltd, St Martins Way, Cambridge Road, Bedford, MK42 0LF.



## Ever thought of thick film?

Thick-film hybrid circuits have been confined to military and high-volume communications markets. However, Radamec Microsystems, who manufacture such circuits, thinks that it is time that they were used in more everyday applications. Combining their cad facilities with special tooling, they can offer a very quick turnaround prototyping service.

The circuits are produced by successive printing and furnace baking of conductors, insulating layers and resistors. The resistors can be very precisely trimmed and, as they share a common alumina substrate, they offer similar ageing and thermal tracking characteristics. A large number of resistors can be included in a circuit, so the thick film is especially suitable for analogue circuits. Components are added using pick-and-place machinery and

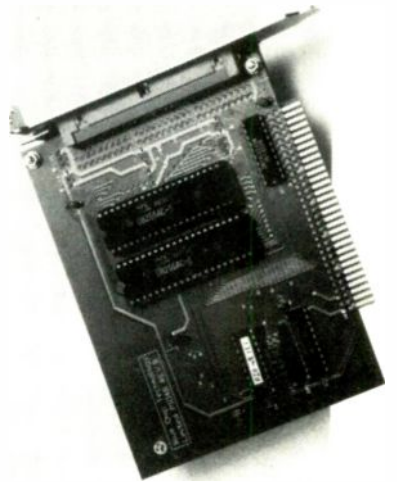
vapour-phase soldering. The system can produce very compact circuits which can be further reduced in size by the direct wire bonding of i.c. chips to the circuit.

Many of the same or analogous techniques can be used in the production of conventional p.c.bs. The company has developed a system for combining surface-mounted and through-hole components on to either or both sides of p.c.b.

Radamec is also offering its manufacturing facilities to start-up companies, or existing companies with new projects, as a 'technology transfer' scheme which includes everything from design and personnel training to production, assembly and delivery. Radamec Microsystems Ltd, 222 Dukes Road, Crowthorne, Berks RG11 6DS. Tel: 0344 775115.

## Programmable i/o for PC

A plug in card for the IBM PC or compatibles has 48 channels, which may be configured as input or output or any combination of the two. It may be used for reading parallel data lines, such as binary-coded decimal, reading sequences of switches and for driving digital outputs. All signals are at t.t.l. levels. Pull-up resistors can be fitted to the card and there is a choice of ribbon cable connector or screw terminals. The board plugs straight into the PC and is suitable for such compatible computers as Amstrad, Olivetti and many others. Blue Chip Technology Ltd, Main Avenue, Hawarden Industrial Park, Deeside, Clwyd CH5 3PP. Tel: 0244 520222.



## Integrated l.c.ds

Legend Custom Displays have the same initials as their products - l.c.ds. They are offering a complete display service and stress that a display should be an integrated part of the product design, not an afterthought. So they are not only providing characters for a specific application but also the colours, connectors, filters, back-lights and all the other parts needed to add a display to a product. For example, they can provide heat-sealed flexible connectors, or silicone elastomer connectors to be used with switches which can overlay a display to provide an interactive system, and they can add non-reflective coatings and electroluminescent back-lighting. Related electronics, including i.c.s designed specifically for a display, are provided in the package as well as various assembly methods, including surface-mounted components and flexible p.c.bs. LCD have a design team to offer solutions to any display problem. Legend Custom Displays Ltd, 4 Arkwright Road, Reading, Berks RG2 0LU. Tel: 0734 876377.

# NEW PRODUCTS

## Harmonic distortion meter

A new fast-Fourier transformation analyser from Hakuto has a built-in distortion measurement function which complies with the methods of testing proposed by new IEC regulations. The proposed regulations, IEC publication 555-2, require that all domestic appliances are tested to ensure that they do not cause harmonic distortion to the mains supply.

The AD3522 analyser can automatically measure t.h.d. and power and display them as graphs or figures. The displayed data can be

printed by an optional hard copy unit. A built-in condition monitor allows the test criteria to be set up, stored and recalled as required for automatic analysis. The instrument offers all the major functions expected in an analyser and is easy to use. The unit may be run from batteries to make it portable. Acoustic inputs enable the checking of noise levels, to ensure that industrial noise is not a public hazard. Hakuto International (UK) Ltd, 33 Eleanor Cross Road, Waltham Cross, Herts EN8 7LF.

## Hard-disc controller on a chip

What is claimed to be the first single-chip disc controller that supports the Enhanced Small Devices Interface (ESDI) standard is available from Advanced Micro Devices. The Am9590 is highly integrated and includes buffer memory for two sectors, direct memory access and a 16-bit microprocessor.

The disc read/write rate is 15Mbit/s which is sufficient to meet the ESDI standard and the device can be programmed to support any combination of up to four hard or

floppy disc drives. It supports a number of double-density floppy disc formats and includes Reed-Solomon error detection and correction algorithms. Most disc operations can be carried out by the Am9590 without any intervention by the host computer processor. The controller may be used with the Am9582 disc data separator which codes and decodes data between the disc and the system. Advance Micro Devices (UK) Ltd, Goldsworth Road, Woking, Surrey GU21 1JT. Tel: 048 62 22121.

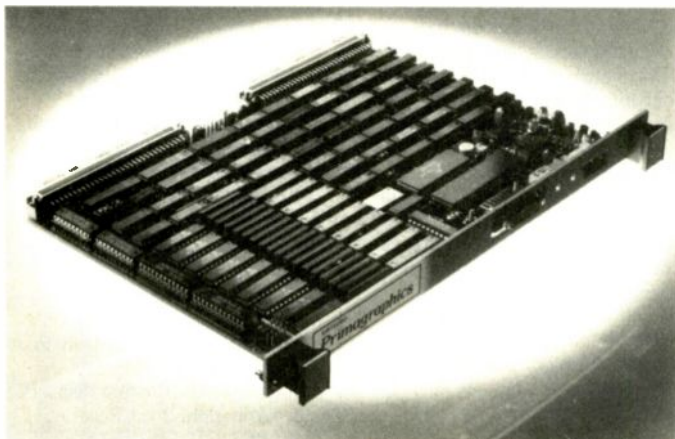
## Starter software for machine vision

A general-purpose image-processing software package is intended for use with the Primagraphics range of VME boards. VCS is an entry-level package aimed at industrial and educational users starting in the field of machine vision. The software takes advantage of the facilities available on the boards including frame grabbing and the ability to store high-quality greyscale or colour images to a high resolution.

The system is programmed by a number of three-letter mnemonics, with some parameters when needed, or by developing programs which call on the extensive library of built-in functions. These include edge

detection, object and character recognition, filtering and convolution, and histograms.

As an example, the software allows the labelling of an image to be stored on a separate overlay plane without affecting the original image. Similarly, a window or 'region of interest' can be processed independently, with markers to show the position on the complete image. The system can be used in such areas as visual inspection, image enhancement, size area and position measurement, object recognition and robot vision. Primagraphics Ltd, Melbourn Science Park, Royston, Herts SG8 6EJ. Tel: 0763 62041.



## Low-cost transputer module

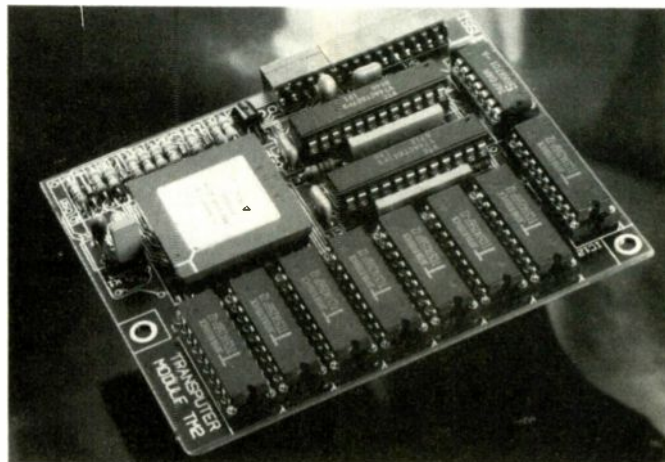
A module incorporating the Inmos T414-15 transputer may be used as a stand-alone development system or in conjunction with a suitable host computer; a PC for example. A PC interface card is available, which enables the running of all transputer development software that is currently available. An assembler and compilers for Occam 2, C, Pascal and Fortran can be supplied.

Costing £650, the TM2 comprises a 95 by 74mm four-layer p.c.b., on which are mounted a transputer (capable of up to 7.5mips and 1Mbyte of d-ram which is made up from 1Mbit (256 x 4) c-mos rams.

A link is provided which configures the memory interface for three or four-cycle operation (user selectable) so that systems may be optimized for cost or performance. The link inputs are static-protected against up to 2000V with Schottky diodes and the outputs are

terminated for 100Ω to match twisted-pair cables.

The TM2 is compatible with Concurrent Techniques' first transputer module the TM1 and, like it, can be supplied with either 15MHz or 20MHz T414 transputers or the T800 floating-point transputer. The latter which includes an on-chip maths coprocessor will deliver up to 2.25Mflops/s. The TM2 can also be used as the basis for a powerful, compact parallel processing system: up to eight TM2s can be mounted on a single Eurocard, giving up to 8Mbytes and 80mips. Applications for the TM2 include robotics, image processing, p.c.b. auto-routing, finite element analysis, pattern recognition, and high-speed distributed databases. Concurrent Techniques, 30 Baldslow Road, Hastings, East Sussex, TN34 2EY. Tel: 0424 714790.



## 80-channel logic analyser

The latest logic analyser from Gould, the K450B, can monitor and capture data across 80 data channels at up to 100MHz with 10ns resolution. It can also be configured to cover half that at twice the speed, i.e. 40 channels at 200MHz with 5ns resolution. Glitch capture in any configuration is 5ns and there is a maximum delay of 1ns between any of the channels.

The instrument is designed to be especially useful in analysing and timing the signals associated with 32-bit processors and is provided with disassemblers for the 68020 and 80386 processors. Similar techniques can be used to analyse VME bus or Multibus signals, and for complex application-specific i.cs. The instrument itself makes much use of asics, including what amounts to a complete 16-channel logic analyser on an e.c.l. chip, containing 50000 logic gates.

Extensive front-panel controls include an auto-race button; the K450B will search through the active

incoming signals and automatically display them in an optimized format. It has a built-in disc drive and can record and date-stamp data records. Set-ups can be retained on the disc and automatically loaded. Communications links for external control include GPIB and RS232 interfaces. The instrument can communicate with and be controlled from a personal computer, even remotely through a modem, and can be programmed to set off an alarm signal if continuously monitoring circuits or systems. Gould cites some digital telephone exchanges which are remotely monitored in this way; the instrument automatically calls a remote control centre if a fault is detected.

The K450B is also designed to be easy to use and its operation will be familiar to those already using Gould instruments. Gould Electronics Ltd, Instrument Systems, Roebuck Road, Hainault, Ilford, Essex IG6 3UE. Tel: 01-500 1000.

# NEW PRODUCTS

## 40-channel logic analyser

A compact 40-channel logic analyser has been designed and made by LJ Electronics in Norwich. The instrument includes a 36-bit word trigger which makes it suitable for use with 8 or 16-bit processors, and includes on-board disassemblers for 6502, 65C02 and Z80 processors. It operates at 10MHz when sampling data on rising or falling edges, and 5MHz if both clock edges are used. It contains enough internal memory to record 511 events on each of four banks. The 4-line by 16-character display is backed up by an RS232 output, a printer output and a waveform output for displaying on an oscilloscope. It can compare blocks of data and supply data reports on channel levels.

At a price of £800, it is claimed to offer as standard many advanced features: included are test probes, a buffer pod and an i.c. test clip. LJ Electronics Ltd, Francis Way, Bowthorpe Industrial Estate, Norwich NR5 9JA. Tel: 0603 748001.

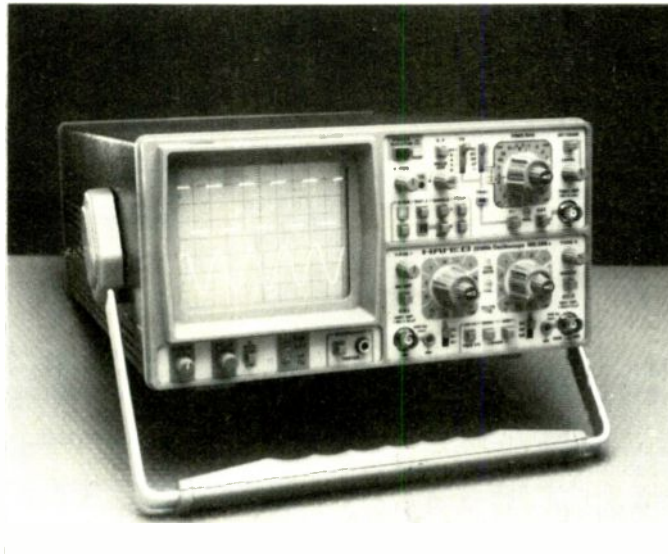


## Light source for optical-fibre testing

Lightweight, handheld optical light sources and power meters from Megger have been designed specifically to test optical-fibre networks. The source projects a measurable amount of light into the fibre which is detected by the appropriate power meter.

Together the instruments can be used to investigate attenuation caused by connectors, splices or the cable itself in any optical network such as telecommunications, computer installations, industrial process controls and lans.

The instruments are suitable for cables up to 1mm diameter. Choice will depend on the cable used and the wavelength required: the OLS 510 light source and OTP 520 power meter are optimized for 850nm; the OLS 610 light source and OTP 620 power source are for 850, 1300 and 1550nm. Electronic Brokers Limited, 140 Camden Street, London, NW1 9PB. Tel: 01 267 7070.



## Low-cost 5MHz oscilloscope

Following closely on the heels of the HM205-1 is the Hameg 505-2 digital storage oscilloscope. This has an increased bandwidth of 5MHz, compared with the 100kHz of its predecessor and also adds dot joining for a smoother display. It has a 1024 by 256 dot display and a 20MHz component test socket for real-time analysis. A led blinks each time a trigger signal is received, to indicate operation of the instrument. An add-

on option which can be retrofitted to other oscilloscopes is an output to an x-y plotter. Two high-impedance probes and a two-year warranty are included in the price of £527. Hameg Ltd are in Luton, Tel: 0582 413174 and the instrument is also available from Paxton Instruments Ltd, 2 Letchworth Business Centre, Avenue 1, Letchworth, Herts SG8 2BB. Tel: 0462 685648.



## Measuring digital jitter

The effect of jitter on digital transmission networks can be determined by the PJM-4 jitter meter from Plymouth-based Wandel & Goltermann. Complex networks need to keep jitter to a minimum as signals may not be transferred correctly. The new instrument meets CCITT 0.171 requirements and in some respects exceeds them. Its synchronization characteristics and low intrinsic jitter result from the use of clock recovery circuits, phase demodulator and weighting filters.

Bit rates can be selected from a wide range and irrespective of the rate, jitter measurements can be made on all types of clock and data signals up to 168MHz. Error recognition is possible for a number of coding systems. Front-panel or remote, automatic operation is possible through an IEC 625 (GPIB) interface. Wandel & Goltermann Ltd, 412 Greenford Road, Greenford, Middlesex UB6 9AH. Tel: 01-575 3020.

## Signal processing on a computer

A library of signal analysis functions is available for use on Hewlett Packard Series 200 and 300 computers. The SignalCalc programs are written in Basic and include time and frequency analysis of signals from on-line processes, production measurements and research experiments. This enhanced version of SignalCalc includes better graphics and a 'calibrate' command for d.c. shift and scaling. Hilbert transforms are used for extended analysis. Fast Fourier transforms are possible with 300dB dynamic range and two-dimensional transforms for arrays of unlimited size. The program can typically complete a 1024-point transform in less than 100ms. With an add-on a-to-d card, the computers can capture data from a variety of sources, process it and produce a graphical output. It can be used for noise and vibration analysis, structural dynamics, seismic analysis, radar systems, network analysis and synthesis, biomedical and neurological studies, speech and acoustic research, image processing and performance testing of a-to-d and d-to-a converters. SignalCalc is produced in the US by the Data Physics Corp. and is available in the UK from Protek, 10 Grosvenor Place, London SW1X 7HH. Tel: 01-245 6844.

## Ammeter for power cables

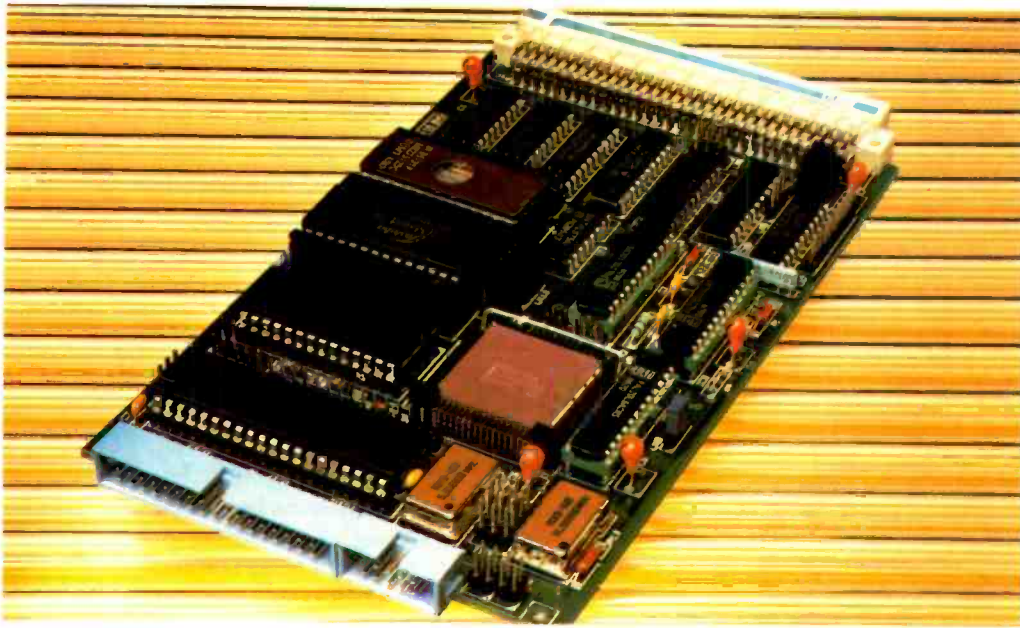
New clamp-on ammeter from TMK uses large, individual, rotary range scales to provide reading of alternating current, voltage and resistance. The jaws of the clamp are specially shaped to provide access to cables in awkward places. The pointer may be locked into position to record a reading taken under difficult circumstances. Five current ranges measure up to 300A, three voltage ranges to 600V and resistance measurement can be up to 5k $\Omega$ , with a 200 $\Omega$  midrange. The meter is supplied with test probes, battery and a case. Harris Electronics (London), 138 Grays Inn Road, London WC1X 8AX. Tel: 01-837 7937.







# NEW PRODUCTS



## Network adaptor for VME

A VME-bus module from Amplicon is designed to interface between the VME bus and an Ethernet local-area network and includes 128byte ram to act as an Ethernet buffer. The Ethernet controller performs the link level protocol at 10Mbit/s. Interrupts from this controller can generate an interrupt or a service request on the VME bus. The network controller includes network access, memory management, error reporting, packet handling and processor interface functions. The module includes a serial interface adaptor, which is a Manchester protocol coder/decoder compatible with Ethernet and with the IEEE-802.3 specification. The serial adaptor includes a noise filter, can quickly latch on to an incoming signal and collision detection/conversion. It also acts as an interface between the network controller and the external cable.

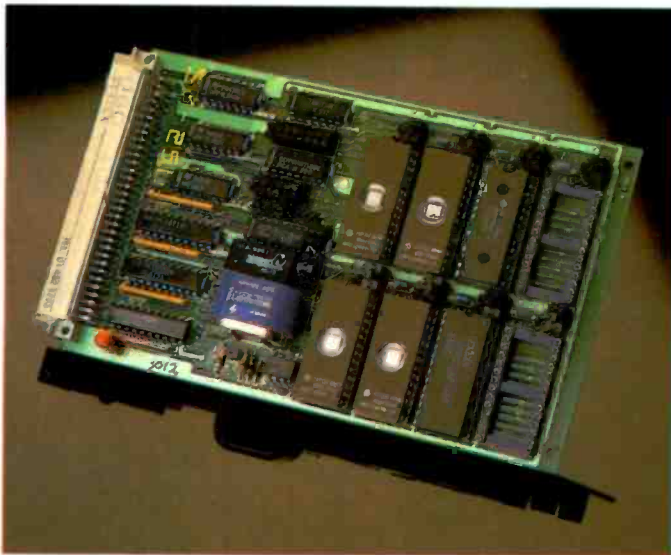
The module is built on a six-layer p.c.b. with internal power and ground planes to minimize noise and increase reliability. Amplicon Electronics Ltd, Richmond Road, Brighton, E. Sussex BN2 3RL. Tel: 0273 608331.

## STE card runs PC programs three times faster

Programs developed on an IBM-PC can be downloaded to the Celeste 188 card and then be run three times faster, according to Control Universal. The p.c.b. uses the 10MHz 80188 processor and up to 256Kbytes of no-wait-state memory. It also includes programmable interrupt controllers, allowing vectored interrupts from up to eight STE bus

attention-request lines and 11 on-board sources, which can be assigned levels of priority by the software to provide flexibility in complex real-time control applications. STE-bus arbiter and system control functions are provided, along with link-programmed master/slave configurations. All is included on a single-height Eurocard. Software is

available for applications development on a PC. A machine-code monitor is used for debugging. Terminal and downloading facilities are provided for the PC as well as a set of utilities for program development on a 'C' compiler. Control Universal Ltd, 137 Ditton Walk, Cambridge CB5 8QF. Tel: 0223 244448.



## Battery-backed STE-bus memory

The SM256 is an eight-bit memory card for the STE bus. It has eight sockets to take any mixture of ram, eprom or eeprom up to a maximum of 256Kbytes. The battery back-up can be directed to support specific sockets. Battery supply is switched in automatically when the supply voltage drops or on detection of a system-reset signal. Flexible memory addressing allows the memory to be mapped anywhere

within the 1Mbyte STE bus address space and individual sockets can be switched out of the memory map to avoid clashes with other memory devices. Jumpers on the board allow the selection of access times to suit the memory chips in use. The board is manufactured by DSP Design and is available through Dean Microsystems Ltd, 7 Horseshoe Park, Pangbourne, Berks RG8 7JW. Tel: 07357 5155.

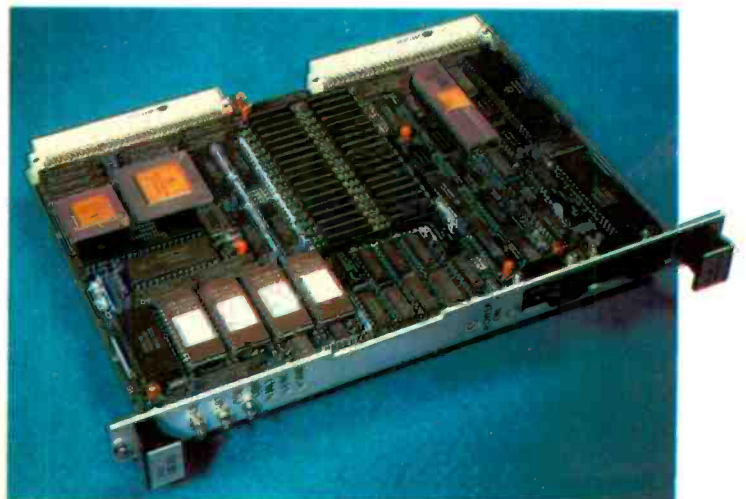
## OS-9 on a 68020 VME card

An OS-9 development and target system is the intended application of the Plessely PME68-23 VME processor card, which is based on the 68020 processor. A typical development system consists of only two boards. PME68-23 can support a terminal, printer and floppy-disc drive. A second card, PME-SCSI-1 can provide a hard-disc interface.

The OS-9/68K 'Professional' operating system can be resident on the card in a rom. Additional software support includes file

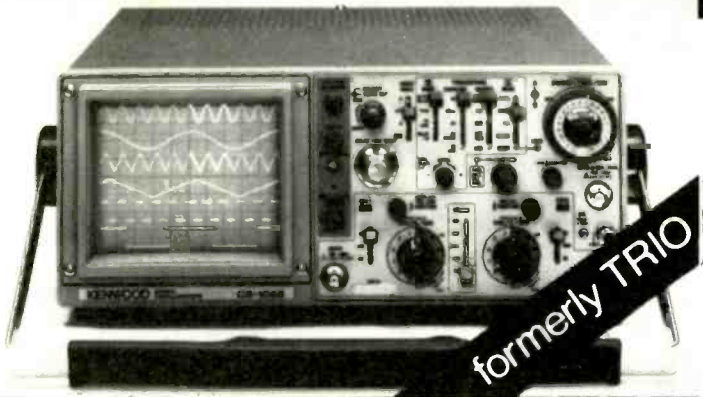
management, a set of utilities, screen editor, 'C' compiler and a number of high-level languages.

Once the operating code has been compiled, the 68-23 board can form the basis of a target system, since the on-board rom and 4Mbyte dram can remove the need for any external memory of storage. A number of elements can be configured to suit a specific requirement by Dean Microsystems Ltd, 7 Horseshoe Park, Pangbourne, Berks RG8 7JW. Tel: 0703 5155.



# KENWOOD Oscilloscopes

bandwidths from 20MHz to 150MHz  
prices from £319 to £1695 (+ vat)



Trio oscilloscopes are back with a new name, new models, higher specifications and lower prices.

Take the Kenwood CS-1065 illustrated here; a 60MHz, dual-timebase, three-channel oscilloscope costing only £795. It's part of an extensive range from one of Japan's most experienced producers.

Thurlby hold every model in stock for immediate delivery. Contact us now for a copy of the full-range brochure listing technical specifications and prices.

Thurlby Electronics Ltd. Tel: (0480) 63570  
New Road, St Ives, Cambridgeshire. PE17 4BG England.

ENTER 63 ON REPLY CARD

## The world's most advanced low-cost bench multimeter!

Thurlby 1905a £349 + VAT



### A complete high performance bench DMM

- 5 1/2 digits; 0.015% acc; 1 µV, 1mΩ, 1nA.
- Full ac and current functions as standard

### A sophisticated computing and logging DMM

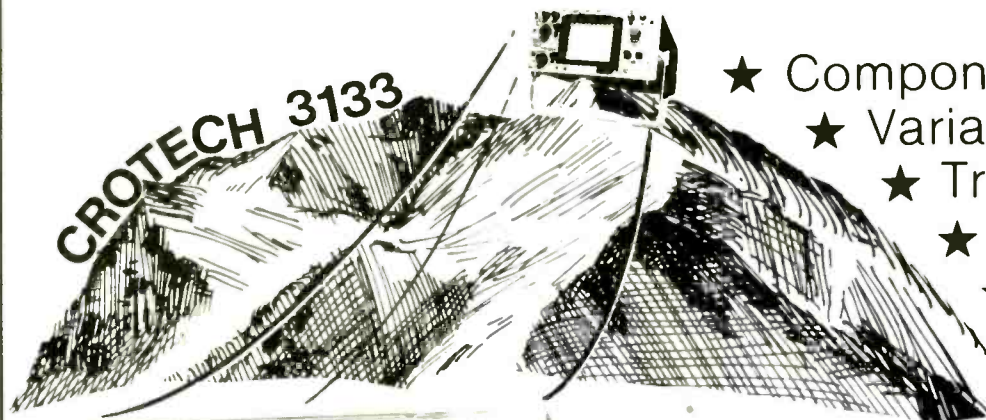
- Linear scaling with offset; null/relative
- Percentage deviation; running average
- dBV, dBm general logarithmic calculations
- Limits comparison; min and max storage
- 100 reading timed data logging
- RS232 and IEEE-488 interface options

Thurlby Electronics Ltd  
New Road, St. Ives, Cambs. PE17 4BG  
Tel: (0480) 63570

**Thurlby**   
designed and built in Britain

ENTER 64 ON REPLY CARD

# CONQUERING NEW HEIGHTS



- ★ Component Comparator
- ★ Variable Hold Off
- ★ Triple DC Source
- ★ DC - 25 MHz
- ★ 40ns/div
- ★ 2mV/div
- ★ Low Cost

**£319\***



*Yes its 25MHz for £319*

To scale the heights, just call us for your FREE copy of our catalogue

\*(Ex VAT & Delivery)

**Crotech Instruments Limited**

2 Stephenson Road, St. Ives, Huntingdon, Cambs. PE17 4WJ  
Telephone: (0480) 301818

ENTER 43 ON REPLY CARD

# RADIO BROADCAST

## Czech bits in Japan transmission

Czechoslovak Radio gained its first experience of a live inter-continental digital-stereo transmission back in November 1985, when a concert given by the Czechoslovak Radio symphony orchestra was relayed to FM Tokyo via the Indian Ocean Intelsat V satellite and the German Raisting earth station, using a Sony 1610 p.c.m. processor with 16-bit linear quantization, 44.1 kHz sampling rate and television o.b. link. Since then experimental transmissions have been made from CD records and the successive introduction of digital techniques is planned for six main areas of broadcast audio: sound recording; live transmission; transmission from CD records and digital audio tape recordings; sound signal processing; preservation of sound recordings; and restoration of historical recordings.

It is recognized that analogue and digital audio techniques will co-exist for a long period as mutually overlapping systems. This is seen as being partly for economic reasons but also because there remain problems still to be solved in parts of the electroacoustic chain and the standardization of different systems. Nevertheless it is felt that progressive 'digitalization' already offers significant improvements in audio and calls for further development of those parts of the system that remain analogue, while eliminating the weakest part of the analogue chain by recording in digits. Czechoslovak Radio intends to digitize fully its sound library with the aid of F1/701 processors and Beta video recorders on the grounds not only of technical quality and elimination of ageing but also on grounds of space and economics.

On display at the BKSTS conference and exhibition at Brighton was the "Computer Enhanced Digital Audio Restoration (CEDAR)" system developed by the National Sound Archive in collaboration with Cambridge Electronic Designs. This system is designed to eliminate thumps, bangs and scratch noise and can

deal with disc, cylinder, acetates and film recordings using software designed for IBM or compatible computer systems. Although developed for use at the National Sound Archive in Kensington, the system is likely to be marketed next year.

Sony Broadcast are planning to market professional digital audio tape equipment throughout Europe this autumn. First equipment will be the PCM-2500 rack-mounted machine with analogue sampling frequencies of 44.1 and 48 kHz, while the digital input can also sample at 32 kHz. A professional portable digital audio tape recorder, type PCM-2000, is due to be launched early next year.

The combination of digital audio with video segments on the new 5-in 'CDV' discs developed by Philips and Sony was a major feature of the 1987 International Summer Electronics Show at Chicago alongside digital audio tape players and Super-VHS video cassette recorders. The 5-in CDV discs combine 20 minutes of digital sound with a 5-minute video clip. The recording industry sees CDV as a means of marketing the video promotion clips that have become an important part of album sales and artist promotion. Industry sees it as an attempt to relaunch video discs that will stand or fall on the number of titles available. In the USA there are some 40 million v.c.r.s in homes, compared with less than 250,000 video disc players.

---

## Voltage transients in the home

An August "The Cook Report" (ITV) had the energetic Roger Cook enquiring into the series of fires and damaged domestic electrical and electronic appliances suffered by two unfortunate householders in Gloucestershire and Somerset. Although there were heavy hints that the cause could be secret military research into high-powered radar or simulated nuclear e.m.p. tests, the point was also made that both of the affected houses were at the end of overhead electricity

distribution routes and that there was some evidence of transient overvoltages, with the problems arising when a number of such voltage spikes occurred in rapid succession. One of the victims had even been taken into police custody on one occasion, apparently on the suspicion that he was somehow generating the voltage spikes himself!

Perhaps the most surprising aspect of such incidents is their rarity. Many years ago, a Mullard investigation showed that, for example, at Dudley during a period of six weeks a voltage transient detector recorded many brief overvoltages including seven of 40 to 70 per cent above normal and one of over 100 per cent. At Cheam, in a period of some 12 weeks, the recorded overvoltages amounted to four of 40 to 70 per cent and eight of 70 to 100 per cent above normal.

Transient overvoltages, often lasting only a few microseconds yet capable of destroying unprotected solidstate devices and power-supply units, tend to arise mainly from switching operations and lightning strikes and near strikes. Switching into or out of inductive loads can be dealt with by more effective suppression, but lightning discharges with their steep wavefronts of electromagnetic pulses remain a problem that will not go away.

Because of the greater use of overhead, three-phase supply lines, overvoltage transients tend to be more severe in rural areas and are of too brief duration to show up on the usual meters used to check complaints of incorrect supply voltage.

The Electricity Council Research Centre at Capehurst has recently set up an improved automatic-direction-finding system to record the number and location of lightning strikes, which each year cost the electricity supply industry millions of pounds yet have remained a largely unquantified phenomenon. The damage caused by lightning (and conceivably by nuclear e.m.p. simulation tests) on consumers and on communications and broadcasting equipment, antenna masts and towers, similarly remains largely unqualified. Good protection of equipment against direct or in-

direct strikes on masts and towers is costly and there is a dearth of reliable statistics about the cost-effectiveness of existing protection techniques. Few organizations have any means of recording strikes that do not result in immediate equipment damage and thus lack knowledge of the extent to which existing protection is effective.

The ECRC have recently refurbished and modified their network of four automatic d/f radio receiving stations set up some years ago to locate lightning discharges in the UK, but found to be unreliable in operation due largely to inaccurate bearings resulting from polarization errors ('night effect'). The new techniques have been designed to minimize these errors by using at each unattended d/f station three vertical loops at relative angles of 120°, instead of the usual orthogonal crossed loops plus a sense antenna, and also a horizontal loop from which the horizontally polarized component of lightning e.m.p. (the main cause of polarization errors) can be derived and nulled out from the computer location as recorded at the Capehurst centre.

ECRC believe this modified system should achieve a mean bearing error on lightning spherics of only  $\pm 0.5^\circ$  and should be capable of automatically recording and locating the position of lightning strikes throughout the country to within 3 to 10km. The detector system now operates at e.l.f. (2 kHz) rather than 10 kHz since the amount of horizontally-polarized component of lightning e.m.p. is significantly less at this extremely low frequency.

---

*Radio Broadcast was written by PATHAWKER*



PHONE  
0474 60521  
4 LINES

**P. M. COMPONENTS LTD**  
SELECTRON HOUSE, SPRINGHEAD ENTERPRISE PARK  
SPRINGHEAD RD, GRAVESEND, KENT DA11 8HD

TELEX  
966371  
TOS-PM



**A selection from our  
stock of branded valves**

Table with multiple columns listing various valve types and their prices. Includes categories like MULLARD, EFB6, HFR9, PL82, V241C/1K, 3B26, 68A6, 6L15, 16AQ3, 5728, 59.50, etc.

**CALLERS WELCOME**  
OPEN MON-THUR 9AM-5.30PM  
FRI 9AM-5.00PM  
'24-HOUR ANSWERPHONE  
SERVICE'  
**ACCESS & BARCLAYCARD**  
PHONE ORDERS WELCOME  
UK ORDERS P&P £1  
PLEASE ADD 15% VAT  
EXPORT ORDERS WELCOME  
CARRIAGE AT COST  
PLEASE SEND YOUR  
ENQUIRIES FOR SPECIAL  
QUOTATIONS FOR LARGE  
REQUIREMENTS.

# TELEVISION BROADCAST

## Paying for tv

For broadcasters and the broadcast equipment industry, the decade since the publication in March 1977 of the 522-page Annan Committee report on the future of broadcasting will surely go down in history as the age of confusion. The go-stop-go on direct broadcasting from satellites, the fervent espousal by the government of cable-tv, but its refusal to provide tax incentives or any form of public funding, have delayed change. On the other hand the government moved with almost undue haste to implement the recommendation of the interim and final reports of the Merriman committee to banish UK television broadcasting from v.h.f. Bands 1 and 3.

This hasty decision is now being challenged by the new CSPI (now part of US consultants Booz Allen & Hamilton International) 214-page report on "Subscription Television" (HMSO, £9.50) which stresses (page 162) that "the terrestrial channels are a very valuable national resource, providing much the cheapest method of access for UK households to television programming."

This down-to-earth report, prepared by Dr Charles Jonscher, casts a refreshingly impartial and cool look at the 1986 Peacock Committee's belief that the UK television licence fee should be phased out in favour of a partially competitive broadcasting market by scrambling all BBC and possibly also ITV/Channel 4 off-air broadcasts and financing them through viewer subscription, including possibly pay-per-view arrangements. The report shows that it is still almost impossible to estimate the future impact of cable and satellites (both d.b.s. and satellite-to-cable) with several possible views on growth rates. But the report concludes firmly that there is at present an unsatisfied need for premium television for which the public would be prepared to pay.

The report accepts that the technology necessary for implementing subscription services on terrestrial channels is already available (at least with the limited technique of scrambling only the sound channel).

Present technology, it is shown, could handle payment per channel or per programme and could be made compatible with various payment mechanisms, including the use of 'smart cards' bought from High Street shops. But even in the long term when there might be many subscribers the administrative costs would be of the order of £5 to £8 per annual subscription compared with the present £3 or so cost of licence-fee collection.

The CSPI report puts forward three main options for providing premium television that are not mutually exclusive:

(1) night-time down-loading to domestic video cassette recorders of scrambled feature films on BBC2 and/or Channel 4;

(2) rescheduling BBC2 to provide a subscription service for part of the time;

(3) setting up additional terrestrial television network(s) for subscription services.

It is option (3) that is the most interesting to broadcast engineers, since it implies virtually a reversal of parts of the 1983 Merriman report that some consider were accepted by government with almost unseemly haste. Mobile radio was promised more spectrum than the industry had asked for, but its allocation has been slow because of the spectre of mutual interference with television in or from France, Belgium, Holland and Ireland. Then again the spectacular growth of 900 MHz cellular systems and the related recognition that v.h.f. mobile radio spectrum congestion is less severe than had been thought, have made the Merriman recommendations seem more and more idiosyncratic.

CSPI consider that two opportunities exist for fifth or sixth terrestrial channels with substantial or partial national coverage. They suggest a fifth service could be fitted into u.h.f. Bands 4 and 5 by taking advantage of the currently unused frequency-channels 35, 36 37 and 38 (the gap between Bands 4 and 5). Channel 35 is due to become available in Europe next year, 37 in 1994, 38 might be shared with radioastronomy and, while 36 is

reserved in the UK for aeronautical radar, this could be changed by government decision. One cannot help feeling that since radioastronomers are concerned with extremely weak signal reception they are hardly likely to agree with CSPI that Channel 38 could be shared.

The reallocation of some v.h.f. spectrum to UK television could, it is suggested by CSPI, follow in the wake of the earlier CSPI report to DTI on the deregulation of the spectrum, with broadcasters becoming free to bid for spectrum in competition with other users, including mobile radio services. If both u.h.f. and v.h.f. channels were available, CSPI believe there could be new local or regional subscription services without affecting the four existing BBC/IBA channels.

But hanging over the report there remains the uncertainty about the extent to which the demand for more choice and premium television will be met by expansion, however slow, of cable, satellite and video libraries. Market research consultants, business plans, etc. are still coming up with widely differing estimates of possible growth rates and much will depend, for example, on the retail cost of satellite receivers. However, the CSPI report must surely mark the demise of government hopes of replacing the licence-fee by subscription charges, though it could result in renewed pressure for the BBC to accept advertising.

## Teaching e.m.c.

In the June Television Broadcast I noted Professor Mike Darnell's appeal for more academic interest in the problems of electromagnetic compatibility (e.m.c.) He has suggested that the importance of e.m.c. is still not fully appreciated in the academic sphere and is not recognized as a true academic discipline, and that no specialist e.m.c. engineers are being produced within the higher educational system.

On other occasions I have suggested that it is perhaps even

more important that all electronic engineering training should include the teaching of more awareness of the problems posed by e.m.c., e.m.i., r.f.i., etc. and that this field of expertise should not be left entirely to specialist engineers. It seems particularly important that the many engineers concerned with digital electronics should be more aware of the fact that high-speed pulses rushing around such products as personal computers can and do pollute the nearby radio spectrum, and similarly that in the coming era of universal hand-held transceivers for cordless telephones, cellular radio and radio paging, all domestic electronics will need to be reasonably immune to local r.f. fields.

It was therefore interesting to learn from Peter Jackson (Head of Electronics Group) and David Lauder (Senior Lecturer) that The Hatfield Polytechnic has already identified the need for more widely-based e.m.c. teaching. An introduction to e.m.c. has been included as part of the revised syllabus for their B.Eng/B.Eng(Hons) degree courses in electrical and electronic engineering currently submitted for re-validation. The introduction to e.m.c. forms part of a proposed "advanced digital techniques" course to be taken by all their electrical and electronic engineering degree students in their third year.

The Hatfield Polytechnic also runs courses for graduate engineers in industry. A two-week "digital systems design" course includes an introduction to e.m.c. In addition, a new one-week course on e.m.c. and reliability will be approximately 50 per cent devoted to e.m.c.

It is much to be hoped that other centres of higher engineering education will follow Hatfield's path.

*Television Broadcast was written by PATHAWKER.*

# RADIO COMMUNICATIONS

## Using the E-layer

At the URSI national colloquium, R. Fricker (BBC) showed how the microcomputer program used by the BBC for predicting the field strength and coverage of its h.f. transmitters has been further refined by taking into account propagation via the E-layer over distances up to 2000km at times when the E-layer largely prevents signals from reaching the F-layers.

Manual field-strength prediction studies were started by the BBC some 20 years ago; later this was extended using a programmable calculator and eight years ago further extended and transferred to a microcomputer program, based in part on the US "minimuf" program, but with added refinements. Since then, the predictions have been extensively compared with listener reports, reports from BBC relay bases on the h.f. single-sideband feeds, and with observations on the reception of other broadcasters' transmitters at BBC monitoring stations. The method that has evolved is claimed to be "reasonably accurate in predicting the propagation, and gives a good estimate of field strength". The method had helped to show what actually happens on h.f. signal paths, can be used for distances up to 30,000 km and has provided explanations for some unexpected results where these have deviated from the predictions.

It has shown, for example, that some signals during summer daytime that are cut off from the F-layer by the lower E-layer can still provide an effective service at distances up to about 2000 km by E-mode reflection, a mode not previously considered in the computer program. It was realised that this mode, taken in conjunction with lowering the minimum angle of vertical-radiation-pattern elevation to  $0.5^\circ$ , has the effect of adding an extra h.f. broadcasting band for several hours of summer daytime for target coverage areas up to about 2000 km distant. It had been known for more than 20 years that predictions based solely on F-layer propagation gave frequencies that seemed too low at this season of the year.

Incorporation of the E-mode into the BBC computer program has removed one of the last known discrepancies between predictions and observations.

The possibility of propagating signals at frequencies between about 20 MHz and (occasionally) up to 150 MHz during the unpredictable Sporadic-E conditions has long been known and utilized by radio amateurs. But there has been considerable speculation, since the release of frequencies around 50 MHz to some (now all) British amateurs since 1985, about the fact that transatlantic contacts have been made each year at around the height of the Sporadic-E season in June/July despite this being during a minimum period of the eleven-year sunspot cycle. The distances seem too great to be accounted for by single-hop SpE unless enhanced by some form of chordal hop or entrapment, and the chances of "double-hop SpE" seem unlikely. It has been appreciated for some twenty years that the thin sheets of intense ionization of Sporadic-E differ from the normal ionospheric layers in being composed of patches of metallic atoms, mainly magnesium, silicon and iron ions that are possibly the remains of burnt-up meteorites swept together by wind shears in the upper atmosphere.

A possible explanation for the summer transatlantic openings on 50 MHz may have emerged from the extensive investigation of Sporadic-E propagation that has been carried out over several years at the University College of Wales—Aberystwyth.

## Easier h.f.?

The 4th National Colloquium of the International Union of Radio Science (URSI), held at Sheffield University, provided a good opportunity to learn about current research projects at British universities, the Rutherford-Appleton Laboratory, British Antarctic Survey and industry. URSI interest tends to focus on radio propagation, including some pretty esoteric aspects of ionospheric and tropospheric anomalies, but is also concerned with scientific and communications satellites, man-made interference, antenna design and

terrestrial communications systems.

In this last category, Dr J.N. Hopkinson of Plessey (Roke Manor) described field trials of a new adaptive h.f. telegraph/data link designed to be as simple to operate as a car radio telephone, and indicative of the recent revival of interest in h.f. communications. He pointed out that while the development of communications satellites has revolutionized the quality and reliability of long-distance radio communications, such systems still represent a significant cost to users. For example, the fitting of an Inmarsat satellite terminal to every merchant ship is still a long way off. H.f. is being looked at afresh, particularly for applications where the infrastructure of satellite and cable systems is impracticable or uneconomic or vulnerable to disruption.

In the congested h.f. spectrum, the successful operation of a 24-hour h.f. link has demanded considerable operator skill and experience as well as dash of the "black art". On the other hand, the equipment is relatively inexpensive and, if used properly, can provide an effective service at low data rates. An experimental link, aimed at using low-cost computing power to eliminate the need for skilled operators, has been tested for about eight months between Roke Manor and Caswell, near Northampton, a path length of about 132 km, sufficient to eliminate reception of ground-wave signals but very vulnerable to the diurnal changes in ionospheric propagation. A 60-watt marine transceiver is used with a 50-meter-high broadband biconical monopole antenna with computing power provided by an IBM XT computer.

Some 80 spot frequencies between about 2 and 25 MHz are programmed into the system, weighted towards the lower frequencies. Each hour a full band scan is made automatically; then on one of a number of predicted calling frequencies the outstation is offered a menu of five channels that have been shown to be open; the working frequency is then chosen automatically and changed on the basis of lowest error rate. The program incorporates fall-back frequen-

cies in the event of contact being lost.

The link was operated 24 hours per day on five days per week and has generated some illuminating comparisons between predicted m.u.f. channels and the measured available channels. In general it is clear that lower and much higher frequencies than those predicted are often open for traffic, in part because the link can safely use channels near the actual m.u.f. rather than the o.w.f. (optimum working frequency), usually regarded as 85 per cent. of the m.u.f., and can also take full advantage of the many days on which predictions still prove conservative.

With a character error rate of less than one in a million, the average daily throughput achieved some 32,800 characters per hour, with better than 36 Kch/h for 49.1 per cent of the time (maximum rate 53 Kch/h). It fell to less than 12Kch/h for only 11.8 per cent of time. Transmission rate adapts to channel conditions and comprises 75, 150 or 300 baud with various degrees of error correction.

*Radio Communications was compiled by PAT HAWKER.*

## Correction

**Universal voltage-controlled oscillator.**

One or two slips occurred in the above article, which appeared in our July issue.

In Fig.2, the large-signal forward transconductance  $V_1$  and  $V_3$  should have been noted as  $\tan \alpha_1$  and  $\tan \alpha_2$  respectively. In the first paragraph on p.708, five lines below equations (3), the line should read "linearly, and  $\Phi$  is the phase shift of the amplifier". In the second paragraph from the top of the third column on the same page, line 4 should read "... the gate or base bias...". The caption to Fig.5 refers obscurely to "logic current" which, believe it or not, should be "large amount".

Mr Dekker has supplied details of Reference 1, which arrived too late for the relevant issue. The issue of AEU in which his paper appeared was Vol.41, No 3, May/June, pps129-132.





# ERS — PRINTERS — PRINTERS — PRINTERS

## SUPER DEAL? NO - SUPER STEAL THE FABULOUS 25 CPS "TEC STARWRITER"

Made to the very highest spec the **TEC STARWRITER FP1500-25** features a very heavy duty die cast chassis and **DIABLO** type print mechanism giving superb registration and print quality. Micro-processor electronics offer full **DIABLO/QUME** command compatibility and full control via **CPM WORDSTAR ETC.** Many other features include bi-directional printing, switchable 10 or 12 pitch, full width 381mm paper handling with up to 163 characters per line, friction feed rollers for single sheet or continuous paper, internal buffer, standard **RS232** serial interface with handshake. Supplied absolutely **BRAND NEW** with 90 day guarantee and **FREE** daisy wheel and dust cover. Order **NOW** or contact sales office for more information. Optional extras **RS232** data cable **£10.00**. Tech manual **£7.50**. Tractor Feed **£140.00**. Spare daisy wheel **£3.50**. Carriage & Ins. (UK Mainland) **£10.00**.



NOW ONLY £499 + VAT

## DIY PRINTER MECH

Brand New surplus of this professional printer chassis gives an outstanding opportunity for the **Student, Hobbyist or Robotics** constructor to build a **printer - plotter - digitiser** etc, entirely to their own specification. The printer mechanism is supplied ready built, aligned and pre tested but **WITHOUT** electronics. Many features include all metal chassis, phosphor bronze bearings, 132 character optical shaft position encoder, NINE needle head, 2 x two phase 12V stepper motors for carriage and paper control, 9.5" Paper platen etc etc. Even a manufacturer's print sample to show the unit's capabilities!! Overall dimensions 40 cm x 12 cm x 21 cm.

Sold **BRAND NEW** at a **FRACTION** of cost **ONLY £49.50 + pp £4.50**.

## TELETYPE ASR33 DATA I/O TERMINALS

Industry standard, combined ASCII 110 baud printer, keyboard and 8 hole paper tape punch and reader. Standard **RS232** serial interface. Ideal as cheap hard copy unit or tape prep. for CNC and NC machines. **TESTED** and in good condition. Only **£250.00** floor stand **£10.00**. Carr & Ins. **£15.00**.

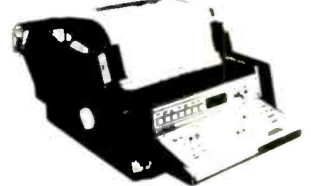
## EX NEWS SERVICE PRINTERS

Compact ultra reliable quality built unit made by the **USA EXTEL Corporation**. Often seen in major Hotels printing up to the minute News and Financial information, the unit operates on **5 UNIT BAUDOT CODE** from a Current loop, **RS232** or **TTL** serial interface. May be connected to your micro as a low cost printer or via a simple interface and filter to any communications receiver to enable printing of worldwide **NEWS, TELEX** and **RTTY** services.

Supplied **TESTED** in second hand condition complete with **DATA, 50** and **75 baud xtals** and large paper roll.

<b>TYPE AE11</b> 50 Column	<b>ONLY £49.95</b>
Spare paper roll for AE11	<b>£4.50</b>
<b>TYPE AF11R</b> 72 Col. + Ribbon	<b>£65.00</b>
<b>TYPE AH11R</b> 80 Col. ASCII/BAUDOT	<b>£185.00</b>
Carriage and Insurance <b>£7.50</b>	

## GE TERMIPRINTER



A massive purchase of these desk top printer terminals enables us to offer you these quality **30 or 120 cps** printers at a **SUPER LOW PRICE** against their original cost of over **£1000**. Unit comprises of full **QWERTY** electronic keyboard and printer mech with print face similar to correspondence quality typewriter. Variable forms tractor unit enables full width - up to **13.5** inch column paper, upper - lower case, standard **RS232** serial interface, internal vertical and horizontal tab settings, standard ribbon, adjustable baud rates, quiet operation plus many other features. Supplied complete with manual. Guaranteed working **GE30 £130.00**. **GE1200 120 cps £175.00**. Untested **GE30 £65.00**. Optional floor stand **£12.50** Carr & Ins. **£10.00**.

## SEMICONDUCTOR 'GRAB BAGS'

Mixed Semis amazing value contents include transistors digital, linear, IC's, triacs, diodes, bridge recs, etc etc. All devices guaranteed brand new full spec with manufacturer's markings, fully guaranteed.

**50+ £2.95 100+ £5.15**  
**TTL 74 Series.** A gigantic purchase of an "across the board" range of **74 TTL series IC's** enables us to offer **100+** mixed "mostly TTL" grab bags at a price which two or three chips in the bag would normally cost to buy. Fully guaranteed all IC's full spec. **100+ £6.90**, **200+ £12.30**, **300+ £19.50**

## MAINS FILTERS

CURE those unnerving hang ups and data glitches caused by mains interference with professional quality filters. **SD5A** match-box size up to **1000 watt 240 V Load** **ONLY £5.95**. **L12127** compact completely cased unit with 3 pin fitted socket up to **750 watts ONLY £9.99**.

## EPROM COPIERS

The amazing **SOFTY 2** The "Complete Toolkit" for copying, writing, modifying and listing **EPROMS** of the **2516, 2716, 2532, 2732** range. Many other functions include integral keyboard, cassette interface, serial and parallel i/o UHF modulator ZIF socket etc. **ONLY £195.00 + pp £2.50**.

"**GANG OF EIGHT**" intelligent Z80 controlled 8 gang programmer for ALL single 5v rail EPROMS up to 27128. Will copy 8 27128 in **ONLY 3 MINUTES**. Internal LCD display and checking routines for **IDIOU PROOF** operation. Only **£395.00 + pp £3.00**.

"**GANG OF EIGHT PLUS**" Same spec as above but with additional **RS232** serial interface for down line loading data from computer etc. **ONLY £445.00 + pp £3.00**

Data sheets on request

## COOLING FANS

Keep your hot parts **COOL** and **RELIABLE** with our range of **COOLING FANS** **ETRI 126LF21 240v 5 blade equipment fan** Dim. **80 x 80 x 38mm** **£9.95**. **ETRI 99XUOI 240v Slimline** Dim. **92 x 92 x 25mm**, equipment fan, **NEW £9.95**. **GOULD JB-3AR** Dim. **3" x 3" x 2.5"** compact very quiet running **240v operation** **NEW £6.95**. **MUFFIN-CENTRAUR BOXER** standard **120 - 120 x 38mm fans** Order **110v DR 240v 3 or 5 blade**. **NEW at £10.50** or tested **EX EQUIPMENT £5.50**. Low Voltage DC Fans. **BUHLER 89.11.22** 8-18v DC micro miniature reversible. Uses brushless servo motor, almost silent running, guaranteed **10,000 hr** life. Measures only **82 x 82 x 22mm**. Current cost **£35.00** **DUR PRICE ONLY £13.95** complete with data. **120 x 120 x 38mm (4" DC fans)** **PANASONIC FB-12C12H 12v DC 5 blade £18.00**. **PAPST 4124X 24 - 28v DC 5 blade £18.00**. 100's of other fans Ex Stock.

Call for Details, Post & Packing on all fans **£2.00**

## 20,000 FEET OF ELECTRONIC AND COMPUTER GOODIES

ENGLAND'S LARGEST SURPLUS STORE - SEEING IS BELIEVING!!

## DEC CORNER

**PDP 1140** System comprising of CPU, 124k memory & MMU 15 line **RS232** interface. **RP02** 40 MB hard disk drive. **TU10** 9 track 800 BPI Mag tape drive, dual track system. **VT52 VDU**, etc. etc. Tested and running **£3,750.00**

**BA11-MB 3.5" Box, PSU, LTC** **£395.00**

**DH11-AD 16" x RS232 DMA interface** **£1,900.00**

**DLV11-J4 x EIA interface** **£350.00**

**DLV11-E Serial Modem support** **£190.00**

**DUP11 Synch. Serial data i/o** **£650.00**

**DQ200 Dialog - multi RK controller** **£495.00**

**DZ11-B 8 line RS232 mux board** **£650.00**

**KDF11-B M8189 PDP 1123 PLUS** **£1,100.00**

**LA30 Printer and Keyboard** **£80.00**

**LA36 Decwriter EIA or 20 mA loop** **£270.00**

**MS11-JP Unibus 32kb Ram** **£80.00**

**MS11-LB Unibus 128kb Ram** **£450.00**

**MS11-LD Unibus 256kb Ram** **£850.00**

**PDP11/05 Cpu Ram, i/o etc** **£450.00**

**PDP11/40 Cpu, 124k MMU** **£1,850.00**

**RT11 ver 3B documentation kit** **£70.00**

**RK05-J 2.5 Mb disk drives** **£650.00**

**KL8 JA PDP 8 async i/o** **£175.00**

**M18E PDP 8 Bootstrap option** **£75.00**

**VT50 VDU and Keyboard** **£175.00**

**VT52 VDU and RS232 interface** **£250.00**

## MAG TAPE DRIVES

Many **EX STOCK** computer tape drives and spares by **PERTEC, CIPHER, WANGO, DIGIDATA, KENNEDY** etc. Special offer this month on **DEI Cartridge** tape drives **ONLY £450.00 each**.

CALL FOR DETAILS

## COMPUTER/SYSTEM CABINET & PSU

All in one quality computer cabinet with integral switched mode PSU, mains filtering, and twin fan cooling. Originally made for the famous **DEC PDP8** computer system costing thousands of pounds. Made to run 24 hours per day the psu is fully screened and will deliver a massive **+5v DC at 17 amps, +15v DC at 1 amp** and **-15v DC at 5 amps**. The complete unit is fully enclosed with removable top lid, filtering, trip switch, power and run leds mounted on ali front panel, rear cable entries, etc. etc. Units are in good but used condition - supplied for 240v operation complete with full circuit and tech. man. Give your system that professional finish for only **£49.95 + carr. 19" wide 16" deep 10.5" high**. Useable area **16" w 10.5" h 11.5" d**.

Also available less psu, with fans etc. Internal dim. **19" w, 16" d, 10.5" h**. **£19.95**. Carriage **£8.75**

## 66% DISCOUNT ON ELECTRONIC COMPONENTS EQUIPMENT

Due to our massive bulk purchasing programme, which enables us to bring you the best possible bargains, we have thousands of IC's, Transistors, Relays, Caps, PCB's, Sub-assemblies, Switches etc. etc. surplus to OUR requirements. Because we don't have sufficient stocks of any one item to include in our ads we are packing all these items into the **BARGAIN OF A LIFETIME**. Thousands of components at giveaway prices. Guaranteed to be worth at least 3 times what you pay. Unbeatable value and perhaps one of the most consistently useful items you will every buy!!! Sold by weight.

2.5kIs **£5.25 + pp £1.25**  
10kIs **£11.25 + pp £2.25**

5 kIs **£6.90 + £1.80**  
20kIs **£19.50 + pp £4.75**

Give your **VT100** a Birthday!!!  
Brand New **VT100** Keyboards  
only **£85.00**

**1000's** of **EX STOCK** spares for **PDP8, PDP8A PDP11, PD 1134** etc. SAE. for list. or CALL sales office for details.

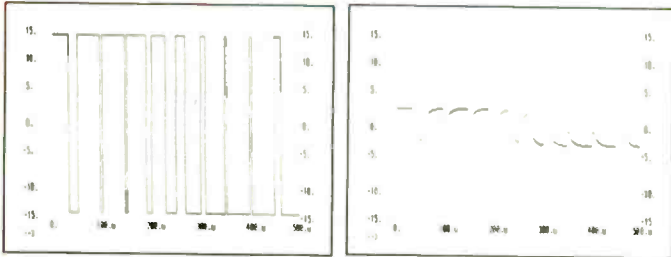
**ALL TYPES OF COMPUTER EQUIPMENT AND SPARES WANTED FOR PROMPT CASH PAYMENT.**

**1000's** of other **EX STOCK** items including **POWER SUPPLIES, RACKS, RELAYS, TRANSFORMERS, TEST EQUIPMENT, CABLE, CONNECTORS, HARDWARE, MODEMS, TELEPHONES, VARIACS, VDUs, PRINTERS, POWER SUPPLIES, OPTICS, KEYBOARDS** etc. etc. Give us a call for your spare part requirements. Stock changes almost daily.

Don't forget, **ALL TYPES** and **QUANTITIES** of electronic surplus purchased for **CASH**

ENTER 60 ON REPLY CARD

# BANG



LOOK WHAT HAPPENED TO THE NICE CLEAN PWM SIGNAL WHEN THE LOAD WAS CONNECTED.

If we had prototyped this chopper circuit, we might have found out what was wrong after a few buckets of hard-to-get components. As it was, the solder never touched our irons. Skillful engineering was rewarded with a thorough understanding gained from an ECA-2 simulation run on an IBM PC compatible yet ECA-2 costs just £675 + VAT



Try a little Monte-Carlo spread with your chips. Are you wondering why your filters are a little off today? ECA-2 will run a Monte-Carlo tolerance simulation (random component variations within the tolerance bands) and compile statistics. ECA-2 will also give you worst cases for both gain and phase.

Worried about the weather? The sun may not shine out of ECA-2 but it does allow you to check dissipations and the effects of temperature changes.



Whether you work with DC servo or microwave circuits, ECA-2 can almost certainly help. But just to make sure you are in a position to benefit from what we believe is the most powerful circuit simulator available for IBM PCs, we shall be pleased to send you a demonstration disk with an example of your own circuit (small please) on it.

- |   |   |
|---|---|
| <b>Transient analysis</b> - timing diagrams plotted   | <b>Macro models</b> - Up to 64 connections per model to main circuit, no limit on number or size  |
| <b>DC analysis</b> - DC transfer curves plotted   | <b>Probe</b> - Signals may be sampled or injected anywhere  |
| <b>AC analysis</b> - Bode curves (gain and phase) plotted also phase delay output   | <b>Dual mode</b> - Interactive mode has powerful editing and interrupting facilities. Batch mode for heavy work allows you to come back |
| <b>Fourier analysis</b> - Transients output in frequency domain   | <b>High capacity</b> - Sparse matrix technique allows typically over 500 nodes in 512K memory   |
| <b>Tolerancing</b> - Monte Carlo and Worst Case   | <b>High Speed</b> - 8087 (or 80287) coprocessors supported  |
| <b>Temperature</b> - Components temperature effects supported   | <b>Reference Manual</b> - A ring-bound reference manual of over 300 pages is an integral part of ECA-2                                  |
| <b>Non-linear simulation</b> - Breakpoints and polynomials supported  | <b>No risk trial</b> - If you need more convincing, ring us for details of money-back trial   |
| <b>Full diode model</b> - $I = I_0 \{ \exp[(V/V_T) - 1] - 1 \}$   |   |
| <b>Complex components</b> - Resistors may have inductance etc. etc  |   |
| <b>Variables</b> - Component characteristics can be made to vary with both time and frequency according to any function. Offset currents may be imposed |   |

New modulator facility for voltage controlled Rs, Cs & Ls

## SERIOUS CAD AT LIGHTEARTED PRICES

Probe around Miteyspice's computer model of your circuit. More informative, more fun and faster than a breadboard. Plot the AC & DC characteristics, quantify bandwidth with the digitising cursor, sweep components, investigate temperature and noise (20 param Ebers Moll model) and when perfect, lay it out and etch it accurately with PCB using an ordinary DM printer. These programs have too many superb features to cover here, please send for details.

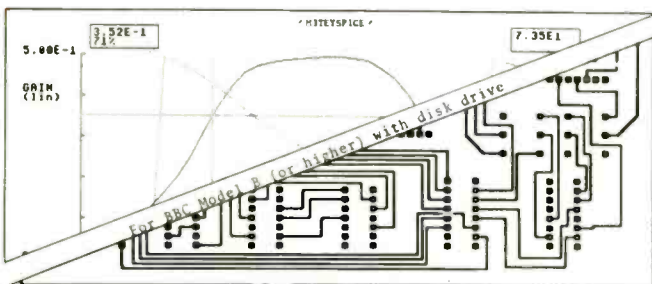
★ Just released ★

### MITEYSPICE

incorporating the unbeatable Microspice circuit simulator (£119 + VAT)

### P.C.B.

Pineapple's acclaimed "a utility I thoroughly recommend" Julian Rogers *Micro User* March '87 circuit board drafting program (£85 + VAT)



Those Engineers Ltd

100a Fortune Green Road • West Hampstead • London NW6 1DS  
Tel 01 435 2771 E-Mail One to One Box 23332001 Tr. 8950511 (ansdk ONEONE G) Quoting box 23332001

ENTER 44 ON REPLY CARD

# THE JOURNAL FOR PROFESSIONAL ENGINEERS ELECTRONICS & WIRELESS WORLD

# INDUSTRY INSIGHT 88

STARTING IN 1988 IS A SERIES OF FEATURES ON THE WORKING OF THE ELECTRONICS INDUSTRY, EACH ONE BEING A BOUND-IN SECTION OF THE JOURNAL WITH ITS OWN COVER AND TITLE — **Industry Insight**. Each **Industry Insight** is a well researched, **discerning analysis** of a particular **sector of the electronics industry**, which presents both the **technical aspect — design and development — and the market viewpoint.**

## FEBRUARY — INSTRUMENTATION

A REVIEW OF THE STATE OF THE INSTRUMENT MANUFACTURING INDUSTRY, FOCUSED ON THE AREAS OF WAVEFORM DISPLAY, FREQUENCY MEASUREMENT AND DIGITAL MEASUREMENT OF VOLTAGE AND CURRENT. CONTEMPORARY DESIGN TECHNIQUES ARE EXPLORED, POSSIBLE FUTURE DEVELOPMENTS INVESTIGATED AND A SECTION ON THE CHARACTERISTICS OF CURRENTLY AVAILABLE EQUIPMENT INCLUDED.

## APRIL — COMMUNICATIONS

THE SECOND IN THE SERIES IS CONCERNED WITH THE EXPLODINGLY DEVELOPING FIELD OF ELECTRONIC COMMUNICATION OF VOICE AND DATA, USING RADIO OR CABLE TECHNIQUES. WE LOOK AT PRIVATE MOBILE RADIO, LOCAL-AREA NETWORKS AND THE FACILITIES OFFERED BY VIDEO SERVICES SUCH AS PRESTEL. THE WAY AHEAD IN P.M.R. IS NOT ALWAYS CLEAR, IN VIEW OF POLITICAL AND SPECTRUM CONSIDERATIONS: INDUSTRY EXPERTS PRESENT THEIR VIEWS.

## JUNE — SEMICONDUCTORS

INSIGHT NUMBER 3 CONSIDERS THE SEMICONDUCTOR ARENA, IN PARTICULAR DIGITAL SIGNAL PROCESSORS, LOGIC ARRAYS, MICROWAVE DEVICES AND MICROPROCESSORS. THE ECONOMICS OF USING APPLICATION-SPECIFIC DEVICES IS THE SUBJECT OF INVESTIGATION AND THERE IS COMMENT ON THE PRACTICAL CONSIDERATIONS OF USING MODERN, VERY HIGH SPEED DEVICES IN PRODUCTION. A WAFER-FABRICATION PLANT IS DESCRIBED AND THE PROCESSES OF MANUFACTURE ILLUSTRATED.

TO ADVERTISE WITHIN  
INDUSTRY INSIGHT

RING

JAMES SHERRINGTON

ON 01 661 8640

NOW

## The problems with experts

Expert systems are computer data bases based on human knowledge. There are obstacles to the effective introduction of such systems, which are the lack of access to the building tools and the lack of information about the ones that do exist. To overcome the problems, the National Computing Centre has produced a package of software, advice and information called "Expert System Resource Pack."

The pack provides users with the resources to make the right strategic and decisions on the approach to such systems, product selection, choice of application, and investment and resource planning. It provides versions of five expert-system building tools. These are Crystal, Expert Edge, Savoir, SuperExpert and Xi Plus. Also included are 26 case studies of UK organizations, a disc-based software directory of expert-system products and suppliers and special discounts on training or consultancy. The package costs £1250 and contains all that is needed to build and use a small expert system to help the user make an objective appraisal of current technology and its applications, without the commitment of heavy investment in one specific development tool.

## Digital radio messages for gasmen

We reported some years ago on the experimental communications system being developed by the British Gas Research Station in Newcastle-upon-Tyne. This has now come to fruition and is to undergo trials in the North Thames region of British Gas. Because of the overcrowded airwaves and the time taken to communicate with service vans, British Gas decided on a digital system. The development plan resulted in the Gascord 1200 system, which uses data transmission to enhance the capacity of each radio channel. It also provides automatic management of large, single-frequency radio networks and the facility to



## Computer translation by telephone

Experimental equipment at BT's research laboratories has successfully translated spoken English into spoken French and French into English. The prototype system can also translate English into German and Spanish, Swedish and Italian and the reverse are still under development. On completion the system will be able to communicate between any pair of the programmed languages; Swedish into Italian or German into French.

Each speaker has a microphone linked to a Merlin 5200 personal computer. One participant speaks slowly and clearly into the microphone and the computer will digitize the speech and read back what it thinks it has heard. The speaker confirms that that was what was actually said with a "yes", or a "oui" and the computer then transmits it to the distant computer which translates it and synthesizes the speech in the other language. Conversations can be quite slow and at present somewhat limited. The system has access to about 400 phrases in common business use. This actually only involves recognition of about a hundred words which can be placed in context within the phrase, thus reducing the word-recognition task required. It does not try to translate names and can recognize proper names, so Mr Wood remains Mr Wood even in translation, and does not become Monsieur Bois or Herr

Holz. Names are repeated in the original speaker's voice. The system involves three areas of research; speech recognition, the linguistic phrasebook used to make the translation and speech synthesis. It has been found that there is less possibility of error if the vocabulary is restricted. Research has also found that there are a number of phrases which can be recognized by a minimum of keywords. All but four of the phrases contain at least three of the keywords, so it is possible to recognize the phrase. Even if a particular speaker varies the mode of expression the phrase can still be recognized. The speech synthesizers and recognizers use commercially available hardware - the phrasebook and translations have been prepared by expert linguists. The system needs to be trained to recognize a voice: further developments hope to remove this stricture and become voice independent, and to increase the vocabulary. Recognition of stress, intonation and the choice of particular words may reveal subtle meanings which could eventually be translated. It is also hoped that the quality of the synthesizers will more nearly approach real speech. It all goes to confirm what the British Raj always believed: that if you speak slowly and clearly in English, any foreigner will understand you, even a computer - and with a computer you needn't shout!

transmit and receive data in text form. This has cut the time of a typical call from 45 seconds for a verbal communication to just eight seconds for a data transmission. Transmission rate is 1200bit/s and can combine speech and data communications between base and mobile van and between vans. It uses up to six base stations from up to four operator positions. Each van is fitted with a hand-held portable computer and radio modem and messages received or to be transmitted can be stored in memory. Special error-correction techniques have been employed to ensure a high degree of reliability. The system automatically chooses the best base station to communicate with a particular mobile. It is controlled from a central computer but there is also a front-end processor to provide the error correction.

Mobiles can be selectively called by the base station. When a vehicle is being contacted, there is a visible and/or audible indication which tells the mobile operator to call base. Calls from the vehicle are queued in order of arrival, though there is a queue-jumping system in cases of emergency. The operator calls the base by pressing an emergency key or indicates the current state of play by one of ten other status keys, one of which is a request for speech contact. Protocol built into the system automatically acknowledges the receipt of calls. If a call is not acknowledged, it is automatically retransmitted, but will be aborted if the second attempt is unsuccessful. The trial area includes some of the busiest parts of central London. The theory is that if it works in one of the most heavily congested areas for radio communications in the country, it should work anywhere.

## Avo independent again

A company management buyout worth £13M has enabled Avo to take itself away from Thorn EMI. Avo International is now the name of a parent holding company for the international group of seven companies with manu-

facturing and marketing facilities in the UK, US, France and Germany. Avo's headquarters remain in Dover but the British branch will now be known as Megger Instruments, even though they will continue to make Avo multimeters as well as the Megger products. Measurement Ltd (formerly Thorn EMI Measurement and once Systron Donner) will remain a distributor of test, measurement and other equipment. Biddle Instruments in Pennsylvania makes high-voltage insulation testers, and Electron Technology in New Jersey makes electronic glassware. There are also two distributors in France and Tet, a manufacturer of linear power supplies in Germany. The group, under the leadership of its managing director Bill Goldfinch, feels it is in a strong position to maintain its share of the test and measurement market.

## Welding in strong magnetic fields

It is impossible to use arc welding equipment near a strong magnetic field: it deflects the flame. Or it did until Cambridge Magnetics came up with an idea. Put a coil round the work and neutralize the magnetic field with an equal and opposite one. The idea was developed by Syscon and their first success story was during field trials of the Zeromag, as it is called. Some highly magnetic pipes needed welding for use in the North Sea. Attempts to demagnetize them had failed and they were impossible to weld. Along came the prototype and the pipes were joined within minutes. Syscon live in Cambridge Science Park.

## Static still a problem

Random electrostatic charges are damaging electronics components and are still a cause for concern within the electronics industry. This is the message inherent in a new research project to be carried out by ERA Technology. They are looking into electrostatic discharge

equipment and will identify the types that are most effective. The equipment will then be used to develop a test system to see which pins on microcomponents are most susceptible to discharge. The initial stages will require a complete re-examination of the test procedures.

ERA Technology are in Leatherhead, Tel: 0732 374151, and would be happy to supply further information.

## Thermal images eliminate hot spots

A thermal-imaging technique has been developed at the Georgia Institute of Technology in Atlanta to help pinpoint the overheated trouble spots in v.l.s.i. circuits. The system uses a modified infra-red camera directed by a computer. By identifying the hot spots, it may be possible to avoid them by changing the positions of component parts of the circuit or modifying the substrate. One example of the work carried out was the modification of some chips for Schlumberger. Some of their oil exploration equipment was already subjected to high temperatures, but the hot spots were identified and the circuits modified. The work has been carried out under the direction of Professor William Black.

## IEEIE accredits training programmes

The IEEIE has been granted 'authorized body' status by the Engineering Council and can accredit industrial training programmes for Technician Engineers and Engineering Technicians. The authorization is additional to that already granted to the Institution for accrediting academic courses.

Already over 100 schemes have received official approval and have been registered by the IEEIE and any company wishing to seek accreditation should contact the IEEIE, Savoy Hill House, Savoy Hill, London WC2R 0BS.

## Daresbury research laboratory is 25

The nuclear physics laboratory at Daresbury is celebrating its 25th birthday. In 1962 Professor Alec Merrison was given approval by the then Ministry of Science to build a laboratory equipped with 4GeV electron synchrotron, called NINA. It took five years to build NINA and the first experimental data was produced during 1968. From then until 1977, when NINA was closed down, experiments added much to our knowledge of particle physics and the fundamental particles which together make all matter. During the same period it became apparent that NINA could also be used as a source of synchrotron light for studying atoms, molecules and the 'larger' particles. Eventually a new electron storage ring was specifically designed to continue these experiments, unhampered by the demands of the fundamental particle physicists. This was the synchrotron radiation source (SRS) which came into use in 1981. The SRS produces intense beams of ultra-violet light and X-rays and these have been invaluable for studies in biology, chemistry and materials as well as physics. Recent improvements to the quality of the ultra-violet and X-ray beams have been achieved and the first users are now beginning to take data.

The Nuclear Structure Facility (NSF) is a 70m tower dominating the site and is used to produce beams of ions for research into the basic structure and reaction of nuclei. Some recent discoveries were the superdeformed nuclei and the detection of zirconium 80. The total energy suppression shield array (TESSA) has led towards the production of the world's largest gamma ray detector. Other activities at the Daresbury laboratories include scientific computing, electronics research and the high-quality engineering facilities needed to support the research programmes.

A new project has been instituted to develop ways of using the transputer-based supercomputers and a team has started work on the development of software for the project.

## EXHIBITIONS & CONFERENCES

**22 - 23 September**  
**Computer Networks;** short course at the IIT, Sheffield. See 8 September for details.

**23 - 27 September**  
**PCW 87;** 10th Personal Computer World Show, Olympia, London.

**29 September - 1 October**  
**NAV 87;** Navigation data, dissemination and display conference and exhibition. Heathrow Penta Hotel. Organized by the Royal Institute of Navigation. Tel: 01-589 5021.

**Semiconductor International;** design, assembly, test, materials and chemicals. NEC Birmingham. Cahners Exhibitions. Tel: 01-891 5051.

**5 - 8 October**  
**HDTV 87;** International colloquium, Ottawa, Ontario, Canada. Details from HDTV Colloquium, Journal Tower North, 300 Slater Street, Ottawa, Ontario K1A 0CB, Canada.

**6 - 8 October**  
**Internecon** packaging show and conference. Metropole Hotel, Brighton. Cahners Exhibitions. Tel: 01-891 5051.

**13 - 15 October**  
**Computer Graphics 87.** Wembley Exhibition Centre. Online International. Tel: 01-868 4466.

**27 - 30 October**  
**BIAS '87** 21st international automation, instrumentation and microelectronics exhibition and conference. Milan, Italy. Exhibition Secretariat, EIOM, Viale Premuda 2, 20129 Milano, Italy.

**3 - 5 November**  
**Comex 87;** mobile radio exhibition and conference. Sandown Park Exhibition Centre. Frametrack Ltd. Tel: 01-653 2657.

**17 - 19 November**  
**Electronic Displays 87;** Kensington Exhibition Centre, London. Network Events. Tel: 0280 815226.

**23 - 26 November**  
**Digital Information exchange;** professional digital audio seminar, at London Zoo. Details from Peter Woodcock. Tel: 0992 583557.

**14 - 17 December**  
**Land mobile radio;** Fourth International IERE conference. University of Warwick, Coventry. IERE. Tel: 01 388 3071.

# Frequency Calibration Dependent on the 200kHz Droitwich Transmission?

## Upgrade to a traceable MSF off-air Standard before the change to 198kHz.

The Radiocode Clocks Model RFS1000 represents a significant advance in off-air Frequency Standard design and offers important advantages over conventional instruments based on broadcast transmissions.

- Traceable to NPL
- No Scheduled Frequency Changes
- Instant and Automatic Operation
- 24-hour Transmission
- Self-Contained, Battery-Powered, Portable Unit
- High Noise Immunity
- Long Range
- Real Time Synchronisation



**The RFS1000 costs only £485**+£10 carriage. VAT extra.



Available from:

**Thoroughbred Direct Sales Ltd.**  
25 St Margaret's Green, Ipswich, Suffolk IP4 2BN.

**Tel: (0473) 225951**

ENTER 10 ON REPLY CARD

## Happy Memories

Part type	1 off	25-99	100 up
4164 150ns Not Texas.....	1.05	.95	.90
41256 150ns.....	2.59	2.45	2.35
41256 120ns.....	2.75	2.55	2.40
41464 120ns.....	3.45	3.20	2.99
2114 200ns Low Power .....	1.75	1.60	1.55
6116 150ns Low Power .....	1.40	1.25	1.20
6264 150ns Low Power .....	2.75	2.55	2.40
62256 120ns Low Power .....	10.95	10.25	9.65
2716 450ns 5 volt.....	3.20	Call	Call
2532 450ns.....	5.40	"	"
2732 450ns.....	3.20	"	"
2732A 250ns .....	3.95	"	"
2764 250ns Suit BBC.....	2.85	"	"
27128 250ns Suit BBC.....	3.95	"	"
27256 250ns.....	4.55	"	"
27512 250ns.....	8.45	"	"

Low profile IC sockets: Pins 8 14 16 18 20 24 28 40  
Pence 5 9 10 11 12 15 17 24

Please ask for quote on higher quantities or items not shown.

Data free on memories purchased, enquire cost for other.

Write or 'phone for list of other items including our 74LS series and a DISCOUNT ORDER FORM.

Please add 50p post & packing to orders under £15 and VAT to total. Access orders by 'phone or mail welcome.

Non-Military Government & Educational orders welcome for minimum invoice value of £15 net.

**HAPPY MEMORIES (WW),  
FREEPOST, Kington,  
Herefordshire HR5 3BR.**

**Tel: (054 422) 618**

(No stamp required)

ENTER 62 ON REPLY CARD

## HART - The Firm for QUALITY

### LINSLEY-HOOD 300 SERIES AMPLIFIER KITS

Superb integrated MosFet amplifier kits with an unbeatable pedigree; circuit design by John Linsley-Hood and engineering by HART.

Ultra easy assembly and set-up with sound quality to please the most discerning listener. Ideal basis for any domestic sound systems if quality matters to you. Buy the complete kit and save pounds off the individual component price.

K300-35, 35 Watt, Discount price for Complete Kit. K300-45, 45 Watt, Discount price for Complete Kit.

RLH48.5. Reprints of Original Articles from 'HiFi News' ..... £1.05 no VAT

### LINSLEY-HOOD SUPER HIGH QUALITY AM/FM TUNER SYSTEM

Our very latest kit for the discerning enthusiast of quality sound and an exotic feast for lovers of designs by John Linsley-Hood. A combination of his ultra high quality FM tuner and stereo decoder described in "Electronics Today International" and the Synchrodyne AM receiver described in "Wireless World". The complete unit is cased to match our 300 Series amplifiers. Novel circuit features in the FM section include ready built pre-aligned front end, phase locked loop demodulator with a response down to DC and advanced sample and hold stereo decoder together make a tuner which sounds better than the best of the high-priced exotica but, thanks to HART engineering, remains easy to build. The Synchrodyne section with its selectable bandwidth provides the best possible results from Long and Medium wave channels, so necessary in these days of split programming. If you want the very best in real HiFi listening then this is the tuner for you. Since all components are selected by the designer to give the very best sound this tuner is not cheap, but in terms of it's sound it is incredible value for money. To cater for all needs four versions are available with variations up to the top of the range full AM/FM model, with any unit being upgradeable at any time. Send for our fully illustrated details.

### HIGH QUALITY REPLACEMENT CASSETTE HEADS

Do your tapes lack treble? A worn head could be the problem. Tape heads are constantly improving and fitting one of our latest replacement heads could restore performance to better than new! Standard mountings fit most decks and our TC1 Test Cassette will make it easy to set the azimuth spot on. As we are the actual importers you get prime parts at lowest prices. All our heads are suitable for Dolby machines.



HC20 Permalloy Stereo Head. Good quality standard head fitted as original equipment on many decks..... £7.66

HS16 Sandust Alloy Super Head. Quite simply the best. Longer life than permalloy, higher output than ferrite, fantastic frequency response ..... £14.86

HQ551 4-Track head for auto-reverse or quadrophonic use. Full specification record and play head ..... £14.60

Special Offer Stereo R/P Heads..... £2.49

4-Track Auto-Reverse Play Head..... £3.50

HS9510 2/4 Stereo DC Erase Head ..... £6.70

HQ751E 4/4 Erase compatible with HQ551..... £39.70

Full data on these and other heads in our range are contained in our free list.

### HART TRIPLE-PURPOSE TEST CASSETTE TC1

One inexpensive test cassette enables you to set up VU (Dolby) level, head azimuth and tape speed without test equipment. Vital when fitting new heads. Complete with instructions ..... £4.66

Send for your FREE copy of our lists with full details of our complete range of Kits, Components, PCBs, Cassette Heads and Decks:- Overseas please send 5 IRCs for Airmail Post.

Please add VAT to all prices. Postage on orders up to £10 - 50p. £10 to £49 - £1. Over £50 - £1.50.



**ELECTRONIC KITS LTD**

1, Penylar Mill, Oswestry, Shropshire SY10 9AF

24 hr SALES LINE (0691) 652894 Please add VAT

# APPOINTMENTS

Advertisements  
accepted up to  
12 noon October 5  
for November issue

**DISPLAYED APPOINTMENTS VACANT:** £25 per single col. centimetre (min. 3cm).  
**LINE advertisements (run on):** £5.50 per line, minimum £45 (prepayable).  
**BOX NUMBERS:** £12 extra. (Replies should be addressed to the Box Number in the advertisement, c/o Quadrant House, The Quadrant, Sutton, Surrey SM2 5AS).  
**PHONE:** SUSAN PLATTS, 01-661 3033 (DIRECT LINE)

*Cheques and Postal Orders payable to REED BUSINESS PUBLISHING and crossed.*

Philips Communications  
& Security

## APPLICATIONS SPECIALIST

### Radio Paging Cambridge

**P**hilips Communications and Security, leaders in professional audio communications, is seeking a young professional audio engineer to join its project team to provide project and product support to the field sales staff. He/she will be involved in first line systems design and production of quotations as well as giving general advice on application possibilities and obtaining Dept. Trade and Industry approvals.

It is likely that the successful candidates will have a minimum of HNC in Telecoms, with substantial experience in communications and/or professional audio with a working knowledge of general software requirements for radio paging. A clean driving licence is essential (a company car is not provided).

Please apply to Ann Macnab, Personnel Manager, Philips Communications & Security, Cromwell Road, Cambridge CB1 3HE.  
Tel: 0223 245191.



# PHILIPS

## Pro-Audio Service Engineers

c £14K

Our client, a leading supplier of professional audio equipment to the broadcast and sound recording industry seeks experienced service engineers to work with professional tape machines and microphones. This will involve occasional visits to customers sites. Tape machine experience and a knowledge of the industry are essential. RF/Radio Amateur/Live recording experience useful. An excellent benefit package applies. *Interested?*

**Professional &  
Technical  
Appointments**

ELECTRONICS DIVISION

**Contact:**  
Mike Jones  
Professional  
and Technical  
Appointments  
(0256) 470704

WWHC1

## Hardware/Software/Systems

£9,000 - £25,000

As a leading recruitment consultancy we have a wide selection of opportunities for high calibre Design, Development, Systems and supporting staff throughout the UK. If you have experience in any of the following then you should be talking to us for your next career move.

**ARTIFICIAL INTELLIGENCE \* IMAGE PROCESSING \* ANALOGUE DESIGN  
MICRO HARDWARE & SOFTWARE \* GUIDED WEAPONS \* C \* PASCAL  
ADA \* RF & MICROWAVE \* ELECTRO-OPTICS \* SIMULATION \* C#  
REAL TIME PROGRAMMING \* SYSTEMS ENGINEERING \* ACOUSTICS  
SONAR \* RADAR \* SATELLITES \* AVIONICS \* CONTROL \* ANTENNA  
VLSI DESIGN**

Opportunities exist with National, International and consultancy companies offering excellent salaries and career advancement.

To be considered for these and other requirements contact John Spencer or Stephen Morley or forward a detailed CV in complete confidence quoting Ref. WW/66.



STS Recruitment, 85 High Street, Winchester,  
Hants SO23 9AP. Tel: (0962) 69478 (24 hrs).

# WE

Due to its continuing successes the Waverley Division of Dowty Maritime Systems Ltd has requirements for the following staff:

### ENGINEER/TECHNICIANS

#### Commissioning Engineer

Preparation of sonar systems and peripheral equipments to enable Factory Acceptance Tests to be conducted. Prime responsibilities will be to establish operational systems, spares, equipments, and PBC's. An HNC/D qualification is expected, together with experience gained preferably at system level. Fault finding ability an advantage.

#### Product Support Technician

Primarily setting-to-work of Thermal Printers which are state of the art proprietary Waverley products. Assistance with sea trials, other products, and customer field service is required from time to time. Applicants should hold a minimum of ONC, ideally HNC/D in electronics, with three years' experience.

#### Repairs Technician

The successful candidate will be capable of diagnosing electronic faults to component level, setting-to-work, calibration and final inspection of refurbished items. In addition, the capability to conduct comprehensive electronic and mechanical surveys returned for repair will be expected. Qualifications sought are ONC/TEC III or equivalent together with a minimum of three years' experience.

Vacancies also exist in our Production Area for:

#### Prototype Wirepersons

To work on the wiring of electronic cabinets and sub-assemblies. Applicants must have the ability to work directly from drawings and schedules. 2/3 years' experience of working to the high standards required is essential.

Salaries offered will depend upon ability and experience. Some relocation assistance will be paid where appropriate.

Please write, or phone immediately for an application form (CV's welcome) to:

Terri Houghton, Personnel Officer, Dowty Maritime Systems, Waverley Division, 10 Cambridge Road, Granby Industrial Estate, Weymouth DT4 9TJ. Tel: 0305 784738, ext 174.

507

# DOWTY



Sinclair House, 74 Willoughby Lane, London N17 0SF  
Telephone 01-808 3050

**THE UK's No. 1 ELECTRONICS AGENCY**  
ELECTRONICS ENGINEERS if you are looking for a job in DESIGN, FIELD SERVICE, TECHNICAL SALES or SOFTWARE ENGINEERING.

Telephone NOW for one of our FREE Jobs lists or send a full cv to the address below.  
Vacancies throughout the UK to £18000 pa.

**Capital Appointments Ltd., FREEPOST London N17 0BR.**  
Please send me your list for ..... Engineers  
Name ..... (WWW)  
Address .....  
..... Post Code .....



**01-808 3050 - 24 HOURS**

**UNIVERSITY OF BIRMINGHAM**  
Department of Sport and Exercise Sciences  
*Electronics bias*

## A TECHNICIAN

is required to play a major role in providing technical expertise in the development of new teaching courses and research programmes. The duties will involve development and construction of electronic equipment, and some use of computing skills plus assisting in the exercise physiology laboratory measuring human subjects using a variety of sophisticated research apparatus. Applicants should be qualified in Applied Biology or Electronics and have previous laboratory experience. Ref: 9460, Salary £7,696-9,086 pa.

Please write or telephone for application forms to:  
Personnel Office, Birmingham University, PO Box 363, Birmingham B15 2TT.  
Tel: 021-472 1301, ext 2452

An Equal Opportunities Employer

498

*Electronics Technicians, Electricians*

# YOU CAN'T CHANGE THE WORLD.

**But you can make a world of difference.**

Skills taken for granted in this country are vital to members of poorer Third World communities.

In a world which by and large does nothing about poverty and injustice (let alone hunger), VSO volunteers work directly with those seeking to become more self-reliant:

No one can change the world. But as a VSO volunteer, you could make a world of difference.

**We have several jobs in electronics and electrical work for February 1988 departure overseas. Most of the electronics jobs are in the repair and maintenance of a variety of control systems. The electrical jobs are principally in the training of school leavers in basic electrical installation in domestic and light industrial work. All the jobs require people who enjoy working with others and passing on their skills. If you have a relevant skill and qualification please apply now.**

You should be without dependants and willing to work for the local rate of pay. Postings are for two years - although many choose to stay longer - and most U.K. employers should be prepared to grant leave of absence.

For more information please complete and return.

I'm interested. I have the following training/experience:



**Join the human race.**

Charity no. 313757.

Name .....

Address .....

EWV/10/87

Post to: Enquiries Unit, Voluntary Service Overseas,  
9 Belgrave Square, London SW1X 8PW. (24p S.A.E. appreciated)

## CLIVEDEN

Technical Recruitment

### DEVELOPMENT ENGINEER

R.F. Transmitter/Receiver Design a & d circuits - DC to microwave.  
Surrey. Ref: 5/1597

c. £15,000

Surrey. Ref: 1/1024

### CALIBRATION ENGINEER

Electronic test & measurement equipment. Analogue & Digital.

To £12,000

Herts. Ref: 5/1598

### P.C.B. DESIGNER

Experienced with P.C.B. layout techniques and use of CAD.

c. £11,000

Hants. Ref: 5/1590

### SOFTWARE ENGINEER

Team leader. Realtime UNIX. Experience - PASCAL, CORAL or C.

To £18,000

Berks Ref: 4/076

### TEST & SERVICE ENGINEERS

Computer peripherals to component level.

To £11,000

Hants. Ref: 5/1590

### DESIGN ENGINEER

Design and develop digital micro based control systems.

To £17,000

Hants. Ref: 5/1590

We have hundreds of other Electronic and Computer vacancies to £18,000.

Apply

Cliveden Technical Recruitment,

92 The Broadway, Bracknell, Berks RG12 1AR  
Tel: 0344 489489 (24 hr)

Cliveden Technical Recruitment

163 Bittern Road, Southampton  
Tel: 0703 229094

# Electronic Engineers - What you want, where you want!

TJB Electrochemical Personnel Services is a specialised appointments service for electrical and electronic engineers. We have clients throughout the UK who urgently need technical staff at all levels from Junior Technician to Senior Management. Vacancies exist in all branches of electronics and allied disciplines - right through from design to marketing - at salary levels from around **£8,000 - £25,000.**

If you wish to make the most of your qualifications and experience and move another rung or two up the ladder we will be pleased to help you. All applications are treated in strict confidence and there is no danger of your present employer (or other companies you specify) being made aware of your application.

TJB ELECTROTECHNICAL PERSONNEL SERVICES,

12 Mount Ephraim, Tunbridge Wells, Kent. TN4 8AS.



Tel: 0892 510051  
(24 Hour Answering Service)

Please send me a TJB Appointments Registration form.

Name .....

Address .....

(861)

# TRAINEE RADIO OFFICERS



Are you looking for a secure shore-based job which offers a rewarding career in the forefront of modern Telecommunications technology... then consider joining GCHQ as a Trainee Radio Officer. Training involves a 32 week residential course, (plus 6 weeks extra if you cannot touch type) after which you will be appointed RADIO OFFICER and undertake a variety of specialist duties covering the whole of the spectrum from DC to light.

**We offer you: Job Security · Good Career Prospects · Opportunities for Overseas Service · Attractive Salaries... and much more.**

To be eligible you must hold or hope to obtain an MRGC or HNC in a Telecommunications subject with an ability to read morse at 20wpm.

Anyone with PMG, MPT or 2 years relevant radio operating experience is also eligible. The Civil Service is an equal opportunities employer.

**Salaries:** Starting pay for trainees is age pointed to 21 years. For those aged 21 or over entry will be at £6,572. After training an RO will start at £9,758 rising by 5 annual increments to £14,387 inclusive of shift and weekend working allowance.

Write or telephone for an application form to:-



THE RECRUITMENT OFFICE, GCHQ, ROOM A 1108  
OAKLEY, PRIORS ROAD, CHELTENHAM, GLOS GL52 5AJ  
OR TELEPHONE (0242) 232912 3

## WANTED

**STEWART OF READING**  
110 WYKEHAM ROAD,  
READING RG6 1PL.  
TEL: 0734 68041

**TOP PRICES PAID FOR ALL  
TYPES OF SURPLUS TEST  
EQUIPMENT, COMPUTER  
EQUIPMENT, COMPONENTS  
etc. ANY QUANTITY**

**ROGERS AVIATION LIMITED**  
require an

## AVIONICS BENCH ENGINEER

To work on a range of general aviation  
equipment at Cranfield Airfield, Beds.  
Ring: Engineering Manager on (0234)  
750661 for job application.

Salary commensurate with experience.

504

## GOLLEDGE

### ELECTRONICS

**QUARTZ CRYSTALS,  
OSCILLATORS AND FILTERS** of  
all types. Large stocks of standard  
items. Specials supplied to order.  
Personal and export orders welcomed -  
SAE for lists please. OEM support thru:  
design advice, prototype quantities,  
production schedules. Golledge  
Electronics, Merriott, Somerset YA16  
5NS. Tel: 0460 73718. (2472)

**PLATINUM, GOLD, SILVER  
SCRAP.** Melted assayed and paid for  
within 24 hours relay contacts, thermo  
couples, crucibles. Also printed circuit  
boards, plugs, connectors, palladium,  
rhodium, tantalum and ruthenium. We  
have the technology to do the difficult  
refining jobs that others can't handle.  
Totally free sampling service. Send  
samples or parcels (Regd post) or  
contact Eric Henderson, 0773 570141.  
Steinbeck Refineries (UK) Ltd,  
Peasehill Industrial Estate, Ripley,  
Derbyshire DE5 3JG. No quantity too  
large or small. 495

## ARTICLES FOR SALE

**TO MANUFACTURERS, WHOLESALERS  
BULK BUYERS. ETC.**

## LARGE QUANTITIES OF RADIO, TV AND ELECTRONIC COMPONENTS FOR DISPOSAL

SEMICONDUCTORS, all types, INTEGRATED CIRCUITS, TRANSISTORS,  
DIODES, RECTIFIERS, THYRISTORS, etc. RESISTORS, C/F, M/F, W/W, etc.  
CAPACITORS, SILVER MICA, POLYSTYRENE, C280, C296, DISC  
CERAMICS, PLATE CERAMICS, etc.

ELECTROLYTIC CONDENSERS, SPEAKERS, CONNECTING WIRE, CABLES,  
SCREENED WIRE, SCREWS, NUTS, CHOKES, TRANSFORMERS, etc.  
**ALL AT KNOCKOUT PRICES** - Come and pay us a visit ALADDIN'S CAVE

**TELEPHONE: 445 0749/445 2713**

R. HENSON LTD.

21 Lodge Lane, North Finchley, London, N.12  
(5 minutes from Tally Ho Corner)

(1613)

**MANY GREAT BARGAINS.** Ex-  
stock Electronic Components, Test  
Equipment, Computers, Peripherals,  
Word Processors. Contact:- Tech  
Supplies, 191 Winchester Avenue,  
Denny, Stirlingshire, FK6 6QE. Tel:  
(0324) 825627. No order to small. Open  
9am-4pm and 7.30pm-10pm 7 days. 502

**BRIDGES** waveform/transistor  
analysers. Calibrators, Standards,  
Millivoltmeters. Dynamometers. KW  
meters, Oscilloscopes. Recorders.  
Signal generators - sweep, low  
distortion, true RMS, audio, R.M.,  
deviation. Tel: 040 376236. (2616)

DEPARTMENT OF ELECTRICAL  
AND ELECTRONIC ENGINEERING  
SOFTWARE ENGINEERING  
DIGITAL & ANALOGUE ELECTRONICS  
COMMUNICATION ENGINEERING  
MATHEMATICS

## LECTURER II/SENIOR LECTURERS

(Temporary Posts)

£9,810-£14,871/£13,830-£17,088

Applications are invited for lecturing posts in the Engineering  
disciplines above.

Candidates should have recent industrial/research/consultancy  
experience.

The Department - a leader in Information Technology and one  
of the largest engineering departments in the country - currently  
comprises 45 academic and 30 support staff.

The academic programme includes a large postgraduate  
course in Information Technology, courses leading to Enhanced  
(B.Eng.) and Extended (M.Eng.) Degrees, Technician Engineer  
qualifications and postgraduate studies by research. Department  
research and consultancy interests extend to many branches of  
Electrical and Electronic Engineering, Software Engineering and  
Knowledge Based Systems.

Application forms and further details are available from  
the Personnel Department, South Bank Polytechnic,  
Borough Road, London SE1 0AA. Telephone: 01-928 3512  
(answering service 9.00am to 6.00pm).

Please quote Ref: ACAD. Closing date: 30th September, 1987  
An Equal Opportunities Employer

**South Bank  
Polytechnic**

Teaching for tomorrow  
in the heart of London

500

## ELECTRONICS TECHNICIAN

A vacancy exists in the Department of Physics, University of  
Leeds, for an Electronics Technician to work with the Polymer  
Research Group.

Duties will include the development, construction, modification  
and operation of equipment in addition to fault diagnosis, testing,  
calibration and maintenance. Candidates should have an HNC or  
equivalent qualification with experience in analogue and digital  
electronics. Experience of valve equipment, BBC computers and  
peripherals, would be an advantage but not essential. The post is  
externally funded and will initially be for one year, possibly  
extending to three years. Salary according to age, qualifications  
and experience in the range £8,800 to £10,640.

CV with details and two referees to be sent to:  
**The Contracts Officer, University of Leeds Industrial  
Services Ltd, 175 Woodhouse Lane, Leeds LS2 3AR,  
marked "Confidential".**

511

## BILLINGTON VALVES

39 Highlands Road, Horsham, W. Sussex RH13 5LS.  
Tel: 0403 044084; Fax: 0403 210108; Telex: 87271 PRODSS G.

Valves and Transistors - Rareties our

**Speciality!** phone your enquiry or send SAE today for  
brand new catalogue. Enquiries from govt depts, universities  
and dealers welcome. Overseas enquiries welcome - French,  
German, Japanese spoken by arrangement

We stock HT transformers (50VA to 3KVA) plus Variacs,  
constant voltage (0.1%) Send for list or quotation. We also  
stock capacitors and transmitter components - SAE quotation

**We will buy Valves and Transistors.**  
Complete shop clearance etc. welcome. Distance no object,  
equipment, circuit boards and RF plugs considered. Listing and  
price required appreciated

## CONNECTORS

**ZERO INSERTION FORCE  
NEW DESIGN - LOW COST - HIGH QUALITY**

Details SAE:

**JASP INTERNATIONAL**  
14 Tudor Close, Wokingham,  
Berks RG11 2LR (trade welcome).  
Tel: 0734 782084, Tlx: 849021

510



## ARTICLES FOR SALE

Portapower-8 NiCad battery £15. Marconi V.F. Bridge £23. CRT's Mullard 0G-16-22 £30. VCR 157B £15. SE9/2A/P31. Cinel 6E84F £29. E.4504 (CV1391) £15. NC15 £12. 001 A (CV1522) £15. 40 (C £15. DH3.91 (CV2302) £10.890 £10.958 £10. 4EP7E20. 20-amp variable power resistance £15. 2-gang series/parallel 2A/4A £15. 4A/8A ditto £15. 1.2A single £E. Mullard tube MW 6/2C20. EHT meter 0-6KV £12. 12 v DC to 1500c.s PSU's £15. Halogen Leak Detector (G.E.) in pocket case with manual £18. Teddington - KM Refrigerant Thermal Expansion Valve £5. Small gearboxes £3. large £10. 12/24 v. blower £8. Fire-Lite Alarms Inc. Sensor Switch Unit, mains or battery operation, also turn on emergency light £3.50 (rapid check facility). Tektronix oscilloscope, dual time-base, delay etc., £125. Tek plug-ins IA2 £49. CA £39. 53/54K £25. 'Q' (transducer & strain gauge) £35. Stroboscope. Centrifuge. Pestle & Mortar. glassware, Silica crucible, silica tube. Aspirator etc. Tektronix probes £12.50. Monocular microscope £85. Stereoscopic. Prismatic binocular microscope £195. 60 W. 60 W. IC amps £6.50. ea. 4-drawer cabinets containing variety mechanical components £10 ea. 1920's BBC-type carbon microphone, marble case. in support frame £50. Pre-war, chrome, car spot/fog lights £10 ea. First world-war set American socket spanners, wood case £25. 1920's valve tool £6. Pre-war badge bars £5 ea. Refractometer. Original 9.5mm cine camera parts/spares. 19" rack mounting cabinets £10. Etc. etc.

040-376236. 2016

## FOR SALE

### AM LOW BAND MOBILE RADIO SYSTEM

Comprising: 64 No GEC 660. 25 No GEC 666. 24 No. GEC 665. 1 No TAIT 162. 1 No MOTAFONE MF5AM. 3 No PYE W15AM. 12 No PYE AM10. 4 No AWA TR265. 1 No MARCONI RC 680. 3 No GEC RC550 Portables and Charger. 2 No PF2AM Portables and Charger. 3 No PYE F27 BASE WITH 10 No LCU's. 3 No PYE AM10FRX. 1 NO PYE F30 BASE. 1 No GEC RC760 BASE WITH 2 No LCU's.

Viewing Phone: Mr G. Smith, Market Rasen 842557.

Offers must be made in writing in plain sealed envelope marked "Offer for RADIO SYSTEM" to the Director of Highways and Planning, Lincolnshire County Council, City Hall, Fourth Floor, Beaumont Fee, Lincoln LN1 1DN to arrive not later than 2.30 pm on 30 September 1987.

509

**TEST EQUIPMENT FOR SALE:**  
Signal generators, TV pattern generators, scopes, power supplies, y-t recorders, DMM's etc, too many to list, write (with sae) for more information and prices to Box No. 478

478

## TEST EQUIPMENT GOOD USED EQUIPMENT ALWAYS AVAILABLE

Solortron 1172 frequency response analyser £1,250.00  
Advance OS3000 40MHz dual trace scope £275.00  
Advance DS1000A 15MHz dual trace scope £150.00  
Tektronix 7603 100MHz with plug-in's £750.00

Considerably more always in stock send for lists.

### BUYING or DISPOSING contact

COOKE INTERNATIONAL

Unit 4, Fordingbridge Site, Main Road,  
Barnham, Bognor Regis, West Sussex PO 22 0EB.  
Tel: 0243 68 5111/2

505

When replying to  
**classified advertisements,  
readers are recommended  
to take steps to protect  
their interest before  
sending money**

## 173 MHZ FM TELEMETRY + TELECOMMAND RADIO LINKS

- Remote Switching
- Voltage Monitoring
- Serial Data Transmission

## ADENMORE LTD

27 Longshott Estate, Bracknell RG12 1RL.  
Tel: (0344) 52023

## SERVICES

### CIRCOLEC

## THE COMPLETE ELECTRONIC SERVICE

Artwork, Circuit Design, PCB Assembly, Test & Repair Service, Q.A. Consultancy, Prototypes, Final Assembly. Full PCB Flow Soldering Service.

Quality workmanship by professionals at economic prices.  
Please telephone 01-646 5686 for advice or further details.

**TAMWORTH MANOR  
302-310 COMMONSIDE EAST, MITCHAM**

(1391)

**P.C.B.'s DESIGNED.** Artwork capacity available for single/double sided, P.T.H. and multi-layer P.C.B.'s, also silk screens, solder masks, labels etc. For C.A.D./Photoplot, artwork & photography, contact Mr. Williams, 49 Westbourne, Honeybourne, Evesham, Worcs, WR11 5PT. Tel? 0386 832152.

409

**QUICK BOARD DESIGNS.** A speedy printed circuit design service to get ideas into practice. Circuit design, PCB artwork, prototypes, everything from concept to production. Tel: 01-404 0020.

499

## DESIGN SERVICE

Design Development and CAD PCB Design/Artwork. Analogue and digital design and development to production. Microcontroller development facilities. 4 bit H400 and 8 bit 6305 one time programmables. 6805 & 6809 NMOS & CMOS. Emulators for 6305 and 6805 microcontrollers for sale.

MED, 20 Greenock Road,  
Streatham, London SW16 5XG.  
Tel: 01-679 7109

485

**TURN YOUR SURPLUS** i.c.s transistors etc. into cash, immediate settlement. We also welcome the opportunity to quote for complete factory clearance. Contact COLES-HARDING & CO, 103 South Brink, Wisbech, Cambs. 0945 584188. (92)

## ARTICLES WANTED

## WANTED

Test equipment, receivers, valves, transmitters, components, cable and electronic scrap and quantity. Prompt service and cash.

## M & B RADIO

86 Bishopsgate Street  
Leeds LS1 4BB  
0532 435649

9956

## ARTICLES FOR SALE

### G.W.M. RADIO LTD

40/42 Portland Road, Worthing, Sussex.  
Tel: 0903 34897

Constantly changing stock of interesting items for callers. Receivers, Racal RA17's and Eddystone 730/4's in excellent condition now in stock. Datel 2412 modem units, 2/1G 250/8 modules 1, 2, & 3 in modem case assembly £30 inc p&p. Ex-navy quartz chronometers clear 7cm dial in wood case £27 inc p&p.

# CLASSIFIED ADVERTISEMENTS

## Use this Form for your Sales and Wants

PLEASE INSERT THE ADVERTISEMENT INDICATED ON FORM BELOW

To "Electronics & Wireless World" Classified Advertisement Dept., Quadrant House, The Quadrant, Sutton, Surrey SM2 5AS

- Rate £5.50 PER LINE. Average six words per line. Minimum £45 (prepayable).
- Name and address to be included in charge if used in advertisement.
- Box No. Allow two words plus £12.
- Cheques, etc., payable to "Reed Business Publishing" and cross "& Co." 15% VAT to be added.

NAME .....

ADDRESS .....

.....

.....

				REMITTANCE VALUE.....	ENCLOSED

PLEASE WRITE IN BLOCK LETTERS. CLASSIFICATION..... NUMBER OF INSERTIONS..... (1)

**MATMOS LTD**, 1 Church Street, Cuckfield, West Sussex RH17 5JZ.

Tel: (0444) 414484/454377

**COMPUTER APPRECIATION**, 111 Northgate, Canterbury, Kent CT1 1BH

Tel: Canterbury (0227) 470512. Telex: 966134 COMPAG G

**STOP PRESS**

**PANASONIC LATEST MODEL JU363** 3½ Disc Drive, brand new, 1/3 height with standard interface for IBM etc, etc .....£59.50

**DATA GENERAL ECLIPSE CS/60 SYSTEM** comprising: ECLIPSE processor with 512kbytes MOS memory, 5 line terminal MUX type 005-8599, 2x50mbyte cartridge disc drives Model 6067-4. DATA .....£3,500.00  
**DATA GENERAL NOVA 1200 SYSTEM** comprising: processor with 64kbytes core memory, magnetic tape drive Model 6021-2, 9 track 800 bpi, Phoenix 14" cartridge disc drive Model 6050, 5mbytes fixed + 5mbytes removable .....£1,250.00  
**NOVA 1200 SYSTEM** comprising: processor with 64kbytes core memory, Model 5006-A 16 line terminal MUX, Model 6050-D cartridge disc drive .....£1,250.00  
**microNOVA SYSTEM** comprising 3' rack with: 8 slot backplane, box & PSU, 12mbyte 14" Winchester disc drive .....£750.00  
**AS ABOVE**, but with addition of cartridge tape backup .....£950.00  
**microNOVA SYSTEM**, all unused, comprising desktop mounted: Model E8711-N processor, Model E6267A dual half-height 5¼" floppy disc drives, Model E6271 5¼" Winchester disc drive, Model E8694-B2 power supply, Model 6261-2 monochrome monitor .....£385.00  
**microNOVA Model MPT/100 SYSTEM** with the following features: terminal sized desktop unit, mN602 processor with 64kbytes RAM, 2xRS232 interfaces, connector for microNOVA I/O bus, dual DSDD 5¼" floppy disc drives, 83 keyboard, green screen 12" monitor, 25x80 .....£385.00  
**DATA GENERAL Model 6220 8" Winchester drive, 5mbyte** .....£150.00  
**DATA GENERAL Model 6041 DASHER TP1 printer**. Serial interface 300/600B .....£150.00  
**DATA GENERAL Model 6052 DASHER VDU TERMINAL**. All Baud rates to 19200B .....£150.00  
**DATA GENERAL DASHER 100 terminal** .....£95.00  
**PLESSEY Model T24 V22/V22 bis MODEM**. Compact, automatic modem featuring the latest technology and the highest possible data rate over the ordinary phone system. Offers: both V22 & V22bis compatibility, 1200/2400 Baud operation with auto bit rate recognition, operation on both ordinary phone (PSTN) and private circuit (PC), auto call and auto answer, duplex operation allowing simultaneous transmission and reception of data at 2400 Baud in both directions over a single phone line, compact size (9"x9"x2½"), BT approved and suitable for new PRESTEL V22bis service. Price includes software for use with public domain comms packages for IBM PC. BRAND NEW .....£299.00  
**VICTOR SpeedPac IBM PC ACCELERATOR**. Half-wide 80286 accelerator card for IBM PC and compatibles. With 8kbyte cache memory and 7.2mhz 80286 processor. Offers AT/Personal System 2 performance for a fraction of the cost. Runs up to 7.5 times faster. BRAND NEW .....£199.00  
**ITT SCRIBE III WORD PROCESSING SYSTEM**. Professional system originally selling at around £6,000 without printer. Now offered with software included and a variety of different options (including hard disc, comms, etc) available. The system is available from us ALL BRAND NEW at the cost of current budget systems, but with office-quality performance and features. With dual processor workstation (TI 9995 & Z80H), 12" green display with slow scrolling, 128kbytes RAM, dual 500kbyte SHUGART 5¼" floppy disc drives, and comprehensive software .....£299.00  
**MATMOS TERMINAL MATMOS PC** with Ver.2 EPROM for terminal emulation. Probably the lowest cost terminal available anywhere. With set-up menu and with data rates up to 9600 Baud. Machine is easily modified for split Baud rate operation. 75/1200B, EPROM plugs into ROM socket accessible from exterior. Emulation is VT-52 compatible for cursor addressing; and for character attributes as far as the MATMOS PC allows. MICROSOFT BASIC is still available from the keyboard. (EPROM card on its own, £20.00; EPROM card with socket only for user's own EPROM, £8.00) BRAND NEW .....£89.00

**HITACHI Model 305S/SX 3" disc drives**. With SHUGART compatible interface as for 5¼" drives. Uncased. 125K (single density) or 250K (double density); 40 track; 100 tpi; soft sector; 3ms track to track time; standard 34 way edge connector; 12V and 5V powered (standard connector) with overall 3.7W typical power consumption. These drives have been tested by us on the BBC with DFS, on the AMSTRAD 6128 and on the TATUNG EINSTEIN, and are also known to be suitable for the AMSTRAD 664 and as a second drive for the AMSTRAD 464. Single sided, 250kb unformatted. BRAND NEW. Data cables are available from us for the AMSTRAD 6128 & BBC at £7.50, and an installation pack including data and power cables with instructions is available for the TATUNG Einstein at £12.00 .....£24.95  
**KIMTRON Model ADM 85H VDU**. 24x80 intelligent VDU with TELEVIDEO 920/925 emulation. Features include, non volatile set-up with status line, auxiliary port, all Baud rates 50-19200 Baud, cursor addressing, etc .....£185.00  
**DEC PDP 11/73 SYSTEM** with DVZ11 asynchronous multiplexor, DLV11 serial interface, BA11-SB 9x4 backplane, TANDON 8" floppy disc drive with DILOG Model RXV-21 controller, 2x AMPLEX PYXIS 27 5¼" Winchester disc drives with DILOG DG 614 controller. All contained in DEC cabinet with DEC power control, 512kb memory .....£3,950.00  
**FUJITSU Model M2230AS 5¼" WINCHESTER disc drive**. 6.65mbyte capacity unformatted, 16/32 sectors, 320 cylinders. With ST506 interface. BRAND NEW .....£75.00  
**DEC Model BA11MF box**, power supply and 8 bit slot backplane for Q-bus. BRAND NEW .....£185.00  
**ADAC Model 1822 128kbyte CMOS memory for Q-bus**. With battery back-up .....£175.00  
**HATFIELD INSTRUMENTS Type 2105 ohm attenuator** .....£40.00  
**BRYANS Model 45000 UV recorder** with 6x45001 amplifiers 1mV/cm - 50V/cm and chart speeds from 1mm/min - 500mm/s. Timing line interval is adjustable from 0.002s-10s and Record Duration 0.5s-20s. With remote control facility .....£195.00  
**HEWLETT PACKARD Model 59307A dual VHF switch**. DC to 500MHz 50 ohm switch for HP-IB .....£185.00  
**HEWLETT PACKARD Model 5045A digital IC tester** with CONTROL Model H310 automatic handler. With IEEE interface and print out of test results either pass/fail or full diagnostic including pin voltages at point of failure. With full complement of pin driver cards and complete with substantial library of mag card test programs for 74 series TTL and other ICs. CONTROL handler allows fully automatic testing of ICs which are sorted into 2 bins. Price includes a second HP5045A (believed fully operational) for maintenance back-up .....£1,950.00  
**TEKTRONIX Model 577 SEMICONDUCTOR CURVE TRACER**. With 5 heads for various diodes and transistors. In excellent condition .....£1,750.00  
**TIME ELECTRONICS Model 9810 programmable power supply** .....£160.00  
**TIME ELECTRONICS Model 505 DC current source**, 0.05%. With leather case .....£55.00  
**KRATOS MS30 DOUBLE BEAM MASS SPECTROMETER**. Approximately 8 years old. With gas and direct introduction sample probes and with gas chromatograph inlet system. Output spectra are available directly via a HEWLETT PACKARD storage display and a UV recorder. An on-line DATA General DS60 computer system, which includes a graphics printer and two TEKTRONIX 4014 terminals, analyses output .....POA  
**SPECTRA PHYSICS Model 170 HIGH OUTPUT ARGON ION LASER**. 20 Watt output laser (including approx 2W UV output) with tube newly refurbished .....POA

Please note:  
 VAT and carriage must be added to all prices. Please enquire for details.  
 \*All new equipment is guaranteed for 6 months.

ENTER 50 ON REPLY CARD

# INDEX TO ADVERTISERS

Appointments Vacant Advertisements appear on pages 1074-1077

PAGE	PAGE	PAGE	PAGE
Adcola Products .....1033	Farnell Instruments Ltd..... IFC	Kestrel Electronic Comp.....1039	Raedek Electronics .....1022
Air Link Transformers .....1052	Field Electric Ltd .....996	Langrex Supplies .....1044	Ralfe Electronics .....982
BAF Box Ltd.....1034	Fluke (GB) Ltd ..... Advert Card	Levell Electronics .....1052	Second Test..... IBC
BICC - Vero Electrical .....1005	Gould Electronics Ltd .....981	L J Electronics.....1034	Sherwood Data Systems .....1056
Cambridge Kits.....1022	Hameg Oscilloscopes.....1006	MA Instruments.....1039	Slee Electronic Comp .....982
Carston Electronics.....995,1055	Happy Memories .....1073	Maplin Electronic Supplies ...1011	Stewarts of Reading .....1060
Cirkut Distribution .....1055	Harrison Electronics.....1033	MBS Technirent.....1032	Surrey Electronics Ltd .....1011
Colomor (Electronics) Ltd.....1034	Hart Electronic Kits .....1073	Micro Concepts.....1018	Target Electronics.....1034
Computer Appreciation .....1078	Henry's Audio Electronics.....1021	MQP Electronics .....1006	Taylor Bros (Oldham) .....988
Crotech Instruments.....1062	Henson, R, Ltd.....1012	North East Satellite Systems 996	Technomatic Ltd .....1050/1051
Dean Microsystems .....1039	Hilomost Ltd .....1011	Number One Systems.....1060	Test and Transducer Show ...1056
Display Electronics .....1068/1069	ICOM (UK) Ltd .....1039	Pineapple Software .....1012	Thandar Electronics .....1055
Electronic Brokers .....976,OBC	Ines GmbH .....1033	PM Components .....1064/1065	Thoroughbred Direct Sales....1073
Electronic Source The .....1055	Instrument Rentals.....985	Quarthand.....1006/1052	Those Engineers.....1070
Elektronik Export-Import .....1012	Johns Radio.....1022		Thurby Electronics .....1062
EMS Mfg. Ltd .....1033			Triangle Digital Services.....1022
Engineering Solutions.....1052			Valradio Power .....1012
			Webster Electronics .....1011
			Withers, R. Communication 1060

**OVERSEAS ADVERTISEMENT AGENTS**

France and Belgium: Pierre Mussard, 18-20 Place de la Madelaine, Paris 75008.

United States of America: Jay Feinman, Reed Business Publishing Ltd., 205 East 42nd Street, New York, NY 10017 - Telephone (212) 867 2080 - Telex 23827.

Printed in Great Britain by E.T. Heron (Print) Ltd, Crittall Factory, Braintree Road, Witham, Essex CM8 3QO, and typeset by Graphac Typesetting, 181/191 Garth Road, Morden, Surrey SM4 4LL, for the proprietors, Reed Business Publishing Ltd, Quadrant House, The Quadrant, Sutton, Surrey SM2 5AS. © Reed Business Publishing Ltd 1987. Electronics and Wireless World can be obtained from the following: AUSTRALIA and NEW ZEALAND: Gordon & Gotch Ltd. INDIA: A. H. Wheeler & Co. CANADA: The Wm, Dawson Subscription Service Ltd., Gordon & Gotch Ltd. SOUTH AFRICA: Central News Agency Ltd; William Dawson & Sons (S.A.) Ltd. UNITED STATES: Eastern News Distribution Inc., 14th Floor, 111 Eighth Avenue, New York, N.Y. 10011.

# SECOND

# TEST

# TEST and MEASUREMENT EQUIPMENT

## AUDIO TEST EQUIPMENT

LEADER LFM 3615 Wow/Flutter Meter .....	STG £ 650
LEADER LAV 191 Audio Tester .....	275

## COMMUNICATIONS EQUIPMENT

SPECTRON D101 Datascope .....	3500
TEKELEX CHAMELEON TTX06 Protocol Analyser .....	15000

## DIGITAL VOLTMETERS

DANA 5900 6½ Digit Multimeter .....	800
FLUKE 8025 6½ Digit + IEEE 488 .....	1250
FLUKE 8050A 4½ Digit Multimeter .....	250
HEWLETT PACKARD 3468 6½ Digit with HPIL .....	400

## DIGITAL THERMOMETERS

FLUKE 2176A .....	500
DIGITRON .....	100

## LOGIC ANALYSERS

FLUKE 9010A + Z80 Pod .....	3500
HP 1610A 32 Channel .....	1500
TEKTRONIX 1240 N16 + 3 D2 Cards .....	8000

## FREQUENCY COUNTERS

FLUKE 1920A 9½ Digit 5Hz - 500MHz .....	900
HP 5315A + Opt 3 DC 10CMHz .....	900

## MAINS ANALYSERS & TEST EQUIPMENT

AVO RM215L/2 Insulation Tester .....	450
ASSOCIATED RESEARCH Hipot Tester .....	900
DRANETZ 626 Mains Analyser .....	3250
626 PA 6001-1 Plug In .....	750
626 6002 - A1 Plug In .....	750
626 6003 - 1 Plug In .....	1500
ELGAR 1001B Variable Voltage & Frequency Source .....	1350
GOULD GS 2552 Power Conditioner .....	500
ROD L (Inc) M100 AV-S-5 Hipot Tester .....	1500
ROD L 25 AMP Ground Tester .....	1250
SHAFFNER NSG .....	900

## OSCILLOSCOPES

BWD 540 100MHz Delay T/B .....	500
HP 1741A 100MHz Analog Storage Delay T/B .....	2400
TEKTRONIX 468 Digital Storage Oscilloscope .....	4500
TEKTRONIX 475A DM44 250MHz Delay T/B .....	2500
TEKTRONIX 2215 60MHz Delay T/B .....	700
TEKTRONIX 2236 100MHz DVM Frequency Control Delay T/B .....	1500
TEKTRONIX 2337 100 MHz Ruggedised DVM + Delay T/B .....	2500
TRIO 0013030 100KHz Oscilloscope .....	125
TRIO CS2100 100MHz Delay T/B .....	1500

## POWER SUPPLIES

BEHA 30v 3A Single PS .....	STG £ 60
DELTA ELECTRONICS SM 6020 60v 20A VAR. ....	900
LAMBDA 5v 60A Fixed .....	700
RACAL DANA K9232 DUAL PS .....	175
SORENSEN 60v 10A Var. ....	525
WEIR 423-460 60v 3A Variable .....	175
WEIR 413-430 30v 1A Variable .....	175

## PROM PROGRAMMERS

DATA IO 29A c/w Unipack .....	
Unipack 2 .....	
Logic Pack .....	
303A - 002 .....	
303A - 001 .....	5000
DATA IO 16 Gang Programmer .....	1000
GP INDUSTRIAL UV141 UV Eraser .....	75
RS 301 - 791 UV Eraser .....	100

## RFI TEST EQUIPMENT

SCHWARZBECK NSLK 8127 Artificial Mains Network .....	1250
SCHWARZBECK FMLK 1518 Low Frequency Receiver .....	7000
SCHWARZBECK VUME 152CA VHF UHF RF1 Receiver .....	8250
SCHWARZBECK FMZL 1514 Field Intensity Accessories .....	2500

## SEMI CONDUCTOR TEST EQUIPMENT

MASTECH SEMICONDUCTOR TESTER 2610R3 .....	3000
TEKTRONIX 576 Curve Tracer .....	7500
3H CORP Linear IC Tester 3H202 .....	1150

## SPECTRUM ANALYSERS

TAKEDA TIKEN TR4132 .....	2500
---------------------------	------

## µ PROCESSOR DEVELOPMENT SYSTEMS

TEKTRONIX 8002A + Z80 Emulator .....	1500
TEKTRONIX 4024 VDU .....	450
INTEL iSBC 661 Chassis + 8085 Eval. Kit .....	600
NEC 80C42 Evaluation kit .....	400

## MISCELLANEOUS

FEEDBACK EW6 Power Meter .....	250
FLUKE Y8100 Current Gun 200A .....	160
FLUKE 80K40 HV Probe .....	50
FW BELL 615 Gaussmeter .....	1200
GENRAD 1864 Megohmmeter .....	1200
GOSSEN Light Meters .....	50
LEVELL TM14 Insulation Tester .....	175
P.S. PH Meter 610-540 .....	50
SAUNDERS 100HF Crystal Impedance Meter .....	650
SHACKMAN 700 Polaroid Camera .....	300

*Prices are subject to availability and are exclusive of VAT*

**SECOND TEST LTD. 25 CHANCERY LANE DUBLIN 8**  
**Tel: Dublin 775166 • Telex 91446 • Fax 781136**

# Electronic Brokers Instruments for Industry Blue Book



**GRUNDIG**



**HAMEG**  
**thandar**



## **T**he Blue Book that must be read!

**Send for your Free copy NOW**

Please enclose business card or letterhead

Name \_\_\_\_\_

Position \_\_\_\_\_

Company \_\_\_\_\_

Address \_\_\_\_\_

Post code \_\_\_\_\_ Tel \_\_\_\_\_

Private individuals please send £5 to cover post and packaging.

Electronic Brokers introduce the essential guide for users, specifiers and purchasers of test and measurement equipment – The Blue Book. More than just a catalogue, the 256 page Blue Book includes technical and applications information in addition to comprehensive guides and product specifications.

There are 16 sections from oscilloscopes to analysers, signal sources, multimeters, communications and television test equipment . . . plus much more. And as you would expect from the leading distributor in the industry all the leading major manufacturers are included.

The Blue Book will be an invaluable source of information for you – Secure your FREE personal hard back copy today by sending off the coupon with a business card or letterhead.

**Electronic Brokers Ltd, 140/146 Camden Street, London NW1 9PB**  
**Fax: 01-267 7363. Telex: 298694. Tel: 01-267 7070.**