



Platen Roller Maintenance Kit

Installation Instructions

This kit includes the parts and documentation necessary to install the Platen Roller Kit into the following printers: Xi4™, XiIIIPlus™ Series Rxi™, R-140, 105SL™, and 105SLPlus. Before proceeding, verify that your kit contains the items for your printer listed below.

Parts List

Figure 1 • Kit Contents

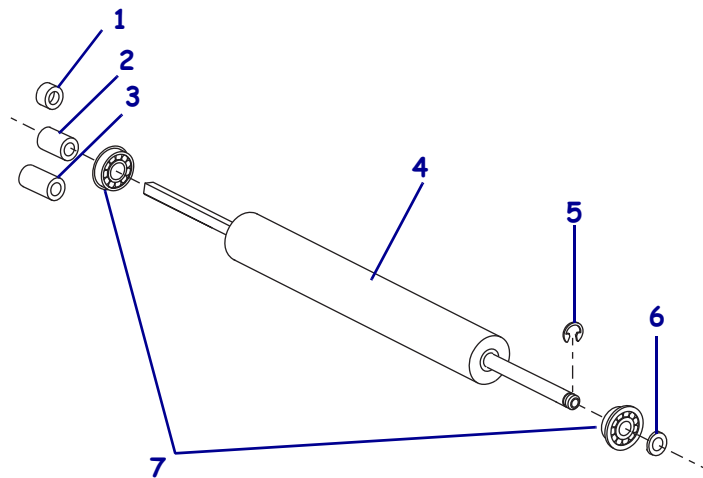

Table 1 • Parts List

✓	Item	Qty	Part Number	Description
	Ref	1	G22101M	Platen Roller Maintenance Kit, 220XiIIIPlus and 220Xi4
	Ref	1	G46278M	Platen Roller Maintenance Kit, 170XiIIIPlus, R170Xi, and 170Xi4
	Ref	1	G40038M	Platen Roller Maintenance Kit, R-140 and 140XiIIIPlus and 140Xi4
	Ref	1	G41011M	Platen Roller Maintenance Kit, 110XiIIIPlus, 110Xi4, R110Xi4, 200/300 dpi
	Ref	1	G41016M	Platen Roller Maintenance Kit, 110XiIIIPlus, 600 dpi
	Ref	1	G32011M	Platen Roller Maintenance Kit, 105SL
	Ref	1	P1004592	Platen Roller Maintenance Kit, 110Xi4 and R110Xi4, 600 dpi
	1	1	HW22004-1	Small Spacer, 0.395 × 0.185 (sold in quantities of 25)
	2	1	HW22004-2	Large Spacer, 0.395 × 0.310 for use on 220Xi4 and 105SL (sold in quantities of 25)
	3	1	HW22004-3	Large Spacer, 0.395 × 0.340 for use on 110Xi4, 140Xi4, 170Xi4, and 105SLPlus (sold in quantities of 10)
	4	1	<i>N/A</i>	Platen Roller
	5	1	HW33810	C-ring, 0.250 (sold in quantities of 100)
	6	1	HW30247	Flat Washer, 0.4200 × 0.2600 × 0.0747 (sold in quantities of 25)
	7	2	49688	Flanged Ball Bearing
N/A = Not available as a separate part (listed for identification purposes only).				
Bold = Part available for purchase.				

Tools Required



Tools • You need these tools to complete this procedure:

- Phillips Screwdriver Set
- Standard Hex Key (Allen wrench) Set
- Metric Hex Key (Allen wrench) Set
- Long Metric Hex Key (Allen wrench) Set with a 25 cm (10 in.) minimum shaft length
- Small Flat-blade Screwdriver Set
- 0.020 in. Shim or Feeler Gauge
- Torque Wrench – calibrated in inch-pounds
- 11303 Spring Gauge 2200g
- Antistatic Wriststrap and Mat

Remove the Electronics Cover

Which model of printer are you working on?

If you have a...	Then...
<i>XiIIIPlus</i> R-140 RXi 105SL	Continue with <i>Remove the XiIIIPlus R-140, RXi and 105SL Electronics Cover.</i>
Xi4 RXi4 105SLPlus	Go to <i>Remove the Xi4, RXi4, and 105SLPlus Electronics Cover</i>

Remove the *XiIIIPlus* R-140, RXi and 105SL Electronics Cover



Note • Retain all parts removed during disassembly, unless otherwise directed.



Caution • A qualified service technician must perform this installation.



1. **Caution** • Turn off (O) the printer and disconnect it from the power source before performing the following procedure.

Turn off (O) the printer, and then disconnect the AC power cord and all data cables.

2. See [Figure 3](#). Remove the electronics cover by removing the two mounting screws securing it.
3. Lift up from the rear of the electronics cover, and then lift the electronics cover off the printer.

Figure 2 • Remove the Electronics Cover

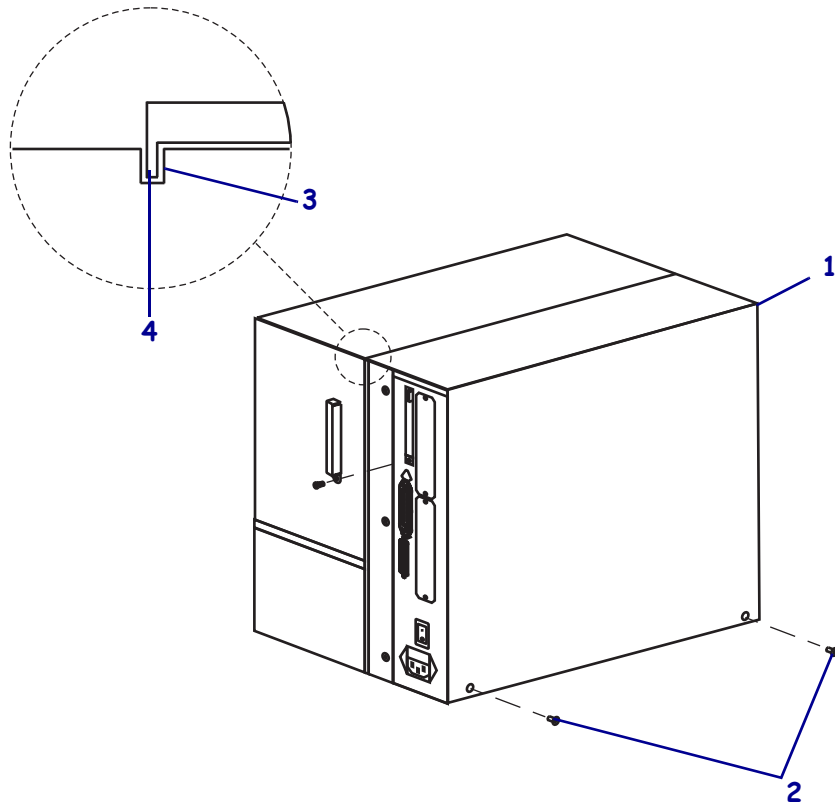

1	Electronics cover
2	Electronics cover mounting screws (2)
3	Channel
4	Lip of cover

4. Are you replacing the upper platen roller?

If...	Then...
Yes	Continue with <i>Remove the Old Upper Platen Roller</i> .
No	Go to <i>Remove the Old Lower Platen Roller</i> on page 10.

Remove the Xi4, RXi4, and 105SL*Plus* Electronics Cover



Note • Retain all parts removed during disassembly, unless otherwise directed.



- Caution** • Turn off (O) the printer and disconnect it from the power source before performing the following procedure.

Turn off (O) the printer, and then disconnect the AC power cord and all data cables.

- See [Figure 3](#). Remove the electronics cover by removing the three mounting screws securing it.

Figure 3 • Remove the Electronics Cover

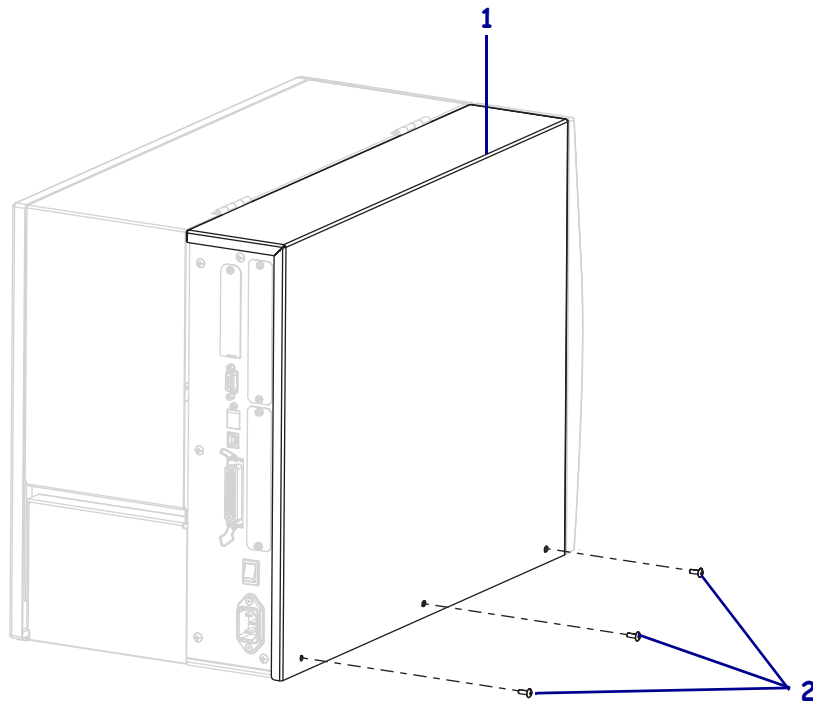

1	Electronics cover
2	Mounting screws (3)

- Lift up on the rear of the electronics cover, and then lift the electronics cover off the printer.
- Are you replacing the upper platen roller?

If...	Then...
Yes	Continue with <i>Remove the Old Upper Platen Roller</i> .
No	Go to <i>Remove the Old Lower Platen Roller</i> on page 10.

Remove the Old Upper Platen Roller

1. See [Figure 4](#). Align the three access holes in the ribbon take-up pulley with the three mounting screws.
2. Loosen, but do not remove, the three mounting screws.
3. Slide the ribbon take-up assembly toward the front of the printer to remove the tension on the main drive belt.
4. Remove the drive belt.
5. Loosen, but do not remove, the two set screws in the platen pulley assembly.

Figure 4 • Main Drive Belt

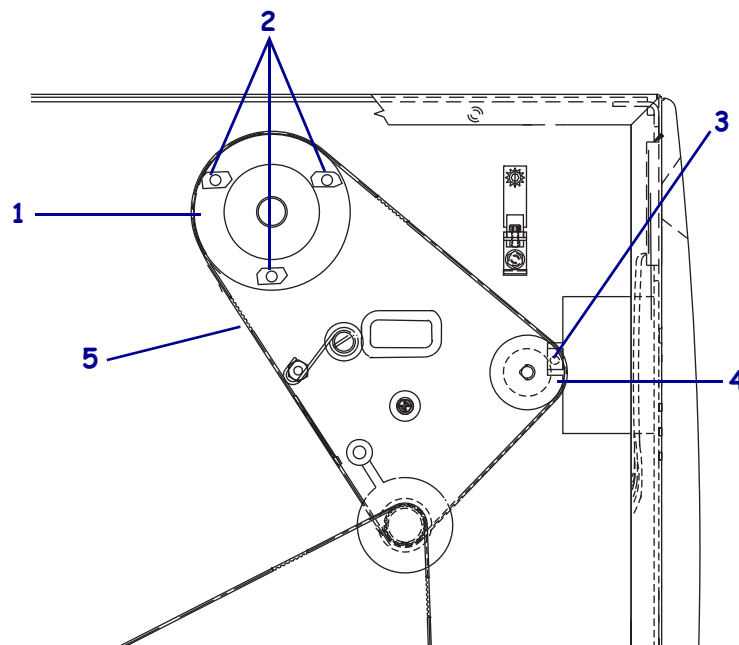

1	Ribbon take-up pulley
2	Ribbon take-up access holes (3)
3	Inside peel/tear-off bar mounting screw
4	Upper platen roller pulley
5	Main drive belt

6. Remove the platen pulley from the platen roller shaft.
7. See [Figure 5](#). Using a piece of a label (or masking tape), mark the peel/tear-off bar to identify the top and right side for reinstallation.
8. Remove the peel/tear-off bar.

7 | Platen Roller
Remove the Old Upper Platen Roller



9. **Caution** • Wear protective eyewear when installing or removing E-rings, C-clips, snap rings, springs, and mounting buttons. These are under tension and could fly off.

Remove the C-clip.

10. Slide the platen roller as far to the left as possible and remove the right bearing.
11. Slide the platen roller to the right and remove the roller.
12. Remove the left bearing.

Figure 5 • Remove the Tear Bar and Platen Roller

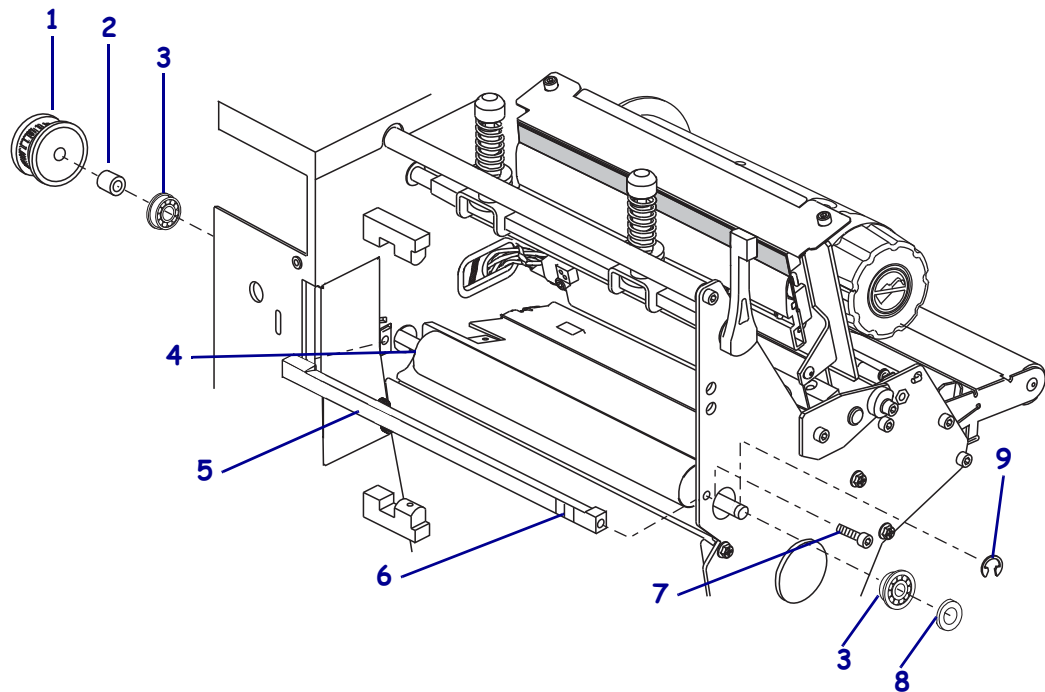

1	Platen roller pulley	6	Mark top right side with label or tape.
2	Large spacer (all models)	7	Peel/tear-off bar outside mounting screw
3	Flanged roller bearings (2)	8	Washer
4	Platen roller	9	C-clip
5	Peel/tear-off bar		

Install the New Upper Platen Roller

1. See [Figure 5](#). Install a flanged bearing, flange facing out, into right side of the print mechanism.
2. Insert the long end of the platen roller shaft through the hole in the main frame.
3. Slide the short end into the flanged bearing previously installed.
4. Install the washer included in the kit onto the right end of the platen roller shaft as shown.



-
5. **Caution** • Wear protective eyewear when installing or removing E-rings, C-clips, snap rings, springs, and mounting buttons. These are under tension and could fly off.
-

Install the C-clip onto the shaft.

6. From the electronics side, install the left flanged bearing, flange facing out, onto the long end of the platen roller shaft.
7. Reinstall the peel/tear-off bar using the markings for top and right side.
8. Loosely install both of the peel/tear-off bar mounting screws.
9. Ensure that there is a gap between the platen roller, and then peel/tear-off bar approximately the thickness of a business card.
10. Tighten both peel/tear-off bar mounting screws.
11. Slide the large spacer onto the left side of the platen roller shaft.



Note • For upper platen roller replacement, the small spacer is not used and should be discarded.

12. Slide rewind platen pulley onto the shaft and align the two set screws with the flat surfaces of the shaft.
13. Leave approximately a 0.5 mm (0.020 in.) gap between the C-clip and washer on the media side of the platen roller shaft.
14. Tighten the two set screws of the platen roller pulley.

15. See [Figure 6](#). Reinstall the main drive belt onto the outer most pulley of the stepper motor pulley, onto the platen pulley, and then slide it onto the take-up spindle pulley.

Figure 6 • Install the Drive Belt

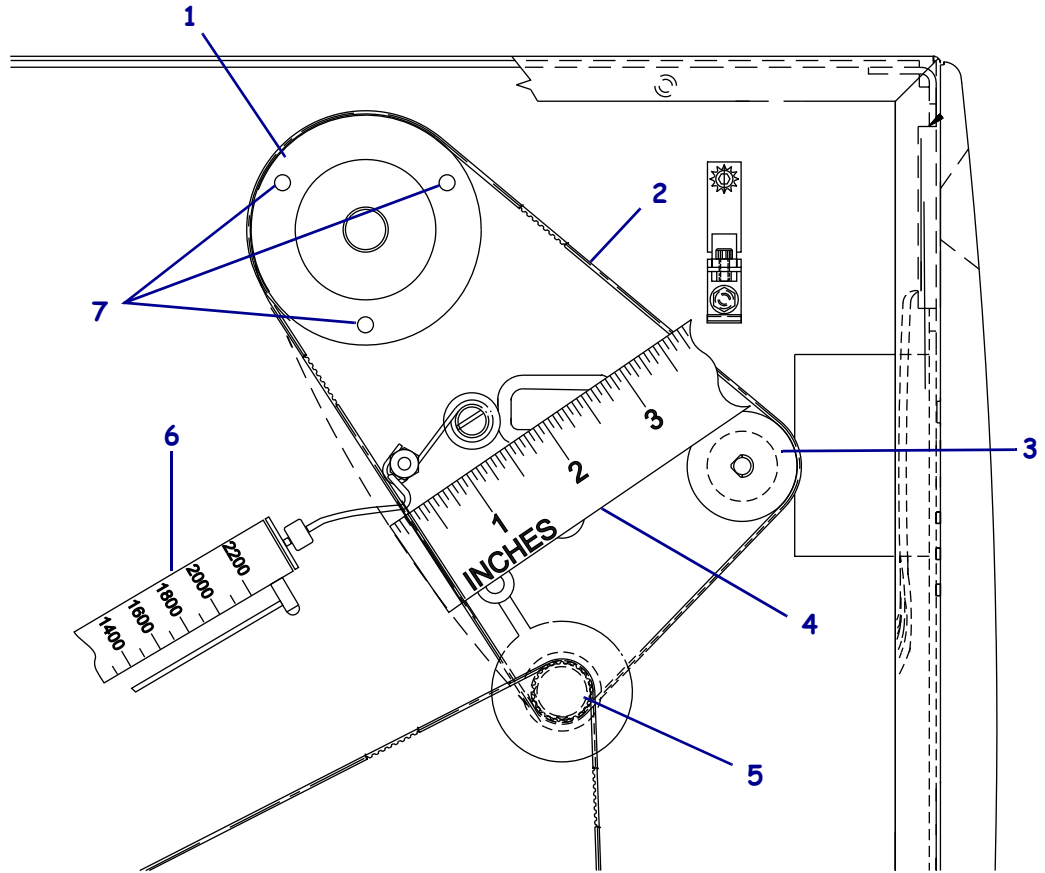

1	Ribbon take-up pulley
2	Belt
3	Platen pulley
4	Measuring device
5	Stepper motor pulley
6	Spring gauge
7	Access holes (3)

16. Hook a 2200-gram spring gauge to the belt as shown in [Figure 6](#), and carefully slide the ribbon take-up spindle assembly to the left to increase belt tension.
17. When a gauge reading of 2000 grams \pm 250 grams (4.5 lbs. \pm 0.5 lbs.) creates a deflection of 6 mm (1/4 in.), tighten the three mounting screws to a torque of 2.3 N•m (20 inch-pounds).

Remove the Old Lower Platen Roller

1. Turn the printer off (O) and remove the AC power cord. Remove the communications cable.
2. Open the media cover and remove all media and ribbon.
3. See [Figure 7](#). Remove the rewind plate by sliding it off of the print mechanism.

Figure 7 • Rewind Plate Removal and Installation

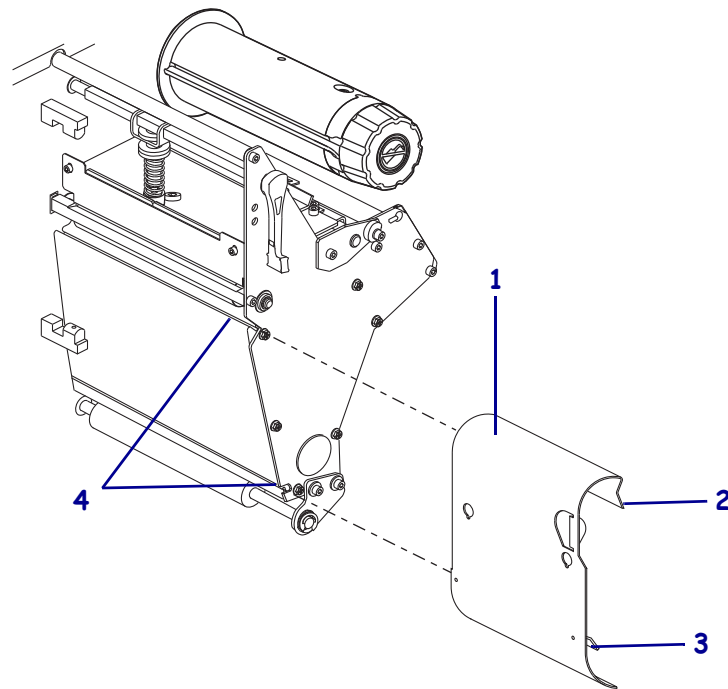

1	Rewind plate
2	Lip
3	Adjustable hook plate
4	Slot

4. What model printer are you working on?

If have a...	Then...
140XiIIIPlus 170XiIIIPlus 220XiIIIPlus R-140 R170Xi	Continue with <i>Remove the 140XiIIIPlus, R-140, 170XiIIIPlus, R170Xi and 220XiIIIPlus DC Power Supply.</i>
140Xi4 170Xi4 220Xi4	Go to <i>Remove the 140Xi4, 170Xi4, and 220Xi4 DC Power Supply</i> on page 13.
105SL 110XiIIIPlus R110Xi	Go to <i>Remove the 105SL, R110Xi and 110XiIIIPlus AC/DC Power Supply</i> on page 15.
110Xi4 R110Xi4	Go to <i>Remove the 110Xi4 and R110Xi4 Power Supply</i> on page 16.
105SLPlus	Go to <i>Remove the 105SLPlus Power Supply</i> on page 20.

Remove the Power Supply

Remove the 140XiIIIPlus, R-140, 170XiIIIPlus, R170Xi and 220XiIIIPlus DC Power Supply



1. **Caution** • Observe proper electrostatic safety precautions when handling static-sensitive components such as circuit boards and printheads.

Connect yourself to an antistatic device.

2. Unplug all wire connectors from the DC power supply assembly (note their positions).
3. See [Figure 8](#). Remove the mounting screw and two nuts securing the DC power supply assembly.
4. Remove the DC power supply assembly from the printer.

Figure 8 • Remove and Install the DC Power Supply

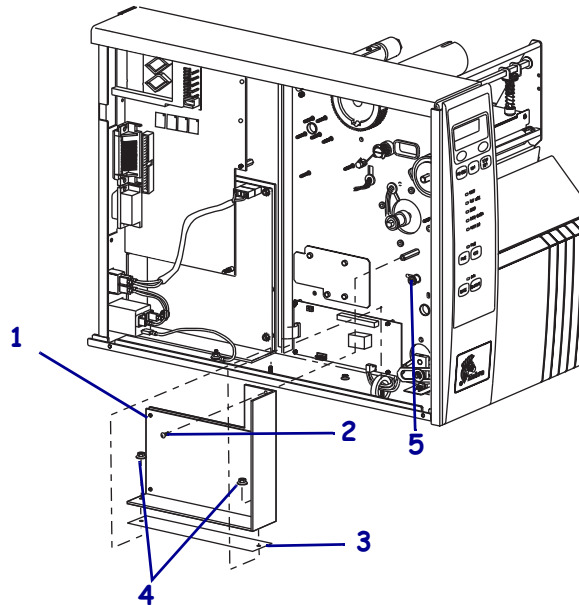

1	DC power supply
2	Mounting screw
3	Pad
4	Mounting nuts (2)
5	Idler pulley

Remove the 140Xi4, 170Xi4, and 220Xi4 DC Power Supply



1. **Caution** • Observe proper electrostatic safety precautions when handling static-sensitive components such as circuit boards and printheads.

Connect yourself to an antistatic device.

2. See [Figure 9](#). Make note of all cables connected to the DC power supply, and then remove them.

Figure 9 • Remove all Cables

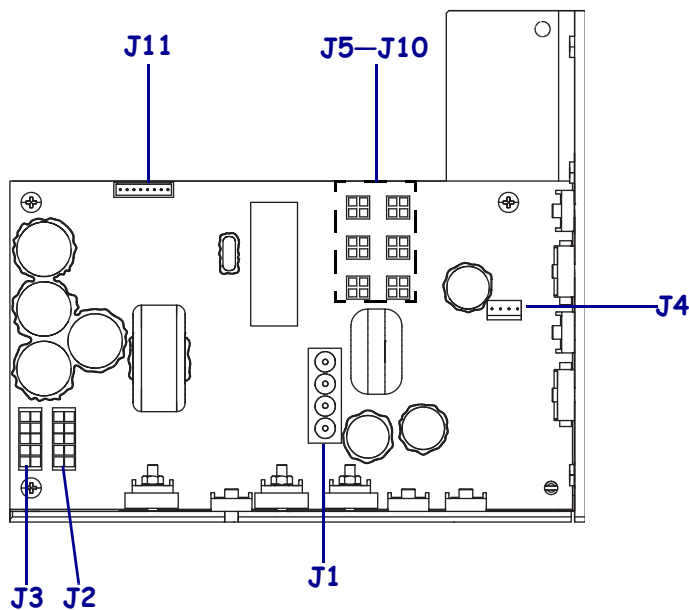

J1	AC input from AC power supply
J2	Printhead power
J3	Printhead power
J4	Stepper motor
J5-J10	DC output to options
J11	Data cable from main logic board

3. See [Figure 10](#). Remove the mounting screw, and then remove the two mounting nuts.

Figure 10 • Remove the DC Power Supply

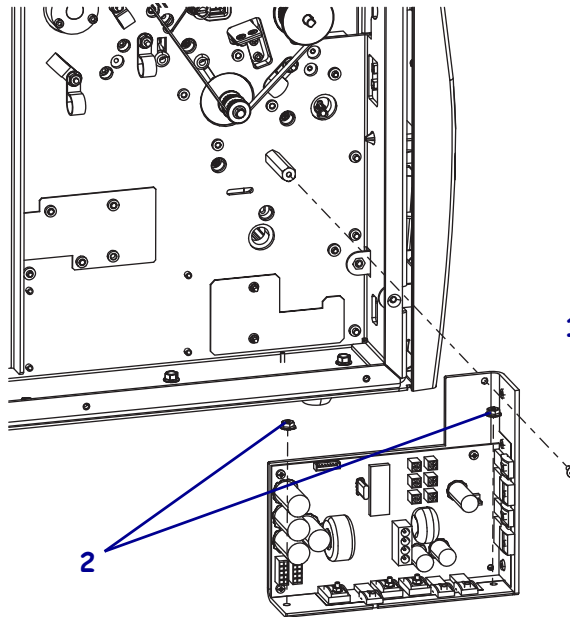

1	Mounting screw
2	Mounting nuts (2)

4. Lift the DC power supply out of the printer.

Remove the 105SL, R110Xi and 110XiIIIPlus AC/DC Power Supply



1. **Caution** • Observe proper electrostatic safety precautions when handling static-sensitive components such as circuit boards and printheads.

Connect yourself to an antistatic device.

2. Disconnect the cable tie and remove it from the insulation shield.



Caution • Certain components located under the insulation shield can store a residual charge for as long as 10 minutes after power has been removed. Use extreme care when removing the power supply. Handle the board only around the outer edges

3. See [Figure 11](#). Remove and retain the two screws securing the insulation shield to the standoffs on the power supply. Carefully unwrap the top of the shield and remove it from the power supply.

Figure 11 • Remove and Install the AC/DC Power Supply

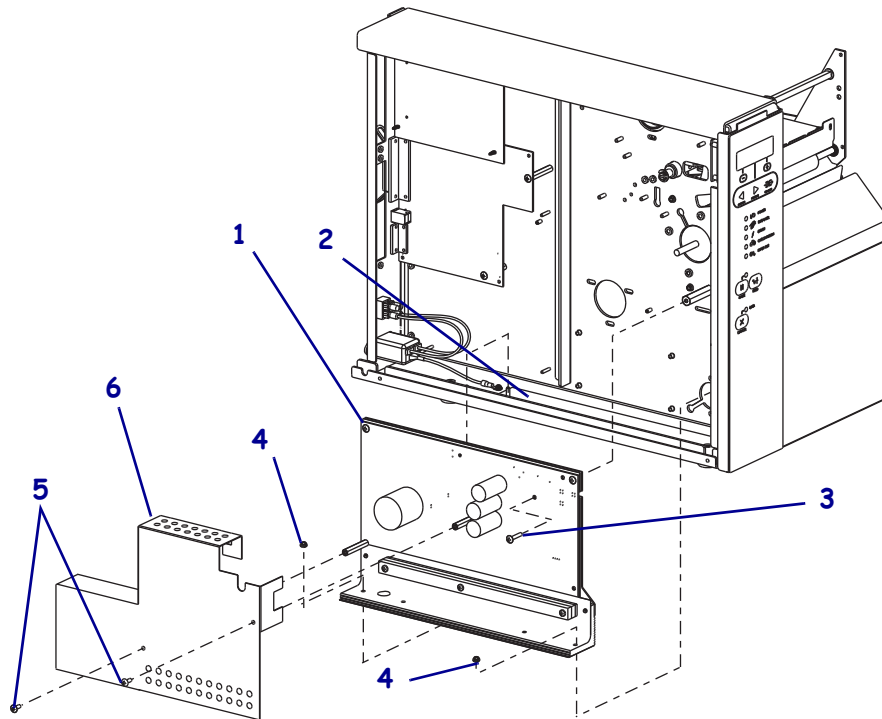

1	AC/DC power supply
2	Heat-conduction pad
3	Power supply mounting screw
4	Power supply mounting nuts (2)
5	Power supply shield mounting screws (2)
6	Power supply shield

4. See [Figure 11](#). Unplug all connectors from the AC/DC power supply.
5. Remove the mounting screw and two nuts securing it.
6. Remove the power supply assembly.



Important • Save the black heat-conduction pad for reuse.

Remove the 110Xi4 and R110Xi4 Power Supply

1. See [Figure 12](#). Remove the AC power connector from the AC/DC power supply.

Figure 12 • Disconnect the AC Power Input Cable

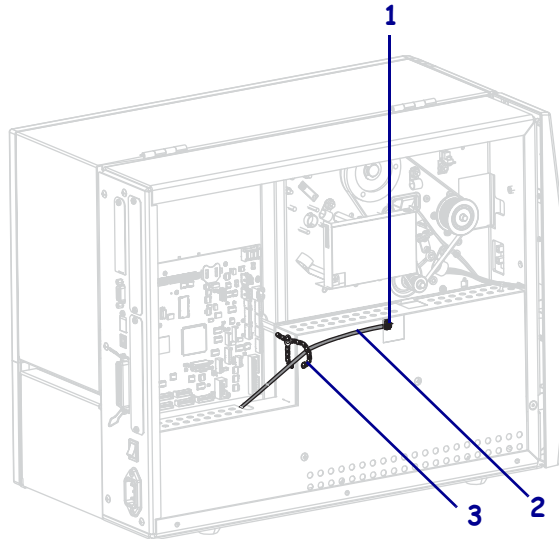

1	AC power connector
2	AC power cable
3	White plastic beaded cable tie

2. Open and remove the white plastic beaded cable tie going through the left corner of the AC/DC power supply shield and around the AC power connector cable. Save this cable tie for reinstallation.



3. **Caution** • Certain components located under the insulation shield can store a residual charge for as long as 10 minutes after power has been removed. Use extreme care when removing the power supply. Handle the board only by the outer edges.

See [Figure 13](#). Remove the AC/DC power supply shield.

- a. Remove the AC/DC power supply shield mounting screws.
- b. Pull the AC/DC power supply shield flaps from behind the AC/DC power supply, and then remove the AC/DC power supply shield.

Figure 13 • Remove the AC/DC Power Supply Shield

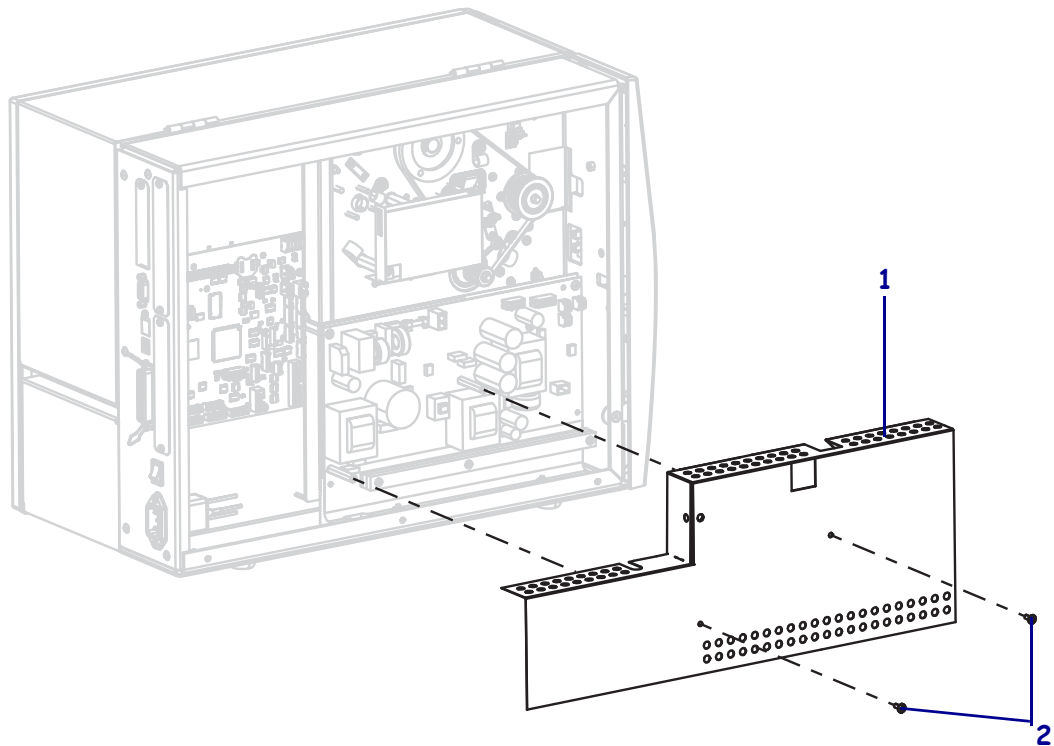

1	AC/DC power supply shield
2	Shield mounting screws (2)



4. **Caution** • Observe proper electrostatic safety precautions when handling static-sensitive components such as circuit boards and printheads.

Connect yourself to an antistatic device.

5. See [Figure 14](#). Make note of all cables connected to the AC/DC power supply, and then remove them.

Figure 14 • Remove All Cables

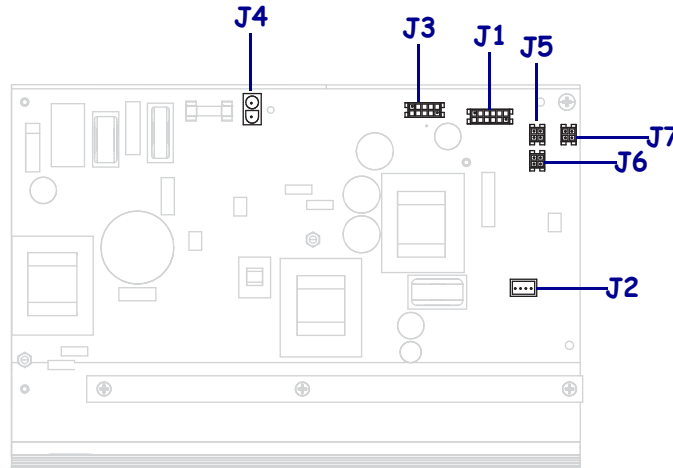

J1	Control connector to P26 on the Main Logic Board
J2	Stepper motor connector
J3	Head voltage connector
J4	AC power input connector
J5	DC output connector
J6	DC output connector
J7	DC output connector

6. See [Figure 15](#). Remove the two mounting screws and nuts securing the AC/DC power supply.

Figure 15 • Remove the AC/DC Power Supply

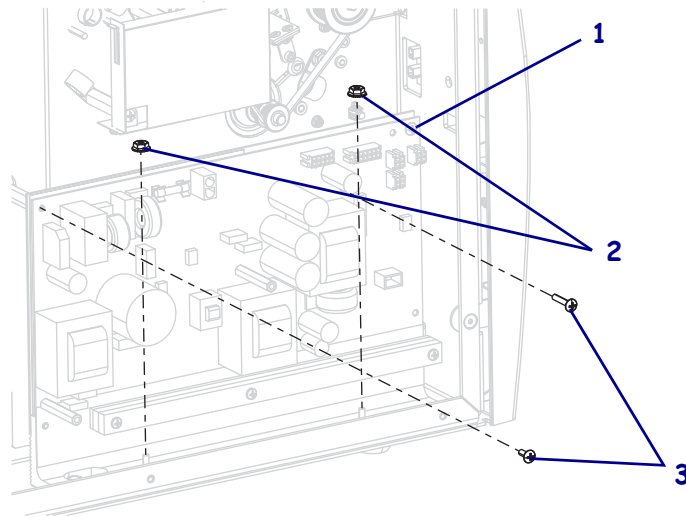

1	AC/DC power supply
2	Power supply mounting nuts (2)
3	Power supply mounting screws (2)

7. See [Figure 16](#). Lift the AC/DC power supply assembly off the mounting studs and out of the printer.

Figure 16 • Remove the AC/DC Power Supply

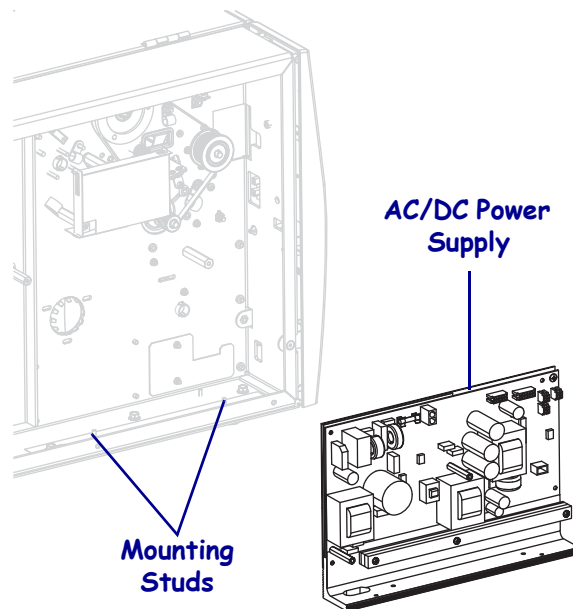

Remove the 105SL*Plus* Power Supply



1. **Caution** • Observe proper electrostatic safety precautions when handling static-sensitive components such as circuit boards and printheads.

Connect yourself to an antistatic device.

2. See [Figure 17](#). Disconnect all cables connected to the power supply.

Figure 17 • Power Supply Interconnect

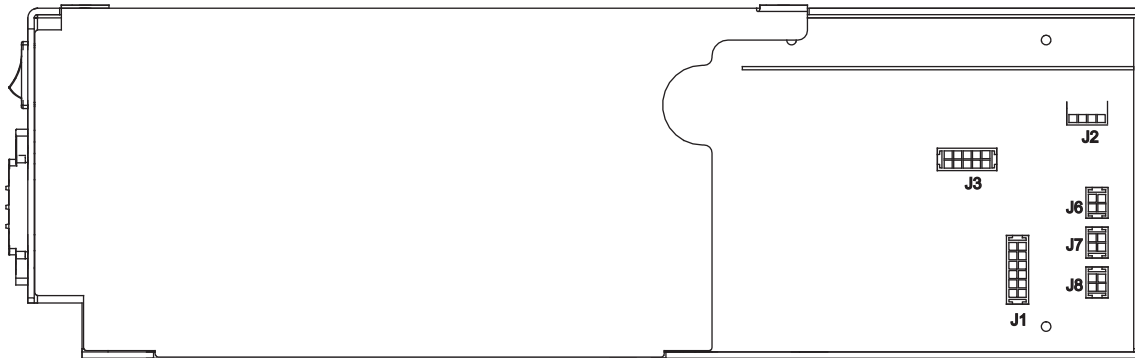

J1	Printhead Power Cable Connector	J6	DC Power Output Connector
J2	Stepper Motor Cable Connector	J7	DC Power Output Connector
J3	MLB Power Cable Connector	J8	DC Power Output Connector

3. See [Figure 18](#). Disconnect the cables connected to P19 and P29 on the main logic board (MLB).

Figure 18 • Main Logic Board Interconnect

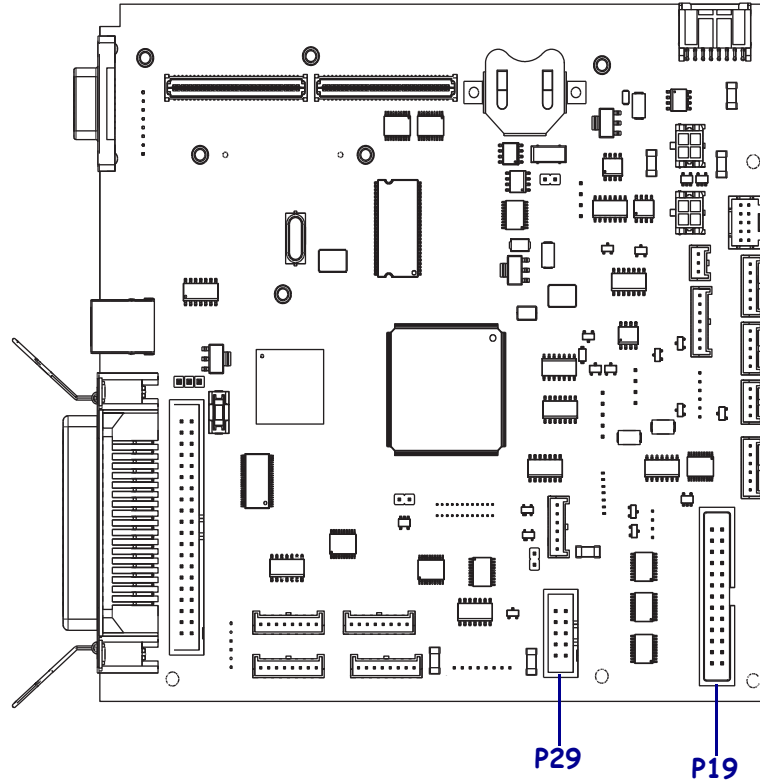

4. See [Figure 19](#). Remove the two cover mounting.

Figure 19 • Remove the Power Supply

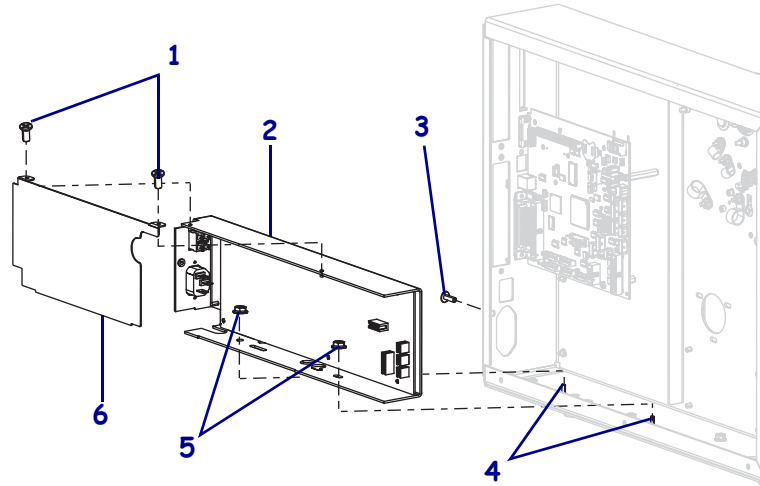

1	Cover mounting screws (2)
2	Power supply
3	Power supply mounting screw
4	Power supply mounting studs
5	Power supply mounting nuts (2)
6	Power supply cover

5. Remove and discard the power supply cover.
6. Remove and discard the power supply mounting screw.
7. Remove the and discard two power supply mounting nuts.
8. Lift the power supply out of the printer.

Remove the Rewind Drive Belt

1. See [Figure 20](#). Locate and remove the access hole plug.

Figure 20 • Locate the Print Mechanism Lower Access Hole

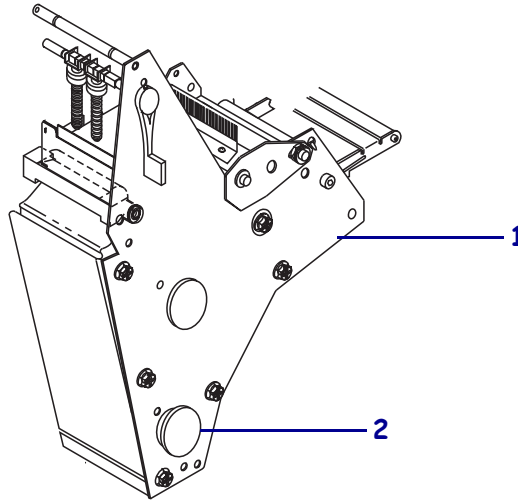

1	Print mechanism side plate
2	Lower access hole

2. Using a hex key (Allen wrench) with a 25 cm (10 in.) minimum shaft length, reach through the hole and loosen the idler pulley mounting screw.

- See [Figure 21](#). Slide the idler pulley assembly toward the front of the printer to relieve the tension on the rewind drive belt, and then remove the belt.

Figure 21 • Rewind Belt

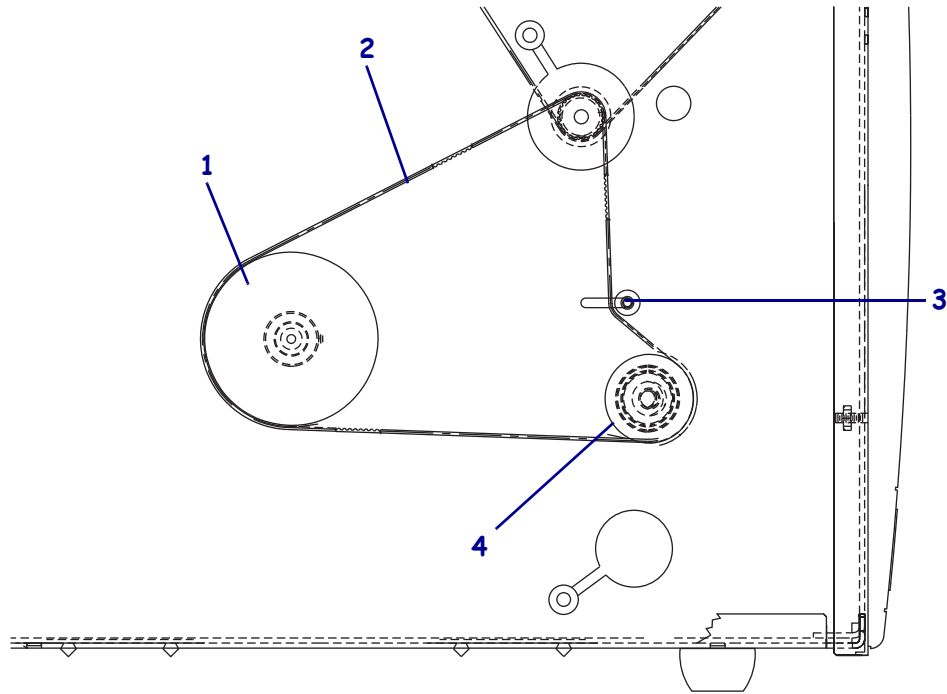

1	Rewind pulley
2	Rewind drive belt
3	Idler pulley
4	Lower platen pulley

- Loosen, but do not remove, the two set screws in the rewind platen pulley.
- Pull the rewind platen pulley off of the lower platen roller shaft.

- See [Figure 22](#). Remove the two screws securing the roller adjust plate to the print mechanism.

Figure 22 • Lower Platen Roller Removal and Installation

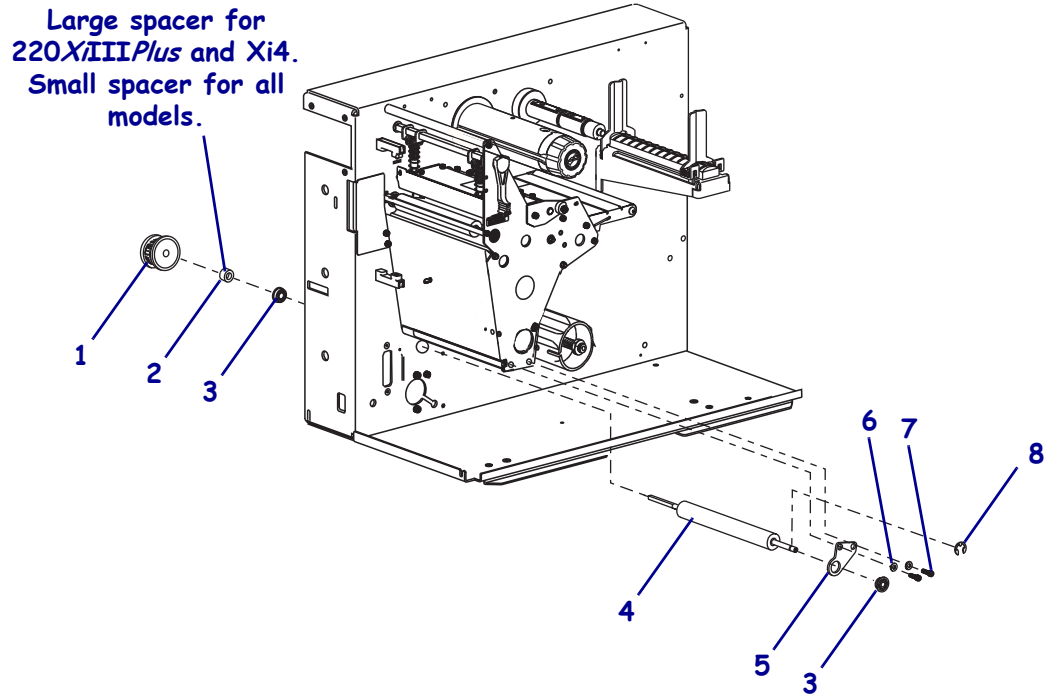

1	Lower platen roller pulley
2	Spacer
3	Flanged bearing
4	Lower platen roller
5	Lower platen roller adjust plate
6	Flat washers (2)
7	Mounting screws (2)
8	C-clip

- Remove the roller adjust plate and lower platen roller.
- Remove the old bearing from the printer main frame.



- Caution** • Wear protective eyewear when installing or removing E-rings, C-clips, snap rings, springs, and mounting buttons. These are under tension and could fly off.

Remove the C-clip from the end of the old platen roller.

- Slide the roller adjust plate off of the old platen roller shaft and remove the bearing.

Install the New Lower Platen Roller



Note • Do not reuse the old bearings.

1. Install a new flanged bearing on the roller adjust plate with the flange facing out.
2. Install a new flanged bearing into the main frame from the media side.
3. Insert the long of the shaft new platen roller through the bearing in the main frame.
4. Slide the flanged bearing and roller adjust plate onto the right end of the platen roller shaft.
5. Reinstall the two washers and mounting screws to secure the roller adjust plate.



Note • For lower platen roller replacement (Peel/Rewind Option only), the outer washer on the platen roller shaft is not used and should be discarded.

6. Slide the C-clip into the groove on the right end of the platen roller shaft.



Note • For lower platen roller replacement, the small spacer is used for all models except the *220XiIIIPlus* and *220Xi4*.

7. On the electronics side, slide the spacer onto the shaft.
8. Slide the rewind platen pulley onto the platen roller and align the two set screws with the flat surfaces of the platen roller.
9. Leave approximately 0.5 mm (0.020 in.) gap between C-clip and roller adjust plate on the media side of the platen roller shaft.
10. Tighten the two set screws on the rewind platen pulley. Both set screws must be on flat portions of the shaft.

Reinstall the Rewind Drive Belt

1. See [Figure 23](#). Reinstall the rewind drive belt. Hook a 2200-gram spring gauge to the belt and carefully slide the idler gear assembly to the left to increase belt tension.

Figure 23 • Adjust the Rewind Drive Belt Tension

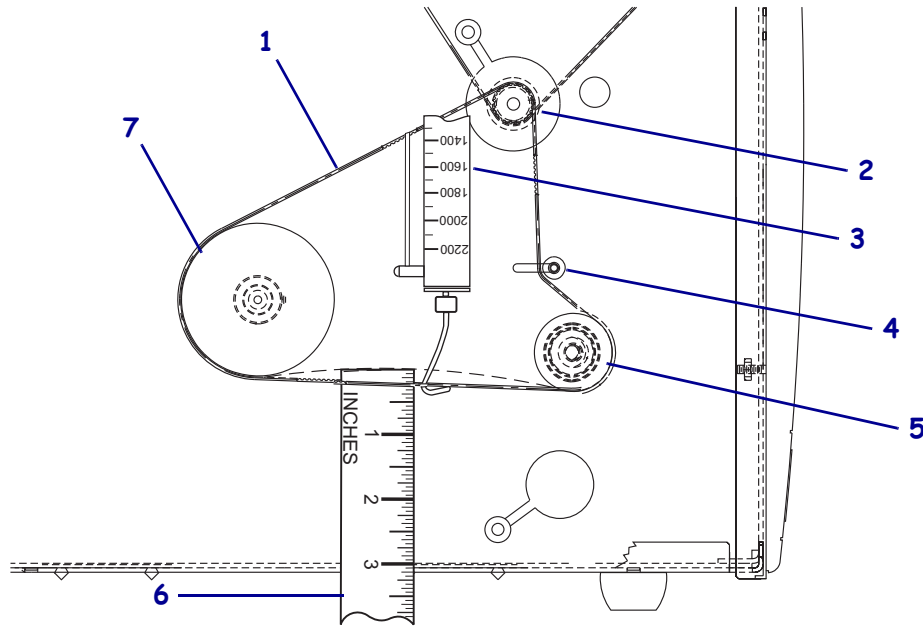

1	Rewind drive belt
2	Stepper motor pulley
3	Spring gauge
4	Idler pulley
5	Lower peel roller pulley
6	Measuring device
7	Rewind spindle pulley

2. When a gauge reading of 2000 grams \pm 250 grams (4.5 lbs. \pm 0.5 lbs.) creates a deflection of 1/4 inch (6 mm), tighten the idler pulley mounting screw to a torque of 2.3 N•m (20 inch-pounds).
3. See [Figure 20 on page 23](#). Reinstall the plug into the lower access hole.

4. Which model printer are you working on?

If have a...	Then...
R-140 R170Xi 105SL 140XiIIIPlus 170XiIIIPlus 220XiIIIPlus	<ul style="list-style-type: none"> a. See Figure 8 on page 12. Reinstall the DC power supply into the printer. Reconnect all connectors. b. See Figure 7 on page 10. Reinstall the rewind plate by sliding it onto the print mechanism. c. Go to Reinstall the 105SL, R-140, and XiIIIPlus Electronics Cover on page 30.
110XiIIIPlus R110Xi	<ul style="list-style-type: none"> a. See Figure 11 on page 15. Ensure the heat-conduction pad is in position. Move the cables out of the way while installing the AC/DC power supply assembly. b. Reinstall the mounting screw and nuts securing the power supply assembly. c. Reconnect all the cable connectors on the power supply. d. Reinstall the insulation shield, ensuring the top is dressed properly. Secure the insulation shield to the standoffs with two screws. e. Dress the wire harnesses across the top of the insulation shield, and secure them with the cable tie. f. See Figure 7 on page 10. Reinstall the rewind plate by sliding it onto the print mechanism. g. Go to Reinstall the 105SL, R-140, and XiIIIPlus Electronics Cover on page 30.
110Xi4 R110Xi4	<ul style="list-style-type: none"> a. See Figure 16 on page 19 and Figure 15 on page 19. Set the AC/DC power supply into the printer and then reinstall the two mounting nuts and mounting screws. b. See Figure 14 on page 18. Reinstall all cables except the AC input cable. c. See Figure 13 on page 17. Reinstall the AC/DC power supply shield and secure it. Ensure the shield flaps are tucked in between the power supply and the aluminum mounting plate. d. See Figure 12 on page 16. Connect the AC power input cable and then reinstall the white plastic beaded cable tie. e. Go to Reinstall the Xi4, RXi4, and 105SLPlus Electronics Cover on page 31.

If have a...	Then...
140Xi4 170Xi4 220Xi4	<ul style="list-style-type: none"> a. See Figure 10 on page 14. Set the DC power supply into the printer and then reinstall the two mounting nuts and one mounting screw. b. See Figure 9 on page 13. Reconnect all cables to the DC power supply. c. Go to Reinstall the Xi4, RXi4, and 105SLPlus Electronics Cover on page 31.
105SLPlus	<ul style="list-style-type: none"> a. See Figure 19 on page 22. Remove the power supply from the kit. b. Remove the covering. c. remove the two screws attached to the power supply. d. Slide the cover off the power supply. e. Align the two mounting studs in the printer with the two mounting holes in the power supply. f. Set the new power supply into the printer. g. Slide the power supply to the rear of the printer. h. Install the power supply mounting screw. i. Install the two power supply mounting nuts. j. Install the power supply cover using the two mounting screws. k. See Figure 17 on page 20. Connect all connectors removed earlier. l. Install the cable going to P25 on the Main Logic Board into the cable clamp.

Reinstall the Electronics Cover

Reinstall the 105SL, R-140, and *XIII Plus* Electronics Cover

1. See [Figure 24](#). Reinstall the electronics cover by aligning the cover so that it slips over the main frame.
2. Reinstall the mounting screws to secure the electronics cover.

Figure 24 • Install the Electronics Cover

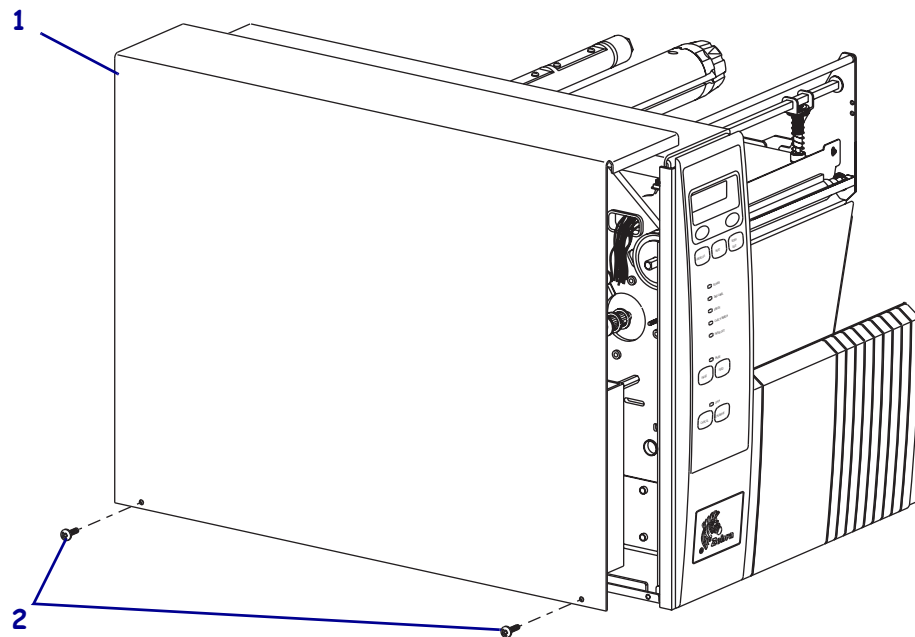

1	Electronics cover
2	Mounting screws (2)

3. **Caution** • When you are loading media or ribbon, remove all jewelry that could come into contact with the printhead or other printer parts.

Reinstall the media and ribbon.

Reinstall the Xi4, RXi4, and 105SL*Plus* Electronics Cover

1. See [Figure 3 on page 5](#). Reinstall the electronics cover by aligning the cover so that it slips over the main frame.
2. Reinstall the mounting screws to secure the electronics cover.
3. Reconnect the AC power cord and all data cables.
4. Press and hold PAUSE while turning on (I) the printer. Observe the printer Power-On Self Test and examine the test labels for proper print quality.
5. Is the liner material tracking off to one side?

If...	Then...
No	The installation is complete.
Yes	Continue with Adjust the Lower Platen Roller .

Adjust the Lower Platen Roller

1. See [Figure 22](#). Loosen the two screws securing the roller adjust plate to the print mechanism.
2. Move the roller adjust plate in the appropriate direction to compensate for the tracking and tighten the screws.



Note • Moving the roller adjust plate toward the front of the printer moves the liner material away from the roller adjust plate. Moving the roller adjust plate toward the rear of the printer moves the liner material toward the roller adjust plate.

3. Repeat [step 1](#) and [step 2](#) until the required results are achieved.

The installation is complete.



Printed in
on chlorine-free
recycled paper.



47456L-004