



CARD DESIGN & PRINT SOFTWARE

# CardStudio™ 2.0

## USER GUIDE

---

September 2023 | Version 2.5.5 | CardStudio™ V2.5



**ZEBRA**

## Copyright

© 2023 ZIH Corp. and/or its affiliates. All rights reserved. ZEBRA and the stylized Zebra head are trademarks of ZIH Corp., registered in many jurisdictions worldwide. All other trademarks are the property of their respective owners.

**COPYRIGHTS & TRADEMARKS:** For complete copyright and trademark information, go to [www.zebra.com/copyright](http://www.zebra.com/copyright)

**WARRANTY:** For complete warranty information, go to [www.zebra.com/warranty](http://www.zebra.com/warranty)

**END USER LICENSE AGREEMENT:** For complete EULA information, go to [www.zebra.com/eula](http://www.zebra.com/eula)

This document contains information proprietary to Zebra Technologies Corporation. This document and the information contained within is Copyrighted by Zebra Technologies Corporation and may not be duplicated in full or in part by any person without written approval from Zebra Technologies Corporation. While every effort has been made to keep the information contained within current and accurate as of the date of publication, no guarantee is given that the document is error-free or that it is accurate with regard to any specification. Zebra Technologies Corporation reserves the right to make changes, for product improvement, at any time.

## Terms of Use

**Proprietary Statement** This manual contains proprietary information of Zebra Technologies Corporation and its subsidiaries (“Zebra Technologies”). It is intended solely for the information and use of parties operating and maintaining the equipment described herein. Such proprietary information may not be used, reproduced, or disclosed to any other parties for any other purpose without the express, written permission of Zebra Technologies.

**Product Improvements** Continuous improvement of products is a policy of Zebra Technologies. All specifications and designs are subject to change without notice.

**Liability Disclaimer** Zebra Technologies takes steps to ensure that its published Engineering specifications and manuals are correct; however, errors do occur. Zebra Technologies reserves the right to correct any such errors and disclaims liability resulting therefrom.

**Limitation of Liability** In no event shall Zebra Technologies or anyone else involved in the creation, production, or delivery of the accompanying product (including hardware and software) be liable for any damages whatsoever (including, without limitation, consequential damages including loss of business profits, business interruption, or loss of business information) arising out of the use of, the results of use of, or inability to use such product, even if Zebra Technologies has been advised of the possibility of such damages. Some jurisdictions do not allow the exclusion or limitation of incidental or consequential damages, so the above limitation or exclusion may not apply to you.

# Table of Contents

CardStudio™ 2.0 User Guide Introduction	9
CardStudio™ 2.0 User Guide General Information	11
Specifications	11
Minimum Hardware specifications	11
Software	11
Supported Printers	12
CardStudio™ 2.0 User Guide Download and Install	14
Download the CardStudio™ 2.0 Software	14
Install CardStudio™ 2.0	15
Registration of the Software Edition	19
Online Registration	19
Successful Registration	19
DesignStudio Interface	20
DesignStudio Navigation	22
Main Menu	22
File	22
Store	22
Edit	23
View	23
Options	23
Help	23
Quick Menu	24
DesignStudio Start a Card Design	27
New Card Design	27
Open existing Card Design	28
Digital ID Card Design	29
Start new card design with Digital ID	29
Design Digital ID	29
Wallet Pass Card Design	30
Start new card design with Wallet Pass	30
Design Wallet Pass	30
DesignStudio The Store	34
Card Design from the Store	34
Browse the Store	34
My items	36
Credits from the Store	37

DesignStudio Card Design Menu	39
Preview	39
Card settings	39
Dynamic Fields	40
DesignStudio Elements	42
Element Properties	47
Text element properties	47
Image element properties	47
Passport Photo element properties	48
Signature element properties	48
Barcode element properties	49
Dynamic logo element properties	49
Element Position	50
Resize and rotate elements on the canvas	50
Element Style	51
Border & Background	51
Color & Transparency	51
DesignStudio Print a Card Design	53
PrintStudio Interface	55
PrintStudio Navigation	56
Main menu	56
File	56
Store	56
Edit	57
Record	57
Options	57
Views	57
Help	57
Quick menu	58
A. New	58
B. Open existing Project	58
C. Undo	58
D. Redo	58
E. Add a new record	58
F. Delete a selected record	58
G. Filter records	59
H. Refresh Data	59
I. Print all selected records	60
J. Send Digital ID	60
K. CardStudio Design	60
Project Card Designs	61
Card designs overview	61

PrintStudio Create a Project	63
New Project	63
Create a New Project	64
1. Project structure	64
2. Biometric settings	65
3. View configuration	66
4. Status Check	67
5. Card designs	68
6. Triggers	69
7. Create project	70
Create a New CardStudio Project with database connection	71
1. Data sources	71
2. Image sources	72
3. View configuration	73
4. Status Check	74
5. Card designs	75
6. Triggers	76
7. Create project	77
Create copy of an existing Project	78
1. Select project	78
2. Copy project	79
Import Project from Excel	80
1. Data source	80
2. Project structure	81
3. Biometric settings	82
4. View configuration	83
5. Status Check	84
6. Card designs	85
7. Triggers	86
8. Import Project	87
New Project from BadgeMaker 7 Project	88
1. Select BadgeMaker 7 Project	88
2. Project structure	89
3. Biometric settings	90
4. View configuration	91
5. Triggers	92
6. Import Project	93
New Project from IDPro 7 Project	94
1. Select IDPro 7 Project	94
2. Project structure	95
3. Biometric settings	96
4. View configuration	97
5. Triggers	98
6. Import Project	99
PrintStudio Open Project	101

PrintStudio The Store	103
Projects from the Store	103
Browse the Store	103
My items	105
Credits from the Store	106
PrintStudio Import Data	108
Import an Excel file or CSV data file	109
1. Data source	109
2. Configuration	109
3. Import data	111
Import BadgeMaker 7 project data	112
1. Data source	112
2. Configuration	113
3. Import data	114
Import IDPro 7 data	115
1. Data source	115
2. Configuration	116
3. Import data	117
PrintStudio Import Photos	118
PrintStudio Export Data	120
PrintStudio Export Photos	121
PrintStudio Project Settings	123
Detail View	123
Gallery view	124
Biometric settings	125
Card Designs	126
Card designs assignment	127
Project structure	128
Triggers	129
Manage Project	130
Status Check	131
PrintStudio Link Card Design to record	133
PrintStudio Records	135
Add Records	135
1. Add a new record	135
2. Photo	136
3. Signature	137
Print records	138

PrintStudio Digital ID	140
How to send a Digital ID to your card holders.	140
Send Digital ID	141
PrintStudio Trigger Examples	142
How to add a trigger to a project that reads the card serial number	143
Step 1. Open your project	143
Step 2. Create an extra column for the card serial numbers	143
Step 3. Add the trigger after printing to read the card serial number to your project	144
Increment number Trigger	145
PrintStudio Database Connection	148
Setting up a PrintStudio Database connection	149
How to set up a PrintStudio Project with Database connection	149
Connect with database	150
Changes when working with PrintStudio with external database connection	153
PrintStudio Encode	155
Contactless Encoding	155
SmartCard Editor	155
Creating a MIFARE Classic Template using the CCI Editor	155
Information about Sector Data	157
Creating a MIFARE DESfire template using the CCI Editor	158
Creating a UHF Gen 2 Template using the CCI Editor	160
UHF Gen 2 Content Data options	161
Encoding with PrintStudio	163
Supported standards	164
CardStudio Status Check	166
CardStudio 2.0 Smart Badge bundles	166
Design a card or digital ID with a Status Check QR-code	167
Setup the new card design	167
Design the Status Check card design	168
Create a new Status Check project and connect your Status Check card design	169
Create a new project	169
Step 1. Project Structure	169
Step 2. Biometric settings	170
Step 3. View configuration	170
Step 4. Status Check	171
Step 5. Card designs	172
Step 6. Triggers	173
Step 7. Create project	174
Update, revoke and replace a Status Check QR-code	175

# CardStudio™ 2.0 User Guide

## Introduction



# CardStudio™ 2.0 User Guide

## Introduction

CardStudio™ 2.0 is a full-feature card design and printing software application with complete capabilities for card design, data management and card production. CardStudio is provided in four editions: Classic, Standard, Enterprise and Professional. All four editions integrate the required features for ID card design and production.

### Classic:

CardStudio 2.0 Classic edition allows you to design and print professional photo IDs and other type of card designs with a new easy-to-use interface with design and print features.

### Standard:

CardStudio 2.0 Standard edition allows you to create, manage and print high grade card designs with a new easy-to-use interface with design, data management and print features. Including internal database, Excel and .csv file integration for ID records, 2D bar codes, Digital ID and advanced print functionality.

### Enterprise:

Designed for enterprise applications, the CardStudio 2.0 Enterprise edition allows you to create and print professional photo IDs and other type of card designs with a new easy-to-use interface with design, data management and print features. Including internal database, Excel and .csv file integration for ID records, 2D bar codes, Digital ID and advanced print functionality. Enterprise edition includes advanced features to connect to multiple databases, ODBC data sources and multiple projects, for advanced card design, issuance and data management capabilities.

### Professional:

Created for advanced enterprise applications that require smart card encoding support, CardStudio 2.0 Professional edition allows you to create, print and encode professional card designs with a new easy-to-use interface and design and print features. Including internal database, Excel and .csv file integration for ID records, 2D bar codes, Digital ID and advanced print functionality. Professional also offers the advanced features to connect to multiple databases and ODBC data sources, and multiple projects for advanced card design, issuance and data management capabilities.

CardStudio™ 2.0 is desktop-based card production software developed to design card layouts, manage, add or import card data, capture photos and signatures as well as one-click printing, making the card production process quick and easy.

CardStudio™ 2.0 is a combination of two specific modules that each have their own area of expertise. DesignStudio focuses on creating perfect card layouts and PrintStudio can handle your data with the ease of well-known spreadsheet software.

DesignStudio gives you the all the needed tools to create a front and back design with images, logo's, shapes and dynamic data. You will be able to create a template with placeholders that help determine the layout of dynamic data. For example: where a passport photo should be placed, a signature or the first and last name of a person.

As a user, you can manage data and layouts for different types of ID cards using different types of printers. PrintStudio gives you the basic tools to import, add and manage data like card holder information, passport photos and signatures. This data can then be connected to a card design or multiple card layouts and selected for printing. CardStudio™ 2.0 imports and prints large amounts of data and cards and makes your card production process faster and more efficient.

Any Windows PC with a network connection can be used to install CardStudio™ 2.0. This PC needs to have an internet connection to download the installation file, register the software and keep the software up to date with automatic updates.

*This manual does not describe the installation of printers or other peripherals like a camera or signature pad.*

*Please refer to the manufacturer's manuals for further information on these devices. Before working with the software, first install the Zebra Windows printer driver so the Zebra Printer is ready to print cards.*

# CardStudio™ 2.0 User Guide

## General Information

# CardStudio™ 2.0 User Guide

## General Information

It is essential, when you or your organization choose CardStudio™ 2.0 for your card design, data management and card production, to make sure to have the correct hardware to install the software on. We strongly advise a Windows PC for installation, that creates an optimal work environment for the CardStudio™ 2.0 software and supports the correct peripheral devices like card printers.

### Specifications

#### Minimum Hardware specifications

Processor Intel Pentium Dual core

G640 2,8 Ghz or equal

Memory 2GB

Free Disk space 4GB

Graphics 1024 x 768

Monitor/Mouse/keyboard

3 available USB ports

(printer/webcam/signature pad)

#### Software

Supported Operating Systems:

Windows 10 (32 bit & 64 bit)

Windows 11 (32 bit & 64 bit)

.NET Framework version:

4.7.0

## Supported Printers

Updates for support of new printers are added regularly by means of automatic software updates.

Manufacturer	Type	Single sided	Double sided	Batch Printing	True Black	Print job Preferences	Contactless Encoding	MAGstripe Encoding	Remark
Zebra	ZXP Series 1	✓	-	✓	✓	✓	-	✓	
Zebra	ZXP Series 3	✓	✓	✓	✓	✓	✓	✓	
Zebra	ZXP Series 7	✓	✓	✓	✓	✓	✓	✓	
Zebra	ZXP Series 8	✓	✓	✓	✓	✓	✓	✓	
Zebra	ZXP Series 9	✓	✓	✓	✓	✓	✓	✓	
Zebra	ZCL10	✓	✓	✓	✓	✓	-	-	
Zebra	ZC100	✓	-	✓	✓	✓	-	-	
Zebra	ZC300/350	✓	✓	✓	✓	✓	✓	✓	

# CardStudio™ 2.0 User Guide Installation

# CardStudio™ 2.0 User Guide

## Download and Install

Download the CardStudio™ 2.0 Software

Download the latest version of the CardStudio™ 2.0 at:

<https://cardstudio.zebra.com>

or use the optional “[USB Card-Drive](#)” if provided.

The link will download the installer file that will look like this:



CardStudio-Setup\_2.5.11

Double-click the icon to open a pop-up verifying you are sure you would like to run the installer. Click '[Run](#)' to start the CardStudio™ 2.0 installation wizard.

## Install CardStudio™ 2.0

A. If you would like to run the installer and setup CardStudio™ 2.0 on your system, click the “Run” button. If you do not want to install CardStudio™ 2.0, click on the “Cancel” button.

B. Click on the “Next” button to continue the installation of CardStudio™ 2.0.

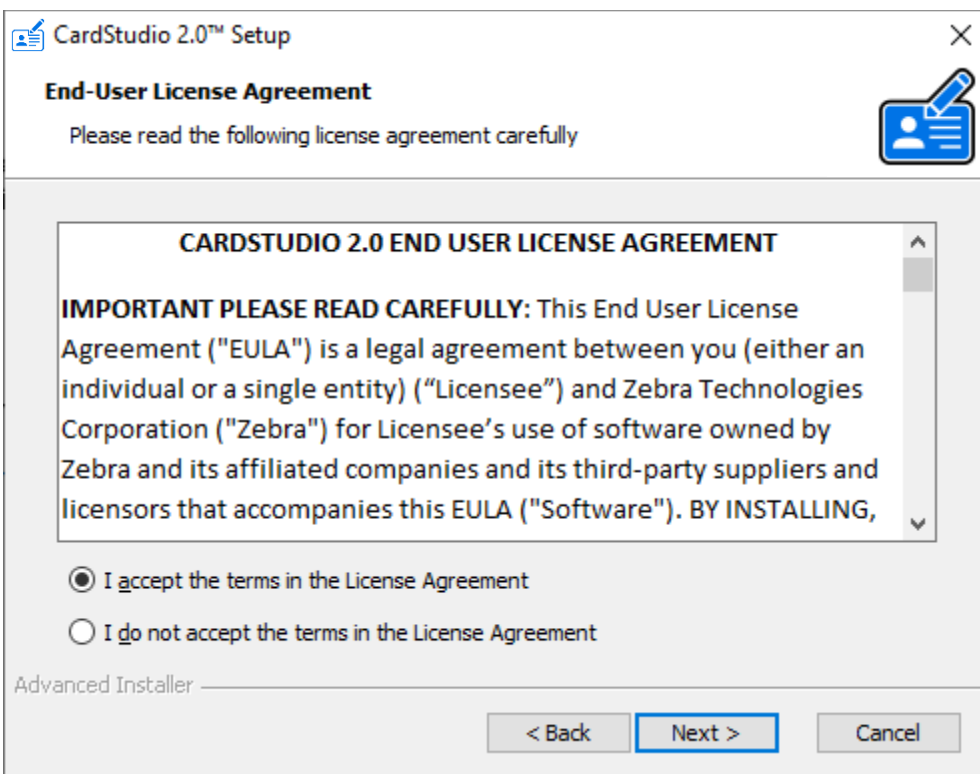
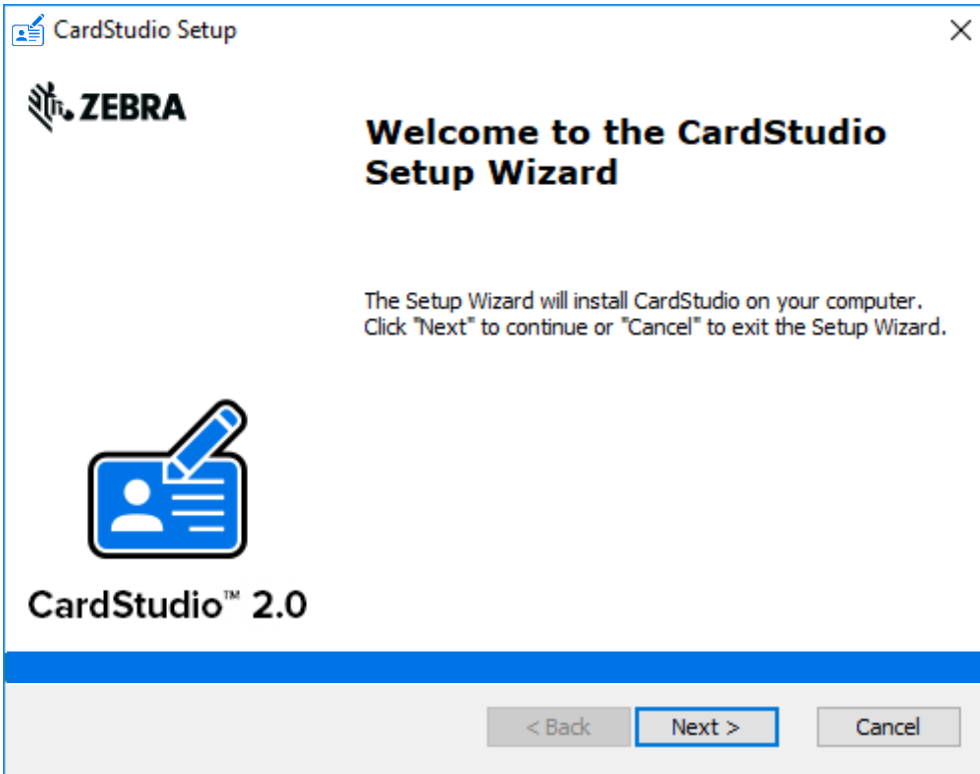

C.1 The “Features” tab: The third step in the installation process is to select how you would like to install CardStudio. You can select the features you would like to install. DesignStudio, PrintStudio, Demo projects and the SmartCard Editor are selected by default. If you would like to only install PrintStudio or DesignStudio, just un-check the boxes of the features you do not want to install.

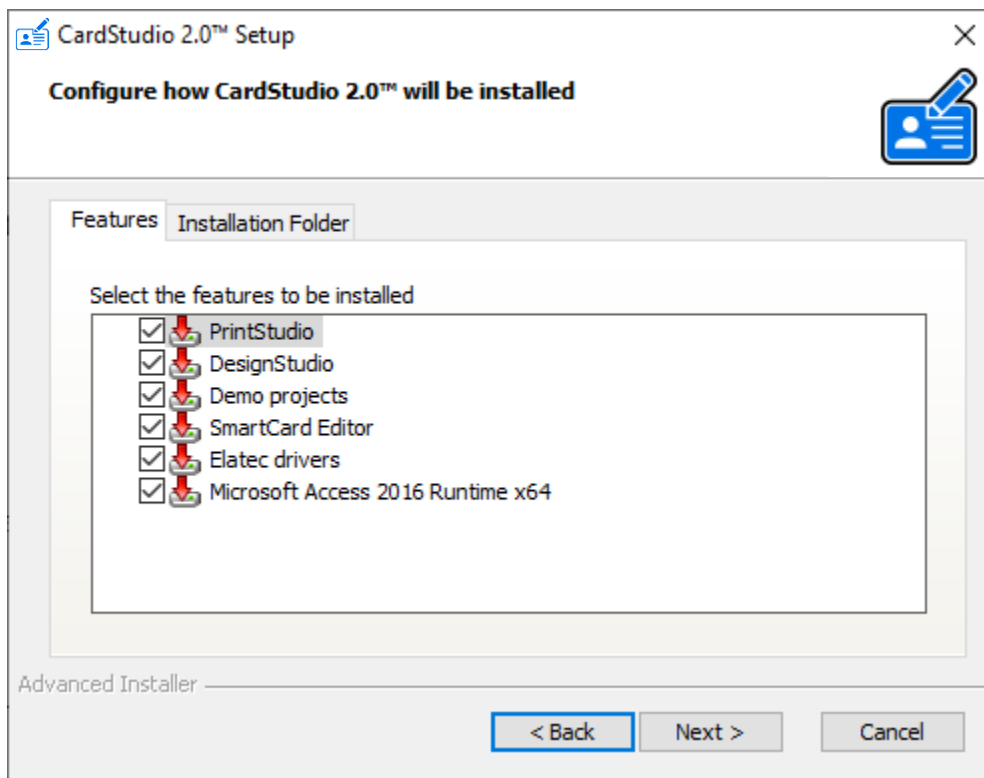

C.2 The “Installation Folder” tab: The second tab of the third step is to select the location where you would like to install CardStudio™ 2.0. You can select this by clicking on the browse button and browse to the desired location. If you do not have a specific location for CardStudio™ 2.0 leave the default location.

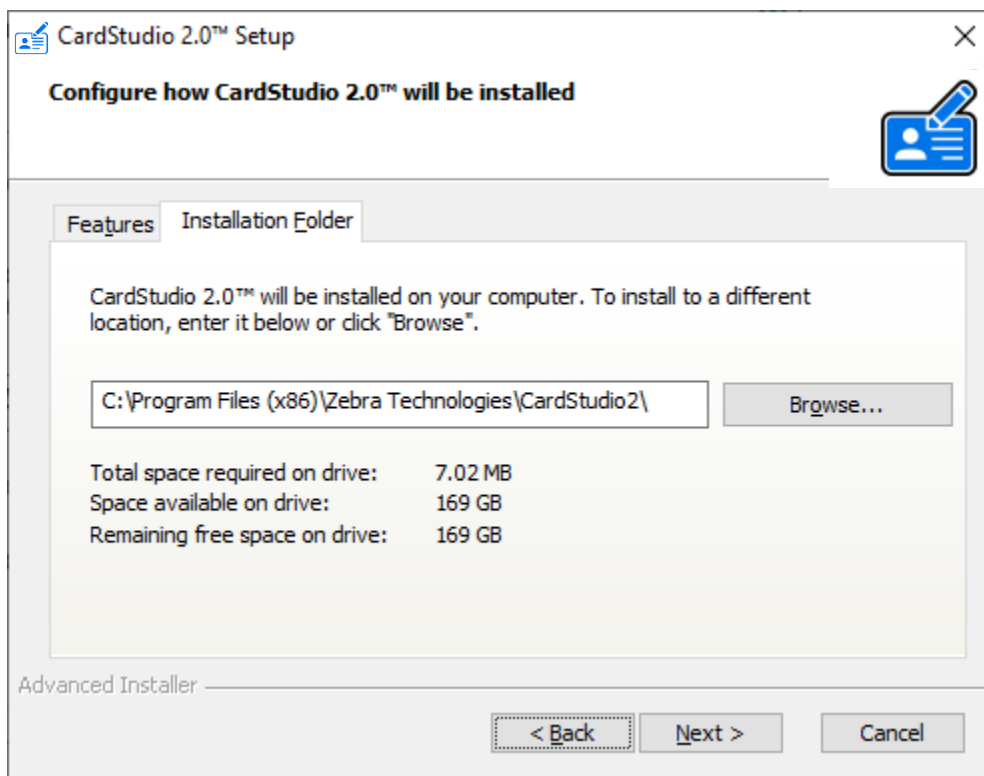



D. The installer is now ready to begin the CardStudio™ 2.0 installation. Click the “Install” button to begin the installation. If you want to review or change any of your installation settings, click on the “Back” button. Click “Cancel” to exit the installer.

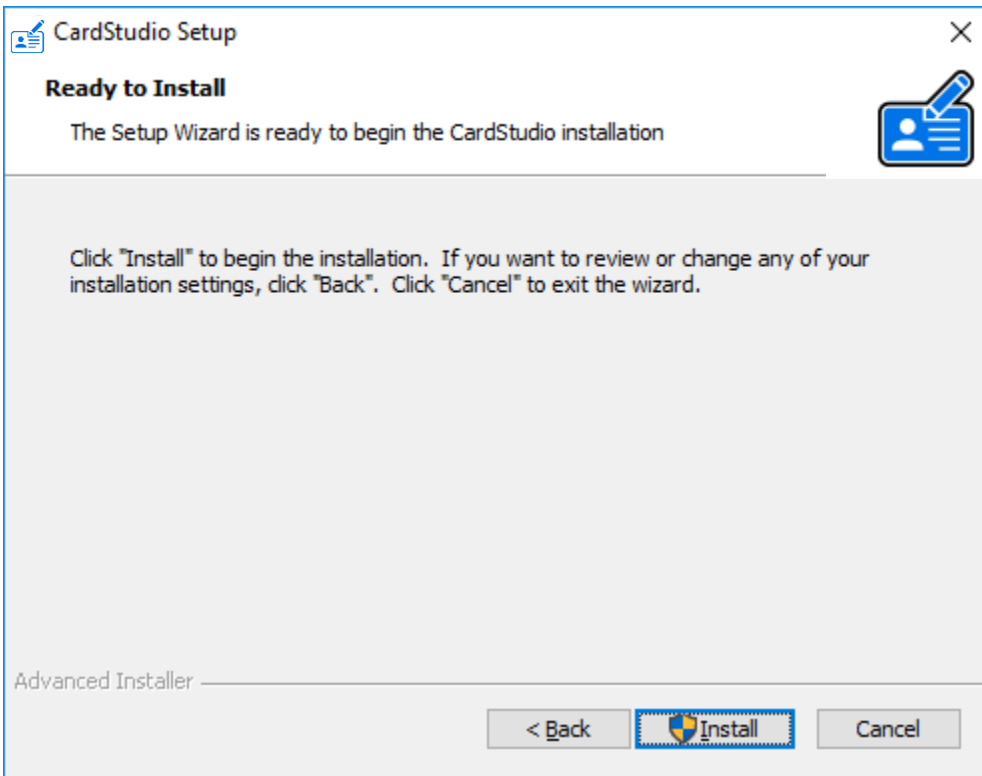

E. The installation is now in process. This may take a couple of minutes. A pop-up window will appear to make sure that you want to run the installation. Click “Yes” to continue.

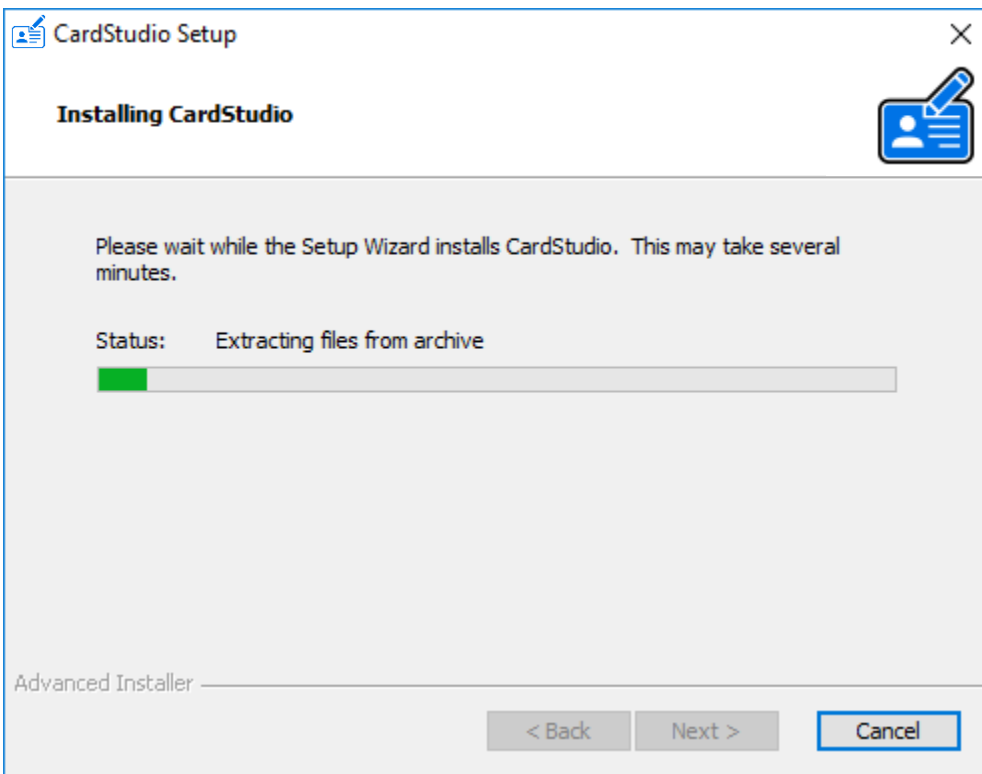

F. The installation is complete click the “Finish” button to exit the installer.



G. After completing the installation, 3 shortcuts will appear on your desktop. For CardStudio™ 2.0, only DesignStudio and PrintStudio are needed. When installing CardStudio Classic only one desktop icon will appear, only DesignStudio is needed. If you have CardStudio Standard or above, you will have 2 or 3 desktop Icons.

If you would like to start creating a new card layout, double-click on the “DesignStudio” icon:



If you would like to start a project and add card data, double-click on the “PrintStudio” icon:



Start the SmartCard Editor to create an encoding file, double-click on the “SmartCard Editor” icon:

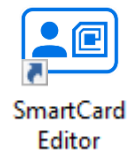

Before you start CardStudio™ 2.0, a license key is needed for the registration of an edition.

## Registration of the Software Edition

When [DesignStudio](#) or [PrintStudio](#) starts for the first time, a registration window will pop-up, this is where the license key can be entered, and the CardStudio Software activated.

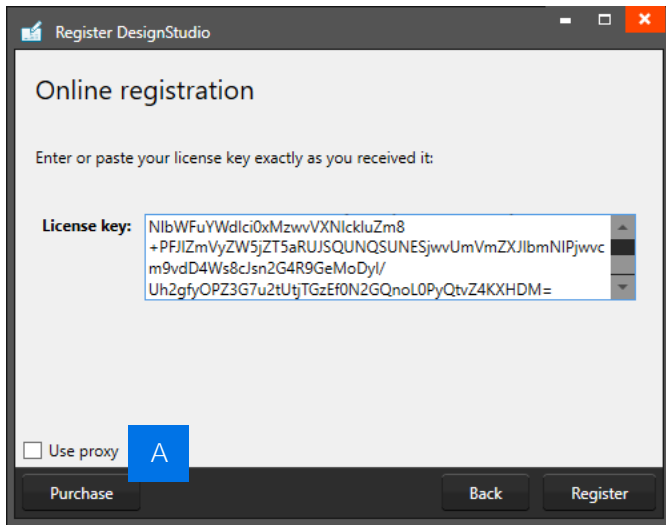

Example of the CardStudio online registration license key window with License Key entered.

### Online Registration

You will be requested to enter a license key. The license key will be provided by our License Manager. The license key must be entered (copy-paste), when the key is valid, the software will start. The next time the software will not require the license key to be entered.

Test keys can have a time restriction and may expire on a given date. (View the License Manager User Guide for more information on license keys).

A. Check the “[Use Proxy](#)” box and enter the information needed to connect through a Proxy server in your network.

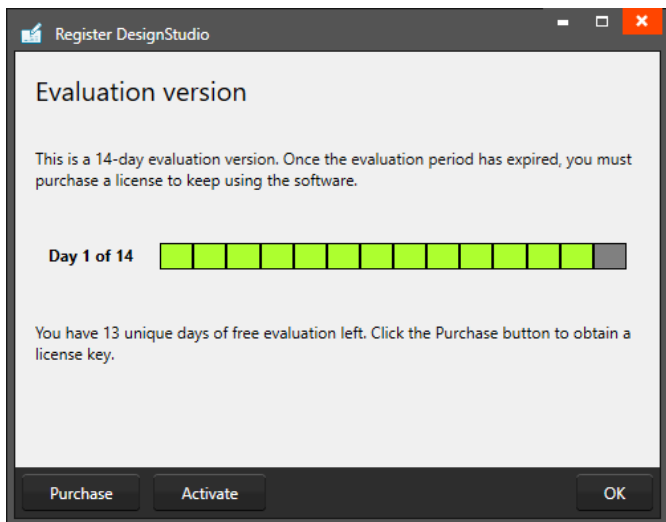
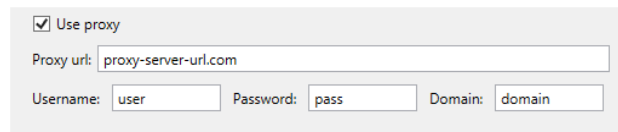

Example of a successful online registration of a CardStudio demo key.

### Successful Registration

When you copy-paste the correct key you will see that the registration is successful. In this case it is a demo key that shows the evaluation time. Click the “[OK](#)” button to start working with CardStudio.

# CardStudio™ 2.0 User Guide DesignStudio



# DesignStudio Interface

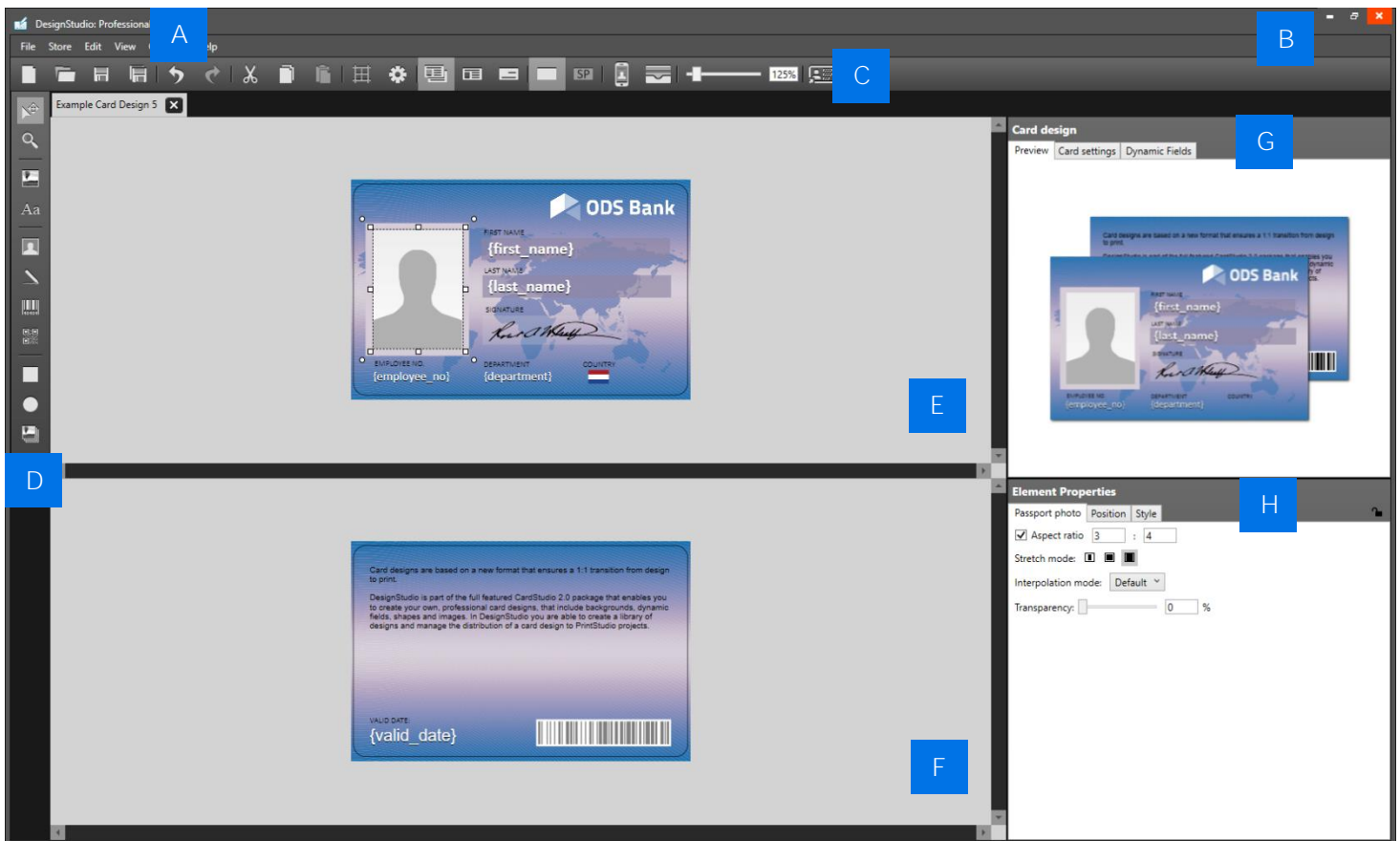

- A. Main menu
- B. Window menu
- C. Quick menu
- D. Toolbar
- E. Workspace/Canvas Front
- F. Workspace/Canvas Back
- G. Card Design:  
Preview / Card Settings / Dynamic Data Fields
- H. Element Properties

# DesignStudio

## Navigation

DesignStudio makes the card design process as easy, fast and intuitive as possible. Accommodating the users in your organization, set with the task of designing the ID-cards. Using a user-friendly overview that shows all the tools needed and is easy to navigate.

### Window navigation

The window navigation gives the option to **A.** minimize, **B.** maximize or **C.** close.



### Main Menu

The main menu offers the options: “File”, “Store”, “Edit”, “View”, “Options” and “Help”

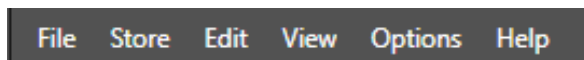

The main menu offers 4 sub-menus.

### File

The first button offers the main functions needed to start, use, save and end CardStudio Design:

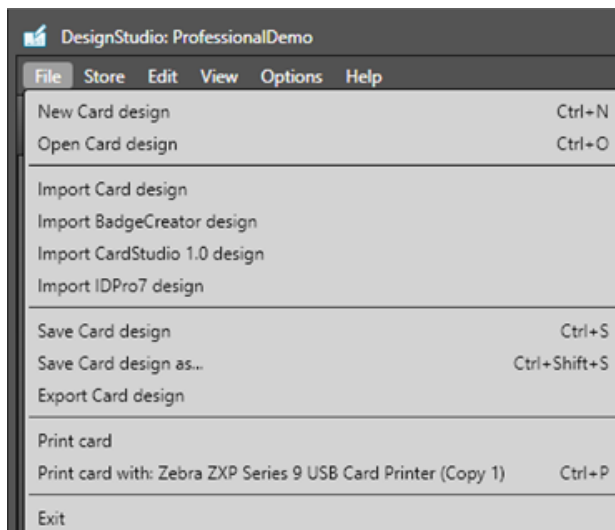

- *New Card design:*

Create a blank new layout for your ID card or use **CTRL+N**

- *Open Card design:*

Open an existing card design to adjust or use **CTRL+O**

- *Import BadgeCreator design:*

Import designs created in BadgeCreator.

- *Import CardStudio 1.0 design:*

Import designs created in CardStudio 1.0.

- *Import IDPro7 design:*

Import old designs created in IDPro7.

- *Save Card design:* To save a Card Design click here or use **CTRL+S**.

- *Save Card design as:* To save a Card Design using another name

click here or use **CTRL+Shift+S**. It is also a simple way to create a duplicate of your design.

- *Export Card design:* Card designs can be exported from Design Studio as a zip file, ready to send or upload.
- *Print card:* The Classic Edition allows you to print your design from DesignStudio. Click to select a printer, set preferences and print.
- *Print card with:* When a default printer is setup, you can skip the printer preferences and print directly with the default printer. Click here, use the printer button in the quick menu or use **CTRL+P**.
- *Exit:* This button will let you exit DesignStudio.

### Store

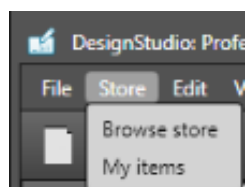

The second button offers the Store, you can find free or premium products like card design templates and example projects ready to place in “My items” and download or purchase credits to your account and send Digital IDs. Use the example card designs or projects to get inspired or adjust for own use.

- *Browse store:* Open the store with a selection of card designs or projects for you to choose from.

- *My items:* Overview of your selected/purchased card designs or projects from the store, ready to

download and use.

## Edit

The third button will offer all the edit functions that you use during the design process:

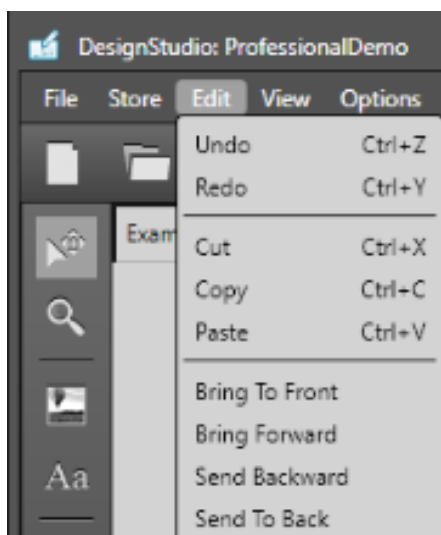

- *Undo*: Undo previous design steps. You can use the short cut [CTRL+Z](#).
- *Redo*: Redo design steps you undid [CTRL+Y](#).
- *Cut*: To relocate an object (image, text, placeholder) on the canvas use the cut button. You can use the short cut [CTRL+X](#).
- *Copy*: To copy an object (image, text, placeholder) on the canvas use the copy button. You can use the short cut [CTRL+C](#).
- *Paste*: To paste a copied or cut object (image, text, placeholder) on the canvas use the cut button. You can use the short cut [CTRL+V](#).
- *Bring To Front*: To bring an element to the front of the design.
- *Bring Forward*: To bring an element one step forward in the design.
- *Send Backward*: To send an element one step backward in the design.
- *Send To Back*: To send an element to the back of the design.

## View

The fourth button controls the CardStudio dashboard view, make specific views visible or invisible:

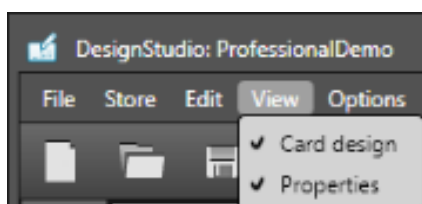

- *Card Design*: See the design preview, card settings and the dynamic fields.
- *Element Properties*: Adjust the different type of elements by clicking on an element and use the Element Properties to make changes.

## Options

The fifth button controls the CardStudio dashboard view, make specific views visible or invisible:

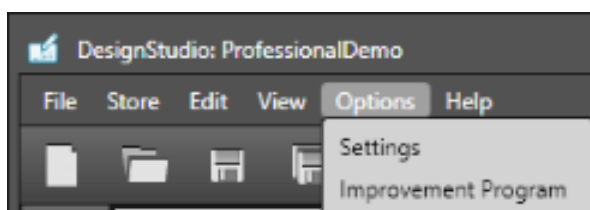

- *Settings*: Change Design Studio settings like enabling the grid, changing the language or the path to save card designs to.
- *Improvement Program*: Help optimize the quality of DesignStudio, by participating anonymously in the DesignStudio Improvement Program.

## Help

The Help button offers information about DesignStudio and an online user guide:

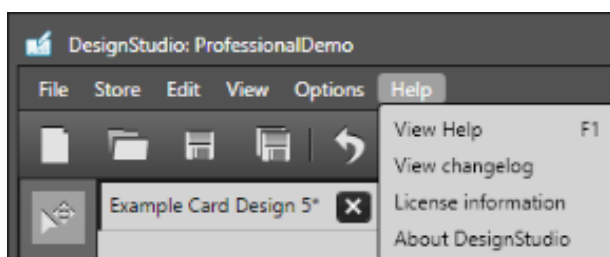

- *View Help*: Opens the online user guide or use the shortcut [F1](#).
- *View changelog*: Shows the changes and updates made in the software.
- *License Information*: Shows the specific license information, the edition, the reference, versions and activation date.
- *About DesignStudio*: Pop-up with version and developer information.

## Quick Menu

The Quick Menu offers a selection of large visual buttons often used in the card design process, allowing for quick and easy navigation.



### A. Create new Card design

Starts a new Card design.

### B. Open existing Card design

Open an existing Card design.

### C. Save

It is important to save your layout while designing. Quickly saves the card design.

### D. Save as

Saves your design under another name.

### E. Undo

Undo design steps you made.

### F. Redo

Redo design steps you made.

### G. Cut

To place an element somewhere else, use this button to cut and replace the image. Just select the element you want to replace, click on the cut button and then click on the paste button to place it somewhere else.

### H. Copy

To copy elements, select the element, then click on the copy button. The element is ready to be pasted anywhere on the front or back of the design canvas.

### I. Paste

If you cut or copy an element, click on the paste button to place the element on the front or the back of the canvas.

### J. Show/hide grid

Make a grid visible or invisible. A grid can help you be more precise with your design. Having the grid to align elements. When the grid option is selected it will auto-snap elements in place whilst using your mouse. Once placed, the arrow keys allow free movement of elements.





## K. Settings

Settings gives a couple of options:

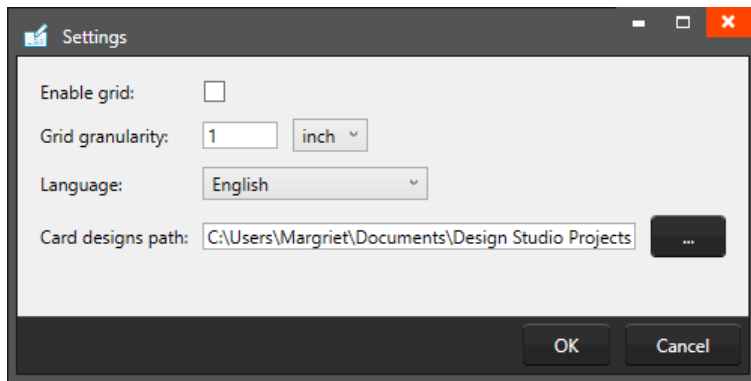

- Check or uncheck the enable grid checkbox to enable or disable the grid.
- Determine the scale of the grid.
- Set the language used in the designer. Languages supported: *English, French, Spanish, German, Turkish, Polish, Russian and Dutch*. Other languages will be supported soon.
- Determine your own project path, where you would like to open and save your designs.
- To confirm settings, click “OK”, to cancel settings, click “Cancel”.
- To exit settings, click “X”.

## L. Show front and back designers

View the canvas for the front and back side of the layout.

## M. Show front designer only

View the canvas for the front side of the layout.

## N. Show back designer only

View the canvas for back side of the layout.

## O. Design layer

This is the base layer to work in to design your (YMCK or monochrome) card layout.

## P. Specialty panel

This is a specialty panel to work in if you want your specialty panel (like an pearl panel) to have a certain design or pattern. (Be aware that a specific printer and ribbon are needed to add specific layers with a design or pattern.)

## Q. Digital ID Designer

Create a Digital ID design next to the standard card design to use on a mobile device. Send the Digital ID to your card holders with PrintStudio. Digital ID is available for the CardStudio Standard, Enterprise, or Professional Edition.

## R. Wallet Pass Designer

Create a Digital ID Design as a Wallet pass next to the standard card design to use on a mobile device. Send the Wallet pass to your card holders with PrintStudio. Digital ID is available for the CardStudio Standard, Enterprise, or Professional Edition.

## S. Scale slider

Use this slider to zoom the canvas view in or out.

## T. Print Card Design

This Quick menu button is only available in the CardStudio CLASSIC edition and allows you to add one record of data and print your card design from Design Studio. You can only use Zebra printers to print you card designs.

## U. PrintStudio

This Quick button lets you open PrintStudio and continue with your card production process.

# DesignStudio

## Start a Card Design

# DesignStudio

## Start a Card Design

To start and work on a card design, start a new design or open an existing design.

### New Card Design

A. Go to “File” in the main menu and click on “New Card design”.

Or click on the icon below in the quick menu:



When clicking on the new card design link or button a setup window will pop-up.

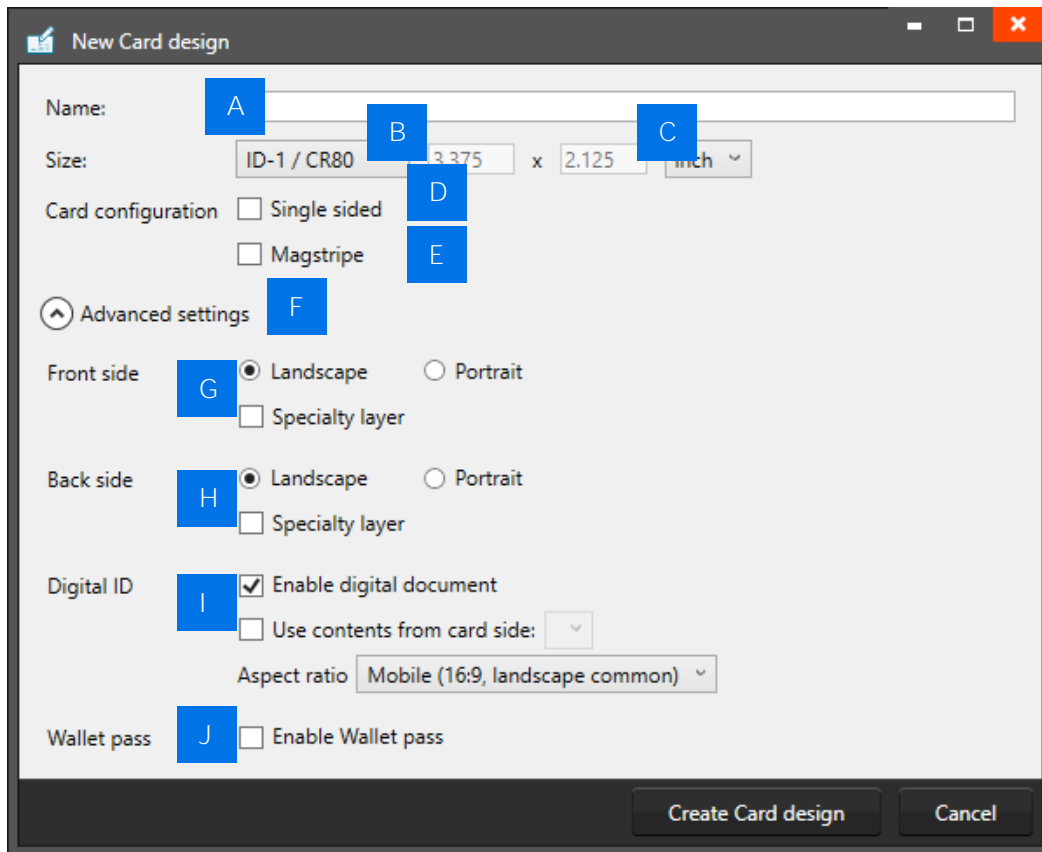
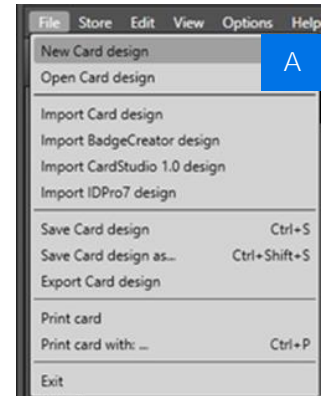

Fig. Example of new card design setup window.

- A. Enter the name for the layout. The exclamation mark at the end appears when the field is not filled, or the name already exists. The ‘OK’ button is not accessible until a unique name is given.
- B. The size of the card can be chosen from a drop down.
- C. Define a custom size for your layout.
- D. Check this box if the design is single sided.
- E. Check this box if the design is for a card with Magstripe.
- F. Click to open the advanced settings, like the orientation, specialty layer or Digital ID options.
- G. Check the orientation of the design for the front and if you want to add a specialty layer to your design.
- H. Check the orientation of the design for the back and if you want to add a specialty layer to your design.
- I. Check the box to enable the Digital ID design as an extra option next to the standard design. Digital ID has the option to use the content from the standard card design or to design your own digital ID and set the aspect ratio for this design.
- J. Check the box to enable the Wallet pass design as an extra option next to the standard design.

## Open existing Card Design

B. To open an existing Card Design go to “File” in the main menu and click on “Open Card design”.

Or click on the icon below in the quick menu:

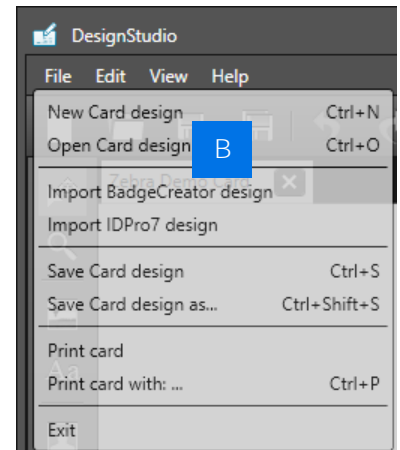

When clicking on the new card design link or button, a selection window will pop-up. All available existing designs are displayed, select a layout for editing. You can open multiple layouts at the same time.

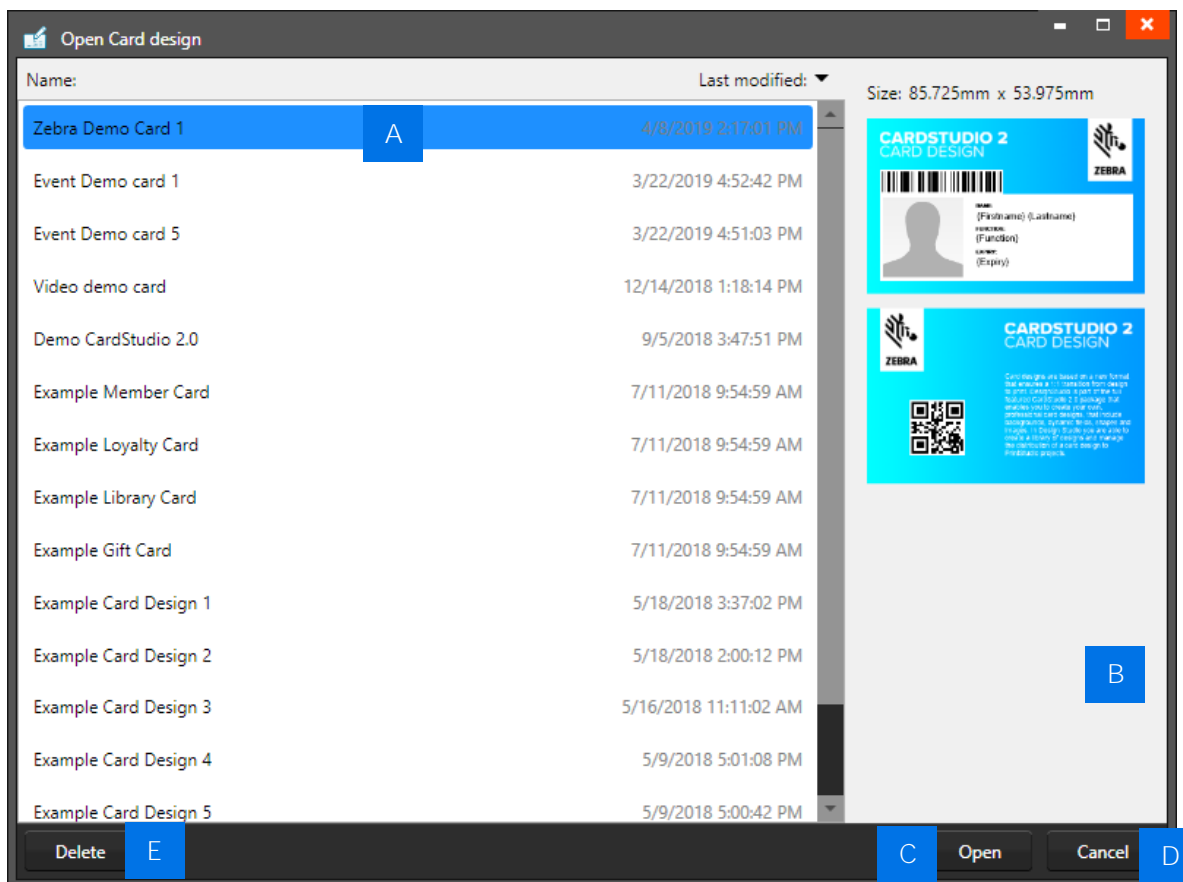

Example of the Open Card design pop-up window.

- A. Select one of the existing designs.
- B. View the layout of the design selected.
- C. Open the selected design.
- D. Cancel opening a design.
- E. Delete a selected design.

## Digital ID Card Design

Next to the standard card design you use to print on plastic ID badges, you can also create a Digital ID design. Digital ID is available for the CardStudio Standard, Enterprise, or Professional Edition.

The digital design feature offers two options, Digital ID as a PDF and as a Wallet pass .pkpass format. Let us first look at how to create a Digital ID design as a PDF.

### Start new card design with Digital ID

- A. Open the DesignStudio software and use the quick menu to start a new card design with a Digital ID design. Set the configuration of the new card design to CR80 and choose to enable or disable the box for single-sided design. For an advanced setup, like the Digital ID options open the advanced settings.
- B. Select the landscape mode for example for the standard card design and enable the Digital ID design.
- C. Digital ID has the option to use the content from the standard card design or to design your own digital ID and set the aspect ratio for this design. In this example we will create an extra design for the Digital ID in portrait mode for mobile devices.
- D. Click the “Create Card Design” button to start with the new design with Digital ID.

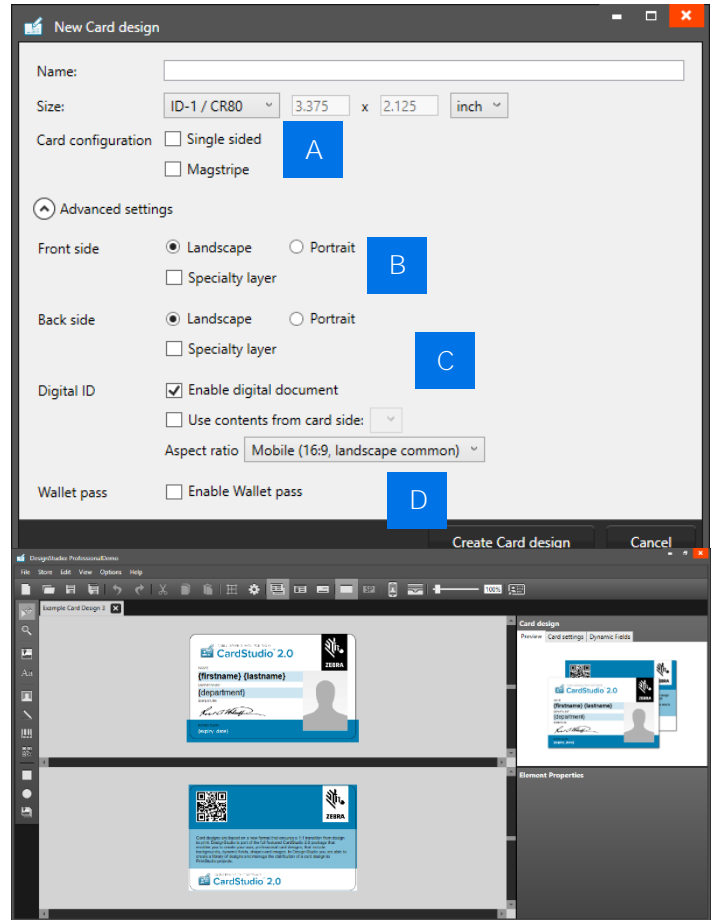

The card design now has the extra Digital ID design option. First start to create the standard card design, add your design, like a background, logo, text, QR-code or photo placeholder.

### Design Digital ID

With the standard card design finished, start with the design for the Digital ID.

- A. To go to the canvas for the Digital ID click on the Mobile icon in the quick menu.



This layout will have a similar look and feel as the standard card design, but for mobile use this layout is set to portrait mode, so the Digital ID is easy to use on a phone. The toolbar and all the elements can also be used for the Digital ID design, if you want to use the same elements as your standard card design, copy and paste them to this canvas.

When the design for the Digital ID is finished, be sure to save the card design. You are now ready to send your card holders a digital ID as a PDF using PrintStudio.

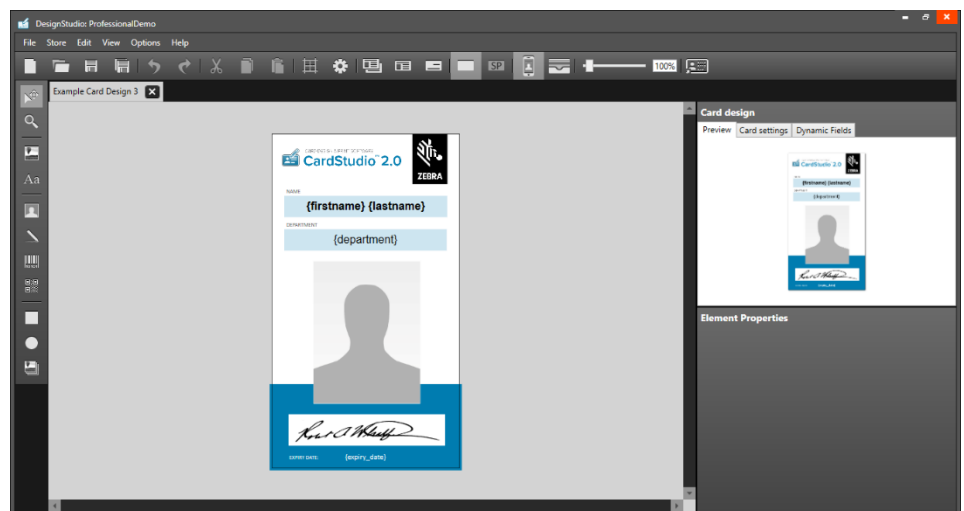

## Wallet Pass Card Design

Next to the standard card design you use to print on plastic ID badges, you can also create a Digital ID design. Digital ID is available for the CardStudio Standard, Enterprise, or Professional Edition. The digital design feature offers two options, Digital ID as a PDF and as a Wallet pass .pkpass format. Let us take a look at the Wallet Pass.

A Wallet pass with the .pkpass extension can be opened with the Apple Wallet app on iPhone or the PassWallet app on an Android phone. With the wallet app you can keep a digital version of your credit or debit cards, store cards, boarding passes, movie tickets, coupons, rewards cards, student ID cards and more in one place on your phone.

### Start new card design with Wallet Pass

- A. Open DesignStudio and click the New Card Design icon in the quick menu, to setup a new card design with a Wallet Pass design for mobile use. Set the configuration of the new card design to CR80 and choose to enable or disable the box for single-sided design. For an advanced setup, like the Digital ID options open the advanced settings. For an advanced setup, like the Digital ID options open the advanced settings.
- B. Select the landscape or portrait mode for the front and back of the standard card design.
- C. Enable the Wallet pass.
- D. Click the “Create Card Design” button to start with this new design.

The card design now has the extra Wallet Pass option. First start to create the standard card design, add your design, like a background, logo, text, QR-code or photo placeholder.

### Design Wallet Pass

With the standard card design finished, start with the design for the Wallet Pass.

- A. To go to the canvas for the Wallet pass click on the Wallet icon in the quick menu.



The design for the Wallet pass is different and restricted to a specific layout template as required by the .pkpass format standard.

- A. The Wallet pass template shows two screens.
- B. Click on the background of the pass for the general setting of the Wallet Pass, in the Element properties you will see a couple of options.

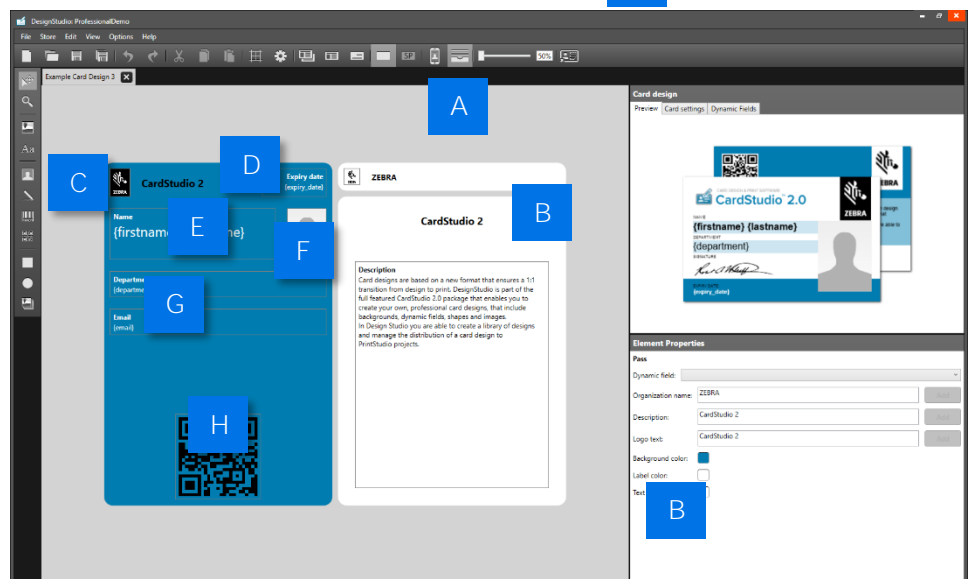

1. Starting with the Company or Organization name.
2. Description for the Wallet Pass
3. Logo text if needed. For this Wallet pass design keep the logo text empty.
4. It is also possible to add a dynamic field to one of the text fields.
5. You can also select the background, label, and text color for the Wallet pass.

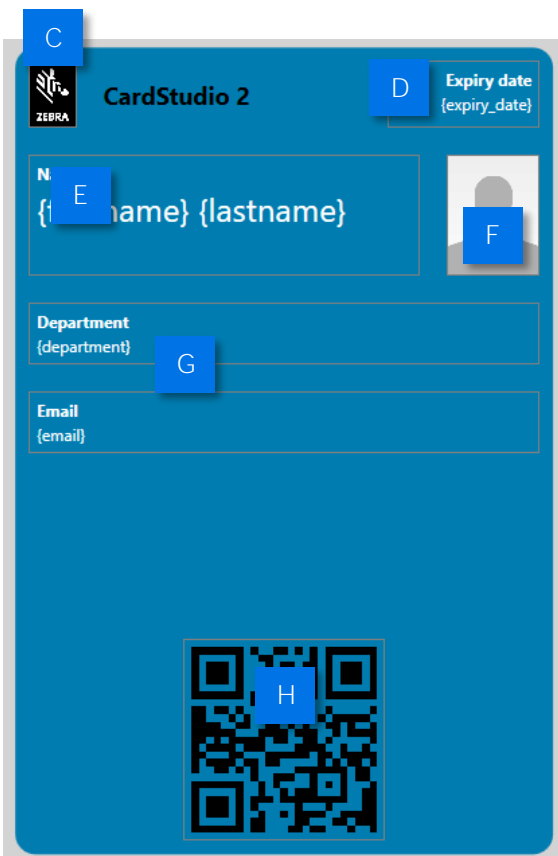
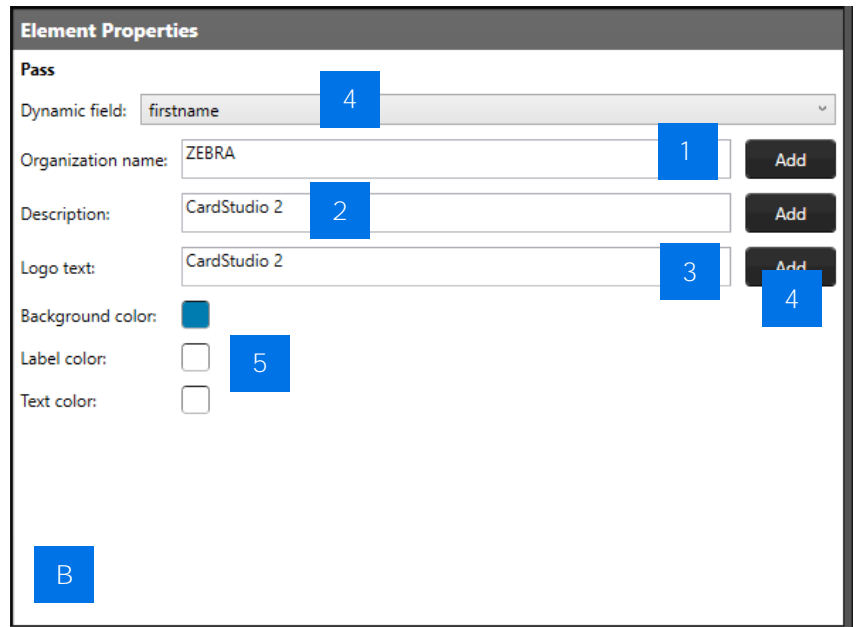

C. The image element displayed in the top left corner is for a logo image. Click on the element, go to element properties, and select a type of image from the dropdown. The logo in this design is a static image.

Use the “Select image” button to add the needed logo and click “Open”.

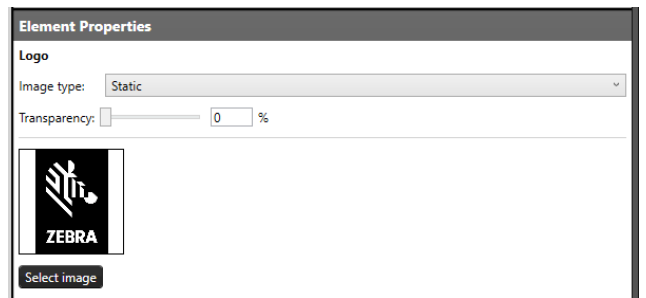

D. To the top right corner text fields can be added. Click on the element and go to element properties, You can add an expiry date here for example. First add the label name and add the expiry dynamic field to the value. Select the “expiry\_date” dynamic field from the dropdown at the top and click on the “Add” button next to the Value field.



E. The text element below the logo displays a larger font and can be used for the card holder name in this design.



F. Next to the name is an option to add an image and used for the passport photo. Set the image type to “Biometric” and the biometric type to Passport photo.

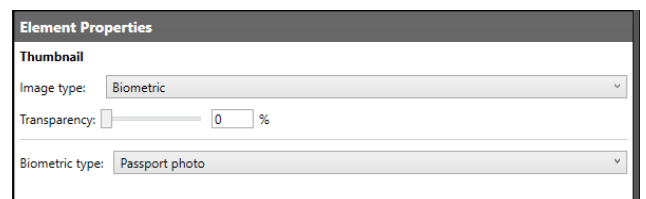

G. Now add text fields with dynamic fields for Function, Department and Email for example in the two text elements still available below.

H. Click on the QR-code, keep type set to QR-code and add a website link for example.

I. It is possible to add extra information, dynamic fields, and an icon on the second screen.

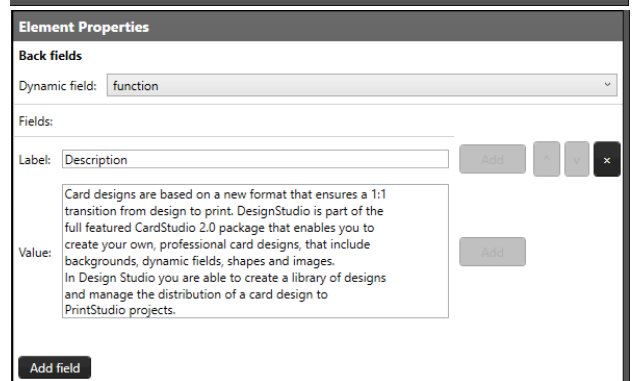
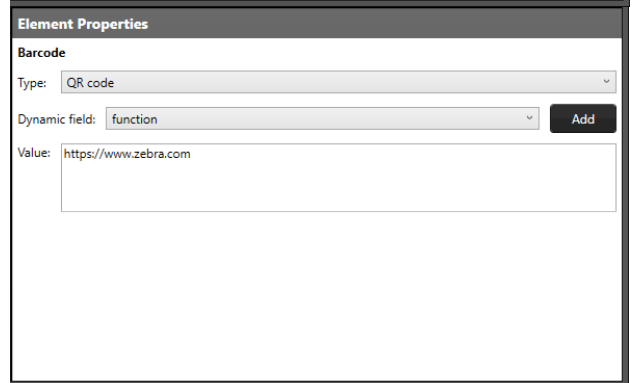
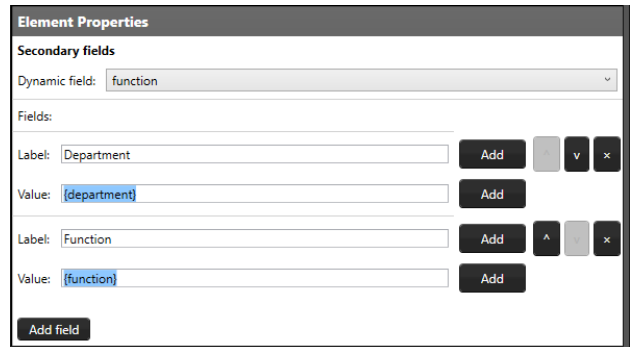
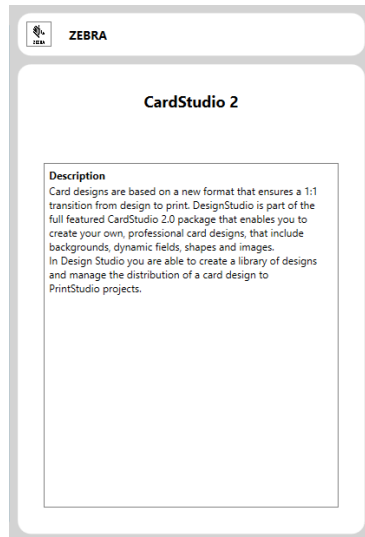

The design for the Wallet pass is finished, be sure to save the card design. You are now ready to send your card holders a Digital ID in the form of a Wallet pass using PrintStudio.

Next to the user guide you can also watch tutorial videos about Digital ID: <https://cardstudio.zebra.com/digital-id>



# DesignStudio The Store

# DesignStudio

## The Store

The Store available in CardStudio 2.0 offers free & premium card design templates, example projects and credits for you to select, purchase and download.

### Card Design from the Store

Browse the Store to select and download one of the example card designs to start with. Get inspired and adjust the example designs to your own liking.

Projects that also have a digital ID setup show the Digital ID icon:

For more information watch the “How to” videos on Digital ID:

<https://cardstudio.zebra.com/digital-id>



Projects setup with the Status Check feature show the Status Check icon:

For more information watch the “How to” videos on Status Check:

<https://cardstudio.zebra.com/status-check>



### Browse the Store

To browse the store, go to “Store” in the main menu and click on “Browse store”.

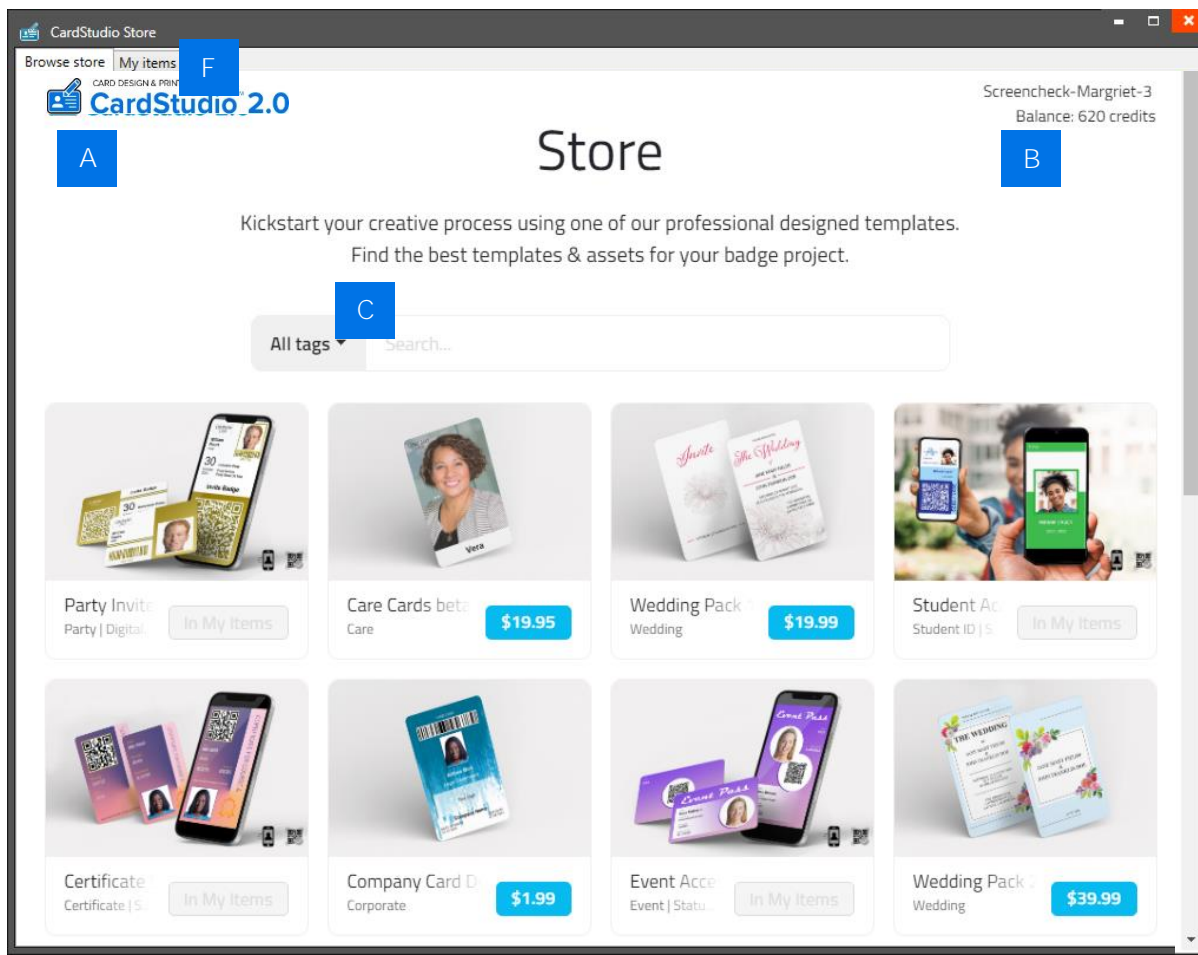

- A. Store: Overview of all the products (card designs, projects and credits) available to select for free or to purchase and add to “My items”.
- B. Overview of your account name and a balance of the credits available in your account.
- C. Filter the overview of card designs by specific tags. Use the drop-down button to select a tag or search card design bundles by name.
- D. Click on the bundle image to learn more about the bundle and its card designs.

- E. Click on “Add to My items” or “Proceed to Payment” if it is a premium product to add the product to “My Items” and make them available for download.



E

- F. In Tab “My Items” is where you can find the products like card designs you selected for free or purchased. Select the product to download and use it in CardStudio.

## My items

All the selected and purchased products (Card Design Templates or Example Projects) from the Store can be found in “My items”. These Products will always be available for you as specific customer ready to download.

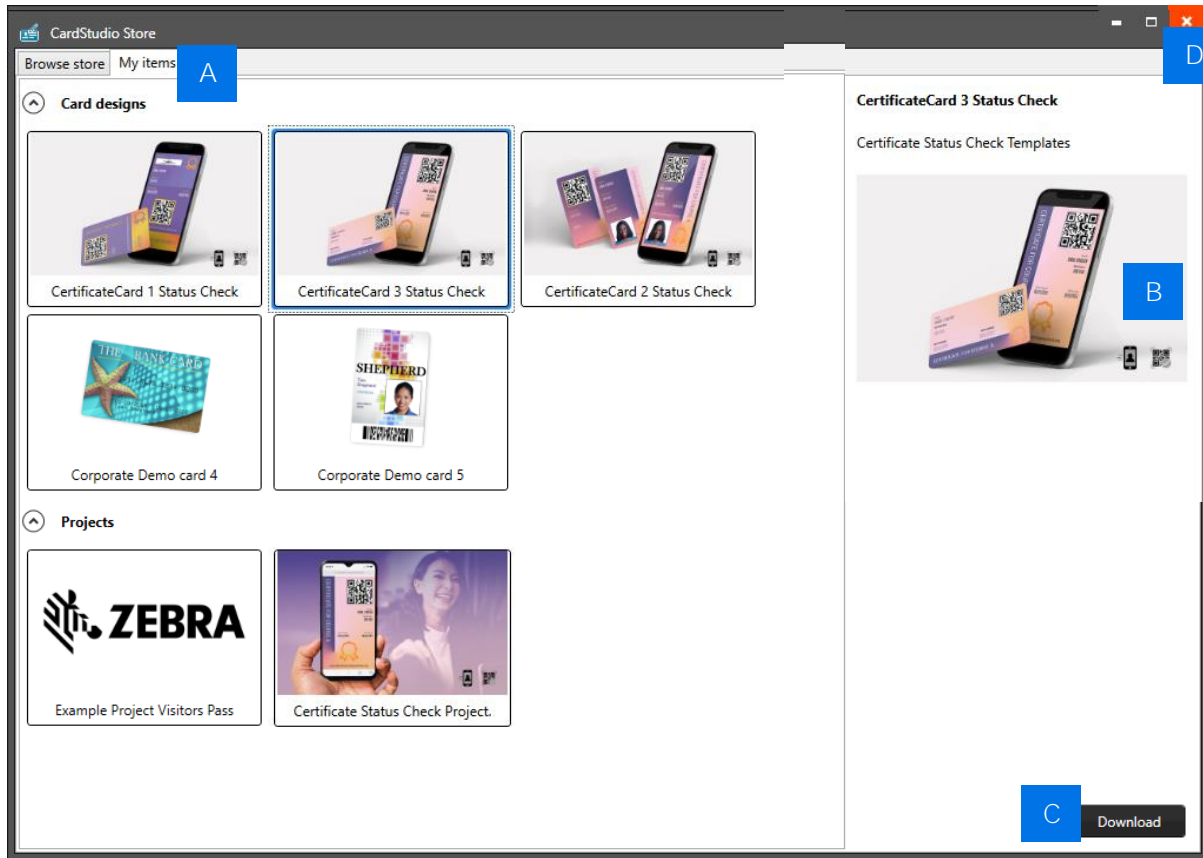

- A. My items: overview of all the selected or premium products from the Store ready to select and download.
- B. Preview images of the selected card design.
- C. Click on “Download” if you would like to download the selected card design to your DesignStudio or project to your PrintStudio.

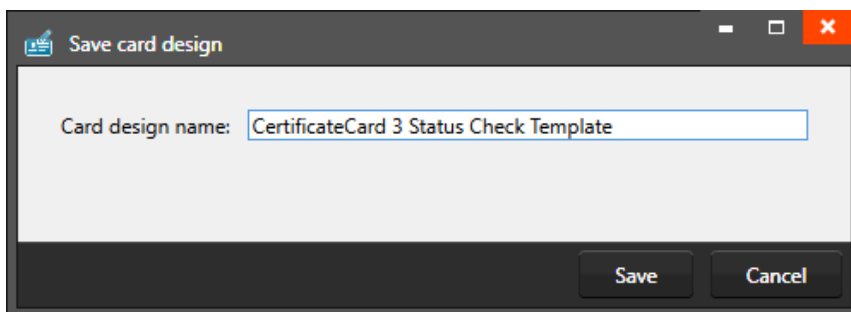

Give the downloaded card design or project a name. After saving, the design or project is opened automatically in DesignStudio or PrintStudio. The card design or project is now ready to be used in your CardStudio 2.0.

- D. Click on the “Close” button to close the My items pop-up.

## Credits from the Store

When you create a Digital ID design for your card holders, for them to use on their mobile, credits are needed in your CardStudio account, to be able to send the Digital ID in PrintStudio. CardStudio offers a standard set of free credits for users to try the Digital ID feature. More credits can be purchased in the Store. Credits can also be purchased in the form of vouchers at a selection of Zebra CardStudio 2 Resellers.

Go to the “[Store](#)” in the main menu and select “[Browse store](#)”. The Store opens in a pop-up with an overview of all the available products. Maximize the window to have a good overview of all the products.

In the top left corner, you can check your credit balance. Scroll down to navigate to the credits.

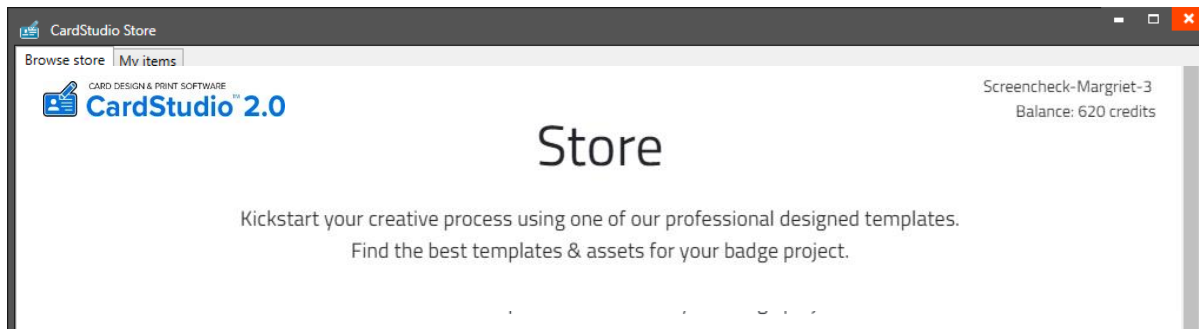

A couple of credit bundles are available to choose from, select the bundle that works best for you. It costs 10 credits to issue a Digital ID, 5 credits to issue a Status Check QR-code and 2 credits to update an existing Status Check Card.

Looking to purchase a higher number of credits, contact your local reseller.

If you purchased a Zebra Voucher from your reseller, enter your Zebra Voucher code and redeem credits of that voucher.

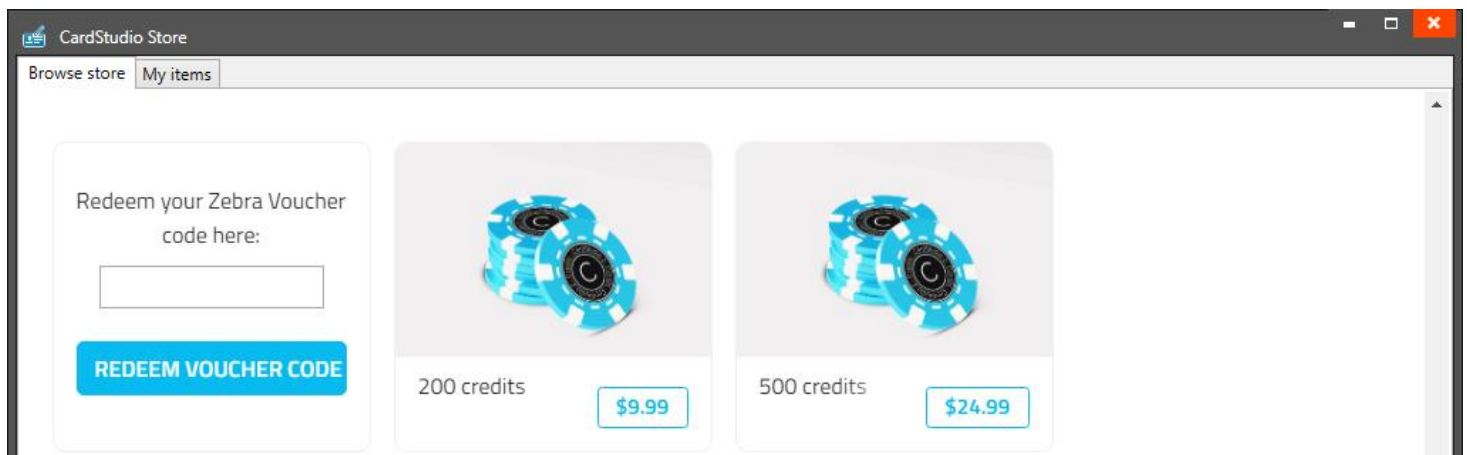

Click on the price button to proceed to the checkout and purchase the credit bundle. Agree with the terms and conditions, click the “[Proceed to payment](#)” button and choose the payment method to complete the order. Choose to pay with a Credit Card or PayPal-account. After a successful payment, the purchased credit is added to your CardStudio account.

Use the “[return to store](#)” button to check the credit balance again in the top left corner. You are now set to send a Digital ID to your card holders.

# DesignStudio Card Design View

Preview, Card Settings and Dynamic Field

# DesignStudio

## Card Design Menu

The Card Design window presents three tabs: [Preview](#), [Card Settings](#) and [Dynamic Fields](#).

### Preview

The Preview tab shows a preview of the card; the preview allows you to toggle from front to back by clicking the image.



Example of the Preview tab in the Card Design view.

### Card settings

The Card Settings tab offers information on the card design settings. Change or edit the settings of the card design. The elements already placed will not be affected, when for example changing a layout from landscape to portrait. Next to the orientation of the design you can enable or disable the specialty layer, the design option for a Digital ID and/or the Wallet pass.

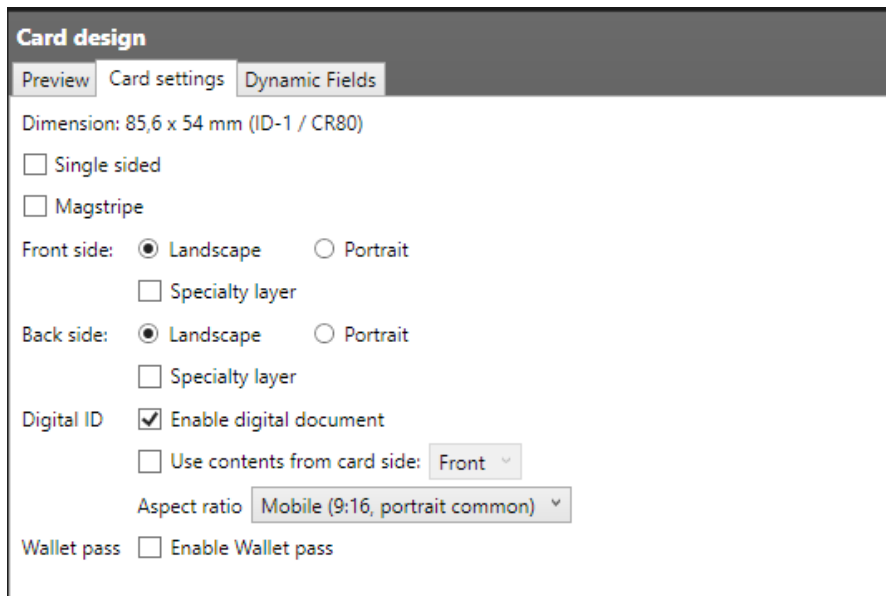

Example of the Card Settings tab in the Card Design Menu.

## Dynamic Fields

With the start of a new card design it is important to create the needed dynamic fields for a card design. Dynamic data represents data that need to be on a card design for different card holders. For example: First name, Last name or Department. When dynamic data is linked to project data, the dynamic data placeholder will be replaced with the card holder data.

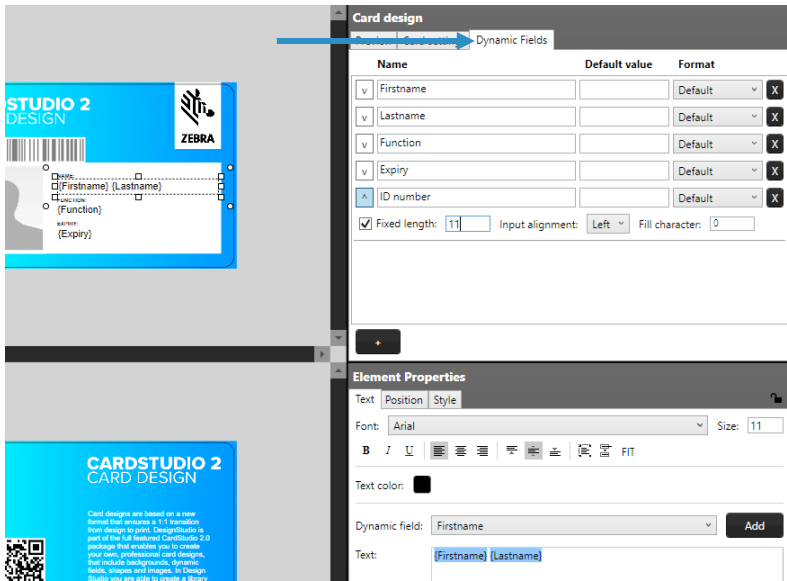

The tab “Dynamic fields” in the card design view will give a list of the dynamic fields in the layout. When a text element is added to the card design, and the text in the text element has a name {between curly braces}, DesignStudio will detect this as a dynamic field name and will be added to the list of Dynamic fields.

The user can delete, change and edit the field names and enter default values to be used as preview.

Fig. Example of the Dynamic Fields settings tab in the Card design menu.

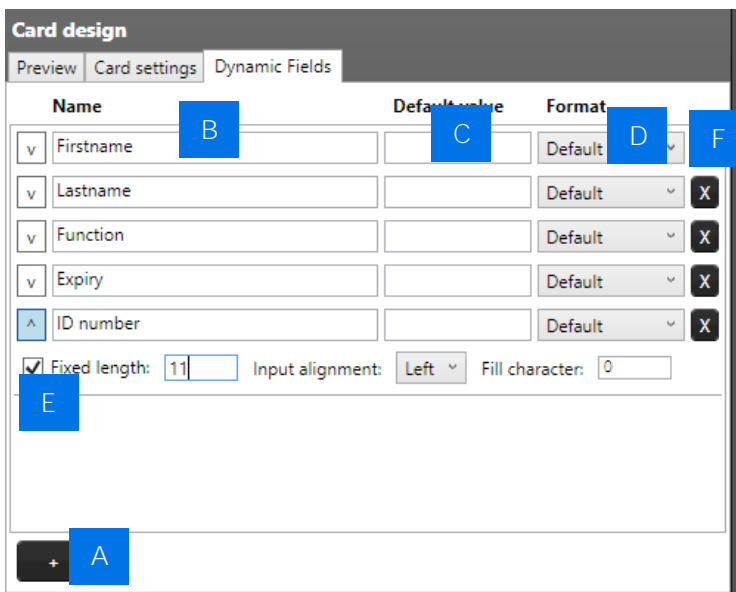

- A. Add a new dynamic field to the list by clicking on the “+” button.
- B. Enter a dynamic field name by clicking on it and rename it from, for example, “Dynamic Field 1” to “first\_name”.
- C. It is possible to enter a default value for the fields. For example, the default value for “department” can for example be “Sales”.
- D. A dynamic field can have a certain format, the dropdown menu offers a couple of options. For example, the value of a certain dynamic text field needs to be “CAPITALIZED”.
- E. It is possible to give dynamic fields a fixed length, input alignment and a fill character. This helps when the dynamic data must be a specific fixed length, for example ID numbers or for specific Magstripe input. Click on the arrow before the dynamic field to open the extra options. The fixed length gives the option to set the number of characters, input alignment allows you to set the input from left or right and fill character lets you fill the empty space with a specific character.
- F. Click on the “X” button to delete a dynamic field.



# DesignStudio Elements

# DesignStudio

## Elements

### Element Tool Menu

To create and edit a design you need to work with the toolbar setup on the left side. The tool bar offers the following functions:



#### A. Select/move tool

The arrow tool is used to select an element. This tool also allows you to move an element in the layout. When an element is selected, a move icon appears on the mouse over and can be used to move or resize an element.

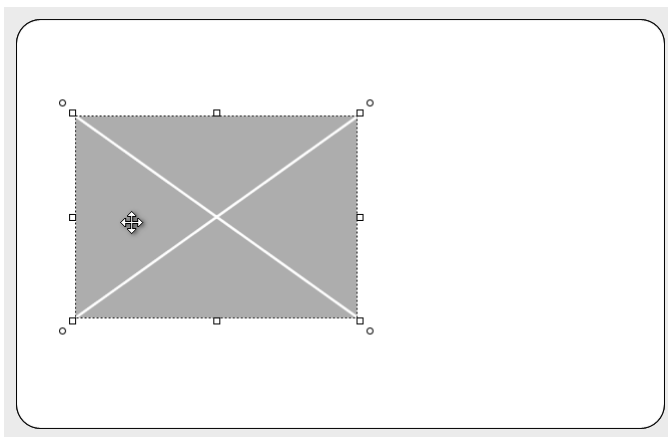



#### B. Zoom tool

The zoom function is enabled and will zoom in on the layout.

At a click of the mouse the zoom is increased one step, when using CTRL and a click of the mouse the zoom is decreased by one step.

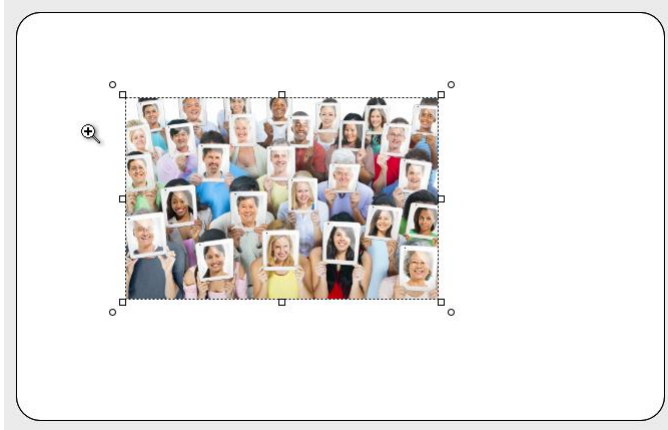

#### C. Image tool

The image tool is used to place an image element in the layout.

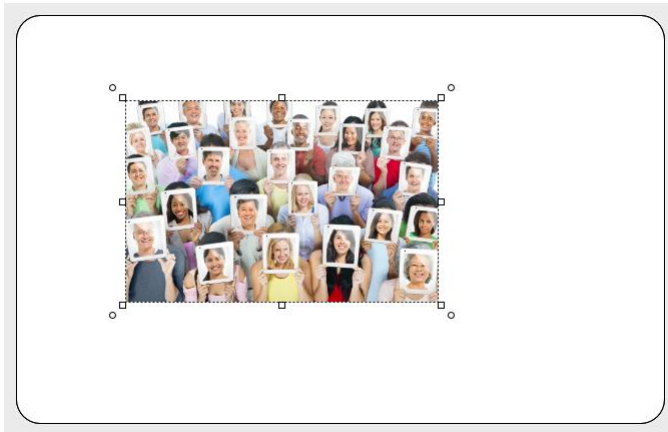

#### D. Text tool

The text tool can be used to add static and dynamic text to the design. Use the Text Element properties to edit and add text and/or dynamic text to the box. Select the element and go to Element properties to edit the text in the text editor.

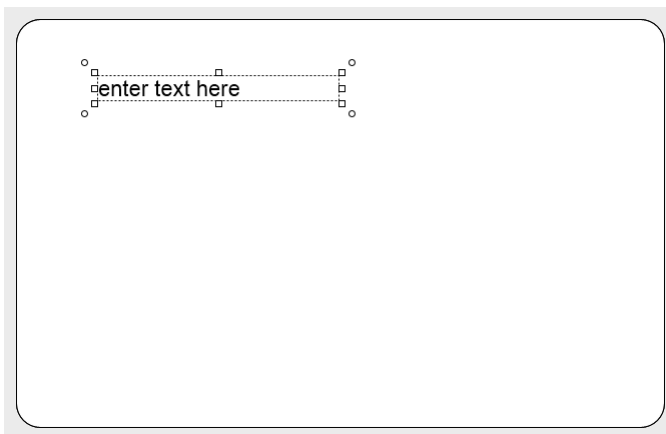



#### E. Passport photo tool

The Photo element is used to place a placeholder for the passport photo on the layout. The photo element can scale within proportions. When the design is linked to data in for example a PrintStudio project, the placeholder will be replaced by a real passport photo from the project data.

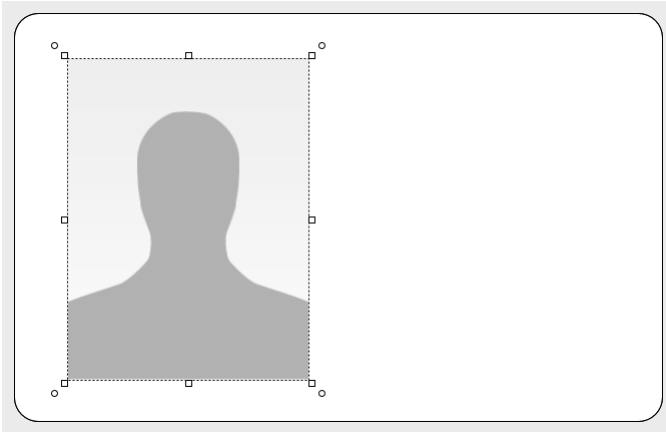

#### F. Signature tool

The Signature element is used to place a placeholder for the signature on the layout. The signature element can scale within proportions. When the design is used and connected to data in for example a PrintStudio project, the placeholder will be replaced by a real signature from the project data.

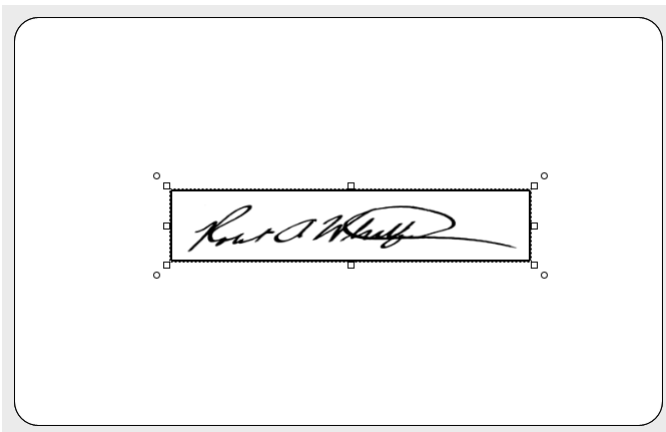



#### G. [Barcode tool](#)

The Barcode element is used to place a placeholder for a barcode on the layout. The element can scale within proportions. Different types of barcodes are available to select in the element properties. Barcodes that are scaled too small might not work. Test barcodes in your design with the data before continuing.

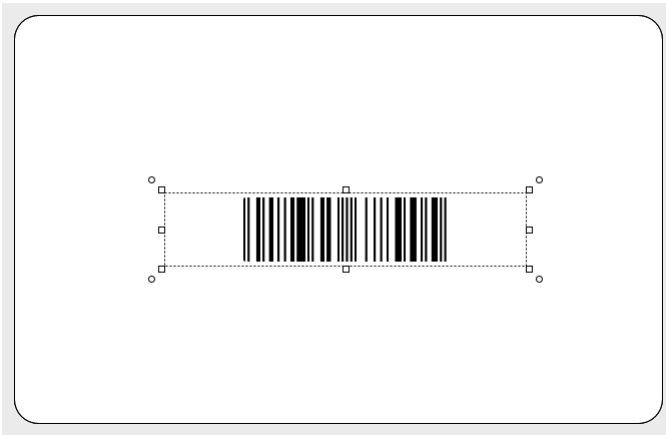

#### H. [2D Barcode tool](#)

The 2D Barcode element is used to place a placeholder for a 2D barcode on the layout. The element can scale within proportions. When the design is linked to data in a PrintStudio project, the placeholder will be replaced by a real 2D barcode. There are different types of 2D barcodes available to select in the element properties.

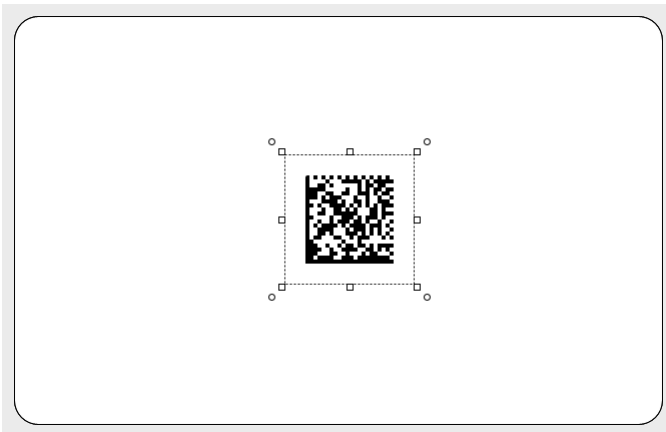



#### I. [Square tool](#)

The rectangular element can be used for frames and boxes in the layout. Line option: To draw a line with the square tool, select the square element and go to the element properties. Enter the desired height and width of the line. Switch to the Style tab, set border thickness to 0 and add the background color of your choice.

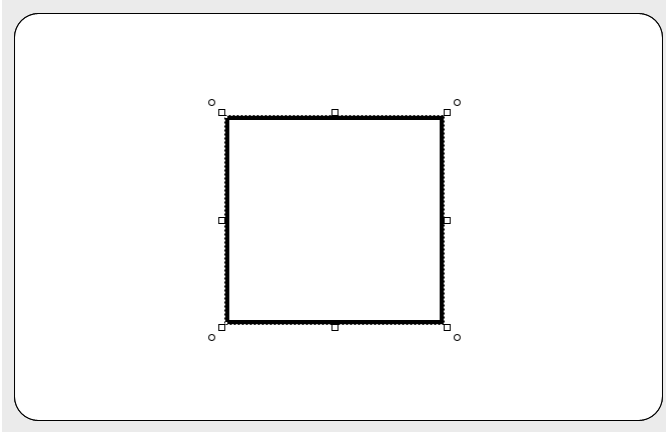

#### J. [Circle tool](#)

The circle element is used for elements like circles and ellipsoids.

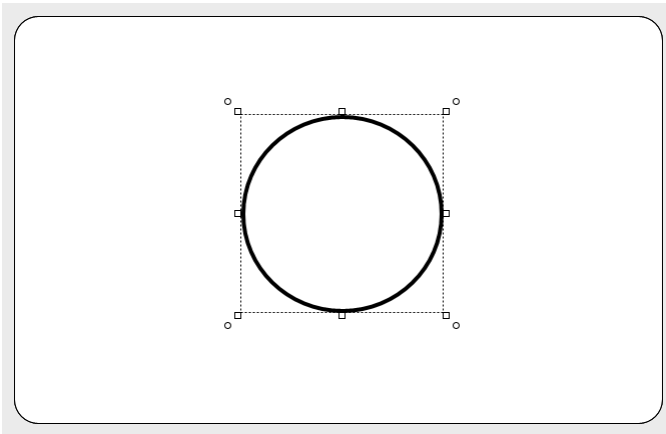

#### K. [Dynamic logo tool](#)

The Dynamic logo element is used to place a placeholder for a dynamic logo on the layout. The element can scale within proportions. When the design is linked to data in a PrintStudio project the placeholder will be replaced by one of the dynamic logos.

For more explanation on the dynamic logo read [Dynamic logo element properties](#).

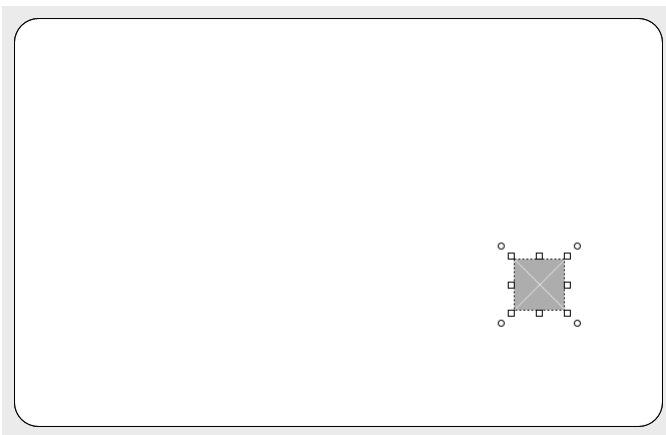

## Element Properties

The element properties window has three tabs: [Element edit](#), [Element position](#) and [Element style](#) tab.

Depending on the type of element, this tab will allow the user to view and/or edit the information of the element. When the values are changed, they are reflected immediately in the design; there is no need to hit an enter button. The user can make changes in one window and observe the result in the other window at the same time and vice versa. It depends on the preference of the user to create the layout in a graphical environment or a data element environment.

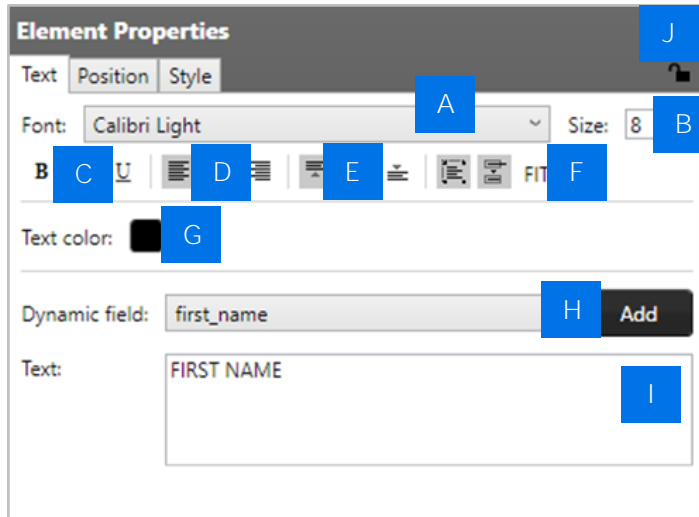

Example of the Text element properties

### Text element properties

- A. Change Font
- B. Change Size
- C. Edit style into [bold](#), [italic](#) and [underlined](#).
- D. Outline the text left, center or right
- E. Align the text to top, center or bottom of the box.
- F. Wrap text automatically, let text be cut off when being too long or set the text to automatically fit the text box.
- G. Change text color by clicking the Text color box
- H. Choose to add a dynamic field to the text box below by selecting one from the drop-down menu and clicking on the “Add” button.
- I. Enter all your text here.
- J. Click the lock icon to lock an element. A locked element cannot move or be selected during the design process.



: element is not locked.



: element is locked.

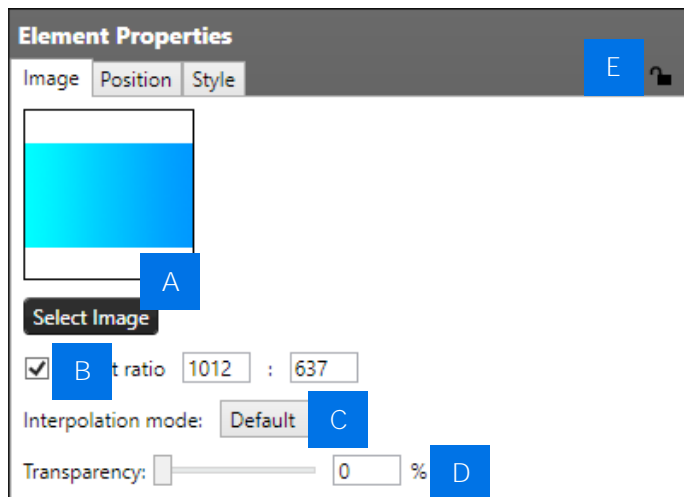

Example of the Image element properties

### Image element properties

- A. Select an image from your computer by clicking on the “[Select Image](#)” button.
- B. Choose to bind the ratio
- C. As a specialty feature you are able to use the “[Interpolation mode](#)” to control image quality during scaling. There are 4 interpolation modes you can choose from:

*Default*  
*Bicubic*  
*Bilinear*  
*NearestNeighbor*

Keep this setting “[Default](#)” when you do not have experience with the interpolation modes.

- D. Use the slider or enter a percentage to change the transparency of the image.
- E. Click the lock icon to lock an element, so it cannot move during the design of the card.



: element is not locked.



: element is locked.

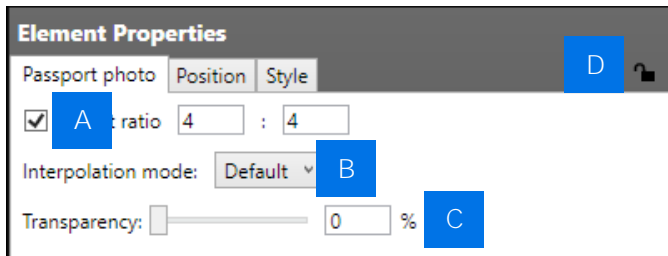

Example of the Passport Photo element properties

### Passport Photo element properties

- A. Check box to bind the element to a certain ratio or adjust the ratio.
- B. As a specialty feature you are able to use the “Interpolation mode” to control image quality during scaling. There are 4 interpolation modes you can choose from:

*Default*  
*Bicubic*  
*Bilinear*  
*NearestNeighbor*

Keep this setting “Default” when you do not have experience with the interpolation modes.

- C. Use the slider or enter a percentage to change the transparency of the image.
- D. Click the lock icon to lock an element, so it cannot move during the design of the card.



: element is not locked.



: element is locked.

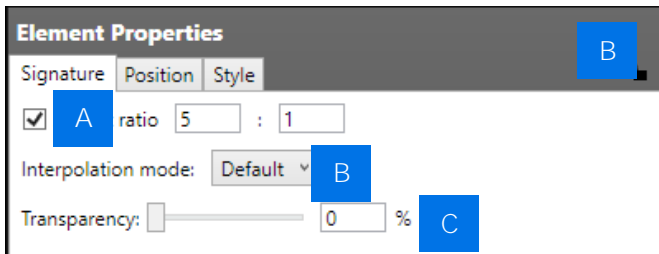

Example of the Signature element properties

### Signature element properties

- A. Check box to bind the element to a certain ratio or adjust the ratio.
- B. As a specialty feature you are able to use the “Interpolation mode” to control image quality during scaling. There are 4 interpolation modes you can choose from:

*Default*  
*Bicubic*  
*Bilinear*  
*NearestNeighbor*

Keep this setting “Default” when you do not have experience with the interpolation modes.

- C. Use the slider or enter a percentage to change the transparency of the image.
- D. Click the lock icon to lock an element, so it cannot move during the design of the card.



: element is not locked.



: element is locked.



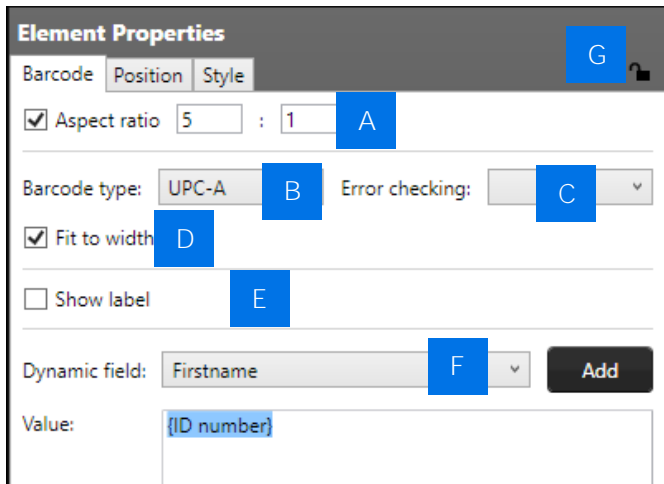

Example of the barcode element properties.

### Barcode element properties

- A. Check this box to bind the element to a certain ratio
- B. Choose a barcode type by clicking on the drop-down menu and select the barcode type.
- C. Select a form of error checking from this list to ensure a correct working barcode.
- D. Check this box to fit the barcode to the complete width.
- E. If you want the barcode to show a label with the actual data, check the show label check box.
- F. Select the dynamic field that you want the barcode to reflect, click the “Add” button to add the dynamic field to the value. Barcodes cannot represent all data, make sure the data can be translated to the selected barcode type.
- G. Enter a default value or combine it with a dynamic field.
- H. Click the lock icon to lock an element, so it cannot move during the design of the card.



: element is not locked.



: element is locked.

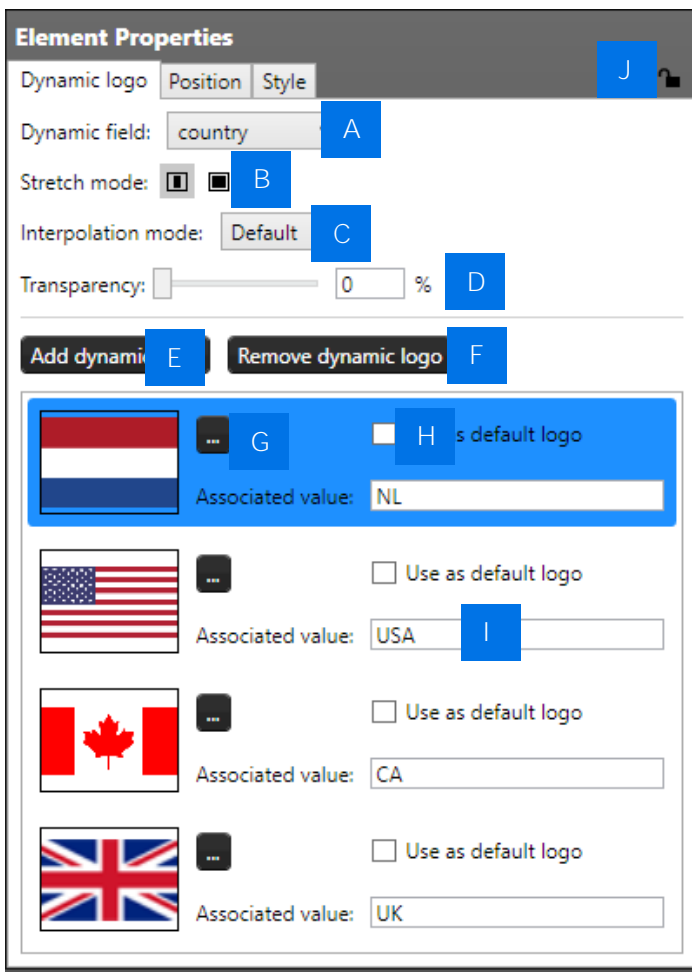

Example of the dynamic logo element properties.

### Dynamic logo element properties

- A. Select the dynamic field that needs to reflect the dynamic logo.
- B. Select if you want the logo to be the correct ratio or if you want it to fill the whole field.
- C. As a specialty feature you are able to use the “Interpolation mode” to control image quality during scaling. There are 4 interpolation modes you can choose from:  
  - Default
  - Bicubic
  - Bilinear
  - NearestNeighbor
- D. Use the slider or enter a percentage to change the transparency of the image.
- E. Click on this button to add another dynamic logo.
- F. When you want to delete a dynamic logo select the logo you want to delete first and then click on the “Remove dynamic logo” button.
- G. Select an image for your dynamic logo by clicking on this button.
- H. Check the default box if you want this image to show up as the default dynamic logo image.
- I. Add the associated value of your dynamic logo into this field.



J. : element is not locked.



: element is locked.

## Element Position

To change the position of an element, use the arrow tool or select the element and click on to the second tab “Position” in the Element properties. Here the position, dimension and margin of an element can be adjusted, rotated or arranged to the back or front.

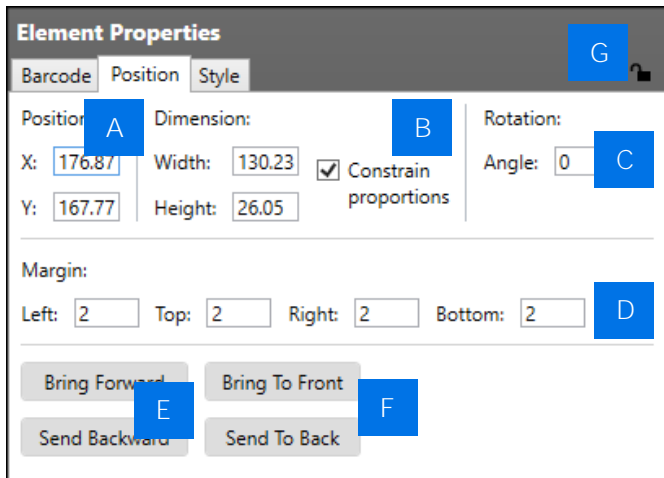

Example of the position of an element.

- A. Determine the position of the used element.
- B. Scale your element giving a width or a height. Check the check-box to constrain proportions.
- C. Rotate the element by entering an angle number, 0 to 360.
- D. Give elements margin space, enter space for the left side, top, right and bottom of the element.
- E. To arrange an element one step forward or backward against the other elements, click on these buttons.
- F. To bring an element completely on top or to the background, click on these buttons.
- G. Click the lock icon to lock an element, so it cannot move during the design of the card.



: element is not locked.



: element is locked.

## Resize and rotate elements on the canvas

The canvas represents the front and/or back of the card layouts and can be used to place, edit and/or move elements. When an element is selected the size of the element can be changed using the arrows/squares at the corners of the elements. The element can also be rotated using the circles at the corner of the elements.

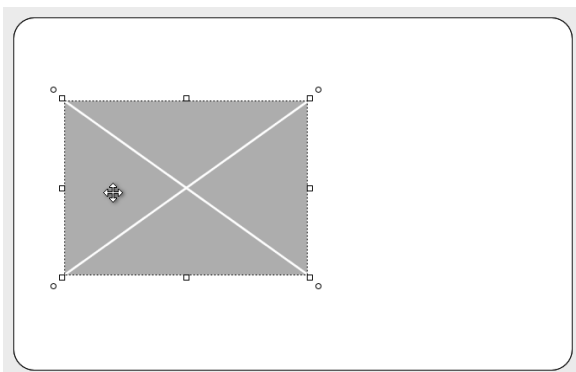

Example of an image element placed on the front of a card.

Increase/decrease the width or height of an element. The arrow appears when the mouse is hovered over/near the edge of the element.

The height and width of the element can be changed at the same time. The arrow appears when the mouse is hovered over/near one of the corners of the element.

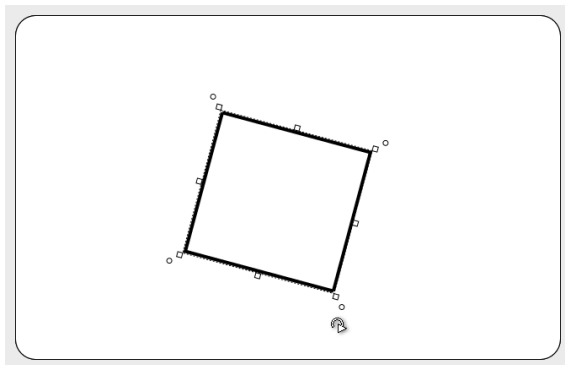

Example of a rotated shape element placed on the back of a card.

The orientation of the element can be rotated when the arrow appears. The arrow appears when the mouse is hovered just outside one of the corners of the element.

## Element Style

### Border & Background

To change the style of an element, click on the element and go to the third tab “**Style**” of the Element Properties view.

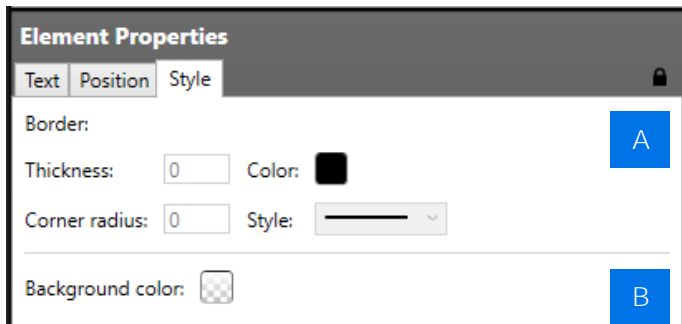

Example of the style tab

- A. Add a border, change the thickness of the of the border, its color or style.
- B. Add a background color.

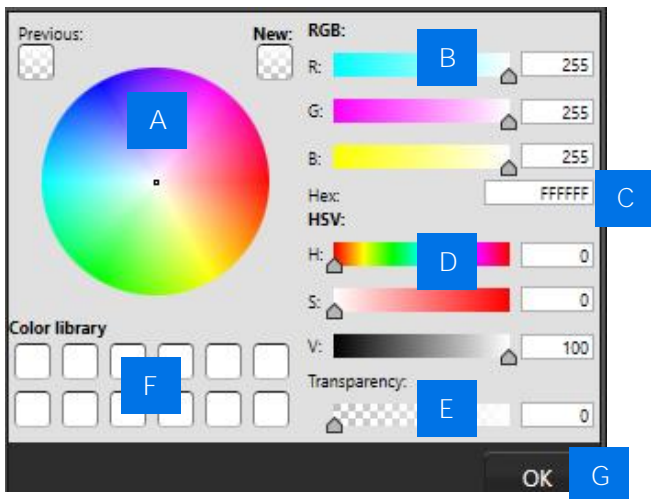

Example of the Color pop-up menu

### Color & Transparency

Choose a color for the border or the background using the color pop-up window. There is a selection of color options to choose from. Use the RGB, Hex or HSV code to select a specific color. You can use:

- A. The color picker.
- B. Use the RGB sliders or type in the percentage.
- C. Fill in the Hex code for the color.
- D. HSV sliders or type in the percentage.
- E. Add Transparency or type in the percentage.
- F. Use a color library for specific colors. Select an empty slot in the library and set your color using the options A - E.
- G. Click on “**Ok**” when you have selected the correct color and transparency of the border or background.

# DesignStudio Print Card Design

# DesignStudio

## Print a Card Design

With the CardStudio Classic Edition it is possible to design and print your card design from DesignStudio using the Zebra Card Printers. After the design process click on the “Print” button in the Quick Menu:



When a printer is not setup, a printer setup window appears the first time:

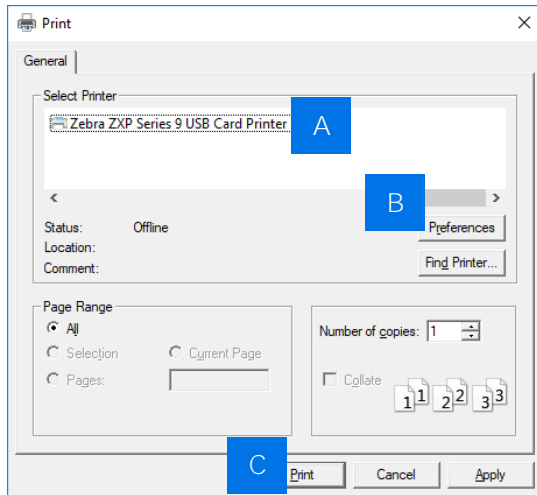

A. Select the Zebra Card Printer you would like to print your card design with.

B. Set your printer preferences, make sure the correct default settings of the printer driver have already been set.

C. Click on the “Print” button to proceed. To change the printer settings for the quick menu print button, go to the “File” and click on the “Print card” link.

Before printing the card design it is possible to personalize the Card Design with cardholders’ data. For Example, capturing a passport photo. If the card design does not have personalized data, proceed to the print button.

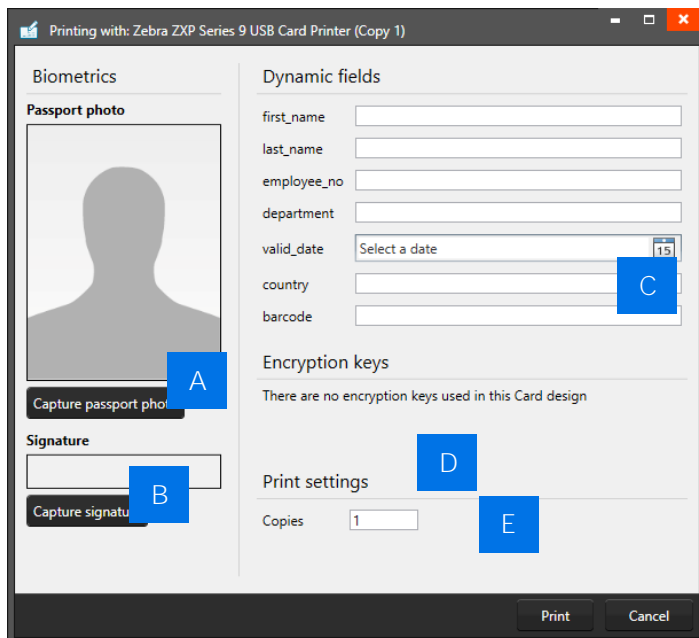

A. Passport photo: Capture or add a photo to the card design.

B. Signature: Capture or add a signature to the card design.

C. Enter data for the dynamic fields in your card design. It is only possible to enter data for 1 card holder, if personalized.

D. Enter number of copies to print.

E. Click on the “Print” button to print your card design.

# CardStudio™ 2.0 User Guide

## PrintStudio

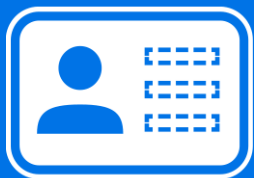

# PrintStudio Interface

The dashboard of PrintStudio offers the following sections:

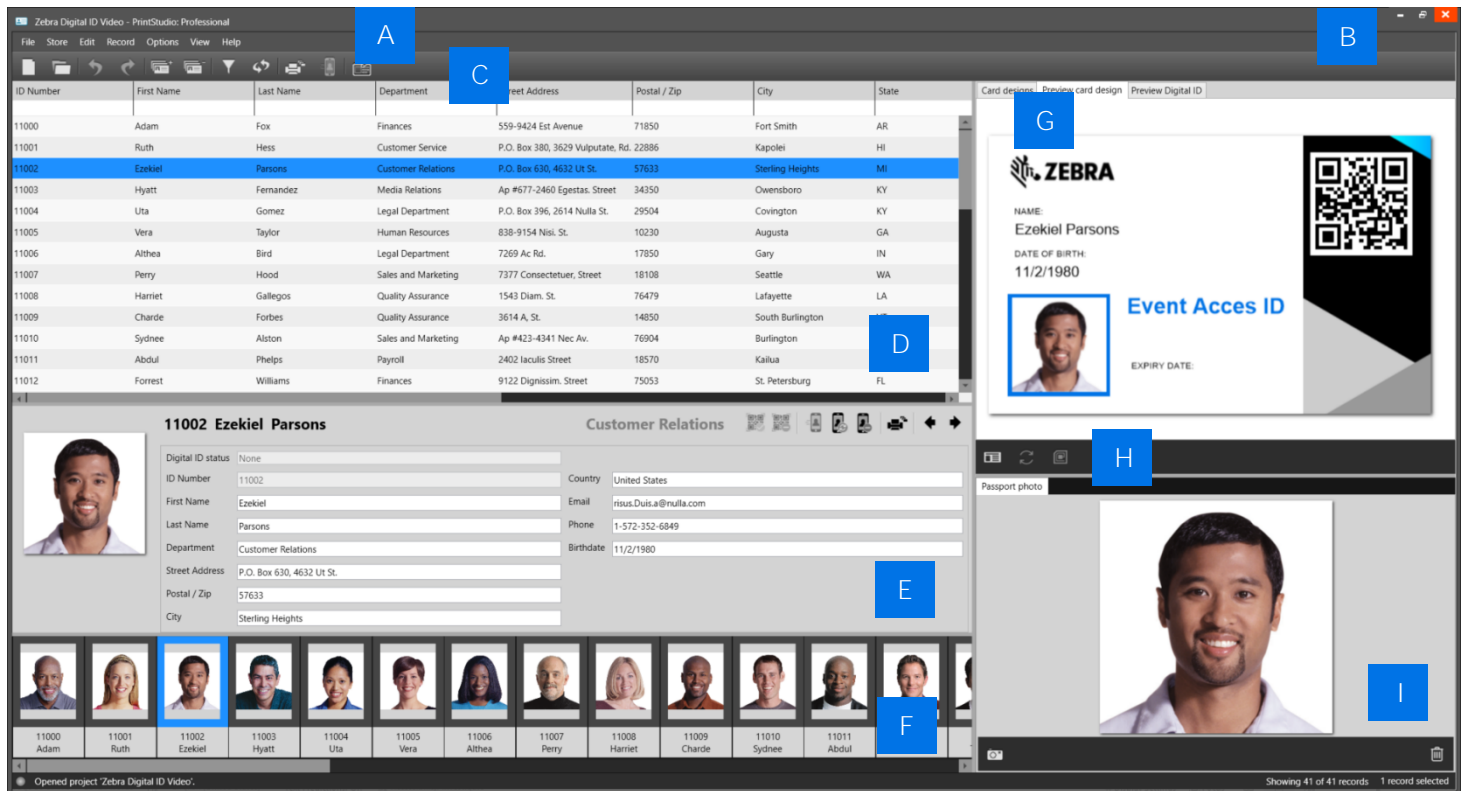

Example of the PrintStudio dashboard overview

- A. Main menu
- B. Window menu
- C. Quick menu
- D. Grid View
- E. Detail View
- F. Photo Slider View
- G. Project card designs overview and preview
- H. Project card design quick menu
- I. Photo and Signature preview

# PrintStudio

## Navigation

PrintStudio makes the elaborate card design process as easy, fast and intuitive as possible. Accommodating the users in your organization that are set with the task of managing data and printing cards. Using a user-friendly overview that shows all the tools and is easy to navigate.

### Window navigation

The window navigation gives the option to **A.** minimize, **B.** maximize or **C.** close.



### Main menu

The main menu offers the options: **File**, **Store**, **Edit**, **Record**, **Options**, **View** and **Help**



The Main Menu has 6 submenus:

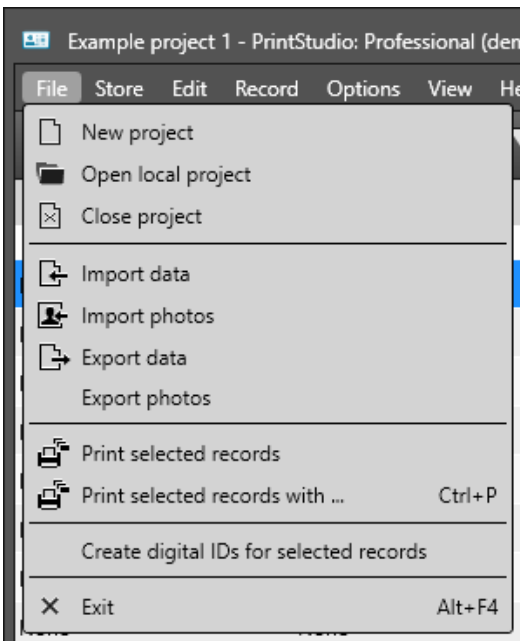

#### File

The File menu offers the main functions needed to start, use, manage and exit a PrintStudio Project:

- *New project*: Start a new project in PrintStudio.
- *Open project*: Open an existing project made in PrintStudio.
- *Close project*: Close the Print Studio project.
- *Import data*: Import data from an Excel file, BadgeMaker 7 or IDPro7 project.
- *Import photos*: Batch import photos or signatures.
- *Export project data*: Export the record data to an CSV file.
- *Print selected records*: Print the records selected in the Grid view.
- *Print selected records with...*: Print quickly with an already set printer.
- *Create Digital IDs for selected records*: Send the linked Digital ID design to the selected card holders by email. You need credits in your account to send Digital IDs.
- *Exit*: Exit PrintStudio

#### Store

The second button offers the Store, you can find free or premium products like card design templates and example projects ready to place in “My items” and download or purchase credits to your account and send Digital IDs. Use the example card designs or projects to get inspired or adjust for own use.

- *Browse store*: Open the Store and browse a selection of card designs and projects.
- *My items*: Overview of your selected/purchased card designs or projects from the store, ready to download and use.

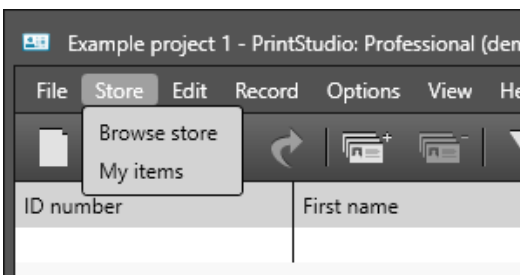



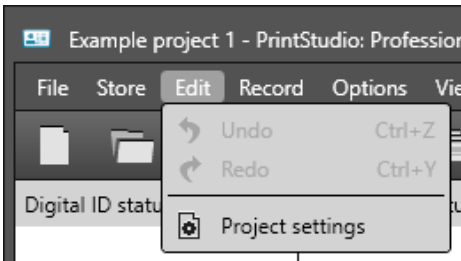

### Edit

The Edit menu offers the edit functions and project settings that you use during the data managing process:

- *Undo*: Undo recent actions made in your project.
- *Redo*: Redo actions you undid in your project.
- *Project Settings*: Change project settings or link card designs to a project.

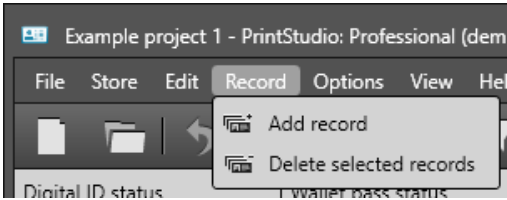

### Record

The Record menu give you control over the records being able to add new records or delete existing records.

- *Add new record*: Add new card holder data, photo and or signature.
- *Delete selected record*

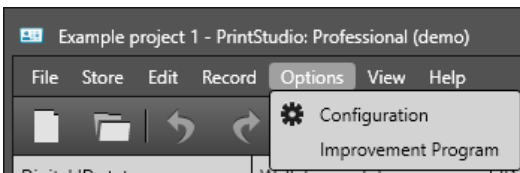

### Options

The Options menu brings you to the configurations of the application like date and language settings.

- *Configuration*:

- A. Configure the language, you can choose from English, German, Spanish, French,
- B. Date format, setup the date and time format for your project.
- C. Project folder, in what folder you would like to save your projects.
- D. Print settings, like setting the default printer and/or card reader.
- E. Set the Digital ID progress window to appear after a digital ID process started.

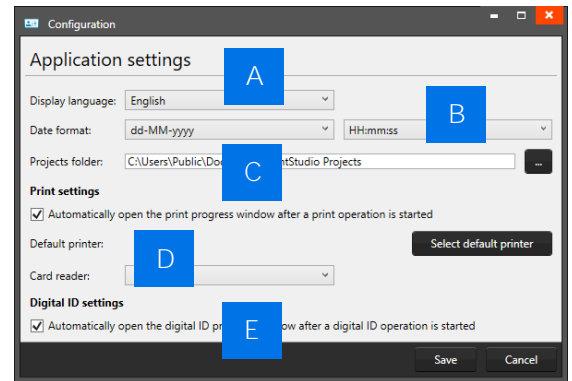

- *Improvement Program*: Here you can join our Improvement Program. If you join, information will be periodically collected anonymous about how you use PrintStudio.

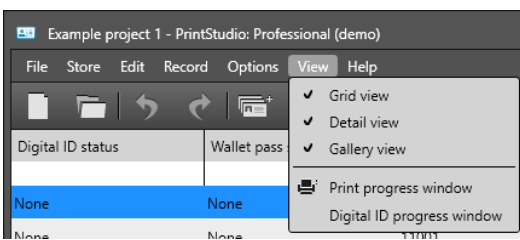

### Views

The Views menu makes it possible to make certain views in the main window visible or invisible.

- *Grid View*
- *Detail View*
- *Gallery (Photo Slider) View*
- *Print Status Window*
- *Digital ID Progress Window*

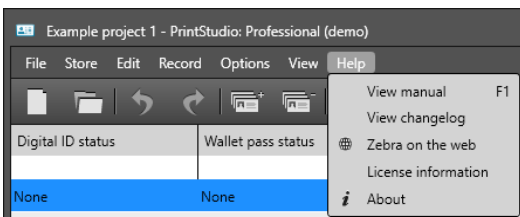

### Help

For more information on the application or a user guide click on the Help button.

- *View manual*
- *View changelog*
- *ScreenCheck on the web*
- *License information*
- *About*

## Quick menu

When opening PrintStudio two Quick buttons appear in the middle of the interface. The buttons give two options, continue working with an existing project or creating a new project.

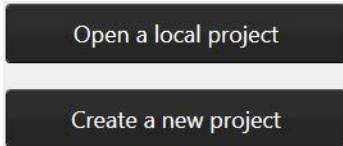

The Quick menu offers a selection of large visual buttons often used in the card production process making navigation quick and easy.

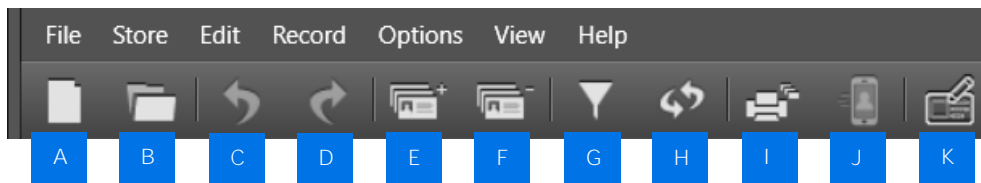

*Quick menu view with large visual buttons*

- A. New  
Click to start a new Project.
- B. Open existing Project  
Click to open an existing project.
- C. Undo  
Undo actions done working in the project.
- D. Redo  
Redo an action that was undone working in the project.
- E. Add a new record  
Records are single data rows that contain all the information of one person. Click to add a new record to the project. This means putting in new information for a new card holder, adding a photo and if needed adding a signature.
- F. Delete a selected record  
Records are single data rows that contain all the information of one person. Click to delete the selected record(s) from the project.

#### G. Filter records

Have a lot of data in your data grid? This button will be helpful giving you all kinds of different filter options to search for specific groups or a certain person. You can add multiple filter sets. Every filter set can have one or more filter rules. You can combine one or more filter sets to make your search more specific.

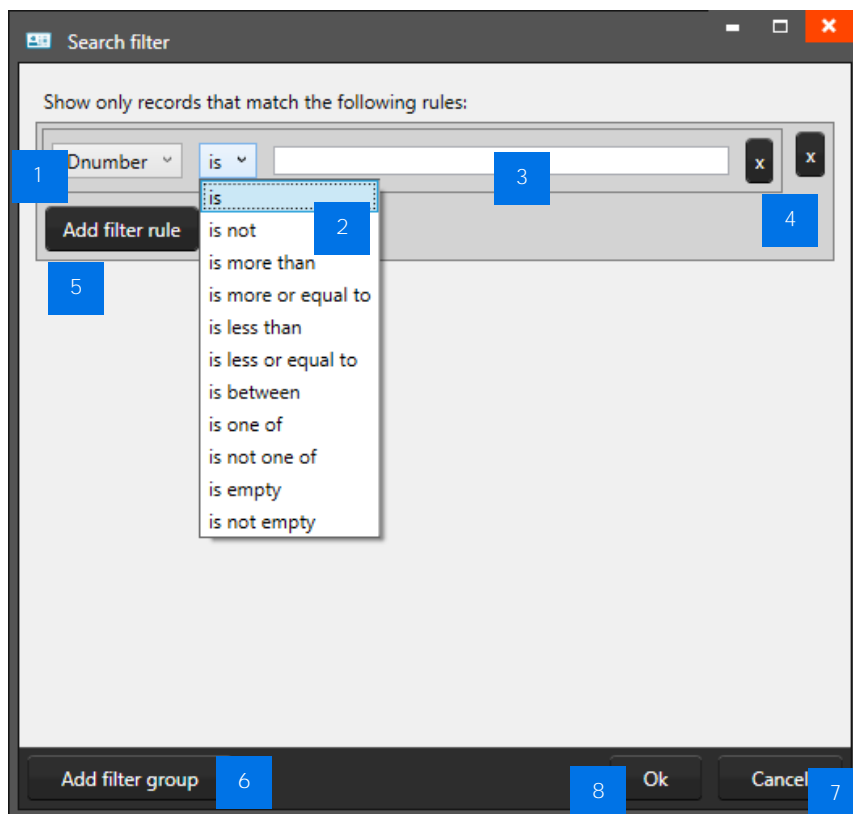

Example of the filter options window that pop-up after clicking the filter button in the Quick menu.

1. To setup a filter rule starts with selecting one of the fields that you want to search in. This will narrow a search and make it faster.
2. After selecting the field, you need to select how specific you want to match the field with the criteria in field 3. If the value is very specific choose “is”, if you do not want it to be too specific you can choose “Starts with”.
3. Enter the information you are looking for depending on a specific search or a group search. For example, you could enter a complete index number to find a certain person or just the start of a number.
4. The “X” buttons are to delete a filter rule or a filter set.
5. Click on this button to add a new filter rule to this filter set to narrow your search.
6. Click on this button when you want to add a new filter set. Example: You use a filter set when searching for two different type of records and need to add a separate search.
7. Cancel filter option.
8. To start the search/filter process click on the “Ok” button.

#### H. Refresh Data

This button allows you to refresh data when working with CardStudio Connect projects making sure all data is up to date with the connected data bases.

I. Print all selected records  
Print all selected records

1. To print one or more records, select them and click the print button to print the records, using the most recent printer setup. On first-time use, the printer dialogue will be displayed.

A print window pops up, so you can select the printer you installed for the card printing process. This manual does not describe the installation of printers. Please refer to the manufacturers manuals for further information on these devices. After selecting the printer, click on the “Print” button.

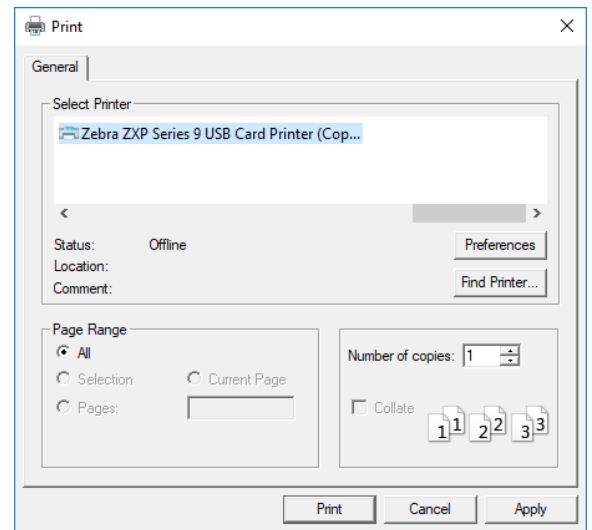

Example printer setup window.

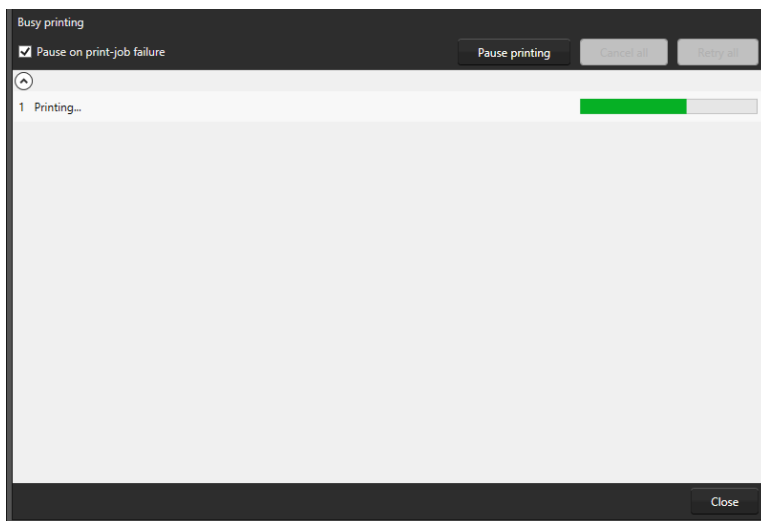

Example of the Card printing progress window.

2. A print progress window will pop-up that will show you the progress of the cards that are being printed.

J. Send Digital ID



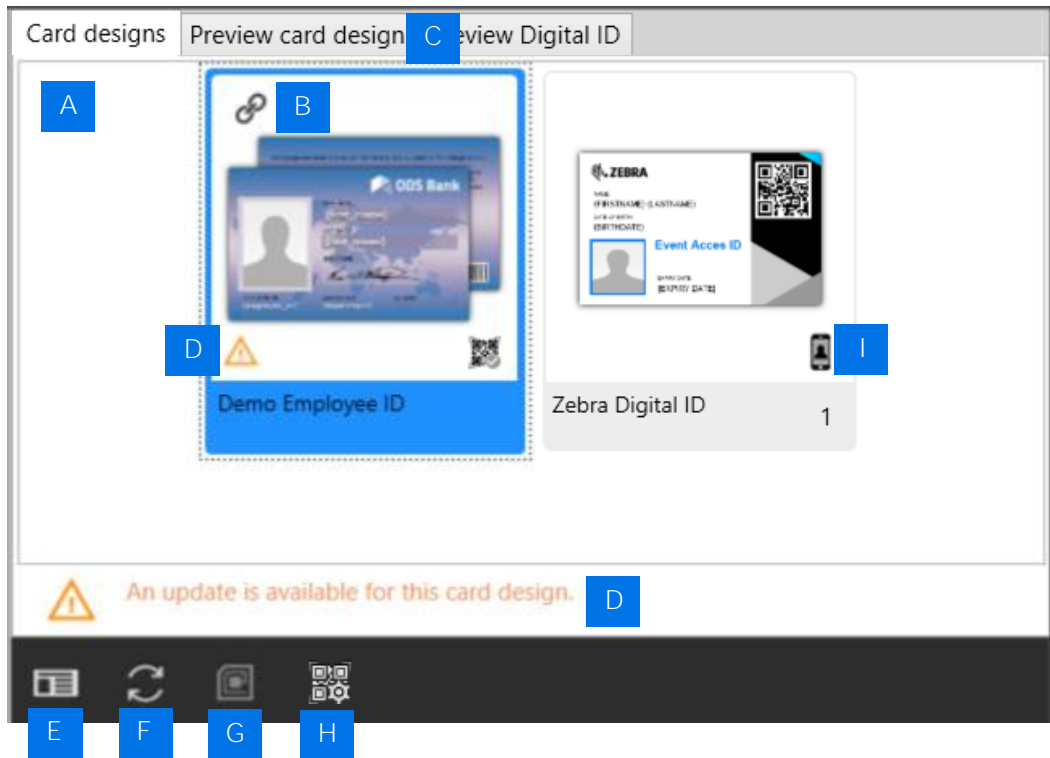

Send the linked Digital ID design to the selected card holders by email. You need credits in your account to send Digital IDs. Purchase credits in the store.

K. CardStudio Design

This quick menu button lets you open CardStudio Design and continue with creating or adjusting your card design.



Card designs overview

- A. The card designs overview shows the designs added to this specific project
- B. The link icon allows you to link one or more selected records to this card design.
- C. Select a record and click on the Preview card design or Preview Digital ID tab to see a preview of the card design / Digital ID linked to the record.
- D. The warning icon lets you know an action is needed for this card design. An action can be that an update is available for the design for example. F. Update a card design using the update icon in the quick menu.
- E. The card design icon gives a quick navigation to the card design settings of the selected card.
- F. Update a card design using the update icon in the quick menu
- G. With the encode icon you can quickly navigate to the encode settings of the selected card. If a card design does not have encoding, the icon will be greyed out.
- H. With the status check settings icon you can quickly navigate to the status check settings of the selected card.
- I. A card design can have a digital ID design, a Status Check or encoding linked to it. The icons show what type of card design it is. [Card design icons:](#)
  -  Card design has Digital ID Design
  -  Card design has Wallet Pass Design
  -  Card design has a Status Check link
  -  Card design has a CCI-file (encoding) linked

# PrintStudio

## Create a Project

# PrintStudio

## Create a Project

To setup a PrintStudio project, start with the setup of a new project or open an existing one.

### New Project

A. Go to File in the main menu and click on “New”.

Or click on the icon below in the quick menu:

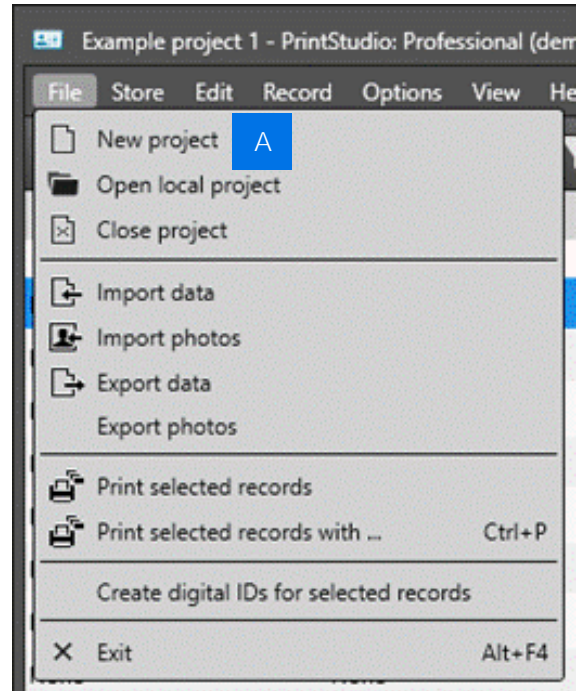

Click on the “New project” link or button a “Create New Project”, a selection window will pop-up. You can select one of the six options to start a new project.

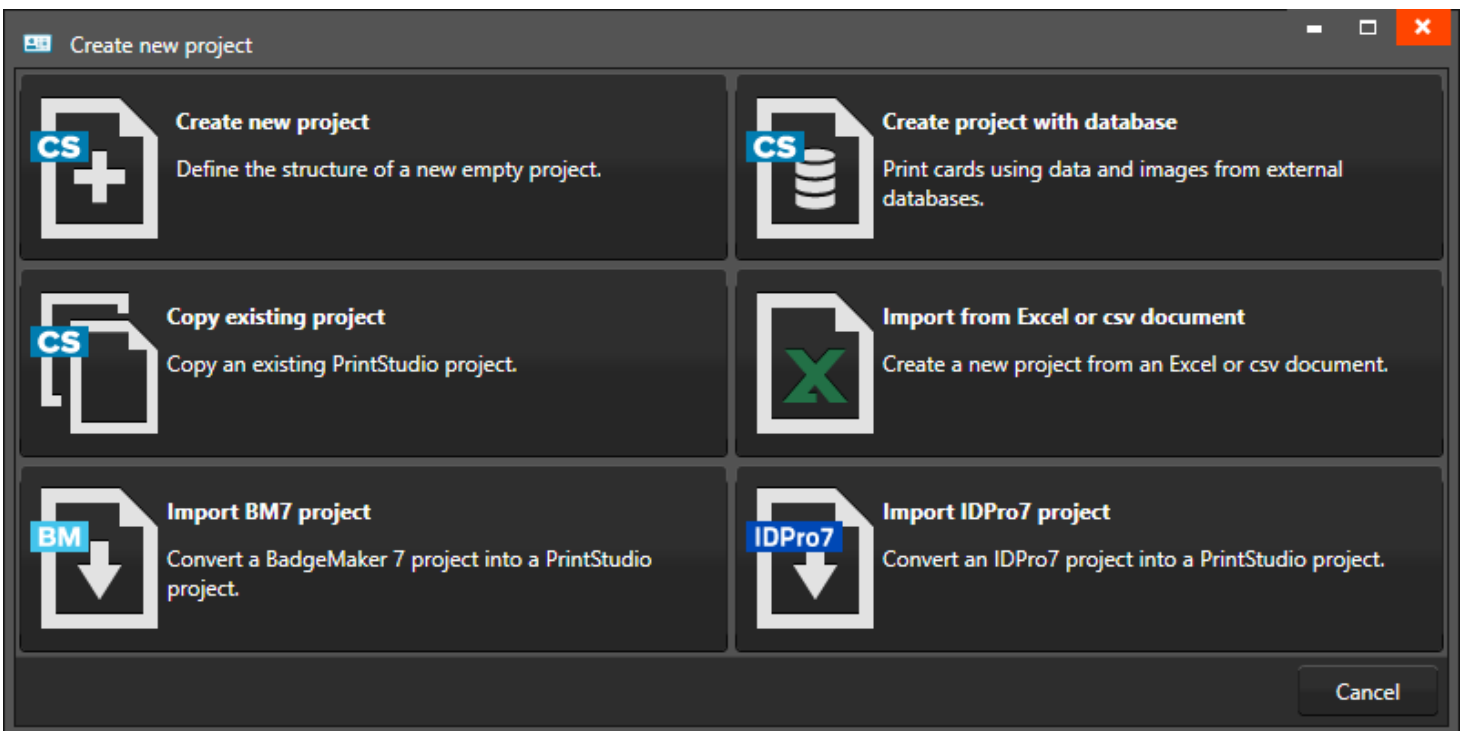

Example of the selection window to create a new project.

## Create a New Project

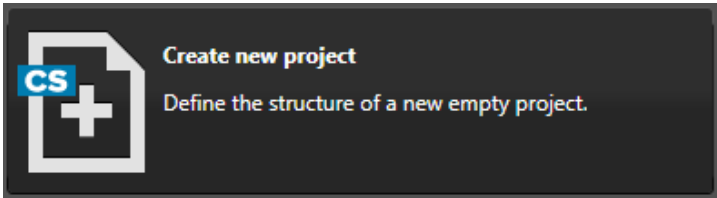

Click on “[Create a New Project](#)” to start with a blank data grid and setup your own database field names. A **couple of default fields are supplied to speed up the setup process.** Change the default fields or add extra fields as needed.

### 1. Project structure

Step 1. Setup the project structure by adding the project data fields.

The screenshot shows the "Create new PrintStudio project" dialog, specifically the "Project structure" step. At the top, there is a progress bar with seven steps: 1. Project structure (active), 2. Biometric settings, 3. View configuration, 4. Status Check, 5. Card designs, 6. Triggers, and 7. Create project. Below the progress bar, the "Project name" field contains "Zebra Demo Project". A table lists several data fields with columns for Name, Type, Required, Unique, and Default value. Each field has a corresponding "X" button to delete it. At the bottom, there are buttons for "Add new property", "Previous step", "Next step", and "Cancel".

Name	Type	Required	Unique	Default value	
ID	Whole	<input checked="" type="checkbox"/>	<input checked="" type="checkbox"/>		X
<input type="checkbox"/> Is auto-incrementing					
Name	Text	<input type="checkbox"/>	<input type="checkbox"/>		X
Last name	Text	<input type="checkbox"/>	<input type="checkbox"/>		X
Date of birth	Date	<input type="checkbox"/>	<input type="checkbox"/>	Select a date 15	X
Email	Text	<input type="checkbox"/>	<input type="checkbox"/>		X
Number of cards	Whole number	<input type="checkbox"/>	<input type="checkbox"/>		X
<input type="checkbox"/> Is auto-incrementing					
Card status	Options list	<input checked="" type="checkbox"/>	<input type="checkbox"/>	No card	X
<input type="checkbox"/> Expand to view and modify available values					

*Example of step 1. New project: add project data columns*

- A. Type in the name for your new project.
- B. Put in the database field name.
- C. Set the data type. Select if the data are number or text for example.
- D. Check these boxes if the field needs to be “Required” and or “Unique”.
- E. With the default input field, you can add a standard value to your data field. Existing empty fields and new records will automatically show the default value you add to this data field.
- F. Click on the “X” button to delete a data field from the project structure setup.
- G. Enable auto-increment for “Whole number” data fields, to let for example the ID number increase by one for every new record automatically.
- H. Click on the “Add new property” button and add and describe the data field names you want to use in your new project.
- I. Click on the “Next step” button to go to step 2. and configure the detailed and gallery view.



## 2. Biometric settings

During step 2, you can enable the biometric images you need in your project and determine how they will be stored.

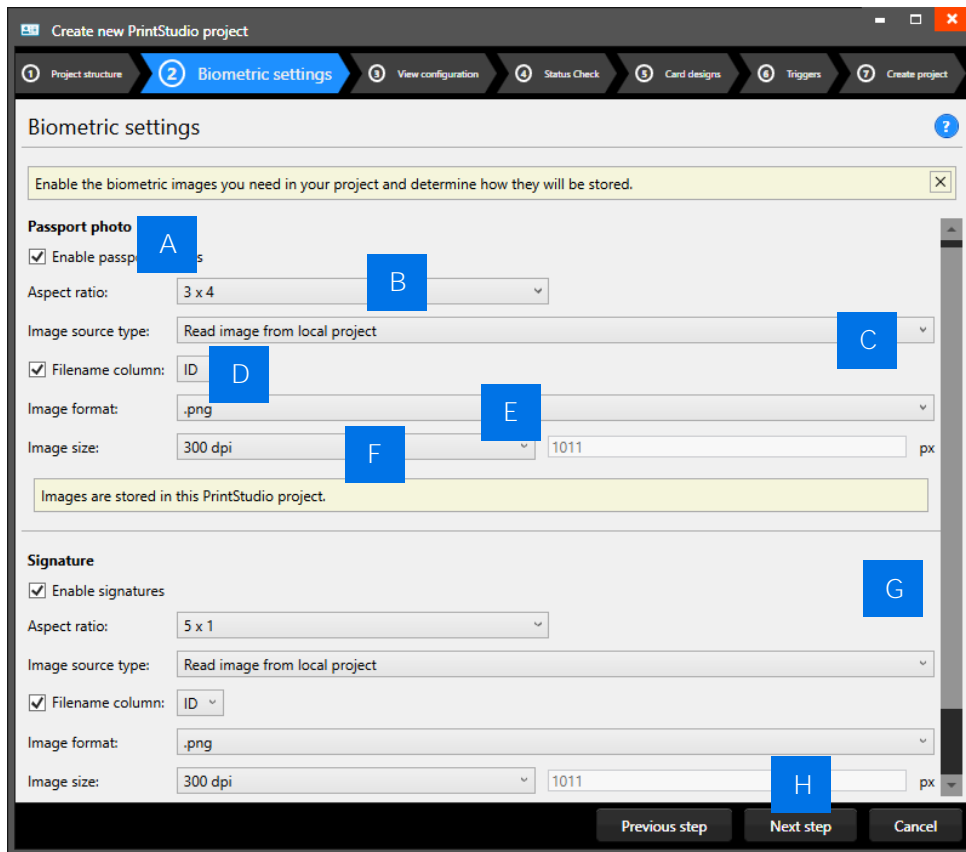

Fig. Example of step 2. New project: Biometric settings

- A. The box for passport photos makes photos visible in the project and enables you to add photos.
- B. After checking the box, you can determine the ratio of the photo.
- C. Select how and where photos will be saved within your project.
- D. Check this box if you want to use data columns to represent the filename.



Example of photo's that have filenames corresponding with their ID number.

- E. Select the image format (.png, .jpg or .bmp) the photos need to be saved as within your project.
- F. Here you can select what size the photos need to be saved as within your project.
- G. The process for signatures works the same as the photo settings.
- H. Click on the "Next step" button to go to step 3 and configure the view configuration.

### 3. View configuration

During step 3, choose the default configuration or adjust the setup for Detailed and Gallery view.

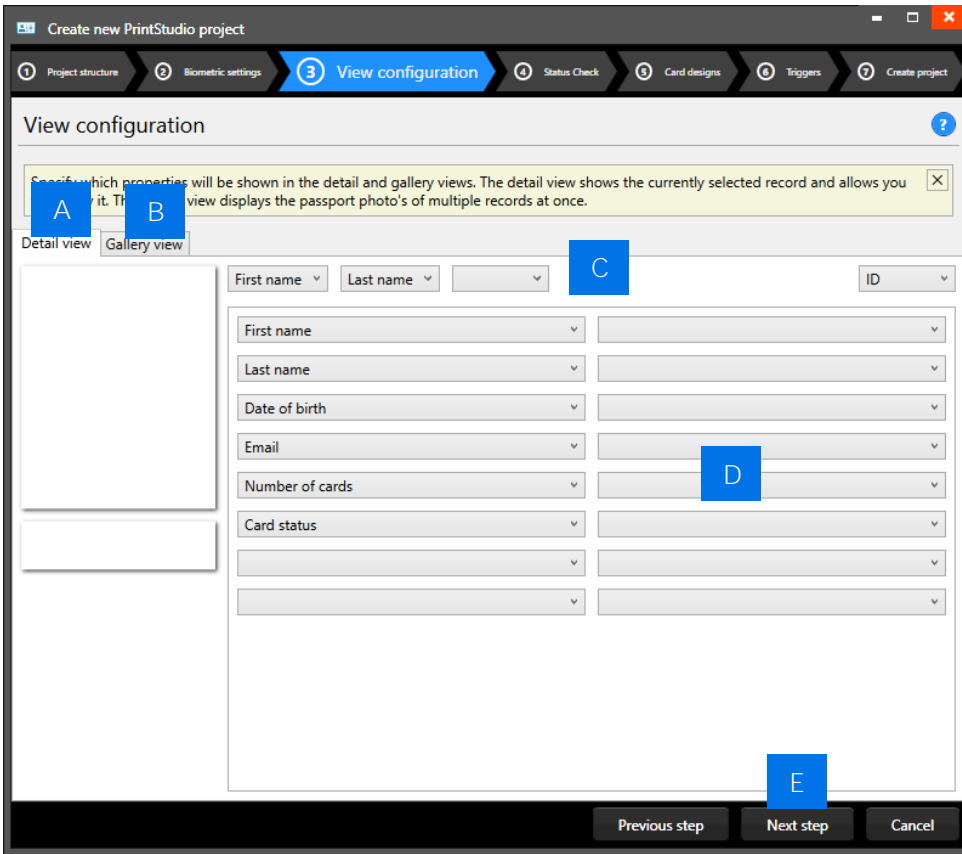

Example of step 3. New project: view configuration

- A. Tab to configure Detailed view showing specific cardholders' information.
- B. Tab to configure Gallery view showing cardholders photos.
- C. Setup the title for the detailed view.
- D. Setup the information that will be shown in the detailed view.
- E. Click on the “Next step” button to go to step 4, and add triggers to the project.

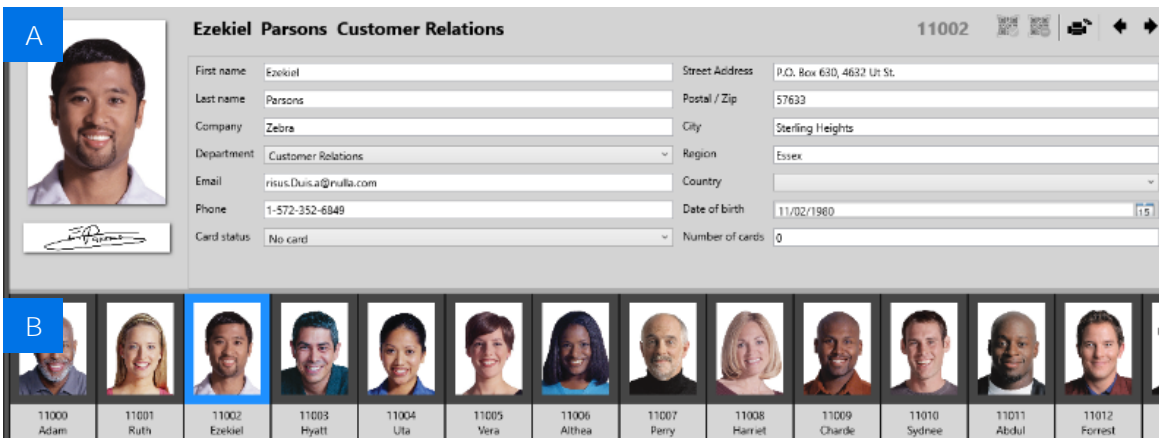

Example of the A. Detailed view and the B. Gallery view

## 4. Status Check

Step 4. Allows you to select and setup the Status Check template. With Status Check it is now possible to scan a QR-code on a printed card or Digital ID and get status feedback. Status Check is an optional fee-based feature that allows you to add a live 2D barcode to your printed or Digital ID Card. This QR-Code contains a unique secure URL that displays a Status Check page with a near, current or up-dated status of a data field you configure in your project. It costs 5 credits to issue a Status Check QR-code and 2 credits to update an existing Status Check Card.

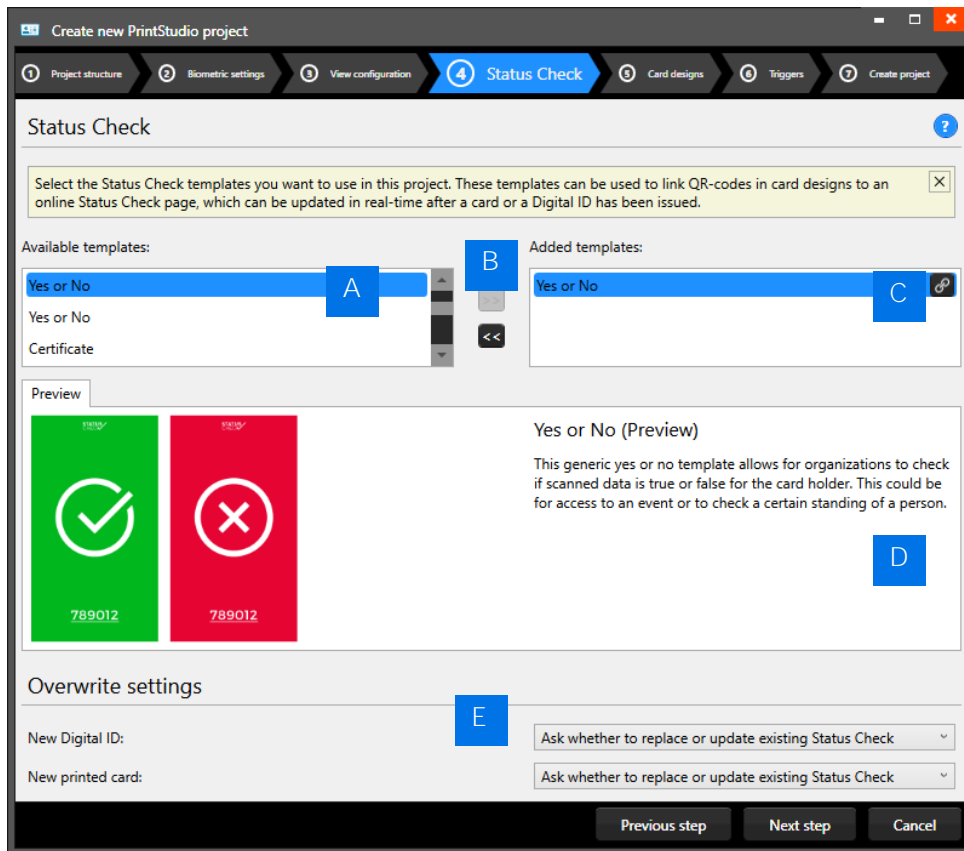

A. Select one of the available Status Check templates from this list. For example, to check the status of training certifications, membership, academic standing, or special access.

B. Click on the “>>” button to add a template to this new project. Click on the “<<” button to remove a selected card design from your project.

C. A Status Check template in your project has an icon available, this is the “Bindings” icon:



Click on the bindings icon to edit the bindings for the dynamic data of the Status Check template and to select the option list to use for validation. The bindings window pops up automatically after adding a template to your project.

D. Preview of the Status Check template selected. You can see the design for positive feedback (green)

and negative feedback (red) and a short description on how to use the template.

E. Select the overwrite settings for your Status Check QR-code on your card and digital ID. The QR-code link will be generated as soon as a card gets printed, or a digital ID issued. You can choose for: Generate new Status Check, Update existing Status Check, Update existing Status Check if out of date or Ask whether to replace or update existing Status Check.

### Status Check template bindings

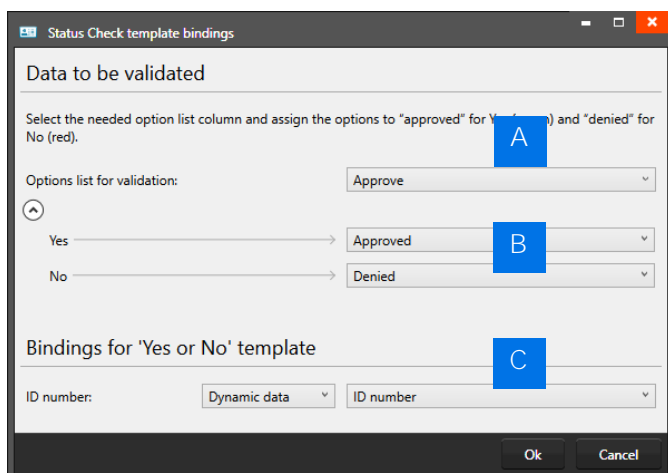

The bindings window pops up automatically after adding a template to your project. The selected “Yes or No” template allows organizations to check if scanned data is true (green) or false (red).

A. Click on the dropdown menu to select one of the options lists to use for Status Check to validate. PrintStudio makes all the data field option lists previously defined in your project available to choose from. We will use the “Approve” option list, we added to the project structure, to validate in this example.

B. Set -Yes- to “true” to approve and -No- to “false” to deny access to each of the activities.

C. The templates can also show Static or Dynamic data from your project. This template shows the card holders’ ID number. Bind this ID to the ID number in your project.

## 5. Card designs

Step 5. allows you to add card designs to your new project.

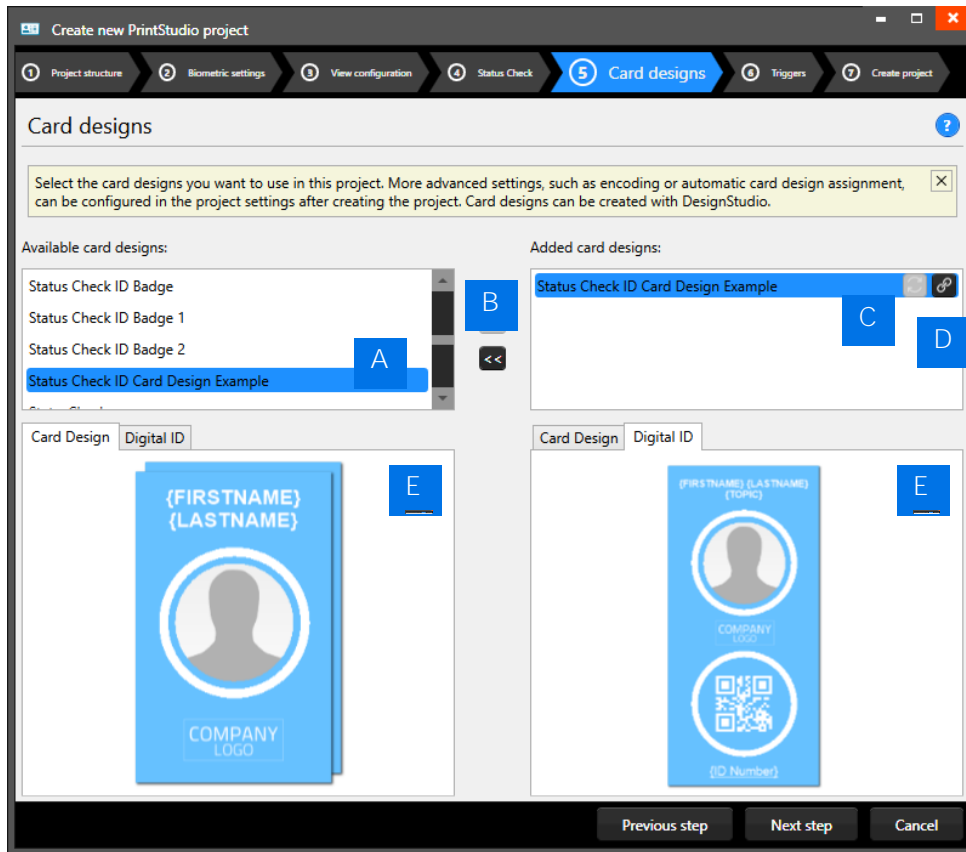

A. Select one of the available designs.

B. Click on the “>>” button to add a selected design to your project. Click on the “<<” button to remove a selected card design from your project.

C. A card design in your project has two icons available, this is the “Update” icon:



An adjusted card design can be updated to the latest version by clicking on the update icon.



D. A card design in your project has two icons available, this is the “Bindings” icon:

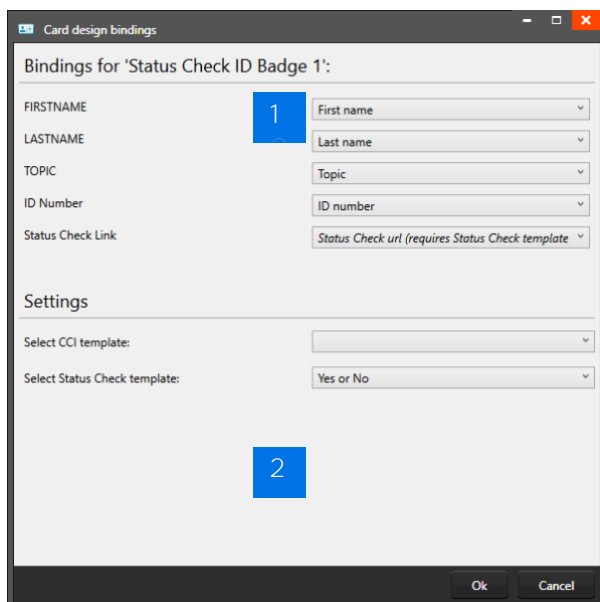

Click on the bindings icon to edit the bindings for the dynamic data of the card design. The bindings window pops up automatically after adding a design to your project.

The data binding tool is a powerful option in PrintStudio. When you add a new layout or update a layout you will be prompted to create the data bindings. Dynamic fields used and created in your layout may differ from the naming or spelling of a name that exists in your Project database. Therefore, you will be allowed to create the data bindings.

### 1. Card Design bindings

The dynamic fields that are created in the card design are presented to the left and you can bind these dynamic fields to the database fields of your project.

### 2. Settings

**CCI template:** Bind a CCI encode template to your card design to encode the card during production. For more information go to “[PrintStudio Encode](#)”. If you do not need to encode with this card

design, you can leave this option blank.

**Status Check template:** Bind the Status Check Template you set available in your project to the Status Check card design. A Status Check link will be generated for the QR-code in the design as soon as the card or digital id is printed or issued. If you do not need this card design to have a Status Check QR-code leave this option blank.

E. The preview of the Card Designs offers two tabs with a preview of the card design and one of the digital ID. If the card design has a front and a back, you can toggle between the two by clicking on the design in the preview.

## 6. Triggers

Step 6. allows you to setup triggers for your project. Triggers can be used to automatically change data in your project on a certain condition or event.

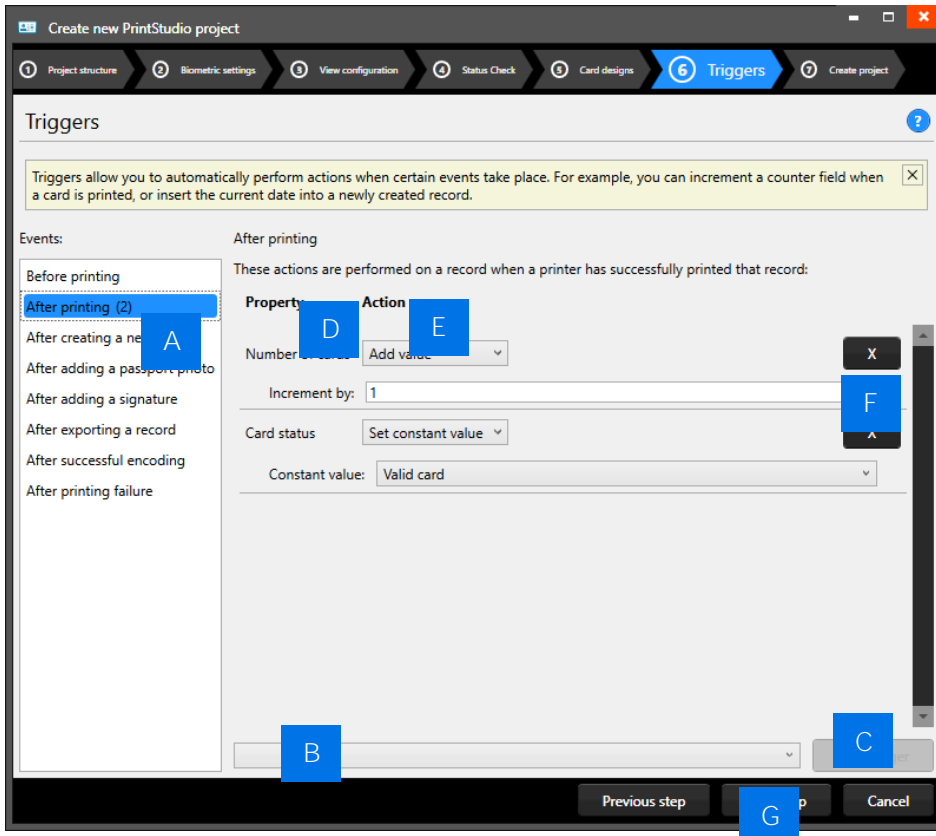

Example of step 5. New project: Triggers

- A. Select one of the events from this list and add specific triggers. PrintStudio will automatically wait for the event to occur before performing the action that is linked to the trigger.
- B. All data columns of the new project are listed. Select one of the columns to link a trigger action to it.
- C. Click on the “Add trigger” button to add the trigger to the data column and specify the trigger with events and actions.
- D. The property shows you the selected data column.
- E. Select the action you want to connect to the data column from the drop-down menu and define the action.
- F. Click on the “X” button to delete a trigger from an event.
- G. Click on the “Next step” button to go to step 6. and create the project.

Define the action that is performed once the event has been met. Some actions are only available for specific columns (for example, incrementing number values can only be done on Number type columns). All changes need to be saved before they become active. Understand that triggers might cause your original data to change, so make sure no vital data is lost when working with triggers.

## 7. Create project

During step 7, the application will start creating your new project after you click on the A. “Create project” button. If there are problems, read the feedback provided and click on the B. “Previous” button to go back and make the needed adjustments.

You are now ready to start adding records to your data grid.

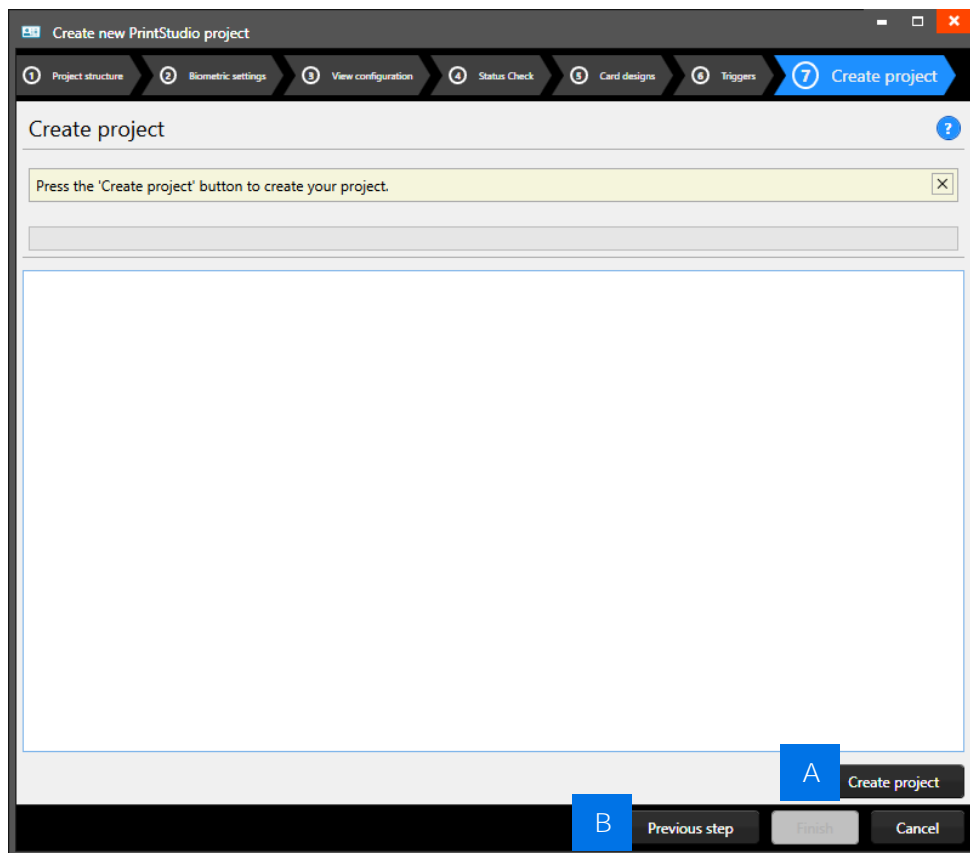

Example of step 6. New project: Create project.

## Create a New CardStudio Project with database connection

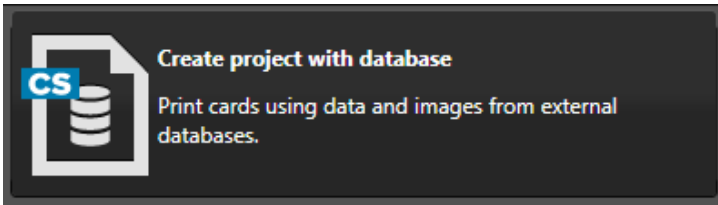

To create a new CardStudio project with database you need the CardStudio 2.0 Enterprise or Professional Edition. Go to the [CardStudio Database Connection](#) Chapter for more information.

### 1. Data sources

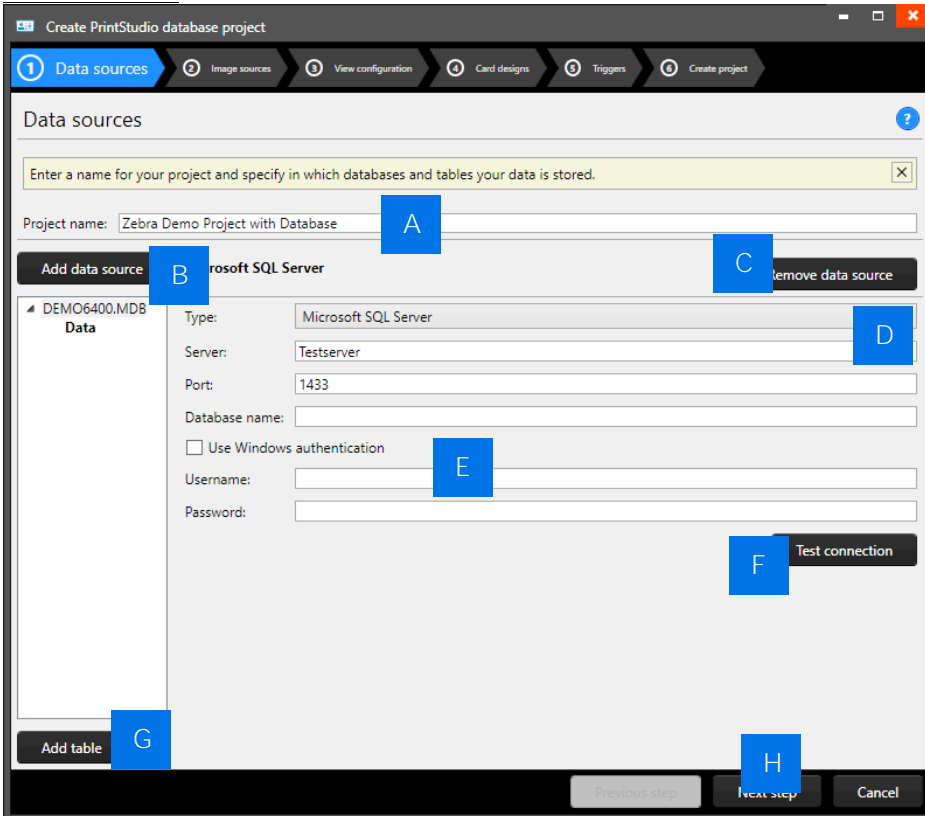

Example of a New PrintStudio Database project with Microsoft SQL database connection step 1: data sources

- A. Give your PrintStudio Database project a unique name.
- B. Click on “[Add data source](#)” to add a database connection to your new project.
- C. Select an added database connection and click on “[Remove data source](#)” to remove a connection.
- D. Select the type of Database you want to connect with, give the server name, port number and database name.  
Several database types are supported:
  - *Microsoft SQL Server*
  - *Microsoft Access files*
  - *MySQL Server*
  - *Oracle Server*
  - *ODBC*
- E. When an external database is secured with credentials you can add those credentials here.
- F. Click on “[Test connection](#)” to test the connection with the external database.
- G. Select the added database connection and click on “[Add table](#)” to add a table from your database to the project.
- H. Click on “[Next](#)” to continue to the next step.

## 2. Image sources

Step 2. Let you specify where your biometric images are located.

The screenshot shows the 'Image sources' configuration window. At the top, a progress bar indicates the current step is 'Image sources'. Below the title bar, there is a yellow instruction box: 'Here you can specify where your biometric images are located.' The 'Passport photo' section includes a checked checkbox 'Enable signatures' (labeled A), an aspect ratio dropdown set to '5 x 1' (labeled B), and another checked checkbox 'Enable passport photos' with an aspect ratio dropdown set to '3 x 4'. The 'Image source type' dropdown is set to 'Read image from local project' (labeled C). The 'Image size' dropdown is set to '300 dpi' (labeled D) and the text input is '1011 px'. A yellow box below indicates 'Images are stored in this PrintStudio project.' The 'Signature' section has identical settings for 'Image source type' (labeled C) and 'Image size' (labeled D). At the bottom, the 'Next step' button is highlighted with a blue box labeled E.

Example of a new project with database connection to a Microsoft SQL database step 2. Image sources.

- A. Check the box when you want to add signatures and or passport photos to your project.
- B. After checking the box, you can determine the ratio of the photo.
- C. Select the image source, from where the images need to be imported into your project.
- D. Select what size the photos need to be saved as, within your project.
- E. Click on the “Next step” button to go to step 3. and configure the detailed and gallery view.



### 3. View configuration

Step 3. Choose the default configuration or adjust the setup for Detailed and Gallery view.

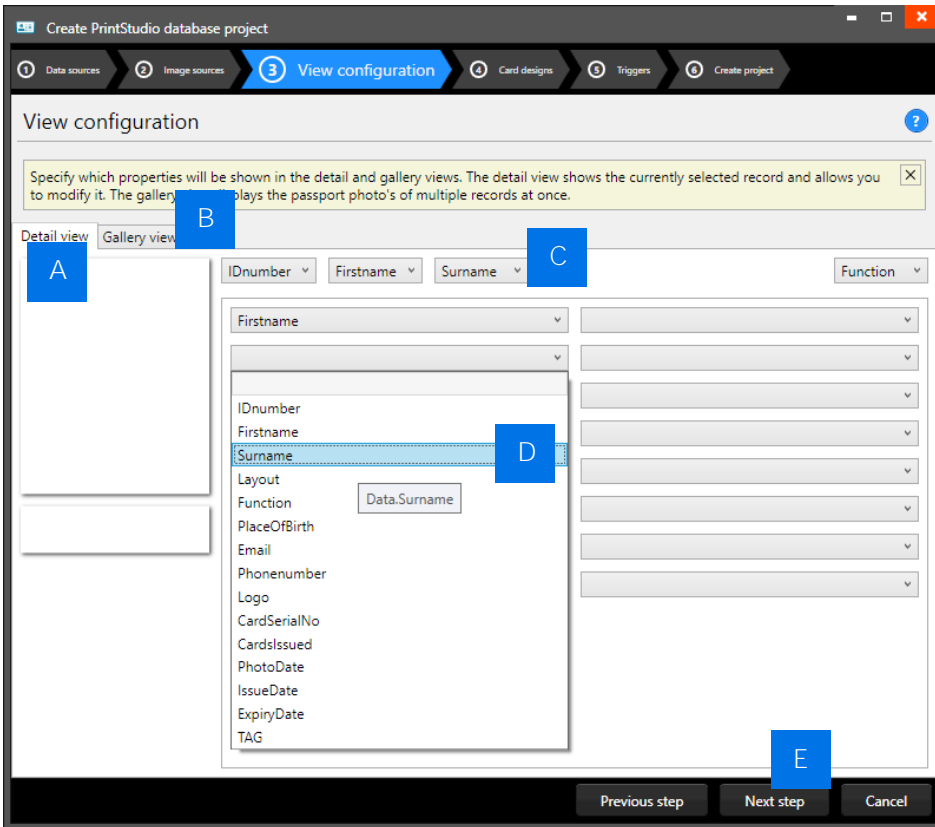

Example of step 3. New project with database: View configuration

- A. Tab to configure Detailed view, showing specific card holders information.
- B. Tab to configure Gallery view, showing card holders photos.
- C. Setup the title for the detailed view.
- D. Setup the information that will be shown in the detailed view.
- E. Click on the “Next step” button to go to step 3. and add triggers to the project.

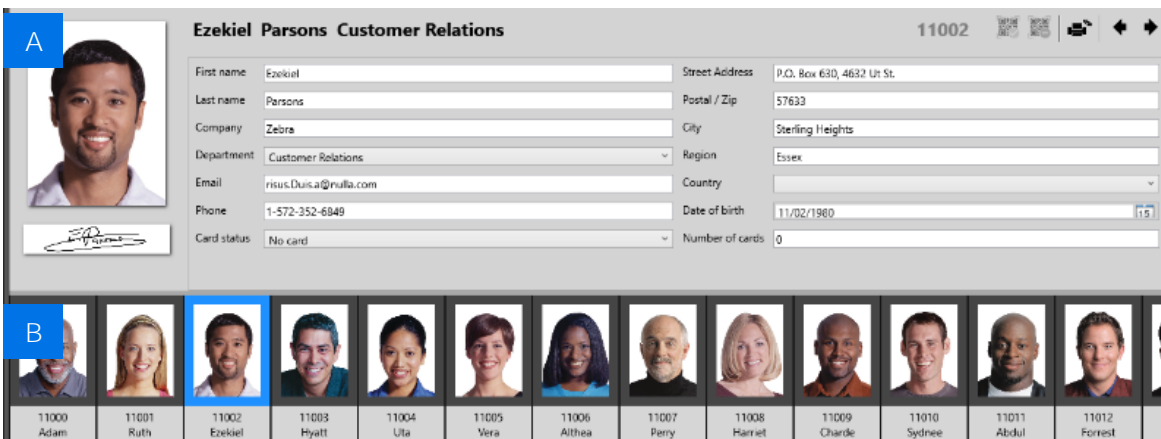

Example of the A. Detailed view and the B. Gallery view

## 4. Status Check

Step 4. Allows you to select and setup the Status Check template. With Status Check it is now possible to scan a QR-code on a printed card or Digital ID and get status feedback. Status Check is an optional fee-based feature that allows you to add a live 2D barcode to your printed or Digital ID Card. This QR-Code contains a unique secure URL that displays a Status Check page with a near, current or up-dated status of a data field you configure in your project. It costs 5 credits to issue a Status Check QR-code and 2 credits to update an existing Status Check Card.

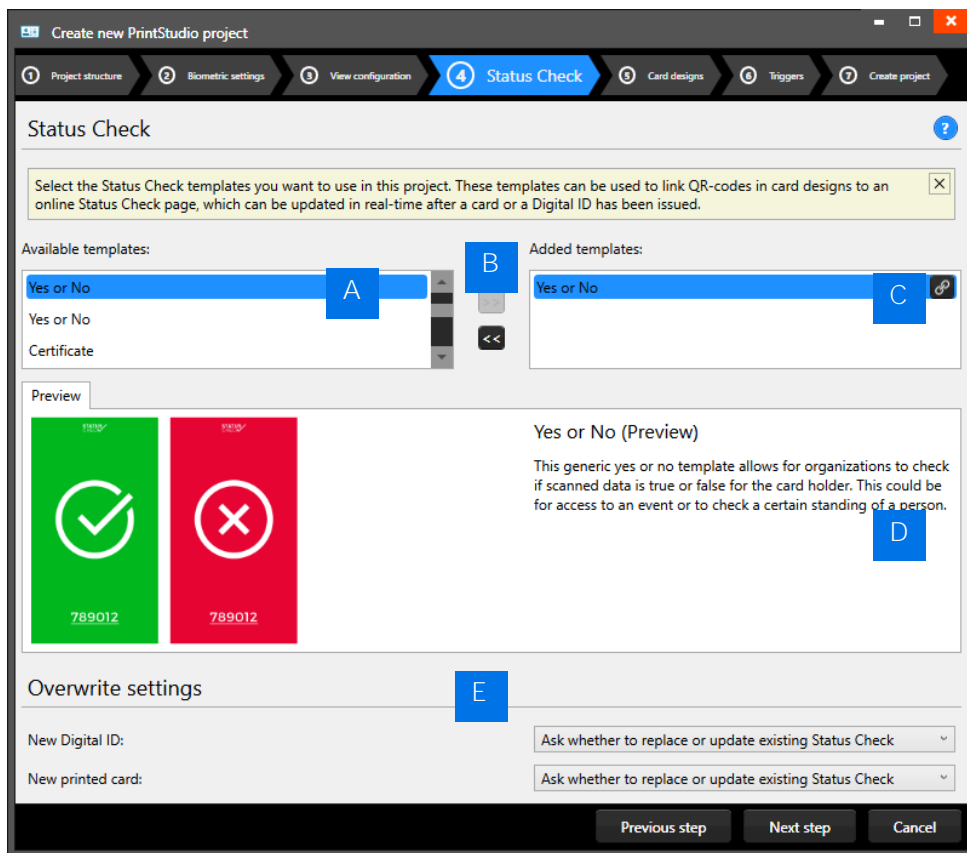

A. Select one of the available Status Check templates from this list. For example, to check the status of training certifications, membership, academic standing, or special access.

B. Click on the “>>” button to add a template to this new project. Click on the “<<” button to remove a selected card design from your project.

C. A Status Check template in your project has an icon available, this is the “Bindings” icon:



Click on the bindings icon to edit the bindings for the dynamic data of the Status Check template and to select the option list to use for validation. The bindings window pops up automatically after adding a template to your project.

D. Preview of the Status Check template selected. You can see the design for positive feedback (green) and negative feedback (red) and a short description on how to use the template.

E. Select the overwrite settings for your Status Check QR-code on your card and digital ID. The QR-code link will be generated as soon as a card gets printed, or a digital ID issued. You can choose for: *Generate new Status Check, Update existing Status Check, Update existing Status Check if out of date or Ask whether to replace or update existing Status Check.*

### Status Check template bindings

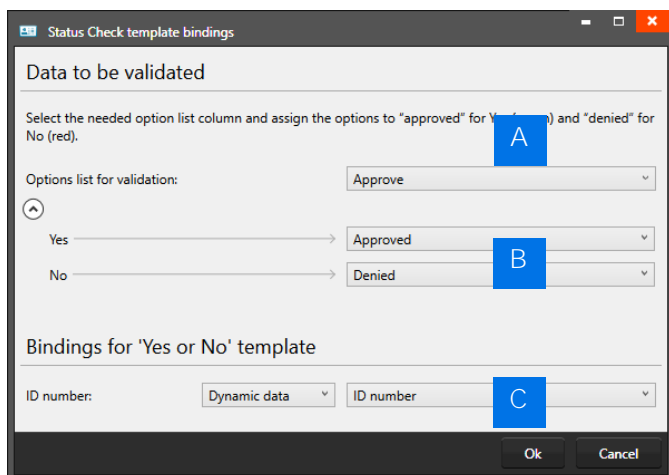

The bindings window pops up automatically after adding a template to your project. The selected “Yes or No” template allows organizations to check if scanned data is true (green) or false (red).

A. Click on the dropdown menu to select one of the options lists to use for Status Check to validate. PrintStudio makes all the data field option lists previously defined in your project available to choose from. We will use the “Approve” option list, we added to the project structure, to validate in this example.

B. Set -Yes- to “true” to approve and -No- to “false” to deny access to each of the activities.

C. The templates can also show Static or Dynamic data from your project. This template shows the card holders’ ID number. Bind this ID to the ID number in your project.

## 5. Card designs

Step 5. allows you to add card designs to your new project.

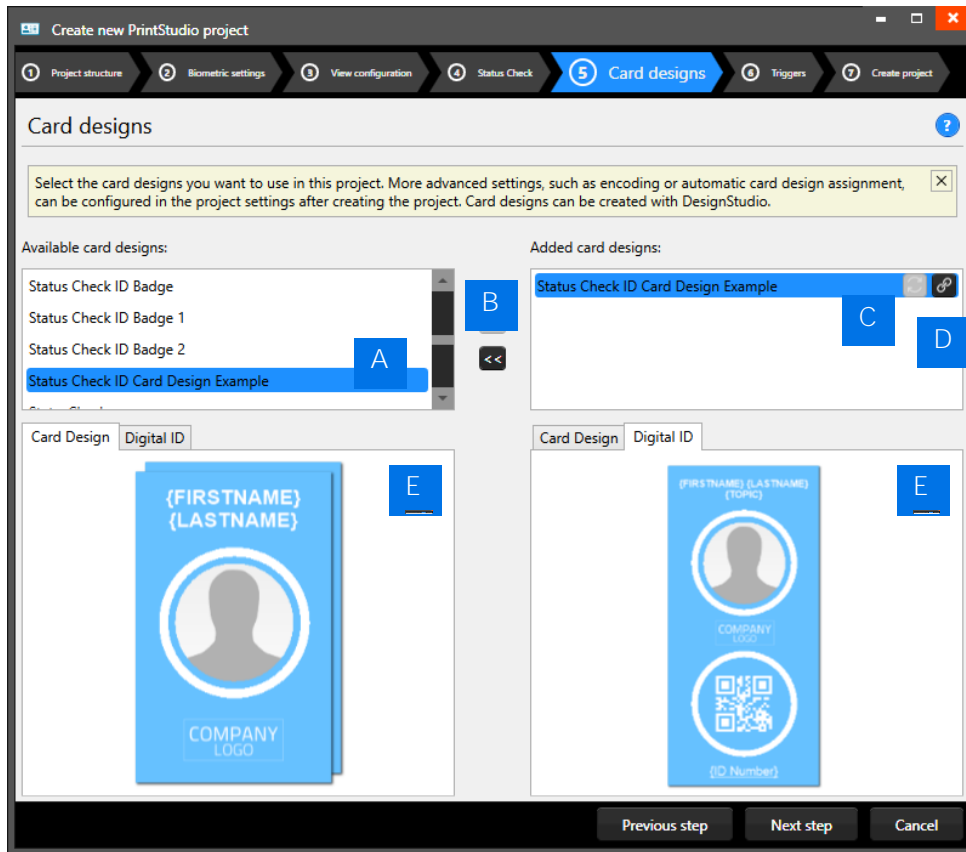

A. Select one of the available designs.

B. Click on the “>>” button to add a selected design to your project. Click on the “<<” button to remove a selected card design from your project.

C. A card design in your project has two icons available, this is the “Update” icon:



An adjusted a card design can be updated to the latest version by clicking on the update icon.



D. A card design in your project has two icons available, this is the “Bindings” icon:

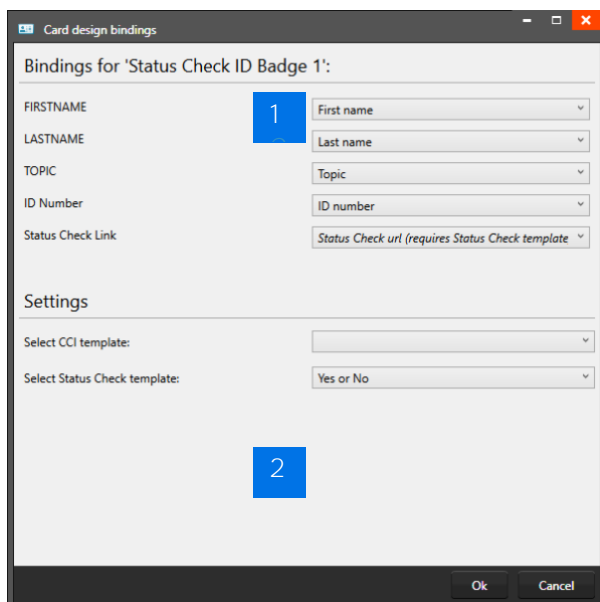

Click on the bindings icon to edit the bindings for the dynamic data of the card design. The bindings window pops up automatically after adding a design to your project.

The data binding tool is a powerful option in PrintStudio. When you add a new layout or update a layout you will be prompted to create the data bindings. Dynamic fields used and created in your layout may differ from the naming or spelling of a name that exists in your Project database. Therefore, you will be allowed to create the data bindings.

### 1. Card Design bindings

The dynamic fields that are created in the card design are presented to the left and you can bind these dynamic fields to the database fields of your project.

### 2. Settings

**CCI template:** Bind a CCI encode template to your card design to encode the card during production. For more information go to “[PrintStudio Encode](#)”. If you do not need to encode with this card

design, you can leave this option blank.

**Status Check template:** Bind the Status Check Template you set available in your project to the Status Check card design. A Status Check link will be generated for the QR-code in the design as soon as the card or digital id is printed or issued. If you do not need this card design to have a Status Check QR-code leave this option blank.

E. The preview of the Card Designs offers two tabs with a preview of the card design and one of the digital ID. If the card design has a front and a back, you can toggle between the two by clicking on the design in the preview.

## 6. Triggers

Step 6. allows you to setup triggers for your project. Triggers can be used to automatically change data in your project on a certain condition or event.

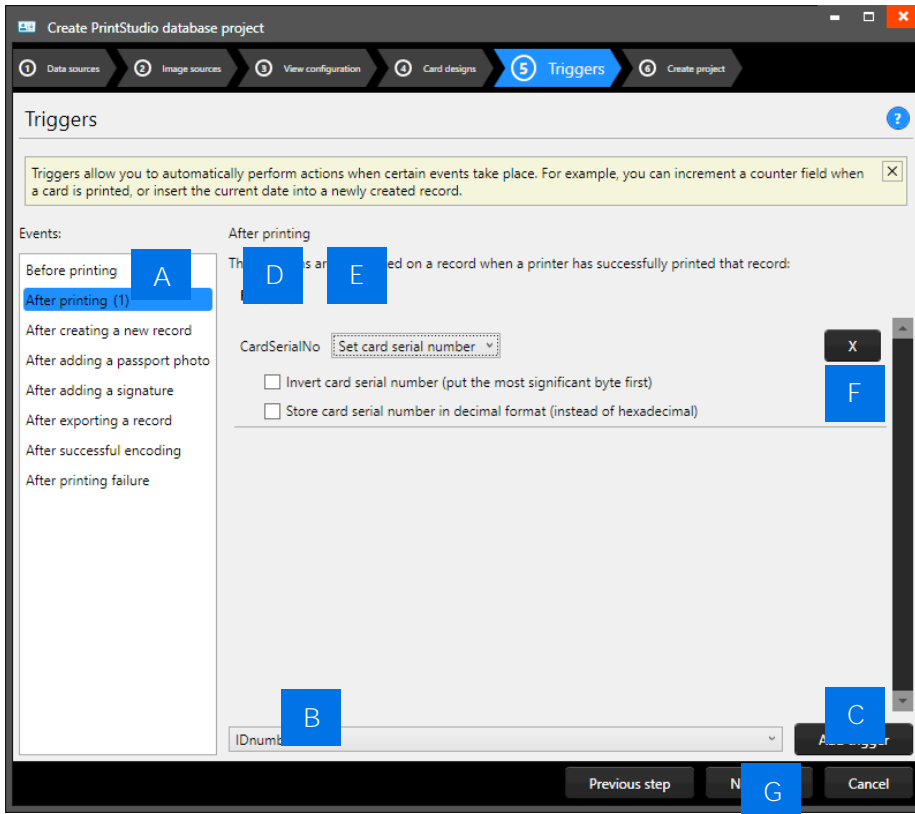

Example of step 5. New project with database: Triggers

- A. Select one of the events from this list and add specific triggers. PrintStudio will automatically wait for the event to occur before performing the action that is linked to the trigger.
- B. All data columns of the new project are listed. Select one of the columns to link a trigger action to it.
- C. Click on the “Add trigger” button to add the trigger to the data column and specify the Trigger with events and actions.
- D. The property shows you the selected data column.
- E. Select the action you want to connect to the data column from the drop-down menu and define the action.
- F. Click on the “X” button to delete a trigger from an event.
- G. Click on the “Next step” button to go to step 5. and create the project.

Define the action that is performed once the event has been met. Some actions are only available for specific columns (for example, incrementing number values can only be done on Number type columns). All changes need to be saved before they become active. Please be aware that triggers might cause your original data to change, so make sure no vital data is lost when working with triggers.

## 7. Create project

Step 7. Will create your new project after you click on the A. “Create project” button. If there are problems read the feedback provided and click on the B. “Previous” button to go back and make the needed adjustments.

You are now ready to start adding records to your data grid.

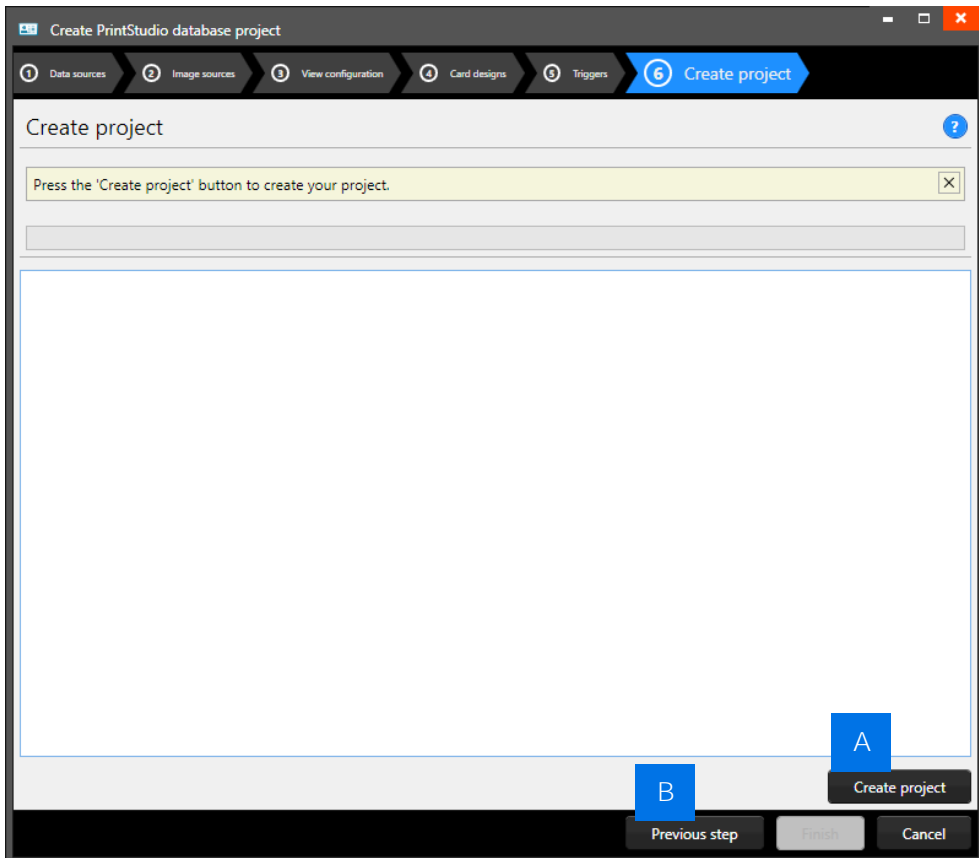

*Example of step 6. New project with database: Create project.*

## Create copy of an existing Project

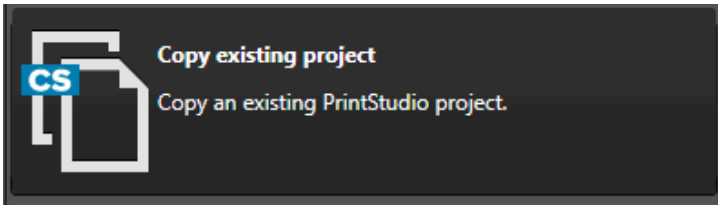

With PrintStudio a new project can be created based on an existing project. Click on the “Copy existing project” to create a new project as a copy of another project.

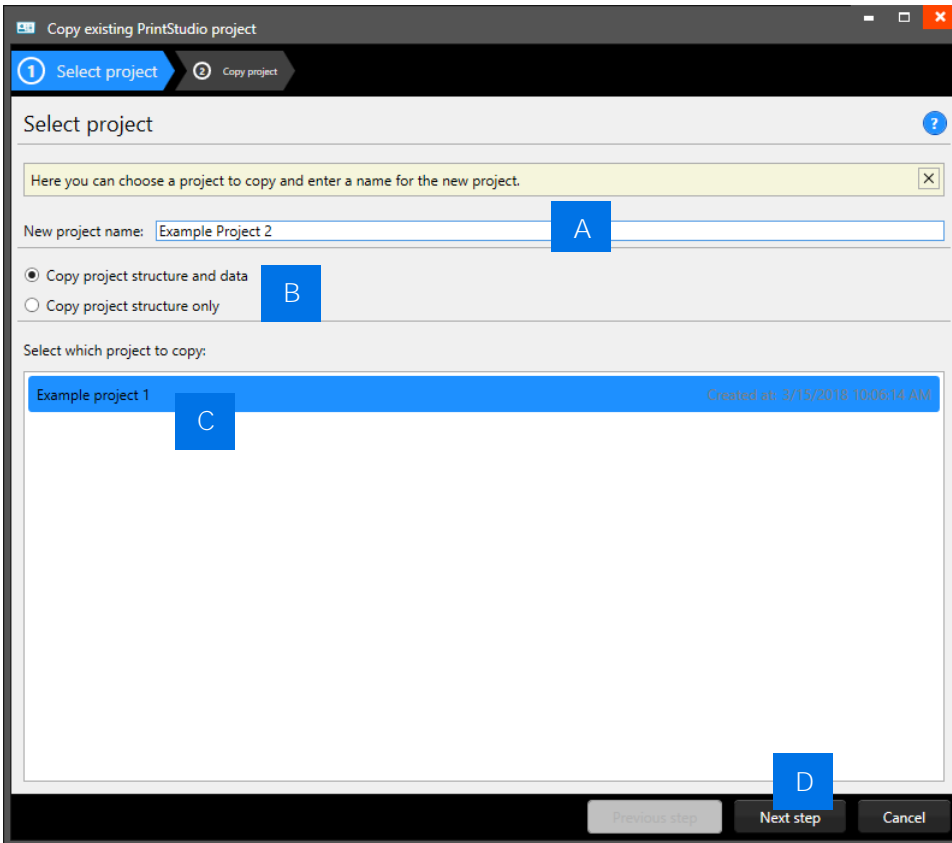

*Example of step 1. New project: Copy existing project.*

### 1. Select project

- A. Rename the project.
- B. Select a copy with data or structure only. Select structure if you only want the data field setup and not the content of the previous project.
- C. Select an existing project from the list presented.
- D. Click on the “Next step” button to create the copy project.

## 2. Copy project

Step 2. creates a copy of the project after you click on the A. “Create project” button. Select B. to make changes in the previous step. You are now ready to start adding records to your data grid.

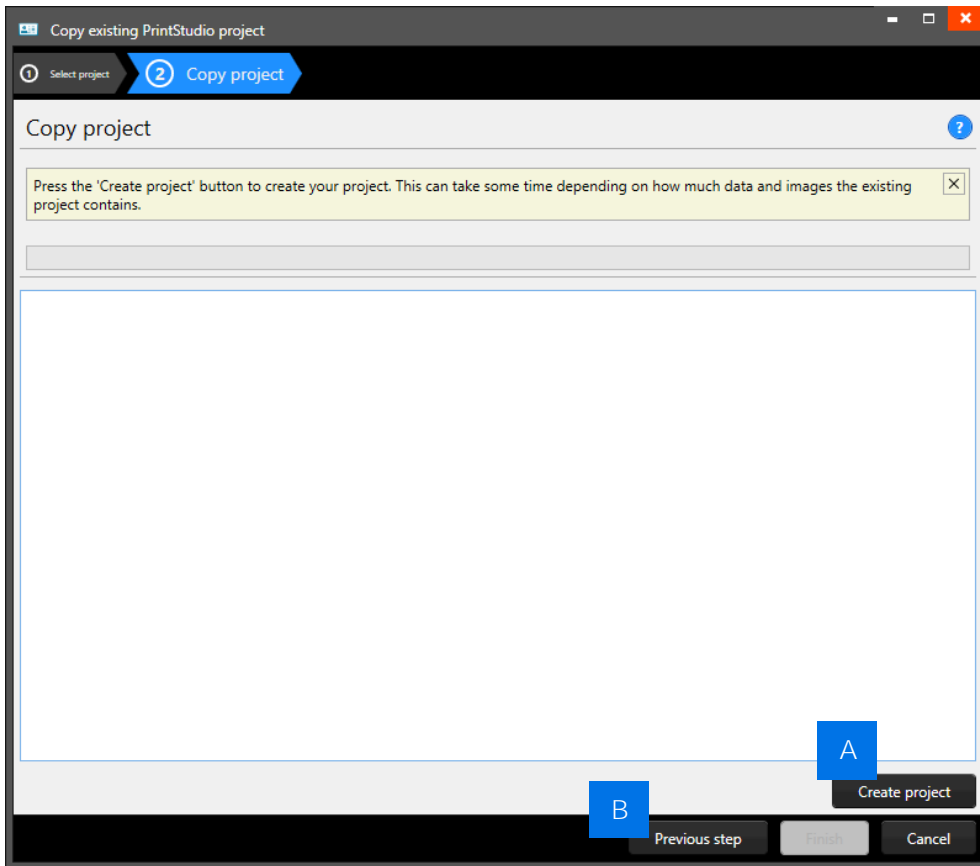

Example of step 2. New project: Copy project.

## Import Project from Excel

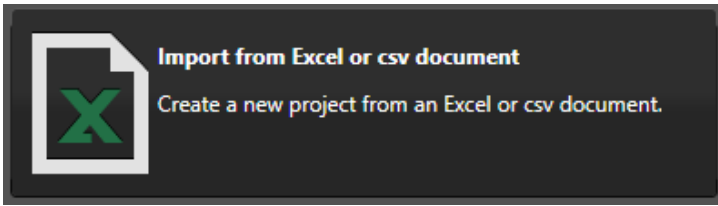

PrintStudio also offers to create new projects based on Excel files. PrintStudio will base the project structure on the Excel structure and will import all the data from the Excel file into the new project.

### 1. Data source

Step 1. Select the Excel file and Worksheet needed for the setup of the new project. You can also add a Photo source and or Signature Source if needed.

The screenshot shows the 'Create project from Excel file' dialog box. It has a progress bar at the top with steps 1 through 8. Step 1, 'Excel file', is active. The dialog contains a text box for the Excel file path, a worksheet dropdown menu, a date format dropdown, a checkbox for selecting the row with column names, a table preview, and settings for passport photo and signature imports. Blue callout boxes A through I point to specific UI elements.

ID Number	First Name	Last Name	Department	Street Address	Postal / Zip	City	State	Country	Email
11000	Adam	Fox	Finances	559-9424 Est Avenue	71850	Fort Smith	AR	United States	aliquam.er
11001	Ruth	Hess	Customer Service	P.O. Box 380, 3629 Vulputate, Rd.	22886	Kapolei	HI	United States	ligula.cons
11002	Ezekiel	Parsons	Customer Relations	P.O. Box 630, 4632 Ut St.	57633	Sterling Heights	MI	United States	risus.Duis.e

Example of step 1. New project imported from excel file: Data source.

- A. Click on this button and select the Excel/CSV file you want to import and create a new project with.
- B. Select the worksheet you want to use from the drop-down menu.
- C. Select the date format you are using in the Excel file.
- D. Select the row that contains the column names.
- E. Select the column that connects with the unique photo names (for example: ID number or index).
- F. Select the folder that contains the cardholders' photos.
- G. Select the column that connects with the unique signature names (for example: ID number or index).
- H. Select the folder that contains the signatures.
- I. Click on the "Next step" button to continue to second step.



## 2. Project structure

Step 2. Name the new project and check the imported Excel data structure. Change, delete or add data columns here in the new project structure.

Source column	Name	Type	Required	Unique	Default value	
ID Number	ID Number	Whole number	<input checked="" type="checkbox"/>	<input checked="" type="checkbox"/>		X
	<input type="checkbox"/> Is auto-incrementing					
First Name	First Name	Text	<input type="checkbox"/>	<input type="checkbox"/>		X
Last Name	Last Name	Text	<input type="checkbox"/>	<input type="checkbox"/>		X
Department	Department	Text	<input type="checkbox"/>	<input type="checkbox"/>		X
Street Address	Street Address	Text	<input type="checkbox"/>	<input type="checkbox"/>		X
Postal / Zip	Postal / Zip	Whole number	<input type="checkbox"/>	<input type="checkbox"/>		X
	<input type="checkbox"/> Is auto-incrementing					
City	City	Text	<input type="checkbox"/>	<input type="checkbox"/>		X
State	State	Text	<input type="checkbox"/>	<input type="checkbox"/>		X

Example of step 2. New project from Excel file: Project data columns

- A. Type in the name for your new project.
- B. Put in the project data column name.
- C. Set the data type. Select if the data are number or text for example. The following types of database fields are supported:
  1. **Whole Number**, when selecting this type, you can select 'auto-increment'. When a new record is created the number will be the highest number in the project increased by 1.
  2. **Text**
  3. **Decimal number**
  4. **Option list**, when this list type is selected, you can add and delete the values from the list that is presented for this database field. When you change a datatype from text to option list, PrintStudio automatically generates a list based on the data already in that data field.
- D. Check these boxes if the field needs to be "Required" and/or "Unique".
- E. With the default input field, you can add a standard value to your data field, existing empty fields and new records will automatically get the default value you add to this data field.
- F. Click on the "X" button to delete a data field from the project structure setup.
- G. Click on the "Add new property" button and add and describe the data field names you want to use in your new project.
- H. Click on the "Next step" button to go to step 2. and configure the detailed and gallery view

### 3. Biometric settings

Step 3. Enable the biometric images needed in the new project and determine how they will be stored.

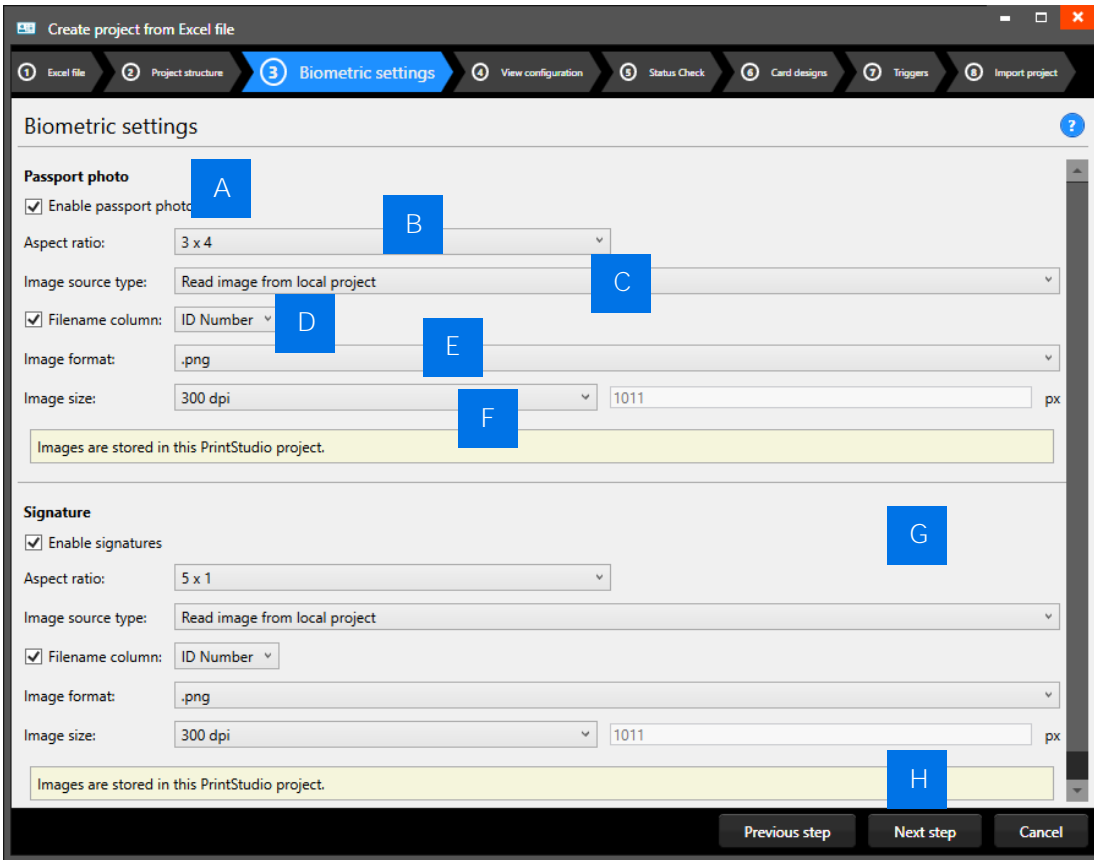

Example of step 3. New project from Excel file: Biometric settings

- A. The box for passport photos makes photos visible in the project and enables you to add photos.
- B. After checking the box, you can determine the ratio of the photo.
- C. Select how and where photos will be saved within your project.
- D. Check this box if you want to use data columns to represent the filename.



Example of photo's that have filenames corresponding with their ID number.

- E. Select the image format (.png, .jpg or .bmp) the photos need to be saved as within your project.
- F. Here you can select what size the photos need to be saved as within your project.
- G. The process for signatures works the same as the photo settings.
- H. Click on the “Next step” button to go to step 3 and configure the view configuration.

## 4. View configuration

Step 4. Choose the default configuration or adjust the setup for Detailed and Gallery view.

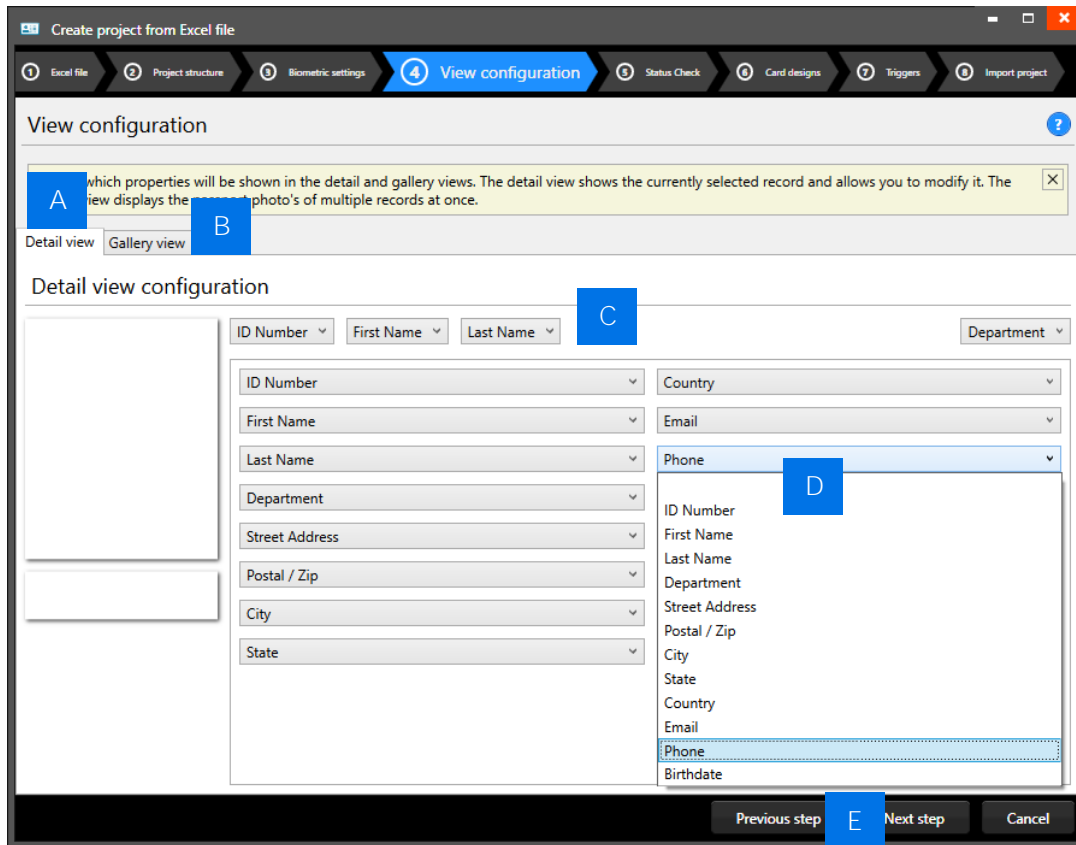

Example of step 4. New project from Excel file: View configuration

- A. Tab to configure Detailed view, showing specific cardholders' information.
- B. Tab to configure Gallery view, showing cardholders photos.
- C. Setup the title for the detailed view.
- D. Setup the information that will be shown in the detailed view.
- E. Click on the “Next step” button to go to step 5. and add triggers to the project.

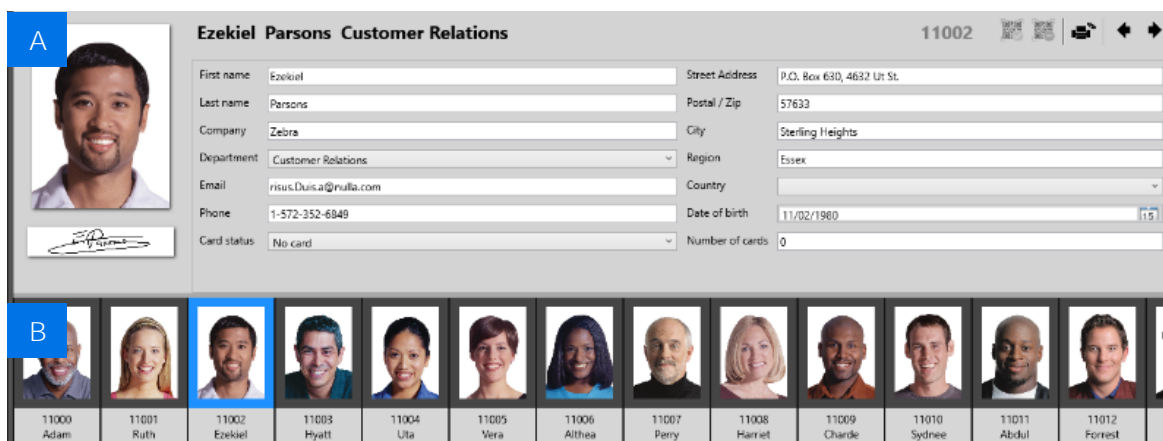

Example of the A. Detailed view and the B. Gallery view

## 5. Status Check

Step 5. Allows you to select and setup the Status Check template. With Status Check it is now possible to scan a QR-code on a printed card or Digital ID and get status feedback. Status Check is an optional fee-based feature that allows you to add a live 2D barcode to your printed or Digital ID Card. This QR-Code contains a unique secure URL that displays a Status Check page with a near, current or up-dated status of a data field you configure in your project. It costs 5 credits to issue a Status Check QR-code and 2 credits to update an existing Status Check Card.

A. Select one of the available Status Check templates from this list.

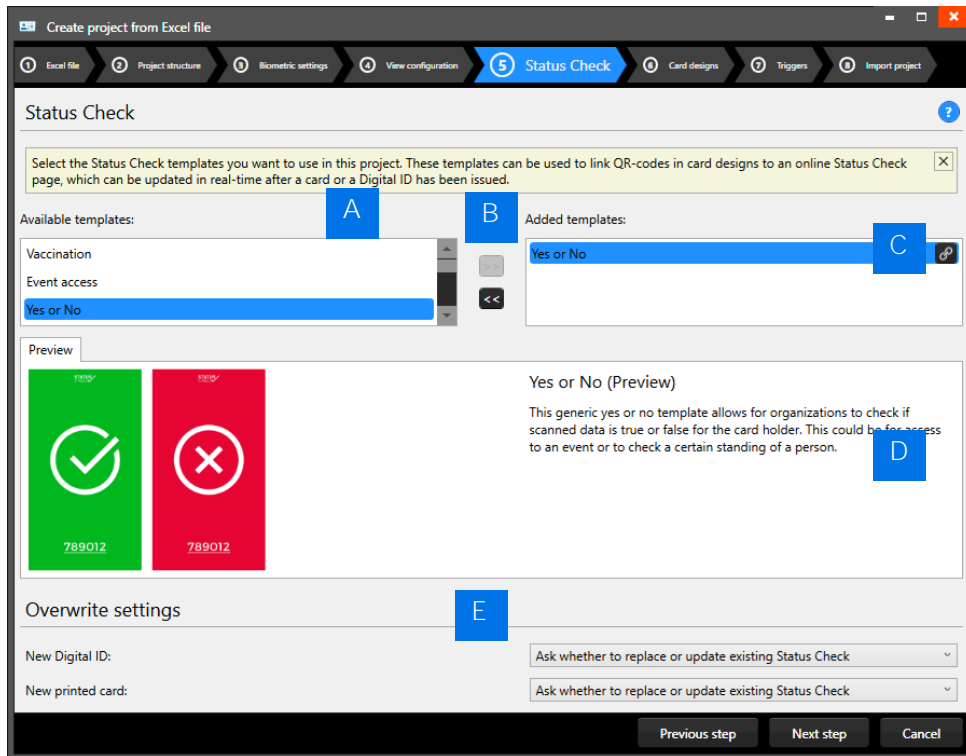

For example, to check the status of training certifications, membership, academic standing, or special access.

B. Click on the “>>” button to add a template to this new project. Click on the “<<” button to remove a selected card design from your project.

C. A Status Check template in your project has an icon available, this is the “Bindings” icon:



Click on the bindings icon to edit the bindings for the dynamic data of the Status Check template and to select the option list to use for validation. The bindings window pops up automatically after adding a template to your project.

D. Preview of the Status Check template selected. You can see the design for positive feedback (green) and negative feedback (red) and a short description on how to use the

template.

E. Select the overwrite settings for your Status Check QR-code on your card and digital ID. The QR-code link will be generated as soon as a card gets printed, or a digital ID issued. You can choose for: *Generate new Status Check, Update existing Status Check, Update existing Status Check if out of date or Ask whether to replace or update existing Status Check.*

### Status Check template bindings

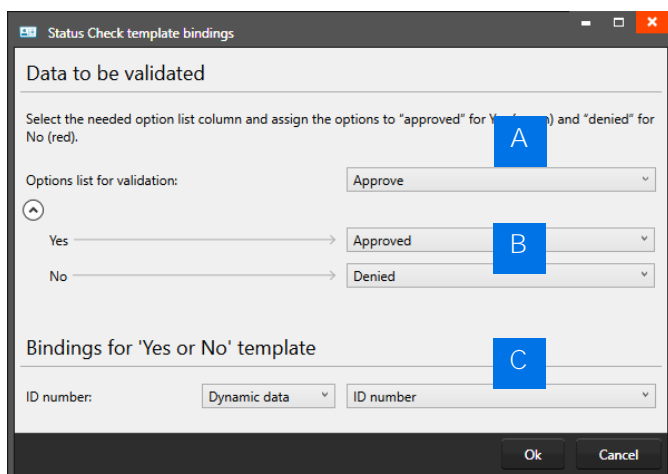

The bindings window pops up automatically after adding a template to your project. The selected “Yes or No” template allows organizations to check if scanned data is true (green) or false (red).

A. Click on the dropdown menu to select one of the options lists to use for Status Check to validate. PrintStudio makes all the data field option lists previously defined in your project available to choose from. We will use the “Approve” option list, we added to the project structure, to validate in this example.

B. Set -Yes- to “true” to approve and -No- to “false” to deny access to each of the activities.

C. The templates can also show Static or Dynamic data from your project. This template shows the card holders’ ID number. Bind this ID to the ID number in your project.

## 6. Card designs

Step 6. allows you to add card designs to your new project.



A. Select one of the available designs.

B. Click on the “>>” button to add a selected design to your project. Click on the “<<” button to remove a selected card design from your project.

C. A card design in your project has two icons available, this is the “Update” icon:



An adjusted a card design can be updated to the latest version by clicking on the update icon.

D. A card design in your project has two icons

available, this is the “Bindings” icon:

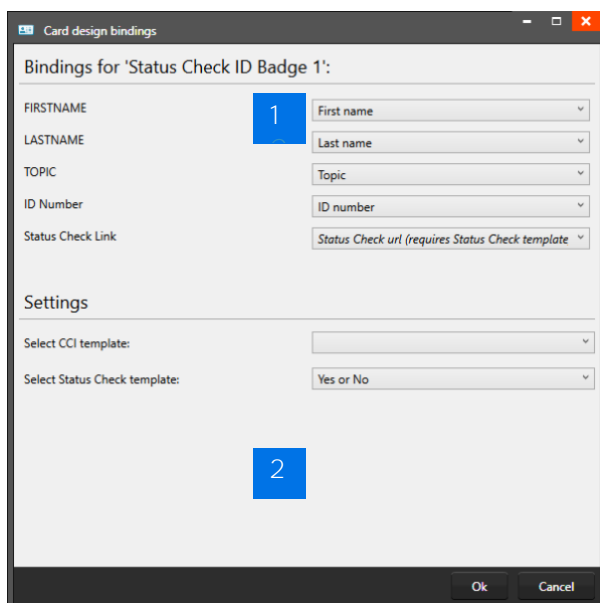

Click on the bindings icon to edit the bindings for the dynamic data of the card design. The bindings window pops up automatically after adding a design to your project.

The data binding tool is a powerful option in PrintStudio. When you add a new layout or update a layout you will be prompted to create the data bindings. Dynamic fields used and created in your layout may differ from the naming or spelling of a name that exists in your Project database. Therefore, you will be allowed to create the data bindings.

### 1. Card Design bindings

The dynamic fields that are created in the card design are presented to the left and you can bind these dynamic fields to the database fields of your project.

### 2. Settings

**CCI template:** Bind a CCI encode template to your card design to encode the card during production. For more information go to “[PrintStudio Encode](#)”. If you do not need to encode with this card

design, you can leave this option blank.

**Status Check template:** Bind the Status Check Template you set available in your project to the Status Check card design. A Status Check link will be generated for the QR-code in the design as soon as the card or digital id is printed or issued. If you do not need this card design to have a Status Check QR-code leave this option blank.

E. The preview of the Card Designs offers two tabs with a preview of the card design and one of the digital ID. If the card design has a front and a back, you can toggle between the two by clicking on the design in the preview.

## 7. Triggers

Step 7. Allows you to setup triggers for your project. Triggers can be used to automatically change data in your project on a certain condition or event.

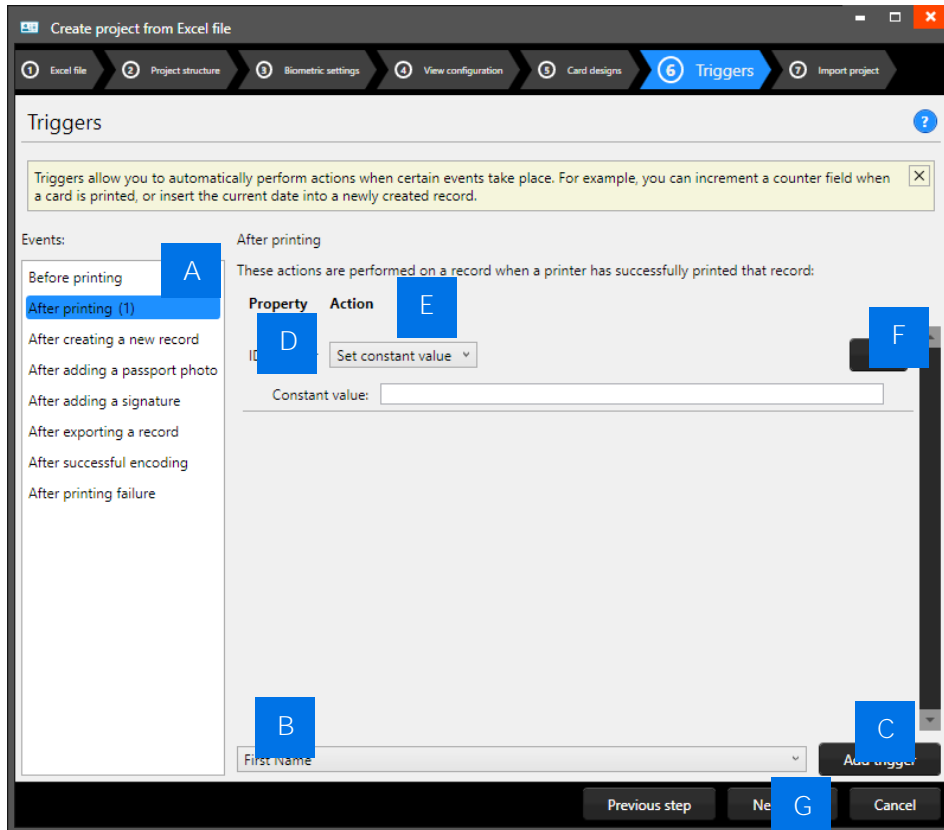

Example of step 6. New project from Excel file: Triggers

- A. Select one of the events from this list and add specific triggers. PrintStudio will automatically wait for the event to occur before performing the action that is linked to the trigger.
- B. All data columns of the new project are listed. Select one of the columns to link a trigger action to.
- C. Click on the “Add trigger” button to add the trigger to the data column and specify the trigger with events and actions.
- D. The property shows you the selected data column.
- E. Select the action you want to connect to the data column from the drop-down menu and define the action.
- F. Click on the “X” button to delete a trigger from an event.
- G. Click on the “Next step” button to go to step 7. and create the project.

Define the action that is performed once the event has been met. Some actions are only available for specific columns (for example, incrementing number values can only be done on Number type columns). All changes need to be saved before they become active. Please be aware that triggers might cause your original data to change, so make sure no vital data is lost when working with triggers.

## 8. Import Project

Step 8. Creates the new project imported from an Excel file as soon as you click on the A. “Create project” button. B. Click on the “Previous step” button to make any changes before creating the project.

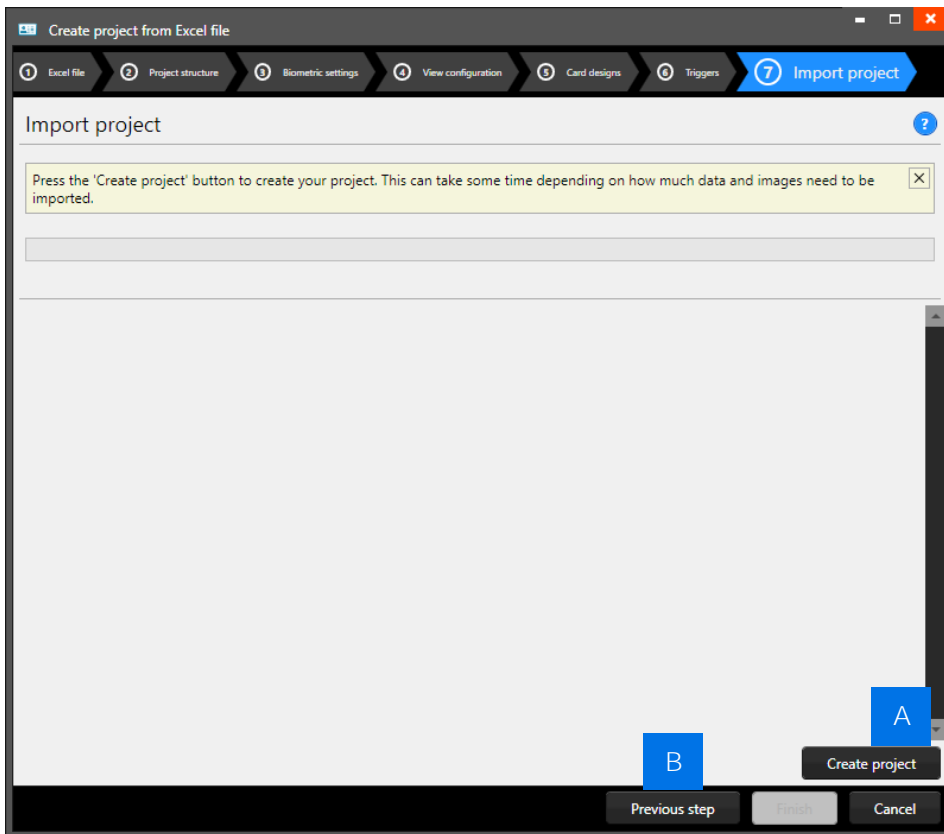

Example of step 6. New project: import new Excel project.

## New Project from BadgeMaker 7 Project

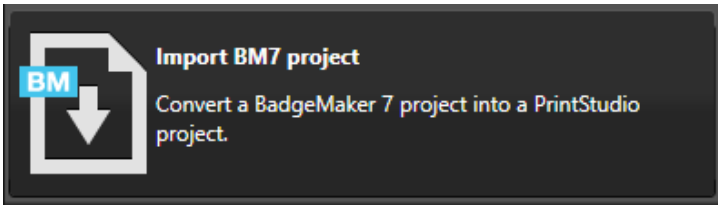

### 1. Select BadgeMaker 7 Project

PrintStudio supports creating new projects based on a former BadgeMaker 7 (Classic) project.

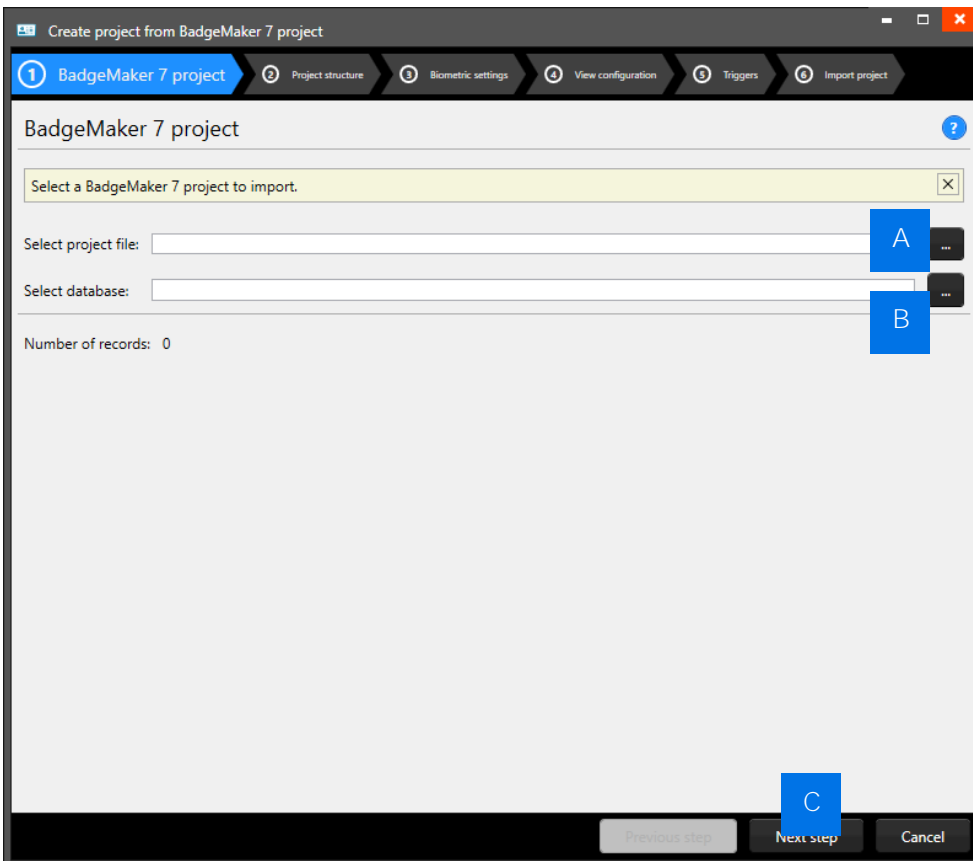

*Example of step 1. New project from a BadgeMaker 7 project: Select BadgeMaker 7 Project*

- A. Click on this button to select the BadgeMaker 7 project.
- B. Click on this button to select the BadgeMaker 7 database.
- C. Click on the “Next step” button to go to step 2. and check the project structure.



## 2. Project structure

Step 2. Name the new project and check the imported BadgeMaker 7 structure. Change, delete or add data columns here in the new Project structure.

Source column	Name	Type	Required	Unique	Default value	
IDnumber	IDnumber	Whole number	<input checked="" type="checkbox"/>	<input checked="" type="checkbox"/>		X
	<input checked="" type="checkbox"/> Is auto-incrementing					
Firstname	Firstname	Text	<input type="checkbox"/>	<input type="checkbox"/>		X
Surname	Surname	Text	<input type="checkbox"/>	<input type="checkbox"/>		X
Layout	Layout	Text	<input type="checkbox"/>	<input type="checkbox"/>	STUDENTCARD	X
Function	Function	Text	<input type="checkbox"/>	<input type="checkbox"/>		X
PlaceOfBirth	PlaceOfBirth	Text	<input type="checkbox"/>	<input type="checkbox"/>		X
Email	Email	Text	<input type="checkbox"/>	<input type="checkbox"/>		X
Phonenumber	Phonenumber	Text	<input type="checkbox"/>	<input type="checkbox"/>		X
Logo	Logo	Text	<input type="checkbox"/>	<input type="checkbox"/>		X

Example of step 2. New project from a BadgeMaker 7 project: Project data columns.

- A. Type in the name for your new project.
- B. Put in the column name
- C. Set the data type. Select if the data are number or text for example. The following types of database fields are supported:
  1. [Whole Number](#), when selecting this type, you can select 'auto-increment'. When a new record is created the number will be the highest number in the Project increased by 1.
  2. [Text](#)
  3. [Decimal number](#)
  4. [Option list](#), when this list type is selected, you can add and delete the list values from the list that is presented for this database field. When you change a datatype from text to option list, PrintStudio automatically generates a list based on the data already in that data field.
- D. Check these boxes if the field needs to be “[Required](#)” and/or “[Unique](#)”.
- E. With the default input field, you can add a standard value to your data field, existing empty fields and new records will automatically get the default value you add to this data field.
- F. Click on the “X” button to delete a data field from the project structure setup.
- G. Click on the “[Add new property](#)” button and add and describe the data field names you want to use in your new project.
- H. Click on the “[Next step](#)” button to go to step 3.

### 3. Biometric settings

Step 3. Enable biometric images (Passport photos and/or Signatures) for the new project and setup how these images will be stored.

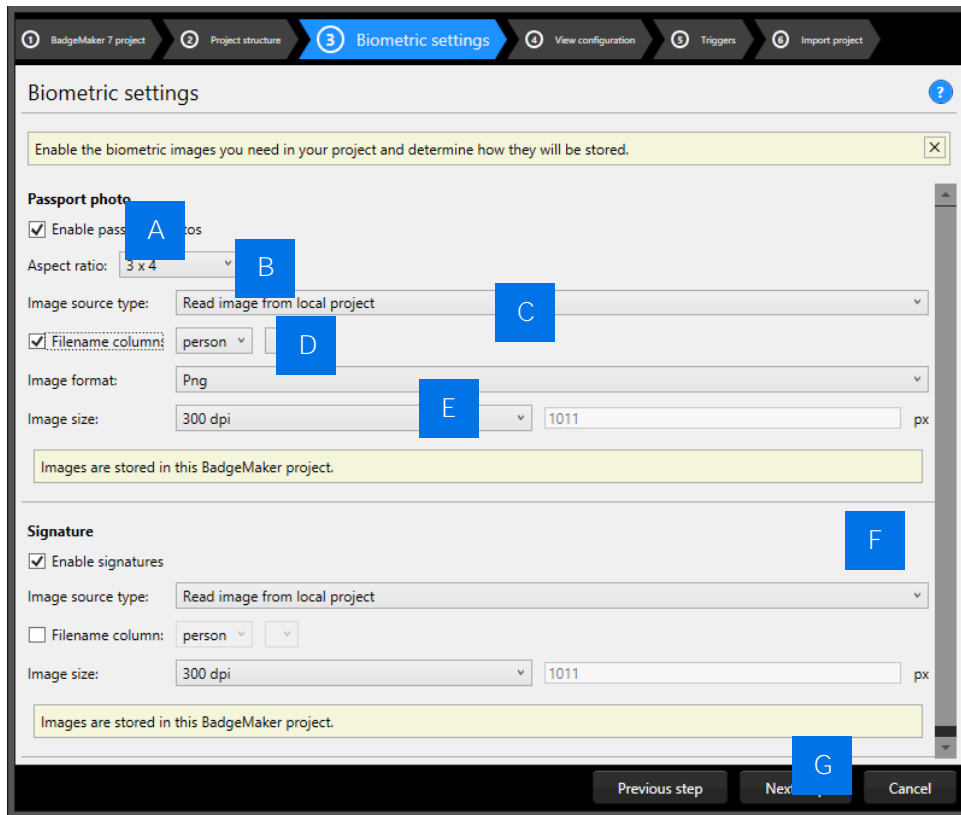

Example of step 3. New project from BadgeMaker 7: Biometric settings

- A. The box for passport photos make photos visible in the project and enables you to add photos.
- B. Determine the ratio of the photo with the drop-down menu.
- C. Select how and where photos will be saved within your project.
- D. Check this box if you want to use data columns to represent the filename.



Example of photo's that have filenames corresponding with their ID number.

- E. Select the image format (.png, .jpg or .bmp) the photos need to be saved as within your project.
- F. Select the dpi and size of the photos that will be created and saved within your project.
- G. The checkbox for the signatures allows you to make signatures visible in the project and enables you to add passport photos. The signature section works similar as the passport photo section above. Click on the “Next step” button to go to step 3. and configure the detailed and gallery view

## 4. View configuration

Step 4. Choose for the default configuration or adjust the setup for the Detailed and Gallery view in the new project.

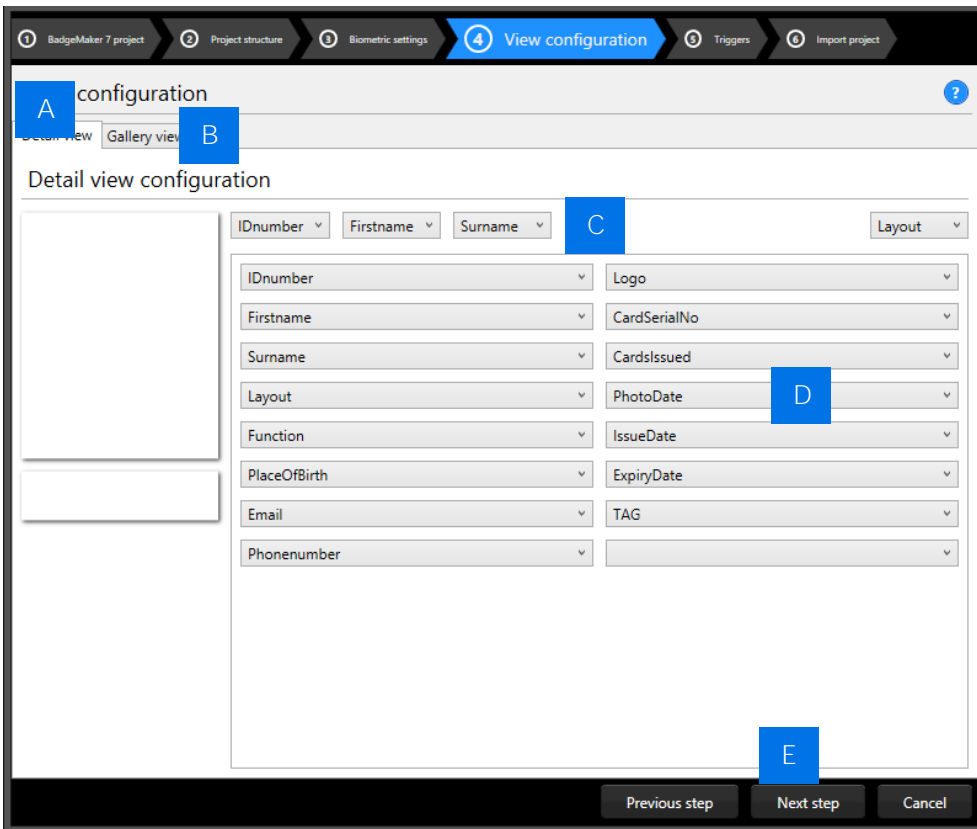

Example of step 4. New project from BadgeMaker 7: View configuration

- A. Tab to configure Detailed view showing specific **cardholders'** information.
- B. Tab to configure Gallery view showing cardholders photos.
- C. Setup the title for the detailed view.
- D. Setup the information that will be available in the detailed view. Use the detailed view to have a clear overview of the card holders' data and make quick adjustments to the data.
- E. Click on the "Next step" button to go to step 5. and add triggers to the project.

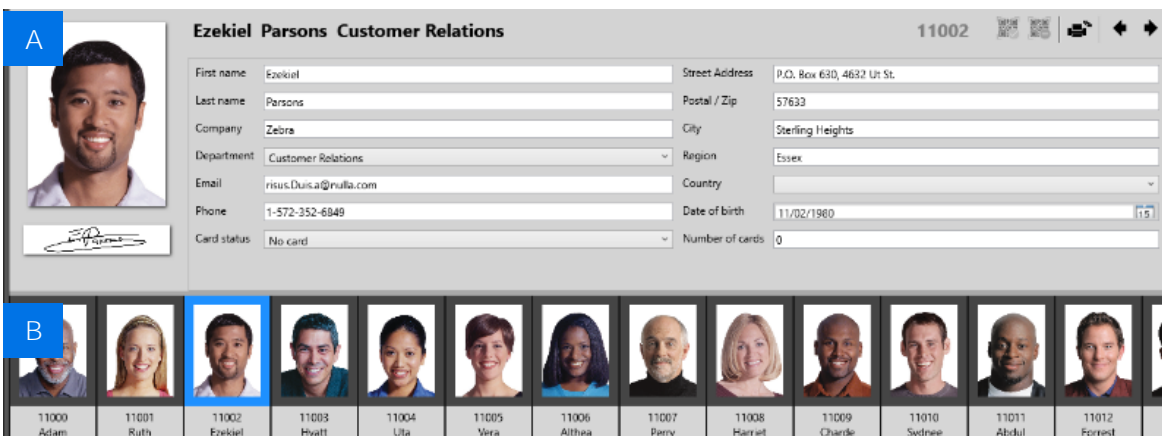

Example of the A. detailed view and the B. gallery view

## 5. Triggers

Step 5. Allows you to setup triggers for your project. Triggers can be used to automatically change data in your project on a certain condition or event.

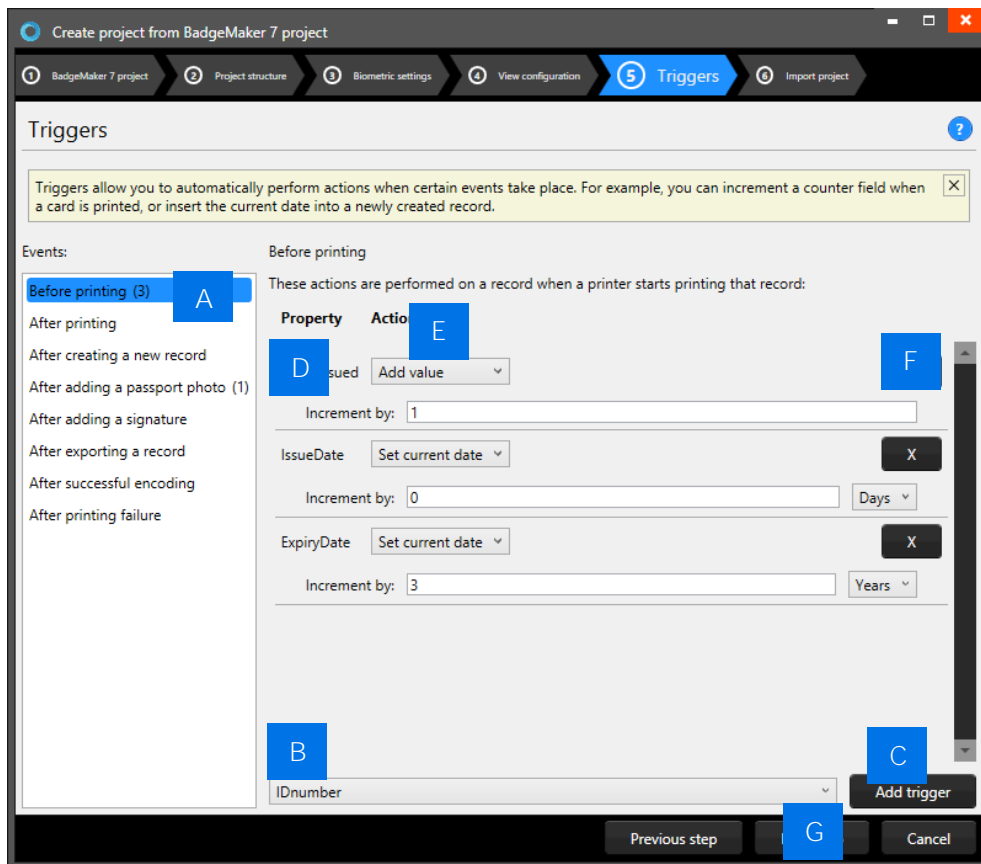

Example of step 5. New project from BadgeMaker 7: Triggers

- A. Select one of the events from this list and add specific triggers. PrintStudio will automatically wait for the event to occur before performing the action that is linked to the trigger.
- B. All data columns of the new project are listed. Select one of the columns to link a trigger action to it.
- C. Click on the “Add trigger” button to add the trigger to the data column and specify the trigger with events and actions.
- D. The property shows you the selected data column.
- E. Select the action you want to connect to the data column from the drop-down menu and define the action.
- F. Click on the “X” button to delete a trigger from an event.
- G. Click on the “Next step” button to go to step 6. and create the project.

Define the action that is performed once the event has been met. Some actions are only available for specific columns (for example, incrementing number values can only be done on Number type columns). All changes need to be saved before they become active. Understand that Triggers might cause your original data to change, so make sure no vital data is lost when working with Triggers.

## 6. Import Project

Step 6. Creates the new project based on the BadgeMaker 7 project as soon as you click on the A. “Create project” button.

B. Click on the “Previous step” button to make any changes before creating the project.

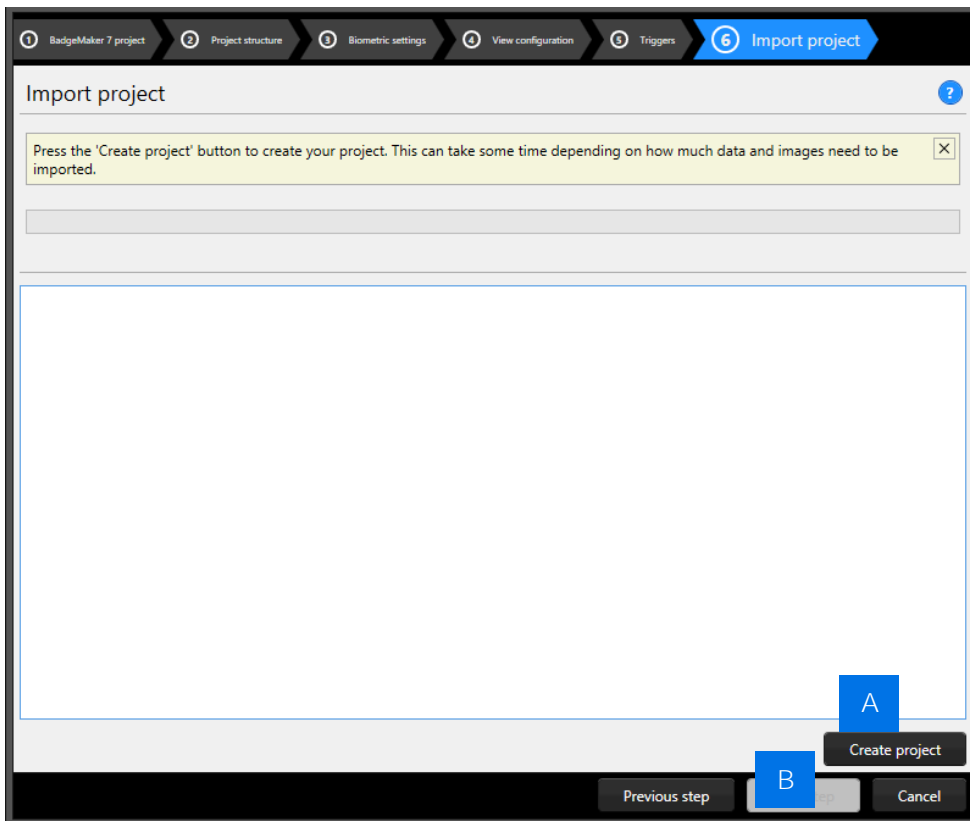

*Example of step 6. New project from a BadgeMaker 7 project.*

## New Project from IDPro 7 Project

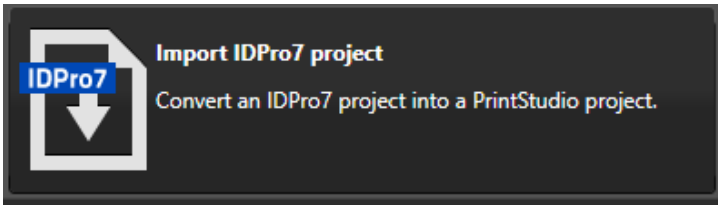

### 1. Select IDPro 7 Project

PrintStudio supports creating new projects based on a former IDPro 7 project.

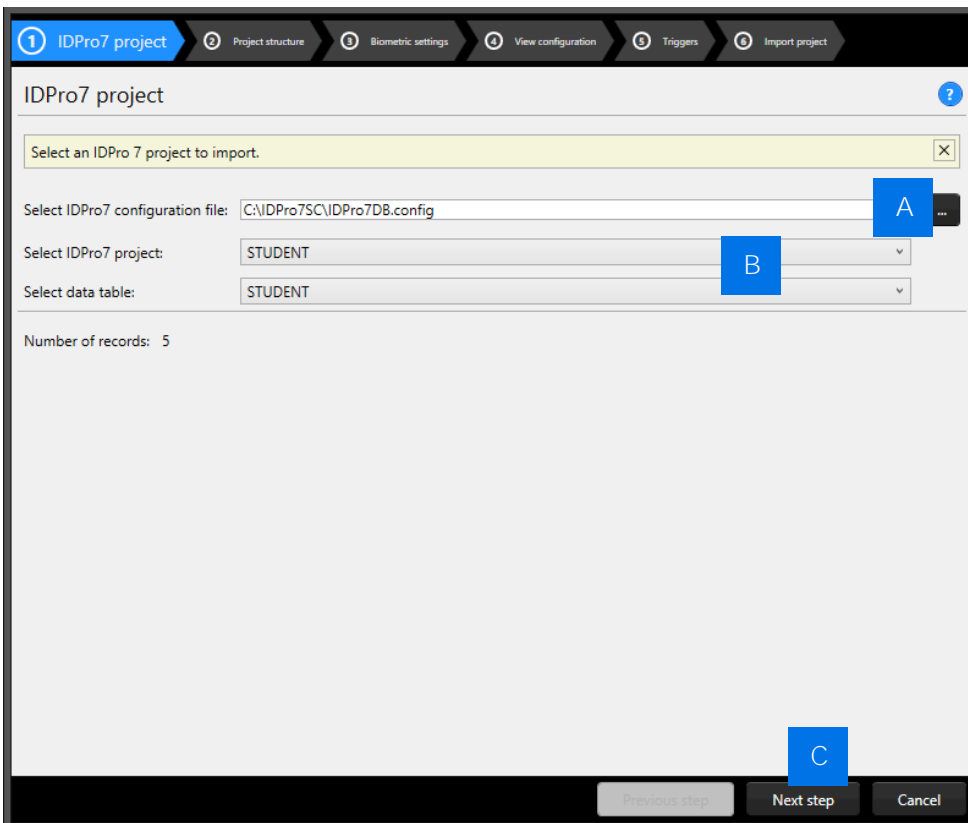

*Example of step 1. New project: Select IDPro 7 Project*

- A. Click on this button to select the IDPro 7 configuration file from your computer.
- B. Click on the dropdown menu to select the IDPro 7 project and the table you would like to use to setup the new project.
- C. Click on the “[Next step](#)” button to go to step 2. and check or adjust the project structure.

## 2. Project structure

Step 2. Name the new project and check the imported IDPro 7 structure. Change, delete or add data columns here in the new project structure.

The screenshot shows the 'Project structure' configuration screen. At the top, there is a progress bar with steps: 1 IDPro7 project, 2 Project structure (highlighted), 3 Biometric settings, 4 View configuration, 5 Triggers, and 6 Import project. Below the progress bar, there is a text input field for 'Project name' containing 'STUDENT'. Below that is a table of data columns:

Source column	Name	Type	Required	Unique	Default value	
Student Number	Student N	Whole	<input checked="" type="checkbox"/>	<input checked="" type="checkbox"/>	0	X
	<input type="checkbox"/> Is auto-incrementing					
Student Type	Student Type	Options list	<input type="checkbox"/>	<input type="checkbox"/>	Full Time	X
	<input type="button" value="Expand to view and modify available values"/>					
Firstname	Firstname	Text	<input type="checkbox"/>	<input type="checkbox"/>		X
Lastname	Lastname	Text	<input type="checkbox"/>	<input type="checkbox"/>		X
Date Of Birth	Date Of Birth	Date	<input type="checkbox"/>	<input type="checkbox"/>	Select a date	X
Card No.	Card No.	Whole number	<input checked="" type="checkbox"/>	<input checked="" type="checkbox"/>	0	X
	<input type="checkbox"/> Is auto-incrementing					
Expiry Date	Expiry Date	Date	<input type="checkbox"/>	<input type="checkbox"/>	Select a date	X

At the bottom, there is a button 'Add new property' and a 'Next step' button.

Example of step 2. New project from an IDPro 7 project: Project data columns.

- A. Type in the name for your new project.
- B. Put in the column name
- C. Set the data type. Select if the data are number or text for example. The following types of database fields are supported:
  1. **Whole Number**, when selecting this type, you can select 'auto-increment'. When a new record is created the number will be the highest number in the project increased by 1.
  2. **Text**
  3. **Decimal number**
  4. **Option list**, when this list type is selected, you can add and delete the list values from the list that is presented for this database field. When you change a datatype from text to option list, PrintStudio automatically generates a list based on the data already in that data field.
- D. Check these boxes if the field needs to be "Required" and/or "Unique".
- E. With the default input field, you can add a standard value to your data field, existing empty fields and new records will automatically get the default value you add to this data field.
- F. Click on the "X" button to delete a data field from the project structure setup.
- G. Click on the "Add new property" button and add and describe the data field names you want to use in your new project.
- H. Click on the "Next step" button to go to step 3.

### 3. Biometric settings

Step 3. Enable biometric images (Passport photos and/or Signatures) for the new project and setup how these images will be stored.

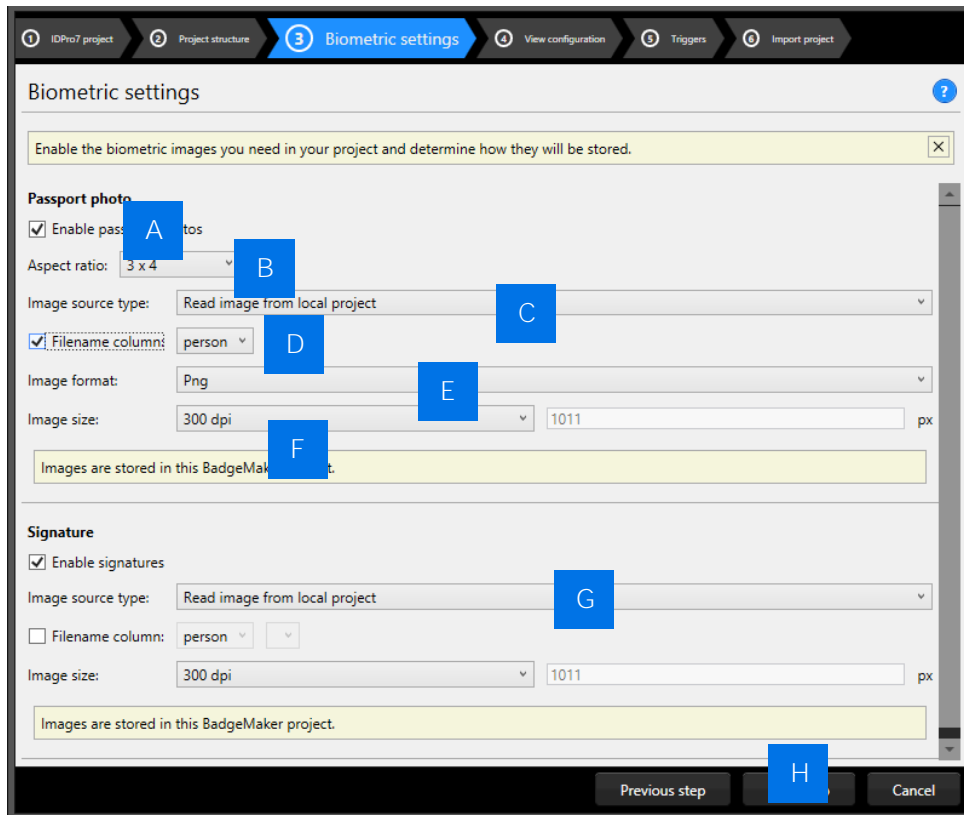

Example of step 3. New project from IDPro 7: Biometric settings

- A. The checkbox for passport photos allows you to make photos visible in the project and enable to add photos.
- B. After checking the box, determine the ratio of the photo in the drop-down menu.
- C. Select how and where photos will be saved that are used in the project.
- D. Check this box to use data columns to represent the filename of the photo (for example a person's ID number).



Example of photo's that have filenames corresponding with their ID number.

- E. Select the image format (png, jpg or bmp) that the image needs to be saved as.
- F. Here you can select what size the photos need to be saved as within your project.
- G. The checkbox for the signature allow you to make signatures visible in the project and enable to add signatures. The signature section works the same as the Passport photo section above.
- H. Click on the “Next step” button to go to step 4. and configure the detailed and gallery view.



#### 4. View configuration

Step 4. Choose the default configuration or adjust the setup for the Detailed and Gallery view in the new project.

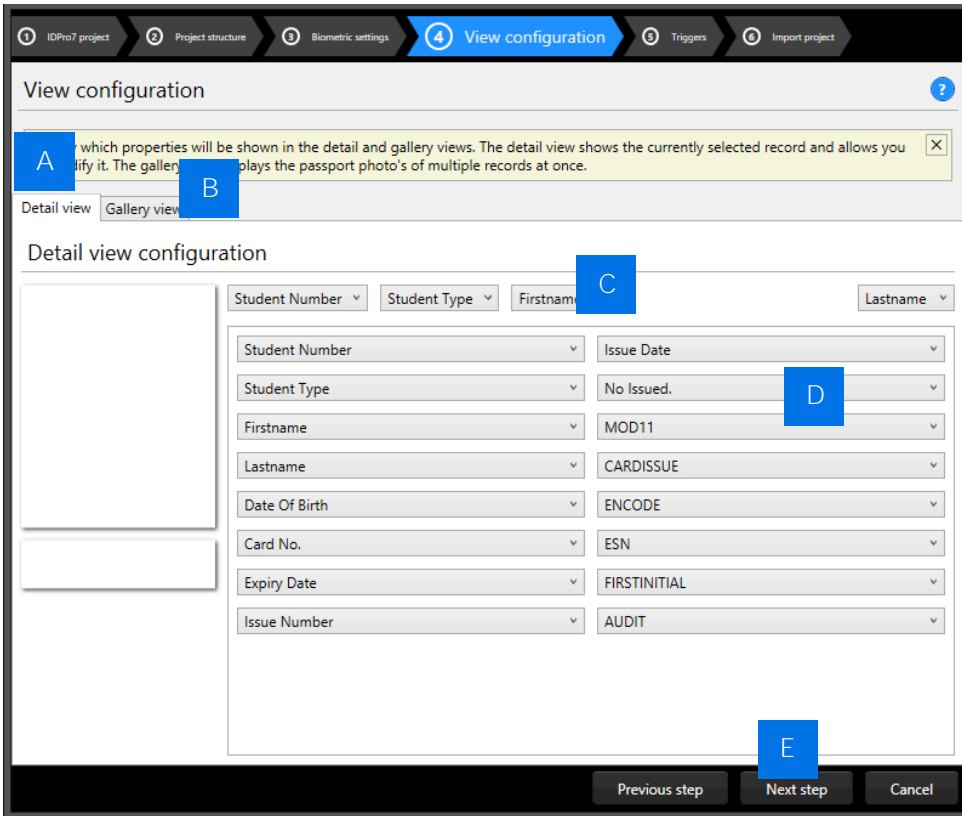

Example of step 4. New project from IDPro 7: View configuration

- A. Tab to configure Detailed view showing specific card holders information.
- B. Tab to configure Gallery view showing card holders photos.
- C. Setup the title for the detailed view.
- D. Setup the information that will be available in the detailed view. Use the detailed view to have a clear overview of the card holders' data and make quick adjustments to the data.
- E. Click on the "Next step" button to go to step 5. and add triggers to the project.

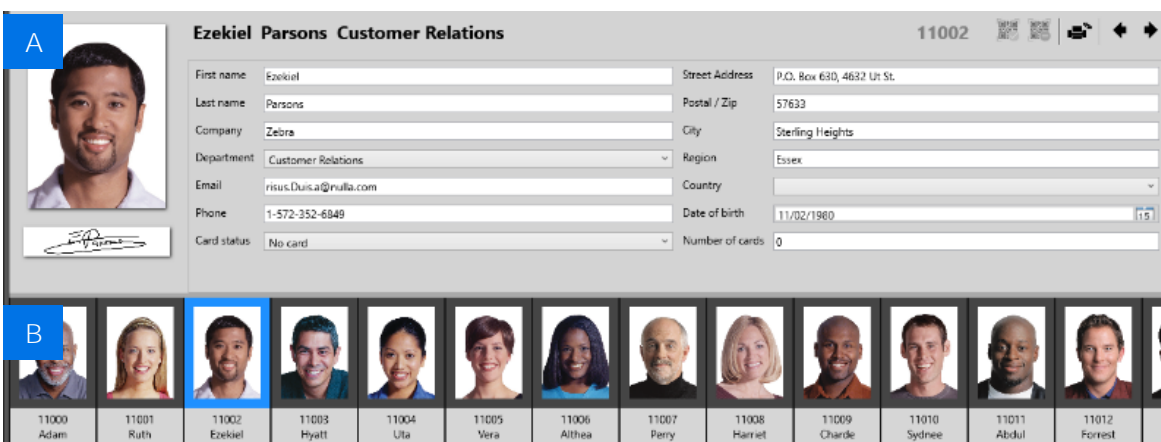

Example of the A. Detailed view and the B. Gallery view

## 5. Triggers

Step 5. Allows you to setup triggers for your project. Triggers can be used to automatically change data in your project on a certain condition or event.

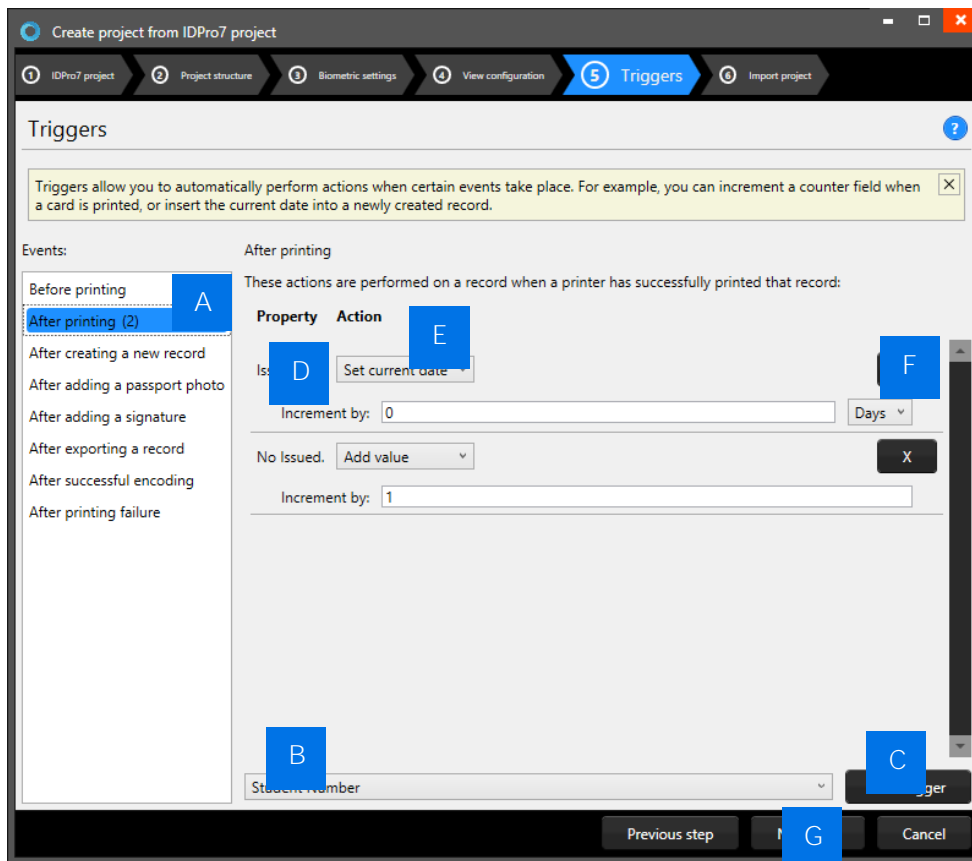

Example of step 5. New project from IDPro 7: Triggers

- A. Select one of the events from this list and add specific triggers. PrintStudio will automatically wait for the event to occur before performing the action that is linked to the trigger.
- B. All data columns of the new project are listed. Select one of the columns to link a trigger action to it.
- C. Click on the “Add trigger” button to add the trigger to the data column and specify the trigger with events and actions.
- D. The property shows you the selected data column.
- E. Select the action you want to connect to the data column from the drop-down menu and define the action.
- F. Click on the “X” button to delete a trigger from an event.
- G. Click on the “Next step” button to go to step 6. and create the project.

Define the action that is performed once the event has been met. Some actions are only available for specific columns (for example, incrementing number values can only be done on Number type columns). All changes need to be saved before they become active. Please be aware that triggers might cause your original data to change, so make sure no vital data is lost when working with triggers.

## 6. Import Project

Step 6. Creates the new project based on the IDPro 7 project as soon as you click on the A. “Create project” button. B. Click on the “Previous step” button to make any changes before creating the project.

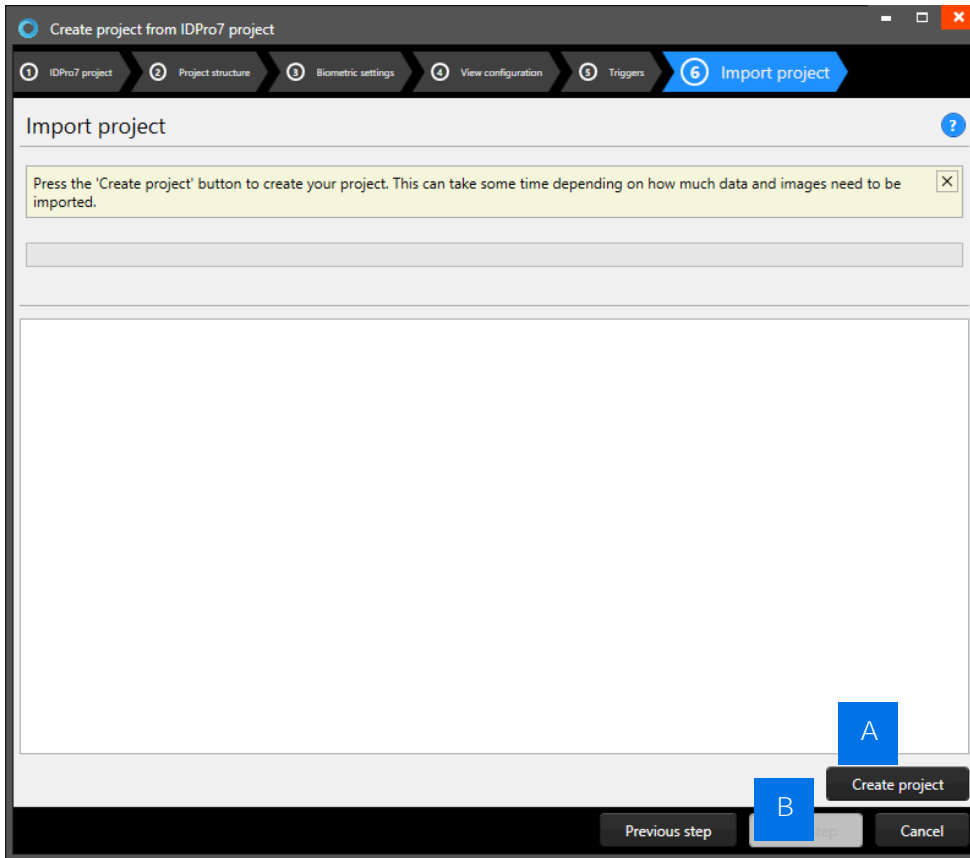

Example of step 6. New project: import IDPro 7 project.

# PrintStudio Open Project

# PrintStudio

## Open Project

To open an existing Project select the “Open” link or button. All available existing projects are displayed, select the project that needs to be opened.

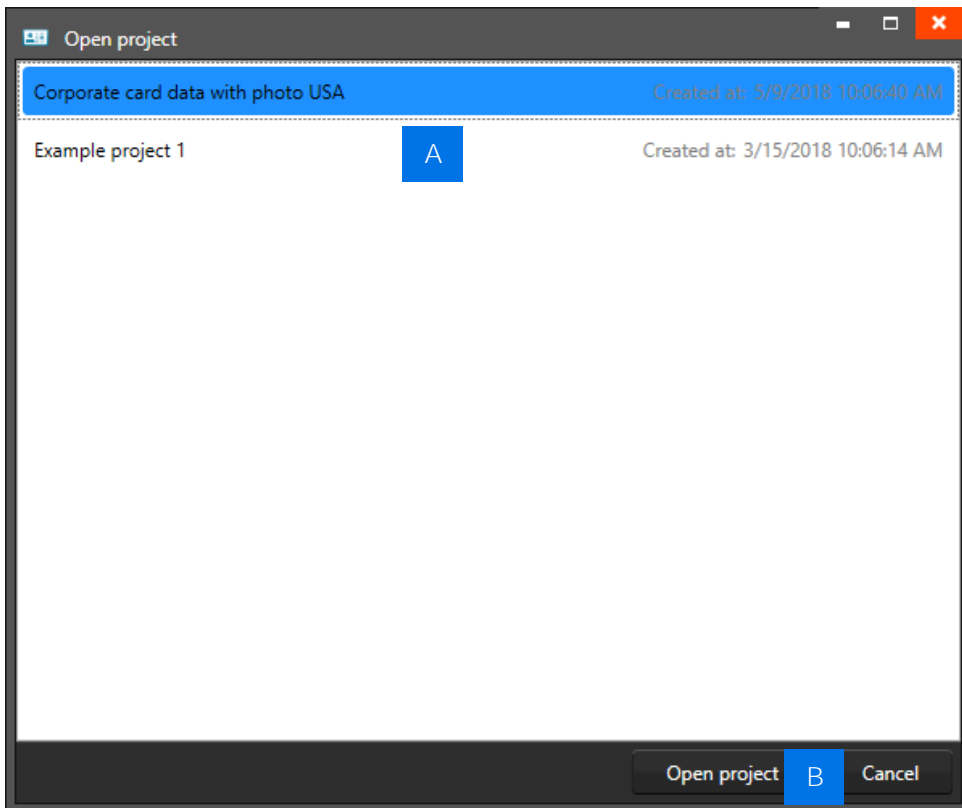

*Example of the Open existing project popup window.*

- A. Select one of the existing projects
- B. Click on the “Open project” button.

# PrintStudio The Store

# PrintStudio

## The Store

The Store available in CardStudio 2.0 offers free & premium card design templates, example projects and credits for you to select, purchase and download.

### Projects from the Store

Browse the Store to select and download one of the example Projects to start with. Get inspired and adjust the example project to your own liking.

Projects that also have a digital ID setup show the Digital ID icon:  
For more information watch the “How to” videos on Digital ID:  
<https://cardstudio.zebra.com/digital-id>



feature show the Status Check icon:  
For more information watch the “How to” videos on Status Check:  
<https://cardstudio.zebra.com/status-check>



Projects setup with the Status Check

### Browse the Store

To browse the store, go to “Store” in the main menu and click on “Browse store”.

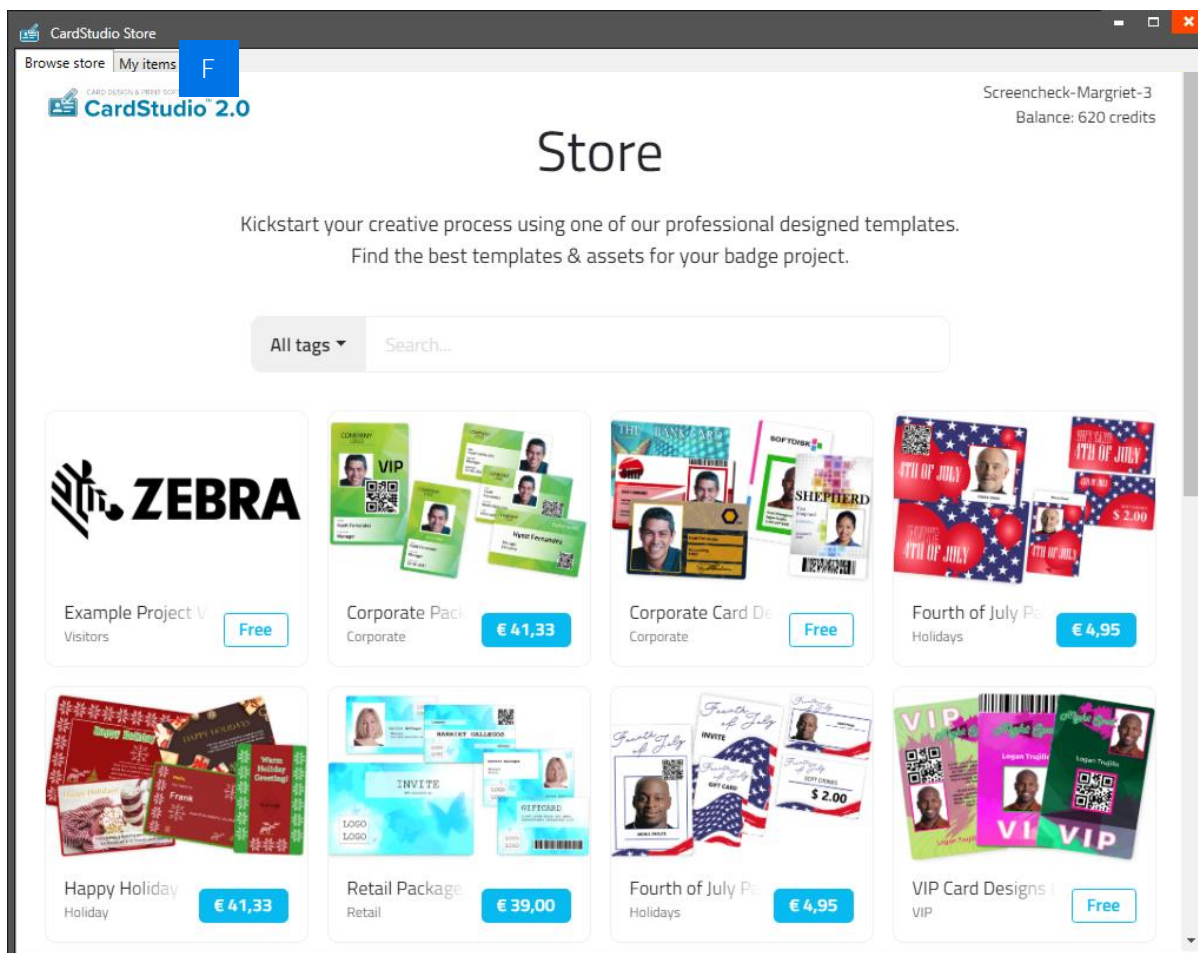

- Store: Overview of all the products (card designs, projects, and credits) available to select for free or to purchase and add to “My items”.
- Overview of your account name and a balance of the credits available in your account.
- Filter the overview of card designs by specific tags. Use the drop-down button to select a tag or search card design bundles by name.
- Click on the bundle image to learn more about the bundle and its card designs.

- E. Click on “Add to My items” or “Proceed to Payment” if it is a premium product to add the product to “My Items” and make them available for download.



E

- F. In Tab “My Items” is where you can find the products like card designs you selected for free or purchased. Select the product to download and use it in CardStudio.



## My items

All the selected and purchased products (Card Design Templates or Example Projects) from the Store can be found in “My items”. These Products will always be available for you as specific customer ready to download.

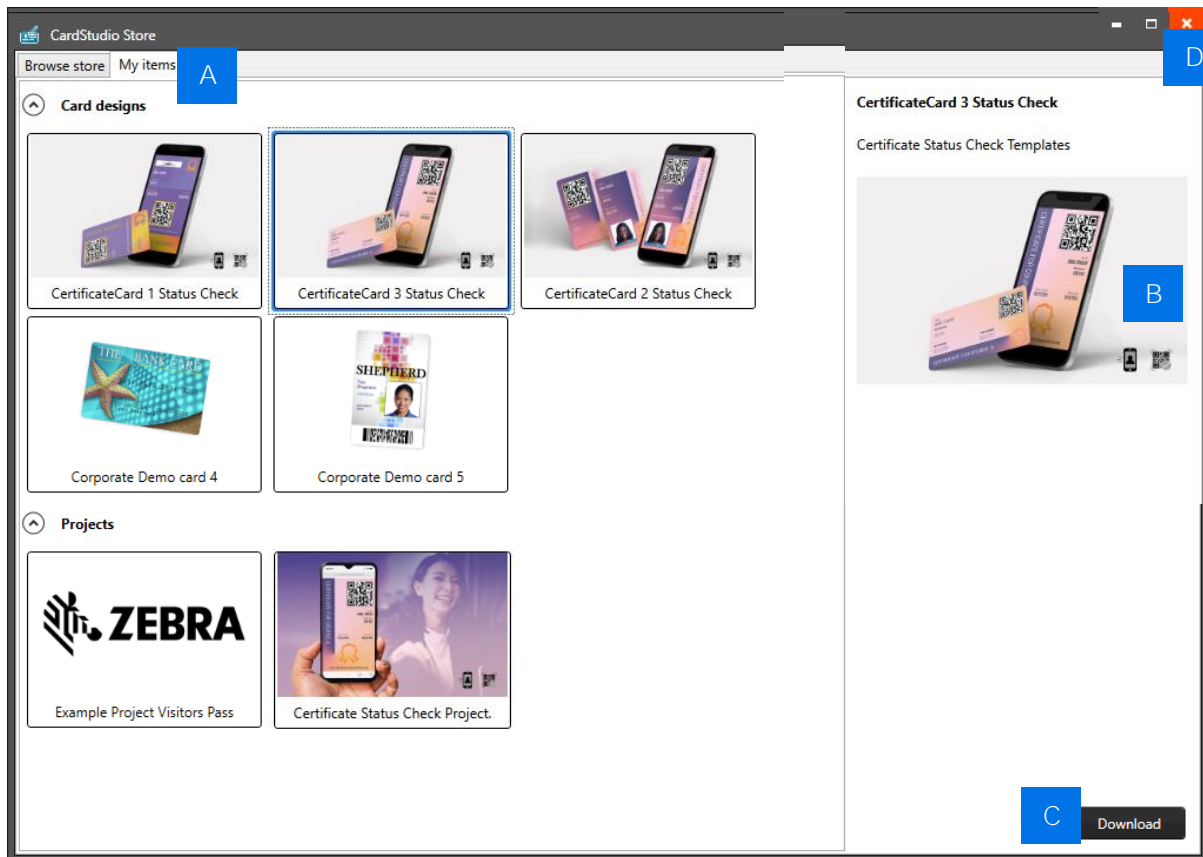

- E. My items: overview of all the selected or premium products from the Store ready to select and download.
- F. Preview images of the selected card design.
- G. Click on “Download” if you would like to download the selected card design to your DesignStudio or project to your PrintStudio.

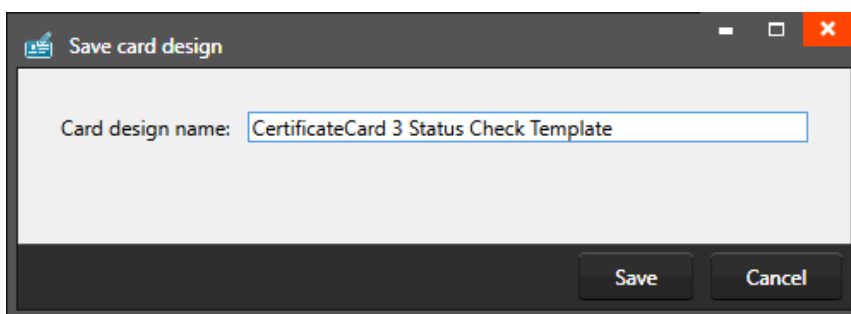

Give the downloaded card design or project a name. After saving, the design or project is opened automatically in DesignStudio or PrintStudio. The card design or project is now ready to be used in your CardStudio 2.0.

- H. Click on the “Close” button to close the My items pop-up.

## Credits from the Store

When you create a Digital ID design for your card holders, for them to use on their mobile, credits are needed in your CardStudio account, to be able to send the Digital ID in PrintStudio. CardStudio offers a standard set of free credits for users to try the Digital ID feature. More credits can be purchased in the Store. Credits can also be purchased in the form of vouchers at a selection of Zebra CardStudio 2 Resellers.

Go to the “[Store](#)” in the main menu and select “[Browse store](#)”. The Store opens in a pop-up with an overview of all the available products. Maximize the window to have a good overview of all the products.

In the top left corner, you can check your credit balance. Scroll down to navigate to the credits.

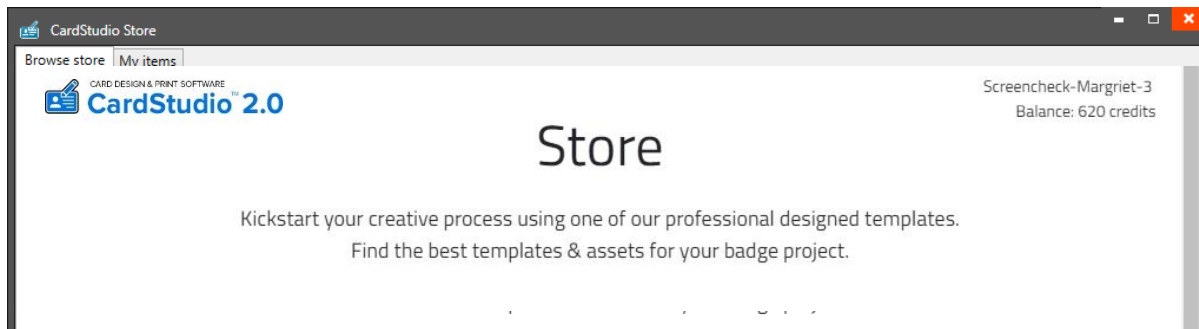

A couple of credit bundles are available to choose from, select the bundle that works best for you. It costs 10 credits to issue a Digital ID, 5 credits to issue a Status Check QR-code and 2 credits to update an existing Status Check Card.

Looking to purchase a higher number of credits, contact your local reseller.

If you purchased a Zebra Voucher from your reseller, enter your Zebra Voucher code and redeem credits of that voucher.

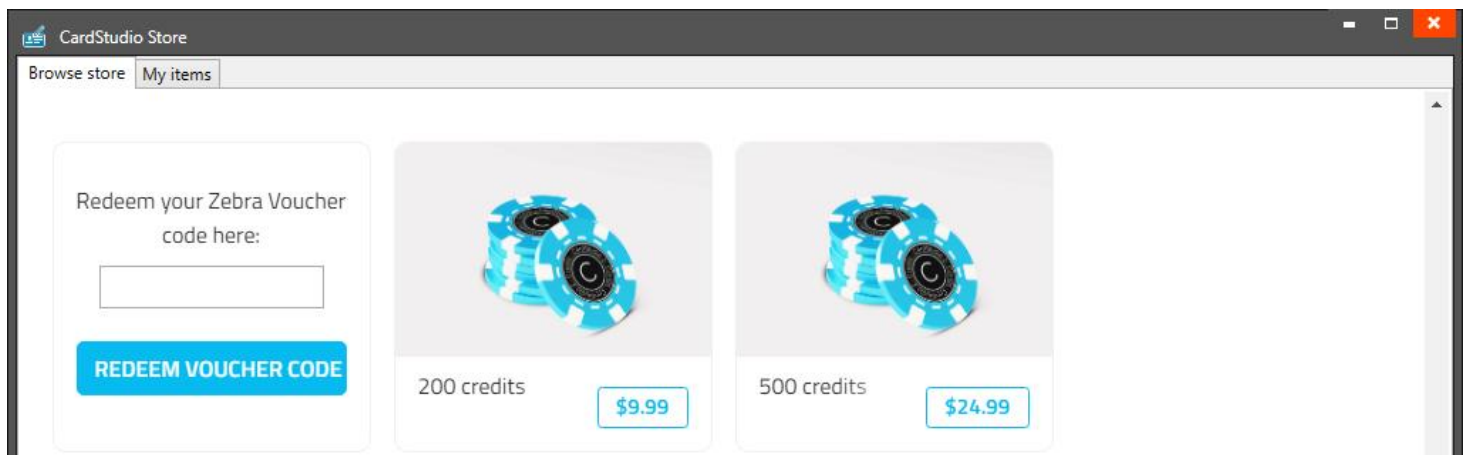

Click on the price button to proceed to the checkout and purchase the credit bundle. Agree with the terms and conditions, click the “[Proceed to payment](#)” button and choose the payment method to complete the order. Choose to pay with a Credit Card or PayPal-account. After a successful payment, the purchased credit is added to your CardStudio account.

Use the “[return to store](#)” button to check the credit balance again in the top left corner. You are now set to send a Digital ID to your card holders.

# PrintStudio Import Data

# PrintStudio

## Import Data

Import data into a PrintStudio project if more data from for example, a former project or an output from an HR-system is needed. PrintStudio offers the import of data from an Excel/CSV file, BadgeMaker 7 project or an IDPro 7 project.

Go to the Main Menu and click on “File”, select “Import data”:

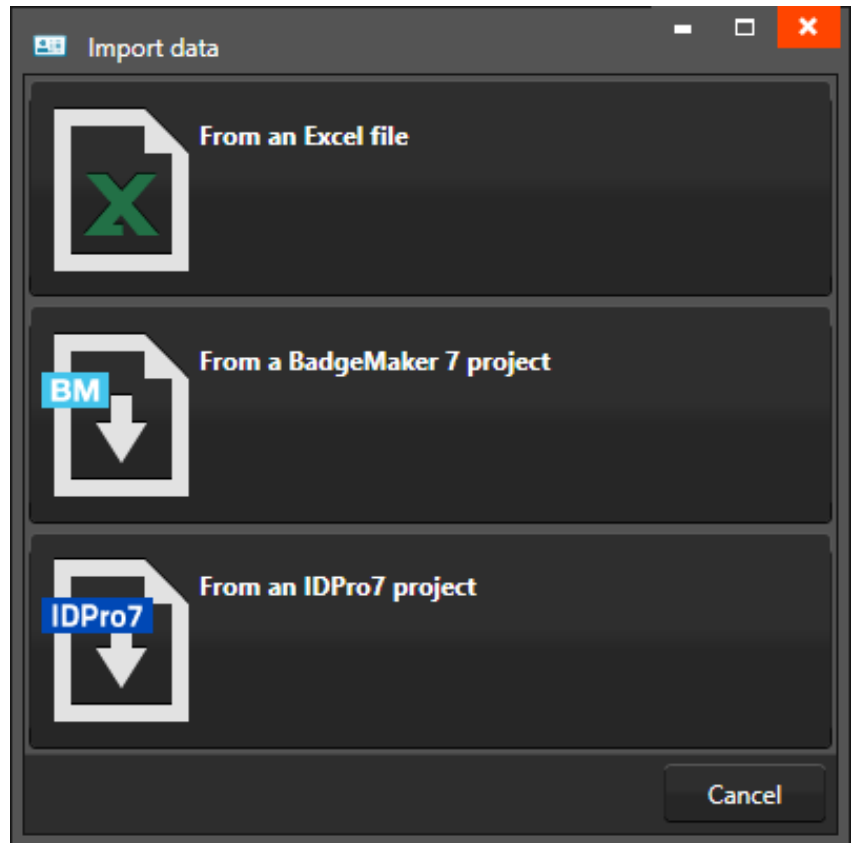
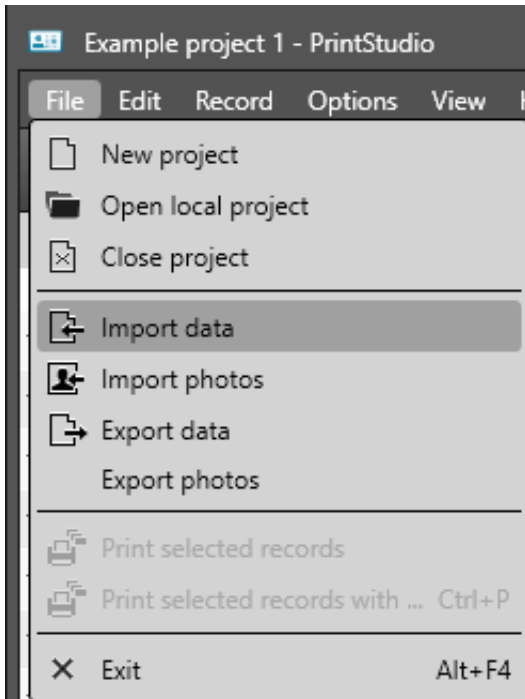

*Example of the import data popup window.*

## Import an Excel file or CSV data file

To import data into the PrintStudio Project from an Excel file click on the first button “From an Excel file”.

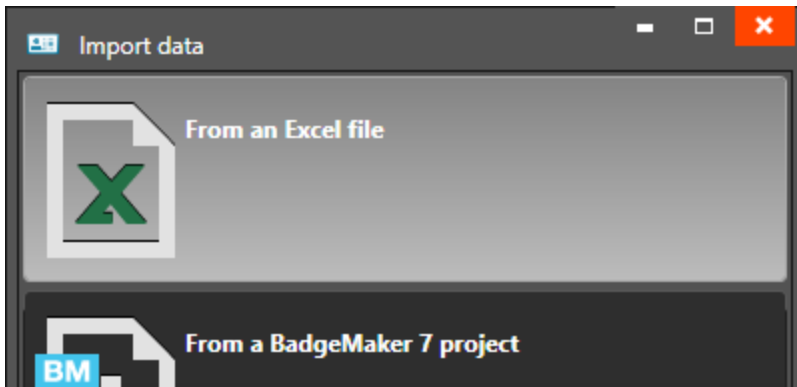

### 1. Data source

Step 1. Select the Excel file and Worksheet needed for the import of the data. A Photo source and/or Signature Source can be added if needed.

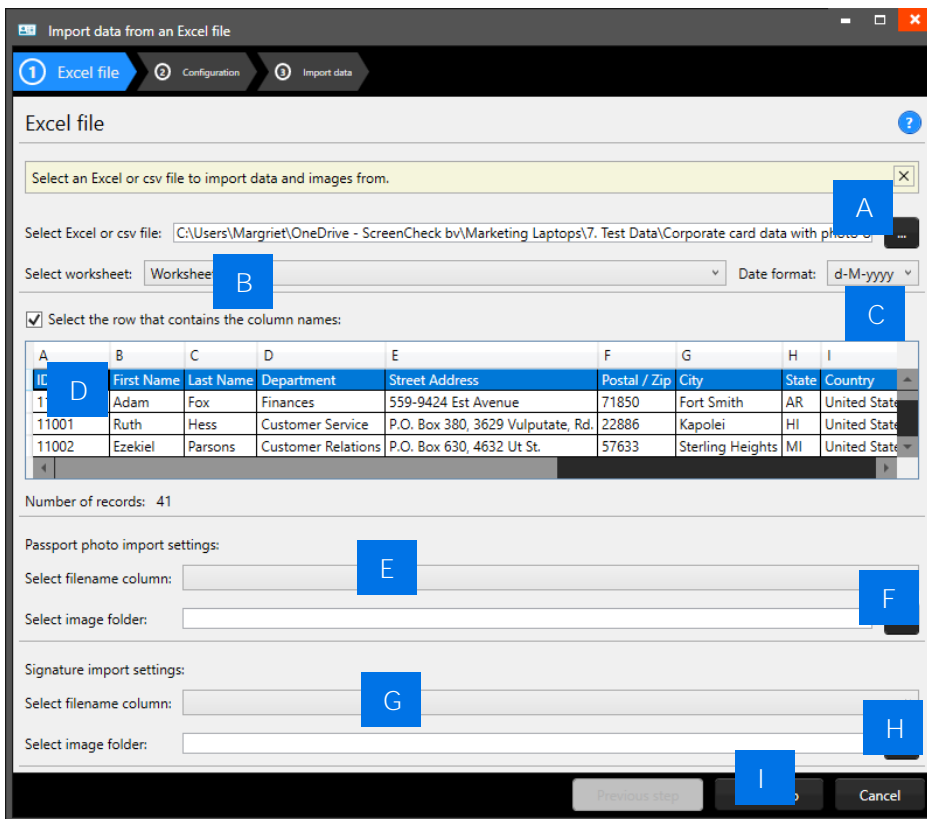

Example of the import data popup window.

- A. Click on this button and select the Excel/CSV file you want to import and select the worksheet you want to use from the drop-down menu below.
- B. Select the row that contains the column names.
- C. Select the column that connects with the unique photo names (for example: ID number or index)
- D. Select the folder that contains the card holders' photos
- E. Select the column that connects with the unique signature names (for example: ID number or index)
- F. Select the folder that contains the signature images
- G. Click on the “Next step” button to continue to second step.

### 2. Configuration

Step 2. Configure how the data will be imported into the project and handles the existing data.

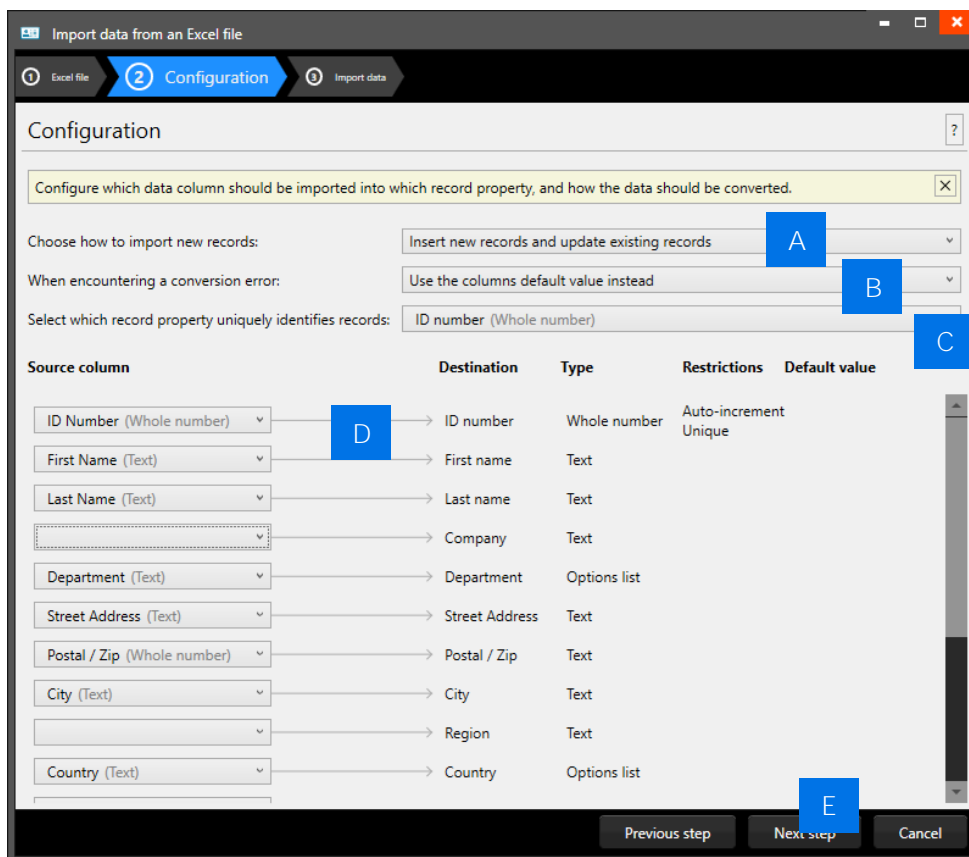

Example of the import Excel/CSV data popup window.

- A. Choose how imported data/new records will be handled. The drop-down menu gives you three options
- B. Select what happens when encountering a conversion error.
- C. Select one of the fields of the excel data which uniquely identifies data in the data source.
- D. Connect the source columns with the destination columns, PrintStudio will connect the columns with similar names automatically.
- E. Click on the “Next step” button to continue to import the data.

### 3. Import data

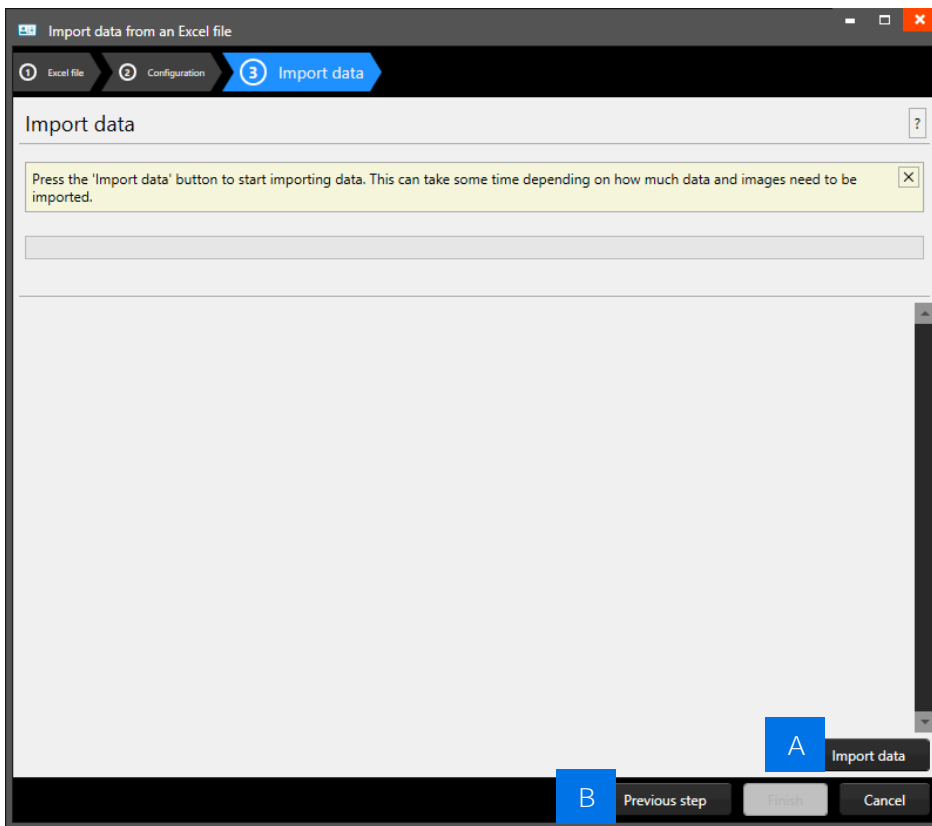

Example of step 3. Import data

Step 3. is processing the import of the Data. **A.** Click on the “Import data” button to start importing the data from your Excel file. **B.** Click on the “Previous step” button to make any changes before creating the project.

## Import BadgeMaker 7 project data

To import data into the project from a BadgeMaker 7 project click on the first button “From a BadgeMaker 7 project”.

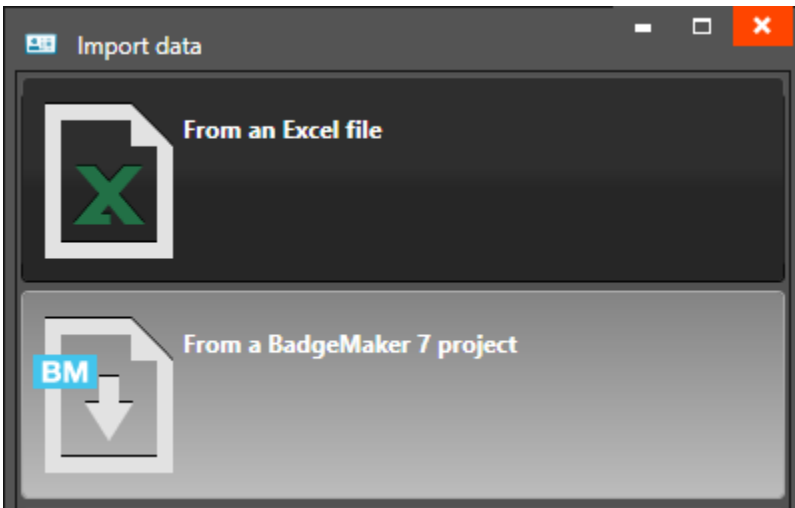

### 1. Data source

Step 1. Select the BadgeMaker 7 project file and database needed for the import of the data.

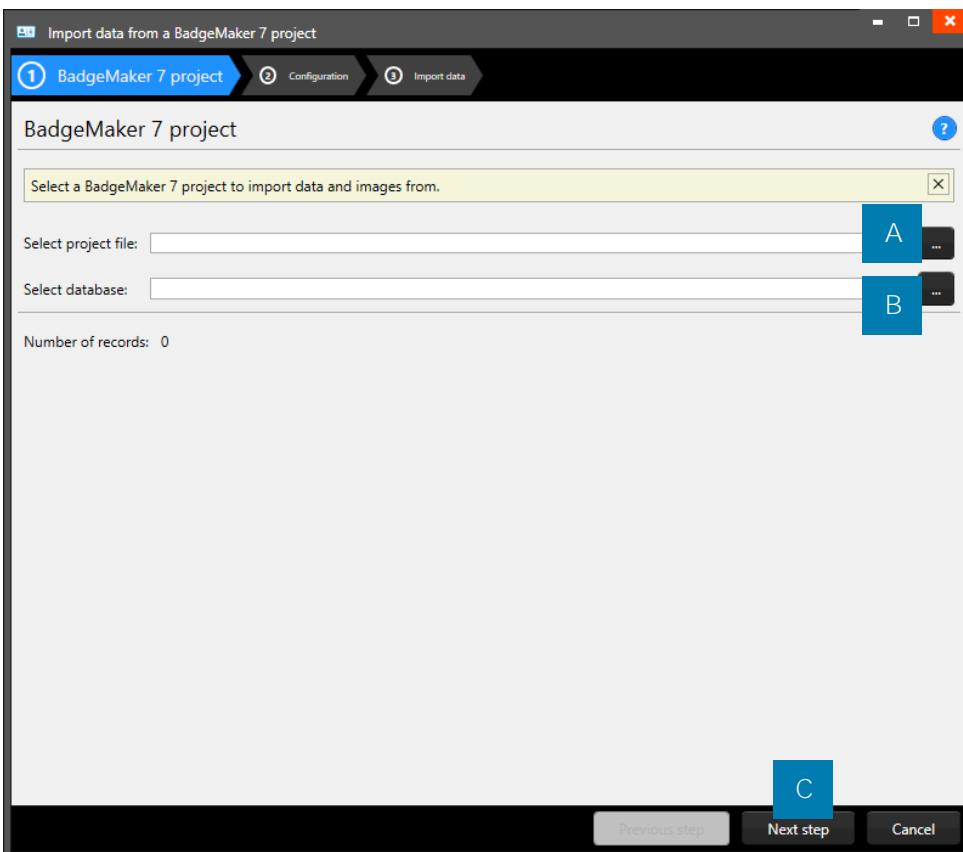

*Example of the import data popup window.*

- A. Click on this button to select the BadgeMaker 7 project from your computer.
- B. Click on this button to select the BadgeMaker 7 database from your computer.
- C. Click on the “Next step” button to go to step 2.



## 2. Configuration

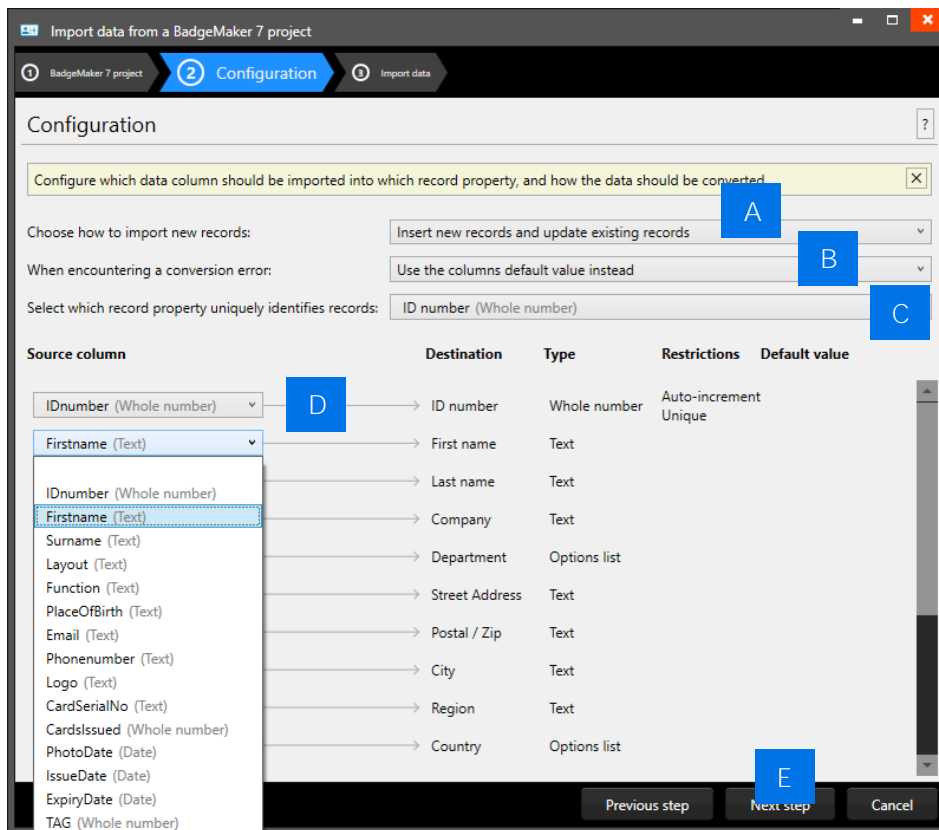

Example of the import of BadgeMaker 7 data popup window.

- A. Choose how imported data/new records will be handled. The drop-down menu gives you three options
- B. Select what happens when encountering a conversion error.
- C. Select one of the fields of the excel data which uniquely identifies data in the data source.
- D. Connect the source columns with the destination columns, PrintStudio will connect the columns with similar names automatically.
- E. Click on the “Next step” button to continue to import the data.

### 3. Import data

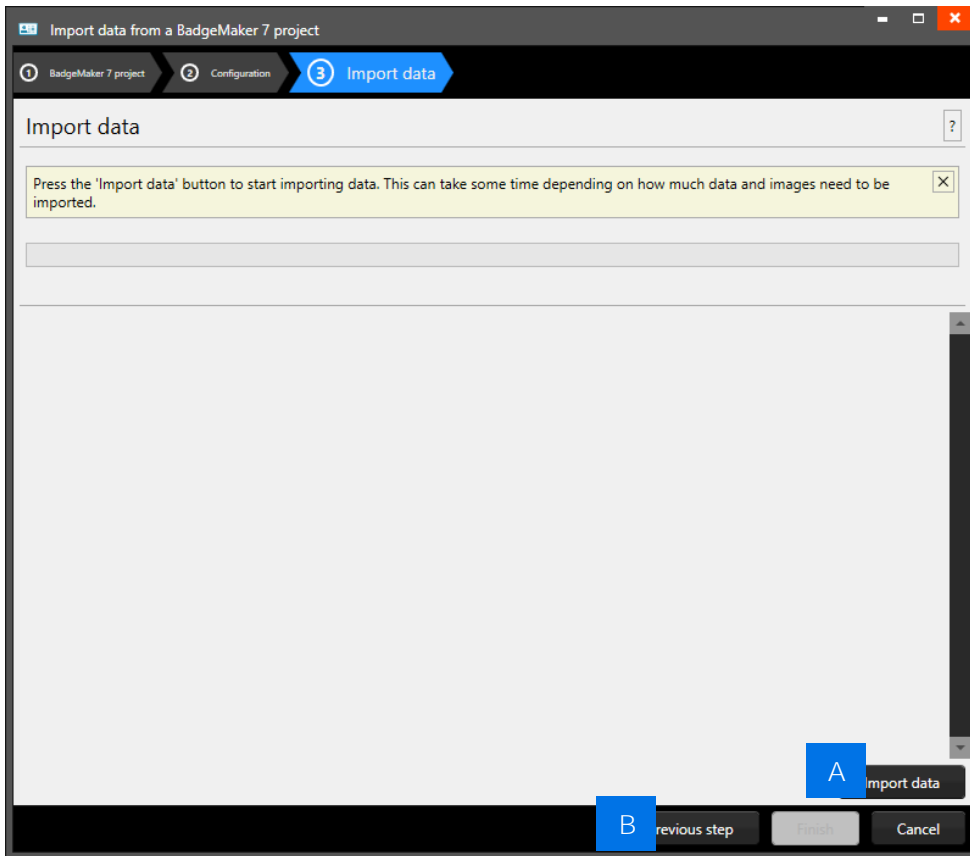

Example of step 3. Import data

Step 3. is processing the import of the Data. A. Click on the “Import data” button to start importing the data from your Excel file. B. Click on the “Previous step” button to make any changes before creating the project.

## Import IDPro 7 data

To import data into the PrintStudio Project from an IDPro 7 project click on the first button “[From an IDPro 7 project](#)”.

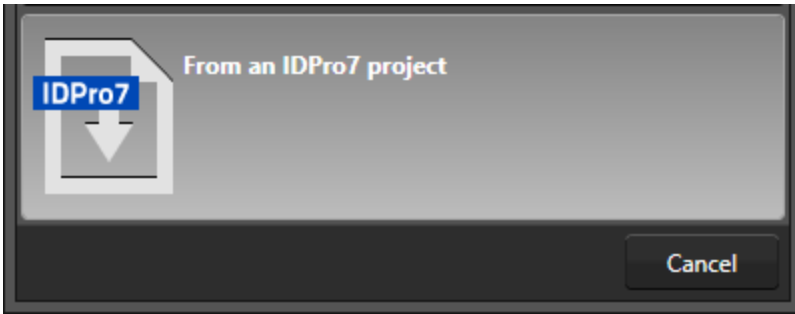

### 1. Data source

Step 1. Select the IDPro 7 configuration file and the project needed for the import of the data.

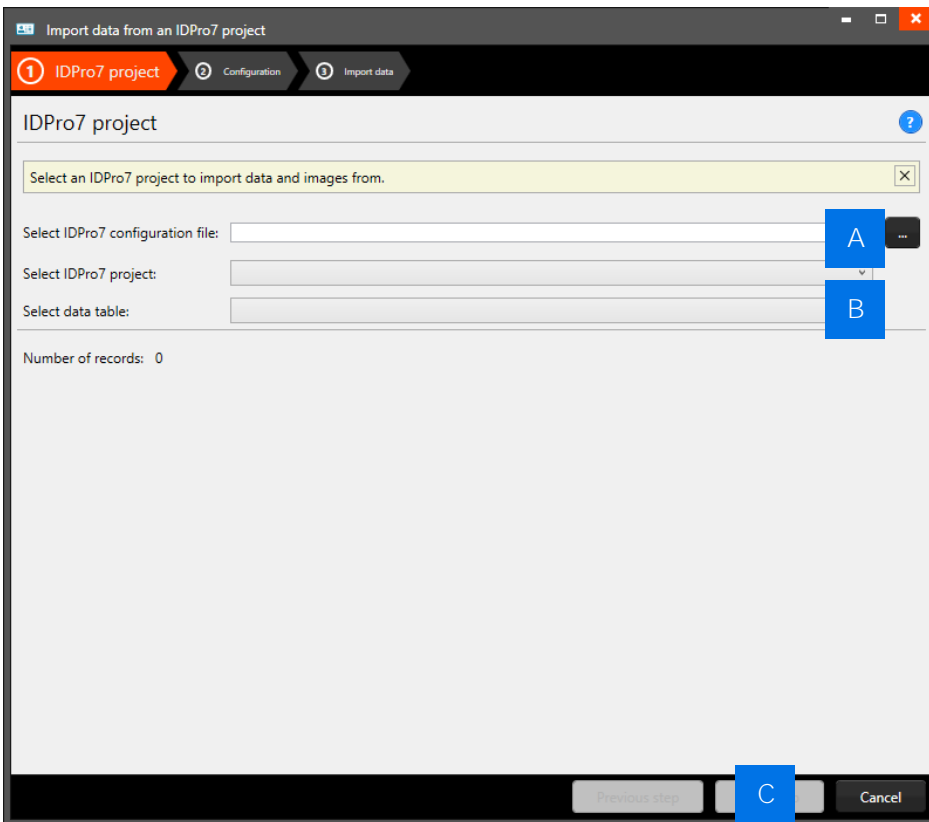

*Example of the import data popup window.*

- A. Click on this button to select the IDPro 7 configuration file from your computer.
- B. Click on the dropdown menu to select the IDPro 7 project and table.
- C. Click on the “[Next step](#)” button to go to step 2.

## 2. Configuration

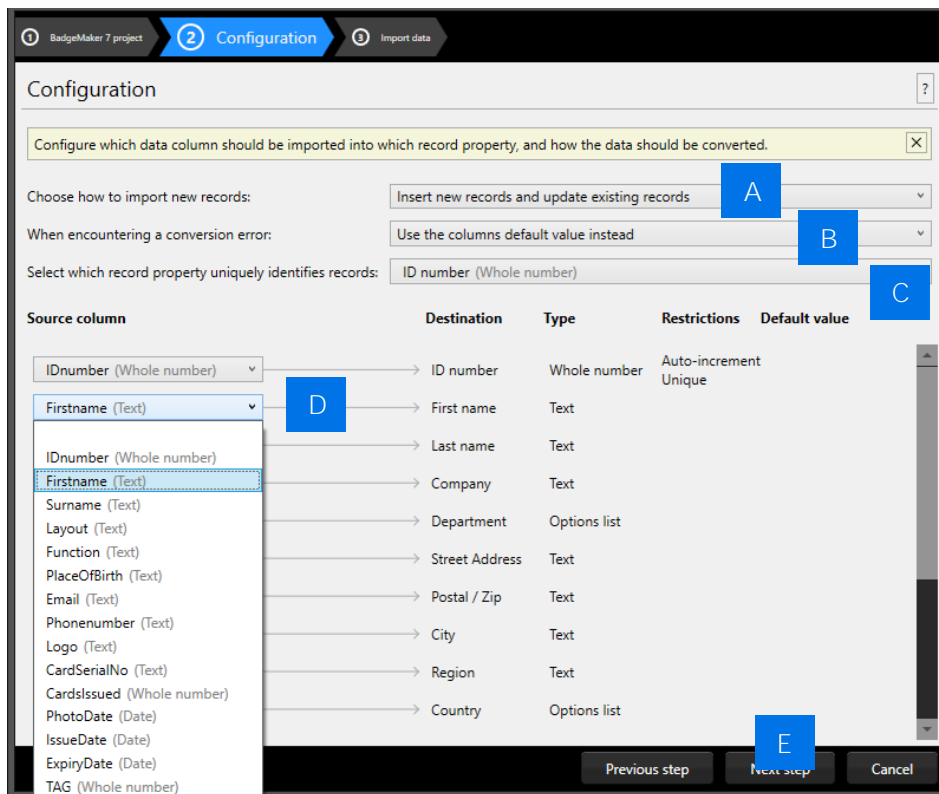

Example of the import of IDPro 7 data popup window.

- A. Choose how imported data/new records will be handled. The drop-down menu gives you three options.
- B. Select what happens when encountering a conversion error.
- C. Select one of the fields of the excel data which uniquely identifies data in the data source.
- D. Connect the source columns with the destination columns, PrintStudio will connect the columns with similar names automatically.
- E. Click on the “Next step” button to continue to import the data.

### 3. Import data

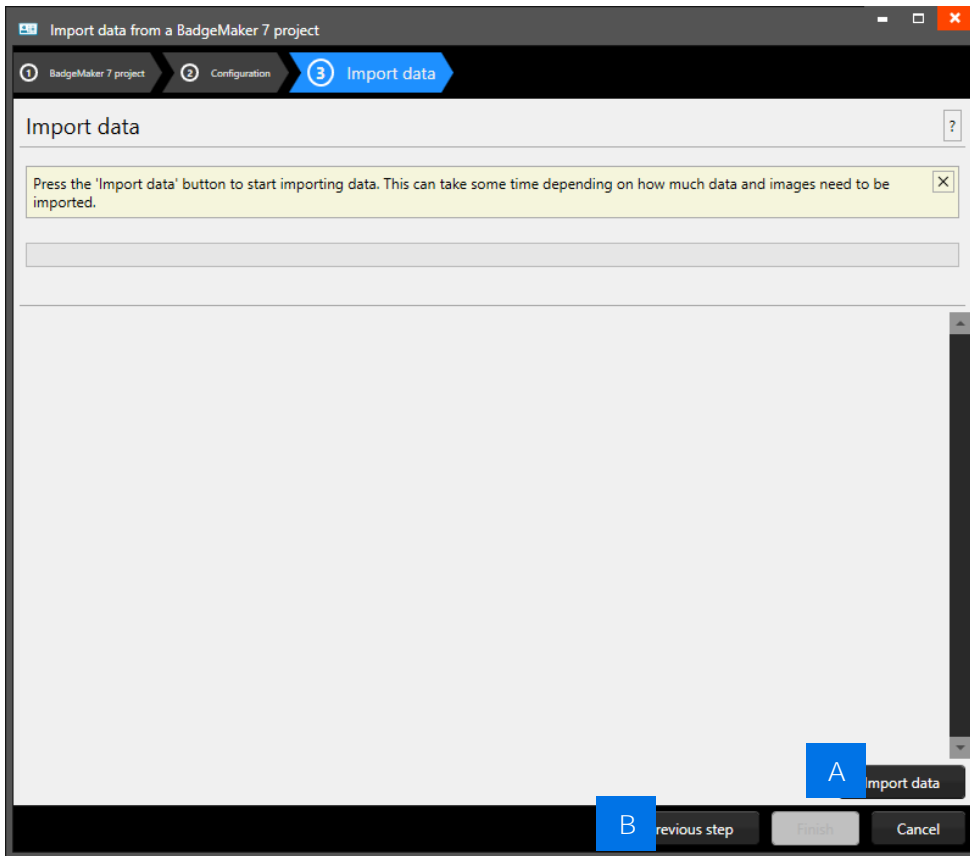

Example of step 3. Import data

Step 3. is processing the import of the Data. A. Click on the “Import data” button to start importing the data from your Excel file. B. Click on the “Previous step” button to make any changes before creating the project.

# PrintStudio

## Import Photos

At step 1. Biometric data you have the option to select the folders you would like to import from for your passport photos and or signature images.

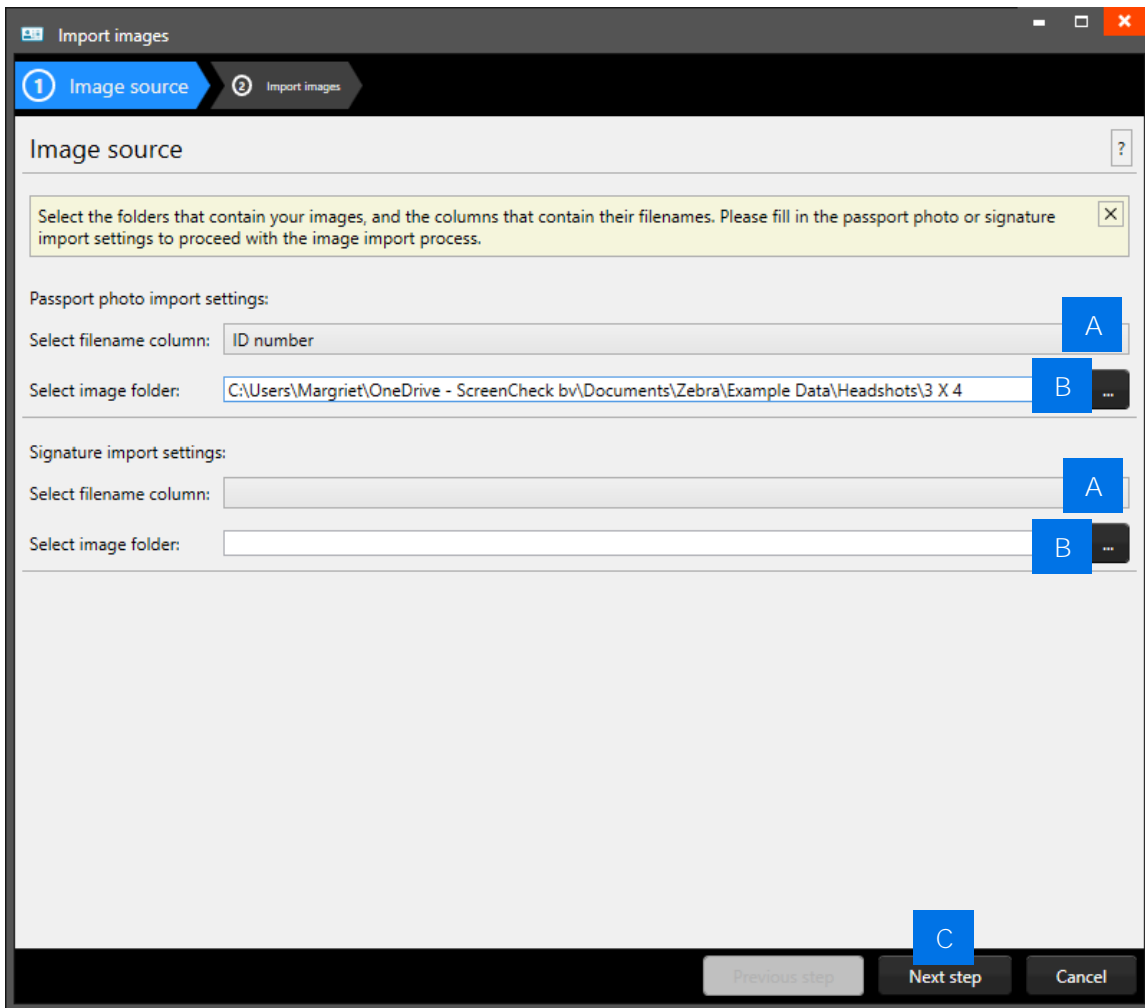

Example of importing biometric data.

- A. Select the data field that contains the unique data like the photos and or signature names.
- B. Click on this button and select the photos and or signatures folder you want to import from. The images need to have a unique name that can be connected to one of the unique fields.
- C. Click on the “Next step” button to continue to import the photos and or signatures.

# PrintStudio Export Data

# PrintStudio

## Export Data

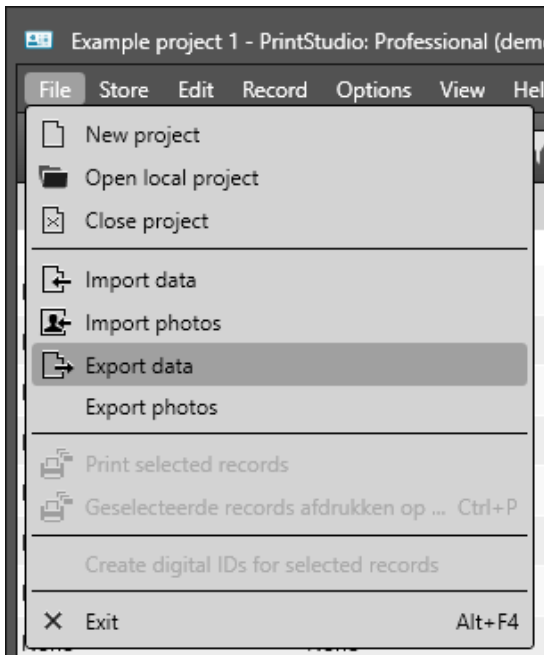

To export data first select the records you would like to export. Select all records or make a selection of records. Go to the Main menu, click on “File” and select “Export data” in the submenu:

- A. Select to export all records or a selection of records.
- B. Now click on the “Export” button and a CSV file will be generated.

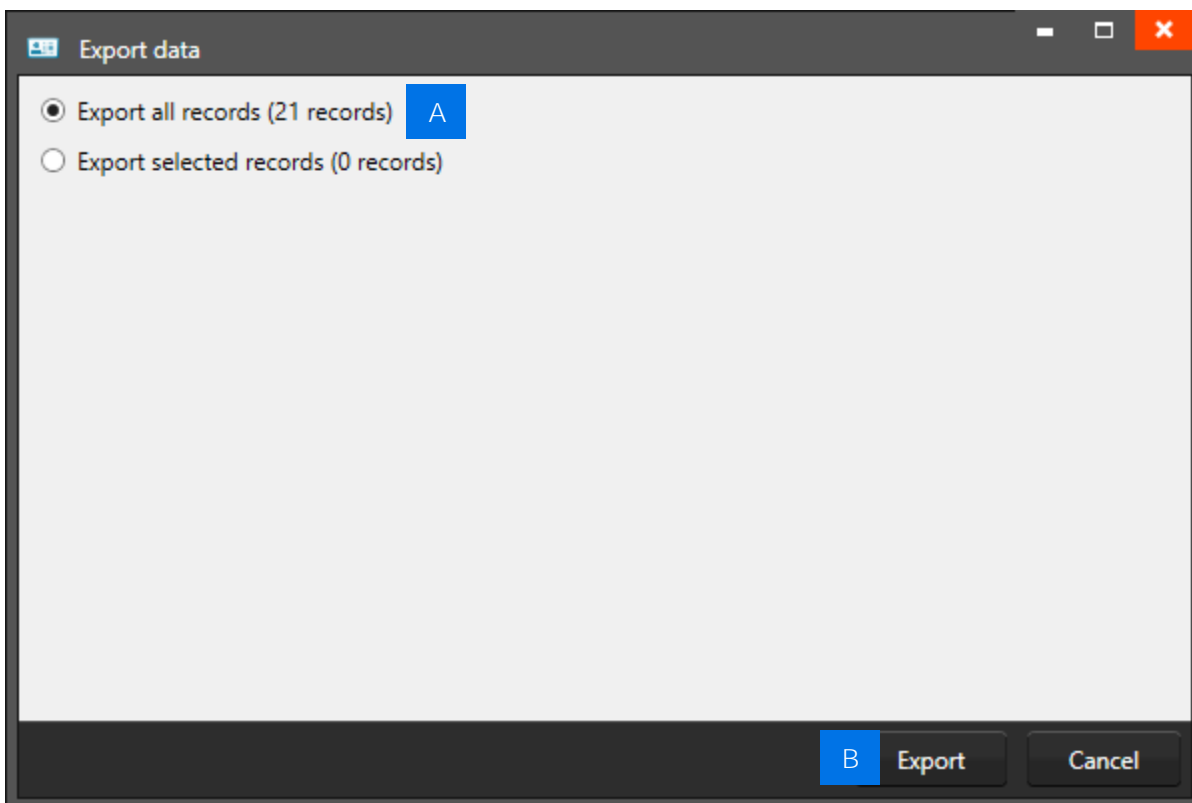

*Example of exporting PrintStudio project data.*



# PrintStudio

## Export Photos

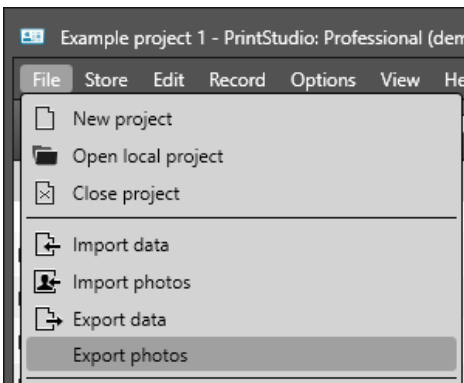

The Export photos function gives the option to export passport photos and or signature images.

To export data first select the records you would like to export. Select all records or make a selection of records. Go to the Main menu, click on “File” and select “Export photos” in the submenu.

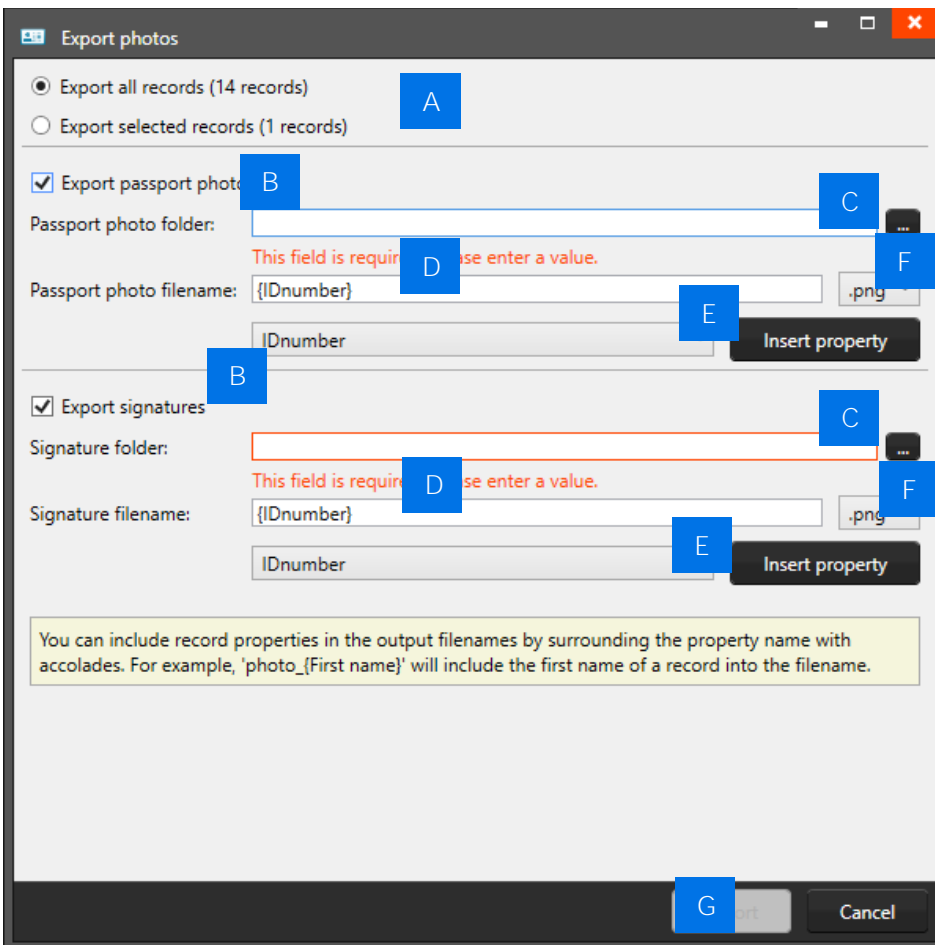

Example of exporting CardStudio project images.

- A. To export data first select if you would like to export all records or a selection you made.
- B. Check the boxes to choose to export photos and/or signatures.
- C. Click on this button and select the photos and or signatures folder to export to.
- D. Give the exported images a name.
- E. You can include column properties in the output filenames by selecting a column and clicking on “insert property”. For example: “{ID number}”.
- F. Select the file type: jpg, png or bmp.
- G. Click on the “Next step” button to continue to export the photos and or signatures.

# PrintStudio Project Settings

# PrintStudio

## Project Settings

To change the Project Settings go to the Main Menu, click on “Edit” and select “Project Settings” in the sub menu. Go to Project Settings to change the setup, project structure or to add and manage Card Designs in your project. Make sure you click on the “Save” button when making changes.

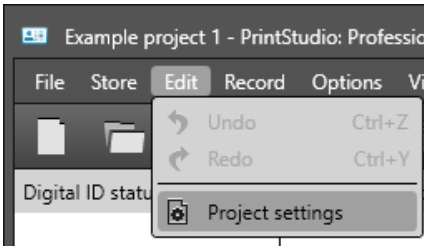

### Detail View

Configure the layout of the detail view. The detail view is the view shown in the middle of the dashboard, giving you detailed information of a record. Use the detailed view to quickly adjust record data.

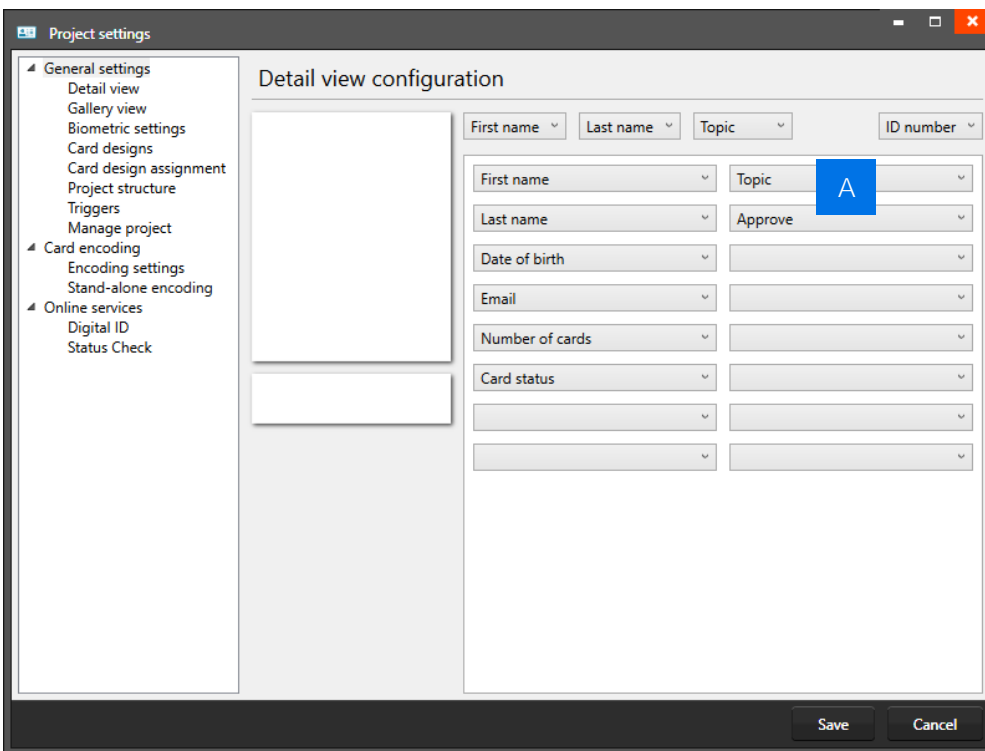

Example of the Project settings: Detailed view configuration

- A. Use the drop-down menus to select where you want to see certain data fields. At the top are usually the most important fields selected like the first name, last name and ID number.

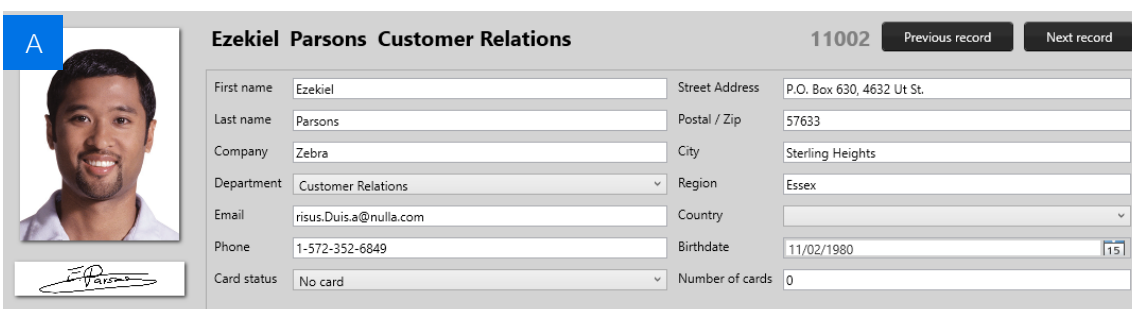

Example of the A. Detailed view in the PrintStudio Dashboard.

## Gallery view

The Gallery View is the Photo slide presentation. Gallery view lets you find a persons' record very easy when people are showing up at the front desk to change or replace a card. In the Gallery setting you can select 2 (two) database fields that are presented with the Photo. You can select First name and Last name or choose for the record ID or any other database field.

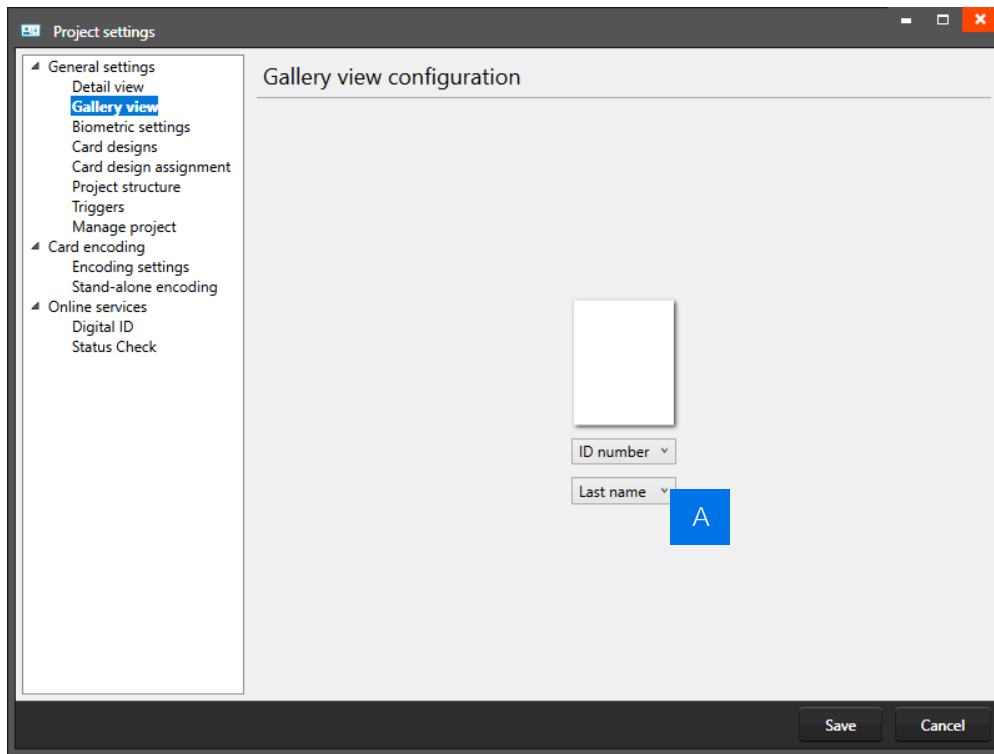

Example of the Preview Project settings: Gallery view

- A. In the Gallery setting you can select 2 (two) database fields that are presented with the Photo. You can select First name and Last name or chose for the record ID or any other database field.



Example of the A. Gallery view in the PrintStudio Dashboard.

## Biometric settings

The Biometric settings is for managing the Passport Photos and/or Signatures in the project. Add Photo's and Signatures or adjust the settings for the photos or signatures.

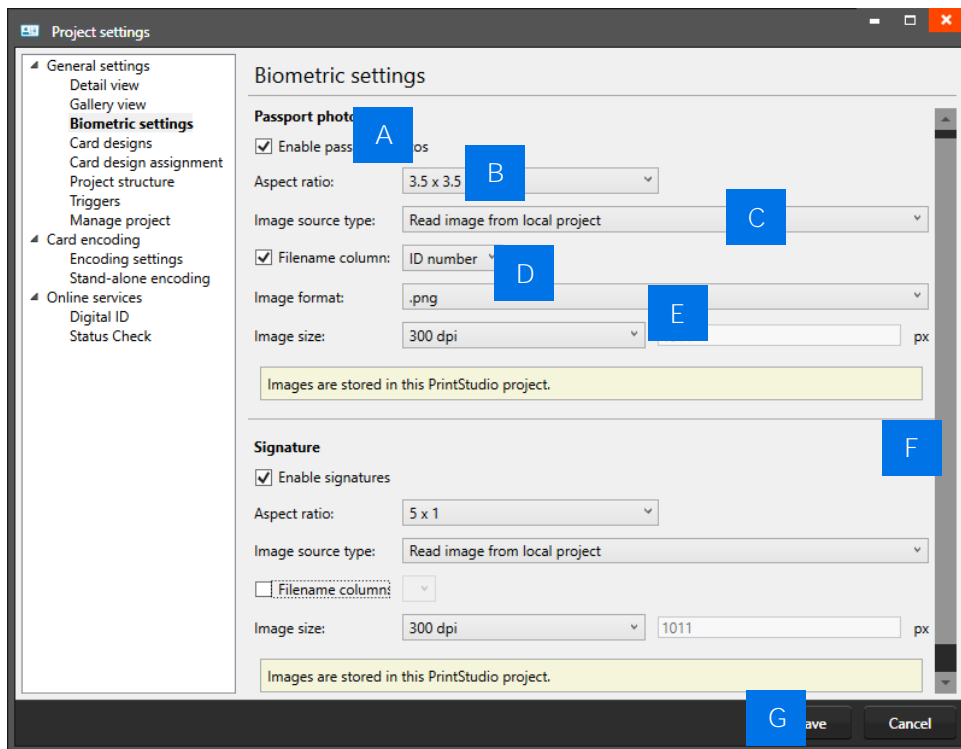

Example of the Project settings: Biometric settings

- A. The checkbox for passport photos allows you to make photos visible in the project and enables you to add photos.
- B. Determine the ratio of the photo with the drop-down menu.
- C. Select how and where photos will be saved within your project.
- D. Check this box if you want to use data columns to represent the filename.



Example of photo's that have filenames corresponding with their ID number.

- E. Select with what dpi and size the photos need to be saved within your project.
- F. The checkbox for the signature allows you to make signatures visible in the project and enable you to add signatures. The signature section works the same as the passport photo section above.
- G. Click on the “Next step” button to go to step 3. and configure the detailed and gallery view.

## Card Designs

Add and manage Card Designs in your project.

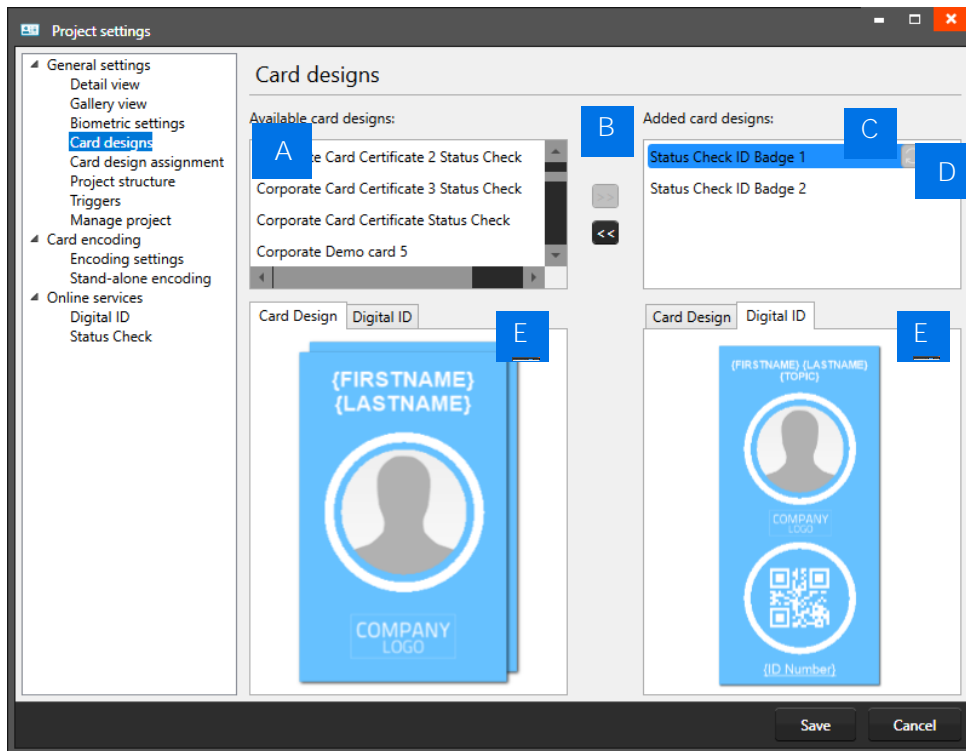

A. Select one of the available designs.

B. Click on the “>>” button to add a selected design to your project. Click on the “<<” button to remove a selected card design from your project.

C. A card design in your project has two icons available, this is the “Update” icon:



An  adjusted a card design can be updated to the latest version by clicking on the update icon.

*Example of the Project settings: Card Designs*

D. A  card design in your project has two icons

available, this is the “Bindings” icon:

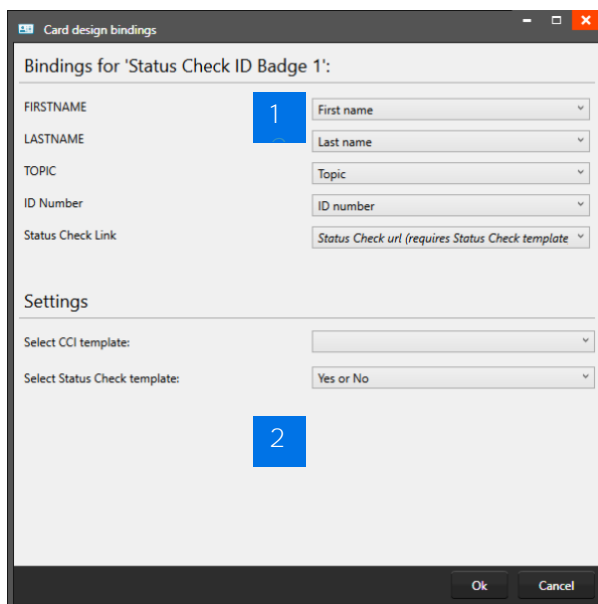

Click on the bindings icon to edit the bindings for the dynamic data of the card design. The bindings window pops up automatically after adding a design to your project.

The data binding tool is a powerful option in PrintStudio. When you add a new layout or update a layout you will be prompted to create the data bindings. Dynamic fields used and created in your layout may differ from the naming or spelling of a name that exists in your Project database. Therefore, you will be allowed to create the data bindings.

### 1. Card Design bindings

The dynamic fields that are created in the card design are presented to the left and you can bind these dynamic fields to the database fields of your project.

### 2. Settings

**CCI template:** Bind a CCI encode template to your card design to encode the card during production. For more information go to “[PrintStudio Encode](#)”. If you do not need to encode with this card design, you can leave this option blank.

**Status Check template:** Bind the Status Check Template you set available in your project to the Status Check card design. A Status Check link will be generated for the QR-code in the design as soon as the card or digital id is printed or issued. If you do not need this card design to have a Status Check QR-code leave this option blank.

E. The preview of the Card Designs offers two tabs with a preview of the card design and one of the digital ID. If the card design has a front and a back, you can toggle between the two by clicking on the design in the preview.

## Card designs assignment

It is possible to assign the card designs using a specific project column.

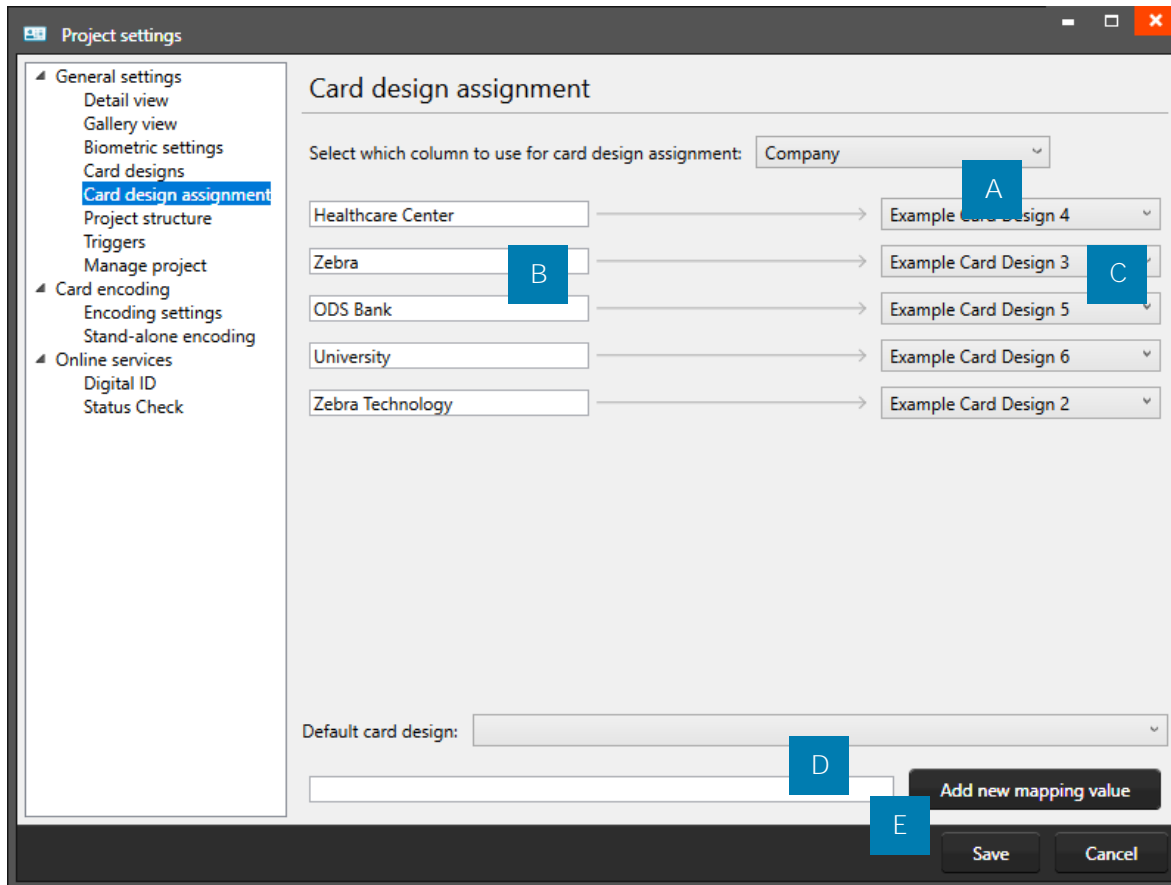

Example of the Project settings: Card design assignment

- A. Click on the drop-down menu to select the column. In the example we select the Company column. There is a different card design for every Company in the project.
- B. Enter the value that needs to be linked to a specific card design. In the example company names are entered.
- C. Select one of the available card designs from the drop-down menu and link the design to the value entered in the input field (B).
- D. Select one of the card designs from the drop-down menu as the default design for all the data not corresponding with the values entered above.
- E. Enter another value to add to the mapping and click the “Add new mapping value”. For example if you would like to add another company with a new company design.

## Project structure

The project structure settings is for managing your structure. You can create, edit or delete data columns in your project.

Name	Type	Required	Unique	Default value	
<input type="text" value="ID number"/>	Whole Number	<input checked="" type="checkbox"/>	<input checked="" type="checkbox"/>	<input type="text"/>	<input type="button" value="X"/>
<input checked="" type="checkbox"/> Is auto-incrementing		<input type="checkbox"/>	<input type="checkbox"/>	<input type="text"/>	<input type="button" value="X"/>
<input type="text" value="First name"/>	Text	<input type="checkbox"/>	<input type="checkbox"/>	<input type="text"/>	<input type="button" value="X"/>
<input type="text" value="Last name"/>	Text	<input type="checkbox"/>	<input type="checkbox"/>	<input type="text"/>	<input type="button" value="X"/>
<input type="text" value="Company"/>	Text	<input type="checkbox"/>	<input type="checkbox"/>	<input type="text"/>	<input type="button" value="X"/>
<input type="text" value="Department"/>	Options list	<input type="checkbox"/>	<input type="checkbox"/>	<input type="text"/>	<input type="button" value="X"/>
<input type="checkbox"/> Expand to view and modify available values					
<input type="text" value="Street Address"/>	Text	<input type="checkbox"/>	<input type="checkbox"/>	<input type="text"/>	<input type="button" value="X"/>
<input type="text" value="Postal / Zip"/>	Text	<input type="checkbox"/>	<input type="checkbox"/>	<input type="text"/>	<input type="button" value="X"/>
<input type="text" value="City"/>	Text	<input type="checkbox"/>	<input type="checkbox"/>	<input type="text"/>	<input type="button" value="X"/>
<input type="text" value="Region"/>	Text	<input type="checkbox"/>	<input type="checkbox"/>	<input type="text"/>	<input type="button" value="X"/>
<input type="button" value="Add new property"/>					

Example of the Project settings: Project structure

- A. Enter the column name.
- B. Set the data type. Select if the data are number or text for example. The following types of database fields are supported:
  1. **Whole Number**, when selecting this type, you can select 'auto-increment'. When a new record is created the number will be the highest number in the Project increased by 1.
  2. **Text**
  3. **Decimal number**
  4. **Option list**, when this list type is selected, you can add and delete the list values from the list that is presented for this database field. When you change a datatype from text to option list, PrintStudio automatically generates a list based on the data already in that data field.
- C. Check these boxes if the field needs to be "Required" and/or "Unique".
- D. With the default input field, you can add a standard value to your data field, existing empty fields and new records will automatically get the default value you add to this data field.
- E. Click on the "X" button to delete a data field from the project structure setup.
- F. Click on the "Add new property" button and add and describe the data field names you want to use in your new project.



## Triggers

Setup triggers for your project. Triggers can be used to automatically change data in your project on a certain condition or event.

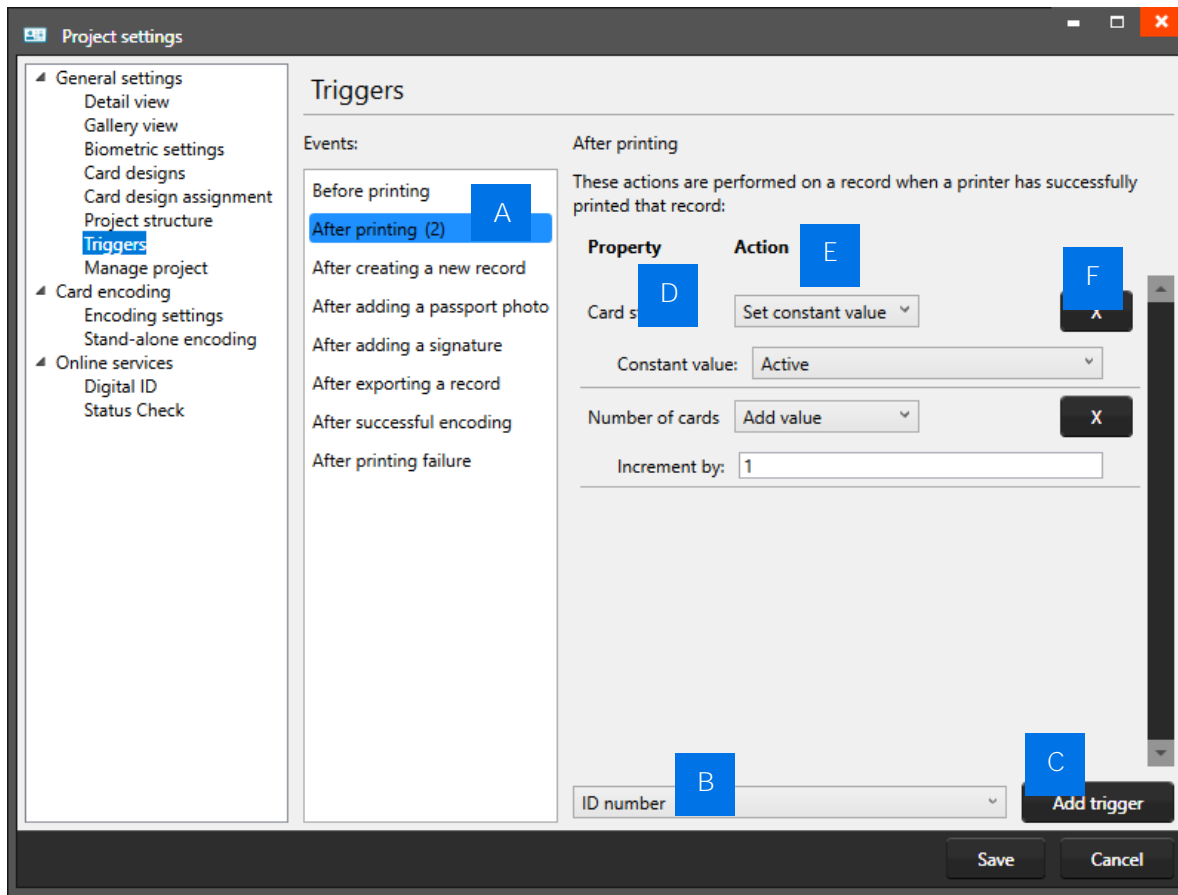

Example of Project Settings: Triggers

- A. Select one of the events from this list and add specific triggers. PrintStudio will automatically wait for the event to occur before performing the action that is linked to the trigger.
- B. All data columns of the new project are listed. Select one of the columns to link a trigger action to it.
- C. Click on the “Add trigger” button to add the trigger to the data column and specify the trigger with events and actions.
- D. The property shows you the selected data column.
- E. Select the action you want to connect to the data column from the drop-down menu and define the action.
- F. Click on the “X” button to delete a trigger from an event.

Define the action that is performed once the event has been met. Some actions are only available for specific columns (for example, incrementing number values can only be done on number type columns). All changes need to be saved before they become active. Understand that triggers might cause your original data to change, so make sure no vital data is lost when working with triggers.

## Manage Project

Delete your project. You are able to completely delete the current project you are working on.

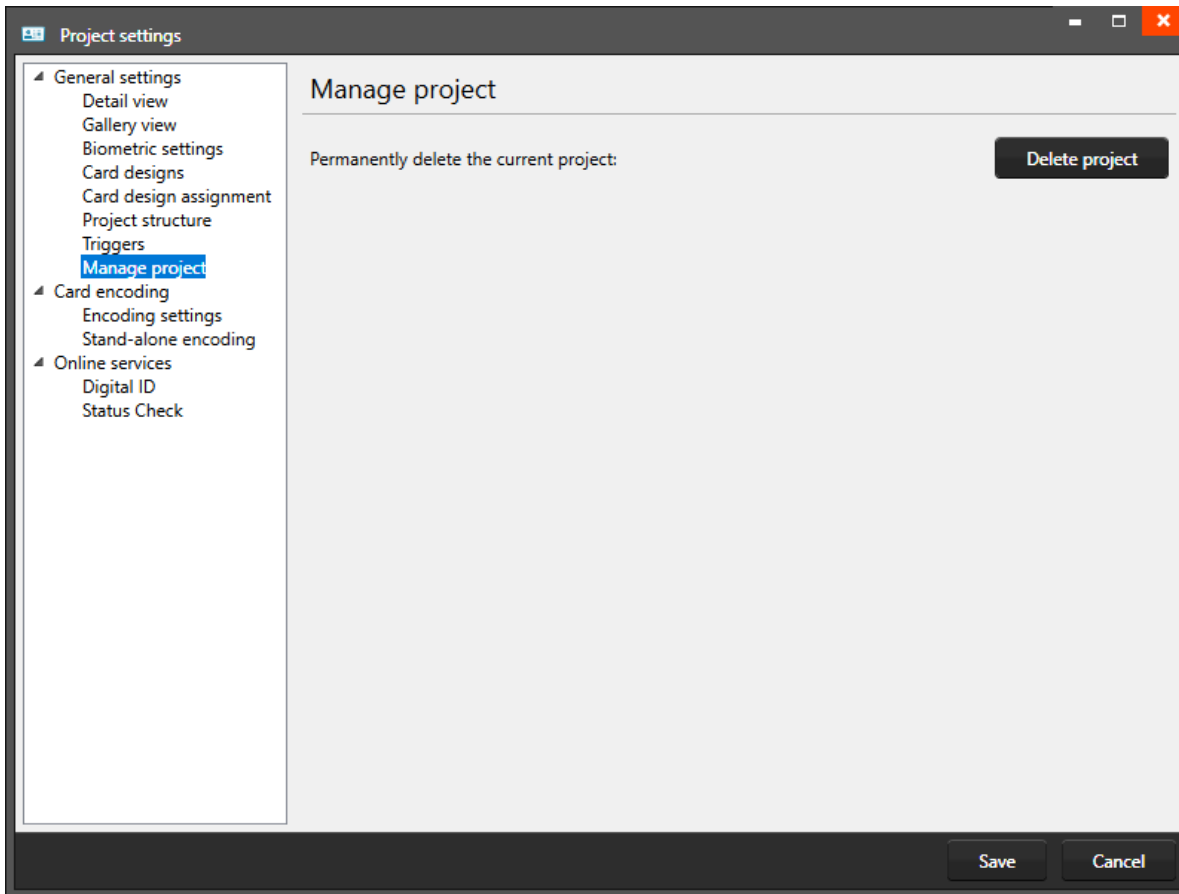

*Example of the Project settings: Project management*

## Status Check

Setup a Status Check template for your Project. With Status Check it is now possible to scan a QR-code on a printed card or Digital ID and get status feedback. Status Check is an optional fee-based feature that allows you to add a live 2D barcode to your printed or Digital ID Card. This QR-Code contains a unique secure URL that displays a Status Check page with a near, current or up-dated status of a data field you configure in your project. It costs 5 credits to issue a Status Check QR-code and 2 credits to update an existing Status Check Card.

- A. Select one of the available Status Check templates from this list.  
For example, to check the status of training certifications, membership, academic standing, or special access.

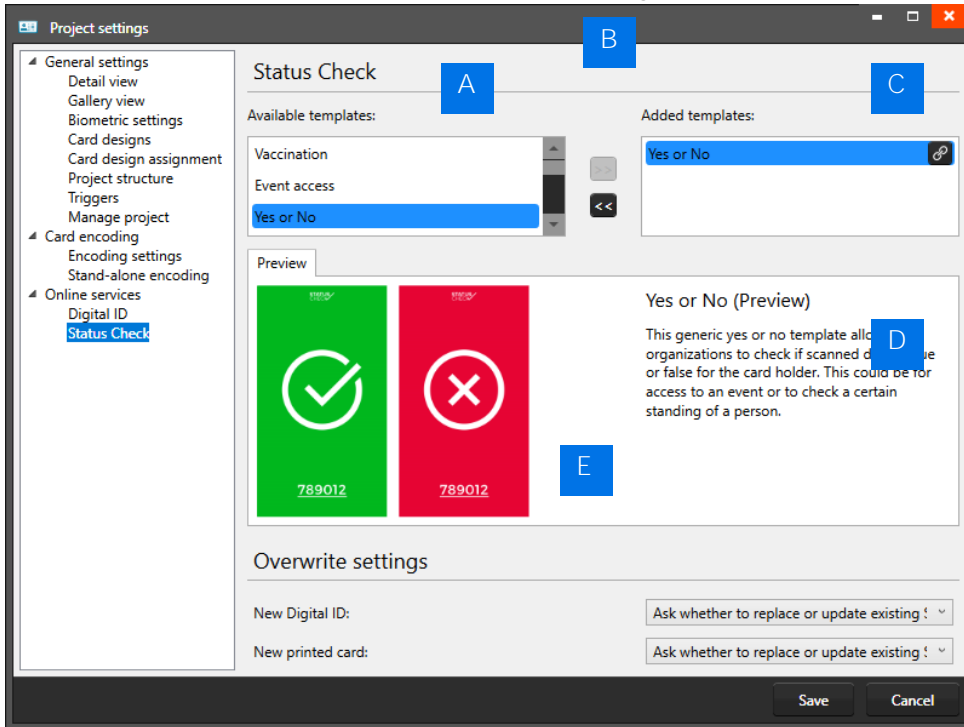

- B. Click on the “>>” button to add a template to this new project.  
Click on the “<<” button to remove a selected card design from your project.

- C. A Status Check template in your project has an icon available, this is the “Bindings” icon:



Click on the bindings icon to edit the bindings for the dynamic data of the Status Check template and to select the option list to use for validation. The bindings window pops up automatically after adding a template to your project.

- D. Preview of the Status Check template selected. You can see the design for positive feedback (green) and negative feedback (red) and a short description on how to use the template.

- E. Select the overwrite settings for your Status Check QR-code on your card and digital ID. The QR-code link will be generated as soon as a card gets printed, or a digital ID issued. You can choose for:  
*Generate new Status Check, Update existing Status Check, Update existing Status Check if out of date or Ask whether to replace or update existing Status Check.*

## Status Check template bindings

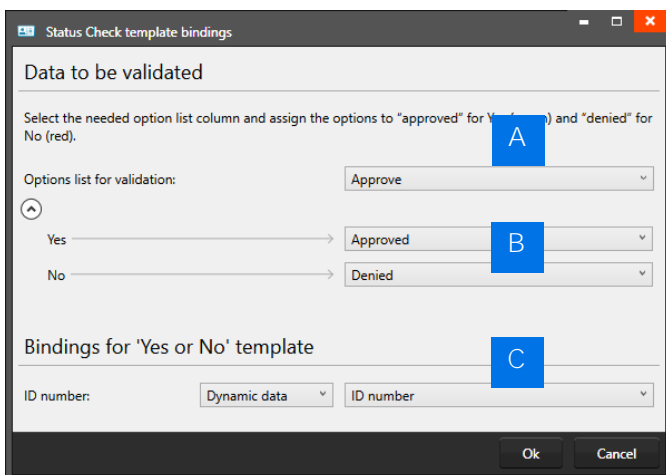

The bindings window pops up automatically after adding a template to your project. The selected “Yes or No” template allows organizations to check if scanned data is true (green) or false (red).

- A. Click on the dropdown menu to select one of the options lists to use for Status Check to validate. PrintStudio makes all the data field option lists previously defined in your project available to choose from. We will use the “Approve” option list, we added to the project structure, to validate in this example.

- B. Set -Yes- to “true” to approve and -No- to “false” to deny access to each of the activities.

- C. The templates can also show Static or Dynamic data from your project. This template shows the card holders’ ID number. Bind this ID to the ID number in your project.

# PrintStudio Link Card Design to record

# PrintStudio

## Link Card Design to record

Link your records to your Card Design, so you can print a card.

When a data record is selected click on the “Link” button of one of the card designs in the Card Designs Gallery view to connect the design to the record. To change the connection to a different lay-out the user can click on the “Unlink” button and link another design. It is possible to select multiple data records at the same time and connect the selected records to a lay-out. Use CTRL+A, + CTRL or +SHIFT, Use CTRL+A to select all records.



# PrintStudio Records

# PrintStudio Records

Records are single data rows that contain all the information of one person. There is a button for adding and deleting a record.

## Add Records

Records are single data rows that contain all the information of one person. There is a button for adding and deleting a record manually. (To add multiple records, choose to import an excel file for example.)



### 1. Add a new record

If you add a record, a new pop-up window will appear to enter the new record data. The entry form allows the user to enter the data and Capture Photo and/or Signature.

#### 1. Information

- A. Enter the needed information for each field and click on the
- B. “Next Step” button.

A screenshot of a web-based form titled 'Data' with tabs for 'Passport photo' and 'Signature'. The form contains several input fields: 'ID number' (highlighted in orange with a red error message 'This field is required. Please enter a value.'), 'First name', 'Last name', 'Company', 'Department', 'Street Address', 'Postal / Zip', 'City', 'Region', 'Country', 'Email', 'Phone', 'Birthdate', 'List Name', and 'Expiry Date' (pre-filled with '01-01-2019' and a green checkmark). At the bottom, there are four buttons: 'Previous step', 'Next step' (highlighted in blue with a white 'B'), 'Add record', and 'Cancel'. A blue square with a white 'A' is positioned over the 'First name' field.

Example of the information tab when adding a new record.

## 2. Photo

- A. Select the source of camera you want to use from the drop-down menu. You can choose to use your web cam or a TWAIN camera that you installed and connected to your computer.
- B. Click on the “Start automatic capture” button. The application will detect your face automatically and take three pictures. You can select one of the three pictures to add to the new record.
- C. The Photo functionality will show you the camera view.
- D. Click on the “Capture photo” button. The Photo functionality will show you the camera view. You are also able to upload an image from your computer. Click on the “Open file...” button to select an image from a file.
- E. To change the camera setting click on the drop-down to select the capture resolution and click the settings icon to adjust more settings. These settings can be different depending on the camera.
- F. “Next Step” button.

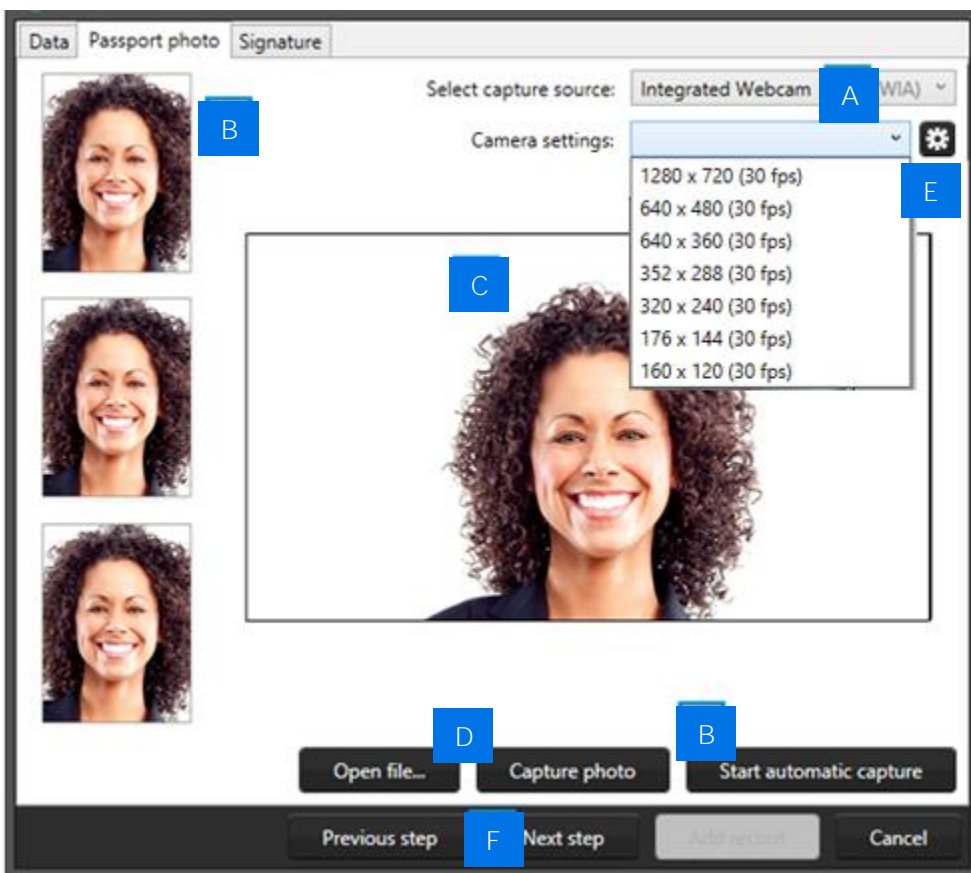
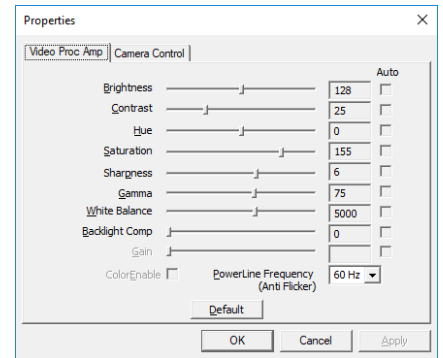

Example of the photo tab when adding a new record.



### 3. Signature

- A. Connect the signature pad to the PC. Use a signature pad to write a signature into this field.
- B. Scale the signature using the slider.
- C. Select a signature from file.

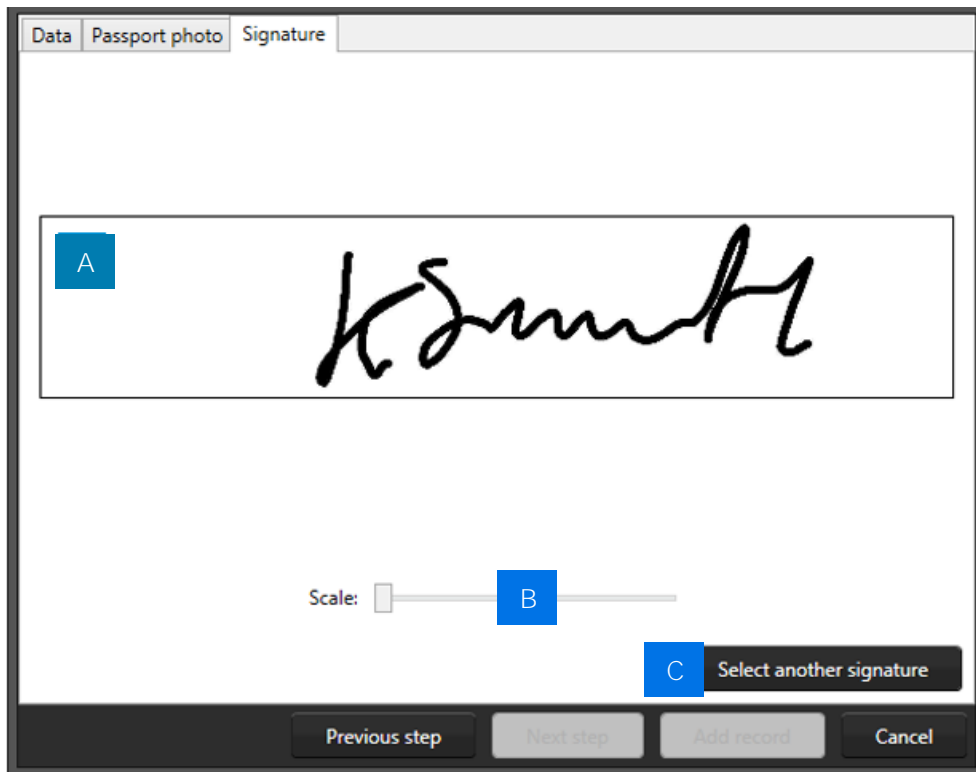

*Example of the signature tab when adding a new record.*

## Print records

To print a certain record, select it and then click on the print button in the quick menu or go to File and click on the print link.

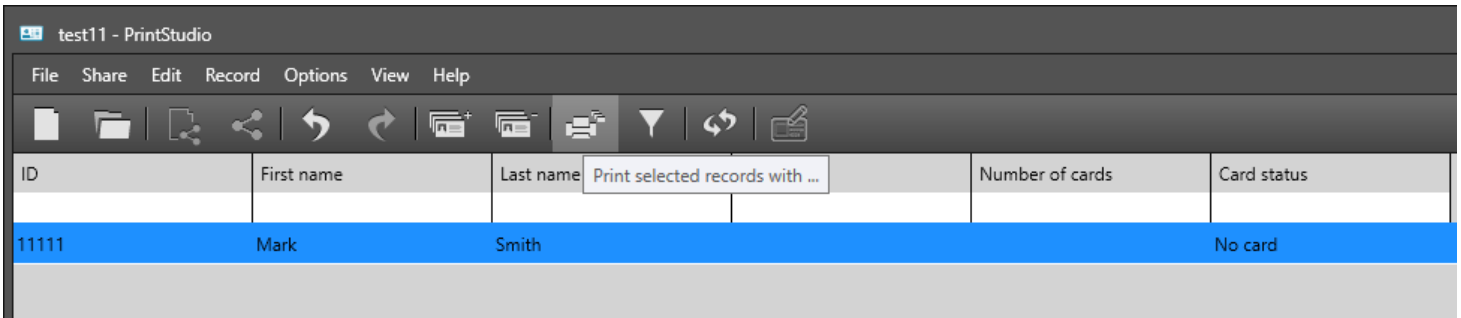

- A. A print window appears, and you can select the printer you installed for the card printing process. This manual does not describe the installation of printers. Please refer to the Zebra Card Printer manuals for further information on these devices. After you select the printer you click on the “Print” button.

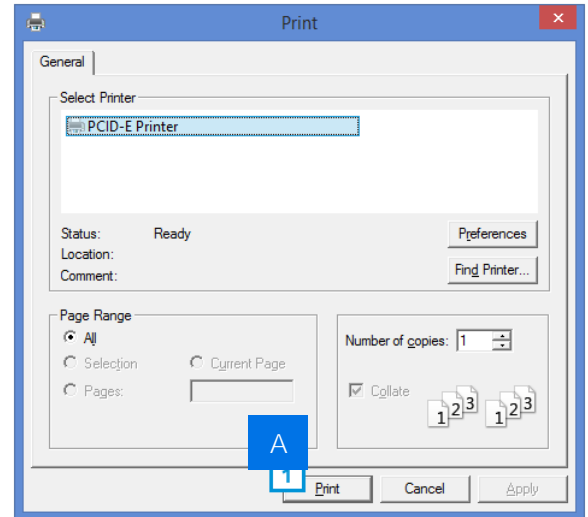

Example printer setup window.

- B. A print progress window will pop up that will show you the progress of the cards that are being printed.

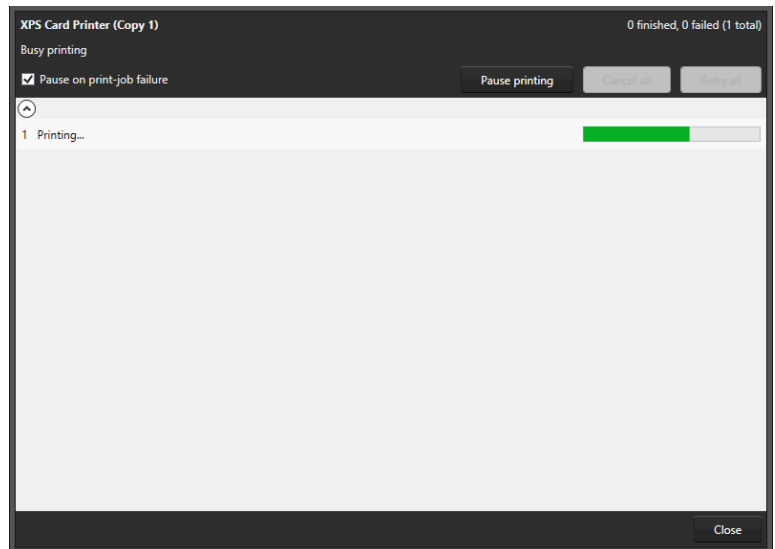

# PrintStudio Digital ID

# PrintStudio

## Digital ID

With CardStudio, you can now create a Digital ID design in DesignStudio and issue it in PrintStudio next to the standard card design you use to print on plastic ID badges. Digital ID is available for the CardStudio Standard, Enterprise, or Professional Edition. The digital design feature offers two options, Digital ID as a PDF also to be opened in the Zebra Digital ID app and as a Wallet pass.

How to send a Digital ID to your card holders.

Start PrintStudio and open an existing project with records of card holders that need a Digital ID.

First step is to enable Digital ID, select a Digital ID format for this project and connect a card design with a Digital ID design. Navigate to the main menu, click on **“Edit”** and then on **“Project Settings”**.

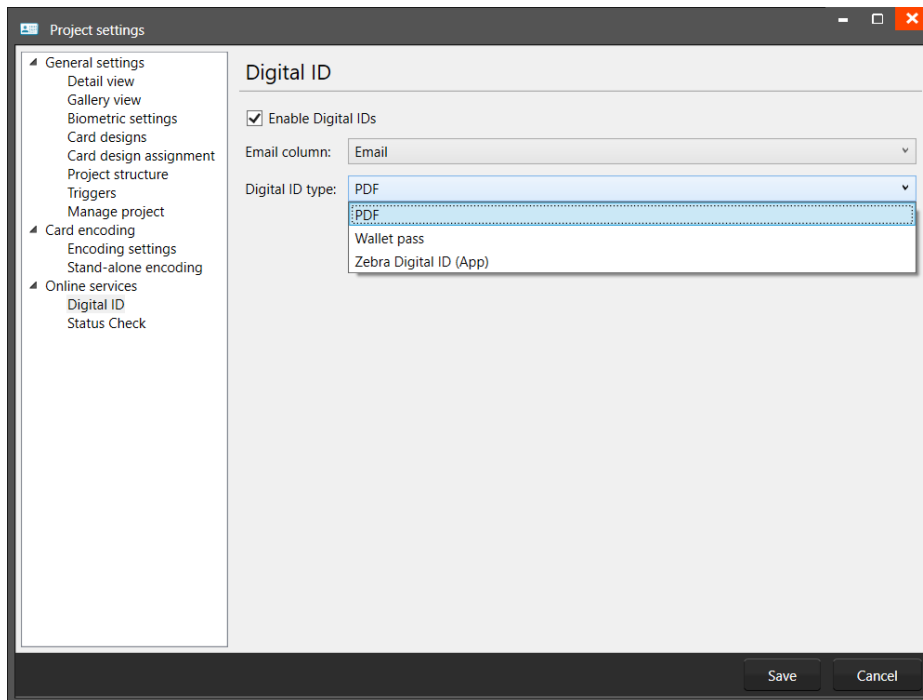

Go to **“Online services”** and click on **“Digital ID”**. Check the box to enable Digital IDs, select the column that represents the emails in your project and select the Digital ID type.

PDF: a Digital ID as a PDF-file is send to your card holder by email to use on their mobile device.

Wallet pass: a Digital ID as a Wallet pass .pkpass format is send to your card holder by email to open in the Wallet pass app on their mobile device.

Zebra Digital ID: is a Digital ID issued to your card holder for them to accept and open in the Zebra Digital ID app on their mobile device.

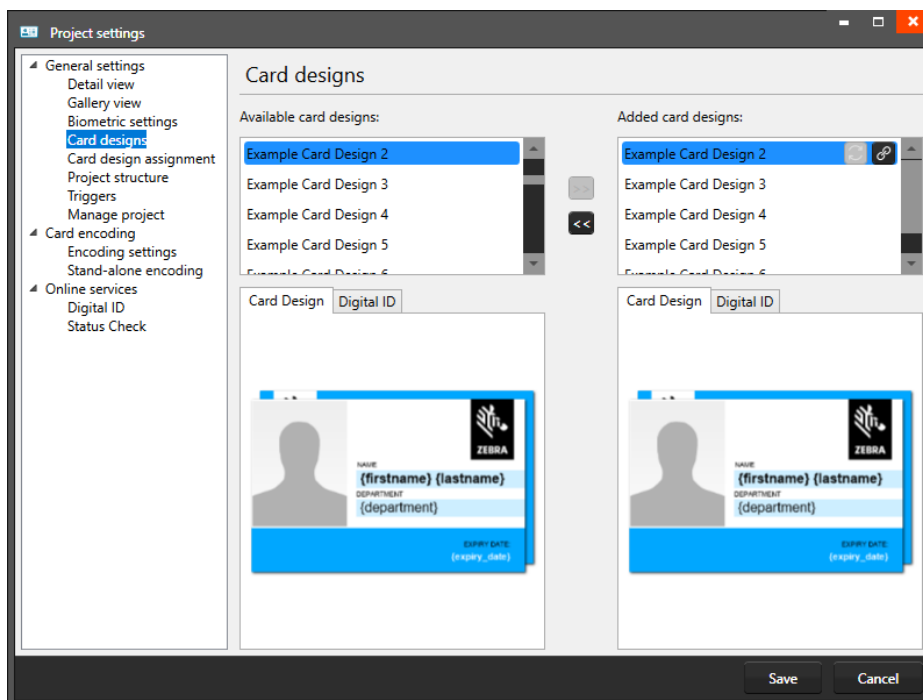

Now go to **“Card Designs”**, select the card design with the Digital ID design you created for this project, add the design to this project and bind the dynamic fields from the card design to the data columns.

Do not forget to save the settings to enable Digital ID and add the card design to the project.

## Send Digital ID

To send the Digital ID select the needed records and link them to the new card design. Make sure you have enough credits in your account. To send a Digital ID you need 10 credits. Credits can be purchased in the Store.

ID Number	First Name	Last Name	Department	Street Address	Postal / Zip	City
11000	Adam	Fox	Finances	559-9424 Est Avenue	71850	For
11001	Ruth	Hess	Customer Service	P.O. Box 380, 3629 Vulputate, Rd.	22886	Ka
11002	Ezekiel	Parsons	Customer Relations	P.O. Box 630, 4632 Ut St.	57633	St
11003	Hyatt	Fernandez	Media Relations	Ap #677-2460 Egestas, Street	34350	Or
11004	Uta	Gomez	Legal Department	P.O. Box 396, 2614 Nulla St.	29504	Co
11005	Vera	Taylor	Human Resources	838-9154 Nisi, St.	10230	Au
11006	Althea	Bird	Legal Department	7269 Ac Rd.	17850	Ge
11007	Perry	Hood	Sales and Marketing	7377 Consectetur, Street	18108	Se
11008	Harriet	Gallegos	Quality Assurance	1543 Diam, St.	76479	La

The option to create and send Digital ID's is now available in the Quick menu for the selected records.

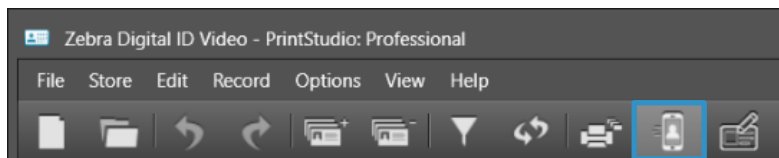

Click on the “[Create Digital IDs](#)” icon and watch the progress of sending the Digital IDs in the pop-up. You have the option to pause, cancel or retry processing the Digital ID's.

The Card Holder now receives an email with a link to retrieve the Digital ID. The link first opens a Terms of Use page for the card holder to agree to, after which the Digital ID can be downloaded and will also be sent by email.

The PDF or Wallet pass can now be used as a temporary or permanent way of mobile identification.

For more information and tutorials of the Digital ID feature, visit: <https://cardstudio.zebra.com/digital-ID>

# PrintStudio Trigger Examples

# PrintStudio

## Trigger Examples

Triggers can be used to automatically change data in your project on a certain condition or event.

How to add a trigger to a project that reads the card serial number

### Step 1. Open your project

Open an existing project with card designs and data.

### Step 2. Create an extra column for the card serial numbers

We want to add an extra column to the project, so PrintStudio can write the card serial number for a record that has been printed to the card serial number column in the project.

Go to “Edit” in the main menu and go to “Project Settings” and click on “Project Structure”. Click on “Add new property” and name this text data column:

[Card Serial Number](#).

The screenshot shows the 'Project settings' dialog box with the 'Project structure' tab selected. The left sidebar contains a tree view with 'Project structure' highlighted. The main area displays a table of properties:

Name	Type	Required	Unique	Default value	
Email	Text	<input type="checkbox"/>	<input type="checkbox"/>		X
Phone	Text	<input type="checkbox"/>	<input type="checkbox"/>		X
Date of birth	Date	<input type="checkbox"/>	<input type="checkbox"/>	Select a date [15]	X
Expiration date	Date	<input type="checkbox"/>	<input type="checkbox"/>	01-01-2015 [15]	X
Year	Whole number	<input type="checkbox"/>	<input type="checkbox"/>	2018	X
<input type="checkbox"/> Is auto-incrementing					
Card status	Options list	<input checked="" type="checkbox"/>	<input type="checkbox"/>	No card	X
Expand to view and modify available values					
Number of cards	Whole number	<input checked="" type="checkbox"/>	<input type="checkbox"/>	0	X
<input checked="" type="checkbox"/> Is auto-incrementing					
Card Serial Number	Text	<input type="checkbox"/>	<input type="checkbox"/>		X

At the bottom of the dialog, there is an 'Add new property' button, and 'Save' and 'Cancel' buttons.

Keep the data type “text”. Now click on “Save”.

Step 3. Add the trigger after printing to read the card serial number to your project

Go to “Edit” in the main menu and go to “Project Settings” and click on “Triggers”. We will now add a trigger on the event “after printing”. Click on the event “After printing”. Now select the data field from the dropdown we would like to add a trigger on “Card Serial Number” and click on “Add Trigger”.

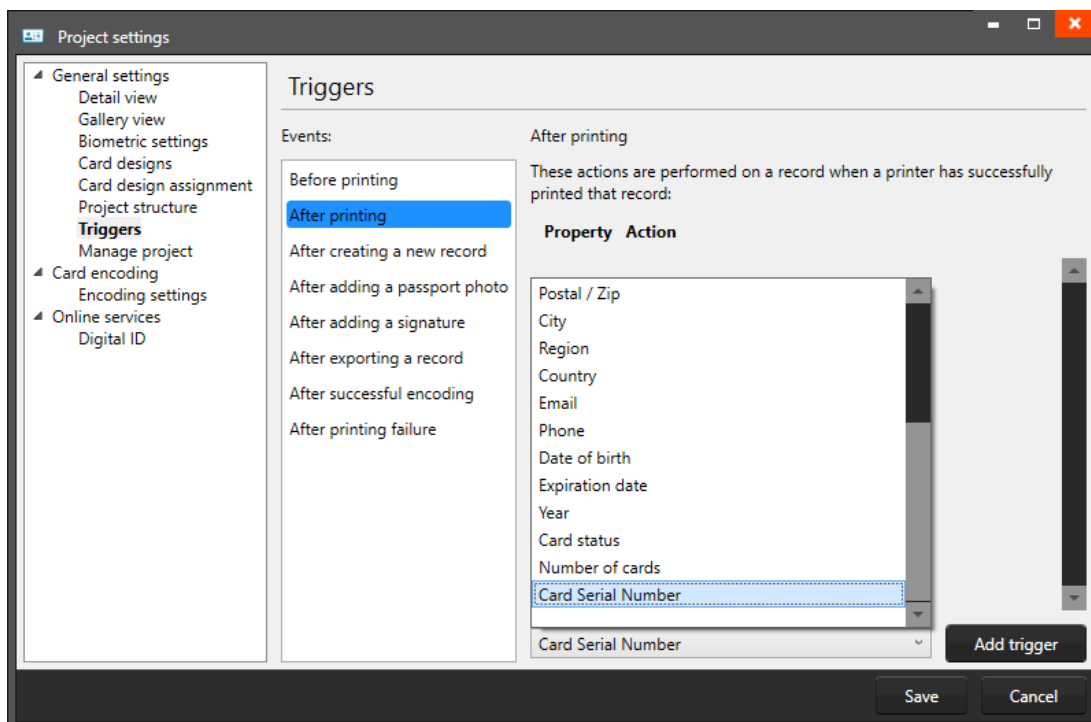

### Set the trigger to “Set card serial number”

After adding the trigger for the Card Serial Number data column, select the action “Set card serial number” from the dropdown menu. Also check the first box on how to write the serial number to significant byte first, same as the encoding file.

Do not forget to save this trigger setup.

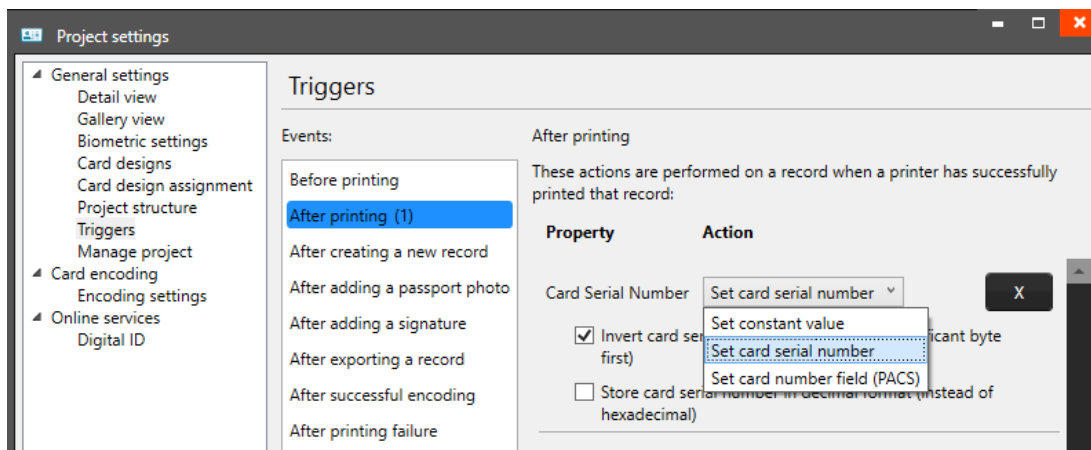

You have now setup the trigger and PrintStudio will add the card serial number to the column for the record that has been printed.



## Increment number Trigger

When you want to add a number of cards issued or total number of cards printed into your project you can use a Trigger to have it automatically added to your records.

First, add a numeric column to your project (i.e. Card issue number).

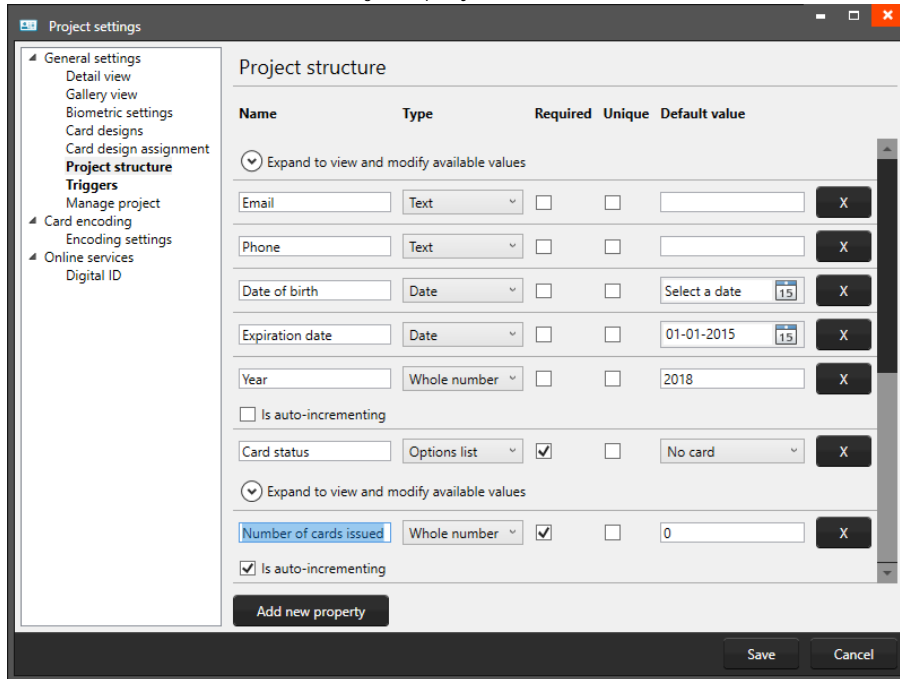

For a project counter, set the Trigger to Before printing, select the new column and make sure to set the Current Counter value to 1. 0 will leave the first card uncounted.

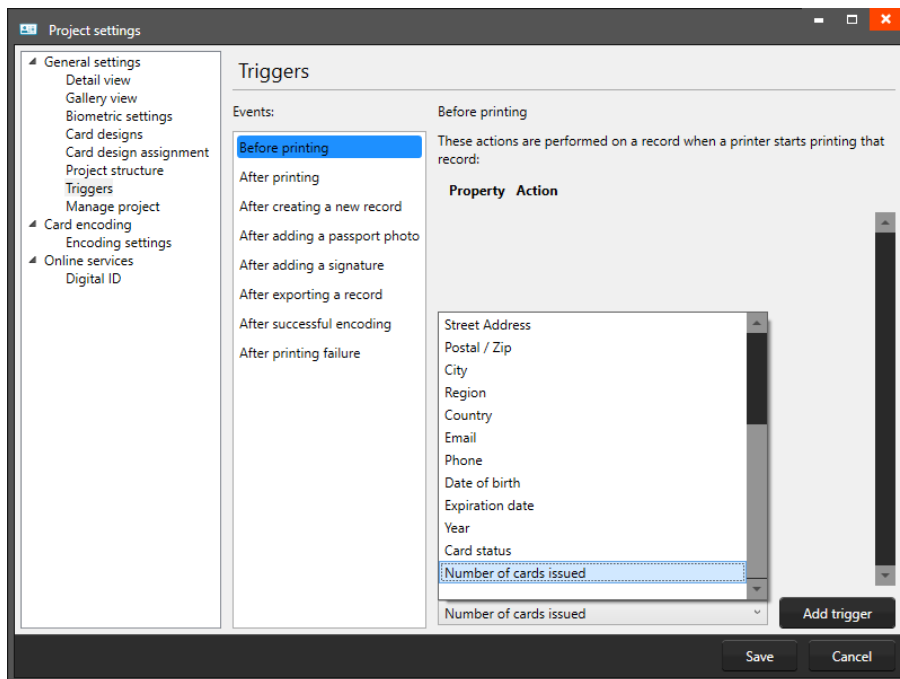

Note: when the Trigger is set for After printing, the first card will not display any number as that field is still empty and the second card will start at the number given to the Current Counter value, usually 1.

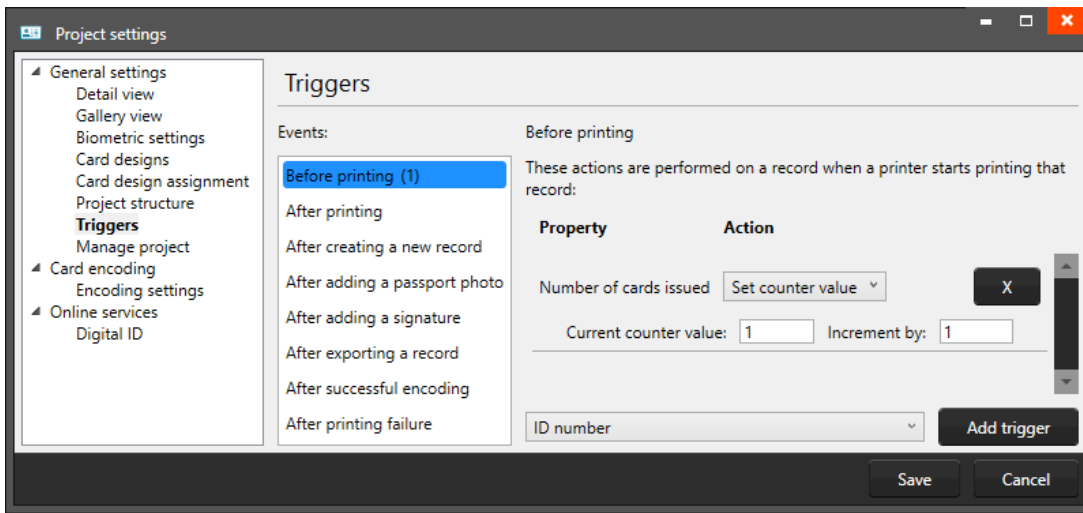

For a card count per record, set the trigger to Before printing and set the dropdown to Add Value:

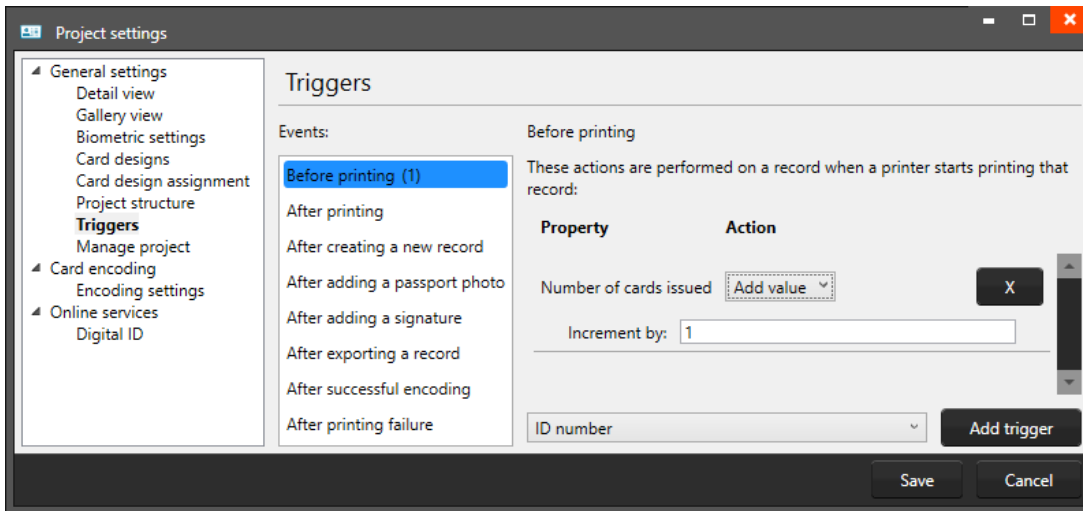

To print this number on your card, add the corresponding dynamic field to your card design.

# PrintStudio Database Connection

# PrintStudio

## Database Connection

PrintStudio Project with database connection allows users to connect with external databases, and use the data to complement their local project, or even base the entire project upon. There are four types of databases supported:

- Microsoft SQL Server
- Microsoft Access files
- MySQL Server
- Oracle Server

Choosing from one of these four settings is highly recommended, however it is also possible to connect to a database through an ODBC driver. Connecting with one of the supported databases allows you to make full use of the database's functionality. For example: PrintStudio will automatically lock tables when adding or updating records, it will automatically detect user rights and allows you to work with views.

Connecting with a data source through an ODBC driver provides you with more basic functionality, but it will suffice for most single-user environments. PrintStudio projects with database connection will automatically detect any available ODBC drivers on the system, if the required ODBC driver is not listed, it can be installed using the Microsoft update website or tool in your operating system.

*Note: CardStudio™ 2.0 does not create an external database for you, it only creates a connection to an existing external database.*

The screenshot below shows the Project Settings dialog, where the option for PrintStudio projects with an external database connection will be present depending on the CardStudio Edition you purchased.

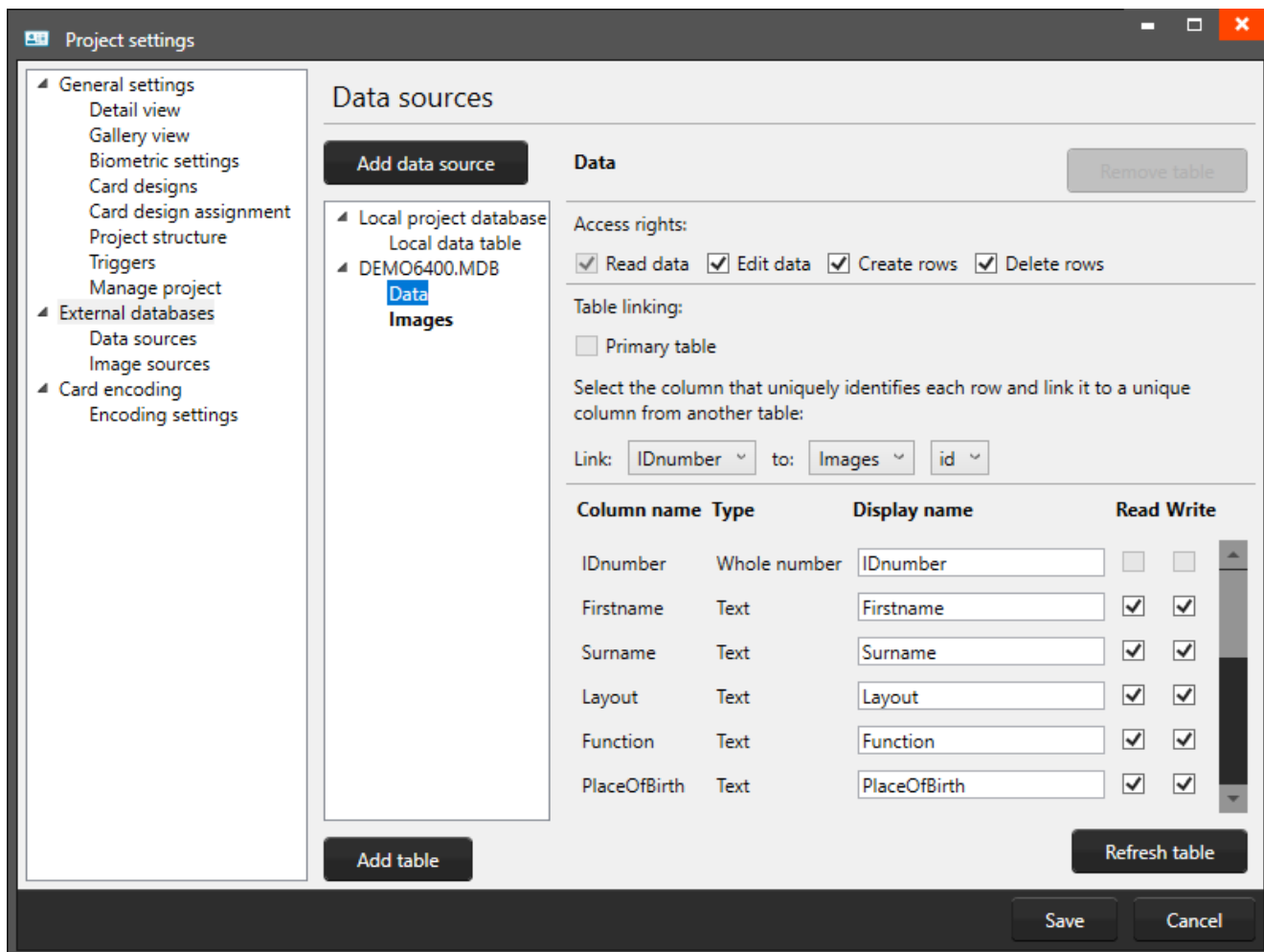

## Setting up a PrintStudio Database connection

### How to set up a PrintStudio Project with Database connection

Follow these steps if you want to create a project using an external data source as your primary source of information. Start by creating a new project.

A. Click the New Project icon and select “[Create project with database](#)” from the dialog.

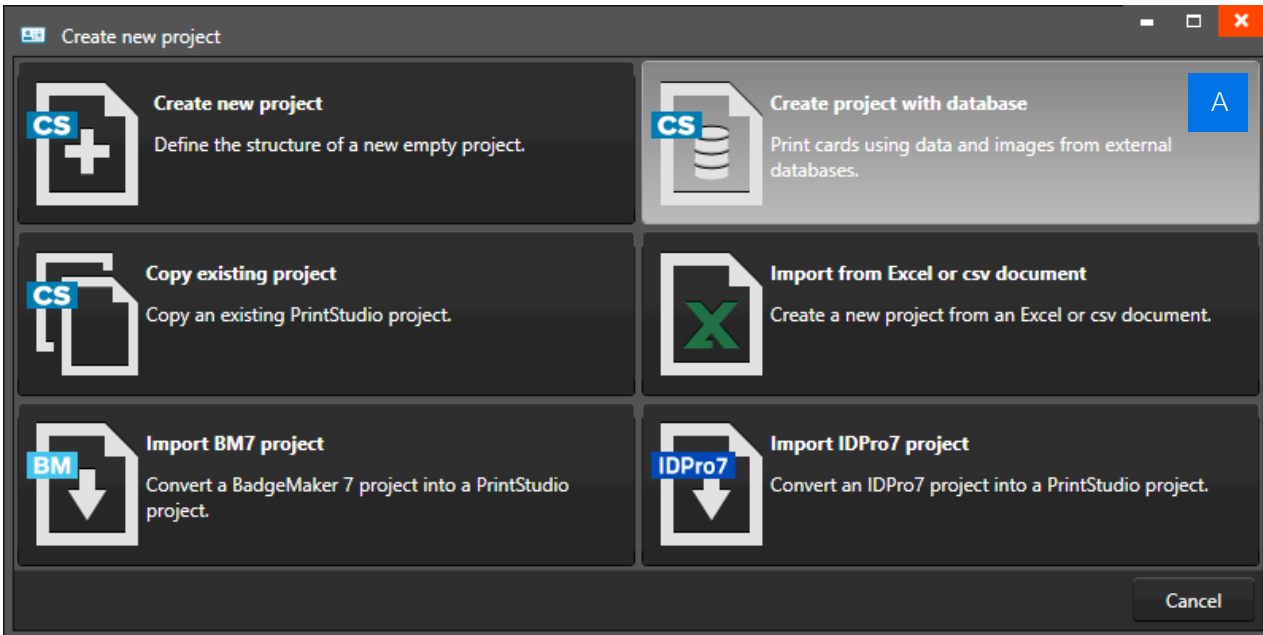

*Example of a New Project pop-up window: Create project with database.*

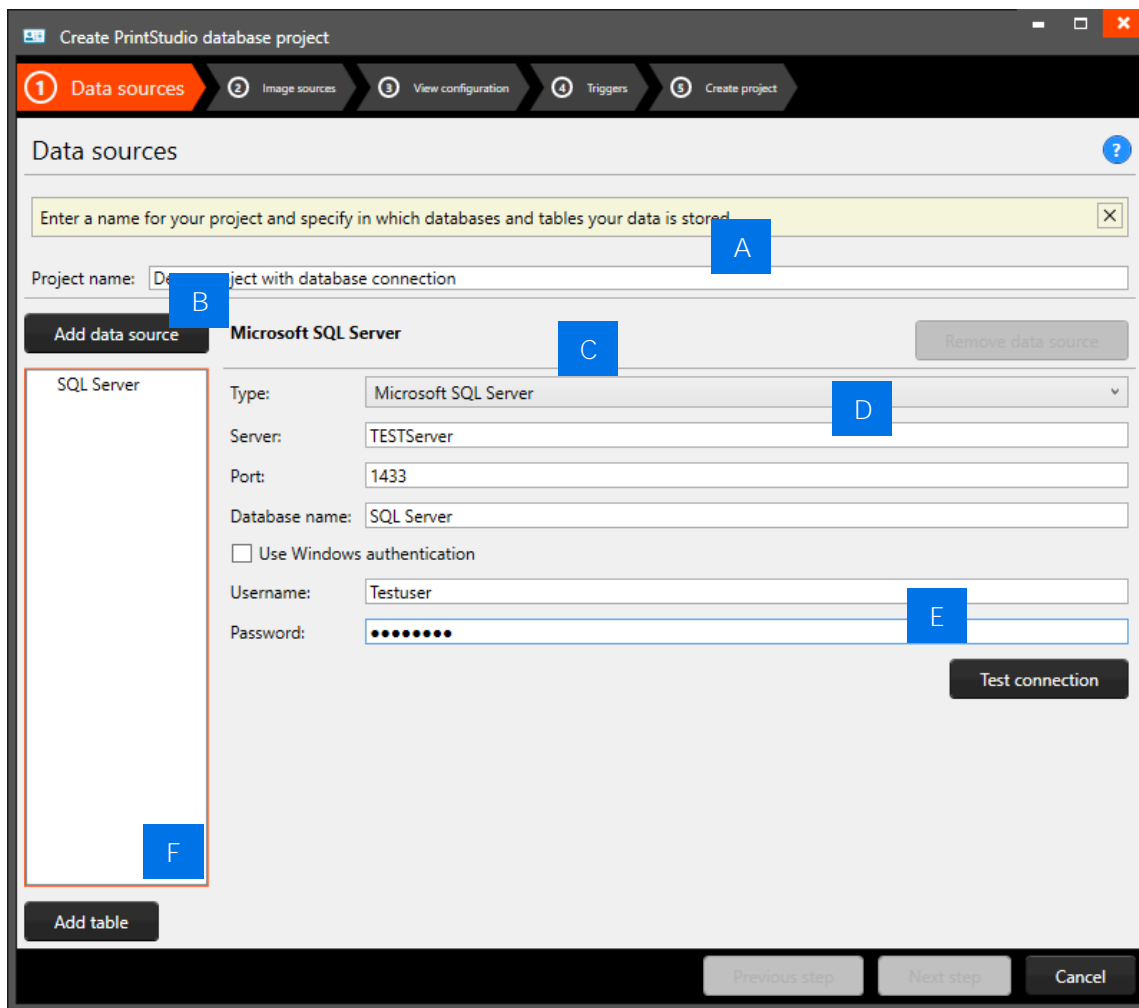

Example of a new PrintStudio Project with external database connection step 1: data sources.

- A. Enter the name of your New PrintStudio project with database connection.
- B. Click on the “Add data source” to connect the database with your external database.
- C. Select the type of database you would like to connect with. Different types of databases are supported:

#### Configuring a Microsoft SQL Server data source

After selecting Microsoft SQL Server as the type of data source, you can fill in all information required to connect to the server.

- D. **Server:** Path or IP address to the server. If the server is hosted on another system in the network, it can be either addressed as \\servername or the IP address of the server. Information such as the database name, username and password, in most cases are provided by your database administrator.

*Note: to be able to work with a Microsoft SQL Server, an active network connection must be available.*

#### Configuring a Microsoft Access data source

To define a Microsoft Access data source, select the option from the drop-down list, and find the path to your database by choosing the Browse (“...”) button behind the Filename field.

Please note that a username and password may not be required for your Microsoft Access file, in which case these fields can be left empty.

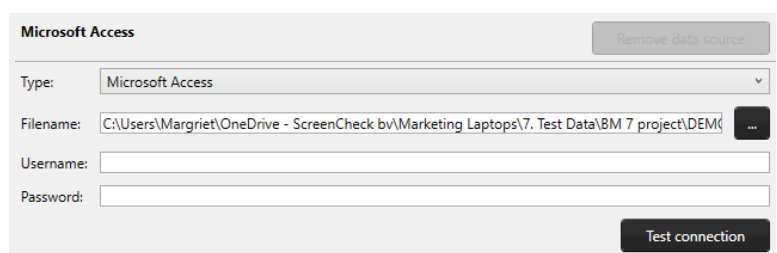

## Configuring a MySQL or Oracle data source

Configuring a MySQL or Oracle server as a data source is done the same way as defining a Microsoft SQL Server data source.

**Server:** Path or IP address to the server. If the server is hosted on another system in the network, it can be either addressed as \\servername or the IP address of the server.

**Port:** Databases have a standard or adjusted port number. PrintStudio uses the standard port number when the input field is left empty. Information such as the port number, database name, username and password, in most cases are provided by your database administrator.

*Note: to be able to work with a MySQL or Oracle Server, an active network connection must be available.*

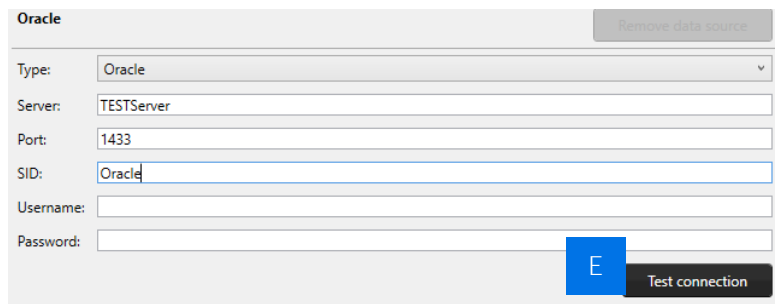

The screenshot shows the 'Oracle' configuration dialog box. It has a title bar with 'Oracle' and a 'Remove data source' button. The fields are: Type: Oracle (dropdown), Server: TESTServer, Port: 1433, SID: Oracle, Username: (empty), Password: (empty). A blue square with the letter 'E' is positioned over the 'Test connection' button.

## Configuring a data source through an ODBC driver

After selecting ODBC as the type of data source, select one of the ODBC drivers installed on your system. Please note that Windows may have more than one driver installed per file extension.

After selecting the driver, you can provide a direct path to your database file. This can be a local path (C:\Example\Example.mdb) or a remote path (\\Server\Example\Example.mdb).

*Note: To be able to open your project using a remote directory, an active network connection must be available.*

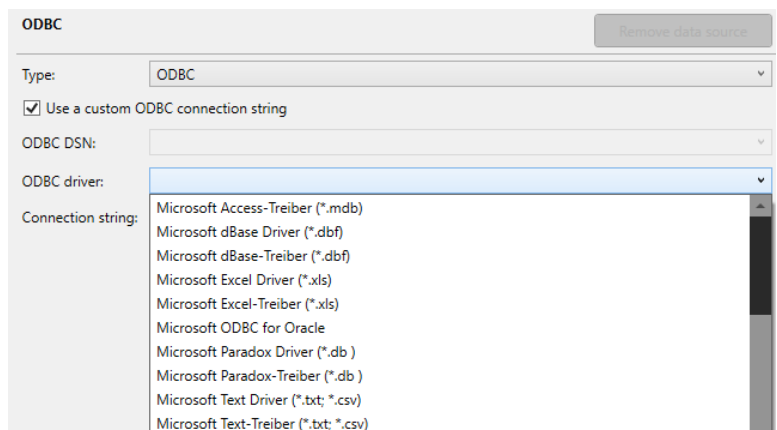

The screenshot shows the 'ODBC' configuration dialog box. It has a title bar with 'ODBC' and a 'Remove data source' button. The fields are: Type: ODBC, Use a custom ODBC connection string: checked, ODBC DSN: (empty), ODBC driver: (dropdown menu), Connection string: (empty). The dropdown menu is open, showing a list of drivers including Microsoft Access-Treiber, Microsoft dBase Driver, Microsoft Excel Driver, Microsoft Excel-Treiber, Microsoft ODBC for Oracle, Microsoft Paradox Driver, Microsoft Paradox-Treiber, Microsoft Text Driver, and Microsoft Text-Treiber.

- E. After configuring the data source, click the button “**Test connection**”. Once the pop-up reports “**Database connection successful**” you can proceed. If the connection cannot be established, the dialogue will report a detailed overview of the problem. Check all information and make sure a connection with the external server is available before trying again.

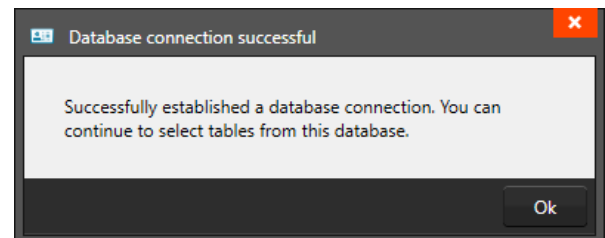

- F. Once the connection is established, click “**Add table**” to continue configuring your data source. A pop-up dialogue will list all tables available for you.

Microsoft SQL Server will likely only list database tables, where other files (such as MS Access databases) might also list tables otherwise invisible to the user.

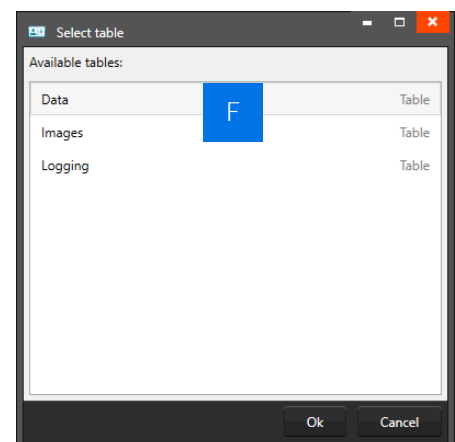

The screenshot shows a 'Select table' dialog box. It has a title bar with 'Select table' and a 'Remove data source' button. The text inside says: 'Available tables:'. Below this is a table with three rows: 'Data', 'Images', and 'Logging', each with a 'Table' label to its right. A blue square with the letter 'F' is positioned over the 'Data' row. There are 'Ok' and 'Cancel' buttons at the bottom right.

Configure the database tables for the project

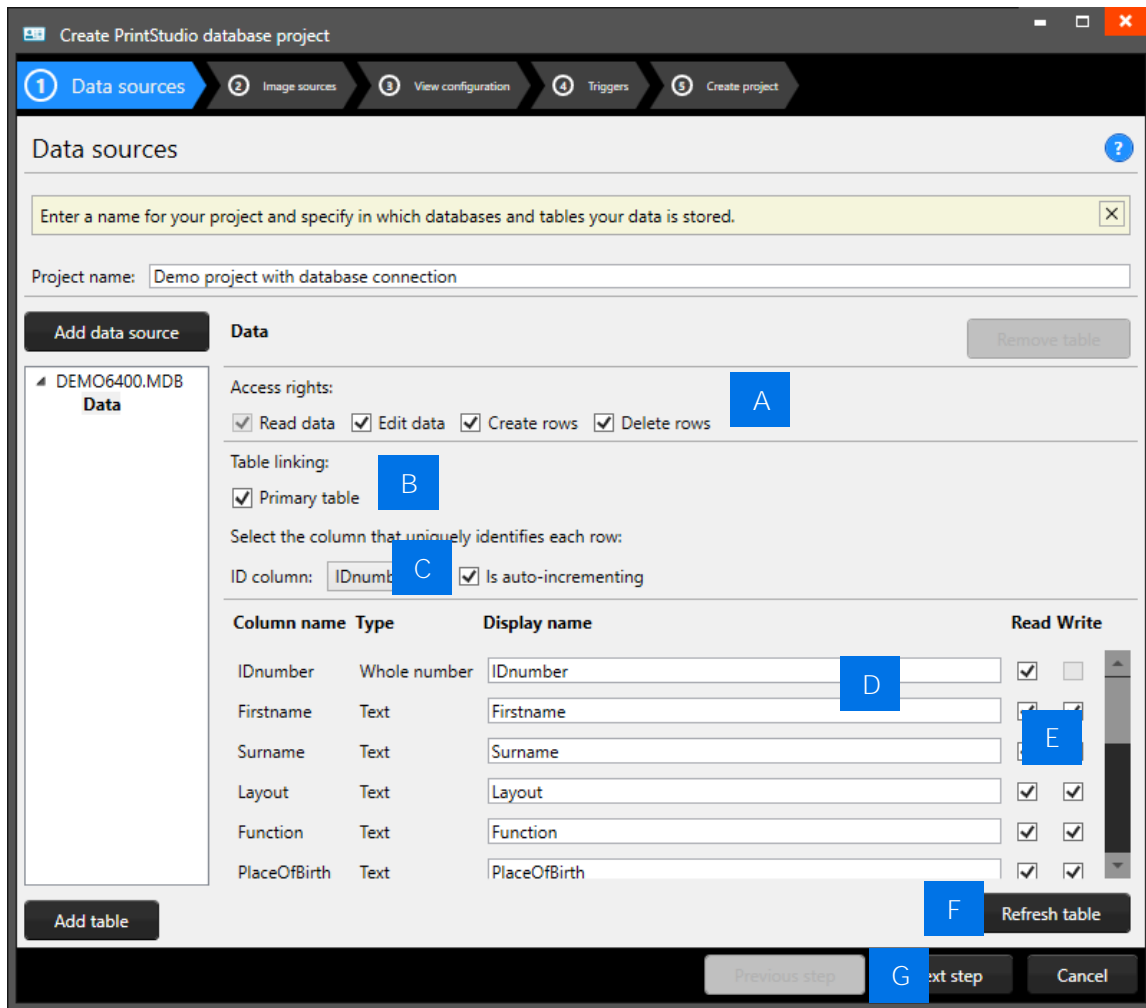

- A. After selecting a table, you can configure the rights to the table, and to each of the listed columns in the table. Users connecting with a Microsoft SQL Server can create and remove rows, whereas users connecting through an ODBC database will only be able to select the “Edit data” checkbox for existing rows.
- B. The newly created data source will have the “Primary table” checkbox checked. This setting can only be altered during the process of defining the data sources, so make sure that the primary table is correctly configured.
- C. For a primary table, you can define the “ID column” this is a column containing unique, numeric data. For secondary tables, you must define its relation to the primary table or to one of the tables linked to the primary table. This means that each table will have to contain a column containing a corresponding type and kind of data. It is advised to keep the column marked as “ID column” as read-only or even hidden if the data in the column is not crucial to users working with the data grid.
- D. Edit the display names of the column as you see fit for your PrintStudio Project.
- E. The list of columns can be used to define certain restrictions to each column such as “Read” or “Write”. By default, columns will be marked as “Read”. Think carefully about what data to manage through PrintStudio, and what data should be managed by other external systems.
- F. Click on the “Refresh table” to make sure that all the data loaded from the database table is up to date.
- G. Click on the “Next step” and finish the next steps and create the project. With the second step you can define the image sources for Passport Photos and Signatures in your project. You can choose from three different options:



### 1. Read image from local project

Selecting this option stores captured images along with the CardStudio Identity project files. This option can be used to capture new image data.

### 2. Read or download image from path or URL

This option allows you to read images from a remote directory either on a server or on a network drive. This can only be used to *read* image data. New data cannot be captured.

### 3. Read image from database (blob)

This allows you to read an image from a specific column in the database marked as BLOB (Binary Large Object). This option can be used to both read existing data and capture new image data to the database.

## Changes when working with PrintStudio with external database connection

There are a couple of changes that may be noticeable when working with PrintStudio connecting to an external database in comparison to regular PrintStudio projects.

### Loading times

The time it takes to load your project, or to process changes to your database may increase. This is due to the time it takes to transfer data over the network, login to the database or retrieve data from the external data sources.

### Grayed-out columns

Columns that have been marked as “read only” will have a grey background color when selected. It simply means that you will not be able to alter data for that specific column.

### Data from local or external database

When working with multiple data sources, it can become confusing to remember what information belongs to what data source. In order to clarify, PrintStudio labels sources with <table\_name>.<column\_name>. This means that a column “Firstname” coming from a table called “Students” will be displayed as “Students.Firstname”. In the project this will display when hovering over a column name.

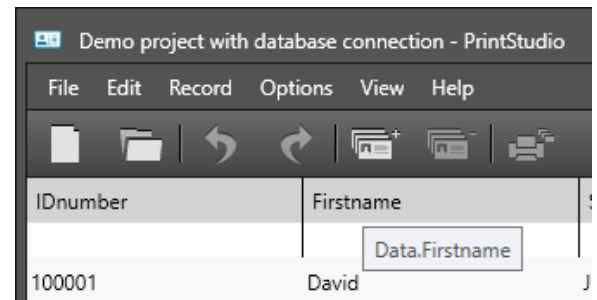

### Updating or adding pictures

Depending on the read or write access restrictions and the configuration of image sources in your project, you may or may not be able to add new images.

### Project has stopped working

PrintStudio cannot prevent external data sources from changing. If a file gets removed, or a database gets changed, it might cause your PrintStudio project to stop working. Always consult with your database administrator to ensure that data you need in your PrintStudio Project is made redundantly available to you.

### Default values

When creating a new project, or when altering a project structure, you can define certain default values for your column types. However, when using PrintStudio with an external database connection, these default values will be only filled for new records or when manually entering the information into the field. The reason for this is because the local project data does not contain the same amount of records as the external sources, and new records are never created automatically.

# PrintStudio Encode

# PrintStudio Encode

CardStudio Professional allows you to encode data from your PrintStudio project onto a smart card. With CardStudio Professional, CardStudio introduces a new file format, named CCI, that is used to contain all information related to the encoding of the card, which can easily and securely be shared with other parties who collaborate on the same project.

## Contactless Encoding

The CardStudio Professional encode functionality currently supports the encoding of MIFARE Classic, MIFARE Plus, DESfire, IClass, UHF Gen2 and proximity cards. Encoding is done using card printers that are fitted with a “reader” such as the HID Omnikey or the Springcard Crazy Writer.

## SmartCard Editor

The SmartCard Editor is a tool that is made available to all users of the CardStudio software editions. This tool allows you to create an encoding template for MIFARE Classic, MIFARE Plus, DESfire, IClass, UHF Gen2 and proximity cards using all the major features for each of the standards. To encode your smartcards and use the CCI-files created with the SmartCard Editor you need CardStudio Professional edition.

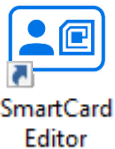

## Creating a MIFARE Classic Template using the CCI Editor

Launch the SmartCard Editor, which will open to a blank window. Choose “File” → “New” → “Mifare Classic (1k)” or “Mifare Classic (4k)” depending on your project requirements.

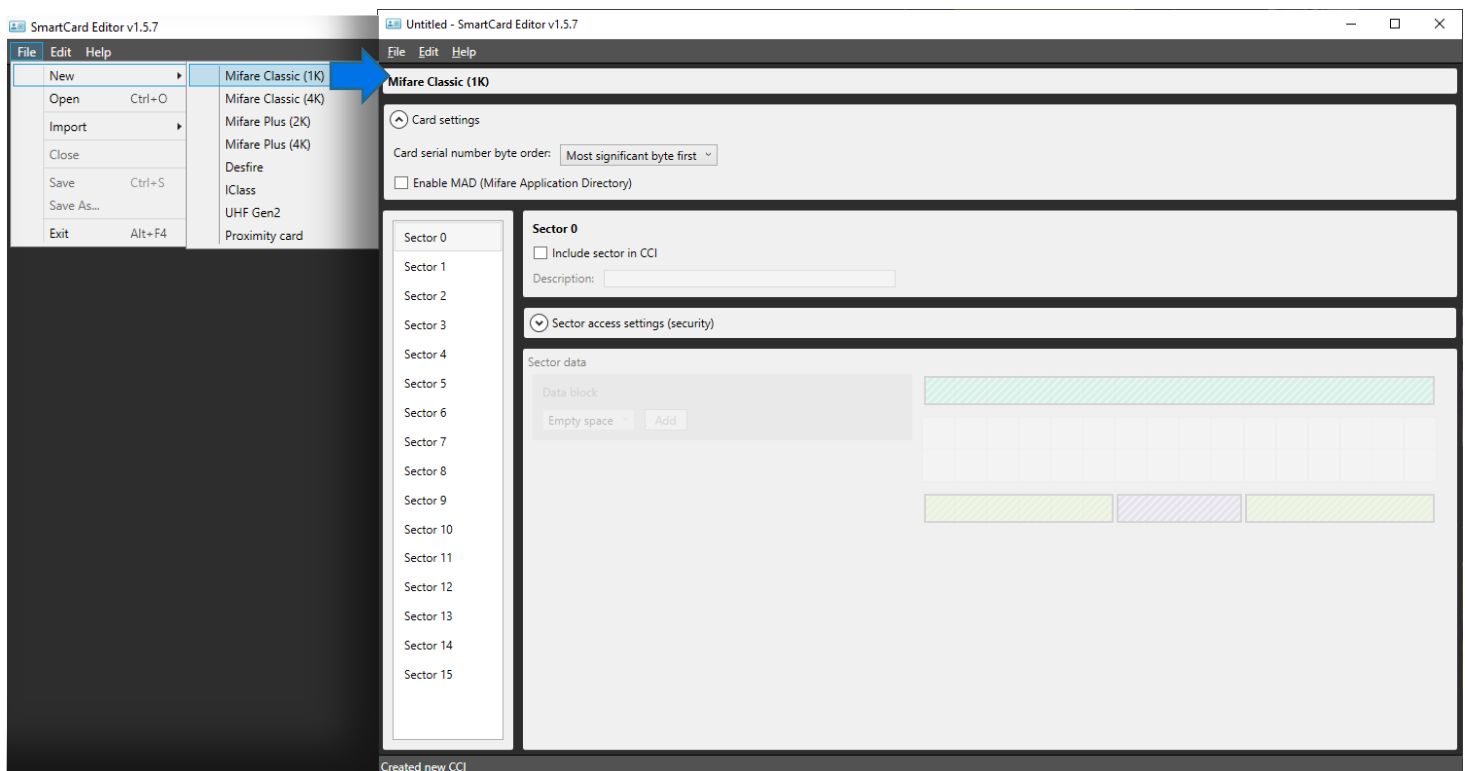

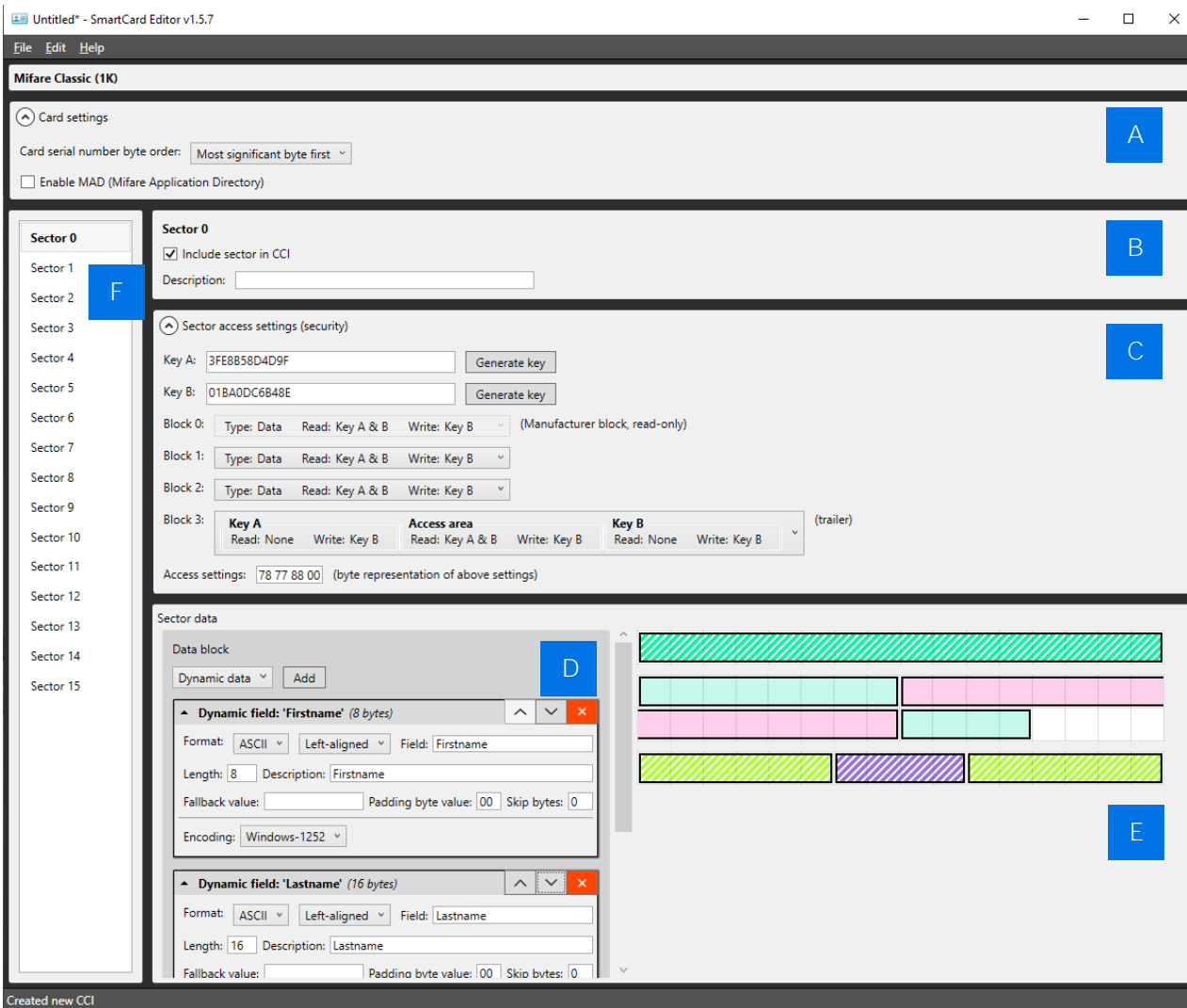

- A. The Card Settings are displayed on top of the screen. You can define whether the card should use MAD Sectors (Mifare Application Directory documents directory-like structure that describes how sectors on card are used) or not. Enabling this setting will have an impact on specific sectors and their contents. It will also automatically generate Key A for sector 0 (and sector 16 for 4K cards).
  - B. Description of the sector.
  - C. Define keys, determine read and write settings for each of the four data blocks.
  - D. Create data segments to fill the available space.
  - E. The CCI Editor visualizes any data that will be encoded onto the Smart Card to give the user a better view of the amount of used and available space in each sector. Certain blocks (such as Block 0 on Sector 0, and the Trailer Block on all sectors) are reserved for manufacturer information and storing keys. These are not available to the user and are displayed as hatched.
- Each square represents one byte of information. When adding sector data, the length of the data is visualized on the right. Each item in the list is given a slightly different color to make it easier to understand how the data is transferred to the card.
- F. List of sectors is displayed, 16 for 1K cards, 40 for 4K cards. Depending on the settings, each of the sectors can contain information that will be encoded onto the card using PrintStudio.

## Information about Sector Data

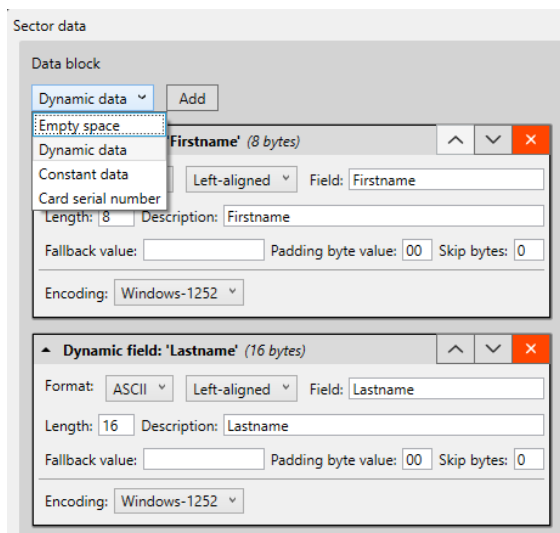

### Empty Space

This item can be used to indicate a specific part of a sector that will never be used.

### Dynamic Data

This is information that will be added to the card by your CardStudio project. Like adding card designs, when you add a CCI file to your project, a pop-up will allow you to bind columns in your project to each of these items. You must always ensure that the data in your project corresponds with the settings you have chosen in terms of length and data type. The following data types are available.

- ASCII All standard ASCII characters are allowed.
- Numeric 0 ... 9
- Alphabetic A ... Z and a ... z
- Alpha-numeric A ... Z, a ... z and 0 ... 9
- Alphabetic and special A ... Z, a ... z and Punctuation marks
- Alpha-numeric and special A ... Z, a ... z, 0 ... 9 and Punctuation marks
- Binary-coded decimal (5) 0 ... 9, two digits in one byte, maximum 5 bytes
- Binary-coded decimal 0 ... 9, two digits in one byte
- Binary-coded decimal date YYYYMMDD each two digits in one byte
- Decimal 0.00 (Fixed point)
- Wiegand-26 Facility and card codes with parity
- Hexadecimal 0123456789ABCDEF
- Octal 012345678
- Binary 01

In addition, you can add a description of the sector data to remind you of certain agreements.

### Constant Data

Constant or Static data is data that is manually entered in the CCI file and will never change. The format of this piece of information can be of any of the types mentioned in the Dynamic Data section.

### Card serial number

This is a 10, 7 or 4-byte, data section which will automatically contain the card serial number when the card is being encoded.

Using these options, you can create any type of CCI file. Once completed, you can save your work in either an unencrypted file (XML) or an encrypted CCI file. If you choose the latter option, you will be required to enter a password that will also be required when adding the CCI file to your CardStudio Identity project.

## Creating a MIFARE DESfire template using the CCI Editor

DESfire cards take an entirely different approach to encoding compared to MIFARE Classic or Plus cards. With DESfire, you can define Applications and Files that contain information, each with specific access settings. Similar to MIFARE Classic, launch the SmartCard Editor, which will open to a blank window. Choose “File” → “New” → “DESFire”.

- A. The Card settings panel will allow you to define general rules for your encoding template. A DESFire card features a Card master key that can be used to re-encode or erase the card at any time. All keys for DESFire cards can be encoded using 3DES, 3K3DES or AES encrypted keys. A key can be either generated or entered manually.

The other options for the Card settings dialog are self-explanatory but must be decided with caution as they will impact how flexible the card can be used after being encoded. In addition to the default DESFire features, reset keys are implemented that allow for cards to be repurposed, by users even though the Card master key might not be available. Distributing the Card master key might not be desirable because of possible security liabilities. Multiple Reset keys can be created to supply to different vendors.

The screenshot displays the DESfire software interface with the following sections:

- Card settings:** Includes a dropdown for "Card serial number byte order" (Most significant byte first (mirrored)), a "Card master key" section with a dropdown set to "AES", a text field containing "82A88655011B697D89314799B68169B2", a "0" field, and a "Generate key" button. Checkboxes include "Master key can be changed later" (checked), "Authentication required for directory access" (unchecked), "Authentication required for creating / deleting applications" (checked), and "Card configuration can be changed later" (checked).
- Reset keys:** A note states "Reset keys are not a Desfire feature, but they allow our encoding software to repurpose existing cards." with an "Add key" button.
- Application Settings:** A list on the left shows "Application 000001". The settings panel includes: "Description" (A sample DESfire application), "Application ID" (000001), "Encryption type" (AES), "Master key can be changed" (checked), "Authentication required for directory access" (unchecked), "Authentication required for file creating / deleting" (checked), "Key settings can be changed" (unchecked), "Change key settings" (Authenticate with application master key), "Enable ISO file ID support" (unchecked), "Iso file ID" field, and "DF name" field.
- Application keys:** Includes an "Add key" button, a "0" field, a text field containing "C9F762F37206E0F07C701975F448CFD0", a "0" field, a "Generate key" button, and an "X" button.

Buttons at the bottom include "Add application", "Remove application", "Add file", and "Remove file".

- B. Once Card settings have been defined, an application can be created by choosing “Add application” on the bottom left of the screen. Doing so will automatically create an application titled “000001”.

- C. On the right side of the screen, information can be entered to define the Application such as a Description, an ID (Hexadecimal value) and the Encryption type. For each application, settings are available that define future use of the application such as allowing the Master key to be changed or Authentication settings for accessing the data in the application.

- D. Each application can have up to 10 keys that can be distributed to vendors for use of the application.

- E. Once finished, choose “Add file” to create a file named “File 0” for the currently selected application.
- F. Each file will contain a Description and a File number. Communication mode determines the way in which the file can exchange data. It is highly recommended to use the Encrypted setting, as the Plain (unencrypted) mode should only be used for data that does not contain sensitive information. All DESFire file types are supported to accommodate integration with access control or payment systems that support the DESFire standard. For general purposes, select the “Standard data file” from the dropdown list. Each file has individual settings for Read, Write and Read/Write access, as well as an access rule for changing these settings after encoding the card.
- G. Standard file types require you to set the total file size. Keep in mind that this must be equal to or greater than the total amount of bytes that are used by your file data. In our example, the total amount of data used is 42 bytes, but the file is given 64 bytes instead.

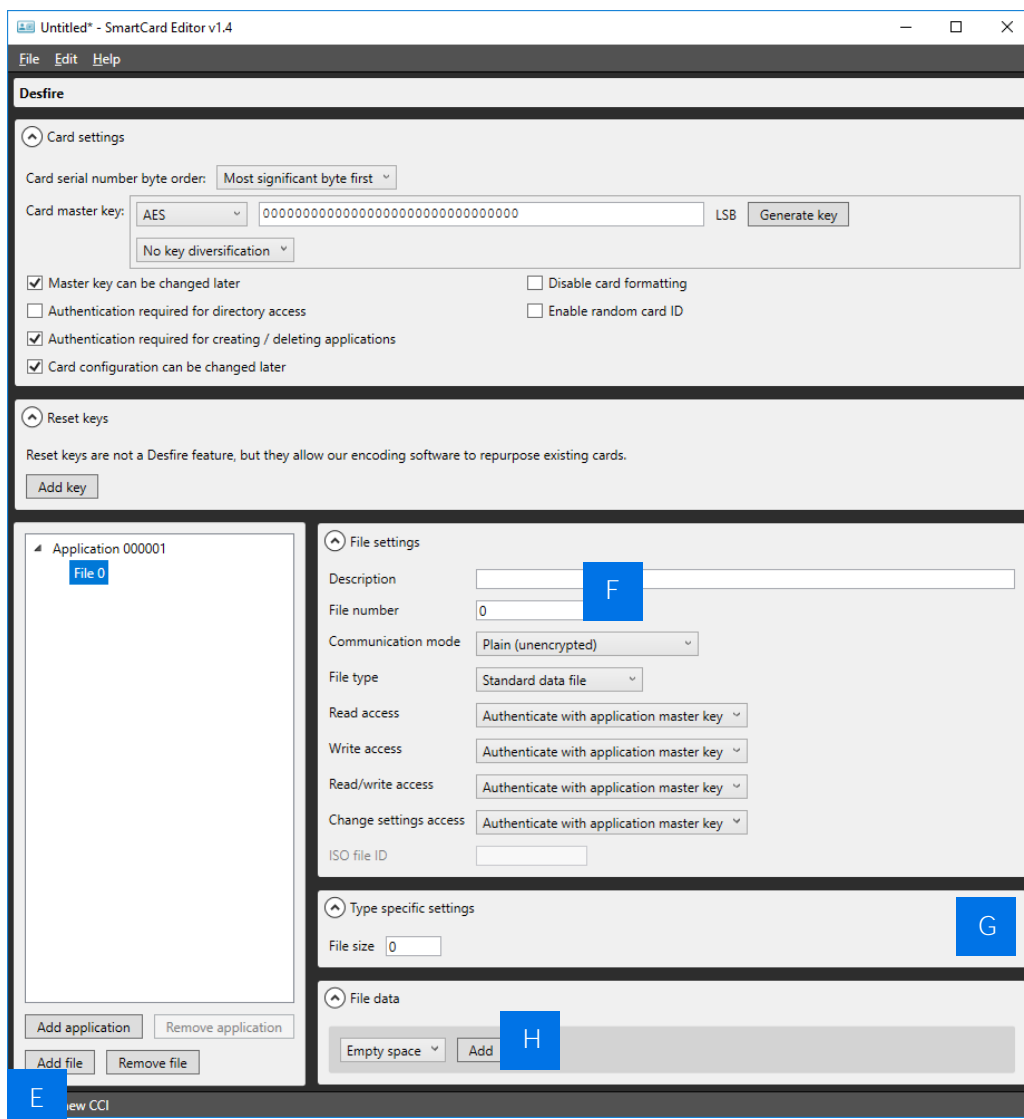

- H. File data is added to the File in a similar fashion to defining MIFARE Classic or Plus templates. Select a data type from the dropdown box and choose “Add” to create a new data block. Define the data format and alignment, as well as the field as this will be the identifier once the CCI file is linked to your PrintStudio project.

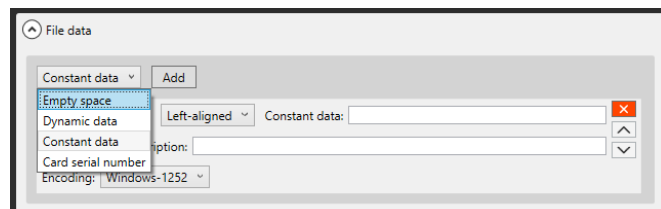

Each DESFire template can contain a maximum of 32 applications, and each application can contain a maximum of 32 files.

Once completed, the template can be either saved to a human-readable XML format, or a password-encrypted CCI format. Both can be used to encode cards in your CardStudio Identity project.

## Creating a UHF Gen 2 Template using the CCI Editor

Print and Encode Zebra's UHF Gen 2 RFID Cards with the Zebra® ZXP Series 7™ Printer. Maximize safety, security and convenience for customers, guests and employees — and heighten efficiency in your people identification and management applications — with Zebra's next-generation ultra-high-frequency (UHF) radio frequency identification (RFID) card. It's the world's first passive RFID card to provide a read range of up to 50 feet. Because this RFID card can be read from afar even through badge holders, handbags, pockets and backpacks, you can use it to streamline and ease congestion in your identification, access control and transaction processes. The UHF Gen 2 chip houses four memory banks where the data is stored. Some have different bit allocations between the four banks to allow for more user memory or a longer EPC number.

Let us start creating a CCI file to encode a UHF Gen 2 card. Launch the SmartCard Editor, which will open to a blank window. Choose “File” → “New” → “UHF Gen2”

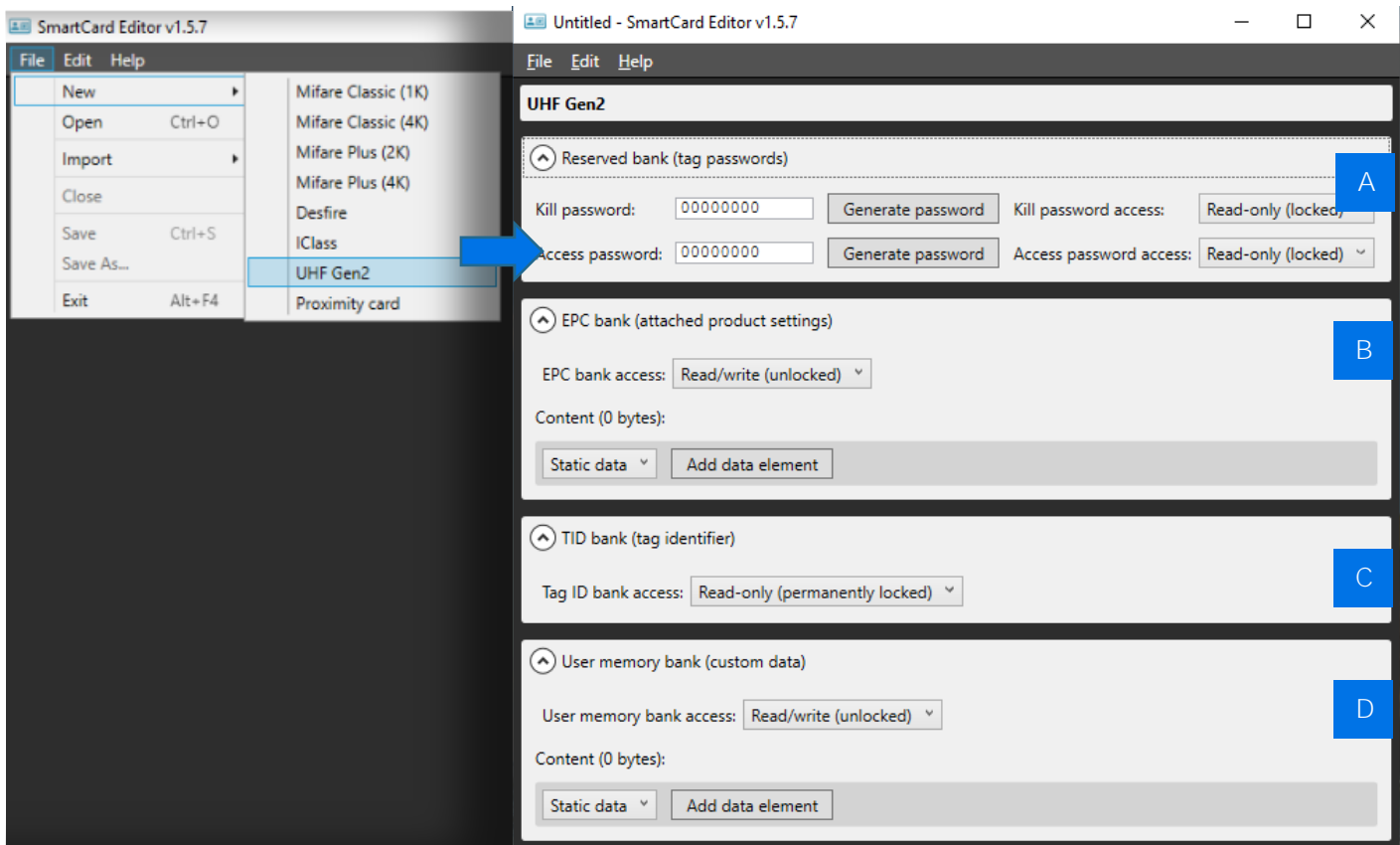

- A. Reserved bank (tag passwords): The Reserved memory bank allow you to lock or unlock the read and write functions of the RFID chip data. Generate the Kill password and the Access password for the card and determine if the access for these passwords is: Read/write (unlocked), Read/write (permanently unlocked), Read-only (locked), Read-only (permanently locked).
- B. EPC bank (attached product settings): Determine the EPC bank access by selecting one of the locked or unlocked options in the dropdown menu. Add content like static data, dynamic data or the card serial number to this bank using the dropdown menu and then clicking the “Add data element”. The tag identification code is written to the EPC (Electronic Product Code) memory. It is the encoding that allows to assign this number to the tag. This number is written in the chip’s memory and can then be read by a suitable RFID reader. During encoding, this number can be protected, it cannot be modified or deleted.
- C. TID bank (Tag identifier): The manufacturer’s unique identification number is written in the TID (Tag Identifier) memory. This is incremented in the chip at the time of its manufacture.
- D. User memory bank (Custom data): User memory is optional and provides a place for user-defined data. The user equipped with an RFID reader can write information in the tag or read information already entered. First set the access to the user memory bank using the dropdown and selecting to lock or unlock this bank. Add content like static data, dynamic data or the card serial number to this bank using the dropdown menu and then clicking the “Add data element”. User Memory ranges from 32 bits to over 64k

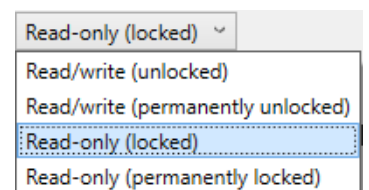



## UHF Gen 2 Content Data options

The EPC bank and the User memory bank have the option to add content data using data elements. The dropdown menu gives several data element options to add.

The basic data elements:

### Empty Space

This item can be used to indicate a specific part of a sector that will never be used.

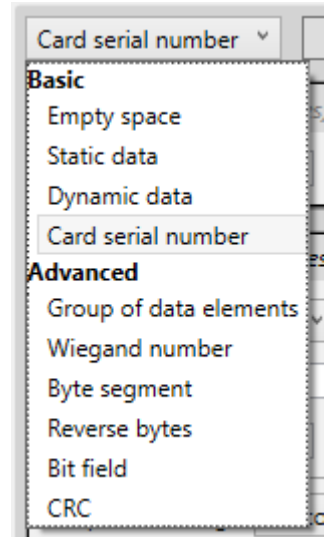

### Static Data

Static data is data that is manually entered in the CCI file and will never change. The format of this piece of information can be of any of the types mentioned in the Dynamic Data section.

### Dynamic Data

This is information that will be added to the card by your CardStudio project. Like adding card designs, when you add a CCI file to your project, a pop-up will allow you to bind columns in your project to each of these items. You must always ensure that the data in your project corresponds with the settings you have chosen in terms of length and data type.

The following data types are available:

- characters are allowed.
- Numeric 0 ... 9
- Alphabetic A ... Z and a ... z
- Alpha-numeric A ... Z, a ... z and 0 ... 9
- Alphabetic and special A ... Z, a ... z and Punctuation marks
- Alpha-numeric and special A ... Z, a ... z, 0 ... 9 and Punctuation marks
- Binary-coded decimal (5) 0 ... 9, two digits in one byte, maximum 5 bytes
- Binary-coded decimal 0 ... 9, two digits in one byte
- Binary-coded decimal date YYYYMMDD each two digits in one byte
- Decimal 0.00 (Fixed point)
- Wiegand-26 Facility and card codes with parity
- Hexadecimal 0123456789ABCDEF
- Octal 012345678
- Binary 01

In addition, you can add a description of the sector data to remind you of certain agreements.

### Card serial number

This is a 10, 7 or 4-byte, data section which will automatically contain the card serial number when the card is being encoded. The card serial number is unique for every card.

The advanced data elements:

Group of data elements

This option lets you join multiple data elements into one group

Wiegand number

Encode a site code and card number in Wiegand format.

Byte segment

Takes a specific byte segment from its input.

Reverse bytes

Reverse the bytes from its input: The first byte becomes the last.

Bit field

Takes specific bits from its input and packs them into a compact format.

CRC

Calculates a CRC (Cyclic Redundancy Check) for its input

The screenshot displays the configuration interface for several data elements in CardStudio. The main window title is 'Content (32 bytes)'. The interface is organized into a list of expandable panels, each with a title bar containing an up arrow, a down arrow, and a close button (X).

- Group of 2 elements (32 bytes):** Includes a 'Description' field, a 'Content' field, and a 'Dynamic data' dropdown with an 'Add data element' button.
- Wiegand number (4 bytes):** Features a 'Format' dropdown (set to 'H10301 (26-bit)'), an 'Alignment' dropdown (set to 'Right'), and a 'Description' field. Below this is a 'Total bit length' field (set to 26) and a 'Layout' bar with three colored segments (red, green, blue). It also has a 'Value field (consecutive)' dropdown and an 'Add component' button.
- 'Facility code' value field (8 bits, starting at bit 1):** Includes 'Name' (Facility code), 'Position' (1), 'Length' (8), and 'Take bits from' options. It has an 'Input' section with a 'Static data' dropdown and an 'Add data element' button.
- 'Card number' value field (16 bits, starting at bit 9):** Includes 'Name' (Card number), 'Position' (9), 'Length' (16), and 'Take bits from' options. It has an 'Input' section with a 'Static data' dropdown and an 'Add data element' button.
- Even parity bit (bit 0, covering 13 bits: 0-12):** Includes 'Parity' (Even), 'Position' (0), and 'Covered bits' (0-12).
- Odd parity bit (bit 25, covering 13 bits: 13-25):** Includes 'Parity' (Odd), 'Position' (25), and 'Covered bits' (13-25).
- Byte segment (16 bytes):** Includes 'Take' (16) bytes from the 'start' of the input, with an option to 'Skip the first 0' bytes. It has a 'Padding byte' field (set to 00) and an 'Input' section with a 'Static data' dropdown and an 'Add data element' button.
- Reverse bytes (0 bytes):** Includes an 'Input' section with a 'Static data' dropdown and an 'Add data element' button.
- Bit field (0 bytes):** Includes a 'Bit segments' section with an 'Add bit segment' button.
- CRC (2 bytes):** Includes an 'Algorithm' dropdown (set to 'CRC-16/ISO-IEC-14443-3-A'), 'Bit-length' (16), 'Polynomial' (1021), and 'Initial value' (C6C6). It has a checked 'Reflect output' checkbox and an 'Output xor mask' field (set to 0000). It has an 'Input' section with a 'Static data' dropdown and an 'Add data element' button.

Using these options, you can create any type of CCI file. Once completed, you can save your work in either an unencrypted file (XML) or an encrypted CCI file. If you choose the latter option, you will be required to enter a password that will also be required when adding the CCI file to your CardStudio Identity project.

## Encoding with PrintStudio

Encoding with CardStudio Identity has been fully integrated into the printing process. The most important step to enable encoding for your project is to add your CCI file to your project. Go to the Project Settings panel, and select Encoding Settings from the Card encoding tab.

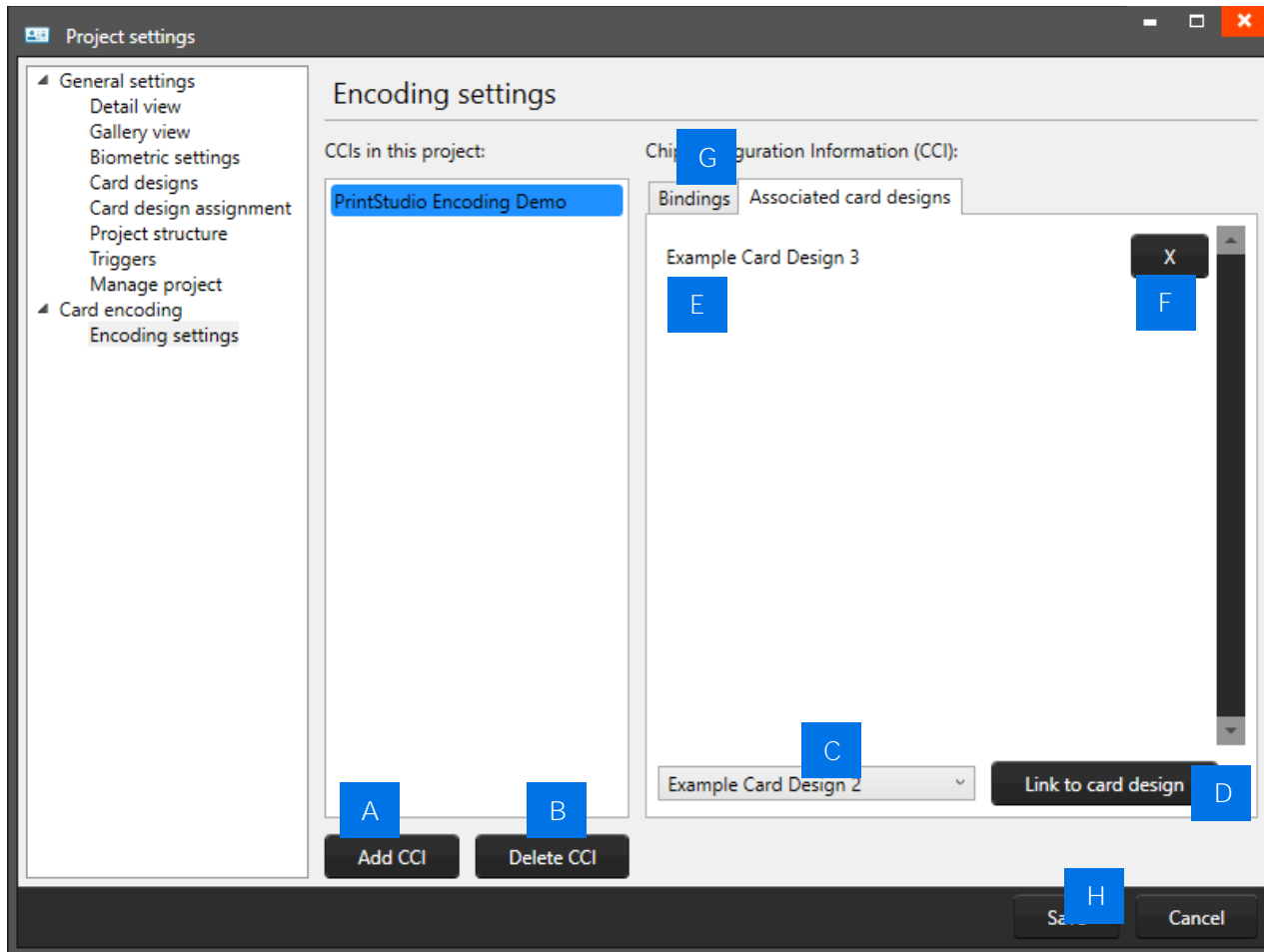

A. Click on the “Add CCI” button and select the CCI-file you created with the CCI-editor and want to add to your CardStudio project to connect to the card designs. When your CCI-file has been secured with a password you first have to fill in the correct password before the file is added to your project.

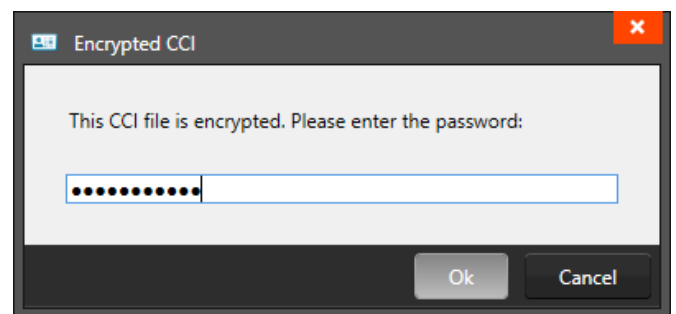

- B. When you added the wrong CCI-file or want to delete an old file you can select the file from the list and click on the “Delete CCI” button to delete the CCI-file from your project.
- C. Select the CCI-file from the list and like to connect to a card design, then select the card design from the drop-down list.
- D. Click on the “Link to card design” to link the card design to the CCI-file. Card holder Records with this card design will be encoded with CCI-file linked to the card design.
- E. Overview of all the card designs connected to the CCI-file.
- F. Click on the “X” button to unlink a card design from the CCI-file.

- G. You can bind dynamic data fields from your CCI-file to the data columns of your project just by clicking on the “Bindings” tab and selecting one of the data columns from the drop-down menu.
- H. Click on the “Save” button to save the bindings and CCI files connected to your project card designs. You are now ready to encode your cards. Select the records connected to the correct card design/CCI-file and click on the print button.

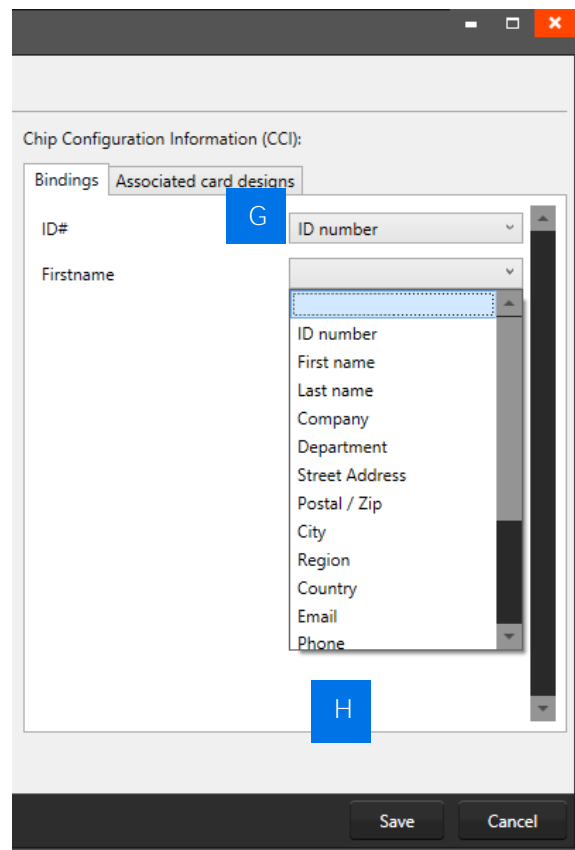

*Note: You might need to configure your printer to perform both Encoding and Printing tasks at the same time, otherwise PrintStudio might list your print action as failed, even though encoding did take place.*

#### Supported standards

CardStudio Encode currently supports MIFARE Classic, MIFARE Plus and MIFARE DESFire standards.

# CardStudio Status Check

# CardStudio

## Status Check



Status Check is a new feature available in CardStudio 2.0. With Status Check it is now possible to scan a QR-code on a printed card or Digital ID and get status feedback.

The Zebra Status Check is an optional fee-based feature that allows you to add a live 2D barcode to your printed or Digital ID Card. This QR-Code contains a unique secure URL that displays a Status Check page with a near, current or up-dated status of a data field you configure in your local CardStudio Project.

With CardStudio, you can now create a QR-code on a card design or digital ID and connect it to a Status Check Template in PrintStudio. Status Check is available for the CardStudio Standard, Enterprise, or Professional Edition.

Existing CardStudio users can purchase a Status Check card design or project from the CardStudio In-App Store to get started or upgrade to one of the CardStudio 2.0 Smart Badge Editions.

See the “How to” Status Check videos on: <https://cardstudio.zebra.com/status-check>

### CardStudio 2.0 Smart Badge bundles

For the users who want to get started with Digital ID and Status Check right away, the Zebra CardStudio Smart Badge offering is available with updated versions of the CardStudio 2.0 Editions bundled with new Status Check templates, card designs, projects, and extra credits.

Smart Badge Editions	SKU	Included Bundle Components
CardStudio 2.0 Smart Badge Standard	CSR2-STD-SB00-E	<ul style="list-style-type: none"> <li>- CardStudio 2.0 Smart Badge Standard Edition</li> <li>- Sample Status Check Card Designs available for download from “My Items”</li> <li>- 3 Status Check Projects available to choose from in “My Items”, choose wisely which one to download, Standard only allows to work with 1 Project.</li> <li>- 2,000 Credits</li> </ul>
CardStudio 2.0 Smart Badge Enterprise	CSR2-ENT-SB00-E	<ul style="list-style-type: none"> <li>- CardStudio 2.0 Smart Badge Enterprise Edition</li> <li>- Sample Status Check Card Designs available for download from “My Items”</li> <li>- 5 Status Check Projects available for download from “My Items”</li> <li>- 5,000 Credits</li> </ul>
CardStudio 2.0 Smart Badge Professional	CSR2-PRO-SB00-E	<ul style="list-style-type: none"> <li>- CardStudio 2.0 Smart Badge Professional Edition</li> <li>- Sample Status Check Card Designs available for download from “My Items”</li> <li>- 8 Status Check Projects available for download from “My Items”</li> <li>- 10,000 Credits</li> </ul>

## Design a card or digital ID with a Status Check QR-code

### Setup the new card design

Start DesignStudio, click on the “new card design” icon to create a new card design with Digital ID.



When clicking on the new card design link or button a setup window will pop-up.

- A. Give the new design a name.
- B. Set the configuration of the new card design to CR80 and open the advanced settings.
- C. Select the portrait mode for the card design.
- D. Enable Digital ID also to set in portrait mode.
- E. Click the “Create Card Design” button to start with the status check card design.

First step is to setup up the needed dynamic fields.

- A. Click on the “+” button to add a new dynamic field.
- B. Add First name, Last name, Event, ID number and most important for this example, a Status Check Link.

## Design the Status Check card design

Now create the standard card design, add a background color and a circle with the shape tool on the front and the back, logo, text, photo placeholder set to be a circle and most important the QR-code.

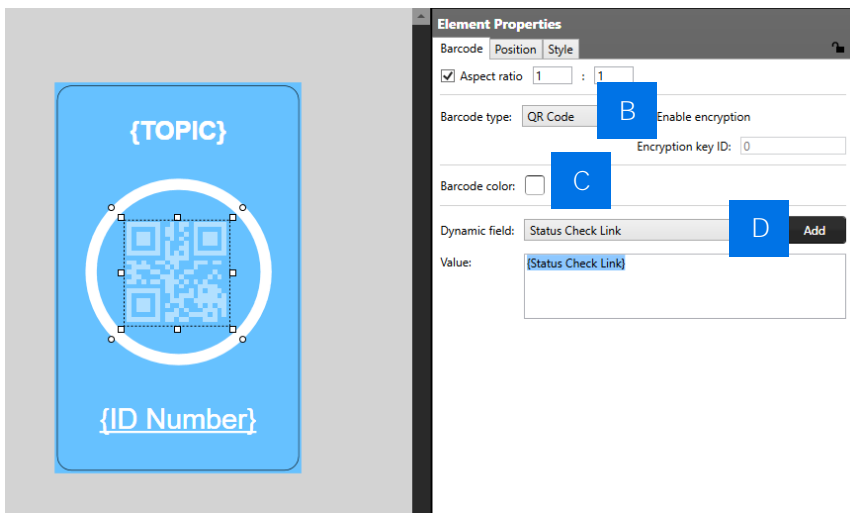
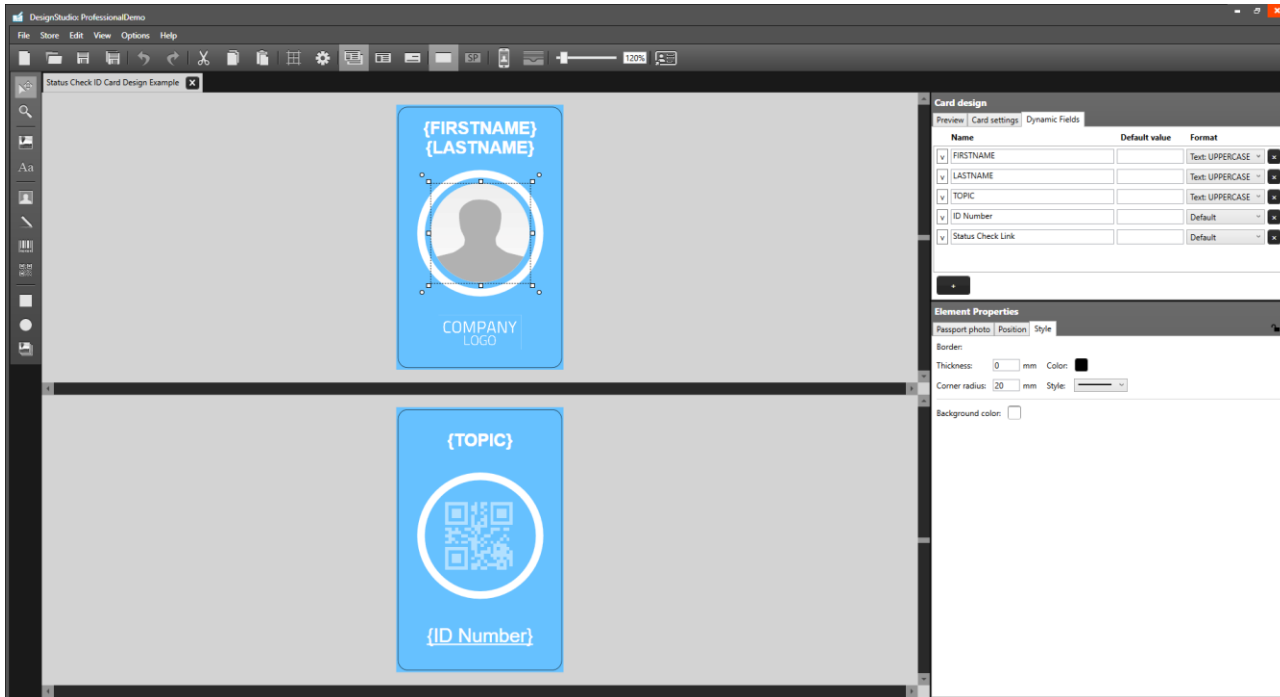

- A. Click on the QR-code element and click on the back of the card to add the barcode to your design.
- B. Set the barcode type to QR-code
- C. The barcode color to white
- D. Select the “Status Check Link” dynamic field from the drop-down menu and click on the “Add” button add the field to the value of the barcode.

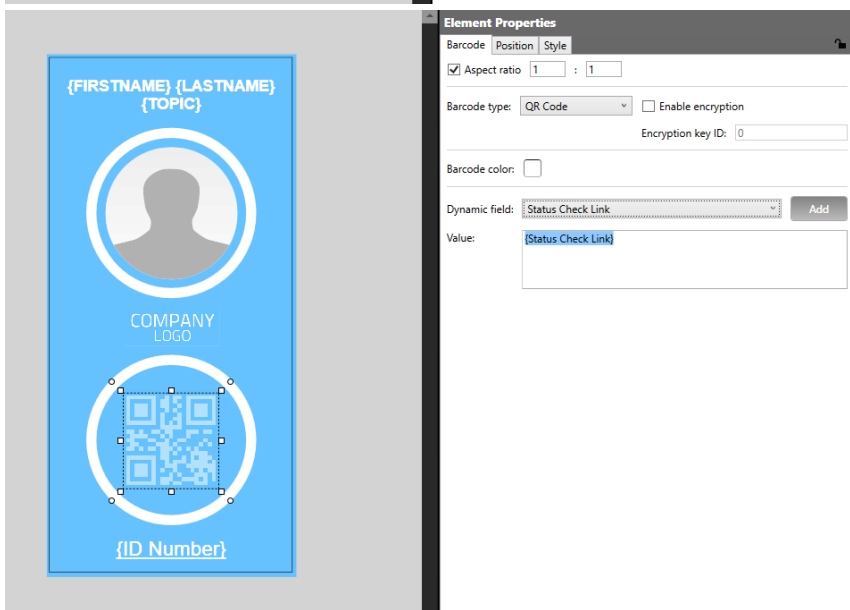

Click on the Digital ID icon in the quick menu, create a similar Digital ID design, of course also add a QR-code.

Add the Status Check Link to the QR-code, the same as with the printed card design.

The Status Check card design and digital ID are finished, be sure to save the card design.

You are now ready to add the card design to the project in PrintStudio and connect a Status Check Template.



Create a new Status Check project and connect your Status Check card design

### Create a new project

- A. Start PrintStudio, click on the new project icon in the quick menu and create a new project.

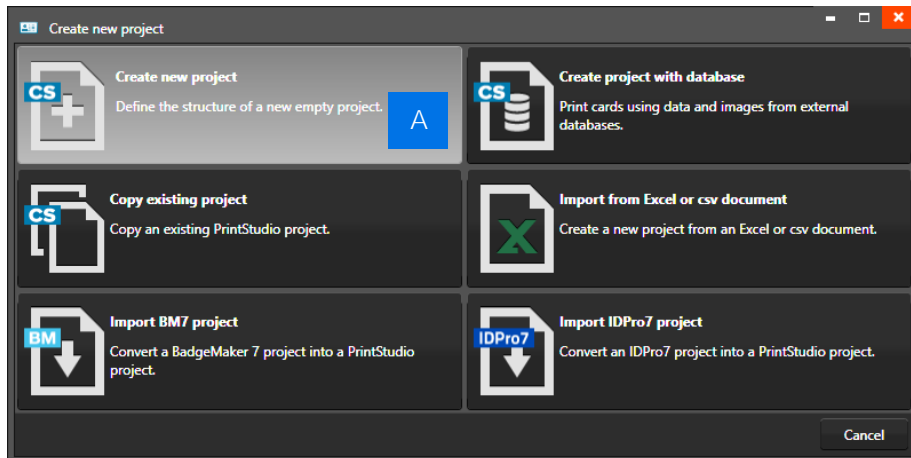

### Step 1. Project Structure

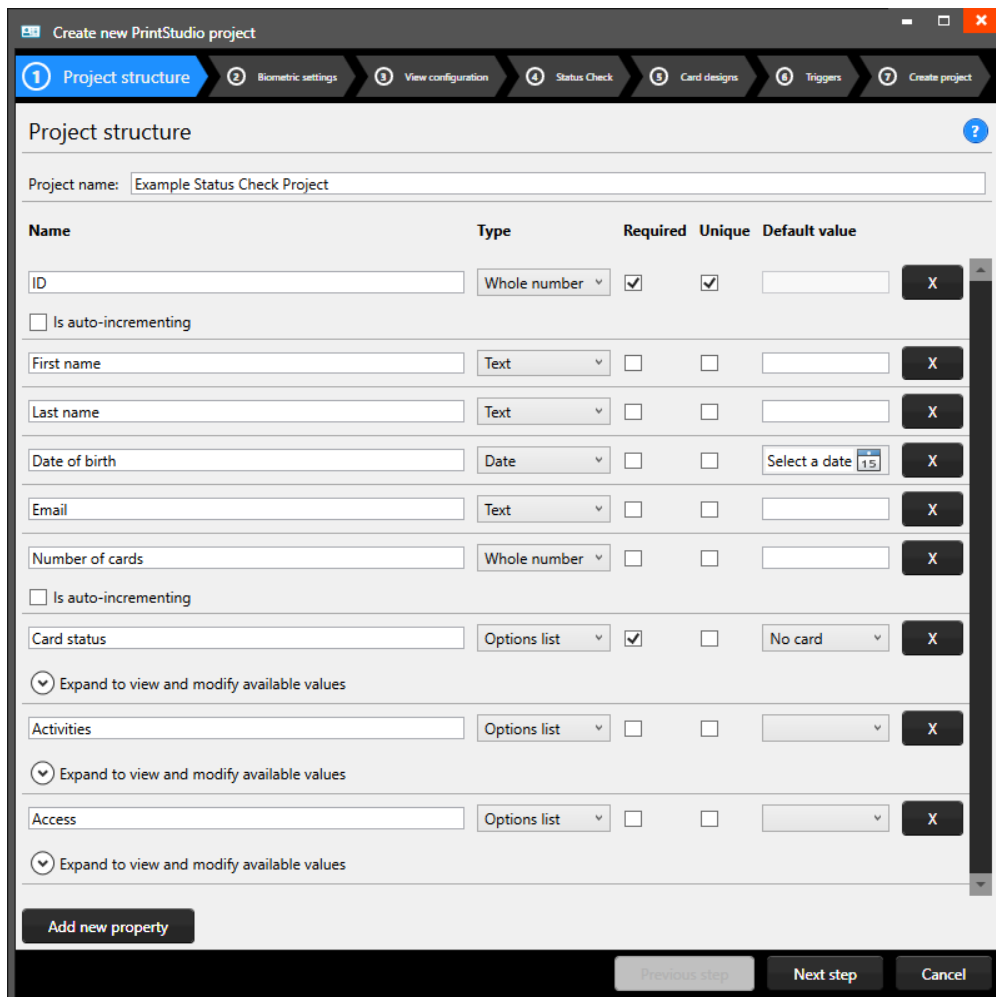

The first step is the setup of your project structure. Give the new Status Check project a name.

The structure offers a couple of default data columns, use the default, and add the data fields you need for Status Check and your Card Design.

In this example project we will check the status of access to an activity, so we will add an options list with activities: activity 1, 2 and 3, an expiry date field and an Access option list. Add Yes and No to this access option list.

Click on the “Next step” button to go to step 2. Biometric settings.

## Step 2. Biometric settings

Create new PrintStudio project

1 Project structure 2 **Biometric settings** 3 View configuration 4 Status Check 5 Card designs 6 Triggers 7 Create project

### Biometric settings

Enable the biometric images you need in your project and determine how they will be stored.

**Passport photo**

Enable passport photos

Aspect ratio: 3 x 4

Image source type: Read image from local project

Filename column: ID

Image format: .png

Image size: 300 dpi 1011 px

Images are stored in this PrintStudio project.

**Signature**

Enable signatures

Aspect ratio: 5 x 1

Image source type: Read image from local project

Filename column:

Image size: 300 dpi 1011 px

Images are stored in this PrintStudio project.

Previous step Next step Cancel

Only enable the passport photos for this project and determine how they will be stored.

## Step 3. View configuration

Create new PrintStudio project

1 Project structure 2 Biometric settings 3 **View configuration** 4 Status Check 5 Card designs 6 Triggers 7 Create project

### View configuration

Specify which properties will be shown in the detail and gallery views. The detail view shows the currently selected record and allows you to modify it. The gallery view displays the passport photo's of multiple records at once.

Detail view Gallery view

First name Last name Access ID

First name	Activities
Last name	Access
Date of birth	Number of cards
Email	Card status

Previous step Next step Cancel

Go on to the "Next step" and adjust the setup for Detailed and Gallery view to your liking.

## Step 4. Status Check

Step 4. Allows you to select and setup the Status Check template. With Status Check it is now possible to scan a QR-code on a printed card or Digital ID and get status feedback. Status Check is an optional fee-based feature that allows you to add a live 2D barcode to your printed or Digital ID Card. This QR-Code contains a unique secure URL that displays a Status Check page with a near, current or up-dated status of a data field you configure in your project. It costs 5 credits to issue a Status Check QR-code and 2 credits to update an existing Status Check Card.

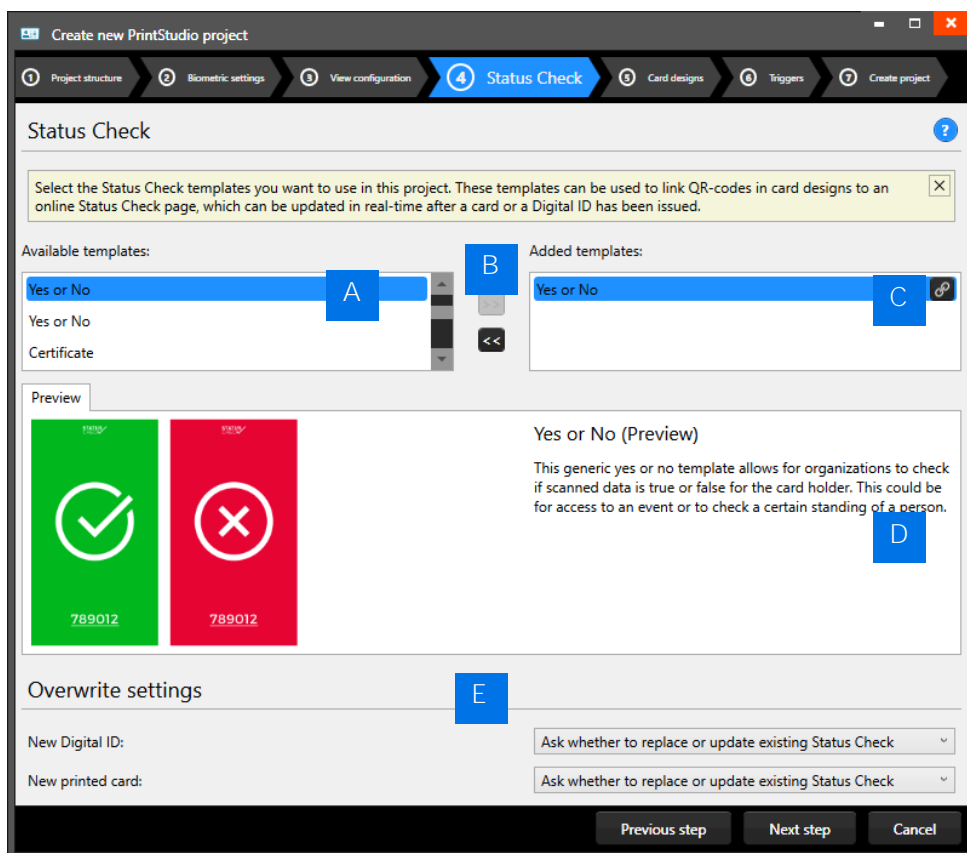

A. Select one of the available Status Check templates from this list. For example, to check the status of training certifications, membership, academic standing, or special access.

B. Click on the “>>” button to add a template to this new project. Click on the “<<” button to remove a selected card design from your project.

C. A Status Check template in your project has an icon available, this is the “Bindings” icon:



Click on the bindings icon to edit the bindings for the dynamic data of the Status Check template and to select the option list to use for validation. The bindings window pops up automatically after adding a template to your project.

D. Preview of the Status Check template selected. You can see the design for positive feedback (green) and negative feedback (red) and a short description on how to use the

template.

- E. Select the overwrite settings for your Status Check QR-code on your card and digital ID. The QR-code link will be generated as soon as a card gets printed, or a digital ID issued. You can choose for: *Generate new Status Check, Update existing Status Check, Update existing Status Check if out of date or Ask whether to replace or update existing Status Check.*

## Status Check template bindings

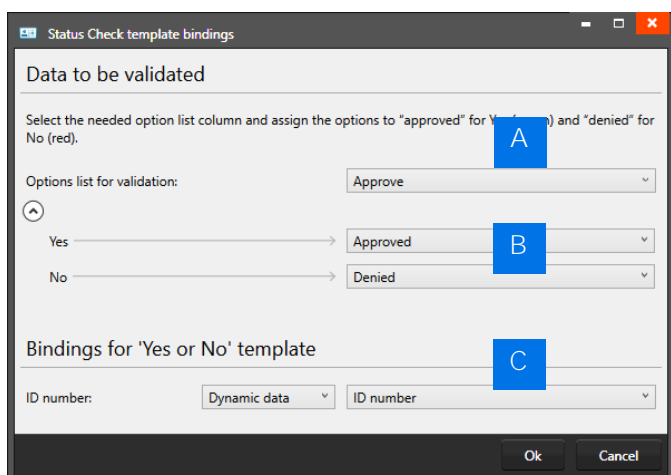

The bindings window pops up automatically after adding a template to your project. The selected “Yes or No” template allows organizations to check if scanned data is true (green) or false (red).

E. Click on the dropdown menu to select one of the options lists to use for Status Check to validate. PrintStudio makes all the data field option lists previously defined in your project available to choose from. We will use the “Approve” option list, we added to the project structure, to validate in this example.

Set -Yes- to “true” to approve and -No- to “false” to deny access to each of the activities.

## Step 5. Card designs

Step 5. allows you to add card designs to your new project.

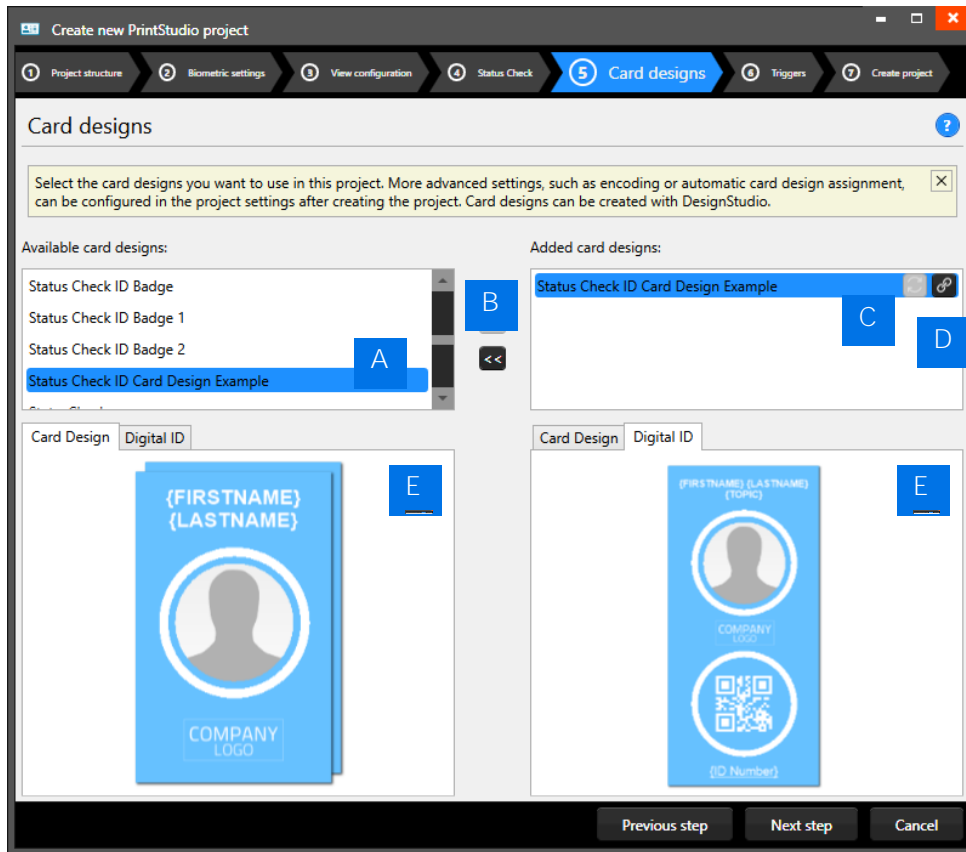

A. Select one of the available designs.

B. Click on the “>>” button to add a selected design to your project. Click on the “<<” button to remove a selected card design from your project.

C. A card design in your project has two icons available, this is the “Update” icon:



An adjusted a card design can be updated to the latest version by clicking on the update icon.



D. A card design in your project has two icons available, this is the “Bindings” icon:

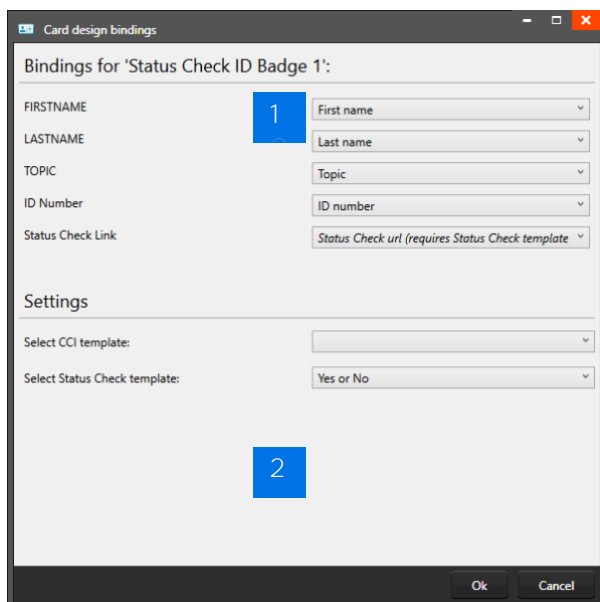

Click on the bindings icon to edit the bindings for the dynamic data of the card design. The bindings window pops up automatically after adding a design to your project.

The data binding tool is a powerful option in PrintStudio. When you add a new layout or update a layout you will be prompted to create the data bindings. Dynamic fields used and created in your layout may differ from the naming or spelling of a name that exists in your Project database. Therefore, you will be allowed to create the data bindings.

### 3. Card Design bindings

The dynamic fields that are created in the card design are presented to the left and you can bind these dynamic fields to the database fields of your project.

### 4. Settings

**CCI template:** Bind a CCI encode template to your card design to encode the card during production. For more information go to [“PrintStudio Encode”](#). If you do not need to encode with this card

design, you can leave this option blank.

**Status Check template:** Bind the Status Check Template you set available in your project to the Status Check card design. A Status Check link will be generated for the QR-code in the design as soon as the card or digital id is printed or issued. If you do not need this card design to have a Status Check QR-code leave this option blank.

E. The preview of the Card Designs offers two tabs with a preview of the card design and one of the digital ID. If the card design has a front and a back, you can toggle between the two by clicking on the design in the preview.

## Step 6. Triggers

Step 6. allows you to setup triggers for your project. Triggers can be used to automatically change data in your project on a certain condition or event.

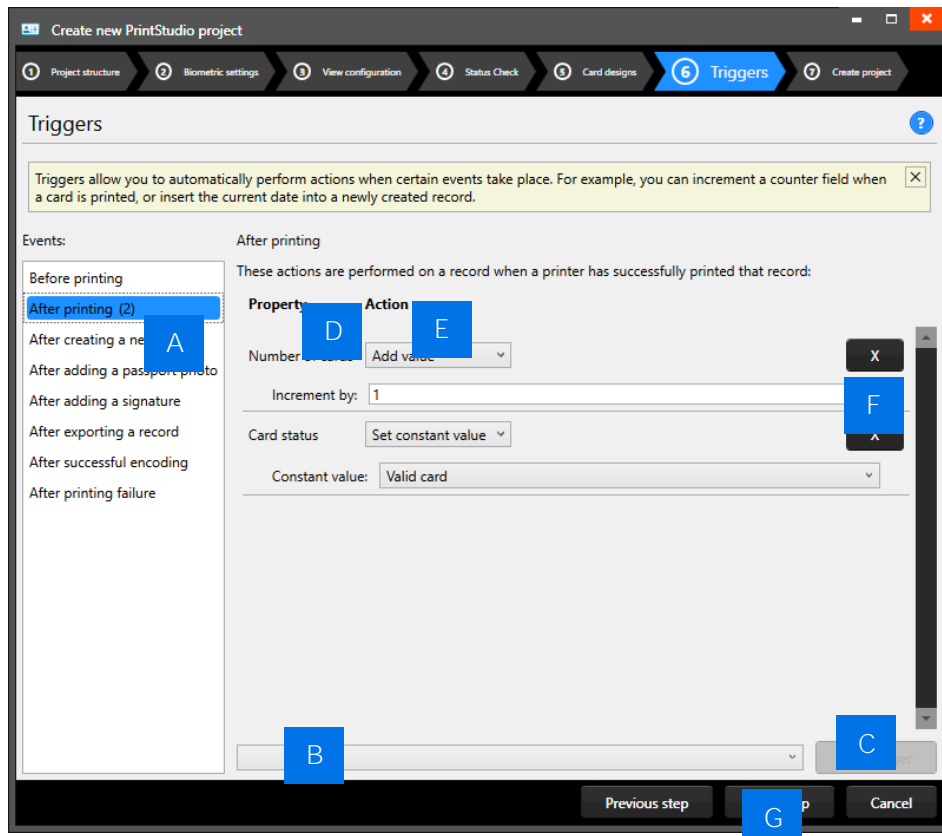

Example of step 5. New project: Triggers

- A. Select one of the events from this list and add specific triggers. PrintStudio will automatically wait for the event to occur before performing the action that is linked to the trigger.
- B. All data columns of the new project are listed. Select one of the columns to link a trigger action to it.
- C. Click on the “Add trigger” button to add the trigger to the data column and specify the trigger with events and actions.
- D. The property shows you the selected data column.
- E. Select the action you want to connect to the data column from the drop-down menu and define the action.
- F. Click on the “X” button to delete a trigger from an event.
- G. Click on the “Next step” button to go to step 6. and create the project.

We will leave step 6. Triggers on default and create our new Status Check Project.

## Step 7. Create project

During step 7, the application will start creating your new project after you click on the A. “Create project” button. If there are problems, read the feedback provided and click on the B. “Previous” button to go back and make the needed adjustments.

You are now ready to work with the Status Check project and produce your Status Check card or Digital ID.

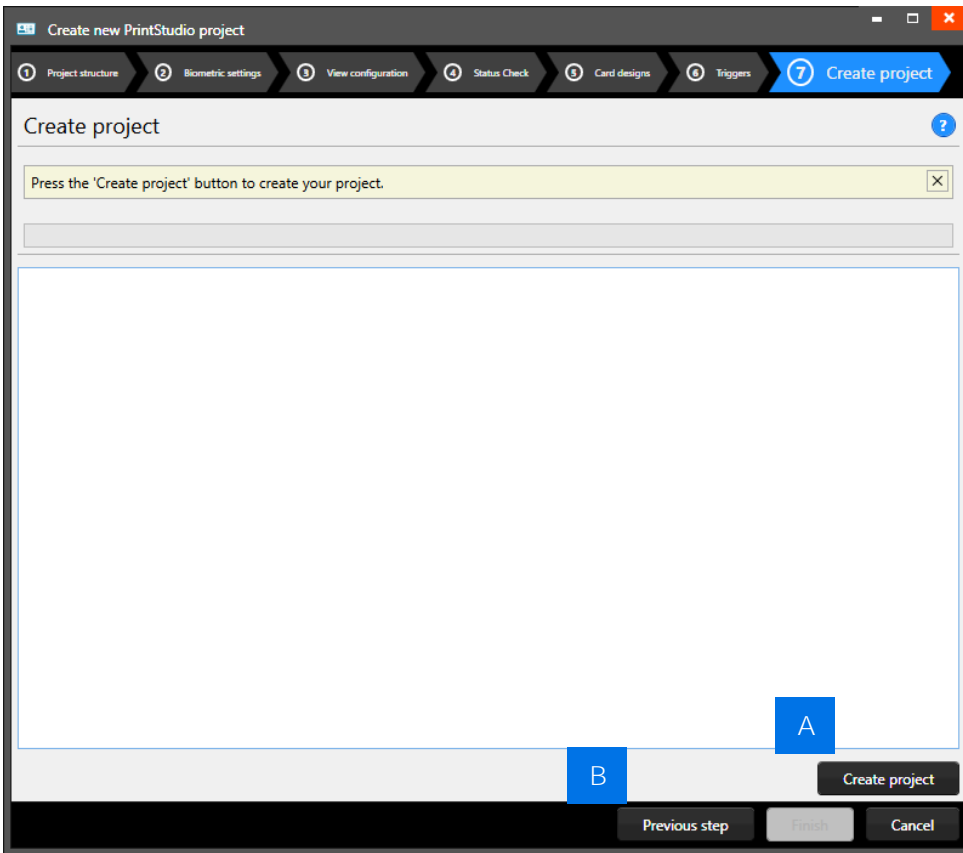

Example of step 6. New project: Create project.

## Update, revoke and replace a Status Check QR-code

Start PrintStudio and open an existing Status Check project with records of card holders that have an active Status Check QR-code. When printing a physical card or issuing a Digital ID with Status Check QR-code, the QR-code will also automatically generate with the correct link and become visible in the card preview.

**Peter Facers ACTIVITY** 498136

First name: Peter Topic: ACTIVITY

Last name: Facers Approve: Yes

Date of birth: 11/07/1979

Email: Facers@statuscheckbasicdemo.org

Number of cards: 0

Card status: No card

- A. To update a Status Check QR-code. Change the approve status of this record from “Yes” to “No” and update the QR-code by clicking on the “[Status Check sync](#)” button: 

Scan the QR-code and the new status shows up as access denied. Change it back to “Yes”, update the QR-code and refresh the page to see the approved status again. Every update of the Status Check QR-code will deduct 2 credits from your account.

- B. To revoke a Status Check QR-code for a printed card. After you revoked a Status Check QR-Code from a printed card, the QR-code will give back revoked. Select the record, click on the “[Status Check revoke](#)” button: 

- C. To revoke and the Status Check QR-code for a Digital ID. Select the record, click on the “[Revoke Digital ID](#)” button: 

When you reissue a new Digital ID, click on the “[Issue Digital ID](#)” button:   
The Status Check will be regenerated with a new QR-code.

- D. When you reprint the card after the status check revoke for this record, the Status Check QR-code will be regenerated with a new QR-code.