

SPECIFIC CONDUCTANCE AND pH MEASUREMENTS IN SURFACE WATERS: AN INTRODUCTION FOR PARK NATURAL RESOURCE SPECIALISTS



**WATER
RESOURCES
FIELD
SUPPORT
LABORATORY**

WRFSL Report No. 84-3



**WATER RESOURCES FIELD SUPPORT LABORATORY
NATIONAL PARK SERVICE
COLORADO STATE UNIVERSITY
FORT COLLINS, COLORADO 80523**

The Water Resources Report Series of the National Park Service, Water Resources Field Support Laboratory, Colorado State University, Fort Collins, Colorado, provides the means for distributing to National Park Service regional and field staff the results of studies and other scientific information useful for the management, preservation and protection of the water and related riparian resources of the National Park System.

The Water Resources Report Series is not a substitute for the open scientific and technical literature. The degree of editing depends on usage, as the Series is designed to be flexible in format and content. The Series encompasses the disciplines of hydrology, geology, biology, ecology and engineering and provides for the retention and dissemination of research information which:

1. Directly address water resources management problems in the parks;
2. Are primarily literature reviews or bibliographies pertaining to water resources problems;
3. Present compilations of basic scientific data; and
4. Discuss methodologies for collecting water quality and quantity information in the National Park System.

The reports may present the results of research conducted by the National Park Service, other agencies, universities, or independent research institutions.

Requests for Water Resources Field Support Laboratory reports should be addressed to:

Director
Water Resources Field Support Laboratory
National Park Service
107C Natural Resources
Colorado State University
Fort Collins, Colorado 80523

NOTE: Use of trade names does not imply U. S. Government endorsement of commercial products.

SPECIFIC CONDUCTANCE AND pH MEASUREMENTS
IN SURFACE WATERS: AN INTRODUCTION
FOR PARK NATURAL RESOURCE SPECIALISTS

WRFSL REPORT NO. 84-3

by

Sam Kunkle
Watershed Hydrologist
WRFSL

and

Juliette Wilson
Research Associate
WRFSL/CSU

September, 1984

Water Resources Field Support Laboratory
National Park Service
Colorado State University
Fort Collins, Colorado 80523

ABSTRACT

Specific electrical conductance and pH are described and discussed in terms of their usefulness to National Park Service personnel as measures of water quality. Information is provided on the techniques for monitoring specific conductance and pH; the units of measure used; the relationship of pH and conductance to stream hydrologic processes; different types of monitoring equipment used and their relative advantages and disadvantages; interpretation of pH and conductance data; problems with monitoring equipment; and hints for the proper use and care of equipment. Suppliers of conductance and pH monitoring equipment are provided in the Appendix. Suggestions for further reading and reference are made, and an annotated bibliography is included.

QUALIFICATION STATEMENT

The information on pH and conductivity meters included in this report was compiled from a comprehensive review of specification sheets, brochures and catalogs from the manufacturers of such equipment known to us at this time. Mention of brand names does not constitute endorsement by the Water Resources Field Support Laboratory, the National Park Service, or the U.S. Government. Likewise, omission of any brand represents an oversight by the authors.

ACKNOWLEDGMENTS

This report was prepared with the aid of Tom Ricketts and Greg Lynch, Technical Assistants. Special thanks is due Dana Heimbecker, Chemistry Department, Colorado State University, for his advice on chemical questions. We extend our sincere appreciation to the following individuals whose review comments were invaluable in improving the clarity and technical accuracy of this report:

Jill Baron, Research Biologist, WRFSL

Terry Boyle, Research Ecologist, WRFSL

Kelly Cash, Assistant Superintendent, Coulee Dam NRA

Dave DeWalle, Professor of Forest Hydrology, Pennsylvania State University

Pam Edwards, Chemist, USDA Forest Service

Jim Osmun, Orion Research Corporation

Carroll Schell, Chief, Resources Management, Acadia NP

Gary Smillie, Hydrologist, CSU/WRFSL

Karen Tillman, Graduate Assistant, CSU/WRFSL

Jim Wood, Science Publications Editor, NPS

Finally, we are grateful to the companies that generously supplied photographs for the many figures in this report.

TABLE OF CONTENTS

	<u>Page</u>
ABSTRACT	i
QUALIFICATION STATEMENT	ii
ACKNOWLEDGMENTS	ii
LIST OF FIGURES	iv
LIST OF TABLES	iv
INTRODUCTION	1
SPECIFIC CONDUCTANCE	3
1. What is Specific Conductance?	3
2. Units Commonly Used	5
3. Adjusting Raw SEC Data to 25 Degrees	5
4. Conductance Levels Typically Found in Natural Waters	7
5. Conductance as an Index of TDS	8
6. How Pollutants Affect Conductance	10
7. Cell Constants	11
8. Calibrating the Meter and Cell	12
9. Interpreting Conductance Data	12
MEASURING pH	15
1. What is pH?	15
2. Units Commonly Used	16
3. Some Examples of pH in Park Waters	16
4. Stream Biology as Related to pH, Alkalinity and Acidity	19
5. Common Measurement Techniques for pH	20
6. Accuracy of pH Meter Measurements	20
7. Types of Meters	22
8. Electrodes	23
9. Special Electrodes	28
10. Connectors	28
11. Buffers and Buffering Effects	29
12. Drift and Low Ionic Questions	31
13. Slope and Temperature	32
14. Readout Styles	34
15. Further Notes on pH Measurements	34
APPENDIX I. CONVERSION EQUATIONS FOR USE WITH pH VALUES	38
APPENDIX II. TEMPERATURE CONVERSION TABLE AND COMPANY LISTS	40
REFERENCES	48
ANNOTATED BIBLIOGRAPHY	49

LIST OF FIGURES

<u>Figure</u>		<u>Page</u>
1	An example of a pocket-sized conductivity meter	3
2	An example of a standard-sized conductivity meter	4
3	The specific electrical conductance of KCl at various temperatures	6
4	An example illustrating the relationship of TDS and specific conductance	9
5	Specific conductances of solutions of salts at various concentrations	10
6	Example of specific electrical conductance (SEC) relationships to stream discharge	13
7	Weighted monthly hydrogen ion concentration and pH of precipitation and streamflow	18
8	pH indicator paper	21
9	Standard-sized pH meter with electrode and case	21
10	Multiple-purpose probe	24
11	Typical electrode pair	25
12	Typical combination electrode	26
13	Typical U.S. Standard and PIN connector	29
14	Typical BNC connector	29
15	Drift in the potential of an ion electrode in a solution	31
16	Readings over time of a typical "quick-response" electrode and a conventional electrode	32
17	Slope: the relationship of pH and electrode potential in millivolts at different temperatures	33

LIST OF TABLES

<u>Table</u>		<u>Page</u>
1	Selecting a cell constant for a specific electrical conductance meter	11
2	Familiar examples of pH values	15
3	Comparison of gel-filled and refillable combination electrodes	27
4	Comparison of epoxy-bodied and glass-bodied electrodes	27

SPECIFIC CONDUCTANCE AND pH MEASUREMENTS
IN SURFACE WATERS: AN INTRODUCTION
FOR PARK NATURAL RESOURCE SPECIALISTS

INTRODUCTION

Natural resource specialists working in national parks, forests and recreation areas frequently need to carry out tests to detect water pollution or to monitor water quality in streams and lakes. Two common tests useful in such work are specific electrical conductance (SEC) and pH. Both are relatively easy to measure in the field or laboratory. This paper describes the methods and equipment used for determining these two common water quality parameters. We have attempted to present the information at an introductory level for park personnel who have little or no prior experience or training in water resources work.

We assume some readers will need to purchase equipment, so we have included the names and addresses of companies that sell pH and conductance meters (Tables C and D in Appendix II). For persons wanting more of the chemical theory and further details on pH and conductance monitoring techniques, the annotated bibliography should be a useful guide.

This paper is intended only as an introduction to the topic. Readers who intend to implement pH and conductance monitoring programs should obtain more in-depth technical references to have on hand. We recommend the following three books as a good basic set:

- Van Loon's Chemical Analysis of Inorganic Constituents of Water (good explanations of analyses)
- American Public Health Association's Standard Methods for the Examination of Water and Wastewater (an essential laboratory reference)
- Hem's Study and Interpretation of the Chemical Characteristics of Natural Water (good explanations of water quality relationships in the field).

These three references collectively cost about \$160, but they are worth the investment to anyone who wants to obtain greater quality control and a more thorough understanding of the monitoring data involved. Details on how to order these books appear in the annotated bibliography.

SPECIFIC CONDUCTANCE

1. What is Specific Conductance?

The ability of a water sample to conduct electricity is called specific electrical conductance (SEC). Frequently referred to as conductance or conductivity, SEC is measured with meters such as the ones illustrated in Figures 1 and 2.



Fig. 1. An example of a pocket-sized conductivity meter. The probe is in the lower right. (Courtesy of LaMotte Chemical Products Co.)

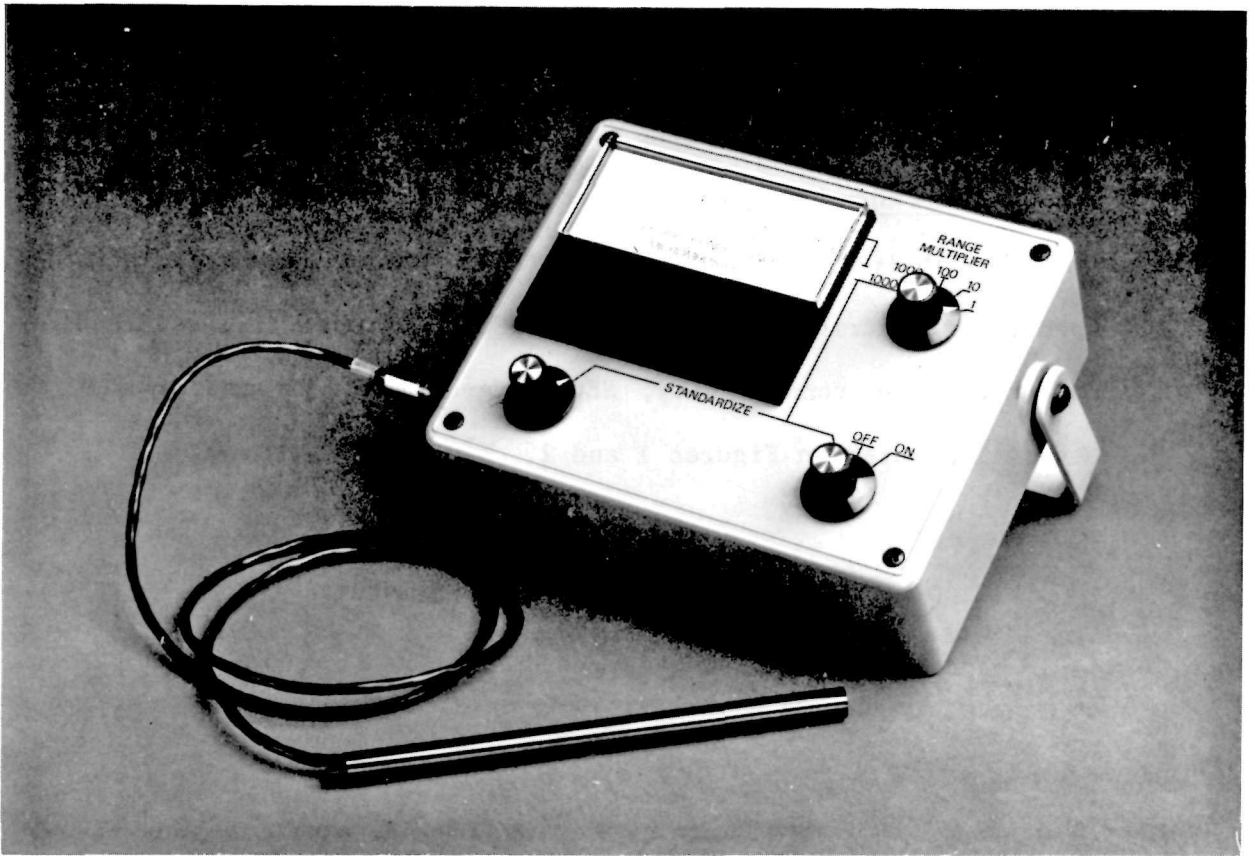

Fig. 2. An example of a standard-sized portable conductivity meter, with the probe in the foreground. (Courtesy of Markson Science, Winter 1984 Catalog)

A conductivity meter uses a circuit called a Wheatstone bridge, which is designed to measure a water sample's resistance to conducting electricity. Resistance is the reciprocal of conductivity ($R = 1/\text{conductance}$). Some meters read out in both resistance and conductance units; however, many simple meters read out only in conductance units.

The probe part of a portable conductivity meter typically consists of a pair of electrodes of precise size that are set a specific distance apart. The standard distance is one centimeter, which is reflected in the "per cm" part of conductance units, discussed below. When the probe is immersed in a water sample, an electrical current is sent through the water and the resistance is then measured by the meter. Another special

type of cell or probe is the "pipette cell," which draws in a small sample of water and acts much like an eyedropper with a built-in electrode. Pipette cells are useful if water samples are too small to allow immersion of the standard probes.

2. Units Commonly Used

Nearly all available specific conductance data at present appear in units of micromhos per centimeter ($\mu\text{mhos/cm}$) at 25°C. Some newer instruments now read in millisiemens per meter (mS/m) or microsiemens per centimeter ($\mu\text{S/cm}$) since siemens, rather than mhos, is now officially the internationally recommended unit (Minear and Keith, 1982). The unit $\mu\text{mhos/cm}$ is equivalent to $\mu\text{S/cm}$. To derive millisiemens per meter (mS/m), divide $\mu\text{S/cm}$ or $\mu\text{mhos/cm}$ by 10. The International System of Units (SI) considers mS/m as the appropriate SI term (APHA, 1981), but most researchers and workers still prefer $\mu\text{S/cm}$ since it yields convenient whole numbers and is equivalent to the familiar $\mu\text{mhos/cm}$ which until recently has always been used. In addition, many major equipment manufacturers continue to use $\mu\text{mhos/cm}$ units on their instruments; so at this point, no one unit is universal.

3. Adjusting Raw SEC Data to 25 Degrees

Since specific electrical conductance is highly temperature-dependent (Figure 3), raw data from a meter must be adjusted to a standard 25°C before any data points can be compared. Some of the more elaborate SEC meters are designed to automatically make this temperature correction, but most inexpensive, portable meters do not. In fact, experience by our laboratory has shown that some meter manufacturers do not inform users that a correction is essential.

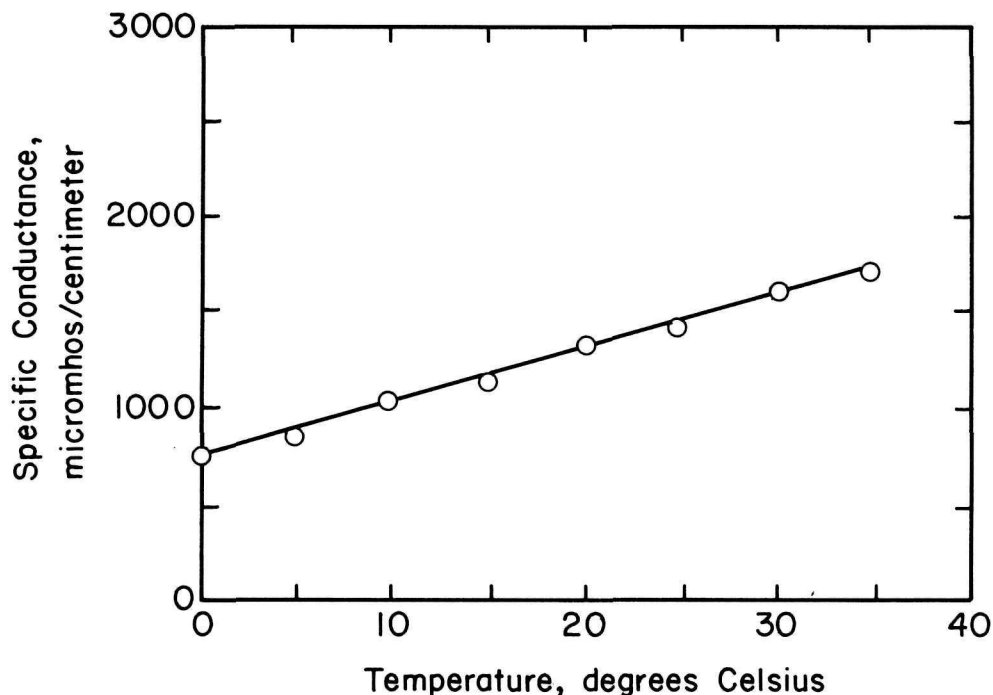

Fig. 3. The specific electrical conductance of a 0.01 molar solution of potassium chloride at various temperatures. (From Hem, 1983, p. 98.)

To make the temperature correction, a rough rule of thumb for field approximations is that the specific electrical conductance of a sample changes two percent for each 1°C departure from 25°C. The actual calculation for correction is:

(Equation 1)

$$SEC_{25} = \frac{(SEC_M)(10^6)K}{1 + 0.0191(t_M - 25)}$$

where: SEC_{25} = corrected SEC value, adjusted to what it would be at 25°C temperature

SEC_M = actual SEC reading from the meter before any correction

t_M = temperature of the water at the time SEC_M is read

K = cell constant; a value (provided by the manufacturer) which is dependent on the size of cell used on a particular meter (see Section 7)

Van Loon (1982) provides a most useful temperature correction table based on Equation 1. This table gives a simple multiplication factor

for each 0.1°C increment from 4°C to 30°C. To correct raw field conductance readings to 25°C, each reading is simply multiplied by the factor indicated in the table for the temperature at which the reading was made. (This table is reproduced in Appendix II.)

Meters equipped with automatic temperature-correcting devices should be checked periodically. To do this, a reading may be taken of a sample of "standard" 0.01 N potassium chloride (KCl) reference solution at various temperatures as the standard solution is warmed or cooled in a water bath. By observing the meter readings at different temperatures, it is possible to see if the correction device is functioning properly. On some meters where the correction circuit has an on-off switch, the automatically-corrected values can be compared to those obtained by applying Equation 1 to uncorrected values. An occasional check along these lines is recommended in case an automatic correcting device malfunctions.

4. Conductance Levels Typically Found in Natural Waters

The specific electrical conductance (SEC) of a water sample depends primarily on (1) the nature, number and types of ions present which account for the water's ionic strength, and (2) the temperature of the water. Pure distilled, deionized water has a conductivity very close to zero. Streams running through granitic, silicon or other hard geological formations, as they do in many of our igneous western mountains, will frequently conduct in the 10-50 $\mu\text{S}/\text{cm}$ range (10-50 $\mu\text{mhos}/\text{cm}$) and sometimes even lower. On the other hand, water flowing through limestone formations in Appalachia will more likely be in the 150-500 $\mu\text{S}/\text{cm}$ range. Streams in arid parts of the Western U.S. that are influenced by alkalinity or salinity typically fall into the 1000-5000 $\mu\text{S}/\text{cm}$ range.

Some saline lakes and brines, such as the brines produced by oil well drilling, can show conductances of several thousand or even over 100,000 $\mu\text{S}/\text{cm}$ (Rainwater and Thatcher, 1960). At conductances greater than 10,000 $\mu\text{S}/\text{cm}$, water density becomes significantly greater than 1.0 g/cm^3 (Hem, 1970) so that water of this density will seek the bottom of a water body. It is therefore easy to detect some of these natural differences in SEC.

5. Conductance as an Index of TDS

Specific electrical conductance often correlates well with the total dissolved solids (TDS) found in natural (i.e., basically unpolluted) waters, since these TDS consist principally of inorganic calcium and magnesium compounds and other naturally-occurring inorganic chemicals and salts—all substances that make water conduct electricity in very nearly direct proportion to their concentrations (Figure 4). TDS is determined by filtering and then evaporating a water sample, weighing the remaining residue, and expressing the TDS as mg/L. In some cases, TDS also can be estimated by totaling the results of the cation and anion analyses that were derived through chemical analysis of the sample.

Because the TDS/SEC relationship is usually linear, specific conductance often is used to estimate TDS by multiplying the SEC value by a factor, usually between 0.55 and 0.9. (The factor will vary from one location to another since individual streams differ in their chemical composition. Therefore, it is best to derive the factor empirically for a given stream.) In the example in Figure 4, multiplying the conductance values by approximately 0.6 yields TDS.

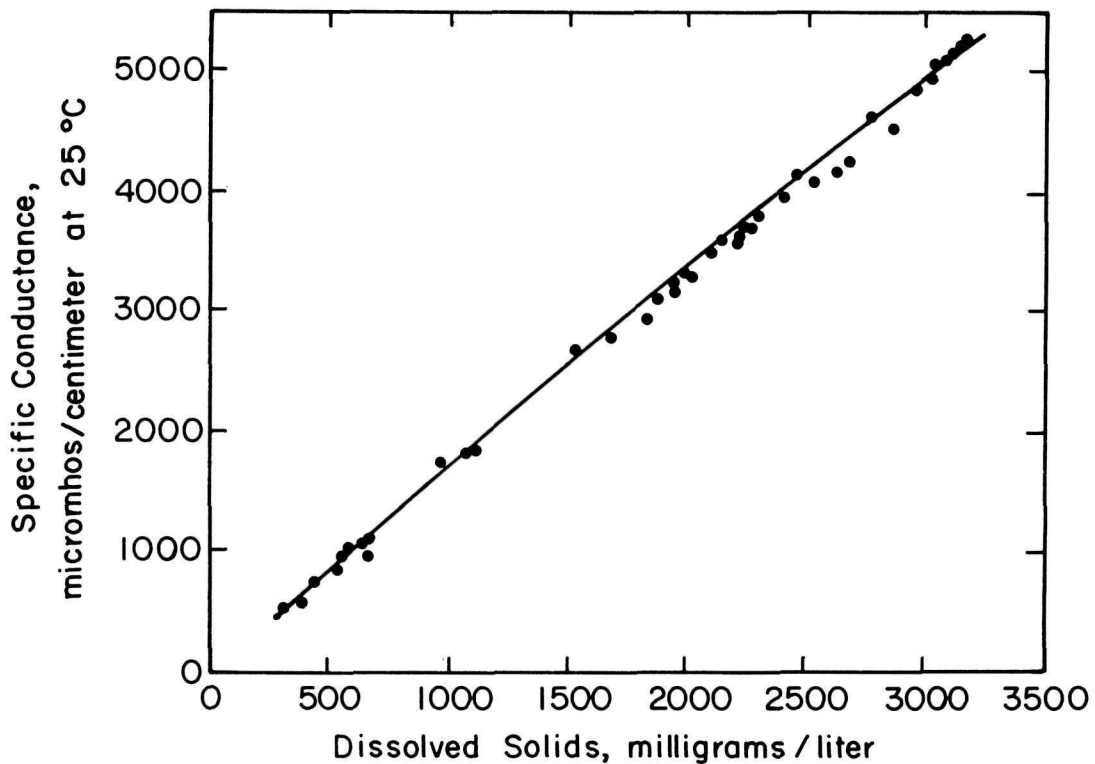

Fig. 4. An example illustrating the relationship of TDS and specific conductance. (Adapted from Hem, USGS Water Supply Paper 1473, 1983, p. 100, based on data from the Gila River in Arizona.)

A general rule of thumb is:

(Equation 2)

$$\text{SEC} \times 0.65 = \text{TDS}$$

where SEC = specific electrical conductance

and TDS = total dissolved solids

(APHA, 1981; Van Loon, 1982).

Specific conductance also serves as an extra check on inorganic analyses of water samples. For example, a collection of samples from a given watershed will often show a consistent relationship between the concentration of the major cations (Ca, Mg, K, Na) and conductance. If, however, one isolated sample varies greatly in this relationship, a chemical analytical problem may be indicated.

6. How Pollutants Affect Conductance

In addition to the natural substances described above, many inorganic pollutants, because of their high ionization, will affect conductance measurements (Figure 5). Examples of such pollutants include: the salts (NaCl and CaCl_2) used in winter road de-icing; nitrates and phosphates in sewage and manure; the inorganic nutrients in fertilizers; sulfates, iron and manganese compounds found in runoff from strip-mined lands; the principal acids (H_2SO_4 and HNO_3) in acid rain; metals from other inorganic substances leaking from old dumps; and brines from oil drilling. In addition, specific conductance measurement is an excellent field tool for determining the point where inorganic pollutants are flowing into a stream.

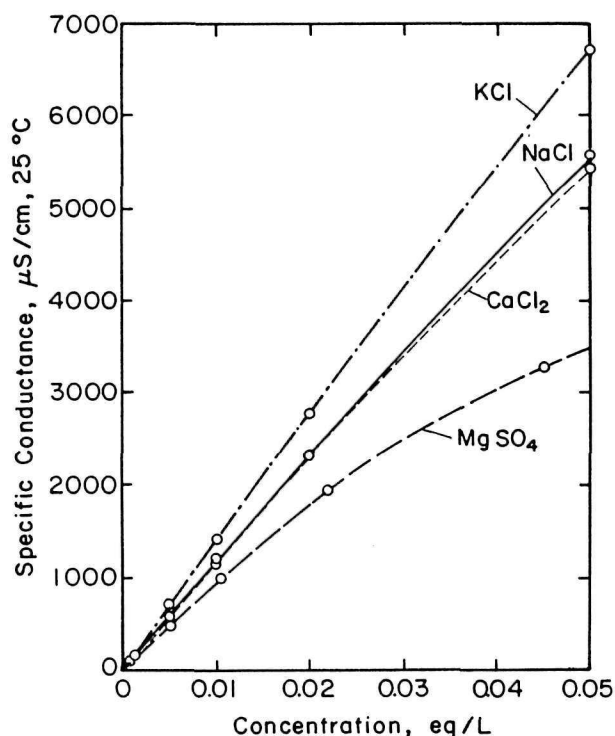

Fig. 5. Specific conductances of solutions of salts at various concentrations. (Adapted from Minear and Keith, 1982, p. 154, with permission.)

As opposed to inorganic substances, dissolved organic substances are ionized very little and therefore do not add much conductance to water. For example, sluggish, dark-colored bayou or swamp waters can have high organic concentrations yet still exhibit low conductances, e.g., 25-75 $\mu\text{S}/\text{cm}$. Likewise, many manufactured organic pollutants, such as organic solvents and many of the pesticides and herbicides, are not readily detected by conductivity measurements.

7. Cell Constants

The probe of a conductivity meter comes rated for an exact "cell constant." A factory-rated cell constant (K) of 1.00 is generally a close approximation, and in fact is typically slightly lower or higher than 1.00. Therefore, many meters will have an adjustment where the exact cell constant can be entered when calibrating the meter. In other cases, the cell constant is entered in Equation 1, which is then applied to the meter's raw readings. Some meters will have a switch to allow for use of different cell constants. For example, one meter can be switched to a cell constant of 1.0 for use in most waters and 10.0 for use in very saline waters. A rough rule of thumb for selecting a cell constant is presented in Table 1.

Table 1. Selecting a cell constant for a specific electrical conductance meter. Taken from Van Loon, 1982, p. 49.

<u>Cell Constant</u>	<u>Conductivity Ranges</u>
0.1	0 to 100 $\mu\text{S}/\text{cm}$
1.0	100 to 100,000 $\mu\text{S}/\text{cm}$
10.0	above 100,000 $\mu\text{S}/\text{cm}$

Since most park and recreation area waters fall into the 100-100,000 $\mu\text{S}/\text{cm}$ conductivity range, they can be conveniently measured

with a cell constant of 1.0. However, the extremely soft waters in some western mountain areas and pristine lakes are more accurately measured with a cell constant of 0.1. A 10.0 cell constant may be necessary where oil field brines or industrial effluents are encountered.

8. Calibrating the Meter and Cell

Several of the listed references (e.g., APHA, 1981; Van Loon, 1982) provide all the details on meter and cell calibration. A meter and cell should be checked against a standard solution of potassium chloride (KCl), usually 0.01 Normal. The standard 0.01 N KCl reference solution conducts 1,413 $\mu\text{S}/\text{cm}$ at 25°C. It also can be diluted; for example, a 0.001 N KCl solution at 25°C conducts 147.0 $\mu\text{S}/\text{cm}$, so the dilution and change in conductance is very close to linear. Standard Methods (APHA, 1981) gives tables on dilutions, concentrations, temperature relationships and step-by-step operations for calibrating meters and cells. If a meter and cell read too high or too low, some meters can then be corrected to match the standard solution. For simple, unadjustable meters, a multiplication correction factor must be applied to all readings, so that a modified constant (K) is used with Equation 1.

9. Interpreting Conductance Data

Hydrologic (streamflow) data are almost always needed in order to interpret SEC data from flowing waters. For example, during the spring snowmelt season or during storms in many areas, stream conductance will typically drop drastically (Figure 6). This is because the trickle of ion-rich, mineral-laden ground water in the stream is greatly diluted by the large volumes of rain or melting snow, which are very mineral-poor compared to the ground water. The same dilution concept works in

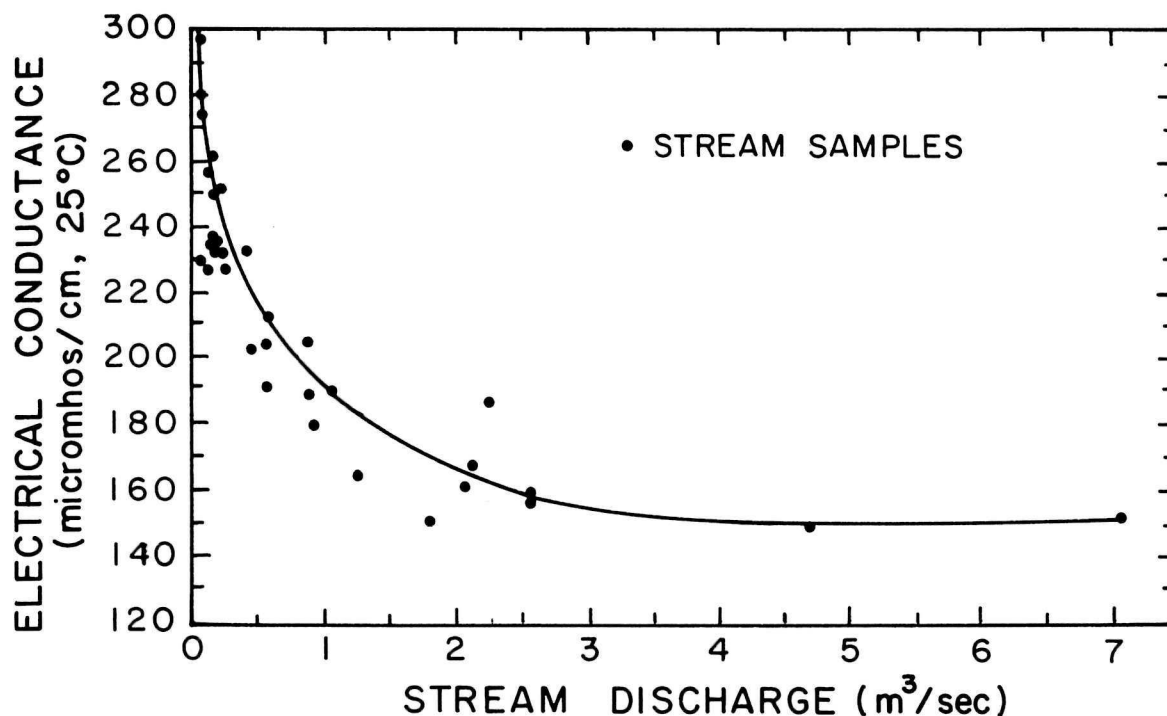

Fig. 6. Example of specific electrical conductance (SEC) relationships to stream discharge in a Vermont headwater stream. (Taken from Kunkle and Comer, 1972.)

reverse during dry periods when ground water makes up nearly all the streamflow. In this instance, conductances go up markedly because the calcium, silica or other constituents picked up in the ground are not diluted. The dilution principles also apply to "point source" pollution loads as well. For example, a sewer pipe's main contributions to conductance (including chloride $[Cl^-]$ and other ions in the sewage) will be diluted in the same way as the ground-water ions are diluted, as described above.

Surface pollutants or "nonpoint" sources of pollutants occasionally will be washed into a stream or other water source during storms. Silt and other visible surface pollutants, however, usually will not add much conductance since they are not in chemical solution. For this reason, a stream's conductance during heavy rainstorms often will be drastically lower than its conductance during low, cleaner-appearing flows. From a

chemical point of view, the turbid flow is actually cleaner than the clear, pre-storm flow.

In summary, conductance typically drops dramatically during high flows, regardless of whether the conductance is due to natural groundwater ions or due to pollution ions, since both are diluted. For all the reasons described in this section, interpretation of conductance data requires some hydrologic data. Even a reasonable estimate of stream discharge will be valuable for interpreting conductance values.

MEASURING pH

1. What is pH?

The measurement of pH provides an index of the acidity or basicity of water or other solutions. The pH scale ranges from 0 to 14, where values of 0 to 7 pH are acidic, pH 7 is neutral, and values of 7 to 14 pH are basic. Examples are given in Table 2.

Table 2. Familiar examples of pH values, with some references taken from LaMotte (no date) and from Hem (1970).

Substance	pH of Substance
Household lye	13.6
0.1 Normal NaOH	13.0
Ammonia	11.4
Baking soda	8.4
Sea water	7.7 to 8.2
Typical western trout stream	6.5
Distilled water exposed to air	5.6 to 5.7
Typical rain (not acid)	4.8 to 6.0
Bog waters, typical	3.5 to 4.0
Acid rain in NE US, typical	3.4 to 4.3
Vinegar	2.9
Severe acid mine runoff	2.6
Lemon juice	2.3
0.1 Normal HCl	1.0
Battery acid	0.3

Acids contain hydrogen ions (H^+). The activity or effective concentration of these H^+ ions is measured by pH, where $pH = -\log_{10}[H^+]$. (The p in pH stands for power, and the H represents hydrogen [Westcott, 1978].) The pH scale provides a convenient expression of the activity of these H^+ ions in positive numbers. Because each pH number is actually a negative logarithm of the H^+ ion effective concentration, the smaller the pH number, the more H^+ ions there are—thus, the greater the acidity. Note that moles per liter of H^+ are essentially mg/L H^+ , since hydrogen has an atomic weight nearly equal to one.

Because the pH scale is logarithmic, a change of one pH unit represents a ten-fold change in effective concentration of H^+ ions. This means that the potential for biological impact greatly increases as the pH reading moves further away from pH 7. For example, pH 4.0 rain is 10 times more acidic than pH 5.0 rain, but pH 3.0 is 100 times more acidic than pH 5.0. This is one of the reasons why biologists become concerned as the average pH of rain moves further down the scale: the units are increasingly potent.

2. Units Commonly Used

Scientists frequently express acidity in terms of effective concentrations of H^+ ions, using equivalent weights, e.g., microequivalents of H^+ per liter ($\mu\text{eq/L } H^+$). The advantages of using units such as $\mu\text{eq/L } H^+$ are: (1) changes in acid strength are linear, not logarithmic as with pH, so graphic comparisons are more meaningful; (2) H^+ numbers in $\mu\text{eq/L}$ are numerically comparable to other chemical parameters expressed in $\mu\text{eq/L}$, whereas pH is a unique unit; (3) $\mu\text{eq/L}$ values are statistically useful, whereas pH presents problems—for example, pH numbers cannot be statistically averaged and give valid results; and (4) $\mu\text{eq/L } H^+$ or other variations on equivalent weights or mg/L can be used in calculating chemical budgets. Formulas for conversion of $\mu\text{eq/L } H^+$ and pH are given in Appendix I.

3. Some Examples of pH in Park Waters

Measurements of pH can help detect certain pollutants in water or help appraise water quality conditions in streams, lakes, rain and other waters. Below are some common field observations of pH measurements.

- Sea water normally is about pH 8.0 to 8.2 at the surface and a few tenths lower in deeper water (U.S. EPA, 1976).
- Acid mine drainage in streams commonly will push pH values to below 4.0, occasionally below 3.5 and sometimes even below 3.0 in seriously affected streams. Mine acids are strong and not easily buffered. When abandoned mine shafts continue to leak water into low-flowing streams during drought periods, the pollution will be worse than during normal flow times because there is less dilution.
- pH is a good index of acidity and frequently relates closely to nitrate (NO_3^-), sulfate ($\text{SO}_4^{=}$) and chloride (Cl^-) measurements.
- Naturally alkaline streams in the southwestern U.S. will often show pH values over 8.0.
- Well-buffered streams or springs in limestone watersheds will likely show pH readings close to neutral, or from 7.0 to 8.0, since the buffering helps stabilize pH.
- The organic layer in a forest can buffer rainwater entering an adjoining watershed.
- Waters in swamps, bogs, and marshes with many weak (poorly ionized) organic acids in the water will frequently show pH readings below 5.0. These weak acids are much more easily buffered than those associated with acid mine drainage.

Parks located in upper watersheds often are relatively free from pollution. The pH of natural, unpolluted waters is mainly controlled by the carbonate system, that is, the interactions of carbon dioxide (CO_2), carbonic acid (H_2CO_3), bicarbonates (HCO_3^-) and carbonates ($\text{CO}_3^{=}$). In most unpolluted streams there are daily as well as hydrologic fluctuations the carbonate system, with a resultant change in stream pH. For

example, during the day aquatic plant photosynthesis reduces CO_2 and adds O_2 to waters, and during warm periods bacterial decomposition adds CO_2 to water. These processes can raise and lower pH since the amount of CO_2 controls the amount of carbonic acid in the carbonate system.

In some waters, seasonal fluctuations from such sources as meltwater and acid precipitation may also be evident. At the same time, buffering in a watershed may enable a stream's pH to remain relatively stable. Hornbeck et al. (1976) have illustrated seasonal variation in the pH of precipitation at Hubbard Brook (Figure 7); in this case, the pH of the receiving water remains fairly constant due to the buffering effect of forest vegetation and soils. (Note in Figure 7 the parallel use of pH and $\mu\text{eq/L}$ values.)

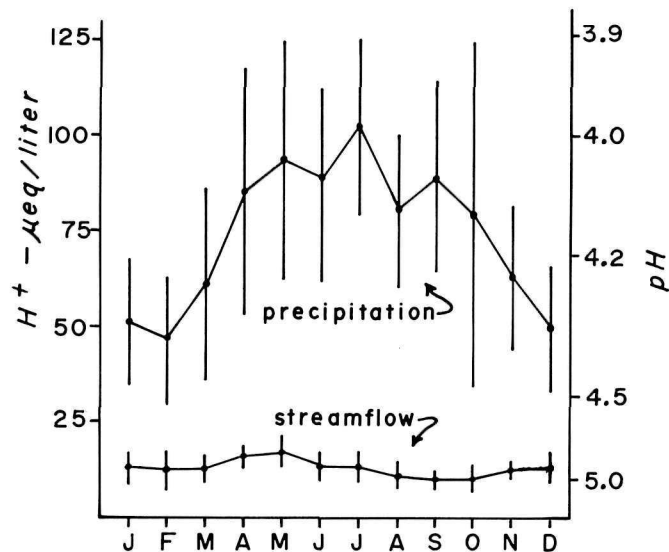

Fig. 7. Weighted monthly hydrogen ion concentration and pH of precipitation and streamflow at Hubbard Brook, New Hampshire, from 1965 to 1974. The vertical lines for each month represent one standard deviation. (From Hornbeck et al., 1976, p. 607. Reprinted with permission.)

4. Stream Biology as Related to pH, Alkalinity and Acidity

Streams generally need some calcium buffering in order to be biologically productive ("fertile") and suitable for fish. Although pH is one of the indices of the suitability of a given stream for fish, the pH readings per se do not show the strength or capacity of the calcium buffering, i.e., how much acid the calcium buffering can counteract or how much calcium is available for use biologically. A measurement of alkalinity (a quantitative titration with an acid solution) is necessary for determining this buffering capacity or strength. Similarly, a pH value does not quantify acid strength; it won't show, for example, whether acids in a stream are mostly weak (organic acids from a bog) or strong (H_2SO_4 from acid mines). A titration (using NaOH) for acidity is necessary to quantify this acid strength.

Fish species vary in their sensitivity to pH changes, although basically all species are sensitive to sudden fluctuations in pH. A pH range of 6.5 to 9.0 appears to provide adequate protection for the life of most freshwater fish and bottom-dwelling invertebrates (U.S. EPA, 1976). Stocked fish will sometimes tolerate wider ranges of pH, but reproduction may be adversely affected.

pH also affects the toxicity of various substances in water. For example, some metals may become more lethal at lower pH levels. In addition, low pH levels also may contribute to the release of an increased number of materials. For instance, one of the major concerns with acid rain is that its associated low pH conditions can mobilize (release) aluminum, which is harmful to some fish species.

5. Common Measurement Techniques for pH

Three common ways to measure pH are: (1) color indicator solutions used in titrations, where an approximate pH determination can be obtained visually; (2) inexpensive pH paper strips of the litmus paper type which are designed to change colors and thus allow approximate determinations of pH; and (3) pH meters, which provide more accurate measurements of water samples (Miller, 1982). The latter two are most commonly used in park work.

The pH papers, made with various dyes, are sensitive to about ± 0.3 pH units and are handy for field reconnaissance. They can be used, for example, for testing the pH of waters and soils in mining areas where an approximate pH value would help detect pollution sources. Some companies that sell pocket-sized pH paper test kits include Hellige, Taylor, LaMotte, and EM Science (Figure 8). For most park water quality monitoring applications, however, pH meters used on-site in the field are the most accurate and preferred measurement technique. Figure 9 shows a typical portable pH meter and electrode. Suppliers of pH meters are listed in Table C in the Appendix.

6. Accuracy of pH Meter Measurements

A high quality meter (costing between \$500 and \$1000) will normally read out to the closest 0.01 pH unit; one can round off and realistically expect to measure to ± 0.1 pH unit. Simple pocket meters (costing about \$150-\$400) are less accurate, and determination to within ± 0.2 is probably a more realistic expectation despite 0.01 readouts on the digits. Reporting pH to 0.01 unit levels is not realistic with the meters typically used under field conditions in natural resources work.



Fig. 8. pH indicator paper. (Courtesy of EM Science)



Fig. 9. Standard-sized pH meter with electrode and case. (Courtesy of LaMotte Chemical Products Co.)

7. Types of Meters

When a pH electrode is immersed in water, it acts as a battery and develops a tiny voltage. This voltage can be measured in millivolts by a high-impedance input amplifier—in other words, a pH meter. Although all pH meters operate under the same principle, the level of sophistication varies with the different types of meters insofar as the sensitivity of the meters, or the way in which the temperature compensation or other adjustments work. The different pH meters may be separated into four general categories:

1) Mini- or pocket-sized portable meters:

These battery-powered meters are about the size of a pocket calculator and come with a protective case. Lightweight and therefore useful for backpacking, canoeing and other transporting, these instruments may cost more than the larger units due to their compact design; however, they are not always as accurate.

2) Standard-sized portable meters:

These meters are approximately the size of a cigar box and are light enough to use in the field. They may be both battery- and AC-powered, and most come with a carrying case and buffer solutions. They typically are more accurate than the pocket-sized meters and are available in inexpensive, simple models suitable for screening work and in more expensive, sophisticated models.

3) Bench meters:

These units provide the greatest measurement accuracy but they are not designed for field use. They are recommended as a

laboratory back-up to the portable meters for verifying field sample measurements. Size is typically that of a shoe box. Many models have expanded scales for extra-sensitive readouts. Various kinds of probes may be connected to the unit.

4) Combination portable meters:

These meters are particularly useful when time and space are primary considerations (as they are on a boat, for instance). The meters use a special multiple-electrode probe (Figure 10) that can measure conductivity, dissolved oxygen and temperature in addition to pH. The measurement of turbidity can also be included on certain meters for additional cost. With some of these combination instruments, measurement accuracy is lessened due to the several capacities that are built into the single, compact probe. There are multiple-purpose probes on the market that are built for greater accuracy; however, they can be much more expensive than a set of individual probes. In addition, the multiple-parameter instruments are sometimes more difficult to keep in calibration given the smaller parts, compactness, and greater fragility. There is no saving in cost in buying a combination meter rather than individual instruments of comparable quality.

8. Electrodes

Many electrodes are available for use on pH meters. This section briefly describes those pH electrodes that are commonly used on field pH meters in natural resources work.

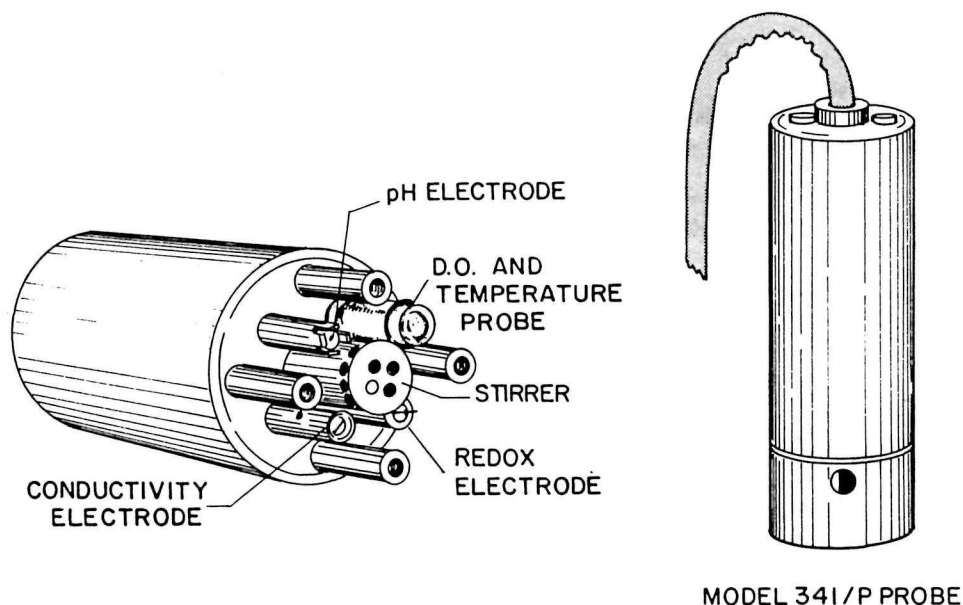

Fig. 10. Multiple-purpose probe. (Taken from ECO Instruments brochure, p. 3, with permission.)

To make a pH measurement, two electrodes are needed—a pH glass electrode and a reference electrode (Figure 11). In portable meters for field use, and in most other meters as well, these two electrodes are virtually always constructed as a single unit. The pH electrode has a special glass membrane which allows comparison of the concentrations of H^+ ions inside and outside the electrode. This difference in the two concentrations produces a potential or charge difference across the membrane which can be related to the H^+ concentration in the water sample. This potential can be measured relative to the potential generated by a reference electrode. The reference electrode provides a constant potential which is not affected by the water sample and to which the potential from the glass pH electrode may be compared. From the difference measured between the two electrode potentials, the meter determines and displays the resulting pH value.

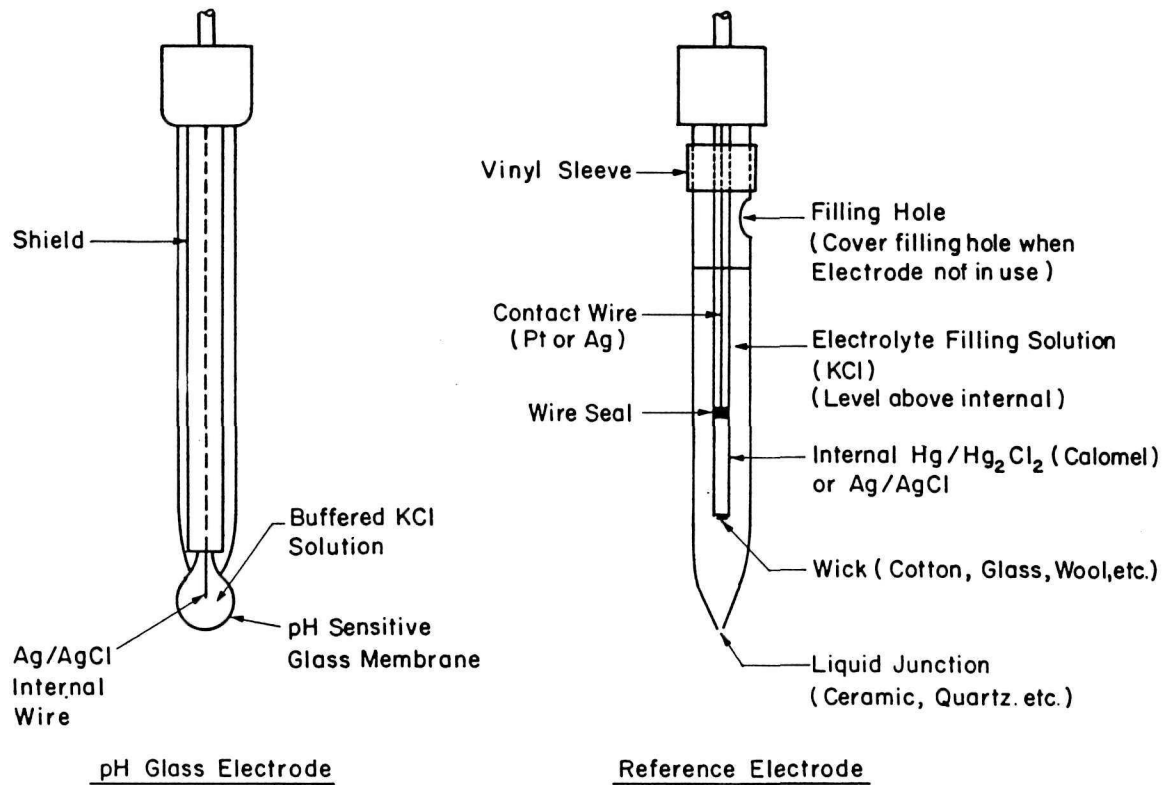
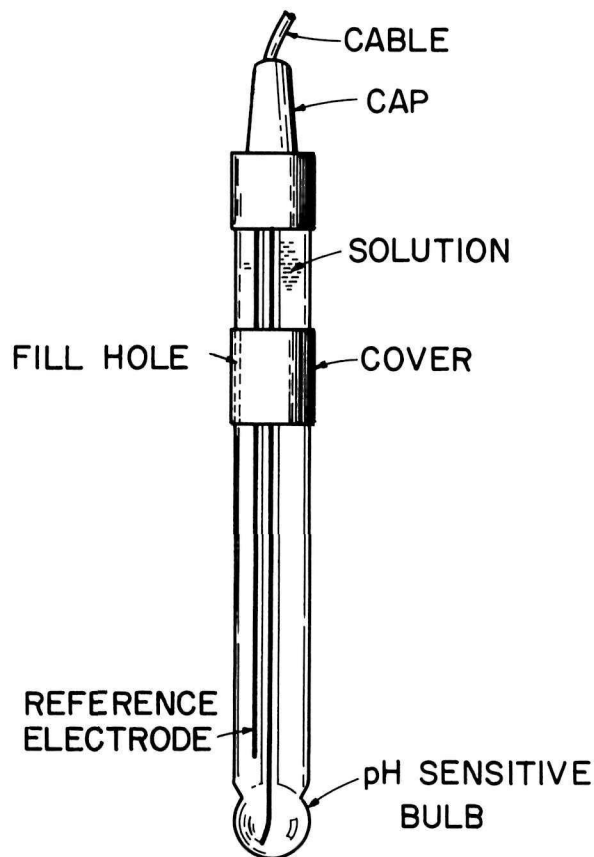

Fig. 11. Typical electrode pair. (Adapted from Beckman, 1982, p. 50, with permission.)

The two types of reference electrodes most often used are the silver-silver chloride (Ag/AgCl) and the Calomel (Hg/Hg₂Cl₂). Both electrodes yield reasonably accurate results when used in waters at temperatures normally encountered in nature. However, in waters above 60°C the Ag/AgCl electrode must be used, since the Calomel internal is damaged or destroyed at elevated temperatures (Beckman, 1982).

When the pH and reference electrodes are combined into one unit, it is called a combination electrode (Figure 12). Combination electrodes are systems in which the reference electrode concentrically encloses the measuring electrode. This design helps reduce erratic readings, and its compactness enhances handling ease in the field.



THE pH ELECTRODE

Fig. 12. Typical combination electrode. (Adapted from Chemtrix Co. 1984 Catalog, with permission.)

The combination electrode is available in two types, the gel-filled and the refillable. Both types may have either epoxy or glass bodies. These variations are compared in Tables 3 and 4.

Selection of the proper electrode will depend upon the intended use as well as personal choice. The glass-bodied reference electrode is suitable for laboratory use where a high degree of accuracy and the quality afforded by glass is desired, and where breakage is not likely. For field use, the sturdier epoxy-bodied electrodes are the practical alternative. Personal preference will to a large extent determine whether a gel-filled or a refillable combination electrode is selected. Some considerations would include degree of accuracy, the amount of

Table 3. Comparison of gel-filled and refillable combination electrodes.

Gel-filled Combination Electrode	Refillable Combination Electrode
<ul style="list-style-type: none"> • permanently filled, so there is little to no maintenance and no leakage 	<ul style="list-style-type: none"> • filling solution must be maintained and care taken to avoid any leakage
<ul style="list-style-type: none"> • shorter life than refillables due to eventual drying out; cannot be refilled 	<ul style="list-style-type: none"> • long life since refilling, cleaning, and rehabilitation are possible; various procedures for reviving
<ul style="list-style-type: none"> • moderate accuracy (± 0.1 pH for many) suitable for more buffered streams or polluted waters 	<ul style="list-style-type: none"> • high accuracy (± 0.01 pH for many) suitable for less buffered, more pristine waters
<ul style="list-style-type: none"> • exceptionally sturdy with protection for glass electrodes 	<ul style="list-style-type: none"> • adequately sturdy with reasonable care
<ul style="list-style-type: none"> • modification not possible 	<ul style="list-style-type: none"> • filling solutions can be modified to allow for specialized procedures, such as low ionic measurements

Table 4. Comparison of epoxy-bodied and glass-bodied electrodes.

Epoxy-bodied Electrode	Glass-bodied Electrode
<ul style="list-style-type: none"> • sturdy and essentially unbreakable; good for field use 	<ul style="list-style-type: none"> • breakable; sensitive to rugged use
<ul style="list-style-type: none"> • reasonably easy to clean under most circumstances 	<ul style="list-style-type: none"> • very easy to clean
<ul style="list-style-type: none"> • suitably accurate, but less so than glass-bodied electrode 	<ul style="list-style-type: none"> • slightly higher accuracy and greater stability than epoxy-bodied electrode

maintenance required, longevity, and durability. Users who primarily will be measuring pristine waters will want a low ionic strength electrode or may need to consider a special procedure (one is described in Section 15) which would require a refillable electrode.

Electrodes can leak, crack, stop up, become contaminated and have other problems. They can age to the point of being unreliable, and some gel-filled units may need replacement in less than two years. A clogged electrode is responsible for many difficulties in measuring pH. Instructions for storage, care, rinsing and rehabilitation of electrodes are specific for each type and need to be followed accordingly.

9. Special Electrodes

A few companies sell many types of special ion-selective electrodes for measuring other ions besides H^+ . These special electrodes are made for use with high quality bench model pH meters with expanded scales, which provide the sensitivity necessary for measurement of the specific ion. Sales brochures will often indicate easy and precise measurements from these electrodes; however, care should be taken since interferences in many natural waters can be complicated, and the easy-to-read data can sometimes be difficult to interpret. In such cases, even calibration of the electrode may require a special knowledge of water chemistry.

10. Connectors

Connectors for electrodes come in several different forms, but in the U.S. the two most commonly used are the U.S. Standard and PIN and the BNC connectors (Figures 13 and 14). They are found in various lengths from 12 inches to 20 feet (0.30 to 6 meters). Care should be exercised when selecting an electrode to ensure that the accompanying

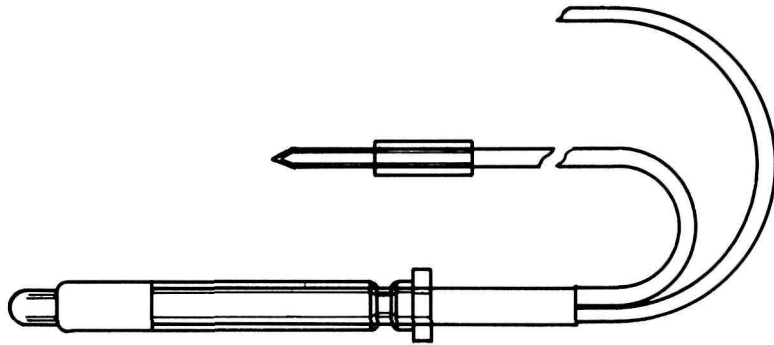

Fig. 13. Typical U.S. Standard and PIN connector. (Adapted from Beckman, 1982, p. 55, with permission.)

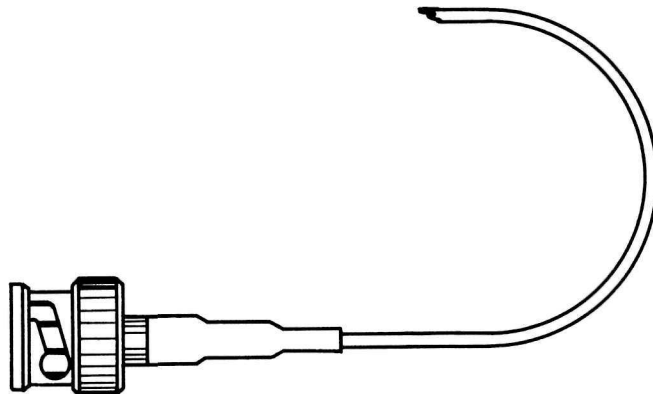

Fig. 14. Typical BNC connector. (Adapted from Beckman, 1982, p. 55, with permission.)

cable will connect properly to the meter, as most meters will accept only one type of connector.

11. Buffers and Buffering Effects

A buffer is a solution with a specific pH value that resists changes in pH as a dilution or concentration of the buffer solution

occurs. Buffer solutions can be prepared artificially, but, as mentioned earlier, natural buffering systems also exist. For example, in natural waters in limestone areas, carbonates typically exert a buffering effect. In this situation moderate additions of acids or bases (such as acid rain) may not greatly change stream pH; however, massive inputs (such as drainage from acid mines) can overwhelm the buffering capacity of a stream and change its pH.

Commercial buffer solutions used for calibrating pH meters are available either as pre-mixed liquid or as compact powders or pills to which water must be added. Buffers of pH 4 and pH 7 are normally used for meter calibration for field work in parks.

Frequent checking of the pH meter with buffers is important in order to maintain accuracy of the readings. Some field workers check against a buffer or two before every reading. More typically, a buffer check is conducted several times a day. A word of caution regarding readings on buffers: buffers are "easily" read by pH meters since they are highly ionized. Therefore, a quick response of a pH meter to the correct reading of a commercial buffer solution does not necessarily mean that the meter is giving correct readings in natural water. An electrode that responds quickly (in less than one minute) to a buffer may be too old or too weak to read pH in natural, and especially in low-ionized, water in a reasonable amount of time (less than about eight minutes). In such cases the manufacturer's recommendations for restoration should be followed, and if the electrode does not respond, it should be replaced.

12. Drift and Low Ionic Questions

An initial pH value on a meter will gradually change or drift toward some final value (Figure 15). Drift is often a problem when taking low ionic pH readings, as when reading pH in very poorly buffered waters in pristine areas of parks or when water is very cold. A pH reading in such situations will not be valid unless the probe remains in the sample for at least five, and often ten, minutes in order to allow the pH readout to stabilize.

Various electrodes designed for quick response or more rapid stabilizing are now on the market. One of these is the Ross electrode, priced at about \$175 (Figure 16). Corning claims a 99.9% accurate

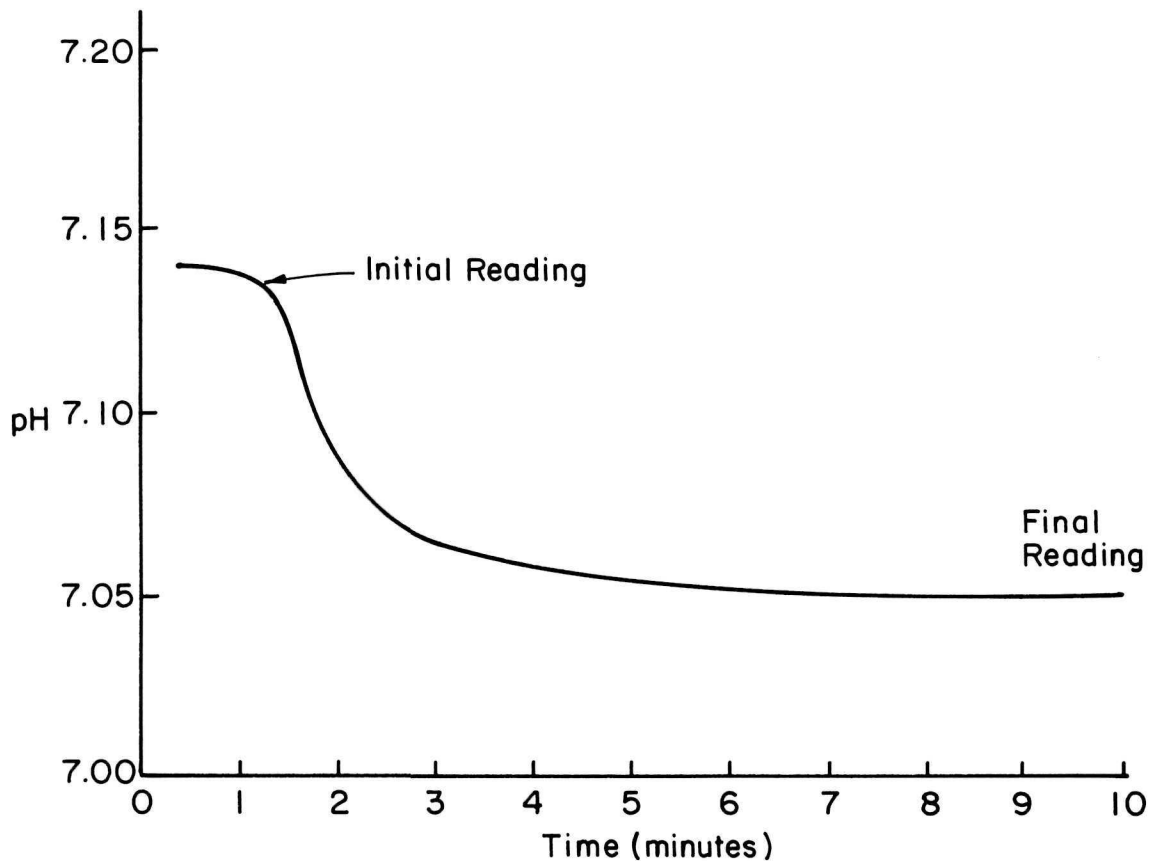

Fig. 15. Drift in the potential of an ion electrode in a solution (constant temperature and composition).

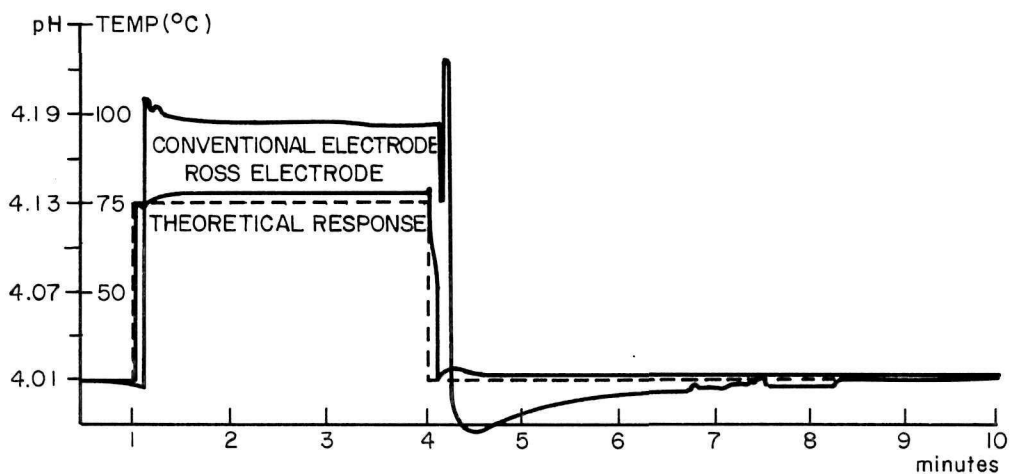

Fig. 16. Readings over time of a "quick-response" electrode and a conventional electrode. (Taken from Orion flyer, 1982b. Reprinted with permission.)

reading in 5.0 seconds, even in low ionic waters, for its X-EL electrode. These quick-response electrodes will cost two to three times that of a standard electrode supplied with most meters but may be preferred due to the several-minute savings in time. In pristine waters where little natural buffering is present, a low ionic electrode (costing about \$75) should be used to obtain valid readings.

Amplifier drift also can cause errors in long-term (several hour) measurements. A good meter should not drift more than 2 mV in ten hours (Westcott, 1978). Many manufacturers provide instructions for drift-testing their meters.

13. Slope and Temperature

The electrode potential in millivolts (the meter readout) has a constant relationship to the concentration of H^+ ions in any given solution. This constant relationship is the slope, that is, the slope

of a line in a graph which compares changes in millivolts (voltage) with changes in H^+ ion concentration (pH) (Figure 17).

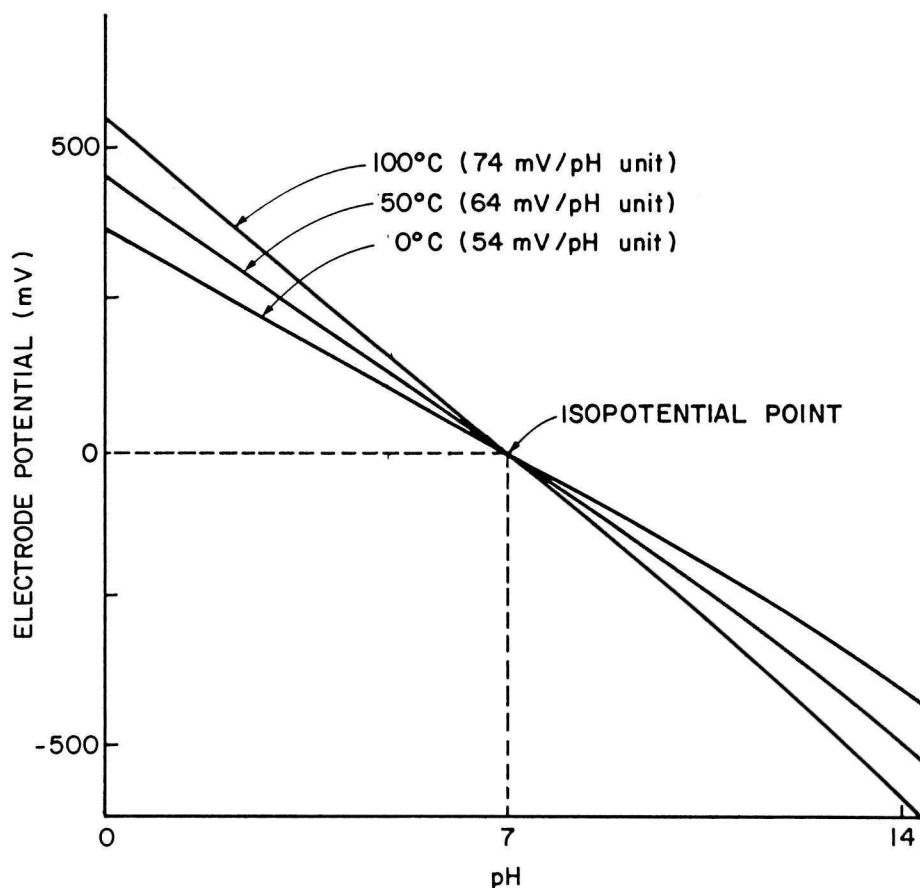

Fig. 17. Slope: the relationship of pH and electrode potential in millivolts at different temperatures. (Taken from Orion, 1982a, p. A-5. Reprinted with permission.)

In theory, a meter which has been calibrated to a pH 4 buffer solution should produce a reading of 7 when tested against a pH 7 buffer solution. In practice, however, a meter will not always make precise readings from one buffer to another since its actual slope may not exactly follow the theoretical line. For this reason, good (but more expensive) meters will have a slope adjustment knob. The slope control adjusts the meter so it will correct for this deviation from the

theoretical slope. Without a slope control, a meter can only be calibrated with one buffer. Therefore, it is best to buy a meter with the slope correction feature.

Since slope is temperature-dependent, some form of temperature compensation control (sometimes automatic) also will be built into a meter with slope control. The effect of temperature on slope also can be seen in Figure 17. At 25°C, for example, a pH unit represents 59.16 mV, whereas at 100°C it represents 74.04 mV. The neutral pH 7 is the starting or isopotential point (Westcott, 1978).

14. Readout Styles

Meters have a variety of readout styles, including digital, analog and expanded scale. The most popular style for field use is the digital readout. For bench models, an analog readout is sometimes preferred, especially if the meter is also to be used for titrations; the rate of change is easier to see on the analog than on the digital readout. Expanded scales are useful for working in small ranges, as when readings are falling mostly within one pH unit.

15. Further Notes on pH Measurements

The purpose of this paper is not to give step-by-step procedures for pH measurement. All new meters and electrodes from reputable companies will come with instructions. Nonetheless, a few salient points are worth emphasizing.

- 1) Allow enough time (up to about eight minutes for many electrodes) when taking a pH reading. A common error in measuring pH is to take the reading too quickly, before it has stabilized. Cold water measurements in particular require extra time.

- 2) In many parks low ionic strength (especially pure) waters make pH measurement more difficult. In addition to the low ionic and specially filled electrodes discussed earlier, a special procedure can be used for low ionic measurements. In this process the electrodes are rinsed well with deionized water, and a drop of saturated potassium chloride (KCl), a neutral salt, is added to each 50 ml of sample. Some electrodes automatically perform this procedure by trickling saturated KCl into the sample. Another option is to use a pair of electrodes rather than a combination electrode, since a more sensitive reference electrode can be selected for use in very low ionic waters.
- 3) Buffer solutions are inexpensive, so use them generously. Calibrate with various solutions at the same temperature and check to be sure that a meter accurately repeats its reading in going back to a solution a second time.
- 4) Do not try to save money by buying inexpensive pH meters or mediocre electrodes. Simple meters are adequate for measuring concentrated solutions in some industrial and treatment plant settings, and they can be useful as standby meters or for approximate measurements in field reconnaissance work. For primary use in park work, however, a quality meter from a major instrument manufacturer is the best investment.
- 5) Have a second pH meter on hand and make a few comparison readings for every batch of field samples. These comparison readings can illuminate problems such as the sudden malfunctioning of an electrode. Keep a spare electrode soaking and ready for replacement as needed.

- 6) Avoid subjecting pH meters to vibrations, as such movement can break down the electrodes. Use a foam-padded carrier in the truck or backpack.
- 7) Over 90 percent of the time, instrument problems involve the electrode(s) and not the meter (Corning, 1983). Common electrode problems include clogging of the internal junction (this is the most frequent problem), gel layer deterioration, coating of the electrode, and the need to exchange KCl solution in an electrode. In most cases, these problems occur as a result of aging or improper storage. A more extensive list of common electrode problems can be acquired from the Corning Co. (1983). Beckman's Bulletin 7707-A (1982) also contains a useful guide for trouble-shooting. The major companies provide recommendations for rehabilitating, storing, testing, and calibrating their electrodes. Follow the manufacturer's recommended procedures for proper electrode storage, including use of a storage solution suited to the particular electrode. Some companies provide storage solutions for their electrodes.
- 8) Since rinsing electrodes with deionized water and blotting them with "Kimwipes" is advised between samples, these two items or some type of water purification system should be included in the field equipment. If the refillable type of electrode is being used, extra filling solution should also be kept on hand.
- 9) The gel-filled electrodes age more quickly, but eventually all pH electrodes will need replacement. A slowly-responding electrode is signalling its need to be retired.

- 10) Electrodes are constantly being improved. Sometimes it will be advantageous to substitute one of these improved electrodes for the standard electrode that comes with a meter. Companies selling a variety of specialized pH or ion-selective electrodes include: Beckman, Brinkmann, Chemtrix, Corning, Graphic Controls, Ingold, Markson, Orion, Phoenix Electrodes, Radiometer America and Russell. It is worth requesting their brochures. Some of the companies sell pH maintenance kits, which include all solutions and instructions for electrode rehabilitation. When purchasing extra electrodes, remember to ensure that the accompanying cable connector will fit your meter. A mismatch of the two is a mistake that can easily be made!
- 11) Many larger companies have research departments or service units that will answer questions pertaining to their equipment and its use. In a quick telephone call one can find out, for example, how to check the electronics of a meter for drift and other problems.
- 12) Finally, it should be clear by now that "quick and easy" pH readings are not so quick and easy if valid, reliable readings are sought. On the other hand, it is careful attention to detail which results in data that are both accurate and useful.

APPENDIX I

CONVERSION EQUATIONS FOR USE WITH pH VALUES

The conversion formulas for $\mu\text{eq/L}$ of H^+ and pH are:

$$\text{(Equation A-1)} \quad \mu\text{eq/L of H}^+ = \frac{10^6}{10^{\text{pH of the sample}}}$$

$$\text{(Equation A-2)} \quad \text{pH of a sample} = \log \left[\frac{10^6}{\mu\text{eq/L of H}^+} \right]$$

where $\mu\text{eq/L}$ = microequivalents per liter.

To give examples of the calculations:

What is a sample of pH 4.8 in terms of $\mu\text{eq/L H}^+$?

$$\mu\text{eq/L H}^+ = \frac{10^6}{10^{\text{pH}}} = \frac{10^6}{10^{4.8}} = 15.85 \mu\text{eq/L}$$

What is the pH of a sample with 93.0 $\mu\text{eq/L H}^+$?

$$\text{pH} = \log \left[\frac{10^6}{\mu\text{eq/L of H}^+} \right] = \text{pH } 4.03$$

Other useful related chemical terms, units and routine conversions are summarized below.

Table A. A review of the basic terms, units, abbreviations and equivalents useful for working with pH, H^+ and acidity data and for comparing to other water chemistry data.

-
- (1) Milliequivalent weight = a substance's atomic weight in milligrams (mg) divided by its valence; e.g., calcium equivalent weight = $40.08/2$, since Ca^{++} = valence 2 and Ca's atomic weight = 40.08.
 - (2) A 1.00 Normal solution (1.00 N) of a substance has one equivalent weight of the substance per liter.
 - (3) Milliequivalent per liter (meq/L) of a substance = 1/1000 of an equivalent/liter; microequivalent per liter ($\mu\text{eq/L}$) = 1/1000 of a meq/L.
 - (4) Meq/L of a substance = (mg/L of it) \div (meq weight of the substance) where mg/L is milligrams per liter (a mg = 1/1000 of a gram).
-

APPENDIX II

TEMPERATURE CONVERSION TABLE AND COMPANY LISTS

Table B. Temperature correction factors to compute specific conductance values at 25.0°C. (Taken from Van Loon, J. C., ed., Chemical Analysis of Inorganic Constituents of Water, p. 53. Copyright 1982, CRC Press, Inc., Boca Raton, Florida. Reprinted with permission.)

°C	Multiplication factor									
	0	0.1	0.2	0.3	0.4	0.5	0.6	0.7	0.8	0.9
4	1.521	1.518	1.515	1.512	1.509	1.506	1.503	1.500	1.497	1.494
5	1.491	1.488	1.485	1.482	1.479	1.476	1.474	1.471	1.468	1.465
6	1.462	1.459	1.456	1.453	1.450	1.447	1.444	1.442	1.439	1.436
7	1.433	1.430	1.427	1.424	1.421	1.419	1.416	1.413	1.410	1.407
8	1.405	1.402	1.399	1.396	1.393	1.391	1.388	1.385	1.382	1.380
9	1.377	1.374	1.371	1.369	1.366	1.363	1.360	1.358	1.355	1.352
10	1.350	1.347	1.344	1.341	1.339	1.336	1.333	1.331	1.328	1.325
11	1.323	1.320	1.318	1.315	1.312	1.210	1.307	1.304	1.302	1.299
12	1.297	1.294	1.292	1.289	1.286	1.284	1.281	1.279	1.276	1.274
13	1.271	1.268	1.266	1.263	1.261	1.258	1.256	1.253	1.251	1.248
14	1.246	1.243	1.241	1.238	1.236	1.234	1.231	1.229	1.226	1.224
15	1.221	1.219	1.216	1.214	1.212	1.209	1.207	1.204	1.202	1.199
16	1.197	1.195	1.192	1.190	1.188	1.185	1.183	1.180	1.178	1.176
17	1.173	1.171	1.169	1.166	1.164	1.162	1.159	1.157	1.155	1.153
18	1.150	1.148	1.146	1.143	1.141	1.139	1.136	1.134	1.132	1.130
19	1.129	1.125	1.123	1.121	1.118	1.116	1.114	1.112	1.110	1.107
20	1.106	1.103	1.101	1.099	1.096	1.094	1.092	1.090	1.088	1.085
21	1.084	1.081	1.079	1.077	1.075	1.073	1.070	1.068	1.066	1.064
22	1.062	1.060	1.058	1.056	1.053	1.051	1.049	1.047	1.045	1.043
23	1.041	1.039	1.037	1.035	1.033	1.031	1.028	1.026	1.024	1.022
24	1.020	1.018	1.016	1.014	1.012	1.010	1.008	1.006	1.004	1.002
25	1.000	0.998	0.996	0.994	0.992	0.990	0.988	0.986	0.984	0.982
26	0.980	0.978	0.976	0.974	0.972	0.971	0.969	0.967	0.965	0.963
27	0.961	0.959	0.957	0.955	0.953	0.951	0.949	0.947	0.946	0.944
28	0.942	0.940	0.938	0.936	0.934	0.932	0.931	0.929	0.927	0.925
29	0.923	0.921	0.919	0.918	0.916	0.914	0.912	0.910	0.908	0.907
30	0.905	0.903	0.901	0.899	0.898	0.896	0.894	0.892	0.890	0.889

Table C. Principal companies selling pH and conductivity meters or meters with multiple measuring capability. We have not listed distributors.

Name of Companies	pH Meters ¹				Conductivity Meters ¹			Multiple-purpose Probes
	Stan Port	Mini Port	Reco Port	Bench Types	Stan Port	Mini Port	Bench Types	
ALPHA-M	0		0	0				
ANALYTICAL MEASUREMENTS	0	0	0	0				
APPLIKON ²				0				
BARNSTEAD							0	
BECKMAN IND.					0		0	
BECKMAN INST. ²	0			0				
BRINKMANN	0			0	0		0	
CAMBRIDGE	0				0			PH, CO, TP [PORT]
CHEMTRIX	0	0		0	0	0	0	
COLE-PARMER	0	0		0	0	0	0	
CORNING	0	0		0				
DELTA		0						
ECO	0	0		0	0	0	0	PH, CO, TP, DO, RE [PORT]
ECOLOGIC INST.	0						0	
ENDECO	0		0		0			DO, TP [RECO,PORT]
EXTECH	0	0		0	0	0	0	PH, CO, DO, TP [BEN,PORT]
FISHER SCIENTIFIC	0	0		0	0			
GAM RAD ²		0		0				
GREAT LAKES ³	0	0	0	0	0	0		
HACH	0			0	0		0	
HELLIGE	0	0			0			
HORIBA	0	0		0	0			PH, CO, TP, DO, TU [PORT]
HYDROLAB	0		0		0			PH, CO, DO, TP
INGOLD ²								PH, RE; PH, TP [BEN, PORT]
KAHL SCIENTIFIC	0			0			0	
LAMOTTE	0			0	0		0	
LEEDS AND NOR.	0	0		0			0	

Table C. Continued.

Name of Companies	pH Meters ¹				Conductivity Meters ¹			Multiple-purpose Probes
	Stan Port	Mini Port	Reco Port	Bench Types	Stan Port	Mini Port	Bench Types	
MARKSON	0	0		0	0		0	
MARTEK	0			0	0		0	PH, CO, DO, TP [PORT]
MONTEDORO	0		0		0			PH, CO, DO, TP [PORT]
MYRON L	0				0			
NESTER	0	0		0				
ORION ²	0	0		0			0	
PHOENIX ²		0						
POPE			0					
PRESTO TEK	0	0		0	0	0	0	PH, CO, DO, TP [BEN,PORT]
RADIOMETER ²	0			0	0		0	
SARGENT-WELCH	0	0		0	0		0	
THORNTON							0	
WESCAN							0	
YOKOGAWA		0				0		
YSI					0		0	

¹ Abbreviations: Stan Port = standard or typical size portable; Mini Port = miniature or pocket-size portable; Reco Port = recording portable; PH = pH; CO = conductance; DO = dissolved oxygen; RE = redox potential; TP = temperature; TU = turbidity; BEN = bench or laboratory type; PORT = portable; RECO = recording.

² Supplier of specific ion electrodes.

³ Also sold under O.I. Corp. label.

Table D. Addresses and telephone numbers of companies selling pH, turbidity, conductivity, oxygen content, and combination meters and accessories.

Alpha-M Corporation
3009 Wildflower
Dallas, TX 75229
(214) 620-0021

Brinkmann Instruments Co.
Division of Sybron Corporation
Cantiague Road
Westbury, NY 11590
(516) 334-7500

Analytical Measurements, Inc.
31 Willow Street
Chatham, NJ 07928
(201) 273-7500

Cambridge Scientific Industries
P.O. Box 265
Cambridge, MD 21613
(800) 638-9566
(301) 228-5111

Applikon Dependable Instruments
5904 Bee Caves Road
Austin, TX 78746
(512) 328-0210

Cargille Laboratories
55 Commerce Drive
Cedar Grove, NJ 07009
(201) 239-6633

Barnstead Co., The
Division of Sybron Corp.
225 Rivermore St.
Boston, MA 02132
(617) 327-1600
Telex 940-616

Chemtrix, Inc.
163 S.W. Freeman
Hillsboro, OR 97213
(503) 648-0762

Bausch and Lomb
Analytical Systems Div.
820 Linden Avenue
Rochester, NY 14625
(716) 385-1000

Cole-Parmer
7425 N. Oak Park Avenue
Chicago, IL 60648
(312) 647-7600
(800) 323-4340

Beckman Industrial Corp.
Division of Rosemont Engineering
2400 Harbor Boulevard
Fullerton, CA 92634
(714) 773-8106

Corning Medical and Scientific
Corning Glass Works
Medfield Industrial Park
Medfield, MA 02052
(617) 359-7711
(800) 255-3232

Beckman Instruments, Inc.
ElectroChemistry Applications
Support
P.O. Box C-19600
Irvine, CA 92713
(714) 833-0751

Delta Analytical
250 Marcus Boulevard
Hauppauge, NY 11787
(516) 273-6600

Table D. Continued.

ECO Instruments
One Bridge Street
Newton, MA 02158
(617) 964-8360

Hach Company
P.O. Box 389
57th St. & Lindbergh Parkway
Loveland, CO 80537
(303) 669-3050
TWX 910-930-9038

Ecologic Instrument Division
132 Wilbur Place
Bohemia, NY 11716
(516) 567-9000

Hellige, Inc.
877 Stewart Avenue
Garden City, NY 11530
(516) 222-0300

ENDECO, Inc.
13 Marconi Lane
Marion, MA 02738
(617) 748-0366

Horiba Instruments, Inc.
1021 Duryea Avenue
Irvine, CA 92714
(714) 540-7874

EXTECH International Corporation
114 State Street
Boston, MA 02109
(617) 227-7090

Hydrolab Corporation
P.O. Box 9406
Austin, TX 78766
(512) 255-8841

Fisher Scientific
585 Alpha Drive
Pittsburgh, PA 15238
(412) 784-2600

Ingold Electrodes, Inc.
One Burt Road
Andover, MA 01810
(617) 470-1102

Gam Rad, Inc.
46191 Grand River
Novi, MI 48050
(313) 348-1005 or (800) 521-3272

KAHL Scientific
P.O. Box 1166
El Cajon, CA 92022-1166
(619) 444-2158

Graphic Controls Corp.
Industrial Products Division
P.O. Box 1271
Buffalo, NY 14240
(716) 853-7500

LaMotte Chemical Products Co.
P.O. Box 329
Chestertown, MD 21620
(301) 778-3100

Great Lakes Instruments, Inc.
8855 North 55th Street
P.O. Box 23056
Milwaukee, WI 53223
(414) 355-3601
Telex 26-9685

Leeds & Northrup Instruments
Sumneytown Pike, North
Wales, PA 19454
(215) 643-2000

Table D. Continued.

Markson Science 7815 S. 46th Street Phoenix, AZ 85040 (800) 528-5114 (602) 894-5317	Phoenix Electrode Company 6103 Glenmont Houston, TX 77801 (713) 772-6666 (800) 231-6069 Telex 794-509
Martek Instruments, Inc. 17302 Daimler Street P.O. Box 16487 Irvine, CA 92713 (714) 540-4435	Pope Scientific, Inc. P.O. Box 495 Menomonee Falls, WI 53051 (414) 251-9300
Montedoro-Whitney 2741 E. McMillan Road San Luis Obispo, CA 93401 (805) 543-1233, (805) 543-7337, (800) 235-4104	Presto Tek Corporation 7321 N. Figueroa St. Los Angeles, CA 90041 (213) 257-7585
Myron L Company 6231 C Yarrow Drive Carlsbad, CA 92008-4893 (619) 438-2021 Telex 695009	Radiometer America, Inc. 811 Sharon Drive Westlake, OH 44145 (216) 871-8900 Telex 985-276
L. G. Nester Company Buck & Sassafras Streets P.O. Box 666 Millville, NJ 08332 (609) 825-0254	Russell pH Ltd. Station Road Auchtermuchty Fife, KY 14 7DP Scotland Telex 76598
New Brunswick Scientific Co., Inc. P.O. Box 986/44 Talmadge Road Edison, NJ 08818 (201) 287-1200 (800) 631-5417	Sargent-Welch Scientific Co. 7300 North Linder Avenue P.O. Box 1026 Skokie, IL 60077 (312) 667-0600 Telex 72-4442
O. I. Corporation P.O. Box 2980 College Station, TX 77841-2980 (409) 693-1711	Soiltest, Inc. P.O. Box 931 Evanston, IL 60204 (800) 323-1242
Orion Research 840 Memorial Drive Cambridge, MA 02139 (800) 225-1480	Terriss Consolidated Industries 807 Summerfield Avenue P.O. Box 110 Asbury Park, NJ 07712 (201) 988-0909

Table D. Continued.

Thornton Associates, Inc.
87 Beaver Street
Waltham, MA 02154
(617) 899-1400

Turner Designs
2247 Old Middlefield Way
Mountain View, CA 94043-2489
(415) 965-9800

Wescan Instruments, Inc.
3018 Scott Boulevard
Santa Clara, CA 95050
(408) 272-3519

Yokogawa Corp. of America
2 Dart Road
Shenandoah, GA 30265
(404) 253-7000

YSI Scientific
Scientific Division
Yellow Springs Instrument
Co., Inc.
Yellow Springs, OH 45387
(513) 767-7241

REFERENCES

- American Public Health Association. 1981. Standard methods for the examination of water and wastewater. Washington, D.C.
- Beckman Instruments, Inc. 1982. The Beckman handbook of applied electrochemistry. Bulletin 7707-A. Irvine, CA.
- Chemtrix, Inc. 1984 catalog. Hillsboro, OR.
- Corning Medical and Scientific, Corning Glass Works. 1983. pH/ISE marketing newsletter, No. 0008. Medford, MA.
- Hem, J. D. 1970. Study and interpretation of the chemical characteristics of natural water. 2nd ed. U.S. Geological Survey Water-Supply Paper 1473. U.S.G.S., Alexandria, VA.
- Hornbeck, J. W., G. E. Likens, and J. S. Eaton. 1976. Seasonal patterns in acidity of precipitation and their implications for forest stream ecosystems, pp. 597-609. In L. S. Dochinger and T. A. Seliga (eds.), Proceedings of the First International Symposium on Acid Precipitation and the Forest Ecosystem. USDA Forest Service General Technical Report NE-23.
- Kunkle, S. H., and G. H. Comer. 1972. Suspended, bed and dissolved sediment loads in the Sleepers River, Vermont. USDA Report ARS-41-188. Agricultural Research Service, State College, PA.
- LaMotte Chemical Products Co. n.d. pH, buffers and acid-base titrations. Chestertown, MD.
- Miller, Carol E. 1982. pH profile. Markson Science, Inc., Phoenix, AZ.
- Minear, R. A., and L. H. Keith. 1982. Water analysis, Vol. 1: Inorganic species, Part 1. Academic Press, New York.
- Orion Research Corp. 1982a. Handbook of electrode technology. Cambridge, MA.
- Orion Research Corp. 1982b. Ross pH electrodes. (Flyer.) Cambridge, MA.
- Rainwater, F. H., and L. L. Thatcher. 1960. Methods for collection and analysis of water samples. U.S. Geological Survey Water-Supply Paper 1454. U.S.G.S., Alexandria, VA.
- U.S. Environmental Protection Agency. 1976. Quality criteria for water. Washington, D.C.
- Van Loon, J. C. (ed.) 1982. Chemical analysis of inorganic constituents of water. CRC Press, Inc., Boca Raton, FL.
- Westcott, C. C. 1978. pH measurements. Academic Press, Inc., Orlando, FL.

ANNOTATED BIBLIOGRAPHY

- American Public Health Association. 1981. Standard methods for the examination of water and wastewater. 1135 p. (APHA, 1015 Fifteenth St. NW, Washington, DC, 20005) Sometimes considered the "Bible" of water analysis, this volume provides the procedures most commonly used for laboratory analysis of water for most constituents.
- American Society for Testing and Materials. 1971. Annual book of ASTM water standards, Part 31: Water. ASTM. 100 p. (ASTM, 1916 Race Street, Philadelphia, PA 19103) A book similar to Standard Methods, periodically updated, for reference on laboratory procedures for analysis.
- Beckman Instruments, Inc. 1982. The Beckman handbook of applied electrochemistry, Bulletin 7707-A. 128 p. (Beckman Instruments, Inc., P.O. Box C19600, Irvine, CA 92713) The material is naturally slanted toward selling Beckman products and for this reason is incomplete in a few areas. Well-prepared and comprehensive small book on pH measurements containing much useful information. Free on request.
- Chemtrix, Inc. (163 SW Freeman, Hillsboro, OR 97123). Catalog describing products. Includes useful, general information on pH and specific ions.
- Corning Medical and Scientific, Corning Glass Works (Medfield Industrial Park, Medfield, MA 02052). "pH/ISE Marketing Newsletters," nos. 0008 and 0016 (1983). These two issues list trouble-shooting tips on electrodes and pH meters.
- Environment Canada. 1983. Sampling for water quality. 58 p. (Copies available free from Editorial and Publications Division, Inland Waters Directorate, Environment Canada, Ottawa, Canada KAI 0E7.) This is a nicely prepared, useful summary of field procedures for water sampling which contains some good suggestions.
- Hem, J. D. 1970. Study and interpretation of the chemical characteristics of natural water. 2nd ed. Geological Survey Water-Supply Paper 1473. 363 p. (For sale by the Distribution Branch, U.S. Geological Survey, 604 South Pickett St., Alexandria, VA 22304.) This is one of the best and most used comprehensive reviews on the sources and levels of chemicals in natural waters, emphasizing the inorganic constituents as typically found in streams.
- Kunkle, S. H., and G. H. Comer. 1972. Suspended, bed and dissolved sediment loads in the Sleepers River, Vermont. USDA Report ARS-41-188. Agricultural Research Service, Land and Water Research Building, State College, PA 16802. 31 p.

- LaMotte Chemical Products Co., Educational Products Div. n.d. (P.O. Box 329, Chestertown, MD 21620). Booklet entitled "pH, Buffers and Acid-Base Titrations," 16 p. Provides general descriptions of pH and acidity and includes examples.
- Miller, Carol E. 1982. pH profile. 14 p. (Available from Markson Science, Inc., 7815 S. 46th St., Phoenix, AZ 85040.) This booklet offers a good and basic discussion of pH and its measurement and includes troubleshooting ideas.
- McKee, J.E., and H.W. Wolf. 1978 reprint of 1963 edition. Water quality criteria. Publication No. 3-H. California State Water Resources Control Board. 548 p. (State Water Resources Control Board, P.O. Box 100, Sacramento, CA 95801) A classic "oldie but goodie" reference on pollutants found in water with bioassay results, tolerance limits and other details on water pollution criteria and standards.
- Minear, R.A., and L.H. Keith. 1982. Water analysis, Vol. 1: Inorganic species, Part 1. Academic Press. 287 p. (Academic Press, Inc., 111 Fifth Ave., New York, NY 10003) A fairly theoretical book for readers seeking an in-depth theoretical discussion of turbidity, specific conductance, redox potential, alkalinity and acidity.
- Orion Research Corp. 1982. Handbook of electrode technology. Orion Research Corporation. About 150 p.; irregularly numbered. (Orion Research Inc., 840 Memorial Dr., Cambridge, MA 02139) A dictionary-type book describing terms and equipment relating to specific ion determinations.
- Orion Research Corp. (840 Memorial Dr., Cambridge, MA 92139). Flyer describing the "Ross" electrode; other pamphlets and lists describing the different types of specific ion electrodes the company supplies. (Orion is probably the biggest dealer in this specialty.)
- Rainwater, F.H., and L.L. Thatcher. 1960. Methods for collection and analysis of water samples. U.S. Geological Survey Water-Supply Paper 1454. 310 p. An older book, but still very useful, if available. A similar, newer book by EPA is its Handbook for Sampling and Sample Preservation of Water and Wastewater. EPA-600/4-82-029. September, 1982. 402 p. A good basic reference.
- UNESCO. 1978. Water quality surveys. 350 p. Book by IHD-WHO Working Group on Quality of Water (For sale by UNIPUB, (212)-764-2791). A comprehensive volume describing in detail how to plan and undertake a water quality study. The various parameters and techniques for measuring them are discussed along with laboratory design, data handling and analysis, and the particularities of different water systems.

- U.S. Environmental Protection Agency. 1976. Quality criteria for water. U.S. EPA Office of Water and Hazardous Material. 256 p. (U.S. Government Printing Office, Washington, DC 20402) This booklet lists many of the common water polluting materials of concern and gives EPA criteria (acceptable water pollution levels) for each.
- Van Loon, J.C. (ed). 1982. Chemical analysis of inorganic constituents of water. CRC Press, Inc. 248 p. (CRC Press, Inc., 2000 Corporate Blvd., N.W., Boca Raton, FL 33431) A general procedure book, similar to Standard Methods.
- Westcott, C. C. 1978. pH measurements. Academic Press. 172 p. (Academic Press, Inc., Orlando, FL 32887). This book provides a readable, fairly in-depth presentation of the principles of pH measurement and discusses electrodes, buffer solutions, and measurement techniques.



As the Nation's principal conservation agency, the Department of the Interior has responsibility for most of our nationally owned public lands and natural resources. This includes fostering the wisest use of our land and water resources, protecting our fish and wildlife, preserving the environment and cultural value of our national parks and historical places, and providing for the enjoyment of life through outdoor recreation. The Department assesses our energy and mineral resources and works to assure that their development is in the best interests of all our people. The Department also has a major responsibility for American Indian reservation communities and for people who live in island territories under U.S. administration.

U.S. DEPARTMENT OF THE INTERIOR

NATIONAL PARK SERVICE

WATER RESOURCES FIELD SUPPORT LABORATORY

107C NATURAL RESOURCES

COLORADO STATE UNIVERSITY

FORT COLLINS, COLORADO 80523

OFFICIAL BUSINESS
PENALTY FOR PRIVATE USE \$300POSTAGE AND FEES PAID
U. S. DEPARTMENT OF THE INTERIOR
INT-417