

# THE BENCHMARK OF INDICATING MEASURING INSTRUMENTS. **MARAMETER.**



The latest information on MARAMETER products can be found on our website:

**[www.mahr.com](http://www.mahr.com), WebCode 211**

► | MaraMeter is the ideal measuring instrument for highly precise measurements of internal and external diameters on either an individual part or on serial components. Our indicating measuring instruments obtain the best results due to their constant measuring force, their exact transmission lever system as well as their high parallelism on the measuring faces. For special measuring tasks such as threads, teeth, grooves or precision mechanical parts MaraMeter offers the right solution. | ◀

## ► | MaraMeter. Indicating Measuring Instruments

### Indicating Measuring Instruments for Outside Dimensions, Indicating Snap Gages

**MaraMeter 1000 P / 300 P / 840 F / 840 FC / 840 FH /  
840 FG / 840 FM / 840 FS** **9- 2**

With fixed or interchangeable measuring faces

**MaraMeter 840 E** **9-18**

For extremely high precision

**MaraMeter 852 / 852 TS / 853** **9-19**

For threads, pitches, roots, serrations

### Portable Thickness Gages

**MaraMeter 22 P / 26 P / 838 A / 838 B / 838 AB / 57 B** **9-26**

With digital and/or analog display

### Caliper Gages

**MaraMeter 49 P / 838 TA / 838 EA / 838 TI / 838 EI** **9-33**

With digital and/or analog display

### Depth Gages

**MaraMeter 837 / 65 P-40 / 75 P-30 / 75 P-30 / 75 B-1** **9-41**

### Indicating Measuring Instruments for Inside Dimensions,

**Dimentron® Plug Inside Diameter Gages** **9-46**

Designed for high production I.D. gaging

**MaraMeter 844 D** **9-51**

Indicating Plug Gage for rapid testing of serial components

**MaraMeter 844 K** **9-58**

Self-centering Dial Bore Gage

**MaraMeter 1280 P Adjustable Bore Gages** **9-63**

Superior accuracy for production and inspection

**MaraMeter 844 N / NH / NR / NB** **9-66**

Self-centering Dial Bore Gage

**MaraMeter 844 Z** **9-72**

Dial Bore Gage for internal serrations

# MaraMeter. Indicating Snap Gages

## OVERVIEW

▶ | The Indicating Snap Gages **MaraMeter** 840 F / 300 P-1 are ideal for highly accurate and reliable results on cylindrical work pieces with a narrow tolerance. | ◀

### MaraMeter 840 F

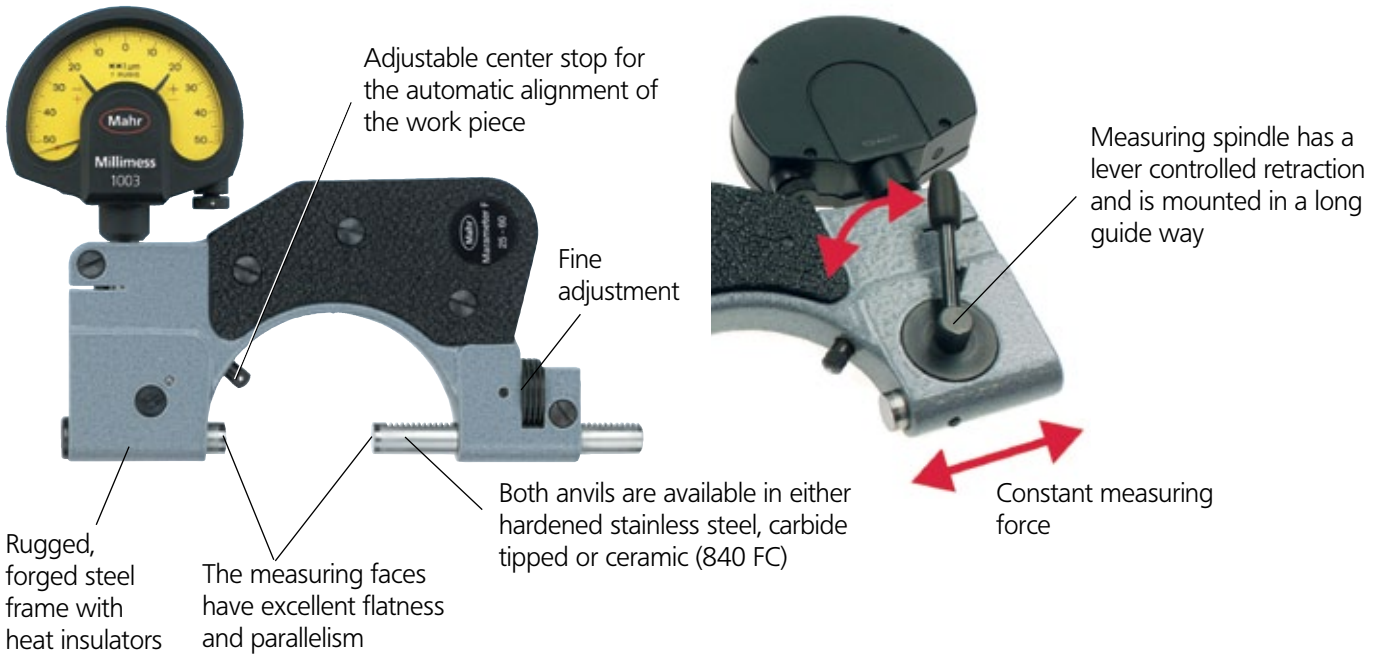

### MaraMeter 300 P-1

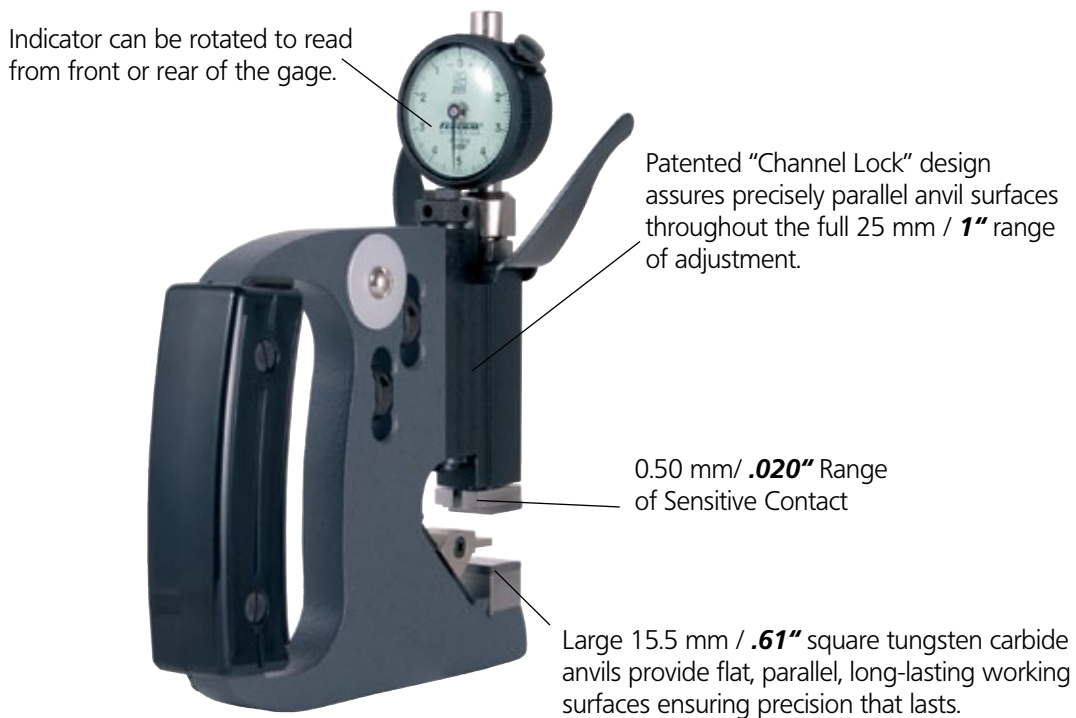

## Advantages of the Snap Gage 840 F compared to a Micrometer

### • Reduced Measuring Uncertainty

The MaraMeter Indicating Snap Gages have a notably reduced measuring uncertainty in comparison to a Micrometer.

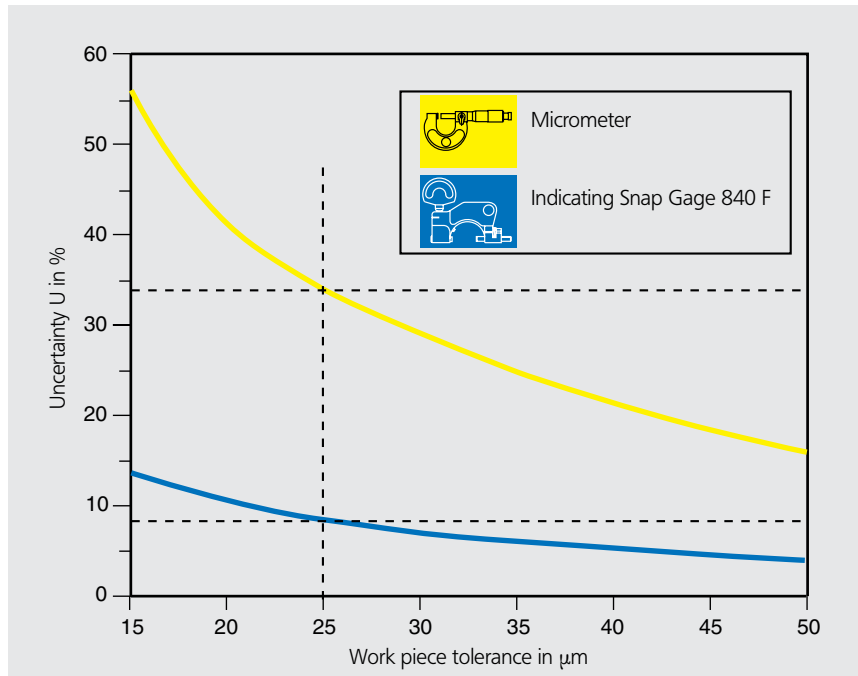

Measuring Uncertainty U is dependent upon the tolerance of the work piece

### • Better utilization of the tolerance zone

Example:  
Work piece tolerance 25 μm

The measured value in the uncertainty range can lie outside of the tolerance range, therefore the utilized tolerance of the micrometer is reduced to only 32% (8 μm).

With a MaraMeter Indicating Snap Gage 840 F, 83% (20.8 μm) of the work piece tolerance can be utilized.

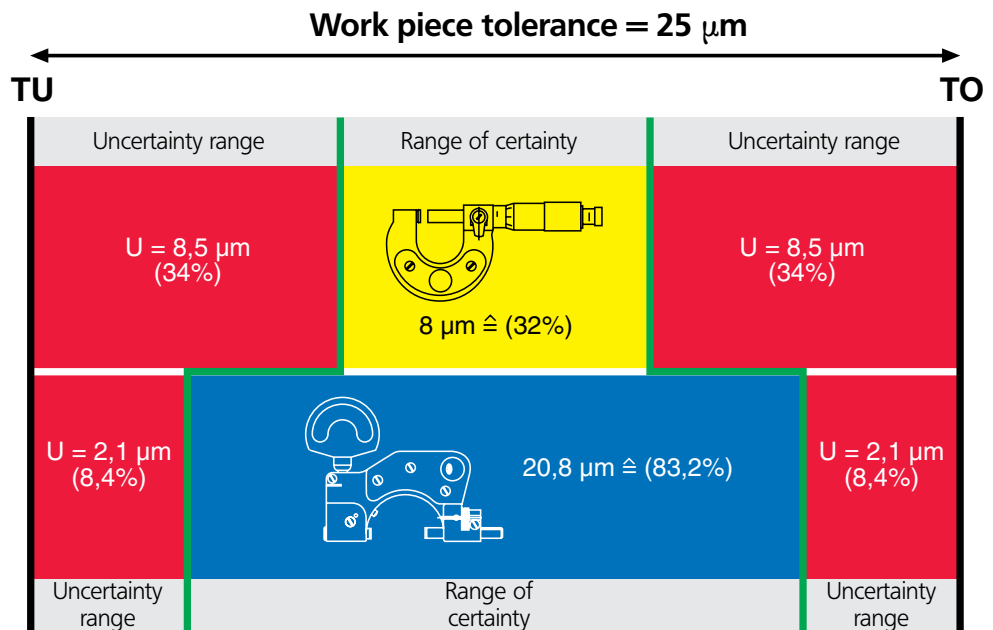

### Advantage:

With the Indicating Snap Gage the tolerance zone can be used to far greater extent, thus reducing the production costs.

## Snap Gages for Outside Diameters 1000P



The economical way to check outside diameters on the shop floor.

### Features

- Flat lower anvil (reference) adjustable over a broad range.
- Radiused upper anvil (sensitive) spring-loaded to counter balance the weight of the gage.
- 0.01 mm grads. on Metric Models. .0005" grads. on Inch Models.
- 0.50 mm / .020" Range of Sensitive Contact.
- Indicator can be rotated to read from front or rear of the gage.
- Anvils are tungsten carbide for long life.

**1000P-3**  
0.01 mm or .0005" Dial Indicator normally furnished

### Technical Data

mm	Capacity	Reference Anvil Diameter mm / inch	Order no. Metric	Order no. Inch
	(inch)			
0 - 25	(0 - 1")	13 / .50"	1000P-1M*	1000P-1*
19 - 50	(.75 - 2")	13 / .50"	1000P-2M*	1000P-2*
44 - 82	(1.75 - 3.25")	13 / .50"	1000P-3M	1000P-3
76 - 114	(3 - 4.5")	16 / .625"	1000P-4M	1000P-4
102 - 152	(4 - 6")	16 / .625"	1000P-5M	1000P-5
152 - 203	(6 - 8")	19 / .75"	1000P-6M	1000P-6
203 - 254	(8 - 10")	19 / .75"	1000P-7M	1000P-7

Series 1000P gages with greater capacity, alternate Indicators, alternate contact configurations, or other modification to suit specific applications are available – contact Mahr Federal.

\* Insulated grip not available.

## Snap Gages for Outside Diameters 300P

Superior precision for  
O.D. checks



**EDI-301P-1**  
BA-26 Bench Stand (not included)

### Features

- Patented "Channel Lock" design assures precisely parallel anvil surfaces throughout the full 25 mm / 1" range of adjustment.
- All Series 300P Snap Gages are fully adjustable with positive position locking at any point within the range.
- 0.50 mm / .020" Range of Sensitive Contact.
- Snap Gages available over a wide range of sizes, styles, and readout configurations.
- Large 15.5 mm / .61" square tungsten carbide anvils provide flat, parallel, long lasting working surfaces ensuring precision that lasts.
- Indicator can be rotated to read from front or rear of the gage.
- Optional lift-lever model (301P) available for retracting the upper anvil.
- All adjustments accomplished using a single hex wrench (furnished).

### Technical Data

Style	Normally Furnished Indicating Instruments Readings	Snap Style	Separately, Order no.
12I/22I	<b>.0001"</b>	Flat Anvil	<b>IDT-102/IDT-106</b>
O1I/P1I	0.002 mm	Flat Anvil	<b>IDS-206/IDS-208</b>
2034201	0.0005 mm / <b>.00002"</b>	Flat Anvil	<b>2034201</b>
B5M/C5M	<b>.0005"</b>	Groove Anvil	<b>IDS-101/IDS-105</b>
O6I/P6I	0.010 mm	Groove Anvil	<b>IDS-207/IDS-209</b>
Max $\mu$ m®III (1)	selectable (3)	All	<b>2033109</b>
Max $\mu$ m®III (2)	selectable (3)	All	<b>2033119</b>
with Air Probe		All	*
for 2500:1			
with Electronic Gage Heads		All	*



**A300P-2**

\* Call Mahr Federal.

(1) With no Data Output

(2) With Data Output (6 pin)

(3) Selectable Readings – 0.001 mm / 0.005 mm / 0.0005 mm / .0001" / .0005" / .00002"

## Snap Gages for Outside Diameters 300P

### Technical Data

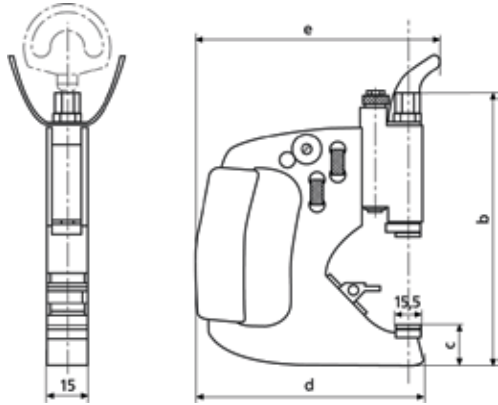

### Dimensions

Meas. range mm / <i>inch</i>	b	c	d	e
0 - 25.4 / <b>0-1"</b>	150 / <b>6"</b>	29 / <b>1.16"</b>	145 / <b>5.8"</b>	158 / <b>6.3"</b>
25.4 - 50.8 / <b>1-2"</b>	175 / <b>7"</b>	29 / <b>1.16"</b>	141 / <b>5.6"</b>	154 / <b>6.16"</b>
50.8 - 76.2 / <b>2-3"</b>	200 / <b>8"</b>	29 / <b>1.16"</b>	155 / <b>6.2"</b>	167 / <b>6.7"</b>
76.2 - 101.6 / <b>3-4"</b>	226 / <b>9"</b>	29 / <b>1.16"</b>	167 / <b>6.7"</b>	180 / <b>7.2"</b>
101.6 - 127 / <b>4-5"</b>	251 / <b>10"</b>	29 / <b>1.16"</b>	180 / <b>7.2"</b>	193 / <b>7.7"</b>
127 - 152.4 / <b>5-6"</b>	278 / <b>11"</b>	30 / <b>1.2"</b>	203 / <b>8"</b>	215 / <b>8.6"</b>
152.4 - 177.8 / <b>6-7"</b>	303 / <b>12"</b>	30 / <b>1.2"</b>	213 / <b>8.5"</b>	226 / <b>9"</b>
177.8 - 203.2 / <b>7-8"</b>	329 / <b>13"</b>	30 / <b>1.2"</b>	231 / <b>9.2"</b>	244 / <b>9.7"</b>
203.2 - 228.6 / <b>8-9"</b>	335 / <b>13.5"</b>	30 / <b>1.2"</b>	248 / <b>9.9"</b>	261 / <b>10.4"</b>

### Ordering Information

Plain Anvils (Anvils included in price – choose from list below)

	No Indicator 3/8" Adaptor	No Indicator 3/8" Adaptor With Lift Lever	No Indicator 8 mm Adaptor	No Indicator 8 mm Adaptor With Lift Lever	With Dial Indicator 3/8" Adaptor .0001" Grads	With Dial Indicator 3/8" Adaptor With Lift Lever	With µMaxµm //	With Maxµm ///
0 - 1"	OMI-300P-1	OMI-301P-1	2003100	2003110	300P-1	301P-1	EDI-300P-1	EMD-300P-1
1 - 2"	OMI-300P-2	OMI-301P-2	2003101	2003111	300P-2	301P-2	EDI-300P-2	EMD-300P-2
2 - 3"	OMI-300P-3	OMI-301P-3	2003102	2003112	300P-3	301P-3	EDI-300P-3	EMD-300P-3
3 - 4"	OMI-300P-4	OMI-301P-4	2003103	2003113	300P-4	301P-4	EDI-300P-4	EMD-300P-4
4 - 5"	OMI-300P-5	OMI-301P-5	2003104	2003114	300P-5	301P-5	EDI-300P-5	EMD-300P-5
5 - 6"	OMI-300P-6	OMI-301P-6	2003105	2003115	300P-6	301P-6	EDI-300P-6	EMD-300P-6
6 - 7"	OMI-300P-7	OMI-301P-7	2003106	2003116	300P-7	301P-7	EDI-300P-7	EMD-300P-7
7 - 8"	OMI-300P-8	OMI-301P-8	2003107	2003117	300P-8	301P-8	EDI-300P-8	EMD-300P-8
8 - 9"	OMI-300P-9	OMI-301P-9	2003108	2003118	300P-9	301P-9	EDI-300P-9	EMD-300P-9
9 - 10"	OMI-300P-10	OMI-301P-10	2063910	2064110	300P-10	301P-10	EDI-300P-10	EMD-300P-10
10 - 11"	OMI-300P-11	OMI-301P-11	2063911	2064111	300P-11	301P-11	EDI-300P-11	EMD-300P-11
11 - 12"	OMI-300P-12	OMI-301P-12	2063912	2064112	300P-12	301P-12	EDI-300P-12	EMD-300P-12
12 - 13"	OMI-300P-13	OMI-301P-13	2063913	2064113	300P-13	301P-13	EDI-300P-13	EMD-300P-13
13 - 14"	OMI-300P-14	OMI-301P-14	2063914	2064114	300P-14	301P-14	2063714	EMD-300P-14
14 - 15"	2063315	2063415	2063915	2064115	2063515	2063615	2063715	2063815
15 - 16"	2063316	2063416	2063916	2064116	2063516	2063616	2063716	2063816
16 - 17"	2063317	2063417	2063917	2064117	2063517	2063617	2063717	2063817
17 - 18"	2063318	2063418	2063918	2064118	2063518	2063618	2063718	2063818
18 - 19"	2063319	2063419	2063919	2064119	2063519	2063619	2063719	2063819
19 - 20"	2063320	2063420	2063920	2064120	2063520	2063620	2063720	2063820

Blade Anvils (Anvils included in price – choose from list below)

					.0005" Grads	.0005" Grads		
0 - 1"	OMI-300P-31	OMI-301P-31	2063931	2064131	300P-31	301P-31	EDI-300P-31	EMD-300P-31
1 - 2"	OMI-300P-32	OMI-301P-32	2063932	2064132	300P-32	301P-32	2063732	EMD-300P-32
2 - 3"	OMI-300P-33	OMI-301P-33	2063933	2064133	300P-33	301P-33	2063733	EMD-300P-33
3 - 4"	OMI-300P-34	OMI-301P-34	2063934	2064134	300P-34	301P-34	2063734	EMD-300P-34
4 - 5"	OMI-300P-35	OMI-301P-35	2063935	2064135	300P-35	301P-35	2063735	EMD-300P-35
5 - 6"	2063336	2063436	2063936	2064136	2063536	2063636	2063736	2063836
6 - 7"	2063337	2063437	2063937	2064137	2063537	2063637	2063737	2063837
7 - 8"	2063338	2063438	2063938	2064138	2063538	2063638	2063738	2063838
8 - 9"	2063339	2063439	2063939	2064139	2063539	2063639	2063739	2063839

Larger capacities available on request.

To specify Metric models, add suffix "M" to the Model number. To specify Digital Output, add suffix "D" to Model numbers of EMD-300P and EMD-301P Series Gages. To specify both, add suffix "MD" to Model numbers of EMD-300P and EMD-301P Series Gages.

**Examples:** 300P-2 specifies a Snap Gage with a 12I (.0001" grad.) Dial Indicator, 25-50 mm / 1-2" capacity. EMD-301P-33D specifies a Groove Diameter Snap Gage with lift lever, 50-76 mm / 2-3" capacity, AL-110 Blade Anvils, 2033119 (selectable units and resolution) Maxµm/// Indicator with Digital Output

## Snap Gages for Outside Diameters 300P

### Accessories



**BA-71**  
Bench Stand for Disc Masters



**Groove Diameter Snap Gages** – One pair of anvil inserts must be specified with each gage. Stocked anvils (shown below) are hardened steel. If no other anvils are specified, AL-110 will be provided.

**Anvil Inserts** – For all Series 300P-30 and 301P-30 groove gages (2 required per gage).

**Order no.**

**Bench Stand for Gages**

Clamps 300P and 1000P Series Gages firmly. A 6.4 mm / .25" mounting hole allows permanent fastening to bench surface.

**BA-26**

**Bench Stand for Disc Masters**

Holds any AGD style 3 Disc up to 127 mm / 5" diameter and 27 mm / 1.12" wide. Two 6.4 mm / 0.25" mounting holes allow permanent fastening to bench surface

**BA-71**

**Gaging pressure options**

For EMD, OMI and Dial Indicator models

Lighter  
Heavier

**SP-192**  
**SP-118**

For EDI models only

Lighter  
Heavier

**2243295**  
**2243297**

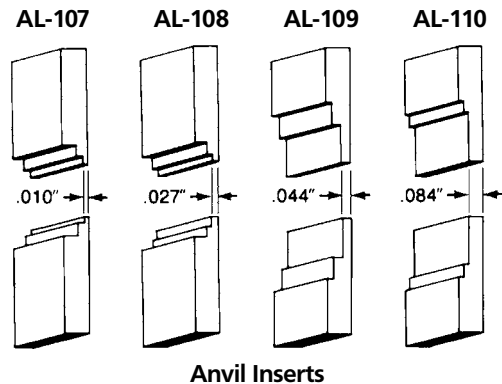

**Anvil Inserts**

**Plain Anvil Options  
Front View**

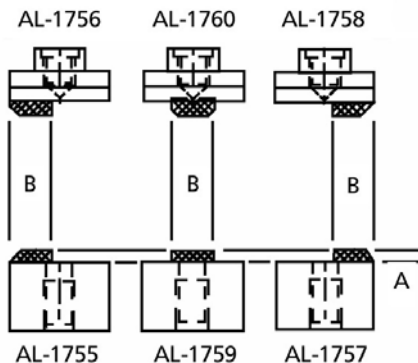

A = 2mm/.080in  
B = 6.35mm/.250in

**Blade Anvils**

Width mm / inch	Depth mm / inch	Order no. Steel	T.C.
0.25 / .010"	0.76 / .030"	AL-107	AL-1741
0.69 / .027"	1.02 / .040"	AL-108	AL-1742
1.12 / .044"	4.83 / .19"	AL-109	AL-1743
2.13 / .084"	6.35 / .25"	AL-110*	AL-1744

\* normally provided



## Indicating Snap Gages 840 F / 840 FC MaraMeter F



### Features

- For cylindrical parts such as shafts, bolts and spindles, for thickness and length measurements
- Rugged, forged steel frame with heat insulators
- Measuring spindle is mounted in long guide way with lever-controlled retraction
- Anvil spindle can easily be fine adjusted
- Measuring spindle and anvil spindle are both made of hardened stainless steel, carbide-tipped or ceramic (840 FC) measuring faces
- Adjustable center stop for automatic alignment
- Maximum wear resistance due to non-contact positioning in conjunction with carbide-tipped measuring faces
- Constant measuring force as a result of built-in spring, thus eliminating user influence
- Universally applicable and extremely versatile. Each instrument spans a broad measuring range, within this range any dimension and fit can be very quickly and easily adjusted
- Supplied with: Wooden case, steel flat contact points 903

### Technical Data

	Measuring range		Repeatability $f_w$ $\mu\text{m}$	Distance of moveable anvil mm	Measuring force** N	Measuring face		Order no.*
	mm	(inch)				Flatness $\mu\text{m}$	Parallelism $\mu\text{m}$	
<b>840 F</b>	0 - 25	(0 - 1")	$\leq 0.5$	2	7.5	$\leq 0.2$	$\leq 1$	<b>4450000</b>
	25 - 60	(1 - 2.36")	$\leq 0.5$	2	7.5	$\leq 0.2$	$\leq 2$	<b>4450001</b>
	50 - 100	(2 - 4")	$\leq 1$	2.5	7.5	$\leq 0.2$	$\leq 2$	<b>4450002</b>
	100 - 150	(4 - 6")	$\leq 1$	2.5	7.5	$\leq 0.2$	$\leq 2$	<b>4450003</b>
	150 - 200	(6 - 8")	$\leq 1$	2.5	7.5	$\leq 0.2$	$\leq 2$	<b>4450004</b>
<b>840 FC</b>	0 - 25	(0 - 1")	$\leq 1$	2	7.5	$\leq 0.2$	$\leq 1$	<b>4450100</b>
	25 - 60	(1 - 2.36")	$\leq 1$	2	7.5	$\leq 0.2$	$\leq 2$	<b>4450101</b>

\* Excludes indicating instrument

\*\* Further measuring forces are available on request

## Indicating Instruments

All indicating instruments that has a 8 mm mounting shank may be used. Recommended are:

Dial Comparator	Readings		Order no.	
	mm	/ inch	mm	/ inch
Millimess 1004 / 1004 Z	5 $\mu\text{m}$	/.0001"	4333000	/ 4333900
Millimess 1003 / 1003 Z	1 $\mu\text{m}$	/.00005"	4334000	/ 4334900
Millimess 1003 XL	2 $\mu\text{m}$		4334001	
Millimess 1002 / 1002 Z	0.5 $\mu\text{m}$	/.00002"	4335000	/ 4335900
Extramess 2000	0.2 $\mu\text{m}$	/.00001"	4346000*	
	0.5 $\mu\text{m}$	/.00002"		
	1 $\mu\text{m}$	/.00005"		
Extramess 2001	0.2 $\mu\text{m}$	/.00001"	4346100*	
	0.5 $\mu\text{m}$	/.00002"		
	1 $\mu\text{m}$	/.00005"		
$\mu\text{Max}\mu\text{m II}$	0.0005 mm	/.00002"	2034205**	



2000



1003

Digital Indicators see Chapter 5

Electrical Indicating Instruments see Chapter 7

\* 230 V, for 115 V please refer to page 6-5

\*\* requires contact 4360107

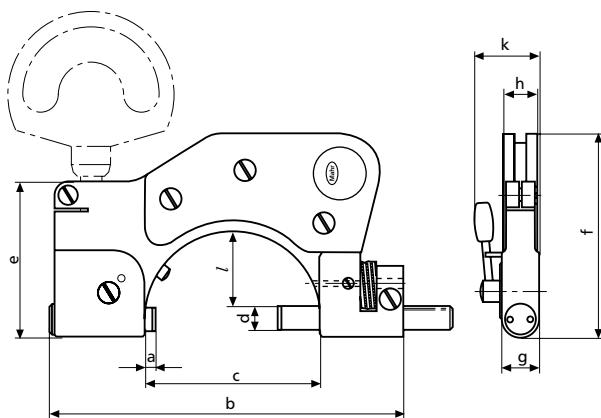

Meas. range	0 - 25 mm	25 - 60 mm	50 - 100 mm	100 - 150 mm	150 - 200 mm
a*	5	5	6.5	6.5	6.5
b	97	140	193	258	316
c	34	68	110	162	212
d	8	9	10	12	12
e	54	60	60	70	75
f	65	77	103	141	171
g	12	13	14	16	16
h	13	13	13	12	12
k	23	25	28	31	31
l	14	30	54	81	106

\* In initial position

## Accessories

Reference Discs 390 see Chapter 13

Gage Blocks see Chapter 13

Holder 840 Fk and Stand 840 Ff see Page 9-15

## Indicating Snap Gage 840 FH with interchangeable anvils

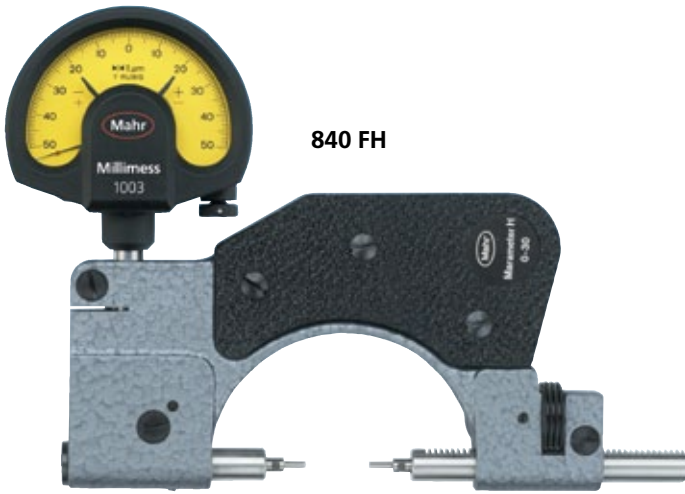

### Features

- Measuring spindle and anvil spindle have precision tapered bores for mounting interchangeable anvils 40 He
- For cylindrical parts such as shafts, bolts and spindles
- Rugged, forged steel frame with heat insulators
- Measuring spindle is mounted in long guide way with lever-controlled retraction
- Anvil spindle can easily be fine adjusted
- Measuring spindle and anvil spindle and both made from hardened stainless steel
- Maximum wear resistance due to non-contact positioning
- Constant measuring force as a result of built-in spring, thus eliminating user influence
- Universally applicable
- All kinds of measurement problems can be solved with the broad range of interchangeable anvils
- Supplied with: Wooden case, steel flat contact points 903, spanner DIN 902-3.5

### Technical Data

	Measuring range*		Repeatability $f_w \mu\text{m}$	Distance of moveable anvil mm	Measuring force N	Order no.**
	mm	(inch)				
840 FH	0 - 30	(0 - 1.18")	≤ 1	2	7.5	4451000
	30 - 80	(1.18 - 3")	≤ 1	2.5	7.5	4451005

\* Measuring is dependent upon the length of the anvils being used

\*\* Excludes indicating instrument (and anvils)

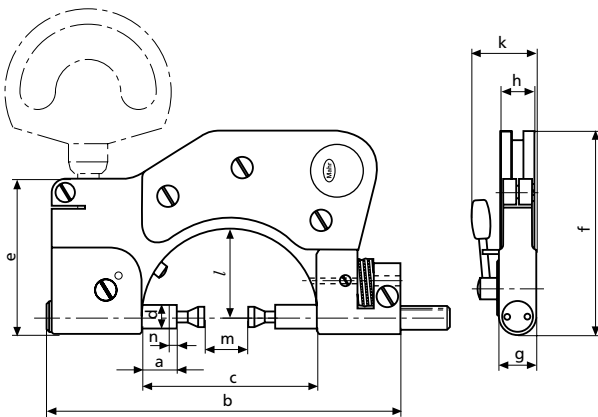

Meas. range	840 FH	
m (mm)	0 - 30	30 - 80
a*	12.5	7.5
b	140	193
c	68	110
d	9	10
e	60	60
f	77	103
g	13	13
h	13	13
k	25	28
l	34	59
n**	2	2.5

\* In initial position

\*\* Distance of moveable anvil

## Interchangeable Anvils for Indicating Snap Gage 840 FH

with tapered shank

Catalog no.	Features	Order no.
40 He 0H*	Flat faces	4152036
40 He 1	Stepped flat faces	4152011
40 He 1H*	Stepped flat faces	4152033
40 He 2	Stepped flat faces	4152012
40 He 2H*	Stepped flat faces	4152032
40 He 3	Discs	4152013
40 He 4	Discs with V-groove	4152014
40 He 5	Blades	4152015
40 He 6	Offset blades	4152016
40 He 7	Recessed blades	4152017
40 He 8	Recessed flat faces with V-grooves on sleeve	4152018
40 He 9	Recessed flat faces with slip on support	4152019
40 He 10	With clearance bores	4152020
40 He 11	Point	4152021

\* Carbide version

## Indicating Instruments

All indicating instruments that has a 8 mm mounting shank may be used. Recommended are:

Dial Comparator	Readings		Order no.
	mm	/ inch	
Millimess 1004 / 1004 Z	5 μm /	.0001"	4333000/4333900
Millimess 1003 / 1003 Z	1 μm /	.00005"	4334000/4334900
Millimess 1003 XL	2 μm /		4334001
Millimess 1002 / 1002 Z	0.5 μm /	.00002"	4335000/4335900
Extramess 2000	0.2 μm /	.00001"	
	0.5 μm /	.00002"	4346000*
	1 μm /	.00005"	
Extramess 2001	0.2 μm /	.00001"	
	0.5 μm /	.00002"	4346100*
	1 μm /	.00005"	
μMax μm II	.0005 mm /	.00002"	2034205**

Digital Indicators see Chapter 5

Electrical Indicating Instruments see Chapter 7

\* 230 V, for 115 V please refer to page 6-5 \*\* requires contact 4360107

## Accessories

**Spanner** (Included in scope of supply) for 840 FH, to loosen anvils

**Order no. 4880210**

**Reference Discs 390** see Chapter 13

**Gage Blocks** see Chapter 13

**Holder 840 Fk** and **Stand 840 Ff** see Page 9-15

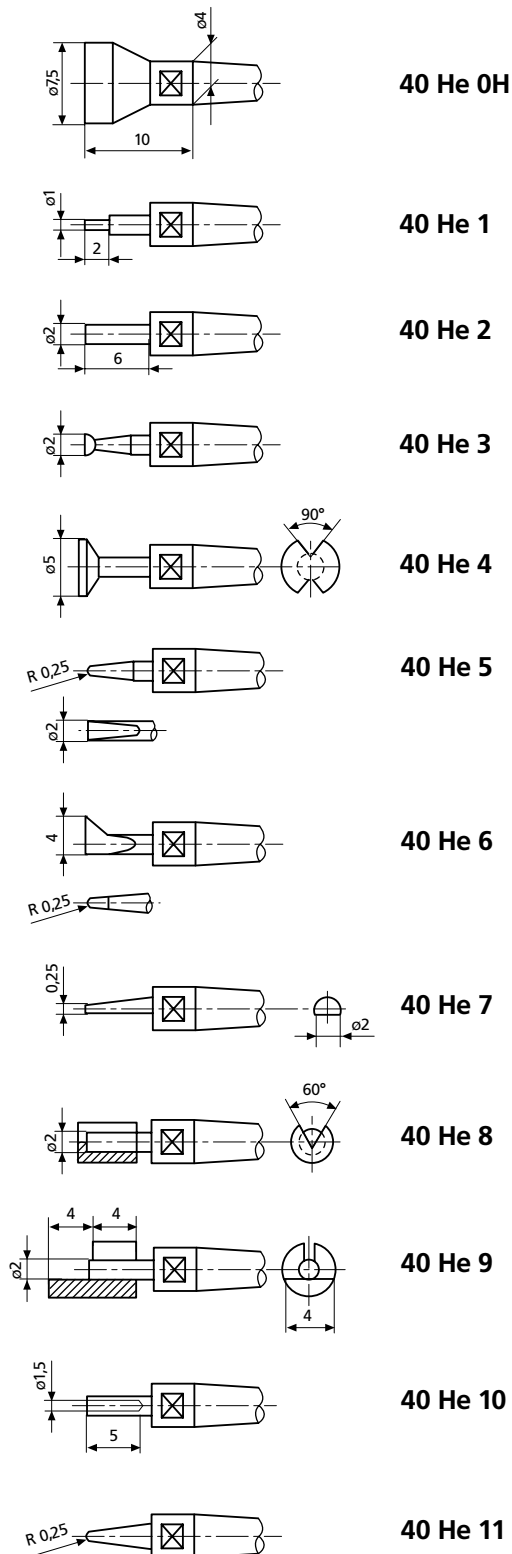

## Indicating Snap Gages 840 FG with interchangeable anvils



### Features

- Measuring spindle and anvil spindle have a M 2.5 connection thread, thus enabling the use of interchangeable anvils that are also used in dial indicators and dial comparators
- For cylindrical parts such as shafts, bolts and spindles
- Rugged, forged steel frame with heat insulators
- Measuring spindle is mounted in long guide way with lever-controlled retraction
- Anvil spindle can easily be fine adjusted
- Measuring spindle and anvil spindle and both made from hardened stainless steel
- Maximum wear resistance due to non-contact positioning
- Constant measuring force as a result of built-in spring, thus eliminating user influence
- Universally applicable
- All kinds of measurement problems can be solved with the broad range of interchangeable anvils
- Supplied with: Wooden case, steel flat contact points 903

### Technical Data

	Measuring range*		Repeatability $f_w \mu\text{m}$	Distance of moveable anvil mm	Measuring force N	Order no.**
	mm	(inch)				
<b>840 FG</b>	0 - 50	(0 - 2")	≤ 0.5	2	7.5	<b>4454000</b>
	40 - 90	(1.57 - 3.57")	≤ 0.5	2.5	7.5	<b>4454001</b>

\* Measuring is dependent upon the length of the anvils being used

\*\* Excludes indicating instrument (and anvils)

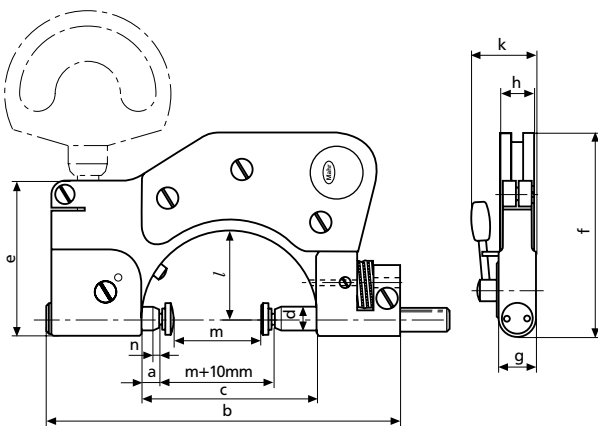

#### Meas. range 840 FG

m (mm)	0 - 50	40 - 90
<b>a*</b>	5	6.5
<b>b</b>	140	193
<b>c</b>	68	110
<b>d</b>	9	10
<b>e</b>	60	60
<b>f</b>	77	103
<b>g</b>	13	14
<b>h</b>	13	13
<b>k</b>	25	28
<b>l</b>	34	59
<b>n**</b>	2	2.5

\* In initial position

\*\* Distance of moveable anvil

## Interchangeable Anvils for Indicating Snap Gage 840 FG

Catalog no.	Features	Order no.			
901 H	Standard contact point with carbide ball, ball dia. 3 mm	4360002			
902 H	Spherical contact point, with carbide face, R = 6 mm				
	Length <i>l</i> in mm				
	10	4360041			
	15	4360043			
	20	4360044			
903 H*	Flat contact point, carbide tipped	4360101 4360103 4360105 4360106			
	Length <i>l</i> in mm				
	6				
	10				
	15				
	20				
904 H	Conical contact point, carbide tipped	4360131			
906 H	<b>Ball Contact Points</b> with carbide ball, manufacturing tolerance ball dia. 0/-6 µm				
<b>Ball dia. d</b> mm	<i>l</i> mm	<b>Order no.</b>	<b>Ball dia. d</b> mm	<i>l</i> mm	<b>Order no.</b>
1	8.5	4360150	5.5	9	4360161
1.25	8.5	4360151	6	9	4360162
1.5	8.5	4360152	6.35 (1/4")	9	4360163
1.75	8.5	4360153	6.5	10	4360164
2	8.5	4360154	7	10	4360165
2.5	8.5	4360155	7.5	11	4360166
3	8.5	4360156	8	11	4360167
3.5	8.5	4360157	8.5	12	4360168
4	8.5	4360158	9	12	4360169
4.5	8.5	4360159	10	13	4360170
5	9	4360160			

## Indicating Instruments

All indicating instruments that has a 8 mm mounting shank may be used. Recommended are:

Dial Comparator	Readings		Order no.
	mm	/ inch	
Millimess 1004 / 1004 Z	5 µm /	.0001"	4333000/4333900
Millimess 1003 / 1003 Z	1 µm /	.00005"	4334000/4334900
Millimess 1003 XL	2 µm /		4334001
Millimess 1002 / 1002 Z	0.5 µm /	.00002"	4335000/4335900
Extramess 2000	0.2 µm /	.00001"	
	0.5 µm /	.00002"	4346000*
	1 µm /	.00005"	
Extramess 2001	0.2 µm /	.00001"	
	0.5 µm /	.00002"	4346100*
	1 µm /	.00005"	
µMaxµm II	.0005 mm /	.00002"	2034205**

Digital Indicators see Chapter 5

Electrical Indicating Instruments see Chapter 7

\* 230 V, for 115 V please refer to page 6-5 \*\* requires contact 4360107

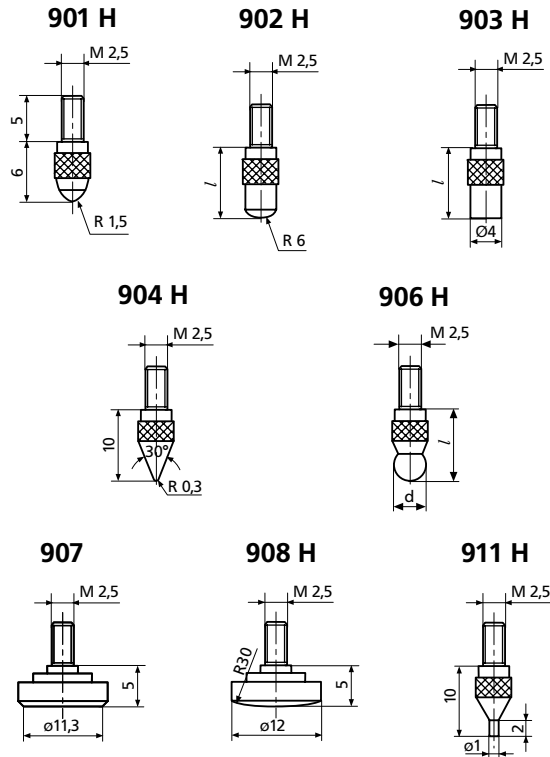

Catalog no.	Features	Order no.
907	Flat contact plates* steel, dia. 11.3 mm, A = 1 cm <sup>2</sup>	4360200
907 H	Flat contact plates*, carbide tipped, dia. 7 mm	4360201
908	Spherical contact plates, steel	4360210
908 H	Spherical contact plates, carbide tipped	4360211
911 H	Pin contact point, carbide tipped, dia. 1 mm, plan	4360240

\* When using a flat contact plate the opposite facing anvil must be a spherical contact plate.

## Accessories

Reference Discs 390 see Chapter 13

Gage Blocks see Chapter 13

Holder 840 Fk and Stand 840 Ff see Page 9-15

## Indicating Snap Gages 840 FM MaraMeter M with measuring jaws

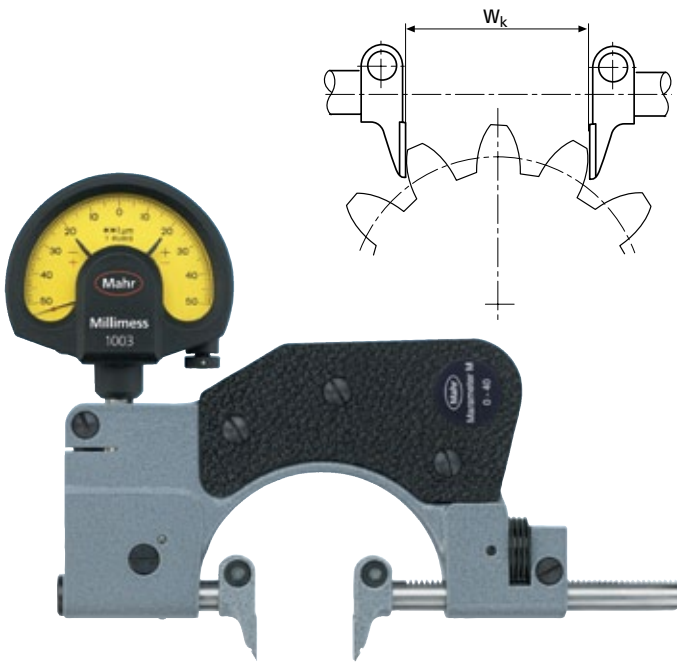

### Features

- For diameters of small hubs, registers, shoulders on shafts and groove widths as well as for tooth span  $W_k$  as indirect, reference-free determination of tooth thickness on spur gears with straight and helical teeth
- Rugged, forged steel frame with heat insulators
- Measuring spindle is mounted in long guide way with lever-controlled retraction
- Anvil spindle can easily be fine adjusted
- Maximum wear resistance due to non-contact positioning in conjunction with carbide-tipped measuring faces
- Measuring spindle and anvil spindle made of hardened stainless steel; with extending carbide-tipped measuring jaws
- Constant measuring force as a result of built-in spring, thus eliminating user influence
- Universally applicable and extremely versatile, each instrument spans a broad measuring range, within this range any dimension and fit can be very quickly and easily adjusted
- Supplied with: Wooden case, steel flat contact points 903

### Technical Data

	Measuring range		Repeatability $f_w$ $\mu\text{m}$	Measuring force N	Measuring face			Tooth span measurements as per module $m$	Order no.*
	mm	(inch)			Area mm	Flatness $\mu\text{m}$	Parallelism $\mu\text{m}$		
<b>840 FM</b>	0 - 40	(0 - 1.57")	1	7.5	12 x 12	$\leq 0.5$	$\leq 2$	0.5	<b>4452000</b>
	40 - 80	(1.57 - 3")	1	7.5	12 x 12	$\leq 0.5$	$\leq 3$	0.5	<b>4452001</b>
	80 - 130	(3 - 5")	1	9	15 x 17	$\leq 0.5$	$\leq 3$	1.0	<b>4452002</b>
	130 - 180	(5 - 7")	1	9	15 x 17	$\leq 0.5$	$\leq 3$	1.0	<b>4452003</b>

\* Excludes indicating instrument

### Dimensions

Meas. range (mm)	0 - 40	40 - 80	80 - 130	130 - 180
Dist mov. anvil n (mm)	2	2.5	2.5	2.5
<b>a*</b>	14	14	19	15
<b>b</b>	140	193	258	316
<b>c</b>	68	110	162	212
<b>e</b>	60	60	70	75
<b>f</b>	77	103	141	171
<b>g</b>	13	14	16	16
<b>h</b>	13	13	12	12
<b>k</b>	25	28	31	31
<b>l</b>	34	59	87	112
<b>m</b>	12	12	17	17
<b>p</b>	12	12	15	15
<b>t</b>	11	11	17	17

\* In initial position

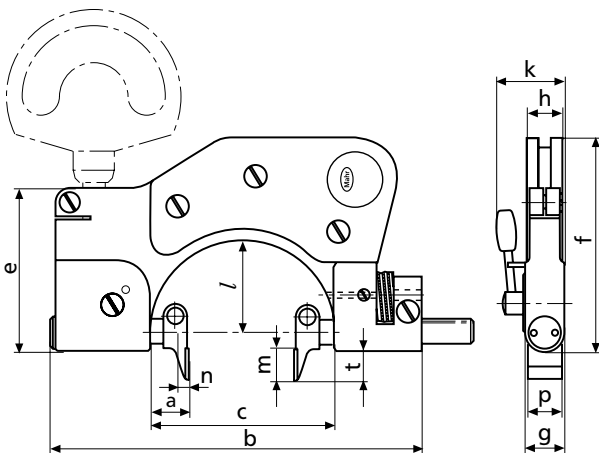

### Accessories

Indicating instruments, see Page 9-9  
 Reference Discs 390 see Chapter 13  
 Gage Blocks see Chapter 13  
 Holder 840 Fk and Stand 840 Ff see Page 9-15

## Accessories for Dial Indicators and Dial Comparators



### Holder 840 Fk for Dial Indicators and Dial Comparators

- For attaching to the following measuring instruments **840 F/FC, 840 FH, 840 FG, 840 FM** and **852**
- Straight transfer of the spindle movement to the indicator
- Following the Abbe principle allows an even higher degree of accuracy than the already excellent level obtained with the standard set-up employing 90° transmission
- When the indicating instrument is in the shown position it is often easier to read
- For stationary application when in conjunction with the **Stand 840 Ff**

Catalog no.	Suitable for instruments with measuring ranges (mm)					Order no.
	840 F/FC	840 FH	840 FG	840 FM	852	
<b>840 Fk/1</b>	0 - 25					<b>4450050</b>
<b>840 Fk/2</b>	25 - 60	0 - 30	0 - 50	0 - 40	0 - 45	<b>4450051</b>
<b>840 Fk/3</b>	50 - 100	30 - 80	40 - 90	40 - 80	45 - 85	<b>4450052</b>
<b>840 Fk/4</b>	{ 100 - 150 150 - 200			80 - 130 130 - 180	85 - 140 140 - 190	<b>4450053</b>



### Stand 840 Ff

- For stationary application in conjunction with the following measuring instruments **840 F/FC, 840 FH, 840 FG, 840 FM, 840 E** and **852**
- User has both hands free for insertion of work piece and retraction of moving spindle
- Indicating instrument is always in operator's field of vision
- Rugged, rigid cast-iron stand with clamp for locking the indicating snap gage
- Indicating snap gage is locked in mounting hole for dial comparator
- Only in conjunction with **Holder 840 Fk**

Catalog no.	Suitable for instruments with measuring ranges (mm)					Order no.
	840 F/FC	840 FH	840 FG	840 FM	852	
<b>840 Ff</b>	{ 0 - 25 25 - 60	0 - 30	0 - 50	0 - 40	0 - 45	<b>4450020</b>



## Indicating Snap Gages 840 FS MaraMeter S



### Features

- For all kinds of cylindrical work pieces, whether directly on a machine tool or in the production control
- Rigid frame; convenient handle with heat insulators open on one end to eliminate heat transfer from user's hand
- Both spindles are made of hardened stainless steel and mounted in long guide ways
- Carbide-tipped measuring faces slightly chamfered at the front to facilitate positioning
- Projects over width of frame for measurement of narrow registers or when measuring directly at shoulders
- Maximum accuracy. Straight transfer of spindle movement to indicator. During the measurement, the weight of the gage rests on the anvil spindle
- Adjustable center stop for automatic alignment
- Indicating instrument is protected against possible impact during handling by a laterally projecting guard
- Direct indication and evaluation of measurement results
- Universally applicable and extremely versatile, each instrument spans a broad measuring range, within this range any dimension and fit can be very quickly and easily adjusted
- Constant measuring force as a result of built-in spring, thus eliminating user influence
- Supplied with:  
Wooden case, allen key

### Technical Data

	Measuring range		Repeatability $f_w$ $\mu\text{m}$	Measuring force N	Distance of moveable anvil mm	Measuring faces		Weight kg	Order no.*
	mm	(inch)				Flatness $\mu\text{m}$	Parallelism $\mu\text{m}$		
840 FS	10 - 30	(.39 - 1.18")	1	13.5	0.7	$\leq 0.5$	$\leq 3$	0.6	4455000
840 FS	30 - 60	(1.18 - 2.36")	1	13.5	0.7	$\leq 0.5$	$\leq 3$	0.9	4455001
840 FS	60 - 100	(2.36 - 4")	1	13.5	0.7	$\leq 0.5$	$\leq 3$	1.3	4455002
840 FS	100 - 150	(4 - 6")	1	15	0.7	$\leq 0.5$	$\leq 3$	1.7	4455003
840 FS	150 - 200	(6 - 8")	1	15	0.7	$\leq 0.5$	$\leq 3$	2.0	4455004
840 FS	200 - 250	(8 - 10")	1	15	0.7	$\leq 0.5$	$\leq 3$	2.2	4455005
840 FS	250 - 300	(10 - 12")	1	15	0.7	$\leq 0.5$	$\leq 3$	2.5	4455006
840 FS	300 - 350	(12 - 14")	1	15	0.7	$\leq 0.5$	$\leq 4$	3.3	4455007
840 FS	350 - 400	(14 - 16")	1	15	0.7	$\leq 0.5$	$\leq 4$	3.3	4455008
840 FS	400 - 450	(16 - 18")	1	15	0.7	$\leq 0.5$	$\leq 4$	4.3	4455009
840 FS	450 - 500	(18 - 20")	1	15	0.7	$\leq 0.5$	$\leq 4$	4.7	4455010

\* Excludes indicating instrument

## Technical Data

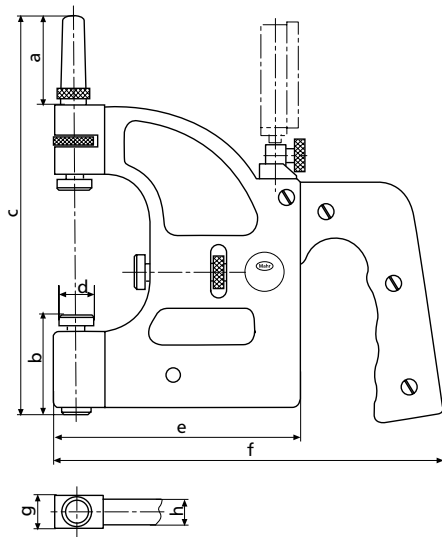

### Dimensions

Meas. range mm	dia. d	a	b	c	e	f	g	h
10 - 30	18	37	46	154	87	161	17	15
30 - 60	18	45	51	199	122	196	17	15
60 - 100	22	56	62	260	154	228	20	18
100 - 150	22	71	62	335	189	263	20	18
150 - 200	22	71	62	385	214	288	20	18
200 - 250	22	71	62	436	248	322	20	18
250 - 300	22	71	62	487	280	354	20	18
300 - 350	22	71	62	537	310	384	20	18
350 - 400	22	71	62	587	350	424	20	18
400 - 450	22	71	62	637	380	454	20	18
450 - 500	22	71	62	687	410	484	20	18

## Accessories

### Indicating Instruments

All indicating instruments that has a 8 mm mounting shank may be used. Recommended are:

Dial Comparator	Readings		Order no. mm / inch
	mm	inch	
Millimess 1004 / 1004 Z	5 $\mu\text{m}$	.0001"	4333000/4333900
Millimess 1003 / 1003 Z	1 $\mu\text{m}$	.00005"	4334000/4334900
Millimess 1003 XL	2 $\mu\text{m}$		4334001
Millimess 1002 / 1002 Z	0.5 $\mu\text{m}$	.00002"	4335000/4335900
Extramess 2000	0.2 $\mu\text{m}$	.00001"	
	0.5 $\mu\text{m}$	.00002"	4346000*
Extramess 2001	1 $\mu\text{m}$	.00005"	
	0.2 $\mu\text{m}$	.00001"	
	0.5 $\mu\text{m}$	.00002"	4346100*
$\mu\text{Max}\mu\text{m II}$	1 $\mu\text{m}$	.00005"	
	.0005 mm	.00002"	2034205**

Digital Indicators see Chapter 5

Electrical Indicating Instruments see Chapter 7

\* 230 V, for 115 V please refer to page 6-5 \*\* requires contact 4360107



2000



1003

## Electronic Snap Gage 840 E MaraMeter E for extremely high accuracy



### Features

- Inductive measuring system incorporated directly into frame
- Readings selectable down to 0.01  $\mu\text{m}$
- Rugged, forged steel frame with heat insulators
- Measuring spindle mounted in extra long guideway with lever-controlled retraction
- Anvil spindle can easily be fine adjusted
- Measuring spindle and anvil spindle made of hardened stainless steel; measuring faces carbide-tipped
- Adjustable center stop for automatic alignment
- Extremely accurate due to the straight transfer of spindle movement to the inductive measuring system according to the Abbe principle
- Universally applicable and extremely versatile, each instrument spans a broad measuring range, within this range any dimension and fit can be very quickly and easily adjusted
- Maximum wear resistance due to non-contact positioning in conjunction with carbide-tipped measuring faces
- Constant measuring force as a result of built-in spring, thus eliminating user influence
- Supplied with:  
Wooden case

### Technical Data

	Measuring range	Readings / Resolution adjustable to*	Measuring force	Measuring faces dia.	Repeatability $f_w$	Measuring faces Parallelism	Order no.**
	mm	$\mu\text{m}$	N	mm	$\mu\text{m}$	$\mu\text{m}$	
<b>840 E</b>	0 - 25	0.01	4.5	7.5	$\leq 0.1$	$\leq 0.3$	<b>4453000</b>

\* Depending upon which indicating instrument is being used

\*\* Excludes indicating instrument

### Accessories

**Reference Discs 390** see Chapter 13

**Gage Blocks** see Chapter 13

**Stand 840 Ff** see Page 9-15

#### Recommended indicating instruments:

Electrical indicating instruments; recommended are C1216M, C1208M and 1240; please refer to Chapter 7



C 1208M



1240

## Indicating Bench Snap Gage 852 TS



### Applications

- For rapid measurements of diameters of cylindrical parts (shafts, bolts and shanks)
- For measuring pitch, root and outside diameters of all kinds of external threads as well as serrations
- For thickness and length measurement
- Particularly suited for batch produced parts

### Features

- Rugged steel frame, can be inclined up to 45° from the sturdy base
- Measuring spindle and anvil spindle are both made of hardened stainless steel, with mounting bore for insertion of interchangeable anvils
- Anvil spindle can easily be fine adjusted
- Height adjustable stop
- Constant measuring force as a result of built-in spring, thus eliminating user influence
- Universally applicable and extremely versatile, each instrument spans a broad measuring range
- Scope of supply: TC-tipped -anvils dia. D= 3.5 mm, Dial Comparator 1003

## Technical Data

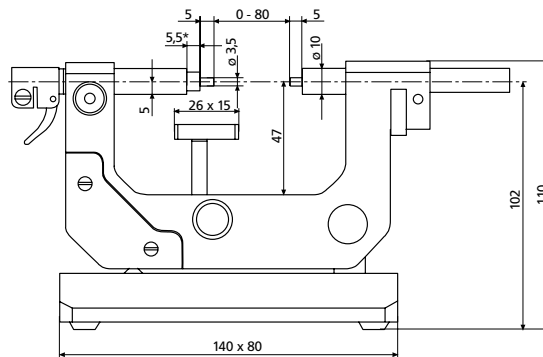

Measuring range**		Repeatability	Retraction	Measuring force	Measuring face	Mounting dia.	Order no.
mm	(inch)	$f_w$ μm	mm	N	Parallelism μm		
0 - 80	(0 - 3.15")	1	1.2	6.5	≤ 2	8 mm	<b>4510030***</b>
						8 mm	<b>4510031 +</b>
						.375"	<b>4510035 +</b>

\* In initial position

\*\* Depending upon which anvils are being used

\*\*\* Delivery with a different indicating instrument is available upon request

+ Excludes indicating instrument, order indicating instrument separately.

## Accessories

Order no.

Standard TC-tipped anvils,  
dia. D= 3.5 mm

**4510840**

**Interchangeable Anvils** please refer to Pages 9-24 and 9-25

## Indicating Thread Snap Gage 852



### Features

- For measuring pitch, root and outside diameters of all kinds of external threads as well as serrations
- Rugged, forged steel frame with heat insulators
- Measuring spindle is mounted in long guide way with lever-controlled retraction
- Anvil spindle can easily be fine adjusted
- Measuring spindle and anvil spindle are both made of hardened stainless steel, with mounting bore for insertion of interchangeable anvils
- Adjustable center stop for automatic alignment
- Maximum wear resistance due to non-contact positioning
- Constant measuring force as a result of built-in spring, thus eliminating user influence
- Universally applicable and extremely versatile. each instrument spans a broad measuring range
- Supplied with: Wooden case, steel flat contact points 903

### Technical Data

	Measuring range*		Repeatability $f_w$ $\mu\text{m}$	Measuring force N	Order no.**
	mm	(inch)			
852	0 - 45	(0 - 1.77")	1	7.5	4510000
852	45 - 85	(1.77 - 3.34")	1	7.5	4510001
852	85 - 140	(3.34 - 5.51")	1	9	4510002
852	140 - 190	(5.51 - 7.48")	1	9	4510003

\* Depending upon which anvils are being used, purchase separately

\*\* Excludes indicating instrument and anvils

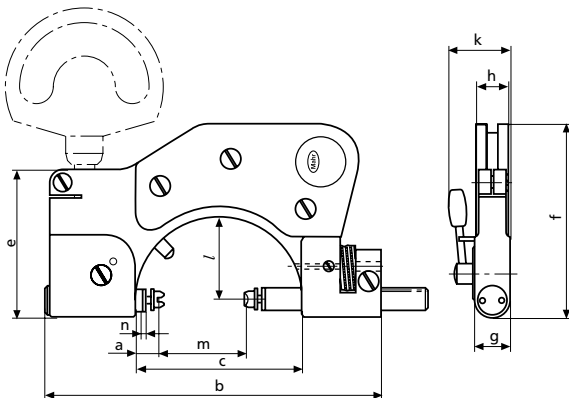

Meas. range m (mm)	0-45	45-85	85-140	140-190
Dist mov. anvil n (mm)	2	2.5	2.5	2.5
a*	13	8	10	6
b	140	193	258	316
c	68	110	162	212
e	60	60	70	75
f	77	103	141	171
g	13	14	16	16
h	13	13	12	12
k	25	28	31	31
l	34	59	87	112

a\* = In initial position

## Technical Data

### Indicating Instruments

All indicating instruments that has a 8 mm mounting shank may be used. Recommended are:

Dial Comparator	Readings mm / inch	Order no. mm / inch
Millimess 1004 / 1004 Z	5 µm / .0001"	4333000/4333900
Millimess 1003 / 1003 Z	1 µm / .00005"	4334000/4334900
Millimess 1003 XL	2 µm	4334001
Millimess 1002 / 1002 Z	0.5 µm / .00002"	4335000/4335900
Extramess 2000	0.2 µm / .00001"	
	0.5 µm / .00002"	4346000*
	1 µm / .00005"	
Extramess 2001	0.2 µm / .00001"	
	0.5 µm / .00002"	4346100*
	1 µm / .00005"	
µMaxµm II	.0005 mm / .00002"	2034205**

Digital Indicators see Chapter 5

Electrical Indicating Instruments see Chapter 7

\* 230 V, for 115 V please refer to page 6-5 \*\* requires contact 4360107



2000



1003

### Accessories

Interchangeable Anvils please refer to Pages 9-19

Holder 840 Fk and Stand 840 Ff (for 0-45 mm) see Page 9-15

## Indicating Thread Snap Gage 853 for taps



### Features

- For pitch, root and outside diameters on taps in conjunction with interchangeable anvils
- Measuring spindle mounted in long guideway, lever-controlled retraction with mounting bore for interchangeable anvils
- Anvil spindle adjustable with thumbscrew via worm and rack, for mounting interchangeable support yokes
- Measuring spindle and anvil spindle are made of hardened stainless steel
- Further features are similar to the model 852; for details please refer to Page 9-20
- Supplied with: Wooden case, steel flat contact points 903

### Technical Data

	Measuring range		Repeatability $f_w$ $\mu\text{m}$	Measuring force  N	Order no.*
	mm	(inch)			
<b>853</b>	1.2 - 35	(.04 - 1.37")	2	75	<b>4511000</b>
<b>853</b>	35 - 75	(1.37 - 3")	2	75	<b>4511001</b>

\* Excludes indicating instrument and the support yokes 853 q & anvils

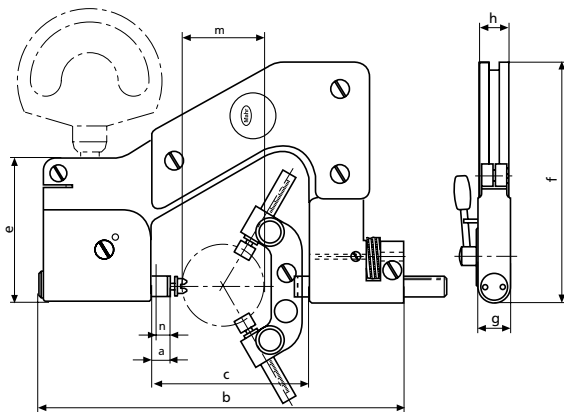

Meas. range m (mm)	1.2-35	35-75
Dist mov. anvil n (mm)	8	8
a*	12	11.5
b	152	192
c	66	110
e	60	65
f	98	125
g	14	14
h	11.5	14

a\* = In initial position

## Technical Data

### Interchangeable Support Yokes 853 q

Depending upon the number of flutes, allowance has to be made for a compensation factor when reading the result. See table below:

	No. of flutes of taps	For measuring range mm	Compensation factor**	Order no.
<b>853 qk 3</b>	3	1.2 - 35	x 1	<b>4511024</b>
<b>853 qk 5</b>	5	1.2 - 35	x 1.34	<b>4511026</b>
<b>853 qk 7</b>	7	1.2 - 35	x 1.42	<b>4511028</b>
<b>853 qg 3</b>	3	35 - 75	x 1	<b>4511025</b>
<b>853 qg 5</b>	5	35 - 75	x 1.34	<b>4511027</b>
<b>853 qg 7</b>	7	35 - 75	x 1.42	<b>4511029</b>

\*\* Allowance is to be made for other compensation methods when using the Holder 840 Fk

### Indicating Instruments

All indicating instruments that has a 8 mm mounting shank may be used.  
Recommended are:

		Readings	Order no.
<b>MarCator</b>	<b>810 S</b>	0.001 mm	<b>4311000</b>
<b>Millimess</b>	<b>1004/1004 Z</b>	5 µm / <b>.0001"</b>	<b>4333000/4333900</b>
<b>Millimess</b>	<b>1010/1010 Z</b>	0.01 mm / <b>.0005"</b>	<b>4332000/4332900</b>
<b>MarCator</b>	<b>1087R/1087 ZR</b>	1 µm / <b>.00005"</b>	<b>4337660/4337670</b>

### Accessories

**Interchangeable Anvils** see from Pages 9-24 and 9-25



## Interchangeable Anvils for 852, 852 TS and 853

For pitch, root and outside diameters. Special wear-resistant hardened steel. With cylindrical mounting shank and retainer ring which ensures locking while permitting rotation in bore of indicating snap gages.

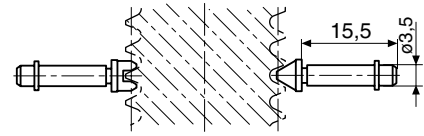

### Sets consist of:

#### For pitch diameters

852 - 1 V-anvil and 1 blade  
853 - 1 V-anvil and 2 radiused blades

#### For root diameters

852 - 1 V-anvil and 1 blade  
853 - 1 V-anvil and 2 blades

#### For outside diameters

852 - 2 flat-face anvils  
853 - 3 flat-face anvils

### Anvils for pitch diameters for 852 and 852 TS

Metric thread (60°)			Whitworth thread (55°)			American UST thread (60°)		
Pitch	V-anvil	Blade	Pitch range	V-anvil	Blade	Pitch range	V-anvil	Blade
mm	Order no.	Order no.	tpi	Order no.	Order no.	tpi	Order no.	Order no.
0.2*	4173007	4173707	40 - 32	4173043	4173743	60 - 48	4173113	4173813
0.25*	4173008	4173708	32 - 24	4173044	4173744	48 - 40	4173114	4173814
0.3*	4173009	4173709	24 - 18	4173045	4173745	40 - 32	4173115	4173815
0.35*	4173010	4173710	18 - 14	4173046	4173746	32 - 24	4173116	4173816
0.4*	4173011	4173711	14 - 10	4173047	4173747	24 - 18	4173117	4173817
0.45*	4173012	4173712	10 - 7	4173048	4173748	18 - 14	4173118	4173818
0.5 - 0.7	4173000	4173700	7 - 4.5	4173049	4173749	14 - 10	4173119	4173819
0.7 - 1	4173001	4173701	4.5 - 3	4173050	4173750	10 - 7	4173120	4173820
1.25 - 2	4173002	4173702	3 - 2.5	4179408	4179410	7 - 4.5	4173121	4173821
2 - 3.5	4173003	4173703				4.5 - 3	4173122	4173822
3.5 - 5	4173004	4173704						
5 - 7	4173005	4173705						
7 - 9	4173006	4173706						

### Anvils for pitch diameters for Indicating Thread Snap Gage 853

Metric thread (60°)			Whitworth thread (55°)			American UST thread (60°)		
Pitch	V-anvil	Blade	Pitch range	V-anvil	Blade	Pitch range	V-anvil	Blade
mm	Order no.	Order no.	tpi	Order no.	Order no.	tpi	Order no.	Order no.
0.2	4173051	4174007	40 - 32	4173043	4176043	60 - 48	4173124	4176113
0.25	4173052	4174008	32 - 24	4173044	4176044	48 - 40	4173125	4176114
0.3	4173053	4174009	24 - 18	4173045	4176045	40 - 32	4173115	4176115
0.35	4173054	4174010	18 - 14	4173046	4176046	32 - 24	4173116	4176116
0.4	4173055	4174011	14 - 10	4173047	4176047	24 - 18	4173117	4176117
0.45	4173056	4174012	10 - 7	4173048	4176048	18 - 14	4173118	4176118
0.5 - 0.7	4173000	4174000	7 - 4.5	4173049	4176049	14 - 10	4173119	4176119
0.7 - 1	4173001	4174001	4.5 - 3	4173050	4176050	10 - 7	4173120	4176120
1.25 - 2	4173002	4174002	3 - 2.5	4179408	4179411	7 - 4.5	4173121	4176121
2 - 3.5	4173003	4174003				4.5 - 3	4173122	4176122
3.5 - 5	4173004	4174004						
5 - 7	4173005	4174005						
7 - 9	4173006	4174006						

### Carbide anvils for 852, 852TS and 853

1.25 - 2	4511105	4511104
2 - 3.5	4511108	4511107
3.5 - 5	4511140	4511139
5 - 7	4511142	4511141

\* V-anvil covers 3 pitches

## Interchangeable Anvils for 852 and 852 TS

### Ball Anvils

For measuring gears and for special applications. Carbide ball. With cylindrical mounting shank and retainer ring. For mounting into mounting bores of thread micrometers 40 Z and 852.

Shank dia. 3.5 mm  
Shank length 15.5 mm  
Manufacturing tolerance  
Ball dia.  $\pm 2 \mu\text{m}$

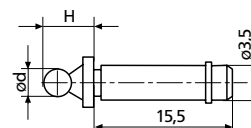

dia. d mm	H mm	Order no.	dia. d mm	H mm	Order no.	dia. d mm	H mm	Order no.
0.5	5.0	<b>4179150</b>	1.65	6.2	<b>4179168</b>	3.048	7.5	<b>4179182</b>
0.551	5.1	<b>4179151</b>	1.7	6.2	<b>4179169</b>	3.2	7.7	<b>4170570</b>
0.62	5.1	<b>4179152</b>	1.75	6.3	<b>4170553</b>	3.25	7.8	<b>4170566</b>
0.623	5.1	<b>4179153</b>	1.782	6.3	<b>4179170</b>	3.4	7.9	<b>4179183</b>
0.63	5.1	<b>4179154</b>	1.8	6.3	<b>4179171</b>	3.5	8.0	<b>4170558</b>
0.722	5.2	<b>4179155</b>	1.829	6.3	<b>4179172</b>	3.658	8.2	<b>4179184</b>
0.862	5.4	<b>4179156</b>	1.9	6.4	<b>4179173</b>	3.7	8.2	<b>4170571</b>
0.895	5.4	<b>4179157</b>	2	6.5	<b>4170554</b>	4	8.5	<b>4170559</b>
0.965	5.5	<b>4179158</b>	2.032	6.5	<b>4170568</b>	4.5	9.0	<b>4170560</b>
1	5.5	<b>4170550</b>	2.2	6.7	<b>4170569</b>	4.835	9.3	<b>4179185</b>
1.1	5.6	<b>4179159</b>	2.25	6.8	<b>4170564</b>	5	9.5	<b>4170561</b>
1.118	5.6	<b>4179160</b>	2.284	6.8	<b>4179174</b>	5.25	9.8	<b>4179186</b>
1.125	5.6	<b>4179161</b>	2.386	6.9	<b>4179175</b>	5.486	10.0	<b>4179187</b>
1.25	5.8	<b>4170551</b>	2.438	6.9	<b>4179176</b>	5.5	10.0	<b>4170562</b>
1.35	5.9	<b>4179162</b>	2.5	7.0	<b>4170556</b>	6	10.5	<b>4170563</b>
1.372	5.9	<b>4179163</b>	2.667	7.2	<b>4179177</b>	6.096	10.6	<b>4179188</b>
1.385	5.9	<b>4179164</b>	2.704	7.2	<b>4179178</b>	6.35	10.9	<b>4179189</b>
1.5	6.0	<b>4170552</b>	2.713	7.2	<b>4179179</b>	6.5	11.0	<b>4170567</b>
1.524	6.0	<b>4179165</b>	2.721	7.2	<b>4179180</b>	7	11.5	<b>4170572</b>
1.54	6.0	<b>4179166</b>	2.743	7.2	<b>4179181</b>	8	12.5	<b>4170573</b>
1.6	6.1	<b>4179167</b>	2.75	7.3	<b>4170565</b>	9	13.5	<b>4170574</b>
			3	7.5	<b>4170557</b>	10	14.5	<b>4170575</b>

Further sizes are available upon request (material: steel or carbide)

### Roller Blades

For measuring gears and for special applications. The measuring roller is made of carbide. To be mounted in the mounting bores of the 40 Z and 852.

Shank dia. 3.5 mm  
Shank length 15.5 mm  
Manufacturing tolerance  
Ball dia.  $\pm 2 \mu\text{m}$

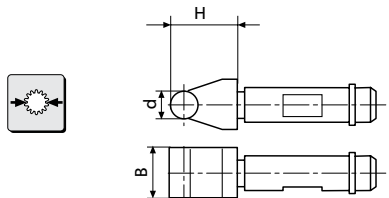

Further sizes are available upon request (material: steel)

dia. d mm	Dimension H mm	Dimension B dia. mm	Order no.
1	5.5	5	<b>4510200</b>
1.25	5.8	5	<b>4510201</b>
1.5	6.0	5	<b>4510202</b>
1.75	6.3	5	<b>4510203</b>
2	6.5	5.5	<b>4510204</b>
2.5	7.0	5.5	<b>4510206</b>
3	7.5	5.5	<b>4510207</b>
3.5	8.0	5.5	<b>4510208</b>
4	8.5	5.5	<b>4510209</b>
4.5	9.0	5.5	<b>4510210</b>
5	9.5	6	<b>4510211</b>
5.5	10.0	6	<b>4510212</b>
6	10.5	6	<b>4510213</b>

### For outside diameters

#### Anvil 40 Za, flat

Measuring face dia. 7.5 mm  
with 853 smallest  
measurable O.D. dia. 5 mm

Hardened steel **Order no. 4173210**  
Carbide tipped **Order no. 4511190**

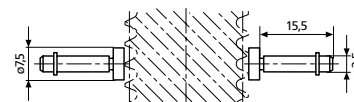

## Portable Thickness Gages 22 P

Portable measurement of sheet materials and small parts

### Features

- Indicator built into gage frame for maximum ruggedness.
- Lift-lever for one-hand operation.
- Continuous reading dials with revolution counter for absolute measurement of thin materials, plastic films, a small parts.
- 6.3 mm / .25" diameter, flat steel contacts.
- Digital models can be Left/Right hand operated or front mounted and used with BA-26 Stand for bench applications.



22P-15



2057541 with 4337651 1086 ZR Digital Indicator (front mounted) and BA-26 Stand (Stand not included)



2057541 with 4337651 1086 ZR Digital Indicator

### Technical Data

Metric	Inch	Capacity		Throat Depth		Graduation	
		mm	inch	mm	inch	mm	inch
22P-10M	22P-11	0 - 2.54	0 - .10"	28.6	1.13"	.002	.0001"
22P-15M	22P-15	0 - 12.70	0 - .50"	50	2"	.01	.001"
22P-20M	22P-20	0 - 25	0 - 1"	50	2"	.01	.001"
2057541		25	0 - 1"	50	2"	.001	.00005" (Resolution)

## Portable Thickness Gages 26 P



26P-7

### Features

- Push-down movement.
- Molded body fits shape of hand; built-in indicator.
- Gage is normally open for easy part entry. Push-down button to close the contacts.
- Rugged and compact for roving inspection.
- 6.3 mm / .25" diameter, flat steel contacts.

### Technical Data

Metric	Inch	Capacity mm / <i>inch</i>	Throat Depth mm / <i>inch</i>	Graduation mm / <i>inch</i>
26P-7M	26P-7	0 - 7.6 / 0 - .30"	16 / .63"	.01 / .001"

## Portable Thickness Gages 838

838 A



838 B



### Features

- Rugged sturdy frame made from hard aluminum
- Built-in Digital or Dial Indicator
- With a lifting lever for the moveable upper measuring spindle
- Convenient heat insulated handle, open at one end
- Versions with a throat depth of 200 mm have a removable stand

### Thickness Gage 838 A

- With flat measuring faces
- For measuring soft materials for example; foil, felt, rubber, paper and cardboard

### Thickness Gage 838 B

- With spherical measuring faces
- For measuring hard materials for example; sheet metal, hardboard, wooden panels and panes of glass

### Technical Data

	Throat depth		Measuring range		Measuring face dia. mm	Measuring face radius mm	Order no. with Indicator 810 0.01 mm Res	Order no. with Indicator 1075 R 0.005mm/.0001" Res	Order no. Wooden case
	mm	(inch)	mm	(inch)					
<b>838 A</b>	50	(2")	0 - 20	(0 - .750")	11.3 = 1 cm <sup>2</sup>	-	<b>4495000</b>	<b>4495120</b>	<b>4495050</b>
	100	(4")	0 - 20	(0 - .750")	11.3 = 1 cm <sup>2</sup>	-	<b>4495001</b>	<b>4495121</b>	<b>4495051</b>
	200	(8")	0 - 20	(0 - .750")	11.3 = 1 cm <sup>2</sup>	-	<b>4495002</b>	<b>4495122</b>	<b>4495052</b>
	50	(2")	0 - 20	(0 - .750")	20 = 3.14 cm <sup>2</sup>	-	<b>4495103</b>	<b>4495125</b>	<b>4495050</b>
	100	(4")	0 - 20	(0 - .750")	20 = 3.14 cm <sup>2</sup>	-	<b>4495104</b>	<b>4495126</b>	<b>4495051</b>
	200	(8")	0 - 20	(0 - .750")	20 = 3.14 cm <sup>2</sup>	-	<b>4495105</b>	<b>4495127</b>	<b>4495052</b>
	50	(2")	0 - 20	(0 - .750")	30 = 7.06 cm <sup>2</sup>	-	<b>4495109</b>	<b>4495130</b>	<b>4495050</b>
	100	(4")	0 - 20	(0 - .750")	30 = 7.06 cm <sup>2</sup>	-	<b>4495110</b>	<b>4495131</b>	<b>4495051</b>
	200	(8")	0 - 20	(0 - .750")	30 = 7.06 cm <sup>2</sup>	-	<b>4495111</b>	<b>4495132</b>	<b>4495052</b>
<b>838 B</b>	50	(2")	0 - 20	(0 - .750")	12	30	<b>4495010</b>	<b>4495135</b>	<b>4495050</b>
	100	(4")	0 - 20	(0 - .750")	12	30	<b>4495011</b>	<b>4495136</b>	<b>4495051</b>
	200	(8")	0 - 20	(0 - .750")	12	30	<b>4495012</b>	<b>4495137</b>	<b>4495052</b>

838 AB



## Features

- Rugged sturdy frame made from hard aluminum
- Built-in Digital or Dial Indicator or Dial Comparator
- With a lifting lever for the moveable upper measuring spindle
- Convenient heat insulated handle, open at one end

## Thickness Gage 838 AB

- Lower measuring face is flat
- Upper measuring face is spherical
- For measuring hard materials for example; sheet metal and hardboard

## Technical Data

	Throat depth	Measuring range	Measuring face dia.	Measuring face radius	Order no.	Order no.	Order no.
	mm (inch)	mm (inch)	mm lower	mm upper	with Indicator 810 0.01 mm Res	with Indicator 1075 R 0.005mm/.0001" Res	Wooden case
<b>838 AB</b>	50 (2")	0 - 20 (0 - .750")	11.3 = 1 cm <sup>2</sup>	30	<b>4495504</b>	<b>4495140</b>	<b>4495050</b>
flat / spherical	100 (4")	0 - 20 (0 - .750")	11.3 = 1 cm <sup>2</sup>	30			

	Throat depth	Measuring range	Measuring face dia.	Measuring face radius	Order no.	Order no.	Order no.
	mm (inch)	mm (inch)	mm lower	mm upper	with Indicator 1075 R 0.005mm/.0001" Res	with Comparator 1003 1 μm Res	Wooden case
<b>838 AB</b>	50 (2")	0 - 20 (0 - .750")	11.3 = 1 cm <sup>2</sup>	30	<b>4495145</b>	<b>4495519</b>	<b>4495050</b>
flat / spherical	100 (4")	0 - 20 (0 - .750")	11.3 = 1 cm <sup>2</sup>	30			

## Dead Load Thickness Gages 57B



2057551

### Features

- Solid casting with ribbed frame provides strength and rigidity for accurate measurements.
- 0.003 mm / .0001" parallelism with tables up to 19 mm / .75" diameter.
- 283 g / 10 oz. dead load weight for constant gaging pressure.
- 10 mm / .407" diameter flat upper 54.0 mm / 2.125" lower contacts.
- Indicator mounts with adjustable back for quick positioning for each gaging requirement.
- Available with Dial Indicator or Digital Electronic Indicator.
- Gage is supplied with a lift lever so work can be easily placed between the table and contact.
- Four-inch throat depth for part clearance.

### Technical Data

Metric	Order no.	Inch	Capacity mm / <i>inch</i>	Description
57B-14M	57B-14		0 - 2.5 / <b>0 - .10"</b>	Dial Indicator readout with 2.5 mm / .10" sensitive range and .002 mm / .0001" grads.
57B-15M	57B-15		0 - 25 / <b>0 - 1"</b>	Dial Indicator readout with 25 mm / 1" sensitive range and .01 mm / .001" grads.
2057551				1086 R Digital Indicator with 25 mm / 1" range and .001 mm / .00005" resolution.

*Alternate Indicators and contact points available upon request.  
Contact Mahr Federal.*

## Wire Insulation Thickness Gages 57B

For checking wall thickness of wire insulation and other small-diameter tubular parts



2057750

### Features

- Using the basic design of the Model 57B-13 (Model 57B-13M — Metric) Gage, the lower contact is PT-103, 1.10 mm / .043" diameter rod, mounted horizontally. The upper contact is a flat chisel contact, in line with the rod. By slipping tubular parts onto the lower contact, the gage can measure the thickness of the wall of the tube. An auxiliary weight on the Indicator provides a total dead-load weight of 25 grams. (Replacement lower rod: PS-43)

### Technical Data

Metric	Order no.	Inch	Capacity mm / inch	Description
57B-13M	57B-13		7.62 / 0 - .30"	Dial Indicator readout with 7.6 mm / .30" sensitive range and 0.01 mm / .0005" grads.
2057550				1086 Digital Indicator with 25 mm / 1" range and 0.001 mm / .00005" resolution.
<b>Options</b>				
	PT-2245			0.050 mm / .02" diameter Pin, Lower Contact Assembly

### Measuring Compressible Materials

Compressible materials such as paper, plastics, rubber or fabrics must be measured under controlled conditions. Many materials have measurement standards specified by A.S.T.M., U.L., or other industry standards organizations. Measurement standards specify dead load weight, upper and lower contact configurations, and Indicator resolution.

Series 57B Gages are easily modified to meet most of these industry standards. Mahr Federal has on file designs for the measurement of paper, latex foam rubber, sponge rubber, vulcanized rubber, asbestos tape and cloth, sheet and roll felt, and many other materials. When inquiring, specify A.S.T.M. Specification Number, if possible.

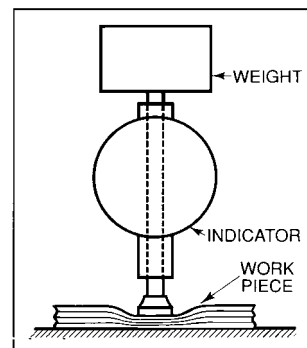



## Thickness Gages 57B Bench Style



57B-12

### Features

- Solid casting with ribbed frame provides strength and rigidity for accurate measurements.
- Gage is furnished with a lift lever so work can be easily placed between the contacts.
- Large 54 mm/ 2.125" diameter lower anvil provides convenient stage for small parts or flat materials.
- 4.75 mm/ .187" diameter radiused upper contact normally provided.
- 102 mm/ 4" throat depth for part clearance.
- Indicator mounts with adjustable back for quick positioning for each gaging requirement.
- Available with Dial Indicator or Digital Electronic Indicator.

### Technical Data

Metric	Order no.	Inch	Capacity mm / <i>inch</i>	Description
57B-11M	57B-11		0 - 25 / 0 - 1"	Dial Indicator readout with 25 mm / 1" sensitive range and .01 mm / .001" grads.
2057548				1086 Digital Indicator with 25 mm/ 1" range and .001 mm / .00005" resolution.
	EMD-57B-11		0 - 21.5 / 0 - .85"	MaxumIII Digital Indicator with selectable range and resolution, 2033101.
	EDI-57B-11			1086 Digital Indicator with 2 mm / .08" sensitive range, .0005 mm / .00002" resolution.
57B-12M	57B-12		0 - 12.5 / 0 - .5"	Dial Indicator readout with 12.50 mm/ .50" sensitive range and .01 mm / .0005" grads.
2057549				1086 Digital Indicator with 12.50 mm / .50" range and .001 mm / .00005" resolution.

*Alternate Indicators and contact points available upon request.  
Contact Mahr Federal.*

## Caliper Gages 49P

The most widely used gages for checking medium tolerance dimensions on patterns, castings, forgings, dies, sheet metal.

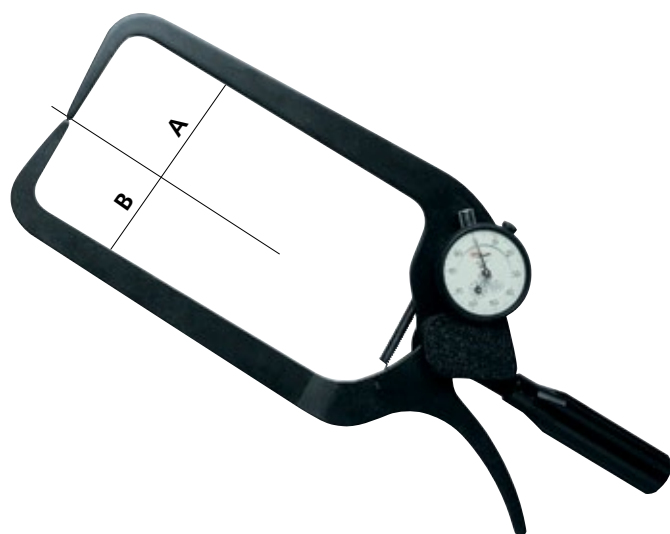

49P

### Features

- The most widely used gages for checking medium tolerance dimensions on patterns, castings, forgings, dies, sheet metal.
- Generous clearance on jaws reaches over non-measured part protrusions for easy access to areas where thickness must meet critical dimensional specs.
- Retraction lever is conveniently located for one-hand operation.
- .02 mm or .1 mm / .01", .001", or 1/64" grads. available.
- Continuous reading dials with revolution counters normally provided.
- Cylindrical radius steel contact tips normally furnished.

### Technical Data

Metric	Order no.		Capacity* mm / <i>inch</i>	Gaging Depth mm / <i>inch</i>	Minimum Graduation mm / <i>inch</i>	A	B
		Inch					
49P-17M	49P-17		0 - 50 / <b>0 - 2"</b>	100 / <b>4"</b>	0.02 / <b>.001"</b> grads.	1-1/4	1-1/4
49P-19M	49P-19		0 - 50 / <b>0 - 2"</b>	200 / <b>8"</b>	0.02 / <b>.001"</b> grads.	2-9/16	2
49P-1M	49P-1		0 - 75 / <b>0 - 3"</b>	100 / <b>4"</b>	0.1 / <b>.01"</b> grads.	1-1/4	1-1/4
49P-2M	49P-2		0 - 75 / <b>0 - 3"</b>	200 / <b>8"</b>	0.1 / <b>.01"</b> grads.	2-9/16	2

\* Ordinarily this gage is used as a comparator. The actual measuring range of the instrument is 38 mm / 1.50".  
If the gage is used for direct linear measurement, chordal errors may need to be corrected.  
Contact Mahr Federal Technical Assistance for details.

### Special Applications

**Series 49P and 149P Caliper Gages** have many design possibilities. Specially shaped arms of various lengths can be designed to reach inaccessible spots or get around obstructions to make measurements possible which might otherwise go unchecked. For alternate contact shapes or materials, alternate capacities and gaging depths, and special designs to meet your application contact Mahr Federal Technical Assistance.

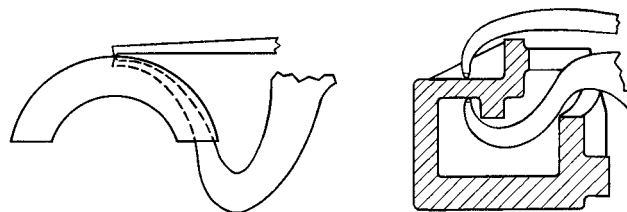

## Gages (Metric) for External Measurement 838 TA to measure thickness and wall thicknesses

### Features

- Contact points are made from carbide
- Absolute measuring instrument
- Easy to operate, very habile and portable
- Easy to read tolerance markers
- IP protection class IP65 according to EN 60529
- Supplied with:  
Test certificate



### Application

- For measuring thicknesses and wall thicknesses

### Technical Data and Dimensions

Measuring range	Meb mm	0 - 10	0 - 20	0 - 20	0 - 50	0 - 50
Readings	Skw mm	0.005	0.01	0.01	0.05	0.05
Error limit	G mm	0.015	0.03	0.03	0.05	0.05
Repeatability limit	r mm	0.005	0.01	0.01	0.025	0.025
Measuring depth	L mm	35	85	85	167	169
Contact point - length (move.)	Hb mm	19.1	24.6	24.6	30	30
Contact point - length (fixed)	Hf mm	18.6	24.6	2.5	30	4.3
Contact point - ball dia.	D mm	1.5	1.5	1.5	3	3
Measuring force	F N	0.8 - 1.2	1.1 - 1.6	1.1 - 1.6	0.8 - 1.7	0.8 - 1.7
<b>Order no.</b>		<b>4495550</b>	<b>4495551</b>	<b>4495552</b>	<b>4495555</b>	<b>4495556</b>

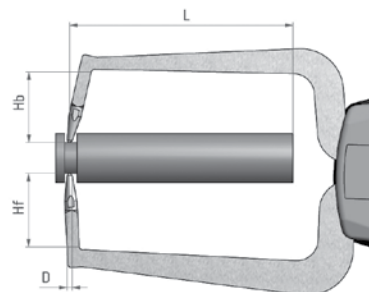

## Gages (Inch) for External Measurement 838 TA to measure thickness and wall thicknesses

### Features

- Contact points are made from carbide
- Absolute measuring instrument
- Easy to operate, very habile and portable
- Easy to read tolerance markers
- IP protection class IP65 according to EN 60529
- Supplied with:  
Test certificate



### Application

- For measuring thicknesses and wall thicknesses

### Technical Data and Dimensions

Measuring range	Meb	<i>inch</i>	0 - .40"	0 - .80"	0 - .80"	0 - 2.0"	0 - 2.0"
Readings	Skw	<i>inch</i>	.0002"	.0005"	.0005"	1"	1"
Error limit	G	<i>inch</i>	.0008"	.0015"	.0015"	2"	2"
Repeatability limit	r	<i>inch</i>	.0002"	.0005"	.0005"	.001"	.001"
Measuring depth	L	<i>inch</i>	1.37"	3.2"	3.2"	6.6"	6.7"
Contact point - length (move.)	Hb	<i>inch</i>	.75"	.97"	.97"	1.18"	1.18"
Contact point - length (fixed)	Hf	<i>inch</i>	.75"	.97"	.097"	1.18"	.17"
Contact point - ball dia.	D	<i>inch</i>	.06"	.06"	.06"	.12"	.12"
Measuring force	F	N	0.8 - 1.2	1.1 - 1.6	1.1 - 1.6	0.8 - 1.7	0.8 - 1.7
<b>Order no.</b>			<b>4495950</b>	<b>4495951</b>	<b>4495952</b>	<b>4495955</b>	<b>4495956</b>

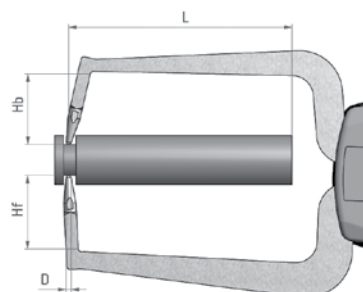

## Electronic Gages for External Measurement 838 EA to measure thickness and wall thicknesses

### Features

#### Functions:

ON/OFF, mm/inch, TOL (enter tolerance limit values), ABS (display can be set to zero, without losing the reference to the Preset value), DATA (Data transmission via connection cable)

- High contrast analog and digital LCD
- Specified measuring programs according to application
- Absolute/Relative measuring program
- Tolerance is displayed with 2 LEDs
- Data interface: Digimatic, USB
- Energy supply: Battery operation
- Protection class IP 67 according to EN 60529
- Supplied with: Instruction manual, Battery, Test certificate



### Applications

- For measuring thicknesses and wall thicknesses

### Technical Data and Dimensions

Measuring range	Meb	mm	0 - 10	0 - 20	0 - 20	0 - 30	0 - 50	0 - 30	0 - 50
Resolution	Skw	mm	0.005	0.01	0.01	0.02	0.02	0.02	0.02
Error limit	G	mm	0.015	0.03	0.03	0.04	0.06	0.04	0.06
Repeatability limit	r	mm	0.005	0.01	0.01	0.02	0.04	0.02	0.04
Measuring depth	L	mm	35	85	85	116	167	116	169
Contact point - length (move.)	Hb	mm	19.1	24.6	24.6	30	30	30	30
Contact point - length (fixed)	Hf	mm	18.6	24.6	2.5	30	30	4	4.3
Contact point - ball dia.	D	mm	1.5	1.5	1.5	3	3	3	3
Measuring force	F	N	0.8 - 1.2	1.1 - 1.6	1.1 - 1.6	0.9 - 1.6	0.8 - 1.7	0.9 - 1.6	0.8 - 1.7
<b>Order no.</b>			<b>4495560</b>	<b>4495561</b>	<b>4495562</b>	<b>4495563</b>	<b>4495564</b>	<b>4495565</b>	<b>4495566</b>

### Accessories

		Order no.
<b>Battery</b> Alkaline AAA 1.5 V		<b>4243073*</b>
<b>Data Connection Cable</b> USB (1.5 m)	838 usb	<b>4495079</b>
<b>Data Connection Cable</b> Digimatic (1.5 m)	838 di (A)	<b>4495083</b>

\* 2 batteries are required

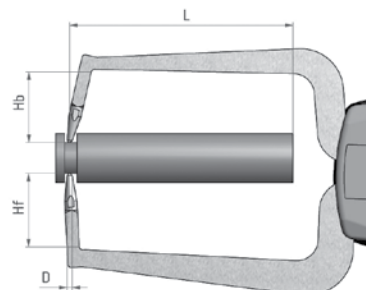

## Electronic Gages for Internal Measurement 838 EI for measuring bores and internal grooves

### Features

#### Functions:

ON/OFF, mm/inch, TOL (enter tolerance limit values), ABS (display can be set to zero, without losing the reference to the Preset value), DATA (Data transmission via connection cable)

- High contrast analog and digital LCD
- Specified measuring programs according to application
- Absolute/Relative measuring program
- Tolerance is displayed with 2 LEDs
- Data interface: Digimatic, USB
- Energy supply: Battery operation
- Protection class IP 67 according to EN 60529
- Supplied with: Instruction manual, Battery, Test certificate



### Applications

- For measuring bores and internal grooves

### Technical Data and Dimensions

Measuring range	Meb	mm	5 - 15	10 - 30	20 - 40	30 - 50	40 - 60	50 - 70	13 - 43	30 - 60	50 - 80
Resolution	Skw	mm	0.005	0.01	0.01	0.01	0.01	0.01	0.02	0.02	0.02
Error limit	G	mm	0.015	0.03	0.03	0.03	0.03	0.03	0.04	0.04	0.04
Repeatability limit	r	mm	0.005	0.01	0.01	0.01	0.01	0.01	0.02	0.02	0.02
Measuring depth	L	mm	35	85	85	85	85	85	127	132	132
Groove depth	A	mm	2.3	5.2	7.0	7.0	8.3	8.3	5.7	6.2	8.3
Groove width	B	mm	0.8	1.2	1.2	1.2	1.2	1.2	1.6	1.8	2.4
Contact point - length (move.)	Hb	mm	2.5	5.4	7.3	7.3	12.2	12.2	5.7	6.5	8.5
Contact point - length (fixed)	Hf	mm	2.5	5.4	7.3	7.3	12.2	12.2	5.7	6.5	8.5
Contact point - ball dia.	D	mm	0.6	1	1	1	1	1	1.3	1.5	2
Measuring force	F	N	0.8 - 1.2	1.1 - 1.6	1.1 - 1.6	1.1 - 1.6	1.1 - 1.6	1.1 - 1.6	1.2 - 1.7	1.2 - 1.7	1.2 - 1.7

#### Order no.

**4495590 4495591 4495592 4495593 4495594 4495595 4495598 4495599 4495600**

### Accessories

	Order no.
<b>Battery</b> Alkaline AAA 1.5 V	<b>4243073*</b>
<b>Data Connection Cable</b> USB (1.5 m)	<b>4495079</b>
<b>Data Connection Cable</b> Digimatic (1.5 m)	<b>4495083</b>

\* 2 batteries are required

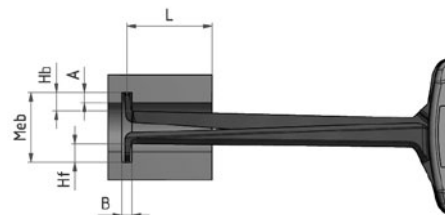

## Gages (Metric) for Internal Measurement 838 TI for measuring bores and internal grooves

### Features

- Contact points are made from carbide
- Absolute measuring instrument
- Easy to operate, very habile and portable
- Easy to read tolerance markers
- IP protection class IP65 according to EN 60529
- Supplied with:  
Test certificate



### Applications

- For measuring bores and internal grooves

### Technical Data and Dimensions

Measuring range	Meb	mm	5 - 15	10 - 30	20 - 40	30 - 50	40 - 60	50 - 70	15 - 65	40 - 90
Readings	Skw	mm	0.005	0.01	0.01	0.01	0.01	0.01	0.05	0.05
Error limit	G	mm	0.015	0.03	0.03	0.03	0.03	0.03	0.05	0.05
Repeatability limit	r	mm	0.005	0.01	0.01	0.01	0.01	0.01	0.025	0.025
Measuring depth	L	mm	35	85	85	85	85	85	188	192
Groove depth	A	mm	2.3	5.2	7.0	7.0	8.3	8.3	5.5	8.3
Groove width	B	mm	0.8	1.2	1.2	1.2	1.2	1.2	1.9	2.4
Contact point - length (move.)	Hb	mm	2.5	5.4	7.3	7.3	12.2	12.2	6	8.5
Contact point - length (fixed)	Hf	mm	2.5	5.4	7.3	7.3	12.2	12.2	6	8.5
Contact point - ball dia.	D	mm	0.6	1	1	1	1	1	1.5	2
Measuring force	F	N	0.8 - 1.2	1.1 - 1.6	1.1 - 1.6	1.1 - 1.6	1.1 - 1.6	1.1 - 1.6	0.9 - 1.9	0.9 - 1.9
<b>Order no.</b>			<b>4495580</b>	<b>4495581</b>	<b>4495582</b>	<b>4495583</b>	<b>4495584</b>	<b>4495585</b>	<b>4495586</b>	<b>4495587</b>

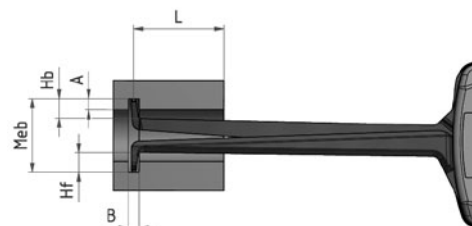

## Gages (Inch) for Internal Measurement 838 TI for measuring bores and internal grooves

### Features

- Contact points are made from carbide
- Absolute measuring instrument
- Easy to operate, very habile and portable
- Easy to read tolerance markers
- IP protection class IP65 according to EN 60529
- Supplied with:  
Test certificate



### Applications

- For measuring bores and internal grooves

### Technical Data and Dimensions

Measuring range	Meb	<i>inch</i>	.20-.60"	.40-1.20"	.80-1.60"	1.20-2.00"	1.60-2.40"	2.00-2.80"	.60-2.60"	1.60-3.60"
Readings	Skw	<i>inch</i>	.0002"	.0005"	.0005"	.0005"	.0005"	.0005"	.001"	.001"
Error limit	G	<i>inch</i>	.0008"	.0015"	.0015"	.0015"	.0015"	.0015"	.002"	.002"
Repeatability limit	r	<i>inch</i>	.0002"	.0005"	.0005"	.0005"	.0005"	.0005"	.001"	.001"
Measuring depth	L	<i>inch</i>	1.37"	3.2"	3.2"	3.2"	3.2"	3.2"	7.5"	7.6"
Groove depth	A	<i>inch</i>	.09"	.19"	.26"	.26"	.31"	.31"	.2"	.2"
Groove width	B	<i>inch</i>	.032"	.06"	.08"	.08"	.08"	.08"	.08"	.1"
Contact point - length (move.)	Hb	<i>inch</i>	.097"	.21"	.29"	.29"	.33"	.33"	.25"	.33"
Contact point - length (fixed)	Hf	<i>inch</i>	.097"	.21"	.29"	.29"	.33"	.33"	.25"	.33"
Contact point - ball dia.	D	<i>inch</i>	.024"	.04"	.04"	.04"	.04"	.04"	.06"	.08"
Measuring force	F	N	0.8 - 1.2	1.1 - 1.6	1.1 - 1.6	1.1 - 1.6	1.1 - 1.6	1.1 - 1.6	0.9 - 1.9	0.9 - 1.9
<b>Order no.</b>			<b>4495980</b>	<b>4495981</b>	<b>4495982</b>	<b>4495983</b>	<b>4495984</b>	<b>4495985</b>	<b>4495986</b>	<b>4495987</b>

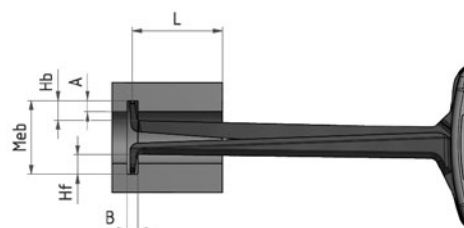



# Definition of Terms Specifications for inspection and test acceptance procedure of mechanical and electronic caliper gages

## 1. Basics

The inspection only follows approximately the testing methods and procedures of the German standard DIN 878 for dial gages and the testing statements for caliper gages according to VDI/VDE/DGQ 2618 sheet 12.1 and 13.1. The gages are referred to without special reference as gages for 'absolute' measurements and adjustable zero point.

## 2. Definitions

Definitions of length checking techniques see DIN 2257 part 1 and part 2 (see Illustration).

### 2.1 Application range Awb

Application range Awb of a gage corresponds to the sum of adjusting and measuring range.

### 2.2. Measuring range Meb

The measuring range of an indicating gage represents the range of measuring values in which agreed error limits must not be exceeded.

### 2.3 Reading Zw

The reading Zw of a numerical interval of a numerical scale is the modification of the value of a measured variable that causes the modification of the indication by one interval. The numerical interval corresponds to the scale interval of a line scale and is indicated in the unity of the measured variable.

### 2.4 Scale interval Skw

The scale interval Skw is indicated on the scale, i.e. 0.01 mm. It corresponds to the measuring value between two scale graduation marks.

### 2.5 Deviation within the measuring range f<sub>M</sub>

The deviation within the measuring range (range of deviation) f<sub>M</sub> represents the distance of ordinates between the highest and the lowest position in the deviation diagram when the movable caliper arm closes. The **error limits G** for f<sub>M</sub> is symmetrically positioned to the zero line.

The deviation in the partial measuring range f<sub>t</sub> can only be determined by using electronic testing methods during the preparation of certificates of quality.

### 2.6 Repeatability f<sub>w</sub>

Repeatability f<sub>w</sub> is a characteristic value for deviations of the measured variable within the measuring range in the same motion direction of the movable caliper arm (usually n is 5).

The limits of error f<sub>w</sub> are referred to with **repeatability limit r**.

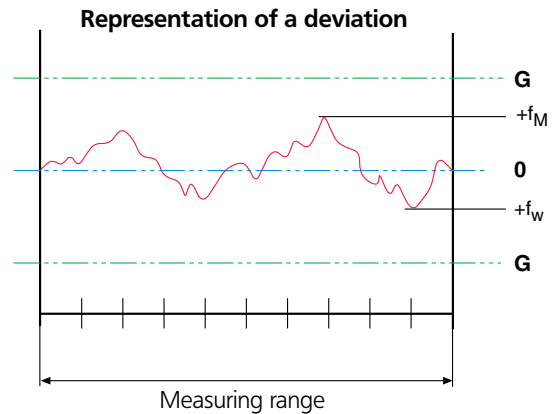

## Measuring Capacity of Internal Measuring Instruments

Data listed in the table referring to groove depth A, groove width B and measuring depth L are only meant to be rough guidelines. For each type of instrument there is dependence of these three values from each other and on the application range Awb. This is shown in the adjacent table of examples. For each inside measuring instrument this table is available upon request in conjunction with a detailed data sheet.

Groove depth A (mm)	Application range Awb (mm)										
	10	11	12	13	14	15	16	17	18	19	20
0	0/55	0/55	0/56	0/56	0/57	0/57	0/57	0/57	0/57	0/57	0/58
0.5		1.4/55	1.4/56	1.4/56	1.4/56	1.4/56	1.4/56	1.4/56	1.4/57	1.4/57	1.4/57
1			1.4/56	1.4/56	1.4/56	1.4/56	1.4/56	1.4/56	1.4/56	1.4/56	1.4/57
1.5				1.4/55	1.4/55	1.4/55	1.4/55	1.4/56	1.4/56	1.4/56	1.4/56
2					1.4/55	1.4/55	1.4/55	1.5/55	1.5/55	1.5/56	1.5/56
2.5						1.4/55	1.5/55	1.5/55	1.6/55	1.6/55	1.6/55
3							1.5/54	1.6/54	1.6/55	1.6/55	1.6/55
3.5								1.6/54	1.6/54	1.6/54	1.6/55
4									1.7/54	1.7/54	1.7/54
4.5										1.7/53	1.8/54

Relationship W/L

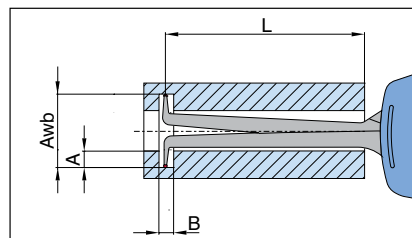

B = Min. groove depth (mm)  
L = Max. usable caliper arm length (mm)

Example: Awb = 12      B = 1.4  
              A = 0.5        L = 56

## Indicating Depth Gage 837



### Features

- Cross beam is hard chrome plated and hardened
- Measuring faces are finely lapped
- Supplied with: Cross beam, Anvil 902 12 mm

### Technical Data

Length of cross beam mm	Width of cross beam mm	Flatness of the cross beam	Mounting hole mm	Order no.*
80	16	DIN 876/0	8H7	4494010
100	16	DIN 876/0	8H7	4494011
150	20	DIN 876/0	8H7	4494012

\* Excludes indicating instrument

### Accessories

#### Spherical Contact Points 902

Depth measuring range* mm	L mm	Order no.
10 - 20	25	4360015
20 - 30	35	4360017
30 - 40	45	4360026
40 - 50	55	4360031
50 - 60	65	4360035
60 - 70	75	4360020
70 - 80	85	4360036
80 - 90	95	4360029

\* for Indicators with a 10 mm measuring range

#### Indicating Instruments

Recommended are:

Indicator	Readings / Resolution mm	Measuring range mm	Order no.
810 AT	0.01	10	4311060
1075 R	0.01	12.5	4336010
1086 R	0.01	25	4337130
1086 R	0.01	50	4337131

## Indicating Depth Gage 65P-40, 75P-30



75P-35



75P-30



65P-40

### Features

- **65P-40** has a "V" shaped base and a needle contact. Movement is "Push-Down" style. Ideal for measuring etch depth, pits, or small, shallow recesses.
- **75P-30** Depth Gages have rectangular, flat base and a radiused contact point. 75P-30 is supplied with contact point, for measuring depths from the base as a reference. Contact points for other depths are available upon request.
- **75P-35** Depth Gages have three interchangeable contact points, allowing inspection of depths to 76 mm / 3". Check depths against a setting

### Technical Data

Order no. Metric	Order no. Inch	Capacity	Range of Sensitive	Graduation Contact	Base Dimensions	Contact Style/ Length
65P-40M	65P-40	0-2 mm / <b>0-.075"</b>	0-2 mm / <b>0-.075"</b>	0.01 mm / <b>.0005"</b>	64 mm / <b>2.50"</b>	Needle
75P-30M	75P-30	0-4 mm / <b>0-.15"</b>	0-4 mm / <b>0-.15"</b>	0.01 mm / <b>.0005"</b>	64x14 mm / <b>2.5x.56"</b>	radiused: 3 mm / <b>.13"</b>
75P-35M	75P-35	0-75 mm / <b>0-3"</b>	0-75 mm / <b>0-3"</b>	0.01 mm / <b>.001"</b>	64x14 mm / <b>2.5x.56"</b>	(3) radiused: 3 mm / <b>.13"</b> 28 mm / <b>1.13"</b> 54 mm / <b>2.13"</b>

## Depth Gages 75P-50



75P-52 with Setting Master

### Features

- Modular depth gages for all applications.
- Single and multi-purpose bases with choice of Dial Indicator for comparative or direct measurement.
- Indicator collet mounting allows easy interchangeability of Indicators and bases — use one Indicator with several bases or change Indicators to meet range requirements.
- Family of contact points available to cover wide range of depth measurement applications.
- Setting masters available with anvil ground to specified depth ( $\pm 0.0025$  mm /  $\pm .0001$ " in accuracy).

### Technical Data

• **For Comparative Measurement:** Unless otherwise specified, a comparative measurement Indicator will be furnished. Correct contact point will be furnished for the gaging depth specified.

Metric: Furnished with .01 mm grads. / 2.50 mm range, balance dial.

Inch: Furnished with .0005" grads. / .075" range, balanced dial.

• **For Direct Measurement:** (Special Order) Contact point for 0-25 mm / 0-1" depth will be furnished unless otherwise specified.

Metric: Model SP6IS (0.01 mm grads. / 25 mm range, continuous dial with revolution counter).

Inch: Model 28ISN (.001" grads. / 1" range, continuous dial with revolution counter).

Digital: Model 2034212 (.001 mm/.00005" resolution, 25 mm / 1" range)

• For long range models contact Mahr Federal.

**Base Dimensions** (all bases are 15 mm / .59" high x 19 mm / .75" wide)

Order no.	Length	Width	Diameter	Measuring Positions	Base only Model*	
Metric	Inch	mm / inch	mm / inch			
75P-50M	75P-50	50 / 2"	19 / .75"	—	One	BA-42
75P-51M	75P-51	76 / 3"	19 / .75"	—	One	BA-43
75P-52M	75P-52	102 / 4"	19 / .75"	—	Two	BA-44
75P-53M	75P-53	152 / 6"	19 / .75"	—	Three	BA-45
75P-54M	75P-54	203 / 8"	19 / .75"	—	Three	BA-46
75P-55M	75P-55	—	—	19 / .75"	One	BA-47
75P-56M	75P-56	—	—	32 / 1.25"	One	BA-76

### Ordering Information

**When ordering please specify:**

1. Model Number.
2. Comparative or Direct Measurement.
3. Depth to be gaged.
4. Master Setting Block, if required.
5. Any special or optional features such as special contact points, Indicator Housing, or alternate Indicators.

\* If base only is specified, it is supplied without the indicator holding collet, model AD-87.

Order collet separately if required.

## Depth Gages 75P-50

### Contact Points

To increase the versatility of any **75P-50** Series Depth Gage, additional contacts may be used to extend the capacity of the gage. Specify additional contact points required from the table at right.

To order the entire set of points, order by Model **PT-750** Contact Point Set.

Gaging Depth			Contact Point	$\mu$ Max $\mu$ m
mm	/	inch	model*	
0.00	- 1.60	/ 0 - .063"	PT-201	PT-564
1.60	- 4.80	/ .063 - .188"	PT-232	PT-14
4.80	- 8	/ .188 - .313"	PT-305	PT-564
8	- 11	/ .313 - .438"	PT-565	PT-31
11	- 14	/ .438 - .563"	PT-239	PT-201
14	- 17.50	/ .563 - .688"	PT-50	PT-232
17.50	- 21	/ .688 - .813"	PT-235	PT-305
21	- 24	/ .813 - .938"	PT-241	PT-565
24	- 27	/ .938 - 1.063"	PT-100	PT-239
27	- 30	/ 1.063 - 1.188"	PT-51	PT-50
30	- 33.40	/ 1.188 - 1.313"	PT-243	PT-235
33.4	- 37	/ 1.313 - 1.438"	PT-696	PT-241
37	- 40	/ 1.438 - 1.563"	PT-101	PT-100
40	- 43	/ 1.563 - 1.688"	PT-245	PT-51
43	- 46	/ 1.688 - 1.813"	PT-102	PT-243
46	- 49	/ 1.813 - 1.938"	PT-566	PT-696
49	- 52.4	/ 1.938 - 2.063"	PT-247	PT-101

\* For "C" size dial indicators, "EDI-" and  $\mu$ Max $\mu$ m Digital Indicators.

### Semi-finished Model

0-25 mm/ 0-1"	25-50 mm/ 1-2"	Gaging Positions	Used with Model	"A"	"B"	"C"	"D"
<b>MR-501</b>	<b>MR-502</b>	One	75P-50, 75P-30/35	25 mm/ 1"	25 mm/ 1"	—	—
<b>MR-511</b>	<b>MR-512</b>	One	75P-51	38 mm/ 1.5"	38 mm/ 1.5"	—	—
<b>MR-521</b>	<b>MR-522</b>	Two	75P-52	50 mm/ 2"	25 mm/ 1"	25 mm/ 1"	—
<b>MR-531</b>	<b>MR-532</b>	Three	75P-53	75 mm/ 3"	25 mm/ 1"	25 mm/ 1"	25 mm/ 1"
<b>MR-541</b>	<b>MR-542</b>	Three	75P-54	102 mm/ 4"	25 mm/ 1"	25 mm/ 1"	25 mm/ 1"
<b>MR-551</b>	<b>MR-552</b>	One 75P-56	75P-55, .68"	17 mm/ .68"	17 mm/ .68"	—	—

Six different setting masters are available for Series 75P Models. Setting masters are available in two styles: Finished (ground to final size) and Semi-finished (assembled but not ground to final size). Finished depths available from 0 - 50 mm / 0 - 2". Unground Anvil can be purchased separately. Specify **Model AL-89**.

For multi-position masters, please specify the anvil location. Protective Housings for the Dial Indicator are available, see page 5-23.

For Series 75P-50 style depth gages with alternate Indicators, greater gaging depth, alternate contact configurations or other modifications, contact Mahr Federal Technical Assistance.

For master finished to size, specify size and add suffix "F". Example: MR-502F, size 1.265" (Master for 75P-50 set to 1.265").

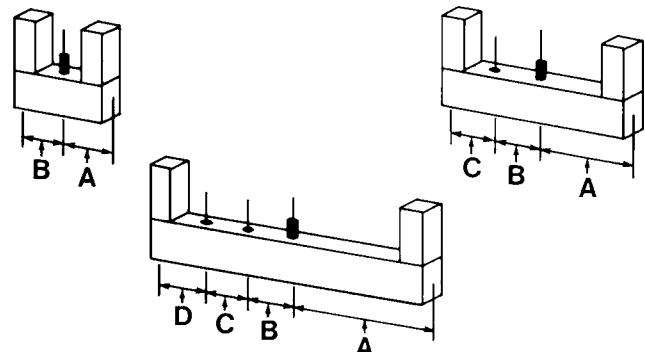

## Bench Depth Gages 75B-1

For inspecting small parts



75B-1

### Features

- Available with Dial Indicator (75B-1 Models) or Max $\mu$ m<sup>®</sup>/// and  $\mu$ Max $\mu$ m<sup>®</sup>/// Digital Electronic Indicators (EMD-75B and XLI-75B Models).
- 89 x 102 mm / 3.50 x 4" hardened, ground work surface provides excellent reference surface.
- Four #10-32 tapped holes provided for mounting part location fixturing.
- Indicator adjustable vertically over 32 mm / 1.25".
- Two contact points provided, 6 mm / .25" and 32 mm / 1.25" to check features up to 50 mm / 2" deep.

### Technical Data

Metric	Order no. Inch	Indicator Range / Graduation or Resolution
75B-1M	75B-1	25 mm / .01 mm ( <b>1" / .001"</b> ) graduation Dial Indicator.
EMD-75B-1		Max $\mu$ m <sup>®</sup> /// Digital Indicator with selectable range and resolution, 2033201.
2057552		1086 R Digital Indicator, 25 mm / <b>1"</b> range, .001 mm / <b>.00005"</b> resolution
2057553		1086 R Digital Indicator, 12 mm / <b>.50"</b> range, .001 mm / <b>.00005"</b> resolution

To specify Digital Output on EMD-75B Models, add suffix "D". Example = EMD-75B-1D.  
Output is standard with 1086 R and EDI models.



1086 R

## Dimetron® Plug Gages

### The Dimetron System - Built for Performance



Dimetron Plug Assembly – shown with *Maxium®III* Indicator, Housing and Handle



Special depth gaging applications



Shown with bench stand 2239307 & plug holder 2248358

The Dimetron plug gage, which is formed by the plug body, the panto-assembly with contacts and the transfer rod, is the measuring system comprising the Dimetron plug. It can be interchanged by simply unscrewing it from the display assembly.

The **plug body** is made from through hardened 440 stainless steel, tempered and ground, with hardness 52-56 HRC, guides the plug gage; its easy entry guide facilitate introduction into the bore.

Standard **contacts** are made of tungsten carbide and based on the bore diameter range, come in two possible radii. Other contact materials are available based on the part being measured. Diamond, Ruby or hard-chrome-covered contacts are also available. Diamond or ruby contacts are suggested for soft aluminum or highly wearing applications; hard chromed ones (1000 HV) for aluminum and relevant alloys. Also based on the thickness of the surface available options cylindrical contacts may be ordered.

Either 2 or 4 steel spring assemblies **form panto-spring assemblies**. The design of the transfer assembly is determined by the diameter of the plug. This panto-design produces true straight-line transfer to the Vee-rod.

A **transfer rod**, with spherical tungsten carbide tip, slides on a tempered steel V-shaped guide and inclined plane, transferring the measurement to the display device. This unique floating system has been designed and tested to resist for over 10,000,000 measuring cycles.

Though designed for the toughest shop conditions, wear items do occasionally need replacement. Because of the individual components **service is fast and easy**. All parts are available separately from Mahr Federal and with standard tools, can be replaced in minutes to help maintain up time on the floor.

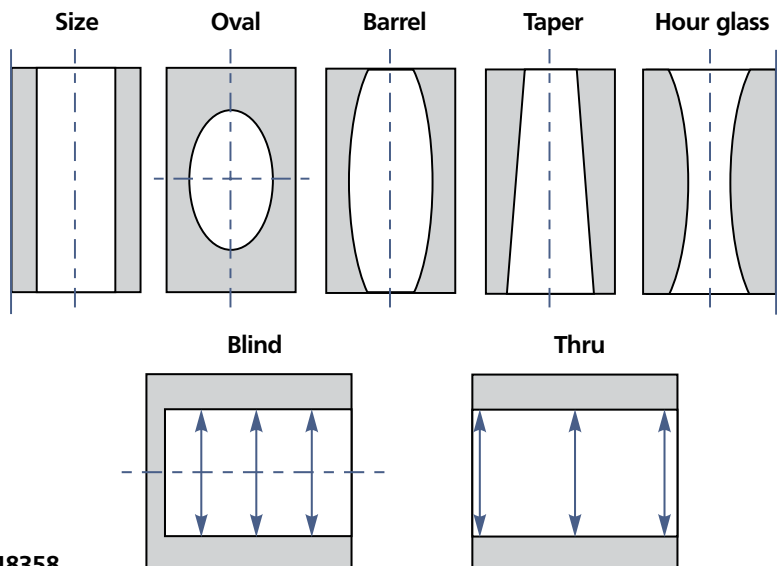

## Dimentron® Plug Inside Diameter Gages



**Thru-hole and Blind Hole Dimentron Plugs**

### Features

- Designed for high production I.D. gaging.
- High chrome content; hardened stainless steel bodies ground precisely for specified size measurement.
- Plug tooling interchangeable for quick changeover.
- Measuring is easy – just insert plug into diameter and read. No rocking needed.
- Set to nominal dimension with a single master ring.
- Long life: Tungsten carbide contacts and vee rod ensure durable motion transfer.
- Three styles of plugs available – Thru-hole, Blind Hole and Super-blind.
- Open design rinses clean easily.
- Explore bores for taper, barrel shape, bell-mouth and 2-point out-of-round.
- Stop Collars available for all standard sizes.
- Captive vee rod design.

### Technical Data

#### Blind Hole Plugs

Use Dimension "A" below. Dimension "B" is 4 mm / .157".

#### Super-blind Plugs

Use Dimension "A" below. Dimension "B" is 2 mm / .08", for 5.5 mm / .217" & up .108" for 3.2 mm / .125" to 5.5 mm / .217"

#### Super-Super blind Plugs

Use Dimension "A" below. Dimension "B" is 0.79 mm / .031". (4.500" to 9.000" are not available with this model.)

### Dimention Plug Dimensions

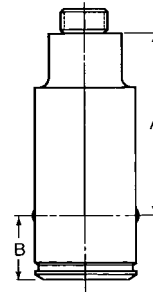

**Blind Hole Plugs**



*A Dimentron Plug Gage with digital Electronic Indicator makes a compact, portable hand tool.*

#### Thru-hole Plugs

Sizes above	To and include	A	B	Group*
mm / inch	mm / inch	mm / inch	mm / inch	
3.2 / .125"	5.5 / .217"	31.4 / 1.23"	6.4 / .25"	no group*
5.5 / .217"	8.2 / 0.322"	34.8 / 1.37"	6.5 / .256"	5
8.2 / .322"	9.5 / .375"	34.8 / 1.37"	6.5 / .256"	6
9.5 / .375"	12.7 / 0.50"	35.4 / 1.39"	13 / .512"	8
12.7 / .50"	19.05 / .75"	35.4 / 1.39"	13 / .512"	8
19.05 / .75"	25 / 1"	48.3 / 1.90"	16 / .63"	12
25 / 1"	38 / 1.50"	48.3 / 1.90"	16 / .63"	12
38 / 1.50"	63 / 2.50"	46.7 / 1.84"	19 / .748"	12
63 / 2.50"	114.3 / 4.5"	46.7 / 1.84"	19 / .748"	12
114.3 / 4.50"	228.6 / 9.0"	46.7 / 1.84"	9.5 / .375"	12

\* Group Number specifies thread size on gaging plugs. Threaded bushings are provided with each plug to allow mounting to Maxym® Adaptor or Electronic Handle Assembly.

\*\* Only available as Thru- and Blind Hole Small Bore Probe. For larger or smaller plugs, alternate contact materials, extended gaging depths, more clearance, or other plug modifications - contact Mahr Federal Technical Assistance.



## Dimentron® Plug Inside Diameter Gages



shown with 1087 Digital Indicator and Housing

**Dimentron Plug Assembly**  
shown with Maxµm III Indicator,  
Housing and Handle

### Ordering Information

When ordering specify:

1. Diameter
2. Tolerance
3. Gaging depth
4. Plug style
5. Contact type — polished chrome steel or tungsten carbide
6. Stop collar

#### Gaging Range:

Dimentron Plugs are ground to one of four measuring ranges, based on part tolerance.

### Technical Data

Sizes above mm / inch	To and include mm / inch	Metric M01 Inch 050 mm / inch	Maximum Part Tolerance			
			M02 100 mm / inch	M05 200 mm / inch	M08 400 mm / inch	
3.18 / .1250"	3.62 / .1426"	±0.025 / ±.0010"	±0.038 / ±.0015"			
3.62 / .1426"	5.52 / .2171"	±0.025 / ±.0010"	±0.046 / ±.0018"	±0.076 / ±.0030"		
5.50 / .2171"	7.94 / .3125"	±0.025 / ±.0010"	±0.046 / ±.0018"	±0.069 / ±.0027"	±0.102 / ±.0040"	
7.94 / .3125"	9.50 / .375"	±0.030 / ±.0012"	±0.051 / ±.0020"	±0.069 / ±.0027"	±0.127 / ±.0050"	
9.50 / .3750"	12.7 / .500"	±0.038 / ±.0015"	±0.058 / ±.0023"	±0.086 / ±.0034"	±0.137 / ±.0054"	
12.7 / .5000"	19.05 / .750"	±0.038 / ±.0015"	±0.069 / ±.0027"	±0.102 / ±.0040"	±0.165 / ±.0065"	
19.05 / .750"	25.4 / 1.000"	±0.038 / ±.0015"	±0.076 / ±.0030"	±0.127 / ±.0050"	±0.180 / ±.0071"	
25.4 / 1.000"	38 / 1.500"	±0.038 / ±.0015"	±0.076 / ±.0030"	±0.152 / ±.0060"	±0.221 / ±.0087"	
38 / 1.500"	114.3 / 4.50"		±0.076 / ±.0030"	±0.152 / ±.0060"	±0.254 / ±.0100"	
114.3 / 4.5"	229 / 9.00"			±0.152 / ±.0060"	±0.254 / ±.0100"	

Order Maxµm Indicator and Accessories separately.

#### Maxµm III Indicator

Inch: Specify **2033101** (**2033111** if Digital Output is required) for .00005" resolution, .0001" grad., and "0" on the Indicator in the 12 o'clock position.  
For "0" at 6 o'clock position, specify **2033201**.

Metric: Specify **2033101** (**2033111** if Digital Output is required) for 0.001 mm resolution, 0.001 mm grad., and "0" at 12 o'clock.  
For "0" at 6 o'clock position, specify **2033201**.

**EKT-1120-W1** is required to mount the Maxµm III Indicator to Dimentron Plugs. (Specify **EKT-1120-W2** for Maxµm III Indicators with 8 mm stems). This adaptor kit includes mounting adaptor, hex wrench, and flat-end, contact point for the Indicator.

Other models include:

**EKT-1120-W3** — EDI/Dial .375" stem — 4-48 thread

**EKT-1120-W4** — EDI/Dial 8 mm stem — 2.5 thread

**EKT-1120-W6** — 1002 - 1010 8 mm stem — 2.5 thread

#### Protective Housings for Plugs over 50 mm/ 2"

**EHG-1172** For Maxµm III Indicators without Output. Requires in-line or pistol style grip Handle (**HA-88** Handle and **AT-124** Adaptor).  
**EHG-1198** For Maxµm III Indicators with Output. Requires pistol style grip Handle (**HA-88** and **AT-124** Adaptor).

**B-12668** For Maxµm III Indicators with Output. Complete with in-line style handle. **AT-125** Bench Stand Adaptor permits the Maxµm Indicator in a Protective Housing to be clamped in **BA-26** Bench Stand. (See pages 9-5 and 9-7)

## Dimentron® Plug Inside Diameter Gages

### With Electronic Gage Heads

Gage heads are mounted to Dimentron Plugs using HA-88 and AD-140 Adaptor. Electronic Gage Heads can be ordered separately. The following Handle Assemblies include Adaptor, Wrenches and Gage Head:

### Handle Assemblies

Order no.	Description
EHA-1146	Flat Contact 3 m / 11 ft, coiled cable
EHA-1145	Flat Contact 1.5 m / 5 ft, straight cable

### Accessories

#### Base, BA-100

Heavy cast base has tooling plate allowing plug to be mounted vertically or horizontally. Can be used with Electronic Gage Heads or Maxµm Remote Transducers or Maxµm/// Digital Transducers.

#### Stop Collars

Stop collars are available for all Dimentron Plugs.



Right Angle Adaptor  
AT-155

### Extensions

Extensions for Dimentron Plugs are available for Plugs over 9.5 mm / .375". See table below:

Group 8 Plugs 9.3 mm/.366" O.D.	Group 12 Plugs 16 mm/.63" O.D.	Extension Length
EX-204	EX-210	50 mm / 1.97"
EX-205	EX-211	100 mm / 3.94"
EX-206	EX-212	200 mm / 7.87"

Consists of 1280P Indicator and Handle Assembly with stocked adaptor:

Order no.	Minimum graduation
Inch 550P-10	Dial Indicator .0001"
Metric 550P-20	Dial Indicator .002 mm
EDI-550P-10	(with 2034101) .00005" / .001 mm
EDI-550P-20	(with 2034201) .00002" / .0005 mm



EDI-550P-10



Remote Maxµm Transducer or Maxµm///  
Digital Transducer Dimentron Plug  
Handle/ Adaptor: HA-141



BA-100 (Dimentron Plug not included)

## Dimetron® Plug Inside Diameter Gages

This table depicts available readouts for Dimetron Plug Inside Diameter Gages. After making a Plug selection, follow the chart for all the components needed to make up a gaging system suited to your application.

Dimetron Plug Gage	Adaptors	Handles	Readout	Housing Housings	Handle
--------------------	----------	---------	---------	------------------	--------

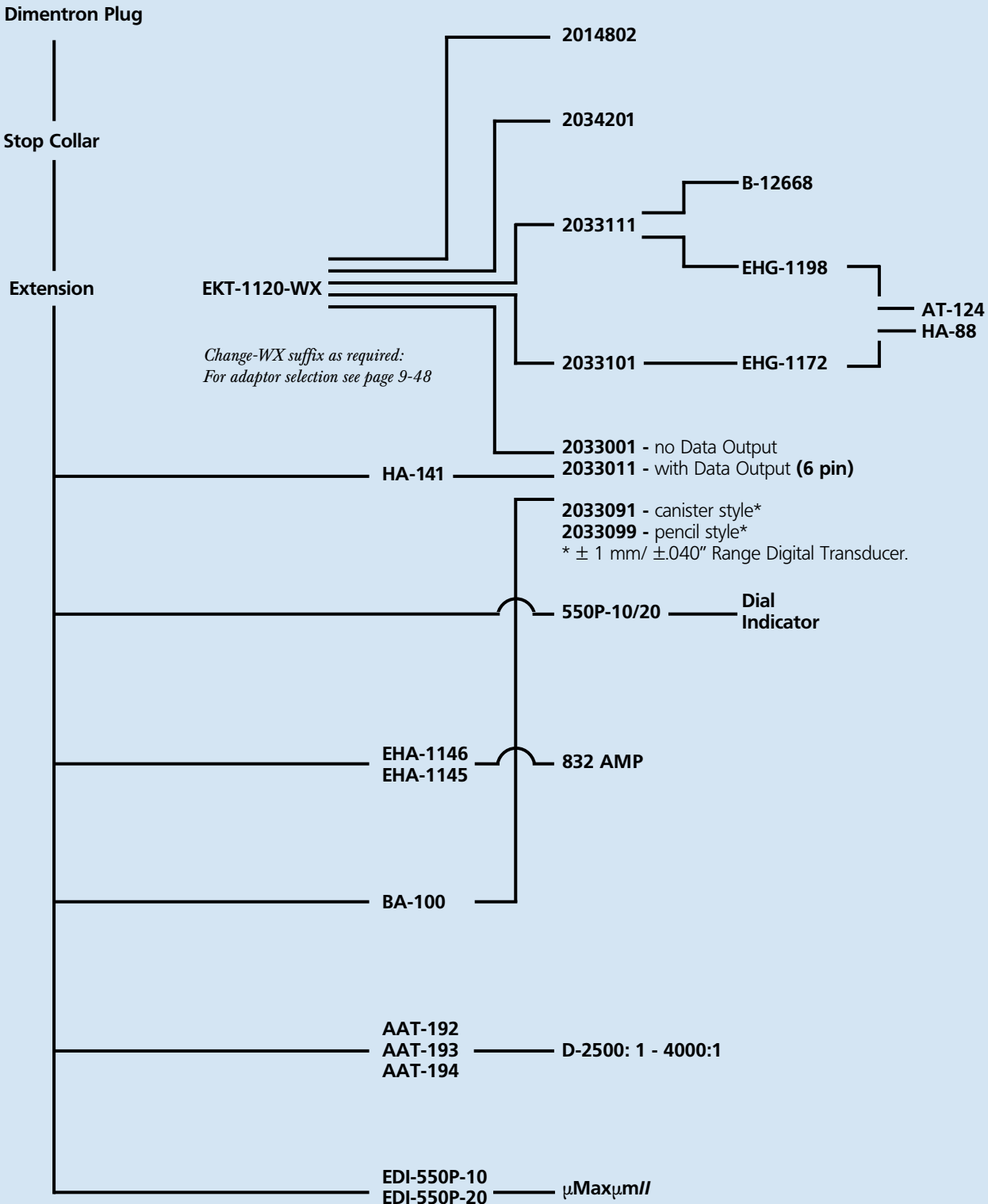

## Indicating Plug Gages 844 D



### Features

- For the rapid testing of diameter, roundness and conicity of bores
- Especially suitable for testing batches with tight tolerances
- No rocking in the bore is required to determine the reversal point
- Therefore ideal for use in conjunction with a digital indicating instrument and for subsequent processing of measured values
- Measuring head has a hardened chromium plated guide cylinder and carbide tipped anvils
- The carbide expanding pin transfers radial movement to indicating instrument
- Constant measuring force as a result of built-in spring, thus eliminating user influence
- Measuring head, holder, depth extension, right angle attachments and depth stops are part of an extensive modular system

### Technical Data of the Measuring Heads

Nominal diameter of the bore	Measuring range starting from the minimum bore dimension to be measured	
	844 Dk/844Dkr	844 Dks (from 4 mm)
2.98 - 8 mm	= - 0.02 + 0.1 mm	= - 0.02 + 0.1 mm
over 8 - 16 mm	= - 0.02 + 0.15 mm	= - 0.02 + 0.15 mm
over 16 - 32 mm	= - 0.02 + 0.2 mm	= - 0.02 + 0.15 mm
over 32 - 70 mm	= - 0.03 + 0.2 mm	= - 0.03 + 0.15 mm
over 70 - 200 mm	= - 0.04 + 0.2 mm	= - 0.04 + 0.15 mm

When placing an order please quote the nominal diameter and tolerances, for example:

Bore diameter	Tolerance	
35 D7	+ 80	+105 $\mu\text{m}$
35 H7	+ 0	+25 $\mu\text{m}$
35 R7	- 50	-25 $\mu\text{m}$

The diameter of the guide cylinder is produced between 0.02 and 0.07 mm smaller than the minimum dimension of the bore to be checked.

#### Example:

Plug Gage 844 Dk for bore 35 D7  
 Nominal diameter: 35 mm  
 Minimum dimension: 35.080 mm  
 Maximum dimension: 35.105 mm  
 Meas. range: 35.050 - 35.280 mm

### Accuracy

Hysteresis  
 Repeatability  
 Linearity  
 Linearity 844 Dks >8 mm

$f_U \leq 0.4 \mu\text{m}$   
 $f_W \leq 1 \mu\text{m}$   
 $\leq 1 \%$   
 $\leq 2 \%$

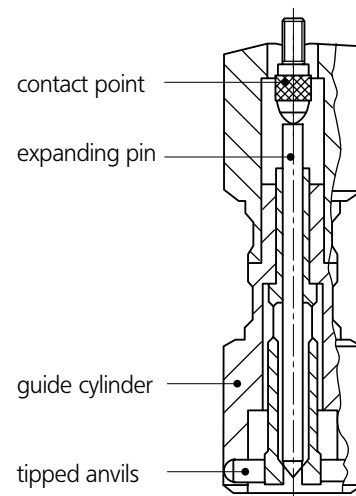

## Plug Gages

### Measuring Head 844 Dk, Standard version

	Nominal <sup>①</sup> diameter		Manufacturing <sup>②</sup> tolerance	Meas. range <sup>③</sup> dia. d	Order no.	
	mm	mm	mm			
over	2.98 - 3.99		-0.02/-0.04	0.1	<b>4480184*</b>	
	3.99 - 8		-0.02/-0.04	0.1	<b>4478200*</b>	
over	8 - 16		-0.02/-0.04	0.15	<b>4478201</b>	
over	16 - 25		-0.02/-0.05	0.2	<b>4478202</b>	
over	25 - 32		-0.02/-0.05	0.2	<b>4478204</b>	
over	32 - 44		-0.02/-0.06	0.2	<b>4478205</b>	
over	44 - 50		-0.03/-0.06	0.2	<b>4478206</b>	
over	50 - 60		-0.03/-0.06	0.2	<b>4478207</b>	
over	60 - 70		-0.03/-0.06	0.2	<b>4478208</b>	
over	70 - 80		-0.04/-0.07	0.2	<b>4478209</b>	
over	80 - 90		-0.04/-0.07	0.2	<b>4478210</b>	
over	90 - 100		-0.04/-0.07	0.2	<b>4478211</b>	
over	100 - 110		-0.04/-0.07	0.2	<b>4478212</b>	
over	110 - 120		-0.04/-0.07	0.2	<b>4478213</b>	
over	120 - 130		-0.04/-0.07	0.2	<b>4478214</b>	
over	130 - 140		-0.04/-0.07	0.2	<b>4478215</b>	
over	140 - 150		-0.04/-0.07	0.2	<b>4478216</b>	
over	150 - 160		-0.04/-0.07	0.2	<b>4478217</b>	
over	160 - 170		-0.04/-0.07	0.2	<b>4478218</b>	
over	170 - 180		-0.04/-0.07	0.2	<b>4478219</b>	
over	180 - 190		-0.04/-0.07	0.2	<b>4478220</b>	
over	190 - 200		-0.04/-0.07	0.2	<b>4478221</b>	

① Nominal diameter = smallest bore diameter  
 ② dia. d in reference to the smallest bore diameter

③ Measuring range refers to the nominal diameter  
 \* With Adaptor for connection to the holder

## Plug Gages

Measuring Head 844 Dks, for blind holes, to measure almost to the base of a bore

	Nominal <sup>①</sup> diameter mm	Manufacturing <sup>②</sup> tolerance mm	Meas. range <sup>③</sup> dia. d mm	Order no.	
	4 - 8	-0.02/-0.04	0.10	<b>4478285*</b>	
over	8 - 16	-0.02/-0.04	0.15	<b>4478245</b>	
over	16 - 25	-0.02/-0.05	0.15	<b>4478230</b>	
over	25 - 32	-0.02/-0.05	0.15	<b>4478232</b>	
over	32 - 44	-0.02/-0.06	0.15	<b>4478233</b>	
over	44 - 50	-0.03/-0.06	0.15	<b>4478234</b>	
over	50 - 60	-0.03/-0.06	0.15	<b>4478235</b>	
over	60 - 70	-0.03/-0.06	0.15	<b>4478236</b>	
over	70 - 80	-0.04/-0.07	0.15	<b>4478237</b>	
over	80 - 90	-0.04/-0.07	0.15	<b>4478238</b>	
over	90 - 100	-0.04/-0.07	0.15	<b>4478239</b>	
over	100 - 110	-0.04/-0.07	0.15	<b>4478240</b>	
over	110 - 120	-0.04/-0.07	0.15	<b>4478241</b>	
over	120 - 130	-0.04/-0.07	0.15	<b>4478242</b>	
over	130 - 140	-0.04/-0.07	0.15	<b>4478243</b>	
over	140 - 150	-0.04/-0.07	0.15	<b>4478244</b>	

① Nominal diameter = smallest bore diameter  
 ② dia. d in reference to the smallest bore diameter

③ Measuring range refers to the nominal diameter  
 \* With adaptor for connection to the holder

## Plug Gages

**Measuring Head 844 Dkr**, with an extended guide cylinder to measure through holes from the edge of a bore, ideal for narrow parts

	Nominal <sup>①</sup> diameter mm	Manufacturing <sup>②</sup> tolerance mm	Meas. range <sup>③</sup> dia. d mm	Order no.	
over	2.98 - 3.99 3.99 - 8	-0.02/-0.04 -0.02/-0.04	0.1 0.1	<b>4478272*</b> <b>4478250*</b>	
over	8 - 16	-0.02/-0.04	0.15	<b>4478251</b>	
over	16 - 25	-0.02/-0.05	0.2	<b>4478252</b>	
over	25 - 32	-0.02/-0.05	0.2	<b>4478254</b>	
over	32 - 44	-0.02/-0.06	0.2	<b>4478255</b>	
over	44 - 50	-0.03/-0.06	0.2	<b>4478256</b>	
over	50 - 60	-0.03/-0.06	0.2	<b>4478257</b>	
over	60 - 70	-0.03/-0.06	0.2	<b>4478258</b>	
over	70 - 80	-0.04/-0.07	0.2	<b>4478259</b>	
over	80 - 90	-0.04/-0.07	0.2	<b>4478260</b>	
over	90 - 100	-0.04/-0.07	0.2	<b>4478261</b>	
over	100 - 110	-0.04/-0.07	0.2	<b>4478262</b>	
over	110 - 120	-0.04/-0.07	0.2	<b>4478263</b>	
over	120 - 130	-0.04/-0.07	0.2	<b>4478264</b>	
over	130 - 140	-0.04/-0.07	0.2	<b>4478265</b>	
over	140 - 150	-0.04/-0.07	0.2	<b>4478266</b>	
over	150 - 160	-0.04/-0.07	0.2	<b>4478267</b>	
over	160 - 170	-0.04/-0.07	0.2	<b>4478268</b>	
over	170 - 180	-0.04/-0.07	0.2	<b>4478269</b>	
over	180 - 190	-0.04/-0.07	0.2	<b>4478270</b>	
over	190 - 200	-0.04/-0.07	0.2	<b>4478271</b>	

① Nominal diameter = smallest bore diameter  
 ② dia. d in reference to the smallest bore diameter

③ Measuring range refers to the nominal diameter  
 \* With adaptor for connection to the holder

## Modular Unit System 844 D

### Standard Holder 844 Kg/844 Dg - Standard version

With locking clamp for an indicating instrument and a connecting thread for a measuring head. Heat insulated handle. The model 844 Dg is made from Invar steel.

Cat. no.	Connecting thread g	Length L mm	Handle dia. D mm	Order no.
844 Kg	M6 x 0.75	50	14	4470851
844 Dg	M10 x 1	150	26	4478851

### Short Holder 844 Dgk - Short version

With locking clamp for an indicating instrument and a connecting thread for a measuring head. Heat insulated handle.

Cat. no.	Connecting thread g	Length L mm	Handle dia. D mm	Order no.
844 Dgk	M10 x 1	61	26	4478050

### Holder 844 Dge for Inductive Measuring Probes

With long sleeve for shock and waterproof mounting of inductive measuring probes. Strain relief clamp for probe cable. Threaded connection for measuring heads. Heat insulated handle.

Cat. no.	Connecting thread g	Length L mm	Handle dia. D mm	Order no.
844 Dge	M6 x 0.75	195	33	4478020
	M10 x 1	195	33	4478021

### Right Angle (Elbow) Attachment

For measuring difficult to reach bores, e.g. in tight spaces, on a machine tool or when work piece bores are inconveniently located. For screwing in between holder and measuring head.

Cat. no.	Connecting thread g mm	Elbow		Order no.
		Length L mm	Height H mm	
844 Kw	M6 x 0.75	26.5	22.5	4470110
844 Dw	M10 x 1	36.7	17	4478110

844 Kg / 844 Dg

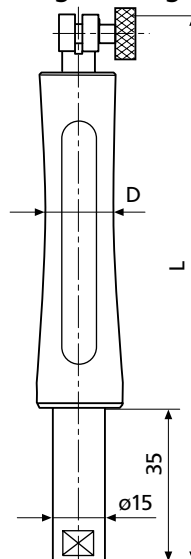

844 Dge

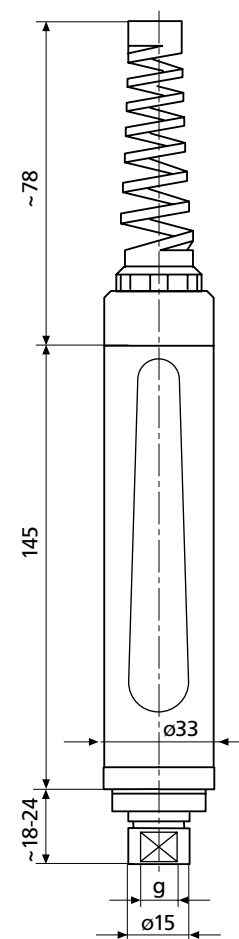

844 Dgk

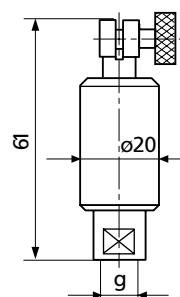

844 Kw / 844 Dw

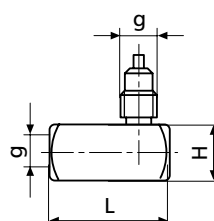



## Modular Unit System 844 D

### Extensions

For extra-deep bores. Screws in between holder and measuring heads. Several extensions can be screwed together as of 8 mm. Models 844 Dv and 844 Dvk made of **Invar steel**.

Cat. no.	Connecting thread g	Length L mm/inch	dia. D mm/inch	Order no.
844 Dvk	M6x0.75/M3.5x0.35	64 / 2.5"	3.8 / .15"	4478080
844 Kv	M6 x 0.75	64 / 2.5"	8 / .32"	4470070
844 Dv	M10 x 1	64 / 2.5"	15 / .6"	4478070
844 Dv	M10 x 1	80 / 3"	15 / .6"	4478071
844 Dv	M10 x 1	100 / 4"	15 / .6"	4478072
844 Dv	M10 x 1	125 / 5"	15 / .6"	4478073
844 Dv	M10 x 1	250 / 10"	15 / .6"	4478074
844 Dv	M10 x 1	500 / 20"	15 / .6"	4478075

### Depth Stops

For limiting depth of insertion of measuring head in bore. Can be attached to Extensions 844 Kv or 844 Dv. With clamping screw.

Cat. no.	Mounting hole dia. d mm/inch	Stop surface dia. A mm/inch	Height h mm/inch	Order no.
844 Kt	8 / .32"	24 / 1"	60 / 2.36	4470115
844 Dt	15 / .6"	45 / 1.8"	30 / 1.18	4478115
844 Dt	15 / .6"	75 / 3"	30 / 1.18	4478116
844 Dt	15 / .6"	110 / 4.3"	30 / 1.18	4478117
844 Dt	15 / .6"	160 / 6.3"	30 / 1.18	4478118
844 Dt	15 / .6"	220 / 8.6"	30 / 1.18	4478119

### Depth Stop Rings

For limiting depth of insertion of measuring head in bore. Clamped onto the measuring head.

Cat. no.	Mounting hole dia. d mm	Stop surface dia. A mm/inch	Height h mm/inch	Order no.
844 Dtr	3 - 5	27 / 1.1"	10 / .4"	4478130
	> 5 - 8	30 / 1.2"	10 / .4"	4478130
	> 8 - 11	33 / 1.3"	10 / .4"	4478130
	> 11 - 15	37 / 1.5"	10 / .4"	4478130
	> 15 - 20	42 / 1.7"	10 / .4"	4478130
	> 20 - 25	50 / 1.9"	12 / .5"	4478131
	> 25 - 30	55 / 2.1"	12 / .5"	4478131
	> 30 - 35	60 / 2.3"	12 / .5"	4478131
	> 35 - 40	65 / 2.5"	12 / .5"	4478131
	> 40 - 45	70 / 2.8"	12 / .5"	4478131
> 45 - 50	75 / 3.0"	12 / .5"	4478132	
> 50 - 60	85 / 3.3"	12 / .5"	4478132	
> 60 - 70	95 / 3.7"	12 / .5"	4478132	
> 70 - 80	105 / 4.1"	12 / .5"	4478132	
> 80 - 90	115 / 4.5"	12 / .5"	4478133	
> 90 - 100	125 / 4.9"	12 / .5"	4478133	

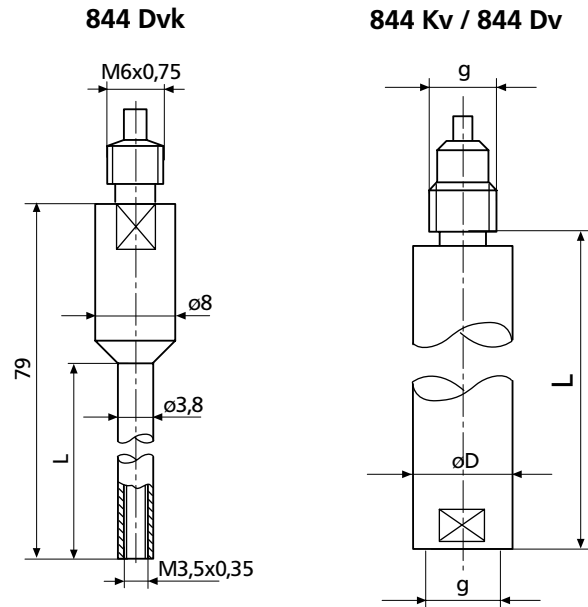

### 844 Kt / 844 Dt

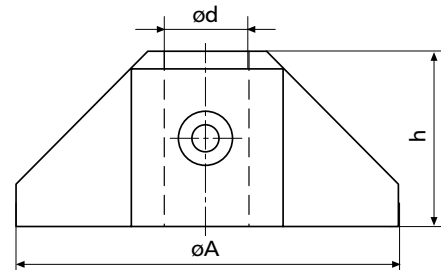

### 844 Dtr

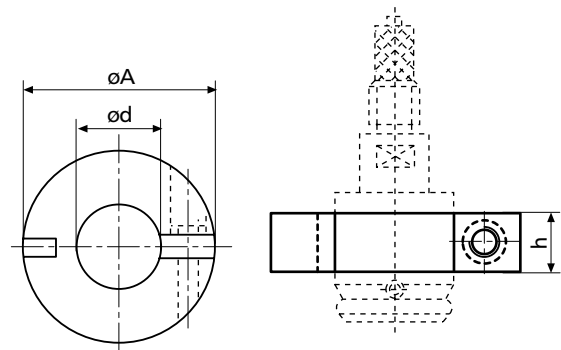

Modular units	Diameter of Measuring Heads			
	2.98 - 8 mm	8 - 16 mm	over 16 mm	
844 Kg	4470851			
844 Dg	4478851			
844 Dgk	4478050			
844 Dge	4478020		4478021	
844 Dvk 844 Kv 844 Dv	4478080	4470070	4478070 to 4478076	
844 Kt 844 Dt	4470115		4478115 to 4478119	
844 Kw 844 Dw	4470110		4478110	
844 Dk 844 Dks 844 Dkr				
355 E	see page 9-71			
Modular unit	Diameter of Measuring Heads			
	2.98 - 20 mm	20 - 44 mm	44 - 80 mm	80 - 100 mm
844 Dtr	4478130	4478131	4478132	4478133

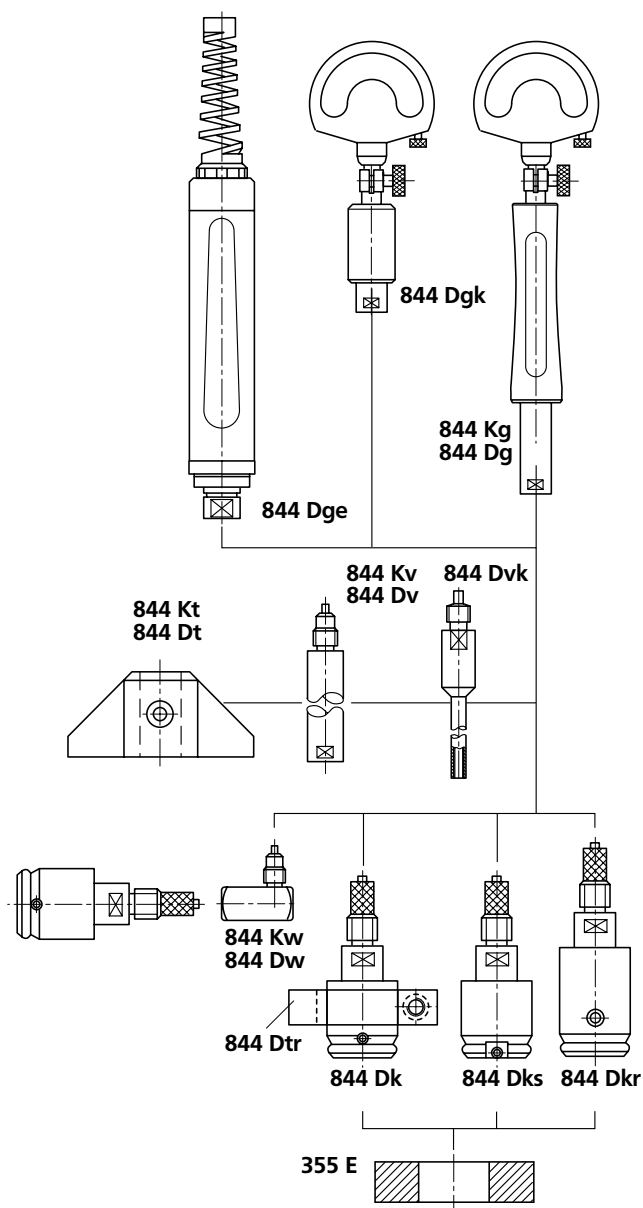

## Indicating Instruments

All indicating instruments that has a 8 mm mounting shank may be used. Recommended are:

Indicator	Readings	Order no.
Millimess 1004	5 $\mu\text{m}$	4333000
Millimess 1003	1 $\mu\text{m}$	4334000
Millimess 1002	0.5 $\mu\text{m}$	4335000
MarCator 1086 R	1 $\mu\text{m}$	4337620
MarCator 1086 Ri	1 $\mu\text{m}$	4337624
Extramess 2000	0.2 $\mu\text{m}$ , 0.5 $\mu\text{m}$ , 1 $\mu\text{m}$	4346000
Extramess 2001	0.2 $\mu\text{m}$ , 0.5 $\mu\text{m}$ , 1 $\mu\text{m}$	4346100
Millimar C 1208 M	0.1 $\mu\text{m}$ , 1 $\mu\text{m}$	5312080
Millimar P 2004 M		5323010

Digital Indicators see Chapter 5

Electrical Indicating Instruments see Chapter 7

## Adjustment of Plug Gages 844 D

### Ring Gage 355 E:

Special wear-resistant gage steel. Hardened and lapped. With actual deviation engraved.

Dimensions: DIN 2250, type C  
 Manufacturing tolerance: DIN 2250  
 Available diameters: see page 13-19

## Self-Centering Dial Bore Gages 844 K Intramess



### Features

- Measuring the diameter, roundness and conicity of bores
- Spring-loaded halves of measuring probe are split via expanding pin with precision lapped taper. This movement is transferred to indicating instrument
- Maximum wear-resistance due to hard chrome plating. From 4 mm alternatively with carbide tipped available on request
- Constant measuring force as a result of built-in spring thus eliminating user influence
- Highly versatile, each gage covers a large range. Within the respective limits, quickly and easily adjustable to any size and any type of measuring application
- Measuring probe, holder, depth extensions, right-angle attachments and depth stops are part of an extensive modular system
- Supplied with: Holder, probe, expanding pin and a wooden case, excludes an indicating instrument

### Technical Data

#### Complete Instrument

- 844 K** Measuring heads hard chrome plated, expanding pin made of stainless steel
- 844 KH** Measuring heads carbide tipped on both sides, carbide expanding pin
- 844 KS** Blind hole measuring heads hard chrome plated, expanding pin made of stainless steel

Catalog no.	Measuring range mm	Number of measuring probes	Order no.*
<b>844 K</b>	0.47 - 0.97	6	<b>4470000</b>
	0.95 - 1.55	5	<b>4470001</b>
	1.5 - 4.2	10	<b>4470002</b>
	3.7 - 7.3	7	<b>4470003**</b>
	6.7 - 10.3	7	<b>4470004**</b>
	9.4 - 18.6	9	<b>4470005**</b>
<b>844 KH</b>	1.5 - 4.2	10	<b>4471002</b>
	3.7 - 7.3	7	<b>4471003**</b>
	6.7 - 10.3	7	<b>4471004**</b>
	9.4 - 18.6	9	<b>4471005**</b>
<b>844 KS</b>	1.5 - 4.2	10	<b>4482163</b>
	3.7 - 7.3	7	<b>4482164**</b>
	6.7 - 10.3	7	<b>4482165**</b>
	9.4 - 18.6	9	<b>4482166**</b>

\* Excludes an indicating instrument

\*\*Additionally includes measuring force spring 4470828 and disk 4470821

#### Accuracy

##### Deviation of linearity

- ≤ 2 % measuring ranges 0.47-1.55 mm
- ≤ 1 % measuring ranges 1.5-18.6 mm

##### Repeatability

- 1 µm manual measurement
- ≤ 0.5 µm measurement with Stand 844 Kst and Floating Holder 844 Ksts

#### Indicating Instruments

All indicating instruments that has a 8 mm mounting shank may be used. Recommended are:

Indicators	Readings	Order no.
<b>Millimess 1004</b>	5 µm	<b>4333000</b>
<b>Millimess 1003</b>	1 µm	<b>4334000</b>
<b>Millimess 1003 XL</b>	2 µm	<b>4334001</b>
<b>Millimess 1002</b>	0.5 µm	<b>4335000</b>
<b>Extramess 2000</b>	0.2 µm, 0.5 µm, 1 µm	<b>4346000</b>
<b>Extramess 2001</b>	0.2 µm, 0.5 µm, 1 µm	<b>4346100</b>
<b>MarCator 1087 BR</b>	1 µm, 2 µm, 4 µm, 10 µm	<b>4337662</b>
<b>MarCator 1087 Bri</b>	1 µm, 2 µm, 4 µm, 10 µm	<b>4337664</b>

Digital Indicators see Chapter 5

Electrical Indicating Instruments see Chapter 7

## Modular Unit System for 844 K Standard Measuring Probes

In addition complete Dial Bore Gages 844 K, modular units area available for assembly as required to suit an individual measuring task and or application.

### Measuring Probe 844 Kk, Expander Pin, individual Ring Gage for 844 Ke

Nominal dimension mm	Measuring range mm	Measuring depth mm	Measuring probe hard chrome plated	Expanding pin steel	Measuring probe carbide tipped	Expander pin carbide	Ring gage			
0.50	0.47 - 0.53	1.25	4470586	4470801			4482300			
0.55	0.52 - 0.58	1.5	4470587				4482301			
0.60	0.57 - 0.67	1.7	4470588	4470802			4482302			
0.70	0.65 - 0.77	2.2	4470589				4482303			
0.80	0.75 - 0.87	2.55	4470590				4482304			
0.90	0.85 - 0.97	2.65	4470591	4470803			4482305			
1.00	0.95 - 1.15	10.5	4470592				4482306			
1.10	1.07 - 1.25	10.5	4470593				4482307			
1.20	1.17 - 1.35	10.5	4470594				4482308			
1.30	1.27 - 1.45	10.5	4470595				4482309			
1.40	1.37 - 1.55	10.5	4470596				4482310			
1.75	1.50 - 1.90	16	4470597	4470804	4471234	4471207	4482311			
2.00	1.80 - 2.20	16	4470598				4471206	4482312		
2.25	2.05 - 2.45	16	4470599	4470805	4471812	4471819	4482313			
2.50	2.30 - 2.70	21	4470600				4471813	4482314		
2.75	2.55 - 2.95	21	4470601				4471814	4482315		
3.00	2.80 - 3.20	21	4470602				4471208	4482316		
3.25	3.05 - 3.45	21	4470603				4471815	4482317		
3.50	3.30 - 3.70	21	4470604				4471816	4482318		
3.75	3.55 - 3.95	21	4470605				4471817	4482319		
4.00	3.80 - 4.20	21	4470606				4471204	4482320		
4.00	3.70 - 4.30	38	4470607				4470806	4471607	4471200	4482320
4.50	4.20 - 4.80	38	4470608							4471608
5.00	4.70 - 5.30	38	4470609	4471609	4482322					
5.50	5.20 - 5.80	38	4470610	4471610	4482323					
6.00	5.70 - 6.30	38	4470611	4471611	4482324					
6.50	6.20 - 6.80	38	4470612	4471612	4482325					
7.00	6.70 - 7.30	38	4470613	4471613	4482326					
7.50	7.20 - 7.80	38	4470615	4471615	4482327					
8.00	7.70 - 8.30	38	4470616	4471616	4482328					
8.50	8.20 - 8.80	45	4470617	4471617	4482329					
9.00	8.70 - 9.30	45	4470618	4471618	4482330					
9.50	9.20 - 9.80	45	4470619	4471619	4482331					
10.00	9.70 - 10.30	45	4470620	4471620	4482332					
10.00	9.40 - 10.60	45	4470621	4470808	4471621	4471202	4482332			
11.00	10.40 - 11.60	45	4470622				4471622	4482333		
12.00	11.40 - 12.60	45	4470623				4471623	4482334		
13.00	12.40 - 13.60	45	4470624				4471624	4482335		
14.00	13.40 - 14.60	45	4470625				4471625	4482336		
15.00	14.40 - 15.60	45	4470626				4471626	4482337		
16.00	15.40 - 16.60	80	4470627				4471627	4482338		
17.00	16.40 - 17.60	80	4470628				4471628	4482339		
18.00	17.40 - 18.60	80	4470629				4471629	4482340		



for further technical data (e.g. nominal dimensions up to 40 mm) see **WebCode 11070**

Nominal dimension mm	L mm	H 1 mm
0.50	19.50	0.25
0.55	19.50	0.27
0.60	19.50	0.29
0.70	19.50	0.31
0.80	19.50	0.33
0.90	19.50	0.35
1.00 - 1.40	19.50	0.60
1.75 - 2.25	25.30	0.90
2.50 - 4.00	30.60	1.20
4.00 - 10.00	47.30	2.00
10.00 - 18.00	48.50	3.30

#### Minimum measurement height

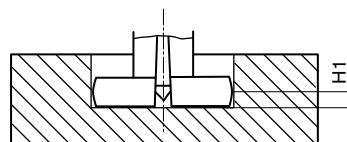

## Modular Unit System for 844 KS Blind Hole Measuring Probes

In addition to complete Dial Bore Gages 844 KS, modular units are available for assembly as required to suit a individual measuring task and or application.

### Blind Hole Measuring Probe 844 Kk, Blind Hole Expander Pin

Nominal dimension mm	Measuring range mm	Measuring depth mm	Blind hole measuring probe hard chrome plated	Blind hole expander pin steel
1.75	1.50 - 1.90	16	4482228	4482176
2.00	1.80 - 2.20	16	4482229	
2.25	2.05 - 2.45	16	4482230	
2.50	2.30 - 2.70	21	4470301	
2.75	2.55 - 2.95	21	4482227	
3.00	2.80 - 3.20	21	4482178	
3.25	3.05 - 3.45	21	4482179	
3.50	3.30 - 3.70	21	4470300	
3.75	3.55 - 3.95	21	4482188	4482177
4.00	3.80 - 4.20	21	4482180	
4.00	3.70 - 4.30	38	4482057	
4.50	4.20 - 4.80	38	4482162	
5.00	4.70 - 5.30	38	4482056	
5.50	5.20 - 5.80	38	4470953	
6.00	5.70 - 6.30	38	4482140	
6.50	6.20 - 6.80	38	4482055	
7.00	6.70 - 7.30	38	4482108	4482028
7.50	7.20 - 7.80	38	4482204	
8.00	7.70 - 8.30	38	4482054	
8.50	8.20 - 8.80	45	4482206	
9.00	8.70 - 9.30	45	4482170	
9.50	9.20 - 9.80	45	4482182	
10.00	9.70 - 10.30	45	4470375	
10.00	9.40 - 10.60	45	4482205	
11.00	10.40 - 11.60	45	4482042	
12.00	11.40 - 12.60	45	4482112	
13.00	12.40 - 13.60	45	4482102	
14.00	13.40 - 14.60	45	4482181	
15.00	14.40 - 15.60	45	4482202	
16.00	15.40 - 16.60	80	4482021	
17.00	16.40 - 17.60	80	4482203	
18.00	17.40 - 18.60	80	4482113	

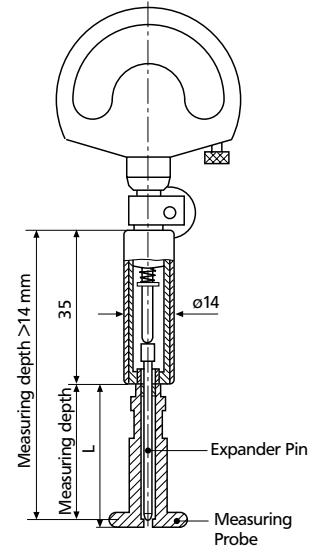

844 Kk

### Minimum measurement height

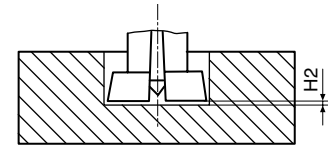

Nominal dimension mm	L mm	H 2 mm
1.75	2.25	25.30
2.50	4.00	30.60
4.00	10.00	47.30
10.00	18.00	48.50

 for further technical data (e.g. nominal dimensions up to 40 mm) see **WebCode 11070**

## Ring Gage Sets 844 Ke

For setting Dial Bore Gages 844 K, 844 KH and 844 KS. Supplied in sets to match the measuring ranges of these instruments. Can be stored in the wooden case of the bore gages.

Diameter tolerance  $\pm 1 \mu\text{m}$

Ring Gages 844 Ke are only available with the diameters shown in the table.

For all other dimensions, Ring Gages 355 E with dimensions as per DIN 2250 and with actual deviation engraved are available.

For Meas. range mm	Diameter mm	Order no.
0.47 - 0.97	0.5/0.55/0.6/0.7/0.8/0.9	4470160
0.95 - 1.55	1/1.1/1.2/1.3/1.4	4470161
1.5 - 4.2	1.75/2/2.25/2.5/2.75/ 3/3.25/3.5/3.75/4	4470162
3.7 - 7.3	4/4.5/5/5.5/6/6.5/7	4470163
6.7 - 10.3	7/7.5/8/8.5/9/9.5/10	4470164
9.4 - 18.6	10/11/12/13/14/15/ 16/17/18	4470165

## Modular Unit System for 844 K

### Holder 844 Kg

With locking clamp for an indicating instrument and a connecting thread for a **Measuring Head 844 Kk**. Heat insulated handle

Order no. 4470851

### Extensions 844 Kv

For extra-deep bores. Screws in between Holder 844 Kg and Measuring Head 844 Kk for measuring range 10-18 mm. Length 64 mm,  $\varnothing$  8 mm,

Order no. 4470070

### Right Angle Attachment 844 Kw

For measuring bores which are difficult to reach, e.g. in tight spaces, on machine tools or when work piece bores are inconveniently located. For screwing in between Holder 844 Kg and Measuring Head 844 Kk

Order no. 4470110

### Lifter 954

Facilitates insertion of measuring probe in bore by lifting measuring spindle of dial comparator.

Order no. 4372030

### Depth Stop 844 Kt

For checking diameter of bores at prescribed depth. Only to be used with Extension 844 Kv.

Order no. 4470115

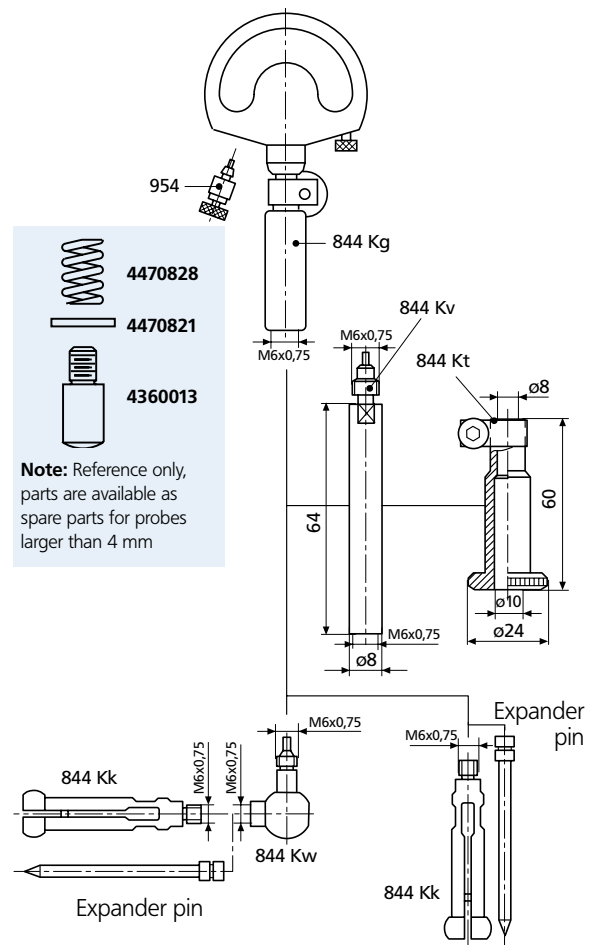

## Measuring Probes for Special Applications

For measurement of blind holes, diameters of recesses, distances between plane-parallel surfaces, etc. special models of measuring probes are available on request.

1. Measurement of the diameter of recesses

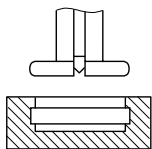

2. Measurement of plane-parallel surfaces

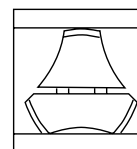

3. Measurement of polygon bores

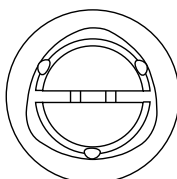

4. Measurement of inside serrations, see 844 Z Page 9-72

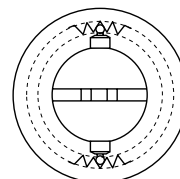

## Accessories

### Stand 844 Kst



### Floating Holder 844 Ksts



#### Features

For quick checks of bores in small work pieces. Hardened table plate can be raised with lever, thus moving test piece into position. Plate can be clamped at any height for checking eccentricity. Particularly suited to use with digital indicators, where appropriate in conjunction with data printers or computer equipment, in cases where the determination of the reversal point is inappropriate.

Table dia.	58 mm
Throat depth of arm	45 mm
Table stroke	30 mm
Max. work piece height	ca. 100 mm

**Order no. 4470100**

#### Features

For use in conjunction with Stand 844 Kst. Enables measuring probe to find common axis of bore and measuring instrument quickly and easily on insertion into hole, thus providing optimum measuring speed and high accuracy. Particularly suitable for small diameters, as measuring confidence is considerably enhanced.

**Order no. 4470105**

### Angle Stop 844 Ka

Facilitates positioning of cylindrical work pieces under measuring instrument. For clamping to Stand 844 Kst.

**Order no. 4470120**

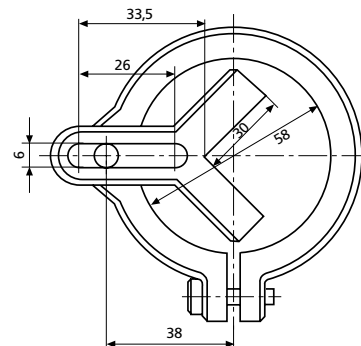

## Adjustable Bore Gages 1280 P

Superior Accuracy for Production and Inspection.



1280P Shown wireless Digital Indicators and 1280P-1W1

### Features

- Rugged construction for long life and low maintenance: Stainless steel gaging head, one piece centralizing yoke with replaceable tungsten carbide balls.
- Heavy duty housing protects Indicator.
- Flow-through design makes Series 1280P Bore Gages swish clean, no disassembly required.
- Outstanding stability: Holds mastered value.
- Bore gages may be furnished with various Dial or Digital Indicators.
- Digital bore gages are available with standard or advanced indicators.
  - Standard models 1075 R and 1086 R provide live reading with data output.
  - Advanced models, Maxum III and 1087 R, provide dynamic memory that hold the reading of a diameter measured in a single sweep.
- Wireless data collection with 1086 Ri, 1087 Ri provides more flexibility of movement during the measurement and increased portability by bringing the gage to the part.

### Technical Data

#### With Dial Indicator

Range of Sensitive Contact: 0.63 mm / **.025"**,  
0.002 mm / **.0001"** grad.

#### With Maxum®/III Indicators

Range of Sensitive Contact: 0.39 mm / **.020"**  
Resolution: 0.001 mm / **.00005"** resolution,  
0.001 mm / **.001"** grad.

If gage capacity is 25 mm / 1" or greater, the Maxum®/III Indicator is covered with a cast aluminum protective housing.

If under 25 mm / 1" capacity, the protective housing is not normally furnished.

With Dial Indicator	With Maxum®/III Digital Indicators	Capacity mm/inch	Gaging Depth mm/inch	End of Head to Contact mm/inch
1280P-1W1	1282P-1W1	12 - 25 / <b>.50 - 1"</b>	76 / <b>3"</b>	2.77 / <b>.11"</b>
1280P-2W2	1282P-2W2	25 - 50 / <b>1 - 2"</b>	152 / <b>6"</b>	4.37 / <b>.17"</b>
1280P-3W2	1282P-3W2	50 - 203 / <b>2 - 8"</b>	152 / <b>6"</b>	7.92 / <b>.31"</b>
1280P-1W2	1282P-1W2	12 - 25 / <b>.50 - 1"</b>	152 / <b>6"</b>	2.77 / <b>.11"</b>
1280P-2W3	1282P-2W3	25 - 50 / <b>1 - 2"</b>	305 / <b>12"</b>	4.37 / <b>.17"</b>
1280P-3W3	1282P-3W3	50 - 203 / <b>2 - 8"</b>	305 / <b>12"</b>	7.92 / <b>.31"</b>

See matrix on next page.

Note: Model numbers do not include extensions.

**Series 1280P** Adjustable Bore Gages are normally furnished with adjusting wrenches. Reference contacts for particular measurement sizes must be specified separately (see table on following page). If not specified, T.C. contacts will be furnished. For alternate gaging depths, contact materials, and other modifications are available.

Example: **1282P-3MW3** with **PT-156** and **EX-224** specifies an Adjustable Bore Gage with tungsten carbide reference contact and an extension to cover the range from 75 mm / 3" to 89 mm / 3.5".

The Gage is furnished with a Metric Maxum/III Indicator, **2033119** (which has selectable resolution, units and includes Digital Output).



## Adjustable Bore Gages 1280 P

### Ordering Information

To order the correct bore gage to suit your measurement application, start with the base Model Number: **128XP-XXXX** and substitute the X with the appropriate number or letter from the boxes below:

**128 X P - X X X X**

**Indicator**

- 0 – Dial Indicator
- 2 – Maxµm®III with Output

**Capacity**

- 1 – 12.50 - 25 mm / **.50 - 1"** gaging depth to 305 mm / **12"**
- 2 – 25 - 50 mm / **1 - 2"** gaging depth to 610 mm / **24"**
- 3 – 50 - 200 mm / **2 - 8"** gaging depth to 1220 mm / **48"**

**Units**

- Omit for Inch
- M** – Metric

**Configuration**

- W** – Gage only
- S** – Complete kit with steel contacts\*
- T** – Complete kit with T.C. contacts\*

*\* Each kit is complete with components needed for capacity ranging from 12.70 - 203 mm / .50 - 8". A fitted case is furnished for all models with a gaging depth 150 mm / 6" or under. It contains a Dial or MaxµmIII Indicator with each tube assembly and all contacts, extensions, extenders, locknuts and necessary wrenches.*

**Gaging Depth**

- 1 – 76 mm / **3"**
- 2 – 150 mm / **6"**
- 3 – 300 mm / **12"**
- 4 – 450 mm / **18"**
- 5 – 600 mm / **24"**
- 6 – 760 mm / **30"**
- 7 – 910 mm / **36"**
- 8 – 1220 mm / **48"**

**Example:** If you chose **1282P-3S5** as your model number, you would have chosen an Inside Diameter gage with MaxµmIII Indicator, 50 - 200 mm / 2 - 8" capacity, inch units, having a complete kit with steel contacts and a gaging depth of 600 mm / 24". Metric equivalent Model would be: **1282P-3MS5**.

## Handles / Housing

All 1280P gages have a removable handle as a part of the Indicator Housing.

All 1282P gages can be equipped with a handle which projects at 90° to the gage housing.

1282P gages with capacity 12-25 mm / .50-1" are not normally furnished with a protective housing. Handles and Housings may be ordered separately.

For Handles order **HA-88** with **AT-124** Adaptor. For Housings order **EHG-1198**.

## Gaging Extensions

Specify the Reference Contact Gaging Extensions required from the table below. For all diameters below 50 mm / 2" the Reference Contact is integral with each Extension. For diameters over 50 mm / 2" the Reference Contact is separate and interchangeable among Extension Sets.



**1282P-1W1**  
(Output Cable not included)

## Technical Data

Diameter to be measured mm/ <i>inch</i>	Extension Required		Used on Gage Model Numbers
	Carbide	Steel	
12 - 16 / <b>.50 - .625"</b>	<b>PT-562</b>	<b>PT-558</b>	1280P-1xxx
16 - 19 / <b>.625 - .75"</b>	<b>PT-567</b>	<b>PT-559</b>	
19 - 22 / <b>.75 - .875"</b>	<b>PT-568</b>	<b>PT-560</b>	1282P-1xxx
22 - 25 / <b>.875 - 1"</b>	<b>PT-557</b>	<b>PT-561</b>	
25 - 32 / <b>1 - 1.25"</b>	<b>PT-554</b>	<b>PT-555</b>	1280P-2xxx
32 - 38 / <b>1.25 - 1.50"</b>	<b>PT-553</b>	<b>PT-556</b>	
38 - 45 / <b>1.50 - 1.75"</b>	<b>PT-552</b>	<b>PT-569</b>	1282P-2xxx
45 - 50 / <b>1.75 - 2"</b>	<b>PT-550</b>	<b>PT-551</b>	

For the gaging diameters listed below, select one Contact Point and at least one Extension Set.

Contact Point:	Extension Required	Used on Gage Models
Carbide	PT-156	1280P-3XXX
Steel	PT-2224	1282P-3XXX

Extension Sets:	Diameter to be Measured mm/ <i>inch</i>	Extension Sets	Used on Gage Models
	50 - 64 / <b>2 - 2.5"</b>	<b>EX-222</b>	
	64 - 76 / <b>2.5 - 3"</b>	<b>EX-223</b>	
	76 - 89 / <b>3 - 3.5"</b>	<b>EX-224</b>	1280P-3XXX
	89 - 100 / <b>3.5 - 4"</b>	<b>EX-225</b>	
	100 - 127 / <b>4 - 5"</b>	<b>EX-223 with EX-226</b>	1282P-3XXX
	127 - 152 / <b>5 - 6"</b>	<b>EX-225 with EX-226</b>	
	152 - 178 / <b>6 - 7"</b>	<b>EX-223 with EX-228</b>	
	178 - 200 / <b>7 - 8"</b>	<b>EX-225 with EX-228</b>	

## Self-Centering Dial Bore Gages 844 N / 844 NH Intramess

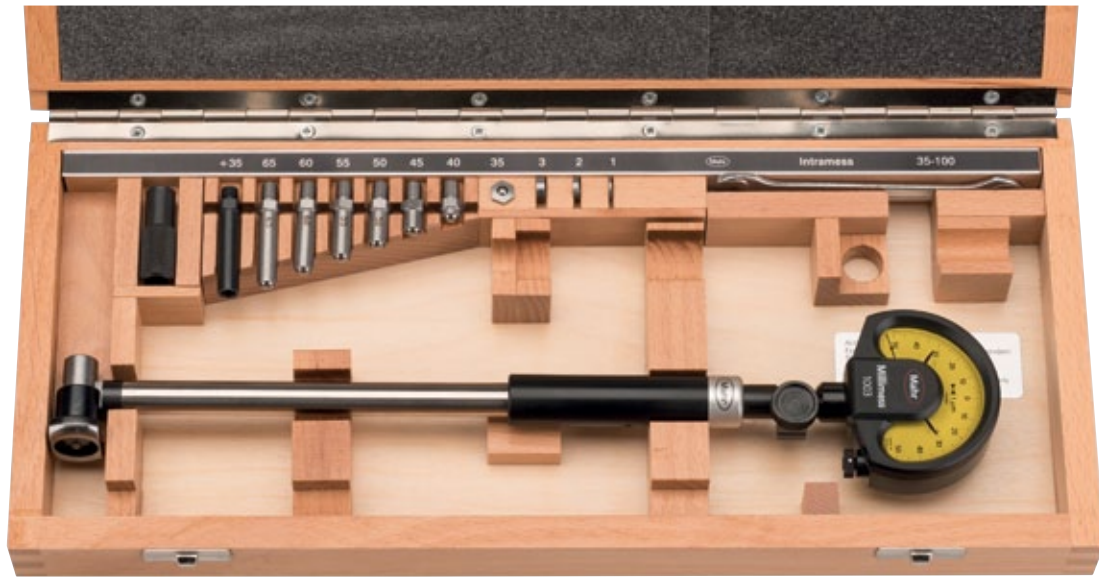

### Features

- Measuring the diameter, roundness and conical form of a bore as well as the distances of plane-parallel surfaces
- Measuring head consists of a carbide-tipped moving anvil and an interchangeable stationary anvil which has a hardened steel ball; alternatively a carbide ball is available
- Transmission lever system transfers movement of the movable anvil to indicating instrument
- The broad centering bridge ensures automatic centering in the bore
- Insensitive to temperature due to both the shank and transfer rod being made from heat resistant **Invar steel**
- Highly resistant to wear and tear due to the carbide tipped moving anvil
- Constant measuring force due to built-in spring thus eliminating user influence
- Universally applicable and extremely versatile as every instrument spans a broad measuring range, within this range it is quick and easy to adjust to any size
- Measuring head, holder, extensions, right-angle attachments and depth stops are all part of this extensive modular system
- Supplied with: Holder, measuring head, stationary anvil, wooden case, excludes an indicating instrument

### The comparison between Invar and Standard steel

**Invar steel** has a particularly low expansion coefficient and thus makes the instrument totally insensitive to any kind of heat. Body heat from the user, increases in ambient temperature have no influence on the measuring results.

The graph on the right compares the Invar steel version to a standard type. Both gages were hand-held and thus influenced by body heat. The deviation when using Invar steel is negligible.

Change in length due to heat

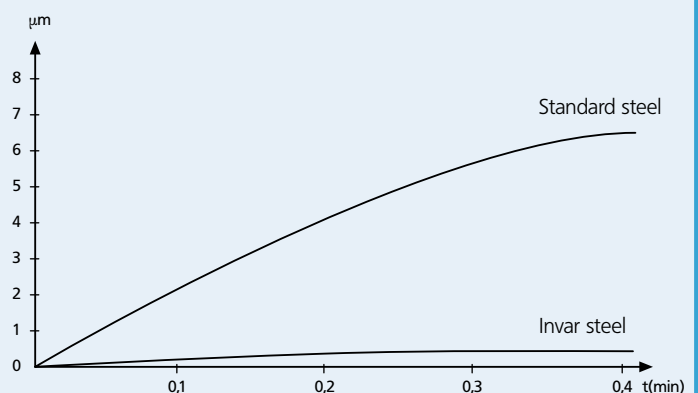

## Technical Data

Measuring range		Error limit	Repeatability	Hysteresis	Order no* 844 N	Order no* 844 NH
mm	(inch)	$G_e$ $\mu\text{m}$	$f_w$ $\mu\text{m}$	$f_u$ $\mu\text{m}$		
18 - 50	(.7 - 2")	2	0.5	2.5	4474000	4475000
35 - 100	(1.4 - 4")	2	0.5	2.5	4474001	4475001
100 - 250	(4 - 10")	2	0.5	2.5	4474002	4475002
250 - 400	(10 - 16")	3	1.5	3.5	4474003	4475003
400 - 800	(16 - 32")	3	1.5	3.5	4474004	4475004
250 - 800	(10 - 32")	3	1.5	3.5	4474005	4475005

\* Excludes indicating instrument

## Complete Instrument

**844 N** Carbide-tipped moving anvil; stationary anvil with steel ball

**844 NH** Moving anvil **and** stationary anvil are carbide-tipped

Measuring range	a	b	c	d	e
mm (inch)					
18 - 50 (.7 - 2")	5.35	8	115	63	22
35 - 100 (1.4 - 4")	8.5	12	148	80	22
100 - 250 (4 - 10")	11.5	18	230	100	25
250 - 400 (10 - 16")	16	24	366	110	28
400 - 800 (16 - 32")	17.5	24	366	110	28

## Indicating Instruments

All indicating instruments that has a 8 mm mounting shank may be used. Recommended are:

Indicator	Readings mm / inch	Order no. mm / inch
Millimess	1004/1004 Z	5 $\mu\text{m}$ / .0001" 4333000/4333900
Millimess	1003/1003 Z	1 $\mu\text{m}$ / .00005" 4334000/4334900
Millimess	1003 XL	2 $\mu\text{m}$ 4334001
Millimess	1002/1002 Z	0,5 $\mu\text{m}$ / .00002" 4335000/4335900
Extramess	2001	0,2 $\mu\text{m}$ / .00001" 4346100*
		0,5 $\mu\text{m}$ / .00002" 4346100*
		1 $\mu\text{m}$ / .00005" 2034205**
$\mu\text{Max}\mu\text{m II}$	0,0005 mm / .00002"	2034205**
	0,001 mm / .00005"	
MarCator	1087 BR	0,002 mm / .0001" 4337662
		0,004 mm / .0005"
		0,010 mm / .001"
		0,001 mm / .00005"
MarCator	1087 BRi	0,002 mm / .0001" 4337664
		0,004 mm / .0005"
		0,010 mm / .001"

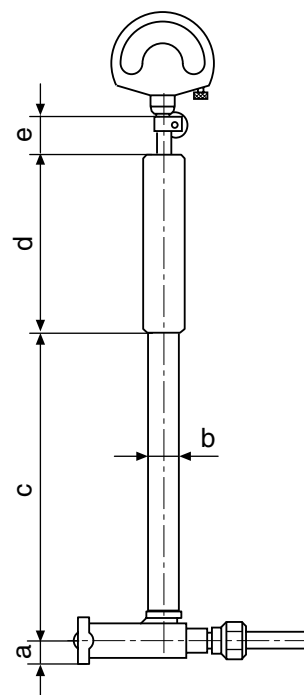

Digital Indicators see Chapter 5

Electrical Indicating Instruments see Chapter 7

\* 230 V, for 115 V please refer to page 6-5 \*\* requires contact 4360043

## Modular Unit System 844 N

In addition to complete Dial Bore Gages 844 N, modular units can also be compiled as required to suit a individual measuring task and or application.

### Measuring Head 844 Nk, steel

### Measuring Head 844 NHk, carbide

With built-in lever transmission system, carbide-tipped anvil and extra-wide centering bridge. With interchangeable stationary anvil. Threaded connection for Holders 844 Ng and 844 Ngk.

Measuring range mm	(inch)	Order no. 844 Nk	Order no. 844 NHk
18 - 50	(.7 - 2")	4474151	4474156
35 - 100	(1.37 - 4")	4474152	4474157
100 - 250	(4 - 10")	4474153	4474158
250 - 400	(10 - 16")	4474154	4474159
400 - 800	(16 - 32")	4474155	4474160

### Extension Set 844 Nes

For extending range of Measuring Head 844 Nk/NHk from 250-400 mm to 800 mm. Consists of additional centering bridge and two extensions.

Order no.: 4474010

### Holder 844 Ng

Shank and transfer rod made of heat-resistant Invar steel. With a locking clamp for indicator.

For meas. range mm (inch)	L mm/inch	d1 mm/inch	d2 mm/inch	Order no.
18 - 50 (.7 - 2")	200 / 8"	14 / .6"	8 / .3"	4474040
35 - 100 (1.37 - 4")	250 / 10"	18 / .7"	12 / .5"	4474041
100 - 250 (4 - 10")	350 / 14"	26 / 1.0"	18 / .7"	4474042
250 - 800 (10 - 32")	500 / 20"	30 / 1.2"	24 / 9"	4474043

### Short Holder 844 Ngk

Shank and transfer rod made of heat-resistant Invar steel. With a locking clamp for an indicator.

For meas. range mm (inch)	L mm/inch	d1 mm/inch	d2 mm/inch	Order no.
18 - 50 (.7 - 2")	120 / 5"	14 / .6"	8 / .3"	4474050
35 - 100 (1.37 - 4")	120 / 5"	18 / .7"	12 / .5"	4474051
100 - 250 (4 - 10")	150 / 6"	26 / 1.0"	18 / .7"	4474052
250 - 800 (10 - 32")	250 / 10"	30 / 1.2"	24 / 9"	4474053

### Right Angle Attachment 844 Nw

For measuring difficult to reach bores, e.g. in tight spaces, inconveniently located or on machine tools. For screwing in between 844 Ng or 844 Ngk and 844 Nk/NHk.

For meas. ranges mm	(inch)	Length* L mm/inch	Bore depth mm/inch	Order no.
18 - 50	(.7 - 2")	66 / 2.6"	45 / 1.8"	4474070
35 - 100	(1.37 - 4")	80 / 3.1"	55 / 2.2"	4474071
100 - 250	(4 - 10")	105 / 4.1"	70 / 2.8"	4474072

\* With measuring heads 844 Nk/NHk

### Extension 844 Nv

For extra deep bores. For screwing in between 844 Ng and 844 Nk/NHk. Shank and transfer rod made of Invar steel.

For instruments mm	(inch)	Length L (mm/inch)	Order no.
18 - 50	(.7 - 2")	250 / 9.8"	4474066
35 - 100	(1.37 - 4")	250 / 9.8"	4474060
100 - 250	(4 - 10")	250 / 9.8"	4474061
		500 / 19.7"	4474062
250 - 800	(10 - 32")	250 / 9.8"	4474063
		500 / 19.7"	4474064

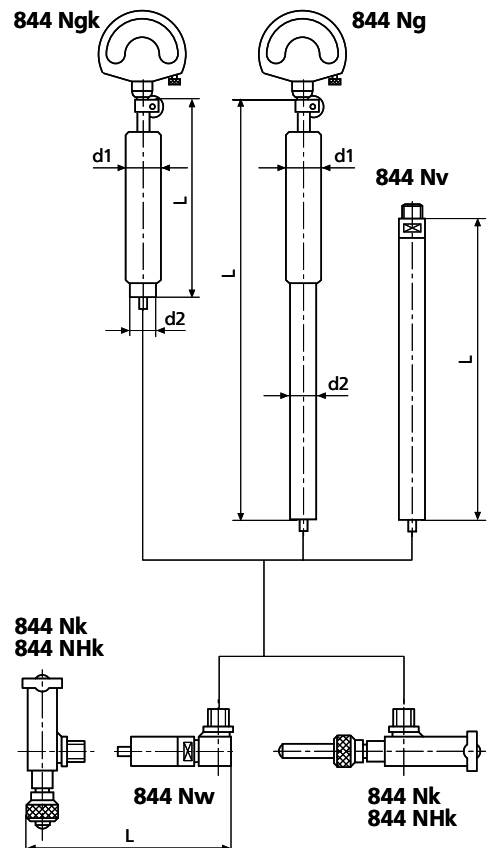

## Self-Centering Dial Bore Gages 844 NR

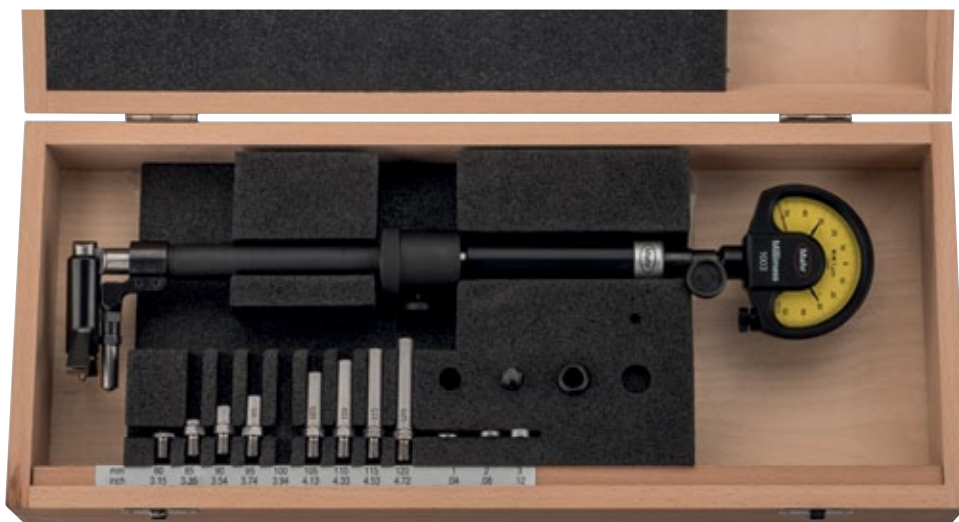

### Applications

- Ideal for measuring difficult to reach bore diameters, grooves and recesses.

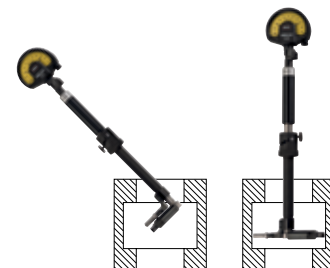

### Features

- Measuring head consists of a carbide-tipped moving anvil and an interchangeable stationary anvil with a carbide ball
- Transmission lever system transfers movement of the movable anvil to indicating instrument
- The broad centering bridge ensures automatic centering in the bore
- Insensitive to temperature due to both the shank and transfer rod being made from heat resistant **Invar steel** (for further information see page 9-66)
- Highly resistant to wear and tear due to the carbide tipped moving anvil
- Constant measuring force due to built-in spring thus eliminating user influence
- Universally applicable and extremely versatile as every instrument spans a broad measuring range, within this range it is quick and easy to adjust to any size
- Supplied with: Measuring holder, measuring head, anvil spindle, wooden case, excludes indicator

### Technical Data

Measuring range		Error limit	Repeatability	Hysteresis	Order no*
mm	(inch)	$G_e$ μm	$f_w$ μm	$f_u$ μm	
50 - 70	(2 - 2.8")	2	1	2.5	4474580
60 - 100	(2.4 - 4")	2	1	2.5	4474590
80 - 150	(3.2 - 6")	2	1	2.5	4474600
120 - 220	(4.7 - 8.7)	3	1.5	3.5	4474610
180 - 360	(7.1 - 14.2")	3	1.5	3.5	4474620
290 - 530	(11.4 - 20.7")	3	1.5	3.5	4474630

\* Excludes indicating instrument

### Dimensions

Measuring range	a	b	c	d	e	f
mm (inch)						
50 - 70 (2 - 2.8")	5	12	60	60	203	6
60 - 100 (2.4 - 4")	7	15	110	80	264	8
80 - 150 (3.2 - 6")	7	15	110	80	264	8
120 - 220 (4.7 - 8.7)	7.5	15	110	80	264	10
180 - 360 (7.1 - 14.2")	11	23	150	90	343	10
290 - 530 (11.4 - 20.7")	15	30	170	90	409	10

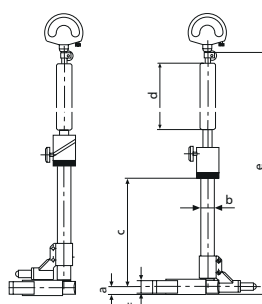

### Indicating Instruments

All indicating instruments that has a 8 mm mounting shank may be used.

Recommendations see page 9-67

Digital Indicators see Chapter 5  
Electrical Indicating Instruments see Chapter 7

## Self-Centering Dial Bore Gages 844 NB



### Applications

- Ideal for measuring blind holes. Can be measured almost to the base of a bore

### Features

- Measuring head consists of a carbide-tipped moving anvil and an interchangeable stationary anvil with a carbide ball
- Transmission lever system transfers movement of the movable anvil to indicating instrument
- The broad centering bridge ensures automatic centering in the bore
- Insensitive to temperature due to both the shank and transfer rod being made from heat resistant **Invar steel** (for further information see page 9-66)
- Highly resistant to wear and tear due to the carbide tipped moving anvil
- Constant measuring force due to built-in spring thus eliminating user influence
- Universally applicable and extremely versatile as every instrument spans a broad measuring range, within this range it is quick and easy to adjust to any size
- Supplied with: Measuring holder, measuring head, anvil spindle, wooden case, excludes indicator

### Technical Data

Measuring range		Error limit	Repeatability	Hysteresis	Order no*
mm	(inch)	$G_e$ $\mu\text{m}$	$f_w$ $\mu\text{m}$	$f_u$ $\mu\text{m}$	
20 - 50	(0.79 - 2")	4	1	2.5	4474179
50 - 110	(2 - 4.33")	2.5	1	2.5	4474180
110 - 300	(4.33 - 11.81")	2.5	1	3	4474186

\* Excludes indicating instrument

### Dimensions

Measuring range		a	b	c	d	e
mm	(inch)					
20 - 50	(0.79 - 2")	1.5	10	77	60	163
50 - 110	(2 - 4.33")	1.5	12	60	60	144
110 - 300	(4.33 - 11.81")	2	18	90	90	163

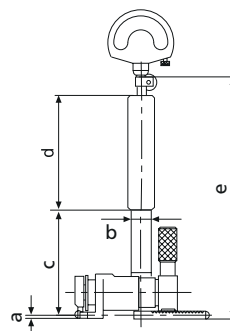

### Indicating Instruments

All indicating instruments that has a 8 mm mounting shank may be used.

Recommendations see page 9-67

Digital Indicators see Chapter 5  
Electrical Indicating Instruments see Chapter 7

## Accessories to set and adjust Dial Bore Gages

### 1. Setting Device

Uses standard gage blocks for setting any bore diameter and any tolerance. Replaces ring gages and is universally applicable.

### 2. Ring Gage 355 E

Special wear-resistant gage steel. Hardened and lapped. With actual deviation engraved

Dimensions: DIN 2250, type C  
 Manufacturing tolerance: DIN 2250  
 Available diameters: see page 13-19



355 E

### Components

#### Measuring Jaw 844 em

Measuring range mm	Dimensions (inch)	Dimensions mm/inch	Order no.
18 - 800 (.7 - 32")	60 x 9.5 x 9	2.36 x .37 x .35"	4470095

#### Setting Bridge 844 Neb

Measuring range mm	Width (inch)	Width mm/inch	Height mm/inch	Order no.	
18 - 250 (.7 - 10")	70	2.75"	12	.47"	4474080
18 - 400 (.7 - 16")	165	6.49"	17	.67"	4474081
18 - 800 (.7 - 32")	320	12.59"	20	.78"	4474082

#### Gage Block Holder 420 h

Clamping range mm	Clamping range (inch)	Order no.
0 - 70	(0 - 2.75")	4800120
0 - 120	(0 - 4.72")	4800121
100 - 220	(4 - 8.66")	4800122
100 - 420	(4 - 16.53")	4800123
400 - 820	(16 - 32.28")	4800124

#### Stand 844 ef

For mounting setting device up to 420 mm

Order no. 4470098

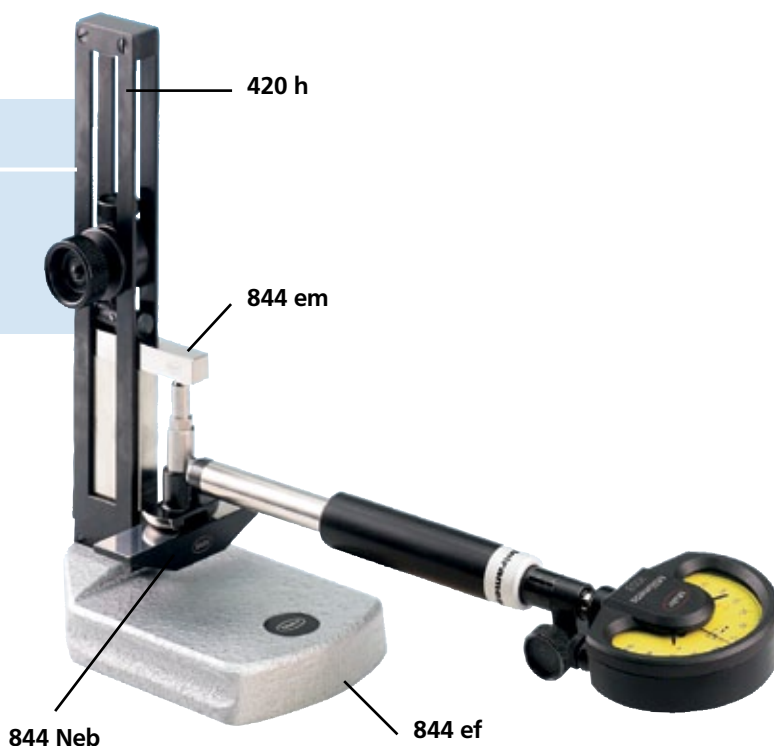



## Dial Bore Gage for Internal Serrations 844 Z



**Dial Bore Gage 844 Z**  
 Diametrical two ball measurement "M<sub>dk</sub>" from **3.5 - 333 mm**

**Modular Unit Parts 844 Kk**  
 "M<sub>dk</sub>" from **3.5 - 26.1 mm**  
 (see table below)

**Modular Unit Parts 844 Z**  
 "M<sub>dk</sub>" **26 - 333 mm** (see table on opposite page)

### Modular Unit Parts:

Diametrical two ball measurement „M<sub>dk</sub>“ from **3.5 - 26.1 mm**

Ball dimension M <sub>dk</sub> (mm)	Order no. ball dia. 1-5 graduation 0.5	Ball dia. according to table	Order no. ball dia. 7.5-10 graduation 0.5	Expander pin Steel
3.5 - 4.1	4482450	4482550		4470806
4.0 - 4.6	4482451	4482551		
4.5 - 5.1	4482452	4482552		
5.0 - 5.6	4482453	4482553		
5.5 - 6.1	4482454	4482554		
6.0 - 6.6	4482455	4482555		
6.5 - 7.1	4482456	4482556		
7.0 - 7.6	4482457	4482557		
7.5 - 8.1	4482458	4482558		
8.0 - 8.6	4482459	4482559		
8.5 - 9.1	4482460	4482560		4470808
9.0 - 9.6	4482461	4482561		
9.3 - 10.6	4482462	4482562	4482662	
10.3 - 11.6	4482463	4482563	4482663	
11.3 - 12.6	4482464	4482564	4482664	
12.3 - 13.6	4482465	4482565	4482665	
13.3 - 14.6	4482466	4482566	4482666	
14.5 - 16.1	4482467	4482567	4482667	
15.5 - 17.1	4482468	4482568	4482668	
16.5 - 18.1	4482469	4482569	4482669	
17.5 - 19.1	4482470	4482570	4482670	
18.5 - 20.1	4482471	4482571	4482671	
19.5 - 21.1	4482472	4482572	4482672	
20.5 - 22.1	4482473	4482573	4482673	
21.5 - 23.1	4482474	4482574	4482674	
22.5 - 24.1	4482475	4482575	4482675	
23.5 - 25.1	4482476	4482576	4482676	
24.5 - 26.1	4482477	4482577	4482677	

Table (Sizes in mm)

0.500 - 0.551 - 0.620 - 0.623 - 0.630 - 0.722 - 0.862 - 0.895 - 0.965 - 1.100 - 1.118 - 1.125 - 1.250  
 1.350 - 1.372 - 1.385 - 1.524 - 1.540 - 1.600 - 1.650 - 1.700 - 1.750 - 1.782 - 1.800 - 1.829 - 1.900  
 2.032 - 2.250 - 2.284 - 2.386 - 2.438 - 2.667 - 2.704 - 2.713 - 2.721 - 2.743 - 2.750 - 3.048 - 3.250  
 3.400 - 3.658 - 4.835 - 5.250 - 5.486 - 5.500 - 6.000 - 6.096 - 6.350 - 6.500 - 7.000

### Features

- For diametrical two ball measurement M<sub>dk</sub>, to obtain the pitch diameter and conical form of internal gears in any position and at any depth
- Constant measuring force due to built-in spring thus eliminating user influence
- Anvils, measuring heads, holder, spacer (intermediate piece) and depth extensions form a very comprehensive modular system which can rapidly be converted to measure further gear sizes
- For ball dimensions from 3.5 to 26.1 mm use the 844 Kk with carbide ball anvils and in conjunction with an expander pin
- For ball dimensions >26 mm the measuring heads 844 z1 or 844 z2 with the appropriate modular units are to be employed
- Maximum wear resistance due to carbide ball anvils

### Lifting Knob 954

enables the dial bore gage to gently guided into the serration. The measuring spindle of the indicating instrument can also be lifted.

Order no. 4372030

### Holder 844 Kg

with a clamping device for the indicating instrument. The mounting bore diameter 8 mm

Order no. 4470851

### Extension 844 Kv

for measuring in depth bores; length 64 mm

Order no. 4470070

### 844 Kk Anvil

for internal serrations. ball dimension „M<sub>dk</sub>“ from

3.5 - 26.1 mm

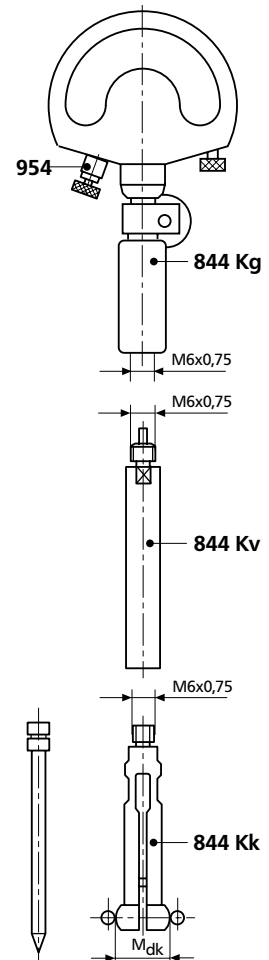

## Modular Unit Parts

Diametrical two ball measurement from  $M_{dk}$  26-333 mm

### Measuring Heads

**844 z1**, for  $M_{dk}$  26 - 130,5 mm

**844 z2**, for  $M_{dk}$  48.5 - 333 mm

### Order no.

**4485000**

**4485001**

### Floating Ball Anvils with carbide ball

	Grad. (mm)	Ball dia. mm	
<b>844 z3</b> Meas. range 3 mm, for Meas. Head 844 z1	0.5	1.0 - 5.0	<b>4488300</b>
		acc. to table	<b>4488301</b>
	0.5	7.5 - 10	<b>4488302</b>
<b>844 z4</b> Meas. range 3 mm, for Meas. Head 844 z2	0.5	1.0 - 5.0	<b>4488310</b>
		acc. to table	<b>4488311</b>
	0.5	7.5 - 10	<b>4488312</b>

### Ball Anvils with carbide ball

<b>844 z5</b> , Length 2.5 mm	0.5	1.0 - 5.0	<b>4488320</b>
		acc. to table	<b>4488321</b>
	0.5	7.5 - 10	<b>4488322</b>
<b>844 z6</b> , Length 5.0 mm	0.5	1.0 - 5.0	<b>4488330</b>
		acc. to table	<b>4488331</b>
	0.5	7.5 - 10	<b>4488332</b>
<b>844 z7</b> , Length 7.5 mm	0.5	1.0 - 5.0	<b>4488340</b>
		acc. to table	<b>4488341</b>
	0.5	7.5 - 10	<b>4488342</b>
<b>844 z8</b> , Length 10.0 mm	0.5	1.0 - 5.0	<b>4488350</b>
		acc. to table	<b>4488351</b>
	0.5	7.5 - 10	<b>4488352</b>
<b>844 z15</b> , Length adjustable from 24-34 mm	0.5	1.0 - 5.0	<b>4488360</b>
		acc. to table	<b>4488361</b>
	0.5	7.5 - 10	<b>4488362</b>

### Spacer (intermediate piece)

	Length (mm)	
<b>844 z9</b>	10	<b>4486501</b>
<b>844 z10</b>	20	<b>4486502</b>
<b>844 z11</b>	40	<b>4486503</b>
<b>844 z12</b>	80	<b>4486504</b>
<b>844 z13</b>	100 *	<b>4486505</b>

### Wooden case

**4485013**

\* Only for 844 z2

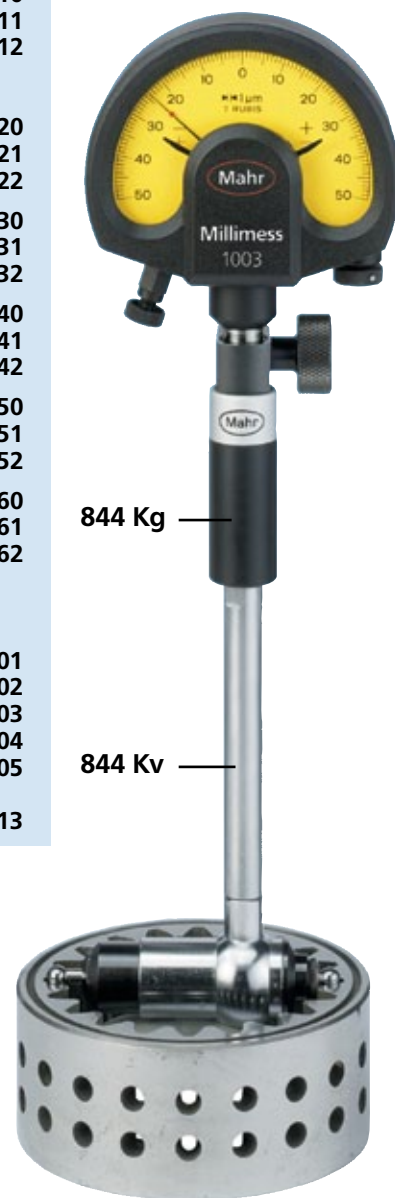
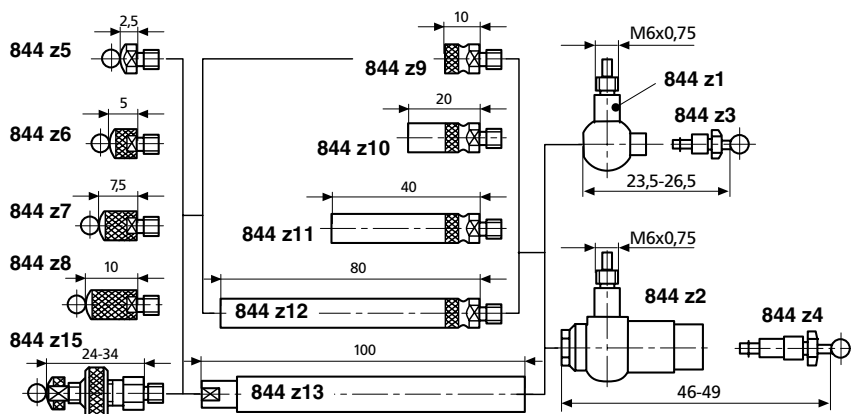

844 Kg

844 Kv

## Dial Bore Gage for Internal Serrations 844 Z

### Selecting Modular Unit Parts Measuring Head 844 z1 and Floating Ball Anvil 844 z3

M <sub>dk</sub> in mm	844 z5	844 z6	844 z7	844 z8	844 z15	844 z9	844 z10	844 z11	844 z12	844 z13
26.0 - 29.0	x									
28.5 - 31.5		x								
31.0 - 34.0			x							
33.5 - 36.5				x						
36.0 - 39.0	x					x				
38.5 - 41.5		x				x				
41.0 - 44.0			x			x				
43.5 - 46.5				x		x				
46.0 - 49.0	x						x			
47.5 - 60.5					x					
48.5 - 51.5		x					x			
51.0 - 54.0			x				x			
53.5 - 56.5				x			x			
56.0 - 59.0	x					x	x			
57.5 - 70.5					x	x				
58.5 - 61.5		x				x	x			
61.0 - 64.0			x			x	x			
63.5 - 66.5				x		x	x			
66.0 - 69.0	x							x		
67.5 - 80.5					x		x			
68.5 - 71.5		x						x		
71.0 - 74.0			x					x		
73.5 - 76.5				x				x		
76.0 - 79.0	x					x		x		
77.5 - 90.5					x	x	x			
78.5 - 81.5		x				x		x		
81.0 - 84.0			x			x		x		
83.5 - 86.5				x		x		x		
86.0 - 89.0	x						x	x		
87.5 - 100.5					x			x		
88.5 - 91.5		x					x	x		
91.0 - 94.0			x				x	x		
93.5 - 96.5				x			x	x		
96.0 - 99.0	x					x	x	x		
97.5 - 110.5					x		x	x		
98.5 - 101.5		x				x	x	x		
101.0 - 104.0			x			x	x	x		
103.5 - 106.5				x		x	x	x		
107.5 - 120.5					x		x	x		
117.5 - 130.5					x		x	x		

#### Example:

Diametrical two ball meas. M <sub>dk</sub>	73.0 mm
Ball dia.	5.486 mm

When placing an order please quote the ball diameter of the modular unit system for 844 z3 - 844 z8, as well as 844 z15. On the basis of the above specified example above result several combinations that are possible to choice from is dependent upon the work piece. For further details please refer to the illustration on Page 9-67.

The measuring application can be solved with either one of the following 4 versions:

Type	Description	Ball dia. mm	Length mm	Order no.
<b>Version 1</b>				
844 z1	Meas. Head		23.5-26.5	4485000
844 z3	Floating Ball Anvil	5.486		4488301
844 z7	Ball Anvil	5.486	7.5	4488341
844 z11	Spacer		40.0	4486503
<b>Meas. range</b>			71.0-74.0	
<b>Version 2</b>				
844 z1	Meas. Head		23.5-26.5	4485000
844 z3	Floating Ball Anvil	5.486		4488301
844 z15	Ball Anvil	5.486	24.0-34.0	4488361
844 z10	Spacer		20.0	4486502
<b>Meas. range</b>			67.5-80.5	
<b>Version 3</b>				
844 z2	Meas. Head		46.0-49.0	4485001
844 z4	Floating Ball Anvil	5.486		4488311
844 z6	Ball Anvil	5.486	5.0	4488331
844 z10	Spacer		20.0	4486502
<b>Meas. range</b>			71.0-74.0	
<b>Version 4</b>				
844 z2	Meas. Head		46.0-49.0	4485001
844 z4	Floating Ball Anvil	5.486		4488311
844 z15	Ball Anvil	5.486	24.0-34.0	4488361
<b>Meas. range</b>			70.0-83.0	

### Determination of setting values

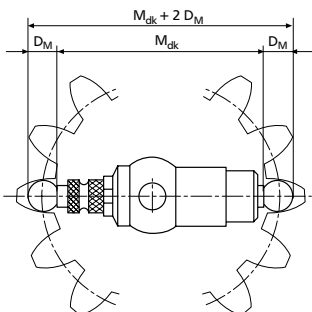

$D_M$  = Ball diameter of the ball anvil

$M_{dk}$  = Diametrical two ball measurement

$M_{dk} + 2 D_M$  = Setting value (length of the gage block required for setting)

### Indicating Instruments

All indicating instruments that has a 8 mm mounting shank may be used. Recommended are:

Dial Comparator	Readings mm / inch	Order no. mm / inch
Millimess 1004/1004 Z	5 $\mu$ m / .0001"	4333000/4333900
Millimess 1003/1003 Z	1 $\mu$ m / .00005"	4334000/4334900

Digital Indicators see Chapter 5  
Electrical Indicating Instruments see Chapter 7

