



PHONES

(044) 360-7-130
(050) 336-0-130
(063) 788-0-130
(067) 233-0-130
(068) 282-0-130

130
COM.UA

Internet store of
autogoods



ICQ
294-0-130
597-0-130

SKYPE
km-130

CAR RECEIVERS — Receivers • Media receivers and stations • Native receivers • CD/DVD changers • FM-modulators/USB adapters • Flash memory • Facia plates and adapters • Antennas • Accessories |
CAR AUDIO — Car audio speakers • Amplifiers • Subwoofers • Processors • Crossovers • Headphones • Accessories | TRIP COMPUTERS — Universal computers • Model computers • Accessories |
GPS NAVIGATORS — Portable GPS • Built-in GPS • GPS modules • GPS trackers • Antennas for GPS navigators • Accessories | VIDEO — DVR • TV sets and monitors • Car TV tuners • Cameras • Videomodules
• Transcoders • Car TV antennas • Accessories | SECURITY SYSTEMS — Car alarms • Bike alarms • Mechanical blockers • Immobilizers • Sensors • Accessories | OPTIC AND LIGHT — Xenon • Bixenon • Lamps
• LED • Stroboscopes • Optic and Headlights • Washers • Light, rain sensors • Accessories | PARKTRONICS AND MIRRORS — Rear parktronic • Front parktronic • Combined parktronic • Rear-view mirrors
• Accessories | HEATING AND COOLING — Seat heaters • Mirrors heaters • Screen-wipers heaters • Engine heaters • Auto-refrigerators • Air conditioning units • Accessories | TUNING — Vibro-isolation
• Noise-isolation • Tint films • Accessories | ACCESSORIES — Radar-detectors • Handsfree, Bluetooth • Windowlifters • Compressors • Beeps, loudspeakers • Measuring instruments • Cleaners • Carsits
• Miscellaneous | MOUNTING — Installation kits • Upholstery • Grilles • Tubes • Cable and wire • Tools • Miscellaneous | POWER — Batteries • Converters • Start-charging equipment • Capacitors
• Accessories | MARINE AUDIO AND ELECTRONICS — Marine receivers • Marine audio speakers • Marine subwoofers • Marine amplifiers • Accessories | CAR CARE PRODUCTS — Additives • Washer fluid •
Care accessories • Car polish • Flavors • Adhesives and sealants | LIQUID AND OIL — Motor oil • Transmission oil • Brake fluid • Antifreeze • Technical lubricant



In store "130" you can find and buy almost all necessary goods for your auto in Kyiv and other cities, delivery by ground and postal services. Our experienced consultants will provide you with exhaustive information and help you to chose the very particular thing. We are waiting for you at the address

<http://130.com.ua>



PERFORMANCE SERIES CAR AUDIO SPEAKERS

125, 126, 1269
224, 225, 226, 257, 269
424, 425, 426, 457, 428
960, 962, 1072
B5A, B6A, C4, C5A, C6A, C36

WELCOME

Thank you for buying a DLS Performance series speaker.

This manual will show you how to do a correct installation. Please read the entire manual before beginning the installation.

Install the speakers yourself if you feel confident with our instructions and if you have the proper tools. However if you feel unsure, turn over the installation job to someone better suited to it.

INSTALLATION

Mount the speakers in the door or in the dashboard of your car. Normally they will fit in the factory pre-made mounting holes. If you want an improved sound reinforce with a baffle of MDF-board or similar. An installation high up on the door side is to be preferred. An alternative installation is in so called kick panels down on each side of the floor with the speakers facing up- and inwards towards the listener.

For two- or three way speaker systems with separate tweeter an installation of the tweeter close to the bass/mid element is to be preferred. The tweeter can also be installed on the dash-board, or recessed in the door with the accessories in the tweeter box.

It is important to fasten the speakers properly in order to avoid bad sound or rattling.

For speakers with separate filters in boxes or similar it is vital that they are attached properly to the interior of the vehicle to avoid rattling. Don't place them close to the internal wiring of the car, this can cause interference.

Avoid to install filter boxes in the door sides because they can easily be broken because of rattling or moisture. Make sure the cables don't get jammed causing a short circuit to ground. This can damage the output circuits of the head unit or amplifier.

All models except for 257 and 457 comes with grilles.

The tweeter installation for kits with separate tweeter is described on last page, or in the instruction sheet coming with the tweeters.

SPEAKER ENCLOSURES

If you want to install the speaker in an enclosure the normal size for a sealed type is:

4" (10 cm) speakers	: 2-4 liters
5,25" (13 cm) speakers	: 6-8 liters
6,5" (16,5 cm) speakers	: 10-12 liters
8" (20 cm) speakers	: 15-20 liters
6 x 9" speakers	: 15-20 liters
7 x 10" speakers	: 20-25 liters

These volumes are only a guideline, they can vary between different speakers. Contact your local DLS dealer for more exact information about your specific speaker.

SPEAKERS 125, 126 & 1269

DLS 125 & 126 & 1269 are coaxial speaker with integrated filter.

COAXIAL SPEAKERS 224, 225, 226, 257, 269 & 960, 1072.

The 224, 269, 960 and 1072 models have an integrated tweeter filter. DLS 225, 226 and 257 have a separate cable filter wrapped in plastic cover. Inside the cover there is both a lowpass filter for the woofer and a highpass filter for the tweeter. On next page you can see how to connect the filter.

The filters must be used, if you connect without them the sound becomes bad and you will destroy the tweeter.

COAXIAL SPEAKERS 424, 425, 426, 457, 428 & 962.

These speakers have a separate filter box with lowpass filter for the woofer and a highpass filter for the tweeter. The tweeter level can be adjusted inside the filter box in two steps, high and low. Install the filter box in a dry place. On next page you can see how to connect the filter.

The filters must be used, if you connect without them the sound becomes bad and you will destroy the tweeter.

TWO-WAY SYSTEMS B5A & B6A

These systems have a separate tweeter. The filters are separate lowpass and highpass in small plastic boxes with selectable tweeter level in two steps. The bass/mid speaker driver uses the new DLS EFR technology for improved sound quality.

On next page you can see how to connect the filter.

The filters must be used, if you connect without them the sound becomes bad and you will destroy the tweeter.

TWO/THREE-WAY SYSTEMS C4, C5A, C6A & C36

The 2-way systems have a separate tweeter. The filters are separate lowpass and highpass in small plastic boxes with selectable tweeter level in three steps inside. C36 is a 3-way system with a filter box where you can connect a woofer, a midrange speaker and a tweeter. The tweeter level can be adjusted in three steps inside the filter box. On next page you can see how to connect the filter.

The C5A and C6A bass/mid speaker driver uses the new DLS EFR technology for improved sound quality.

The filters must be used, if you connect without them the sound becomes bad and you will destroy the tweeter.

SPEAKER FACTS FOR DLS PERFORMANCE SERIES

Model	Woofers	Mid	Tweeter	Nom. power	Max power	Sensitivity	Magnet size	Inst. depth	Mounting hole	Crossover
125	13 cm / 5,25"	50 mm	16 mm / 0,63"	50 W	80 W	92 dB	70 mm / 2,75"	50 mm / 1,97"	120 mm / 4,72"	Integrated
126	16,5 cm / 6,5"		16 mm / 0,63"	50 W	80 W	92 dB	80 mm / 3,15"	28 mm / 2,28"	145 mm / 5,7"	Integrated
1269	6 x 9"		50 mm / 2"	60 W	120 W	92 dB	80 mm / 3,15"	75 mm / 3"	150x220 mm / 5,9x8,7"	Integrated
224	10 cm / 4"		16 mm / 0,63"	50 W	80 W	93 dB	70 mm / 2,75"	50 mm / 1,97"	102 mm / 4"	Integrated
225	13 cm / 5,25"		16 mm / 0,63"	50 W	80 W	92 dB	80 mm / 3,15"	54 mm / 2,12"	120 mm / 4,72"	Integrated
226	16,5 cm / 6,5"		16 mm / 0,63"	50 W	80 W	92 dB	80 mm / 3,15"	52 mm / 2"	145 mm / 5,7"	Integrated
269	6 x 9"		16 mm / 0,63"	80 W	120 W	92 dB	100 mm / 3,94"	80 mm / 3,15"	150x220 mm / 5,9x8,7"	Integrated
257	5 x 7"		16 mm / 0,63"	50 W	80 W	92 dB	80 mm / 3,15"	60 mm / 2,36"	130 x 185 mm / 5,1x7,3"	Integrated
424	10 cm / 4"		20 mm / 0,8"	50 W	80 W	94 dB	80 mm / 3,15"	58 mm / 2,28"	102 mm / 4"	Separate box
425	13 cm / 5,25"		20 mm / 0,8"	60 W	90 W	93 dB	90 mm / 3,54"	61 mm / 2,4"	117 mm / 4,6"	Separate box
426	16,5 cm / 6,5"	20 mm / 0,8"	60 W	90 W	94 dB	100 mm / 4"	62 mm / 2,44"	145 mm / 5,7"	Separate box	
428	20 cm / 8"	25 mm / 1"	80 W	120 W	94 dB	105 mm / 4,1"	87 mm / 3,43"	185 mm / 7,282	Separate box	
457	5 x 7"	20 mm / 0,8"	60 W	90 W	93 dB	100 mm / 4"	58 mm / 2,28"	130 x 185 mm / 5,1x7,3"	Separate box	
960	6 x 9"	50 mm	20 mm / 0,8"	80 W	120 W	93 dB	100 mm / 4"	83 mm / 3,27"	150x220 mm / 5,9x8,7"	Integrated
962	6 x 9"	50 mm	25 mm / 0,8"	80 W	120 W	93 dB	100 mm / 4"	83 mm / 3,27"	150x220 mm / 5,9x8,7"	Separate box
1072	7" x 10"	50 mm	piezo	100 W	150 W	92 dB	110 mm/4,3"	87 mm/3,42"	156x225 mm/6,15x8,86"	Integrated
B5A*	13 cm / 5,25"		16 mm / 0,63"	50 W	80 W	91 dB	80 mm / 3,15"	63 mm / 2,48"	117 mm / 4,6"	Separate LP/HP
B6A*	16,5 cm / 6,5"		16 mm / 0,63"	50 W	80 W	91 dB	80 mm / 3,15"	63 mm / 2,48"	146 mm / 5,75"	Separate LP/HP
C4	10 cm / 4"		20 mm / 0,8"	50 W	80 W	92 dB	70 mm / 2,75"	58 mm / 2,28"	102 mm / 4"	Cable filter
C5A*	13 cm / 5,25"		20 mm / 0,8"	50 W	80 W	93 dB	80 mm / 3,15"	60 mm / 2,36"	120 mm / 4,72"	Separate boxes
C6A*	16,5 cm / 6,5"		20 mm / 0,8"	60 W	90 W	93 dB	80 mm / 3,15"	63 mm / 2,48"	156 mm / 5,75"	Separate boxes
C36	16,5 cm / 6,5"	4"	20 mm / 0,8"	60 W	90 W	93 dB	80 / 70 mm	63 / 58 mm	146 / 102 mm	Separate boxes

* Speakers using the DLS EFR technology for improved sound quality.

RUNNING-IN PERIOD

Allow the speakers to play for at least 15-20 hours. After this time the performance is correct.

SPEAKER PHASING

To be sure to have the correct speaker polarity (phase) you can check this by using a 1,5 Volt battery. Connect a cable from the battery plus-pole to the speaker plus, and a cable from the battery minus to the speaker minus. If the speakers are correctly connected the speaker cone should move outwards on both right and left channel. This check must be made on the cables going from the speakers, to the output terminals of your car stereo or amplifier.

CONNECTION OF SPEAKERS

For speakers with integrated filters you just connect like this. Make sure the polarity is correct for both left and right side.

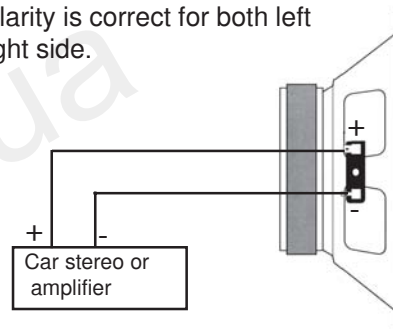

FILTER/CROSSOVER INSTALLATIONS

Filter installation and connection of coaxial speakers 424, 425, 426 and 457

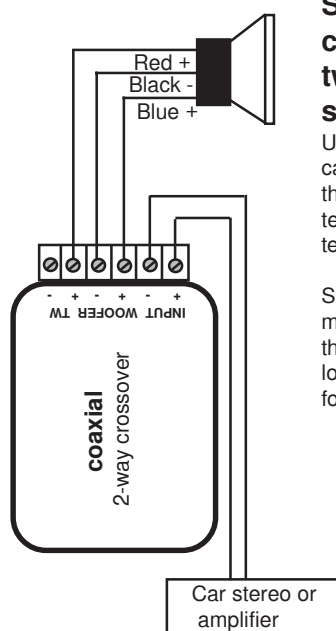

Speaker connection and tweeter level select:

Use the red, blue and black cables to connect between the filter box and speaker terminal. Note the speaker terminal colour marking.

Select tweeter level by moving the jumper inside the filter box between high / low. Make your own tests for best result.

Filter installation and connection of coaxial speakers 962 and 428

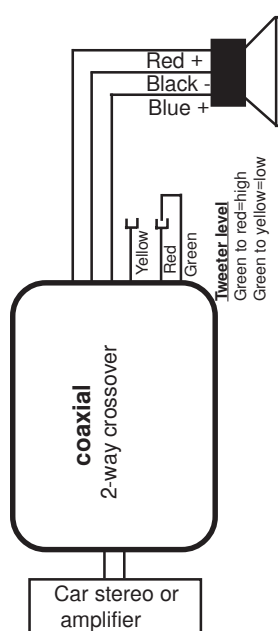

On the cable filter box without screw terminals the level select is made on the outside by connecting the green cable to either the red or yellow one coming out from the box.

Tweeter level select:
High level: Connect green and red wire.

Low level: Connect green and yellow wire.

FILTER/CROSSOVER INSTALLATIONS

Filter installation B5A and B6A

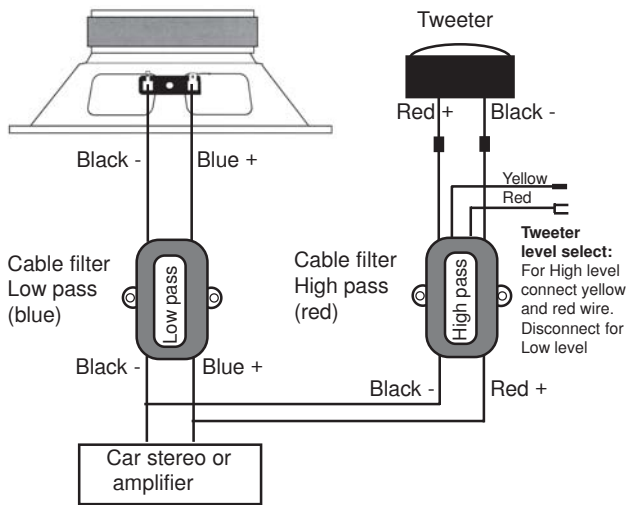

Filter installation C5A

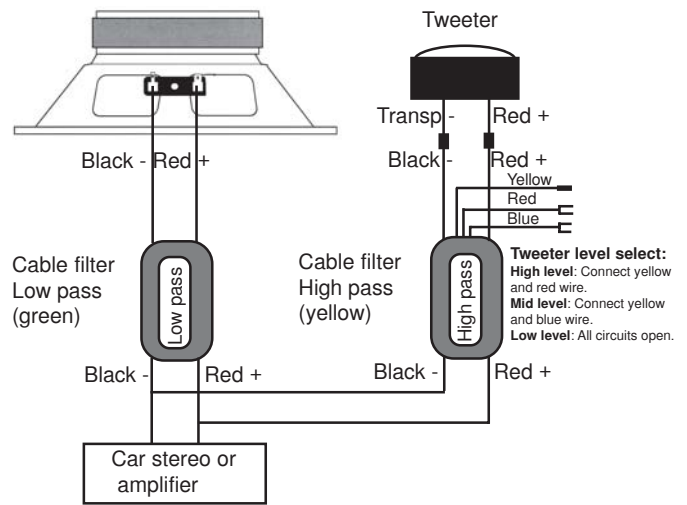

Filter installation C4

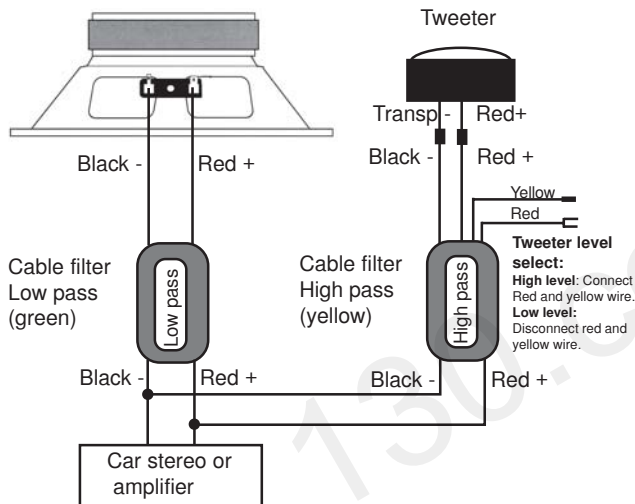

Filter installation C6A

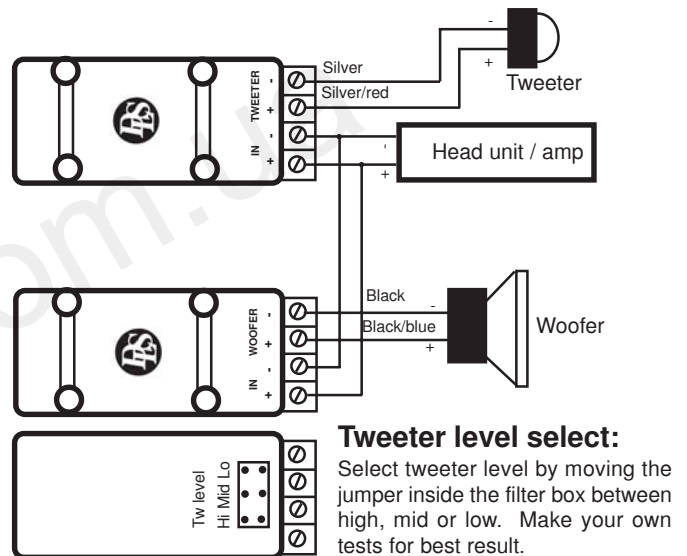

Filter installation and connection of C36

CONNECT/DISCONNECT THE MIDBASS, JUMPER J1:
If you want to run the midbass driver with an active crossover using a separate amplifier, and run the midrange and tweeter through the passive filter box, you must move the jumper J1 to position OUT. The normal position for this jumper is IN.

TWEETER LEVEL SELECT, JUMPER J2:
The tweeter level can be selected in three step by moving jumper J2 between 0, -2dB or -4dB. The lowest tweeter level is achieved in the -4dB position.

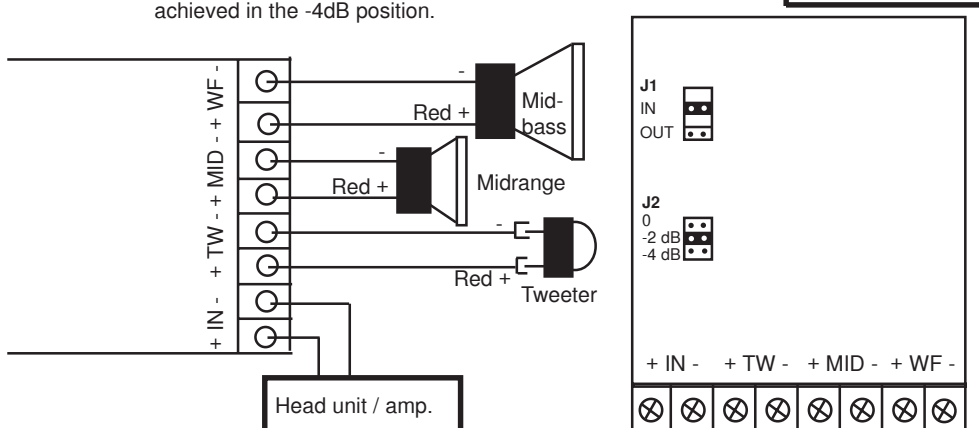

Filter installation 225, 226 and 257

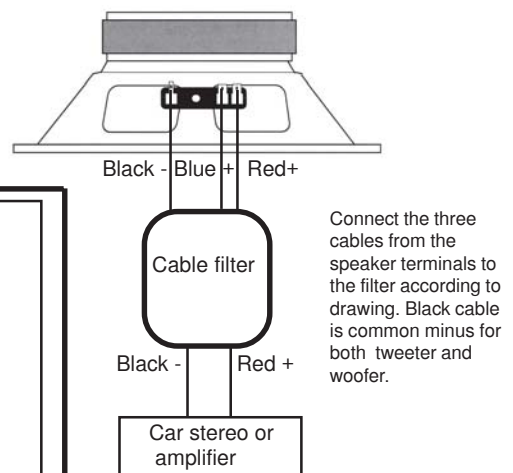

TWEETER INSTALLATION T20

T20 can be mounted on the dashboard with the plain cup (1), the angled cup (2), or recessed in a doorside. These tweeters are included in the C4, C5, C6 and C36 speaker kits.



SURFACE MOUNTING:

Plain mounting: Use only the plain mounting cup (1) (it's normally mounted at delivery). Attach to surface with the two screws or double adhesive tape.

Angled mounting: Remove the plain mounting cup by bending with a small screw driver in the gap (A). Attach the tweeter element to the angled cup (2) as shown on picture 3. Pull the cable through the center hole. Now the tweeter can be mounted in two different angles. Attach to the surface with the two screws or double adhesive tape.

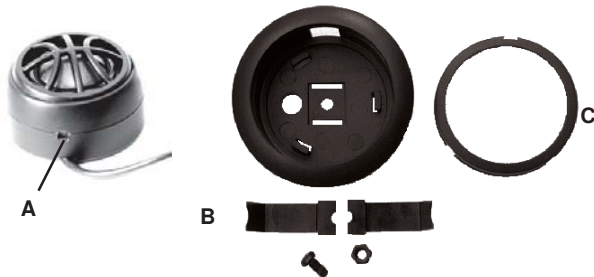

RECESSED MOUNTING:

Drill a hole in the door side with a diameter of 48 mm / 1,89". The installation becomes easier if the door side is removed from the door. Put the two metal wings through the two tracks in the center of the cup, just as the picture shows, and attach them with the M4 screw and nut through the center hole. Put the tweeter element into the cup with the cable going out through the bottom hole. Attach the tweeter element to the plain cup using the mounting ring (C) attached between the cup and the tweeter element. The metal wings (B) should be on the back side of the door panel, holding the cup in place.

FACTS ABOUT DLS T20 TWEETER

Size	20 mm / 0,8"
Nom. power (RMS)	50 Watts, 80 Watts max
Freq. range	1,5 kHz-20 kHz
Sensitivity	93 dB
Magnet diameter	20 mm / 0,8" neodymium magnet
Mounting depth	20 mm / 0,8" (recessed mounting)
Mounting hole	48 mm / 1,89" (recessed mounting)
Cone material	Silk

TWEETER INSTALLATION T16

T16 can be mounted on the dashboard with the angled cup (1), or recessed in a doorside. These tweeters are included in the B5 and B6 speaker kits.



SURFACE MOUNTING:

Angled mounting: Put the cable through the hole in the rear end of the angled cup. The tweeter is attached to the cup by pressing them together. Attach the cup to the surface with the double adhesive tape.

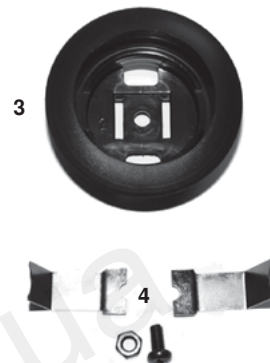

RECESSED MOUNTING:

You need a hole with a diameter of 43 mm / 1,7". Put the two metal wings through the two tracks in the center of the cup, just as the picture shows, and attach them with the M4 screw and nut through the center hole. The cup is attached to the door side when the metal wings is pressed to the back side of the door.

Put the tweeter element into the cup with the cable going out through the bottom hole. Then attach the element by putting it into the cup.

FACTS ABOUT DLS T16 TWEETER

Size	16 mm / 0,63"
Nom. power (RMS)	50 Watts, 80 Watts max
Freq. range	2 kHz-20 kHz
Sensitivity	91 dB
Magnet diameter	20 mm / 0,8" neodymium magnet
Mounting depth	20 mm / 0,8" (recessed mounting)
Mounting hole	43 mm / 1,7" (recessed mounting)
Cone material	Mylar

WARRANTY SERVICE

This speaker is covered by warranty, depending on the conditions in the country where it is sold. If the speaker is returned for service, please include the original dated receipt with the product.



Technical Assistance

For technical assistance ask the shop where the product was sold or the distributor in your very country. You can always phone the DLS Helpdesk in Sweden + 46 31 840060 or send an e-mail to info@dls.se. Information can also be found on our WEB-site www.dls.se

We follow a policy of continuous advancement in development. For this reason all or part of specifications & designs may be changed without prior notice.



DLS Svenska AB
P.O. Box 13029
SE-40251 Göteborg, Sweden
Tel: +46 31 840060
Fax: +46 31 844021
E-mail: info@dls.se
www.dls.se