



# A new species of *Janiralata* Menzies, 1951 (Isopoda: Janiridae) from Japanese bathyal waters, with a review of the associations with invertebrates among the species of *Janiralata*

Mizuki Ohta<sup>1</sup>, Tsuyoshi Takano<sup>2</sup>, Shigeaki Kojima<sup>1,3</sup> and Yoji Narimatsu<sup>4</sup>

<sup>1</sup>Atmosphere and Ocean Research Institute, The University of Tokyo, Kashiwa-shi, Chiba, 277-8564, Japan

<sup>2</sup>Meguro Parasitological Museum, Meguro-ku, Tokyo, 153-0064, Japan

<sup>3</sup>Department of Natural Environmental Studies, Graduate School of Frontier Sciences, The University of Tokyo, Kashiwa-shi, Chiba, 277-8563, Japan

<sup>4</sup>Hachinohe Field Station, Fisheries Resources Institute, Fisheries Research and Education Agency, Hachinohe-shi, Aomori, 031-0841, Japan

Version of Record, first published online August 31, 2023, with fixed content and layout in compliance with Art. 8.1.3.2 ICZN. LSID: zoobank.org:pub:94C94E3C-B9F4-4C8F-AAFF-2FDC8548A802.

Correspondence: M. Ohta, E-mail: [m.ohta@aori.u-tokyo.ac.jp](mailto:m.ohta@aori.u-tokyo.ac.jp)

## ABSTRACT

Isopods of the genus *Janiralata* Menzies, 1951 (Asellota: Janiridae) are known from shallow and deep waters of the Northern Hemisphere. Most species are free-living, but some are symbiotic on the surface of other benthic invertebrates. We obtained from three beam- and four otter-trawl hauls 18 *Janiralata* asellote specimens from the bathyal zone off the Pacific coasts of Tohoku, northeastern Japan. Partial nucleotide sequences of the mitochondrial cytochrome *c* oxidase subunit I (COI) gene (505 bp) were determined for 16 of the 18 collected specimens. Non-significant genetic differences (< 0.8%) indicated that the individuals were conspecifics. Morphological analysis indicated that all the specimens belonged to a single species, *Janiralata plana* **sp. nov.** based on the unique morphology of the anterolateral and distolateral projections on the head and pleotelson, surface and lateral margins of the body, antennula article 1, and of the male pleopod 1. Six of the 18 collected specimens were found attached to the surface of an unidentified sea anemone (Hormathiidae), ten to the solasterid starfish *Crossaster borealis* Fisher, 1906 and two were obtained from the bottom sediment. Three COI haplotypes of the new species were shared by individuals from two neighboring sites, which suggests that genetic isolation occurs on a relatively narrow horizontal scale, although the bathymetric distribution range was rather wide. We describe a case study of the geographic and bathymetric distributions of an asellote species with low dispersal ability and its genetically differentiated populations. Such approach could help elucidate the diversity and distribution of deep-sea organisms and their diversification processes.

**KEY WORDS:** Asellota, Crustacea, deep sea, DNA barcoding, population structure, symbiosis

## INTRODUCTION

Isopods of the suborder Asellota (Peracarida: Crustacea) inhabit freshwater and marine environments, and are known as one of the most species-rich groups in the deep sea (Hessler & Thistle, 1975). Among marine asellotes, species belonging to the families Munnopsidae Lilljeborg, 1864 and Desmosomatidae G.O. Sars, 1897 possess swimming legs that allow them to swim, whereas the other members are bottom-dwellers that live in bottom sediments or on hard substrates on the seabed (Hessler & Strömberg, 1989; Shimomura & Nunomura, 2013).

The asellote family Janiridae G.O. Sars, 1897 is one of the best-known groups in the superfamily Janiroidea G.O. Sars, 1897. The family includes over 150 described species in 20 genera (WoRMS, 2023) that inhabit various aquatic environments, including freshwater, brackish waters, and marine environments from the intertidal to the bathyal zones (Birstein, 1970; Shimomura & Nunomura, 2013). Shimomura (2009) listed 11 species belonging to five genera from Japanese waters, including species inhabiting both shallow and deep waters.

Janirids are regarded as having no parasitic phase although they were often observed attaching to other benthic invertebrates

(Shimomura, 2009). Many janirids have been found on other organisms: species of the genera *Carpas* Richardson, 1902, *Ianiropsis* G.O. Sars, 1897, and *Janira* Leach, 1814 from the surface of corals, those of *Carpas*, *Ianiropsis*, *Ectias* Richardson, 1906, and *Janiralata* Menzies, 1951 from the surface or aquiferous systems of sponges, *Carpas*, *Ianiropsis*, *Janaira* Moreira & Pires, 1977 from the surface of starfishes (e.g., Hatch, 1947; Kensley, 1976; Pires, 1995; Mortensen, 2001; Doti & Wilson, 2010; Doti et al. 2014). Such behavior has been described as instances of “commensalism” (Wilson, 1997). The attachment of janirids can be nevertheless problematic for the fishing industry. Janirids attach to the surface of farmed animals, such as sea cucumbers, and injure the body surface of hosts when creeping, thus reducing the commercial value and can even result in the death of such animals (Wakayama Prefectural Fisheries Experiment Station, 2016). Despite its significance in ecology and fisheries science, the attachment behavior of janirids has thus far only been reported in a few species and from limited geographic areas; therefore, the diversity of symbiotic species, their geographic distribution, and substrate specificity require investigation.

The most species-rich genus of the family, *Janiralata* (WoRMS, 2023), is distributed from the shallow-subtidal to the bathyal zone at a depth of 3,250 m (Birstein, 1970) in the Northern Hemisphere, especially the Northwest Pacific (Kusakin, 1988; Kim et al., 2022). Some species have been reported to attach to echinoderms. For example, individuals of *Janiralata chuni* (Thielemann, 1910) collected at depths of 93–158 m off Misaki, Kanagawa Prefecture, Japan, were found to attach to the body surface of *Asterias amurensis* Lütken, 1871 (Asteroidea) (Shimomura, 2006), and *Janiralata solasteri* (Hatch, 1947) collected from Hood Canal, Washington, USA attached to *Solaster stimpsoni* Verrill, 1880 (Solasteridae) (Hatch, 1947). The latter species, however, was also observed attached to sunken wood under rearing conditions (Hessler & Strömberg, 1989), suggesting low specificity for habitat substrates. We recently discovered a species of *Janiralata* attached to the surface of the solasterid starfish *Crossaster borealis* Fisher, 1906 and an unidentified sea anemone, Hormathiidae sp., at 425–1,559 m off the Pacific coast of Tohoku, the landward slope of the Japan Trench. We describe herein it as a new species, *Janiralata plana* sp. nov., and report on its ecology and population genetic structure.

## MATERIALS AND METHODS

Eighteen *Janiralata* individuals were collected between 425 and 1,559 m off Tohoku, northeastern Japan, during two research cruises of R/V *Shinsei-maru* (Japan Agency for Marine-earth Science and Technology, JAMSTEC), and during surveys the Pacific cod and walleye pollock recruitment and snow-crab distribution by R/V *Wakataka-maru* (Japan Fisheries Research and Education Agency) in April 2022 (Fig. 1, Table 1, Supplementary material Table S1). Specimens were collected using a 3-m beam trawl (BT) or an otter trawl and fixed in 99.5% ethanol or frozen on board after photographing. The *Janiralata* specimens were observed under a StemiDV4 dissection microscope (Carl Zeiss, Oberkochen, Germany) and an Optiphot compound microscope (Nikon, Tokyo, Japan). The terminology used for the description followed that of Shimomura

(2006) and the classification of the species based on Wilson & Wägele (1994), Menzies (1951), Kussakin (1972), and Jang (1991).

Partial nucleotide sequences of the mitochondrial cytochrome *c* oxidase subunit I (COI) gene were determined from 16 specimens (Supplementary material Table S1). Total DNA was extracted from one to three pereopods using a DNeasy Blood and Tissue Kit (QIAGEN, Hilden, Germany). Partial fragments of the COI gene were amplified by PCR using the primer sets LCO1490 (forward: 5'-GGT CAA CAA ATC ATA AAG ATA TTG G-3') and HCO2198 (reverse 5'-TAA ACT TCA GGG TGA CCA AAA AAT CA-3') (both Folmer et al., 1994), or LCO1490 and *Coxr2* (reverse 5'-TCT ATC CCA ACT GTA AAT ATR TGR TG-3') (Cheng et al., 2013). PCR amplification was performed using TaKaRa Ex Premier DNA polymerase (TaKaRa Bio, Shiga, Japan) as follows: initial denaturation at 94 °C for 60 s, followed by 35 cycles consisting of denaturation at 98 °C for 10 s, annealing at 42 °C for 15 s, and extension at 68 °C for 30 s. PCR products were purified using ExoSAP-express (Thermo-Fisher Scientific, Waltham, MA, USA). Sequencing reactions were prepared using a BigDye Terminator Cycle Sequence Kit v3.1 (Applied Biosystems, Foster City, CA, USA). After purification using a BigDye XTerminator Purification Kit (ABI), nucleotide sequences were determined using an ABI

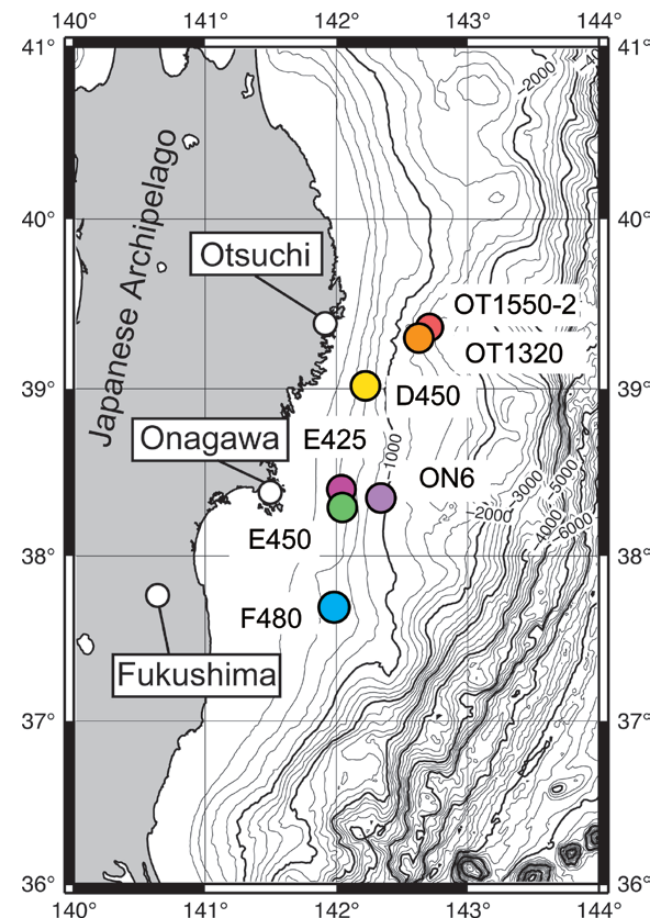
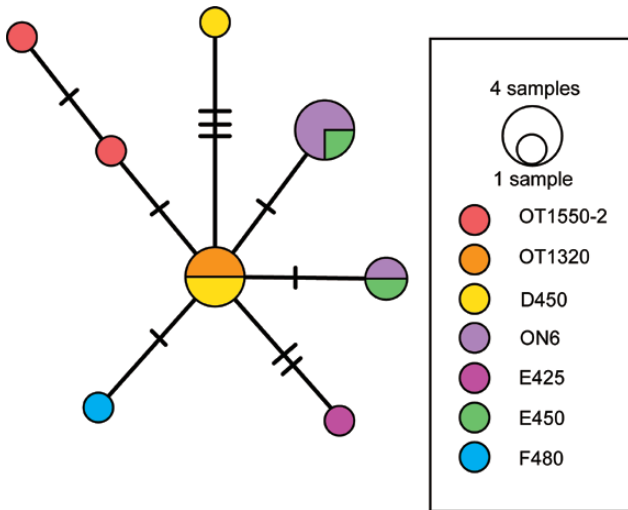

Figure 1. Sampling sites around the northeastern Japanese Archipelago. The details of sampling sites summarized in Table 1.

**Table 1.** Sampling sites where *Janiralata plana* sp. nov. was collected.

Site	Cruise No.	Date	Coordinates	Depth (m)	Gear	No. of individuals
OT1550-2	KS-20-15	1 Oct. 2020	39°20.97'–19.96'N 142°42.05'–41.73'E	1,559–1,557	3 m BT	3
OT1320	KS-20-15	2 Oct. 2020	39°19.49'–20.81'N 142°35.71'–35.76'E	1,337–1,306	3 m BT	2
D450	Wakataka April 2022	17 April 2022	39°01.92'N 142°10.48'E	450	Otter trawl	3
ON6	KS-16-18	11 Nov. 2016	38°23.96'–22.97'N 142°20.08'–20.06'E	871–880	3 m BT	6
E425	Wakataka April 2022	18 April 2022	38°26.00'N 139°13.39'E	425	Otter trawl	1
E450	Wakataka April 2022	22 April 2022	38°23.75'N 142°03.91'E	450	Otter trawl	2
F480	Wakataka April 2022	21 April 2022	37°41.93'N 141°59.00'E	480	Otter trawl	1

**Figure 2.** Haplotype network based on the nucleotide sequences of the mitochondrial COI gene (505 bp) of *Janiralata plana* sp. nov.

3130xl automated DNA sequencer at the Atmosphere and Ocean Research Institute (AORI), The University of Tokyo.

The COI gene sequences obtained were aligned using the ClustalW package in MEGA X (Kumar *et al.*, 2018). A haplotype network was created using the TCS method (Clement *et al.*, 2000) implemented in PopART software (Leigh & Bryant, 2015), based on an overlapping 505-bp region.

Type materials were deposited in the National Museum of Nature and Science, Tokyo (NSMT). The extracted DNA were stored at AORI, The University of Tokyo.

## RESULTS

Six *Janiralata* individuals were found attached to an unidentified sea anemone (Hormathiidae) and ten to the solasterid starfish *Crossaster borealis*. Two additional individuals were found in mud sediment without hosts. These may have been crawling freely on the bottom or fallen off hosts during sampling.

### Genetic analysis

Partial nucleotide sequences of the COI gene were successfully obtained from 16 individuals; the obtained sequences varied among the specimens from 505 to 785 bp presumably due to the preservation conditions. A 505-bp matrix was therefore offered for inferring the haplotype network (Fig. 2). Eight

haplotypes were identified in total, which were deposited to the DDBJ/EMBL/GenBank databases with accession numbers LC773543–LC773558. The maximum uncorrected *p*-distance was 0.8% among the newly obtained sequences. Three haplotypes were shared by individuals from two neighboring sites (Fig. 1). No genetic trends were found among the individuals from the starfish, sea anemone, and bottom sediment.

The individuals were identified as a single species based on molecular and morphological data, and hereby described as *Janiralata plana* sp. nov.

### Taxonomy

**Family Janiridae** G.O. Sars, 1897

**Genus *Janiralata*** Menzies, 1951

*Type species: Janiralata davisi* Menzies, 1951

**Remarks:** The genus was established by Menzies (1951). Ten genera were synonymized under *Janiralata* (Wilson & Wägele, 1994). The serrated proximal third of ventral margin of the propodus of pereopod 1 is a key diagnostic character of this genus (Wilson & Wägele, 1994).

***Janiralata plana* sp. nov.**

(Figs. 3A, B, 4, 5, 6)

**Material examined:** Holotype: male, 5.3 mm, NSMT-Cr 31499, off Otsuchi, Iwate, Honshu Island, Japan (39°19.49'–20.81'N, 142°35.71'–35.76'E; 1,337–1,306 m: R/V *Shinsei-maru* cruise KS-20-15, station OT-1320) (type locality), sorted from soft sediment, collected by 3 m beam trawl on 2 October 2020. Paratypes: male, 6.4 mm body length, NSMT-Cr 31501, off Otsuchi, Iwate, Honshu Island, Japan (39°20.97'–19.96'N, 142°42.05'–41.73'E; 1,559–1,557 m: R/V *Shinsei-maru* cruise KS-20-15, station OT-1550-2) attached to aboral side of starfish *Crossaster borealis*, collected by 3 m beam trawl on 1 October 2020; female, 5.9 mm, NSMT-Cr 31500, from type locality, attached to aboral side of *C. borealis*. See [Supplementary material Table S1](#) for voucher specimens.

**Diagnosis:** Head without rostrum and anterolateral projection. Eye length not exceed half of head length. Body flattened, length ~3× as wide, translucent pale yellow, without brown chromatophores, dorsal surface smooth. Coxal plates smooth, visible on dorsal view. Pereopod 1 slightly shorter than posterior pereopods, propodus with 9 serrations. Pleotelson distal margin

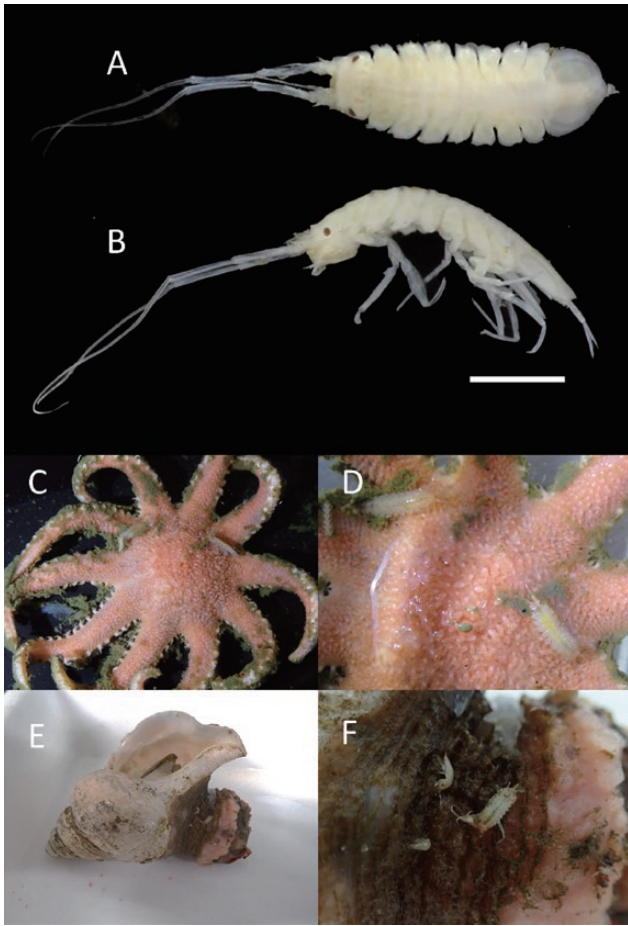

**Figure 3.** *Janiralata plana* sp. nov., dorsal and lateral views (A, B). *J. plana* sp. nov. on *Crossaster borealis* (C, D), on Hormathiidae sp. attached to a buccinid snail (*Neptunea* sp.) (E, F). Scale bar: A, B = 2 mm.

rounded. Male pleopod 1 apex curved medially, without conical knobs. Pleopod 3 exopod without plumose setae. Uropod biramous, endopod slightly longer than exopod.

**Description of holotype and paratype males:** Body (Fig. 4A) flattened, length  $\sim 3\times$  as wide, translucent pale yellow, without brown chromatophores, dorsal surface smooth. Pereonites 2–4 coxae bilobed, all coxae similar in size; all pereonites coxae visible dorsally. All pereonites without lateral or anterolateral processes. Pleotelson rounded, length  $\sim 0.9\times$  as wide, distal margin slightly pointed, without any processes; lateral margins with numerous fine setae.

Cephalon slightly narrower than pereonite 1, trapezoidal, length  $\sim 1/2\times$  as width; frontal margin slightly convex, without rostrum; anterolateral projections small, not acute. Eyes on dorsal side, small, dark brown, anterolaterally directed.

Antennulae (Fig. 5B, C): article 1 conical with distal fine, simple seta; article 2 slightly shorter than article 1, distally with 2 long simple and 2 long bloom setae; article 3 as long as article 2, with 3 long distal setae; with 18 flagellar articles, each article excluding last 2 with short, simple distal seta and last two articles with an aesthetasc.

Antenna (Fig. 4B, C): article 1 broad, with a distolateral seta; article 2 shorter than article 1, without setae; article 3 trapezoi-

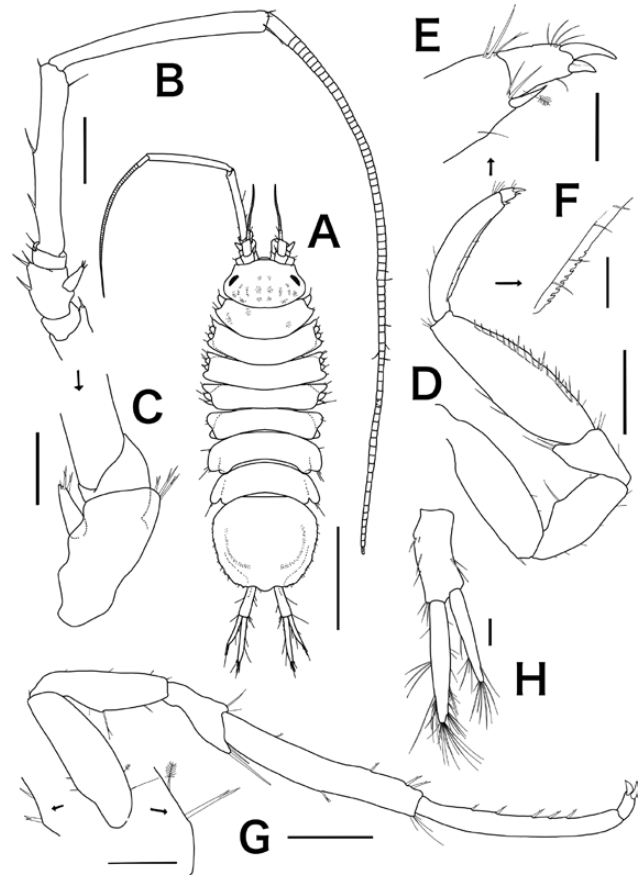

**Figure 4.** *Janiralata plana* sp. nov., paratype male (NSMT-Cr 31501) (A–G), holotype male (NSMT-Cr 31499) (H), dorsal view (A), antenna (B), magnified view of antenna (C), pereopod 1 (D), magnified view of pereopod 1 (E, F), pereopod 2 (G), uropod (H). Scale bars: A = 2 mm, B, D, G = 500  $\mu\text{m}$ , C, H = 200  $\mu\text{m}$ , E, F = 100  $\mu\text{m}$ .

dal, with lateral simple and 2 distal unequal bifid setae, conspicuous scale with distal simple and 2 unequal bifid setae; article 4 shorter than article 3, with 2 distal setae; article 5 length  $\sim 6\times$  as article 4, with 2 long lateral and 2 distal setae; article 6 longest, length  $\sim 1.2\times$  as article 5, with 3 distal setae; flagellum multiarticulate, length  $\sim 3\times$  as article 6, article 1 longest, last 20 articles with a few black chromatophores.

Left mandible (Fig. 5G): palp article 1 without setae; article 2 with 2 long setulate setae and 3 short setae distolaterally; article 3 as long as article 1, with row of many short robust setae ventrally and row of many fine setae distally; incisor with 4 cusps; lacinia mobilis with 4 teeth, spine row with 7 robust setulate setae.

Right mandible (Fig. 5H): palp article 1 with 3 long setae distally; article 2 with row of 5 simple setae distolaterally; article 3 with row of many simple setae laterally and 6 simple setae distally; incisor with 4 cusps, spine row with 9 robust setulate setae; molar process with some setae distally.

Maxillula (Fig. 5E): inner lobe with 8 robust setae distally; outer lobe with 8 robust denticulate setae distally and many fine setae laterally and medially.

Maxilla (Fig. 5F): inner lobe with 1 setulate robust seta and many fine setae distally, medially; 2 outer lobes each with 3 robust setae apically and many fine setae medially.

Maxilliped (Fig. 5A): endite width subequal to palp, with 8 serrate and some simple setae distally, 3 coupling hooks medially. Palp with 5 articles, article 1 with a distolateral simple seta; article 2 with distolateral, some lateral, 2 medial, 4 distomesial simple setae; article 3 distally broad, with 2 distolateral and 14 distomesial simple setae; article 4 narrow, with 8 distal simple setae; article 5 as wide as article 4, with 6 distal and some lateral simple setae. Exopod triangular, slightly tapered distally.

Pereopod 1 (Fig. 4D, E, F): basis length  $2\times$  as wide with a distal unequal bifid seta; ischium length  $\sim 2/3\times$  as basis with a dorsolateral unequal bifid seta; merus triangular, long distally, with 2 simple distal setae and mediolateral and 2 mediolateral setae; carpus long, broadened at center, length equal to basis, mediolateral with  $\sim 20$  robust short setae, 2 dorsal simple and 3 distal simple setae; propodus with a row of 9 subequal serrations on proximal third of ventral margin, slightly shorter than carpus, length  $6\times$  as wide, 2 dorsolateral and some mediolateral simple setae, distal margin with a unequal bifid seta and 2 simple thin setae of different length, medial margin with a stout and 2 simple thin setae; dactylus short, with 2 claws and 5 simple fine and a bloom setae.

Pereopod 2 (Fig. 4G): basis resemble pereopod 1, with long dorsolateral unequal bifid seta and 2 spiniform mediolateral setae; ischium longer than pereopod 1, with long dorsolateral

unequal bifid seta; merus resembles to pereopod 1; carpus long, not broadened at center, length  $7\times$  as wide, with 3 mediolateral and 2 mesial and dorsolateral short unequal bifid setae and 3 simple distal setae of different length; propodus long, length  $10\times$  as wide, some dorsolateral simple and 5 mediolateral unequal bifid setae; dactylus with 2 claws. Pereopods 2–7 all resemble each other but pereopods 5–7 (pereopod 6 figured; Fig. 5D) propodus with a dorsolateral bloom seta.

Pleopod 1 (Fig. 6A): distal tips laterally expanded, with projecting subtriangular lateral lobes tapered laterally, slightly curved anteriorly; distal margins with pair of small protrusions.

Pleopod 2 (Fig. 6B): protopod length  $\sim 2\times$  as width, with 7 distal setae; endopod slightly wider than appendix masculina, appendix masculina robust, elongated, surpassing distal margin of protopod; exopod distalmedially placed on protopod, no surpassing distal margin of protopod.

Pleopod 3 (Fig. 6C): endopod  $\sim 1.6\times$  as protopod, with 3 distal plumose setae; exopod with 2 articles, article 1  $\sim$ twice as article 2, with many lateral fine short setae; article 2 with many lateral fine setae and  $\sim 17$  distomedial and medial simple short setae.

Pleopod 4 (Fig. 6D): endopod slightly curved and oval,  $\sim 3\times$  as width; exopod slightly narrower than endopod.

Pleopod 5 (Fig. 6E): semicircular,  $\sim 2\times$  as long as width.

Uropod (Fig. 4H): length  $\sim 0.7\times$  as pleotelson, bearing numerous long simple setae; biramous; sympod rectangular,

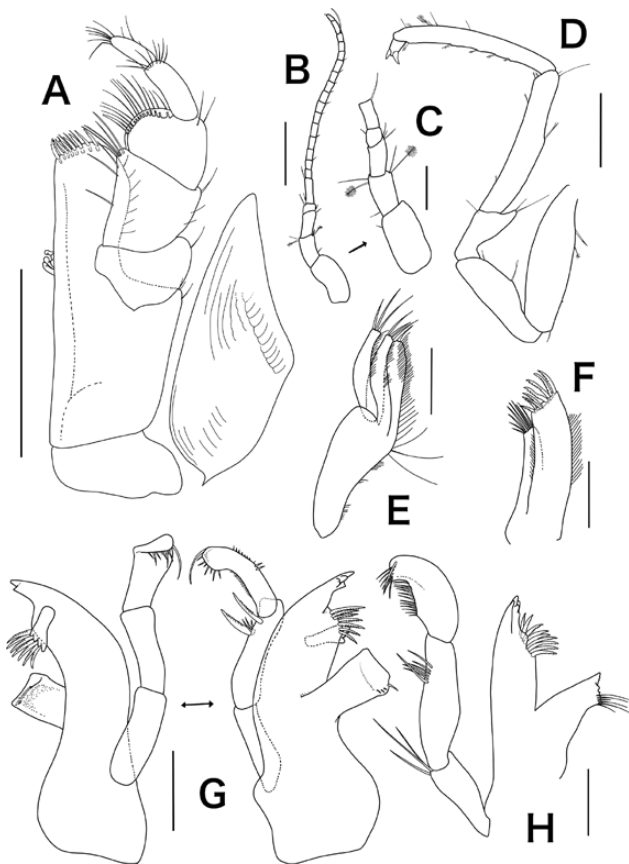

**Figure 5.** *Janiralata plana* sp. nov., holotype male (NSMT-Cr 31499) (A–C, E–H), paratype male (NSMT-Cr 31501) (D). Right maxilliped (A), antennulae (B), magnified view of antennulae (C), pereopod 6 (D), maxillula (E), maxilla (F), left mandible with mandibular palp (F), right mandible with mandibular palp (G). Scale bars: A = 500  $\mu$ m, B, D–H = 200  $\mu$ m, C = 100  $\mu$ m.

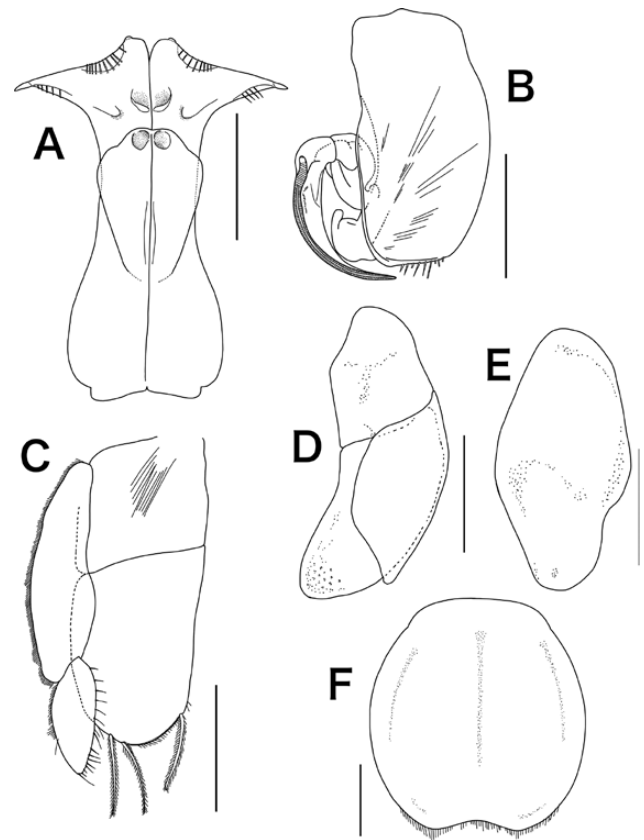

**Figure 6.** *Janiralata plana* sp. nov., holotype male (NSMT-Cr 31499) (A–E), paratype female (NSMT-Cr 31500) (F). Pleopod 1 (A), pleopod 2 (B), pleopod 3 (C), pleopod 4 (D), pleopod 5 (E). Operculum of female (F). Scale bars: A–F = 500  $\mu$ m.

**Table 2.** Reports of species of *Janiralata* attached to other invertebrates.

Species	Distribution depths	Substrates	References
<i>Janiralata solasteri</i> (Hatch, 1947)	50–295 m	<i>Solaster stimpsoni</i> Verrill, 1880 (Asteroidea) sunken wood	Hatch, 1947 Kussakin, 1988 Hessler & Strömberg, 1989
<i>Janiralata rajata</i> Menzies, 1951	0–37 m	Eggs of <i>Raja binoculata</i> (Rajiformes)	Kussakin, 1988
<i>Janiralata chuni</i> (Thielemann, 1910)	93–158 m	<i>Asterias amurensis</i> Lütken, 1871 (Asteroidea)	Shimomura, 2006
<i>Janiralata sagamiensis</i> Shimomura, 2006	15 m	Sponges	Shimomura, 2006
<i>Janirelara plana</i> sp. nov.	425–1,559 m	<i>Crossaster borealis</i> Fisher, 1906 (Asteroidea) Hormathiidae sp. (Anthozoa)	Herein

elongated; rami tapered, slightly longer than sympod, endopod slightly longer than exopod.

*Description of paratype female:* Similar to holotype male. Pereonites laterally and dorsally smooth. Operculum (Fig. 6F) distally concave; length as long as maximum width, marginally setose.

*Etymology:* The species name *plana*, Latin for “flat” or “plain”. It was appropriately named after the characteristic feature of the species: flattened and having no body projections or setae.

*Remarks:* The new species is assigned to the genus *Janiralata* based on the combination of the following characters: the absence of anterolateral and distolateral projections on the head and pleotelson respectively, smooth surface and lateral margins of the body, antennula article 1 slightly curved dorsally, and inward curved male pleopod 1 without conical knobs.

Wilson & Wägele (1994) divided the species of *Janiralata* into four morphological groups and the new species shows the following characters of the “*rajata*-group”: reduced rostrum and reduced anterolateral projection of the cephalon, a distally-rounded pleotelson and pleopod 3 exopod without plumose setae. According to Wilson & Wägele (1994) and Kim & Yoon (2021), this group contains six species: *J. koreaensis* Jang, 1991 from Bijin Island, southern Korean Peninsula; *J. microphthalma* Kussakin, 1972 and *J. modesta* Mezhov, 1981 from Urup Island, Kuril Islands; *J. obliterated* Kussakin, 1972 from a seamount in the central Pacific; *J. rajata* Menzies, 1951 from northern California; and *J. sagamiensis* Shimomura, 2006 from Sagami Bay, Japan. *Janiralata plana* sp. nov. can be distinguished from five of these species by the following: a remarkably long uropod (*vs. J. microphthalma* and *J. obliterated*); no anterolateral projection on the cephalon (*vs. J. modesta* and *J. sagamiensis*); and slightly small eye lobes, not reaching half of the cephalon (*vs. J. rajata*). *Janiralata plana* sp. nov. most closely resembles *J. koreaensis* but differs as follows: dorsal surface without dark brown pigments; antennula article 1 slightly curved dorsally; and male pleopod 1 apex curved medially with no conical knobs (*vs. J. koreaensis*). Moreover, the distributions of these two species differ geographically and bathymetrically. *Janiralata koreaensis* has only been collected in South Korea at 8–80.4 m depths (Jang, 1991; Kang et al., 2019). In addition to the named taxa, four undescribed species have been reported from the Santa Maria Basin in the north-eastern Pacific (Wilson, 1997). *Janiralata plana* sp. nov. can be distinguished from these undescribed species by the following

characteristics: a smooth head without brown chromatophores or cephalic anterolateral projections (*vs. Janiralata* sp. A and B in Wilson (1997)); and small eye lobes, not reaching half of the cephalon (*vs. Janiralata* sp. C and D in Wilson (1997)).

## DISCUSSION

### Substrate specificity

The specimens we collected were identified as a single species, *J. plana* sp. nov., based on morphology of the dorsal surface, cephalon, and pleotelson as well as DNA barcoding. Conspecific individuals were observed attached to starfishes and a sea anemone. The species of *Janiralata* that have been reported from the body surfaces of other invertebrates, including the new species, are summarized in Table 2. Hessler & Strömberg (1989) nevertheless reported *Janiralata solasteri* as living on hard substrates such as bark and wood in aquaria as with the other *Janiralata* species, despite *J. solasteri* having been collected from a starfish in nature by Hatch (1947). These observations suggest that the species of *Janiralata* exhibit low host specificity. In general, *Janiralata* species prefer hard substrates (Wilson, 1997), and the new species may attach to echinoderms and cnidarians because the surfaces of these invertebrates are harder than the sandy mud bottom of the sampling sites.

Two individuals of *J. plana* sp. nov., sorted from the bottom sediment could have been crawling freely on the sea bottom. Alternatively, they may have been detached from the host or the substrate during trawling. Individuals, however, were not obtained when sorting the bottom sediment collected by trawling at the sites where the new species was found on the invertebrate hosts. As *Janiralata* species are presumed to be detritivores (Hessler & Strömberg 1989), they might consume detritus accumulating on the surface of other invertebrates and could then not be obligate symbionts.

### Wide bathymetrical range of new species

The depth of the sampling sites for *J. plana* sp. nov. ranged from 425 to 1,559 m. The longest horizontal distance between the sites was approximately 200 km. Despite the small genetic differences found among the specimens (0–0.8%), only specimens from geographically close sites (< 50 km) shared a haplotype (Fig. 2). As with most species of asellotes, *J. plana* sp. nov. lacks swimming legs and has no larval stage. Therefore, this result may be attributable to low dispersal ability and thus limited gene flow between local populations of the new species. Another congener,

*J. hexadentata* Birstein, 1970, also shows a wide bathymetric distribution despite its lack of swimming ability. This species has been described from the Kuril-Kamchatka Trench at depths of 1,440–3,250 m and has never been reported elsewhere (Birstein, 1970).

The wide bathymetric range of the species of *Janiralata* not having swimming appendages is notable. A small genetic distance was observed within a depth range of approximately 1,000 m in *J. plana* sp. nov.. These results contrast with the genetic differentiation along the depth gradient observed in swimming asellotes (Munnopsidae and Desmosomatidae). Members of these families potentially have a higher dispersal ability than *Janiralata* species. The presence of cryptic species and species complexes along the depth gradient has recently been suggested by molecular analysis for some morphospecies of Munnopsidae and Desmosomatidae, which have been considered to have wide horizontal and vertical distributional ranges (e.g., Raupach et al., 2007; Brix et al., 2014). For example, the desmosomatid *Chelator insignis* (Hansen, 1916) was reported to have a large genetic distance among three clades at depths of 2,750, 1,390, and 900 m and above (Brix et al., 2014). A depth difference of 500 m may have hindered gene flow in these morphospecies. Similar analyses and accumulation of data on asellotes with various dispersal characteristics may elucidate the relationships between the distribution ranges and ecological characteristics of asellote species.

#### SUPPLEMENTARY MATERIAL

Supplementary material is available at *Journal of Crustacean Biology* online.

S1 Table. List of specimens studied, with their habitat and accession numbers.

#### ACKNOWLEDGEMENTS

We thank the crew and researchers of R/V *Shinsei-maru* and *Wakataka-maru* for their support during the cruises KS-16-18 and KS-20-15, and during the Pacific cod and walleye pollock recruitment and snow-crab distribution surveys in April 2022. The two cruises of R/V *Shinsei-maru* were conducted as part of Tohoku Ecosystem-Associated Marine Science (TEAMS). Starfishes were kindly identified by Takanobu Mogi of the Department of Biological Sciences, Graduate School of Science, The University of Tokyo. We also thank Editage ([www.editage.com](http://www.editage.com)) for English-language editing and two anonymous reviewers and the editors of *Journal of Crustacean Biology* for their constructive comments. This study was partly funded by a JSPS KAKENHI grant (19H00999) and JST SPRING, Grant Number JPMJSP2108.

#### REFERENCES

- Birstein, J.A. 1970. Additions to the fauna of isopods (Crustacea, Isopoda) of the Kurile-Kamchatka Trench. Part I. In: *Fauna of the Kurile-Kamchatka Trench and its environment* (V.G. Bogorov, ed.), pp 292–340. Academy of Sciences of the USSR, P. P. Shirshov Institute of Oceanology, Moscow.
- Brix, S., Svavarsson, J. & Leese, F. 2014. A multi-gene analysis reveals multiple highly divergent lineages of the isopod *Chelator insignis* (Hansen, 1916) south of Iceland. *Polish Polar Research*, **35**: 225–242.
- Cheng, F., Wang, M., Sun, S., Li, C. & Zhang, Y. 2013. DNA barcoding of Antarctic marine zooplankton for species identification and recognition. *Advances in Polar Science*, **24**: 119–127.
- Clement, M., Posada, D.C.K.A. & Crandall, K.A. 2000. TCS: a computer program to estimate gene genealogies. *Molecular Ecology*, **9**: 1657–1659.
- Doti, B.L. & Wilson, G.D. 2010. The genera *Carprias* Richardson, *Ianiropsis* Sars and *Janaira* Moreira & Pires (Isopoda: Asellota: Janiridae) from Australia, with description of three new species. *Zootaxa*, **2625**: 1–39.
- Doti, B.L., Roccatagliata, D. & Lopez, G.J. 2014. An inverse latitudinal biodiversity pattern in asellote isopods (Crustacea, Peracarida) from the Southwest Atlantic between 35° and 56°S. *Marine Biodiversity*, **44**: 115–125.
- Folmer, O., Black, M., Hoeh, W., Lutz, R. & Vrijenhoek, R. 1994. DNA primers for amplification of mitochondrial cytochrome c oxidase subunit I from diverse metazoan invertebrates. *Molecular Marine Biology and Biotechnology*, **3**: 294–299.
- Hansen, H.J. 1916. Crustacea Malacostraca. III. V. The order Isopoda. In: *The Danish Ingolf-Expedition*, Vol. 3(5) (H. Hagerup, ed.), pp 1–262, Biancolexoas, Copenhagen.
- Hatch, M.H. 1947. The Chelifera and Isopoda of Washington and adjacent regions. *University of Washington Publications in Biology*, **10**: 155–274.
- Hessler, R.R. & Strömberg, J. 1989. Behavior of janiroidean isopods (Asellota), with special reference to deep-sea genera. *Sarsia*, **74**: 145–159.
- Hessler, R.R. & Thistle, D. 1975. On the place of origin of deep-sea Isopods. *Marine Biology*, **32**: 155–165.
- Jang, I.K. 1991. A new species of the genus *Janiralata* (Crustacea, Isopoda, Janiridae) from Korea. *Korean Journal of Zoology*, **34**: 64–68.
- Kang, S.M., Lee, H.G., Kim, S.L., Choi, J.W., Park, C.H. & Yu, O.H. 2019. Species composition and community structure of macrobenthos during fall on the Dokdo Coast, Korea. *Ocean and Polar Research*, **41**: 47–61 [in Korean].
- Kensley, B.F. 1976. Isopodan and tanaidacean Crustacea from the St. Paul and Amsterdam islands, southern Indian Ocean. *Annals of the South African Museum*, **69**: 261–323.
- Kim, S.H. & Yoon, S.M. 2021. Description of *Janiralata sagamiensis* (Isopoda, Asellota, Janiridae) from Korean Waters. *Animal Systematics, Evolution and Diversity*, **37**: 146–153.
- Kim, S.H., Kim, J.G. & Yoon, S.M. 2022. Description of two new janirid isopods (Isopoda, Asellota, Janiridae) from Korean waters. *Zootaxa*, **5178**: 532–546.
- Kumar, S., Stecher, G., Li, M., Knyaz, C. & Tamura, K. 2018. MEGA X: molecular evolutionary genetics analysis across computing platforms. *Molecular Biology and Evolution*, **35**: 1547 [<https://doi.org/10.1093/molbev/msy096>].
- Kussakin, O.G. 1972. Isopoda from the coastal zone of the Kurile Islands. I. Janiridae and Jaeropsidae from Urup Island. *Crustaceana*, **Supplement 3**: 155–165.
- Kussakin, O.G. 1988. *Marine and brackishwater Crustacea (Isopoda) of cold and temperate waters of northern hemisphere*. Vol. 3, Suborder Asellota Part 1. Opredeliteli Faune SSSR, Academy of Sciences, USSR, Moscow [in Russian].
- Leach, W.E. 1814. Crustaceology. In: *The Edinburgh Encyclopaedia*, vol. 7(2). (D. Brewster, ed.), pp 385–437, 765–766. William Blackwood, Edinburgh.
- Leigh, J.W. & Bryant, D. 2015. PopART: full feature software for haplotype network construction. *Methods in Ecology and Evolution*, **6**: 1110–1116.
- Menzies, R.J. 1951. New marine isopods, chiefly from northern California, with notes on related forms. *Proceedings of the United States National Museum*, **101**: 105–156.
- Mezhov, B.V. 1981. Isopoda. In: *Benthos of the Submarine mountains Marcus-Necker and adjacent Pacific regions*. (P.P. Shirshov, ed.), pp 62–82. Academy of Sciences of the U.S.S.R., P. P. Shirshov Institute of Oceanology, Moscow.
- Moreira, P.S. & Pires, A.M. 1977. *Janaira gracilis*, a new genus and species of ianirid isopod from Brazil. *Crustaceana*, **33**: 23–32.
- Mortensen, P.B. 2001. Aquarium observations on the deep-water coral *Lophelia pertusa* (L., 1758) (Scleractinia) and selected associated invertebrates. *Ophelia*, **54**: 83–104.

- Pires, A.M.S. 1995. The janirid isopods (Crustacea, Isopoda, Asellota) living on the sea star *Echinaster brasiliensis* Müller & Troschel at São Sebastião channel, Southeastern Brazilian coast, with description of a new species. *Revista Brasileira de Zoologia*, **12**: 303–312.
- Raupach, M.J., Malyutina, M., Brandt, A. & Wägele, J. W. 2007. Molecular data reveal a highly diverse species flock within the munnopsoid deep-sea isopod *Betamorpha fusiformis* (Barnard, 1920) (Crustacea: Isopoda: Asellota) in the Southern Ocean. *Deep-Sea Research Part II: Topical Studies in Oceanography*, **54**: 1820–1830.
- Richardson, H. 1902. The marine and terrestrial isopods of the Bermudas, with descriptions of new genera and species. *Transactions of the Connecticut Academy of Sciences*, **11**: 277–310, pls. 37–40.
- Richardson, H. 1906. Isopodes. In: *Expédition Antarctique Française (1903-1905) Sciences Naturelles: Documents Scientifiques*. (J. Charcot, ed.), pp 1–22. Masson & Cie, Paris.
- Sars, G.O. 1897. Tribe 4. Asellota. In: *An account of the Crustacea of Norway with short descriptions and figures of all the species. Volume II. Isopoda*. Bergen Museum, Bergen, Norway.
- Shimomura, M. 2006. Asellote isopods (Crustacea: Peracarida) of Sagami Bay, Central Japan. *Memoirs of the National Science Museum, Tokyo*, **41**: 43–63.
- Shimomura, M. 2009. A review of the taxonomy of marine Asellota from Japan (Crustacea: Isopoda). *TAXA, Proceedings of the Japanese Society of Systematic Zoology*, **27**: 17–27 [in Japanese].
- Shimomura, M., & Nunomura, N. 2013. Isopoda from Japan (22). *Aquabiology*, **207**: 374–377 [in Japanese].
- Thielemann, M. 1910. Beiträge zur Naturgeschichte Ostasiens. Herausgegeben von Dr. F. Doflein. Beiträge zur Kenntnis der Isopodenfauna Ostasiens. *Abhandlungen der mathematisch-Physikalischen Classe der Königlich Bayerischen Akademie der Wissenschaft Supplementarischer Band 2 (Abhandlung 3)*: 1–109, pls. 1–2.
- Wakayama Prefectural Fisheries Experiment Station. 2016. *Manual for the production of sea cucumber seeds and seedlings in Wakayama Prefecture* [[https://www.pref.wakayama.lg.jp/prefg/071001/sub3\\_9\\_d/fil/namakomanual\\_1.pdf](https://www.pref.wakayama.lg.jp/prefg/071001/sub3_9_d/fil/namakomanual_1.pdf)] (accessed on 5 July 2023) [in Japanese].
- Wilson, G.D. 1997. The Suborder Asellota. In: *Taxonomic atlas of the benthic fauna of the Santa Maria Basin and Western Santa Barbara Channel*. (J.A. Blake & P.H. Scott, eds.), pp 59–120. Santa Barbara Museum of Natural History, Santa Barbara, CA, USA.
- Wilson, G.D. & Wägele, J.W. 1994. Review of the family Janiridae (Crustacea: Isopoda: Asellota). *Invertebrate Systematics*, **8**: 683–747.
- WoRMS. World Register of Marine Species [<https://www.marinespecies.org>] accessed 2023-07-05.