



REVIEW ARTICLE

Hormonal signalling in cereal aleurone

Paul C. Bethke¹, Robert Schuurink² and Russell L. Jones^{1,3}

¹ Department of Plant and Microbial Biology, University of California, Berkeley, CA 94720–3102, USA

² Max Planck Institute, Carl Von Linneweg 10, D-50829 Köln, Germany

Received 23 January 1997; Accepted 2 May 1997

Abstract

The cereal aleurone is an excellent model system for hormonal signalling in plants. When treated with gibberellins (GAs), cereal aleurone layers and aleurone protoplasts initiate signalling cascades that result in the synthesis and secretion of hydrolytic enzymes, most notably α -amylases. Abscisic acid (ABA) antagonizes the effects of GA and stimulates the production of ABA-up-regulated proteins. Receptors for GA and ABA have been localized to the aleurone cell PM, and evidence suggests that another ABA receptor functions within the cytoplasm. Cytosolic and membrane-bound second messengers have been identified and signal transduction pathways are beginning to be understood. Transacting factors that regulate the transcription of hormonally induced genes have been cloned and bring us closer to linking cytosolic signals to changes in gene expression. In this review, recent data pertaining to hormonal signalling in cereal aleurone are summarized. Relationships between signalling and effector molecules are discussed, and models for hormone-induced signalling pathways are proposed.

Key words: Cereal aleurone, hormonal signalling, gibberellin, abscisic acid, gene expression.

Introduction

Research on the cereal aleurone spans at least two centuries

The cereal aleurone is one of the most intensively investigated tissues in plants. Because of its importance in malting and brewing, chemists and biologists have carried out detailed studies of barley grain function for nearly 200 years. α -Amylases from cereals were the first enzymes to be studied in detail. A factor responsible for modifying

starch was identified in wheat extracts in 1811 by Kirchoff (quoted in Fischer and Stein, 1960), and malt diastase (α -amylase) was the first enzyme to be isolated and partially purified (Payen and Persoz, 1833). The origin of α -amylase and other starch-modifying enzymes within the cereal grain was a matter of considerable controversy among botanists at the end of the last century. Haberlandt (1890) argued that the aleurone layer was the source of diastase in germinating grain, but his views were disputed by many, including Brown and Morris (1890), who argued that digestive enzymes were produced by the scutellum epithelium. The role of the aleurone layer in the production of endosperm-modifying enzymes remained controversial through the early part of the 20th century, and EC Miller in his plant physiology text (1931) stated, 'There is much evidence, however, that the aleurone layer has no secretory powers'.

The cereal aleurone responds to gibberellins and abscisic acid

Interest in the cereal aleurone as an experimental system was rekindled in 1960 by publications from L Paleg in Australia and H Yomo in Japan. These workers showed independently that gibberellic acid (GA₃) and gibberellin A1 (GA₁) stimulated the production of α -amylase by de-embryonated barley grain (Paleg, 1960a; Yomo, 1960). Based on his experiments Paleg (1960b) speculated that an endogenous gibberellin (GA) produced by the barley embryo played a role in regulating the production of enzymes by barley endosperm. He supported this hypothesis by pointing out that GA-like substances could be isolated from barley and malt (Radley, 1959). Subsequently, numerous researchers have used exogenous GAs to stimulate the production of hydrolytic enzymes from de-embryonated cereal grain, aleurone layers and aleurone protoplasts.

Many experiments support the view that endogenous

³ To whom correspondence should be addressed. Fax: +1 510 642 4995. E-mail: rjones@nature.berkeley.edu

GAs play a role in regulating α -amylase production by the aleurone layer of barley (Skadsen, 1993; Zwar and Chandler, 1995), rice (Mitsunaga and Yamaguchi, 1993) and wheat (Lenton *et al.*, 1994). In the case of barley, for example, a dwarf mutant of the Himalaya cultivar that is deficient in endogenous GAs has reduced levels of endosperm α -amylase as well as reduced rates of leaf growth (Zwar and Chandler, 1995). Application of exogenous GA₃ to this dwarf mutant increases both α -amylase production and leaf growth, indicating that GAs play a role in regulating aleurone activity *in vivo*.

The extent to which newly synthesized GAs are required for regulation of the aleurone layer is not known. Großelindemann *et al.* (1991) could not inhibit α -amylase production by aleurone layers of Himalaya barley with inhibitors of GA biosynthesis, even though leaf elongation in Himalaya seedlings was reduced in inhibitor-treated plants. These experiments suggest that *de novo* GA biosynthesis may not be required to stimulate α -amylase production by the aleurone layer.

The cereal aleurone is also responsive to added abscisic acid (ABA) (Hetherington and Quatrano, 1991; Chandler and Robertson, 1994). ABA both inhibits many GA-induced responses and promotes responses that are unique to this hormone. There is limited information, however, on the role of ABA as an endogenous regulator of aleurone function in cereals. ABA is present in aleurone layers and embryos of barley and wheat (Ried and Walker-Simmons, 1990), and in barley, the amount of this regulator is higher in aleurone layers of dormant cultivars (Schuurink *et al.*, 1993). Although evidence linking ABA directly to *in vivo* function is lacking, ABA is a useful tool for studying hormonal signalling in the aleurone cell.

This review focuses on recent advances in understanding the mechanisms of hormone perception and signal transduction using the cereal aleurone as a model system. Recently published work is reviewed and an attempt is made to integrate this information into models that explain hormone action in the cereal aleurone.

The cereal aleurone as an experimental system for studying plant hormone action

The ultrastructure of aleurone cells reflects their function

Many aspects of the cereal aleurone make it a unique and versatile experimental system. The aleurone layer consists of from one (oat, maize, rye, wheat) to several (rice, barley) layers of uniform, highly differentiated cells (Fig. 1A). Aleurone cells of mature, dry barley grain are surrounded by a thick, hemicellulosic wall and do not undergo further cell division. The aleurone layer can be removed from the adhering dead starchy endosperm, and a uniform population of protoplasts (Fig. 1B) can

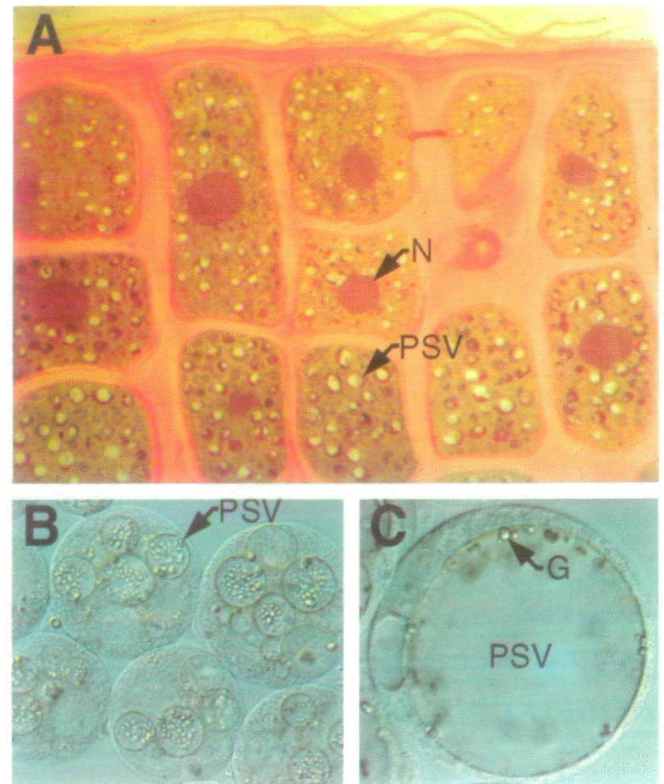

Fig. 1. Photomicrographs of a barley aleurone layer (A) and barley aleurone protoplasts (B, C). (A) Transverse section through aleurone cells of barley. Each cell contains a prominent nucleus (N) and numerous PSVs. (B) Early stage barley aleurone protoplasts, each containing numerous PSVs. (C) Late stage barley aleurone protoplast with a single PSV occupying most of the cell. A phytin globoid (G) is indicated by the arrow.

be prepared from the isolated layer using enzymes (Hooley, 1982).

The cytoplasm of the aleurone cell is characterized by numerous protein storage vacuoles (PSVs), often referred to as aleurone grains, that almost fill the cell (Fig. 1). This organelle plays a key role in the response of the aleurone to hormones. PSVs store proteins that become hydrolysed following GA-treatment to provide the amino acids necessary for secretory protein synthesis (Bethke *et al.*, 1996). PSVs are also the principal store of minerals in the cereal grain. Minerals are sequestered in PSVs as phytin, an insoluble crystalline complex of K, Mg, and Ca with phytic acid (inositol hexaphosphate). This crystalline inclusion is also referred to as the globoid (Fig. 1). X-ray microanalysis has shown that approximately 75% of barley grain P, K, Mg, and Ca is stored in the aleurone layer (Stewart *et al.*, 1988). The PSVs increase in size and coalesce with time of incubation of aleurone layers or protoplasts until one large central vacuole is formed (Fig. 1C). The process of vacuolation of aleurone layer cells and protoplasts is hastened by the presence of GA in the incubation medium (Jones and Price, 1970; Bush *et al.*, 1986).

Lipid bodies or oleosomes that store neutral lipids are also prominent organelles in the aleurone cell, occupying as much as 30% of the cell's volume (Jones, 1969a). Oleosomes consist of a triglyceride core surrounded by a half-unit membrane (Huang, 1992). In the aleurone cell oleosomes remain attached to the endoplasmic reticulum (ER) from which they originate (S Hillmer and RL Jones, unpublished results), and to the surface of PSV (Fernandez and Staehelin, 1985). The observation that oleosomes are attached to the surface of PSV supports the hypothesis that some types of PSVs originate directly from the ER (Okita and Rogers, 1996). Stored neutral lipids provide the aleurone cell with a carbon source that can be used before endosperm mobilization begins as well as fatty acids that can be used for membrane synthesis. That fatty acids are metabolized by aleurone cells is supported by several lines of evidence. Aleurone cells have numerous glyoxysomes containing malate synthase and isocitrate lyase (Jones, 1972; Schuurink *et al.*, 1996), and isolated aleurone layers can synthesize sucrose, presumably by gluconeogenesis (Chrispeels *et al.*, 1973).

The endomembrane system is also a prominent feature of the aleurone cell following GA treatment (Jones, 1969b; Jones and Price, 1970; Cornejo *et al.*, 1988). The ER of GA-treated barley aleurone is organized into flattened stacks of rough surfaced membranes, a characteristic of cells that are synthesizing large amounts of secretory proteins (Chrispeels, 1991). The Golgi apparatus is also prominent in GA-treated aleurone cells, and the number and size of cisternae and associated vesicles increases following exposure to GA (Cornejo *et al.*, 1988).

Aleurone layers and protoplasts respond similarly to GA and ABA

Since the aleurone layer is a secretory tissue, considerable attention has been paid to the effects of GA and ABA on the synthesis of secreted hydrolases (for reviews see Fincher, 1989; Jones and Jacobsen, 1991). This review focuses on responses in the aleurone cell to GA and ABA that precede the onset of hydrolase synthesis. These responses include altered gene expression and changes in the concentration of signalling molecules as well as higher order effects requiring the integration of multiple signalling pathways or effectors. A partial list of these responses is presented in Table 1, and many of them are described in detail below. Figure 2 shows the times at which several GA-induced responses of the aleurone layer occur. Clearly, the synthesis and secretion of hydrolases are relatively late events when compared to GA-induced changes in putative signals such as the concentration of cytosolic free Ca^{2+} ($[Ca^{2+}]_i$), cytosolic pH (pH_i), 3'5' cyclic guanosine monophosphate (cGMP), and calmodulin (CaM) (Fig. 2).

With the exception of timing, the response of barley

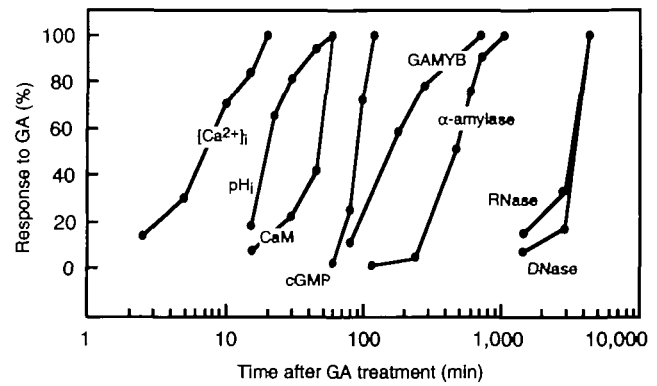

Fig. 2. Time-course of GA-induced responses of barley and wheat aleurone layers. Data were extracted from (Chandler *et al.*, 1984; Brown and Ho, 1986; Heimovaara-Dijkstra *et al.*, 1994a; Gubler *et al.*, 1995; Bush, 1996; Penson *et al.*, 1996; Schuurink *et al.*, 1996).

aleurone protoplasts to GA and ABA is almost identical to the response of aleurone layers. Aleurone protoplasts and layers secrete a similar spectrum of hydrolases in response to GA, but the onset of secretion is delayed and the rate of secretion is reduced in protoplasts relative to aleurone layers (Fig. 3). Other differences in the biochemical and molecular responses of aleurone protoplasts and layers to GA tend to be minor and are related to the wall-less nature of the protoplast. Cells of the intact aleurone layer, for example, are interconnected by a large number of plasmodesmata, an observation that was first made in the 19th century by Tangl (1885). The function of plasmodesmata in aleurone cells is not understood, but it is unlikely that their disruption when making protoplasts (Taiz and Jones, 1973) can be without consequence to the aleurone cell. Another aspect of protoplast isolation and culture that is likely to affect their response to stimuli is that they are cultured in a solution of high osmolarity (about 1000 mOsM), whereas aleurone layers are incubated in solutions of much lower osmolarity (about 50 mOsM). The difference in turgor pressure at the plasma membrane (PM) in walled aleurone layer cells is likely to be profoundly different from that in aleurone protoplasts and may affect the ability of these cells to respond to stimuli.

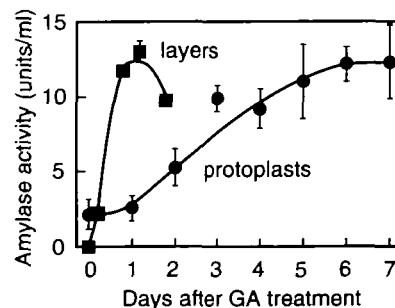

Fig. 3. Time course of α -amylase secretion by GA-treated barley aleurone layers and barley aleurone protoplasts.

Table 1. *Hormone-induced responses in cereal aleurone*

Parameter	Response	Reference
Responses to GA		
Signalling molecules		
[Ca ²⁺] _i	Rapid, sustained increase	(Bush, 1996)
pH _i	Transient decrease	(Heimovaara-Dijkstra <i>et al.</i> , 1994a)
cGMP	Transient increase	(Penson <i>et al.</i> , 1996)
CaM	Slow, sustained increase	(Schuurink <i>et al.</i> , 1996)
Gene expression		
CaM	Increase	(Schuurink <i>et al.</i> , 1996)
α-Amylase	Increase	(Chandler <i>et al.</i> , 1984)
GAMYB	Increase	(Gubler <i>et al.</i> , 1995)
MAP kinase	Decrease	(Huttly and Phillips, 1995)
Storage globulin	Decrease	(Heck <i>et al.</i> , 1993)
Higher order effects		
Hydrolase secretion	Increase	(Jones and Jacobsen, 1991)
Protease activity	Increase	(Bethke <i>et al.</i> , 1996)
Citrate and phosphate release	Increase	(Drozdowicz and Jones, 1995)
Vacuolation	Accelerates	(Hooley, 1982)
Cell death	Promotes	(Kuo <i>et al.</i> , 1996)
Responses to ABA		
Signalling molecules		
[Ca ²⁺] _i	Decrease	(Wang <i>et al.</i> , 1991)
pH _i	Transient increase	(Van der Veen <i>et al.</i> , 1992)
MAP kinase activity	Increase	(Knetsch <i>et al.</i> , 1996)
EmBP-1	Unknown	(Guiltingan <i>et al.</i> , 1990)
Gene expression		
Em	Increase	(Marcotte <i>et al.</i> , 1988)
ASI	Increase	(Leah and Mundy, 1989)
Rab-16	Increase	(Mundy and Chua, 1988)
PHAV1	Increase	(Hong <i>et al.</i> , 1988)
HVA1/HVA22	Increase	(Shen and Ho, 1995)
Dehydrin	Increase	(Robertson <i>et al.</i> , 1995)
α-Amylase	Decrease	(Chandler <i>et al.</i> , 1984)
GAMYB	Decrease	(Gubler <i>et al.</i> , 1995)
Higher order effects		
Secretion of hydrolases	Decrease	(Jones and Jacobsen, 1991)
Malate release	Increase	(Drozdowicz and Jones, 1995)
Citrate and phosphate release	Decrease	(Drozdowicz and Jones, 1995)
Vacuolation	Slows	(Hooley, 1982)
Cell death	Retards	(Kuo <i>et al.</i> , 1996)

Although GA-treated aleurone protoplasts respond more slowly than GA-treated aleurone layers, wall-less cells offer several advantages that make them exceptionally useful experimental tools. The absence of the cell wall allows experimental manipulations such as patch clamping (Bush *et al.*, 1988) and DNA transfection (Lin *et al.*, 1996). Protoplasts also facilitate procedures such as microinjection (Gilroy and Jones, 1994), *in situ* immunolocalization (Schuurink *et al.*, 1996), and the monitoring of amylase secretion from single cells (Hillmer *et al.*, 1993).

Perception of GA and ABA by cereal aleurone

Receptors for ABA and GA have yet to be isolated from plants, but a great deal of experimentation has been carried out with the cereal aleurone in attempts to isolate receptors and to establish their location within the cell. Experiments to isolate cellular fractions from aleurone tissue that bound GAs were begun in the 1970s (see

Kende and Gardner, 1976, for a review of earlier work). These approaches relied on cell fractionation techniques and the use of equilibrium dialysis and affinity chromatography with radiolabelled GA₁ and GA₃ to detect binding, but these approaches proved unsuccessful (Kende and Gardner, 1976). More recently, several novel approaches have been used to localize the GA and ABA receptors in the aleurone cell. These have included the use of cell impermeant forms of GA, microinjection to introduce GA or ABA into the cell, photoaffinity labelling, and anti-idiotypic antibodies.

GA is perceived at the plasma membrane of the aleurone cell

To localize the GA receptor in the aleurone of wild oat (*Avena fatua*), Hooley *et al.* (1991) carried out a series of elegant experiments with a non-permeable form of GA₄. Hooley *et al.* (1991) covalently coupled GA₄ to Sepharose 6B beads (approximately 120 μm diameter) via a spacer

arm on carbon 17 of GA₄ that allowed the GA₄ molecule to protrude about 2 nm from the surface of the Sepharose bead. Whereas the GA₄-Sepharose complex was able to induce the production of α -amylase in wild oat protoplasts, it did not stimulate α -amylase production when presented to isolated wild oat aleurone layers (Hooley *et al.*, 1991). This experiment provides convincing support for the hypothesis that the GA receptor in the wild oat aleurone cell is at the surface of the cell.

A different experimental approach has shown that the GA receptor is located at the surface of the barley aleurone protoplast (Gilroy and Jones, 1994). Microinjection was used to introduce GA₃ or inactive GA₈ into the cytosol of aleurone protoplasts. The response of the cell to microinjected GAs was compared with the response of the cell to externally applied hormone (Gilroy and Jones, 1994). In these experiments the responses monitored were α -amylase secretion (Hillmer *et al.*, 1993), vacuolation (Bush *et al.*, 1986), and expression of the glucuronidase reporter gene fused to a hormonally responsive α -amylase promoter (Lanahan *et al.*, 1992). These microinjection experiments showed that aleurone protoplasts did not respond when GA₃ was introduced into the cytosol. Only when cells were exposed to GA₃ by adding it to the incubation medium did they respond to the hormone (Gilroy and Jones, 1994).

Photoaffinity labelling has been a powerful tool for investigating ligand interactions. Although earlier attempts to isolate GA-binding proteins by this technique failed (Kende and Gardner, 1976), more recent work with improved photoaffinity probes has produced encouraging results. Hooley and his colleagues have synthesized photoactivatable analogues of GA₄ that retain biological activity and have used these probes to isolate photoaffinity-labelled proteins from wild oat aleurone as well as other GA-responsive tissues (R. Hooley, personal communication). This group has isolated several proteins from oat aleurone and pea shoots that are candidates for the GA receptor.

Anti-idiotypic antibodies have proven to be powerful tools in investigations of hormone action in animal cells, and they have been used to a limited extent in investigations of plant hormone action (reviewed by Hooley *et al.*, 1992). Anti-idiotypic antibodies were prepared by immunizing rabbits with a monoclonal antibody that recognized domains of the GA₄ molecule that are thought to confer biological activity. These anti-idiotypic antibodies antagonized GA₄ in wild oat protoplasts and caused agglutination of protoplasts (Hooley *et al.*, 1992). These results have been interpreted as showing that the anti-idiotypic antibodies interact with molecules on the surface of oat protoplasts and that these molecules play a role in the response of the protoplast to GA₄.

Other circumstantial evidence supports the concept that the GA receptor is located at the PM of the aleurone cell

(Goodwin and Carr, 1972; Musgrave *et al.*, 1972; Hooley *et al.*, 1992). There appears to be little correlation between presumed GA uptake rates and biological activity. For example, GA₁, GA₄ and 2,2-dimethyl GA₄ differ in hydrophobicity, and hence in the rate at which they are expected to cross the PM. Yet there was no difference in the amount of α -amylase produced by *Avena fatua* protoplasts incubated in these three GAs (Beale *et al.*, 1985). Likewise, although GA₃ is thought to enter cells in the protonated form (O'Neill *et al.*, 1986), external pH has a inconsistent effect on the response of aleurone cells to GA₃. Goodwin and Carr (1972) found that the response of aleurone layers to GA₃ (pKa 3.97) was not affected by pH over the range of 4.4–5.2. Sinjorgo *et al.* (1993), however, found that the sensitivity of barley aleurone layers to GA₃ increased as external pH decreased from pH 6 to pH 3.7.

An alternative explanation for the lack of a correlation between GA uptake and the response of the aleurone is that rapid metabolism of GA prevents the accumulation of the hormone in the cytosol. Studies of GA₁ metabolism have shown that a steep gradient of GA concentration (high outside, low inside) is maintained across the PM (Musgrave *et al.*, 1972; Nadeau *et al.*, 1972). GA₁ was rapidly metabolized by barley aleurone layers to inactive GA₁ glucoside or GA₈, and estimates indicate that the cytosolic GA₁ concentration was as much as two orders of magnitude lower than that in the external medium (Hooley *et al.*, 1992). Rapid metabolism of GAs in the aleurone cell has important consequences for GA signalling. Hormone metabolism provides a mechanism for removal of the GA signal. Signal propagation, therefore, is likely to continue only as long as active GAs are perceived by the cell. The existence of GA metabolizing enzymes in the cytosol, however, does not necessarily rule out the existence of cytosolic receptors.

ABA is perceived by the aleurone cell both at the PM and at an internal site

Microinjection was used to localize the ABA receptor in barley aleurone cells (Gilroy and Jones, 1994; Gilroy, 1996). Because many responses of the aleurone cell to ABA are to inhibit GA-stimulated events, experiments were designed to ask whether GA-induced responses were inhibited when ABA was microinjected into the cytosol or presented to the surface of the aleurone protoplast. The conclusion from these experiments was similar to that drawn from the experiments using microinjection of GA, namely that a receptor for ABA is localized to the PM of the barley aleurone cell (Gilroy and Jones, 1994; Gilroy, 1996). Using a similar experimental strategy, Schroeder and co-workers concluded that the ABA receptor in guard cells is also localized to the cell's surface (Anderson *et al.*, 1994).

Microinjection experiments also indicate that an additional receptor for ABA is present within the aleurone cell (Gilroy, 1996). Gilroy used a reporter gene construct in which the promoter of the ABA-inducible wheat gene *Em* (Marcotte *et al.*, 1988) was fused to GUS. When the *Em*-GUS construct and ABA were microinjected into the aleurone cytosol, *Em*-GUS expression was increased (Gilroy, 1996). These data led Gilroy to conclude that there are at least two sites of ABA perception in the barley aleurone cell. One at the PM leads to down-regulation of GA-induced α -amylase gene expression; the other within the cell leads to up-regulation of the ABA-inducible gene *Em* (Gilroy, 1996).

Signal transduction from the plasma membrane to the cytosol

As discussed above, compelling evidence suggests that receptors for both GA and ABA exist at the PM of cereal aleurone cells. How hormone binding to these receptors is transduced into a cytosolic signal is unclear. Further signal propagation may utilize signalling molecules, such as G-proteins and lipids, associated with the PM. The activity of PM ion channels or pumps may be stimulated or inhibited. These changes in activity might couple hormone perception to cytosolic second messengers such as Ca^{2+} or pH. Figure 4 presents models for transduction of ABA- (Fig. 4A) and GA-signals (Fig. 4B) in cereal aleurone. Although these models are supported by the data discussed below, they will certainly be refined as additional data become available.

G-proteins and lipids may link hormone perception to cytosolic signals

G-proteins and lipids may link hormone perception at the PM to cytosolic signalling pathways. A paradigm for these initial links in the signal transduction chains leading to cellular response is phosphoinositide signalling in animals. In this signalling system, binding of an extracellular signalling molecule to its receptor activates a heterotrimeric G-protein. The G_{α} -subunit of this protein, in turn, activates a phospholipase that cleaves phosphatidyl inositol-bisphosphate into inositol trisphosphate (IP_3) and diacylglycerol (DAG). IP_3 and DAG both act as second messengers in signal transduction cascades.

The presence of GTP-binding proteins in the PM of barley aleurone cells has been shown directly by Wang *et al.* (1993). Following SDS-PAGE and protein blotting on to nitrocellulose, PM proteins with molecular weights of 22–24 kDa and 16 kDa bound [α - ^{32}P]GTP. GTP binding was competed by unlabelled GTP, $\text{GTP}_{\gamma}\text{S}$, GDP and $\text{GDP}\beta\text{S}$, but not ATP or $\text{ATP}_{\gamma}\text{S}$. Whether these proteins function as signalling molecules in cereal aleurone is unknown. *In vitro* binding of GTP to PM proteins was

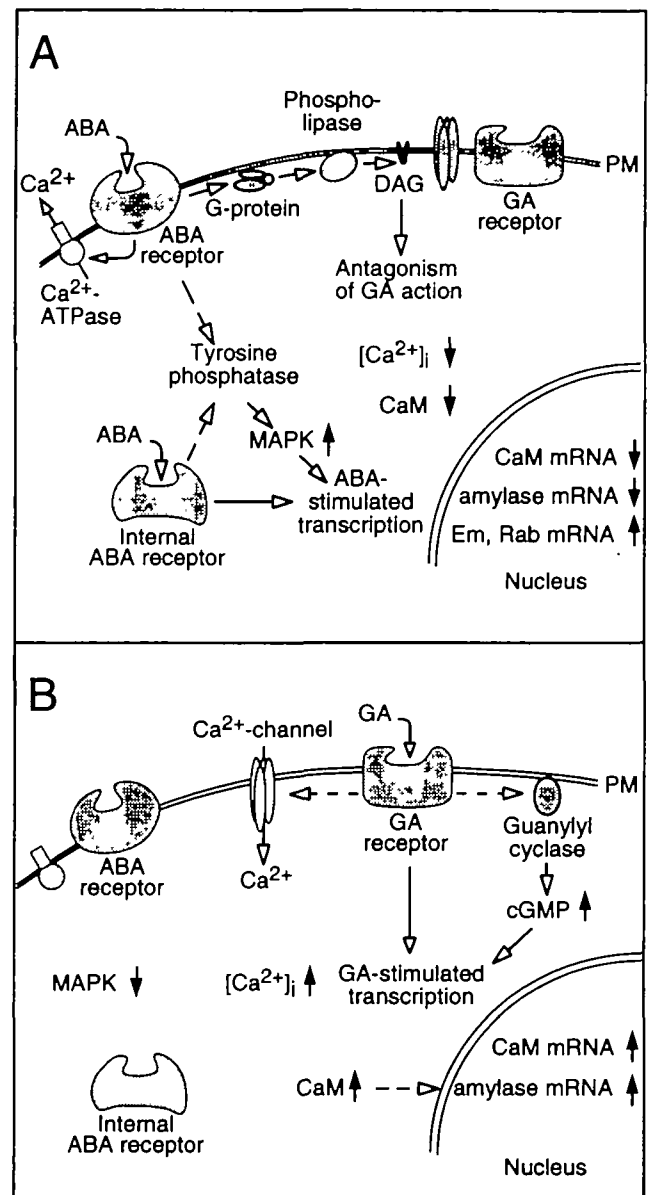

Fig. 4. Models of ABA- (A) and GA- (B) signalling pathways in cereal aleurone. (A) ABA binds to receptors at the PM and within the cell. Binding to the receptor on the external face of the PM leads to reductions in $[\text{Ca}^{2+}]_i$ and CaM, and antagonism of GA-action. This ABA signal may be transduced via a pathway involving G-proteins and DAG. ABA binding to an internal receptor stimulates transcription of *Em* and other ABA-specific genes and inhibits transcription of CaM and α -amylase. A signalling pathway that includes a tyrosine phosphatase and a MAP kinase is also proposed. (B) GA binds to a receptor on the external face of the PM. This stimulates influx of Ca^{2+} from the apoplast and increases $[\text{Ca}^{2+}]_i$. GA binding increases the amount of cGMP and stimulates the transcription and translation of several genes including those for α -amylase and CaM. Unfilled arrowheads designate signalling pathways. Filled arrowheads indicate an increase or decrease in the adjacent parameter.

unaffected by coinubation of isolated PM with GTP and either 100 μM ABA or 100 μM GA_3 .

In the same report (Wang *et al.*, 1993), protein blots were probed with anti-ras Y13–259 and with antibodies

to a conserved sequence in animal G-proteins. Both antibodies recognized proteins of 34–36 and 22–24 kDa. The anti-ras antibody recognized other proteins as well. It is possible, therefore, that barley aleurone contains proteins structurally similar to the subunits of heterotrimeric G-proteins.

A different approach toward assessing the role of G-proteins in aleurone cells has been taken by Richard Hooley's group. They prepared degenerate oligonucleotide primers based on sequences conserved between plant and mammalian $G\alpha$ and $G\beta$ subunits. These primers were used in the polymerase chain reaction (PCR) to amplify cDNAs prepared from GA_1 -treated *Avena fatua* aleurone layers (Jones *et al.*, 1996). The resulting PCR products were cloned and found to have sequence similarity with $G\alpha$ and $G\beta$ subunits. The transcripts for these products appeared to be expressed at very low levels and may be part of multigene families. It is not known if any of these proteins are localized to the PM.

Although the data discussed above (Wang *et al.*, 1993; Jones *et al.*, 1996) are consistent with the hypothesis that GTP-binding proteins play a role in signalling at the PM in cereal aleurone, further confirmation through biochemical or genetic characterization is required. This is particularly true in light of experiments done by Jones *et al.* (1995) and Kuo *et al.* (1996). Mastoparan, pertussis toxin (PTX) and cholera toxin (CTX) effect G-protein action in animal cells. Mas 7, an analogue of mastoparan, stimulated α -amylase production in aleurone protoplasts from *Avena fatua* (Jones *et al.*, 1995). This stimulation was inhibited by PTX and CTX. PTX and CTX also reduced the inhibitory effect of ABA on GA-induced α -amylase production. PTX and CTX, however, did not inhibit GA-stimulated α -amylase secretion. In a second report (Kuo *et al.*, 1996), mastoparan, PTX and CTX had no effect on secretion of α -amylase from GA-induced wheat aleurone layers. These data provide some support for the hypothesis that G-proteins are involved in ABA signalling, but little support for the hypothesis that they play a role in GA signalling.

To test for the involvement of DAG in aleurone signal transduction, Ritchie and Gilroy (1996) applied 1,2-dioctanoyl glycerol (1,2-DG), an active analogue of DAG, to barley aleurone protoplasts. 1,2-DG mimicked the effects of ABA. 1,2-DG prevented GA-induced α -amylase gene transcription and α -amylase secretion, but stimulated transcription of the ABA-inducible genes *ASI* and *Em*. Although $[Ca^{2+}]_i$ increases following GA-treatment in the absence of 1,2-DG (see below), it does not increase in its presence. These effects of 1,2-DG were relatively specific, as they were not seen with 1,3-DG. In mammals DAG stimulates protein phosphorylation by activation of protein kinase C. In aleurone cells a stimulation of protein kinase activity by 1,2-DG or DAG has not been demonstrated.

ABA treatment causes a transient hyperpolarization of aleurone plasma membrane

ABA-induced signalling at the PM may not be restricted to G-proteins and lipids. Changes in PM electrical potential may also be involved. Such changes could be used to modulate the activities of voltage-regulated ion channels or H^+ -coupled transporters. Heimovaara-Dijkstra *et al.* (1994b) used the lipophilic cation tetraphenylphosphonium to measure the membrane potential of barley aleurone protoplasts before and after application of ABA. Following ABA treatment (50 μ M), a rapid depolarization of the PM was observed. From a mean resting value of -53 mV, membrane potential decreased an average of 9 mV, with peak hyperpolarization occurring 20 s after ABA addition. Membrane potential returned to resting levels within 1 min despite the continued presence of ABA. This brief hyperpolarization occurred at ABA concentrations of 10^{-9} to 10^{-4} M, with 10^{-8} M and greater giving the maximal change in membrane potential. Since a small, statistically insignificant hyperpolarization was observed with the ABA analogues (\pm) *cis/trans* α -ionylidene acidic acid and (\pm) *cis/trans* ABA-glucose ester, the change in membrane potential was rather specific for ABA. Inhibitors of P-type ATPases, diethylstilbestrol (DES) and miconazole, both prevented ABA-stimulated hyperpolarization, suggesting that the proton pump was an early target of ABA signalling. In other experiments, ABA induced Rab gene expression, but ABA in the presence of 100 μ M DES greatly reduced the amount of Rab mRNA that accumulated during a 1.5 h incubation period (Heimovaara-Dijkstra *et al.*, 1994b). Whether this reduction in Rab mRNA was caused by loss of a hyperpolarization signal or by sustained inhibition of P-type ATPases is not known.

Calcium fluxes through the aleurone plasma membrane are an essential component of hormone signalling

A critical component of hormonal signalling is regulation of $[Ca^{2+}]_i$ (Bethke *et al.*, 1995; Bush, 1995). In plants $[Ca^{2+}]_i$ acts as a second messenger for many environmental and hormonal signals (Bush, 1995). Increases in $[Ca^{2+}]_i$ can either activate enzymes directly (Roberts and Harmon, 1992) or indirectly through Ca^{2+} -binding proteins such as CaM. Spatial inhomogeneity in $[Ca^{2+}]_i$ allows for targeting of the Ca^{2+} -signal to specific regions of a cell or tissue. As shown in Fig. 4, $[Ca^{2+}]_i$ plays a key role in the response of the aleurone cell to hormonal signals.

Data suggest that GA-treatment of aleurone cells results in calcium influx from the apoplast. Gilroy and Jones (1992) and Bush (1996) demonstrated that GA-induced increases in $[Ca^{2+}]_i$ (see below) were dependent on extracellular Ca^{2+} ($[Ca]_o$). At low $[Ca]_o$, $[Ca^{2+}]_i$ no longer increased following GA-treatment. Further,

when barley aleurone cells were imaged with a confocal microscope (Gilroy and Jones, 1992) or an intensified CCD camera (Bush, 1996), the highest $[Ca^{2+}]_i$ was observed near the periphery of the cell. These observations are consistent with GA-stimulated Ca^{2+} entry through the PM as a mechanism for elevating $[Ca^{2+}]_i$. Calcium is presumed to enter aleurone cells through an as yet unidentified PM Ca^{2+} channel. The existence of a Ca^{2+} channel has been postulated on thermodynamic grounds and by analogy to hormonally-regulated, channel-mediated Ca^{2+} influx in stomatal guard cells (Schroeder and Hagiwara, 1990).

Reduction of $[Ca^{2+}]_i$ from elevated concentrations may involve the activity of a PM Ca^{2+} -ATPase. Bush and Wang (1995) presented biochemical evidence for a PM Ca^{2+} -ATPase in wheat aleurone. These investigators used isolated membrane vesicles to characterize the principal Ca^{2+} transport activities in wheat aleurone cells. One of these, designated Type III, was found to be associated with PM marker enzymes. Transport was ATP-dependent and inhibited by the P-type ATPase blocker erythrosin B (0.1 μ M) and the CaM antagonist W7 (100 μ M). Activity was not stimulated by bovine brain CaM. The K_m for Ca^{2+} was 2 μ M, suggesting a role in reducing $[Ca^{2+}]_i$ to resting levels following a Ca^{2+} -increasing stimulus.

Signal transduction within the cytosol

In the aleurone cell, hormone perception and early signal transduction events occur at the PM. These signals must be propagated throughout the cytosol, where biochemical activities must be co-ordinated in order to synthesize and secrete hydrolases efficiently. $[Ca^{2+}]_i$, acting in conjunction with CaM, is thought to be essential for this co-ordination (Bethke *et al.*, 1995). Additional signals, however, are also important. As illustrated in Fig. 4, these may include cGMP, cytosolic protons as well as protein phosphorylation. Cross-talk between each of these signalling components is likely. Temporal or spatial convergence of signalling pathways may encode information specifying an appropriate cellular response.

Changes in the concentration of cytosolic calcium are central to hormone-mediated responses in the aleurone cell

As discussed above, Ca^{2+} is thought to enter the aleurone cell from the apoplasm following GA stimulation. Since the site of Ca^{2+} entry is close to the site of hormone perception, Ca^{2+} entry may be an early event in the signal transduction chains leading from GA binding to hydrolase secretion. Evidence for this comes from the work of Douglas Bush (1996). Bush loaded wheat aleurone layers with the Ca^{2+} -sensitive dye fluo-3 and monitored fluorescence in the cytoplasm before, during and after perfusion with 5 μ M GA_3 . Within a few minutes of

GA_3 addition, $[Ca^{2+}]_i$ began to increase. The sustained $[Ca^{2+}]_i$ was 100–500 nM higher than the baseline concentration and was attained within 30–90 min of adding GA_3 . This increase in $[Ca^{2+}]_i$ was dependent on perception of an active GA. GA_8 , a biologically inactive GA did not increase $[Ca^{2+}]_i$, nor was an increase detected in aleurone cells from the GA-insensitive wheat mutant D6899. A similar, though slower increase in $[Ca^{2+}]_i$ following GA-treatment was reported for protoplasts of barley aleurone (Gilroy and Jones, 1992).

The increase in $[Ca^{2+}]_i$ brought about by GA_3 can be antagonized by ABA (Gilroy and Jones, 1992). When barley aleurone protoplasts were first treated with GA_3 and then with GA_3 plus ABA, $[Ca^{2+}]_i$ increased during GA_3 treatment, but decreased to the baseline concentration in the presence of ABA. This effect of ABA on $[Ca^{2+}]_i$ is consistent with the hypothesis that ABA antagonizes GA action by preventing a sustained increase in $[Ca^{2+}]_i$.

When ABA was applied to non-GA-treated aleurone cells, a rapid decrease in $[Ca^{2+}]_i$ was observed (Wang *et al.*, 1991). Fluorescence from the Ca^{2+} -sensitive dye indo-1/AM decreased within seconds of ABA addition, reaching a steady intensity in about 10 s. Whether this represents a new steady-state for $[Ca^{2+}]_i$ is not known as only short term measurements were made. The magnitude of the decrease in $[Ca^{2+}]_i$ depended upon ABA concentration. A 20–70 nM decrease was observed with 10–50 μ M ABA, and a decrease of about 150 nM was observed at 500 μ M ABA (Wang *et al.*, 1991). The importance of the latter value is questionable given the unphysiologically high ABA concentration. Changes in $[Ca^{2+}]_i$ were insensitive to the Ca^{2+} -channel blockers nifedipine (35 μ M) and verapamil (150 μ M), but were sensitive to the Ca^{2+} -antagonists La^{3+} and Cd^{2+} . Wang *et al.* suggested that ABA-treatment may lower $[Ca^{2+}]_i$ by activating a PM Ca^{2+} -ATPase.

The calcium-binding protein calmodulin is an important second messenger in cereal aleurone

Transduction of calcium signals is often accomplished through the use of intermediary Ca^{2+} -binding proteins. Of these, the best known is CaM. The binding of Ca^{2+} to CaM results in a conformational change that increases the affinity of CaM for CaM-activated enzymes. In this manner, changes in $[Ca^{2+}]_i$ may modulate changes in enzyme or transporter activity. In cereal aleurone, CaM is thought to be an essential component of signal transduction pathways leading from GA-perception to hydrolase secretion (Gilroy, 1996). A role for CaM in ABA-signalling has also been proposed (Hetherington and Quatrano, 1991).

In barley aleurone, the amounts of CaM mRNA and CaM protein are both under hormonal control. Schuurink

et al. (1996) found that physical stimulation of aleurone layers increased the amount of CaM mRNA. Although this increase in CaM mRNA occurred whether aleurone layers were subsequently incubated in H₂O, 10 mM CaCl₂ or 5 μM GA₃, it was prevented by incubation in 5 μM ABA. In contrast to CaM mRNA, CaM protein, as measured by densitometry of protein blots, did not increase in aleurone layers treated with H₂O, CaCl₂ or GA₃ (Schuurink *et al.*, 1996). Hence the amount of CaM protein in barley aleurone is under post-transcriptional control. Incubation in 5 μM GA₃ plus 10 mM CaCl₂, conditions that lead to α-amylase secretion, doubled the amount of CaM protein. These data are consistent with previous experiments of Gilroy and Jones (1993), who found that treatment of barley aleurone layers with GA₃ plus CaCl₂ increased CaM protein by 50% as measured by a radio-immunoassay.

The increase in CaM protein described by Schuurink *et al.* (1996) was approximately linear with time during the first 8 h of incubation with hormone. In the same set of experiments, GA₃ plus CaCl₂-treatment increased α-amylase mRNA after a lag of about 2 h. These data are consistent with the hypothesis that CaM acts as an intermediate in the GA-induced signal transduction pathways leading to hydrolase secretion (Figs 2, 4). GA-stimulated increases in CaM protein combined with GA-stimulated increases in [Ca²⁺]_i would increase the amount of Ca²⁺-CaM several fold. This Ca²⁺-activated CaM would then stimulate the activity of enzymes or transporters required for hydrolase synthesis or secretion (Fig. 5).

In an elegant set of experiments, Simon Gilroy directly examined the roles of [Ca²⁺]_i and CaM in GA- and ABA-signalling (Gilroy, 1996). By using microinjection to introduce Ca²⁺, Ca²⁺ chelators and CaM into barley aleurone protoplasts, he has either mimicked or abolished hormonally induced changes in [Ca²⁺]_i and CaM (Gilroy, 1996). In the absence of GA, mimicking GA-induced changes in [Ca²⁺]_i and CaM did not result in secretion of α-amylase, vacuolation of protoplasts, or expression of the glucuronidase reporter gene fused to an α-amylase promoter (Amy-GUS). When a sustained increase in [Ca²⁺]_i was blocked by the Ca²⁺-chelator diazo-2, α-amylase secretion, but not Amy-GUS expression, was prevented. This later observation is consistent with earlier experiments demonstrating that GA in the absence of external Ca²⁺ increases the transcription of α-amylase mRNA, but does not lead to α-amylase secretion (Deikman and Jones, 1985). When barley CaM was microinjected into barley aleurone protoplasts, either in the presence or absence of elevated [Ca²⁺]_i, responses typical of GA-treatment were not observed in the absence of GA (Gilroy, 1996). Hence, although elevated [Ca²⁺]_i is required for α-amylase secretion, neither elevated

[Ca²⁺]_i nor Ca²⁺-CaM are sufficient for induction of α-amylase secretion or aleurone cell vacuolation.

Gilroy (1996) also treated aleurone protoplasts that had been incubated in 5 μM GA₃ for 24 h with 5 μM ABA for 3 h. This ABA treatment caused [Ca²⁺]_i, Amy-GUS expression and α-amylase secretion to decrease (Gilroy, 1996). When [Ca²⁺]_i was maintained at GA-stimulated levels, however, Amy-GUS expression and α-amylase secretion continued. Likewise, microinjection of 1–10 μM CaM also blocked the antagonistic effects of ABA on Amy-GUS expression and α-amylase secretion. These data suggest that ABA antagonizes GA action by reducing [Ca²⁺]_i or the amount of Ca²⁺-CaM.

ABA induces a set of genes distinct from those induced by GA (Table 1). Gilroy introduced Ca²⁺ and CaM into the cytosol of barley aleurone protoplasts to see if low levels of [Ca²⁺]_i or CaM were required for expression of the glucuronidase reporter gene fused to the wheat Em promoter (Em-GUS). Artificial elevation of [Ca²⁺]_i or CaM in ABA-treated protoplasts did not reduce Em-GUS expression. Since ABA-induced gene expression was unchanged when [Ca²⁺]_i was high, it is unlikely that all ABA-induced signalling pathways are regulated by [Ca²⁺]_i or CaM. Significantly, microinjection of ABA into barley aleurone protoplasts increased expression of Em-GUS. These data suggest that an internal receptor for ABA (see above) may be linked to a Ca²⁺-independent signalling pathway (Fig. 4).

Barley aleurone cells express genes encoding CaM-binding proteins

To identify targets for Ca²⁺-CaM in barley aleurone cells, Schuurink and Jones (1995) used a molecular approach. Using *Arabidopsis* CaM-2 coupled to horse radish peroxidase as a probe, they were able to screen expression cDNA libraries made of barley aleurone RNA for cDNAs encoding CaM binding proteins. Several cDNAs were identified, one of which was similar to a CaM-binding protein of unknown function from maize (Reddy *et al.*, 1993). Their research focused on clone HvCBT1 which had high homology to the inward rectifying potassium channel KAT1 from *Arabidopsis* and to catfish olfactory channels (Anderson *et al.*, 1992; Goulding *et al.*, 1992). Overall similarity between HvCBT1 and KAT1 and the olfactory channel was 46% and 47%, respectively. These ion channels are characterized by six transmembrane domains, a pore between the fifth and sixth transmembrane domain and a cyclic nucleotide binding domain in the carboxyl-terminus. The olfactory channels have a CaM binding domain near the N-terminus. Homology with KAT1 and olfactory channels is limited in the pore domain. This suggests that HvCBT1 may be a member of a new class of ion channels from plants, but this hypothesis must be confirmed by a functional assay.

Olfactory channels are able to respond to a wide concentration of cAMP and cGMP *in vitro* (between 1 μ M and 1 mM), and their responsiveness to these two cyclic nucleotides decreases dramatically in the presence of CaM (Liu *et al.*, 1994). This suggests a mechanistic basis for the wide range of GA concentrations (10^{-12} to 10^{-7} , Hooley, 1982) to which aleurone cells respond.

Cyclic GMP may be a transient second messenger in GA signalling

It is clear that signal transduction in the aleurone cell is not dependent solely on $[Ca^{2+}]_i$ and the amount of CaM. Other signal transduction chains and other signalling molecules are required. One of these signalling molecules may be cGMP. Penson *et al.* (1996) present compelling evidence that cGMP is required for barley aleurone layers to respond fully to GA. When aleurone layers were treated with 5 μ M GA₃, a transient increase in cGMP was measured using a radio-immunoassay. Maximal cGMP content occurred 2 h after hormone treatment and was about 3-fold higher than that of controls. cGMP levels then decreased, so that 4 h after hormone treatment they were equal to those in untreated controls. An inhibitor of guanylyl cyclase, LY-83583, reduced this transient increase in cGMP when applied at 200 μ M. Accumulation of α -amylase and GAMYB mRNAs and secretion of α -amylase protein were inhibited by LY-83583. Inhibition of α -amylase secretion by LY-83583 was observed at concentrations greater than 100 μ M with an IC_{50} of 120 μ M. The membrane permeant cGMP analogue dibutyryl cGMP at 400 μ M nearly restored α -amylase secretion to control levels in the presence of 120 μ M LY-83583. Dibutyryl-cAMP at the same concentration did not reverse the effects of LY-83583, suggesting a specific cGMP effect. Dibutyryl-cGMP in the absence of GA did not induce the accumulation of α -amylase mRNA or the secretion of α -amylase protein. ABA-treatment of aleurone layers did not change the cGMP content of the layers, and LY-83583 had a relatively small effect on the accumulation of Rab21 mRNA in layers treated with ABA. Taken together, these data led the authors to conclude that cGMP plays a key role in GA- but not ABA-signalling in barley aleurone cells (Penson *et al.*, 1996). cGMP-binding proteins involved in GA-signalling are unknown, although HvCBT1 may bind cGMP near its carboxyl-terminus.

Cytosolic pH may function as a second messenger for hormonal signals

The concentration of protons in the cytosol may function as a second messenger in plant signal transduction in much the same way that the concentration of calcium ions does. Cross-talk between signal transduction chains utilizing pH_i and $[Ca^{2+}]_i$ as second messengers has been

proposed (Felle, 1988). In barley aleurone, changes in pH_i resulting from treatment with ABA or GA have been reported. Van der Veen *et al.* (1992) determined pH_i of aleurone protoplasts using a null-point method. In this method, detergent permeabilization of protoplasts releases cytosolic contents into weakly buffered media. The pH of the medium is measured before and after detergent addition. The procedure is repeated several times using media buffered to pHs that span pH_i . When medium pH is unchanged by detergent permeabilization of cells, the pH of the buffered medium is taken as representative of pH_i . Within 1 h of ABA-treatment (5 μ M), pH_i of barley aleurone protoplasts increased by approximately 0.14 pH unit (Van der Veen *et al.*, 1992). GA₃ treatment (10 μ M) of protoplasts had the opposite effect on pH_i . Within 1 h of GA₃ addition, pH_i decreased approximately 0.18 pH unit (Heimovaara-Dijkstra *et al.*, 1994a). Addition of both ABA and GA₃ to the protoplast incubation medium resulted in an intermediate change in pH_i (Heimovaara-Dijkstra *et al.*, 1994a). Changes in pH_i were transient. Within 6 h of treatment with either ABA or GA, pH_i returned to control levels.

Across a wide range of ABA concentrations, dose-response curves for cytosolic alkalization and Rab-16 mRNA accumulation in aleurone cells were similar (Van der Veen *et al.*, 1992). When protoplasts were treated with the weak acids 5,5-di-methyl-2,4-oxazolidinedione or potassium propionate, treatments thought to decrease pH_i , accumulation of Rab-16 mRNA was greatly reduced. Incubation with the weak bases methylamine or NH₄Cl had little effect. The authors suggest that alkalization of the cytosol is necessary but not sufficient for ABA-regulated gene expression. Confirmation of these data with a less invasive method of pH measurement is eagerly awaited. At present, no cytosolic targets for pH-mediated signal transduction have been identified in aleurone cells.

Protein phosphorylation is required for GA and ABA signalling in aleurone cells

Regulation of cellular activities by reversible protein phosphorylation is a ubiquitous process in animals and plants. In cereal aleurone, phosphorylation is important in the signalling pathways linked to GA and ABA perception. Kuo *et al.* (1996), found that okadaic acid (OA), an inhibitor of protein phosphatases types 1 and 2A, prevented GA-responses when applied to wheat aleurone layers at 100 nM. In these experiments, $[Ca^{2+}]_i$ did not increase, α -amylase secretion was inhibited and cell death induced by GA was prevented. OA decreased accumulation of α -amylase mRNA in GA-treated layers by 96%. In ABA-treated layers, OA decreased accumulation of PHAV1 mRNA by 64%. In similar experiments with the serine/threonine protein kinase inhibitors staurosporine (50 μ M) and K252a (50 μ M), no reduction in α -amylase secretion was observed (Kuo *et al.*, 1996).

The effects of protein phosphatase inhibitors on aleurone cell signalling have also been characterized by Heimovaara-Dijkstra *et al.* (1996). Of the six inhibitors they tested, phenylarsine oxide (PAO), calyculin A (CA) and OA inhibited ABA-induced gene expression. Treatment with PAO, CA or OA resulted in increased phosphorylation of two 40 kDa proteins. This hyperphosphorylation coincided with an increase in tyrosine phosphorylation of two 40 kDa proteins as detected with anti-tyrosine antibodies.

Transduction of extracellular signals in higher eukaryotes is accomplished by phosphorylation cascades and by phosphorylation/dephosphorylation of effector molecules. Phosphorylation cascades, as exemplified by the Ras/MEK/MAPK kinase cascade, operate by sequential phosphorylation of several protein kinases (Johnson and Vaillancourt, 1994). Phosphorylation activates each kinase and promotes phosphorylation of the next kinase in the chain. Each kinase may also phosphorylate effector molecules. For example, MAP kinase phosphorylates protein kinases, transcription factors, components of the cytoskeleton and other enzymes (Johnson and Vaillancourt, 1994). In this way, phosphorylation promotes branching of the signal transduction pathway and leads to co-ordination of the response throughout the cell.

Knetsch *et al.* (1996) demonstrated that ABA-treatment of barley aleurone protoplasts increased MAP kinase activity. Activity in immunoprecipitates, as measured by the phosphorylation of myelin basic protein, was stimulated more than 4-fold by ABA. Activity was maximal about 3 min after hormone treatment, and returned to basal levels after approximately 5 min. When anti-phosphotyrosine antibodies rather than antibodies to the MAP kinase ERK1 were used to immunoprecipitate Triton X-100- and SDS-soluble proteins, the time-course for MAP kinase activity in the precipitated material was similar. Experiments with the protein tyrosine phosphatase inhibitor PAO indicated that tyrosine dephosphorylation was required for ABA-activation of MAP kinase and for ABA-induced accumulation of rab16 mRNA (Knetsch *et al.*, 1996). The authors suggest that ABA induces tyrosine phosphorylation of MAP kinase during MAP kinase activation. They further propose that activity of a protein tyrosine phosphatase is part of the signal transduction chain linking ABA perception to MAP kinase activation and ABA-inducible gene expression (Fig. 4). The effect of GA-treatment on MAP kinase activity is unclear. No effect was observed by Knetsch *et al.* (1996), but GA reduced the accumulation of mRNA for a MAP kinase homologue in oat aleurone layers (1995).

A putative ribosomal kinase (Ask11) has been cloned from oat aleurone by Huttly and Phillips (1995). Accumulation of transcripts for this kinase in GA-treated aleurone layers was substantially higher than in layers

incubated in the absence of hormone. The authors speculate that Ask11 may phosphorylate ribosomal proteins and that this may play a role in GA-stimulated protein synthesis.

Endomembrane targets for hormonally induced signals

The evidence presented above suggests that $[Ca^{2+}]_i$, CaM, cGMP, pH_i , protein kinases, and protein phosphatases are all players in the regulation of hormonally induced responses within the aleurone cell. To bring about the appropriate response, however, each of these signal transduction intermediates must interact with one or more effector molecules. Because the primary function of the aleurone cell is the synthesis and secretion of hydrolases, processes which require co-ordination of activities within the PSV, ER and Golgi apparatus, some of the signal transduction chains leading from GA- or ABA-perception are linked to the endomembrane system. As illustrated in Fig. 5, transporters in the ER and PSV and PSV proteases are likely targets for these signals.

Calcium transport into the endoplasmic reticulum is via a CaM-stimulated Ca^{2+} -ATPase

α -Amylase is a Ca-containing metalloprotein that is produced at high rates on the rough ER of aleurone cells.

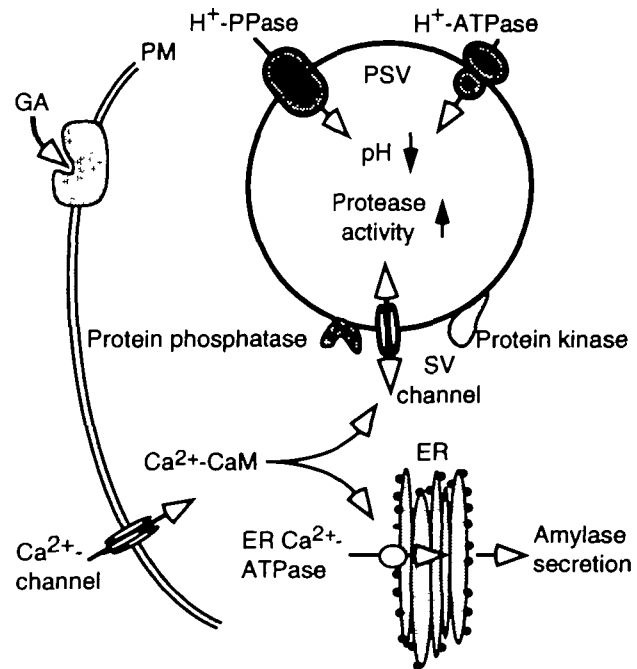

Fig. 5. Endomembrane targets of hormonal signalling in cereal aleurone. GA stimulates acidification of the PSV lumen and increases the activity of PSV proteases. The second messenger Ca^{2+} -CaM stimulates the activity of an ER Ca^{2+} -ATPase and regulates the activity of the SV channel. Tonoplast-associated protein phosphatase and protein kinase also modulate the activity of this channel.

Replenishment of Ca^{2+} within the lumen of the ER, therefore, is required for continued amylase synthesis (Bush *et al.*, 1989). Bush *et al.* (1993) measured rates of Ca^{2+} -transport (CaT) into microsomal vesicles from barley aleurone layers and found that the rate of CaT was greatly increased by GA_3 -treatment. Maximal rates of transport were found in membrane fractions that had the highest rates of cytochrome *c* reductase activity, indicating that the transporter was likely to be in the ER. Calcium transport was significantly reduced by vanadate, but only minimally reduced by NO_3^- . This suggested to the authors that the transporter was a P-type Ca^{2+} -ATPase. When layers were treated with ABA, there was less CaT in all membrane fractions than when layers were treated with GA_3 . For layers incubated in both $5\ \mu\text{M}$ GA_3 and $5\ \mu\text{M}$ ABA, or $5\ \mu\text{M}$ GA_3 and then $5\ \mu\text{M}$ ABA, GA_3 -stimulated CaT was eliminated. This antagonistic effect of ABA on CaT was not the result of reduced ER membrane or ER protein. Since CaT increased for at least 16 h following GA_3 -treatment, the authors proposed that regulation was at the level of gene expression. They noted that their data were consistent with synthesis of either new Ca^{2+} -transporters or of a regulatory protein such as CaM.

Subsequently, Gilroy and Jones (1993) showed that CaT could be stimulated at least 5-fold by adding 500 nM CaM to ER microsomes isolated from non- GA -treated barley aleurone layers. No stimulation was observed when CaM was added to microsomes from GA -treated layers. The CaM inhibitor W7, however, reduced the rate of CaT into microsomes from GA -treated layers. This suggested that CaM or a CaM-like protein remained bound to ER microsomes and was sufficient for full activation of a Ca^{2+} -ATPase. A calcium transporter in wheat similar to the barley ER Ca^{2+} -ATPase has been characterized by Bush and Wang (1995). As in barley, CaT into isolated membrane vesicles from GA -treated aleurone layers was not stimulated by exogenous CaM, but was inhibited by W7. Calcium transport activity in barley ER increased at a nearly constant rate for at least 16 h following GA -treatment (Bush *et al.*, 1993). The kinetics of this rise in CaT activity are similar to those for CaM protein (Schuurink *et al.*, 1996). It is likely, therefore, that GA -stimulation of ER CaT is mediated by CaM.

Effector molecules that respond to hormonal signals are present on the tonoplast of aleurone PSVs

The PSV in cereal aleurone contains storage proteins and mineral nutrients. Following imbibition, protein reserves are hydrolysed by PSV proteases, and minerals such as K, Mg and P are released from phytin by phytases. The products of these reactions are transported through the PSV tonoplast and are used for hydrolase synthesis and embryo nutrition. Evidence is accumulating that processes

within the PSV are co-ordinated with those in the cytoplasm by hormonal signals (Fig. 5). The activity of cysteine proteases within the PSV, for example, is upregulated by GA_3 -treatment of barley aleurone protoplasts (Bethke *et al.*, 1996). Using proteolytic activity gels, Bethke *et al.* showed that incubation of protoplasts in GA_3 ($5\ \mu\text{M}$) for 18 h increased the activity of at least three cysteine proteases. Two of these activities were undetectable in ABA-treated protoplasts and the third was present but reduced. No proteolysis was detectable when activity gels were incubated in pH 6.5 buffer, but two of the cysteine proteases were active at pH 5.5 and all three at pH 4.5 (Bethke and Jones, unpublished data).

Because these PSV proteases are inactive at neutral pH, acidification of the PSV lumen may be an important regulator of storage protein mobilization. Swanson and Jones (1996) measured the pH of barley aleurone PSVs using the pH-sensitive dye BCECF-AM. They showed that incubation of protoplasts with GA_3 for 20 h promotes acidification of the PSV lumen. The pH of untreated PSVs was 6.6, whereas that of PSVs in GA_3 -treated protoplasts was 5.8. This may underestimate the degree of acidification as BCECF is insensitive to pH below about 5.5. The onset of vacuolar acidification began shortly after GA_3 -treatment. Measurements of *in vivo* vacuolar pH were made before and after GA_3 addition to the media surrounding aleurone protoplasts. Within 2 h the pH within PSVs had decreased. ABA treatment did not result in vacuolar acidification. The pH of PSVs in protoplasts treated with ABA for 20 h was 6.7. How the process of vacuolar acidification is regulated is not known. Immunoblot analyses suggested that differences in abundance of tonoplast H^+ -pumps between PSVs in ABA- or GA -treated protoplasts are unlikely to account for differences in vacuolar pH. Swanson and Jones (1996) demonstrated that approximately equal amounts of V-type H^+ -ATPases and H^+ -PPiases were present in the tonoplast of PSVs from both ABA- and GA -treated protoplasts.

Another target of Ca^{2+} -CaM in the aleurone cell is the slow-vacuolar (SV) channel. The SV channel is an abundant cation channel that may play an important role in Ca^{2+} -signalling (Ward and Schroeder, 1994). In barley aleurone PSVs, Bethke and Jones (1994) have shown that the activity of the SV channel is modulated by Ca^{2+} -CaM. Using the patch-clamp technique they demonstrated that SV channel activity was stimulated by increasing external free Ca^{2+} . Activity of the channel increased as Ca^{2+} was increased above 600 nM. At high Ca^{2+} ($100\ \mu\text{M}$) the CaM inhibitors W7 and trifluoperazine reduced SV channel activity by more than 90%. Channel activity inhibited by W7 could be partially restored by addition of CaM. CaM on its own increased the sensitivity of the channel to Ca^{2+} . In the presence of CaM, specific current through SV channels increased ~3-fold at $2.5\ \mu\text{M}$

Ca^{2+} and over 13-fold at $10 \mu\text{M}$ Ca^{2+} . In the absence of added CaM, whole-vacuole SV currents in PSVs from ABA-treated protoplasts were 58% less than those in PSVs from GA-treated protoplasts. It is likely that this represents differences in the regulatory environment within the cells from which PSVs were isolated rather than differences in channel density within the tonoplast.

Activity of the SV channel is also regulated by reversible protein phosphorylation (Bethke and Jones, 1997). When isolated PSVs were treated with the protein phosphatase inhibitor OA (20 nM), whole-vacuole channel activity was reduced by 60%. When the OA-insensitive protein phosphatase calcineurin was added to PSVs in the presence of OA, activity was restored to control levels. These data suggested that protein dephosphorylation activated the SV channel. Bethke and Jones (1997) also found that protein phosphorylation could activate the channel. Purified CaM-like domain protein kinase (CDPK) stimulated channel activity at both low (200 μM) and high (2 mM) ATP concentrations. A model for regulation of the barley aleurone SV channel in which phosphorylation occurs at two sites was proposed. Phosphorylation at one site promotes channel opening and phosphorylation at a second site promotes channel closure. At least one of the protein phosphatases and one of the protein kinases that modulate SV channel activity were present in isolated PSVs.

The aleurone cell nucleus contains CaM

Although hormonally-induced changes in mRNA synthesis are well characterized for the aleurone cell (see below), only tentative links between hormone perception and gene expression have been established. One of these may be CaM. Immunolocalization of CaM within barley aleurone protoplasts suggests that the nucleus contains a significant pool of CaM (Schuurink *et al.*, 1996). The function of this nuclear CaM is unknown, but work in Raymond Zielinski's laboratory suggests that it may modulate gene expression. Szymanski *et al.* (1996) found at least four DNA-binding proteins in cauliflower nuclear extracts that also bound CaM. Significantly, CaM enhanced the binding of these proteins to the C/G-box in the *Arabidopsis Cam-3* promoter. The *Arabidopsis* transcription factor TGA3 also bound CaM and this enhanced its binding to the *Cam-3* promoter. These data suggest a mechanism whereby changes in Ca^{2+} or CaM can be transduced into changes in gene expression.

Hormonal signalling results in GA- and ABA-specific gene expression

The responses of aleurone cells to GA and ABA described above precede increases in α -amylase mRNAs (see Fig. 2) and increases in ABA-up-regulated mRNAs. To address

the question of how mRNA levels of GA and ABA inducible genes are regulated in aleurone cells, their genes and promoters have been isolated. Promoter-reporter constructs have been prepared and transiently expressed in aleurone protoplasts and aleurone layers. Transacting factors that interact with specific elements in these promoters or that regulate the expression of these promoters have been identified. The data from these experiments using cereal aleurone have significantly increased our understanding of phytohormone-regulated gene expression.

Multiple regulatory elements within the promoters of GA- and ABA-inducible genes confer hormone specific expression

Of the genes that are regulated by GA and ABA, the best characterized are those for α -amylases. A key regulatory step in the production of α -amylase protein is synthesis of α -amylase mRNAs. Run-on transcription studies with nuclei from barley and wild oat aleurone protoplasts and transient expression of promoter-reporter constructs in aleurone protoplasts and layers suggest that GA and ABA control α -amylase synthesis at the transcriptional level (Jacobsen and Beach, 1985; Zwar and Hooley, 1986). A role for additional translational control has not been excluded.

The promoters of hormone-inducible genes contain multiple sequence elements that act together to confer high levels of hormone-dependent transcription (Fig. 6). Regions essential for hormone regulated expression in the promoters of barley and wheat α -amylase genes have been identified using deletion and linker-scan analyses (Gubler and Jacobsen, 1992; Rogers and Rogers, 1992; Tregear *et al.*, 1995; Lin *et al.*, 1996). In the promoters of α -amylase genes from wheat (Tregear *et al.*, 1995), rice (Tanida *et al.*, 1994) and barley (Gubler and Jacobsen, 1992), three highly conserved elements are present within 300 bp of the transcription start site. These three elements, the pyrimidine (C/TCTTTT), TAACAA/GA, and TATCCAC/T boxes are sufficient for GA-induction and were named the GA-responsive complex (GARC) by Gubler and Jacobsen (1992). Experiments using rice transformed with the GUS reporter gene driven by the -232 to +31 region of the *RAmy1A* promoter confirmed that these boxes are sufficient for developmental, temporal and hormonal regulation of the α -amylase promoter in germinating grain (Itoh *et al.*, 1995).

A limited number of gain-of-function experiments have been done using the boxes conserved in the promoters of GA-inducible genes. Skriver *et al.* (1991) showed that multiple copies of the sequence GGCCGATAACAAACTCCGGCC attached to a minimal 35S cauliflower mosaic virus promoter were able to confer proper GA-responsive and ABA-repressive

expression. This 21 base sequence was called the GA₃ responsive element (GARE). These experiments suggest that there is functional redundancy between the binding sites on the GARE and those on the GARC. Remarkably, it is still unclear which nucleotides within the GARE are responsible for ABA-repressible expression. It is evident, however, that the ACGT core which plays a dominant role in ABA up-regulated gene expression (see below) is absent from the GARE (Giraudat *et al.*, 1994). Other gain-of-function experiments (Lanahan *et al.*, 1992; Rogers and Rogers, 1992) showed that a single element (GTAACAGAGTCTGG) was able to direct GA-regulated transcription of the low *pI* α -amylase promoter, but only when a second short sequence identified as O2S (Opaque-2 similar) was also present. This GTAACAGAGTCTGG element, which contains the TAACAGA sequence of the GARC is similar to a sequence motif found in the GARE. This motif, UTAACAUANTCYGG, where U is a purine, Y is a pyrimidine and N is any nucleotide, is highly conserved in cereal α -amylase gene promoters (Huang *et al.*, 1990). The O2S box was termed a coupling element (CE) (Fig. 6). O2S in conjunction with another CE (box 5) of the low *pI* α -amylase promoter (Fig. 6) increased the transcription of a high *pI* α -amylase promoter containing the three-element GARC. These experiments indicate that unidentified CEs in high *pI* α -amylase promoters may enhance transcription. A low *pI* α -amylase promoter from wheat appears to have regions upstream of the pyrimidine box other than OS2 that are required for high levels of GA-induced expression (Huttly *et al.*, 1992).

Transcription of several ABA-inducible genes requires promoter sequences containing an ACGT core sequence. This sequence is present in the promoters of HVA1 and HVA22, two genes that are up-regulated by ABA in barley aleurone layers (Shen and Ho, 1995; Shen *et al.*, 1996). Loss- and gain-of-function promoter studies using GUS as the reporter have shown that boxes containing the ACGT core (ABA responsive element, ABRE) in HVA1 and HVA22 are necessary for ABA-inducible gene expression. ABREs, however, are not capable of directing

ABA up-regulation by themselves; CEs are also needed for ABA responsiveness. Two different ABA response complexes (ABRCs), each containing an ABRE and a CE, were sufficient to confer ABA responsiveness to the HVA1 and HVA22 promoters (Shen *et al.*, 1996). The promoter of dehydrin, another ABA-up-regulated barley gene, also contains an element with an ACGT core, but a CE has not been identified in this promoter (Robertson *et al.*, 1995). Inconsistencies between transcriptional activity of the dehydrin promoter and the accumulation of dehydrin mRNA indicate that experiments that measure run-on transcription and mRNA stability need to be done with ABA-up-regulated genes in barley aleurone.

Transacting factors control expression of α -amylase genes

Several approaches have been used to search for transacting factors interacting with *cis*-elements in α -amylase promoters. Classic DNaseI footprinting and gel retardation studies identified sequence-specific interactions between nuclear proteins and promoter regions of rice, wheat and barley α -amylases (Rushton *et al.*, 1992; Sutliff *et al.*, 1993; Goldman *et al.*, 1994; Mitsunaga *et al.*, 1994). In general, the DNaseI footprinting and gel retardation assays are consistent with the promoter-reporter studies described above. Sutliff *et al.* (1993), for example, demonstrated that a fraction from a nuclear protein extract bound to the promoter of a barley low *pI* α -amylase gene at regions corresponding to the GARE and the TATCCAT elements. Significantly, this binding activity was shown to be induced by GA.

Another method used to identify trans-acting factors conferring hormone-specific gene expression is to screen expression cDNA libraries with promoter sequences. Rogers *et al.* (1995) screened expression cDNA libraries made of mRNA from barley aleurone cells with hexamers of the GARE (Fig. 6). A cDNA encoding a novel 60-kDa protein (GAB1) with an unusual, repeated zinc finger domain and a nuclear localization signal was cloned using this strategy (J Rogers and J Mundy, personal communication). Within the zinc finger domains, Cys and His residues required for zinc and DNA binding were determined by *in vitro* mutagenesis and binding assays. The nuclear localization signal was shown to function in onion cells. When transiently overexpressed in barley aleurone cells, GAB1 repressed expression of the low *pI* α -amylase promoter (J Rogers and J Mundy, personal communication; Rogers *et al.*, 1995). A similar approach was used by Rushton *et al.* (1995) to clone two cDNAs encoding proteins that bind to the OS2 motif in the promoters of wheat and wild oat low *pI* α -amylase genes. These proteins each contain a conserved region of 56–58 amino acids that contain a putative zinc finger. Binding to OS2 regions was abolished by the chelators 1,10-*o*-phenanthroline and EDTA, which supports the hypothesis that these proteins bind zinc *in vivo*.

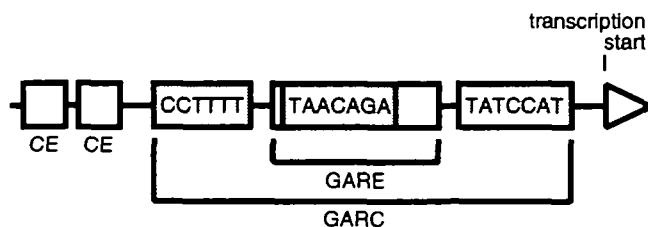

Fig. 6. Diagrammatic representation of the promoter of a low *pI* α -amylase gene. The shaded boxes are collectively referred to as the GARC. The GARE is composed of the TAACAGA box of the GARC and additional bases to either side of it. Two CEs are shown upstream of the GARE. The size and spacing of the boxes in the figure are not to scale.

MYB proteins are transcriptional activators that are found in plants as well as animals. These proteins contain conserved DNA-binding domains and a carboxyl-terminal activator domain. Binding of MYB proteins to DNA is sequence specific. Gubler *et al.* (1995) observed that the TAACAAA element in the GARC has two possible c- and v-MYB binding sites. They cloned a MYB cDNA from barley aleurone cells by screening an expression cDNA library with a 170-bp probe containing the sequence coding for the DNA-binding domain of the maize C1 MYB protein. mRNA abundance for this GAMYB increased following GA-treatment of barley aleurone prior to the increase in α -amylase mRNA (Fig. 2). These data suggested that GAMYB may regulate the transcription of α -amylase. To test this hypothesis, Gubler *et al.* (1995) transiently overexpressed GAMYB in barley aleurone layers. In the absence of added GA, GAMYB was able to stimulate transcription of a high *pI* α -amylase promoter fused to the GUS reporter gene. A TAACAAA-like sequence is also present in the GA-regulated promoter of barley 1–3,1–4 β -glucanase isoenzyme II (Wolf, 1992), suggesting that its promoter may be regulated by GAMYB. Other GA-regulated genes such as a cathepsin B-like gene from wheat (Cejudo *et al.*, 1992), a carboxypeptidase gene from rice (Washio and Ishikawa, 1992), a putative ubiquitin-conjugating enzyme from rice (Chen *et al.*, 1995), and two cysteine proteinase genes from barley (Mikkonen *et al.*, 1996), however, do not appear to have a TAACAAA box in their promoters. Transacting factors other than MYB, therefore, may activate these promoters. This would allow for temporal or stimulus-specific control of GA-regulated transcription. Alternatively, other related sequences may function as GAMYB-binding sites.

Recently a putative ubiquitin-conjugating enzyme (UBC) from rice was shown to transactivate the rice *Osamy-C* promoter (Chen *et al.*, 1995). *Osamy-C* is induced by GA, but promoter deletions revealed a domain between –230 and –158 that repressed this GA-inducible activity (Chen *et al.*, 1995). Co-expression of *Osamy-C* with UBC overcame this repression, suggesting that the –230/–158 domain of *Osamy-C* binds a repressor protein that UBC targets for proteolysis. The role of UBC in the GA-inducibility of the full length *Osamy-C* promoter, however, has not been investigated. This role might be minor since repression attributed to the –230/–158 region was masked by upstream promoter domains.

The region of the *Osamy-C* promoter between –230 and –158 has been shown to interact with at least five proteins from imbibed rice grain (Kim *et al.*, 1992). Two of these are present in rice aleurone independent of GA treatment. The –230/–158 region also contains a sequence homologous to the cAMP responsive element of cAMP regulated promoters in mammalian cells

(Deutsch *et al.*, 1988). A similar element was found in a high *pI* α -amylase promoter and shown to repress GA-inducible transcription in barley (Gubler and Jacobsen, 1992). No proteins have been identified that bind to either of these cAMP-like responsive elements.

Figure 7A shows a model of how the transacting factors described above might influence the transcription of α -amylase genes. In this model, GA increases the amount of GAMYB protein. GAMYB then binds to the GARE and increases transcription of α -amylase genes. GAB1, the other transacting factor that binds to the GARE, inhibits transcription of α -amylase genes in the absence of GA. When present, VP1 increases the affinity of GAB1 for the GARE and represses α -amylase gene expression (Hoecker *et al.*, 1995). How GAMYB and GAB1 compete for the GARE and how this affects the activity of the α -amylase promoter remain unanswered.

Transacting factors have been identified that regulate the expression of ABA-inducible genes

ABA may act on the ABRE in the GARE via a viviparous1 (VP1) homologue. VP1 is a transcriptional activator of maize that prevents precocious germination. A VP1-homologue has been cloned from rice (OSVP1) and its transcript was detected in developing seeds and imbibed mature embryos (Hattori *et al.*, 1994). The presence of OSVP1 in the aleurone layer, however, was not determined and this remains an important issue. VP1 transiently expressed in barley aleurone cells repressed the GA-stimulated up regulation of a 1.8 kbp high *pI* α -amylase promoter (Hoecker *et al.*, 1995). VP1 enhanced the binding of many transcription factors to elements with an ACGT core (Hill *et al.*, 1996). It is suggested, as indicated in Fig. 7A, that a VP1-like transcription factor might increase the affinity of GAB1 for the GARE.

Most efforts to clone transacting factors interacting with *cis*-elements in ABA upregulated promoters have focused on the *Em* gene of wheat. A cDNA encoding EmBP-1, a protein with affinity for the ABRE in the *Em* promoter, was cloned from a wheat embryo cDNA library (Guiltinan *et al.*, 1990). The maize VP1 gene product enhanced binding of EmBP-1 to its binding site (Hill *et al.*, 1996). This is consistent with the observations that VP1 is able to activate the *Em* promoter *in vivo*. Recently it was shown that VP1 can also transactivate the ABRC in HVA1, but not the ABRC in HVA22, suggesting that VP1 can differentiate between ABRCs in mediating an ABA response (Shen *et al.*, 1996). OSVP1 is able to transactivate OSEm, a rice gene homologous to the wheat *Em* gene (Hattori *et al.*, 1995). Hattori's results strongly suggest that OSVP1 activated the OSEm promoter by interacting with a protein, perhaps an EmBP-1 homologue, that binds to an ACGT containing ABRE. It is very likely that homologues of EmBP-1 also exist in

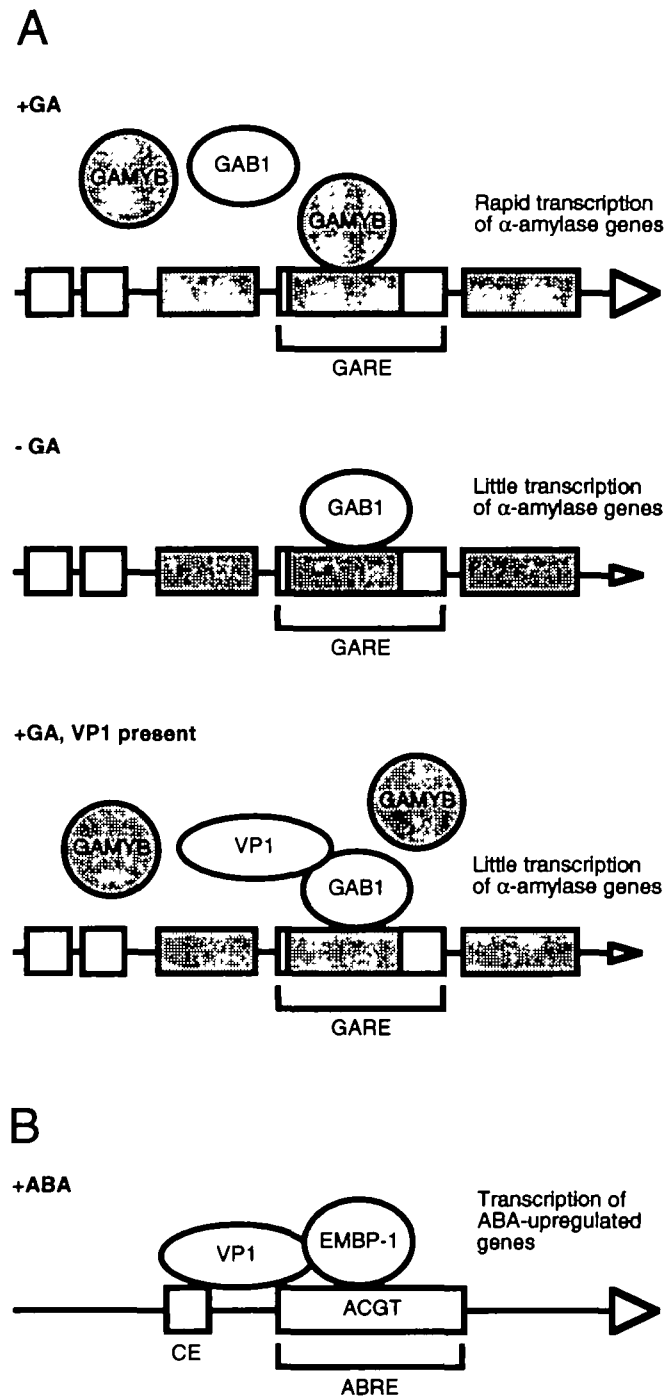

Fig. 7. Regulation of GA- (A) and ABA-inducible promoters (B) by transacting factors. (A) Binding of GAB1 to the α -amylase GARE represses expression of α -amylase genes in the absence of GA. GA reduces this repression by stimulating the production of the transactivator GMYB. Binding of GAB1 to the GARE may be enhanced by VP1. (B) Transcription of ABA-up-regulated genes such as the wheat *Em* gene is promoted by the transactivator EMBP-1. VP1 may promote transcription by interacting with EMBP-1, and perhaps with CEs.

barley. One strategy for identifying such homologues from barley aleurone would be to screen for proteins that interact both with the ACGT cores in HVA1 and with VP1. Figure 7B shows a model of how transacting factors might regulate the transcription of an ABA-up-regulated gene such as the wheat *Em* gene. In this model, VP1 binds to EMBP-1 and increases its affinity for the ABRE. Binding of EMBP-1 stimulates transcription of the gene. Interaction between VP1 and a CE may stabilize the VP1/EMBP-1/ABRE complex.

The mechanism of VP1-mediated activation of ABA-inducible genes is clearly different from that of VP1-mediated repression of α -amylase genes. The N-terminal domain of VP1 is required for activation of the *Em* gene, whereas domains in the middle part of VP1 are required for repression of α -amylase genes. Repression of α -amylase expression is ABA-independent, but VP1 and ABA have a synergistic effect on *Em* expression. It would be interesting to determine the regions in GA-regulated promoters that are required for regulation by VP1. Without doubt it is necessary to determine whether VP1 functions *in vivo* both during seed development and during the transition to seed germination.

Enormous progress has been made in understanding hormone-regulated gene expression by using aleurone cells as a model system. It is clear that the timing and level of expression of GA-inducible genes is reflected in the composition of their promoters. Some transacting factors might be master regulatory proteins for entire classes of GA-inducible genes. ABA-inducible promoters contain their own specific promoter elements and several appear to be differentially regulated by VP1. In parallel with ongoing studies to identify additional transacting factors, it is now possible to study interactions between previously identified transacting factors and other nuclear or cytosolic proteins. This may provide a link between the signal transduction components described above and proteins which directly regulate transcription.

Concluding remarks

Two centuries of biochemical and ultrastructural research on the cereal aleurone have provided the framework for establishing hormonal signalling pathways. Many of the responses of the cereal aleurone to GA and ABA have been characterized. Receptors for GA and ABA have been localized, and efforts are underway to isolate them. Components of the signal transduction chains linking hormone perception to cellular response have been identified, and more are sure to be found. The effects of hormones on gene expression are becoming well understood. Much has been learned about hormonal signalling in cereal aleurone, but much more remains unknown. Additional signalling molecules must be identified in order to link hormone receptors to their downstream effectors

securely. The number of signalling pathways and the extent of cross-talk between them must be determined, and links must be found which join cytosolic signals to transcriptional events. Only when the interplay between signalling molecules, signalling pathways and downstream effectors is known, will it be understood how the activities of the aleurone cell are differentially regulated in response to hormone perception.

Acknowledgements

We would like to thank Eleanor Crump for assisting us in the preparation of this manuscript. The work of the authors has been supported by the National Science Foundation and the United States Department of Agriculture.

References

- Anderson BE, Ward JM, Schroeder JI. 1994. Evidence for an extracellular reception site for abscisic acid in *Commelina* guard cells. *Plant Physiology* **104**, 1177–83.
- Anderson JA, Huprikar SS, Kochian LV, Lucas WJ. 1992. Functional expression of a probable *Arabidopsis thaliana* potassium channel in *Saccharomyces cerevisiae*. *Proceedings of the National Academy of Sciences, USA* **89**, 3736–40.
- Beale MH, Hooley R, MacMillan J. 1985. Gibberellins: structure–activity relationships and the design of molecular probes. In: Bopp M, ed., *Plant growth substances 1985*. Twelfth international conference on plant growth substances. Heidelberg: Springer-Verlag, 65–73.
- Bethke PC, Gilroy S, Jones RL. 1995. Calcium and plant hormone action. In: Davies PJ, ed. *Plant hormones. Physiology, biochemistry and molecular biology*. Dordrecht, The Netherlands: Kluwer Academic Publishers, 298–317.
- Bethke PC, Hillmer S, Jones RL. 1996. Isolation of intact protein storage vacuoles from barley aleurone. *Plant Physiology* **110**, 521–9.
- Bethke PC, Jones RL. 1994. Ca²⁺-calmodulin modulates ion channel activity in storage protein vacuoles of barley aleurone cells. *The Plant Cell* **6**, 277–85.
- Bethke PC, Jones RL. 1997. Reversible protein phosphorylation regulates the activity of the slow-vacuolar ion channel. *The Plant Journal* (in press).
- Brown HT, Morris GH. 1890. Researches on the germination of some of the Graminae. *Journal of the Chemical Society, London* **57**, 458–528.
- Brown PH, Ho T-HD. 1986. Barley aleurone layers secrete a nuclease in response to gibberellic acid. *Plant Physiology* **82**, 801–6.
- Bush DS. 1995. Calcium regulation in plant cells and its role in signaling. *Annual Review of Plant Physiology and Plant Molecular Biology* **46**, 95–122.
- Bush DS. 1996. Effects of gibberellic acid and environmental factors on cytosolic calcium in wheat aleurone cells. *Planta* **199**, 89–99.
- Bush DS, Biswas AK, Jones RL. 1993. Hormonal regulation of Ca²⁺ transport in the endomembrane system of the barley aleurone. *Planta* **189**, 507–15.
- Bush DS, Cornejo M-J, Huang C-N, Jones RL. 1986. Ca²⁺-stimulated secretion of α -amylase during development in barley aleurone protoplasts. *Plant Physiology* **82**, 566–74.
- Bush DS, Hedrich R, Schroeder JI, Jones RL. 1988. Channel-mediated K⁺ flux in barley aleurone protoplasts. *Planta* **176**, 368–77.
- Bush DS, Sticher L, Van Huystee R, Wagner D, Jones RL. 1989. The calcium requirement for stability and enzymatic activity of two isoforms of barley aleurone α -amylase. *The Journal of Biological Chemistry* **264**, 19392–8.
- Bush DS, Wang T. 1995. Diversity of calcium-efflux transporters in wheat aleurone cells. *Planta* **197**, 19–30.
- Cejudo FJ, Ghose TK, Stabel P, Baulcombe DC. 1992. Analysis of the gibberellin-responsive promoter of a cathepsin B-like gene from wheat. *Plant Molecular Biology* **20**, 849–56.
- Chandler PM, Robertson M. 1994. Gene expression regulated by abscisic acid and its relation to stress tolerance. *Annual Review of Plant Physiology and Plant Molecular Biology* **45**, 113–41.
- Chandler PM, Zwar JA, Jacobsen JV, Higgins TJV, Inglis AS. 1984. The effect of gibberellic acid and abscisic acid on α -amylase mRNA levels in barley aleurone layers: studies using an α -amylase cDNA clone. *Plant Molecular Biology* **3**, 407–18.
- Chen X, Wang B, Wu R. 1995. A gibberellin-stimulated ubiquitin-conjugating enzyme gene is involved in α -amylase gene expression in rice aleurone. *Plant Molecular Biology* **29**, 787–95.
- Chrispeels MJ. 1991. Sorting of proteins in the secretory system. *Annual Review of Plant Physiology and Plant Molecular Biology* **42**, 21–53.
- Chrispeels MJ, Tenner AJ, Johnson KD. 1973. Synthesis and release of sucrose by the aleurone layer of barley: regulation by gibberellic acid. *Planta* **113**, 35–46.
- Cornejo MJ, Platt-alloia KA, Thomson WW, Jones RL. 1988. Effects of GA₃ and Ca²⁺ on barley aleurone protoplasts: a freeze-fracture study. *Protoplasma* **146**, 157–65.
- Deikman J, Jones RL. 1985. Control of α -amylase mRNA accumulation by gibberellic acid and calcium in barley aleurone layers. *Plant Physiology* **78**, 192–8.
- Deutsch P, Hoeffler JP, Jameson JL, Habener JF. 1988. Cyclic AMP and phorbol ester-stimulated transcription mediated by similar DNA elements that bind distinct proteins. *Proceedings of the National Academy of Sciences, USA* **85**, 7922–6.
- Drozdowicz YM, Jones RL. 1995. Hormonal regulation of organic and phosphoric acid release by barley aleurone layers and scutella. *Plant Physiology* **108**, 769–76.
- Felle H. 1988. Cytoplasmic free calcium in *Riccia fluitans* L. and *Zea mays* L.: interaction of Ca²⁺ and pH? *Planta* **176**, 248–55.
- Fernandez DE, Stachelin LA. 1985. Structural organization of ultrarapidly frozen barley aleurone cells actively involved in protein secretion. *Planta* **165**, 455–68.
- Fincher GB. 1989. Molecular and cellular biology associated with endosperm mobilization in germinating cereal grains. *Annual Review of Plant Physiology and Plant Molecular Biology* **40**, 305–46.
- Fischer EH, Stein EA. 1960. α -Amylases. In: Boyer PD, Lardy H, Myrbäck K, eds. *The enzymes*, 4. New York: Academic Press, 313–43.
- Gilroy S. 1996. Signal transduction in barley aleurone protoplasts is calcium dependent and independent. *The Plant Cell* **8**, 2193–209.
- Gilroy S, Jones RL. 1992. Gibberellic acid and abscisic acid co-ordinately regulate cytoplasmic calcium and secretory activity in barley aleurone protoplasts. *Proceedings of the National Academy of Sciences, USA* **89**, 3591–5.
- Gilroy S, Jones RL. 1993. Calmodulin stimulation of unidirectional calcium uptake in the endoplasmic reticulum of barley aleurone. *Planta* **190**, 289–96.
- Gilroy S, Jones RL. 1994. Perception of gibberellin and abscisic

- acid at the external face of the plasma membrane of barley (*Hordeum vulgare* L.) aleurone protoplasts. *Plant Physiology* **104**, 1185–92.
- Giraudat J, Parcy F, Bertauche N, Gosti F, Leung J, Morris P-C, Bouvier-Durand M, Vartanian N. 1994. Current advances in abscisic acid action and signalling. *Plant Molecular Biology* **26**, 1557–77.
- Goldman S, Mawal YR, Tanida I, Wu R. 1994. Studies of a gibberellin-dependent DNA-binding protein related to the expression of a rice α -amylase gene. *Plant Science* **99**, 75–88.
- Goodwin PB, Carr DJ. 1972. The induction of amylase synthesis in barley aleurone layers by gibberellic acid. I. response to temperature. *Journal of Experimental Botany* **23**, 1–7.
- Goulding EH, Ngai J, Kramer RH, Colicos S, Axel R, Siegelbaum SA, Chess A. 1992. Molecular cloning and single-channel properties of the cyclic nucleotide-gated channel from catfish olfactory neurons. *Neuron* **8**, 45–58.
- Großelindemann E, Graebe JE, Stöckl D, Hedden P. 1991. ent-Kaurene biosynthesis in germinating barley (*Hordeum vulgare* L., cv. Himalaya) caryopses and its relation to α -amylase production. *Plant Physiology* **96**, 1099–104.
- Gubler F, Jacobsen JV. 1992. Gibberellin-responsive elements in the promoter of a barley high-*pl* α -amylase gene. *The Plant Cell* **4**, 1435–41.
- Gubler F, Kalla R, Roberts JK, Jacobsen JV. 1995. Gibberellin-regulated expression of a *myb* gene in barley aleurone cells: evidence for Myb transactivation of a high-*pl* α -amylase gene promoter. *The Plant Cell* **7**, 1879–91.
- Guiltinan MJ, Marcotte WRJ, Quatrano RS. 1990. A plant leucine zipper protein that recognizes an abscisic acid response element. *Science* **250**, 267–71.
- Haberlandt G. 1890. Die Kleberschicht des Gras-Endosperms als Diastase ausscheidendes Drüsengewebe. *Berichte Deutsche Botanische Gesellschaft* **8**, 40–8.
- Hattori T, Terada T, Hamasuna ST. 1994. Sequence and functional analyses of the rice gene homologous to the maize *Vp1*. *Plant Molecular Biology* **24**, 805–10.
- Hattori T, Terada T, Hamasuna ST. 1995. Regulation of the *Osem* gene by abscisic acid and the transcriptional activator VP1: analysis of *cis*-acting promoter elements required for regulation by abscisic acid and VP1. *The Plant Journal* **7**, 913–25.
- Heck GR, Chamberlain AK, Ho T-HD. 1993. Barley embryo globulin I gene, *Beg1*: Characterization of cDNA, chromosome mapping and regulation of expression. *Molecular and General Genetics* **239**, 209–18.
- Heimovaara-Dijkstra S, Heistek JC, Wang M. 1994a. Counteractive effects of ABA and GA₃ on extracellular and intracellular pH and malate in barley aleurone. *Plant Physiology* **106**, 359–65.
- Heimovaara-Dijkstra S, Nieland TJJ, Van Der Meulen RM, Wang M. 1996. Abscisic acid-induced gene-expression requires the activity of protein(s) sensitive to the protein-tyrosine phosphatase inhibitor phenylarsine oxide. *Plant Growth Regulation* **18**, 115–23.
- Heimovaara-Dijkstra S, Van Duijn B, Libbenga KR, Heidekamp F, Wang M. 1994b. Abscisic acid-induced membrane potential changes in barley aleurone protoplasts: a possible relevance for the regulation of rab gene expression. *Plant Cell Physiology* **35**, 743–50.
- Hetherington AM, Quatrano RS. 1991. Mechanisms of action of abscisic acid at the cellular level. *New Phytologist* **119**, 9–32.
- Hill A, Nantel A, Rock CD, Quatrano RS. 1996. A conserved domain of the *viviparous-1* gene product enhances the DNA binding activity of the bZIP protein EmBP-1 and other transcription factors. *Journal of Biological Chemistry* **271**, 3366–74.
- Hillmer S, Gilroy S, Jones RL. 1993. Visualizing enzyme secretion from individual barley (*Hordeum vulgare*) aleurone protoplasts. *Plant Physiology* **102**, 279–86.
- Hoecker U, Vasil IK, McCarty DR. 1995. Integrated control of seed maturation and germination programs by activator and repressor functions of *Viviparous-1* of maize. *Genes and Development* **9**, 2459–69.
- Hong B, Uknes SJ, Ho T-HD. 1988. Cloning and characterization of a complementary DNA encoding a messenger RNA rapidly-induced by ABA in barley aleurone layers. *Plant Molecular Biology* **11**, 495–506.
- Hooley R. 1982. Protoplasts isolated from aleurone layers of wild oat (*Avena fatua* L.) exhibit the classic response to gibberellic acid. *Planta* **154**, 29–40.
- Hooley R, Beale MH, Smith SJ. 1991. Gibberellin perception at the plasma membrane of *Avena fatua* aleurone protoplasts. *Planta* **183**, 274–80.
- Hooley R, Beale MH, Smith SJ, Walker RP, Rushton PJ, Whitford PN, Lazarus CM. 1992. Gibberellin perception and the *Avena-fatua* aleurone: do our molecular keys fit the correct locks? *Biochemical Society Transactions* **20**, 85–9.
- Huang AHC. 1992. Oil bodies and oleosins in seeds. *Annual Review of Plant Physiology and Plant Molecular Biology* **43**, 177–200.
- Huang N, Sutcliffe TD, Litts JC, Rodriguez RL. 1990. Classification and characterization of the rice α -amylase multigene family. *Plant Molecular Biology* **14**, 655–68.
- Huttly AK, Phillips AL. 1995. Gibberellin-regulated expression in oat aleurone cells of two kinases that show homology to MAP kinase and a ribosomal kinase. *Plant Molecular Biology* **27**, 1043–52.
- Huttly AK, Phillips AL, Tregear JW. 1992. Localisation of *cis* elements in the promoter of a wheat α -*Amy2* gene. *Plant Molecular Biology* **19**, 903–11.
- Itoh K, Yamaguchi J, Huang N, Rodriguez RL, Akazawa T, Shimamoto K. 1995. Developmental and hormonal regulation of rice α -amylase (*RAmy1A*)-*gusA* fusion genes in transgenic rice seeds. *Plant Physiology* **107**, 25–31.
- Jacobsen JV, Beach LR. 1985. Evidence for control of transcription of α -amylase and ribosomal RNA genes in barley aleurone protoplasts by gibberellic acid and abscisic acid. *Nature* **316**, 275–7.
- Johnson GL, Vaillancourt RR. 1994. Sequential protein kinase reactions controlling cell growth and differentiation. *Current Opinion in Cell Biology* **6**, 230–8.
- Jones HD, Desikan R, Plakidou-Dymock S, Hooley R. 1995. $G\alpha$ and $G\beta$ subunit genes and signal transduction in *A. fatua* aleurone. In: *15th International Conference on Plant Growth Substances*, Minneapolis, Minnesota USA.
- Jones HD, Smith S, Plakidou-Dymock S, Hooley R. 1996. $G\alpha$ and $G\beta$ subunit genes and signal transduction in *Avena fatua* aleurone. *Journal of Experimental Botany* **47**, Supplement 5.
- Jones RL. 1969a. The effect of ultracentrifugation on fine structure and α -amylase production in barley aleurone cells. *Plant Physiology* **44**, 1428–38.
- Jones RL. 1969b. Gibberellic acid and the fine structure of barley aleurone cells. I. Changes during the lag-phase of α -amylase synthesis. *Planta* **87**, 119–33.
- Jones RL. 1972. Fractionation of the enzymes of the barley aleurone layer: evidence for a soluble mode of enzyme release. *Planta* **103**, 95–109.
- Jones RL, Jacobsen JV. 1991. Regulation of synthesis and transport of secreted proteins in cereal aleurone. *International Review of Cytology* **126**, 49–88.

- Jones RL, Price JM. 1970. Gibberellic acid and the fine structure of barley aleurone cells. III. Vacuolation of the aleurone cell during the phase of ribonuclease release. *Planta* **94**, 191–202.
- Kende H, Gardner G. 1976. Hormone binding in plants. *Annual Review of Plant Physiology* **27**, 267–90.
- Kim JK, Cao J, Wu R. 1992. Regulation and interaction of multiple protein factors with the proximal promoter regions of a rice high pI α -amylase gene. *Molecular and General Genetics* **232**, 383–93.
- Knetsch ML, Wang M, Snaar-Jagalska BE, Heimovaara-Dijkstra S. 1996. Abscisic acid induces mitogen-activated protein kinase activation in barley aleurone protoplasts. *The Plant Cell* **8**, 1061–7.
- Kuo A, Cappelluti S, Cervantes-Cervantes M, Rodriguez M, Bush DS. 1996. Okadaic acid, a protein phosphatase inhibitor, blocks calcium changes, gene expression, and cell death induced by gibberellin in wheat aleurone cells. *The Plant Cell* **8**, 259–69.
- Lanahan MB, Ho T-HD, Rogers SW, Rogers JC. 1992. A gibberellin response complex in cereal α -amylase gene promoters. *The Plant Cell* **4**, 203–11.
- Leah R, Mundy J. 1989. The bifunctional α -amylase/subtilisin inhibitor of barley: nucleotide sequence and patterns of seed-specific expression. *Plant Molecular Biology* **12**, 673–82.
- Lenton JR, Appleford NEJ, Croker SJ. 1994. Gibberellins and α -amylase gene expression in germinating wheat grains. *Plant Growth Regulation* **15**, 261–70.
- Lin W, Gopalakrishnan B, Muthukrishnan S. 1996. Transcription efficiency and hormone-responsiveness of α -amylase gene promoters in an improved transient expression system from barley aleurone protoplasts. *Protoplasma* **192**, 93–108.
- Liu M, Chen T-Y, Ahamed B, Li J, Yay K-W. 1994. Calcium-calmodulin modulation of the olfactory cyclic nucleotide-gated cation channel. *Science* **266**, 1348–54.
- Marcotte WRJ, Bayley CC, Quatrano RS. 1988. Regulation of a wheat promoter by abscisic acid in rice protoplasts. *Nature* **335**, 454–7.
- Mikkonen A, Porali I, Cercos M, Ho T-hD. 1996. A major cysteine proteinase, EPB, in germinating barley seeds: structure of two intronless genes and regulation of expression. *Plant Molecular Biology* **31**, 239–54.
- Miller EC. 1931. *Plant physiology*. New York: McGraw-Hill.
- Mitsunaga S-I, Rodriguez RL, Yamaguchi J. 1994. Sequence-specific interactions of a nuclear protein factor with the promoter region of a rice gene for α -amylase, *RAmy3D*. *Nucleic Acids Research* **22**, 1948–53.
- Mitsunaga S-I, Yamaguchi J. 1993. Induction of α -amylase is repressed by uniconazole, an inhibitor of the biosynthesis of gibberellin, in a dwarf mutant of rice, Waito-C. *Plant and Cell Physiology* **34**, 243–9.
- Mundy J, Chua N-H. 1988. Abscisic acid and water-stress induce the expression of a novel rice gene. *EMBO Journal* **7**, 2279–86.
- Musgrave A, Kays SE, Kende H. 1972. Uptake and metabolism of radioactive gibberellins by barley aleurone. *Planta* **102**, 1–10.
- Nadeau R, Rappaport L, Stolp CF. 1972. Uptake and metabolism of ^3H -gibberellin A_1 by barley aleurone layers: response to abscisic acid. *Planta* **107**, 315–24.
- O'Neill SD, Keith B, Rappaport L. 1986. Transport of gibberellin A_1 in cowpea membrane vesicles. *Plant Physiology* **80**, 812–17.
- Okita TW, Rogers JC. 1996. Compartmentation of proteins in the endomembrane system of plant cells. *Annual Review of Plant Physiology and Plant Molecular Biology* **47**, 327–50.
- Paleg L. 1960a. Physiological effects of gibberellic acid. I. On the carbohydrate metabolism and amylase activity of the barley endosperm. *Plant Physiology* **35**, 293–9.
- Paleg L. 1960b. Physiological effects of gibberellic acid. II. On starch hydrolyzing enzymes of barley endosperm. *Plant Physiology* **35**, 902–6.
- Payen A, Persoz J. 1833. Mémoire sur la diastase, les principaux produits de ses réactions et leurs applications aux arts industriels. *Annales de Chimie* **53**, 73–92.
- Penson SP, Schuurink RC, Fath A, Gubler F, Jacobsen JV, Jones RL. 1996. cGMP is required for gibberellic acid-induced gene expression in barley aleurone. *The Plant Cell* **8**, 2325–33.
- Radley M. 1959. The occurrence of gibberellin-like substances in barley and malt. *Chemistry and Industry Issue* **27**, 877–8.
- Reddy ASN, Takezawa DHF, Fromm H, Poovaiah BW. 1993. Isolation and characterization of two cDNAs that encode for calmodulin-binding proteins from corn root tips. *Plant Science* **94**, 109–17.
- Ried JL, Walker-Simmons MK. 1990. Synthesis of ABA-responsive, heat stable proteins in embryonic axes of dormant wheat grains. *Plant Physiology* **93**, 662–7.
- Ritchie S, Gilroy S. 1996. The regulation of the response of barley aleurone protoplasts to GA and ABA by elements of the phospholipid signal transduction pathway. *Plant Physiology* **111**, 153.
- Roberts DM, Harmon AC. 1992. Calcium-modulated proteins: targets of intracellular signals in higher plants. *Annual Review of Plant Physiology and Plant Molecular Biology* **43**, 375–414.
- Robertson M, Cuming AC, Chandler PM. 1995. Sequence analysis and hormonal regulation of a dehydrin promoter from barley, *Hordeum vulgare*. *Physiologia Plantarum* **94**, 470–8.
- Rogers JC, Rogers SW. 1992. Definition and functional implications of gibberellin and abscisic acid *cis*-acting hormone response complexes. *The Plant Cell* **4**, 1443–51.
- Rogers JC, Rogers SW, Mundy J. 1995. Biochemical and molecular dissection of hormone regulated transcription from barley. In: *15th International Conference on Plant Growth Substances*, Minneapolis, Minnesota, USA. 23.
- Rushton PJ, Hooley R, Lazarus CM. 1992. Aleurone nuclear proteins bind to similar elements in the promoter regions of two gibberellin-regulated α -amylase genes. *Plant Molecular Biology* **19**, 891–901.
- Rushton PJ, Macdonald H, Huttly AK, Lazarus CM, Hooley R. 1995. Members of a new family of DNA-binding proteins bind to a conserved *cis*-element in the promoters of α -amy2 genes. *Plant Molecular Biology* **29**, 691–702.
- Schroeder JI, Hagiwara S. 1990. Repetitive increases in cytosolic Ca^{2+} of guard cells by abscisic acid activation of non-selective Ca^{2+} permeable channels. *Proceedings of the National Academy of Sciences, USA* **87**, 9305–9.
- Schuurink RC, Chan PV, Jones RL. 1996. Modulation of calmodulin mRNA and protein levels in barley aleurone. *Plant Physiology* **111**, 371–80.
- Schuurink RC, Jones RL. 1995. A putative CaM and cyclic-nucleotide-regulated ion channel from barley. *Journal of Cellular Biochemistry, Supplement* **19A**, 153.
- Schuurink RC, van Duijn G, Heidekamp F. (1993). Is abscisic acid involved in barley aleurone dormancy. In: Walker-Simmons MK, Ried JL, eds. *Pre-harvest sprouting in cereals*. St. Paul: American Association of Cereal Chemists, 224–35.
- Shen Q, Ho T-HD. 1995. Functional dissection of an abscisic acid (ABA)-inducible gene reveals two independent ABA-responsive complexes each containing a G-box and a novel *cis*-acting element. *The Plant Cell* **7**, 295–307.

- Shen Q, Zhange P, Ho T-HD. 1996. Modular nature of abscisic acid (ABA) response complexes: composite promoter units that are necessary and sufficient for ABA induction of gene expression in barley. *The Plant Cell* **8**, 1107–19.
- Sinjorgo KMC, De Vries MA, Heistek JC, Van Zeijl MJ, Van Der Veen SW, Douma AC. 1993. The effect of external pH on the gibberellic acid response of barley aleurone. *Journal of Plant Physiology* **142**, 506–9.
- Skadsen R. 1993. Aleurones from a barley with low α -amylase activity become highly responsive to gibberellin when detached from the starchy endosperm. *Plant Physiology* **102**, 195–203.
- Skriver K, Olsen FL, Rogers JC, Mundy J. 1991. *Cis*-acting DNA elements responsive to gibberellin and its antagonist abscisic acid. *Proceedings of the National Academy of Sciences, USA* **88**, 7266–70.
- Stewart A, Nield H, Lott JNA. 1988. An investigation of the mineral content of barley grains and seedlings. *Plant Physiology* **86**, 93–7.
- Sutliff TD, Lanahan MB, Ho T-HD. 1993. Gibberellin treatment stimulates nuclear factor binding to the gibberellin response complex in a barley α -amylase promoter. *The Plant Cell* **5**, 1681–92.
- Swanson SJ, Jones RL. 1996. Gibberellic acid induces vacuolar acidification in barley aleurone. *The Plant Cell* **8**, 2211–21.
- Szymanski DB, Liao B, Zielinski RE. 1996. Calmodulin isoforms differentially enhance the binding of cauliflower nuclear proteins and recombinant TGA3 to a region derived from the *Arabidopsis Cam-3* promoter. *The Plant Cell* **8**, 1069–77.
- Taiz L, Jones RL. 1973. Plasmodesmata and an associated cell wall component in barley aleurone tissue. *American Journal of Botany* **60**, 67–75.
- Tangl E. 1885. Studien über das Endosperm einiger Gramineen. *Sitzungsberichte der Akademie der Wissenschaften zu Wien* **92**, 168–97.
- Tanida I, Kim J-K, Wu R. 1994. Functional dissection of a rice high-pI α -amylase promoter. *Molecular and General Genetics* **244**, 127–34.
- Tregear JW, Primavesi LF, Huttly AK. 1995. Functional analysis of linker insertions and point mutations in the α -Amy2/54 GA-regulated promoter. *Plant Molecular Biology* **29**, 749–58.
- Van der Veen R, Heimovaara-Dijkstra S, Wang M. 1992. Cytosolic alkalization mediated by abscisic acid is necessary, but not sufficient, for abscisic acid-induced gene expression in barley aleurone protoplasts. *Plant Physiology* **100**, 699–705.
- Wang M, Sedee NJA, Heidekamp F, Snaar-Jagalska BE. 1993. Detection of GTP-binding proteins in barley aleurone protoplasts. *FEBS Letters* **329**, 245–8.
- Wang M, Van Duijn B, Schram AW. 1991. Abscisic acid induces a cytosolic calcium decrease in barley aleurone protoplasts. *FEBS Letters* **278**, 69–74.
- Ward J, Schroeder JI. 1994. Calcium-activated K^+ channels and calcium-induced calcium release by slow vacuolar ion channels in guard cell vacuoles implicated in the control of stomatal closure. *The Plant Cell* **6**, 669–83.
- Washio K, Ishikawa K. 1992. Structure and expression during the germination of rice seeds of the gene for a carboxypeptidase. *Plant Molecular Biology* **19**, 631–40.
- Wolf N. 1992. Structure of the genes encoding *Hordeum vulgare* (1–3,1–4)- β -glucanase isoenzymes I and II and functional analysis of their promoters in barley aleurone protoplasts. *Molecular and General Genetics* **234**, 33–42.
- Yomo H. 1960. Studies on the α -amylase activating substance. IV. On the amylase activating action of gibberellin. *Hakko Kyokaiishi* **18**, 600–2.
- Zwar JA, Chandler PM. 1995. α -Amylase production and leaf protein synthesis in a gibberellin-responsive dwarf mutant of Himalaya barley (*Hordeum vulgare* L.). *Planta* **197**, 39–48.
- Zwar JA, Hooley R. 1986. Hormonal regulation of α -amylase gene transcription in wild oat (*Avena fatua* L.) aleurone protoplasts. *Plant Physiology* **80**, 459–63.